

**HITACHI**

Reliable solutions

PART NO. ENMNHK-NA1-1

# Operator's Manual

# ZW

# 550-6

# Wheel Loader

ZW550-6 WHEEL LOADER OPERATOR'S MANUAL

ENMNHK-NA1-1

 **Hitachi Construction Machinery Co., Ltd.**

URL:<http://www.hitachi-c-m.com>



This book is printed on recycled paper.

PRINTED IN JAPAN (T) 2018, 03

Serial No. 005201 and up

## INTRODUCTION

**Read this manual** carefully to learn how to operate and service your machine correctly. Failure to do so could result in personal injury or machine damage.

**This standard specification machine** can be operated under the following conditions without being modified.  
Atmospheric Temperature: -20 °C to 45 °C (-4 °F to 113 °F)  
Altitude: 0 m to 2000 m (0 ft to 6600 ft)

In case the machine is used under conditions other than described above, consult your authorized dealer.

**This manual should be considered** a permanent part of your machine and should remain with the machine when you sell it.

**This machine is of metric** design. Measurements in this manual are metric. Use only metric hardware and tools as specified.

**Right-hand and left-hand** sides are determined by facing in the direction of forward travel.

**Write product identification numbers** in the Machine Numbers section. Accurately record all the numbers to help in tracing the machine should it be stolen. Your dealer also needs these numbers when you order parts. If this manual is kept on the machine, also file the identification numbers in a secure place off the machine.

Use only diesel fuel with quality specified in JIS K-2204, EN-590 or ASTM D-975 which contents 15 ppm or lower sulfur.

Also use fuel that complies with solid contamination level of class 18/16/13 of ISO4406-1999 (solid contamination includes dust). If the fuel specified above is not used, exhaust gas that exceeds the regulation values may be discharged, causing serious problem on the engine. Consult your authorized dealer.

**Warranty** is provided as a part of Hitachi's support program for customers who operate and maintain their equipment as described in this manual. The warranty is explained on the warranty certificate which you should have received from your dealer.

This warranty provides you with the assurance that Hitachi will back its products where defects appear within the warranty period. In some circumstances, Hitachi also provides field improvements, often without charge to the customer, even if the product is out of warranty.

**Should the equipment be abused, or modified to change its performance beyond the original factory specifications, the warranty will become void and field improvements may be denied.**

Setting fuel delivery above specifications or otherwise overpowering machines will result in such action.

Only qualified, experienced operators officially licensed (according to local law) should be allowed to operate the machine. Moreover, only officially licensed personnel should be allowed to inspect and service the machine.

**PRIOR TO OPERATING THIS MACHINE, INCLUDING COMMUNICATION SYSTEM, IN A COUNTRY OTHER THAN A COUNTRY OF ITS INTENDED USE, IT MAY BE NECESSARY TO MAKE MODIFICATIONS TO IT SO THAT IT COMPLIES WITH THE LOCAL REGULATORY STANDARDS (INCLUDING SAFETY STANDARDS) AND LEGAL REQUIREMENTS OF THAT PARTICULAR COUNTRY. PLEASE DO NOT EXPORT OR OPERATE THIS MACHINE OUTSIDE OF THE COUNTRY OF ITS INTENDED USE UNTIL SUCH COMPLIANCE HAS BEEN CONFIRMED. PLEASE CONTACT HITACHI CONSTRUCTION MACHINERY CO., LTD. OR ANY OF OUR AUTHORIZED DISTRIBUTOR OR DEALER IF YOU HAVE ANY QUESTIONS CONCERNING COMPLIANCE.**

In this manual, urea water is indicated as DEF/AdBlue®. "DEF" stands for the Diesel Exhaust Fluid. AdBlue® is a registered trademark of the Verband der Automobilindustrie e.V. (VDA).



## WARNING

Breathing diesel engine exhaust exposes you to chemicals known to the State of California to cause cancer and birth defects or other reproductive harm.

- Always start and operate the engine in a well-ventilated area.
- If in an enclosed area, vent the exhaust to the outside.
- Do not modify or tamper with the exhaust system.
- Do not idle the engine except as necessary.

For more information go to [www.P65warnings.ca.gov/diesel](http://www.P65warnings.ca.gov/diesel).

This product can expose you to chemicals including Lead and Lead Compounds, and Ethylene glycol, which are known to the State of California to cause cancer and birth defects or other reproductive harm. For more information go to [www.P65Warnings.ca.gov](http://www.P65Warnings.ca.gov).

Battery posts, terminals and related accessories contain lead and lead compounds.

### WASH HANDS AFTER HANDLING !

Ethylene Glycol, which is used in some anti-freeze or coolants. No level is considered safe.

**DO NOT ingest ethyleneglycol in any manner.**

All information, illustrations and specifications in this manual are based on the latest product information available at the time of publication. The right is reserved to make changes at any time without notice.

# INDEX

MACHINE NUMBERS

SAFETY

SAFETY LABELS

COMPONENTS NAME

OPERATOR'S STATION

BREAK-IN

OPERATING THE ENGINE

MOVING THE MACHINE

OPERATING THE MACHINE

TRANSPORTING

MAINTENANCE

MAINTENANCE UNDER SPECIAL ENVIRONMENTAL CONDITIONS

STORAGE

TROUBLESHOOTING

SPECIFICATIONS

INDEX



# CONTENTS

<b>MACHINE NUMBERS .....</b>	<b>1</b>	Evacuating in Case of Fire.....	S-30
<b>SAFETY .....</b>	<b>S-1</b>	Beware of Exhaust Fumes.....	S-31
Recognize Safety Information .....	S-1	Precautions for Welding and Grinding .....	S-31
Understand Signal Words.....	S-1	Avoid Heating Near Pressurized Fluid Lines .....	S-31
Follow Safety Instructions.....	S-2	Avoid Applying Heat to Lines Containing Flammable Fluids .....	S-32
Prepare for Emergencies.....	S-3	Precautions for Handling Accumulator and Gas Damper.....	S-32
Wear Protective Clothing.....	S-3	Precautions for Diesel Exhaust Fluid (DEF).....	S-32
Protect Against Noise .....	S-4	Remove Paint Before Welding or Heating .....	S-33
Inspect Machine .....	S-4	Beware of Asbestos and Silicon Dust and Other Contamination.....	S-33
General Precautions for Cab.....	S-5	Prevent Battery Explosions .....	S-34
Use Handrails and Steps .....	S-6	Service Air Conditioning System Safely .....	S-34
Never Ride Attachment.....	S-6	Handle Chemical Products Safely.....	S-35
Adjust Operator's Seat.....	S-6	Dispose of Waste Properly.....	S-35
Ensure Safety Before Rising from or Leaving Operator's Seat .....	S-7	Notes on Aftertreatment Device .....	S-36
Fasten Your Seat Belt .....	S-7	Precautions for Communication Terminal.....	S-36
Move and Operate Machine Safely .....	S-8	Precaution for Communication Terminal Equipment .....	S-37
Handle Starting Aids Safely .....	S-8	Articulation Stopper (Lock Bar) .....	S-38
Operate Only from Operator's Seat .....	S-9	Joystick Steering System ON/OFF .....	S-39
Jump Starting .....	S-9	ROPS (Roll Over Protective Structure).....	S-40
Investigate Job Site Beforehand .....	S-10	<b>SAFETY LABELS.....</b>	<b>S-41</b>
Equipment of Head Guard, ROPS, FOPS.....	S-11	<b>COMPONENTS NAME.....</b>	<b>1-1</b>
Provide Signals for Jobs Involving Multiple Machines....	S-11	Components Name .....	1-1
Keep Riders Off Machine .....	S-12	<b>OPERATOR'S STATION .....</b>	<b>1-3</b>
Drive Safely .....	S-12	Aftertreatment Device.....	1-3
Drive Machine Safely (Work Site).....	S-13	Automatic Regeneration .....	1-5
Drive Safely with Bucket Loaded .....	S-14	Repeated Inhibiting of Exhaust Filter Cleaning .....	1-6
Drive on Snow Safely .....	S-14	Cab Features.....	1-7
Travel on Public Roads Safely.....	S-15	Front Console.....	1-8
Avoid Injury from Rollaway Accidents.....	S-15	Joystick Steering.....	1-9
Avoid Accidents from Backing Up and Turning .....	S-16	Right Console.....	1-10
Avoid Positioning Bucket or Attachment Over Anyone.....	S-17	Fingertip Control Type .....	1-10
Avoid Tipping.....	S-17	Multi-Function Joystick Type .....	1-11
Never Undercut a High Bank.....	S-18	Monitor Panel .....	1-12
Dig with Caution.....	S-18	Parking Brake Indicator (Red).....	1-13
Perform Truck Loading Safely .....	S-18	Brake Oil Low Pressure Indicator (Red).....	1-13
Avoid Power Lines.....	S-19	Hydraulic Oil Level Indicator (Red).....	1-13
Precautions for Operation.....	S-19	Low Steering Oil Pressure Indicator (Option) (Red) .....	1-14
Precautions for Lightning.....	S-19	Transmission Warning Indicator (Red).....	1-14
Object Handling .....	S-20	Communication Error Indicator (Yellow) .....	1-14
Protect Against Flying Debris .....	S-20	Discharge Warning Indicator (Red).....	1-14
Park Machine Safely.....	S-21	Engine Warning Indicator (Red) .....	1-15
Store Attachments Safely .....	S-21	Overheat Indicator (Red) .....	1-15
Transport Safely .....	S-22	Engine Oil Low Pressure Indicator (Red) .....	1-15
Handle Fluids Safely—Avoid Fires.....	S-23	Air Filter Restriction Indicator (Red).....	1-16
Practice Safe Maintenance .....	S-24	Preheat Indicator (Yellow).....	1-16
Warn Others of Service Work .....	S-25	Coolant Temperature Gauge.....	1-17
Support Machine Properly.....	S-25	Fuel Gauge.....	1-17
Stay Clear of Moving Parts .....	S-26	Turn Signal Indicator (Green) .....	1-18
Support Maintenance Properly.....	S-26	High Beam Indicator (Blue).....	1-18
Prevent Parts from Flying .....	S-27	Work Light Indicator (Yellow).....	1-18
Prevent Burns.....	S-27	Clearance Light Indicator (Green) .....	1-18
Replace Rubber Hoses Periodically.....	S-28	Control Lever Lock Indicator (Red).....	1-18
Avoid High-Pressure Fluids.....	S-28		
Prevent Fires.....	S-29		

## CONTENTS

Multi Function Monitor .....	1-19	Key Switch.....	1-89
Feature .....	1-19	Accelerator Pedal.....	1-90
Screen Configuration.....	1-19	Brake Pedal .....	1-90
Default Setting .....	1-20	Service Brake .....	1-90
Basic Screen.....	1-21	Declutch Brake.....	1-90
How to Use Screens.....	1-22	Joystick Steering.....	1-91
Displaying Basic Screen .....	1-22	Joystick Steering Lever .....	1-91
Monitor Operation .....	1-26	Forward/Reverse Switch.....	1-91
Alarm Occurrence Screen.....	1-27	Joystick Steering System Switch .....	1-91
Remedy.....	1-29	Shift Switch .....	1-92
DEF/SCR System Alarm.....	1-32	Light Switch.....	1-93
DEF/AdBlue® Level Alarm .....	1-32	Wiper Switch .....	1-94
Urea SCR System Malfunction .....	1-33	Wiper Operation.....	1-94
Aftertreatment Device Regeneration .....	1-34	Front/Rear Wiper Switch.....	1-95
Aftertreatment Device Regeneration Status		Right Console/Switches .....	1-96
Display .....	1-34	Fingertip Control Type .....	1-96
Automatic regeneration (Auto-regeneration).....	1-35	Loading Control Levers .....	1-97
Manual Regeneration.....	1-36	Lift Arm Control Lever .....	1-97
Main Menu.....	1-37	Bucket Control Lever .....	1-97
Ride Control Drive Speed Setting (Option).....	1-38	Right Console/Switches .....	1-99
Dual Lift Arm Auto-Leveler .....	1-39	Multi-Function Joystick Type .....	1-99
Height Kickout ON/OFF, Stop Height Setting .....	1-40	Loading Multi-Function Joystick Lever (Option).....	1-100
Lower Kickout ON/OFF, Stop Height Setting .....	1-41	Auxiliary Control Lever (Option) .....	1-101
Brightness Adjustment.....	1-42	Turn Signal Switch.....	1-101
Mail (Option) .....	1-44	Loading Control Lever Lock Switch .....	1-102
Setting Menu .....	1-46	Armrest Adjust Handle .....	1-102
Date and Time.....	1-47	Declutch Position Switch.....	1-103
Time Adjustment .....	1-47	Travel Mode Selector Switch .....	1-104
Date Adjustment.....	1-49	Power Mode Selector Switch .....	1-105
Display Mode Setting .....	1-51	2nd/3rd Speed Limit Switch (Option) .....	1-105
Auto Idling Stop.....	1-53	Fan Reverse Rotation Switch .....	1-106
Auto Idling Stop: ON/OFF .....	1-53	OFF .....	1-106
Acting Time Setting.....	1-54	AUTO .....	1-106
Rear View Camera Monitor .....	1-55	Manual Operation .....	1-107
Aftertreatment Device Regeneration Inhibited .....	1-57	Hydraulic Coupler Switch (Option).....	1-107
Setting Procedure .....	1-57	Secondary Steering Operation Check Switch	
Transmission Setting.....	1-59	(Optional) .....	1-108
Shift Change Delay Mode Setting .....	1-59	Aftertreatment Device Regeneration Switch .....	1-108
Lockup Setting.....	1-61	Ride Control Switch (Option) .....	1-109
Traction Control Setting .....	1-63	AUTO.....	1-109
Parallel/Tandem Switching Height Setting .....	1-65	OFF .....	1-109
Warm Up Operation .....	1-67	Hold Switch .....	1-110
Display Item Selection.....	1-69	Quick Power Switch.....	1-111
Main Menu Display Order Change.....	1-71	Right Console Slide Lever.....	1-111
Information Menu.....	1-73	DSS (Down Shift Switch).....	1-112
Operation Condition .....	1-74	Horn Switch .....	1-113
Fuel Consumption .....	1-74	Cigar Lighter (24 V DC Electrical Outlet) .....	1-114
Maintenance .....	1-76	Using Cigar Lighter.....	1-114
Maintenance Notice.....	1-76	Ash Tray.....	1-114
Time Remains and Maintenance Interval.....	1-78	Auto Air Conditioner .....	1-115
Troubleshooting .....	1-80	Feature .....	1-115
Monitoring.....	1-82	Components Name .....	1-116
Front Console Switches, Pedals, and Joystick Steering... 1-85		Controller Part Name and Function .....	1-117
Hazard Switch .....	1-86	Mode/Temperature Control Switch .....	1-117
Work Light Switch .....	1-87	Fan/AUTO Switch .....	1-118
Parking Brake Switch.....	1-88	Air Conditioner ON/OFF Switch.....	1-118

# CONTENTS

Circulation/Fresh Air Switch.....	1-118	Warm Up.....	3-12
Defroster Switch.....	1-118	Cold Weather Warm Up.....	3-13
Cab Heater Operation.....	1-119	Stopping Engine.....	3-15
Cooling Operation.....	1-120	<b>MOVING THE MACHINE .....</b>	<b>4-1</b>
Defroster Operation.....	1-121	Driving the Machine.....	4-1
Cool Head/Warm Feet Operation.....	1-121	Precautions for Starting to Move .....	4-1
Tips for Optimal Air Conditioner Usage .....	1-122	Starting to Move.....	4-2
For Rapid Cooling .....	1-122	Shift Range of Auto Transmission .....	4-5
When Windows Become Fogged .....	1-122	Power Mode Selector .....	4-6
Off-Season Air Conditioner Maintenance.....	1-122	Shift Change Delay Mode .....	4-6
Adjusting Operator's Seat (Air Suspension Type Seat).....	1-123	Parking Brake Switch.....	4-7
Components Name .....	1-123	Drive Speed Change (Manual Shift) .....	4-8
Rear Tray .....	1-124	Changing Forward/Reverse Drive Direction.....	4-8
Electric Power Output (Option).....	1-124	Steering.....	4-9
Fuse Box.....	1-125	Secondary Steering (Option) .....	4-10
Fuse Box A .....	1-126	Emergency Stop and Restart of Operation .....	4-11
Fuse Box B.....	1-126	Precautions for Traveling .....	4-12
Hot/Cool Box.....	1-127	Operating in Water or on Soft Ground.....	4-13
Tray and Drink Holder.....	1-127	Precautions for Driving on Slopes.....	4-14
Cab.....	1-128	Precautions to be Taken if Machine Failure Occurs.....	4-15
Front Interior Light.....	1-130	Stop .....	4-16
Rear Interior Light .....	1-130	Parking .....	4-18
Sun Visor .....	1-131	Emergency Stopping .....	4-19
Emergency Exit Hammer.....	1-131	When the Engine has Stalled During Operation .....	4-19
Coat/Hat Hook.....	1-131	Auto Brake.....	4-20
Upper Switch Panel (Option).....	1-132	<b>OPERATING THE MACHINE .....</b>	<b>5-1</b>
Rotary Light Switch (Option).....	1-132	Loading Control Levers .....	5-1
Outside Rear View Mirror.....	1-133	Fingertip Control Type .....	5-1
Inside Rear View Mirror .....	1-133	Loading Multi-Function Joystick Lever (Option) .....	5-3
Cab Door.....	1-133	Control Lever Lock .....	5-4
Door Open/Close Lever.....	1-134	Control Lever Lock Operation .....	5-4
Window Open/Close Levers .....	1-134	Declutch Position Switch.....	5-5
Battery Disconnect Switch .....	1-135	Adjustment of Bucket Auto Leveler.....	5-6
Switch Operation .....	1-136	Adjustment of Bucket Angle Switch.....	5-8
Articulation Stopper (Lock Bar) .....	1-137	Adjustment of Dual Lift Arm Auto Leveler.....	5-10
Towing Pin .....	1-138	Auto Idling Stop.....	5-11
Inspection/Maintenance Access Covers .....	1-139	Auto Idling Stop Operating Condition.....	5-12
Rear Grille .....	1-140	Aftertreatment Device Manual Regeneration .....	5-13
Steps.....	1-141	Manual Regeneration Procedure .....	5-13
Tool Box .....	1-141	Before Operation .....	5-16
Vandal-Resistant Devices.....	1-142	Precautions for Operation.....	5-16
<b>BREAK-IN .....</b>	<b>2-1</b>	Ensure Safety When Operating on Road Shoulders .....	5-16
Break-in Period for New Machine.....	2-1	Avoid Overloading.....	5-17
Work Mode for Break-in .....	2-1	Avoid Rapid Steering Changes and/or Sudden Braking.....	5-17
<b>OPERATING THE ENGINE .....</b>	<b>3-1</b>	Avoid Operation with Loads on Only One Side.....	5-17
Inspect Machine Daily Before Starting .....	3-1	Excavation.....	5-18
Check Before Starting .....	3-3	Loading Accumulated Soil.....	5-18
Starting Engine .....	3-6	Digging and Loading Level Ground.....	5-19
Starting in Cold Weather.....	3-8	Grading .....	5-20
Preheating .....	3-8	Loading .....	5-21
Check After Starting .....	3-9	Load and Carrying Method .....	5-21
Check Monitor Operation .....	3-9	Loader and Dump Truck Combination Method.....	5-22
Check Engine Noise and Exhaust Gas Color.....	3-9	V-Shape Loading.....	5-22
Using Booster Batteries .....	3-10	I-Shape Loading .....	5-22

# CONTENTS

Dumping into Truck or Hopper.....	5-23	Change Planetary Gear Oil.....	7-38
Dozing .....	5-24	Replace Axle Oil Cooler Line Filter (Option) .....	7-39
Stock Piling .....	5-24	Clean Axle Oil Cooler Fins (Option) .....	7-40
Removing Snow.....	5-25	D. Hydraulic System.....	7-41
Lifting Wheel Loader .....	5-25	Inspection and Maintenance of Hydraulic	
Precautions for After Operation.....	5-26	Equipment .....	7-41
<b>TRANSPORTING .....</b>	<b>6-1</b>	Check Hydraulic Oil Level .....	7-43
Transporting by Road .....	6-1	Change Hydraulic Oil.....	7-44
Selecting a Trailer .....	6-1	Bleed Air from the Hydraulic System.....	7-45
Loading/Unloading on Trailer.....	6-2	Clean Suction Filter .....	7-46
Ramp/Loading Dock.....	6-2	Clean Pilot Oil Filter .....	7-47
Loading/Unloading on Trailer .....	6-3	Line Filter in Steering Circuit .....	7-47
Loading.....	6-3	Line Filter in Brake Circuit.....	7-48
Fastening Machine for Transporting .....	6-4	Replace Hydraulic Oil Return Filter.....	7-49
Transporting Wheel Loader (Urgent Situation) .....	6-5	Replace Air Breather Element.....	7-50
Precautions for Driving On Roads.....	6-5	Check Pilot Circuit Accumulator Function, Gas	
Precautions for Towing .....	6-6	Leakage, Looseness, and Damage .....	7-51
Releasing Parking Brake .....	6-7	Check Ride Control Accumulator Function, Gas	
Towing Method.....	6-9	Leakage, Looseness, and Damage (Option) .....	7-52
Lifting Machine .....	6-10	Check Gas Pressure in Ride Control Accumulator	
<b>MAINTENANCE.....</b>	<b>7-1</b>	(Option).....	7-52
Correct Maintenance and Inspection Procedures.....	7-1	Check Gas Pressure in Steering Accumulator.....	7-52
Check the Hour Meter Regularly.....	7-3	Check Hoses and Lines .....	7-53
Layout.....	7-4	Service Recommendations for Hydraulic	
Lubrication Guide.....	7-5	Fittings.....	7-56
Preparations for Inspection and Maintenance .....	7-6	Flat Face O-ring Seal Fitting (ORS Fitting).....	7-56
Articulation Lock.....	7-8	Metal Face Seal Fittings.....	7-56
Inspection/Maintenance Access Covers .....	7-9	E. Fuel System .....	7-57
Rear Grille .....	7-10	Check Fuel Level.....	7-57
Inspection and Maintenance Table.....	7-11	Recommended Fuel .....	7-57
Kind of Oils.....	7-15	About Biodiesel Fuel .....	7-57
Grease .....	7-15	Refueling .....	7-58
Engine Oil .....	7-15	Drain Water and Sediment from Fuel Tank.....	7-58
Transmission Oil .....	7-15	Drain Fuel Filter.....	7-59
Axle Oil.....	7-16	Draining Procedures (Pre-Filter).....	7-59
Hydraulic Oil .....	7-16	Bleed Air from the Fuel System .....	7-60
Recommended Coolant .....	7-16	Air Bleeding Procedure .....	7-60
List of Consumable Parts .....	7-17	If Air Mixed After Common Rail.....	7-61
A. Greasing.....	7-19	Replace Fuel Main Filter Element .....	7-62
B. Engine .....	7-25	Replace Fuel Pre-Filter Element .....	7-64
Check Engine Oil Level .....	7-25	Clean Fuel Pump Strainer.....	7-66
Change Engine Oil .....	7-26	Clean Fuel Priming Solenoid Pump Strainer.....	7-67
Replace Engine Oil Filter.....	7-28	Check Fuel Hoses .....	7-69
C. Power Train .....	7-30	F. Air Cleaner.....	7-71
Check Transmission Oil Level.....	7-30	Replace Air Cleaner Element.....	7-71
Change Transmission Oil.....	7-31	G. Cooling System .....	7-72
Clean Suction Strainer.....	7-31	Coolant.....	7-72
Change Transmission Oil Filter.....	7-31	Check Coolant Level .....	7-73
Clean Transmission and Torque Converter		Check Drive Belt .....	7-74
Air Breathers.....	7-34	Measurement of Deflection Amount and Vibration	
Check Axle Oil Level.....	7-35	Frequency .....	7-74
Check Differential Gear Oil Level .....	7-35	Adjusting Drive Belt.....	7-74
Check Planetary Gear Oil Level.....	7-36	Replacing Drive Belt .....	7-75
Change Axle Oil.....	7-37	Change Coolant.....	7-76
Change Differential Gear Oil .....	7-37	Clean Radiator/Oil Cooler Cores and Other Cooling	
		System .....	7-79



# CONTENTS

H. Electrical System.....	7-80	Specified DEF/AdBlue® .....	7-105
Batteries .....	7-80	Check DEF Level .....	7-106
Electrolyte Level Check .....	7-82	Refill DEF .....	7-106
Check Electrolyte Specific Gravity .....	7-83	Clean DEF Strainer.....	7-107
Replace Batteries .....	7-84	DEF Exchange Procedure.....	7-108
Check Monitor Functions and All Other Instrument		Replace DEF Supply Module Main Filter.....	7-109
Operation .....	7-84	Check Dosing Module.....	7-110
Check Work Lights.....	7-85	Replace DEF Tank Inlet Filter .....	7-110
Check Horn and Backup Alarm .....	7-85	N. Miscellaneous.....	7-111
Check Electrical Harnesses and Fuses .....	7-86	Check Bucket Teeth .....	7-111
Fuse Box A .....	7-87	Check and Replace Seat Belt and Lower Tether.....	7-112
Fuse Box B .....	7-87	Check ROPS, ROPS Mounting Bolts, and Cab .....	7-112
I. Brake System.....	7-88	Check Windshield Washer Fluid Level .....	7-113
Check Right and Left Brake Interlocking		Check Play Amount in Joystick Steering	
Performance.....	7-88	Movement.....	7-113
Check Brake Performance .....	7-88	Check Accelerator Pedal Operation, and Exhaust	
Check Play in Brake Pedal Stroke .....	7-88	Gas Color and Noise .....	7-114
Check Parking Brake Force .....	7-89	Exhaust Gas Color and Noise .....	7-114
Check Parking Brake Gear Oil Level.....	7-90	Check Rearview Mirror and Inside Rearview	
Change Parking Brake Gear Oil.....	7-91	Mirror .....	7-115
Check Accumulator Function, Gas Leakage,		Check Steps and Handrails for Damage and	
Looseness, and Damage .....	7-92	Looseness.....	7-115
Check Brake Disks (Service and Parking).....	7-93	Clean Engine Compartment and Hood .....	7-116
Check Gas Pressure in Accumulator.....	7-93	Check Sound Absorbing Mat Around Engine .....	7-116
J. Tire.....	7-94	Check and Adjust Valve Clearance.....	7-116
Check and Replace Tire (Tire Pressure).....	7-94	Check Engine Compression Pressure .....	7-116
Check Air Pressure .....	7-94	Check and Clean Starter and Alternator.....	7-116
Check Tire for Damage.....	7-95	Check Fuel Injector.....	7-117
Check Wheel Bolt Torque .....	7-95	Check Turbocharger.....	7-117
Replace Tire.....	7-95	Check and Adjust Engine Controller (ECM) .....	7-117
Tire Sizes to be Used.....	7-96	Check and Clean EGR Valve.....	7-117
Driving on Public Roads: Standard Pressure.....	7-96	Check and Clean EGR Cooler .....	7-117
Tire Rotation.....	7-97	Check Urea SCR System .....	7-117
Rotation Procedure.....	7-97	Cleaning of Rear View Camera Lens.....	7-118
How to Check Wear Amount (Tread Design Groove		Retighten Front Axle and Rear Axle Support	
Depth).....	7-97	Mounting Bolts.....	7-118
Removal and Installation of Tire.....	7-98	Check Tightening Torque of Nuts and Bolts.....	7-119
Tire Wheel.....	7-98		
K. Air Conditioner .....	7-99	<b>MAINTENANCE UNDER SPECIAL ENVIRONMENTAL</b>	
Clean/Replace Air Conditioner Circulation/		<b>CONDITIONS .....</b>	<b>9-1</b>
Fresh Air Filters .....	7-99	Maintenance Under Special Environmental Conditions...9-1	
Clean Fresh Air Filter.....	7-99	Precautions for Maintenance During Cold Weather	
Clean Circulation Air Filter.....	7-100	Season.....	9-2
Check Air Conditioner .....	7-101	<b>STORAGE .....</b>	<b>10-1</b>
Check Air Conditioner Piping .....	7-101	Storing the Machine.....	10-1
Check Air Conditioner Condenser .....	7-102	Removing the Machine from Storage .....	10-2
Check Air Conditioner Compressor Belt .....	7-102	<b>TROUBLESHOOTING.....</b>	<b>11-1</b>
Compressor Belt Tension Adjustment		Troubleshooting .....	11-1
Procedure .....	7-102	1. Engine.....	11-1
Check Refrigerant .....	7-103	2. Engine Auxiliaries.....	11-1
Replace Air Conditioner Receiver Dryer .....	7-103	3. Engine does not Start. ....	11-2
Check Compressor and Pulley.....	7-103	4. Control Lever.....	11-3
Check Compressor .....	7-103	5. Hydraulic System.....	11-3
L. Aftertreatment Device .....	7-104	6. Drive Function .....	11-4
Check and Clean Aftertreatment Device.....	7-104	7. Others.....	11-5
M. Urea SCR System.....	7-105		

## CONTENTS

---

<b>SPECIFICATIONS .....</b>	<b>12-1</b>
Specifications.....	12-1
Intended Use .....	12-1
<b>INDEX.....</b>	<b>14-1</b>

---

# MACHINE NUMBERS

The manufacturing Nos. explained in this group is the individual number (serial No.) given to each machine and hydraulic components. These numbers are requested when inquiring any information on the machine and/or components. Fill these serial Nos. in the blank spaces in this group to immediately make them available upon request.

## Machine

Model/type : \_\_\_\_\_

Product  
Identification Number : \_\_\_\_\_

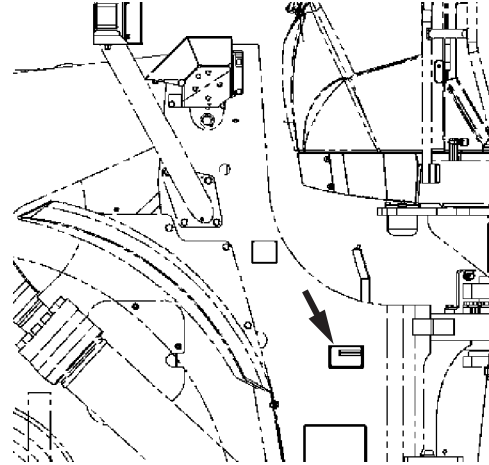

550SN\_plate\_US

## Engine

TYPE : \_\_\_\_\_

MFG. NO. : \_\_\_\_\_

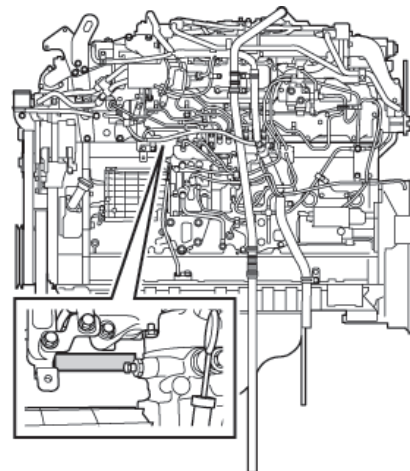

6WG1\_SN

# MACHINE NUMBERS

---

## Aftertreatment Device

**SCR**

TYPE : \_\_\_\_\_

MFG. NO. : \_\_\_\_\_

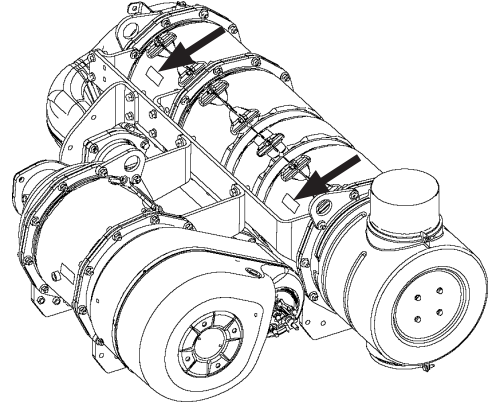

95Z7B-SCR4

**DOC**

TYPE : \_\_\_\_\_

MFG. NO. : \_\_\_\_\_

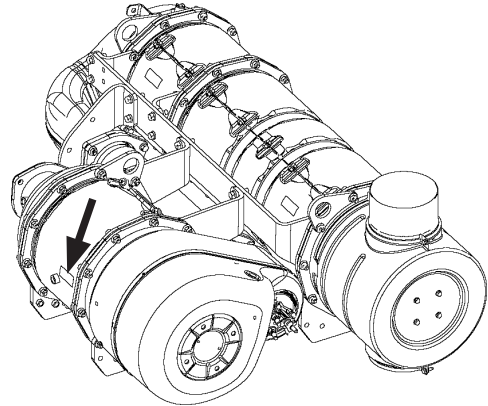

95Z7B-SCR4

## SAFETY

---

### Recognize Safety Information

- These are the **SAFETY ALERT SYMBOLS**.
  - When you see these symbols on your machine or in this manual, be alert to the potential for personal injury.
  - Follow recommended precautions and safe operating practices.

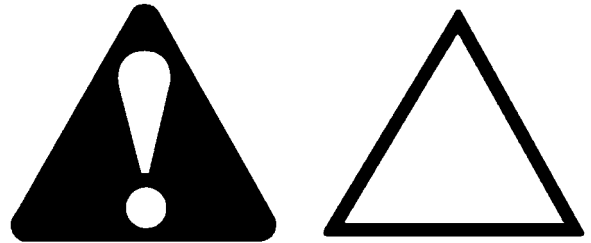

SA-2644

### Understand Signal Words

- On machine safety signs, signal words designating the degree or level of hazard - **DANGER**, **WARNING**, or **CAUTION** - are used with the safety alert symbol.
  - **DANGER** indicates an imminently hazardous situation which, if not avoided, will result in death or serious injury.
  - **WARNING** indicates a potentially hazardous situation which, if not avoided, could result in death or serious injury.
  - **CAUTION** indicates a potentially hazardous situation which, if not avoided, may result in minor or moderate injury.
  - **DANGER or WARNING safety signs** are located near specific hazards. General precautions are listed on **CAUTION safety signs**.
  - Some safety signs do not use any of the designated signal words above after the safety alert symbol has been used on this machine.
- To avoid confusing machine protection with personal safety messages, a signal word **IMPORTANT** indicates a situation which, if not avoided, could result in damage to the machine.
-  **NOTE** indicates an additional explanation for an element of information.



**IMPORTANT**



SA-1223

## SAFETY

---

### Follow Safety Instructions

- Carefully read and follow all safety signs on the machine and all safety messages in this manual.
- Safety signs should be installed, maintained and replaced when necessary.
  - If a safety sign or this manual is damaged or missing, order a replacement from your authorized dealer in the same way you order other replacement parts (be sure to state machine model and serial number when ordering).
- Learn how to operate the machine and its controls correctly and safely.
- Allow only trained, qualified, authorized personnel to operate the machine.
- Keep your machine in proper working condition.
  - Unauthorized modifications of the machine may impair its function and/or safety and affect machine life.
  - Do not modify any machine parts without authorization. Failure to do so may deteriorate the part safety, function, and/or service life. In addition, personal accident, machine trouble, and/or damage to material caused by unauthorized modifications will void Hitachi Warranty Policy.
  - Never attempt to modify or disassemble the inlet/exhaust parts and the exhaust filter. Avoid giving shocks on the exhaust filter by striking elements with other objects or dropping the elements. Failure to do so may affect the exhaust gas purifying device, possibly damaging it or lowering its performance.
  - Do not use attachments and/or optional parts or equipment not authorized by Hitachi. Carefully read and follow all instructions for use and safety in the operator's manual for the attachment. Failure to do so may deteriorate the safety, function, and/or service life of the machine. In addition, personal accident, machine trouble, and/or damage to material caused by using unauthorized attachments and/or optional parts or equipment will void Hitachi Warranty Policy.
- The safety messages in this SAFETY chapter are intended to illustrate basic safety procedures of machines. However it is impossible for these safety messages to cover every hazardous situation you may encounter. If you have any questions, you should first consult your supervisor and/or your authorized dealer before operating or performing maintenance work on the machine.



SA-003

# SAFETY

## Prepare for Emergencies

- Be prepared if a fire starts or if an accident occurs.
  - Keep a first aid kit and fire extinguisher on hand.
  - Thoroughly read and understand the label attached on the fire extinguisher to use it properly.
  - To ensure that a fire extinguisher can be always used when necessary, check and service the fire extinguisher at the recommended intervals as specified in the fire extinguisher manual.
  - Establish emergency procedure guidelines to cope with fires and accidents.
  - Keep emergency numbers for doctors, ambulance service, hospital, and fire department posted near your telephone.



SA-437

## Wear Protective Clothing

- Wear close fitting clothing and safety equipment appropriate to the job.

You may need:

- A hard hat
- Safety shoes
- Safety glasses, goggles, or face shield
- Heavy gloves
- Hearing protection
- Reflective clothing
- Wet weather gear
- Respirator or filter mask.

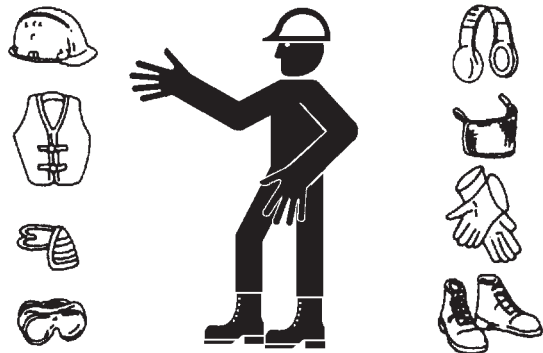

SA-438

Be sure to wear the correct equipment and clothing for the job. Do not take any chances.

- Avoid wearing loose clothing, jewelry, or other items that can catch on control levers or other parts of the machine.
- Operating equipment safely requires the full attention of the operator. Do not wear radio or music headphones while operating the machine.

## SAFETY

---

### Protect Against Noise

- Prolonged exposure to loud noise can cause impairment or loss of hearing.
- Wear a suitable hearing protective device such as earmuffs or earplugs to protect against objectionable or uncomfortably loud noises.



SA-434

---

### Inspect Machine

- Inspect your machine carefully each day or shift by walking around it before you start it to avoid personal injury.
- In the walk-around inspection, be sure to cover all points described in the "Inspect Machine Daily Before Starting" section in the operator's manual.



SA-435



## SAFETY

---

### General Precautions for Cab

- Before entering the cab, thoroughly remove all dirt and / or oil from the soles of your work boots.  
If any controls such as a pedal is operated while with dirt and / or oil on the soles of the operator's work boots the operator's foot may slip off the pedal, possibly resulting in a personal accident.
- Do not leave parts and / or tools lying around the operator's seat. Store them in their specified locations.
- Avoid storing transparent bottles in the cab. Do not attach any transparent type window decorations on the windowpanes as they may focus sunlight, possibly starting a fire.
- Refrain from using music headphones or mobile telephones in the cab while operating the machine.
- Keep all flammable objects and / or explosives away from the machine.
- After using the ashtray, always cover it to extinguish the match and / or tobacco.
- Do not leave cigarette lighters in the cab. When the temperature in the cab increases, the lighter may explode.
- Use proper floor mat dedicated to the machine.  
If another floor mat is used, it may be displaced and contact with the accelerator or brake pedals during operation, resulting in serious injury or death.
- Never weld, drill or in any way modify the ROPS without approval from the manufacturer.

## SAFETY

---

### Use Handrails and Steps

- Falling is one of the major causes of personal injury.
  - When you get on and off the machine, always face the machine and maintain a three-point contact with the steps and handrails.
  - Do not use any controls as handholds.
  - Never jump on or off the machine. Never mount or dismount a moving machine.
  - Be careful of slippery conditions on platforms, steps, and handrails when leaving the machine.
  - Never get on and off the machine with tools in your hands.



SA-439

---

### Never Ride Attachment

- Never allow anyone to ride attachment or the load. This is an extremely dangerous practice.

---

### Adjust Operator's Seat

- A poorly adjusted seat for either the operator or the work at hand may quickly fatigue the operator leading to misoperations.
  - The seat should be adjusted whenever changing the operator for the machine.
  - The operator should be able to fully depress the pedals and to correctly operate the control levers with his back against the seat back.
  - If not, move the seat forward or backward, and check again.
  - Adjust the rear view mirror position so that the best rear visibility is obtained from the operator's seat. If the mirror is broken, immediately replace it with a new one.



SA-462

## SAFETY

---

### Ensure Safety Before Rising from or Leaving Operator's Seat

- Before rising from the operator's seat to open / close either side window or to adjust the seat position, be sure to first lower the front attachment to the ground and then move the control lever lock switch to the lock (🔒) position. Failure to do so may allow the machine to unexpectedly move when a body part unintentionally comes in contact with a control lever, possibly resulting in serious personal injury or death.
- Before leaving the machine, be sure to first lower the front attachment to the ground and then move the control lever lock switch to the lock (🔒) position. Turn the parking brake switch ON, and the key switch OFF to stop the engine.
- Before leaving the machine, close all windows, doors, and access covers and lock them up.

---

### Fasten Your Seat Belt

- If the machine should overturn, the operator may become injured and / or thrown from the cab. Additionally the operator may be crushed by the overturning machine, resulting in serious injury or death.
- Prior to operating the machine, thoroughly examine webbing, buckle and attaching hardware. If any item is damaged or worn, replace the seat belt or component before operating the machine.
- Be sure to remain seated with the seat belt securely fastened at all times when the machine is in operation to minimize the chance of injury from an accident.
- We recommend that the seat belt be replaced every three years regardless of its apparent condition.

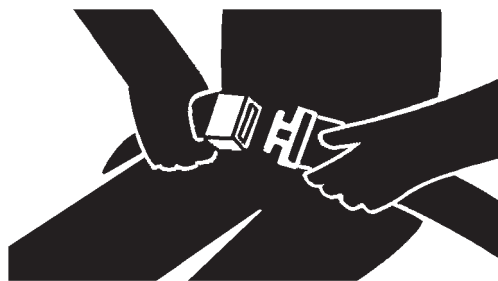

SA-237

## SAFETY

---

### Move and Operate Machine Safely

- Bystanders can be run over.
  - Take extra care not to run over bystanders. Be advised that there may be blind spots with rear view camera. Confirm the location of bystanders before moving, swinging, or operating the machine by sight and mirrors as well as the rear view monitor.
  - Always keep the travel alarm and horn in working condition (if equipped). It warns people when the machine starts to move.
  - Use a signal person when moving, or operating the machine in congested areas. Coordinate hand signals before starting the machine.
  - Use appropriate illumination. Check that all lights are operable before operating the machine. If any faulty illumination is present, immediately repair it.
  - Ensure the cab door, windows, doors and covers are securely locked.
  - Check the mirrors and the monitor in the CAB for problems.  
If there is, replace the problem part(s) or clean the mirror, camera and the monitor.  
Refer to Rear View Monitor section on the cleaning of the camera and the monitor.



SA-398

---

### Handle Starting Aids Safely

Starting fluid:

- Starting fluid is highly flammable.
  - Keep all sparks and flame away when using it.
  - Keep starting fluid well away from batteries and cables.
  - Remove container from machine if engine does not need starting fluid.
  - To prevent accidental discharge when storing a pressurized container, keep the cap on the container, and store it in a cool, well-protected location.
  - Do not incinerate or puncture a starting fluid container.



SA-293

## SAFETY

---

### Operate Only from Operator's Seat

- Inappropriate engine starting procedures may cause the machine to runaway, possibly resulting in serious injury or death.
  - Start the engine only when seated in the operator's seat.
  - NEVER start the engine while standing on the tire or on ground.
  - Do not start engine by shorting across starter terminals.
  - Before starting the engine, confirm that all control levers are in neutral.
  - Before starting the engine, confirm the safety around the machine and sound the horn to alert bystanders.



SA-431

---

### Jump Starting

- Battery gas can explode, resulting in serious injury.
  - If the engine must be jump started, be sure to follow the instructions shown in the "OPERATING ENGINE" chapter in the operator's manual.
  - The operator must be in the operator's seat so that the machine will be under control when the engine starts. Jump starting is a two-person operation.
  - Never use a frozen battery.
  - Failure to follow correct jump starting procedures could result in a battery explosion or a runaway machine.



SA-032

## SAFETY

---

### Investigate Job Site Beforehand

- When working at the edge of an excavation or on a road shoulder, the machine could tip over, possibly resulting in serious injury or death.
  - Investigate the configuration and ground conditions of the job site beforehand to prevent the machine from falling and to prevent the ground, stockpiles, or banks from collapsing.
  - Make a work plan. Use machines appropriate to the work and job site.
  - Reinforce ground, edges, and road shoulders as necessary. Keep the machine well back from the edges of excavations and road shoulders.
  - When working on an incline or on a road shoulder, employ a signal person as required.
  - Confirm that your machine is equipped with a FOPS cab before working in areas where the possibility of falling stones or debris exist.
  - When the footing is weak, reinforce the ground before starting work.
  - When working on frozen ground, be extremely alert. As ambient temperatures rise, footing becomes loose and slippery.
  - Beware of the possibility of fire when operating the machine near flammable objects such as dry grass.



SA-447

## SAFETY

---

### Equipment of Head Guard, ROPS, FOPS

In case the machine is operated in areas where the possibility of falling stones or debris exist, equip a head guard, ROPS, or FOPS according to the potential hazardous conditions. (The standard cab for this machine corresponds to ROPS and FOPS.) Any modification of the ROPS structure will modify its performances and its certification will be lost.

ROPS: Roll-Over Protective Structure  
FOPS: Falling Object Protective Structure

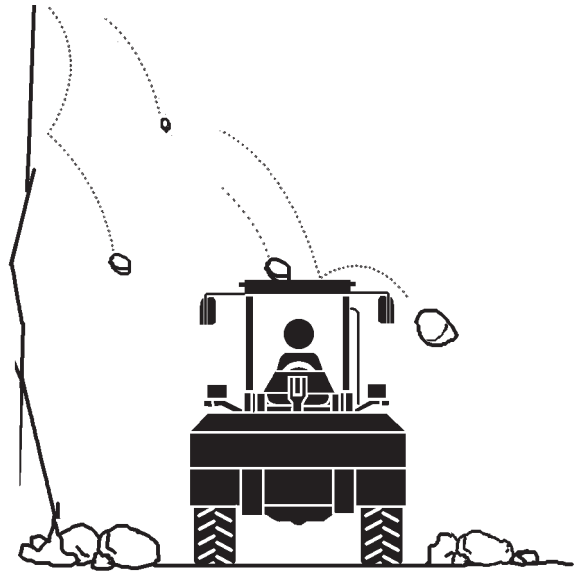

SA-521

---

### Provide Signals for Jobs Involving Multiple Machines

- For jobs involving multiple machines, provide signals commonly known by all personnel involved. Also, appoint a signal person to coordinate the job site. Make sure that all personnel obey the signal person's directions.



SA-481

## SAFETY

---

### Keep Riders Off Machine

- Riders on machine are subject to injury such as being struck by foreign objects and being thrown off the machine.
- Only the operator should be on the machine. Keep riders off.
- Riders also obstruct the operator's view, resulting in the machine being operated in an unsafe manner.



SA-427

---

### Drive Safely

- Beware of the possibility of slipping and/or turning over the machine when driving on a slope.
- When driving on level ground, hold the bucket at mark (A) 545 mm (21.5 in) above the ground as illustrated.
- Avoid traveling over any obstacles.
- Drive the machine slowly when driving on rough terrain.
- Avoid quick direction changes. Failure to do so may cause the machine to turn over.
- If the engine stops while driving, the steering function becomes inoperative. Immediately stop the machine by applying the brake to prevent personal accident.



SA-448



# SAFETY

## Drive Machine Safely (Work Site)

- Before driving the machine, always confirm that the steering wheel and/or joystick steering and forward/reverse lever (switch) direction corresponds to the direction you wish to drive.
  - Be sure to detour around any obstructions.
- Driving on a slope may cause the machine to slip or overturn, possibly resulting in serious injury or death.
  - When driving up or down a slope, keep the bucket facing the direction of travel, approximately 545 mm (21.5 in) (A) above the ground.
  - If the machine starts to skid or becomes unstable, immediately lower the bucket to the ground and stop.
- Driving across the face of a slope or steering on a slope may cause the machine to skid or overturn. If the direction must be changed, move the machine to level ground, then, change the direction to ensure safe operation.

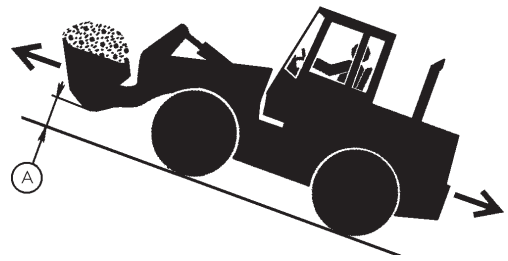

SA-449

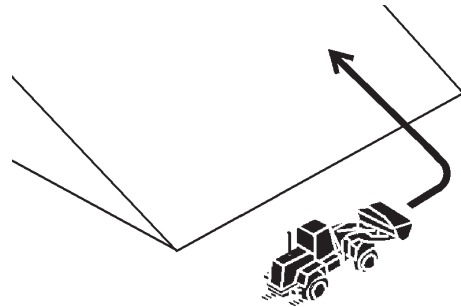

SA-450

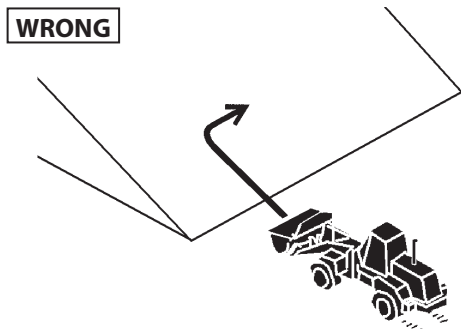

SA-451

## SAFETY

---

### Drive Safely with Bucket Loaded

- If the machine is operated incorrectly while driving with the bucket loaded, the machine may turn over. Be sure to follow all of the instructions indicated below.
  - When driving the machine on a job site with the bucket loaded, hold the bucket as low as possible to keep the machine balanced and to have good visibility.
  - Do not exceed the rated load capacity. Always operate the machine within the rated load capacity.
  - Avoid fast starts, stops, and quick turns. Failure to do so may result in personal injury and / or death.
  - Avoid rapid drive direction changes which could possibly cause personal injury and / or death.



SA-400

---

### Drive on Snow Safely

- Beware of the possibility of slipping or turning over the machine when driving on frozen snow surfaces.
  - The machine may slip more easily than expected on frozen snow surfaces even if the incline is small. Reduce speed when driving. Avoid fast starts, stops and quick turns.
  - Road shoulder and / or set-up utilities covered with snow are difficult to locate. Be sure where they are before removing snow.
  - Be sure to use tire chains when driving on snow.
  - Avoid applying the brake for quick stops on snow. If a quick stop is required, lower the bucket to the ground.

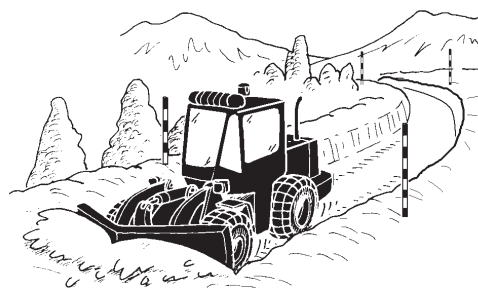

SA-452

## SAFETY

### Travel on Public Roads Safely

- This machine is not allowed to drive on public roads with the bucket loaded.
  - Be sure to empty the bucket.
  - Hold the bucket at mark (A) 545 mm (21.5 in) above the road surface as illustrated.



SA-453

### Avoid Injury from Rollaway Accidents

- Death or serious injury may result if you attempt to mount or stop a moving machine.

To avoid rollaways:

- Select level ground when possible to park machine.
- Do not park the machine on a grade.
- Lower the bucket to the ground.
- Put the forward / reverse lever (switch) in neutral.
- Run the engine at low idle speed without load for 5 minutes to cool down the engine.
- Turn the control lever lock switch to the lock (🔒) position.
- Turn the parking brake switch ON.
- Stop the engine and remove the key from the key switch.
- Block both tires and lower the bucket to the ground.
- Position the machine to prevent rolling.
- Park at a reasonable distance from other machines.



SA-457

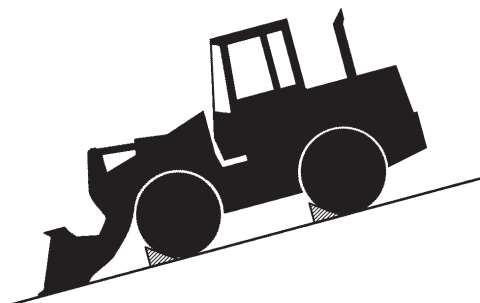

SA-458

## SAFETY

---

### Avoid Accidents from Backing Up and Turning

- Make sure no one is working under or close to the machine before backing up or turning the machine to avoid personal injury and / or death by being run over or entangled in the machine.
- Keep all personnel away from the machine by sounding the horn and / or using hand signals. Use extra care to be sure no one is in from the articulation area before turning the machine.
- Keep windows, mirrors, and lights in good condition.
- Reduce travel speed when dust, heavy rain, fog, etc., reducing the visibility.
- In case good visibility is not obtained, use a signal person to guide you.



SA-383



SA-312

## SAFETY

---

### Avoid Positioning Bucket or Attachment Over Anyone

- Never allow the bucket or attachment to pass over co-workers and / or the dump truck operator's cab. Falling material from the bucket or contact with bucket or attachment may cause serious personal accidents and / or damage to the machine.
- Avoid carrying the bucket or attachment over the co-workers to ensure safe operation.



SA-518

---

### Avoid Tipping

**DO NOT ATTEMPT TO JUMP CLEAR OF TIPPING MACHINE. MACHINE WILL TIP OVER FASTER THAN YOU CAN JUMP FREE, POSSIBLY RESULTING IN SERIOUS PERSONAL INJURY OR DEATH. IF TIPPING OVER OF THE MACHINE IS PREDICTED, SECURELY HOLD THE STEERING WHEEL, LEVER OR ANY FIXED EQUIPMENT TO PREVENT YOUR BODY FROM BEING THROWN OUT OF THE MACHINE.**

**MACHINE WILL TIP OVER FASTER THAN YOU CAN JUMP FREE**

**FASTEN YOUR SEAT BELT**

- The danger of tipping is always present when operating on a grade, possibly resulting in serious injury or death.

To avoid tipping:

- Be extra careful before operating on a grade.
  - Prepare machine operating area flat.
  - Keep the bucket low to the ground and close to the machine.
  - Reduce operating speeds to avoid tipping or slipping.
  - Avoid changing direction when traveling on grades.
  - NEVER attempt to travel across a grade steeper than 5 degrees if crossing the grade is unavoidable.
  - Reduce speed as necessary when swinging loads.
- Be careful when working on frozen ground.
  - Temperature increases will cause the ground to become soft and make ground travel unstable.

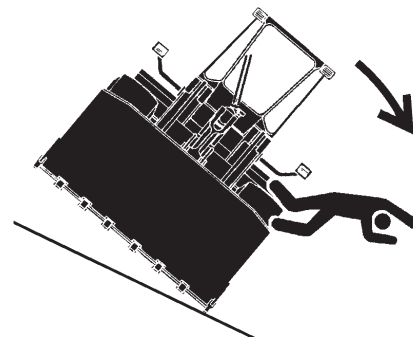

SA-463

## SAFETY

---

### Never Undercut a High Bank

- The edges could collapse or a land slide could occur causing serious injury or death.



SA-519

---

### Dig with Caution

- Accidental severing of underground cables or gas lines may cause an explosion and / or fire, possibly resulting in serious injury or death.
  - Before digging, check the location of cables, gas lines, and water lines.
  - Keep the minimum distance required by law, from cables, gas lines, and water lines.
  - If a fiber optic cable should be accidentally severed, do not look into the end. Doing so may result in serious eye injury.
  - Contact your local “diggers hot line” if available in your area, and / or the utility companies directly. Have them mark all underground utilities.



SA-396

---

### Perform Truck Loading Safely

- Do not operate the machine involuntarily. Unexpected machine movement may cause personal injury and / or death.
  - Do not lower the bucket with the lift arm control lever in the FLOAT position. The bucket may free fall, possibly causing personal injury and / or death.
  - Always select a level surface for truck loading.



SA-397

## SAFETY

---

### Avoid Power Lines

Serious injury or death can result from contact with electric lines.

Never move any part of the machine or load closer to any electric line than 3 m (10 ft) plus twice the line insulator length.

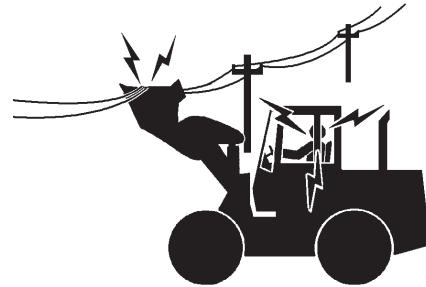

SA-455

---

### Precautions for Operation

- If the front attachment or any part of the machine comes in contact with an overhead obstacle, both the machine and the overhead obstacle may become damaged, and personal injury may result.
  - Take care to avoid coming in contact with overhead obstacles with the bucket or arm during operation.

---

### Precautions for Lightning

- The machine is vulnerable to lightning strikes.

In the event of an electrical storm, immediately stop operation, and take the following actions.

- If you are around the machine, evacuate to a safe place far away from the machine.
- If you are in the cab, stay in the cab until lightning has passed and safety is secured. Close the cab doors and windows. Lower the bucket to the ground, and stop the engine. Put your hands on your lap to avoid contact with any metal surfaces. Never go out of the cab.

After the electrical storm has passed and safety is secured, check all of the machine safety devices for any failure. If any failed safety devices are found, operate the machine only after repairing them.

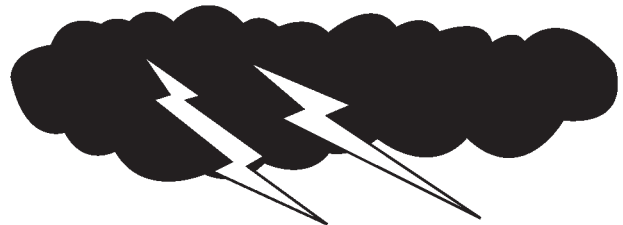

M4GB-05-001

## SAFETY

---

### Object Handling

#### CRANING OPERATION USING THE MACHINE IS NOT ALLOWED.

- If a lifted load should fall, any person nearby may be struck by the falling load or may be crushed underneath it, resulting in serious injury or death.

Never attach a sling or chain to the bucket teeth or to the attachment (fork or grapple for example). They may come off, causing the load to fall.



SA-132

---

### Protect Against Flying Debris

- If flying debris hit eyes or any other part of the body, serious injury may result.
  - Guard against injury from flying pieces of metal or debris; wear goggles or safety glasses.
  - Keep bystanders away from the working area before striking any object.

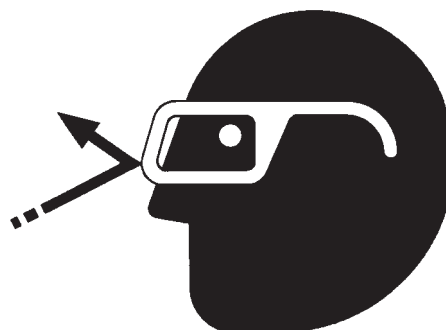

SA-432



## SAFETY

---

### Park Machine Safely

To avoid accidents:

- Park the machine on a firm, level surface.
- Lower bucket to the ground.
- Put the forward / reverse lever (switch) in neutral, and turn the parking brake switch (lever) ON (parking brake) position.
- Run the engine at low idle speed without load for 3 minutes.
- Turn key switch to OFF to stop engine.
- Remove the key from the key switch.
- Turn the control lever lock switch to the lock (🔒) position.
- Close windows, roof vent, and cab door.
- Lock all access doors and compartments.



SA-456

---

### Store Attachments Safely

- Stored attachments such as buckets, hydraulic hammers, and blades can fall and cause serious injury or death.
- Securely store attachments and implements to prevent falling. Keep children and bystanders away from storage areas.

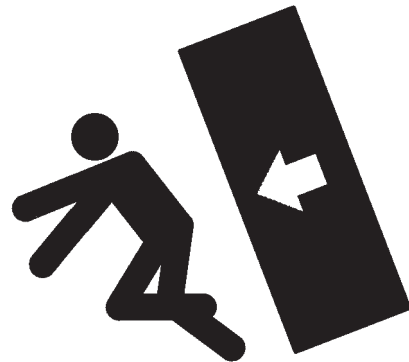

SA-034

## SAFETY

---

### Transport Safely

- Be careful because the machine may turn over when loading or unloading the machine on or off of a truck or trailer.
  - Observe the related regulations and rules for safe transportation.
  - Select an appropriate truck or trailer for the machine to be transported.
  - Be sure to use a signal person.
  - Always follow the following precautions for loading or unloading:
    1. Select solid and level ground.
    2. Always use a ramp or deck strong enough to support the machine weight.
    3. Use a low speed gear.
    4. Never steer the machine while being on the ramp. If the traveling direction must be changed while being on the ramp, unload the machine from the ramp, reposition the machine on the ground, then try loading again.
    5. After loading, install the lock bar (articulation stopper) to securely hold the articulation mechanism.
    6. Chock the front and rear of tires. Securely hold the machine to the truck or trailer deck with heavy chains of wire cables.

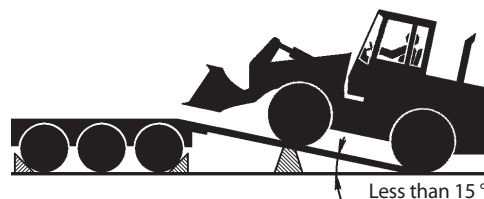

SA-454

Be sure to further follow the details described in the TRANSPORTING chapter.

## SAFETY

---

### Handle Fluids Safely—Avoid Fires

- Handle fuel with care; it is highly flammable. If fuel ignites, an explosion and / or a fire may occur, possibly resulting in serious injury or death.
  - Do not refuel the machine while smoking or when near open flame or sparks.
  - Always stop the engine before refueling the machine.
  - Fill the fuel tank outdoors.
- All fuels, most lubricants, and some coolants are flammable.
  - Store flammable fluids well away from fire hazards.
  - Do not incinerate or puncture pressurized containers.
  - Do not store oily rags; they can ignite and burn spontaneously.
  - Securely tighten the fuel and oil filler caps.



SA-018



SA-019

# SAFETY

## Practice Safe Maintenance

To avoid accidents:

- Understand service procedures before starting work.
- Keep the work area clean and dry.
- Do not spray water or steam inside cab.
- Never lubricate or service the machine while it is moving.
- Keep hands, feet and clothing away from power-driven parts.

Before servicing the machine:

1. Park the machine on a level surface.
2. Lower the bucket to the ground.
3. Run the engine at low idle speed without load for 3 minutes.
4. Turn the key switch to OFF to stop engine. Wait for some seconds and turn the key switch to ON again.
5. Relieve the pressure in the hydraulic system by moving the control levers several times.
6. Turn the control lever lock switch to the LOCK (🔒) position.
7. Turn the key switch to OFF, and remove the key from the key switch.
8. Attach a "Do Not Operate" tag on the control lever.
9. Connect the front and rear chassis with articulation stopper.
10. Allow the engine to cool.

- Refer to page 7-6 "Preparations for Inspection and Maintenance".
- If a maintenance procedure must be performed with the engine running, do not leave machine unattended.
- Never work under a machine raised by the lift arm.
- Inspect certain parts periodically and repair or replace as necessary. Refer to the section discussing that part in the "MAINTENANCE" chapter of this manual.
- Keep all parts in good condition and properly installed.
- Fix damage immediately. Replace worn or broken parts. Remove any buildup of grease, oil, or debris.
- When cleaning parts, always use nonflammable detergent oil. Never use highly flammable oil such as fuel oil and gasoline to clean parts or surfaces.
- Disconnect battery ground cable (-) before making adjustments to electrical systems or before performing welding on the machine.



SA-028



SA-312



SA-134



SA-527

## SAFETY

---

- Sufficiently illuminate the work site. Use a maintenance work light when working under or inside the machine.
- Always use a work light protected with a guard. In case the light bulb is broken, spilled fuel, oil, antifreeze fluid, or window washer fluid may catch fire.



SA-037

---

### Warn Others of Service Work

- Unexpected machine movement can cause serious injury.
  - Before performing any work on the machine, attach a “Do Not Operate” tag on the control lever. This tag is available from your authorized dealer.



ZZDT17389

---

### Support Machine Properly

- Never attempt to work on the machine without securing the machine first.
  - Always lower the attachment to the ground before you work on the machine.
  - If you must work on a lifted machine or attachment, securely support the machine or attachment. Do not support the machine on cinder blocks, hollow tires, or props that may crumble under continuous load. Do not work under a machine that is supported solely by a jack.



SA-527

## SAFETY

---

### Stay Clear of Moving Parts

- Entanglement in moving parts can cause serious injury.
  - To prevent accidents, care should be taken to ensure that hands, feet, clothing, jewelry and hair do not become entangled when working around rotating parts.

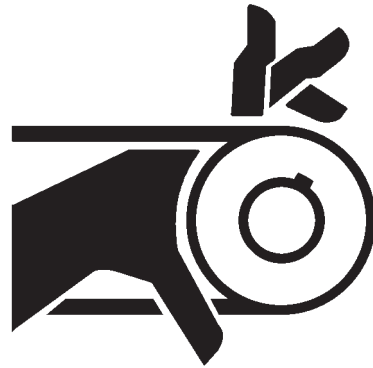

SA-026

### Support Maintenance Properly

- Explosive separation of a tire and rim parts can cause serious injury or death.
  - Do not attempt to mount a tire unless you have the proper equipment and experience to perform the job. Have it done by your authorized dealer or a qualified repair service.
  - Always maintain the correct tire pressure. DO NOT inflate tire above the recommended pressure.
  - When inflating tires, use a chip-on chuck and extension hose long enough to allow you to stand to one side and not in front of or over the tire assembly. Use a safety cage if available.
  - Inspect tires and wheels daily. Do not operate with low pressure, cuts bubbles, damaged rims, or missing lug bolts and nuts.
  - Never cut or weld on an inflated tire or rim assembly. Heat from welding could cause an increase in pressure and may result in tire explosion.

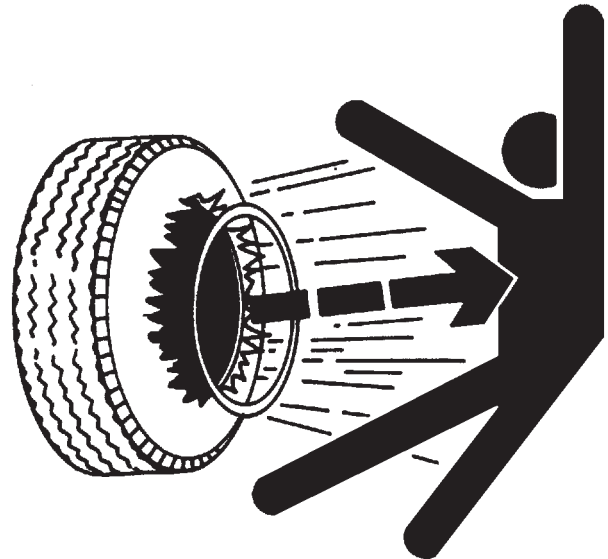

SA-249

## SAFETY

---

### Prevent Parts from Flying

- Travel reduction gears are under pressure.
  - As pieces may fly off, be sure to keep body and face away from AIR RELEASE PLUG to avoid injury.
  - GEAR OIL is hot. Wait for GEAR OIL to cool, then gradually loosen AIR RELEASE PLUG to release pressure.

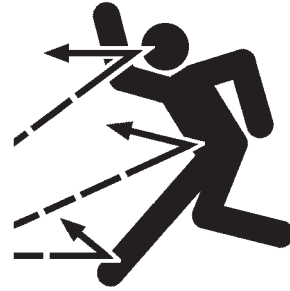

SA-344

---

### Prevent Burns

Hot spraying fluids:

- After operation, engine coolant is hot and under pressure. Hot water or steam is contained in the engine, radiator and heater lines. Skin contact with escaping hot water or steam can cause severe burns.
  - Avoid possible injury from hot spraying water. DO NOT remove the radiator cap until the engine is cool. When opening, turn the cap slowly to the stop. Allow all pressure to be released before removing the cap.
  - The hydraulic oil tank is pressurized. Again, be sure to release all pressure before removing the cap.



SA-039

Hot fluids and surfaces:

- Engine oil, gear oil and hydraulic oil also become hot during operation. The engine, hoses, lines and other parts become hot as well.
  - Wait for the oil and components to cool before starting any maintenance or inspection work.



SA-225

## SAFETY

### Replace Rubber Hoses Periodically

- Rubber hoses that contain flammable fluids under pressure may break due to aging, fatigue, and abrasion. It is very difficult to gauge the extent of deterioration due to aging, fatigue, and abrasion of rubber hoses by inspection alone.
  - Periodically replace the rubber hoses. (See the page of “Periodic replacement of parts” in the operator’s manual.)
- Failure to periodically replace rubber hoses may cause a fire, fluid injection into skin, or the front attachment to fall on a person nearby, which may result in severe burns, gangrene, or otherwise serious injury or death.



SA-019

### Avoid High-Pressure Fluids

- Fluids such as diesel fuel or hydraulic oil under pressure can penetrate the skin or eyes causing serious injury, blindness or death.
  - Avoid this hazard by relieving pressure before disconnecting hydraulic or other lines.
  - Tighten all connections before applying pressure.
  - Search for leaks with a piece of cardboard; take care to protect hands and body from high-pressure fluids. Wear a face shield or goggles for eye protection.
  - If an accident occurs, see a doctor familiar with this type of injury immediately. Any fluid injected into the skin must be surgically removed within a few hours, or gangrene may result.



SA-031

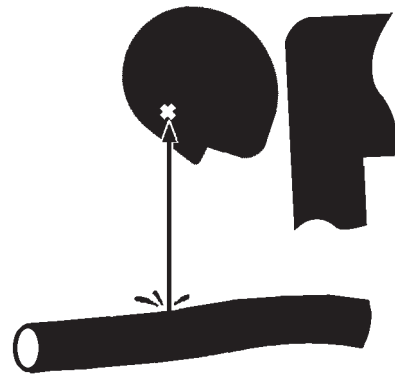

SA-292

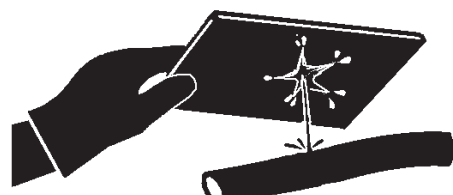

SA-044



## SAFETY

---

### Prevent Fires

#### Check for Oil Leaks:

- Fuel, hydraulic oil and lubricant leaks can lead to fires.
  - Check for oil leaks due to missing or loose clamps, kinked hoses, lines or hoses that rub against each other, damage to the oil-cooler, and loose oil-cooler flange bolts.
  - Tighten, repair or replace any missing, loose or damaged clamps, lines, hoses, oil-cooler and oil-cooler flange bolts.
  - Do not bend or strike high-pressure lines.
  - Never install bent or damaged lines, pipes, or hoses.
  - Replace fuel hoses and hydraulic hoses periodically even if there is no abnormality in their external appearance.



SA-019

#### Check for Shorts:

- Short circuits can cause fires.
  - Clean and tighten all electrical connections.
  - Check before each shift or after eight (8) to ten (10) hours operation for loose, kinked, hardened or frayed electrical cables and wires.
  - Check before each shift or after eight (8) to ten (10) hours operation for missing or damaged terminal caps.
  - DO NOT OPERATE MACHINE if cable or wires are loose, kinked, etc.
  - Never attempt to modify electric wirings.

#### Clean up Flammable Materials:

- Spilled fuel and oil, and trash, grease, debris, accumulated coal dust, and other flammables may cause fires.
  - Prevent fires by inspecting and cleaning the machine daily, and by removing adhered oil or accumulated flammables immediately. Check and clean high temperature parts such as the exhaust outlet and mufflers earlier than the normal interval.
  - Do not wrap high temperature parts such as a muffler or exhaust pipe with oil absorbents.
  - Do not store oily cloths as they are vulnerable to catching fire.
  - Keep flammables away from open flames.
  - Do not ignite or crush a pressurized or sealed container.
  - Wire screens may be provided on openings on the engine compartment covers to prevent flammable materials such as dead leaves from entering. However, flammable materials which have passed through the wire screen may cause fires. Check and clean the machine every day and immediately remove accumulated flammable materials.

## SAFETY

---

### Check Key Switch:

- If a fire breaks out, failure to stop the engine will escalate the fire, hampering fire fighting.  
Always check key switch function before operating the machine every day:
  1. Start the engine and run it at low idle.
  2. Turn the key switch to the OFF position to confirm that the engine stops.
- If any abnormalities are found, be sure to repair them before operating the machine.

### Check Heat Shields:

- Damaged or missing heat shields may lead to fires.
  - Damaged or missing heat shields must be repaired or replaced before operating the machine.
  - If hydraulic hoses are broken while the engine cover is open, splattered oil on the high temperature parts such as mufflers may cause fire. Always close the engine cover while operating the machine.

---

### Evacuating in Case of Fire

- If a fire breaks out, evacuate the machine in the following way:
  - Stop the engine by turning the key switch to the OFF position if there is time.
  - Use a fire extinguisher if there is time.
  - Exit the machine.
  - If the cab doors do not open, break them with a hammer to make an escapeway.
- In an emergency, if the cab door can not be opened, break the front or rear window panes with the emergency evacuation hammer to escape from the cab. Refer to the explanation pages on the Emergency Evacuation Method.



SA-393



SS-1510

## SAFETY

---

### Beware of Exhaust Fumes

- Prevent asphyxiation. Engine exhaust fumes can cause sickness or death.
- If you must operate in a building, be sure there is adequate ventilation. Either use an exhaust pipe extension to remove the exhaust fumes or open doors and windows to bring enough outside air into the area.
- PM (Particle Matter) combustion may generate white smoke during aftertreatment device regeneration. Do not attempt to perform aftertreatment device manual regeneration in a badly ventilated indoors.

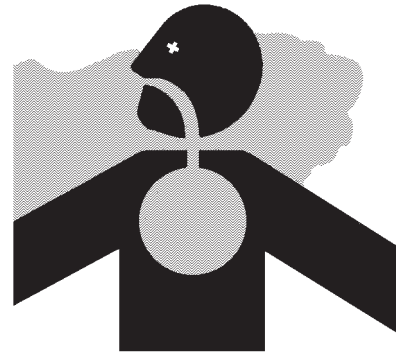

SA-016

---

### Precautions for Welding and Grinding

- Welding may generate gas and / or small fires.
  - Be sure to perform welding in a well ventilated and prepared area. Store flammable objects in a safe place before starting welding.
  - Only qualified personnel should perform welding. Never allow an unqualified person to perform welding.
- Grinding on the machine may create fire hazards. Store flammable objects in a safe place before starting grinding.
- After finishing welding and grinding, recheck that there are no abnormalities such as the area surrounding the welded area still smoldering.

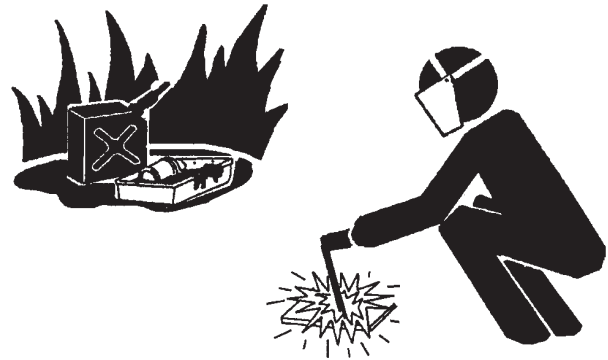

SA-818

---

### Avoid Heating Near Pressurized Fluid Lines

- Flammable spray can be generated by heating near pressurized fluid lines, resulting in severe burns to yourself and bystanders.
  - Do not heat by welding, soldering, or using a torch near pressurized fluid lines or other flammable materials.
  - Pressurized lines can be accidentally cut when heat goes beyond the immediate flame area. Install temporary fire-resistant guards to protect hoses or other materials before engaging in welding, soldering, etc.



SA-030

## SAFETY

---

### **Avoid Applying Heat to Lines Containing Flammable Fluids**

- Do not weld or flame cut pipes or tubes that contain flammable fluids.
- Clean them thoroughly with nonflammable solvent before welding or flame cutting them.

---

### **Precautions for Handling Accumulator and Gas Damper**

High-pressure nitrogen gas is sealed in the accumulator and the gas damper. Inappropriate handling may cause explosion, possibly resulting in serious injury or death.

Strictly comply with the following items:

- Do not disassemble the unit.
- Keep the units away from open flames and fire.
- Do not bore a hole, do not cut by torch.
- Avoid giving shocks by hitting or rolling the unit.
- Before disposing the unit, sealed gas must be released. Consult your nearest authorized dealer.

---

### **Precautions for Diesel Exhaust Fluid (DEF)**

- Diesel exhaust fluid (DEF), commonly referred to as AdBlue®, is an aqueous urea solution used as a consumable in selective catalytic reduction (SCR) to lower NOx concentration in the exhaust emissions from the engine. It is a non-flammable and non-hazardous solution, and harmful effects are not expected under normal conditions of use.
- In case of a fire, DEF would decompose and generate ammonia gas when heated to 160 °C (320 °F) or higher. Ammonia gas may cause lung injury and potentially is fatal if inhaled. It is a corrosive gas and the liquefied gas can cause frostbite and corrosive injury to eyes and skin. In case of contact, immediately flush skin with plenty of water at least 15 minutes while removing contaminated clothing. Get medical attention if symptoms occur.
- DEF is corrosive to steel, aluminium, copper and brass, etc. If DEF is spilled on your vehicle, wipe off and rinse with water.
- For the handling of DEF, follow handling precautions on Material Safety Data Sheet. Have suitable emergency equipment for fires, spills and leaks readily available. Practice good housekeeping. Maintain handling equipment. Comply with applicable regulations.

## SAFETY

---

### Remove Paint Before Welding or Heating

- Hazardous fumes can be generated when paint is heated by welding, soldering, or using a torch. If inhaled, these fumes may cause sickness.
  - Avoid potentially toxic fumes and dust.
  - Do all such work outside or in a well-ventilated area. Dispose of paint and solvent properly.
  - Remove paint before welding or heating:
    1. If you sand or grind paint, avoid breathing the dust. Wear an approved respirator.
    2. If you use solvent or paint stripper, remove stripper with soap and water before welding. Remove solvent or paint stripper containers and other flammable material from area. Allow fumes to disperse at least 15 minutes before welding or heating.



SA-029

---

### Beware of Asbestos and Silicon Dust and Other Contamination

- Take care not to inhale dust produced in the work site. Inhalation of asbestos fibers may be the cause of lung cancer. Inhalation of silicon dust and other contamination may cause sickness.
  - Depending on the work site conditions, the risk of inhaling asbestos fiber, silica dust or other contamination may exist. Spray water to prevent asbestos fibers, silica dust or other contamination from becoming airborne. Do not use compressed air.
  - When operating the machine in a work site where asbestos fibers, silica dust or other contaminations might be present, be sure to operate the machine upwind, and wear a mask rated to prevent the inhalation of asbestos, silica dust or other contaminations.
  - Keep bystanders out of the work site during operation.
  - Asbestos might be present in non-genuine parts. Use only genuine Hitachi Parts.



SA-029

## SAFETY

---

### Prevent Battery Explosions

- Battery gas can explode.
  - Keep sparks, lighted matches, and flame away from the top of battery.
  - Never check battery charge by placing a metal object across the posts. Use a voltmeter or hydrometer.
  - Do not charge a frozen battery; it may explode. Warm the battery to 16 °C (60 °F) first.
  - Do not continue to use or charge the battery when electrolyte level is lower than specified. Explosion of the battery may result.
  - Loose terminals may produce sparks. Securely tighten all terminals.
  - Connect terminals to the correct electrical poles. Failure to do so may cause damage to the electrical parts or fire.
- Battery electrolyte is poisonous. If the battery should explode, battery electrolyte may be splashed into eyes, possibly resulting in blindness.
  - Be sure to wear eye protection when checking electrolyte specific gravity.



SA-032

---

### Service Air Conditioning System Safely

- If spilled onto skin, refrigerant may cause a cold contact burn.
  - Refer to the instructions described on the container for proper use when handling the refrigerant.
  - Use a recovery and recycling system to avoid leaking refrigerant into the atmosphere.
  - Never touch the refrigerant.



SA-405

## SAFETY

---

### Handle Chemical Products Safely

- Direct exposure to hazardous chemicals can cause serious injury. Potentially hazardous chemicals used with your machine include such items as lubricants, coolants, paints, and adhesives.
- A Safety Data Sheet (SDS) provides specific details on chemical products: physical and health hazards, safety procedures, and emergency response techniques.
- Check the SDS before you start any job using a hazardous chemical. That way you will know exactly what the risks are and how to do the job safely. Then follow procedures and use recommended equipment.
- See your authorized dealer for SDS's (available only in English) on chemical products used with your machine.



SA-2579

---

### Dispose of Waste Properly

- Improperly disposing of waste can threaten the environment and ecology. Potentially harmful waste used with Hitachi equipment includes such items as oil, fuel, coolant, DEF/AdBlue®, brake fluid, filters, and batteries.
- Use leakproof containers when draining fluids. Do not use food or beverage containers that may mislead someone into drinking from them.
- Do not pour waste onto the ground, down a drain, or into any water source.
- Air conditioning refrigerants escaping into the air can damage the Earth's atmosphere. Government regulations may require a certified air conditioning service center to recover and recycle used air conditioning refrigerants.
- Inquire on the proper way to recycle or dispose of waste from your local environmental or recycling center, or from your authorized dealer.

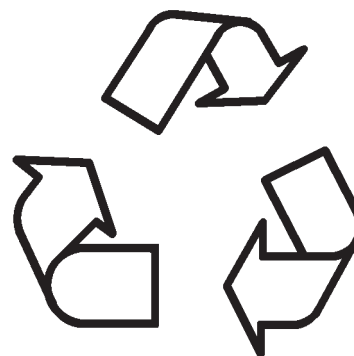

SA-226

## SAFETY

---

### Notes on Aftertreatment Device

#### About Aftertreatment Device

The aftertreatment device removes particulate matter (PM) and NOx (Nitrogen Oxide) from the exhaust gas. Follow the instructions below to prevent the aftertreatment device from being damaged.

**⚠ WARNING: Exhaust gas from the aftertreatment device, muffler, exhaust piping and tail piping becomes hot during and right after engine running and regeneration of aftertreatment device. Keep away from the exhaust system or hot gas from the exhaust piping during regeneration. Be careful to avoid skin contact with exhaust gas. It may cause severe burns.**

- White smoke may be generated during aftertreatment device regeneration. Do not attempt to perform aftertreatment device manual regeneration in a badly ventilated area.
- Ammonia odor may occur during aftertreatment device regeneration temporarily, but is not a trouble.
- Do not touch water coming directly out of the aftertreatment device. The water is mildly-acidic by oxidation catalyst mounted in the aftertreatment device. If filter water spills on your skin, immediately flush it out with clean water.

---

### Precautions for Communication Terminal

- Electrical wave transmitted from the communication terminal may cause malfunction of other electronic devices. Inquire to the device manufacturer for information on electrical wave disturbance when using an electronic device near the communication terminal.
- Never attempt to disassemble, repair, modify or displace the communication terminal, antennas or cables. Failure to do so may result in damage and/or fire to the base machine or to the communication terminal. (When required to remove or install the communication terminal, consult your authorized dealer.)
- Do not pinch or forcibly pull cables, cords or connectors. Failure to do so may cause a short or broken circuit that may result in damage and/or fire to the base machine or to the communication terminal.



# SAFETY

## Precaution for Communication Terminal Equipment

This machine has a communication terminal equipment emitting electrical waves installed inside the rear tray situated at the back of the operator's seat. There is a possibility that a medical device, including an implantable device such as a cardiac pacemaker, could be affected and malfunction due to the electrical waves emitted from the communication terminal equipment.

Any person fitted with a medical device such as the above should not use this machine, unless the medical device and the rear tray are at least 22 centimeters (8.662 inches) apart at all times. If this condition cannot be met, please contact your authorized dealer and have the person in charge stop the communication terminal equipment from functioning completely and confirm that it is not emitting electrical waves. This machine is equipped with a communication terminal type A or type B. Consult your authorized dealer for the type of communication terminal.

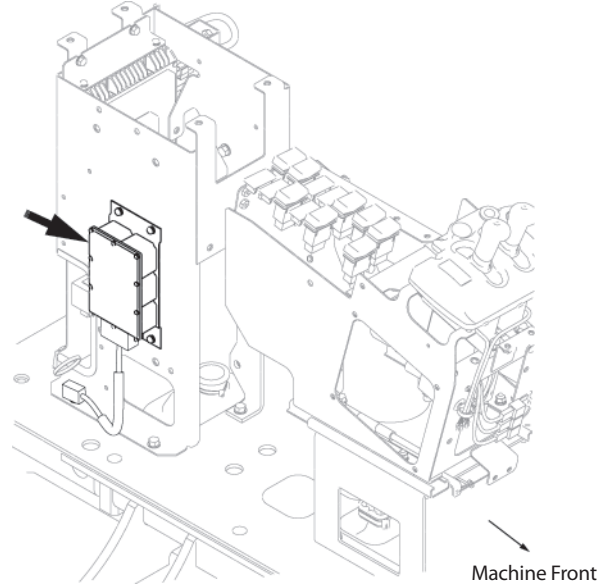

90MNEC-01-046

Specific Absorption Rate ("SAR") (measured by 10 g per unit) of communication terminal equipment:

	Type A	Type B
E-GSM900	0.573 W/kg (914.8 MHz)	0.12 W/kg (897.6 MHz)
DCS-1800	0.130 W/kg (1710.2 MHz)	0.06 W/kg (1748.0 MHz)
WCDMA Band I	0.271 W/kg (1950.0 MHz)	0.05 W/kg (1950.0 MHz)
WCDMA Band VIII	-	0.10 W/kg (892.6 MHz)

 **NOTE:** Please contact to your authorized representative if you want to know which terminal model A or B is installed.

\* This data was measured by having each type of communication terminal equipment, such as the communication terminal equipment used with this machine, and a human body set apart by 3 cm (1.18 inches).

\* SAR is a measure of the amount of radio frequency energy absorbed by the body when using a wireless application such as a mobile phone.

\* In the United States, the SAR limit set by the Federal Communications Commission is at or below 1.6 watts per kilogram (W/kg) taken over the volume containing a mass of 1 gram of tissue that is absorbing the most signal.

## SAFETY

### Articulation Stopper (Lock Bar)

**⚠ WARNING:** With articulation stopper in **LOCKED** position, machine will not steer; which, while operating, could cause an accident, injury or death. Do not lock Articulation Stopper during normal operation.

Articulation stopper locks the front and rear chassis to prevent them from sudden articulation during inspection or transportation. Refer to page 7-8.

To lock:

1. Align the front and rear chassis straight ahead.
2. Remove lock bolt (2) to release articulation stopper (1) from the rear chassis.
3. Turn the link and fix the end to the bracket on the front chassis (as shown).
4. Insert the pin and clip pin. (This is the **LOCKED** position.)

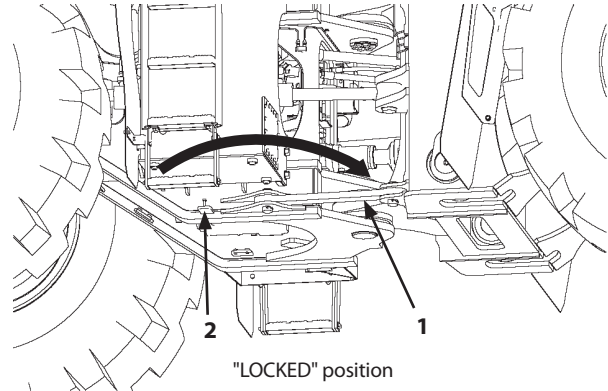

MNHE-07-005

To unlock:

1. Remove the clip pin and pin from the end of articulation stopper (1) on the front chassis bracket.
2. Turn the link to the rear chassis bracket.
3. Fix the end by tightening lock bolt (2). (This is the **STORED** position.)

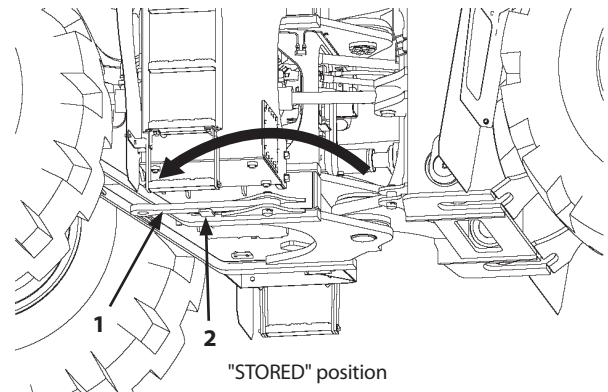

MNHE-07-004

# SAFETY

## Joystick Steering System ON/OFF

**⚠ WARNING: Accidental movement of the stick while getting on or off the machine may cause unexpected movement of the machine resulting in an accident, injury, or death.**

Always stop, and properly park the machine and turn off the joystick steering system while getting on or off the machine.

To turn OFF:

1. Push the lock button, hold lever (2) and lift armrest (1) to the fully raised position before getting off the machine.
2. When armrest (1) is fully raised, the joystick steering system is turned off automatically.
3. Then indicator lamp (3) on the monitor display goes out.

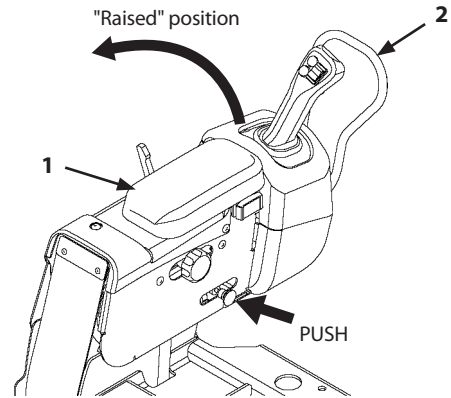

115Z7B-1-10-3

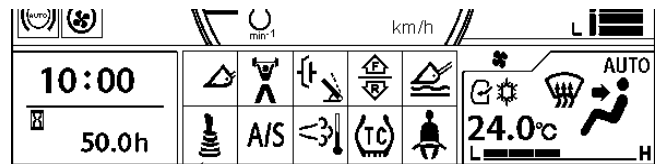

95Z7B-3-7-1

To turn ON:

1. Before operating the machine, lower armrest (1) back to the operating position.
2. When armrest (1) is completely lowered the joystick steering system is turned on automatically.
3. Then indicator lamp (3) on the monitor display turns on.

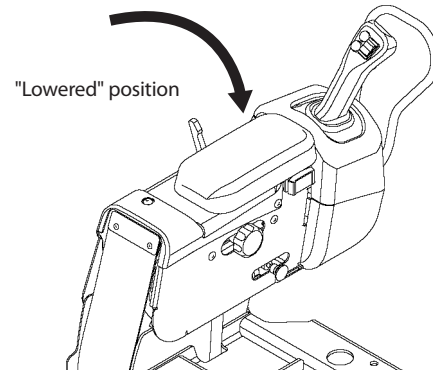

115Z7B-1-10-3

## SAFETY

### ROPS (Roll Over Protective Structure)

The Roll Over Protective Structure (ROPS) is attached to protect the cab in case of a machine rollover.

- ⚠ WARNING: Operating with damaged or improperly mounted ROPS could serious injury or death. Be sure to observe the following:**
- Whenever seated, fasten the seat belt.
  - Do not modify ROPS, such as drilling or welding.
  - Do not use ROPS deformed.
  - If any damage or loose bolts (1) are found, do not operate until repaired.
  - Never repair or modify ROPS without manufacturer's approval and instructions.

Be sure the ROPS is:

- in place.
- properly attached (no bolts loose or missing).
- not damaged.
- not modified.

Periodically check the ROPS bolts (1) to be sure they are in place and tight.

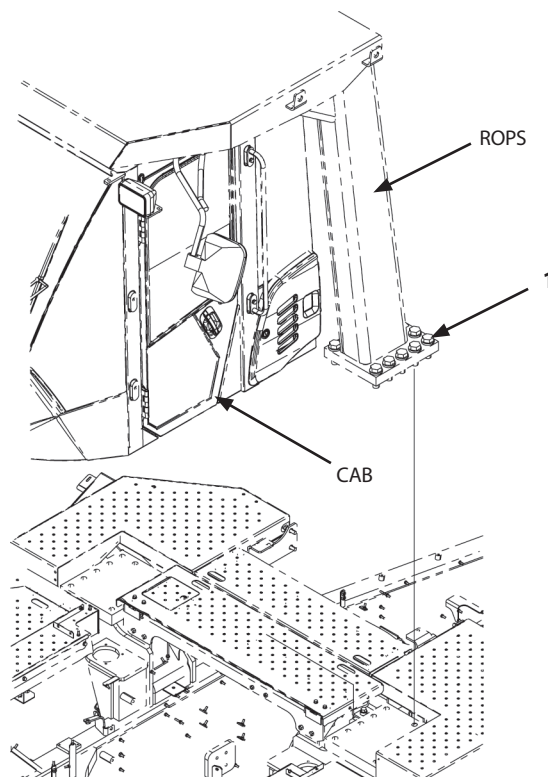

115Z7-ROPS

## SAFETY LABELS

All safety signs and their locations on the machine are illustrated in this group. Become familiar with the contents of the safety labels by reviewing them on the machine and understanding them, to ensure safe machine operation. Always keep the safety labels clean. In case a safety sign is lost or no longer readable, immediately-obtain a new replacement and affix it again in position on the machine. Use the part No. indicated under the bottom right corner of each safety label when placing an order for it to the authorized dealer.

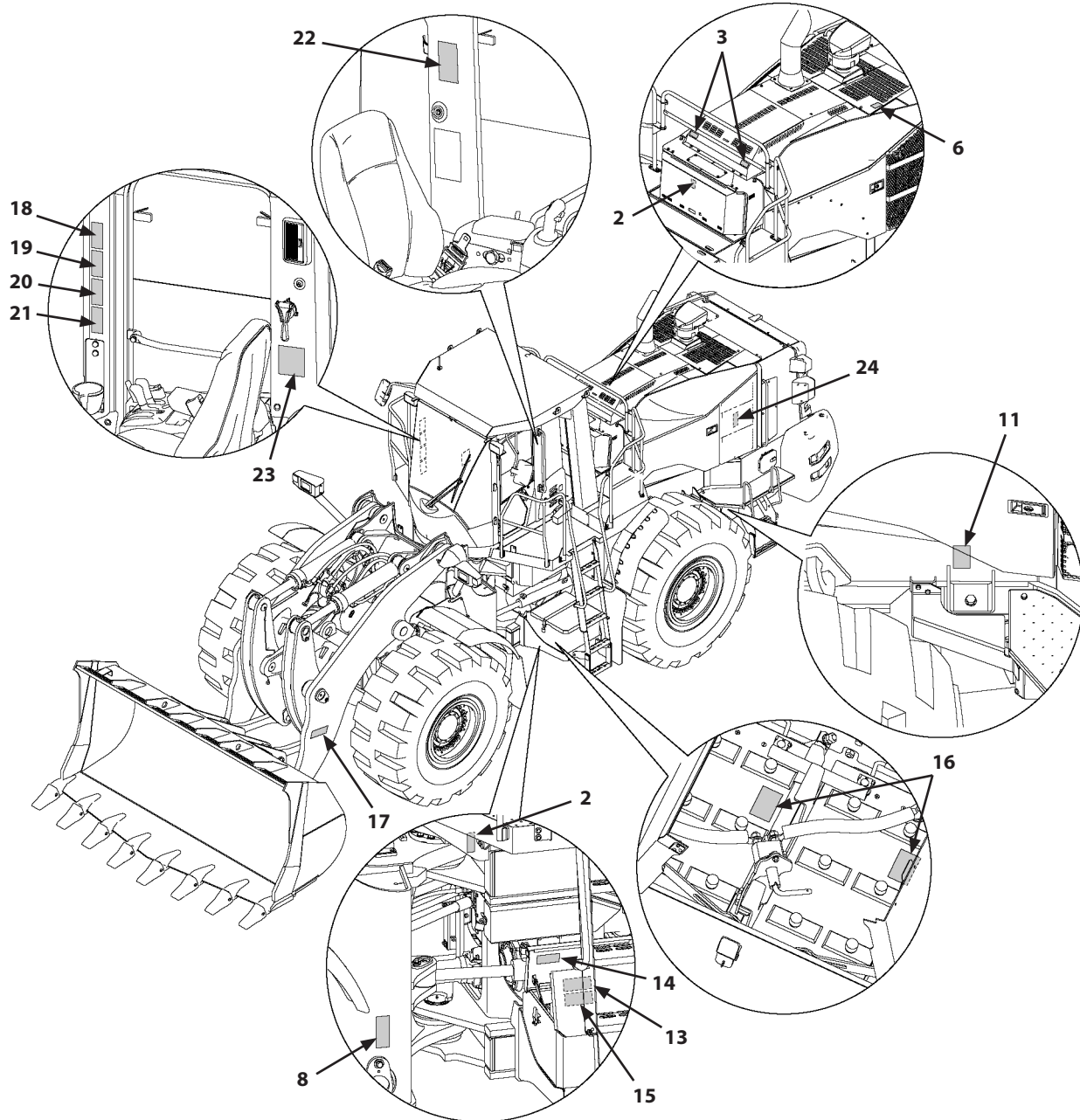

115Z7B-S-41US

# SAFETY LABELS

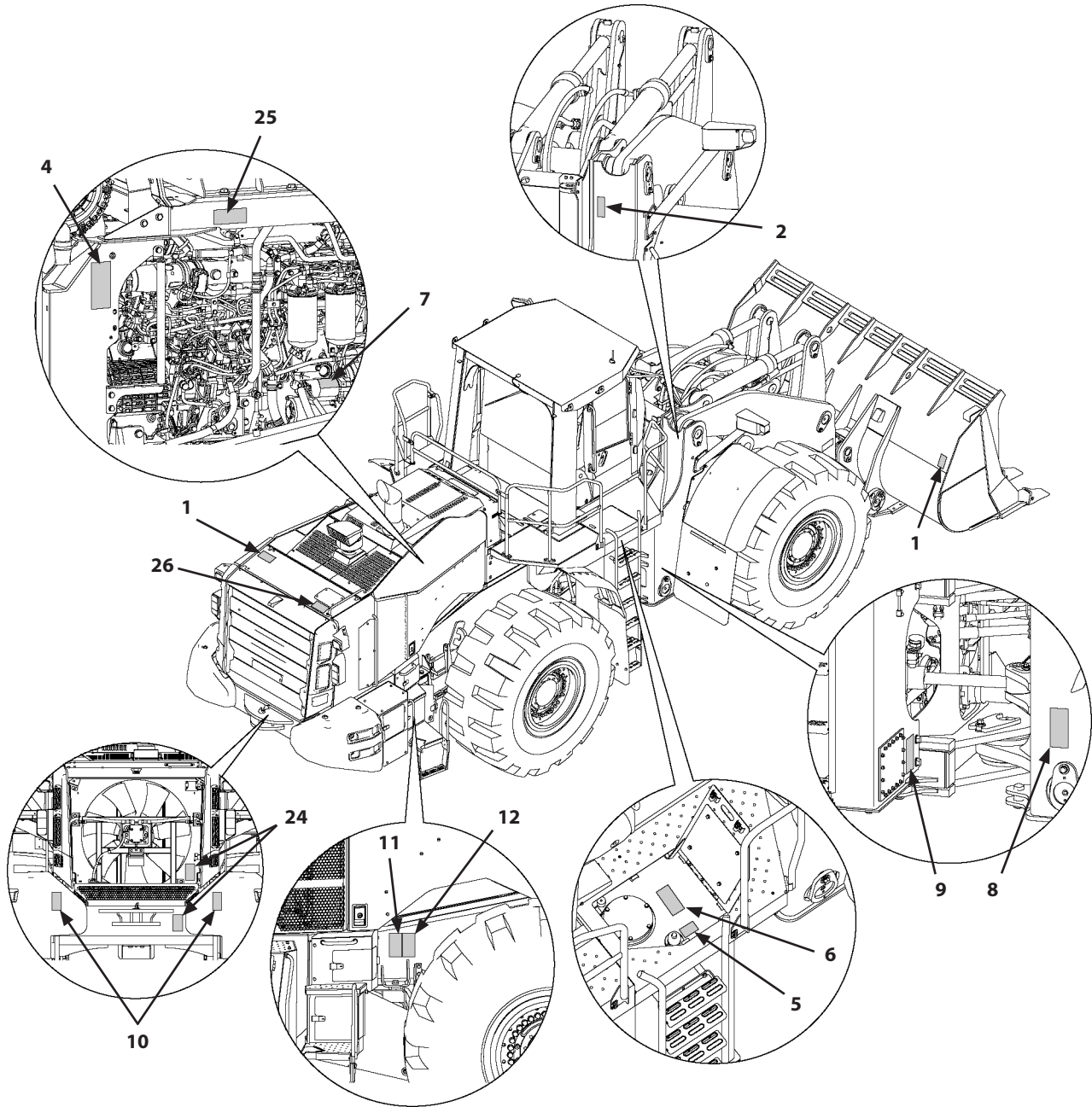

115Z7B-S-42US

# SAFETY LABELS

## 1. Bucket and Hood

**CAUTION:** Sign indicates a fall hazard.

- Do not step on or stand in this area.



label 44787-24370

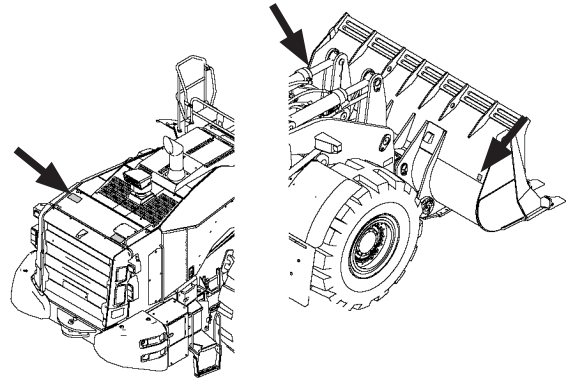

115Z7B-S-49

## 2. Accumulator residual pressure

**WARNING:** Oil injection hazard.

- Nitrogen accumulator contains compressed gas and fluid which could result in death or serious injury. Release the oil pressure from all brake circuits before removing any oil lines or piping. Do not attempt to service or repair an accumulator unless properly trained and equipped.

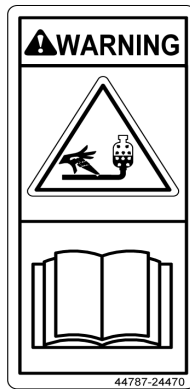

label 44787-24470

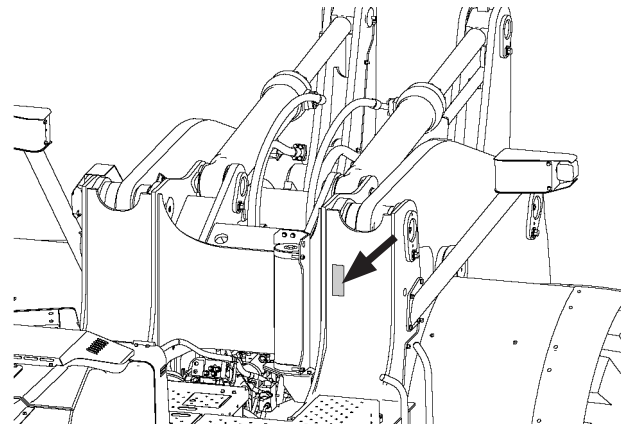

115Z7B-S-53

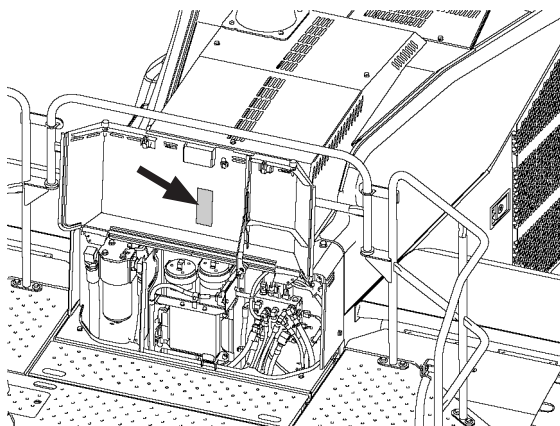

115Z7B-S-43

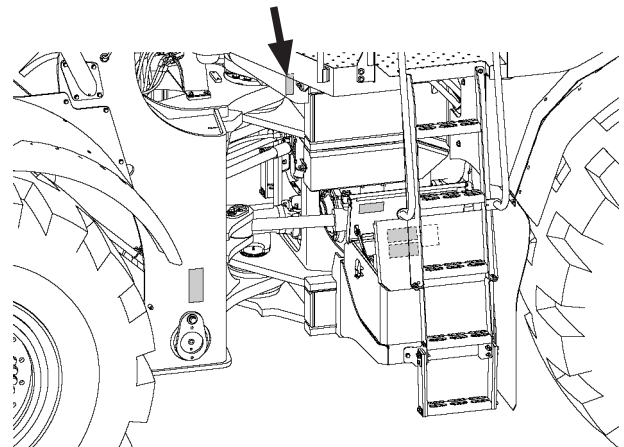

115Z7B-S-44

## SAFETY LABELS

### 3. Both Sides of Oil Cooler and Engine Housing On the Rear Fenders (Both Sides)

#### **WARNING: Burn Hazard**

- Avoid skin contact with highly heated parts such as the engine, muffler, etc. immediately after operation of the machine. Severe burns may result.



label 44787-24990

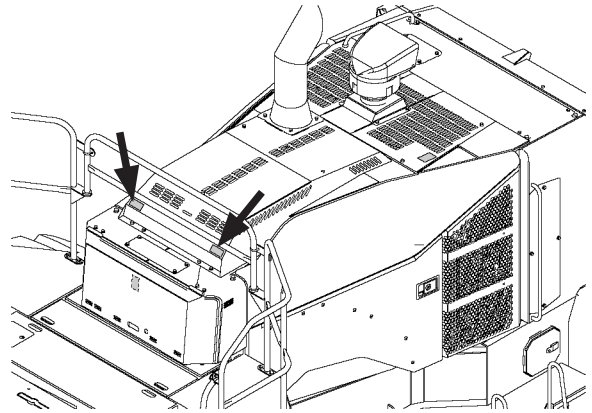

115Z7B-S-45

### 4. Use no starting fluid

#### **WARNING: Explosion Hazard**

- Do not use ether. This engine is equipped with electric heater starting aid. Use of ether could cause explosion and could result in death or serious injury.

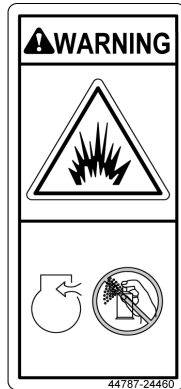

label 44787-24460

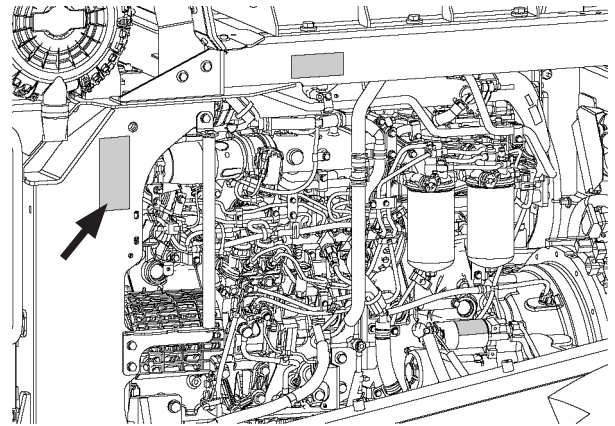

115Z7B-S-46



## SAFETY LABELS

### 5. Top of Hydraulic Oil Tank

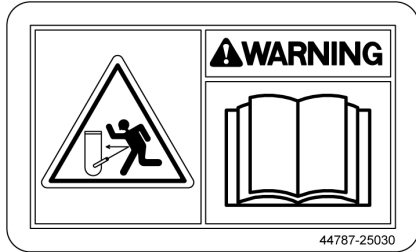

label 44787-25030

#### **⚠ WARNING: Burn Hazard**

- Sign indicates a burn hazard from the pressurized tank spurting hot oil if the oil inlet is uncapped during or right after operation.  
Read manual for safe and proper handling.

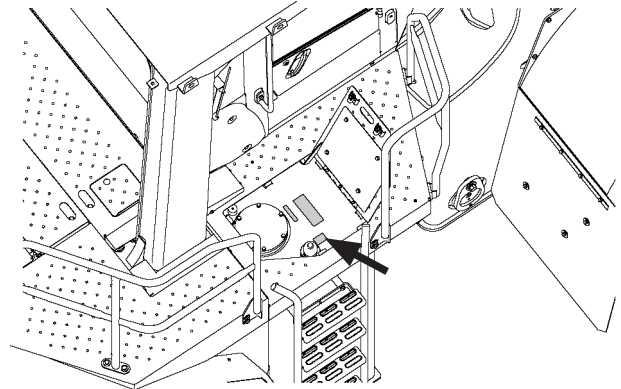

115Z7-S-43K

### 6. Top of Coolant Reservoir Tank and Hydraulic Tank

#### **⚠ WARNING: Burn Hazard**

- Pressurized system: spray of hot fluid could result in death or serious injury. Allow system to cool and vent pressure slowly before servicing.

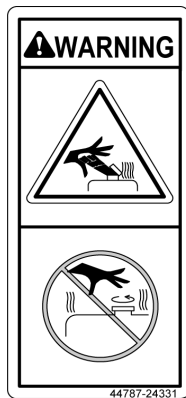

label 44787-24331

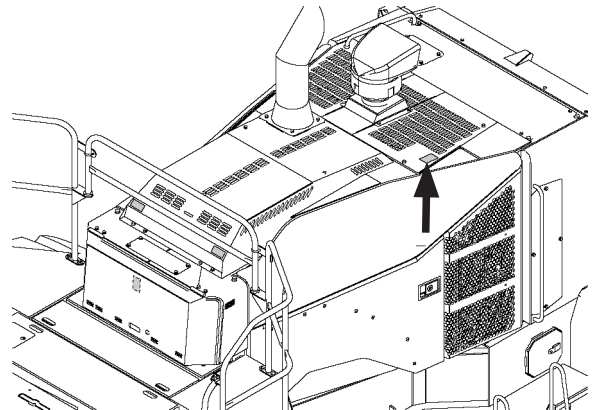

115Z7B-S-45

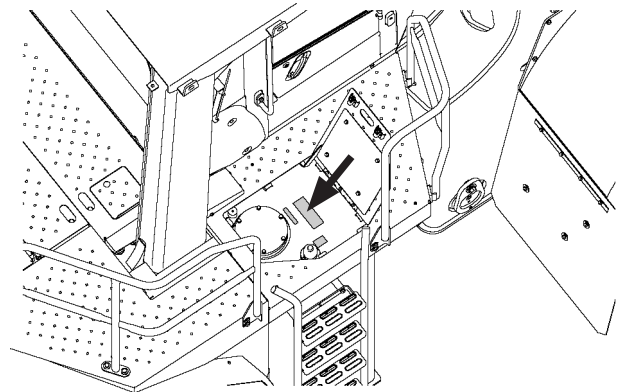

115Z7-S-43K

## SAFETY LABELS

### 7. Side of Engine Starter

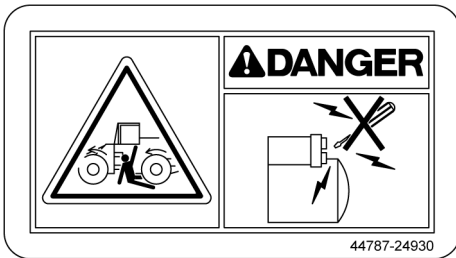

label 44787-24930

#### **⚠ DANGER: Runover Hazard**

- If the engine is not started correctly the machine may suddenly start to move. Start the engine from the operator's seat only.

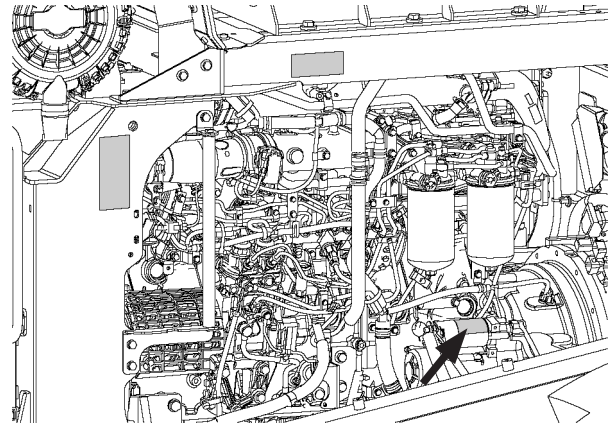

115Z7B-S-46

### 8. Both Sides of Front Chassis

#### **⚠ DANGER: Crush Hazard**

- The articulation area becomes a pinch point when steering the machine. Keep all personnel away from the articulation area during operation of the machine.



label 44787-24360

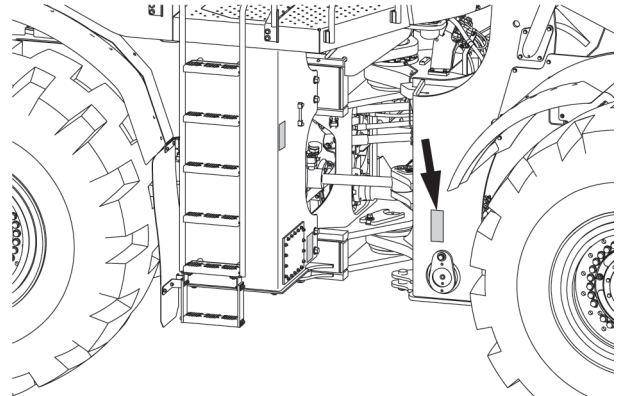

115Z7-S-44L1

### 9. Top of Right Rear Chassis Articulation Stopper

#### **⚠ WARNING: Crush Hazard**

- The articulation area becomes a pinch point when steering the machine. Be sure to install the articulate lock bar (stopper) during inspection/maintenance work and transportation of the machine.

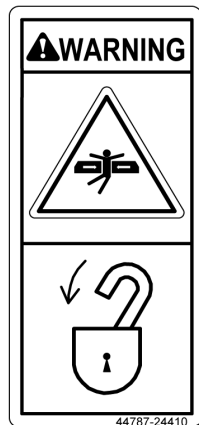

label 44787-24410

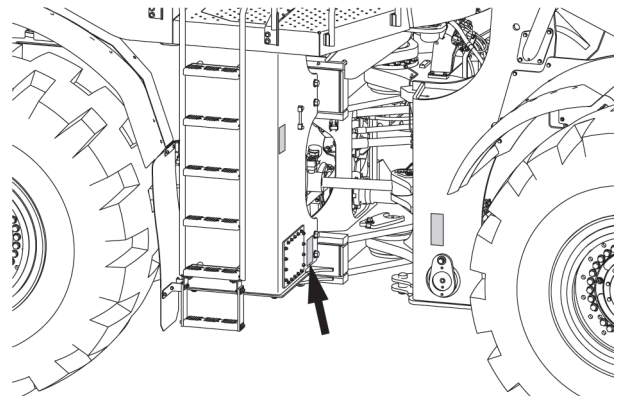

115Z7-S-44L2

## SAFETY LABELS

### 10. Both Sides of Counterweight

#### **WARNING: Runover Hazard**

- Avoid injury or fatality from being run over with the machine. Keep everyone away from the machine when operating.

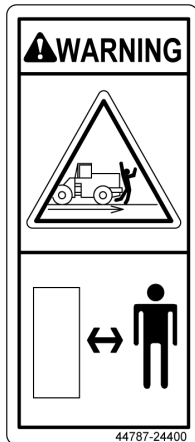

label 44787-24400

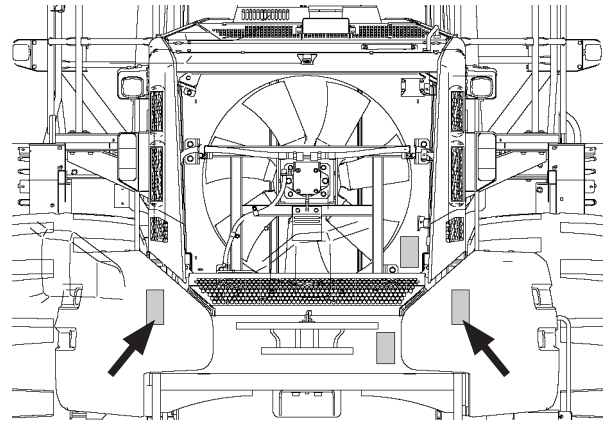

115Z7B-S-47

### 11. Bottoms at Both Right and Left Side Covers of Rear Chassis

#### **WARNING: Entanglement Hazard**

- Sign indicates a hazard of rotating parts, such as belt. Turn off before inspection and maintenance.

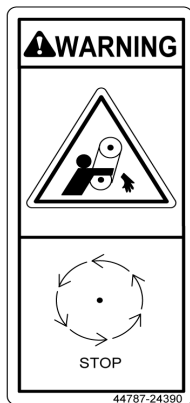

label 44787-24390

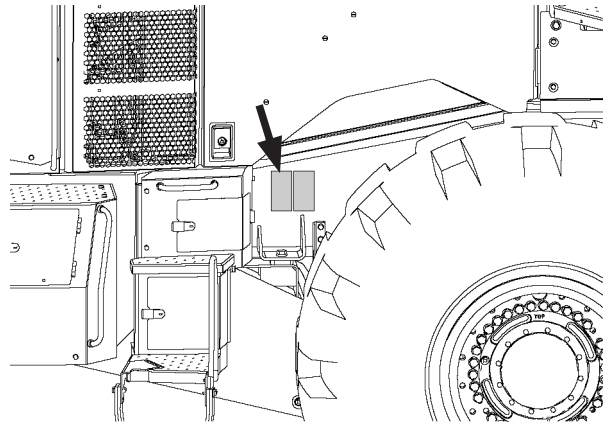

115Z7B-S-48

### 12. Bottoms at Both Right and Left Side Covers of Rear Chassis

#### **WARNING: Runover Hazard**

- Machine movement, if engine starts in gear, could result in death or serious injury.
  - Do not start engine by shorting across starter terminals.
  - Do not start engine while standing on ground.

Make sure to start engine only from operator's seat with transmission in neutral and parking brake applied.

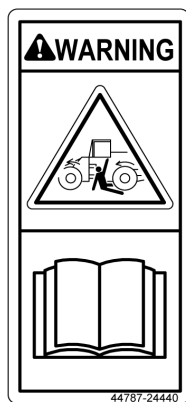

label 44787-24440

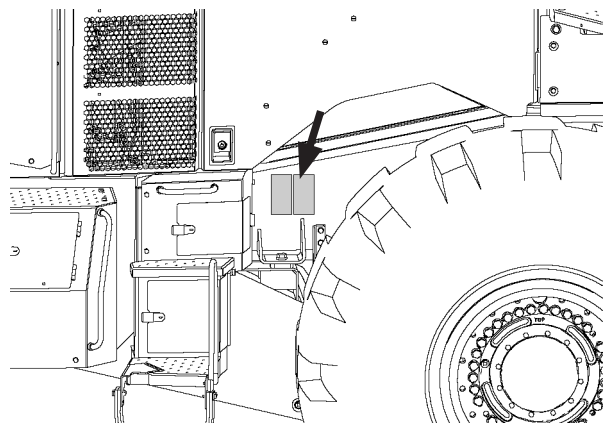

115Z7B-S-48

## SAFETY LABELS

### 13. Inside Battery Box

#### **CAUTION: Shock Hazard**

- Sign indicates a possible shock hazard from handling battery terminals. Read manual for safe and proper handling.



label 44787-24350

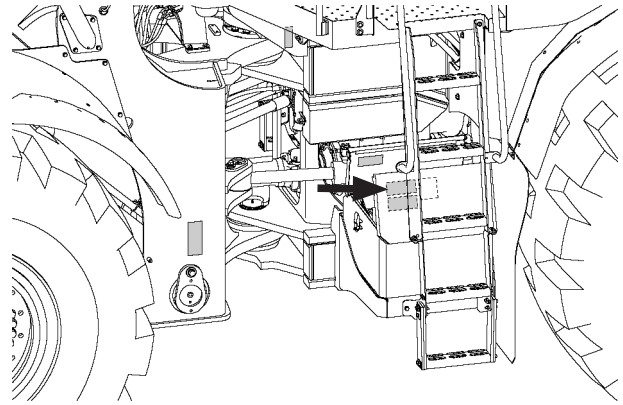

115Z7B-S-44

### 14. Inside Battery Box

#### **WARNING: Explosion Hazard**

- Sign indicates an explosion hazard. Keep fire and open flames away from this area.



label 44787-24340

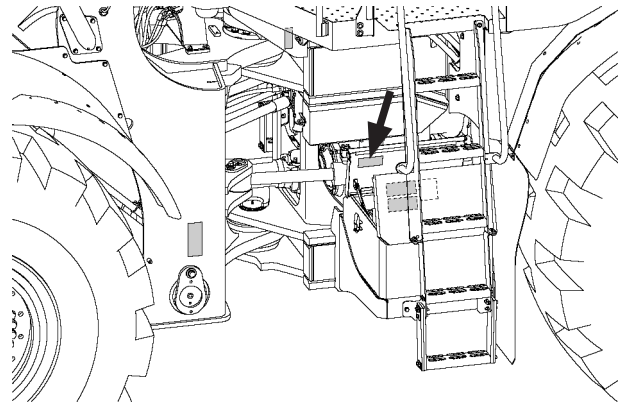

115Z7B-S-44

### 15. Inside Battery Box

#### **CAUTION: Chemical Burn Hazard**

- Skin contact with electrolyte will cause burns. Splashed electrolyte into eyes will cause blindness. Do not touch or come in contact with electrolyte solution.

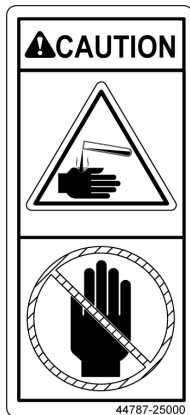

label 44787-25000

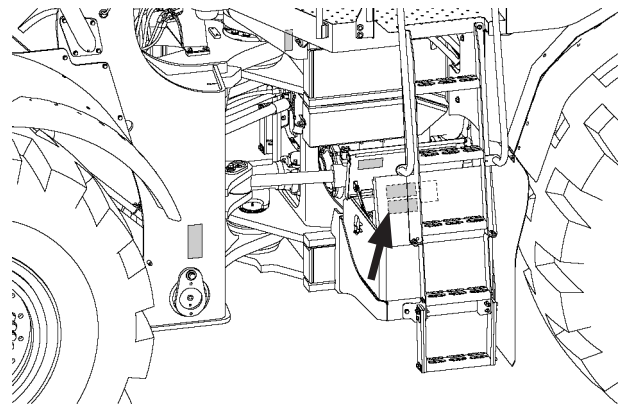

115Z7B-S-44

## SAFETY LABELS

### 16. Top of Battery

#### Recycle Batteries

- Batteries contain lead and acid. Obey all local and federal laws and regulation on disposal of batteries and electrolyte solution.

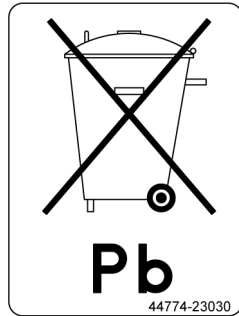

label 44774-23030

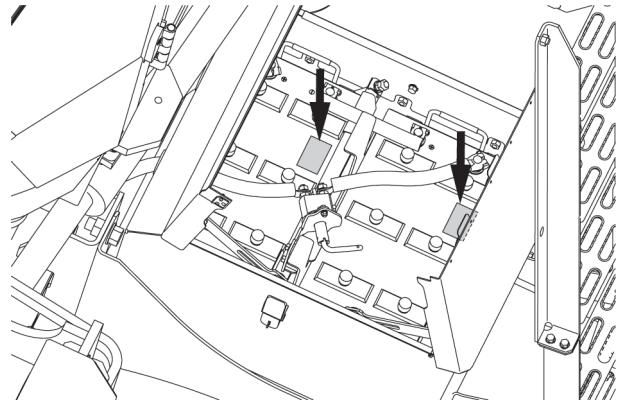

115Z7-S-47G1

### 17. Both Sides of Lift Arm

#### **DANGER: Crush Hazard**

- During operation, loads may spill from the bucket and/or the bucket may suddenly fall. Never allow anyone to approach the machine with lift arms raised.



label 44787-24420

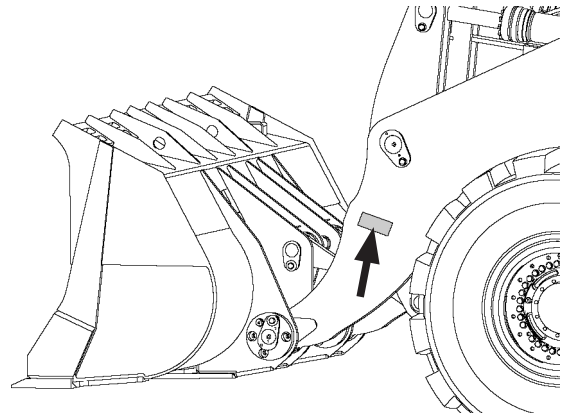

115Z7B-S-54

## SAFETY LABELS

18. Cab Inside Right Front Column (First safety sign from the top)

### **WARNING**

- Prior to operation, maintenance, disassembling, and transportation of the machine, be sure to read and understand the Operator's Manual.

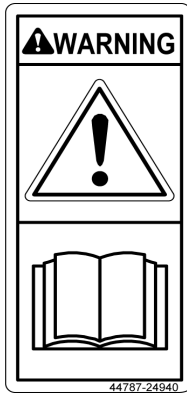

label 44787-24940

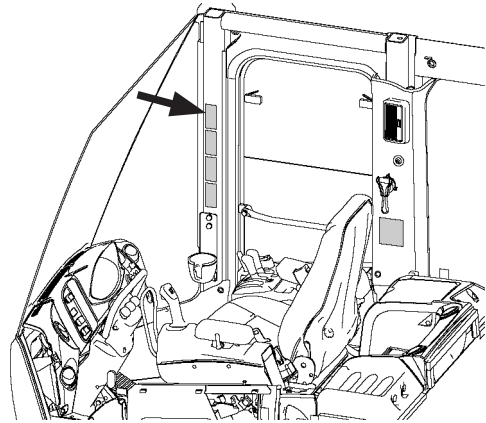

115Z7B-S-50

19. Cab Inside Right Front Column (2nd safety sign from the top)

### **DANGER: Electrocutation Hazard**

- Sign indicates an electrocution hazard if machine is brought too near electric power lines. Keep a safe distance from electric power lines.

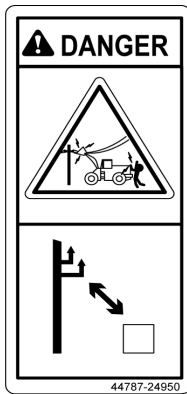

label 44787-24950

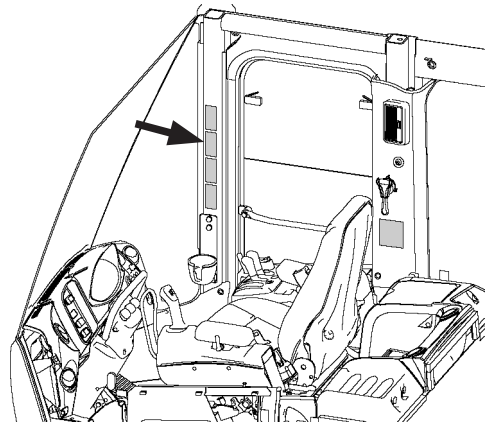

115Z7B-S-50

20. Cab Inside Right Front Column (3rd safety sign from the top)

### **WARNING: Runover or Entanglement Hazard**

- If the parked machine starts moving unexpectedly, personal injury or death due to entanglement in moving parts or running over by the machine may result. Before leaving the machine, set the park brake to parking position, lower the front attachment to the ground, lock the control levers, and remove the key from the key switch.



label 44787-24960

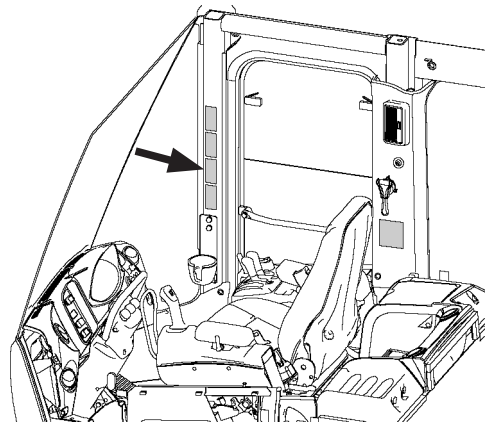

115Z7B-S-50

## SAFETY LABELS

### 21. Cab Inside Right Front Column (4th safety sign from the top)

#### **WARNING: Rollover Hazard**

- To minimize the injury due to an overturning accident, be sure to fasten the seat belt prior to operating the machine.



label 44787-24970

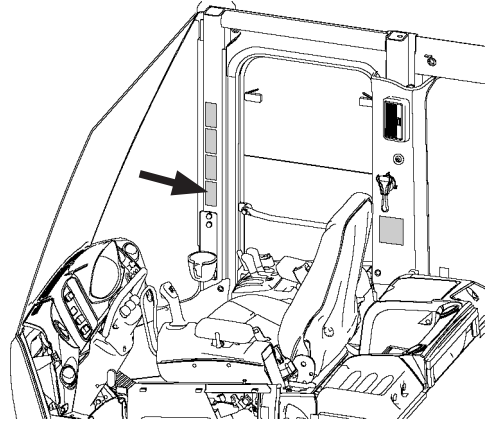

115Z7B-S-50

### 22. Cab Inside Left Rear Column

#### **WARNING: Runover Hazard**

- Be sure that the backup alarm is operable when the machine is put in reverse.



label 44787-24680

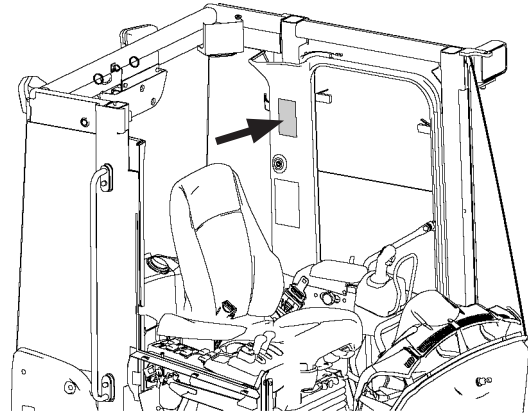

115Z7B-S-51

### 23. Cab Inside Right Rear Column

#### **CAUTION: Steering Hazard**

- Unlock articulation stopper before operating machine.

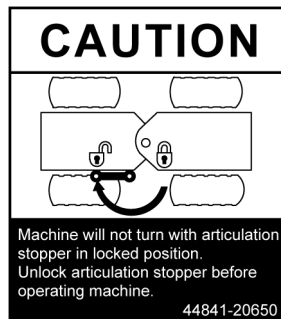

label 44841-20650

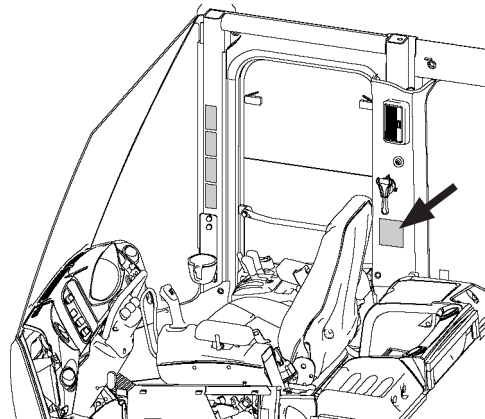

115Z7B-S-50

## SAFETY LABELS

### 24. Both Right and Left Side of Engine Housing Frame

#### **WARNING: Entanglement Hazard**

- Sign indicates a hazard of rotating parts, such as fan. Turn off before inspection and maintenance.

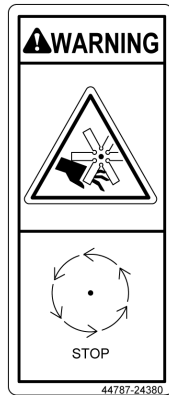

label 44787-24380

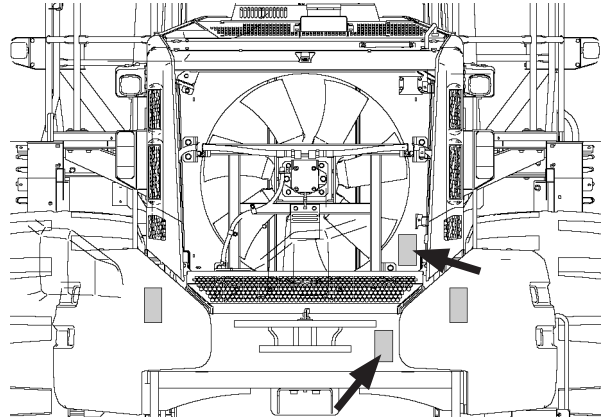

115Z7B-S-47

### 25. EGR Cooler

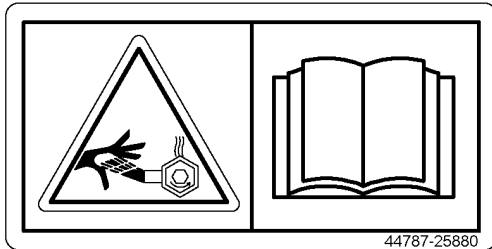

label 44787-25880

#### **WARNING: Burn Hazard**

- Pressurized system: spray of hot fluid could result in death or serious injury.  
Allow system to cool and vent pressure slowly before servicing.

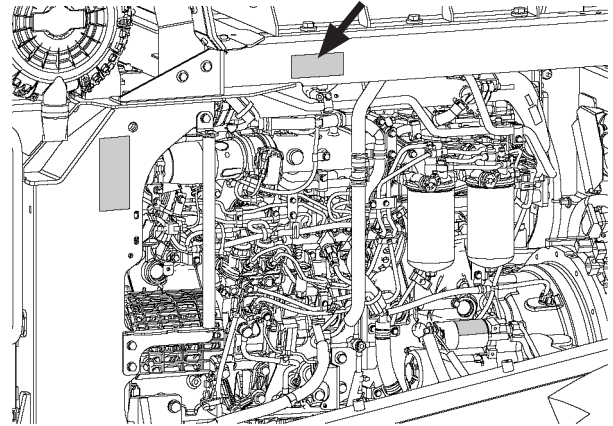

115Z7B-S-46

### 26. Radiator Cap Cover (Coolant Replacement Instruction)

## IMPORTANT

Improper procedure of replacing coolant can cause severe engine damage such as burned EGR cooler due to trapped air pockets.

- Open the EGR cooler air bleeder plug before replacing the coolant.
- ALWAYS follow the coolant replacement procedure shown in the Operation and Maintenance Manual.
- Start the engine only after confirming the coolant is replaced as instructed.

44787-25890

label 44787-25890

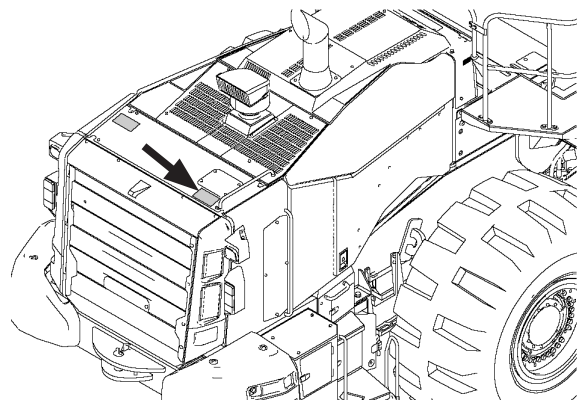

115Z7B-S-52



## COMPONENTS NAME

### Components Name

- 1- Bucket Teeth
- 2- Bucket
- 3- Bell Crank (Lever)
- 4- Bucket Cylinder
- 5- Front Combination Light  
(Headlight/Turn Signal/Clearance Light/Hazard Light)
- 6- Outside Rear View Mirror
- 7- Front Work Light
- 8- ROPS (Over the Cab)
- 9- Rear Fender
- 10- Front Fender
- 11- Lift Arm Cylinder
- 12- Lift Arm
- 13- Battery (Two on the left side)
- 14- Fuel Filler Port
- 15- Rear Work Light
- 16- Aftertreatment Device (Inside the cover)
- 17- Exhaust Pipe
- 18- Hydraulic Oil Tank
- 19- Articulation Lock Bar
- 20- Rear Combination Light  
(Turn Signal/Hazard Light/Tail Light/Brake Light/Backup Light)
- 21- Counterweight
- 22- Towing Pin
- 23- Cooling Unit
- 24- DEF Tank

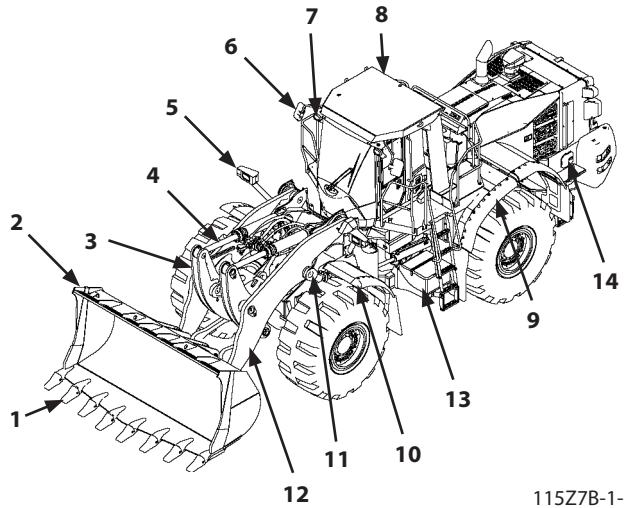

115Z7B-1-1-1

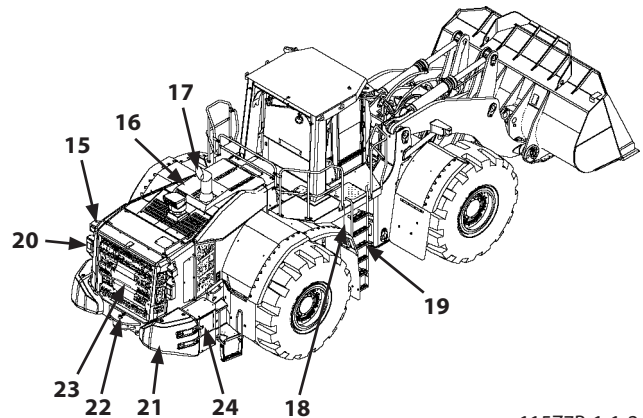

115Z7B-1-1-2

## COMPONENTS NAME

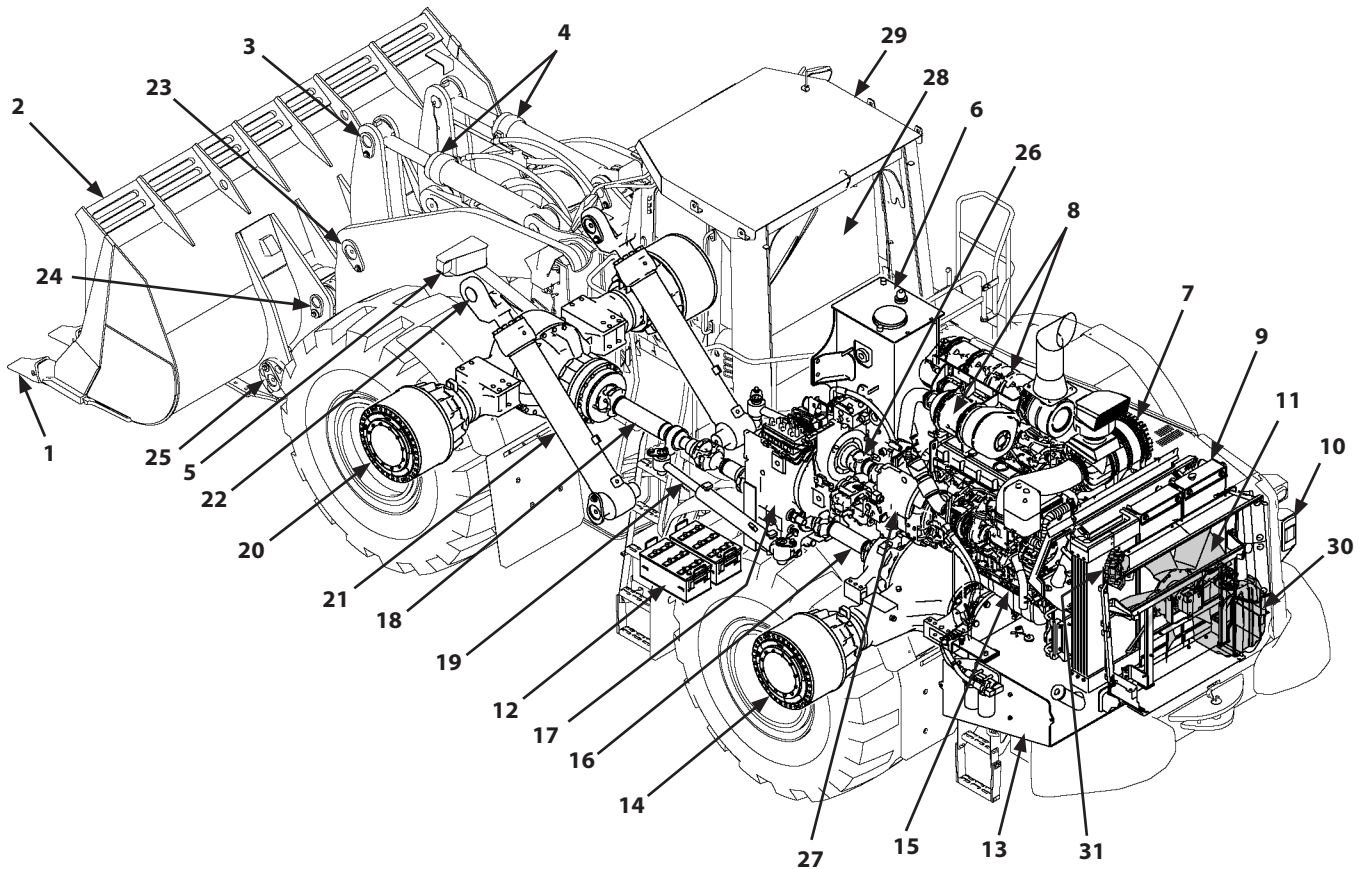

115Z7B-1-2-1

- |   |   |
|---|---|
| 1- Bucket Teeth                                   | 17- Transmission                              |
| 2- Bucket   | 18- Second (Front and Center) Propeller Shaft |
| 3- Bucket Cylinder Rod Pin                        | 19- Steering Cylinder                         |
| 4- Bucket Cylinder                                | 20- Front Axle                                |
| 5- Front Combination Lamp                         | 21- Lift Arm Cylinder                         |
| 6- Hydraulic Oil Tank                             | 22- Lift Arm Cylinder Rod Pin                 |
| 7- Air Cleaner                                    | 23- Bell Crank (Lever) Pin                    |
| 8- Aftertreatment Device                          | 24- Bucket Link Pin                           |
| 9- Radiator, Oil Cooler, and Other Cooling System | 25- Bucket Hinge Pin                          |
| 10- Rear Combination Lamp                         | 26- First (Main) Propeller Shaft              |
| 11- Radiator Fan                                  | 27- Torque Converter                          |
| 12- Battery                                       | 28- Cab                                       |
| 13- Fuel Tank                                     | 29- ROPS (Roll Over Protective Structure)     |
| 14- Rear Axle                                     | 30- DEF Tank                                  |
| 15- Engine  | 31- DEF Supply Module                         |
| 16- Third (Rear) Propeller Shaft                  |   |

## OPERATOR'S STATION

---

### Aftertreatment Device

The machine is equipped with the aftertreatment system combining Diesel Oxidation Catalyst (DOC) block (1) with Selective Catalytic Reduction (SCR) block (2) to remove nitrogen oxide (NOx) from the exhaust gas in order to meet governmental emissions regulations.

The DOC reduces harmful substances in exhaust gas by chemical reaction, then DEF is injected in dosing module (injection chamber) (3) and mixed into the exhaust stream. DEF decomposed to ammonia and CO<sub>2</sub>. SCR catalyst converts NOx into harmless nitrogen gas and water vapor by accelerating chemical reaction with the ammonia. The remaining ammonia is decomposed into nitrogen and water by DOC in SCR block (2).

Follow the instructions below to prevent the aftertreatment device from being damaged.

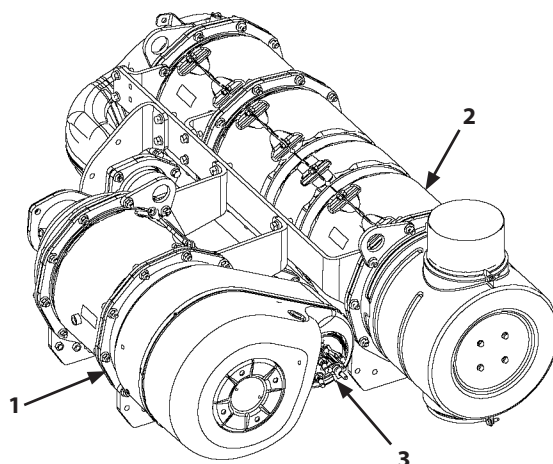

95Z7B-SCR4

#### IMPORTANT:

- Refer to 1-35 for further information.
- Exhaust gas from the aftertreatment device, and exhaust piping becomes hotter during and right after engine running and regeneration of aftertreatment device. Be careful not to let your skin contact any part of exhaust system or hot gas from the exhaust piping. It may cause severe burns.
- If flammable objects such as dried leaves or paper scraps are around the aftertreatment device, they may cause a fire.
- Before maintaining the machine, stop the engine and make sure the engine has cooled down sufficiently to prevent burns.
- Be sure to use fuel that complies with JIS K-2204, EN-590 and ASTM D-975 which contains 15 ppm or lower sulfur. If the fuel described above is not used, exhaust gas that exceeds the regulation values may be discharged and serious problems may arise on the engine.

## OPERATOR'S STATION

---

- **Refill DEF which meets JIS or ISO (International Organization for Standardization). If improper liquid (diesel oil, kerosene or gasoline) is refilled in the DEF tank, fire or system failure may result.**
- **Use only recommended engine oil. Using engine oil other than the recommended may result in malfunction of the aftertreatment device.**
- **Contaminated fuel, incorrect fuel additives, gasoline, kerosene or other incorrect fluids will damage the fuel injection system and will lead to engine malfunction, which is not covered by warranty. Incorrect fuels will also damage the aftertreatment device.**  
*Use only clean Ultra Low Sulfur Diesel (ULSD) fuel without additives that contain metal elements, oil distillates or alcohol. These items will permanently damage the aftertreatment device and are not covered by warranty.*
- **Do not modify the machine without authorization. Never attempt to modify the air inlet and exhaust parts such as the air duct, aftertreatment device and the exhaust outlet. Also never attempt to disassemble the aftertreatment device.**
- **Avoid giving shocks on the aftertreatment device by hitting elements with other objects or dropping the device. Failure to do so may affect the aftertreatment device, possibly damaging it or lowering its performance.**
- **It is normal to see white smoke appear during regeneration. It is not caused by a malfunction. Do not attempt to perform aftertreatment device manual regeneration indoors in an area that is not well ventilated or free from flammables.**
- **Ammonia odor may occur during aftertreatment device regeneration temporarily, but is not a trouble.**
- **Consult your authorized dealer for checking or repairing the aftertreatment device.**

## OPERATOR'S STATION

---

### Automatic Regeneration

White deposition may accumulate inside the aftertreatment device. An automatic regeneration (Auto-regeneration) mode is designed to automatically clean the aftertreatment device at regular intervals. The auto-regeneration may start during operation of the machine; you can continue to operate the machine. (Refer to 1-35).

 NOTE:

- Usually, auto-regeneration starts after the previous regeneration at regular intervals (either auto or manual).
- If auto-regeneration interval becomes shorter, consult your authorized dealer.

Auto-regeneration may be "terminated" early (inhibited) when in the presence of flammable materials, such as flammable airborne debris, wood dust, grain dust, dried leaf debris, or other flammable risks.

However, when "early termination" (inhibiting regeneration) happens often, the system will sense this and eventually call for a manual regeneration using manual regeneration switch (1). The regeneration request symbol will show, indicating that manual regeneration is required. Refer to page 1-37 for further information.

 NOTE:

- The auto-regeneration may be terminated depending on the machine operating condition.
- Do not stop the engine during regeneration unless it is absolutely necessary to do so.

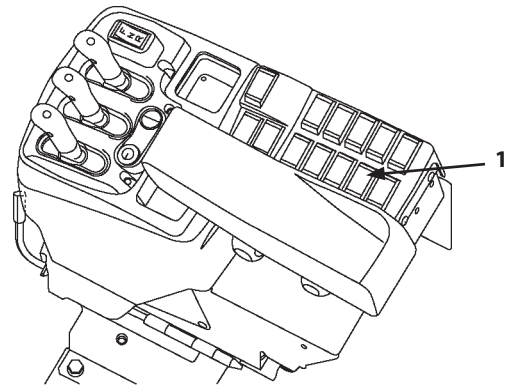

MNEC-01-041

## OPERATOR'S STATION

---

### Repeated Inhibiting of Aftertreatment Device Cleaning

**IMPORTANT:** When the machine is operated without performing manual regeneration, the aftertreatment device may be damaged. Immediately move the machine to a safe area and perform manual regeneration.

- If auto-regeneration is inhibited or interrupted, the following auto-regeneration will be accompanied by the aftertreatment device manual regeneration request. It is required to perform manual regeneration as soon as requested.



*NOTE: The manual regeneration request indicator remains ON until a regeneration process completes successfully.*

- When leaving machine without running aftertreatment device regeneration, gradual derate will be applied to the engine (refer to 1-36).  
If manual regeneration does not work, call your local authorized dealer to repair the aftertreatment device.
- When SCR system errors are accompanied, take required action immediately (refer to 1-33).

## OPERATOR'S STATION

---

### Cab Features

- 1- Front Defroster
- 2- Front Console
- 3- Operator's Seat
- 4- Right Console
- 5- Document Holder
- 6- Hot/Cool Box
- 7- Rear Defroster
- 8- Glove Compartment
- 9- Cup Holder
- 10- Floor Mat

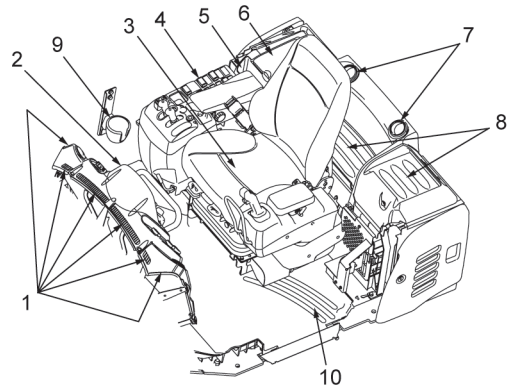

115Z7-1-7-1

# OPERATOR'S STATION

## Front Console

- 1- Air Conditioner Front Vent
- 2- Hazard Switch
- 3- Work Light Switch
- 4- Parking Brake Switch
- 5- Monitor Panel
- 6- Accelerator Pedal
- 7- Brake Pedal
- 8- Front Window Wiper Switch
- 9- Rear Window Wiper Switch
- 10- Light Switch
- 11- Key Switch
- 12- Multi Function Monitor/Air Conditioner Switch Panel
- 13- Ash Tray
- 14- Cigar Lighter
- 15- Brake/Declutch Pedal

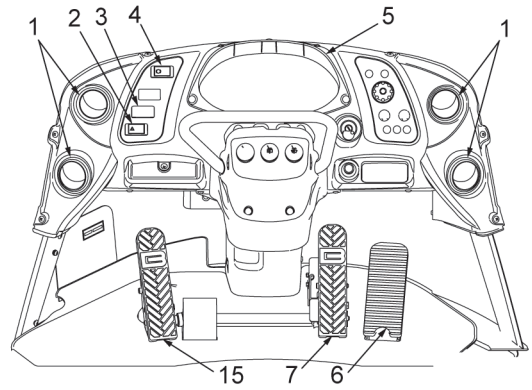

115Z7-1-8-1

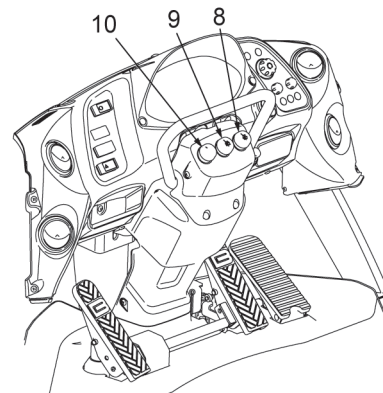

115Z7-1-8-2

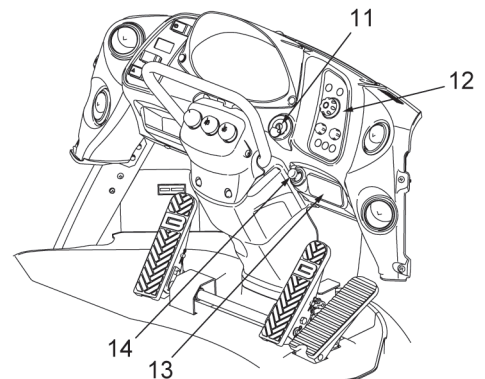

115Z7-1-8-3



## OPERATOR'S STATION

---

### Joystick Steering

- 21- Forward/Reverse Switch
- 22- Joystick
- 23- Shift Up Switch
- 24- Shift Down Switch
- 25- Hold Switch (Under the Joystick)
- 26- Horn Switch (Under the Joystick)
- 27- Joystick Steering System Switch
- 28- Armrest Lock Release Button
- 29- Armrest Adjust Handle
- 30- Support Bar
- 31- Armrest

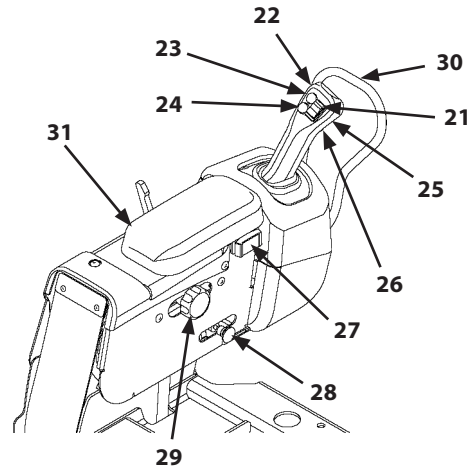

115Z7B-1-10-3

# OPERATOR'S STATION

## Right Console

### Fingertip Control Type

- 1- Auxiliary Control Lever (Option)
- 2- Bucket Control Lever
- 3- Lift Arm Control Lever
- 4- Turn Signal Switch
- 5- Control Lever Lock Switch
- 6- Declutch Position Switch
- 7- Travel Mode Selector
- 8- Power Mode Selector
- 9- Auxiliary
- 10- Fan Reverse Rotation Switch
- 11- Hydraulic Coupler Switch (Option)
- 12- Auxiliary
- 13- Aftertreatment Device Regeneration Switch
- 14- Secondary Steering Operation Check Switch (Option)
- 15- Auxiliary
- 16- 2nd/3rd Speed Limit Switch (Option)
- 17- Ride Control Switch (Option)
- 19- Armrest
- 20- Hold Switch
- 21- Right Console Slide Lever
- 22- DSS (Down Shift Switch)
- 23- Horn Switch
- 24- Quick Power Switch

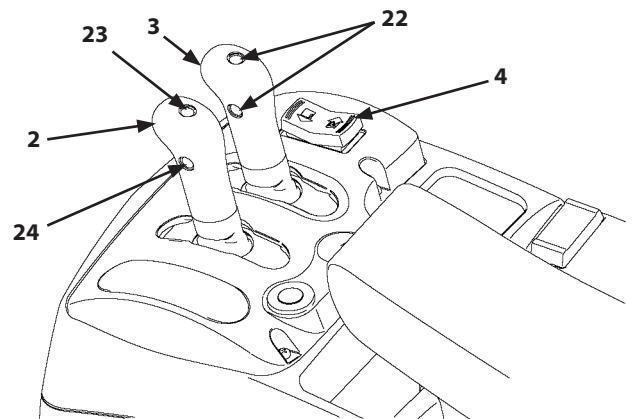
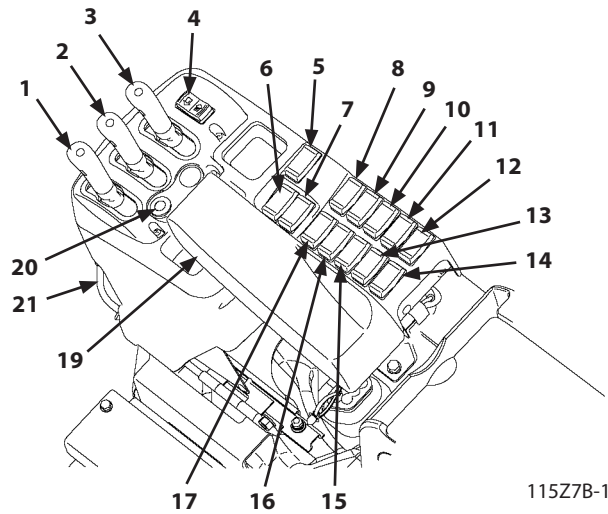

# OPERATOR'S STATION

## Right Console

### Multi-Function Joystick Type

- 1- Turn Signal Switch
- 2- Multi-Function Joystick Lever
- 3- Quick Power Switch
- 4- DSS (Down Shift Switch)
- 5- Auxiliary Control Lever (Option)
- 6- Control Lever Lock Switch
- 7- Declutch Position Switch
- 8- Travel Mode Selector Switch
- 9- Power Mode Selector Switch
- 10- Auxiliary
- 11- Fan Reverse Rotation Switch
- 12- Hydraulic Coupler Switch (Option)
- 13- Auxiliary
- 14- Secondary Steering Operation Check Switch (Option)
- 15- Aftertreatment Device Regeneration Switch
- 16- Auxiliary
- 17- 2nd/3rd Speed Limit Switch (Option)
- 18- Ride Control Switch (Option)
- 19- Armrest Adjust Handle
- 20- Armrest
- 21- Right Console Slide Lever
- 22- Hold Switch (Under the Lever)
- 23- Horn Switch (Under the Lever)

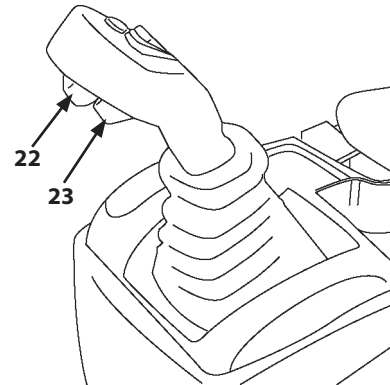
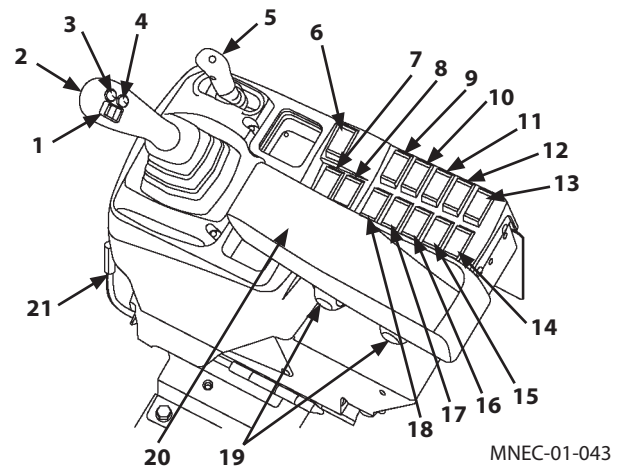

# OPERATOR'S STATION

## Monitor Panel

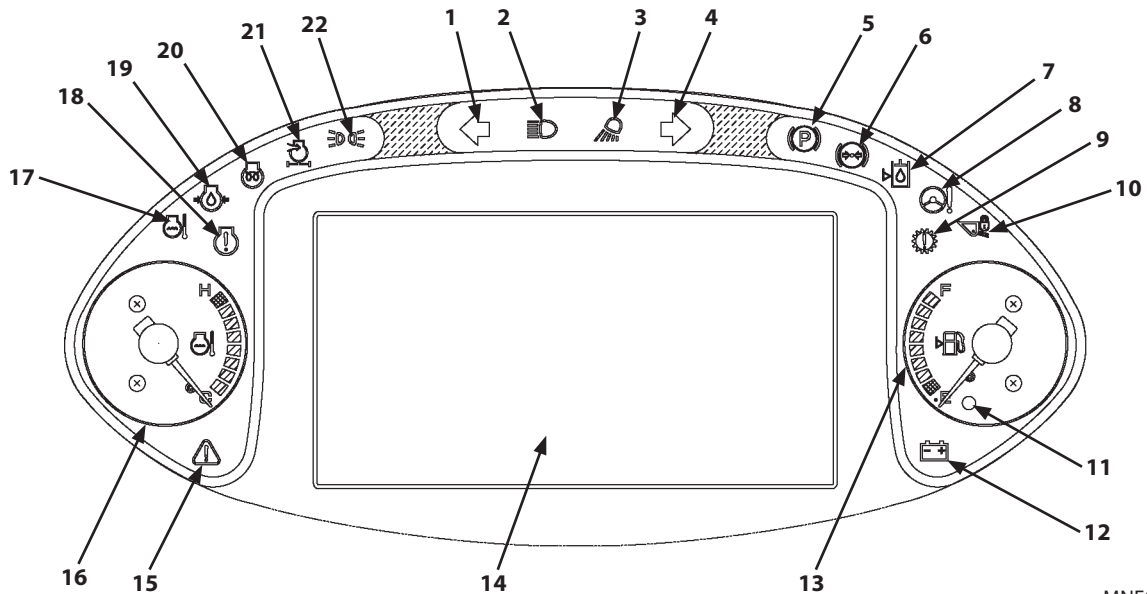

MNEC-01-001

- |   |  |
|---|--|
| 1- Left Turn Signal Indicator                   | 12- Discharge Warning Indicator          |
| 2- High Beam Indicator                          | 13- Fuel Gauge                           |
| 3- Work Light Indicator                         | 14- Multi Function Monitor               |
| 4- Right Turn Signal Indicator                  | 15- Communication System Error Indicator |
| 5- Parking Brake Indicator                      | 16- Coolant Temperature Gauge            |
| 6- Brake Oil Low Pressure Indicator             | 17- Overheat Indicator                   |
| 7- Hydraulic Oil Level Indicator                | 18- Engine Warning Indicator             |
| 8- Low Steering Oil Pressure Indicator (Option) | 19- Engine Oil Low Pressure Indicator    |
| 9- Transmission Warning Indicator               | 20- Preheat Indicator                    |
| 10- Control Lever Lock Indicator                | 21- Air Filter Restriction Indicator     |
| 11- Fuel Level Indicator                        | 22- Clearance Light Indicator            |

## OPERATOR'S STATION

---

### Parking Brake Indicator (Red)

The parking brake indicator will light when the parking brake is applied.

If the forward/reverse switch (or lever) is moved to either the forward (F) or the reverse (R) position when the parking brake is applied, the alarm buzzer will sound. Return the forward/reverse switch (or lever) to neutral (N) and release the parking brake.



M4GB-01-012

### Brake Oil Low Pressure Indicator (Red)

**⚠ WARNING: Stop machine operation if the brake oil pressure lowers. Failure to do so may result in personal injury or death. If the indicator comes ON, immediately stop machine operation.**

If the brake oil pressure lowers, the brake oil low pressure indicator and the service indicator will light, and the alarm buzzer will sound.

Immediately move the machine to a safe area, set the machine in the park position and stop the engine. Inspect the brake system for any abnormality.

When the brake oil pressure is recovered, the buzzer stops and the indicator goes off.



M4GB-01-013

### Hydraulic Oil Level Indicator (Red)

**⚠ WARNING: Stop machine operation if the hydraulic oil level lowers. Failure to do so may result in personal injury or death. If the red indicator comes ON, immediately stop machine operation.**

If the hydraulic oil level lowers, the hydraulic oil level indicator and the service indicator will light, and the alarm buzzer will sound. Immediately move the machine to a safe area, set the machine in the park position and stop the engine. Check hydraulic oil level and any oil leaks from hydraulic circuit.

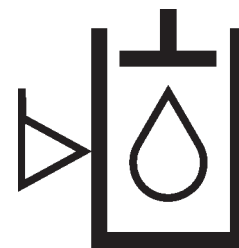

MNEC-01-057

## OPERATOR'S STATION

---

### Low Steering Oil Pressure Indicator (Option) (Red)

**IMPORTANT:** The secondary steering system shall only be used temporarily when the steering oil pressure has dropped. If continuously used, it may damage the system.

If the steering oil pressure decreases, the low steering oil pressure indicator and the service indicator will light, and the alarm buzzer will sound. Immediately move the machine to a safe area, set the machine in the park position and stop the engine.



M4GB-01-016

### Transmission Warning Indicator (Red)

If any serious abnormality occurs in the transmission and/or transmission related parts, the red indicator will light. If the transmission warning indicator and the service indicator light, immediately move the machine to a safe area, set the machine in the park position and stop the engine. Contact your nearest authorized dealer for machine inspection.



M4GB-01-024

### Communication Error Indicator (Yellow)

When communication system malfunction occurs, the communication error indicator lights.



M4GB-01-011

### Discharge Warning Indicator (Red)

If low alternator voltage occurs, the discharge warning indicator will light. If high alternator voltage occurs, the discharge warning indicator and the service indicator will light. Inspect the alternator and the battery system.

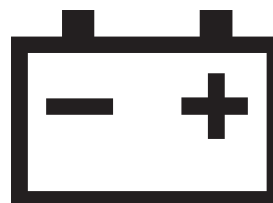

M4GB-01-018

## OPERATOR'S STATION

---

### Engine Warning Indicator (Red)

If any serious abnormality occurs in the engine and/or engine related parts, the red indicator will light.

If the engine warning indicator and the service indicator light, immediately move the machine to a safe area, set the machine in the park position and stop the engine. Contact your nearest authorized dealer for machine inspection.



M4GB-01-019

### Overheat Indicator (Red)

If the engine coolant temperature increases to an abnormally high range, the red indicator will light, the service indicator will flash, and the alarm buzzer will sound. Stop operation. Run the engine at slow idle speed to lower the coolant temperature.

When required, let engine cool, check coolant level, and add coolant if needed.



M4GB-01-020

### Engine Oil Low Pressure Indicator (Red)

**⚠ WARNING:** If the engine is kept running with the engine oil pressure low, damage to the engine may result. Immediately stop machine operation and stop the engine if the indicator lights.

If the engine oil pressure becomes low, the low engine oil pressure indicator will light, the service indicator will flash, and the alarm buzzer will sound.

Immediately move the machine to a safe area, set the machine in the park position and stop the engine. Inspect the engine oil pressure system and the oil level.



M4GB-01-021

**📝 NOTE:** Cold oil temperature or operating on a steep slope may also cause the indicator to light.

## OPERATOR'S STATION

---

### Air Filter Restriction Indicator (Red)

If the air cleaner element becomes clogged, the air filter restriction indicator and the service indicator light. Immediately stop the engine and inspect the air cleaner element. Replace the element, if necessary.

 **NOTE:** This indicator may unexpectedly light when the coolant temperature gauge indicates the center or lower position.  
It turns off automatically when the coolant temperature increases.

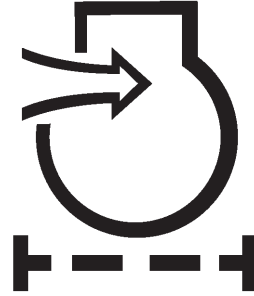

M4GB-01-023

### Preheat Indicator (Yellow)

The engine is being preheated as long as the preheat indicator stays ON. When the preheat indicator goes OFF, engine preheating is completed.



M4GB-01-031



## OPERATOR'S STATION

### Coolant Temperature Gauge

The engine coolant temperature is indicated with a needle. When the needle stays in the range (1) during operation, the coolant temperature is normal. If the engine coolant temperature becomes abnormally high, the service indicator will flash and the alarm buzzer will sound. Stop machine operation and run the engine at low idle to lower the coolant temperature. After the coolant temperature lowers, stop the engine for inspection. Visually inspect coolant level in reservoir. In case the needle does not move at all, error in the electrical system is suspected. Contact your nearest authorized dealer for machine inspection.

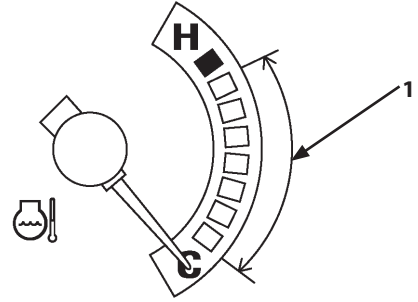

M4GB-01-028

### Fuel Gauge

The fuel level is indicated by the needle. Refuel before the needle reaches in the red range "E". When the needle reaches in the red range (E), the fuel level indicator lights.

 **NOTE:** The fuel level indicator may light even if the indicator needle does not reach the red range (E), depending on the tilt angle of machine.

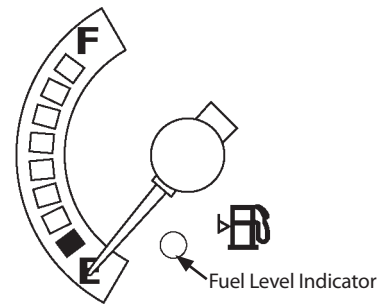

MNEC-01-002

## OPERATOR'S STATION

---

### Turn Signal Indicator (Green)

When the turn signal lever is operated, the turn signal and the turn signal indicator start flashing.



M4GB-01-032

### High Beam Indicator (Blue)

When the head lights are used at the high beam position, the indicator will light.



M4GB-01-033

### Work Light Indicator (Yellow)

When the work lights are turned ON, this indicator will light.



MNDB-01-052

### Clearance Light Indicator (Green)

When the clearance lights are turned ON, this indicator will light.



M4GB-01-035

### Control Lever Lock Indicator (Red)

When the control lever lock switch is in ON position, the control lever lock indicator will light.



MNEC-01-004

# OPERATOR'S STATION

## Multi Function Monitor

### Feature

The multi function monitor displays various meters, indicators, operation mode selection and maintenance screen.

### Screen Configuration

The multi function monitor consists of the following screens.

There are 7 menus, and a further 13 sub menus.

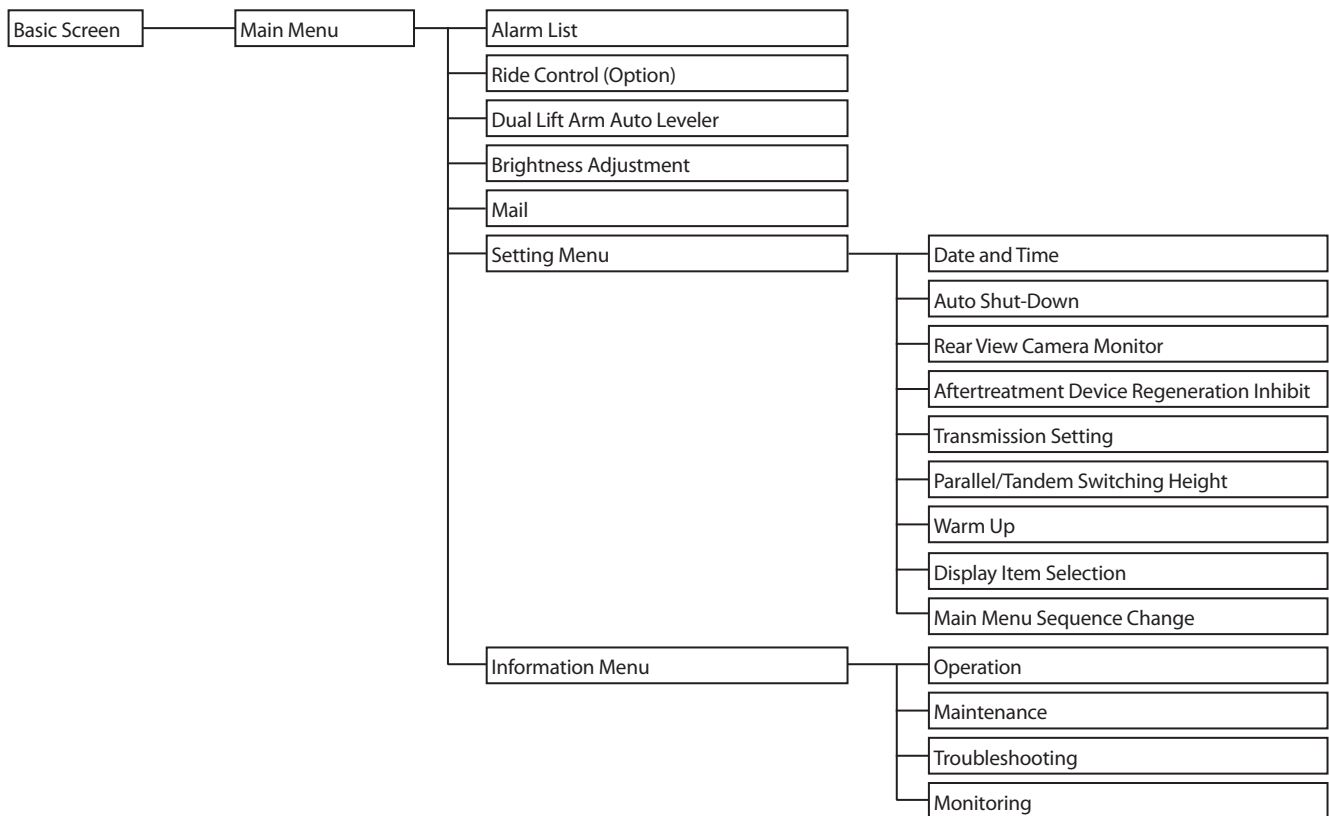

## OPERATOR'S STATION

### Default Setting

Function	Item	Default
Auto Shut-Down	ON/OFF of auto idling-stop function	ON
	Time period for auto idling-stop activation	5 min
Rear View Camera Monitor	ON (Constant display) OFF (No display) AUTO (Display at reverse operation only)	AUTO
Aftertreatment Device Regeneration Inhibited	Inhibit regeneration	OFF
Shift Change Delay Mode (Transmission Setting)	ON/OFF of shift (travel speed) change delay mode	OFF
Lockup	ON/OFF of transmission lock-up function	ON
Traction Control	ON/OFF of traction control	OFF
Parallel/Tandem Switching Height	Height at parallel or tandem circuit operation are switched	Lift arm is level to the ground
Warm Up	Increases engine speed at engine start to help warm up in cold environment	OFF

 **NOTE:** Typical functions are shown in the table. Check the initial values of other functions on each monitor screen.

# OPERATOR'S STATION

## Basic Screen

- 1- Engine Tachometer
- 2- Economy (ECO) Indicator
- 3- Speedometer
- 4- Transmission Oil Temperature Gauge
- 5- DEF Level Gauge
- 6- Air Conditioner Display
- 7- Ride Control Indicator (Option)
- 8- Seat Belt Indicator
- 9- Forward/Reverse Selector Switch Indicator
- 10- Declutch Indicator
- 11- Aftertreatment Device Indicator
- 12- Power Mode Indicator
- 13- Auto Idling Stop Indicator
- 14- Dual Lift Arm Auto Leveler Indicator
- 15- Clock, Hour Meter, Odometer
- 16- Fan Reverse Rotation Indicator
- 17- Shift Hold Display
- 18- Transmission Auto-shifting Indicator
- 19- F-N-R/Shift Position Indicator
- 20- Auto Brake Indicator
- 21- Joystick Steering Indicator
- 22- Traction Control Indicator
- 23- Torque Converter Lock-Up Indicator

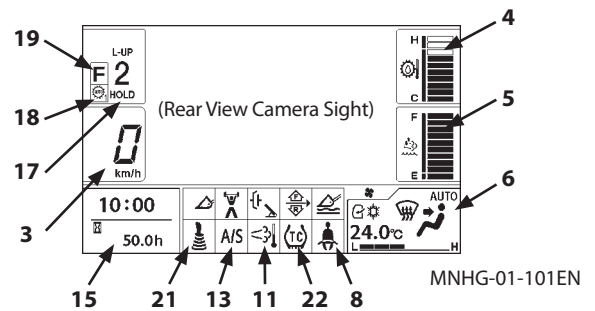
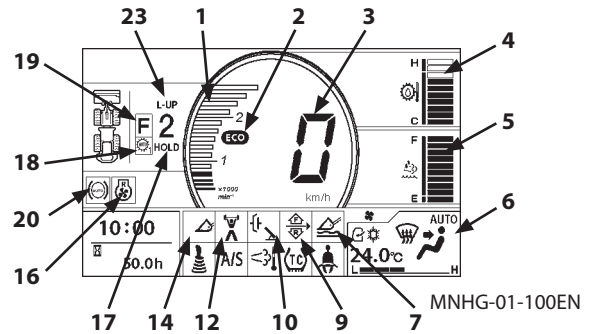

When Rear View Monitor is Operative

# OPERATOR'S STATION

## How to Use Screens

### Displaying Basic Screen

**IMPORTANT:** Start the engine after the basic screen is displayed.

When the key switch is turned to the ON position, the starting screen displays for about two seconds and the basic screen displays.



Starting Screen MNEK-01-102EN

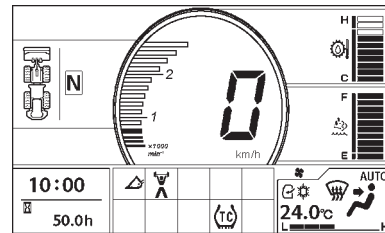

Basic Screen MNHG-01-103EN

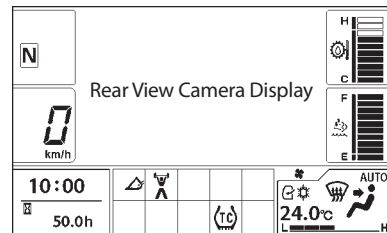

Basic Screen MNHG-01-104EN  
(When Rear View Monitor is Operative)

## OPERATOR'S STATION

- Engine Tachometer (1)  
Engine tachometer (1) indicates the speed of currently running engine in a gauge form. (200 min<sup>-1</sup> step or "RPM")  
If the engine overspeeds, the color of the gauge changes.
- ECO Indicator (2)  
ECO indicator (2) lights when the engine runs in energy efficient condition.  
It turns OFF when the driving speed is 2 km/h (1.2 mph) or lower or under heavy driving load.

 **NOTE:** You may push the down shift switch when the ECO indicator goes OFF while operating on a slope or operation such as snow removal. (Refer to DSS (Down Shift Switch) section)

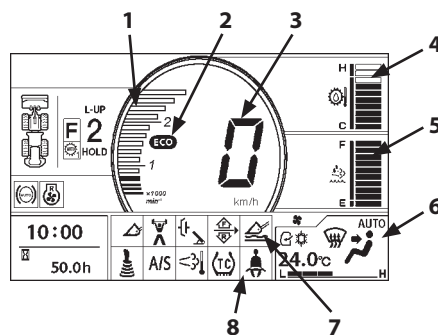



MNHG-01-100EN

- Speedometer (3)  
Speedometer (3) indicates the present driving speed.
- Transmission Oil Temperature Gauge (4)  
Transmission Oil Temperature Gauge (4) depicts transmission oil temperature as a gauge. When the bar reaches the red range, the oil temperature is abnormal.  
If the oil temperature becomes abnormally high, the alarm buzzer will sound and the warning indicator will be displayed.
- DEF Level Gauge (5)  
DEF level gauge (5) displays the remaining DEF amount.  
When DEF level becomes low, the last segment turns yellow.

**IMPORTANT: If the engine runs with low DEF level, the engine power reduces gradually. When the gauge turns yellow, immediately refill DEF. (See page 1-33 for the alarm level.)**

- Air Conditioner Display (6)  
Air conditioner display (6) displays operating condition of the air conditioner.
- Ride Control Indicator (7) (Option)  
Ride control indicator (7) is displayed when the ride control switch is in ON position.
- Seat Belt Indicator (8)  
The indicator turns ON when the key switch is turned ON, and turns OFF 5 seconds after the engine starts.

## OPERATOR'S STATION

- **Forward/Reverse Selector Switch Indicator (9)**  
The forward/reverse indicator lights when the forward/reverse switch on the joystick steering is usable by turning on the joystick steering system switch. (Refer to OPERATING THE ENGINE.)
  
- **Declutch Indicator (10)**  
The declutch indicator lights when the declutch position switch on the right console is in ON position.
  
- **Aftertreatment Device Indicator (11)**  
Displays condition of the aftertreatment device.
  
- **Power Mode Indicator (12)**  
Power mode indicator shows symbol (  ) when the power mode is activated (ON).
  
- **Auto Idling Stop Indicator (A/S) (13)**  
When the auto idling stop is turned ON from the menu screen, the auto idling stop indicator is displayed.  
When the key switch is turned ON while the auto idling stop down is enabled, the auto idling stop indicator blinks for 10 seconds.
  
- **Dual Lift Arm Auto Leveler Indicator (14)**  
When the height kickout is ON (enabled),  is displayed.  
When the lower kickout is ON,  is displayed.
  
- **Clock, Hour Meter, Odometer (15)**

Clock	:	Indicates the present time. 24-h/12-h display can be selected. (Refer to "Date and Time" for switching the display mode.)
Hour Meter	:	Total (accumulated) machine operation hours counted since the machine started working, are displayed in hours (h). One digit after the decimal point indicates tenths of an hour (6 minutes).
Odometer	:	Total machine traveling distance is indicated by changing display mode.

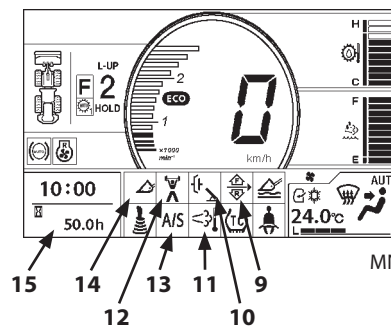

MNHG-01-100EN



## OPERATOR'S STATION

- Fan Reverse Rotation Indicator (16)  
Displays rotating direction of the fan.  
Normal Rotation → The icon is not displayed.  
Changing Rotational Direction → The icon blinks.  
Reverse Rotation → The icon lights ON.

- HOLD Display (17)  
Hold display (17) is displayed when the hold switch on the side console is in ON position.

- Transmission Auto-shifting Indicator (18)  
Transmission auto-shifting indicator (18) displays condition of the travel mode switch. It is not displayed at manual mode.

- F-N-R/Shift Position Indicator (19)  
F-N-R/Shift Position Indicator (19) displays machine operating condition (status of the transmission).

### F-N-R Display

F-N-R indicator displays status of the transmission.

- Forward → F
- Neutral → N
- Reverse → R

### Shift Position Indicator

It displays currently engaged gears. It is not displayed at neutral position.

- Forward : 1st - 4th
- Reverse : 1st - 3rd

- Auto Brake Indicator (20)  
Auto brake indicator (20) appears when the auto brake works due to excessive machine speed or when direction is changed while running at the specified speed or faster. It automatically turns off when the machine speed decreases below within the safety speed limit. Refer to Auto Brake in "MOVING THE MACHINE" section.
- Joystick Steering Indicator (21)  
Joystick steering indicator appears when the joystick steering is made effective by turning on the armrest switch. Refer to "OPERATING THE ENGINE".
- Traction Control Indicator (22)  
Traction control indicator (22) appears when the traction control is turned ON by the setting menu. Refer to page 1-63.
- Torque Converter Lock-Up Indicator (23)  
T/C lock-up indicator (23) appears during the lockup shifting. Refer to page 4-5.

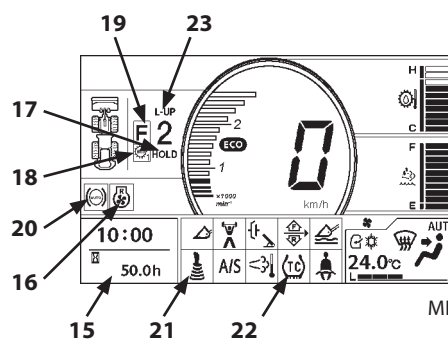

# OPERATOR'S STATION

## Monitor Operation

- Select/Confirm Knob (1)

Push : Push this switch while the basic screen is displayed, the Main Menu Screen opens.  
Push this switch after the menu screen, the action is confirmed.

Rotate : Cursor moves.

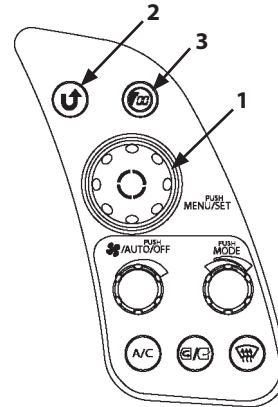

MNEC-01-006

Multi Function Monitor/Air Conditioner Switch Panel

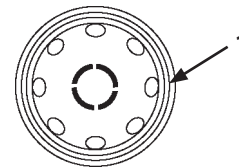

MNEC-01-078

- Return to Previous Screen (2)  
Push this switch to return to the previous screen.

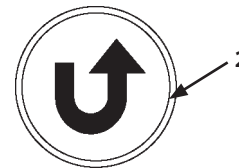

MNEC-01-079

- Return to Basic Screen (3)  
Allows any screen to return to the basic screen.

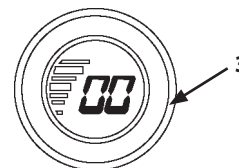

MNEC-01-080

# OPERATOR'S STATION

## Alarm Occurrence Screen

In case any abnormality occurs, alarm symbols (1) and service indicator (3) are displayed on the basic screen.

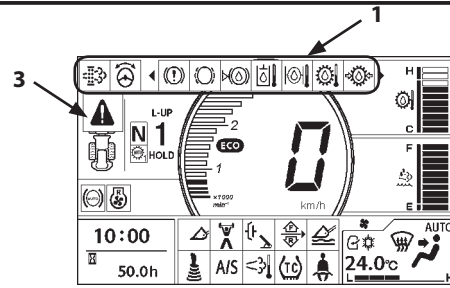

Basic Screen

MNHG-01-290EN

If 8 or more alarms are generated, the alarm symbols (1) can be scrolled by rotating selector knob (2).  
When the rear view monitor is operating, service indicator (3) is displayed.

**NOTE:** When any of the warning indicators light on, service indicator (3) also appears.

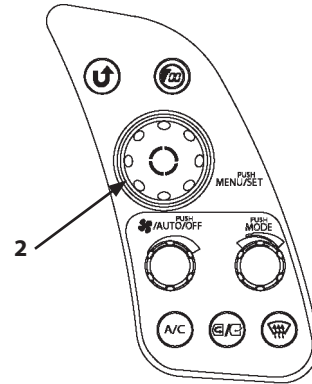

MNEC-01-006

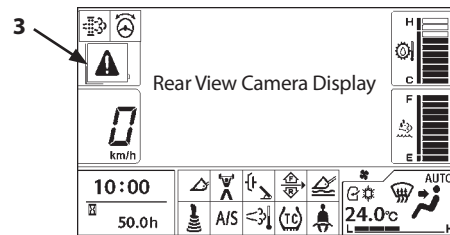

Basic Screen

MNHG-01-291EN

(Operating Rear View Monitor)

# OPERATOR'S STATION

Follow the procedure below to display detailed information for an alarm.

Push selector knob (1) on the basic screen to display the main menu.

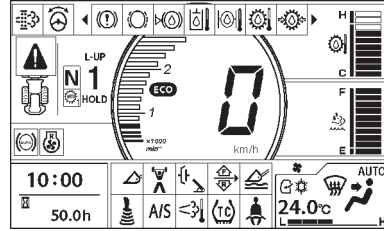

MNHG-01-290EN

Rotate selector knob (1) to select the alarm list, and push selector knob (1).

**NOTE:** The main menu displays the alarm list (faults) only when an alarm occurs.

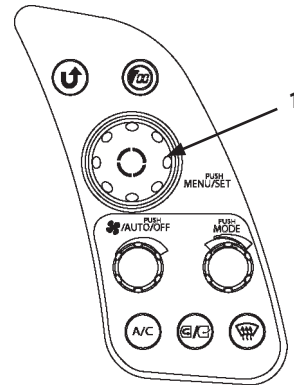

MNEC-01-006

Rotate selector knob (1) to select a required alarm from the alarm list, and push selector knob (1).

**NOTE:** The alarm list contains only active faults or alarms.

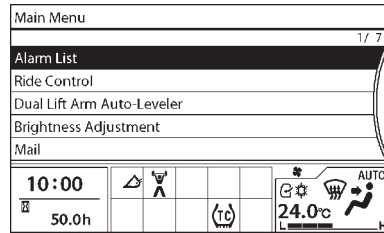

MNHG-01-105EN

Detailed information of the selected alarm will be displayed.

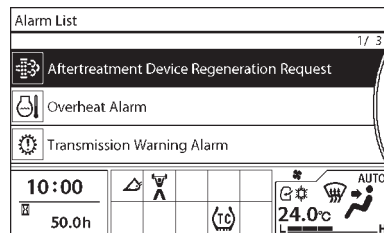



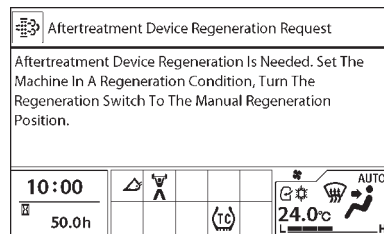







MNHG-01-106EN



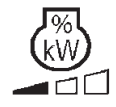
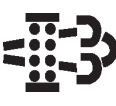

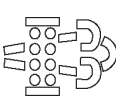
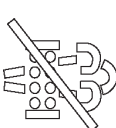
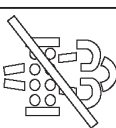







MNHG-01-107EN







## OPERATOR'S STATION

Remedy		
Display	Contents of Alarms	Remedy
	System Failure Alarm	Communication system is abnormal. Consult your nearest authorized dealer.
	Brake Oil Pressure Alarm	Brake oil pressure has decreased. Immediately stop the machine and check the brake system.
	Low Steering Oil Pressure Alarm	Steering oil pressure has decreased. Immediately stop the machine and check the steering system.
	Secondary Steering Alarm (Blinking)	The secondary steering oil pressure does not reach the specified pressure. Inspect the secondary steering system.
	Hydraulic Oil Level Alarm	Hydraulic oil level is low. Immediately stop the machine, check hydraulic oil level and any oil leaks from hydraulic circuit.
	Urea Alarm	DEF/AdBlue® level is low or urea SCR system is abnormal. Refill DEF/AdBlue® if level is low. Contact your nearest authorized dealer for system malfunction.
	Engine Output Restriction	Engine output is restricted.
	Aftertreatment Device Alarm (Blinking) (Red)	Aftertreatment device is abnormal. Immediately set the machine in the park position, stop the engine, apply parking brake, and contact your authorized dealer.
	Aftertreatment Device Regeneration System Failure	Aftertreatment device is abnormal. Immediately set the machine in the park position, stop the engine, apply parking brake, and contact your authorized dealer.
	Aftertreatment Device Regeneration Request (Blinking) (Yellow)	The aftertreatment device needs regeneration. Apply control lever lock and run the engine at slow idle speed. Make the machine possible to perform regeneration, and set the aftertreatment device switch to the regeneration position.
	Aftertreatment Device Regeneration Inhibit Alarm (Lighting) (Yellow)	Manual regeneration was tried but not possible as it is inhibited by setting. Move the machine to a safe area, turn regeneration inhibition OFF, and perform manual regeneration. Refer to page 1-57 to turn regeneration inhibition OFF.
	Aftertreatment Device Auto Regeneration Inhibit Alarm (Lighting) (Yellow)	Auto regeneration was tried but not initiated as it is inhibited by setting. Refer to page 1-57.
	Engine Overheat Alarm	Coolant temperature is above normal. Stop operation. Run the engine at slow idle speed to lower the coolant temperature. When needed, add coolant.

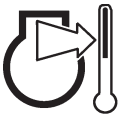
## OPERATOR'S STATION

Display	Contents of Alarms	Remedy
	Hydraulic Oil Overheat Alarm	Hydraulic oil temperature is above normal. Stop operation. Run the engine at slow idle speed to lower the oil temperature.
	Axle Oil Temperature Alarm	Axle oil temperature is above normal. Check if the service brake drags.
	Transmission Oil Temperature Alarm	Transmission oil temperature is above normal. Stop operation. Run the engine at slow idle speed to lower the oil temperature. Use correct range for machine operation, and do not stall torque converter.
	Engine Trouble Alarm	Engine or engine related parts are abnormal. Immediately set the machine in the park position, apply parking brake, stop the engine and contact your authorized dealer.
	Transmission Alarm	Transmission or transmission related parts are abnormal. Immediately set the machine in the park position, apply parking brake, stop the engine and contact your authorized dealer.
	Engine Oil Pressure Alarm	Engine oil pressure has decreased. Immediately stop the engine, and apply parking brake. Check the engine oil system and oil level.
	Boost Temperature Rise Alarm	Intake air temperature is abnormally high. Stop operation. Check intercooler for clogging and intake air piping connections.
	Auto Brake Warning Alarm	Auto brake system is abnormal. Safely park the machine and stop the engine immediately. Check hydraulic oil level and auto brake system for damages and leaks.
	Transmission Filter Clogging	Transmission filter elements are clogged. Replace transmission oil filter following the instruction in the operator's manual.
	Transmission Oil Pressure Alarm	Transmission oil pressure is too low. Safely park the machine. Check transmission oil level and check for leaks.
	Main Pump Oil Pressure Alarm	Main pump oil pressure has decreased. Stop machine operation, and apply parking brake. Check the piping of front attachment for oil leaks.

## OPERATOR'S STATION

Display	Contents of Alarms	Remedy
	Exhaust Temperature Rise Alarm	Exhaust temperature is abnormally high. Stop machine operation, apply parking brake, and check the exhaust lines.
	Intake Air Temperature Rise Alarm	Intake air temperature is abnormally high. Stop machine operation and apply parking brake. Check for any abnormality such as disconnected intake air piping.
	Battery Charge Alarm	Electrical system charge is abnormal. Inspect the alternator and the battery system.
	Fuel Temperature Alarm	Fuel temperature is abnormally high. Stop machine operation and apply parking brake. Run the engine at slow idle speed to lower the fuel temperature.
	Air Cleaner Clogging	Air filter elements are clogged. Clean or replace air cleaner element.
	Fuel Filter Restriction Alarm	Fuel filter is clogged. Replace fuel filter element.
	EGR Gas Temperature Alarm	EGR gas temperature is abnormally high. Stop operation, apply parking brake, and check EGR cooler, EGR cooler coolant circulation circuit, coolant level and intake air and exhaust piping for any abnormality.

## OPERATOR'S STATION

### DEF/SCR System Alarm

When the DEF level becomes low and/or the Urea SCR system malfunctions, the engine performance is controlled depending on the status.

The operator is alerted with alarm indicators.







Move and park the machine in a safe place and follow the displayed message, or troubleshooting guide for the accompanied alarms.

#### DEF/AdBlue® Level Alarm

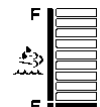
Display of the DEF gauge changes depending on the DEF level.

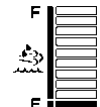
The engine speed and output level control is as follows.

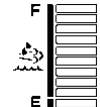
 **NOTE:** Set the FNR controller to neutral or apply the parking brake to show the alarm message on the monitor.







Level Gauge	Alarm Indicator		Status/Inducement
 (Yellow)	 (Red, light)	<div style="border: 1px solid black; padding: 5px; text-align: center;">                         REFILL DEF/AdBlue                     </div>	DEF level is low. Refill DEF.
 (Red)	 (Red, slow blink)	<div style="display: flex; align-items: center; gap: 10px;"> <div style="border: 1px solid black; padding: 5px; text-align: center;">                             REFILL DEF/AdBlue                         </div>  </div>	DEF is insufficient. Refill DEF. Engine output is restricted.
 (Red)	 (Red, fast blink)	<div style="display: flex; align-items: center; gap: 10px;"> <div style="border: 1px solid black; padding: 5px; text-align: center;">                             REFILL DEF/AdBlue                         </div> <div style="background-color: black; color: white; padding: 5px; text-align: center;">                             No Power                         </div> </div>	DEF tank is empty. Refill DEF. Engine output and speed are restricted.

 **CAUTION:** When DEF tank becomes empty, the engine runs but machine operation is disabled until DEF is supplied.



## OPERATOR'S STATION

### Urea SCR System Malfunction

Alarm Indicator		Status/Inducement
 (Red, light)	<b>Exh. System</b> 	Urea SCR system is broken.
 (Red, slow blink)	<b>Exh. System</b>  	Urea SCR system is broken. Engine output is restricted.
 (Red, fast blink)	<b>No Power Exh. System</b> 	Urea SCR system is broken. Engine output and speed are restricted. Contact your authorized dealer for service.

# OPERATOR'S STATION

## Aftertreatment Device Regeneration

To keep the system working correctly, periodically, the collected deposit is removed by purging it at a high temperature. This process is known as "regeneration".

The regeneration is done in three ways; automatic regeneration (abbreviated as auto-regeneration), manual regeneration, and service regeneration.

### Aftertreatment Device Regeneration Status Display

Aftertreatment device display (1) displays the regeneration level of the aftertreatment device.



This symbol indicates that the exhaust temperature is higher than normal during the aftertreatment device regeneration. It lights while auto-regeneration or manual regeneration is in process.)

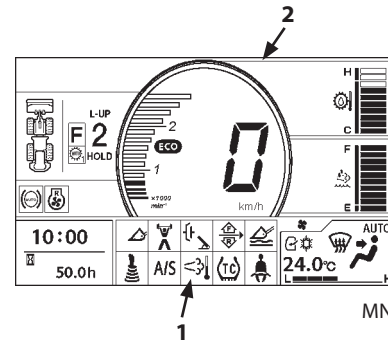

## OPERATOR'S STATION

---

### **Automatic regeneration (Auto-regeneration)**

The machine automatically increases the exhaust temperature during normal operation to purge the deposit.

There are no actions on the part of the operator when auto-regeneration is performed.

- *Auto-regeneration may start while operating the machine, and there is no need to stop the machine when this happens.*
- *Engine speed may change and white smoke may occur. This is not abnormal.*
- *Auto-regeneration is a normal maintenance process, and is not a malfunction.*
- *Do not stop the engine or regeneration once auto-regeneration has started, unless it is absolutely necessary.*

Auto-regeneration may not be completed due to system limitations while operating the machine. If this occurs, the aftertreatment device regeneration request will appear on the monitor panel. Refer to page 5-16 to perform manual regeneration.



This symbol indicates that the aftertreatment device regeneration is set to the "inhibited" position. Regeneration can not be performed while this indicator is shown.

**IMPORTANT: Set the aftertreatment device regeneration to "inhibited" while operating in a flammable environment (Refer to page 1-57).**

# OPERATOR'S STATION

## Manual Regeneration

When the deposit level increases to a level that is more than an auto-regeneration can remove, a manual regeneration is required.

The yellow regeneration symbol (shown below)(1) and service indicator (2) appear to make the operator aware that this is required.



(Blinking, Yellow)

This symbol indicates that the aftertreatment device manual regeneration is required.

Perform manual regeneration (Refer to page 5-13 for the procedure.)



(Lighting, Yellow)

This symbol indicates that the aftertreatment device regeneration is inhibited.

It is displayed when the manual regeneration is requested while regeneration "inhibited" feature has been applied.

Move the machine to a safe place.  
Perform manual regeneration by pressing manual regeneration switch (3).  
(Refer to page 1-57 for more information.)

The manual regeneration must be performed as soon as possible, and it will take the loader out of service for about 10~20 minutes.

Refer to page 5-13 for the manual regeneration procedure.

**NOTE:** When the manual regeneration starts, regeneration indicator (4) turns ON. If it does not appear when pressing switch (3), the manual regeneration is not activated. Contact your authorized dealer for repair.



(Lighting, Yellow)

The engine trouble alarm (in yellow) may occur if the machine is being operated without performing a manual regeneration. It may be necessary to clean, repair or replace the aftertreatment device after removing the device depending on its condition.

Immediately set the machine in the park position, apply parking brake, stop the engine and consult your authorized dealer.

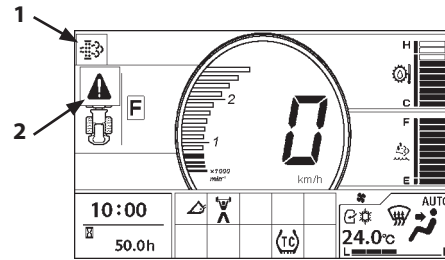

Basic Screen

MNHG-01-280EN

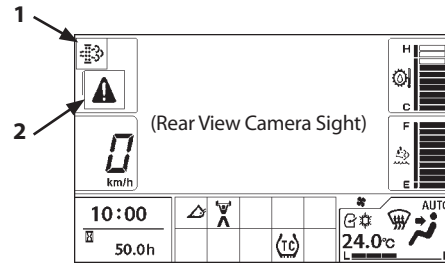

Basic Screen

MNHG-01-281EN

(Operating Rear View Monitor)

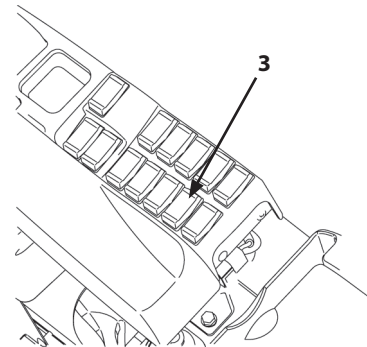

115MNEC-07-01

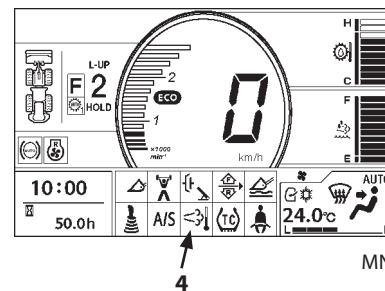

MNHG-01-100EN

# OPERATOR'S STATION

## Main Menu

**IMPORTANT:** If the forward/reverse lever is in the forward or reverse position, the basic screen is displayed. (You can not change to the other screen.) When the forward/reverse lever is changed to forward or reverse position while displaying the main menu screen, the screen changes back to the basic screen.

Press selector knob (2) while displaying basic screen (1) to display Main Menu screen (3).

The main menu screen contains the items shown in the figure to the right. The alarm list is displayed only when an alarm is generated.

Ride control (option) and Mail (option) menus will not be displayed unless they are set beforehand.

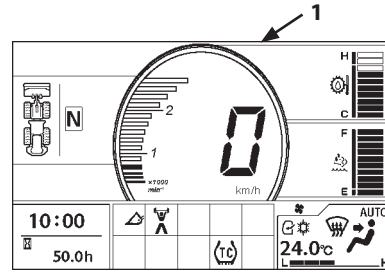

MNHG-01-103EN

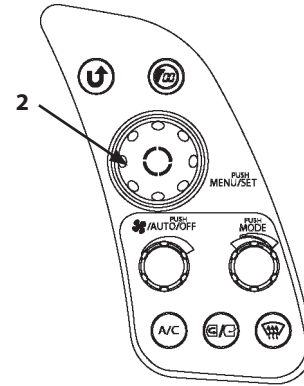

MNEC-01-006

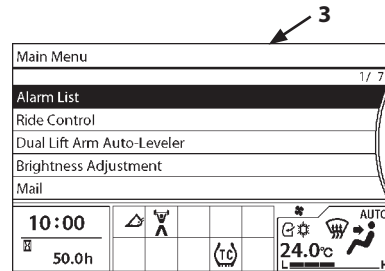

MNHG-01-105EN

# OPERATOR'S STATION

## Ride Control Drive Speed Setting (Option)

1. Press selector knob (2) while displaying basic screen (1) to display Main Menu screen (3).

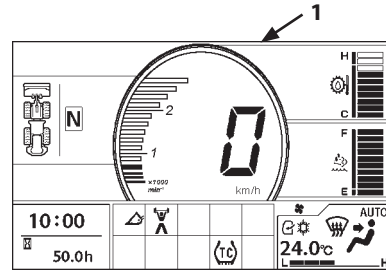

MNHG-01-103EN

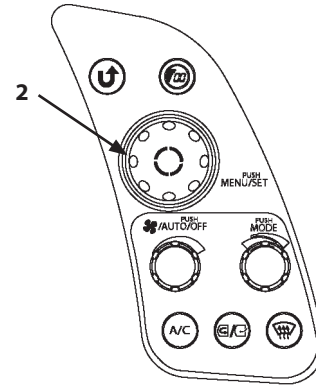

MNEC-01-006

2. Rotate selector knob (2) to highlight Ride Control (4).

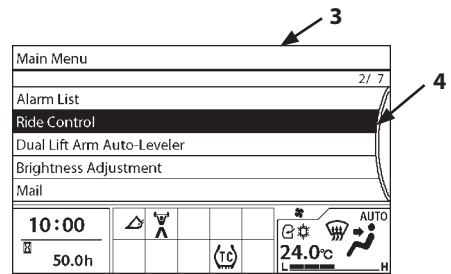

MNHG-01-108EN

3. Press selector knob (2) to display Ride Control Drive Speed Setting screen (5).

4. Press selector knob (2) once and then rotate it clockwise to increase set speed at 1 km/h (0.6 mph) interval. Rotate the selector knob (2) counterclockwise to decrease set speed at 1 km/h (0.6 mph) interval.

(The set vehicle speed can be changed within the set range.)

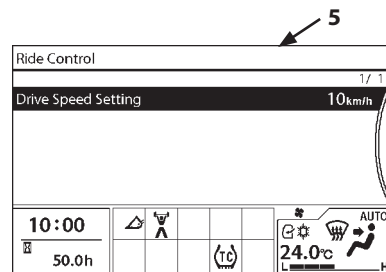

MNHG-01-109EN

 **NOTE:** When the speed is at 0 km/h (0 mph), the ride control function is constantly ON.

5. Press selector knob (2) to complete the changes of setting.

# OPERATOR'S STATION

## Dual Lift Arm Auto-Leveler

1. Press selector knob (2) while displaying basic screen (1) to display Main Menu screen (3).

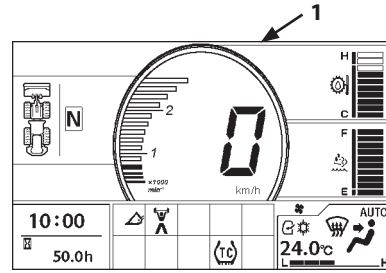

MNHG-01-103EN

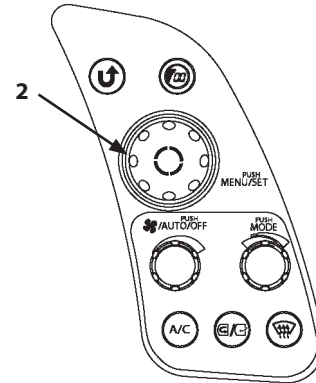

MNEC-01-006

2. Rotate selector knob (2) to highlight Dual Lift Arm Auto-Leveler (4).

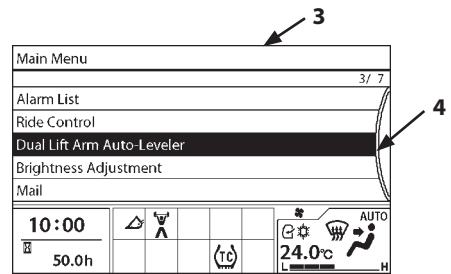

MNHG-01-110EN

3. Press selector knob (2) to display Dual Lift Arm Auto-Leveler screen (5).
4. Rotate selector knob (2) to select Height Kickout (6) or Lower Kickout (7).
5. Press selector knob (2).

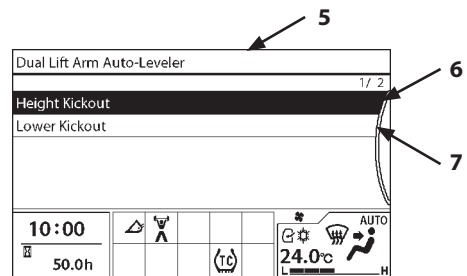

MNHG-01-111EN

## OPERATOR'S STATION

### Height Kickout ON/OFF, Stop Height Setting

- Rotate selector knob (2) to highlight ON (8).
- ON/OFF Selection

Press selector knob (2) to turn ON (enabled).  
(A box next to ON turns green.)

This enables the setting of the lift arm height.

Press selector knob (2) again to turn OFF (disabled).

When the height kickout is ON (enabled), indicator  (12) will be displayed on the monitor.

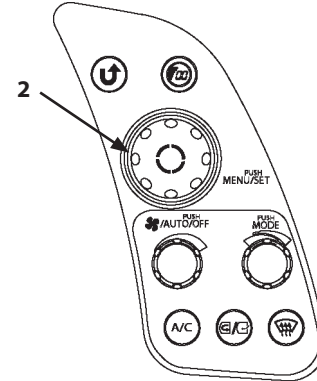

MNEC-01-006

- Display content

Segment (10) indicates current set value of the height kickout.

Segment (11) indicates current height of the lift arm.

- Setting Operation

When the height kickout is ON (enabled), the lift arm stop height can be set.

When the lift arm height changes by operating the lift arm control lever, the height is displayed on segment (11).

When the lift arm height is within the setting range, the mark  (9) will be displayed.

Rotate selector knob (2) to highlight  (9).

Press selector knob (2) to change the height kickout setting value.

When the height kickout set value changes, the value displayed on segment (10) will change accordingly.

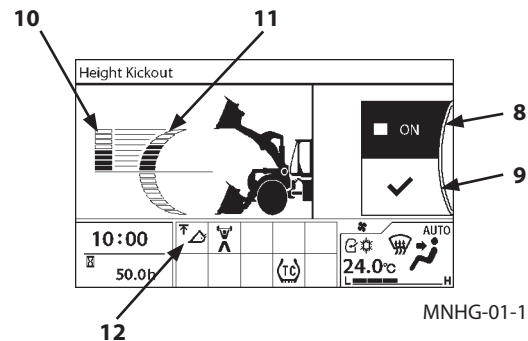

MNHG-01-112EN



## OPERATOR'S STATION

### Lower Kickout ON/OFF, Stop Height Setting

- Rotate selector knob (2) to highlight ON (8).
- ON/OFF Selection

Press selector knob (2) to turn ON (enabled).  
(A box next to ON turns green.)

This enables the setting of the lift arm height.

Press selector knob (2) again to turn OFF (disabled).

When the lower kickout is ON (enabled), indicator  (12) will be displayed on the monitor.

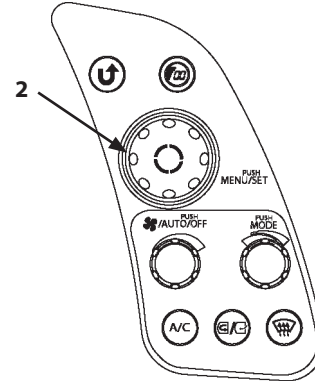

MNEC-01-006

- Display content

Segment (10) indicates current set value of the lower kickout.

Segment (11) indicates current height of the lift arm.

- Setting Operation

When the lower kickout is ON (enabled), the lift arm stop height can be set.

When the lift arm height changes by operating the lift arm control lever, the height is displayed on segment (11).

When the lift arm height is within the setting range, the mark  (9) will be displayed.

Rotate selector knob (2) to highlight  (9).

Press selector knob (2) to change the lower kickout setting value.

When the lower kickout setting value changes, the value will be displayed on segment (10).

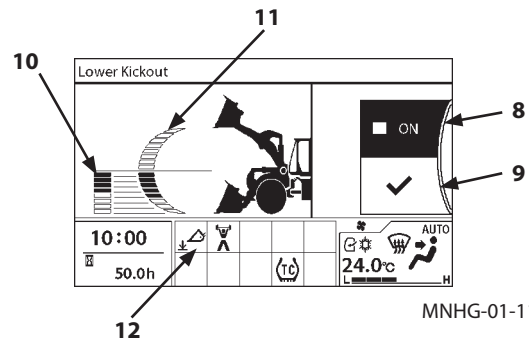

MNHG-01-113EN

# OPERATOR'S STATION

## Brightness Adjustment

1. Press selector knob (2) while displaying Basic Screen (1) to display Main Menu screen (3).

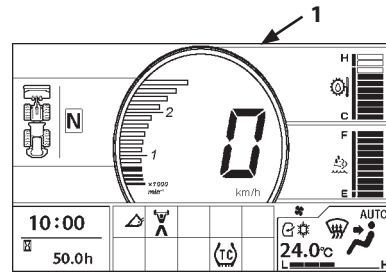

MNHG-01-103EN

2. Rotate selector knob (2) to highlight Brightness Adjustment (4).

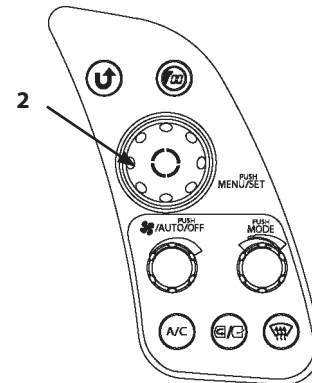

MNEC-01-006

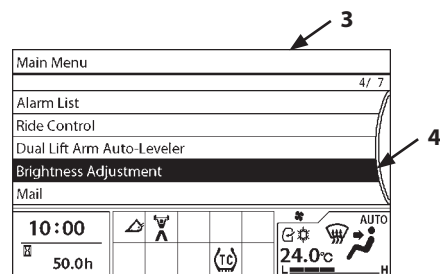

MNHG-01-120EN

## OPERATOR'S STATION

- Press selector knob (2) to display Brightness Adjustment screen (5).

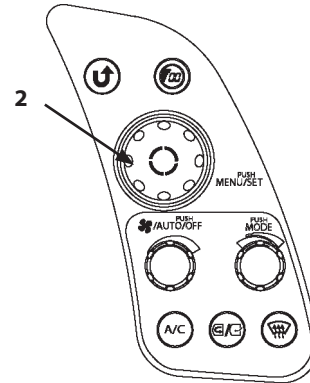

- Rotate selector knob (2) clockwise to make the screen brighter, counterclockwise to make the screen darker.

MNEC-01-006

 **NOTE:** When the machine's head light switch is turned ON, the monitor screen changes to night mode and mark (6) is displayed. Brightness can be adjusted for day mode and night mode respectively.

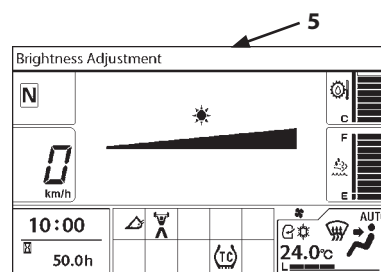

MNHG-01-121EN

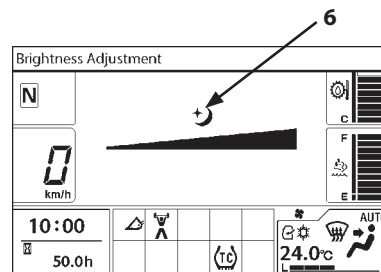

MNHG-01-122EN

# OPERATOR'S STATION

## Mail (Option)

**IMPORTANT:** This function is available only to a machine equipped with a communication terminal.  
**When using the mail function, consult your nearest authorized dealer.**

1. Press selector knob (2) while displaying Basic Screen (1) to display Main Menu screen (3).

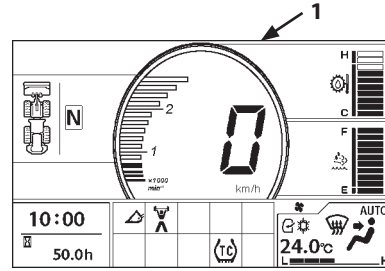

MNHG-01-103EN

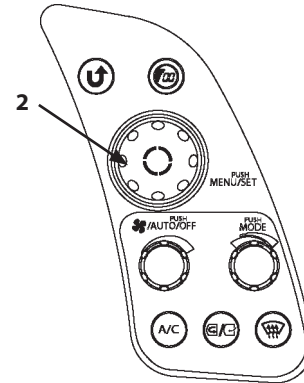

MNEC-01-006

2. Rotate selector knob (2) to highlight Mail (4).

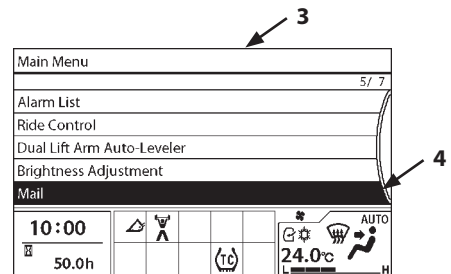

MNHG-01-130EN

3. Press selector knob (2) to display Mail screen (5).

4. Rotate selector knob (2) to highlight desired request.

5. Press selector knob (2) to send mail information to the communication terminal.

- General Request
- Fuel Replenishment Request
- Service Maintenance Request
- Forwarding Request

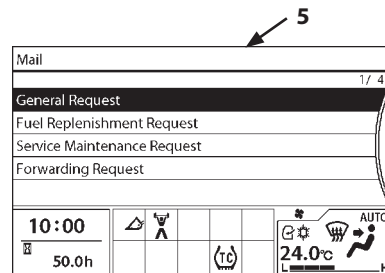

MNHG-01-131EN

## OPERATOR'S STATION

6. While mail information is sent to the communication terminal, the message "Wait." is displayed on the screen.

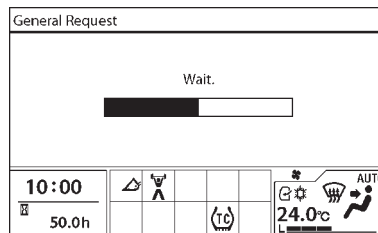

MNHG-01-132EN

7. When the communication terminal completes receiving mail information, the message "Request Was Accepted." is displayed on the screen.

Push back key  (6) to return to the Mail screen.

8. Then, a mail is sent from the communication terminal to the central server.

 **NOTE:** Depending on the machine's operating environment or signal strength, the mail may not be sent.

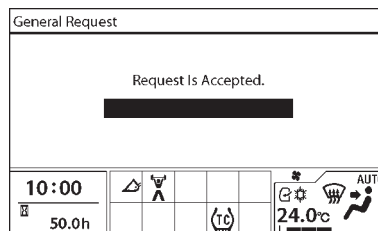

MNHG-01-133EN

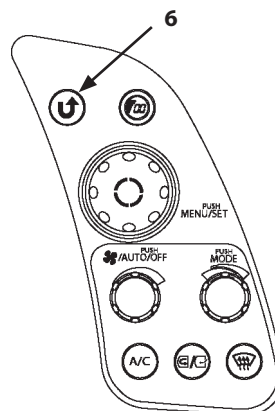

MNEC-01-006

 **NOTE:** When the communication terminal could not receive the mail, the message "Failed." is displayed on the screen.

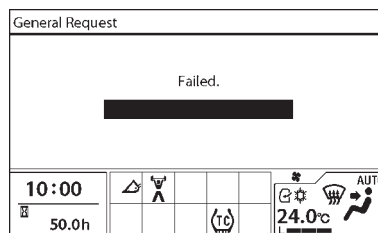

MNHG-01-134EN

# OPERATOR'S STATION

## Setting Menu

Setting menu consists of date and time setting, auto idling stop setting, and rear view camera monitor setting.

1. Press selector knob (2) while displaying basic screen (1) to display Main Menu screen (3).

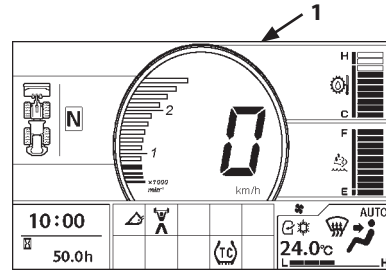

MNHG-01-103EN

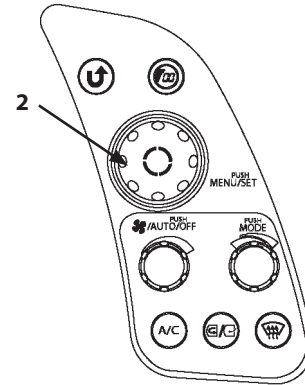

MNEC-01-006

2. Rotate selector knob (2) to highlight Setting Menu (4).

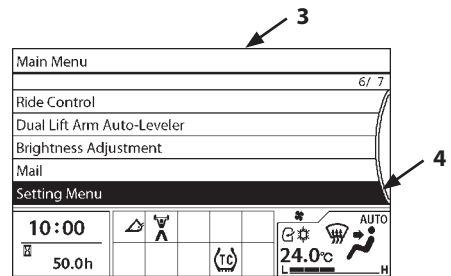

MNHG-01-140EN

3. Press selector knob (2) to display Setting Menu screen (5).

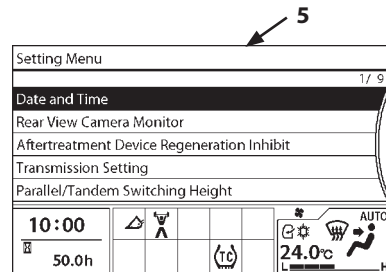

MNHG-01-141EN

# OPERATOR'S STATION

## Date and Time

Time, date and display mode can be set on this screen. Year-month-day format and 24h/12h display mode are selected in the display setting.

### Time Adjustment

1. Press selector knob (2) while displaying Basic Screen (1) to display Main Menu screen (3).

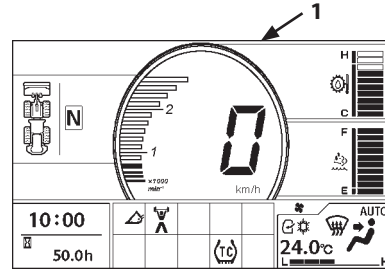

MNHG-01-103EN

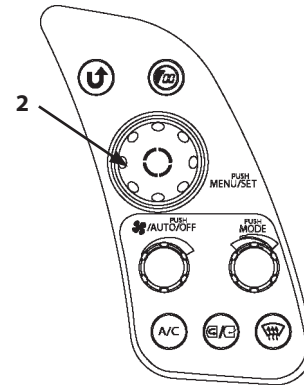

MNEC-01-006

2. Rotate selector knob (2) to highlight Setting Menu (4).

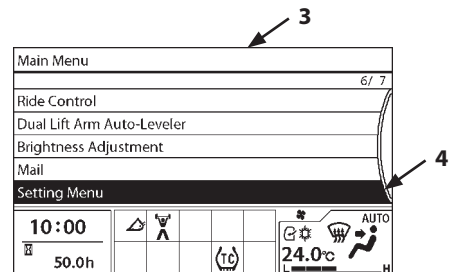

MNHG-01-140EN

3. Press selector knob (2) to display Setting Menu screen (5).
4. Rotate selector knob (2) to highlight Date and Time (6).

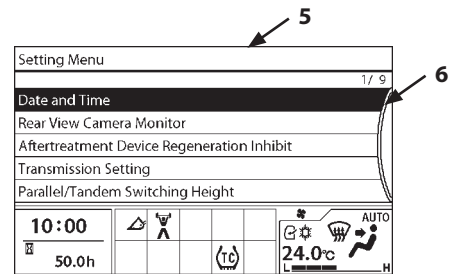

MNHG-01-141EN

# OPERATOR'S STATION

- Press selector knob (2) to display Date and Time screen (7).

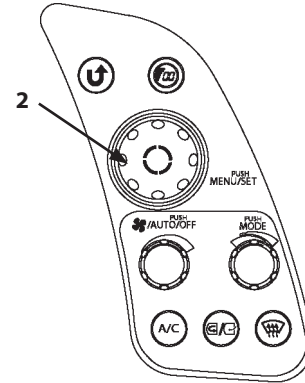

MNEC-01-006

- Rotate selector knob (2) to highlight Time Setting (8).
- Press selector knob (2) to display Time Setting screen (9).

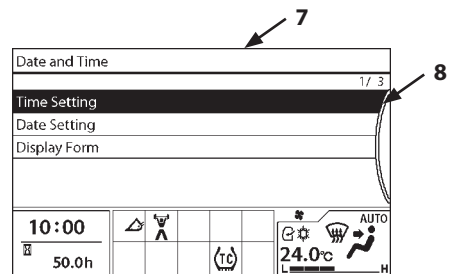

MNHG-01-142EN

- Rotate selector knob (2) to highlight Hour or Minute and push selector knob (2).
- Rotate selector knob (2) to adjust the clock. Rotate clockwise to adjust the number upwards, and counterclockwise to decrease it.
- Push selector knob (2) to end the time setting procedure.
- Rotate selector knob (2) to highlight ✓ (11). Push selector knob (2) to make the change.

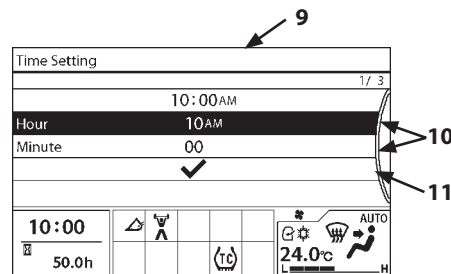

MNHG-01-143EN

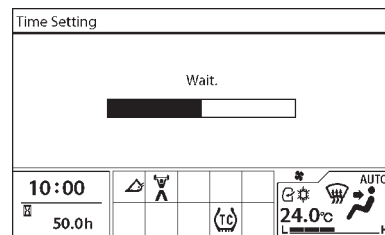

MNHG-01-144EN



# OPERATOR'S STATION

## Date Adjustment

1. Press selector knob (2) while displaying Basic Screen (1) to display Main Menu screen (3).

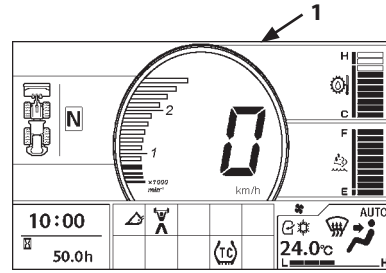

MNHG-01-103EN

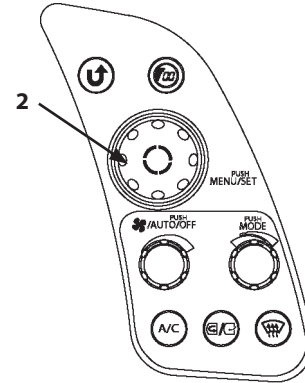

MNEC-01-006

2. Rotate selector knob (2) to highlight Setting Menu (4).

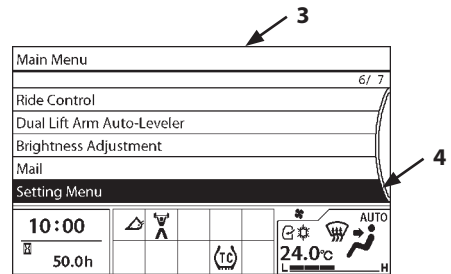

MNHG-01-140EN

3. Press selector knob (2) to display Setting Menu screen (5).

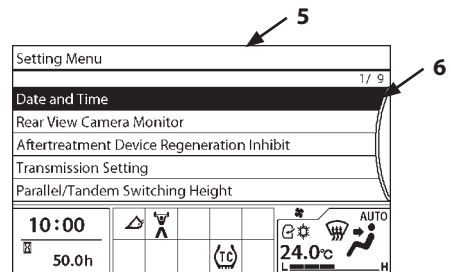

MNHG-01-141EN

4. Rotate selector knob (2) to highlight Date and Time (6).

# OPERATOR'S STATION

- Press selector knob (2) to display Date and Time screen (7).

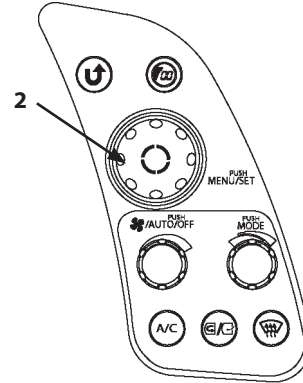

MNEC-01-006

- Rotate selector knob (2) to highlight Date Setting (8).
- Press selector knob (2) to display Date Setting screen (9).

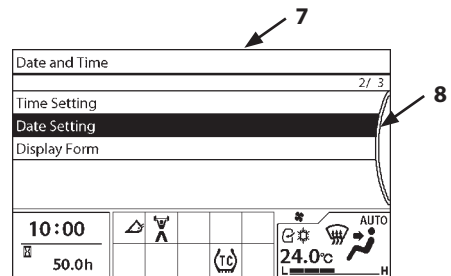

MNHG-01-145EN

- Rotate selector knob (2) to highlight Year, Month or Day and push selector knob (2).
- Rotate selector knob (2) to adjust the date. Rotate clockwise to adjust the number upwards, and counterclockwise to decrease it.
- Push selector knob (2) to end the date setting procedure.
- Rotate selector knob (2) to highlight ✓ (11). Push selector knob (2) to make the change.

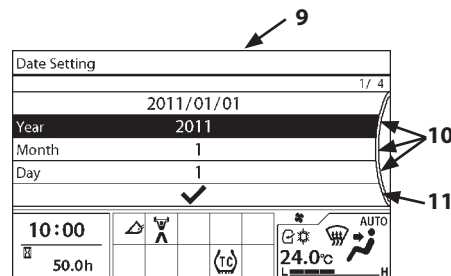

MNHG-01-146EN

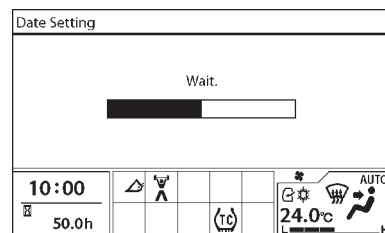

MNHG-01-147EN

# OPERATOR'S STATION

## Display Mode Setting

1. Press selector knob (2) while displaying Basic Screen (1) to display Main Menu screen (3).

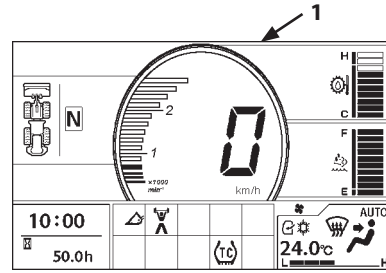

MNHG-01-103EN

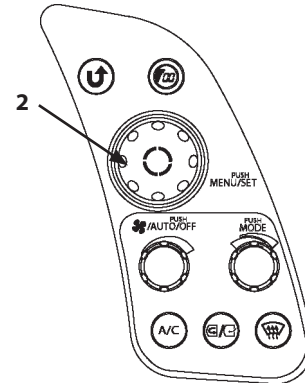

MNEC-01-006

2. Rotate selector knob (2) to highlight Setting Menu (4).

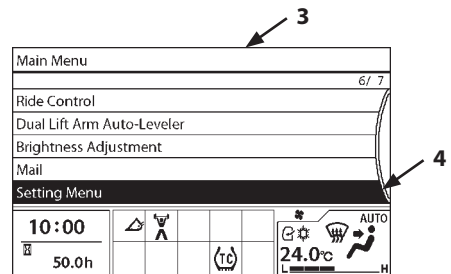

MNHG-01-140EN

3. Press selector knob (2) to display Setting Menu screen (5).

4. Rotate selector knob (2) to highlight Date and Time (6).

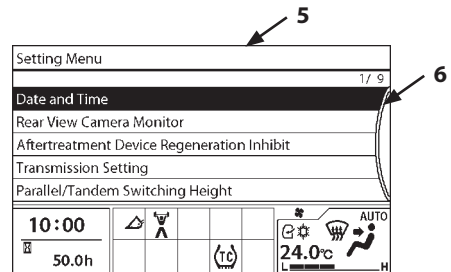

MNHG-01-141EN

# OPERATOR'S STATION

- Press selector knob (2) to display Date and Time screen (7).

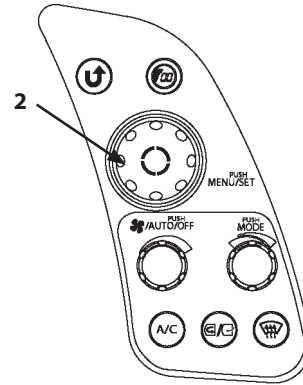

MNEC-01-006

- Rotate selector knob (2) to highlight Display Form (8).

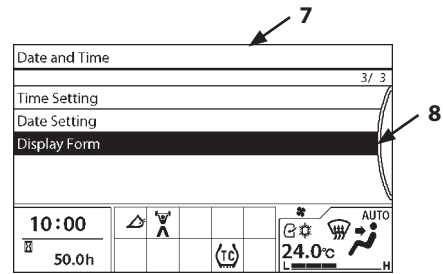

MNHG-01-148EN

- Press selector knob (2) to display Display Form screen (9).

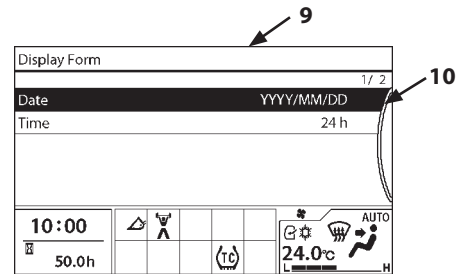

MNHG-01-149EN

- Rotate selector knob (2) to highlight Date (10) and push selector knob (2).

Date : Each time selector knob (2) is pushed, the date format is changed as follows: YYYY/MM/DD → MM/DD/YYYY → DD/MM/YYYY → YYYY/MM/DD.



Time : Each time selector knob (2) is pushed, the time format is changed as follows: 12 h → 24 h → 12 h.



# OPERATOR'S STATION

## Auto Idling Stop

**WARNING:** This function automatically idles, then stops the engine. Take extra care on the work and environment when using this function.

The auto idling stop function can be set in this screen. Set the auto idling stop time and enable the function beforehand (set to ON).

The engine automatically stops after the preset time when machine is parking under the following conditions:

- Parking brake switch: ON (parking brake is applied)
- Service brake pedal: released (service brake pedal is not applied)
- Throttle pedal: released
- Transmission position: Neutral
- No steering wheel or joystick steering (option) operation
- No loading lever operation

30 seconds before the engine stops, the monitor displays a message that the engine will be stopped and the indicator (7) starts flashing.

The buzzer also sounds. The buzzer sounds once at 30 seconds before, intermittently sounds from 15 seconds, and then stops after 15 seconds.

When the machine is in the operating state or any of the above listed conditions is not satisfied before stopping the engine, the auto idling stop is disabled and the engine will not stop.

**IMPORTANT:** Do not leave the machine after auto idling stop. Failure to do so may discharge the batteries.

### Auto idling stop: ON/OFF

1. Press selector knob (2) while displaying Basic Screen (1) to display Main Menu screen (3).
2. Rotate selector knob (2) to highlight Setting Menu (4).
3. Press selector knob (2) to display Setting Menu screen (5).
4. Rotate selector knob (2) to highlight Auto Shut-Down (6).

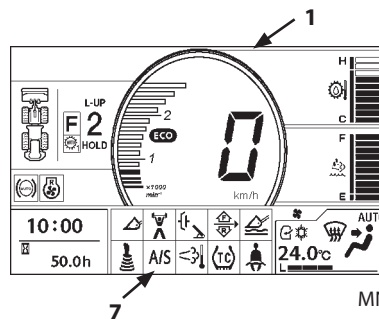

MNHG-01-100EN

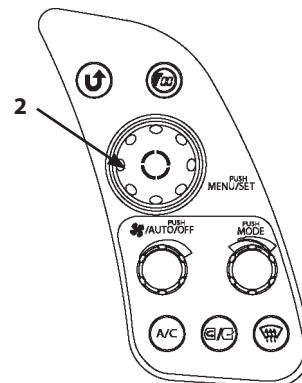

MNEC-01-006

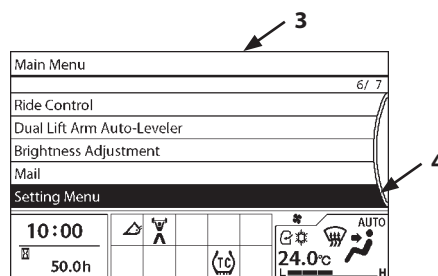

MNHG-01-140EN

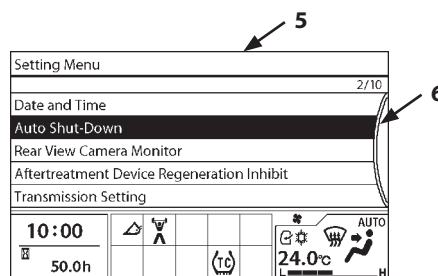

MNHG-01-150EN

# OPERATOR'S STATION

- Press selector knob (2) to display Auto Shut-Down screen (7).

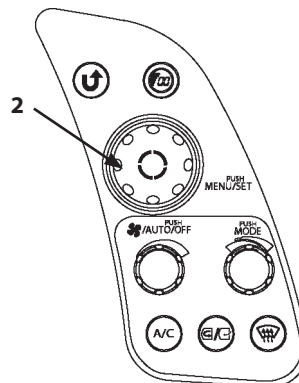

- Rotate selector knob (2) to highlight ON (8).
- Press selector knob (2) to set the auto idling stop function ON and indicator (11) will be lit. Press selector knob (2) again to set the auto idling stop function OFF and indicator (11) goes off.

MNEC-01-006

**NOTE:** When the function is ON, the mark "■" is displayed in green. When the function is OFF, the mark "■" is displayed in gray.

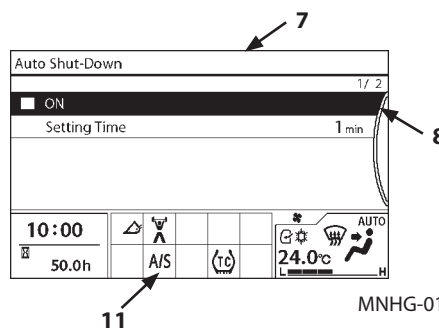

MNHG-01-151EN

## Acting Time Setting

- On the Auto Shut-Down screen, rotate selector knob (2) to highlight Setting Time (9) and push selector knob (2).
- Rotate selector knob (2) clockwise to extend idle time by 1 minute steps. Rotate selector knob (2) counterclockwise to decrease idle time by 1 minute steps.
- Press selector knob (2) to make the change.

**NOTE:** The idle time can be set to 1, 2, 3, 4, 5, 7, 10, 15, 20, 25 or 30 minutes. Observe local and federal engine idling regulations.

**NOTE:** 30 seconds before the engine stops, the monitor will display "Engine Shut-Down Soon." message (10).

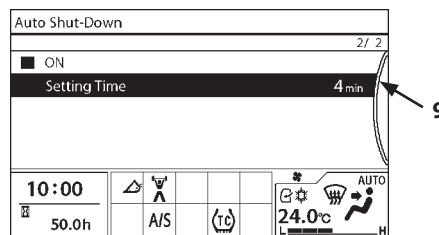

MNHG-01-152EN

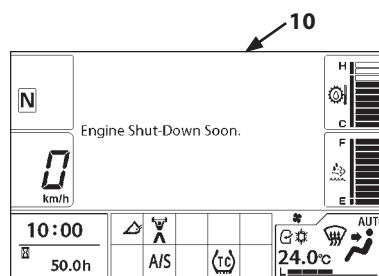

MNHG-01-153EN

# OPERATOR'S STATION

## Rear View Camera Monitor

**IMPORTANT:** The image displayed on the rear view monitor is meant only as an aid. Actual position and distance of people and objects in the rear view monitor will be different from the actual view. When operating the machine, pay thorough attention to the surroundings with use of mirrors and windows.

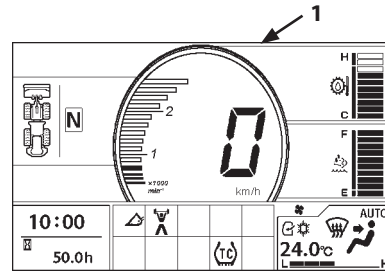

MNHG-01-103EN

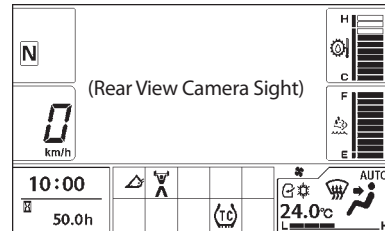

Operating Rear View Monitor MNHG-01-104EN

1. Press selector knob (2) while displaying Basic Screen (1) to display Main Menu screen (3).

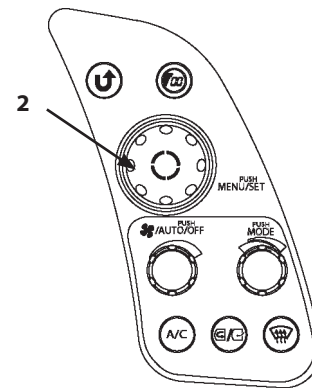

MNEC-01-006

2. Rotate selector knob (2) to highlight Setting Menu (4).

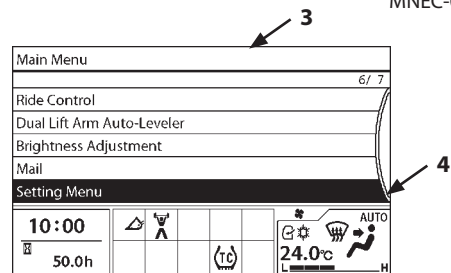

MNHG-01-140EN

3. Press selector knob (2) to display Setting Menu screen (5).

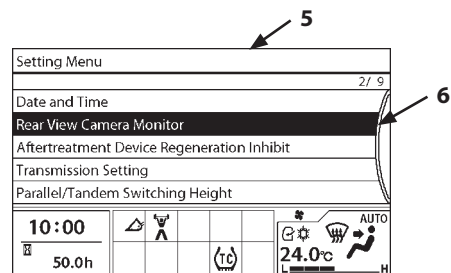

MNHG-01-160EN

4. Rotate selector knob (2) to highlight Rear View Camera Monitor (6).

## OPERATOR'S STATION

- Press selector knob (2) to display Rear View Camera Monitor screen (7).

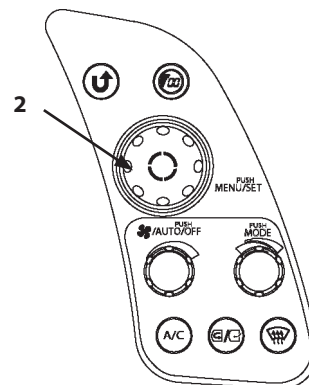

- Press selector knob (2) to turn the rear view camera monitor ON/OFF/AUTO.
- When the rear view camera monitor is ON, rear view image is continuously displayed on the basic screen.

When the rear view camera monitor is AUTO, rear view image is displayed on the basic screen only at reverse travel.

When the rear view camera monitor is OFF, rear view image is not available.

MNEC-01-006

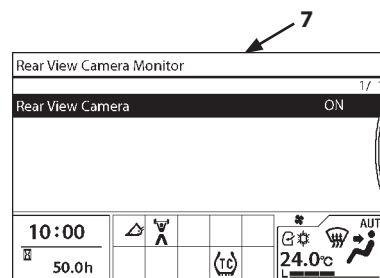

MNHG-01-161EN

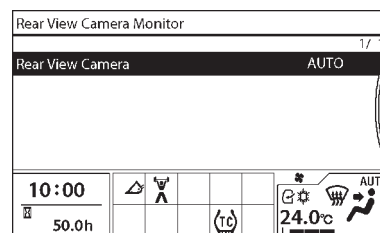

MNHG-01-162EN

**IMPORTANT:** In order to obtain a clear image, clean the camera lens and the monitor display before operating the machine. In bad weather or extreme dust, more frequent cleaning will be required.

 **NOTE:** The monitor and camera lens surface is a resin (plastic) product. Lightly wipe the surface with a wet clean cloth. Never use an organic solvent.

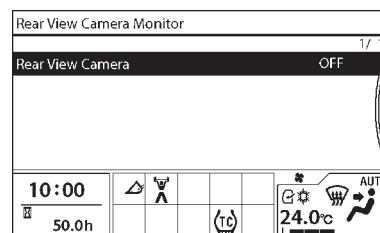

MNHG-01-163EN

**IMPORTANT:**

- Never attempt to change the mounting position of the rear view camera.
- Consult your authorized dealer if any abnormality is found on the rear view image.



# OPERATOR'S STATION

## Aftertreatment Device Regeneration Inhibited

**IMPORTANT:** The aftertreatment device regeneration can be inhibited at this screen to prevent auto regeneration while operating the machine in a flammable area or indoors.

### Setting Procedure

1. Press selector knob (2) while displaying Basic Screen (1) to display Main Menu screen (3).

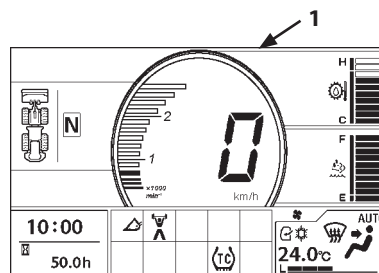

MNHG-01-103EN

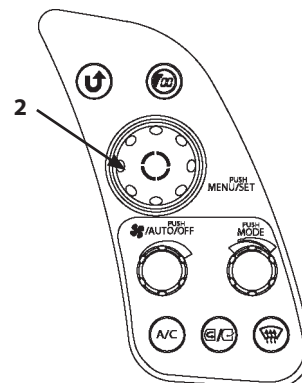

MNEC-01-006

2. Rotate selector knob (2) to highlight Setting Menu (4).

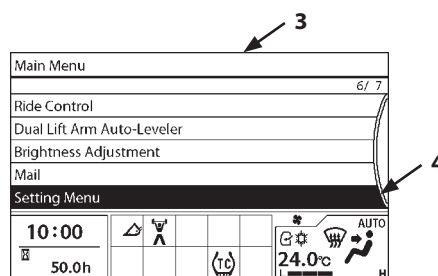

MNHG-01-140EN

3. Press selector knob (2) to display Setting Menu screen (5).

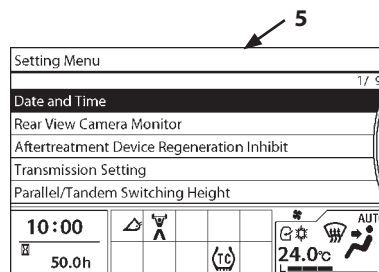

MNHG-01-141EN

# OPERATOR'S STATION

- Rotate selector knob (2) to highlight Aftertreatment Device Regeneration Inhibited (6).

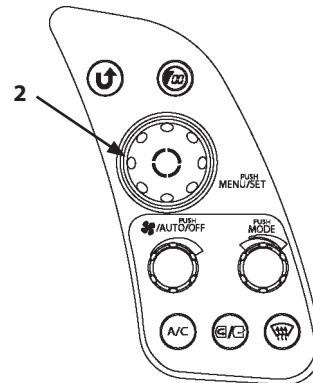

MNEC-01-006

- Press selector knob (2) to display Aftertreatment Device Regeneration Inhibited screen (7).

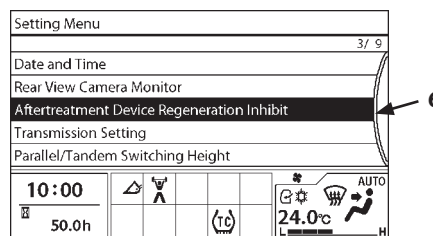

MNHG-01-170EN

- Rotate selector knob (2) to highlight ✓ (8), and press selector knob (2) to display Aftertreatment Device Regeneration Inhibited screen (9).

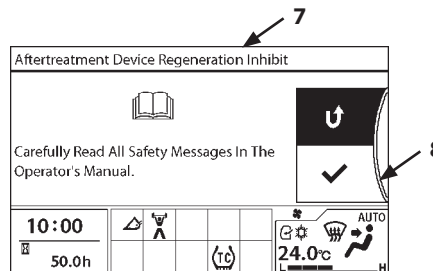

MNHG-01-171EN

- Rotate selector knob (2) to highlight ON (10). Confirmation screen is added.

Press selector knob (2) to turn Aftertreatment Device Regeneration Inhibited ON. Press selector knob (2) again to turn Aftertreatment Device Regeneration Inhibited OFF.

When ON is selected, regeneration inhibited icon (11) will be displayed on the monitor.

**NOTE:** When the function is ON, the mark "■" is displayed in green. When the function is OFF, the mark "■" is displayed in gray.

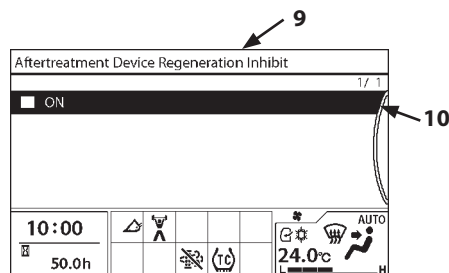

MNHG-01-172EN

**IMPORTANT:** This procedure will inhibit both automatic and manual regeneration. When the machine is operated with the aftertreatment device regeneration inhibited, the aftertreatment device becomes clogged more quickly than expected. When the aftertreatment device regeneration request is displayed, move the machine to a safe place. Perform the manual regeneration following the specified procedure. Failure to do so may damage the aftertreatment device. Refer to page 5-13 for the manual regeneration.

# OPERATOR'S STATION

## Transmission Setting

### Shift Change Delay Mode Setting

Refer to page 4-6 for Shift Change Delay Mode.

1. Press selector knob (2) while displaying Basic Screen (1) to display Main Menu screen (3).

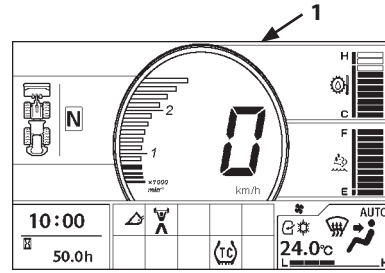

MNHG-01-103EN

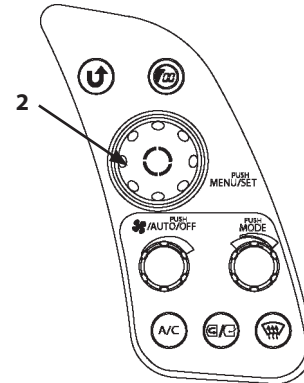

MNEC-01-006

2. Rotate selector knob (2) to highlight Setting Menu (4).

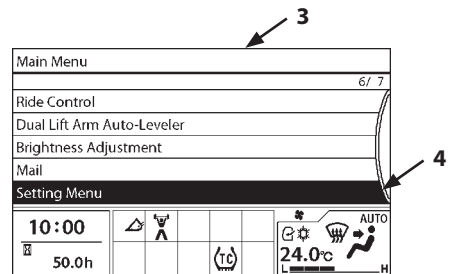

MNHG-01-140EN

3. Press selector knob (2) to display Setting Menu screen (5).

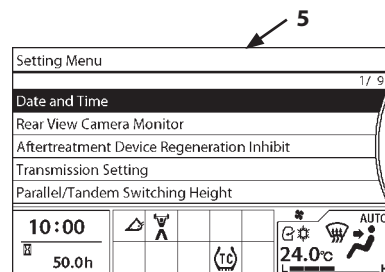

MNHG-01-141EN

# OPERATOR'S STATION

4. Rotate selector knob (2) to highlight Transmission Setting Menu (6).

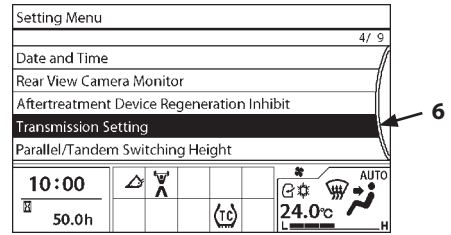

MNHG-01-180EN

5. Press selector knob (2) to display Transmission Setting screen (7).

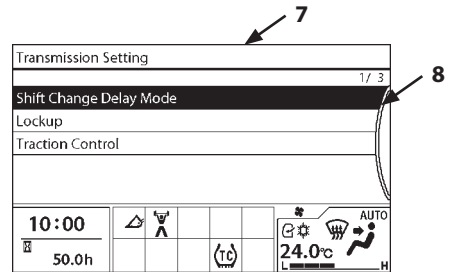

MNHG-01-181EN

6. Rotate selector knob (2) to highlight Shift Change Delay Mode (8).

7. Press selector knob (2) to display Shift Change Delay Mode screen (9).

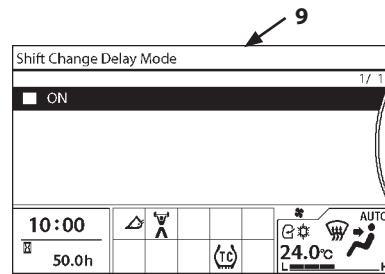

MNHG-01-182EN

8. Press selector knob (2) to turn ON (enabled).

When ON (enabled) is selected, background of the Speed Gear Stage display (10) turns blue.

Press selector knob (2) again to turn OFF (disabled).

**NOTE:** When the function is ON, the mark "■" is displayed in green. When the function is OFF, the mark "■" is displayed in gray.

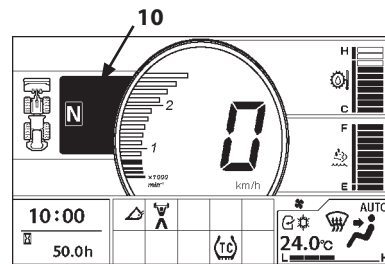

MNHG-01-183EN

# OPERATOR'S STATION

## Lockup Setting

Lock-up clutch is provided for efficient power transmission from the engine, that helps to improve fuel efficiency and have higher ground speed.

Use this setting to activate the lockup shifting (refer to page 4-5).

 **NOTE:** The lock-up control directly links the transmission to the engine when the Auto Shift Mode 1 or 2 is selected.

1. Press selector knob (2) while displaying Basic Screen (1) to display Main Menu screen (3).

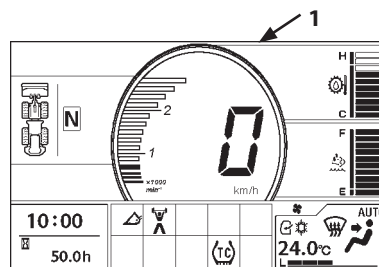

MNHG-01-103EN

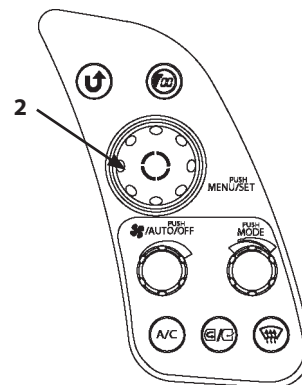

MNEC-01-006

2. Rotate selector knob (2) to highlight Setting Menu (4).

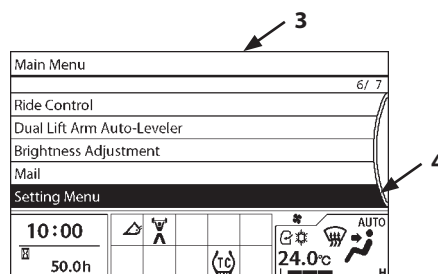

MNHG-01-140EN

3. Press selector knob (2) to display Setting Menu screen (5).

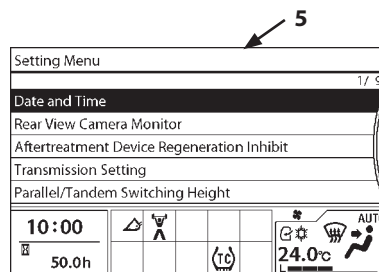

MNHG-01-141EN

# OPERATOR'S STATION

- Rotate selector knob (2) to highlight Transmission Setting Menu (6).

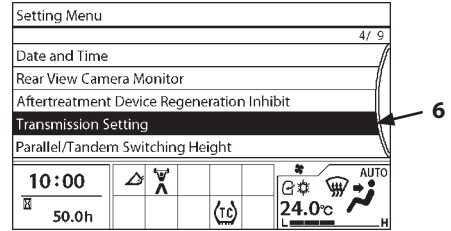

MNHG-01-180EN

- Press selector knob (2) to display Transmission Setting screen (7).

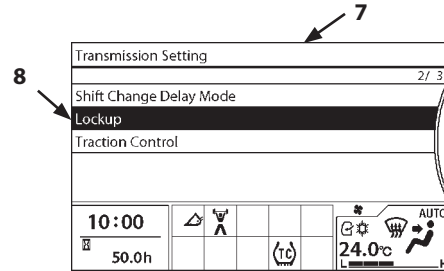

MNHG-01-184EN

- Rotate selector knob (2) to highlight Lockup (8).

- Press selector knob (2) to display Lockup setting screen (9).

- Press selector knob (2) to turn ON.

When ON is selected, "L-UP" indicator (10) turns ON when the lockup clutch is engaged.

Press selector knob (2) again to turn OFF (disabled).

 **NOTE:** When the function is ON, the mark "■" is displayed in green. When the function is OFF, the mark "■" is displayed in gray.

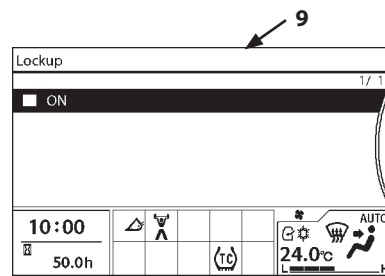

MNHG-01-185EN

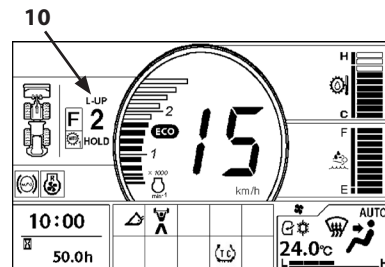

95Z7B-1-60-4

# OPERATOR'S STATION

## Traction Control Setting

If the tire is ready to spin, by keeping the traction control function ON, the engine speed is temporarily slowed down and tire spin is reduced. This increases tire life.

1. Press selector knob (2) while displaying Basic Screen (1) to display Main Menu screen (3).

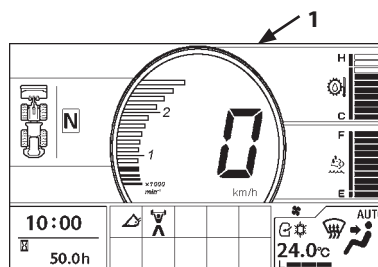

MNEK-01-103EN

2. Rotate selector knob (2) to highlight Setting Menu (4).

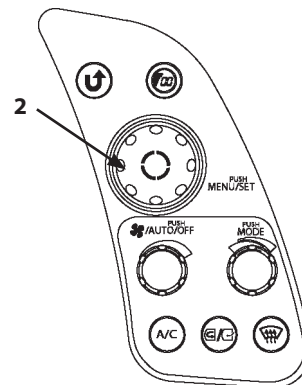

MNEC-01-006

3. Press selector knob (2) to display Setting Menu screen (5).

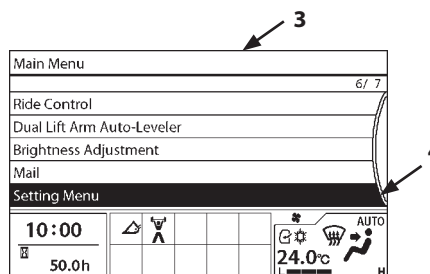

MNEK-01-140EN

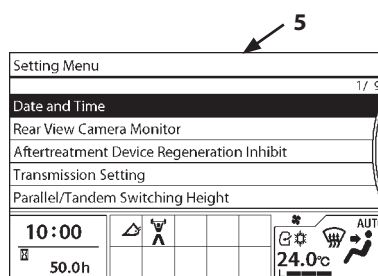

MNEK-01-141EN

## OPERATOR'S STATION

4. Rotate selector knob (2) to highlight Transmission Setting Menu (6).

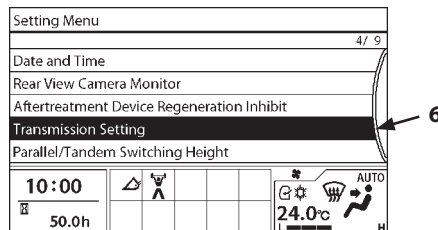

MNEK-01-180EN

5. Press selector knob (2) to display Transmission Setting screen (7).

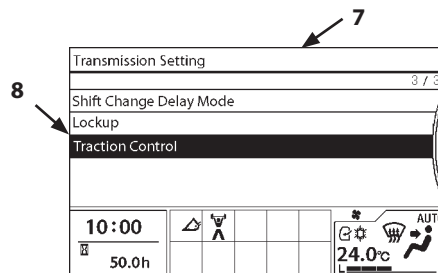

95Z7-01-05

6. Rotate selector knob (2) to highlight Traction Control (8).

7. Press selector knob (2) to display Traction Control screen (9).

8. Press selector knob (2) to turn ON.

When ON is selected, traction control indicator (10) appears on the monitor.

Press selector knob (2) again to turn OFF.

 **NOTE:** When the function is ON, the mark "■" is displayed in green. When the function is OFF, the mark "■" is displayed in gray.

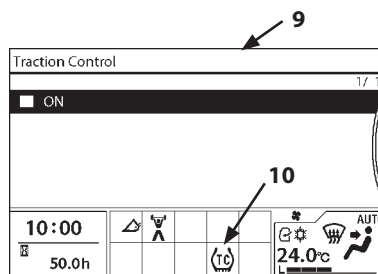

MNHG-01-187EN



# OPERATOR'S STATION

## Parallel/Tandem Switching Height Setting

With parallel/tandem circuits, the lift arm and bucket can be operated at the same time, under a set height. This setting is adjustable.

1. Press selector knob (2) while displaying basic screen (1) to display main menu screen (3).

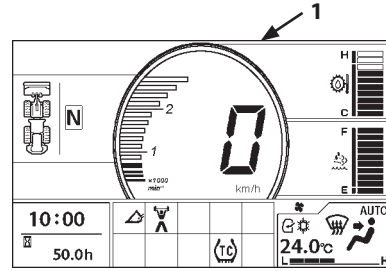

MNHG-01-103EN

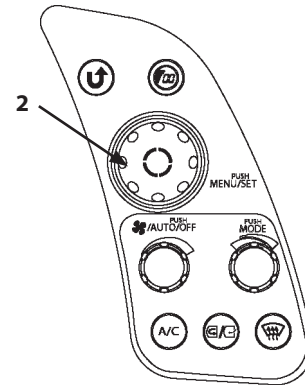

MNEC-01-006

2. Rotate selector knob (2) to highlight Setting Menu (4).

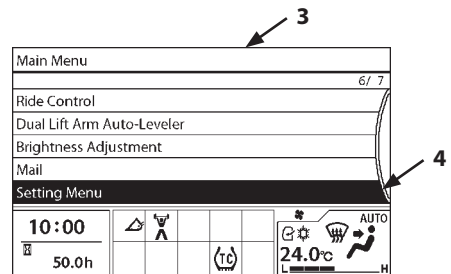

MNHG-01-140EN

3. Press selector knob (2) to display Setting Menu screen (5).

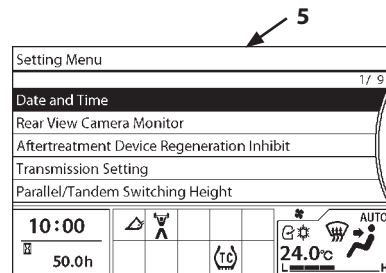

MNHG-01-141EN

## OPERATOR'S STATION

- Rotate selector knob (2) to highlight Parallel/Tandem Switching Height (6).

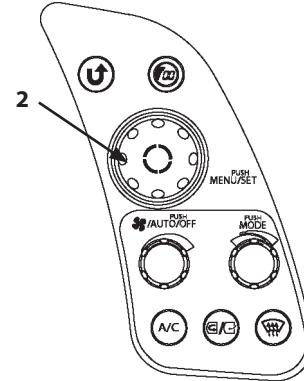

MNEC-01-006

- Press selector knob (2) to display Parallel/Tandem Switching Height screen (7).
- When the lift arm height changes by operating the lift arm control lever, the height is displayed on segment (8).
- When the lift arm height is within the setting range, mark ✓ (9) will be displayed.
- Press selector knob (2) to change parallel/tandem control height setting value.
- When the parallel/tandem control height setting value changes, the value will be displayed on segment (10).

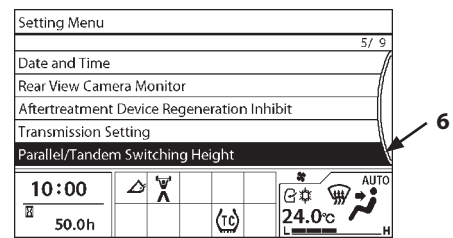

MNHG-01-190EN

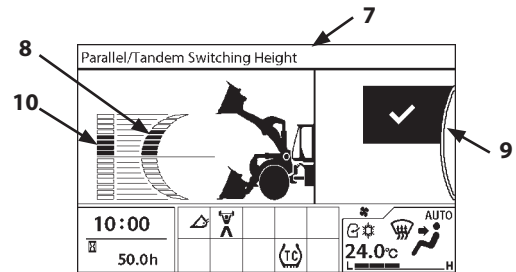

MNHG-01-191EN

**NOTE:** Under the set value, the lift arm and bucket can be operated at the same time (parallel operation circuit). Over the set value, the bucket operation has priority (tandem operation circuit).

# OPERATOR'S STATION

## Warm Up Operation

Refer to "Cold Weather Warm Up" (page 3-13) for the operation when using this setting.

1. Press selector knob (2) while displaying basic screen (1) to display main menu screen (3).

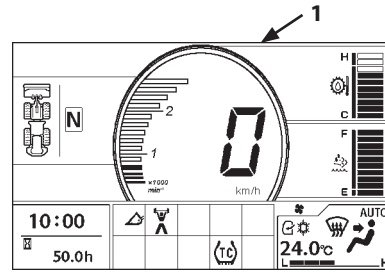

MNHG-01-103EN

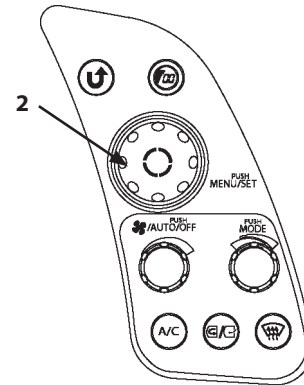

MNEC-01-006

2. Rotate selector knob (2) to highlight Setting Menu (4).

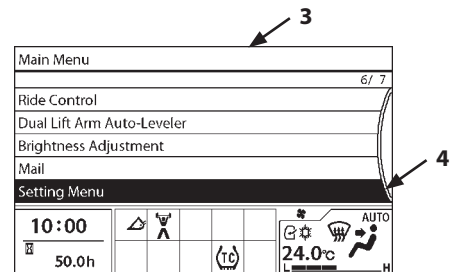

MNHG-01-140EN

3. Press selector knob (2) to display Setting Menu screen (5).

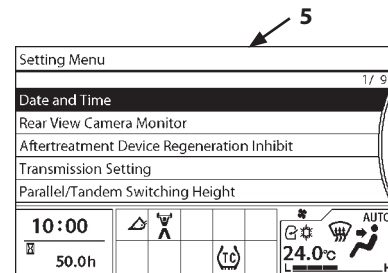

MNHG-01-141EN

# OPERATOR'S STATION

4. Rotate selector knob (2) to highlight Warm Up (6).

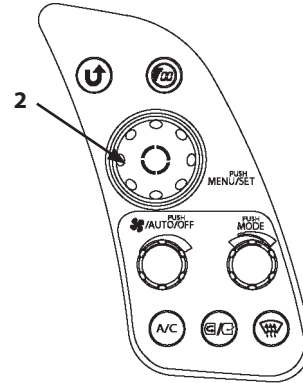

MNEC-01-006

5. Press selector knob (2) to display Warm Up Setting screen (7).

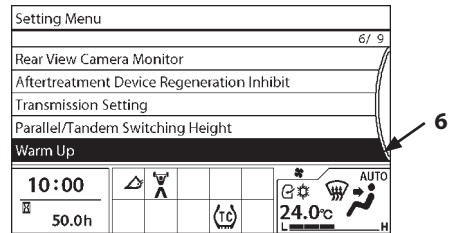

MNHG-01-200EN

6. Press selector knob (2) to turn ON (enabled).

Press selector knob (2) again to turn OFF (disabled).

**NOTE:** When the function is ON, the mark "■" is displayed in green. When the function is OFF, the mark "■" is displayed in gray.

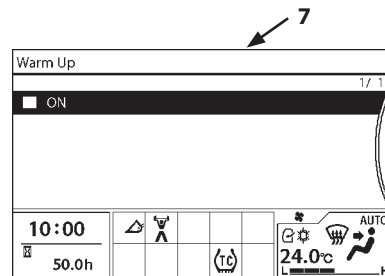

MNHG-01-201EN

# OPERATOR'S STATION

## Display Item Selection

Unit system displayed on the monitor can be selected in this screen.

1. Press selector knob (2) while displaying basic screen (1) to display main menu screen (3).

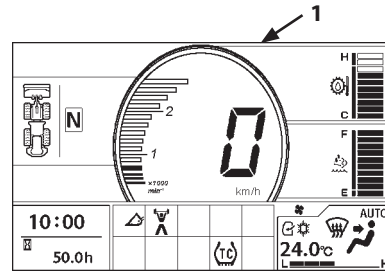

MNHG-01-103EN

2. Rotate selector knob (2) to highlight Setting Menu (4).

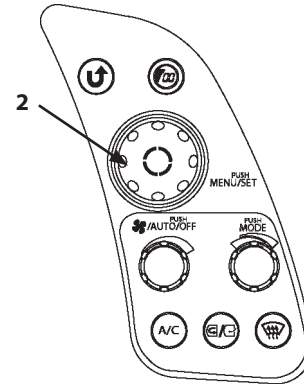

MNEC-01-006

3. Press selector knob (2) to display Setting Menu screen (5).
4. Rotate selector knob (2) to highlight Display Item Selection (6).

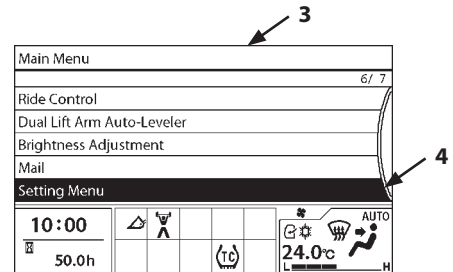

MNHG-01-140EN

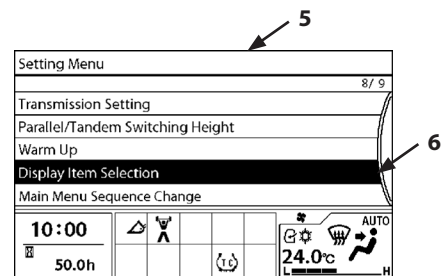

MNHG-01-220EN-KC

# OPERATOR'S STATION

- Press selector knob (2) to display Display Item Selection screen (7).

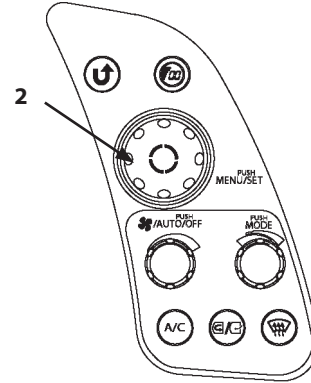

MNEC-01-006

- Rotate selector knob (2) to highlight Unit. Press selector knob (2) to set the unit (Metric or US system).
- Rotate selector knob (2) to highlight Accumulated Operation Display. Press selector knob (2) to set the display (hour meter) or ODO (odometer).

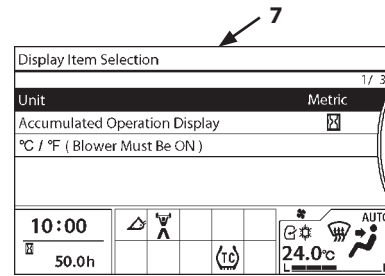

MNHG-01-221EN

- Before changing °C and °F, turn the blower of the air conditioner ON.

Rotate selector knob (2) to highlight desired unit system (°C or °F) (8). Press selector knob (2) to set the unit.

When pressing selector knob (2), "Wait." will be displayed (9) and then the change will be completed.

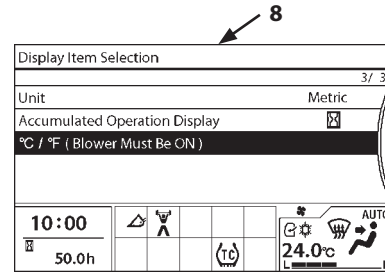

MNHG-01-222EN

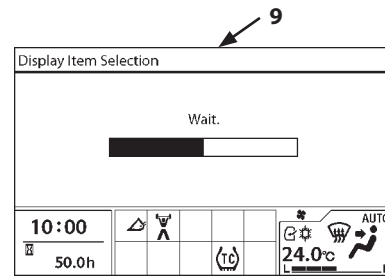

MNHG-01-223EN

# OPERATOR'S STATION

## Main Menu Display Order Change

Menu sequence of "Ride Control" (option), "Dual Lift Arm Auto Leveler", "Brightness Adjustment" and "Mail" can be changed in this screen. Frequently used menu can be located on top of the screen.

1. Press selector knob (2) while displaying Basic Screen (1) to display Main Menu screen (3).

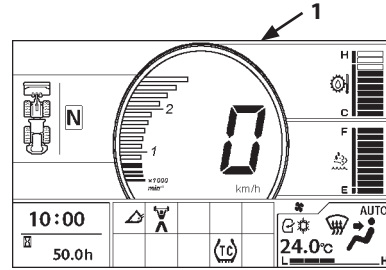

MNHG-01-103EN

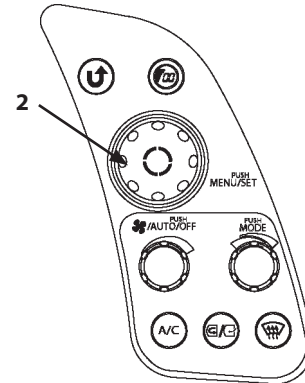

MNEC-01-006

2. Rotate selector knob (2) to highlight Setting Menu (4).

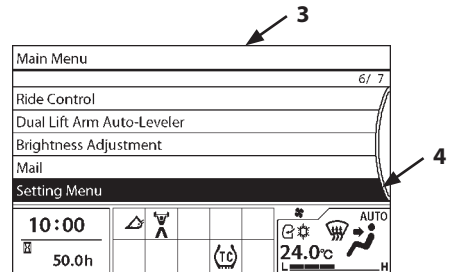

MNHG-01-140EN

# OPERATOR'S STATION

3. Press selector knob (2) to display Setting Menu screen (5).
4. Rotate selector knob (2) to highlight Main Menu Sequence Change (6).

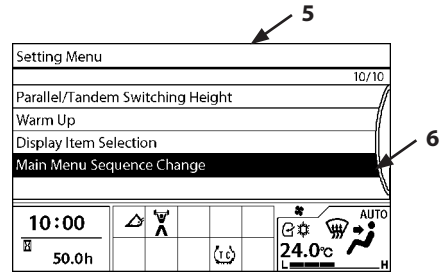

MNHG-01-230EN-KC

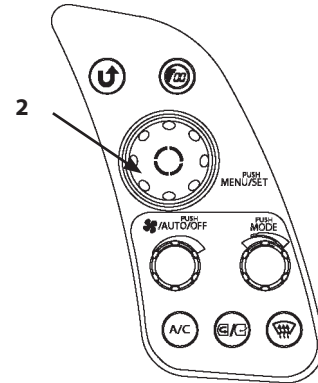

MNEC-01-006

5. Press selector knob (2) to display Main Menu Sequence Change screen (7).
6. Rotate selector knob (2) to highlight a menu to be on the top of the screen. Press selector knob (2) to set the menu to the top of the screen.

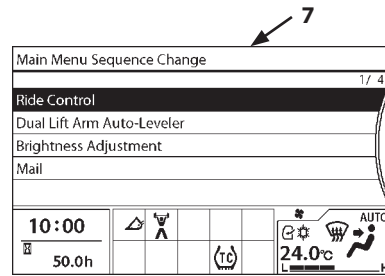

MNHG-01-231EN



# OPERATOR'S STATION

## Information Menu

The information menu includes Operation, Maintenance, Troubleshooting and Monitoring.

1. Press selector knob (2) while displaying Basic Screen (1) to display Main Menu screen (3).

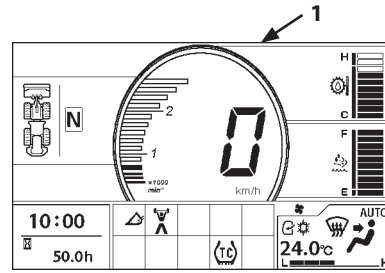

MNHG-01-103EN

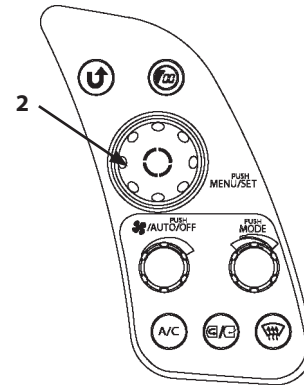

MNEC-01-006

2. Rotate selector knob (2) to highlight Information Menu (4).

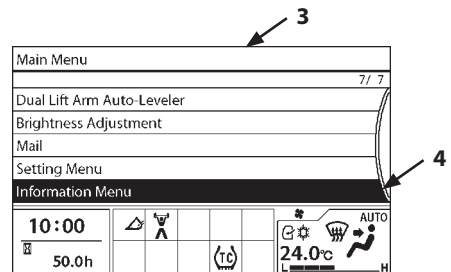

MNHG-01-240EN

3. Press selector knob (2) to display Information Menu screen (5).

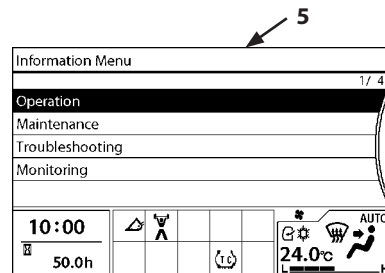

MNHG-01-241EN-KC

# OPERATOR'S STATION

## Operation Condition

The Operation screen displays fuel consumption, operating hours, and fuel consumption rate from resetting of the monitoring unit.

### Fuel Consumption

1. Press selector knob (2) while displaying Basic Screen (1) to display Main Menu screen (3).

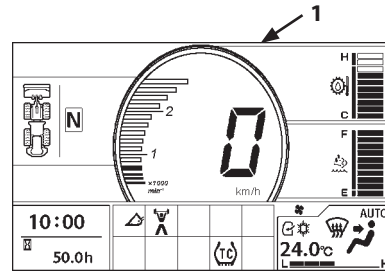

MNHG-01-103EN

2. Rotate selector knob (2) to highlight Information Menu (4).

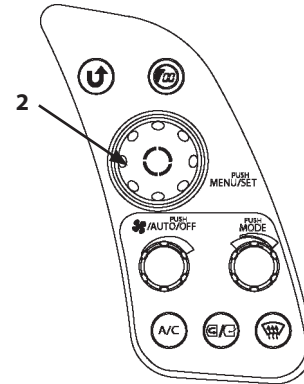

MNEC-01-006

3. Press selector knob (2) to display Information Menu screen (5).
4. Rotate selector knob (2) to highlight Operation (6).

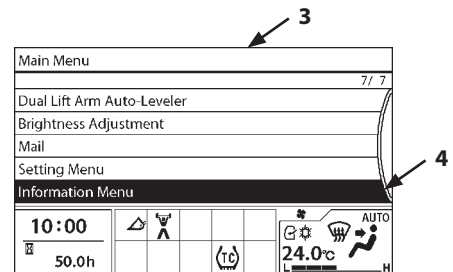

MNHG-01-240EN

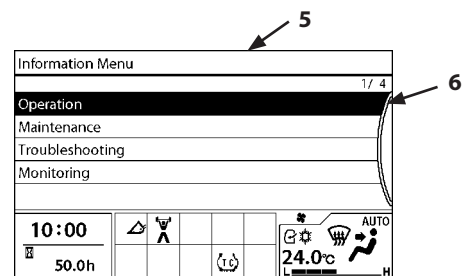

MNHG-01-241EN-KC

## OPERATOR'S STATION

5. Press selector knob (2) to display Operation screen (7).

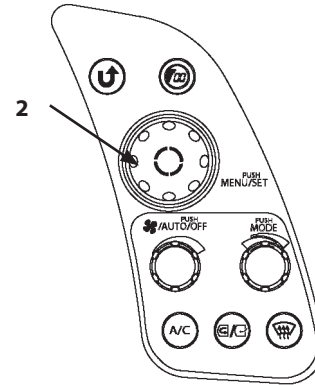

6. Rotate selector knob (2) to highlight Fuel Consumption (8) or Machine Information (9).

MNEC-01-006

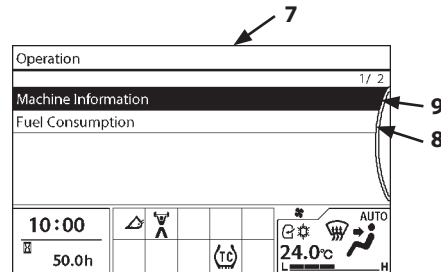

7. Press selector knob (2) while selecting Fuel Consumption (8) to display Fuel Consumption screen (10).

MNHG-01-242EN

The Machine Operation Hours, Fuel Consumption, and Average Fuel Consumption Rate can be checked on Fuel Consumption screen (10).

Push selector knob (2) to return the previous screen.

To clear the fuel consumption and machine operation hours, rotate selector knob (2) to highlight CLEAR (11), and then press selector knob (2).

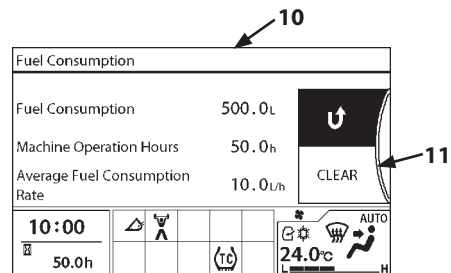

MNHG-01-243EN

**IMPORTANT: Total fuel consumption and fuel consumption rate depend on the operating environment and the operation method of the machine.**

**The values shown on the screen are just for reference.**

**A difference could arise between actual fuel consumption and fuel consumption as displayed on the monitor unit.**

8. Press selector knob (2) while selecting Machine Information (9) to display Machine Information screen (12).

MNHG-01-244EN

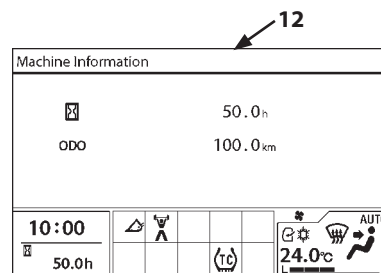

# OPERATOR'S STATION

## Maintenance

The maintenance screen includes maintenance notice, remaining hours until the next maintenance, and maintenance intervals.

### Maintenance Items

- Engine Oil
- Engine Oil Filter
- Hydraulic Oil
- Hydraulic Oil Pilot Filter
- Hydraulic Oil Return Filter
- Transmission Oil
- Transmission Oil Filter
- Front Axle Oil
- Rear Axle Oil
- Air Cleaner Filter Element
- Fuel Filter
- Air Conditioner Filter
- DEF/AdBlue® Supply Module Main Filter
- Fuel Solenoid Pump Filter
- Oil Separator Filter
- User Setting 1
- User Setting 2

### Maintenance Notice

1. Press selector knob (2) while displaying Basic Screen (1) to display Main Menu screen (3).
2. Rotate selector knob (2) to highlight Information Menu (4).
3. Press selector knob (2) to display Information Menu screen (5).
4. Rotate selector knob (2) to highlight Maintenance (6).

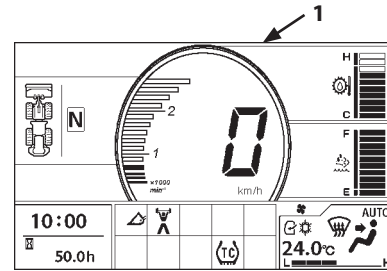

MNHG-01-103EN

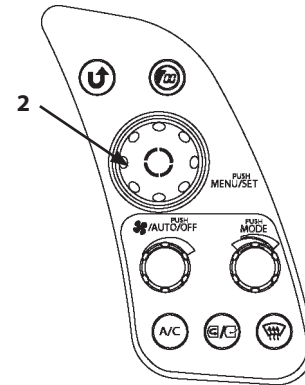

MNEC-01-006

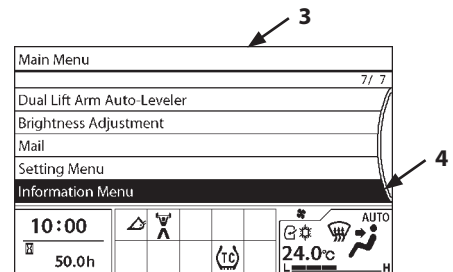

MNHG-01-240EN

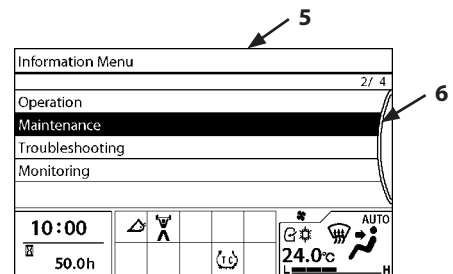

MNHG-01-245EN-KC

# OPERATOR'S STATION

5. Press selector knob (2) to display Maintenance screen (7).

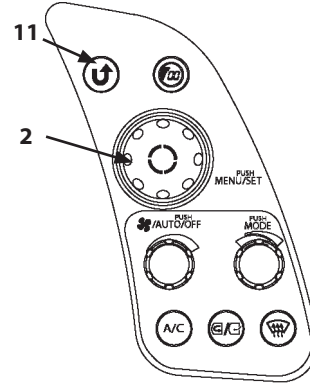

6. Rotate selector knob (2) to highlight Maintenance Notice (8).

7. Press selector knob (2) to turn the Maintenance Notice ON. Press selector knob (2) again to turn the Maintenance Notice OFF.

ON : When the required interval is reached, an information message is displayed on the screen.  
 OFF : No notification message is displayed.

MNEC-01-006

**NOTE:** When the required interval for an item is reached, screen (9) is displayed for 10 seconds when the key is switched ON. Press Return button (11) to delete the notification. When checking the maintenance items from the menu, an item where the set time has been reached are marked with a wrench (10).

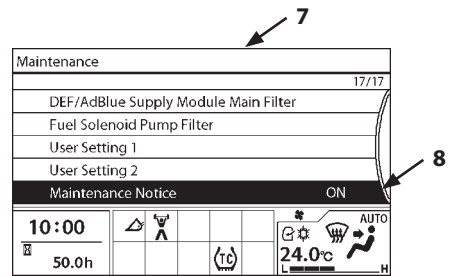

MNHG-01-246EN

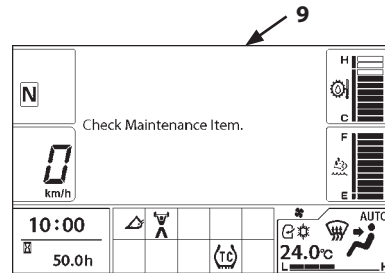

MNHG-01-247EN

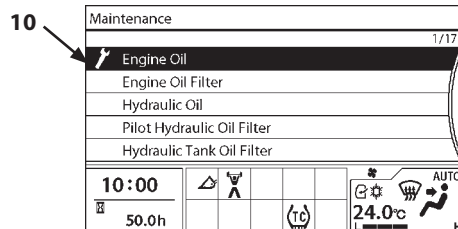

MNHG-01-248EN

# OPERATOR'S STATION

## Time Remains and Maintenance Interval

1. Press selector knob (2) while displaying Basic Screen (1) to display Main Menu screen (3).

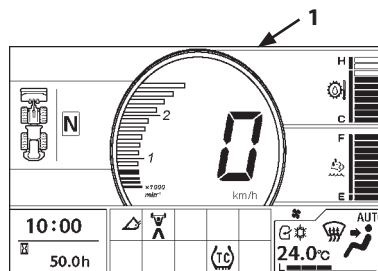

MNHG-01-103EN

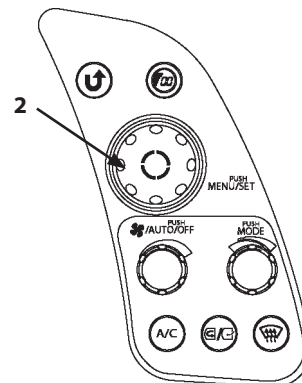

MNEC-01-006

2. Rotate selector knob (2) to highlight Information Menu (4).

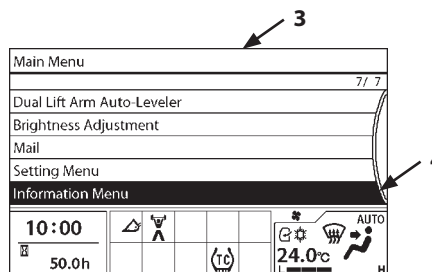

MNHG-01-240EN

3. Press selector knob (2) to display Information Menu screen (5).
4. Rotate selector knob (2) to highlight Maintenance (6).

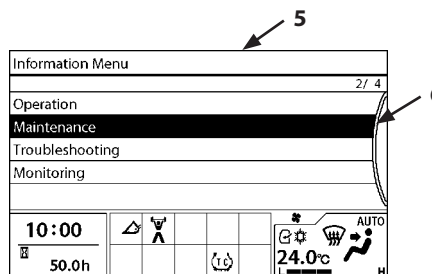

MNHG-01-245EN-KC

# OPERATOR'S STATION

5. Press selector knob (2) to display Maintenance screen (7).

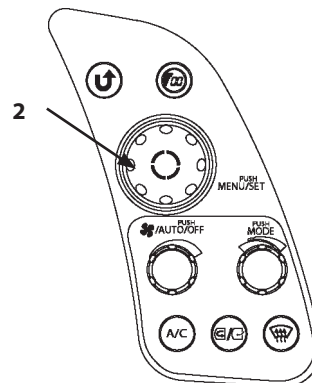

MNEC-01-006

6. Rotate selector knob (2) to highlight a maintenance item to be checked (8). (In the right example, Engine Oil is selected.)

7. Press selector knob (2) to display the time remaining for the selected maintenance item.

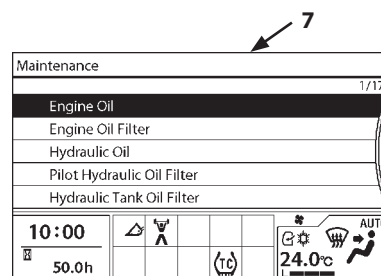

MNHG-01-251EN

## Resetting Data

To reset the remaining time data, rotate selector knob (2) to highlight RESET (9), and then push selector knob (2).

The value of the remaining hours is reset to that of the maintenance interval. The previous change date/hour is updated with the current date and time.

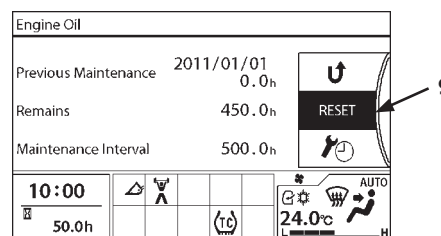

MNHG-01-249EN

## Maintenance Interval Setting

To change the maintenance interval, rotate selector knob (2) to highlight  (11), and then press selector knob (2).

The background color of Maintenance Interval (10) changes, then turn selector knob (2) to adjust the time, and then push selector knob (2) to enable the change.

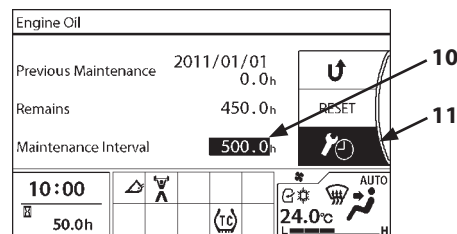

MNHG-01-250EN

# OPERATOR'S STATION

## Troubleshooting

An active fault code generated by the controller connected to the controller area network is displayed on this screen.

1. Press selector knob (2) while displaying Basic Screen (1) to display Main Menu screen (3).

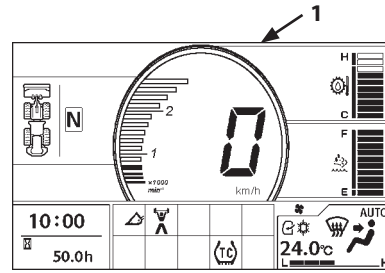

MNHG-01-103EN

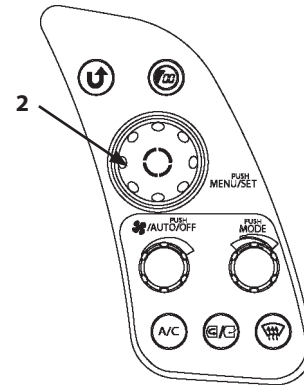

MNEC-01-006

2. Rotate selector knob (2) to highlight Information Menu (4).

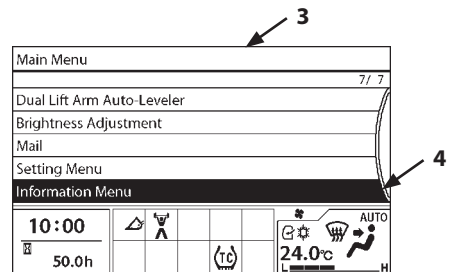

MNHG-01-240EN

3. Press selector knob (2) to display Information Menu screen (5).

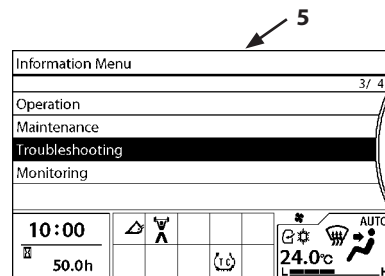

MNHG-01-260EN-KC



# OPERATOR'S STATION

4. Rotate selector knob (2) to highlight Troubleshooting (6).

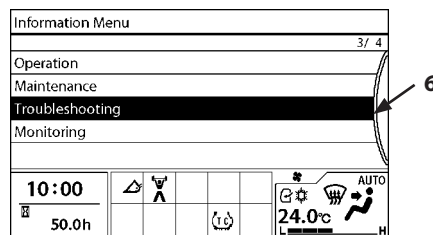

MNHG-01-260EN-KC

5. Press selector knob (2) to start troubleshooting. After displaying "Wait." message, the screen displays controller troubleshooting (7).

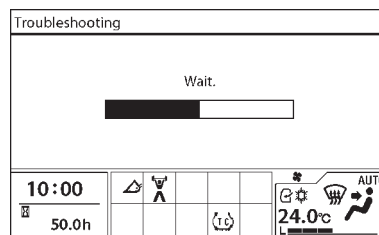

95MNEC-01-261EN

6. Active fault codes are displayed at the right side of each item. Rotate selector knob (2) to highlight an item displaying the fault codes.

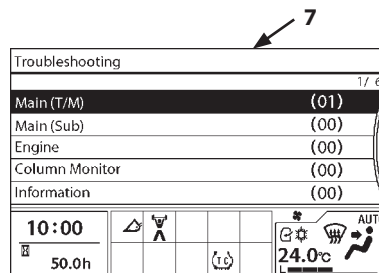

95MNEC-01-262EN

7. Press selector knob (2) to display active fault code (8).  
Up to 20 fault codes can be displayed.

**IMPORTANT: Send the troubleshooting result to your nearest authorized service representative as soon as possible.**

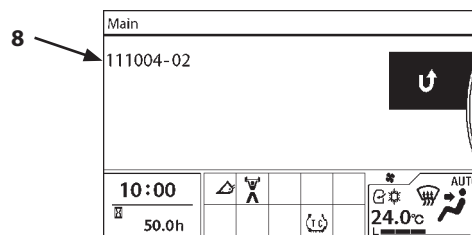

95MNEC-01-263EN

# OPERATOR'S STATION

## Monitoring

1. Press selector knob (2) while displaying Basic Screen (1) to display Main Menu screen (3).

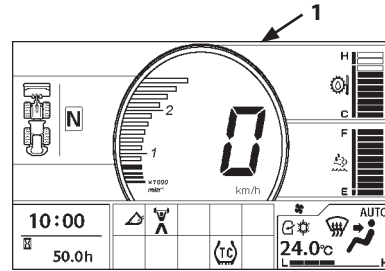

MNHG-01-103EN

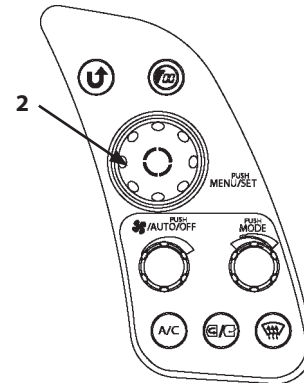

MNEC-01-006

2. Rotate selector knob (2) to highlight Information Menu (4).

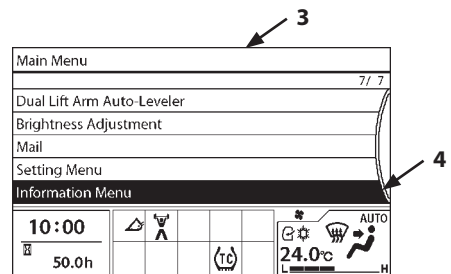

MNHG-01-240EN

3. Press selector knob (2) to display Information Menu screen (5).
4. Rotate selector knob (2) to highlight Monitoring (6).

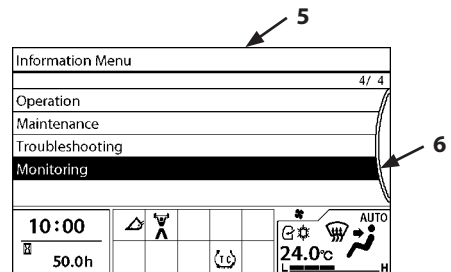

MNHG-01-270EN-KC

## OPERATOR'S STATION

5. Press selector knob (2) to display Monitoring screen (7).

 **NOTE:**

- When the "PM Accumulation" bar reaches the right end, auto-regeneration takes place. However, auto-regeneration may not be performed depending on the machine condition.
- The PM Accumulation is not displayed during regeneration.

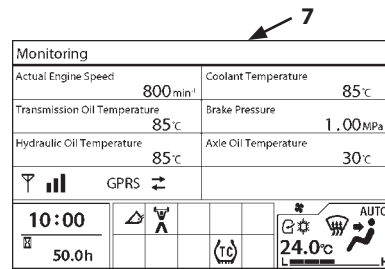

MNHG-01-271EN



## OPERATOR'S STATION

### Front Console Switches, Pedals, and Joystick Steering

- 1- Hazard Switch
- 2- Work Light Switch
- 3- Parking Brake Switch
- 4- Key Switch
- 5- Accelerator Pedal
- 6- Brake Pedal
- 7- Front Window Wiper Switch
- 8- Rear Window Wiper Switch
- 9- Light Switch
- 10- Brake/Declutch Pedal
- 11- Forward/Reverse Switch
- 12- Shift Up Switch (without steering wheel)  
Quick Power Switch (with steering wheel)
- 13- Shift Down Switch (without steering wheel)  
Down Shift Switch (DSS) (with steering wheel)
- 14- Joystick Steering System Switch
- 15- Horn Switch
- 16- Hold Switch

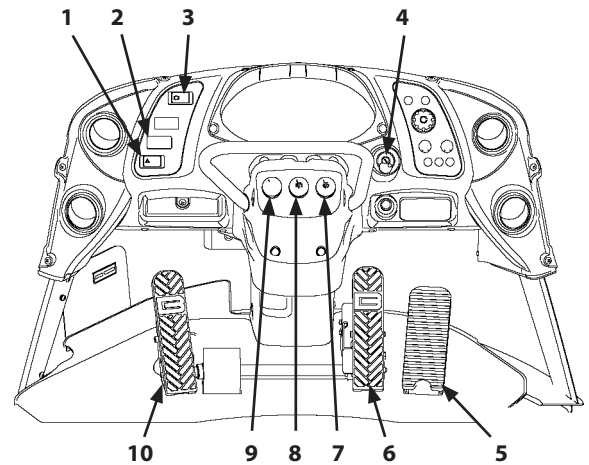

115Z7B-1-81-1

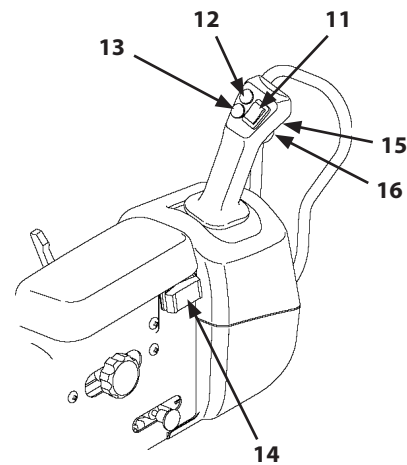

95Z7-1-85-1

# OPERATOR'S STATION

## Hazard Switch

**IMPORTANT:** Do not leave the hazard switch (1) in the "▲" or "ON" position for a long time with the engine stopped. The batteries will become discharged.

When a machine failure occurs, use this switch to inform other vehicles that the machine is in an emergency situation.

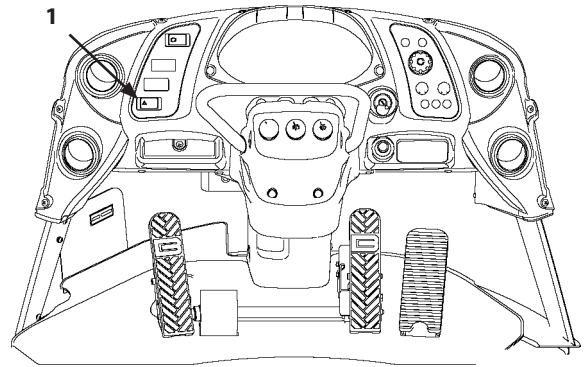

115Z7B-1-81-1

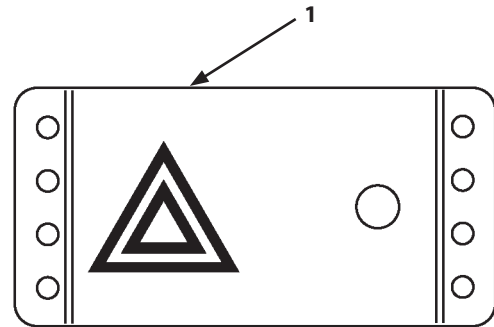

When the "▲" on hazard switch (1) is pressed, front and rear turn signals (hazard light) (2) on both right and left sides start flashing. Press the opposite side of hazard switch (1) to turn the hazard signals OFF.

M4GB-01-065

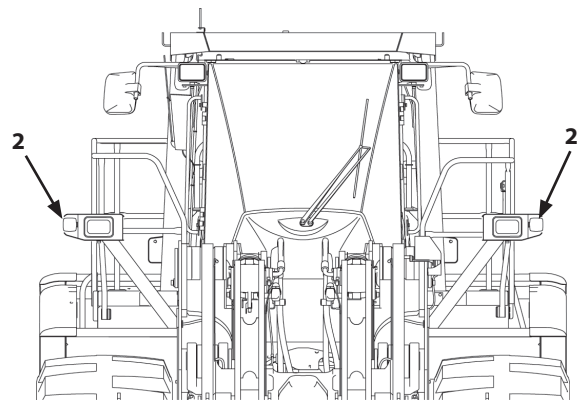

115Z7\_front

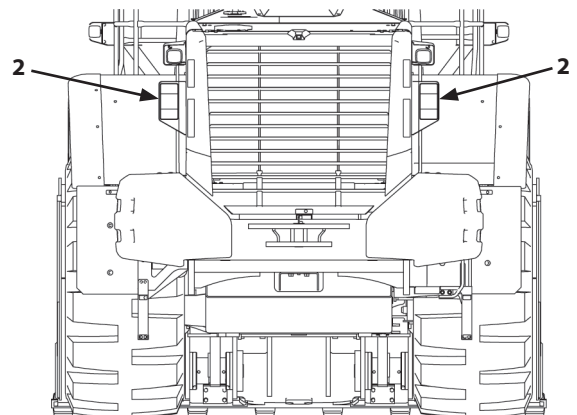

115Z7\_rear

# OPERATOR'S STATION

## Work Light Switch

Press the mark  on switch (1) while the light switch is in tail, low, or high position to turn front work lights (2) ON. Rear work lights (3) stay OFF.

 **NOTE:** Refer to page 1-91 for the light switch position.

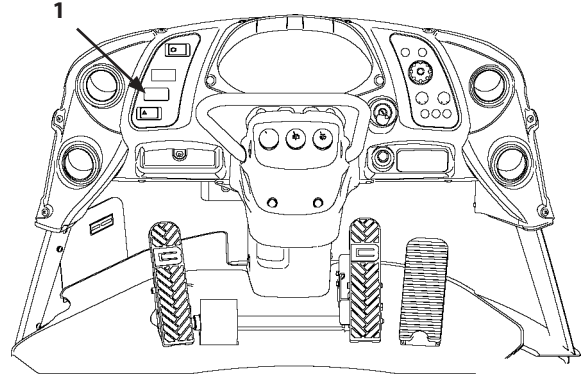

115Z7B-1-81-1

When the side with mark  on switch (1) is pressed, both front work lights (2) and rear work lights (3) are turned ON.

 **CAUTION:** Do not turn the work lights ON while driving on a public road.

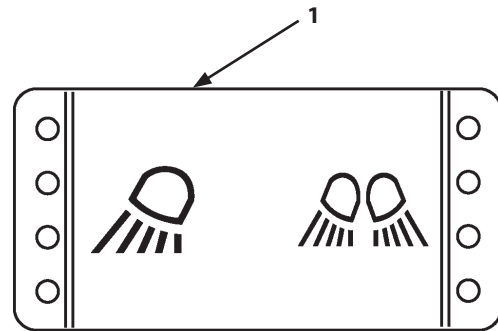

M4GB-01-067

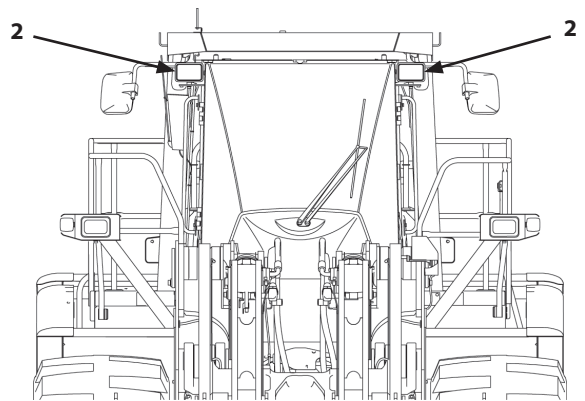

115Z7\_front

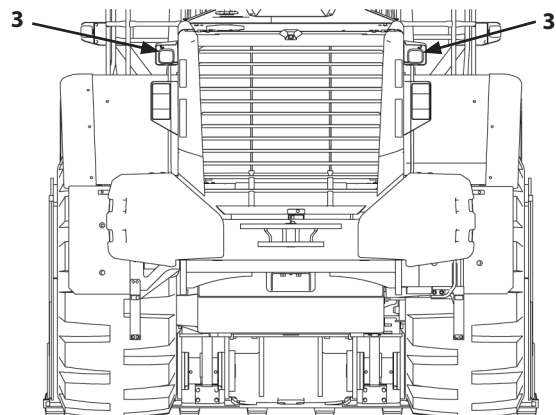

115Z7\_rear

# OPERATOR'S STATION

## Parking Brake Switch

### ⚠ WARNING:

- To prevent accidents due to rolling away of the machine, after parking the machine or before leaving the machine, be sure to apply the parking brake.
- Never apply the parking brake while the machine is moving except in an emergency.
- Apply the parking brake only after the machine has stopped.
- Failure to do so may cause sudden deceleration of the machine travel speed, possibly creating a dangerous situation. Also, premature wear and/or damage to the parking brake may result. After the parking brake has been applied in an emergency while moving the machine, have the parking brake checked at your nearest Kawasaki dealer.

When parking brake switch (1) is turned ON, the parking brake is applied; parking brake indicator (2) will be shown. Press the OFF side of parking brake switch (1) to release the parking brake. Check that parking brake indicator (2) goes OFF by pressing the switch firmly clicks.

### ✎ NOTE:

- The parking brake is released by hydraulic pressure only when the engine is running.
- To ensure safe operation, the machine should not travel when the parking brake is applied, even if forward/reverse switch (3) of the joystick steering is set to the forward (F) or reverse (R) position.
- To ensure safe operation, when the engine is stopped, the parking brake is applied even if parking brake switch (1) is in the OFF or released position. Before restarting the engine, ensure the forward/reverse switch (3) is in "neutral" position for safety.
- The parking brake will be applied when the key is turned OFF.

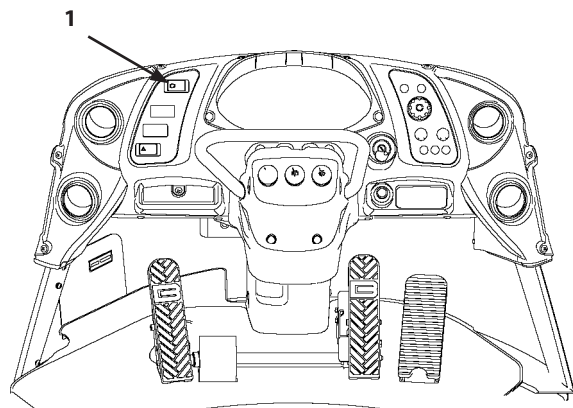

115Z7B-1-81-1

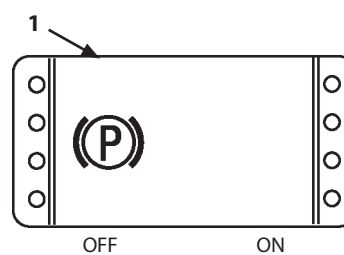

MNEC-01-058

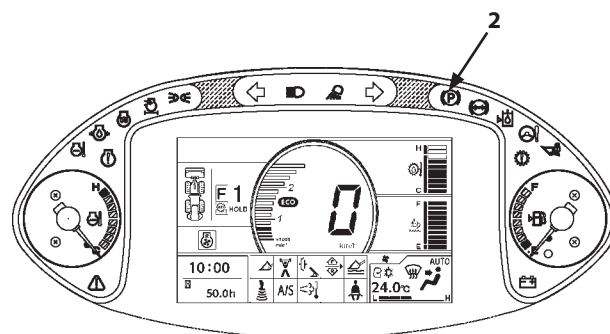

MNEK-01-500

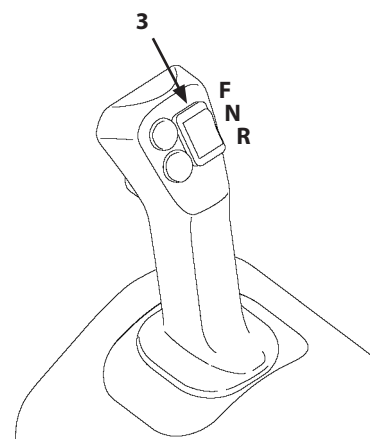

115Z7B-4-4-1



# OPERATOR'S STATION

## Key Switch

**⚠ WARNING:** Before starting the engine, return the forward/reverse switch (or lever) to neutral (N), apply the parking brake, lock the neutral lever lock, and lock the control lever. Refer to the descriptions in the OPERATING ENGINE section for the detail information.

**⚠ WARNING:** Never turn key switch (1) OFF while moving the machine. Failure to do so will result in inoperable steering and brake pedal functions, and the parking brake will suddenly apply.

OFF- Engine Off  
ACC- Radio  
ON- Power ON  
START- Engine Start

**📌 NOTE:** Engine pre-heating is controlled automatically by the engine control system.

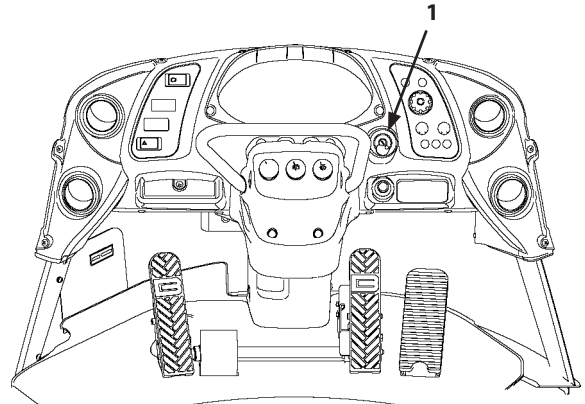

115Z7B-1-81-1

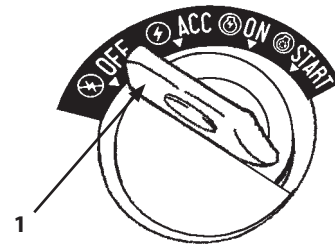

M4GB-01-089

# OPERATOR'S STATION

## Accelerator Pedal

When accelerator pedal (3) is applied, the engine speed increases. When released, the engine speed decreases.

 **NOTE:** The engine speed may change due to the machine control regardless of the operation of the accelerator pedal.

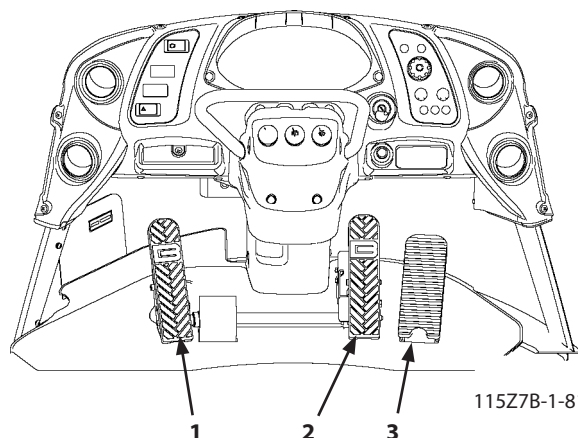

115Z7B-1-81-1

## Brake Pedal

### WARNING:

- Avoid sudden brake application when moving machine, possibly creating a hazardous situation. The machine may lose its balance.
- Unless necessary, do not rest your foot on the brake pedal to prevent the brake pads, discs, and clutch from wearing out prematurely.
- Keep the areas around the brake pedals clean to prevent dust and/or grit from accumulating. The brake may not be fully released and become inoperable.

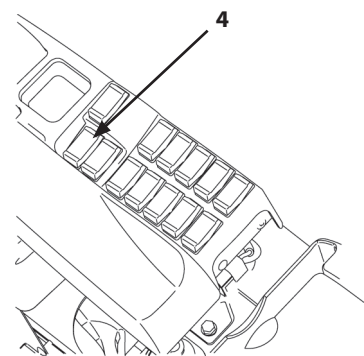

115MNEC-07-01

Left and right brake pedals (1), (2) can function as the service brake. Left pedal (1) also functions as declutch brake by switching declutch position switch (4).

### Service Brake

Brake pedals (1), (2) function as normal brake by setting declutch position switch (4) to OFF (Neutral) position. Be sure to turn clutch cut position switch (4) OFF (Neutral) before traveling down or on a slope.

### Declutch Brake

Brake pedal (1) functions as a declutch brake by setting declutch position switch to the ON . Use this mode when performing loading work or while stopping machine.

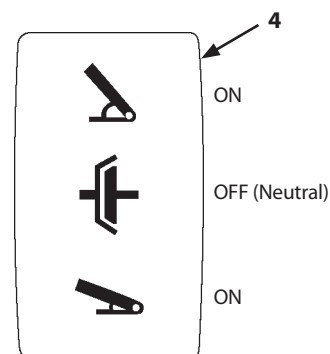

MNEC-01-025

# OPERATOR'S STATION

## Joystick Steering

Joystick steering system allows quick easy steering on one joystick type lever. The transmission forward and reverse changeover switch and the shift up/down buttons are built into the joystick steering. This allows the operator to change the direction and speed of the machine without releasing the joystick steering.

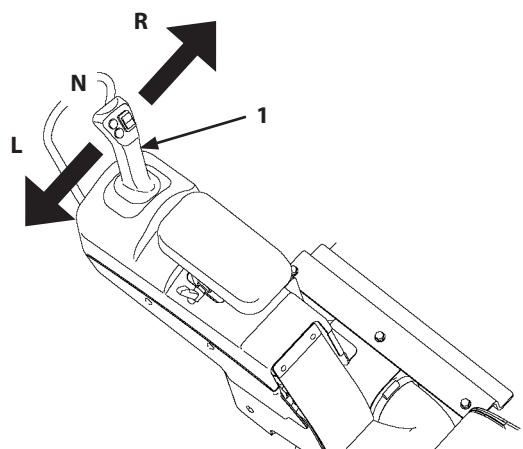

115Z7B-1-91-1

### Joystick Steering Lever

When joystick steering lever (1) is moved from the neutral (centered) to the right or left, the machine articulates (steers) right or left. Refer to page 4-9 for the steering.

### Forward/Reverse Switch

Changes the machine drive direction from forward to reverse and vice versa.  
 Set forward/reverse switch (2) to the F position to travel the machine forward.  
 Set forward/reverse switch (2) to the R position to drive the machine in reverse.

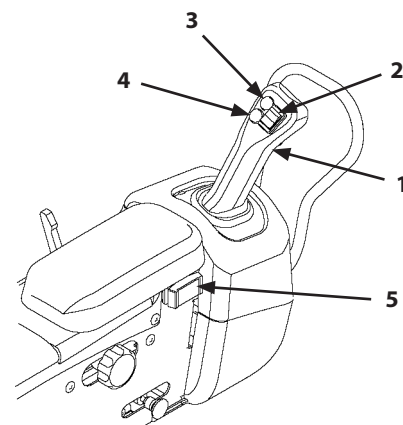

115Z7B-1-81-2

**IMPORTANT:** Never attempt to shift forward/reverse switch (2) while letting the machine travel at high speed (3 or 4 speed). Failure to do so will cause engine to have excessively high RPM's, leading to hazardous situation. Also, it may cause damage to the transmission.

**NOTE:** The engine will not be started unless the forward/reverse switch (2) is in the neutral position.

### Joystick Steering System Switch

When pressing joystick steering system switch (5), F/R selector switch indicator (6) turns ON, and the machine can move forward/reverse using forward/reverse switch (2). Refer to OPERATING THE ENGINE.

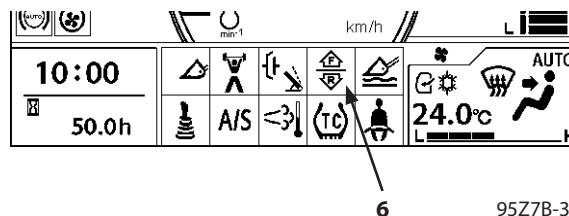

95Z7B-3-7-1

## OPERATOR'S STATION

---

### Shift Switch

Press shift switch (3) to shift up the gear.

Press shift switch (4) to shift down the gear.

Select a proper shift for the work.

**IMPORTANT: The joystick steering lever and switches are designed to operate with low effort.**

**Do not press and twist the lever and switches firmly. Damage to them may result.**

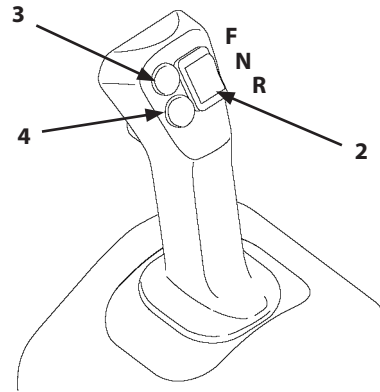

115Z7B-4-4-1

# OPERATOR'S STATION

## Light Switch

Light switch (1) has four positions; OFF, tail, high and low. As shown below, each light comes ON (☀) or OFF (X) according to the selected position of the light switch.

- 2- Headlight
- 3- Clearance Light
- 4- Tail Light

Light Switch Position	Headlight		Clearance Light	Tail Light	Monitor Panel Light
	High	Low			
○ (OFF)	X	X	X	X	X
⊥ (Tail)	X	X	☀	☀	☀
☰D (Low)	X	☀	☀	☀	☀
☰D (High)	☀	X	☀	☀	☀

**NOTE:** The light switch position ⊥ (Tail) keeps lit even if the key switch is turned OFF. It is used as a parking light when parking the machine by a public road.

**IMPORTANT:** Do not hold the switch position at "ON" for a long time with the engine stopped. The batteries will become discharged.

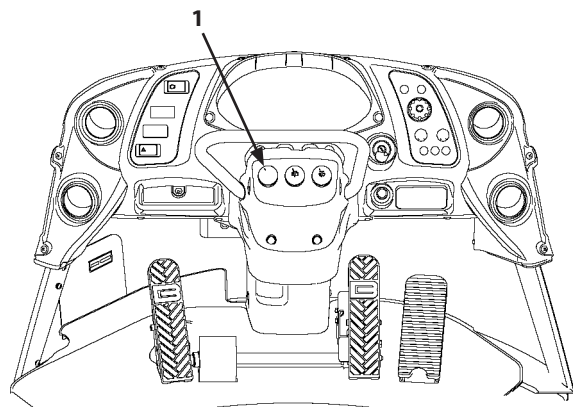

115Z7B-1-81-1

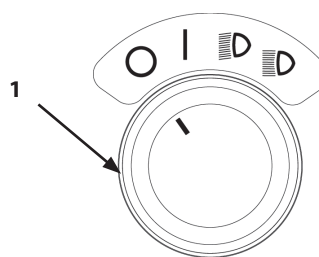

115Z7-AK-Light SW

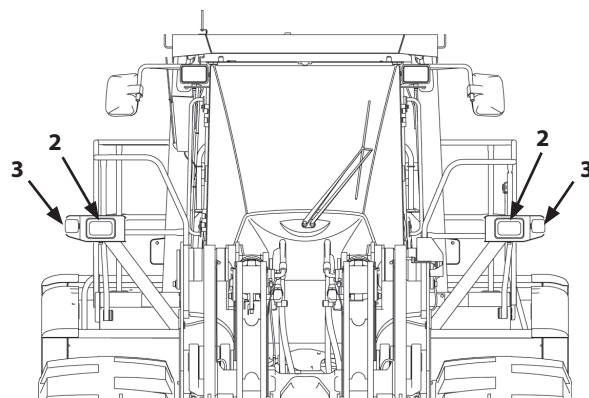

115Z7\_front

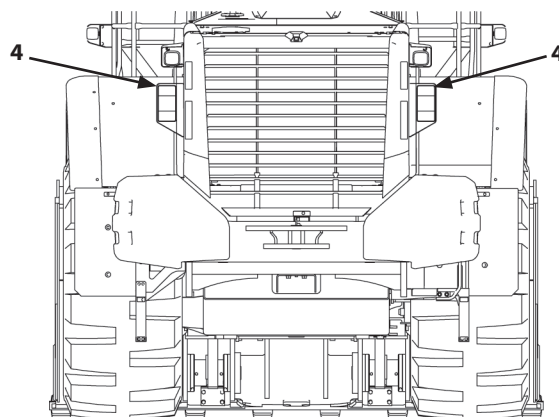

115Z7\_rear

## OPERATOR'S STATION

---

 **NOTE:** When the light switch position (high) is selected, high beam indicator (6) comes ON.

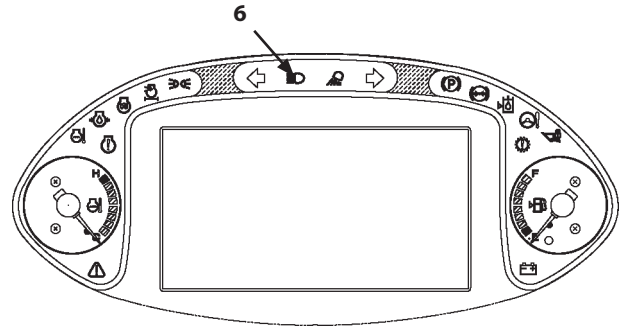

MNEC-01-073

### Wiper Switch

#### Wiper Operation

**IMPORTANT:** The windshield surface, the wiper blade, the wiper motor and the relay may be damaged due to dry or frozen condition of the wiper blade and the windshield.

- Before operating the windshield wiper, remove snow, ice or dust heavy debris from the windshield surface. If the windows are frozen over, defrost them.
- Use anti-freeze type washer fluid in freezing weather.
- Squirt windshield washer fluid on the dry windshield before operating the wiper. Besides, continuous operation of the wiper with windshield at semiarid condition (sprinkling of snow or rain) may cause failure of the wiper. Use wiper intermittently to protect it from damage.
- In case of machine equipped with hot-wire heater (for windshield), continuous operation of the windshield wiper with the heater switch kept ON for a long time may cause the wiper blades to be burnt damaged by heat.
- Inspect the wiper blades weekly. Replace as necessary.

## OPERATOR'S STATION

### Front/Rear Wiper Switch

Operate wiper switches (1)(2) to move the front and rear windshield wipers.

**IMPORTANT: The washer motor may become damaged if washer fluid is continuously used for more than 20 seconds or the washer motor pump switch is operated with no fluid in the washer tank. Take care about the switch operation time and the fluid level in the washer tank.**

**Do not operate the washer motor for too long and keep the washer fluid at the correct level. In freezing weather, use windshield washer solvent that will not freeze.**

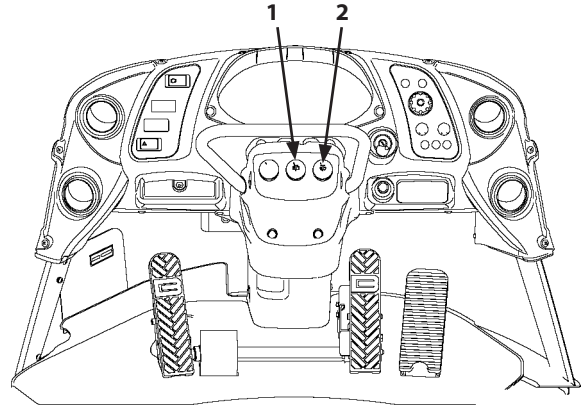

115Z7B-1-81-1

### Front Window Wiper Switch

HI : The front windshield wiper operates at fast speed.

LO : The front windshield wiper operates at slow speed.

INT : The front windshield wiper intermittently operates.

OFF : The front windshield wiper stops moving and the wiper blade is returned to the pre-start position.

(Push) : Washer fluid squirts from the front nozzle and the front windshield wiper operates.

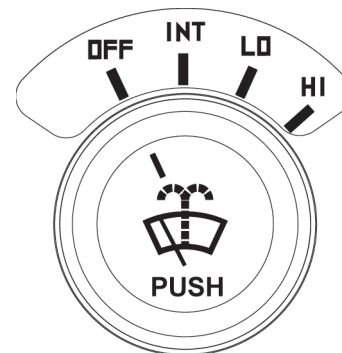

Front Window Wiper Switch

115Z7-AK-F Wiper SW

### Rear Window Wiper Switch

ON : Rear windshield wiper operates.

OFF : The rear windshield wiper stops moving and the wiper blade is returned to the pre-start position.

(Push) : Washer fluid squirts from the rear nozzle and the rear windshield wiper operates.

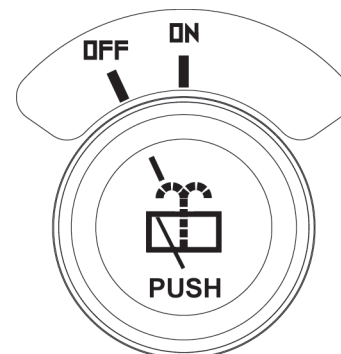

Rear Window Wiper Switch

115Z7-AK-R Wiper SW

# OPERATOR'S STATION

## Right Console/Switches

### Fingertip Control Type

- 1- Auxiliary Control Lever (Option)
- 2- Bucket Control Lever
- 3- Lift Arm Control Lever
- 4- Turn Signal Switch
- 5- Control Lever Lock Switch
- 6- Declutch Position Switch
- 7- Travel Mode Selector
- 8- Power Mode Selector
- 9- Auxiliary
- 10- Fan Reverse Rotation Switch
- 11- Hydraulic Coupler Switch (Option)
- 12- Auxiliary
- 13- Aftertreatment Device Regeneration Switch
- 14- Secondary Steering Operation Check Switch (Option)
- 15- Auxiliary
- 16- 2nd/3rd Speed Limit Switch
- 17- Ride Control Switch (Option)
- 19- Armrest
- 20- Hold Switch
- 21- Right Console Slide Lever
- 22- DSS (Down Shift Switch)
- 23- Horn Switch
- 24- Quick Power Switch

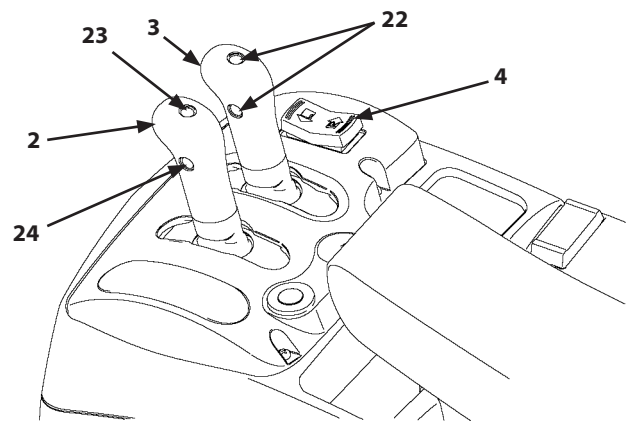
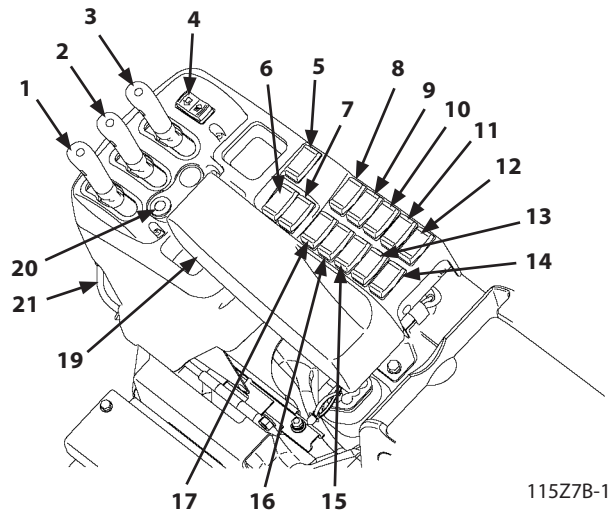



# OPERATOR'S STATION

## Loading Control Levers

The lift arm control lever and the bucket control lever are used to operate the lift arm and/or bucket.

### Lift Arm Control Lever (1)

Lever Position	Lift Arm Operation
C	Float (Detent): The lift arm free falls and can be moved as loads are applied. The lever will stay in this position.
B	Lift Arm Lower
N	Hold: The lift arm is stopped and held in that position.
A	Lift Arm Raise
F	Detent: The lift arm is held in the raise position with the detent.

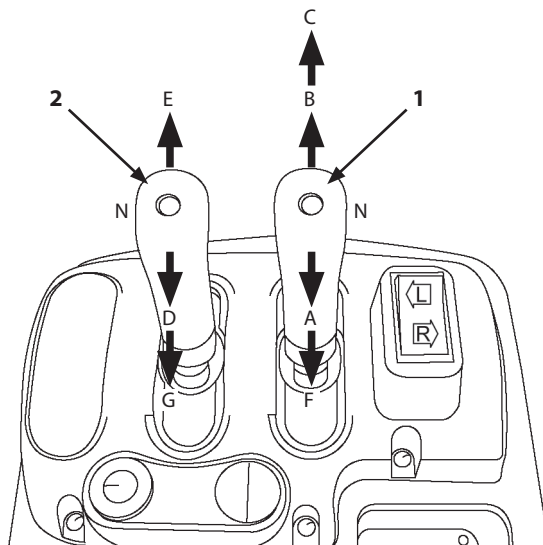

MNEC-03-003-1

### Bucket Control Lever (2)

Lever Position	Bucket Operation
E	Bucket Dump: The bucket is tilted forward to dump the bucket.
N	Hold: The bucket is stopped and held in that position.
D	Bucket Tilt (or roll back): The bucket is tilted back; (also this is the transportation position).
G	Detent: When the bucket control lever is moved from the bucket dump position to the bucket tilt (or roll back) position, the bucket control lever is held in this position with the detent.

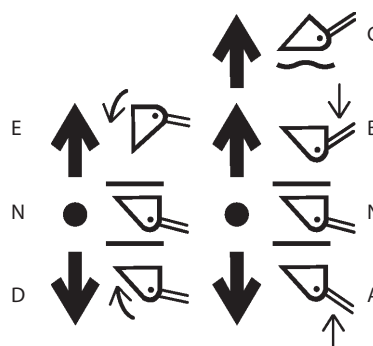

M4GB-01-072

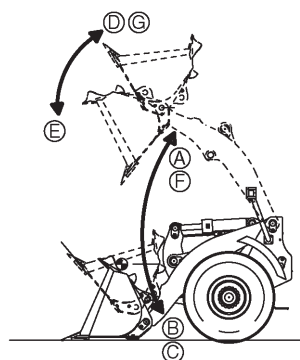

M4GB-01-073

### NOTE:

- When applying the lift arm control lever (1) in the "Raise" position (A), the lever is moved (F) until the lift arm reaches the position set at the height kickout. When the lift arm moves to the preset position, lift arm control lever (1) automatically moves to "Neutral" (N) position.
- When applying the bucket control lever (2) in the "Tilt" position (D) after bucket dump operation; the lever is moved (G) until the bucket moves to the position preset by the bucket auto leveler. When the bucket moves to the preset position, bucket control lever (2) automatically moves to "Neutral" (N) position.

## OPERATOR'S STATION

- When pushing down the lift arm control lever to the "Float" position (C), the lift arm moves to the position preset at lower kickout and is held in that position. When the lift arm moves to the preset position, the lift arm control lever automatically moves to "Neutral" (N) position.

 **NOTE:** When operating the machine in the Float (C) position, lower the bucket on the ground by setting the lift arm lower position (B), and then tilt the lever to the Float position.

 **NOTE:** Be advised that the turn signal switch has been changed on S/N 5101 and thereafter.

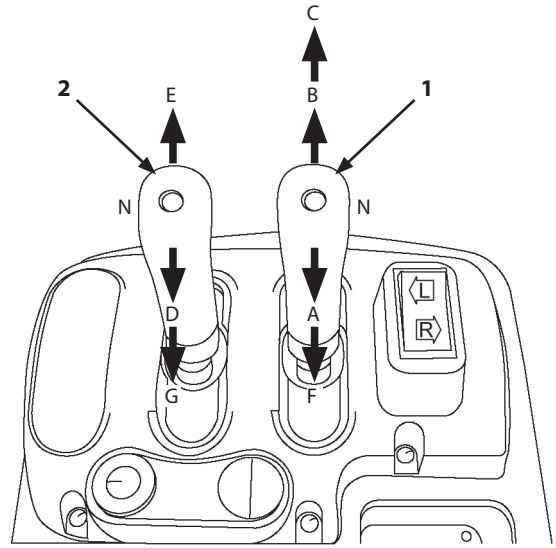

MNEC-03-003-1

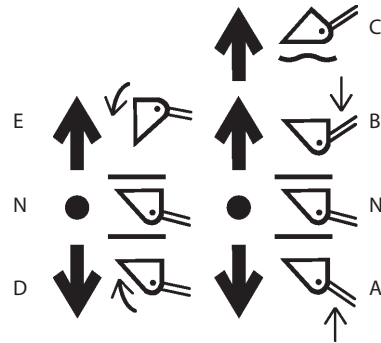

M4GB-01-072

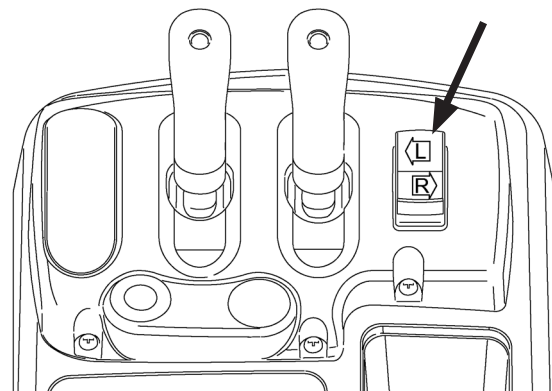

115Z7-1-92-1

## OPERATOR'S STATION

### Right Console/Switches

#### Multi-Function Joystick Type

- 1- Turn Signal Switch
- 2- Multi-Function Joystick Lever
- 3- Quick Power Switch
- 4- DSS (Down Shift Switch)
- 5- Auxiliary Control Lever (Option)
- 6- Control Lever Lock Switch
- 7- Declutch Position Switch
- 8- Travel Mode Selector Switch
- 9- Power Mode Selector Switch
- 10- Auxiliary
- 11- Fan Reverse Rotation Switch
- 12- Hydraulic Coupler Switch (Option)
- 13- Auxiliary
- 14- Secondary Steering Operation Check Switch (Option)
- 15- Aftertreatment Device Regeneration Switch
- 16- Auxiliary
- 17- 2nd/3rd Speed Limit Switch
- 18- Ride Control Switch (Option)
- 19- Armrest Adjust Handle
- 20- Armrest
- 21- Right Console Slide Lever
- 22- Hold Switch (Under the Lever)
- 23- Horn Switch (Under the Lever)

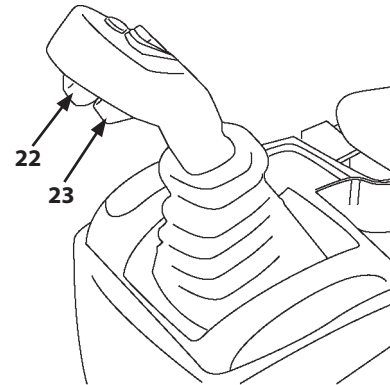
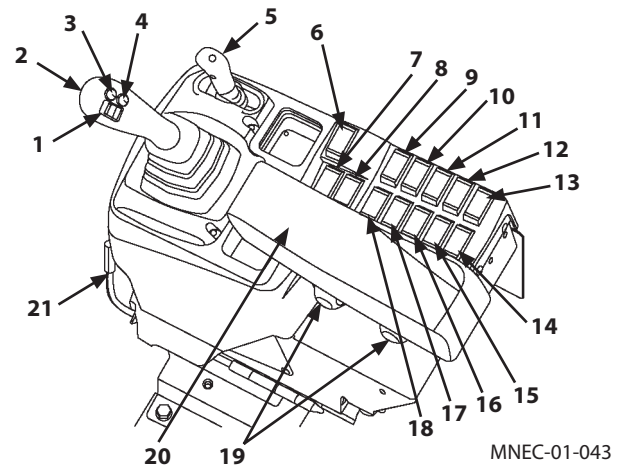

# OPERATOR'S STATION

## Loading Multi-Function Joystick Lever (Option)

The multi-function joystick lever is used to operate the lift arm and/or bucket.

Lever Position	Bucket Operation
C	Float (Detent): The lift arm free falls and can be moved as loads are applied. The lever is held in this position.
B	Lift Arm Lower
N	Hold: The lift arm is stopped and held in that position.
A	Lift Arm Raise
F	Detent: The lift arm is held in the raise position.
G	Detent: When the multi-function joystick lever is moved from the bucket dump position to the bucket tilt position, the multi-function joystick lever is maintained in this position.
D	Bucket Tilt: The bucket is tilted back, taking the transportation position.
N	Hold: The bucket is stopped and held in that position.
E	Bucket Dump: The bucket is tilted forward to dump the bucket load.

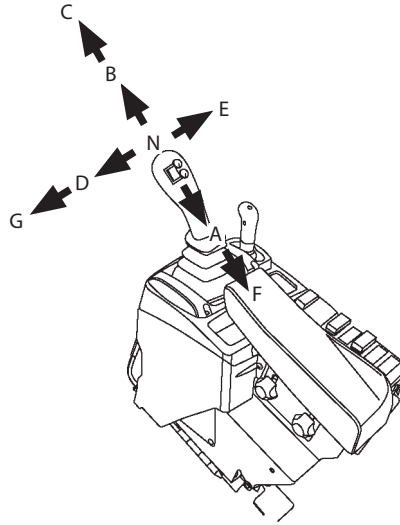

MNEC-01-059

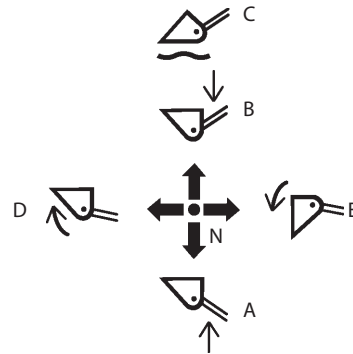

M4GB-01-074

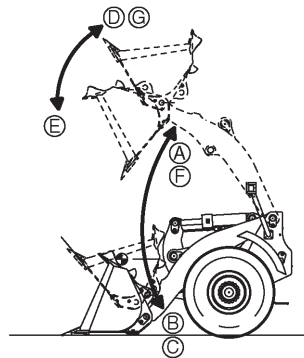

M4GB-01-073

# OPERATOR'S STATION

## Auxiliary Control Lever (Option)

An optional control lever (1) can be installed to control the attachment.

Refer to the operator's manual for the attachment how to use this lever.

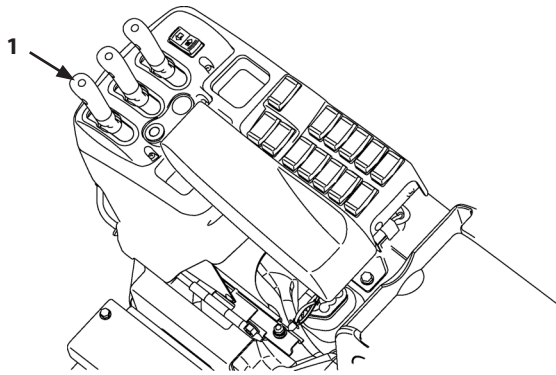

115Z7-1-9-4a

Fingertip Control Type

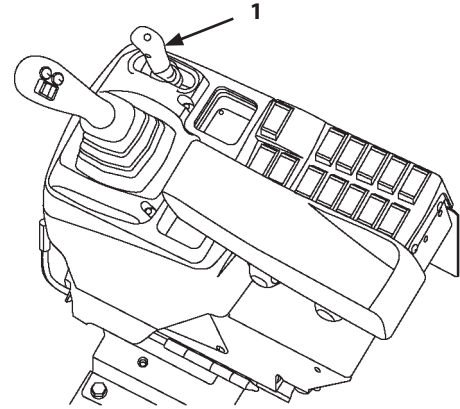

MNEC-01-043

Multi-Function Joystick Type

## Turn Signal Switch

Indicates the drive change direction to persons and/or other vehicles by operating turn signal switch (4).

L- Left Turn

R- Right Turn

 **NOTE:** This switch (4) does not return automatically to neutral when the joystick steering lever is returned to center.

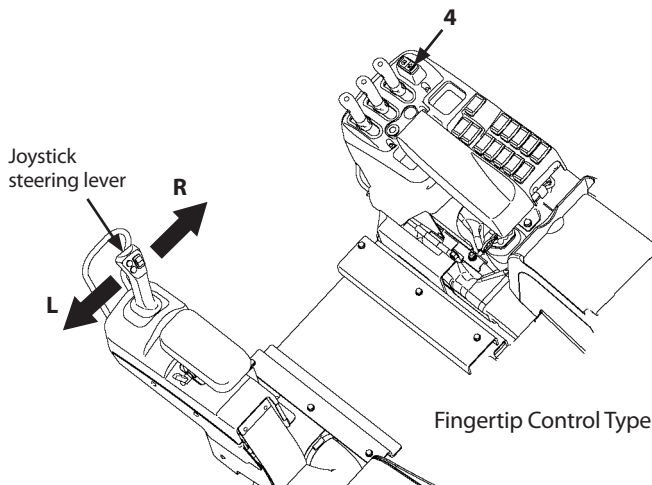

115Z7B-4-9-1

Fingertip Control Type

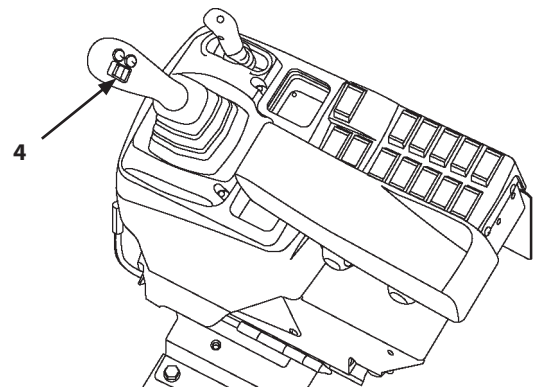

Multi-Function Joystick Type

MNEC-01-043

## OPERATOR'S STATION

### Loading Control Lever Lock Switch

#### **⚠ WARNING:**

- Before leaving the operator's seat, be sure to stop the engine. Place the boom and bucket in a level, safe position. Then, set control lever lock switch (1) to the lock (🔒) position.
- Always check to be sure that the control lever lock switch is set in the lock (🔒) position before transporting the machine or leaving the machine at the end of the shift.

Refer to section 5-4 for details.

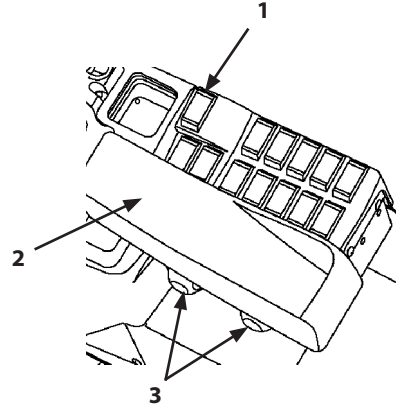

115Z7B-07-01

Control lever lock switch (1) is provided to prevent unexpected machine operation, if the operator mistakenly comes in contact with the bucket and/or lift arm control lever when getting on or off the machine. When control lever lock switch (1) is placed to unlock (🔓) position, the loading control lever becomes operable.

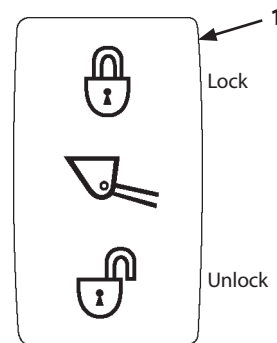

MNEC-01-015

### Armrest Adjust Handle

The armrest is provided so that the operator can operate the lever with an arm on the armrest, for comfort and ease.

Loosen handle (1) and position the armrest height to fit the operator's preference, tighten handle (1) to fix the armrest.

- L : Loosen
- R : Tighten

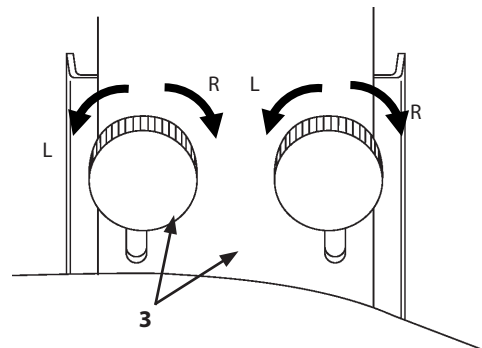

M4GB-01-077

# OPERATOR'S STATION

## Declutch Position Switch

Declutch position switch (2) changes the function of left brake pedal.

Operating declutch position switch (2) turns the declutch function ON and OFF.

- Declutch ON

By depressing left brake pedal, the clutch is disengaged and brake is applied without transmitting the drive power to the tires.



: Clutch disengages while lightly depressing the left brake pedal: (Suitable for loading work on a level surface.)



: Clutch disengages while deeply depressing the left brake pedal: (Suitable for work on a slope.)

- Declutch OFF

When depressing left or right brake pedal, brake is applied while driving power is transmitting to the tires.



*NOTE: When starting to ascend a slope, turn declutch position switch (2) OFF (neutral), depress the left brake pedal. Gradually release the left brake pedal while depressing the accelerator pedal to easily start ascending the slope.*

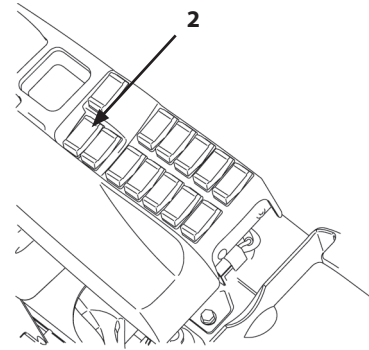

115MNEC-07-01

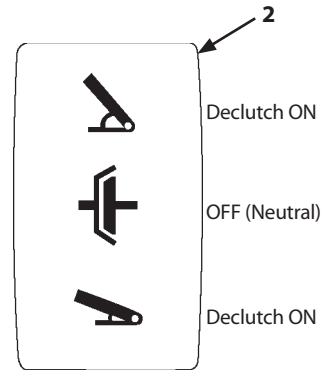

MNEC-01-025

# OPERATOR'S STATION

## Travel Mode Selector Switch

Travel mode selector switch (1) selects the travel mode. Selecting the manual mode "⚙️" by using travel mode selector switch (1) switch 1 sets the transmission to manual mode, which allows manual shift change by using shift switch (2). AUTO 1 and AUTO 2 are choices selectable at auto-shift mode. Select the most efficient mode for the travel and work condition.

Be sure to stop the machine and set forward/reverse switch (3) in the neutral (N) position before operating travel mode selector switch (1).

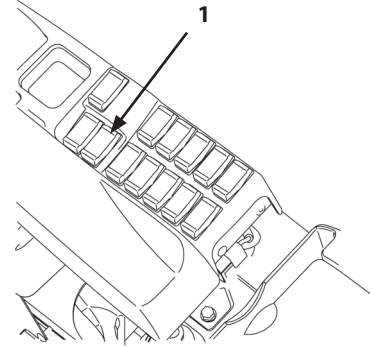

115MNEC-07-01

- Manual Mode : Manual gear shift (The gear shifts according to the shift switch.)
- AUTO 1 Mode : Starts out traveling at 2nd speed. When traveling load increases, it automatically shifts from 2nd to 1st speed. (Auto DSS function) This mode is suited for heavy digging work or climbing a slope.
- AUTO 2 Mode : Starts out traveling at 2nd speed. This mode shifts between 2nd ~ 3rd ~ 4th speeds. This mode is suited for loading loose material, removing snow or a similar application.

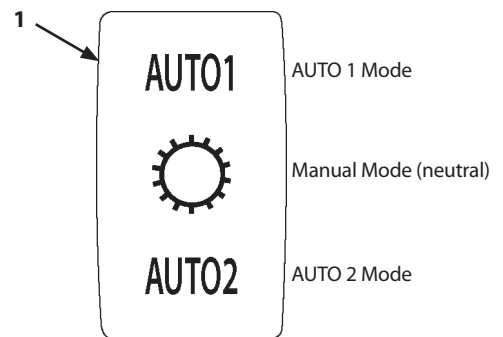

MNEC-01-024

Refer to "MOVING THE MACHINE" section.

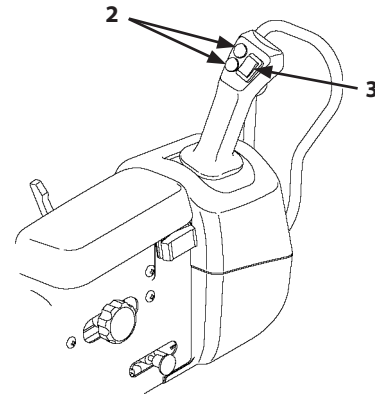

95Z7-1-85-1



# OPERATOR'S STATION

## Power Mode Selector Switch

Two operation modes are available and can be selected by power mode selector switch (1) depending on the applications.

Each time the switch is pressed, the power mode is activated (ON) and deactivated (OFF) alternately.

**Power mode (ON)** : The power mode is suitable for heavy digging work prioritizing work effectiveness.  
Under auto shifting mode, the gear is shifted in regular engine RPM's ( $\text{min}^{-1}$ ) and shift mapping.

**Power mode (OFF)** : When the power mode is turned OFF, the machine operates putting more emphasis on lowering fuel consumption.  
Under auto shifting mode, the gear is shifted with lower engine RPM's ( $\text{min}^{-1}$ ) and shift mapping.

When the power mode is activated, the symbol (  ) is displayed on the power mode indicator of the monitor screen.

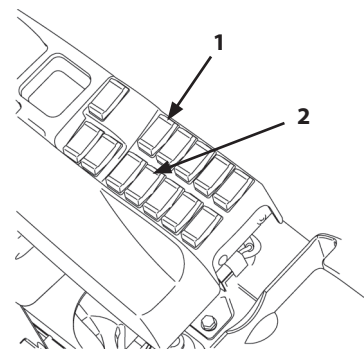

115MNEC-07-01

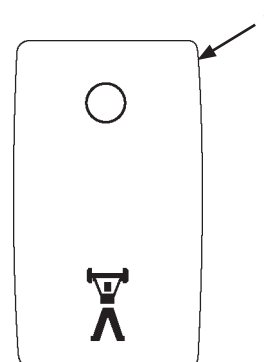

MNEC-01-016

## 2nd/3rd Speed Limit Switch (Option)

A three-position switch (1) is provided to enable the operator to limit the maximum gear to 2nd or 3rd range while driving in auto shift mode. This is used exclusively with the optional joystick steering without the steering wheel/shift lever.

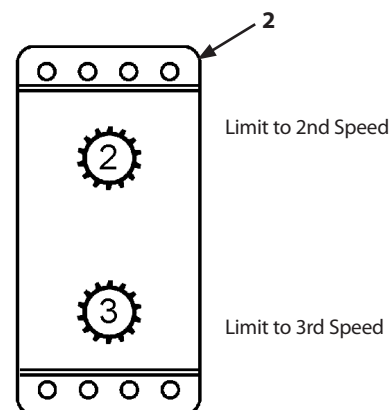

95Z7B-1-112-1

## OPERATOR'S STATION

### Fan Reverse Rotation Switch

Fan reverse rotation switch (1) reverses the hydraulic driven fan. In case the radiator is clogged, rotate the hydraulic driven fan in reverse direction to blow out the clogged dust. It is recommended to carry out the fan reverse rotation regularly to prevent the cooling system from clogging.

#### OFF

When fan reverse rotation switch (1) is set to OFF position, the fan turns in normal direction.

#### AUTO

When fan reverse rotation switch (1) is set to AUTO position, the fan rotates in the normal direction for 10 minutes for the first time. Then, the fan automatically reverses rotation and again return to the normal direction. (Normal rotation → Reverse rotation → Normal rotation → )

After that it keeps normal rotation for 30 minutes. The reverse rotation time is 60 seconds (1 minute). (90 seconds (1.5 minutes) at low temperature)

In case abnormal situation occurs such as engine coolant overheating or high refrigerant pressure of the air conditioner, the duration time of reverse rotation may be shortened to protect devices from damage.

 **NOTE:** After depressing the AUTO side of this switch, the fan auto-reversing function remains activated as the switch position is kept being depressed until it is manually returned to OFF or ON position.

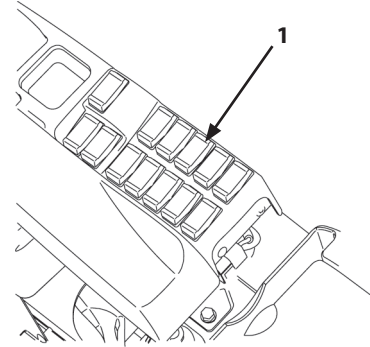

115MNEC-07-01

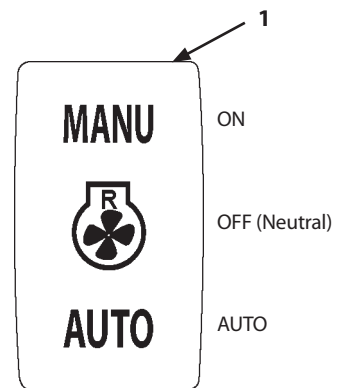

MNEC-01-019

# OPERATOR'S STATION

## Manual Operation

### IMPORTANT:

- Fan rotating direction can be manually changed when the engine is running. Each time the ON side of fan reverse rotation switch (1) is pressed, the fan's rotating direction switches alternatively. While switching the fan rotating direction, fan reverse rotation indicator (2) flashes. When the fan rotates in reverse direction, indicator (2) stays ON. When fan reverse rotation switch (1) is pressed while fan reverse rotation indicator (2) turns ON, indicator (2) starts flashing. When the fan rotates in normal direction, fan reverse rotation indicator (2) goes OFF. Do not press fan reverse rotation switch (1) while indicator (2) is flashing.
- Always operate the switch while parked with the parking brake. When the parking brake is released, the fan reverse condition is automatically canceled after 1 minute. In case abnormal situation occurs such as engine coolant overheating, reverse rotation may forcibly be stopped, or fan reverse rotation switch may be disabled.

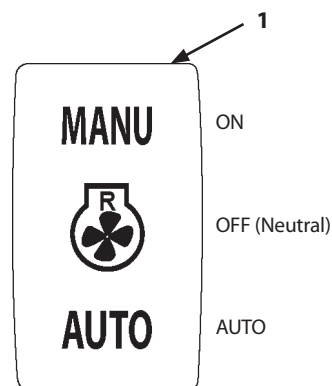

MNEC-01-019

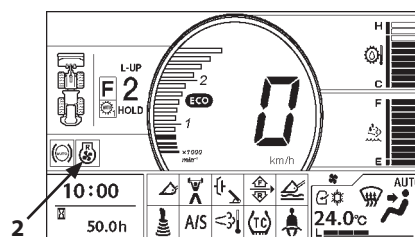

MNHG-01-100EN

1. Close the side cover and the rear grille before operating the switch.
2. Start the engine. Be sure to confirm that the parking brake is applied. Press ON side of fan reverse rotation switch (1) once. Fan reverse rotation indicator (2) should start flashing. Approximately 1 minute later, the fan rotates in reverse direction, and fan reverse rotation indicator (2) stays ON.
3. After operation, press fan reverse rotation switch (1) again to return the fan rotation to the normal direction.

## Hydraulic Coupler Switch (Option)

An optional hydraulic coupler switch can be installed. Refer to the operator's manual for the optional switch for information.

## OPERATOR'S STATION

### Secondary Steering Operation Check Switch (Option)

Use this switch to check if the secondary steering pump is operable.

While the ON side of switch (1) is being pressed, secondary steering pump operates.

Secondary steering indicator (2) lights ON while the pump is operating.

After checking, release switch (1) to turn it OFF.

**IMPORTANT: Conduct test only within 2 second.**

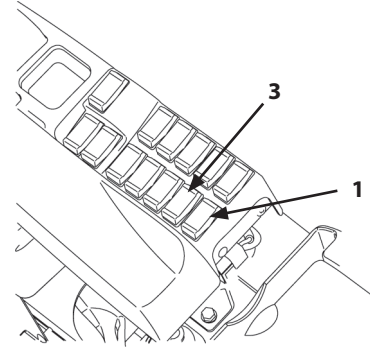

115MNEC-07-01

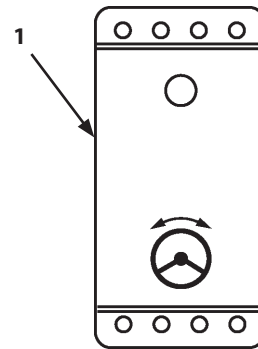

M4GB-01-088

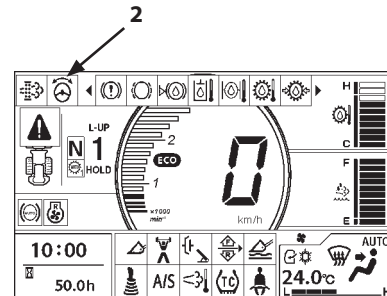

MNHG-01-290EN

### Aftertreatment Device Regeneration Switch

Use this switch (3) to start the aftertreatment device manual regeneration procedures when it is requested. Refer to page 5-13 for details.

# OPERATOR'S STATION

## Ride Control Switch (Option)

### WARNING:

- To ensure safety, operate the ride control switch only after parking the machine with the bucket lowered to the ground.
- When operating the machine with the front attachment in the float position (scooping, grading, or snow removal), always turn the ride control switch OFF. Failure to do so may allow the front attachment to unexpectedly move up or down when the ride control system is activated.
- When operating the machine with the ride control ON, control the machine speed so as not to cause sudden impacts to the machine. Ride control accumulator will carry high pressure causing gas leakage.

The ride control system dampens the vertical movement of the front attachment during operation so that comfortable machine ride quality is obtained. As stable drive operation is achieved, bucket load spill can be lessened.

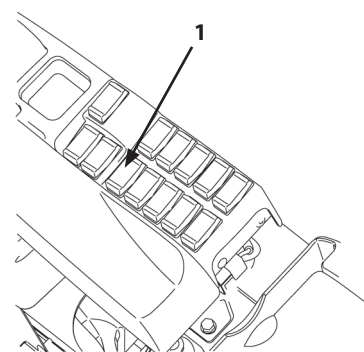

115MNEC-07-01

### AUTO

When ride control switch (1) is turned to AUTO, the drive speed sensor and the controller is activated. Then, when the drive speed increases above the preset travel speed, the ride control system automatically operates. When the drive speed decreases below the preset travel speed, the ride control system becomes inoperable. When ride control switch (1) is turned to AUTO mode, the ride control indicator (2) on the monitor display comes ON.

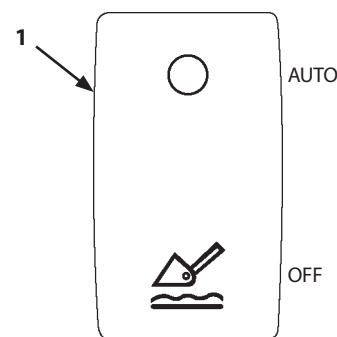

Only AUTO is provided

MNEC-01-022

### OFF

When ride control switch (1) is turned OFF, ride control indicator (2) on the monitor display goes OFF and the ride control system becomes inoperable.

When the key switch is in the OFF position, the ride control system does not operate even if ride control switch (1) is in the AUTO position. When the engine is stopped while ride control switch (1) is in AUTO, the ride control is turned OFF.

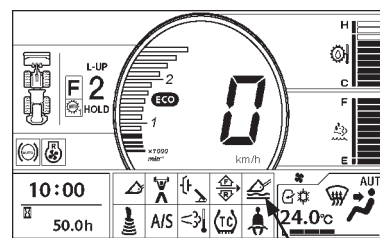

2

MNHG-01-100EN

## OPERATOR'S STATION

---

### Hold Switch

Press hold switch (1) while letting the machine travel in the auto shift mode, and the machine holds the speed gear range that is currently displayed on the monitor.

Operate one of the following to release the hold function:  
Press the hold switch again, Change the gear range,  
Change the travel mode, or Press DSS (down shift switch).

 **NOTE:** Lockup clutch does not function while holding the speed range.

- Loading Control Lever

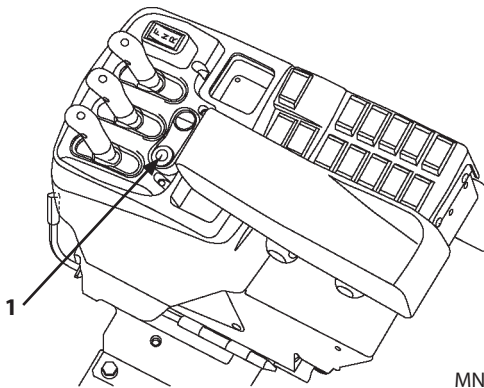

MNEC-01-041

Fingertip Control Type

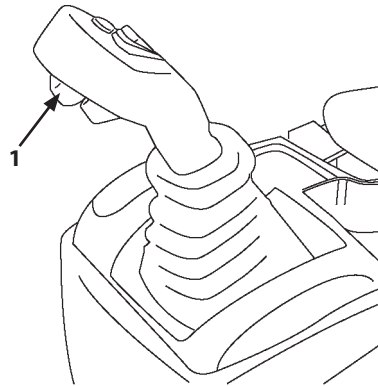

MNEC-01-044

Multi-Function Joystick Type (Option)

- Joystick Steering Lever

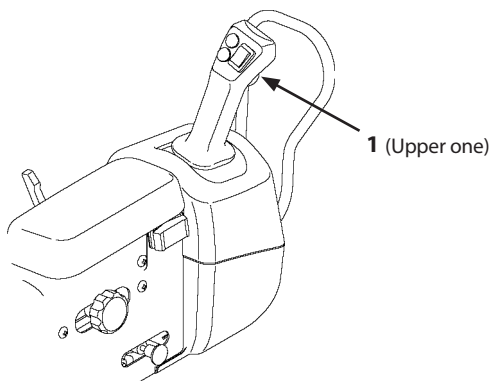

95Z7-1-85-1

# OPERATOR'S STATION

## Quick Power Switch

By pressing quick power switch (1) when the power mode is OFF, the power mode is temporarily activated. (The power mode indicator on the monitor shows symbol (  ).)

 **NOTE:** The quick power switch is operable only in the following cases.

- An added push is needed during digging (tractive) operation.
- Need a little more acceleration or travel speed while ascending on a slope.

When operating under low load or the forward/reverse switch is in "Neutral" (N) position, the mode will not change to power mode even if quick power mode switch is pressed. The switch selection is ruled invalid.

Also, even if the machine is in the power mode, it is canceled when the following conditions are met.

- When operating load is decreased while digging.
- When the quick power mode switch is pressed.
- The forward/reverse switch is operated.
- While driving in the auto-shift mode, the gear shifts up to the selected gear stage.

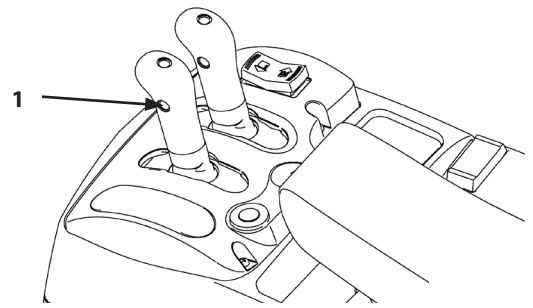

115Z7-1-107-2

Fingertip Control Type

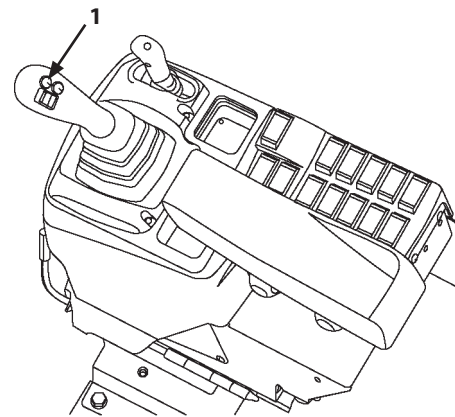

MNEC-01-043

Multi-Function Joystick Type

## Right Console Slide Lever

Adjust the position of the right console as follows.

1. While tilting lever (2) to the right, adjust the position of the right console by sliding it back or forth. Holding and moving armrest (3) maybe easier to move the console.

Slide quantity: 90 mm (3.5 in)

2. After the adjustment, put back lever (2) to the original position.

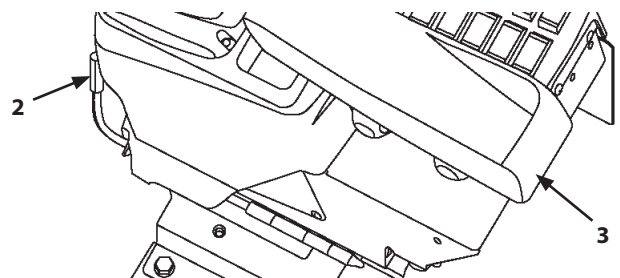

115MNEC-01-043

# OPERATOR'S STATION

## DSS (Down Shift Switch)

Press DSS (1) to down shift the gear.  
Set the shift gear to 2nd speed for normal operation.  
By pressing DSS (1) while digging with the machine in forward, the gear automatically shifts to 1st speed, which increases drive force and digging force.  
Once forward/reverse switch (2) is set to reverse (R), the gear returns to 2nd speed.

Press DSS (1) when ECO indicator (3) turns OFF while operating on a slope or during snow removal. In this case, the gear temporarily shifts down to 1st speed by pressing DSS (2), but it automatically returns to 2nd speed when traveling load is reduced.

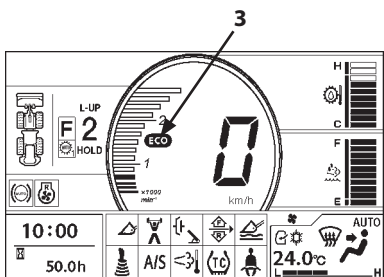

MNHG-01-100EN

**NOTE:** When in auto shift mode or manual shift mode, each time DSS (1) is pressed, the gear down shifts to 1st speed. When in auto shift mode, press and hold DSS (1) to down shift from 4th speed, 3rd speed, 2nd speed, and then to 1st speed.

**NOTE:** When DSS (2) is pressed during lockup shift range, the speed range is downshifted by one. (Pressing DSS during 4th L-UP moves down to 3rd shift range.)

**NOTE:** This switch (2) works only in Manual traveling mode; has no function in AUTO1 or AUTO2 mode.

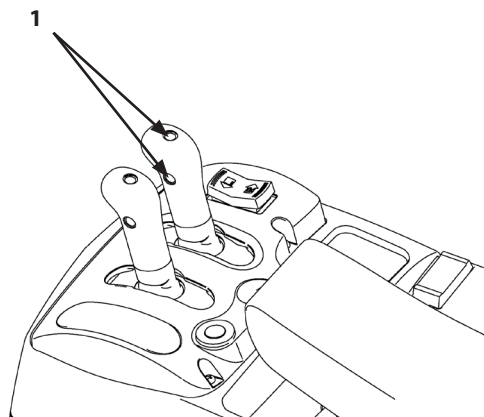

Fingertip Control Type

115Z7-1-107-2

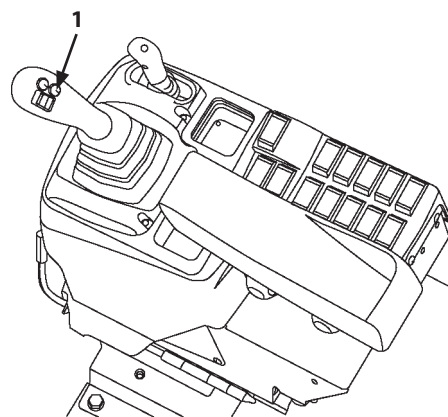

Multi-Function Joystick Type

MNEC-01-043

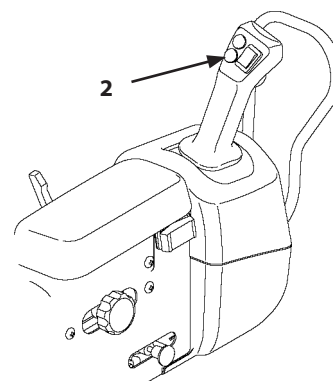

95Z7-1-85-1



# OPERATOR'S STATION

## Horn Switch

Press horn switch (1) to sound the horn.  
The horn switches are provided on the control lever and the joystick steering to improve operator comfort.

- Loading Control Lever

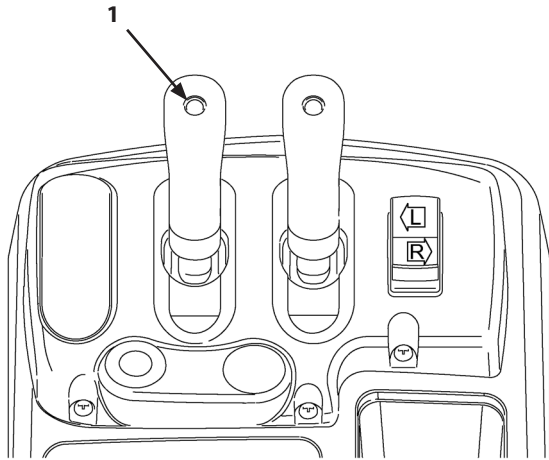

Fingertip Control Type

115Z7-1-92-1

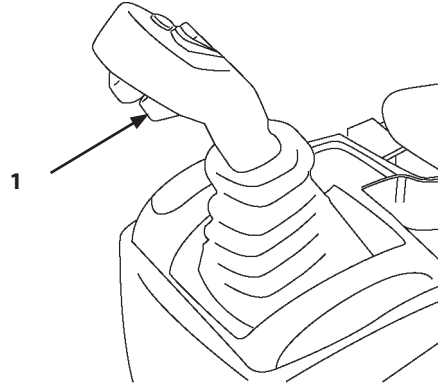

Multi-Function Joystick Type

MNEC-01-044

- Joystick Steering Lever

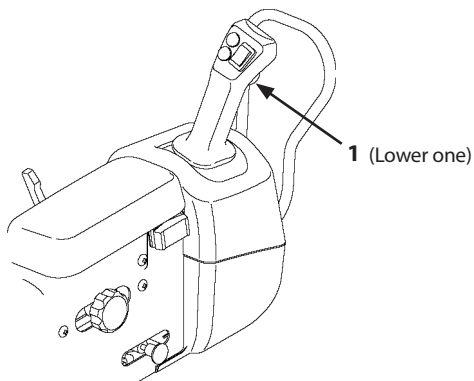

95Z7-1-85-1

## OPERATOR'S STATION

### Cigar Lighter (24 V DC Electrical Outlet)

#### Using Cigar Lighter

**⚠ WARNING:** Never touch other than insulated the knob part. Otherwise, it may result in severe burns.

**IMPORTANT:** In case the cigar lighter does not pop out automatically after 30 seconds after pushing the cigar lighter in, pull out the cigar lighter manually. Then, consult the your nearest authorized dealer.

1. Turn the key switch (1) ON.
2. Press and release the lighter knob (2).
3. The cigar lighter knob will return to the original position when the lighter becomes hot. Pull the cigar lighter out to use.
4. After using the cigar lighter, insert the cigar lighter into the panel until the knob is seated in the original position and not pressed in.

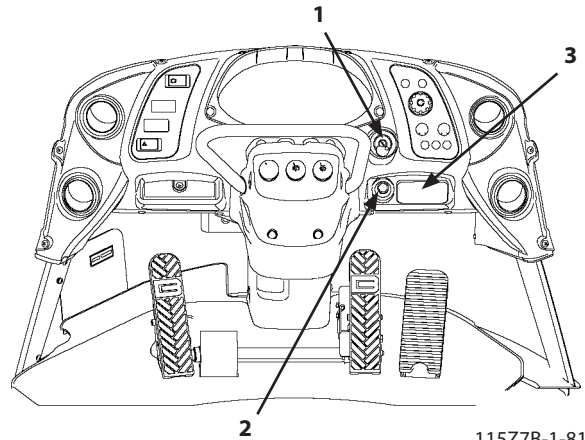

115Z7B-1-81-1



**⚠ CAUTION:** Do not connect accessories that use power other than 24 V DC (MAX. 5 A). Damage to the batteries and accessories may result.

**Do not use this socket to supply the power for a long time without running the engine. The batteries may be discharged.**

M4GB-01-089

### Ash Tray

**⚠ WARNING:** Take precautions against fires.

Use this ash tray (3) when smoking in the cab.

### Auto Air Conditioner

#### Feature

- Full Auto-Temperature Control:  
Automatically controls the cab temperature to maintain the temperature set by the temperature control switch regardless of outside air temperature and insolation.
- Max. Cooling and Heating:  
Maximum cooling or heating can be obtained by rotating the temperature control switch clockwise (32°C) (90°F) or counterclockwise (18°C) (64°F) respectively.
- Preheating:  
During preheating the cab in winter with the foot vent selected, the air volume is reduced to Low until the coolant temperature rises to prevent cool air from entering the cab.

 **NOTE:** *Even in the summer season, the engine high idle speed may be higher when cool than the normal operating temperature speed due to quick warm-up mode.*

# OPERATOR'S STATION

## Components Name

- 1- Monitor
- 2- Control Panel
- 3- Temperature Control Switch (Rotate)/Mode Switch (Press)
- 4- Defroster Switch
- 5- Circulation/Fresh Air Switch
- 6- Air Conditioner ON/OFF Switch
- 7- Fan (Rotate)/Auto Switch (Press)

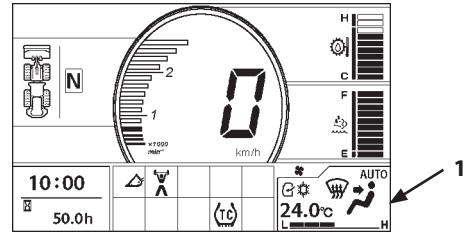

MNHG-01-103EN

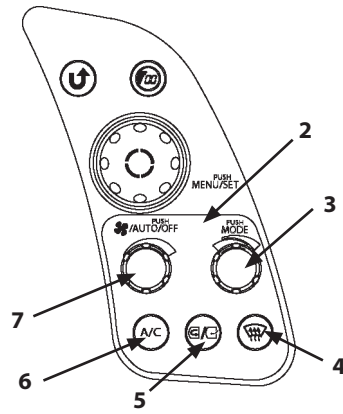

MNEC-01-006

- 8- Defroster Vent
- 9- Rear Vent
- 10- Foot Vent
- 11- Air flows out of front vent and the defroster vents.

NOTE:

- Except for the foot vent (10) and defroster vent (8), all vents are provided with louvers to adjust the air flow direction.
- In addition, the louvers on front vent (11) and rear vent (9) can be completely opened and closed by hand.

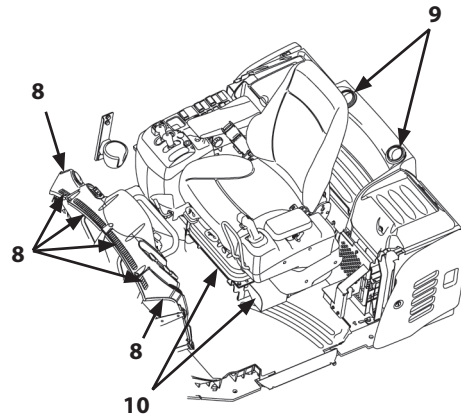

11527-1-115-3

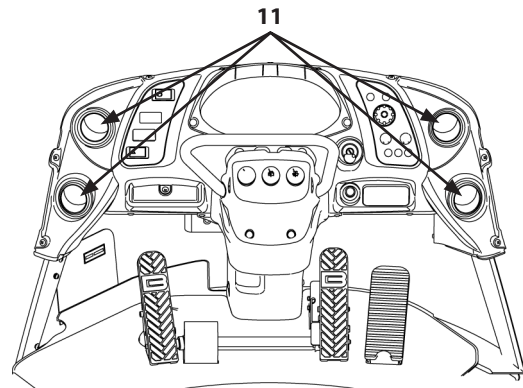







115MNEC-01-37

# OPERATOR'S STATION

## Controller Part Name and Function

### Mode/Temperature Control Switch

- Mode Switch (3)  
Selects the air vent. The selected air vent is indicated on monitor (1).

-  : Front Vent Mode
-  : Front/Rear Vent Mode
-  : Front/Rear/Foot Vent Mode
-  : Foot Vent Mode
-  : Foot/Defroster Vent Mode
-  : Defroster Vent Mode

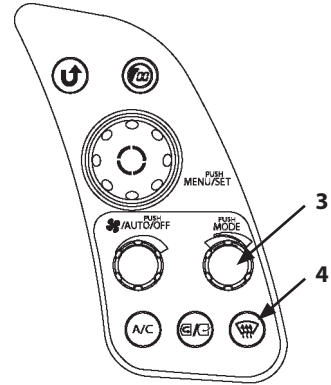

MNEC-01-006

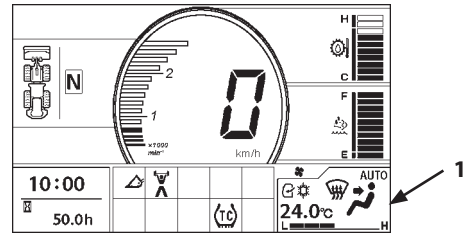

MNHG-01-103EN

Each time mode switch (3) is pressed, the vent location can be changed in 6 stages as illustrated below.



Press defroster switch (4) to change defroster  vent mode.

- AUTO mode  
The air vent location is automatically selected.
- Temperature Control Switch (3):  
Sets temperature in the cab.  
Temperature in the cab can be set from 18.0 to 32.0 °C (64 to 90 °F) by rotating temperature control switch (3).  
Temperature can be set by 0.5 °C (33 °F) increments.  
The set-temperature is displayed on monitor (1).

# OPERATOR'S STATION

## Fan/AUTO Switch

- Blower Switch (7)
  - When the AUTO indicator (8) is ON, the blower speed is automatically controlled.
  - When AUTO indicator (8) is OFF, the blower speed is controlled in 6 steps.  
Rotate blower switch (7) clockwise to increase blower speed. Rotate blower switch (6) counterclockwise to decrease blower speed.  
The monitor (1) indicates the corresponding blower fan speed.
- AUTO Switch (7)  
Press AUTO Switch (7) while the air conditioner OFF, it turns AUTO. Press AUTO switch (7) while operating the air conditioner, it stops operation.

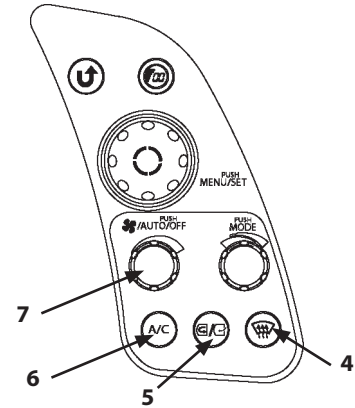

MNEC-01-006

## Air Conditioner ON/OFF Switch (6)

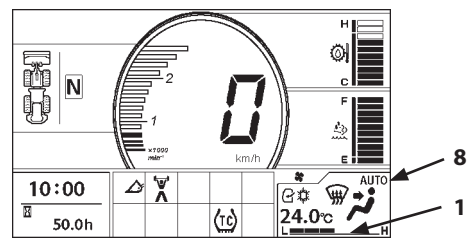

The air conditioner (cooling, dehumidifying) will turn on and the air conditioner indicator  will be displayed on the monitor when air conditioner ON/OFF switch (6) is pressed.



MNHG-01-103EN

## Circulation/Fresh Air Switch (5)

It switches over the air intake port to recirculation mode and fresh air mode.

Icon of the selected mode will be displayed on the monitor. Recirculation mode , Fresh air mode: .

## IMPORTANT:

- **When running the air conditioner for a long time, turn the lever to Fresh position once an hour to perform ventilation and cooling.**
- **If you smoke when the air conditioner is on, the smoke may hurt your eyes. In such a case, open the window and turn the lever to Fresh for a while for ventilation and cooling to drive smoke out.**

## Defroster Switch (4)

Press defroster switch (4) to select defroster vent mode and the icon  will be displayed on the monitor.

## OPERATOR'S STATION

### Cab Heater Operation

#### 1. AUTO switch (7):

According to signals sent from various sensors, the air conditioner amplifier automatically selects the air flow inlet ports, and air temperature, and controls the blower speed.

#### 2. Temperature Control Switch (3):

Adjust the temperature in the cab by using temperature control switch (3).

#### 3. Other Functions and Operations

- Operate Mode switch (3) to manually select the air vent.
- Operate blower switch (7) to manually control the blower speed.
- Operate circulation/fresh air switch (5) to maintain the air vent in the fresh air mode or circulation mode.

Usually the cab heater turns the dehumidifier function OFF, however, it turns ON by turning A/C ON by using air conditioner ON/OFF switch (6).

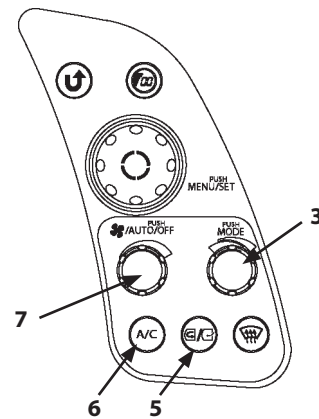

MNEC-01-006

## OPERATOR'S STATION

### Cooling Operation

#### 1. AUTO switch (7):

Press AUTO switch (7) to set the air conditioner AUTO mode. According to signals sent from various sensors, the air conditioner amplifier automatically selects the air flow-in vents, air suction ports, and air flow-in temperature at the vent, and controls the blower speed.

#### 2. Temperature Control Switch (3):

Adjust the temperature in the cab by using temperature control switch (3).

#### 3. Other Functions and Operations

- Operate Mode switch (3) to manually select the air vent.
- Operate blower switch (7) to manually control the blower speed.
- Operate circulation/fresh air switch (5) to maintain the air vent in the fresh air mode or circulation mode.

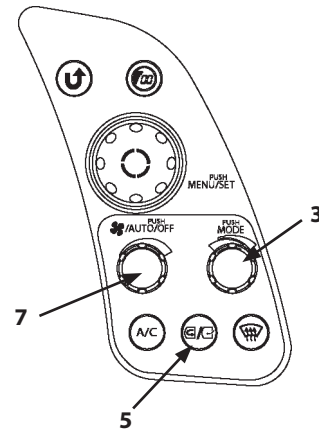



MNEC-01-006



## OPERATOR'S STATION

### Defroster Operation

1. Press defroster switch (4) to change defroster  vent mode; the fresh air mode and air conditioner will turn ON.
2. Temperature in the cab can be adjusted by operating temperature control switch (3).
3. Operate fan switch (7) to adjust flow.
4. Operate mode switch (3) to change  foot/defroster mode.

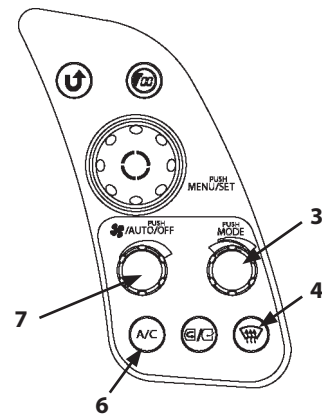

MNEC-01-006

### Cool Head/Warm Feet Operation

Cool and warm air is simultaneously supplied to the head vents and feet vents respectively.

1. Rotate blower switch (7) to adjust the blower speed.
  2. Press MODE switch (3) to display the front and rear vent mark  on the monitor.
- Turn A/C ON by using air conditioner ON/OFF switch (6).

Control air temperature inside the cab by using temperature control switch (3).

## OPERATOR'S STATION

### Tips for Optimal Air Conditioner Usage

#### For Rapid Cooling

Temperature in the cab may rise over 80 °C (176 °F) when the machine is exposed to sun light in the summer. In this case, ventilate air in the cab first by opening the windows for rapid cooling.

After starting the engine, press AUTO switch (6). Set temperature to "18.0" on the monitor by using temperature control switch (5). Turn circulation mode ON from air conditioner setting screen on the monitor. Close the window when the cab cools down to the ambient temperature.

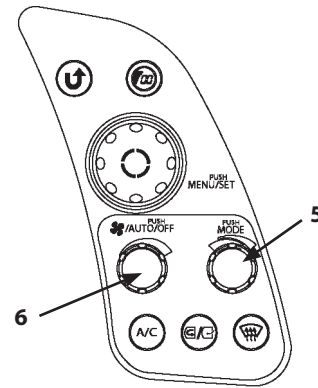

MNEC-01-006

#### When Windows Become Fogged

If the insides of the windows become fogged during rainy weather or on humid days, operate the air conditioner to aid in keeping the windows clear. When the atmosphere is very damp, and if the air conditioner has run excessively, the outside of the windows may become fogged. If this happens, turn up the air temperature selection to adjust the temperature in the cab.

#### Off-Season Air Conditioner Maintenance

To protect each part of the compressor from a lack of lubricant, operate the air conditioner at least once a month for several minutes with the engine running at a slow speed during off-season.

#### IMPORTANT:

- Refer to the item "Check Air Conditioner Filter" in the Maintenance Section for maintenance of the air conditioner filters.
- Always clean the auto air conditioner sensor for effective air conditioner performance. Avoid placing any obstructions around the sensor.

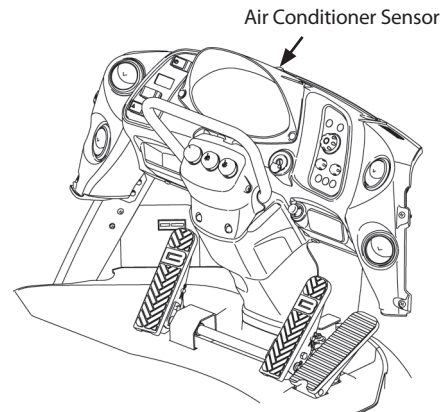

115Z7-1-121-2

## OPERATOR'S STATION

### Adjusting Operator's Seat (Air Suspension Type Seat)

Adjust the seat for comfort and so that the pedals may be pushed fully down when the operator's back is fully against the seat back.

#### Components Name

- 1- Lumbar Support Adjustment
- 2- Reclining Angle Adjustment
- 3- Damper Adjustment
- 4- Fore-Aft Position Adjustment

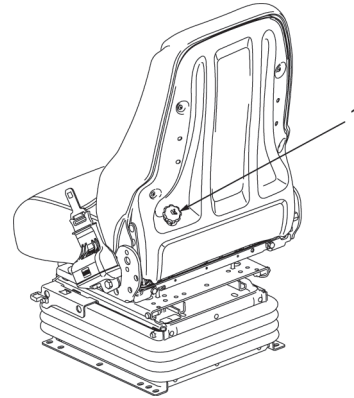

115Z7-1-117-2

1. Turn adjustment knob (1) for desired lumbar support.
2. Lift handle (2) and allow the back cushion to angle forward, or lean backward into the cushion. Release the handle at desired position.
3. With the key turned "ON" push the knob (3) to increase the air pressure. This will raise the seat and make a firmer ride. Pull the knob (3) to reduce the air pressure (air will be vented). This will lower the seat and make a softer ride.

When properly adjusted the seat will not "bottom out" over rough terrain.

4. Lift handle (4) and move the seat forward or backward.

Release handle (4) at one of the several positions.

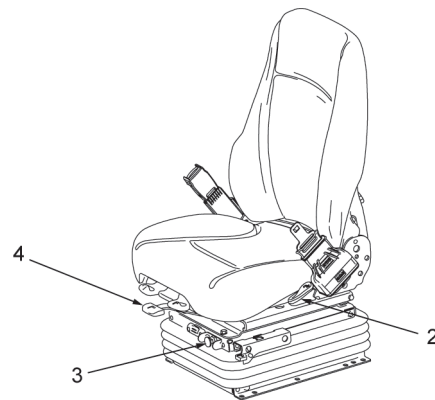

115Z7-1-117-1

## OPERATOR'S STATION

### Rear Tray

- 1- Document Holder
- 2- Hot/Cool Box
- 3- Electric Power Output (12 VDC, 15 A) (Option)
- 4- Glove Compartments, Tray
- 5- Fuse Box

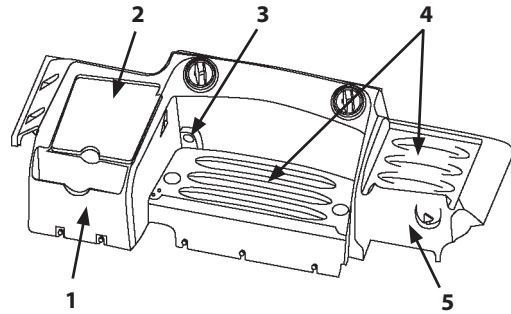

115MNEC-01-46

### Electric Power Output (Option)

Use the electric power output (Max. 60W) such as electric power to an instrument used for inspection/ maintenance work such as an illumination light.

**IMPORTANT: DC 12 volt electric power can be utilized. Never connect accessories that use power other than 12 V. Damage to the batteries and accessories may result. Do not supply power to accessories for a long time without running the engine. The batteries may be discharged.**



M4GB-01-089

1. Remove the cover.
2. Insert the socket of the accessory to be used into the electric power output port.
3. Turn the key switch (6) ON. Power is supplied to the connected accessory.
4. After completing operation of the accessory, disconnect the accessory. Reinstall the cover.

## OPERATOR'S STATION

### Fuse Box

**IMPORTANT: If a fuse blows, turn the key switch OFF. After checking and correcting the cause of the trouble, replace the fuse with a new one.**

The slow blow fuses (1 and 2) function as a "safety valve" to prevent excess current from flowing through, and to protect the electrical system.

The fuse capacity varies depending on its corresponding circuit. Be sure to replace the blown fuses only with the specified one.

When checking fuses, check the fuse A, B and slow blow fuses in the battery box (1 and 2) in this order.

1- 140 A x 2

2- 70 A x 2

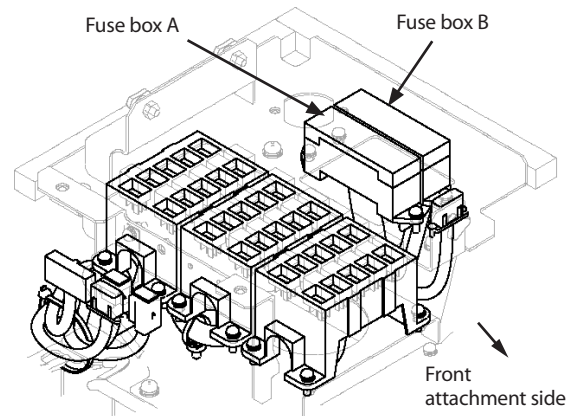

FuseBox\_550

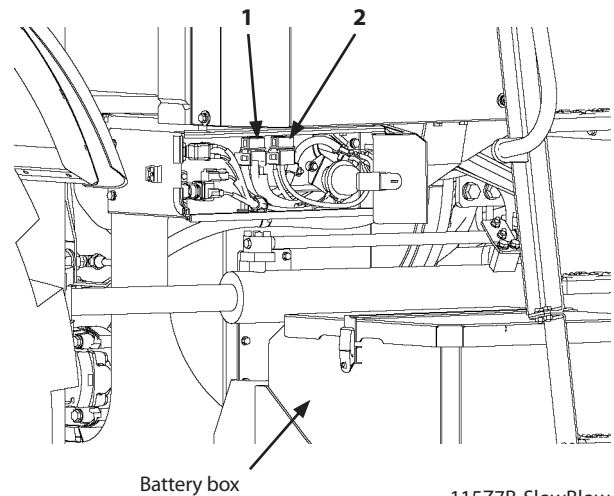

115Z7B-SlowBlow

## OPERATOR'S STATION

### Fuse Box A

- |   |  |
|---|--|
| <ul style="list-style-type: none"> <li>10- Parking solenoid<br/>5 A</li> <li>9- Air conditioner 1<br/>10 A</li> <li>8- Stop lamp, Turn signal<br/>5 A</li> <li>7- Back lamp, Back buzzer<br/>5 A</li> <li>6- Head lamp (left)<br/>5 A</li> <li>5- Working lamp (front)<br/>20 A</li> <li>4- Front wiper<br/>15 A</li> <li>3- 24 V cigar lighter<br/>20 A</li> <li>2- Head lamp (right)<br/>5 A</li> <li>1- CONTROLLER (SUB)<br/>10 A</li> </ul> | <ul style="list-style-type: none"> <li>20- Option 4 (Joystick steering)<br/>(5 A)</li> <li>19- Option 3 (Fuel pump)<br/>15 A</li> <li>18- SCR DCU<br/>20 A</li> <li>17- ECM DCU (POWER ON)<br/>10 A</li> <li>16- SCR sensor<br/>20 A</li> <li>15- Air conditioner 2<br/>20 A</li> <li>14- Starter key SW<br/>10 A</li> <li>13- Seat heater<br/>15 A</li> <li>12- Option 2 (ACC1)<br/>(20 A)</li> <li>11- Radio (USA)<br/>10 A</li> </ul> |
|---|--|

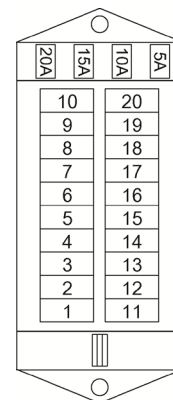

90Z7B-FuseBoxA

### Fuse Box B

- |   |  |
|---|--|
| <ul style="list-style-type: none"> <li>10- ECM<br/>30 A</li> <li>9- CONTROLLER (SUB)<br/>10 A</li> <li>8- Main controller, DSZ, Monitor,<br/>Load dump relay, GPS, GSM, OPT C/U<br/>10 A</li> <li>7- Flasher unit<br/>10 A</li> <li>6- Horn<br/>10 A</li> <li>5- Option CAN<br/>5 A</li> <li>4- Option 1 (battery)<br/>(15 A)</li> <li>3- DC/DC converter, 12 V cigar socket,<br/>Tachograph (option)<br/>20 A</li> <li>2- Lighting switch<br/>10 A</li> <li>1- DC/DC power ON<br/>5 A</li> </ul> | <ul style="list-style-type: none"> <li>20- Secondary steering (option)<br/>5 A</li> <li>19- High beam<br/>10 A</li> <li>18- Rear wiper<br/>10 A</li> <li>17- Working lamp (rear)<br/>20 A</li> <li>16- Loader control<br/>5 A</li> <li>15- MC solenoid power<br/>10 A</li> <li>14- Parking relay<br/>5 A</li> <li>13- Power ON<br/>10 A</li> <li>12- Position 2<br/>5 A</li> <li>11- Position 1<br/>5 A</li> </ul> |
|---|--|

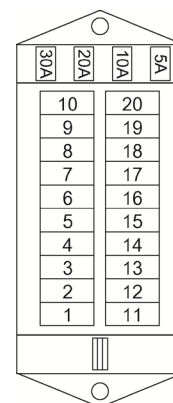

90Z7B-FuseBoxB

## OPERATOR'S STATION

---

### Hot/Cool Box

Cool or warm air from the air conditioner or heater is routed to hot & cool box (1) so that food or a drink can be temporarily stored.

Use a container with a tight cap in the hot/cool box.

- If the A/C is on, cool air is sent into the box.
- If the heater is on, warm air is sent into the box.

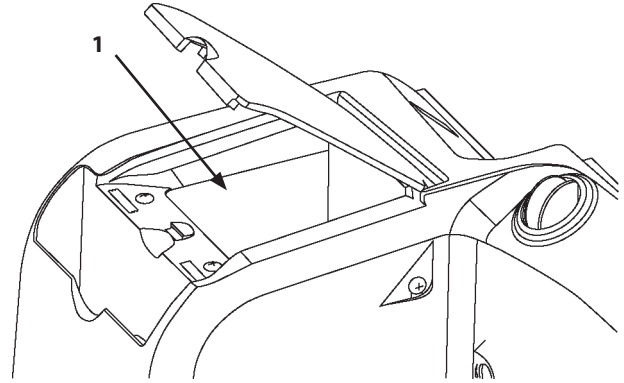

MNEC-01-048

### Tray and Drink Holder

**IMPORTANT:** Tray (2) is not waterproof type. Be careful not to spill liquid on the tray.

Place a bottle with a plug or cap on drink holder (3).

Wipe up any spills with a damp cloth.

Secure anything stored in this area to avoid loose objects in the cab.

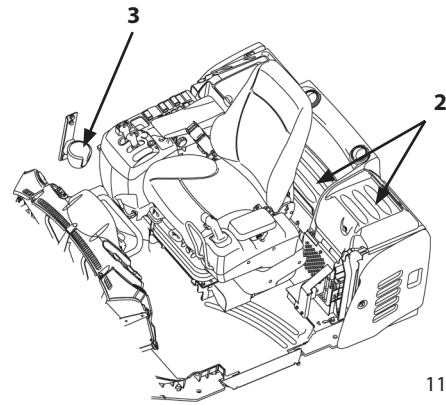

115Z7-1-126-2

# OPERATOR'S STATION

## Cab

The ROPS (Roll Over Protective Structure) is attached to Cab (1) as standard equipment.

1- Cab

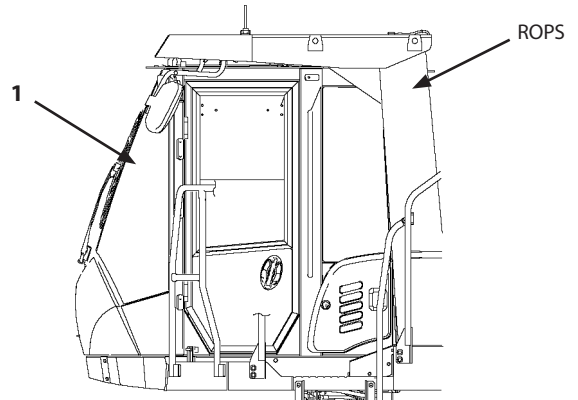

115Z7B-1-128-1

2- Speakers

3- Front Interior Light

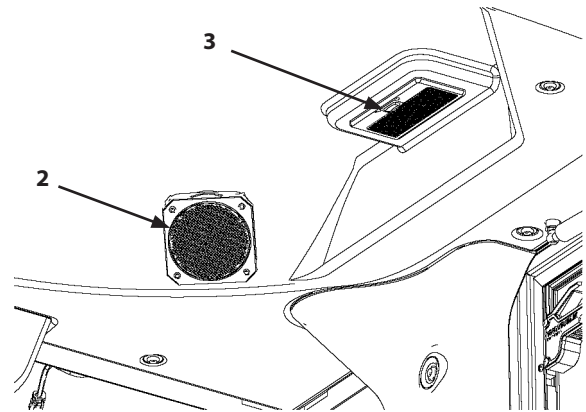

115Z7B-1-128-2

4- Sun Visor

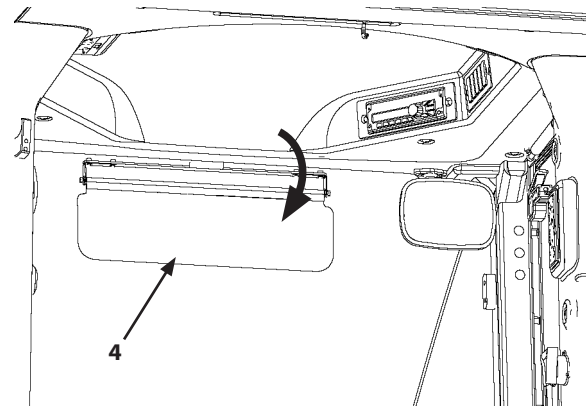

115Z7B-1-128-3



## OPERATOR'S STATION

---

- 5- Radio
- 6- Cab Switch Panel (Option)
- 7- Inside Rear View Mirror

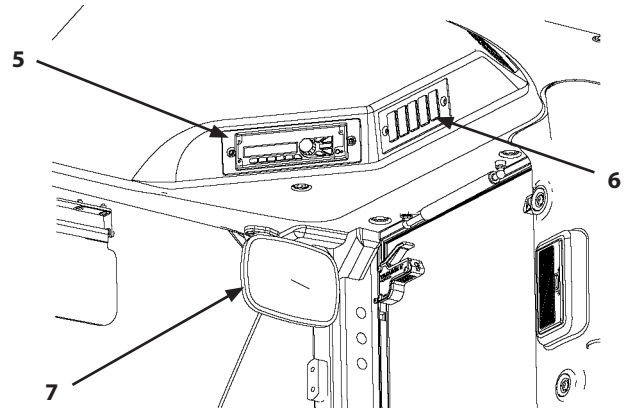

115Z7B-1-129-1

- 8- Rear Interior Light
- 9- Emergency Exit Hammer

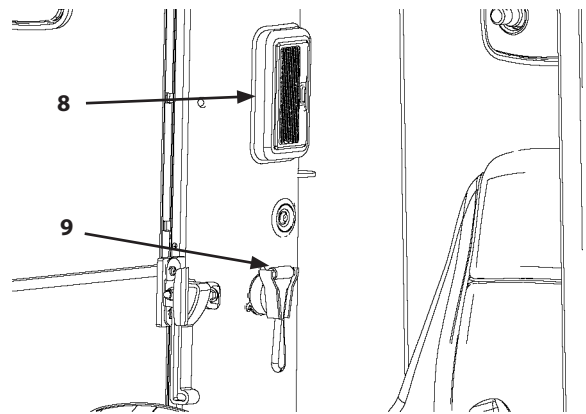

115Z7B-1-129-2

- 10- Coat/Hat Hook

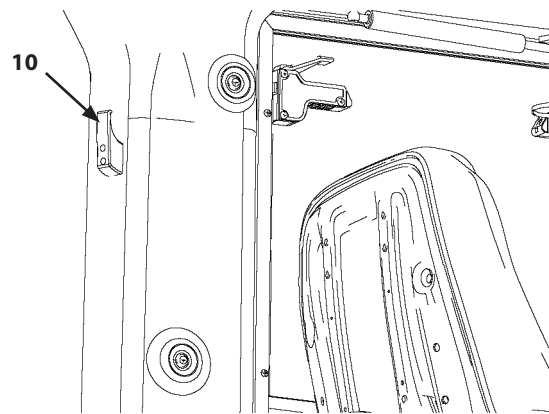

115Z7B-1-129-3

# OPERATOR'S STATION

## Front Interior Light

Slide to ON side of switch (1) to turn the interior light ON.  
The front interior light switch has three operation positions.

- ON: The light (2) turns and stays ON.
- Neutral: When the cab door is opened, the light (2) turns ON. When closed, the light (2) goes OFF.
- OFF: The light (2) remains OFF.

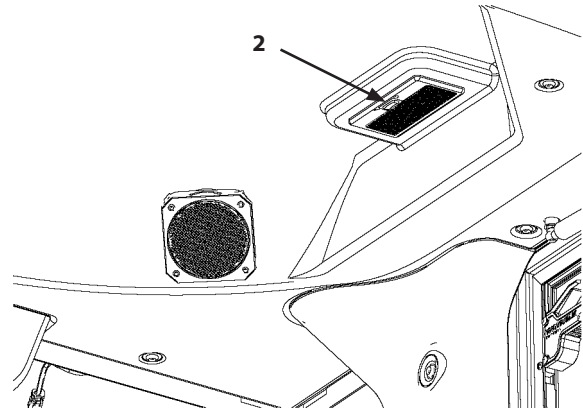

115Z7B-1-128-2

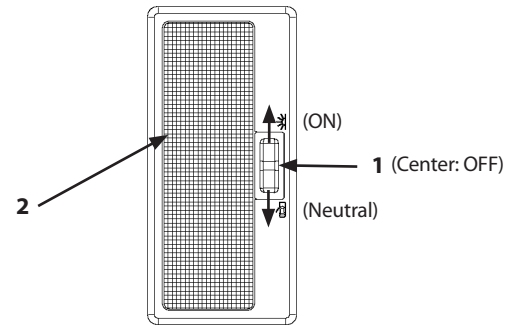

115Z7B-1-130-2

## Rear Interior Light

Slide to ON side of switch (1) to turn the interior light ON.  
The rear interior light switch has three operation positions.

- ON: The light (3) turns and stays ON.
- Neutral: When the cab door is opened, the light (3) turns ON. When closed, the light (3) goes OFF.
- OFF: The light (3) remains OFF.

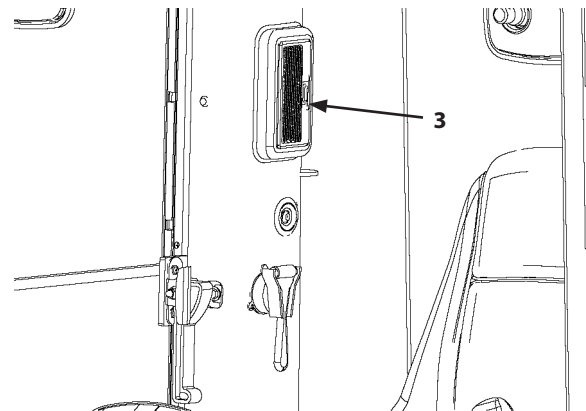

115Z7B-1-129-2

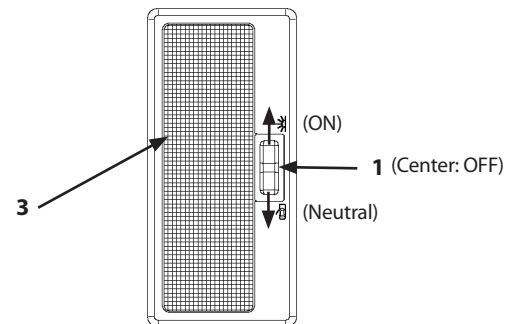

115Z7B-1-130-2

## OPERATOR'S STATION

### Sun Visor

When sunlight is strong, use sun visor (4) by hanging its edge from the cab top down to a desired place.

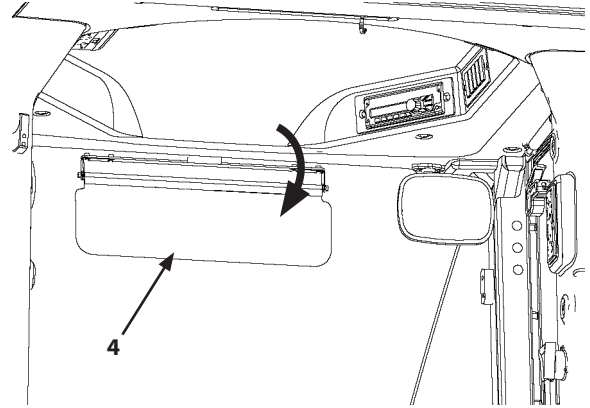

115Z7B-1-128-3

### Emergency Exit Hammer

In case the cab door becomes difficult or impossible to open if an emergency situation occurs, exit machine by breaking the windowpane using the provided hammer.

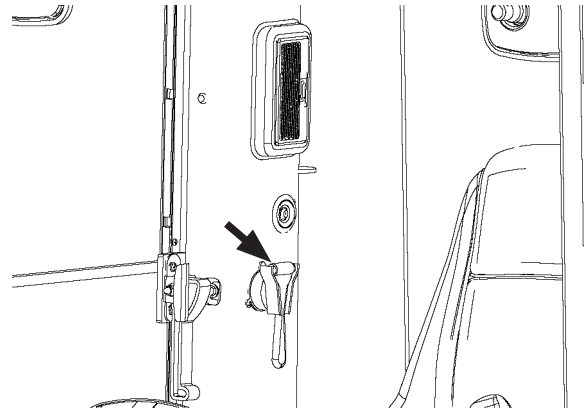

115Z7B-1-129-2

### Coat/Hat Hook

Use to hang your coat, hat, etc.

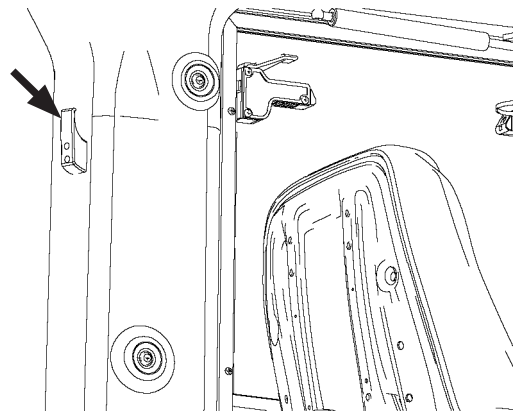

115Z7B-1-129-3

## OPERATOR'S STATION

### Upper Switch Panel (Option)

- 1- Rotary Light Switch
- 2- Auxiliary
- 3- Auxiliary
- 4- Auxiliary
- 5- Auxiliary

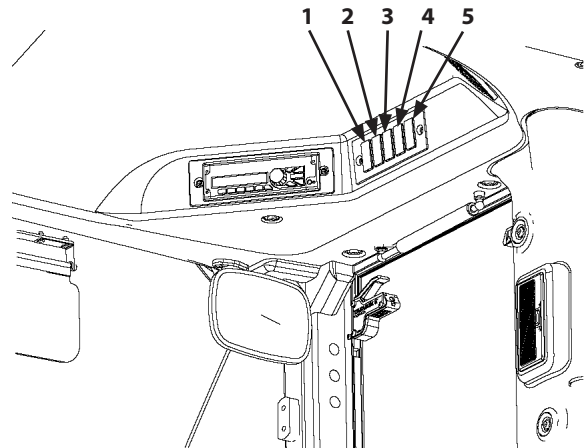

115Z7B-1-129-1

### Rotary Light Switch (Option)

Press either upper part or lower part of the switch to turn the rotary light ON. Press middle part of the switch to turn OFF.

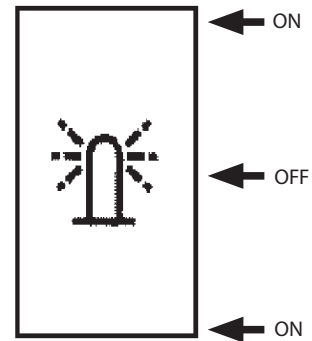

M4GB-01-125

## OPERATOR'S STATION

### Outside Rear View Mirror

**⚠ WARNING:** Do not move the machine in reverse by relying on only the range of vision the rear view mirror (1) provides. Use the rear view mirror only as a visual aid during travel. Be sure to confirm safety by looking to the rear when moving the machine in reverse.

Comfortably adjust seat, then adjust the rear view mirrors so that good rear vision can be obtained. Adjust the mirrors so that persons standing on left and right back-end of the machine (or object with height of 1 m (3 ft) and 30 cm (12 in) in diameter) can be recognized from the operator's seat. Always keep the mirrors clean.

**✎ NOTE:** Optional extensions and other mirror types are available.

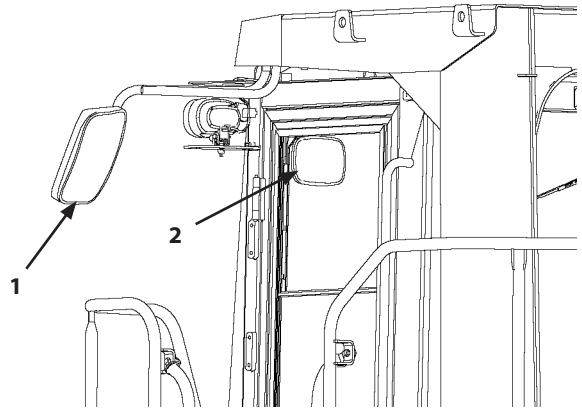

115Z7B-1-133-1

### Inside Rear View Mirror

Always keep room rear view mirrors (2) clean.

### Cab Door

**⚠ CAUTION:** When entering or leaving the cab, securely close the doors.

**✎ NOTE:** Unless the cab door is securely closed, the room light switch keeps the room light ON. Securely close the cab door.

3- Door Lock (Starter key is used)

4- Door Open/Close Lever

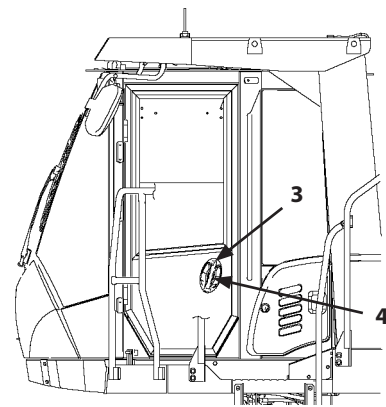

115Z7B-1-128-1

## OPERATOR'S STATION

### Door Open/Close Lever

When opening the door, while lifting door lock knob (5), pull lever (6) to disengage the door lock.

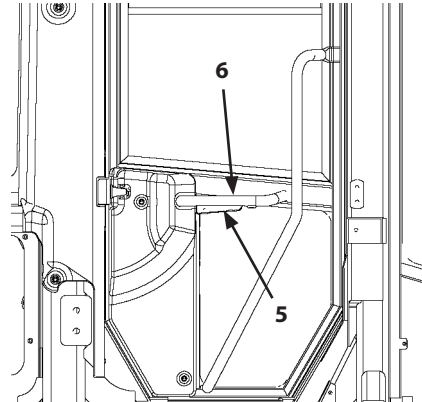

115Z7B-1-134-1

### Window Open/Close Levers

When window open/close levers (7) on both sides are simultaneously pressed, the window is unlocked, allowing the windowpanes to move.

When window open/close levers (7) are released, stoppers are engaged in the nearest steps so that the window is locked in that position.

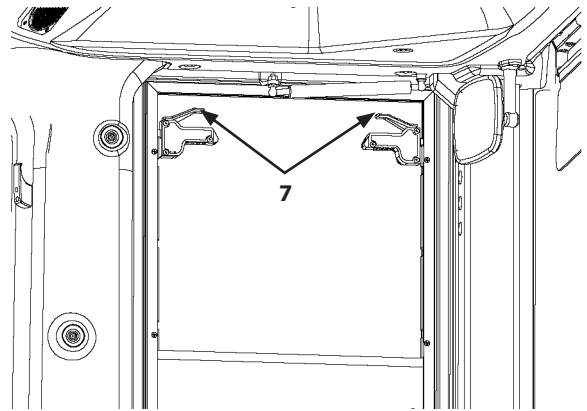

115Z7B-1-134-2

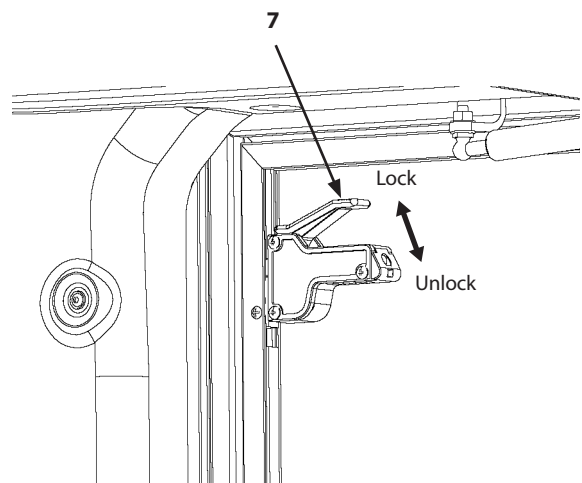

115Z7B-1-134-3

## OPERATOR'S STATION

---

### Battery Disconnect Switch

**IMPORTANT:** Never attempt to turn the battery disconnect switch OFF while engine running. Failure to do so may damage the electrical system.

**⚠ WARNING:** After stopping the engine, the DEF pump keeps operating to return the DEF in piping to the DEF tank. Do not turn the battery disconnect switch OFF while pump running. Failure to do so may damage the SCR system.

The battery disconnect switch is different from the engine start key switch. When the battery disconnect switch is turned OFF, the electrical system will completely be isolated from the battery. No current will flow through the entire electrical system.

Before turning the battery disconnect switch OFF, be sure to turn the key switch OFF and wait 5 minutes or more after the engine stops before turning battery disconnect switch. Because controllers communicate with each other and record information after the engine stops, battery power is required for a minimum of 5 minutes.

Use the battery disconnect switch only for the following purposes; otherwise, turn it ON.

- Before maintaining and repairing the electrical system
- Before storing the machine for long period (Discharge prevention)
- Theft prevention after use.

Turn the battery disconnect switch ON before starting the engine.

The battery disconnect switch is located inside of the battery box.

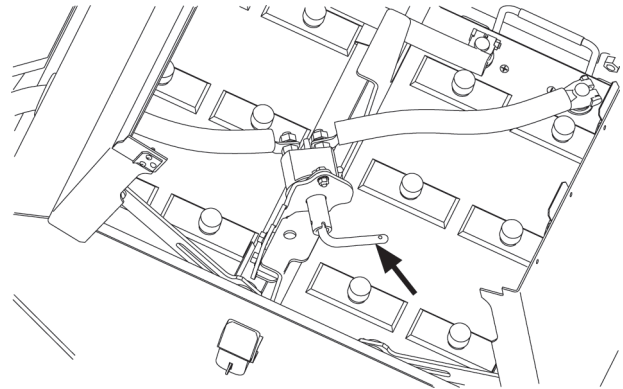

115Z7-batterySW2

## OPERATOR'S STATION

### Switch Operation

1. Open battery box cover (1).

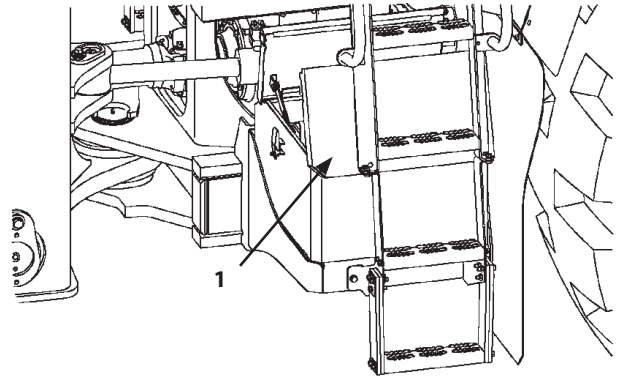

115Z7-BatterySW1

2. When lever (2) is parallel to the ground, battery disconnect switch (3) turns ON. The lever can not be removed when lever (2) points right.

When operating the machine with battery disconnect switch (3) ON, close cover (1).

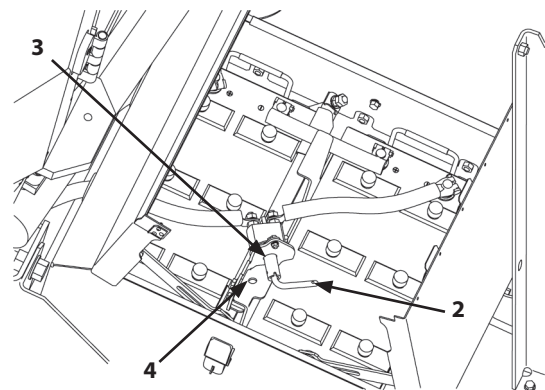

115Z7-batterySW

3. When turning lever (2) 90° counterclockwise (the lever points down to the ground), battery disconnect switch (3) turns OFF. Lever (2) can be removed from battery disconnect switch (3) when it is in OFF position.
4. Insert lever (2) removed from switch (3) into hole (4) of the holder.
5. Close cover (1).

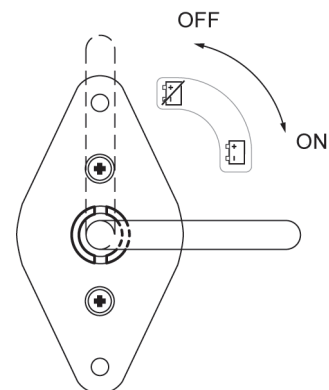

115Z7-batterySW ON-OFF



## OPERATOR'S STATION

### Articulation Stopper (Lock Bar)

**⚠ WARNING:**

- Before servicing or transporting the machine, be sure to engage lock bar (1).
- Before driving the machine, be sure to disengage the lock bar (1) from the front chassis and fasten the lock bar to the rear chassis with lock bolt (2).

Articulation lock bar (1) locks the front and rear chassis to prevent articulation between the front and rear chassis when servicing or transporting the machine. Refer to page S-38 for details.

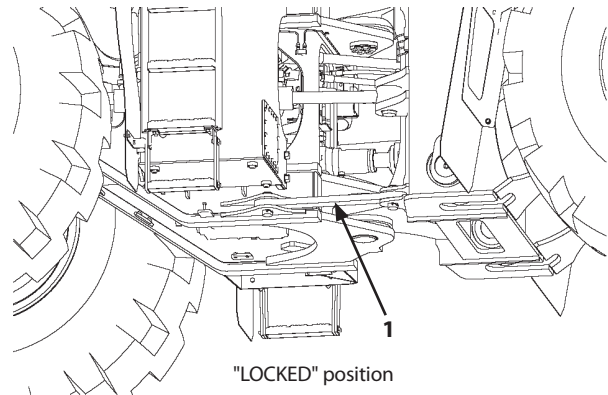

MNHE-07-005

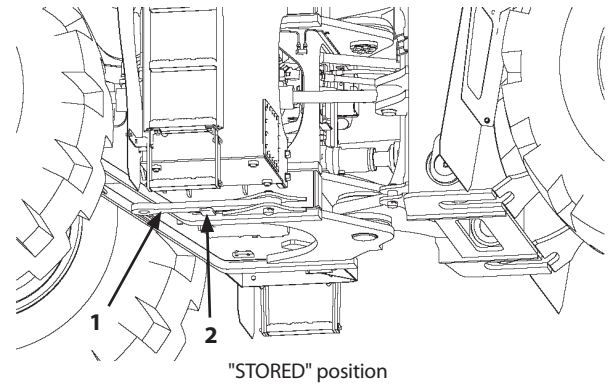

MNHE-07-004

## OPERATOR'S STATION

### Towing Pin

**⚠ WARNING:** Since towing is a potentially dangerous operation, perform only when there is an emergency or crisis situation.

**IMPORTANT:** To prevent excessive wear of tires and for safety, avoid towing requiring more than the available towing force, and keep the specified speed during towing.

**Available towing force (Power Mode ON):**  
352 kN (35950 kgf) (79132 lbf)

**Towing speed: 10 km/h (6.2 mph) or less**

Towing pin (2) is located on the back end of the machine. It is used for towing another machine, being towed from the rear side, or fastening the machine on a trailer deck for transportation.

Pull up the front end, or push down the rear end, of stopper (1) to pull out towing pin (2).

Tie or loop the towing rope, strap, or cable and let it pass through the hole.

**IMPORTANT:** DO NOT use eye plate (3) on the rear chassis when pull out or rescue this machine from the rear side. Use eye plates (3) on the front chassis when pull the machine from the front side. Contact your nearest authorized dealer for the necessary information or assistance.

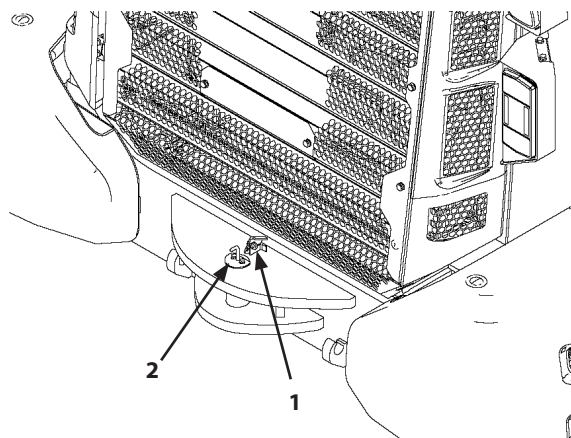

115Z7B-1-141-4

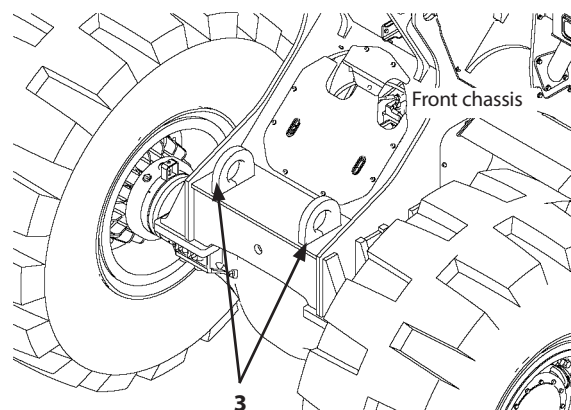

115Z7B-1-141-2

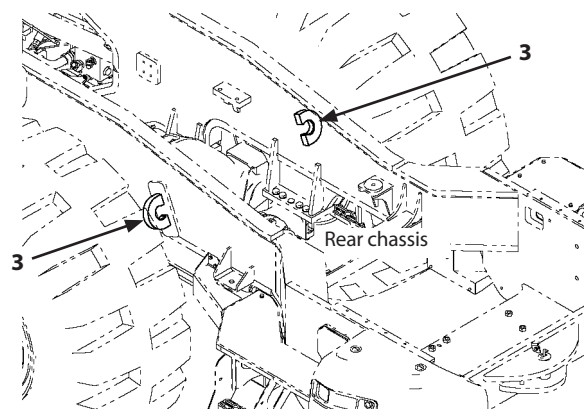

115Z7B-1-141-3

## OPERATOR'S STATION

### Inspection/Maintenance Access Covers

**CAUTION:**

- Always close side covers (1) and top cover (3) when moving and/or operating machine.
- Do not keep the side cover open on a slope or when a strong wind is blowing. Failure to do so may be dangerous because the side cover may unexpectedly move or close.
- Take care not to pinch fingers when opening/closing side cover (1) and/or top cover (3).
- When fully opening side cover (1), lock lever (5) automatically slides and is positioned in the lock position. Make sure that lock bar (5) is firmly positioned to lock the cover.
- To release the lock, pull wire (4) and release the end of lock bar (5) from the lock position.
- Never attempt to stand on fender (2) if side cover (1) is provided with fender (2).

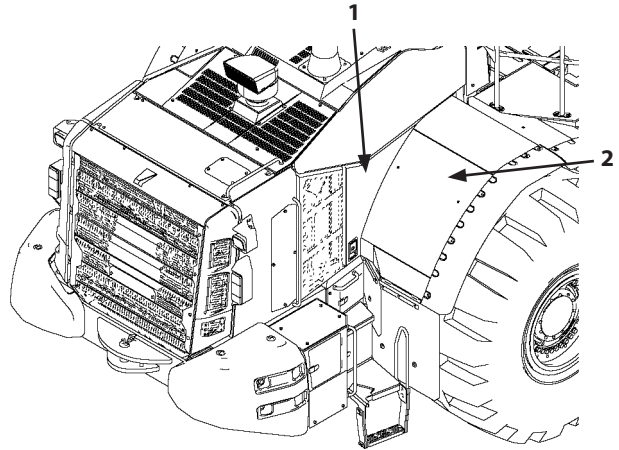

115Z7B-1-142-1

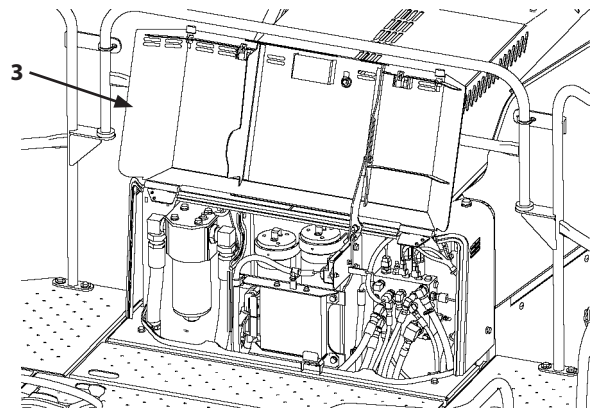

115Z7B-1-142-2

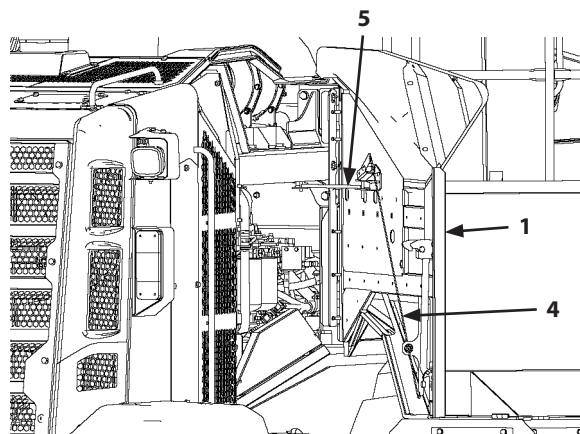

115Z7B-1-142-3

## OPERATOR'S STATION

### Rear Grille

**⚠ WARNING:** Open or close rear grille (4) only after stopping the engine. It is very dangerous if you are entangled in the cooling fan. Before operating the machine, always check that the rear grille is well latched.

**🔑 NOTE:** The starter key cannot be removed from latch (3) while rear grille (4) is being opened.

Remove bolt caps (1) and bolts (2). Release latch (3) with the starter key to unlock rear grille (4). The rear grille opens and the cooling fan can be cleaned.

After closing rear grille (4), turn and remove starter key (3) to lock rear grille (4). Tighten bolts (2) and install caps (1).

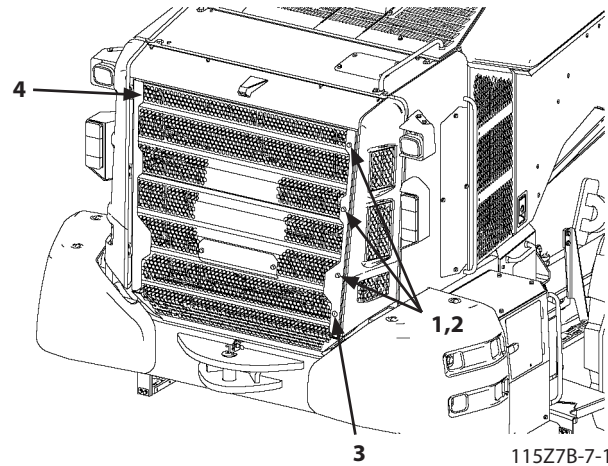

115Z7B-7-10-1

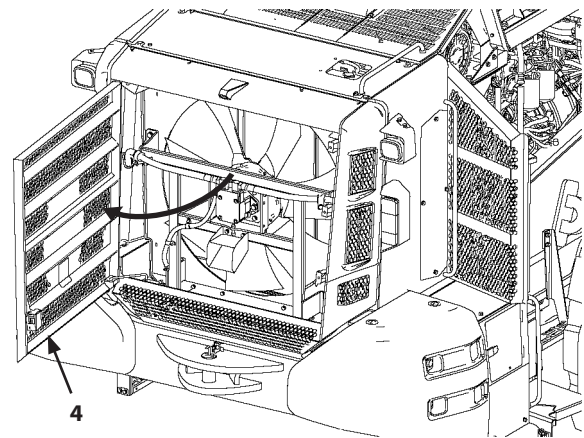

115Z7B-7-10-2

# OPERATOR'S STATION

## Steps

**⚠ WARNING:** When getting on and off the machine, use steps and handrails to support your body with at least three points of contact. Getting on and off the machine with less than three support points may cause you to slip, possibly resulting in a falling accident.

Although the steps are provided on both sides of the machine, only use the steps on the left side for cab entry. The control levers are located on the right side, obstructing easy access.

Right side steps are for emergency exit only.

Inspect the steps and handrails daily. Immediately repair or replace any that are missing, loosen or damaged. Clean the steps of any mud, snow or ice before entering or exiting the cab.

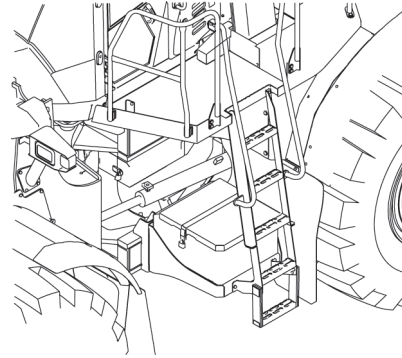

115Z7-1-144-1

## Tool Box

There is a grease gun holder (1) in the battery box. Use pocket (2) in the urea tank box to store tools.

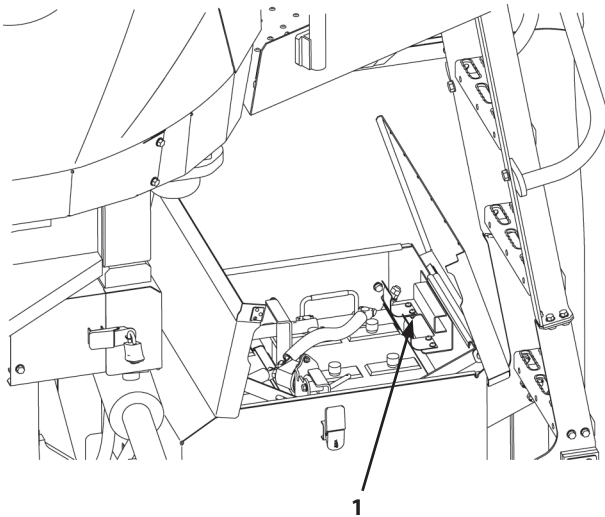

115Z7-1-144-2

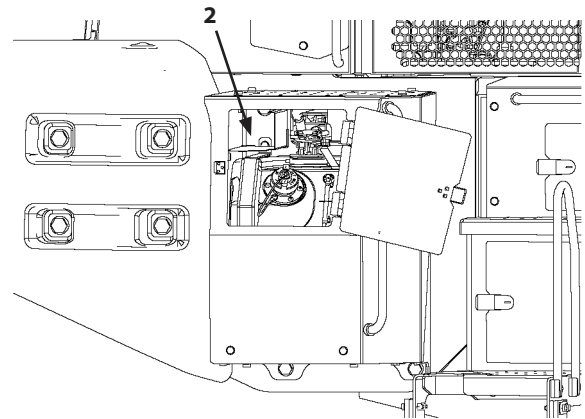

115Z7B-1-144-3

## OPERATOR'S STATION

### Vandal-Resistant Devices

Locks can be installed to transmission oil inlet cap cover (1), battery box cover (2), and relay and fuse box cover (3).

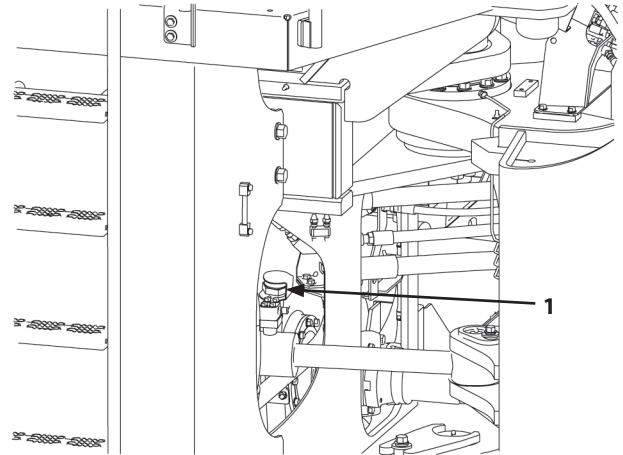

115Z7-Vandal-1

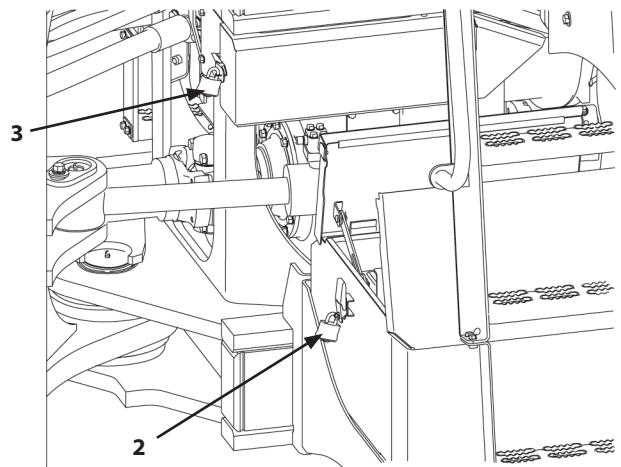

115Z7-Vandal-4

## OPERATOR'S STATION

### Vandal-Resistant Devices (continue from previous page)

Fuel tank cap (4), side covers (5), and air conditioner fresh air filter (6) can be locked with the starter key.

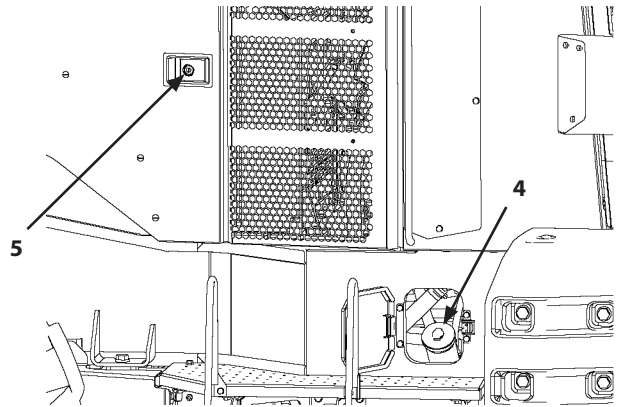

115Z7B-1-146-1

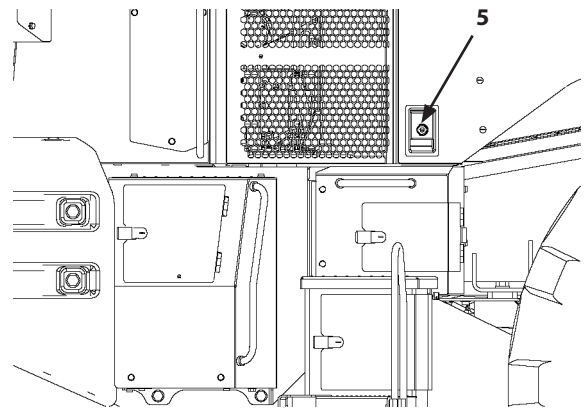

115Z7B-1-146-2

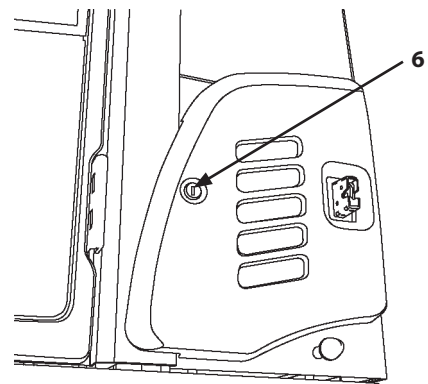

MNEC-01-055





## BREAK-IN

---

### Break-in Period for New Machine

Machine life and performance will be greatly affected by the treatment during operation and maintenance of the machine, but especially so during the initial operation.

**IMPORTANT: Always correctly warm the machine up to operating temperatures before running the machine ! This is always a requirement for good machine life.**

**IMPORTANT: The machine must be operated appropriately as the new parts start to wear during the “break-in” period.**

**If the new machine is abused, especially during the beginning break-in period, it will significantly reduce the operative life of the machine.**

**This abuse can be in many forms, including, but not limited to, the following.**

- Overloading in any from:
  - Bucket
  - Ballast
  - At drawbar
  - Others
- Hitting unmovable objects
- Using brakes during operation and burning friction material
- Running hydraulic system pressure over relief setting pressures too often and heating the oil excessively
- Tractively twisting the boom arms or chassis
- Running through impassible terrain
- Not decelerating while changing machine direction
- Scaling out heavy materials like heavy rock while in forward motion, causing the bucket to catch and break free, and catch materials again
- Other types of poor treatment

The machine must never be abused, and must be treated carefully while during the break-in period.

- Operate and maintain the machine well
- Generously lubricate it, especially during the first 100 hours

### Work Mode for Break-in

For the first 100 hours of operation, avoid using the power mode and perform the following:

- Thoroughly walk around and inspect the machine for damage
- Warm up the machine after engine start up
- Avoid sudden starts and stops
- Moderately load the machine and operate modestly at below 2/3 capacity

 **NOTE:** Refer to page 1-103 for the power mode.



## OPERATING THE ENGINE

### Inspect Machine Daily Before Starting

Perform the required daily check before starting the engine.

- Refer to "Maintenance" section for detailed information.

Check Points	Check Contents
1. Brake System	1. The brake pedal stroke is appropriate, brake performance is sufficient, and the brakes apply evenly.
	2. The parking brake performance is good and holds on grades.
2. Tires	1. Tire pressure is appropriate.
	2. No cracks and damage observed.
	3. No excessive wear observed.
	4. No metal pieces, stones or other foreign material found.
3. Wheel Disk	Mounting condition of the wheel disk is correct.
4. Lights and Turn Signals	They light up or flash normally, with clear view and no lens damage.
5. Outside Rear View Mirror and Inside Rear View Mirror	Appropriate visibility.
6. Reflectors and Registration Plate	Clearly visible and no damage found.
7. Previously reported damage.	Repaired.
8. Engine	1. Oil level
	2. Oil condition - no antifreeze or contaminants present
	3. Coolant level
	4. All drive belts
	5. Starts easily
	6. Exhaust does not smoke excessively
	7. No excess noise from exhaust
	8. No fluid leaks; no oil or antifreeze under engine
	9. No hose or line damage
	10. All coolers clean and clear, not clogged
	11. No missing or loose bolts in engine area
	12. Check fuel pre-filter bowl (drain if needed)

## OPERATING THE ENGINE

Check Points	Check Contents
9. Chassis	<ol style="list-style-type: none"> <li>1. Oil leaks of the transmission and the axle</li> <li>2. Level, leaks and contamination of the fuel tank. Drain water from fuel tank.</li> <li>3. Level and leaks of the hydraulic oil tank</li> <li>4. Operation, play and operating force of control levers and steering wheel</li> <li>5. Operation of hydraulic equipment. Oil leaks and damage to piping and hoses.</li> <li>6. Deformation, damage, and abnormal noise of chassis parts</li> <li>7. Washer fluid level</li> <li>8. Level, leaks and contamination of the DEF tank</li> <li>9. DEF leaks of pipe lines and hoses</li> <li>10. Clean around the aftertreatment device.</li> </ol>
10. Loader	<ol style="list-style-type: none"> <li>1. Oil leaks and damage to cylinders, pipe lines and hoses</li> <li>2. Loose, worn and missing cutting edges</li> <li>3. Wear and damage to the bucket</li> <li>4. Lubrication of the loader parts</li> <li>5. Damage to the pin lock bolts, stoppers and links</li> <li>6. Loose and missing mounting bolts/nuts</li> </ol>
11. Others	<ol style="list-style-type: none"> <li>1. Operation of instruments, switches, lights and buzzer/horn</li> <li>2. Damage and deformation to the ROPS and cab</li> <li>3. Abnormal outside appearance of machine</li> <li>4. Looseness of the battery terminals</li> <li>5. Wear, damage, and expiration date of the seat belt</li> <li>6. Damaged to the steps and handrails</li> </ol>

# OPERATING THE ENGINE

## Check Before Starting

1. If your machine is equipped with the battery disconnect switch, check that the switch is in the ON position.

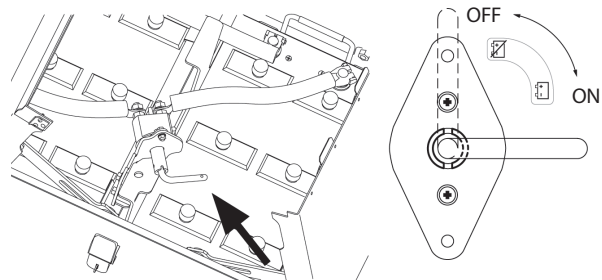

115Z7-3-3-1

2. Lower armrest (1) fully to the operating position until it is locked. Hold support bar (2) when moving armrest.
3. The joystick steering system is automatically turned on, and indicator lamp (3) on the monitor display turns on.
4. Check that forward/reverse switch (4) is in the neutral (N) position.

 **NOTE:** Unless forward/reverse switch (4) is in neutral (N), the engine will not start.

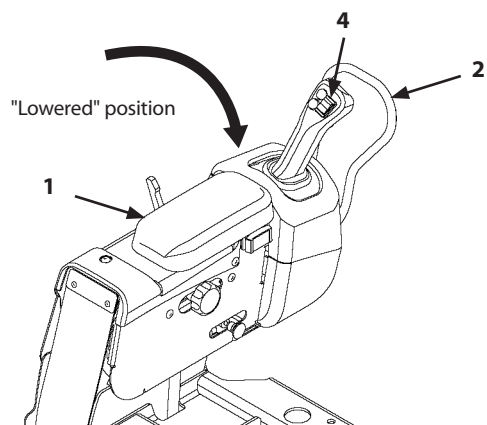

115Z7B-1-10-3

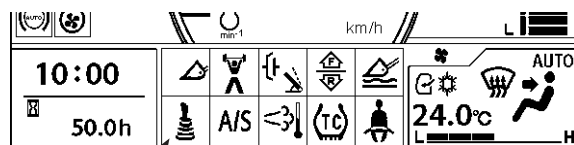

3

95Z7B-3-7-1

## OPERATING THE ENGINE

5. Check that parking brake switch (5) is in the ON position.

After the engine starts and checking indicator bulbs and display (refer to page 3-6), check that parking brake indicator is ON.

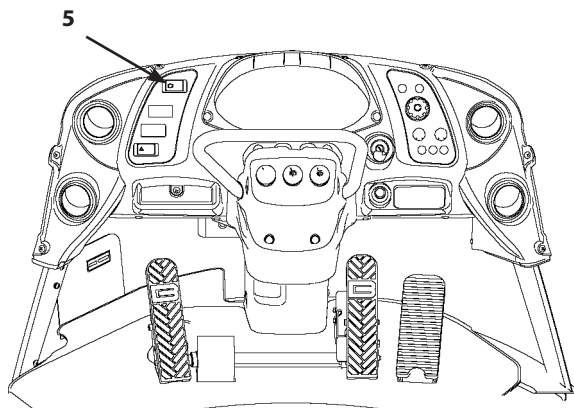

115Z7B-1-81-1

6. Check that bucket control lever (6) and lift arm control lever (7) are in the neutral (N) position.
7. Check that control lever lock switch (8) is in the locked position.

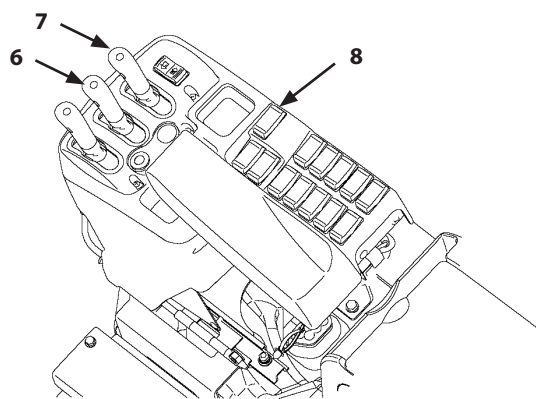

Fingertip Control Type

115Z7B-1-9-4

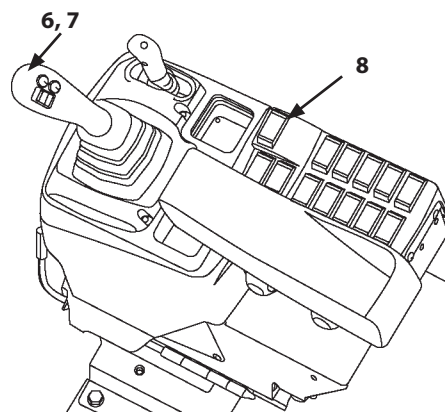

Multi-Function Joystick Type

MNEC-01-043

## OPERATING THE ENGINE

---

6. Adjust the position of outside rear view mirror (9) and inside rear view mirror (10) so that the best rear visibility can be obtained.

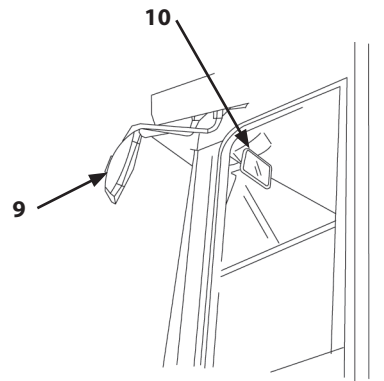

115Z7-01-126

7. While seated on the operator's seat with your back in contact with the backrest, adjust each function of the seat so that the brake pedal can be fully applied.
8. Fasten seat belt (11) along your body without kinking or twisting it. Be sure the buckle firmly snaps when coupled and works as it should, and the retractor and anti-synch mechanism work as designed.
9. Inspect seat belt.

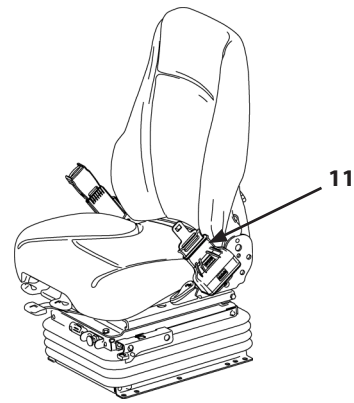

115Z7-3-4-3

# OPERATING THE ENGINE

## Starting Engine

Follow the following steps to start the engine.

1. Check that parking brake switch (1) is ON, with parking brake set. Make sure the armrest is fully lowered and locked in position.
2. Turn key switch (2) ON.
3. Check that joystick steering indicator (3) is turned ON.

 **NOTE:** The armrest may not be positioned correctly if joystick steering indicator (3) is not ON.

4. Check indicator bulbs and display.

When key switch (2) is turned ON, all indicators and the warning lights come and stay ON for 2 seconds. Then, they go OFF afterward. Any indicator and/or warning light that fails to light at this time is a burned bulb.

However, the indicators for brake oil pressure (4) (When the brake pressure is low) and discharge warning indicator (5) will continue to stay ON, and it will go OFF only after the engine is started and circuits are filled.

Preheating will automatically start with the key switch ON. The preheat indicator (6) will automatically come ON when needed.

 **NOTE:** When the key switch is turned ON, the maintenance notification for the item whose maintenance interval has expired displays for 10 seconds. The display will disappear when the Return switch (⤴) is pressed, forward/reverse switch is set in Forward (F) or Reverse (R) position.

5. Check that parking brake indicator (7) is ON. When the preheat lamp goes OFF (the engine has preheated), sound the horn to clear any personnel away from the area surrounding the machine.

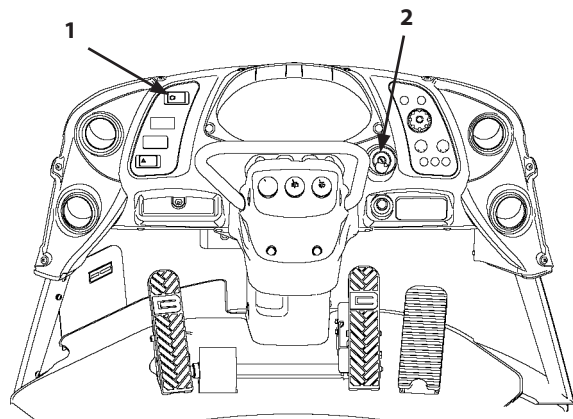

115Z7B-1-81-1

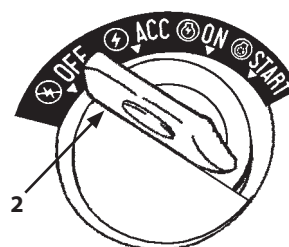

M4GB-01-089

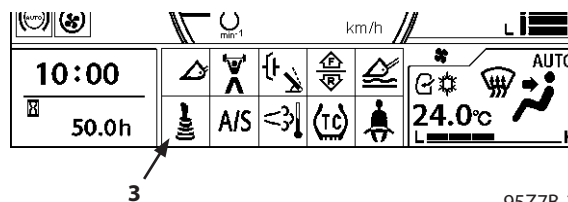

95Z7B-3-7-1

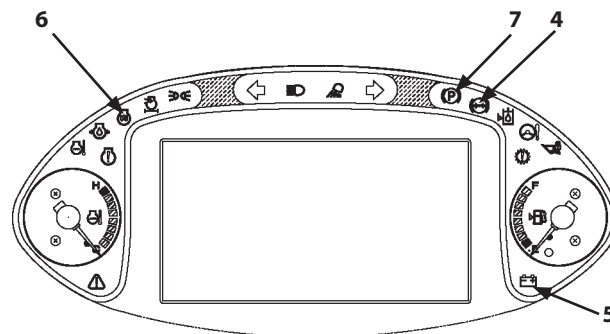

MNEC-01-073



## OPERATING THE ENGINE

- Turn joystick steering system switch (8) ON. The F/R selector switch indicator (9) turns ON.

**NOTE:** Turn ON joystick steering system switch (8) after turning key switch to ON position. Otherwise, the machine cannot move forward/reverse.

**IMPORTANT:** Never operate the starter for more than 15 seconds at a time. If the engine fails to start, return key switch to OFF. Wait for more than 60 seconds, then try again.

Failure to do so may damage the starter or discharge the batteries.

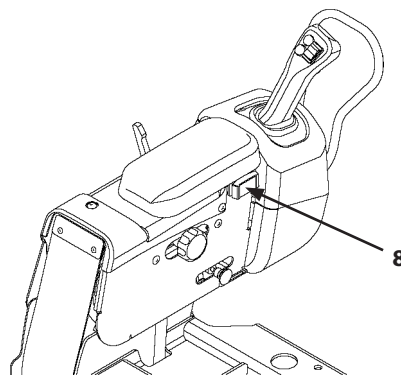

115Z7B-1-10-3

- Turn key switch (2) to START position to rotate the starter. The engine will start. Do not step on accelerator pedal (10).
- As soon as the engine starts, release the key switch.

The key switch will automatically return to the ON position. Run the engine at low idle without applying accelerator pedal (10).

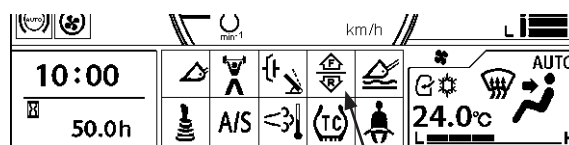

9

95Z7B-3-7-1

**IMPORTANT:** At starting the engine, the engine RPM ( $\text{min}^{-1}$ ) is kept at low idle for maximum 35 seconds when the coolant or hydraulic oil temperature is low, or for 3 seconds if these temperatures are in the acceptable operation range. After this period, the engine RPM will increase by applying the accelerator pedal (3).

**WARNING:** Do not operate the machine while the engine RPM is being kept at low idle, otherwise, the machine or the front attachment could unexpectedly move that may result in serious injury.

- Perform checks to be done after starting the engine and warm up by referring to page 3-9.

**IMPORTANT:** If the armrest is raised after starting the engine, above steps 1 through 6 must be repeated to move the machine forward/reverse using the joystick steering lever.

**NOTE:**

- If the machine is equipped with the secondary steering, the secondary steering auto-check sound may be heard after starting the engine.
- White smoke may occur for several minutes after the engine starts, this is not a malfunction.

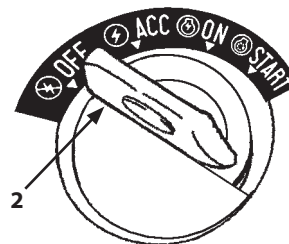

M4GB-01-089

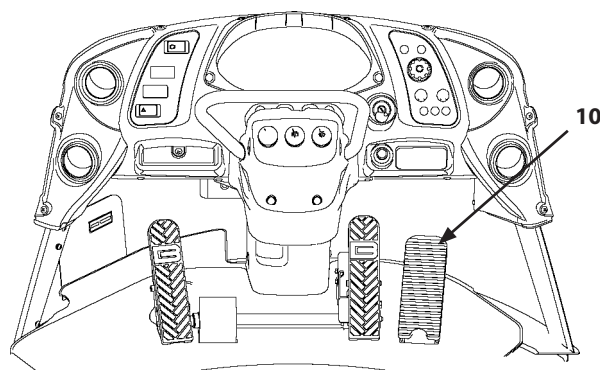

115Z7B-1-81-1

# OPERATING THE ENGINE

## Starting in Cold Weather

### Preheating

1. Turn the key switch (1) ON. The coolant temperature sensor is activated so that the engine is automatically preheated.
2. Preheat indicator (2) should turn ON. As long as the preheat indicator stays ON, the engine is being heated.

#### NOTE:

- Preheating time varies depending on the coolant temperature.
- Headlights, working lights or room light may become dim during engine preheating in the cold environment.

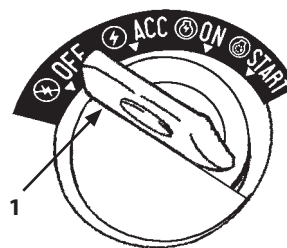

M4GB-01-089

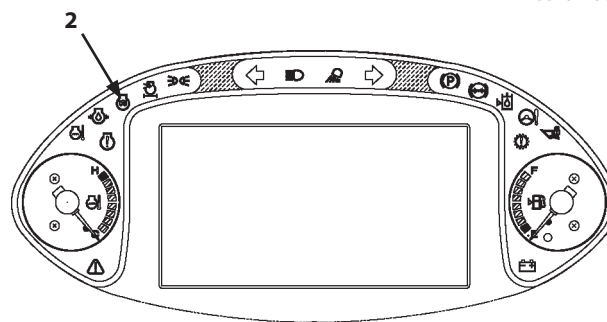

MNEC-01-073

3. Turn joystick steering system switch (3) ON. The F/R selector switch indicator (4) turns ON.

#### NOTE:

Turn ON joystick steering system switch (3) after turning key switch to ON position. Otherwise, the machine cannot move forward/reverse.

4. As soon as preheat indicator (2) turns OFF, turn key switch (1) to START position to rotate the starter. As soon as the engine starts, release the key switch. The key switch will automatically return to the ON position. Run the engine at low idle without applying accelerator pedal (5).

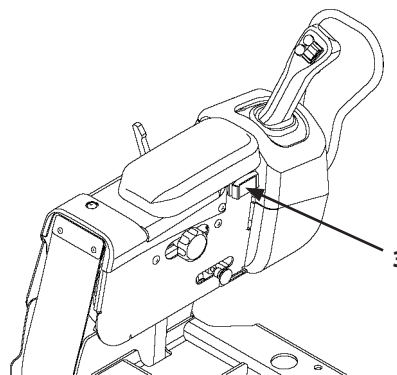

115Z7B-1-10-3

**IMPORTANT:** At starting the engine, the engine RPM ( $\text{min}^{-1}$ ) is kept at low idle for maximum 35 seconds to warm up the coolant, hydraulic oil, etc. After this period, the engine RPM will increase by applying the accelerator pedal (5).

**WARNING:** Do not operate the machine while the engine RPM is being kept at low idle, otherwise, the machine or the front attachment could unexpectedly move that may result in serious injury.

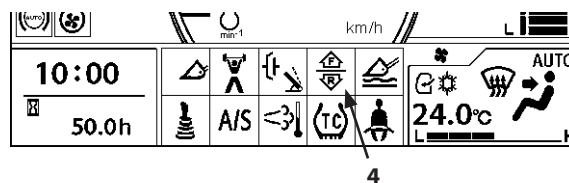

95Z7B-3-7-1

5. Perform checks to be done after starting the engine by referring to the following section.

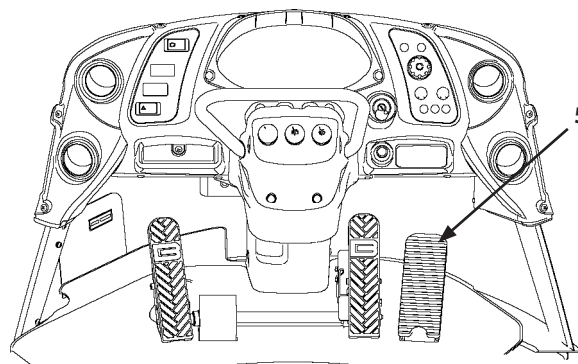

115Z7B-1-81-1

# OPERATING THE ENGINE

## Check After Starting

**IMPORTANT:** If any abnormality is found in the monitor functions, immediately stop the engine and investigate the cause of the trouble.

### Check Monitor Operation

1. Check that service indicator (1) is OFF.
2. Check that discharge warning indicator (2) is OFF.

In case the discharge warning indicator stays ON, immediately stop the engine. Inspect the alternator and battery system for problems.

3. Check that low engine oil pressure indicator (3) is OFF.

In case the low engine oil pressure indicator stays ON, immediately stop the engine. Inspect the engine oil pressure system and the oil level.

4. Check that engine coolant temperature gauge (4) is within the blue range.

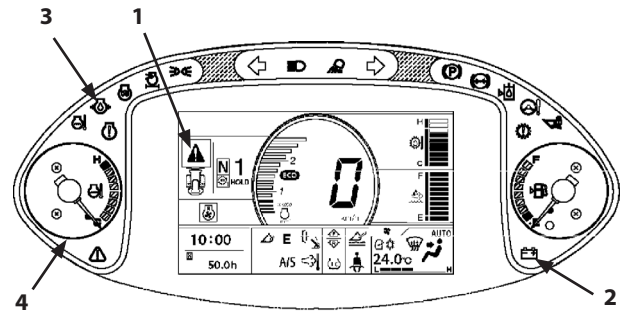

95Z7B-3-9-1

 **NOTE:** To check indicator bulbs and the buzzer function, when the key switch is turned ON, monitor indicators come ON and continue to stay ON for approx. 2 seconds.

### Check Engine Noise and Exhaust Gas Color

Check that the engine noise and exhaust gas color is normal.

 **NOTE:** Check the exhaust gas color as follows. (After warm-up operation, run the engine with no loads.)

Clear or light blue	:	Normal (Perfect combustion)
Black	:	Abnormal (Imperfect combustion, abnormal exhaust filter, abnormal fuel system)
White	:	Abnormal (Oil is leaking into the combustion chamber, abnormal exhaust filter, abnormal fuel system)

 **NOTE:** White smoke may occur for several minutes after the engine starts, this is not a malfunction.

## OPERATING THE ENGINE

---

### Using Booster Batteries

**IMPORTANT:** The machine electrical system is a 24 volt negative (-) ground. Use only 24 volt booster batteries with sufficient capacity.

**WARNING:**

- An explosive gas is produced while batteries are in use or being charged. Keep open flames and sparks away from the battery area. Do not continue to use or charge the battery when electrolyte level is lower than specified. Explosion of the battery may result.
- Park the machine and a machine with the booster batteries on a dry or concrete surface, not on steel plates. If the machine is parked on steel plates, the machine is equivalent to a continuously grounded machine so that dangerous unexpected current flow may result.
- Never connect a positive terminal to a negative terminal, as a dangerous short circuit will occur.

If the machine batteries are completely discharged so that when starting the engine using booster batteries is necessary, do the following procedure.



SA-032

## OPERATING THE ENGINE

### 1. Connecting the booster batteries

- 1.1 Stop the engine on the booster battery mounted machine.
- 1.2 Connect one end of red booster cable (1) to the positive (+) terminal of the machine battery, and the other end to the positive (+) terminal of the booster battery.
- 1.3 Connect one end of black booster cable (2) to the negative (-) terminal of the booster batteries, and then connect the other end of the cable to the bolt of black cable (3) on machine frame side that connects the negative (-) terminal of the machine battery and machine frame. In the last connection to the bracket, sparks may fly so keep the machine batteries as far away as possible from the bracket.
- 1.4 After securely connecting the booster cables, start the engine on the booster battery mounted machine.
- 1.5 Start the engine on the machine.
- 1.6 After the engine starts, leave the booster batteries connected long enough so as not to overload alternator, then disconnect booster cables (1 and 2) in the following steps.

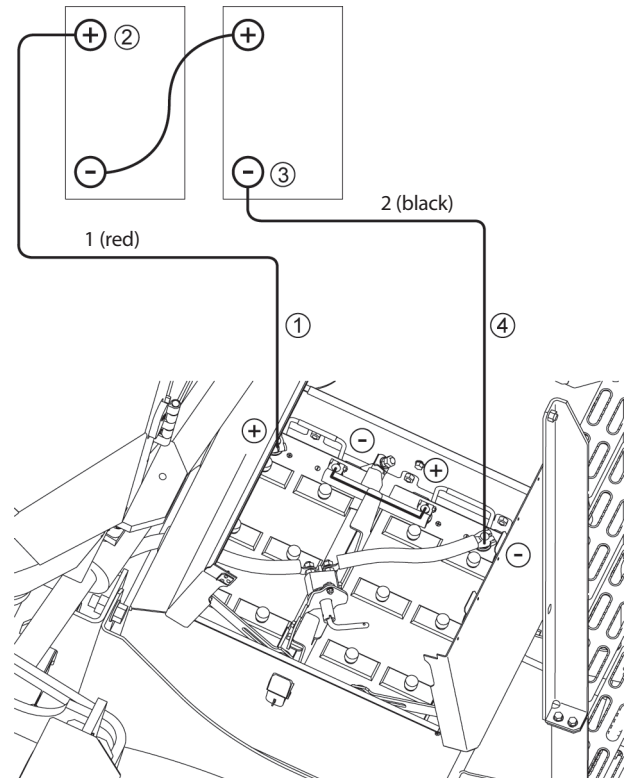

11527-3-10

### 2. Disconnecting the booster cables

- 2.1 Disconnect black negative (-) cable (2) from the machine frame first.
- 2.2 Disconnect the other end of black booster cable (2) from the negative terminal of the booster batteries.
- 2.3 Disconnect one end of red booster cable (1) from the positive terminal of the booster battery.
- 2.4 Disconnect the other end of red booster cable (1) from the positive terminal of the machine battery.

## OPERATING THE ENGINE

### Warm Up

**IMPORTANT:** At starting the engine, the engine RPM ( $\text{min}^{-1}$ ) is kept at low idle for maximum 35 seconds to warm up the coolant or hydraulic oil.

After this period, the engine RPM will increase by applying the accelerator pedal (3).

**WARNING:** Do not operate the machine while the engine RPM is being kept at low idle, otherwise, the machine or the front attachment could unexpectedly move that may result in serious injury.

**CAUTION:** Operating the machine without warm up causes damage to the engine and hydraulic components. Be sure to perform warm up not only to protect the hydraulic components from being damaged but also to ensure safe operation.

If the machine is operated with the hydraulic oil temperature below  $20^{\circ}\text{C}$  ( $68^{\circ}\text{F}$ ), damage to the hydraulic components may result. After starting the engine, perform warm up as described below before operating the machine until the hydraulic temperature is above  $20^{\circ}\text{C}$  ( $68^{\circ}\text{F}$ ).

1. While releasing accelerator pedal (3), run the engine at low idle speed for about 3~5 minutes with no load.
2. Increase the engine revolutions to  $1200 \text{ min}^{-1}$  (RPM's). Raise the bucket above the ground and hold bucket control lever (1) in the tilt position for 10 seconds. (Do not operate control levers other than the bucket control lever at this time.)

**IMPORTANT:** Excessively repeated operation of bucket control lever (1) could generate abnormal surge pressure, damaging in hydraulic parts.

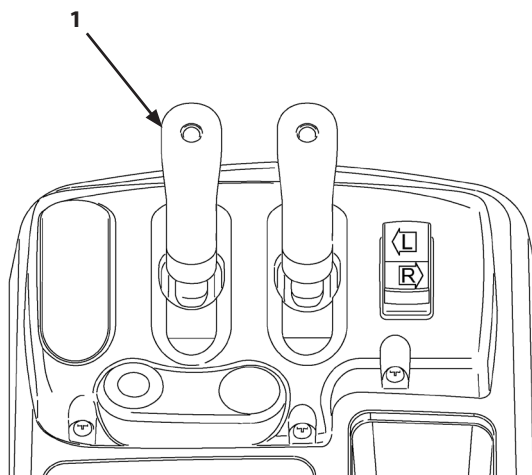

115Z7-1-92-1

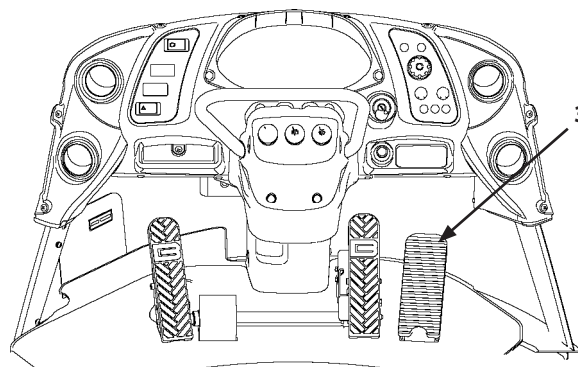

115Z7B-1-81-1

## OPERATING THE ENGINE

### Cold Weather Warm Up

**IMPORTANT:** At starting the engine, the engine RPM ( $\text{min}^{-1}$ ) is kept at low idle for maximum 35 seconds to warm up the coolant or hydraulic oil.

After this period, the engine RPM will increase by applying the accelerator pedal (3).

**IMPORTANT:** Do not idle the engine for excessively long periods of time. Long periods of idling (more than 10 minutes) can damage an engine because combustion chamber temperatures drop so low the fuel can not burn completely. This will cause carbon to form in the injector spray holes and on the piston rings and can result in stuck valves.

**WARNING:** Do not operate the machine while the engine RPM is being kept at low idle, otherwise, the machine or the front attachment could unexpectedly move that may result in serious injury.

**CAUTION:** In case the hydraulic oil temperature is low, perform cold weather warm up. Operate the machine only after loading linkage speed is normal. Operating the machine without warming up first causes damage to the engine and hydraulic components. Be sure to perform warm up, not only to protect the hydraulic components from being damaged, but also to ensure safe operation.

1. Run the engine at slow idle speed for more than 5 minutes to warm up.

If the [Warm Up Operation] in the multi-monitor setting menu is set to "ON" (enabled), the engine speed automatically increases from slow idle to  $1000 \text{ min}^{-1}$  (rpm) and enters warm-up mode when hydraulic oil temperature is  $0^{\circ}\text{C}$  ( $32^{\circ}\text{F}$ ) or lower.

Further, when either hydraulic oil temperature reaches  $30^{\circ}\text{C}$  ( $86^{\circ}\text{F}$ ) or higher, or engine coolant temperature reaches  $40^{\circ}\text{C}$  ( $104^{\circ}\text{F}$ ) or higher, the warm-up mode is automatically canceled, and the engine runs in slow idle mode.

(Do not operate the machine until the needle of coolant temperature gauge (1) starts moving.)

**NOTE:**

- At this time, do not operate the engine in slow or fast speed. Use medium engine speeds for safe and quick warm up.
- Refer to page 1-67 for Warm Up Operation setting menu.
- When auto idling-stop setting is ON, the engine may stop during warm up. To avoid this situation, deactivate the auto idling-stop or set the auto idling-stop activating time longer. Refer to page 1-53 for Auto Idling Stop setting menu.

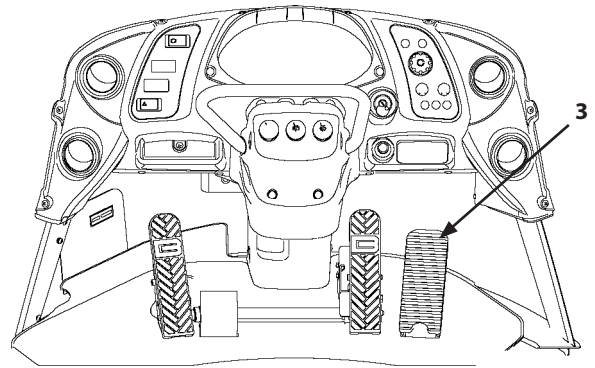

115Z7B-1-81-1

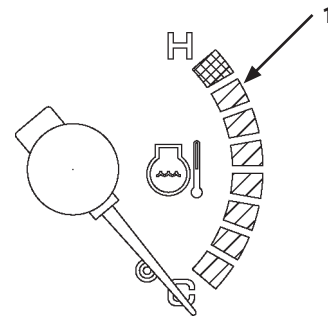

MNEC-03-002

## OPERATING THE ENGINE

---

2. Fully extend the bucket cylinder.

 *NOTE: Do not continuously operate the bucket control lever for more than 10 seconds at a time. Do not bang linkage when cold.*

3. Slowly and fully retract the bucket cylinder.

 *NOTE: Do not continuously operate the bucket control lever for more than 10 seconds at a time. Do not bang linkage when cold.*

4. Repeat steps 1 to 3 above until the loading linkage speed is normal. When the air temperature is lower than 0°C (32°F), extend the warm up time by running the engine at about 1200~1500 min<sup>-1</sup> (RPM's).

 *NOTE: Headlights, working lights or room light may become dim during engine preheating in the cold environment.*



# OPERATING THE ENGINE

## Stopping Engine

Stop the engine in the following manner.

**IMPORTANT:** Never stop the engine while moving the machine.

If the engine stops, the steering system may become inoperable, or it may cause other malfunctions or seizure of parking brake.

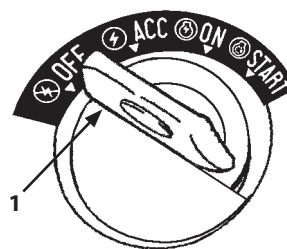

1. Lower and level the bucket before stopping the engine.

M4GB-01-089

**IMPORTANT:** If an engine equipped with a turbocharger is stopped without first cooling down at low rpm's, the lubricant on the turbocharger bearing and seal surfaces may be dissipated due to the intense heat inside the turbocharger, possibly damaging the turbocharger.

2. Run the engine at low idle speed for 5 minutes to cool the engine.
3. Turn the key switch (1) to OFF position to stop the engine.
4. Press LOCK (Ⓛ) side of control lever lock switch (2).
5. Make sure that the light switch is turned OFF.

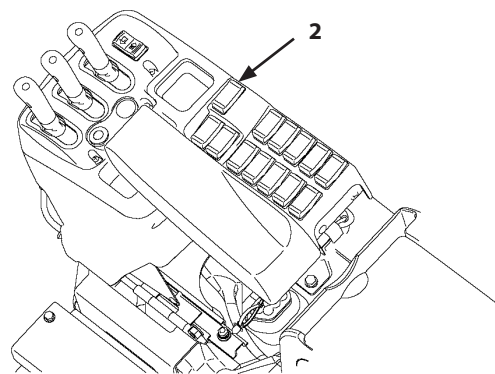

Fingertip Control Type

115Z7B-1-9-4

 **NOTE:** Do not idle for excessively long periods. Observe local and federal engine idling regulations.

When stopping the machine, refer to page 4-16 for further procedures.

When parking the machine, refer to page 4-18 for further procedures.

**IMPORTANT:** After stopping the engine, the DEF pump keeps operating to return the DEF in piping to the DEF tank. Do not turn the battery disconnect switch OFF while pump running (for approx. 5 minutes). Failure to do so may damage the SCR system.

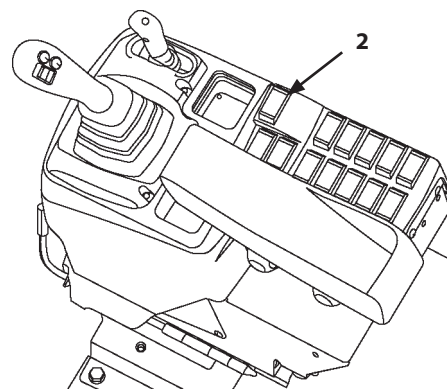

Multi-Function Joystick Type

MNEC-01-043



## MOVING THE MACHINE

### Driving the Machine

Correct operation will result in extending the service life of each part and component as well as saving fuel and oil. Always be sure to safely and efficiently operate the machine while paying attention to the following points.

**IMPORTANT: The engine must be started and ready for driving correctly by referring to the previous section "OPERATING THE ENGINE".**

#### Precautions for Starting to Move

1. Perform a thorough walk-around inspection. Conduct correct start-up procedure.
2. After raising the lift arm, set the lift arms and bucket in the operating position.
3. Before driving on public roads, set the machine to the driving position as illustrated to the right.
4. Be sure to press lock (1) side of control lever lock switch so that the linkage will not move even if the control levers are accidentally moved.

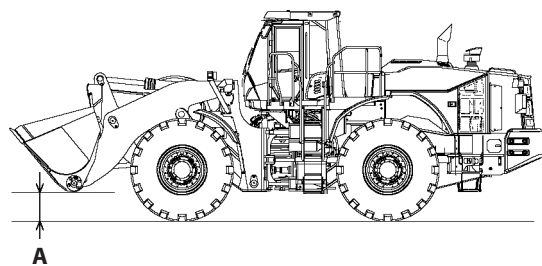

Position  
A: 545 mm (21.5 in)

115Z7B-4-1-1

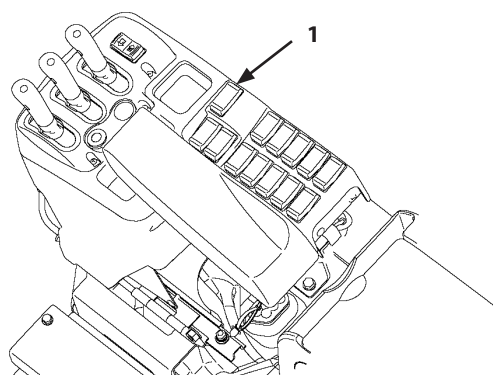

Fingertip Control Type

115Z7B-1-9-4

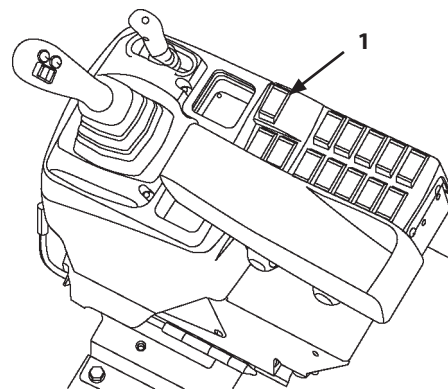

Multi-Function Joystick Type

MNEC-01-043

# MOVING THE MACHINE

## Starting to Move

**WARNING:** Start to move the machine only after checking that no personnel and/or obstacles are present around the machine.

Never turn ride control switch (4) (option) to ON position when traveling the machine or raising the bucket. Before turning the ride control switch (4) ON, stop the machine and confirm that no one is around the bucket. Avoid turning ride control switch (4) to ON position while moving the machine. Failure to do so may automatically move the lift arm up or down.

Refer to page 1-109 for detailed information of ride control switch (4).

1. Check that none of the warning indicators except parking brake indicator (1) on the monitor panel are ON when engine is running.
2. Set the front attachment in the operating position by operating control levers (2) (3).

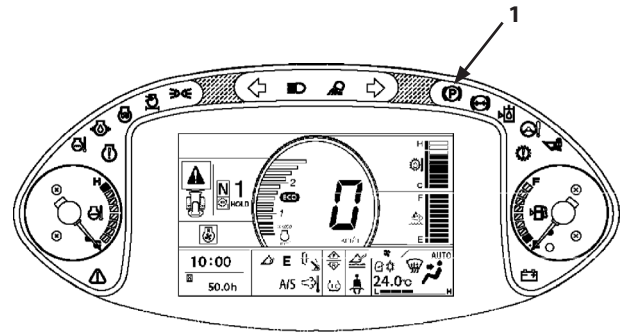

95Z7B-3-9-1

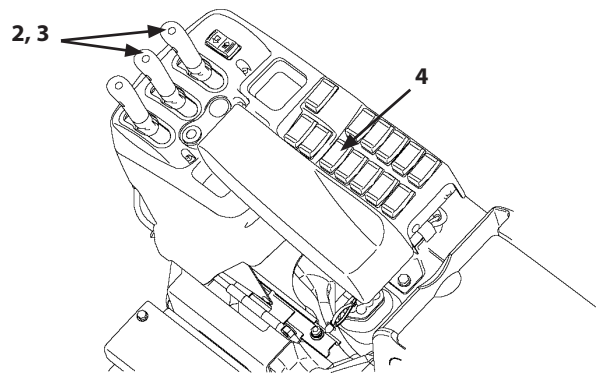

Fingertip Control Type

115Z7B-1-9-4

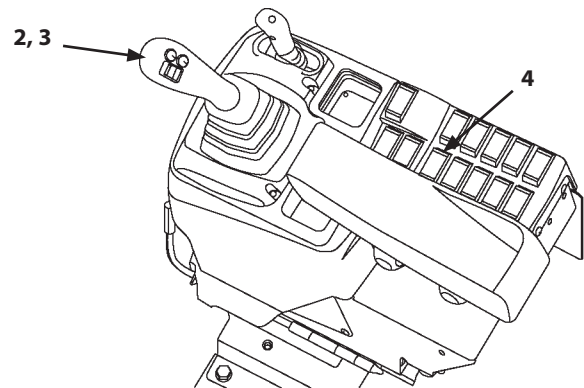

Multi-Function Joystick Type

MNEC-01-043

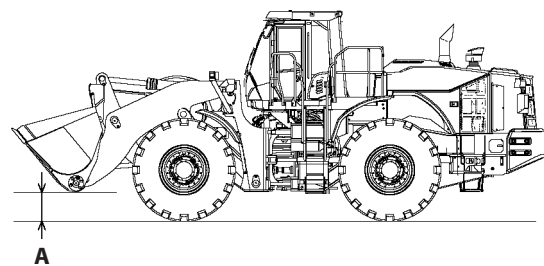

Position  
A: 545 mm (21.5 in)

115Z7B-4-1-1

## MOVING THE MACHINE

- Step on brake pedal (6) or (7) and press parking brake switch (8) to the OFF position to release the parking brake.

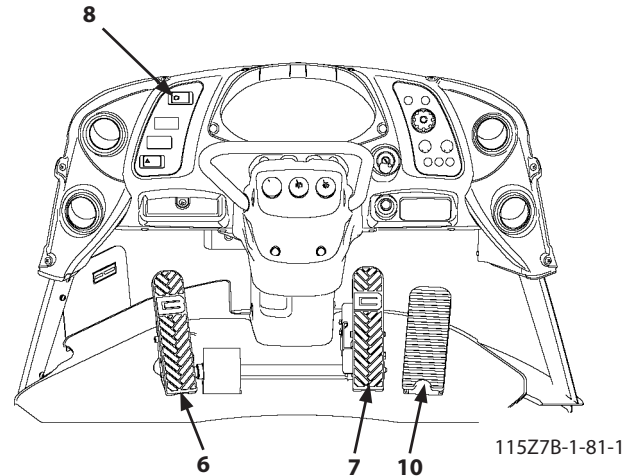

Check that at this time parking brake indicator (1) goes OFF.

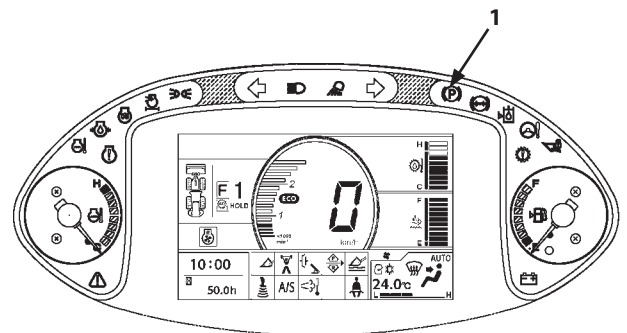

**NOTE:** When starting to ascend a slope, turn declutch switch (9) (OFF (clutch engaged)), and depress the brake pedal (6). Gradually release the brake pedal while depressing the accelerator pedal to easily start ascending a slope.

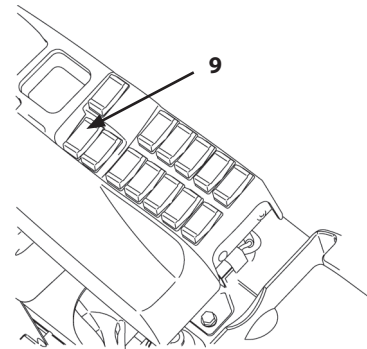

## MOVING THE MACHINE

### 4. Manual Shift (M)

After setting forward/reverse switch (11) to either forward (F) or reverse (R) position, press the shift switch (12) to the desired position. The transmission gear position can be shifted in 4 ranges in the forward and 3 ranges in the reverse mode. Select the most appropriate transmission range position according to the operating conditions.

#### Manual Mode:

Manual shift mode.

The transmission gear is shifted by pressing shift up/down switches (12).

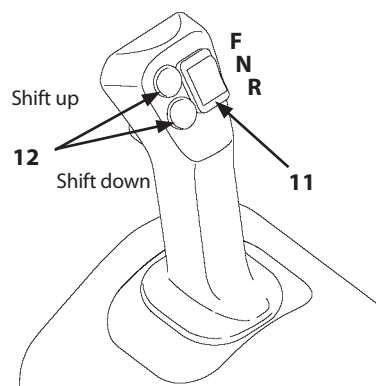

115Z7B-4-4-1

### 5. Auto Shift

Set forward/reverse switch (11) to (F) or (R). Select the most appropriate transmission range position according to the operating conditions. Select the most appropriate travel pattern by operating travel mode selector (13).

#### AUTO 1 Mode:

This mode sets 1st range as the minimum speed gear stage.

Start traveling with 2nd range. When driving load increases, it automatically shifts to 1st range.

This mode is suited for heavy digging work or ascending on a slope.

#### AUTO 2 Mode:

This mode sets 2nd range as the minimum speed gear stage.

This mode is suited for removing snow or lighter applications.

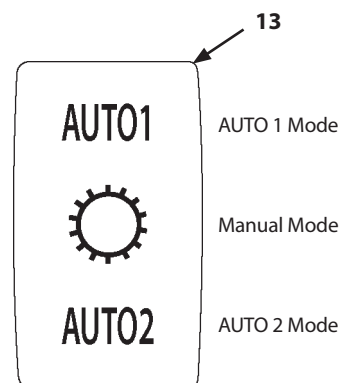

MNEC-01-024

#### NOTE:

- Avoid operating this switch while machine is moving.
- Do not use this switch on a slope. Use of the Quick Power Switch is recommended to have more acceleration while ascending on a slope.  
(Refer to page 1-111 for Quick Power Switch.)

### 7. Release brake pedals (7) and step on accelerator pedal (10) to start traveling.



## MOVING THE MACHINE

### Power Mode Selector

Pressing power mode selector switch (14) alternately activates (ON) and deactivates (OFF) the power mode. When the power mode is activated (ON), the indicator "A" appears on the monitor display.

The power mode is suited for heavy digging work prioritizing work effectiveness. Under auto shifting mode, the gear is shifted in regular RPM's (min<sup>-1</sup>) and shift mapping.

 **NOTE:** When the power mode is OFF, the machine operates prioritizing fuel consumption. Under auto shifting mode, the gear is shifted in early timing.

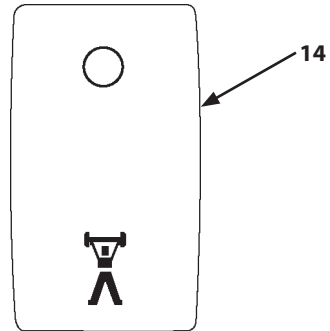

MNEC-01-016

### Shift Change Delay Mode

When travel mode selector (13) is set in AUTO 1 or AUTO 2, the shift up timing in 2nd range → 3rd range is delayed. Loading work can be easily done in 2nd range position.

#### Shift Up Delay

**Forward movement :** The gear shifts up when moving the machine at high speed in 2nd range for 8 seconds or longer. The gear will not shift while the lift arm is raising. The forward shift up delay will operate only one time when the bucket is in the operating position. When the bucket is lower at digging position, the shift delay always operates.

**Reverse movement :** The gear shifts up when operating the machine at high speed in 2nd range for 8 seconds or longer. The shift up delay always operates.

 **NOTE:**

- This does not apply when the lockup clutch is used; shift up timing from 2nd range to 2nd lock-up, or from 2nd lock-up to 3rd range is not delayed.
- Capability to activate or not activate the shift change delay mode is selected via the transmission setting menu on the monitor. Refer to page 1-59 for details.

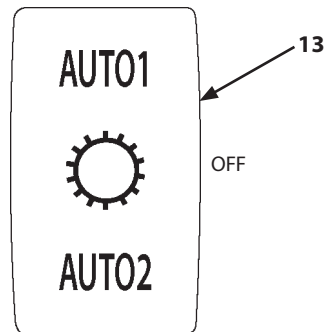

MNEC-01-024



# MOVING THE MACHINE

## Parking Brake Switch

### WARNING:

- To prevent accidents due to running away of the machine, after parking the machine or before leaving the machine, be sure to apply the parking brake.
- Never apply the parking brake switch (1) while moving the machine except in an emergency. Premature wear and/or damage to the parking brake may result. After the parking brake has been applied in an emergency while moving the machine, have the parking brake checked at your nearest authorized dealer.

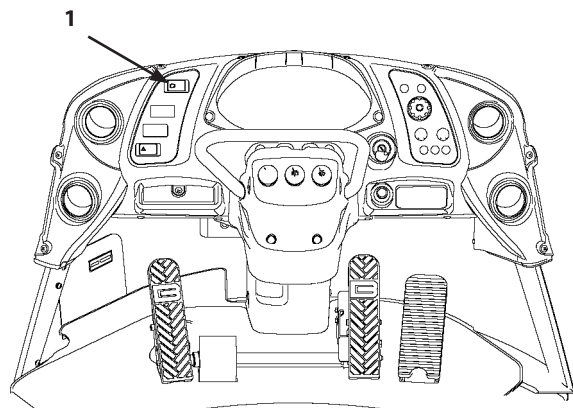

115Z7B-1-81-1

1. Press the OFF side of parking brake switch (1) to release the parking brake. Check that parking brake indicator (2) goes OFF by pressing the switch firmly twice.

Press the ON side of parking brake switch (1) to apply the parking brake.

Operate the parking brake after stopping the machine on level ground.

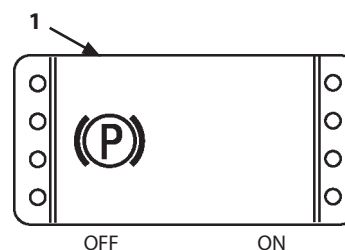

MNEC-01-058

 NOTE: While running the engine, when the parking brake is applied with forward/reverse switch (3) in neutral, parking brake indicator (2) comes ON.

2. While running the engine, when the parking brake is applied with forward/reverse switch (3) in either the forward (F) or reverse (R) position, parking brake indicator (2) comes ON, and the alarm buzzer sounds. F-N-R display (4) of the monitor display indicates "N" not "R". The display will not indicate "F" and "R" until the parking brake is released.

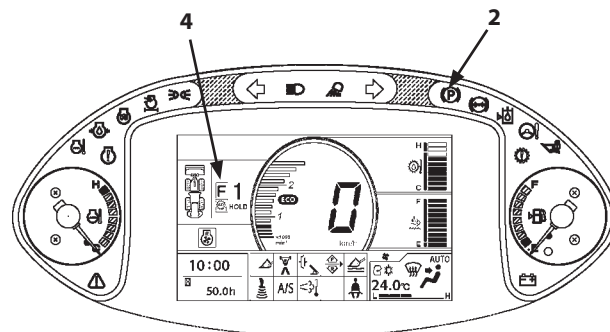

MNEK-01-500

3. To ensure safe operation, when the engine is stopped, the parking brake is applied even if parking brake switch (1) is in the OFF position.

In this case even after the engine is restarted, the parking brake will not be released. After starting the engine, push the ON position of parking brake switch (1) once. Then, push the OFF position parking brake switch (1) to release the parking brake.

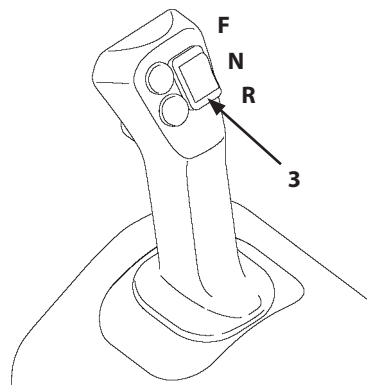

115Z7B-4-4-1

# MOVING THE MACHINE

## Drive Speed Change (Manual Shift)

The transmission gear range of 2nd, 3rd and 4th can be selected with shift switch (1).

- 1st and 2nd ranges : To be used for excavation and loading work
- 3rd and 4th ranges : To be used for traveling over long distances.

### NOTE:

- Avoid rapid gear changes using shift switch (1) while traveling at high speed. Shift the gear range only after reducing the travel speed by releasing the accelerator pedal.
- Refer to item 5 on page 4-4 for the auto-shifting mode.

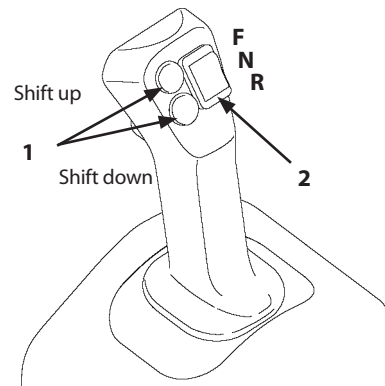

115Z7B-4-4-1

## Changing Forward/Reverse Drive Direction

### WARNING:

- Before changing the forward/reverse drive direction, confirm that the direction of drive is clear.
- To ensure operator's safety and ensure the longevity of the power train, change the machine drive direction only after sufficiently slowing down the machine.

1. Press the OFF position of parking brake switch (3).
2. Set forward/reverse switch (2) to the desired position.

- F : Forward Driving
- N : Neutral
- R : Reverse Driving

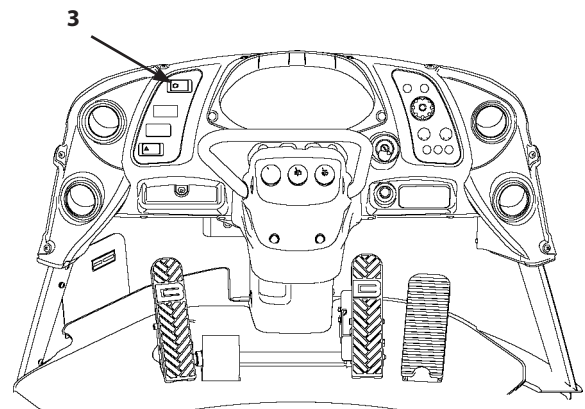

115Z7B-1-81-1

# MOVING THE MACHINE

## Steering

### ⚠ WARNING:

- Avoid sudden steering while moving the machine at high speeds, while moving on a steep slope, or while raising the lift arms. Failure to do so may cause the machine to turn over.
- Never attempt to stop the engine while steering the machine. If the engine is stopped, the steering wheel will lock and the parking brake will be applied so that steering will be impossible. Never stop the engine while moving the machine.
- Never steer while raising the lift arm high as it is extremely dangerous and may cause the machine to turn over.

**IMPORTANT:** Make sure that both joystick steering indicator (1) and F/R selector switch indicator (2) are turned on before operating joystick steering (3). Refer to page 3-6 for these indicators.

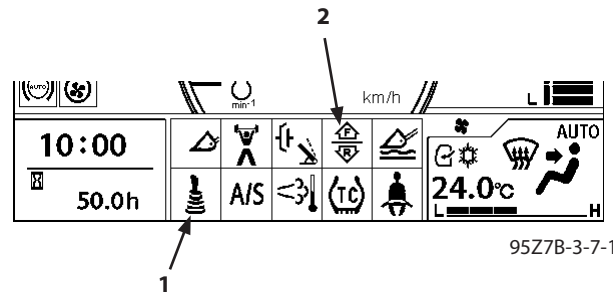

Turn joystick steering (3) toward the direction you intend to steer the machine during operation.

- When joystick steering (3) is moved from the neutral (centered) position to the right (or left), the machine steer to the right (or left).
- When joystick steering (3) is returned to the neutral position, the machine stops steering.
- The further joystick steering (3) is moved to the side, the faster the machine steers (proportional steering).

### IMPORTANT:

- Excessive force will damage the joystick steering. Do not jam, slap, or force the joystick steering beyond its normal range.
- Avoid putting excessive force down on the armrest. Never sit on the armrest.

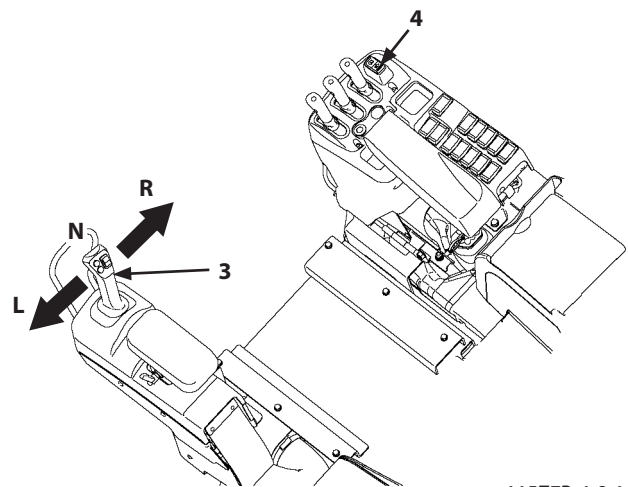

**NOTE:** This machine has an articulated frame design. The front and rear chassis are coupled by connection pins (center pins) so that the rear wheels follow the tracks of the front wheels. Turn the joystick steering slowly so as to follow the motion of the machine.

## MOVING THE MACHINE

---

### Secondary Steering (Option)

If the oil pressure in the steering system lowers, the secondary steering system is activated so that steering operation can be achieved. If the secondary steering system is activated, the secondary steering indicator lights and the buzzer sounds. Immediately park the machine in a safe location. Then, contact your nearest authorized dealer. The secondary steering can be used for 60 seconds.

**IMPORTANT: The secondary steering system is provided for an emergency use. If continuously used for more than 60 seconds, damage to the system may result.**

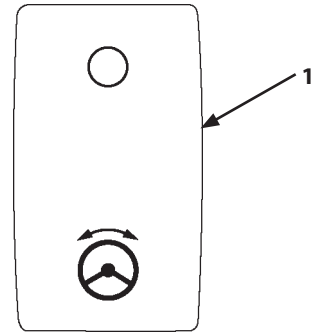

MNEC-01-020

Even though the machine is equipped with the secondary steering system, if the steering function becomes inoperable while moving machine, press secondary steering check switch (1) on the right console to activate the secondary steering system. Then, immediately park and stop the machine in a safe location.

 **NOTE:**

- The secondary steering auto-check sound may be heard for two seconds after starting the engine.
- Before operating the machine, press secondary steering check switch (1) to confirm that the secondary steering pump operates normally.

## MOVING THE MACHINE

---

### Emergency Stop and Restart of Operation

Follow the tips described below when required to stop or restart operation when an emergency has occurred.

1. Slowly release the accelerator pedal. Depress the service brake pedal to stop the machine.
2. Slowly depress the accelerator pedal while releasing service brake pedal to move the machine again.
3. In case the machine is required to park the machine for a long period of time, return the forward/reverse switch to neutral (N), turn the parking brake switch ON, and apply the parking brake to ensure safety.
4. During long load and carry applications, the lift arm position may lower due to inner hydraulic oil leaks. When required to adjust the lift arm position, temporarily stop machine, return the forward/reverse switch to neutral, apply the parking brake by turning the parking brake switch ON. Then, after repositioning the position of lift arm and bucket, begin moving the machine again. Always allow the machine to maintain correct drive position.

## MOVING THE MACHINE

---

### Precautions for Traveling

When operating, observe the previously noted operating precautions along with the others shown below to ensure safe and correct operation.

 **WARNING:**

- **In case a tire is punctured while driving, securely hold the steering wheel and slowly reduce the drive speed.**

**If the service brake is suddenly applied while a tire is punctured, steering may lose control, possibly creating an accident. Never apply the brake quickly if a tire is punctured.**

- **Never mount or dismount a moving machine. Never allow any personnel other than the operator to ride on the machine when operating.**
- Even after break-in is complete, avoid running the engine at high RPM's ( $\text{min}^{-1}$ ) under no load.
- If any abnormal condition such as an abnormal noise, vibration, or smell is noticed while operating, immediately stop the engine and inspect the machine for any trouble.
- Avoid using sudden steering or braking as much as possible because your machine and other machines may become involved in a hazardous condition.
- Road speeds of this machine are lower than most automobiles. Always give the right of way to automobiles.
- Make it a habit to periodically scan the gauges and instruments. If any abnormality is recognized, immediately stop the machine and check the machine for the cause of the trouble.
- When required to drive on the road shoulder or in tight spaces, use a signal person or signal car.
- Slowly approach a crossing while paying attention to the visibility ahead and in the opposite lane.

## MOVING THE MACHINE

---

### Operating in Water or on Soft Ground

**IMPORTANT:** If the axles, transmission, etc. should become submerged under water to the point that water enters into them, they must be reconditioned immediately, otherwise the inner gears may wear excessively, or the machine may become damaged. Contact your nearest authorized dealer for inspection and maintenance.

- Do not submerge the front and rear axles, transmission, or front and rear propeller shafts in water or mud. Avoid operating in water as much as possible.
- If operating in water or mud is unavoidable, do not allow the machine to be submerged deeper than allowable depth (A) (up to the bottom of the axle housing). Reduce the allowable depth in case the river bed is feared to be rugged or water is flowing fast.
- When operating on muddy ground, mud can easily accumulate on the chassis even if the chassis is not heavily submerged in mud. Check regularly and clean as necessary.

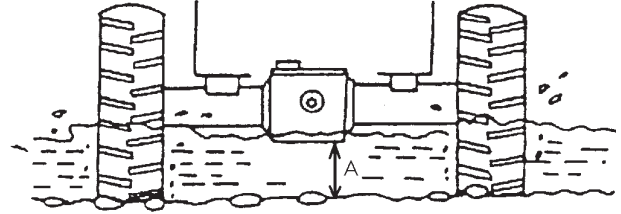

M4GB-04-003

 **NOTE:** After operation is complete, be sure to wash and lubricate all areas which were submerged.

## MOVING THE MACHINE

---

### Precautions for Driving on Slopes

 **WARNING:**

- **Never allow the machine to descend a slope with the forward/reverse switch (or lever) in neutral (N). This will not only cause the excessive engine revolutions to malfunction but also cause other engine and machine troubles.**
- **When descending a slope, use normal resistance to travel as exerted by the engine through the drive train. Apply the brakes only when absolutely required. If the brake is continuously used while descending a slope, the brake temperature will increase, possibly decreasing braking performance.**

**If overheating of the brake system is noticed, immediately park the machine in a safe location. Restart and operate the machine only after the brake system is sufficiently cooled.**

- **When descending a slope, do not operate the machine at a speed faster than the maximum travel speed. Failure to do so may damage the machine and/or a serious accident may result.**

When steering on a slope, lower the loader front to increase the machine stability. Do not steer on a steep slope since this may cause the machine to turn over.

When descending a slope, descend in a low drive range with engine resistance applied.

Do not operate the machine at a speed faster than the maximum travel speed.

In case the engine stalls on a slope, immediately step on the service brake pedal, lower the loader arms to the ground and stop the machine. The parking brake is automatically applied when the engine is stopped regardless of the position of the parking brake switch. Before restarting engine, return the forward/reverse switch to neutral (N) and turn the parking brake switch ON.

- Before descending a slope, confirm that the service and parking brake systems work normally.
- In case the hydraulic oil and lubricant temperatures are low, the machine gradability may decrease. Before climbing a steep slope, warm up the machine.



## MOVING THE MACHINE

---

### Precautions to be Taken if Machine Failure Occurs

- Keep alert. While paying attention to the vehicles following you, slowly reduce the travel speed and park the machine on the road shoulder away from flow of traffic.
- Lower the lift arms.
- Set the parking brake.
- Indicate that the machine is disabled. Unless a sign is used, collision with a following vehicle from behind may result.

Be sure to indicate that the machine is disabled by one or more of the following methods.

- Use disabled machine triangles.
- Turn the hazard lights ON.
- Use an emergency signal instrument (emergency signal light or reflective triangles).

 **WARNING: Do not spill oil on the road surface. Oil spillage may cause another vehicle to slide, possibly creating a serious accident.**

- In case of hydraulic oil leaks, immediately repair the machine. If oil gets on the road surface, take the highest priority to notify the following vehicles of this danger. Then, remove the leaked oil as soon as possible.
- In case the repairing the machine by yourself is impossible, contact your nearest authorized dealer.

## MOVING THE MACHINE

### Stop

1. Avoid sudden deceleration. Smoothly reduce operating speed.

Release accelerator pedal (1) and step on brake pedal (2) to stop the machine.

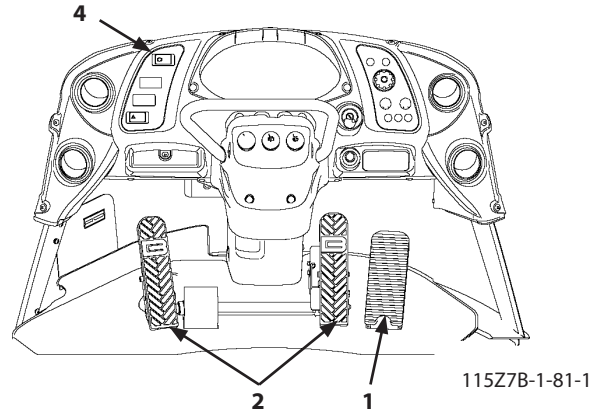

2. Set forward/reverse switch (3) to neutral (N).
3. Press the ON position of parking brake switch (4).

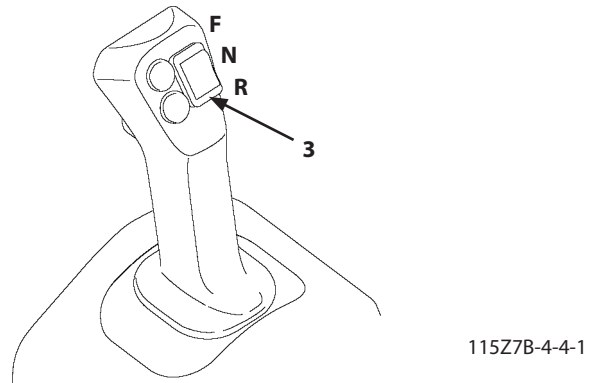

4. Level the bucket with the surface of the ground and lower the bucket to the ground by operating control levers (5, 6).
5. Press lock (Ⓐ) side of control lever lock switch (7).

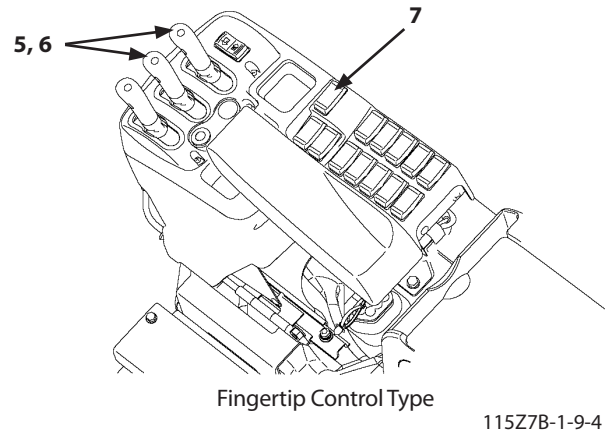

**IMPORTANT:** This machine is equipped with a turbocharged engine. Therefore if the engine is stopped without first cooling down at low RPM's, the lubricant on the turbocharger bearing and seal surfaces may be dissipated due to the intense heat present inside turbocharger, possibly damaging the turbocharger.

6. Run the engine at slow idle speed for 5 minutes to cool the engine.

 **NOTE:** Do not idle for excessively long periods. Observe local and federal engine idling regulations.

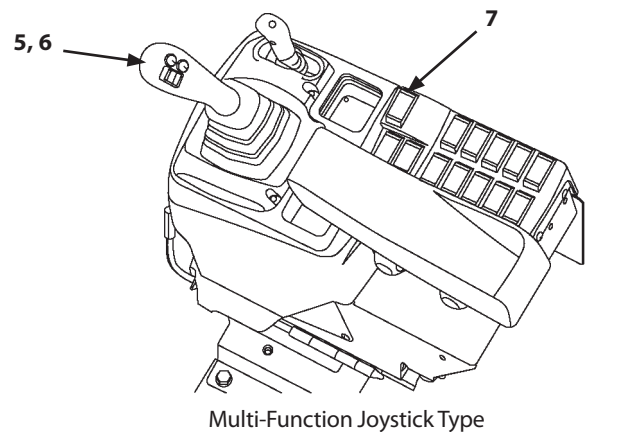

## MOVING THE MACHINE

**IMPORTANT:** Do not leave the machine with key switch (8) in ACC position. This may discharge the batteries.

Be sure to turn key switch to OFF position before leaving the machine.

7. Turn key switch (8) to OFF position to stop the engine. Remove the key from the switch.

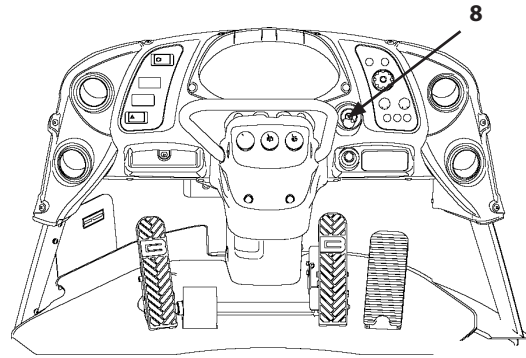

115Z7B-1-81-1

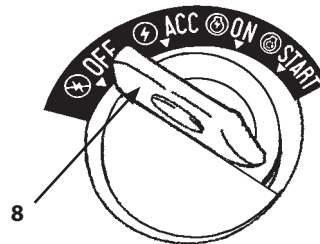

M4GB-01-089

8. Push lock button (9) and lift armrest (10) to the fully raised position
9. Before leaving the machine, turn OFF the light switch, close and lock all the windows, cab doors, and covers.

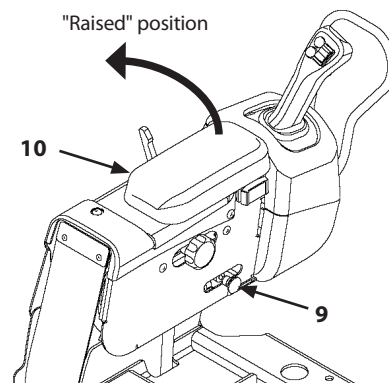

115Z7B-1-10-3

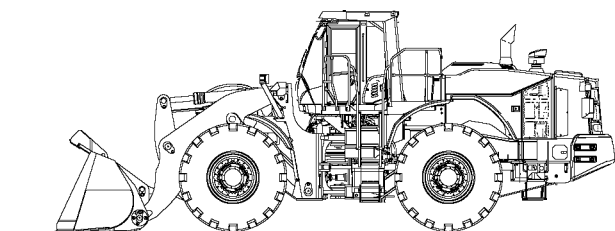

Stop and Parking Position

115Z7B-BKT

# MOVING THE MACHINE

## Parking

**IMPORTANT:** When parking the machine with cab door and windows open, cab electrical components may be damaged by bad weather. Always close windows, roof vent and cab doors when parking the machine.

1. Stop and park the machine on level surface. Lower the bucket to the ground.
2. Turn parking brake switch (1) ON.

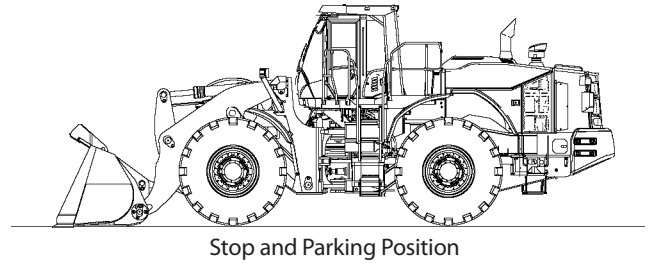

**IMPORTANT:** This machine is equipped with a turbocharged engine. Therefore if the engine is stopped without first cooling down at low RPM's, the lubricant on the turbocharger bearing and seal surfaces may be dissipated due to the intense heat present inside turbocharger, possibly damaging the turbocharger.

3. Run the engine at low idle speed to cool the engine for a few minutes.

 **NOTE:** Do not idle for excessively long periods. Observe local and federal engine idling regulations.

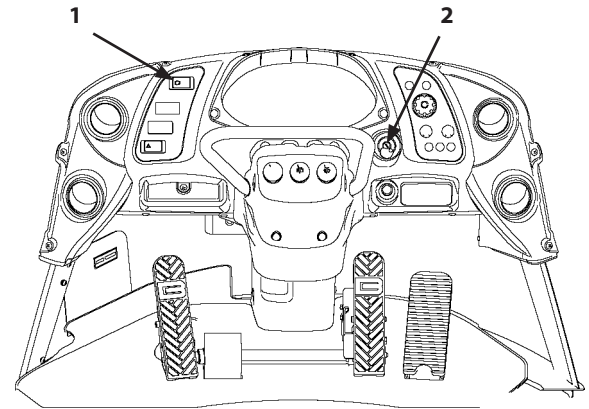

4. Turn key switch (2) to OFF position to stop the engine. Remove the key from the switch.
5. Press lock (A) side of control lever lock switch (3).

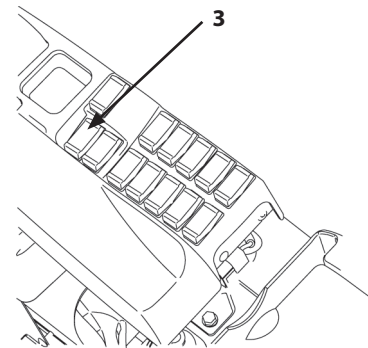

6. Push lock button (4) and lift armrest (5) to the fully raised position.
7. Before leaving the machine, turn OFF the light switch, close and lock all the windows, cab doors, and covers.

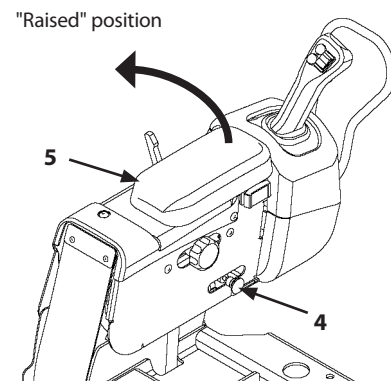

## MOVING THE MACHINE

---

### Emergency Stopping

#### **When the Engine has Stalled During Operation:**

Pressurized oil in the accumulator acts on the brake when the brake pedal is depressed. Immediately park and stop the machine in a safe location. At this time, do not repeatedly apply the brake pedal.

The brake oil pressure will be quickly reduced so that the brakes become inoperable.

If the machine does not stop even if the brake pedal is applied, press the parking brake switch ON side to stop the machine.

The steering wheel will become hard to rotate as the hydraulic system becomes inoperable.

In the event any above mentioned symptom occurs, immediately trace the cause of the problem. In case a complicate failure has occurred, consult your nearest authorized dealer.

## MOVING THE MACHINE

### Auto Brake

Auto brake applies the service brakes and turns on the warning buzzer when the machine speed exceeds the preset limit. Auto brake indicator (1) appears on the monitor panel (refer to page 1-25).

This feature protects the transmission from excessive speed.

In case of the direction change, the warning buzzer does not turn on, only the service brakes are applied and auto brake indicator (1) appears.



115Z7B-4-20-1

**IMPORTANT: When auto brake applies, machine may slow down suddenly. Be prepared. Wear seat belt.**

Auto brake works under the following conditions.

- Over speed  
If the machine runs above the following speeds forward or reverse;

Shift Range	Forward	Reverse
1	14.9 km/h (9.3 mph)	14.9 km/h (9.3 mph)
2	21.6 km/h (13.4 mph)	23.8 km/h (14.8 mph)
2L	15.4 km/h (9.6 mph)	17.0 km/h (10.6 mph)
3	35.8 km/h (22.3 mph)	35.8 km/h (22.3 mph)
3L	26.0 km/h (16.2 mph)	28.7 km/h (17.8 mph)
4	35.8 km/h (22.3 mph)	---
4L	35.8 km/h (22.3 mph)	---

 **NOTE:** When the machine speed reaches the specified machine maximum speed at the 4th speed range, the engine speed automatically reduces before the auto brake is applied to keep within the safety speed limit. Still the auto brake should operate if the machine speed exceeds the speed mentioned above or higher at each speed range.

- Direction change  
When the direction is changed while running over the following speed.

Shift Range	Speed
1st, 2nd	12.0 km/h (7.5 mph)
3rd, 4th	8.0 km/h (5.0 mph)

 **NOTE:** The above specified speeds are applicable to machines with standard tires (35/65R33). When using tires in other size, contact to your local representative.

# OPERATING THE MACHINE

## Loading Control Levers

### Fingertip Control Type

The fingertip control lever is used to operate the lift arm and/or bucket.

### Lift Arm Control Lever (1)

Lever Position	Lift Arm Operation
C	Float (Detent): The lift arm free falls and can be moved as loads are applied. The lever will stay in this position.
B	Lift Arm Lower
N	Hold: The lift arm is stopped and held in that position.
A	Lift Arm Raise
F	Detent: The lift arm is held in the raise position with the detent.

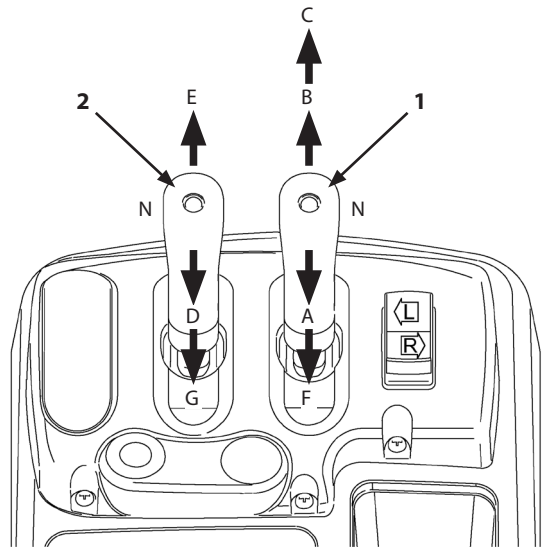

115Z7-1-92-1

### Bucket Control Lever (2)

Lever Position	Bucket Operation
E	Bucket Dump: The bucket is tilted forward to dump the bucket.
N	Hold: The bucket is stopped and held in that position.
D	Bucket Tilt (or Roll Back): The bucket is tilted back; (also this is the transportation position.)
G	Detent: When the bucket control lever is moved from the bucket dump position to the bucket tilt position, the bucket control lever is held in this position with the detent.

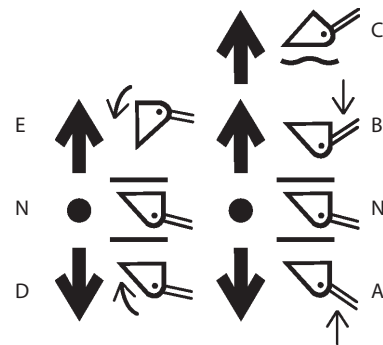

M4GB-01-072

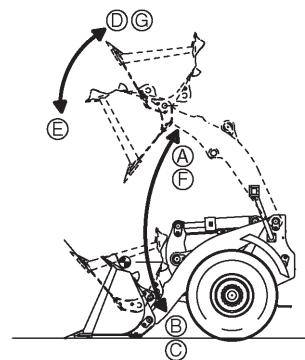

M4GB-01-073

## OPERATING THE MACHINE

 NOTE:

1. When applying lift arm control lever (1) in the "Raise" position (A), the lever is moved (F) until the lift arm reaches the position preset by the lift arm kickout. When the lift arm moves the preset position, lift arm control lever (1) automatically moves to the Neutral (N) position.
2. When applying bucket control lever (2) in the "Tilt" position (D) after bucket dump operation, the lever is moved (G) until the bucket reaches the position preset by the bucket auto leveler. When the bucket reaches the preset position, bucket control lever (2) automatically moves to the Neutral (N) position.
3. When pushing down lift arm control lever (1) to the "Float" position (C), the lift arm moves to the position preset by lift arm auto-leveler system and is held in that position. When the lift arm moves to the preset position, lift arm control lever (1) automatically moves to the "Neutral" (N) position. (Machine is equipped with the lift arm auto-leveler system)

 NOTE: When operating the machine in Float (C) position, first hold the lift arm at the float position; then further tilt the lever to the Float position, and lower the lift arm on the ground.

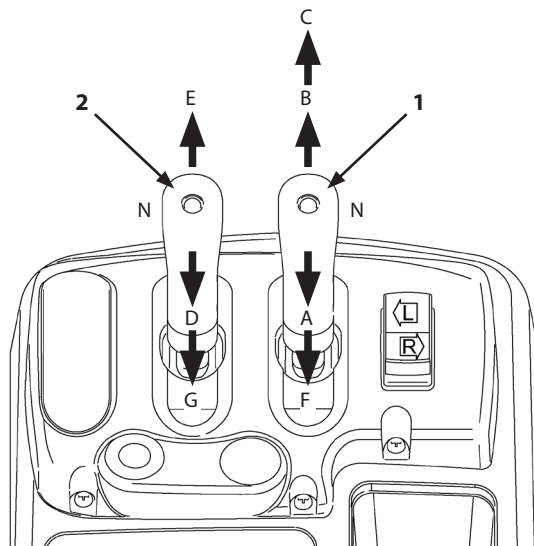

115Z7-1-92-1

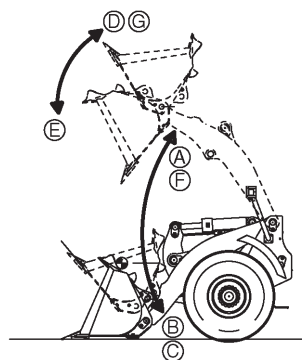

M4GB-01-073



# OPERATING THE MACHINE

## Loading Multi-Function Joystick Lever (Option)

The multi-function joystick lever is used to operate the lift arm and/or bucket.

Lever Position	Lift Arm/Bucket Operation
C	Float (Detent): The lift arm free falls and can be moved as loads are applied. The lever will stay in this position.
B	Lift Arm Lower
N	Hold: The lift arm is stopped and held in that position.
A	Lift Arm Raise
F	Detent: The lift arm is held in the raise position with the detent.
G	Detent: When the multi-function joystick lever is moved from the bucket dump position to the bucket tilt position, the multi-function joystick lever is held in this position with the detent.
D	Bucket Tilt (or Roll Back): The bucket is tilted back, taking the transportation position.
N	Hold: The bucket is stopped and held in that position.
E	Bucket Dump: The bucket is tilted forward to dump the bucket load.

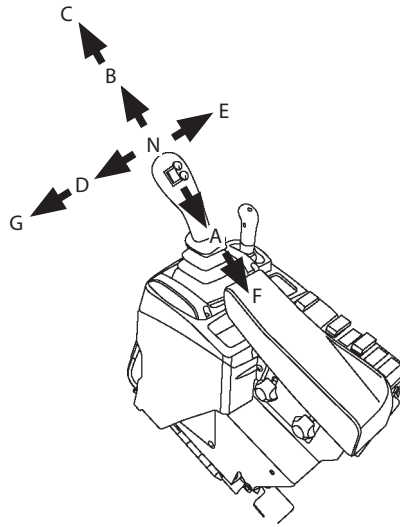

MNEC-01-059

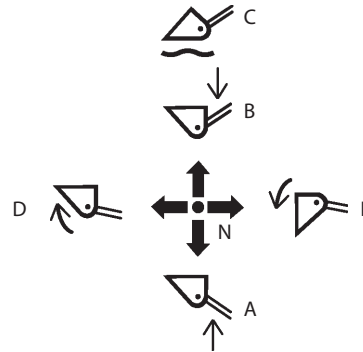

M4GB-01-074

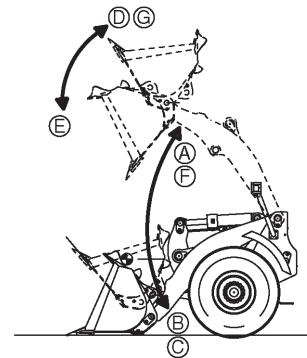

M4GB-01-073

## OPERATING THE MACHINE

### Control Lever Lock

#### WARNING:

- Be sure to press lock (🔒) side of control lever lock switch (1).
- Before leaving the operator's seat, be sure to stop the engine. Then, set control lever lock switch (1) to the lock (🔒) position.
- Always check to be sure that the control lever lock switch is set in the lock (🔒) position before transporting the machine or leaving the machine at the end of the shift.

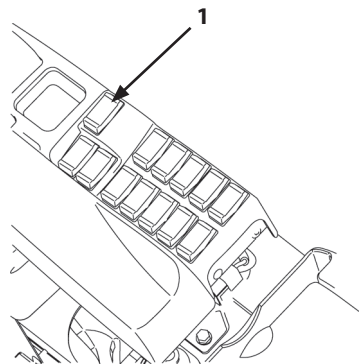

115MNEC-07-01

Control lever lock switch (1) is provided to prevent unexpected machine operation if the operator were to mistakenly come in contact with the bucket and/or lift arm control lever when getting on or off the machine. When control lever lock (1) is placed in unlock (🔓) position, the control lever becomes operable.

#### Control Lever Lock Operation

- When leaving the operator's seat:
  1. Park the machine on solid level ground. Lower the bucket to the ground. Return all levers to neutral. Set the parking brake. Stop the engine.
  2. Press lock (🔒) side of control lever lock switch (1).
- Before starting operation:

Before starting operation, check that control lever lock switch (1) is in the unlock (🔓) position.

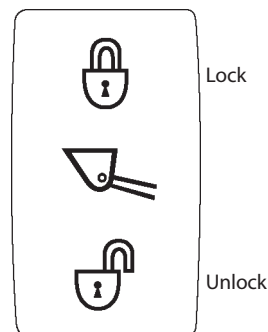



MNEC-01-015

# OPERATING THE MACHINE

## Declutch Position Switch

To perform digging (scooping) or loading operation, declutch position switch (1) can be set to any position . Turn the declutch position switch ON to let the engine speed and power be applied to loading circuits.

- [ ] side (Declutch)

By depressing left brake pedal (3), the clutch is disengaged and brake is applied without transmitting the power to the drive train.

 : Declutch ON when lightly depressing the left pedal (3)



(Suited to loading work on a level surface or on a gentle slope.)

 : Declutch ON when firmly applying the left pedal (3)

(Suited to operate on a steep slope)

- OFF [] (Clutch Engaged)

By depressing brake pedals (3) or (4), brake is applied while power is transmitted to the drive train.

 **NOTE:** When starting to ascend a slope, turn declutch position switch (1) OFF [] (clutch engaged), depress the left brake pedal. Gradually release the left brake pedal (3) while applying accelerator pedal (5) to easily start ascending a slope.

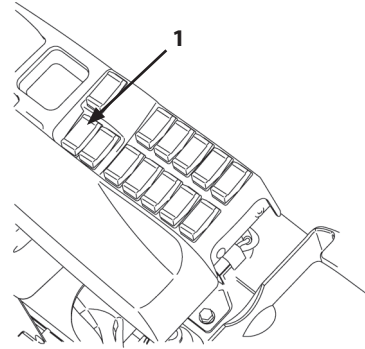

115MNEC-07-01

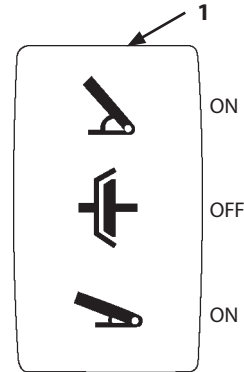

MNEC-01-025

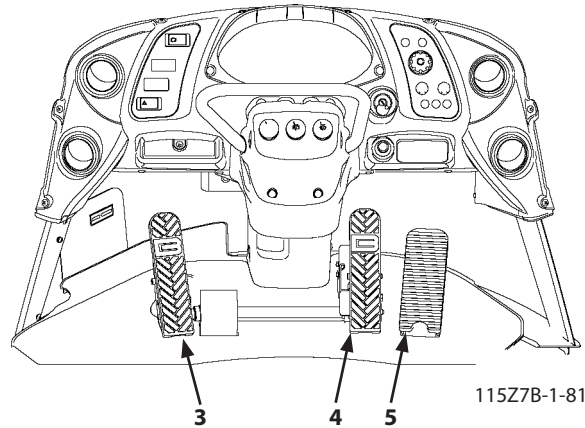

115Z7B-1-81-1

## OPERATING THE MACHINE

### Adjustment of Bucket Auto Leveler

#### **⚠ WARNING: CRUSH HAZARD**

- Be careful to avoid injury and/or death when adjusting the bucket auto leveler.
- Stop the engine. Lower the loader arm and bucket to the ground to release oil pressure.
- Apply the parking brake to prevent unexpected movement of the machine. Chock wheels with blocks. Keep bystanders away from the vicinity of the machine.

The bucket auto leveler automatically stops the bucket movement when level. (When the machine is shipped from the factory, the bucket positioner is preset so that the bucket is stopped with the bucket bottom parallel with the road surface.)

For example, after discharging material into a truck or a hopper, when bucket control lever (4) is placed to detent position (G), the lever is held in that position. Then, when the bucket is returned to the preset angle position, the bucket is automatically stopped and the lever is returned to neutral (N).

The bucket auto leveler is preset so that when the bucket bottom becomes parallel with the road surface, bucket movement is stopped. Nevertheless, when required to tilt the bucket forward or backward beyond the level position, adjust the bucket auto leveler by moving the mounting position of the proximity switch (2), relative to rod (3).

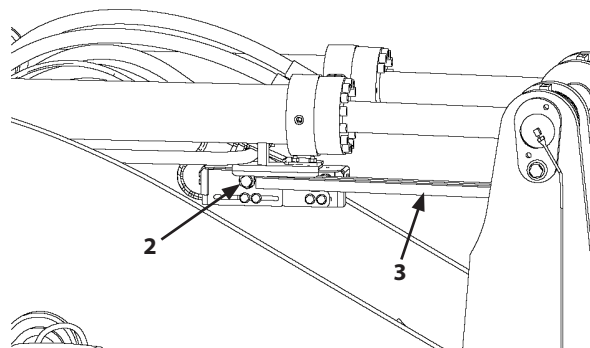

95Z7B-5-6-1

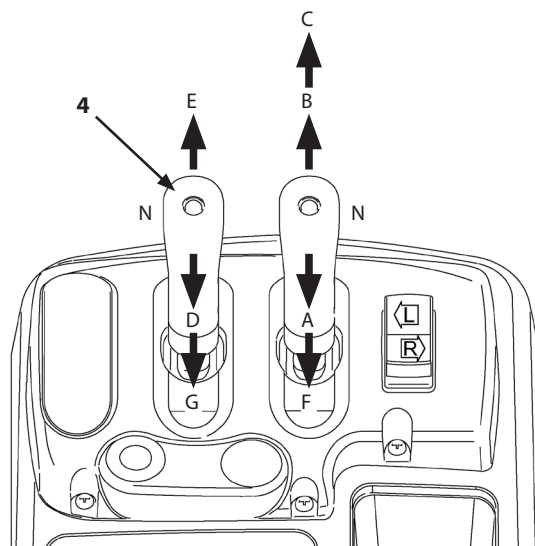

115Z7-1-92-1

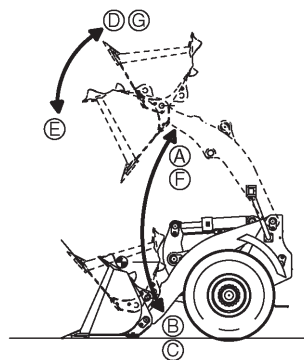

M4GB-01-073

## OPERATING THE MACHINE

### Adjustment Procedures

**IMPORTANT: Do not operate the machine with the bucket dumped more than 10°.**

1. After moving the bucket to the desired digging angle, stop the engine.
2. Loosen bolt (2). Slide the end edge of rod (3) up to the center of proximity switch (4) (orange color).  
Then, tighten bolt (2) to fix bracket (1).

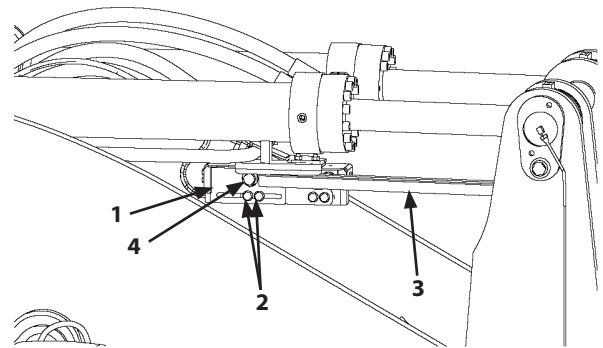

95Z7B-5-6-1

3. Loosen the proximity switch mounting nut and adjust the clearance between rod (3) and proximity switch (4) to  $5 \pm 2$  mm ( $0.2 \pm 0.08$  in).  
After adjusting, securely tighten the mounting nut.
4. After adjustment start the engine. Check that the bucket can be stopped at the desired angle position.

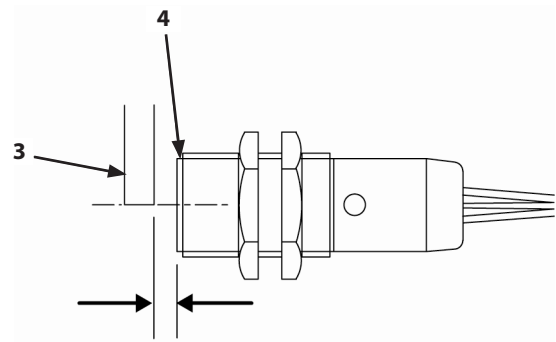

OM0128a

## OPERATING THE MACHINE

---

### Adjustment of Bucket Angle Switch

**⚠ WARNING: CRUSH HAZARD**

- Be careful to avoid injury and/or death when adjusting the bucket angle switch.
- Stop the engine. Lower the loader arm and bucket to the ground to release oil pressure.
- Apply the parking brake to prevent unexpected movement of the machine. Chock wheels with blocks. Keep bystanders away from the vicinity of the machine.

The bucket angle switch detects the bucket angle during operation for the judgment of the lock up or digging power control activation.

When the machine is shipped from the factory, the bucket roll back angle is 30 degree from the road surface.

When required to roll back the bucket beyond this preset level position, adjust the bucket angle switch by moving the mounting position of the proximity switch (4), relative to rod (3).

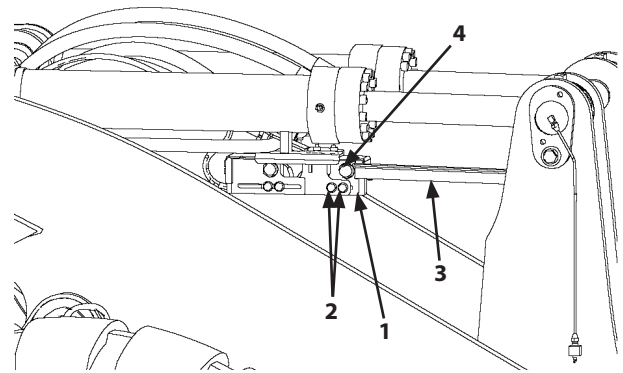

95Z7B-5-8-1

## OPERATING THE MACHINE

### Adjustment Procedures

**IMPORTANT: Do not operate the machine with the bucket dumped more than 10°.**

1. After moving the bucket to the desired operating angle, stop the engine.
2. Loosen bolt (2).  
Slide the end edge of rod (3) up to the center of proximity switch (4) (orange color).  
Then, tighten bolt (2) to fix bracket (1).

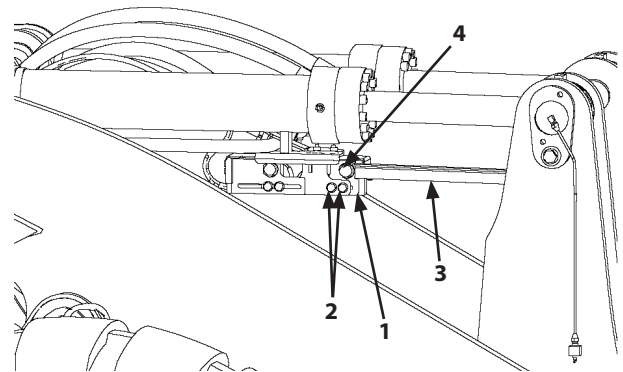

95Z7B-5-8-1

3. Loosen the proximity switch mounting nut and adjust the clearance between rod (3) and proximity switch (4) to  $5 \pm 2$  mm ( $0.2 \pm 0.08$  in).

After adjusting, securely tighten the mounting nut.

4. After adjustment start the engine. Check that the bucket can be stopped at the desired angle position.

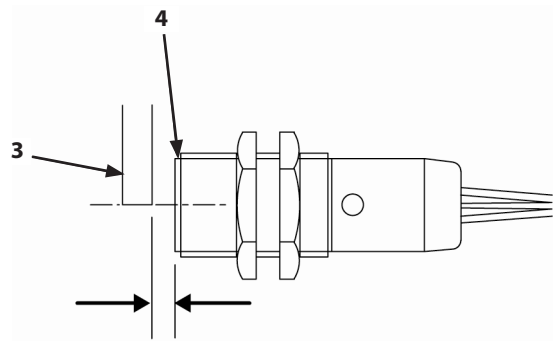

OM0128a

## OPERATING THE MACHINE

---

### Adjustment of Dual Lift Arm Auto Leveler

 **WARNING:**

- **Take extra care to prevent injury and/or death when adjusting the lift arm auto leveler (kickout).**
- **Apply the parking brake to prevent the machine from moving unexpectedly. Chock the wheels with blocks. Keep bystanders away from the vicinity of the machine.**

**IMPORTANT:**

- **When the lift arm auto leveler (kickout) function is activated with the bucket loaded, the bucket may stop at the set position.**
- **Height setting of lowering direction can not be done when the lift arm is above the horizontal position of the lift arms. Also, height setting of raising direction can not be done when the lift arm is below the horizontal position of the lift arms.**

The lift arm auto leveler is a device that automatically stops the lift arm at the preset position while lowering or raising the lift arm. It is convenient to change the setting of stop position by using this function when the machine is constantly used in a specific way, such as when loading trucks that are equipped with side boards of the same height.

Refer to "Dual Lift Arm Auto Leveler Switch" in the OPERATOR'S STATION section to adjust the stop position.



## OPERATING THE MACHINE

### Auto Idling Stop

**⚠ WARNING:** This function automatically stops the engine. Carefully operate within the work environment when using this function.

When the auto idling stop function is ON (enabled), the engine automatically stops after the preset time from the state in which the specified conditions are met (see the operating condition on the next page).

30 seconds before the engine stop, monitor (2) displays a message that engine will be stopped and indicator (1) starts flashing. Also the buzzer sounds. The buzzer sounds once at 30 seconds before, intermittently sounds from 15 seconds, and then stops after 15 seconds.

The auto idling stop is disabled and the engine will not stop if any of the conditions on the next page is not satisfied.

**IMPORTANT:** Ensure that the ON or OFF status of auto idling stop indicator (1). If the indicator is ON, the auto idling stop function will be activated.

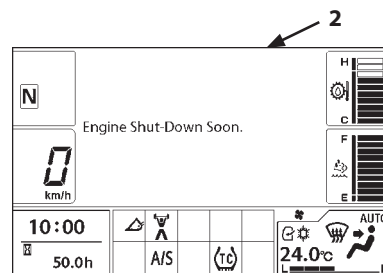

MNHG-01-153EN

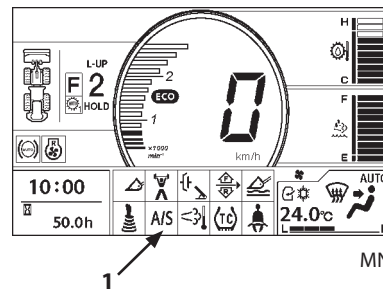

MNHG-01-100EN

## OPERATING THE MACHINE

### Auto Idling Stop Operating Condition

- The engine is running.
- The parking brake switch is ON.
- The accelerator pedal is not depressed.
- The brake pedal is not depressed.
- The loading control lever is not operated.
- The joystick steering is not operated.
- The forward/reverse switch is in neutral (N).
- Coolant, hydraulic oil and transmission temperature are not high.
- The exhaust filter manual regeneration is not operating.

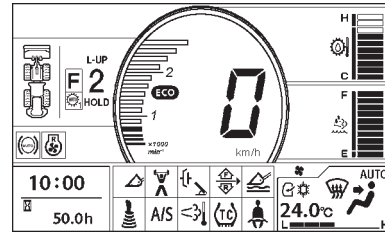

MNHG-01-100EN

### IMPORTANT:

- **When the engine stops because of the auto idling stop function, turn the key switch to ACC or OFF once and then turn it to START to restart the engine. Do not leave the machine after auto idling stop. This may discharge the batteries.**
- **When the key switch is turned to OFF position while the auto idling stop function is ON, the setting will remain ON at the next startup.**

Refer to page 1-53 for setting the auto idling stop function.

# OPERATING THE MACHINE

## Aftertreatment Device Manual Regeneration

When manual regeneration is needed, symbol (1) and service indicator (2) as shown to the right will be displayed. Perform manual regeneration in the following procedure.

### IMPORTANT:

**Park the machine in a safe area where exhaust temperatures will not damage property or other potential flammable sources.**

**Be sure that there are no flammable materials in the engine area, including, but not limited to:**

- Coal dust.
- Wood chip particles, saw dust.
- Animal feed products (straw, hay, grain dust, etc.)
- Inorganic man made debris; plastics, paper, refuse, etc.
- Any other loose flammable debris.

### Manual Regeneration Procedure

1. Park the machine in a safe and open place. Place the transmission in neutral. Apply parking brake. Lower the front attachment level to the ground.
2. Verify that items are set as shown below.

Forward/Reverse Switch	:	N (Neutral)
Accelerator Pedal	:	UP (OFF)
Parking Brake Switch	:	ON
Loading Control Lock Switch (4)	:	LOCK (Ⓐ)
Aftertreatment Device Regeneration Inhibited Setting	:	OFF
Hydraulic oil temperature	:	5~70°C (41~158°F)
Coolant temperature	:	70°C (158°F) or higher
Remaining fuel alarm	:	does not light.
DEF/AdBlue® alarm	:	does not occur.

3. Press the aftertreatment device regeneration switch (3).

### NOTE:

- When "Aftertreatment Device Regeneration Inhibited" is preset to ON, manual regeneration cannot be started. Refer to page 1-57.
- Refer to pages 1-5 and 1-35 for Automatic Regeneration and more information.

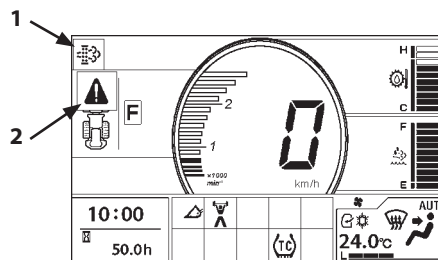

Basic Screen

MNHG-01-280EN

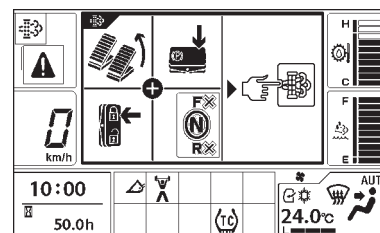

Manual Regeneration Request Screen

MNHG-01-282EN

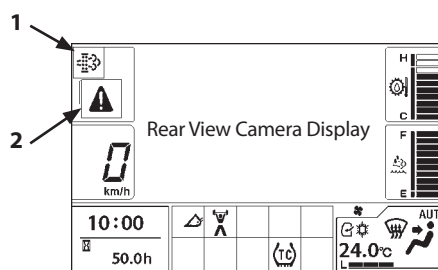

Basic Screen  
(When Rear View Camera ON)

MNHG-01-281EN

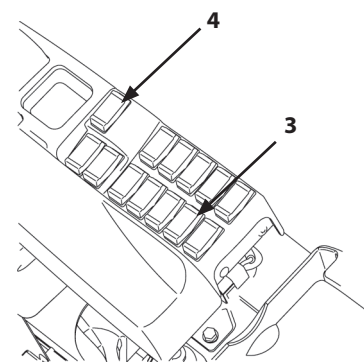

115MNEC-07-01

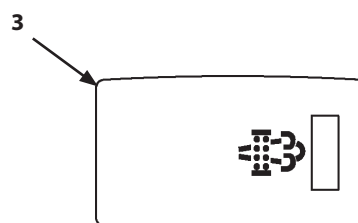

MDAA-05-002

## OPERATING THE MACHINE

4. When aftertreatment device switch has been pressed, screen (5) appears as shown to the right and manual regeneration starts. The bar graph on the screen (6) indicates regeneration progress.

 **NOTE:** The manual regeneration cannot start unless the following items are as indicated.

Item	Condition
Accelerator pedal	UP (OFF)
Forward/reverse switch	Neutral
Parking switch	ON
Control lever lock switch (4)	ON

If any of the listed items are changed, or the key is turned to the "OFF" position, the regeneration process will be aborted. If the manual regeneration has been aborted, start the process over again.

 **NOTE:**

- The engine sound may change and the engine RPM may increase when the manual regeneration starts. This is not a malfunction.
- White smoke may temporarily be generated from the tail pipe during the regeneration process. This is not a malfunction.
- Coolant temperature may increase during the manual regeneration.
- Regeneration period depends on the ambient temperature.
- Just after machine operation, manual regeneration period becomes shorter than when the engine temperature is low.

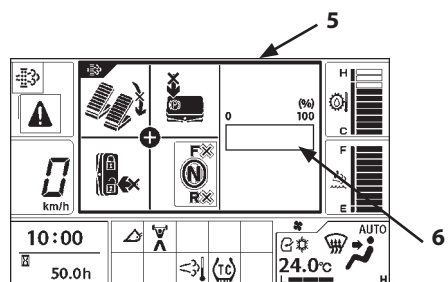

MNHG-01-283EN

## OPERATING THE MACHINE

### 5. Manual Regeneration Completed (Successful)

When manual regeneration is completed, "Regeneration Has Completed." message will be displayed and the regeneration symbol disappears.

### 6. Manual Regeneration Failed (Unsuccessful)

If the message "Regeneration Has Failed." appears on the monitor panel, start the regeneration process over again.

Failure to regenerate manually may be caused by a problem not in the above list, such as malfunction of a sensor that affects regeneration at a low ambient temperature.

 **NOTE:** *Aftertreatment device regeneration cannot be started when the hydraulic oil temperature is too high. Run the engine at low idle to lower the oil temperature, and restart the procedure.*

 **NOTE:** *If aftertreatment device regeneration switch (3) is pressed when the ambient temperature is low, it may take long to start the aftertreatment device regeneration process. Before pressing aftertreatment device regeneration switch (3), increase the coolant temperature to about 70°C (158°F) until the coolant temperature gauge needle starts moving. Refer to page 3-13 for warm-up in cold weather.*

**IMPORTANT:** If regeneration must be interrupted, press manual regeneration switch (3) again. The message "Regeneration Has Failed." will be displayed on the monitor, and the machine becomes operable. In this case, manual regeneration must be done later. Perform the manual regeneration again as soon as possible.

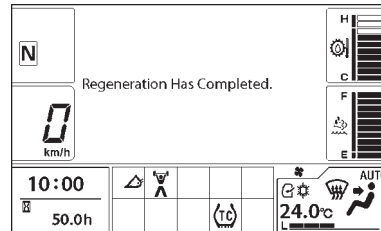

MNHG-01-284EN

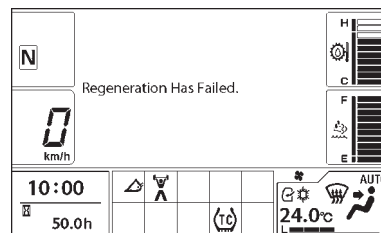

MNHG-01-285EN

## OPERATING THE MACHINE

---

### Before Operation



**WARNING:**

- Be sure to install only authorized buckets and other work tools.
- Never modify or increase the capacity of the bucket or other work tools without first receiving authorization. Do not overload the machine by installing additional counterweights. This may result in personal injury and/or machine trouble.

### Precautions for Operation



**WARNING:**

- Confirm work site safety before starting work.
- Use the machine equipped with FOPS and ROPS if the machine is to be operated in the areas where the possibility of rollover or falling stones exists.
- If operation on excessively soft ground is required, operate the machine only after stabilizing the soil.
- Be sure to wear close fitting clothing and safety equipment appropriate for the job, such as a hardhat, etc. when operating the machine.
- Clear all persons and obstacles away from the area of operation and machine movement. Always be aware of all hazards within the area around the machine while operating.

### Ensure Safety When Operating on Road Shoulders



**CAUTION:** Stabilize the soil before operating the machine on soft road shoulders.

## OPERATING THE MACHINE

---

### Avoid Overloading



**WARNING:**

- Do not penetrate the bucket into piles of soil and/or gravel at fast travel speed.
- Avoid excavating or scooping loads when the machine is articulated, which could possibly cause the machine to turn over.

**IMPORTANT:** Avoid machine abuse by allowing the bucket or attachment to receive loads at only one side. Damage to the machine may result.

### Avoid Rapid Steering Changes and/or Sudden Braking



**WARNING:** Always maintain a flat work site surface. Avoid rapid steering changes and sudden braking while raising the lift arm with the bucket loaded to prevent the machine from turning over.

### Avoid Operation with Loads on Only One Side



**WARNING:** Avoid machine abuse by allowing the bucket to receive loads at only one side. Machine rollover or deformation of the lift arm may result.

# OPERATING THE MACHINE

## Excavation

### Loading Accumulated Soil

#### IMPORTANT:

- Do not dig or scoop with machine frame articulated.
- Avoid operating the machine with the front wheels raised off the ground. Machine traction force is reduced and excessive loads are applied to the undercarriage.

Scoop load while moving the machine forward as described below. As load increases the wheels begin to slip, slightly raise the lift arm to increase tire grip.

 NOTE: When loading rocks or hard packed material, the use of bucket teeth is recommended.

1. Move the machine forward to the material. Steer the machine in a straight ahead position when entering the material.
2. Lower the bucket parallel to the ground. Drive the bucket straight into the material.

 NOTE: Use approximately 1/2 - full engine speed.

3. Raise the lift arm while running the machine forward slowly in 1st or 2nd speed. Use 2nd speed for loose materials.
4. Move the bucket control lever to the "Roll Back" and the "Hold" position several times to get more material in the bucket. When the bucket is filled, move the bucket control lever to the "Roll Back" position.

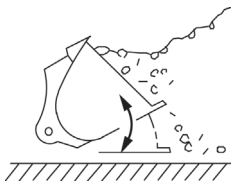

OM0115-Z7

5. Move the machine with the bucket rolled back fully and held at the driving position.

 NOTE: Steer the machine in a straight ahead position when entering the material. Aim the center of the bucket at the protruding portion of the material.

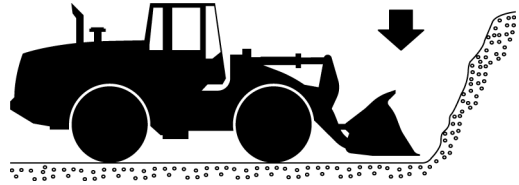

M4GB-05-003

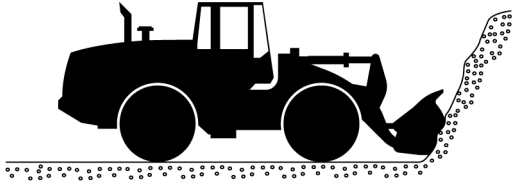

M4GB-05-004

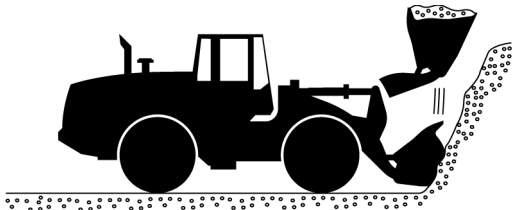

M4GB-05-005

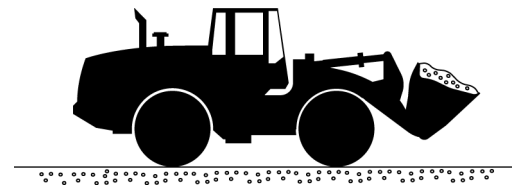

M4GB-05-006

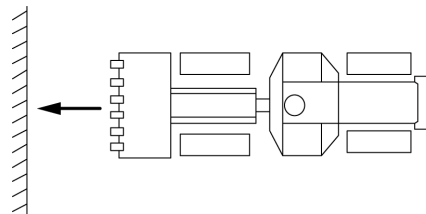

OM0111

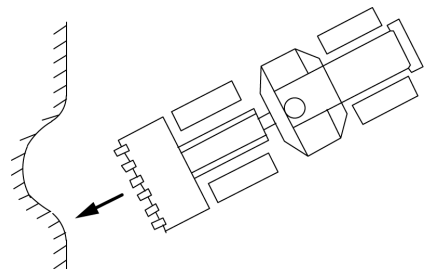

OM0112



## OPERATING THE MACHINE

---

### Digging and Loading Level Ground

**IMPORTANT:** While excavating with the bucket or fork, never apply excessive force to the tooth tips with the bucket or fork tilted more than 10°. This may result in cracks or damage to the front attachment.

Slightly position the bucket teeth downward (0 to 10 degrees) and dig the ground while moving the machine forward as described below. Always take care not to apply loads to only one side of the bucket.

1. Position the bucket teeth slightly downward (dump forward 10 degrees or less).
2. While moving the machine forward in 1st or 2nd speed, roll the bucket forward so that the ground surface is gradually lifted. Increase engine speed as the bucket digs deeper.
3. Adjust the digging depth by operating the lift arm or bucket.
4. When the bucket is filled, move the machine with the bucket fully rolled back. Clear the ground and hold at the driving position.



M4GB-05-007

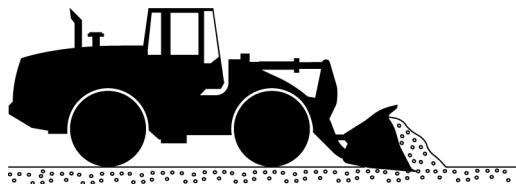

M4GB-05-008

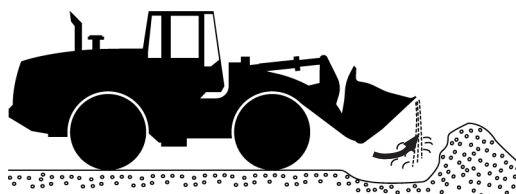

M4GB-05-009

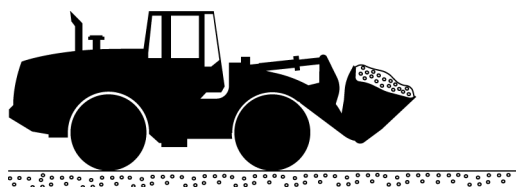

M4GB-05-010

## OPERATING THE MACHINE

### Grading

**⚠ WARNING:** When operating a machine equipped with ride control and the lift arm control lever in the float position, when performing works as soil scooping, land grading, or snow removal, be sure to turn the ride control switch OFF. Failure to do so may allow the ride control system to operate so that the front attachment may automatically move up and down.

**IMPORTANT:** Perform grading work while moving the machine in reverse. If grading work is performed by moving the machine forward, severe loads are applied to the front attachment, possibly creating cracks or damage to the front attachment.

1. After filling the bucket, dump the bucket gradually to spread soil while moving the machine in reverse.
2. Lower the bucket edge onto the ground. Grade and level the ground surface while driving the machine in reverse with the bucket edge dragging.
3. After filling the bucket with a load such as soil, position the bucket level with the ground surface. Finish the ground surface utilizing the bucket weight.

At this time, move the machine in reverse with the lift arm held in the FLOAT position.

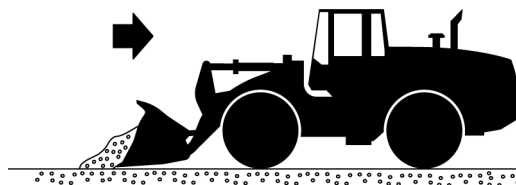

M4GB-05-011

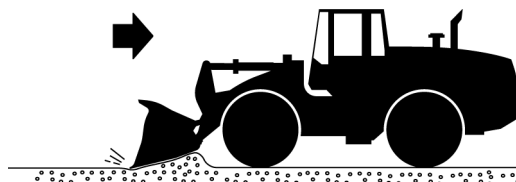

M4GB-05-012

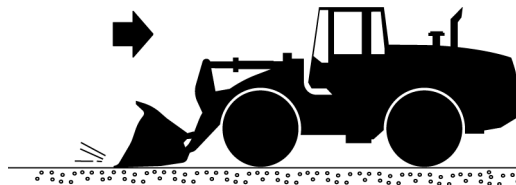

M4GB-05-013

# OPERATING THE MACHINE

## Loading

### IMPORTANT:

- **Always maintain a clean surface for machine operation.**  
Cleaning of materials such as soil and stones spilled on the work surface will reduce wear and/or damage on tires.
- **When carrying loads in the bucket, pay attention to the road surface conditions. Operate the machine at such speed so that the load will not spill out of the bucket, while positioning the bucket at the driving position.**
- **Refrain from banging bucket against the bucket stopper as much as possible when removing stuck material, like clay, from the bucket. This may result in damage to the front attachment.**  
Remove material stuck to the bucket with water under pressure.

Loading is dumping the handling material onto a truck or into a hopper.

Loading work is performed in either the load and carrying method or loader and dump truck method. Select either method depending on the work site conditions while taking the cost and safety into account.

### Load and Carrying Method

#### WARNING:

- **Be sure to provide a tire stopper (1) in front of the hopper.**
- **Before raising the lift arm, slightly tilt the bucket back and forth to stabilize the load in the bucket to avoid injury or damage to the machine from falling of loose material.**  
**Avoid raising the lift arm on a slope.**
- **When approaching a hopper with the lift arm raised never steer the loader. Slowly move the machine. Never rapidly operate the machine to prevent roll over.**

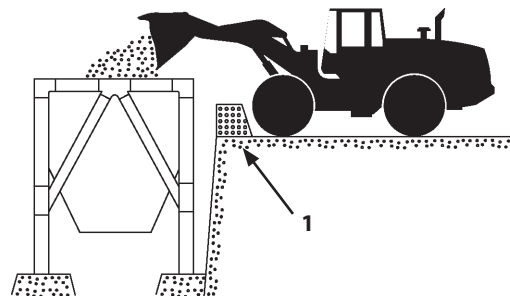

M4GB-05-014

A wheel loader performs work process of loading, carrying, and dumping in sequence. Generally, when the carrying distance is 30 to 100 m (33 to 109 yd), this method is employed.

Make an upgrade slope of approx. 3° around a hopper when dumping into the hopper. Be sure to provide a level area 10 m (33 ft) apart from the hopper and tire stopper (1) at the hopper edge. Reduction in travel speed will assist operator's braking operation effort.

## OPERATING THE MACHINE

### Loader and Dump Truck Combination Method

#### WARNING:

- **Always maintain a flat and clean work site surface. Avoid rapid turns and/or sudden braking while raising the lift arm with the bucket loaded to prevent the machine from tipping over.**
- **Do not insert the bucket into a loading face at fast speed, possibly resulting in an accident.**

A loader carries out loading and carrying, and dumping is carried out by a dump truck. Either V- or I-shape loading method is used in this method. Depending on the work site conditions and matching with available trucks, select the most efficient method.

#### V-Shape Loading

1. Park a dump truck in a spot located at approx. 60° angle toward the loading face. After loading material, travel the wheel loader in reverse and turn its direction so that the wheel loader faces the parked dump truck at a right angle. Then, travel forward to carry material onto the dump truck.
2. Position the wheel loader so that the material can be loaded around the center of the dump body. In case the dump body is longer than twice the bucket width, load from the front to rear position of the dump body in order.
3. When dumping sticky material such as clay, move the bucket lever back and forth to lightly hit the bucket to the stoppers.  
  
Use a small steering angle to operate the machine efficiently.
4. Before raising the lift arm to the maximum height with the bucket full, lightly tap the bucket while low to stabilize the material in the bucket and help prevent the material from spilling from the backside of the bucket.

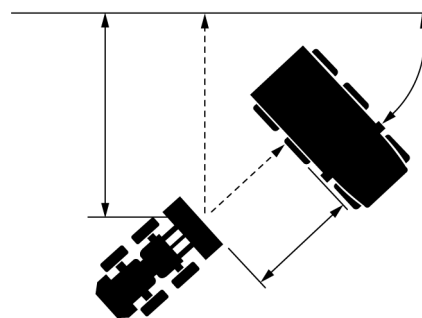

M4GB-05-015

#### I-Shape Loading

Park a dump truck in a direction parallel to the loading face. After loading material into the bucket, move the wheel loader straight in reverse. Then, move a dump truck to a spot between the loading face and the wheel loader. Move the wheel loader forward to load material into the dump truck body.

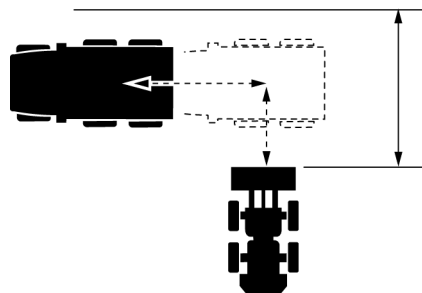

M4GB-05-016

## OPERATING THE MACHINE

### Dumping into Truck or Hopper

**WARNING:**

- **When boom is raised, machine stability is reduced and could cause machine to tip over causing serious injury or death.**
- **Do not make quick turns or abrupt braking when boom is raised.**
- **Keep boom low for best stability especially on slopes.**

1. Move the lift arm control lever to the "Raise" position to raise the loaded bucket while approaching the truck or the hopper.
2. Use the declutch switch in the "ON" position if working on a level site.  
When the left brake pedal (declutch pedal) is step on, the transmission is placed automatically in neutral and the lift arm rises faster.
3. Return the lift arm control lever to the "Hold" position when the bucket reaches the enough height to clear the truck or hopper sideboards.  
If the lift arm is equipped with the kickout device, the lift arm will automatically stop and the lift arm control lever will return to the "Hold" position when the bucket reaches the preset height.  
Holding the lift arm control lever in the "Raise" position will continue to raise the lift arm if required.
4. Position the machine in the center of the truck body or hopper to dump the load.
5. Push the bucket control lever forward to the "Dump" position to empty the bucket.
6. Roll back the bucket to clear the truck or hopper sideboards and lower the lift arm while reversing the machine.

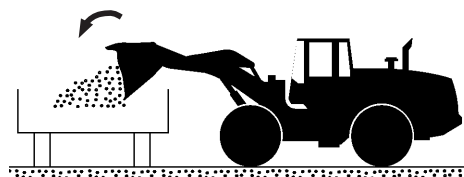

90M4GB-05-14

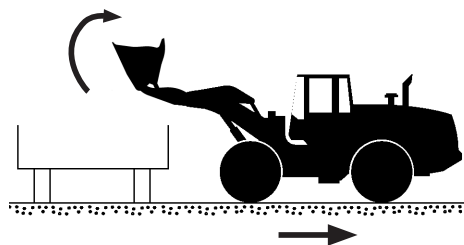

90M4GB-05-14a

## OPERATING THE MACHINE

### Dozing

#### IMPORTANT:

- Dozing or pushing with dumped bucket or attachment may cause severe damage to linkages. It may also cause engine over-heating and torque converter over-heating.
- Never attempt to forcibly push piled material higher than the bucket capacity. Premature wear of the tires due to slipping and/or waste of fuel may result.
- Never apply great force to the cutting edge with the cutting edge tilted forward more than 10°. Failure to obey so may result in damage such as cracks to the working tools. Keep bucket or attachment bottom parallel to ground.

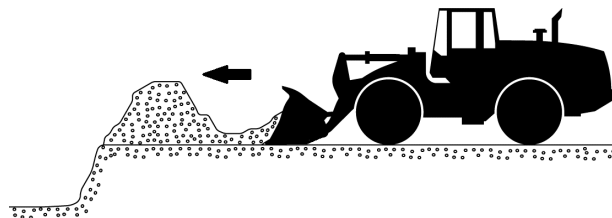

M4GB-05-017KC

Dozing with a wheel loader means a working method performed by a wheel loader using the wheel loader bucket in place of a bulldozer blade. This operation method is employed when reclaiming land or dumping material into a hopper, that is below ground level.

Set the bucket bottom parallel with the ground surface and move the wheel loader forward.

### Stock Piling

- ⚠ WARNING:** Do not pile material on soft ground. Steering on soft ground may easily cause the machine to tip over.

Take care not to scrape the ground with the counterweight while working.

The machine may become unstable, possibly causing the machine to turnover.



M4GB-05-018

## OPERATING THE MACHINE

### Removing Snow

**⚠ WARNING:** When operating a machine equipped with ride control and the lift arm control lever in the float position, when performing work as soil scooping, land grading, or snow removal, be sure to turn the ride control switch OFF. Failure to do so may allow the ride control system to operate so that the front attachment may automatically move up and down.

**⚠ CAUTION:** Remove snow in the same method as employed in general loading work. However, pay attention to slippage of tires traction and obstacles that may be covered with snow.

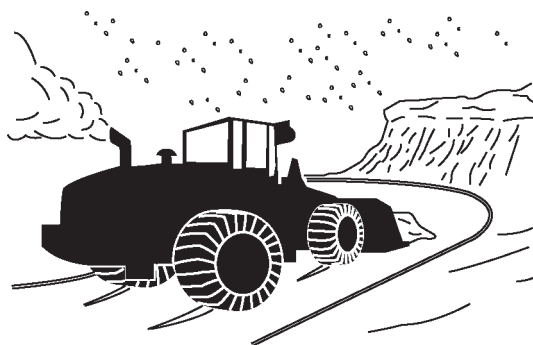

M4GB-05-019

Precautions for removing snow

- Avoid sudden starting and stopping as well as rapid steering of the machine.
- Use tire chains on all four wheels.
- Pay attention to the presence of the utility facilities such fire hydrants, manholes, curbs, roadside drains, etc. The facilities or the machine may be damaged.

### Lifting Wheel Loader

**⚠ WARNING:**

- Be sure to use lifting tools and set the articulation stopper (lock bar) in the LOCK position. (Refer to page 1-137.)
- Never allow any person to ride on the machine to be lifted.
- Never allow any person to enter below the lifted machine. Before fully lifting the machine above the ground, check that the hooks are securely attached to the machine and the machine is well balanced while lifting the machine slightly above the ground.

Refer to the "LIFTING MACHINE" in the TRANSPORTING section.

Lifting of the machine may be needed when loading the machine onto a ship or truck for repairing and/or transporting.

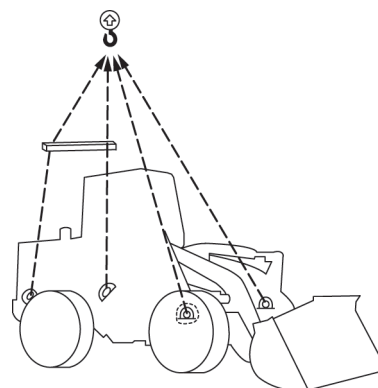

115MNEC-05-01

## OPERATING THE MACHINE

---

### Precautions for After Operation

1. After finishing operation, move the machine to firm, level ground where no possibility of falling stones, ground collapse, or floods are present.

(Park the machine referring to the "Parking" in the "MOVING THE MACHINE" chapter.)

2. Refill the fuel tank.

**⚠ CAUTION:** Wash the machine when needed. In areas of exposed metal, spray a light coat of rust-preventive oil to protect the machine from rusting. If the machine continues to be used with rust developing in areas like cylinder rods, oil leaks may occur.

**IMPORTANT:** If hard rain is expected or the machine is to be stored, wrap the muffler with a tarpaulin to prevent water from entering the exhaust system and engine.

3. Clean the machine.



## OPERATING THE MACHINE

- Maintenance for long term machine storage after engaging in snow removal. (Refer to STORAGE section.)

Anti-freeze agents such as salt (sodium chloride or calcium chloride) usually are scattered on snow covered roads. When the machine is stored for a long time after engaging in snow removal work, perform the following maintenance to protect the machine from being corroded and/or damaged by corrosive chemicals or elements.

**IMPORTANT: Take care not to spray water directly to electrical parts, harnesses and connectors.**  
**Most lights such as the headlights, work lights, and turn signal lights are water resistant.**

- Clean the machine thoroughly.  
Clean each cylinder rod (plated areas) and the radiator with extra care.
- After positioning the machine for storage, carefully coat each cylinder rod (plated areas) with rust-preventive oil.
- Lubricate all pins while referring to A Greasing Section in the Maintenance Guide List.

**CAUTION:** When removing the batteries, disconnect the ground cable from the battery terminal first (covered with a black vinyl cap).

- Remove the batteries and store them in a dry cool place.  
When the batteries are not removed, disconnect the ground terminal cable.

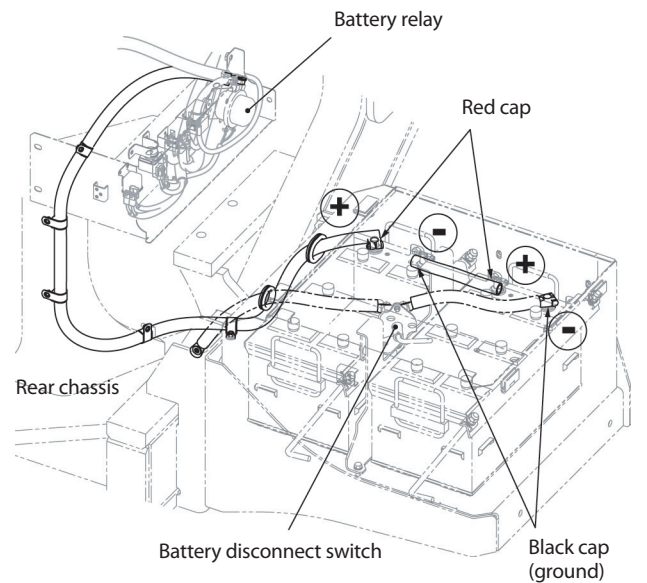

115Z7-5-24



# TRANSPORTING

---

## Transporting by Road

When transporting the machine on public roads, be sure to first understand and follow all local regulations.

1. For transporting using a trailer, check the width, height, length and weight of the trailer when the machine is loaded.
2. Investigate beforehand the conditions of the route to be traveled, such as dimensional limits, weight limits, and traffic regulations. Take any detours that may be needed into account.

In some cases, getting approval from the authority concerned, disassembling the machine to bring it within dimensional limits or weight limits of local regulations may be necessary.

## Selecting a Trailer

Provide an appropriate trailer while referring to the weight and dimensions shown in the specifications. When transporting the machine within the weight and dimensions shown in the specifications by a trailer, it may be possible to transport the machine without disassembling.

## TRANSPORTING

### Loading / Unloading on Trailer

**⚠ WARNING:** Be sure to use a loading dock or a ramp for loading/unloading.

Always load and unload the machine on a firm, level surface.

#### Ramp/Loading Dock:

1. Before loading, thoroughly clean the ramps, loading dock and flatbed. Dirty ramps, loading docks, and flatbeds with oil, mud, or ice on them are slippery and dangerous.
2. Chock (1) the truck and trailer wheels while using a ramp or loading dock.
3. Ramps must be the right size and able to bear the load. Be sure that the incline of the ramp is less than 15°.
4. Loading docks must be the right size and able to bear the load. to support the machine and have an incline of less than 15°.

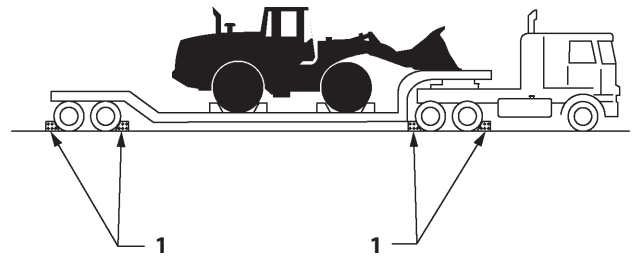

M4GB-06-001

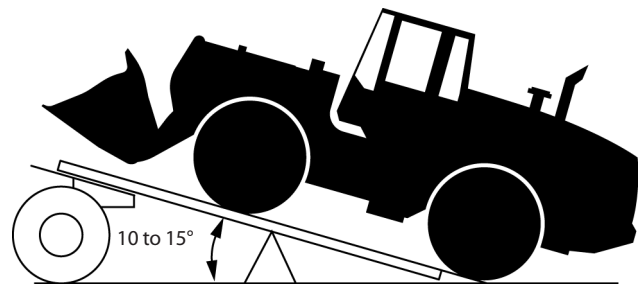

M4GB-06-002

# TRANSPORTING

## Loading / Unloading on Trailer

### WARNING:

- Keep machine straight while moving up or down a ramp since turning on a ramp may cause the machine to turn over. Never attempt to steer the machine on a ramp. If the travel direction must be changed on a slope, move the machine back to the flat surface on flatbed. Then, after changing the travel direction, begin to move again.
- Select AUTO 2 for auto-shifting, or select 2nd speed for manual shifting.

### Loading

1. Load the machine so that the center line of the machine aligns with the center line of the trailer flatbed.
2. Slowly move the machine on the ramp.
3. Lower the bucket onto the trailer deck.
4. Stop the engine. Remove the key from the key switch.
5. Operate the control lever several strokes to relieve pressure in the cylinders.
6. Move the control lever lock switch in the lock (🔒) position.
7. Securely close the windows and cab doors to protect the cab from rain. Cover the exhaust outlet. Failure to do this will damage the engine.
8. Install the articulation stopper (lock bar) (1) to prevent the machine from articulating.

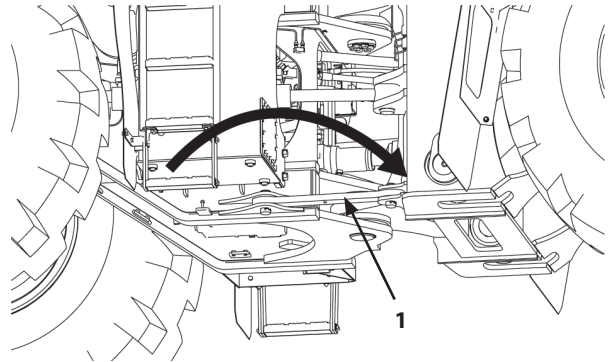

115Z7-AK-LOCK

## TRANSPORTING

### Fastening Machine for Transporting

**⚠ WARNING:** Fasten the machine chassis to the trailer securely with chains and cables. While traveling, loads may shake around, move forward or backward or to the sides.

1. Apply the parking brake. Slowly rest the bucket on the trailer deck or load-carrying platform.
2. Place blocks (1) in front of and behind the tires to prevent the machine from moving.
3. Securely fasten the machine and the front attachment to the truck or trailer platform with heavy chains or wire cables.

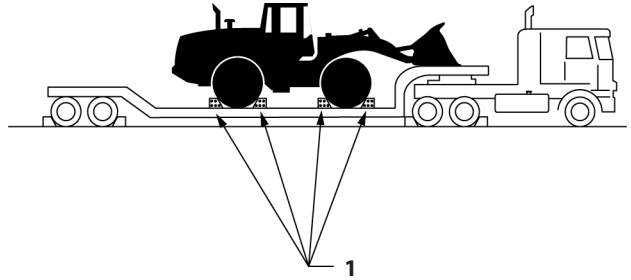

M4GB-06-003

The machines for export are provided with lifting eyes. (Option) Use these eyes for securing the machine.

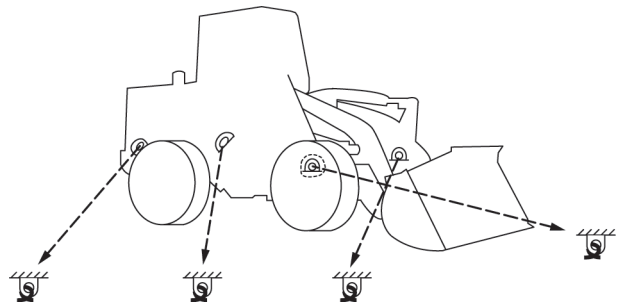

115MNEC-06-02

## TRANSPORTING

---

### Transporting Wheel Loader (Urgent Situation)

The following procedures shall only be applied to cases when urgently moving the wheel loader a short distance is required. When required to transport the wheel loader long distance, use a trailer.

#### Precautions for Driving On Roads

Avoid driving the wheel loader long distances at high-speed as much as possible as it may overheat the tires, possibly resulting in premature tire damage and/or wear. Keep the following points in mind when transporting the wheel loader by driving on roads.

- Observe the rules and regulations associated to this wheel loader, and travel carefully.
- Recommended tire pressures and traveling speeds may vary depending on the type of tires used and the road conditions. Consult your nearest authorized dealer.
- Check the tire pressure before self-traveling when the tires are cool.
- After driving the wheel loader for 30 minutes, allow the wheel loader to park for 30 minutes and meanwhile, check the tires and every part of the machine for any abnormality, and also check the oil and coolant levels.
- Keep the bucket empty when traveling.
- Do not drive the machine with the tires containing calcium chloride or dry ballast, which accelerate heating.

## TRANSPORTING

### Precautions for Towing

**⚠ WARNING:** Never attempt to tow the machine if the brake system is in need of repair. Ask your nearest authorized dealer to repair the machine. Operate the machine only after repairs is completed.

Avoid towing the machine as much as possible. If the machine must be towed, be careful about the following points.

**IMPORTANT:** Do not tow the machine with the parking brake applied. Damage to the parking brake may result.

- If the engine is operable:  
Keep the engine running so that the steering and brake system are operable. Release the parking brake.
- If the engine is inoperable:  
Removing the propeller shafts
  - When the parking brake cannot be released, manually release the parking brake. (Refer to the "Releasing Parking Brake" on page 6-7.) Then, disconnect the front and rear propeller shafts. At this time, wedge wheel stoppers at all tires to prevent the machine from moving.
  - The steering system is inoperable when the engine is stopped. Changing the hydraulic hose connections between the rod end side and the head end side only of one steering cylinder enables the steering wheel operation.

**🔧 NOTE:** Be careful not to spill oil when disconnecting the hoses. Be sure to catch the oil.

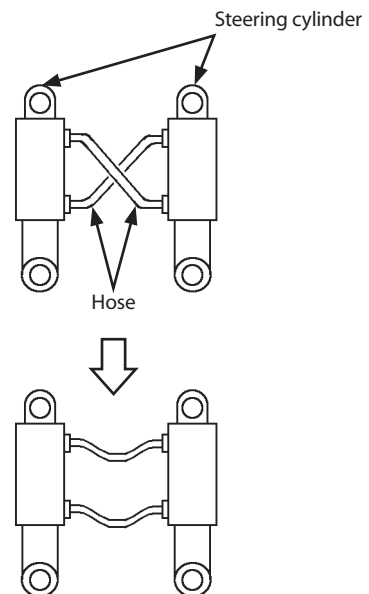

M4GB-06-007



## TRANSPORTING

---

### Releasing Parking Brake

 **WARNING:**

- **Once the parking brake is released, the machine becomes impossible to stop with the parking brake system, possibly resulting in personal injury or death.**
- **Before releasing the parking brake be sure to chock tires with wheel stoppers.**

 **CAUTION:**

- **As soon as towing is complete, connect the parking brake.**
- **Towing only when moving the machine to a place where the machine is inspected and/or serviced. Avoid towing to move the machine over a long distance.**

Release the parking brake manually only when the parking brake switch becomes inoperable due to any abnormality or failure in the brake system such as a pump.

# TRANSPORTING

## Procedures

### WARNING:

- Once the parking brake is released, the machine becomes impossible to stop with the parking brake system.
- Chock all tires to prevent the machine from moving.
- Before restarting to operate the machine, consult your nearest authorized dealer to have the parking brake adjusted.

1. Remove lock bolt (3) on the front differential and remove flange nuts (4) from both parts (A).

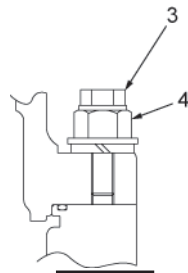

Detail of A

95Z7-6-8-2

2. Loosen hose band (5) and remove rubber cap (6) from manual release bolt (2).
3. Install the flange nuts, which were removed at step 1, to manual release bolt (2).
4. Tighten flange nuts (4) alternately and evenly until contacting with housing (1).
5. Then, tighten flange nuts (4) until you feel the nuts are rather tight; the brake is released.

 NOTE: After contacting with housing (1), approximately 3 or 4 additional turns of the flange nuts will release the parking brake.

6. After finishing the work, install flange nuts (4) to the original positions. Secure flange nuts (4) with lock bolts (3). Install rubber caps (6) to manual release bolts (2) and secure rubber caps (6) with hose bands (5).

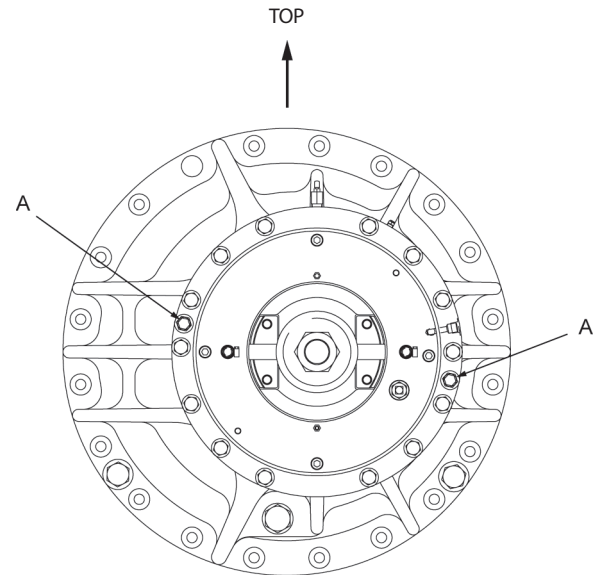

115Z7-6-8-1

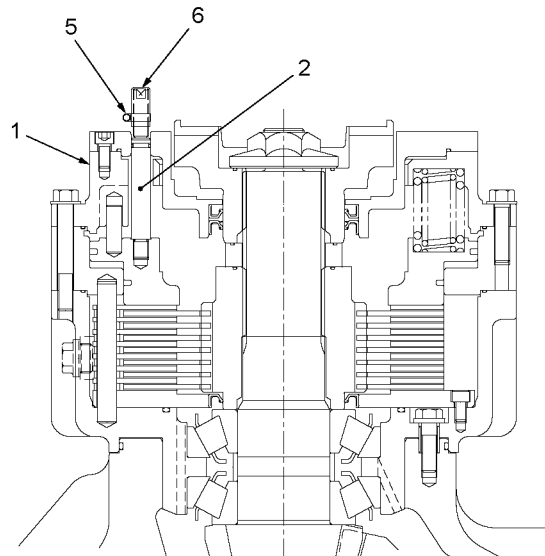

115Z7-6-8-2

# TRANSPORTING

## Towing Method

Attach wire ropes to the machine when the machine must be towed, in such cases when the machine cannot be moved from soft ground under its own power.

### CAUTION:

- Use wire cable having the strength more than approx. 150 % of the machine weight.
- Towing from the front end of the machine

Attach wire ropes to the machine using eye plates on the front chassis as indicated in the illustration. Always use soft material at the corners between the front chassis and wire cables to prevent damage to the wire cables.

- Towing from the rear end of the machine

Attach wire ropes to the machine using the towing pin on the rear chassis as indicated in the illustration. Always use the lock pin after completely inserting the drawbar pin to prevent the wire cables from coming off.

 NOTE: Refer to page 1-138 for towing pin.

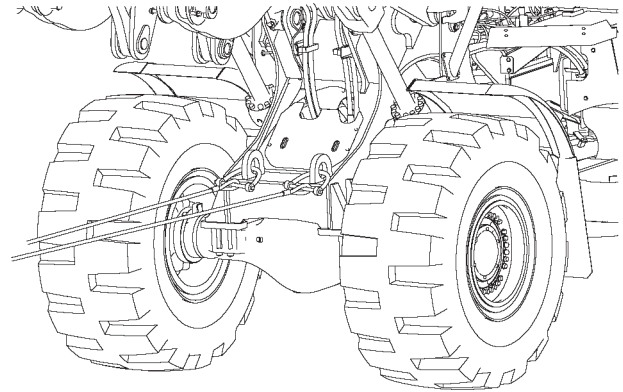

Front chassis

MNHE-05-003

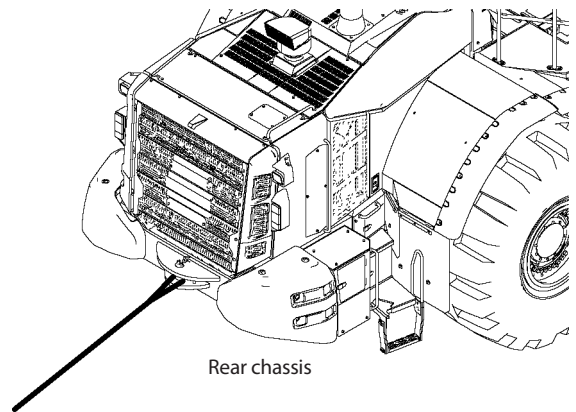

Rear chassis

115Z7B-6-9-2

# TRANSPORTING

## Lifting Machine

### WARNING:

- The lifting tools are optional. Install specified lifting tools at your nearest authorized dealer.
- Use lifting cables and other lifting tools that are free from any damage and/or aging, and properly rated for the load.
- Consult your nearest authorized dealer for correct lifting procedures, and size and types of lifting cable and tools.
- Before lifting the machine, move the control lever lock switch to the lock (🔒) position to prevent the machine from moving unexpectedly.
- Rigidly secure the front and rear chassis using the articulation stopper (lock bar) so that the machine front and rear chassis will not steer.
- Incorrect lifting procedure and/or incorrect wire cables may cause the machine to move (shift) while being lifted, resulting in machine damage and/or injury of personnel.
- Do not lift the machine quickly. Excessive load will be applied to the wire cables and/or lifting tools, and may cause them to break.
- Do not allow anyone to come close to or under the raised machine.

### Lifting

1. Straighten the machine and lower the front attachment as illustrated to the right.
2. Move the control lever lock switch in the lock (🔒) position.
3. Rigidly secure the front and rear chassis using the articulation stopper (lock bar) (Refer to page 1-137).
4. Stop the engine. Remove the key from the key switch.
5. Use cables long enough so that the cables do not come in contact with the machine chassis when the machine is lifted.

Wrap some protectors around wire ropes and/or support bar as required to prevent the sheet metal from being damaged. Be sure to use the specified lifting tools.

6. Set the crane in an appropriate position on a firm, level surface.
7. Attach the cable to the lifting tools.
8. Load machine slowly and carefully, as desired.

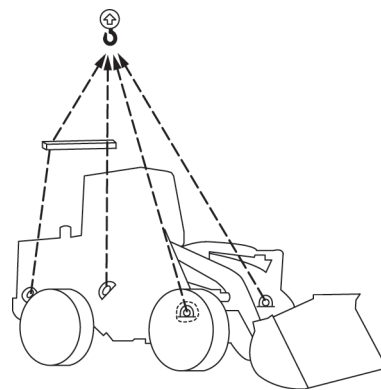

115MNEC-05-01

# MAINTENANCE

---

## Correct Maintenance and Inspection Procedures

Learn how to service your machine correctly. Follow the correct maintenance and inspection procedures shown in this manual.

Inspect machine daily before starting.

- Check controls and instruments.
- Check coolant, fuel, DEF and oil levels.
- Check for leaks, kinked, frayed or damaged hoses and lines.
- Walk around machine checking general appearance, noise, heat, etc.
- Check for loose or missing parts.



SA-005

If there is any problem with your machine, repair it before operating or contact your authorized dealer for repairs.

### IMPORTANT:

- **Use only recommended coolant, fuel, DEF, and lubricants.**
- **Be sure to use only genuine Hitachi parts. Failure to do so may result in serious injury or death and/or machine breakdown.**
- **Failure to use recommended coolant, fuel, DEF, lubricants, and genuine Hitachi parts will result in loss of Hitachi product warranty.**
- **Never adjust engine governor.**  
**Never adjust hydraulic system relief valve.**
- **Protect electrical parts from water and steam.**
- **Never spray high pressure water or steam to the transmission oil filler port, transmission air breather, and vicinity of the axle air breather.**
- **Never disassemble electrical components such as main controller, sensors, etc.**
- **Never adjust parts of engine fuel system.**  
**Never adjust hydraulic equipment.**
- **Using bad quality fuel, drainage agent, fuel additives, gasoline, kerosene or alcohol refueled or mixed with specified fuel may deteriorate performance of fuel filters and cause surface problems between moving parts at lubricated contacts in the injector. It also affects the engine and aftertreatment device parts, leading to malfunction.**
- **Use Hitachi genuine high performance filter.**

## MAINTENANCE

---

- Machine Information Controller

This machine provides a machine information controller that stores machine operation information for preventive maintenance.

When maintaining the machine, our authorized service man may download the stored information via satellite.

Consult with your nearest authorized dealer for detailed function of this device.

- Communication Terminal Operation (Option)

It is not necessary to check or operate the communication terminal however if any abnormality is found, consult your nearest authorized dealer.

Before installing any covering attachment such as a head guard, consult your nearest authorized dealer.

Never spray water on the communication terminal and wiring.

- Inquire on the proper way to recycle or dispose of oil, fuel, coolant, DEF, filters, batteries and other waste from your local environmental or recycling center, or from your authorized dealer.

## MAINTENANCE

---

### **Check the Hour Meter Regularly**

Refer to the List of Check and Maintenance for information about lubricants, check and adjustment intervals. The lubrication chart is affixed on the left side of the front chassis. Refer to 7-5 page.

This manual recommends grouping the intervals into three categories as follows:

- Daily Check : To be conducted daily before operation (every 10 hours)
- Monthly Check : To be regularly conducted once per month (every 250 hours)
- Annual Check : To be regularly conducted once per year (every 2000 hours)

Check and maintenance intervals shown in this manual are those for the machines to be operated under normal conditions. In case the machine is operated under more severe conditions, shorten the intervals.

# MAINTENANCE

## Layout

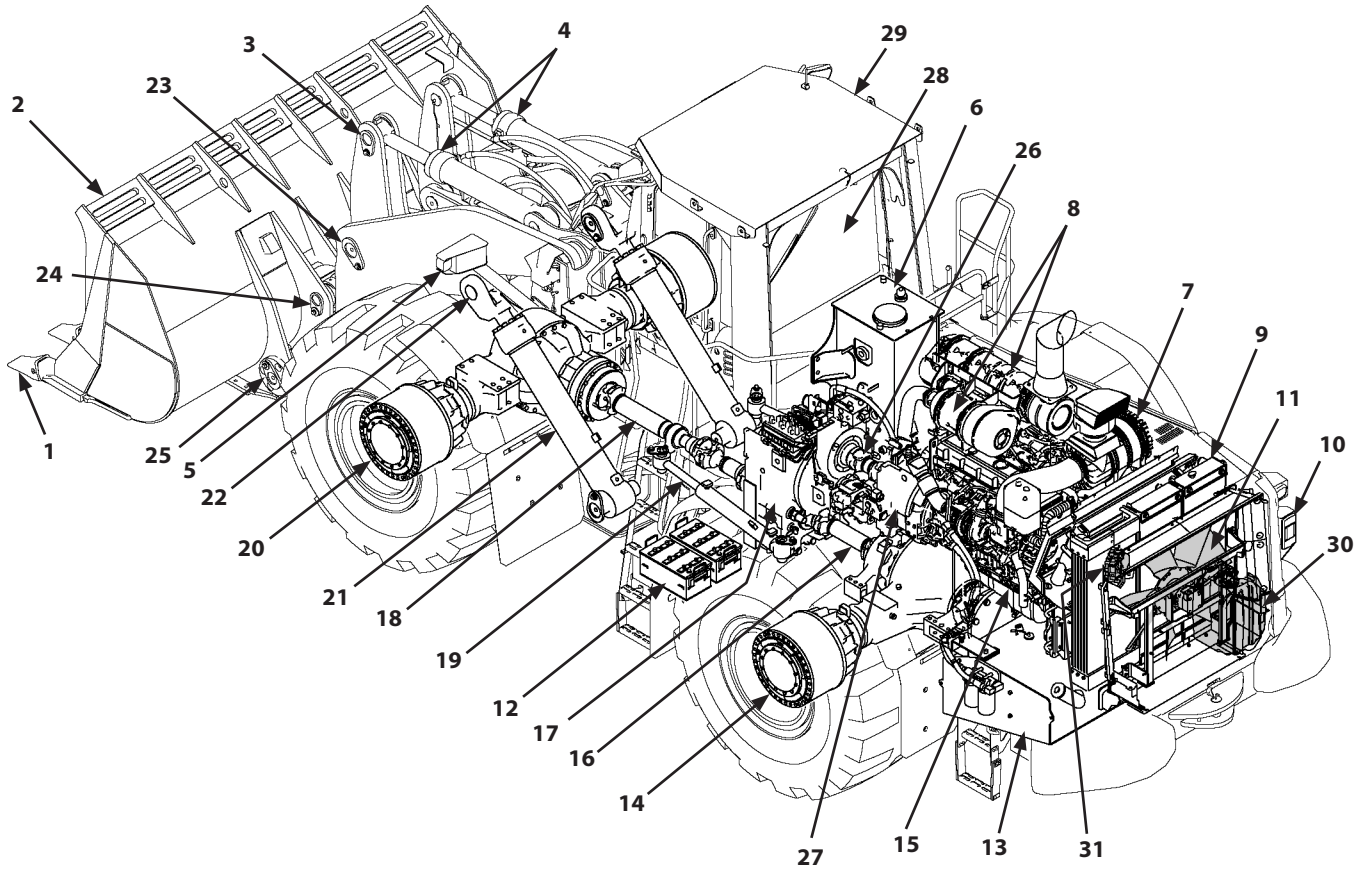

115Z7B-1-2-1

- 1- Bucket Teeth
- 2- Bucket
- 3- Bucket Cylinder Rod Pin
- 4- Bucket Cylinder
- 5- Front Combination Lamp
- 6- Hydraulic Oil Tank
- 7- Air Cleaner
- 8- Aftertreatment Device
- 9- Radiator, Oil Cooler, and Other Cooling System
- 10- Rear Combination Lamp
- 11- Radiator Fan
- 12- Battery
- 13- Fuel Tank
- 14- Rear Axle
- 15- Engine
- 16- Third (Rear) Propeller Shaft
- 17- Transmission
- 18- Second (Front and Center) Propeller Shaft
- 19- Steering Cylinder
- 20- Front Axle
- 21- Lift Arm (Boom) Cylinder
- 22- Lift Arm (Boom) Cylinder Rod Pin
- 23- Bell Crank (Lever) Pin
- 24- Bucket Link Pin
- 25- Bucket Hinge Pin
- 26- First (Main) Propeller Shaft
- 27- Torque Converter
- 28- Cab
- 29- ROPS (Roll Over Protective Structure)
- 30- DEF Tank
- 31- DEF Supply Module



# MAINTENANCE

## Lubrication Guide

The lubrication chart is affixed on the left side of the front chassis. Lubricate and/or service the parts at the intervals as instructed in the chart so that all necessary maintenance can be performed regularly.

- Lubrication Chart

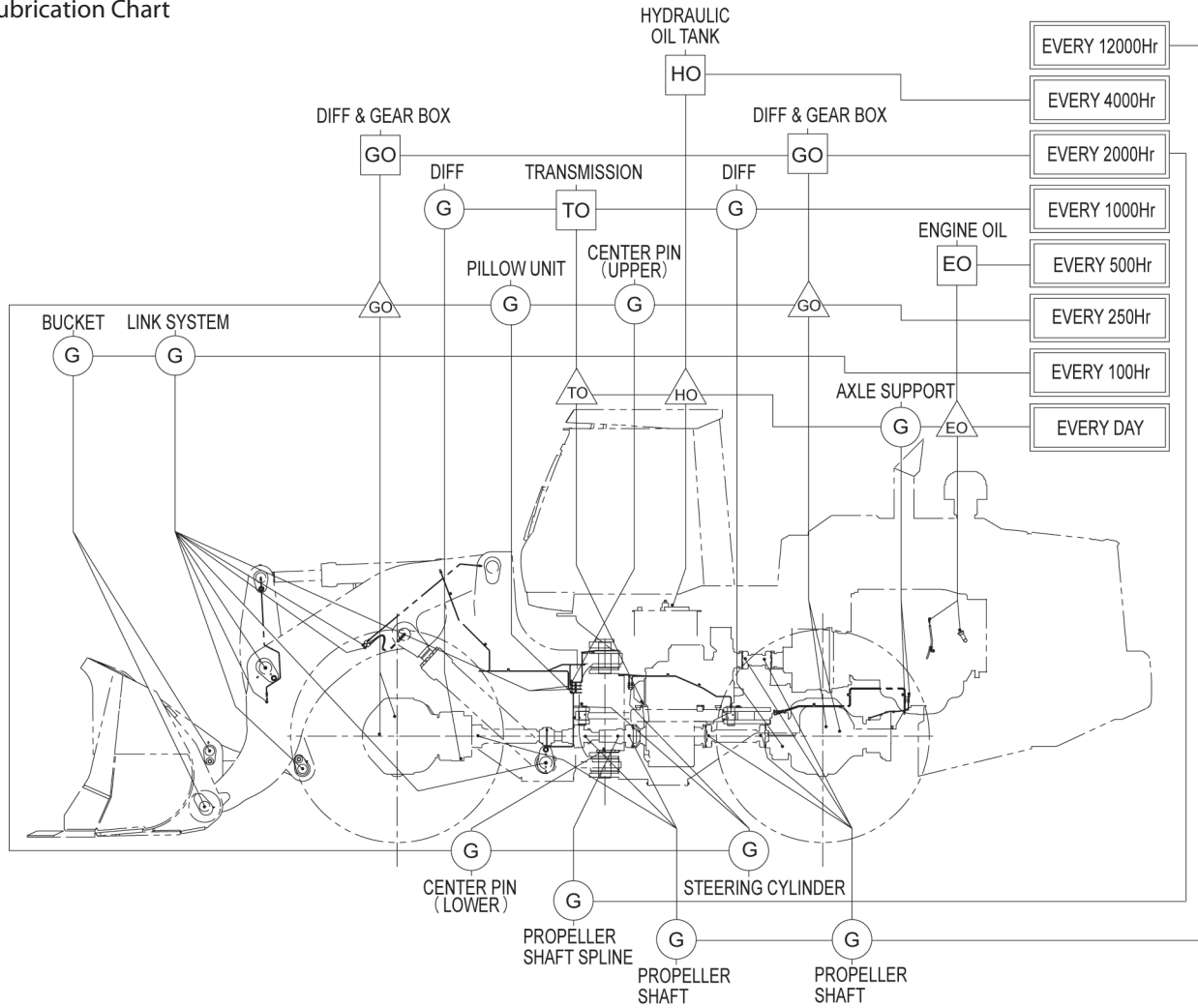

115Z7-44794-24380

- Symbols

The following symbols are used in the lubrication chart.

○ Grease point	G Multipurpose grease	HO Hydraulic oil
△ Check and add if necessary	GO Gear oil	TO Engine oil
□ Oil replacement	EO Engine oil	

## MAINTENANCE

### Preparations for Inspection and Maintenance

**⚠ WARNING:** If ride control switch (3) (option) is in the AUTO position, the lift arm may unexpectedly rise. To avoid an accident due to unexpected movement of the lift arm and bucket, always turn ride control switch (3) OFF before beginning the inspection and/or maintenance of the machine.

**⚠ CAUTION:** If the machine is unexpectedly moved, a serious accident may result. Be sure to apply the parking brake when parking the machine.

Unless specified otherwise, park the machine by following the procedures below before beginning the inspection and/or maintenance work.

1. Park the machine on a solid level surface.
2. Lower the working tools such as the bucket level to the ground.
3. Turn ride control switch (3) OFF.
4. Set forward/reverse switch (4) on the joystick steering to the neutral position. Push the lock button and fully raise armrest (5) until it locks in the raised position.

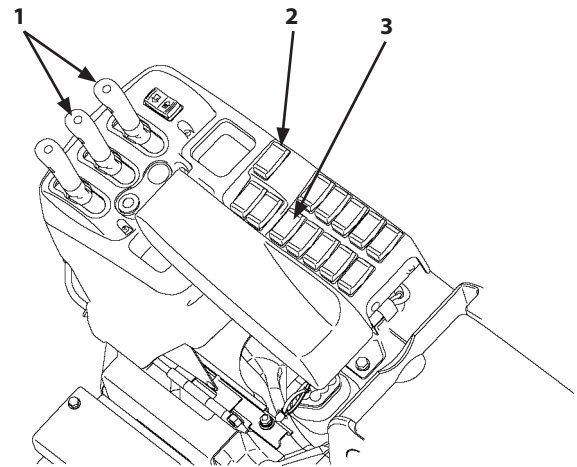

115Z7B-1-9-4

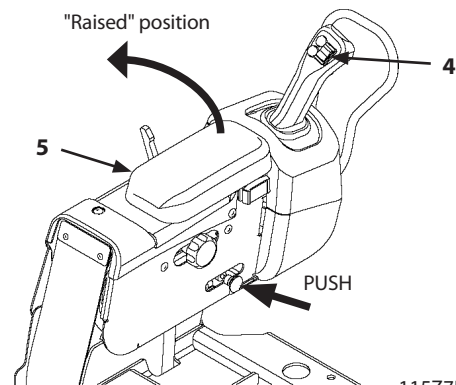

115Z7B-1-10-3

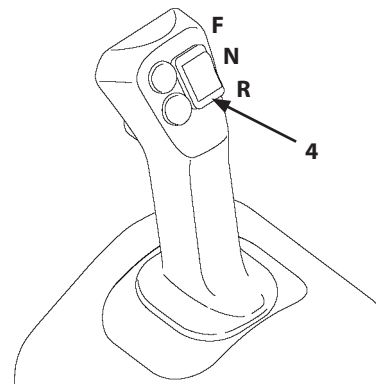

115Z7B-4-4-1

## MAINTENANCE

5. Apply the parking brake (Turn parking brake (6) ON.)
6. Chock the tires.
7. Run the engine at low idle speed for a few minutes to cool the engine. Turn key switch (7) OFF to stop the engine. Again, turn key switch (7) ON and place control lever lock switch (2) to the unlock (U) position.
8. Fully operate the lift arm and bucket control levers (1) 3 to 4 strokes to release residual pressure in the hydraulic system.
9. In case inspection and/or maintenance must be performed with the engine running, use a signal person.
10. Be sure to place control lever lock switch (2) to the lock (L) position.
11. Turn key switch (7) OFF and remove the key.
12. Start working only after putting an "UNDER INSPECTION/MAINTENANCE" tag in a highly visible place such as on the cab door or the control lever.

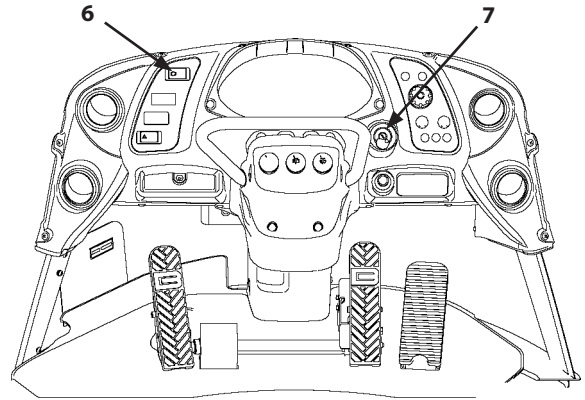

115Z7B-1-81-1

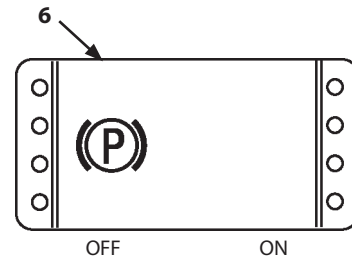

MNEC-01-058

**⚠ WARNING:** Never attempt to maintain the machine when the engine is running. If the engine must be run while working, do the following.

- One person should be in the operator's seat and ready to stop the engine while communicating with other workers.
- When working around moving parts is unavoidable, pay special attention to ensure that hands, feet, and clothing do not become entangled.
- If parts or tools are dropped or inserted into the fan or the belt, they may fly off or be cut off. Do not drop or insert parts and tools into the moving parts.
- Move control lever lock switch (2) to lock (L) position so that the front attachment will not move.
- Never touch the control levers and pedals. If operating the control levers or pedals is unavoidable, signal co-workers to move to a safe place.

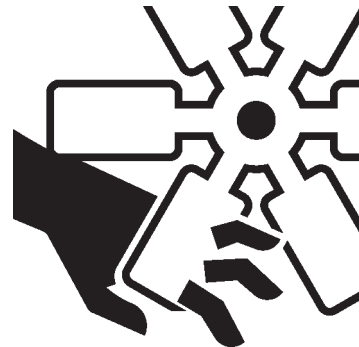

SA-2294

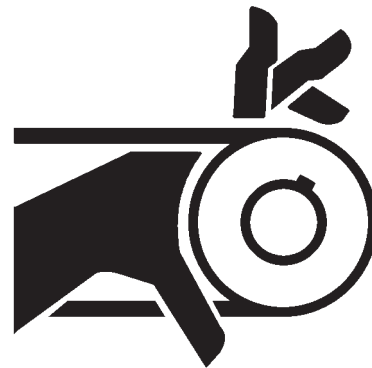

SA-026

# MAINTENANCE

## Articulation Lock

**⚠ WARNING:** With articulation stopper in **LOCKED** position, machine will not steer; which, while operating, could cause an accident, injury or death. Do not lock Articulation Stopper during normal operation.

Articulation stopper locks the front and rear chassis to prevent them from sudden articulation during inspection or transportation.

To lock:

1. Align the front and rear chassis straight ahead.
2. Remove lock bolt (2) to release articulation stopper (1) from the rear chassis.
3. Turn the link and fix the end to the bracket on the front chassis (as shown).
4. Insert the pin and clip pin. (This is the LOCKED position.)

To unlock:

1. Remove the clip pin and pin from the end of articulation stopper (1) on the front chassis bracket.
2. Turn the link to the rear chassis bracket.
3. Fix the end by tightening lock bolt (2). (This is the STORED position.)

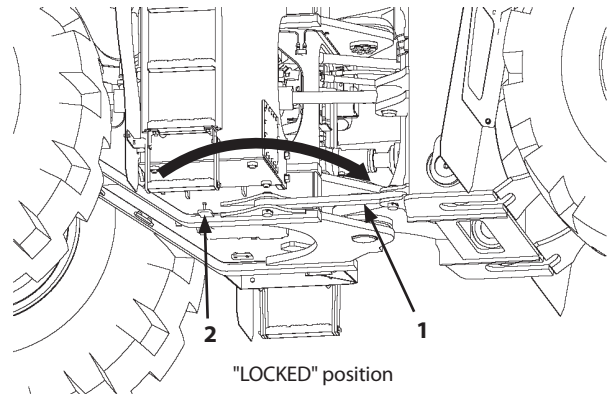

MNHE-07-005

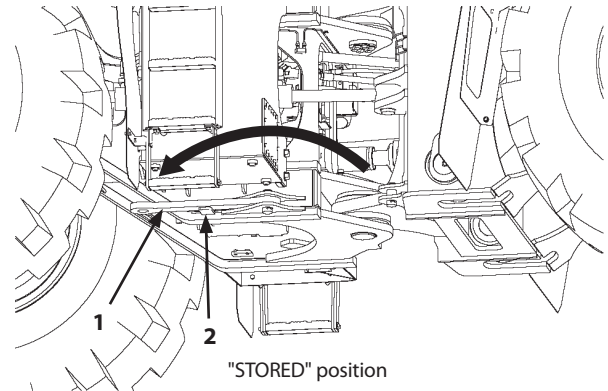

MNHE-07-004

# MAINTENANCE

## Inspection/ Maintenance Access Covers

### ⚠ CAUTION:

- Always close side covers (1) and top cover (3) during operation.
- Do not keep side covers (1) open on a slope or when a strong wind is blowing. Failure to do so may be dangerous because side cover (1) may unexpectedly close.
- Take care not to pinch your fingers when opening/closing the side covers (1) and/or top cover (3).
- In case the machine is equipped with the fenders (2) on side covers (1), never ride on the fenders (2).

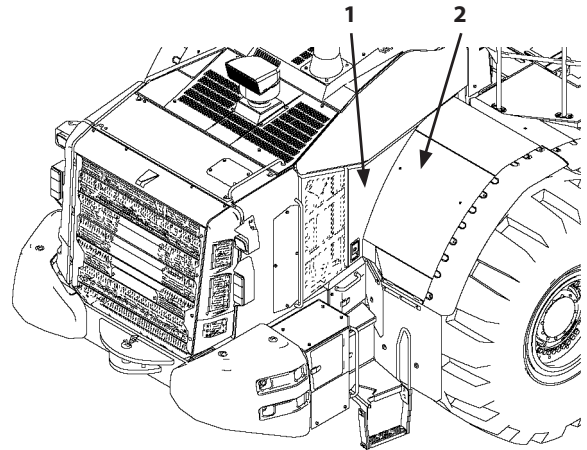

115Z7B-1-142-1

1. When opening side cover (1), pull latch (6).
2. When fully opening side cover (1), lock lever (5) automatically slides and is positioned in the lock position. Make sure that lock bar (5) is firmly positioned to lock the cover.
3. To release the lock, pull wire (4) and release the end of lock bar (5) from the lock position.

 **NOTE:** Top cover (3) is locked when fully opened. Make sure it is secured before starting work.

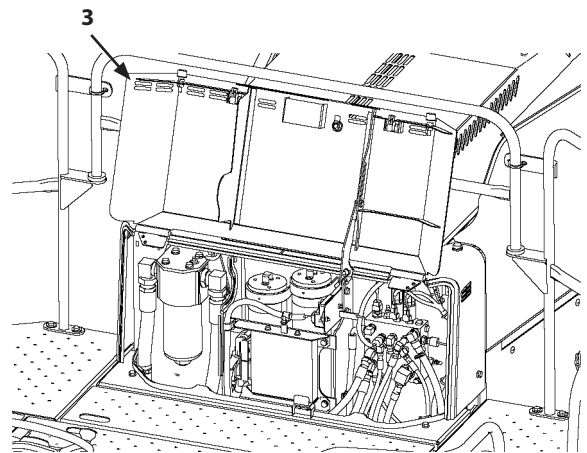

115Z7B-1-142-2

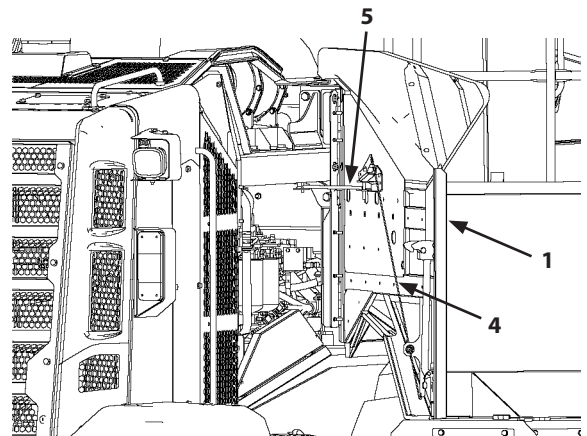

115Z7B-1-142-3

## MAINTENANCE

### Rear Grille

**⚠ WARNING:** Open or close rear grille (4) only after stopping the engine. It is very dangerous if you are entangled in the cooling fan. Before operating the machine, always check that the rear grille is well latched.

**✎ NOTE:** The starter key cannot be removed from latch (3) while rear grille (4) is being opened.

Remove bolt caps (1) and bolts (2). Release latch (3) with the starter key to unlock rear grille (4). The rear grille opens and the cooling fan can be cleaned.

After closing rear grille (4), turn and remove starter key (3) to lock rear grille (4). Tighten bolts (2) and install caps (1).

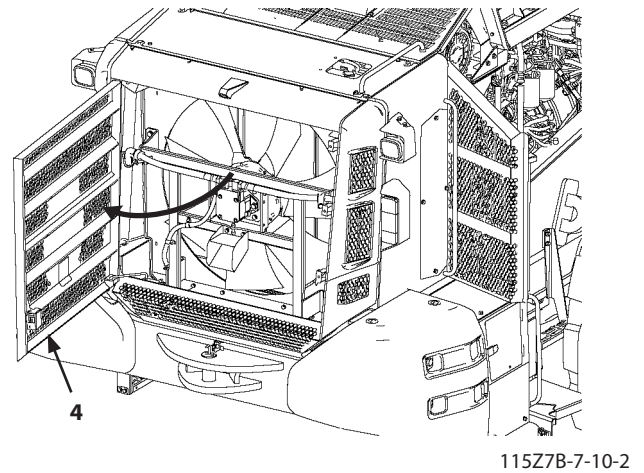
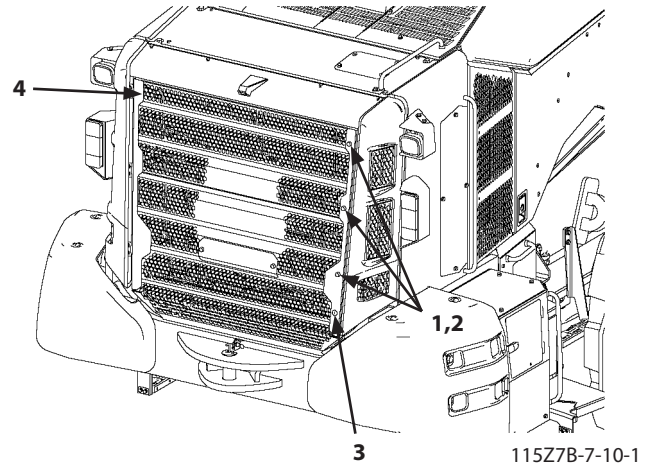

# MAINTENANCE

## Inspection and Maintenance Table

Check and/or carry out the maintenance at intervals of the specified operating hours below or the calendar date, whichever comes first.

<b>IMPORTANT</b>
Severe applications require more frequent maintenance. Severe conditions include heavy dust, extremely abrasive material, caustic chemicals, extremely wet conditions or abnormally hot or cold ambient temperatures.

△: First time replacement or cleaning only

Section	Item for check	Operating hours										Page
		10	50	100	250	500	1000	2000	3000	4000	4500	
Engine	Check Engine Oil Level	○										7-25
	Check Coolant Level	○										7-73
	Check DEF Level	○										7-106
	Check Accelerator Pedal Operation, and Exhaust Gas Color and Noise	○										7-114
	Check Pre-Filter Bowl (and drain if needed)	○										7-59
	Check Fuel Level	○										7-57
	Check Drive Belt (and adjust if needed)	○										7-74
	Check Fuel Hoses	○										7-68
	Replace Engine Oil and Oil Filter Element					○						7-26, 7-28
	Clean Radiator / Oil cooler Cores and Other Cooling System					*3 ○						7-79
	Replace Fuel Main Filter					○						7-62
	Replace Fuel Pre-Filter					○						7-64
	Clean Fuel Supply Pump Strainer					○						7-66
	Clean Fuel Priming Solenoid Pump Strainer						○					7-67
	Drain Fuel Tank Sump						○					7-58
	Check and Adjust Valve Clearance						○					7-116
	Check Engine Compression Pressure						○					7-116
	Check and Clean Starter and Alternator						○					7-116
	Check Sound Absorbing Mat Around Engine						○					7-116
	Replace DEF Supply Module Filter Element										○	7-109
	Check and Adjust Engine Controller (ECM)										○	7-117
	Check Turbocharger										○	7-117
	Check Fuel Injector										○	7-117
	Check Urea SCR System										○	7-117
	Check Dosing Module										○	7-110
	Replace DEF Tank Inlet Filter										○	7-110
	Replace Air Cleaner Element	Outer	Each time monitor indicator illuminates									7-71
		Inner	At the time of the fifth replacement of the outer element (or every 2 years)									
	Change Coolant										○	7-76
	Check and Clean Aftertreatment Device											As required, when regeneration indicator comes ON

**NOTE:** \*3: Shorten maintenance intervals when the machine is operated under severe conditions or when the machine is continuously operated for a long period of time.

## MAINTENANCE

△: First time replacement or cleaning only

Section	Item for check	Operating hours									Page
		10	50	100	250	500	1000	2000	4000	4500	
Transmission & Torque Converter	Check Transmission Oil Level	○									7-30
	Replace Transmission Oil Filter Cartridge				△		○				7-31
	Replace Transmission Oil and Clean Suction Strainer				△		○				7-31
	Clean Transmission/Torque Converter Air Breathers						○				7-34
Axle system	Check Tire for Damage	○									7-95
	Greasing (Axle Support)	○									7-21
	Check Tire (Tire Pressure)	○									7-94
	Greasing (Propeller Shaft Pillow Block Bearing)				○						7-23
	Check Differential Gear Oil Level				○						7-35
	Check Planetary Gear Oil Level				○						7-36
	Check Wheel Bolt Torque		△				○				7-95
	Replace Axle Oil Cooler Line Filter (Option)						○				7-39
	Greasing (Axle Seal)						○				7-24
	Greasing (Propeller Shaft Spline)							*3 ○			7-23
	Replace Differential Gear Oil							○			7-37
	Replace Planetary Gear Oil							○			7-38
	Retighten Front Axle and Rear Axle Support Mounting Bolts		△					○			7-118
	Greasing (Main (1st) Propeller Shaft)									Every 12000 hours *3 ○	7-22
	Greasing (Front (2nd) Propeller Shaft)									Every 12000 hours *3 ○	7-22
	Greasing (Center (2nd) Propeller Shaft)									Every 12000 hours *3 ○	7-23
	Greasing (Rear (3rd) Propeller Shaft)									Every 12000 hours *3 ○	7-23
Clean Axle Oil Cooler Fins (Option)									As required ○	7-40	
Steering system	Check Play Amount in Joystick Steering	○									7-113
	Greasing (Steering Cylinder)	*1 △			○						7-20
	Clean Pilot Oil Filter							○			7-47
	Check Gas Pressure in Accumulator							○			7-52
Brake system	Check Parking Brake Force	○									7-89
	Check Right and Left Brake Interlocking Performance	○									7-88
	Check Parking Brake Gear Oil Level				○						7-90
	Check Accumulator Function, Gas Leakage, Looseness, and Damage					○					7-92
	Replace Parking Brake Gear Oil							○			7-91
	Check Brake Disks (Service and Parking)							○			7-93
	Check Gas Pressure in Accumulator							○			7-93
	Clean Pilot Oil Filter							○			7-48

 NOTE:

\*1: Add grease daily during first 50 hours of operation. In case the machine is engaged in excavation in mud, water or snow, add grease after each work shift.

\*3: Shorten maintenance intervals when the machine is operated under severe conditions or when the machine is continuously operated for a long period of time.



## MAINTENANCE

△: First time replacement or cleaning only

Section	Item for check	Operating hours									Page
		10	50	100	250	500	1000	2000	4000	4500	
Loading system	Check Hydraulic Oil Level	○									7-43
	Check Bucket Teeth	○									7-111
	Check Hoses and Lines for Leaks	○									7-53
	Check Hoses and Lines for Cracks, Bends, Etc.				○						7-53
	Greasing	*1 △		*2 ○							7-19
	Check Ride Control Accumulator Function, Gas Leakage, Looseness, and Damage (Option)					○					7-52
	Replace Hydraulic Tank Oil Return Filter						○				7-49
	Replace Air Breather Element							○			7-50
	Check Pilot Circuit Accumulator Function, Gas Leakage, Looseness, and Damage							○			7-51
	Check Gas pressure in Ride Control Accumulator (Option)							○			7-52
	Change Hydraulic Oil and Clean Suction Filter								*4 ○		7-44, 7-46
Chassis	Check Outer and Inner Rear View Mirrors	○									7-115
	Check ROPS, ROPS Mounting Bolts, and Cab	○									7-112
	Check and Replace Seat Belt and Lower Tether	○	Every 3 years								7-112
	Clean Engine Room and Hood	○									7-116
	Check Steps, Grab Handles and Handrails	○									7-115
	Check Windshield Washer Fluid Level	○									7-113
	Greasing (Center Pin)				○						7-21
Electrical system	Check All Monitor Functions and Instrument Operation	○									7-84
	Check Horn and Back Up Alarm Operation	○									7-85
	Check Work Lights	○									7-85
	Check Electrical Harnesses and Fuses		○								7-86
	Check Battery Electrolyte Level			○							7-82
	Check Electrolyte Specific Gravity				○						7-83

 NOTE:

\*1: Add grease daily during first 50 hours of operation. In case the machine is engaged in excavation in mud, water or snow, add grease after each work shift.

\*2: After 50 hours of operation, carry out greasing every 100 hours of operation afterwards. Shorten greasing intervals when the machine is operated under severe conditions or when the machine is continuously operated for a long period of time.

\*4: Hydraulic oil changing interval differs according to the kind of hydraulic oil used.

## MAINTENANCE

△: First time replacement or cleaning only

Section	Item for check	Operating hours									Page
		10	50	100	250	500	1000	2000	4000	4500	
Air Conditioner	Clean/Replace Air Conditioner Circulation/Fresh Air Filters			*3○			○				7-99
	Check Air Conditioner Compressor Belt (and adjust if needed)						○				7-102
	Check Refrigerant Level						○				7-103
	Check Air Conditioner Condenser						○				7-102
	Check Air Conditioner						○				7-101
	Check Air Conditioner Piping						○				7-101
	Check Compressor and Pulley							○			7-103
	Replace Air Conditioner Receiver Dryer	Every 3 years or 6000 hours ○									7-103
Others	Check Tightening Torque of Bolts and Nuts		△					○			7-119

 NOTE:

\*3: Shorten maintenance intervals when the machine is operated under severe conditions or when the machine is continuously operated for a long period of time.

## MAINTENANCE

### Kind of Oils

#### Grease

Kind of Grease	Multipurpose-type Lithium Grease
Application	Chassis Lubrication, Front Attachment Joint Pins
Air Temperature	-20 to 45 °C (-4 to 113 °F)
Oil Specification	NLGI 2 EP

 **NOTE:**

- Be sure to use a lithium-based grease for universal joints and a propeller shaft spline. If other types of chassis grease are used, premature wear and/or a noise emission may result.
- NLGI No. 2 grease is suitable for most temperatures and some auto-lube systems. Use NLGI No. 1 or No. 0 grease for extremely low temperature.

#### Engine Oil

**IMPORTANT: Use engine oil equivalent to DH-2 specified in JASO or CJ-4, API. Failure to do so may reduce the engine performance and/or shorten the engine service life. Please be noted that all engine failures caused by using engine oil other than specified are excluded from Hitachi Warranty Policy. Consult your nearest authorized dealer for the unclear points.**

Kind of Oil	Engine Oil	
Application	Engine Crank Case	
Air Temperature	-20 to 30 °C (-4 to 86 °F)	-15 to 40 °C (5 to 104 °F)
Oil Specification	API CJ-4, JASO DH-2	
	SAE10W-30	SAE15W-40
	SAE10W-40	

#### Transmission Oil

Kind of Oil	Engine Oil
Application	Transmission and Torque Converter
Air Temperature	-20 to 45 °C (-4 to 113 °F)
Oil Specification	API CF 10W Class

 **NOTE:** When the atmospheric temperature is below -20 °C: Contact your authorized dealer.

## MAINTENANCE

### Axle Oil

Kind of Oil		Gear Oil	
Application		Axle & Wet Disc Brake	
Air Temperature		-25 to 45 °C (-13 to 113 °F)	
Recommended Product	Hitachi	High Gear Oil TKTT15150-4th	
Alternative Product		TO-4 SAE50 Fluid, TO-4M Fluid, with 6% friction modifier	

 **NOTE:**

- When using TO-4 SAE50 or TM-4M Fluid other than the listed recommended products, add 6% additive to prevent or eliminate service brake application noise. Recommended additive package: HCM 9990A or equivalent.
- The acceptable ambient temperature when using TO-4 SAE50 Fluid should fall within the range -15 to 45°C (5 to 113°F).  
The acceptable ambient temperature when using TO-4M Fluid should fall within the range -30 to 45°C (-22 to 113°F).

### Hydraulic Oil

Kind of Oil		Hydraulic Oil	
Application		Hydraulic System (Hydraulic Oil Tank)	
Air Temperature		-20 to 45 °C (-4 to 113 °F)	
Change Interval		4000 hours	2000 hours
Recommended Product	Hitachi	Super EX 46HN	-
Alternative Product		-	JCMAS HK VG46W

 **NOTE:**

- Never mix hydraulic oils containing zinc with zinc-free hydraulic oils as hydraulic system component damage could result.
- Use appropriate oil of viscosity depending on the temperature. Low temperature viscosity will differ depending on each product. Contact each hydraulic oil manufacture directly.

### Recommended Coolant

Refer to page 7-72 for information.

## MAINTENANCE

### List of Consumable Parts

#### 1. Filter Elements

	Part No.
Engine Oil Filter	4696643
Fuel Main Filter	YA00033486
Fuel Pre-Filter Element	4906070100
Air Cleaner Element (Outer)	3098171070
Air Cleaner Element (Inner)	3098171060
Hydraulic Oil Tank Suction Filter	4033560150
Hydraulic Oil Tank Filter (with O-ring)	YA00026486
Pilot Oil Filter (Brake Circuit)	4033060610
Pilot Oil Filter (Steering Circuit)	3098170720
Transmission Oil Filter	3098170620
Oil Tank Air Breather Valve Element	3098170990
Air Conditioner Circulating Air Filter	YA00001490
Air Conditioner Fresh Air Filter	4251527
Air Conditioner Receiver Dryer	4552070070
Axle Oil Filter (option)	4034470090
DEF/AdBlue® Supply Module Main Filter	YA00047054
DEF/AdBlue® Tank Inlet Filter	YA60050027

#### 2. Drive Belts

	Part No.
Air Conditioner Drive Belt	4300160090
Alternator Drive Belt	4690909

 **NOTE:** The part numbers are subject to change without notice.  
Refer to the parts catalog.

## MAINTENANCE

### 3. Combination Light and Other Light

		Part No.	
Head Light	Head Light Assembly	4436232	
	Bulb	4434679 (24 V, 70/75 W)	
Front Combination Light	Front Combination Light Assembly	2640242432	
	Lens	Front	4661233
		Rear	4661234
	Bulb	3848070930	
Work Light	Front Work Light Assembly	4336570	
	Bulb	3848071100	
	Lens	4570171270	
	Rear Work Light Assembly	4489060370	
	Bulb	3848071120	
	Lens	4570171280	
Rear Combination Light	Rear Combination Light Assembly	4488160490	
	Lens	Amber	4570171160
		Clear	4570171170
		Red	4570171180

### 4. Slow Blow Fuses

	Part No.
70A	4315073
140A	YA00021809

 **NOTE:** The part numbers are subject to change without notice. Refer to the parts catalog.

# MAINTENANCE

## A. Greasing

**CAUTION:** Apply the parking brake and the articulation stopper (lock bar) (Refer to page 7-8).

**NOTE:**

- Until break-in is performed for more than 50 hours, lubricate the machine every day to get initial lubrication.
- In case excavation is made in mud, water or snow, lubricate the machine after operation is complete.
- Add high quality grease through the grease fittings. After removing contamination around the grease fitting, add grease. After greasing, thoroughly remove the old grease that was pushed-out from the seals and grease at the grease zerk nipple.

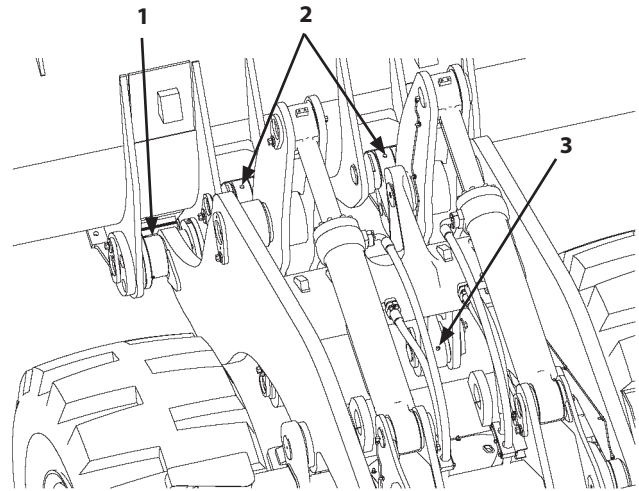

MNHE-07-009

1. One point each to right and left bucket hinge pins (1).  
--- every 100 hours
2. One point each to right and left bucket link pins (2 and 3).  
--- every 100 hours
3. One point to bucket cylinder pin (4).  
--- every 100 hours  
One point to bucket cylinder rod pin (5).  
--- every 100 hours
4. One point to bell crank pin (6).  
--- every 100 hours
5. One point each to right and left lift arm cylinder rod pins (7).  
--- every 100 hours
6. One point each to right and left lift cylinder pins (8).  
--- every 100 hours  
One point each to right and left lift arm pivot pins (9).  
--- every 100 hours

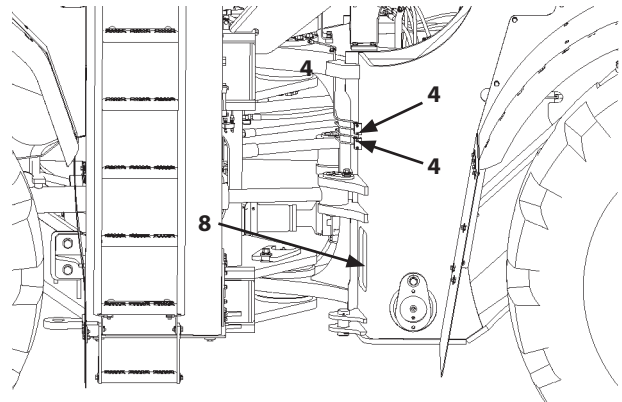

MNHE-07-010

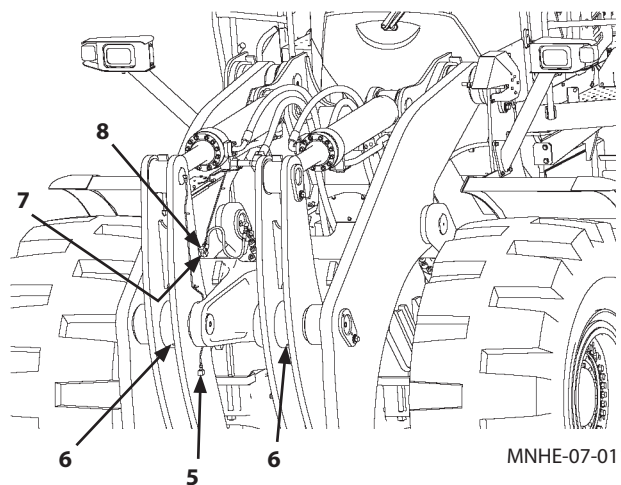

MNHE-07-011

## MAINTENANCE

---

7. Two points to right steering cylinder pins (10 and 11).  
--- every 250 hours

Cylinder right front (10)  
Cylinder right rear (11)

8. Two points to left steering cylinder rod pins (12 and 13).  
--- every 250 hours

Cylinder left front (12)  
Cylinder left rear (13)

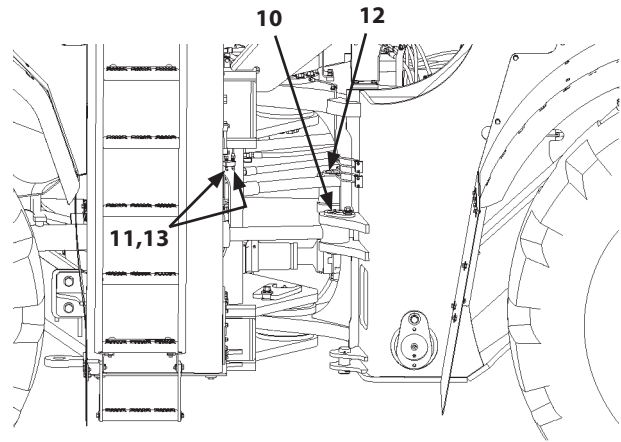

MNHE-07-010



## MAINTENANCE

---

9. One point each to upper and lower center hinge pins (14 and 15).

--- every 250 hours

Upper (14)

Lower (15)

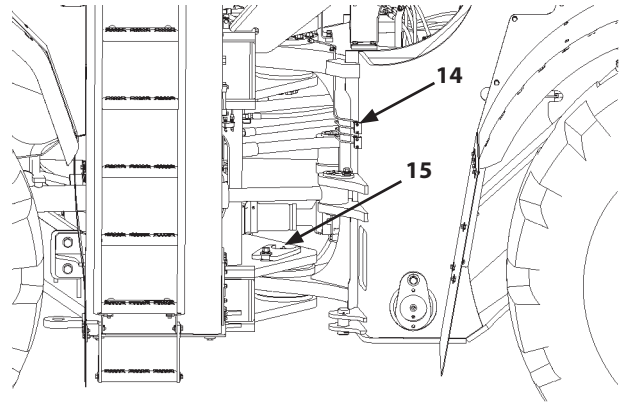

MNHE-07-010

10. One point each to front and rear axle support pins (16 and 17).

--- every 10 hours

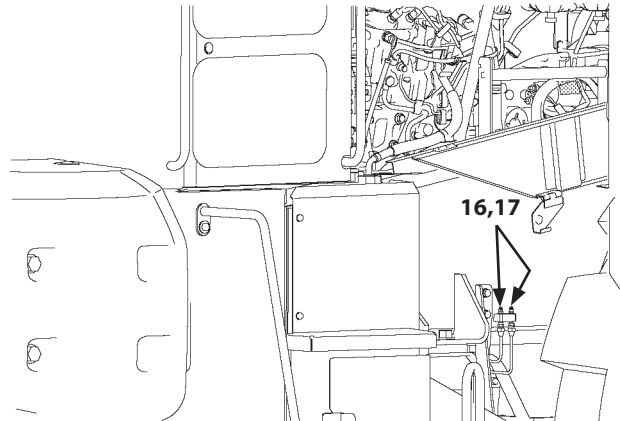

MNHE-07-012

## MAINTENANCE

11. Two points to main propeller shaft universal (26).  
--- every 12000 hours

 **NOTE:** When the machine is continuously operated under severe conditions for a long time, shorten the greasing intervals.

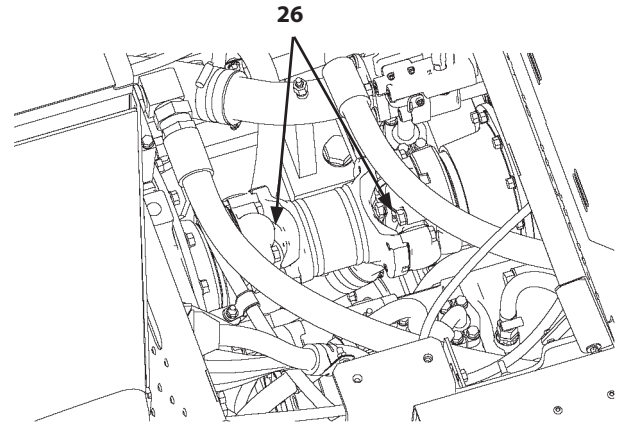

MNHE-07-017

12. One point to front (second) propeller shaft universal (18).  
--- every 12000 hours

 **NOTE:** When the machine is continuously operated under severe conditions for a long time, shorten the greasing intervals.

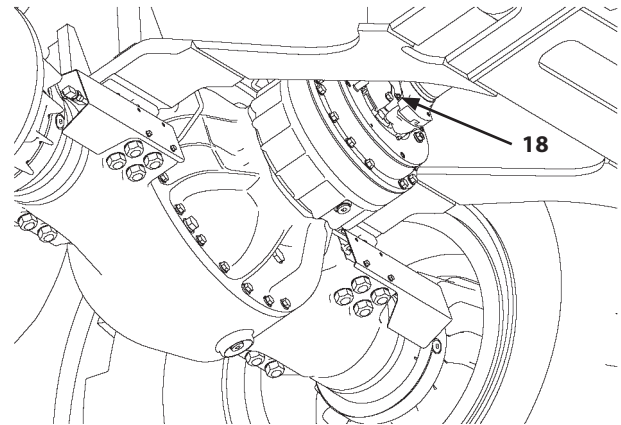

MNHE-07-013

## MAINTENANCE

13. One point to propeller shaft pillow unit (19).  
--- every 250 hours

14. One point to center (second) propeller shaft universal front (20).  
--- every 12000 hours

One point to center (second) propeller shaft universal rear (22).  
--- every 12000 hours

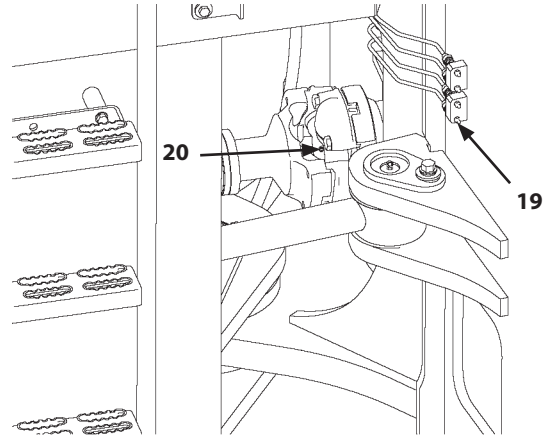

MNHE-07-014

15. One point to center (second) propeller shaft splines (21).  
--- every 2000 hours

 **NOTE:** When greasing spline (21), steer the machine fully to the right or left, and stop the engine. Lubricate the fitting, start the engine and slowly turn the machine from side to side 2 or 3 times after greasing to lubricate the spline enough.

**IMPORTANT:** When greased with the machine positioned in straight, remove the fitting on the sleeve yoke before starting the engine.

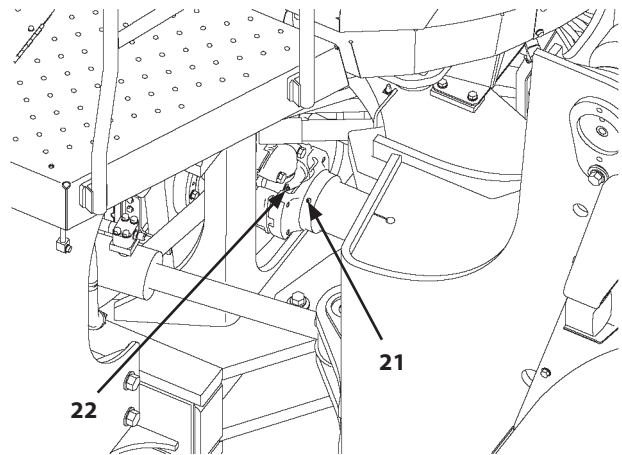

MNHE-07-015

16. Two points to rear (third) propeller shaft universal (23).  
--- every 12000 hours

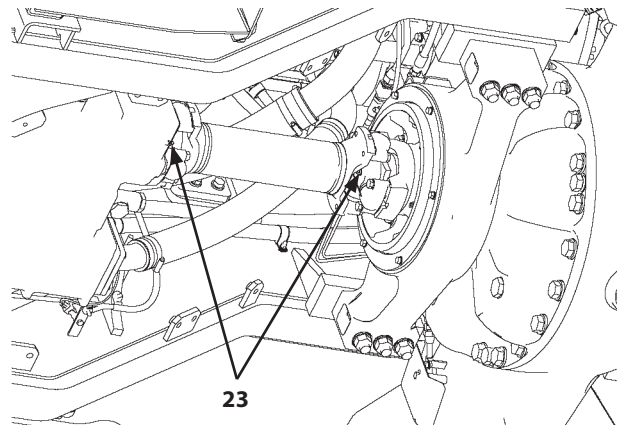

MNHE-07-016

## MAINTENANCE

17. One point each to front and rear axle seal (24).

--- every 1000 hours

- Remove breather nipple (25).
- Fill grease from grease nipple (24) until it spills out of breather nipple (25) hole.
- Wipe the spilled grease and install breather nipple (25).

 **NOTE:** Breather nipple (25) is located on the top, opposite position of grease nipple (24).

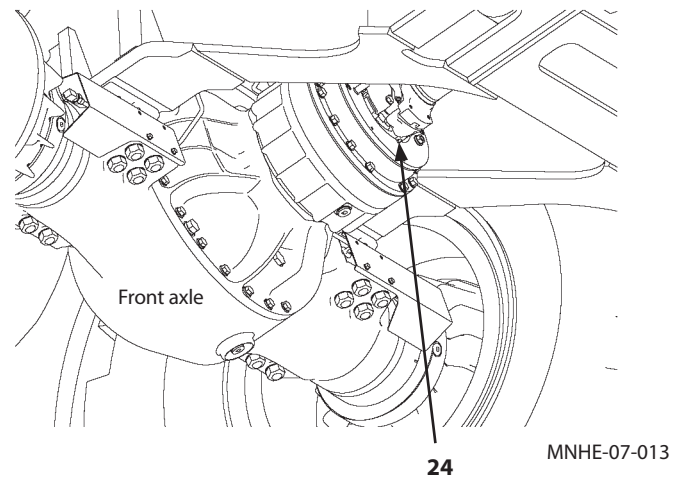
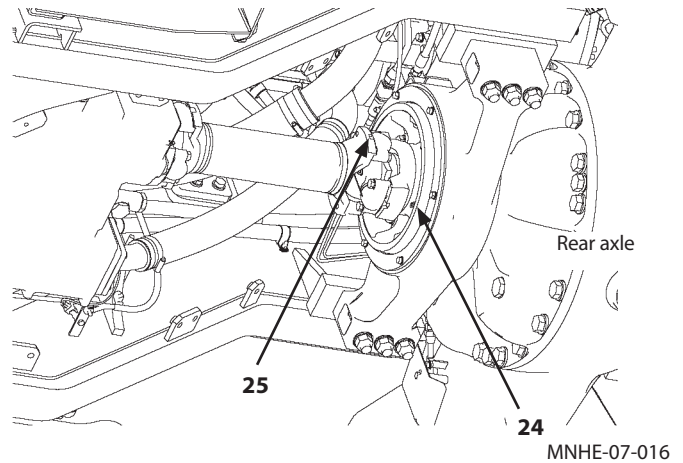

# MAINTENANCE

## B. Engine

- 1** Check Engine Oil Level  
--- every 10 hours (machine parked on a level surface before starting the engine)

**IMPORTANT:** Incorrect engine oil level may cause engine trouble (The oil level should be between the upper and lower marks on oil level gauge (1)).

If engine oil level is too high, lower the oil level to the proper place before starting the engine.

Check oil level before starting the engine. If the engine has been running, stop the engine and wait at least 30 minutes before checking the oil level.

Pull out oil level gauge (1). Check for mixing of foreign matter or contamination in the oil. Wipe oil level gauge (1) with cloth, re-insert it into the pipe to the end, and then pull it out again. The oil level should be between the [HIGH] and [LOW] marks on oil level gauge (1).

If oil level is below the [LOW] mark, add the recommended engine oil via oil filler (2).

If oil level exceeds the [HIGH] mark, loosen drain plug (3) to drain excess oil.

🔑 : Plug (3): 78.5 N-m (8.0 kgf-m, 58 lbf-ft)

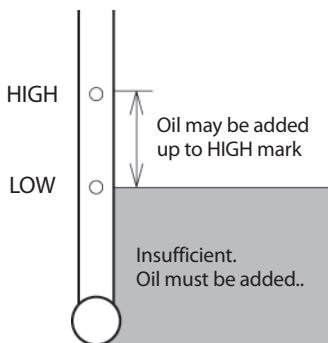

95Z7-7-25-3

**NOTE:** Level the machine when adding oil or inspecting oil level. When required to check oil level after operating the machine, first stop the engine. Wait for more than 30 minutes. Then check oil level. (This means that the oil will return to the oil pan, then oil level can be checked.) In case the oil color changes, severe contamination, and/or mixing of foreign matter may be seen, change the oil.

**CAUTION:** Do not spill oil while changing oil. Spilled fuel, oil, and other flammables may cause fires.

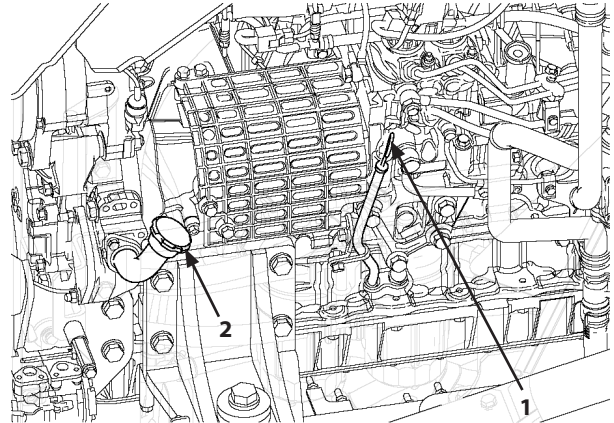

95Z7B-7-25-1

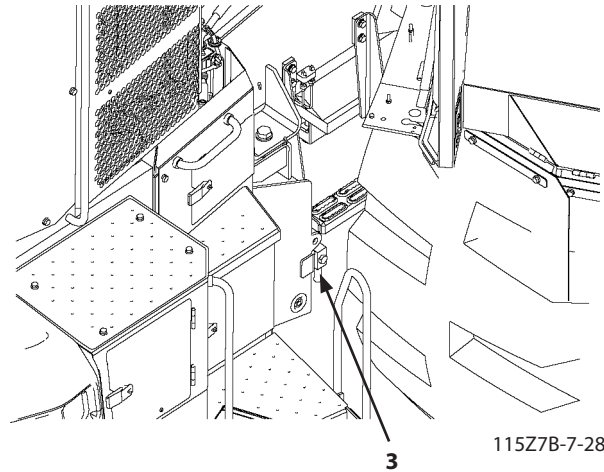

115Z7B-7-28-3

## MAINTENANCE

### 2 Change Engine Oil --- every 500 hours

**⚠ WARNING:** Immediately after the machine has been operated, all engine parts are hot. Wait for the engine to cool before starting any maintenance work. Failure to do so may cause severe burns.

**📌 NOTE:** Improper disposal of waste oil can threaten the earth's environment and ecology. Dispose the waste oil in accordance with the local regulation and/or law. Be sure to replace the engine oil filter when changing the engine oil at the same time.

1. Park the machine following the same procedures as described on page 7-6 for preparation of inspection/maintenance work.
2. Clean the areas around the drain plug and the oil filler.
3. Arrange a 60 liter (16 gallons) - capacity container to receive the drain oil.
4. Loosen drain plug (3) provided on the fuel tank side to allow oil to drain.
5. Drain oil from the oil filter cartridge.

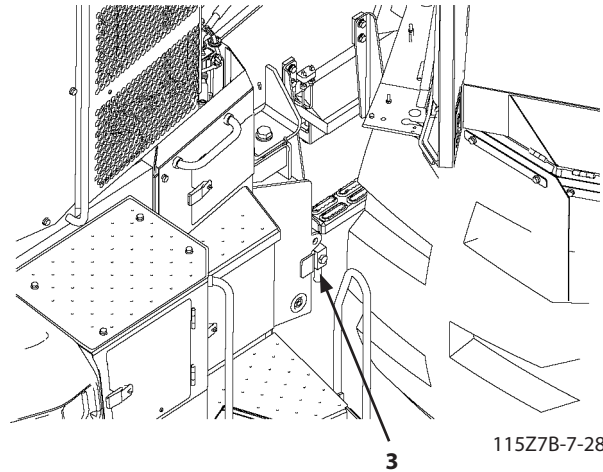

115Z7B-7-28-3

## MAINTENANCE

6. Allow oil to drain through a clean cloth to check if any foreign matters such as metal pieces are not in the oil.
7. Install a new oil filter.  
(Refer to the descriptions for **3** *Replace Engine Oil Filter.*)
8. Securely tighten drain plug (3).  
Tightening torque: 78.5 N·m (8.0 kgf·m, 58 lbf·ft)
9. Remove oil filler cap (2).  
Supply the specified amount of approved engine oil.  
Refer to "Kind of Oils" - "Engine Oil" on page 7-15.  
57 liters (15 gallons)

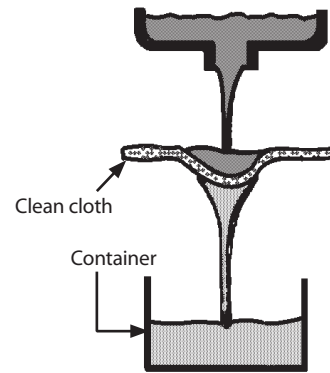

M4GB-07-020

### IMPORTANT:

- **When filling oil, take care not to allow foreign matter to enter.**
  - **Do not spill oil. Wipe off spilled oil, if any, as it may cause fires.**
10. Securely tighten oil filler cap (2).
  11. Check that the oil level is between the maximum and minimum level scales on oil level gauge (1).
  12. Wait 5 minutes after refueling and, start the engine.
  13. Keep the engine running at low idle speed for 5 minutes, check the sealing surfaces for any oil leakage, and stop the engine.
  14. About 20 minutes later, recheck the oil level. If necessary, add oil.

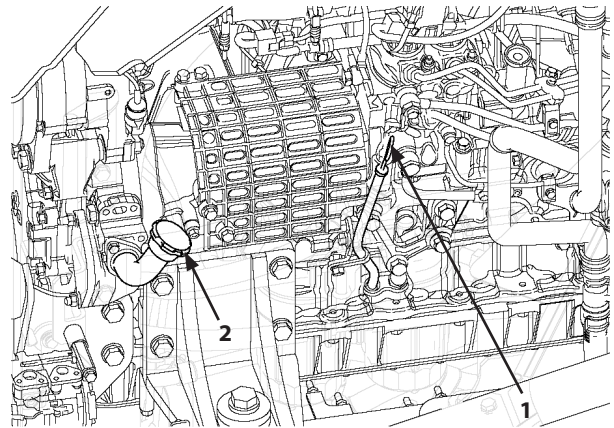

95Z7B-7-25-1

## MAINTENANCE

### 3 Replace Engine Oil Filter

--- every 500 hours (each time when engine oil is changed)

**WARNING:** Immediately after the machine has been operated, all engine parts are hot. Wait for the engine to cool before starting any maintenance work. Failure to do so may cause severe burns.

1. Park the machine following the same procedures as described on page 7-6 for preparation of inspection/maintenance work.

#### IMPORTANT:

- When replacing oil filters (1), make sure to replace both of them at the same time.
- When installing the oil filter, make sure that the gasket is not caught at the rim. This could cause oil leakage.
- Any dirt on the cock or plug must be wiped off before installing it.
- Do not perform abrupt engine idling, which may cause an engine failure.
- After replacement, run the engine and confirm that there is no oil leakage from the area around the filter.

2. Clean around the oil filler cap so that foreign matter does not enter. Remove the oil filler cap.
3. Place a container of approx. 60 L (16 gallons) capacity under the oil pan and drain plug (2) to receive the drain oil.
4. Remove oil pan drain plug (2) to drain the oil. Retighten the plug.

**NOTE:** After all oil has been drained, inspect the cloth for any debris such as small pieces of metal.

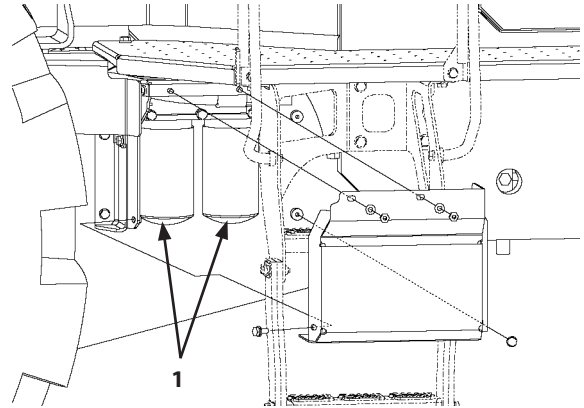

115Z7B-7-27-2

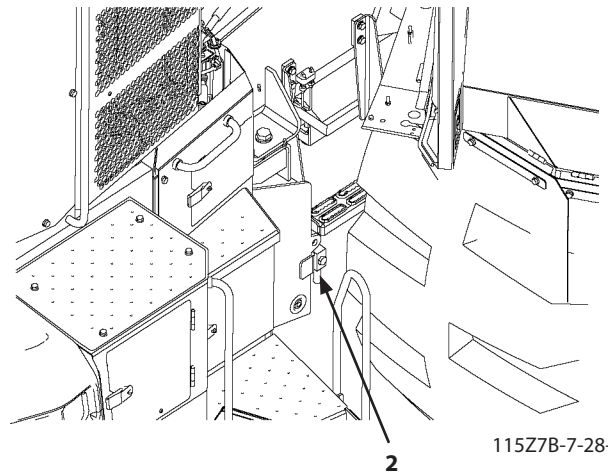

115Z7B-7-28-3



## MAINTENANCE

5. Remove element (3) by turning it counterclockwise with the tool (oil filter wrench).
6. Apply a thin coat of clean engine oil to the gasket of a new element.

### IMPORTANT:

- Do not reuse element (1).
  - When replacing oil filter elements, make sure to replace both of them at the same time.
7. Install a new element.  
Screw in the element until the gasket comes in contact with the seal surface. Then tighten it by one more turn using the tool (oil filter wrench).
  8. Replace the other filter element in the same manner.
  9. Confirm that the oil pan drain cock or plug is securely tightened.
  10. Remove the oil level gauge and carefully supply the specified amount of engine oil from the oil filler.
  11. Install the oil level gauge and the filler cap.
  12. Start the engine 5 minutes after refueling.
  13. While running the engine at low idle, check the oil filter, drain cock, and sealing surfaces for any oil leakage.
  14. Stop the engine. About 20 minutes later, recheck the oil level. If necessary, add oil.

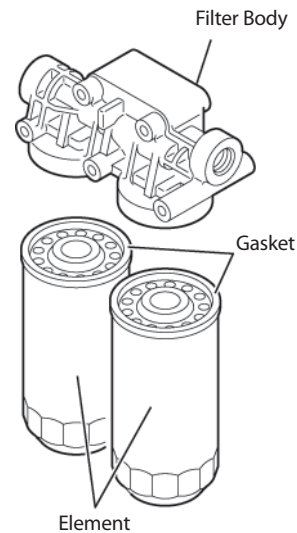

MNHE-07-068

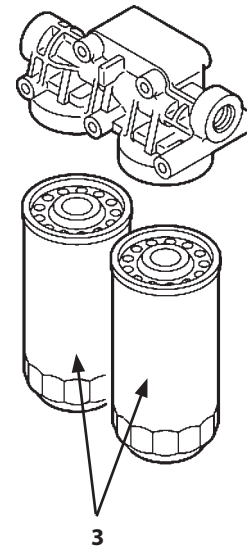

# MAINTENANCE

## C. Power Train

### 1 Check Transmission Oil Level --- every 10 hours (daily)

#### ⚠ WARNING:

- Move forward/reverse switch (or lever) to neutral and turn parking brake switch ON.
- After leveling the bucket on the ground, move the control lever lock switch to the lock (🔒) position.
- Set the articulation stopper (lock bar) (Refer to page 7-8).

#### IMPORTANT:

- Do not start the engine when the transmission oil level is low. Damage to the transmission may result. Do not use transmission oils other than those listed in the "Transmission Oil".
- Never spray high pressure water to the cap and vicinity of the cap. Water may enter into the transmission, damage to the transmission may result.

1. Park the machine on level ground, apply the parking brake, and lower the attachment onto the ground.
2. Check the oil level with engine at low idle.
3. At low oil temperature, check if the oil surface level is within the "COLD" window of sight gauge (2).
4. At high oil temperature, check if the oil surface level is within the "HOT" window of sight gauge (2).
5. If the oil level is lower than the specified, add recommended oil from filler port (1) while the engine is at idle. Do not overfill.

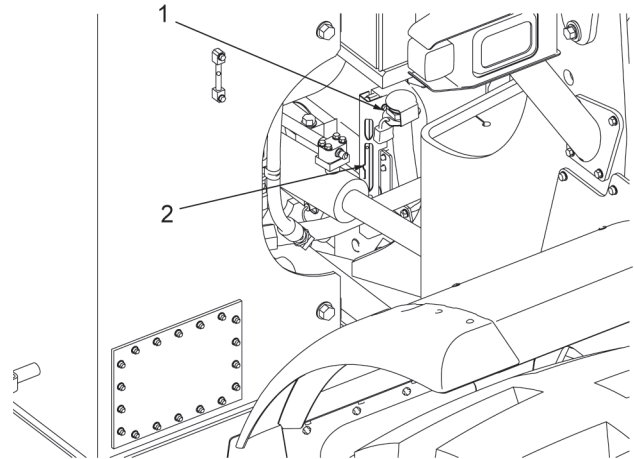

115Z7-7-29-1

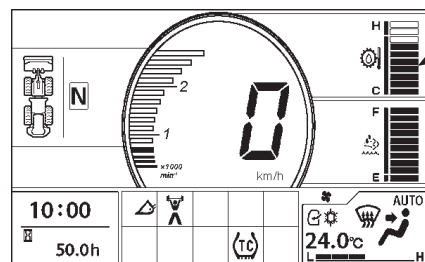



Transmission oil temperature gauge

MNHG-01-103EN

## MAINTENANCE

- 2** Change Transmission Oil  
--- every 1000 hours (250 hours at first change only)
- 3** Clean Suction Strainer  
--- when changing transmission oil
- 4** Change Transmission Oil Filter  
--- every 1000 hours (250 hours at first change only)

 **NOTE:** Be sure to replace the transmission oil filter when changing the transmission oil.

 **WARNING:** Unexpected movement of the machine may cause a serious accident. When parking the machine, turn off the joystick steering system by fully raise armrest (1). Then, turn off parking brake switch (2) to apply parking brake and stop the engine.

 **WARNING:** Before changing oil, install articulation stopper (lock bar) (3) to securely hold the front and rear chassis to avoid an accident due to unexpected machine movement.

**IMPORTANT:** Do not use transmission oils other than those listed in the "Kind of Oils" - "Transmission Oil".

1. Operate the machine until the transmission oil is heated to the appropriate temperature.
2. Park the machine and follow the procedures as described on page 7-6 for preparation of inspection/maintenance work.
3. Make sure to turn off the joystick steering system, and to install articulation stopper (3) to lock the front and rear chassis.

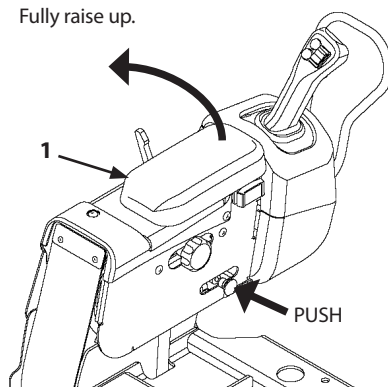

115Z7B-1-10-3

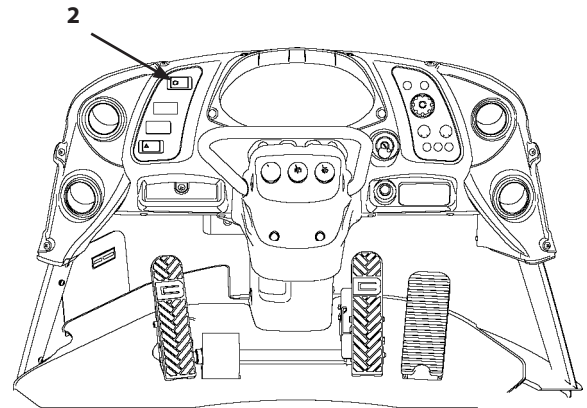

115Z7B-1-81-1

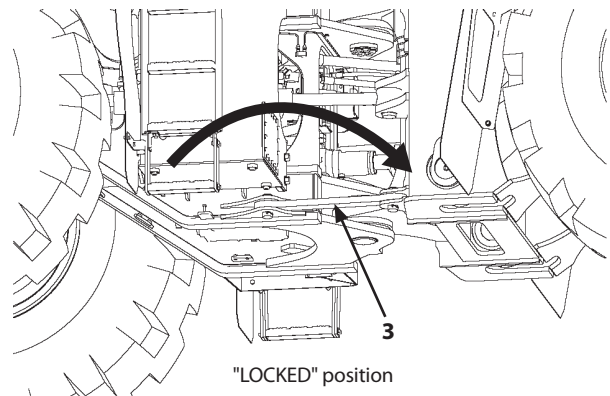

MNHE-07-005

## MAINTENANCE

**IMPORTANT:** The machine is equipped with a turbocharged engine. Cool down before stopping the engine. Failure to do so may cause the lubricant on the turbocharger bearing and seal surfaces to be dissipated due to the intense heat present inside the turbocharger, possibly damaging the turbocharger.

4. Turn the key switch OFF to stop the engine. Leave the machine untouched for 10 minutes.

5. Prepare a container of more than 120 L (32 gal) capacity to receive the oil.

6. Remove drain plug (5) from the transmission bottom to drain the oil. Dispose of the oil in accordance with local regulations.

7. Loosen four bolts (6) with a 14 mm wrench.

8. Remove flange (7) together with the pipe and suction strainer (8).

9. Remove set screw (9) using a 2.5 mm (0.1 in) hex (allen) wrench from strainer (8).

10. Remove suction strainer (8) from flange (7). Brush off any debris and clean with solvent.

 **NOTE:** It is normal for a few fine particles to be on strainer (8). Large pieces or a large quantity of particles indicates a problem. Contact your authorized dealer if you find excessive debris.

11. Reassemble and reinstall strainer (8), gasket (7) and the drain plug with a new gasket (10).

12. Tighten four bolts (6).

Tightening torque: 53 N·m (5.4 kgf·m) (39 lbf·ft)

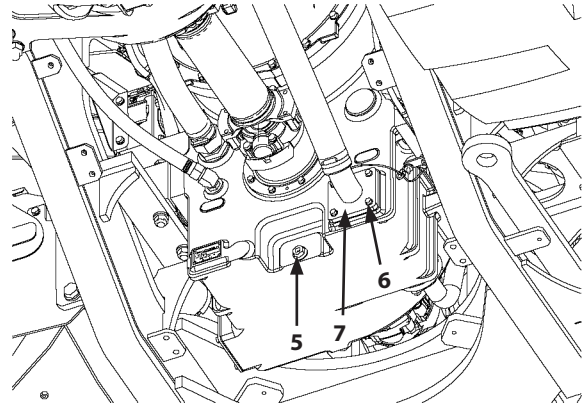

115Z7B-7-32-1

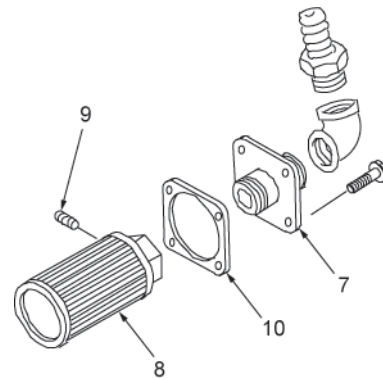

95Z7-7-32-2

## MAINTENANCE

13. Prepare a container of about 4 L (1 gal) capacity under oil filter (11).
14. Remove the drain plug on the bottom of the filter case with a 24 mm (0.94 in) wrench.
15. Using a 46 mm (1.8 in) wrench, remove the filter case.
16. Replace the element, and seals with new ones. Properly dispose of the oil and filter.
17. Clean the filter case with solvent.
18. Clean the filter head gasket surface.

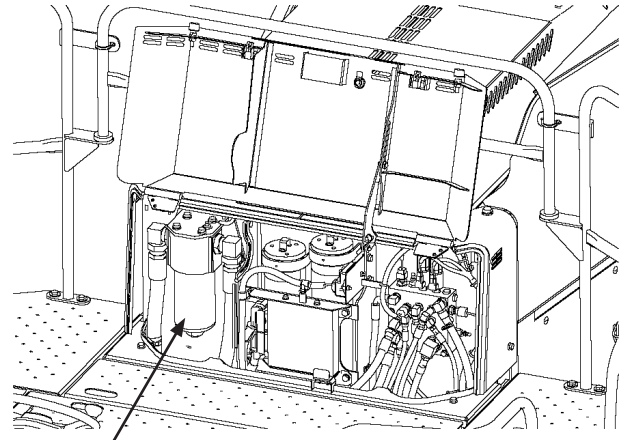

19. After coating the new filter gasket surface with new oil, reinstall the filter on the filter head.

 :  $98 \pm 9.8 \text{ N}\cdot\text{m}$  ( $10 \pm 1 \text{ kgf}\cdot\text{m}$ ) ( $72.3 \pm 7.2 \text{ lbf}\cdot\text{ft}$ )

20. Clean and install the oil drain plug.

 :  $59 \pm 5 \text{ N}\cdot\text{m}$  ( $6 \pm 0.5 \text{ kgf}\cdot\text{m}$ ) ( $43.4 \pm 3.6 \text{ lbf}\cdot\text{ft}$ )

21. Refill the specified amount of oil through transmission oil filler port (12).

90 liters (24 gallons)

22. Start the engine and keep it running for two minutes.

23. Check that the oil level is within the specified range in oil level gauge (13). Refill as necessary.

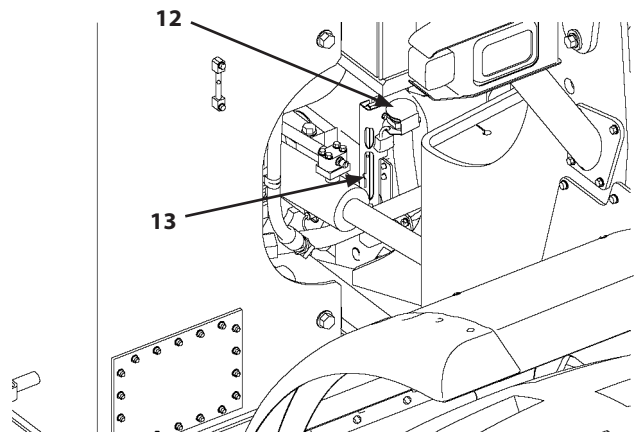

### NOTE:

- Never reuse element (11).
- Check for any oil leakage at the drain plug and the filter mounting area.

## MAINTENANCE

### 5 Clean Transmission and Torque Converter Air Breathers

--- every 1000 hours

1. Open two top covers (decks) (1) behind the cab by removing two each of fixing bolts (2). Lock the covers in the opened position.
2. Clean the vicinity around air breathers (3, 4).  
Put a cover on the air breather port to prevent foreign matter from entering.

**WARNING:** Be sure to wear safety glasses when cleaning the air breather with compressed air.

3. Clean the air breather using compressed air.  
If completely contaminated, wash the air breather with a cleaning solvent, blow it dry and reinstall it.
4. Take care not to allow foreign matter to enter when reinstalling the air breather.
5. Close covers (1) and tighten bolts (2).

**WARNING:** Be sure to tighten bolts (2) to prevent covers (1) from opening or falling down unexpectedly.

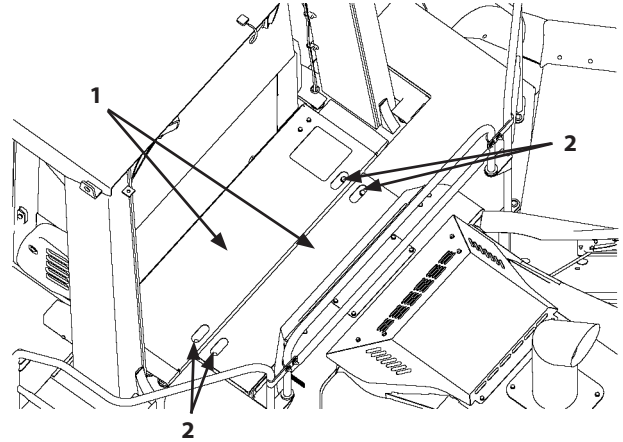

115Z7B-7-37-3

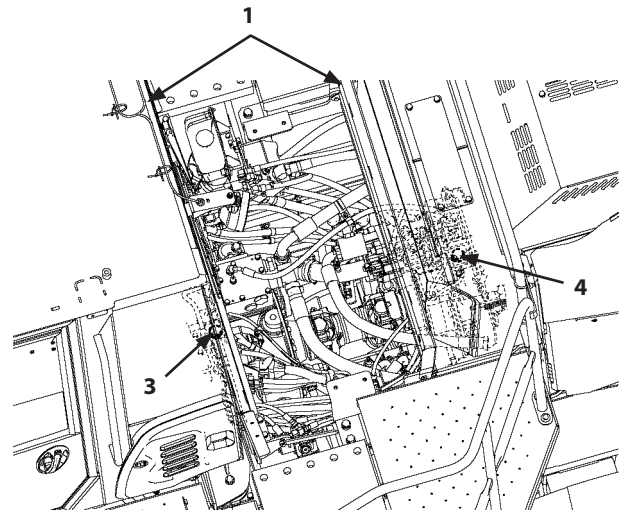

115Z7B-7-37-2

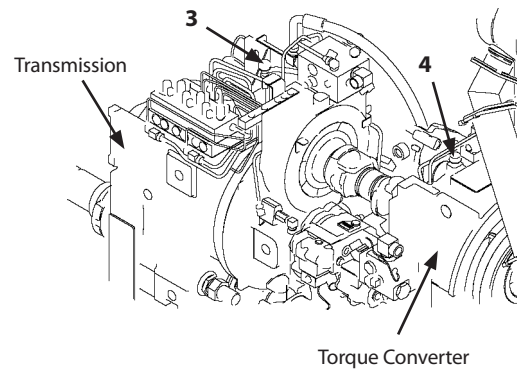

115Z7B-7-37-4

# MAINTENANCE

## 6 Check Axle Oil Level --- every 250 hours

1. Park the machine and follow the procedures as described on page 7-6 for preparation of inspection/maintenance work.

 **NOTE:** Adjust so that the "TOP" mark on the planetary gear housing comes top. See the illustration on the next page.

2. Install articulation stopper (lock bar) (1) to the front and rear of the chassis by following the procedures described on page 7-8.

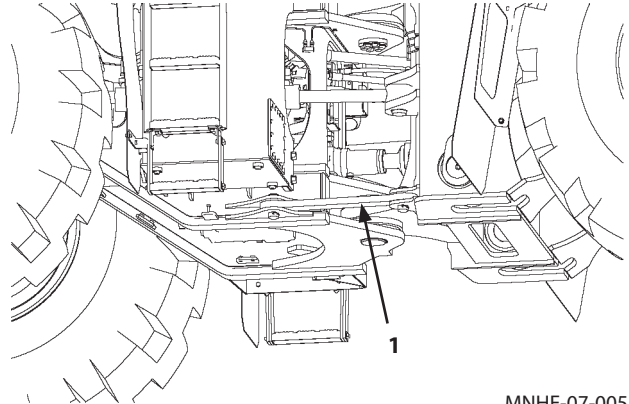

MNHE-07-005

## Check Differential Gear Oil Level

3. Clean the vicinity of oil level plug (2).
4. Remove oil level plug (2) from the axle housing.
5. If the oil level is lower than the plug, add the specified oil through the level plug hole.

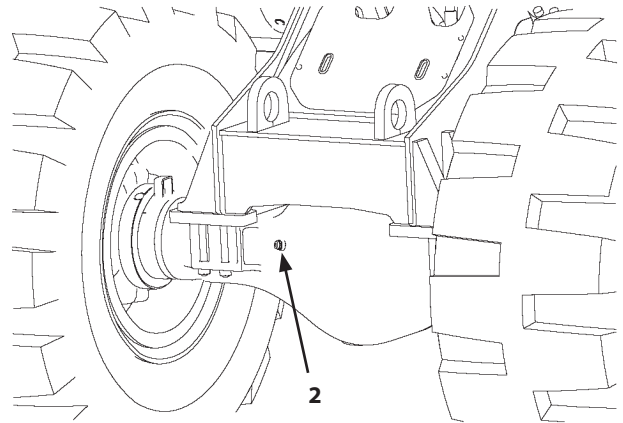

Front Axle

MNHE-07-024

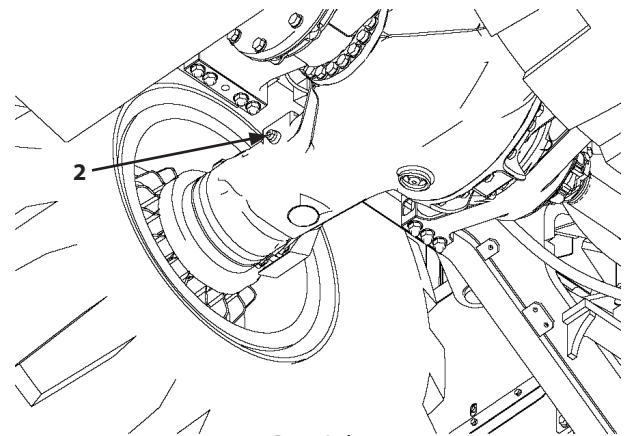

Rear Axle

115Z7B-7-35-3

## MAINTENANCE

---

### Check Planetary Gear Oil Level

 **NOTE:** Check the oil level on all four wheels.

6. Clean the vicinity of oil level plug (4).
7. Check that "TOP" mark (3) on the planetary gear housing comes top as shown. If not, move the machine and adjust the position.
8. Make sure to turn ON the parking brake switch, lower the attachment to the ground, and stop the engine.
9. Remove oil level plug (4) on the housing.
10. If the oil level is lower than the plug, add the specified oil through the level plug hole.
11. Magnetic plugs are used for the planetary gear housing. Wipe off the small amount of fine metallic powder that normally sticks to the plugs. If abnormal debris is found, determine the cause and correct it.
12. If there is any sign of water in the oil, drain and replace the oil. Oil containing water looks milky. Dispose of the drained oil properly.
13. Install and tighten the level plug.

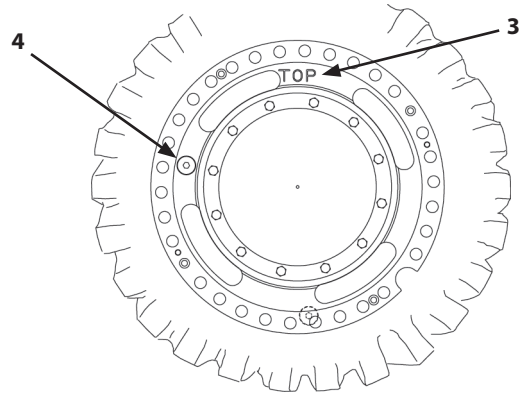

115Z7-7-40-2



# MAINTENANCE

## 7 Change Axle Oil --- every 2000 hours

**WARNING:** Be cautious about the following items.

- Starting repair work immediately after operation may cause burns. Wait for oil temperature to lower.
- Lock the front and rear chassis with the articulation stopper (lock bar).

**IMPORTANT:** Do not use axle oils other than those listed in the "Kind of Oils" - "Axle Oil".

1. Park the machine and follow the procedures as described on page 7-6 for preparation of inspection/maintenance work.

**NOTE:** Adjust so that the "TOP" mark on the planetary gear housing comes top. See the illustration on the next page.

2. Install articulation stopper to the front and rear of the chassis by following the procedures described on page 7-8.

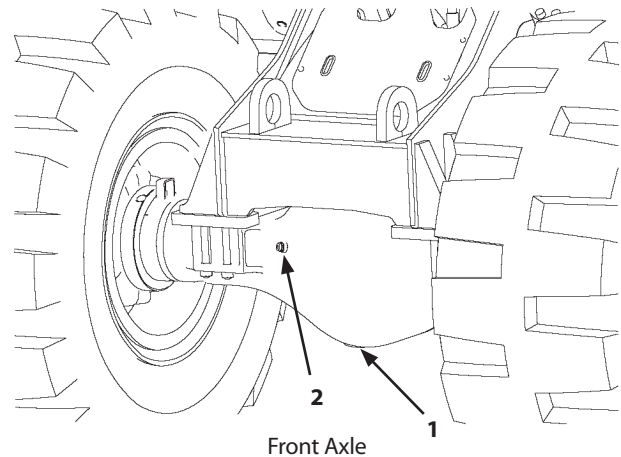

Front Axle

MNHE-07-024

## Change Differential Gear Oil

3. Clean the vicinity around drain plug (1) and the oil drain plug hole.
4. Arrange a container of 120 liters (32 gallons) capacity to receive the drain oil.
5. Remove drain plug (1) to drain the oil.
6. Securely tighten drain plug (1).
7. Refill the specified amount of oil through oil level plug (2) hole.

Front differential: 115 liters (30.4 gallons)

Rear differential: 115 liters (30.4 gallons)

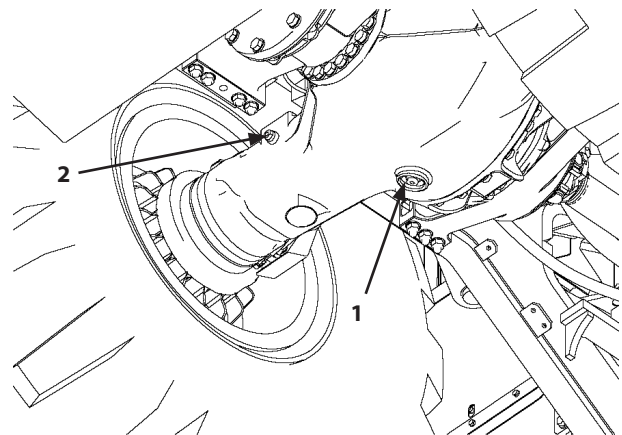

Rear Axle

115Z7B-7-35-3

**IMPORTANT:** It takes time for oil to fully lubricate the overall front axle. After installing the plug, operate the machine slowly for several minutes. Then, stop the engine and check the axle for any oil leaks.

**NOTE:** It is recommended to drive the machine to increase the axle oil temperature to 20 °C (68 °F) or higher for smooth priming of oil. Check the oil level again and fill up to the level plug (2).

8. Check the oil level. (Refer to Check Axle Oil Level.)

## MAINTENANCE

### Change Planetary Gear Oil

9. Check that "TOP" mark (3) on the planetary gear housing comes top as shown. If not, move the machine and adjust the position.
10. Make sure to turn ON the parking brake switch, lower the attachment to the ground, and stop the engine.
11. Clean the vicinity of drain plug (5) and the oil drain plug hole.
12. Arrange a container of 32.5 liters (8.6 gallons) capacity or larger to receive the drained oil.
13. Remove drain plug (5) to drain oil.

 **NOTE:** Plug (5) can be also used to drain oil, when accessible.

14. Securely tighten drain plugs (5).
15. Refill the specified amount of oil through oil level plug (4).  
Supplied oil amount: 32.5 liters (8.6 gallons)/gear

**IMPORTANT:** It takes time for oil to fully lubricate the overall front axle. After installing the plug, operate the machine slowly for several minutes. Then, stop the engine and check the axle for any oil leaks.

16. Check the oil level. (Refer to Check Axle Oil Level.)

 **NOTE:** Total amount of supplied oil is 180 L (47.6 gal) per axle assembly:

Differential: 115 liters (30.4 gallons)

Planetary gear: 32.5 liters (8.6 gallons) x 2

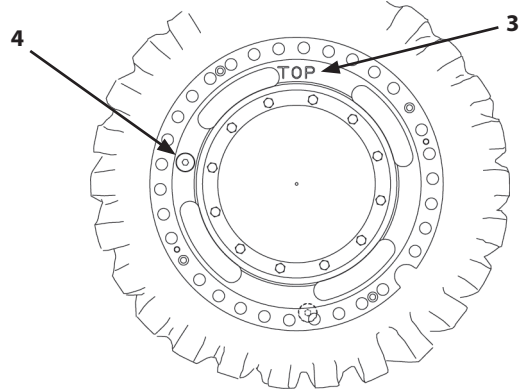

115Z7-7-40-2

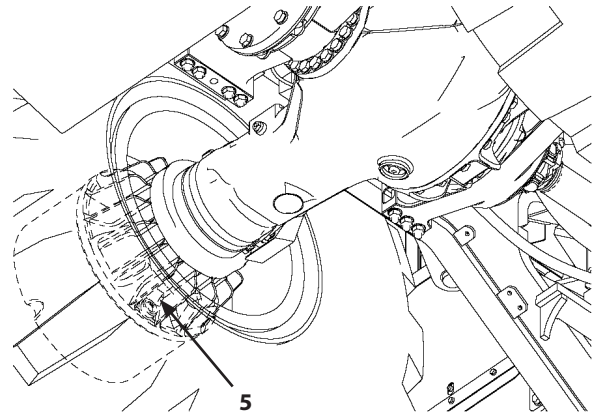

115Z7B-7-38-3

## MAINTENANCE

8

### Replace Axle Oil Cooler Line Filter (Option)

--- every 500 hours

**WARNING:** Be cautious about the following items.

- Starting repair work immediately after operation may cause burns. Wait for oil temperature to lower.
- Lower the attachment to the ground.
- Put the transmission shift lever in neutral. Apply parking brake. Place "DO NOT OPERATE" tag on steering wheel or steering lever (option).

1. Park the machine following the same procedures as described on page 7-6 for preparation of inspection/maintenance work. Stop the engine.
2. Remove the cover, if necessary, and line filters (2) for axle oil cooler (1).  
Using a filter wrench, turn the oil filter cartridge counterclockwise to remove it. Properly dispose of them.
3. Clean the oil filter head gasket surface.
4. Fill the new filter cartridges with clean axle oil.
5. Apply a light film of gear oil to the gasket surface of the new filter cartridge.
6. Install and tighten the filter clockwise by hand until the gasket contacts filter head surface. Then tighten it an additional three-fourths to one turn using a filter wrench. Do not overtighten it.
7. Replace another filter (2) in the same manner.

**IMPORTANT:** Be sure to replace two oil filters (2) at the same time.

8. Idle the engine for 5 minutes to inspect for leaks at the filter.

**NOTE:** Refer to the instructions supplied with the filter.

9. Check the oil level.

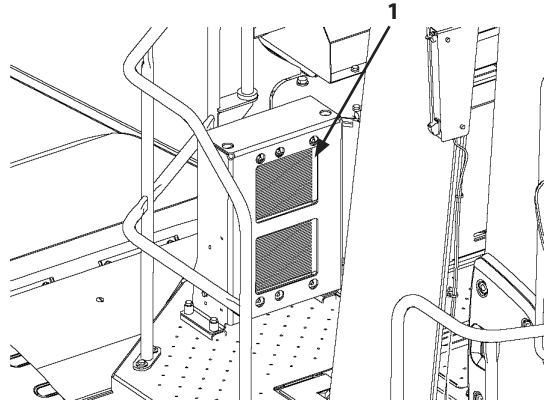

115Z7B-7-38-2

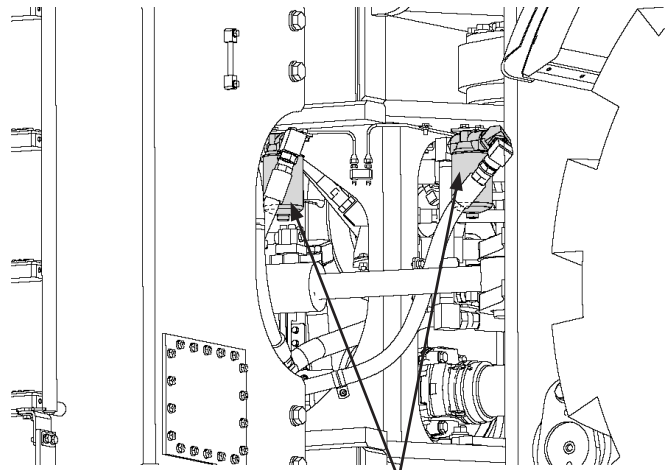

115Z7B-7-38-1

## MAINTENANCE

### 9 Clean Axle Oil Cooler Fins (Option) --- as required

1. Park the machine following the same procedures as described on page 7-6 for preparation of inspection/maintenance work. Stop the engine.

**IMPORTANT: High pressure air or water may damage oil cooler fins.**

**When used for cleaning purposes, the pressure of compressed air should be at 196 kPa (28 psi) or less. When using high-pressure water, keep the nozzle a distance of at least 500 mm (20 in) away from the core surface, applying the water jet perpendicular to the core.**

**Move nozzle from side to side; not up and down.**

2. Blow off mud, dirt, or clogging debris from the axle oil cooler (1) fins with compressed air. Use a pressure washer to remove harder debris.
3. Reverse the direction to flush all debris from the oil cooler fins.

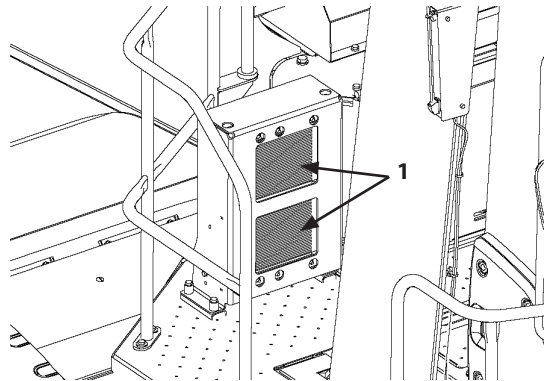

115Z7B-7-38-2

# MAINTENANCE

## D. Hydraulic System

### Inspection and Maintenance of Hydraulic Equipment

**⚠ CAUTION:** During operation, the parts of the hydraulic system become very hot. Allow the machine to cool down before beginning inspection or maintenance.

1. Park the machine following the same procedures as described on page 7-6 for preparation of inspection/maintenance work.
2. Begin servicing hydraulic components only after components, hydraulic oil and lubricants are completely cooled, and after releasing residual circuit pressures.
  - 2.1 Release internal pressure.
  - 2.2 Be sure to relieve the air pressure from the hydraulic oil tank by pressing air bleed valve (1).
  - 2.3 Allow the machine to cool down.

Note that servicing heated and pressurized hydraulic components may cause hot parts and/or oil to fly off or escape suddenly, possibly resulting in personal injury.

Keep body parts and face away from plugs or screws when removing them.

Hydraulic components may be pressurized even when cooled.

Service only on a flat, solid and level surface.

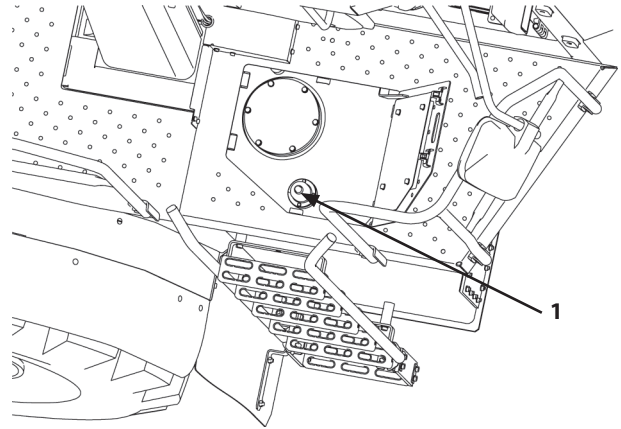

115Z7-7-37-1

## MAINTENANCE

---

### IMPORTANT:

- **When connecting hydraulic hoses and pipes, take special care to keep seal surfaces free from dirt and to avoid damaging them. Keep these precautions in mind:**
- **Wash hoses, pipes, and the tank interior with a washing liquid and thoroughly wipe it out before reconnecting them.**
- **Only use O-rings that are free of damage or defects. Be careful not to damage them during reassembly.**
- **Do not allow high pressure hoses to twist when connecting them. The life of twisted hoses will be shortened considerably.**
- **Carefully tighten low pressure hose clamps. Do not overtighten them.**
- **When adding hydraulic oil, always use compatible oils; do not mix brands of oil. The machine is filled with Super EX 46HN when it is shipped from the factory. When selecting to use another brand of oil listed in the table "Kind of Oils" - "Hydraulic Oil", be sure to completely replace the oil in the system.**
- **Do not use hydraulic oils other than those listed in the table "Kind of Oils" - "Hydraulic Oil".**
- **Never run the engine without oil in the hydraulic oil tank.**

# MAINTENANCE

## 1 Check Hydraulic Oil Level --- every 10 hours (daily)

**IMPORTANT:** If the oil level is not viewed in the level gauge, immediately refill hydraulic oil up to the correct level. Failure to do so may result in a serious failure in the hydraulic system. If the oil level is higher than the level gauge, drain oil down to the appropriate level using a pump.

1. Park the machine following the same procedures as described on page 7-6 for preparation of inspection/maintenance work.
2. Check oil level with level gauge (1) on the hydraulic oil tank. Float (2) must be seen on the gauge. If necessary, add oil.

 **NOTE:** During cold weather season, check the oil level after warming up the hydraulic oil by referring to the instructions described in the "Warm up" group.

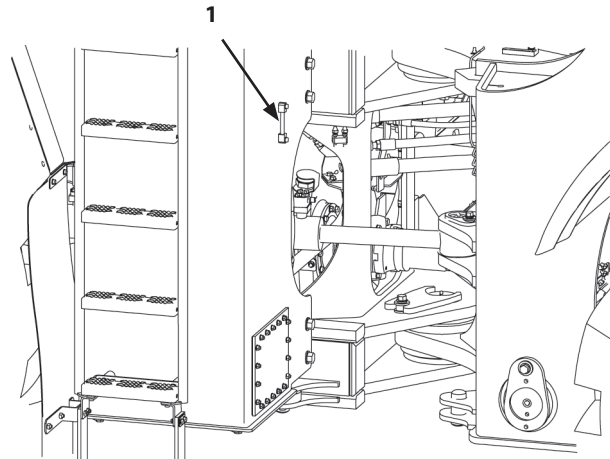

115Z7-7-39-1

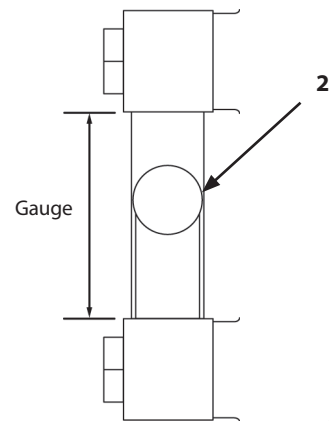

90M4GB-07-160

# MAINTENANCE

## 2 Change Hydraulic Oil --- every 4000 hours

**WARNING:** Hydraulic oil becomes hot during operation. Severe burns may result if skin comes in contact with hot hydraulic oil. Wait for the oil to cool before starting any maintenance work. Release trapped hydraulic circuit pressure by using the loader control levers.

**IMPORTANT:** Do not use hydraulic oils other than listed in the "Recommended Hydraulic Oil".

1. Park the machine and stop the engine following the same procedures as described on page 7-6 for preparation of inspection/maintenance work.
2. Install articulation stopper (lock bar) (1) to the front and rear of the chassis by following the procedures described on page 7-8.
3. Before changing the hydraulic oil, be sure to relieve the air pressure from the hydraulic oil tank (4) by pressing air bleed valve (2).

**IMPORTANT:** When changing hydraulic oil, take care not to permit foreign matters such as dirt, water, and /or sand to enter into the hydraulic oil tank.

4. Remove air bleed valve (2).  
Arrange a container of approx. 500 liters (130 gallons).  
Remove drain plugs (7) from drain tank (4).  
Drain plug width across flat: 24 mm (0.95 in)
5. Remove cleaning cover (5) on the side of hydraulic oil tank (4). Clean the tank bottom with cleaning oil. Install the cover and a new gasket to the original position after cleaning out tank.  
Cover mounting nut width across flat: 14 mm (0.55 in)

**NOTE:** Make sure to replace the cover gasket with new one.

6. Install drain plugs (7).

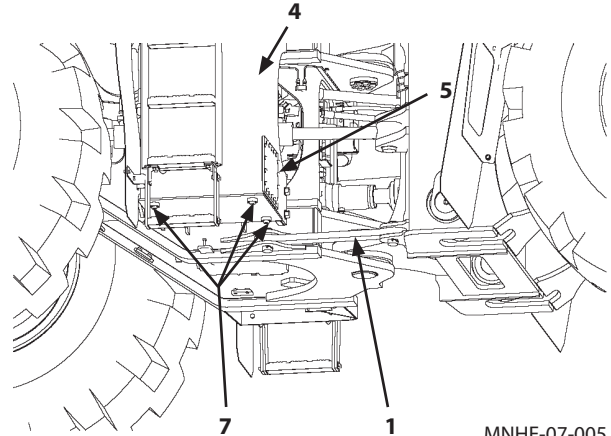

MNHE-07-005

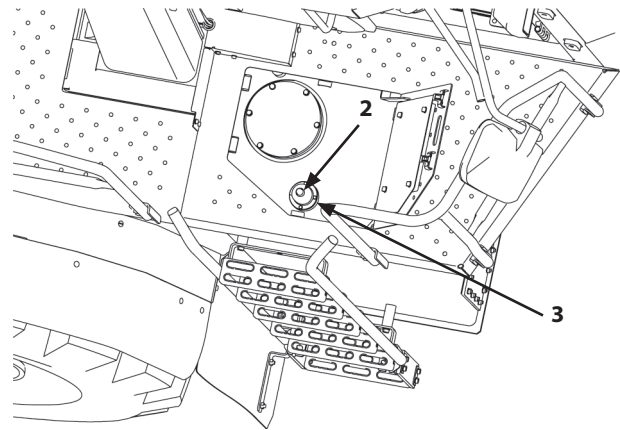

115Z7-7-37-1

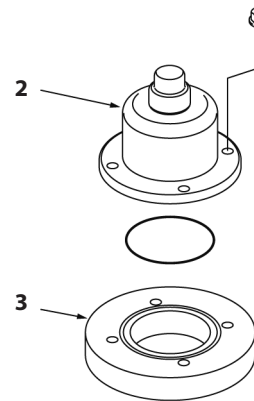

MNHG-07-004



## MAINTENANCE

7. Supply hydraulic oil through filling port (3) while checking the oil level at level gauge (6). Refer to "Kinds of Oils" - "Hydraulic Oil" on page 7-16.

* Capacity of hydraulic oil tank	Total oil capacity in the hydraulic system
300 liters (79 gallons)	550 liters (145 gallons)

\* At level gauge center (Tank capacity: 398 L (105 gal))

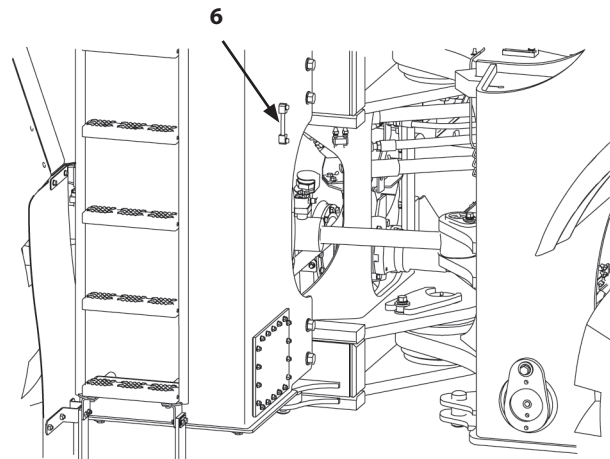

115Z7-7-39-1

8. While filling oil into the hydraulic tank, make sure the oil coming out of bleed screws (A, B) does not contain air bubbles.

 **NOTE:** When the secondary steering system is used, also check the oil from bleed screw (C).

**IMPORTANT:** When changing hydraulic oil, take care not to permit foreign matter such as dirt, water, and /or sand to enter into the hydraulic oil tank.

### Bleed Air from the Hydraulic System

9. After changing hydraulic oil or replacing the return filter, pilot filter and/or suction filter, bleed air from the hydraulic system following the procedures below.
- 9.1 After supplying oil, start the engine. Do not exceed 1000 RPM ( $\text{min}^{-1}$ ). Move the bucket and lift arm cylinders several times to bleed air mixed in the hydraulic circuit. Do not operate the cylinders to the end of cylinder stroke, and do not apply a heavy load to the cylinders.
- 9.2 Rest the bucket on the ground to resume the hydraulic oil level check position.
- 9.3 Stop the engine. Check the oil level. Add oil as needed.
10. Stop the engine. Check for any oil leakage. Check the oil level using level gauge (6).

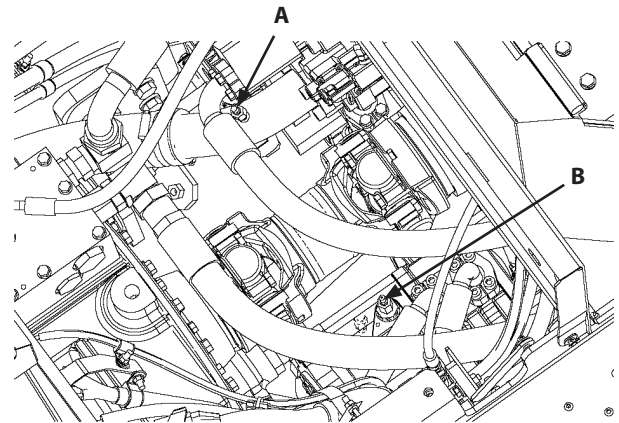

115Z7B-7-23-3

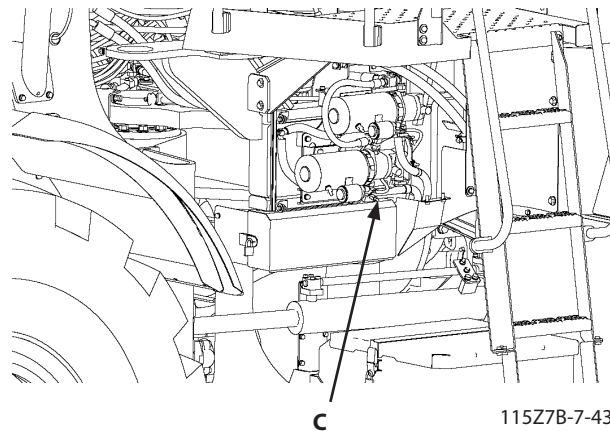

115Z7B-7-43-1

## MAINTENANCE

### 3 Clean Suction Filter

--- each time the hydraulic oil is changed.

**IMPORTANT:** This upper tank area must be very clean prior to beginning this procedure. Failure to clean the top of tank may lead to hydraulic system problems due to system contamination.

Two suction filters are located on the bottom of the hydraulic oil tank. Clean the suction filters when changing hydraulic oil.

1. After draining hydraulic oil, remove cover (1) with gasket. Remove lock nuts (2) and washers (3), and remove suction filters (4) from the oil pipe.

When removing the suction filter, take care not to allow trapped dust to fall into tank.

**IMPORTANT:** A few small particles in the strainer is normal. Large metal, rubber pieces, or a large amount of fine particles is abnormal. If found, contact your authorized dealer.

2. Clean the suction filter and the hydraulic oil tank inside with cleaning solvent. Swab out cleaning oil with a lint free cloth.
3. Install cleaned suction filters (4) to the oil pipe, and tighten lock nuts (2) with washers (3).

 : 38 N·m (3.9 kgf·m, 28 lbf·ft)

4. Install cover (1) and a new gasket with nuts.

 **NOTE:** Make sure to replace the cover gasket with new one.

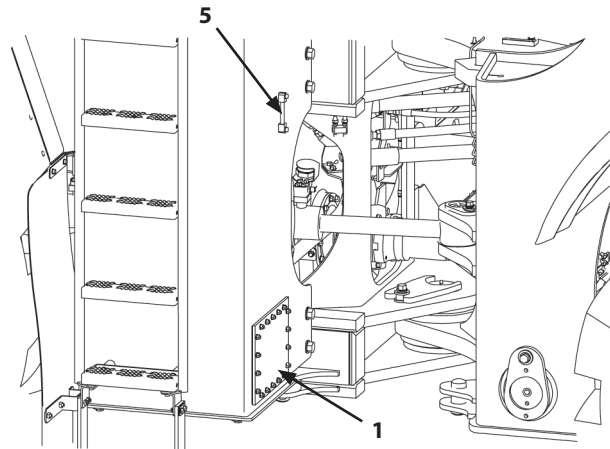

115Z7-7-39-1

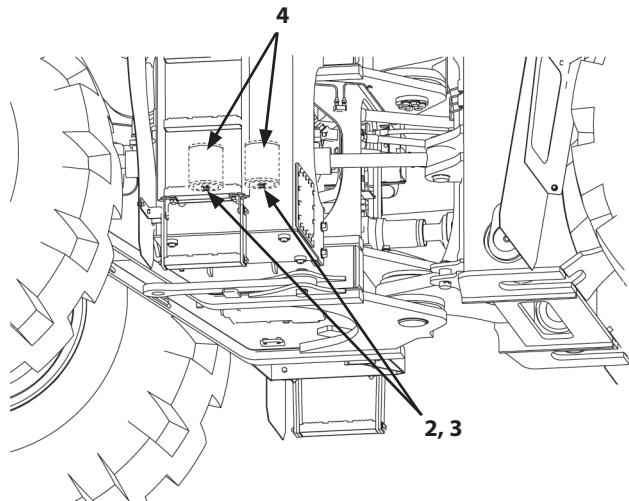

115Z7-7-42-2

5. Fill the tank to level with the specified volume of oil through the oil supply port. Check the oil level at the oil sight gauge.
6. Start the engine. While slowly raising or lowering the arm and tilting the bucket forward and backward, check for any abnormality. Stop the engine. Check the oil level using level gauge (5).

# MAINTENANCE

## 4 Clean Pilot Oil Filter --- every 2000 hours

**⚠ WARNING:** Hydraulic oil becomes hot during operation. Severe burns may result if skin comes in contact with hot hydraulic oil. Wait for the oil to cool before starting any maintenance work.

**IMPORTANT:** Remove trapped hydraulic circuit pressure by using the loader control levers.

1. Park the machine following the same procedures as described on page 7-6 for preparation of inspection/maintenance work.
2. Install articulation stopper (lock bar) to the front and rear of the chassis by following the procedures described on page 7-8.
3. Before removing the filter element, be sure to relieve the air pressure from the hydraulic oil tank by pressing air bleed valve (1).

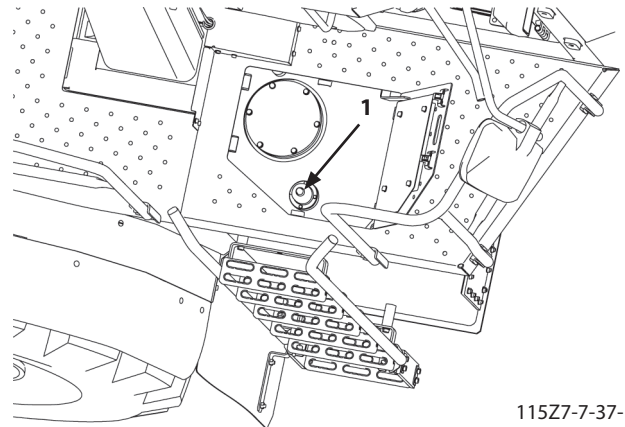

115Z7-7-37-1

### [ Line Filter in Steering Circuit (Reducing Valve Unit (2)) ]

4. Remove plug (4) with O-ring (5).

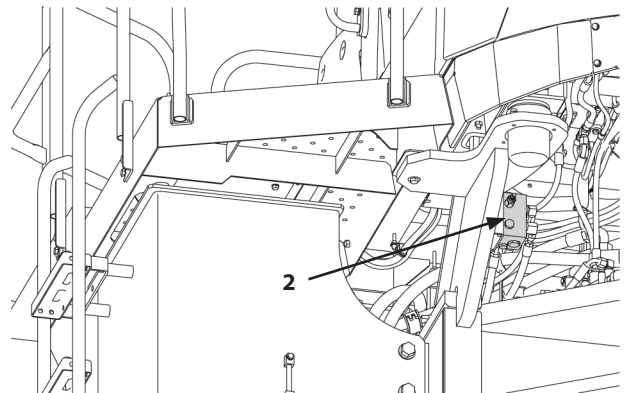

115Z7-7-49-2

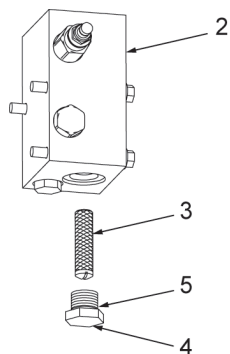

95Z7-7-43-4

**⚠ WARNING:** Be sure to wear safety glasses when cleaning the air breather with compressed air [less than 0.2 MPa (2 kgf/cm<sup>2</sup>)].

5. Take out filter element (3) inside using a screwdriver (-), and clean it by applying air or cleaning solution from the oil flow outlet side.
6. Install the cleaned filter, O-ring and tighten plug (4).

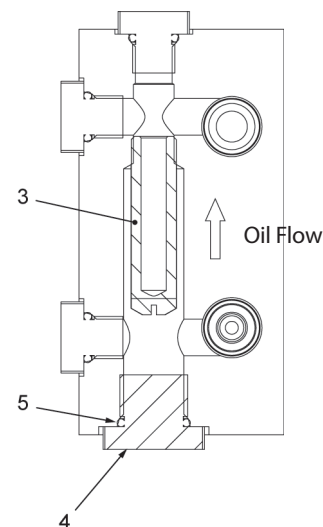

90Z7-38511-31770

## MAINTENANCE

### [ Line Filter in Brake Circuit ]

7. Place a suitable container under combination valve (6).
8. Disconnect hoses (7, 8) and remove bolt (9).

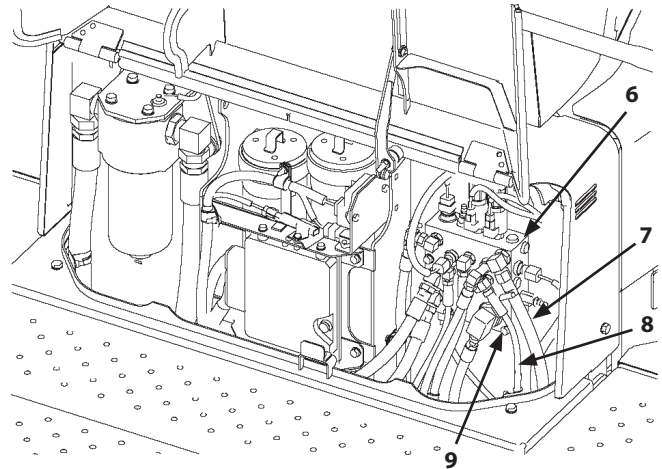

MNHE-07-031

**WARNING:** Be sure to wear safety glasses when cleaning the air breather with compressed air.

9. Remove adapter (10) and filter (11) from the valve, and clean filter (11) by applying air or cleaning solution from the oil flow outlet side.
10. Install the cleaned filter (11) with washer (12) and O-ring (13), and tighten adapter (10).
11. After replacing the return filter element, bleed air from the hydraulic pump and check the oil level in the hydraulic oil tank.  
(Refer to the descriptions for "Bleed air from the hydraulic system" in item [2](#).)

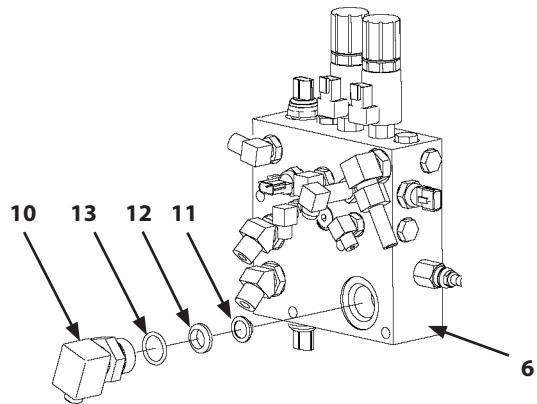

115Z7B-7-45-2

**CAUTION:** If the machine is operated without bleeding the air mixed in the hydraulic circuit, damage to the hydraulic pump may result.

**NOTE:** Clean the filters at the regular intervals to maintain clean hydraulic oil and extend the service life of the hydraulic components.

# MAINTENANCE

## 5 Replace Hydraulic Oil Return Filter --- every 1000 hours

**⚠ WARNING:** Hydraulic oil becomes hot during operation. Severe burns may result if skin comes in contact with hot hydraulic oil. Wait for the oil to cool before starting any maintenance work.

Especially when removing the filter, be careful that the remaining oil in the filter does not spill.

### Replacement Procedures

1. Park the machine following the same procedures as described on page 7-6 for preparation of inspection/maintenance work.
2. Install articulation stopper (lock bar) to the front and rear of the chassis by following the procedures described on page 7-8.
3. Clean the vicinity around cover plate (1).
4. Get a container and workshop towels to hold the spilled oil and the element.  
Relieve the air pressure from the hydraulic oil tank by pressing air bleed valve (6).
5. Loosen bolts (2) (6 used) to remove cover (1) and O-ring (3).  
When removing cover (1), slowly remove the cover while pressing the cover downward so that spring (4) does not fly off. Slowly permit cover to rise, then carefully remove.
6. Remove spring (4), and element (5).
7. Replace element (5) and O-ring (3) with new ones.  
Install new element and new O-ring in the hydraulic oil tank.
8. Install cover (1) with bolts (2) (6 used).

 : 50 N·m (5.0 kgf·m)

9. After replacing the return filter element, bleed air from the hydraulic pump and check the oil level in the hydraulic oil tank. [Refer to the descriptions for "Bleed air from the hydraulic system" in item **2**.]  
If the machine is operated without bleeding the air mixed in the hydraulic circuit, damage to the hydraulic pump may result.

**✎ NOTE:** Replace the element at the regular intervals to maintain clean hydraulic oil and extend the service life of the hydraulic components.

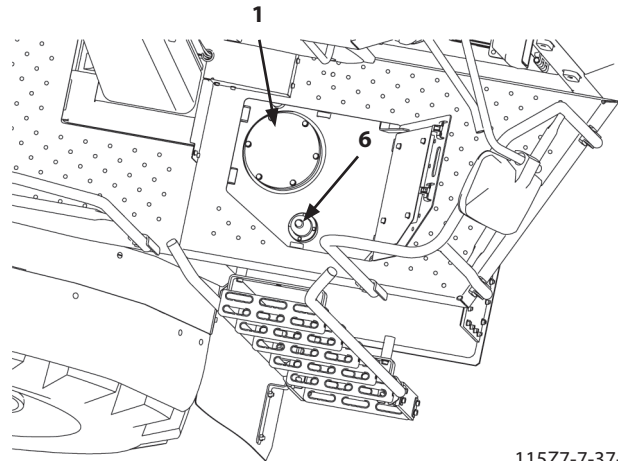

115Z7-7-37-1

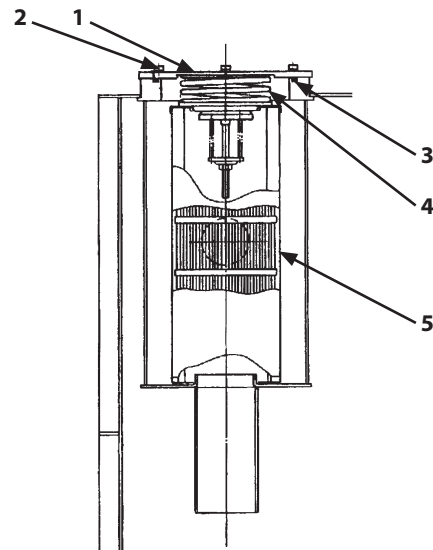

M4GB-07-052

## MAINTENANCE

### 6 Replace Air Breather Element --- every 2000 hours

**WARNING:** Hydraulic oil becomes hot during operation. Severe burns may result if skin comes in contact with hot hydraulic oil. Wait for the oil to cool before starting any maintenance work.

#### Replacement Procedures

1. Park the machine following the same procedures as described on page 7-6 for preparation of inspection/maintenance work.
  2. Before replacing the filter element, be sure to relieve the air pressure from the hydraulic oil tank by pressing air bleed valve (1).
  3. Remove cap (2) and remove nut (3) by rotating it counterclockwise.
  4. Rotate cover (4) counterclockwise and remove it. Remove element (5).
  5. Install new element (5). Tighten cover (4) clockwise. After cover (4) comes in contact with the inside element, tighten the cover 1/4 turn further.
  6. Install and tighten nut (3). Install cap (2).
-  (3): 8~10 N·m (0.8~1.0 kgf·m, 6~7.4 lbf·ft)
7. Take care not to allow water or dust to enter the clearance (air discharge port) between cover (4) and body (6).

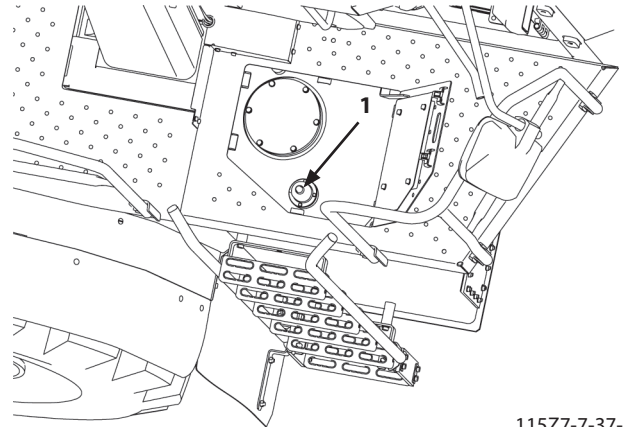

115Z7-7-37-1

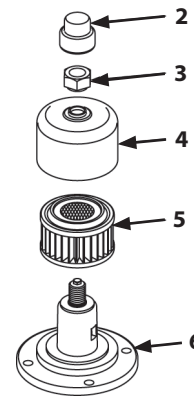

T4A breather valve

**NOTE:** Replace the element at the recommended regular intervals to keep the hydraulic oil clean and to extend the service life of the hydraulic equipment.

## MAINTENANCE

### 7 Check Pilot Circuit Accumulator Function, Gas Leakage, Looseness, and Damage --- every 2000 hours

 **NOTE:** The loading pilot pressure is supplied from the accumulators in the brake circuit.

 **WARNING:** Allow only qualified personnel to handle the accumulator.

- High-pressure nitrogen gas is enclosed in the accumulator. (N<sub>2</sub> is inert.)
- Never strike the accumulator. Keep the accumulator away from heat sources.
- Do not weld the accumulator housing.
- Be sure to release oil pressure before starting to work on pilot circuits.

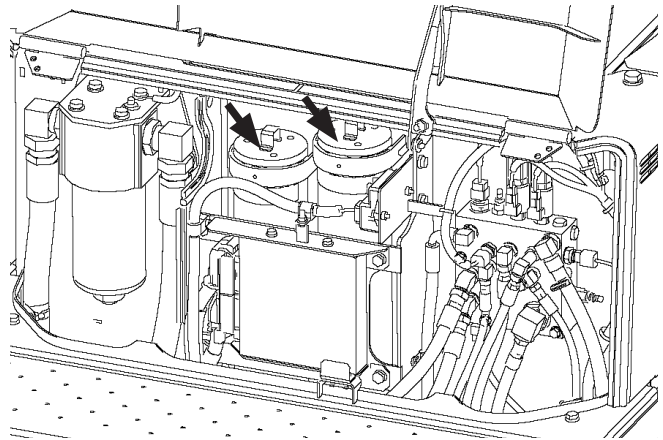

115Z7B-1-142-4

1. Park the machine following the same procedures as described on page 7-6 for preparation of inspection/maintenance work.
2. Raise the lift arm at the maximum height, and then set the lift arm control lever in the Neutral (N) position.
3. Turn the key switch OFF to stop the engine.
4. Turn the key switch to ON position. (Do not start the engine.)
5. Confirm the safety around the machine.
6. Place the lift arm control lever to FLOAT position (C) and lower the bucket 1 m (3 ft) off the ground within 2 minutes after stopping the engine.
7. Place the lift arm control lever to the LOWER position (B) and lower the bucket the rest of the way to the ground.
8. Ensure the lift arm does not stop halfway. If the lift arm stops halfway, the accumulator function may be deteriorated. Consult your nearest authorized dealer for check and repair.

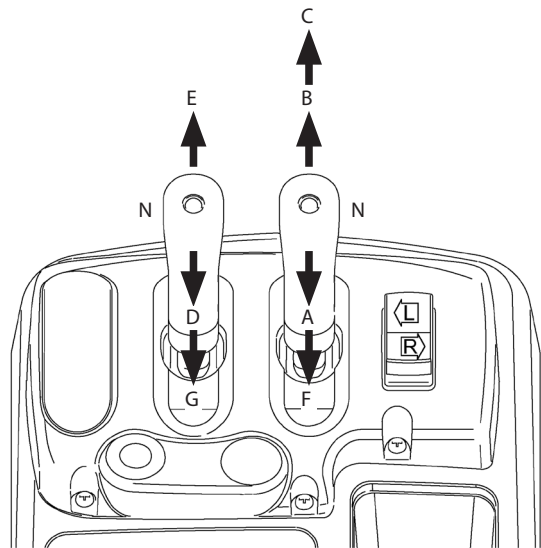

115Z7-1-92-1

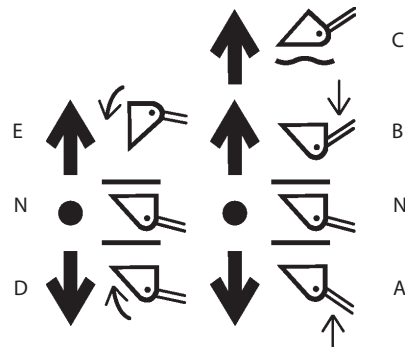

M4GB-01-072

## MAINTENANCE

### 8 Check Ride Control Accumulator Function, Gas Leakage, Looseness, and Damage (Option) --- every 500 hours

**⚠ WARNING:** Allow only qualified personnel to handle the accumulator.

- High-pressure nitrogen gas is enclosed in the accumulator. (N<sub>2</sub> is inert.)
- Never strike the accumulator. Keep the accumulator away from heat sources.
- Do not weld the accumulator housing.
- Be sure to release oil pressure before starting to work on ride control circuit.

Let the machine travel with the ride control switch turned from AUTO to OFF to compare the machine's vertical vibration during travel.

Travel the machine at the speed faster than "Ride Control Drive Speed Setting" displayed on the multi-monitor. If the machine's vertical vibration is not dampened when letting the machine travel with the ride control function activated, the accumulator may be faulty. Consult your nearest authorized dealer for check and repair.

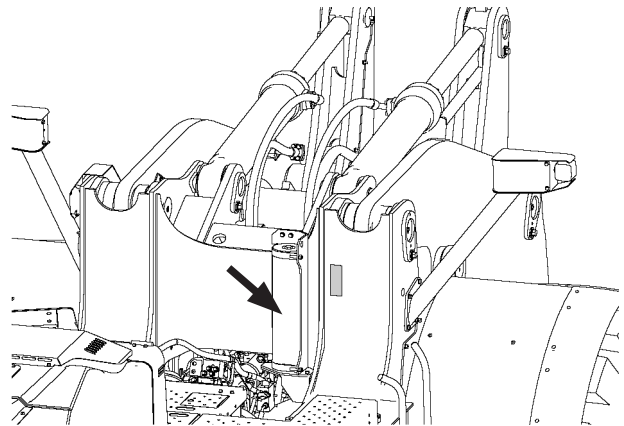

115Z7B-S-53

### 9 Check Gas Pressure in Ride Control Accumulator (Option) --- every 2000 hours

Check the gas pressure at a regular interval. Ask your nearest authorized dealer for checking.

### 10 Check Gas Pressure in Steering Accumulator --- every 2000 hours

Check the gas pressure at a regular interval. Ask your nearest authorized dealer for checking. While steering the machine, if you feel pulsation or vibration and machine does not turn smoothly, contact your nearest authorized dealer for the gas pressure checking.

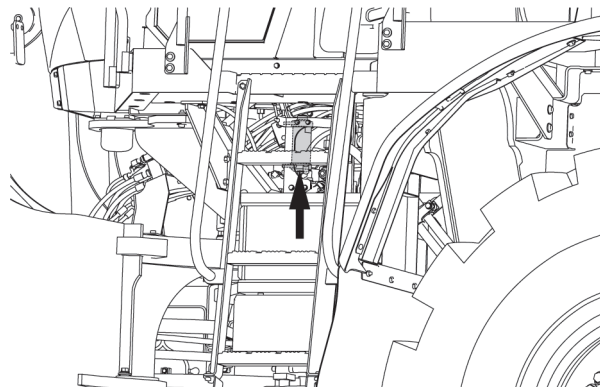

115Z7-7-53-1



## MAINTENANCE

11

### Check Hoses and Lines

- every 10 hours (daily) for leaks
- every 250 hours for cracks, bends, etc.

**WARNING:** High pressure fluid can penetrate the skin causing serious injury.

To avoid this hazard, search for leaks with a piece of cardboard.

Protect hands and body from high-pressure fluids.

If an accident occurs, immediately see a doctor familiar with this type of injury.

Any fluid injected into the skin must be surgically removed within a few hours or serious infection may result.

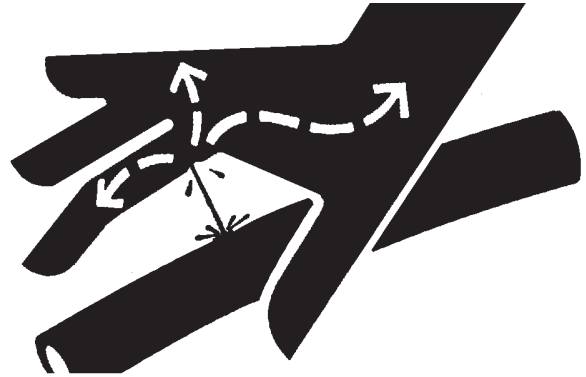

SA-031

**WARNING:** Hydraulic oil and lubricant leaks can lead to fire that may result in serious injury.

To avoid this hazard :

- Park the machine on a solid, level surface.

Lower the bucket to the ground.

Stop the engine. Remove key from the key switch. Push the control lever lock switch to the lock (🔒) position.

- Check for missing or loose clamps, kinked hoses, lines or hoses that rub against each other, damaged oil cooler, and loose oil cooler flange bolts, for leaks.

Check hoses, lines and oil cooler at the check points indicated below for leaks and other damage that may result in future leaks.

If abnormalities are found, repair them, as shown in Tables 1-2.

- Tighten, repair or replace any missing, loose or damaged clamps, hoses, lines, oil cooler, and loose oil cooler flange bolts.

Do not bend or strike high-pressure lines.

Never install bent or damaged hoses or lines.



SA-292

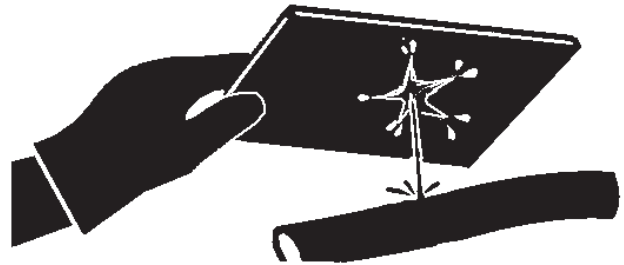

SA-044

# MAINTENANCE

Table 1. Hoses

Interval (hours)	Check Points	Abnormalities	Remedies
Daily	Hose covers	Leak (1)	Replace
	Hose ends	Leak (2)	Replace
	Fittings	Leak (3)	Retighten or replace hose or O-ring
Every 250 hours	Hose covers	Crack (4)	Replace
	Hose ends	Crack (5)	Replace
	Hose covers	Exposed reinforcement (6)	Replace
	Hose covers	Blister (7)	Replace
	Hose	Bend (8)	Replace (Use proper bend radius)
	Hose	Collapse (9)	Replace (Use proper bend radius)
	Hose ends and fittings	Deformation or Corrosion (10)	Replace

 **NOTE:** Refer to the illustrations in Fig. 1 for each check point location or for a description of the abnormality. Use genuine Hitachi parts.

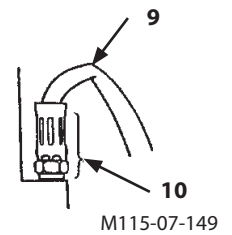
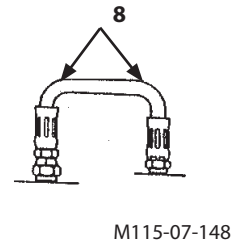
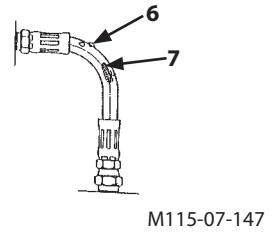
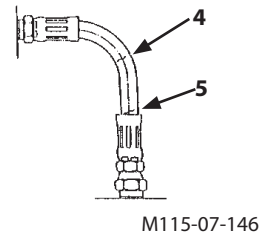
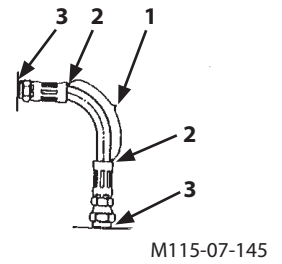
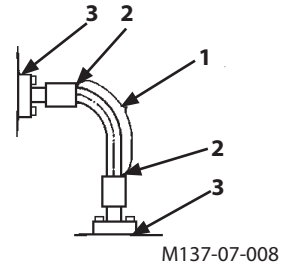
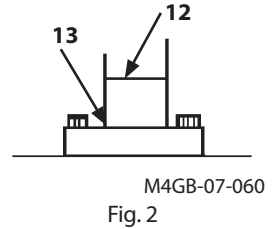
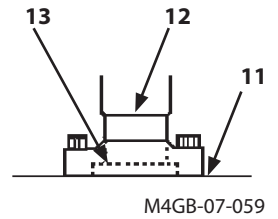

Fig. 1

# MAINTENANCE

Table 2. Lines

Interval (hours)	Check Points	Abnormalities	Remedies
Daily	Contact surfaces of flange joints	Leak (11)	Replace O-ring and/or retighten bolts
	Welded surfaces on joints	Leak (12)	Replace
Every 250 hours	Joint neck	Crack (13)	Replace
	Welded surfaces on joints	Crack (12)	Replace
	Clamps	Missing	Replace
		Deformation	Replace
Loose		Retighten	



**NOTE:** Refer to the illustrations in Fig. 2 for each check point location or for a description of the abnormality. Use genuine Hitachi parts.

## MAINTENANCE

### Service Recommendations for Hydraulic Fittings

Two hydraulic fitting designs are used on this machine.

#### Flat Face O-ring Seal Fitting (ORS Fitting)

An O-ring is used on the sealing surfaces to prevent oil leakage.

1. Inspect fitting sealing surfaces (6). They must be free of dirt or defects.
2. Replace O-ring (1) with a new one when assembling fittings.
3. Lubricate O-ring (1) and install it into groove (3) using petroleum jelly to hold it in place.
4. Tighten fitting (2) by hand, pressing the fitting joint together to ensure O-ring (1) remains in place and is not damaged.
5. Tighten fitting (2) or nut (4) to the torque values shown. Do not allow hose (5) to twist when tightening fittings.
6. Check for leaks. If oil leaks from a loose connection, do not tighten fitting (2). Open the connection, replace O-ring (1) and check for correct O-ring position before tightening the connection.

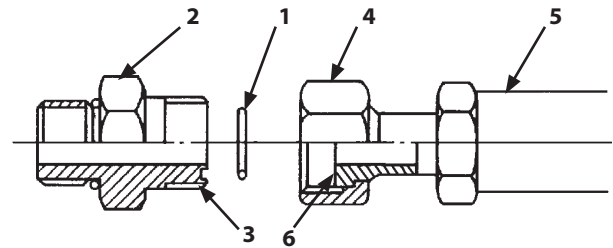

M104-07-033

#### Metal Face Seal Fittings

Fittings are used on smaller hoses and consist of a metal flare and a metal flare seat.

1. Inspect flare (10) and flare seat (9). They must be free of dirt or obvious defects.
2. Tighten fitting (7) by hand.
3. Tighten fitting (7) or nut (8) to the torque values shown. Do not allow hose (5) to twist when tightening fittings.

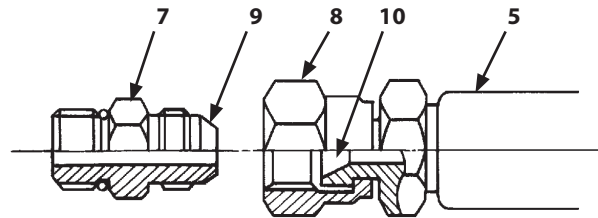

M202-07-051

# MAINTENANCE

---

## E. Fuel System

- 1** Check Fuel Level  
--- every 10 hours (daily)

 **WARNING:** Fuel is flammable. Keep fuel away from fire hazards.

**IMPORTANT:** Always fill the fuel tank with the specified diesel fuel. Failure to do so may cause engine trouble and also making it difficult for the engine to start. Use of diesel fuel with sulfur content less than 15 mg/kg (15 ppm) is required.

### Recommended Fuel

Use only super high quality or high quality DIESEL FUEL (ASTM 975D). Kerosene must NOT be used.

Use of poor quality fuel, tank cleaning solvents, unapproved fuel additives, gasoline, kerosene or alcohol refueled or mixed with specified fuel may deteriorate performance of fuel filters and cause friction problems in the injectors. It also may affect other engine parts, leading to malfunction.

Using fuel other than ultra low-sulfur diesel fuel has adverse effects on the engine and the aftertreatment device, which may result in malfunction.

### About Biodiesel Fuel

Biodiesel fuel is made by refining various vegetable oils or animal fats.

**IMPORTANT:** When blended with Ultra-Low Sulfur Diesel (ULSD) fuel it may be used only if:

- It is used in blends of B5 (5% biodiesel/95% ULSD).
- It is supplied by a BQ9000 Certified Marketer – check [www.bq9000.org](http://www.bq9000.org).
- It meets the ASTM D6751 standard for B100 biodiesel before blending.
- The biodiesel is properly stored and filtered prior to use in the loader.

 **CAUTION:**

- Concentrations greater than B5 (5%) may cause engine trouble that is not covered by warranty.
- Using biodiesel will increase fuel consumption and reduce power compared to 100% ULSD.
- Biodiesel will experience restricted flow as temperatures drop and may become waxy before 100% ULSD.
- Biodiesel storage can lead to water contamination from absorption and microbial growth greater than 100% USLD.
- The higher the concentration of biodiesel the more likely damage to the engine and emissions controls will occur.
- Biodiesel has a limited storage life and must be used within 45 days of manufacture.

# MAINTENANCE

## Refueling

1. Park the machine following the same procedures as described on page 7-6 for preparation of inspection/maintenance work.

**IMPORTANT:** The turbocharger may be damaged if the engine is not properly shut down.

**WARNING:** Handle fuel carefully. Shut the engine off before fueling. Do not smoke while you fill the fuel tank or work on fuel system.

2. Check fuel gauge (1) on the monitor panel. Add fuel if necessary.

**IMPORTANT:** Keep all dirt, dust, water and other foreign materials out of the fuel system.

3. To avoid condensation, fill the tank at the end of each day's operation from filler port (2). Take care not to spill fuel on the machine or ground.

Fuel tank capacity:

648 liters (171 gallons)

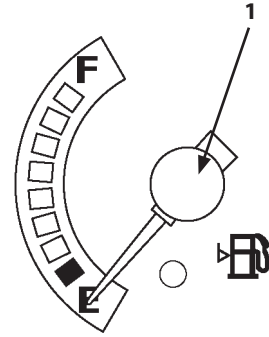

MNEC-01-002

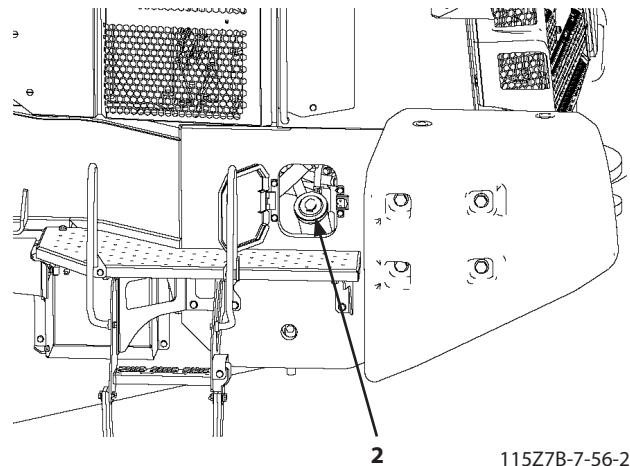

115Z7B-7-56-2

## 2 Drain Water and Sediment from Fuel Tank --- every 1000 hours

Before starting to operate the machine, loosen drain plug on the fuel tank bottom and drain water and/or sediment from the fuel tank.

Tighten plug when no more water is draining, and only fuel drainage is seen.

Drain plug (hex) width across flat: 24 mm (0.94 in), or  
Hex socket width across flat: 12 mm (0.47 in)

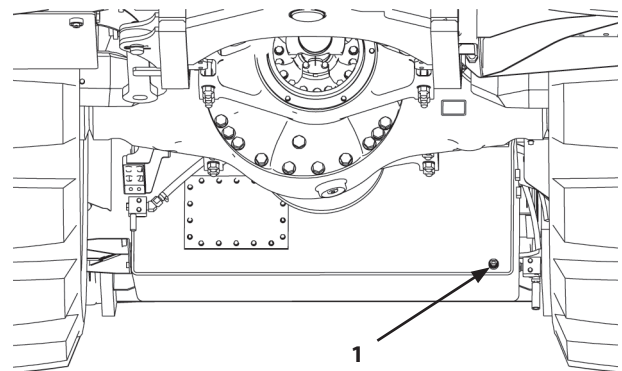

115Z7-7-56-1

# MAINTENANCE

## 3 Drain Fuel Filter --- every 10 hours (daily)

**IMPORTANT:** Drain fuel filter daily before starting operation. The engine may be damaged if you do not drain fuel filter daily. Drained water should contain fuel. Follow the local regulations when disposing it.

Fuel pre-filters have water separator function, which allows float to rise as water accumulates. Be sure to drain the accumulated water daily until float goes to the bottom of case.

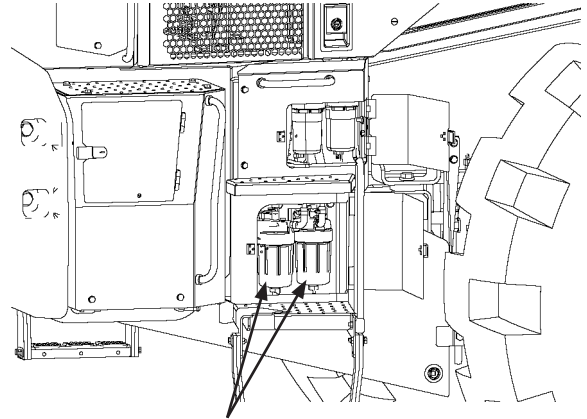

Fuel Pre-Filter

115Z7B-7-59-1

### Draining Procedures (Pre-Filter)

1. Remove two bottom plates (4) of the pre-filter box by removing the flanged bolt.
2. Connect transparent drain hose (2) stored in the tool box to drain (1).
3. Place 0.5 liters or larger capacity container under drain hose (2) to collect the drained water.

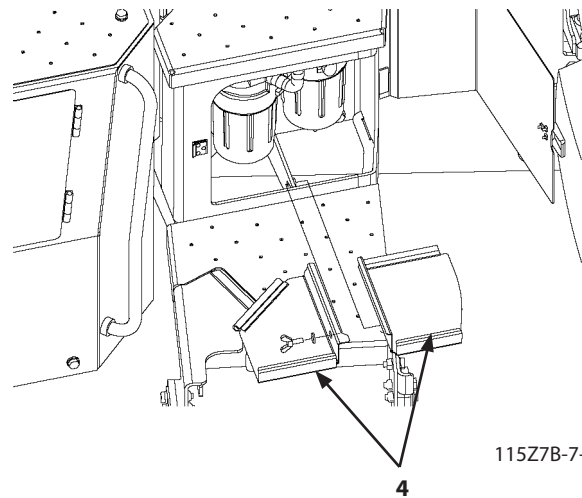

115Z7B-7-59-2

4. Rotate drain (1) on the bottom of the filter counterclockwise. Drain the water accumulated in the filter until float (5) goes to the bottom of case. If it is difficult to drain, loosen plug (3) on the top of the fuel pre-filter.

Wrench size: 14 mm (0.55 in)

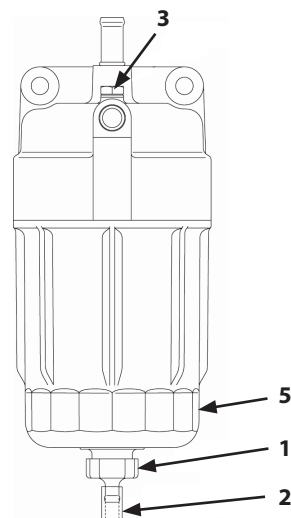

95Z7-7-59-2

## MAINTENANCE

5. After draining water, securely tighten drain (1) and plug (3). Draining off of two pre-filters.

Tightening torque:

Drain (1):  $2.5 \pm 0.5$  N·m ( $0.25 \pm 0.05$  kgf·m,  $1.8 \pm 0.4$  lbf·ft)

Plug (3):  $10 \pm 2$  N·m ( $1.0 \pm 0.2$  kgf·m,  $0.74 \pm 0.15$  lbf·ft)

6. Start the engine. Check drain (1) and plug (3) for fuel leaks.

**IMPORTANT:** After draining water from the fuel filter, bleed air from the fuel supply system.

**IMPORTANT:** Do not use alcoholic gas dryer fuel additives to remove water in fuel to avoid cracks in the pre-filter transparent case.

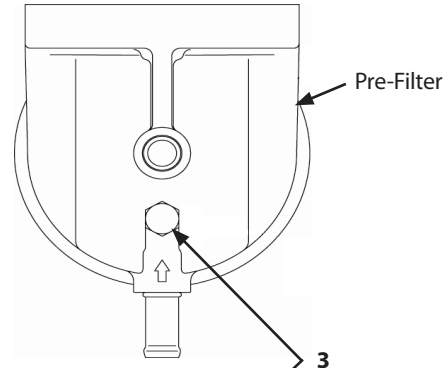

95Z7-7-59-1

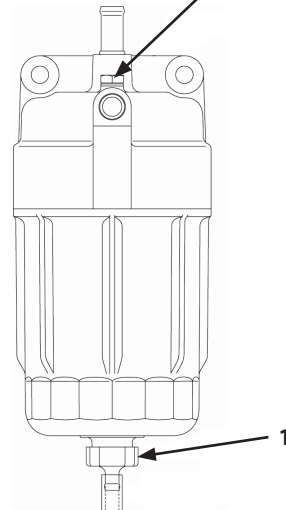

95Z7-7-59-2

### Bleed Air from the Fuel System

Air in the fuel system may make the engine hard to start or make it run rough or not run at all.

After draining water and sediment from the fuel filter, replacing the fuel filter, cleaning the fuel pump strainer or running the fuel tank dry, be sure to bleed the air from the fuel system according to the following procedure.

### Air Bleeding Procedure

This machine is equipped with a fuel priming solenoid pump (6).

**CAUTION:** Fuel leaks may lead to fires.

1. Turn the key switch to ON position. Fuel priming solenoid pump (6) operates to help prime the fuel system.

**IMPORTANT:** DO NOT start the engine.

2. Loosen air bleed plug (7) at the outlet port of fuel priming solenoid pump (6).  
Loosen air bleed plug (9) on supply pump (8).  
Loosen air bleed plug (12) on fuel main filter (11).

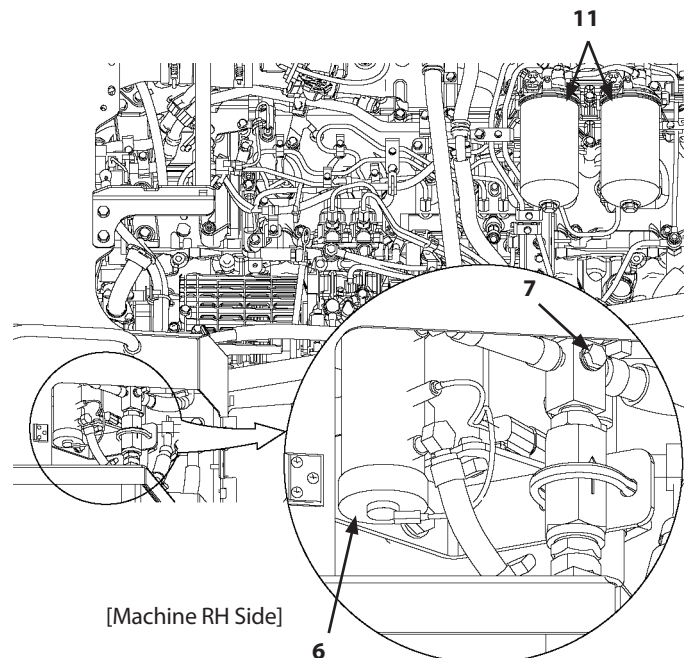

115Z7B-7-61-3



## MAINTENANCE

3. Keep the key switch at ON position while operating priming pump (9) of supply pump (7) until fuel with no air bubbles comes out from air bleed plug (6) at the outlet port of fuel priming solenoid pump (5). Tighten air bleed plug (6).
4. Bleed air of supply pump (7) and fuel main filter (10) in the same manner respectively. Verify that fuel with no air bubbles come out from air bleed plugs (8)(11).
5. Keep the key switch at ON position for at least 30 seconds after priming main fuel filter (10).
6. Once the engine is started, slowly increase the engine speed while air is purged from the fuel line.
7. Check the fuel supply system for fuel leaks.

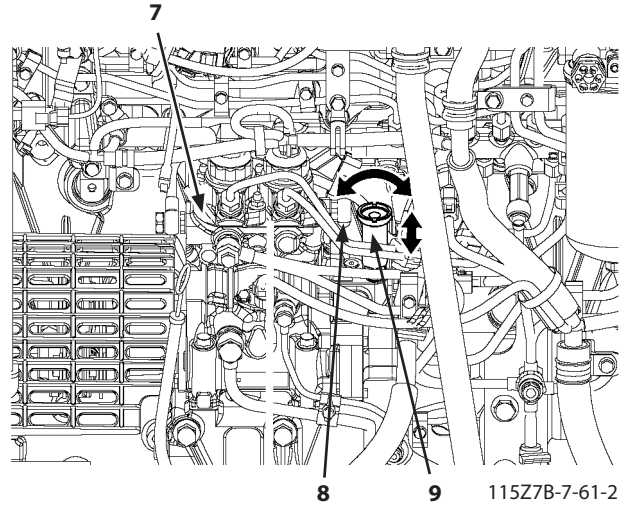

**IMPORTANT:** Even if air is not thoroughly bled of fuel priming solenoid pump (5) at step 3, do not hold the key switch in the ON position for more than 5 minutes. In this case, first return the key switch to the OFF position. Then, after waiting for more than 30 seconds, turn the key switch ON again. Failure to do so may cause damage to fuel priming solenoid pump (5) and/or discharging the batteries.

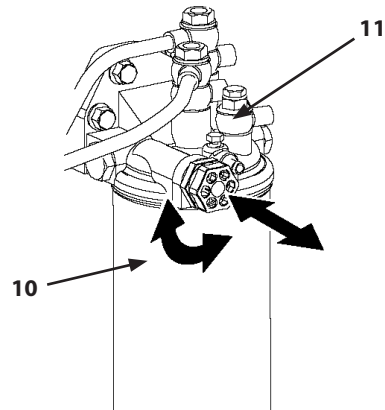

### If Air Mixed After Common Rail

**⚠ WARNING: INJECTION HAZARD**  
Fuel under high pressure  
High pressure common rail, high pressure lines fuel lines and high pressure fuel injection lines contain high pressure fuel.  
High pressure fuel injection into skin can cause injury or death.  
Keep hands away from injection lines while turning engine with starter or while running engine.

In case air mixed in the fuel system due to lack of fuel and the engine is difficult to start, release air by following the procedure given below.

1. Bleed air until supply pump (7) inlet sufficiently according to the above-mentioned procedures.
2. Operate starter motor for long cranking within 20 seconds. If engine fails to start, return key switch to OFF. Wait more than about 60 seconds, and then try again.

## MAINTENANCE

4

### Replace Fuel Main Filter Element

--- every 500 hours or when fuel filter restriction indicator is lit

**CAUTION:** Depending on the circumstance, diesel fuel is flammable. When inspecting or performing service or repairs on the fuel system, to reduce the possibility of fire and resulting severe personal injury, death, or property damage, never smoke or allow sparks or flames (such as pilot lights, electrical switches, or welding equipment) in the work area.

#### IMPORTANT:

- Be sure to use only genuine Hitachi elements for the fuel main filter element and the pre-filter element. Failure to do so may lower engine performance and/or shorten the engine service life.
- Make sure that debris, water, steam, or cleaning solution does not get inside the fuel system.

1. Prepare 1 liter (1 quart) or larger capacity container to hold the drained fuel.
2. Loosen and remove fuel main filter (1) using the provided filter wrench.

**NOTE:** Make sure the filter gasket (2) does not stick to the filter head.

3. Apply a light film of clean engine oil to gasket surface of the new filter.

**IMPORTANT:** Do not fill fuel main filter (1) with fuel before installation.

4. Install empty fuel main filter (1) to the filter head.

**CAUTION:** Mechanical overtightening can distort the threads as well as damage the filter element seal or filter canister.

5. Tighten the filters an additional two-thirds turn after the gasket contacts the filter head surface. Follow the instructions supplied with the filter.

**NOTE:** Main filter (1) tightening torque: 25 N·m (2.5 kgf·m, 18.5 lbf·ft)

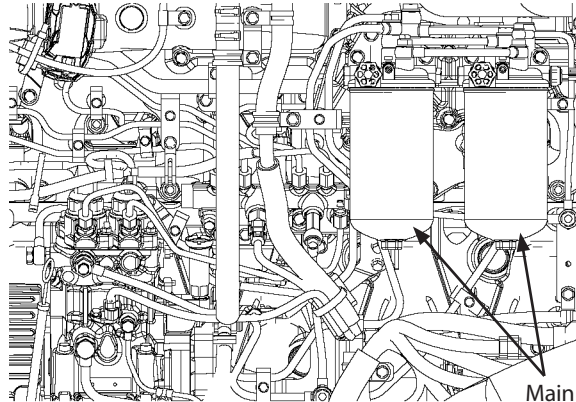

Main Filter

115Z7B-7-58-1

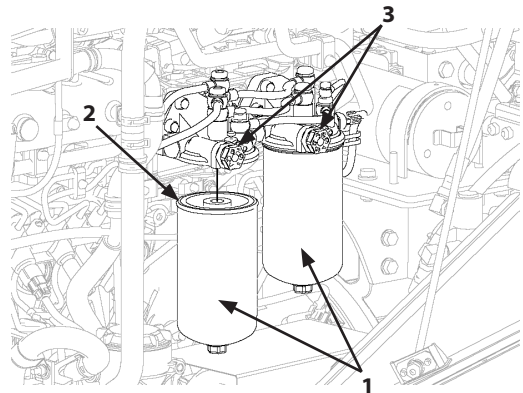

95Z7B-7-64-2

## MAINTENANCE

---

 **WARNING:** When servicing the engine, do not rotate engine with a high pressure fuel system joint open. Rotating the engine can create highly pressurized fuel in the fuel system. High-pressure fuel spray can penetrate the skin, resulting in serious personal injury or death.

6. Repeat for the other filter.

7. Turn the starter key to the ON position.

**IMPORTANT: Do not start the engine.**

8. Allow the fuel lift pump to prime the fuel system while leaving the starter key to the ON position for 30 seconds. Then, turn OFF the key to OFF position for 30 seconds.

It can be necessary to repeat this process two or three times.

9. Turn the starter key to the START position.

If the engine does not start, repeat above steps 7 and 8.

 **NOTE:** Refer to "Bleed Air from the Fuel System" in item **3**.

## MAINTENANCE

- 5** Replace Fuel Pre-Filter Element  
---every 500 hours or when fuel filter restriction indicator is lit

### IMPORTANT:

- Be sure to use only genuine Hitachi elements for the fuel main filter element and the pre-filter element. Failure to do so may lower engine performance and/or shorten the engine service life.
- Do not allow dirt and/or water to enter the fuel system.
- Never pre-fill the filters.

### Procedures:

1. Connect transparent drain hose (6) stored in the tool box to drain (5).
2. Place 1 liter (1 quart) or larger capacity container under drain hose (6) to hold the drained water.
3. Loosen air bleed plug (7) and drain (5). Drain fuel until the filter is empty.

After draining fuel, remove drain (5) and replace the gasket at drain (5).

4. Remove transparent filter case (11) using the provided filter wrench.
5. When transparent filter case (11) is removed, the element and O-ring for transparent filter case (11) is exposed. Remove the element by hand.

### IMPORTANT:

- When cleaning transparent filter case (11), use clean diesel oil. DO NOT use acid or alcohols solvent such as parts cleaning detergent, oil with gas dryer, etc. These organic material may cause cracks or cloud on the resin case.
- Do not overtighten the filter case.

6. Install a new element. Replace transparent filter case O-ring and tighten transparent filter case (11) using the special tool.

 :  $30 \pm 2 \text{ N}\cdot\text{m}$  ( $3 \pm 0.2 \text{ kgf}\cdot\text{m}$ ,  $22 \pm 1.5 \text{ lbf}\cdot\text{ft}$ )

Wrench size: 14 mm (0.55 in)

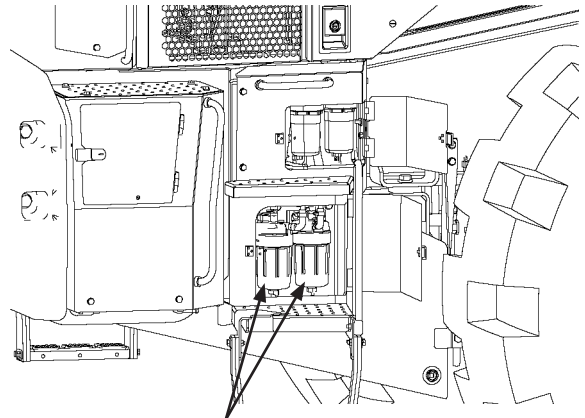

Fuel Pre-Filter

115Z7B-7-59-1

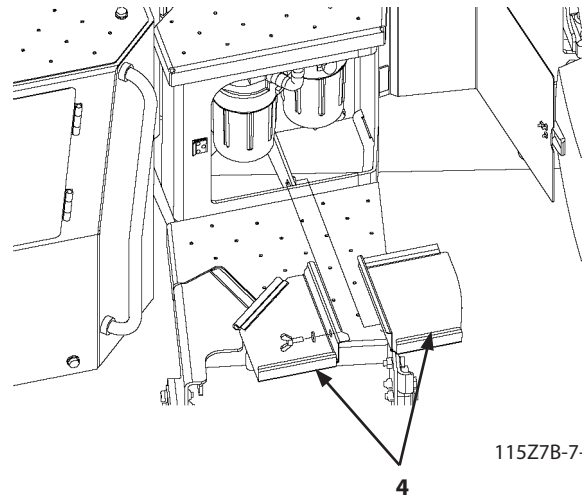

115Z7B-7-59-2

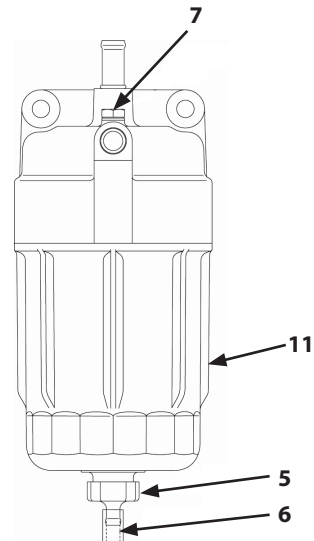



95Z7-7-59-2

## MAINTENANCE

---

7. Tighten air bleed plug (7) and drain (5).

 (5):  $2.5 \pm 0.5$  N·m ( $0.25 \pm 0.05$  kgf·m,  $1.8 \pm 0.4$  lbf·ft)

 (7):  $10 \pm 2$  N·m ( $1.0 \pm 0.2$  kgf·m,  $0.74 \pm 0.15$  lbf·ft)

8. Repeat for the other filter.

9. Turn the starter key to the ON position.

**IMPORTANT: Do not start the engine.**

10. Allow the fuel priming solenoid pump to prime the fuel system while leaving the starter key to the ON position for 30 seconds. Then, turn OFF the key to OFF position for 30 seconds. It can be necessary to repeat this process two or three times.

11. Turn the starter key to the START position.  
If the engine does not start, repeat above steps 9 and 10.

(Refer to "Bleed Air from the Fuel System" in item 3.)

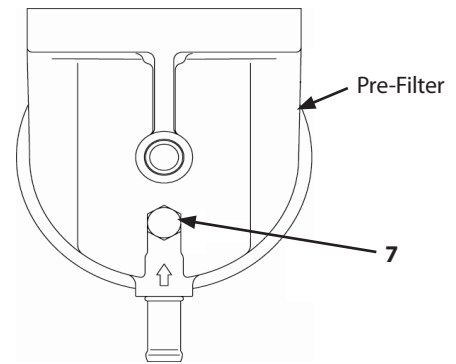

95Z7-7-59-1

## MAINTENANCE

### 6 Clean Fuel Supply Pump Strainer --- every 500 hours

#### IMPORTANT:

- The supply pump strainer is assembled into the joint bolt located at the inlet side of the supply pump. This joint bolt is a component which cannot be disassembled, so do not pull out the strainer inside.
- When cleaning the fuel strainer, do not disassemble the strainer from the joint bolt (clean it while being assembled).

1. Loosen joint bolt (1) and take out fuel strainer (2) being assembled with joint bolt (1) from the fuel pipe on the supply pump.
2. Clean the strainer in clean diesel fuel and blow off dust with high-pressure air.

#### IMPORTANT: After cleaning the fuel strainer, bleed air from the fuel supply system.

3. Reinstall strainer (2), tighten joint bolt (1) and closely check the air-tightness of the strainer.

#### **WARNING:** After installing the strainer, wipe off any spilled fuel.

4. Start the engine and run at low idle, and check for fuel leaks.

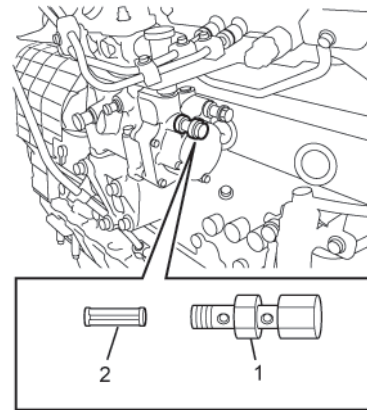

95Z7-7-63-1

## MAINTENANCE

### **7** Clean Fuel Priming Solenoid Pump Strainer --- every 1000 hours

#### **Cleaning**

When the strainer is disassembled, be sure to replace the gasket.

Install the cover and the magnet only after thoroughly cleaning them.

After being assembled, closely check the air-tightness of the strainer.

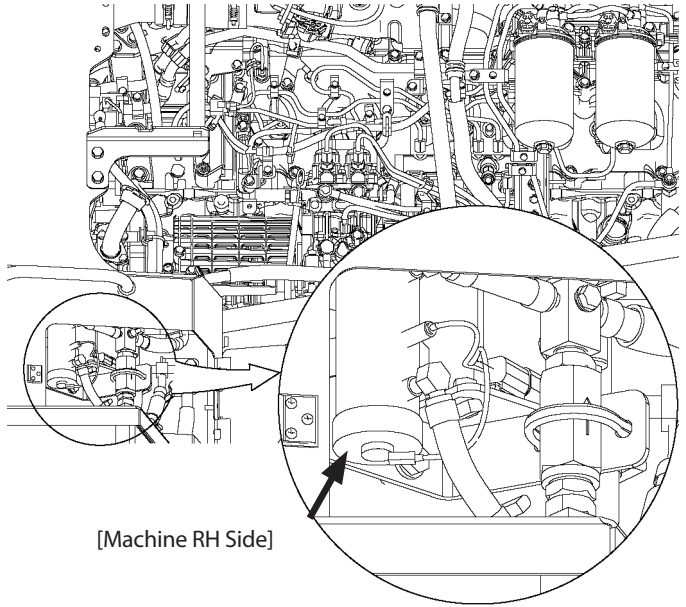

115Z7B-7-61-3

## MAINTENANCE

### Disassembling/ Assembling

1. To remove cover (1), loosen with a wrench.  
After cover (1) is removed, gasket (2), strainer (3), and gasket (4) are easily removed in order.
2. Wash strainer (3) with solvent.
3. Install the strainer in the reverse order of disassembling. At that time, install gasket (2) into cover (1) first.  
Then, securely tighten cover (1) to pump (5) using a wrench.

 NOTE: Wrench size: 17 mm

### IMPORTANT:

- Only clean and replace the strainer as well as gaskets (2) and (4) while servicing the fuel pump. Never attempt to disassemble other parts.
- Gasket (4) can get caught in the bore of pump (5), making it difficult to remove the gasket, but do not disassemble the cylinder of pump (5). If the gasket is difficult to remove, do not disassemble other parts but stretch gasket (4) to remove it. Use a new gasket (4) for assembling.

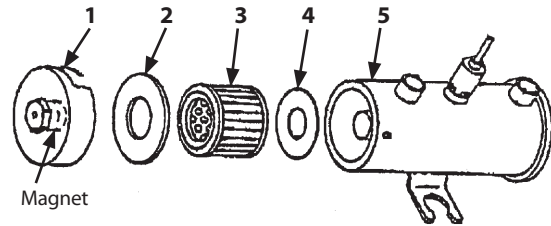

M1GR-07-004

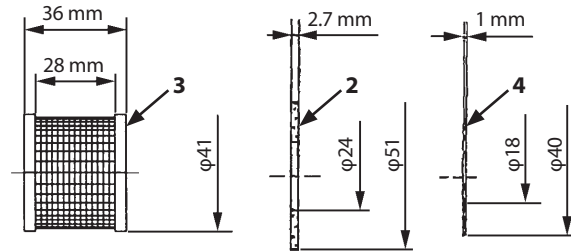

M1U1-07-006

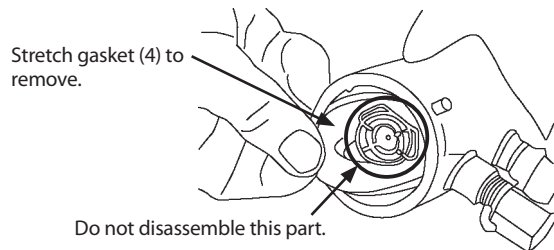

MDAA-07-053

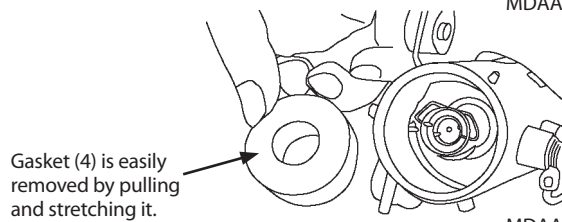

MDAA-07-054



# MAINTENANCE

## 8 Check Fuel Hoses --- every 10 hours (daily)

**⚠ CAUTION:** Fuel leaks can lead to fires that may result in serious injury.

- Escaping combustible fluid can cause fires. Check for kinked hoses, hoses that chafe against each other, and signs of fuel leaks.
- Repair or replace loose or damaged hoses.
- Never reinstall bent or damaged hoses.

According to the check points shown below, check hoses for oil leaks and damage.  
If any problem is found, replace or retighten as instructed in the table.

Hose			
Interval (hours)	Check Points	Problems	Remedies
Daily	Hose ends	Leak (1)	Retighten or replace
	Hose covers	Wear, crack (2)	Replace
Every 250 hours	Hose covers	Crack (3)	Replace
	Hose ends	Crack (4)	Replace
	Hose	Bend (5), Collapse (6)	Replace
	Hose fittings	Corrosion (7)	Replace

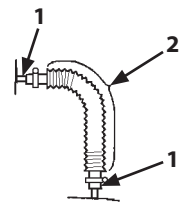

M137-07-003

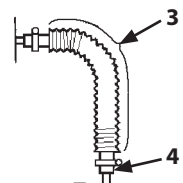

M137-07-004

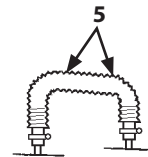

M137-07-005

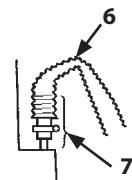

M137-07-006



# MAINTENANCE

## F. Air Cleaner

### 1 Replace Air Cleaner Element

**Outer element --- each time the monitor indicator illuminates.**

**Inner element --- at the time of the fifth replacement (or every 2 years) of the outer element**

Air cleaner (1) is comprised of double elements, outer element (6) and inner element (5).

1. Park the machine following the same procedures as described on page 7-6 for preparation of inspection/maintenance work.

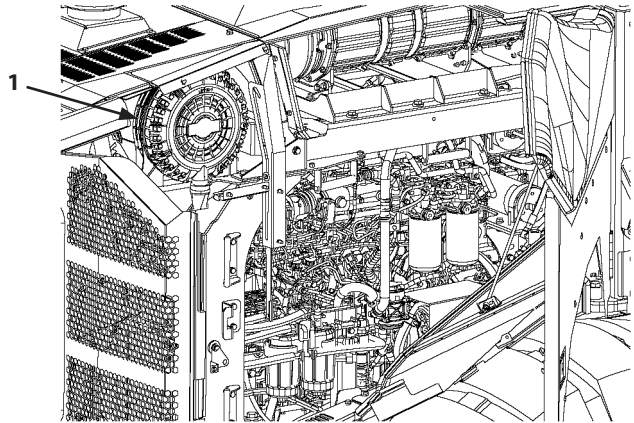

95Z7B-7-69-2

**IMPORTANT: Do not allow foreign matter such as dirt to enter the engine when replacing elements.**

2. Remove clip band (3) and remove cover (2).  
Clean out dust from inside cover (2) thoroughly.
3. Remove outer element (6) by slowly pulling it out.  
Replace outer element with new one.

**IMPORTANT: Do not reuse inner and outer element (5, 6).**

4. In case the air filter restriction indicator lights soon after replacing outer element (6), replace both outer and inner elements with new ones.  
Inner element (5) is threaded.

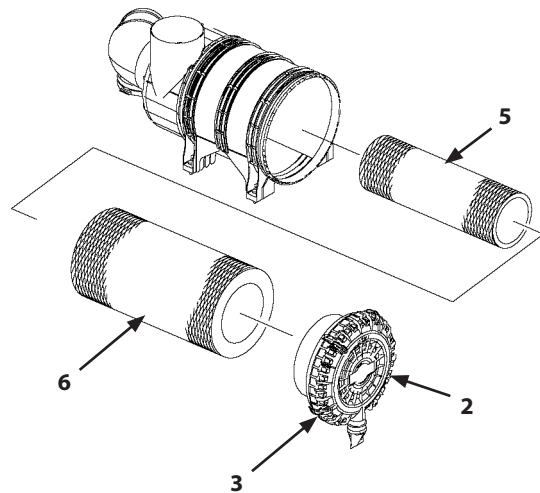

95Z7B-7-69-3

5. Confirm that gasket (7) fits properly onto cover (2).
6. Install cover (2) in the original position.
7. After replacing is complete, run the engine at slow speed. Then, check that the air filter restriction indicator is not ON.

# MAINTENANCE

## G. Cooling System

### Coolant

Use fresh water or normal tap water as the coolant water. Do not use strong acid or alkaline water. Use of the genuine Hitachi Long-Life Coolant (LLC) mixed by 33 to 50 % is recommended.

If the air temperature is expected to fall below 0 °C (32 °F), fill the cooling system with Long-Life Coolant (LLC) and soft water mix. As a general rule, the ratio of LLC should range between 33% and 50% as shown in the table below. If the ratio is below 33%, the system may develop rust, and if it is above 50%, the engine may overheat.

LLC Mixing Table

Air temperature °C (°F)	Mixing ratio %	Coolant Capacity: 88.0 liter (23.2 gallons)	
		LLC liter (gallon)	Soft Water liter (gallon)
-15 (5.0)	33	29.0 (7.7)	59.0 (15.5)
-20 (-4.0)	38	33.4 (8.8)	54.6 (14.4)
-25 (-13)	43	37.8 (10.0)	50.2 (13.2)
-30 (-22)	48	42.2 (11.1)	45.8 (12.1)

 **NOTE:** To avoid water impurity and minerals, a premixed coolant is recommended to use.

### WARNING:

- **Antifreeze is poisonous; if ingested, it can cause serious injury or death. Induce vomiting and get emergency medical attention immediately.**
- **When storing antifreeze, be sure to keep it in a clearly marked container with a tight lid. Always keep ANTIFREEZE out of the reach of children.**
- **Be careful of fire hazards. LLC is specified as a dangerous substance in the fire protection law.**
- **If antifreeze is accidentally splashed into eyes, flush with water for 10 to 15 minutes and get emergency medical attention.**
- **When storing or disposing of antifreeze, be sure to comply with all local regulations.**

# MAINTENANCE

## 1 Check Coolant Level --- every 10 hours (daily)

Check the coolant level at reservoir tank (1). The normal coolant level is between the FULL and LOW marks on side surface of reservoir tank (1).

In case no coolant is present in reservoir tank (1), add the coolant mixture via cap hole (2) on reservoir tank (1).

- When refilling a long life coolant (LLC), use the same brand product and the same mixture ratio as already used in the machine.
- If only water is refilled, the mixture ratio in the long life coolant (LLC) is diluted so that anti-rust and antifreeze effect in the coolant will become diluted and less affective.

**IMPORTANT: If the coolant level is low, EGR cooler is heated up, and damaged.**

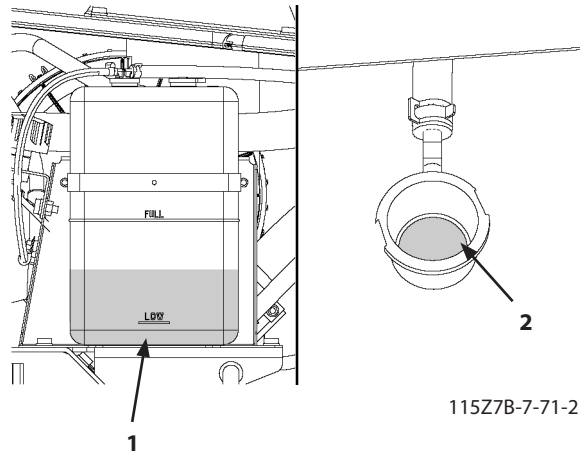
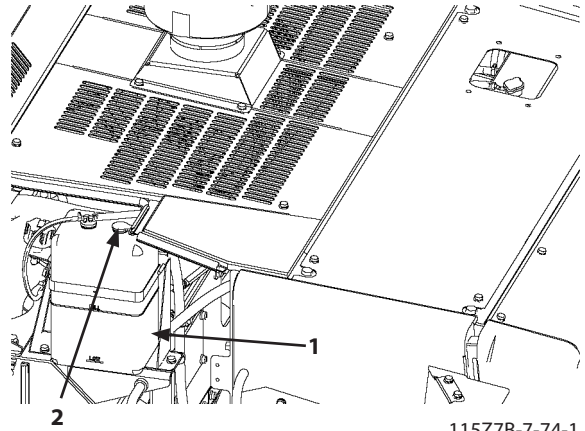

## MAINTENANCE

2

### Check Drive Belt

--- every 10 hours (daily)

**Adjust, Replace --- as necessary**

Press the center of the belt with a hand, and check whether the belt deflects only slightly.

Also, check the belt for a damage.

### Measurement of Deflection Amount and Vibration Frequency

1. Press the middle of the belt with a force of 98 N (approx. 10 kgf, 22 lbf), and check whether the amount of deflection is within the following range.  
Fan belt deflection value: 6~8 mm (0.2~0.3 in)
2. When the value is not within the range, adjust the tension.
3. Check the belt for a damage such as a scratch and crack.
4. When the belt adjusting allowance is no longer available, when crack, damage or abnormal wear is found, or when the belt squeaks during driving even after the belt tension has been adjusted, replace the belt.

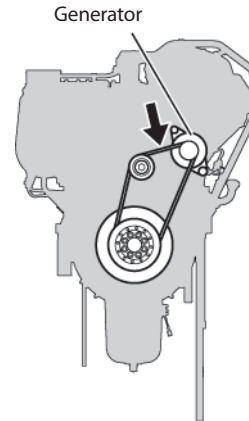

95Z7-7-68-1

### Adjusting Drive Belt

1. Loosen idler pulley's lock nut (1).  
Lock nut (1): 137~157 N·m (14~16 kgf·m, 101~116 lbf·ft)
2. Turn the generator and idler pulley adjusting bolts (2, 3) to adjust the belt tension to be within the standard value range.
3. After the adjustment, firmly tighten loosened lock nut (1) to the specified torque.

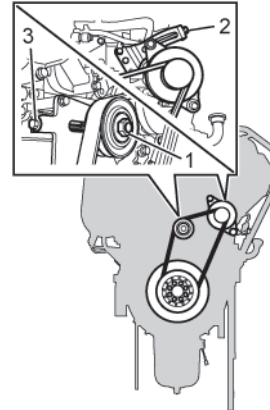

95Z7-7-68-2

## MAINTENANCE

---

### Replacing Drive Belt

1. Loosen idler pulley's lock nut (1) and adjusting bolt (3).
2. Remove the belt.
3. Install a new belt, and adjust the belt tension.
4. Turn the generator and idler pulley adjusting bolts (2, 3) to adjust the belt tension to be within the standard value range.
5. After the adjustment, firmly tighten loosened lock nut (1) to the specified torque.  
Lock nut (1): 137~157 N·m (14~16 kgf·m, 101~116 lbf·ft)
6. After the adjustment, run the engine at the idling speed for approx. 5 minutes, and then stop the engine to recheck the belt tension.

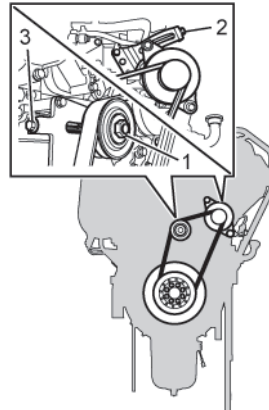

95Z7-7-68-2

### CAUTION:

- **When the generator is fixed, the belt tension slightly changes, so check the belt tension again after the generator is fixed.**
- **If the lock nut that is fixing the idler pulley is not tightened securely, it may be loosened by the vibrations generated during engine operation, which may cause damage to the components or an accident.**

# MAINTENANCE

3

## Change Coolant

--- every 3000 hours or two years

**WARNING:** Do not remove the radiator cap (1) until the coolant temperature in the radiator has cooled. Hot steam and coolant may spout out, possibly causing severe burns. After the coolant temperature cools, slowly loosen the cap to release the inside pressure before removing cap (1).

**NOTE:** Refer to page 7-72 for coolant specification. When other than the recommended LLC is used, contact your nearest authorized dealer for the replacement interval.

1. Park the machine following the same procedures as described on page 7-6 for preparation of inspection/maintenance work.
2. Install articulation lock bar to the front and rear of the frame by following the procedures described on page 7-12.
3. Prepare a container to capture approx. 88 liters (23.2 gallons) of drained coolant. Recycle or properly dispose of the used coolant.
4. Remove radiator cap (1).  
Open radiator drain plug (2) and engine oil cooler drain plug (3) to completely drain the coolant. Remove impurities such as scale at the same time.
5. Close radiator drain plug (2) and engine oil cooler drain plug (3).

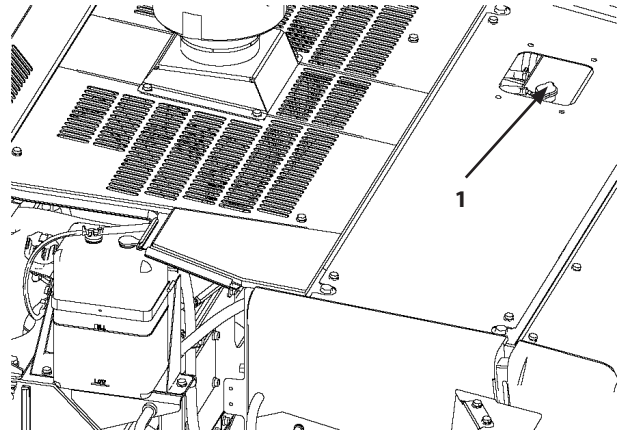

115Z7B-7-74-1

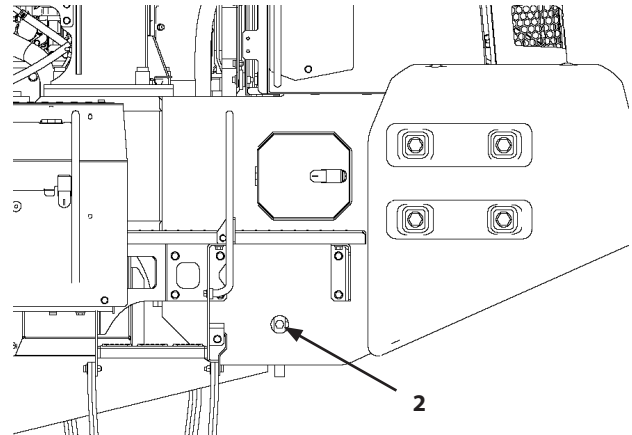

115Z7B-7-74-2

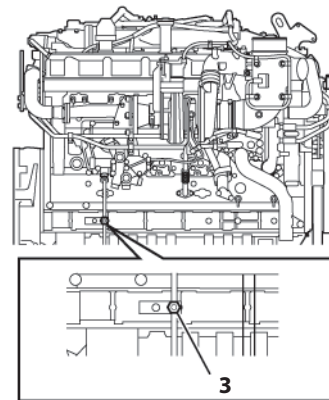

95Z7-7-69-3



## MAINTENANCE

- Slightly loosen air bleeder valve (7) of the EGR (Exhaust Gas Recirculation) cooler.

**IMPORTANT: Be sure to loosen the plug before supplying the coolant.**

- Prepare a container of more than 5 liters (1.3 gallons) capacity under the outlet (8) of the hose from air bleeder valve (7).
- Supply low impurity soft water or tap water together with the specified LLC. When adding coolant, do so slowly (less than 5 L (5 quart)/minute) to avoid mixing air in the system. Tighten valve (7) when coolant comes out from outlet (8).

Tightening torque: 23.5 N·m (17.3 lbf·ft)

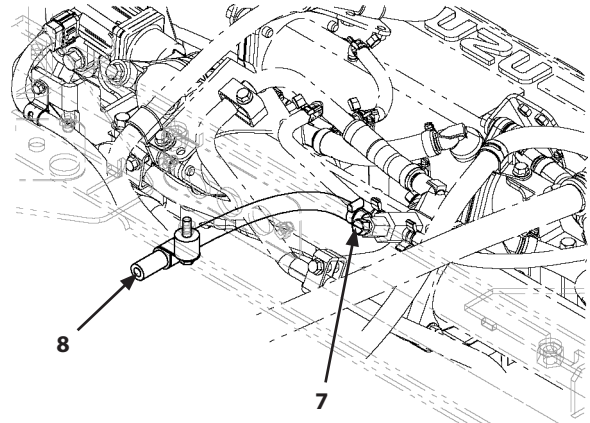

115Z7B-7-75-1

- Continue to supply coolant up to the bottom level (4) of the radiator filler port.
- To drain any residual air pockets from the EGR coolers, open air bleeder valve (7) again and allow 4 liters (1.0 gallon) or more to drain out of outlet (8). Tighten valve (7) after the bleeding is complete.

Tightening torque: 23.5 N·m (17.3 lbf·ft)

- Refill the coolant to the bottom level (4) of the radiator filler port.

 **NOTE:** The drained coolant in the above step 9. can be used.

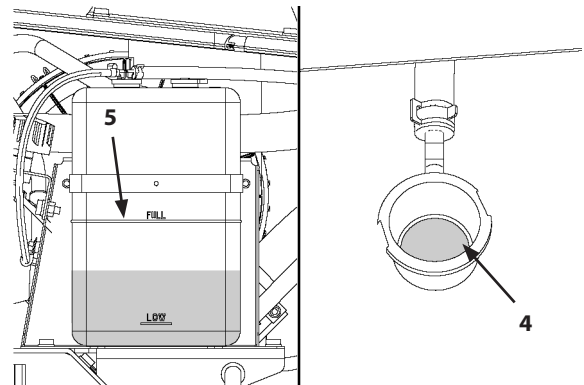

115Z7B-7-71-2

- Tighten radiator cap (1) firmly.
- Supply the LLC up to "FULL" level line (5) of the radiator sub tank.
- Start the engine and run the engine at low idle for about 5 minutes, and stop the engine. The coolant level should be lowered as the mixed air in the coolant is released.

**IMPORTANT: Take care the coolant temperature not to reach 75°C (167°F) or higher while idling the engine.**

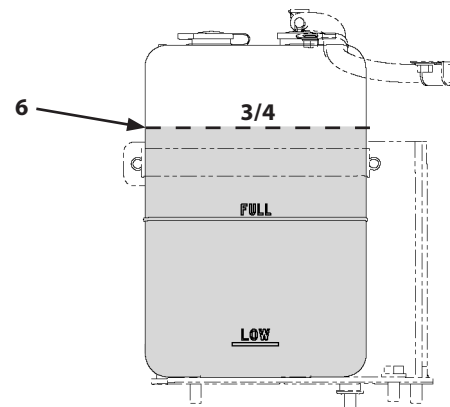

95Z7B-7-75-3

- Wait until the engine and the coolant are cooled. Remove radiator cap (1) and supply the coolant to the bottom level (4) of the radiator filler port. If the coolant level in the radiator is abnormally low, check for possible leakage.
- Tighten radiator cap (1) firmly.
- Add the coolant in the sub tank to 3/4 level (6).

## MAINTENANCE

18. Start the engine. Press power mode selector switch (9) to activate the power mode.
19. Select "Information Menu" - "Monitoring" menu to display the coolant temperature on the monitor. (Refer to p. 1-80 Monitoring.)
20. Wait until the engine temperature reach the normal operation range.
21. Then, run the engine at higher speed until the coolant temperature reaches 80°C (176°F). To quickly increase the coolant temperature, turn the declutch switch to OFF, fully depress the brake pedal, set the shift lever to the second speed range, the parking brake SW to OFF, and operate the bucket lever.

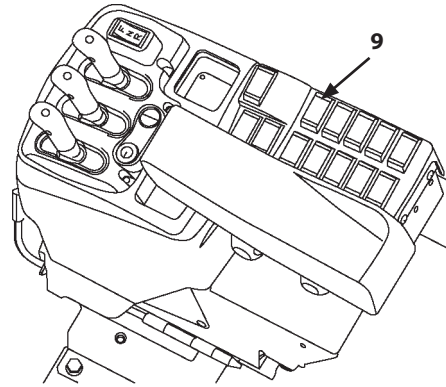

MNEC-01-041

 **NOTE:** This operation shows the main menu display on the monitor panel. Display the coolant temperature monitoring screen according to the above step 18.

22. After the coolant temperature reaches 80°C (176°F), keep running the engine at high idle for at least 6 minutes. (This opens the engine thermostat and releases the air between the radiator and the engine.) Keep the coolant temperature at 80°C (176°F) or higher during this high idle operation.

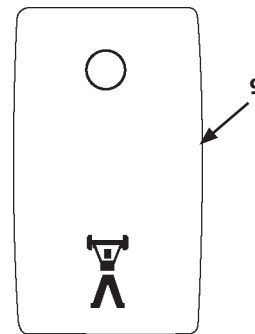

MNEC-01-016

**IMPORTANT: Failure to keep the engine at high idle and the coolant temperature at 80°C (176°F) or above for at least 6 minutes may result in air remaining in the EGR coolers and EGR cooler damage.**

23. While running the engine at high idle, turn the heater ON. This is to bleed the air of the heater circuit. (You may turn OFF the heater after running for 1 minute.)
24. Run the engine at low idle speed for about 5 minutes and stop the engine. Wait until the engine is fully cooled.

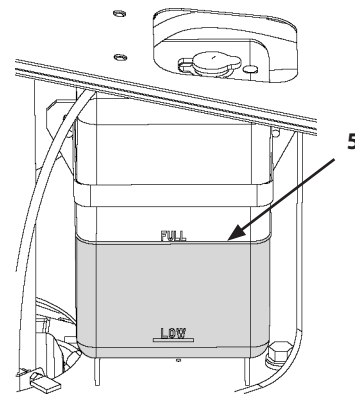

97Z7-7-89-6

25. Check the coolant level in the sub tank and add coolant to "FULL" level (5). If the sub tank is empty, the engine cooling system may have some problem. Check the engine and cooling system. Consult your nearest authorized dealer for assistance.

## MAINTENANCE

### 4 Clean Radiator/Oil Cooler Cores and Other Cooling System

--- every 500 hours or when the core is clogged.

**WARNING:** When using compressed air pressure [less than 0.2 MPa (2 kgf/cm<sup>2</sup>, 30 PSI)], wear safety glasses or goggles.

**IMPORTANT:** If compressed air with the pressure of more than 0.2 MPa (2 kgf/cm<sup>2</sup>, 30 PSI) or tap water with high delivery pressure is used for cleaning, damage to the radiator/oil cooler fins may result. Keep the nozzle away from the core surface more than 500 mm (20 inch).

#### (Over the Side Cover)

Check and clean engine charge air cooler (1), HVAC condenser (2), and fuel cooler (3).

#### (Over the Rear Grille)

**WARNING:** Make sure the fan is not rotating before opening the rear grill.

Check and clean hydraulic oil cooler (4), radiator (5), torque converter oil cooler (6), and hydraulic driven fan (7).

In case dirt or dust sticks to the radiator/oil cooler cores, clean the radiator/oil cooler cores with compressed air pressure [less than 0.2 MPa (2 kgf/cm<sup>2</sup>, 30 PSI)] or tap water to maintain the cooling system performance at a good level.

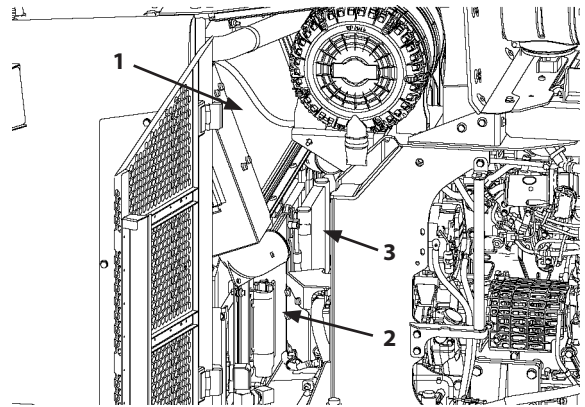

115Z7B-7-77-1

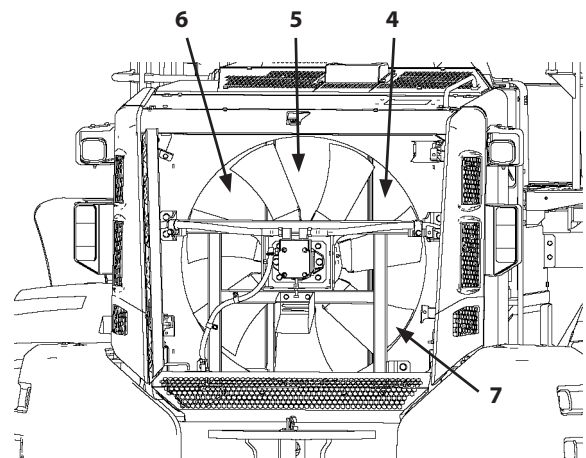

115Z7B-7-77-2

# MAINTENANCE

## H. Electrical System

### IMPORTANT:

- Improper radio communication equipment and associated parts, and/or improper installation of radio communication equipment may effect the machine's electronic parts, causing involuntary movement of the machine.
- Also, improper installation of electrical equipment may cause machine failure and/or a fire on the machine.
- Be sure to consult your authorized dealer when installing any type of equipment or additional electrical parts, or when replacing electrical parts.
- Never attempt to disassemble or modify the electrical/electronic components. If replacement or modification of such components is required, contact your authorized dealer.

### 1 Batteries

#### ⚠ WARNING:

- Battery gas can explode. Keep sparks and flames away from batteries. Check batteries only when cool.
- Use a flashlight to check the battery electrolyte level.
- Do not continue to use or charge the battery when electrolyte level is lower than specified. Explosion of the battery may result.
- Sulfuric acid in battery electrolyte is poisonous. It is strong enough to burn skin, eat holes in clothing, and cause blindness if splashed into the eyes.

#### Avoid hazard by:

1. Filling batteries in a well-ventilated area.
2. Wearing eye protection and rubber gloves.
3. Avoiding breathing fumes when electrolyte solution is added.
4. Avoiding spilling or dripping electrolyte solution.
5. Using proper booster battery starting procedures.

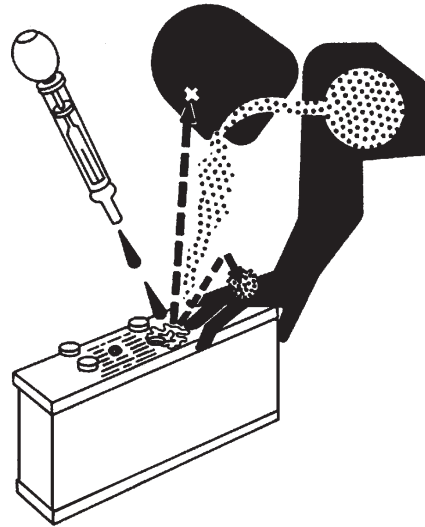

SA-036

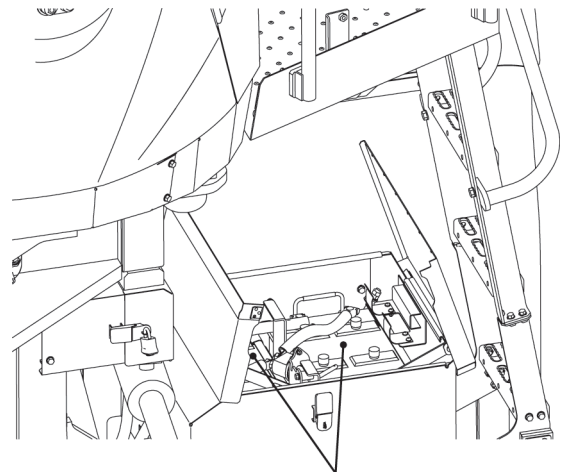

Batteries

11527-7-71-1

## MAINTENANCE

---

**If you spill acid on yourself, call 911, then:**

1. Flush your skin with water.
2. Apply baking soda or lime to help neutralize the acid.
3. If splashed in eyes, flush with water for 10 to 15 minutes. Get medical attention immediately.

**If acid is swallowed, call 911, then:**

1. Drink large amounts of water or milk.
2. Then drink milk of magnesia, beaten eggs, or vegetable oil.
3. Get medical attention immediately.

**IMPORTANT:** Add water to batteries when cool weather before you begin operating your machine for the day, or else charge the batteries.

**IMPORTANT:** If the battery is used with the electrolyte solution level lower than the specified level, the battery performance may deteriorate quickly.

**IMPORTANT:** Do not refill electrolyte solution more than the specified upper level. Electrolyte solution may spill, damaging painted surfaces and/or corroding other machine parts.

 **NOTE:** *In case electrolyte solution is filled above the specified upper level line or beyond the bottom end of the sleeve, remove the excess electrolyte solution until the electrolyte solution level is down to the bottom end of the sleeve by using a pipette. After neutralizing the removed electrolyte solution with sodium bicarbonate, flush it with plenty of water, otherwise, consult the battery manufacturer.*

# MAINTENANCE

## Electrolyte Level Check

--- every 100 hours (Do this when machine is cold.)

1. Check the electrolyte solution level at least once a month.
2. Park the machine on level ground and stop the engine.
3. Check the electrolyte solution level.

3.1 When checking the level from the battery side: Clean around the level check lines with a wet towel. Do not use a dry towel. Static electricity may spark, causing the battery gas to explode. Check if the electrolyte solution level is between U.L (Upper Level) and L.L (Lower Level). In case the electrolyte solution level is lower than the middle level between the U.L and L.L, immediately refill with distilled water or commercial battery fluid. Be sure to refill with distilled water before recharging (operating the machine). After refilling, securely tighten the filler caps.

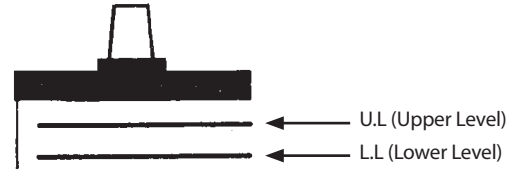

M146-07-109

3.2 When impossible to check the level from the battery side or no level check mark is indicated on the side:

After removing the filler plug from the top of the battery. Check the electrolyte solution level by viewing through the filler port. Use a flash light and a mirror to do this. It is difficult to accurately judge the electrolyte solution level in this case. Therefore, when the electrolyte solution level is flush with the U.L, the level is correct. Referring to the illustrations to the right, check the level.

When the electrolyte solution level is lower than the bottom end of the sleeve, refill with distilled water or commercial battery fluid up to the bottom of the sleeve. Be sure to refill with distilled water before recharging (operating the machine). After refilling, securely tighten the filler caps.

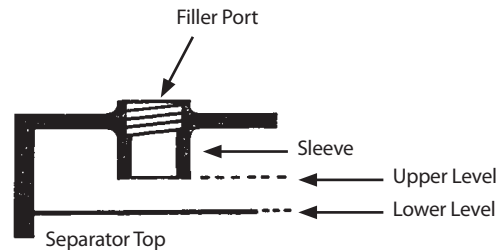

M146-07-110

Correct



Since the electrolyte solution surface touches the bottom end of the sleeve, the electrolyte solution surface is raised due to surface tension so that the electrode ends are seen curved.

M146-07-111

Lower



When the electrolyte solution surface is lower than the bottom end of the sleeve, the electrode ends are seen straight.

M146-07-112

- 3.3 When an indicator is available to check the level, use it.
4. Always keep the battery areas clean to prevent battery discharge. Check terminals for looseness and/or corrosion. Coat terminals with grease or petroleum jelly to prevent corrosion build up.

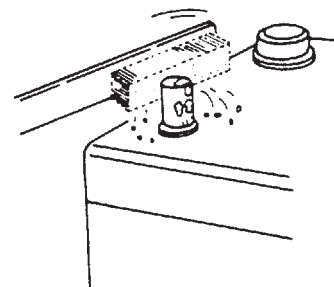

M409-07-072

# MAINTENANCE

## Check Electrolyte Specific Gravity

--- every 250 hours

### ⚠ CAUTION:

- Battery gas can explode. Keep sparks and flames away from batteries. Use a flashlight and a mirror to check the battery electrolyte solution level.
- Sulfuric acid in battery electrolyte solution is poisonous. It is strong enough to burn skin, eat holes in clothing, and cause blindness if splashed into the eyes.
- Never check the battery charge by placing a metal object across the posts. Use a battery tester or hydrometer.
- Always remove the grounded (-) battery lead first and attach it last.

### Avoid hazard by:

1. Filling batteries in a well-ventilated area.
2. Wearing eye protection and rubber gloves.
3. Avoiding breathing fumes when electrolyte solution is added.
4. Avoiding spilling or dripping electrolyte solution.
5. Using proper booster battery starting procedures.

If you spill acid on yourself, call 911, then:

1. Flush your skin with water.
2. Apply baking soda or lime to help neutralize the acid.
3. If splashed in eyes, flush with water for 10 to 15 minutes. Get medical attention immediately.

If acid is swallowed, call 911, then:

1. Drink large amounts of water or milk.
2. Then drink milk of magnesia, beaten eggs, or vegetable oil.
3. Get medical attention immediately.

**IMPORTANT:** Check the specific gravity of the electrolyte when it is cool, not immediately after operation.

Check the electrolyte specific gravity in each battery cell.

The lowest limit of the specific gravity for the electrolyte varies depending on electrolyte temperature. The specific gravity should be kept within the range shown below. Charge the battery if the specific gravity is below the limit.

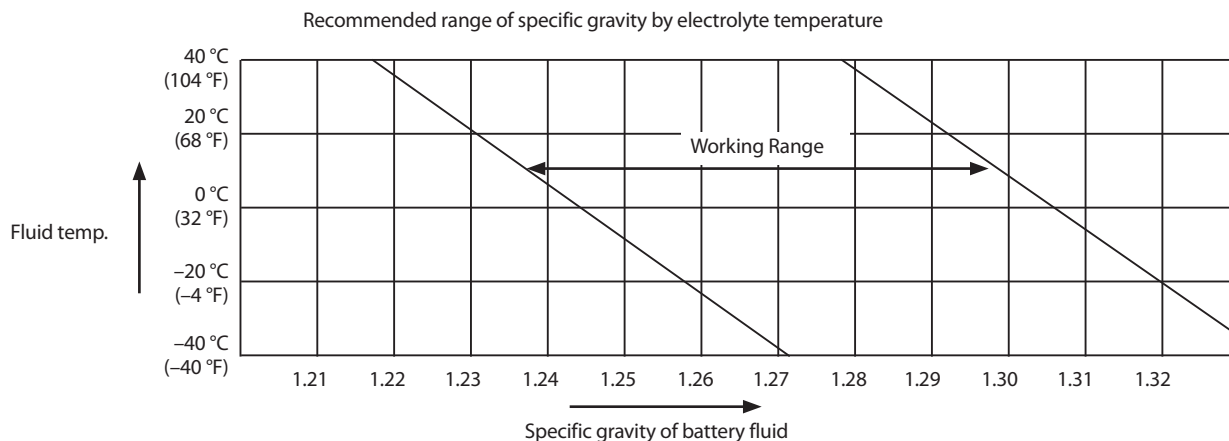

# MAINTENANCE

## Replace Batteries

**IMPORTANT:** Before adjusting electrical system or welding on the machine, disconnect the negative side of the battery, or turn the battery disconnect switch to OFF position.

Your machine has two 12-volt batteries (1) with negative (-) ground.

If one battery in a 24-volt system has failed but the other is still good, replace the failed battery with an operable battery of the same type. For example, replace a failed maintenance-free battery with a new maintenance-free battery.

Different types of batteries may have different rates of charge. This difference could overload one of the batteries and cause it to fail.

 **NOTE:** When replacing batteries (1), remove bolts (2) (5 used) and remove box (3) surrounding the batteries.

 : 17 mm

 : 53 N·m (5.4 kgf·m, 39 lbf·ft)

Box (3) weight: 25 kg (55 lb)

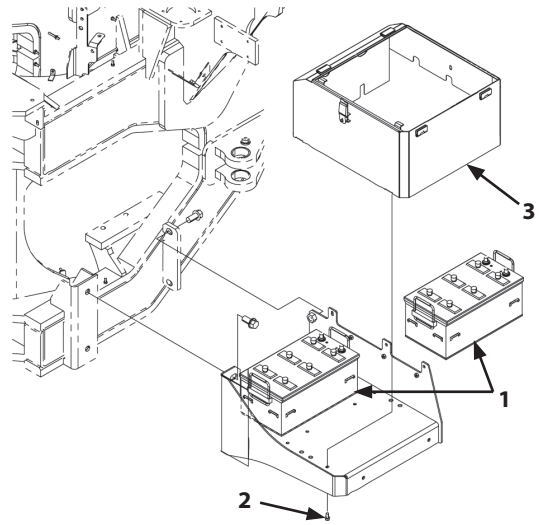

115Z7-07-81

## **2** Check Monitor Functions and All Other Instrument Operation

--- every 10 hours (daily)

Run the engine at low idle when checking the instruments. The monitor indicates alarm, caution and confirmation status in red, orange, and normal operative condition in blue or green respectively.

Check each gauge or meter if its needle is moved with the key switch ON. The needle shall be moved to the blue range when normal and to the red range when abnormal. Refer to the Group of Operator's Station in Section 1 for more information.



## MAINTENANCE

3

### Check Work Lights

--- every 10 hours (daily)

**CAUTION:** If any burned-out light is found, immediately replace it with a new one.

Visually check all work lights (1) that they normally illuminate and/or flash from the front and rear sides of the machine.

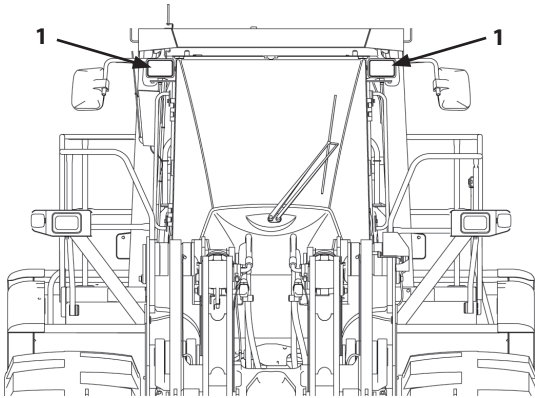

115Z7\_front

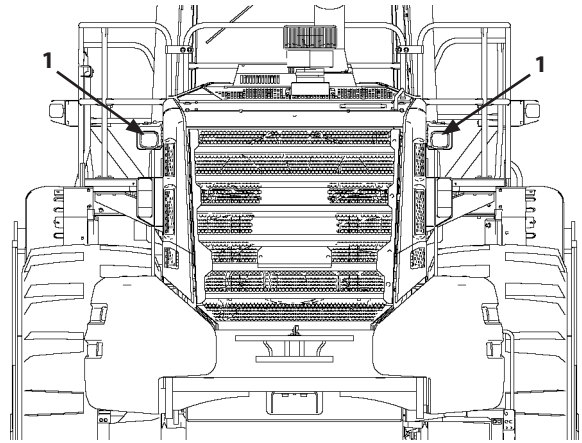

115Z7B-1-86-4

4

### Check Horn and Backup Alarm

--- every 10 hours (daily)

**WARNING:** Before checking the horn and/or the backup alarm, always apply the parking brake and clear the machine area of other personnel.

The horn switch button is located at the steering wheel center and on the right console.

In case the machine is equipped with a multi-function joystick lever, the horn switch is located on the multi-function joystick lever.

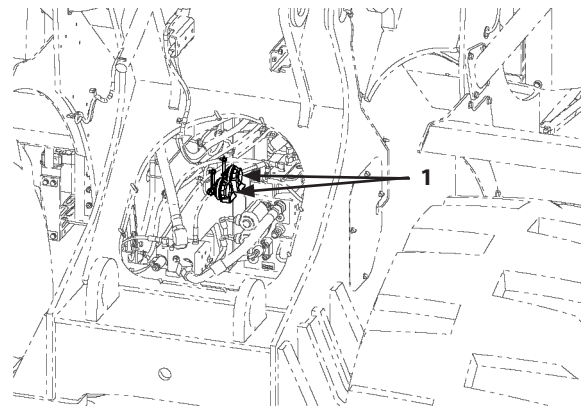

115Z7B-7-84-3

**NOTE:** Refer to page 1-8 through 1-11 for the location of these switches.

Horn (1) is located on the front chassis.

Backup alarm (2) is located at the left side of the rear grille. Check that backup alarm (2) correctly sounds by operating either the forward/reverse lever or the forward/reverse switch to the reverse drive side.

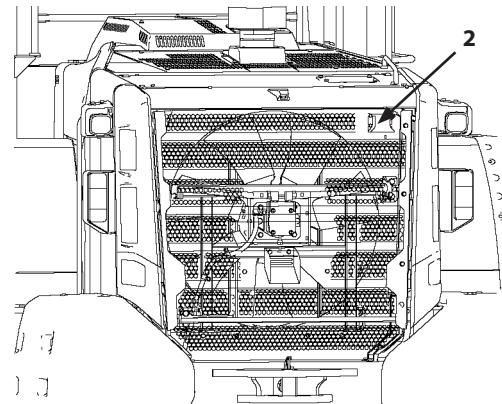

115Z7B-7-84-2

## MAINTENANCE

### 5 Check Electrical Harnesses and Fuses --- every 50 hours

**CAUTION:** If dirt or dust is adhered on the wirings or relays, it may cause fire.

Check the electrical harness and terminals of the batteries, starter motor, and alternator for loose connection and/or short circuit (broken shield). If any burned mark or a burning odor is noticed at a harness, consult your nearest authorized dealer.

#### Replace Fuse

1. If any electrical equipment becomes inoperable, first check the fuses in the fuse boxes (A, B) located in the left console in the operator's station.
2. One or two each spare fuse for respective fuse capacities is provided in the fuse boxes (A, B).
3. Finally, check slow blow fuses (1, 2) located on the left side of the machine.

1- 140 A x 2

2- 70 A x 2

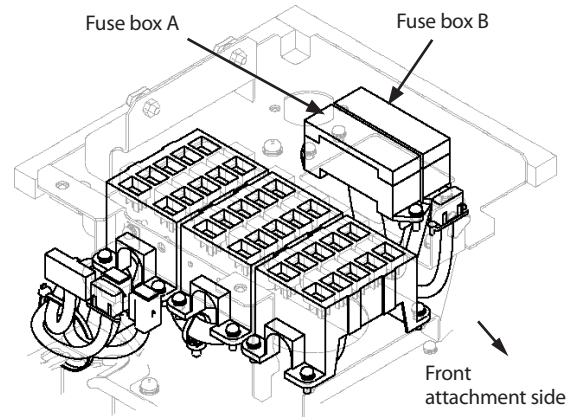

FuseBox\_550

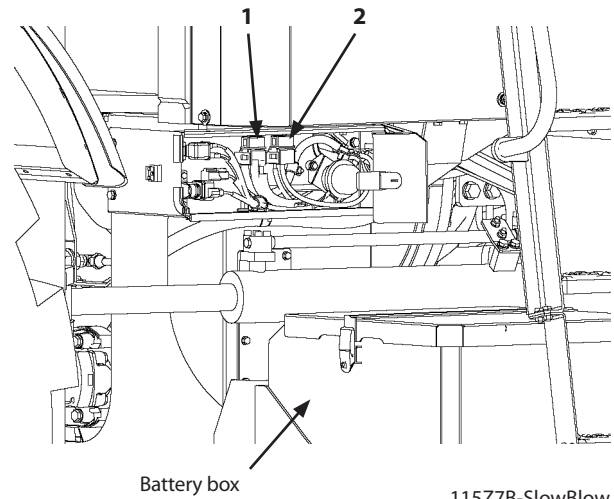

115Z7B-SlowBlow

# MAINTENANCE

## Fuse Box A

- |                                  |   |
|----------------------------------|---|
| 10- Parking solenoid<br>5 A      | 20- Option 4 (Joystick steering)<br>(5 A) |
| 9- Air conditioner 1<br>10 A     | 19- Option 3 (Fuel pump)<br>15 A          |
| 8- Stop lamp, Turn signal<br>5 A | 18- SCR DCU<br>20 A                       |
| 7- Back lamp, Back buzzer<br>5 A | 17- ECM DCU (POWER ON)<br>10 A            |
| 6- Head lamp (left)<br>5 A       | 16- SCR sensor<br>20 A                    |
| 5- Working lamp (front)<br>20 A  | 15- Air conditioner 2<br>20 A             |
| 4- Front wiper<br>15 A           | 14- Starter key SW<br>10 A                |
| 3- 24 V cigar lighter<br>20 A    | 13- Seat heater<br>15 A                   |
| 2- Head lamp (right)<br>5 A      | 12- Option 2 (ACC1)<br>(20 A)             |
| 1- CONTROLLER (SUB)<br>10 A      | 11- Radio (USA)<br>10 A                   |

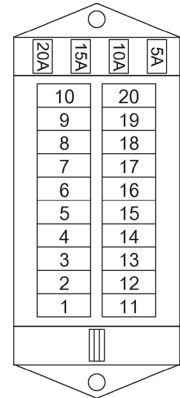

90Z7B-FuseBoxA

## Fuse Box B

- |   |  |
|---|--|
| 10- ECM<br>30 A   | 20- Secondary steering (option)<br>5 A |
| 9- CONTROLLER (SUB)<br>10 A   | 19- High beam<br>10 A                  |
| 8- Main controller, DSZ, Monitor,<br>Load dump relay, GPS, GSM, OPT C/U<br>10 A | 18- Rear wiper<br>10 A                 |
| 7- Flasher unit<br>10 A   | 17- Working lamp (rear)<br>20 A        |
| 6- Horn<br>10 A   | 16- Loader control<br>5 A              |
| 5- Option CAN<br>5 A  | 15- MC solenoid power<br>10 A          |
| 4- Option 1 (battery)<br>(15 A)   | 14- Parking relay<br>5 A               |
| 3- DC/DC converter, 12 V cigar socket,<br>Tachograph (option)<br>20 A           | 13- Power ON<br>10 A                   |
| 2- Lighting switch<br>10 A  | 12- Position 2<br>5 A                  |
| 1- DC/DC power ON<br>5 A  | 11- Position 1<br>5 A                  |

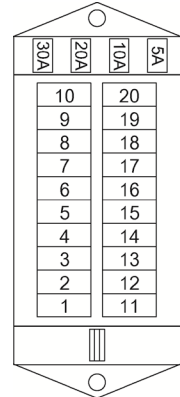

90Z7B-FuseBoxB

# MAINTENANCE

## I. Brake System

### 1 Check Right and Left Brake Interlocking Performance

--- every 10 hours (daily)

**WARNING:** Put up a do not enter sign for the range of 100 m (110yd) ahead in the forward machine travel direction. Arrange a safety monitor person.

**WARNING:** Do not allow dust and/or soil to accumulate in vicinity (3) of the brake pedal. The brake may lose traction.

While stepping on brake pedal (1), check the pedal movement, the brake performance, and the play in the pedal stroke for any problems.

If dust and/or soil accumulates in vicinity (3) of the brake pedal, remove the accumulated dust and/or soil.

#### Check Brake Performance

1. Turn "OFF" the declutch switch.
2. Firmly step on the left hand brake pedal.
3. Release the parking brake.
4. Select the transmission shift lever 2nd and FORWARD.
5. Slowly accelerate the engine to full speed.
6. The machine should not move.

**IMPORTANT:** If machine moves when firmly step on right hand brake with transmission in 2nd and FORWARD, there is some problem with service brake.  
**Do not operate until problem has been corrected.**

#### Check Play in Brake Pedal Stroke

Measure the pedal stroke at pedal tip (2) by pressing the pedal with your hand until you feel an intermittent feed back from the pedal.

Correct Play (2): 4 to 13 mm (0.16 to 0.51 inch)

If the play is outside the specified range, consult your nearest authorized dealer. In case poor performance is noticed, consult your nearest authorized dealer. Get the machine checked and repaired.

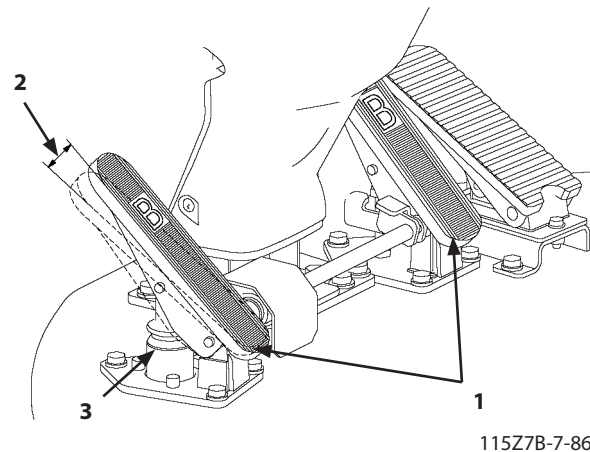
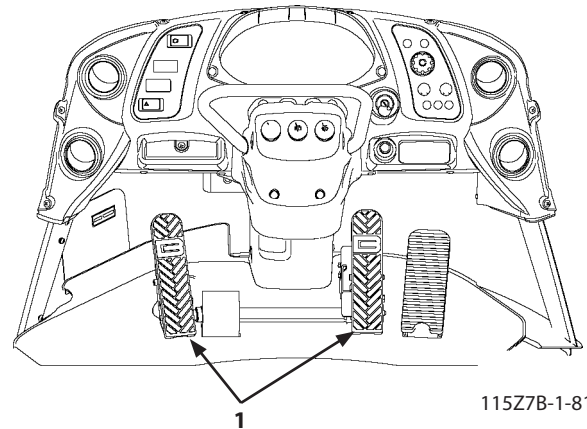

## MAINTENANCE

### 2 Check Parking Brake Force --- every 10 hours (daily)

**⚠ WARNING:** Check the machine in a place where no one is present or ahead in the drive traveling direction. Keep bystanders away from the machine.

After confirming the service brakes work normally, test the parking brake.

1. Move the machine to a safe open place on a 15 degrees inclining dry surface slope.
2. Stop the machine with the service brake.
3. Turn ON parking brake switch (1).
4. Release the service brakes.
5. The machine should not move.

**IMPORTANT:** If machine moves when parking brake switch is ON, there is some problem with parking brake. Consult your nearest authorized dealer. Do not operate until problem has been corrected.

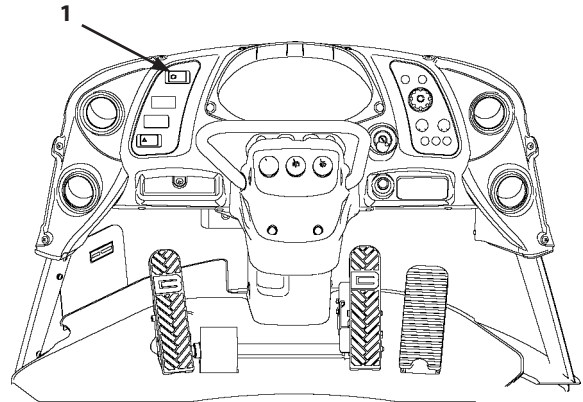

115Z7B-1-81-1

## MAINTENANCE

### **3** Check Parking Brake Gear Oil Level --- every 250 hours

1. Park the machine following the same procedures as described on page 7-6 for preparation of inspection/maintenance work.
2. Install articulation stopper (lock bar) (1) to the front and rear of the chassis by following the procedures described on page 7-8.
3. Clean the vicinity of oil plugs (2, 3).
4. Remove oil level plugs (2, 3) for oil level check.
5. Fill the oil from plug (2) until oil comes out of plug (3).
6. Install and tighten plugs (2, 3).

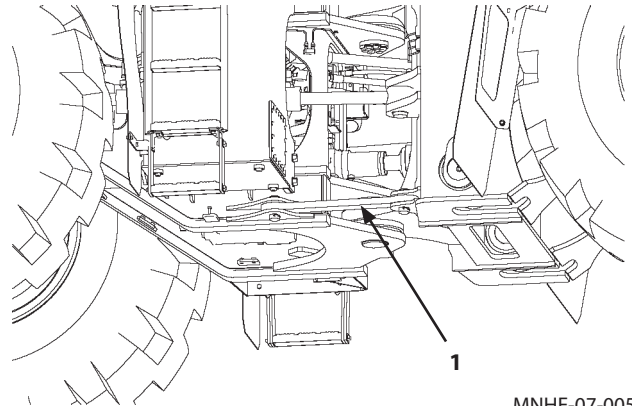

MNHE-07-005

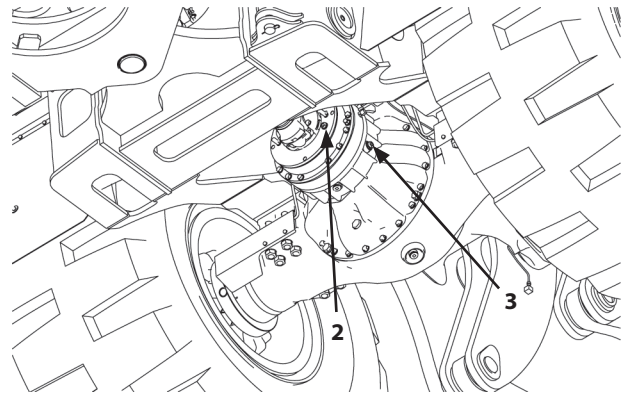

115Z7-7-91-2

## MAINTENANCE

4

### Change Parking Brake Gear Oil

--- every 2000 hours



**WARNING:** Be cautious about the following items.

- Starting repair work immediately after operation may cause burns. Wait for oil temperature to lower.
- Lock the front and rear chassis with the articulation stopper (lock bar).

**IMPORTANT:** Do not use parking brake gear oils other than those listed in the "Kind of Oils" - "Axle Oil".

1. Park the machine following the same procedures as described on page 7-6 for preparation of inspection/maintenance work.



**NOTE:** Adjust so that the "TOP" mark on the planetary gear housing comes top. See the illustration on the next page.

2. Install articulation stopper to the front and rear of the chassis by following the procedures described on page 7-8.
3. Clean the vicinity around plugs (1, 2, 3) and the oil drain plug holes.
4. Arrange a container of 3 liters (0.8 gallons) capacity to receive the drain oil.
5. Remove drain plug (1) to drain the oil.
6. Remove oil filling port plug (2) and oil level check port plug (3).
7. Securely tighten drain plug (1).
8. Refill the recommended oil through oil filling port (2) until the oil comes out of oil level check port (3).  
Parking Brake: 3 liters (0.8 gallons)
9. Install and tighten port plugs (2, 3).

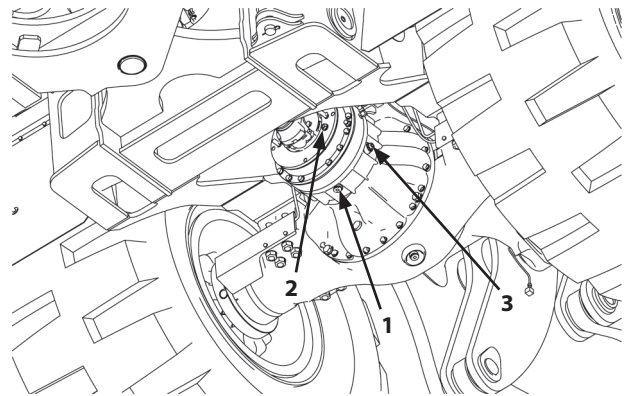

115Z7-7-91-2

## MAINTENANCE

- 5** Check Accumulator Function, Gas Leakage, Looseness, and Damage  
--- every 500 hours

**⚠ WARNING:** Allow only qualified personnel to service the accumulator.

- High-pressure nitrogen gas is enclosed in the accumulator. (N<sub>2</sub> is inert, and will not burn.)
- Never strike the accumulator. Keep the accumulator away from heat sources.
- Do not weld the accumulator housing.
- Be sure to release oil pressure before starting to work on the brake circuit.

1. Check that alarm function is activated:

Check that when the brake pedal is strongly stepped more than 5 strokes with the key switch ON and the engine stopping, the monitor indicators come ON.

2. Note that alarm function is deactivated:

Start the engine. Run the engine at 1,200 RPM (min<sup>-1</sup>) to pressurize the accumulator. Check that when the pressure builds in the accumulator, the alarm buzzer stops sounding and the brake oil pressure indicator goes OFF.

3. Note how many times the brake pedal is stepped:

Check that the brake pedal can be stepped more than 3 strokes before the monitor indicators come ON with the key switch ON, the engine stopping, and brake oil pressure gauge in the right of the monitor display indicates the maximum level.

Three points described above must be confirmed as operational. Besides the above points, check the accumulator for gas leakage, looseness, and damage. If any abnormality is found, immediately consult your nearest authorized dealer.

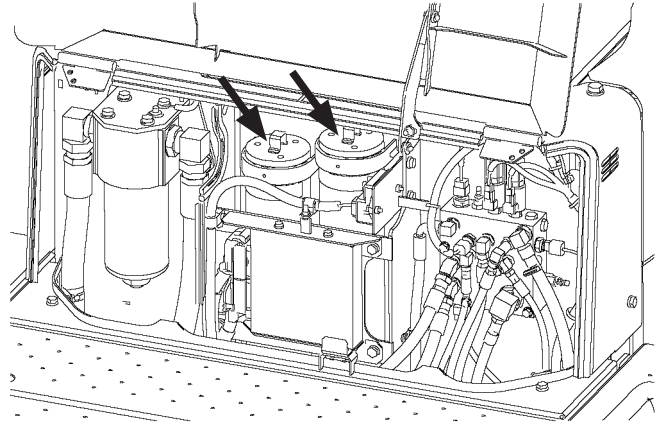

115Z7B-1-142-4



## MAINTENANCE

### **6** Check Brake Disks (Service and Parking) --- every 2000 hours

Service brake (1) is a closed wet type multi-plate hydraulic brake, and is incorporated in the axle housing.

Parking brake (2) is also a closed wet type brake. Parking brake (2) is mounted in the front axle.

Consult your nearest authorized dealer for checking.

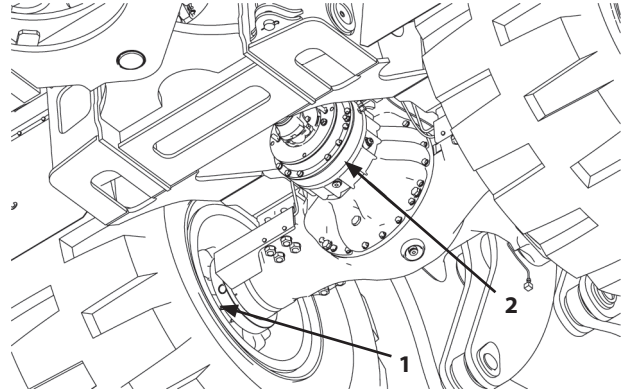

115Z7-7-91-2

### **7** Check Gas Pressure in Accumulator --- every 2000 hours

Check the gas pressure at a regular interval. If the machine is operated with the gas pressure lower than specified value, normal brake performance and/or loading performance may not be to specifications achieved, possibly creating very hazardous situations. Ask your nearest authorized dealer for checking.

 **NOTE:** Check the accumulator for the ride control equipped machine in the same manner.

# MAINTENANCE

## J. Tire

### 1 Check and Replace Tire (Tire Pressure) Check appearance --- 10 hours (daily)

 **NOTE:** Check tire pressure when appearance is questionable or each week (50 hours)

Replace --- as necessary

### **WARNING:**

- Secure the front and rear chassis with the articulation stopper (lock bar and pins).
- When inflating tires, stand behind the tread and use the self-attaching chuck with a line extension.
- Avoid welding near tires, which could potentially cause the tires to explode.
- A tire may explode if it is smoking due to intense heat such as if the machine catches fire.
- Never weld on rims. Replace defective rims.

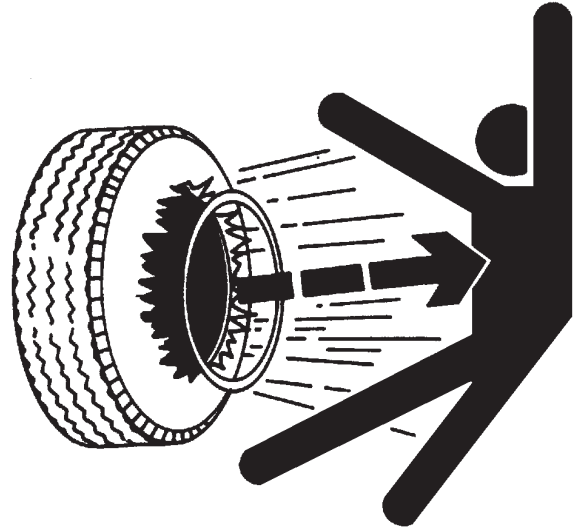

SA-249

### IMPORTANT:

- Always maintain the correct tire pressure.
- Even if only one tread pattern has worn out, replace the tire with new one. Tires must be evenly sized. Before operating the machine, check the tires for damage.
- When replacing one tire, use a new tire having the same tread pattern and specification as the other tires.

### Check Air Pressure

1. Measure air pressure when the tires are cool before operating the machine.

Radial tire (standard)	Standard Air pressure	
	Front	Rear
35/65R33	471~490 kPa (4.8~5.0 kgf/cm <sup>2</sup> ) (68~71 PSI)	373~392 kPa (3.8~4.0 kgf/cm <sup>2</sup> ) (54~57 PSI)

Bias ply tire (option)	Pattern	Standard Air pressure	
		Front	Rear
29.5-29-28PR	L4, L5	520~539 kPa (5.3~5.5 kgf/cm <sup>2</sup> ) (75~78 PSI)	422~441 kPa (4.3~4.5 kgf/cm <sup>2</sup> ) (61~64 PSI)
35/65-33-24PR		422~441 kPa (4.3~4.5 kgf/cm <sup>2</sup> ) (61~64 PSI)	324~343 kPa (3.3~3.5 kgf/cm <sup>2</sup> ) (47~50 PSI)

2. Check tires for damage and/or excessive wear.

## MAINTENANCE

### 2 Check Tire for Damage --- every 10 hours (daily)

**CAUTION:** If tire has external damaged such as deep cuts, an accident due to puncture or burst of the tire may occur, possibly resulting in injury or death.

Check the external appearance of tires for damage.

### 3 Check Wheel Bolt Torque --- every 500 hours (50 hours at fist time only)

Be sure to check the wheel bolt torque by turning the bolt clockwise.

Tightening Torque: 892 N·m (91 kgf·m, 658 lbf·ft)

#### Replace Tire

**CAUTION:** Secure the front and rear chassis with the articulation stopper (lock bar and pins).

**IMPORTANT:** Height of the machine may change according to the types of tires to be installed. Do not change the specifications of the machine by using unauthorized tire sizes.

1. Park the machine following the same procedures as described on page 7-6 for preparation of inspection/maintenance work.
2. Install the articulation stopper to the front and rear of the chassis by following the procedures described on page 7-8.
3. Loosen all wheel bolts one turn. Note which way the tread pattern is facing.
4. After jacking up the machine, securely support the machine with blocks.
5. Remove the wheel bolts. Replace the tire.
6. With the tire raised off the ground, lightly tighten the wheel bolts in order as illustrated to the right.
7. Lower the machine. Retighten the wheel bolts to the above torque specification and in the order as illustrated to the right.

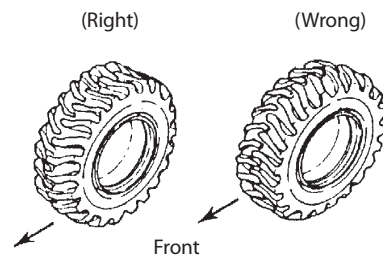

M4GB-07-104

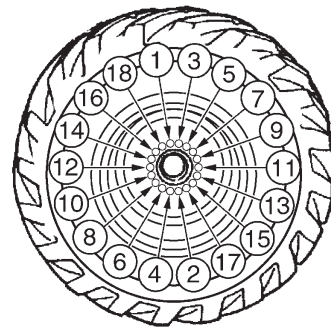

M4GB-07-102

**NOTE:** This illustrates that a bolt at diagonal position, not the next one, should be tighten as shown. The number of wheel bolts may differ.

## MAINTENANCE

### Radial tire

Size	Air pressure	
	Front	Rear
35/65R33	471~490 kPa (4.8~5.0 kgf/cm <sup>2</sup> ) (68~71 PSI)	373~392 kPa (3.8~4.0 kgf/cm <sup>2</sup> ) (54~57 PSI)

### Bias ply tire

Size	Pattern	Air pressure	
		Front	Rear
29.5-29-28PR	L4	520~539 kPa (5.3~5.5 kgf/cm <sup>2</sup> ) (75~78 PSI)	422~441 kPa (4.3~4.5 kgf/cm <sup>2</sup> ) (61~64 PSI)
	L5		
35/65-33-24PR	L4	422~441 kPa (4.3~4.5 kgf/cm <sup>2</sup> ) (61~64 PSI)	324~343 kPa (3.3~3.5 kgf/cm <sup>2</sup> ) (47~50 PSI)
	L5		

Adjust air pressure according to the job site conditions.  
Adjust tire pressure in conformity with the work mode the machine is engaged in.

#### **Tire Sizes to be Used**

Consult your nearest authorized dealer or tire manufacturer for more detailed information.

#### **Driving on Public Roads: Standard Pressure**

- Loading/excavation on normal ground surface: Standard or slightly higher than standard pressure
- Heavy-duty excavation: Higher pressure in the standard pressure range
- Operation on soft or sandy terrain: Slightly lower than standard pressure

 **NOTE:** Apply the same air pressure to snow tires.

*For tires with other patterns, or special operating conditions consult the tire manufacture.*

*For liquid tire ballast consult your authorized dealer or the tire dealer.*

# MAINTENANCE

## Tire Rotation

Rotate tires when uneven or abnormal wear is recognized on either front or rear, or right and left tire. Tire rotation is recommended to achieve uniformity of wear on tires for good tire service life.

**⚠ WARNING:** This must have no external damage, such as heavy cuts, large bubbled protrusions or other damage that can lead to tire failure. If tires have such problems, they may fail with a blow-out, and cause an injury or death, or otherwise damage property.

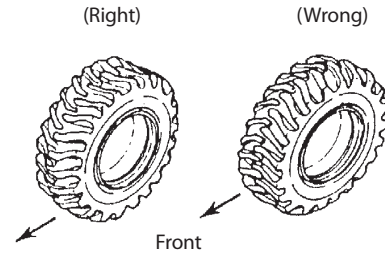

M4GB-07-104

## Rotation Procedure

- Switch tires only between the front and rear positions. Do not switch the tires between diagonal positions.
- Align the tire rotation direction with the tire tread design pattern. Tread design pattern direction (option) will affect not only economy of tire but also safety of operation.

## How to Check Wear Amount (Tread Design Groove Depth):

Measure the groove depth at 1/4 tread width position [shown with X mark (1) in the figure].

Use limit of the groove depth shall be approx. 85 % of the new tire groove depth. In case extreme uneven wear or exposed rubbing strips are found, replace the tire even before reaching 85 %.

**IMPORTANT:** The tire sizes must be close to even, or mechanical damage will result to the drive train. When installing replacement tires, be sure that the tire sizes and design are the same. It is recommended to replace all four tires at the same time.

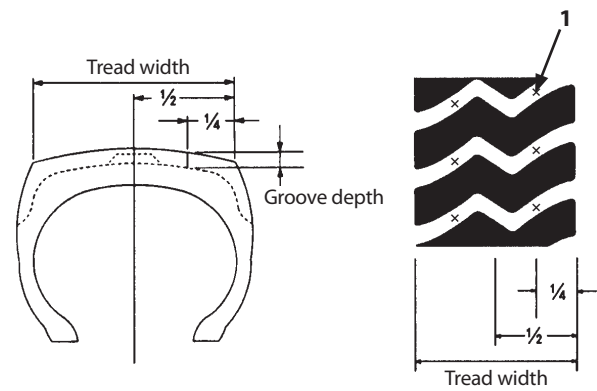

M4GB-07-103

## MAINTENANCE

---

### Removal and Installation of Tire

**⚠ WARNING:** A wheel and tire assembly is a very heavy part so that removal and installation of a tire is hazardous and difficult work. In addition, a crane to lift a tire is required when removing or installing the tire to the wheel. Consult your nearest authorized dealer or a professional tire sales shop for tire removal and installation work. When jacking up the machine, observe the following points.

- Select dry, solid and flat ground for a work site.
- Work in a group of more than two persons. One person to mainly do the work and others to work as assistants and/or ensure safety.
- Do not use the bucket to raise the front wheels.
- Do not raise the machine off the ground higher necessary.
- When one axle is raised off the ground, block the tires at the axle that is still in contact with the ground.
- After the machine is raised off ground, be sure to block the machine using rigid supports. If wooden blocks are used for "cribbing" support, use only hard wood blocks. Never use soft wood for support. Never leave the machine to be supported only by jacks.
- The rear wheels oscillate. Insert wooden blocks between the axle and the chassis to stop oscillation.
- When removing the wheel bolts, lift the wheel with a crane so that the wheel bolt remaining at the top position is removed lost.

 Wheel bolt: 892 N·m (91 kgf·m, 658 lbf·ft)

### Tire Wheel

**⚠ WARNING:** Use only reliable and professional tire repair shops to do tire repair or replacements. Only authorized professional repair shops should be permitted to assemble and inflate tires. Rusty rims that have been deeply corroded must not be reused. Replace them with new rims.

# MAINTENANCE

## K. Air Conditioner

### 1 Clean/Replace Air Conditioner Circulation/Fresh Air Filters

Clean filters --- every 100 hours (or once a week whichever come first)

Replace filter --- after cleaning filters 10 times (or when the filters are severely clogged)

#### Clean Fresh Air Filter

1. Remove the filter:

The fresh air filter is installed behind cover (1) on the left rear side of the cab exterior.  
Open cover (1) with the starter key.

2. Loosen wing nuts (3) and remove plate (2).

3. Remove fresh air filter (4).

**WARNING:** When using compressed air pressure, wear safety glasses or goggles.

#### IMPORTANT:

- If compressed air delivery pressure is high, damage to the filter fins may result.
- Always use compressed air at the lower pressure than 0.2 MPa (2kgf/cm<sup>2</sup>, 30 PSI).
- Keep the nozzle more than 500 mm (20 in) away from the core surface.

4. Clean fresh filter (4) using compressed air.

#### IMPORTANT:

- Incorrect installation of the filter may cause dust to enter into the air conditioner, causing malfunction or breakdown of the air conditioner.
- Before installing the filter element, clean off dust around the mounting area; install the filter element with extra care.
- Keep cab doors closed when operating machine.

3. Install the cleaned fresh air filter or a new filter by following the filter removal procedure described in step 1 in the reverse order.

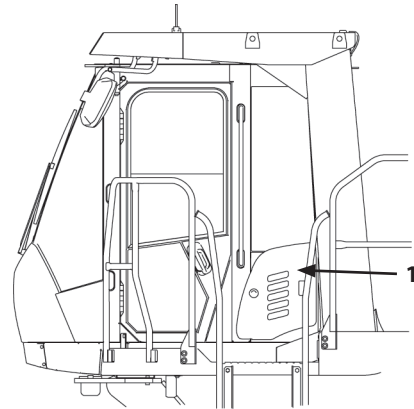

115Z7-7-97-1

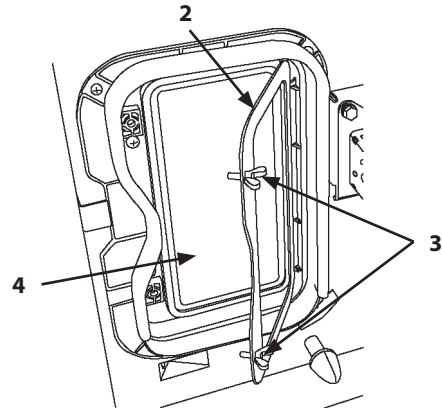

MNEC-07-043

## MAINTENANCE

---

### Clean Circulation Air Filter

1. Loosen knob (5) and remove retainer (6) to tilt cover (7) forward.

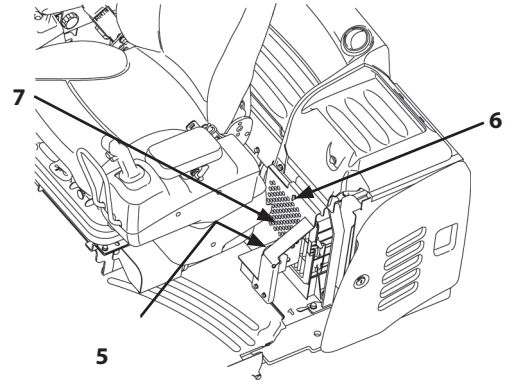

115Z7-7-99-1

2. Hold handle (8) and pull handle (8) toward you to remove circulation air filter (9).

**IMPORTANT: Do not use compressed air or water to clean filter (9) as damage to the filter fins may result.**

3. Clean circulation air filter (9) using a vacuum clean or lightly tapping to dust the filter.

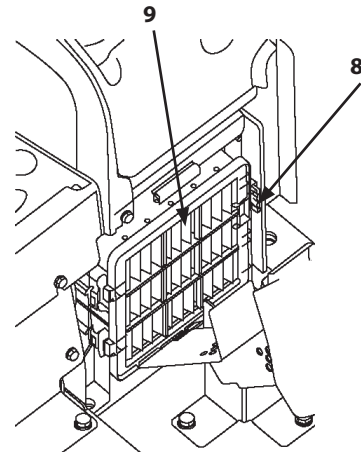

115MNEC-07-044

**IMPORTANT: Inappropriate installation of the filter may cause dust to enter into the air conditioner, causing malfunction or breakdown of the air conditioner. Before installing the filter element, clean off dust around the mounting area; install the filter element with extra care. Keep cab doors closed when operating machine.**

4. Install the cleaned circulation air filter or a new filter by following the filter removal procedure described in step 1 in the reverse order.



## MAINTENANCE

---

### **2** Check Air Conditioner --- every 6 months

Check the air conditioner switch panel, air conditioner unit, and condenser mounting areas for any troubles, and check hoses for any damage.

 **NOTE:** *When the season to use the air conditioner comes close, check the air conditioner to get it ready to use at all times. When not required to use the air conditioner for a long period of time, operate the air conditioner in the cooling mode once a week to prevent lack of lubrication.*

#### **CAUTION: Avoid steam cleaning**

**Do not clean the compressor and receiver tank with steam. The high temperature will cause the refrigerant gas pressure to increase, possibly causing the hoses to break. This could injure personnel.**

### **3** Check Air Conditioner Piping --- every 6 months

 **IMPORTANT: If any leakage is found, repair or replace the corresponding pipes. Tighten the joint bolts to specification.**

Check the piping for deformation and/or damage. If a pipe joint is contaminated with oil, refrigerant leakage may be suspected. Check for leakage using a refrigerant gas leak detector.

## MAINTENANCE

### 4 Check Air Conditioner Condenser --- every 6 months

If condenser (1) is covered with dirt and/or insects, air conditioner cooling performance will be reduced. Remove dirt or stain foreign material from fins of condenser (1) using tap water. In case the condenser has been severely contaminated, use a soft brush or a plastic fin comb tool. Do not use a hard brush, which may damage the fins.

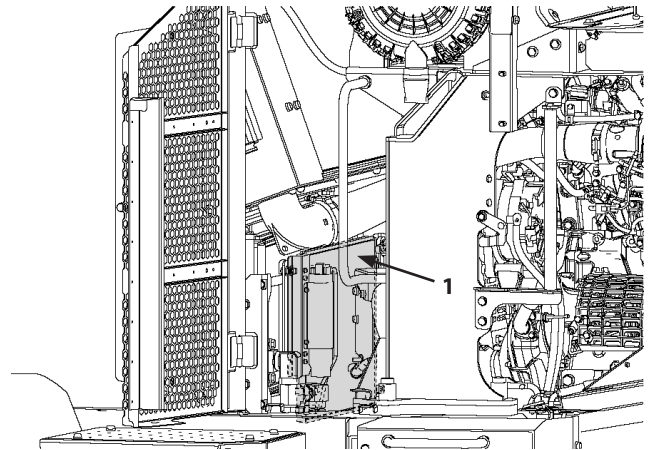

115Z7B-7-102-1

### 5 Check Air Conditioner Compressor Belt --- every 6 months

Check the belt for abnormal deflection and damage. Check HVAC belt tension by using tension gauge.

Belt tension:  $412 \pm 49$  N ( $42 \pm 5$  kgf,  $93 \pm 11$  lbf)

 **NOTE:** The belt tension should be  $588 \pm 98$  N ( $60 \pm 10$  kgf,  $132 \pm 22$  lbf) when the belt is replaced with new one.

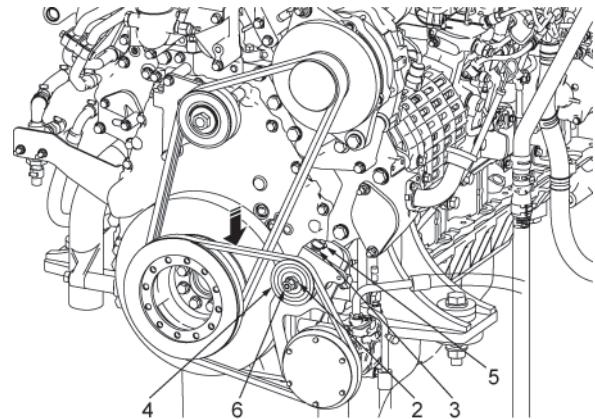

95Z7-7-92-2

#### Compressor Belt Tension Adjustment Procedure

1. Loosen lock nuts (2, 6) of tension pulley (4).
2. Remove plate (5) and tension pulley (4) to adjust belt tension by turning belt tension adjustment bolt (3).
3. After adjustment, securely tighten lock nuts (2, 6) and mount plate (5).

Nut (2):  $52.5$  N·m ( $5.35$  kgf·m,  $38.7$  lbf·ft)

# MAINTENANCE

## 6 Check Refrigerant --- every 6 months

1. Start the engine and run at approximately 1500 min<sup>-1</sup> (rpm).
2. Turn the air conditioner switch to ON. Set the blower switch to HI and set the temperature control switch to the coolest position (18 °C (65 °F) on the monitor screen).
3. Operate the air conditioner 2 to 3 minutes. Check if cool air comes out from the vent in the cab.
4. In case any abnormality is found in the air conditioner, consult your nearest authorized dealer.

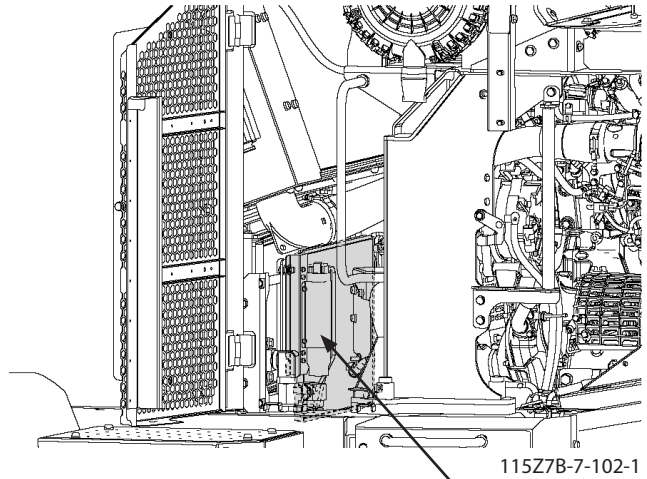

## 7 Replace Air Conditioner Receiver Dryer --- Every 3 years or 6000 hours

**IMPORTANT: Do not release refrigerant into the atmosphere as this is illegal. Comply with refrigerant regulations.**

Before charging refrigerant, all the refrigerant must be recovered from the system. Consult your nearest authorized dealer to replace receiver dryer (1) or to charge the refrigerant.

 **NOTE:** This machine uses new refrigerant R134a.

Type	Refrigerant No.	Quantity kg
HFC	R134a	1.00 ± 0.05

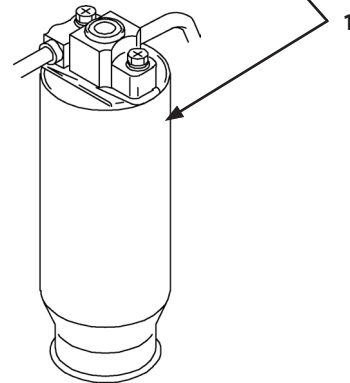

90Z7-OM0144

## 8 Check Compressor and Pulley --- once a year

Check the compressor and its vicinity for abnormality in operation, oil, or refrigerant leakage. Check the pulley for abnormal noise.

### Check Compressor

After operating the air conditioner for 5 to 10 minutes, check temperature at both the high pressure pipe and the low pressure pipe. Normally, the high pressure pipe must be hot and the low pressure pipe must be cool.

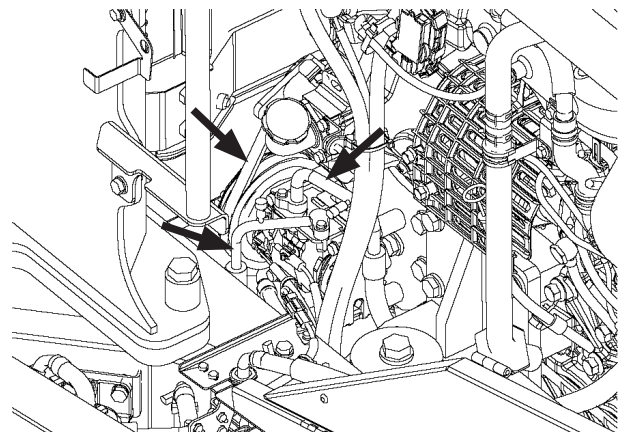

# MAINTENANCE

## L. Aftertreatment Device

### 1 Check and Clean Aftertreatment Device --- as required

#### IMPORTANT:

- Check and clean flammable objects on the area around the aftertreatment device daily.
- Do not disassemble the machine support parts and sensors.

 NOTE: When the machine is operated in dusty areas, refer to "9-1 Maintenance Under Special Environmental Conditions".

1. Open the left side cover.
2. Check exhaust pipe (1) and pipe (2) for cracks. Check the aftertreatment device units for loose or disconnection. Check the lagging cover for breaks.

 NOTE: Do not remove the lagging cover.

3. Check the connectors and harnesses of NOx sensors (3), temperature sensors (4) and dosing module (5) for abnormality.
4. Close the side cover.

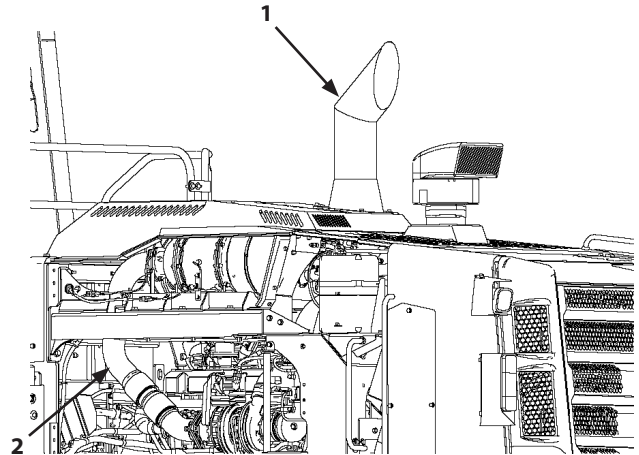

115Z7B-7-104-1

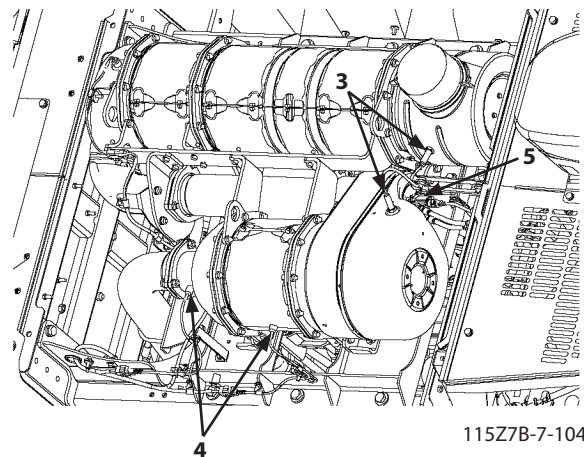

115Z7B-7-104-2

## MAINTENANCE

---

### M. Urea SCR System

#### WARNING:

- Fill the specified DEF into the DEF tank.
- If improper DEF is refilled, fire or system failure may result. If improper liquid is refilled in the DEF tank, consult your authorized dealer for check or repair.

#### Specified DEF/AdBlue®

Refill DEF/AdBlue® which meets Japanese Industrial Standards (JIS K2247), International Organization for Standardization (ISO 22241) or Deutsche Industrie Normen (DIN 70070).

If improper liquid (diesel oil, kerosene or gasoline) is refilled in the DEF tank, fire or system failure may result.

The specified DEF is colorless and odorless solution (urea 32.5%, water 67.5%) which begins to freeze at -11 °C (12 °F). Store the DEF in -10 to 30°C (14 to 86°F) environment.

#### CAUTION:

- DEF is colorless and harmless solution. It is harmless when contacting with the body, however, it may cause skin to become inflamed according to the constitution.  
Flush DEF with clean water when it contacts on the skin.
- If you swallow DEF by mistake, drink 1 or 2 cups of water or milk and seek immediate medical attention.
- If DEF is accidentally splashed into eyes, flush with water for 15 minutes or longer and get emergency medical attention.

#### IMPORTANT:

- Use dedicated container recommended by the business entity who is handling DEF to store DEF. Do not use general container, a container used for other purpose and contaminated container because the quality of DEF deteriorates.
- The DEF is non-combustibility, however, move DEF to the safe place when fire accident occurs.
- Wash out spilled DEF with clean water.
- Seal the container and store it in well ventilated indoor. Even if DEF freezes by chance, the quality does not change right after its freezing.
- Unless water evaporates, DEF will not transubstantiate within guarantee period as long as it is sealed by airtight stopper.
- Do not pour waste DEF and its containers onto the ground, and do not allow waste to flow into rivers and/or lakes. When disposing DEF, make sure to let authorized industrial waste disposal contractor dispose it appropriately.

# MAINTENANCE

## 1 Check DEF Level

---daily

Park the machine on a level surface. Lower the bucket to the ground. Check the DEF level with DEF gauge (1). Add DEF if necessary.

### Refill DEF



#### CAUTION:

- Refill DEF/AdBlue® which meets Japanese Industrial Standards (JIS K2247), International Organization for Standardization (ISO 22241) or Deutsche Industrie Normen (DIN 70070) in DEF tank (2). If low density DEF is refilled, alarm will be generated, restricting machine operation. Do not dilute DEF with water.
- Use rubber gloves for protection during operation. Wash DEF with clean water when it contacts on the skin.

1. Park the machine following the same procedures as described on page 7-6 for preparation of inspection/maintenance work.
2. DEF tank (2) is located in the cover at left rear of the machine. Open and secure the cover (3) by turning stopper plate (4) downward.
3. Clean dust and mud around the filler port of DEF tank with clean cloth.
4. Remove cap (5) from DEF tank (2) and refill DEF. Be sure to stop refilling before the float comes to the "FULL" line (6) on the level gauge.

#### IMPORTANT:

- Take care not to allow dust and/or water to enter the DEF tank when refilling.
- If DEF is filled above the "FULL" line, the system may be damaged during operation or DEF tank (2) may be broken when frozen.

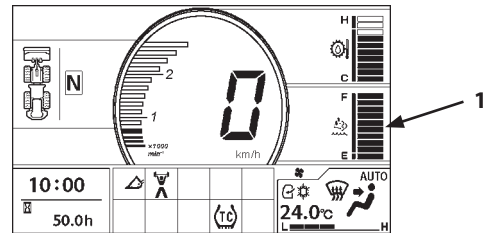

MNHG-01-103EN

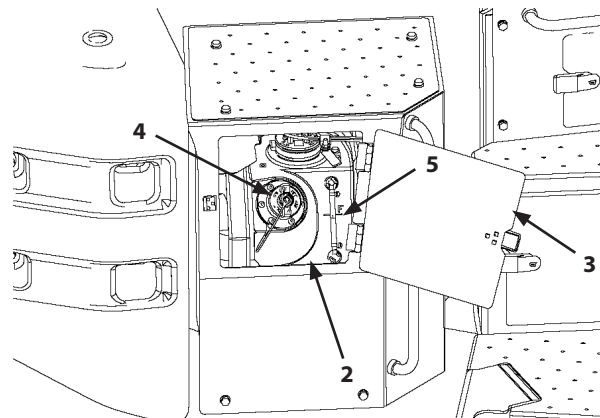

115Z7B-7-106-2

## MAINTENANCE

5. Install cap (5) after refilling DEF. Close the tank cover (3).

### IMPORTANT:

- **Do not get on top of DEF tank (2) or sensors and piping on the tank. Failure to do so may damage the machine.**
- **White deposition may be observed when DEF is dried naturally; it is normal. Wash out DEF deposition with soft water. Never use a high pressure washer.**

### NOTE:

- Wipe spilled DEF and wash spilled area with plenty of water.
- Flow sound may be heard from the tank after the engine stops. It is the sound of returning DEF from piping to the tank, not the malfunction.
- DEF will freeze under low temperature, deteriorate (ammonification) under high temperature. Store the DEF in -10 to 30°C (14 to 86°F) environment.
- Use dedicated container (purchased container) to store or carry DEF. Or use polyethylene resin tank or stainless tank.

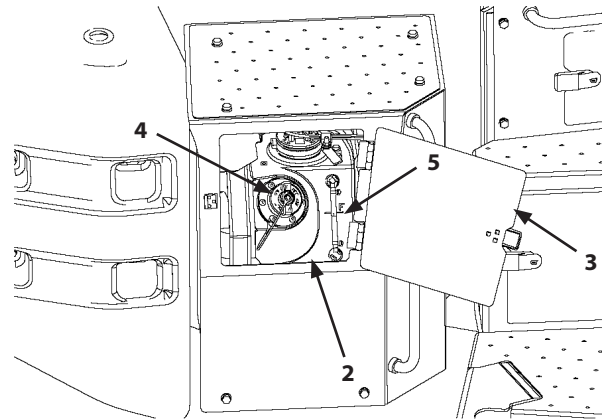

115Z7B-7-106-2

### Clean DEF Strainer

Check strainer (6) installed at the inlet of DEF tank, and clean it as needed.

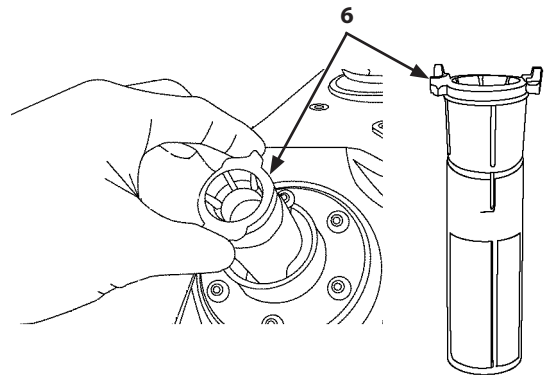

95Z7B-7-126-3

**⚠ CAUTION:** Use rubber gloves and goggles or safety glasses for protection during operation. Wash DEF with clean water when it contacts on the skin. If splashed in eyes, flush with water for 10 to 15 minutes. Get medical attention immediately.

**IMPORTANT:** Take care not to allow dirt and/or water to enter the DEF tank while checking or cleaning strainer (6).

1. Take out strainer (6) from the DEF inlet port.

### IMPORTANT:

- **Use compressed air at the lower pressure than 0.2 MPa (30 PSI).**
  - **Completely dry strainer before reinstalling to avoid water from entering.**
2. Clean strainer (6) by applying compressed air or flushing with tap water.
  3. Install strainer (6) at the DEF inlet port.

** NOTE:** Consult your nearest authorized dealer if DEF spills out while filling even after cleaning strainer (6).

# MAINTENANCE

## DEF Exchange Procedure

--- As required

**CAUTION:** Use rubber gloves and goggles or safety glasses for protection during operation. Wash DEF with clean water when it contacts on the skin.

**IMPORTANT:** When contaminated or deteriorated DEF is used, malfunction may result. Change DEF periodically to keep cleanliness in the tank.

1. Remove bolts (1) with washers and remove cover (2).
2. Place 60 liter (16 gal) or larger capacity container under drain plug (3).
3. Slowly loosen drain plug (3) to drain DEF.
4. Tighten drain plug (3) after draining DEF.  
⌘ : 13 mm  
⌘ :  $19.5 \pm 4 \text{ N}\cdot\text{m}$  ( $2.0 \pm 0.4 \text{ kgf}\cdot\text{m}$ ) ( $14.4 \pm 3 \text{ lbf}\cdot\text{ft}$ )
5. Fix cover (2) with bolts (1) with washers.
6. Remove the cap from DEF tank and refill DEF.  
Amount of DEF: 57 liters (15 gallons)

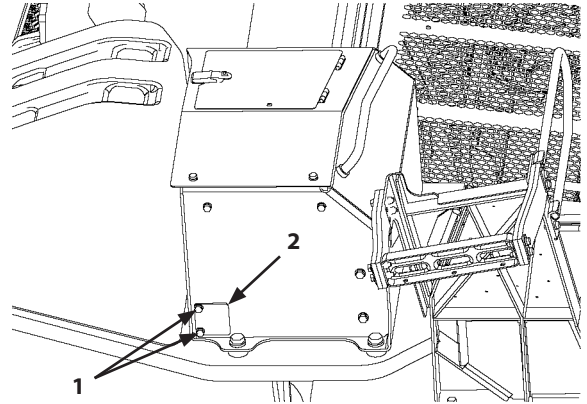

115Z7B-7-108-1

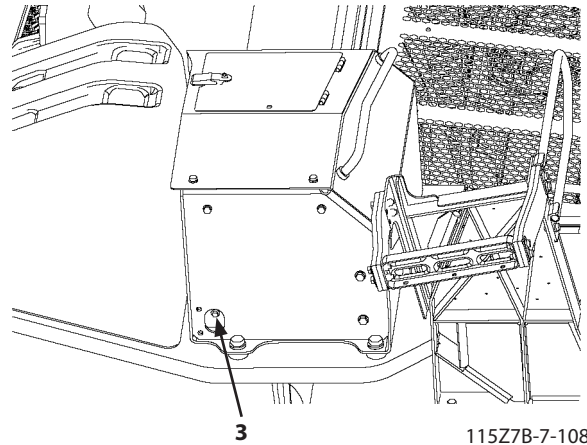

115Z7B-7-108-2



# MAINTENANCE

## 2 Replace DEF Supply Module Main Filter --- every 4500 hours

A filter (4) is mounted in the DEF pump. Periodically replace filter (4).

**CAUTION:** Use rubber gloves and goggles or safety glasses for protection during operation. Wash DEF with clean water when it contacts on the skin.

### IMPORTANT:

- Take care not to allow dirt and/or water to enter the DEF tank while replacing filter (4).
- Check for leaks around the mounting position after replacement.
- White deposition may be observed when DEF is dried naturally; it is normal. Wash out DEF deposition with clean water. Never use a high pressure washer.
- After stopping the engine, the DEF pump keeps operating. Wait for 3 minutes or more after turning OFF the key switch until the pump stops running.

1. Park the machine following the same procedures as described on page 7-6 for preparation of inspection/maintenance work.

**NOTE:** The DEF supply module (DEF pump) is located on the frame left rear of the machine.

2. Remove bolts (1), nuts (5, 6) with washers, and covers (7, 8, 9).
3. Remove cap (3) from the DEF pump.

4. Pull out filter (4) inside the supply module. As it is tightly mounted, it can not be pulled by hands. Use tools such as pliers. Replace filter (4) assembly when replacing filter (4) of DEF supply module.

5. Install new filter (4), and tighten cap (3).

 : Cap (3): 20±5 N·m (14.75±3.7 lbf·ft)

6. Fix covers (7, 8, 9) with bolts (1) and nuts (5, 6) with washers.

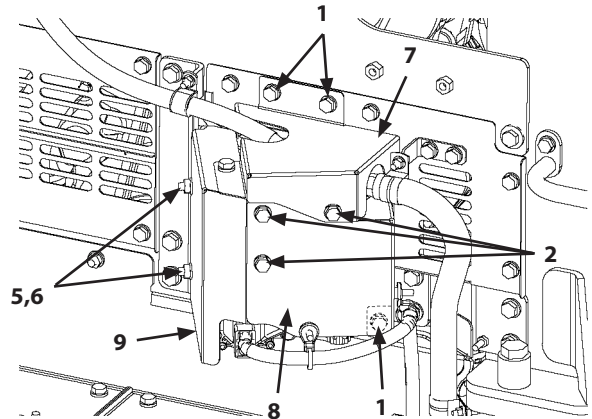

115Z7B-7-109-1

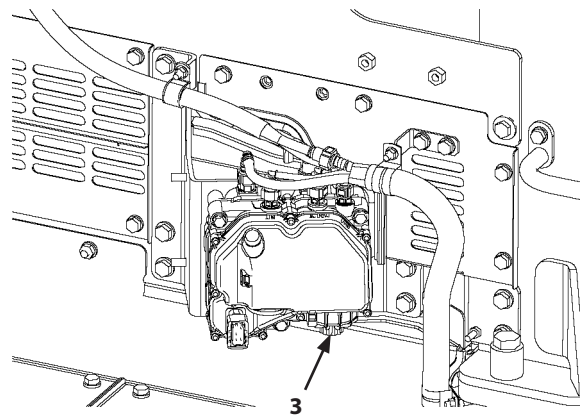

115Z7B-7-109-2

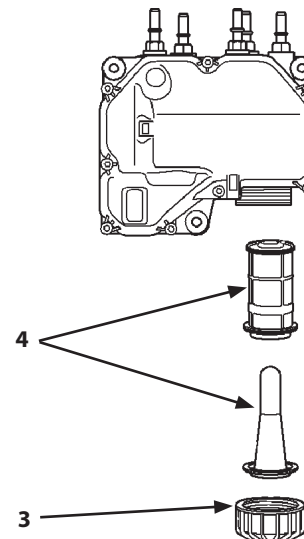

MDC1-07-044

## MAINTENANCE

### 3 Check Dosing Module --- every 4500 hours

Contact your nearest authorized dealer for checking.

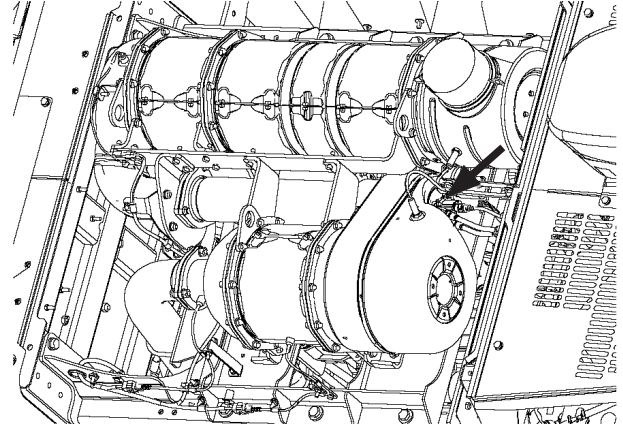

115Z7B-7-104-2

### 4 Replace DEF Tank Inlet Filter --- every 4500 hours, or when DEF spills out while filling

**IMPORTANT:** Do not clean or reuse DEF tank inlet filter (1).

Locate filter (1) inside the DEF tank covering DEF tank inlet cap (2).

Replacement of filter (1) is required regularly or if DEF spills out while pouring it from the tank inlet port. Contact your nearest authorized dealer for assistance.

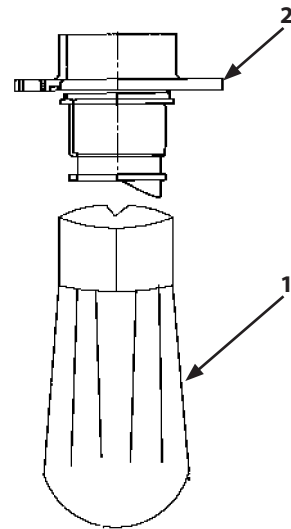

95Z7B-7-126-2

# MAINTENANCE

## N. Miscellaneous

### 1 Check Bucket Teeth --- every 10 hours (daily)

Check bucket teeth for wear and looseness, and replace them as needed.

#### Replace

**WARNING:** Guard against injury from flying pieces of metal. Wear goggles or safety glasses, hard hat and face shield.

1. Raise the bucket to an appropriate height with the bucket bottom parallel to the ground. Insert hard wood support blocks under the bucket to support it. Stop the engine.
2. Remove lock pin (1) and remove bucket teeth (2) from adapter nose (4) using tool (3).

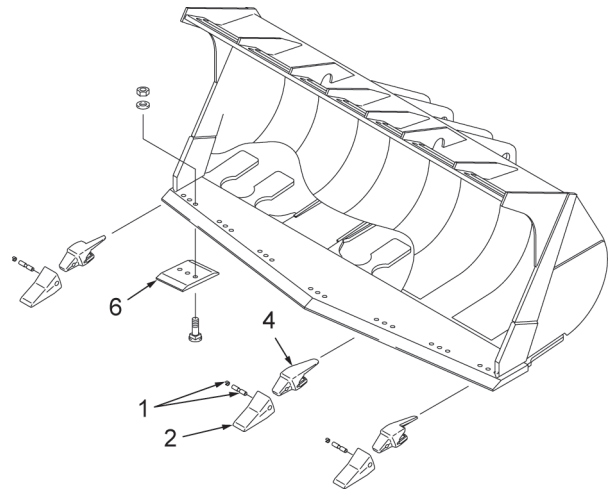

115Z7-7-95-1

3. Install new teeth (2) onto adapter (4).

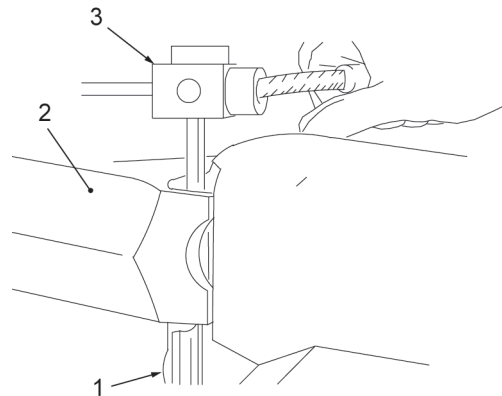

95ZV0014

4. Install lock pin (1) with the guide rib (5) facing back.

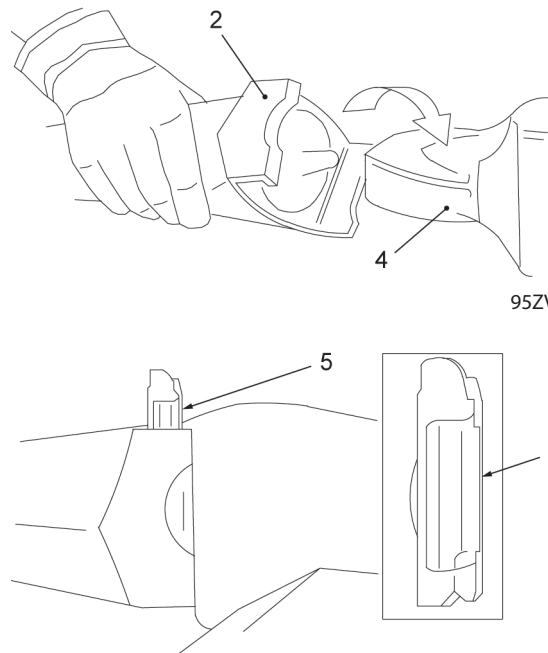

95ZV0015

95ZV0016

## MAINTENANCE

5. Tap lock pin (1) into the flush ear using a hammer.
6. Replace segments (6) with new ones.  
Segment mounting bolt tightening torque:  
1-1/4-7UNC bolt: 2402 N·m (245 kgf·m, 1772 lbf·ft)
7. Retighten nuts (6) after a few hours of operation.

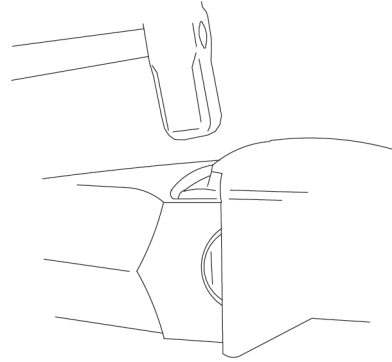

95ZV0017

### **2** Check and Replace Seat Belt and Lower Tether Check --- every 10 hours (daily) Replace --- every 3 years

Examine buckle (1), attaching hardware (2) and seat belt web. Replace the seat belt web, buckle, or attaching hardware if they are damaged, or worn. Also check the wind-up condition of the seat belt.

Replace seat belt and lower tether every 3 years, regardless of appearance.

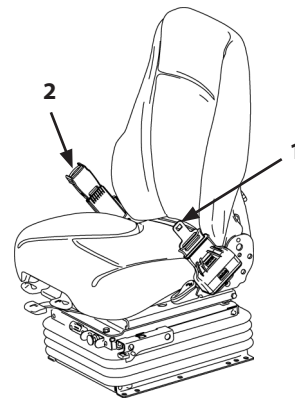

115Z7-3-4-3

### **3** Check ROPS, ROPS Mounting Bolts, and Cab --- every 10 hours (daily)

Check the appearance of ROPS (1) and Cab (3) for any abnormal damage or deformation. Check the condition of ROPS mounting bolts (2). Retighten them, if loosened.

Tightening torque:  
Bolt (2): 1421 N·m (145 kgf·m, 1048 lbf·ft)

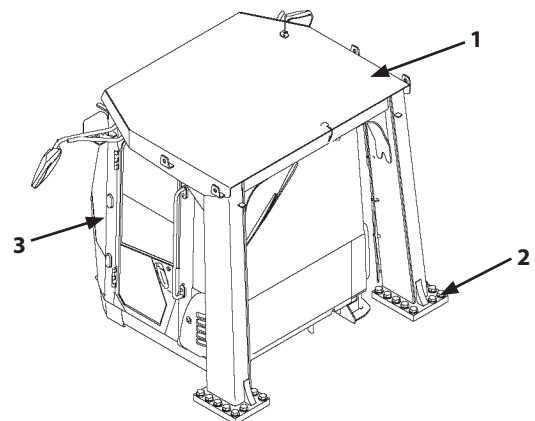

MNHE-07-055

## MAINTENANCE

### 4 Check Windshield Washer Fluid Level --- every 10 hours (daily)

**IMPORTANT:** Keep all dirt, dust and other foreign materials out of the tank.

Check the fluid level. If necessary, add the fluid.

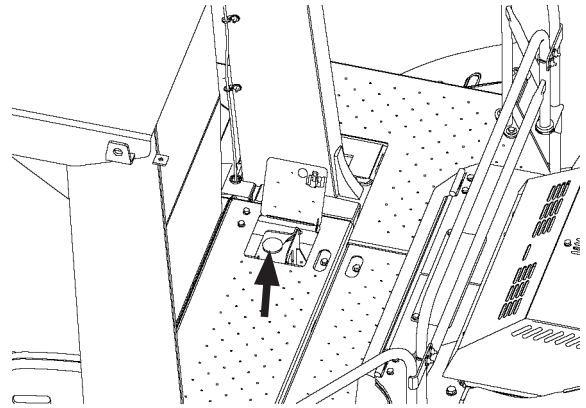

115Z7B-7-112-3

### 5 Check Play Amount in Joystick Steering Movement --- every 10 hours (daily)

Check that play (1) in joystick steering movement is correct. In addition, check that the chassis steering stoppers come in contact with the opposing chassis surface stopper when the steering lever is fully moved and that the steering cylinders operate normally.

1. Start the engine. Turn the parking brake switch ON.
2. Slightly lift the bucket above the ground. Place control lever lock (2) in the lock (🔒) position.
3. While running the engine at slow speed, slightly and slowly move the joystick steering right and left. Measure the beginning movement distance from the center (neutral) position of steering lever until both right and left steering cylinders start moving (check the movement of the bucket and/or tires).

Appropriate play amount (1): 5~13 mm (0.2~0.5 in)

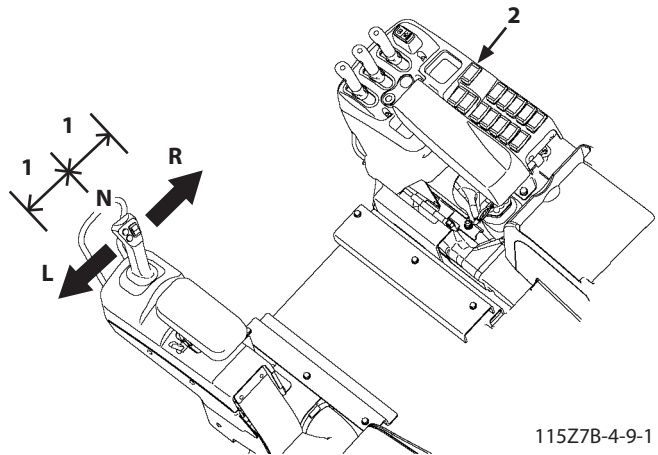

115Z7B-4-9-1

 **NOTE:** If too much steering play is found or if the joystick steering lever does not move smoothly, consult your nearest authorized dealer for checking.

## MAINTENANCE

### 6 Check Accelerator Pedal Operation, and Exhaust Gas Color and Noise

--- every 10 hours (daily)

**WARNING:** Move the forward/reverse switch (or lever) to neutral. Apply the parking brake. After resting the bucket level to the ground, block the wheels.

While slowly stepping on accelerator pedal (1), check that the engine speed smoothly increases. Then, while slowly returning accelerator pedal (1), check that the engine speed smoothly decreases.

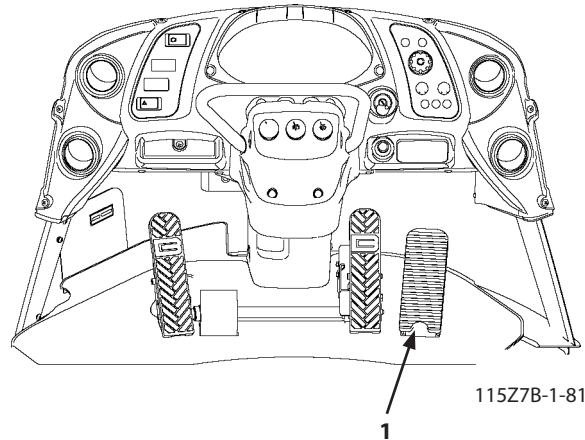

#### Exhaust Gas Color and Noise:

**DANGER:** Exhaust inhalation hazard. Ventilate the shop with fresh air when carrying out warming up warm-up operation indoor. Failure to do so may cause asphyxiation from exhaust gas, resulting in death or severe injury.

**IMPORTANT:** This machine is equipped with the engine that meets Interim Tier 4 emission requirements. Never attempt to modify the inlet and exhaust system.

Exhaust gas color is normally transparent or light blue. Although exhaust gas color slightly becomes white immediately after the engine is started or quickly accelerated, this symptom is not abnormal. If the exhaust gas color turns black, white, brown, or gray, check the engine oil level and the fuel supply system for any abnormality. In addition, check that no abnormal noise is heard coming from the engine or muffler.

## MAINTENANCE

### 7 Check Rearview Mirror and Inside Rearview Mirror

--- every 10 hours

Check that inside rearview mirror (1) and rearview mirror (2) are adjusted correctly.  
Check inside rearview mirror (1) and rearview mirror (2) for contamination or damage to the mirror glass.  
Clean if needed.

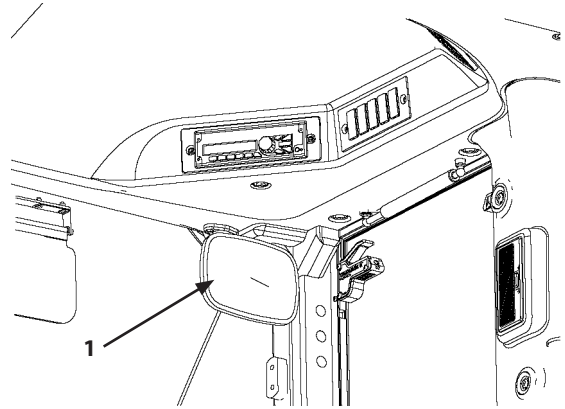

115Z7B-1-129-1

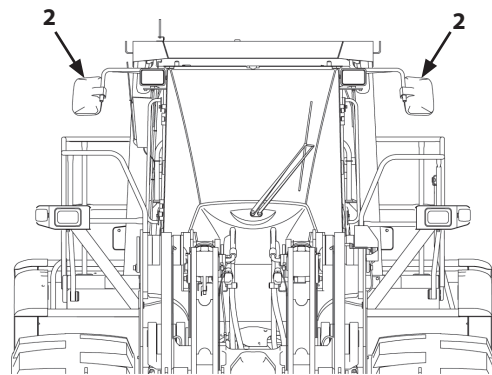

115Z7\_front

### 8 Check Steps and Handrails for Damage and Looseness

--- every 10 hours

Check steps (3) and handrails (4) for damage, looseness and contamination. If oil, grease or mud are on the steps and/or handrails (4), remove it.  
If the steps (3) and/or handrails (4) become damaged or loosened, immediately replace.  
Do not repair handrails or steps. Repairs can fail unexpectedly. Be sure to replace damaged steps or handrails.

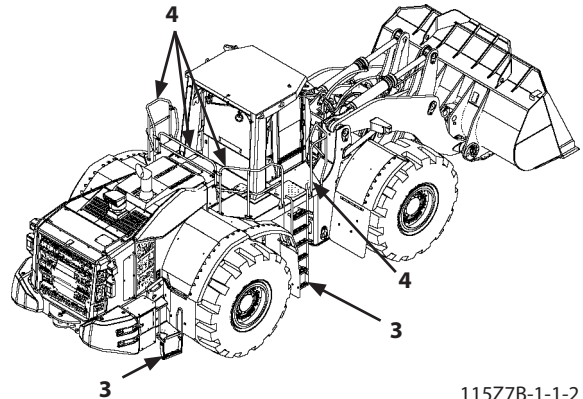

115Z7B-1-1-2

## MAINTENANCE

---

### **9** Clean Engine Compartment and Hood --- every 10 hours (daily)

**CAUTION:** Dust or debris accumulated in the engine compartment or around the hood may come in contact with high temperature sections near the exhaust filter, muffler, engine or hood, possibly causing fires.

Open the side access cover and check if dust and /or chips debris are accumulated in the engine compartment and/or above the engine.  
Remove the accumulated dust and debris and/or dust from the engine areas.

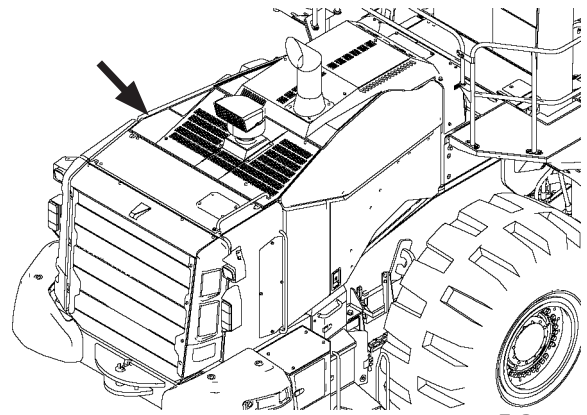

11527B-7-117-1

### **10** Check Sound Absorbing Mat Around Engine --- every 10 hours (daily)

**CAUTION:** If the sound absorbing mat in the engine compartment loosens, the mat may come in contact with high temperature sections of the engine, possibly resulting in fires.

Check if the sound absorbing mat around the engine has loosened. If any part of the mat is found loose, immediately contact your nearest authorized dealer for repair.

### **11** Check and Adjust Valve Clearance --- every 1000 hours

Consult your nearest authorized dealer for check and repair.

### **12** Check Engine Compression Pressure --- every 1000 hours (or once a year whichever comes first)

Consult your nearest authorized dealer for check and repair.

### **13** Check and Clean Starter and Alternator --- every 1000 hours

Consult your nearest authorized dealer for check and repair.



## MAINTENANCE

---

**14** **Check Fuel Injector**  
--- every 4500 hours

Consult your nearest authorized dealer for check and repair.

**15** **Check Turbocharger**  
--- every 4500 hours

Consult your nearest authorized dealer for check and repair.

**16** **Check and Adjust Engine Controller (ECM)**  
--- every 4500 hours

Consult your nearest authorized dealer for check and repair.

**17** **Check and Clean EGR Valve**  
--- every 4500 hours

Consult your nearest authorized dealer for check and repair.

**18** **Check and Clean EGR Cooler**  
--- every 4500 hours

Consult your nearest authorized dealer for check and repair.

**19** **Check Urea SCR System**  
--- every 4500 hours

Consult your nearest authorized dealer for check and repair.

## MAINTENANCE

---

### **20** Cleaning of Rear View Camera Lens --- every 10 hours (daily)

Oil, dust, moisture band, or others may obscure the image from the camera lens.

If image is not clear, clean the lens by gently wiping surface of the camera lens with a damp cloth.

**IMPORTANT: Never use organic solvent.  
Do not apply excessive force as it may damage the camera.**

### **21** Retighten Front Axle and Rear Axle Support Mounting Bolts --- every 2000 hours **Maintenance required only during first time 50 operating hours.**

Check front and rear axle support mounting bolts for looseness.

Refer to page 7-120 for details.

## MAINTENANCE

### 22 Check Tightening Torque of Nuts and Bolts --- every 2000 hours (50 hours at first time only)







Check tightness after the first 50 hours then every 2000 hours.

Tighten or retighten nuts and bolts to the torque specified on the following pages.

For the tightening torque of other nuts and bolts used on this machine, refer to the following table.

 **NOTE:** Check nuts and bolts for looseness and missing daily before and after operation. If any loose or missing nuts and/or bolts are found, retighten or supply replacement parts.

#### Tightening Torque Chart

Bolt Dia. mm (in)	Tightening torque N·m (kgf·m) (lbf·ft)									Wrench size mm		
	   (11T)			   (8T)			 (4T)			Hexagon Bolt (8~11T)	Flanged Bolt (8T)	Socket Bolt
6 (0.24)							3~4	(0.3~0.4)	(2.2~3)	10	10	5
8 (0.31)	30	(3)	(22)	20	(2)	(14.8)	10	(1)	(7.4)	13	12	6
10 (0.39)	65	(6.5)	(48)	50	(5)	(36.9)	20	(2)	(14.8)	17	14	8
12 (0.47)	110	(11)	(81)	90	(9)	(66.4)	35	(3.5)	(25.8)	19	17	10
14 (0.55)	180	(18)	(133)	140	(14)	(104)	55	(5.5)	(40.6)	22		12
16 (0.63)	270	(27)	(199)	210	(21)	(155)	80	(8)	(59)	24	22	14
18 (0.71)	400	(40)	(295)	300	(30)	(221)	120	(12)	(88.5)	27		14
20 (0.79)	550	(55)	(406)	400	(40)	(295)	170	(17)	(125)	30	27	17
22 (0.87)	750	(75)	(553)	550	(55)	(406)	220	(22)	(162)	32		
24 (0.94)	950	(95)	(700)	700	(70)	(516)	280	(28)	(207)	36	32	19
27 (1.06)	1400	(140)	(1033)	1050	(105)	(774)	400	(40)	(295)	41		
30 (1.18)	1950	(195)	(1438)	1450	(145)	(1069)	550	(55)	(406)	46		
33 (1.30)	2600	(260)	(1918)	1950	(195)	(1438)	750	(75)	(553)	50		
36 (1.42)	3200	(320)	(2360)	2450	(245)	(1807)	950	(95)	(700)	55		

 **CAUTION:** If counterweight mounting bolts are loosened, consult your nearest authorized dealer.

#### IMPORTANT:

- Apply lubricant to bolts and nuts to lower friction except plated bolts and nuts.
- Remove soil, dust, and/or dirt from the nut and bolt thread surfaces before tightening.
- Tighten nuts and bolts to specifications. If tightened with excessively low or high torque, missing or breakage of nuts and/or bolts may result.

## MAINTENANCE

### 1. Front axle mounting bolt

Bolt diameter	30 mm (1.2 in)
Quantity	12
Wrench size	46 mm
Tightening torque	1420 N·m (145 kgf·m, 1045 lbf·ft)

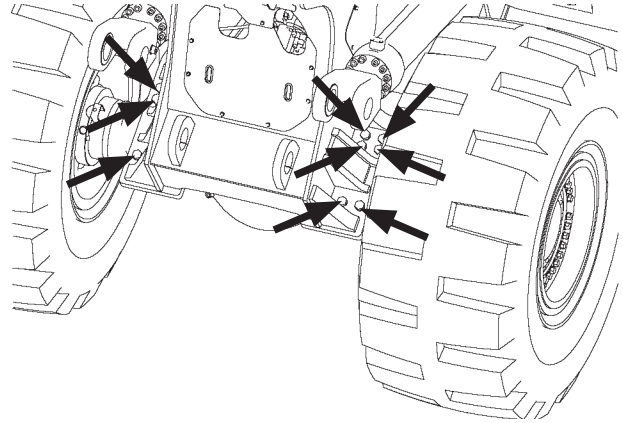

MNHE-07-057

### 2. Rear axle support mounting bolt

Bolt diameter	24 mm (0.95 in)
Quantity	14
Wrench size	36 mm
Tightening torque	721 N·m (73.5 kgf·m, 532 lbf·ft)

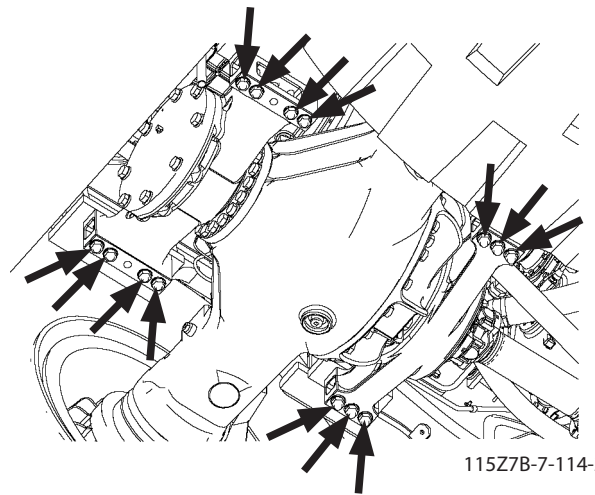

115Z7B-7-114-2

### 3. Wheel rim mounting bolt

Bolt diameter	24 mm (0.95 in)
Quantity	124
Wrench size	32 mm
Tightening torque	892 N·m (91 kgf·m, 658 lbf·ft)

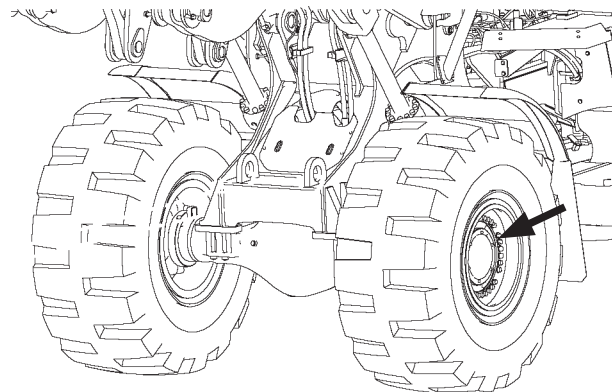

MNHE-07-058

# MAINTENANCE

## 4. Propeller shaft mounting bolt

### First propeller shaft

Bolt diameter	12 mm (0.47 in)
Quantity	8
Wrench size	19 mm
Tightening torque	142 N·m (14.5 kgf·m, 105 lbf·ft)

 **NOTE:** Apply Loctite #262 or equivalent.

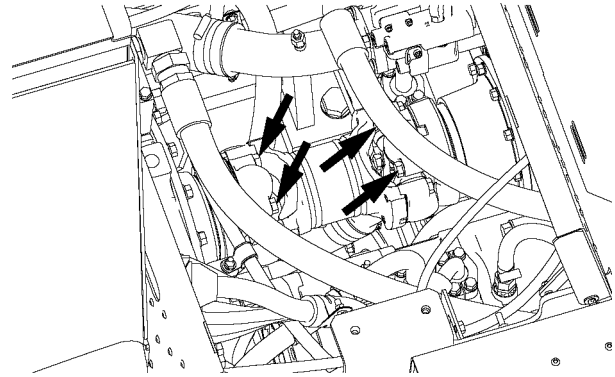

View from Top (Open Deck)

115Z7-7-114-1

### Second propeller shaft

Bolt diameter	14 mm (0.55 in)
Quantity	8
Wrench size	22 mm
Tightening torque	221 N·m (22.5 kgf·m, 163 lbf·ft)

 **NOTE:** Apply Loctite #262 or equivalent.

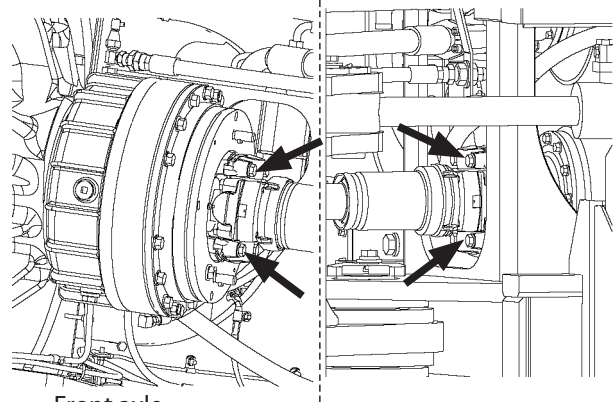

Front axle

115Z7B-7-135-2

### Third propeller shaft

Bolt diameter	12 mm (0.47 in)
Quantity	8
Wrench size	19 mm
Tightening torque	142 N·m (14.5 kgf·m, 105 lbf·ft)

 **NOTE:** Apply Loctite #262 or equivalent.

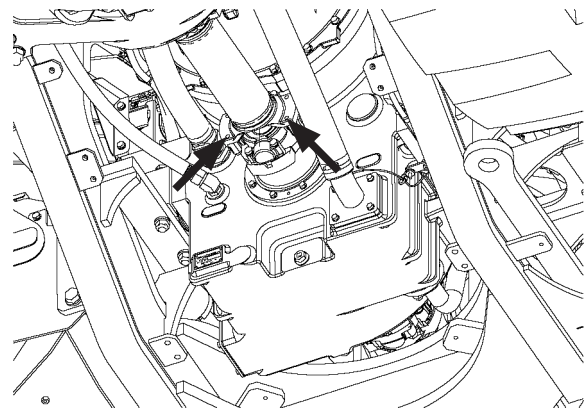

115Z7B-7-32-1

## MAINTENANCE

### 5. Propeller shaft support bearing mounting bolt

Bolt diameter	20 mm (0.8 in)
Quantity	2
Wrench size	30 mm
Tightening torque	400 N·m (40 kgf·m, 295 lbf·ft)

 **NOTE:** Apply Loctite #262 or equivalent.

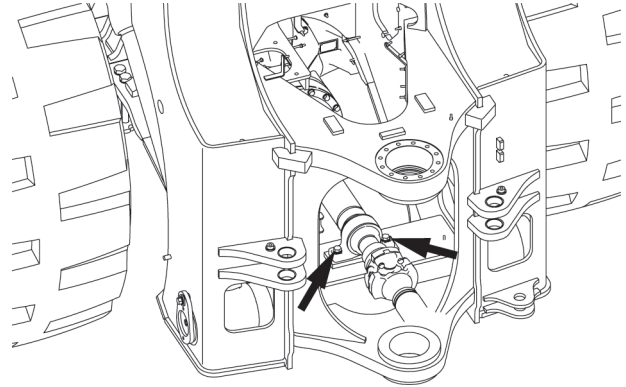

115Z7-7-114-2

### 6. Transmission mounting bolt: Bracket

#### Bolt A

Bolt diameter	20 mm (0.8 in)
Quantity	8
Wrench size	30 mm
Tightening torque	400 N·m (40 kgf·m, 295 lbf·ft)

 **NOTE:** Apply Loctite #262 or equivalent.

#### Bolt B

Bolt diameter	20 mm (0.8 in)
Quantity	2
Wrench size	30 mm
Tightening torque	550 N·m (55 kgf·m, 406 lbf·ft)

 **NOTE:** Apply lubrication oil.

#### Bolt C

Bolt diameter	16 mm (0.63 in)
Quantity	8
Wrench size	24 mm
Tightening torque	210 N·m (21 kgf·m, 155 lbf·ft)

 **NOTE:** Apply Loctite #262 or equivalent.

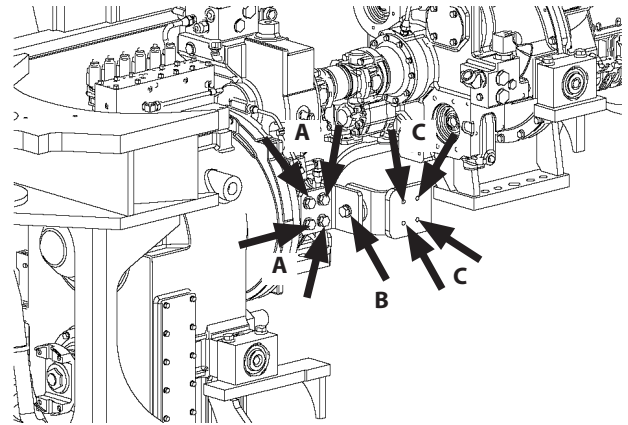

115Z7B-7-135-1

## MAINTENANCE

### 7. Transmission mounting bolt: Cushion rubber

#### Bolt A

Bolt diameter	20 mm (0.8 in)
Quantity	4
Wrench size	30 mm
Tightening torque	550 N·m (55 kgf·m, 406 lbf·ft)

#### Bolt B

Bolt diameter	16 mm (0.63 in)
Quantity	2
Wrench size	24 mm
Tightening torque	210 N·m (21 kgf·m, 155 lbf·ft)

 **NOTE:** Apply lubrication oil (both A and B).

### 8. Torque converter mounting bolt: Cushion rubber

#### Bolt C

Bolt diameter	20 mm (0.8 in)
Quantity	4
Wrench size	30 mm
Tightening torque	550 N·m (55 kgf·m, 406 lbf·ft)

#### Bolt D

Bolt diameter	16 mm (0.63 in)
Quantity	2
Wrench size	24 mm
Tightening torque	210 N·m (21 kgf·m, 155 lbf·ft)

 **NOTE:** Apply lubrication oil (both C and D).

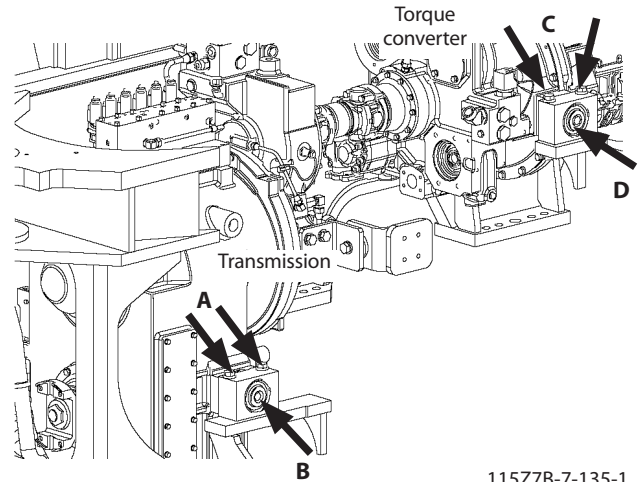

115Z7B-7-135-1

### 9. Engine mounting bolt

#### Bolt A: Bracket

Bolt diameter	14 mm (0.55 in)
Quantity	8
Wrench size	22 mm
Tightening torque	142 N·m (14.5 kgf·m, 105 lbf·ft)

 **NOTE:** Apply Loctite #262 or equivalent.

#### Bolt B: Cushion rubber

Bolt diameter	20 mm (0.8 in)
Quantity	2
Wrench size	30 mm
Tightening torque	550 N·m (55 kgf·m, 406 lbf·ft)

 **NOTE:** Apply lubrication oil.

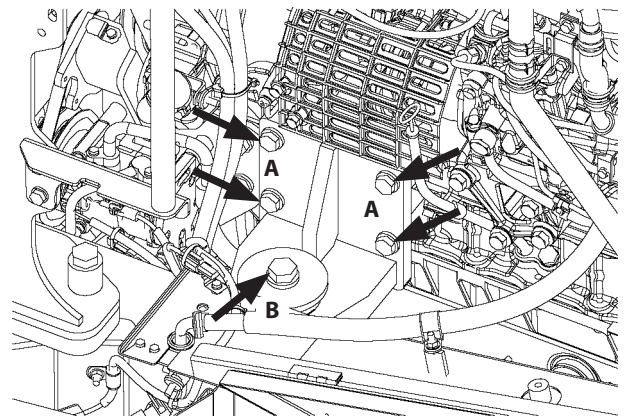

115Z7B-7-115-2

## MAINTENANCE

### 10. Aftertreatment device mounting bolt

#### Bolt A

Bolt diameter	12 mm (0.5 in)
Quantity	8
Wrench size	19 mm
Tightening torque	90 N·m (9 kgf·m, 66 lbf·ft)

#### Bolt B

Bolt diameter	10 mm (0.4 in)
Quantity	20
Wrench size	17 mm
Tightening torque	50 N·m (5 kgf·m, 37 lbf·ft)

#### Bolt C

Bolt diameter	16 mm (0.63 in)
Quantity	6
Wrench size	24 mm
Tightening torque	210 N·m (21 kgf·m, 155 lbf·ft)

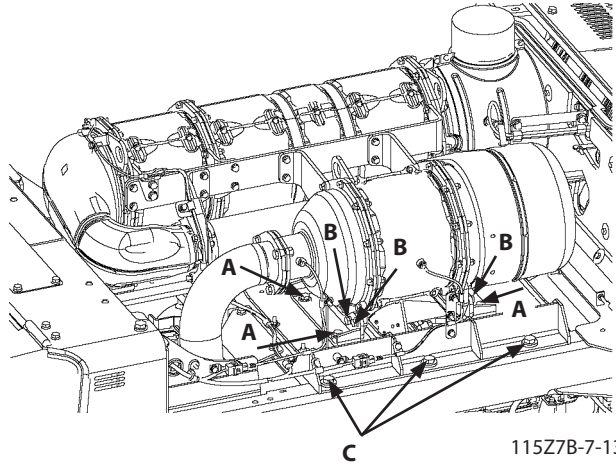

115Z7B-7-137-1

### 11. Counterweight mounting bolt

Bolt diameter	24 mm (0.95 in)
Quantity	8
Wrench size	36 mm
Tightening torque	721 N·m (73.5 kgf·m, 531 lbf·ft)

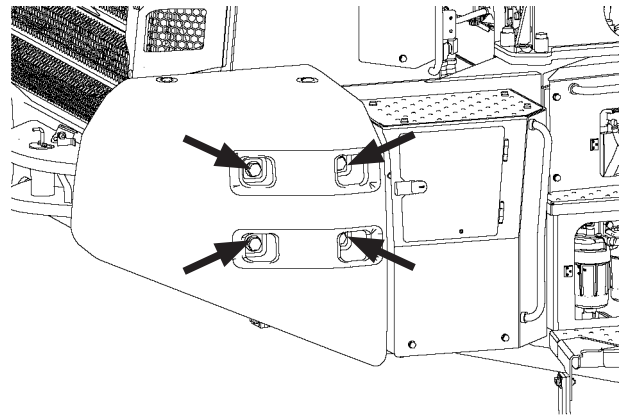

115Z7B-7-137-4



## MAINTENANCE

### 12. Top center pin upper flange lock

Bolt diameter	20 mm (0.8 in)
Quantity	12
Wrench size	30 mm
Tightening torque	400 N·m (40 kgf·m, 295 lbf·ft)

### 13. Top center pin lower bushing lock

Bolt diameter	20 mm (0.8 in)
Quantity	6
Wrench size	30 mm
Tightening torque	675 N·m (69 kgf·m, 498 lbf·ft)

 **NOTE:** Apply lubrication oil.

### 14. Bottom center pin lock

Bolt diameter	20 mm (0.8 in)
Quantity	1
Wrench size	30 mm
Tightening torque	550 N·m (55 kgf·m, 406 lbf·ft)

### 15. Steering cylinder pin lock

Bolt diameter	16 mm (0.63 in)
Quantity	4
Wrench size	24 mm
Tightening torque	210 N·m (21 kgf·m, 155 lbf·ft)

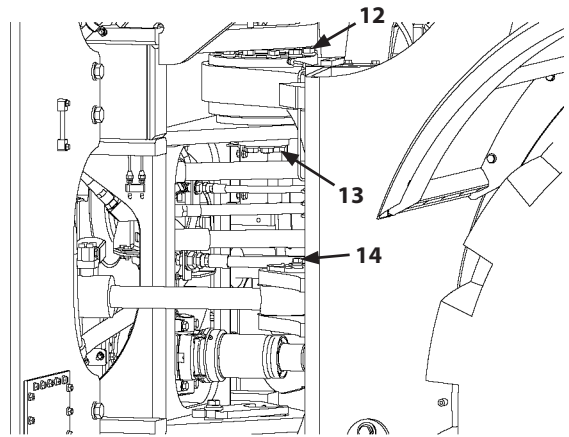

115Z7B-7-137-3



MNHE-07-014

# MAINTENANCE

## 16. Loader front pin lock

Bolt A (indicated by bold arrows)

Bolt diameter	20 mm (0.8 in)
Quantity	18
Wrench size	30 mm
Tightening torque	550 N·m (55 kgf·m, 406 lbf·ft)

Bolt B	
Bolt diameter	24 mm (0.95 in)
Quantity	16
Wrench size	36 mm
Tightening torque	700 N·m (70 kgf·m, 516 lbf·ft)

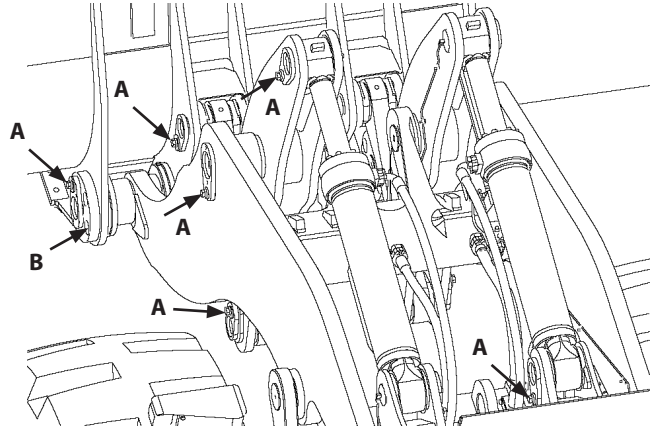

115Z7B-7-138-1

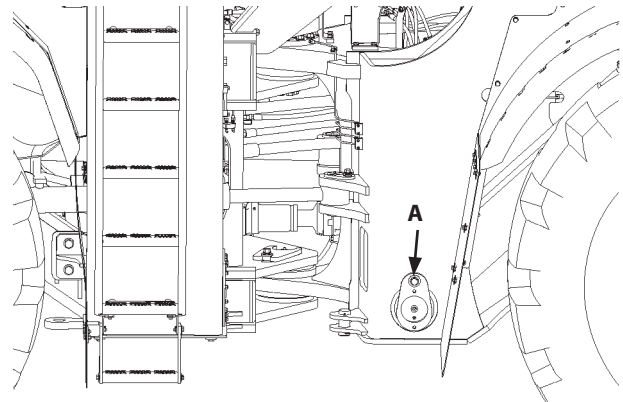

MNHE-07-010

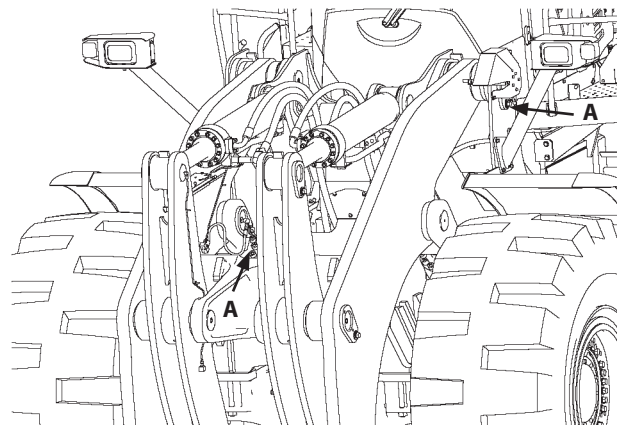

MNHE-07-011

## MAINTENANCE

### 17. Radiator mounting bolt

#### Bolt A

Bolt diameter	16 mm (0.63 in)
Quantity	8
Wrench size	24 mm
Tightening torque	210 N·m (21 kgf·m, 155 lbf·ft)

#### Bolt B (Radiator core)

Bolt diameter	10 mm (0.39 in)
Quantity	4
Wrench size	17 mm
Tightening torque	44 N·m (4.5 kgf·m, 32.5 lbf·ft)

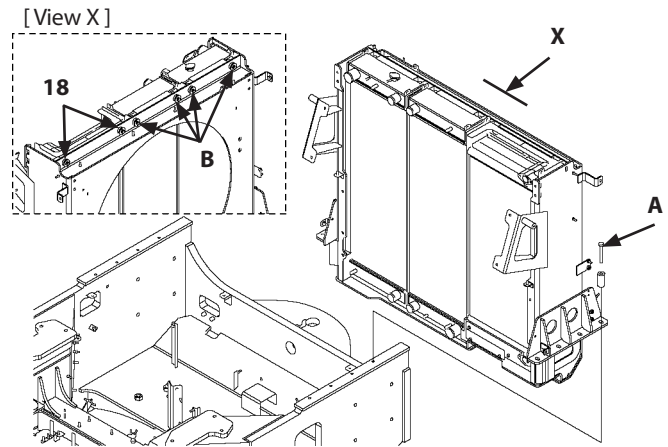

115Z7B-7-139-1

### 18. T/C oil cooler mounting bolt

Bolt diameter	10 mm (0.39 in)
Quantity	2
Wrench size	17 mm
Tightening torque	50 N·m (5 kgf·m, 37 lbf·ft)

## MAINTENANCE

### 19. Cooler assembly mounting bolt

Bolt A: Air conditioner condenser

Bolt diameter	8 mm (0.3 in)
Quantity	4
Wrench size	13 mm
Tightening torque	10.2~15.2 N·m (1.0~11.7 kgf·m, 7.5~11.2 lbf·ft)

Bolt B: Hydraulic oil cooler

Bolt C: Fuel cooler

Bolt D: Air cooler

Bolt diameter	12 mm (0.47 in)
Quantity	12
Wrench size	19 mm
Tightening torque	90 N·m (9 kgf·m, 66.4 lbf·ft)

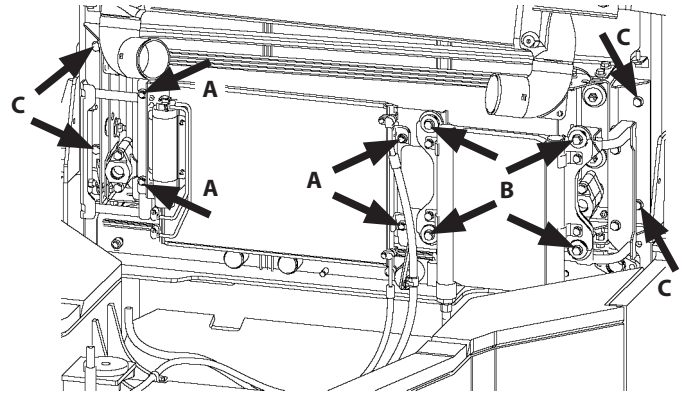

115Z7B-7-140-1

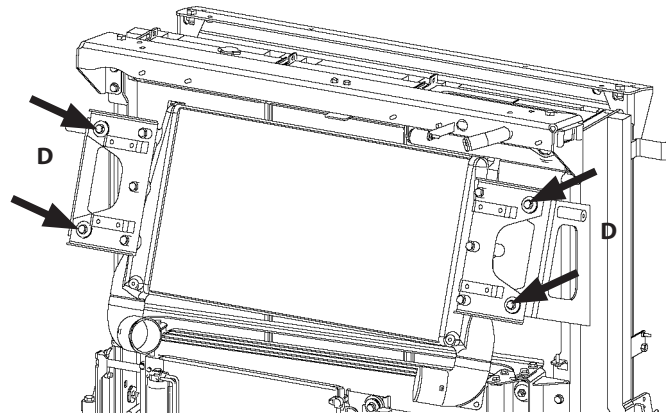

115Z7B-7-140-2

### 20. Air conditioner compressor mounting bolt

Bolt diameter	8 mm (0.3 in)
Quantity	4
Wrench size	13 mm
Tightening torque	24.5~29.4 N·m (2.5~3 kgf·m, 18~21.7 lbf·ft)

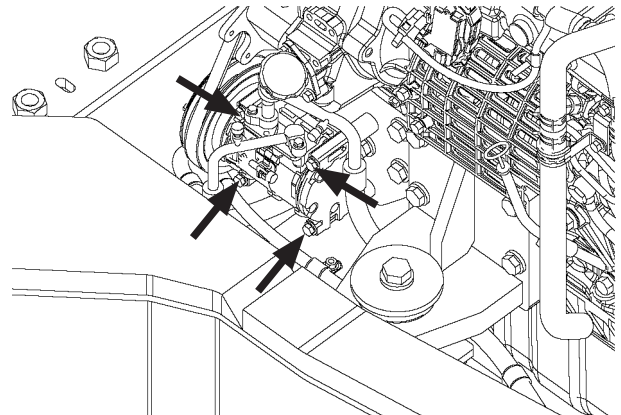

115Z7B-7-140-3

## MAINTENANCE

### 21. Cab cushion rubber mounting bolt

Bolt diameter	16 mm (0.63 in)
Quantity	4
Wrench size	22 mm
Tightening torque	210 N·m (21 kgf·m, 155 lbf·ft)

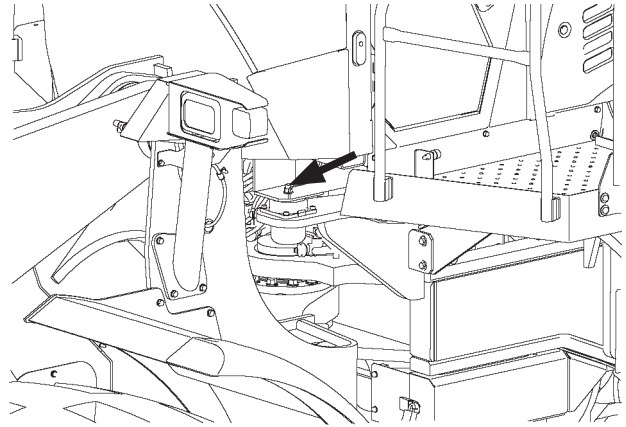

MNHE-07-066

### 22. ROPS mounting bolt

Bolt diameter	30 mm (0.63 in)
Quantity	22
Wrench size	46 mm
Tightening torque	1421 N·m (145 kgf·m, 1048 lbf·ft)

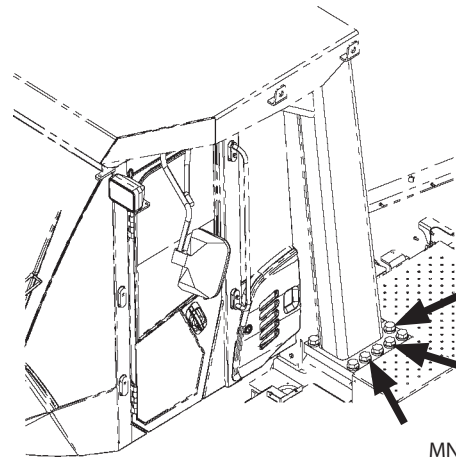

MNHE-07-070

## MAINTENANCE

### 23. Space edge (segment) mounting bolt

Bolt diameter	1-1/4-7UNC in
Quantity	21
Wrench size	51 mm
Tightening torque	2402 N·m (245 kgf·m, 1772 lbf·ft)

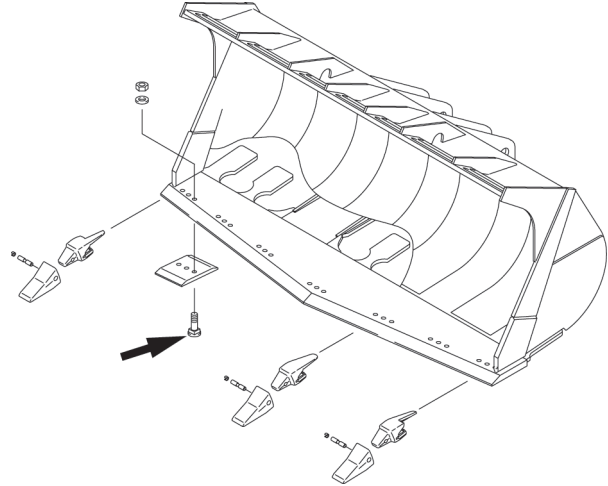

115Z7-7-95-1a

### 24. Wear plate mounting bolt

Bolt diameter	7/8-9UNC in
Quantity	8
Wrench size	36 mm
Tightening torque	834 N·m (85 kgf·m, 615 lbf·ft)

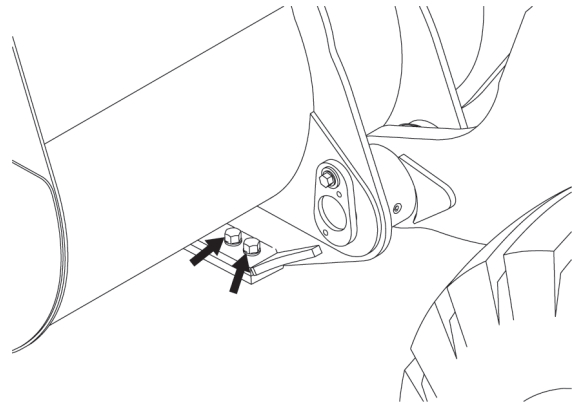

90Z7-7-113-2

### 25. Combination valve mounting bolt

Bolt diameter	10 mm (0.39 in)
Quantity	4
Wrench size	14 mm
Tightening torque	50 N·m (5 kgf·m, 37 lbf·ft)

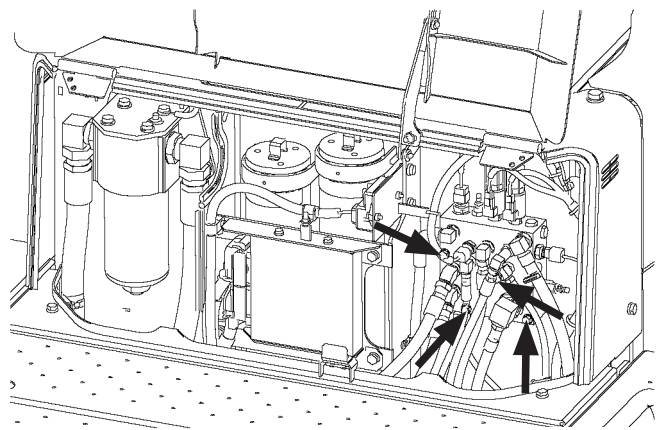

115Z7B-1-142-4

## MAINTENANCE UNDER SPECIAL ENVIRONMENTAL CONDITIONS

### Maintenance Under Special Environmental Conditions

**⚠ WARNING:**

- **Before operating the machine in a river, check the riverbed conditions in advance.**
- **Avoid driving the machine into a river where the riverbed is steep and deep or the stream is rapid.**

Operating Conditions	Precautions for Maintenance
Muddy Soil, Rainy or Snowy Weather	Before Operation : Check tightness of plugs and all drain cocks.
	After Operation : Clean the machine and check for cracks and damage. Check for loose or missing bolts and nuts. Lubricate all necessary parts. If the machine should be submerged in water more than approximately 450 mm water may get into the brake device (like the park brake), resulting in poor braking performance. Watch out when starting/stopping the machine.
Near the Ocean (or near chemical treatment place)	Before Operation : Check tightness of plug and all drain cocks.
	After Operation : Thoroughly clean the machine with fresh water to wash off salt. Service electrical equipment often to prevent corrosion.
Dusty Atmosphere	Air Cleaner : Clean the element regularly at shorter service intervals when indicator illuminates.
	Radiator : Clean the oil cooler and the radiator cores.
	Fuel, DEF : Clean the filter element and strainer regularly at shorter service intervals.
	Aftertreatment Device, Engine : Clean them frequently to prevent deposits or dirt. Apply "Aftertreatment Device Regeneration Inhibit" setting as needed.
	Electrical Equipment : Clean them regularly, in particular, the commutator surface of the alternator and starter.
Rocky Ground	Chassis : Check for damage on tires, for loose, cracked, worn, and damaged bolts and nuts.
	Front Attachment: : Standard attachment may be damaged when digging rocky ground. Use a heavy duty bucket. Consult your nearest authorized dealer.
Freezing Weather	Fuel : Use high quality fuel suitable for low temperature. Check the fuel tank breather pipe freezing.
	Lubricant : Use high quality low viscosity hydraulic oil and engine oil.
	Engine Coolant : Be sure to use antifreeze.
	Battery : Fully charge the batteries regularly at shorter service intervals. If not charged fully, electrolyte may freeze.
	Tires and Chassis : Keep tires and chassis clean. Park the machine on a hard surface to prevent the tires from freezing to the ground.
	DEF : Keep 80% of tank capacity when storing at -10°C (12°F) or lower. The DEF tank maybe broken if DEF is frozen.
When handling old paper and/or industrial waste	Engine compartment : Remove old paper and/or waste accumulated around the radiator and in the engine compartment, possibly causing overheating or fires of the machine if not removed.
	Air cleaner : Clean the element at shorter intervals.
	Fuel system : Clean and replace the elements and the filters at shorter intervals.
	Loader chassis : Remove the accumulated paper and/or waste from the surroundings around the loader chassis and the attachment. Failure to do so may cause damage of the machine.
	Radiator : Wash as frequently as possible to prevent corrosion due to chemical materials.

**IMPORTANT:** If material to be handled is a substance that causes corrosion such as salt or chemical, consult your nearest authorized dealer. Special modification or treatment may be needed for the machine. If the machine continues to be used, malfunction may occur due to corrosion.  
Consult your nearest authorized dealer when the machine is operated under special condition (s).

## MAINTENANCE UNDER SPECIAL ENVIRONMENTAL CONDITIONS

---

### Precautions for Maintenance During Cold Weather Season

Before the atmospheric temperature below  $-0^{\circ}\text{C}$  ( $32^{\circ}\text{F}$ ), note the following points.

- Water and oil in the machine will freeze. Never use water without antifreeze. Use correct windshield washing solution so that windshield washer tanks and pumps will not freeze.
- Road surfaces may freeze so that tires may slip.
- Oil viscosity changes and oil thickens.

Keeping the above points in mind, follow the below:

1. Refill fluids such as water and lubricants prior to operation (except fuel).
2. Mix LLC (long life coolant) in the radiator (coolant). When this machine is shipped from the factory, LLC is supplied.
3. Change the engine oil in the engine crankcase to cold weather type oil.
4. Use fuel (#1 diesel fuel). To prevent condensation on the inside wall in the fuel tank, fully refill the fuel tank with #1 diesel fuel after each shift.
5. If the electrolyte solution in the battery case freezes, damage to the battery case may result. Keep the batteries fully charged. After completing work, turn all lights OFF. When finished with work, run the engine at low idle for a few minutes to cool down. This will help rebuild battery charge when lights and other equipment are off.

In extreme cold, remove the batteries and store them in a warm indoor place. When it is possible to measure and adjust the specific gravity of the electrolyte solution, increase the specific gravity of the electrolyte up to 1.280. Do not increase more than 1.280.

6. Use anti-freeze type washer fluid.

After taking the measures as recommended above, start operation of the machine.



## MAINTENANCE UNDER SPECIAL ENVIRONMENTAL CONDITIONS

---

 **DANGER:** Ventilate the area with fresh air when carrying out warm-up operation indoors. Failure to do so may cause asphyxiation from exhaust gas, resulting in death or severe injury.

7. After preheating, start and warm up the engine.
8. After warming up the engine, warm up the loading hydraulics. Slowly operate the control levers to move the cylinders full stroke several times. Do not force cylinders to go to the end of their stroke.
9. Road surfaces covered with snow, especially when snow has been compacted, will be frozen. Use tire chains on all four wheels.
10. Take anti-freeze measures after completing operation.
  - Spray keyholes with light oil. Cover the keyhole by sticking a tape on.
  - Rubber parts such as wiper blades may freeze. Keep other parts away from the rubber parts. Warm up cab prior to use of wipers.
  - Remove packed snow from around the axles, articulation joint and inside the machine with a bar or brush. Be careful not to damage electrical wiring.
  - In case it is impossible to store the machine indoors, park the machine on a level dry surface and cover the machine with a large machine cover.
  - Keep 80% of tank capacity when storing DEF. The DEF tank maybe broken if frozen.

 **NOTE:** DEF may start freezing at  $-10^{\circ}\text{C}$  ( $12^{\circ}\text{F}$ ). Freezing does not affect its performance once thawed.



## STORAGE

### Storing the Machine

**⚠ WARNING:** When servicing indoors for long term storage, open windows and doors to maintain good air ventilation to prevent asphyxiation. Check all lubricants before operating the machine after bring stored.

**Apply the parking brake while storing.**

If the machine is to be stored for more than one month, observe the following precautions so that its function will not be impaired during storage.

#### PRECAUTION ITEMS FOR LONG-TIME STORAGE

Item	Contents of Work
Wash Machine	Wash the machine to remove mud and/or dust.
Supply Oil and Grease	Check for low level/contamination of lubricating oil. Refill or change as necessary. Grease all joints. Apply a thin coat of oil to exposed metal and parts susceptible to rust. (i.e. cylinder rods etc.) Fill up fuel tank completely to prevent rust in the fuel tank.
Battery	Remove and fully charge the batteries, then store them in a warm place. If the machine is equipped with the battery disconnect switch, turn the disconnect switch OFF.
Coolant	Check that anti-freeze is within specifications. Use a rust inhibitor. Thoroughly wash the radiator by water and then dry it.
DEF	Make sure to store DEF at 30°C (86°F) or lower. When stored for a month or more at around 40°C (104°F), DEF may decompose. If it smells like ammonia when opening the storage container, do not use it. DEF may start freezing at -10°C (12°F). Freezing does not affect its performance once thawed. Never use a container used for any other liquid or oil. Contaminated DEF will cause the SCR system to work incorrectly, resulting in a vehicle operating illegally.
Prevention of Dust and Moisture	Store the machine in a dry garage and cover it.
Tools	Inspect and repair, then store.
Periodic Operation	Operate the machine at least once a month to lubricate the parts. At this time, check the coolant and lubrication oil levels. Charge the batteries.

**IMPORTANT:** If the machine is not periodically operated, damage to hydraulic equipment may result due to insufficient lubrication.

**✎ NOTE:** Periodic operation means that a series of operations such as drive, and loader front lift arms, bucket, and steering operation are repeated a few times after performing warm-up.

*Before operating the loader front attachment and steering wheel, remove rust-prevention oil coated on the hydraulic cylinder rods.*

## STORAGE

---

### Removing the Machine from Storage

 **WARNING:** When servicing indoors for long term storage, open windows and doors to maintain good air ventilation to prevent asphyxiation. Check all lubricants before operating the machine after bring stored.

Apply the parking brake while storing.

### IMPORTANT:

- Lubricants will deteriorate during storage of the machine.
- Thoroughly check coolant, lubricants and adequately perform lubrication operation before resuming operation. Avoid quick operation. Failure to do so may cause damage to the engine, hydraulic equipment, transmission, axle, etc. due to insufficient lubrication or coolant.
- If lubrication running is not performed for more than three months, start the engine by following the procedure below.
  1. Crank the engine (operate starter motor without running the engine) for three seconds and stop 10 seconds. Repeat this process three times.
  2. Start the engine. Run the engine at low idle for three minutes. Then carry out lubrication running for cylinders. Be careful not to fully stroke cylinders.

Starting the engine or operating cylinders without the procedure above, it may cause damage to the machine such as engine seizure.

## STORAGE

---

1. Remove covers.
2. Remove grease from the cylinder rods if coated.
3. Fill the fuel tank. Bleed air from the fuel system. Check all fluid levels.
4. Adjust alternator and fan belt tension.
5. Check the oil level. Add oil as needed.
6. Test battery electrolyte solution and install the batteries.  
If the machine is equipped with the battery disconnect switch, turn the disconnect switch ON.
7. Start the engine. Run the engine at less than 1,000 RPM's for several minutes before full load operation.
8. Repeat the process several times.
9. Stop the engine. Check each device for oil leaks.
10. Replace the fuel filter and engine oil filter with new one as needed. Change engine oil.
11. Check clamps of the suction hoses, air cleaner hoses and radiator hoses. Retighten them as needed.
12. Recheck radiator coolant.

Before operating, check the machine in accordance with the descriptions in "Daily Check before Starting the Engine" on page 3-1 and warm up.



## TROUBLESHOOTING

### Troubleshooting

If any machine trouble has occurred, immediately repair it. Make certain the cause of the trouble and take necessary measures to prevent the reoccurrence of the same trouble. In case troubleshooting is difficult, or measures marked with \* must be taken, consult the nearest authorized dealer. Never attempt to adjust, disassemble, or repair the hydraulic and/or electrical/electronic parts/components.

#### 1. Engine

Consult the nearest authorized dealer for the engine troubleshooting.

#### 2. Engine Auxiliaries

Problem	Cause	Solution
Batteries will not charge.	Broken battery separator	Replace
	Faulty regulator	* Adjust and replace
	Faulty ground line	* Repair
	Faulty alternator	* Repair and replace
Batteries discharge quickly after being charged.	Shorted cable	* Repair and replace
	Shorted battery separator	* Repair and replace
	Increased sediment in battery	* Clean
Coolant temperature is too high.	Low coolant level	Add
	Slow fan speed	* Repair, Replace fan motor and pump
	Damaged rubber hose	* Replace
	Faulty thermostat	* Replace
	Faulty coolant temperature gauge	* Replace
	Cooling system passages dirty	Flush cooling system
	Radiator core or oil cooler core plugged	Clean radiator and oil cooler
Radiator screen plugged	Clean screen	

## TROUBLESHOOTING

### 3. Engine does not Start.

Problem	Cause	Solution
The starter does not turn.	Reduced battery voltage	Charge the batteries. Replace.
	High resistance in the starter circuit	* Clean and/or retighten the battery terminals and starter terminals
	Faulty key switch	* Replace
	Damaged wire harness	* Repair or replace
	Faulty battery relay	* Replace
	Blown slow blow fuse link	* Replace
	The forward/reverse selector lever is in either the forward or reverse position.	Return to neutral.
	Faulty starter	* Repair or replace
Although the starter turns, the engine does not start.	Battery disconnect switch is OFF.	Turn the switch to ON position.
	Use of poor quality fuel, insufficient fuel, lack of fuel	Change fuel. Refill tank with good quality fuel.
	Faulty glow plug	* Replace glow plug
	Air mixed in the fuel supply line	Bleed air
	Faulty injection pump or nozzle	* Repair or replace
Engine speed does not increase.	Reduced compression pressure	* Repair or replace
	During fan reversing operation, the F, R, or parking switch was deactivated or the Fan reverse rotation switch was turned OFF.	Rotate the fan in normal direction. Refer to the fan reverse switch on page 1-106.
	DEF tank is empty.	Supply DEF.
Although the engine cranks, running speed is low and easy to stall.	The accelerator pedal function is abnormal.	Replace the accelerator pedal or parts.
	Deteriorated engine oil	Change engine oil
	Contaminated injection nozzle	* Replace
	Clogged fuel filter	Replace
	Clogged feed pump strainer	Clean
	Air mixed in the fuel supply line	Bleed air
Poor fuel quality	Replace	

 **NOTE:** \* Consult your nearest authorized dealer.



## TROUBLESHOOTING

### 4. Control Lever

Problem	Cause	Solution
Hard to move	Rusted joint	* Lubricate or repair
	Worn pusher	* Replace
Does not move smoothly	Worn pusher	* Repair or replace
	Faulty pilot valve	* Replace
Does not return to neutral	Faulty pilot valve	* Replace
The lever is tilted in the neutral position due to increase in play	Worn joint	* Repair or replace
	Faulty pilot valve	* Replace
The lever is not held with magnetic detent.	Faulty magnetic solenoid	* Replace
	Faulty sensor	* Replace

### 5. Hydraulic System

After the machine has been kept stowed stored for a long time, air in the oil may be separated and accumulate in the upper section in the cylinder, causing slow response time in operation or reducing cylinder power. In case these symptoms appear, repeatedly operate all actuators several times.

Problem	Cause	Solution
Loader front and travel functions are inoperable (hydraulic pump noise level increases).	Faulty hydraulic pump	* Repair, Replace
	Lack of hydraulic oil	Refill
	Broken suction pipe and/or hose	* Repair, Replace
All actuators have no power.	Malfunction due to worn hydraulic pump	* Replace
	Decrease in set pressure of main relief valve in control valve	* Clean, Adjust
	Lack of hydraulic oil	Refill
	Trapped foreign matter in hydraulic oil tank suction filter	Clean
	Aeration in suction side	Retighten
Only one actuator is inoperable.	Broken control valve spool	* Replace
	Trapped foreign matter in valve spool	* Repair, Replace
	Broken pipe and/or hose	* Repair, Replace
	Loose pipe line joint	Retighten
	Broken O-ring at pipe line joint	* Replace
	Broken actuator	* Repair, Replace
Only one cylinder is inoperable or has no power.	Broken oil seal in cylinder	* Repair, Replace
	Oil leaf due to damage to cylinder rod	* Repair, Replace
Oil overheats	Clogged oil cooler	* Clean, Replace
	Slow fan speed	* Repair, Replace motor and pump
	Weak tension of engine fan belt	Adjust
Oil leak from low pressure hose	Loose clamp	Retighten
	Faulty suction manifold	* Repair, Replace

 **NOTE:** \* Consult the nearest authorized dealer.

## TROUBLESHOOTING

### 6. Drive Function

Problem	Cause	Solution
Joystick steering lever is heavy to operate.	Faulty steering pump	* Repair, Replace
	Faulty steering device	* Repair, Replace
	Malfunction of steering cylinder	* Repair, Replace
	Relief valve set pressure reduction	* Adjust
	Low tire air pressure	* Inflate
Steering turns in unexpected direction.	One side brake is applied or dragged.	* Adjust
Joystick steering operation is not possible using the joystick steering lever.	Joystick steering system is not turned on.	Turn the key switch on, lower the armrest, turn the joystick steering system switch on, and start the engine, in this order. (Refer to page 3-3.)
	Joystick steering lever failure (the switch works but it will not steer).	* Repair, Replace
	Armrest switch failure	* Repair, Replace
	Controller failure	* Repair, Replace
Transmission shifting (F and R) does not work using the joystick steering F/R switch.	Joystick steering system is not turned on.	Turn the key switch on, lower the armrest, turn the joystick steering system switch on, and start the engine, in this order. (Refer to page 3-3.)
	F/R switch failure	* Repair, Replace
	Armrest switch failure	* Repair, Replace
	Controller failure	* Repair, Replace
Joystick steering system does not turn off when the armrest is fully raised.	Armrest switch failure	* Repair, Replace
	Controller failure	* Repair, Replace
	Defective wiring	* Repair, Replace
Joystick steering lever movement is hard or stiff or does not return to neutral when released.	Defective joystick steering lever	* Repair, Replace
Accelerator pedal is heavy to operate.	Rusted joint	* Lubricate, Repair
Accelerator pedal play is excessive.	Worn joint	* Replace, Repair
Parking brake Does not work properly	Worn brake disk and/or pads	* Replace
	Faulty parking brake solenoid valve	* Repair or replace
Service brake does not work properly	Malfunction of brake valve	* Repair or replace
	Oil leak from brake line, Air mixing	* Repair. Bleed air
Service brake is dragging.	Malfunction of brake valve	* Repair or replace
	Faulty brake pedal	* Repair or replace
	Corrosion of brake pedal parts	Clean and lubricate
	Pebbles in area of brake pedals	Remove - clean area
Service brake fluid loss (hydraulic oil).	Oil leak from brake line and/or hose connector	* Retighten or repair
	Oil leak due to brake piston seal (inside axle)	* Repair

 NOTE: \* Consult the nearest authorized dealer.

(Continued)

## TROUBLESHOOTING

### 6. Drive Function (Continued)

Problem	Cause	Solution
Transmission is noisy.	Lack or deterioration of gear oil	Refill, replace
	Worn inner parts in transmission	* Repair, Replace
	Broken gear or bearing	* Repair, Replace
Oil temperature increases.	Faulty fan rotation	* Repair or adjust
Propeller shaft vibrates.	Bent propeller shaft	* Repair, Replace
	Loosened parts, Loss of balance	* Retighten, Adjust
Propeller shaft is noisy	Excessively worn spline	* Replace
	Worn or seized spider bearing	* Replace
	Loosened parts	* Retighten
	Insufficient greasing	Grease
Front and/or rear axle is noisy	Worn or broken gears	* Replace
	Lack or deterioration of gear oil	Refill, Replace
	Worn bearings, Excess play	* Replace
	Excess play on shaft spline	* Repair, Replace
Front and/or rear axle does not transmit power.	Broken axle	* Repair
	Broken gears	* Repair

 **NOTE:** \* Consult the nearest authorized dealer.

### 7. Others

The machine may have a noise, excessive vibration, and abnormal smell when any trouble occurs. Always beware of the machine conditions during operation.



# SPECIFICATIONS

## Specifications

### Intended Use

This product is designed for loading, excavation, grading, dozing and/or scooping.  
Refer to "OPERATING THE MACHINE" for further information.

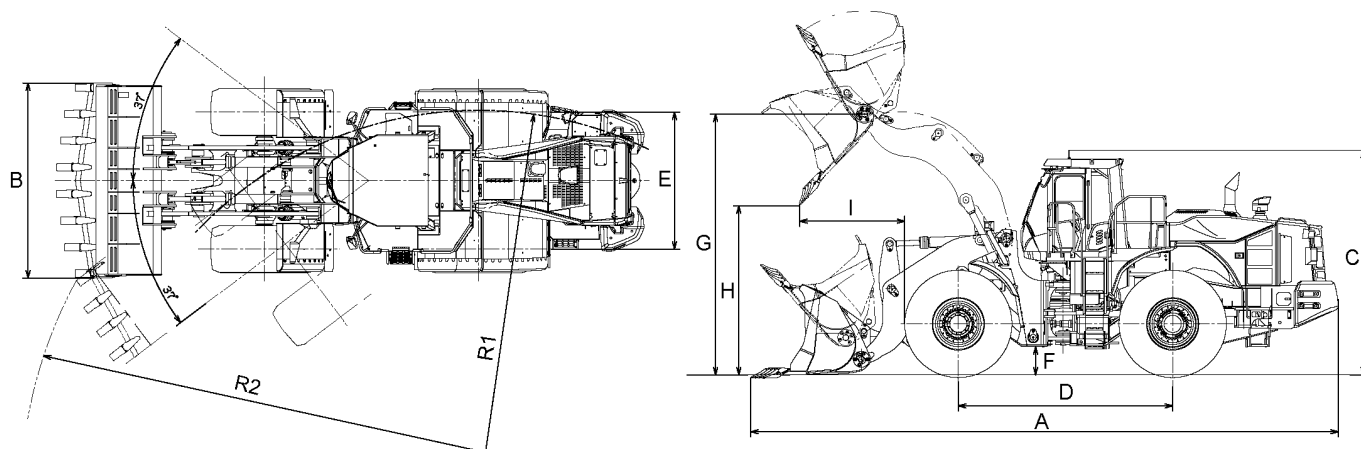

115Z7B-AK-RVT

Bucket Capacity: heaped	m <sup>3</sup> (Y <sup>3</sup> )	6.3 (8.3)
Operating Weight	kg (lb)	47430 (104565)
Tipping Load (Full Turn)	kg (lb)	27380 (60365)
Engine		ISUZU 6WG1
A: Overall Length	mm (in)	11370 (450)
B: Overall Width (Bucket)	mm (in)	3770 (150)
C: Overall Height	mm (in)	4195 (165)
D: Wheel Base	mm (in)	4150 (165)
E: Tread	mm (in)	2650 (105)
F: Ground Clearance	mm (in)	545 (20)
G: Bucket Hinge Height	mm (in)	5040 (200)
H: Dumping Clearance (45 °)	mm (in)	3270 (130)
I: Dumping Reach (45 °)	mm (in)	2045 (81)
R1: Minimum Rotation Radius	mm (in)	7545 (295)
R2: Minimum Rotation Radius	mm (in)	8835 (348)
Travel Speed Forward/Reverse	km/h (mph)	35.1 / 24.6 (21.8 / 15.3)
Transmission Speeds (F/R)	-	4/3
Articulation Angle (Left/Right) deg	(°)	37
Tire Size	-	35/65R33 (L5)

 **NOTE:** These specifications are subject to change without notice.



## INDEX

24 V DC Electrical Outlet .....	1-114	Automatic Regeneration .....	1-5
2nd/3rd Speed Limit Switch (Option) .....	1-105	Automatic regeneration (Auto-regeneration) .....	1-35
<b>A</b>		Auxiliary Control Lever (Option) .....	1-101
Accelerator Pedal.....	1-90	Avoid Accidents from Backing Up and Turning .....	S-16
Accelerator Pedal Operation, Check.....	7-114	Avoid Applying Heat to Lines Containing Flammable Fluids .....	S-32
Accumulator Function, Gas Leakage, Looseness, and Damage, Check.....	7-92	Avoid Heating Near Pressurized Fluid Lines .....	S-31
Adjust Operator's Seat .....	S-6	Avoid High-Pressure Fluids.....	S-28
Adjusting Drive Belt.....	7-74	Avoid Injury from Rollaway Accidents.....	S-15
Adjusting Operator's Seat (Air Suspension Type Seat)..	1-123	Avoid Operation with Loads on Only One Side.....	5-17
Adjustment of Bucket Angle Switch.....	5-8	Avoid Overloading.....	5-17
Adjustment of Bucket Auto Leveler .....	5-6	Avoid Positioning Bucket or Attachment Over Anyone.....	S-17
Adjustment of Dual Lift Arm Auto Leveler .....	5-10	Avoid Power Lines.....	S-19
After Operation, Precaution .....	5-26	Avoid Rapid Steering Changes and/or Sudden Braking.....	5-17
After Starting, Check .....	3-9	Avoid Tipping.....	5-17
Aftertreatment Device.....	1-3, 7-104, S-36	Axle Oil .....	7-16
Aftertreatment Device Manual Regeneration .....	5-13	Axle Oil, Change.....	7-37
Aftertreatment Device Regeneration .....	1-34	Axle Oil Cooler Fins (Option), Clean.....	7-40
Aftertreatment Device Regeneration Inhibited .....	1-57	Axle Oil Cooler Line Filter (Option), Replace.....	7-39
Aftertreatment Device Regeneration Status Display .....	1-34	Axle Oil Level, Check .....	7-35
Aftertreatment Device Regeneration Switch.....	1-108	Axle Support Mounting Bolts, Retighten.....	7-118
Aftertreatment Device, Check and Clean .....	7-104	<b>B</b>	
Air Bleeding Procedure, Fuel System.....	7-60	Backup Alarm, Check .....	7-85
Air Breather Element, Replace .....	7-50	Basic Screen.....	1-21
Air Cleaner .....	7-71	Batteries.....	7-80
Air Cleaner Element, Replace .....	7-71	Batteries, Replace .....	7-84
Air Conditioner.....	7-99	Battery Disconnect Switch.....	1-135
Air Conditioner, Check.....	7-101	Battery Disconnect Switch Operation .....	1-136
Air Conditioner, Components Name.....	1-116	Before Operation .....	5-16
Air Conditioner, Controller Part Name and Function ...	1-117	Before Starting, Check .....	3-3
Air Conditioner, Feature .....	1-115	Beware of Asbestos and Silicon Dust and Other Contamination.....	S-33
Air Conditioner Compressor Belt, Check .....	7-102	Beware of Exhaust Fumes.....	S-31
Air Conditioner Condenser, Check.....	7-102	Biodiesel Fuel.....	7-57
Air Conditioner Filters, Clean/Replace .....	7-99	Bleed Air from the Fuel System .....	7-60
Air Conditioner ON/OFF Switch.....	1-118	Bleed Air from the Hydraulic System .....	7-45
Air Conditioner Piping, Check.....	7-101	Booster Batteries.....	3-10
Air Conditioner Receiver Dryer, Replace .....	7-103	Brake Oil Low Pressure Indicator (Red).....	1-13
Air Conditioner Usage .....	1-122	Brake Pedal .....	1-90
Air Filter Restriction Indicator (Red).....	1-16	Brake Performance, Check .....	7-88
Air Pressure, Check.....	7-94	Brake System.....	7-88
Air Suspension Type Seat .....	1-123	Break-in Period for New Machine.....	2-1
Air Suspension Type Seat, Components Name .....	1-123	Brightness Adjustment.....	1-42
Alarm Occurrence Screen.....	1-27	Bucket Angle Switch, Adjustment.....	5-8
Alternator, Check and Clean.....	7-116	Bucket Auto Leveler, Adjustment.....	5-6
Armrest Adjust Handle .....	1-102	Bucket Control Lever .....	1-97
Articulation Lock.....	7-8	Bucket Teeth, Check .....	7-111
Articulation Stopper.....	1-137, S-38	<b>C</b>	
Asbestos .....	S-33	Cab.....	1-128
Ash Tray.....	1-114	Cab, Check .....	7-112
Auto Air Conditioner .....	1-115	Cab Door.....	1-133
Auto Brake.....	4-20	Cab Features.....	1-7
Auto Idling Stop.....	1-53, 5-11	Cab Heater Operation.....	1-119
Auto Idling Stop, Acting Time Setting .....	1-54		
Auto Idling Stop, ON/OFF.....	1-53		
Auto Idling Stop Operating Condition .....	5-12		
Auto Transmission, Shift Range.....	4-5		

## INDEX

Change Axle Oil.....	7-37	Check Parking Brake Gear Oil Level .....	7-90
Change Coolant .....	7-76	Check Pilot Circuit Accumulator Function, Gas Leakage, Looseness, and Damage.....	7-51
Change Differential Gear Oil .....	7-37	Check Planetary Gear Oil Level.....	7-36
Change Engine Oil .....	7-26	Check Play Amount in Joystick Steering Movement.....	7-113
Change Hydraulic Oil .....	7-44	Check Play in Brake Pedal Stroke .....	7-88
Change Parking Brake Gear Oil .....	7-91	Check ROPS .....	7-112
Change Planetary Gear Oil.....	7-38	Check ROPS Mounting Bolts .....	7-112
Change Transmission Oil .....	7-31	Check Rearview Mirror and Inside Rearview Mirror .....	7-115
Change Transmission Oil Filter .....	7-31	Check Refrigerant.....	7-103
Changing Forward/Reverse Drive Direction.....	4-8	Check Ride Control Accumulator Function, Gas Leakage, Looseness, and Damage (Option).....	7-52
Check Accelerator Pedal Operation.....	7-114	Check Right and Left Brake Interlocking Performance...	7-88
Check Accumulator Function, Gas Leakage, Looseness, and Damage.....	7-92	Check Service Brake Disks .....	7-93
Check After Starting .....	3-9	Check Sound Absorbing Mat Around Engine.....	7-116
Check Air Conditioner.....	7-101	Check Steps .....	7-115
Check Air Conditioner Compressor Belt .....	7-102	Check Tightening Torque of Nuts and Bolts .....	7-119
Check Air Conditioner Condenser.....	7-102	Check Tire Pressure .....	7-94
Check Air Conditioner Piping.....	7-101	Check Tire for Damage .....	7-95
Check Air Pressure.....	7-94	Check Transmission Oil Level .....	7-30
Check Axle Oil Level .....	7-35	Check Turbocharger .....	7-117
Check Backup Alarm .....	7-85	Check Urea SCR System .....	7-117
Check Before Starting .....	3-3	Check Wheel Bolt Torque.....	7-95
Check Brake Performance .....	7-88	Check Windshield Washer Fluid Level.....	7-113
Check Bucket Teeth .....	7-111	Check Work Lights.....	7-85
Check Cab .....	7-112	Check and Adjust Engine Controller (ECM) .....	7-117
Check Compressor .....	7-103	Check and Adjust Valve Clearance .....	7-116
Check Compressor and Pulley .....	7-103	Check and Clean Aftertreatment Device .....	7-104
Check Coolant Level.....	7-73	Check and Clean Alternator.....	7-116
Check DEF Level.....	7-106	Check and Clean EGR Cooler.....	7-117
Check Differential Gear Oil Level .....	7-35	Check and Clean EGR Valve .....	7-117
Check Dosing Module .....	7-110	Check and Clean Starter .....	7-116
Check Drive Belt.....	7-74	Check and Replace Lower Tether.....	7-112
Check Electrical Harnesses.....	7-86	Check and Replace Seat Belt.....	7-112
Check Electrolyte Specific Gravity .....	7-83	Check the Hour Meter Regularly.....	7-3
Check Engine Compression Pressure.....	7-116	Cigar Lighter (24 V DC Electrical Outlet) .....	1-114
Check Engine Noise.....	3-9	Circulation Air Filter, Clean.....	7-100
Check Engine Oil Level .....	7-25	Circulation/Fresh Air Switch .....	1-118
Check Exhaust Gas Color .....	3-9, 7-114	Clean Axle Oil Cooler Fins (Option).....	7-40
Check Fuel Hoses.....	7-69	Clean Circulation Air Filter.....	7-100
Check Fuel Injector .....	7-117	Clean DEF Strainer.....	7-107
Check Fuel Level .....	7-57	Clean Engine Compartment.....	7-116
Check Fuses .....	7-86	Clean Fresh Air Filter.....	7-99
Check Gas Pressure in Accumulator .....	7-93	Clean Fuel Priming Solenoid Pump Strainer .....	7-67
Check Gas Pressure in Ride Control Accumulator (Option) .....	7-52	Clean Fuel Pump Strainer .....	7-66
Check Gas Pressure in Steering Accumulator .....	7-52	Clean Hood .....	7-116
Check Handrails .....	7-115	Clean Pilot Oil Filter .....	7-47
Check Horn .....	7-85	Clean Radiator/Oil Cooler Cores and Other Cooling System.....	7-79
Check Hoses and Lines.....	7-53	Clean Suction Filter.....	7-46
Check Hydraulic Oil Level.....	7-43	Clean Suction Strainer .....	7-31
Check Instrument Operation .....	7-84	Clean Torque Converter Air Breathers.....	7-34
Check Monitor Functions .....	7-84	Clean Transmission Air Breathers .....	7-34
Check Monitor Operation.....	3-9	Clean/Replace Air Conditioner Circulation/Fresh Air Filters .....	7-99
Check Noise .....	7-114	Cleaning of Rear View Camera Lens .....	7-118
Check Parking Brake Disks .....	7-93		
Check Parking Brake Force.....	7-89		



# INDEX

Clearance Light Indicator (Green) .....	1-18	Drive Belt, Adjusting.....	7-74
Coat/Hat Hook.....	1-131	Drive Belt, Check.....	7-74
Cold Weather Warm Up.....	3-13	Drive Belt, Replace .....	7-75
Communication Error Indicator (Yellow) .....	1-14	Drive Function, Troubleshooting .....	11-4
Communication Terminal Equipment, Precaution.....	S-37	Drive Machine Safely (Work Site).....	S-13
Communication Terminal, Precaution .....	S-36	Drive Safely.....	S-12
Components Name .....	1-1	Drive Safely with Bucket Loaded .....	S-14
Compressor, Check .....	7-103	Drive Speed Change (Manual Shift) .....	4-8
Compressor Belt Tension Adjustment Procedure.....	7-102	Drive on Snow Safely .....	S-14
Control Lever Lock .....	5-4	Driving On Roads, Precaution .....	6-5
Control Lever Lock Indicator (Red).....	1-18	Driving on Public Roads: Standard Pressure.....	7-96
Control Lever Lock Operation.....	5-4	Driving on Slopes, Precaution .....	4-14
Control Lever, Troubleshooting.....	11-3	Driving the Machine.....	4-1
Cool Box.....	1-127	DSS (Down Shift Switch).....	1-112
Cool Head/Warm Feet Operation .....	1-121	Dual Lift Arm Auto Leveler, Adjustment .....	5-10
Coolant.....	7-72	Dual Lift Arm Auto-Leveler .....	1-39
Coolant, Change .....	7-76	Dumping into Truck or Hopper .....	5-23
Coolant Level, Check.....	7-73	<b>E</b>	
Coolant Temperature Gauge.....	1-17	EGR Cooler, Check and Clean .....	7-117
Cooling Operation .....	1-120	EGR Valve, Check and Clean .....	7-117
Cooling System .....	7-72	Electric Power Output (Option).....	1-124
Correct Maintenance and Inspection Procedures.....	7-1	Electrical Harnesses, Check.....	7-86
<b>D</b>		Electrical System.....	7-80
Date .....	1-47	Electrolyte Level Check .....	7-82
Date Adjustment .....	1-49	Electrolyte Specific Gravity, Check .....	7-83
Declutch Brake .....	1-90	Emergency Exit Hammer .....	1-131
Declutch Position Switch.....	1-103, 5-5	Emergency Stop and Restart of Operation .....	4-11
DEF Exchange Procedure .....	7-108	Emergency Stopping .....	4-19
DEF Level, Check.....	7-106	Engine.....	7-25
DEF Strainer, Clean.....	7-107	Engine, Troubleshooting .....	11-1
DEF Supply Module Main Filter, Replace .....	7-109	Engine Auxiliaries, Troubleshooting .....	11-1
DEF Tank Inlet Filter, Replace.....	7-110	Engine Compartment, Clean.....	7-116
DEF/AdBlue Level Alarm.....	1-32	Engine Compression Pressure, Check.....	7-116
DEF/SCR System Alarm.....	1-32	Engine Controller (ECM), Check and Adjust .....	7-117
Default Setting .....	1-20	Engine Noise, Check.....	3-9
Defroster Operation .....	1-121	Engine Oil .....	7-15
Defroster Switch .....	1-118	Engine Oil, Change .....	7-26
Diesel Exhaust Fluid (DEF), Precaution .....	S-32	Engine Oil Filter, Replace .....	7-28
Differential Gear Oil, Change .....	7-37	Engine Oil Level, Check .....	7-25
Differential Gear Oil Level, Check .....	7-35	Engine Oil Low Pressure Indicator (Red) .....	1-15
Dig with Caution.....	S-18	Engine Warning Indicator (Red) .....	1-15
Digging and Loading Level Ground .....	5-19	Engine does not Start, Troubleshooting .....	11-2
Discharge Warning Indicator (Red).....	1-14	Ensure Safety Before Rising from or Leaving Operator's Seat .....	S-7
Display Item Selection.....	1-69	Ensure Safety When Operating on Road Shoulders .....	5-16
Display Mode Setting.....	1-51	Equipment of Head Guard, ROPS, FOPS.....	S-11
Displaying Basic Screen .....	1-22	Evacuating in Case of Fire.....	S-30
Dispose of Waste Properly.....	S-35	Excavation.....	5-18
Door Open/Close Lever.....	1-134	Exhaust Fumes.....	S-31
Dosing Module, Check .....	7-110	Exhaust Gas Color, Check .....	3-9, 7-114
Down Shift Switch (DSS).....	1-112	<b>F</b>	
Dozing .....	5-24	Fan Reverse Rotation Switch.....	1-106
Drain Fuel Filter .....	7-59	Fan Reverse Rotation Switch, AUTO .....	1-106
Drain Water and Sediment from Fuel Tank.....	7-58	Fan Reverse Rotation Switch, Manual Operation .....	1-107
Draining Procedures (Pre-Filter).....	7-59		
Drink Holder .....	1-127		

# INDEX

Fan Reverse Rotation Switch, OFF .....	1-106	Horn Switch .....	1-113
Fan/AUTO Switch .....	1-118	Horn, Check .....	7-85
Fasten Your Seat Belt .....	S-7	Hoses and Lines, Check .....	7-53
Fastening Machine for Transporting .....	6-4	Hot/Cool Box .....	1-127
Fingertip Control Type .....	1-10, 1-96, 5-1	Hour Meter, Check Regularly .....	7-3
Flat Face O-ring Seal Fitting (ORS Fitting) .....	7-56	How to Check Wear Amount (Tread Design Groove Depth) .....	7-97
Fogged Windows .....	1-122	How to Use Screens .....	1-22
Follow Safety Instructions .....	S-2	Hydraulic Coupler Switch (Option) .....	1-107
FOPS .....	S-11	Hydraulic Oil .....	7-16
Forward/Reverse Switch .....	1-91	Hydraulic Oil Level Indicator (Red) .....	1-13
Fresh Air Filter, Clean .....	7-99	Hydraulic Oil Level, Check .....	7-43
Front Console .....	1-8	Hydraulic Oil Return Filter, Replace .....	7-49
Front Console Switches .....	1-85	Hydraulic Oil, Change .....	7-44
Front Interior Light .....	1-130	Hydraulic System .....	7-41
Front/Rear Wiper Switch .....	1-95	Hydraulic System, Bleed Air .....	7-45
Fuel, Recommended .....	7-57	Hydraulic System, Troubleshooting .....	11-3
Fuel Consumption .....	1-74	<b>I</b>	
Fuel Gauge .....	1-17	I-Shape Loading .....	5-22
Fuel Hoses, Check .....	7-68	If Air Mixed After Common Rail .....	7-61
Fuel Injector, Check .....	7-117	Information Menu .....	1-73
Fuel Level, Check .....	7-57	Inside Rear View Mirror .....	1-133
Fuel Main Filter Element, Replace .....	7-62	Inspect Machine .....	S-4
Fuel Pre-Filter Element, Replace .....	7-64	Inspect Machine Daily Before Starting .....	3-1
Fuel Priming Solenoid Pump Strainer, Clean .....	7-67	Inspection and Maintenance Table .....	7-11
Fuel Pump Strainer, Clean .....	7-66	Inspection and Maintenance of Hydraulic Equipment... ..	7-41
Fuel System .....	7-57	Inspection/Maintenance Access Covers .....	1-139, 7-9
Fuel System, Bleed Air .....	7-60	Instrument Operation, Check .....	7-84
Fuse Box .....	1-125	Intended Use .....	12-1
Fuse Box A .....	1-126, 7-87	Investigate Job Site Beforehand .....	S-10
Fuse Box B .....	1-126, 7-87	<b>J</b>	
Fuses, Check .....	7-86	Joystick Steering .....	1-9, 1-85, 1-91
<b>G</b>		Joystick Steering Lever .....	1-91
Gas Pressure in Accumulator, Check .....	7-93	Joystick Steering System ON/OFF .....	S-39
Gas Pressure in Ride Control Accumulator (Option), Check .....	7-52	Joystick Steering System Switch .....	1-91
Gas Pressure in Steering Accumulator, Check .....	7-52	Jump Starting .....	S-9
General Precautions for Cab .....	S-5	<b>K</b>	
Grading .....	5-20	Keep Riders Off Machine .....	S-12
Grease .....	7-15	Key Switch .....	1-89
Greasing .....	7-19	Kind of Oils .....	7-15
Grinding, Precaution .....	S-31	<b>L</b>	
<b>H</b>		Layout .....	7-4
Hammer, Emergency Exit .....	1-131	Lift Arm Control Lever .....	1-97
Handle Chemical Products Safely .....	S-35	Lifting Machine .....	6-10
Handle Fluids Safely - Avoid Fires .....	S-23	Lifting Wheel Loader .....	5-25
Handle Starting Aids Safely .....	S-8	Light Switch .....	1-93
Handling Accumulator, Precaution .....	S-32	Lightning, Precaution .....	S-19
Handling Gas Damper, Precaution .....	S-32	List of Consumable Parts .....	7-17
Handrails, Check .....	7-115	Load and Carrying Method .....	5-21
Hazard Switch .....	1-86	Loader and Dump Truck Combination Method .....	5-22
Head Guard .....	S-11	Loading .....	5-21, 6-3
Height Kickout ON/OFF, Stop Height Setting .....	1-40	Loading Accumulated Soil .....	5-18
High Beam Indicator (Blue) .....	1-18	Loading Control Lever Lock Switch .....	1-102
Hold Switch .....	1-110	Loading Control Levers .....	1-97, 5-1
Hood, Clean .....	7-116		

# INDEX

Loading Multi-Function Joystick Lever (Option)....	1-100, 5-3	Outside Rear View Mirror.....	1-133
Loading/Unloading on Trailer.....	6-2	Overheat Indicator (Red).....	1-15
Lock Bar.....	5-38	<b>P</b>	
Lockup Setting.....	1-61	Parallel/Tandem Switching Height Setting.....	1-65
Low Steering Oil Pressure Indicator (Option) (Red).....	1-14	Park Machine Safely.....	5-21
Lower Kickout ON/OFF, Stop Height Setting.....	1-41	Parking.....	4-18
Lower Tether, Check and Replace.....	7-112	Parking Brake Disks, Check.....	7-93
Lubrication Guide.....	7-5	Parking Brake Force, Check.....	7-89
<b>M</b>		Parking Brake Gear Oil Level, Check.....	7-90
MACHINE NUMBERS.....	1	Parking Brake Gear Oil, Change.....	7-91
Mail (Option).....	1-44	Parking Brake Indicator (Red).....	1-13
Main Menu.....	1-37	Parking Brake Switch.....	1-88, 4-7
Main Menu Display Order Change.....	1-71	Pedals.....	1-85
Maintenance.....	1-76, 7-1	Perform Truck Loading Safely.....	5-18
Maintenance During Cold Weather Season, Precaution...9-2		Pilot Circuit Accumulator, Check.....	7-51
Maintenance Interval.....	1-78	Pilot Oil Filter, Clean.....	7-47
Maintenance Notice.....	1-76	Pilot Oil Filter, Line Filter in Brake Circuit.....	7-48
Maintenance Under Special Environmental Conditions...9-1		Pilot Oil Filter, Line Filter in Steering Circuit.....	7-47
Manual Regeneration.....	1-36	Planetary Gear Oil Level, Check.....	7-36
Manual Regeneration Procedure.....	5-13	Planetary Gear Oil, Change.....	7-38
Manual Shift, Drive Speed Change.....	4-8	Play Amount in Joystick Steering Movement, Check...7-113	
Measurement of Deflection Amount and Vibration		Play in Brake Pedal Stroke, Check.....	7-88
Frequency.....	7-74	Power Lines, Avoid.....	5-19
Metal Face Seal Fittings.....	7-56	Power Mode Selector.....	4-6
Mode/Temperature Control Switch.....	1-117	Power Mode Selector Switch.....	1-105
Monitor Functions, Check.....	7-84	Power Train.....	7-30
Monitor Operation.....	1-26	Practice Safe Maintenance.....	5-24
Monitor Operation, Check.....	3-9	Precaution for Communication Terminal Equipment....	5-37
Monitor Panel.....	1-12	Precautions for After Operation.....	5-26
Monitoring.....	1-82	Precautions for Communication Terminal.....	5-36
Move and Operate Machine Safely.....	5-8	Precautions for Diesel Exhaust Fluid (DEF).....	5-32
MOVING THE MACHINE.....	4-1	Precautions for Driving On Roads.....	6-5
Multi Function Monitor.....	1-19	Precautions for Driving on Slopes.....	4-14
Multi Function Monitor, Feature.....	1-19	Precautions for Grinding.....	5-31
Multi Function Monitor, Screen Configuration.....	1-19	Precautions for Handling Accumulator.....	5-32
Multi-Function Joystick Type.....	1-11, 1-99	Precautions for Handling Gas Damper.....	5-32
<b>N</b>		Precautions for Lightning.....	5-19
Never Ride Attachment.....	5-6	Precautions for Maintenance During Cold Weather	
Never Undercut a High Bank.....	5-18	Season.....	9-2
Noise, Check.....	7-114	Precautions for Operation.....	5-16, 5-19
Notes on Aftertreatment Device.....	5-36	Precautions for Starting to Move.....	4-1
<b>O</b>		Precautions for Towing.....	6-6
Object Handling.....	5-20	Precautions for Traveling.....	4-12
Off-Season Air Conditioner Maintenance.....	1-122	Precautions for Welding.....	5-31
Operate Only from Operator's Seat.....	5-9	Precautions to be Taken if Machine Failure Occurs.....	4-15
Operating in Water or on Soft Ground.....	4-13	Preheat Indicator (Yellow).....	1-16
OPERATING THE ENGINE.....	3-1	Preheating.....	3-8
OPERATING THE MACHINE.....	5-1	Preparations for Inspection and Maintenance.....	7-6
Operation, Precaution.....	5-16, 5-19	Prepare for Emergencies.....	5-3
Operation Condition.....	1-74	Prevent Battery Explosions.....	5-34
Operator's Seat (Air Suspension Type Seat),		Prevent Burns.....	5-27
Adjusting.....	1-123	Prevent Fires.....	5-29
Operator's Seat, Adjust.....	5-6	Prevent Parts from Flying.....	5-27
OPERATOR'S STATION.....	1-3	Protect Against Flying Debris.....	5-20
		Protect Against Noise.....	5-4

## INDEX

Provide Signals for Jobs Involving Multiple Machines....	S-11	Roll Over Protective Structure (ROPS).....	S-40
Pulley, Check .....	7-103	ROPS, Check .....	7-112
<b>Q</b>		ROPS (Roll Over Protective Structure).....	S-11, S-40
Quick Power Switch.....	1-111	ROPS Mounting Bolts, Check .....	7-112
<b>R</b>		Rotary Light Switch (Option).....	1-132
Radiator/Oil Cooler Cores and Other Cooling System,		Rotation Procedure.....	7-97
Clean.....	7-79	Rubber Hoses Periodically, Replace.....	S-28
Ramp/Loading Dock .....	6-2	Rubber Hoses, Replace Periodically.....	S-28
Rapid Cooling .....	1-122	<b>S</b>	
Rear Grille .....	1-140, 7-10	SAFETY .....	S-1
Rear Interior Light .....	1-130	Safety Information .....	S-1
Rear Tray .....	1-124	SAFETY LABELS .....	S-41
Rear View Camera Lens.....	7-118	Seat Belt, Check and Replace.....	7-112
Rear View Camera Monitor .....	1-55	Seat Belt, Fasten .....	S-7
Rear View Mirror.....	1-133	Secondary Steering (Option) .....	4-10
Rear Wiper Switch .....	1-95	Secondary Steering Operation Check Switch	
Rearview Mirror and Inside Rearview Mirror, Check.....	7-115	(Option) .....	1-108
Recognize Safety Information .....	S-1	Selecting a Trailer .....	6-1
Recommended Coolant.....	7-16	Service Air Conditioning System Safely .....	S-34
Refill DEF.....	7-106	Service Brake.....	1-90
Refrigerant, Check.....	7-103	Service Brake Disks, Check.....	7-93
Refueling .....	7-58	Service Recommendations for Hydraulic Fittings .....	7-56
Releasing Parking Brake.....	6-7	Setting Menu .....	1-46
Remedy .....	1-29	Shift Change Delay Mode.....	4-6
Removal and Installation of Tire.....	7-98	Shift Change Delay Mode Setting .....	1-59
Remove Paint Before Welding or Heating .....	S-33	Shift Range of Auto Transmission.....	4-5
Removing Snow.....	5-25	Shift Switch.....	1-92
Removing the Machine from Storage.....	10-2	Silicon Dust.....	S-33
Repeated Inhibiting of Exhaust Filter Cleaning.....	1-6	Sound Absorbing Mat Around Engine, Check.....	7-116
Replace Air Breather Element .....	7-50	Specifications.....	12-1
Replace Air Cleaner Element.....	7-71	Specified DEF/AdBlue .....	7-105
Replace Air Conditioner Receiver Dryer.....	7-103	Starter, Check and Clean.....	7-116
Replace Axle Oil Cooler Line Filter (Option).....	7-39	Starting Engine .....	3-6
Replace Batteries .....	7-84	Starting in Cold Weather.....	3-8
Replace DEF Supply Module Main Filter .....	7-109	Starting to Move.....	4-2
Replace DEF Tank Inlet Filter .....	7-110	Starting to Move, Precaution .....	4-1
Replace Engine Oil Filter .....	7-28	Stay Clear of Moving Parts .....	S-26
Replace Fuel Main Filter Element .....	7-62	Steering.....	4-9
Replace Fuel Pre-Filter Element .....	7-64	Steps.....	1-141
Replace Hydraulic Oil Return Filter .....	7-49	Steps, Check .....	7-115
Replace Rubber Hoses Periodically.....	S-28	Stock Piling .....	5-24
Replace Tire .....	7-95	Stop .....	4-16
Replace Tire (Tire Pressure) .....	7-94	Stopping Engine.....	3-15
Replacing Drive Belt .....	7-75	STORAGE.....	10-1
Retighten Front Axle and Rear Axle Support Mounting		Store Attachments Safely .....	S-21
Bolts.....	7-118	Storing the Machine.....	10-1
Ride Control Accumulator (Option), Check.....	7-52	Suction Filter, Clean.....	7-46
Ride Control Drive Speed Setting (Option).....	1-38	Suction Strainer, Clean .....	7-31
Ride Control Switch (Option) .....	1-109	Sun Visor .....	1-131
Ride Control Switch, AUTO.....	1-109	Support Machine Properly.....	S-25
Ride Control Switch, OFF .....	1-109	Support Maintenance Properly .....	S-26
Right Console.....	1-10, 1-96	Switches.....	1-96
Right Console Slide Lever.....	1-111	<b>T</b>	
Right Console/Switches .....	1-99	Tightening Torque of Nuts and Bolts, Check.....	7-119
Right and Left Brake Interlocking Performance, Check..	7-88	Time.....	1-47

## INDEX

Time Adjustment.....	1-47	Wear Protective Clothing.....	S-3
Time Remains and Maintenance Interval.....	1-78	Welding, Precaution.....	S-31
Tips for Optimal Air Conditioner Usage.....	1-122	Wheel Bolt Torque, Check.....	7-95
Tire.....	7-94	When Windows Become Fogged.....	1-122
Tire (Tire Pressure), Replace.....	7-94	When the Engine has Stalled During Operation.....	4-19
Tire Pressure, Check.....	7-94	Window Open/Close Levers.....	1-134
Tire Rotation.....	7-97	Windshield Washer Fluid Level, Check.....	7-113
Tire Sizes to be Used.....	7-96	Wiper Operation.....	1-94
Tire Wheel.....	7-98	Wiper Switch.....	1-94
Tire for Damage, Check.....	7-95	Work Light Indicator (Yellow).....	1-18
Tire, Removal and Installation.....	7-98	Work Light Switch.....	1-87
Tire, Replace.....	7-95	Work Lights, Check.....	7-85
Tool Box.....	1-141	Work Mode for Break-in.....	2-1
Torque Converter Air Breathers, Clean.....	7-34		
Towing Method.....	6-9		
Towing Pin.....	1-138		
Towing, Precaution.....	6-6		
Traction Control Setting.....	1-63		
Transmission Air Breathers, Clean.....	7-34		
Transmission Oil.....	7-15		
Transmission Oil Filter, Change.....	7-31		
Transmission Oil Level, Check.....	7-30		
Transmission Oil, Change.....	7-31		
Transmission Setting.....	1-59		
Transmission Warning Indicator (Red).....	1-14		
Transport Safely.....	S-22		
TRANSPORTING.....	6-1		
Transporting Wheel Loader (Urgent Situation).....	6-5		
Transporting by Road.....	6-1		
Travel Mode Selector Switch.....	1-104		
Travel on Public Roads Safely.....	S-15		
Traveling, Precaution.....	4-12		
Tray.....	1-127		
Troubleshooting.....	1-80, 11-1		
Turbocharger, Check.....	7-117		
Turn Signal Indicator (Green).....	1-18		
Turn Signal Switch.....	1-101		
<b>U</b>			
Understand Signal Words.....	S-1		
Upper Switch Panel (Option).....	1-132		
Urea SCR System.....	7-105		
Urea SCR System Malfunction.....	1-33		
Urea SCR System, Check.....	7-117		
Use Handrails.....	S-6		
Use Steps.....	S-6		
<b>V</b>			
V-Shape Loading.....	5-22		
Valve Clearance, Check and Adjust.....	7-116		
Vandal-Resistant Devices.....	1-142		
<b>W</b>			
Warm Up.....	3-12		
Warm Up Operation.....	1-67		
Warn Others of Service Work.....	S-25		

