



Backhoe Loader

Part Number	Machine Model	Serial Numbers
9803/7110	2CX, 2DX	657001 to 763230
	210, 212	481196 Onwards



Publication No.
S2-eng



Copyright © 2004 JCB SERVICE. All rights reserved. No part of this publication may be reproduced, stored in a retrieval system, or transmitted in any form or by any other means, electronic, mechanical, photocopying or otherwise, without prior permission from JCB SERVICE.

Issued by JCB Technical Publications, JCB Service, World Parts Centre, Beamhurst, Uttoxeter, Staffordshire, ST14 5PA, England. Tel +44 1889 590312 Fax +44 1889 593377

World Class
Customer Support

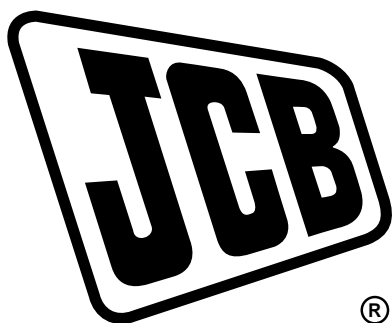

Service Manual

2CX, 2DX, 210, 212
& VARIANTS

Backhoe Loader

From M/c No. 657001 TO
763230
&
481196 Onwards

PUBLISHED BY THE
TECHNICAL PUBLICATIONS DEPARTMENT
OF JCB SERVICE; © WORLD PARTS CENTRE,
CHEADLE ROAD, UTTOXETER, ST14 7BS
ENGLAND
Tel. ROCESTER (01889) 590312
PRINTED IN ENGLAND

Publication No. 9803/7110

General Information	1
Care & Safety	2
Routine Maintenance	3
Attachments	A
Body & Framework	B
Electrics	C
Controls	D
Hydraulics	E
Transmission	F
Brakes	G
Steering	H
Engine	K

Introduction

This publication is designed for the benefit of JCB Distributor Service Engineers who are receiving, or have received, training by JCB Technical Training Department.

These personnel should have a sound knowledge of workshop practice, safety procedures, and general techniques associated with the maintenance and repair of hydraulic earthmoving equipment.

Renewal of oil seals, gaskets, etc., and any component showing obvious signs of wear or damage is expected as a matter of course. It is expected that components will be cleaned and lubricated where appropriate, and that any opened hose or pipe connections will be blanked to prevent excessive loss of hydraulic fluid and ingress of dirt. Finally, please remember above all else **SAFETY MUST COME FIRST!**

The manual is compiled in sections, the first three are numbered and contain information as follows:

1	=	General Information - includes torque settings and service tools.
2	=	Care & Safety - includes warnings and cautions pertinent to aspects of workshop procedures etc.
3	=	Routine Maintenance - includes service schedules and recommended lubricants for all the machine.

The remaining sections are alphabetically coded and deal with Dismantling, Overhaul etc. of specific components, for example:

A	=	Attachments
B	=	Body & Framework ...etc.

The page numbering in each alphabetically coded section is not continuous. This allows for the insertion of new items in later issues of the manual.

Section contents, technical data, circuit descriptions, operation descriptions etc are inserted at the beginning of each alphabetically coded section.

All sections are listed on the front cover; tabbed divider cards align directly with individual sections on the front cover for rapid reference.

Where a torque setting is given as a single figure it may be varied by plus or minus 3%. Torque figures indicated are for dry threads, hence for lubricated threads may be reduced by one third.

With the exception of slewing operations 'Left Hand' and 'Right Hand' are as viewed from the rear of the machine facing forwards.

*

Machine Nomenclature

In this Service Manual, reference is made to machine models, e.g. 2CX, 2DX, these are European machine model names. North American machine models have different names, the table below shows the European and the equivalent North American nomenclature.

European		North American
2CX	=	210S
2DX	=	213S

Contents	Page No.
Machine Identification Plate	1 - 1
Typical Machine Identification Number	1 - 1
Typical Engine Identification Number	1 - 1
Unit Identification	1 - 2
Torque Settings	2 - 1
Service Tools Numerical List	3 - 1
Service Tools	
Electrics	4 - 1
Hydraulics	4 - 2
Transmission	4 - 5
Engine	4 - 7
Sealing and Retaining Compounds	5 - 1

Machine Identification Plate

Your machine has an identification plate mounted on the right hand side of the machine just below the driver's cab door. The serial numbers of the machine and its major units are stamped on the plate.

The serial number of each major unit is also stamped on the unit itself. If a major unit is replaced by a new one, the serial number on the identification plate will be wrong. Either stamp the new number of the unit on the identification plate, or simply stamp out the old number. This will prevent the wrong unit number being quoted when replacement parts are ordered.

The machine and engine serial numbers can help identify exactly the type of equipment you have.

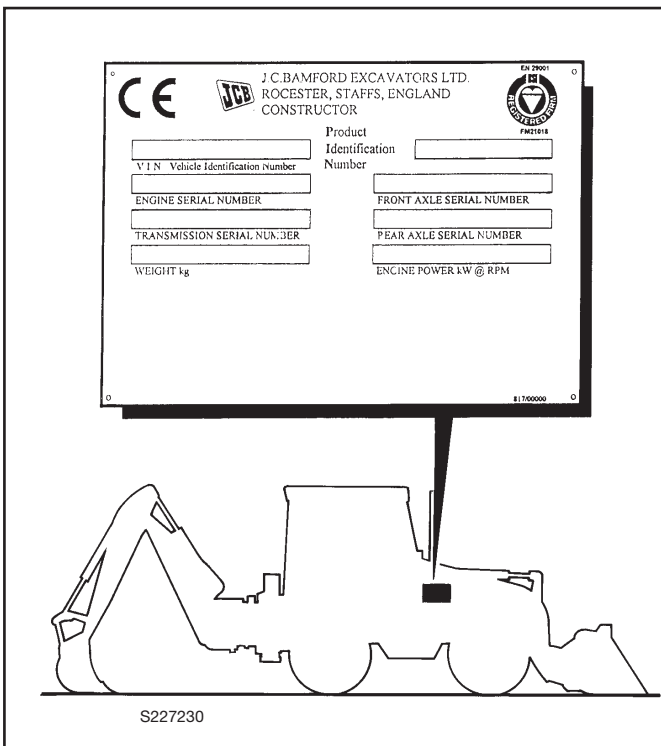

* Typical Machine Identification Number

SLP 2DX T S R E 123456
 A B C D E F G

- A World Manufacturer Identification
- B Machine Model
- C Steer Type (T= 2WS, F=4WS)
- D Build Type (S=Sideshift, C=Centremount, L=Loader)
- E Year of Manufacture:

R = 1994	1 = 2001
S = 1995	2 = 2002
T = 1996	3 = 2003
V = 1997	4 = 2004
W = 1998	5 = 2005
X = 1999	6 = 2006
Y = 2000	7 = 2007
- F Manufacturer Location (E = England)
- G Machine Serial Number:

*

Typical Engine Identification Number

AB 50262 U 500405 P
 A B C D E

- A Engine Type
AB = 4 cylinder turbo
- B Build Number
- C Country of Origin
- D Engine Sequence Number
- E Year of Manufacture

Unit Identification

The engine serial number is stamped on a plate mounted on the left hand side of the cylinder block (looking towards the front of the machine).

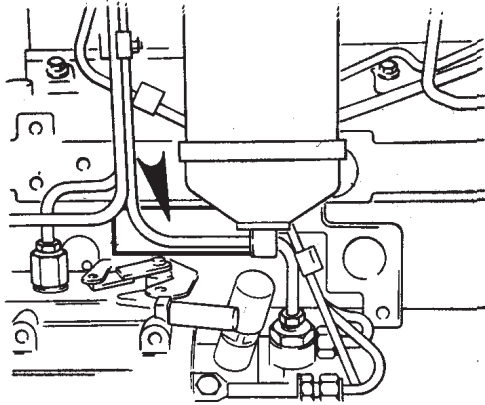

The rear axle serial number is stamped on a plate mounted to the front face of the axle, as shown below.

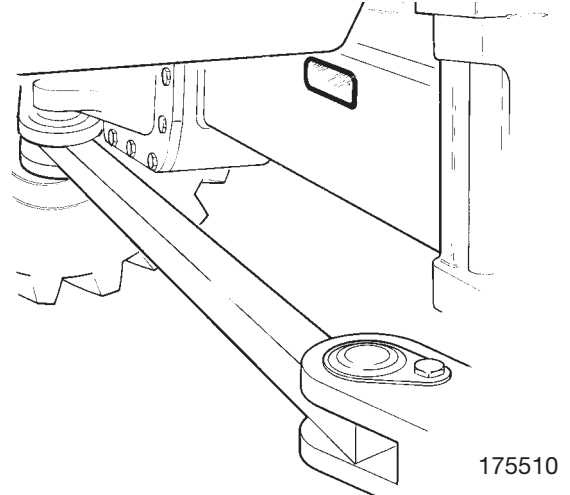

The Syncro Shuttle serial number is stamped on a label which is mounted to the rear face of the unit.

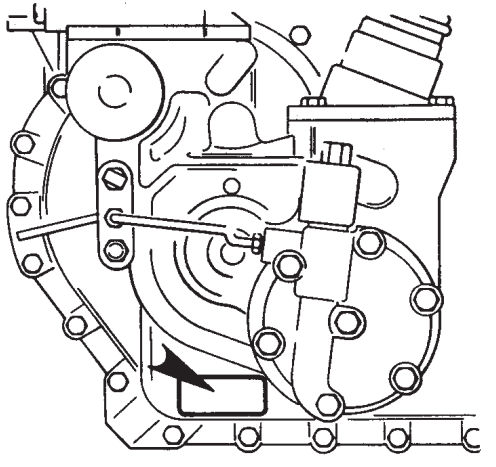

The front axle serial number is stamped on a plate mounted to the rear face of the axle, as shown below.

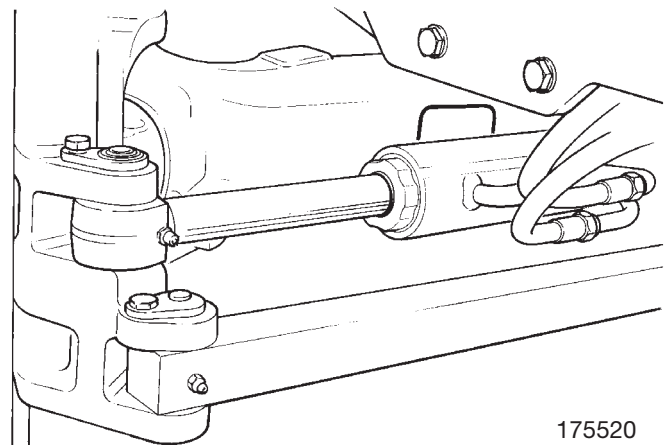

Torque Settings

Use only where no torque setting is specified in the text. Values are for dry threads and may be within three per cent of the figures stated. For lubricated threads the values should be REDUCED by one third.

UNF Grade 'S' Bolts

Bolt Size in	Hexagon (A/F)		Torque Settings		
	(mm)	in	Nm	kgf m	lbf ft
1/4	(6.3)	7/16	14	1.4	10
5/16	(7.9)	1/2	28	2.8	20
3/8	(9.5)	9/16	49	5.0	36
7/16	(11.1)	5/8	78	8.0	58
1/2	(12.7)	3/4	117	12.0	87
9/16	(14.3)	13/16	170	17.3	125
5/8	(15.9)	15/16	238	24.3	175
3/4	(19.0)	11/8	407	41.5	300
7/8	(22.2)	15/16	650	66.3	480
1	(25.4)	11/2	970	99.0	715
1 1/4	(31.7)	17/8	1940	198.0	1430
1 1/2	(38.1)	21/4	3390	345.0	2500

Metric Grade 8.8 Bolts

Bolt Size	Hexagon (A/F)		Torque Settings		
	(mm)	mm	Nm	kgf m	lbf ft
M5	(5)	8	7	0.7	5
M6	(6)	10	12	1.2	9
M8	(8)	13	28	3.0	21
M10	(10)	17	56	5.7	42
M12	(12)	19	98	10	72
M16	(16)	24	244	25	180
M20	(20)	30	476	48	352
M24	(24)	36	822	84	607
M30	(30)	46	1633	166	1205
M36	(36)	55	2854	291	2105

Note: All bolts used on JCB machines are high tensile and must not be replaced by bolts of a lesser tensile specification.

Service Tools Numerical List

	Page No.		Page No.		
816/00189	Blanking Cap	4 - 6	892/00301	Flow Test Adapter	4 - 7
816/00190	Blanking Ca	4 - 6	892/00302	Flow Test Adapter	4 - 7
816/00193	Blanking Cap	4 - 6	892/00304	Flow Test Adapter	4 - 7
816/00196	Blanking Cap	4 - 6	* 892/00334	Ram Seal Fitting Tool	4 - 6
816/00197	Blanking Cap	4 - 6	892/00347	Gauge Connector	4 - 4
816/00294	Blanking Cap	4 - 6	892/00706	Test Probe	4 - 5
816/15118	Pressure Test Adapter	4 - 4	892/00812	Drive Coupling Spanner	4 - 7
816/20008	Adapter	4 - 4	892/00822	Splined Bolt Socket	4 - 8
816/50043	'T' Adapter	4 - 6	892/00833	Annulus Removal Tool	4 - 8
816/55038	Pressure Test 'T' Adapter	4 - 4	892/00843	Folding Stand	4 - 1
816/55040	Pressure Test 'T' Adapter	4 - 4	892/00844	Long Knife	4 - 2
816/60096	'T' Adapter	4 - 6	892/00845	Cartridge Gun	4 - 1
892/00041	De-glazing Tool	4 - 9	892/00846	Glass Extractor Handles	4 - 2
892/00047	'T' Adapter	4 - 6	892/00847	Nylon Spatula	4 - 3
892/00048	'T' Adapter	4 - 6	892/00848	Wire Starter	4 - 2
892/00055	Blanking Plug	4 - 6	892/00849	Braided Cutting Wire	4 - 2
892/00056	Blanking Plug	4 - 6	* 892/00956	Timing Pin	4 - 9
892/00057	Blanking Plug	4 - 6	* 892/01016	Ram Seal Protection Sleeve 25 mm	4 - 6A
892/00059	Blanking Plug	4 - 6	* 892/01017	Ram Seal Protection Sleeve 30 mm	4 - 6A
892/00060	Blanking Plug	4 - 6	* 892/01018	Ram Seal Protection Sleeve 40 mm	4 - 6A
892/00074	Female Connector	4 - 6	* 892/01019	Ram Seal Protection Sleeve 50 mm	4 - 6A
892/00075	Female Connector	4 - 6	* 892/01020	Ram Seal Protection Sleeve 50 mm	4 - 6A
892/00077	Female Connector	4 - 6	* 892/01021	Ram Seal Protection Sleeve 60 mm	4 - 6A
892/00137	Hose	4 - 5	* 892/01022	Ram Seal Protection Sleeve 60 mm	4 - 6A
892/00153	Test Block for Excavator A.R.V.	4 - 5	* 892/01023	Ram Seal Protection Sleeve 65 mm	4 - 6A
* 892/00167	Ram Seal Protection Sleeve 90mm	4 - 6A	* 892/01024	Ram Seal Protection Sleeve 70 mm	4 - 6A
892/00174	Measuring Cup	4 - 8	* 892/01025	Ram Seal Protection Sleeve 75 mm	4 - 6A
892/00179	Bearing Press	4 - 7	* 892/01026	Ram Seal Protection Sleeve 80 mm	4 - 6A
892/00180	Seal Fitting Tool	4 - 6	* 892/01027	Piston Seal Assembly Tool	4 - 6A
892/00223	Hand Pump	4 - 5	926/15500	Rubber Spacer Blocks	4 - 3
892/00224	Extractor	4 - 8	992/00800	Extractor	4 - 8
892/00225	Adapter - Impulse Extractor	4 - 7	992/01003	Plug	4 - 5
892/00252	Test Block	4 - 5	992/10200	Body for Hamworthy A.R.V.	4 - 5
892/00253	Pressure Test Kit	4 - 4	992/02400	Tee-piece	4 - 5
892/00255	Pressure Test Adapter	4 - 4	992/04000	Torque Multiplier	4 - 8
892/00256	Pressure Test Adapter	4 - 4	992/07609	Bearing Adapter	4 - 8
892/00257	Pressure Test Adapter	4 - 4	992/09300	Spanner	4 - 5
892/00258	Pressure Test Adapter	4 - 4	992/09400	Spanner	4 - 5
892/00259	Pressure Test Adapter	4 - 4	992/10800	Spanner	4 - 5
892/00260	Pressure Test Adapter	4 - 4	992/12300	12v Mobile Oven	4 - 1
892/00261	Pressure Test Adapter	4 - 4	992/12400	Static Oven - 2 Cartridge	4 - 1
892/00262	Pressure Test 'T' Adapter	4 - 4/4 - 5	992/12600	Static Oven - 6 Cartridge	4 - 1
892/00263	Pressure Test 'T' Adapter	4 - 4	992/12800	Cut-out Knife	4 - 2
892/00264	Pressure Test 'T' Adapter	4 - 4	992/12801	'L' Blades	4 - 2
892/00265	Pressure Test 'T' Adapter	4 - 4	993/59400	End Float Setting Tool	4 - 8
892/00268	Flow Monitoring Unit	4 - 4	993/59500	Bearing Extractor	4 - 7
892/00269	Sensor Head	4 - 4	993/68100	Slide Hammer Kit	4 - 2A
892/00270	Load Valve	4 - 4	993/85700	Battery Tester	4 - 3
892/00271	Adapter	4 - 4	1406/0011	Bonded Washer	4 - 5
892/00272	Adapter	4 - 4	1406/0018	Bonded Washer	4 - 5
892/00274	Adapter	4 - 5	1406/0021	Bonded Washer	4 - 5
892/00275	Adapter	4 - 4	1406/0029	Bonded Washer	4 - 5
892/00276	Adapter	4 - 4	1604/0003	Adapter	4 - 5
892/00277	Adapter	4 - 4	1604/0004	Adapter	4 - 5
892/00278	Gauge	4 - 5	1604/0006	Adapter	4 - 5
892/00279	Gauge	4 - 5	1606/0003	Adapter	4 - 5
892/00282	Shunt	4 - 3	1606/0004	Adapter	4 - 5
892/00283	Tool Kit Case	4 - 3	1606/0007	Adapter	4 - 5
892/00284	Tachometer	4 - 3	1606/0008	Adapter	4 - 5
892/00285	Hydraulic Oil Temperature Probe	4 - 3	1606/0009	Adapter	4 - 5
892/00286	Surface Temperature Probe	4 - 3	1612/0006	Adapter	4 - 4
892/00298	Fluke Meter 85	4 - 3	2401/0103	'O' Ring	4 - 5

Service Tools Numerical List (cont'd)**Page No.**

4104/1310 Hand Cleaner 4 - 1
 The following parts are replacement items for kits and would normally be included in the kit numbers quoted on page 1/3-1.

Replacement item for kit no. 892/00180
 892/00181 Replacement Plastic Boss 4 - 6

Replacement items for kit no. 892/00253
 892/00201 Replacement Gauge 4 - 4
 892/00202 Replacement Gauge 4 - 4
 892/00203 Replacement Gauge 4 - 4
 892/00254 Replacement Hose 4 - 4

Replacement items for kit no. 993/59400
 993/59401 Base Plate 4 - 8
 993/59402 Setting Yoke 4 - 8
 993/59403 Mainshaft Adapter (long) 4 - 8
 993/59404 Mainshaft Adapter (short) 4 - 8
 993/59405 Output Yoke Adapter Plate 4 - 8
 * 993/59406 Setting Yoke Support Pillars 4 - 8

Replacement items for kit no. 993/68100
 993/68101 Slide Hammer 4 - 2A
 993/68102 End Stops 4 - 2A
 993/68103 Adaptor - M20 x 5/8" UNF 4 - 2A
 993/68104 Adaptor - M20 x 1" UNF 4 - 2A
 993/68105 Adaptor - M20 x M20 4 - 2A
 993/68106 Adaptor - M20 x M24 4 - 2A
 993/68107 Bar - M20 x M20 X 800MM 4 - 2A
 993/68108 Adaptor - M20 x 7/8" UNF 4 - 2A
 993/68109 Adaptor - M20 x M12 4 - 2A
 993/68110 Adaptor - M20 x 5/8" UNF (Shoulder) 4 - 2A
 993/68111 Adaptor - M20 x 1/2" UNF 4 - 2A

Service Tools

Section B - Body & Framework

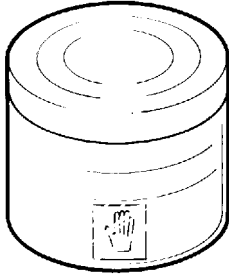

Hand Cleaner - special blend for the removal of polyurethane adhesives.

JCB part number - 4104/1310
(454g; 1 lb tub)

S186240

Cartridge Gun - hand operated - essential for the application of sealants, polyurethane materials etc.

JCB part number - 892/00845

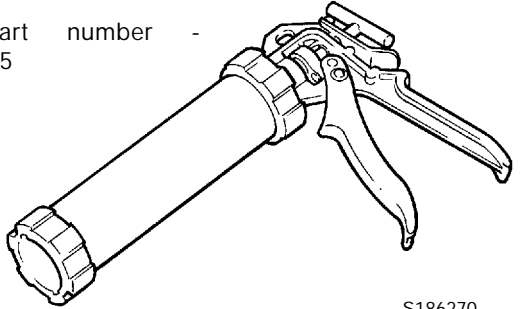

S186270

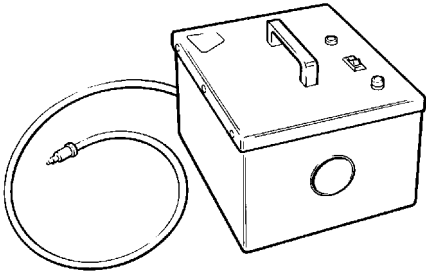

12V Mobile Oven - 1 cartridge capacity - required to pre-heat adhesive prior to use. It is fitted with a male plug (703/23201) which fits into a female socket (715/04300).

JCB part number - 992/12300

S186250

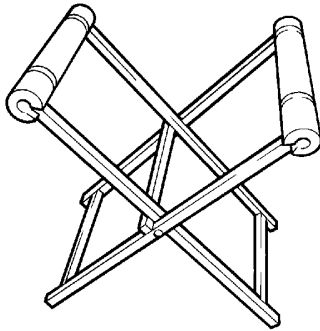

Folding Stand for Holding Glass - essential for preparing new glass prior to installation.

JCB part number - 892/00843

S186280

240V Static Oven - available with 2 or 6 cartridge capacity - required to pre-heat adhesive prior to use. No plug supplied. Note: 110V models available upon request - contact JCB Technical Service.

JCB part number:
992/12400 - 2 Cartridge x 240V
992/12600 - 6 Cartridge x 240V

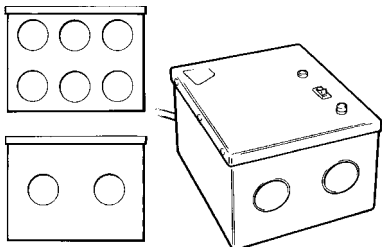

S186260

Glass Lifter - minimum 2 off - essential for glass installation, 2 required to handle large panes of glass. Ensure suction cups are protected from damage during storage.

JCB part number - 892/00842

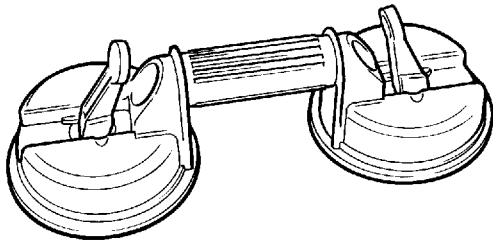

S186300

Service Tools (cont'd)

Section B - Body & Framework

Wire Starter - used to access braided cutting wire (below) through original polyurethane seal.

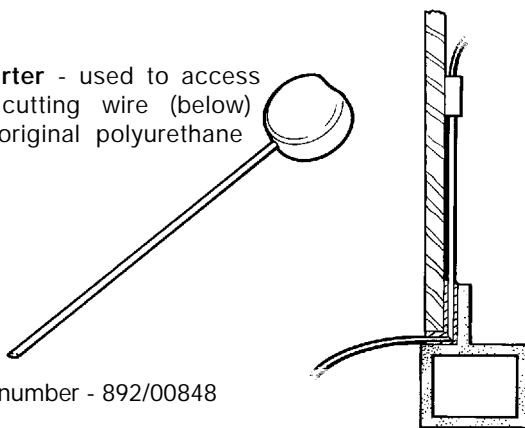

JCB part number - 892/00848

S186310

Cut-Out Knife - used to remove broken glass.

JCB part number - 992/12800

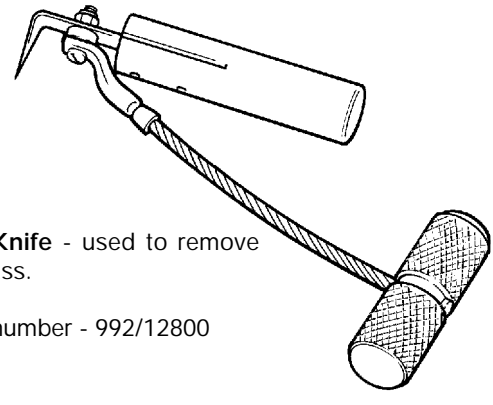

S186340

Glass Extractor (Handles) - used with braided cutting wire (below) to cut out broken glass.

JCB part number - 892/00846

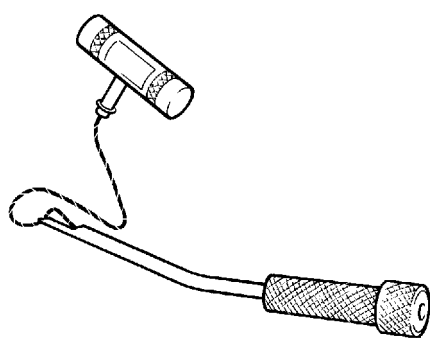

S186320

'L' Blades - 25 mm (1 in) cut - replacement blades for cut-out knife (above).

JCB part number - 992/12801 (unit quantity = 5 off)

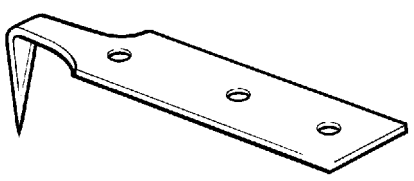

S186350

Braided Cutting Wire - consumable heavy duty cut-out wire used with the glass extraction tool (above).

JCB part number - 892/00849
(approx 25 m length)

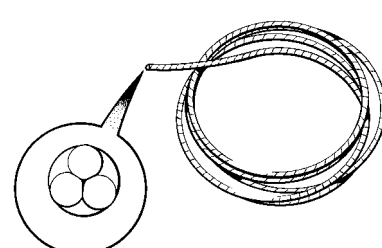

S186330

Long Knife - used to give extended reach for normally inaccessible areas.

JCB part number - 892/00844

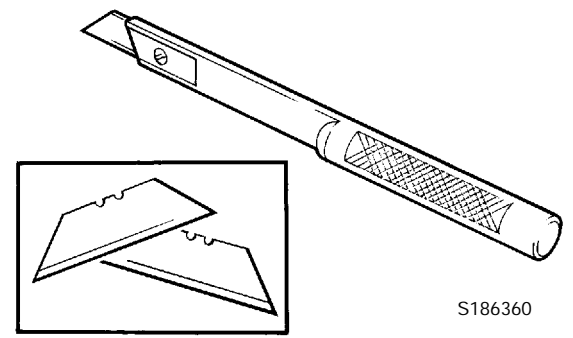

S186360

Service Tools (cont'd)

Section B - Body & Framework

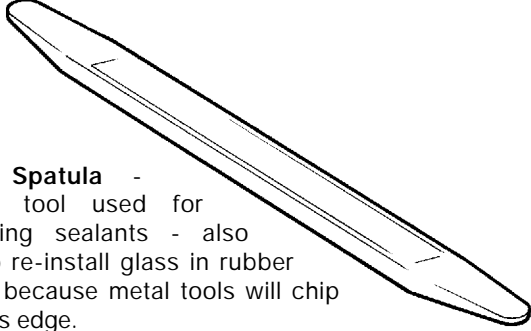

Nylon Spatula - general tool used for smoothing sealants - also used to re-install glass in rubber glazing because metal tools will chip the glass edge.

JCB part number - 892/00847

S186470

Rubber Spacer Blocks - used to provide the correct set clearance between glass edge and cab frame.

JCB part number - 926/15500
(unit quantity = 500 off)



S186550

Section C - Electrics

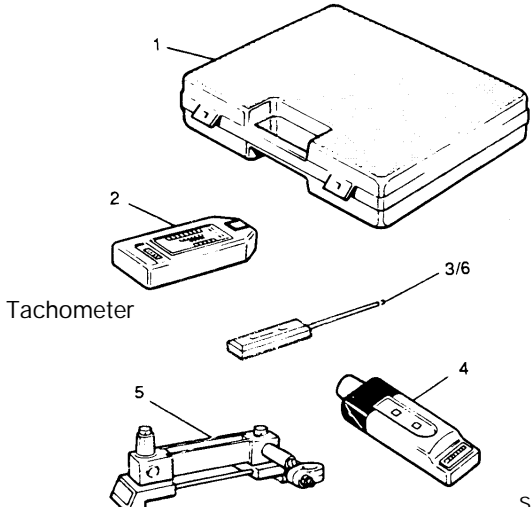

AVO Test Kit

1	892/00283	Tool Kit Case
2	892/00298	Fluke Meter 85
3	892/00286	Surface Temperature Probe
4	892/00284	Venture Microtach Digital
5	892/00282	100 amp Shunt - open type
6	892/00285	Hydraulic Temperature Probe

Tachometer

S188230

*993/85700 Battery Tester

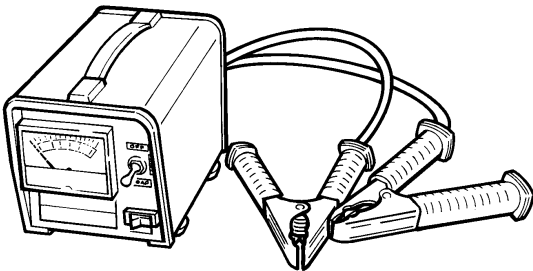

Service Tools (cont'd)

Section E - Hydraulics

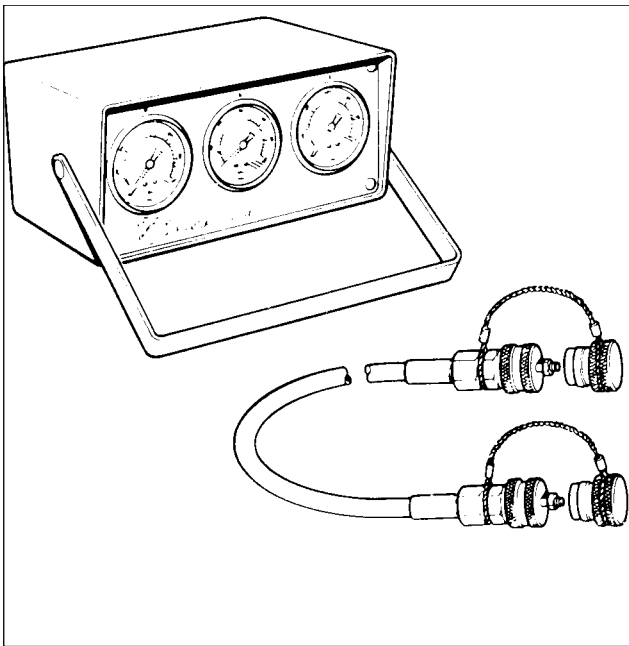

Hydraulic Circuit Pressure Test Kit

- 892/00253 Pressure Test Kit
- 892/00201 Replacement Gauge 0-20 bar (0-300 lbf/in²)
- 892/00202 Replacement Gauge 0-40 bar (0-600 lbf/in²)
- 892/00203 Replacement Gauge 0-400 bar (0-6000 lbf/in²)
- 892/00254 Replacement Hose
- 892/00347 Gauge Connector

S188120

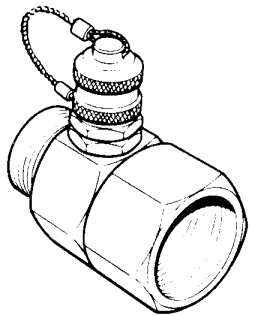

S188130

Pressure Test 'T' Adapters

- 892/00262 1/4 in M BSP x 1/4 in F BSP x Test Point
- 816/55038 3/8 in M BSP x 3/8 in F BSP x Test Point
- 816/55040 1/2 in M BSP x 1/2 in F BSP x Test Point
- 892/00263 5/8 in M BSP x 5/8 in F BSP x Test Point
- 892/00264 3/4 in M BSP x 3/4 in F BSP x Test Point
- 892/00265 1 in M BSP x 1 in F BSP x Test Point

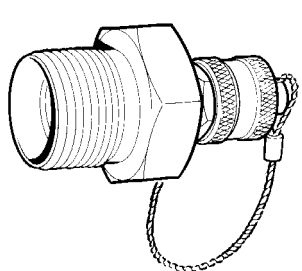

Pressure Test Adapters

- 892/00255 1/4 in BSP x Test Point
- 892/00256 3/8 in BSP x Test Point
- 892/00257 1/2 in BSP x Test Point
- 892/00258 5/8 in BSP x Test Point
- 816/15118 3/4 in BSP x Test Point
- 892/00259 1 in BSP x Test Point
- 892/00260 1.1/4 in BSP x Test Point
- 892/00261 5/8 in UNF x Test Point

S200140

Flow Test Equipment

- 892/00268 Flow Monitoring Unit
- 892/00269 Sensor Head 0 - 100 l/min (0 - 22 UK gal/min)
- 892/00270 Load Valve
- 1406/0021 Bonded Washer
- 1604/0006 Adapter 3/4 in M x 3/4 in M BSP
- 1612/0006 Adapter 3/4 in F x 3/4 in M BSP
- 892/00271 Adapter 3/4 in F x 5/8 in M BSP
- 892/00272 Adapter 5/8 in F x 3/4 in M BSP
- 816/20008 Adapter 3/4 in F x 1/2 in M BSP
- 892/00275 Adapter 1/2 in F x 3/4 in M BSP
- 892/00276 Adapter 3/4 in F x 3/8 in M BSP
- 892/00277 Adapter 3/8 in F x 3/4 in M BSP



S188150

Service Tools (cont'd)

Section E - Hydraulics

892/00252 Test Block for A.R.V.

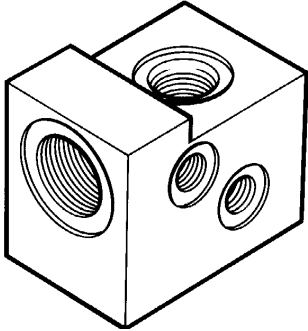

S220840

* Tool Components for Hamworthy A.R.V. testing

1	992/02400	Tee-piece
2	1606/0003	Adapter 3/8 in. x 1/4 in. BSP
3	1406/0011	Bonded Washer
4	2401/0103	'O' Ring
5	1406/0018	Bonded Washer
6	992/01003	Plug
7	992/10200	Body for Hamworthy A.R.V.
8	892/00153	Test Block Excavator A.R.V.

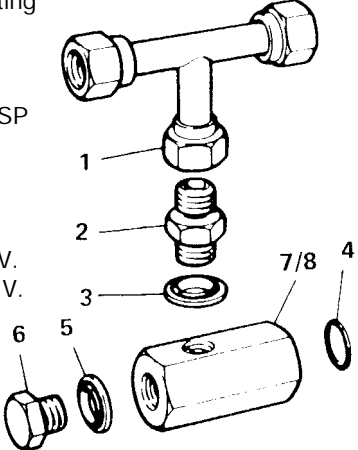

S230730

Hand Pump Equipment

892/00223 Hand Pump
 892/00137 Micro-bore Hose 1/4 in BSP x 5 metres
 892/00274 Adapter 1/4 in M BSP x 3/8 in M BSP Taper
 892/00262 1/4 in M BSP x 1/4 in F BSP x Test Point
 892/00706 Test Probe
 892/00278 Gauge 0 - 40 bar (0 - 600 lbf/in²)

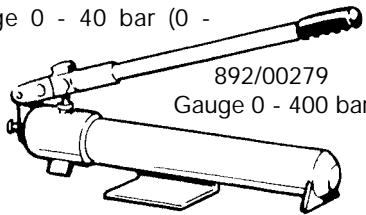

892/00279 Gauge 0 - 400 bar (0 - 6000 lbf/in²)

S193850



Bonded Washers

S188140

1406/0011	1/4 in BSP
1406/0018	1/2 in BSP
1406/0021	3/4 in BSP
1406/0029	1.1/4 in BSP

Male Adapters - BSP x BSP

1606/0003	3/8 in x 1/4 in
1604/0003	3/8 in x 3/8 in
1606/0004	1/2 in x 1/4 in
1606/0007	1/2 in x 3/8 in
1604/0004	1/2 in x 1/2 in
1606/0008	3/4 in x 3/8 in
1606/0009	3/4 in x 1/2 in
1604/0006	3/4 in x 3/4 in

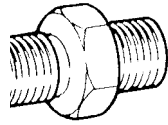

S193860

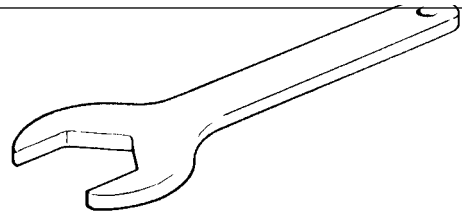

Hexagon Spanners for Ram Pistons and End Caps

992/10800	50 mm A/F
992/09300	55 mm A/F
992/09400	65 mm A/F

S193930

Service Tools (cont'd)

Section E - Hydraulics

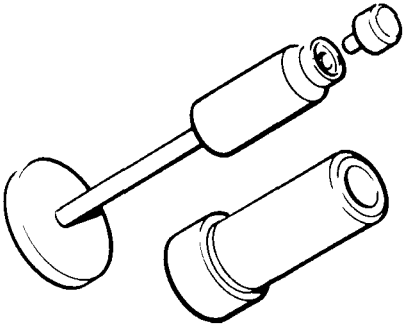

S191750

892/00180 Seal Fitting Tool for fitting 'O' ring and kin ring to Danfoss Orbitrol Unit

892/00181 Replacement Plastic Boss

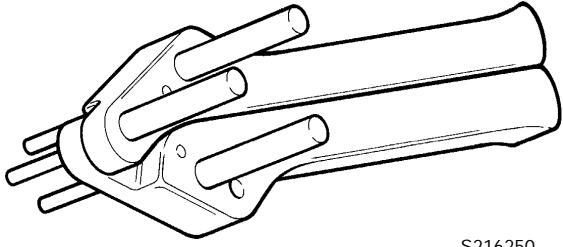

S216250

* 892/003334 Ram Seal Fitting Tool

Female Cone Blanking Plug

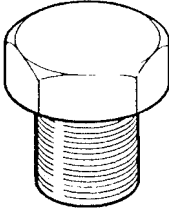

S193870

892/00055	1/4 in BSP
892/00056	3/8 in BSP
892/00057	1/2 in BSP
892/00059	3/4 in BSP
892/00060	1 in BSP

Male Cone Blanking Cap

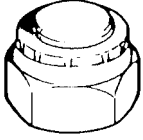

S193880

816/00294	1/4 in BSP
816/00189	3/8 in BSP
816/00190	1/2 in BSP
816/00197	5/8 in BSP
816/00196	3/4 in BSP
816/00193	1 in BSP

'T' Adapters

892/00047	3/8 in BSP (A) x 1/4 in BSP (B)
892/00048	1/2 in BSP (A) x 1/4 in BSP (B)
816/50043	3/4 in BSP (A) x 1/4 in BSP (B)
816/60096	3/4 in BSP (A) x 3/4 in BSP (B)

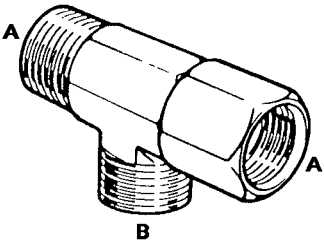

S193890

Female Connectors

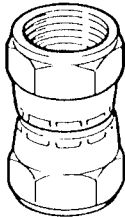

S193900

892/00074	3/8 in BSP x 3/8 in BSP
892/00075	1/2 in BSP x 1/2 in BSP
892/00077	3/4 in BSP x 3/4 in BSP

Service Tools (cont'd)

Section E - Hydraulics

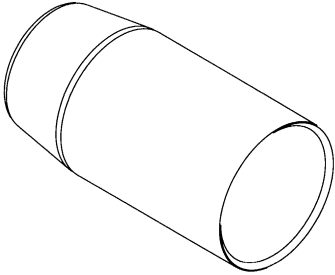

S338410

Ram Seal Protection Sleeves

892/01016	For 25 mm Rod Diameter
892/01017	For 30 mm Rod Diameter
892/01018	For 40 mm Rod Diameter
892/01019	For 50 mm Rod Diameter
892/01020	For 50 mm Rod Diameter (slew ram)
892/01021	For 60 mm Rod Diameter
892/01022	For 60 mm Rod Diameter (slew ram)
892/01023	For 65 mm Rod Diameter
892/01024	For 70 mm Rod Diameter
892/01025	For 75 mm Rod Diameter
892/01026	For 80 mm Rod Diameter
892/00167	For 90 mm Rod Diameter

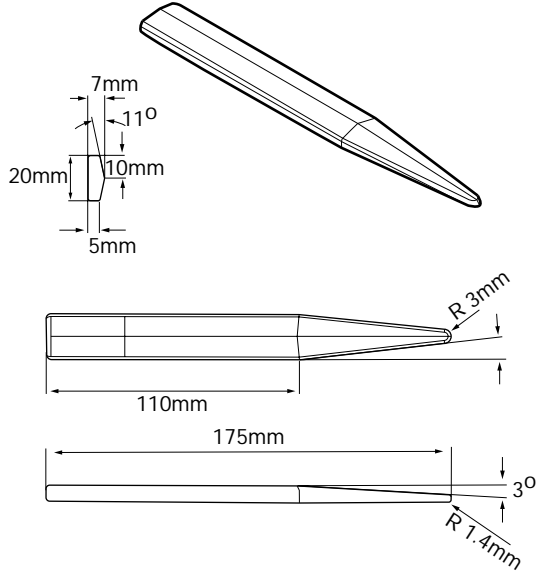

892/01027 Piston Seal Assembly Tool

338500

Service Tools (cont'd)

Section F - Transmission

892/00179 Bearing Press
(use with appropriate adapters)

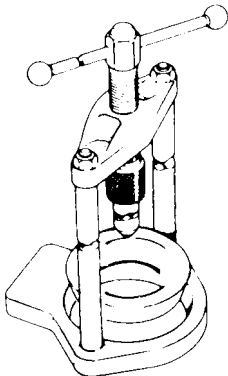

S188200

892/00812 Drive Coupling Spanner for front and rear axle yoke couplings and for 4WD output coupling on Syncro Shuttle

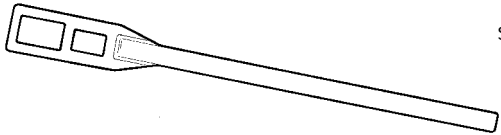

S107750

A 892/00304 Flow Test Adapter
 B 892/00301 Flow Test Adapter
 C 892/00302 Flow Test Adapter

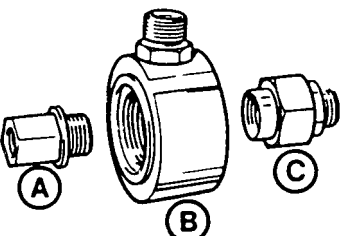

S188210

892/00225 Adapter - Impulse Extractor
 Small 17mm to 25mm
 Medium 25mm to 45mm
 Large 45mm to 80mm

993/59500 Adapter - Impulse Extractor

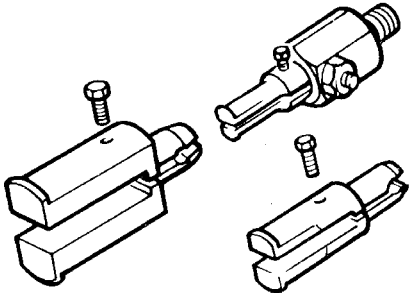

S197080

Service Tools (cont'd)

Section F - Transmission

992/04000 Torque Multiplier (use in conjunction with a torque wrench to give a 5:1 multiplication when tightening pinion nuts)

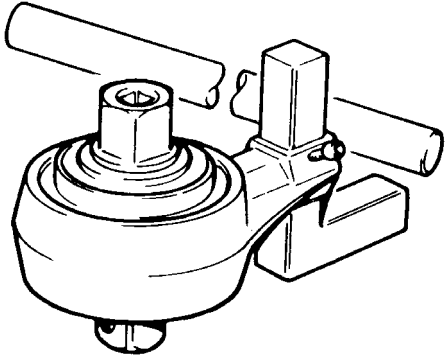

S197030

992/00800 Extractor for removing front axle pivot pin

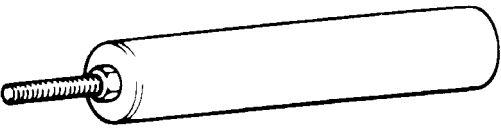

S197050

892/00174 Measuring Cup - Pinion Head Bearing

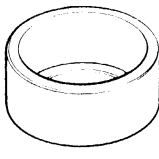

S190770

892/00822 Splined Bolt Socket for driveshafts

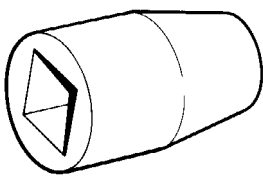

S197060

892/00224 Impulse Extractor Set for Hub Bearing Seals

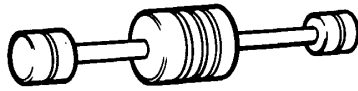

S197070

992/07609 Adapter - Steer/Drive Axle Pinion Bearing Cone



S188160

993/59400 End Float Setting Tool for gearbox:
 :993/59401 Base Plate
 :993/59402 Setting Yoke
 :993/59403 Mainshaft Adapter (long)
 :993/59404 Mainshaft Adapter (short)
 :993/59405 Output Yoke Adapter Plate
 :993/59406 Setting Yoke Support Pillars

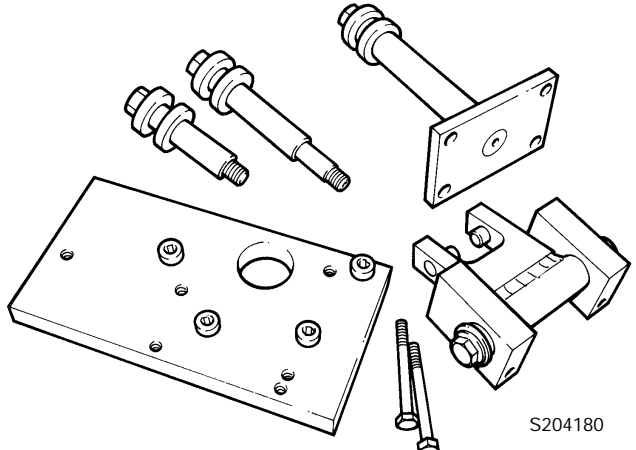

S204180

892/00833 Annulus Removal Tool

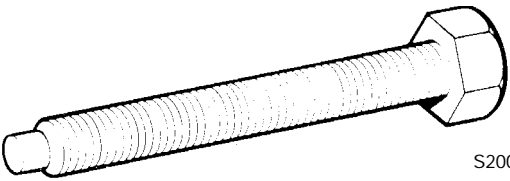

S200170

Service Tools (cont'd)**Section K - Engine**

892/00041 De-glazing Tool for Cylinder Bores (to assist bedding-in of new piston rings)

Note: For other engine tools refer to the Engine Service Manual.

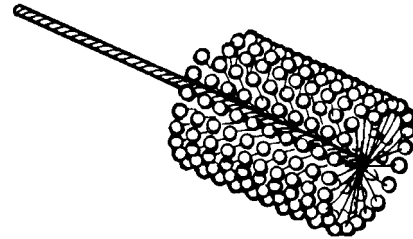

S192390

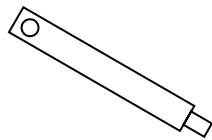

S216250

* 892/00956 Timing pin for fuel injection pump (AK, AM, AR)

Sealing and Retaining Compounds

JCB Multi-Gasket	A medium strength sealant suitable for all sizes of gasket flanges, and for hydraulic fittings of 25-65mm diameter.	4102/1212	
* JCB High Strength Threadlocker	A high strength locking fluid for use with threaded components.	4102/0551	
* JCB Retainer (High Strength)	For all retaining parts which are unlikely to be dismantled.	4101/0651	
* JCB Threadlocker and Sealer	A high strength locking fluid for sealing and retaining nuts, bolts, and screws up to 50mm diameter, and for hydraulic fittings up to 25mm diameter.	4101/0252	
* Threadseal	A medium strength thread sealing compound.	4102/1951	
* Threadlocker	A locking fluid for use on threads larger than 50mm dia.	4101/0451	
* Activator	A cleaning primer which speeds the curing rate of anaerobic products.	4104/0251 4104/0253	150ml 1 litre
* Cleaner / Degreaser	For degreasing components prior to use of anaerobic adhesives and sealants.	4104/1557	400ml
Direct Glazing Kit	For one pane of glass, comprises items marked † below plus applicator nozzle etc.	993/55700	
† Ultra Fast Adhesive	For direct glazing	4103/2109	310 ml
† Active Wipe 205	For direct glazing	4104/1206 4104/1203	30 ml 250 g
† Black Primer 206J	For direct glazing	4201/4906	30 ml
Clear Silicone Sealant	To seal butt jointed glass	4102/0933	
Black Polyurethane Sealant	To finish exposed edges of laminated glass	4102/2309	310 ml
JCB Cleaner & Degreaser	For degreasing components prior to use of anaerobic adhesives and sealants.	4104/1538	Aerosol

Contents	Page No.
Safety Notices	1 - 1
General Safety	2 - 1
Operating Safety	3 - 1
Maintenance Safety	4 - 1
Safety Decals	5 - 1

Safety Notices

In this publication and on the machine, there are safety notices. Each notice starts with a signal word. The signal word meanings are given below.

DANGER

Denotes an extreme hazard exists. If proper precautions are not taken, it is highly probable that the operator (or others) could be killed or seriously injured.

INT-1-2-1

WARNING

Denotes a hazard exists. If proper precautions are not taken, the operator (or others) could be killed or seriously injured.

INT-1-2-2

CAUTION

Denotes a reminder of safety practices. Failure to follow these safety practices could result in injury to the operator (or others) and possible damage to the machine.

INT-1-2-3

All construction and agricultural equipment can be hazardous. When a JCB machine is correctly operated and properly maintained, it is a safe machine to work with. But when it is carelessly operated or poorly maintained it can become a danger to you (the operator) and others.

Do not work with the machine until you are sure that you can control it.

Do not start any job until you are sure that you and those around you will be safe.

If you are unsure of anything, about the machine or the job, ask someone who knows. Do not assume anything.

Remember

**BE CAREFUL
BE ALERT
BE SAFE**

GEN-1-6

General Safety

WARNING

Decals

You can be injured if you do not obey the decal safety instructions. Keep decals clean. Replace unreadable or missing decals with new ones before operating the machine. Make sure replacement parts include warning decals where necessary.

INT-1-3-4

WARNING

Care and Alertness

All the time you are working with or on the machine, take care and stay alert. Always be careful. Always be alert for hazards.

INT-1-3-5

WARNING

Clothing

You can be injured if you do not wear the proper clothing. Loose clothing can get caught in the machinery. Wear protective clothing to suit the job. Examples of protective clothing are: a hard hat, safety shoes, safety glasses, a well fitting overall, ear-protectors and industrial gloves. Keep cuffs fastened. Do not wear a necktie or scarf. Keep long hair restrained.

INT-1-3-6

WARNING

Lifting Equipment

You can be injured if you use faulty lifting equipment. Make sure that lifting equipment is in good condition. Make sure that lifting tackle complies with all local regulations and is suitable for the job. Make sure that lifting equipment is strong enough for the job.

INT-1-3-7

WARNING

Raised Attachments

Raised attachments can fall and injure you. Do not walk or work under raised attachments unless they are safely blocked.

INT-1-3-8

Operating Safety

WARNING

Machine Condition

A defective machine can injure you or others. Do not operate a machine which is defective or has missing parts. Make sure the maintenance procedures in this manual are completed before using the machine.

INT-2-1-2

WARNING

Controls

You or others can be killed or seriously injured if you operate the control levers from outside the cab. Operate the control levers only when you are correctly seated inside the cab.

INT-2-1-3

WARNING

Machine Limits

Operating the machine beyond its design limits can damage the machine, it can also be dangerous. Do not operate the machine outside its limits. Do not try to upgrade the machine performance with unapproved modifications.

INT-2-1-4

WARNING

Engine/Steering Failure

If the engine or steering fails, stop the machine as quickly as possible. Do not operate the machine until the fault has been corrected.

INT-2-1-5

WARNING

Engine

The engine has rotating parts. Do not open the engine cover while the engine is running. Do not use the machine with the cover open.

INT-2-1-6

WARNING

Entering/Leaving

Entering the cab or canopy must only be made where steps and handrails are provided. Always face the machine when entering and leaving. Make sure the step(s), handrails and your boot soles are clean and dry. Do not jump from the machine. Do not use the machine controls as handholds, use the handrails.

INT-2-1-7/1

WARNING

ROPS/FOPS Structure

The machine is fitted with a Roll Over Protection Structure (ROPS) and a Falling Objects Protection Structure (FOPS). You could be killed or seriously injured if you operate the machine with a damaged or missing ROPS/FOPS. If the ROPS/FOPS has been in an accident, do not use the machine until the structure has been renewed. Modifications and repairs that are not approved by the manufacturer may be dangerous and will invalidate the ROPS/FOPS certification.

INT-2-1-9/3

WARNING

Exhaust Gases

Breathing the machine exhaust gases can harm and possibly kill you. Do not operate the machine in closed spaces without making sure there is good ventilation. If possible, fit an exhaust extension. If you begin to feel drowsy, stop the machine at once. Get out of the cab into fresh air.

INT-2-1-10

WARNING

Communications

Bad communications can cause accidents. Keep people around you informed of what you will be doing. If you will be working with other people, make sure any hand signals that may be used are understood by everybody. Work sites can be noisy, do not rely on spoken commands.

INT-2-2-3

WARNING

Ramps and Trailers

Water, mud, ice, grease and oil on ramps or trailers can cause serious accidents. Make sure ramps and trailers are clean before driving onto them. Use extreme caution when driving onto ramps and trailers.

INT-2-2-6

DANGER

Sparks

Explosions and fire can be caused by sparks from the exhaust or the electrical system. Do not use the machine in closed areas where there is flammable material, vapour or dust.

INT-2-2-10

Maintenance Safety

WARNING

Repairs

Do not try to do repairs or any other type of maintenance work you do not understand. To avoid injury and/or damage get the work done by a specialist engineer.

GEN-1-5

WARNING

Modifications and Welding

Non-approved modifications can cause injury and damage. Parts of the machine are made from cast iron; welds on cast iron can weaken the structure and break. Do not weld cast iron. Contact your JCB dealer for advice before modifying the machine.

INT-3-1-2/1

WARNING

Metal Splinters

You can be injured by flying metal splinters when driving metal pins in or out. Use a soft faced hammer or drift to remove and fit metal pins. Always wear safety glasses.

INT-3-1-3

WARNING

Electrical Circuits

Understand the electrical circuit before connecting or disconnecting an electrical component. A wrong connection can cause injury and/or damage.

INT-3-1-4

WARNING

Communications

Bad communications can cause accidents. If two or more people are working on the machine, make sure each is aware of what the others are doing. Before starting the engine make sure the others are clear of the danger areas; examples of danger areas are: the rotating blades and belt on the engine, the attachments and linkages, and anywhere beneath or behind the machine. People can be killed or injured if these precautions are not taken.

INT-3-1-5

WARNING

Petrol

Do not use petrol in this machine. Do not mix petrol with the diesel fuel; in storage tanks the petrol will rise to the top and form flammable vapours.

INT-3-1-6

WARNING

Battery

A battery with frozen electrolyte can explode if it is used or charged. Do not use a machine with a frozen battery. To help prevent the battery from freezing, keep the battery fully charged.

INT-3-1-7

WARNING

Battery Gases

Batteries give off explosive gases. Keep flames and sparks away from the battery. Do not smoke close to the battery. Make sure there is good ventilation in closed areas where batteries are being used or charged. Do not check the battery charge by shorting the terminals with metal; use a hydrometer or voltmeter.

INT-3-1-8

WARNING

Battery Terminals

The machine is negatively earthed. Always connect the negative pole of the battery to earth.

When connecting the battery, connect the earth (-) lead last.

When disconnecting the battery, disconnect the earth (-) lead first.

INT-3-1-9

WARNING

Hydraulic Fluid

Fine jets of hydraulic fluid at high pressure can penetrate the skin. Do not use your fingers to check for hydraulic fluid leaks. Do not put your face close to suspected leaks. Hold a piece of cardboard close to suspected leaks and then inspect the cardboard for signs of hydraulic fluid. If hydraulic fluid penetrates your skin, get medical help immediately.

INT-3-1-10/1

DANGER

Hydraulic Pressure

Hydraulic fluid at system pressure can injure you. Before disconnecting or connecting hydraulic hoses, stop the engine and operate the controls to release pressure trapped in the hoses. Make sure the engine cannot be started while the hoses are open.

INT-3-1-11/1

Maintenance Safety (cont'd)**⚠ WARNING****Diesel Fuel**

Diesel fuel is flammable; keep naked flames away from the machine. Do not smoke while refuelling the machine or working on the engine. Do not refuel with the engine running. There could be a fire and injury if you do not follow these precautions.

INT-3-2-2

⚠ WARNING**Oil**

Oil is toxic. If you swallow any oil, do not induce vomiting, seek medical advice. Used engine oil contains harmful contaminants which can cause skin cancer. Do not handle used engine oil more than necessary. Always use barrier cream or wear gloves to prevent skin contact. Wash skin contaminated with oil thoroughly in warm soapy water. Do not use petrol, diesel fuel or paraffin to clean your skin.

INT-3-2-3

⚠ WARNING**Soft Ground**

A machine can sink into soft ground. Never work under a machine on soft ground.

INT-3-2-4

⚠ WARNING**Counterweights**

Your machine may be fitted with counterweights. They are extremely heavy. Do not attempt to remove them.

INT-3-2-5

⚠ WARNING**Tyres and Rims**

Over-inflated or over-heated tyres can explode. Follow the instructions in this manual for inflating the tyres. Do not weld or cut rims. Get a tyre/wheel specialist to do any repair work.

INT-3-2-6

⚠ WARNING**Hot Coolant**

The cooling system is pressurised when the engine is hot. Hot coolant can spray out when you remove the radiator cap. Let the system cool before removing the radiator cap. To remove the cap, turn it to the first notch and let the system pressure escape, then remove the cap.

INT-3-2-9

⚠ WARNING**Fires**

If your machine is equipped with a fire extinguisher, make sure it is checked regularly. Keep it in the operator's cab until you need to use it.

Do not use water to put out a machine fire, you could spread an oil fire or get a shock from an electrical fire. Use carbon dioxide, dry chemical or foam extinguishers. Contact your nearest fire department as quickly as possible. Firefighters should use self-contained breathing apparatus.

INT-3-2-7/1

⚠ CAUTION**Rams**

The efficiency of the rams will be affected if they are not kept free of solidified dirt. Clean dirt from around the rams regularly. When leaving or parking the machine, close all rams if possible to reduce the risk of weather corrosion.

INT-3-2-10

⚠ CAUTION**Cleaning**

Cleaning metal parts with incorrect solvents can cause corrosion. Use only recommended cleaning agents and solvents.

INT-3-2-11

⚠ CAUTION**'O' rings, Seals and Gaskets**

Badly fitted, damaged or rotted 'O' rings, seals and gaskets can cause leakages and possible accidents. Renew whenever disturbed unless otherwise instructed. Do not use Trichloroethane or paint thinners near 'O' rings and seals.

INT-3-2-12

⚠ WARNING**Jacking**

A machine can roll off jacks and crush you unless the wheels have been chocked. Always chock the wheels at the opposite end of the machine that is to be jacked. Do not work underneath a machine supported only by jacks. Always support a jacked-up machine on axle stands before working underneath it.

INT-3-2-8

⚠ WARNING**Safety Strut**

Raised loader arms can drop suddenly and cause serious injury. Before working under raised loader arms, fit the loader arm safety strut.

2-1-1-6

Maintenance Safety (cont'd)

WARNING

Hydraulic Hoses

Damaged hoses can cause fatal accidents. Inspect the hoses regularly for:

- Damaged end fittings
- Chafed outer covers
- Ballooned outer covers
- Kinked or crushed hoses
- Embedded armouring in outer covers
- Displaced end fittings.

INT-3-3-2

WARNING

To avoid burning, wear protective gloves when handling hot components. To protect your eyes, wear goggles when using a wire brush to clean components.

HYD 1-3

WARNING

A raised and badly supported machine can fall on you. Position the machine on a firm, level surface before raising one end. Ensure the other end is securely chocked. Do not rely solely on the machine hydraulics or jacks to support the machine when working under it.

Disconnect the battery, to prevent the engine being started while you are beneath the machine.

GEN-1-1

WARNING

Make the machine safe before working underneath it. Park the machine on level ground, lower the arms. Apply the parking brake, put the transmission in neutral and stop the engine. Chock both sides of all four wheels.

Disconnect the battery, to prevent the engine being started while you are beneath the machine.

GEN-1-2

WARNING

JCB Extradig Dipper Lubricant

JCB Extradig dipper lubricant contains 1.53% lead. The repeated swallowing of very small quantities can cause chronic lead poisoning. Do not smoke or touch food while handling this lubricant. Dispose of waste (rags etc.) in accordance with local regulations.

2-1-1-8

WARNING

Waxoyl contains turpentine substitute, which is flammable. Keep flames away when applying Waxoyl. Waxoyl can take a few weeks to dry completely. Keep flames away during the drying period.

Do not weld near the affected area during the drying period. Take the same precautions as for oil to keep Waxoyl off your skin. Do not breathe the fumes. Apply in a well-ventilated area.

5-3-1-9

WARNING

Fluoroelastomeric Materials

Certain seals and gaskets (e.g. crankshaft oil seal) on JCB machines contain fluoroelastomeric materials such as Viton, Fluorel and Technoflon. Fluoroelastomeric materials subjected to high temperatures can produce highly corrosive hydrofluoric acid. THIS ACID CAN SEVERELY BURN.

New fluoroelastomeric components at ambient temperature require no special safety precautions.

Used fluoroelastomeric components whose temperatures have not exceeded 300°C require no special safety precautions. If evidence of decomposition (e.g. charring) is found, refer to the next paragraph for safety instructions. DO NOT TOUCH COMPONENT OR SURROUNDING AREA.

Used fluoroelastomeric components subjected to temperatures greater than 300°C (e.g. engine fire) must be treated using the following safety procedure. Make sure that heavy duty gloves and special safety glasses are worn:

- 1 Ensure that components have cooled then remove and place material into plastic bags.
- 2 Thoroughly wash contaminated area with 10% calcium hydroxide or other suitable alkali solution, if necessary use wire wool to remove burnt remains.
- 3 Thoroughly wash contaminated area with detergent and water.
- 4 Contain all removed material, gloves etc. used in this operation in sealed plastic bags and dispose of in accordance with Local Authority Regulations.

DO NOT BURN FLUOROELASTOMERIC MATERIALS.

If contamination of skin or eyes occurs, wash affected area with a continuous supply of clean water or with calcium hydroxide solution for 15-60 minutes. Get medical attention immediately.

INT-3-3-5/1

Safety Decals

Decals on the machine warn you of particular hazards. Each decal is attached close to a part of the machine where there is a possible hazard. Read and make sure you understand the safety message before you work with or on that part of the machine.

Keep all decals clean and readable. Replace lost or damaged decals. The decals and their attachment points are shown on the following page. Each decal has a part number printed on it, use this number to order a new decal from your JCB dealer.

WARNING

If you need eye-glasses for reading, make sure you wear them when reading the safety decals. Decals are strategically placed around the machine to remind you of possible hazards. Do not over-stretch or place yourself in dangerous positions to read the decals.

INT-3-3-4

Safety Decals (cont'd)

2CX

WARNING !

AT THE START OF EACH WORKING PERIOD AND AT LEAST ONCE A DAY, OR IF HAVING DIFFICULTY IN STEERING, CHECK THE ALIGNMENT OF THE ROADWHEELS AND IF NECESSARY RE-ALIGN THE ROADWHEELS. SEE OPERATORS HANDBOOK FOR FURTHER DETAILS.

! WARNING

DO NOT OPERATE OR WORK ON THIS MACHINE UNLESS YOU HAVE READ AND UNDERSTAND THE INSTRUCTIONS AND WARNINGS IN THE OPERATION AND MAINTENANCE MANUAL. FAILURE TO FOLLOW THE INSTRUCTIONS OR HEED THE WARNINGS COULD RESULT IN INJURY OR DEATH. CONTACT ANY J.C.B. DEALER FOR REPLACEMENT COPIES. PROPER CARE IS YOUR RESPONSIBILITY.

DO NOT REMOVE PANEL WHILST ENGINE IS RUNNING

!

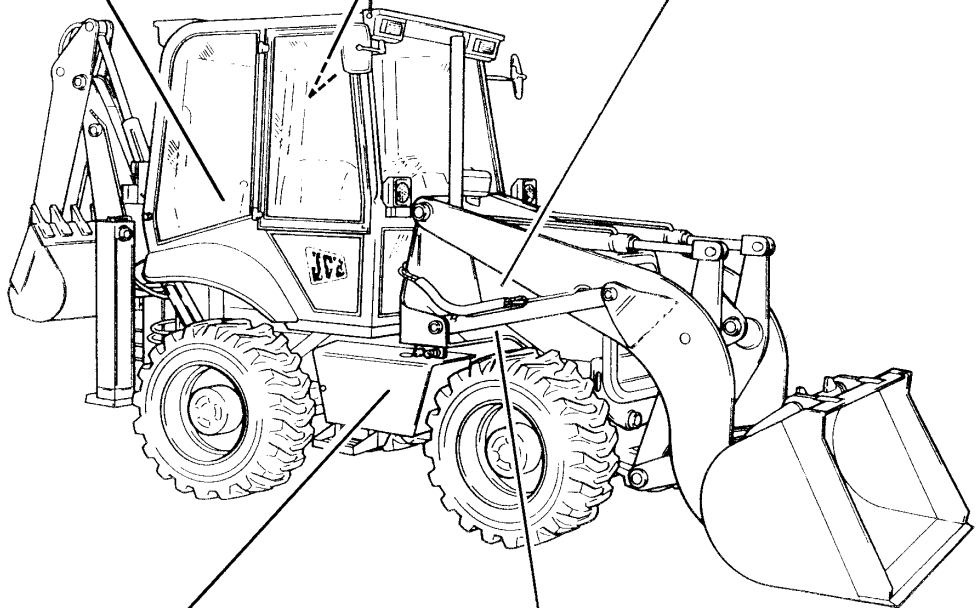

! WARNING

ALWAYS DISCONNECT THE BATTERY CABLES FROM THE BATTERIES BEFORE CLEANING, REPAIRING OR SERVICING THE MACHINE

817/00495

! WARNING

SCISSORS POINT, STAY CLEAR, BLOCK SECURELY FOR SERVICE

817/00492

S198220

Safety Decals (cont'd)

210S



330/70018



330/70047

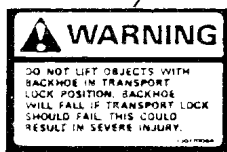
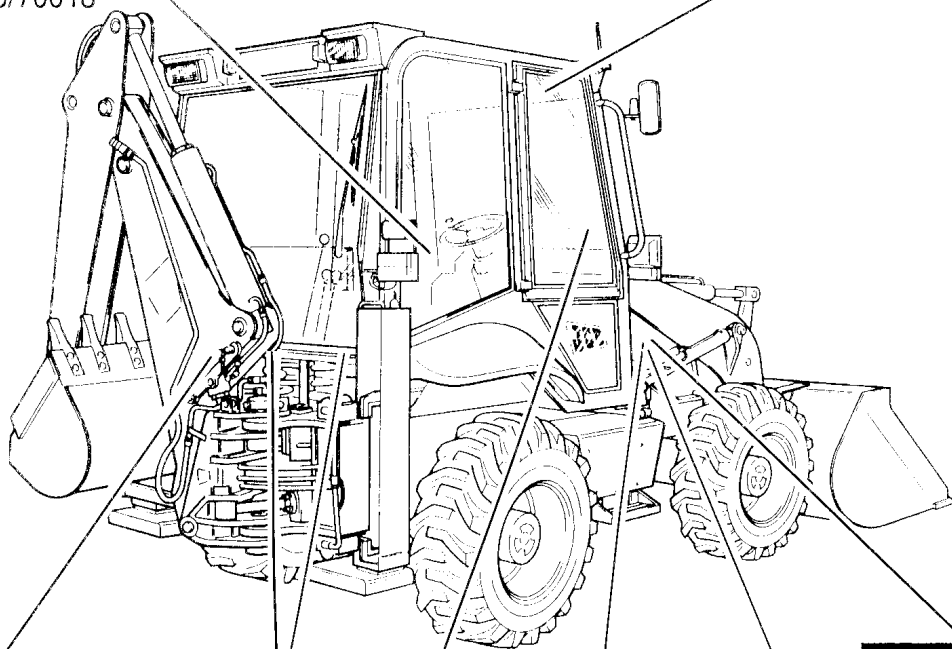

330/70064

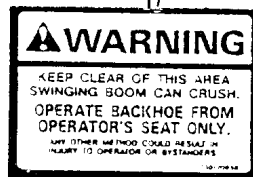

330/70058

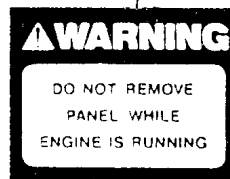

330/71308



330/70049

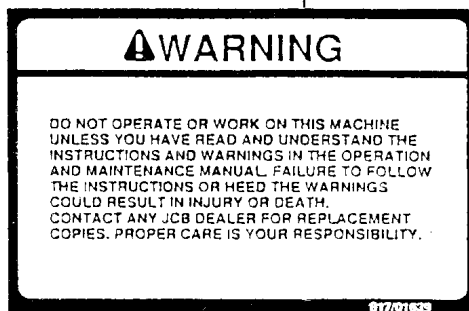

817/01639

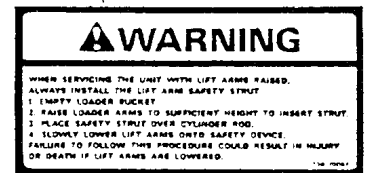

330/70067

This as a preview PDF file from best-manuals.com



Download full PDF manual at best-manuals.com