

VOLVO VN

OPERATOR'S MANUAL



Volvo Trucks. Driving Success.®



Foreword

This manual contains information concerning the operation and function of the Volvo Link System. The information in this manual applies to vehicles built January 2010 and later. Please keep this manual in the vehicle at all times.

Note: Illustrations in this manual are used for reference only and may differ slightly from the actual vehicle. However, key components addressed in this document are represented as accurately as possible.

The National Highway Traffic Safety Administration (NHTSA) and Volvo Trucks North America should be informed immediately if you believe that the vehicle has a defect that could cause a crash, injury or death.

Contact NHTSA by calling the Auto Safety Hotline at 1 (888) 327-4236, by writing to NHTSA, U.S. Department of Transportation, Washington, DC 20590, by TTY at 1 (800) 424-9153, or visit their website at www.nhtsa.dot.gov.

**Volvo Trucks North America, a division of
Volvo Group North America, Inc.**

Greensboro, NC USA

Order number: PV776-21232734

©2010 Volvo Group North America, Inc., Greensboro, NC USA

All rights reserved. No part of this publication may be reproduced, stored in retrieval system, or transmitted in any forms by any means, electronic, mechanical, photocopying, recording or otherwise, without the prior written permission of Volvo Trucks North America, a division of Volvo Group North America, Inc.

Contents

INTRODUCTION.....	1
.....	1
ADVISORY LABEL DEFINITIONS (IN HANDBOOK).....	1
INFORMATION FOR THE OWNER.....	2
EMISSIONS CONTROL COMPLIANCE.....	5
Exhaust and Noise Emissions.....	5
B5 Approval For Volvo US 10 Certified Products.....	6
ENGINES OTHER THAN VOLVO:.....	8
VEHICLE DATA.....	13
Identification and Labels.....	13
SERVICE LITERATURE.....	19
SERVICE ASSISTANCE.....	20
REPORTING SAFETY DEFECTS.....	21
United States.....	21
Canada.....	21
Mexico.....	21
EVENT DATA RECORDING DEVICES.....	22
SAFETY INFORMATION.....	23
GENERAL SAFETY INFORMATION.....	23
Operating the Vehicle.....	23
Operating in Bobtail Mode.....	24
VORAD® COLLISION WARNING SYSTEM.....	26
ADVISORY LABELS.....	27
CAB ENTRY AND EXIT.....	28
General.....	28
General Entry Guidelines.....	31
Driver Side Entry/Exit.....	33
ENTERING SLEEPER FROM SEAT.....	38
Standard Gear Lever.....	38
SAFETY EQUIPMENT.....	40
Warning Triangles, Day Cab.....	41
Sleeper Cab.....	42
SAFETY BELT SYSTEM.....	43
SRS AIRBAG.....	44
SRS System.....	44
INSTRUMENTS AND CONTROLS.....	52
CAB INTERIOR.....	52
INSTRUMENT PANEL.....	53
Tell-Tales.....	53
Colors.....	53
Panel Arrangement.....	54
INSTRUMENT PANEL GAUGE LAYOUT.....	55
Panel A.....	56
Panel B.....	57
Panel C.....	59

Panel D.....	60
Panel E.....	61
Tachometer.....	64
Upper Tell-Tales.....	64
Speedometer.....	64
Front and Rear Brake System Air Pressure Gauges	64
Oil Pressure Gauge	65
Coolant Temperature Gauge	67
Middle and Lower Tell-Tales.....	67
Driver Information Display (DID).....	67
Fuel Level Gauge.....	67
Intake Manifold Pressure Gauge (High Level Cluster Only)	68
Application Air Pressure Gauge (High Level Cluster Only).....	68
Exhaust Pyrometer Gauge (High Level Cluster Only)	69
Exhaust Pyrometer Gauge (High Level Cluster Only)	69
DASH SWITCHES.....	91
Power Take-Off (PTO).....	91
CLIMATE CONTROL SYSTEMS	98
AIR CONDITIONING MANUAL CLIMATE CONTROL (MCC).....	102
SLEEPER CLIMATE UNIT	106
LIGHT CONTROL PANEL	107
SLEEPER CONTROL PANEL (SLEEPER MODELS ONLY)	110
Sleeper Control Panel, High	112
Sleeper Control Panel, Basic.....	114
MISCELLANEOUS CAB EQUIPMENT	122
STEERING COLUMN	125
ADJUSTABLE STEERING COLUMN.....	127
STEERING WHEEL CONTROLS	128
MISCELLANEOUS SWITCHES	129
INTERIOR LIGHTS.....	130
Fresh Air Vent.....	134
CAB VENTILATION, SLEEPER.....	135
Inverter Switch 12 V DC to 120 V AC.....	140
PARKING HEATER (OPTIONAL, SLEEPER MODELS ONLY)	149
ANTENNAS	151
TELEVISION	153
TV Antenna.....	154
COMMUNICATION EQUIPMENT	155
CB Radio.....	155
STORAGE COMPARTMENTS.....	156
SLEEPER BUNKS	169
VN 780, VNL 730, VN 670 OFFICE	184
SLEEPER COMPARTMENT SINK	186
OPERATION.....	192
PRE-TRIP INSPECTION AND DAILY MAINTENANCE.....	192
Pre-Trip Assistance	192

Pre-Trip Inspection Quick List	199
New Vehicle Break-In.....	211
HOOD OPERATION.....	213
SAFETY BELTS.....	230
Safety Restraint VN 430, VN 630, VN 670	238
SEATS, GENERAL	251
NATIONAL STANDARD SEAT	252
NATIONAL COMFORT SEAT.....	253
PASSENGER SEATS	255
ENGINE OPERATION	259
IMMOBILIZER FEATURE	260
CONTROL AWARENESS FEATURE	262
FUEL ECONOMY DRIVING	263
CRUISE CONTROL	270
Volvo Engine Brake (I-VEB).....	272
BRAKE OPERATION.....	273
Parking Brake/Trailer Supply Valves.....	282
Trailer Brake Hand Control	288
ANTI-LOCK BRAKING SYSTEM (ABS)	290
VOLVO ENHANCED STABILITY TECHNOLOGY	292
TRACTION CONTROL SYSTEM (TCS) (OPTIONAL).....	292
Tire Pressure System (If Equipped).....	294
Air Pressure Monitoring and Alert	295
Tire Temperature Monitoring and Alert.....	296
VEHICLE SPEED RETARDING DEVICES	297
STARTING THE ENGINE.....	298
COLD WEATHER OPERATION	306
FIFTH WHEEL INSTRUCTIONS.....	313
Operating the Fifth Wheel Slider.....	332
PERFORMANCE BONUS FEATURE.....	336
Performance Bonus Guide.....	338
AXLES.....	342
Volvo, US10 Emissions Solution	345
Exhaust Aftertreatment System	345
Safety Information	346
Exhaust Aftertreatment System Components and Operation	347
Selective Catalytic Reduction (SCR)	347
Diesel Exhaust Fluid (DEF).....	351
Aftertreatment Diesel Particulate Filter (DPF).....	354
Aftertreatment Control Module (ACM).....	356
Exhaust Aftertreatment System Operation	357
Exhaust Aftertreatment System (ATS) Status.....	367
Driver Warnings and On Board Diagnostics (OBD)	370
On Board Diagnostics (OBD).....	370
Instrument Cluster.....	370
Malfunction Indicator Lamp (MIL).....	372

Aftertreatment DEF Tank Level - Driver Warning & Inducement	373
Aftertreatment DEF Quality - Driver Warning & Inducement	374
Misfilling Diesel or Aftertreatment DEF Tanks.....	375
SCR Tampering - Driver Warning & Inducement	376
Warranty and Maintenance	377
Exhaust Aftertreatment System Maintenance.....	377
Emissions Maintenance	377
Engine Maintenance Intervals.....	378
Engine Gaseous Emission Control Systems	379
Emissions Control System Warranty	380
Engine Gaseous Emissions Control System Warranty	381
Federal Emission Requirements	381
Emission Control System Warranty — California.....	382
Emissions Control System Warranty	385
Oil Change Intervals	387
MAINTENANCE AND LUBRICATION.....	388
DAILY MAINTENANCE	388
TOWING PROCEDURE.....	389
Caging Spring Brake Chambers.....	396
ENGINE OIL LEVEL CHECK.....	403
Engine Maintenance Intervals.....	405
POWER STEERING, GENERAL.....	406
COOLING SYSTEM.....	408
CAB	409
HEADLIGHTS	410
ROOF EXTENDER.....	412
FRONT BUMPER/LICENSE PLATE MOUNTING.....	415
MODIFICATIONS TO VEHICLE	418
WHEELS	420
BATTERY.....	424
Battery Voltage Protection System	433
ELECTRICAL	436
METRIC CONVERSIONS.....	444
METRIC CONVERSIONS	444

Safety Information

IMPORTANT: Before driving this vehicle, be certain that you have read and that you fully understand each and every step of the driving and handling information in this manual. Be certain that you fully understand and follow all safety warnings.

IT IS IMPORTANT THAT THE FOLLOWING INFORMATION BE READ, UNDERSTOOD AND ALWAYS FOLLOWED.

The following types of advisories are used throughout this manual:

DANGER

Danger indicates an unsafe practice that could result in serious personal injury or death. A danger advisory banner is in **white** type on a **black** background with a **black** border.

WARNING

Warning indicates an unsafe practice that could result in personal injury. A warning advisory banner is in **black** type on a **gray** background with a **black** border.

CAUTION

Caution indicates an unsafe practice that could result in damage to the product. A caution advisory is in **black** type on a **white** background with a **black** border.

Note: Note indicates a procedure, practice, or condition that must be followed in order for the vehicle or component to function in the manner intended.

CALIFORNIA PROPOSITION 65 WARNING

Diesel engine exhaust and some of its constituents are known to the State of California to cause cancer, birth defects and other reproductive harm.

CALIFORNIA PROPOSITION 65 WARNING

Battery posts, terminals and other related accessories contain lead and lead compounds, chemical known to the State of California to cause cancer and other reproductive harm.

Batteries also contain other chemicals known to the State of California to cause cancer.

Wash hands after handling.



ADVISORY LABEL DEFINITIONS (IN HANDBOOK)

Cautionary signal words (Danger-Warning-Caution) may appear in various locations throughout this manual. Information accented by one of these signal words must be observed to minimize the risk of personal injury to service personnel, or the possibility of improper service methods which may damage the vehicle or cause it to be unsafe. Additional Notes and Service Hints are used to emphasize areas of procedural importance and provide suggestions for ease of repair. The following definitions indicate the use of these advisory labels as they appear throughout the manual:

DANGER

Danger indicates an unsafe practice that could result in serious personal injury or death. A danger advisory banner is in **white** type on a **black** background with a **black** border.

CAUTION

Caution indicates an unsafe practice that could result in damage to the product. A caution advisory is in **black** type on a **white** background with a **black** border.

WARNING

Warning indicates an unsafe practice that could result in personal injury. A warning advisory banner is in **black** type on a **gray** background with a **black** border.

Note: Note indicates a procedure, practice, or condition that must be followed in order for the vehicle or component to function in the manner intended.

2 INTRODUCTION

INFORMATION FOR THE OWNER

If there are questions on the maintenance and performance of your vehicle, please discuss them with your Volvo Truck dealer. Your authorized dealer is required to have trained mechanics, special tools and spare parts to fully service your vehicle. If necessary, your dealer will contact the manufacturer for any assistance.

In addition to this operators manual, there may be additional instruction/operators manuals supplied by component manufacturers. These manuals are placed in the Owner's Package and placed in the cab. Be sure to read all the manuals thoroughly before operating the vehicle.

Various safety labels may be placed about the components by the component manufacturer. Be sure to read and follow these labels to prevent damage to the vehicle, personal injury or death.

Information in this manual refers to Volvo components and Volvo drivetrain. There is also certain information regarding the Cummins engine. For detailed information on the Cummins engine or non-Volvo engines and/or drivetrains, contact the respective manufacturer.

Establish a Preventive Maintenance Program with the help of your local Volvo Truck dealer. A Preventive Maintenance Program makes it possible to maximize the amount of time your vehicle is up and running, resulting in longer component life. This makes for a safer vehicle by reducing any mechanical failures due to poor maintenance practices.

Various truck warranty coverage plans, contingent on application and weight class, are available. Please contact an authorized Volvo Truck dealer for complete details. Replacement warranty certificates for Volvo Trucks are available from authorized Volvo dealers.

For trucks placed in service after October, 2002 and operating in the USA, Mexico and Canada, Volvo dealers can order copies of the Standard Truck Warranty Certificate and the Premium (Purchased) Truck Coverage Certificate. Warranty Certificate copies and Operator Manuals are available in either English, Spanish or French. Contact your authorized Volvo Truck dealer for more information.

Note: Federal law requires manufacturers to notify owners of its products in the event of a non-compliance to a Federal Motor Vehicle Safety Standard or if a safety-related defect is discovered. If you are not the original owner of this vehicle, please notify us about the change in ownership at the address below or through an authorized Volvo Truck dealer. This is the only way we will be able to contact you if necessary.

Volvo Trucks North America
Attn: Vehicle Registration Dept.
P.O. Box 26115
Greensboro, NC 27402-6115
United States of America

DO NOT Remove this operators manual from the vehicle. It contains important operational and safety information that is needed by all drivers and owners of this vehicle.

Note: Illustrations in this manual are used for reference only and may differ slightly from the actual vehicle; however, key components addressed in the manual are represented as accurately as possible.

This manual covers Volvo VN series vehicles manufactured by Volvo Trucks North America with any of the following designations:

- VNL 780
- VNL 730
- VNL 670
- VNL 630
- VNL 430
- VNL 300 (Daycab)
- VNM 630
- VNM 430
- VNM 200 (Daycab) Roof fairing choice is optional.

4 INTRODUCTION

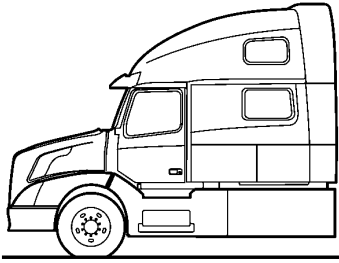

VNL 780

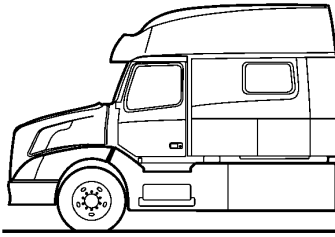

VNL 730

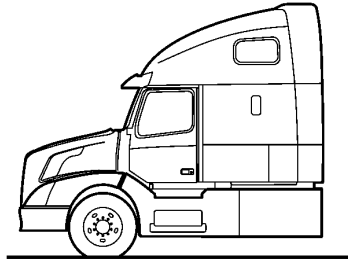

VNL 670

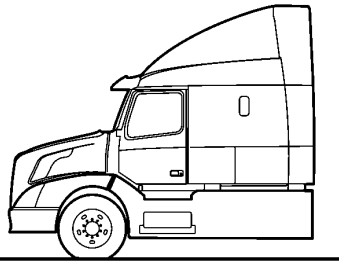

VNL 630

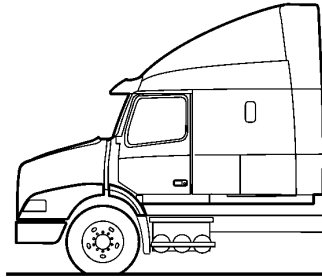

VNM 630

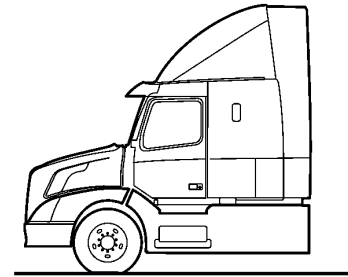

VNL 430

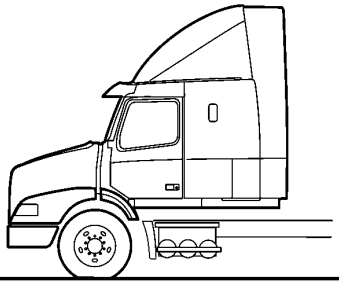

VNM 430

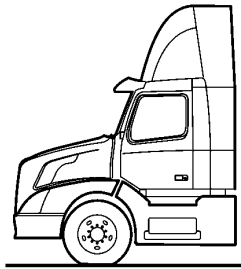

VNL 300

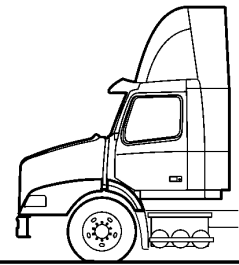

VNM 200

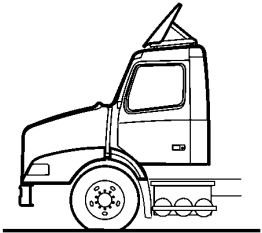

VNM 200

EMISSIONS CONTROL COMPLIANCE

Exhaust and Noise Emissions

General

USA

The Federal Clean Air Act, Section 203 (a) (3), states the following concerning the removal of air pollution control devices or modification of a certified engine to a non-certified configuration:

CAA, Section (a) (3) (A) prohibits any person to remove or render inoperative any (emission control) device or element of design installed on or in a motor vehicle or motor vehicle engine in compliance with regulations under this part prior to its sale and delivery to the ultimate purchaser, and prohibits any person from knowingly removing or rendering inoperative any such device or element of design after such sale and delivery to the ultimate purchaser.” Specifically, please note that no person may make such changes prior to the sale and delivery of the vehicle to the ultimate purchaser, and, in addition, no manufacturer, dealer, or individual may take such action after sale and delivery of the vehicle to the ultimate purchaser. For a manufacturer or dealer, the law provides a penalty of up to \$37,500 for each engine or piece of equipment in violation. For anyone else, the civil penalty is assessed up to \$3,750 for each day an engine or piece of equipment is operated in violation.

Canada

The same conditions that apply in the USA apply to Canada, with one exception. After the vehicle is sold to a retail customer, that is, the end user, the jurisdiction controlling the emission control devices becomes the province in which the vehicle is licensed. No changes should be made that render any or all of the devices inoperative. If the owner/operator wishes to make changes to the emission control devices, check with the provincial authority before changes are made.

Mexico

The same conditions that apply in the USA apply to Mexico. Refer to the Mexican Federal Law for Emission Control which adheres to EPA regulations. No changes should be made that render any or all of the emissions control devices inoperative. If the owner/operator wishes to make changes to the emission control devices, check with the state authority before changes are made.

6 INTRODUCTION

B5 Approval For Volvo US 10 Certified Products

Volvo engines are certified to comply with U.S. EPA and California emissions standards based upon the use of test fuels with specifications established by these regulatory agencies. Alternative fuels, including biodiesel, that are not substantially similar to the required test fuels may adversely affect engine emissions compliance and may impact the performance of certain emissions aftertreatment components. As a result, Volvo does not warrant the engine will conform to applicable Federal or California emissions limits when operated on, or having operated on, biodiesel or other alternative fuels that are not substantially similar to specified test fuels used for certification.

The use of biodiesel up to a maximum of 20% (B20) in and of itself, will not affect the manufacturer's mechanical warranty as to engine or emissions system related components except as limited below with respect to aftertreatment components, provided the bio fuel used in the blend conforms to ASTM D6751, and B1 to B5 blends conform to ASTM D975, and B6 to B20 blends conform to ASTM D7467. Failures of certain emissions aftertreatment components, specifically SCR, DPF and NOx sensors will not be warranted if the failure can be attributed to operation on biodiesel blends from 6 to 20% (B6 to B20) even if the biofuel used in the blend B6 to B20 conforms to ASTM D7467 or any related standard.



CAUTION

Diesel-powered engines for heavy-duty trucks built on or after January 1, 2010 are designed to operate only with Ultra Low Sulfur Diesel (ULSD) fuel. Improper fuel use will reduce the efficiency and durability of engines, permanently damage advanced emissions control systems, reduce fuel economy and possibly prevent the vehicles from running at all. Manufacturer warranties will be voided by improper fuel use. Additionally, burning Low Sulfur Diesel fuel (instead of ULSD fuel) in 2007 and later model year diesel-powered cars, trucks and buses is illegal and punishable with civil penalties.



CAUTION

Ultra Low Sulfur Diesel (ULSD) fuel with a maximum sulfur content of 15 ppm must be used in order to meet Euro4 engine emission requirements. Using otherwise approved diesel fuels with a maximum sulfur content greater than 500 ppm may shorten engine life and void the engine warranty.

Air is always present inside the fuel tanks, entering mainly through the tank ventilation. With the air being heated and cooled, condensation is formed and water is mixed in the fuel. To avoid condensation when the vehicle is parked for longer periods, fill the tanks up to 95% of capacity. Do not fill more than that, as the fuel needs to have room for expansion during the heat of the day.

For additional information about fuel, refer to the Operator's Manual Vehicle Maintenance.

VN: An indicator will appear in the DID screen when there is approximately 3.875 liters (0.9 gallons) remaining in the reservoir.

Note: This indicator is optional. It can be deleted.

 **DANGER**

DO NOT carry extra fuel containers in the cab. Fuel containers, full or empty, may leak, explode or give added fuel to a fire. Failure to follow this precaution may lead to serious personal injury or death.

 **DANGER**

Do not remove the fuel tank cap near an open flame. Diesel fuel vapors are combustible and can cause an explosion or fire, resulting in severe personal injury or death.

 **DANGER**

DO NOT smoke while fueling the vehicle. The glow from the cigar/cigarette can ignite the diesel fuel, causing an explosion resulting in serious personal injury or death.

8 INTRODUCTION

ENGINES OTHER THAN VOLVO:

For specific information on engines other than VOLVO, refer to the engine vendor's publications.

Noise Emissions

Volvo Trucks North America warrants to the first person who purchases this vehicle for purposes other than resale and to each subsequent purchaser, that this vehicle as manufactured by Volvo Trucks North America was designed, built and equipped to conform, at the time it left the control of Volvo Trucks North America, with all applicable U.S. EPA Noise Control Regulations.

This warranty covers this vehicle as designed, built and equipped by Volvo Trucks North America, and is not limited to any particular part, component or system of the vehicle manufactured by Volvo Trucks North America Defects in design, assembly or in any part, component or system of the vehicle as manufactured by Volvo Trucks North America, which, at the time it left the control of Volvo Trucks North America caused noise emissions to exceed Federal standards, are covered by this warranty for the life of the vehicle.

Noise Control System, Operator Inspection and Maintenance Requirements

A Noise Control System Maintenance Log is located in “Noise Control Log”, page 12 . This log should be used to document all Noise Control System related maintenance, whether the maintenance results from a specific noise control system inspection, or a deficiency identified during another general maintenance event.

If additional log space is needed, further entries may be added on a separate sheet of paper. Store these additions with the main log to preserve a comprehensive record. It is recommended that copies of all noise emissions related maintenance invoices be retained.

The following Noise Control System inspection and maintenance instructions contain suggested maintenance intervals. These intervals may need adjustment in order to best accommodate the specific vehicle usage. The following instructions only concern Noise Emissions related items and do not address or modify any general vehicle maintenance requirements.

The following elements make up the Noise Control System:

- Noise Shielding and Insulation Devices
- Cooling System
- Exhaust System /Aftertreatment DPF System
- Intake/Air System
- Engine Control, EGR and Fuel Systems

Tampering with Noise Control System

Federal law prohibits the following acts or the causing thereof:

(1) The removal or rendering inoperative by any person, other than for purposes of maintenance, repair, or replacement, of any device or element of design incorporated into any new vehicle for the purpose of noise control prior to its sale or delivery to the ultimate purchaser or while it is in use;

or

(2) the use of the vehicle after such device or element of design has been removed or rendered inoperative by any person.

Among the acts that constitute tampering are the acts listed below:

- Removal, or rendering inoperative, of any exhaust components, including mufflers, heavy or double-wall exhaust tubing, flexible tubing or exhaust pipe clamping.
- Removal, or rendering inoperative, of the temperature-modulated cooling fan system.
- Removal of the cooling fan shroud.
- Removal, or rendering inoperative, of the air cleaner or air intake in-line silencer.
- Removal of the sound deadening material from the hood or cab tunnel.
- Removal, or rendering inoperative, of the engine speed governor so as to allow engine speed to exceed the manufacturer's specifications.
- Removal of splash shields located inside the wheel housings.
- Removal of engine block shields.
- Removal of engine crankcase shields or insulation.
- Removal of insulated rocker arm covers.

10 INTRODUCTION

- Removal of transmission noise shields.

Noise Shielding and Insulation Devices

Maintenance

Ensure sound shielding and insulating devices are intact. Inspect components for damage. Primary system components requiring noise related inspection include the hood, engine compartment insulating materials (including hood insulation, bulkhead insulation, doghouse insulation, etc.) splash shields, cab skirts, fender shields, and body panels. Inspect all related fasteners, brackets, and clamps for damage and tightness.

Regulatory Compliance

Acts that constitute tampering with the Noise Shielding and Insulation Devices:

Removing or rendering inoperative the engine and/or transmission noise deadening panels, shields or insulating materials.

Removing or rendering inoperative any vehicle body mounted sound insulation components and/or shields (cab or fender shields, skirts, wheel housing splash shields, etc.).

Cooling System



WARNING

DO NOT work near the fan with the engine running or the ignition in the ON position. The engine fan can engage at any time without warning. Anyone near the fan when it turns on could be seriously injured.

Maintenance

Visually inspect cooling system components for damage, and/or misalignment. Primary system components requiring noise related inspection include fan blades, fan clutch, fan shroud, fan ring, and recirculation shields. Check fan blades, fan ring, fan shroud, belt tensioner and recirculation shields for any damage. Verify that fan blades clear the fan ring. Inspect all related fasteners, brackets, and clamps for damage and tightness. Confirm operation of temperature modulated fan clutch.

Regulatory Compliance

Acts that constitute tampering with the Cooling System:

Removing or rendering inoperative cooling system components (such as the temperature modulated fan clutch, fan shroud, fan ring, recirculation shields, etc.).

Exhaust System

**WARNING**

Hot engine! Avoid all movable parts or hot engine parts, exhaust gases, and/or fluids. A hot engine, exhaust, and/or fluids can cause burns.

Maintenance

Make sure the exhaust system is intact. Inspect for damage, misalignment and/or leakage. Primary system components requiring noise related inspection include exhaust manifold, turbocharger, and all exhaust system (rigid and flexible) piping. Closely check the system for exhaust leaks. Special attention should be given to all welds, seams, gaskets, support points, clamps, couplings and connections. Inspect all exhaust system fasteners, brackets, and clamps for damage and tightness.

Regulatory Compliance

Acts that constitute tampering with the Exhaust System:

Removing or rendering inoperative exhaust system components (such as the pipes, clamps, etc.).

Air Intake/Air Induction System

Maintenance

Make sure the air intake system is intact. Inspect components for damage, misalignment and/or leakage. Primary system components requiring noise related inspection include the air cleaner housing, air cleaner element, turbocharger, charge air cooler and intake manifold.

Also inspect all ducts, pipes, hoses, tubing and elbows used to interconnect the system. Special attention should be given to all welds, seams, gaskets, support points, clamps, couplings and connections.

Inspect all intake system fasteners, brackets, and clamps for damage and tightness.

Regulatory Compliance

Acts that constitute tampering with the Air Intake/Air Induction System:

Removing or rendering inoperative air intake/induction system components (filter, filter housings, ducts, etc.).

VEHICLE DATA

Identification and Labels

It is extremely important that the correct vehicle model and serial number are given whenever replacement parts or service literature are ordered. Using these numbers, as well as giving the major component model and serial numbers, will prevent delay and errors in obtaining the correct material. Space is given on the rear inside cover of this manual for noting the main component model and serial numbers.

The full 17-digit Vehicle Identification Number (VIN) is shown on the Vehicle Identification label located in the door opening on the driver's side. Vehicles for export, excluding Canadian vehicles, have the full 17-digit VIN on the frame.

The 8-digit chassis number is embossed into the bottom flange right hand side of the frame rail and the top flange left hand side of the frame rail, 42 inches (1065 mm) back from the front edge of the frame rail. The use of this number is very helpful when ordering parts for your vehicle.

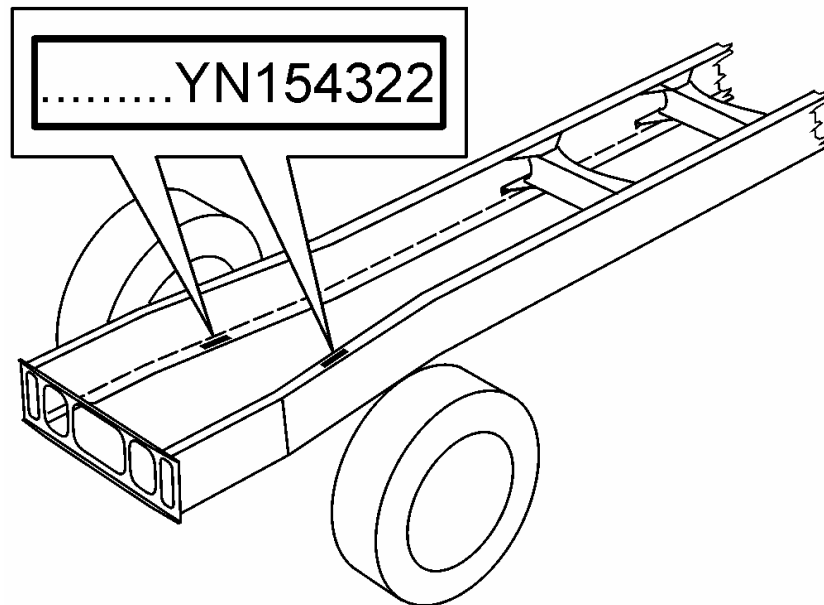

14 INTRODUCTION

Three labels are located in the rear inside frame of the driver side door frame. These labels should not be removed.

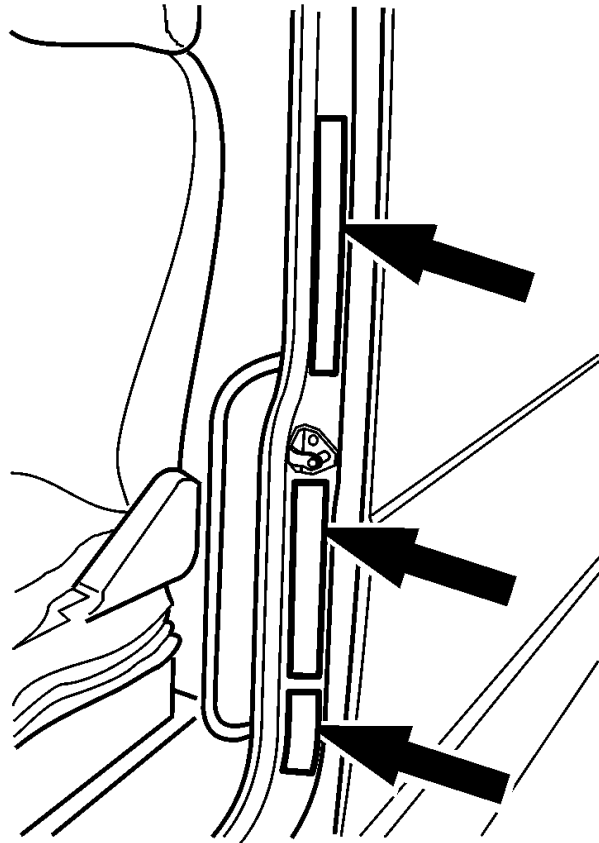

W8003115

Note: To deter tampering with the original build information, the information on the label will be destroyed if the label is removed. If for any reason a label is damaged, contact your authorized Volvo Truck dealer for a replacement.

Vehicle Order

The Vehicle Order is a complete and detailed record of all data pertaining to the assembly of the vehicle. It should be filed in the Owner's office where it will be readily available for reference. Any changes made to the vehicle must become a part of the Vehicle Order and must comply with all applicable Federal Motor Vehicle Safety Standards.

Certification Label

On the top part of the door frame is the Certification label showing the axle and load ratings for the vehicle as it is built. DO NOT exceed these ratings by overloading.

Vehicle Identification Label

The VIN is shown on the Vehicle Identification label. The VIN includes the vehicle make, model series, weight class, engine model, where the vehicle was built and the vehicle serial number. This label also shows the truck model designation, major component model and serial number, cab model and serial number, cab and chassis paint colors, and color numbers.

Noise Emission Control Label

The Noise Emission Control label is located at the bottom of the three labels on the rear inside frame of the driver side door. It is the owner’s responsibility to maintain the vehicle so that it conforms to EPA regulations.

Refer to “Tampering with Noise Control System”, page 9 for a listing of what constitutes tampering with the Noise Emissions Control.

Engine Identification Label

In compliance with Federal emission requirements, an engine information label is affixed to all Volvo diesel engines. This label, which is located on the cylinder head cover at the front of the engine, gives basic engine identification information (engine model, serial number, etc.), advertised

horsepower at rate speed, inlet and exhaust valve lash setting. The Engine family “AVPTH12.8S0” can be used to identify the emission standard under which the engine was certified.

49 State Label below:

VOLVO		IMPORTANT ENGINE INFORMATION		VALVE LASH (JEU SOUPAPES)	
VOLVO POWERTRAIN CORPORATION		RENSEIGNEMENTS IMPORTANTS MOTEUR		INLET ROCKER .2 mm	
ENGINE FAMILY: AVPTH12.8S01		ENGINE MODEL: D13H500	SERIAL NO.: 123456	ADMISSION CULBUTEUR	
FAMILLE DE MOTEURS:		MODELE MOTEUR:	NO. SERIE:	EXHAUST ROCKER 1.0mm	
				ECHAPPEMENT CULBUTEUR	
DISPLACEMENT	ADVERTISED HP @ RPM	FUEL RATE @ ADVERTISED HP	IDLE SPEED	ENGINE BRAKE	
CYLINDREE	PUISS. SPEC. @ TOURS / MIN.	DEBIT DE CARB. @ PUISS. SPEC.	RALENTI	FREIN MOTEUR	
12.8 L	500/1700	308 mm ³ /STROKE	550-700 RPM	I-VEB	
		mm ³ /COUP			
THIS ENGINE CONFORMS TO U.S EPA REGULATIONS APPLICABLE TO 2010 MODEL YEAR. NEW HEAVY-DUTY ENGINES AND HAS A PRIMARY INTENDED SERVICE APPLICATION AS A HEAVY HEAVY-DUTY DIESEL ENGINE.					
Ce moteur est conforme aux réglementations de l'Agence de Protection de l'Environnement des États-Unis applicables aux nouveaux moteurs diesel Heavy duty (Gamme lourde) modèle 2010. La principale application s'adresse aux usages de type gamme lourde (Heavy-heavy-duty).					
EXHAUST EMISSION CONTROL SYSTEM		THIS ENGINE IS CERTIFIED TO OPERATE ON		LABEL NO	
DISPOSITIF ANTI-POLLUTION		ULTRA LOW SULFUR DIESEL FUEL ONLY.		DELEGATED ASSEMBLY 21338476	
EM, EC, TC, CAC, DI, EGR, DPF, SCR					

W2040453

Engine Identification Label — 49 State EPA Approved Engine without California “Clean Idle”

16 INTRODUCTION



CAUTION

To maintain compliance with emission regulations, engine settings should not be changed from those specified on the engine information label.

In compliance with Federal and California emission requirements, an engine information label is affixed to all Volvo

diesel engines. This label, which is located on the cylinder head cover at the front of the engine, gives basic engine identification information (engine model, serial number, etc.), advertised horsepower at rate speed, inlet and exhaust valve lash setting. The Engine family “AVPTH12.8S0” can be used to identify the emission standard under which the engine was certified.

VOLVO		IMPORTANT ENGINE INFORMATION			VALVE LASH (JEU SOUPAPES)		
VOLVO POWERTRAIN CORPORATION		RENSEIGNEMENTS IMPORTANTS MOTEUR			INLET ROCKER .2 mm		
ENGINE FAMILY: AVPTH12.8S01		ENGINE MODEL: D13H500		SERIAL NO.: 123456		ADMISSION CULBUTEUR	
FAMILLE DE MOTEURS:		MODELE MOTEUR:		NO. SERIE:		EXHAUST ROCKER 1.0mm	
						ECHAPPEMENT CULBUTEUR	
DISPLACEMENT	ADVERTISED HP @ RPM	FUEL RATE @	ADVERTISED HP	IDLE SPEED	ENGINE BRAKE		
CYLINDREE	PUISS. SPEC. @ TOURS / MIN.	DEBIT DE CARB. @	PUISS. SPEC.	RALENTI	FREIN MOTEUR		
12.8 L	500/1700	308	mm ³ /STROKE	550-700 RPM	I-VEB	NOx FEL	
			mm ³ /COUP			NOx FNE (g/Bhp-hr)	
THIS ENGINE CONFORMS TO U.S EPA AND CALIFORNIA REGULATIONS APPLICABLE TO 2010 MODEL YEAR NEW HEAVY-DUTY ENGINES AND HAS A PRIMARY INTENDED SERVICE APPLICATION AS A HEAVY HEAVY-DUTY DIESEL ENGINE.							
Ce moteur est conforme aux réglementations de Californie et de l'Agence de Protection de l'Environnement des États-Unis applicables aux nouveaux moteurs diesel Heavy duty (Gamme lourde) modèle 2010. La principale application s'adresse aux usages de type gamme lourde (Heavy-heavy-duty).							
EXHAUST EMISSION CONTROL SYSTEM		THIS ENGINE IS CERTIFIED TO OPERATE ON			DELEGATED ASSEMBLY		LABEL NO
DISPOSITIF ANTI-POLLUTION		ULTRA LOW SULFUR DIESEL FUEL ONLY.					21338527
EM, EC, TC, CAC, DI, EGR, DPF, SCR							

W2040454

Engine Identification Label — 50 State EPA Approved Engine with California “Clean Idle”



CAUTION

To maintain compliance with emission regulations, engine settings should not be changed from those specified on the engine information label.

Note: Both the U.S. EPA and California Air Resources Board requires that each engine be identified with the proper engine

label as shown above. Should this engine label be defaced, destroyed, or removed from the valve cover, it must be replaced immediately. To order a replacement label, please contact Specifications or Parts Interpretations department at 1-800-888-9878, Option 2, who will assist you in obtaining the correct label for your engine.

Clean Idle Engines

The California Air Resources Board (ARB) requires that any engines having tamper-resistant software which limits the time at which the engine can idle at speeds above low idle (550 – 700 rpm). At speeds above low idle, and without a PTO engaged, idle time will be limited to five minutes, after which the engine will revert back to low idle. Vehicles equipped with a Clean Idle engine are identified by a label which is affixed to the left front corner of the hood or on the driver's door below the window, or on a vertical outward facing cab or sleeper panel extending rearward from the lower door position.

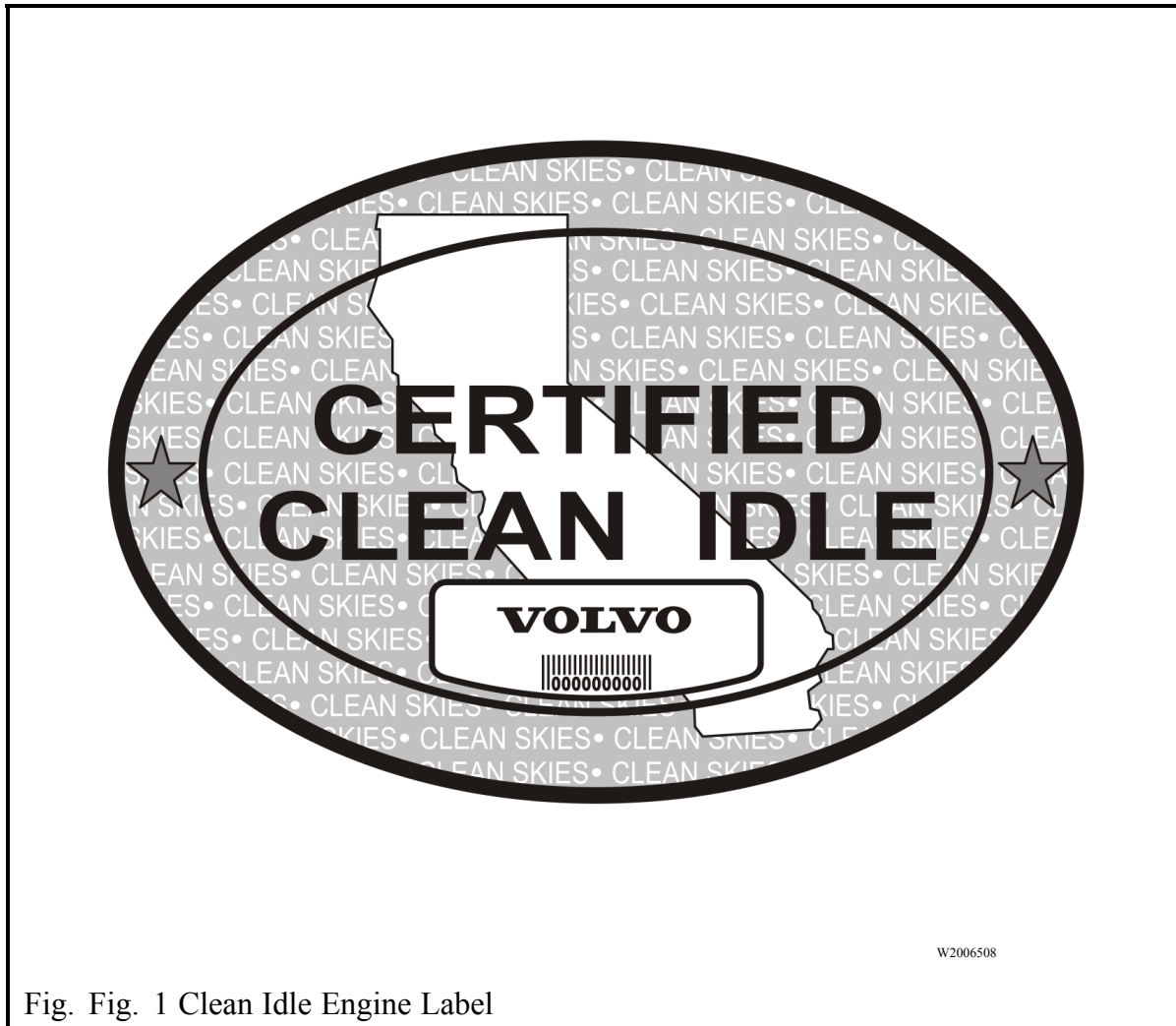
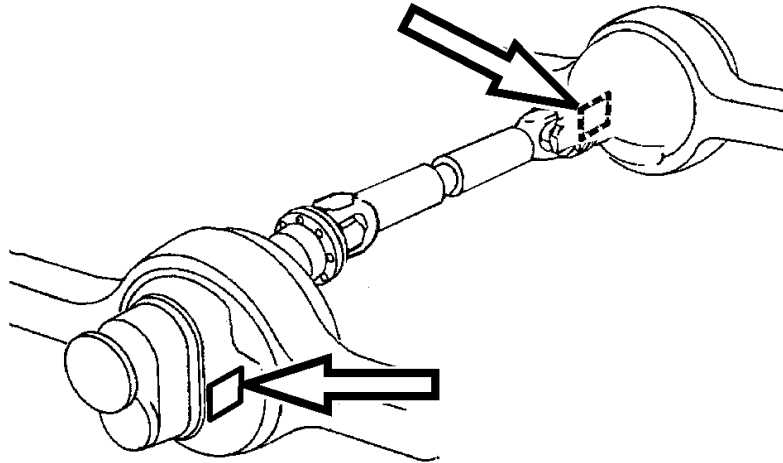

Fig. Fig. 1 Clean Idle Engine Label

18 INTRODUCTION

Component Labels

The Volvo engine serial number is located on the front left side of the cylinder block. The serial number can also be found on the certification label on the valve cover. The axle model and serial number is located on the front left side of the forward drive axle and the front right side of the rear drive axle. It is also located on the front right side of the single axle.



W4002560

SERVICE LITERATURE

To order a single Service Manual or a Service Manual Set for your vehicle, contact your authorized Volvo Truck dealer.

In order to handle the request correctly, you must give the model, year and VIN (**last six digits of VIN only**).

For VIN location, see “Identification and Labels”, page 13.

Service Manual prices will vary depending on the make and model of engine in the vehicle. (A Cummins engine manual is included in your introductory owner’s package).

Note: Please allow 30 days for delivery of Manual.

Name	Company
Address	
Vehicle Model	Phone/Fax
Model Year	VIN
Item 1:	
Item 2:	
Item 3:	
Item 4:	
Item 5:	

SERVICE ASSISTANCE

Your authorized Volvo Truck dealer is trained and equipped to perform expert service on your Volvo vehicle. Your dealer has direct access to Volvo Trucks North America for technical help, parts or service information.

There is also a direct number to Volvo Action Service (VAS), staffed 24 hours a day, if you are in need of assistance. The number to the Customer Support Center is: 1 (800) 528-6586 [or (800) 52-VOLVO]. Also on the internet: www.vas.volvo.com

VAS offers:

Delivery Assurance — If you need roadside assistance, VAS can arrange for load forwarding or equipment rental.

Personal Assurance — Trained staff for handling any vehicle problems.

Uptime Assurance — VAS will locate the nearest service provider and guarantee payment so you can get on the road as soon as possible.

Price Assurance — VAS audits service and parts billing to ensure guaranteed labor rates and preferred parts pricing for Volvo components.

REPORTING SAFETY DEFECTS

United States

If you believe that your vehicle has a defect which could cause a crash, injury or death, you should immediately inform the National Highway Traffic Safety Administration (NHTSA), in addition to notifying Volvo Trucks North America.

If NHTSA receives similar complaints, it may open an investigation and if it finds that a safety defect exists in a group of vehicles, it may order a recall and remedy campaign. However, NHTSA cannot become involved in individual problems between you, your distributor, or Volvo Trucks North America.

To contact NHTSA, either call the U.S. Government's Vehicle Safety Hotline toll-free at 1-888-327-4236 (TTY: 1-800-424-9153); go to <http://www.NHTSA.gov>; or write to: Administrator, National Highway Traffic Safety Administration, 400 Seventh Street, S.W., Washington, DC 20590. You can also obtain other information about motor vehicle safety from the Vehicle Safety Hotline.

Canada

Canadian customers who wish to report a safety-related defect to: Transport Canada Defect Investigations and Recalls, may telephone the toll free hotline at 1-800-333-0510, or contact Transport Canada by mail at Transport Canada, ASFAD, Place de Ville Tower C, 330 Sparks Street, Ottawa ON K1A 0N5.

For additional road safety information, please visit the Road Safety website at <http://www.tc.gc.ca/roadsafety/menu.htm>.

Mexico

Volvo Trucks de Mexico, S.A. de C.V. should be informed immediately if you believe the vehicle has a defect that could cause a vehicle accident, injury or death. Contact Volvo Trucks de Mexico by calling 011-52-55-50-81-68-50 or by writing to: Volvo Trucks de Mexico, S.A. de C.V., Prol. Paseo de la Reforma 600, 1er. Piso 121, Col. Santa Fe Pena Blanca, C.P. 01210, Mexico, D.F. Within Mexico, call 01 (800) 90 94 900.

EVENT DATA RECORDING DEVICES

Your Volvo vehicle is equipped with a device generally referred to as an "event data recorder" or "EDR." Please note that while the term "event data recorder" is typically used throughout the motor vehicle industry, not every EDR is the same; i.e., they do not all record the same data elements. The EDR on your Volvo vehicle records vehicle speed, engine rpm, time and date, plus a variety of pedal and switch positions, both before and after an "event." Sudden vehicle deceleration or the occurrence of certain other vehicle operational characteristics will define (trigger) an "event."

If you have a question about your EDR, please contact your Volvo dealer or regional service office.

GENERAL SAFETY INFORMATION

Operating the Vehicle

 **DANGER**

Never try to operate or work on this vehicle while under the influence of alcohol. Your reflexes can be affected by the smallest amount of alcohol. Drinking and operating this vehicle can lead to an accident, causing serious personal injury or death.

 **WARNING**

All items within the cab must be secured before the vehicle is set in motion. This includes, but is not limited to, drinks, clothes, books, televisions, etc. In the event of a collision, loose items could fly around inside the cab. This could cause personal injury.

Every vehicle, including heavy duty vehicles, have blind spots. The size of blind spots vary from driver to driver and from situation to situation. As a skilled, professional driver, **you** are in the best position to avoid accidents in turns, lane changes or other maneuvers. Volvo Trucks North America provides standard equipment (such as cabs, windshields, window sizes and mirrors), preferred by most owners and drivers under most conditions and in most applications.

However, due to differences in the size of drivers, their seating positions, the use and operation of their vehicles, personal preferences and other factors, no combination of mirrors and other visibility enhancement devices can eliminate all blind spots in every situation.

The safe operation of this vehicle is determined by the **you, the driver**. Because of your special preferences, needs and circumstances, you may choose to add extra mirrors and/or other visibility enhancement devices. If so, contact an authorized Volvo Truck dealer to obtain parts which best fit your personal needs and preferences.

Operating in Bobtail Mode



CAUTION

When operating bobtail, be certain that glad hands, trailer air hoses, electrical cable and connectors are properly stowed and secure. Do not allow them to rub or chafe on other components.

Depending on customer specification, some tractors may be equipped with a bobtail air brake proportioning valve which automatically redistributes the braking force between front and rear axles when not hooked up to a semitrailer (bobtail operation). When operating in bobtail mode, the rear brake chambers receive reduced or proportional brake air pressure. When the tractor is towing a trailer, the rear brake chambers will receive full (normal) brake pressure. For tractors with no proportioning valve, the ABS system automatically controls brake pressure.



DANGER

Under no circumstances should the published GVWR, FAWR, and/or RAWR be exceeded. Failure to observe these precautions can lead to the loss of vehicle control, resulting in a vehicle accident causing serious personal injury or death.

DANGER

DO NOT exceed the load rating of the tires or the vehicle weight ratings. Overloading may result in tire failure causing loss of vehicle control, leading to an accident resulting in severe personal injury or death.

This vehicle has been designed and assembled for a maximum gross vehicle weight rating (GVWR) and a maximum front and rear axle weights rating (FAWR and RAWR). The actual rating for this vehicle can be found on the label attached to the door frame on the driver's side. If any of these three ratings is exceeded and overloading occurs, instability, poor handling, failure of parts and accelerated wear can occur.

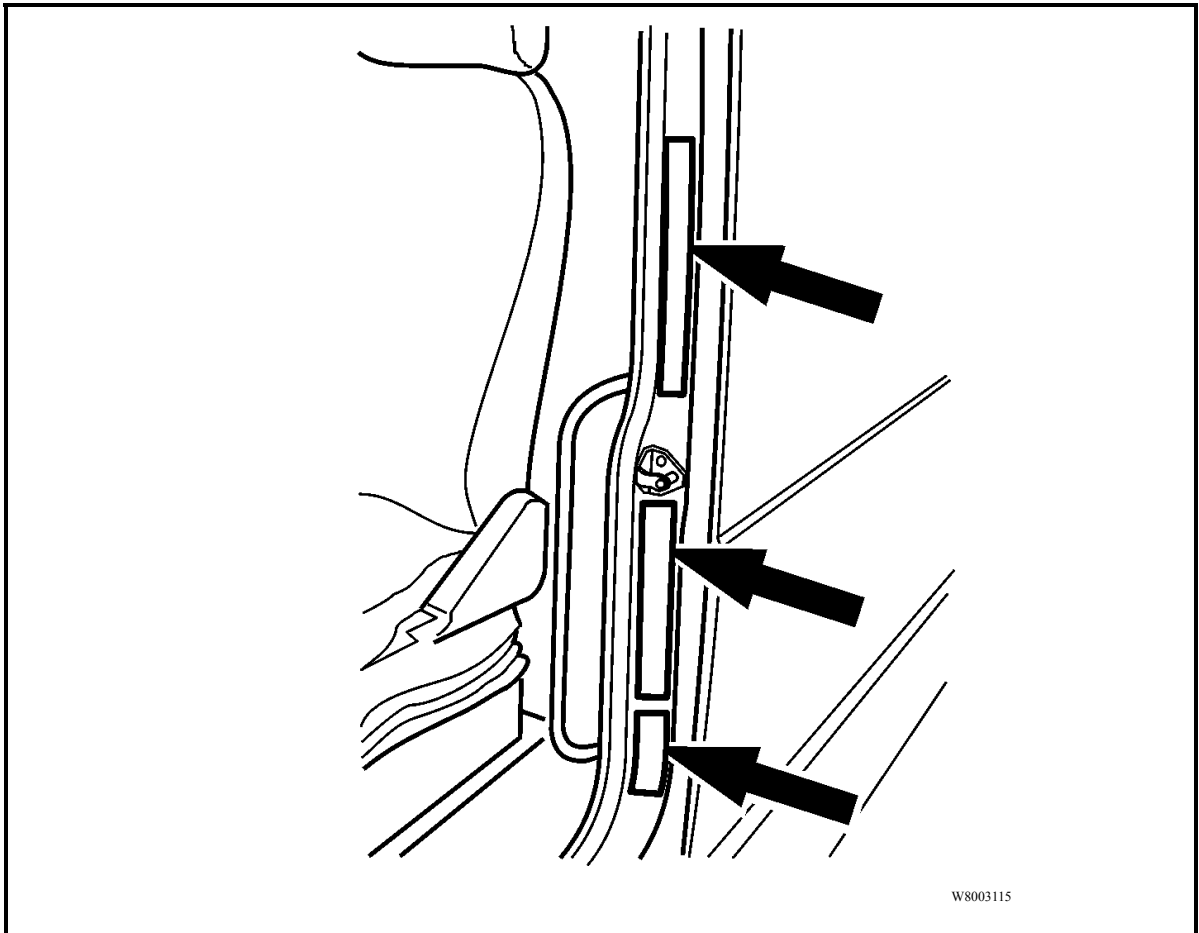

VORAD® COLLISION WARNING SYSTEM

The Eaton® VORAD® computerized Collision Warning System constantly monitors vehicles ahead with a front end-mounted radar and in a blind spot area with an optional side-mounted radar. The Collision Warning System warns the driver of potentially dangerous situations by activating visual and audible alerts.

DANGER

The Eaton® VORAD® Collision Warning System is intended solely as an aid for an alert and conscientious professional driver. It is not to be used or relied upon to operate the vehicle. Use this system together with rear view mirrors and other instrumentation to maintain safe operation of the vehicle. Operate a VORAD® equipped vehicle in the same safe manner as if VORAD® was not installed.

The Eaton® VORAD® Collision Warning System is not a substitute for safe driving procedures nor will it compensate for any driver impairment, such as drugs, alcohol or fatigue.

The Eaton® VORAD® Collision Warning System may provide little or no warning for some hazards like: alerts for pedestrians, animals, oncoming vehicles and cross traffic. SmartCruise will not react to stationary objects and it does not have the capability to stop the vehicle.

Failure to follow these instructions may lead to a vehicle accident resulting in severe personal injury or death.

If your vehicle is equipped with the Eaton® VORAD® Collision Warning System, read the manufacturer's Driver Reference Manual before taking the vehicle on the road.

ADVISORY LABELS

Throughout this book you will find paragraphs labeled Danger, Warning, Caution, Note and Service Hint. Danger, Caution and Warning labels are also found in various locations on the vehicle to alert drivers, operators and service technicians to situations which can cause personal injury or equipment damage. The labels shown are applicable to the VN model chassis at the time of publication and are representative of what can be typically found. (Your vehicle may not contain all of the labels illustrated in this handbook.) These labels are for your benefit. Please look through this section and note the labels, their locations and what they explain. Be sure to replace any label that is damaged.

CAB ENTRY AND EXIT

General

DANGER

DO NOT stand on the steps or any other part of the vehicle while it is in motion. The steps and the back of cab access deck plates are **only** for entering/exiting the vehicle and not for riding on. Failure to heed this warning can result in serious personal injury or death.

DANGER

Steps are designed to be slip resistant and to provide a stable surface for entering or exiting the cab. However, accumulation of ice, dirt, lubricants, etc. on the steps can make entering or exiting hazardous. Always make sure the steps are free from slippery substances. Failure to follow this guideline may result in a fall that can cause serious personal injury or death.

WARNING

To avoid personal injury due to a slip and/or fall, observe all the guidelines explained in this section.

WARNING

Wearing shoes with soles that are dirty or wet increases the chance of injury from slipping and falling. Be careful when entering the cab with dirty or wet soles.

WARNING

Both the operator and passenger should exercise caution when entering or exiting the cab. Use the steps and grab handles to safely get in and out of the cab.

WARNING

Always check the security of cab panel, fairing and steps before use. Ensure that the cab panels or fairings are completely closed and the handles are in the locked position.

CAUTION

DO NOT open fairing while cab door is open, this can result in paint damage on the fairing.

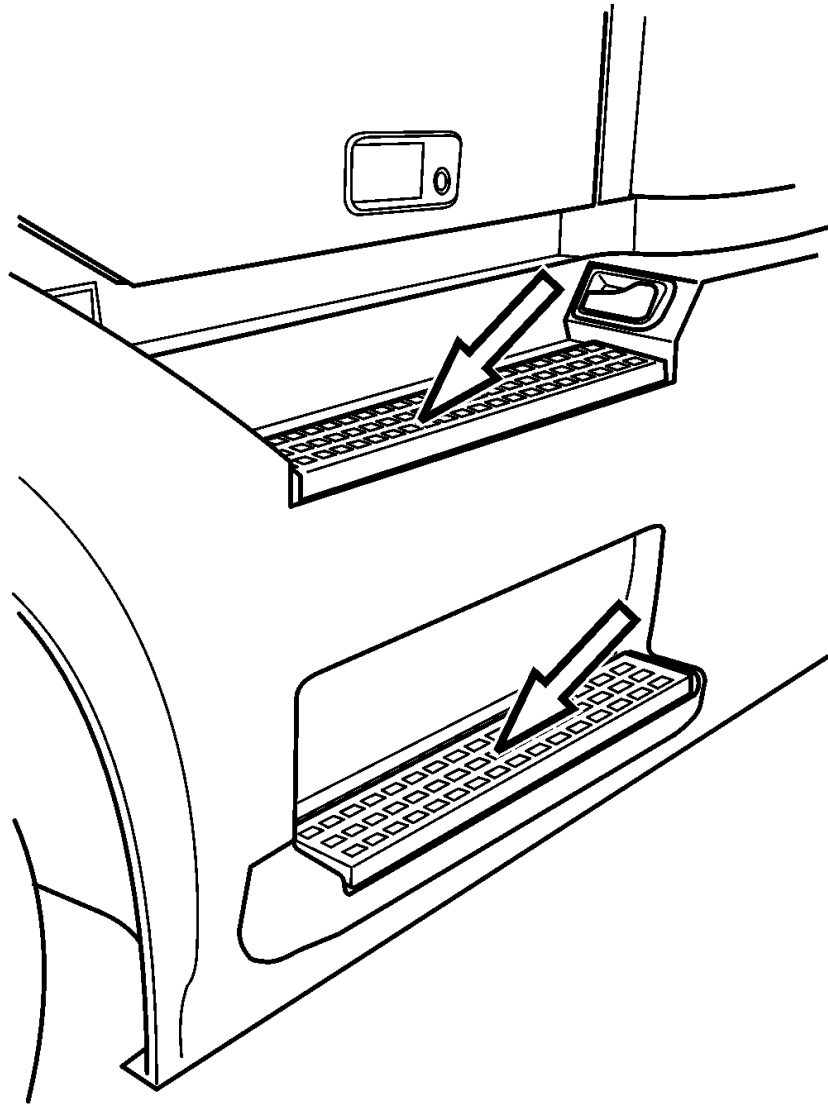

W8003120

VN

30 SAFETY INFORMATION

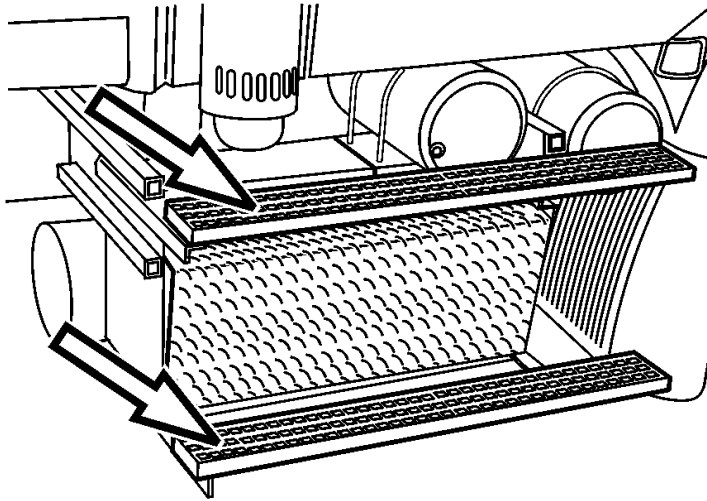

W8003127

VN without Fairings

General Entry Guidelines



WARNING

To avoid personal injury due to a slip and/or fall, observe the following guidelines.

BE SURE TO FOLLOW ALL OF THESE INSTRUCTIONS BEFORE ENTERING OR EXITING THE CAB OR THE AREA BEHIND THE CAB.

- 1 Always have three limbs (one foot and two hands or two feet and one hand) in contact with the vehicle at all times when entering or exiting the cab or the area behind the cab.
- 2 Be certain you have a firm handhold and/or stable foot position before transferring weight to that position. For example, do not start to put weight on a foot until you are certain your foot is properly on the step and will not slip when you transfer your weight.
- 3 **DO NOT** climb on top of the frame, fuel tanks or storage boxes to make trailer hook-ups.
- 4 If the vehicle is equipped with air fairings, do not use the side mounted fairing (wind deflector) brackets and braces as steps or grab handles.
- 5 If the vehicle is equipped with air fairings, do not use the side mounted fairing (wind deflector) brackets and braces as steps or grab handles.
- 6 Be certain that all grab handles, steps and related parts are in good working condition. Any defects should be reported and repaired before using the grab handles and steps.
- 7 Be certain that all grab handles, steps and related parts are in good working condition. Any defects should be reported and repaired before using the grab handles and steps.
- 8 **DO NOT** step on the curved surface of the fuel tanks. They may be slippery from snow, mud, ice, water, spilled fuel or other slippery substances.
- 9 If a step is mounted to the top of the battery box, be certain that the battery box cover is properly fastened before stepping.
- 10 If a vehicle is equipped with removable chassis fairings or cab panels, be certain the fairing or cab panel is properly fastened before using steps.
- 11 **DO NOT** jump from the cab or from the steps to the ground.
- 12 **Always** face the cab when entering or exiting.
- 13 **DO NOT** hold anything in your hands when entering or exiting the cab or the area behind the cab. Log books, cups, clipboards, jackets, luggage and the like can be placed on the cab floor or rear deck plate before entering or exiting.

32 SAFETY INFORMATION

14. Make sure your safety belt is disconnected before exiting the cab.
15. Make sure the safety belt is fully retracted and out of the way prior to entering or exiting the cab.
16. **DO NOT** put your foot on any surface that does not have slip resistant, self-cleaning material. If there is no step material, the surface may be slippery and you may fall.
17. Before entering or exiting, be certain that the soles of your shoes/boots are free from grease, mud or any other substance which could make them slippery.
18. Always put the foot flat on the top of the step. **DO NOT** place your foot on the side or edge of the step.

Driver Side Entry/Exit

WARNING

On vehicles without side fairings or cab panels, always make sure that the battery box cover is securely fastened before stepping up. Failure to fasten the cover may lead to a fall and personal injury.

Open the door. Place any hand-carried items on the cab floor. Grasp the right grab handle with your right hand and the left grab handle with your left hand. Put the right foot fully on the bottom step and pull yourself up to the opening.



W8003112

Slide hands up on the handles, if necessary. Put the left foot on the top step and step up. Step into the cab with the right foot first.
To exit, reverse the process. Do not attempt to exit the cab while carrying any items in your hands.

34 SAFETY INFORMATION

Passenger Side Entry/Exit

Open the door. Place any hand-carried items on the cab floor. Grasp the left grab handle with your left hand and the right grab handle with your right hand. Put the left foot fully on the bottom step and pull yourself up to the opening.

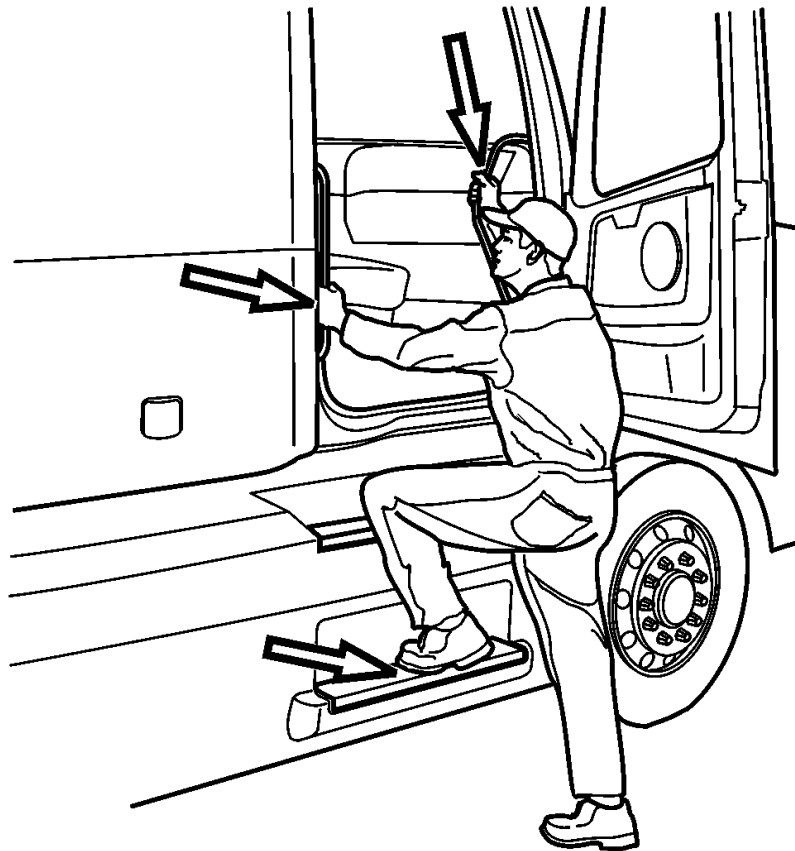

W8003117

Slide hands up on the handles, if necessary. Put the right foot on the top step and step up. Step into the cab with the left foot first.

To exit, reverse the process. Do not attempt to exit the cab while carrying any items in your hands.

Behind the Cab Access



WARNING

Be careful when entering the back-of-cab area with dirty or wet soles. Wearing shoes with soles that are dirty or wet increases the chance of slipping or falling.

When trailer air and electrical connections can not be coupled from the ground, Federal Regulations require commercial carriers to provide back-of-cab access steps, grab handles and plates.

Depending on what option is chosen, grab handles are available in many variations. In each case, make sure to always have three limbs (one foot and two hands or two feet and one hand) in contact with the vehicle at all times when entering or exiting the area behind the cab.

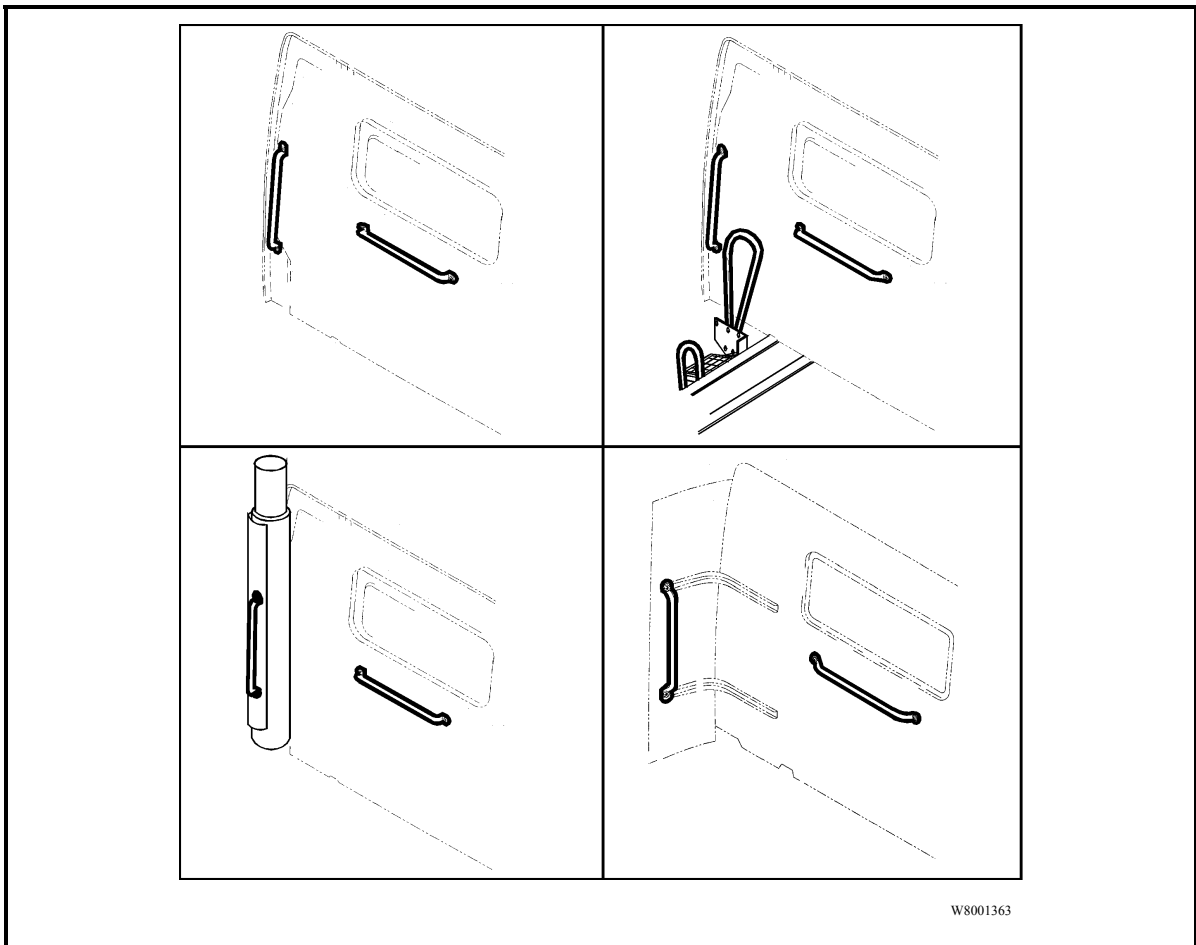

36 SAFETY INFORMATION

Grasp the grab handle to the left with both hands. Put the left foot onto the bottom step and pull yourself up. Put the right foot on the top step and step onto the deck plate with the left foot.



W8003122



WARNING

Always perform trailer hook-ups while standing on the ground. DO NOT climb on top of fuel tanks or frame rails to hook up or disconnect trailer air lines and electrical cord. Use only the metal, slip resistant steps provided to prevent a slip and fall injury.

Stand on the ground when connecting the air and electrical connections to the trailer.

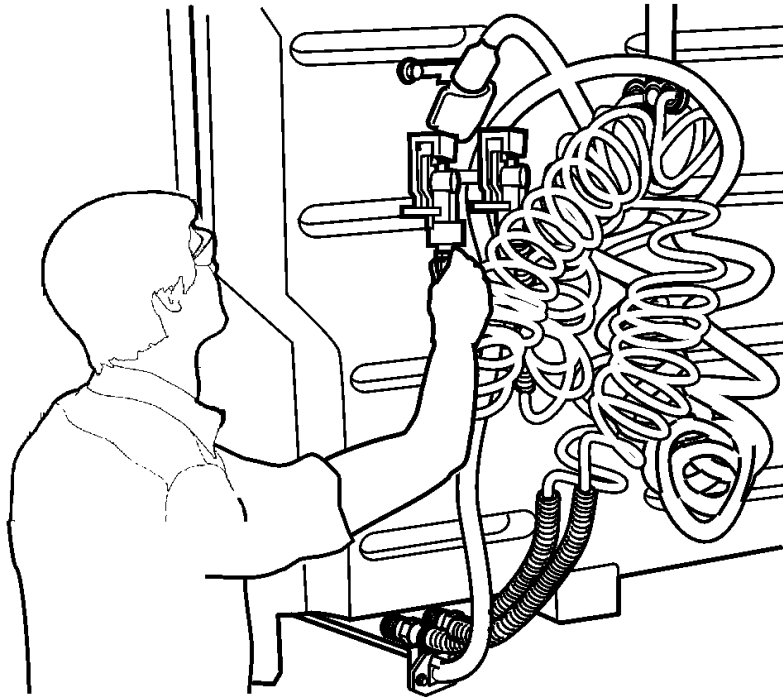

W3005321

ENTERING SLEEPER FROM SEAT

Standard Gear Lever



CAUTION

Be careful when standing to your feet in the seat area, headroom is limiting.

When moving from the driver seat to the sleeper section, follow this procedure:

- Make sure the parking brakes are set.
- Place the gear shift lever in a gear position toward the rear of the vehicle.
- If equipped with an adjustable steering column, move the steering wheel up and forward.
- Place the left hand on the steering wheel and the right hand on the top of the gear lever.
- Move the right foot out to the middle of the floor.
- Lift the upper body, supported by the hands on the steering wheel and the gear lever and step out from the seat area.

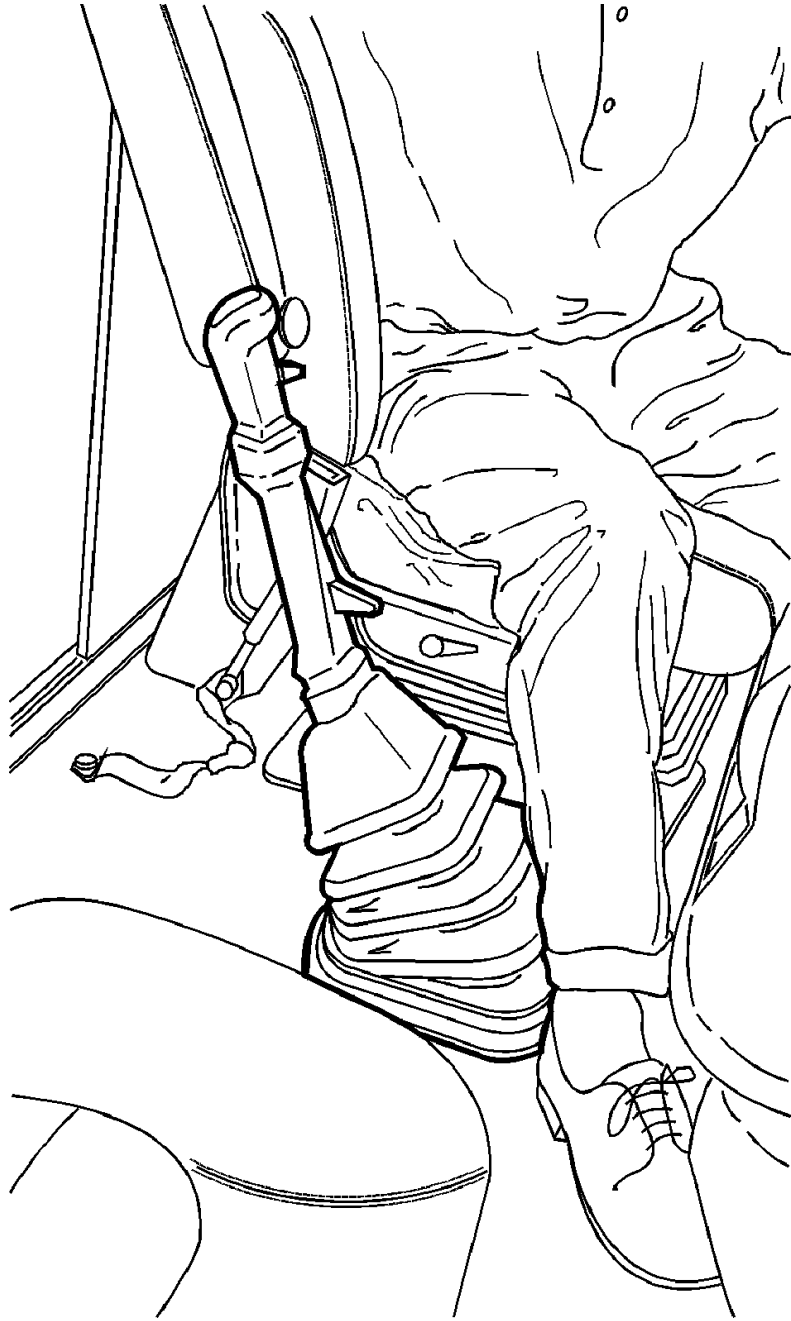

W4001391

SAFETY EQUIPMENT

Safety triangles and fire extinguishers are available as optional equipment. The fire extinguisher should be located by the base of the driver seat, between the seat and the door.

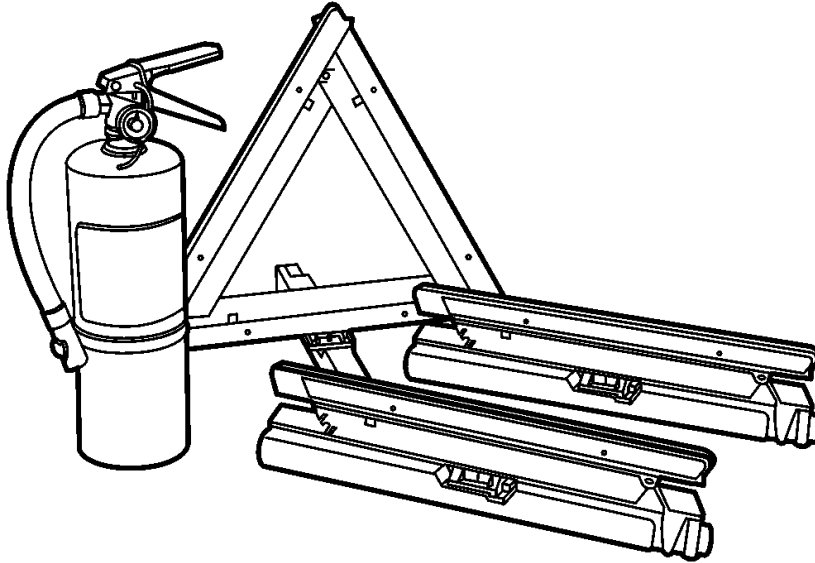

W1000176

Note: Always store the warning triangles in the box after use.

Warning Triangles, Day Cab

The warning triangles are stored in a box that is strapped behind the passenger seat.

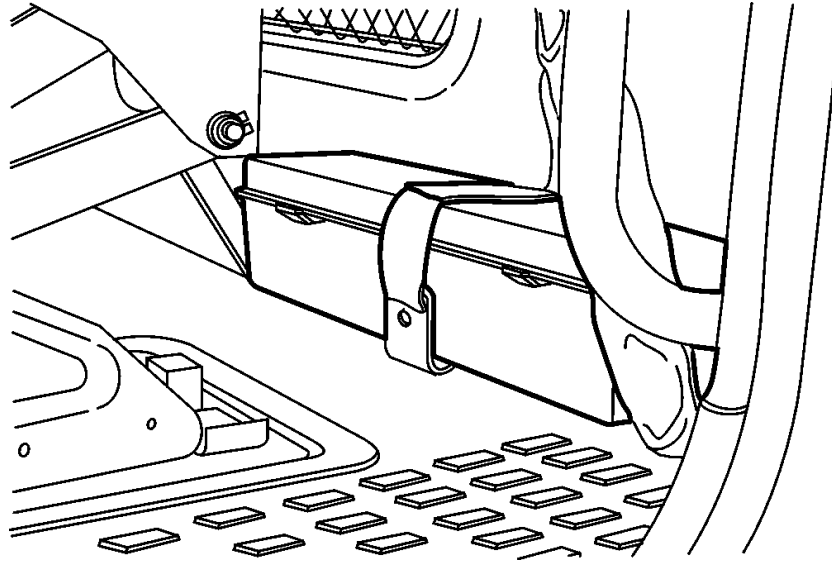

W1000177

Sleeper Cab

The warning triangles are stored in a box, which is inside the exterior luggage compartment.

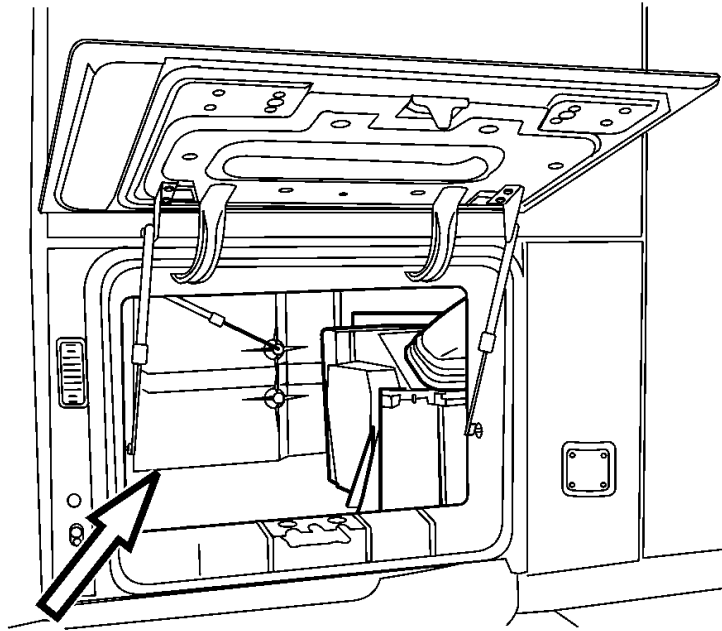

W8003517

SAFETY BELT SYSTEM

The safety belt system is the main restraint application in the vehicle. All vehicles are equipped with this system. For additional information on the safety belt system refer to “SAFETY BELTS”, page 230.

The safety belt system monitors the safety belt latch and vehicle speed. When the vehicle is started the safety belt telltale displays in the cluster. The icon remains on whenever the vehicle is stationary and the safety belt is unbuckled. Whenever the vehicle is moving and the safety belt is unbuckled an audible tone sounds and the safety belt telltale blinks.



W3000625

SRS AIRBAG

The SRS airbag is intended to supplement — not replace — the standard safety belt. The airbag is not deployed when the truck is hit from behind, from the side or if it rolls over. For best protection, sit in a normal, upright position. Always wear the safety belt. For added safety, the vehicle may be equipped with an airbag or SRS (Supplemental Restraint System) as a supplement to the standard three-point anchored safety belt. The SRS is designed to reduce the risk of injury to the driver's face and upper part of the body. Together with the safety belt, the airbag helps prevent the driver from being thrown against the steering wheel, windshield or other hard surfaces in the cab. The Volvo SRS Airbag provides increased protection in frontal collisions, where the vehicle collides with a fixed or heavy object with enough force to activate the sensors which then activate the airbag. Damage to the vehicle is not always proportional to whether the SRS Airbag deploys or not.

The SRS Airbag is not designed to be activated with:

- Collision from the sides
- Collision from the rear
- Rolling over
- Head-on collisions at low speed or against soft objects such as bushes, snow drifts, etc.

SRS System



WARNING

Never attempt to drive with a deployed airbag. With the bag hanging out of the hub of the steering wheel, the truck may be more difficult to steer. In addition, other safety systems may be damaged. Continuous exposure to the smoke and dust created during the deployment of the airbag can cause irritation to the skin and eyes.

The inflatable airbag is folded into the center of the steering wheel. It inflates in the event of a serious collision above a certain level, where the angle of impact, crash severity, speed and nature of the object involved in the collision all play a part in whether or not the airbag is activated.

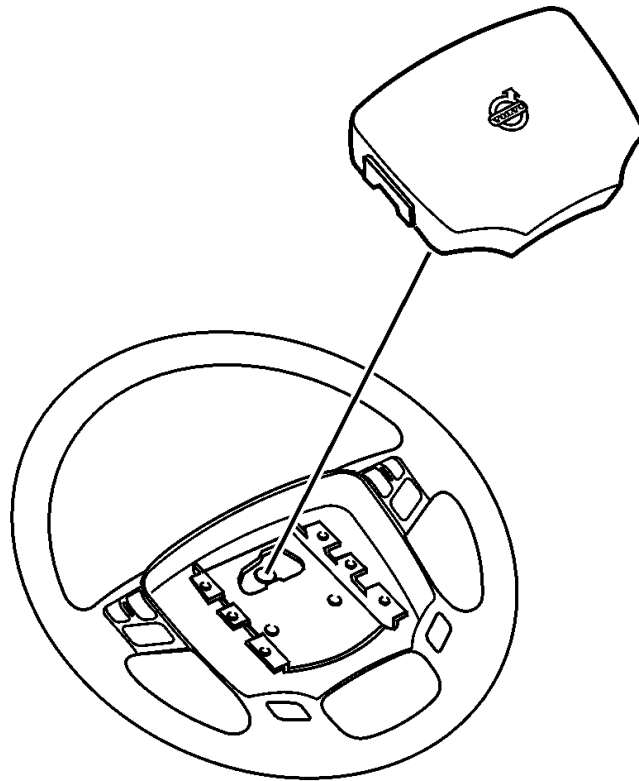

W8003129

The system consists of a gas generator surrounded by the inflatable airbag. In the event of a sufficiently violent collision, a control unit activates the gas generator ignitor and the airbag inflates. To cushion the impact, the airbag deflates when compressed. This also releases some nontoxic smoke into the cab. The entire sequence, from inflation to deflation of the airbag, takes a few tenths of a second.

The SRS system is continually monitored by the control unit. A control unit is mounted on a bracket above the engine cover which detects deceleration. The control unit also contains a standby power unit which can supply the system with power for a short time, in case the normal supply breaks.

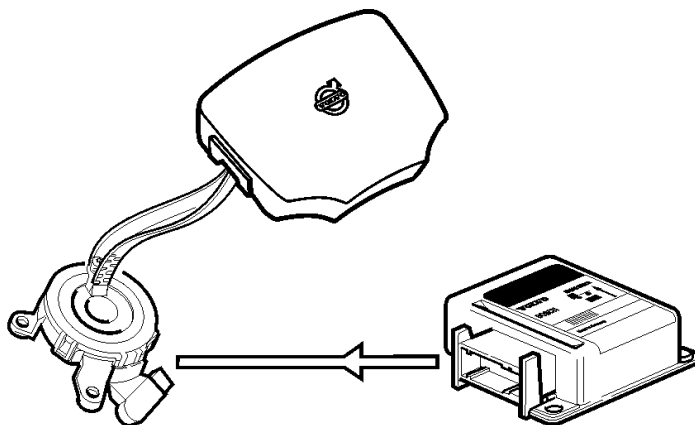

W8003119

If the control unit detects a sufficiently violent deceleration (collision), the system is activated. The gas generator triggers and fills the bag with a nontoxic gas within a few hundredths of a second. During a collision, after the bag is full, gas flows out through two holes in the weave. These holes are large enough to let the airbag collapse slowly, gently catching the driver.

In the event of a problem in the SRS system, an icon is shown in the graphic display in the instrument cluster.



T3008842



CAUTION

The vehicle should be taken to an authorized Volvo Truck dealer immediately if the SRS icon comes on or remains on while the vehicle is being driven.

If a problem develops in the system, the CHECK tell-tale will come on together with the SRS tell-tale.



W3005170

Warning Labels

The label attached to the left-hand sun visor shows the year and month when an authorized Volvo Truck dealer should be contacted for a specific inspection and for a possible replacement of the airbag. This is done to guarantee the function of the airbag after the indicated date. Replace the label when replacing the airbag module. Never attempt to make any adjustments to SRS components yourself.

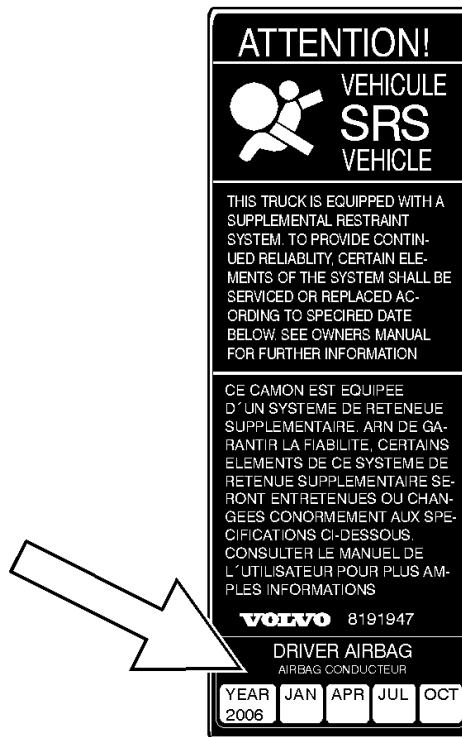

T8006843

Any queries concerning the SRS system should be directed to an authorized Volvo Truck dealer. There is no maintenance required for the SRS system until the date on the warning label located on the left-hand sun visor.

48 SAFETY INFORMATION

Steering shafts and steering wheel should not be removed, adjusted or replaced without following the proper work procedure. Failure to do so can damage the SRS system, which can result in malfunction of the SRS. A warning label is located on the upper steering shaft.

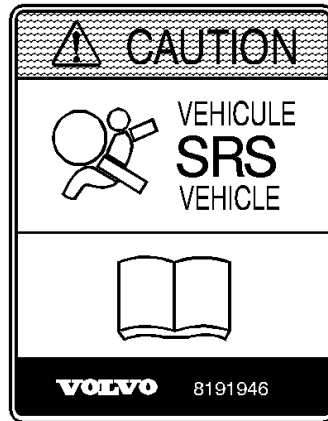

T8006842

There is also a label on the inside of the windshield that indicates the inclusion of an airbag to the vehicle safety features.



T8006841

When equipped with an airbag, a label with the correct procedure for protecting small children and protecting the driver is attached to the left-hand, overhead storage lid or back of sun visor.



W8002741

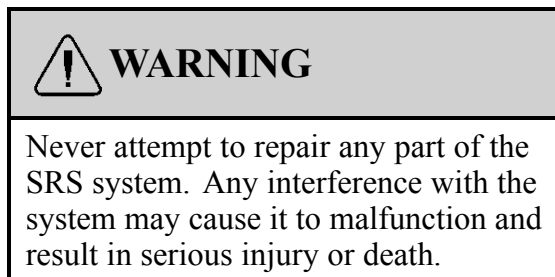

Work on the system may only be carried out by an authorized Volvo Truck dealer.
To allow the SRS system to work as designed:

- Never drive an SRS system equipped vehicle with the hands on the steering wheel pad/airbag module.
- No objects, accessory equipment or stickers may be placed on, attached to or installed near the SRS cover in the center of the steering wheel.

General Information

When is the Airbag Deployed

The airbag is only deployed during a head-on collision, where the vehicle hits a fixed or heavy object with sufficient force. The SRS system registers both the force of the collision and the internal forces caused by the collision. The control unit determines if the collision is sufficiently violent for the airbag to be deployed.

Note: The SRS system is only activated once in a collision. If the airbag has deployed, the following is recommended:

- * Have the vehicle towed to an authorized Volvo Truck dealer. Even if the vehicle can be driven after a collision, it is not recommended to drive the truck with the airbag deployed.
- * Have an authorized Volvo Truck dealer change the components in the SRS system.
- * Only use original Volvo parts when replacing the SRS system components (airbag, safety belt, etc.).

When is the Airbag not Deployed

Not all frontal collisions activate the SRS system. In a collision with a soft object (a snow drift or bush for example, or a hard or fixed object at low speed), there is no need for the SRS system to be activated. The airbag is usually not inflated in response to side-on collisions, impacts from the rear or if the vehicle overturns. The extent of damage to the vehicle is no measure of how well the SRS system works.

Can the Airbag be Deployed Accidentally

The complete SRS system is constructed so that the airbag only inflates in particular collision conditions. The SRS system has its own diagnostic unit which continuously monitors the functioning of the system.

Heart of the Volvo Safety System

The three-point anchored safety belt is the heart of the Volvo safety system. The belt should be worn at all times. The SRS system is intended as a supplement to the three-point anchored safety belt.

52 INSTRUMENTS AND CONTROLS

CAB INTERIOR

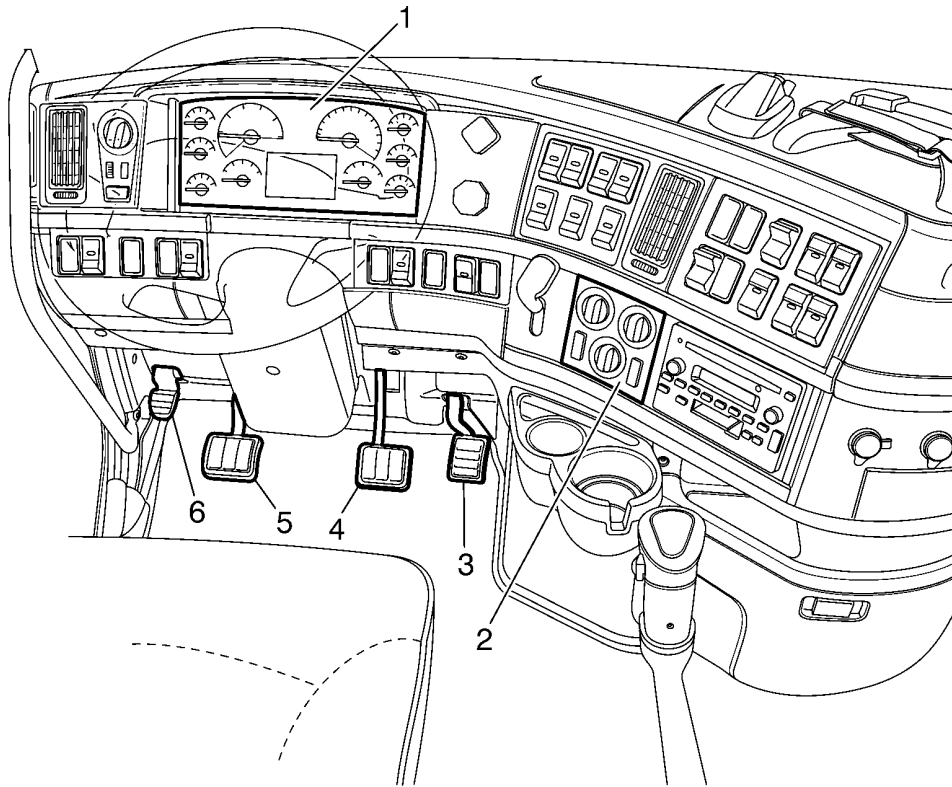

W8003838

- | | |
|-----------------------------|--------------------------------------|
| 1 Instrument Cluster | 4 Brake Pedal |
| 2 Cab Climate Control Panel | 5 Clutch Pedal (if equipped) |
| 3 Accelerator Pedal | 6 Steering Column Tilt Control Pedal |

INSTRUMENT PANEL

Tell-Tales

A tell-tale is a display that indicates the actuation of a device, a correct or defective condition, or a failure to function.

The operator should become familiar with these symbols in order to recognize and react (if necessary) to the indicated condition. Tell-tale symbols are shown in the instrument panel illustrations on the following pages.

Colors

To promote visual recognition internationally, specific colors for tell-tales have been established. Unless governmental regulations (in the area where the vehicle is to be used) or engineering directives specify otherwise, the standard colors are:

- **Blue** — high-beam headlights/engine maintenance
- **Flashing Green** — turn signals
- **Flashing Red** — hazard condition involving the safety of personnel
- **Steady Green** — system in operation
- **Steady Red** — warning, immediate action required
- **Amber** — early warning, such as low fuel or Anti-Lock Brake System (ABS) malfunction

Panel Arrangement

Your view from the driver seat should look something like the illustrations shown. The layout is designed to provide the operator with a good view of the gauges and controls (which are placed so they are within easy reach). The instrument panel, as shown in the following drawing, is broken down into several main sections. For easy identification we refer to them, from left to right, as Panels A, B, C, D, E and F (where necessary).

Note: This section shows the instruments and controls available for this vehicle at the time of publication. However, depending on options, your vehicle may not have all the instruments and controls shown here, and they may not be in the same position.

INSTRUMENT PANEL GAUGE LAYOUT

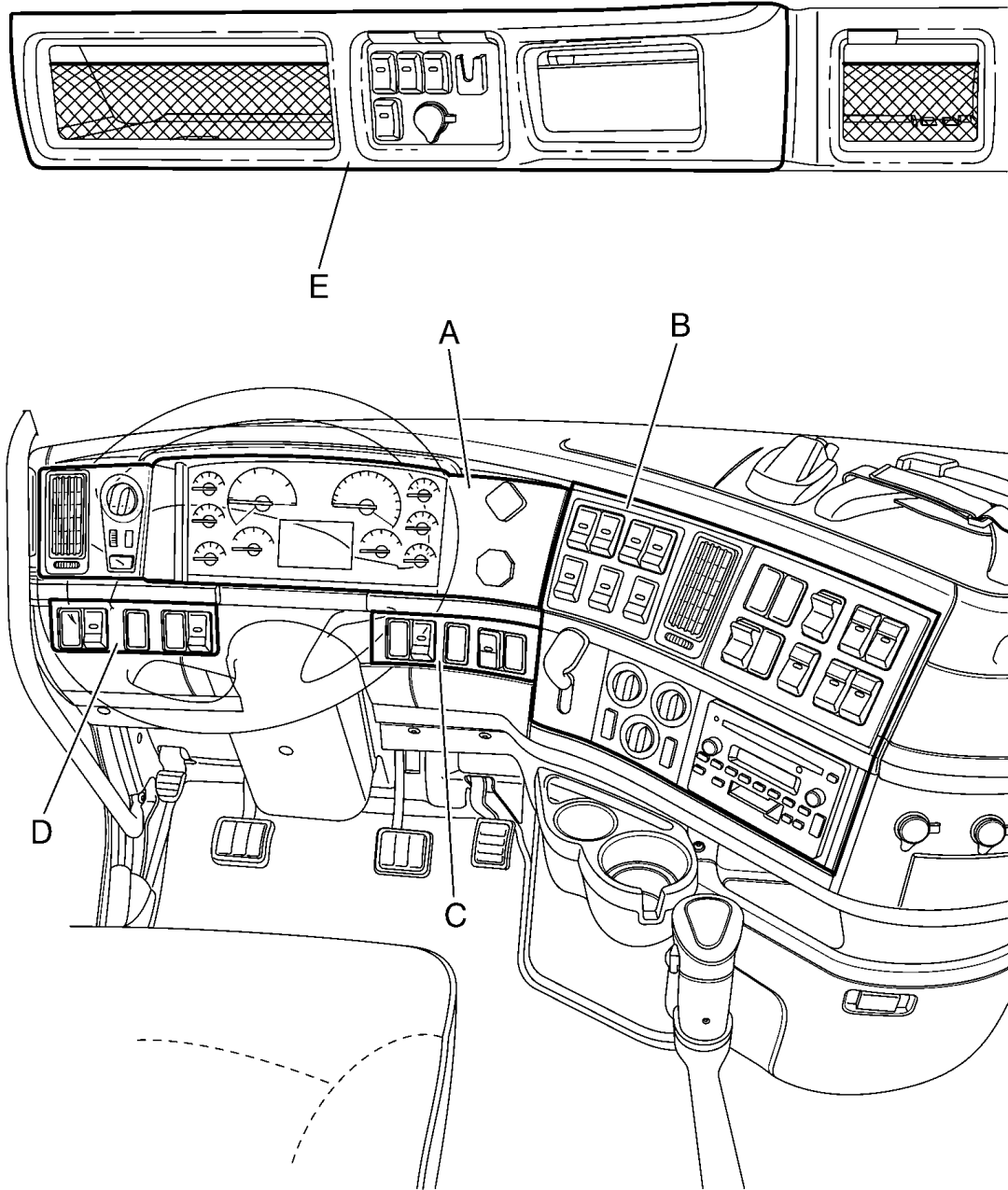

W3007473

Panel Arrangement

56 INSTRUMENTS AND CONTROLS

Panel A

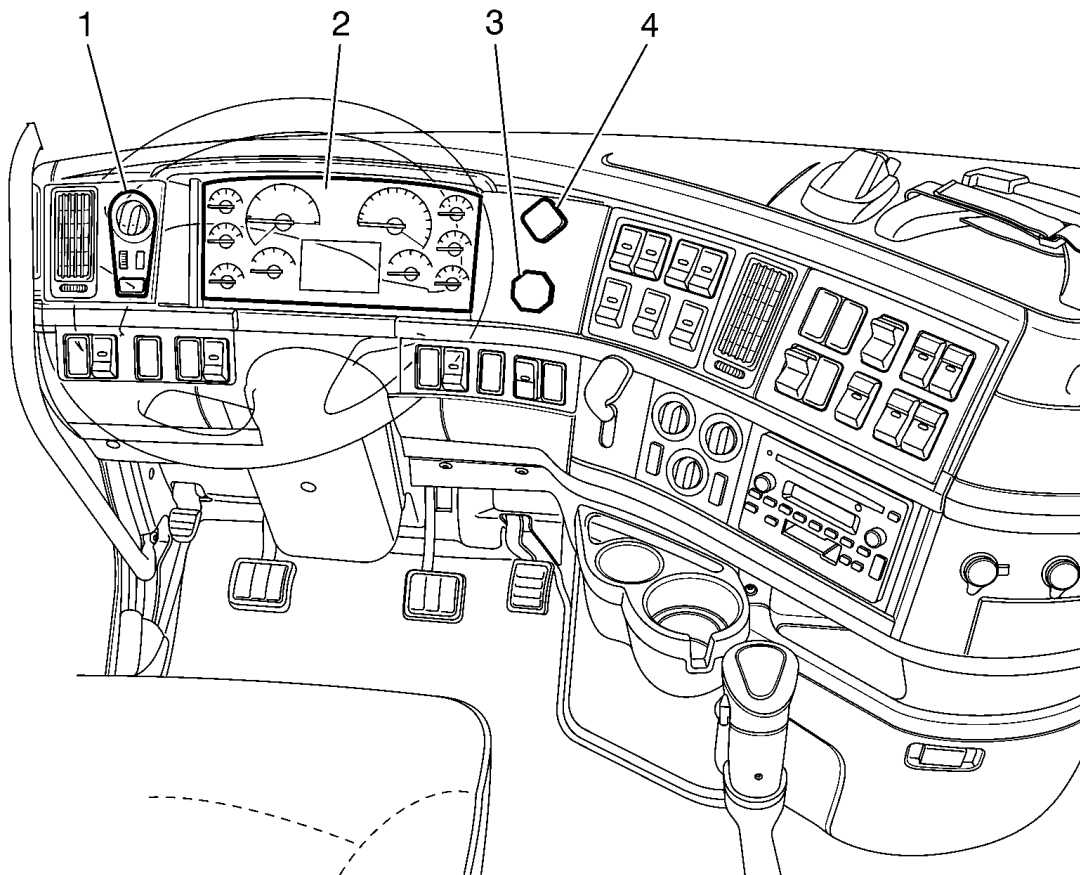

W3007469

- 1 Light Control Panel
- 2 Instrument Cluster
- 3 Trailer Air Supply

4 Tractor Parking Brake

Panel B

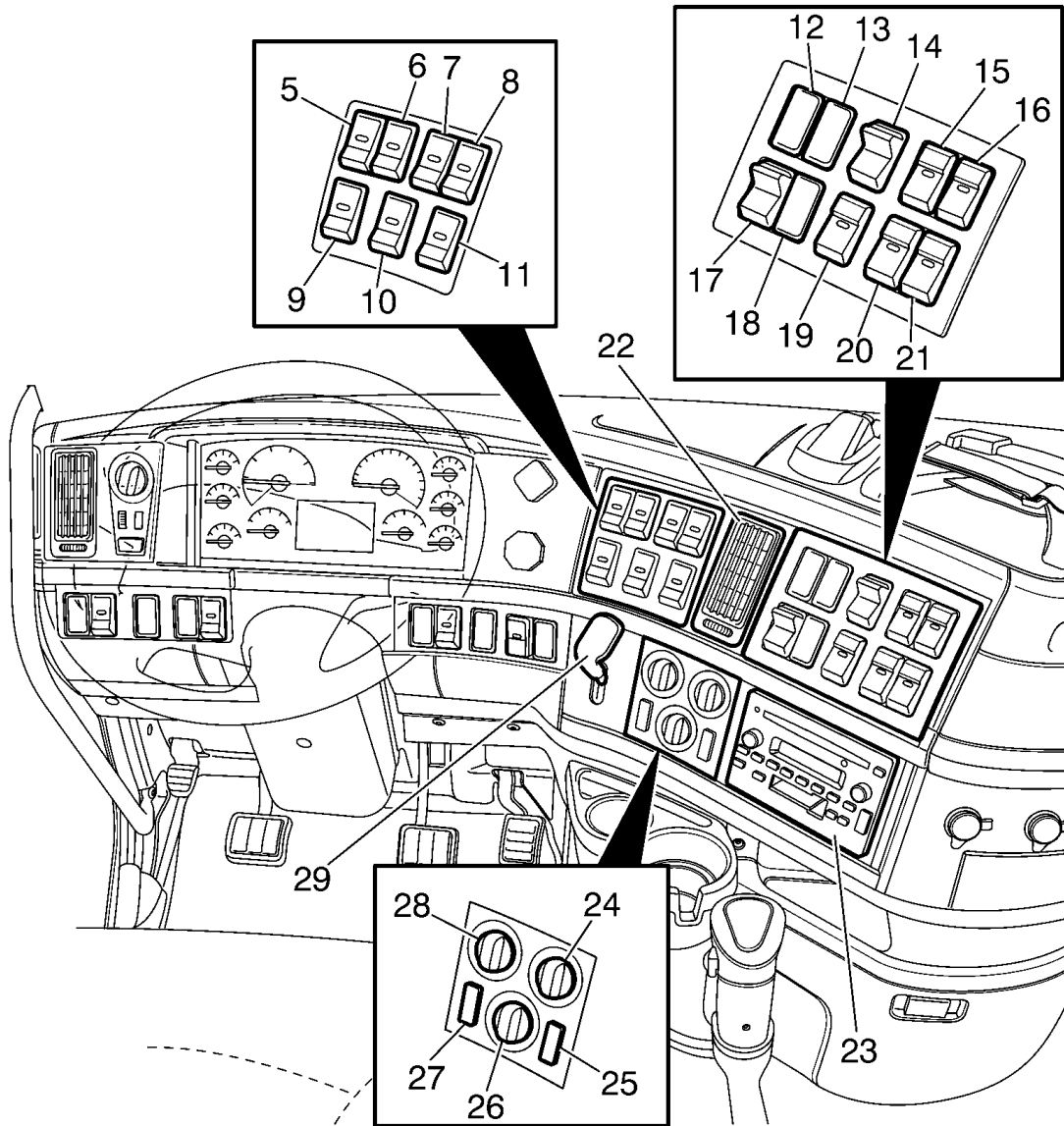

58 INSTRUMENTS AND CONTROLS

<ul style="list-style-type: none">5. Inter-Wheel Differential Lock6. Inter-Axle Differential Lock7. VN: Idle Management Indicator Lamp (ISX ICON) or Optional Switch or Electronically Controlled Suspension (ECS) On/Off or Lift Axle #1 (Pusher)8. VN: Optional Switch or Electronically Controlled Suspension (ECS) Up/Down9. Auxiliary #110. VN: Auxiliary #2 or Temp-A-Start (TAS) Indicator Lamps11. VN: Auxiliary #3 or Temp-A-Start (TAS) On/Off12. Secondary Gauge Cluster13. Secondary Gauge Cluster14. Engine Brake or I-Shift Eco-Roll	<ul style="list-style-type: none">15. VN: Engine Brake Mode Select (ISX) or I-Shift Hill Start Assist16. VN: 5th Wheel Touch Lock (Unlock)17. Marker Interrupt or Secondary Gauge Cluster18. Optional Switch or Secondary Gauge Cluster19. Traction Control20. Suspension Dump21. 5th Wheel Slide or Engine Inside/Outside Air Control22. Air Vent23. Radio24. Fan Speed25. Recirculation26. Air Distribution27. AC ON/OFF28. Temperature Knob29. Trailer Hand Brake Control
---	--

Panel C

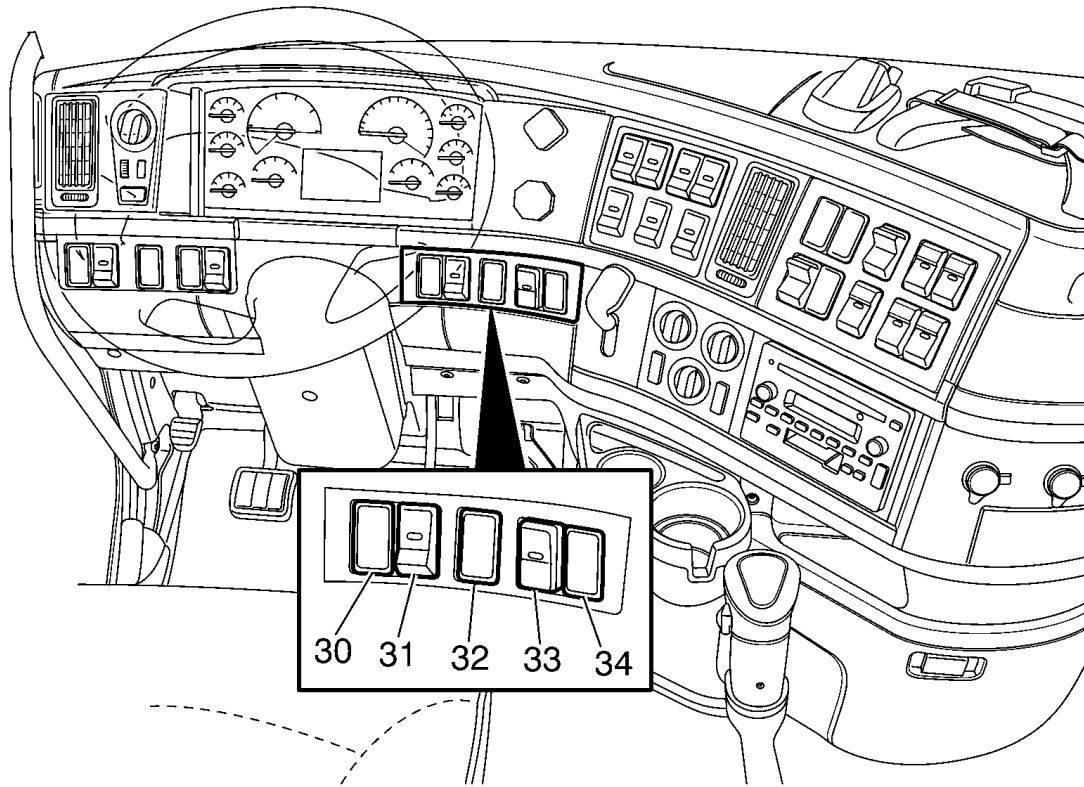

W3007471

- 30. VN: Optional Switch or Passenger Window Lift
- 31. Water in Fuel (Purge Switch)
- 32. Optional Switch or AUX/USB Port
- 33. VN: Sleeper Fan Speed
- 34. VN: Optional Switch or Beacon Lamps

60 INSTRUMENTS AND CONTROLS

Panel D

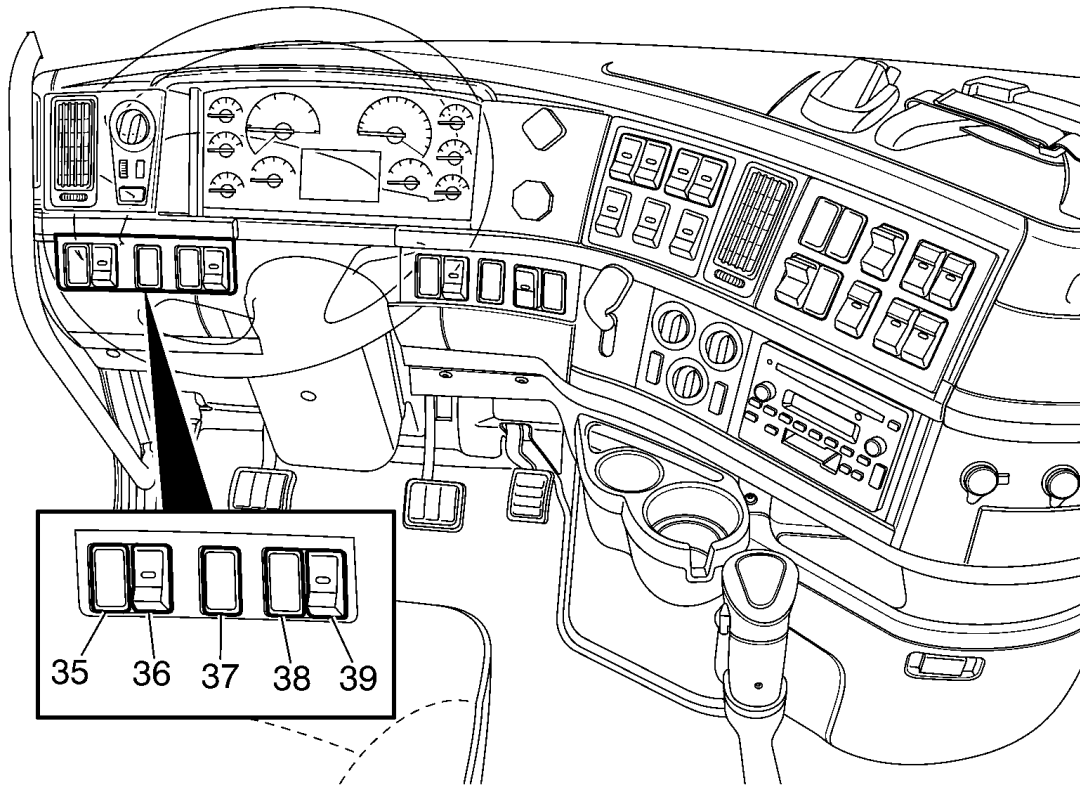

W3007472

- 35. Back of Cab Light
- 36. Optional Switch
- 37. Optional Switch or Power Take-Off (PTO)
- 38. VN: Overhead Bunk Lamp or Passenger Side Mirror IN/OUT
- 39. VN: Side Mirror Heat or Power Take-Off (PTO),

Panel E

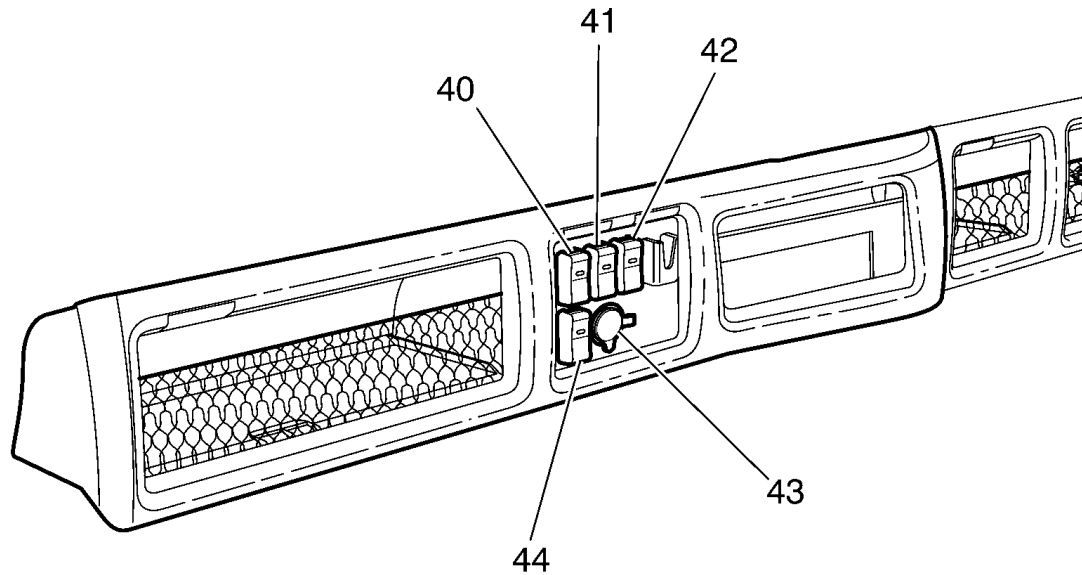

W3007474

- 40. AC Inverter 120 V
- 41. Optional Switch
- 42. Optional Switch
- 43. Power Outlet
- 44. Microphone

Before driving this vehicle, locate the instruments and controls, and become thoroughly familiar with their operation. After starting and when driving, ensure that the instrument readings are normal.

Note: The instruments and controls shown were available for this vehicle at the time of publication. Depending on the options selected, all gauges and tell-tales may not be used in all vehicles.

Note: The dash layout is the same for all Volvo vehicles. However, the switches and certain switch positions are different depending on vehicle options.

62 INSTRUMENTS AND CONTROLS

1. **Light Control Panel** — For more information, please refer to “LIGHT CONTROL PANEL”, page 107

2. Instrument Cluster

There are two instrument cluster levels available: High and Mid level.

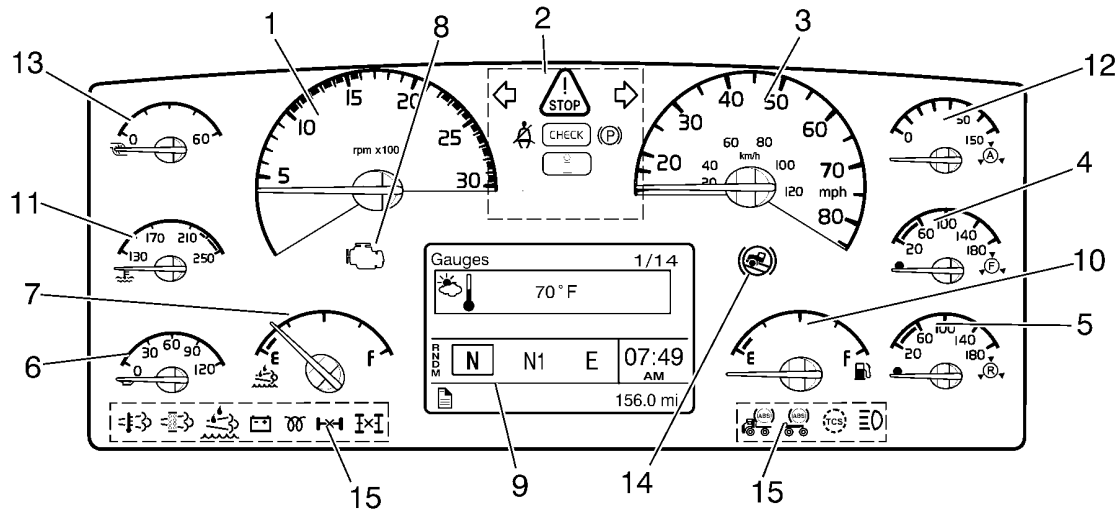

W3034025

High Level Cluster

1. Tachometer
2. Upper Tell-Tales
3. Speedometer
4. Front Brake Air Pressure
5. Rear Brake Air Pressure
6. Oil Pressure
7. Aftertreatment DEF Tank Gauge
8. Malfunction Indicator Lamp (MIL)

9. Driver Information Display (DID)
10. Fuel Level
11. Intake Manifold Pressure
12. Application Air Pressure
13. Exhaust Pyrometer
14. Hill Start Assist
15. Lower Tell-Tales

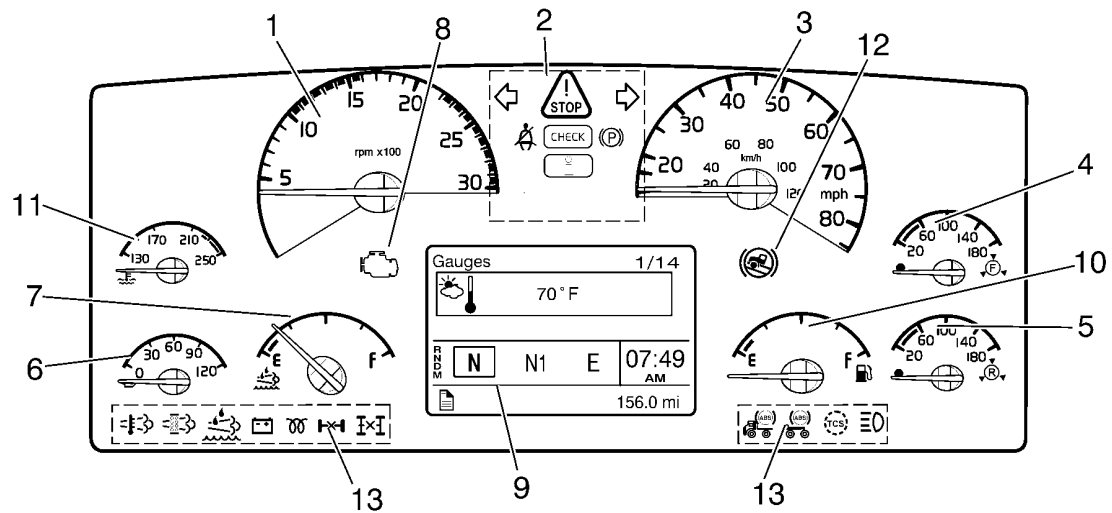

W3034026

Mid Level Cluster

<ol style="list-style-type: none"> 1. Tachometer 2. Upper Tell-Tales 3. Speedometer 4. Front Brake Air Pressure 5. Rear Brake Air Pressure 6. Oil Pressure 7. Aftertreatment DEF Tank Gauge 	<ol style="list-style-type: none"> 8. Malfunction Indicator Lamp (MIL) 9. Driver Information Display (DID) 10. Fuel Level 11. Intake Manifold Pressure 12. Hill Start Assist 13. Lower Tell-Tales
--	---

Tachometer

The tachometer has two colored fields: green and red. Use the green field for normal driving (1000 to 1600 rpm). Use higher engine speeds for maximum engine brake performance. Never allow the engine to go into the red field (greater than 2200 rpm). To achieve maximum fuel economy, use the Performance Bonus Guide feature. This feature helps the driver find the most efficient operating range for the engine. See Performance Bonus Guide for more information.

Upper Tell-Tales

The Stop, Check and Info message tell-tales are located in the upper tell-tales box on the instrument cluster. The left and right turn signal indicators, seat belt tell-tale and parking brake tell-tale are also located in the upper tell-tales box. Refer to the Driver Information Display manual for additional information about the message tell-tales.

Speedometer

The speedometer is driven by the vehicle's electronic system.

Front and Rear Brake System Air Pressure Gauges

The system air gauges are connected to the front and rear circuit tanks via sensors mounted on the pass-through wall. The two gauges should register equal air pressure. By observing the gauge pointers, the operator can detect a pressure drop if an air leak develops and can readily identify the circuit affected.

DANGER

Failure to observe these precautions can result in the loss of braking performance. This can lead to a vehicle accident, which can result in personal injury or death.

If the pressure in a brake circuit air tank drops below approximately 420 kPa (65 psi), the red LED light in the lower left corner of the gauge will come on and the STOP tell-tale warning indicator comes on. In addition, the buzzer comes on if the vehicle starts to move at speed higher than 1.6 km/h (1 mph). If the vehicle is stationary, only the STOP tell-tale warning and red LED light appear.



W3005171

Stop Tell-Tale

If the air pressure drops down below 420 kPa (65 psi) in both systems, the spring brakes will automatically engage to stop the vehicle.

Oil Pressure Gauge

DANGER

Failure to take necessary action when the STOP tell-tale is on can ultimately result in automatic engine shutdown and loss of power steering assist. Vehicle crash can occur, resulting in personal injury or death.

The oil pressure limit is dependent on the engine manufacturer's electronic program. When the oil pressure is too low, the red STOP tell-tale illuminates, the buzzer sounds, and the oil pressure symbol appears on the Driver Information Display (DID) screen. For example, if the engine is at risk, the EECU may derate the engine power. Bring the vehicle to a safe stop where the problem can be checked.



W3005171

Stop Tell-Tale

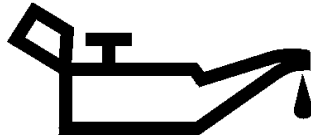

W3003613

Oil Pressure Symbol

Note: The engine will shut down within 30 seconds from when the red STOP tell-tale comes on. Pull off the road as soon as possible without creating a safety hazard.

Coolant Temperature Gauge

The coolant temperature gauge indicates engine coolant temperature. The normal operating temperature for Volvo engines is 80 to 105°C (170 to 215°F). Under normal driving conditions, the temperature must be below the red sector.

The temperature range for the coolant will vary depending on the type of engine, load, grade, ambient air temperature and operating conditions. If the temperature remains below or exceeds the normal temperature range, the cooling system should be checked for problems by an authorized Volvo Truck dealer.

The temperature limit is dependent on the electronic program for the engine model. When coolant temperature is excessive, the red STOP tell-tale will come on and the buzzer will sound. The engine is at risk and the EECU may derate the engine power. Stop at the first safe place where the problem can be checked.



W3005171

Stop Tell-Tale

If the coolant temperature returns to normal shortly after exceeding the limit and no repair is performed, the warning messages go out, but a fault message will be logged.

Middle and Lower Tell-Tales

The middle and lower tell-tales provide vehicle and component status information. For more information, refer to the Driver Information Display manual.

Driver Information Display (DID)

The DID gives the operator necessary and important information about the vehicle and components. For more information about the DID, refer to the Driver Information Display manual.

Fuel Level Gauge

The fuel level gauge is connected to a fuel sensor unit in the fuel tank. There is only one sensor even if the vehicle is equipped with dual tanks.

Intake Manifold Pressure Gauge (High Level Cluster Only)

The intake manifold pressure gauge indicates intake manifold pressure to the engine. The pressure generated by the intake manifold pressure should be the same at a given engine temperature, speed and load. Intake manifold pressure will vary for different engines and vehicle models. By monitoring the gauge, the operator can avoid engine problems.

Application Air Pressure Gauge (High Level Cluster Only)

Air gauges are connected to the air brake system via sensors. They will indicate the brake application pressure from either the front, rear or trailer circuit pressure. The gauge will not register air pressure until the foot brake pedal is depressed or the trailer hand brake is applied.

Exhaust Pyrometer Gauge (High Level Cluster Only)

The exhaust pyrometer gauge indicates the exhaust temperature, which helps the operator get the best efficiency from the engine. Variations in engine load can cause the exhaust temperature to vary. For example, high exhaust gas temperature is the result of prolonged engine lugging or over-fueling. If the pyrometer reading shows that exhaust temperature exceeds normal, reduce fuel to the engine until the exhaust temperature is reduced. Shift to a lower gear if the engine is overloaded.

Exhaust Pyrometer Gauge (High Level Cluster Only)

The exhaust pyrometer gauge indicates the exhaust temperature, which helps the operator get the best efficiency from the engine. Variations in engine load can cause the exhaust temperature to vary. For example, high exhaust gas temperature is the result of prolonged engine lugging or over-fueling. If the pyrometer reading shows that exhaust temperature exceeds normal, reduce fuel to the engine until the exhaust temperature is reduced. Shift to a lower gear if the engine is overloaded.

3. Trailer Air Supply Valve

The trailer air supply valve is a red octagonally-shaped knob. Pull the knob to apply the trailer emergency brakes. Push the knob to pressurize the trailer air reservoir and release the trailer emergency brakes. The trailer air supply valve should not be used for parking. For additional information about the trailer air supply valve, refer to “Parking Brake/Trailer Supply Valves”, page 282.

4. Tractor Parking Brake Valve

The tractor parking brake valve is a yellow diamond-shaped knob. Pull the knob to apply the tractor parking brakes. Push the knob to release the tractor parking brakes. The tractor parking brake valve applies the tractor parking brakes and the trailer brakes, if equipped. For additional information about the tractor parking brake valve, refer to “Parking Brake/Trailer Supply Valves”, page 282.

5. Inter-Wheel Differential Lock

The inter-wheel differential lock eliminates one-wheel spin-out on slippery surfaces and improves traction. The switch has a safety latch to prevent accidental engagement.

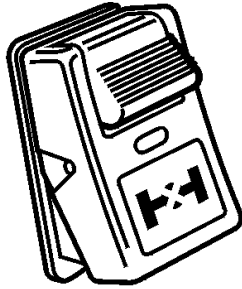
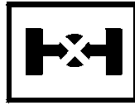

T4015831

Interwheel Differential Lock

When the lock is engaged, a telltale lights up in the instrument cluster.



T3014470

Inter-Wheel Tell-Tale

A differential lock should only be used on a slippery surface, NOT when driving on good road conditions. If a differential lock telltale is activated in the instrument cluster, do not make turns until the telltale has gone out. Refer to INSERT HEAD REF for information on how to properly engage and drive with differential locks engaged.

6. Inter-Axle Differential Lock

The inter-axle differential lock eliminates slipping between axles to improve traction. The switch has a safety latch to prevent accidental engagement.

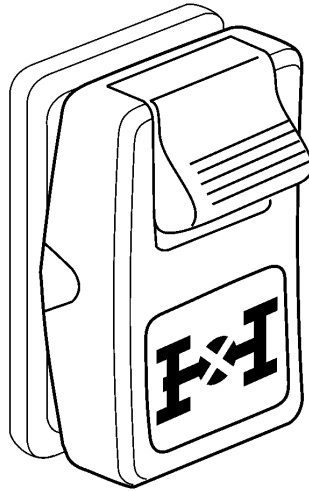

W3028391

When the lock is engaged, a tell-tale lights up in the instrument cluster.



W3006119

Inter-Axle Tell-Tale

A differential lock should only be used on a slippery surface, NOT when driving on good road conditions. If a differential lock tell-tale is activated in the instrument cluster, DO NOT make turns until the tell-tale has gone out. Refer to “AXLES”, page 342 "AXLES" for information on how to properly engage and drive with differential locks engaged.

72 INSTRUMENTS AND CONTROLS

7. Idle Management Indicator Lamp (CUMMINS ISX ICON)

For more information on this lamp, please refer to your vendor engine manual supplied with this vehicle.

OR

Electronically Controlled Suspension (ECS) (ON/OFF)

For more information on this lamp, please refer to your vendor engine manual supplied with this vehicle.

OR

Lift Axle

The vehicle may be equipped with auxiliary lift axles. The lift mechanism operates with air pressure. Press the top part of the switch to raise the axle and press the lower part of the switch to lower the axle. For information about lift axles, refer to “AXLES”, page 342.

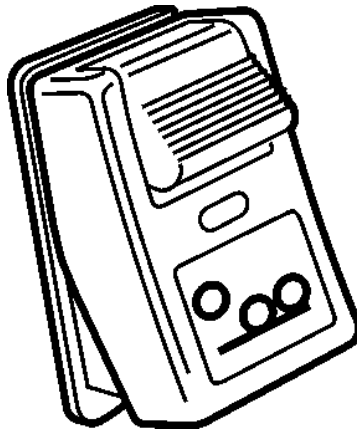

W3005503

Pusher Axle

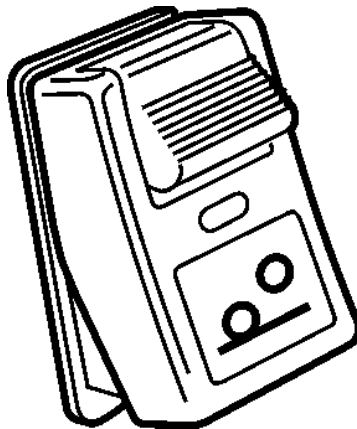

W3005507

Tag Axle

OR

Optional Switch

8. Electronically Controlled Suspension (ECS) (Up/Down)

This is the switch that is defined by the body builder.

OR

74 INSTRUMENTS AND CONTROLS

Lift Axle

The vehicle may be equipped with auxiliary lift axles. The lift mechanism operates with air pressure. Press the top part of the switch to raise the axle and press the lower part of the switch to lower the axle. For information about lift axles, refer to “AXLES”, page 342.

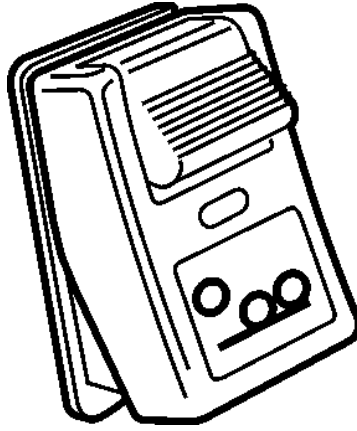

W3005503

Pusher Axle

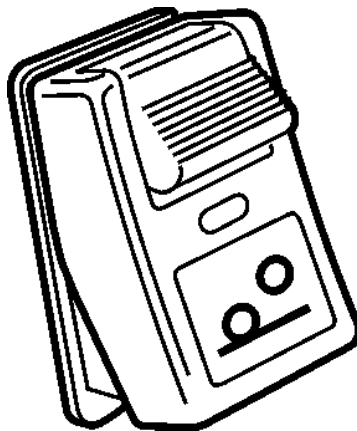

W3005507

Tag Axle

OR

Optional Switch

9. Auxiliary Switches

Generic switches are available for auxiliary functions that are installed by the customer. These switches can be purchased from your authorized Volvo Truck dealer.

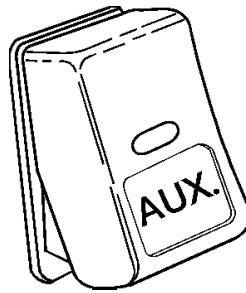

W3005502

Auxiliary Switch

Auxiliary Switches

Generic switches are available for auxiliary functions that are installed by the customer. These switches can be purchased from your authorized Volvo Truck dealer.

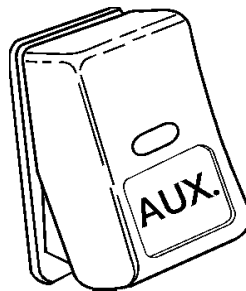

W3005502

Auxiliary Switch

Lift Axle

The vehicle may be equipped with auxiliary lift axles. The lift mechanism operates with air pressure. Press the top part of the switch to raise the axle and press the lower part of the switch to lower the axle. For information about lift axles, refer to "AXLES", page 342.

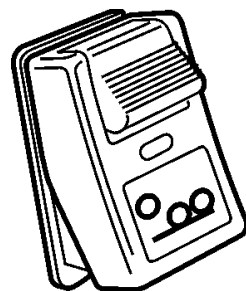

W3005503

Pusher Axle

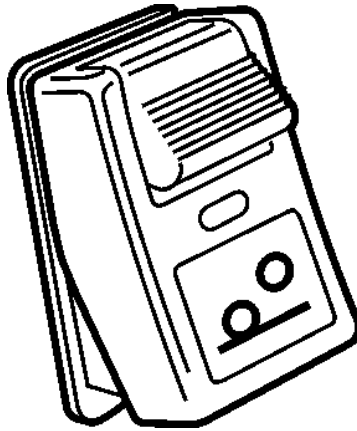

W3005507

Tag Axle

Auxiliary Switches

Generic switches are available for auxiliary functions that are installed by the customer. These switches can be purchased from your authorized Volvo Truck dealer.

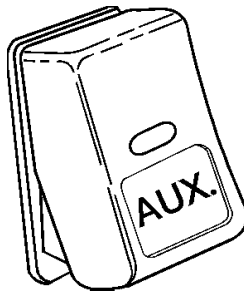

W3005502

Auxiliary Switch

12. and 13. Secondary Gauge Cluster

The secondary gauge is an optional feature, which is available only with the Mid and High level instrument clusters. The instrument cluster receives temperature information from the datalink and then passes the information to the secondary gauge for viewing.

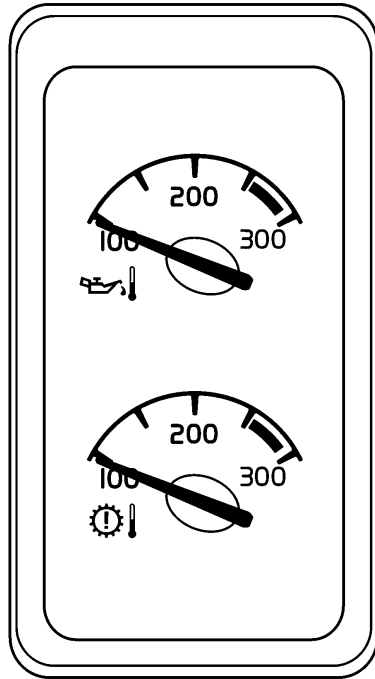

W3006081

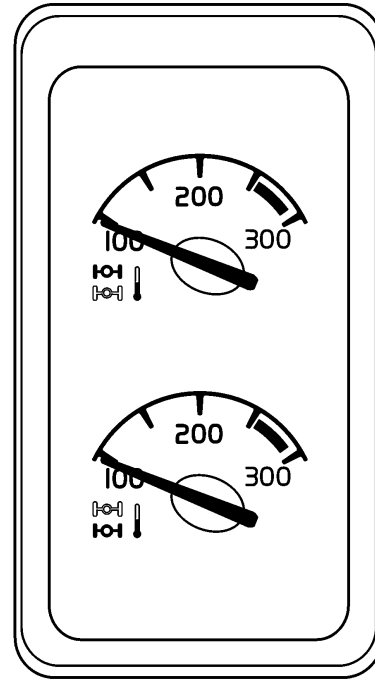

W3006082

Engine/Transmission Temperature Gauge

Front/Rear Axle Temperature Gauge

14. Engine Brake

For more information about the engine brake, see “Volvo Engine Brake (I-VEB)”, page 272.

OR

I-Shift Eco-Roll

For more information on this feature, please refer to the I-Shift Transmission Manual supplied with your vehicle.

15. Engine Brake Mode Select (ISX)

For more information about the engine brake, see “Volvo Engine Brake (I-VEB)”, page 272.

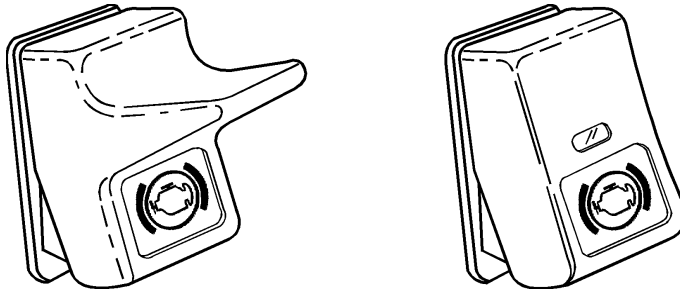

W3002303

OR

I-Shift Hill Start Assist

For more information on this feature, please refer to the I-Shift Transmission Manual supplied with your vehicle.

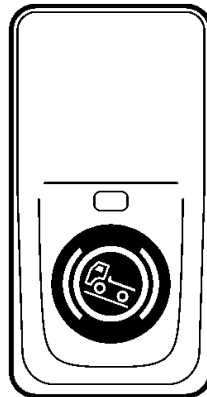

W3028392

OR

Optional Switch

16. Fifth Wheel Touch Lock.

DANGER

Activation of the kingpin lock release switch **ONLY** unlocks the kingpin latch mechanism. To relock the latch mechanism, you **MUST** pull forward and then back up to re-engage the kingpin lock mechanism. Failure to follow these instructions can result in separation of the trailer from the tractor causing personal injury or death.

- Park the vehicle and apply parking brake for tractor trailer.
- Put gearshift in neutral and chock trailer wheels.
- Lower trailer landing gear to ground.
- Disconnect air/electric lines to trailer.
- To release the fifth wheel kingpin lock, push the switch up. This will

release the locking mechanism. Once activated, the switch will not relock the fifth wheel kingpin locking mechanism.

- Release parking brake and drive tractor 12 inches away from the kingpin.
- Deflate air suspension by pressing bottom of suspension switch. After suspension lowers, pull clear of trailer and reinflate suspension. See “FIFTH WHEEL INSTRUCTIONS”, page 313.
- The fifth wheel kingpin lock will only relock if you follow the complete recoupling procedures. See “FIFTH WHEEL INSTRUCTIONS”, page 313.

For more information, refer to “FIFTH WHEEL INSTRUCTIONS”, page 313.

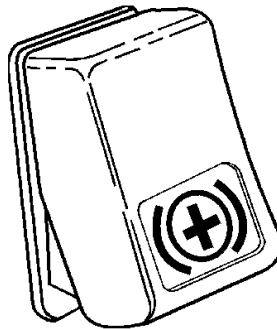

17. Marker Interrupt Switch

This switch interrupts power to the marker lights when held down. When released, it springs back to the ON position and returns power to the marker lights.

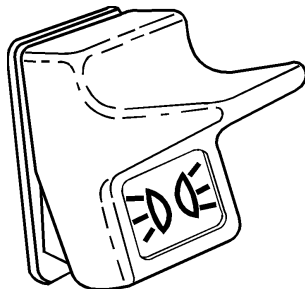

W3001352

Marker Interrupt Switch

18. Secondary Gauge Cluster

The secondary gauge is an optional feature, which is available only with the Mid and High level instrument clusters. The instrument cluster receives temperature information from the datalink and then passes the information to the secondary gauge for viewing.

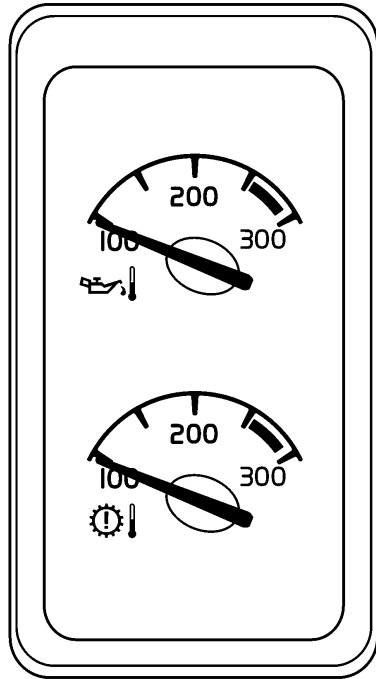

W3006081

Engine/Transmission Temperature Gauge

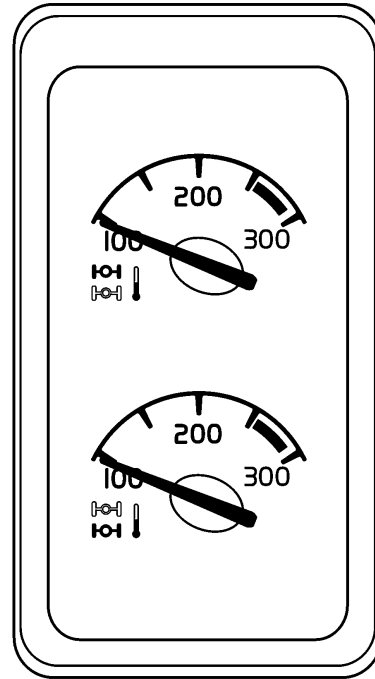

W3006082

Front/Rear Axle Temperature Gauge

OR

Optional Switch

19. Traction Control Shut-Off Switch (TCS)

If the vehicle is equipped with a Traction Control System (TCS), the switch can be used to disable the traction control feature, and therefore increase wheel spin. This may be useful for decreasing the chances of getting bogged down when driving in heavy snow, slush or muddy conditions. Refer to Volvo Exhaust Brake for more information.

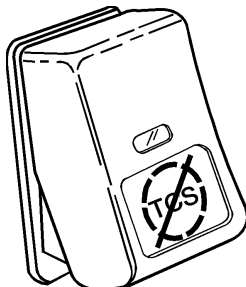

W3001336

Traction Control Switch

20. Suspension Dump Switch

Vehicles with rear air suspension have a control for deflating the air springs. Use this feature when uncoupling from trailers. See “FIFTH WHEEL INSTRUCTIONS”, page 313 for correct operation when uncoupling.

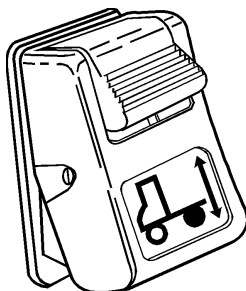

W3001341

Suspension Dump Switch



CAUTION

The vehicle must never be driven with the air springs deflated. Damage to air suspension parts will occur if springs are not inflated properly.

The suspension dump switch has a safety latch to prevent accidental engagement. Depress the latch and press in the bottom part of the switch to deflate the air springs. A tell-tale in the instrument cluster will light up when the switch is in the ON position. This switch controls a chassis-mounted electric over air solenoid valve. When the switch is rocked down to the ON position and the ignition switch is turned to the OFF position, the solenoid valve will no longer have power and the suspension will inflate.

21. Fifth Wheel Slide Switch

DANGER

The release must never be operated while the vehicle is operating on the road. Fifth wheel position adjustment must only be done when stationary. Damage to the fifth wheel, trailer kingpin and slider may occur if not operated properly and may lead to an accident, causing serious personal injury or death.

The sliding fifth wheel uses an air-operated release mechanism and is used for distributing loads more favorably between the front and rear axles to comply with varying state and provincial laws. Depress the latch and press in the bottom part of the switch to release the slider locks. See “Operating the Fifth Wheel Slider”, page 332 for correct operation.

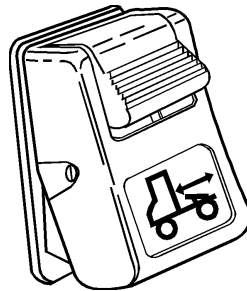

W3001346

Sliding Fifth Wheel Switch

84 INSTRUMENTS AND CONTROLS

OR

Engine Air Control Switch

The engine fresh air control switch controls air flow to the engine air cleaner. In the normal OFF position, air is pulled through the side hood vent, and into the air cleaner. In the ON position, air is pulled from within the engine compartment into the air cleaner. This feature is useful for keeping out cold air or snow for example, when using a snow plow.

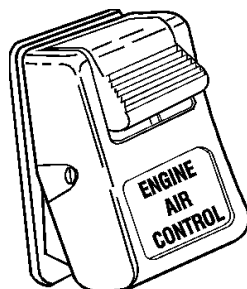

W3005380

Engine Air Control Switch

22. Air Vent

For information about air vents, refer to “Fresh Air Vent”, page 134.

23. Radio

For information about the radio, refer to the radio operating instructions manual.

24. - 28. Cab Climate Controls

For information about cab climate controls, refer to “CLIMATE CONTROL SYSTEMS”, page 98.

29. Trailer Hand Brake Control

The trailer hand brake control engages the trailer brakes. For information about the trailer hand brake control, refer to “Trailer Brake Hand Control”, page 288.

30. Passenger Window Control Switch or Optional Switch

The trailer hand brake control engages the trailer brakes. For information about the trailer hand brake control, refer to “Trailer Brake Hand Control”, page 288.

31. Water-In-Fuel (Purge Switch) (Optional)

The water-in-fuel drain switch is a non-locking switch used to drain the fuel water separator on Volvo engines.

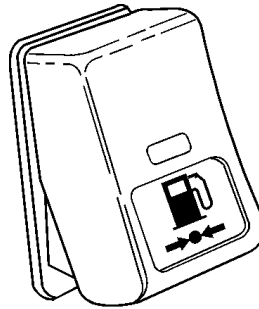

W3005378

Water-In-Fuel Drain Switch

A symbol displayed in the instrument panel indicates when it is recommended to drain the water separator.

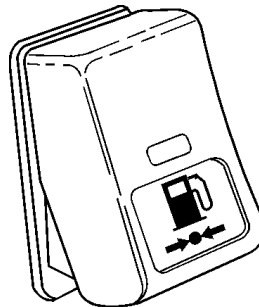

W3005378

Water-In-Fuel Symbol

Stop at the first opportunity and drain the water separator. If the warning symbol frequently recommends that the water separator be drained, then there is a problem with the fuel quality. Drain the fuel tank and refill with fuel of the correct quality.

Draining Procedure

Note: If the engine is started before draining is complete, the process is interrupted.

- 1 Stop the vehicle.
- 2 Apply the parking brake.
- 3 Turn off the engine.
- 4 Place a container under the water separator.
- 5 Turn the ignition key counterclockwise to the "Radio, Accessories" position.
- 6 If the vehicle is equipped with a Mid Instrument Cluster, press the Water-In-Fuel Drain Switch.
- 7 If the vehicle is equipped with a Mid or High Level Instrument Cluster, select "Vehicle Setting"/"Drain Water in Fuel" in the Driver Information Display menu. Press Enter (↵) to request draining. The following menu is displayed.

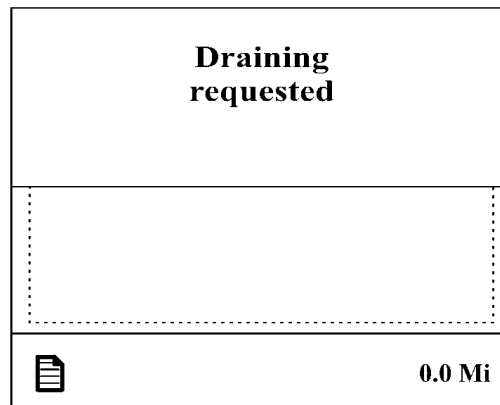

W3028406

- 8 Wait until the water has stopped draining.
- 9 Empty the container in a place where the contents will not cause environmental damage.

33. Sleeper Fan Speed Switch

The sleeper fan switch located in the dash, controls the sleeper fan speed. The switch in the sleeper control module performs the same function as the dash switch. Press the top part of the switch to increase the fan speed, press the lower part to decrease fan speed.

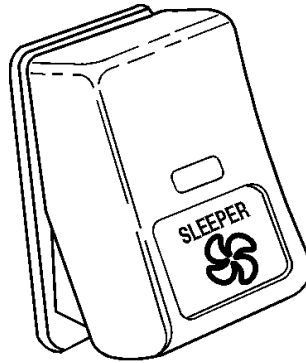

W3005382

Sleeper Fan Speed Switch

Snow Plow Lamps

Vehicles specified with this option have the following:

- Turn ON low beam snow plow head lamps.
- Turn OFF main head lamps, high beam, fog and driving lights.
- In driving mode, DRL remains ON.
- Snow plow direction indicators are available.

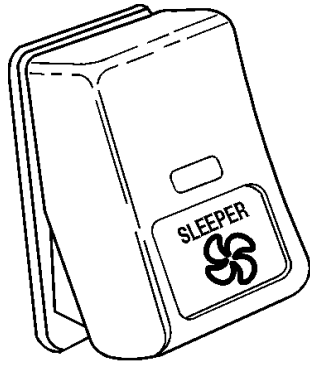

W3005382

Sleeper Fan Speed Switch

34. Beacon Lamps Switch

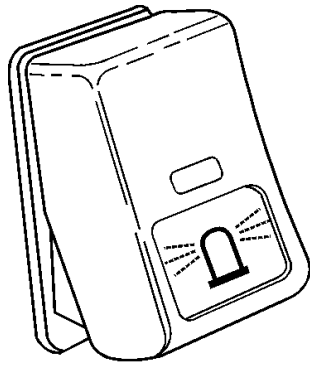

W3005428

Sleeper Fan Speed Switch

OR

Optional Switch

35. Back of Cab Light Switch (Optional)

To activate the back of cab light, press the bottom part of the switch. The light will stay on until the switch is turned to the OFF position. Back of cab lights are available as a flush-mounted light in the middle of the cab rear wall or as a high-mounted light on the side of the cab.

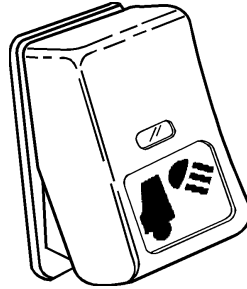

W3001355

Back of Cab Light Switch

36. Optional Switch

37. Power Take-Off

For information about the PTO, refer to “Power Take-Off (PTO)”, page 91.

OR

Optional Switch

38. Sleeper Overhead Bunk Lamp

This switch operates the overhead lighting in the VN sleeper cabs. It is situated on the left-hand side of the dash to allow access to the switch without entering the sleeper section of the cab. Press the bottom of the switch to turn the light ON, press the top of the switch to turn the light OFF.

The switch works together with the switch on the sleeper control panel.

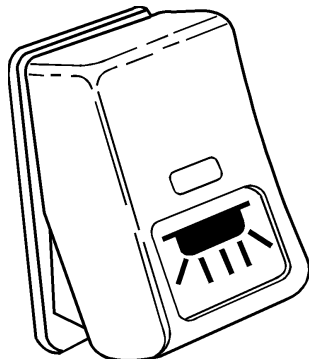

W3001351

Sleeper Overhead Bunk Lamp

OR

Passenger Side Mirror IN/OUT

OR

Power Take-Off

For information about the PTO, refer to “Power Take-Off (PTO)”, page 91.

39. Side Mirror Heat

This switch operates the overhead lighting in the VN sleeper cabs. It is situated on the left-hand side of the dash to allow access to the switch without entering the sleeper section of the cab. Press the bottom of the switch to turn the light ON, press the top of the switch to turn the light OFF.

The switch works together with the switch on the sleeper control panel.

OR

Power Take-Off

For information about the PTO, refer to “Power Take-Off (PTO)”, page 91.

For information about the inverter, refer to “Inverter Switch 12 V DC to 120 V AC”, page 140.

41. Optional Switch

42. Optional Switch

43. Power Outlet

For information about power outlets, refer to “12 Volt Power Outlets”, page 137.

41. Microphone

The microphone is located above the driver in the headliner. It is available on the Mid-Level radio with Blue Tooth/Hands free option. This is what is used to talk into when the phone is connected to the truck. For more information on the microphone, please refer to the Radio Manual that is supplied with the vehicle.

DASH SWITCHES

Power Take-Off (PTO)

There are two basic types of PTOs available: engine-mounted and transmission-mounted.

The transmission-mounted PTO is clutch dependent, which means that operation can be regulated by depressing or releasing the clutch pedal. This PTO should NOT be in use while driving.

The engine-mounted PTO is direct-mounted to the engine and is engaged with a bypass valve operated by the switch. This PTO can be in use while driving.



CAUTION

It is important to only engage the switch when the PTO is required. Leaving the PTO pump engaged when not needed can lead to poor performance and pump damage.

Transmission-Mounted PTO

The transmission-mounted PTO is clutch dependent, which means that operation can be regulated by depressing or releasing the clutch pedal. This PTO should NOT be in use while driving.

Engage the PTO by depressing the clutch pedal and pressing in the bottom part of the switch. Release the clutch pedal to start the PTO.

One or two PTOs can be run at the same time. Applications change depending on customer needs and components.

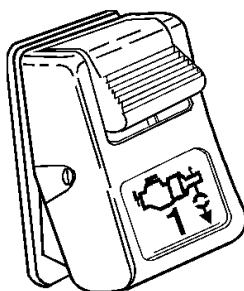

W3005510

Engine-Mounted PTO, VN

The engine should be running at low idle and the vehicle should be stopped or running at very low speed before engaging power take-off. Engage the PTO by depressing the locking tab and at the same time, depressing the main part of the switch. The PTO is now in operation and hydraulic flow can be regulated by the engine speed.

PTO Speed Adjustment

Engage the PTO before adjusting the speed. For the PTO speed adjustment to function, the Cruise Control or idle adjust cannot be active, brake and clutch pedals must be released, and vehicle speed must be under approximately 8 km/h (5 mph).

To set engine speed:

- 1 Set the PTO/CC switch in the ON position.
- 2 Depending on configuration, the engine speed may automatically be selected when the PTO dash switch is activated (Volvo engines only).
- 3 If NOT, then
 - **Volvo engines:** Press the RESUME button to achieve the preset PTO engine speed. Alternatively, the accelerator pedal can be used to achieve the desired engine speed, and press SET+ or SET- to hold that speed
 - **Cummins engines:** Press either the RESUME, SET+, or the RESUME and SET+ buttons simultaneously to achieve one of three possible preset speeds.

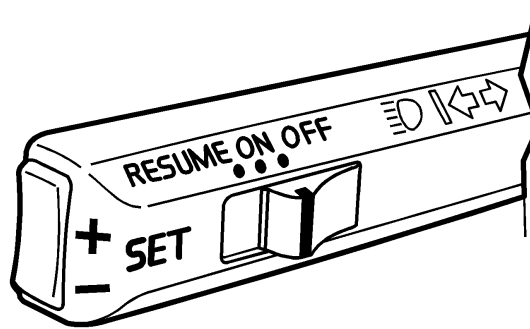

W3002499

To increase/decrease engine speed:

- 1 **Volvo engines:** Press and release the SET+ or SET- toggle switch to increase/decrease speed in increments (increment size depends on programmed value).
- 2 Cummins engines: Press and hold the SET+ or SET- toggle switch to increase/decrease speed. When the switch is released, the engine speed sets at current speed.

To deactivate PTO speed function. Set the PTO/CC switch to the OFF position.

or

2. Depress the service brake pedal.

or

3. Depress the clutch pedal (Programmable).

or

4. Increase vehicle speed above PTO working range (typically 8 km/h [5 mph]).

Engine Brake



DANGER

When operating your tractor bobtail (without a trailer) or on slippery roads, the engine brake switch must be in the OFF position. Failure to follow these instructions can result in loss of vehicle control, serious personal injury or death.



DANGER

A vehicle speed retarding device is not intended to replace the service brake system on your vehicle nor intended to bring your vehicle to a stop. A vehicle speed retarding device is only intended to retard the speed of your vehicle under certain conditions.

Using the retarding device as a brake could result in loss of vehicle control and personal injury or death.

Note: It is normal for a slight delay to occur in the application of a vehicle speed retarding device. When using a device of this type, be sure to think ahead and analyze conditions in order to use the device properly.

Several types of engine brakes can be installed or are standard on certain engines. All are used to reduce wear on the vehicle brake linings.

Several types of engine brakes can be installed or are standard on certain engines. All are used to reduce wear on the vehicle brake linings.

Volvo Variable Geometry Turbo Brake VN

The variable geometry turbo brake is standard equipment on the Volvo 11F and 13F engines. Software is used to close the variable geometry turbocharger, creating retardation. The switch for exhaust brake has two positions: ON/OFF.

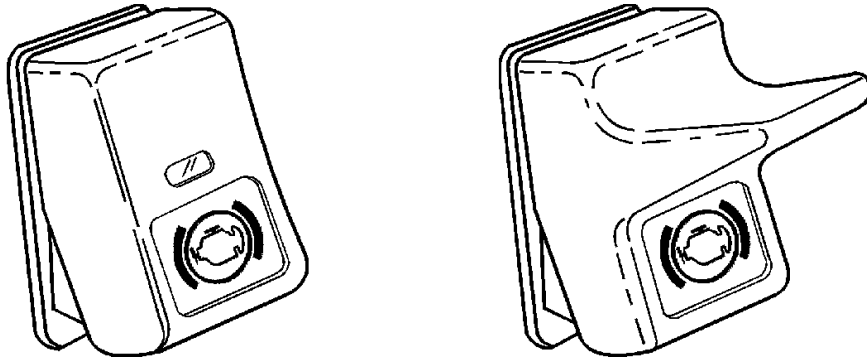

W3005433

Volvo Engine Brake I-VEB

The Volvo Engine Brake (I-VEB) works together with the variable geometry turbocharger to provide retarding horsepower at low engine rpm. The I-VEB is standard equipment on the Volvo 16F engine and optional on the 13F and 11F engines. The I-VEB has a six position control located on the steering column, just forward of the wiper stalk.

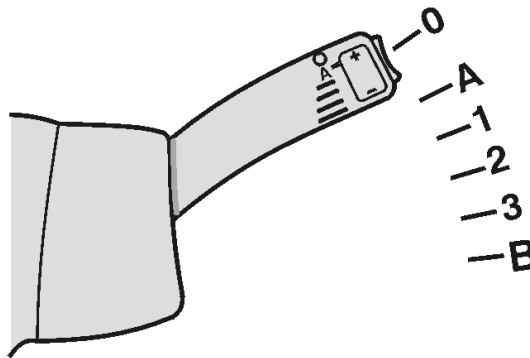

T5012243

- O = Off
- A = Engine Brake Cruise Control ? In this position when Cruise Control is enabled and vehicle speed exceeds the set cruise speed, the I-VEB will engage with infinite control (within the limits of the engine brake) to maintain that speed
- 1 = 40% Engine Braking
- 2 = 70% Engine Braking
- 3 = 100% Engine Braking
- B = I-Shift Brake Program — When ordered in conjunction with the Volvo I-Shift Transmission, the controls are integrated

Cummins ISX Intebrake

Standard: Two dash switches control the 3-level engine brake; the left dash switch controls ON/OFF, the right dash switch controls LOW/MED/HIGH.

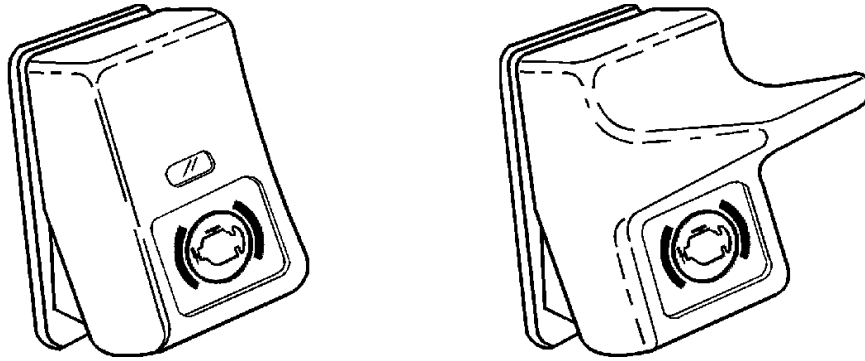

W3005433

Optional: A 6-level retarder stalk switch mounted to the right of the steering column. An ON/OFF switch at the end of the stalk lever enables/disables the engine brake.

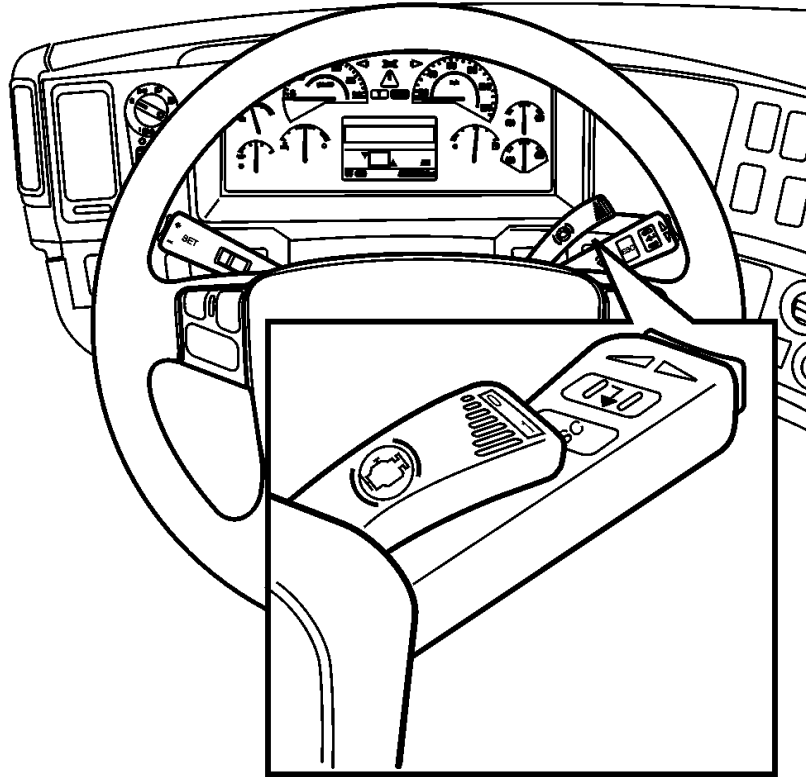

W3005373

CLIMATE CONTROL SYSTEMS

There are two different air conditioning systems. Depending on your vehicle, you will have one of these two air conditioning units installed:

- 1 Electronic Climate Control (EEC)
- 2 Manual Climate Control (MCC)

Note: For both climate control systems (ECC and MCC), after a pre-determined number of "vehicle starts" the climate unit will recalibrate the door positions, which may take several seconds before the airflow returns to the selected distribution mode.

AIR CONDITIONING ELECTRONIC CLIMATE CONTROL (ECC)

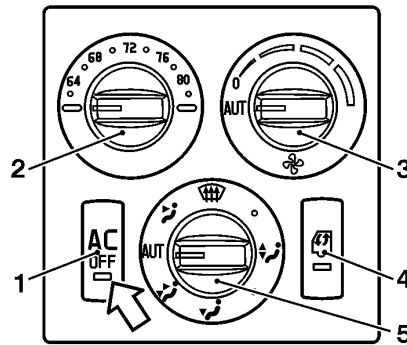

W8003062

- 1 **AC OFF** button: turns the air conditioning OFF. The arrow in the illustration shows the LED light which is AMBER or RED indicating the AC compressor is OFF. The ECC will still try to maintain the selected temperature in the cab without the compressor.
- 2 Temperature Knob
- 3 Fan Speed Knob
- 4 Recirculation Button
- 5 Air Distribution Knob

Recirculation

Press recirculation to circulate the air in the cab. Only a small amount of air is taken directly from outside.

The light in the button comes on when the button is pressed for air recirculation.

Temperature Control Settings ECC

Maximum Cold Setting

The temperature knob should be set to the far left. The fan speed knob should be set to AUTO and the air distribution knob should be on AUTO.

Maximum Heat Setting

The temperature knob should be set to the far right. The fan speed knob should be set to AUTO and the air distribution knob should be on AUTO.

Normal Setting

When the temperature control is set to any temperature between 18°C and 27°C (64°F and 80°F), the ECC automatically adjusts itself close to the selected temperature, similar to a thermostat

Fan Speed

The fan speeds are 1 through 4. The fan will not operate when "0" is selected, but air will flow when set to fresh air mode due to ram air effect when the truck is moving.

- The ECC automatically circulates air at fan speed 4 when there is a big difference between the selected temperature and the temperature measured by the in-cab sensor. However, as the temperature in the cab gets closer to the selected temperature, the fan speed begins to slow down.
- If maximum cold or maximum heat are selected, the ECC automatically circulates air at fan speed 4 when AUT is selected. At any other selected fan speed the system adjusts and conforms to the chosen speed.

Mist and Ice Removal

**DANGER**

DO NOT attempt to drive with the windshield covered by mist, or fog or frost. The visibility is reduced, which could lead to an accident causing severe personal injury or death.

- 1 Turn knob to defrost.
- 2 Rotate the temperature knob to add heat as necessary.
- 3 Set the fan speed knob to maximum (the extreme right).

Use these instructions to keep the windshield clear at all times. Maximum heat output for fast defrosting can only happen after the engine has reached operating temperature. While driving in extreme cold, adding heat to the windshield may change drifting snow to ice, in this case, setting the air distribution to floor and/or panel only may allow the drifting snow to be brushed off by the windshield wiper. Clean the inside of the window using normal window cleaner in order to minimize the risk of misting. Clean more often if a passenger smokes in the cab.

ECC Air Distribution

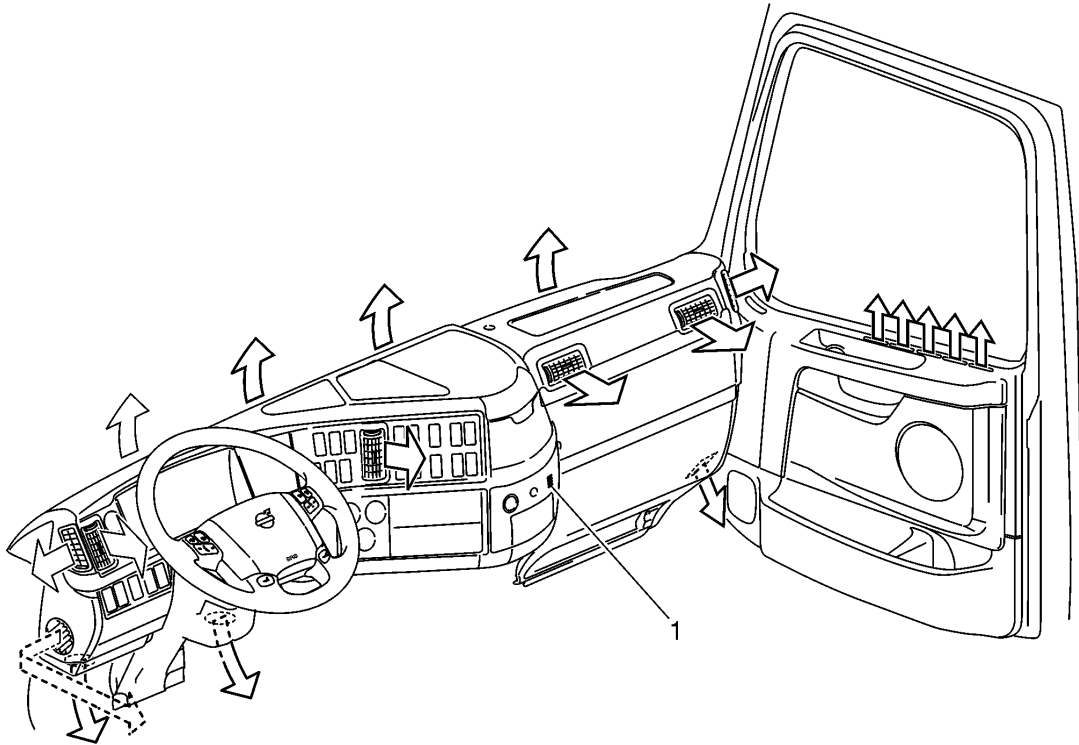

W8003067

1 Temperature Sensor

CAUTION

The temperature sensor shown in the illustration, detects the temperature in the cab. DO NOT cover the sensor, and DO NOT place warm objects, like coffee makers or refrigerators, close to the sensor.

Always allow the dashboard vents (see arrows in illustration) to remain open. Irrespective of how the air distribution is set, a small amount of air will always come from the dashboard vents to ensure the temperature in the cab is correct.

Note: Floor Mode: Unheated air is leaked to the panel vent to balance the heat rising from the floor.

AIR CONDITIONING MANUAL CLIMATE CONTROL (MCC)

One difference in the Manual Climate Control unit is the AC ON button.

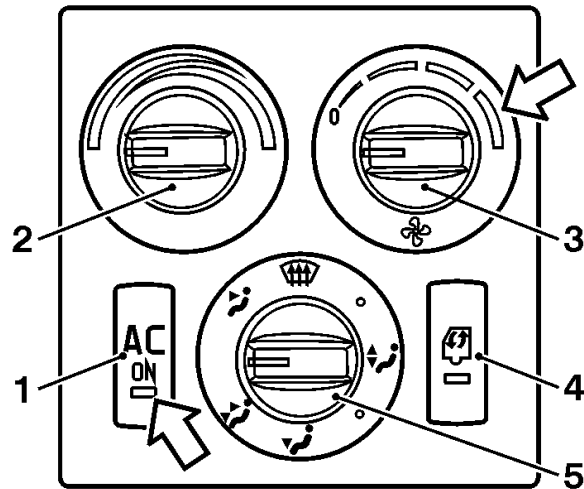

W8003066

- 1 AC ON button turns the air conditioning ON.
- 2 Temperature Control Knob
- 3 Fan Speed Knob
- 4 Recirculation Button
- 5 Air Distribution Knob

Note: The LED light is green when the AC button is depressed. When the AC ON button is NOT depressed and the compressor or AC is heard, this is not a fault in the system. The AC will operate in defrost mode whether the AC ON button is depressed or not.

Recirculation

Press recirculation to circulate the air in the cab. Only a small amount of air is taken directly from outside.

The light in the button comes on when the button is pressed for air recirculation.

Temperature Control Settings MCC

Move the knob to the blue bar for cool air to circulate in the cab, and to the red bar for warm to hot air to circulate in the cab. Select the desired fan speed starting from 1 to 4. "0" is not a fan speed.

Mist and Ice Removal

 **DANGER**

DO NOT attempt to drive with the windshield covered by mist, or fog or frost. The visibility is reduced, which could lead to an accident causing severe personal injury or death.

- 1 Turn knob to defrost.
- 2 Rotate the temperature knob to add heat as necessary.
- 3 Set the fan to maximum (the extreme right).

Use these instructions to keep the windshield clear at all times. Maximum heat output for fast defrosting can only happen after the engine has reached operating temperature. While driving in extreme cold, adding heat to the windshield may change drifting snow to ice, in this case, setting the air distribution to floor and/or panel only may allow the drifting snow to be brushed off by the windshield wiper.

Clean the inside of the window using normal window cleaner in order to minimize the risk of misting. Clean more often if a passenger smokes in the cab.

MCC Air Distribution

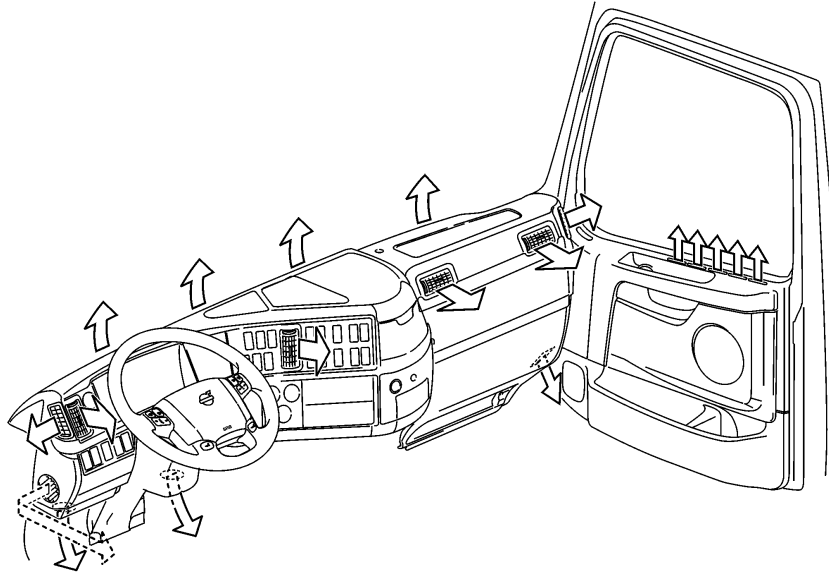

W8003110

Always allow the dashboard vents (see arrows in illustration) to remain open. Irrespective of how the air distribution is set, a small amount of air will always come from the dashboard vents to ensure the temperature in the cab is correct.

Note: Floor Mode: Unheated air is leaked to the panel vent to balance the heat rising from the floor.

 **DANGER**

Diesel engine exhaust and some of its content are known to the state of California to cause cancer, birth defects or other reproductive harm.

If at any time there is any question whether fumes are entering the cab, determine the cause of the fumes and have it corrected as soon as possible. If the vehicle must be driven under these conditions, drive only with all windows open.

Protect against carbon monoxide entry into the cab. Keep the engine exhaust system, cab and cab ventilation system properly maintained. It is recommended that the exhaust system and cab are inspected by a competent technician:

- At every engine oil change.
- Whenever a change is noticed in the sound of the exhaust system.
- Whenever the exhaust system, underbody or cab is damaged.

To allow proper operation of the vehicle ventilation system, keep the inlet grille at the base of the windshield clear of snow, ice, leaves and other obstructions at all times.

DO NOT park the vehicle and let the engine run or idle for more than 10 minutes with the ventilation system control switch in the OFF position. Even with the ventilation system ON, running the engine while parked or stopped for long periods of time is not recommended. Entry of carbon monoxide into the cab is possible with a poorly repaired, damaged or corroded exhaust system or cab.

DO NOT run the engine in confined areas, such as garages or next to a building, any more than necessary. The area must be properly ventilated. When the vehicle must be stopped with the engine running for more than a few minutes:

- Adjust the heating or cooling system to force outside air into the cab. Do this by setting the fan to medium or high speed and with the controls set in any position except for recirculation of air inside of the cab.
- Keep the exhaust pipe area clear to help reduce the buildup of exhaust gas under the vehicle.

SLEEPER CLIMATE UNIT

The sleeper cabs have an A/C and heater unit that is located in the passenger side luggage compartment. The sleeper unit operates from the same heater and air conditioning supply as the main unit. The heater can be operated independently from the main unit as long as the engine is running.

For the air conditioning to operate, the engine must be running, the air conditioning button must be pressed in and the fan control must be set at least for speed 1 on the main control panel.

Air is taken from the sleeper area through a filter in the lower bunk support wall and heated or cooled in the "underbunk" unit. Outlet air can be directed with the vents in the side walls.

For the best results when using the air conditioning, direct the air flow upward in the sleeper area.

LIGHT CONTROL PANEL

Exterior lighting is controlled through the light control panel. The rotary knob controls the parking lights, headlights, and the optional fog and driving lights. The panel also has a dimmer control switch and hazard switch.

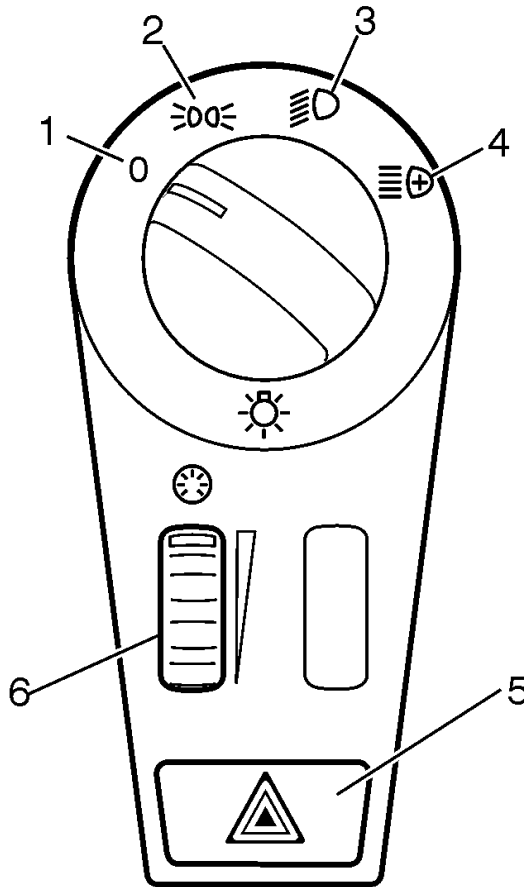

W3005377

- 1 Off
- 2 Parking Lights
- 3 Headlights
- 4 Fog and Driving Lights (Optional)
- 5 Hazard Lights
- 6 Dimmer Control

Fog and Driving Lights

Fog and driving lights are wired so they are turned on only when the headlight control is on. Fog lights are used with the low beam headlights. Driving lights are used with the high beam headlights. Switching from low to high beam will automatically switch from fog lights to driving lights. Driving and fog lights should be used when driving conditions require additional lighting. The driving or fog lights should NOT be used in traffic where they might distract other drivers thereby creating a safety hazard.

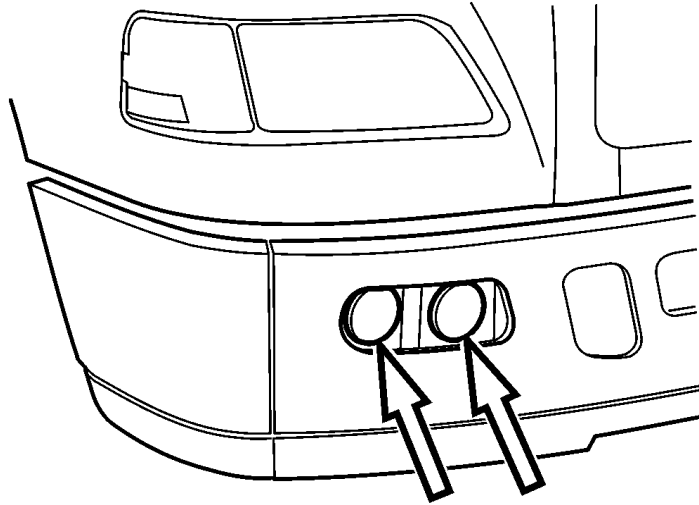

W3005410

VNM Fog and Driving Lights

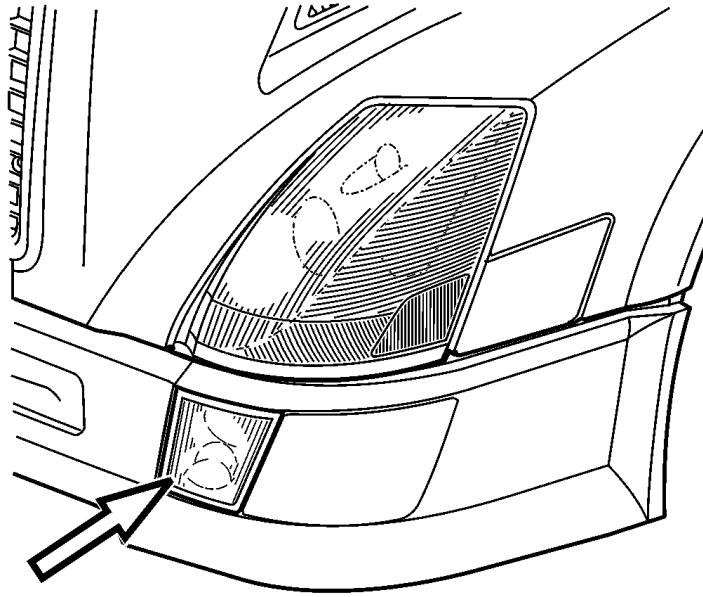

W3005274

VNL Fog and Driving Lights

SLEEPER CONTROL PANEL (SLEEPER MODELS ONLY)

The sleeper control module is located behind the driver's seat. It provides precise temperature control to the sleeper unit. There are separate temperature and fan control systems for the sleeper and the cab area. The driver can control the fan speed in the sleeper using a control switch on the dash. Also, radio controls are available.

Note: If an error occurs while using the Sleeper Control Panel, restart the unit to verify if the error clears out. If the error continues to appear on the unit's display screen, bring in the vehicle for servicing.



CAUTION

To avoid component damage, do not use alcohol based cleaners on the Sleeper Control Panel display screen.



CAUTION

Do Not place magnets or electro-magnetic devices near the Sleeper Control Panel. Doing so may result in damage to the module.

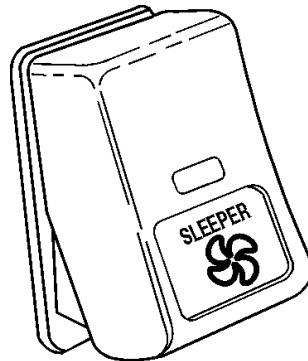

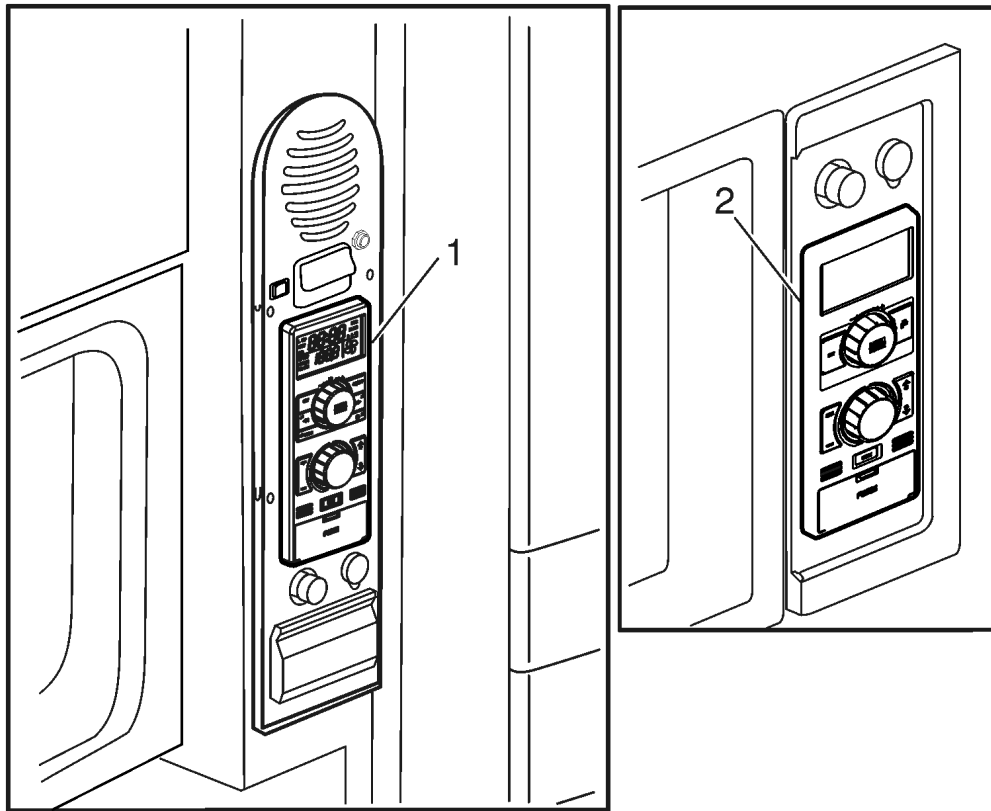

W3030107

1 Panel in VN 730 ,780 and

2 Panel in VN 430, 630, 670

Note: High Sleeper or Basic Sleeper Control Panel are **NOT** cab model dependent

This dual control usage provides optimum comfort to the driver and passenger (if any) in both compartments. The sleeper control module is used to operate the following:

- Auxiliary Heating, Venting and Air Conditioning
- Alarm Clock/Timer
- Interior Sleeper Lights
- Circuit Protection (fuses)
- Low Voltage Disconnect (LVD) Alert and Override Control
- Parking Heater (Optional)
- Parking Heater Shutdown (user selectable) with LVD option only
- Lighting Timer
- Panic (Horn) Switch
- Radio Control (High Version Only)

Sleeper Controls

Sleeper Control Panel, High

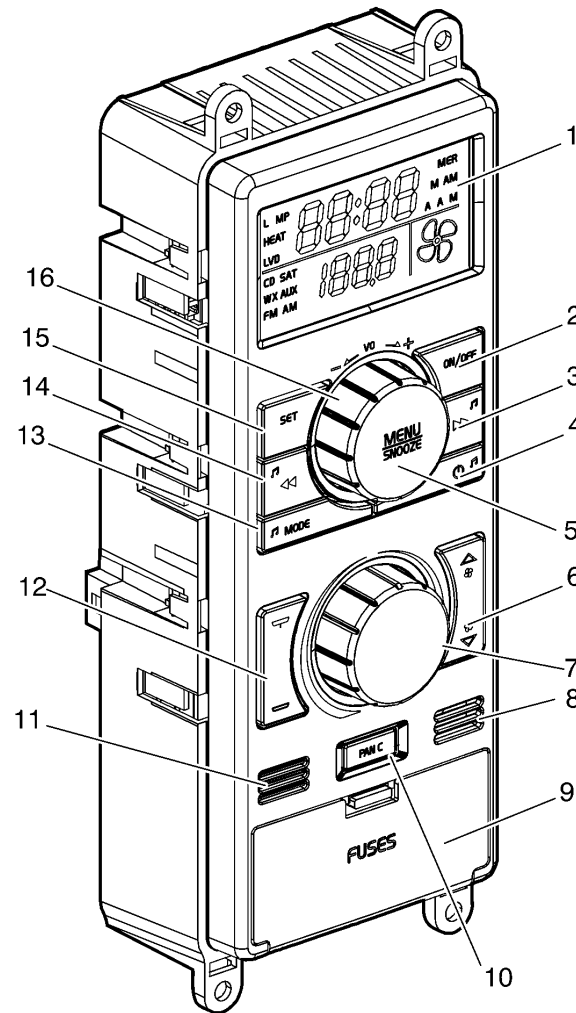

W3030106

- 1 Display Screen: Displays selected information.
- 2 On/Off button
- 3 Radio Forward Scan/Search/Next Track
- 4 Radio Power
- 5 Menu/Snooze Button: This button allows you to adjust settings in the display screen and activate the clock's snooze option.
- 6 Fan Speed Control and Battery Protection Override Switch: This can be controlled from the sleeper control module or from the dash rocker switch.
- 7 Temperature Control Knob: Controls temperature for the Parking Heater and the Auxiliary Heating, Venting and Air Conditioning (A-HVAC).
- 8 Speaker: Sounds when the alarm or timer goes off, or when entering battery protection mode.

9 Fuses

10 Panic button

11 LED: Only used for low voltage conditions.

12 Overhead Lamp Switch: This can be controlled from the sleeper control module or from the dash rocker switch.

13 Mode Switch: Changes mode of radio

14 Radio Reverse Scan/Search/Next Track

15 Set button

16 Increment/Decrement Knob: Use this knob to adjust the Volume level.

Sleeper Control Panel, Basic

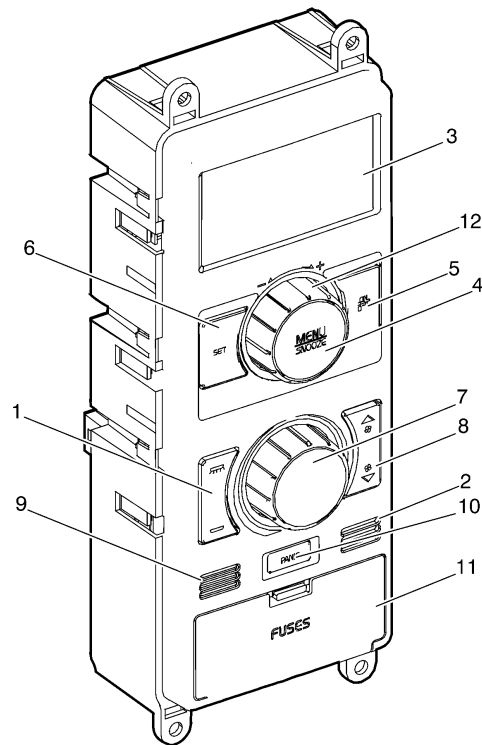

W3030078

- 1 Overhead Lamp Switch: This can be controlled from the sleeper control module or from the dash rocker switch.
- 2 Speaker: Sounds when the alarm or timer goes off, or when entering battery protection mode.
- 3 Display Screen: Displays selected information.
- 4 Menu/Snooze Button: This button allows you to adjust settings in the display screen and activate the clock's snooze option.
- 5 On/Off
- 6 Set button
- 7 Temperature Control Knob: Controls temperature for the Parking Heater and the Auxiliary Heating, Venting and Air Conditioning (A-HVAC).
- 8 Fan Speed
- 9 LED: Only used for low voltage conditions.
- 10 Panic button
- 11 Fuses
- 12 Increment/Decrement Knob: Use this knob to adjust the Volume level.

Set Clock

To set the clock for the Sleeper Control Panel, perform the following:

- 1 Press the **SET** button.
- 2 To set the clock to either '12' or '24' hour increments, use the “+” or “-” knob.
- 3 Press the **SET** button.
- 4 To set the clock Hour, use the “+” or “-” knob.
- 5 Press the **SET** button.
- 6 To set the clock Minute, use the “+” or “-” knob.
- 7 Press the **SET** button to confirm settings.

Once the clock is set to the desired time, the clock displays.

Note: After 7 seconds of inactivity the display returns to clock. Press the SET button to restart.

Note: On vehicles equipped with the High Sleeper Control Panel is connected to the Instrument Cluster and the Clock will automatically be updated by the time message the Instrument Cluster sends out.

Note: On vehicles equipped with the Basic Sleeper Control Panel it is **NOT** connected to the Instrument Cluster so the clock will blink until the user sets the clock.

Note: The clock **Will** need to be set every time the battery disconnect switch is used.

Note: Only 12 hr format shows the AM/PM icon

Note: User settings will be stored in memory, Sleeper Control functions will not be activated when the disconnect switch is turned back on. The user will need to turn the functions back-on manually.

Note: The vehicle is equipped with a battery protection system. The vehicle detects when the batteries are excessively discharged. If this occurs, an indication light and audible alarm are emitted. This indicates that some of the circuits will be disconnected in order to maintain engine starting capacity. If a battery disconnect occurs the defaults for the sleeper control panel are saved. These default settings are available after the battery disconnect is cancelled.

Note: The Panic button activates a 5 second horn audible. The Panic button must be held for 2.5 seconds for the horn to sound. This delay avoids an inadvertent activation of the horn.

Note: After 5 minutes of inactivity the display will shut off.

Dimmer

To adjust the backlighting brightness level, perform the following:

- 1 Press the **MENU** button.
- 2 Press the **SET** button.
- 3 Use the “+” or “-” knob to adjust the brightness level.
- 4 Press the **SET** button to confirm settings.

Once the backlighting brightness is set to the desired level, the display goes back to the clock.

Note: After 7 seconds of inactivity the display returns to clock. Press the MENU button to restart.

Turning Alarm On/Off

To turn the alarm On/Off, perform the following:

- 1 Press the **MENU** button twice.
- 2 Press **ON/OFF**.
- 3 Press the **SET** button to confirm settings.

This process toggles the Alarm between the On/Off position and returns to the clock display. The Alarm icon is toggled on or off accordingly.

Note: After 7 seconds of inactivity the display returns to clock. Press the MENU button to restart.

Setting Alarm Time

To set the alarm time, perform the following:

- 1 Press the **MENU** button twice.
- 2 Press **SET** button.
- 3 Use the “+” or “-” knob to adjust the hour value.
- 4 Press **SET** to accept the set hour.
- 5 Use the “+” or “-” knob to adjust the minute value.
- 6 Press the **SET** button to confirm settings.

Once the alarm time is set the display returns to the clock and the Alarm icon is illuminated.

Note: After 7 seconds of inactivity the display returns to clock. Press the MENU button to restart.

Turning Heater On/Off

To turn the heater On/Off , perform the following:

- 1 Press the **MENU** button three times.
The Heat icon blinks. The heat control value displays either as **OFF**, **Auto** or **Cycle** depending on the previous setting.
- 2 Press **ON/OFF** button to toggle between the On/Off position.
- 3 After selecting the desired setting, press the **SET** button to confirm settings.

The Parking Heater is turned On/Off. The Sleeper Control Panel display returns to the clock. The Heat icon is turned **On/Off** accordingly. The LVD icon is also turned **ON/OFF** depending on the LVD control of the Parking Heater setting, explained below in this section.

Note: After 7 seconds of inactivity the display returns to clock. Press the MENU button to restart.

Setting the Sleeper Control Panel Heat Control Value to Auto

Auto Set a time in the future to automatically turn ON. Will remain ON until manually turned OFF.

To set the Sleeper Control Panel heater to Auto, perform the following:

- 1 Press the **MENU** button three times.
The Heat icon blinks. The heat control value displays either as **OFF**, **Auto** or **Cycle** depending on the previous setting.
- 2 Press the **SET** button, **Heat** is displayed.
- 3 Use “+” or “-” to chose **Auto**.
- 4 Press the **SET** button, **ON/OFF** is displayed.
- 5 Press the **SET** button, time is displayed, Hour is flashing.
- 6 Use the “+” or “-” knob to set Hour.
- 7 Press the **SET** button, Minutes is flashing.
- 8 Use the “+” or “-” knob to set Minutes.
- 9 Press the **SET** button, to confirm settings.

Once the **Auto** setting is confirmed for the parking heater, the Sleeper Control Panel display goes back to the clock. The HEAT icon is also displayed. The LVD Icon is also turned **ON/OFF** depending on the LVD control of the Parking Heater setting, explained below in this section.

Note: After 7 seconds of inactivity the display returns to clock. Press the **MENU** button to restart.

Setting the Sleeper Control Panel Heat Control Value to Cycle **Cycle** Set a cycle time to continuously cycle between **ON/OFF**

To set the Sleeper Control Panel heater to Cycle, perform the following:

- 1 Press the **MENU** button three times.
The Heat icon blinks. The heat control value displays either as **OFF**, **Auto** or **Cycle** depending on the previous setting.
- 2 Press the **SET** button, **Heat** is displayed.
- 3 Use “+” or “-” to chose **Cycle**.
- 4 Press the **SET** button, **ON/OFF** is displayed.
- 5 Press the **SET** button, time is displayed, Hour is flashing.
- 6 Use the “+” or “-” knob to set Hour.
- 7 Press the **SET** button, Minutes is flashing.
- 8 Use the “+” or “-” knob to set Minutes.
- 9 Press the **SET** button, to confirm settings.

Once the **Cycle** setting is confirmed for the parking heater, the Sleeper Control Panel display goes back to the clock. The HEAT icon is also displayed. The LVD Icon is also turned **ON/OFF** depending on the LVD control of the Parking Heater setting, explained below in this section.

Note: After 7 seconds of inactivity the display returns to clock. Press the **MENU** button to restart.

Turning Sleeper Control Panel Timer On/Off

To turn the Sleeper Control Panel Timer on or off, perform the following:

- 1 Press the **MENU** button four times.
The Timer icon blinks on or off.
- 2 Press the **ON/OFF** button until **ON** or **OFF** is displayed.
- 3 Press the **SET** button to confirm settings.

Once the **Timer** setting is confirmed, the Sleeper Control Panel display goes back to the clock. The TIMER icon is also displayed.

Note: After 7 seconds of inactivity the display returns to clock. Press the **MENU** button to restart.

Setting Sleeper Control Panel Timer

To set the Sleeper Control Panel Timer, perform the following:

- 1 Press the **MENU** button four times.
The **TIMER** icon blinks.
- 2 Press the **SET** button.
- 3 To set the Timer minutes, use the “+” or “-” knob.
- 4 Press the **SET** button.
- 5 To set the Timer seconds, use the “+” or “-” knob.
- 6 Press the **SET** button to confirm settings.

Once the Timer is set to the desired time, the display goes back to the clock and the **TIMER** icon is shown.

Note: Alarm will sound when the Timer counter reaches **00:00**. Press the **ON/OFF** button, to turn alarm **OFF** .

Note: After 7 seconds of inactivity the display returns to clock. Press the **MENU** button to restart.

Turning the LVD Audible ON/OFF

To turn the LVD On/Off for the Sleeper Control Panel, perform the following:

- 1 Press the **MENU** button five times.
- 2 Press the **ON/OFF** button.
- 3 Press the **SET** button to confirm settings.

The LVD audible alarm toggles between On/Off and the display goes back to the clock.

Setting the LVD Control of the Parking Heater

To set whether the LVD will turn off the parking heater, perform the following:

- 1 Press the **MENU** button five times.
The **LVD** icon blinks and the display shows **ON**.
- 2 To set the Parking Heater shutdown to **ON/OFF**, press the **SET** button (Heat and **LVD** icon will blink).
- 3 Use the “+” or “-” knob to chose **ON/OFF**.
- 4 Press the **SET** button to confirm settings.

The LVD is set to shut down the parking heater. The display returns to the clock and the **LVD** icon is illuminated The setting is active only if the LVD is set in the On position and the Heater is active.

Note: After 7 seconds of inactivity the display returns to clock. Press the **MENU** button to restart.

Turning the Lamp Timer ON/OFF

Lamp Timer Turns interior lamps off after a set time.

To turn the Lamp Timer On/Off for the Sleeper Control Panel, perform the following:

- 1 Press the **MENU** button six times.
The Lamp Icon flashes.
- 2 Press **ON/OFF**.
- 3 Press the **SET** button to confirm settings.

The Lamp Timer is turned On/Off, and the display returns to the clock. The Lamp icon toggles between On/Off accordingly.

Note: After 7 seconds of inactivity the display returns to clock. Press the **MENU** button to restart.

Setting the Lamp Timer

To set the Lamp Timer, perform the following:

- 1 Press the **MENU** button six times.
The Lamp Icon flashes.
- 2 Press the **SET** button.
- 3 To set the timer minutes, use the “+” or “-” knob.
- 4 Press the **SET** button.
- 5 To set the timer seconds, use the “+” or “-” knob.
- 6 Press the **SET** button to confirm settings..

The Lamp timer is set to the desired time. The display returns to the clock and the Lamp Icon is illuminated.

Note: After 7 seconds of inactivity the display returns to clock. Press the **MENU** button to restart.

MISCELLANEOUS CAB EQUIPMENT

Cup Holders and Trash Compartment

There is a trash bin holder at the lower part of the dash. To open, press the top part of the lid in and the lid will fold out. To close, press the lid in until the latch closes. There are also two dash-mounted cup holders convenient to the driver and passenger.

Trash bin: (Removable), Located below the 12 V power outlet.

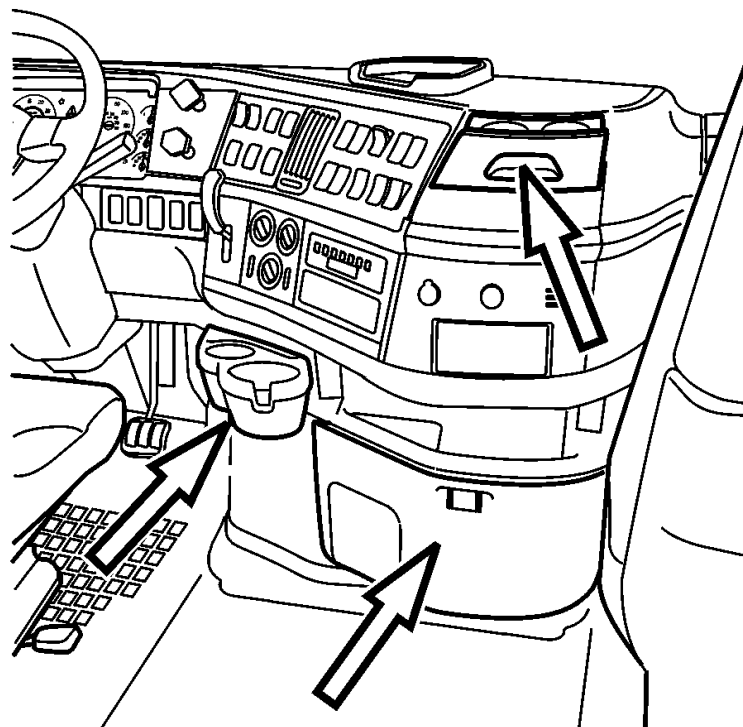

W8003490

- 1 Driver Cup Holder
- 2 Trash Bin
- 3 Passenger Cup Holder

Sleeper cup holder:

Located on the left lower tower cabinet, for the bottom bunk. There is another cup holder located on the left upper tower cabinet for the upper bunk.

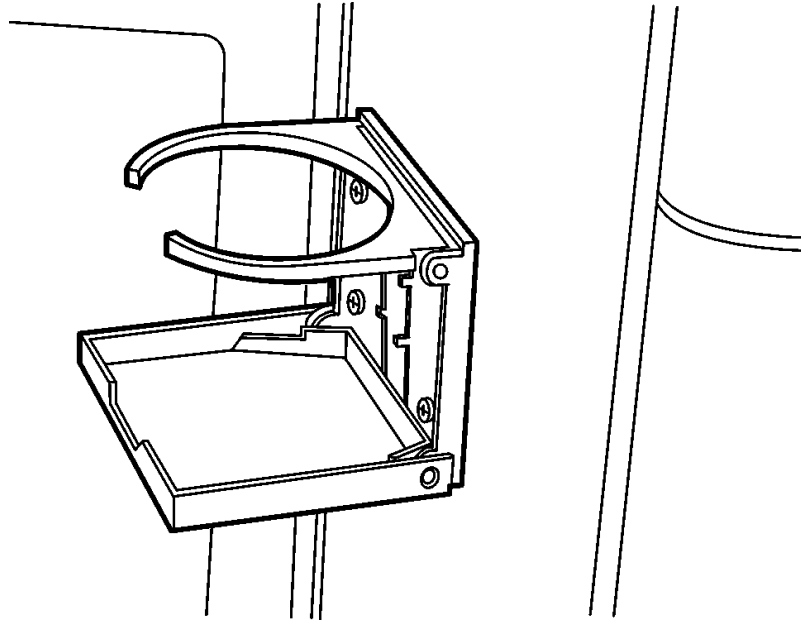

WS003181

Curtains

Curtains are available for all the sleeper cabs to ensure privacy and to darken the cabin from outside light. Various configurations are available. Curtains can cover the whole windshield area or go across the sleeper opening.

When the curtains are not in use, they are stored out of the way and held in place with velcro straps.

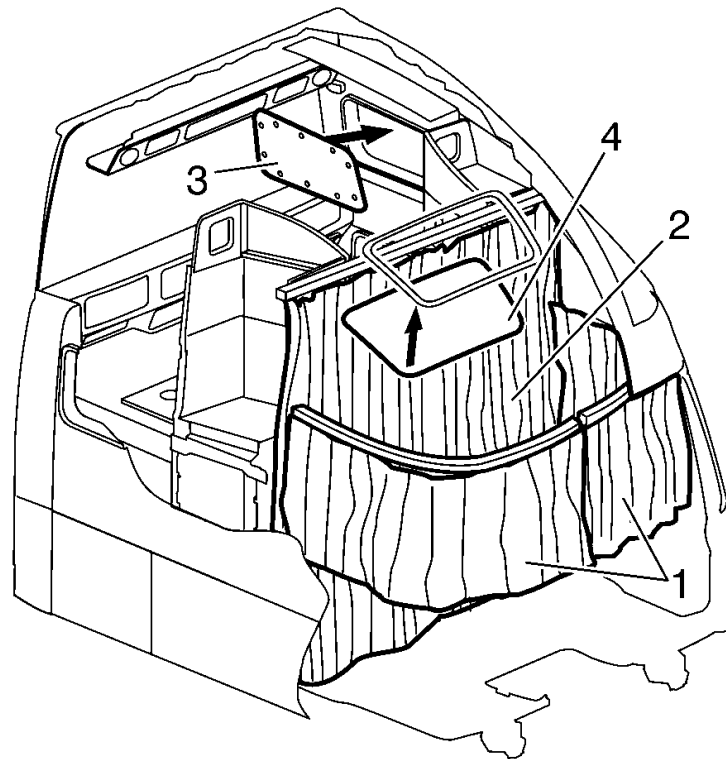

W8028428

- 1 Windshield Curtains
- 2 Sleeper Curtain
- 3 Sleeper Window Cover
- 4 Sky Light Cover

Covers for the VN 670 are to be stored in a rolled-up position in the opening behind the cabinet.

The covers for the VN 780 side windows are stored behind the backrest cushions. All covers are put on with snap buttons that are on the cover and window rim, with the exception of the sky light cover.

STEERING COLUMN

Ignition Switch

The ignition switch is located on the right side of the steering column just under the steering wheel. Standard equipment is a normal ignition switch.

Note: The vehicle is delivered with 2 identical keys. If more keys are needed, order them through your authorized Volvo Truck dealer.

The ignition positions are:

- A — Radio, Accessories
- B — Off
- C — Drive
- D — Start

The key can only be removed when in the B or Off position. For full starting instructions, see “STARTING THE ENGINE”, page 298.

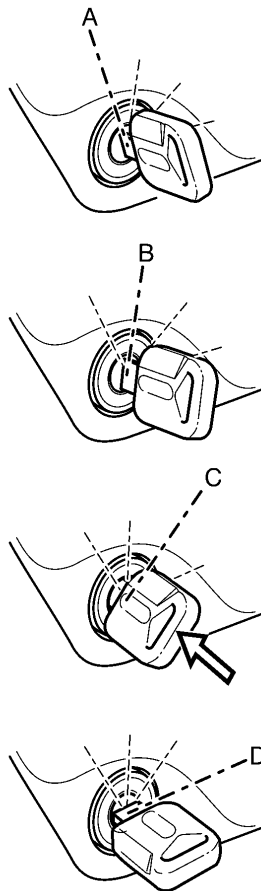

Windshield Wiper/Washer

Note: Make sure the ignition is in the Off position to avoid draining the battery.

The wiper/washer functions are operated by the same lever. The wipers have normal and fast speeds which are activated by moving the lever down one or two positions. To let the wipers engage for a few passes, lightly depress the lever until the wipers start and hold it there. The wipers return to the parking position when the lever is released.

The interval wiper function is engaged by moving the lever up. The normal programmed speed is one pass every 10 seconds. To shorten the interval time, move the lever to normal wipe position and then to the interval position again when the next wiper pass is desired. This way, the interval can be programmed between 1 to 10 seconds between each pass.

To operate the windshield washer, pull the lever toward the steering wheel. If washer fluid needs to be added, use a commercially reputable washer fluid that has good cleaning capability and does not freeze in cold weather.

An indicator will appear in the DID when the washer fluid level is low. See "Windshield Washer Reservoir" on page 435 for washer level capacity. A 10 second activation delay allows for fluid slosh.



W3006064

Note: In the VNM 200 Day Cab (Short fairing) the washer fluid indicator is NOT displayed in the instrument cluster.

ADJUSTABLE STEERING COLUMN

⚠ DANGER

DO NOT try to make adjustments to the steering wheel while the vehicle is moving. Never operate the vehicle with the steering wheel adjusted to its uppermost position (exiting cab position). Make all adjustments before starting the vehicle, to prevent loss of vehicle control, which can cause personal injury or death.

The adjustment device is operated by a pedal on the left side of the floor. To make adjustments, press the pedal down and move the steering column to the desired position, then release the pedal.

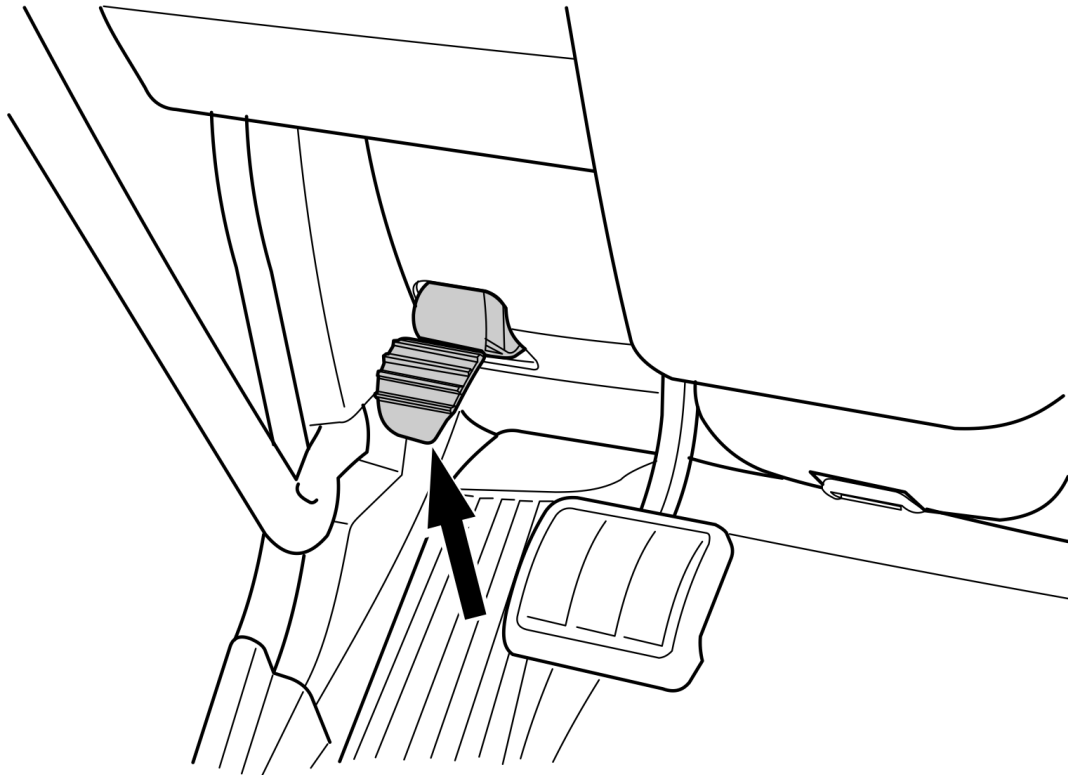

STEERING WHEEL CONTROLS

Left-Hand Controls

- Headlamp Interrupt (Top)
- Marker Interrupt (Bottom)

When either switch is pressed, the corresponding lights toggle from their current state. If OFF they change to ON and if ON they change to OFF. When pressed for more than 3 seconds, the lights revert automatically to the initial state.

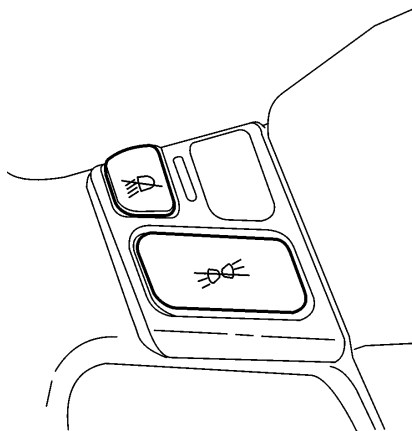

W3005294

Right-Hand Controls

- Radio controls

Press +, up or -, down to change the radio volume.
Press the switch left or right to change radio stations. The radio will seek the next station with a strong signal.

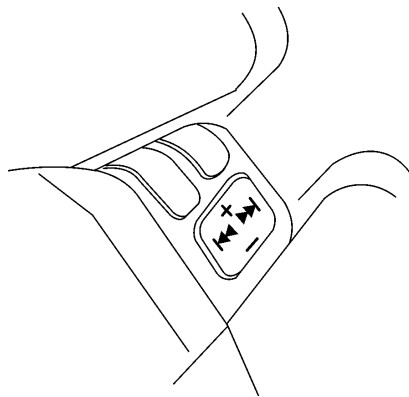

W3005304

MISCELLANEOUS SWITCHES

Horn Switches

Electric and air horns are standard equipment. They are both operated from the steering wheel or center pad.

The airbag can be pressed down anywhere around the edge to engage the air horn.

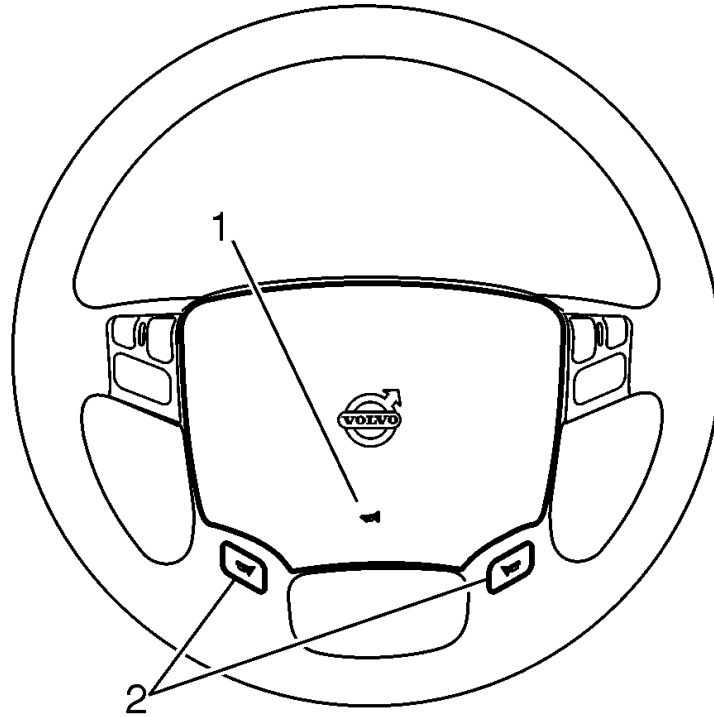

W6001503

- 1 Air Horn
- 2 Electric Horn (city horn)

INTERIOR LIGHTS

The cab is equipped with separate and combined interior and reading lights in various locations in the cab. The front seat overhead lights can be turned on at any time using the switch in the fixture. This is a three-way switch, pressing the lamp turns the light ON, OFF or the light comes on with the door being opened. When the switch is in the middle position, the light does not turn on, even when the door is opened.



WARNING

Using bulbs or lamps other than those specified may result in failures that could overheat and lead to a fire or a vehicle accident caused by improper lighting.

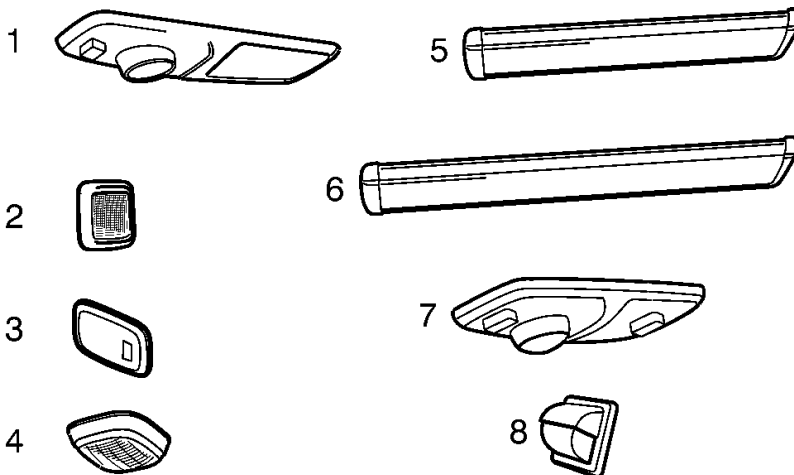

Interior Lights	
Chart Number	Description
1	Overhead Dome Lamp
1	Overhead Dome/Spot Lamp connected to door
2	Door Courtesy Lamp
3	Dome Lamp — Sleeper
4	Reading Lamp under bunk storage
5	Reading Lamp
6	Overhead Lamp — Short
7	Overhead Lamp — Long
8	Overhead Dome/Spot Lamp

Note: To prevent short service lift, DO NOT touch the glass surface of the replacement bulb.

 <b style="font-size: 1.2em; margin-left: 10px;">WARNING
<p>The lamp assemblies may get warm to the touch. DO NOT cover the lamps with any object.</p>

Most of the vehicle interior lights are activated by pressing on a push button on the lower end of the lamp. There are two external switches for the interior lights, one located on the dash panel, to the immediate left of the steering column, and the other is on the sleeper area control panel.

132 INSTRUMENTS AND CONTROLS

The red courtesy light comes on when the door is opened. The lens is red to alert oncoming traffic from the rear that the door is open. It is also used during night driving to light up the floor area and steps without distracting the driver with a glaring light.

 **CAUTION**

DO NOT use sleeves of any kind over bulbs in the interior lamps. The bulbs may over heat causing damage to the fixture including possible fire.

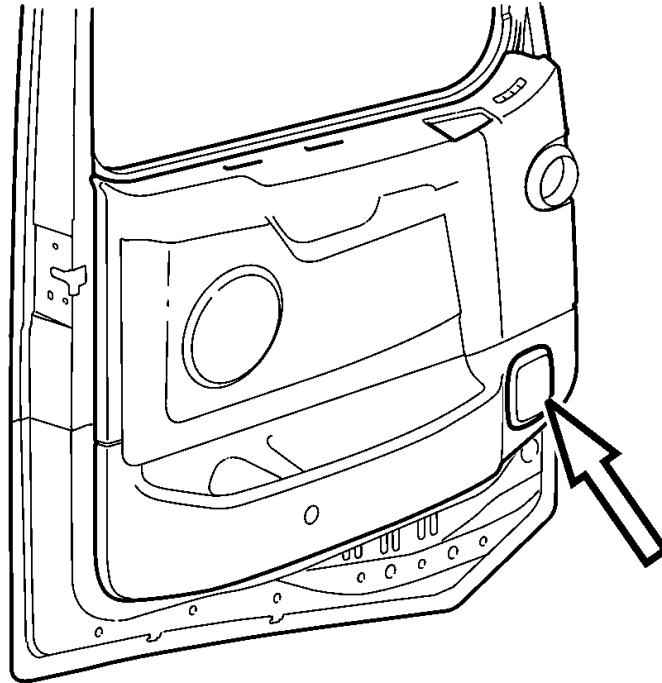

W8003521

The door latch has an internal switch that operates all door-activated lights.

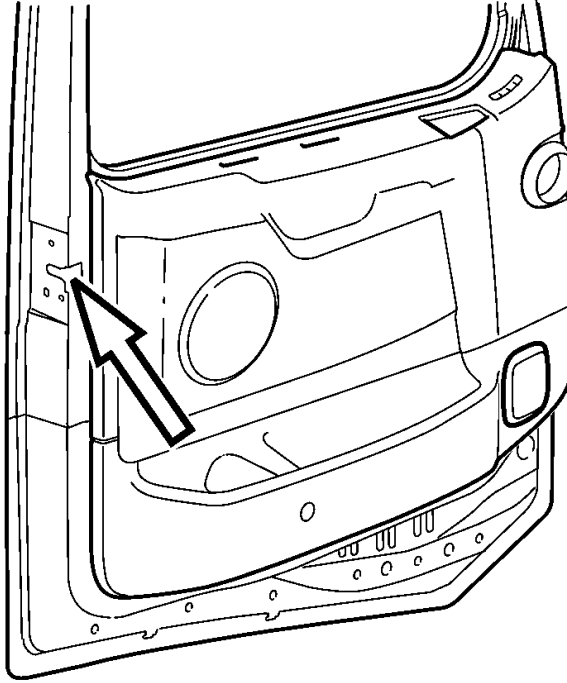

W8003522

Fresh Air Vent

- A. Closed
- B. Open
- C. Vertical Air Flow
- D. Lateral Air Flow

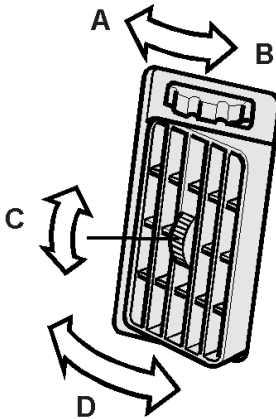

T0008094

When heating the cab, all vents should be closed. However, the vents on the outer parts of the dash can be used for defrosting the cab door windows. When operating the air conditioning, all air vents should be completely open and the air flow directed upward.

DANGER

DO NOT breathe the engine exhaust gas. It contains carbon monoxide, which has no color or odor. Carbon monoxide is a dangerous gas which can cause unconsciousness or death.

CAB VENTILATION, SLEEPER

In sleeper versions (except the VN 780 and VN 730) there is a fresh air vent located on each cab side wall. It opens to two positions so the air flow can be regulated.

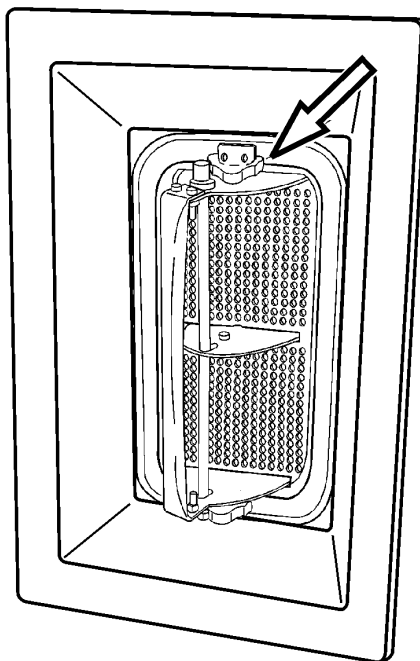

W8003135

The vent also opens toward the front or toward the rear. This can be used for forcing air into the cab (open toward the front) or for venting air out of the cab (open toward the rear).

CAUTION

The vent should not be used during rain, while washing the vehicle or other circumstances where water may enter the cab while the vent is open. To prevent leaks, make sure the handle rollers are on the top center part of the cams.

Earlier production versions of the VN 780 are equipped with four hinged side windows in the sleeper area. Later production versions have two hinged side windows in the sleeper area and two upper vent windows.

Earlier production versions of the VN 670 have only the two upper windows. Later production versions have two upper vent windows.

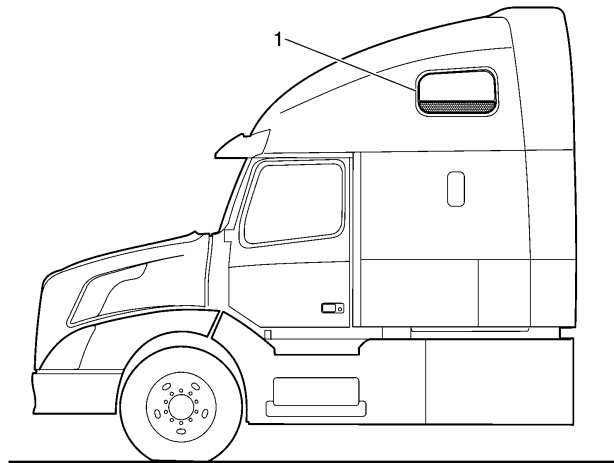
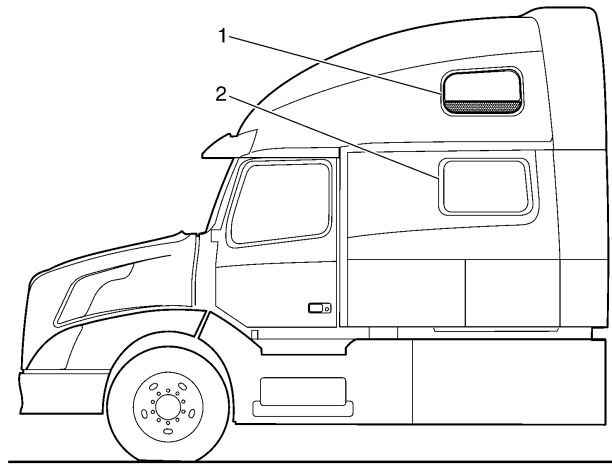

W8003823

- 1 VN 780 and VN 670 Vent Window
- 2 VN 780 Hinged Side Window

The VN 730 is equipped with two hinged side windows in the sleeper area. DO NOT force the window crank mechanism in the fully open position. The mechanism can be damaged if you try to open the window beyond the stop position.



CAUTION

Make sure the windows are closed before washing the cab. Water can enter the cab through the window opening.



CAUTION

Do not open the cab sleeper windows when the vehicle is in motion. Opening the windows while the vehicle is in motion will damage the sleeper windows.

12 Volt Power Outlets

 **CAUTION**

DO NOT connect a device with a current rating in excess of 10 amps or the amount labeled.

There are a number of 12 V outlets that can be accessed in the cab. There is a power outlet on the sleeper control panel. The outlet is covered by a cap that is pulled out for access.

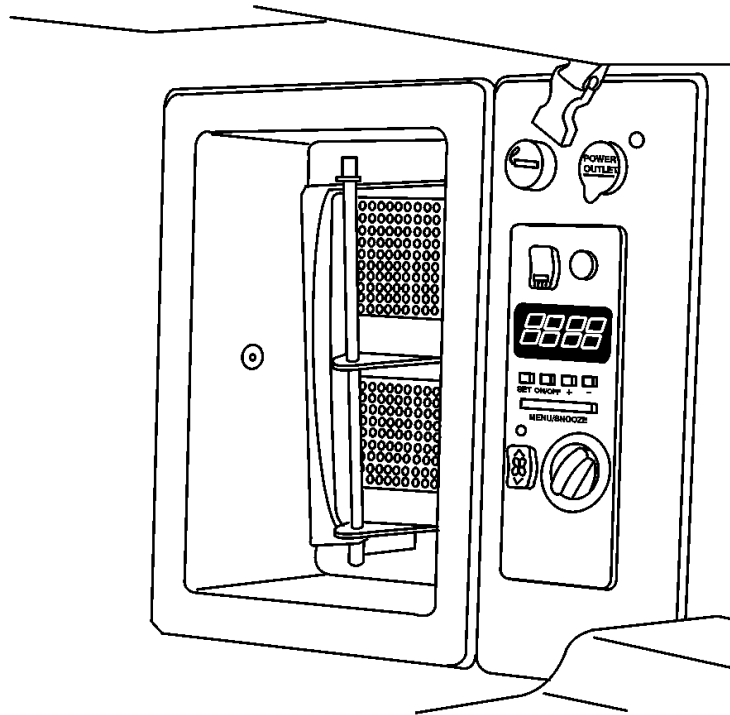

W3005298

The outlet is made for 12 V accessory-type plug.

138 INSTRUMENTS AND CONTROLS

12 Volt Locations

There is an optional power outlet in the driver and passenger side cabinets. Accessories for this cabinet will have ON/OFF switches of their own. The cabinet 12 V outlets are made for 12 V accessory-type plugs.

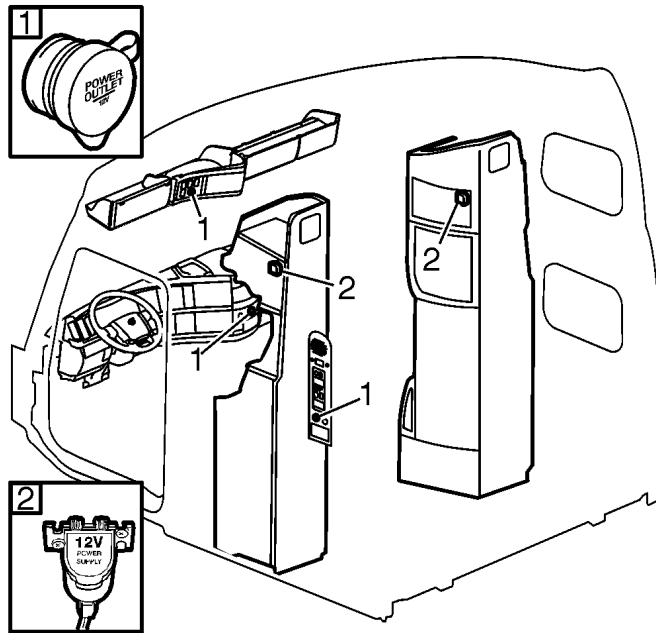

W3005508

VN 780, VN 730

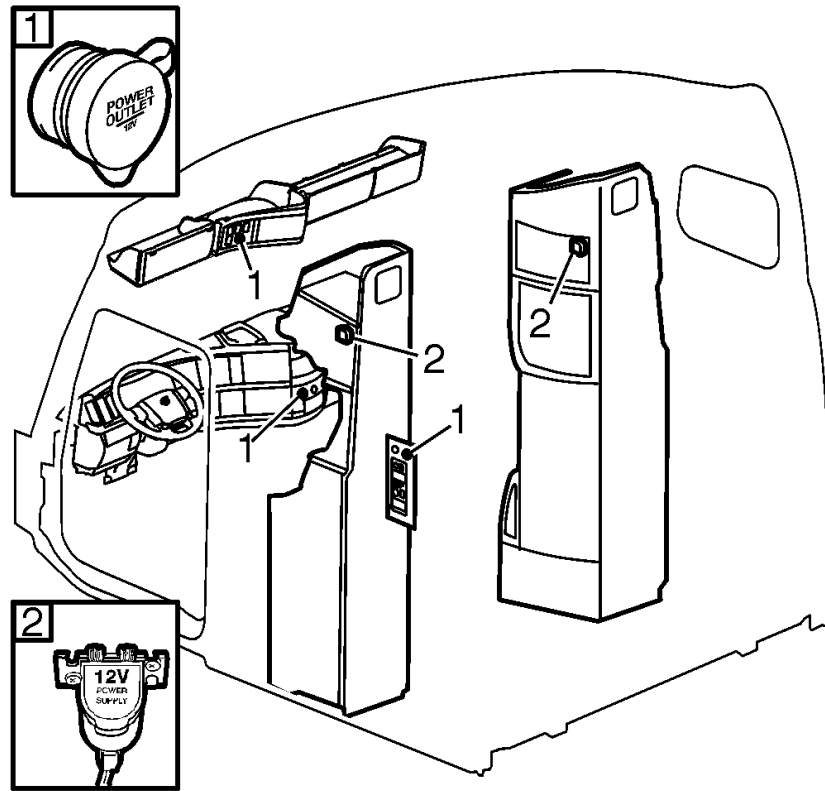

W3005500

VN 780, VN 730

Inverter Switch 12 V DC to 120 V AC

 **DANGER**

When parked on wet ground, avoid using an external power source to connect the cab power plug. Water is a conductor of electricity. In wet conditions, electrical shock can occur which can result in personal injury or death.

This switch turns ON the optional power inverter, located near the battery compartment.

The power inverter takes the DC voltage from the batteries and changes it to AC voltage, which is then fed to the 120 V shore power electrical system within the cab area.

The power inverter option can be ordered only if the 120 V shore power electrical system is specified.

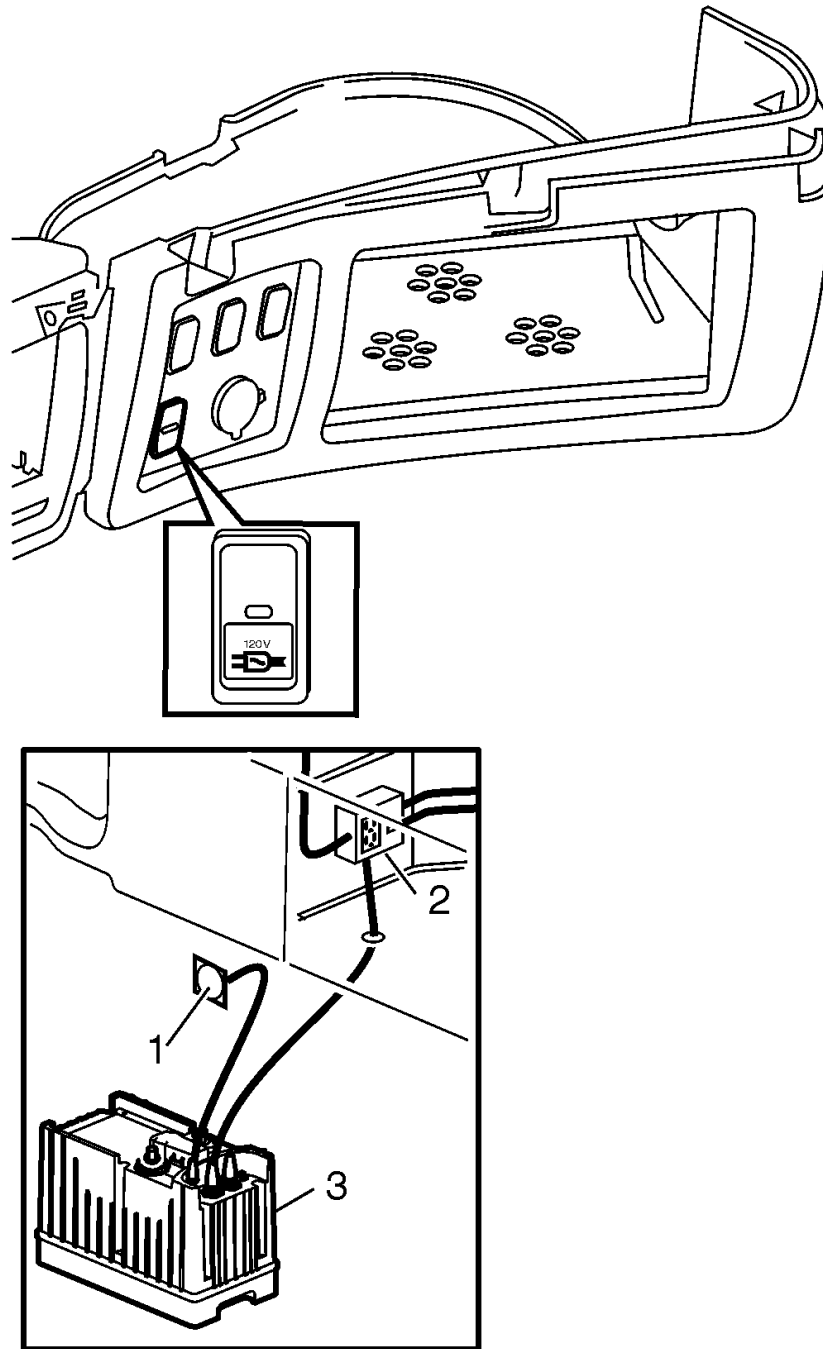

W3005980

This is a typical setup with a factory-installed inverter.

- 1 External Power Plug
- 2 Load Center
- 3 Inverter (if equipped)

Note: A tripped circuit is usually an indication of a fault in the circuit, or of an appliance being supplied with power. Every effort should be made to identify and correct any fault that exists.

120 Volt System and Outlets

**DANGER**

When parked on wet ground, avoid using an external power source to connect the cab power plug. Water is a conductor of electricity. In wet conditions, electrical shock can occur which can result in personal injury or death.

The VN 730, 780, 670 and 630 are available with an optional 120 V AC service, used for longer parking while still living in the vehicle. The 120 V AC service is supplied from outside sources. To hook up the service, there is a socket located behind the driver side door.

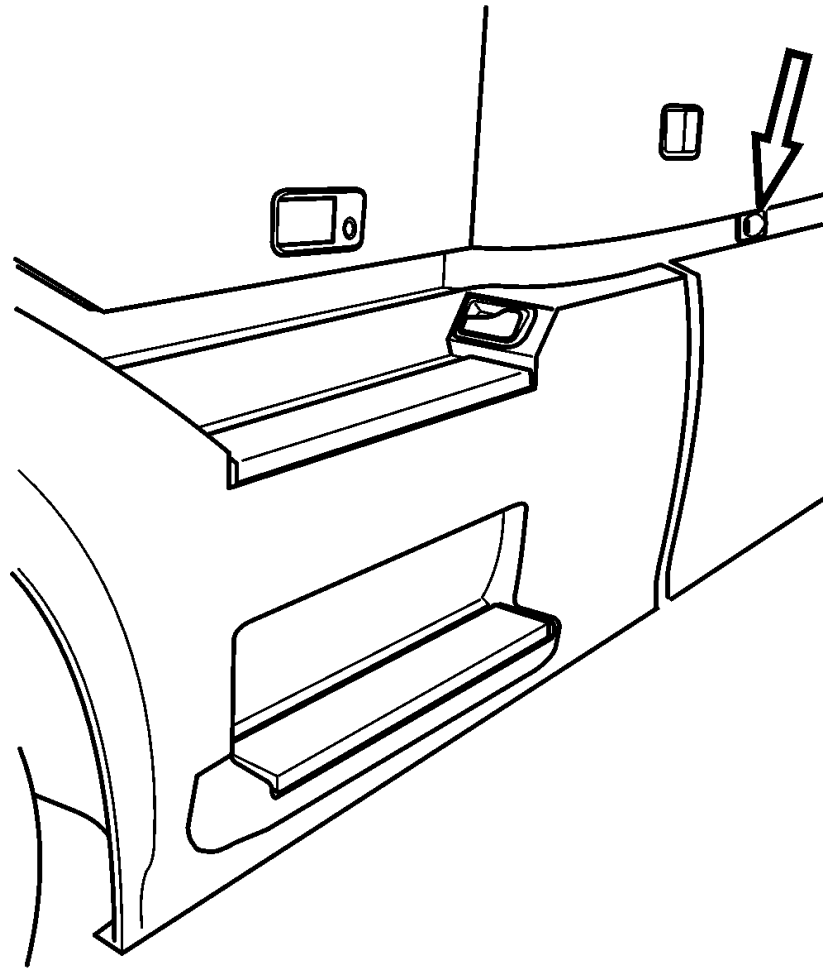

W3005284

Power goes through a circuit breaker box located on the front wall in the driver side luggage compartment. On the right is an ON/OFF switch and on the left is the ground fault circuit interrupter. The controls may also be reached from inside the cab through the hatch under the mattress or cushion.

144 INSTRUMENTS AND CONTROLS

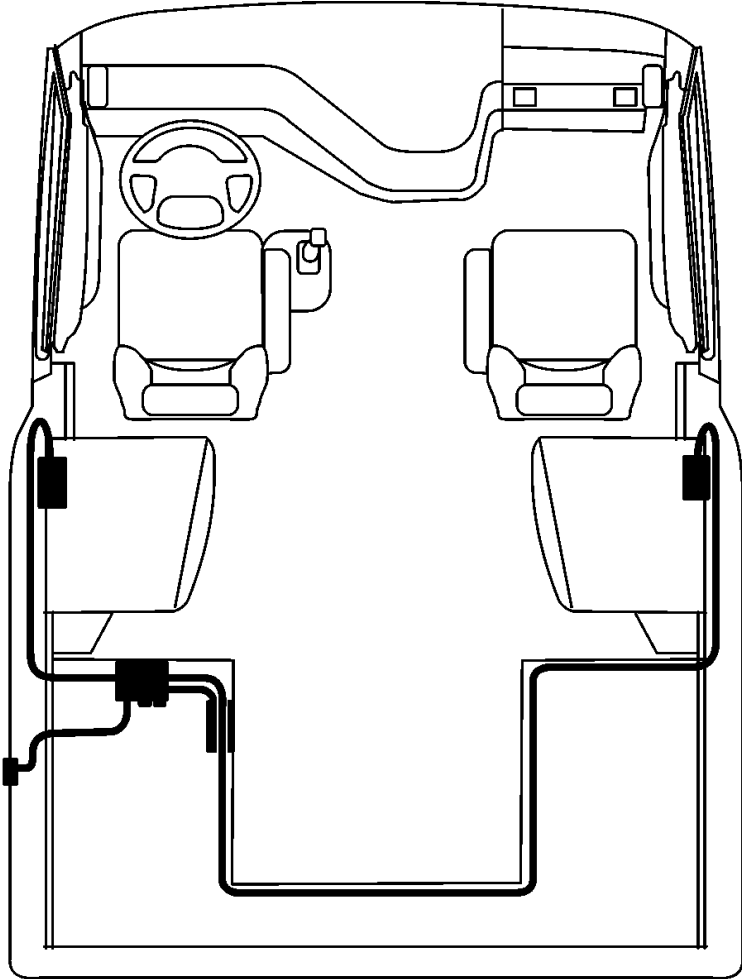

W3005967

From the breaker box in the VN 780 and 730, power goes to the three outlets as a standard feature. In the VN 670 and 630 models, the outlet on the driver side lower bunk box is standard, and the tower cabinet middle compartments (1) each have an optional outlet.

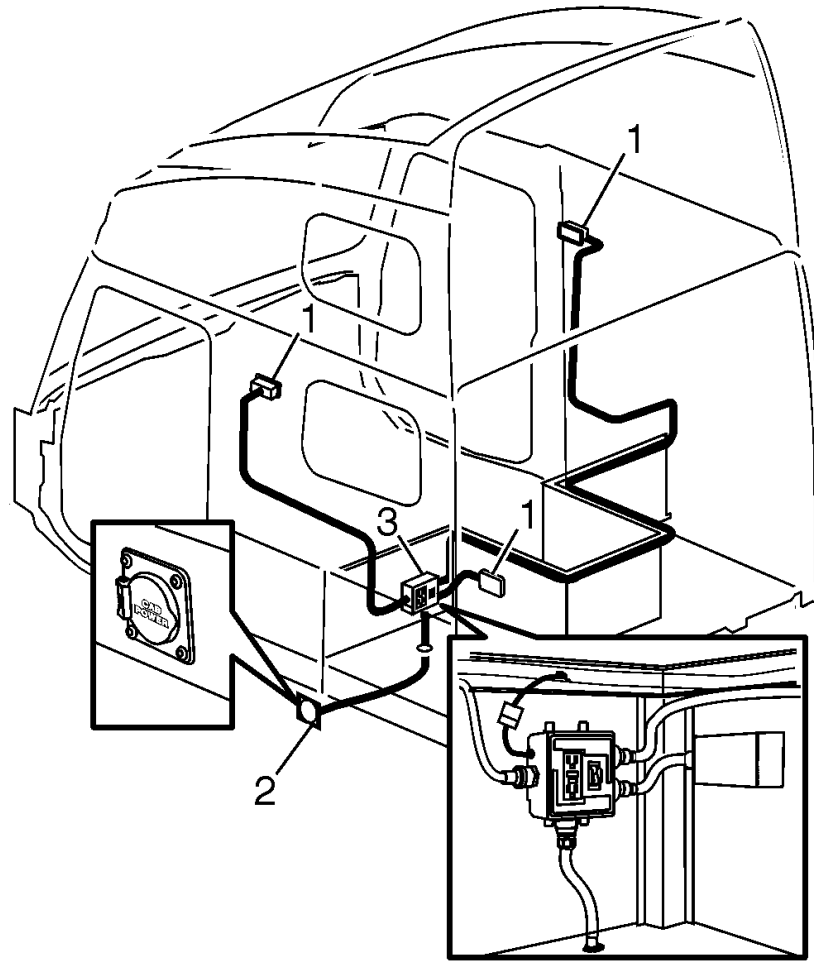

W3005340

- 1 120 Volt Outlet
- 2 External 120 Volt Receptacle
- 3 Circuit Breaker Box

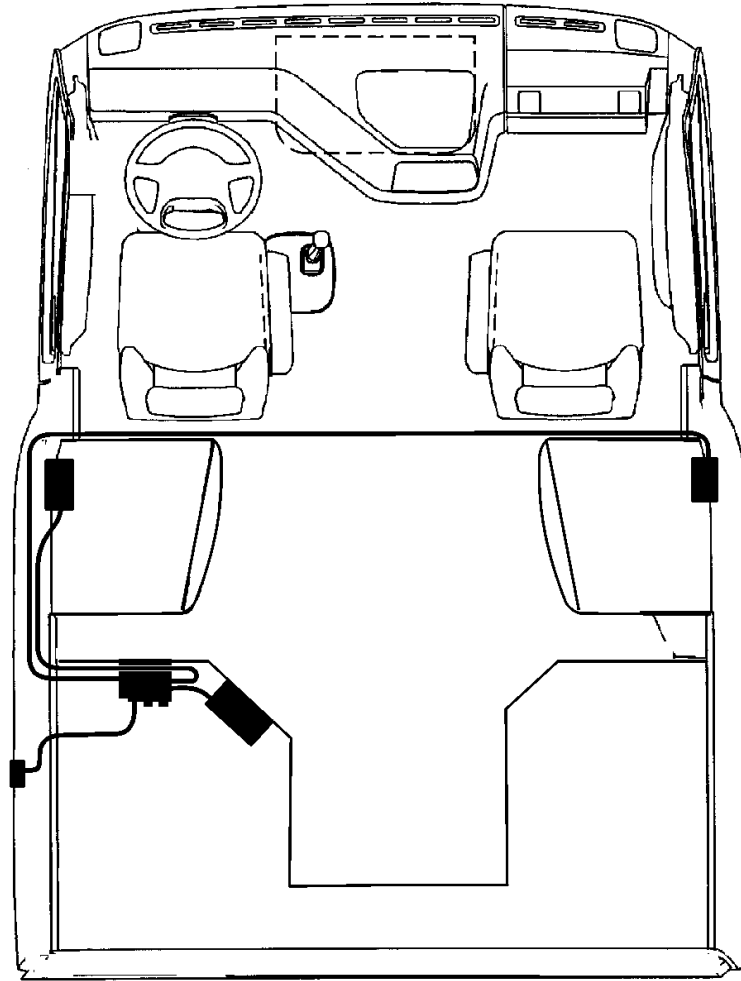

W3005343

120 Volt System Wiring, VN 670, VN 630

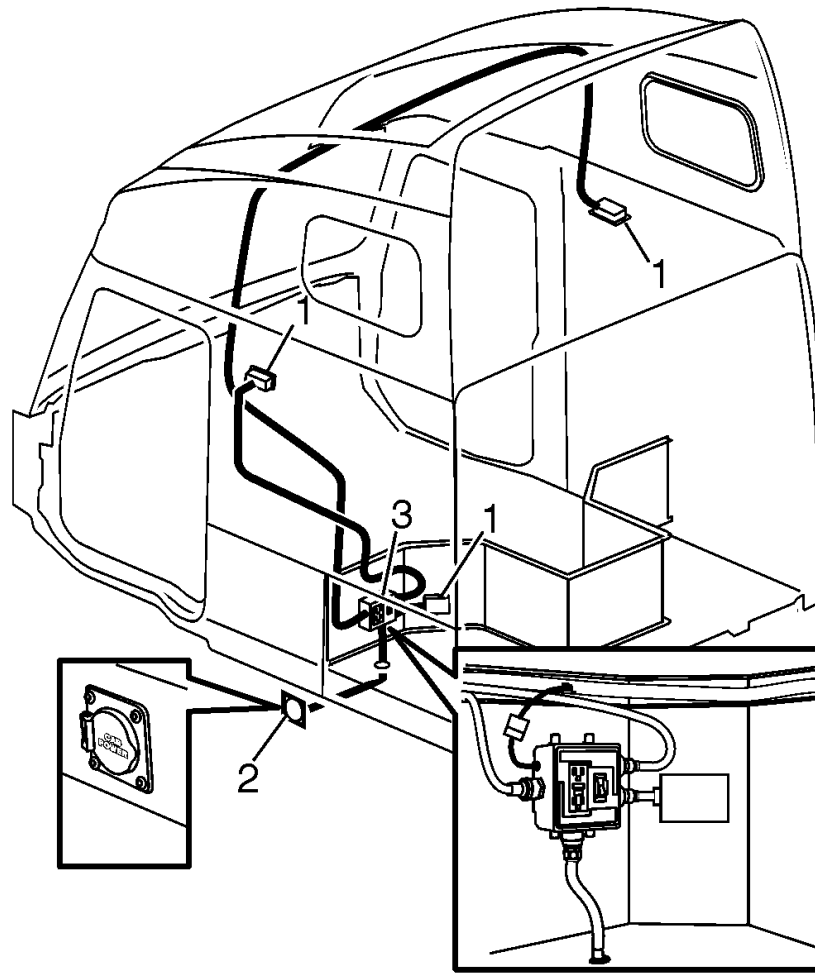

W3005342

120 Volt System Components, VN 670, VN 630

- | | |
|--------------------------------|-----------------------|
| 1 120 Volt Outlet | 3 Circuit Breaker Box |
| 2 External 120 Volt Receptacle | |

Cigar Lighter

To operate the cigar lighter, press the center in until it stays in. The heating element will heat up and pop the lighter out when it is ready for use. The ash tray is located next to the cigar lighter.

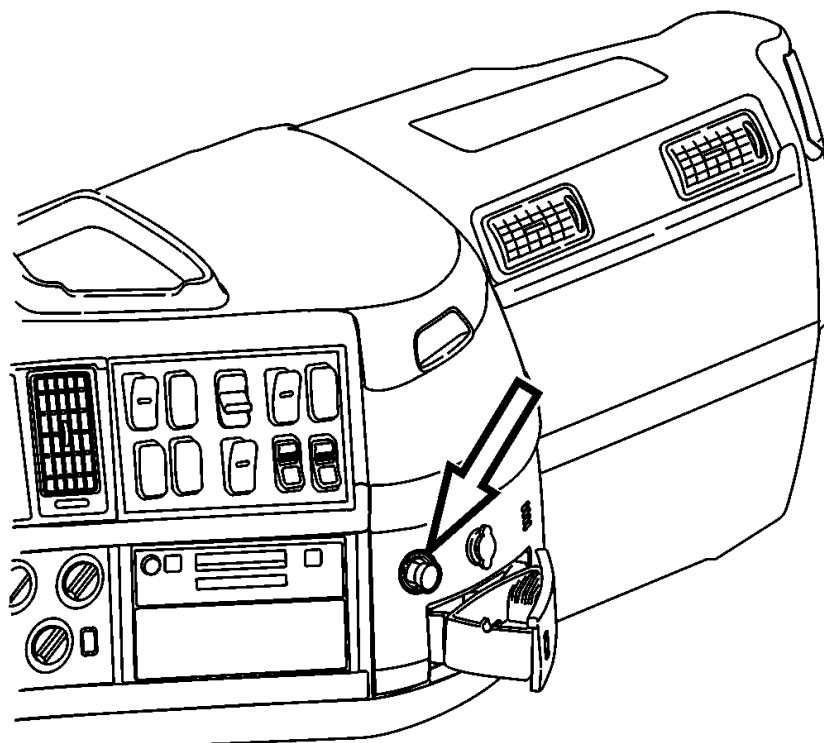

W3005271

The cigar lighter socket is optimized for use with cigar lighter heating element. This socket should not be used as an auxiliary 12 V power supply because there are many aftermarket power plugs available, with different dimensions. Some of these may deform the lighter socket's tangs and cause it not to work properly. If an auxiliary socket is needed, the cigar lighter assembly may be replaced with the approved Volvo 12 V power socket.



CAUTION

DO NOT connect a device with a current rating in excess of 10 amps or the amount labeled.



CAUTION

Using a 12 V power plug in the lighter socket may damage the socket.

PARKING HEATER (OPTIONAL, SLEEPER MODELS ONLY)

DANGER

DO NOT fuel the vehicle or handle flammable liquids in the vicinity of an operating parking heater. The fuel vapors can be ignited, causing an explosion or fire resulting in severe personal injury or death.

WARNING

The parking heater is a very hot object. DO NOT touch the heater when it is in operation or shortly thereafter. Touching a heater may cause burns to exposed skin.

DANGER

DO NOT store flammable items close to the parking heater or put items on top of it. Flammable items should not be closer than 50 mm (2 inches). The item may ignite and cause a fire resulting in severe personal injury or death.

CAUTION

The heater air inlet is located in the bunk wall in front of the heater. DO NOT attempt to put small items or store flat items between the bunk and the cabinet/refrigerator. The air intake can be blocked which causes the heater to overheat and shut down.

DANGER

DO NOT run heater while vehicle is in an enclosed area. The exhaust gasses contain carbon monoxide (CO). If not vented to the atmosphere, there could be a buildup of dangerous levels of CO which may lead to unconsciousness and later death.

The parking heater is a diesel fuel burner that heats the air in the cab. Air is taken from the cab and returned heated. Combustion air and exhaust is taken from, and released to the outside air.

To safeguard from the heater operating after a turnover accident, there is a fuel shut-off valve in the fuel delivery system.

150 INSTRUMENTS AND CONTROLS

Fuel Parking Heater

Note: The parking heater is not available if the vehicle is equipped with a sink.

A fuel heated parking heater is available as an option. It is located in the left-hand luggage compartment. The heater provides automatically regulated heat that is distributed through its own vents into the sleeper section of the cab.

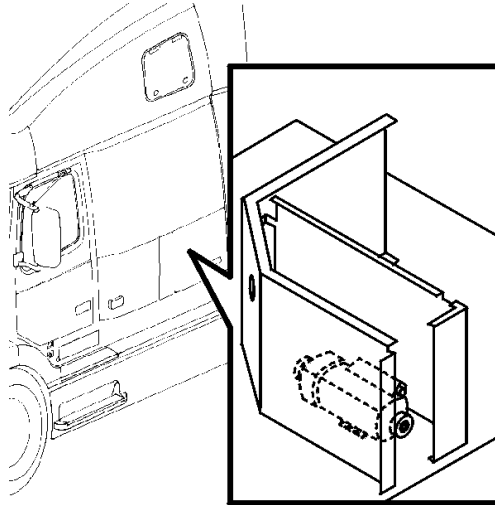

W8002480

ANTENNAS

General

- 1 Multiband
- 2 Multiplexer (Rami)

- 3 Radio AM/FM
- 4 TV Antenna

Multiband Antenna

There are antennas mounted on the top of the mirror brackets for wideband reception. They receive or send signals for radio, CB and telephone. Each antenna carries multiple wire windings that work together with mirror bracket devices to cover the needs of many uses.

If the antenna is damaged, replace it only with a multiband type antenna. A regular antenna does not have the wiring necessary to give good reception for all uses.

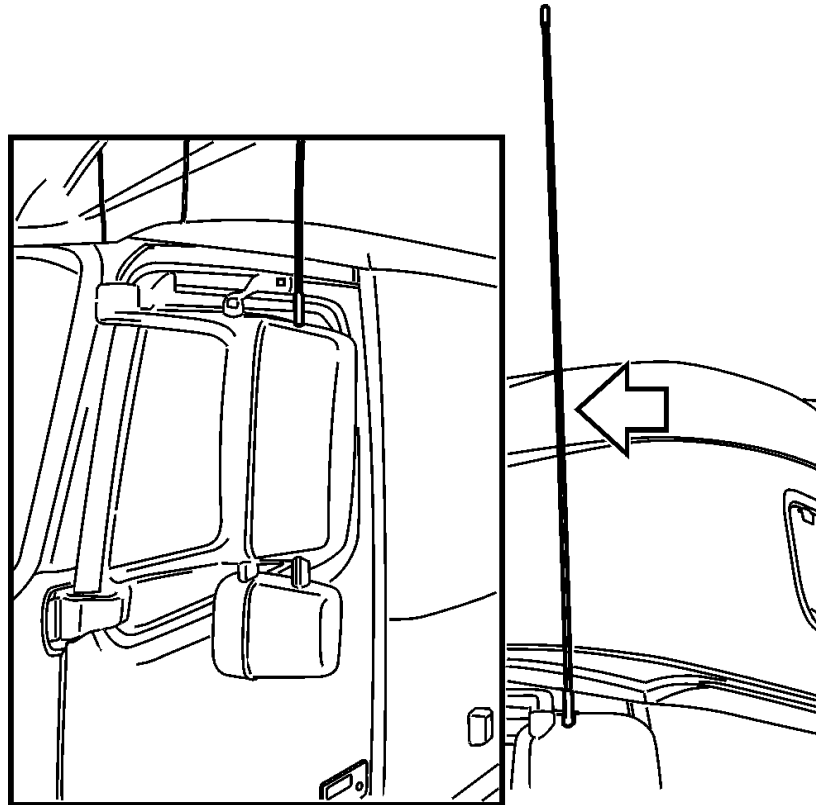

W3005287

Antenna Multiplexer

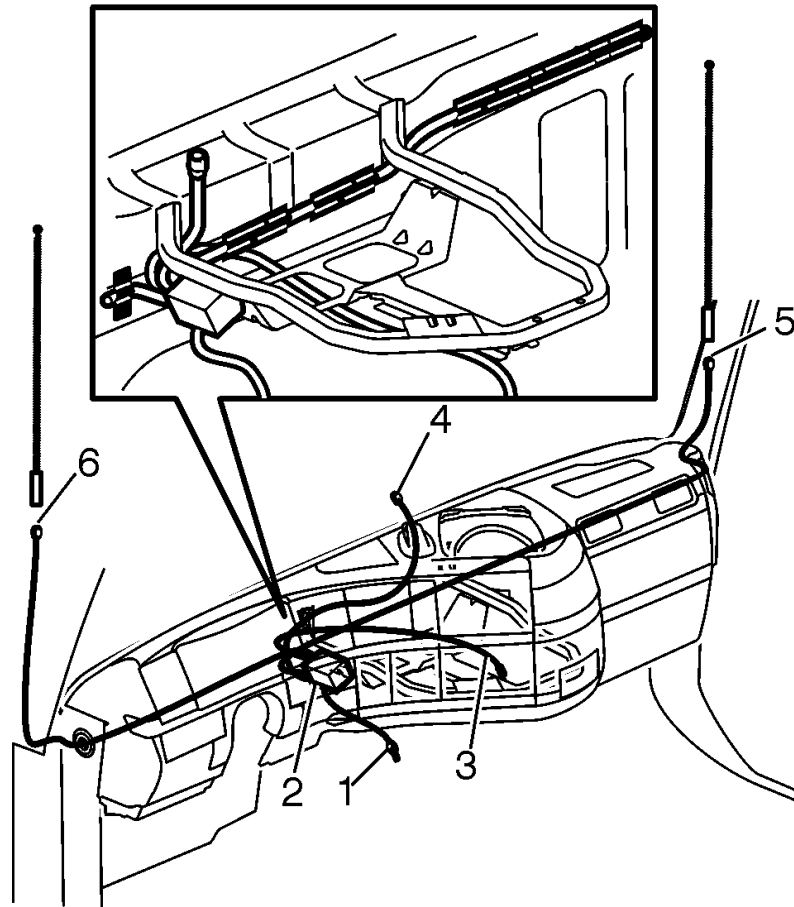

W3005509

- 1 Cellular Phone Antenna Cable
- 2 Radio Antenna Cable Connection
- 3 Phone Cable Connection
- 4 CB Radio Antenna Cable Connection

Communication signals that travel to and from the antennas go through the antenna multiplexer. It is standard in the VN 670 and VN 780, and optional on other models. Coaxial cables for the cellular phone, CB radio and radio are included in the multiplexer system — all using the same set of antennas.

The multiplexer is accessed through the lower dash panels. Cable routing is as shown in the illustration above. Use only genuine Volvo replacement parts for this multiplexer system; standard antennas will give unsatisfactory performance. The windings in the antennas are specific to this system: different sections of the antenna are used for the cellular phone, radio and CB.

Note: The location of the CB may vary. CB connections can be located either in the dash or overhead storage area, depending on vehicle options. See "COMMUNICATION EQUIPMENT" "COMMUNICATION EQUIPMENT", page 155.

TELEVISION



WARNING

All items within the cab must be secured before the vehicle is set in motion. This includes, but is not limited to, drinks, clothes, books, televisions, etc. In the event of a sudden stop or collision, loose items could fly around inside the cab. This could cause personal injury.

The VN 780, VN 730, VN 670 and VN 630 are already equipped for TV with a pre-installed antenna. The TV should be installed in the passenger side cabinet where there is a standard 12 V connection or an optional 120 V connection.

To prevent the TV set from moving when the vehicle is driven, the strap in the TV storage area should be tight around the set. Position the strap across the front corners of the TV.

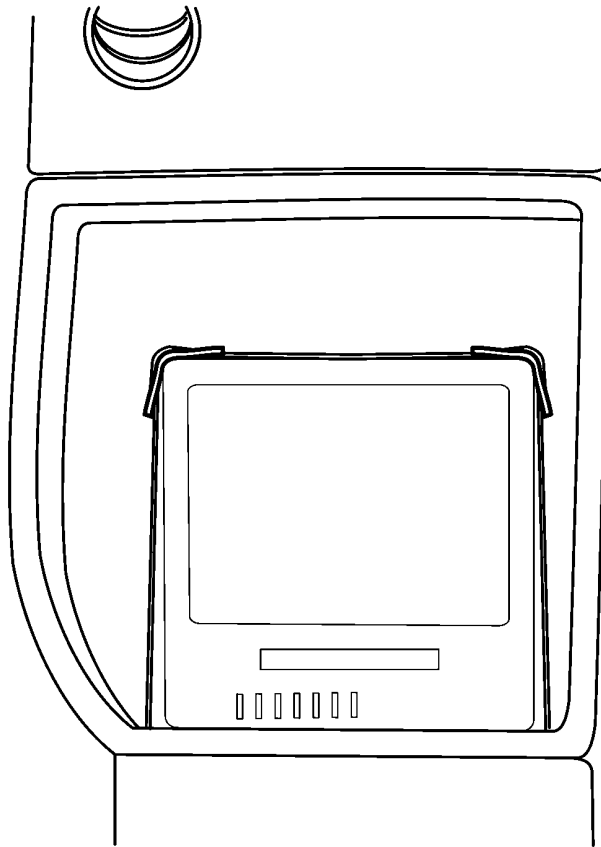

W0002361

There is an optional television speaker available, located in the top of the sleeper switch panel. Beside the speaker, there is a jack for headphones. This is provided for silent viewing of the TV. When the headset jack is plugged in, the speaker is cut out.

Note: The TV prep kit is optional.

TV Antenna



CAUTION

DO NOT pierce or drill through the headliner. The TV antenna may be damaged.

The TV antenna for the VN 780, VN 730 and VN 830 is standard equipment.

COMMUNICATION EQUIPMENT

CB Radio

There is an optional platform provided for a CB radio on top of the dash. The unit is held in place with a strap which can accommodate a variety of sizes.

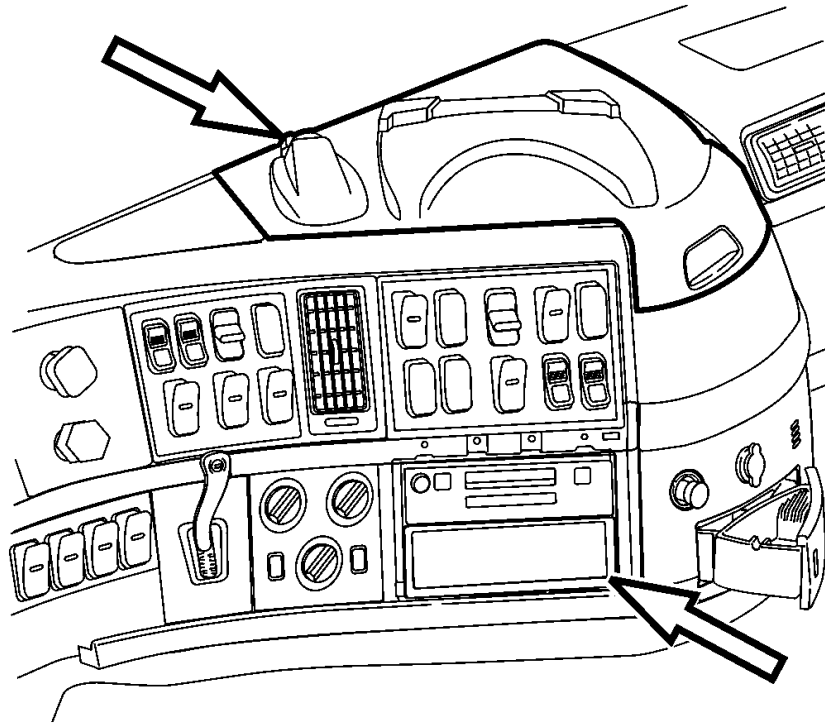

W3006382

The CB radio can also be mounted in the overhead storage. See "STORAGE COMPARTMENTS" "STORAGE COMPARTMENTS", page 156.

Telephone

There is room on the dash for a mobile telephone. This can be hooked up to the multiplex box.

If the vehicle is delivered with a multiplex box, the connecting end of the telephone coaxial cable should be located at the lower dash cover.

Note: The panel must be removed to access the cable.

Road Relay (Optional)

The Road Relay is an engine communication tool that allows the driver to have fuel consumption, time and mileage readouts and also programmed reminders for service intervals. The Road Relay should be permanently mounted directly below the radio. Collected data can be downloaded for use in a stationary computer where the data can be collected and compared over time.

STORAGE COMPARTMENTS

DANGER

Heavy objects must be stored only in the outside storage areas or secured on the floor. Cabinets and storage compartments are designed for clothing and lighter personal effects only. In the event of a collision, heavy, unsecured objects in overhead storage can come loose and cause severe personal injury or death to the driver or passengers.

WARNING

All items within the cab must be secured before the vehicle is set in motion. This includes, but is not limited to, drinks, clothes, books, televisions, etc. In the event of a collision, loose items could fly around inside the cab. This could cause personal injury.

CAUTION

DO NOT overload the cab suspension. Make sure the weight distribution is equal in the cab. Overloading the suspension leads to poor ride and lowered driving comfort.

To prevent the television and microwave oven from moving when the vehicle is driven, the strap in the storage area should be tight around the unit. Position the strap across the front corners of the unit. Periodically, check that the strap is tight and retighten as necessary.

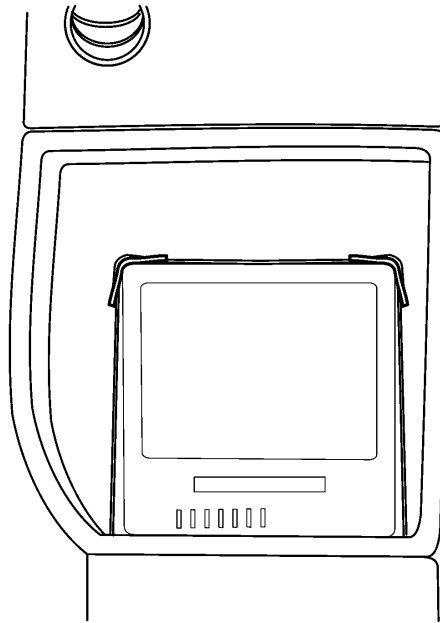

W0002361

Front Overhead Storage

There are two configurations of overhead storage compartments mounted over the windshield: five openings with nets, or CB radio, switch panel, and three openings with nets.

The storage compartments have a maximum storage weight limit of approximately 1.1 kg (2.5 lb.) per opening or a total of 5.6 kg (12.5 lb.) evenly distributed.

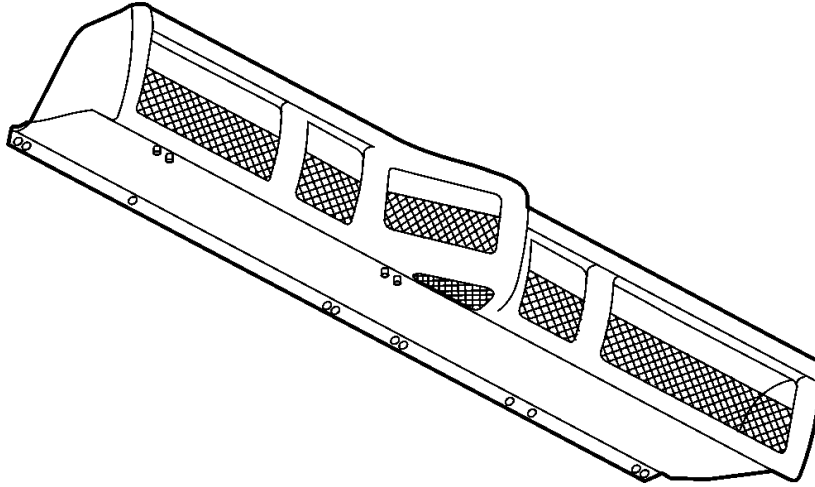

W8003782

Five Openings with Nets

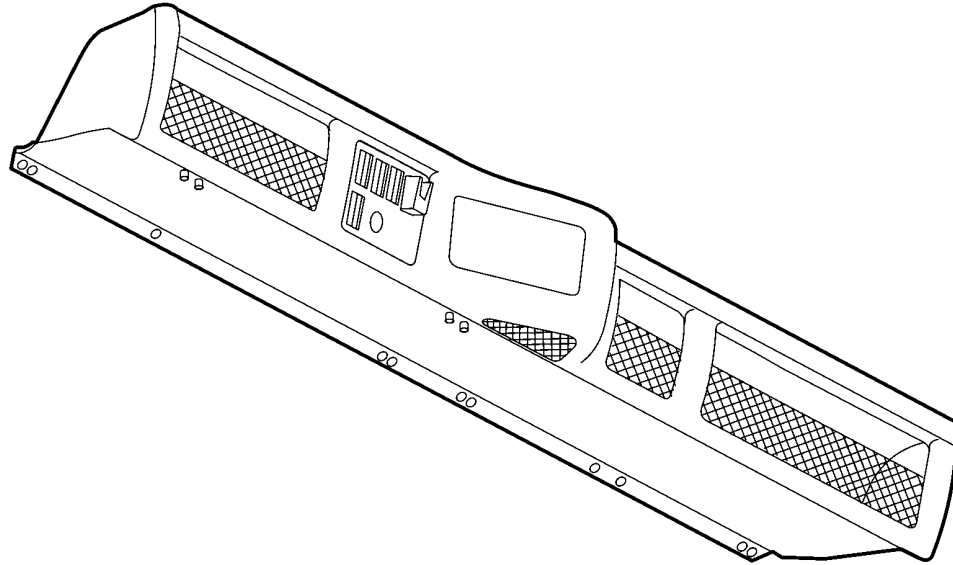

W8003821

CB Radio, Switch Panel and Three Openings with Nets

160 INSTRUMENTS AND CONTROLS

There are two configurations of forward overhead shelves at the front of the sleeper: without cabinets or with cabinets. The storage compartments have a maximum storage weight limit of approximately 3.6 kg (8 lb.) per section.

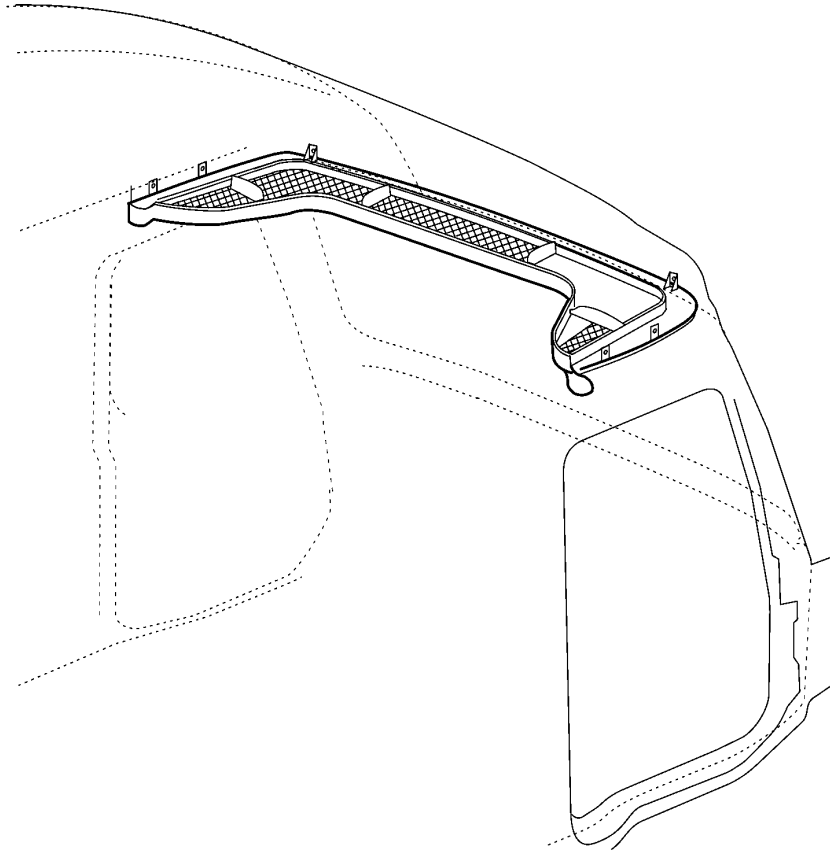

W8003794

Forward Overhead Shelf without Cabinets

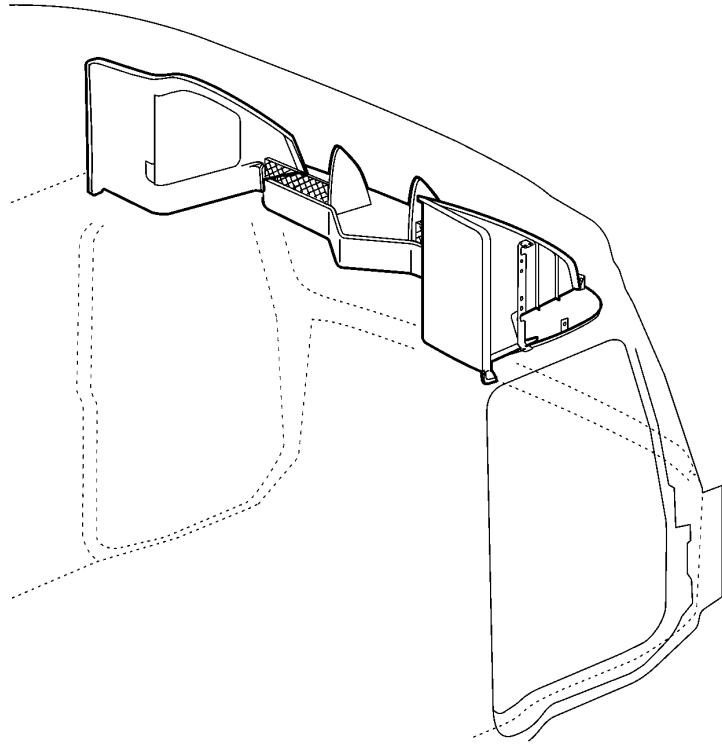

W8003793

Forward Overhead Shelf with Cabinets

162 INSTRUMENTS AND CONTROLS

VN 780 Storage

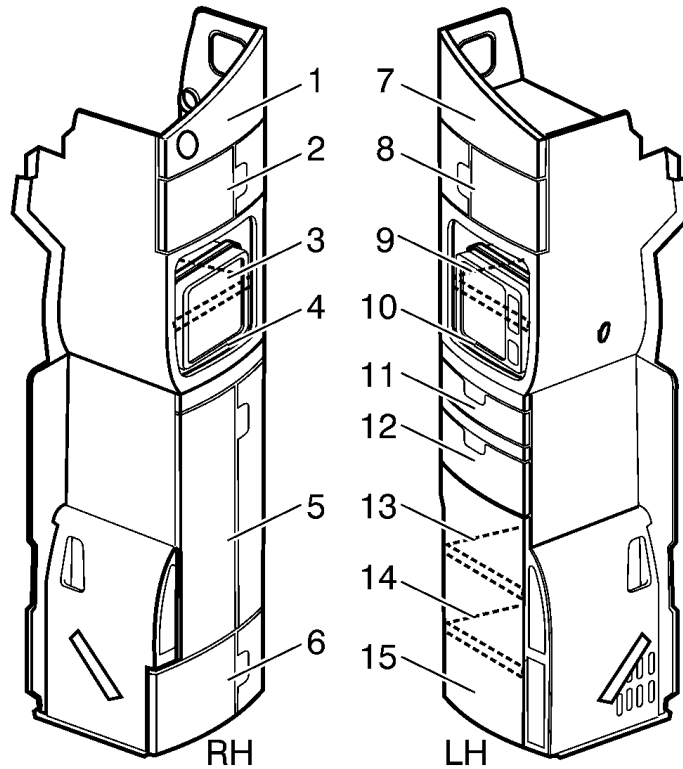

W8003805

1. 3 kg (6.6 lb.)
2. 3 kg (6.6 lb.)
3. 4 kg (8.8 lb.)
4. 15 kg (33.1 lb.) with TV, 6 kg (13 lb.) without TV
5. Hang Rod (Standard) 9 kg (19.8 lb.)
6. (Standard) 18 kg (39.6 lb.)
7. 3 kg (6.6 lb.) 8.3 kg (6.6 lb.)

9. 4 kg (8.8 lb.)
10. 15 kg (33.1 lb.) with TV, 6 kg (13 lb.) without TV
11. 4 kg (8.8 lb.)
12. 5 kg (9.9 lb.)
13. 6 kg (13.2 lb.)
14. 6 kg (13.2 lb.)
15. 45 kg (99 lb.) with refrigerator, 6.5 kg (14 lb.) without refrigerator

VN 780 Bunk Storage

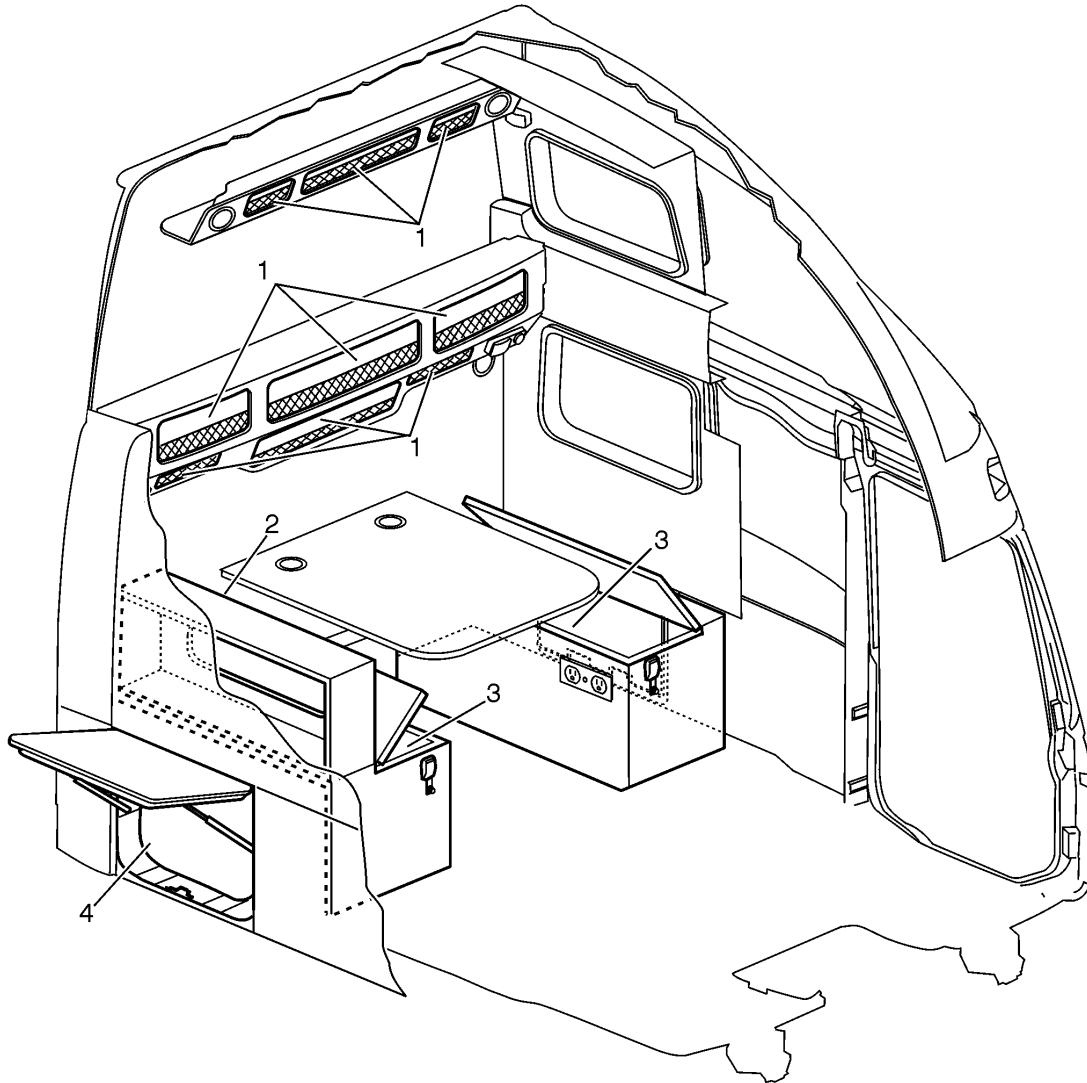

W8003157

- 1 Storage Bins
- 2 Storage Compartment
- 3 Storage Compartment
- 4 Exterior Side Storage Compartment

164 INSTRUMENTS AND CONTROLS

VNL 730 Storage

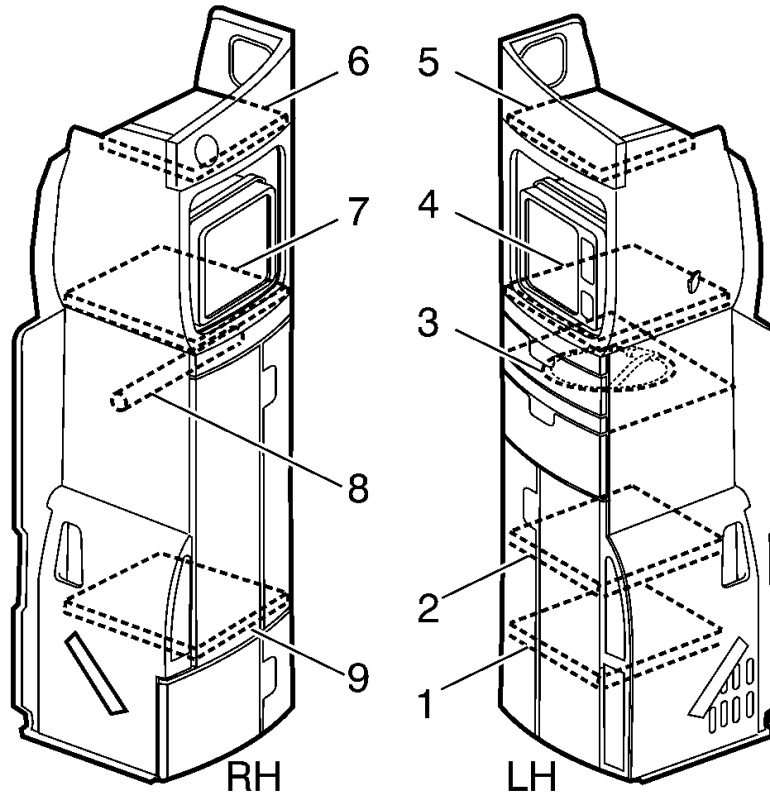

W0002358

- | | |
|--|---------------------------------|
| 1. 6 kg (13 lb.) without refrigerator,
45 kg (99 lb.) equally distributed with
78 L refrigerator | 5. 3 kg (6.6 lb.) |
| 2. 6 kg (13 lb.) without refrigerator,
45 kg (99 lb.) equally distributed with
78 L refrigerator | 6. 3 kg (6.6 lb.) |
| 3. 4 kg (8.8 lb.) | 7. 13.6 kg (30 lb.) |
| 4. 15 kg (33.1 lb.) | 8. 10 kg (22 lb.) on hanger rod |
| | 9. 9 kg (19.8 lb.) |

Note: Do not load the sink, if equipped.

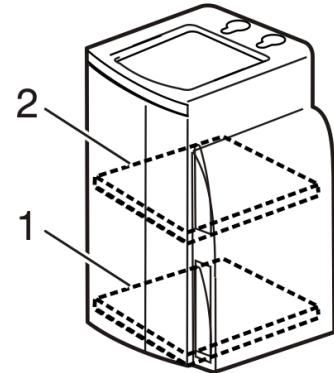
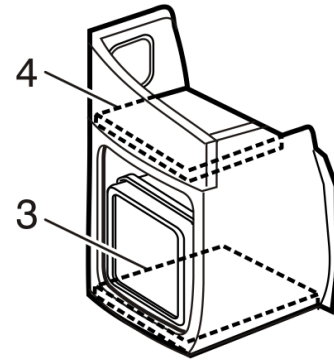
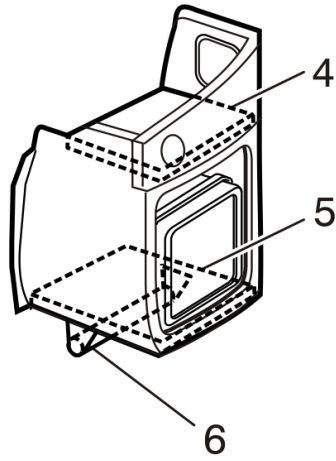

W8028486

Load Limits

166 INSTRUMENTS AND CONTROLS

- 1. 5 kg (9.9 lb.) with 44 L refrigerator
- 2. 4 kg (8.8 lb.) if shelf, 5 kg (9.9 lb.) if refrigerator
- 3. 15 kg (33.1 lb.)
- 4. 3 kg (6.6 lb.)
- 5. 13.6 kg (30 lb.)
- 6. 10 kg (22 lb.) on hanger rod

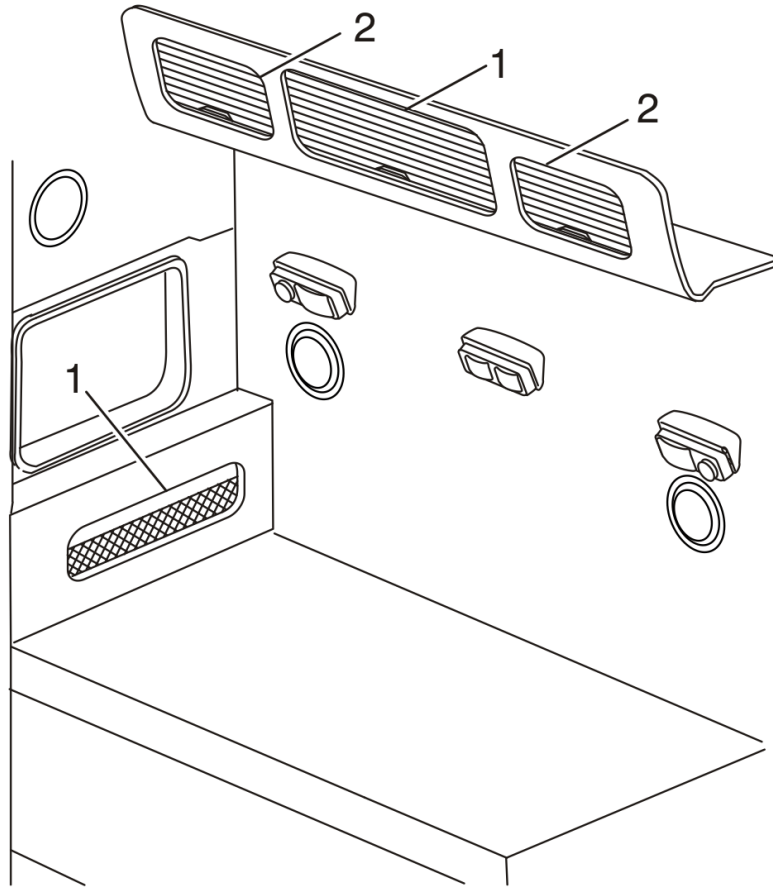

W8028487

Load Limits

- 1. 15 kg (33 lb) with 44 L refrigerator
- 2. 10 kg (22 lb)

VNL 730 Bunk Storage

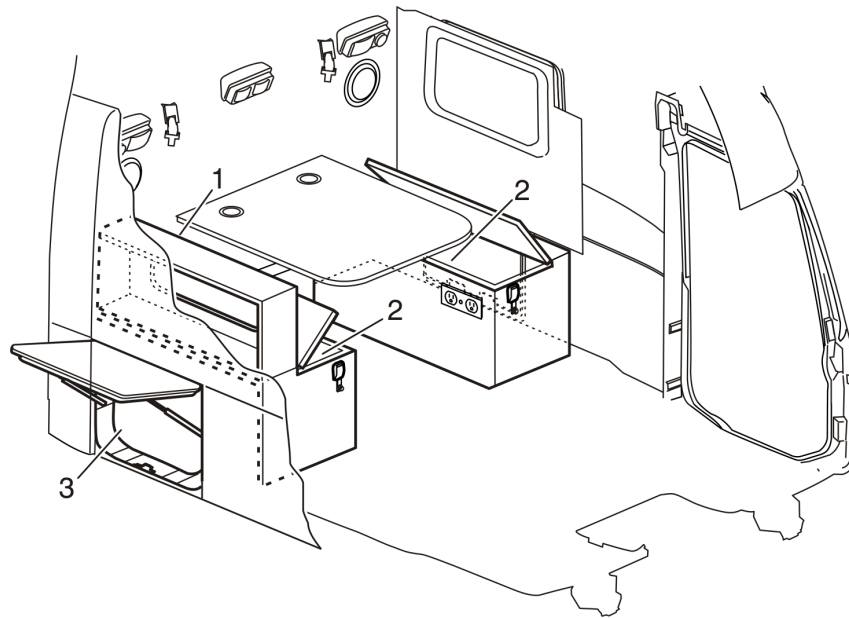

W8028488

Load Limits

1. Storage Compartment
2. Storage Compartment
3. Exterior Side Storage Compartment

168 INSTRUMENTS AND CONTROLS

VN 670, 630, 430

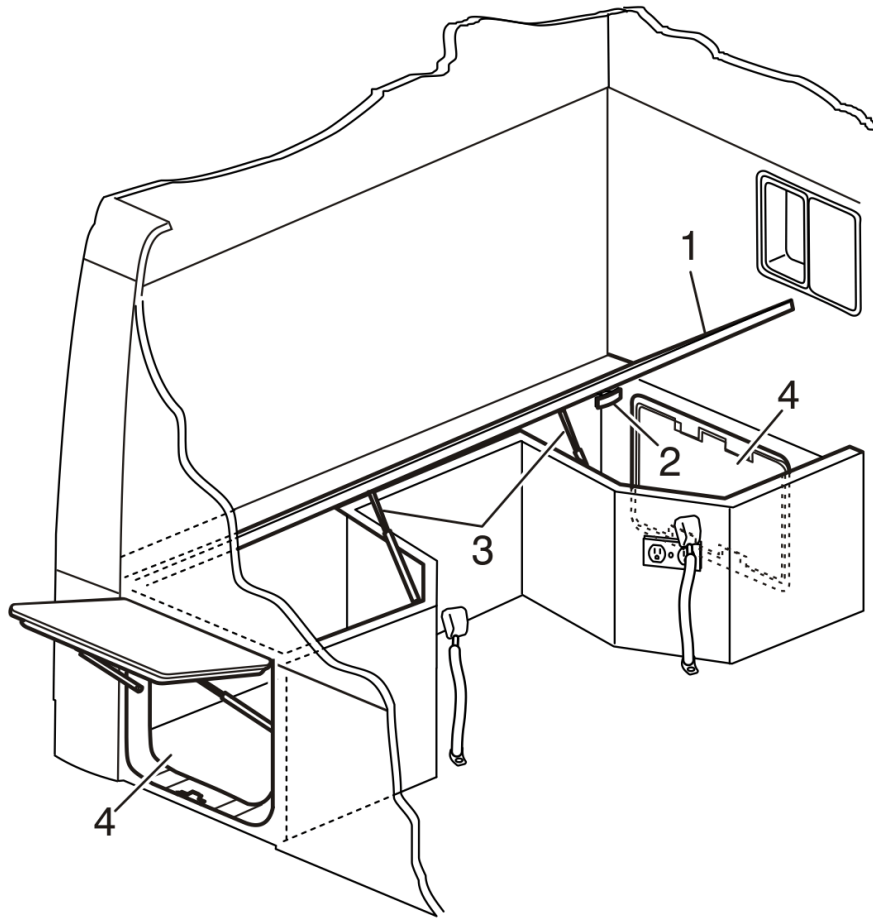

W8028489

Load Limits

1. Lower Bunk Floor Panel
2. Release Handle
3. Restraint Cylinders
4. Outside Storage Compartments

SLEEPER BUNKS

General

Upper and lower bunks are available in the VN 780, 730, 670 and 630 models. The lower bunk is standard while the upper bunk is optional. The VN 430 are equipped with one lower bunk.

The bunks for the VN 670, 630, 430 cover the luggage compartment. They are hinged for access to luggage from inside of the cab.

To gain access, release the latch mechanism and lift by the edge of the bunk platform. Gas springs aid in opening and closing the platform in some models.

The upper bunks for the VN 780, 670 and 630 may also be hinged (optional), and can be raised out of the way. The VN 670 and VN 630 use the safety bunk harness latch to hold up the bunk. The VN 780 has latches on both sides of the wall that hold the bunk in position. To release the latches, pull the latch strap in the middle of the bunk underside.

When the bunk is raised and latched, make sure that the latches on both sides close

170 INSTRUMENTS AND CONTROLS

and hold the bunk properly. For more information on bunk safety restraints, see “Safety Restraint VN 430, VN 630, VN 670 ”, page 238.

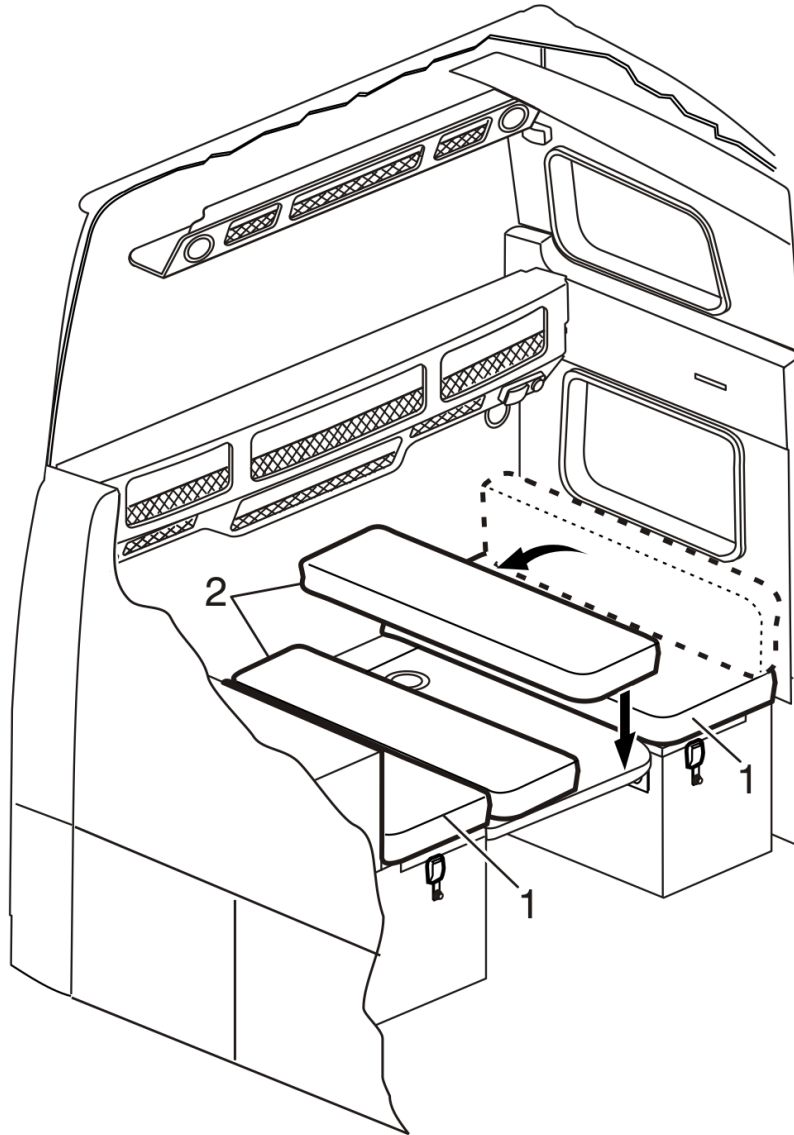

W8028490

1 Cushions: These can be moved and placed to the side.

2 Cushions

VN 780 Sleeper Upper Bunk

DANGER

Always have three limbs (one foot and two hands or two feet and one hand) in contact with the floor, bunk or step at all times when entering or exiting the upper bunk. Failure to follow this procedure can lead to a fall and cause severe personal injury or death.

WARNING

Support the bunk with one hand while releasing the latches. Failure to support the bunk may lead to the bunk falling without control, causing personal injury.

172 INSTRUMENTS AND CONTROLS

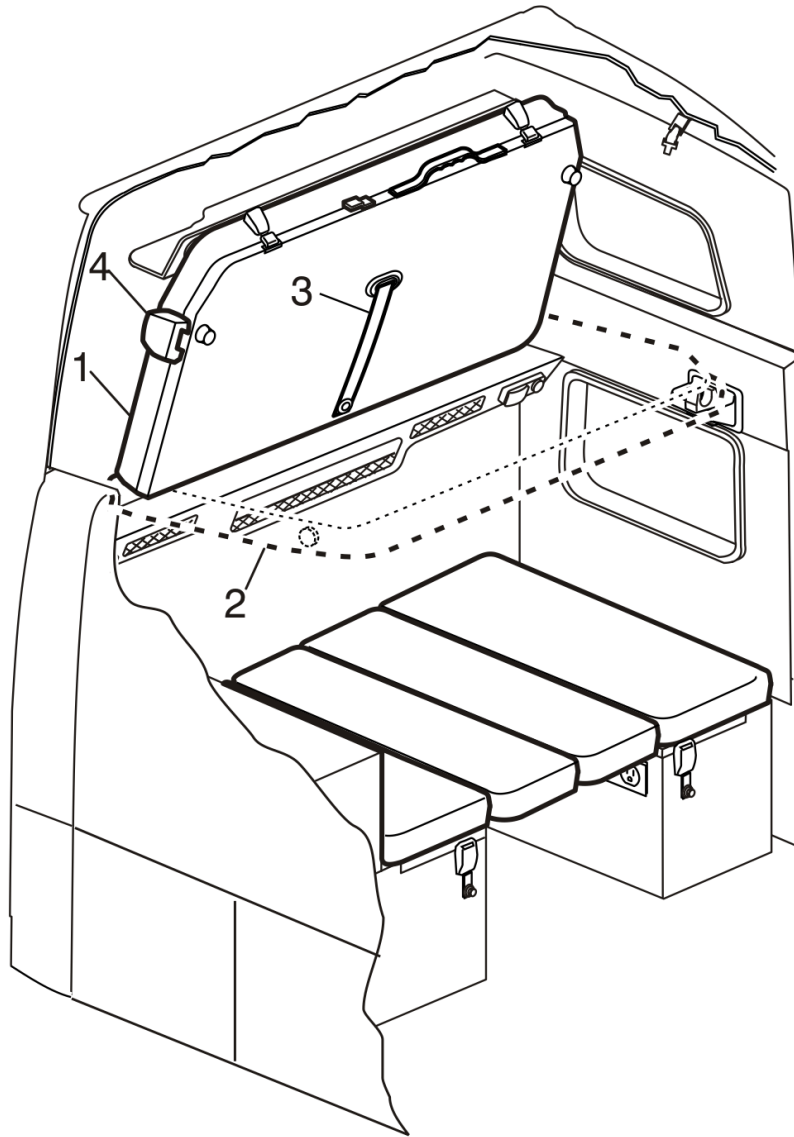

W8028491

- 1 Upper Bunk
- 2 Upper Bunk in Lowered Position
- 3 Release/Pull Strap
- 4 Upper Bunk in Raised Position

VNL 730 Sleeper Bunk

DANGER

Always have three limbs (one foot and two hands or two feet and one hand) in contact with the floor, bunk or step at all times when entering or exiting the upper bunk. Failure to follow this procedure can lead to a fall and cause severe personal injury or death.

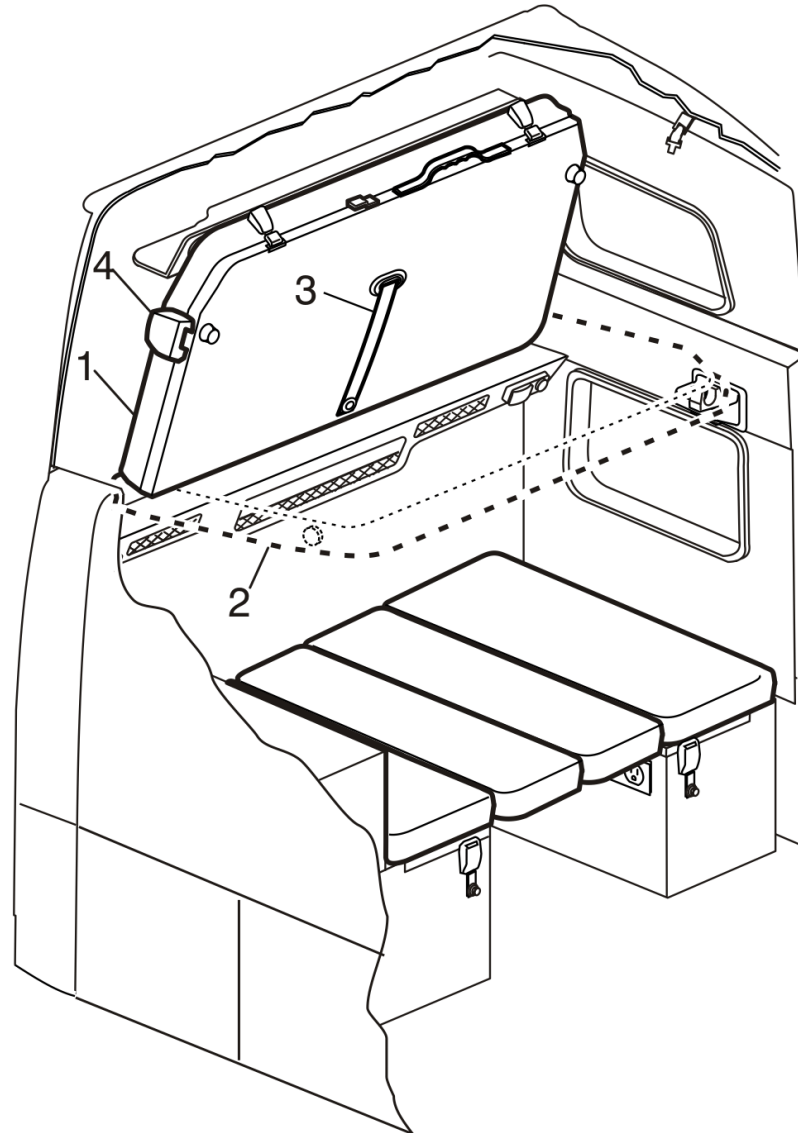

W8028491

- 1 Upper Bunk
- 2 Upper Bunk in Lowered Position
- 3 Release/Pull Strap
- 4 Upper Bunk in Raised Position

174 INSTRUMENTS AND CONTROLS

The VNL 730 can be equipped with a single 53-inch lower bunk, or a 42-inch lower bunk and an upper bunk. For information on bunk safety restraints, see “Safety Restraint VN 430, VN 630, VN 670 ”, page 238.

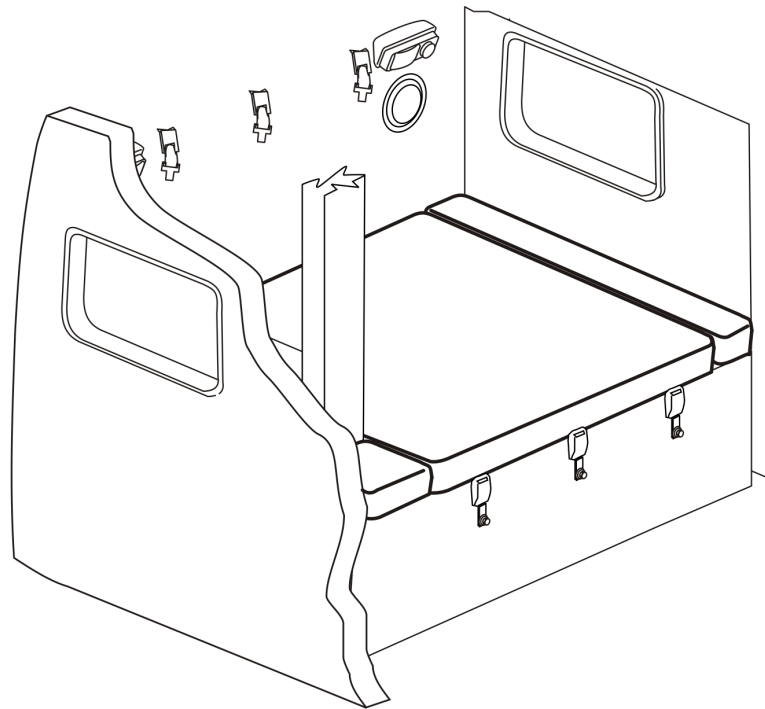

W8028524

53-Inch Lower Bunk

The 42-inch bunk cushions cover the luggage compartment. They can be moved for access to luggage from inside the cab.

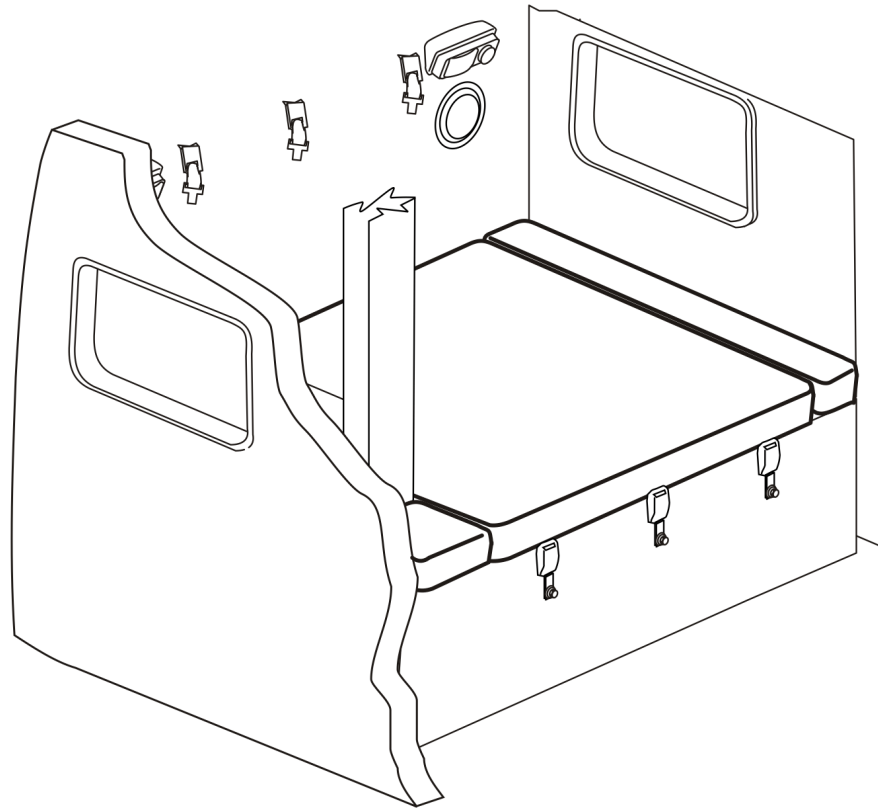

W8028524

- 1 Cushions: These can be moved for access to the luggage compartment.
- 2 Cushions: These can be moved and placed to the side.

176 INSTRUMENTS AND CONTROLS

The upper bunk is hinged and can be raised out of the way. The bunk is supported by a strut on each side in the raised and lowered positions. Use the handle in the middle of the bunk to raise and lower it.

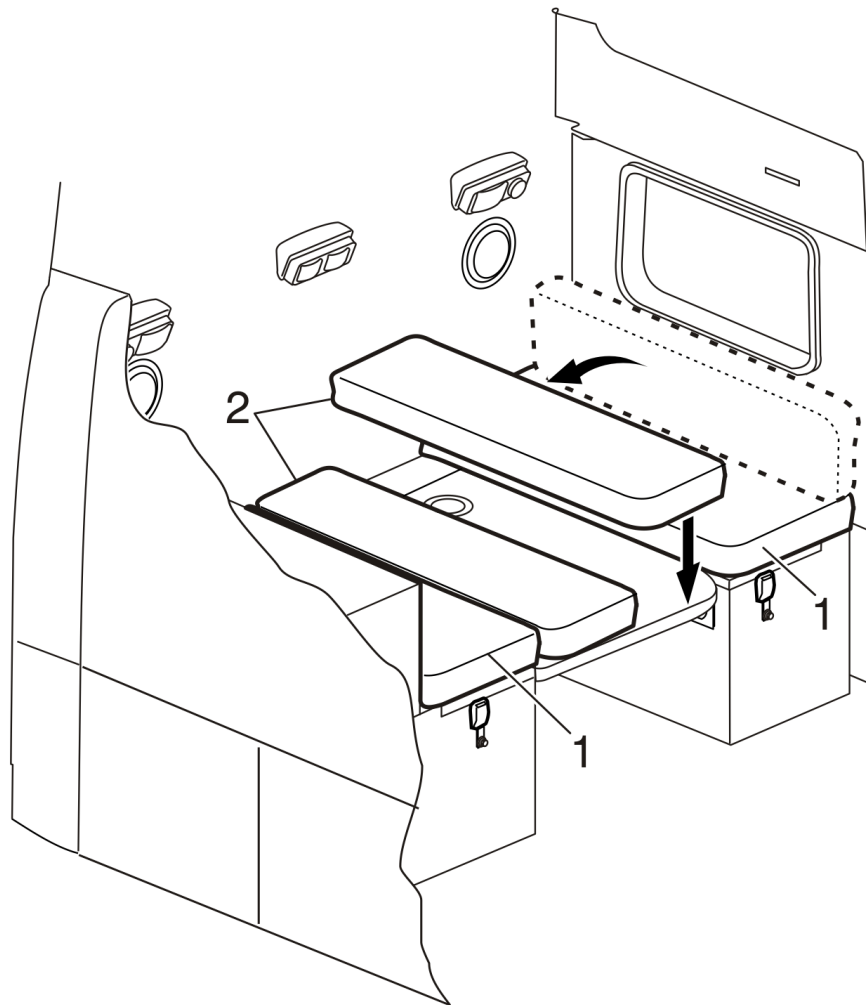

W8028525

- 1 Upper Bunk in Raised Position
- 2 Upper Bunk in Lowered Position
- 3 Support Strut

VN 670, 630 42-Inch Sleeper Bunk

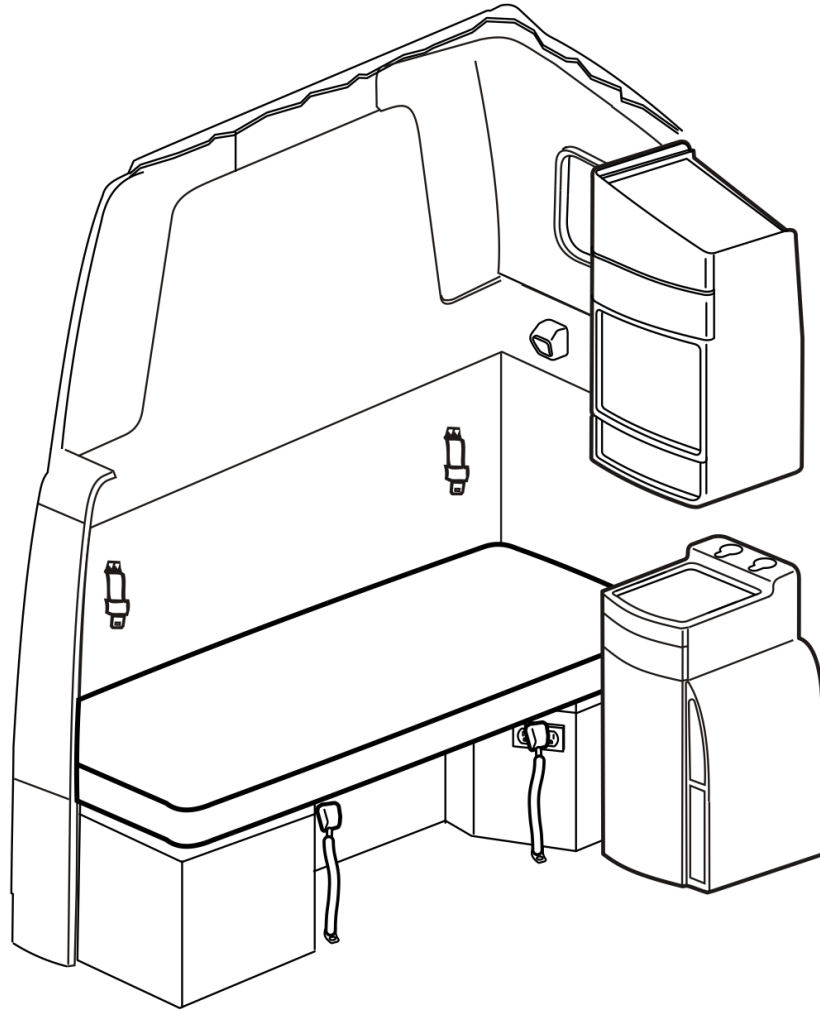

W8028526

VN 670, 630 Lower Bunk



WARNING

Support the bunk with one hand while releasing the latch. Failure to support the bunk may lead to the bunk falling without control, causing personal injury.

178 INSTRUMENTS AND CONTROLS

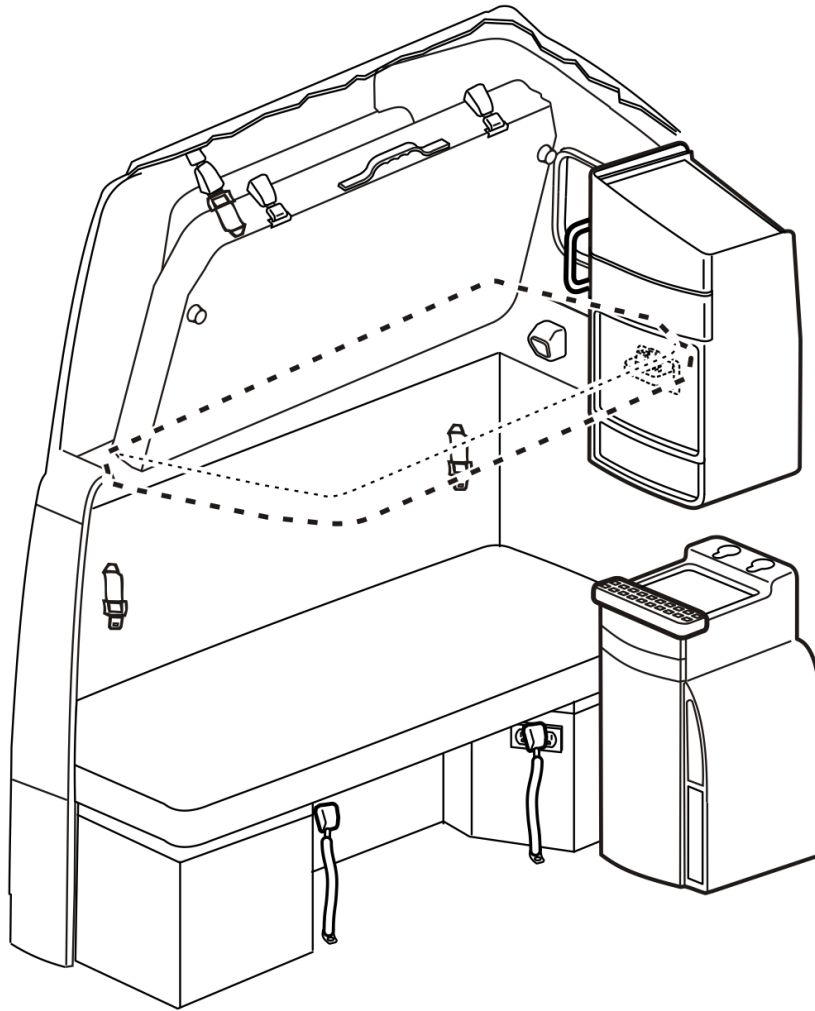

W8028527

VN 670, 630 Lower and Upper Bunks

VN 670 Optional Fold Down Step

In the VN 670 sleeper there is an option on the passenger side which offers a fold down step. See illustration.

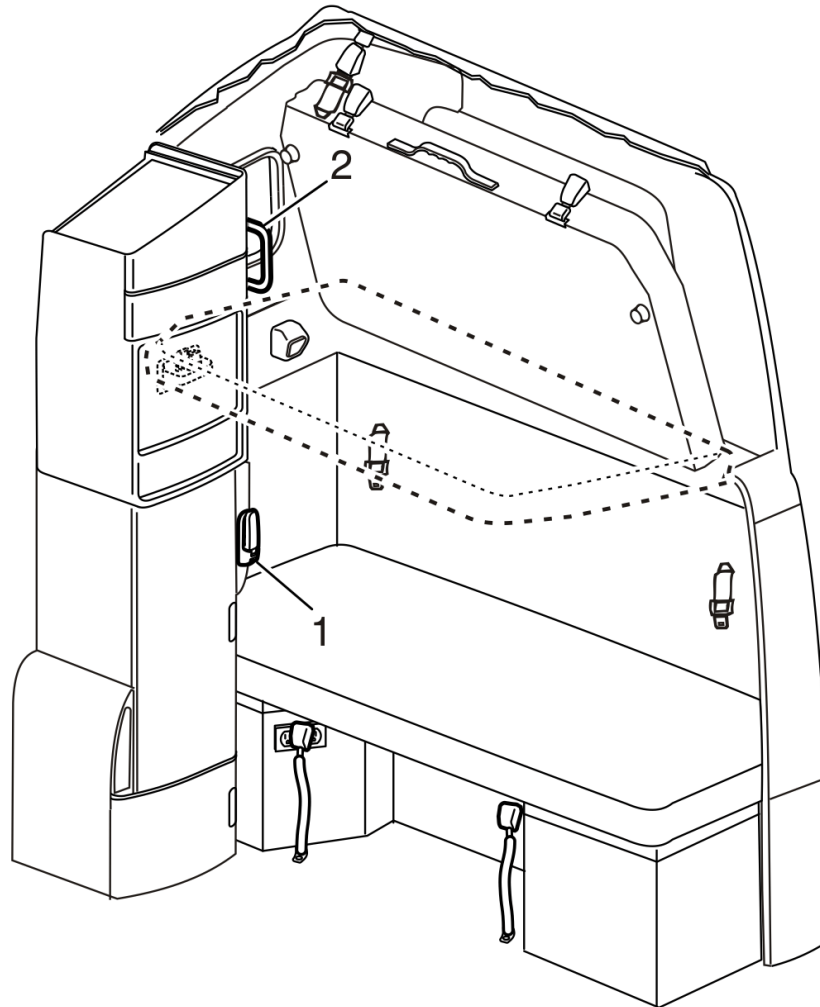

W8028528

- 1 Fold Down Step
- 2 Cabinet Grab Handle

180 INSTRUMENTS AND CONTROLS

VN 670

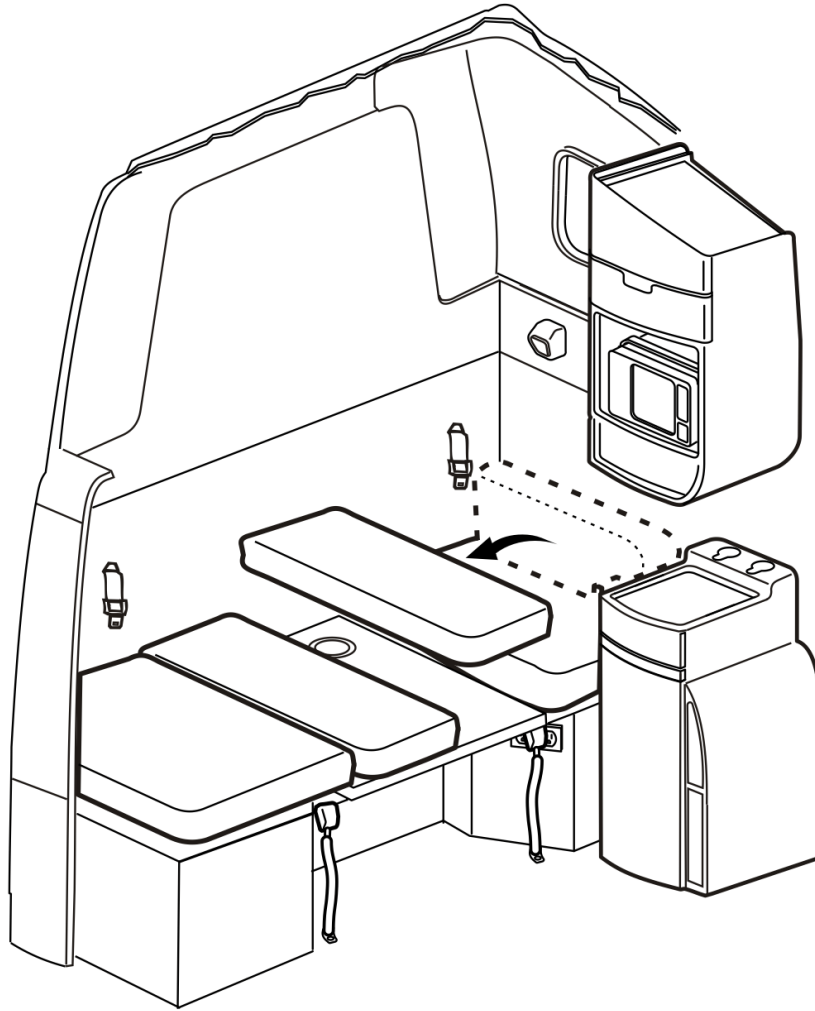

W8028529

Moveable Cushions in Lower Bunk

VN 430 Sleeper Bunk

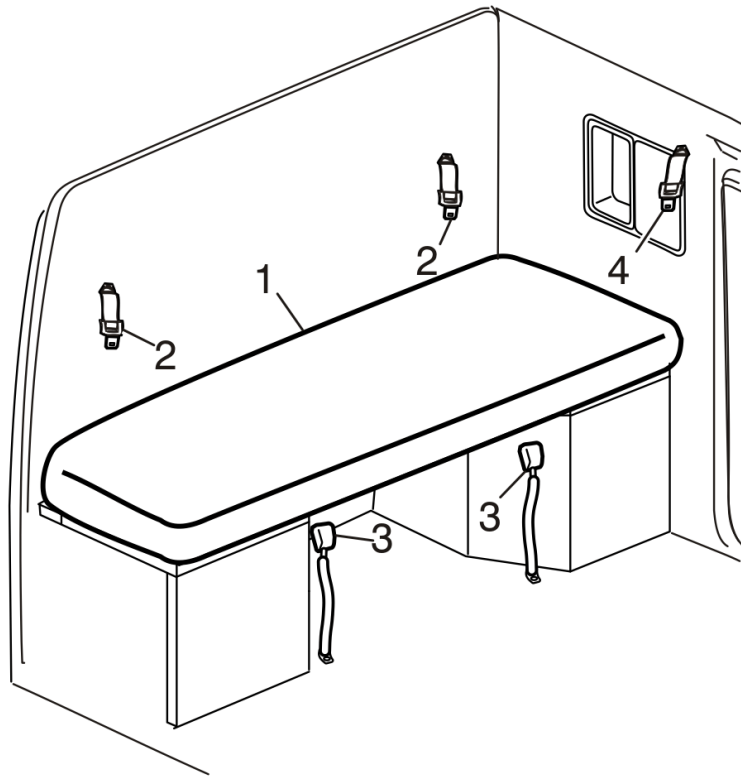

W8028530

- 1 Bunk
- 2 Bunk Restraints
- 3 Lower Bunk Restraint Attachment Buckles
- 4 Tenting Buckles

Upper Bunk Access VN 780

DANGER

Always have three limbs (one foot and two hands or two feet and one hand) in contact with the floor, bunk or step at all times when entering or exiting the upper bunk. Failure to follow this procedure can lead to a fall and cause severe personal injury or death.

WARNING

Support the ladder with one hand while releasing the lock straps. Failure to support the ladder may lead to the ladder falling out, causing injury to leg or foot.

Access to the upper bunk is provided by lowering foldable ladder and securing the ladder into the floor locator (6) and retainer bracket (2) in the upper bunk.

The ladder stored in its collapsed position behind the passenger side cabinet. To release the ladder, unsnap the lock straps. Support the ladder so it does not fall out unaided.

To access the upper bunk, start the climb by grabbing the grab handles with both hands. Place the right foot on the bunk bottom to the right of the cabinet and the left foot on the upper step. Put both feet on the upper step and move the right hand to the upper bunk for support. Swing the upper body into the bunk and sit down.

The grab handle for upper bunk access is located on the cabinet.

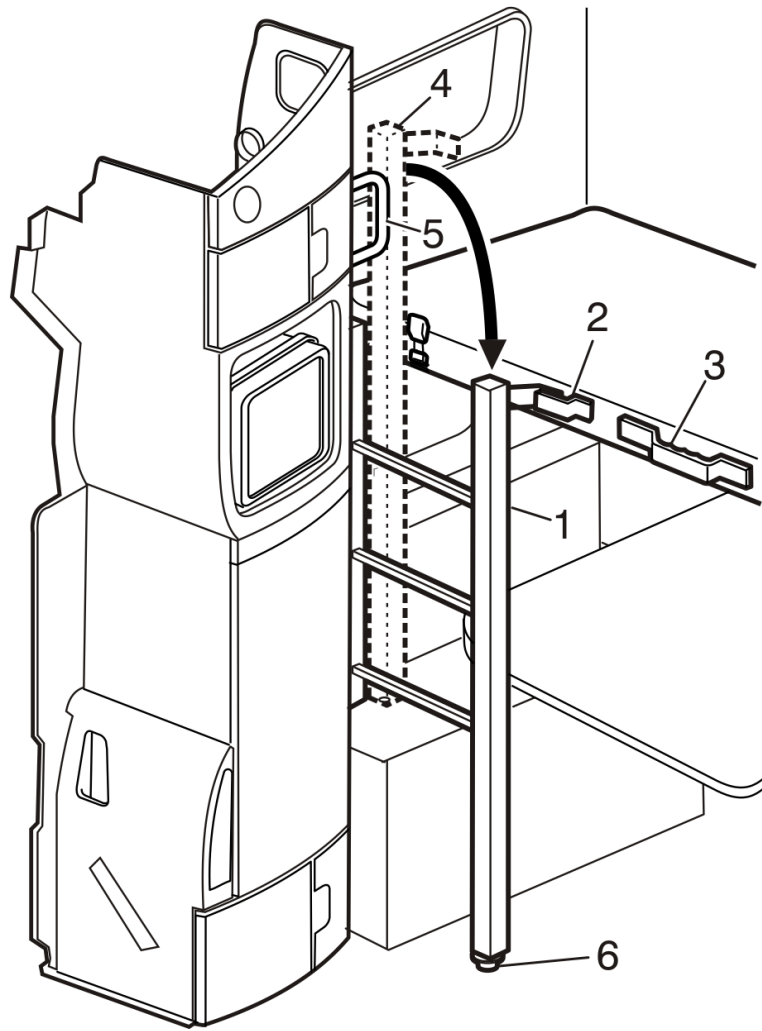

W8028531

- | | |
|--|----------------------------------|
| 1.Ladder in
Down Position | 4.Ladder (Stored) |
| 2.Retainer | 5.Cabinet Grab
Handle |
| 3.Grab Handle
(on Optional
Fixed Bunk,
Grab Handle is
Not Available) | 6.Ladder Security
Positioning |

VN 780, VNL 730, VN 670 OFFICE



DANGER

Do not sit at the table when the vehicle is moving. It is intended for use only when the vehicle is parked. Passengers should be in the passenger seat wearing the safety belt or in the bunk with the bunk restraint attached. Failure to follow these instructions may result in severe personal injury or death in the event of a sudden stop or accident.

To raise table, remove the cushions from the bunk, place them to the sides.

Line up the latch pegs with the holes in the back wall.

Push the table firmly into the holes. Make sure the latches are caught properly by pulling out on the table. When the table is in place, put the cushions in place to form a seat and backrest.

To lower the table, remove the cushions and pull the handle underneath the tabletop to release the latches. Lower the table to its resting position. Place the seat cushions toward the walls and then position the backrest cushions as illustrated. Press down on the cushions in the middle to form a mattress. See "VN 780 Bunk Storage" in this manual.

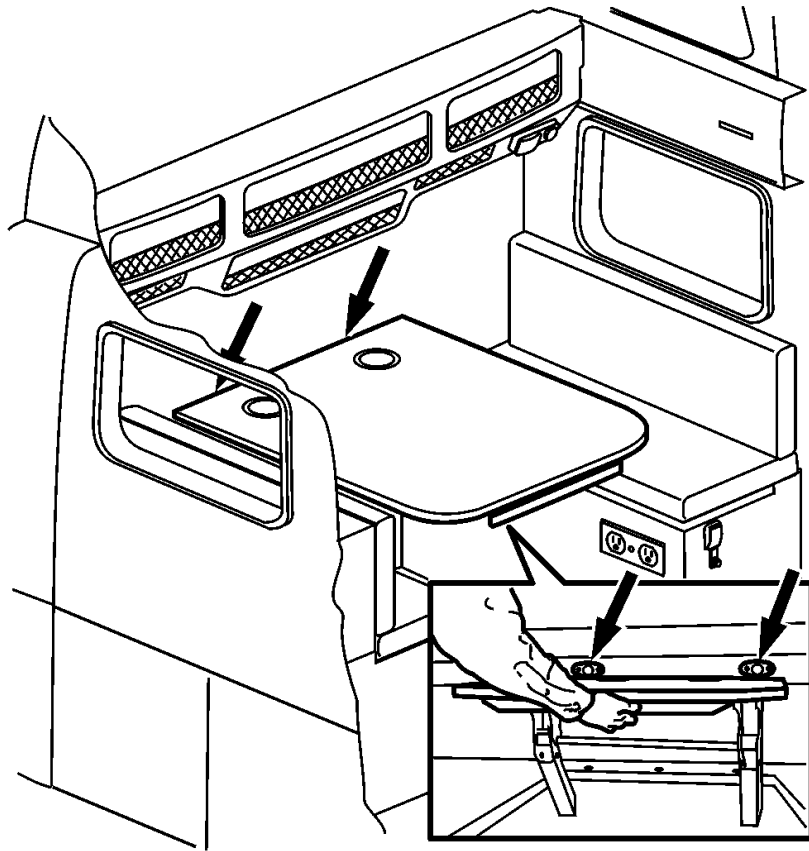

W8003158

SLEEPER COMPARTMENT SINK

A built-in sink is available as optional equipment in some sleeper models. It is located on the left side, in the cabinet behind the driver.

The sink is mounted in the drawer space. To pull out, grasp the drawer lip and release the latch. Pull out until the faucet can be raised without hitting the cabinet.



CAUTION

Never run the pump without water in the freshwater tank. The pump may be damaged if run dry.

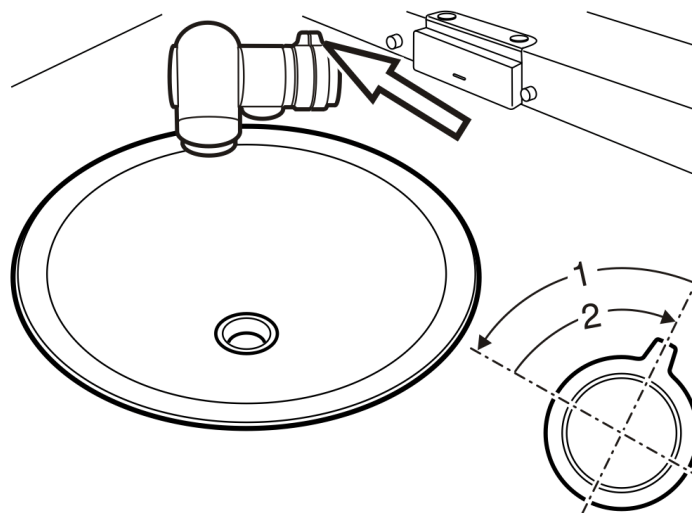

W8028573

1 Increase Flow

2 Decrease Flow

To operate the water pump, there is a combined valve and switch in the knob (see arrow in illustration) on the base. Turn the knob slightly toward you to start the pump; see arrow in illustration. Turn the knob further to increase water flow. When the knob is turned fully back to rest position, the pump will stop.



CAUTION

Make sure the pump is turned off before pushing the drawer in. If the pump continues to deliver water, overflowing water can flood the cab floor.

In the bottom of the sink there is a spring-loaded drain plug that is sealed by pressing down and twisting clockwise. To release for letting water drain off, turn counterclockwise and the spring will lift the plug and open the drain.

Fresh Water Tank

Water is drawn from the fresh water tank (1) located beside the waste water tank (2) in the left-hand side luggage compartment. Refill fresh water tank with potable drinking water only. Tank volume is 9 gallons (34 liters). On top of the tank is a hose (3) that serves as a filler and a vent tube. In the bottom of the tank is a drain valve (4), with a hose attached, for draining the tank to the outside.

188 INSTRUMENTS AND CONTROLS

It is not recommended to keep unused water in the tank for over one month. Clean and refill as necessary.

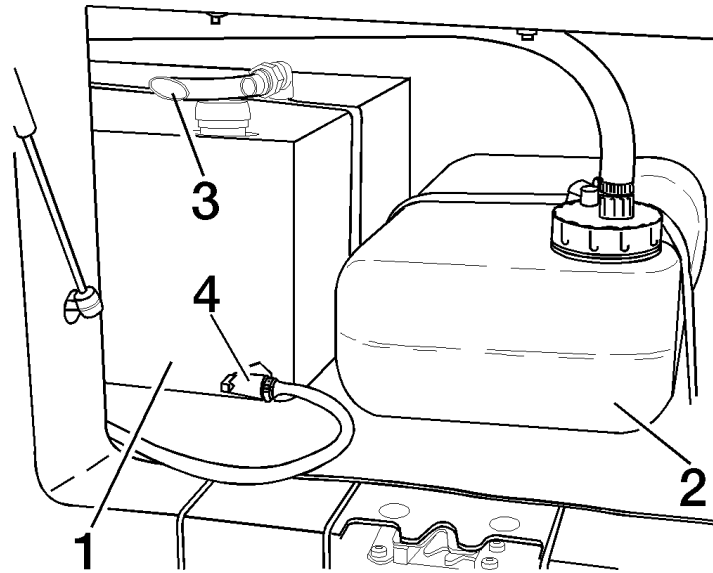

W8002168



CAUTION

USE POTABLE DRINKING WATER ONLY. Verify with the supplier of any water prior to filling the fresh water tank that it is potable to avoid contamination of the tank. In the event that non-potable or contaminated water enters the fresh water tank, it should be drained and the tank should be cleaned out with a good commercial cleaner/disinfectant. The tank should also be tested for purity prior to being used for drinking. It may be necessary to replace the tank if it cannot be cleaned properly.

 **CAUTION**

Fresh water and waste water tanks must be drained if the vehicle is not being used and the outside temperature is below freezing. Also drain the hose from the pump to the faucet. Failure to drain the system may result in component damage due to water forming ice.

To fill the fresh water tank, unscrew the fill hose from the elbow fitting and remove the fill cap (5) from the tank. The fill hose is connected to a hose with a garden hose-type fitting. Before turning the water on, turn the valve handle (6) to close the valve (see lower illustration). When the end of the fill hose is inserted in the water reservoir, open the valve slowly to fill. The valve is fully open when the handle is parallel with the hose.

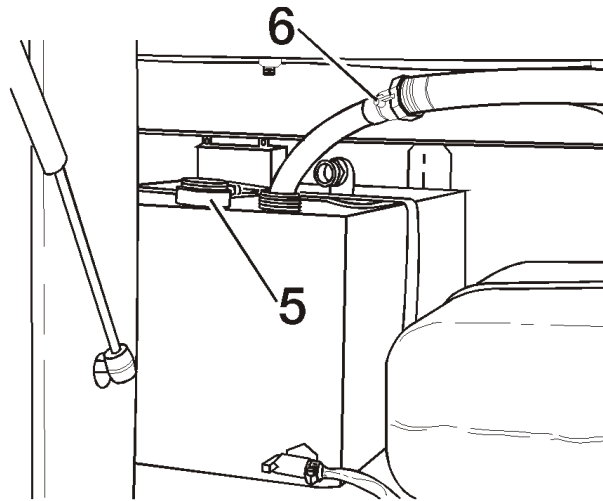

190 INSTRUMENTS AND CONTROLS

When the tank is full, reinstall the fill hose on the elbow fitting. Do not tighten more than finger tight. Make sure that the valve handle is fully open (1) to allow venting. If the valve is left in any of the closed positions (2), the pumped out water may generate an under-pressure in the tank, interfering with the pump operation.

Note: The valve positions are shown as viewed from inside the cab.

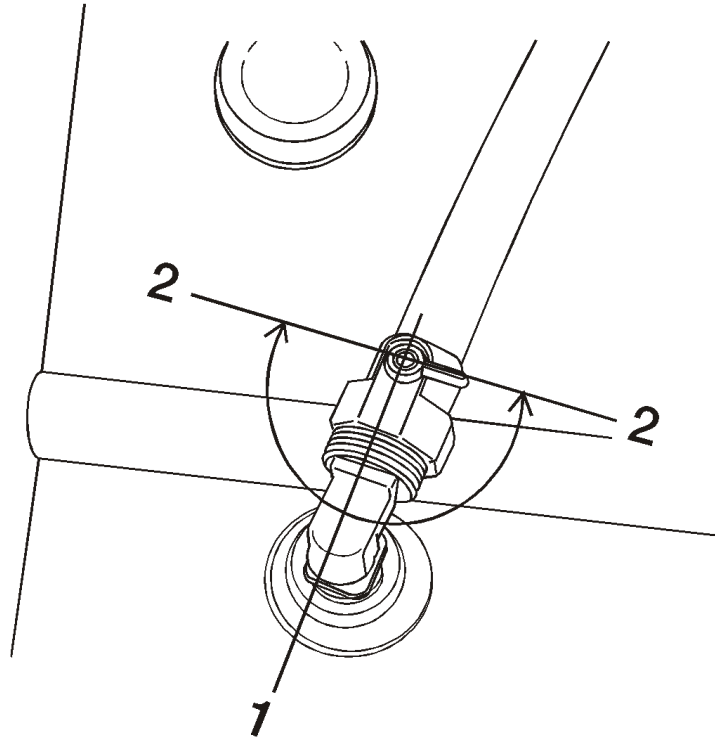

W8028578

Waste Water Tank

When the water is drained from the sink, it is collected in a waste water tank behind the fresh water tank. Waste water tank volume is 19 liters (5 gallons). The tank is fastened to the floor with a strap that can be easily opened for tank removal. Before removing the waste water tank, loosen the strap around the tank and unscrew the drain hose from the inlet cap. Carry the tank to an approved dump station and empty by removing the inlet cap and tilting the tank up to let the waste water drain. Flush the tank with fresh water. Replace the inlet cap, strap the tank into the cab and attach the drain hose.

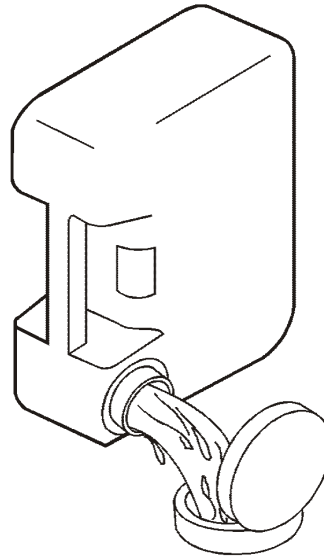

PRE-TRIP INSPECTION AND DAILY MAINTENANCE

DANGER

Before working on or inspecting a vehicle, set the parking brakes, place the transmission in neutral and block the wheels. Failure to do so can result in unexpected vehicle movement and can cause serious personal injury or death.

Safety is the most important and obvious reason for doing a pre-trip inspection. Federal and state laws require inspection performed by the driver. Federal and state inspectors also inspect commercial vehicles. An unsafe vehicle can be placed "out of service" until the driver or owner corrects the deficiency. Owners and operators should familiarize themselves with sections 49 CFR 396.11 and 396.13 concerning Federal requirements for vehicle inspection. Certain other laws may also apply. Section 49 CFR 396.13 states that all motor carrier drivers must complete a written report at the end of each work day for each vehicle operated, covering most of what is covered in the pre-trip list. The report should list all defects or deficiencies discovered by the driver. A pre-trip inspection prepares for the end-of-work report. Starting on the next page are suggested guidelines to be used in performing truck, tractor and trailer pre-trip inspections. Depending on the application of the vehicle being used, these guidelines should be modified to include other necessary inspection points. For example, steps and grab handles should be checked daily on refuse trucks because the operator is getting in and out of the cab more frequently. If any component or system does not pass this inspection, it must be corrected before operating the vehicle. Whenever equipment requires adjustment, replacement, repair or lubrication, refer to the Service Manuals or contact an authorized Volvo Truck dealer for the correct procedures, specifications and intervals. Also, available through the vehicles driver information display (DID) is a pre-trip inspection system that will assist in performing the manual pre-trip inspection.

Pre-Trip Assistance

The Pre-Trip Assistance option is a tool to assist the driver in completing the pre-trip inspection of the vehicle. This option is not a substitute for a complete pre-trip inspection. If any system of the vehicle does not pass inspection, the error must be corrected before operating the vehicle. The available pre-trip tests include a Switch/Circuit Status check, Exterior Light Inspection check, and a Air Leakage check.

Switch/Circuit Status Check

The Switch/Circuit Status check tests the functionality of the switches and their corresponding circuits. To start the check the driver must turn the individual switches on/off. As the switches turn on/off, the cluster updates the DID to show switch option being tested and it's status.

Note: The Hazard and High/Low Switches are momentary switches and return to the OFF position when released during testing.

1. The initial Pre-Trip screen displays.
Using the stalk controls, select Switch Status.

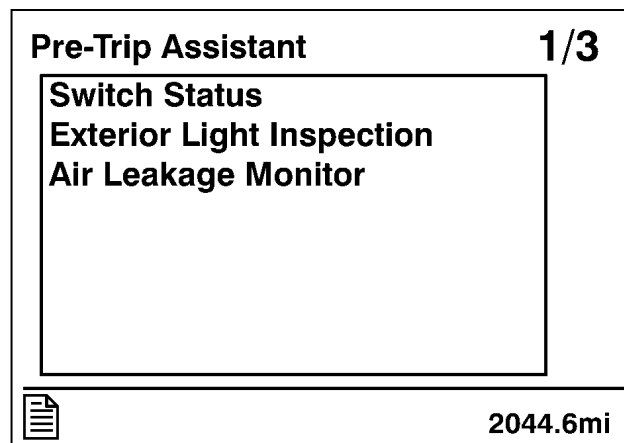

W3035544

2. After the diagnostic is completed, the following screen displays detailing the status of each switch.

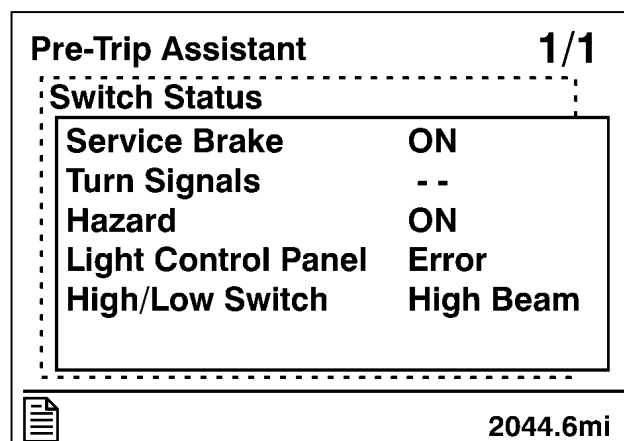

W3035548

Exterior Light Inspection Check

The Exterior Light Inspection check repeatedly turns all exterior lights on/off for the vehicle. This allows the operator to start the test, exit the vehicle and do a visual check that all exterior lighting is functioning properly.

The following exterior lights are cycled through the check:

- Parking
- Hazard
- Turn signals (left and right)
- High/Low beam headlights
- Brake
- Fog/Driving (Optional)

1. From the Pre-Trip Assistant main screen select Exterior Light Inspection.

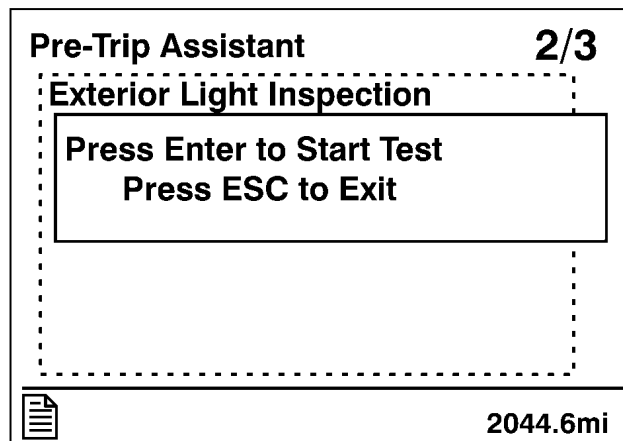

2. The Test Started screen displays. You can stop the test by pressing 'ESC' on the stalk or by starting the ignition.

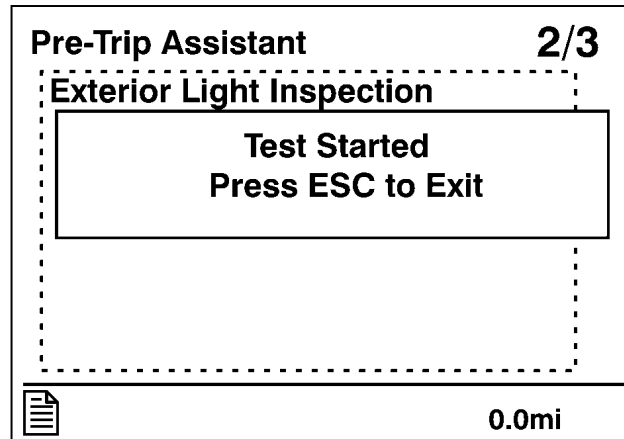

W3035557

Once the test is started all exterior lights flash on and off so that you can perform a visual check.

Air Leakage Check

The Air Leakage check allows the driver to accurately measure the amount of air pressure drop in the front and rear brake air systems. After selecting this test from the DID, you are prompted to apply the service brake for 60 seconds. After applying and holding the service brake for 60 seconds, the DID will display the amount of pressure drop in the brake system.

Before starting the test through the DID, complete the following:

- Start the engine and check that the brake pressure gauges are greater than 136 Nm (100 psi).
 - Turn engine off.
 - Release all brakes and allow the system to settle (air gauge needle stops moving).
1. When running the brake pressure test the following screen displays. Press and hold the brake pedal for a total of 60 seconds.

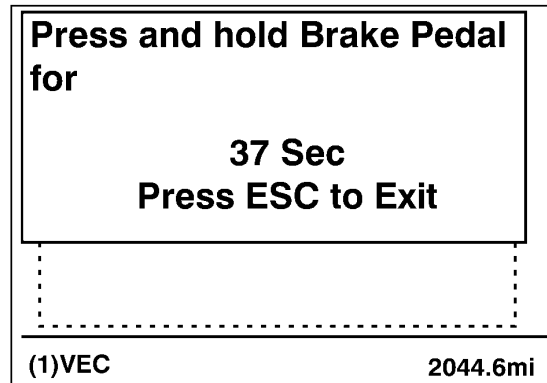

W3035558

If the air tanks are not full, in order to complete the air leakage test, the following screen displays.

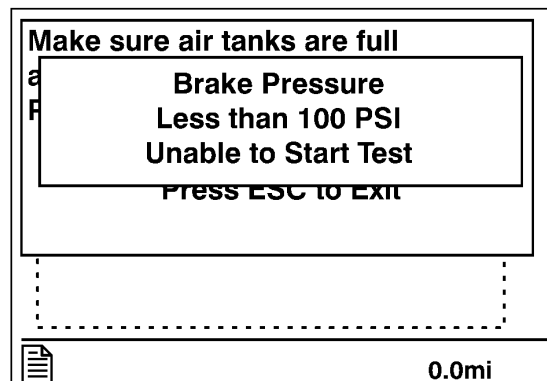

W3035559

2. When the system is ready to be checked, the following screen displays. Press Enter to begin the test.

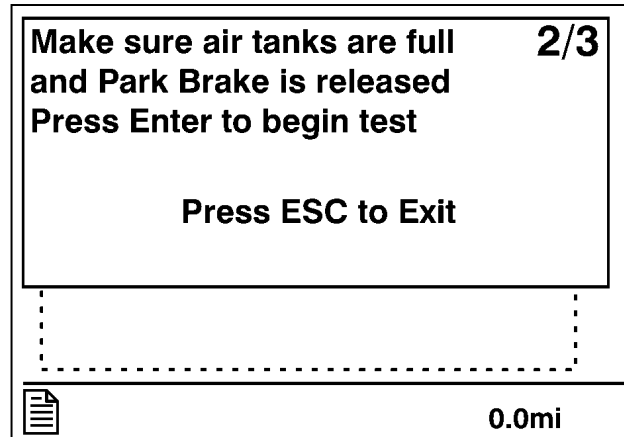

W3035566

Press and hold the brake pedal for 60 seconds. If the brake pedal is not pressed and held for 60 seconds the following warning screen displays.

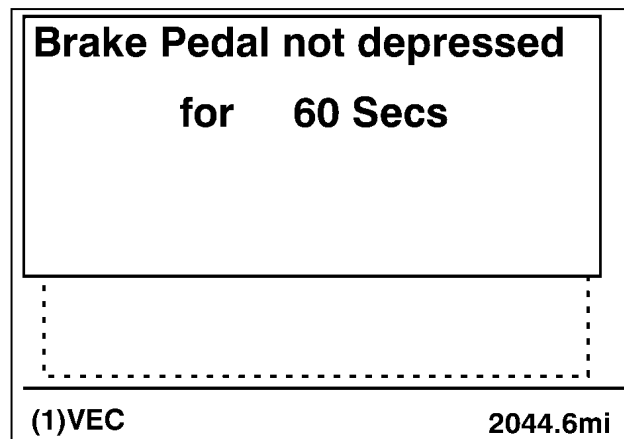

W3035571

3. Once the brake pressure test is completed the pressure leak test results are displayed.

198 OPERATION

Pressure Leak Test Results			
Tank	Before	After	Drop
F	127	127	0
R	129	129	0

(1)VEC	2044.6mi
---------------	-----------------

W3035574

Take your time going through the pre-trip inspection. Remember that a careful pre-trip inspection saves time by eliminating unscheduled stops for correcting a faulty item. The following information has been provided by the American Trucking Association as developed by the D.O.T. Office of Motor Carriers (BMCS).

Pre-Trip Inspection Quick List

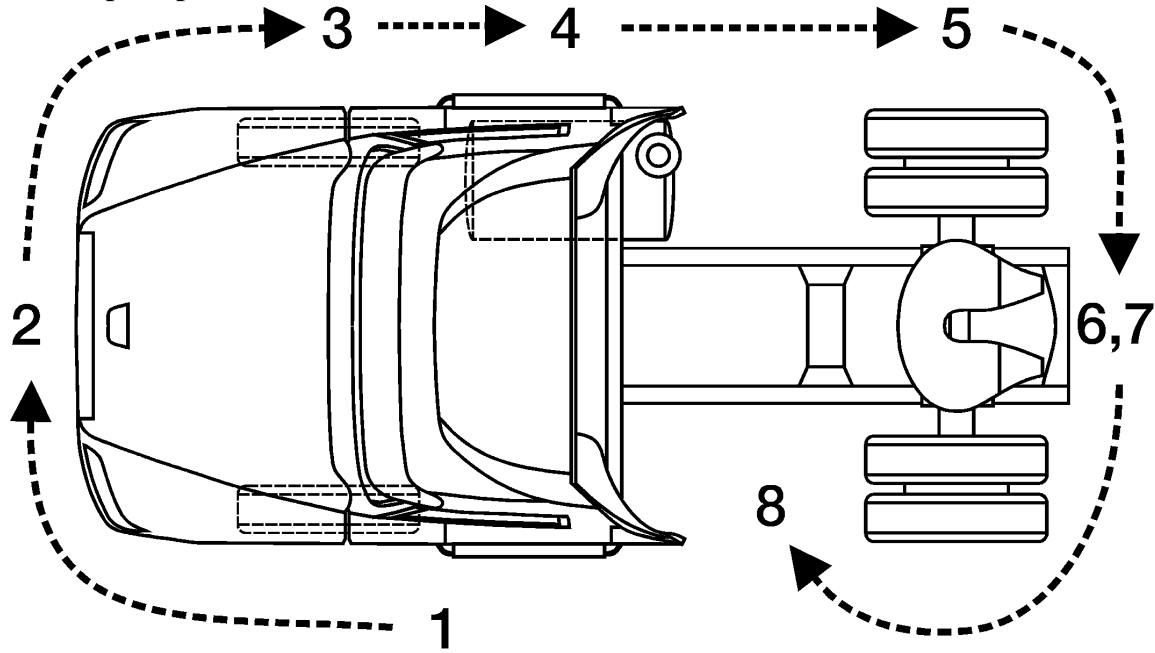

W0001230

VN

Pre-Trip Inspection Quick List

Inspect the vehicle in a circular manner.

Approaching the Vehicle

- Check under the vehicle for oil, fuel, coolant leaks or other signs of damage.
- Check body surfaces for signs of breaks or damage.

Preparation

- Open drain cocks on air tanks to let the tanks drain.
- Chock wheels on vehicle and, if hooked up, trailer.
- Close air tank drain cocks.
- Start the engine and let the air pressure build up to normal. Stop engine check for air leaks.
- Switch on parking lights and hazard lights.
- Apply parking brakes. Listen for air leaks

200 OPERATION

- Raise cab so belts can be checked

Step 1: Left Side of the Cab

Left Front Wheel

- Check condition of wheel rim. Especially look for cracks, missing lockrings, bent or broken studs, missing clamps or lug nuts.
- Check condition of tire: properly inflated, no serious cuts, bulges, tread wear or any signs of misalignment; valve stem not touching wheel, rim or brake drum; valve cap in place.
- Check wheel bearing and hub: no obvious leaking on outside or inside wheel. Verify correct oil level in hub.

Left Front Suspension

- Check condition of spring, spring hangers, shackles, U-bolts: no cracks, breaks or shifting.
- Check shock absorber condition.

Left Front Brake

- Condition of brake drum. With brakes released, look for a noticeable gap between lining and drum. (This check cannot be made if dust covers are in place.)
- Condition of brake air hose.
- Check brake chamber mounting bolts and bracket.
- Check slack adjuster and chamber pushrod travel for proper brake adjustment.

Condition of Front Axle and Steering System, Left Side

- No loose, worn, bent, damaged or missing parts.

Engine Compartment, Left Side

- Check coolant hose condition.
- Check condition of fan drive belts.
- Check engine and surrounding areas for coolant, oil and fuel leaks.
- Check wiring harnesses for signs of damage.

Engine Compartment, Right Side

- Check condition of coolant and heater hoses.
- Check condition of fan drive belts.
- Check engine and surrounding areas for coolant, oil and fuel leaks.
- Check fuel separator sight glass and drain if necessary. Check for leaks.
- Check wiring harnesses for signs of damage.
- Check air filter with brackets and hoses for loose connections or damage. Check filter gauge, if mounted on the filter.

Step 2: Front of Cab Area

Condition of Windshield

- Check for damage and clean if dirty.
- Check windshield wiper arms for proper spring tension.
- Check wiper blades for any damage, "dead" rubber and attachment to arm.

Lights and Reflectors

- Lower cab and inspect parking, clearance and identification lights on cab. They should be clean, operating and of the proper color.
- Reflectors clean and proper color.
- Turn on headlights. High and low beams should be operating and lenses clean. If equipped, check daytime running lights.
- Left and right front turn signal lights clean, operating and proper color.

Grille

- Check that charge air cooler and radiator or bugscreens are clean and undamaged.

Step 3: Right Side of Cab Area

Right Front Wheel

- Check condition of wheel rim. Especially look for cracks, missing lockrings, bent or broken studs, missing clamps or lug nuts.

202 OPERATION

- Check condition of tire: properly inflated, no serious cuts, bulges, tread wear or any signs of misalignment; valve stem not touching wheel, rim or brake drum; valve cap in place.
- Check wheel bearing and hub: no obvious leaking on outside or inside wheel. Verify correct oil level in hub.

Right Front Suspension

- Check condition of spring, spring hangers, shackles, U-bolts: no cracks, breaks or shifting.
- Shock absorber condition.

Right Front Brake

- Condition of brake drum. With brakes released, look for a noticeable gap between lining and drum. (This check cannot be made if dust covers are in place.)
- Condition of brake air hose: check for any chafing.
- Check brake chamber mounting bolts and bracket.
- Check slack adjuster and chamber pushrod travel. With brakes applied or released, look for conspicuously different positions of the slack adjusters for proper brake adjustment..

Condition of Front Axle and Steering System, Right Side

- No loose, worn, bent, damaged or missing parts.

Step 4: Right Saddle Tank Area

Right Fuel Tank(s)

- Securely mounted Diesel and Diesel Exhaust Fluid are not damaged or leaking.
- Fuel lines secure and not leaking. Check that shut-off valves are open.
- Tank(s) full of fuel. Cap on and secure.

Condition of Visible Components

- Rear of engine: not leaking.
- Transmission: not leaking. If equipped with oil cooler, check cooler, hoses and fittings for leaks.

- Check drive shaft.
- Exhaust system: secure, not leaking, not touching wires, fuel or air tubing.
- Frame and cross members: no bends, cracks or breaks.

DPF/SCR check hoses and fittings for leaks.

- Air tubing and electrical wiring: secured against snagging and chafing.

Step 5: Right Rear Vehicle Area

Dual Wheels, One or Two Axles

- Check condition of wheels and rims. Especially look for cracks, missing lockrings, bent or broken spacers, studs, missing clamps or lug nuts.
- Check condition of tires: properly inflated, no serious cuts, bulges, tread wear or any signs of misalignment; valve stems not touching wheels, rims or brake drums; valve caps in place and no objects stuck between the wheels.
- Check that both tires are of same type, for example, not mixed radial and bias type and that their circumferences are matched.
- Check wheel bearing and hub: no obvious leaking on outside or inside wheel.

Suspension

- Check condition of springs (leaf), spring hangers, shackles and U-bolts.
- Axle alignment.

Brakes

- Condition of brake drums. With brakes released, look for a noticeable gap between lining and drum. (This check cannot be made if dust covers are in place.)
- Condition of brake hoses: check for any chafing.
- Check brake chamber mounting bolts and brackets.
- Check slack adjusters and chamber push rod travel. With brakes applied or released, look for conspicuously different positions of the slack adjusters for proper adjustment.
- Check spring brakes.

Step 6: Rear of Vehicle Area

Frame Area

- Frame or cross members not bent, cracked or otherwise damaged or missing.

- Check that air tubing and electrical lines are properly secured to the frame with no damage or chafing.

Lights and Reflectors

- Tail lights, brake lights and turn signal lights: operating, clean and proper color.

Step 7: Coupling System Area

Fifth Wheel

- Securely mounted to the frame.
- No missing or damaged parts.
- Check that trunnion and plate are properly lubricated.

Sliding Fifth Wheel

- Mechanism not worn, bent, damaged or parts missing.
- Properly lubricated.
- All locking pins present and locked in place.
- If air operated: no air leaks.

Air Tubing and Electric Lines Visible From This Point

- Should be secure from dangling.
- Both air lines and electric line should be free from damage, oil and grease.

Step 8: Left Saddle Tank and Left Rear Vehicle Wheels Area

Dual Wheels, One or Two Axles

- Check condition of wheels and rims. Especially look for cracks, missing lockrings, bent or broken spacers, studs, missing clamps or lug nuts.
- Check condition of tires: properly inflated, no serious cuts, bulges, tread wear or any signs of misalignment; valve stems not touching wheels, rims or brake drums; valve caps in place and no objects stuck between the wheels.
- Check that both tires are of same type, for example, not mixed radial and bias type and that their circumferences are matched.
- Check wheel bearing and hub: no obvious leaking on outside or inside wheel.

Suspension

- Check condition of springs (leaf or air), spring hangers, shackles and U-bolts, no cracks, breaks or shifting.

Brakes

- Condition of brake drums. With brakes released, look for a noticeable gap between lining and drum. (This check cannot be made if dust covers are in place.)
- Condition of brake hoses: check for any chafing.
- Check brake chamber mounting bolts and brackets.
- Check slack adjusters and chamber push rod travel. With brakes applied or released, look for conspicuously different positions of the slack adjusters for proper brake adjustment..
- Check spring brakes.

Condition of Visible Components

- Transmission: not leaking.
- Drive shaft: looks OK.
- Exhaust system: secure, not leaking, not touching wires, fuel or air tubing.
- Frame and cross members: no bends, cracks or breaks.
- Air tubing and electrical wiring: secured against snagging and chafing.

Left Fuel Tank(s)

- Securely mounted and not damaged or leaking.
- Fuel lines secure and not leaking. Check that shut-off valves are open.
- Tank(s) full of fuel. Cap on and secure.

Battery Area

- Open the battery box. Battery box securely mounted to vehicle.
- Batteries secured against movement.
- Battery cases not broken or leaking. Battery cables free from damage.
- Tops of batteries and terminals clean and free from foreign material.
- If equipped, replace battery lid and make sure it is securely fastened.

In the Cab

- Check steps and grab handles for looseness or breakage. Also, clean them if there is any substance that makes them slippery, which makes cab entry/exit hazardous.
- Start the engine. If equipped, check that exhaust rain cap opens when accelerating engine.
- Check gauges and tell-tale light function. See the Instruments and Controls section.
- Check function of low air warning.
- Check clutch function. If equipped, check for clutch brake function.
- Check windshield wipers and washers and horns, including back-up alarm, if equipped.
- Clean inside windshield, door windows and instruments. Clean mirrors.
- Check temperature control and defroster. If equipped, check mirror heater.
- Check condition of warning triangles, fire extinguisher and flares.
- Adjust the seat. Check mirror adjustment.
- Check safety belts for function and damage.
- Apply service brakes. After initial drop, pressure should hold steady, or increase slightly, with engine at idle.
- Check steering wheel for excessive free play.
- Check for loose items in the cab. Secure them if necessary.

Hooking Up To Trailer

Hook-Up Preparation

- Check kingpin and mounting plate on trailer, free from wear, bends or damage.
- Chock trailer wheels.

Fifth Wheel or Trailer Hitch

- No visible space between fifth wheel and trailer.
- Locking jaws around the shank and not the head of kingpin.
- Release lever properly seated and safety latch/lock engaged.
- Check all connections to dolly or trailer hitch and safety chains are secured.
- Check function of trailer air supply valve and trailer brakes.

Sliding Fifth Wheel

- Check that fifth wheel is not so far forward that the tractor frame will strike the landing gear during turns.

Note: Refer to the trailer manufacturer's manual for specific information on the trailer checks.

Step 9: Trailer Front Area

Air and Electrical Connections

- Glad hands properly mounted, free from damage and not leaking.
- Trailer cord receptacle properly mounted, free of damage; plug properly seated and safety catch engaged to prevent accidental disconnect.
- Air and electrical lines properly secured against tangling, snagging and chafing with sufficient slack for turns.

Step 10: Right Side of Trailer Area

Landing Gear or Dolly Area

- Fully raised; no missing or damaged parts.
- Crank handle present and secured.
- If power operated, no air/hydraulic leaks.

Spare Wheel(s)

- Carrier or rack not damaged.
- Spare wheel securely mounted in rack.
- Tire and wheel condition adequate for a spare: proper size, properly inflated.

Lights and Reflectors

- Trailer side clearance lights: clean, operating and proper color.
- Reflectors clean and proper color.

Frame and Body

- Frame and crossmembers not bent, cracked, damaged or missing.
- Proper placarding.

- Body parts not damaged or missing.

Step 11: Right Rear Trailer Wheel

Dual Wheels, One or Two Axles

- Check condition of wheels and rims. Especially look for cracks, missing lockrings, bent or broken spacers, studs, missing clamps or lug nuts.
- Check condition of tires: properly inflated, no serious cuts, bulges, tread wear or any signs of misalignment; valve stems not touching wheels, rims or brake drums; valve caps in place and no objects stuck between the wheels.
- Check that both tires are of same type, for example, not mixed radial and bias type and that their circumferences are matched.
- Check wheel bearing and hub: no obvious leaking on outside or inside wheel.

Suspension

- Condition of springs (leaf or air), spring hangers, shackles and U-bolts.
- Axle alignment.
- Condition of torque rod arms.
- If equipped with sliding axles, check position and alignment. Look for damaged, worn or missing parts, all locks present, fully in place and locked.
- Flexible air tubing not cracked, cut, crimped or otherwise damaged. Secured against tangling, dragging and chafing.

Brakes

- Condition of brake drums. With brakes released, look for a noticeable gap between lining and drum. (This check cannot be made if dust covers are in place.)
- Condition of brake hoses: check for any chafing.
- Check brake chamber mounting bolts and brackets.
- Check slack adjusters and chamber push rod travel. With brakes applied or released, look for conspicuously different positions of the slack adjusters for proper brake adjustment..
- Check spring brakes.

Step 12: Rear of Trailer Area

Lights and Reflectors

- Rear clearance, identification and tail lights clean, operating and proper color.
- Reflectors clean and proper color.

Cargo Securement

- Cargo properly blocked, braced, tied, chained, etc.
- Tailboard up and properly secured. End gates free from damage, properly secured in stake pockets.
- Canvas or tarp (if required) properly latched down to prevent water damage, tearing, billowing or blockage of either mirrors or tail lights.
- Rear doors securely closed, latched or locked; required security seals in place.
- Underside guard in place: not cracked, bent or broken.

Step 13: Left Rear Trailer Wheels Area

Dual Wheels, One or Two Axles

- Check condition of wheels and rims. Especially look for cracks, lockrings missing, bent or broken spacers, studs, missing clamps or lug nuts.
- Check condition of tires: properly inflated, no serious cuts, bulges, tread wear or any signs of misalignment; valve stems not touching wheels, rims or brake drums; valve caps in place and no objects stuck between the wheels.
- Check that both tires are of same type, for example, not mixed radial and bias type and that their circumferences are matched.
- Check wheel bearing and hub: no obvious leaking on outside or inside wheel.

Suspension

- Condition of springs (leaf or air), spring hangers, shackles and U-bolts.
- Axle alignment.
- Condition of torque rod arms.
- If equipped with sliding axles, check position and alignment. Look for damaged, worn or missing parts, all locks present, fully in place and locked.
- Flexible air tubing not cracked, cut, crimped or otherwise damaged. It should be secured against tangling, dragging and chafing.

Brakes

210 OPERATION

- Condition of brake drums. With brakes released, look for a noticeable gap between lining and drum. (This check can not be made if dust covers are in place.)
- Condition of brake hoses: check for any chafing.
- Check brake chamber mounting bolts and brackets.
- Check slack adjusters and chamber push rod travel. With brakes applied or released, look for conspicuously different positions of the slack adjusters.
- Check spring brakes.

Step 14: Left Side of Trailer Area

Landing Gear or Dolly Area

- Fully raised; no missing or damaged parts.
- Crank handle present and secured.
- If power operated, no air/hydraulic leaks.

Spare Wheel(s)

- Spare wheel securely mounted in rack with no damage to rack.
- Tire and wheel condition adequate for a spare: proper size, properly inflated.

Lights and Reflectors

- Trailer side clearance lights: clean, operating and proper color.
- Reflectors clean and proper color.

Frame and Body

- Frame and crossmembers not bent, cracked, damaged or missing.
- Proper placarding.
- Body parts not damaged or missing.

Before Leaving the Parking Area

- Remove chocks from the wheels.
- Test trailer hook-up by slowly pulling while applying the trailer brakes with the trailer brake hand control valve.

- Test the service brakes before leaving the parking area.
- Test parking brakes by stopping on a 20% grade and applying the parking brakes. The parking brakes shall hold the combined vehicle and trailer without moving.

New Vehicle Break-In

To ensure many years of reliable, trouble-free operation, the following break-in procedures are recommended:

Note: Oil change, filter change and chassis lubrication are no longer required at the 3,000-mile vehicle break-in interval.

Refer to the preventive maintenance schedules outlined in the *Maintenance and Lubrication Manual (21394653)* for recommended lubrication change intervals for the following items:

- Gear oils (transmission, rear axle carrier[s], front drive axle carrier, transfer case, flywheel PTO)
- Engine oil
- Oil filters
- Fuel filters
- Coolant conditioner

Note: It is important that components be filled with lubricants meeting the specifications as given in the *Maintenance and Lubrication Manual (21394653)*

Note: When checking oil levels, the vehicle must be parked on level ground, and the units at normal operating temperature. Components must be filled to the correct level. DO NOT OVERFILL.

Note: Oil and filter change intervals in this manual pertain to components built by Volvo Truck. For information concerning oil and oil filter change intervals for vendor components, refer to the specific vendor component service literature.

During the First 5000 Kilometers (3000 Miles)

- After the first 200 km (125 miles), retorque the wheel nuts using an accurately calibrated torque wrench. Recheck this torque again after 800 km (500 miles).
- Check oil and coolant levels frequently.
- Check brake and clutch adjustments per recommended maintenance schedule, and adjust as needed.

212 OPERATION

- Observe the instruments often, and shut down the engine at the first sign of any abnormal readings.
- Report all leaks, loose fasteners, unusual noises, etc., to the service representative at the nearest Volvo dealership so they can be checked and corrected.
- Check the spring clip torque (U-bolts). (On REYCO suspensions, also check equalizer nut torque.)
- On chassis equipped with AIRTEK™ front axle air suspensions, retorque the U-bolts.
- Check the U-bolt torque on the Volvo air suspension at the end of the first 1600 km (1000 miles).

After the First 5000 Kilometers (3000 Miles) or Before 6400 Kilometers (4000 Miles) or Before 3 to 4 Months

- Retorque the spring clip (U-bolts). (On REYCO suspensions, also retorque the equalizer nut.)

Note: On chassis equipped with AIRTEK™ front axle air suspensions, check the torque of the front axle U-bolts at 24 000 kilometers (15,000 miles).

At the First A Inspection Interval

- Check front and rear axle alignment and adjust if the alignment is out of specifications.
- Check steering knuckle to axle beam clearance.

Although this quality-built vehicle has been inspected, lubricated and adjusted at the Volvo Trucks Assembly Plant, an occasional air, oil or coolant leak may develop. Quick action to correct these minor items will prevent a major repair later. Take the vehicle to the nearest Volvo service center as soon as any abnormal condition becomes evident.

Initial Valve Adjustment Intervals

Refer to the *Maintenance and Lubrication Manual (21394653)* for detailed information concerning the Initial Valve Adjustment Interval also see page 223.

HOOD OPERATION

! WARNING

Avoid tilting the hood under high or gusty wind conditions. Failure to follow this recommendation may result in the hood unexpectedly closing, which can cause personal injury.

! WARNING

Make sure that no one is in the way of the hood when opening or closing. The hood could injure a person under the hood.

Opening the Hood

The hood is locked down by two latches, one on each side of the back end of the hood. The hood release handle is at the bottom of the steering column. Pull the lever as shown in the illustration to open the hood. The hood is raised about two inches off its resting position and remains there.

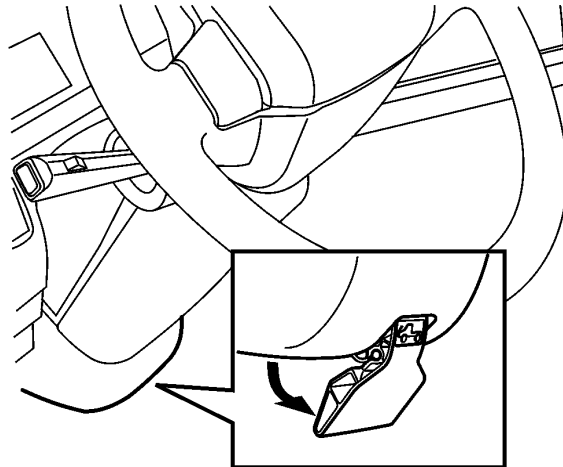

W8003185

214 OPERATION

Make sure the hood can be opened fully without hitting anything. There are two methods for opening the hood.

1. Stand in front of the hood with feet in line with the vehicle. Place feet well apart and grasp the recessed handle in the front part of the hood. Transfer the body weight by leaning away from the hood. Lift the hood until it is past the balance point. Release the hood and let it complete the opening movement unaided.



W8003113

2. Stand at the rear fender edge on the driver side of the vehicle. Lift the hood from under the fender, push the hood forward, release the hood and let it complete the opening movement unaided.

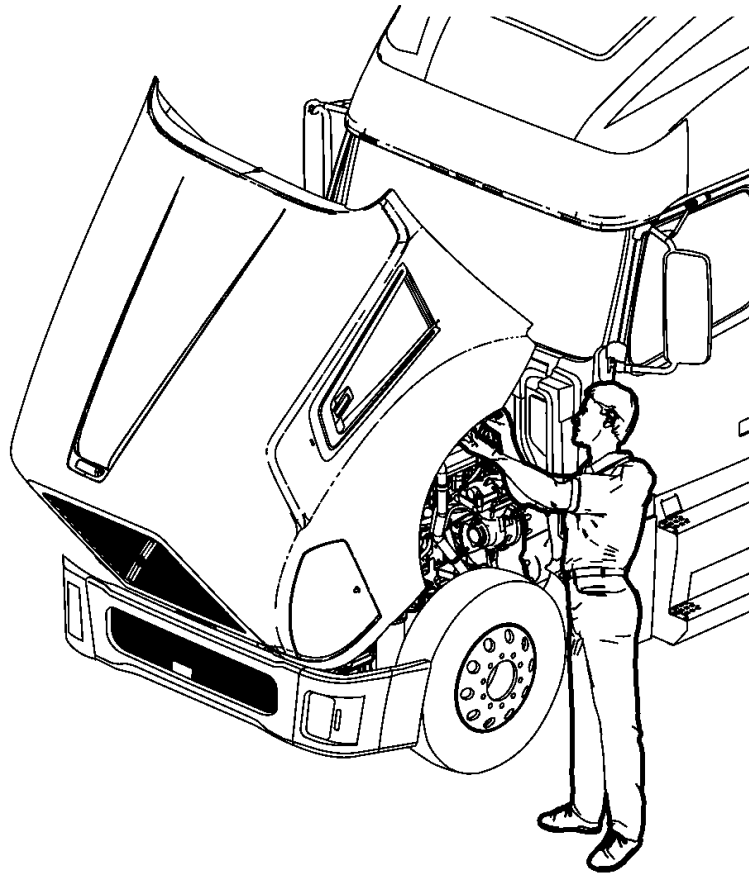

W8003546

Two restraint cylinders will engage during the last part of the opening. The cylinders will slow and dampen the hood down to its resting position.

Closing the Hood

To close the hood, stand with feet well apart, place hands along the front edge of the hood. Bend the knees and let the leg muscles do the work when lifting. Raise the hood up to the halfway point. Carefully guide the hood down with enough speed that the hood latches lock the hood in place when it comes to its normal resting position.

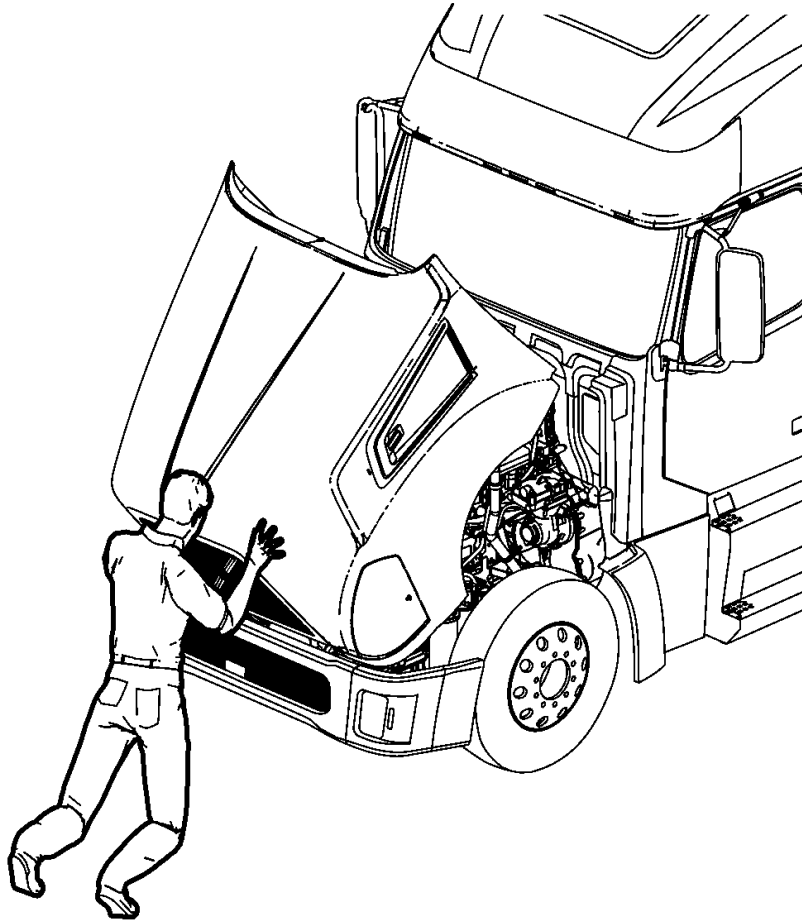

Hood Latch (Optional) VNM 200 Day Cab, Short Fairing

The VNM Day cab hood is opened by unlocking and releasing both sides of the latch located underneath the left and right-hand side panels. See illustration.

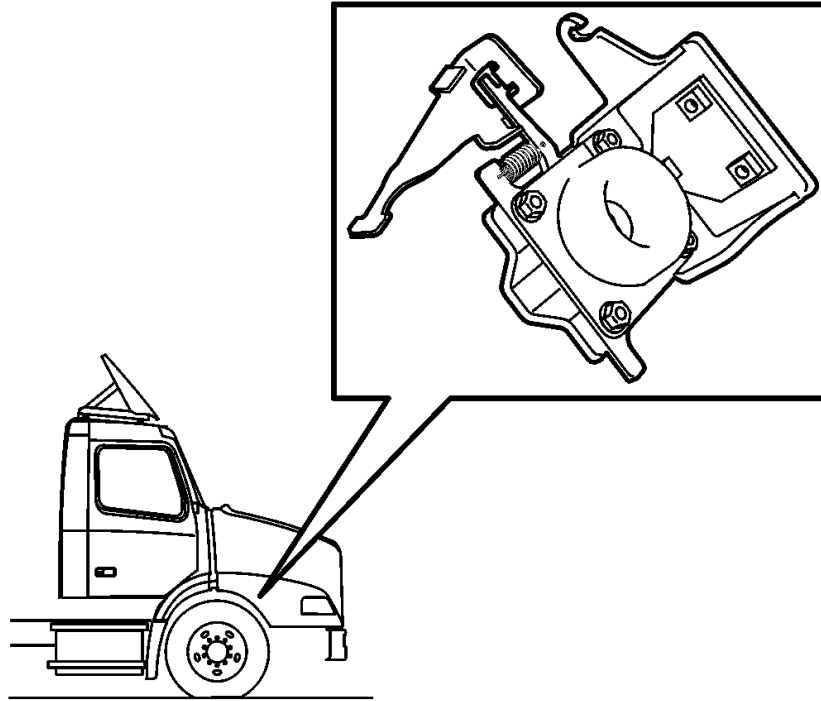

W8003446

CHASSIS FAIRING/STEPS OPEN AND LOCKED POSITIONS



WARNING

Always check security of fairing and steps before use. Ensure that the fairing is completely closed and the handles are in the locked position to prevent injury from slip and fall.

The chassis fairing on the VN vehicle folds up and down for battery and air tank access.



CAUTION

DO NOT open fairing while the cab door is open. This can result in paint damage on the fairing.

To open fairing: Rotate both handles to unlocked position, and pull fairing open.

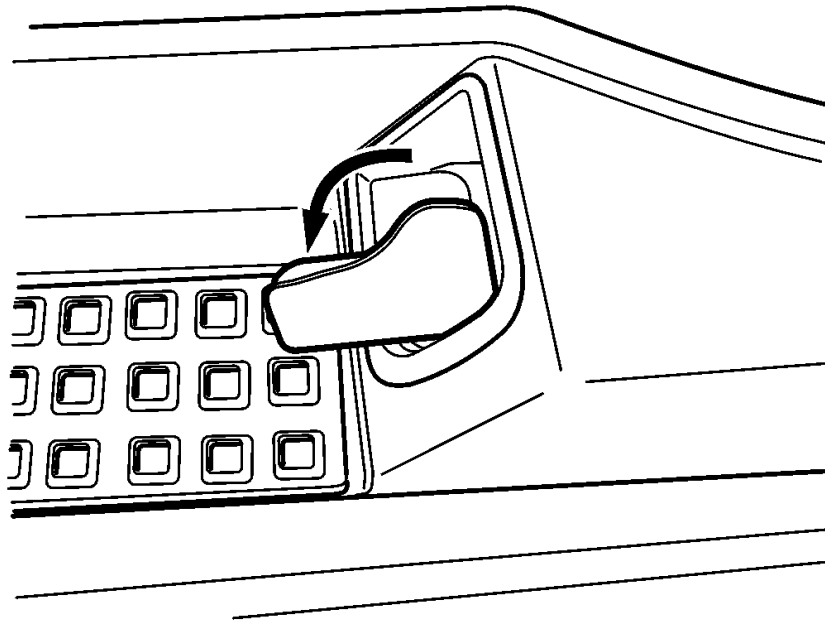

W5001359

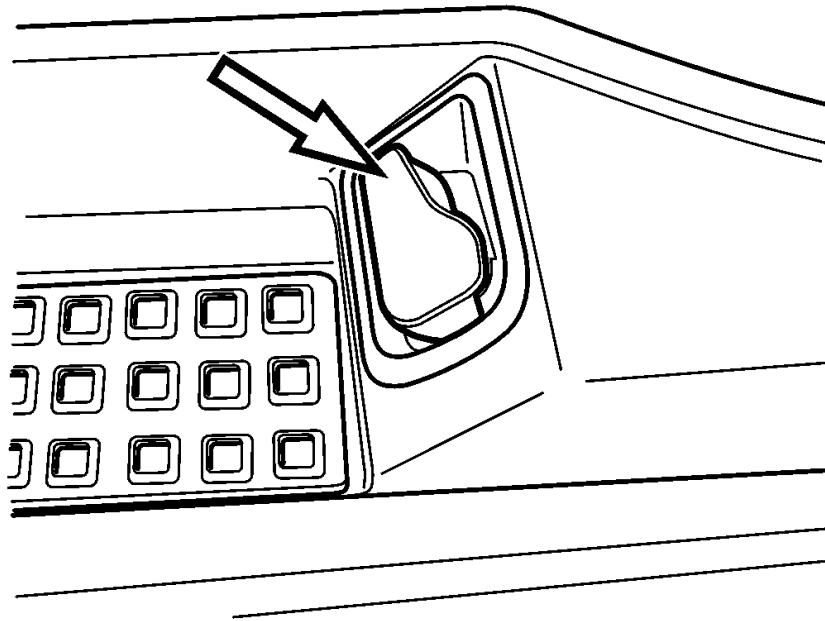

W5001358

1 Unlocked Position

2 Locked Position

Closing and Locking Fairing



WARNING

Make sure the fairing/steps are locked into position. Failure to lock fairing/steps could result in personal injury due to slip and fall.

To close and lock the fairings: Use your fingers to pull the handles to the unlocked position (1) as indicated in the illustration. Push with your palms against the fairings (2). Once the fairing is closed, make sure both handles are returned to the locked position.

Note: Slot 4 must be completely engaged into bushing 3 before fairing is closed and can be locked.

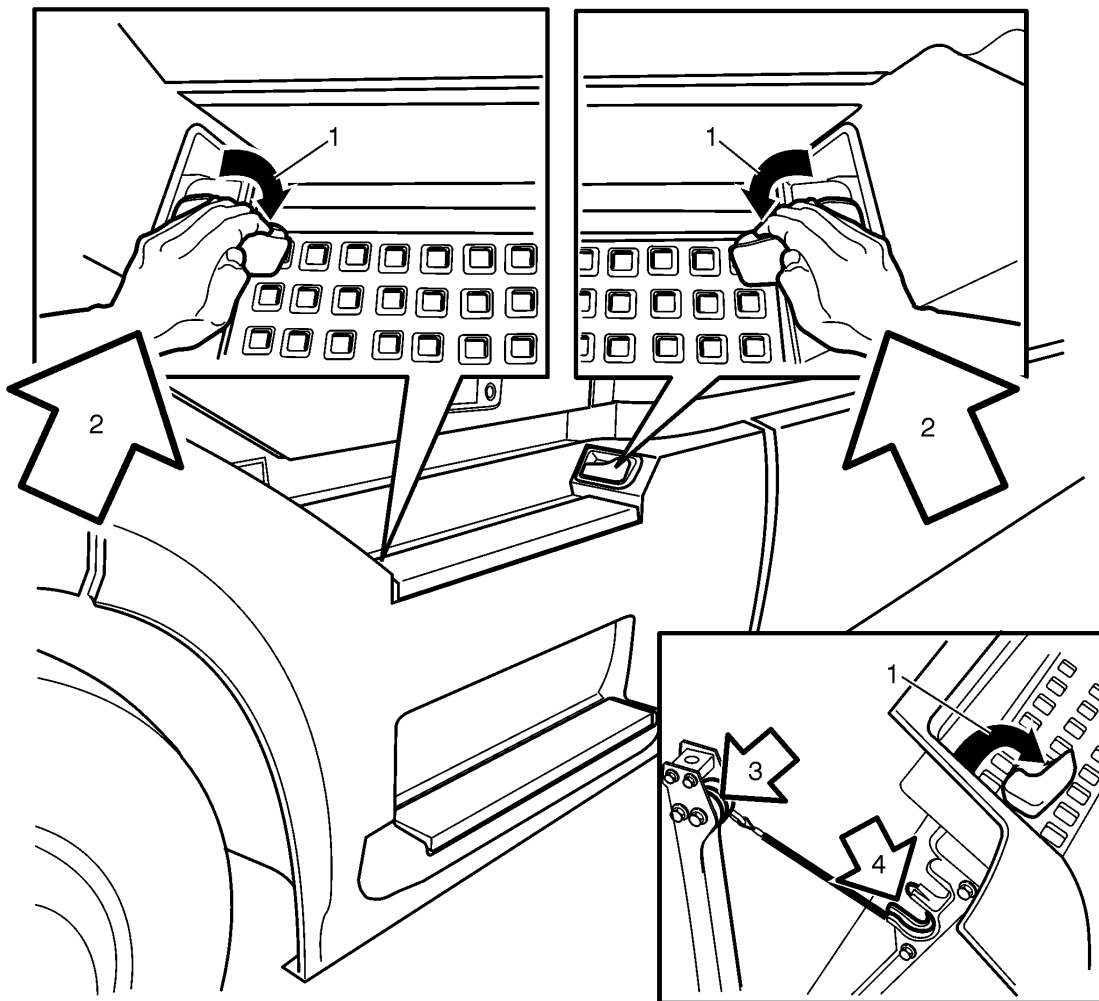

Securing the Fairing/Step

Make sure the handle is rotated to the locked position. Pull on the fairing/step to ensure the fairing/step is locked into position. See illustration.

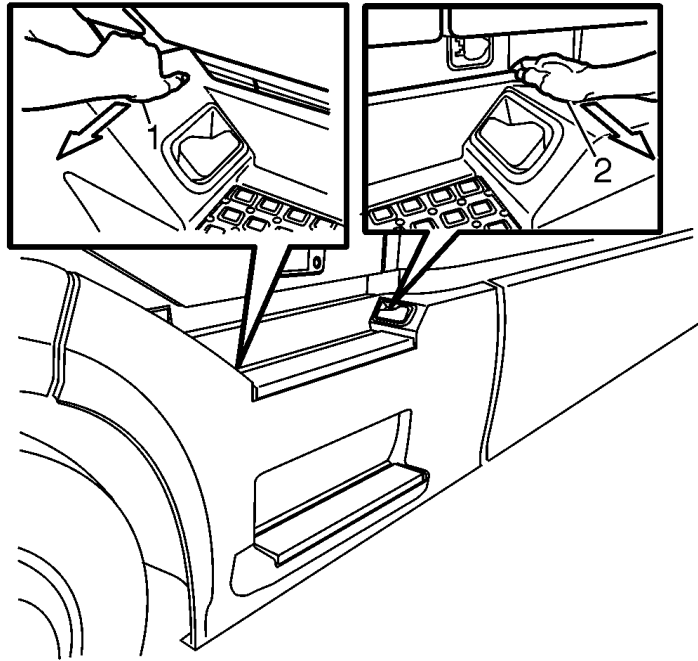

LUGGAGE COMPARTMENT



WARNING

Always place heavy objects in the luggage compartment. Sudden stops or sudden turns could cause personal injury if heavy objects fall from overhead storage shelves.

To gain access to the luggage compartments, there is a pull-ring connected to the lock, located at the lower rear corner of the cab door opening, on each side (not shown). Pull ring to unlock the door. The lock has a safety latch that will hold the door in place, even if the door is not fully locked. To open door, hold pull-ring out while pulling the door out.

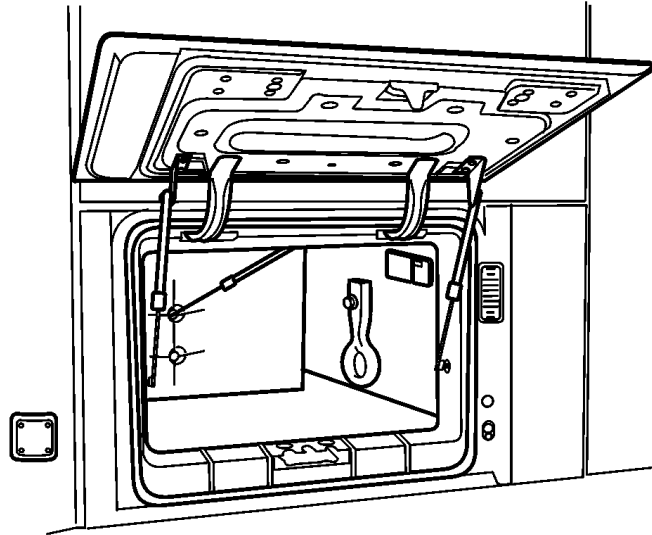

W8003124

The door swings out from the bottom on hinges mounted on the top. To assist in opening and to hold the door open, there are two compressed gas cylinders mounted on each door. The door will swing up by itself when pulled out a short distance and then released. Manually switch the luggage lamp ON. Switch lamp OFF before closing door.

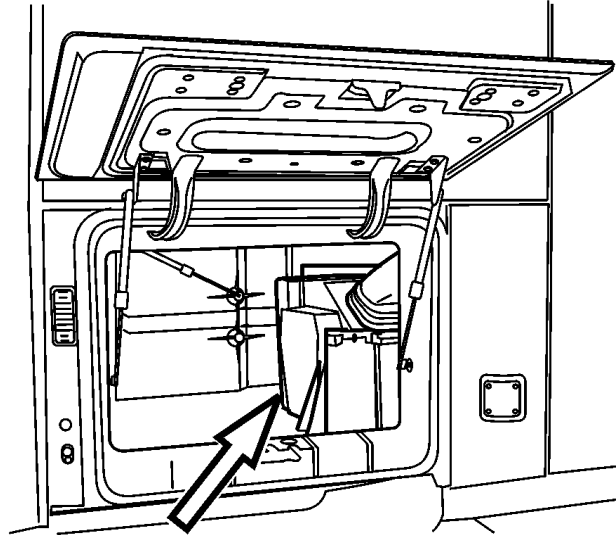

W8003123

Safety equipment and tow hooks are stored in the luggage compartments. If equipped, the sleeper heater and air conditioning unit are located in the passenger side luggage compartment.

CAB DOORS AND DOOR LOCK

DANGER

To lessen the chance of being thrown from the vehicle in case of an accident, always lock the doors and wear the safety belt while driving. Failure to do so can cause serious personal injury or death if involved in an accident.

The cab doors can be unlocked and locked with the same key used for the ignition lock. There is also a keyless remote entry available. Keys can be made to fit only one vehicle or all the vehicles in a fleet of Volvo vehicles. The key fits in the door lock either way. Insert the key and turn it 1/4 turn counterclockwise to unlock or clockwise to lock the door.

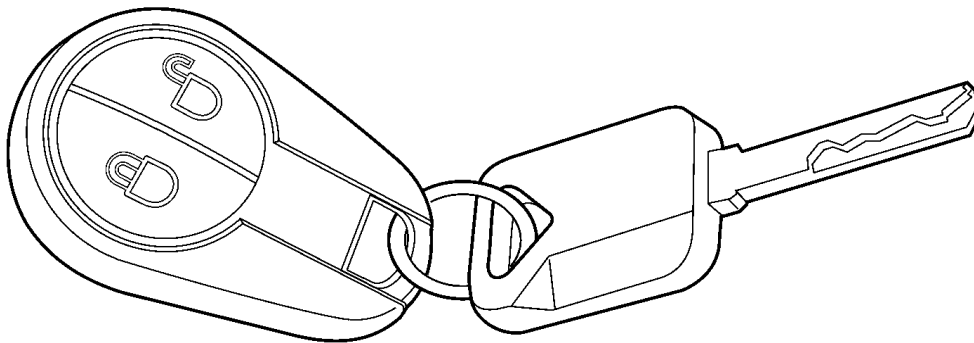

W3028591

- 1 Press once to unlock driver side. Press twice to unlock both doors.
- 2 Press once to lock doors.

Note: The vehicle is delivered with two identical keys. If more keys are needed, order them through your authorized Volvo Truck dealer.

The door locks are mechanically or electronically operated. The lock is activated by either the key from the outside or the door lock handle from the inside. With mechanical locks, only one door can be locked and unlocked at a time. With electrical locks, both doors will be locked and unlocked by operating either the key or the inner door lock handle on either side.

Note: No door can be locked while it is still open. The door must be closed for the lock to work.

With manual locks, to lock either door from inside the cab, push the door lock handle forward. The handle will stay in place, indicating the door is locked. It can be unlocked without opening the door by moving the door lock handle to the middle position.

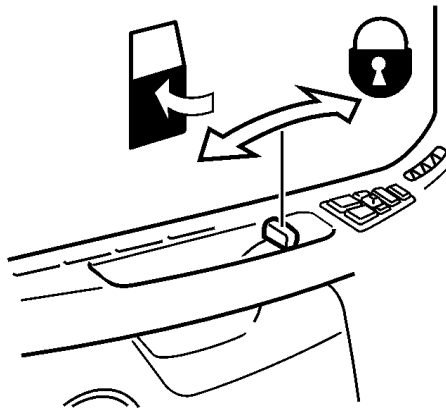

W8003089

Push the lever back to open the door. Push the lever forward to lock the door

226 OPERATION

With electronic locks, to lock both doors from inside the cab, push the door lock handle forward on either door. The handle will stay in place, indicating the door is locked. Either door can be unlocked without opening the door by moving the door lock handle to the middle position. Each door must be unlocked individually from inside the cab. To unlock the doors using the key, insert the key in either door lock. Turn the key to the unlock position to unlock that door. To unlock both doors, turn the key to the unlock position, turn the key to the lock position and turn the key to the unlock position.

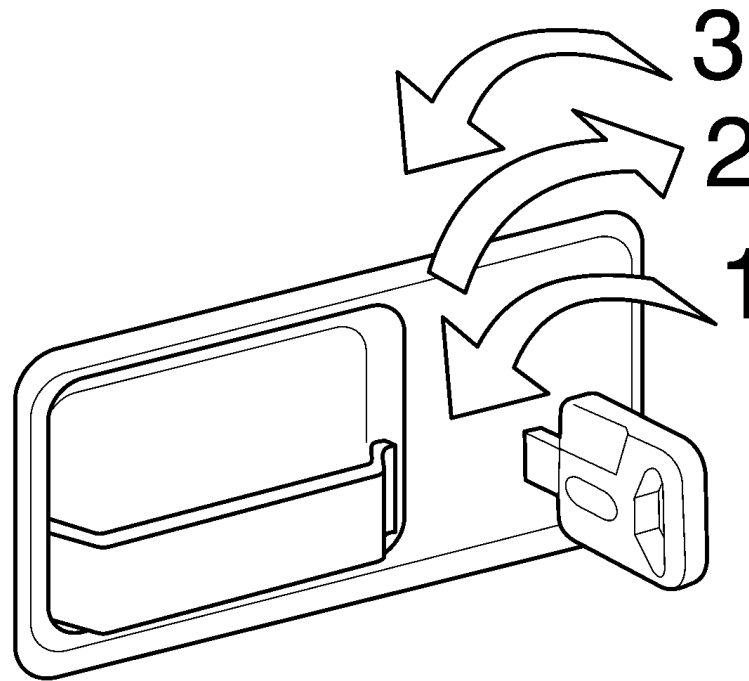

W8028592

Unlocking Electronic Locks

The door has a position lock that enables the door to remain open in two different positions. An indented bar is holding the door at approximately 30° and in the fully open position at approximately 85°.

To close the door from the inside, place the hand in the handhold and pull the door in.

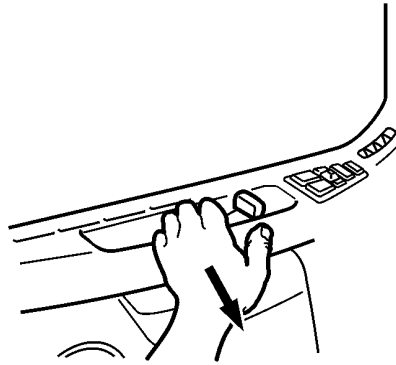

W8003116

To close the door from the outside, place the hand flat against the door lock area and push the door shut.

	CAUTION
DO NOT shut the door by pushing on the door panel. Hard pushing may distort the metal in the door panel.	

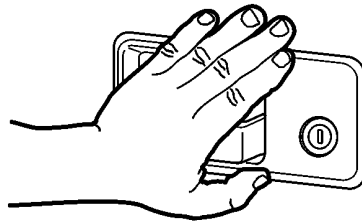

W8003114

Power Door Locks (Optional)

Press button 2 to lock both doors or unlock the passenger door. In the event of a power failure the electrical lock system reverts back to a mechanical functioning system.

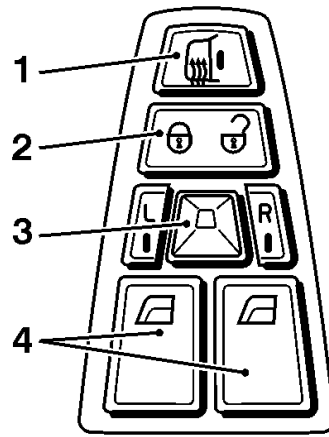

W8003087

Central Locking

The central locking is operated using a remote control. There is no alarm in this unit. The central locking unit provides a means for the driver to electronically control the vehicle's door locks, for increased personal safety and driver comfort.

Unlock Doors Using Remote Control

To unlock the driver door, press the UNLOCK button. The side indicators will flash. To unlock the passenger door, press the UNLOCK button again. The side indicators will flash.

Lock Doors Using Remote Control

Press the LOCK button. The side indicators will flash.

Heated Rear View Mirrors (Optional)

Press button 1 once to start electric heating for 15minutes. The indicator light in the button flashes. The heating is on for 15minutes.

Hold button 1 in for longer than 1second to start electric heating.

The indicator light in the button comes on.

The heating remains on until the engine is switched off.

Heater will run at 100% capacity for the first 30 minutes, after which it reduces to 75% capacity.

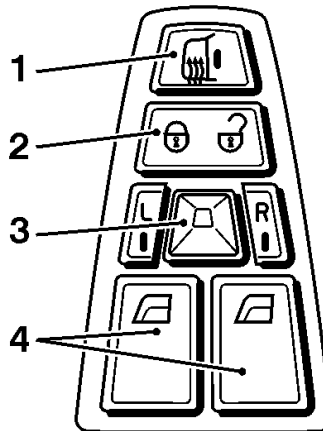

W8003087

Power Rear View Mirrors (Optional)

- 1 Choose the mirror which is to be adjusted by pressing buttons 3.L for left mirror and R for right mirror. The light in the button comes on.
- 2 Adjust the mirror using lever 3.

The light in the button goes OFF after 10minutes. If new adjustments are to be made after this, the mirror must be selected again.

230 OPERATION

Power Windows (Optional)

Open Window (Auto-Down)

- 1 Depress the down position (2) on the button for 1 second.
- 2 Release the button.
- 3 The window opens.

The window stops when it is completely open, when the down position (2) on the button is depressed again or when the up position (1) on the button is depressed. Make small adjustments with short pushes on the button.

Close Window

Depress the up position (1) on the button until the window is completely closed.

SAFETY BELTS

General

DANGER

Safety belts must be properly worn at all times by the driver and all passengers while the vehicle is in motion even if the vehicle is equipped with a Supplemental Restraint System (SRS or air bag). Failure to do so can result in serious personal injury or death in the event of a collision.

DANGER

Fasten the safety belt before starting to drive. Trying to fasten the safety belt while the vehicle is moving may lead to an accident, causing serious personal injury or death.

Safety belt assemblies installed in this vehicle meet FMVSS 209, "Type 1" and "Type 2" requirements. They are recommended for all persons weighing over 25 kg (50 lb.).

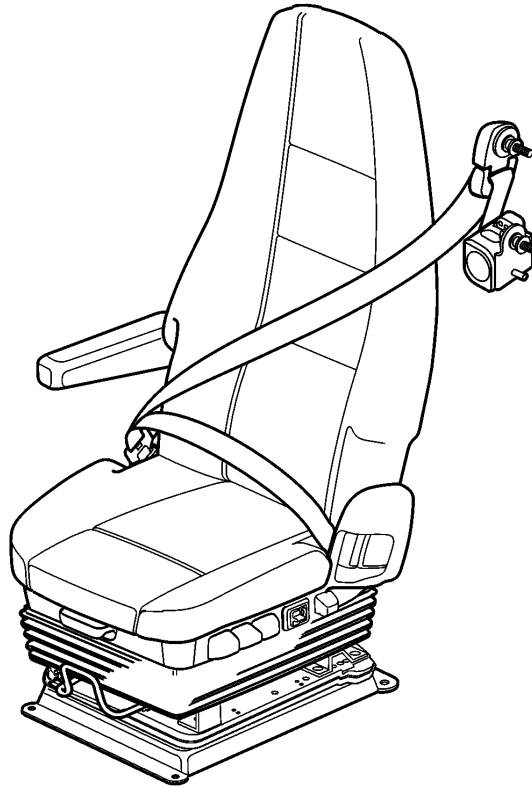

T8009149

A child restraint system should also be provided for each child weighing 25 kg (50 lb.) or less. It should meet the requirements of FMVSS 213, "Child Restraint System." Carefully read and follow all manufacturer's instructions on installation and use. Be certain the child remains in the restraint system at all times while the vehicle is in motion.



W8002741

Safety belts must be worn by the driver and all passengers at all times. Before adjusting or fastening the safety belt, move the seat forward or backward and adjust the seat height as necessary. Sit erect and adjust the seat cushion and seat back for a comfortable driving position. In the event of a collision, a correct driving position maximizes the effectiveness of the safety belt.

There are both Federal and State laws governing the use of safety belts. As laws differ from state to state, make yourself familiar with the current rules.

Tether straps are installed on all suspension-type seats. Tether straps help secure the seat to the floor and are intended to restrain the seat and safety belt in case of an accident or sudden stop.

The tethers are not adjustable and do not need any adjustment.

Operating the Safety Belt

To fasten the safety belt, pull the belt out from the retractor and insert the latch into the buckle. Verify proper lock of the latch by pulling on the latch.

Adjust the slack by pulling on the top part of the belt until the lower part, or the part that crosses the lap, is adjusted to fit "snug." Release the top part and let the retractor pull the belt in.



W8001835

The lap portion of the safety belt should be worn low across the pelvic region (hip bone) and adjusted snugly. Never adjust the lap belt across the abdomen. A push button on the buckle is used to release the safety belt latch by pushing in the button release on the buckle.

234 OPERATION

The buckle portion of the safety belt system is different depending on the seat option chosen. The National Standard and Comfort seat has a separate buckle that is attached to a floor anchor by a seat strap. This seat strap is not adjustable, and does not need to be adjusted.

Comfort Clip Operation

When provided, the comfort clip is located on the shoulder strap just below the D-ring. When adjusting the comfort clip, the following procedure must be followed for proper adjustment:

- 1 Pull out only enough webbing to allow slight pressure to the shoulder and chest. Allow no more than a 25 mm (1 inch) slack when measured between the chest and the belt.
- 2 To activate the clip mechanism feature, lift the lever up to clamp the webbing in place.

Note: When the safety belt is not in use, the clip should be in the open position to allow the seat belt to retract to its proper position. Also make sure that the adjustment of the comfort clip does not interfere with the operation of the safety belt.

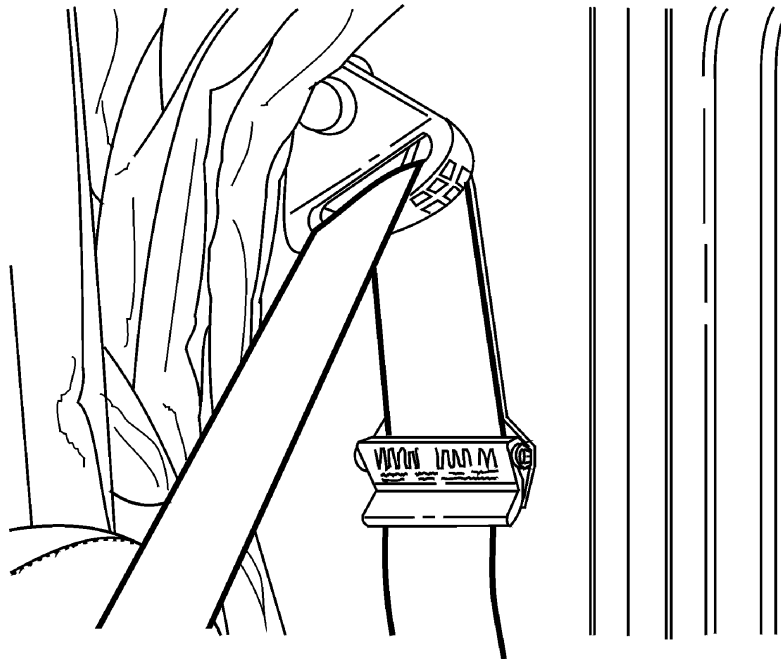

Always adjust the clip so that there is a maximum of 25 mm (1 inch) of slack between the belt and chest (about two fingers width). If a larger slack is allowed, the effectiveness of the safety belt is decreased in the event of a collision.



W8001837

Sleeper Safety Restraint

DANGER

Always use the safety restraint when the vehicle is in motion. Failure to do so not only may cause severe injuries or death to the passenger in the event of an accident, but also poses a danger of injuries to other occupants of the vehicle.

DANGER

Anytime the vehicle is in motion, a passenger using the sleeper bunk should be strapped in using the safety restraint. The top bunk should always be used with the harness in place, whether the vehicle is in motion or not. Falling from the upper bunk can result in severe personal injury or death.

The restraint netting can be used for securing loose articles. Any loose articles that can shift in the cab during hard cornering or braking should be kept restrained.

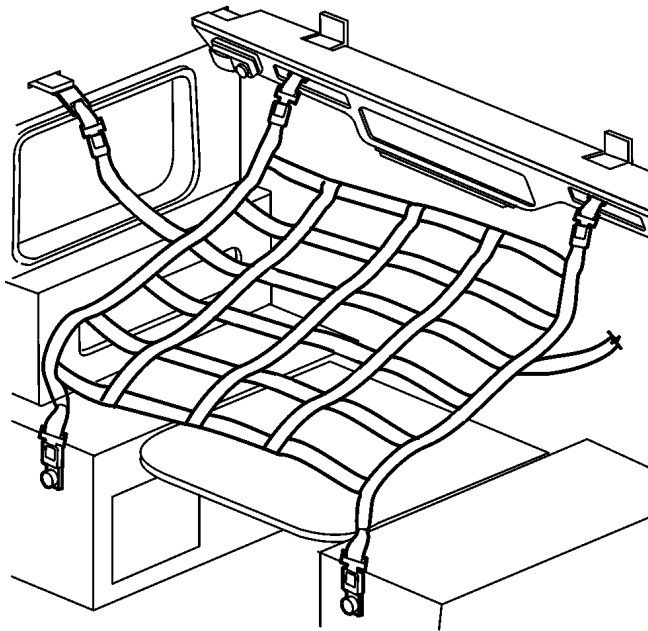

Fasten the restraint by connecting the buckle with the latch. Make sure the belts are not twisted. Test the latch connection by pulling on the belt. If they come apart, reconnect and test again. If the connection cannot be made, replace the belt before using the bunk for sleeping during driving.

To loosen the restraint, press the red release button on the latch. Restraints should be properly stored when not used. Having the restraint laying loose in the cab can be a source for unintentional snagging.

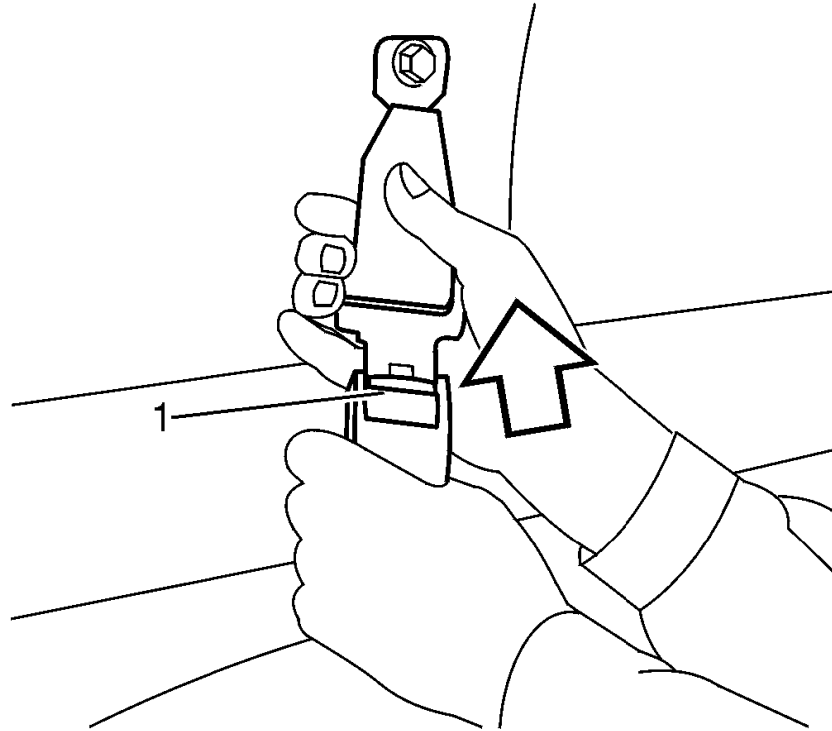

W8002475

1 Release Button

Safety Restraint VN 430, VN 630, VN 670

The restraint has latches in one end and buckles in the other so it can only be installed one way. Connect the restraint to the back wall and the buckles on the floor. Connect the side tethers and adjust the straps to form a "tent" over the bunk (VN 670 upper bunk does not have the "tenting" feature).

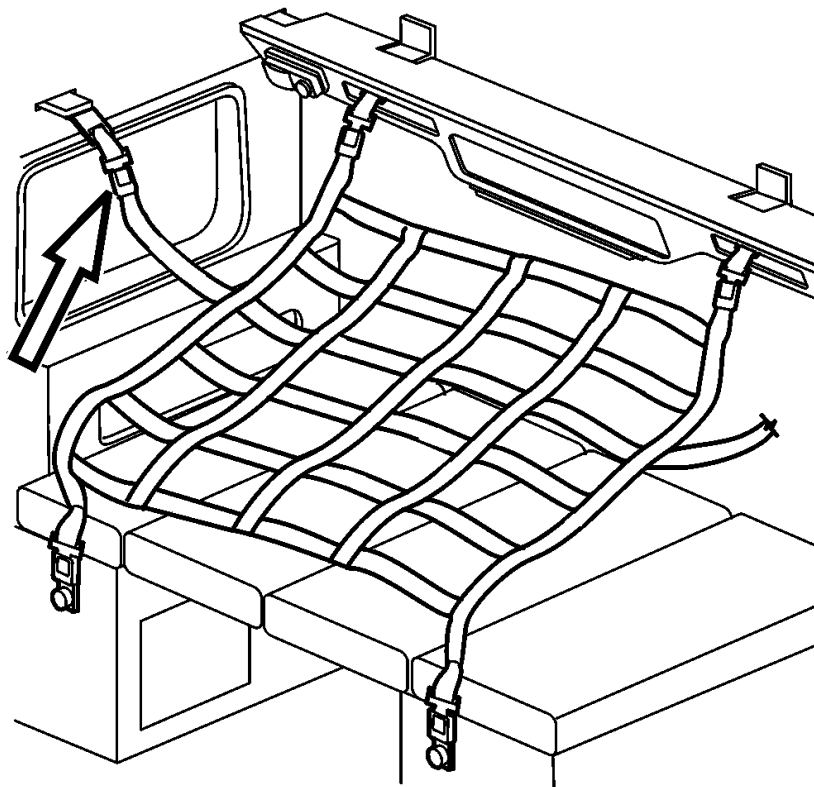

W8003206

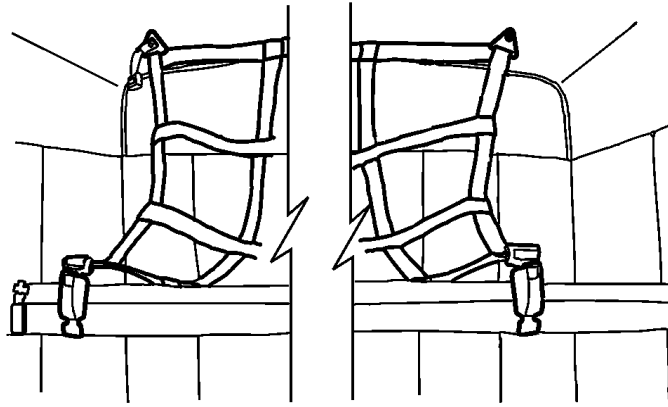

W8003169

Upper Bunk

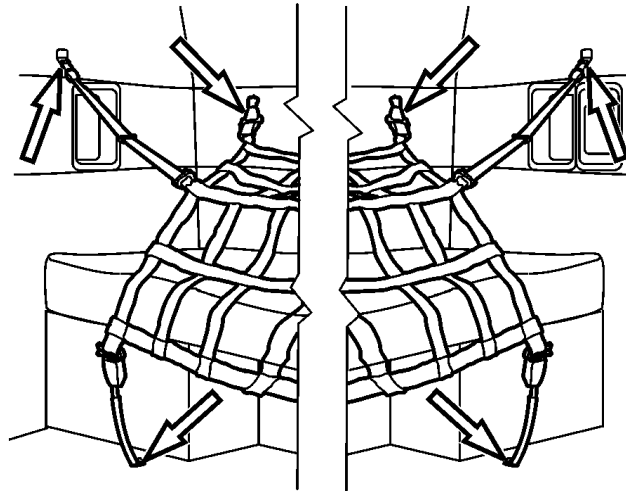

W8003170

Lower Bunk

240 OPERATION

Safety Restraint VN 730

Connect the restraint to the back wall first. The wall connectors are located on the back wall. Connect the lower part of the restraint to the lower buckles. Connect the side tethers and adjust the straps to form a "tent" over the bunk.

Note: The restraints for top and bottom bunks are different. Each belt can only be installed to the correct bunk.

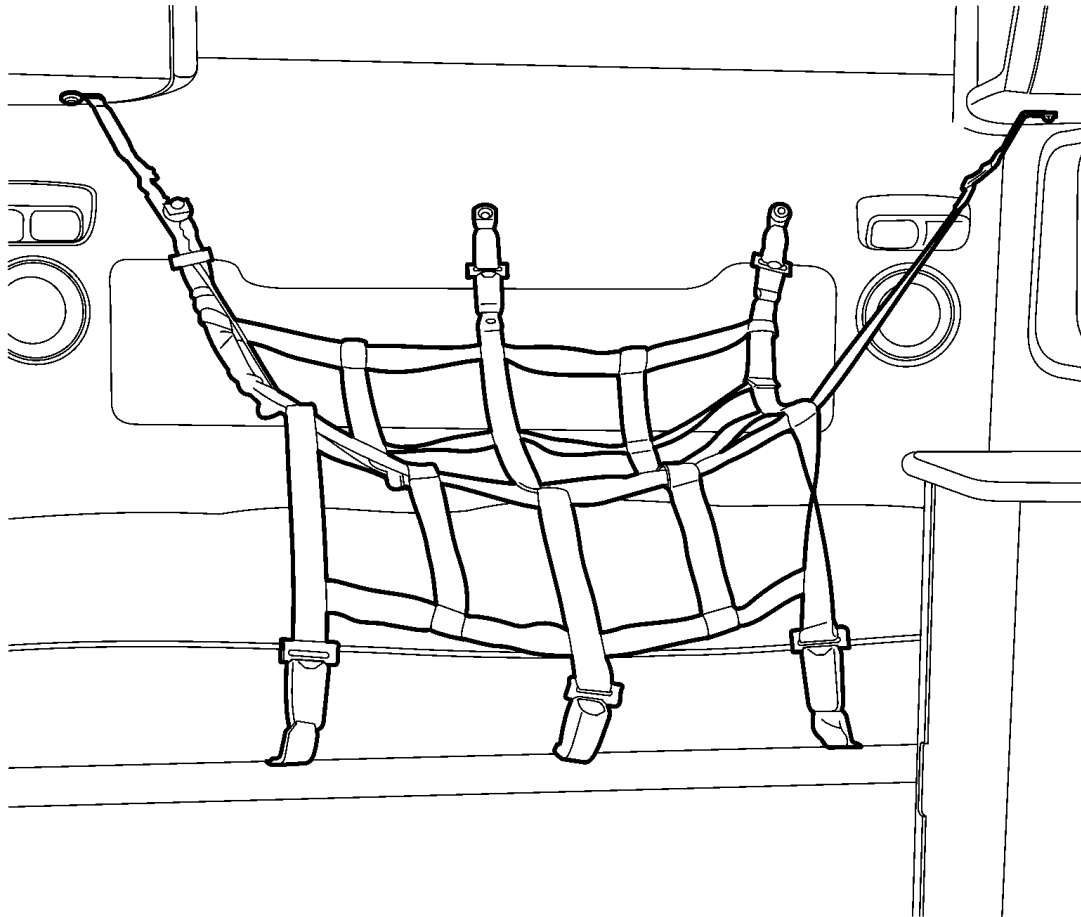

W8003822

53-Inch Lower Bunk

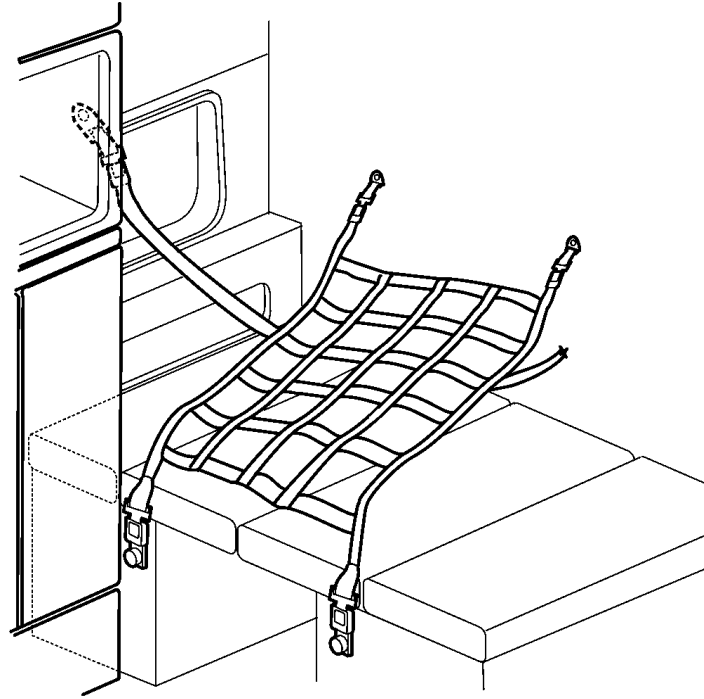

W8028593

42-Inch Lower Bunk

242 OPERATION

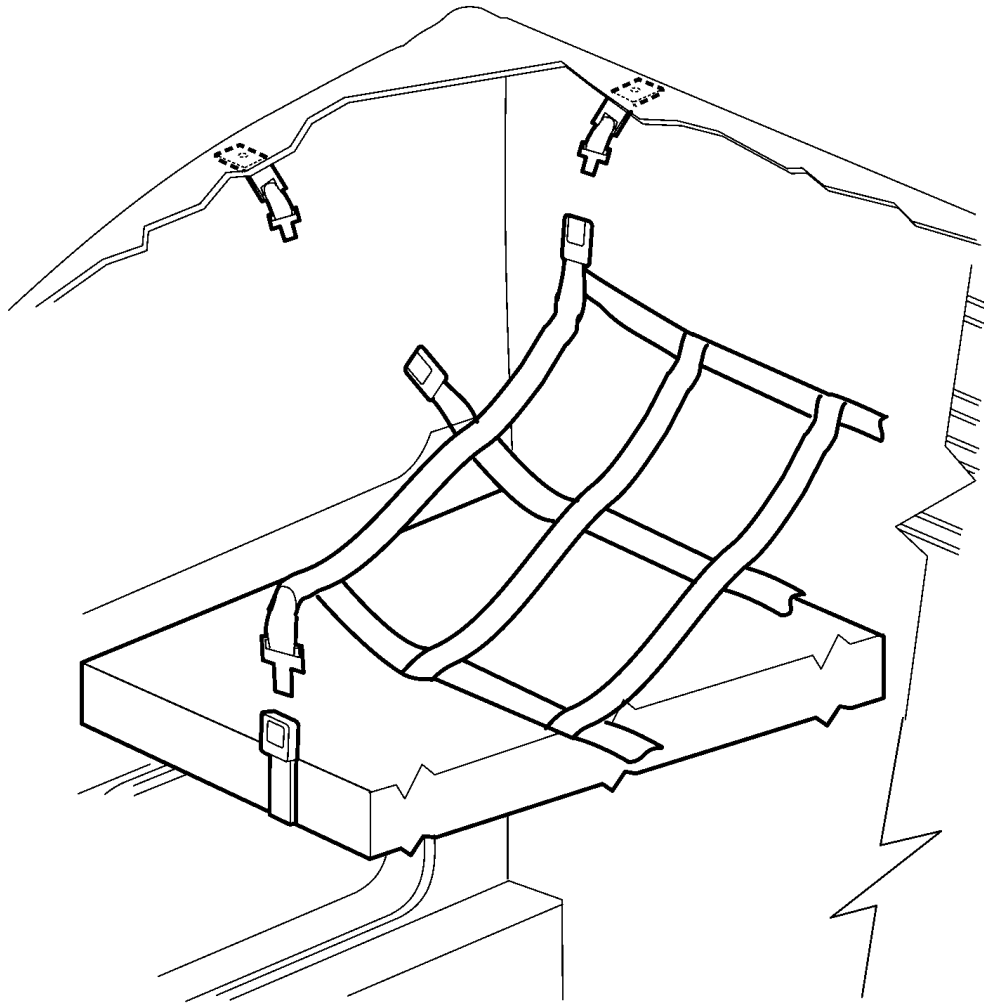

W8028594

Upper Bunk

Safety Restraint VN 780

Connect the restraint to the back wall first. The wall connectors are located in the storage units. Connect the lower part of the restraint to the lower buckles. Connect the side tethers and adjust the straps to form a "tent" over the bunk.

Note: The restraints for top and bottom bunks are different. Each belt can only be installed to the correct bunk.

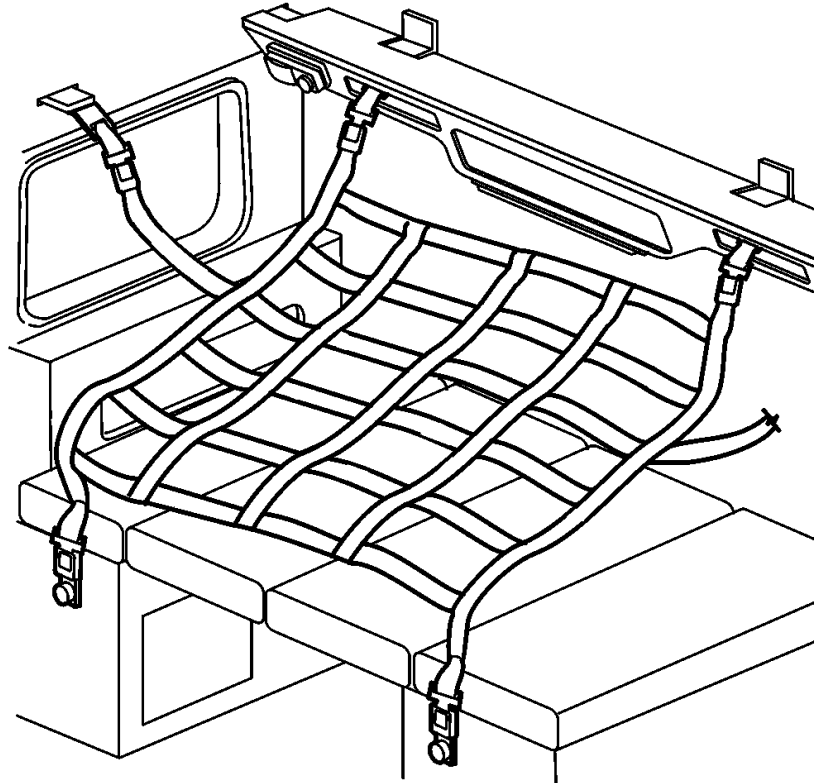

W8003217

Lower Bunk

Inspection

DANGER

Failure to properly inspect and maintain the safety belts can cause serious personal injury or death.

DANGER

It is critical that any time a vehicle has been involved in an accident, the entire safety belt system must be replaced in the vehicle (which also includes the sleeper bunk restraints) if they were in use at the time of the accident. Failure to replace the safety belt system may result in serious injury or death.

DANGER

A damaged safety belt, whether visibly damaged or not, could result in serious personal injury or death in the event of an accident. The safety belt systems should be replaced at least every five years.

DANGER

DO NOT bleach or re-dye the color webbing because it may cause a severe loss of belt strength. This loss of strength could allow the safety belt to break under stress, thus resulting in severe personal injury or death.

Check the belts, buckles, latch plates, retractors, anchorages, and guide loops to ensure that they are working properly. Look for loose/damaged parts (without disassembling) that could keep the restraint system from working properly. If the safety belt, retractor and hardware were in use during a collision, they must be replaced. The restraint system anchorage fasteners must be replaced if necessary. If there is any doubt about the restraint system's effectiveness, replace the entire safety belt assembly.

The following maintenance guidelines detail how to inspect safety belts and tethers for cuts, fraying, extreme or unusual wear of the webbing, etc., and damage to the buckle, retractor, hardware or other factors which indicate that safety belt system replacement is necessary.

Check the web wear at the buckle/latch area. The webbing must be closely examined to determine if there are any cuts, fraying or extreme wear in the webbing. Cuts, fraying or excessive wear would indicate the need for replacement of the safety belt system.

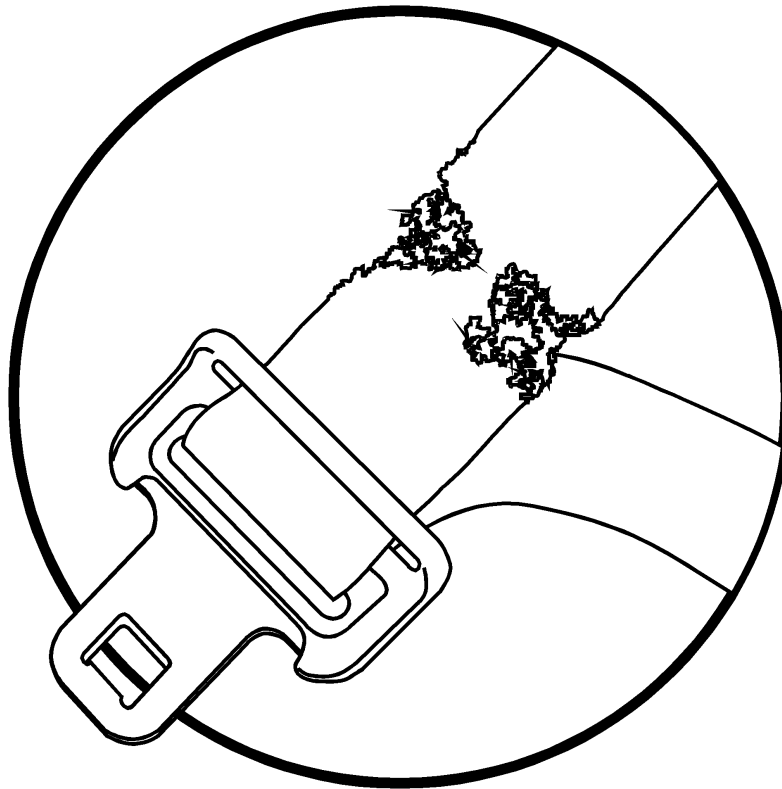

W8001406

246 OPERATION

The D-loop web guide is an area where almost constant movement of the safety belt webbing occurs because of the relative movement between the seat and the cab. This constant movement forms an area where wear will often occur. The webbing must be closely examined to determine if there are any cuts, fraying or extreme wear in the webbing. Cuts, fraying or excessive wear would indicate the need for replacement of the safety belt system.



W8002478

Check the buckle by inserting the latch and verifying proper operation. Determine if the latch plate is worn or deformed. Check the buckle and latch casing for cracks or breakage.

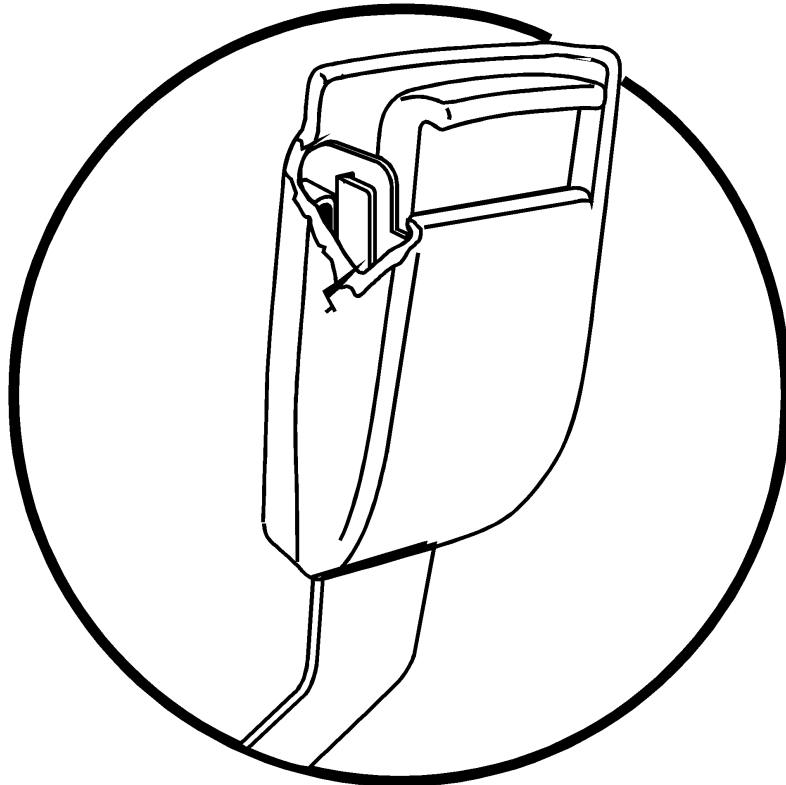

W8001404

248 OPERATION

The retractor web storage device is mounted on the B-pillar, just behind the door in the cab. The retractor is the heart of the safety belt system and can be damaged if abused, even unintentionally. Check the retractor web storage device operation to ensure that it is not locked and that it spools out and retracts the webbing properly.

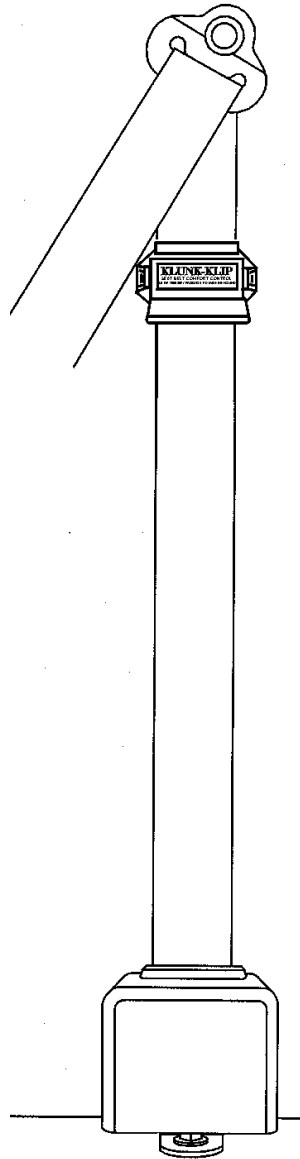

W8002481

If tethers are being used to anchor the safety belts to the floor, make sure that they are properly attached to the seat. Tethers must also be inspected for web wear and proper tightness of mounting hardware.

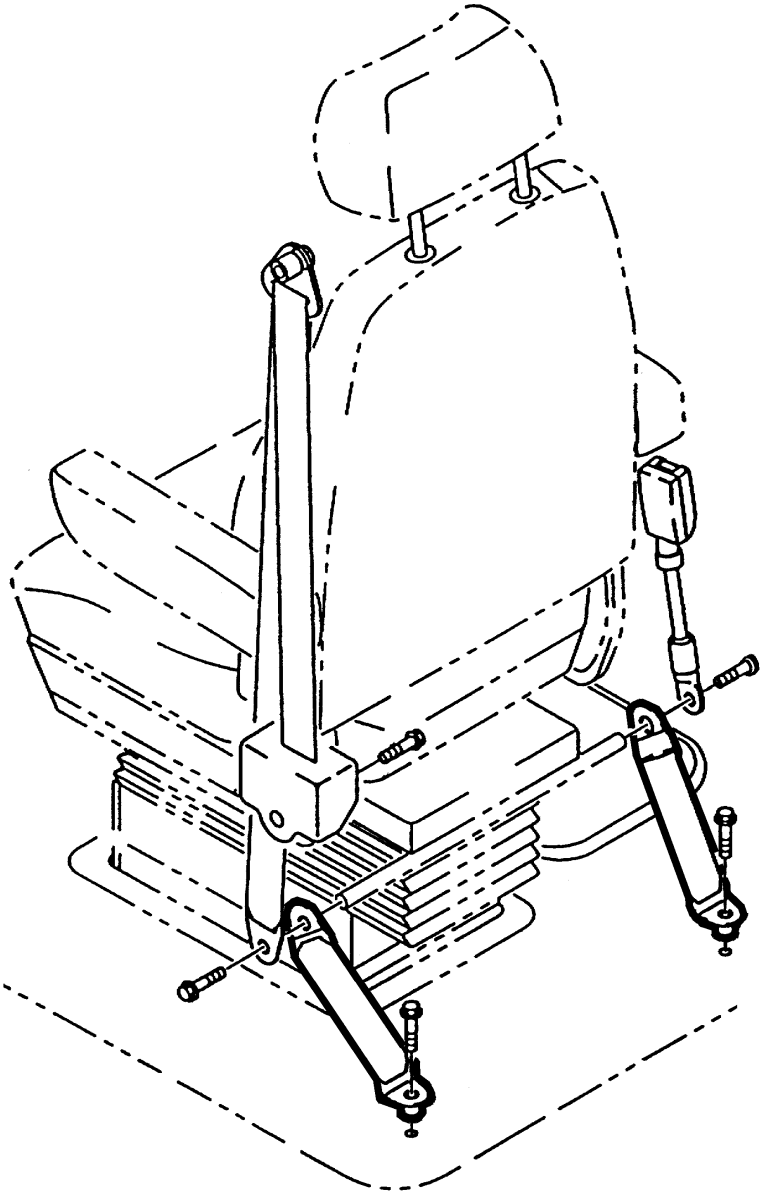

W8001387

All hardware for safety belt mounting points should be evaluated for corrosion. All attachment points of the system should be checked for tightness of mounting hardware. Check the web in areas exposed to ultraviolet rays from the sun or extreme dust or dirt. If the original color of the web in these areas is extremely faded, the physical strength of this web may have deteriorated. If this condition exists, replace the safety belt system.

Important Facts About Safety Belts in Heavy Trucks

The high mileage associated with heavy trucks, the continual relative movement of the seat with the cab, the possible contact with the vehicle seat or other parts of the cab structure, and the potential exposure of this safety belt to severe environmental conditions make it crucial to inspect the seat belt system regularly. It is recommended that the system is inspected every 24,000 km (15,000 miles) or more often if the vehicle is exposed to severe environmental or vocational conditions. Any safety belt system that shows cuts, fraying, extreme or unusual wear, significant discolorations due to ultraviolet ray exposure, dusty-dirty conditions, abrasion to the safety belt webbing or damage to the buckle, latch plate, retractor, hardware or any other obvious problem should be replaced immediately, regardless of the mileage.

Once replacement of the safety belt has been determined necessary, be certain that it is replaced only with a Volvo original replacement safety belt. See your authorized Volvo Truck dealer for replacement. Your Volvo safety belt system has been developed and tested specifically for heavy trucks. Replace it only with the exact same design that the vehicle was equipped with.

If the inspection indicates that any other part of the safety belt system requires replacement, the entire belt system must be replaced. An installation guide is attached to every replacement system, entitled "Three-Point Safety Belt Installation Guide."

There are separate safety belt instruction guides for suspension and stationary seats. Use the proper guide for your type of seat and follow the instructions very closely. It is vitally important that all components are mounted back in the same positions as the original components that were removed. This will maintain the design integrity of the mounting points for the safety belt assembly.

SEATS, GENERAL

Several seats can be used in the vehicles. If the seat installed in the vehicle is not explained in this section, see your authorized Volvo dealer.

Before adjusting or fastening the seat belt, move the seat forward or rearward and adjust the seat height as necessary. Sit erect and adjust the seat cushion and seat back to obtain a comfortable driving position.



DANGER

All adjustments are to be made while the operator is seated and the vehicle is stationary. **DO NOT** adjust the seat position while driving the vehicle. Failure to follow this warning can result in loss of vehicle control, which can result in serious personal injury or death in the event of a vehicle accident.

Driver Seats

- National Standard Seat
- National Comfort Seat
- Bostrom Standard Seat
- Bostrom Comfort Seat

Passenger Seats

- National Standard Seat
- National Comfort Seat
- National Toolbox Seat
- Bostrom Standard Seat
- Bostrom Comfort Seat
- Bostrom Toolbox Seat

NATIONAL STANDARD SEAT

Seat Adjustments

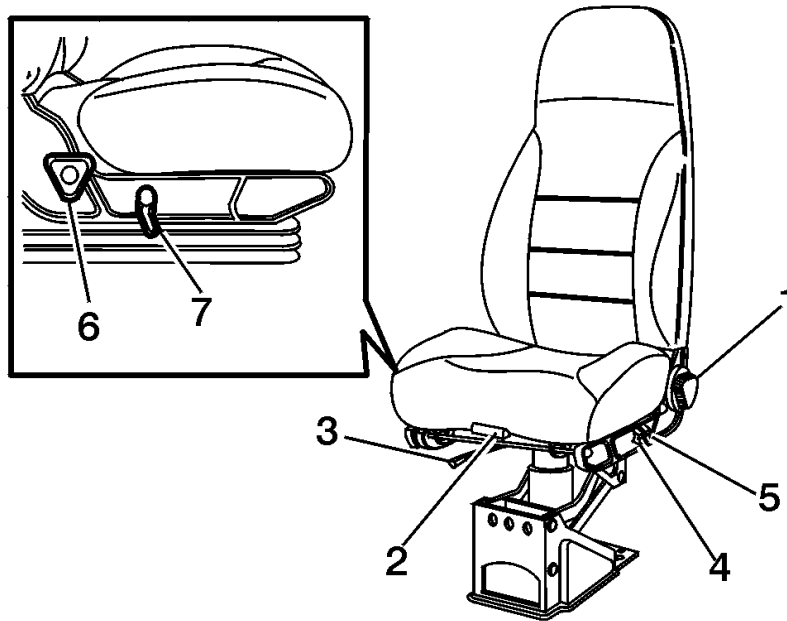

W8002745

National Standard Seat

- 1 Backrest Tilt: By rotating the round handle, the backrest recline angle can be adjusted within 12 degrees.
- 2 Cushion Front Tilt and Length: Pulling the handle up and out adjusts the tilt and length of the seat cushion. Support your body weight with your feet while adjusting.
- 3 Fore and Aft Movement: Press the lever sideways to unlock the seat. Move seat fore or aft to a new position.
- 4 Ride Height Adjustment: Push the upper part of the switch up to increase ride height. Push the lower part of the switch to deflate the airbag and lower the ride height.
- 5 Lumbar Support Adjustment: Push the upper part of the switch to inflate the support for a firmer support. Push the lower part of the switch to deflate the support.
- 6 Cushion Rear Tilt: Rotate the lever to get different height positions. Support your body weight with your feet while adjusting.
- 7 Chugger Snubber: Moving the handle down isolates the seat from the fore and aft movement of the cab.

NATIONAL COMFORT SEAT

Some National Comfort seats are equipped with a BackCycler® feature. Some National Comfort seats have a swivel mount.

Seat Adjustments

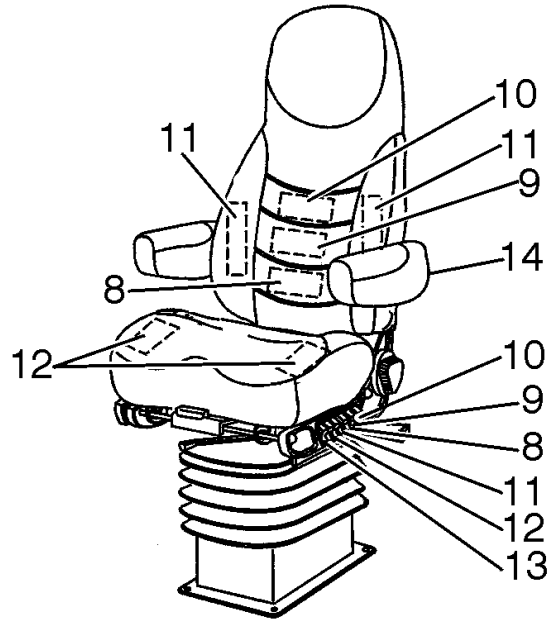

W8002744

National Comfort Seat

- | | |
|------------------------------------|---------------------------------|
| 1. Seat Adjustment
Fore and Aft | 5. Lumbar Support
Adjustment |
| 2. Isolator Lock | 6. Recliner Tilt |
| 3. Cushion Tilt | 7. Armrest Angle
Adjustment |
| 4. Ride Height
Adjustment | |

Bostrom Comfort Seat

Some Bostrom Comfort seats have a swivel mount.

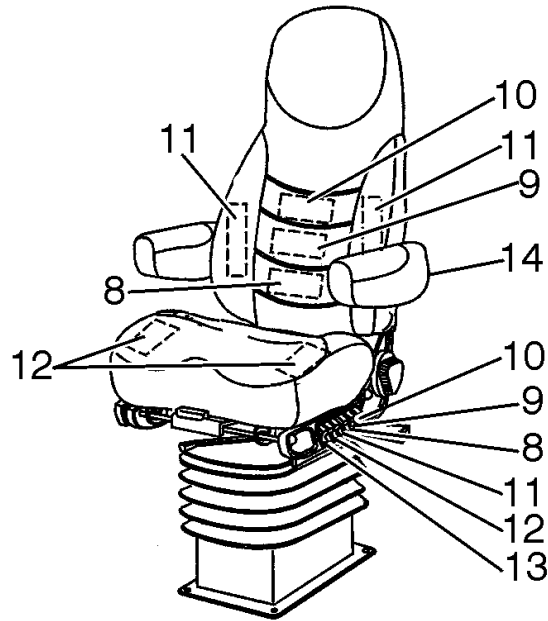

W8002744

National Comfort Seat

1. Seat Adjustment Fore and Aft
2. Isolator Lock
3. Dampening Adjustment
4. Cushion Tilt

5. Ride Height Adjustment
6. Lumbar Support Adjustment
7. Recliner Tilt
8. Armrest Angle Adjustment

PASSENGER SEATS

National Bench Seat

The bench passenger seat has the option for a two-man storage seat. The base of the seat is a storage box that is accessed by lifting the seat cushion up.

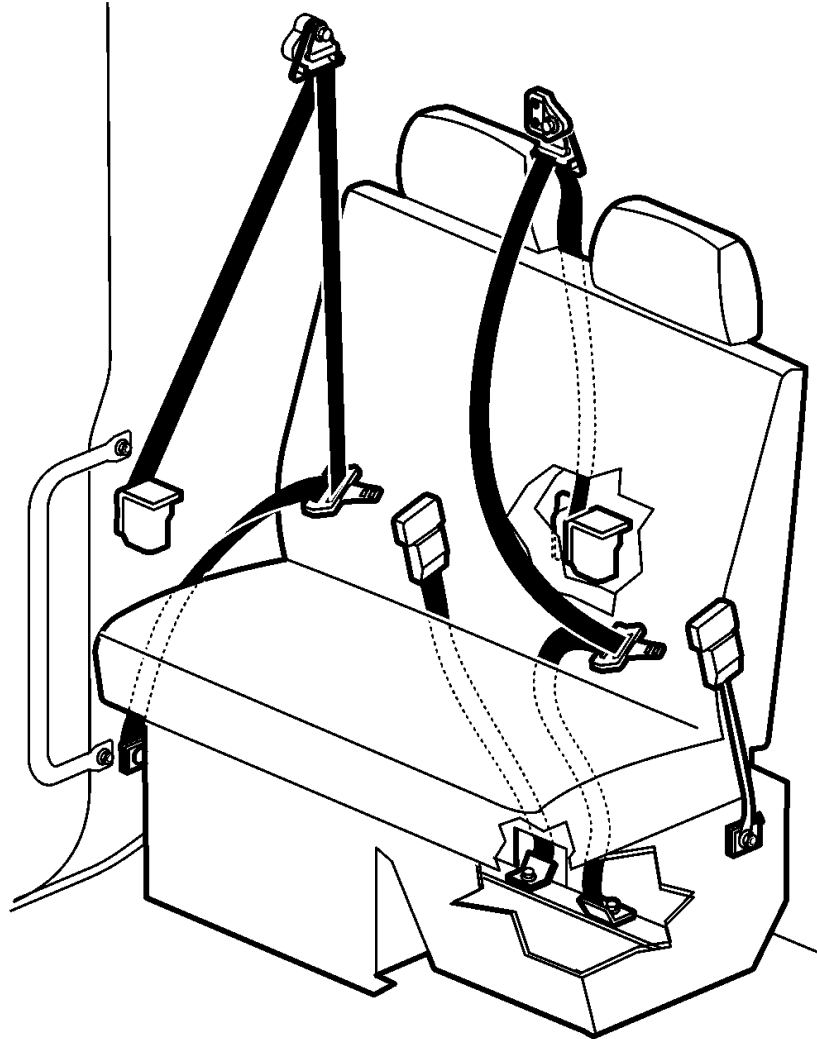

W8003482

National Bench Seat

256 OPERATION

National Toolbox Seat

The toolbox passenger seat has an optional accessible or non-accessible toolbox in the base of the seat. If the toolbox is an option, the storage box is accessed by lifting the seat cushion up.

Note: There is a release latch behind the seat.



W8003146

National Toolbox Seat

Bostrom Toolbox Seat

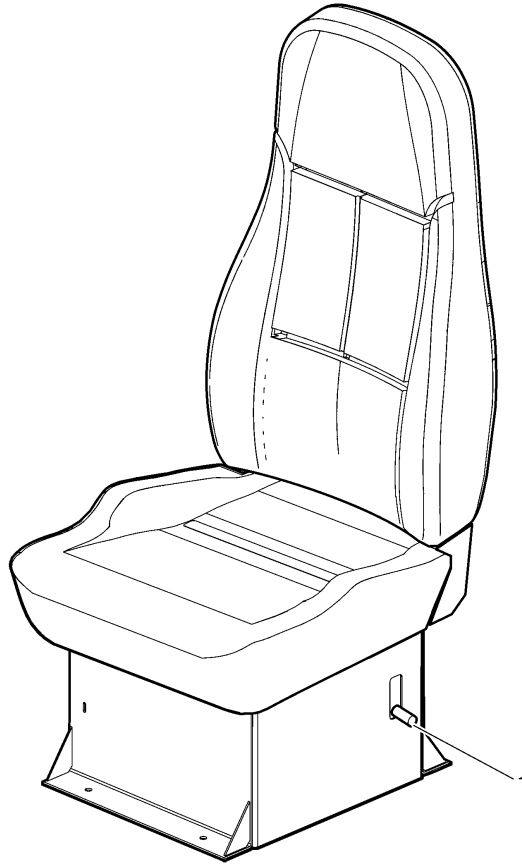

W8003851

Bostrom Toolbox Seat

1 Seat Cushion Release Lever

The toolbox passenger seat has an optional accessible or non-accessible toolbox in the base of the seat. If the toolbox is an option, the storage box is accessed by lifting the seat cushion up.

Note: There is a release latch behind the seat.

No Passenger Seat (Optional)



WARNING

Using a temporary passenger seating without the benefit of proper seat mounting and safety belt can, in the event of a loss of control of the vehicle, cause serious personal injury or death.

In vehicles with no passenger seat installed, **DO NOT** let a passenger ride on temporary seating. This is against the law and can be very dangerous.

ENGINE OPERATION

General

Proper operation, driving techniques and maintenance are key factors in obtaining the maximum life and economy from a modern turbocharged diesel engine. This section has operational information about the components that make up the engine.

When changing gears, avoid lugging to extend engine life. When the engine is operating at full throttle and maximum governed speed cannot be reached or maintained, the engine is lugging. When approaching a hill requiring more power, it is necessary to downshift the transmission as the vehicle goes into the grade.

Accelerating to the governed engine speed will give additional power at approximately the same road speed. For shifting instructions, see the transmission manufacturer's operator's manual.

Always start moving the load in a gear low enough so that the engine can be accelerated to the governed speed. Then shift to the next gear as the engine decelerates. For loaded vehicles, do not skip a gear or lug the engine while getting up to cruising speed. For empty or light loads, it is permissible to skip gears.

When operating on a level highway or at cruising speed, hold the engine speed at approximately 1400 to 1600 rpm for large displacement engines to achieve power and economical fuel consumption.

The operator should understand the operating characteristics of the engine the vehicle is equipped with. Modern diesel engines have maximum torques at much lower engine speeds than in the past. As such, these engines are designed to perform satisfactorily at a lower speed. New transmissions with wide ratio steps between gears demand the use of these engines.

260 OPERATION

This vehicle is equipped with an exhaust aftertreatment system which virtually eliminates exhaust smoke. Exhaust vapor may be visible during a cold start. If exhaust smoke is visible during engine operation, this indicates a problem with the exhaust aftertreatment system. Take the vehicle to an authorized Volvo Truck dealer immediately.

IMMOBILIZER FEATURE

Volvo Engines Only

The Immobilizer Feature is used to prevent the engine from starting. If your vehicle was not ordered with this feature, it may be available from your dealer as an option using VCADS Pro.

To secure the vehicle, the driver needs to enter the correct 3-digit code (PIN code) into the Driver Information Display (DID) via the stalk switch.

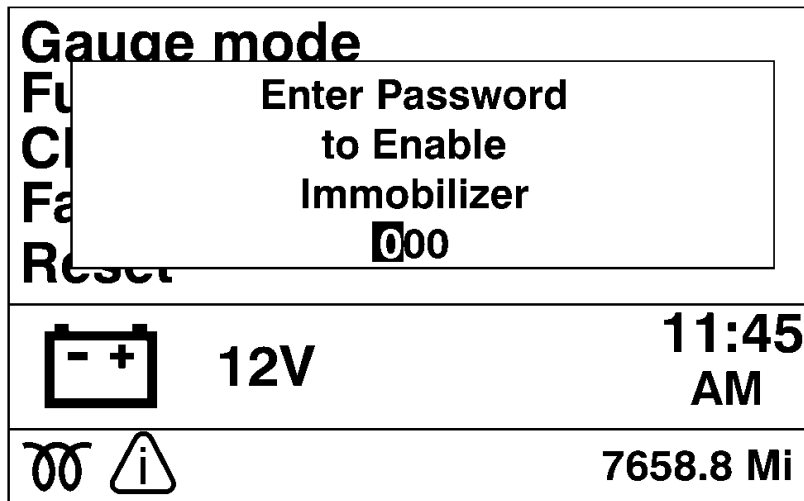

If the vehicle has not been placed in the Immobilizer Mode during the previous key-off, the driver will be able to start the vehicle as normal.
After the password is entered (at shutdown) "Security Mode Active" is displayed.

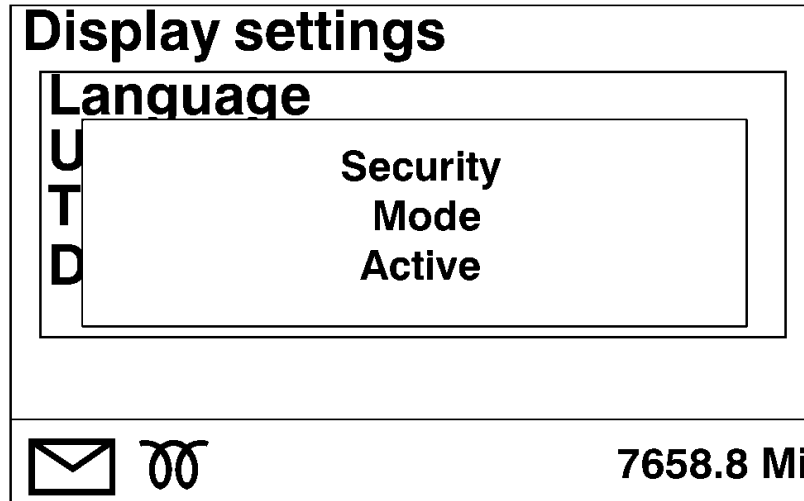

CONTROL AWARENESS FEATURE

Volvo Engines Only

Volvo engine and transmission. In addition, it provides a mechanical safety to the existing Power Take-Off (PTO) functionality.

- Parameters are set in VCADS. If the vehicle exceeds the maximum vehicle speed for the corresponding PTO mode, a message appears on the DID screen as shown:

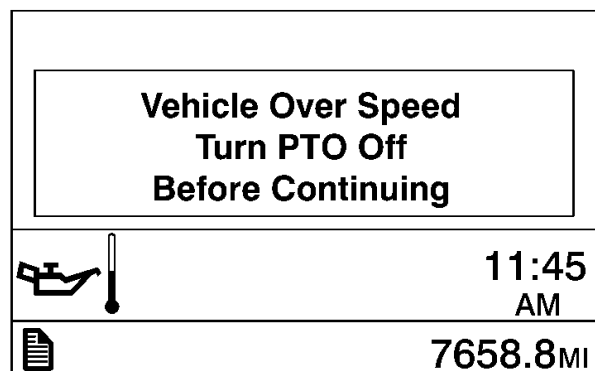

W3006376

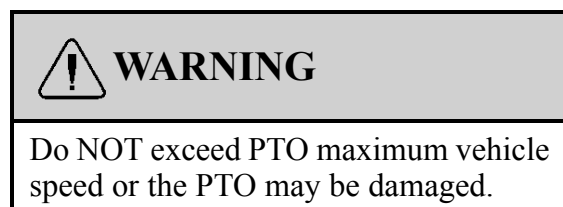

FUEL ECONOMY DRIVING

General

The absolute fuel consumption (counted in liters per 100 kilometers or miles per US gallon) is determined by a large number of circumstances which can be related to one of the following main areas:

- Build specification and equipment
- Service and maintenance
- External environment
- Driving habits

Due to these factors, fuel consumption can vary considerably within what is called "normal fuel consumption." Fuel consumption can vary from over 24 L/100 km (10 mpg) when driving empty on a nice and dry summer road to 67 L/100 km (3.5 mpg) while driving with maximum permitted GVW, with vehicle and trailer, on a hilly and slushy winter road.

Build Specification and Equipment

Whenever a vehicle is used for transportation, its build specification, equipment and gross vehicle weight have a decisive effect on both fuel consumption and performance. The factors which have the greatest influence on fuel consumption are primarily: driveline combination, height of trailer or superstructure, use of air fairings, tire type, number of wheels, gross vehicle weight, and accessories.

Driveline Combination

Engine, transmission and final drive must be selected in such a way that the engine can operate within the economic speed range at normal driving speed. This range is defined as where the engine makes the best use of the energy content of the diesel fuel. A poorly selected rear axle ratio, which results in the engine speed being constantly above the optimum speed, will increase fuel consumption.

Tires

Heavy duty threaded tires increase rolling resistance considerably. For long haul, choose a smoother, ribbed type tire. Choose a lugged type tire only when the added traction in mud and snow is needed.

The number of wheels (axles) has a direct effect on the rolling resistance and, thereby, the fuel consumption. For volume and/or low weight transports, the use of a 4x2 instead of a 6x4 should be considered.

If the tire pressure is too low, the rolling resistance increases and, thereby, increases the fuel consumption. The overall economy is also affected as tire wear increases considerably.

Gross Vehicle Weight

The gross vehicle weight of a vehicle combination has a large impact on the rolling resistance.

Accessories

As a rule, accessories such as roof rack, advertising signs, bug screens, exposed air horns, etc., have a negative effect on fuel consumption.

Service and Maintenance

A modern heavy-duty vehicle requires regular and preventive maintenance to ensure that all its components function as they should. Use the recommended preventive maintenance (PM) program that Volvo Trucks North America has developed for the vehicles. This ensures optimal energy efficiency from all components that are important to fuel consumption.

Brakes

Dragging brakes increase fuel consumption. They should be checked regularly. It is important that the release action of the air valves is fast and that the moving parts of the wheel brakes are checked for good adjustment and operation.

Axles

An axle out of alignment increases rolling resistance. Regularly check the front wheel alignment and axles on both the tractor and trailer/semi-trailer. If they are correct, there will be less rolling resistance and, therefore, lower fuel consumption.

A good sign of an axle or wheel out of alignment is uneven tire wear. Check the tires often.

Engine

Faulty or incorrectly adjusted engine components increase fuel consumption. The list below gives some typical components that can influence fuel consumption:

- Blocked (on the outside) charge air cooler/radiator package
- Faulty thermostat
- Blocked fuel filters
- Blocked air intake filter
- Faulty injectors
- Dirty turbocharger
- Air in fuel system
- Faulty fuel supply pump
- Faulty fuel relief valve
- Faulty fan thermostat/clutch

External Environment

Under unfavorable conditions, the external environment can have a negative effect on fuel consumption. This can be broken down into two main groups: weather and wind, and the nature of the roads. Rain, snow, icy conditions and headwinds have a large negative impact on fuel economy, as do hilly roads and uneven road surfaces.

Headwinds

Headwinds have a large negative impact on fuel consumption. With tailwinds, fuel saving is only marginal.

A good sign of an axle or wheel out of alignment is uneven tire wear. Check the tires often.

Air Temperature

Low ambient temperature contributes to increased fuel consumption.

Rain, Snow and Road Surface

A wet road surface increases rolling resistance and, thereby, fuel consumption. Slush will increase consumption even more. In certain cases, the surface structure of the road can also have a negative effect on fuel consumption.

Gradients

A hilly road with many bends demands a higher output from the engine. The difference between flat, straight roads and hilly, winding roads can amount to as much as a 50 percent increase in fuel consumption.

When choosing your route, avoid hills, rough roads and frequent stops.

Driving Habits

The way in which a vehicle is being driven is the one factor which has the greatest influence on fuel consumption. Correct driving saves fuel and reduces vehicle wear. To achieve optimal running economy, the driver should always remember to:

- Start the engine correctly (especially important in winter season).
- Maintain an even and correct speed.
- Keep the engine at its optimum speed range.
- Use the correct uphill and downhill driving technique.

Starting the Engine

Start the engine according to the instructions in the operator's manual of the engine manufacturer (for a Volvo engine, see "STARTING THE ENGINE" "STARTING THE ENGINE", page 298). A proper start, especially during the cold season, saves fuel and reduces engine wear.

Sluggish lube oil in the engine makes cold starting more difficult. Therefore, it is important to always use engine oil with the correct viscosity. (For the sake of the overall fuel economy, it is also important to have the right viscosity of transmission and rear axle oils.)

A good sign of an axle or wheel out of alignment is uneven tire wear. Check the tires often.

Avoid High Engine Speeds

High engine speeds mean high fuel consumption. "Jerky" driving also increases fuel consumption when the vehicle is constantly accelerated and slowed down. Avoid a higher consumption by steady, even driving.

Refer to each engine manufacturer's operator's manual for information on the engine's optimum operating range.

Rain, Snow and Road Surface

A wet road surface increases rolling resistance and, thereby, fuel consumption. Slush will increase consumption even more. In certain cases, the surface structure of the road can also have a negative effect on fuel consumption.

Hill Driving Technique

Use the inertia of the vehicle to go over the crest of a hill under reduced power. Use gravity to help with acceleration when going down the hill. Build up speed before reaching the next uphill.

Air Tanks

All air tanks on the vehicle should be drained daily. Empty any moisture from air tanks by pulling the drain valve wire or by opening the drain cocks and allowing the air pressure to drain completely. Make sure the drain cocks close properly after draining. During draining the tanks should be checked for condensation fluid even if an automatic drain valve is installed.



WARNING

When draining the air tanks, do not look into the area of the draining air. Dirt or sludge particles may be in the air stream and could cause eye injury.

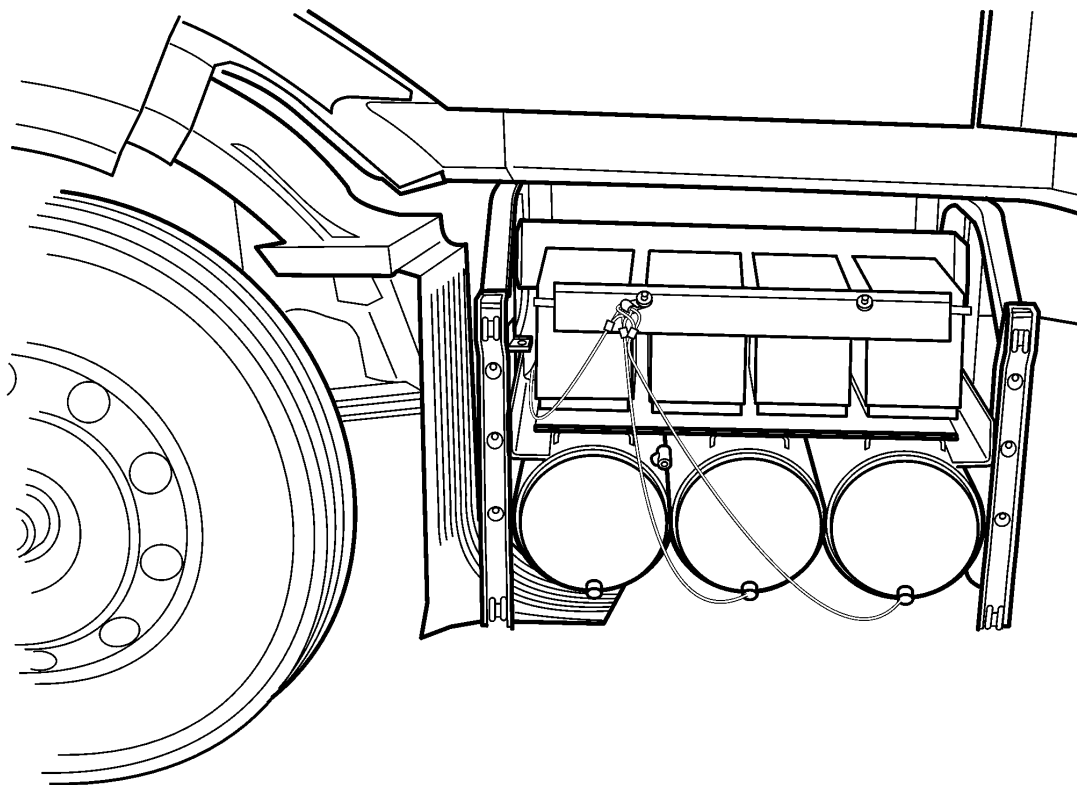

W8003393

Trucks with Wabco air dryers: Periodically drain the purge tank to check for contamination, water, oil, etc.

Trucks with automated Meritor Transmission: Drain the transmission air supply tank located on the right-hand rail daily to check for contamination, water, oil, etc.

Charging Air to Another Vehicle

DANGER

Before working on a vehicle, set the parking brakes, place the transmission in neutral, and block the wheels. Failure to do so can result in unexpected vehicle movement and can cause serious personal injury or death.

There are many methods which may be used to charge the air system of another vehicle. Vehicles equipped with the standard two-valve system (trailer supply and parking brake) must use the following procedure when using the emergency trailer air line as an auxiliary air source, other than to charge the trailer air reservoirs.

- 1 Connect the emergency trailer air line to the auxiliary source.
- 2 Start the engine.

CRUISE CONTROL

DANGER

DO NOT use the cruise control in heavy traffic, with ice/snow on the road or during other unfavorable conditions. This may lead to a loss of vehicle control, causing a vehicle crash, personal injury or death.

Engaging

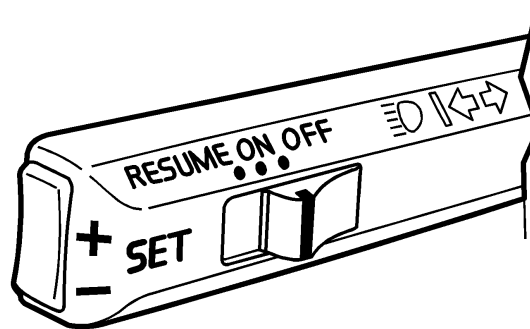

W3002499

To engage and set desired speed:

- 1 Set the cruise control switch to ON.
- 2 When the desired vehicle speed has been reached, momentarily press in the SET+ or SET- switch on the end of the lever.
- 3 To increase speed, press the SET+ switch. A momentary press of the switch (half second or less) will bump up vehicle speed in small increments. Hold down the switch (more than a half second) to ramp up vehicle speed. The vehicle speed will increase as long as the SET+ switch is pressed (speed will not increase above the maximum programmed speed). Release the switch when the desired speed has been reached. The new set speed will be the vehicle speed when the switch is released.
- 4 To decrease speed, press the SET- switch. A momentary press of the switch (half second or less) will bump down vehicle speed in small increments. Hold down the switch (more than a half second) to ramp down vehicle speed. The vehicle speed will decrease as long as the SET- switch is pressed (speed will not decrease below the minimum programmed speed). Release the switch when the desired speed has been reached. The new set speed will be the vehicle speed when the switch is released.

Note: The cruise control cannot be engaged at speeds below approximately 30 km/h (18 mph).

Disengaging

The cruise control is disengaged if the brake is depressed, or if the cruise control switch is set to OFF. If the ignition key is turned back to the accessories position (I), the cruise control system will automatically be disengaged.

If configured, the cruise control will remain engaged if the clutch pedal is depressed for short durations (to allow shifting while in cruise control). However, if the clutch pedal is depressed for an extended period (typically greater than 5 seconds), cruise control will be disengaged.

Resuming Vehicle Speed

The previously selected cruise speed is retained in the memory. When the cruise control switch is pushed to the RESUME position, the vehicle resumes the previously set speed (provided vehicle speed exceeds approximately 15 km/h [10 mph] when the switch is pressed and the speed is not above the maximum programmed speed).

Note: Read the Eaton VORAD Collision Warning System Driver Reference Manual before taking a vehicle equipped with VORAD out on the road.



CAUTION

On vehicles equipped with Eaton VORAD SmartCruise, cruise control is disengaged in the event the SmartCruise system fails to operate. You must stop the truck, turn the ignition off and on, and activate the control twice in order for the cruise control to operate.

Acceleration

Momentary acceleration (such as for passing another vehicle) does not interrupt cruise control operation. After passing, release accelerator and let the vehicle slow to cruise control speed. The previously set speed will then be maintained without having to set the switch to RESUME.

Volvo Engine Brake (I-VEB)

The Volvo Engine Brake (I-VEB) is standard on the Volvo 16F engine and optional on the 13F engine. It has a higher braking effect than the variable geometry turbo brake. When the engine brake is in the A position and cruise control is engaged, the engine brake automatically engages if vehicle speed exceeds the set cruise control speed. The I-VEB will engage with infinite control (within the limits of the engine brake) to maintain that speed.

The Volvo Engine Brake (I-VEB) is standard on the Volvo 16F engine and optional on the 13F engine. It has a higher braking effect than the variable geometry turbo brake. When the engine brake is in the A position and cruise control is engaged, the engine brake automatically engages if vehicle speed exceeds the set cruise control speed. The I-VEB will engage with infinite control (within the limits of the engine brake) to maintain that speed.

BRAKE OPERATION

Brake Safety Information

 **DANGER**

DO NOT inspect or adjust parts or components in the brake system without setting the parking brake, placing the transmission in neutral and securely chocking the wheels. If the vehicle is not secured to prevent uncontrolled vehicle movement, it could roll and cause severe personal injury or death.

 **DANGER**

DO NOT use replacement parts anywhere in the brake system unless it conforms exactly to original specifications. A nonconforming part in your vehicle's brake system could cause a malfunction, leading to loss of control of the vehicle resulting in severe personal injury or death.

 **DANGER**

DO NOT ride the brakes going down steep hills. The brakes could overheat and lose their effectiveness. Always choose a low gear before going down the grade and reduce speed to help control vehicle speed. Losing the brakes going downhill can lead to an accident causing serious personal injury or death.

 **DANGER**

DO NOT operate the vehicle when there is a malfunction in the compressed air system. An air brake system with leaks or other malfunctions may prevent the brake system from operating properly. The vehicle should not be operated until the system is repaired and all brake circuits are working properly. Failure to repair the system can lead to loss of control of the vehicle resulting in severe personal injury or death.

 **DANGER**

The brake system is a critical vehicle safety system. For your safety and for those around you, follow the recommended preventive maintenance checks. If any problems occur, have them investigated immediately by an authorized service facility. Failure to properly maintain the brake system can result in compromised brake efficiency and may lead to loss of control of the vehicle resulting in severe personal injury or death.

 **DANGER**

DO NOT drive through deep water. The brake system can be affected so the braking efficiency is less or the brakes pull the vehicle to one side. This could lead to an accident, personal injury or death.

 **DANGER**

Automatic slack adjusters **MUST NOT** be manually adjusted in an effort to correct excessive push rod stroke, as this condition indicates that a problem exists with the automatic adjuster, installation of the automatic slack adjuster or problems related to components of the foundation brakes. These conditions will not be corrected by manually adjusting the automatic slack adjusters.

Manual adjustment of the automatic slack adjusters is a dangerous practice that could result in serious consequences. This practice gives the vehicle operator a false sense of security about the effectiveness of the brakes, and the brakes will likely soon be out of adjustment again.

General

All Volvo vehicles are designed to meet or exceed all applicable federal brake standards and regulations. They use a dual circuit, compressed air system. It consists of two independent brake systems that use a single set of brake controls. Each circuit is supplied by its own compressed air tank. Both air tanks receive compressed air from the same supply tank (wet tank) and are charged with equal pressure. The two circuits are interconnected for the parking brake system.

 **DANGER**

DO NOT release the parking brake or attempt to move the vehicle until brake air pressure in both circuits is at least 690 kPa (100 psi). Failure to follow this procedure may lead to uncontrolled vehicle movement and cause severe personal injury or death.



DANGER

Never release or drive a truck that has a brake discrepancy — no matter how minor — until it has been repaired or corrected. Failure to repair brake discrepancies can result in compromised brake efficiency and may lead to loss of control of the vehicle resulting in severe personal injury or death.

Air pressures in the two circuits are monitored by two pressure gauges on the right side of the instrument cluster. The primary (rear) brake circuit gauge is marked with an "R" within a symbol and the secondary (front) brake circuit gauge is marked with an "F" within a symbol. The two pointers should register equal or nearly equal pressure. By observing the gauge pointers, the operator is forewarned in the event of a pressure drop in either or both of the circuits.

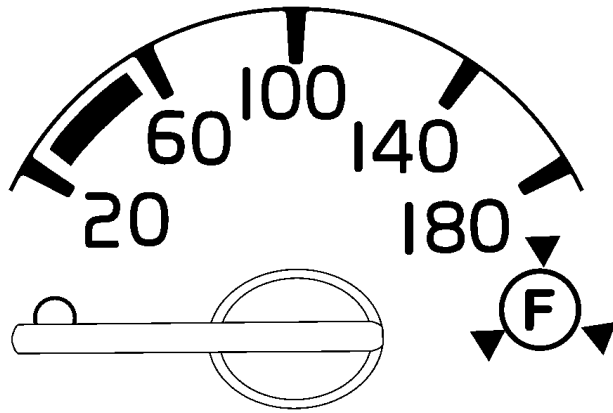

W3006936

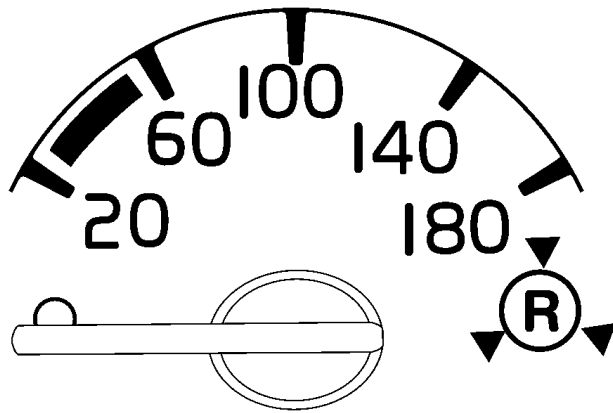

W3006937

Gauge 1 and Gauge 2

Before operating the vehicle, check the air gauges which indicate air pressure. They should not register less than 420 kPa (65 psi).

278 OPERATION

Both circuits are piped into a dual brake valve, which simultaneously applies front and rear axle service brakes during each brake application. In the event of a failure in either one of the circuits, the other circuit becomes the emergency circuit for applying the brakes.

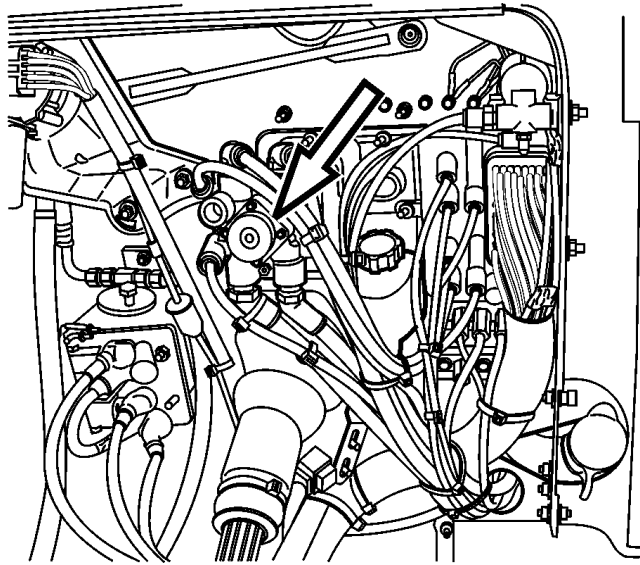

W5001486

- 1 Clutch Fluid Reservoir
- 2 Windshield Washer Fluid Fill
- 3 Brake Valve

DANGER

The Master Warning Tell-Tale and buzzer alerts of a dangerous situation. Air pressure is low and the remaining air volume may not be enough for repeated braking. Failure to heed this warning can result in loss of braking control, vehicle accident and injury or death.



W3005171

Master Warning Tell-Tale

An important feature of the brake system is that an automatic spring brake application does not take place as a result of an air loss in only one of the two circuits. In this case, brake control remains in the foot brake valve. In each air pressure gauge, there is a warning light connected to a low pressure switch that comes on if air pressure goes below 420 kPa (60 psi). At the same time, the buzzer will sound and the main warning tell-tale will come on. This pressure drop warns the operator to make a manual emergency stop before an automatic emergency stop takes place.

Brake System Controls

The air compressor, governor, pressure regulator valve and reservoirs are control devices. Their function is to build up, maintain and control air pressure in the reservoirs. This is so that pressure is held constant between the minimum and maximum range established for air brake operation.

The brake valve, quick release valve, brake chambers and slack adjusters are application devices. They distribute the air pressure and convert its energy into the mechanical force necessary to apply or release the brakes.

Foot Brake Valve

The foot brake valve is directly connected to the brake pedal. The valve gives a progressive output against the pedal travel. This allows better control of the pressure in the first half of the pedal travel. In the last half of the pedal travel, the pressure output increase is faster.

The foot brake valve applies the service brakes, incorporating both the primary and secondary air systems. The primary system controls the rear brakes and the secondary system controls the front brakes. The foot brake valve receives air from the compressed air tanks. Air pressure is then delivered to the wheel brake chambers as required by the amount of pressure exerted on the foot brake pedal. The brake chamber force then applies the wheel brakes.

From the operator's viewpoint, operating the foot brake valve of a vehicle equipped with air brakes differs very little from the operation of a conventionally braked vehicle. Because the operation of the brake pedal requires scarcely more effort than depressing the average throttle pedal, air brakes are naturally much easier to control. If the driver gives full attention to the following suggestions, a little experience will make him/her thoroughly familiar with the air-controlled braking of this vehicle.

DANGER

Failure to observe these precautions can result in loss of vehicle control and serious personal injury or death.

- 1 The best possible stop will be made when the first brake application is as firm as the speed and road condition permit. Then, ease off as the speed is reduced. Never apply the brakes lightly at first and increase the pressure as the speed diminishes.
- 2 DO NOT fan the brake pedal. Fanning gives poor brake performance and wastes air.
- 3 The air brake is designed so that when the brake pedal is fully depressed, an emergency application results. This application should be made only in an emergency situation.
- 4 In making a stop or a slow-down, allow the transmission to remain in gear with the throttle closed, disengaging the clutch only when engine idling speed is reached.
- 5 When parking the vehicle, place the transmission in neutral and set the parking brake before shutting down the engine.
- 6 When descending a long grade, do not use the service brakes too long or too often. The brakes may overheat and lose their effectiveness.
- 7 Before descending a steep grade, the transmission should be shifted into a lower gear and the vehicle speed reduced. Other speed retarding devices should also be used if available (engine brakes, retarders or trailer hand control valves).

Parking Brake/Trailer Supply Valves

Trucks/Tractors may have two air control valves on the instrument panel:

- Trailer Supply (red octagonal knob)
- System Park (yellow diamond knob)

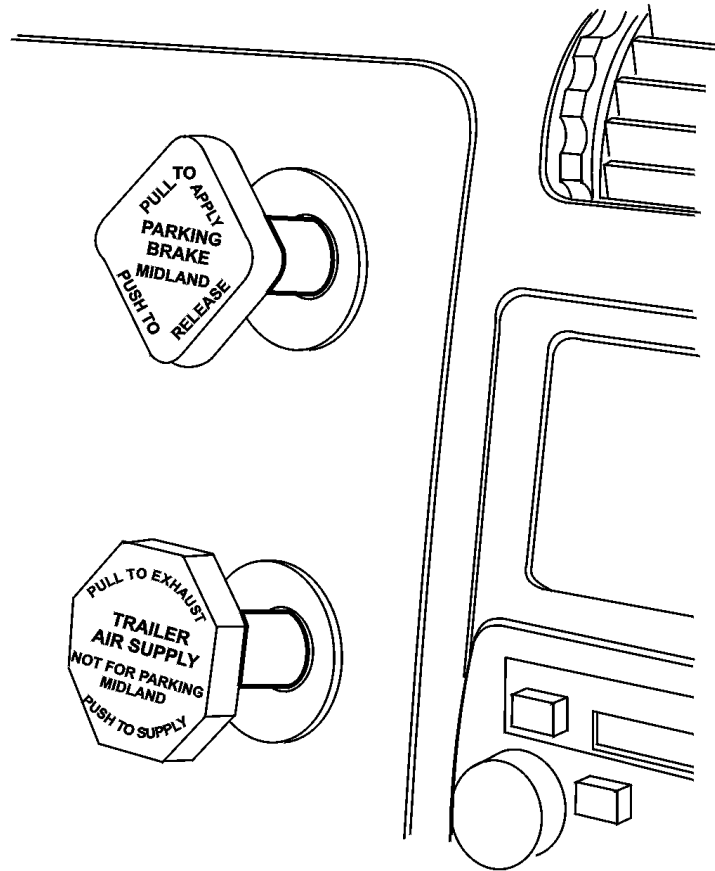

W5001116

The System Park valve knob (yellow) should be pushed in first, after sufficient air pressure is built up (apply foot brake to prevent vehicle from rolling). The Trailer Air Supply valve knob may then be pushed in.

The Trailer Air Supply valve knob and System Park valve knob will automatically pop out if the system pressure (both front and rear circuits) drops to 170 to 240 kPa (25 to 35 psi). The tractor protection valve will then close, the tractor spring brakes will apply and the trailer emergency system will be activated.

On vehicles equipped with the standard two valve system, the operation of one valve together with the other permits the operator to select the desired functions described below:

Red Valve (Trailer Air Supply)	Yellow Valve (System Park)	Function (Mode)
Out	Out	System Park
In	Out	Trailer Charge
In	In	Normal Running
Out	In	Bobtail

Parking Brake Release

VN models have engines equipped with engine electronic control units (EECU). These have two features that may impact the brake system. One is the anti-stall device in the EECU which senses torque demand and automatically controls the engine to compensate and maintain speed. On tractors equipped with parking brakes on only one axle, the anti-stall device keeps the engine from stalling, allowing the driver to pull away with the brakes dragging. This may result in overheated brakes and damaged wheel hubs.



WARNING

Continual dragging of the brakes will cause brakes to overheat. This may lead to wheel end fire. To avoid overheating, make sure both parking brake knobs are pushed in before driving off.

If the yellow knob is pulled out and the red knob is pushed in, a condition is created where the trailer parking brakes are not applied and only the single drive axle brakes are applied. In this condition, the vehicle can be driven away. Therefore, it is very important that the driver make sure the yellow AND red knobs are pushed in all the way before driving the vehicle.

284 OPERATION

There is also an engine shut-down device in the EECU that shuts down the engine after a pre-programmed time in order to save fuel. This is activated when the yellow parking brake knob is pulled out. Therefore, some drivers park and release the parking brakes using only the red knob to keep the engine running. It is then easily overlooked that in a vehicle parked with both the yellow and red knobs activated, only the red knob is pushed in by habit.

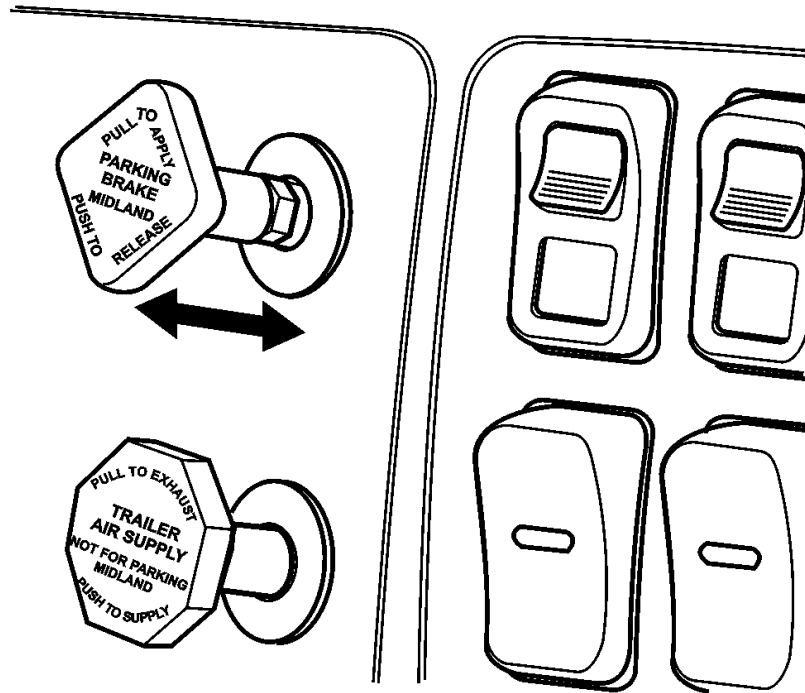

W5001429

Incorrect Parking or Driving Position

Spring Brake for Parking

DANGER

Never leave the vehicle without being certain the parking brakes are set or that other precautions are taken to prevent the vehicle from rolling. Failure to do so can result in serious personal injury or death.

DANGER

Before working on or inspecting a vehicle, set the parking brakes, place the transmission in neutral and block the wheels. Failure to do so can result in unexpected vehicle movement and can cause serious personal injury or death.

The parking brake mechanism uses spring pressure as a separate power medium to apply the service brakes on the driving axles. The parking brake is released by the same compressed air source used to apply the service brakes. Since this brake is released by air pressure, the system must be charged to at least 420 kPa (60 psi) before the parking brake may be released.

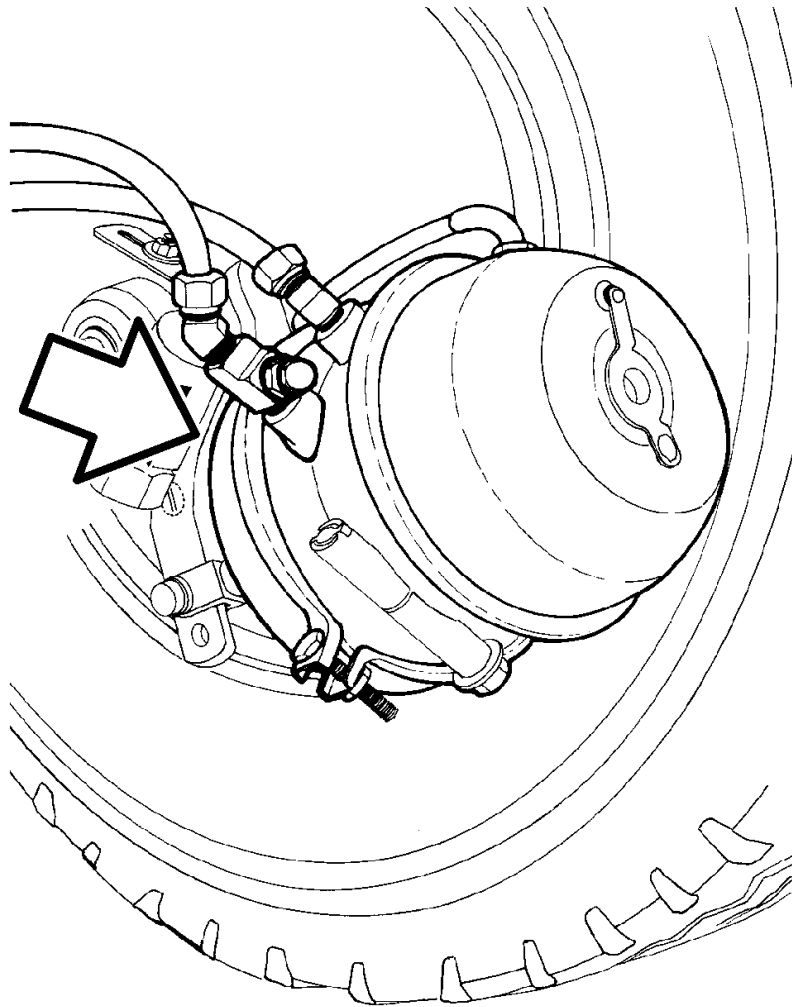

W5001430

The parking brake spring tension is sufficient to hold a fully loaded vehicle on maximum grades permitted on modern highways, provided the brake drums and linings are in good condition and the brakes are properly adjusted.



CAUTION

DO NOT use the spring parking brakes if the service brakes are hot, such as after descending a steep grade. Also, do not use the spring parking brakes during freezing temperatures if the wheel brakes are wet. To do so could damage the brakes, if hot, or may cause them to freeze during cold weather.

If the brakes are wet, drive the vehicle in low gear and lightly apply the brakes to heat and dry them. Allow hot brakes to cool before using the parking spring brakes.

There are several ways to determine if the parking brakes have been set. By pulling out the yellow knob:

- An audible rush of air will be heard when the parking brake knob is pulled. The air exhausts from the park brake valve itself and from the spring brake chambers on the rear axle(s).
- A black ring around the base of the yellow control knob will be seen.
- The engine will stall if an attempt is made to set the vehicle in motion.
- There will be a fluctuation in the air pressure gauge needles.
- The knob cannot be pulled out any further.

 **DANGER**

DO NOT attempt in any way to disassemble or tamper with the spring brake chamber. The force stored in the spring, if suddenly released, can cause serious personal injury or death.

 **DANGER**

DO NOT apply the parking brake while the vehicle is moving. The rear wheels may lock up causing loss of vehicle control leading to an accident, personal injury or death.

Trailer Brake Hand Control

DANGER

The trailer hand brake control is not a parking brake valve and must not be used as one. This brake is not designed to hold the vehicle stationary. Failure to follow these instructions can result in the unintentional movement of the vehicle and may cause personal injury or death.

DANGER

DO NOT use the trailer brake hand control as a parking brake. The brakes could release and the vehicle could roll, causing a vehicle accident, personal injury or death.

The hand control valve for the trailer brakes engages the trailer brakes independently from the vehicle brakes. The valve can be fully or partially engaged but in any partial position it will be overridden by a full application of the foot brake valve. To supply air to the trailer brakes to slow the trailer down, pull the valve handle down. The farther the handle is pulled down, the more air pressure is applied to the trailer brakes. Releasing the self-returning handle releases the trailer brakes.

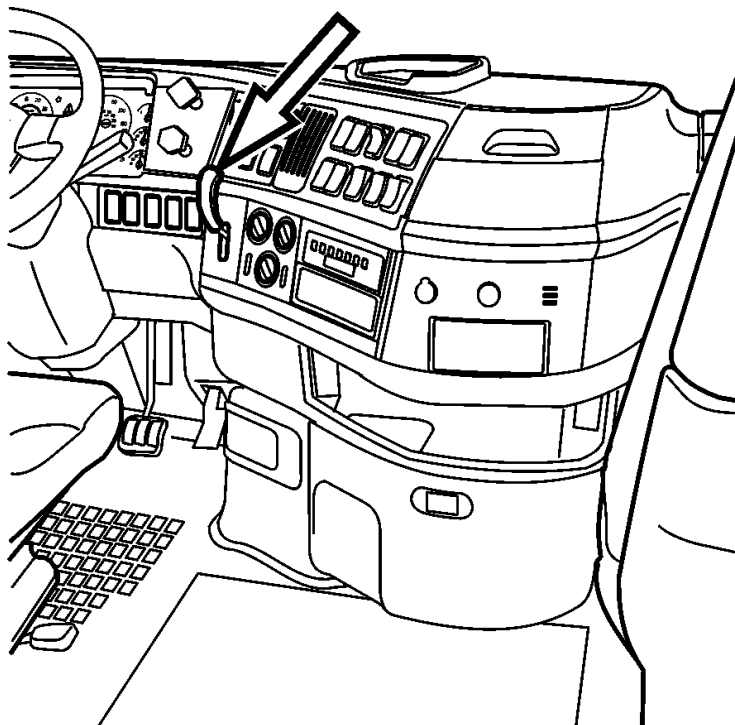

W5001442

The "121" Brake Standard

This manual refers occasionally to "121" brakes. Although some operators believe "121" only applies to vehicles equipped with anti-lock devices, the "121" standard applies to all vehicles that are capable of on-highway operation.

The "121" is a Federal requirement also covering alterations or changes to parts or systems related to the "121" standard once the vehicle has been placed in service. The owner and operator should be aware that it is a violation for any repair facility to make any part or component inoperative when it is required for "121" compliance.

ANTI-LOCK BRAKING SYSTEM (ABS)

The vehicle has a standard brake system, equipped with an electronic speed monitoring and control system, Anti-lock Braking System (ABS). ABS monitors wheel speed continuously but is not involved in controlling the wheel speed unless there is an emergency. In normal braking applications, the standard air brake system is in effect.



WARNING

For proper ABS operation, **DO NOT** change tire sizes. The size of the tires installed during production are programmed into the electronic control unit. Installing different sized tires could result in a reduced brake force, leading to longer stopping distances or accidents.

There is a sensor installed in each wheel on a monitored axle. The sensors transmit information to the electronic control unit (ECU). The ECU interprets the signals and calculates wheel speed, wheel retarding and a vehicle reference speed. If the calculations indicate a wheel lock-up situation, a signal is sent from the ECU to the appropriate ABS modulator valve to reduce braking pressure. During emergency braking, the modulator valve alternately reduces, increases or maintains air pressure in the brake chamber to prevent wheel lock-up.

During emergency or reduced-traction stops, fully depress the foot brake pedal until the vehicle comes to a safe stop. **DO NOT PUMP** the brake pedal. With the brake pedal fully depressed, the ABS will control all wheels to provide steering control and a reduced braking distance.

Although the ABS improves vehicle control during emergency braking situations, the operator still has the responsibility to change driving styles depending on the existing traffic, road and/or weather conditions. For example, the ABS cannot prevent an accident if the driver is speeding or following too closely on slippery surfaces.

The ABS control unit contains a self-testing program that is engaged each time the ignition is turned on. The operator can verify the testing by listening for the ABS modulator valves actuating twice in series. To increase the sound, hold down the foot brake pedal when the ignition is turned on.

If any of the ABS tell-tales come on during driving or do not go out after a short time after turning on the ignition, take the vehicle to an authorized Volvo Truck dealer to repair the ABS or brake system. The vehicle can still be driven with a problem in the ABS system. However, ABS will not be working and the standard braking system will be in effect.



W3005149

ABS Malfunction Truck/Tractor

The instrument cluster also contains an ABS tell-tale lamp, which indicates when there is a problem being reported by the Trailer ABS system.

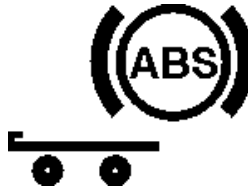

W3005148

ABS Malfunction Trailer

VOLVO ENHANCED STABILITY TECHNOLOGY

Some vehicles are equipped with Volvo Enhanced Stability Technology (VEST). VEST is an advanced stability control system designed to provide both roll stability and under- and over-steer correction in a wide variety of driving conditions. VEST continuously monitors a variety of vehicle parameters and sensors (including steering angle sensor) to determine whether the vehicle is reaching critical stability threshold. At that point, VEST is designed to intervene by instantly de-throttling the engine and applying individual tractor and trailer brakes as needed to regain control.

TRACTION CONTROL SYSTEM (TCS) (OPTIONAL)

 CAUTION
--

DO NOT engage the differential locks while wheels are spinning. Serious damage to the differential will occur. See “AXLES”, page 342 for more information.
--

The Traction Control System (TCS) uses the same wheel sensors as the ABS to determine if one set of drive wheels is spinning faster than the other wheel set. If the TCS determines that a wheel is spinning (with vehicle speed below 40 km/h [25 mph]), it operates the brake system to apply some brake force to stop the spinning wheel(s). This puts the drive power over to the stationary wheel(s). If vehicle speed is above 40 km/h (25 mph), a signal is sent to the engine ECU, which reduces the engine speed to be consistent with vehicle speed. This action helps reduce the amount of wheel spin and gives the operator greater vehicle control.

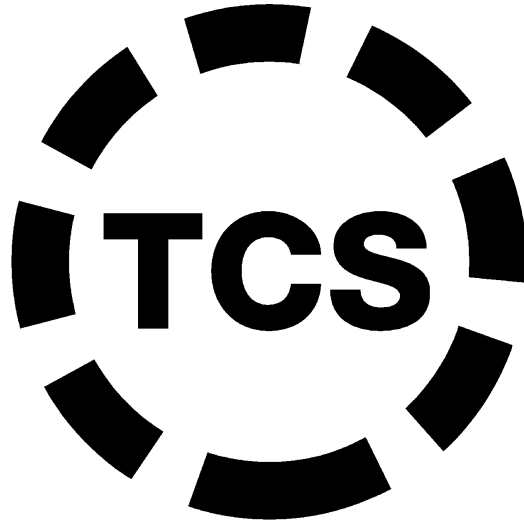

W3000962

The TCS includes a switch to turn off the function. When the switch is in the OFF position, the TCS operates normally to increase traction if the drive wheels begin spinning. When the switch is pressed once, the TCS tell-tale in the instrument cluster blinks continuously, indicating that the TCS is in mud/snow mode.

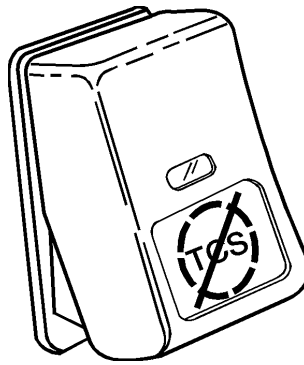

W3001336

The mud/snow mode increases available traction on soft surfaces like snow, slush or mud by slightly increasing the allowable wheel spin. This prevents the wheels from getting bogged down. The TCS will resume normal operation when the TCS switch is pressed again and the TCS tell-tale goes out or when the ignition is turned off.

Tire Pressure System (If Equipped)

The tire pressure/temperature sensor is attached to each wheel with a stainless steel tire strap and is located in line with the wheels valve stem. This self powered sensor is responsible for transmitting the tire cavity pressure and temperature to the system via a radio frequency sign that is received by the system antenna.

1. Tire Pressure

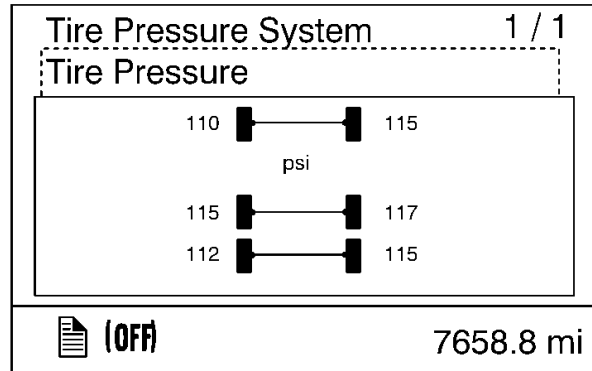

Air Pressure Monitoring and Alert

The air pressure of each programmed tire can be monitored by the operator via the DID. The system monitors tire air pressure in all cab tires independently and alerts the operator of low tire pressures in two stages;

1. Low Pressure Alert — The low pressure alert is triggered when tire pressure is 8% below its “Set Point”. The operator is alerted by an amber warning telltale light/buzzer that is displayed in the instrument cluster. The set point pressure is a nominal tire pressure that is set at the factory.

2. Critically Low Air Pressure — The critically low air pressure alert is triggered when tire pressure is 18% below its “Set Point”. The driver is alerted by a red flashing telltale light/buzzer that is displayed in the instrument cluster. The set point pressure is a nominal tire pressure that is set at the factory.

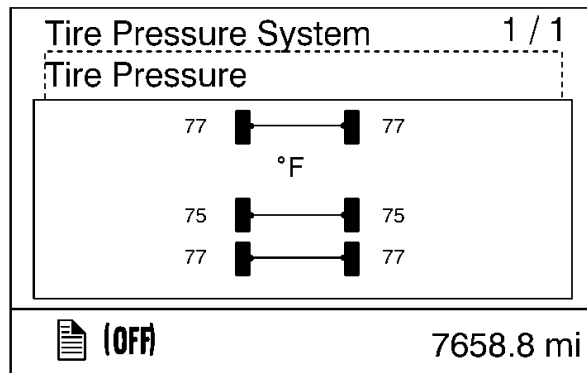

Tire Temperature Monitoring and Alert

The cavity air temperature of each programmed tire can be monitored by the operator via the DID. The system monitors cavity air temperature in all cab tires independently and alerts the operator when any of these tire cavity temperatures reaches 77°C (170°F). The operator is alerted by a red flashing telltale light/buzzer that is displayed in the instrument cluster.

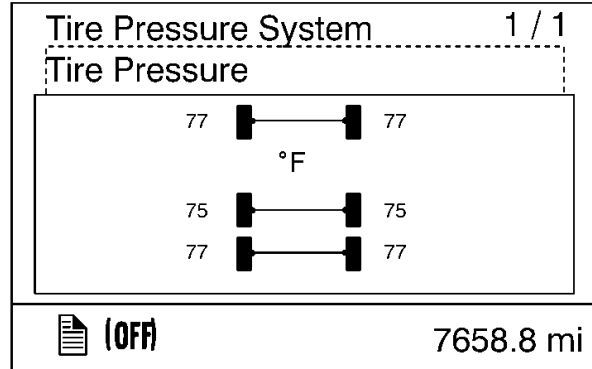

VEHICLE SPEED RETARDING DEVICES

 **DANGER**

When operating a tractor bobtail (without a trailer) or on slippery roads, the engine brake switch must be in the "OFF" position. Failure to follow this instruction can result in loss of vehicle control and serious personal injury or death.

Note: The vehicle ABS will automatically turn off the vehicle speed retarding device, IF one of the sensed rear wheels is locking up as a result of vehicle speed retarding device operation. The vehicle speed retarding device will be turned back on automatically when the wheels become unlocked. Consider switching to a lower braking level if this occurs frequently.

A vehicle speed retarding device is not intended to bring the vehicle to a stop. A vehicle speed retarding device is only intended to retard the vehicle speed under certain conditions.

Note: It is normal for there to be a slight delay in the application of a vehicle speed retarding device. When using devices of this type, be sure to think ahead and analyze conditions in order to use the device properly.

Volvo Variable Geometry Turbo Brake

The variable geometry turbo brake is standard with the Volvo 11F and 13F engine. It uses software to close the variable geometry turbocharger to create retardation.

Note: For both variable geometry turbocharger and engine brakes, use a "one gear" driving strategy when going downhill to keep engine speed up for effective braking (for example: uphill in 7th gear and downhill in 6th).

STARTING THE ENGINE

Start Procedure

Note: For cold weather starting, see “COLD WEATHER OPERATION”, page 306.

These starting and operating procedures should be followed for all engines. For more detailed information about design and function on a non-Volvo engine, read the operator’s manual from the engine manufacturer.

Note: Before starting the engine, see "Instruments and Controls" section for detailed information on how the gauges and tell-tales work.

DANGER

DO NOT use ether or other combustible starting aids in any Volvo engine. Introduction of ether or similar starting aids could cause a fire or explosion resulting in severe property damage, serious personal injury or death.

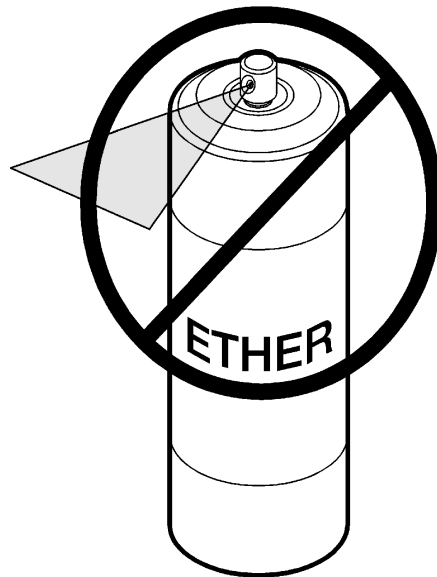

W0001484

DANGER

Never operate the starter without first placing the transmission in neutral or depressing the clutch pedal. Failure to follow these instructions may result in the unintentional movement of the vehicle resulting in property damage, personal injury or death.

1. Before starting the engine, perform the engine pre-trip inspection and daily maintenance checks in on “PRE-TRIP INSPECTION AND DAILY MAINTENANCE”, page 192.
2. Make sure the parking brakes are engaged.
3. Place the transmission in neutral or depress the clutch pedal.

 **CAUTION**

DO NOT crank the engine for more than 30 seconds at a time; wait two minutes after each try to allow the starter to cool. Failure to follow these instructions could cause starter damage.

Note: Some starters are equipped with starter protection. If the engine is running, the starter temperature is too high, the transmission is not in neutral or the clutch pedal is not depressed, starter engagement is inhibited. Also, when the key is turned to the start position, there is a one second delay before the starter is engaged.

Note: The starter will not operator if the PTO is engaged.

4. Turn on the ignition with the switch key. Some tell-tales will come on in a routine check that shows the bulbs and systems are OK. If any of the tell-tales stay lit, that function of the vehicle may not be operable. DO NOT operate the vehicle until the problem is repaired. For an explanation of the tell-tales, Refer to the Driver Information Display Manual.

5. Turn the key to the start position. Release key as soon as the engine has started. For the Volvo engine, the preheater can be engaged to help starting in cold temperatures.

 **CAUTION**

If at start-up, or thereafter, the oil pressure gauge indicates any drop in oil pressure, the engine must be shut down immediately. Failure to stop the engine may cause major engine damage.

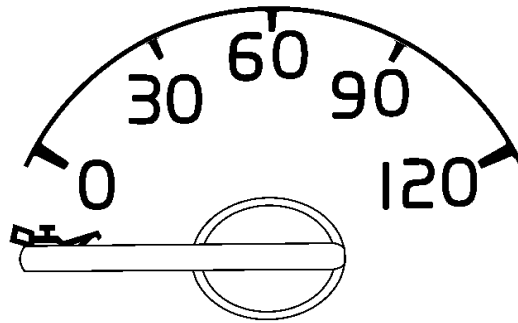

W3006933

6. When the engine has started, it takes a while to send lubricating oil to all bearings and shafts, and between pistons and liners. Wait for the oil pressure gauge to settle at a normal level, then bring engine speed up gradually. Increase speed as it warms up. Check all gauges during warm-up.

7. During warm-up, apply load gradually until the oil temperature reaches 60°C (140°F). To move a loaded vehicle, the minimum coolant temperature must be approximately 50°C (120°F).

Engine Break-In

Engines are run on dynamometers before being shipped from the manufacturer. In most applications, the engine can be put to work immediately, but the operator should be extra observant of the operating conditions shown on the gauges during the initial 100 hours or 5,000 km (3,000 miles).

A more frequent check of the engine compartment for fluid leaks, fluid levels and fastener tightness is also recommended during the initial period.

Engine Overspeed

This vehicle is equipped with a diesel engine and should not be operated in an area with a concentration of hydrocarbon vapors (for example gasoline or diesel fuel fumes). Be especially cautious of low-lying or closed-in areas. The vapors may be drawn into the engine through the air intake and cause the engine to overspeed. Hot carbon and other sparks may come from the exhaust system, and cause an explosion and fire.

If the vehicle is in an area where hydrocarbon vapors may be present, shut the engine off immediately if any abnormalities are experienced. DO NOT leave it unattended.

DANGER

The diesel engine will operate on any fuel which enters the cylinder, whether it is from the injectors or from the air intake system. Therefore, if any solvent is used to flush out the air cleaner element, the engine may overspeed during start-up. Engine damage and severe injury and/or death from burns or explosion can occur.

Idling

Diesel engines are electronically governed. The idle speed is pre-programmed from the manufacturer. Low idle speed is adjustable within certain limits (for most engines between 600 to 750 rpm).

The common belief that idling a diesel engine causes no engine damage is wrong. Idling produces sulfuric acid, which breaks down the oil and eats into bearings, rings, valve stems and engine surfaces.

Note: Avoid excessive idling. If the vehicle is parked for more than 5 minutes, stop the engine. An engine can burn from 3 to 5.5 liters (0.75 to 1.5 gallons) of fuel per hour while idling. During long engine idling periods, the engine coolant temperature may fall below the normal operating range. Incomplete combustion of fuel during the warm-up period can cause dilution of the oil in the crankcase, formation of lacquer or gummy deposits on the valves, pistons and rings, and rapid accumulation of sludge in the engine.

Low Idle Adjustment

DANGER

Before setting the idle, apply the parking brakes and place the transmission in neutral. Failure to do so can result in unexpected vehicle movement and can cause serious personal injury or death.

302 OPERATION

If the engine coolant temperature is above 50°C (122°F), the vehicle is stationary (engine running; accelerator released; parking brake on) and the PTO not engaged, the engine low idle speed can be adjusted with the use of the cruise control function.

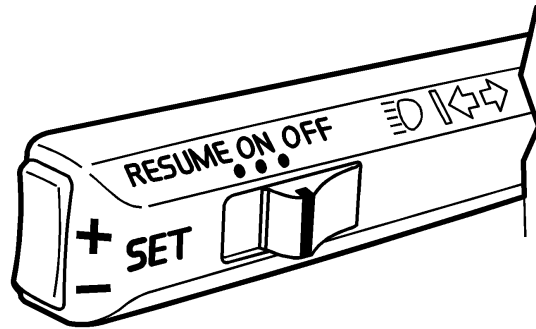

W3002499

- 1 Set the cruise control switch to the ON position.
- 2 Depress the foot brake pedal. Hold it down during the entire procedure.
- 3 Move the cruise control switch to the RESUME position and hold it there for four seconds. Release the switch. The engine speed will drop to the default low idle (Volvo engines), or a slight drop in idle speed will occur (Cummins).
- 4 The idle speed is adjusted up with the SET+ switch. Each time the SET+ switch is pressed momentarily, idle speed will increase approximately 10 rpm (the speed cannot be increased above the maximum allowed by the engine manufacturer).
- 5 The idle speed is adjusted down with the SET- switch. Each time the SET- switch is pressed momentarily, the idle speed will decrease approximately 10 rpm (the speed cannot be adjusted below the low idle set by the engine manufacturer).
- 6 When the desired engine idle speed is reached, push and hold the SET and move the cruise control switch to the RESUME position at the same time and hold them in position for four seconds. Release the switches.
- 7 Release the brake pedal to set the new idle speed. If an error was made during the adjustment procedure, the default idle speed will be maintained.

If the engine coolant temperature is above 50°C (122°F), the vehicle is stationary (engine running; accelerator released; parking brake on) and the PTO not engaged, the engine low idle speed can be adjusted with the use of the cruise control function.

Idle Shutdown Timer

The idle shutdown timer can be programmed to shut the engine down after a specific engine idling time. This programming cannot be changed by the operator, but can be done using special tools. Contact your authorized Volvo Truck dealer for details.

The permitted idle time can be set to the following time intervals:

Volvo – 1 to 40 minutes

Cummins – 1 to 100 minutes

When the idle shutdown feature is enabled, the engine will typically shut down at the set time under the following conditions:

Vehicle speed is 0.

Engine is running at idle speed.

Coolant temperature is above 45°C (113°F).

Parking brake is applied (Volvo engines only).

These are standard choices when the vehicle is delivered. For more information about other customer adaptation choices, contact your authorized Volvo Truck dealer.

Uphill Operation

For best performance, allow engine speed to reach the bottom of the rated torque range before downshifting. Continue to downshift in this manner until a gear is reached that will maintain the desired speed. Continue to operate at the rated torque if the vehicle will make it to the top without a downshift. Begin upshifting as the grade of the hill decreases and the engine begins to accelerate above 1600 rpm. Driving this way will give the best fuel economy and performance.

Note: Allowing the engine to lug down to the end of maximum torque range is permissible if the vehicle is cresting the top of a hill. However, extended operation at engine speeds below the maximum torque range (usually 1000 to 1200 rpm) will raise exhaust temperature and cylinder pressure. This can lead to reduced engine life.

Downhill Operation



CAUTION

DO NOT exceed engine manufacturer's recommended maximum engine speed. Engine damage can occur. If equipped with an engine or exhaust brake, DO NOT exceed 2300 rpm.

On a downgrade, do not coast with the clutch pedal depressed or the transmission in neutral. Select a gear that does not allow the engine speed to exceed the engine manufacturer's maximum engine speed recommendation. Use the engine or exhaust brake and/or the service brakes to control the vehicle speed. A simple rule is to select the same gear used to go up the grade.

High Altitude Operation

Engines lose power when operated at high altitude because the air is too thin to allow burning as much fuel as at sea level. Closely monitor the gauges during high altitude operation. The thinner ambient air reduces the efficiency of the engine cooling system. Engine overheat or cylinder damage could occur if the engine is operated at full load for extended periods at high altitudes in hot weather. Downshift and reduce vehicle speed to reduce engine load when driving on long grades in these conditions. This will help keep engine air intake manifold and coolant temperatures within safe limits.

Stopping the Engine

Allow the engine to slow down and idle for 3 to 5 minutes before shutting it off. This allows the turbo to slow down and the cooling system to dissipate the engine heat. Switch the engine off by turning the ignition key to the B, or OFF, position.



CAUTION

Shutting off an engine immediately after high speed or full load operation can damage the turbo and cause heat stress in the engine. Always let the engine idle for 3 to 5 minutes before shutting it off.



DANGER

Failure to take the necessary precautions when the CHECK or STOP tell-tales are on, can ultimately result in automatic engine shut-down and the loss of power steering. Vehicle crash can occur.

Engine Shut-Down System



CHECK

W3005170



W3005171

The engine shut-down system will automatically derate or stop the engine when one or more of the systems listed below reaches a critical stage:

- High Coolant Temperature
- Low Oil Pressure
- Low Coolant Level
- High Crankcase Pressure
- High Diesel Particulate Filter Soot Level

Derate and shut-down functions may be applied differently, or added to, depending on the engine manufacturer. See the engine operator's manual for more information.

When the shut-down is activated, the tell-tales come on and the buzzer is also activated. From that time it will take 30 seconds before the engine shuts down. In this time period, find a safe place to pull off of the road.

After the engine has been shut down by the system, the override will allow a restart of the engine for 30 seconds. This is so the vehicle may be pulled off the road, if necessary. The alarm will remain activated until repairs have been made to correct the problem.

The operator should not continually override the system as this can cause serious damage to the vehicle's engine.

COLD WEATHER OPERATION

Volvo Engine Cold Start

Note: These cold start instructions are for Volvo engines only. For other engine makes, see the manufacturer's handbook.

DANGER

DO NOT use ether or other combustible starting aids on any Volvo engine. Introduction of ether or similar starting aids could cause a fire or explosion resulting in severe property damage, serious personal injury or death.

Note: Volvo engines have a unique cold start feature. Depending on the ambient temperature, the engine cranks two to four turns without injecting fuel. This provides cleaner combustion at start-up and promotes longer engine life.

When starting a cold engine, the intake air should be warmed up by using the preheater. Turn the ignition key to the drive position and push the key in to request preheater engagement. The preheater does not engage at coolant temperatures above 12°C (54°F). If the coolant temperature is below 12°C (54°F), the preheater will engage and will light the preheater tell-tale between 0 and 50 seconds, depending on the engine coolant temperature.



T3008841

If necessary, once the engine has started, the preheater will reengage (post heating) for the same length of time as the preheat time.

Engines Without Preheater

Engines not equipped with a preheater may, depending on coolant temperature, take longer to start. If this should happen, DO NOT release the ignition key until the engine has started (while still observing the 30 second maximum cranking time).

Ether Start**DANGER**

DO NOT use ether or other combustible starting aids on any Volvo engine. Introduction of ether or similar starting aids could cause a fire or explosion resulting in severe property damage, serious personal injury or death.

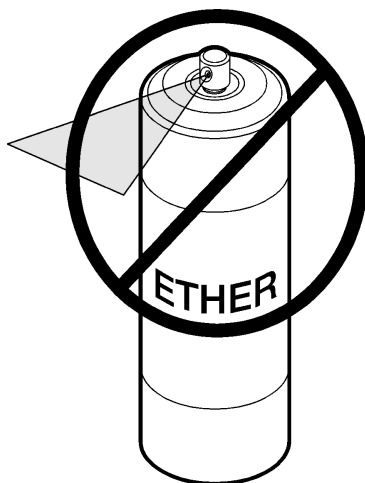

W0001484

Cold Weather Operation

If the engine is in good mechanical condition and the necessary preparations are taken for cold weather operation, ordinary cold weather will not cause difficulty in starting or loss of efficiency.

Cold weather operation does require changes in operating practices, maintenance procedures, lubrication and fuel. Additions to the vehicle, such as heated fuel filters, fuel tank heater, engine block heater, winterfront, etc., can make winter operation easier. Contact your authorized Volvo Truck dealer for the correct accessories and information about installation.

If satisfactory engine temperature is not maintained, increased engine wear will result in higher maintenance cost. Accessories should be designed to be easily disconnected when switching to driving in warmer weather so they do not affect the operation of the engine.

For cold weather operation, follow these recommendations:

- When starting the engine in temperatures below 15°C (5°F), use engine lubricants of lower viscosity. See the Operator's Manual Vehicle Maintenance for additional information.
- When the temperature is below freezing, make sure the concentration of antifreeze in the coolant is sufficient to prevent freezing. Refer to the Operator's Manual Vehicle Maintenance for additional information.
- During cold weather, pay more attention to the condition of the batteries. Test them frequently to ensure sufficient power for starting. A dead battery may freeze.
- Fuel cloud point is the temperature at which wax crystals become visible, which is generally above the pour point of the fuel. To keep the fuel filter elements from plugging with wax crystals, the cloud point should be no higher than the lowest ambient temperature at which the engine must start

To prevent wear and possible damage to the engine when it is cold, gradually bring it up to operating temperature before operating at high engine speeds or full load. After starting and before moving the vehicle, run the engine at 800 to 1000 rpm for 3 to 5 minutes. Operate at partial engine load until the coolant temperature reaches 75°C (165°F).

310 OPERATION

Engine Block Heater (Optional)

An electric engine block heater can be installed for keeping the coolant hot when the vehicle is parked. The heater is mounted through the side of the engine block with the heater coils in the coolant jacket. The heater does not interfere with normal operation and can be permanently installed.

The heater runs on 120 V and has an easily accessible plug, located beside the driver side door. The plug will hook up to a normal extension cable.

Note: Location of the block heater depends on vehicle model.

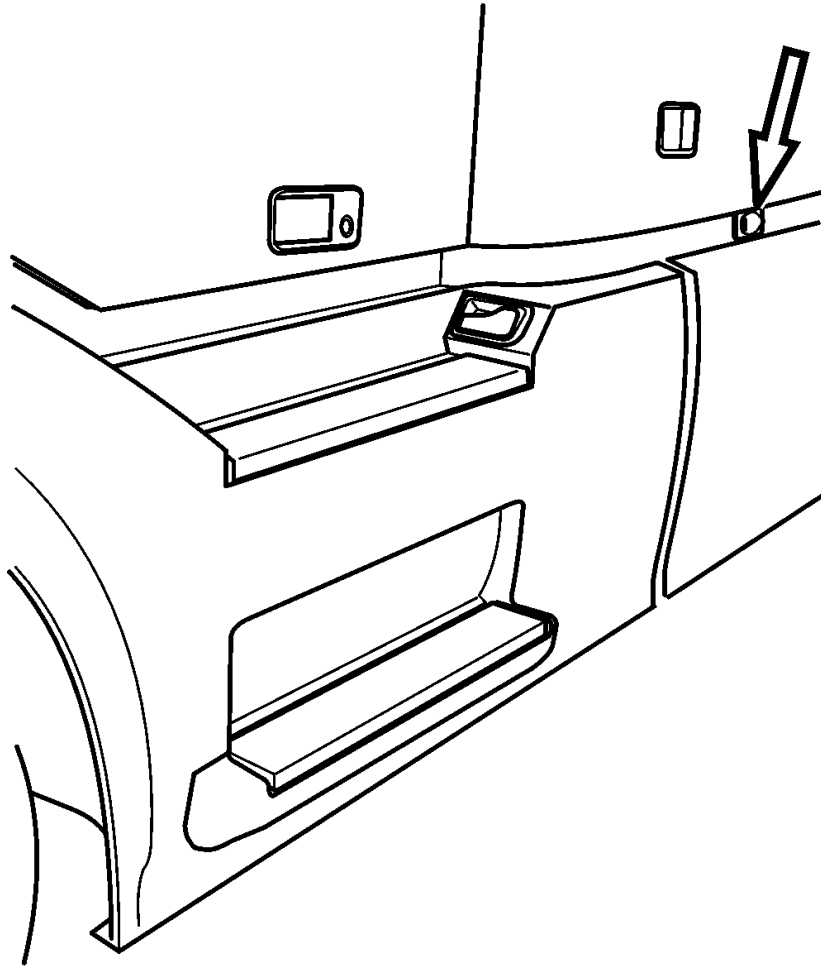

W3005284

Oil Pan Heater (Optional)

Oil pan heaters aid low temperature starting by improving oil flow to critical parts in the engine. This helps prevent engine wear. They are similar to block heaters and are wired into the same plug as the engine coolant heater.

Fuel Heater Filter (Optional)

If running in very cold weather, a heated fuel filter should be added. A number of different fuel heaters are available as options. They are electrically heated and regulated by a thermostat or coolant heated. They are typically built into the primary fuel filter housing.

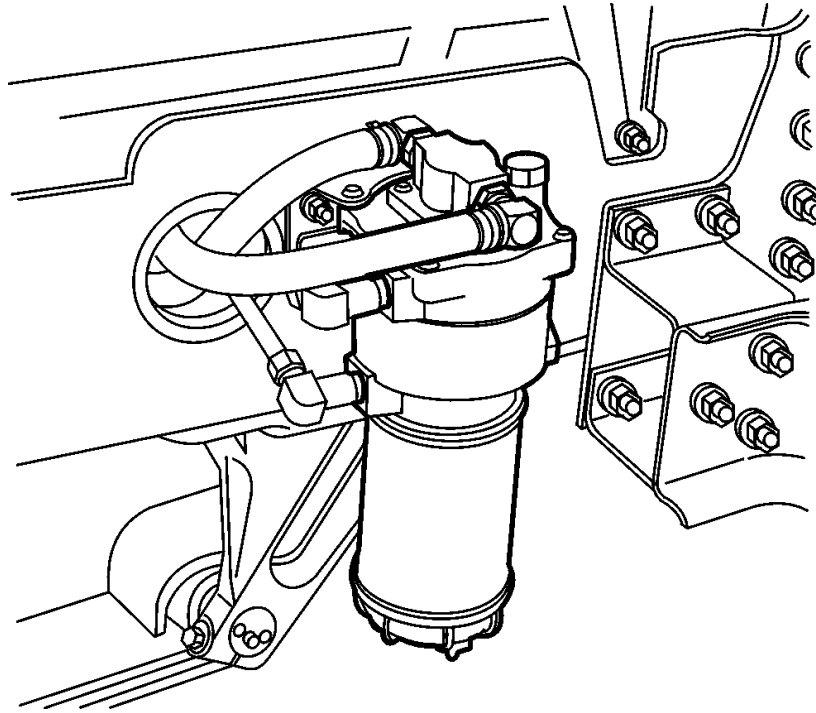

W2003931

Fuel Tank Heater (Optional)

An in-tank fuel heater is also available. In-tank heaters use hot engine coolant to warm the fuel. This prevents wax formation in the fuel during cold season operation. These heaters are thermostatically controlled and will automatically raise the fuel temperature to an optimum level.

Winterfront

Volvo Trucks North America does not recommend the use of winterfronts, shutters or any other shield in front of the grille or radiator package under normal circumstances.

Today's electronically controlled engines are designed to operate in cold temperatures without a winterfront. These devices, if not used properly, can cause higher exhaust temperatures, power loss, excessive fan usage, failure of the charge-air-cooler and a reduction in fuel economy.

Winterfronts are properly used in the wintertime during very cold weather. In these cases, coolant and inlet manifold temperatures must also be carefully monitored and controlled.



CAUTION

Failure to remove the winterfront when temperatures go above severely cold temperatures could cause severe damage to engine, charge-air-cooler and/or loss of fuel economy.

If a winterfront is used, it must conform to these specifications:

- The grille coverage should be such that airflow through to the charge-air-cooler is at a uniform rate over the entire area. This means that a single, small opening in the winterfront is not acceptable.
- Air passage must be distributed evenly across the grille and no more than 85% can be covered.

Please see your authorized Volvo Truck dealer for Volvo recommended winterfronts.

Note: If there is engine or related damage that can be traced to an improperly used winterfront, the warranty is no longer valid for those parts.

FIFTH WHEEL INSTRUCTIONS

Fifth Wheel General Information

 **DANGER**

Always have all fifth wheel maintenance and repairs done by a qualified technician. An incorrect repair can cause the trailer to separate from the tractor causing an accident with serious personal injury or death.

Things to think about with trailer hook-up:

- Check the load distribution between axles.
- Always chock the trailer wheels.
- Grease the plate unless it is a low lube or no lube top plate.
- Verify visually that coupling has occurred.
- Verify visually that plungers have locked on slider.
- Check for slack between the fifth wheel and the trailer kingpin

Follow the instructions on the advisory labels attached to the various manufacturers' fifth wheels. An operator's manual for each fifth wheel is provided in the Owner's package.

314 OPERATION

If the fifth wheel is equipped with a sliding mounting, follow the advisory labels attached to the component. Also, read the literature provided by the manufacturer.

DANGER

Always keep the fifth wheel plate well lubricated to prevent binding between the tractor and trailer. A binding fifth wheel could cause erratic steering and loss of vehicle control that may result in serious personal injury or death.

There are three operating positions for the fifth wheel locking mechanism (ASF fifth wheel is shown as a typical fifth wheel):

Locked — This is the position that the fifth wheel will be in with a trailer hooked up. In the locked position, the operating rod is retracted and the safety latch will freely swing back and forth.

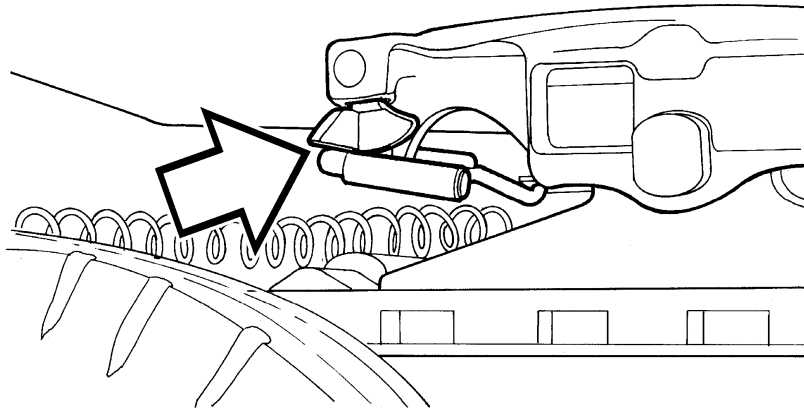

W9000180

Lockset — This is the position the fifth wheel is in when uncoupling the trailer. To achieve the lockset position, the operating rod is pulled out with a slight upward motion. The operating rod shoulder will catch on the plate casting. The safety latch is rotated toward the rear of the fifth wheel.

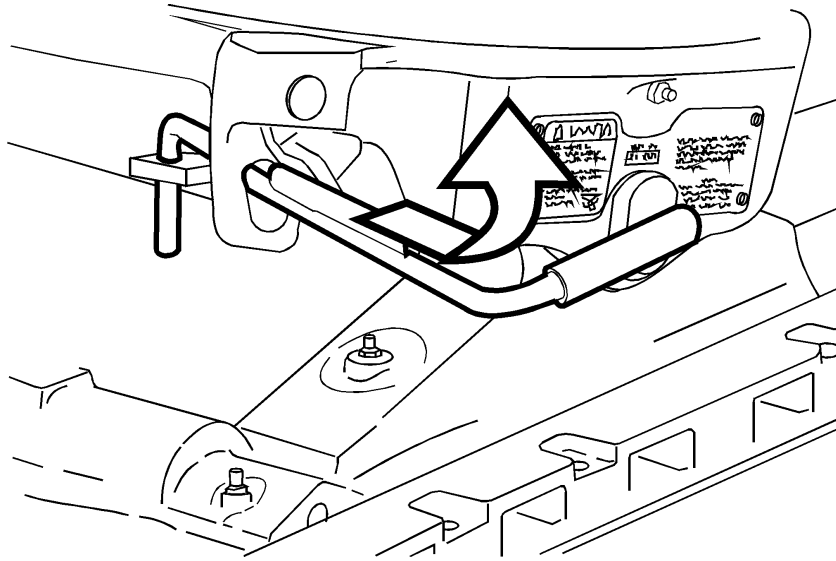

W9000242

Open — This is the position the fifth wheel is in after the trailer is uncoupled. The jaw is open and the operating rod is now dropped down and can be freely moved around. The safety latch is rotated toward the rear of the fifth wheel. This is the position the fifth wheel must be in when being coupled to a trailer.

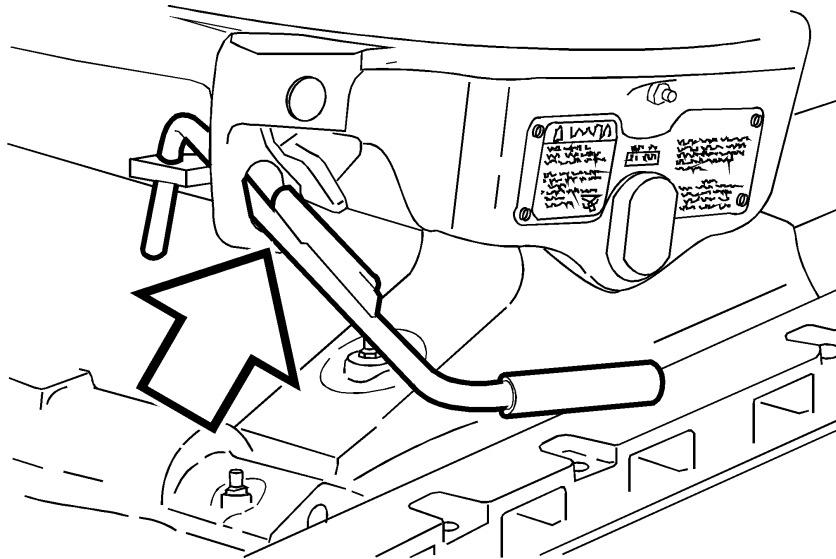

W9000203

316 OPERATION

Fifth Wheel Slider (Optional)

Open — This is the position the fifth wheel is in after the trailer is uncoupled. The jaw is open and the operating rod is now dropped down and can be freely moved around. The safety latch is rotated toward the rear of the fifth wheel. This is the position the fifth wheel must be in when being coupled to a trailer.

Fifth Wheel Slider (Optional)

The fifth wheel comes standard with an air operational slider. To remain within legal weight limits, this feature allows the driver to distribute the load easily on the axles. The air operated slider takes the work out of adjusting the tractor for various trailer loads. The fifth wheel portion is easily adjusted, even with a fully loaded trailer connected.

Movement between the adjustable saddle plate and the stationary base plate rail can result in wear, causing longitudinal, latitudinal and vertical slack. Field repairs can be made to reduce this slack for additional service life.

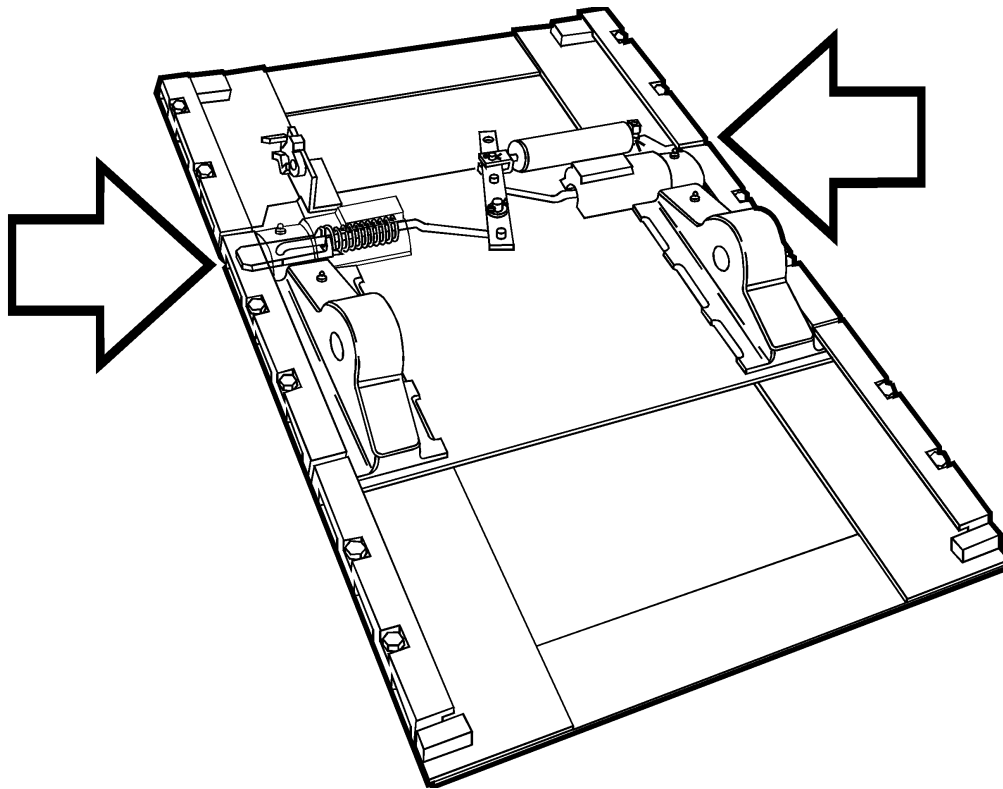

W9000205

Unlocking the Fifth Wheel

Always check out the entire fifth wheel before attempting to couple to a trailer (ASF fifth wheel is shown).

- If not lubricated properly, add grease to the top of the fifth wheel plate.
- Make sure the mounting of the fifth wheel to the frame is tight and in good condition.
- If using a sliding fifth wheel, make sure the slide locking plungers are in a locked position.

The following instructions are for preparing the fifth wheel for coupling to a trailer:
Rotate the safety latch toward the rear of the fifth wheel.

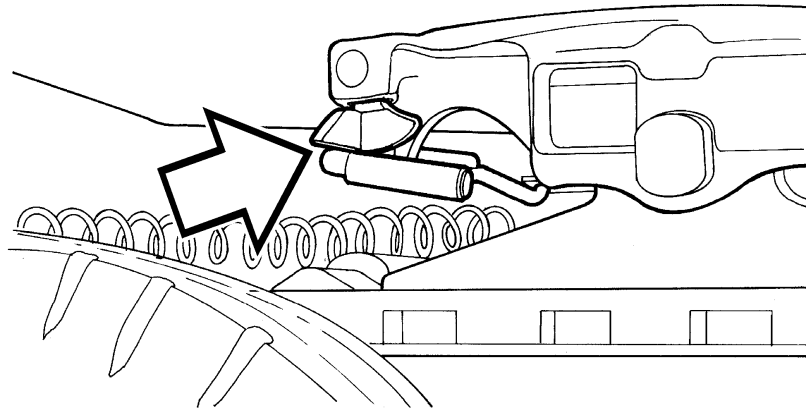

W9000180

318 OPERATION

Using a slight upward motion, pull the operating rod out until the operating rod shoulder is outside the fifth wheel operating slot.

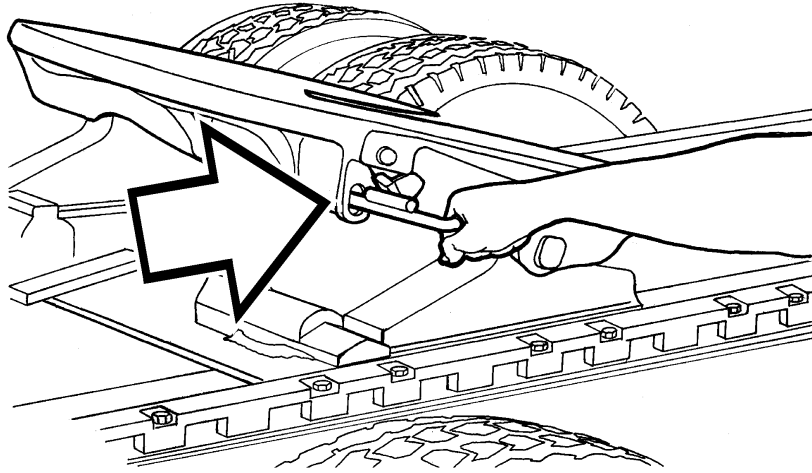

W9000202

When the shoulder of the operating rod is outside of the operating slot, raise the operating rod handle to its maximum upward position.

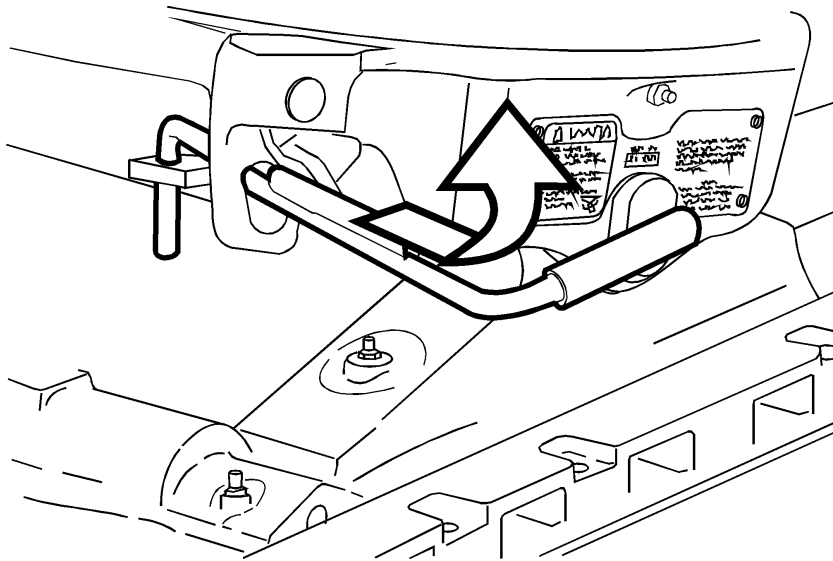

W9000242

Release the operating rod. The upper shoulder of the operating rod should now be in contact with the plate casting above the operating slot. The fifth wheel is now in the lockset position and a trailer can be coupled.

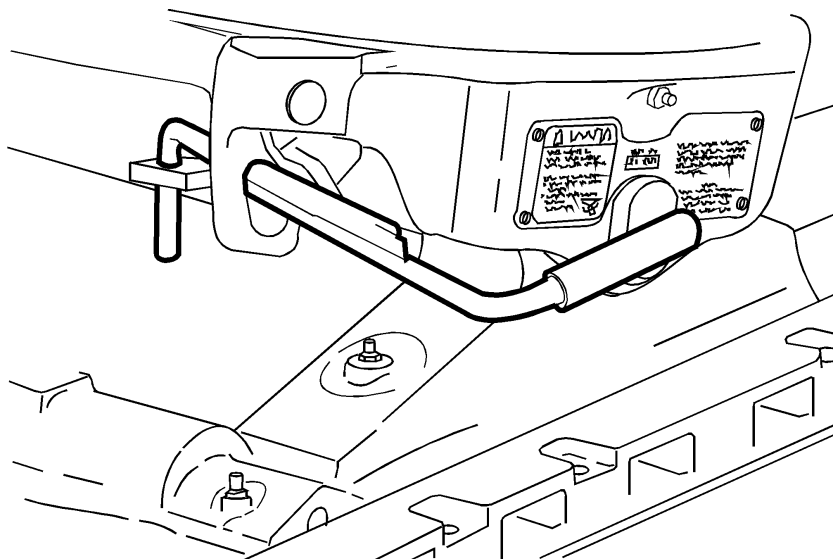

W9000274

Trailer Coupling Procedures

DANGER

It is important that the operating procedures contained in this manual are fully understood and closely followed. Failure to properly couple the tractor and trailer can result in their separation, causing death and property damage. Proper pick-up and coupling to a trailer is a serious matter. A trailer that becomes disconnected while in motion is extremely dangerous to other traffic and may result in death or severe personal injury. To ensure a positive hook-up or coupling, the procedures should be followed in every case.

This procedure covers vehicles with and without air suspension.

320 OPERATION

Using the following procedures, inspect the equipment before coupling to a trailer:
Make sure the fifth wheel is properly lubricated and the jaw is in the open position.

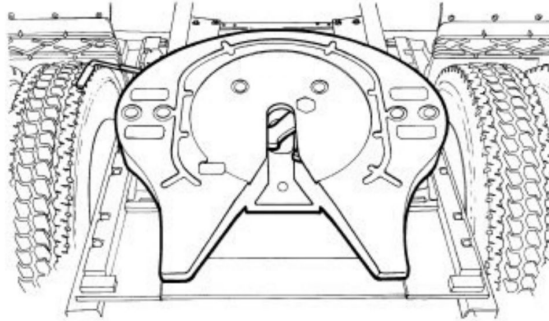

W9000659



WARNING

If the jaw is not in the open position, use a pry bar to rotate the jaw to the open position. The lock is spring loaded. Keep hands away to avoid injury.

Use a pry bar to open the fifth wheel jaw, if necessary.

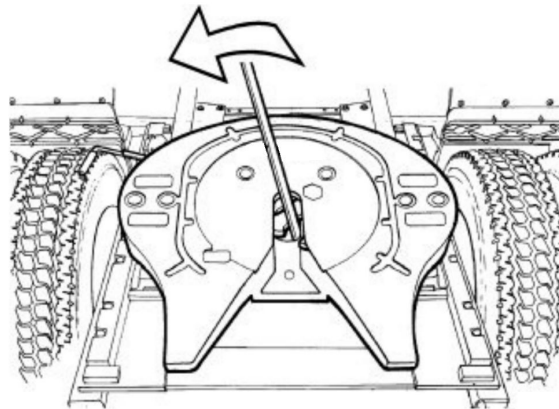

W9000660

Make sure the plate is tilted downward to the proper position at the rear.

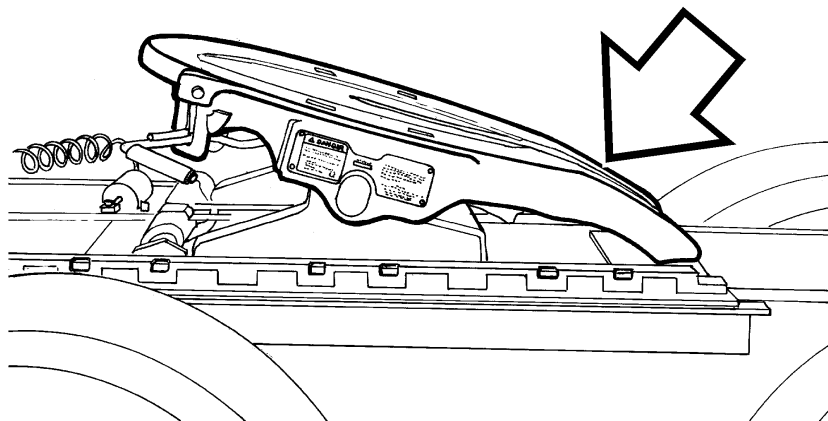

W9000236

Make sure the mounting of the fifth wheel to the tractor frame is tight and in good condition.

Make sure the plate is tilted downward to the proper position at the rear.

If using a sliding fifth wheel, make sure the slide locking plungers are fully engaged.

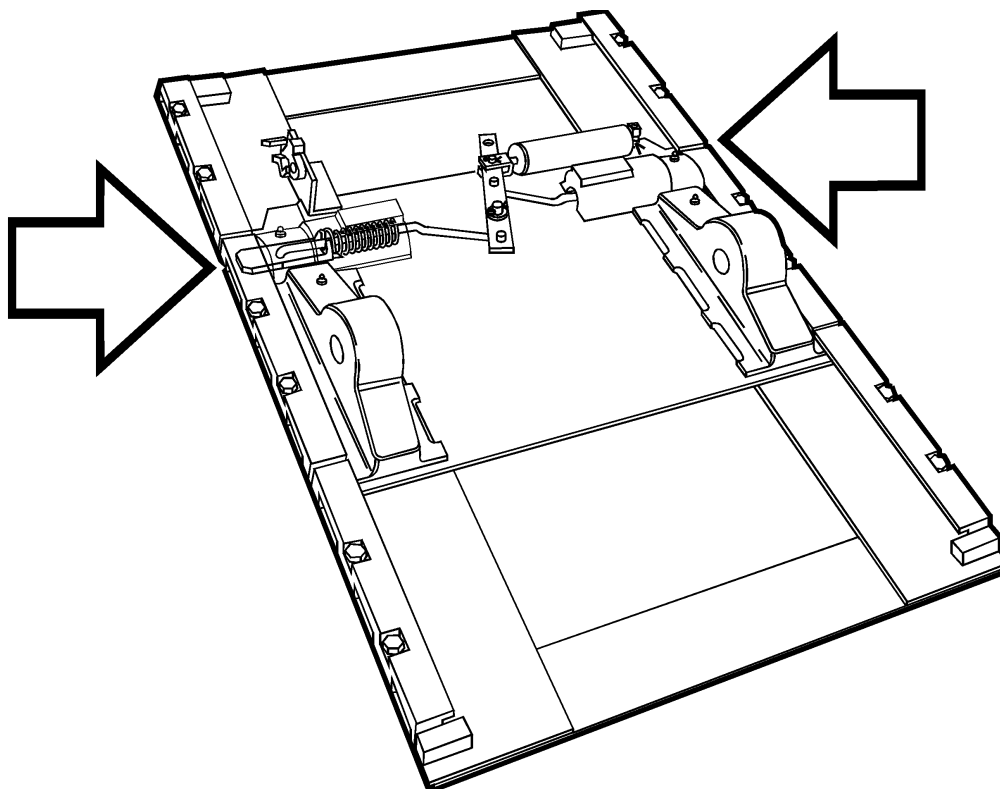

W9000205

322 OPERATION

Chock the trailer wheels. Use two chocks (both on the front and rear of the wheel) on both sides of the trailer.

Back up close to the trailer, centering the kingpin on the throat of the fifth wheel, and STOP.

Note: For tractors with air ride suspension, make sure the suspension control switch is in the "RIDE" position (switch pushed in at the top) and the air springs are inflated.

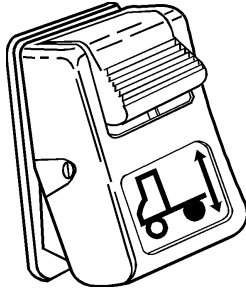

W3001341

Connect the air brake lines and the electrical power cord. Make sure that any slack in the lines is supported so that the brake lines do not become entangled. Set the trailer brakes by pulling out the Trailer Supply control on the dashboard.

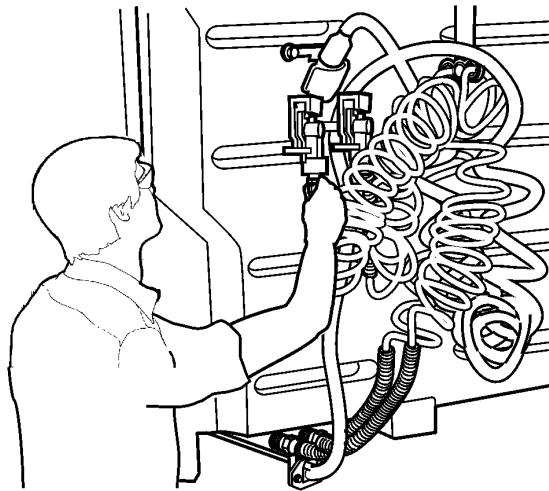

W3005321



CAUTION

Attempting to couple with the trailer at an improper height could result in a false or improper couple and cause damage to the tractor, fifth wheel and trailer.

Check to see that the trailer is at the proper height for coupling. The leading edge of the trailer plate should initially contact the fifth wheel top plate surface about 200 mm (8 in.) behind the pivot point as the tractor backs under the trailer. Raise or lower the trailer landing gear as required to obtain this position.

Back under the trailer, keep the trailer kingpin centered in the throat of the fifth wheel. After picking up the trailer — STOP — then continue backing until the fifth wheel locks firmly on the kingpin. Stopping helps prevent hitting the kingpin too hard.



DANGER

To ensure a positive hook-up or coupling, these procedures should be followed in every case. A trailer that is not connected correctly may disconnect from the tractor while in motion, resulting in an accident, personal injury or death.

324 OPERATION

As an initial check, pull forward to test the completeness of the coupling.

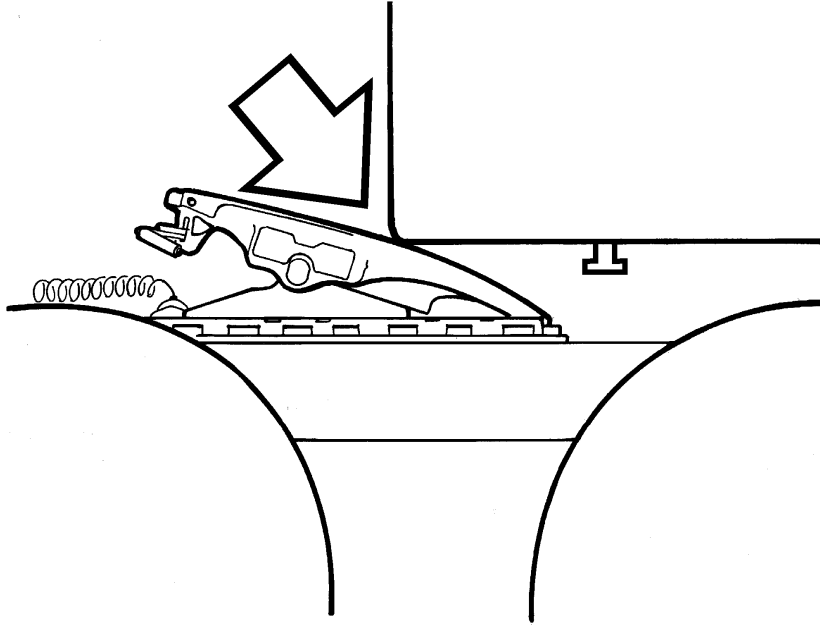

W9000237

A direct visual check is required to ensure proper coupling. Several types of improper couplings will pass the initial pull test. Sound is not reliable. Do not take for granted that you are properly coupled. Get out of the cab and look.

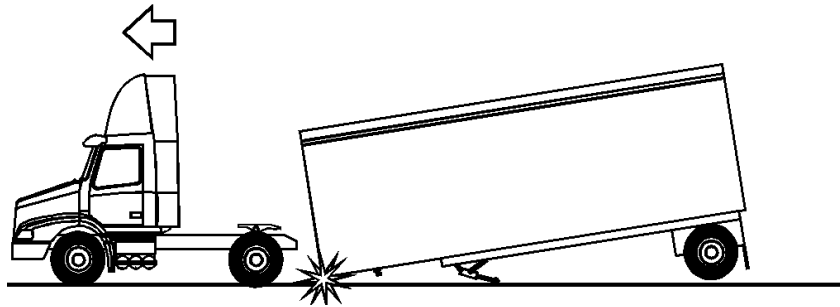

W9000286

Failed Trailer Coupling

Make sure the trailer kingpin is in the jaw slot and that the jaw is closed behind the pin. The kingpin should not overhang the fifth wheel or be caught in the grease groove. To verify that the kingpin is actually in the fifth wheel slot and the jaw is closed, the pin must be visually inspected from the rear. Use a flashlight if necessary.

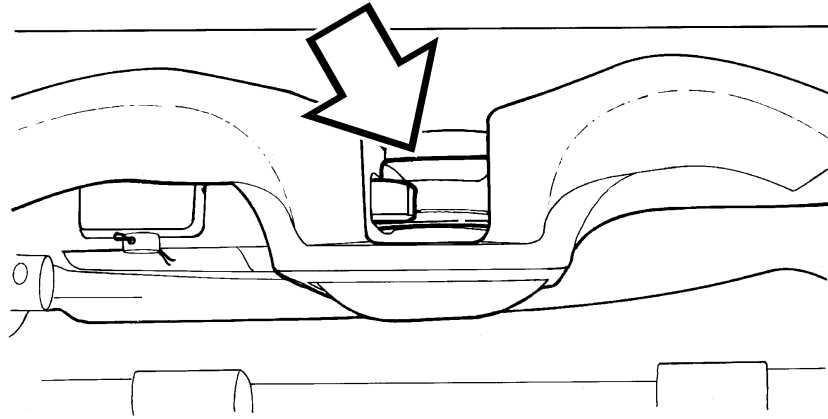

W9000181

Make sure the trailer bed is resting on the top surface of the fifth wheel plate, and that there is no visible gap between the fifth wheel and the trailer bed plate.

326 OPERATION

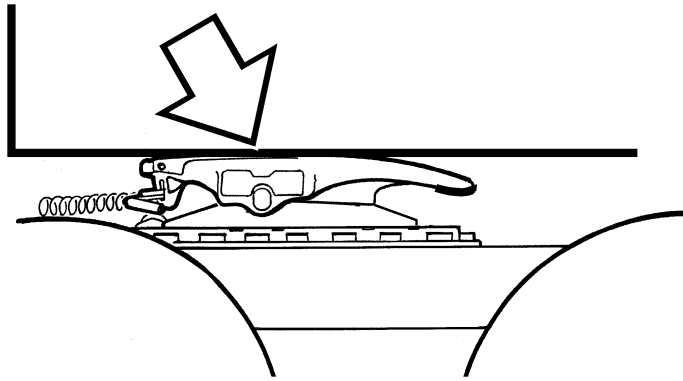

W9000240

Make sure the operating rod is fully retracted, the safety latch is positioned above the handle, and the latch swings freely.

If the fifth wheel is equipped with a manual secondary lock, check to see that it is properly engaged.

Note: If you cannot get a proper coupling, repeat this procedure. DO NOT use any fifth wheel which fails to operate properly.

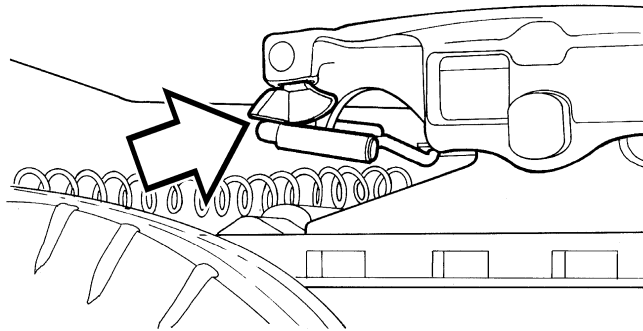

W9000180

Check the kingpin to fifth wheel clearance by moving the tractor backward and forward with the trailer brakes set. If the clearance appears excessive (more than 3 mm [1/8 in.]), or if the jaw does not lock, the fifth wheel should be inspected by a qualified technician before proceeding.

Wind up the trailer landing gear (trailer support) to its fully retracted position. Fold down or remove the crank handle and place it in the crank handle holder.

Check the air brake lines and the trailer light cord connections.

Remove the wheel chocks from the trailer wheels.

Trailer Uncoupling Procedures *For Tractors With Air Ride Suspension*

Set the system park brake on the tractor.

Set the trailer brakes by pulling out the trailer air supply knob.

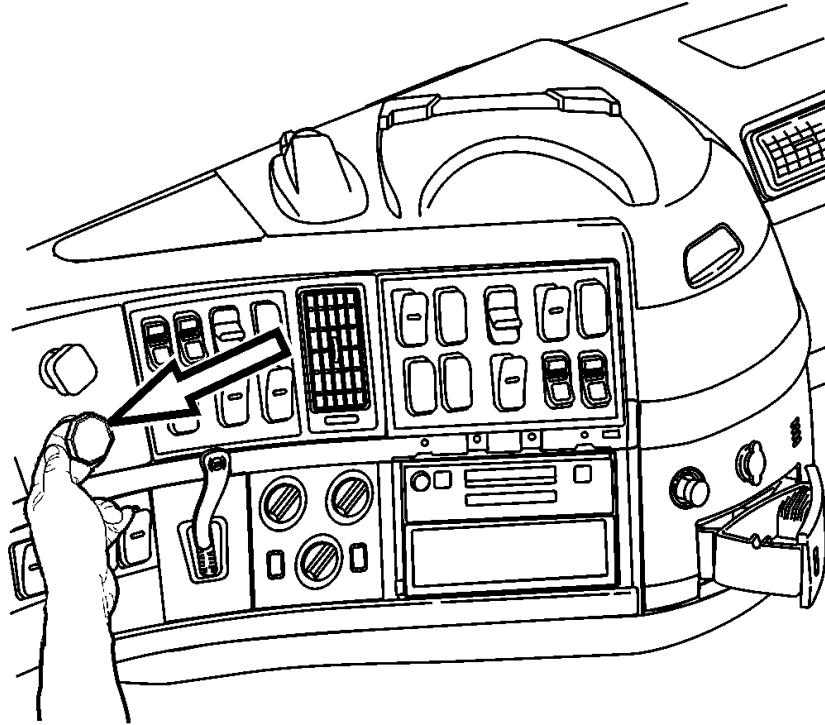

W5001433

Chock the trailer wheels. Use two chocks (one on the front and one on the rear of the wheel) on both sides of the trailer.

Wind down the landing gear until it touches the ground and then give it a few extra turns in low gear. Do not raise the trailer off of the fifth wheel. Fold down or remove the crank handle and place it in the crank handle holder.

Note: In poor ground conditions, it may be necessary to provide a stable base for the landing gear.

328 OPERATION

Disconnect the light cord and air brake lines. Use the dummy air couplings to keep foreign material from entering the brake lines.
Unlock the fifth wheel.

Note: If the operating rod is too difficult to pull, back the tractor up slightly to relieve any kingpin load against the fifth wheel jaw.

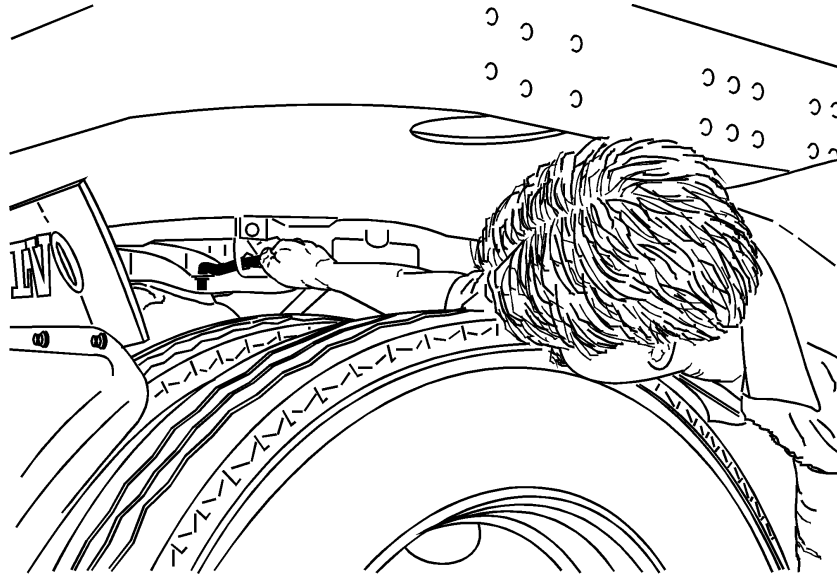

W9000275

Release the tractor park brakes and pull the tractor away from the kingpin about 300 mm (12 in.) and STOP. Do not allow the fifth wheel to leave the underside of the trailer.

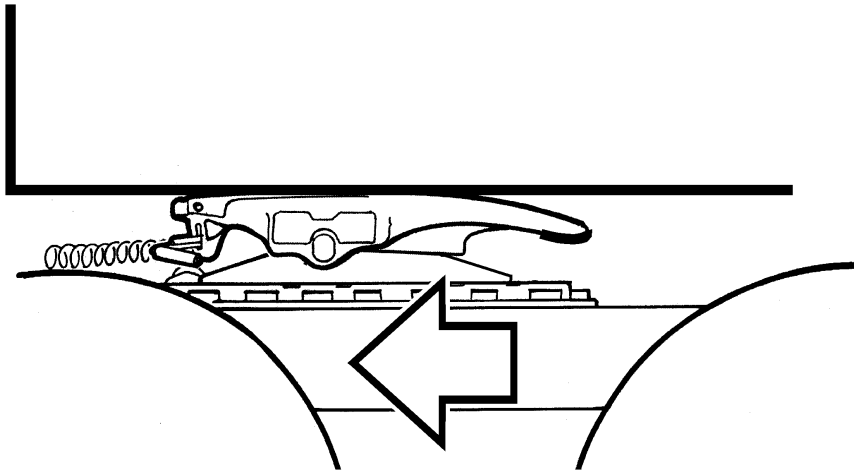

W9000239

Select the "UNCOUPLE" position (push down the latch and press in the bottom part of the switch) on the suspension control switch to deflate the air springs.

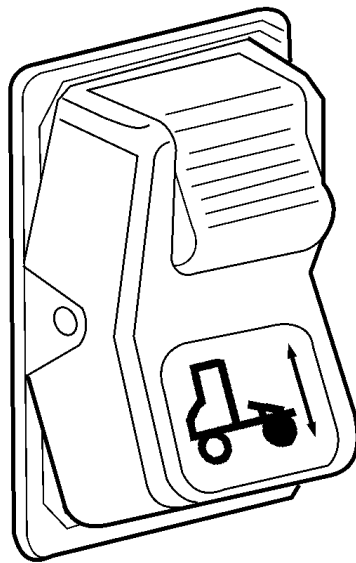

W3006386

330 OPERATION

Wait about 30 seconds for the air springs to deflate.

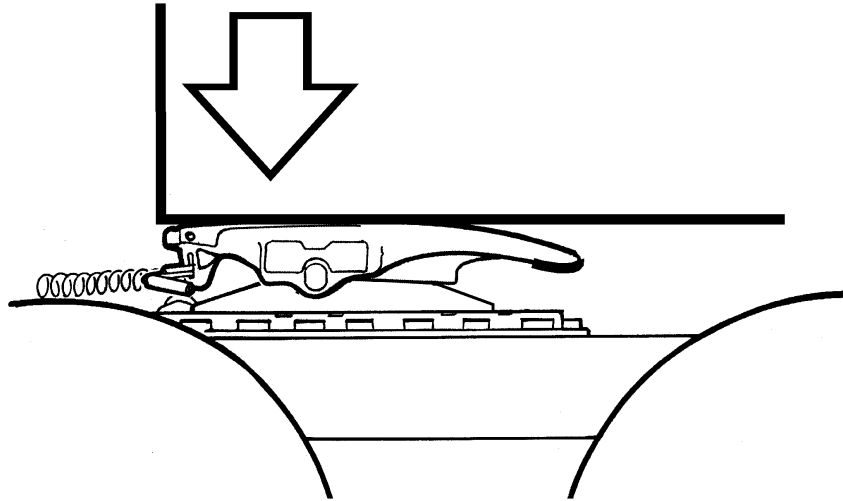

W9000238

With the suspension lowered, pull clear of the trailer and immediately select the "RIDE" position (press the top part of the switch in) on the suspension control. This restores the suspension to operating height.



CAUTION

The vehicle must never be driven with the air springs deflated. Damage to air suspension parts will occur if springs are not inflated properly.

After the trailer is uncoupled, the fifth wheel will be in the open position. The operating rod will drop and can be moved around freely.

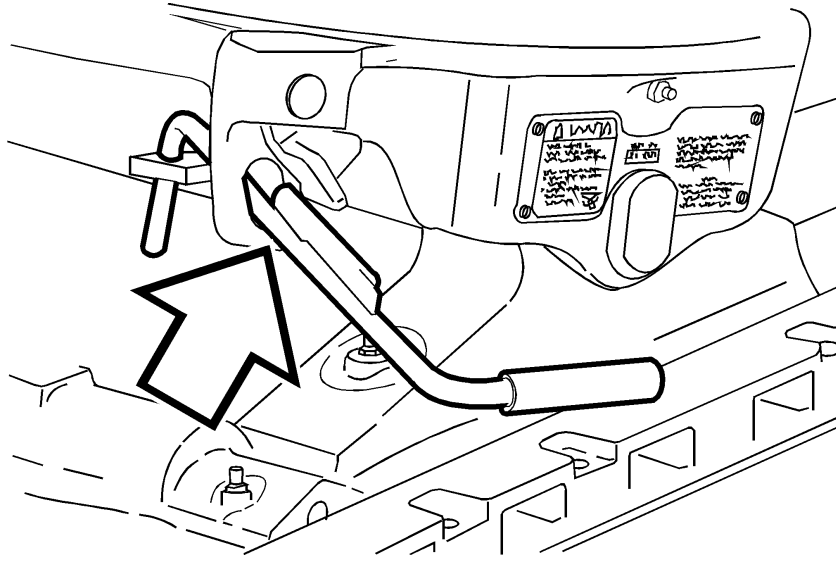

W9000203

Operating the Fifth Wheel Slider



CAUTION

The trailer must be stopped and the trailer brakes locked, or damage to the tractor and/or trailer may result from uncontrolled sliding of the fifth wheel.

Stop the tractor and trailer in a straight line on level ground.
Lock the trailer brakes by pulling out the Trailer Supply knob.
Release the slide locking plungers by moving the switch to the "UNLOCK" position (press down the latch and push in the bottom part of the switch).

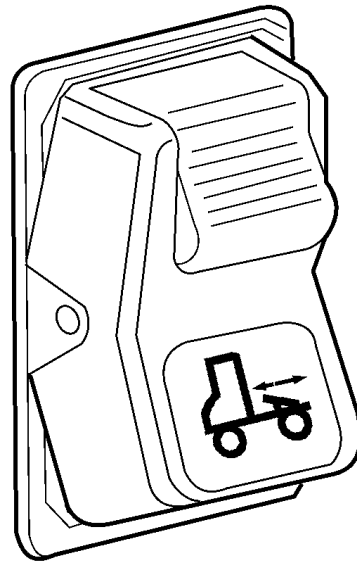

W3006383

Check to see that both of the slide plungers have released. If the plungers do not come out, lower the landing gear to relieve the pressure on the plungers. Lowering the landing gear will also allow the fifth wheel to slide easier.

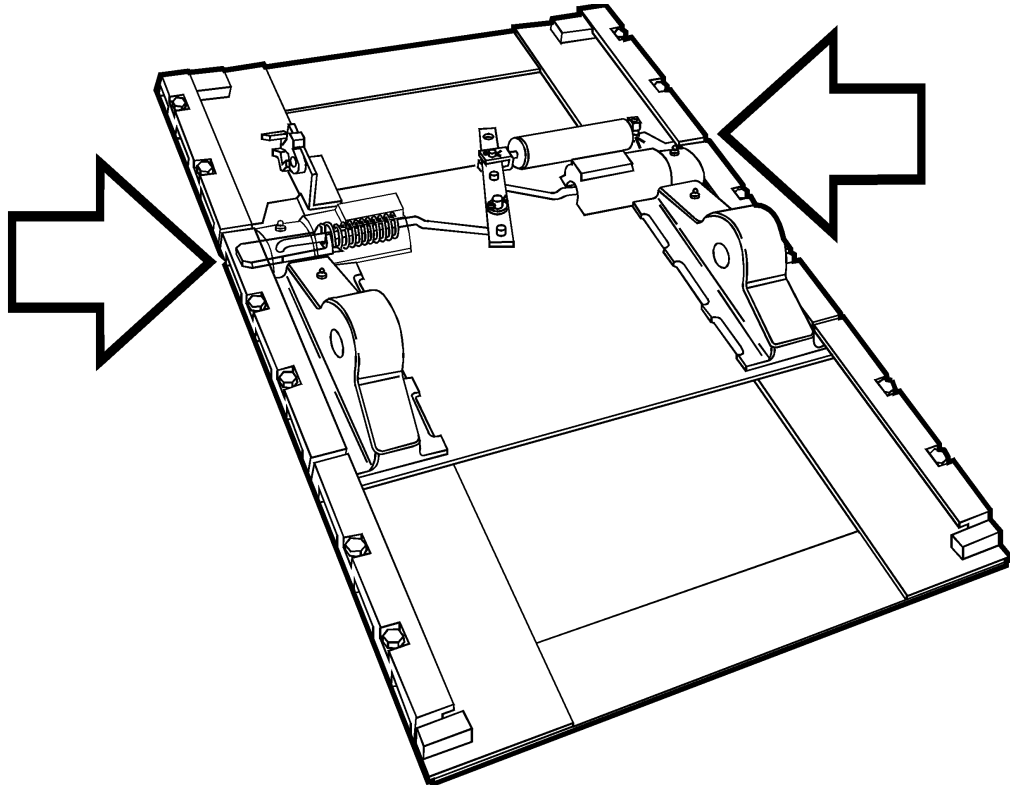

W9000205

Slowly drive the tractor forward or backward to position the fifth wheel.
After sliding the fifth wheel to the desired position, engage the slide locking plungers
by moving the cab switch to the "LOCK" position (press in the top part of the switch).

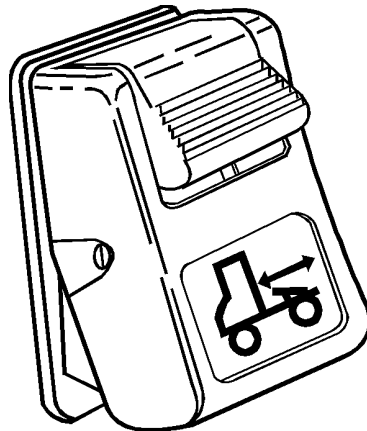

W3001346

334 OPERATION



CAUTION

DO NOT operate the vehicle if the plungers are not fully engaged and the trailer landing gear is not fully retracted. Doing so may cause damage to the tractor, trailer and landing gear.

Visually check to see that the slide plungers are fully engaged. It may be necessary to leave the trailer brakes locked and to move the tractor slightly to engage the slide plungers into the rail.

Wind up the trailer landing gear to its fully retracted position.

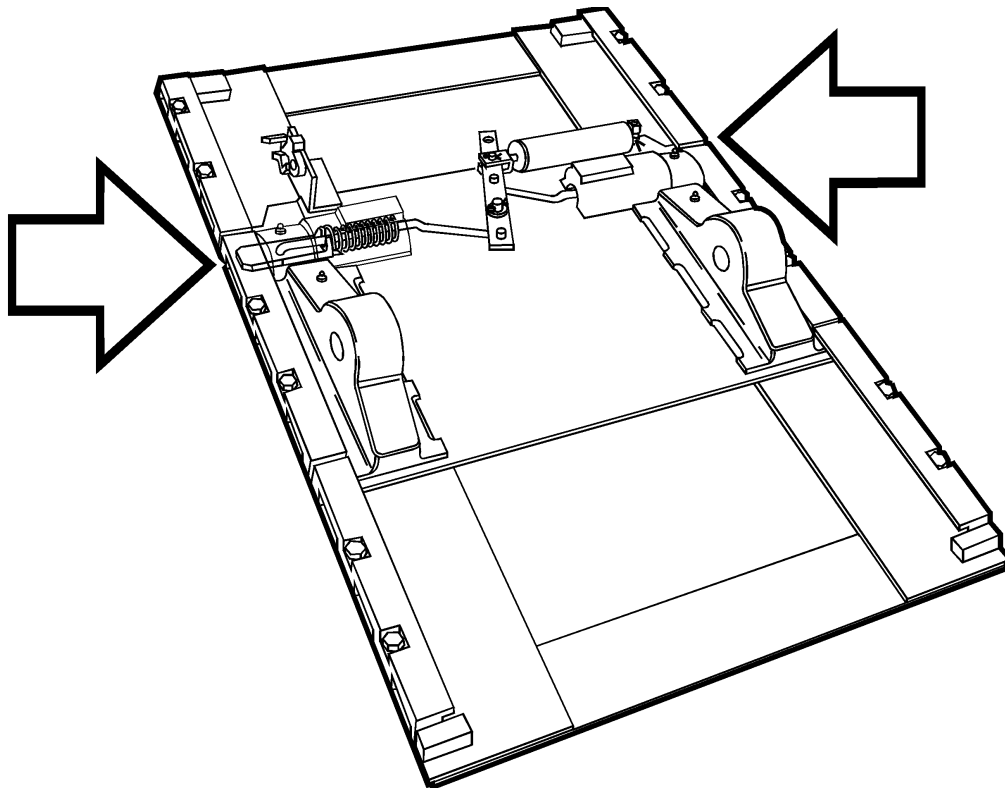

W9000205

Clutch

General

 **DANGER**

Before starting the engine, set the parking brakes and place the transmission in neutral. Failure to do so can result in unexpected vehicle movement and can cause serious personal injury and death.

DO NOT allow the clutch to slip excessively. This would cause excessive heat to be generated and the clutch will be damaged and bring on premature failure. As soon as the vehicle is moving, remove the foot from the pedal for complete clutch engagement. Once the clutch is fully engaged, heat and wear does not affect it. DO NOT shock load the drive line through rapid engagement of the clutch. Extreme care should be taken when driving heavy loads up hills. Always use the lowest gear when starting out under adverse conditions.

When operating a vehicle equipped with a clutch brake, the clutch pedal should not be depressed more than halfway to the floor while shifting, except when the vehicle is at a stop. To re-enter the low gear from neutral or reverse, or to enter reverse gear from neutral or low, the clutch should be depressed all the way to engage the clutch brake. This stops the rotation of the transmission input shaft and provides an easy, quiet gear engagement.

PERFORMANCE BONUS FEATURE

Description

- The Performance Bonus Feature is a tool used to promote driver efficiency.
- This feature rewards the driver with a higher Road Speed Limit (RSL) only if the performance targets set by the fleet management are achieved. Targets are set based upon fuel economy, idle time or a combination of both, or by the Sweet Spot Indicator.
- The reward of higher RSL increases driver productivity and income. It also promotes increased driver and fuel efficiency.

To obtain more information about the Performance Bonus Feature, contact your Volvo dealer.

Note: The Performance Bonus Feature is programmable (by your dealer) using VCADS Pro or VCADS Pro Elite.

Performance Bonus Status Reward



Driver reward is shown in the Driver Information Display screen (DID). Once the ignition is turned ON, the Performance Bonus status appears and remains on the screen for 15 seconds.

Note: Only priority 1 messages will temporarily close the rewards status menu. For additional information about the DID, refer to the Driver Information Display Manual.

		
Performance Bonus		
Bonus achieved		
Break in period		
Max speed 70		
\$\$	Sweet Spot% 66 % (80%)	11:45 AM
🏆 \$	7658.8 Mi	





Rolling Buffer

The "rolling buffer" is set to measure distance driven. The buffer may be set at a short or long distance. A short buffer results in a faster reward, (or loss of reward) which provides driving fuel economy training to the driver, permitting the driver easy memory of the input to the buffer during this short period of time. A long buffer setting allows for the daily activities to "smooth out". In this case the reward is based on weekly/monthly activity.

Fuel Data		4/9
 Fuel Economy 6.8 (7.2) mpg		
\$\$	Sweet Spot% 66 % (80%)	11:45 AM
 \$	7658.8 Mi	

W3028720

The DID will indicate the Performance Bonus status by showing the actual status and target within the parenthesis.

Fuel Data		6/9
  (7.2)	 (25)	\$\$ (80)
6.8	16	66
\$\$	Sweet Spot% 66 % (80%)	11:45 AM
 	7658.8 Mi	



W3028721

Performance Bonus Guide

Volvo Engines Only

The Performance Bonus Guide is an aid that provides comprehensive feedback to the driver about the optimum engine operating range during a trip. If adhered to, this results in improved fuel efficiency. Icons in the Driver Information Display (DID) guide drivers to the most efficient engine operating range for any given engine load and speed. This is referred to as the engine's "Sweet Spot".

The Performance Bonus Guide is inactive at low vehicle speeds. The engine is designed to allow the driver to stay within the Sweet Spot during most normal operating conditions. There may be situations where it is necessary to operate the engine outside the Sweet Spot, however, this will negatively affect fuel consumption.



Status Symbols	Meaning
<p style="text-align: center;">\$\$</p> <p style="text-align: center; font-size: small;">W3006755</p>	<p>Engine Operating in the Sweet Spot Mode. Fuel consumed in this mode will count 100% toward the Sweet Spot Percentage.</p>
<p style="text-align: center;">\$</p> <p style="text-align: center; font-size: small;">W3028749</p>	<p>Engine Operating in a less efficient area of the Sweet Spot Mode. Fuel consumed in this mode will count 50% toward the Sweet Spot Percentage.</p>
<p style="text-align: center;">RPM ▼</p> <p style="text-align: center; font-size: small;">W3006756</p>	<p>Decrease Engine Speed</p>
<p style="text-align: center;">RPM ▲</p> <p style="text-align: center; font-size: small;">W3006757</p>	<p>Increase Engine Speed</p>
<p style="text-align: center;"></p> <p style="text-align: center; font-size: small;">W3006758</p>	<p>Decrease Gas Pedal</p>
<p style="text-align: center;"></p> <p style="text-align: center; font-size: small;">W3006759</p>	<p>Increase Gas Pedal</p>
<p style="text-align: center;">\$\$</p> <p style="text-align: center; font-size: small;">W3006760</p>	<p>Engine Operating Outside Sweet Spot (No guidance)</p>

340 OPERATION

Symbol	Meaning
<p style="text-align: center;">\$\$</p> <p style="text-align: center; font-size: small;">W3006755</p>	<p>Performance Bonus Guide (shows Sweet Spot Percentage [Large Symbol])</p>

Driving Mode



The Sweet Spot Status icons are displayed at the bottom left of the DID screen. The Sweet Spot symbol is displayed at the top of the screen underneath Fuel Data. The Sweet Spot percentage page is displayed in the Fuel Data menu. The DID shows the screen with Sweet Spot Trip Data Percentage.

Fuel Data		7/9
<div style="display: flex; justify-content: space-between; align-items: center;"> <div style="font-size: 2em;">\$\$</div> <div> <p>Sweet Spot %</p> <p>50%</p> </div> </div>		
  <p>75°F</p>	<p>11:45</p> <p>AM</p>	
	<p>7658.8 Mi</p>	

W3028761

In the example shown, 50% means the engine has operated 50% of the driven distance, since the last trip data reset, within the engine's most efficient operating range.

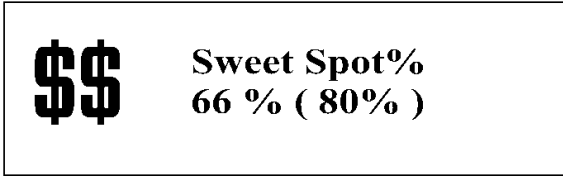
If **Performance Bonus** is enabled, and the Sweet Spot percentage target is a chosen condition, the DID also displays the Sweet Spot target percentage in parenthesis.

Fuel Data		8/9
		
 75°F		11:45 AM
		7658.8 Mi

W3028762

The Performance Bonus Guide is a standard feature for all Volvo engines on vehicles equipped with the mid or high level instrument cluster. Performance Bonus does not work with the basic instrument cluster.

Note: When Sweet Spot percentage is used as a chosen condition in Performance Bonus, the target percentage is programmable by Volvo.

Non-Driving Mode

If **Performance Bonus** is disabled, the Sweet Spot percentage data can be reset by resetting the vehicle trip information.

If **Performance Bonus** is enabled, and the Sweet Spot percentage target is chosen as a condition, the Sweet Spot data CANNOT be reset.

Total Data menu displays the percentage of distance the vehicle has spent in the Sweet Spot during the life of the vehicle.

For more information about this feature, contact your local Volvo Truck dealer.

AXLES

Differential Locks

 **DANGER**

DO NOT drive on dry, paved surface with the differential locks engaged. The vehicle will strive to maintain a straight line. Taking a curve with the differential locks engaged may cause an accident, leading to serious personal injury or death.

 **CAUTION**

Never operate the vehicle with the differentials locked any longer than is necessary, as this places a great strain on the axles and may cause rapid tire wear.

Under normal traction conditions, do not engage the differential locks. If at all possible, do not use the differential locks while taking a curve. With good traction and the differential locks engaged, the vehicle will be understeered and therefore will tend to drive straight in a curve. When using locks on good traction surface, drive cautiously and do not exceed 40 km/h (25 mph). Disengage the locks as soon as possible.

When the differential locks are disengaged, the couplings may be under tension. Disengage the locks by returning the switch to the OFF position. Help with the disengagement by briefly letting up on the accelerator to relieve the torque on the couplings.

The drive axle(s) may be equipped with differential locks. The single drive axle will only have a wheel differential lock. With tandem drive axles, there could be both wheel differential locks and an inter-axle differential lock.

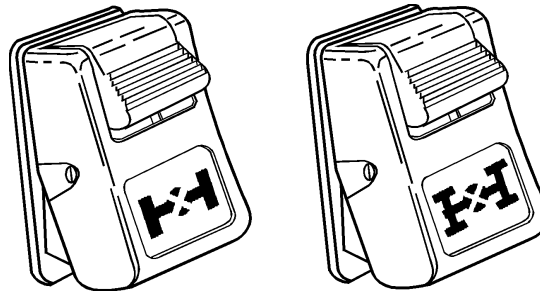

W3001991

The differential lock should be used on icy or slippery surfaces. As soon as the slippery surface has been passed, the differential lock should be disengaged. Differential locks must not, under any circumstances, be engaged when in a wheel-spin situation. Engage the locks ahead of the slippery area. If already slipping, stop the wheels, engage the locks and then continue. If the differential locks are engaged when the wheels are spinning, the differential will be damaged and the rear axle drive unit could possibly fail.

All efforts must be made to avoid spinning the wheels at high speeds on slippery surfaces. This is true whether the differential locks are engaged or not. Excessive wheel spin may result in failure of the cluster gears and other components found within the rear axle housing(s). If you are unable to obtain traction, engage the differential locks as described below. If you are still unable to move the truck, seek assistance from a qualified tow operator.

Engaging the differential locks must always be done as follows “PRE-TRIP INSPECTION AND DAILY MAINTENANCE”, page 192 for switch location):

- 1 Depress the clutch pedal. Wait for the drive wheels to stop spinning.
- 2 Engage the differential lock.
- 3 Engage a suitable gear.
- 4 Carefully release the clutch pedal.

344 OPERATION



CAUTION

DO NOT rely on gauges to determine axle pressure. Weight must be verified on scales, and pressure in the air springs should then be adjusted accordingly.

Regulators for adjusting the air spring pressure are located on the outside of the cab, below the rear corner of the driver side door. Regulators are operated by turning the knob counterclockwise for lowering pressure, and clockwise for increasing pressure.

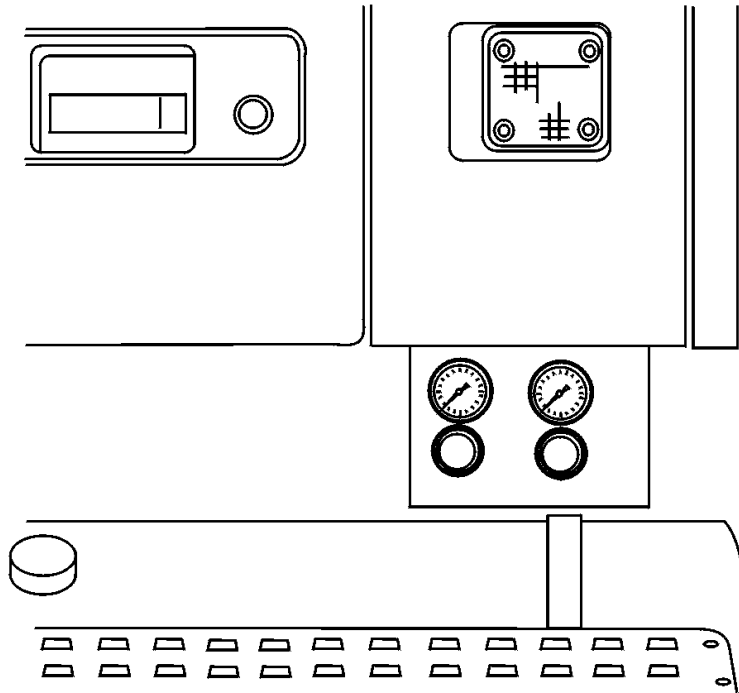

W7001173

Exhaust Aftertreatment System

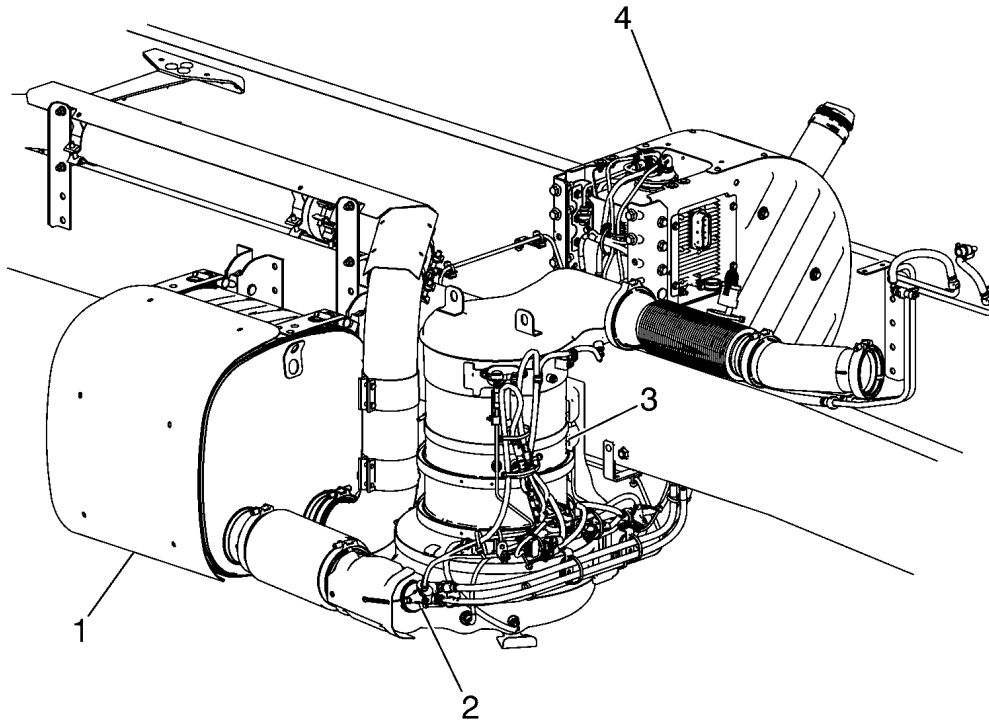

W2029933

1. Selective Catalytic Reduction (SCR) Catalyst
2. Aftertreatment DEF Dosing Unit
3. Aftertreatment Diesel Particulate Filter (DPF)
4. Aftertreatment DEF Tank

Safety Information

Volvo utilizes the use of a Diesel Particulate Filter (DPF) and Selective Catalytic Reduction (SCR) to meet EPA2010 emissions. The system is designed to require very little driver interface to maintain correct operation. The technology utilizes a passive regeneration; requiring no fuel to be injected to clean the DPF. In EPA2007 an active regeneration (fuel was injected) was required to clean out the DPF producing very high exhaust outlet temperatures. Certain vocational duty cycles will require the use of fuel and/or a parked regeneration to clean out built-up soot in the particulate filter. Exhaust temperature will increase during a parked regeneration. When parking the vehicle to perform a parked regeneration keep away from any flammable material, vapors or structures.

DANGER

Exhaust gases and components can be at extremely high temperatures during regeneration. When parking the vehicle, keep away from any flammable materials, vapors, or structures.

DANGER

The temperature of the exhaust system components during the regeneration process can exceed 350 degrees C (660 F). The exhaust gas leaving the system can reach 420 degrees C (788 F). Various factors (including ambient temperature and duration of the regeneration process) determine when these components will return to normal operating temperature after regeneration has completed. Be extremely careful around these hot components. Contact with these components can result in serious personal injury.

Exhaust Aftertreatment System Components and Operation

Selective Catalytic Reduction (SCR)

Selective Catalytic Reduction (SCR) is an emissions-reduction technology with the ability to deliver near-zero emissions of nitrogen oxides (NO_x), a smog-causing pollutant and greenhouse gas. SCR's performance has been proved in millions of miles of real-world truck operations in other countries, as well as in long-term field tests in the U.S.

SCR reduces NO_x emissions to very low levels, while at the same time delivering excellent fuel economy and reliability. The system doesn't change the design or operation of the basic engine. Rather, SCR is an Aftertreatment system which converts NO_x in the exhaust stream into harmless gases. Modern diesels already use exhaust Aftertreatment systems, called diesel particulate filters, to control emissions of another pollutant, soot (also known as particulate matter or PM).

SCR works by injecting Diesel Exhaust Fluid (DEF) into the exhaust. DEF is a solution of ultra-pure water and urea. DEF works with the heat of the exhaust and a catalyst to convert NO_x into nitrogen and water vapor - two harmless and natural components of the air we breathe. The end result is cleaner air, excellent fuel efficiency and a reliable emissions control system for today's modern diesel engine.

348 Volvo, US10 Emissions Solution

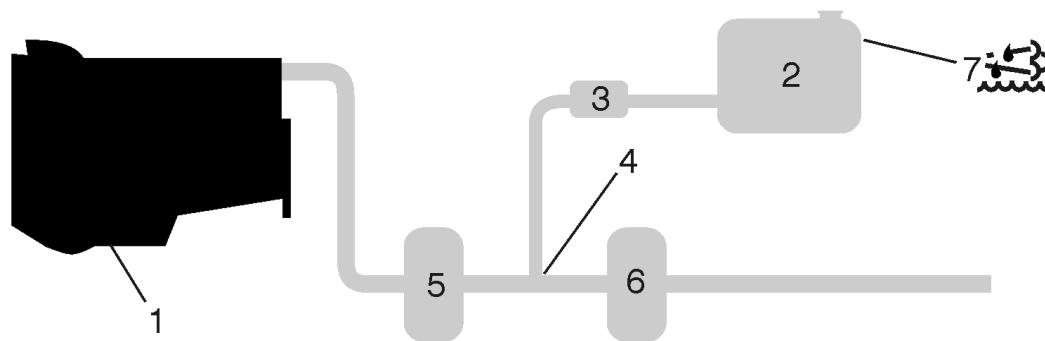

W2031651

1. Diesel Engine
2. Aftertreatment DEF Tank
3. Aftertreatment DEF Pump
4. Aftertreatment DEF Dosing Unit
5. Aftertreatment Diesel Particulate Filter (DPF)
6. Selective Catalytic Reduction (SCR) Catalyst
7. Aftertreatment DEF Tank Gauge

System Operation

- 1 Diesel engine optimized for high performance, low particle emissions and low fuel consumption.
- 2 Aftertreatment DEF tank
- 3 The Aftertreatment Control Module (ACM) continuously monitors and adjusts the Aftertreatment DEF pump pressure in response to current engine load conditions.
- 4 DEF is injected into the exhaust gases in between the Aftertreatment DPF (5) and the SCR catalyst (6).
- 5 Aftertreatment Diesel Particulate Filter (DPF).
- 6 In the SCR catalyst, nitrogen oxides are transformed into harmless nitrogen gas and water.
- 7 The system notifies the driver when it is time to refill tank with DEF.

The Volvo SCR system is simple and effective, with few components. It consists of a Aftertreatment DEF tank positioned near the standard diesel tank, plus a Aftertreatment DEF pump, Aftertreatment DEF Dosing unit and SCR catalyst. The advantage of using DEF is that it enables the engine to use less EGR -- and higher oxygen levels -- for better combustion, while meeting the EPA near-zero NO_x emissions requirement of 0.2 g/hp-hr NO_x. By using DEF, we avoid the disadvantages of increasing EGR to massive levels. This results in better fuel economy from your Volvo engine.



W2055491

Vertical SCR, vertical inlet

350 Volvo, US10 Emissions Solution

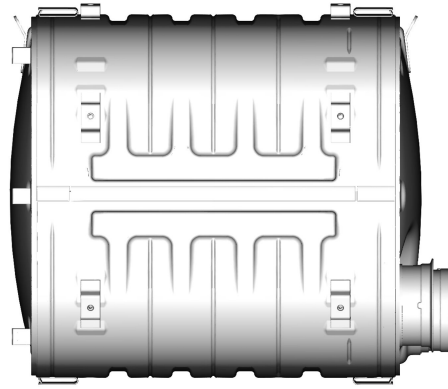

W2055492

Horizontal SCR, full size

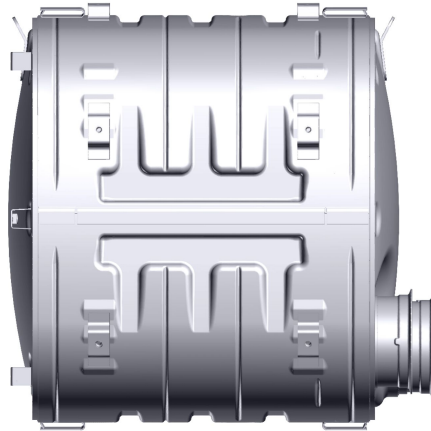

W2055493

Horizontal SCR, compact size



CAUTION

Do not put diesel fuel in the Aftertreatment DEF tank. Diesel fuel, if sprayed into the hot exhaust along with the DEF, could ignite explosively causing a fire resulting in personal injury or damage to the exhaust system.



W3036787

Diesel Exhaust Fluid (DEF)

Diesel Exhaust Fluid (DEF) is a reactant that's key to the SCR process. It's a nontoxic, aqueous solution of urea and ultra-pure water. Urea is a compound of nitrogen that turns to ammonia when heated. The fluid is non flammable, and is not dangerous when handled as recommended. However, it is highly corrosive to certain metals, especially copper and brass. Read the separate section concerning the handling of DEF solution. Use only **Diesel Exhaust Fluid** that is **clearly labeled as meeting ISO-22241** standards, and **certified by the American Petroleum Institute**. The container **must display the API certification seal**. **Never use agricultural or industrial grade urea**. Use of fluids other than API certified Diesel Exhaust Fluid will compromise aftertreatment system performance, increase emissions, and may impact your product warranties. **Never dilute DEF with water or any other fluid.**

It is recommended that DEF not be stored in extreme hot or cold conditions, or for prolonged periods. Follow the instructions for proper storage and handling as indicated on the container or provided with the purchase.

Note: Agriculture mixtures are not pure enough for use in the SCR system and impurities in the solution will compromise the SCR system.

Diesel Exhaust Fluid (DEF) Handling

When handling DEF solution, it is important that electrical connectors to be connected or well encapsulated, otherwise there is a risk that the DEF will cause oxidation that cannot be removed. Water or compressed air do not help, since DEF quickly oxidizes certain metal. If a disconnected connector comes into contact with the DEF solution it must be replaced immediately to prevent the DEF solution from creeping further into the copper wiring, which takes place at a speed of about 60 mm (2.4 in) per hour.

CAUTION

When detaching hoses and components, do not spill DEF on disconnected or unsealed connectors. If DEF is spilled on a disconnected or unsealed connector, the connector must be replaced immediately.

Things to know about spilled Diesel Exhaust Fluid (DEF)

If DEF solution comes into contact with the skin: rinse with plenty of water and remove contaminated clothing.

If DEF solution comes into contact with the eyes: rinse for several minutes and call for medical help if necessary.

If inhaled: breathe fresh air and call for medical help if necessary.

Do not allow the DEF solution to come into contact with other chemicals.

The DEF solution is not flammable. If the DEF solution is exposed to high temperatures, it breaks down into ammonia and carbon dioxide.

The DEF solution is highly corrosive to certain metals, including copper and brass.

If the DEF solution is spilled onto the vehicle, wipe off the excess and rinse with water. Spilled DEF solution can form concentrated white crystals on the vehicle. Rinse off these crystals with water.

Note: Do not flush DEF spillage into the normal drain system.

WARNING

DEF spilled onto hot components will quickly vaporize. Turn your face away!

Diesel Exhaust Fluid (DEF) Availability

DEF will be available in 2.5-gallon containers, 55-gallon drums, 275 gallon IBC and in bulk storage for fleet locations, truck stops and dealerships. All major truck stops, dealers and distributors will carry DEF.

DEF will freeze to a "slush" type consistency at -11 degrees C (12 F), but not to a solid, so just as with diesel fuel, stored DEF needs to be protected from extended periods of severe cold. For more information on DEF and availability please visit the website www.Volvoscr.com or call 1-800-52VOLVO.

Aftertreatment Diesel Particulate Filter (DPF)

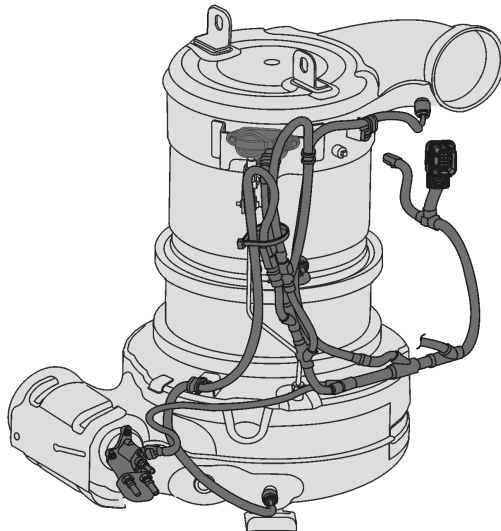

W2030326



CAUTION

Use of diesel fuel other than ULSD and engine oils other than EO-O Premium Plus (or VDS-4), will adversely affect performance, efficiency and durability of the Aftertreatment DPF system and the engine, to the point where the engine may not run at all. Manufacturer's warranties can also be rendered void due to usage of improper fuel. Unapproved fuel additives (including engine oil) are NOT permitted. Blends of No. 1D and No. 2D grades of ULSD are recommended and allowable for cold weather operations.

The exhaust Aftertreatment system virtually eliminates exhaust smoke. White Exhaust vapor (water condensation) may be visible during a cold start. If black exhaust smoke is visible during engine operation, this indicates a problem with the exhaust Aftertreatment system. Take the vehicle to an authorized Volvo Truck dealer immediately.

Vehicles equipped with a 2010 emission compliant engine have an exhaust Aftertreatment system which includes a Selective Catalytic Reduction (SCR) system and a Catalyzed Aftertreatment Diesel Particulate Filter (DPF). The Aftertreatment DPF takes the place of the standard muffler, and it reduces soot and particulate emissions into the atmosphere. Soot and other particulate matter are collected by a filter where it is eventually oxidized. Vehicles equipped with a Aftertreatment DPF require the use of EO-O Premium Plus (or VDS-4) specification high performance diesel engine oil and Ultra Low Sulfur Diesel (ULSD) fuel.

Aftertreatment Control Module (ACM)

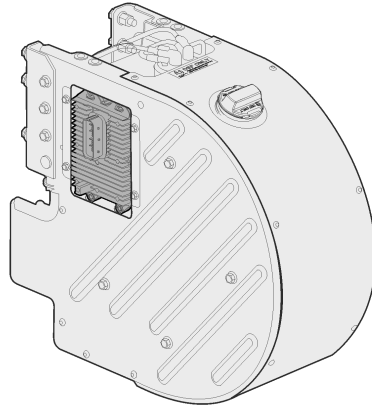

W2029917

The ACM controls the following components in the exhaust Aftertreatment system:

- Aftertreatment DEF Dosing Unit
- Aftertreatment DEF Tank Heater Valve
- Aftertreatment DEF Line Heaters
- Aftertreatment DEF Pump
- Aftertreatment DEF Return Valve
- Aftertreatment DEF Tank Level Sensor

The ACM also monitors the following values in the exhaust Aftertreatment system:

- Aftertreatment DEF Dosing Absolute Pressure
- Aftertreatment DEF Tank Temperature
- Aftertreatment DEF Tank Level
- Aftertreatment DPF Inlet/Outlet Temperature
- Aftertreatment DPF Differential Pressure
- NOX Sensors

The ACM is a stand alone module. Depending on your configuration it may be mounted as part of the DEF tank (as shown above) or on a bracket near the DEF tank.

Exhaust Aftertreatment System Operation

The stalk switch control lever is used to interact with the Driver Information Display (DID) in the center of the instrument cluster. The lever is located on the right-hand side of the steering wheel.

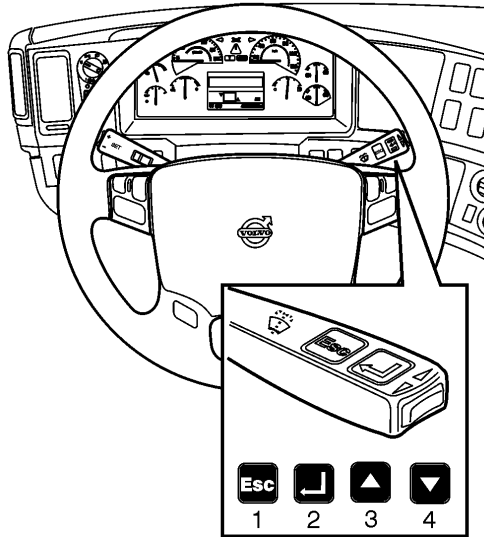

W3005262

- 1 **Esc** or Escape button is used to return to the previous menu or display.
- 2 ↵ or Enter button is used to display a list of menus, open a menu, and select the highlighted area.
- 3 **Up** arrow button is used to scroll up through a menu.
- 4 **Down** arrow button is used to scroll down through a menu.

358 Volvo, US10 Emissions Solution

Aftertreatment Menu

- 1 The Aftertreatment system menu is in the DID. Press the **Esc** button to display the main menus in the DID.
- 2 Use the up and down buttons on the stalk switch to scroll to the Aftertreatment menu.
- 3 Press the ↵ button to select the Aftertreatment menu.

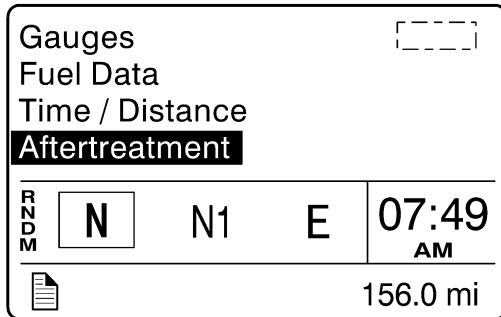

W3007527

The Aftertreatment menu has two submenus: Request Parked REGEN and ATS status.

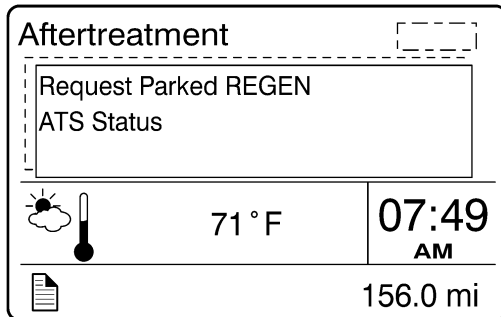

W3054903

Aftertreatment DPF Regeneration

 **CAUTION**

During the Parked Regeneration, the exhaust gas temperature will be elevated. DO NOT park the vehicle with the exhaust outlet near flammable objects such as trees, awnings, etc. that could be damaged by elevated exhaust gas temperatures.

 **CAUTION**

If the vehicle is PARKED in a location that may be hazardous when a parked Regeneration begins (i.e., in close proximity to flammable materials or gases, inside tunnels, parked under flammable objects, etc.), the Aftertreatment DPF Regeneration should be stopped. If Regeneration is stopped by the vehicle operator, it must be initiated at a later time when the vehicle is in a safer location. Regeneration that are stopped and never restarted at a later time, however, will require that the vehicle be taken to an authorized Volvo Truck dealer to have the Aftertreatment parked Regeneration manually started with special service tools.

Note: If passive Regeneration occurs during vehicle operation, idle speed may increase when the vehicle is stopped at a traffic light to maintain proper Regeneration conditions.

360 Volvo, US10 Emissions Solution

There are two types of Aftertreatment DPF Regeneration: Passive regeneration and Parked regeneration.

Passive Regeneration occurs when the exhaust gas within the aftertreatment system is hot enough to burn soot without injecting additional fuel into the DPF system.

On chassis equipped with a US07 aftertreatment system, DPF's needed an active regeneration, that includes this injection of fuel. With the addition of the SCR system active regenerations are no longer needed in US10.

Parked regeneration is initiated manually by the driver when alerted by the dash.

The vehicle must be stationary to begin the regeneration, and remain stationary to complete.

The Aftertreatment DPF Regeneration system is self-monitoring. Under certain duty cycles driver action is needed to perform a parked regeneration. When driver action is needed to perform a parked regeneration the Aftertreatment DPF Regeneration Needed icon on the instrument cluster flashes and the message "Parked REGEN Needed" is displayed. Initiate a parked Aftertreatment DPF regeneration at the next stop.

The Aftertreatment DPF Regeneration system is self-monitoring. When the Aftertreatment Diesel Particulate Filter is becoming full and Aftertreatment DPF regeneration is needed, the Aftertreatment DPF Regeneration Needed icon on the instrument cluster illuminates and the message "Parked REGEN Needed" is displayed. To return to the main menu, press the **Esc** button on the stalk switch.

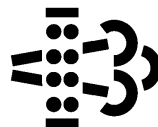

W3007445

Aftertreatment DPF Regeneration Required Icon



W3055322

Parked REGEN Needed

To return to the main menu, press the **Esc** button on the stalk switch.

362 Volvo, US10 Emissions Solution

If the vehicle has not had a parked REGEN completed after the “Parked REGEN Needed” screen displays the vehicle must be stopped. Perform the parked REGEN now. The vehicle will also be in Engine Derate.

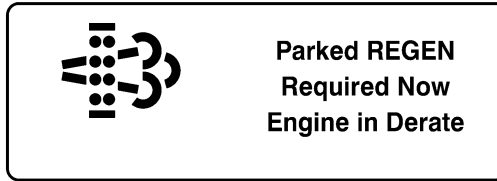

W3055326

Parked REGEN Required Now Engine in Derate

If the vehicle is driven when the “Soot Level High” screen displays. The REGEN is needed immediately.



W3055332

Soot Level High

Volvo, US10 Emissions Solution 363

If a parked REGEN is not done when the "Soot Level High" displays the "Soot Level Critically High" screen displays.



W3055333

Soot Level Critically High

When the ATS Service DID and the Stop Light illuminates screen displays stop the vehicle immediately and perform a Parked Regen. If that Parked Regen doesn't work take the vehicle immediately to a service center for ATS.

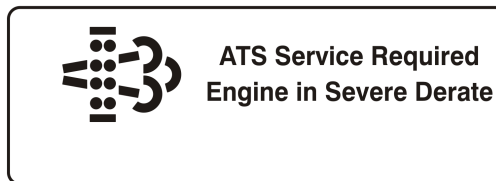

W3055405

ATS Service Required



W3005171

The High Exhaust System Temperature (HEST) Icon comes on when the vehicle temperature becomes excessive. The Icon also comes on during the REGEN.



W3007444

High Exhaust System Temperature (HEST) Icon

Note: It is important to perform a Regeneration when required to avoid engine problems. Long-term engine operation with Aftertreatment DPF Regeneration Required screen displayed may result in a loss of engine performance, reduced horsepower, torque and speed, and temperature derate. Also, the Aftertreatment DPF may become overloaded with soot and require service at a authorized VOLVO dealer.

Aftertreatment DPF Regeneration Required cannot be initiated if it is not required. The following conditions must be met for parked Regeneration:

- Parking brake on and transmission in neutral
- Minimum 10 volts battery charge
- Engine running
- Accelerator and clutch pedal released
- PTO not active
- Parked Aftertreatment Regeneration required, message displayed

Volvo, US10 Emissions Solution 365

If the conditions are not met and a parked REGEN is attempted the “Parked REGEN Conditions Not Met Check Menu Status” screen displays.



W3055181

Parked REGEN Conditions Not Met

Scroll to the Aftertreatment menu in the Driver information Display (DID) and select “ATS Status” to determine why the Regeneration did not initiate.

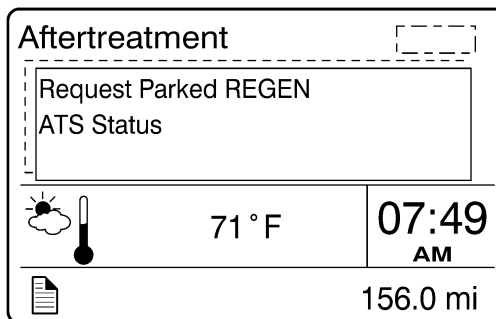

W3054903

366 Volvo, US10 Emissions Solution

If the Aftertreatment DPF Regeneration Required icon is flashing, the Aftertreatment Diesel Particulate Filter is over full. Maintain uninterrupted highway speed for a passive Aftertreatment DPF Regeneration Required or move the vehicle to a safe location and initiate a parked Aftertreatment DPF Regeneration.

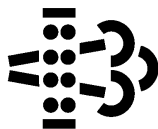

W3007445

Aftertreatment DPF Regeneration Required Icon

If the Aftertreatment DPF Regeneration Required icon is flashing and the CHECK light illuminates, the Aftertreatment Diesel Particulate Filter is critically full. Engine performance will be limited. To avoid further engine derate, immediately move the vehicle to a safe location and initiate a parked Aftertreatment DPF Regeneration , or take the vehicle to an authorized Volvo Truck dealer.



W3005170









If the Aftertreatment DPF Regeneration Required icon is flashing and the STOP light illuminates, a serious engine problem has occurred. The Aftertreatment Diesel Particulate Filter may be over its maximum capacity and the engine may shut down. The vehicle must be taken immediately to an authorized Volvo Truck dealer for service.



W3005171

Refer to the Exhaust Aftertreatment System Information sun visor label for additional Aftertreatment DPF information.

ENGINE EXHAUST AFTERTREATMENT SYSTEMS (EATS)

DEF Indicators:			
	 (solid)	 (flashing)	 (flashing)+ Message
Diesel Exhaust Fluid (DEF) Condition:	The DEF tank is low.	The DEF tank is empty. Engine is in derate mode.	The DEF tank is empty. The vehicle is limited to 5 mph.
DEF Action:	Refill the DEF tank.	Refill the DEF tank now (before adding diesel).	Refill the DEF tank now (before operating vehicle).
DEF Indicators:			
	 (flashing)	 (flashing) 	 (flashing) 
Diesel Particulate Filter (DPF) Condition:	The DPF filter is full.	The DPF filter is overfull. Engine is in derate mode.	The DPF filter may be clogged with soot. Engine is in shutdown mode.
DPF Action:	Initiate a parked regeneration at next available stop.	IMMEDIATELY stop and initiate a parked regeneration.	Service EATS system immediately.
See Operator's Manual for Further Detail			

W8056652

Exhaust Aftertreatment System (ATS) Status

The ATS status submenus provide information about the conditions required for performing a parked DPF Regeneration.

The status can be OK (regeneration allowed), Check (regeneration not allowed) or N/A (not applicable). When ATS Status is selected, the following submenus are available.

To perform a parked Regeneration, the clutch pedal must not be depressed, the service brake must not be engaged and a PTO must not be engaged or the PTO must be able to operate above the minimum engine speed required.

Clutch	OK	▲
Service Brake	OK	
PTO Status	OK	▼

W3054893

368 Volvo, US10 Emissions Solution

To perform a parked Regeneration, the accelerator pedal (AP) must not be depressed, the transmission must be in the neutral position and the vehicle speed must not be zero.

Acc Pedal	OK	▲
Neutral	OK	
Vehicle Speed Above	OK	▼

W3054889

To perform a parked Regeneration, the park brake must be engaged and there can be no active Diagnostic Trouble Codes (DTC) codes.

Park Brake	OK	▲
System Fault	OK	
System Timeout	OK	▼

W3054886

Temporary lockout prevents performing a parked DPF Regeneration when it is not needed. Permanent lockout prevents performing a parked Regeneration when a condition exists that requires vehicle service. Take the vehicle to a Volvo Truck dealer. A minimum engine temperature (ECT) of 35°C (95°F) is required for parked DPF Regeneration.

Temporary Lockout	OK	▲
Permanent Lockout	OK	
Engine Temp	OK	▼

W3054884

When Disable REGEN is selected in the Cancel REGEN submenu, regeneration is inhibited. Select REGEN to allow Aftertreatment DPF Regeneration.

Exhaust Temp	OK	▲
Vehicle Speed Below	OK	
Inhibit Switch	OK	▼

W3054900

Driver Warnings and On Board Diagnostics (OBD)

On Board Diagnostics (OBD)

Beginning with your US 2010 compliant Vehicle, On Board Diagnostics (OBD) is introduced. This is very similar to the On Board Diagnostics (OBD) system that has been required on passenger cars for many years.

On Board Diagnostics (OBD) is a system that monitors the functions of emissions related components and alert

the vehicle operator to any detected need for an emission related repair. When the systems detects a needed repair to an emissions related component it activates the Malfunction Indicator Lamp (MIL).

The list of emissions related components can be found in the Warranty and Maintenance section of this manual.

Instrument Cluster

The Aftertreatment icons are located in the lower left corner of the instrument cluster.

applies to Volvo vehicles equipped with a Volvo or Cummins engine.

Note: The following exhaust Aftertreatment system information

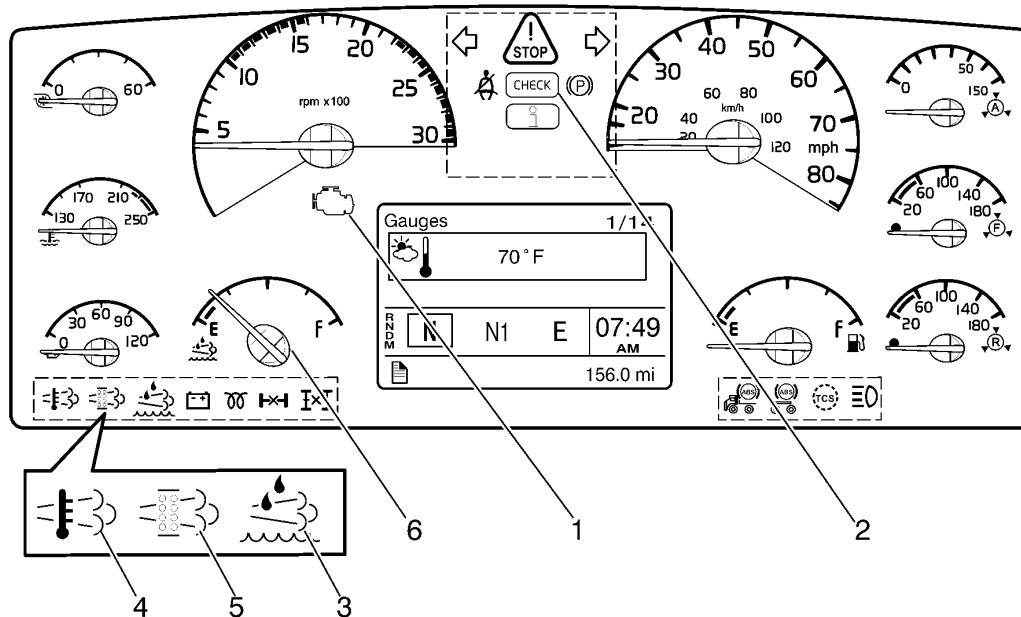

W3031645

1. Malfunction Indicator Lamp (MIL)	2. CHECK Lamp	3. Aftertreatment DEF Low Lamp
4. High Exhaust Temperature (HEST) Lamp	5. Aftertreatment DPF Regeneration Required Lamp	6. Aftertreatment DEF Tank Gauge

Instrument Cluster Icons

Aftertreatment icons are displayed on the instrument cluster. There are three Aftertreatment icons:

- Parked Aftertreatment DPF Regeneration Required
- High Exhaust System Temperature (HEST)
- Aftertreatment DEF Tank Low Level Indicator

The Aftertreatment DPF Regeneration Required icon flashes when the Diesel Particulate Filter is full or overfull and regeneration is needed..

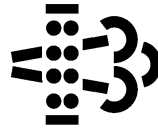

W3007445

Aftertreatment DPF Regeneration Required Icon

The High Exhaust System Temperature icon illuminates when a parked Regeneration is initiated. It also indicates high exhaust gas temperature during a passive regeneration. When the HEST icon is illuminated, do not park or operate the vehicle near people, or any flammable materials, vapors, or structures.



W3007444

High Exhaust System Temperature (HEST) Icon

372 Volvo, US10 Emissions Solution

The Aftertreatment DEF Tank Low Level Indicator icon illuminates when the fluid level is low. It also Flashes when the level becomes critically low.



W2029416

Aftertreatment DEF Tank Low Level Indicator (DEF)

Malfunction Indicator Lamp (MIL)

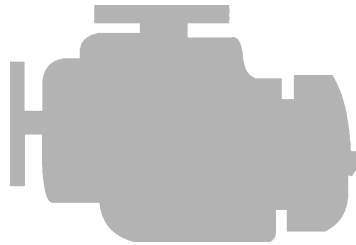

W3031200



MIL Lamp

- MIL indicates government Regulation On Board Diagnostics (OBD) faults
- Lamp may remain active after repair until system operation confirms repair

Aftertreatment DEF Tank Level - Driver Warning & Inducement

Aftertreatment DEF tanks are sized to have no less than two times the diesel fuel tank mileage or hour range





The vehicle instrument cluster has a Aftertreatment DEF Tank Level Gauge

Triggers	Aftertreatment DEF Tank Low Level Indicator	Amber Warning Lamp	Inducement
>12% Aftertreatment DEF Tank Level Gauge (>16% DEF Remaining)	None	None	None
<=12% Aftertreatment DEF Tank Level Gauge (~16% DEF Remaining)	 W2029416	None	None
0% Aftertreatment DEF Tank Level Gauge (~4% DEF Remaining)	 W2029415	None	25% torque reduction
0%Aftertreatment DEF Tank Gauge Insufficient DEF Pump Pressure Diesel Fuel Refueling >15%	 W2029415	None	8 km/h (5 mph) Road Speed Limit (RSL) ¹

¹ Vehicle has to be stationary before 8 km/h (5 mph) RSL becomes Active

Note: "Repeated acts of tampering will result in more severe Inducement."

Aftertreatment DEF Quality - Driver Warning & Inducement

Triggers	Aftertreatment DEF Tank Low Level Indicator	Amber Warning Lamp	Inducement
Good DEF Quality	None	None	None
Poor DEF Quality DTC Initial Detected	None	 <small>W2029417</small>	None
Poor DEF Quality DTC Initial Detected + 10 hours	None	 <small>W2029417</small>	25% torque reduction
Poor DEF Quality DTC Initial Detected + 20 hours Diesel Fuel Refueling >15%	None	 <small>W2029417</small>	8 km/h (5 mph) Road Speed Limit (RSL)
Temporary Exit from 8 km/h (5 mph) Inducement	None	 <small>W2029417</small>	25% torque reduction

Exit conditions for DEF Quality " 8 km/h (5 mph) road speed limit" Inducement:

Next 1 Engine Starts: Return to 25% torque reduction until proper DEF quality evaluation. If poor DEF quality is detected during the next monitoring cycle then and 8 km/h (5 mph) resumed after vehicle stationary for 20 minutes. After 1 engine starts have been exhausted then a Service Tool is required to exit the 8 km/h (5 mph) RSL.

With Scan Tool DTC Clearing: Invoke 25% torque reduction until proper DEF quality evaluation. If poor DEF Quality is detected during the next monitoring cycle then 8 km/h (5 mph) resumed after vehicle stationary for 20 minutes.

Misfilling Diesel or Aftertreatment DEF Tanks

Although diesel fuel and Aftertreatment DEF caps are clearly labeled and filler necks and nozzles are different accidents can happen.

Contamination of fluids by- misfilling of diesel or DEF in the wrong tank may result in vehicle malfunction.

Results of misfilling DEF in Diesel Tank





- Engine may run poorly or not at all
- Injectors may be damaged
- Exhaust system corrosion may occur between turbocharger and Aftertreatment DPF
- On Board Diagnostic (OBD) Diagnostic Trouble Codes (DTC)
- Costly repairs

Results of misfilling diesel in Aftertreatment DEF Tank

- Aftertreatment SCR system may be damaged by Diesel
- SCR Catalyst may be damaged by diesel (chemical damage)
- Emissions may be non-compliant
- On Board Diagnostic (OBD) Diagnostic Trouble Codes (DTC)
- Costly repairs

SCR Tampering - Driver Warning & Inducement

1. Disconnected Aftertreatment DEF tank level sensor	4. Disconnected Aftertreatment DEF pump
2. Blocked Aftertreatment DEF line or dosing unit	5. Disconnected SCR wiring harness
3. Disconnected Aftertreatment DEF dosing unit	6. Disconnected NOx Sensor

Triggers	Aftertreatment DEF Tank Low Level Indicator	Warning Lamp	Inducement
No Tampering	None	None	None
Tampering DTC Pending	None	 <small>W2029417</small>	None
Tampering DTC Confirmed	None	 <small>W2029417</small>	None
Tampering DTC Initial Detected + 10 hour	None	 <small>W2029417</small>	25% torque reduction
Tampering DTC Initial Detected + 40 hours Diesel Fuel Refueling >15%	None	 <small>W2029417</small>	8 km/h (5 mph) road speed limit

Note: "Repeated acts of tampering will result in more severe Inducement."

Warranty and Maintenance

Exhaust Aftertreatment System Maintenance

The vehicle must be taken to an authorized Volvo Truck dealer to remove the ash from the Aftertreatment Diesel Particulate Filter and clean the Aftertreatment Doser.

Emissions Maintenance

1. If owner's manual recommends Aftertreatment DPF replacement within useful life, the manufacturer must pay for the replacement; however, a random failure within the useful life is covered only per the above warranty provisions.
2. First maintenance interval in life of the engine is allowed at 100,000 miles, 3000 hours.

Engine Maintenance Intervals

Component	Operation	Interval
Fuel Filter	Change	Every oil change. Under certain conditions (for example, irregular fuel quality), the fuel/water separator filters may require more frequent replacement.
Air Cleaner	Change	Control lamp indication or 24 months, whichever comes first
Valves/Injectors Lash adjustment, D13H	Initial Adjust	200 000 km (125,000 miles) or 12 months, whichever comes first
Injectors Lash Adjustment, D13H	Adjust	Every 400 000 km (250,000 miles) or 24 months, whichever comes first
Aftertreatment DPF Ash Cleaning	Clean	400 000 km (250,000 miles) or 4,500 hours, whichever occurs first
Aftertreatment Doser	Clean	240 000 km (150,000 miles) or 4,500 hours, whichever occurs first
Aftertreatment Diesel Exhaust Fluid (DEF) Pump Filter	Change	First change at 161 000 km (100,000 miles) 3200 hours or 3 years whichever occurs first, 241,000 km (150,000 miles) 4800 hours or 3 years there after
Aftertreatment Diesel Exhaust Fluid (DEF) Filler Neck Filter	Clean	280 000km (175,000 miles) or 12 months, whichever comes first

Engine Gaseous Emission Control Systems

WARRANTY MAINTENANCE

Note: For emission control systems information on engines other than Volvo, refer to the engine vendor's publication

GASEOUS EMISSION CONTROL SYSTEMS WARRANTY

Volvo Trucks North America warrants the Emission Control Systems on each new Volvo diesel engine in a new Volvo truck to comply with all United States Federal and Canadian emissions regulations applicable at the time of manufacture of the engine, and to be free from defects in material and workmanship under normal use and service up to 60 months, or 100,000 miles, whichever occurs first, provided all Volvo Trucks North America maintenance requirements are followed as described in this manual. All warranty periods are calculated from the date-in-service of the new vehicle. The repair or replacement of defective parts will be made without charge for the cost of parts and, if repairs are made at an authorized Volvo Trucks North America dealership, there will be no charge for labor. Volvo Trucks North America's obligation under this warranty is limited to the repair or replacement, at Volvo Trucks North America's option, of any part(s) of the Emission Control Systems of such engine and/or vehicle found to be defective upon examination by Volvo Trucks North America and provided that such part(s) were returned to Volvo Trucks North America or its nearest authorized Dealer within a reasonable period of time.

Qualifications and Limitations:

Note: Not covered by the Emissions Control Systems Warranty:

- Malfunctions caused by misuse, improper adjustments, modification, alteration, tampering, disconnection, improper or inadequate maintenance and use of improper diesel fuel or DEF.
- Damage resulting from accident, acts of nature or other events beyond the control of Volvo Trucks North America.
- Inconvenience, loss of use of the vehicle, commercial loss of any kind including, but not limited to, consequential or incidental damages
- Any vehicle in which the odometer has been altered or damaged so that mileage cannot be readily determined.

THIS WARRANTY IS EXPRESSLY IN LIEU OF ALL OTHER WARRANTIES AND REPRESENTATIONS OR CONDITIONS, STATUTORY OR OTHERWISE, EXPRESSED OR IMPLIED INCLUDING, BUT NOT LIMITED TO, IMPLIED WARRANTY OF MERCHANTABILITY OR FITNESS FOR A PARTICULAR PURPOSE.

Emissions Control System Warranty

The following engine components are covered by the supplemental emissions control system warranty policy as required by the Federal code of emission regulations.

- 1 Turbocharger Assembly
 - VGT Actuator
- 2 Charge Air Cooler
 - CAC Pipes (Air inlet to/from CAC)
 - CAC Hoses
- 3 Engine Control Module (ECM)
- 4 Injectors
- 5 Engine and Vehicle Wire harness (repair to circuits related to Emissions Warrantable Components)
- 6 Exhaust Gas Recirculation (EGR) Mixer
- 7 EGR Cooler
- 8 EGR Valve and EGR Valve Control
- 9 EGR Pipes - Engine Exhaust Manifold to EGR Cooler
- 10 EGR Pipes - EGR Cooler to Inlet Manifold
- 11 Crankcase Breather
- 12 Crankcase Separator
- 13 Crankcase Tubing and Hoses before Separator
- 14 Aftertreatment Wiring Harness
- 15 After treatment Control Module (ACM)
- 16 Aftertreatment Diesel Particulate Filter (DPF) Assembly
 - A. Aftertreatment DPF Assembly with Aftertreatment Diesel Oxidation Catalyst (DOC)
 - Aftertreatment Doser
 - Diffuser Pipe (Aftertreatment Doser Mounting)
 - Fuel lines to Aftertreatment Doser
 - Aftertreatment Fuel Shutoff Valve
 - Aftertreatment Fuel Pressure Sensor
- 17 Sensors:
 - Discharge Recirculation Valve (DRV) (Heat Mode)
 - Discharge Recirculation Valve (DRV) Solenoid
 - Engine Turbocharger Compressor Bypass Actuator (Heat Mode)
 - Engine Turbocharger Compressor Bypass Actuator Solenoid
 - Engine Exhaust Gas Temperature (EGT) Sensor
 - Aftertreatment DPF Intake Temperature Sensor
 - Aftertreatment DPF Outlet Temperature Sensor
 - Aftertreatment DPF Differential Pressure Sensor
 - Aftertreatment Doser Air Supply Regulator (if applicable), Supply Lines, and Fittings
 - Engine Exhaust Gas Temperature (EGT) Sensor
 - Aftertreatment DPF Intake Temperature Sensor
 - Aftertreatment DPF Outlet Temperature Sensor
 - Aftertreatment DPF Differential Pressure Sensor
 - Crankshaft Position (CKP)
 - Camshaft Position (CMP)
 - Engine Coolant Temperature (ECT)
 - Intake Manifold Air Temperature
 - Intake Manifold Pressure (IMP)
 - EGR Temperature
 - Aftertreatment Outlet NOx
 - Aftertreatment Intake NOx

-
- EGR Differential Pressure
 - Ambient Air Temperature (AAT)
- 18 SCR
- Aftertreatment Selective Catalytic Reduction (SCR) Catalyst
 - Aftertreatment Diesel Exhaust Fluid (DEF) Pump
 - Aftertreatment DEF Dosing Absolute Pressure Sensor
 - Aftertreatment DEF Return Valve
 - Aftertreatment DEF Dosing Valve
 - Aftertreatment DEF Tank
 - Aftertreatment DEF Tank Heater/Sender
- Aftertreatment DEF Tank Heater
 - Aftertreatment DEF Tank Heater Valve
 - Aftertreatment DEF Tank Temperature Sensor
 - Aftertreatment DEF Level Sensor
 - Aftertreatment DEF Heated Lines
19. Instrument Cluster (Repair of microprocessor , OBD MIL, Real Time Clock, Aftertreatment DEF Tank Gauge and, Aftertreatment DEF Tank Low Level Indicator)
20. Exhaust Gas Piping (from Turbocharger to Aftertreatment System)
21. Data Link Connector (DLC)

Engine Gaseous Emissions Control System Warranty

The emission warranty for the diesel particulate filter and SCR Systems covers defects in workmanship only. Normal maintenance, such as cleaning ash from the filter at regular maintenance intervals and cleaning the Aftertreatment fuel injector on Diesel Oxidation Catalyst (DOC) DPF systems, is not covered by the emission warranty. With the Thermal Regeneration DPF system, cleaning the ignition electrodes and fuel injection nozzle at the regular maintenance intervals is considered normal maintenance and not covered by the emission warranty.

Note: In response to customer requests, Volvo Trucks North America, may build vehicles with engines supplied by other manufacturers. In these cases, each engine manufacturer through its service organization, is responsible for emission control systems warranty on all parts of the engine assembly, as furnished.

Federal Emission Requirements

This section covers the requirement of the United States Clean Air Act which states: "The manufacturer shall furnish with each new motor vehicle or motor vehicle engine such written instructions for the maintenance and use of the vehicle or engine by the ultimate purchaser as may be reasonable and necessary to assure the proper functioning of emission control devices and systems. "This section also covers the requirements of the emissions regulations promulgated under the Motor Vehicle Safety Act in Canada.

TAMPERING WITH GASEOUS EMISSION CONTROL SYSTEMS PROHIBITED

The Federal Clean Air Act prohibits the removal or rendering inoperative of any device or element of design installed on or in a motor vehicle or motor vehicle engine in compliance with Federal Emission Regulations by:

- 1 Any person prior to its sale and delivery to the ultimate purchaser, or
- 2 Any manufacturer or distributor after its sale and delivery to the ultimate purchaser, or
- 3 Any person engaged in the business of repairing, servicing, selling, leasing, or trading motor vehicles or motor vehicle engines following its sale and delivery to the ultimate purchaser, or
- 4 Any person who operates a fleet of motor vehicles following its sale and delivery to the ultimate purchaser.

Note: For specifics of the prohibited vehicle/engine modifications refer to the Volvo Body Builders documentation .

Emission Control System Warranty — California

The California Air Resources Board and Volvo Trucks North America. are pleased to explain the California emission control system warranty on your new motor vehicle engine. In California, new motor vehicle engines must be designed, built and equipped to meet the State's stringent anti-smog standards. Volvo Trucks North America. must warrant the emission control system on your engine for the period of time listed below provided there has been no abuse, neglect, or improper maintenance of your engine. Your emission control system may include parts such as the fuel-injection system, turbocharger assembly, electronic control module and other emission-related assemblies.

Where a warrantable condition exists, Volvo Trucks North America. will repair your engine at no cost to you including diagnosis, parts, and labor.

MANUFACTURER'S WARRANTY COVERAGE:

If an emission-related part of your engine is defective, the part will be repaired or replaced by Volvo Trucks North America. This is your emission control system DEFECTS WARRANTY.

OWNER'S WARRANTY RESPONSIBILITIES:

As the motor vehicle engine owner, you are responsible for the performance of the required maintenance listed in this manual. Volvo Trucks North America. recommends that you retain all receipts covering maintenance of your vehicle, but Volvo Trucks North America. cannot deny warranty solely for the lack of receipts or for your failure to ensure the performance of all scheduled maintenance listed in other manuals which were supplied with your vehicle.

You are responsible for presenting your motor vehicle engine to a Volvo dealer as soon as a problem exists. The warranty repairs should be completed in a reasonable amount of time, not to exceed 30 days. As the motor vehicle engine owner, you should also be aware that Volvo Trucks North America. may deny you warranty coverage if your vehicle or a part has failed due to abuse, neglect, improper maintenance, or unapproved modifications.

If you have any questions regarding your warranty rights and responsibilities, you should contact the Volvo Trucks North America. Warranty Activities P.O.Box 26259, Greensboro, NC 27402, or the California Air Resources Board at 9480 Telstar Avenue, El Monte, California 91731.

(Applicable only to vehicles and/or engines certified for sale and registered in the State of California) Volvo Trucks North America. warrants the Emission Control Systems on each new Volvo diesel engine in a new Volvo truck to comply with all State of California emissions regulations applicable at the time of manufacture of the engine, and to be free from defects in material and workmanship under normal use and service up to 60 months, or 100,000 miles, or 3,000 engine operating hours, whichever occurs first, provided all Volvo Trucks North America. maintenance requirements are followed as described in this manual. All warranty periods are calculated from the date-in-service of the new vehicle. The repair or replacement of defective parts will be made without charge for the cost of parts and, if repairs are made at an authorized Volvo Trucks North America. dealership, there will be no charge for labor.

Volvo Trucks North America.'s obligation under this warranty is limited to the repair or replacement, at Volvo Trucks North America.'s option, of any part(s) of Emission Control Systems of such engine and/or vehicle found to be defective upon examination by Volvo Trucks North America. and provided that such part(s) were returned to Volvo Trucks North America. or its nearest authorized Dealer within a reasonable period of time.

384 Volvo, US10 Emissions Solution

Qualifications and Limitations:

Not covered by the Emissions Control Systems Warranty:

- Malfunctions caused by misuse, improper adjustments, modification, alteration, tampering, disconnection, improper or inadequate maintenance and use of improper diesel fuel or DEF.
- Damage resulting from accident, acts of nature or other events beyond the control of Volvo Trucks North America.
- Inconvenience, loss of use of the vehicle, commercial loss of any kind including, but not limited to, consequential or incidental damages.
- Any vehicle in which the odometer has been altered or damaged so that mileage cannot be readily determined.

THIS WARRANTY IS EXPRESSLY IN LIEU OF ALL OTHER WARRANTIES AND REPRESENTATIONS OR CONDITIONS, STATUTORY OR OTHERWISE, EXPRESSED OR IMPLIED INCLUDING, BUT NOT LIMITED TO, IMPLIED WARRANTY OF MERCHANTABILITY OR FITNESS FOR A PARTICULAR PURPOSE.

Emissions Control System Warranty

The following engine components are covered by the supplemental emissions control system warranty policy as required by the California code of regulations.

- 1 Turbocharger Assembly
 - VGT Actuator
 - 2 Charge Air Cooler
 - CAC Pipes (Air inlet to/from CAC)
 - CAC Hoses
 - 3 Engine Control Module (ECM)
 - 4 Injectors
 - 5 Engine and Vehicle Wire harness (repair to circuits related to Emissions Warrantable Components)
 - 6 Exhaust Gas Recirculation (EGR) Mixer
 - 7 EGR Cooler
 - 8 EGR Valve and EGR Valve Control
 - 9 EGR Pipes - Engine Exhaust Manifold to EGR Cooler
 - 10 EGR Pipes - EGR Cooler to Inlet Manifold
 - 11 Crankcase Breather
 - 12 Crankcase Separator
 - 13 Crankcase Tubing and Hoses before Separator
 - 14 Aftertreatment Wiring Harness
 - 15 After treatment Control Module (ACM)
 - 16 Aftertreatment Diesel Particulate Filter (DPF) Assembly
 - A. Aftertreatment DPF Assembly with Aftertreatment Diesel Oxidation Catalyst (DOC)
 - Aftertreatment Doser
 - Diffuser Pipe (Aftertreatment Doser Mounting)
- Fuel lines to Aftertreatment Doser
 - Aftertreatment Fuel Shutoff Valve
 - Aftertreatment Fuel Pressure Sensor
 - Discharge Recirculation Valve (DRV) (Heat Mode)
 - Discharge Recirculation Valve (DRV) Solenoid
 - Engine Turbocharger Compressor Bypass Actuator (Heat Mode)
 - Engine Turbocharger Compressor Bypass Actuator Solenoid
 - Engine Exhaust Gas Temperature (EGT) Sensor
 - Aftertreatment DPF Intake Temperature Sensor
 - Aftertreatment DPF Outlet Temperature Sensor
 - Aftertreatment DPF Differential Pressure Sensor
 - Aftertreatment Doser Air Supply Regulator (if applicable), Supply Lines and Fittings
 - Engine Exhaust Gas Temperature (EGT) Sensor
 - Aftertreatment DPF Intake Temperature Sensor
 - Aftertreatment DPF Outlet Temperature Sensor
 - Aftertreatment DPF Differential Pressure Sensor

386 Volvo, US10 Emissions Solution

17 Sensors:

- Crankshaft Position (CKP)
- Camshaft Position (CMP)
- Engine Coolant Temperature (ECT)
- Intake Manifold Air Temperature
- Intake Manifold Pressure (IMP)
- EGR Temperature
- Aftertreatment Outlet NOx
- Aftertreatment Intake NOx
- EGR Differential Pressure
- Ambient Air Temperature (AAT)
- Aftertreatment DEF Dosing Valve
- Aftertreatment DEF Tank
- Aftertreatment DEF Tank Heater/Sender
- Aftertreatment DEF Tank Heater
- Aftertreatment DEF Tank Heater Valve
- Aftertreatment DEF Tank Temperature Sensor
- Aftertreatment DEF Level Sensor
- Aftertreatment DEF Heated Lines

18 SCR

- Aftertreatment Selective Catalytic Reduction (SCR) Catalyst
- Aftertreatment Diesel Exhaust Fluid (DEF) Pump
 - Aftertreatment DEF Dosing Absolute Pressure Sensor
 - Aftertreatment DEF Return Valve

19. Instrument Cluster (Repair of microprocessor , OBD MIL, Real Time Clock, Aftertreatment DEF Tank Gauge and, Aftertreatment DEF Tank Low Level Indicator)

20. Exhaust Gas Piping (from Turbocharger to Aftertreatment System)

21. Data Link Connector (DLC)

Oil Change Intervals

The length of time an engine can operate before an oil change depends on the quality oil used, the type of fuel used, fuel consumption, engine oil consumption, vehicle application, level of dust in the air, and fuel consumption. The change intervals given in this manual are maximum intervals. If the vehicle is operating in heavy-duty operation, dusty or off-road conditions, etc., reduce the intervals for more frequent oil changes.

Note: Use the information in the table below to determine the operating condition and usage applicable to your vehicle.

Engine Operating Condition	Medium	Heavy	Severe
Total Fuel Consumption (mpg)	more than 6	more than 4.7	more than 3.7
Total Fuel Consumption (L/ 100 km)	less than 39	less than 50	less than 64
D11H and D13H Engine Oil and Filter Change Interval, km (miles) — 36L (38 quart) oil capacity	56 000 (35,000)	40 000 (25,000)	24 000 (15,000)
Note: If idle time is greater than 25%, use the next lower drain interval.			

For additional information about oil change intervals, see your Volvo Truck dealer. Also, refer to Bulletin 175-60, Oil and Filters, Volvo Components.

For a complete list of approved oils, see your Volvo Truck dealer. Also, refer to Bulletin 175-61, Approved Oils, Volvo Components.

DAILY MAINTENANCE

DANGER

Before working on or inspecting a vehicle, set the parking brakes, place the transmission in neutral and block the wheels. Failure to do so can result in unexpected vehicle movement and can cause serious personal injury or death.

CAUTION

Engines equipped with automatic start systems can start automatically. An alarm sounds before automatic start. Failure to turn off ignition before working on fan or belts can result in personal injury.

Note: Make sure that all fluid levels are at their proper levels. If the fluids are not at their proper levels, add as necessary. Refer to the Operator's Manual Vehicle Maintenance for information on what types of fluids are recommended for your Volvo vehicle.

WARNING

Keep yourself clear of all moving or hot engine parts. A hot engine can cause serious burns.

While checking the fluid levels, visually inspect hoses, pipes and their connections for signs of leakage. Inspect the ground under the engine, transmission and rear axle(s) for signs of leakage.

TOWING PROCEDURE

General



WARNING

If a vehicle with air suspension is lifted by the rear frame member, there is a risk that the air springs will separate from the spring plates. When towing has been completed, DO NOT under any circumstances use your hands to reposition the air springs. There is a great risk that your hand will be caught between spring and plate causing personal injury.



WARNING

DO NOT tow a vehicle backwards when equipped with roof air fairings. The fairings act as an air scoop and may break off. Failure to follow this warning may lead to personal injury and vehicle damage.



WARNING

Vehicles with air fairings are tall. Make sure that the total height of the vehicle, when it is raised up behind the wrecker, does not exceed the maximum allowed height for local underpasses. Failure to follow this instruction may lead to personal injury and vehicle damage.



CAUTION

Failure to disconnect the driveshaft, remove the drive axle shaft(s) or lift the drive wheels off the ground before towing or pushing the vehicle, can cause serious transmission damage.

Remove the driveshaft from the rear axle before moving the vehicle, unless it only needs to be moved a small distance for safety reasons. When the transmission is driven from the rear wheels without the engine running, there is no lubrication in the transmission.

Axle shafts must be removed if the vehicle is to be towed at speeds over 40 km/h (25 mph) or for a long distance. Openings should be covered to prevent loss of oil and entry of dirt and grit. Where oil-lubricated bearings are used, openings should be thoroughly sealed with metal discs and new gaskets before towing.

If the vehicle is towed with the drive wheels still in contact with the road surface, the vehicle axle shafts or driveline must be removed or disconnected.

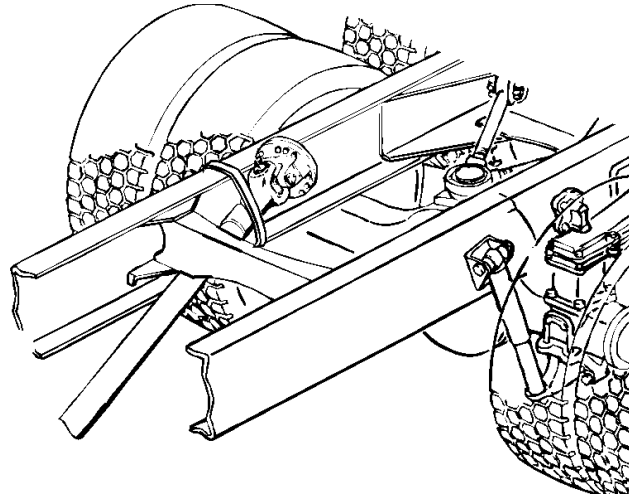

T0006670

The vehicle may now be towed. It is recommended that a wrecker with a lift bar is used since the service brakes will not function. The system must be filled with air to release the parking brake or follow the mechanical spring brake caging procedures on “Caging Spring Brake Chambers”, page 396.

Note: The power steering does not function when towing a vehicle with a disabled engine.

Towing Instructions

DANGER

DO NOT use the tow eyes for raising the front of the vehicle; the tow eyes can break. DO NOT crawl under a vehicle suspended by tow eyes. Failure to follow these instructions can result in serious personal injury or death.

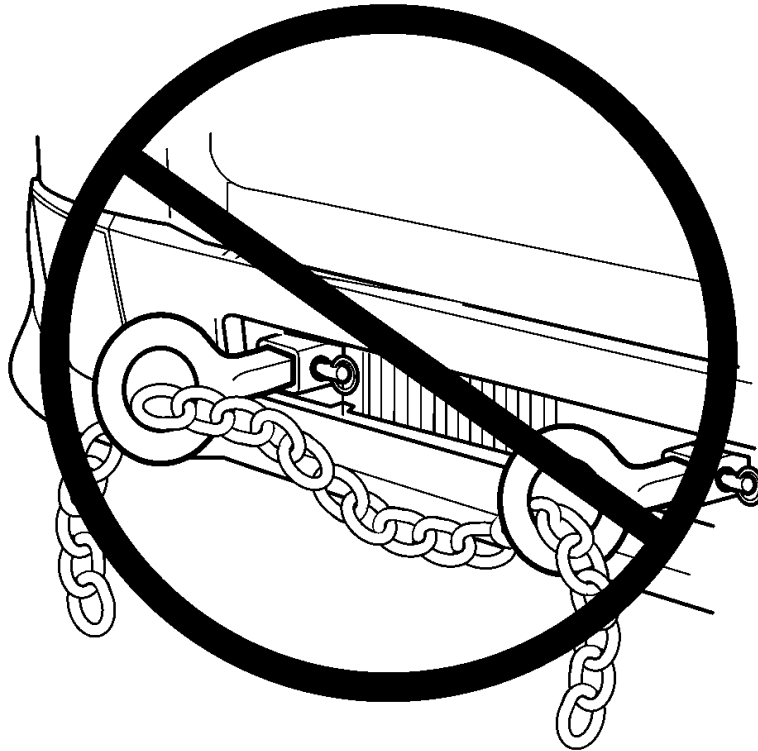

W9000752

Fig. Fig. 2 DO NOT lift or tow vehicle as shown in this illustration.



CAUTION

If the vehicle becomes disabled, it is very important to tow it properly. Failure to do so can cause damage to the frame and body parts. Follow the instructions below to avoid damage.

In the event that the vehicle cannot be reached to place the wrecker lift bar under the front axle, use the optional tow eyes. The front tow eyes are used as a point at the front of the vehicle where the vehicle can be pulled.

On day cab models, the tow eyes are stored bolted to the back of the cab wall.

On sleeper cab models, the tow eyes are stored bolted to the back wall of the luggage compartment wall.

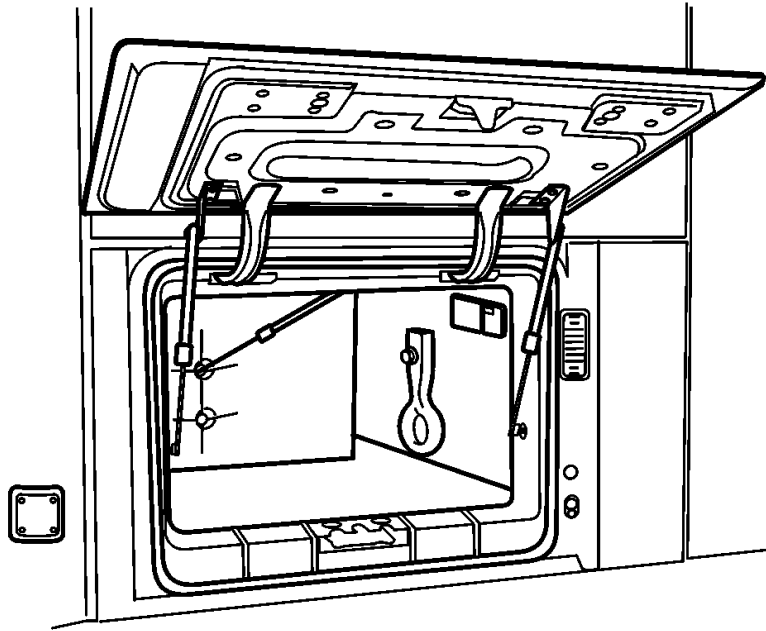

W8003124

The tow eyes are held in place when mounted on the front of the vehicle by tractor pins. These pins are stored in the tow eye mounting holes when not being used. If the vehicle is equipped with the optional rock guard installed, insert the lock pin into the tow hook from the opposite side during installation.

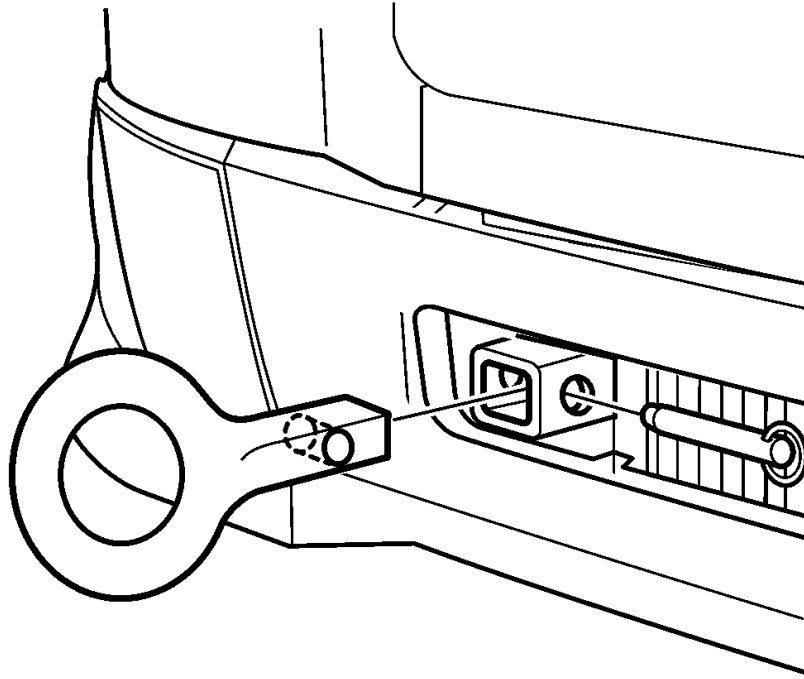

W8003186

394 MAINTENANCE AND LUBRICATION

If the vehicle is equipped with the optional rock/stone guard installed, the driver will have to insert the lock pin into the tow hook from the opposite side during installation.

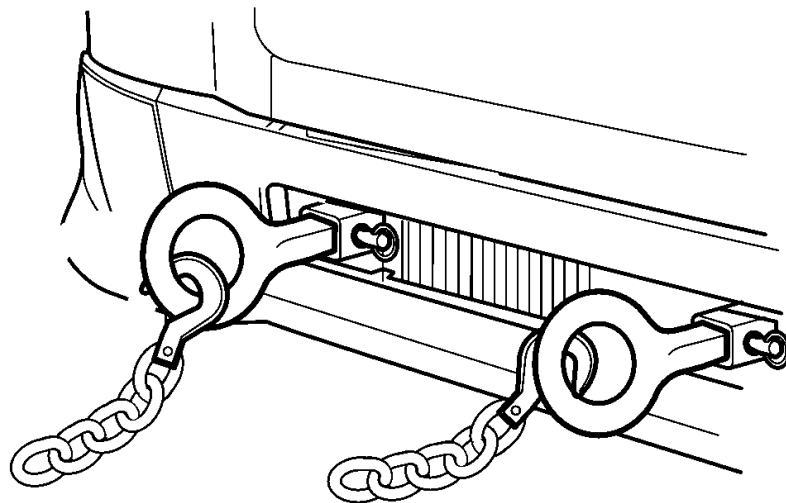

W9000751

When the vehicle is located properly, lift the front and locate the lift bar under the front axle and secure. Using the front axle for towing minimizes the possibility for damage to the vehicle body, frame and suspension.

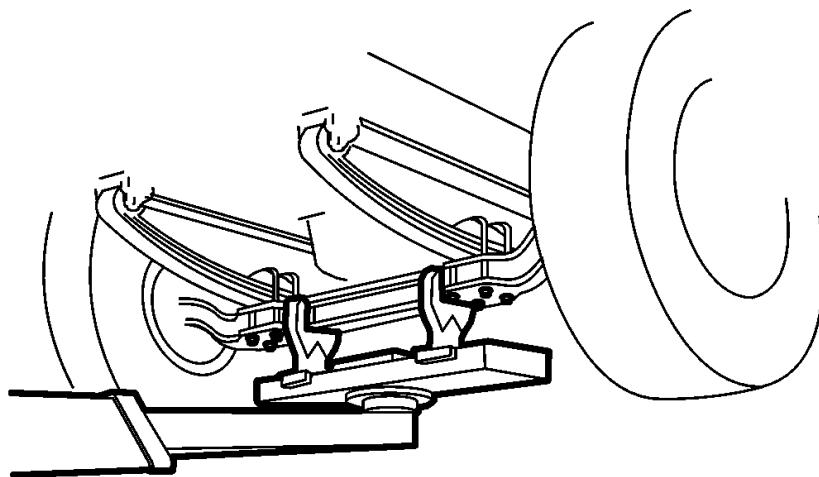

W9000588

Note: When the driveshaft or axle shafts are reinstalled, make sure the nuts are tightened to the correct torques. Also make sure the axle shafts are installed in the proper sides, with the left shaft in the left side and the right shaft in the right side.

Towing Pintle

DANGER

DO NOT exceed the maximum towing capacity of the pintle hook system (4,000 lb.). Exceeding the maximum towing capacity may result in vehicle accident, serious injury or death.

Note: If your vehicle is equipped with a pintle hook system installed by Volvo Trucks North America, please note that the entire pintle hook system — including the frame and attachment to the frame — is rated at a maximum capacity of 1814 Kg (4,000 lb).

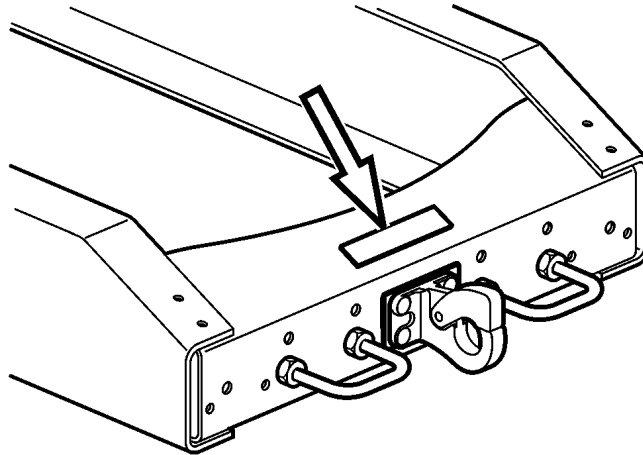

W7001269

Pintle Hook Advisory Label

Acceptable loads per hook:

- Straight pull: Less than or equal to 18 143 kg/hook (40,000 lb).
- Vertical pull: Less than or equal to 5 170 kg/hook (11,400 lb).
- 45° cone (combination loads): Less than or equal to 7239 kg (15,960 lb).

Caging Spring Brake Chambers

 **DANGER**

Always start by chocking the wheels to prevent the vehicle from rolling. Failure to do so can result in unexpected vehicle movement and serious personal injury or death can occur.

 **DANGER**

DO NOT attempt in any way to disassemble or tamper with the spring brake chamber. If the force stored on the spring is suddenly released, it can cause serious personal injury or death.

The parking spring brake chambers may be released mechanically if there is no compressed air available.

Remove the plastic plug in the front end of the chamber. Remove the screw from the holder in the side of the brake chamber. Insert the screw into the front hole and push in until it bottoms. Screw into the cylinder so at least 4 to 6 threads have entered. Install the washer and nut. Tighten the nut. This compresses the brake chamber spring and releases the parking brake.

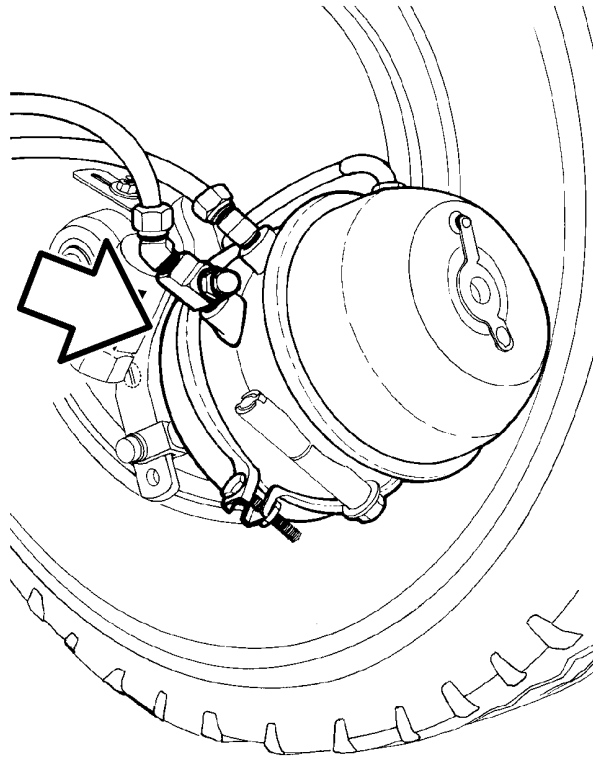

W5001430

Towing Procedure — AIRTEK® Suspension

®HENDRICKSON recommends that a vehicle equipped with a STEERTEK axle be towed using the following methods for ON HIGHWAY or ON ROADWAY applications. Methods listed are in order of preference.

- 1 Wheel lift method, the ideal towing procedure
- 2 Axle fork method
- 3 Towing vehicle from the rear method
- 4 Spring eye and hanger lift method

®HENDRICKSON is not responsible for any damage to the axle, suspension or other vehicle components resulting from any towing method or fixture not authorized by ®HENDRICKSON.

Please contact ®HENDRICKSON Tech. Services with any questions regarding proper towing procedures for vehicles equipped with a STEERTEK axle.

Wheel Lift Method

This method provides the greatest ease for towing the vehicle. Lifting at the tires helps reduce the risk of possible damage to the axle, suspension, and engine components during towing operations. See illustration.

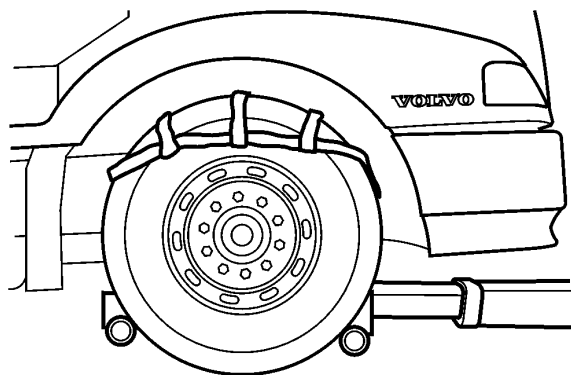



CAUTION

DO NOT tow the vehicle from the axle. Towing the vehicle by the axle will cause scarring and resultant damage to the axle and void warranty.

When lifting a vehicle with an under lift boom, care must be taken not to damage the engine's oil pan. It may also be necessary to remove the front fairing.

This is an alternative method for towing the vehicle, but it requires SPECIAL forks (see illustration showing designated lift points). The following procedure must be used:

- Place a block of wood on top of the boom and lift the vehicle in order to place spacers under tires. This will provide sufficient room under the axle to locate forks in the proper position.
- Install the fork in the boom properly with the angled arm of the fork facing forward.
- Position the forks directly under the center of the bottom axle wraps, and lift vehicle. The indentions in the center of the wrap will locate the forks and maintain their position.
- When securing the vehicle to the boom, use (preferably) nylon safety straps. Chains have a tendency to bind and may cause damage to the axle.

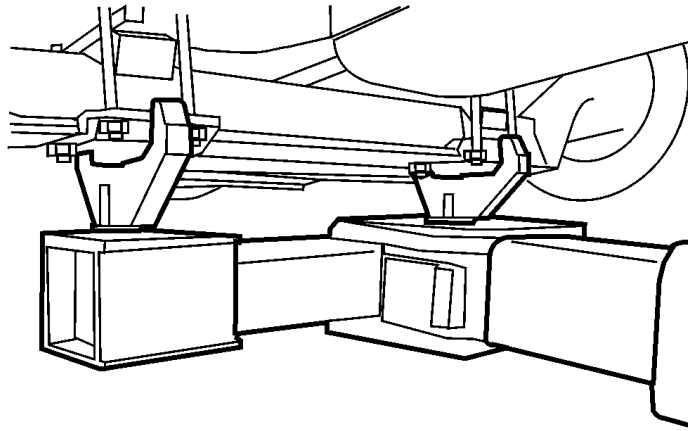

W7001301

Towing Vehicle From Rear Method

This method is preferred when the proper equipment is not available to perform the wheel lift method or the axle fork method, and is necessary for wreckers not equipped with an under lift system.

Spring Eye and Hanger Lift Method

This method is permitted for under lift equipped units. Caution must be taken not to damage the leaf spring (see illustration for proper installation).

- Inspect the ends of the spring cradles for burrs or sharp edges that could damage spring.
- When securing the vehicle to the boom, use (preferably) nylon safety straps. Chains have a tendency to bind and may cause damage to the axle.

Note: When lifting a vehicle with the under lift boom (see illustration) care must be taken not to damage the engine oil pan. It may be necessary to remove front fairing. If necessary, place a block of wood between the top of the boom and the bottom of the axle.

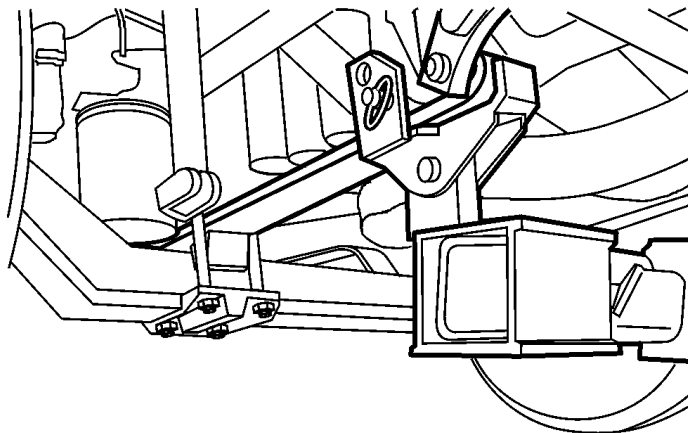

W7001302

Off Roadway Towing Method



WARNING

When a truck is disabled and equipped with a STEERTEK axle, care must be taken to ensure there is no damage to the suspension when towing the vehicle.

The use of a tow strap is necessary to tow a disabled truck into a repair facility. The tow straps should be connected to the tow hooks provided by the manufacturer at the front of the bumper. If the use of tow hooks is not an option, then a tow strap may be wrapped around the front axle (see illustration) in a manner that is acceptable for towing the vehicle into the shop.

DO NOT use a tow chain around the front axle to tow the vehicle. Doing so will damage the axle and void warranty. See illustration.

THE FOLLOWING METHODS IN THESE ILLUSTRATIONS ARE NOT RECOMMENDED FOR ON HIGHWAY TOWING

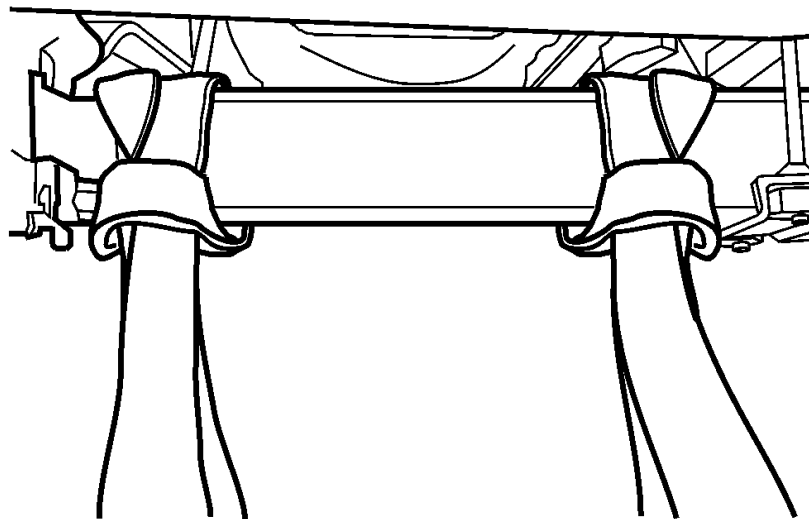

W7001303

Nylon straps are acceptable for only Off roadway towing.

402 MAINTENANCE AND LUBRICATION

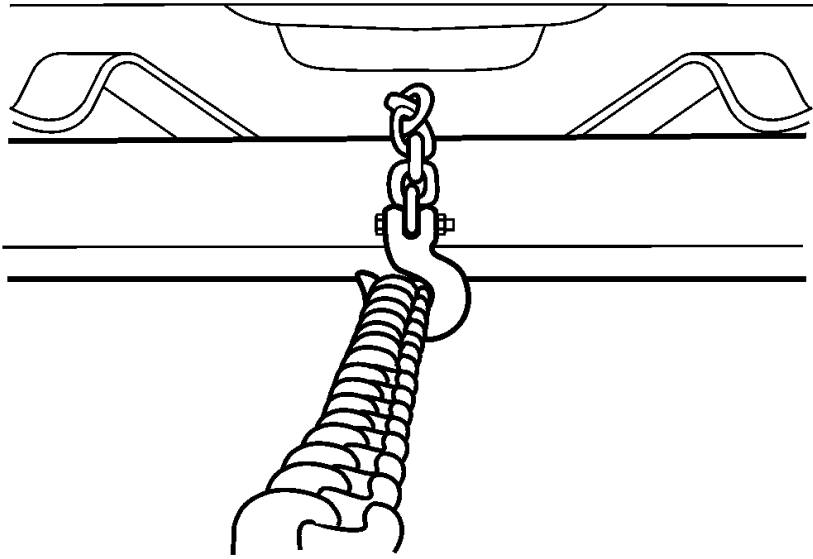

W7001304

Chains are not acceptable for Off roadway towing.

ENGINE OIL LEVEL CHECK



CAUTION

Make sure the oil added is the same type of oil that is in the engine. The wrong type of oil could accelerate wear on engine if not suited for application.

Check the oil level in the engine with the dipstick. The oil level should be between the minimum and maximum marks on the dipstick **DO NOT** overfill!

To add oil to the engine, remove cap from right-side oil fill and fill through the hole. See the Operator's Manual Vehicle Maintenance for correct types of oil used in Volvo engines.

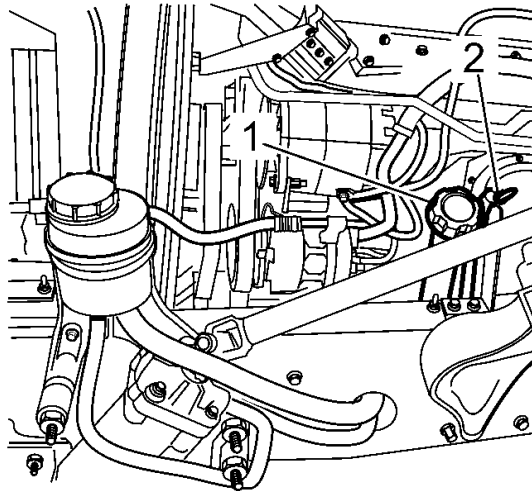

W0056532

- 1 Oil Fill
- 2 Dipstick

Clutch Fluid Check

Check the fluid level in the clutch fluid reservoir. The fluid level should be between the level marks on the reservoir. If fluid needs to be added, use brake fluid, DOT 4.

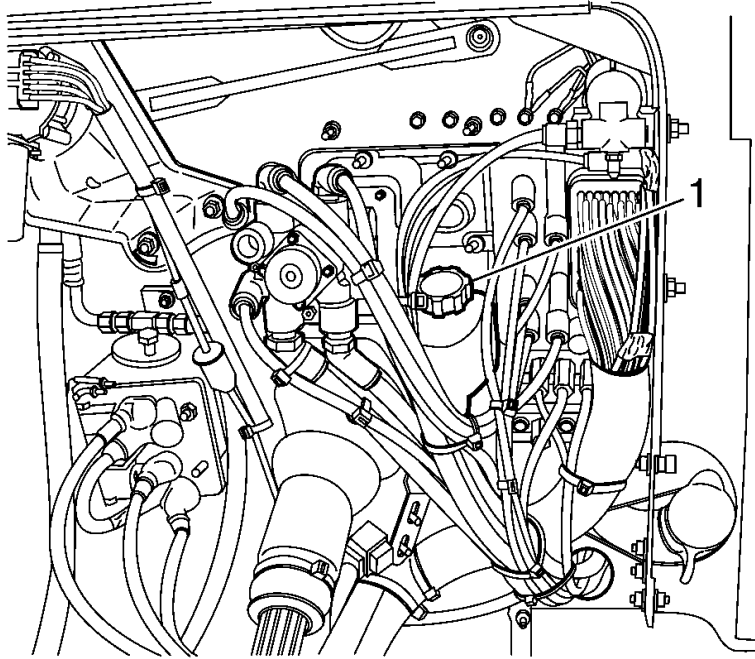

W4056530

1 Clutch Fluid Reservoir

Engine Maintenance Intervals

Components	Operation	Intervals
Water Separator	Filter Change	Every oil change. Under certain conditions (for example, irregular fuel quality), the fuel/water separator filters may require more frequent replacement.
Coolant (Standard)	Change	500,000 km (300,000 miles) or 24 months, whichever comes first
Coolant (ELC)	Change	500,000 km (300,000 miles) or 24 months, whichever comes first
Coolant Filter (Standard)	Change	80,000 km (50,000 miles) or 6 months, whichever comes first
Coolant Filter (ELC)	Change	240,000 km (150,000 miles) or 12 months, whichever comes first
Main drive and accessory drive belts, Highway usage D13H	Change	500,000 km (300,000 miles) or 36 months, whichever comes first
Main drive and accessory drive belts, Vocational usage D13H	Change	240,000 km (150,000 miles) or 12 months, whichever comes first

POWER STEERING, GENERAL

The VN power steering consists of an integrated gear. There is also a power steering pump with fluid container. The pump, driven by the engine, provides hydraulic pressure to the power steering. If the engine is not working, the steering is only manual. With the power steering not working, the effort required to turn the steering wheel is much greater than with power assist. If the power steering assist fails, bring the vehicle to a safe stop. DO NOT drive the vehicle until correcting the cause of the problem.

While operating the vehicle, avoid ruts and obstructions which cause binding condition on the sides of the front wheels. Drive the vehicle out of the rut, then turn the steering wheel. If possible, avoid turning the wheels while the vehicle is at a standstill as this places a considerable load on the power steering system and front axle.

Periodically check the power steering fluid reservoir and keep it filled to the proper level with the recommended fluid. See the Operator's Manual Vehicle Maintenance for more information.

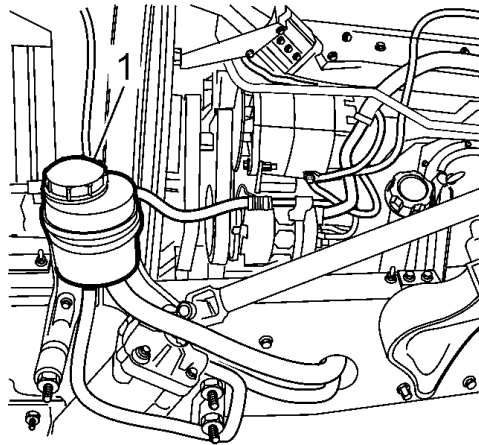

W6056531

1 Power Steering Fluid Reservoir

Windshield Washer Reservoir

Check level in the windshield washer reservoir. If washer fluid needs to be added, use a commercially reputable washer fluid that has good cleaning capability and does not freeze in cold weather.

Windshield Washer Capacity		
Model	Reserve	Total Capacity
VN	6.35 liters (1.5 gallons)	13.70 liters (3.26 gallons)



W2006043

- 1 Clutch Fluid Reservoir
- 2 Windshield Washer Fluid Fill
- 3 Brake Valve

COOLING SYSTEM

Coolant Level Check



WARNING

DO NOT remove the cap to the surge tank while the engine and radiator are still hot and under pressure. Scalding fluid and/or steam may be blown out under pressure if the cap is taken off too soon.



CAUTION

Add only premixed coolant made up of 50% clean water and 50% antifreeze. See the Operator's Manual Vehicle Maintenance for more detailed information.

Check coolant level in the coolant tank. The tank should be full. Add coolant as necessary.

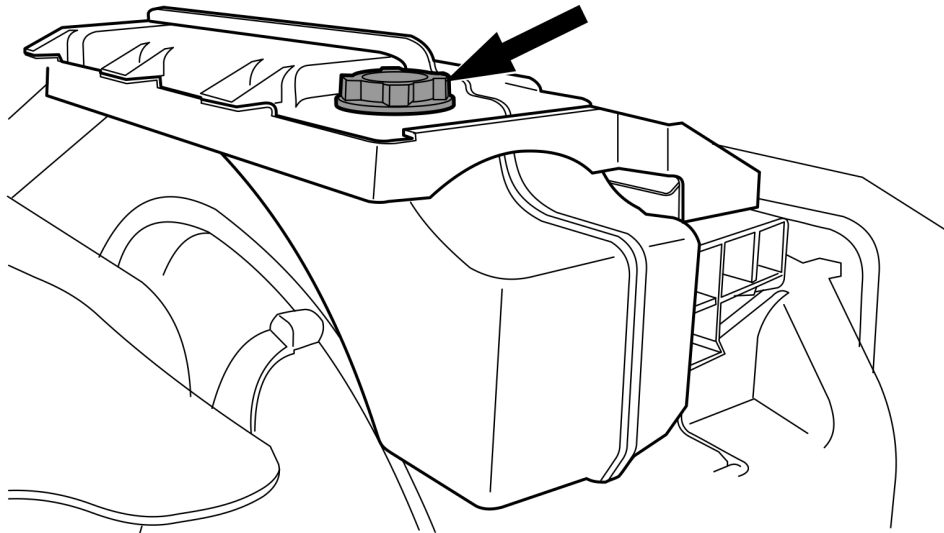

W2006041

1 Fill Cap

CAB

Air going into the cab passes a filter located on the right, front side of the cab. Remove the filter and check it every 19,200 km (12,000 miles).

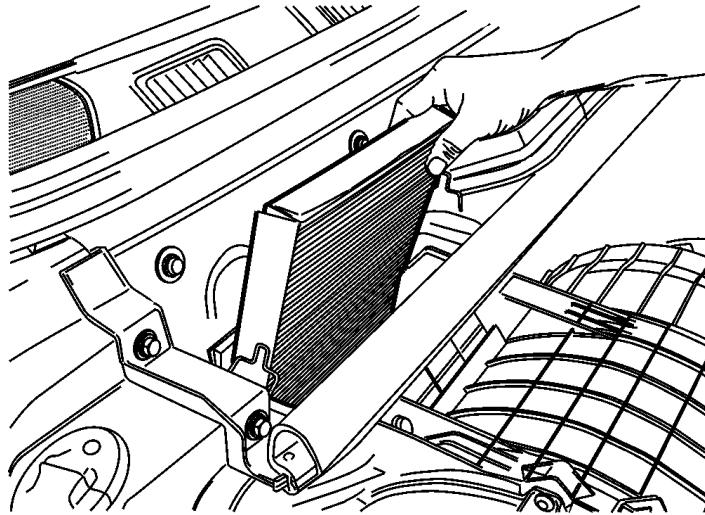

W8003189

The filter should not be cleaned and reused. Replace with a new filter as necessary. Change the filter more often if driving in dusty conditions. A clogged filter decreases the efficiency of the air conditioning system.

If the vehicle is equipped with a sleeper heater-A/C, there is a filter for recirculating air. It is located behind the passenger seat on the bunk support. The filter should be checked after 19,200 km (12,000 miles), more often in dusty conditions. Replace the filter as necessary.

To inspect or to change the filter, open the luggage storage lid and pull out the filter.

HEADLIGHTS

Changing Headlight Bulb

Note: To prevent short service life, DO NOT touch the glass surface of the replacement bulb.

VNM Instructions

The headlight bulb can be accessed from the rear of the headlight assembly. Raise the hood and remove the cover.

Remove the terminal from the back of the bulb by bending up the lock tabs and pulling back at the same time. Turn the lock ring counterclockwise and remove. Pull out the bulb.

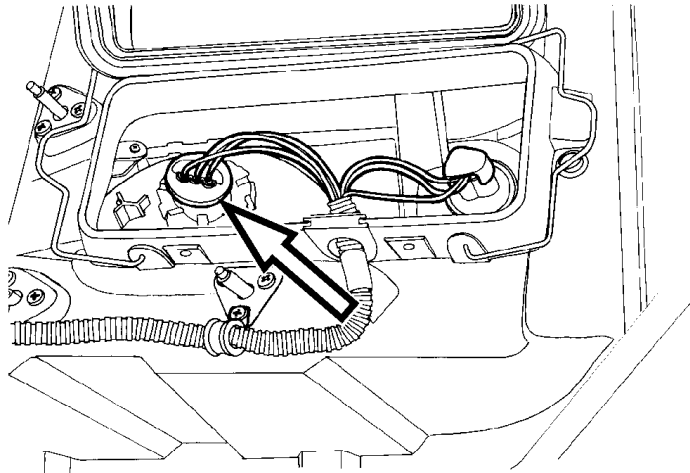

W3004382

VNM

Install the bulb and line up with the location tab by turning it and then push it in until fully seated. Install the lock ring. Push the terminal back on. Check that the rubber seal is clean and then install cover and snap the clamps over it.

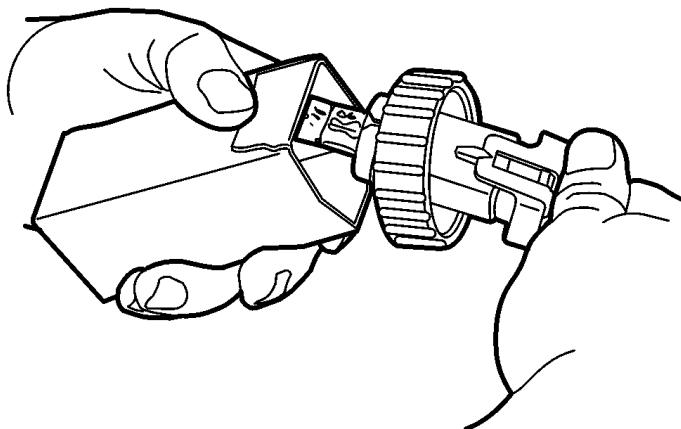

W3004383

VNL Instructions

The headlight bulb can be accessed from the rear of the headlight assembly. Raise the hood. In early production vehicles, remove the bulb cover by turning clockwise. In later production vehicles, the cover can be removed in the normal counterclockwise direction.

Note: In some cases, the cover seal may stick to the housing, which makes removal difficult. Use special tool 85104355 to assist in removal. Contact your authorized Volvo dealer for the tool.

With the cover removed, grasp the bulb assembly and turn counterclockwise to remove. Disengage the wiring connector and remove the bulb from the vehicle. Engage the wiring harness connector to the replacement bulb assembly. Install into the headlamp housing. Check the bulb cover seal and install the bulb cover. Lower the hood and check for proper headlamp operation.

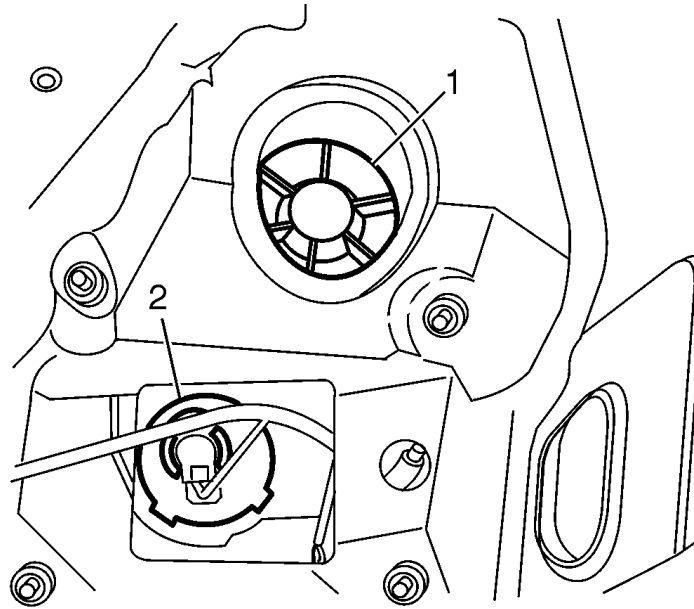

W3005350

- 1 Low Beam Headlight (Cover Installed)
- 2 High Beam Headlight (Cover Removed)

ROOF EXTENDER

The roof extender increases fuel economy. The extender is adjustable to five positions which are shown in the illustration and in the graphs.

The vehicle is delivered with the extender or deflector lowered or down, which is the transport position, see A in illustration.

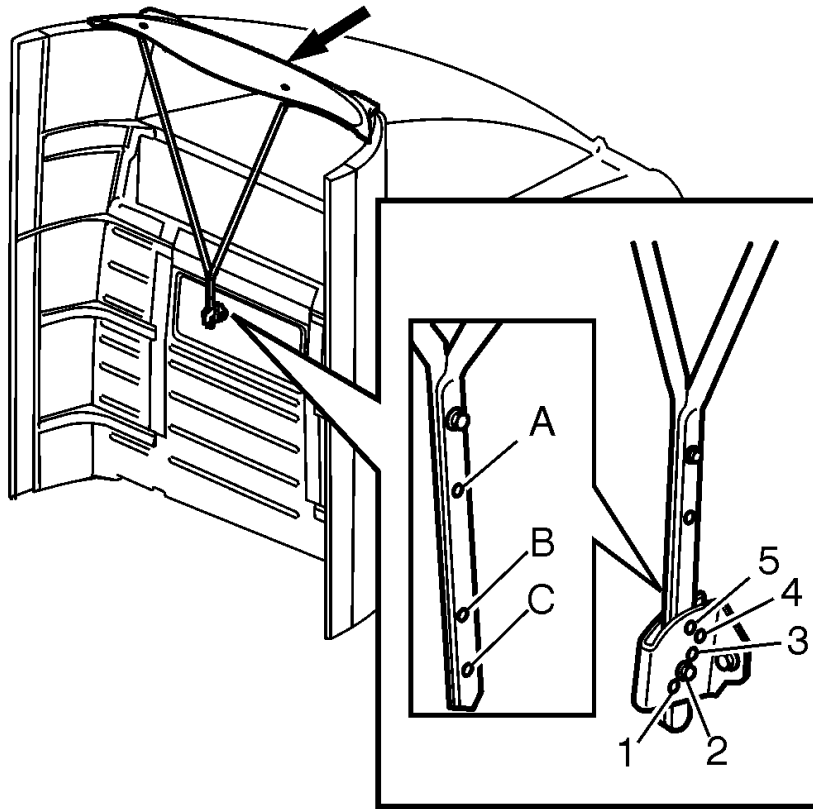

W8003470

To set the extender to normal riding position, measure points H and G, then select positions 1 through 5 in the rod as determined by the adjustment chart.

- H = Height from the top of the trailer to the top of the frame rail.
- G = Gap or distance from the back of the cab to the trailer.
- F = Frame rail height.

Note: For 630 and 670 vehicle models, the frame height must be measured. See F in illustration. If F measures 266 mm (10-1/2 inches), subtract 17 mm (5/8-inch) from the value determined for H.

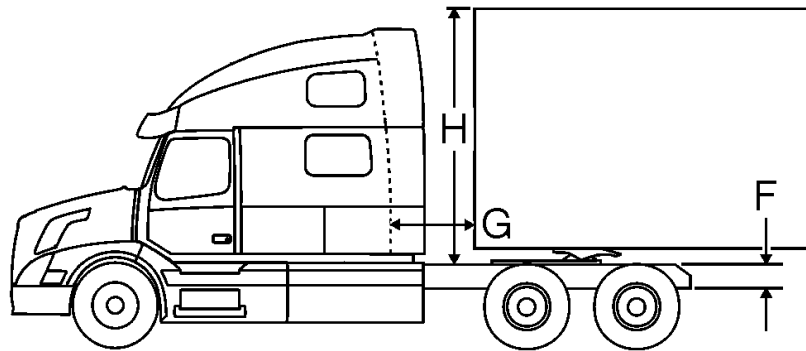

W8003466

VN Roof Extender Measurements

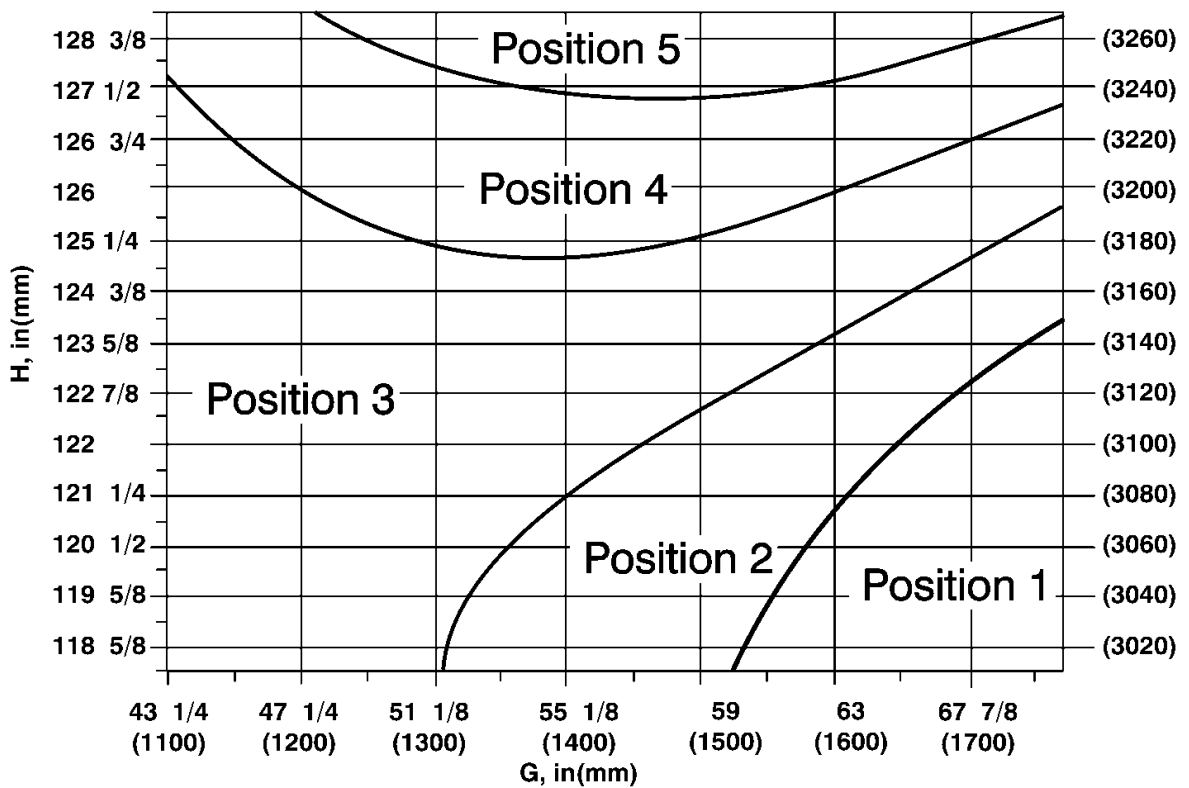

W8003472

VN 630/670 Roof Extender Adjustment Chart

414 MAINTENANCE AND LUBRICATION

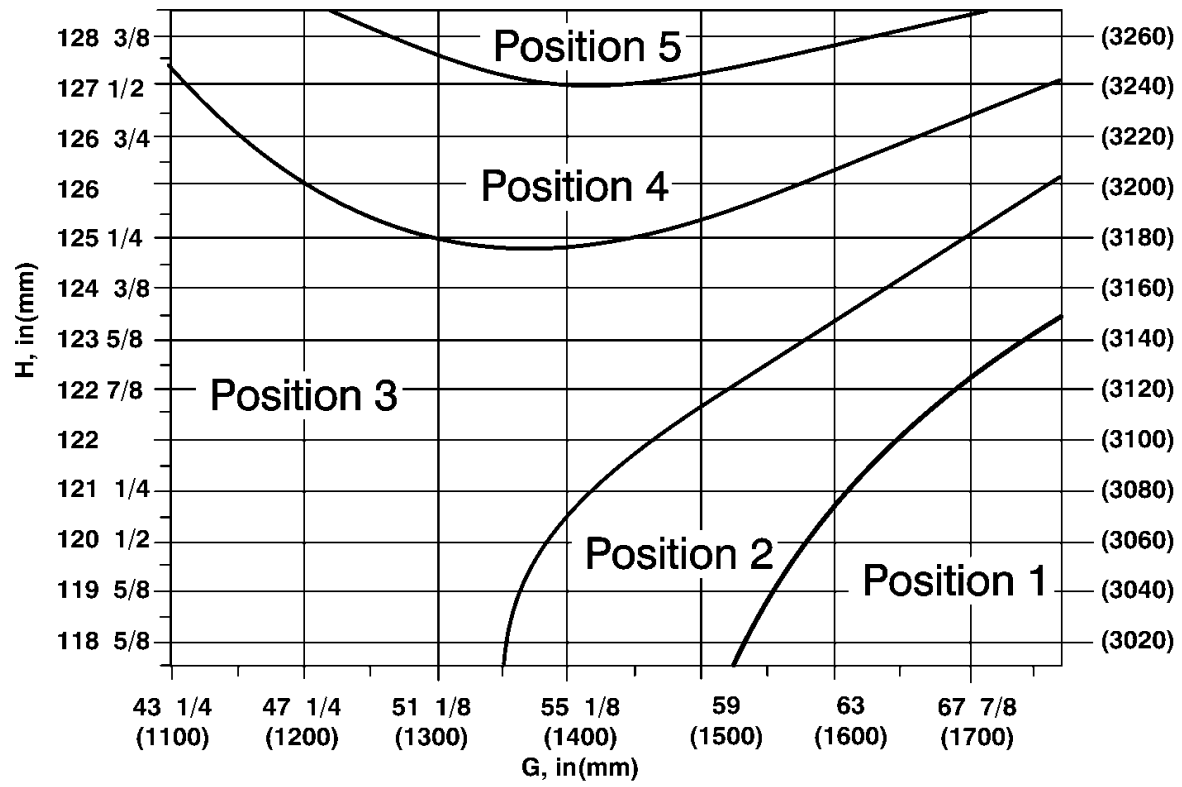

W8003473

VN 630/670 Roof Extender Adjustment
Chart

FRONT BUMPER/LICENSE PLATE MOUNTING



CAUTION

DO NOT cover the opening in the front bumper with a license plate. Covering this hole will restrict airflow to the lower portion of the radiator. This can cause the engine to overheat, which can damage the engine.

When placing the license plate on the vehicle, make sure the opening in the bumper is not covered.

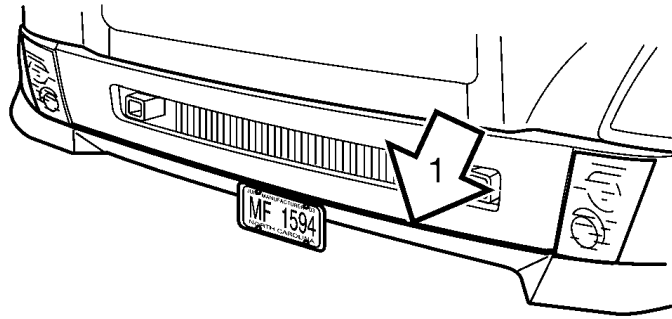

W8003518

416 MAINTENANCE AND LUBRICATION

Multiple License Plate Mounting

Install multiple license plates as shown.

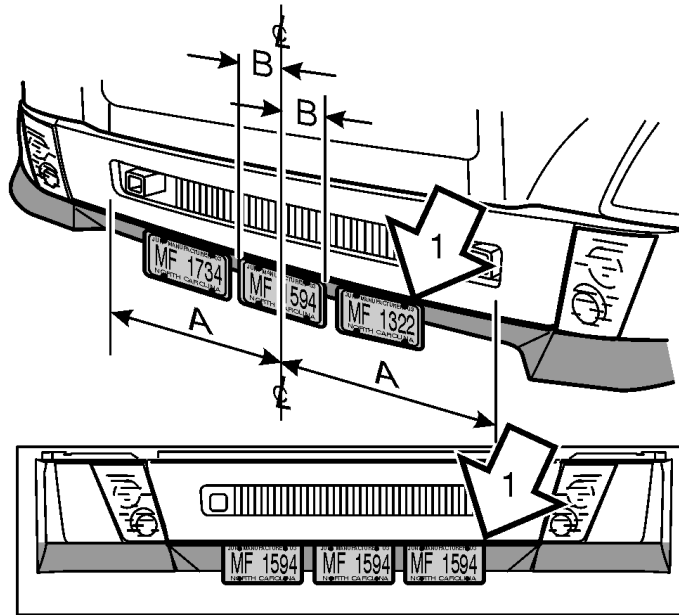

W8003370

VN

VORAD License Plate Mounting

Install multiple license plates as shown.

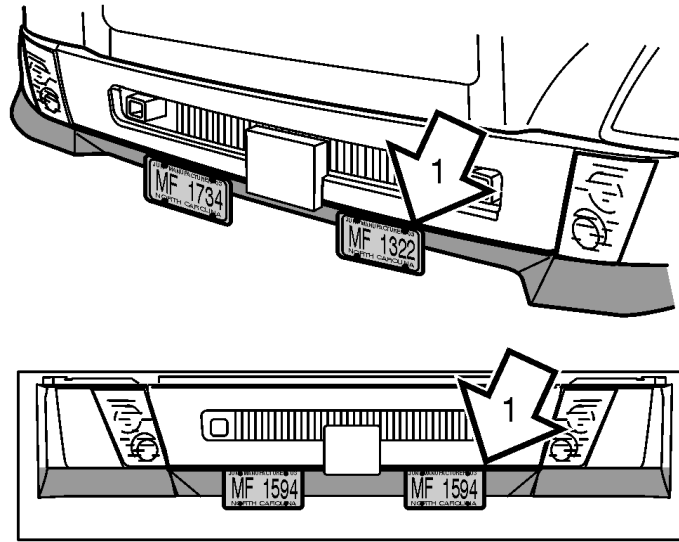

W8003371

Fig. Fig. 3 VN

- 1 Install license plates below this edge.

MODIFICATIONS TO VEHICLE

Chassis Frame



WARNING

DO NOT weld on any part of the frame or drill holes in the top or bottom flanges. Serious structural damage could occur.

Frame side rails are heat treated. No welding is permitted because this can result in structural failure. DO NOT drill through either top or bottom flanges. A warning label is also attached to the frame for information.

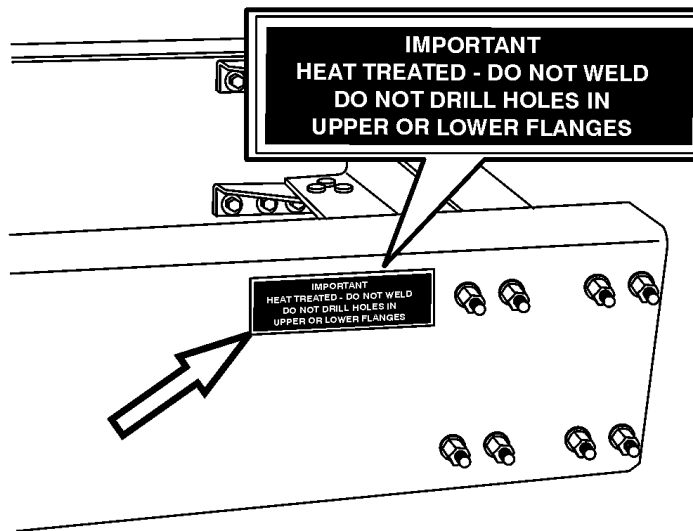

W7001277

Drilling is permitted in the frame web in accordance with a specified hole spacing pattern. Consult an authorized Volvo Truck dealer to obtain approved hole spacing dimensions or refer to the Frame Rail and Cross Member Service Manual.

Frame rail and cross member nuts and bolts should be checked periodically and tightened to the specified torque if necessary.

Frame Alterations

Under no circumstances can the frame be cut and an extension piece added to increase the wheelbase. The only alteration allowed is wheel base shortening, where the only change in the frame rail is a new hole pattern drilled for the new location of the rear suspension.

Welding in Vehicle



CAUTION

Use only electric welders due to the coating on material used to build cabs. Oxygen and Acetylene welding will not bond properly due to coating.

Do not weld anywhere in or on the vehicle before disconnecting batteries, all electronic control units (ECUs) and instrument cluster.
DO NOT use oxy/acetylene welding to repair cab panels.

WHEELS

General

Due to the size, equipment needed and the procedures used to change wheels, this should be done through the Volvo Truck dealer. By having an expert technician perform this procedure, personal injury and property damage may be avoided.

Note: When replacing the wheel equipment or tires, use the same size wheels or tires as originally manufactured. Changing the tire or wheel size will affect brake performance. If changing tire size, ABS and speedometer must be recalibrated.

Check Wheel Nuts Torque

DANGER

Failure to properly tighten the wheel nuts can result in the breakage of wheel studs and the subsequent loss of wheels. Loss of vehicle control and serious personal injury or death can occur.

Check all wheel nuts torque after the first 80 to 160 km (50 to 100 miles) and the first 80 to 160 km (50 to 100 miles) after each tire service. This applies to both single and dual wheels in connection with normal service but should be performed at least every six months.

The torque check is particularly important when rims or brake drums are newly painted. Paint can flake off from these surfaces, causing the nuts to lose their grip and the wheel to loosen.

See the Operator's Manual Vehicle Maintenance for correct procedures on tightening the wheel nuts.

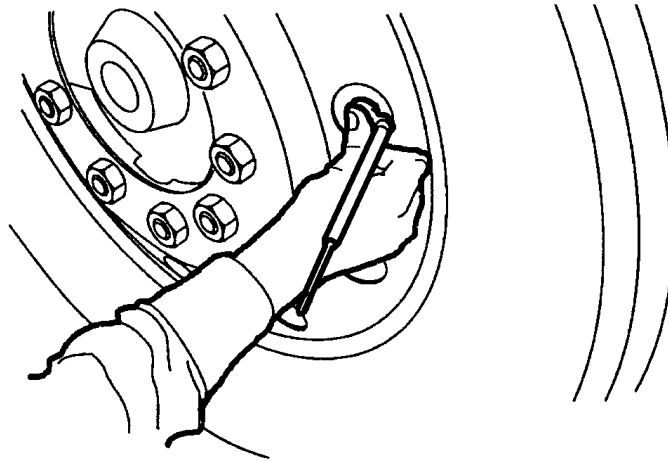

W7001270

Inflating Tires

DANGER

Tires and wheels must be serviced only by a qualified technician. **DO NOT** attempt to perform this work yourself. Inflated tires on wheels contain compressed air and if suddenly released, do so with an explosive force. Serious personal injury or death can occur.

CAUTION

Never bleed the air from hot tires. Increased tire pressure measured in a hot tire is normal. Lower than recommended pressures may cause side wall flexing resulting in increased tire heat. This may cause premature tire failure.

Always check inflation pressures when the tires are cool, using an accurate tire pressure gauge. Check the pressures at regular intervals. If a tire has low air pressure during a mid-trip inspection and the tire is at operating temperature, have the tire checked and then increase the air pressure to the recommended pressure identified on the tire.

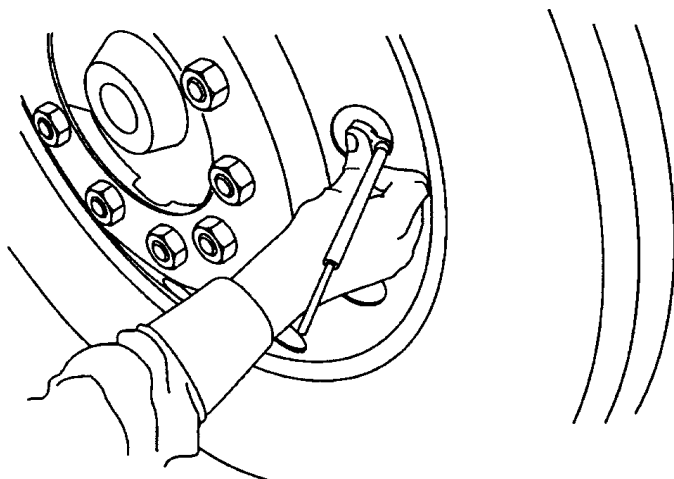

W2002684

For specific information and warranty on rims and tires, contact the tire manufacturer's distributor. Check tires for abnormal wear. Also, check the tread depth.

Wheel Bearing Adjustment

⚠ DANGER

Failure to keep wheel bearings properly adjusted may result in accelerated tire wear, poor handling and, in extreme cases, wheel separation from the hub or from the spindle. It is important that wheel bearings are checked and adjusted regularly. Failure to properly maintain these bearings can ultimately result in loss of vehicle control and cause serious personal injury or death.

For reliable operation and adequate service life, the wheel bearings must be properly adjusted and checked during the service period. Loose wheel bearings could cause premature tire wear and possibly affect vehicle handling. See your authorized Volvo Truck dealer for proper servicing.

Watch carefully for oil leaks and listen for unusual noises. These are indications of worn bearings, bad seals or misadjusted bearings. These are problems which must be corrected as soon as possible.

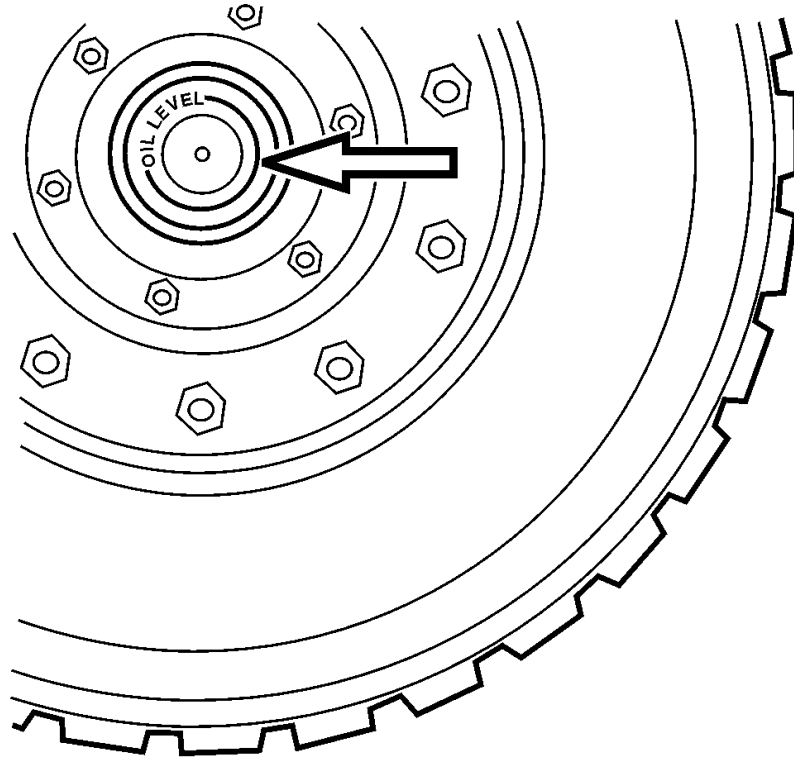

BATTERY

Battery Box Access for Jump Start

DANGER

When inspecting or cleaning batteries, never smoke or expose batteries (or the areas around them) to spark or flames. The battery area may contain an explosive gas mixture that can ignite, causing an explosion, leading to serious personal injury or death.

WARNING

Always wear eye protection when working around batteries to prevent the risk of injury due to contact with sulfuric acid or an explosion.

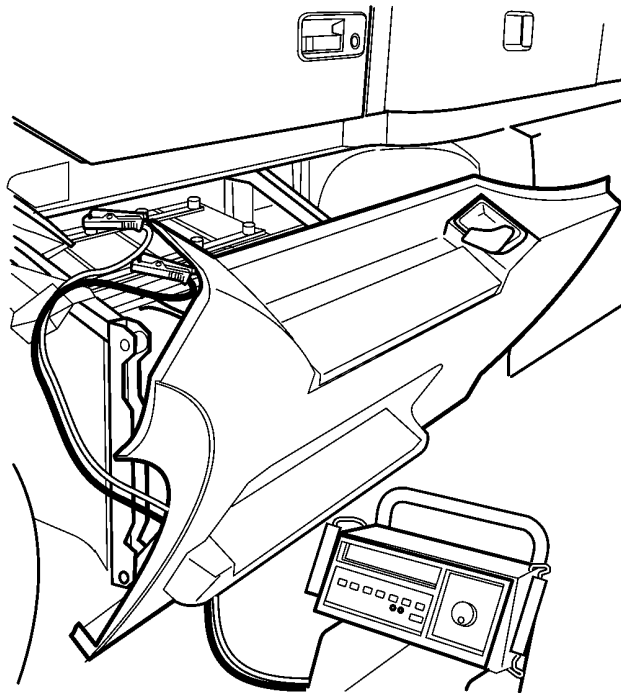

W3006385

DANGER

When installing the battery cover, make sure it is resting properly on the box before fastening the latches. Faulty installation may cause the cover to shift when the steps are used, which may lead to a fall, causing serious personal injury or death.

WARNING

Battery posts, terminals and related accessories contain lead compounds, chemicals known to the state of California to cause cancer and reproductive harm. Wash hands after handling.

The battery cover may also be a base for the cab steps. To remove the cover, unhook the two rubber latches and lift the cover up and out. This applies to the vehicle models without fairings.

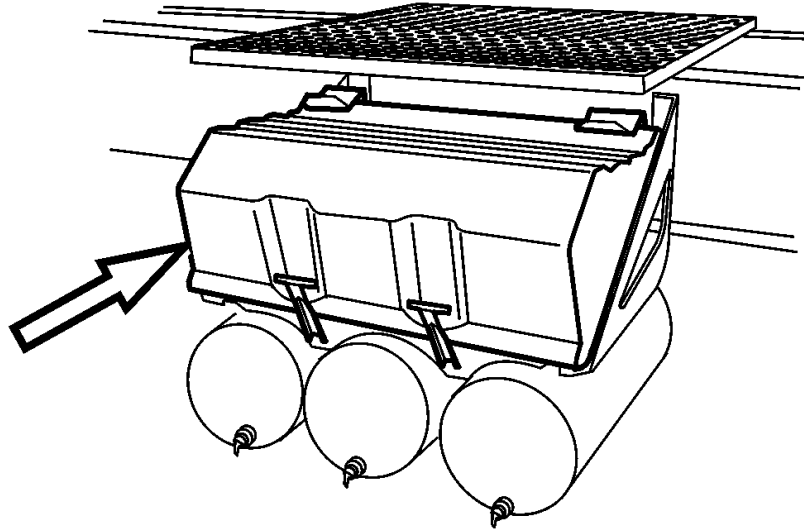

W3005334

There may be up to four batteries installed. Always make sure the batteries are fastened properly in the box.

When disconnecting battery terminals, always disconnect the engine ECU fuse(s) first, then the ECU ground wire(s), then the main ground cable, and finally the main positive cable.

Reverse this order when reconnecting the cables and wires.

Battery Jump Starting and Charging

DANGER

DO NOT attempt to jump-start a vehicle equipped with Delco Maintenance Free batteries if the test indicator is light yellow. Replace the battery instead. Jump-starting may cause battery to explode causing skin burns from acid or serious personal injury or death.

WARNING

Always wear eye protection when working around batteries to prevent the risk of injury due to contact with sulfuric acid or an explosion.

To access the batteries on a vehicle equipped with side fairings, open the fold-out fairing. On the second battery from the front, there are special, larger brass posts installed to accept jumper cables.

When jumping batteries to start an engine, it is important that the jumper cables are connected directly from one set of batteries in one vehicle to the other set of batteries in the other vehicle (unless vehicle is equipped with optional Emergency Start System). This way the cranking current is carried through the proper starter wiring.

Note: Make sure the cables are routed under the fairing, then connected as shown in illustration. Close and lock the fairing before climbing into the cab.

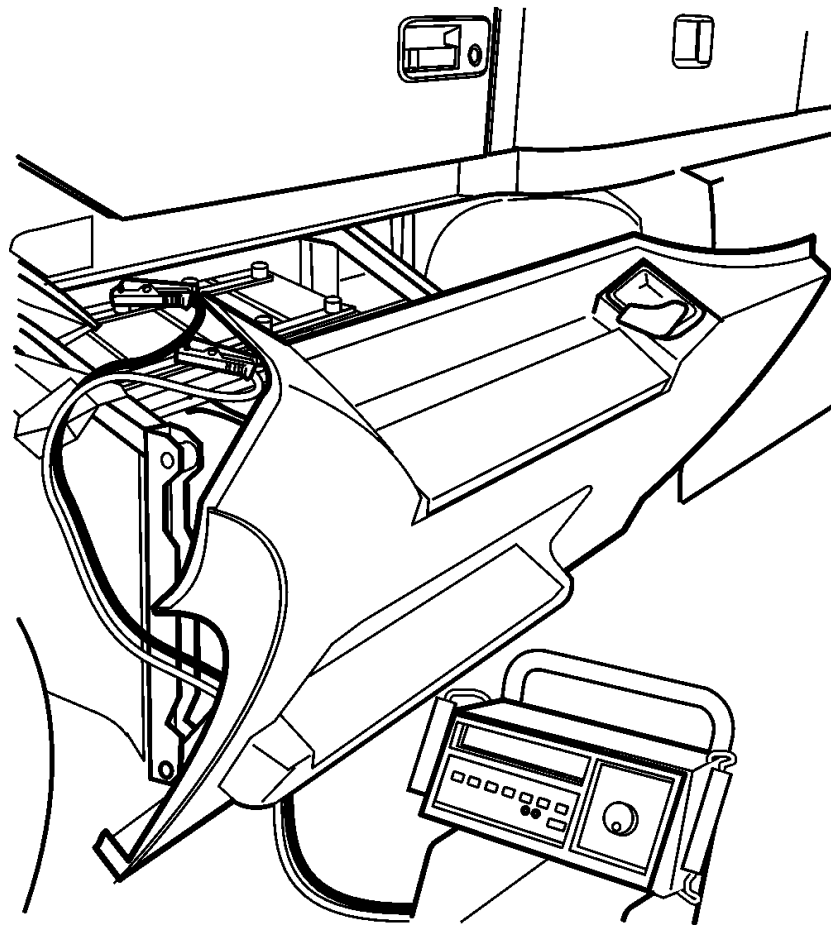

W3005322

Connect the jumper cables in the following sequence:

- Good battery positive,
- Dead battery positive,
- Dead battery negative,
- Disconnect the cables in the reverse order.

Avoid creating sparks by making all connections quickly and firmly. DO NOT permit vehicles to touch each other when jump starting.

Battery to Battery Charging

High voltage machines that are used for work on the vehicle can do damage to the electrical system, especially to its electronic components. Welding or quick-charging machines subject the wiring to excessive voltage, which may result in damage to electrical and electronic components anywhere on the vehicle.

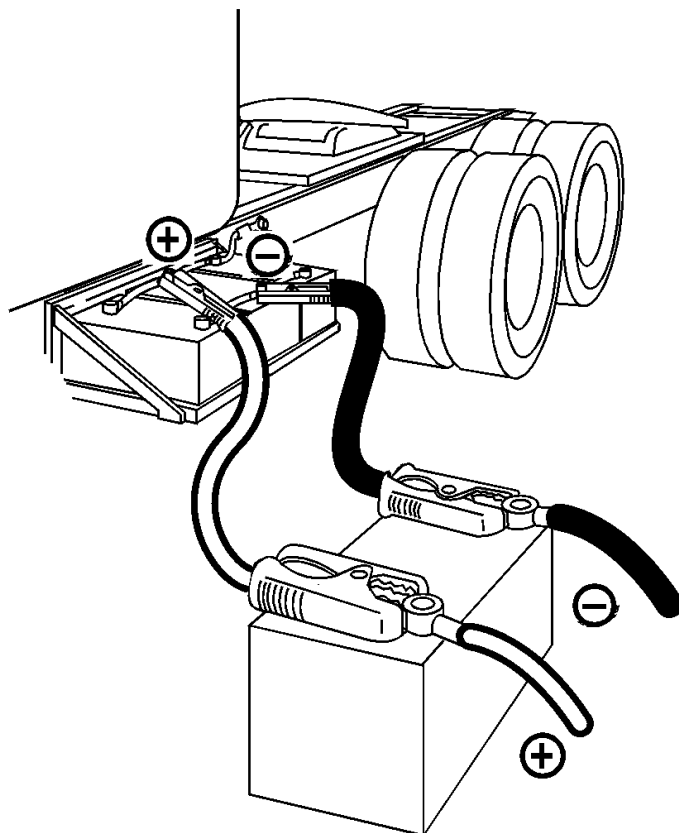

W3006384



CAUTION

Attempting to work on electronic components without proper equipment can damage internal parts due to static electric discharges.

DO NOT work on the electrical system without the proper tools and training. Repair work to the electrical system must always be done by trained professionals. Your Volvo Truck dealer has the right tools and trained technicians.

Battery, Low State of Charge

If the batteries are discharged to the point where they do not have enough stored energy to start the engine, they should be recharged using a low charge current, not to exceed 14.5 to 15.0 volts.

If the vehicle needs to be started immediately, use a starting batteries charger.

Note: If the voltage power is exceeded, this can cause damage to the lighting system and bulbs.

DO NOT use battery chargers with very high "boosting" capability. These produce a high voltage that may cause damage to the vehicle electrical and electronic components.

Welding



CAUTION

Welding on the vehicle can damage the electrical system or components due to the high voltage and current spikes that normally occur when welding. It is preferable to avoid welding on an assembled vehicle. However, if any structure on or in contact with the vehicle must be welded, follow the recommendations below.

430 MAINTENANCE AND LUBRICATION



CAUTION

If there are other ground cables connected to the battery (such as engine ECU, transmission ECU, etc.), disconnect those wires in the sequence shown, then remove the main battery ground cable. Electronic modules may be damaged when their ground(s) are connected/disconnected with the main battery ground disconnected. Therefore, disconnect the main battery ground last or when installing, connect the main ground first.



CAUTION

DO NOT weld on the engine or engine components. Welding on the engine or components mounted on the engine can cause serious damage to the engine ECU.

Before welding on the vehicle, electrical power needs to be disconnected and some components must also be disconnected:
Ignition OFF position.

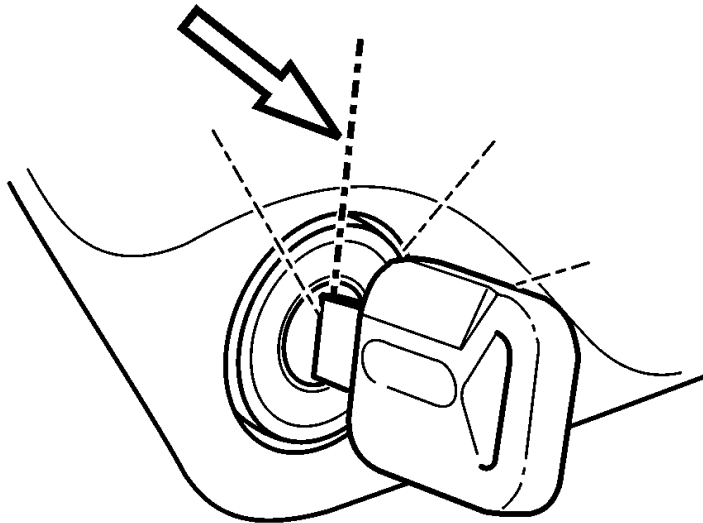

1

The vehicle is equipped with systems that have their own electronics, including vehicle ECU (VECU), ABS, air bag (SRS), gauge cluster and some transmissions. Disconnect each ECU at its electrical connectors.

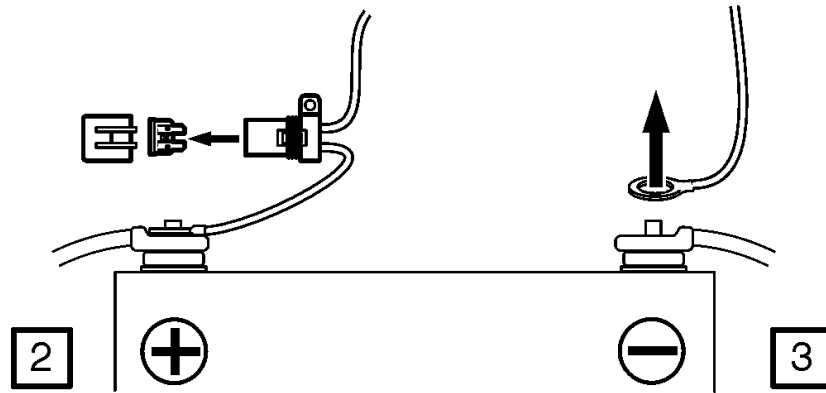

W8003198

Disconnect the power harness (engine electronic control unit [EECU]) and vehicle interface harness at the battery.

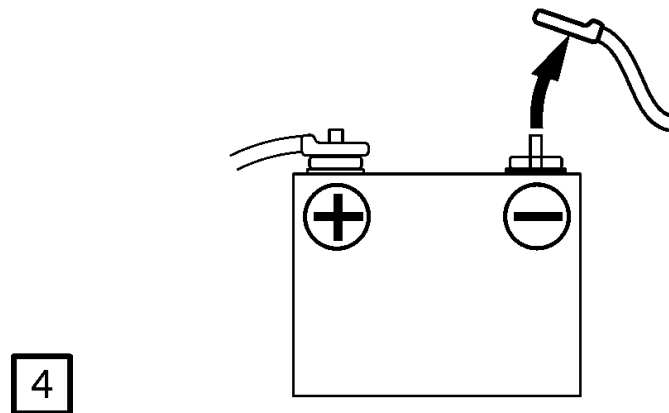

4

W8003199

Disconnect the electrical connections at the negative side of the battery.

432 MAINTENANCE AND LUBRICATION

Reposition or shield any parts that would be damaged by high temperatures during welding.

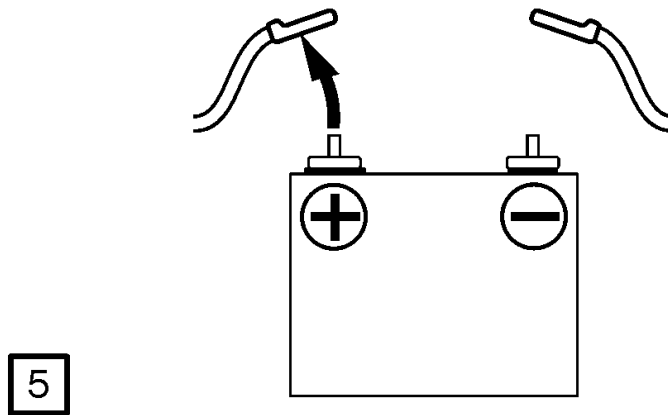

5

W8003200

Complete the battery cable removal by removing the positive cable last.

- Attach the welder ground cable as close to the weld area as possible (6 inches or less from the place being welded).
- DO NOT connect the welder ground cable near any electronic module, such as the EECU or its cooling plate.
- Welding cables should not be allowed to lie on, or run parallel with any wiring.
- Welding cables should not be allowed to lie near any electronic component during welding.
- After welding is complete and the welded areas have cooled, inspect wiring and components for possible shorts, nicks, abrasion or other damage.

Battery Voltage Protection System

The vehicle is equipped with a battery protection system. The vehicle detects when the batteries are excessively discharged and will flash the indication light and sound an audible alarm. Should the battery voltage remain low for an additional 30 seconds the indication light and alarm rate increases (fast flash). This indicates that some circuits will be disconnected in 30 seconds to maintain engine starting capacity.

Once these circuits are disconnected the indication light will have a slower flash rate (every 2 seconds).

To reset the system, press the dash fan control switch or start the engine and allow the vehicle's charging system to recharge the batteries.

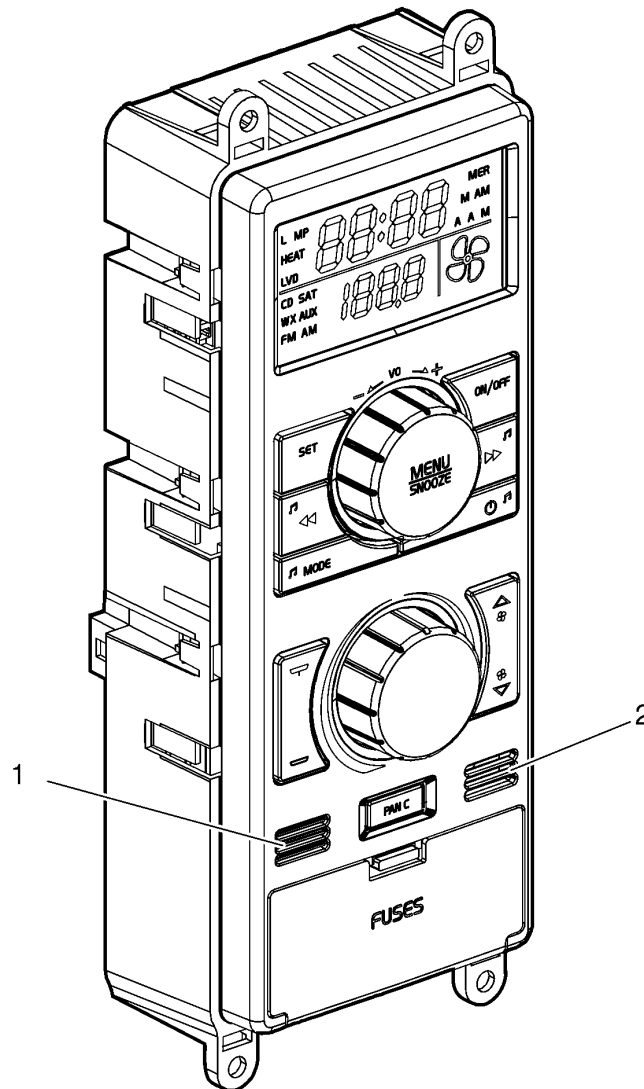

- 1 LED
- 2 Fuses

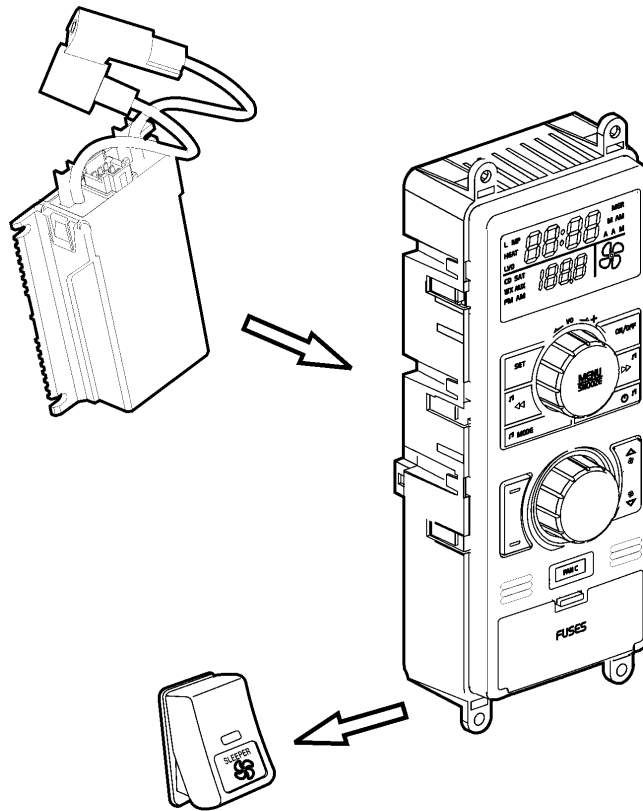

W3030711

Battery Protection Data Flow from LVD

Note: Pressing the fan speed button over rides for approximately 10 minutes, enabling all loads.

When the batteries are charged, either through the vehicle alternator or a connected battery charger, the monitor will automatically restore power to the disconnected circuits.

Unless the batteries are held at an elevated voltage for several hours, they will only develop a "surface" charge. That charge will quickly go away and the system will retrip.

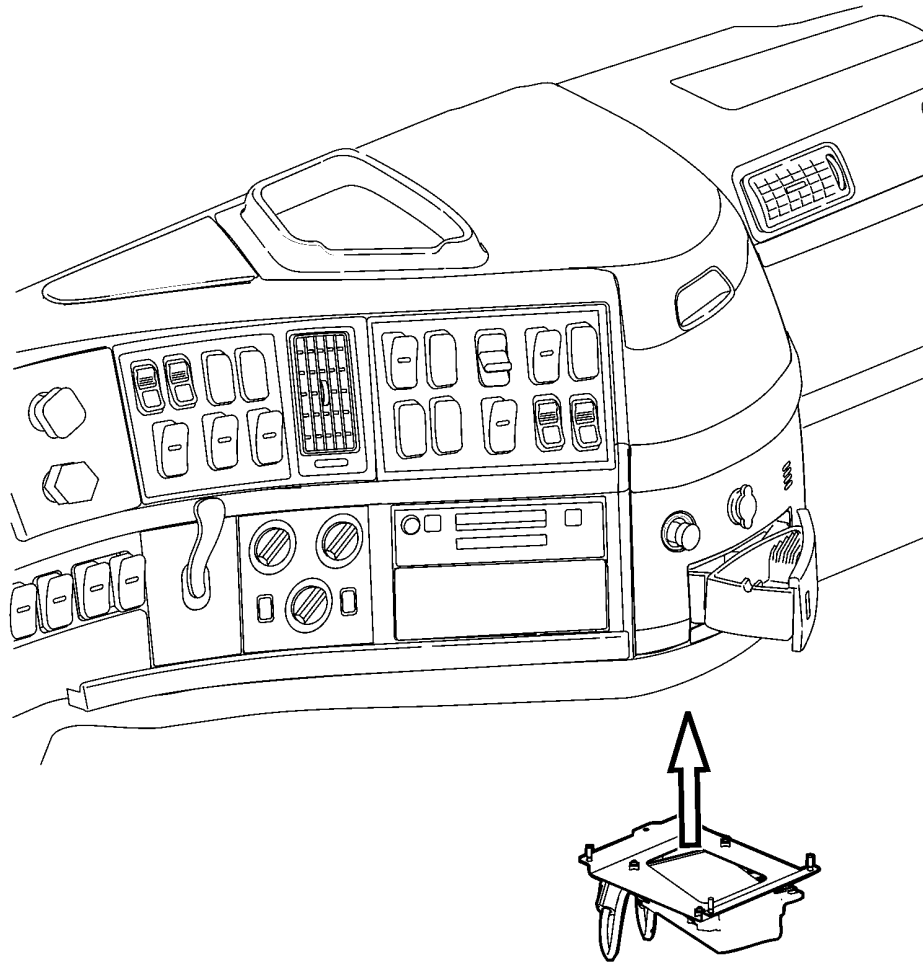

W3030520

In situations where there is a short or overcurrent (over 100 Amps), the battery voltage protection system will initiate a different audible and visual alarm. The alarms are activated at a series of three 30 second intervals. If the short or overcurrent situation is not resolved by the final alarm series, the LVD shuts down in order to protect the vehicle electrical system. If the system is shut down, you must perform a battery disconnect to reset the system.

In situations where overcurrent is the most likely cause (e.g., multiple pieces of electrical equipment on at once), turn off all unnecessary electrical equipment. The system should return to normal. If not, then turn off any remaining equipment and allow the system to return to normal.

If you have turned off all unnecessary equipment, and the alarm is still active, then a vehicle short is the most likely cause. Take the vehicle to a service center for maintenance.

ELECTRICAL

General Safety Guidelines



WARNING

Failure to repair a malfunction in the electrical system can result in serious damage due to vehicle fire. Always let an experienced electrical technician perform repairs. Always determine the source of the fault; do not just treat the symptoms.



WARNING

Always wear eye protection when working around batteries to prevent the risk of injury due to contact with sulfuric acid or an explosion.



WARNING

Before replacing a damaged fuse, turn off all functions for that circuit. Damage to the circuit can happen. Always replace fuses and circuit breakers with the same current/amperage rating. Never substitute a fuse with foil, wire or nails. Increasing fuse or circuit breaker ratings or substituting a fuse with foil, wire or nails may result in electrical circuit overheating and possibly fire.



WARNING

Over-charging a poorly charged battery can cause an explosion, which can lead to serious personal injury.

 **CAUTION**

Attempting to work on electronic components without proper equipment can damage internal parts with static electricity.

 **CAUTION**

Today's vehicles contain a high number of electronic devices. It is very important to exercise caution when working on a modern electrical system, charging batteries or jump starting the engine. To minimize the risk of any damage to the electronic components, follow the procedures below when work is being done to the electrical system.

 **CAUTION**

Welding on the vehicle can damage the electrical system or components due to the high voltage and current spikes that normally occur when welding. It is preferable to avoid welding on an assembled vehicle. However, if any structure on or in contact with the vehicle must be welded, follow the recommendations below.

 **CAUTION**

If there are other ground cables connected to the battery (such as engine ECU, transmission ECU, etc.), disconnect those wires first, then remove the main battery ground cable. Electronic modules may be damaged when their ground(s) are connected/disconnected with the main battery ground disconnected. Therefore, disconnect the main battery ground last or when installing, connect the main ground first.



CAUTION

DO NOT weld on the engine or engine components. Welding on the engine or components mounted on the engine can cause serious damage to the engine ECU.

Note: DO NOT work on the electric system without proper tools and training. Repair work to the electrical system must be done by trained professionals. Your authorized Volvo Truck dealer has the right tools and trained technicians.

Charging System

An alternator with an integrated regulator is used to supply power to the vehicle electrical system. The charging system voltage should be checked periodically to prevent overcharging or undercharging the batteries.

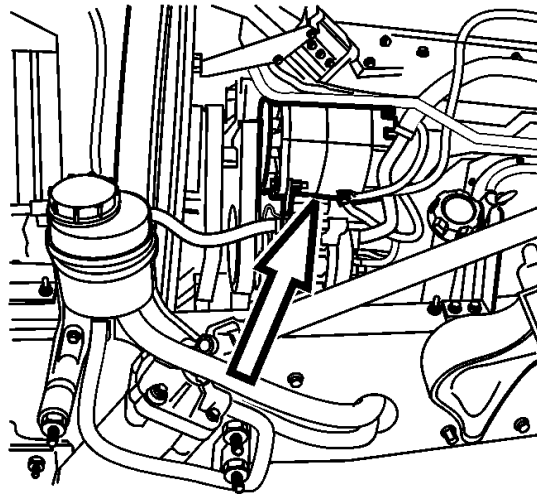

W3005339

Electrical Center

WARNING

Failure to repair a malfunction in the electrical system may result in a vehicle fire and personal injury.

WARNING

Always replace fuses and circuit breakers with the same current/ampere rating. Using larger fuse or circuit breaker ratings may result in electrical circuit overheating and possibly fire.

The vehicle has an electrical center located in the middle of the dash under the top cover.

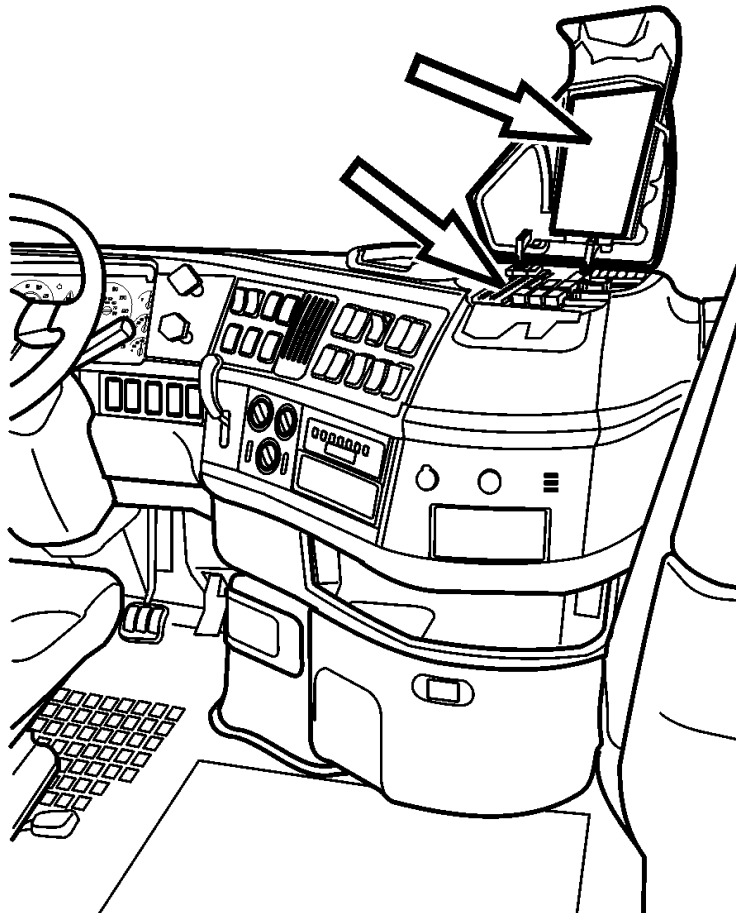

440 MAINTENANCE AND LUBRICATION

The cover panels are fastened with screws. Most relays and fuses are accessible from under the top cover. Since the function of some fuses or relays may change for the vehicle application, refer to the list of functions that is attached beneath each panel.

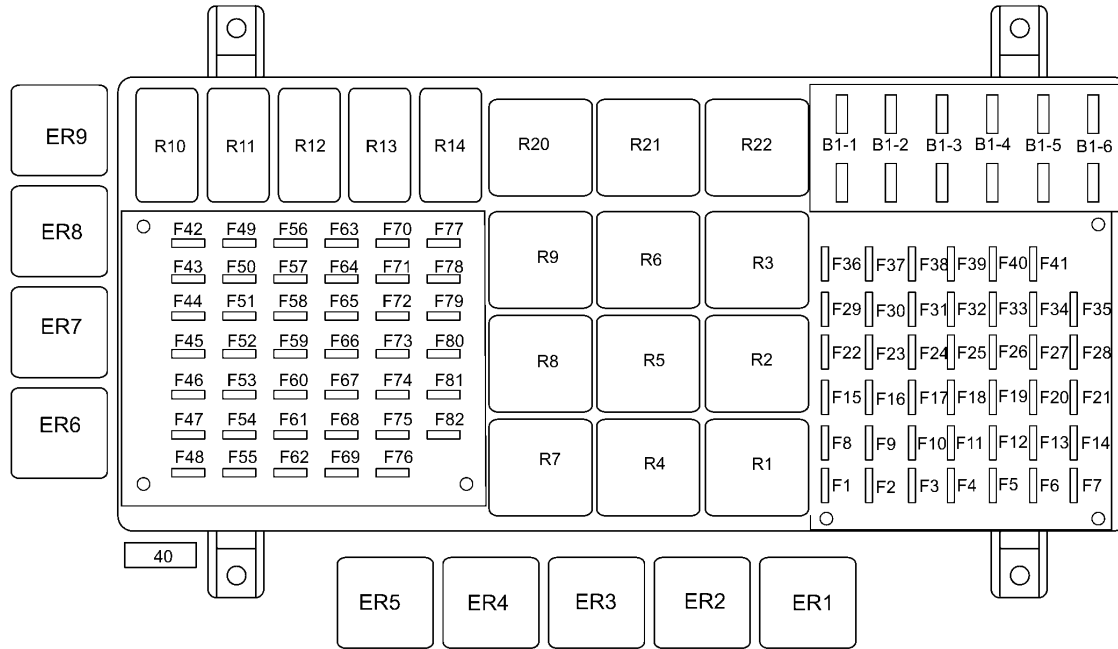

W3007220

Additional relays are located in the left-hand luggage compartment, attached to the sleeper harness.

Note: These relays have limited optional sleeper functions.

Additional fuses are located in the Sleeper Control Panel.

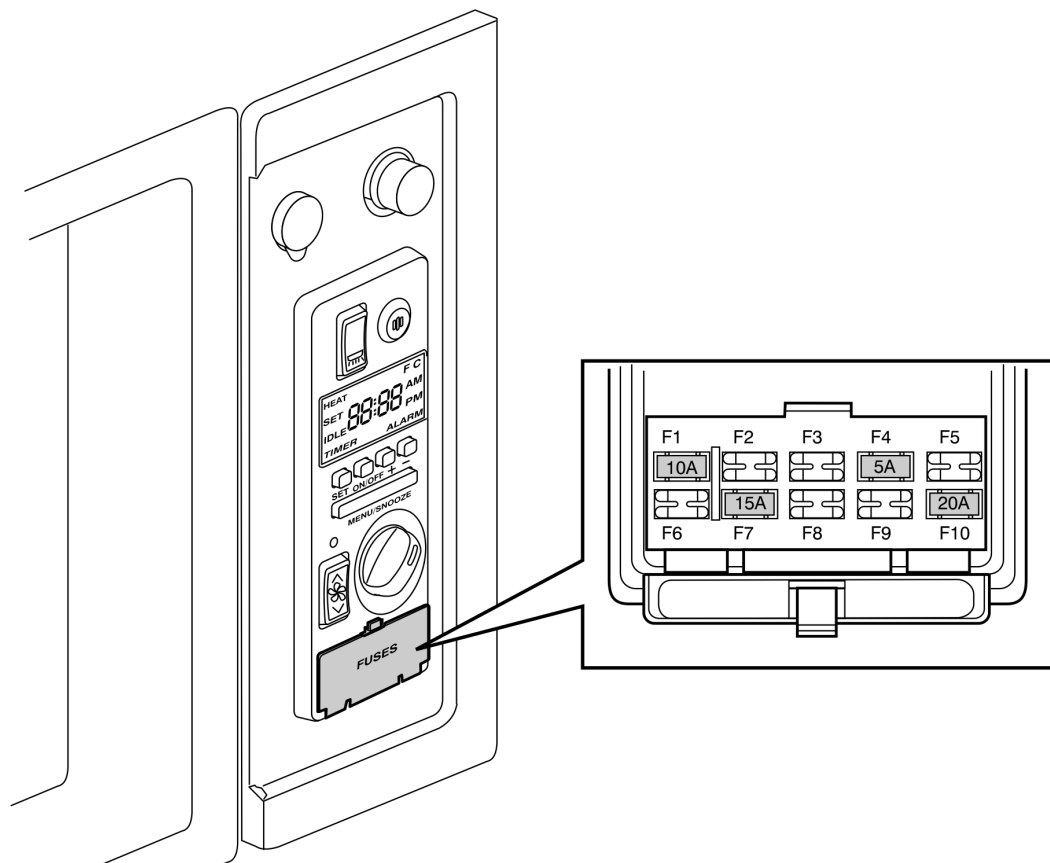

W3007222

Sleeper Control Panel Fuses

Fuses are standard. Reset breakers are available as an option for some circuits. If a fuse continues to blow or disconnect, the circuit has a malfunction and must be repaired.

If a breaker trips, the ignition or main switch must be switched off before the breaker resets.

One type of fuse in the electrical center is termed "mini-fuse." DO NOT use needle-nose pliers to remove fuses.

442 MAINTENANCE AND LUBRICATION

CB Power Studs

CB Studs are available either in the overhead storage compartment, or on the dash.

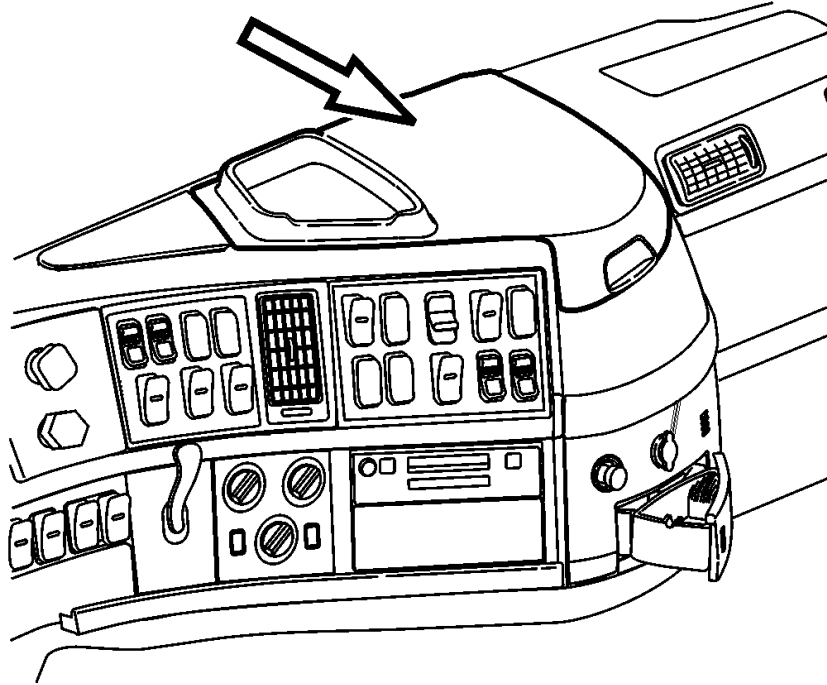

W3005282

The red stud is the positive terminal and the black stud is the ground terminal.
For a proper hook-up, use fork-type connectors on the wires or use "banana" plugs.



CAUTION

If stripped wire ends are used, make sure there are no wire strands that can bridge between the studs.

Before connecting any electrical accessory, make sure it is made for 12 V operation. This circuit is fused at 20 A maximum, or optional circuits are fused at higher amps (30 A). DO NOT overload this circuit.



CAUTION

DO NOT connect a device with a current rating in excess of the amount specified on the fuse and relay panels.

The dash top tray or the overhead radio shelf is available with an optional CB mount power strap to hold different size radios securely in place.

METRIC CONVERSIONS

Note: Use all tools on the fasteners they were made to be used on. Use metric tools on SI metric units only. Never try to use metric tools on U.S. standard fasteners or U.S. standard tools on SI metric units.



CAUTION

Potential external/internal thread mismatch condition(s) may occur with certain metric thread-inch thread fastener combinations, and with fastener combinations involving incompatible metric fastener systems. A given thread mismatch condition can result in thread stripping and/or assembly weakness leading to potential service failure, thereby rendering a vehicle non-operational and/or unsafe for operation. The specific external/internal thread combinations from which such problems can result are identified and set forth in Maintenance and Lubrication Manual (TS494).

SI to U.S. Conversions

25.4 millimeters	=	1 inch
1.61 kilometers	=	1 mile
.473 liter	=	1 pint (U.S. liquid)
.946 liter	=	1 quart (U.S. liquid)
.01639 liter	=	1 cubic inch
1.3558 Newton meters	=	1 pound-foot
.746 kilowatt	=	1 horsepower
6.895 kilopascals	=	1 pound/square inch
(1.8 x degrees Celsius) + 32	=	degrees Fahrenheit
.83267 Imperial gallon	=	1 gallon (U.S. liquid)

U.S. to SI Conversions

.03937 inch	=	1 millimeter
.6214 mile	=	1 kilometer
2.1134 pints (U.S. liquid)	=	1 liter
1.0567 quarts (U.S. liquid)	=	1 liter
61.024 cubic inches	=	1 liter
.7376 pound-foot	=	1 Newton meter
1.34 horsepower	=	1 kilowatt
.145 pound/square inch	=	1 kilopascal
.556 x (degrees Fahrenheit -32)	=	degrees Celsius
1.2009 gallons (U.S. liquid)	=	1 Imperial gallon

VOLVO

Volvo Trucks North America

P.O. Box 26115, Greensboro, NC 27402-6115

Volvo Trucks Canada, Ltd.

5600A Cancross Court, Mississauga, Ontario L5R 3E9

<http://www.volvotrucks.com>