

Service Manual Trucks

Group **30**

New Features
Electrical General
VNL, VNM

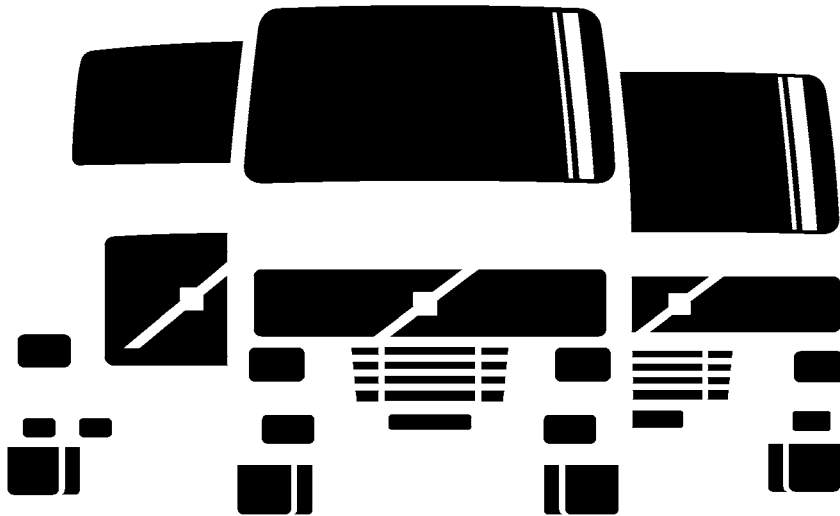

PV776-TSP23760/1

VOLVO

Foreword

The descriptions and service procedures contained in this manual are based on designs and methods studies carried out up to January 1996.

The products are under continuous development. Vehicles and components produced after the above date may therefore have different specifications and repair methods. When this is believed to have a significant bearing on this manual, supplementary service bulletins will be issued to cover the changes.

The new edition of this manual will update the changes.

In service procedures where the title incorporates an operation number, this is a reference to an S.R.T. (Standard Repair Time).

Service procedures which do not include an operation number in the title are for general information and no reference is made to an S.R.T.

The following levels of observations, cautions and warnings are used in this Service Documentation:

Note: Indicates a procedure, practice, or condition that must be followed in order to have the vehicle or component function in the manner intended.

Caution: Indicates an unsafe practice where damage to the product could occur.

Warning: Indicates an unsafe practice where personal injury or severe damage to the product could occur.

Danger: Indicates an unsafe practice where serious personal injury or death could occur.

Volvo Trucks North America, Inc.
Greensboro, NC USA

Order number: PV776-TSP23760/1

© 1996 Volvo Trucks North America, Inc., Greensboro, NC USA

All rights reserved. No part of this publication may be reproduced, stored in retrieval system, or transmitted in any forms by any means, electronic, mechanical, photocopying, recording or otherwise, without the prior written permission of Volvo Trucks North America, Inc..

Contents

General	3	Rear Suspension Cab Unloader Control Valve Replacement	66
Electrical System - VNL, VNM (06.96 to 02.98)	3	Lift Axle Control Valve Replacement	66
Specifications	5	Fifth Wheel Slider Valve Replacement	66
Replacement Wire Sizes	5	Differential Lockout Valve Replacement	66
Tools	7	Axle Lock Control Valve Replacement	66
Special Equipment	7	Dash Air Switch Replacement	66
Design and Function	9	Cigar Lighter Replacement	68
General Circuit Information	9	Hazard Lamp Switch Replacement	69
Circuit Types	11	Auxiliary Light Switch Replacement	69
Starting and Charging System	18	Dash (Left Side) Switch Replacement	69
Electrical Pass-Through for Cab Wiring, Power and Ground	22	Marker Interrupt Switch Replacement	70
Switches and Controls	23	Idle Control Switch Replacement	70
Fuse and Relay Locations	29	Heated Mirror Switch Replacement	70
Lighting System	35	Traction Control (TCS) Switch Replacement	70
Instrumentation	41	Dash (Right Side) Switch Replacement	71
Service Procedures	43	Radio Replacement (Dash Mounted)	72
General Work Practices and Cautions	43	Ignition Power Relay Replacement	74
Soldering/Wire Splicing	46	Accessory Power Relay Replacement	76
Battery Cable Fusible Link Replacement (Battery to Starter)	47	Daytime Running Lamp Control Module Replacement	79
Battery Cable Fusible Link Replacement (Ground Cable)	48	Combi Relay Replacement	80
Ignition Switch Replacement	50	Power Window Switch Replacement (Right or Left)	82
Ignition Switch and Housing Replacement	52	Power Mirror Switch Replacement	83
Horn Contacts Replacement	54	Digital Clock (Sleeper) Replacement	84
Turn Signal/CC Switch Replacement	56	Sleeper Reading Lamp Switch Replacement	86
Windshield Wiper Switch Replacement	58	Sleeper Heater Control Switch Replacement	86
Headlight/Parking Lamp Switch Replacement	60	Sleeper Control Panel Switch Replacement	86
Road Lamp (Fog Lamp) Switch Replacement	62	Windshield Wiper Motor Replacement	87
Dimmer Control (dash illumination) Rheostat Switch Replacement	64	Windshield Wiper Linkage Assembly Replacement	88

Operation Numbers

General

Electrical System - VNL, VNM (06.96 to 02.98)

This manual describes the new electrical features of VN Series vehicles from introduction 06.96 until 02.98, as well as general heavy duty electrical service information. It includes information on new components, circuit types, controls, connectors and the tools commonly used for maintenance.

The electrical systems of VOLVO trucks are designed to withstand the demands of a heavy duty motor truck under all types of operation. Every effort has been made to provide trouble-free operation, easy maintenance and service, and to provide maximum life of the system and its components.

For more information on VNL and VNM electrical circuitry, refer to the vehicle electrical schematics.

Specifications

Replacement Wire Sizes

The size of wire used when installing accessories or repairing existing electrical items is dependent on the length of the wire and power requirements of the accessory. The chart below can be used to determine the proper wire size for 12 volt systems.

To use the chart, mark the appropriate length for the wire being installed in the m/ft column. Also mark the rating in the amps/watts column. Then draw a line connecting the mark in the length column to the one in the rating column. The point where the line crosses the wire size column is the size of the wire required. If the line crosses the wire size column between gauge sizes, round up to the next larger size.

If replacing a wire and the amperage of the circuit is not known, it can be measured using a digital multimeter placed in series in the circuit.

EXAMPLE:

A 12 volt hydraulic pump motor is rated at 20 amps.

The complete length of the circuit (power and ground sides) is approximately 20 feet.

A line drawn from 20 on the length column to 20 on the rating column crosses the wire size column at the 8.

This indicates that the minimum wire size for the application is 8 gauge.

12 VOLTS

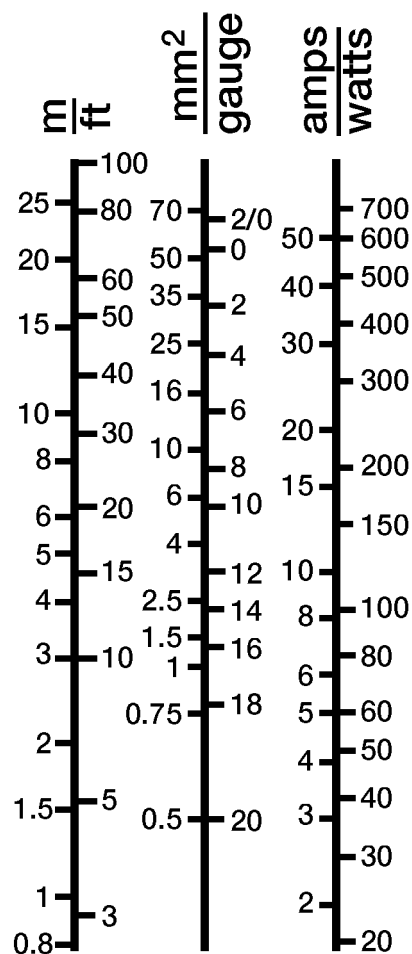

W3001006

Chart for calculating relationship between wire length, gauge and amperage/wattage

Tools

Special Equipment

The following items can be ordered from the vendors listed.

Digital Multimeter (DMM)

A Digital Multimeter (DMM) is one of the most important tools available for electrical troubleshooting. A multimeter such as a Fluke 87 is recommended for troubleshooting. It provides diagnostic capabilities such as current (amperage), resistance and voltage tests, as well as specialized features for automotive troubleshooting. Any circuit can be tested for continuity or short circuits with a low-reading voltmeter.



CAUTION

Never use the ohmmeter mode in a powered circuit, or as a substitute for a voltmeter or ammeter, as damage to the instrument will result. Use the ohmmeter mode only when power is removed from the circuit.

When using a multimeter and the value being tested is unknown, always use the highest scale first and work down to a mid-scale reading whenever possible. This will avoid damage to the instrument.

Before using the DMM to measure resistance, check its calibration by touching the leads together. If there is a reading other than zero, subtract it from measurements made with the DMM.

The following tests can be performed with a DMM:

- Current (amperage) check
- Voltage check
- Resistance check
- Diode check

Anti-Static Wrist Strap

A wrist grounding strap must be worn when working on electronic equipment such as the instrument cluster. This is to prevent electrostatic discharge (ESD), which can damage electronic components. To use the wrist strap in a vehicle, attach the alligator clip to the nearest electrical ground such as a ground terminal or preferably a ground stud.

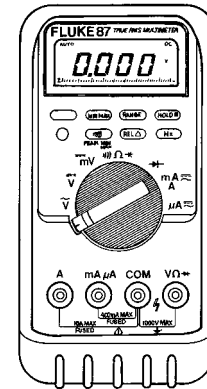

W2001014

Fluke 87 Digital Multimeter
Available from Volvo (P/N 9510060)
or available from your local Fluke dealer

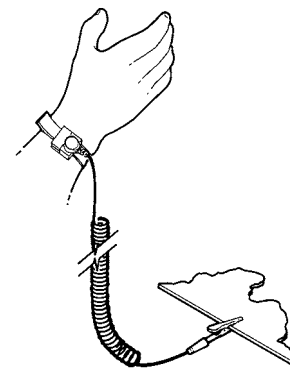

W3000572

Anti-Static Wrist Strap
Available from Kent-Moore (P/N BT-8639-B)
Call 1-800-328-6657

Static Dissipative Mat

Make sure the workbench has an anti-static mat which is grounded to the nearest electrical outlet when working on electronic equipment such as the instrument cluster. When working at the anti-static workbench, always keep a wrist strap connected to the anti-static mat. Note that the Static dissipative kit shown includes both an anti-static mat and wrist strap.

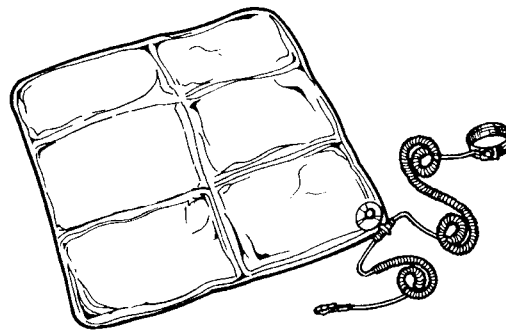

W3000704

Full-Size Type 8501 Static-Dissipative Grounding Kit, Available from Newark (P/N 46F7444)
Call 1-910-292-7240

Rheostat Removal Tool

The rheostat removal tool is used when removing the dash rheostat (see *Service Procedures*).

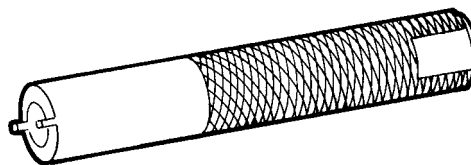

W3000799

Rheostat Removal Tool
Available from Kent-Moore (P/N J-42395)
Call 1-800-328-6657

Window/Mirror Switch Removal Tool

The window/mirror switch removal tool is used to remove the power window and motor/heated mirror switch connectors (see *Service Procedures*).

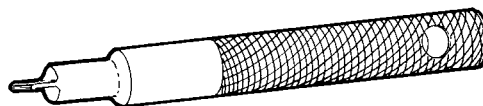

W3000800

Window/Mirror Switch Removal Tool
Available from Kent-Moore (P/N J-42396)
Call 1-800-328-6657

Design and Function

General Circuit Information

Circuit Malfunctions

In an electrical circuit, current completes a path from its source through the component(s), and then back to its source. If it starts at the battery, it must return to the battery. Current will return to the source even in circuits that are not operating properly.

There are three electrical conditions that cause an inoperative circuit; these conditions are known as an "open circuit," a "short circuit" and a "grounded circuit."

Open Circuit

Whenever there is a complete break or interruption in the normal current path, such as a break in wiring from the source of power to the electrical unit or within the unit itself, current will not flow. In a circuit, current normally travels through the wires or cables, to switches and electrical unit(s), such as the starter solenoid and cranking motor, through another wire to ground and back to the source.

A break anywhere along this route results in an open circuit and the complete loss of power. In a sense, the break is a very high resistance in the circuit. However, the symptoms will appear somewhat different than the typical high resistance because there is no current flow. An ammeter will not register at all because there cannot be current flow through an open circuit. A voltmeter, depending on where it is placed in relation to the open circuit, may or may not give a reading. The proper use of meters is covered later in this manual.

Any abnormal resistance reduces the current flow in a circuit and leaves the unit intermittent or non-functioning.

An open or high-resistance circuit may occur as the result of a broken wire within the wiring harness, loose connections at terminals of electrical units, broken wiring within the units, or poor ground connections between the unit and ground. Open circuits, depending on the type and location of the open, can easily create a shorted or a grounded circuit condition.

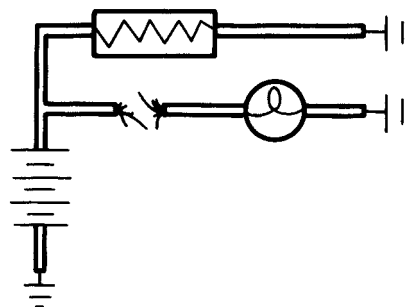

W3000489

Short Circuit

The term short circuit is used to describe another type of condition which can develop in electrical circuits or units. It refers to a circuit that is completed in the wrong way, such as two bare wires touching each other, so that the current bypasses part of the normal circuit. Bypassing part of the normal circuit simply means that the current has found the path of the least resistance and a higher current flow, amperage, results. This can result in blown fuses, open circuit breakers, wiring or component overheating, burned parts and insulation and, of course, non-working components. Hot, smelly insulation is always a sign of trouble. If the wire melts through, there is no electrical path, so the circuit then becomes open.

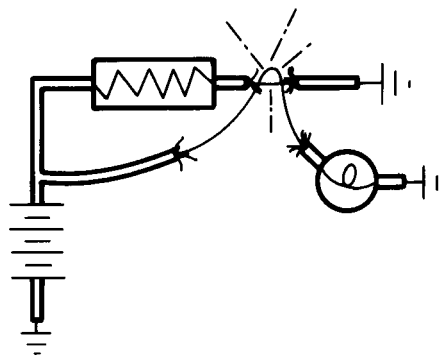

W3000490

Grounded Circuit

A grounded circuit is similar to a short circuit in that the current bypasses part of the normal circuit. In this instance, the current flows directly to ground. This may be caused by a wire touching ground or part of the circuit within a unit coming in contact with the frame or housing of the unit. A grounded circuit may also be caused by deposits of oil, dirt and moisture around connections or terminals.

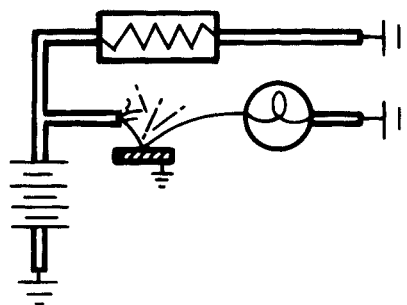

W3000491

Circuit Types

Ohm's Law

Current is the flow of electrons through a conductor, and is measured in amperes. Voltage (measured in volts) is the force or pressure which pushes the current through the conductor. Resistance is opposition to current flow, and is measured in ohms (Ω).

Ohm's Law describes the relationship between voltage (V), current (I) and resistance (R):

$$V = I \times R$$

$$I = V \div R$$

$$R = V \div I$$

Using this formula, if any two of the values in the formula are known, the other value can be found. Ohm's Law tells us that voltage and current increase proportionally. That is, when voltage increases, current will also increase if resistance stays the same. When resistance increases, current will decrease.

Series Circuits

In series circuits, each electrical device is connected to other electrical devices in such a way that there is only one path for the current to follow as it flows from the battery, through the circuit and back to the battery.

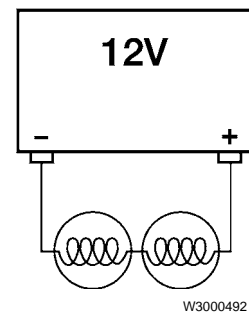

Typical Series Circuit

Ohm's Law in Series Circuits

In a series circuit, the total circuit resistance is the sum of all the resistors in a circuit. In the example below, the values of the 2 resistors are added together for the total circuit resistance.

$$2\Omega + 4\Omega = 6\Omega \text{ total resistance}$$

Apply Ohm's Law to find the total circuit current:

$$I = V \div R$$

$$I = 12 \text{ volts} \div 6\Omega = 2 \text{ amps}$$

Since current is the same at any point in a series circuit, to find the voltage drop across either resistor, use the above current value in the formula:

$$V = I \times R$$

$$V = 2 \text{ amps} \times 2\Omega = 4 \text{ volts}$$

$$V = 2 \text{ amps} \times 4\Omega = 8 \text{ volts}$$

The sum of the voltage drops equals the source voltage:

$$4 \text{ volts} + 8 \text{ volts} = 12 \text{ volts}$$

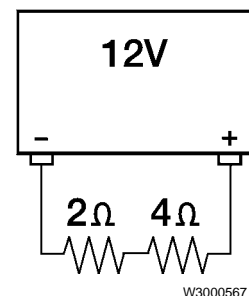

Parallel Circuits

In parallel circuits, electrical devices are connected by parallel wires. The current divides; part of it flows into one device, part into another. The voltage remains the same across each branch of the circuit as though each branch was connected directly to the source voltage.

With circuits in parallel, each circuit can be switched on and off by itself since each receives current independently of the other circuits. The current divides across each branch of the parallel circuit; the sum of the current in each of these branches is the total current in the circuit.

The total resistance in parallel circuits is less than any of the individual resistances.

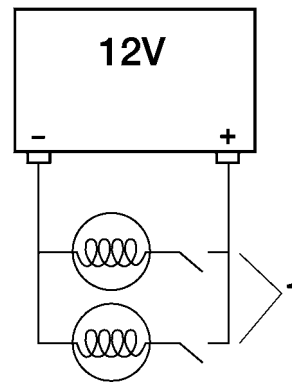

W3000494

Typical Parallel Circuit

Ohm's Law in parallel circuits

In the circuit below, one resistor is 2Ω , and the other is 4Ω . The source voltage is 12 volts. Current must be found for each path individually, as follows.

Apply Ohm's Law to find current across the first resistor:

$$I = V \div R$$

$$I = 12 \text{ volts} \div 2\Omega = 6 \text{ amps}$$

And for the second resistor:

$$I = 12 \text{ volts} \div 4\Omega = 3 \text{ amps}$$

Now, to find the total current, add the current from each of the circuit branches:

$$3 \text{ amps} + 6 \text{ amps} = 9 \text{ amps}$$

Using Ohm's Law, the total circuit resistance can also be found:

$$R = V \div I$$

$$R = 12 \text{ volts} \div 9 \text{ amps} = 1.33\Omega$$

Another way to find total resistance in a parallel circuit with 2 resistors is to divide the product of the 2 resistors by the sum:

$$R = (2\Omega \times 4\Omega) \div (2\Omega + 4\Omega) = 8\Omega \div 6\Omega = 1.33\Omega$$

Notice that the total resistance of 1.33Ω is less than either of the individual resistors in the circuit.

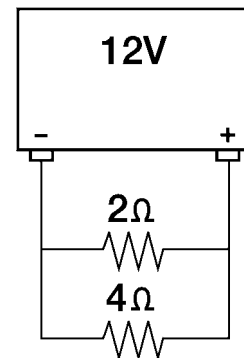

W3000565

Series/Parallel Circuits

A series/parallel circuit consists of some components in series and others are in parallel. In the figure the components side by side are in series since there is only one current path. The two circuits above and below each other are in parallel since there are two current paths.

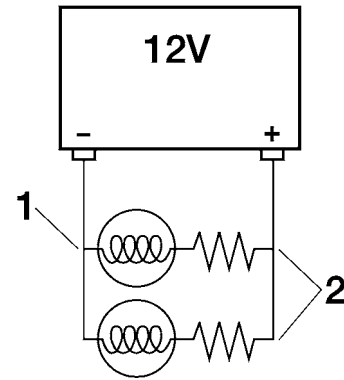

W3000493

Typical Series/Parallel Circuit

Ohm's Law in series/parallel circuits

In series/parallel circuits, the easiest way to find a device value is to look at each part of the circuit separately. For the example below, first find the resistance in each branch. The two 2Ω and 4Ω resistors add to give a resistance of 6Ω for this part of the circuit. For the other 2 resistors, $2\Omega + 1\Omega = 3\Omega$.

To simplify the circuit, think of it as a parallel circuit having a 6Ω and 3Ω resistor.

So, $(6\Omega \times 3\Omega) \div (6\Omega + 3\Omega) = 18\Omega \div 9\Omega = 2\Omega$ total resistance.

The total circuit current, therefore, is:

$$I = V \div R$$

$$I = 12 \text{ volts} \div 2\Omega = 6 \text{ amps}$$

The current through each branch can also be determined.

For the branch of the circuit with the 6Ω total resistance:

$$I = 12 \text{ volts} \div 6\Omega = 2 \text{ amps}$$

So, for each resistor in this branch, the voltage drop is found as follows:

$$V = I \times R$$

For the 2Ω resistor,

$$V = 2 \text{ amps} \times 2\Omega = 4 \text{ volts}$$

For the 4Ω resistor,

$$V = 2 \text{ amps} \times 4\Omega = 8 \text{ volts}$$

The sum of the voltage drops in a series circuit equals the source voltage, so $4 \text{ volts} + 8 \text{ volts} = 12 \text{ volts}$.

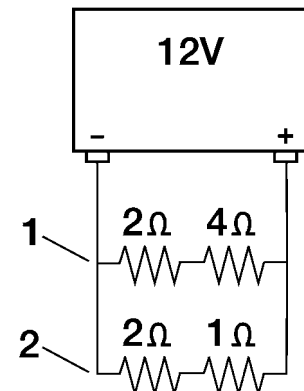

W3000566

Typical Circuit Components

Wiring harnesses, wires & connectors

Each circuit uses a wire of a specific size, based on the current demands for that circuit. The circuit number is stamped into the insulation every 76 mm (3 in.). This aids in proper connections and simplifies circuit tracing.

Insulation is cross-linked and flame resistant. White wires are grounded circuits. Red wires are main power feeds. Black wires are protected with a fuse or circuit breaker, etc.

Some wires are grouped together and encased in a split plastic casing or braided tubing called a loom. This grouping of wires is called a harness. Major wiring harnesses are joined by using a multiple plug and receptacle connector block.

Each harness or wire must be held securely in place by clips or other holding devices to prevent chafing of the insulation.

Terminals used throughout the system are Deutsch, Amp, JAE, KOSTAL and Packard. All terminals are soldered unless prohibited by the terminal manufacturer.

Circuit protection

To protect wiring and equipment from overloads, circuit protectors such as fuses, circuit breakers or fusible links are used.



WARNING

Failure to use proper circuit protection devices in the vehicle can result in personal injury or damage to the vehicle. Replace blown fuses only with fuses of the same rating. Replace fusible links only with proper replacement parts of the exact gauge and length. Failure to use proper circuit protection could overload the circuit, causing possible personal injury and severe damage to the vehicle.

Fuses

The most common protector in the vehicle circuit is a fuse. A fuse consists of a fine wire or strip of metal inside a glass tube or plastic housing. The strip melts and interrupts the flow of current in the circuit when there is an overload caused by an unwanted short or ground. The fuse is designed to melt before the wiring or electrical components in a circuit can be damaged. Naturally, the cause must be located or the new fuse will also blow. Since different circuits handle different amounts of current, fuses of various ratings are used. Fuses are rated in amperes. Be sure to replace a blown fuse with a fuse of the same rating.

A new feature for the VN Series vehicle is the maxi-fuse, which is designed for a larger amount of current than a regular fuse.

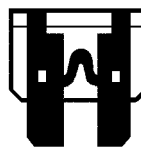

①

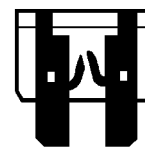

②

W3000484

- 1) Good fuse
- 2) Blown fuse

Fusible links

Fusible links are used to protect high-current circuits against current overload when there is a short to ground. The fusible link is a short length of wire that is smaller in gauge than the wire in the protected circuit. In the event of an overload the fusible link will melt, breaking the circuit and preventing damage to the electrical system. If a fusible link does open, special attention must be paid to finding and repairing the cause.

Fusible links are used in two locations: two are at the starter motor on the positive side feeding the cab main power studs, and one is from ground on the starter motor to engine ground. The fusible links on the positive side are 10 gauge cables 120 mm (4.72 in.) in length. On the ground side, it is an 8 gauge cable.

Diodes

Diodes are used on many of the vehicle's circuits to protect and isolate them from voltage surges, which can occur when a circuit is turned off. Diodes allow voltage to flow in one direction only, like a one-way check valve.

Circuit breakers

Circuit breakers are optional equipment. SAE Type 2 modified reset circuit breakers are the only type of circuit breakers approved for use in VNL or VNM vehicles. They may be used on accessory and ignition circuits only. Circuit breakers protect a circuit from overload. When an overload (high current flow) occurs in a circuit, a bimetallic strip in the breaker is heated. This opens its contact, temporarily breaking the circuit. When this bimetallic strip cools down, it remakes the contact.

Type 2 circuit breakers are opened by current overload and remain open as long as the power is on. A Type 2 circuit breaker keeps the bimetallic strip hot after tripping by diverting a small amount of current through a small coil of resistance wire. If power to the circuit breaker is switched off long enough for the bimetallic strip and resistance wire to cool down, the breaker will automatically reset.

When any circuit breaker trips, it should be viewed as an indication of a possible fault in the circuit. Every effort should be made to identify and correct the fault if one exists.

Switches and relays

Circuit controls are switches or relays. Switches are usually at the beginning of a circuit but can be used to control a ground path. For example, the switch controlling the headlights is at the power end of the circuit, while the door switch controlling the dome light completes the circuit to ground. Relays are remotely controlled switches. They use a low current signal through a coil to control larger currents conducted through their contacts.

A new feature used in the VN Series vehicle is the micro-relay. The micro-relay is smaller in size than a conventional relay, and the pin arrangement is different (see illustration).

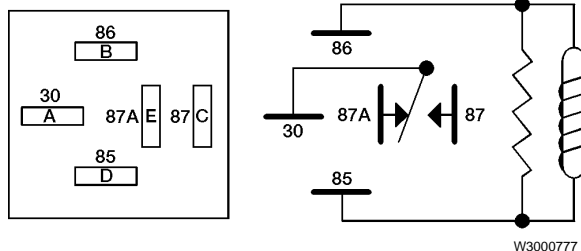

Relay Pin Arrangement and Schematic

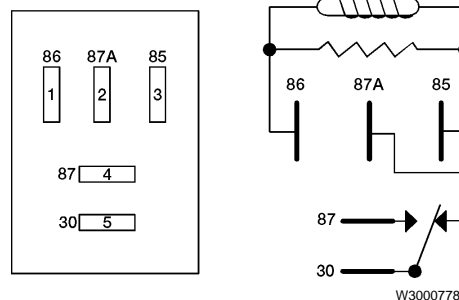

Micro-relay Pin Arrangement and Schematic

Note: Relays are shown from insertion-side view.

Sensors and senders

Many electronic signals used by ECUs and the instrument cluster are supplied by sensors and senders. A sensor or sender sends a signal to a control unit, or to the microprocessor in the instrument cluster. Sensors used in the vehicle system include the vehicle speed sensor, the throttle position sensor and Anti-lock Brake System (ABS) wheel speed sensors.

The vehicle speed sensor is mounted in the transmission and reads the movement of the teeth on the output shaft. It is of an inductive type and sends a fluctuating (sinusoidal) signal to the engine ECU.

An Anti-lock Brake System (ABS) wheel speed sensor is mounted in each monitored wheel. As the wheel spins, the sensor sends a fluctuating signal to the ABS ECU, which the ECU interprets as wheel speed.

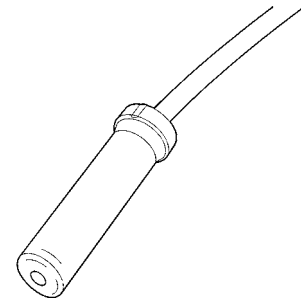

W5000602

Anti-lock Brake Wheel Speed Sensor

The transmission oil temperature sender, shown in the illustration, senses the temperature of the transmission oil, creating a resistance and sending this signal to the instrument cluster. The higher the temperature of the oil, the lower the resistance, and the higher the reading shown on the gauge.

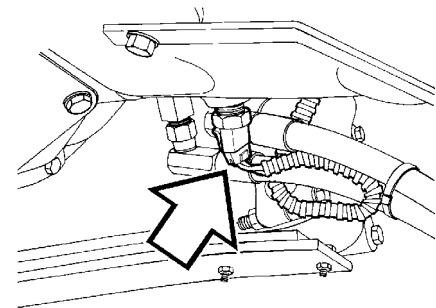

W3000813

Transmission Oil Temperature Sender

The engine oil temperature sender functions similarly, but sends engine oil temperature information to the instrument cluster. The fuel sender, mounted in the fuel tank, transmits the fuel level to the instrument cluster.

Starting and Charging System

Battery Power Supply

Power is supplied from the batteries to the starter solenoid, then from the starter solenoid battery post via wires 1 and 1-A. (Note that each of these wires contains a fusible link.) Wire 1 feeds cab main power stud 1, and 1-A feeds cab main power stud 2.

The batteries also supply constant power to the alternator via the starter solenoid. The starter solenoid post is connected directly to the battery by wire 8, which senses the battery voltage and energizes the alternator for charging the batteries.

- Stud 1 powers the Battery Maxi-fuse bus bar. From this bus bar a Battery Maxi-fuse feeds 1-F to the fuse bus bar for fuse positions 21–24.

Also from the Battery Maxi-fuse bus bar, a Battery Maxi-fuse feeds 1-D to the fuse bus bar for fuse positions 17–20. Another Battery Maxi-fuse feeds 1-C to the fuse bus bar for fuse positions 25–32.

Also from stud 1, wire 1-E goes to the **Accessory Power Relay**.

- From stud 2, wire 1-A goes to the **Ignition Power Relay**. From wire 1-A, 1-B sends battery power to bus bar fuse positions 41–48.

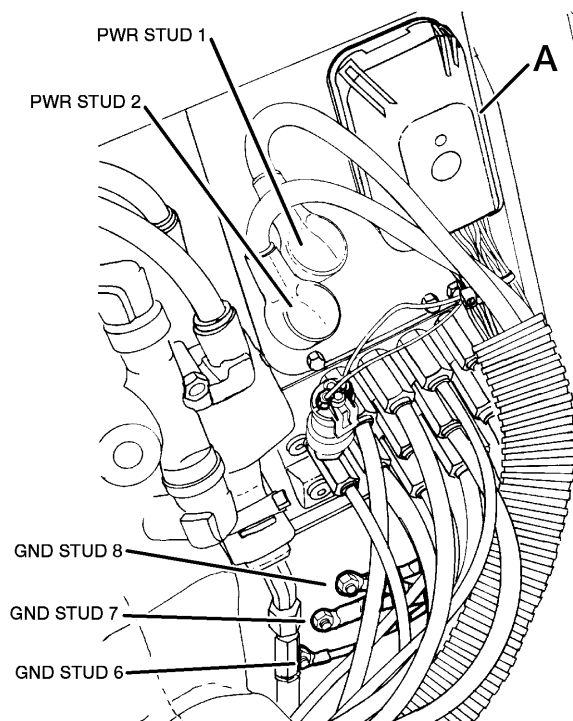

W3000827

A Pass-through for main cab wiring
Main Cab Electrical Pass-Through and Ground
Studs (driver side engine compartment)

Accessory Supply

- From fuse 15, wire 243-A supplies constant battery power to the ignition switch.
- When the ignition switch is switched to the ACCESSORY position, the 195 wire energizes the **Accessory Power Relay**. The relay supplies power to wire 195-A for the bus bar for the Accessory fuse positions 33–40.
- Ground wire 0R-N provides a ground connection from the Accessory Power Relay to the Ignition Power Relay. From the Ignition Power Relay, ground connection 0R-M goes to a passenger side interior ground stud (see section in this manual on *Electrical Pass-through for Cab Wiring, Power and Ground*).

Ignition and Cranking Supply

- From fuse 16, wire 243 supplies constant battery power to the ignition switch.
- When the ignition switch is turned to the IGNITION position, power is supplied to wire 196, which energizes the Ignition Power Relay. From this relay, wire 196 supplies power to the bus bar for the Ignition Maxi-fuses.
- Two of the Ignition Maxi-fuses supply power to the bus bars for the Ignition fuse positions: One Ignition Maxi-fuse feeds wire 196–A to the bus bar for fuse positions 5–12. The other Ignition Maxi-fuse feeds wire 196–B to the bus bar for fuse positions 13–16.
- When the ignition switch is turned to the START position, wire 284 provides power from the ignition switch to energize the starter relay coil. This completes the circuit from the battery to the starter solenoid stud. The solenoid is grounded directly to the starter.

System Ground

- The engine ground is the common ground location on the vehicle. The main cab ground stud 1 and the frame rail ground meet at the engine ground stud. Current is then carried through a fusible link to the starter motor. This fusible link is designed to isolate the positive and negative sides of the battery from each other in the event of a positive battery cable short circuit to the frame rail, cab, or engine. The alternator is grounded by the 0A wire to the engine block.
- Ground stud 1 provides the main ground path to the engine ground for the other cab ground studs. It is installed at the same location as ground stud 7 (see *Starting and Charging System Logic Diagram*).

Starting and Charging System Logic Diagram

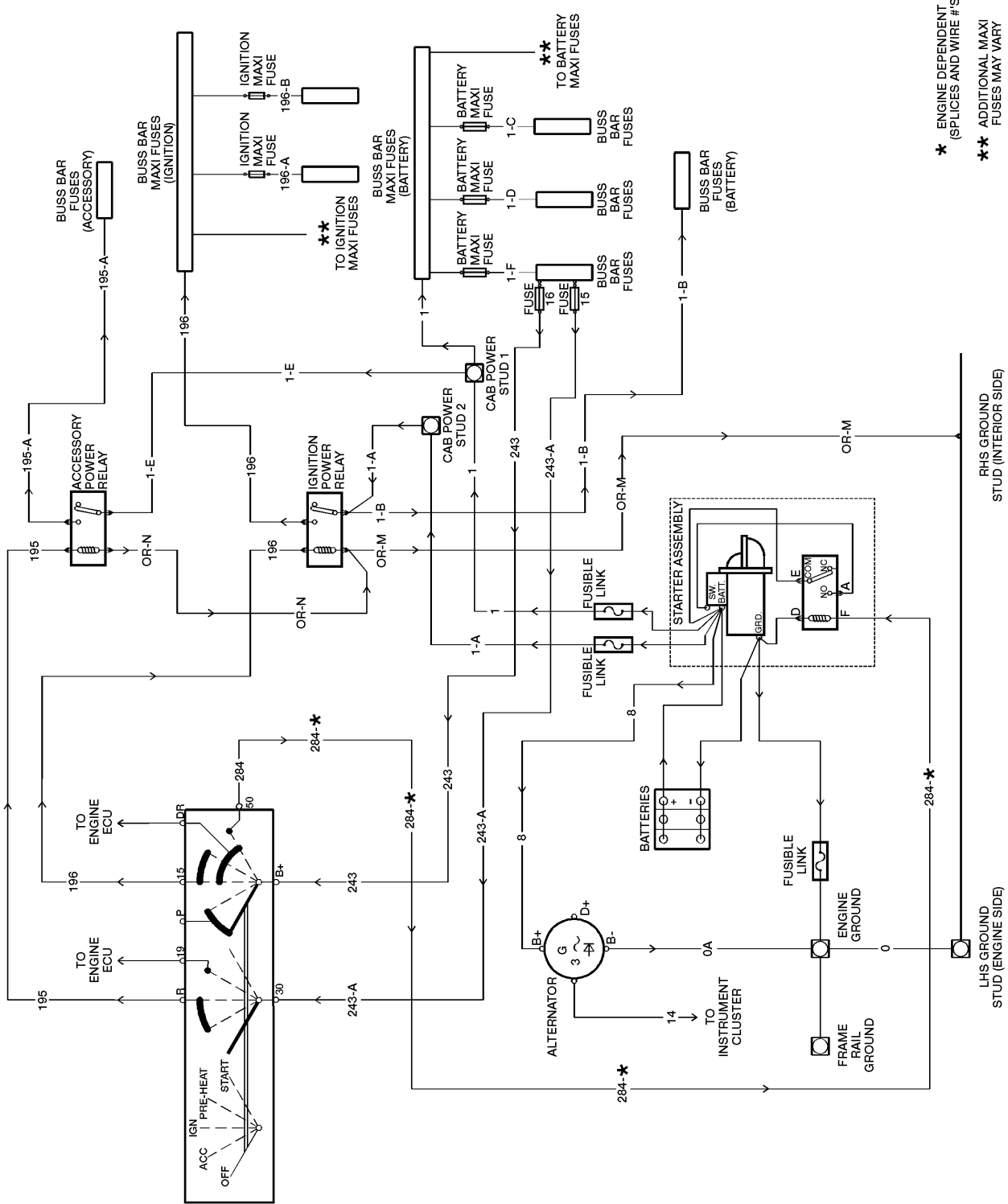

* ENGINE DEPENDENT (SPICES AND WIRE # S)
 ** ADDITIONAL MAXI FUSES MAY VARY

W300072

Ignition Switch

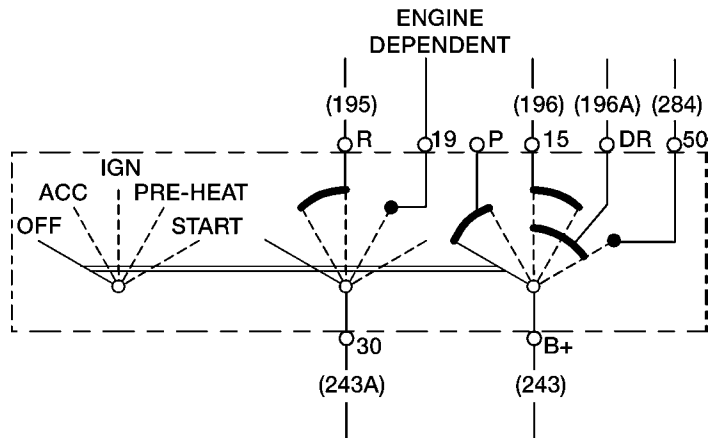

W3000681

Note: Numbers inside parenthesis are circuit numbers.

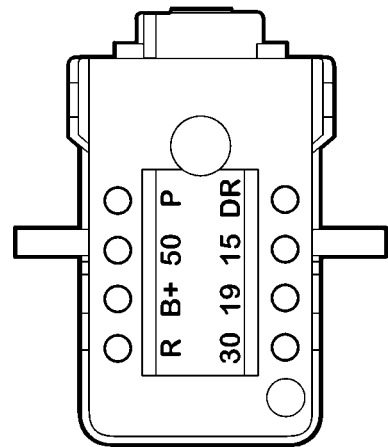

W3000687

Ignition Switch Connector Detail

The ignition switch is mounted in the key lock assembly. It is a single switch of a new double contact design – there is no separate start button. The chart below gives the pin and circuit description.

Pin	Circuit No.	Description
R	195	To accessory power relay
B+	243	+12V Battery supply
50	284	Starter relay feed
P		Not used
30	243A	+12V Battery supply
19	Engine dependent: VOLVO: 245 Detroit Diesel: 591	VOLVO: Preheat request Detroit Diesel: Shutdown override relay feed
15	196	To ignition power relay
DR	196A	Ignition feed to engine ECU

Electrical Pass-Through for Cab Wiring, Power and Ground

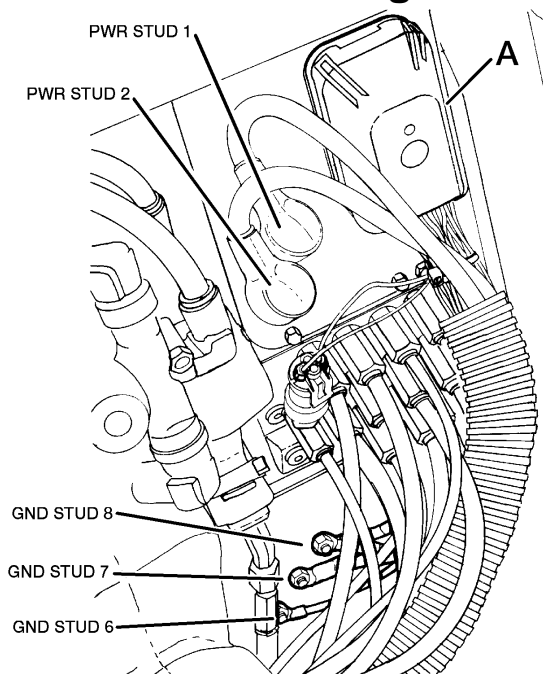

W3000827

A Pass-through for main cab wiring
Main Cab Electrical Pass-Through and Ground Studs (driver side engine compartment)

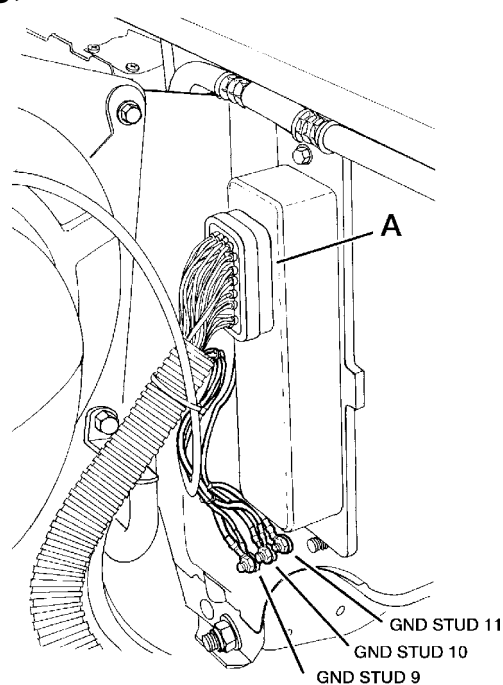

W3000591

A Pass-through for chassis wiring to cab
Cab Electrical Pass-Through and Ground Studs (passenger side engine compartment)

The two main cab cable pass-throughs are on the left and right sides of the bulkhead. The pass-throughs contain connectors which join the inner and outer cable harnesses. The passenger side pass-through contains wiring for chassis mounted components. The driver's side pass-through contains wiring for components mounted under the hood.

Both pass-throughs consist of a protective outer housing and an attachment plate which holds the connectors in position. The pass-through covers can be opened from the outside.

The cab main power studs are located at the left-hand side pass-through. Ground studs are located on the left and right side bulkhead, on both the inside and outside. Each stud has a unique identity number which is used for reference in the vehicle electrical schematics. Torques for the power studs are 10 ± 1.5 Nm (7.4 ± 1.1 ft-lb) for the ground studs, and 10 ± 2 Nm (7.4 ± 1.5 ft-lb) for the main power studs. The **cab main ground stud 1** is located on the driver's side, at ground stud 7. The cab main ground stud is wired directly to the engine ground by a 4 gauge cable, and is the ground path for all of the cab grounds.

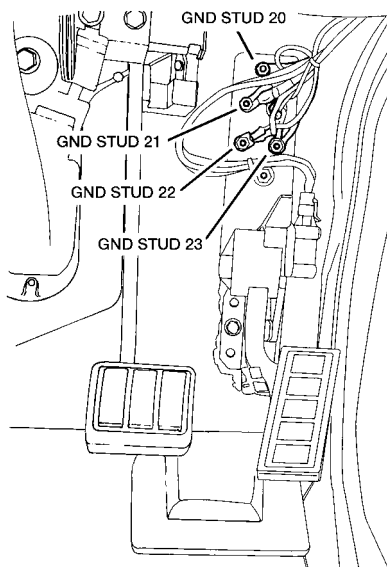

W3000593

Ground Studs (inside cab, driver side)

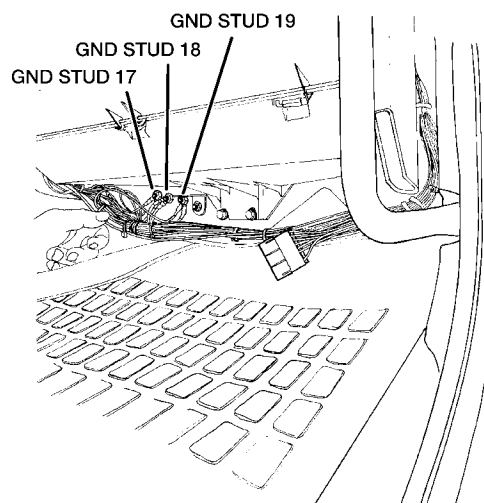

W3000592

Ground Studs (inside cab, passenger side, under heater unit)

Switches and Controls

The switches are of a new design. A number of switches have been given new symbols, for example, the switch for the fog lights and the electric heated side mirrors. All panel-mounted switches feature heavy duty terminals and locking mating connectors. Rocker switches feature illuminated legends with embedded LEDs to indicate *ON* or *OFF* of electrical devices.

The switch for the engine brake is different depending on which engine brake is installed. With the Volvo or Cummins M11 engine brake, there is a single switch with 3 positions: *OFF*, *LOW*, and *HIGH*. With other engine brakes, there are two switches: one with 2 positions, *ON* and *OFF*, and another with 3 positions, *LOW*, *MED*, *HIGH*.

Note: Switches are illustrated from insertion-side view.

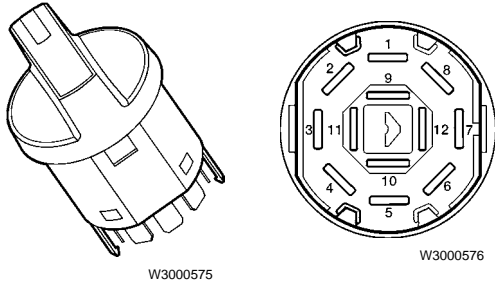
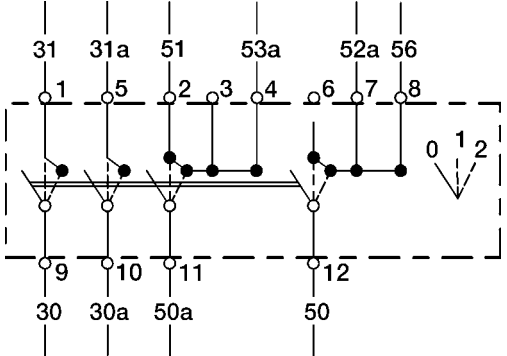
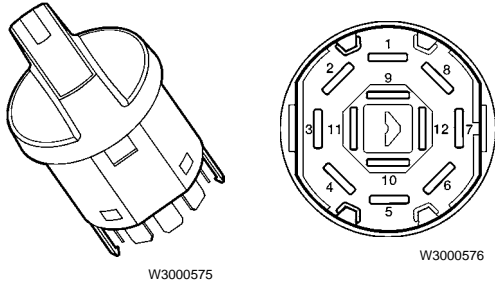
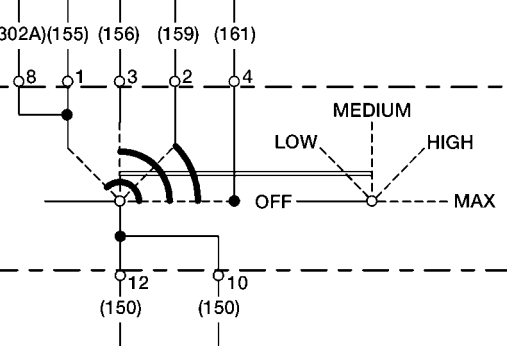
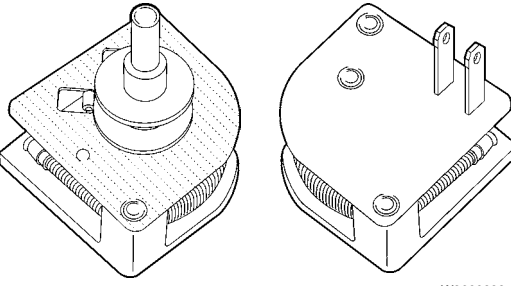
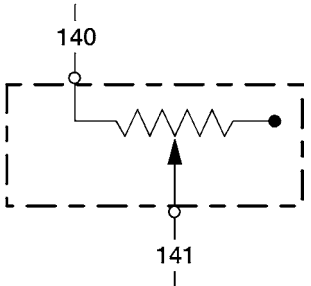
Switch Function	Switch	Internal Switch Logic
Headlamps /Parking lamps		
Heater/AC Blower Motor Control		
Dimmer Control (Dash Illumination)		

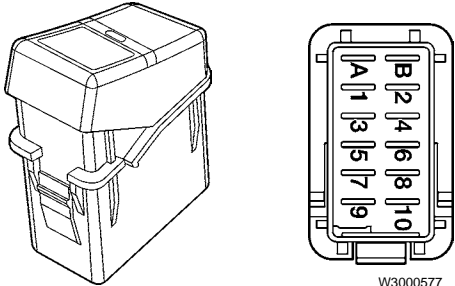
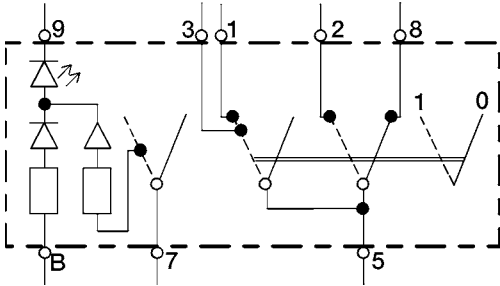
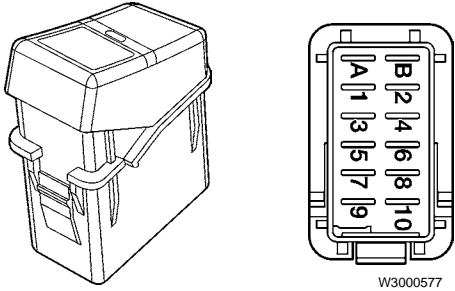
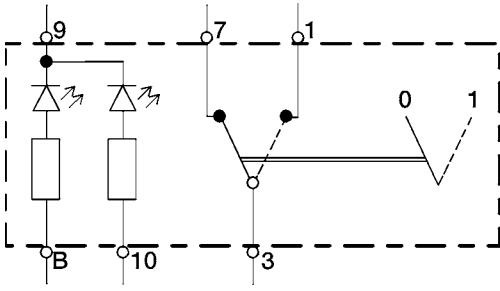
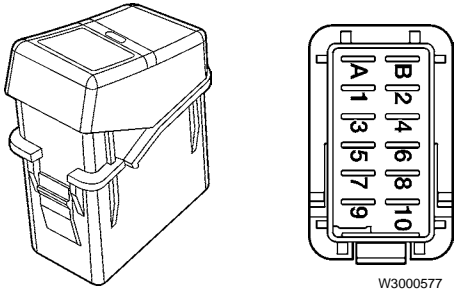
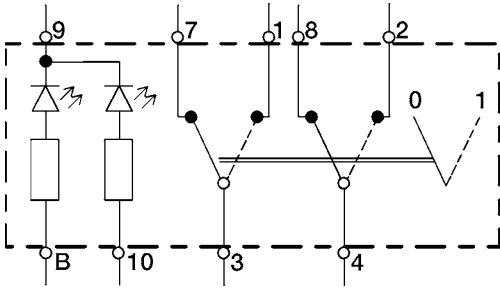
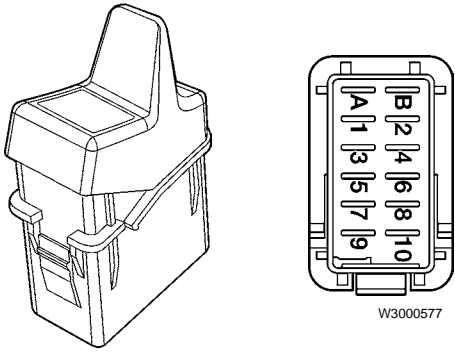
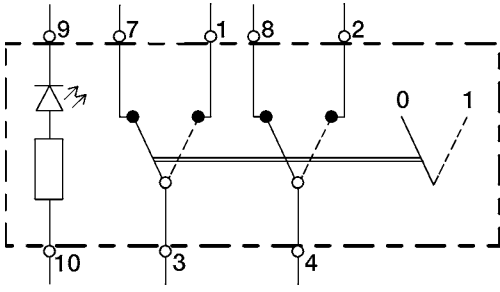
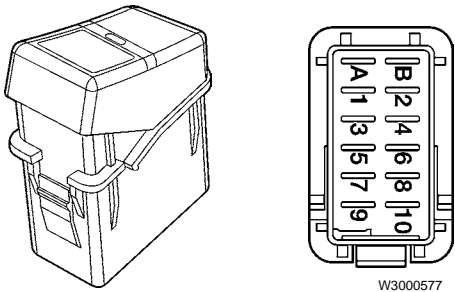
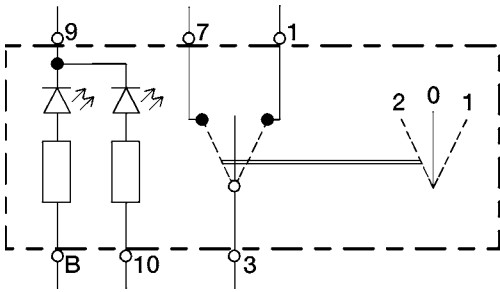
Switch Function	Switch	Internal Switch Logic
Hazard Warning	 <p style="text-align: center;">W3000579</p> <p style="text-align: center;">W3000577</p>	 <p style="text-align: right;">W3000585</p>
Back of Cab Lamp, Heated Mirror, Auxiliary Lamps, Traction Control System	 <p style="text-align: center;">W3000579</p> <p style="text-align: center;">W3000577</p>	 <p style="text-align: right;">W3000588</p>
Power Take Off	 <p style="text-align: center;">W3000579</p> <p style="text-align: center;">W3000577</p>	 <p style="text-align: right;">W3000587</p>
Marker Interrupter	 <p style="text-align: center;">W3000578</p> <p style="text-align: center;">W3000577</p>	 <p style="text-align: right;">W3000586</p>
Idle Diagnostic (Cummins only)	 <p style="text-align: center;">W3000579</p> <p style="text-align: center;">W3000577</p>	 <p style="text-align: right;">W3000584</p>

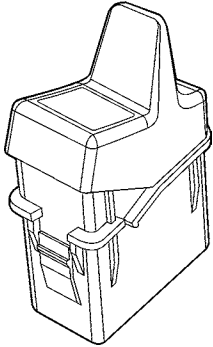
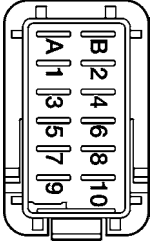
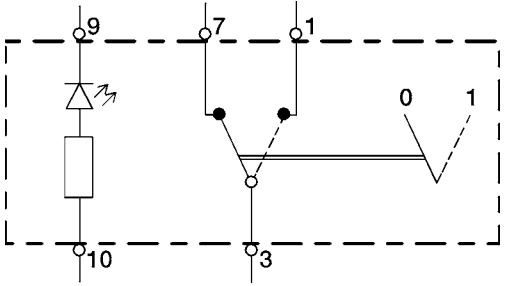
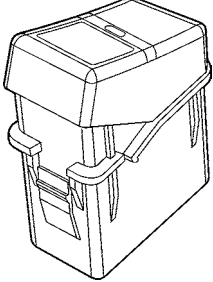
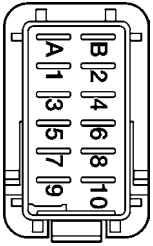
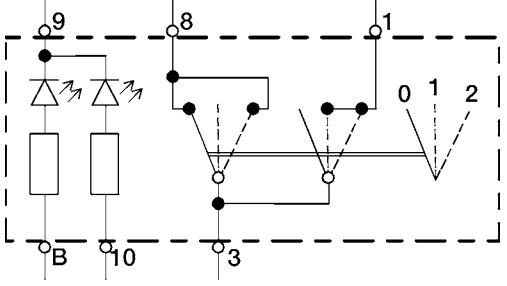
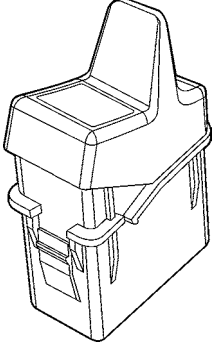
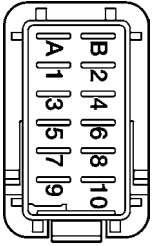
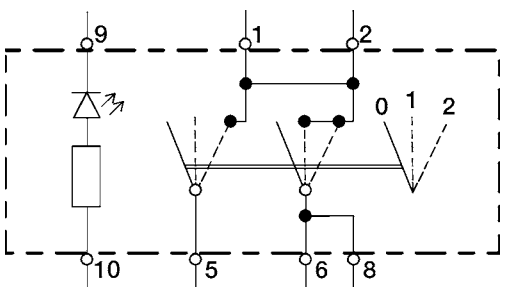
Switch Function	Switch	Internal Switch Logic
Engine Brake On/Off (Caterpillar, Detroit, Cummins N14)	  <p style="text-align: center;">W3000577</p>	 <p style="text-align: right;">W3000589</p>
Engine Brake Low/Med/High (Caterpillar, Detroit, Cummins N14)	  <p style="text-align: center;">W3000577</p>	 <p style="text-align: right;">W3000583</p>
Engine Brake Off/Low/Hi (VOLVO & Cummins M11)	  <p style="text-align: center;">W3000577</p>	 <p style="text-align: right;">W3000597</p>

Pneumatic/Electrical Switches

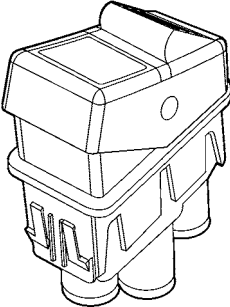
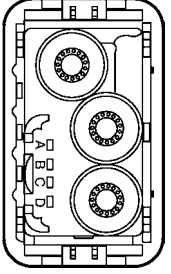
Switch	Switch Function	Terminal			
		A	B	C	D
  <p style="text-align: center;">W3000574 W3000573</p>	Interaxle DLO	To Cluster Telltale Lamp	+12V Supply	Ground	+12V Illumination Control
	Fifth Wheel Slide	To Cluster Telltale Lamp	Not used	Ground	+12V Illumination Control
	Suspension Dump	To Cluster Telltale Lamp	Not used	Ground	+12V Illumination Control
	Interwheel DLO	N/A	Not used	Ground	+12V Illumination Control

Stalk Switches

Wiper/Washer Switch

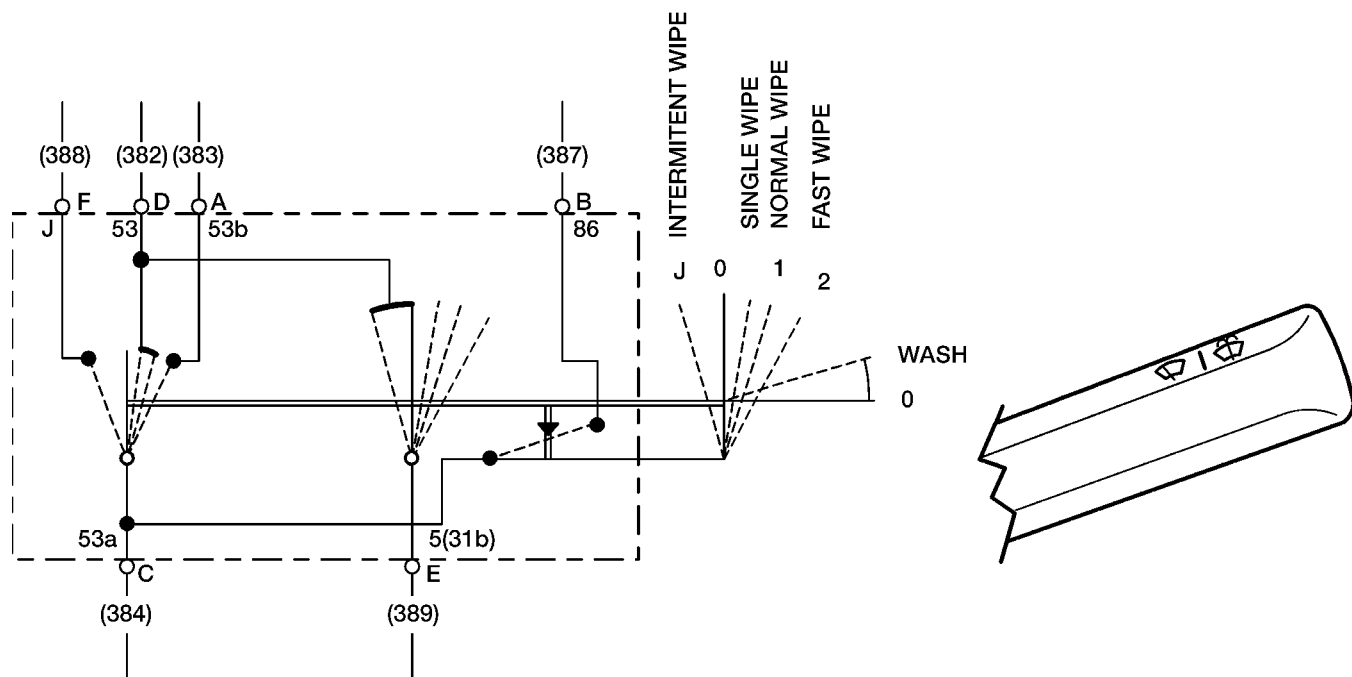

Wiper/Washer Switch

W3000581

Note: Numbers inside parenthesis are circuit numbers.

Controls for the windshield wiper/washer are on the stalk on the right-hand side of the steering column. Intermittent wipers are standard (see section on *Wiper/washer module* in this manual).

Wiper/washer Switch Connector		
Pin	Circuit No.	Description
A	383	High Speed Wiper
B	387	12V Supply to Washer Motor
C	384	12V Supply to Wiper Motor
D	382	Low Speed Wiper
E	389	12V Supply to Wiper Control Module
F	388	12V Supply to Wiper Control Module, Intermittent Speed

Cruise Control, Turn Signal and Headlamp Dimmer Switch

The controls for turn signals, cruise control and high-beam/lowbeam selection are on the stalk switch on the left-hand side of the steering column. The high-beam/lowbeam switch includes a flash-to-pass feature.

It is possible to increase the engine speed with the button on the end of the stalk. To reduce the engine speed, move the switch on the stalk towards "Resume".

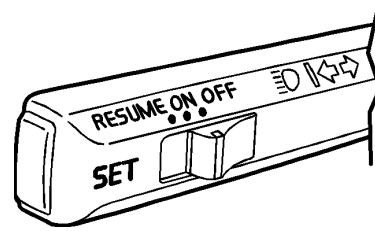

W3000807

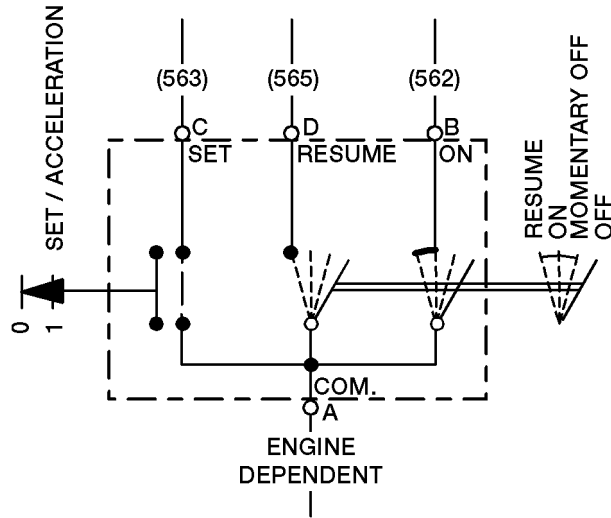

W3000811

Cruise Control Switch

Note: Numbers inside parenthesis are circuit numbers.

Cruise Control Connector		
Pin	Circuit No.	Description
A	558E/559E	Common (Engine dependent)
B	562	Cruise control On
C	563	Cruise control Set
D	565	Cruise control Resume

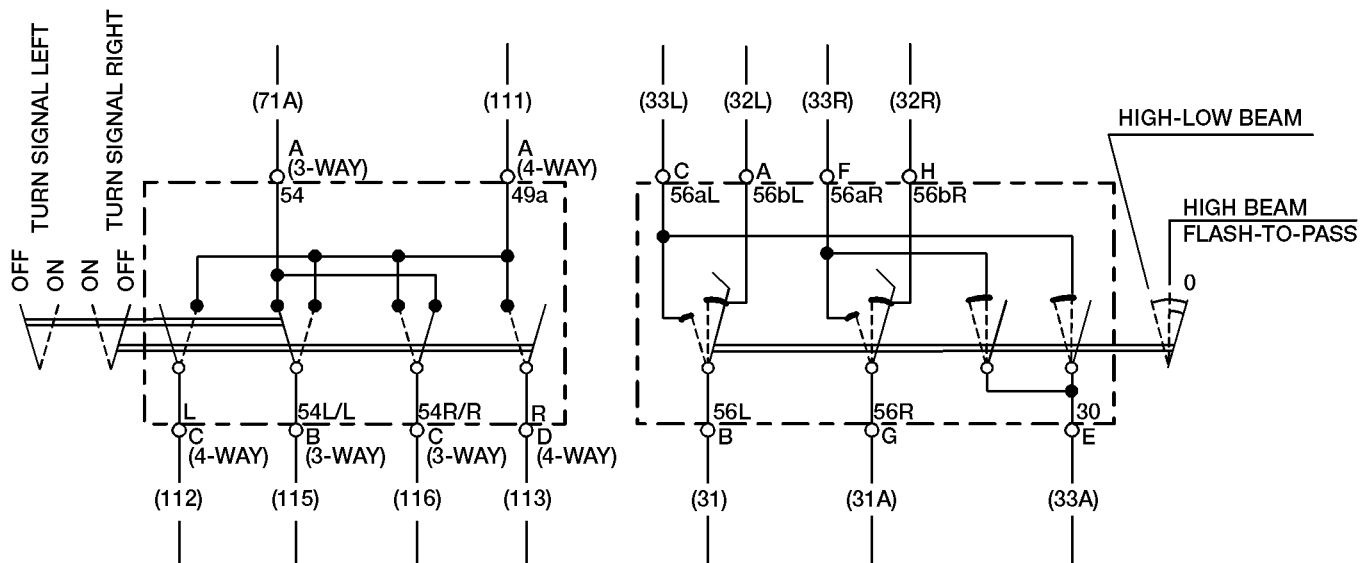

W3000761

Turn Signal and High/Low Beam Switch

Note: Numbers inside parenthesis are circuit numbers.

Turn Signal Connector (3 way)		
Pin	Circuit No.	Description
A	71A	Stop lamp switch output
B	115	Left stop & turn lamp feed
C	116	Right stop & turn lamp feed

Turn Signal Connector (4 way)		
Pin	Circuit No.	Description
A	111	Turn signal switch feed
B		Not used
C	112	Left turn signal lamp & indicator feed
D	113	Right turn signal lamp & indicator feed

Headlamp Dimmer Switch Connector		
Pin	Circuit No.	Description
A	44L	Output to DRL module low beam, left
B	31	Dimmer switch power supply
C	33L	Headlamp high beam ground, left
D		Not used
E	33A	Flash to pass contact
F	33R	Headlamp high beam ground, right
G	31A	Dimmer switch power supply
H	44R	Output to DRL module low beam, right

Fuse and Relay Locations

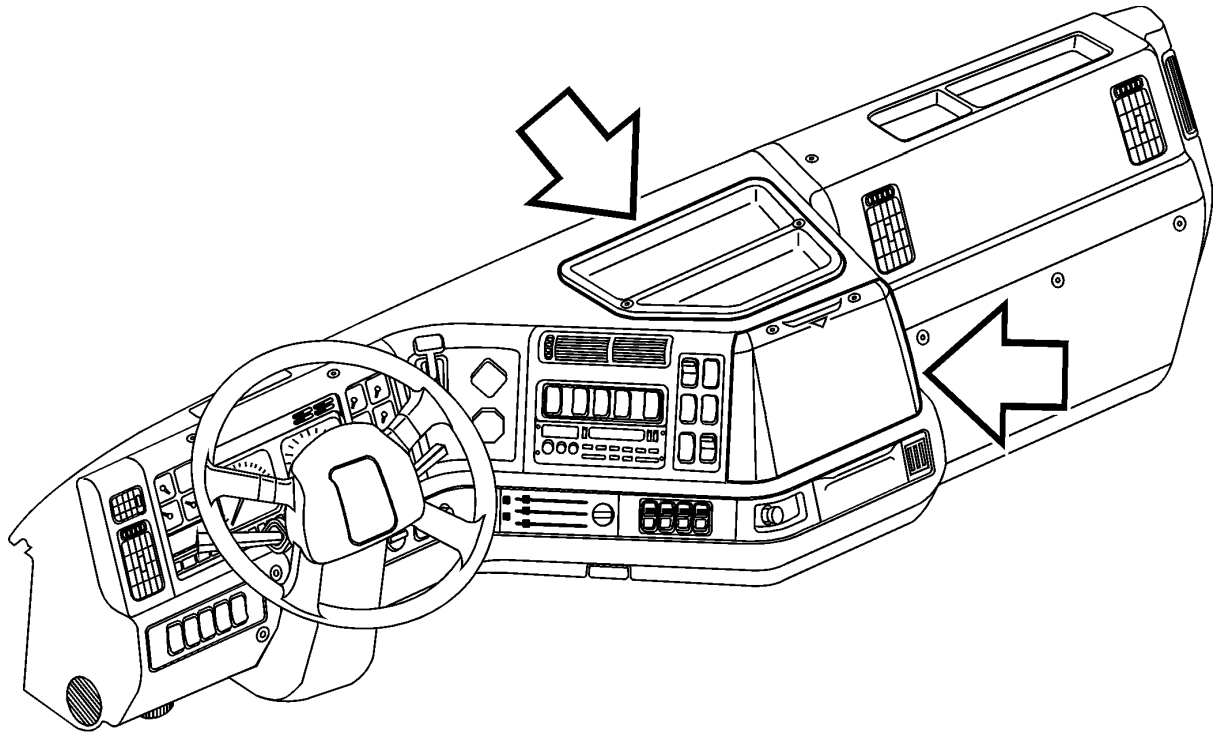

TEC in Center Dash

W8000923

The vehicle's instrumentation, gauges and other electrically controlled parts are wired through the Truck Electrical Center (TEC).

The TEC is located in the center of the dash, just above the engine cover. The relays are accessed through the top panel, and the fuses through the front or top panel. All fuses and relays may not be used in every vehicle. Refer to the decal inside the TEC cover for vehicle's exact fuse locations and ratings.

New features in the TEC include maxi-fuses, micro-relays and additional multifunction modules. The maxi-fuses are designed for larger amounts of current than regular fuses. The micro-relays are smaller in size than conventional relays, and the pin arrangement is different.

Accessory and ignition power relays, and the daytime running light module are mounted under the relay panel. They are accessed by removing the top TEC tray.

Several multifunction modules are also mounted under the relay panel. The combi relay (with VE D12 engine only), windshield wiper module and central door lock module are mounted here. For more information on the combi relay, see the *Electronic Control System, VE D12 – VOLVO* manual. The windshield wiper module and central door lock module are covered later in this manual.

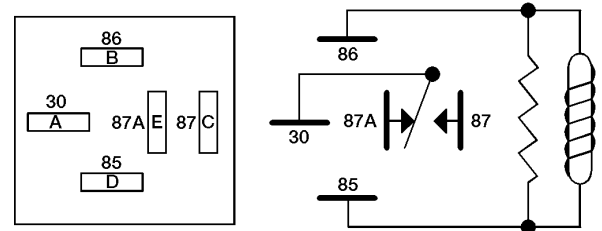

W3000777

Relay Pin Arrangement and Schematic

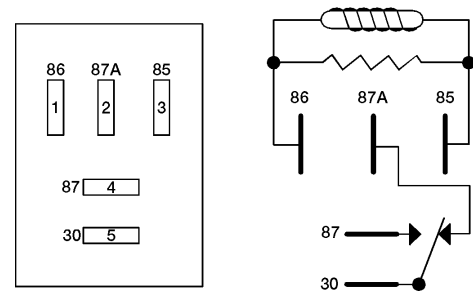

W3000778

Micro-relay Pin Arrangement and Schematic

Note: Relays are shown from insertion-side view.

Relays in Top TEC Panel: #R1–R13

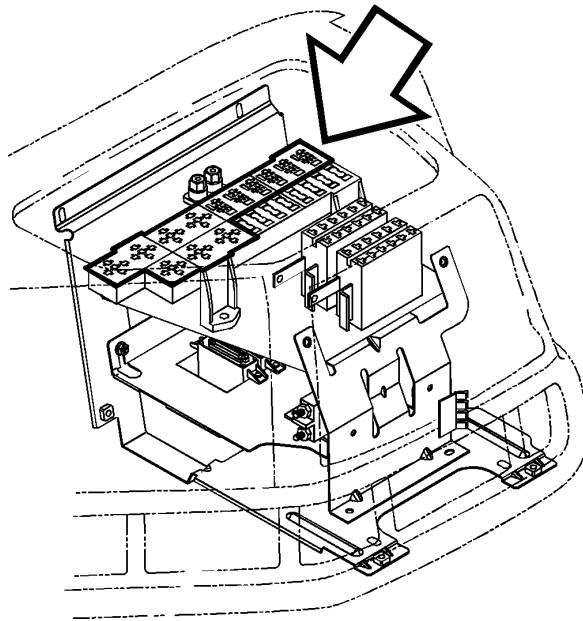

W3000774

Maxi-Fuses:

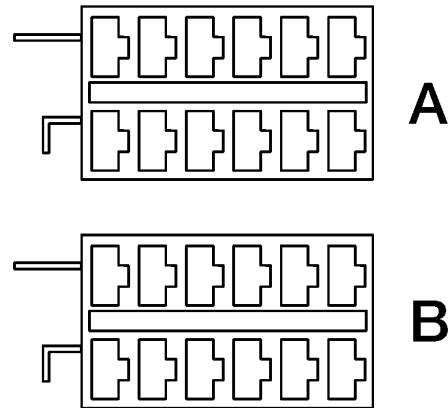
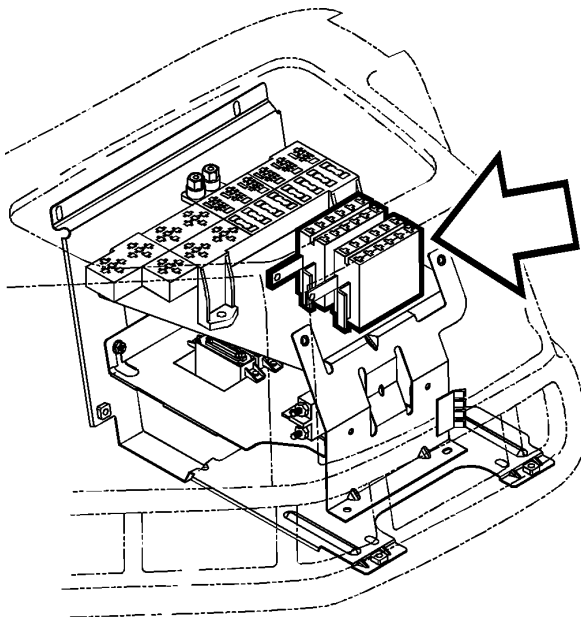

- A Battery Maxi-fuses
- B Ignition Maxi-fuses

W3000828

Fuses in Front TEC Panel: #1–40

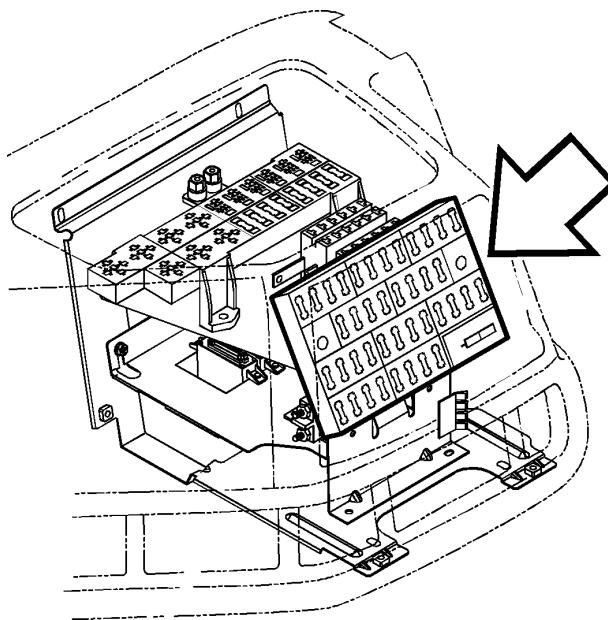

W3000773

Fuses in Top Panel: #41–48

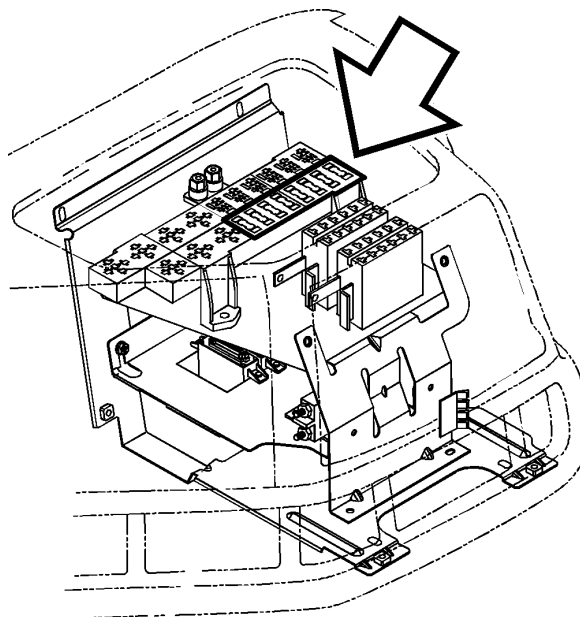

W3000775

Note: Refer to the decal inside the TEC cover for vehicle's exact fuse descriptions and ratings.

Components in Lower TEC Panel

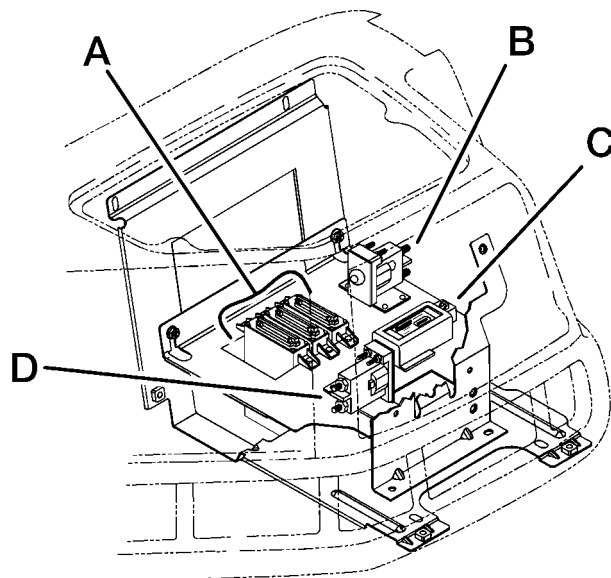

W3000886

- | | |
|---|--|
| A | Central Door Lock Module, Combi Relay, Wiper/Washer Module |
| B | Ignition Power Relay |
| C | Daytime Running Lights Module |
| D | Accessory Power Relay |

Accessory and Ignition Power Relays

The Accessory and Ignition Power relays are used to transfer the heavy current load coming from the battery to the Ignition/Accessory circuits. They are located under the relay panel, and may be accessed for troubleshooting by removing the top TEC tray. For replacement procedure, see Service Procedures. For more information, refer to the vehicle electrical schematics and the section on *Starting and Charging* in this manual.

Intermittent Windshield Wiper/Washer Module

The windshield wiper module uses inputs from the wiper/washer switch to electronically control the wiper and washer motors when intermittent wipers are in use. It is located under the relay panel, and is accessed by removing the top and front TEC center covers, and the fuse and relay panels.

Intermittent wipers are set to make a single sweep every 10 seconds. To shorten the interval, move the stalk to the normal wipe position, then to the intermittent wipe position when the next wiper sweep is desired. The interval can be set to between 1 and 10 seconds.

The wipers will also make a single sweep if the wiper stalk is slightly depressed and held. The wipers return to the park position when the lever is released.

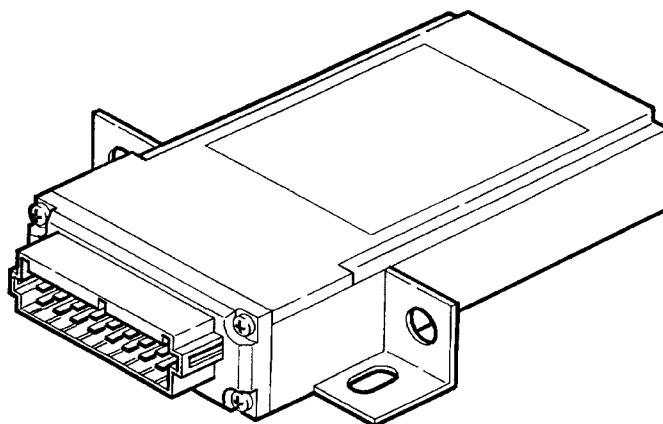
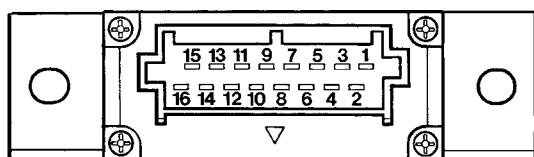

W3000554

Wiper/Washer Module Connector				
Pin	Circuit Number	Description	Input /Output	Characteristics
1	0G	Battery ground	I	Battery (-)
2 3 4 5		Not used		
6	388	Switch, intermittent wiper	I	On = Supply voltage (min. 10mA) Off = 0C
7		Not used		
8	387	Windshield washer motor	I	On = Supply voltage (min. 10mA) Off = 0C
9	384	Power supply	I	Switched battery (+)
10 11 12		Not used		
13	389	Windshield wiper motor	O	Supply voltage (max. 12A) (source)
14		Not used		
15	384	Windshield wiper motor	I	Supply voltage (max. 12A)
16	385	Windshield wiper motor, contact parking position	I	Parking position = Ground

Central Door Lock Module

Central door locks are an optional feature. The central locking can be activated from either the passenger or driver side door lock. If the main supply is activated with one door locked and one unlocked, both sides will be automatically unlocked to prevent the driver being accidentally locked out.

The central door lock module is located under the relay panel, and is accessed by removing the top and front TEC center covers, and the fuse and relay panels.

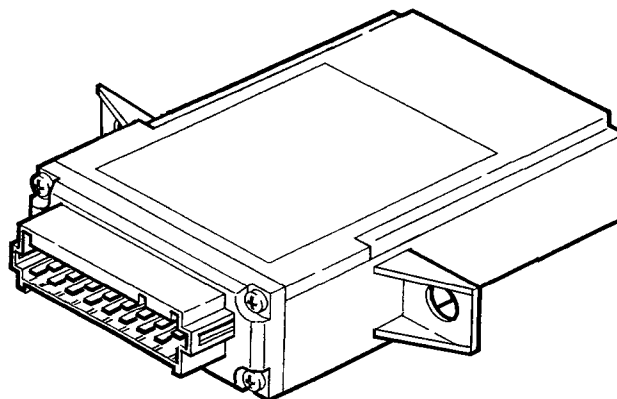
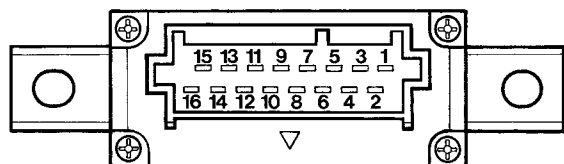

W3000553

Central Door Lock Module Connector				
Pin	Circuit Number	Description	Input /Output	Characteristics
1	710	Battery+ supply voltage	I	Unswitched battery (+) supply
2	713R	To passenger side motor - unlock	O	Internally switched to GND or Unswitched Batt.
3	713L	To driver side motor - unlock	O	Internally switched to GND or Unswitched Batt.
4	714R	To passenger side motor - lock	O	Internally switched to GND or Unswitched Batt.
5	714L	To driver side motor - lock	O	Internally switched to GND or Unswitched Batt.
6 7		Not used		
8	712	To passenger side switch	I	Externally switched to GND or open
9	711	To driver side switch	I	Externally switched to GND or open
10 11 12 13 14 15		Not used		
16	0C-C	Battery ground	I	Battery GND

Lighting System

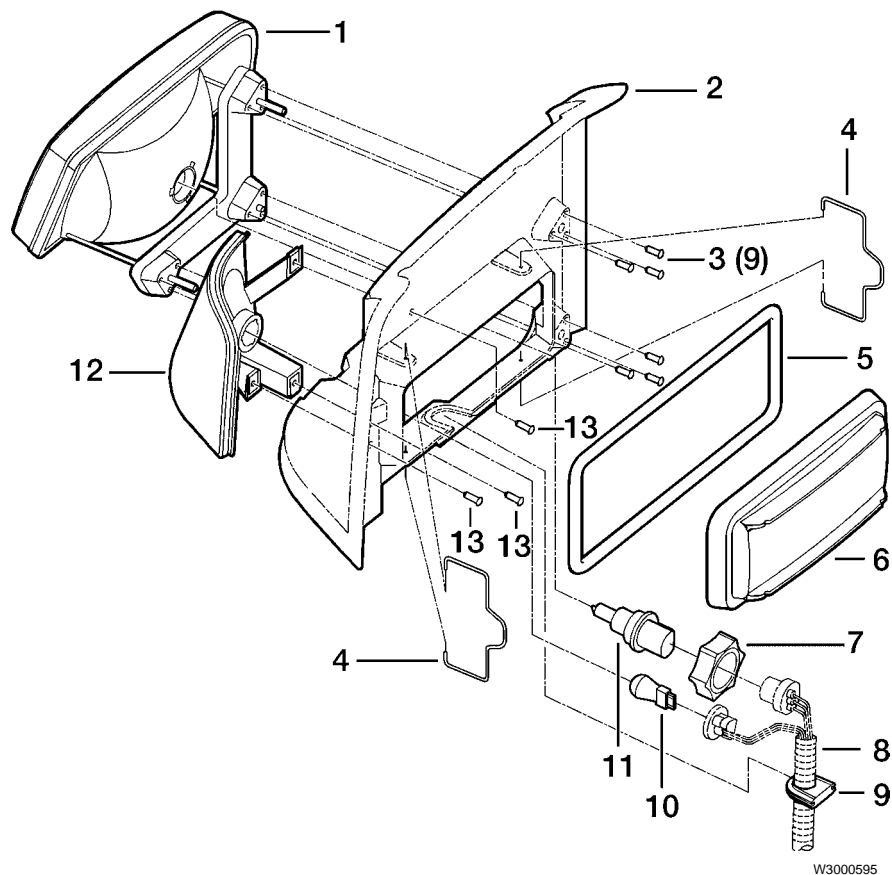

- | | | | | | |
|---|----------------------------------|---|-------------------|----|-------------------|
| 1 | Headlamp | 6 | Rear Access Panel | 10 | Turn Signal Bulb |
| 2 | Hood | 7 | Locking Ring | 11 | Headlamp Bulb |
| 3 | Mounting/Adjust Screws (9 total) | 8 | Wire Harness | 12 | Turn Signal Cover |
| 4 | Spring Clips | 9 | Grommet | 13 | Mounting Screws |
| 5 | Seal | | | | |

The lighting system consists of switches, connectors, wiring and lamp assemblies. All lights in the system are wired from the power source, through a circuit protector at the Truck Electrical Center, and to a switch.

Headlights

The VN Series headlights are of a new design. The right and left headlights are on separate circuits. Each is supplied power from the battery, through a fuse, and controlled by the headlight switch and dimmer switch. The low beam circuit is tied into the Daytime Running Lights circuit. Wiring for the headlights passes from the cab interior to the chassis through the wiring pass-through on the right side of the cowl.

The headlight bulbs (11) can be changed by removing the rear access panel (6), which is held in place by two clips (4). The bulbs for the parking lights and turn signals (10) are also changed by removing the rear access panel (6).

Cab Marker LED Lights (With Sunvisor)

When the sunvisor option is installed, the cab marker lights are sealed LED units. When replacing, the entire LED unit must be replaced. Cab marker lights without the sunvisor option are standard bulbs (see *Bulb Replacement List* in this manual).

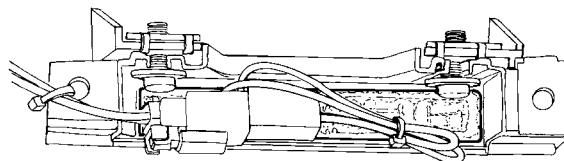

W3001004

Daytime Running Lights

Daytime running lights (DRL) turn the low beam headlamps on, with reduced voltage, whenever the ignition is on and the parking brake is released. The DRLs will come on even though the headlight switch is off. The DRL module is located inside the cab, under the relay panel.

The DRL module reduces the voltage to the headlamps by using pulse width modulation to “pulse” the low beams on and off at a rate of 70 Hz (which is faster than the eye can detect). The reduction in voltage is about 24% RMS of the applied voltage. If the applied voltage is 13.8 VDC, a DC voltmeter such as a Fluke 87 will show the average voltage between 7.5 and 8.5 VDC. The left and right headlamps are controlled separately.

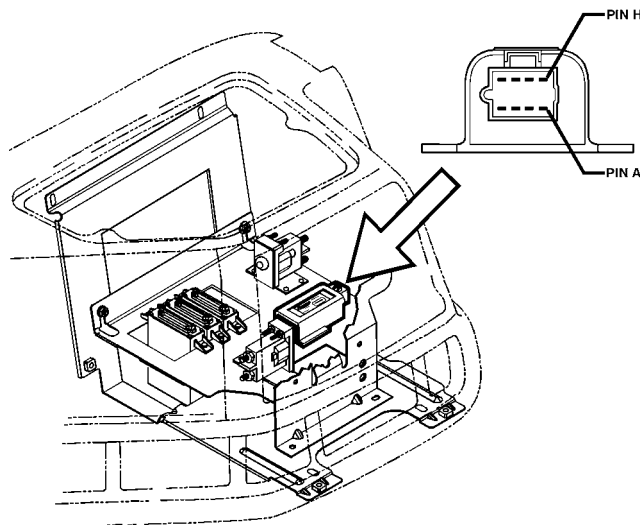

W3000555

Operating voltage	10-19 VDC
Under voltage shutdown	9.5 VDC
Over voltage shutdown	19.5 VDC
Short circuit shutdown current	50 A

Daytime Running Lights Module

Pin	Circuit No.	Description
A	40	12V supply
B	44L/32L	LHS 9V (Low Beam) Output
C	44R/32R	RHS 9V (Low Beam) Output
D	42	Parking Brake Disable
E	0H	Ground
F	41	Ignition Input
G		Not used
H		Not used

Stop/Hazard/Turn Lights

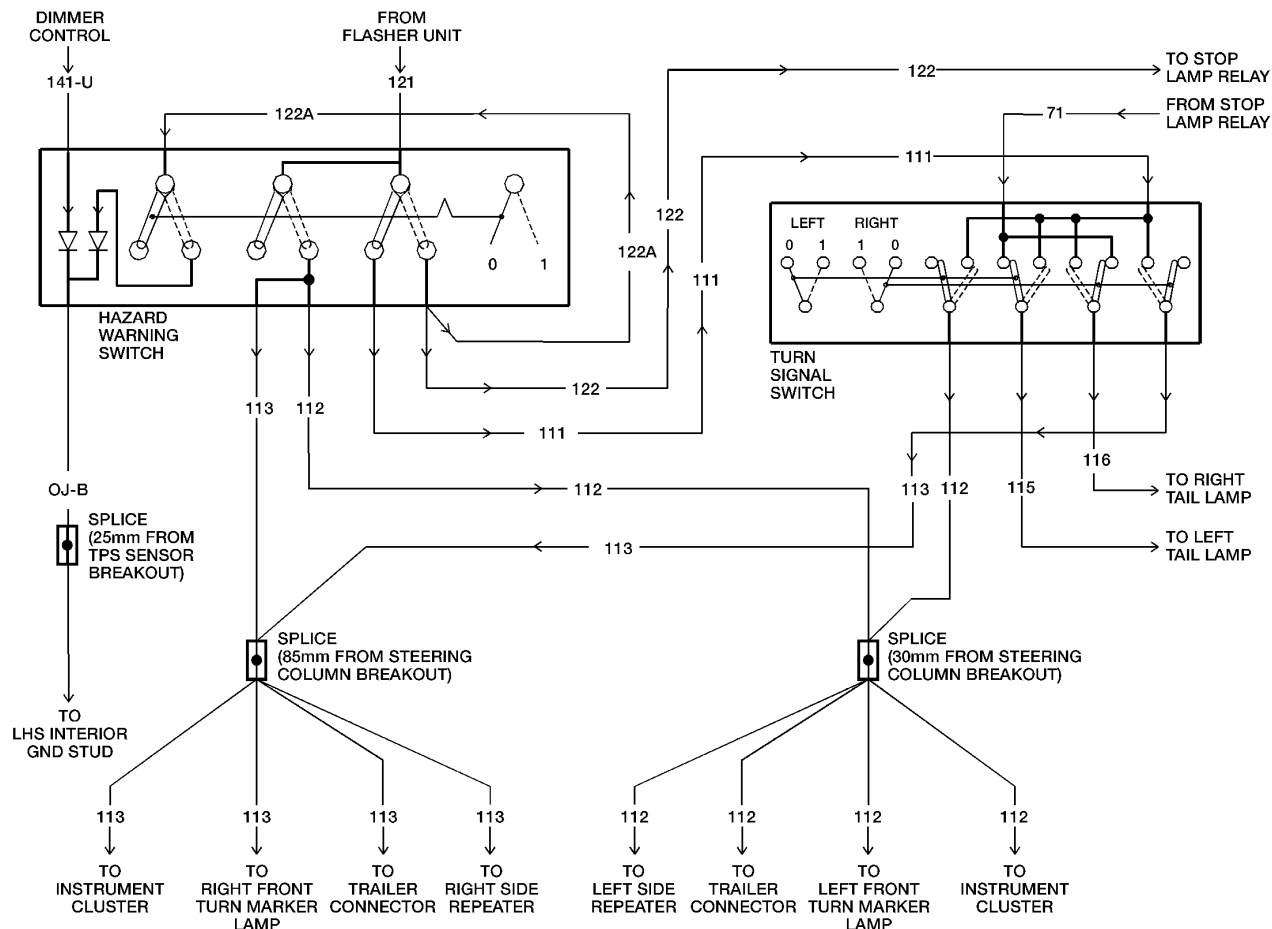

Hazard and Turn Logic Diagram

W3001003

The tail lamps use a single bulb for the stop, hazard and turn indicators. For this reason, the rear hazard and tail lamps function differently than the tractor front and trailer rear signals. Application of the brakes overrides the tractor rear hazards, and turn signals override the tractor brake lights and rear hazards.

Hazard/Turn Lights

- The hazard and turn indicators are powered through a Battery Maxi-fuse through wire 110, which powers the flasher unit. Wire 121 feeds power from the flasher unit to the hazard switch.
- When the hazard switch is *OFF*, wire 111 powers the turn signal switch.
- When the left turn signal is *ON*, power comes through the switch to wires 112 and 115.
- When the right turn signal is *ON*, power comes through the switch to wires 113 and 116.
- When the hazard switch is *ON* (fed by wire 121), wire 122A powers the switch illumination, and power is sent to wires 112 and 113 for the tractor front and trailer turn lights. The hazard switch ground is OJ-B.

Stop/Hazard Lights

- The stop and hazard lights are powered through fuse 29 through wire 70, which powers the stop light switch, located at the driver side cowl in the engine compartment.
- From the stop light switch, wire 75 goes to the tractor stop lamp relay (R6). From wire 75, wire 75A goes to the ECU brake input relay (R5). Power is sent through wire 75A to open the circuit on that relay.
- Relay R5 is grounded by wire 0R-D to the bus bar in the Truck Electrical Center (TEC).
- Wire 75 powers relay R6 from the stop lamp switch and fuse 29. Relay R6 is grounded by wire 0R-L to the bus bar in the TEC. When R6 is switched *ON* it opens the circuit between wires 122 and 71. It also switches wire 71 to +12V by battery power wire 1-B through fuse 48 to wire 76 on relay R6.
- Wire 71 provides power to the turn signal switch, sending power to wires 115 and 116 for the tractor tail lamps. The tail lamps are grounded by wire 0M-D to a stud on the passenger side cowl in the engine compartment.
- From wire 75A at relay R5, power continues on wire 75B to the trailer stop lamp relay (R11). Wire 75B supplies power to the coil on relay R11 to switch the trailer brake relay on. Relay R11 is battery powered through 1-D to fuse 20 and onto wire 77 to relay R11.
- When relay R11 is switched *ON*, wire 77 powers wire 72 to the trailer stop lights. Relay R11 is grounded by 0R-K, which connects to wire 0R-J to the bus bar in the TEC.

Stop/Hazard Lights With Right Turn Signal On

- Wire 113 supplies power to the right front turn light. Ground is through wire 0H-B to a ground stud on the passenger side cowl in the engine compartment. Wire 113 sends a signal to the instrument cluster for the right turn indicator.
- Wire 113 also supplies power to the trailer connector and side repeater. Ground for the side repeater is 0M-A to a passenger side interior ground stud.
- Wire 112 from the flasher unit feeds the left front turn light. Ground is through wire 0H to 0H-A to a passenger side interior ground stud. Wire 112 sends a signal to the instrument cluster for the left turn indicator.
- Wire 112 also supplies power to the trailer connector and side repeater. These lights will continue to flash with the hazard lights on.
- With the right turn switch on, wire 115 will continue to be powered by the stop light circuit. 115 goes to the left tail lamp, which is grounded by 0M-D to a ground stud on the passenger side cowl in the engine compartment.
- The right turn signal will still be powered by wire 111 from the hazard switch. So when the right turn switch is *ON*, the path from the stop light switch on wire 71 is broken, and the circuit between wire 111 and 116 is completed. Wire 116 feeds the right rear turn signal.
- Ground for the right tail light is on the jumper harness from the right to left tail light, then from the left tail light on 0M-D.
- The left circuit is functionally the same as the right. For more information, see the vehicle electrical schematics.

Auxiliary Fog and Driving Lights

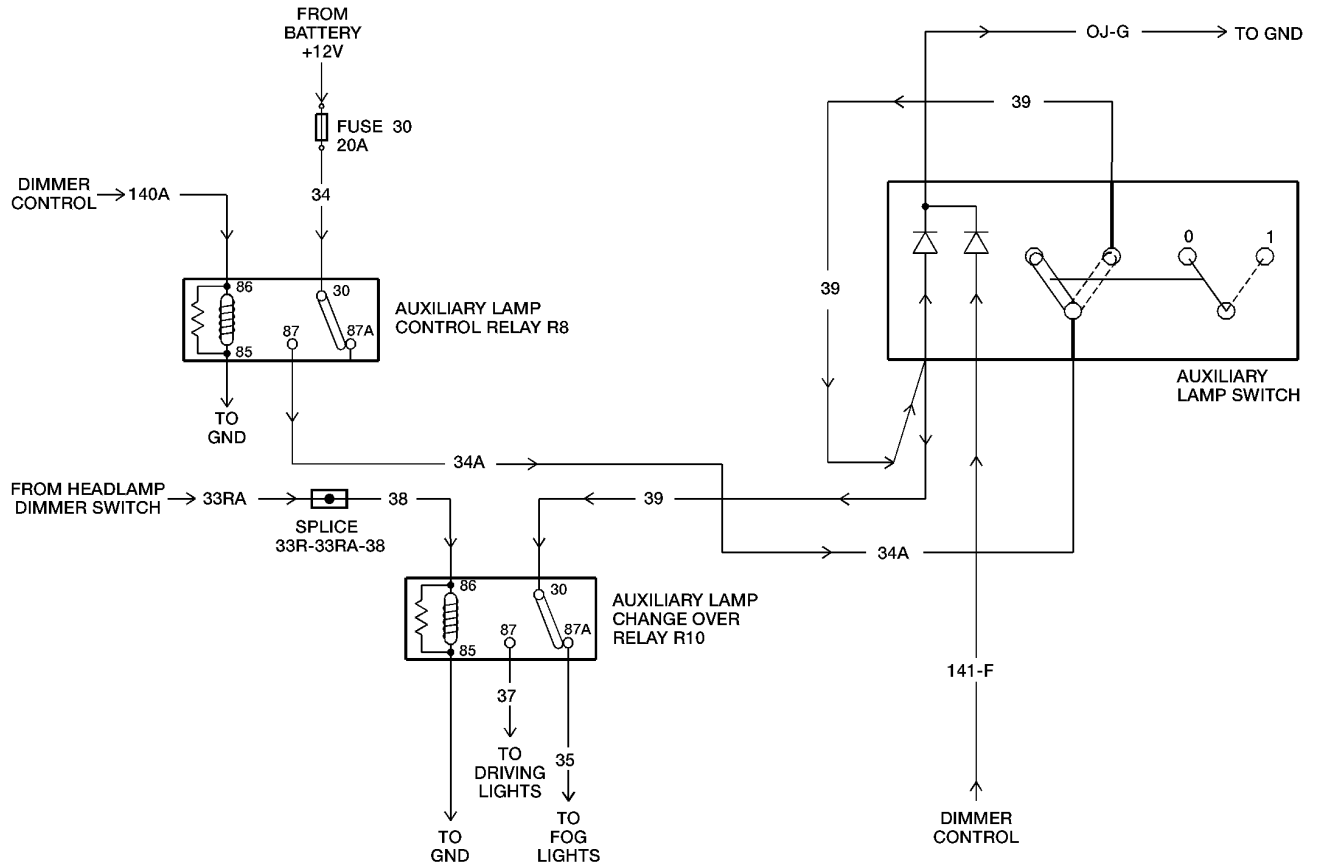

W3001002

Fog and Driving Light Operation				
	Low Beam Headlights	High Beam Headlights	Parking /Marker Lights	Flash To Pass *
Fog Lights	On	Off	On	Off
Driving Lights	Off	On	Off	On

* With Parking/Marker Lights on.

Optional driving and fog lights are mounted in the front bumper. Both of these lights are controlled by a single Auxiliary light switch mounted to the right of the headlight switch on the dash.

Fog and Driving Light Circuit Description

- Fog and driving lights are fed battery power through fuse 30. Fuse 30 feeds relay R8, which is energized by wire 140-A from the dash illumination rheostat and grounded by 0R-G. Relay R8 feeds the Auxiliary (fog and driving) light switch via wire 34-A.

- When the Auxiliary light switch is turned ON power is sent through wire 39 to the LED input on the switch for switch illumination (wire 0J-G provides ground).
- Wire 39 goes from the Auxiliary light switch to the Aux. Lamp Change Over Relay (R10), which is tied to the low beam headlight circuit. The relay sends power over wire 35 to the fog lights. Wire 35 splices into wires 35L and 35R for the left and right lights.
- The fog lights are grounded by wire 0M, then splice with the driving light grounds. The left lights will splice into 0M-A, and the right into 0M-B, which splices into 0M-C and then a ground stud on the right side cowl in the engine compartment. The Change Over Relay is grounded by wire 0R-J.
- Driving lights are turned ON by the Aux. Lamp Change Over Relay (R10), which is powered by the Auxiliary light switch, wire 39.
- When changing from low beams to high beams, the headlight dimmer switch powers wire 38-33RA-33R to change from fog to driving lights. Wire 38 energizes the Change Over relay coil, switching from fog lights to driving lights on wire 37. The Change Over Relay is grounded by wire 0R-J.

Bulb Replacement List

Bulb	Number	Amps
Back of Cab Lamp	1156	2.1
Back-up Lamp	1156	2.1
Cab Marker Lamp (without Sunvisor)	67	0.59
Driving Lamp	H9415	2.93
Fog Lamp	H9420	3.9
Headlamp, High Beam	9007	5.1
Headlamp, Low Beam	9007	4.3
Instrument Cluster Telltale Lamps	3919844 (Volvo)	0.125
Door Courtesy Lamp	67	0.59
Overhead Dome Lamp, Front	1156	2.1
Overhead Dome/Spot Lamp, Front	1156 (dome) 67 (spot)	2.1 0.59
Overhead Dome Lamp, 41" Sleeper, Passenger Side Only	1156	2.1
Overhead Fluorescent Lamp, Sleeper	PL-L 24W/827/4PP (Phillips) 16944 (GE)	2.0
Reading Lamp, Under Bunk Storage Compartment	561 (GE)	0.97
Combined Reading/Spot Lamp, Under Bunk Storage Compartment	561 (GE) (reading) 906 (GE) (spot)	0.97 0.69
Luggage Compartment Lamp	1156	2.1
Side Repeater	1156	2.1
Turn Signal Lamp (front)	3357	2.2
Turn Signal Lamp (rear) /Stop Lamp	1157	2.1
Rear Marker Lamps /License Plate Lamp	1157	0.59

Instrumentation

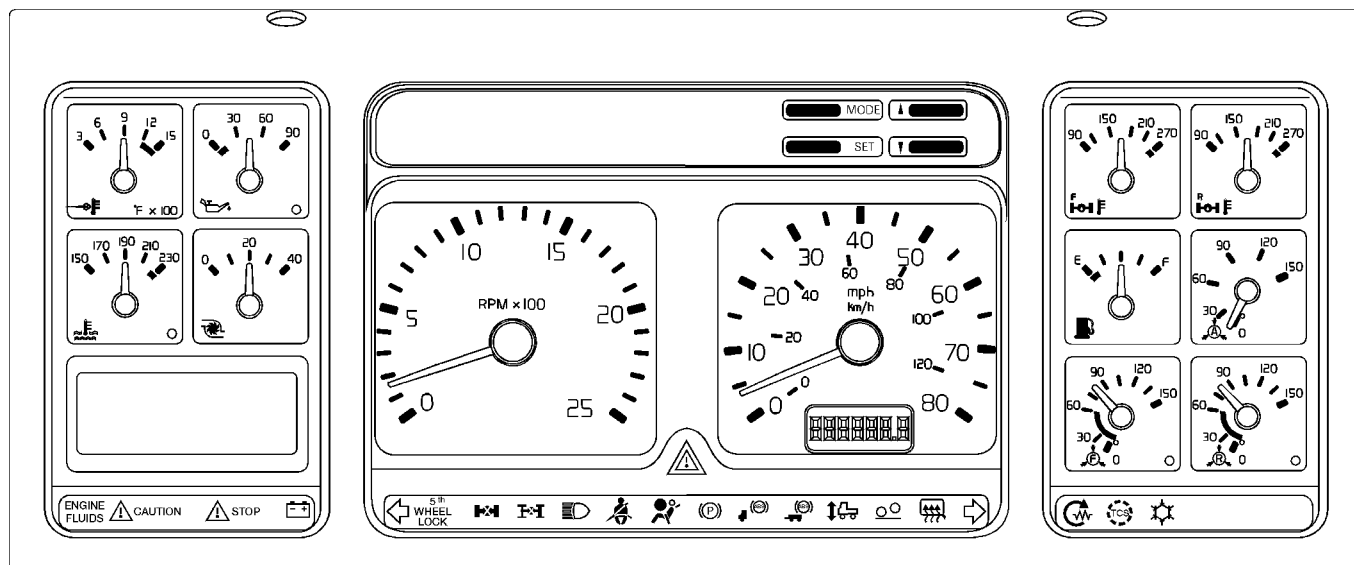

W3000787

The instrumentation is new. There are several variants of instruments, depending on what options have been installed on the vehicle, and on whether the speedometer is mph or km/h. A new feature of the instrument cluster is the graphic display.

The instruments are divided into three groups. The center group is always the same, regardless of which options are installed on the vehicle.

The center instrument group contains, in addition to a number of indicator and warning lamps, the tachometer and speedometer/odometer. Above these instruments are 4 buttons which control the graphic display.

On a truck with the standard instrument cluster, the left-hand instrument section contains instruments for coolant temp. and oil pressure, as well as the graphic display and indicator lamps. Optional pyrometer and turbo gauges may be installed. The Caution and Stop warning lamps are on this side, and are used to warn of engine cautions and engine shutdowns. The other lamps indicate low engine fluid and low voltage.

The right-hand instrument section contains the fuel and brake pressure gauges, and the remainder of the warning lamps. Axle temp. and air pressure gauges may be installed.

For more information on the instrumentation, see the *Instrumentation, VNL, VNM* manual.

Graphic Display

The graphic display is in the lower left-hand side of the instrument cluster. It is operated by the up, down, mode and set buttons in the center section.

With the mode/set buttons, the driver can select the function to be checked. There are both text and graphic displays of many functions. If, for example, the driver checks the voltage, and 12.5 volts is displayed, this is a normal value. If the voltage rises, the display will relay the information that this is an abnormally high value and vice-versa.

The graphic display optionally contains a fuel economy feature which provides information about fuel consumption. Both the average and accumulated consumption can be measured. This feature can show the number of miles or kilometers driven and calculate the distance until the fuel tank is empty. It can also show the average speed of the journey to date and the required average speed to cover a given distance in a given time.

Diagnostic Connector

The connector for electronic system diagnostics is a round 6-pin Deutsch connector located in the driver's side kick panel. It conforms to the industry standard SAE J1708 for serial data communications.

Service Procedures

General Work Practices and Cautions

General Recommendations

This manual provides electrical reference information, as well as suggested methods for service and maintenance. The recommended schedule for maintenance is outlined in the Operator's Manual for each vehicle.

Continual electrical problems may be the result of incomplete or inadequate diagnosis and improper repairs. Unless the root cause of a problem is determined, it will fail again, i.e., a blown fuse will blow again unless the cause of the overload is located. A battery damaged by overcharging will fail again if the regulator is not reset. Make every effort to determine the root cause of a failure.

Checking the following items will help to eliminate some of the most common problems found in heavy duty trucks.

- Shorts in cables and harnesses: The mechanic must be concerned about proper routing and the security of cables and harnesses. Cables that rub and chafe objects or flap around will ultimately lead to short circuit or open circuit conditions (see *Circuit Malfunctions* in this manual).
- Corrosion in sockets and connectors is caused by acids and road salt reacting with the copper. Connections exposed to concentrated splash, spray and wheel wash should be sealed tightly. Periodically check to see that all wiring connections are clean and tight.
- Corrosion is due mainly to poor wire splicing. Wires should not be spliced by twisting them together and wrapping with tape. The proper way to splice two wires together is outlined in Service Procedures. Several hand crimped connectors are available on the market which will result in a good joint or union, but most do not provide a water tight seal.

Important: To splice a wire or repair one that is frayed or broken, always use **rosin flux solder** to bond the splice and **sealant shrink tubing** to cover all splices, joints or bare wires. Never use acid core solder.

- The use of dielectric grease is recommended for all terminals exposed to the weather: salt, dirt, or water. Dielectric grease is needed to provide protection against moisture and the elements.

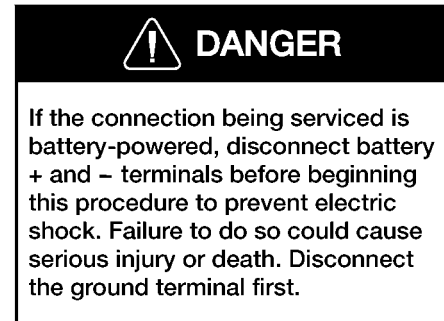

W3000821

To apply dielectric grease, remove the connector from the connection. If corroded, clean with a wire brush. After cleaning, spray a light film of dielectric grease on the terminal to seal out salt, dirt, and moisture.

- When replacing wires, it is important that the correct size wire be used as shown on the applicable wiring diagram or parts book. Each harness or wire must be held securely in place to prevent chafing or damage to the insulation due to vibration. Never replace a wire with one of a smaller size; never replace a fusible link with a wire that is larger, or of a different length.
- A high resistance condition in a circuit is often difficult to find. Symptoms of high resistance include dim or flickering lamps or inoperative components (since current decreases when resistance increases, the components may not be receiving enough current to operate properly). The first step in finding a high resistance problem should be a visual check of all connectors and wires in the circuit. Corrosion or loose, dirty connections could cause a high resistance problem. If a problem is found, repair it and verify correct circuit operation. If this does not fix the problem, use a digital multimeter to check for voltage drop at each of the components in the circuit.
- Many problems are the result of poor grounds. Poor grounds can cause open circuits or intermittent failures.
- Do not use test probes. Pricked holes from test probes/test lights cause future problems (corrosion) by piercing wire insulation.

Battery Charging and Jump Starting

Do not connect battery charging or jump starting cables to any part of an engine electronic system. This can damage sensitive electrical devices. It is preferable not to jump start vehicles which are electronically controlled. The electronic control units can be damaged by voltage spikes and current surges created by jump starting. When charging batteries, always disconnect the battery cables and charge each battery separately. This will prevent the voltage coming into the battery from damaging other system circuits.

Welding

CAUTION

Welding on trucks can damage the vehicle electrical system/components due to the voltage and current spikes that normally occur when welding. It is preferable to avoid welding on an assembled truck, but if any structure on or in contact with the vehicle must be welded, follow the recommendations below:

- Before welding on the vehicle, disconnect power to the component being welded.
- Disconnect both the positive (+) and negative (-) battery cables. Disconnect the negative cable first. Reconnect the positive cable first.
- Disconnect engine/starter ground from the chassis. Disconnect the power harness and vehicle interface harness at the engine Electronic Control Unit (ECU).
- If vehicles are equipped with systems with their own Electronic Control Units (ECUs), such as Anti-lock Brake or some transmission systems, disconnect the system ECU.
- Disconnect the electrical connectors at the rear of the instrument cluster.
- Attach the welder ground cable as close to the weld as possible (no more than 2 feet from the part being welded).
- Do not connect the welder ground cable to the engine ECU or the ECU cooling plate.

WARNING

Do not weld on the engine or engine components. Welding on the engine or components mounted on the engine can cause serious damage to the engine ECU.

Preventing Electrostatic Discharge (ESD)

Anti-static wrist strap and mat

CAUTION

A wrist grounding strap must be worn when working on electronic equipment such as the instrument cluster. This is to prevent electrostatic discharge (ESD), which can damage electronic components. To use the wrist strap in a vehicle, attach the alligator clip to the nearest electrical ground such as a metal mounting screw, a ground terminal or preferably a ground stud.

CAUTION

Make sure the workbench has an anti-static mat which is grounded to the nearest electrical outlet when working on electronic equipment such as the instrument cluster. When working at an anti-static workbench, always keep the wrist strap connected to the anti-static mat. This is to prevent electrostatic discharge (ESD), which can damage electronic components.

Human skin can hold more than 1000 volts of static electricity. Although getting a static shock is annoying, it is not dangerous because there is so little energy stored by clothing. But when dealing with circuits designed to sense differences smaller than 1 volt, electrostatic discharge can be a subtle but destructive problem. Circuit boards mounted in the instrument cluster or in modules mounted elsewhere may not fail immediately after being hit with a static discharge. Rather they may work for a while, then fail for no apparent reason. The culprit then is often the normal warming up and cooling down process of the module, engine or cab interior.

Grounding straps and anti-static mats are available for minimal cost from electronic supply stores. Grounding straps consist of a wrist strap, a coiled extension wire and an alligator clip. Be sure to purchase one with a long enough extension wire to allow free movement.

An anti-static wrist strap is available from Kent-Moore (see *Tools* section of this manual). Call 1-800-328-6657.

An anti-static mat is available from Newark (see *Tools* section of this manual). Call 1-910-292-7240.

Connectors

Packard, AMP, JAE, KOSTAL and Deutsch connectors are used throughout the electrical system. Refer to the connector manufacturer's literature for contact removal, crimping and insertion instructions. Special tools are required for these procedures. If contact removal is attempted with an ordinary pick, there is a good chance that the terminal will be bent or deformed. These terminals must not be reused once they are bent.

Molded-on connectors require complete replacement of the connection. This means splicing a new connector assembly into the harness. It is important that the best possible bond at all wire splices be made by soldering the splices (see Soldering procedure).

Environmental connections are used to isolate terminations from the environment. Environmental connections must not be replaced with standard connections – only with environmental connections. If a connector is replaced with one having more cavities, the unused cavities must be plugged to provide an environmental connection.

Use care when probing the connections or replacing terminals in them; it is possible to short between opposite terminals. If this happens to the wrong terminal part, it is possible that damage may be done to certain components. Always use jumper wires between connectors for circuit checking. Never probe through seals or wire insulation.

When diagnosing for possible open circuits, it is often difficult to locate them by sight because oxidation or terminal misalignment are hidden by the connectors. Merely wiggling a connector or a sensor in the wiring harness may correct the open circuit condition. This should always be considered when an open circuit is indicated while troubleshooting. Intermittent problems may also be caused by oxidized or loose connections.

Steam Cleaning and Pressure Washing

Do not steam clean or pressure wash electrical components or wiring when they are disconnected or removed from the engine. This can damage the components.

Dielectric Grease

The use of dielectric grease is encouraged for all plugs, sockets and connectors. It reduces corrosion by providing protection against moisture and the elements (see *Service Procedures*).

Add-on Electrical Equipment

The electrical system in the vehicle is designed to perform under normal operating conditions without interference from other components.

Failure to properly install additional electrical components may adversely affect the operation of the vehicle, including the engine, electrical charging system, truck body, stereo system and the driver information systems.

Overloaded circuits are usually the result of an "add-on" option being improperly installed. The most common mistakes are:

- Improper installation of the wiring
- Poor terminal installation on the wire
- Improperly protected by a fuse or circuit breaker
- Overloaded circuits

Volvo GM Heavy Truck Corporation assumes no responsibility for any adverse effect upon the vehicle or any of its components or systems which may result from the improper installation of additional electrical equipment which was not supplied or recommended by Volvo GM Heavy Truck Corporation.

Soldering/Wire Splicing

Do not use acid core solder. When replacing wires use the correct wire size as shown in the applicable wiring diagram or parts book. Secure each harness or wire in place to prevent chafing or damage to the insulation due to vibration. Never replace a wire with one of a smaller size or replace a fusible link with a wire of a larger size.

When soldering wiring always use rosin flux solder to bond the splice. Use sealant shrink tubing to cover all splices or bare wires.

It is very important when soldering electrical terminals to obtain a good soldered joint. Use a quality soldering iron such as a Weller Model 440D or equivalent. A good quality soldering iron will offer dual heat in a medium range (145/210 watts). Use Kester alloy SN60, Flux-44 Rosin, 0.80 mm (0.032 in.) maximum diameter or equivalent.

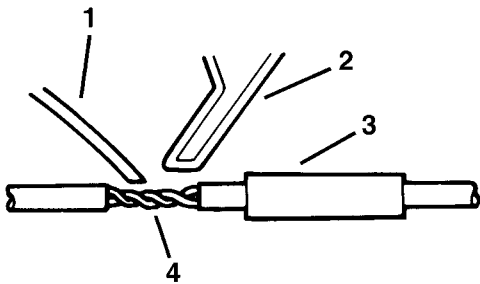

W3000568

Wire splicing

- 1) Solder
- 2) Soldering iron
- 3) Heat shrink tubing with sealant
- 4) Wires twisted

Soldering procedure

1
Clean and tin the soldering iron tip.

2
Clean the terminal to be soldered.

3

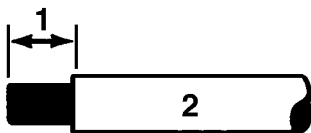

W3000569

- 1) Strip as necessary
- 2) Wire

Strip the wire as necessary to fit the terminal. Do not cut or nick the wire when stripping.

4
Slide a piece of sealant shrink tubing onto the wire.

5
Insert the wire in the terminal and, with a pair of crimpers (as recommended by the connector manufacturer), squeeze the small tabs onto the wire insulation. Not all types of terminals have these tabs. Be certain to use the crimpers recommended by the connector manufacturer. With a blunt instrument, form the bare wire so that it will lay against the soldering area of the terminal.

6

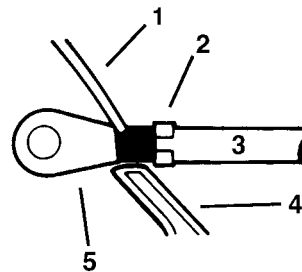

W3000571

- 1) Solder
- 2) Tabs (crimp over wire insulation)
- 3) Wire
- 4) Soldering iron
- 5) Terminal

Using the soldering iron, apply heat to the outside of the terminal while holding the solder on the wire on the inside of the terminal. When a sufficient amount of heat has been transferred from the gun through the terminal and into the wire, the solder will be melted by the wire. Melt a sufficient amount of solder on the wire and withdraw the solder and the tip of the iron.

NOTE: Do not hold the terminal with pliers or anything metal during the solder operation, as heat will be conducted away from the terminal.

7

Slide the sealant shrink tubing over the soldered connection, making sure all exposed wire is covered. Heat the tubing with a heat gun to shrink. Shrink until the tubing is tight around the wire and the sealant is visible out of both ends of the tubing.

3714-03-02-02 Battery Cable Fusible Link Replacement (Battery to Starter)

Removal

1
If a battery side fusible link becomes an open circuit, power will not be supplied to the cab power stud on that circuit (no continuity between the cab stud and starter solenoid). To verify fusible link failure, check for a visible break in the fusible link.

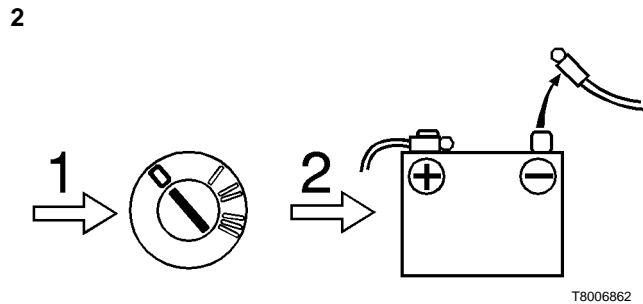

! WARNING

Disconnect the positive (+) and negative (-) terminals before beginning this procedure to prevent electric short circuit. Failure to do so could cause serious component damage. Disconnect the ground terminal first.

3

! CAUTION

Check the electrical system for a short circuit before beginning this procedure to prevent another fusible link from melting. Failure to repair the short circuit which caused the fusible link to melt will result in the new fusible link melting.

4
Loosen the bolt that goes through the battery cable clamping bracket. Remove the cable from the clamp. This will allow the cable to be removed from the solenoid.

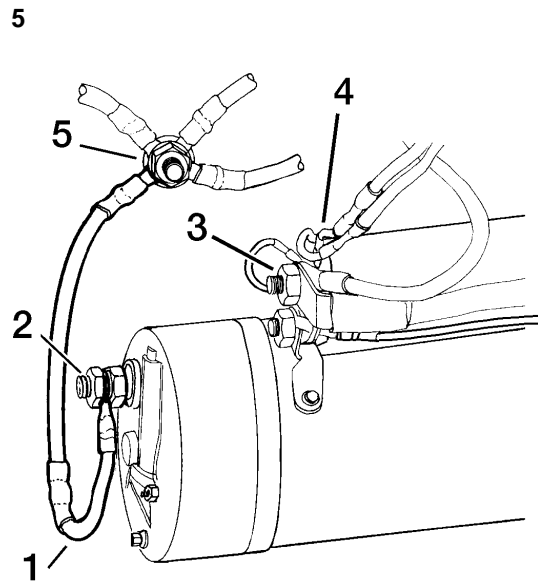

- 1) Ground Side Fusible Link
- 2) Starter Ground Stud
- 3) Starter Solenoid + Post
- 4) Battery Side Fusible Links (2)
- 5) Engine Ground Stud (Note: location varies by engine)

Remove the nut from the starter solenoid post where the fusible link/main battery cable (4) is attached.

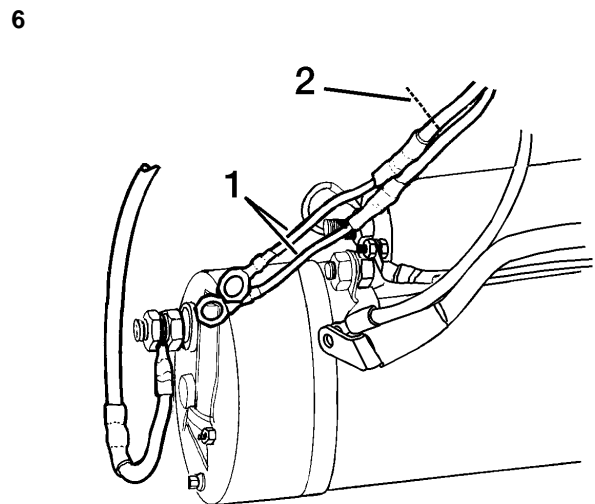

- 1) Fusible Links
- 2) Cut here on link being removed

Once the fusible link is detached from the solenoid, remove the fusible link by cutting through the positive cable just behind the splice clip connecting the fusible link to the cable.

W3000854

Installation

1
Slide a 1–1 1/2 in. piece of heat shrink tubing with sealant onto the positive cable where the fusible link was removed.

2
Strip the insulation back about $\frac{1}{2}$ in. on the cable and on the unterminated end of the new fusible link.

Note: Only use the proper replacement fusible links: on the positive side, they are 10 gauge cables 120 mm (4 3/4 in.) in length.

3
Crimp the fusible link onto the cable using a splice clip and solder the connection.

4
Slide the heat shrink over the soldered connection, making sure all exposed wire is covered. Heat the tubing with a heat gun to shrink. Shrink until the tubing is tight around the wire and the sealant is visible out each end of the heat shrink tubing.

5
Install the wires back onto the solenoid (see illustration in Removal procedure). Torque the nut to 27–34 Nm (238–300 in-lb).

27–34 Nm
(238–300 in-lb)

6
Connect the battery cables into the clamp bracket. Torque the bolt to 23 Nm (200 in-lb). Install the + and - terminals onto the battery, installing the positive terminal first. Torque nuts to 20.3–24.4 Nm (15–18 ft-lb).

23 Nm (200 in-lb)
20.3–24.4 Nm
(15–18 ft-lb)

3714-03-02-01

Battery Cable Fusible Link Replacement (Ground Cable)

Removal

1

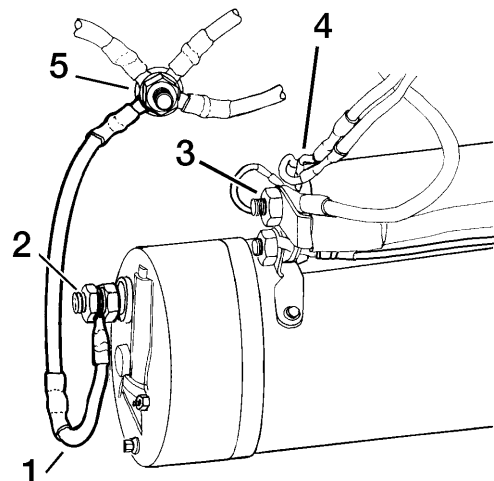

- 1) Ground Side Fusible Link
- 2) Starter Ground Stud
- 3) Starter Solenoid + Post
- 4) Battery Side Fusible Links (2)
- 5) Engine Ground Stud (Note: location varies by engine)

To verify ground fusible link failure, check for a visible break in the fusible link (1).

2

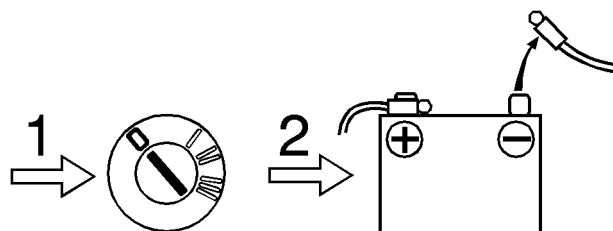

T8006862



WARNING

Disconnect the positive (+) and negative (-) terminals before beginning this procedure to prevent electric short circuit. Failure to do so could cause serious component damage. Disconnect the ground terminal first.

3

CAUTION

Since the ground side fusible link protects the battery and battery cable, check the electrical system for a short circuit before beginning this procedure to prevent another fusible link from melting. Failure to repair the short circuit which caused the fusible link to melt will result in the new fusible link melting.

4

Loosen the bolt on the battery cable clamping bracket. This will allow the negative battery cable to be removed.

5

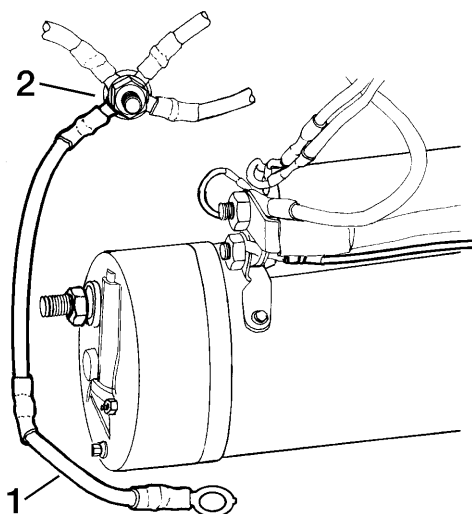

- 1) Fusible Link Removed
2) Engine Ground Stud (Note: location varies by engine)

Remove the nut from the ground stud at the starter solenoid, and remove the fusible link terminal from the starter.

6

Remove the nut on the side of the engine block where the fusible link is connected, and remove the fusible link from the vehicle.

Installation

1

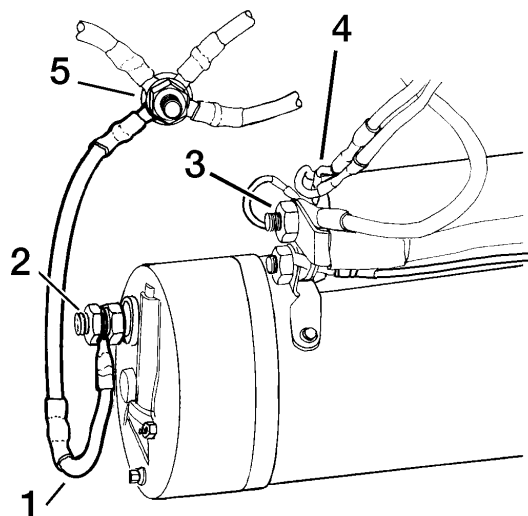

- 1) Ground Side Fusible Link
2) Starter Ground Stud
3) Starter Solenoid + Post
4) Battery Side Fusible Links (2)
5) Engine Ground Stud (Note: location varies by engine)

Install the fusible link terminal and negative battery cable at the starter ground stud. Install the nut and torque to 30.5 ± 3.5 Nm (270 ± 30 in-lb).

30.5 ± 3.5 Nm
(270 ± 30 in-lb)

2

Install the new fusible link cable assembly at the engine block. Torque the nut to 19 ± 4 Nm (168 ± 35 in-lb).

19 ± 4 Nm
(168 ± 35 in-lb)

3

Connect the battery cables into the clamp bracket. Torque the bolt to 23 Nm (203 in-lb). Install the + and - terminals onto the battery, installing the positive terminal first. Torque nuts to $20.3\text{--}24.4$ Nm ($15\text{--}18$ ft-lb).

23 Nm (203 in-lb)
 $20.3\text{--}24.4$ Nm
($15\text{--}18$ ft-lb)

W3000852

3341-03-02-01**Ignition Switch Replacement**

(Includes checking switch function)

Removal From Locking Housing

1

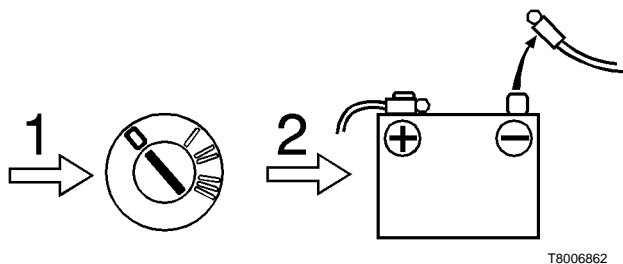

T8006862

**WARNING**

Disconnect the positive (+) and negative (-) terminals before beginning this procedure to prevent electric short circuit. Failure to do so could cause serious component damage. Disconnect the ground terminal first.

2

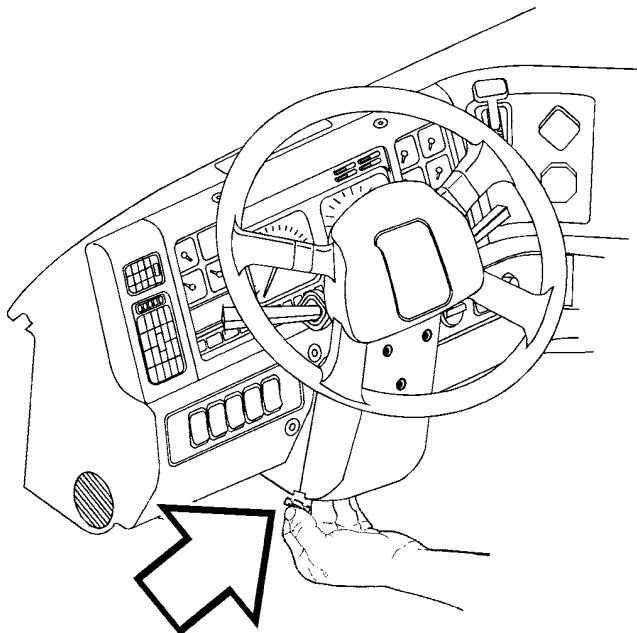

W3000655

Remove the 2 clips at the bottom of the steering column cover.

3

Adjust the steering column up and toward you, where possible. Remove the front steering column cover by removing the 3 torx bolts from the cover and sliding the rubber grommets off of the cover at the stalk switches.

4

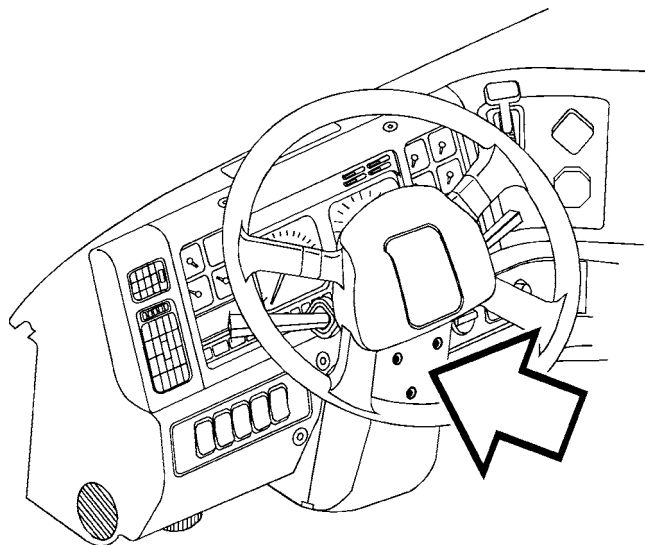

W3000648

Adjust the steering column forward and up where possible. Remove the 3 torx bolts from the rear column cover and remove cover.

5

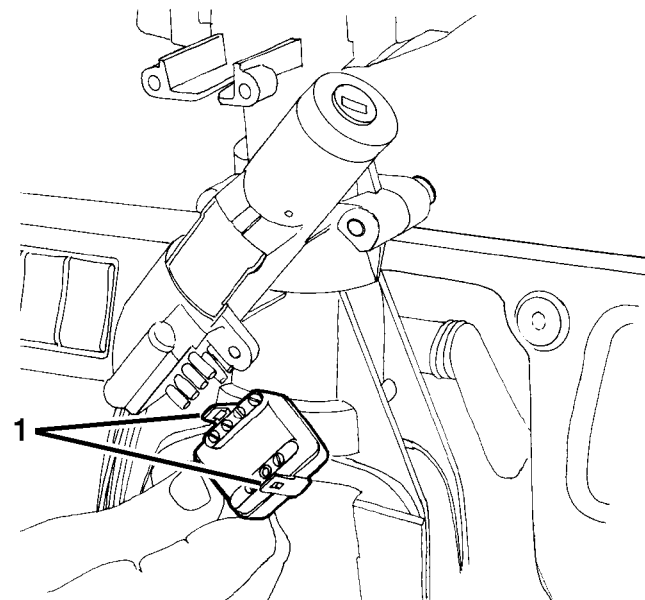

W3001001

1) Locking Clips

Disconnect the ignition switch electrical connector by depressing clips on each side of connector.

6

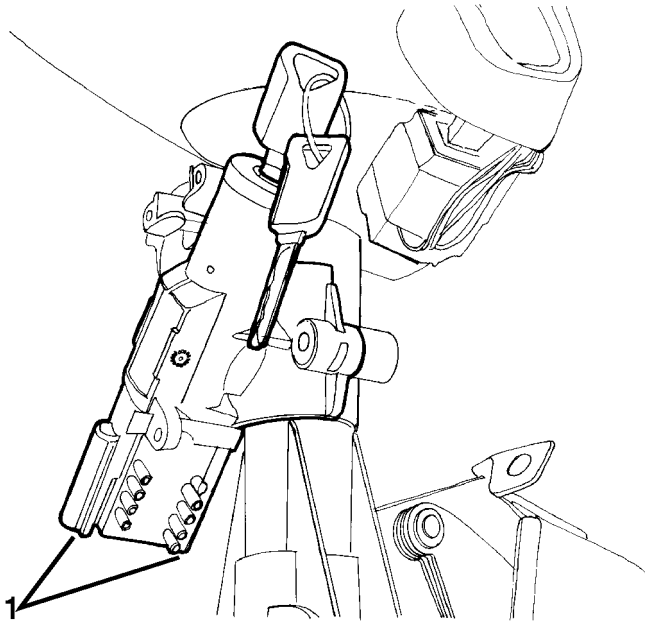

1) Machine Screws

Remove the 2 machine screws on the left and right side of the ignition switch and remove the switch from its housing.

Installation Into Locking Housing

1

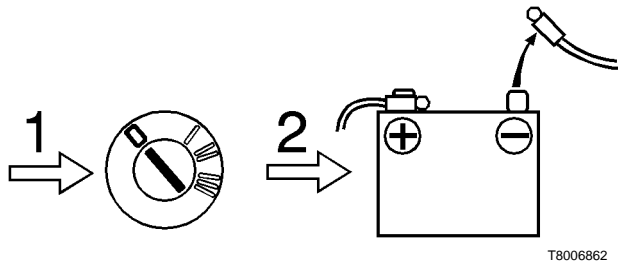

T8006862

! WARNING

Disconnect the positive (+) and negative (-) terminals before beginning this procedure to prevent electric short circuit. Failure to do so could cause serious component damage. Disconnect the ground terminal first.

2

Place switch into locking housing, aligning slots on switch and housing shaft. Holding switch in place, start both screws before tightening (see illustration in Removal procedure). Torque to 1.7 ± 0.5 Nm (15 ± 4 in-lb).

3

Connect the ignition switch electrical connector.

4

Pull steering column back and up, where possible. Install front cover by installing torx bolts. Torque to 5 ± 0.8 Nm (44 ± 7 in-lb).

5

Adjust the steering column forward and up, where possible. Install the rear cover of the steering column by installing torx bolts and attaching rubber grommets at stalk switches. Torque bolts to 5 ± 0.8 Nm (44 ± 7 in-lb).

6

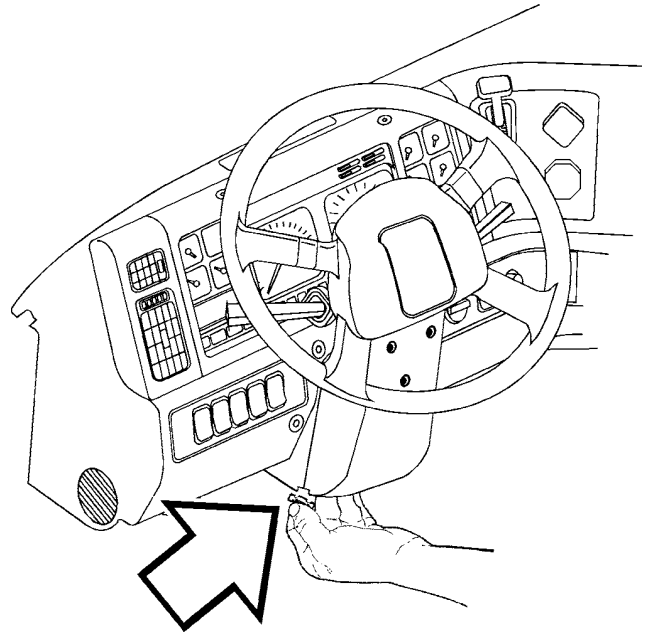

W3000655

Replace the 2 clips on the bottom of the steering column cover.

7

Connect battery cables, positive side first. Torque nuts to $20.3\text{--}24.4$ Nm ($15\text{--}18$ ft-lb).

3341-03-02-02 Ignition Switch and Housing Replacement

(Includes checking switch function)

Removal

1

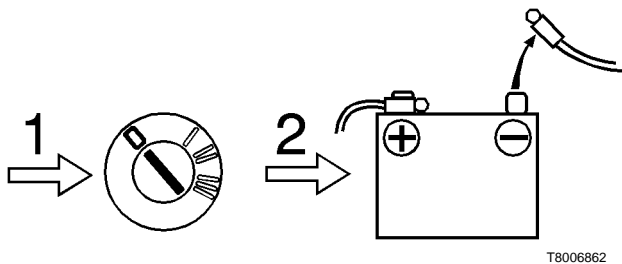

! WARNING

Disconnect the positive (+) and negative (-) terminals before beginning this procedure to prevent electric short circuit. Failure to do so could cause serious component damage. Disconnect the ground terminal first.

2

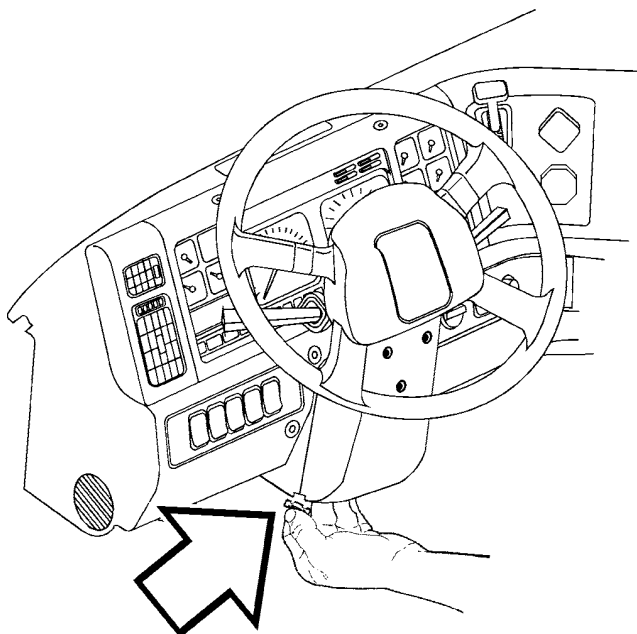

Remove the 2 clips at the bottom of the steering column cover.

3

Adjust the steering column up and toward you, where possible. Remove the front steering column cover by removing the 3 torx bolts from the cover and sliding the rubber grommets off of the cover at the stalk switches.

4

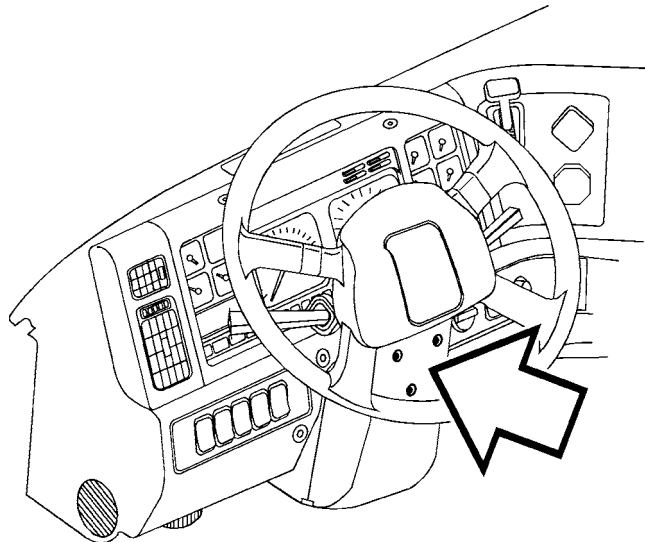

Adjust the steering column forward and up, where possible. Remove the 3 torx bolts from the rear column cover and remove cover.

5

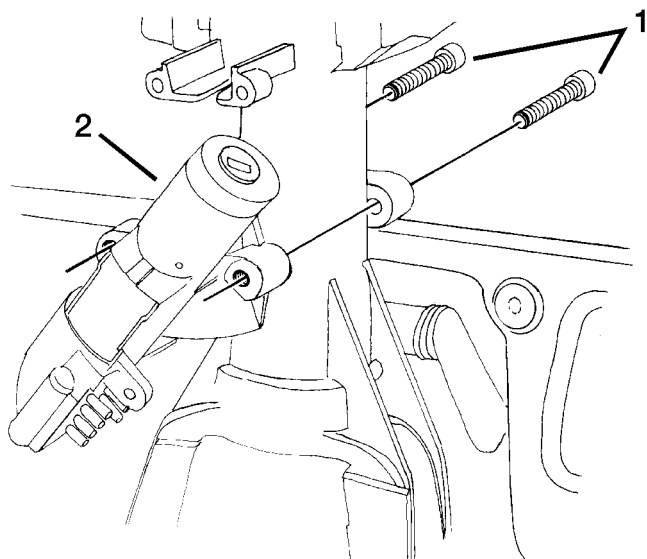

- 1) Bolts
- 2) Switch and Housing Assembly

W3000746

Disconnect the ignition switch electrical connector. Remove the 2 allen bolts from the forward side of the ignition switch housing to remove switch and housing.

Installation

1

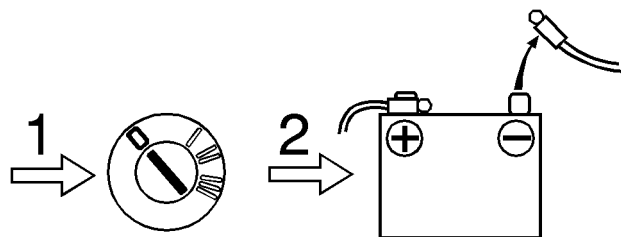

T8006862

WARNING

Disconnect the positive (+) and negative (-) terminals before beginning this procedure to prevent electric short circuit. Failure to do so could cause serious component damage. Disconnect the ground terminal first.

2

Mount the switch and housing on the steering column with the 2 bolts (see illustration in Removal procedure). Torque to 24 ± 4 Nm (18 ± 3 ft-lb).

3

Connect the ignition switch electrical connector.

4

Adjust the steering column up and toward you, where possible. Install front cover by installing torx bolts and attaching rubber grommets at stalk switches. Torque bolts to 5 ± 0.8 Nm (44 ± 7 in-lb).

5

Adjust the steering column forward and up, where possible. Install the rear cover of the steering column. Torque bolts to 5 ± 0.8 Nm (44 ± 7 in-lb).

6

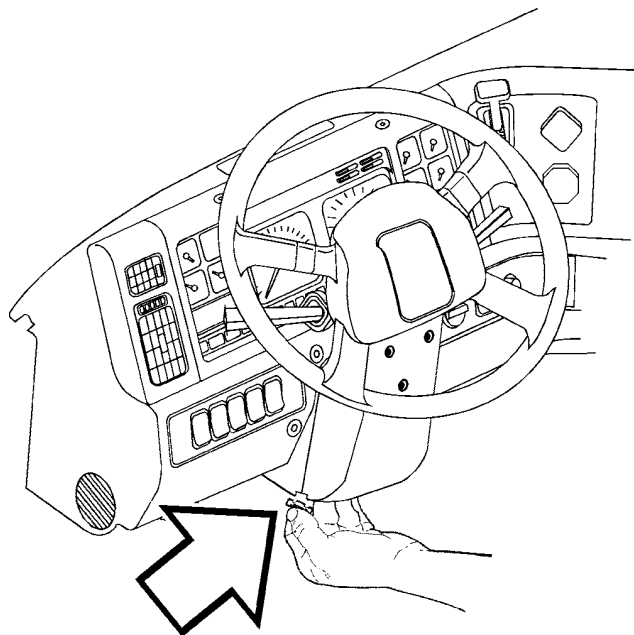

W3000655

Replace the 2 clips on the bottom of the steering column covers.

7

Connect battery terminals, positive side first. Torque nuts to $20.3\text{--}24.4$ Nm ($15\text{--}18$ ft-lb).

3623-03-02-01 Horn Contacts Replacement

Removal

Air Horn Contact

1

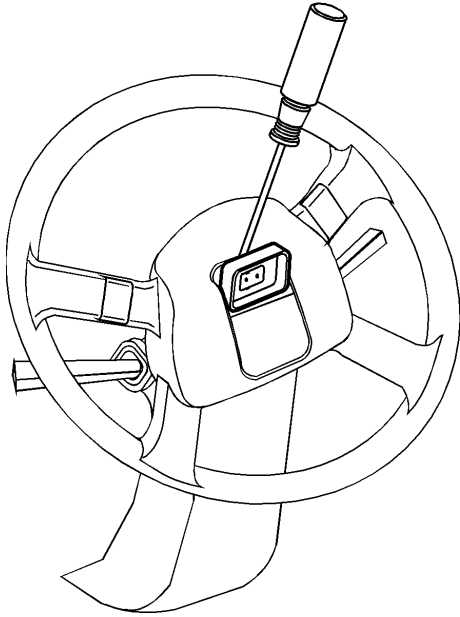

W3000789

Remove the horn button for the electric horn (center of steering wheel) using a No. 1 flat tip screwdriver. Place the screwdriver between the horn button and steering wheel, and gently pry up on the button.

2

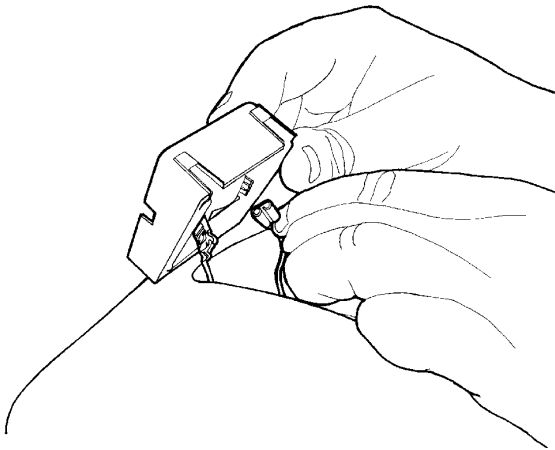

W3000790

Remove the wire connectors from the underneath side of the button.

3

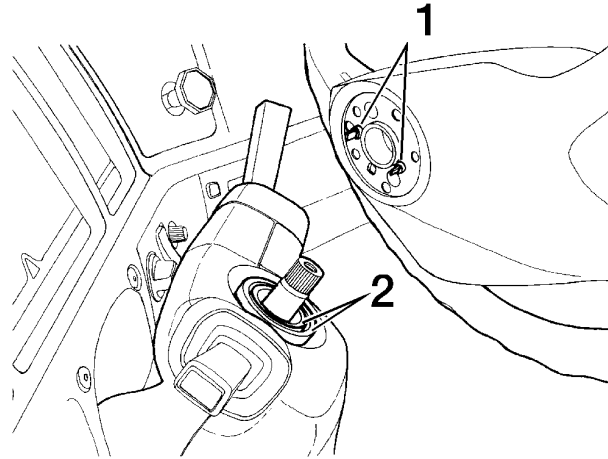

W3000791

- 1) Horn Contacts
- 2) Contact Assembly

Remove the bolt from the steering wheel. Pull the steering wheel from the steering shaft.

4

Remove the 2 clips at the bottom of the steering column cover. Slide the rubber grommets off of the cover at the stalk switches.

5

Adjust the steering column up and toward you, where possible. Remove the 3 torx bolts from the rear column cover and remove cover.

6

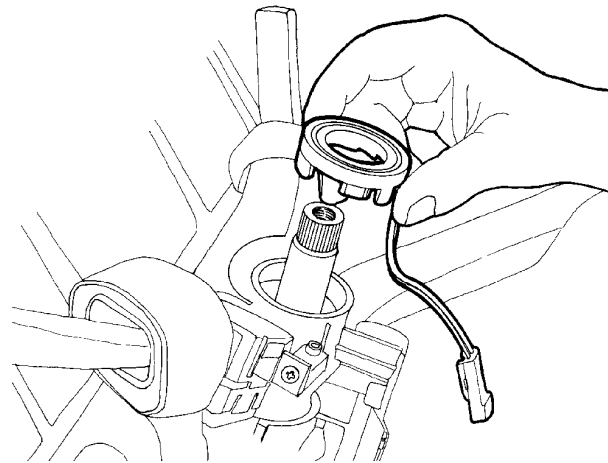

W3000792

Disconnect the connector for the horn contact. Remove the contact assembly from the steering shaft.

7

Remove the contact in the steering wheel with a No. 1 flat tip screwdriver. Push the contact out from the horn button area.

Electric Horn Contact

8

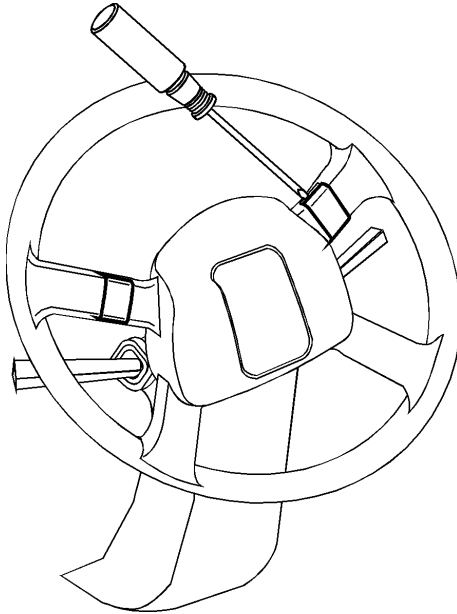

W3000782

Remove the horn buttons by inserting a small, flat tip screwdriver (No. 1) under each of the 2 horn buttons as shown. Gently pry up on the button and remove.

9

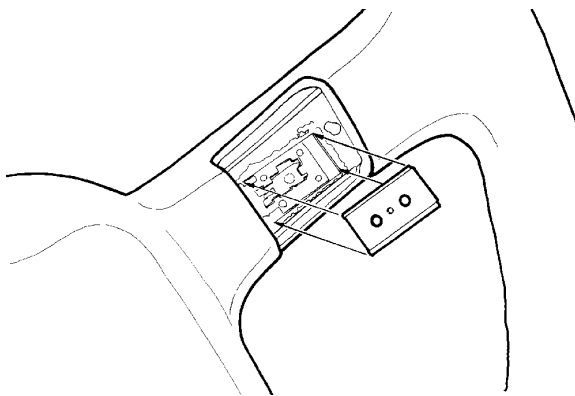

W3000793

Remove the contact strip under the button.

Installation

1

Insert the wire through the hole in the steering wheel where the old contact was. Align with the tab on the contact housing.

2

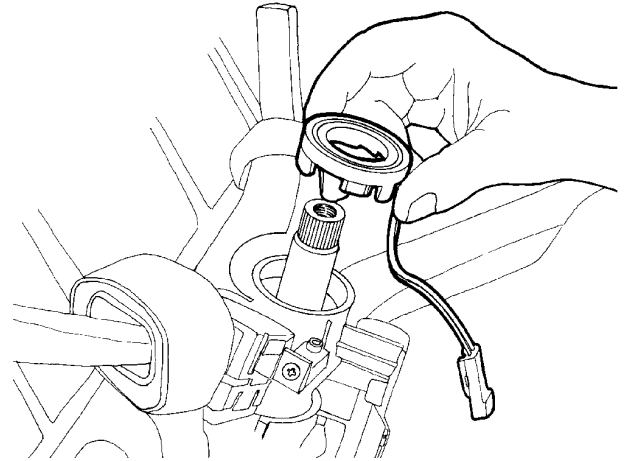

W3000792

Install the horn contact ring onto the steering shaft. The ring should slide down over the shaft. Route the wires as they originally were and connect the electrical connector.

3

Adjust the steering shaft forward and up, where possible. Install the rear cover of the steering column. Torque the 3 bolts to 5 ± 0.8 Nm (44 ± 7 in-lb).

5 ± 0.8 Nm
(44 ± 7 in-lb)

4

Install the 2 clips on the bottom of the steering column covers, and slide the rubber grommets onto the stalk switches.

5

Install the steering wheel onto the shaft, lining up the marks. Install a new bolt and torque to 85 Nm (62.7 ft-lb).

85 Nm
(62.7 ft-lb)

6

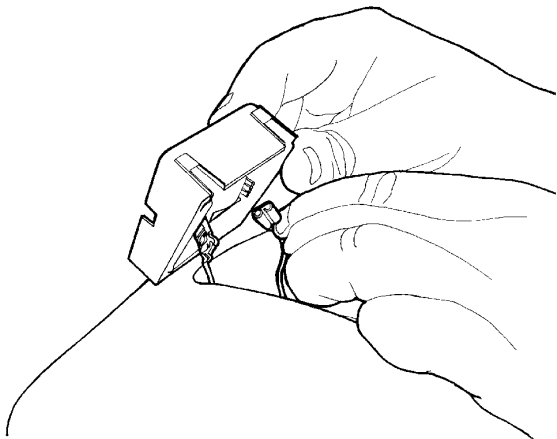

W3000790

Install the air horn button by connecting wire connectors and pushing the button into the steering wheel.

Electric Horn Contact

7

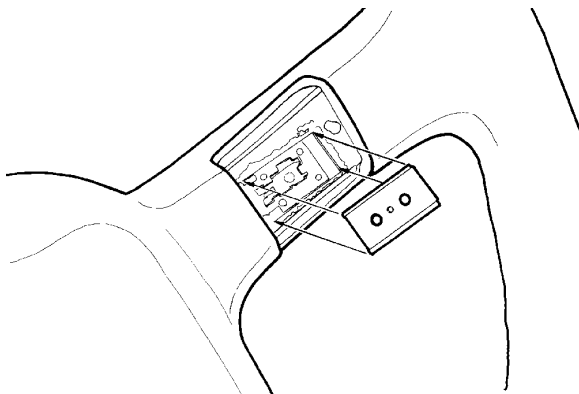

W3000793

Install the city horn buttons by first installing the contact strip. Then insert the button toward the inside of the steering wheel, making certain the dowel is aligned with the hole in the steering wheel. Push the button into place.

3643-03-02-01 Turn Signal/CC Switch Replacement

(Includes checking switch function)

Removal

1

Make certain the vehicle ignition is **OFF** before beginning this procedure.

2

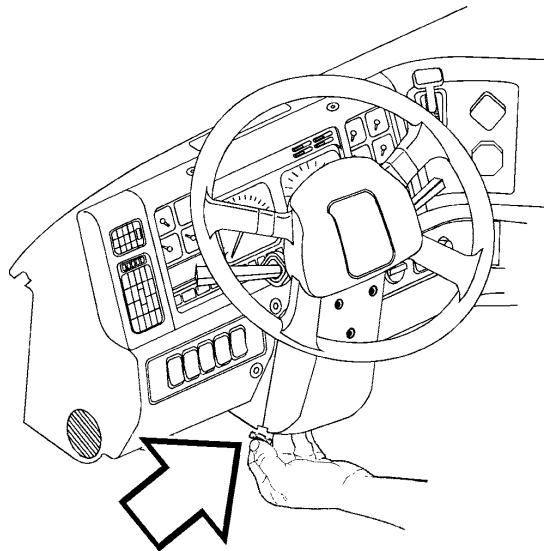

W3000655

Remove the 2 clips at the bottom of the steering column cover.

3

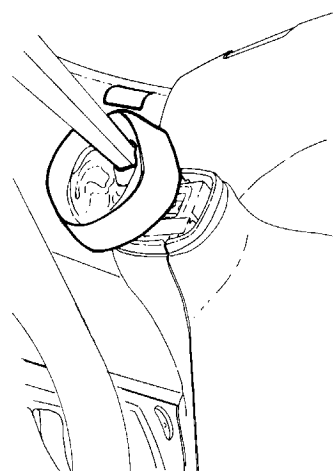

W3000653

Adjust the steering column up and toward you, where possible. Remove the front steering column cover by removing the 3 torx bolts from the cover and sliding the rubber grommets off of the cover.

4

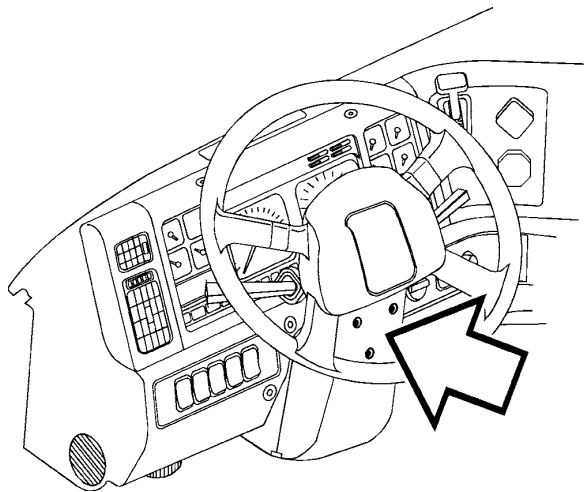

W3000648

Push the steering column forward and up, where possible. Remove the 3 torx bolts from the rear column cover and remove cover.

5

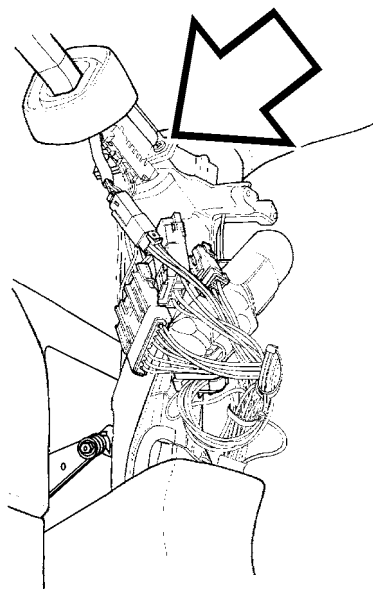

W3000643

Disconnect all electrical connections for turn signals, cruise, and headlamp dimmer switch. Remove the 2 torx bolts on the sides of the switch and remove switch.

Installation

- 1 Mount the switch assembly to steering column with the 2 bolts and connect all electrical connectors. Torque bolts to 5 ± 0.8 Nm (44 ± 7 in-lb).
- 2 Pull steering column back and up, where possible. Install front cover by installing torx bolts. Torque bolts to 5 ± 0.8 Nm (44 ± 7 in-lb).
- 3 Push the steering column forward and up, where possible. Install the rear cover of the steering column by installing torx bolts and attaching rubber grommets at stalk switches. Torque bolts to 5 ± 0.8 Nm (44 ± 7 in-lb).

4

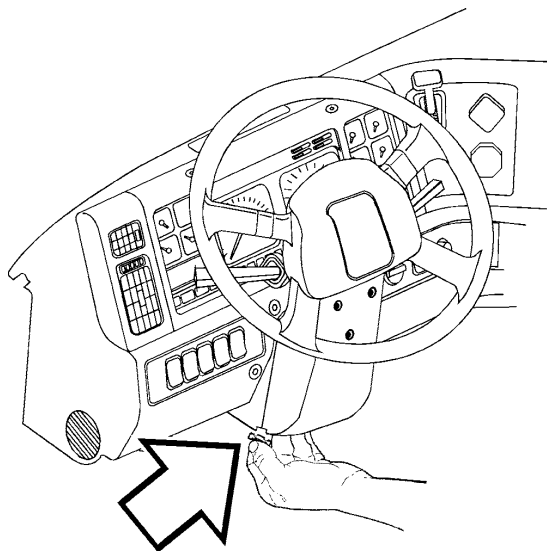

W3000655

Install the 2 clips on the bottom of the steering column cover.

3638-03-02-01 Windshield Wiper Switch Re- placement

(Includes checking switch function)

Removal

1
Make certain the vehicle ignition is **OFF** before beginning this procedure.

2

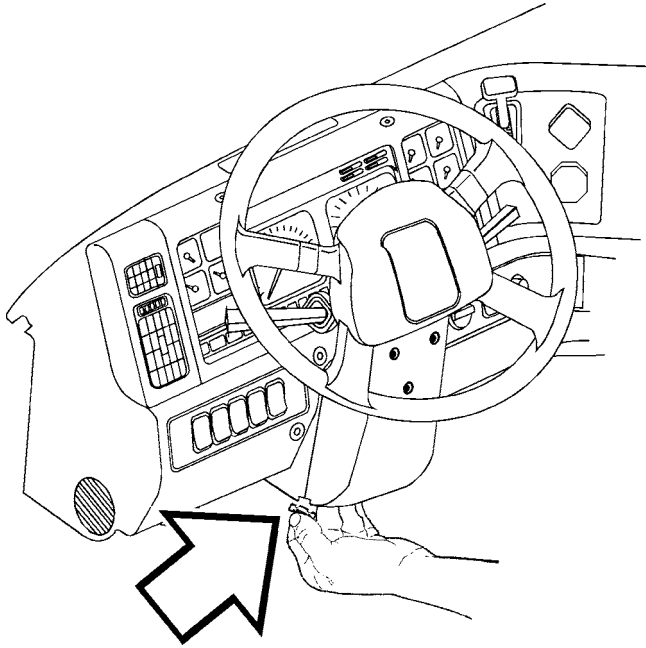

Remove the 2 clips at the bottom of the steering column cover.

W3000655

3

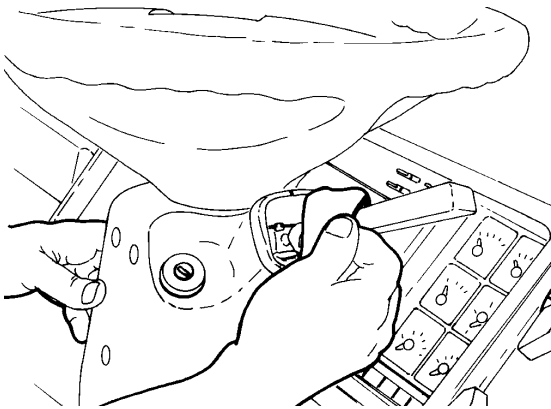

Adjust the steering column up and toward you, where possible. Remove the front steering column cover by removing the 3 torx bolts from the cover and sliding the rubber grommets off of the cover.

W3000654

4

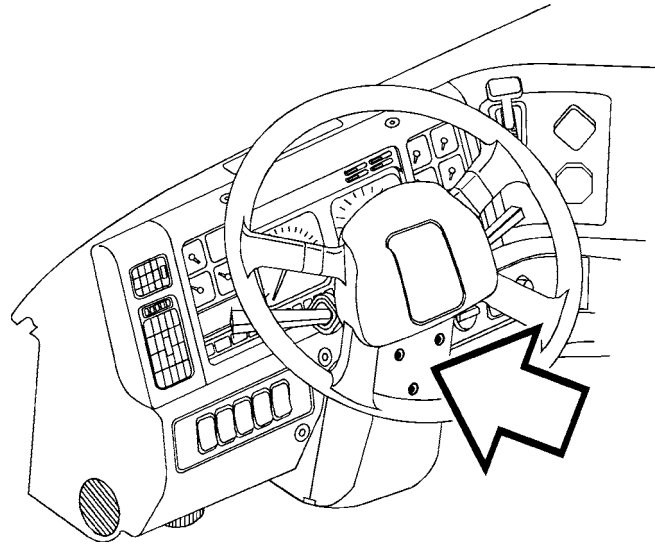

Adjust steering column forward and up, where possible. Remove bolts from rear column cover and remove cover.

W3000648

5

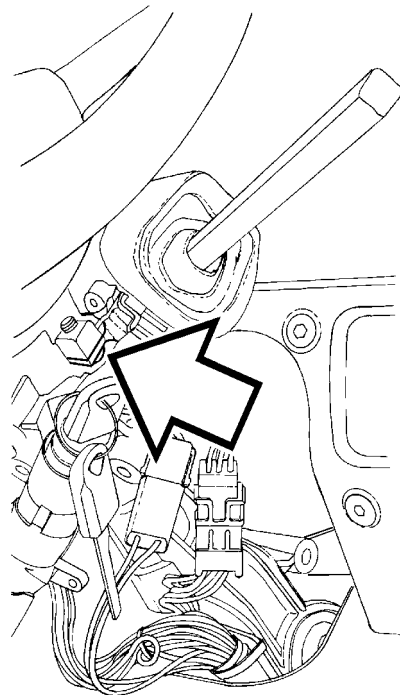

Disconnect electrical connector. Remove the torx bolts on each side of the wiper switch and remove the switch.

W3000652

Installation

1

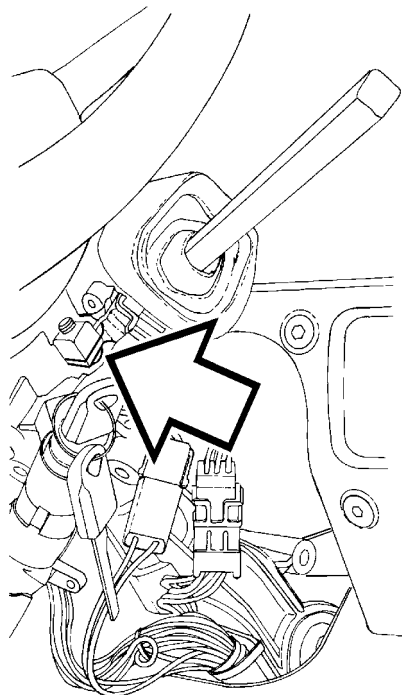

W3000652

Mount the wiper switch to the column with the bolts on each side. Torque to 5 ± 0.8 Nm (44 ± 7 in-lb). Connect electrical connector.

5 ± 0.8 Nm
(44 ± 7 in-lb)

2

Pull steering column back and up, where possible. Install front cover by installing torx bolts. Torque to 5 ± 0.8 Nm (44 ± 7 in-lb).

5 ± 0.8 Nm
(44 ± 7 in-lb)

3

Push steering column forward and up, where possible. Install rear cover of steering column by installing torx bolts and attaching rubber grommets at stalk switches. Torque to 5 ± 0.8 Nm (44 ± 7 in-lb).

5 ± 0.8 Nm
(44 ± 7 in-lb)

4

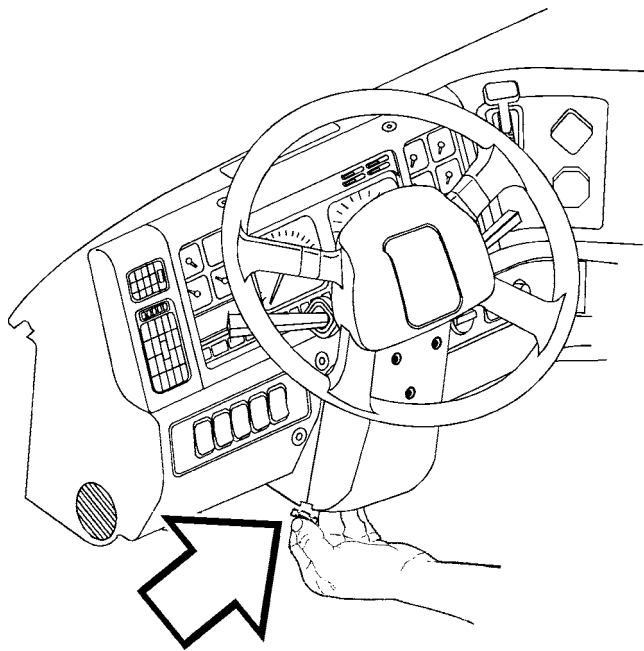

W3000655

Install the 2 clips on the bottom of the steering column cover.

3646-03-02-06 Headlight/Parking Lamp Switch Replacement

(Includes checking switch function)

Removal

1

Make certain the vehicle ignition is **OFF** before beginning this procedure.

2

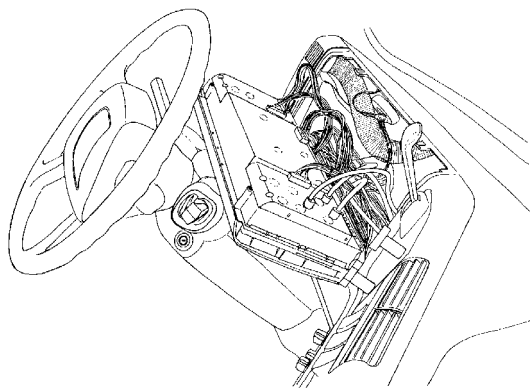

W3000641



CAUTION

Do not leave the cluster face-down for more than 15 minutes, or damage to the gauges may occur. Gauge oil can run out the front of the gauge faces and make the gauges inaccurate.

Remove the two screws at the top of the instrument cluster and lay the cluster face-down on the steering column (if steering column is adjustable, adjust as far back as possible before leaning cluster out).

3

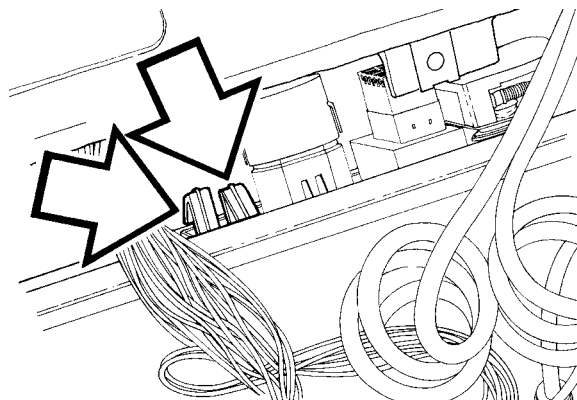

W3000650

To release the switch panel, reach behind the panel and depress the top and bottom clips on the left side.

4

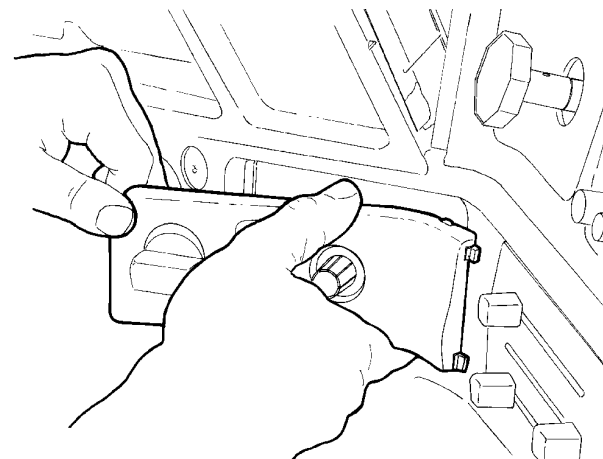

W3000996

Pull the panel through the front of the dash, pulling toward the driver's side to clear tip inserts.

5

Once the switch panel is removed, install the instrument cluster in the dash and tighten the 2 screws at the top of the cluster. Torque to 2 ± 0.3 Nm (17.5 ± 2.5 in-lb).

2 ± 0.3 Nm
(17.5 ± 2.5 in-lb)

6

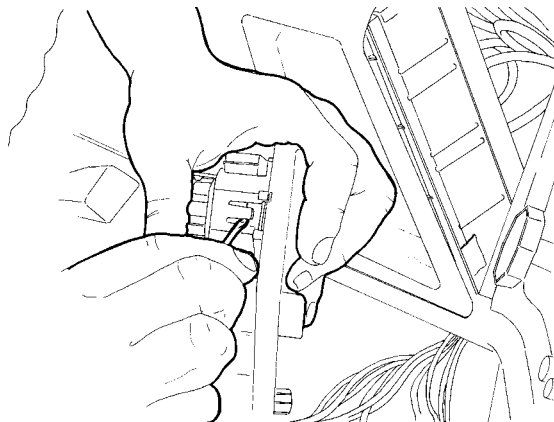

W3000646

Removing Headlight/Parking lamp Switch from Panel

Disconnect connector of switch being removed. Remove switch from panel by pulling locking tabs away from switch with a No. 1 screwdriver.

7

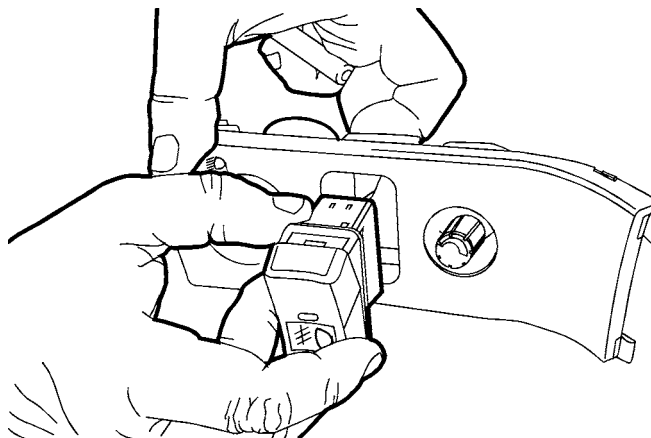

W3000682

Note: The light switch is removed through the front of the panel.

Installation

1

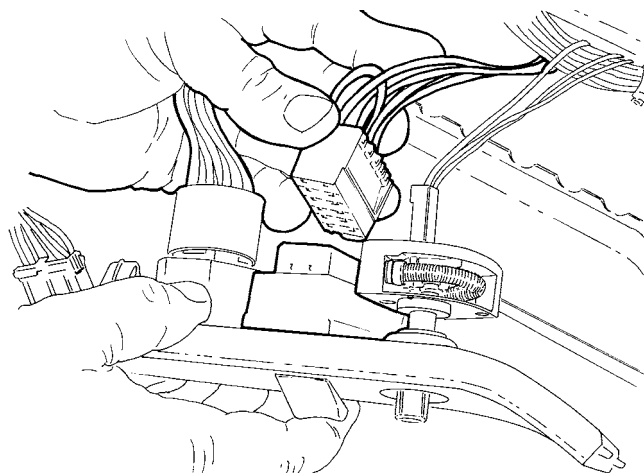

W3000680

Install new headlight/parking lamp switch into panel. Push the switch into the panel until it locks. Push back on the switch to make certain it is locked in the panel. Connect electrical connector.

2

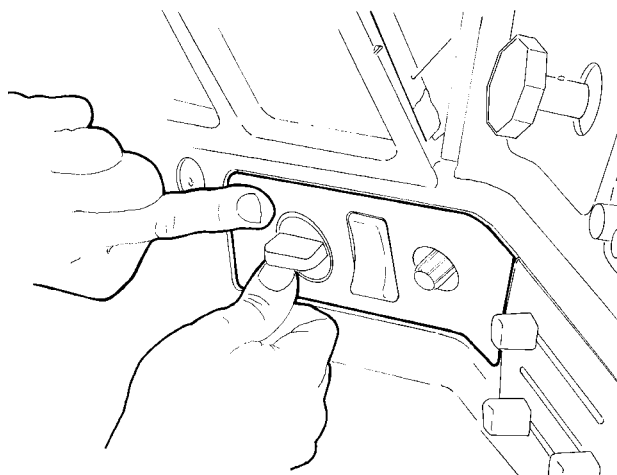

W3000647

Install the panel by inserting tips on right side and pushing the panel into position. The clips will snap in place on the left side.

3646-03-02-07 Road Lamp (Fog Lamp) Switch Replacement

(Includes checking switch function)

Removal

1

Make certain the vehicle ignition is **OFF** before beginning this procedure.

2

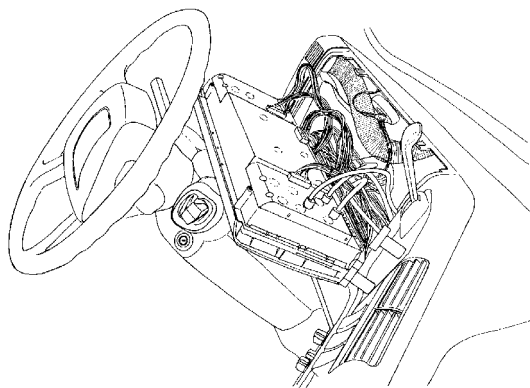

W3000641

CAUTION

Do not leave the cluster face-down for more than 15 minutes, or damage to the gauges may occur. Gauge oil can run out the front of the gauge faces and make the gauges inaccurate.

Remove the two screws at the top of the instrument cluster and lay the cluster face-down on the steering column (if steering column is adjustable, adjust as far back as possible before leaning cluster out).

3

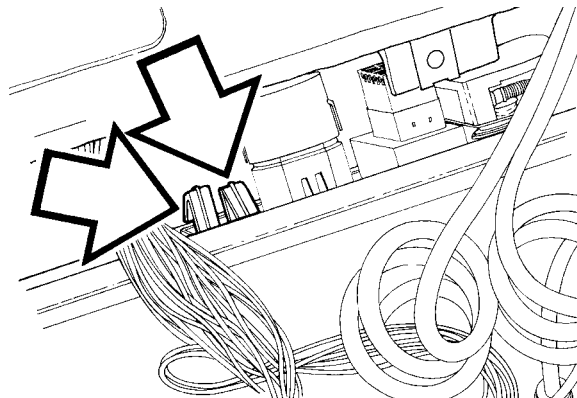

W3000650

To release the switch panel, reach behind the panel and depress the top and bottom clips on the left side.

4

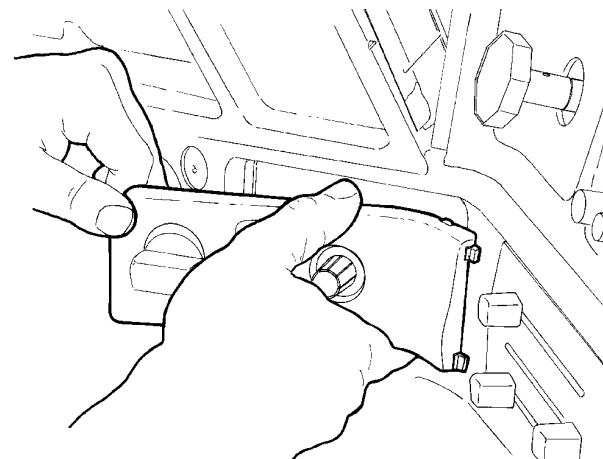

W3000996

Pull the panel through the front of the dash, pulling toward the driver's side to clear tip inserts.

5

Once the switch panel is removed, install the instrument cluster in the dash and tighten the 2 screws at the top of the cluster. Torque to 2 ± 0.3 Nm (17.5 ± 2.5 in-lb).

2 ± 0.3 Nm
(17.5 ± 2.5 in-lb)

6

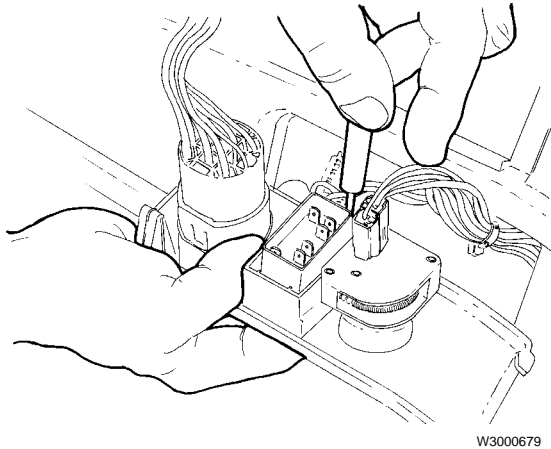

W3000679

Removing Fog/Driving Light Switch from Panel

Disconnect connector of switch being removed. Remove switch from panel by inserting a No. 1 screwdriver into the back of the switch at the top and bottom to release the locking tabs.

7

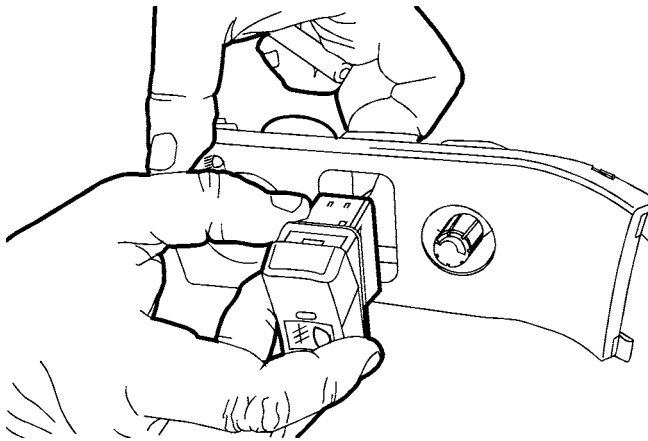

W3000682

Note: The light switch is removed through the front of the panel.

Installation

1

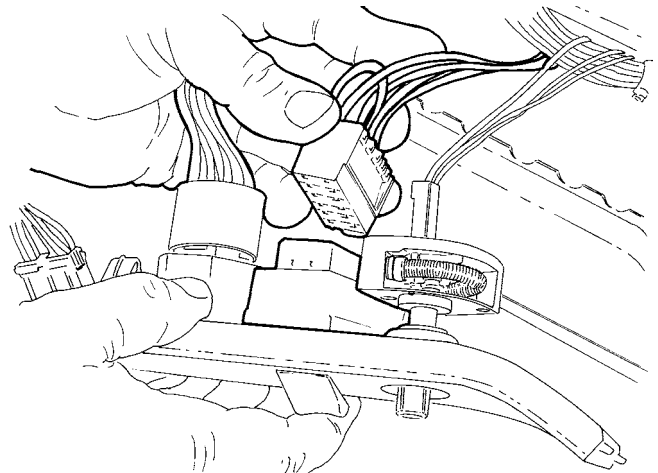

W3000680

Install new fog/driving lamp switch into panel. Push the switch into the panel until it locks. Push back on the switch to make certain it is locked in the panel. Connect electrical connector.

2

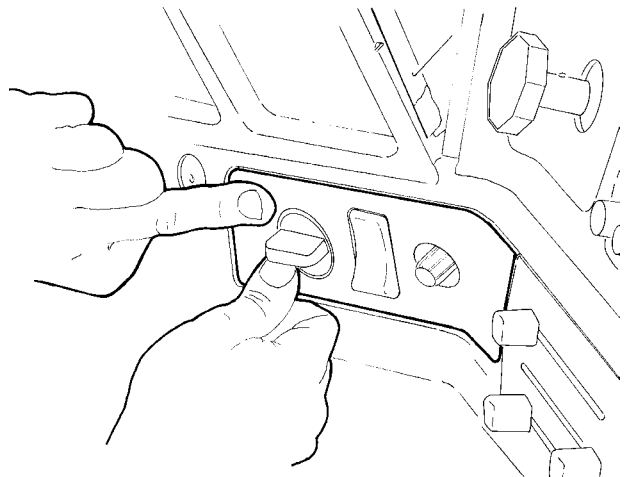

W3000647

Install the panel by inserting tips on right side and pushing the panel into position. The clips will snap in place on the left side.

3646-03-02-12 Dimmer Control (dash illumination) Rheostat Switch Replacement

(Includes checking switch function)

Removal

1
Make certain the vehicle ignition is **OFF** before beginning this procedure.

2

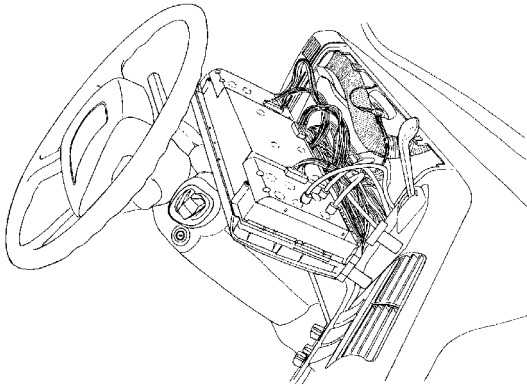

W3000641



CAUTION

Do not leave the cluster face-down for more than 15 minutes, or damage to the gauges may occur. Gauge oil can run out the front of the gauge faces and make the gauges inaccurate.

Remove the two screws at the top of the instrument cluster and lay the cluster face-down on the steering column (if steering column is adjustable, adjust as far back as possible before leaning cluster out).

3

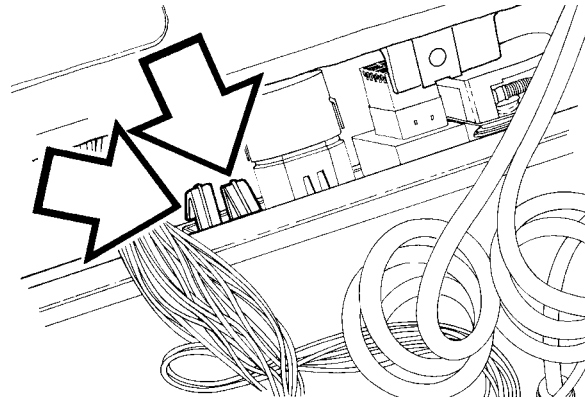

W3000650

To release the dimmer switch panel, reach behind the panel and depress the top and bottom clips on the left side.

4

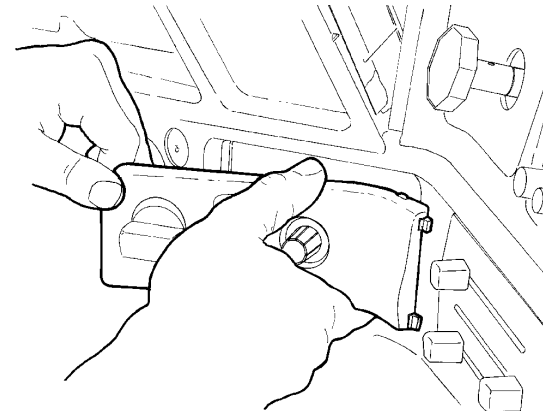

W3000996

Pull the panel through the front of the dash, pulling toward the driver's side to clear tip inserts.

5

Once the panel is removed, install instrument cluster back in its original position and tighten the 2 screws at the top of the cluster. Torque to 2 ± 0.3 Nm (17.5 ± 2.5 in-lb).

2 ± 0.3 Nm
(17.5 ± 2.5 in-lb)

6

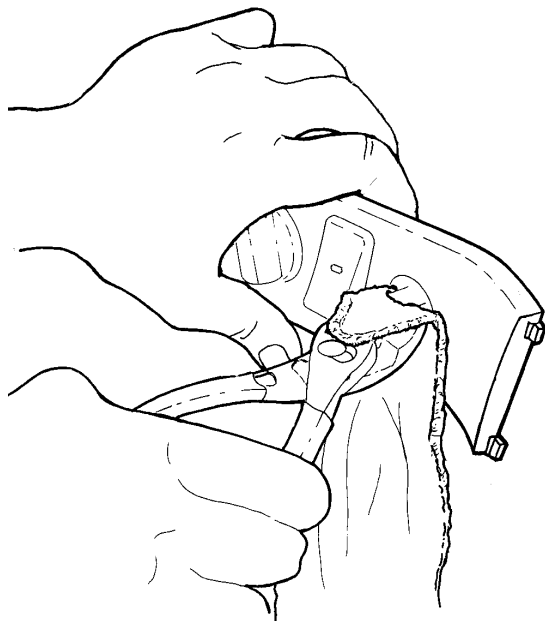

W3000812

Use a rag and a pair of pliers to remove the rheostat knob. Then disconnect the terminal connectors on the switch.

7

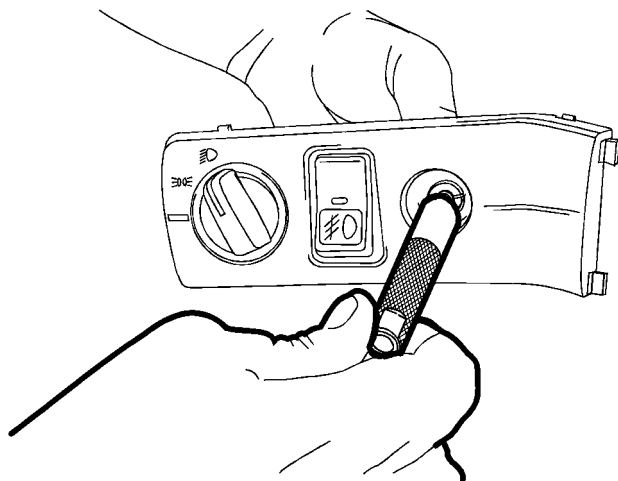

W3000798

Use the rheostat removal tool (Kent—Moore P/N J-42395) to remove the shaft nut from the rheostat.

Installation

1

Install the new rheostat into panel. Install the nut on the rheostat shaft. Connect the terminal connectors and install the knob.

2

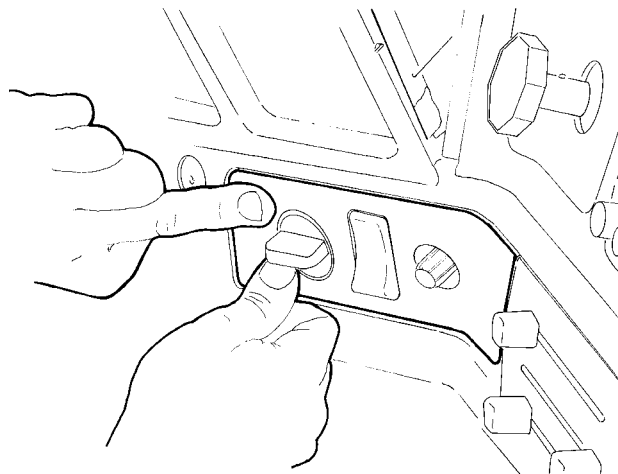

W3000647

Install panel by inserting tips on right side and pushing the panel into position. The clips will snap in place on the left side.

5633-03-02-09 Rear Suspension Cab Unloader Control Valve Replacement

(Includes transfer fittings.)

For service procedure, see “Dash Air Switch Replacement” page 66.

5633-03-02-10 Lift Axle Control Valve Re- placement

(In dash; includes transfer fittings.)

For service procedure, see “Dash Air Switch Replacement” page 66.

5633-03-02-11 Fifth Wheel Slider Valve Re- placement

(In dash; includes transfer fittings.)

For service procedure, see “Dash Air Switch Replacement” page 66.

5633-03-02-12 Differential Lockout Valve Re- placement

(In dash; includes transfer fittings.)

For service procedure, see “Dash Air Switch Replacement” page 66.

5633-03-02-19 Axle Lock Control Valve Re- placement

(In dash; includes transfer fittings.)

For service procedure, see “Dash Air Switch Replacement” page 66.

Dash Air Switch Replacement

(Includes checking switch function)

Removal

1
Make certain the vehicle ignition is **OFF** before beginning this procedure.

2

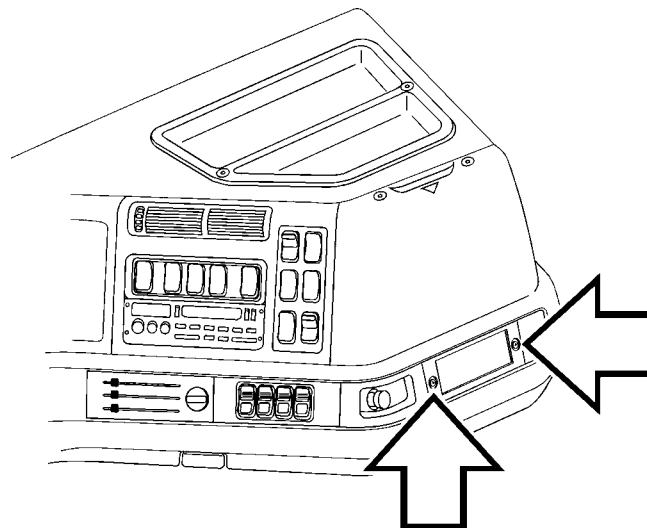

W3000649

Remove the ashtray from the ashtray housing. Remove the 2 screws from the ashtray housing, and remove the housing.

3
Once the ashtray housing is removed, the air switch panel can be removed from the dash. Pull the air switch panel away from the dash and to the left to clear the tip inserts.

4

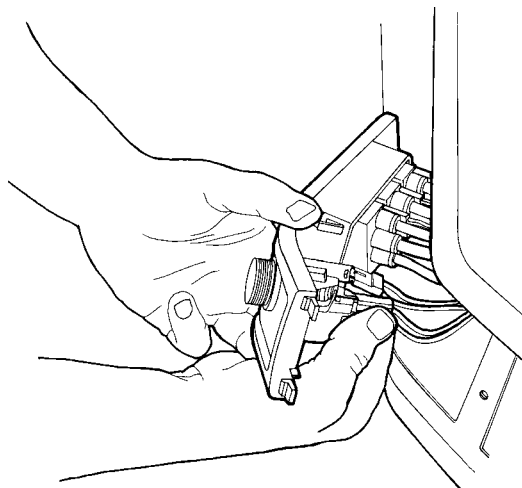

W3000656

Disconnect the 2 terminal connectors from the cigar lighter and the electrical LED connections on the switch being replaced.

5

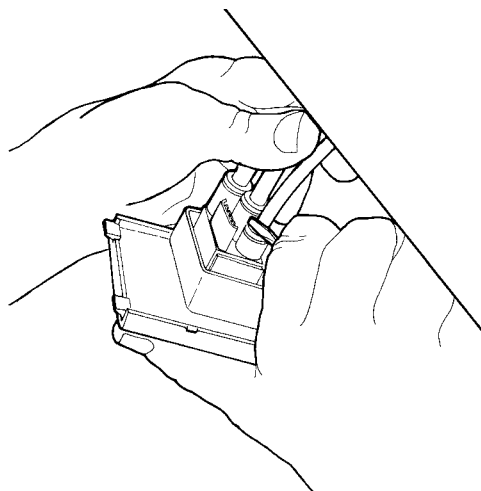

W3000657

**DANGER**

Never disconnect an air system component unless all system pressure has been depleted. Failure to deplete system pressure before disconnecting hoses or components may result in them separating violently and causing serious bodily injury.

Drain air pressure from vehicle system. Mark each air line to keep correct arrangement. Disconnect air lines at switch being replaced by pushing in on the ring and air line, then pulling the air line out.

6

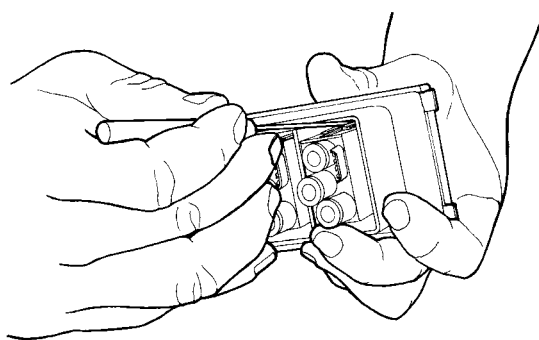

W3000658

To remove switch, insert No. 1 flat tip screwdriver into back of switch at top and bottom to release locking tabs. Push switch out of the panel.

Installation

1

Install new air switch into the panel, pushing the switch into the panel until it locks. Push back on the switch to make certain it is locked in the panel.

2

Connect air lines to the switch, making sure they are installed in the correct position. Be sure to insert airline to line indicated.

3

Connect electrical LED connections on switch, and both cigar lighter connectors.

4

Align and install switch panel in dash.

5

Install ashtray housing with the 2 mounting screws, and place ashtray in housing. Torque screws to 0.4 ± 0.1 Nm (3.5 ± 1 in-lb).

0.4 ± 0.1 Nm
(3.5 ± 1 in-lb)

3647-03-02-02 Cigar Lighter Replacement

(Includes checking component function)

Removal

1

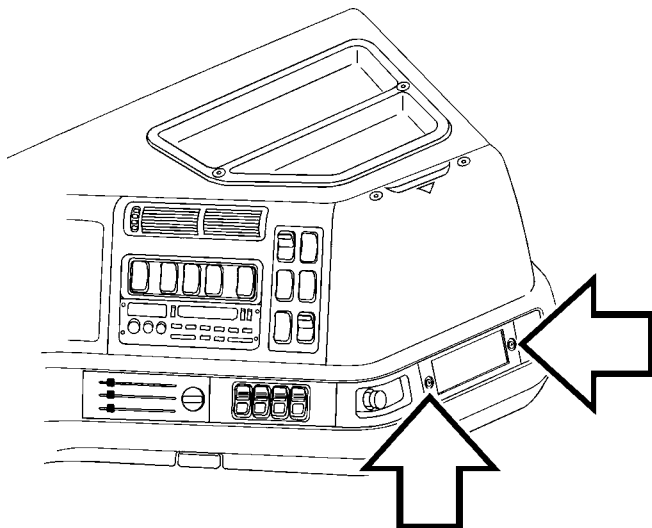

W3000649

Remove the ashtray from the ashtray housing. Remove the 2 screws from the ashtray housing, and remove the housing.

2

Once the ashtray housing is removed, the air switch panel can be removed from the dash. Pull the air switch panel away from the dash and to the left to clear the tip inserts.

3

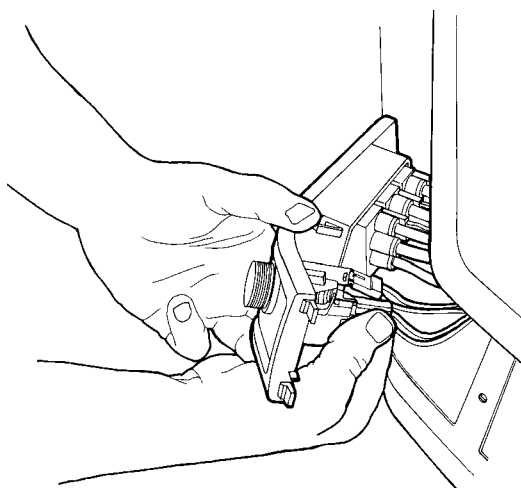

W3000656

Disconnect the 2 terminal connectors at the cigar lighter.

4

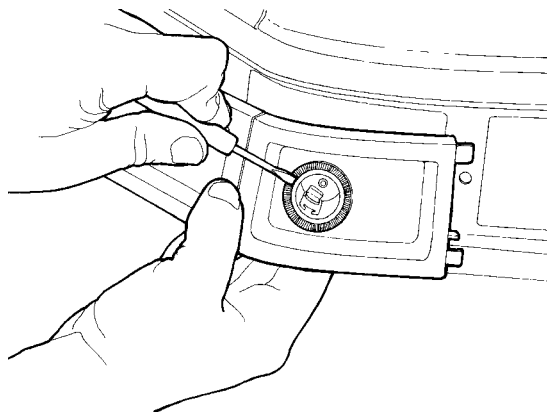

W3000696

Push the lighter housing out of the panel enough to get a small flat tip screwdriver under the lip of the cigar lighter. Remove the lighter from the LED housing, and slide the housing out of the dash.

Installation

1

Install the LED housing back into the panel. Make certain it is properly aligned with the moldings on the housing. Push the cigar lighter housing into the LED housing until it bottoms out.

2

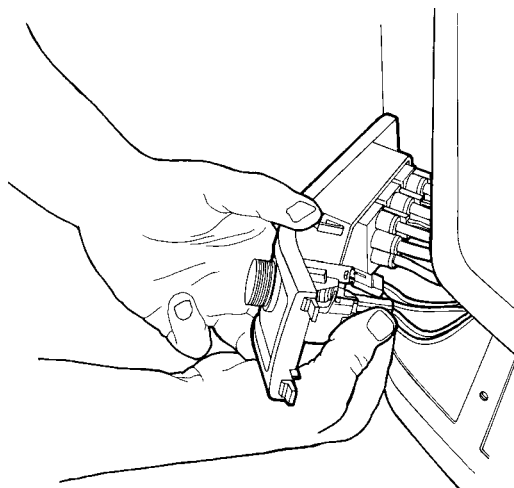

W3000656

Connect both lighter connectors. Align and install the lighter/air switch panel in the dash.

3

Install the ashtray housing with the 2 mounting screws, and install the ashtray in its housing. Torque screws to 0.4 ± 0.1 Nm (3.5 ± 1 in-lb).

0.4 ± 0.1 Nm
(3.5 ± 1 in-lb)

3646-03-02-11 Hazard Lamp Switch Replacement

(Includes checking switch function)

For the service procedure, see “Dash (Left Side) Switch Replacement” page 69.

3646-03-02-22 Auxiliary Light Switch Replacement

(Includes checking switch function)

For the service procedure, see “Dash (Left Side) Switch Replacement” page 69.

Dash (Left Side) Switch Replacement

Removal

1

Make certain the vehicle ignition is **OFF** before beginning this procedure.

2

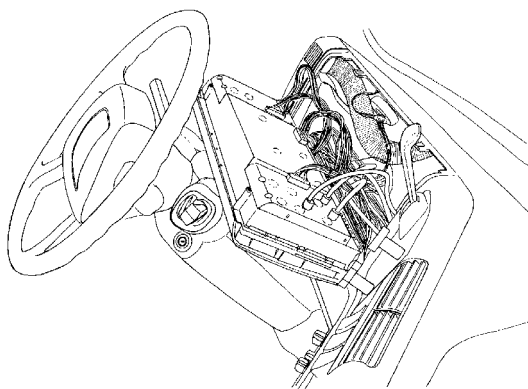

W3000641



CAUTION

Do not leave the cluster face-down for more than 15 minutes, or damage to the gauges may occur. Gauge oil can run out the front of the gauge faces and make the gauges inaccurate.

Remove the two screws at the top of the instrument cluster and lay the cluster face-down on the steering column (adjust steering column back before leaning cluster out, where possible).

3

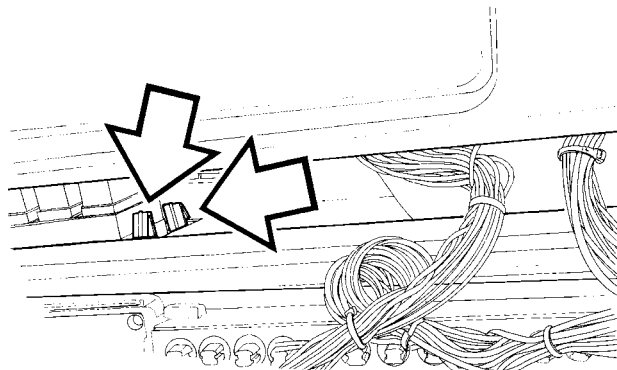

W3000689

To release the switch panel, reach behind the panel and depress the top and bottom clips on the right and left side of the panel.

4

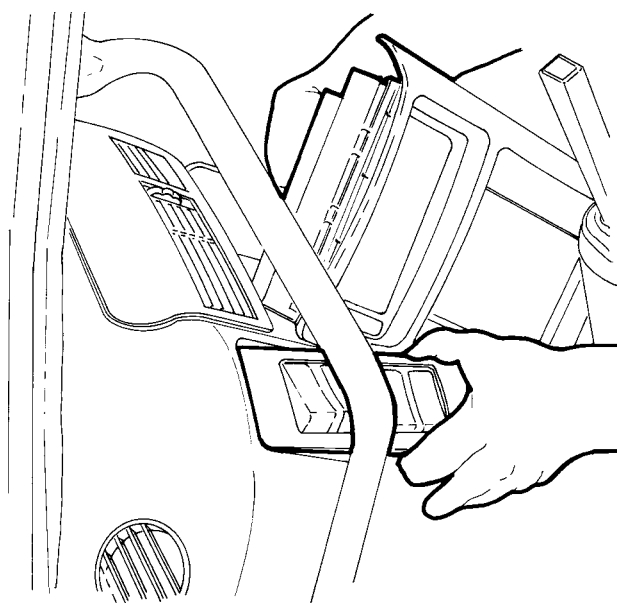

W3000660

Pull the panel through the front of the dash.

5

Once the panel is removed, install the instrument cluster in the dash and tighten the 2 screws at the top of the cluster. Torque to 2 ± 0.3 Nm (17.5 ± 2.5 in-lb).

2 ± 0.3 Nm
(17.5 ± 2.5 in-lb)

6

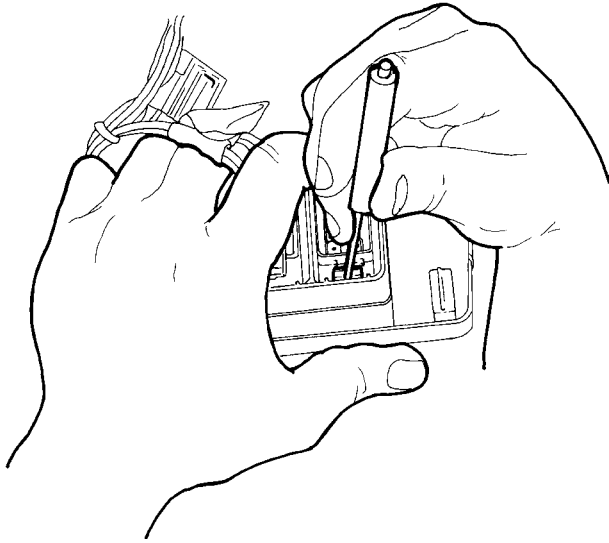

W3000659

Disconnect the electrical connector from the switch to be removed. Insert a small flat tip screwdriver (No. 1) into the bottom of the switch to release the locking tab, then remove the switch from the panel (these switches are removed through the front of the panel).

Installation

1

Install the new switch, pushing the switch into the panel until it locks. Push back on the switch to make certain it is locked in the panel. Connect electrical connector and install panel back in dash.

3646-03-02-24

Marker Interrupt Switch Replacement

(Includes checking switch function)

For service procedure, see "Dash (Right Side) Switch Replacement" page 71.

3646-03-02-25

Idle Control Switch Replacement

(Includes checking switch function)

For service procedure, see "Dash (Right Side) Switch Replacement" page 71.

3646-03-02-26

Heated Mirror Switch Replacement

(Includes checking switch function)

For service procedure, see "Dash (Right Side) Switch Replacement" page 71.

3646-03-02-27

Traction Control (TCS) Switch Replacement

(TCS; includes checking switch function)

For service procedure, see "Dash (Right Side) Switch Replacement" page 71.

Dash (Right Side) Switch Replacement

Removal

1
Make certain the vehicle ignition is **OFF** before beginning this procedure.

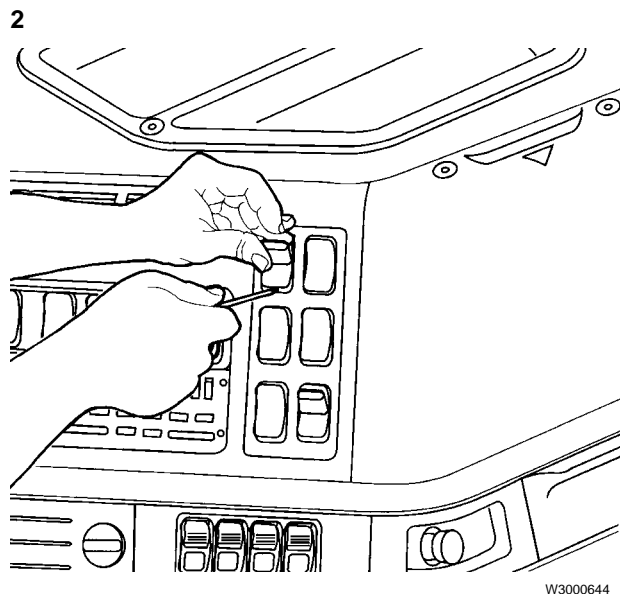

Insert a No. 1 flat tip screwdriver into the bottom of the switch to release the locking tab.

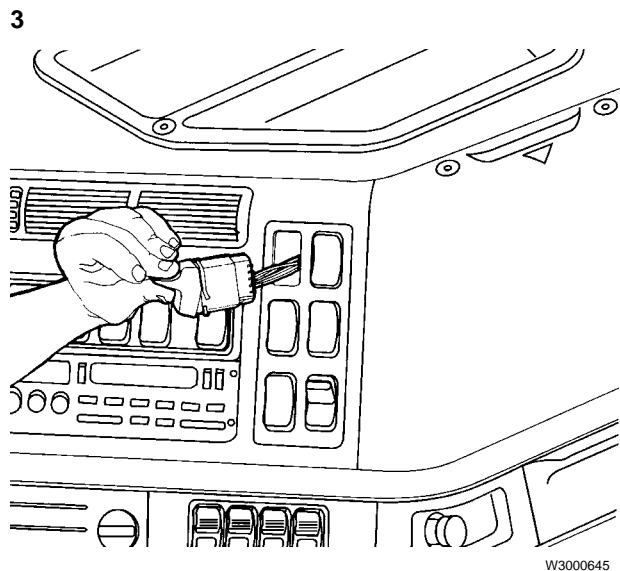

The switch will rock out at the bottom. Pull the switch down from the top and out.

4
Disconnect the electrical connector of the switch being removed.

Installation

1
Connect electrical connection on switch.

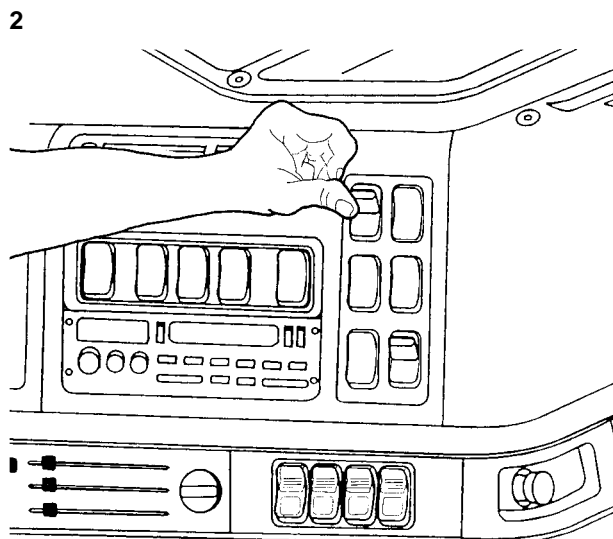

Install the new switch, pushing the switch into the panel until it locks. Push back on the switch to make certain it is locked in the panel.

3911-03-02-01 Radio Replacement (Dash Mounted)

Note: This procedure applies only to the factory-installed, in-dash radio.

Removal

1
Make certain the vehicle ignition is **OFF** before beginning this procedure.

2

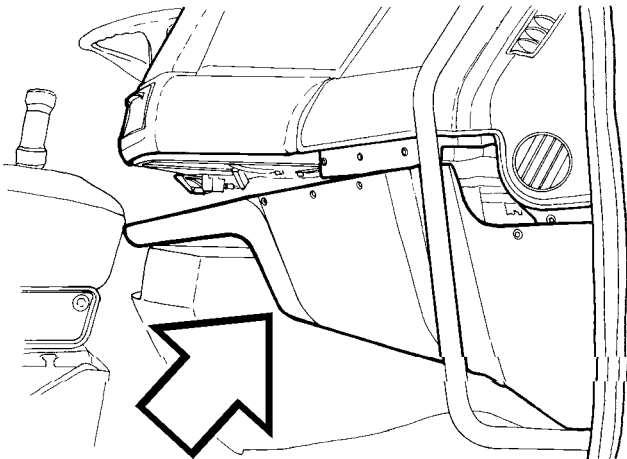

W3001009

Remove the lower trim panel from the dash by removing the 8 torx bolts from the panel.

3

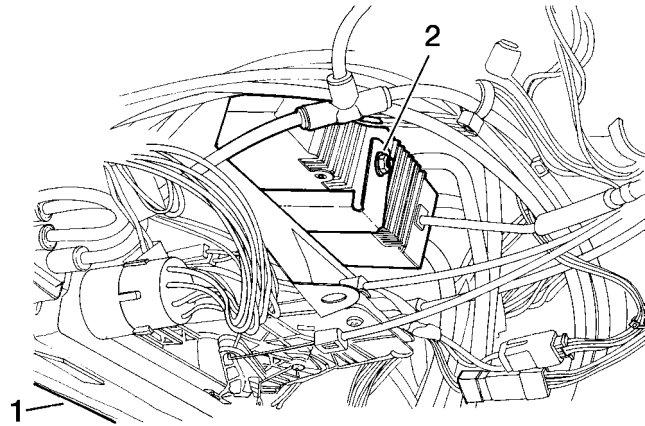

W3000675

- 1 Lower Edge of Dash
- 2 Nut at Radio Mounting Bracket



CAUTION

To avoid damage to the radio or mounting bracket, remove the nut from the rear of the bracket. Failure to remove the nut may result in bending the bracket and damaging the radio.

Remove the nut from the rear of the radio mounting bracket. This nut is accessible through the opening left when the trim panel was removed.

4

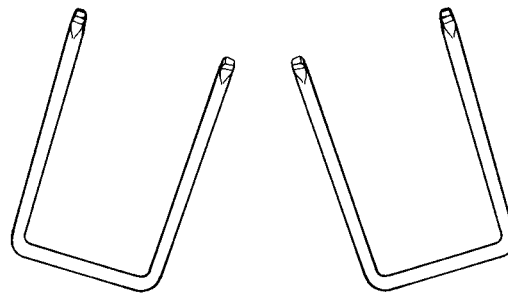

W3000702

Radio removal tools supplied with vehicle

Insert the removal tools into the face of the radio.

5

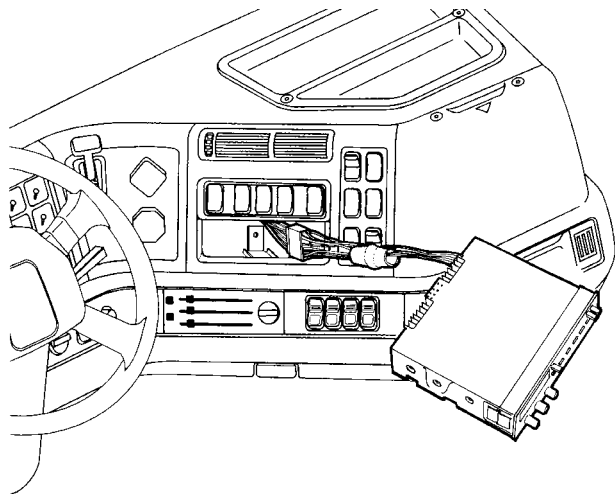

W3000674

When the tools are inserted, pull slightly apart to unlock the radio from the housing. Pull on the removal tools to slide the radio out of the housing. Disconnect the antenna and electrical connector.

Installation

1

Make certain the vehicle ignition is **OFF** before beginning this procedure.

2

Connect radio electrical connector and antenna.

3

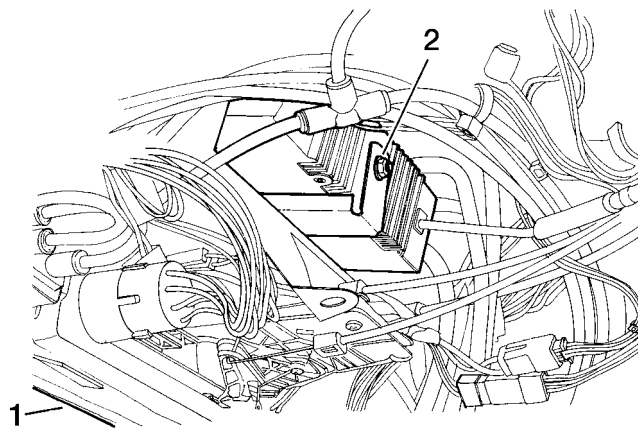

W3000675

- 1 Lower edge of dash
- 2 Nut at radio mounting bracket

Slide the radio into the housing, making sure the stud on the rear of the radio is aligned with the mounting bracket. Install the nut into the bracket to hold the radio in position. Torque to 1.2–1.6 Nm (10–14 in-lb).

1.2–1.6 Nm
(10–14 in-lb)

Note: When sliding the radio into position, make certain the antenna cable and electrical connection do not get between the radio and radio bracket.

4

Install the lower dash trim panel with 8 torx bolts. Torque to 3.5 ± 0.5 Nm (31 ± 4.5 in-lb).

3.5 ± 0.5 Nm
(31 ± 4.5 in-lb)

3645-03-02-02 Ignition Power Relay Replacement

(Includes checking relay function)

Removal

1
Make certain the vehicle ignition is **OFF** before beginning this procedure.

2

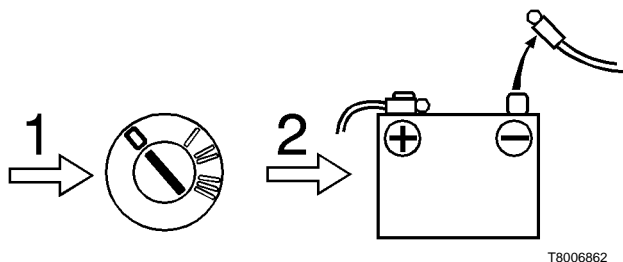

! WARNING

Disconnect the positive (+) and negative (-) terminals before beginning this procedure to prevent electric short circuit. Failure to do so could cause serious component damage. Disconnect the ground terminal first.

3

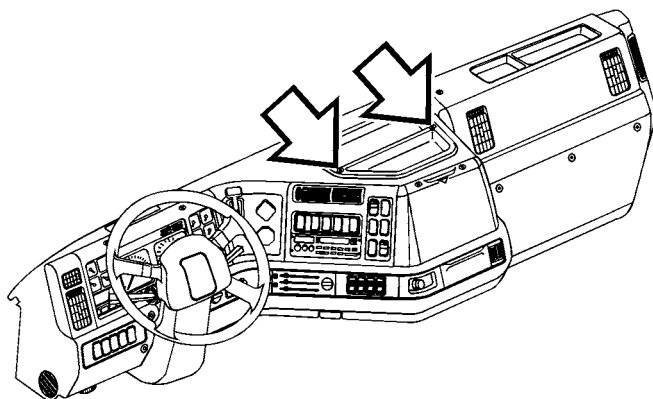

Remove the top cover of the TEC center by removing the 2 screws.

4
Remove the front fuse panel cover by removing the screws from the cover.

5
Remove the ashtray from the ashtray housing. Remove the 2 screws from the ashtray housing, and remove the housing.

6

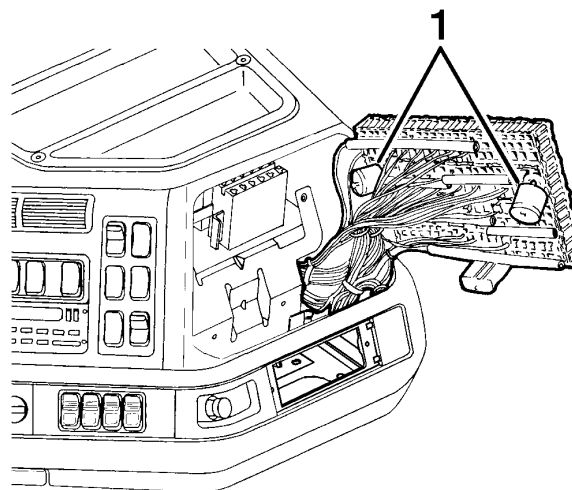

1) Spacers

Remove the 3 torx bolts from the fuse panel, and fold the fuse panel outward from the dash to gain access to the mounting bolts for the top TEC tray. Removing the lower bolt is made easier by inserting the torx driver through the ashtray opening.

Note: Do not lose the 2 plastic spacers on the back of the fuse panel.

7
Remove the top TEC tray by removing 2 torx bolts at the front of the tray, and loosening 2 nuts at the rear.

8

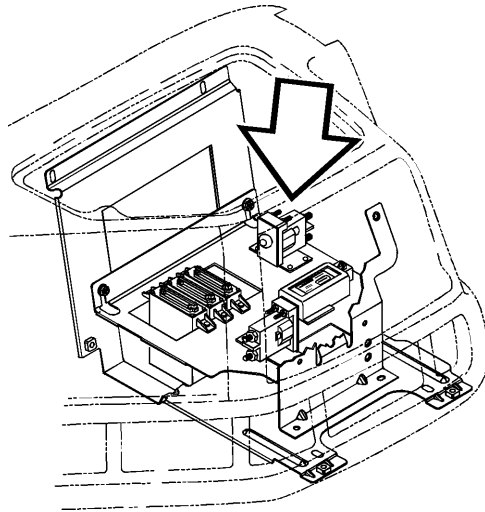

W3000779

Ignition Power Relay

Cut the tie strap from wire 196 to allow for movement. Remove the 196 wire from the Ignition Power relay's small post.

9

Remove wires OR-M and OR-N from the small post. Then remove wires IA and IB from the bottom post. Remove wire 196 from the large top post.

10

Remove the 2 torx bolts from each side of the relay, and lift the relay out of the TEC center.

Installation

1

Install the Ignition Power relay into the lower TEC tray with 2 torx bolts (see illustration in Removal procedure). Torque to 4.5 ± 0.5 Nm (40 ± 5 in-lb).

2

Connect the IA and IB wires to the relay's large lower post. Install nut on the post. Torque to 6.25 Nm (55 in-lb). Install the rubber stud cover.

3

Install the 196 wire on the large top post. Install the nut on the post. Torque to 6.25 Nm (55 in-lb). Install the rubber stud cover.

4

Install the OR-M and OR-N wires to the relay's small top post. Install the 196 wire to the relay's small top post. Torque both of these to 2 ± 0.5 Nm (18 ± 5 in-lb).

5

Install the top TEC tray by sliding the tray's rear slots back onto the nuts. Start the bolts in the tray at the front before tightening. Torque rear nuts to 6 ± 1 Nm (53 in-lb). Torque front bolts to 10 ± 1.5 Nm (89 in-lb).

6

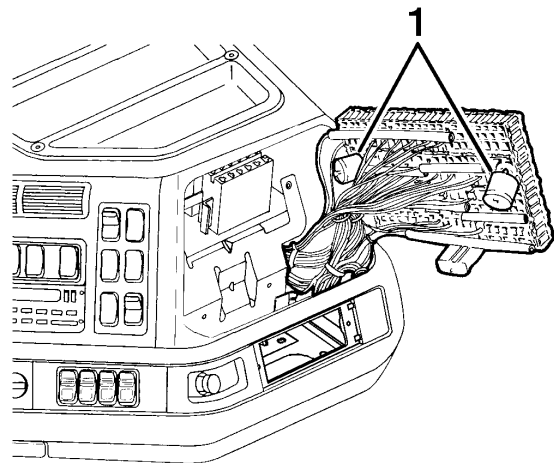

W3001007

1) Spacers

Install the fuse panel with 3 torx bolts, reaching through the ashtray opening to install the lower bolt. Torque to 4.5 ± 0.5 Nm (40 ± 5 in-lb). Align the 2 plastic spacers with the bolts, taking care to route the wires so that none are caught between the spacers and mounting brackets, or between the spacers and fuse panel.

7

Install the ashtray housing and ashtray. Torque ashtray mounting screws to 0.4 ± 0.1 Nm (3.5 ± 1 in-lb).

8

Install the fuse panel cover and the top TEC panel cover. Torque screws to 2.5 ± 0.5 Nm (22 ± 5 in-lb).

9

Connect the battery cables, positive side first. Torque nuts to 20.3–24.4 Nm (15–18 ft-lb).

3645-03-02-04 Accessory Power Relay Re- placement

(Includes checking relay function)

Removal

1
Make certain the vehicle ignition is **OFF** before beginning this procedure.

2



DANGER

Disconnect battery + and - terminals before beginning this procedure to prevent electric shock. Failure to do so could cause serious injury or death. Disconnect the ground terminal first.

W3000826

3

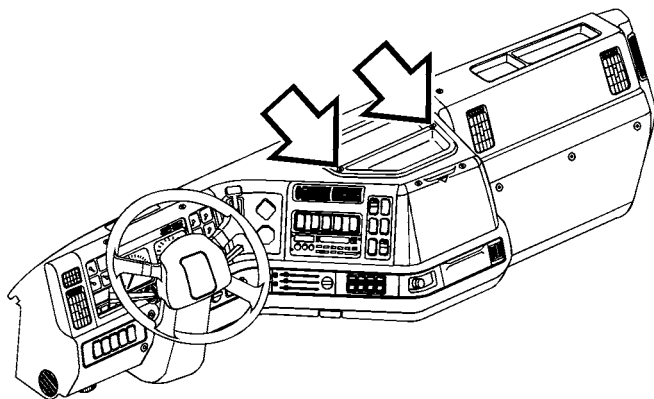

W8000924

Remove the top cover of the TEC center by removing the 2 screws.

4

Remove the fuse panel cover by removing the screws from the cover.

5

Remove the ashtray from the ashtray housing. Remove the 2 screws from the ashtray housing, and remove the housing.

6

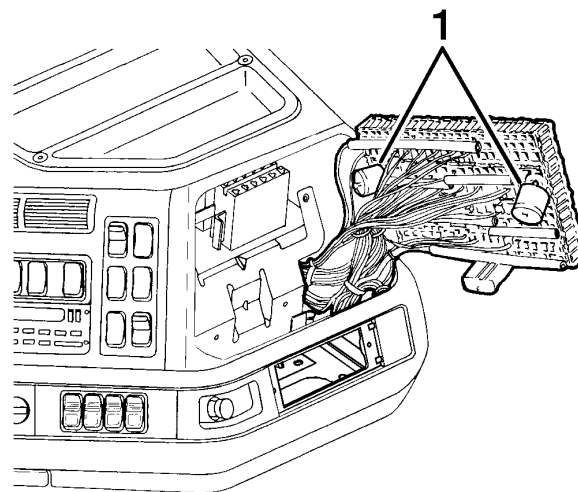

W3001007

1) Spacers

Remove 3 bolts from the fuse panel, and fold the fuse panel outward from the dash to gain access to the mounting bolts for the top TEC tray. Removing the lower bolts is made easier by inserting your hand through the ashtray opening to guide the torx driver.

Note: Do not lose the 2 plastic spacers on the back of the fuse panel.

7

Remove the top TEC tray by removing 2 torx bolts at the front of the tray, and loosening 2 nuts at the rear.

8

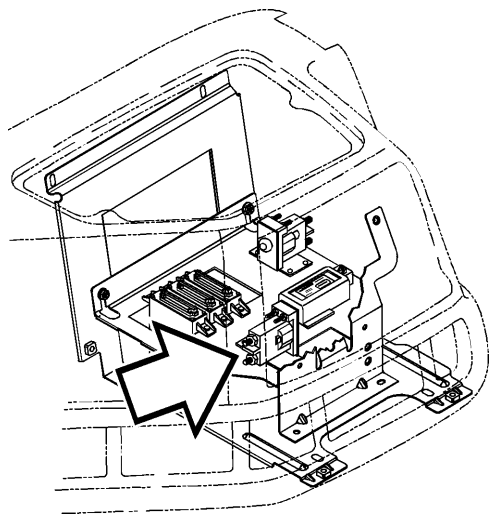

Accessory Power Relay

Remove wire OR-N from the Accessory Power relay's small post. Remove the 195 wire from the other small post. Then remove wire 195-A from the large bottom post, and wire I-E from the large top post.

9

Remove the 2 torx bolts from each side of the relay, and lift the relay out of the TEC center. .

Installation

1

Install the Accessory Power relay into the lower TEC tray with 2 torx bolts (see illustration in Removal procedure). Torque to 4.5 ± 0.5 Nm (40 ± 5 in-lb).

2

Connect the 195-A wire to the relay's large lower post. Install nut on the post. Torque to 6.25 Nm (55 in-lb). Install the rubber stud cover.

3

Install the I-E wire on the large top post. Install the nut on the post. Torque to 6.25 Nm (55 in-lb). Install the rubber stud cover.

4

Install the OR-N wire to the relay's small top post. Torque to 2 ± 0.5 Nm (18 ± 5 in-lb). Install the 195 wire to the relay's other small top post. Torque to 2 ± 0.5 Nm (18 ± 5 in-lb).

5

Install the top TEC tray by sliding the tray's rear slots back onto the nuts. Start the bolts in the tray at the front before tightening. Torque rear nuts to 6 ± 1 Nm (53 ± 10 in-lb). Torque front bolts to 10 ± 1.5 Nm (89 ± 13 in-lb).

6

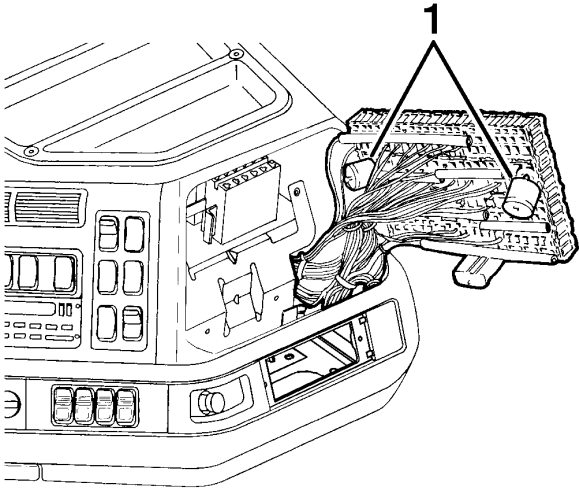

W3001007

1) Spacers

Install the fuse panel with 3 torx bolts. Align the 2 plastic spacers with 2 bolts through the spacers, taking care to route the wires so that none are caught between the spacers and mounting brackets, or between the spacers and fuse panel. Torque to 4.5 ± 0.5 Nm (40 ± 5 in-lb).

7

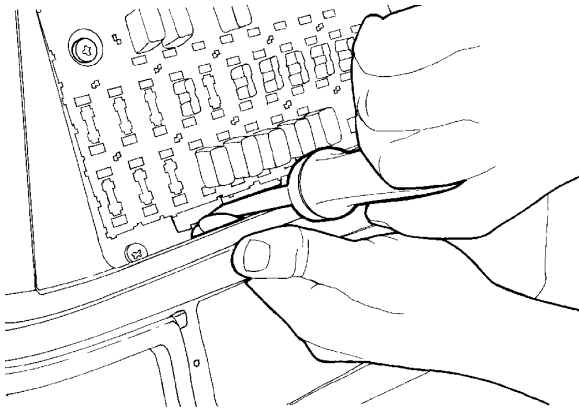

W3000794

Reach through the ashtray opening to install the lower fuse panel bolt. Torque to 4.5 ± 0.5 Nm (40 ± 5 in-lb).

8

Install the ashtray housing and ashtray. Torque ashtray mounting screws to 0.4 ± 0.1 Nm (3.5 ± 1 in-lb).

9

Install the fuse panel cover and the top TEC panel cover. Torque screws to 2.5 ± 0.5 Nm (22 ± 5 in-lb).

10

Connect the battery cables, positive side first. Torque nuts to 20.3–24.4 Nm (15–18 ft-lb).

3563-03-02-01 Daytime Running Lamp Control Module Replacement

(Includes checking component function)

Removal

1
Make certain the vehicle ignition is **OFF** before beginning this procedure.

2

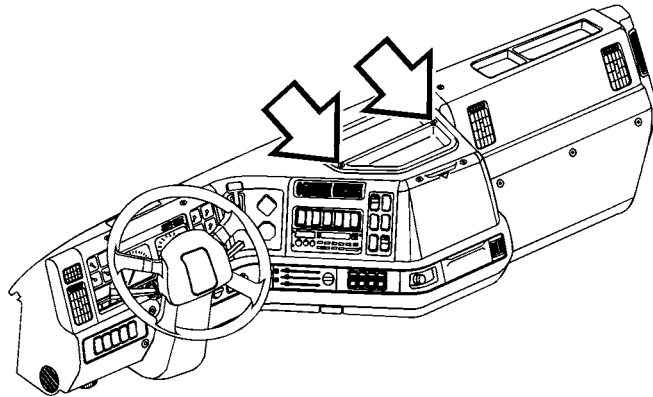

W8000924

Remove the top cover of the TEC center by removing the 2 screws.

3

Remove the fuse panel cover by removing the screws from the cover.

4

Remove the ashtray from the ashtray housing. Remove the 2 screws from the ashtray housing, and remove the housing.

5

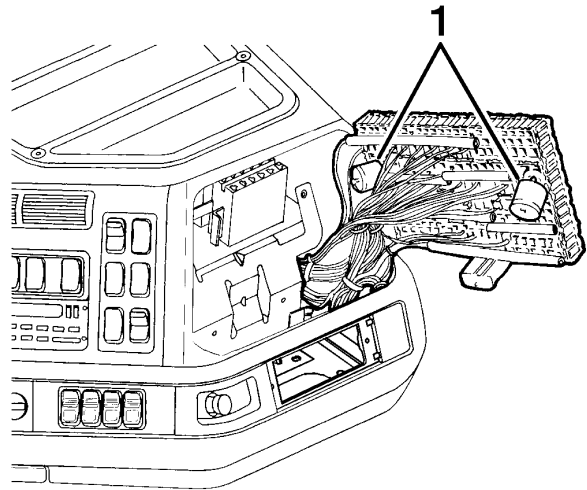

W3001007

1) Spacers

Remove 3 bolts from the fuse panel, and fold the fuse panel outward from the dash to gain access to the mounting bolts for the top TEC tray. Removing the lower bolts is made easier by inserting the torx driver through the ashtray opening.

Note: Do not lose the 2 plastic spacers on the back of the fuse panel.

6

Remove the top TEC tray by removing 2 torx bolts at the front of the tray, and loosening 2 nuts at the rear.

7

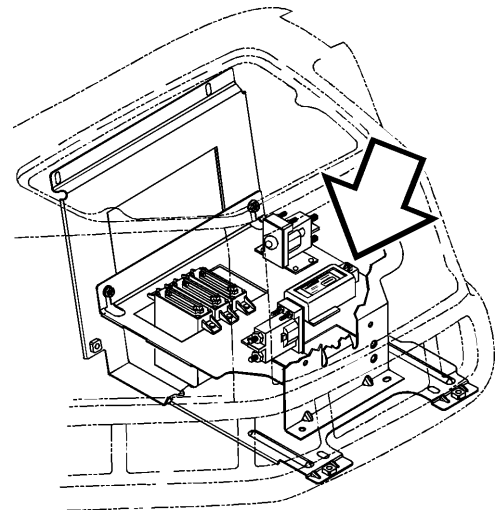

W3000781

Disconnect the daytime running lights (DRL) module electrical connector. Then remove the 2 torx bolts from each side of the DRL module.

Installation

1

Install the DRL module into the lower TEC tray with 2 torx bolts (see illustration in Removal procedure). Torque to 4.5 ± 0.5 Nm (40 ± 5 in-lb).

2

Connect the electrical connector on the DRL module.

3

Install the top TEC tray by sliding the tray's rear slots back onto the nuts. Start the bolts in the tray at the front before tightening. Torque rear nuts to 6 ± 1 Nm (53 ± 1 in-lb). Torque front bolts to 10 ± 1.5 Nm (89 ± 13 in-lb).

4

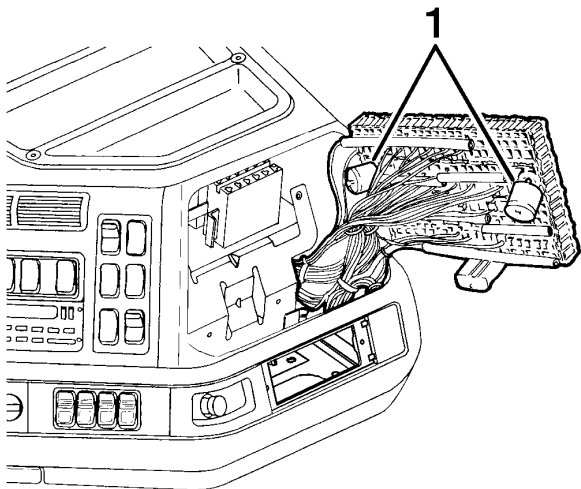

W3001007

1) Spacers

Install the fuse panel with 3 torx bolts, reaching through the ashtray opening to install the lower bolt. Torque to 4.5 ± 0.5 Nm (40 ± 5 in-lb). Align the 2 plastic spacers with the bolts, taking care to route the wires so that none are caught between the spacers and mounting brackets, or between the spacers and the fuse panel.

5

Install the ashtray housing and ashtray. Torque ashtray mounting screws to 0.4 ± 0.1 Nm (3.5 ± 1 in-lb).

0.4 ± 0.1 Nm
(3.5 ± 1 in-lb)

6

Install the fuse panel cover and the top TEC panel cover. Torque screws to 2.5 ± 0.5 Nm (22 ± 5 in-lb).

2.5 ± 0.5 Nm
(22 ± 5 in-lb)

3645-03-02-03

Combi Relay Replacement

Removal

1

Make certain the vehicle ignition is **OFF** before beginning this procedure.

2

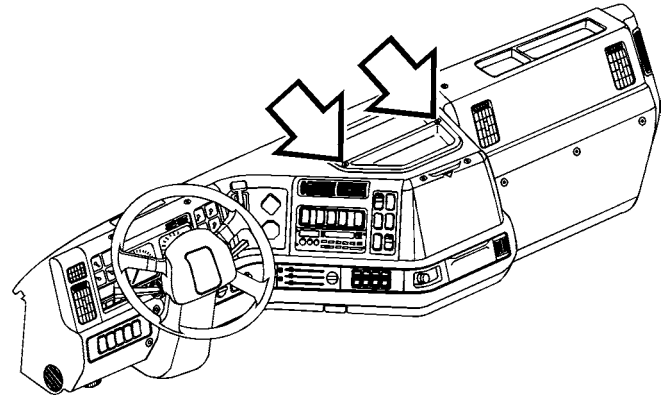

W8000924

Remove the top cover of the TEC center by removing the 2 screws.

3

Remove the fuse panel cover by removing the screws from the cover.

4

Remove the ashtray from the ashtray housing. Remove the 2 screws from the ashtray housing, and remove the housing.

5

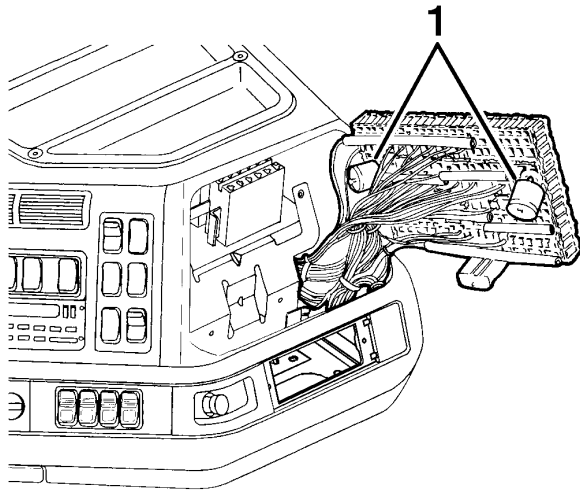

W3001007

1) Spacers

Remove 3 bolts from the fuse panel, and fold the fuse panel outward from the dash to gain access to the mounting bolts for the top TEC tray. Removing the lower bolts is made easier by inserting the torx driver through the ashtray opening.

Note: Do not lose the 2 plastic spacers on the back of the fuse panel.

6

Remove the top TEC tray by removing 2 torx bolts at the front of the tray, and loosening 2 nuts at the rear.

7

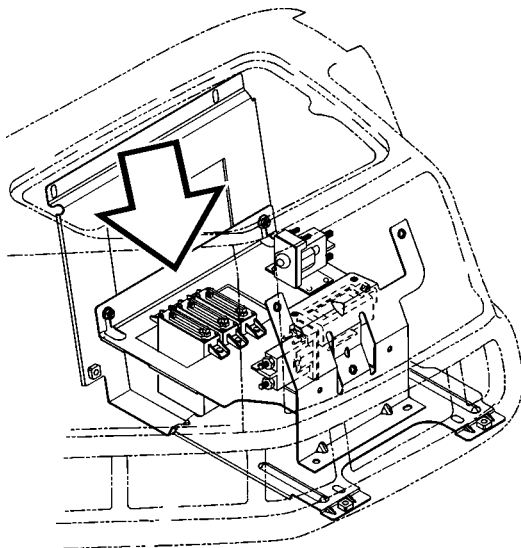

W3000998

Disconnect the module connector, remove mounting screws from the module, and remove the module.

Installation

1

Install the module in the same location where the old module was installed. Bolt the module in place with 2 torx bolts. Torque to 4.5 ± 0.5 Nm (40 ± 5 in-lb). Connect the module electrical connector.

4.5 ± 0.5 Nm
(40 ± 5 in-lb)

2

Install the top TEC tray by sliding the tray's rear slots back onto the nuts. Start the bolts in the tray at the front before tightening. Torque rear nuts to 6 ± 1 Nm (53 ± 1 in-lb). Torque front bolts to 10 ± 1.5 Nm (89 in-lb).

6 ± 1 Nm
(53 ± 1 in-lb)
 10 ± 1.5 Nm
(89 in-lb)

3

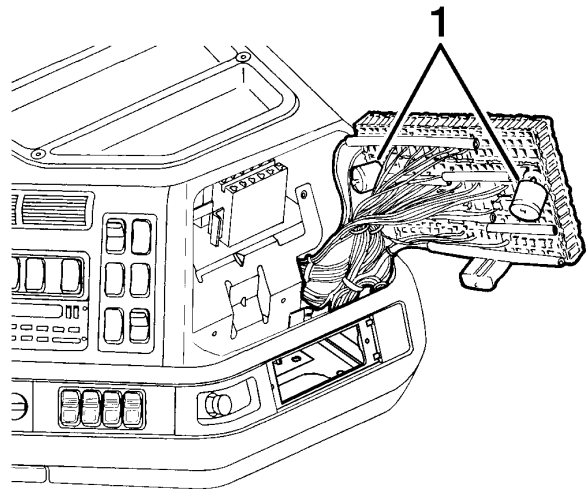

W3001007

1) Spacers

Install the fuse panel with 3 torx bolts, reaching through the ashtray opening to install the lower bolt. Torque to 4.5 ± 0.5 Nm (40 ± 5 in-lb). Align the 2 plastic spacers with the bolts, taking care to route the wires so that none are caught between the spacers and mounting brackets, or between the spacers and fuse panel.

4.5 ± 0.5 Nm
(40 ± 5 in-lb)

4

Install the ashtray housing and ashtray. Torque ashtray mounting screws to 0.4 ± 0.1 Nm (3.5 ± 1 in-lb).

0.4 ± 0.1 Nm
(3.5 ± 1 in-lb)

5

Install the fuse panel cover and the top TEC panel cover. Torque screws to 2.5 ± 0.5 Nm (22 ± 5 in-lb).

2.5 ± 0.5 Nm
(22 ± 5 in-lb)

3646-03-02-02**Power Window Switch Replacement (Right or Left)**

(Includes checking switch function)

Removal

1

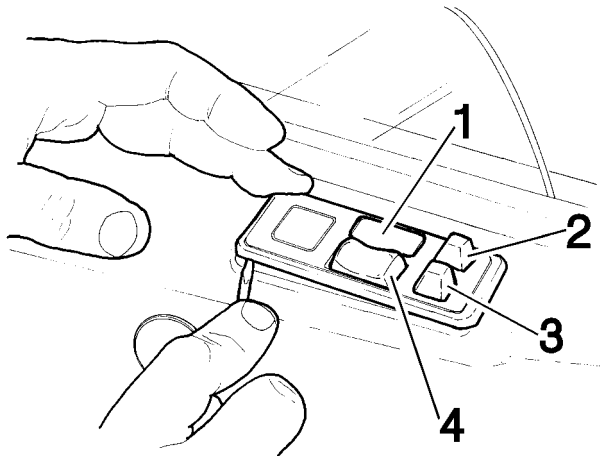

W3000806

Switches on Driver's Side Door

- 1) Location for Driver's Side Window Switch (shown not installed)
- 2) Driver Side Mirror Switch
- 3) Passenger Side Mirror Switch
- 4) Passenger Side Window Switch

Insert a No. 1 screwdriver into the corner of the switch panel to remove it from the door panel.

2

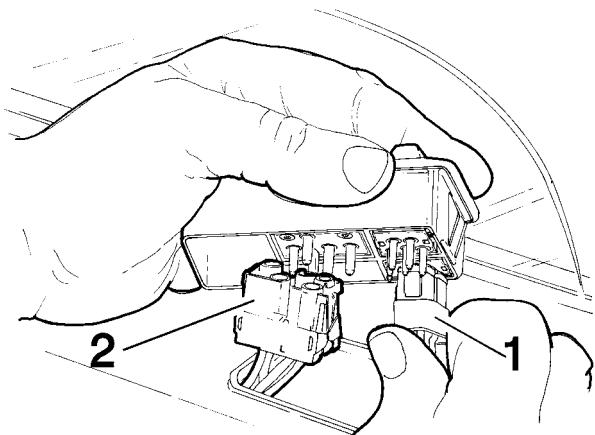

W3000805

- 1) Mirror Switch Connector
- 2) Window Switch Connector

Disconnect all the window switches installed in the panel. Mark the wire connectors to keep the arrangement correct.

3

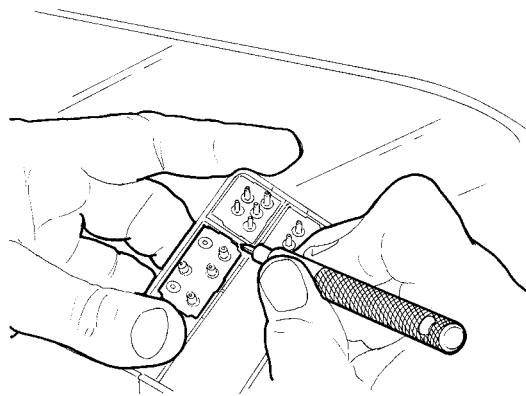

W3000802

Insert the mirror/window switch removal tool between the housing clip and the window switch. When the tool is inserted, push on the switch to clear the switch tabs from the clips. Repeat on the opposite end and push the switch out.

Installation

1

The tabs are different sizes on each end, so make certain the switch is aligned the correct way and push the switch into the housing.

2

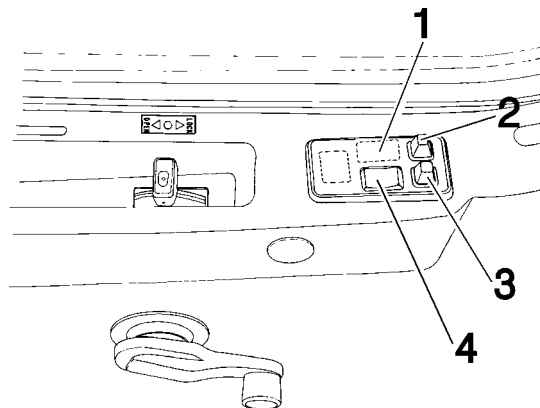

W3000804

Switches on driver's side door

- 1) Location for Driver's Side Window Switch (shown not installed)
- 2) Driver Side Mirror Switch
- 3) Passenger Side Mirror Switch
- 4) Passenger Side Window Switch

Make certain the replaced switch is locked into the panel. Connect the switch connectors and install the assembly into the door panel.

3646-03-02-28 Power Mirror Switch Replacement

(Includes checking switch function)

Removal

1

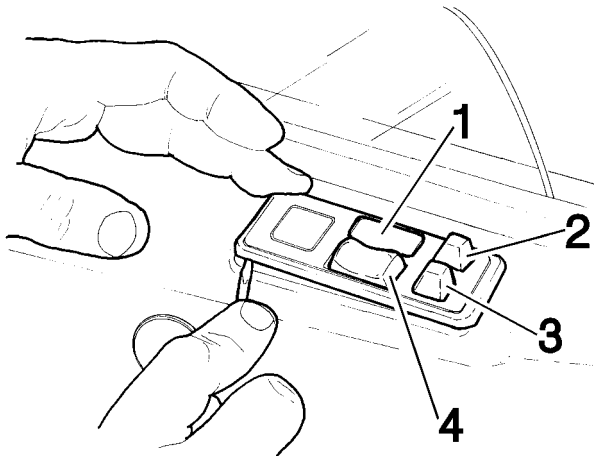

W3000806

Switches on Driver's Side Door

- 1) Location for Driver's Side Window Switch (shown not installed)
- 2) Driver Side Mirror Switch
- 3) Passenger Side Mirror Switch
- 4) Passenger Side Window Switch

Insert a No. 1 screwdriver into the corner of the switch panel to remove it from the door panel.

2

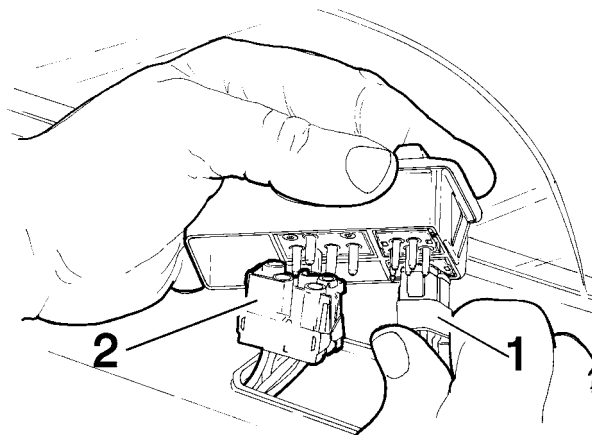

W3000805

- 1) Mirror Switch Connector
- 2) Window Switch Connector

Disconnect all the mirror switches installed in the panel. Mark the wire connectors to keep the arrangement correct.

3

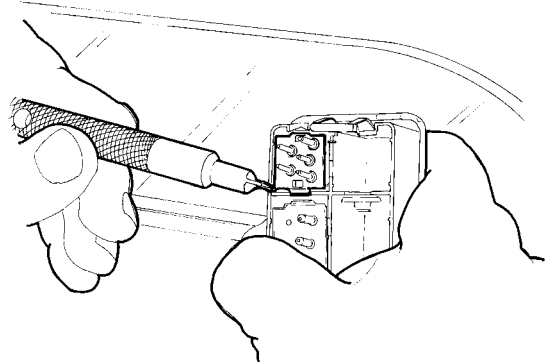

W3000803

Insert the mirror/window switch removal tool between the inner housing lip and the mirror switch. When the tool is inserted, push on the switch to clear the locking tab. Then insert the removal tool between the outer lip and the mirror switch. Keeping a steady pressure, push the switch out of the housing.

Installation

1

Align the tip of the housing with the indentation in the switch. The switch will push into the housing.

2

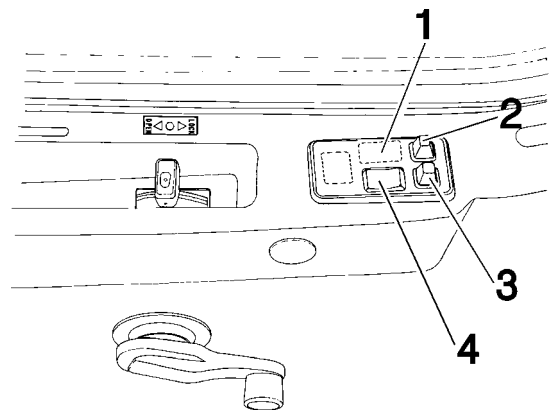

W3000804

Switches on driver's side door

- 1) Location for Driver's Side Window Switch (shown not installed)
- 2) Driver Side Mirror Switch
- 3) Passenger Side Mirror Switch
- 4) Passenger Side Window Switch

Make certain the replaced switch is locked into the panel. Connect the switch connectors and install the assembly into the door panel.

3838-03-02-02 Digital Clock (Sleeper) Re- placement

(Sleeper, includes diagnostics)

Removal

1

Make certain the vehicle ignition is **OFF** before beginning this procedure.

2

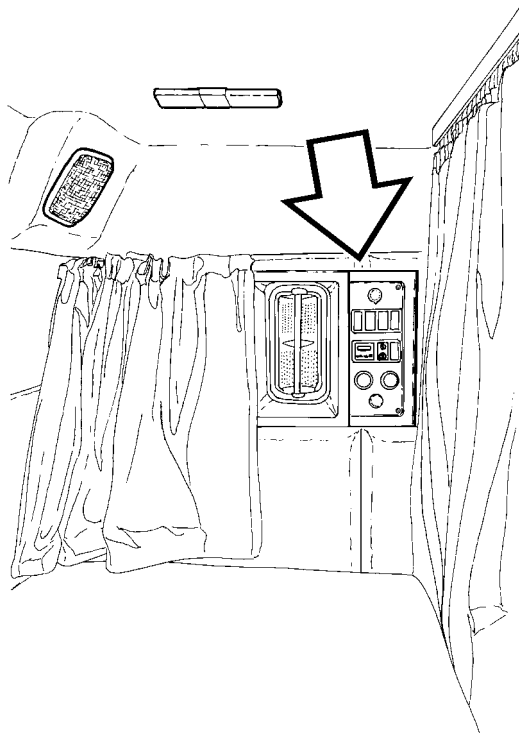

W8000922

Remove the 2 torx bolts from the control panel. Pull the panel out and to the right to clear the 3 plastic tabs on the rear of the panel's left side.

3

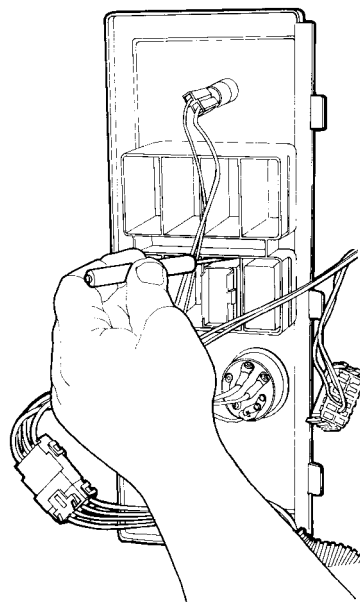

W3000698

Disconnect the clock electrical connector. Using a small flat tip screwdriver, release the locking tabs at the top and bottom of the clock to remove the clock from the panel. The clock will push out through the front of the panel.

Installation

1

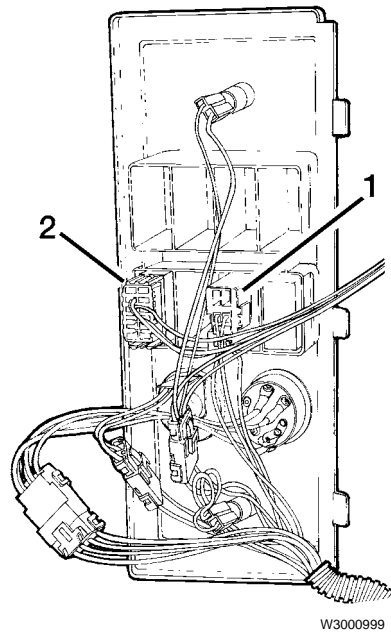

1) Clock 2) Switch

Install the new clock assembly (1) into the control panel and connect the electrical connector

2

Remove the switch(es) in the right-most positions in the rows of switches from the panel before the panel is installed back into the bunk. This allows better clearance when installing the panel. To remove the switch, unplug the switch connector and release the top and bottom locking tabs using a small flat tip screwdriver. The switch will then push out of the front of the panel.

3

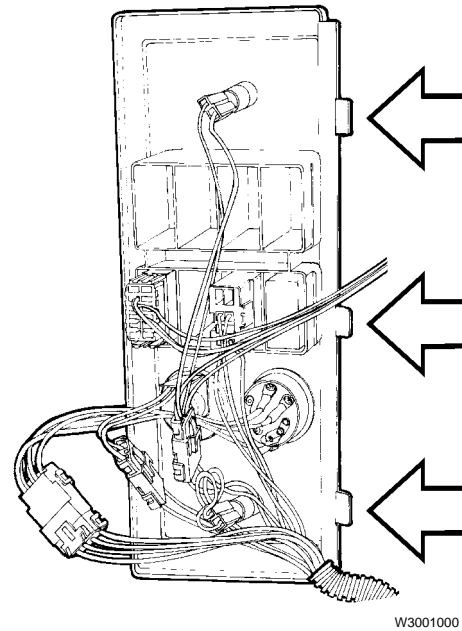

Install the control panel into the bunk by inserting the 3 tabs on the left side back into the air vent trim panel and installing the 2 torx bolts. Torque to 1.5 ± 0.5 Nm (13 ± 5 in-lb).

1.5 ± 0.5 Nm
(13 ± 5 in-lb)

4

Install the bunk light switch back into the panel by connecting the switch electrical connector and pushing the switch into the panel until it locks in place.

5

Gently pull on the switch to make certain it is locked in the panel.

3646-03-02-30 Sleeper Reading Lamp Switch Replacement

(Includes checking switch function)

For service procedure, see "Sleeper Control Panel Switch Replacement" page 86.

3646-03-02-31 Sleeper Heater Control Switch Replacement

(Includes checking switch function)

For service procedure, see "Sleeper Control Panel Switch Replacement" page 86.

Sleeper Control Panel Switch Replacement

Removal

1

Make certain the vehicle ignition is **OFF** before beginning this procedure.

2

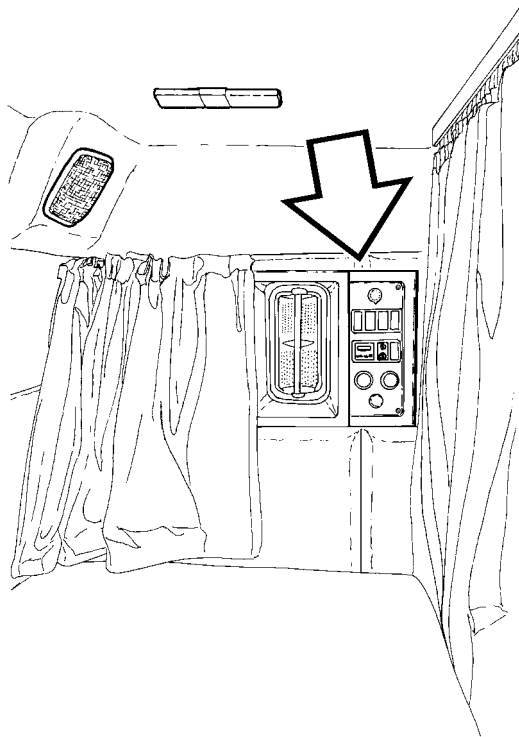

W8000922

Remove the 2 torx bolts from the control panel. Pull the panel out and forward to clear the 3 plastic tabs on the rear of the panel's left side.

3

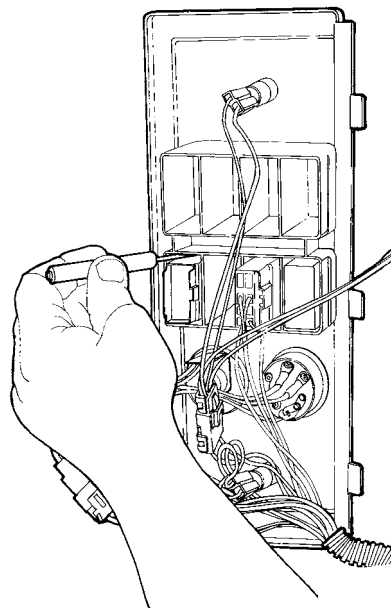

W3000699

Disconnect the switch electrical connector. Using a small flat tip screwdriver, release the locking tabs at the top and bottom of the switch to remove it from the panel.

Installation

1

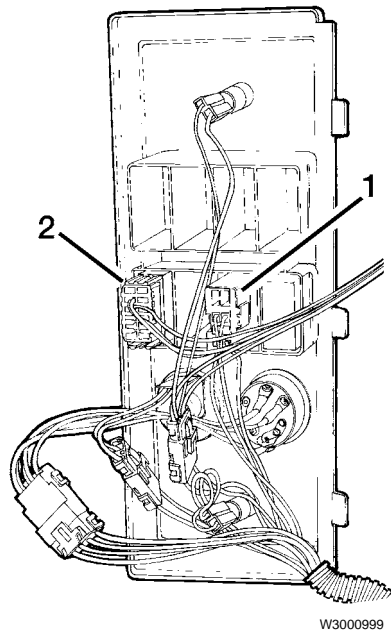

- 1) Clock
2) Switch

Pull the switch electrical connector (2) through the front of the panel. Install the control panel by inserting the 3 tabs on the panel's left side back into the air vent trim panel and installing the 2 torx bolts. Torque bolts to 1.5 ± 0.5 Nm (13 ± 5 in-lb).

Note: When replacing any switch in this control panel, remove the switch(es) in the right-most positions in the rows of switches before installing the panel. This allows better clearance when installing the panel. Install the switch(es) as described in this step.

2

Install the switch back into the panel by connecting the switch electrical connector and pushing the switch into the panel until it locks in place.

3

Gently pull on the switch to make certain it is locked in the panel.

1.5 ± 0.5 Nm
(13 ± 5 in-lb)

3631-03-02-04

Windshield Wiper Motor Replacement

(Includes checking component function)

Removal

1



WARNING

Park the vehicle on a level surface, apply the parking brakes, and block the wheels to avoid possible injury. Failure to do so can result in personal injury and possible damage to the vehicle due to vehicle movement.

Make certain the vehicle ignition is **OFF** before beginning this procedure.

2

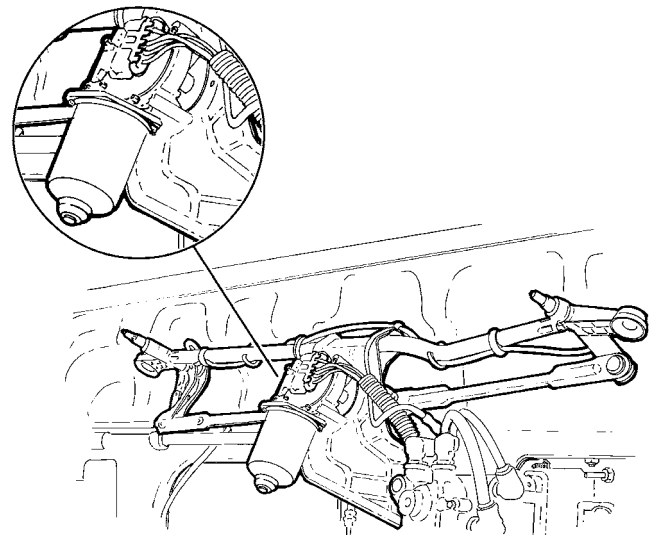

Disconnect the electrical connector from the wiper motor.

3

Remove the nut from the linkage arm, and push the arm from the shaft.

4

Push the linkage arm from the area where the wiper motor is mounted to the housing for access to bolts. Remove the 3 bolts to remove motor.

W3000669

Installation

1
Mount the motor to the housing with 3 bolts. **START** all bolts before tightening. Torque to 40–49 Nm (29–36 ft-lb).

2

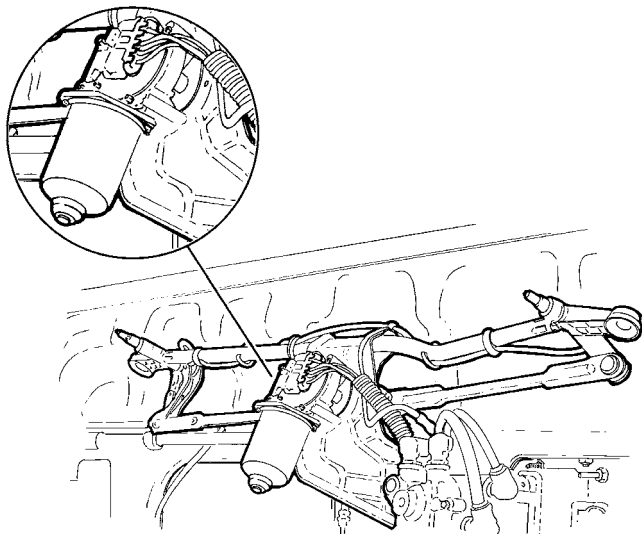

Align the arm from the linkage to the motor. Replace the nut on the shaft and connect the electrical connector. Torque to 10–13 Nm (88–115 in-lb).

W3000669
10–13 Nm
(88–115 in-lb)

3
Test the wiper system to ensure proper operation.

3639-03-02-01 Windshield Wiper Linkage Assembly Replacement

Removal

1

WARNING

Park the vehicle on a level surface, apply the parking brakes, and block the wheels to avoid possible injury. Failure to do so can result in personal injury and possible damage to the vehicle due to vehicle movement.

Make certain the vehicle ignition is **OFF** before beginning this procedure.

2

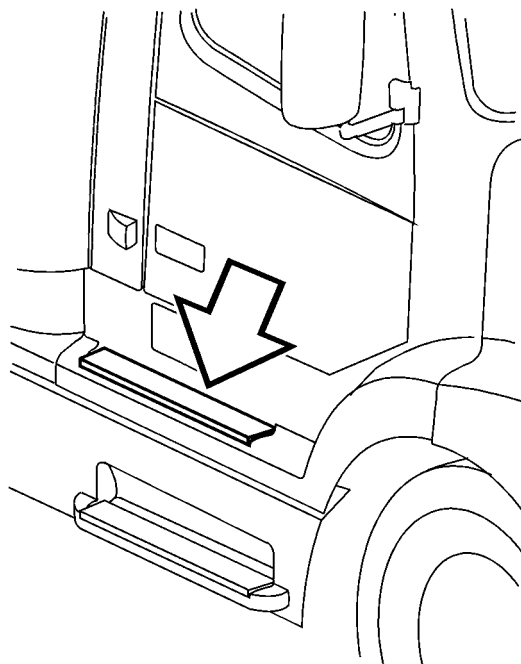

W3000667

Remove 4 torx bolts from the step on the right side of the cab, and remove the step.

3

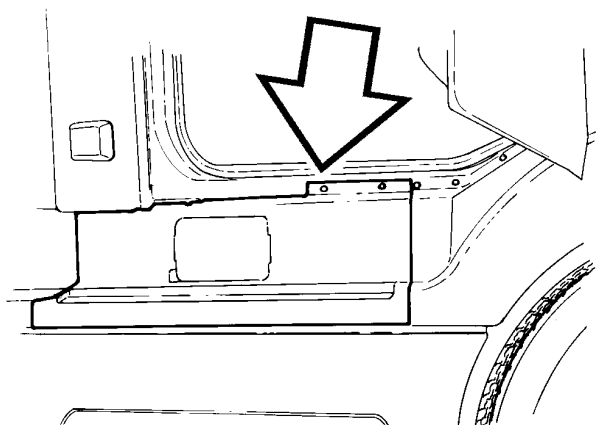

W3000662

Remove the upper tank fairing by removing the 4 torx bolts.

4

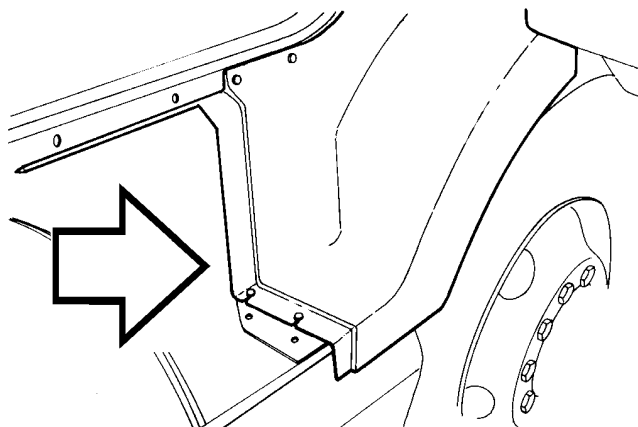

W3000661

Remove 5 torx bolts from the top side of the right quarter fender section in the lower door frame, and 2 bolts from the step bracket. Remove the quarter fender fairing section.

5

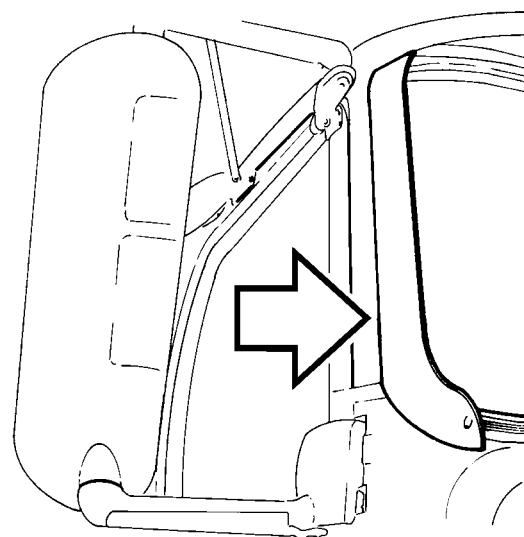

W3000663

Remove 3 screws from the right side drip molding and remove the molding.

6

Remove 3 torx bolts from the bottom of the right side mirror mounting arm.

7

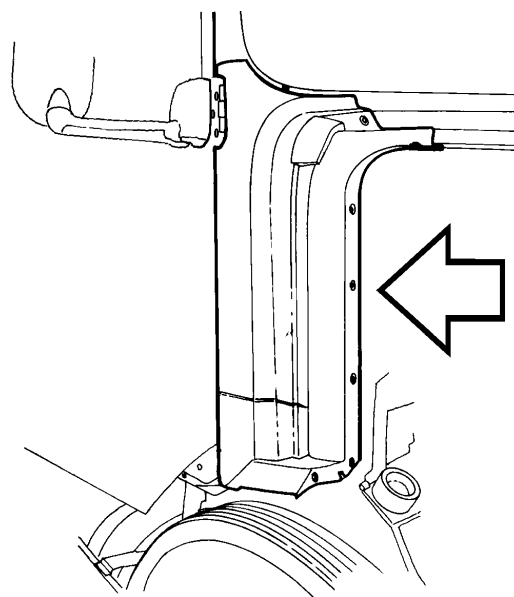

W3000670

Remove the right side cowl panel by removing bolts inside the door jamb and around the cowl panel.

8

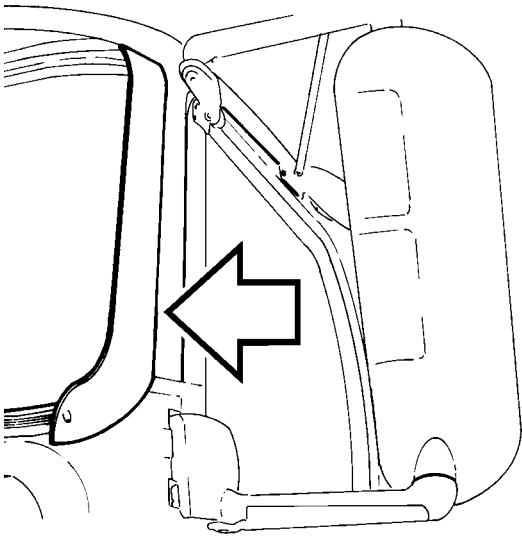

W3000664

Remove 3 screws from the drip molding on the left side of the cab and remove the drip molding.

9

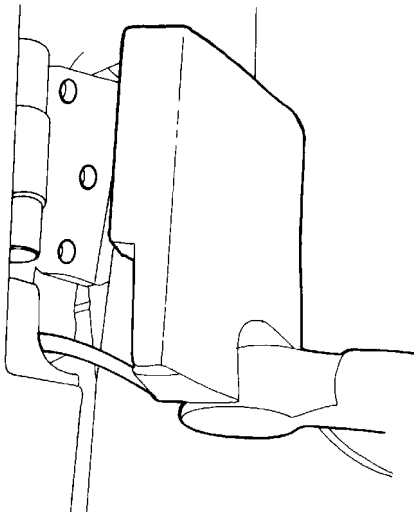

W3000665

Remove 3 torx bolts from bottom of the left side mirror mounting arm.

10

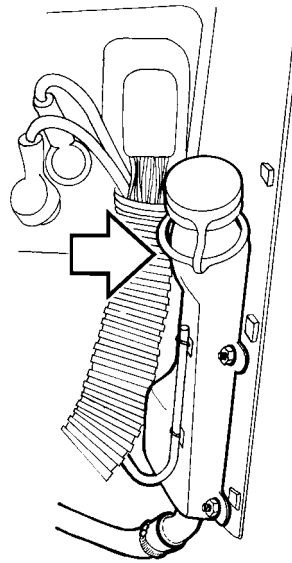

W3000668

Remove the windshield washer bottle by removing the 3 nuts from the washer bottle.

11

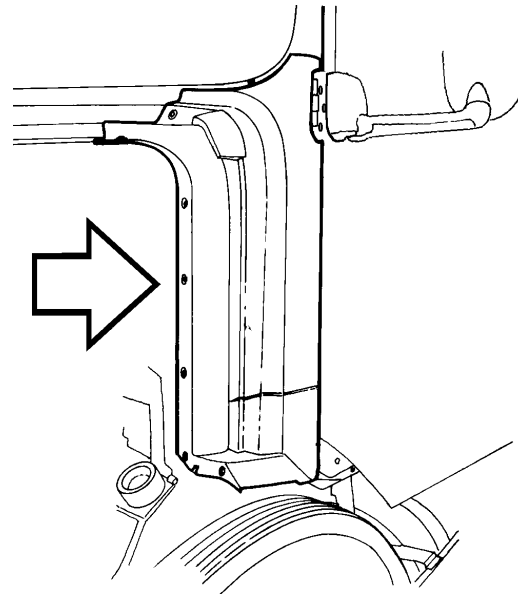

W3000671

Remove the left side cowl panel by removing the remaining bolts around the cowl section and inside the door jamb.

12

Remove the washer hose.

13

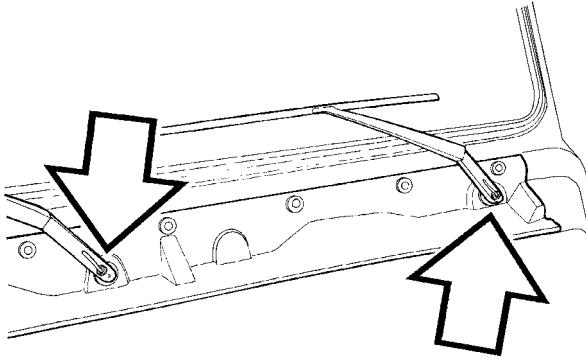

Remove the wiper arm nut from both arms, and remove the wiper arms.

W3000997

14

Remove the cowl panel under the windshield by removing the linkage shaft caps and 11 torx bolts from panel.

15

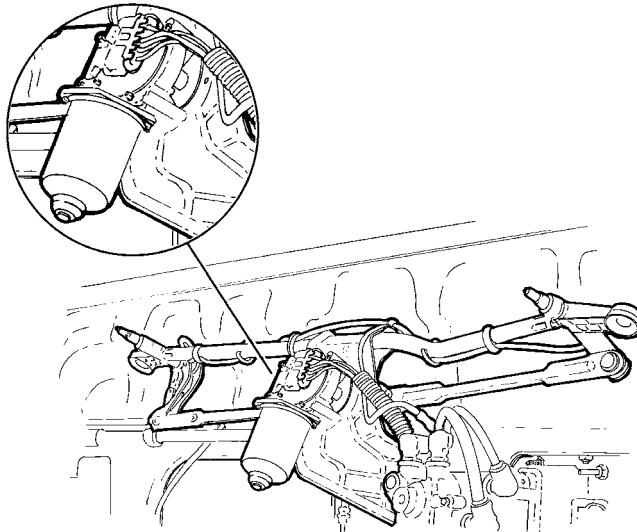

Disconnect the electrical connector from the wiper motor and disconnect the hose to the washer.

W3000669

16

Remove the wiper motor and linkage assembly by removing the 5 torx bolts from assembly.

Removal of wiper motor from linkage assembly

17

Remove the nut from the motor linkage arm and push the arm from the shaft.

18

Push the linkage arm away from the area where the motor is bolted to the housing. Remove 3 bolts from the motor, then remove motor.

Installation

1



WARNING

Park the vehicle on a level surface, apply the parking brakes, and block the wheels to avoid possible injury. Failure to do so can result in personal injury due to vehicle movement.

Make certain the vehicle ignition is **OFF** before beginning this procedure.

Installation of wiper motor to linkage assembly

2

If the motor was not removed from the linkage assembly, skip to step 4. If the motor was removed, mount motor on linkage housing with 3 mounting bolts. **START** all bolts before tightening. Torque to 40–49 Nm (29–36 ft-lb).

40–49 Nm
(29–36 ft-lb)

3

Install the shaft nut to the linkage arm. Make sure the shaft and transmission arm are aligned so that the timing and placement of the wipers will be properly aligned when the wipers are in the **OFF** position. Torque to 10–13 Nm (88–115 in-lb).

10–13 Nm
(88–115 in-lb)

4

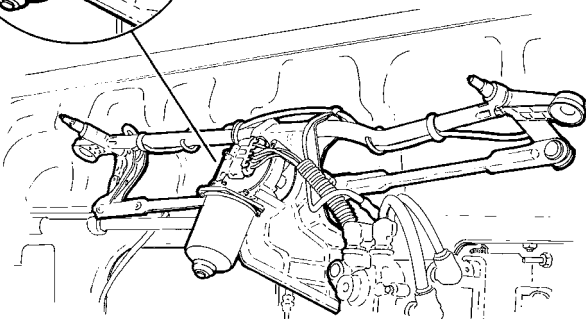
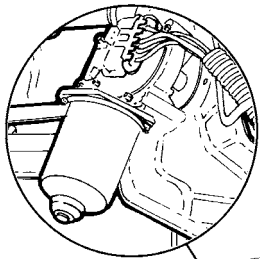

Align the wiper assembly to the cowl, and install it with the 5 torx bolts. Torque to 22.5 ± 2.5 Nm (200 ± 22 in-lb). Connect the electrical connector and washer hose.

W3000669
22.5 ± 2.5 Nm
(200 ± 22 in-lb)

5

Test the wiper system before installing the body panels to ensure proper operation of the system.

6

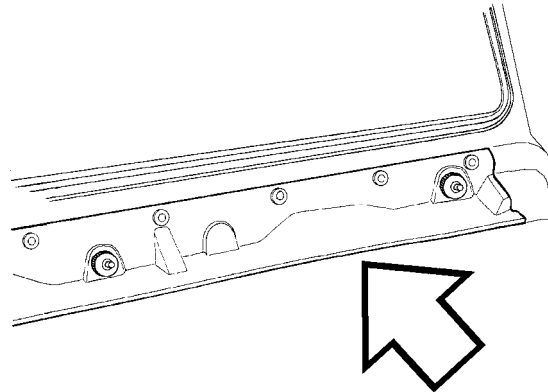

Install the cowl panel with 11 torx bolts. Torque to 24 ± 4 Nm (212 ± 35 in-lb).

W3000673

24 ± 4 Nm
(212 ± 35 in-lb)

7

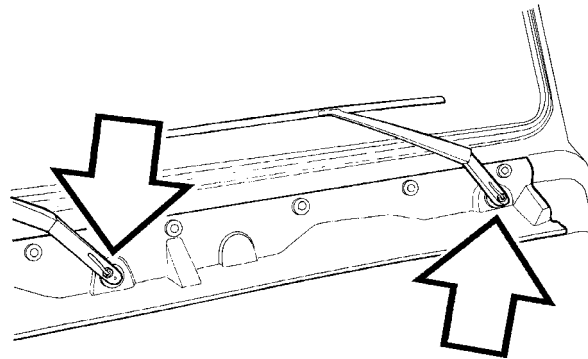

Install the wiper arms and connect washer hoses. Torque the arm nut to 23 ± 3 Nm (203 ± 26 in-lb).

W3000997

23 ± 3 Nm
(203 ± 26 in-lb)

8

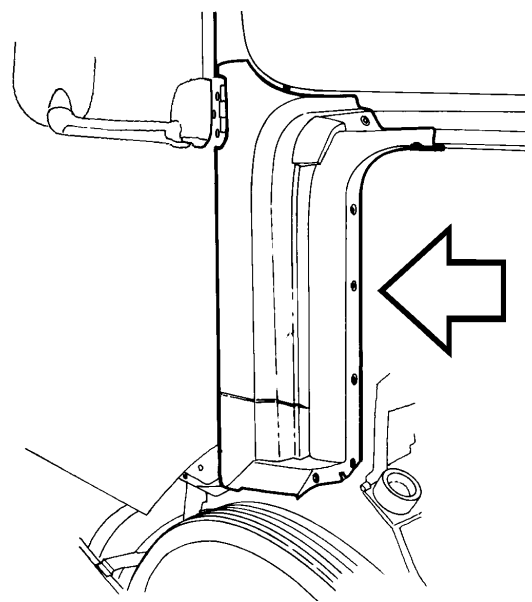

Install the right side cowl panel using bolts on the outside and inside of the door jamb. START all bolts and align the cowl before tightening. Torque to 24 ± 4 Nm (212 ± 35 in-lb).

W3000670

9

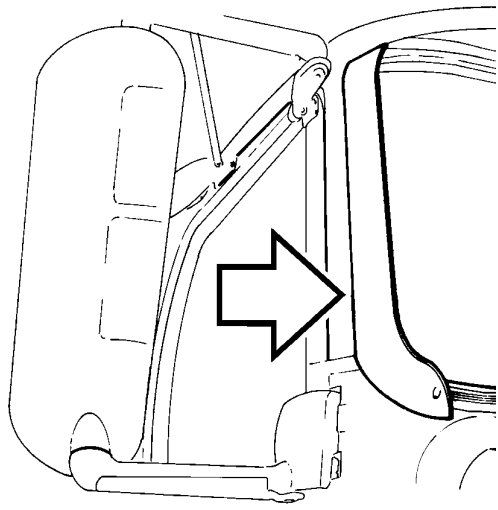

Install the right side drip molding with 3 screws. Torque the top 2 screws to 1.2 ± 0.2 Nm (10.6 ± 2 in-lb), and the bottom to 3 ± 0.5 Nm (26 ± 5 in-lb).

W3000663

10 Install 3 bolts in the lower right side mirror arm. Torque to 24 ± 4 Nm (18 ± 3 ft-lb).

11

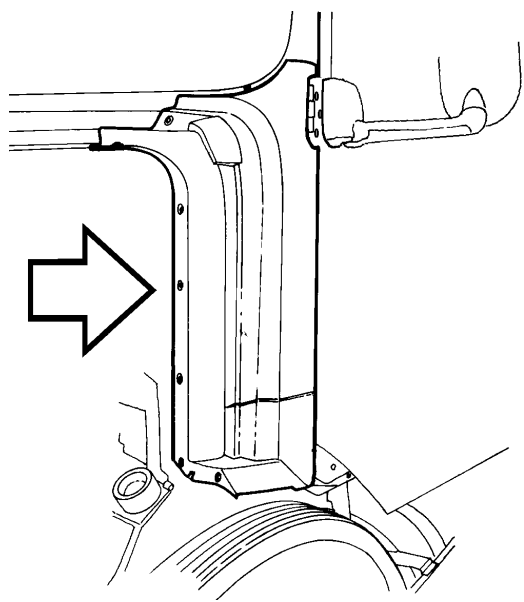

Install the left side cowl panel using bolts on the outside and inside of the door jamb. START all bolts and align the cowl before tightening. Torque to 24 ± 4 Nm (18 ± 3 ft-lb).

W3000671

12

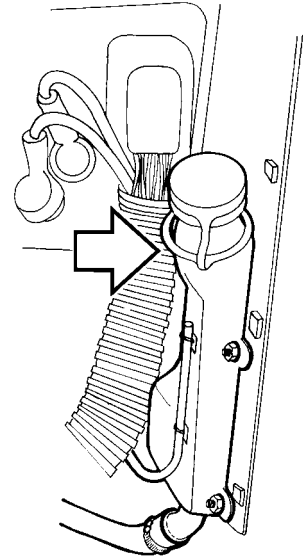

Install the washer bottle. START all bolts, then tighten nuts. Torque to 24 ± 4 Nm (18 ± 3 ft-lb).

W3000668

13

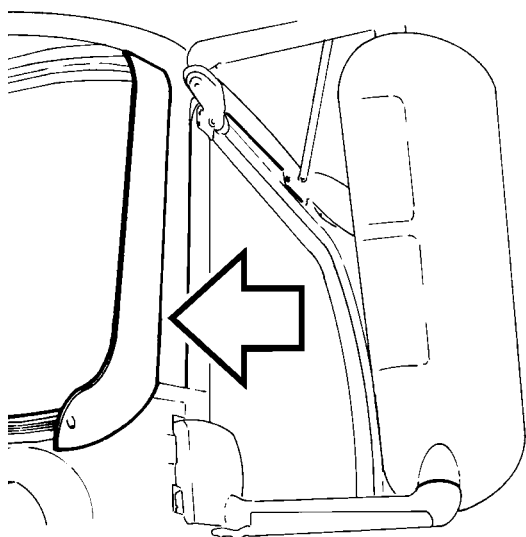

Install the left side drip molding with 3 screws. Torque the top 2 screws to 1.2 ± 0.2 Nm (10.5 ± 2 in-lb), and the bottom to $3 \text{ Nm} \pm 0.5$ (26 ± 5 in-lb).

W3000664

1.2 ± 0.2 Nm
(10.5 ± 2 in-lb)
 $3 \text{ Nm} \pm 0.5$
(26 ± 5 in-lb)

14

Install 3 bolts in the lower left side mirror arm. Torque to 24 ± 4 Nm (18 ± 3 ft-lb).

24 ± 4 Nm
(18 ± 3 ft-lb)

15

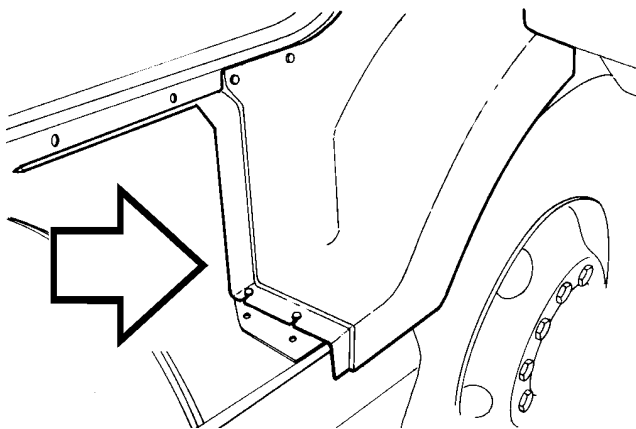

Install the right side quarter fender section. START bolts, but do not tighten until after aligning. Torque to 24 ± 4 Nm (18 ± 3 ft-lb).

W3000661

24 ± 4 Nm
(18 ± 3 ft-lb)

16

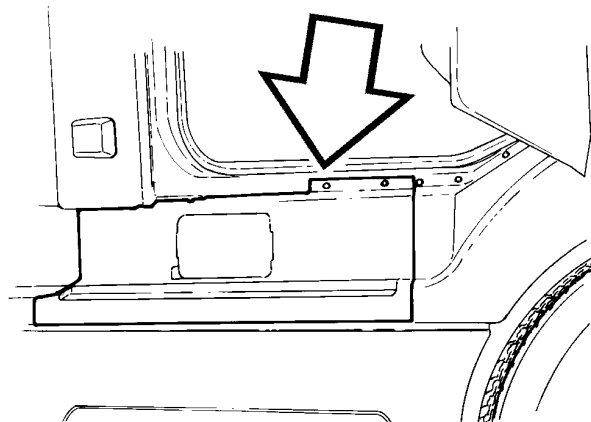

Install the tank fairing. START all bolts, then tighten after aligning fairing. Torque to 24 ± 4 Nm (18 ± 3 ft-lb).

W3000662

24 ± 4 Nm
(18 ± 3 ft-lb)

17

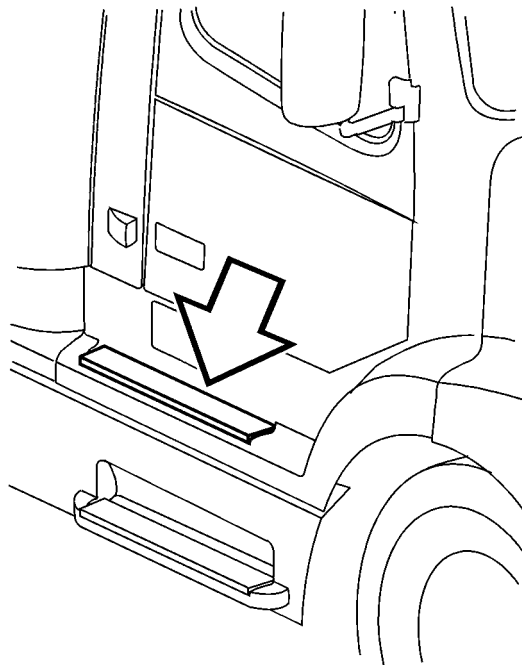

Install the step. START all 4 bolts, then tighten after aligning the step. Torque to 12 ± 1 Nm (105 ± 9 in-lb).

W3000667

12 ± 1 Nm
(105 ± 9 in-lb)

Operation Numbers

3341-03-02-01	Ignition Switch Replacement	50
3341-03-02-02	Ignition Switch and Housing Replacement	52
3563-03-02-01	Daytime Running Lamp Control Module Replacement	79
3623-03-02-01	Horn Contacts Replacement	54
3631-03-02-04	Windshield Wiper Motor Replacement	87
3638-03-02-01	Windshield Wiper Switch Replacement	58
3639-03-02-01	Windshield Wiper Linkage Assembly Replacement	88
3643-03-02-01	Turn Signal/CC Switch Replacement	56
3645-03-02-02	Ignition Power Relay Replacement	74
3645-03-02-03	Combi Relay Replacement	80
3645-03-02-04	Accessory Power Relay Replacement	76
3646-03-02-02	Power Window Switch Replacement (Right or Left)	82
3646-03-02-06	Headlight/Parking Lamp Switch Replacement	60
3646-03-02-07	Road Lamp (Fog Lamp) Switch Replacement	62
3646-03-02-11	Hazard Lamp Switch Replacement	69
3646-03-02-12	Dimmer Control (dash illumination) Rheostat Switch Replacement	64
3646-03-02-22	Auxiliary Light Switch Replacement	69
3646-03-02-24	Marker Interrupt Switch Replacement	70
3646-03-02-25	Idle Control Switch Replacement	70
3646-03-02-26	Heated Mirror Switch Replacement	70
3646-03-02-27	Traction Control (TCS) Switch Replacement	70
3646-03-02-28	Power Mirror Switch Replacement	83
3646-03-02-30	Sleeper Reading Lamp Switch Replacement	86
3646-03-02-31	Sleeper Heater Control Switch Replacement	86
3647-03-02-02	Cigar Lighter Replacement	68
3714-03-02-01	Battery Cable Fusible Link Replacement (Ground Cable)	48
3714-03-02-02	Battery Cable Fusible Link Replacement (Battery to Starter)	47
3838-03-02-02	Digital Clock (Sleeper) Replacement	84
3911-03-02-01	Radio Replacement (Dash Mounted)	72
5633-03-02-09	Rear Suspension Cab Unloader Control Valve Replacement	66
5633-03-02-10	Lift Axle Control Valve Replacement	66
5633-03-02-11	Fifth Wheel Slider Valve Replacement	66
5633-03-02-12	Differential Lockout Valve Replacement	66
5633-03-02-19	Axle Lock Control Valve Replacement	66

VOLVO

Volvo Trucks North America, Inc.

P.O. Box 26115, Greensboro, NC 27402-6115

Volvo Trucks Canada, Ltd.

5600A Cancross Court, Mississauga, Ontario L5R 3E9

<http://www.volvotrucks.volvo.com>