

# INTERACTIVE SCHEMATIC

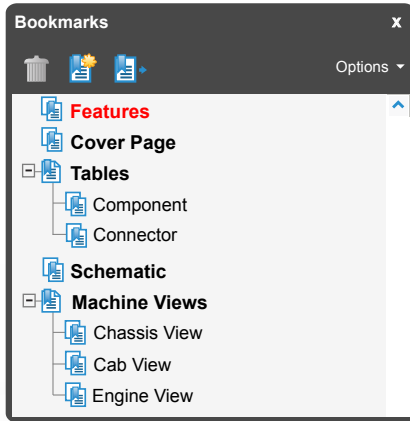

The Bookmarks panel will allow you to quickly navigate to points of interest.

***\*This document is best viewed at a screen resolution of 1024 X 768.***

To set your screen resolution do the following:

**RIGHT CLICK** on the **DESKTOP**.

Select **PROPERTIES**.

**CLICK** the **SETTINGS TAB**.

**MOVE THE SLIDER** under **SCREEN RESOLUTION** until it shows **1024 X 768**.

**CLICK OK** to apply the resolution.

*\*Due to different monitor sizes and PDF reader preferences there may be some variance in linked schematic locations*

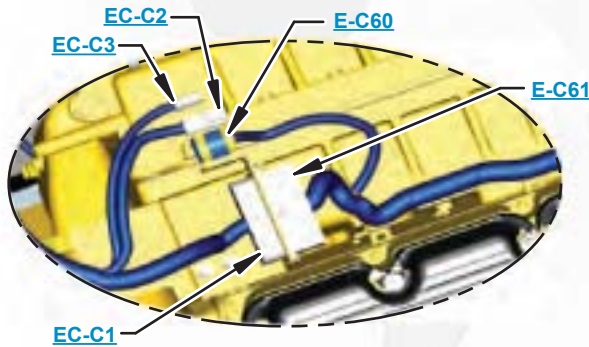

Click on any text that is **BLUE** and underlined. These are hyperlinks that can be used to navigate the schematic and machine views.



[Click here to save a copy of this interactive schematic to your desktop](#)

**VIEW ALL CALLOUTS**

When only one callout is showing on a machine view, clicking on this button will make all of the callouts visible. This button is located in the top right corner of every machine view page.

## HOTKEYS (Keyboard Shortcuts)

	FUNCTION	KEYS
	Zoom In	“CTRL” / “+”
	Zoom Out	“CTRL” / “-”
	Fit to Page	“CTRL” / “0” (zero)
	Hand Tool	“SPACEBAR” (hold down)
	Find	“CTRL” / “F”

ELECTRICAL SYMBOLS				
Pressure Switch	Temperature Switch	Level Switch	Flow Switch	Circuit Breaker

BASIC HYDRAULIC COMPONENT SYMBOLS	
Pump or Motor	Variability
Fluid Conditioner	Spring (Adjustable)

[Click here to view the Schematic Symbols and Definitions page](#)



# SCHEMATIC SYMBOLS AND DEFINITIONS



VALVES			
ENVELOPES			
One Position	Two Position	Three Position	
PORTS			
Two-way	Three-Way	Four-Way	
CONTROL			
Normal Position	Shifted Position	Infinite Position	
CHECK			
Basic Symbol	Spring Loaded	Shuttle	Pilot Controlled

INTERNAL PASSAGEWAYS			
Infinite Positioning	Two Position	Three Position	Cross Flow

CYLINDERS	
Single Acting	Double Acting

ACCUMULATORS	
Spring Loaded	Gas Charged

PUMPS	
FIXED DISPLACEMENT	
Unidirectional	Bidirectional
VARIABLE DISPLACEMENT NON-COMPENSATED	
Unidirectional	Bidirectional

MOTORS	
FIXED DISPLACEMENT	
Unidirectional	Bidirectional
VARIABLE DISPLACEMENT NON-COMPENSATED	
Unidirectional	Bidirectional

ROTATING SHAFTS	
Unidirectional	Bidirectional

BASIC HYDRAULIC COMPONENT SYMBOLS	
Pump or Motor	Variability
Fluid Conditioner	Spring (Adjustable)
Spring	Pressure Compensation
Control Valves	Line Restriction (Variable)
Restriction	Line Restriction (Fixed)
Line Restriction Variable and Pressure Compensated	2-Section Pump
Attachment	Pump: Variable and Pressure Compensated
Hydraulic Energy Triangles	Pneumatic Energy Triangles

PILOT CONTROL		
RELEASED PRESSURE		
External Return	Internal Return	
REMOTE SUPPLY PRESSURE		
Simplified	Complete	Internal Supply Pressure

COMBINATION CONTROLS						
Solenoid	Solenoid or Manual	Solenoid and Pilot	Solenoid and Pilot or Manual	Servo	Thermal	Detent

LINES	
Crossing	Joining

MEASUREMENT		
Pressure	Temperature	Flow

MANUAL CONTROL					
Push-pull Lever	Manual Shutoff	General Manual	Push Button	Pedal	Spring

FLUID STORAGE RESERVOIRS			
Vented	Pressurized	Return Above Fluid Level	Return Below Fluid Level

HYDRAULIC SYMBOLS - ELECTRICAL							
Transducer (Fluid)	Transducer (Gas / Air)	Generator	Electric Motor	Pressure Switch	Pressure Switch (Adjustable)	Temperature Switch	Electrical Wire

ELECTRICAL SYMBOLS				
Pressure Switch	Temperature Switch	Level Switch	Flow Switch	Circuit Breaker

BASIC ELECTRICAL COMPONENT SYMBOLS	
	<b>Fuse:</b> A component in an electrical circuit that will open the circuit if too much current flows through it.
	<b>Switch (Normally Open):</b> A switch that will close at a specified point (temp, press, etc.). The circle indicates that the component has screw terminals and a wire can be disconnected from it.
	<b>Switch (Normally Closed):</b> A switch that will open at a specified point (temp, press, etc.). No circle indicates that the wire cannot be disconnected from the component.
	<b>Ground (Wired):</b> This indicates that the component is connected to a grounded wire. The grounded wire is fastened to the machine.
	<b>Ground (Case):</b> This indicates that the component does not have a wire connected to ground. It is grounded by being fastened to the machine.
	<b>Reed Switch:</b> A switch whose contacts are controlled by a magnet. A magnet closes the contacts of a normally open reed switch; it opens the contacts of a normally closed reed switch.
	<b>Sender:</b> A component that is used with a temperature or pressure gauge. The sender measures the temperature or pressure. Its resistance changes to give an indication to the gauge of the temperature or pressure.
	<b>Relay (Magnetic Switch):</b> A relay is an electrical component that is activated by electricity. It has a coil that makes an electromagnet when current flows through it. The electromagnet can open or close the switch part of the relay.
	<b>Solenoid:</b> A solenoid is an electrical component that is activated by electricity. It has a coil that makes an electromagnet when current flows through it. The electromagnet can open or close a valve or move a piece of metal that can do work.
	<b>Magnetic Latch Solenoid:</b> An electrical component that is activated by electricity and held latched by a permanent magnet. It has two coils (latch and unlatch) that make electromagnet when current flows through them. It also has an internal switch that places the latch coil circuit open at the time the coil latches.

HARNESS AND WIRE SYMBOLS	
<b>Wire, Cable, or Harness Assembly Identification:</b> Includes Harness Identification Letters and Harness Connector Serialization Codes (see sample).	
<b>Harness Identification Letter(s):</b> (A, B, C, AA, AB, AC, ...)	
<b>Harness Connector Serialization Code:</b> The "C" stands for "Connector" and the number indicates which connector in the harness (C1, C2, C3, ...)	
<b>Deutsch connector:</b> Typical representation of a Deutsch connector. The plug contains all sockets and the receptacle contains all pins.	
<b>Sure-Seal connector:</b> Typical representation of a Sure-Seal connector. The plug and receptacle contain both pins and sockets.	

# Schematic

---

## **12M3, 140M3, AND 160M3 Motor Grader Hydraulic System**

---

**12M3:  
N9B1-UP  
N9F1-UP  
N9P1-UP  
N9R1-UP**

**140M3:  
N9D1-UP  
N9G1-UP  
N9J1-UP  
N9M1-UP**

**160M3:  
N9E1-UP  
N9K1-UP  
N9L1-UP  
N9T1-UP**

# COMPONENT TABLE



Component Locations			
Description	Part Number	Schematic Location	Machine Location
Accumulator GP - Blade Cushion (LH) ATCH	348-9256	<a href="#">H-7</a>	<a href="#">1</a>
Accumulator GP - Blade Cushion (RH) ATCH	348-9256	<a href="#">H-6</a>	<a href="#">2</a>
Accumulator GP - Brake			
	Standard	249-3860	<a href="#">D-6</a>
	CE/Arctic	361-8119	<a href="#">D-6</a>
	CRN/Arctic	361-8120	<a href="#">D-6</a>
Block	245-8964	<a href="#">F-6</a>	<a href="#">4</a>
Block - Pump	245-4486	<a href="#">G-3</a>	<a href="#">5</a>
Breather - Hydraulic Tank	9R-9925	<a href="#">F-7</a>	<a href="#">6</a>
Cylinder GP - Scarifier	165-2510	<a href="#">J-8</a>	<a href="#">7</a>
Cylinder GP - Articulation	247-0096	<a href="#">H-7</a>	<a href="#">8</a>
Cylinder GP - Blade Lift (LH)	335-1974	<a href="#">H-6</a>	<a href="#">9</a>
Cylinder GP - Blade Lift (RH)	335-1974	<a href="#">H-5</a>	<a href="#">10</a>
Cylinder GP - Blade Tip	131-7191	<a href="#">J-4</a>	<a href="#">11</a>
Cylinder GP - Centershift	262-1907	<a href="#">J-5</a>	<a href="#">12</a>
Cylinder GP - Ripper	326-2227	<a href="#">H-9</a>	<a href="#">13</a>
Cylinder GP - Sideshift	249-4116	<a href="#">J-5</a>	<a href="#">14</a>
Cylinder GP - Steering			
	Standard	389-6062	<a href="#">I-1</a>
	AWD	384-4547	<a href="#">I-1</a>
Cylinder GP - Wheel Lean	249-5299	<a href="#">J-7</a>	<a href="#">16</a>
Filter GP - Oil (Hydraulic Steering/AWD) (LH)	416-8305	<a href="#">C-11</a>	<a href="#">17</a>
Filter GP - Oil (Hydraulic Steering/AWD) (RH)	416-8305	<a href="#">C-10</a>	<a href="#">18</a>
Filter GP - Oil (Hydraulic Tank Return)	249-2307	<a href="#">F-6</a>	<a href="#">19</a>
Filter GP - Oil (Pilot)	416-8304	<a href="#">G-2</a>	<a href="#">20</a>
Lock GP - Centershift	305-2901	<a href="#">H-4</a>	<a href="#">21</a>
Manifold GP - Control (AWD)	357-3345	<a href="#">E-11</a>	<a href="#">22</a>
Manifold GP - Control (Fan/Brake)	446-7623	<a href="#">F-5</a>	<a href="#">23</a>
Manifold GP - Control (Pilot)	385-8162	<a href="#">G-1</a>	<a href="#">24</a>
Motor GP - AWD (LH)	354-0593	<a href="#">E-13</a>	<a href="#">25</a>
Motor GP - AWD (RH)	354-0593	<a href="#">E-9</a>	<a href="#">26</a>
Motor GP - Circle Drive	105-3196	<a href="#">J-6</a>	<a href="#">27</a>
Motor GP - Hydraulic Fan	359-7527	<a href="#">E-4</a>	<a href="#">28</a>
Orifice AS - Centershift	150-3074	<a href="#">H-4</a>	<a href="#">29</a>
Pump GP - AWD	332-1245	<a href="#">B-9</a>	<a href="#">30</a>
Pump GP - Implement/Steering	393-0742	<a href="#">F-3</a>	<a href="#">31</a>
Pump GP - Secondary Steering	361-2567	<a href="#">E-1</a>	<a href="#">32</a>
Sensor GP - Pressure (Brake Charge)	344-7391	<a href="#">F-6</a>	<a href="#">33</a>
Sensor GP - Pressure (Secondary Steering)	296-5270	<a href="#">E-2</a>	<a href="#">34</a>
Sensor GP - Temperature (Hydraulic Fan Oil)	264-4297	<a href="#">D-4</a>	<a href="#">35</a>
Sensor GP - Temperature (Hydraulic Oil)	264-4297	<a href="#">C-8</a>	<a href="#">36</a>
Sensor GP - Temperature (Hydraulic, Steering)	191-6587	<a href="#">G-1</a>	<a href="#">37</a>
Swivel GP	260-6502	<a href="#">J-5</a>	<a href="#">38</a>
Tank GP - Hydraulic	316-6404	<a href="#">F-8</a>	<a href="#">39</a>
Valve GP - Brake Control	355-7411	<a href="#">E-6</a>	<a href="#">40</a>
Valve GP - Bypass (AWD)	188-8726	<a href="#">C-9</a>	<a href="#">41</a>
Valve GP - Bypass (Hydraulic Fan)	126-0747	<a href="#">F-4</a>	<a href="#">42</a>
Valve GP - Check (Ripper)	434-1357	<a href="#">H-9</a>	<a href="#">43</a>
Valve GP - Control (Steering)	366-6680	<a href="#">J-2</a>	<a href="#">44</a>
Valve GP - Implement (5 Bank)	382-4404	<a href="#">J-3</a>	<a href="#">45</a>
Valve GP - Implement (8 Bank)	382-4409	<a href="#">J-10</a>	<a href="#">46</a>
Valve GP - Rear Implement (3 Bank)	382-4418	<a href="#">H-5</a>	<a href="#">47</a>
Valve GP - Rear Implement (6 Bank)	382-4422	<a href="#">H-11</a>	<a href="#">48</a>
Valve GP - Shutoff (Implement Pilot Oil)	382-2790	<a href="#">G-2</a>	<a href="#">49</a>

## Tap Locations Pressure, Sampling, and Sensor

Tap Number	Description	Schematic Location
<a href="#"><u>A1</u></a>	LH Motor Forward Pressure	<a href="#"><u>D-11</u></a>
<a href="#"><u>A2</u></a>	RH Motor Reverse Pressure	<a href="#"><u>D-11</u></a>
<a href="#"><u>B1</u></a>	RH Motor Forward Pressure	<a href="#"><u>D-12</u></a>
<a href="#"><u>B2</u></a>	LH Motor Reverse Pressure	<a href="#"><u>D-12</u></a>
<a href="#"><u>FBP</u></a>	Fan/Brake Pump Pressure	<a href="#"><u>F-3</u></a>
<a href="#"><u>LL</u></a>	Front AWD Pump Pressure	<a href="#"><u>B-12</u></a>
<a href="#"><u>LS</u></a>	Load Sense Pressure	<a href="#"><u>F-3</u></a>
<a href="#"><u>NN</u></a>	Rear AWD Pump Pressure	<a href="#"><u>B-10</u></a>
<a href="#"><u>PG</u></a>	Implement Pump Pressure	<a href="#"><u>F-2</u></a>
<a href="#"><u>PPG</u></a>	Pilot Pressure	<a href="#"><u>F-2</u></a>
<a href="#"><u>PS1</u></a>	LH Brake Pressure	<a href="#"><u>D-12</u></a>
<a href="#"><u>PS2</u></a>	RH Brake Pressure	<a href="#"><u>E-12</u></a>
<a href="#"><u>SOS</u></a>	Oil Sampling	<a href="#"><u>F-2</u></a>

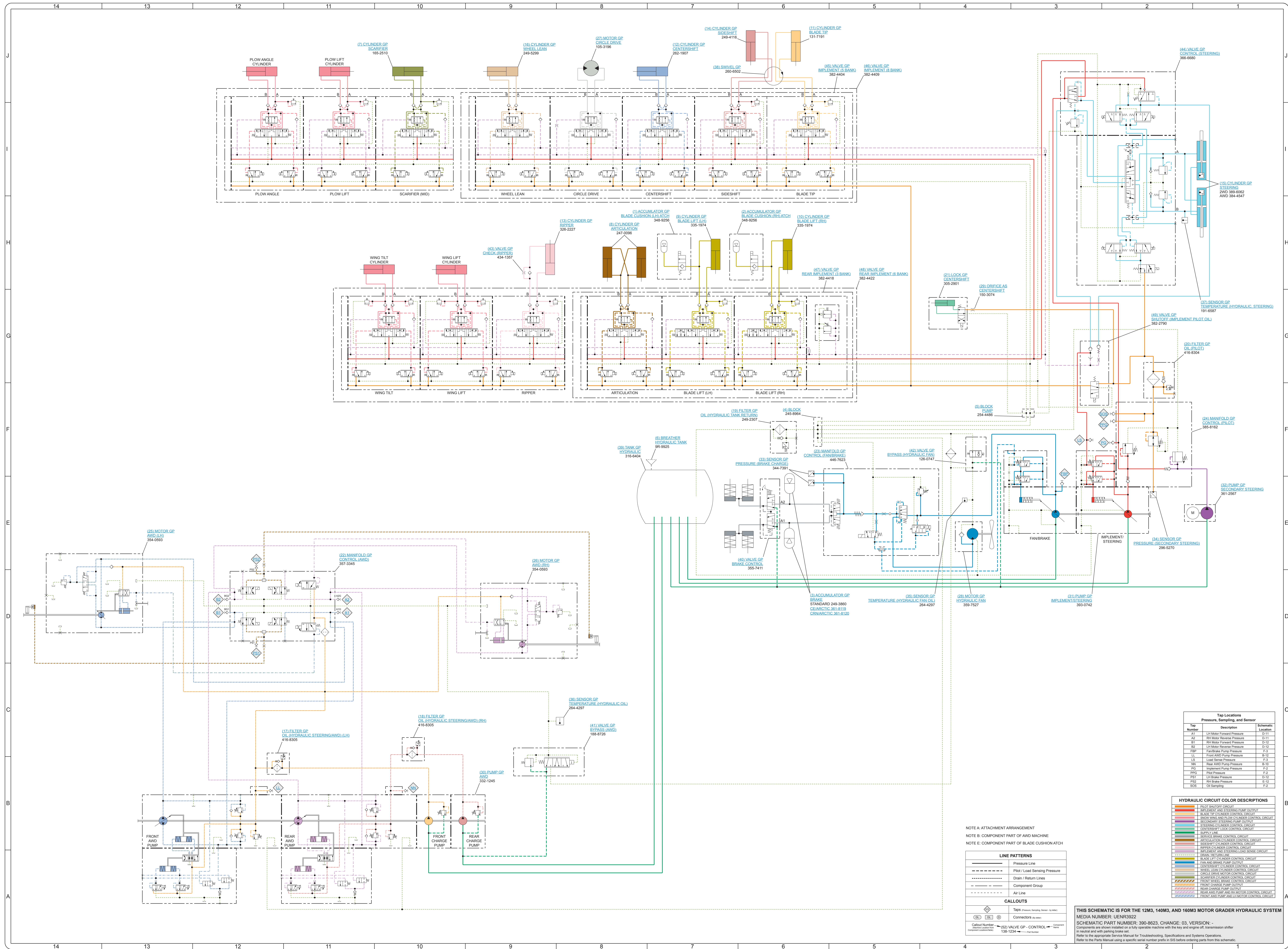

**Tap Locations Pressure, Sampling, and Sensor**

Tap Number	Description	Schematic Location
AT	LH Motor Forward Pressure	D-11
AZ	RH Motor Reverse Pressure	D-11
B1	RH Motor Forward Pressure	D-12
BE	LH Motor Reverse Pressure	D-12
FEP	FanBrake Pump Pressure	F-3
LL	Front AWD Pump Pressure	B-10
LS	Load Sense Pressure	F-3
NN	Rear AWD Pump Pressure	B-10
PS	Implement Pump Pressure	F-2
PPG	Front Pressure	F-2
PSL	LH Brake Pressure	D-12
PSR	RH Brake Pressure	E-12
SS	Oil Sampling	F-2

**HYDRAULIC CIRCUIT COLOR DESCRIPTIONS**

- PILOT SENSING CIRCUIT
- IMPLEMENT AND STEERING PUMP OUTPUT
- BRACE TILT CYLINDER CONTROL CIRCUIT
- FRONT WING AND PLOW CYLINDER CONTROL CIRCUIT
- SECONDARY STEERING PUMP OUTPUT
- TRIMMING CYLINDER CONTROL CIRCUIT
- CENTERSHIFT LOCK CONTROL CIRCUIT
- SOIL LINE
- REAR BRAKE CONTROL CIRCUIT
- ARTICULATION CYLINDER CONTROL CIRCUIT
- SEPARATE CYLINDER CONTROL CIRCUIT
- IMPLEMENT AND STEERING LOAD SENSE CIRCUIT
- DRAIN CIRCUIT
- BLADE LIFT CYLINDER CONTROL CIRCUIT
- FAN AND BRAKE CHARGE CIRCUIT
- CENTERSHIFT CYLINDER CONTROL CIRCUIT
- WHEEL LEAN CYLINDER CONTROL CIRCUIT
- CIRCLE DRIVE MOTOR CONTROL CIRCUIT
- SCARIFIER CYLINDER CONTROL CIRCUIT
- FRONT WHEEL BRAKE CONTROL CIRCUIT
- FRONT CHARGE BRAKE CIRCUIT
- REAR CHARGE BRAKE CIRCUIT
- FRONT AWD PUMP AND LH MOTOR CONTROL CIRCUIT
- FRONT AWD PUMP AND RH MOTOR CONTROL CIRCUIT

**NOTE A: ATTACHMENT ARRANGEMENT**

**NOTE B: COMPONENT PART OF AWD MACHINE**

**NOTE C: COMPONENT PART OF BLADE CUSHION ATTACH**

**LINE PATTERNS**

- Pressure Line
- Pilot / Load Sensing Pressure
- Draw / Return Lines
- Component Group
- Air Line

**CALLOUTS**

- Callout Number
- Component
- Connector

**THIS SCHEMATIC IS FOR THE 12M3, 140M3, AND 160M3 MOTOR GRADER HYDRAULIC SYSTEM**

**MEDIA NUMBER: UENR3922**

**SCHEMATIC PART NUMBER: 390-8623, CHANGE: 03, VERSION: -**

Components are shown installed on a fully operable machine with the key and engine off, transmission in neutral and with parking brake set.

Refer to the appropriate Service Manual for Troubleshooting, Specifications and Systems Operations.

Refer to the Parts Manual using a specific serial number prefix in SIB before ordering parts from this schematic.

# RIPPER

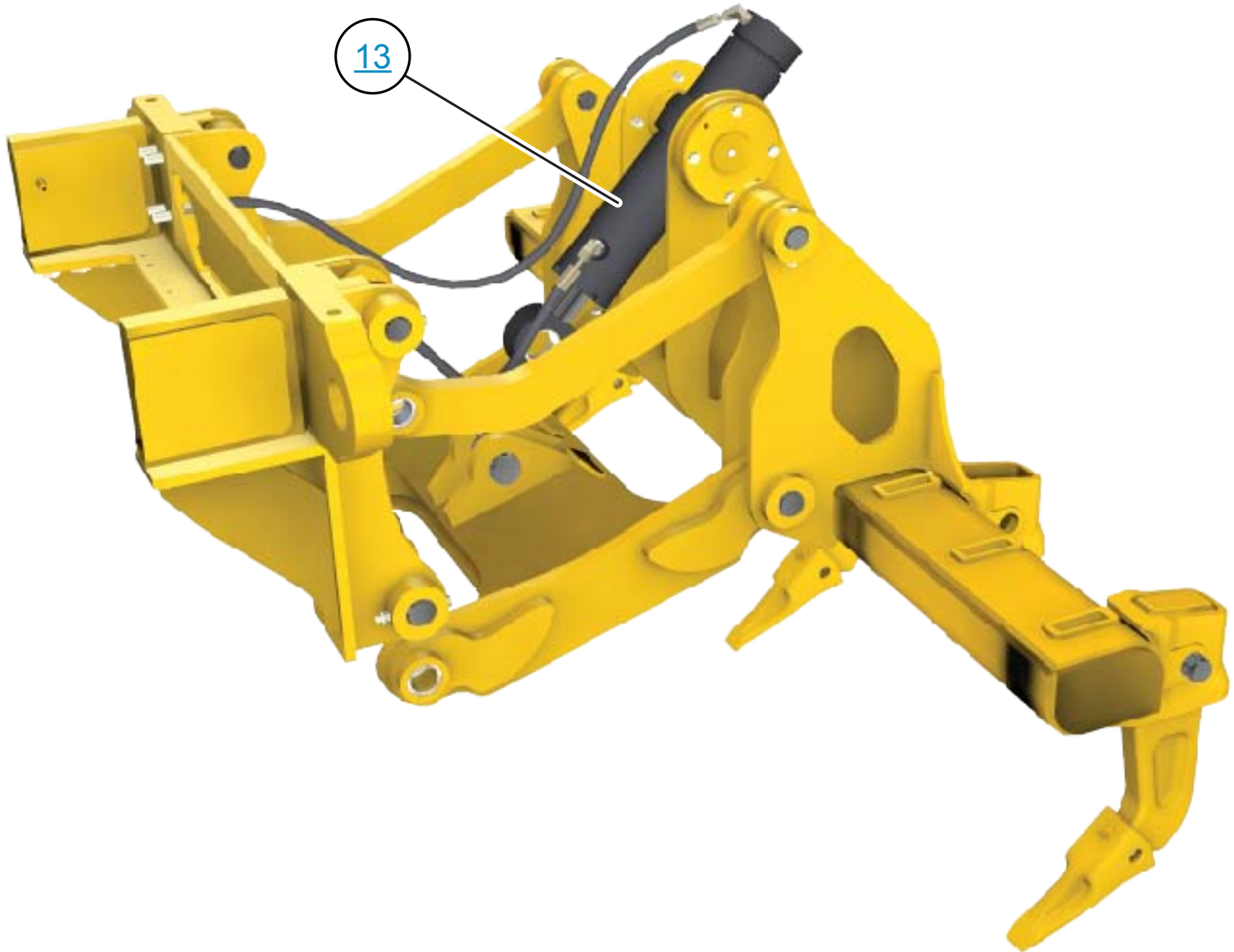

# REAR IMPLEMENT VALVE VIEW

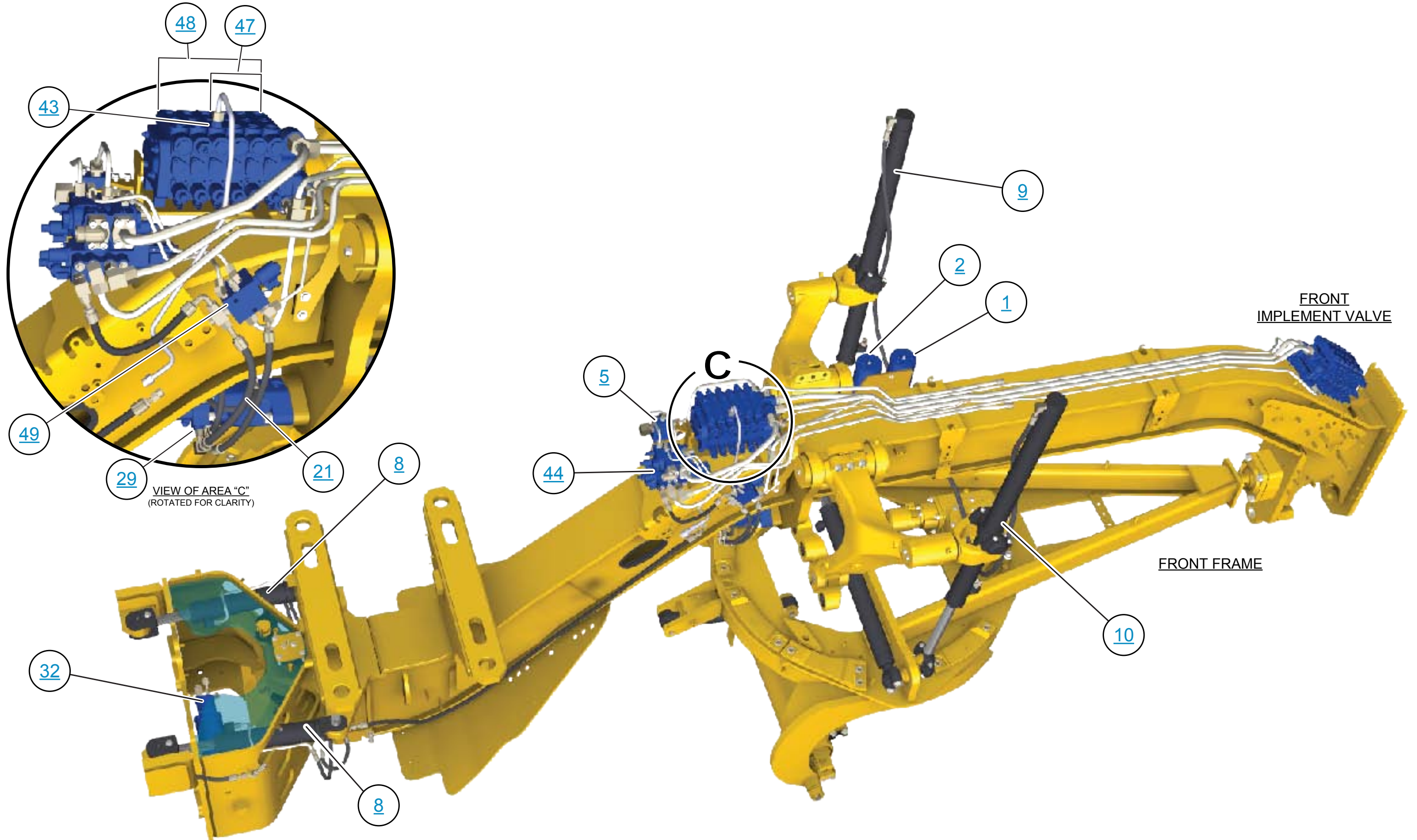



# REAR FRAME VIEW

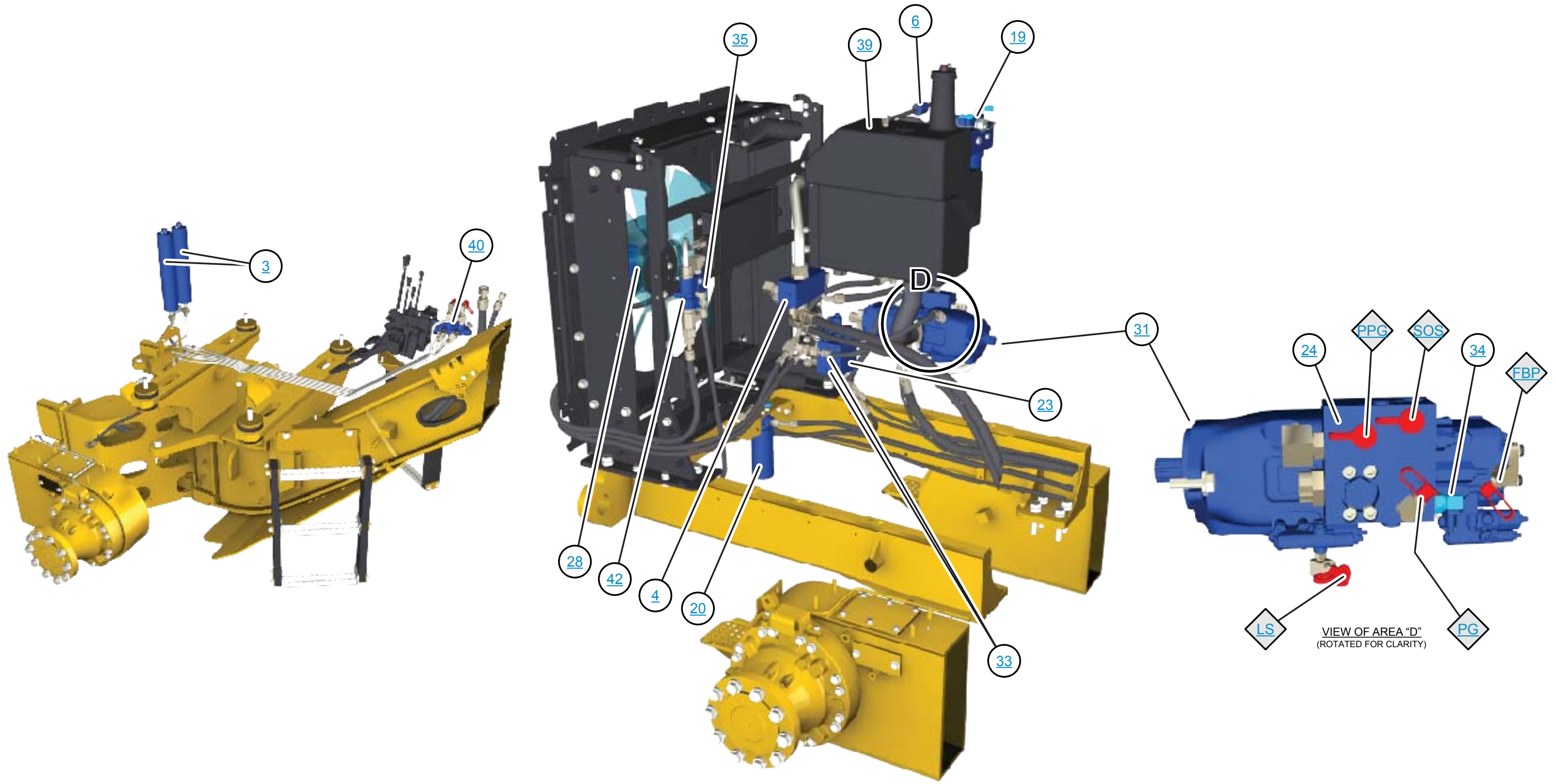

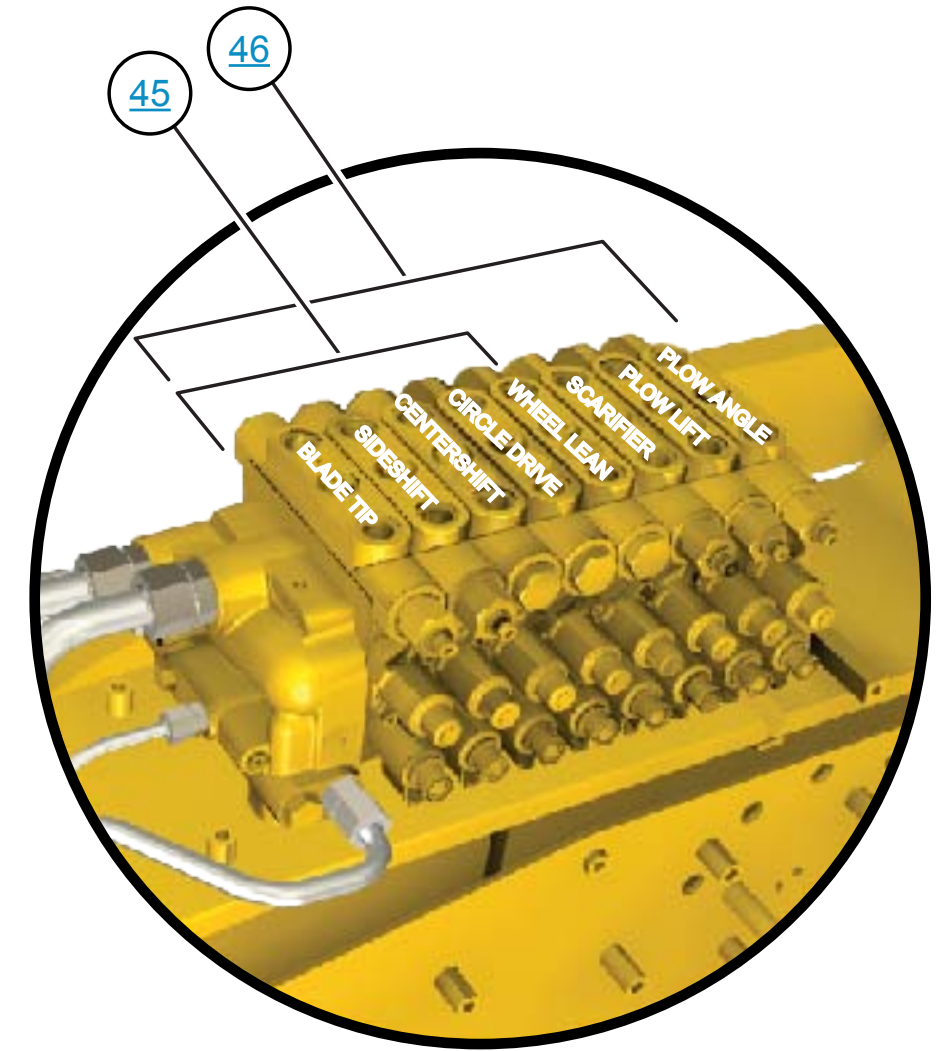
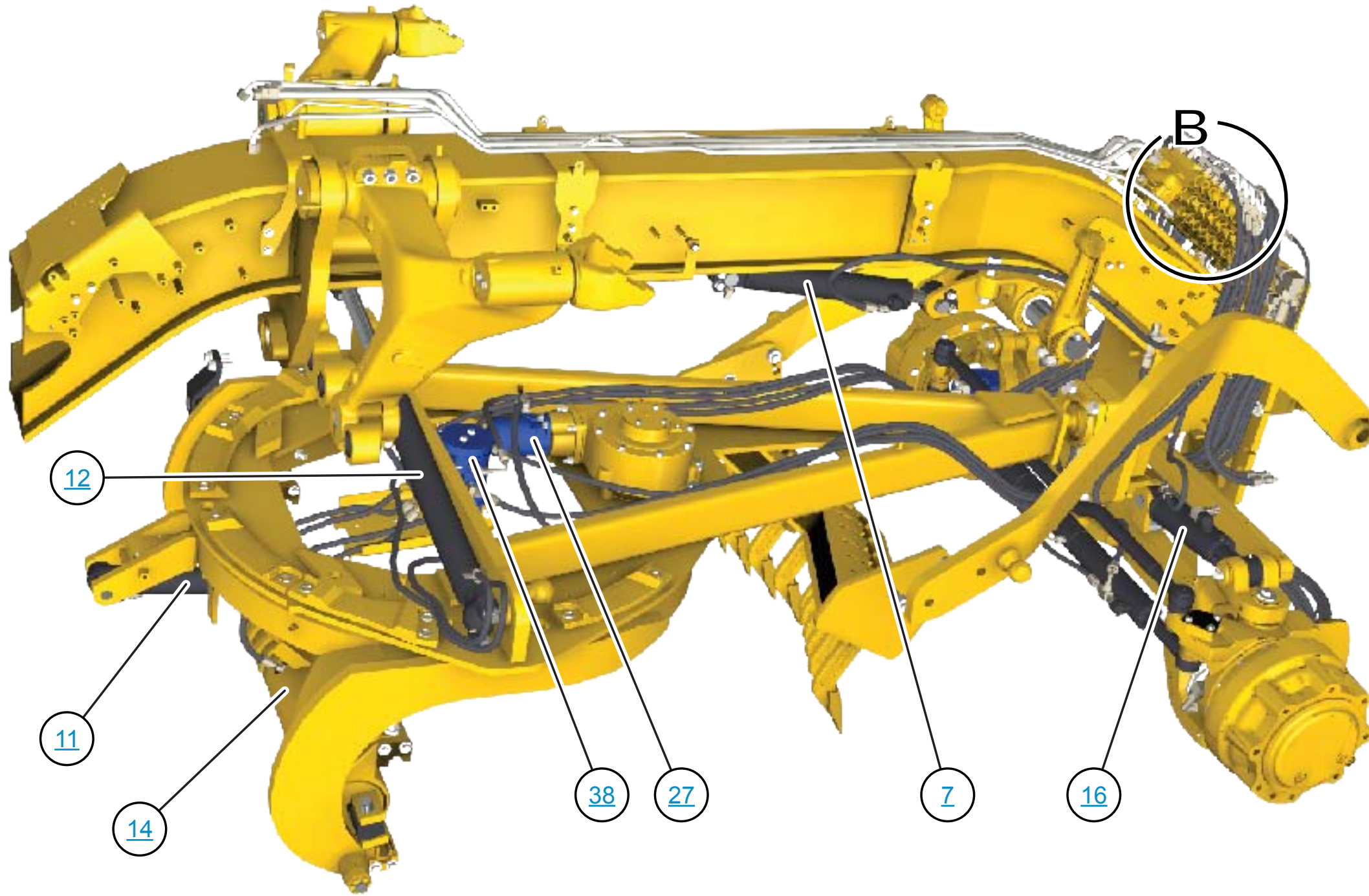

VIEW OF AREA "B"  
(ROTATED AND HOSES REMOVED FOR CLARITY)

