

# Operation & Maintenance Manual

BULLDOZER

**D85EX -15E0**

**D85PX -15E0**

SERIAL NUMBERS 11474 and up

**ecot3**

**⚠ WARNING**

Unsafe use of this machine may cause serious injury or death. Operators and maintenance personnel must read this manual before operating or maintaining this machine. This manual should be kept near the machine for reference and periodically reviewed by all personnel who will come into contact with it.

**NOTICE**

Komatsu has Operation & Maintenance Manuals written in some other languages. If a foreign language manual is necessary, contact your local distributor for availability.

**KOMATSU**

# FOREWORD

## **CALIFORNIA**

### **Proposition 65 Warning**

Diesel engine exhaust and some of its constituents are known to the State of California to cause cancer, birth defects, and other reproductive harm.

## **CALIFORNIA**

### **Proposition 65 Warning**

Battery posts, terminals and related accessories contain lead and lead compounds, chemicals known to the State of California to cause cancer and birth defects or other reproductive harm.

**Wash hands after handling.**

## BEFORE READING THIS MANUAL

This manual gives details of the operation and methods of inspection and maintenance for this machine that must be obeyed in order to use the machine safely. Most accidents are caused by the failure to follow fundamental safety rules for the operation and maintenance of machines.

Read, understand and follow all precautions and warnings in this manual and on the machine before performing operation and maintenance. Failure to do so may result in serious injury or death.

Komatsu cannot predict every circumstance that might involve a potential hazard when the machine is used. Therefore, the safety messages in this manual and on the machine may not include all possible safety precautions. If you carry out any operation, inspection, or maintenance under conditions that are not described in this manual, understand that it is your responsibility to take the necessary precautions to ensure safety. In no event should you or others engage in the prohibited uses or actions described in this manual. Improper operation and maintenance of the machine can be hazardous and could result in serious injury or death.

If you sell the machine, be sure to give this manual to the new owner together with the machine.

Always keep this Operation and Maintenance Manual in the location shown on the right so that all relevant personnel can read it at any time.

### Operation and Maintenance Manual Storing Place

A pocket for storing is provided on the inside of the right and left doors of the operator's cab.

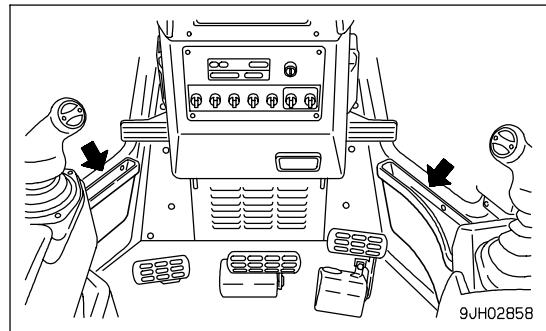

If this manual is lost or damaged, contact your distributor immediately to arrange for its replacement. For details regarding the machine serial No. you will need to provide your Komatsu distributor, see "TABLE TO ENTER SERIAL NO. AND DISTRIBUTOR (PAGE 1-8)".

This manual uses the international units (SI) for units of measurement. For reference, units that have been used in the past are given in ( ).

The explanations, values, and illustrations in this manual have been prepared based on the latest information available as of the date of its publication. Continuing improvements in the design of this machine may lead to additional changes that are not reflected in this manual. Consult Komatsu or your Komatsu distributor for the latest available information concerning your machine or with questions regarding information contained in this manual.

- The numbers in circles in the illustrations correspond to the numbers in ( ) in the text.

(For example: ① → (1))



Komatsu delivers machines that comply with all applicable regulations and standards of the country to which it has been shipped. If this machine has been purchased in another country, it may lack certain safety devices and specifications that are necessary for use in your country. If there is any question about whether your product complies with the applicable standards and regulations of your country, consult Komatsu or your Komatsu distributor before operating the machine.

## IMPORTANT SAFETY INFORMATION

To enable you to use the machine safely, and to prevent injury to operators, service personnel or bystanders, the precautions and warnings included in this manual and the safety signs attached to the machine must always be followed.

To identify important safety messages in the manual and on the machine labels, the following signal words are used.

The "Safety Alert Symbol" identifies important safety messages on machines, in manuals, and elsewhere. When you see this symbol, be alert to the risk of personal injury or death. Follow the instructions in the safety message.

- |  |  |
|--|--|
|  <b>DANGER</b>  | This signal word indicates an imminently hazardous situation which, if not avoided, will result in death or serious injury.        |
|  <b>WARNING</b> | This signal word indicates a potentially hazardous situation which, if not avoided, could result in death or serious injury.       |
|  <b>CAUTION</b> | This signal word indicates a potentially hazardous situation exists which, if not avoided, may result in minor or moderate injury. |

The following signal words are used to alert you to information that must be followed to avoid damage to the machine.

<b>NOTICE</b>	This precaution is given where the machine may be damaged or the service life reduced if the precaution is not followed.
---------------	--

<b>REMARKS</b>	This word is used for information that is useful to know.
----------------	---

# INTENDED USE

## USE OF MACHINE

This Komatsu machine is designed to be used mainly for the following work:

- Dozing
- Cutting into hard or frozen ground or ditching
- Felling trees, removing stumps
- Pushing
- Ripping

See the section "WORK POSSIBLE USING BULLDOZER (PAGE 3-117)" for further details.

## GENERAL VIEW AND DIRECTIONS OF MACHINE

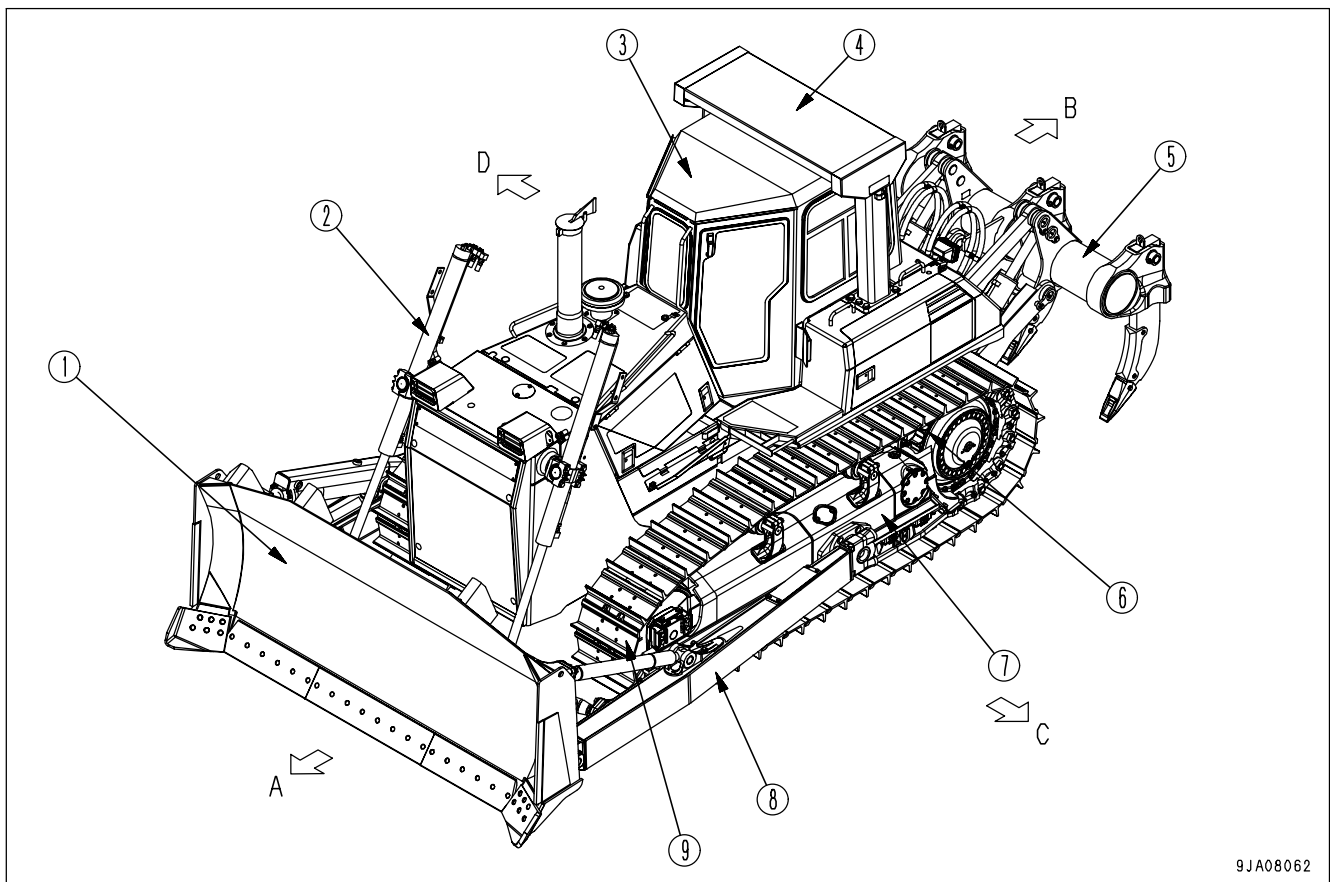

In this manual, the directions of the machine (front,rear,left,right) are determined according to the view from the operator's seat in the direction of travel (front) of the machine.

- |                         |                 |
|-------------------------|-----------------|
| (1) Blade               | (6) Sprocket    |
| (2) Blade lift cylinder | (7) Track frame |
| (3) Cab                 | (8) Frame       |
| (4) ROPS guard          | (9) Track shoe  |
| (5) Ripper              |                 |
| (A) Front               | (C) Left        |
| (B) Rear                | (D) Right       |

**VISIBILITY FROM OPERATOR'S SEAT**

The visibility standards (ISO 5006) for this machine require a view shown in the diagram below.

**PROXIMITY VISIBILITY**

The visibility of this machine in the area 1 m from the outside surface of the machine at a height of 1.5 m is shown in the diagram below. The hatched area (A) shows the area where the view is blocked by part of the machine when mirrors or other aids to visibility are installed as standard. Please be fully aware that there are places that cannot be seen when operating the machine.

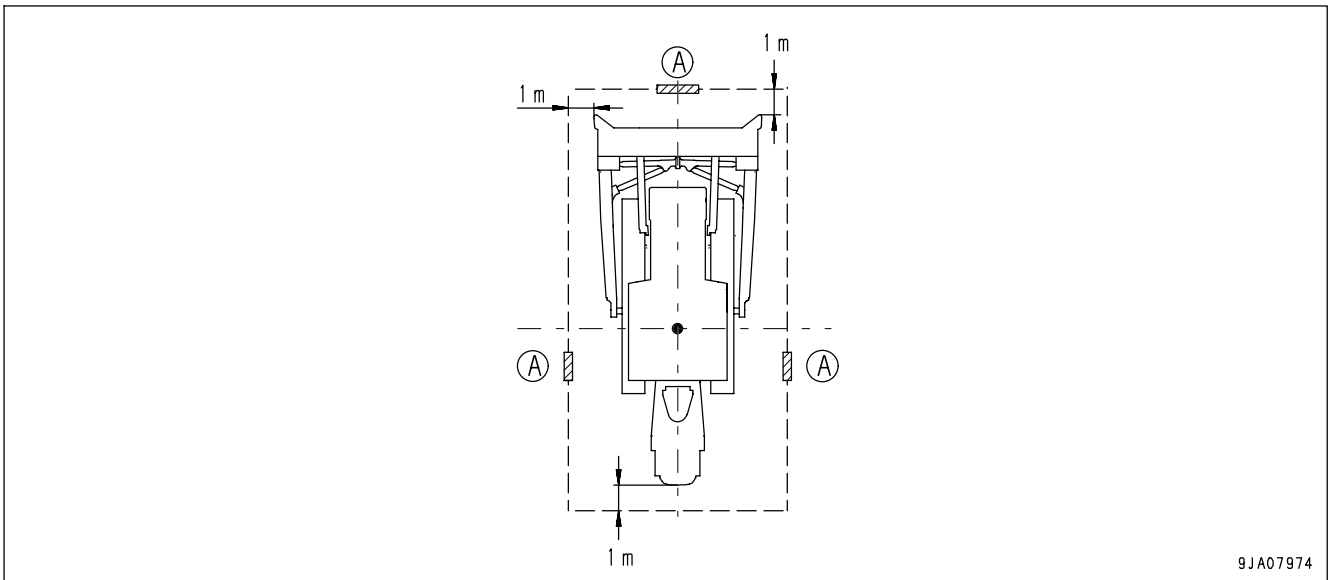

9JA07974

**12M CIRCUMFERENCE VISIBILITY**

The visibility at a radius of 12 m from the machine is as shown in the diagram below. The hatched areas (B) show the areas where the view is blocked when mirrors or other aids to visibility are installed as standard. Please be fully aware that there are places that cannot be seen when operating the machine.

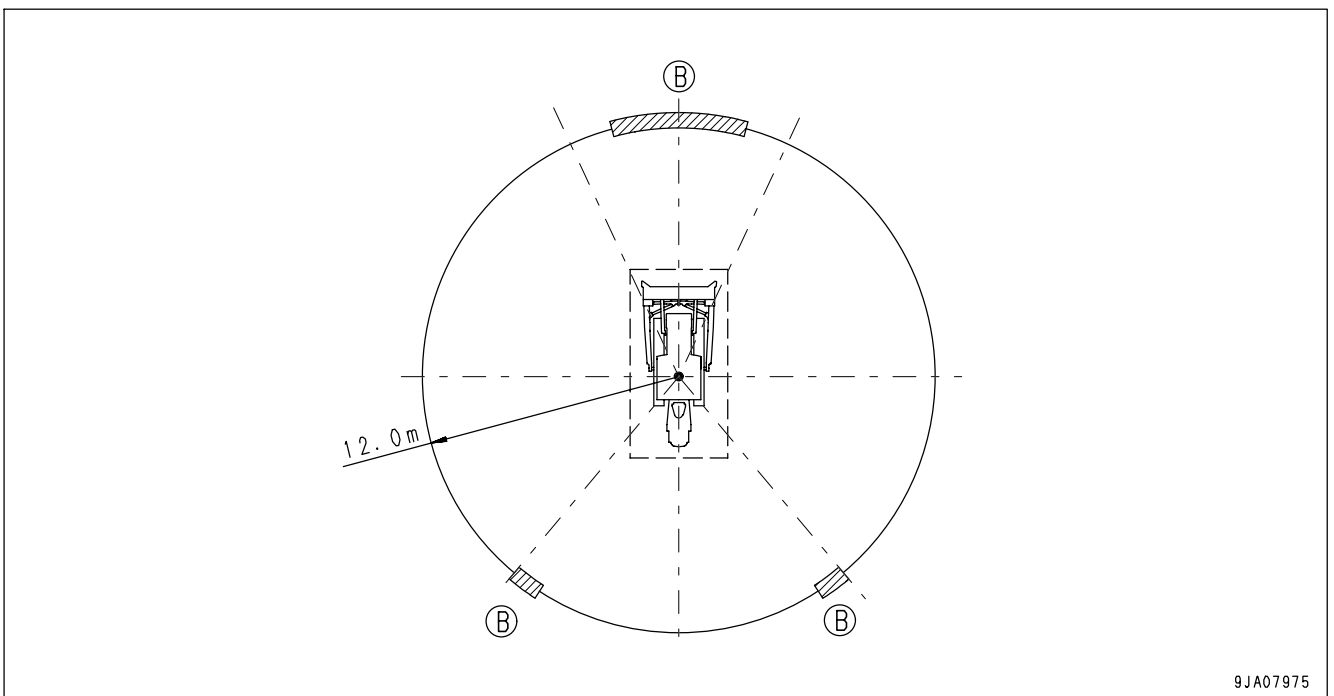

9JA07975

# LOCATION OF PLATES, TABLE TO ENTER SERIAL NO. AND DISTRIBUTOR

When ordering replacement parts, please inform your Komatsu distributor of the following.

## PRODUCT IDENTIFICATION NUMBER (PIN)/MACHINE SERIAL NO. PLATE

This is at the front bottom right of the operator's seat.  
 The design of the nameplate differs according to the territory.

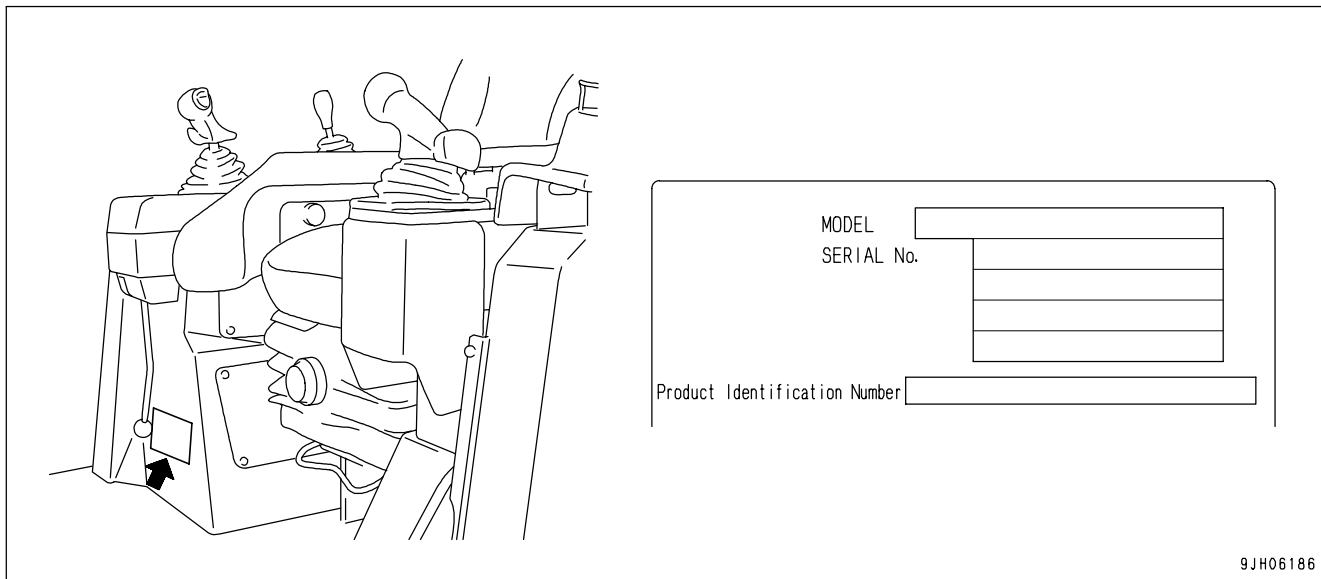

## ENGINE SERIAL NO. PLATE POSITION

The nameplate is provided on the cylinder block near the engine starting motor on the right side of the machine.

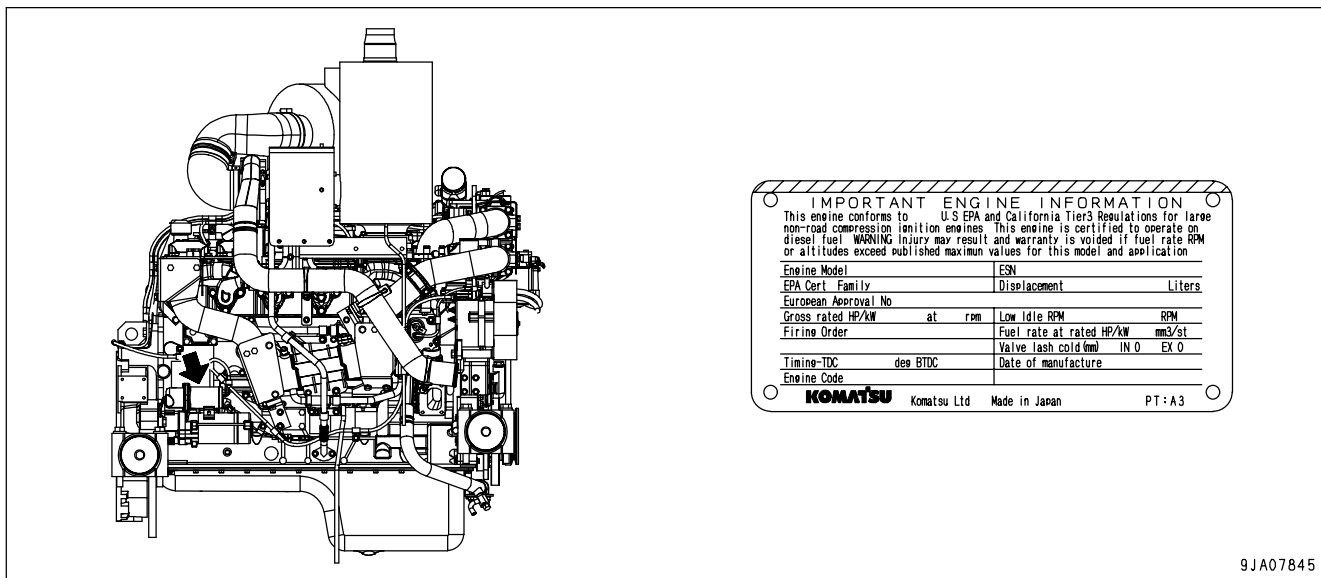

**ADDITIONAL EPA NAMEPLATE**

The auxiliary nameplate is provided on the oil filter bracket on the left side of the machine.

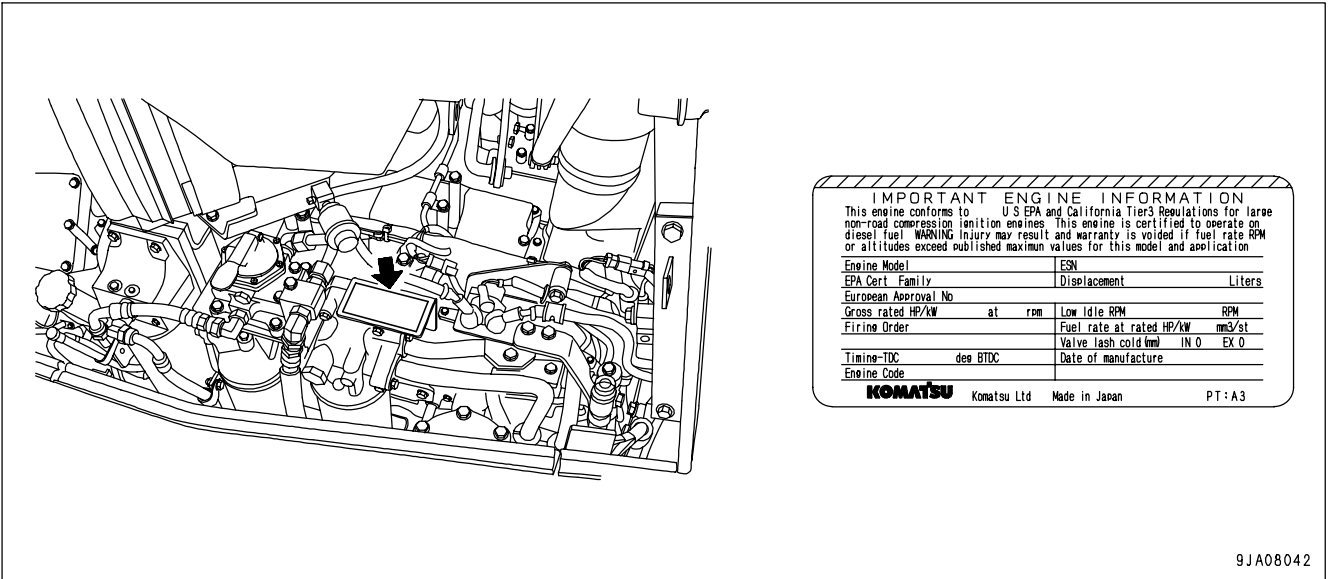

9JA08042

EPA: Environmental Protection Agency, U.S.A.

**BLADE SERIAL NO. PLATE POSITION**

This is located on the upper right of blade back surface.

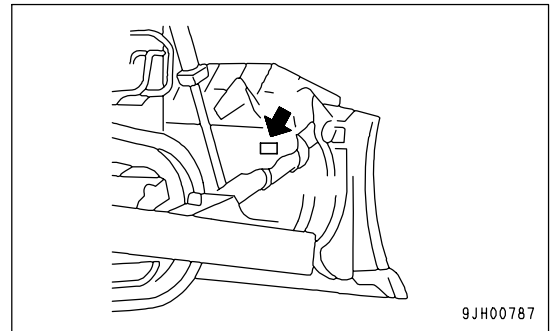

9JH00787

**RIPPER SERIAL NO. PLATE POSITION**

This is located on the left side surface of ripper beam.

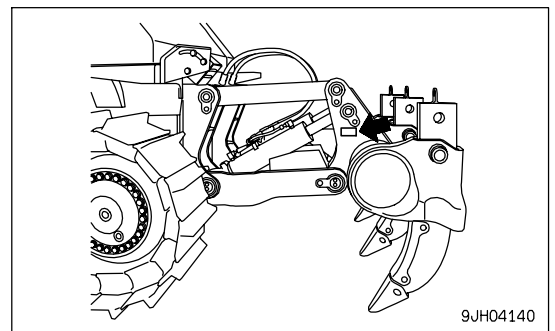

9JH04140



**SERVICE METER POSITION**

The service meter is provided at the lower part of the monitor panel.

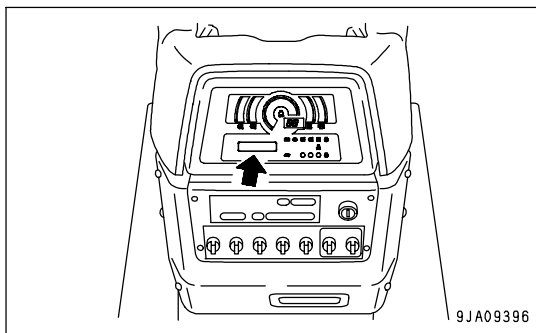

**TABLE TO ENTER SERIAL NO. AND DISTRIBUTOR**

Machine serial No.	
Engine serial No.	
Product identification number (PIN)	
Distributor name	
Address	-----
	-----
	-----
Service Personnel	
Phone/Fax	-----

# CONTENTS

FOREWORD .....	1- 1
BEFORE READING THIS MANUAL .....	1- 2
IMPORTANT SAFETY INFORMATION .....	1- 3
INTENDED USE .....	1- 4
USE OF MACHINE .....	1- 4
GENERAL VIEW AND DIRECTIONS OF MACHINE .....	1- 4
VISIBILITY FROM OPERATOR'S SEAT .....	1- 5
LOCATION OF PLATES, TABLE TO ENTER SERIAL NO. AND DISTRIBUTOR .....	1- 6
PRODUCT IDENTIFICATION NUMBER (PIN)/MACHINE SERIAL NO. PLATE .....	1- 6
ENGINE SERIAL NO. PLATE POSITION .....	1- 6
ADDITIONAL EPA NAMEPLATE .....	1- 7
BLADE SERIAL NO. PLATE POSITION .....	1- 7
RIPPER SERIAL NO. PLATE POSITION .....	1- 7
SERVICE METER POSITION .....	1- 8
TABLE TO ENTER SERIAL NO. AND DISTRIBUTOR .....	1- 8
SAFETY .....	2- 1
SAFETY .....	2- 2
SAFETY LABELS .....	2- 5
POSITIONS OF SAFETY PICTOGRAMS .....	2- 5
SAFETY LABELS .....	2- 6
GENERAL PRECAUTIONS COMMON TO OPERATION AND MAINTENANCE .....	2- 10
PRECAUTIONS BEFORE STARTING OPERATION .....	2- 10
PREPARATIONS FOR SAFE OPERATION .....	2- 10
FIRE PREVENTION .....	2- 12
PRECAUTIONS WHEN GETTING ON OR OFF MACHINE .....	2- 13
DO NOT GET CAUGHT IN WORK EQUIPMENT .....	2- 14
PRECAUTIONS RELATED TO PROTECTIVE STRUCTURES .....	2- 15
UNAUTHORIZED MODIFICATION .....	2- 15
PRECAUTIONS RELATED TO ATTACHMENTS AND OPTIONS .....	2- 15
PRECAUTIONS WHEN RUNNING ENGINE INSIDE BUILDING .....	2- 15
PRECAUTIONS FOR OPERATION .....	2- 16
PRECAUTIONS FOR JOBSITE .....	2- 16
STARTING ENGINE .....	2- 19
OPERATION .....	2- 21
TRANSPORTATION .....	2- 25
TOWING .....	2- 26
PRECAUTIONS FOR MAINTENANCE .....	2- 27
PRECAUTIONS BEFORE STARTING INSPECTION AND MAINTENANCE .....	2- 27
PRECAUTIONS FOR INSPECTION AND MAINTENANCE .....	2- 31
OPERATION .....	3- 1
GENERAL VIEW .....	3- 2
GENERAL VIEW OF MACHINE .....	3- 2
GENERAL VIEW OF CONTROLS AND GAUGES .....	3- 3
EXPLANATION OF COMPONENTS .....	3- 5
FRONT PANEL .....	3- 5
SWITCHES .....	3- 33
CONTROL LEVERS AND PEDALS .....	3- 37
FUSE .....	3- 44
CIRCUIT BREAKER FOR MAIN POWER SUPPLY .....	3- 46

CIRCUIT BREAKER .....	3- 47
ELECTRIC POWER TAKE-OUT ADAPTER .....	3- 47
CAP WITH LOCK .....	3- 48
DOOR - OPEN LOCK .....	3- 50
SASH GLASS INTERMEDIATE LOCK .....	3- 50
DOOR POCKET .....	3- 51
ASHTRAY .....	3- 51
TOOL BOX .....	3- 51
CAR STEREO, HANDLING .....	3- 52
AIR CONDITIONER, HANDLING .....	3- 60
HANDLING HEATER .....	3- 65
EXTERNAL POWER SOURCE TYPE ENGINE PREHEATING HEATER .....	3- 66
OPERATION .....	3- 74
CHECK BEFORE STARTING ENGINE, ADJUST .....	3- 74
STARTING ENGINE .....	3- 93
OPERATIONS AND CHECKS AFTER STARTING ENGINE .....	3- 97
STOPPING ENGINE .....	3-101
MACHINE OPERATION .....	3-102
SHIFTING GEARS .....	3-105
SHIFTING BETWEEN FORWARD AND REVERSE .....	3-110
STEERING MACHINE .....	3-112
PRECAUTIONS FOR OPERATION .....	3-114
WORK POSSIBLE USING BULLDOZER .....	3-117
ADJUSTING POSTURE OF WORK EQUIPMENT .....	3-119
PARKING MACHINE .....	3-123
CHECK AFTER FINISHING WORK .....	3-125
LOCKING .....	3-125
TIPS FOR LONGER UNDERCARRIAGE LIFE .....	3-126
TRANSPORTATION .....	3-129
TRANSPORTATION MEANS .....	3-129
REMOVING CAB .....	3-129
INSTALLATION OF CAB .....	3-130
INSTALLATION OF ROPS .....	3-130
LOADING, UNLOADING WORK .....	3-131
METHOD OF LIFTING MACHINE .....	3-134
PRECAUTIONS FOR TRANSPORTATION .....	3-135
TRAVELING ON ROADS .....	3-135
COLD WEATHER OPERATION .....	3-136
PRECAUTIONS FOR LOW TEMPERATURE .....	3-136
AFTER COMPLETION OF WORK .....	3-137
AFTER COLD WEATHER .....	3-137
LONG-TERM STORAGE .....	3-138
BEFORE STORAGE .....	3-138
DURING STORAGE .....	3-138
AFTER STORAGE .....	3-138
TROUBLESHOOTING .....	3-139
AFTER RUNNING OUT OF FUEL .....	3-139
METHOD OF TOWING MACHINE .....	3-141
IF BATTERY IS DISCHARGED .....	3-143
OTHER TROUBLE .....	3-147

MAINTENANCE -----	4- 1
GUIDE TO MAINTENANCE -----	4- 2
OUTLINE OF SERVICE -----	4- 5
HANDLING OIL, FUEL, COOLANT, AND PERFORMING OIL CLINIC -----	4- 5
RELATING TO ELECTRIC SYSTEM -----	4- 8
HANDLING HYDRAULIC SYSTEM -----	4- 9
WEAR PARTS LIST -----	4- 10
WEAR PARTS LIST -----	4- 10
RECOMMENDED FUEL, COOLANT, AND LUBRICANT -----	4- 12
USE OF FUEL, COOLANT AND LUBRICANTS ACCORDING TO AMBIENT TEMPERATURE ----	4- 13
RECOMMENDED BRANDS, RECOMMENDED QUALITY FOR PRODUCTS OTHER THAN KOMATSU GENUINE OIL -----	4- 14
STANDARD TIGHTENING TORQUES FOR BOLTS AND NUTS -----	4- 15
TORQUE LIST -----	4- 15
PERIODIC REPLACEMENT OF SAFETY CRITICAL PARTS -----	4- 16
SAFETY CRITICAL PARTS -----	4- 16
MAINTENANCE SCHEDULE CHART -----	4- 18
MAINTENANCE SCHEDULE CHART -----	4- 18
SERVICE PROCEDURE -----	4- 20
INITIAL 250 HOURS SERVICE (ONLY AFTER THE FIRST 250 HOURS) -----	4- 20
WHEN REQUIRED -----	4- 21
CHECK BEFORE STARTING -----	4- 46
EVERY 250 HOURS SERVICE -----	4- 47
EVERY 500 HOURS SERVICE -----	4- 54
EVERY 1000 HOURS SERVICE -----	4- 59
EVERY 2000 HOURS SERVICE -----	4- 67
EVERY 4000 HOURS SERVICE -----	4- 73
EVERY 8000 HOURS SERVICE -----	4- 76
SPECIFICATIONS -----	5- 1
SPECIFICATIONS -----	5- 2
ATTACHMENTS, OPTIONS -----	6- 1
GENERAL PRECAUTIONS -----	6- 2
PRECAUTIONS RELATED TO SAFETY -----	6- 2
SELECTION OF TRACK SHOE -----	6- 3
METHOD OF SELECTING SHOES -----	6- 3
PROCEDURE FOR SELECTING RIPPER POINT -----	6- 4
HANDLING TRIMMING DOZER -----	6- 5
GENERAL VIEW -----	6- 5
EXPLANATION OF COMPONENTS -----	6- 6
MAINTENANCE -----	6- 7
SPECIFICATIONS -----	6- 11
HANDLING MACHINES EQUIPPED WITH KOMTRAX -----	6- 12
BASIC PRECAUTIONS -----	6- 12
INDEX -----	7- 1



# SAFETY

## **WARNING**

Please read and make sure that you fully understand the precautions described in this manual and the safety labels on the machine. When operating or servicing the machine, always follow these precautions strictly.

---

## SAFETY

SAFETY LABELS .....	2- 5
POSITIONS OF SAFETY PICTOGRAMS .....	2- 5
SAFETY LABELS .....	2- 6
GENERAL PRECAUTIONS COMMON TO OPERATION AND MAINTENANCE .....	2- 10
PRECAUTIONS BEFORE STARTING OPERATION .....	2- 10
ENSURING SAFE OPERATION .....	2- 10
UNDERSTANDING THE MACHINE .....	2- 10
PREPARATIONS FOR SAFE OPERATION .....	2- 10
PRECAUTIONS REGARDING SAFETY-RELATED EQUIPMENT .....	2- 10
INSPECTING MACHINE .....	2- 10
WEAR WELL-FITTING CLOTHES AND PROTECTIVE EQUIPMENT .....	2- 10
KEEP MACHINE CLEAN .....	2- 11
PRECAUTIONS INSIDE OPERATOR'S COMPARTMENT .....	2- 11
PROVIDE FIRE EXTINGUISHER AND FIRST AID KIT .....	2- 11
IF ANY PROBLEM IS FOUND .....	2- 11
FIRE PREVENTION .....	2- 12
ACTION IF FIRE OCCURS .....	2- 12
PRECAUTIONS TO PREVENT FIRE .....	2- 12
PRECAUTIONS WHEN GETTING ON OR OFF MACHINE .....	2- 13
USE HANDRAILS AND STEPS WHEN GETTING ON OR OFF MACHINE .....	2- 13
NO JUMPING ON OR OFF MACHINE .....	2- 13
NO PEOPLE ON ATTACHMENTS .....	2- 14
PRECAUTIONS WHEN STANDING UP FROM OPERATOR'S SEAT .....	2- 14
PRECAUTIONS WHEN LEAVING MACHINE .....	2- 14
EMERGENCY EXIT FROM OPERATOR'S CAB .....	2- 14
DO NOT GET CAUGHT IN WORK EQUIPMENT .....	2- 14
PRECAUTIONS RELATED TO PROTECTIVE STRUCTURES .....	2- 15
UNAUTHORIZED MODIFICATION .....	2- 15
PRECAUTIONS RELATED TO ATTACHMENTS AND OPTIONS .....	2- 15
PRECAUTIONS WHEN RUNNING ENGINE INSIDE BUILDING .....	2- 15

PRECAUTIONS FOR OPERATION .....	2- 16
PRECAUTIONS FOR JOBSITE .....	2- 16
INVESTIGATE AND CONFIRM JOBSITE CONDITIONS .....	2- 16
WORKING ON LOOSE GROUND .....	2- 16
DO NOT GO CLOSE TO HIGH-VOLTAGE CABLES .....	2- 17
ENSURE GOOD VISIBILITY .....	2- 17
CHECKING SIGNS AND SIGNALMAN'S SIGNALS .....	2- 17
BEWARE OF ASBESTOS DUST .....	2- 18
STARTING ENGINE .....	2- 19
USE WARNING TAGS .....	2- 19
CHECKS BEFORE STARTING ENGINE .....	2- 19
PRECAUTIONS WHEN STARTING .....	2- 20
PRECAUTIONS IN COLD AREAS .....	2- 20
STARTING WITH BOOSTER CABLES .....	2- 20
OPERATION .....	2- 21
CHECKS BEFORE OPERATION .....	2- 21
PRECAUTIONS WHEN TRAVELING IN FORWARD OR REVERSE .....	2- 21
PRECAUTIONS WHEN TRAVELING .....	2- 22
TRAVELING ON SLOPES .....	2- 23
PRECAUTIONS WHEN OPERATING .....	2- 23
METHOD OF USING BRAKES .....	2- 23
TRAVELING ON SNOW-COVERED OR FROZEN SURFACES .....	2- 18
PARKING MACHINE .....	2- 24
TRANSPORTATION .....	2- 25
LOADING AND UNLOADING .....	2- 25
TOWING .....	2- 26
PRECAUTIONS WHEN TOWING .....	2- 26



PRECAUTIONS FOR MAINTENANCE .....	2- 27
PRECAUTIONS BEFORE STARTING INSPECTION AND MAINTENANCE .....	2- 27
DISPLAY WARNING TAG DURING INSPECTION AND MAINTENANCE .....	2- 27
KEEP WORKPLACE CLEAN AND TIDY .....	2- 27
SELECT SUITABLE PLACE FOR INSPECTION AND MAINTENANCE .....	2- 27
ONLY AUTHORIZED PERSONNEL .....	2- 27
APPOINT LEADER WHEN WORKING WITH OTHERS .....	2- 27
STOP ENGINE BEFORE CARRYING OUT INSPECTION AND MAINTENANCE .....	2- 28
TWO WORKERS FOR MAINTENANCE WHEN ENGINE IS RUNNING .....	2- 29
INSTALLING, REMOVING, OR STORING ATTACHMENTS .....	2- 29
PRECAUTIONS WHEN WORKING AT HIGH PLACES .....	2- 29
PRECAUTIONS WHEN WORKING UNDER MACHINE OR WORK EQUIPMENT .....	2- 30
PROPER TOOLS .....	2- 30
PRECAUTIONS FOR INSPECTION AND MAINTENANCE .....	2- 31
PRECAUTIONS WHEN WELDING .....	2- 31
HANDLING BATTERY .....	2- 31
PRECAUTIONS WHEN USING HAMMER .....	2- 32
PRECAUTIONS WITH HIGH-TEMPERATURE COOLANT .....	2- 32
PRECAUTIONS WITH HIGH-TEMPERATURE OIL .....	2- 32
PRECAUTIONS WITH HIGH-PRESSURE OIL .....	2- 33
PRECAUTIONS WITH HIGH-PRESSURE FUEL .....	2- 33
HANDLING HIGH-PRESSURE HOSES AND PIPING .....	2- 33
NOISE .....	2- 33
PRECAUTIONS WITH HIGH-PRESSURE GREASE WHEN ADJUSTING TRACK TENSION .....	2- 34
DO NOT DISASSEMBLE RECOIL SPRING .....	2- 34
HANDLING ACCUMULATOR AND GAS SPRING .....	2- 34
PRECAUTIONS WITH COMPRESSED AIR .....	2- 35
MAINTENANCE OF AIR CONDITIONER .....	2- 35
DISPOSING OF WASTE MATERIALS .....	2- 35
METHOD OF SELECTING WINDOW WASHER FLUID .....	2- 35
PERIODIC REPLACEMENT OF SAFETY CRITICAL PARTS .....	2- 35

## SAFETY LABELS

The following safety labels are used on this machine.

- Make sure that you fully understand the location and content of each safety label, together with the means of avoiding the danger shown.
- To ensure that the contents of safety labels can be read properly, be sure that they are in the correct place and always keep them clean. When cleaning the labels, do not use organic solvents or gasoline. They may cause the labels to peel off.
- If the labels are damaged, lost, or cannot be read properly, contact your Komatsu distributor immediately regarding their replacement. For details concerning the part numbers for the labels, see this manual or the actual label.
- There are also other labels on the machine in addition to the safety labels. Handle those labels in the same way.

## POSITIONS OF SAFETY PICTOGRAMS

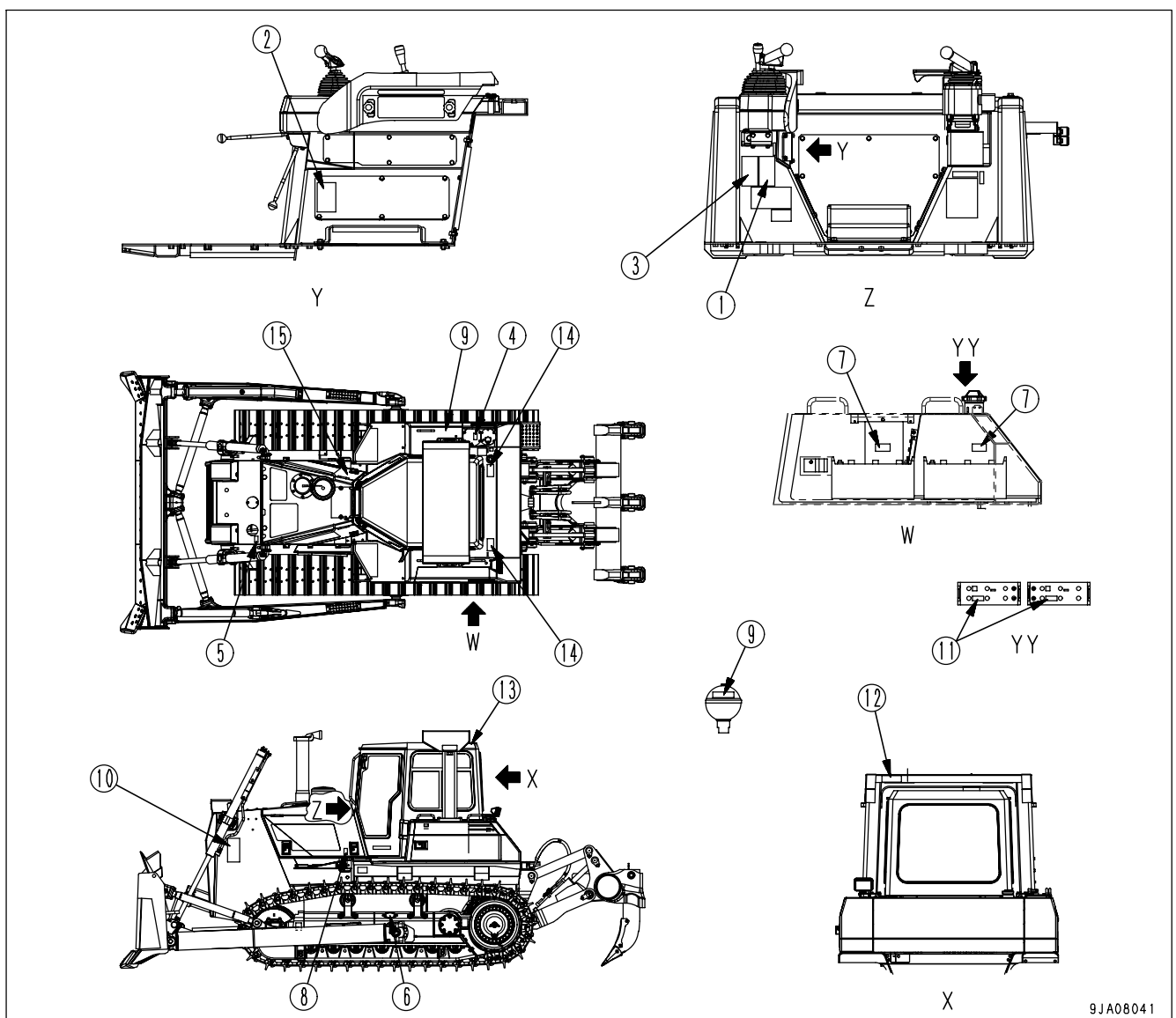

9JA08041

**SAFETY LABELS**

- (1) Caution before operating or maintaining machine  
(09651-03001)

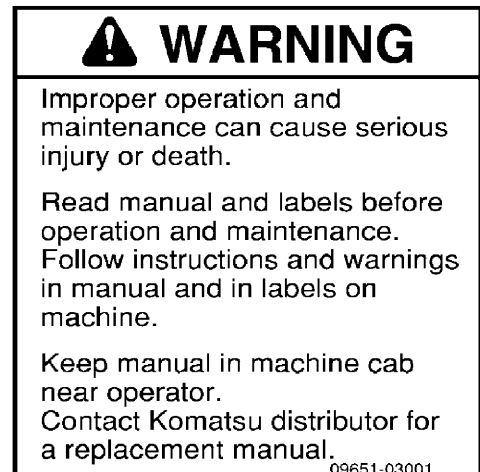

- (2) Caution when traveling in reverse (09802-13000)

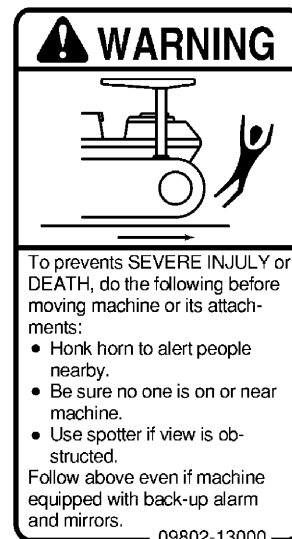

- (3) Caution for leaving the operator's seat (09654-33001)

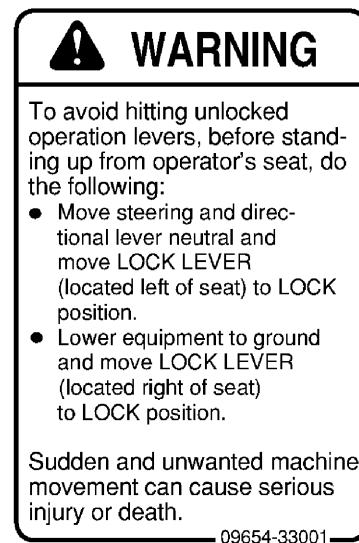

(4) Caution for high-temperature hydraulic oil (09653-03001)



(5) Caution for high-temperature coolant (09668-03001)



(6) Caution when adjusting track tension (09657-03003)

Safety label is attached to the back side of the inspection cover of the track frame.



(7) Caution for handling electric wires (09808-03000)

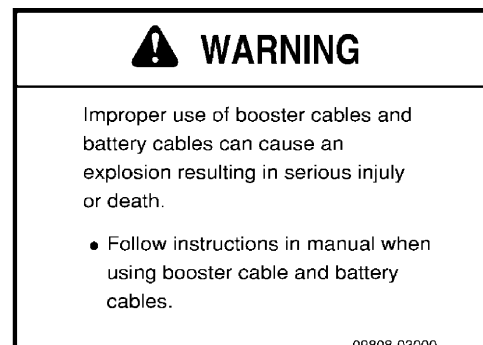

(8) Caution for engine running (09667-03001)

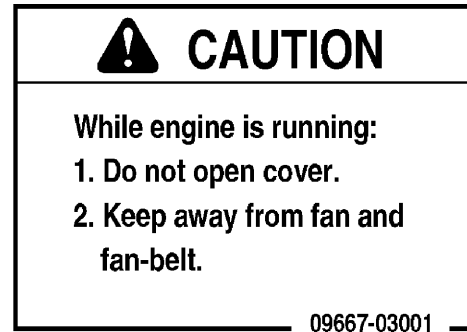

(9) Caution for handling accumulator (09659-53000)



(10) Caution for approach when machine moving (09812-03000)



(11) Precautions when handling battery

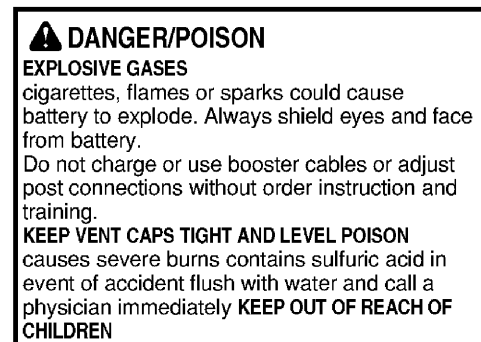

(This plate is stick on the machine by the battery maker.)

(12) ROPS (09620-B2000)

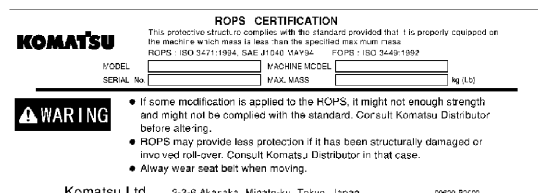

(13) FOPS (09620-C2000)

<b>FOPS CERTIFICATION</b>	
<small>This protective structure was provided to comply with the following standard.</small>	
<b>FOPS - ISO 3449:1992</b>	
MODEL	MACHINE MODEL
SERIAL NO.	MAX. MASS
<p><b>WARNING</b></p> <ul style="list-style-type: none"> <li>• If some modification is applied to the FOPS, it might not be enough strength and might not be complied with the standard. Consult Komatsu Distributor before altering.</li> <li>• FOPS may provide less protection if it has been structurally damaged or involved roll-over. Consult Komatsu Distributor in that case.</li> </ul>	
<small>Komatsu Ltd. 2-3-8 Akasaka, Minato-ku, Tokyo, Japan 09620-C2000</small>	

(14) Roll-over precautions (17A-98-23920)



(15) Jump start prohibited (09842-A0481)



Start the engine only after sitting down in the operator's seat.

Do not attempt to start the engine by short-circuiting the engine starting circuit. Such an act may cause a serious bodily injury or fire.

## GENERAL PRECAUTIONS COMMON TO OPERATION AND MAINTENANCE

Mistakes in operation, inspection, or maintenance may result in serious personal injury or death. Before carrying out operation, inspection, or maintenance, always read this manual and the safety labels on the machine carefully and obey the warnings.

### PRECAUTIONS BEFORE STARTING OPERATION

#### ENSURING SAFE OPERATION

- Only trained and authorized personnel can operate and maintain the machine.
- Follow all safety, precautions, and instructions in this manual when operating or performing inspection or maintenance on the machine.
- If you are not feeling well, or if you are under the influence of alcohol or medication, your ability to safely operate or repair your machine may be severely impaired, putting yourself and everyone else on your job site in danger.
- When working with another operator or with the person on the worksite traffic duty, discuss the content of the operation beforehand and use the determined signals when carrying out the operation.

#### UNDERSTANDING THE MACHINE

Before operating the machine, read this manual thoroughly. If there are any places in this manual that you do not understand, ask the person in charge of safety to give an explanation.

### PREPARATIONS FOR SAFE OPERATION

#### PRECAUTIONS REGARDING SAFETY-RELATED EQUIPMENT

- Be sure that all guards, covers and mirrors are in their proper position. Have guards and covers repaired immediately if they are damaged.
- Understand the method of use of safety features and use them properly.
- Never remove any safety features. Always keep them in good operating condition.

#### INSPECTING MACHINE

Check the machine before starting operations. If any abnormality is found, do not operate the machine until repairs of the problem location have been completed.

#### WEAR WELL-FITTING CLOTHES AND PROTECTIVE EQUIPMENT

- Do not wear loose clothes or any accessories. If these catch on the control levers or protruding parts, there is danger that it may cause the machine to move unexpectedly.
- Always wear a hard hat and safety shoes. If the nature of the work requires it, wear safety glasses, mask, gloves, ear plugs, and safety belt when operating or maintaining the machine.
- If you have long hair and it hangs out from your hard hat, there is a hazard that it may get caught up in the machine, so tie your hair up and be careful not to let it get caught.
- Check that all protective equipment functions properly before using it.

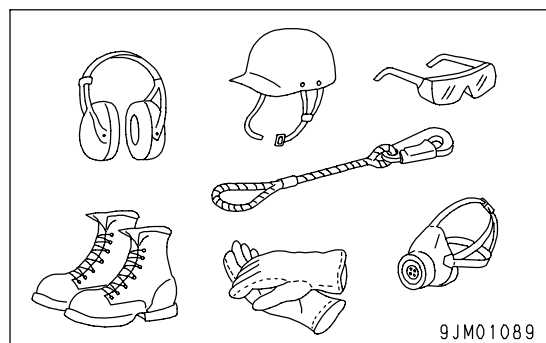

**KEEP MACHINE CLEAN**

- If you get on or off the machine or carry out inspection and maintenance when the machine is dirty with mud or oil, there is a hazard that you will slip and fall. Wipe off any mud or oil from the machine. Always keep the machine clean.
- If water gets into the electrical system, there is a hazard that it will cause malfunctions or misoperation. If there is any misoperation, there is danger that the machine may move unexpectedly and cause serious personal injury or death. When washing the machine with water or steam, do not allow the water or steam to come into direct contact with electrical components.

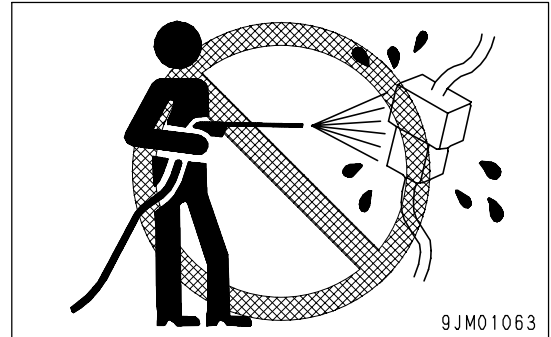
**PRECAUTIONS INSIDE OPERATOR'S COMPARTMENT**

- When entering the operator's compartment, always remove all mud and oil from the soles of your shoes. If you operate the pedal with mud or oil affixed to your shoes, your foot may slip and this may cause a serious accident.
- Do not leave tools or a machine parts lying around inside the operator's compartment. If tools or parts get into the control devices, it may obstruct operation and cause the machine to move unexpectedly, resulting in serious personal injury or death.
- Do not stick suction pads to the window glass. Suction pads act as a lens and may cause fire.
- Do not use a cell phone when driving or operating the machine. This may lead to mistakes in operation, which could cause serious personal injury or death.
- Never bring any dangerous objects such as flammable or explosive items into the operator's compartment.

**PROVIDE FIRE EXTINGUISHER AND FIRST AID KIT**

Always follow the precautions below to prepare for action if any injury or fire should occur.

- Be sure that fire extinguishers have been provided and read the labels to ensure that you know how to use them in emergencies.
- Carry out periodic inspection and maintenance to ensure that the fire extinguisher can always be used.
- Provide a first aid kit in the storage point. Carry out periodic checks and add to the contents if necessary.

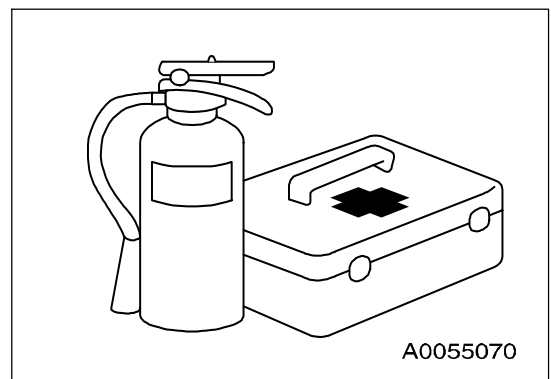
**IF ANY PROBLEM IS FOUND**

If you find any problems in the machine during operation or maintenance (noise, vibration, smell, incorrect gauges, smoke, oil leakage, etc., or any abnormal display on the warning devices or monitor), report to the person in charge and have the necessary action taken. Do not operate the machine until the problem has been corrected.



## FIRE PREVENTION

### ACTION IF FIRE OCCURS

- Turn the start switch OFF to stop the engine.
- Use the handrails and steps to get off the machine.
- Do not jump off the machine. There is the danger of falling and suffering serious injury.

### PRECAUTIONS TO PREVENT FIRE

#### • Fire caused by fuel, oil, antifreeze, or window washer fluid

Do not bring any flame or fire close to flammable substances such as fuel, oil, antifreeze, or window washer fluid. There is danger that they may catch fire. To prevent fire, always observe the following:

- Do not smoke or use any flame near fuel or other flammable substances.
- Stop the engine before adding fuel.
- Do not leave the machine when adding fuel or oil.
- Tighten all fuel and oil caps securely.
- Be careful not to spill fuel on overheated surfaces or on parts of the electrical system.
- After adding fuel or oil, wipe up any spilled fuel or oil.
- Put greasy rags and other flammable materials into a safe container to maintain safety at the workplace.
- When washing parts with oil, use a non-flammable oil. Do not use diesel oil or gasoline. There is danger that they may catch fire.
- Do not weld or use a cutting torch to cut any pipes or tubes that contain flammable liquids.
- Determine well-ventilated areas for storing oil and fuel. Keep the oil and fuel in the determined place and do not allow unauthorized persons to enter.
- When carrying out grinding or welding work on the machine, move any flammable materials to a safe place before starting.

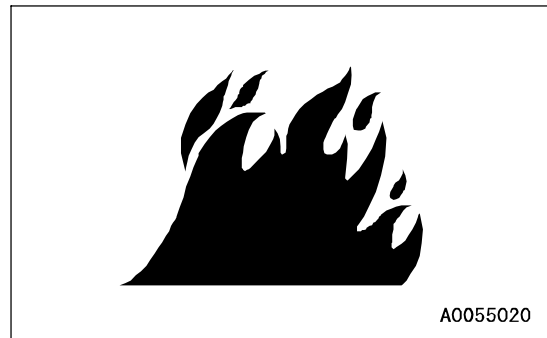

#### • Fire caused by accumulation of flammable material.

Remove any dry leaves, chips, pieces of paper, coal dust, or any other flammable materials accumulated or affixed around the engine, exhaust manifold, muffler, or battery, or inside the undercovers.

#### • Fire coming from electric wiring

Short circuits in the electrical system can cause fire. To prevent fire, always observe the following.

- Keep all electric wiring connections clean and securely tightened.
- Check the wiring every day for looseness or damage. Tighten any loose connectors or wiring clamps. Repair or replace any damaged wiring.

#### • Fire coming from piping

Check that all the hose and tube clamps, guards, and cushions are securely fixed in position.

If they are loose, they may vibrate during operation and rub against other parts. There is danger that this may lead to damage to the hoses and cause high-pressure oil to spurt out, leading to fire, serious personal injury or death.

- **Explosion caused by lighting equipment**
  - When checking fuel, oil, battery electrolyte, or coolant, always use lighting with anti-explosion specifications.
  - When taking the electrical power for the lighting from the machine itself, follow the instructions in this manual.

## PRECAUTIONS WHEN GETTING ON OR OFF MACHINE

### USE HANDRAILS AND STEPS WHEN GETTING ON OR OFF MACHINE

To prevent personal injury caused by slipping or falling off the machine, always do as follows.

- Use the parts marked by arrow A in the diagrams when getting on or off the machine.

Never use the parts marked by arrow B when getting on or off the machine. Use them only when moving along the top of the track or when checking or carrying out maintenance inside the side cover, or when filling the tank with oil.

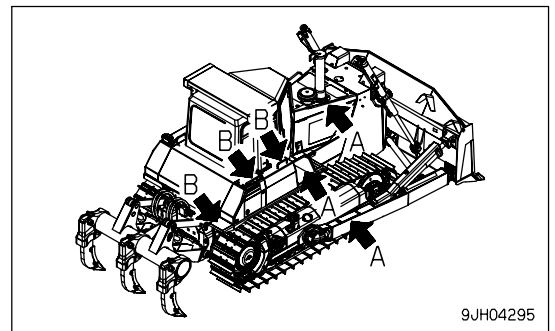
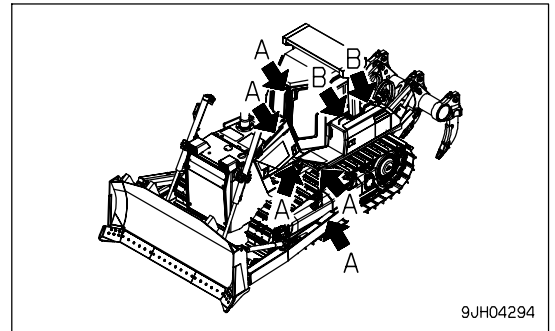

- Always face the machine and maintain at least three-point contact (both feet and one hand, or both hands and one foot) with the handrail and steps to ensure that you support yourself.

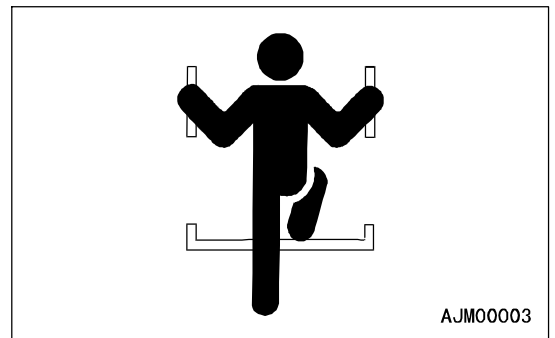

- Before getting on or off the machine, check the handrails and steps, and if there is any oil, grease, or mud on them, wipe it off immediately. In addition, repair any damage and tighten any loose bolts.
- Do not grip the control levers and work equipment lock lever when getting on or off the machine.
- Never climb on the engine hood or covers where there are no non-slip pads.
- Do not get on or off the machine while holding tools in your hand.

### NO JUMPING ON OR OFF MACHINE

- Never jump on or off the machine. Never get on or off a moving machine.
- If the machine starts to move when there is no operator on the machine, do not jump on to the machine and try to stop it.

**NO PEOPLE ON ATTACHMENTS**

Never let anyone ride on the work equipment or other attachments. There is a hazard of falling and suffering serious personal injury or death.

**PRECAUTIONS WHEN STANDING UP FROM OPERATOR'S SEAT**

When standing up from the operator's seat to adjust the operator's seat, always lower the work equipment completely to the ground, set work equipment lock lever (1) and parking brake lever (2) to the LOCK position (L), and stop the engine.

If the control lever is touched by accident, there is danger that the machine may suddenly move and cause serious personal injury.

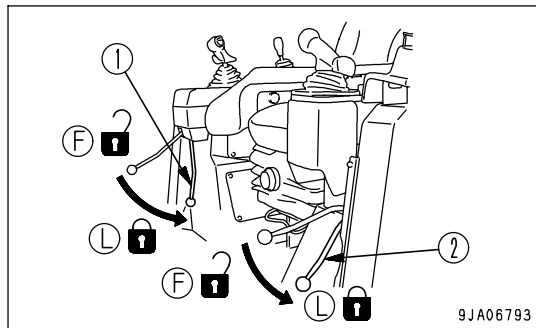

**PRECAUTIONS WHEN LEAVING MACHINE**

If the proper procedures are not taken when parking the machine, the machine may suddenly move off by itself, and this may lead to serious personal injury or death. Always do the following.

- When leaving the machine, always lower the work equipment completely to the ground, set work equipment lock lever (1) and parking brake lever (2) to the LOCK position (L), and stop the engine.

Always lock all parts, take the key with you and leave it in the specified place.

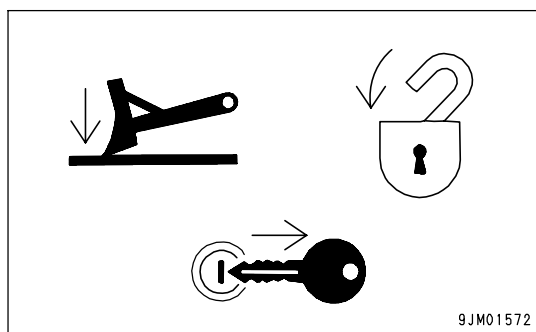
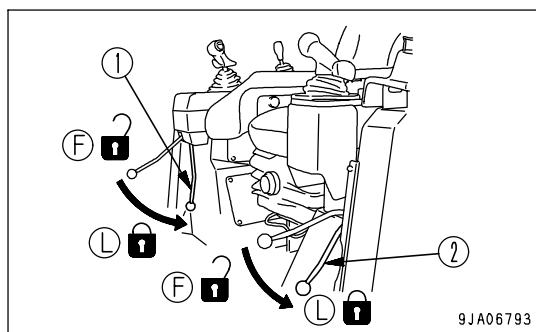

**EMERGENCY EXIT FROM OPERATOR'S CAB**

Machines equipped with a cab have doors on the left and right sides. If the door on the one side does not open, escape from the door on the other side.

**DO NOT GET CAUGHT IN WORK EQUIPMENT**

The clearance in the area around the work equipment changes according to the movement of the link. If you get caught, you may suffer serious personal injury or death. Do not allow anyone to come close to any rotating or extending/retracting portion.

## PRECAUTIONS RELATED TO PROTECTIVE STRUCTURES

The operator's compartment is equipped with a structure (ROPS, FOPS) to protect the operator by absorbing the impact energy. If the machine weight (mass) exceeds the certified value (shown on the ROLL-OVER PROTECTIVE STRUCTURE (ROPS) CERTIFICATION plate), ROPS will not be able to fulfill its function. Do not increase machine weight beyond the certified value by modifying the machine or by installing attachments to the machine. Also, if the function of the protective equipment is impeded, the protective equipment will not be able to protect the operator, and the operator may suffer injury or death. Always observe the following.

- If the machine is equipped with a protective structure, do not remove the protective structure and carry out operations without it.
- If the protective structure is welded, or holes are drilled in it, or it is modified in any other way, its strength may drop. Consult your Komatsu distributor before carrying out any modifications.
- If the protective structure is damaged or deformed by falling objects or by rolling over, its strength will be reduced and it will not be able to fulfill its function properly. In such cases, always contact your Komatsu distributor for advice on the method of repair.
- Even if the protective structure is installed, always fasten your seat belt properly when operating the machine. If you do not fasten your seatbelt properly, it cannot display its effect.

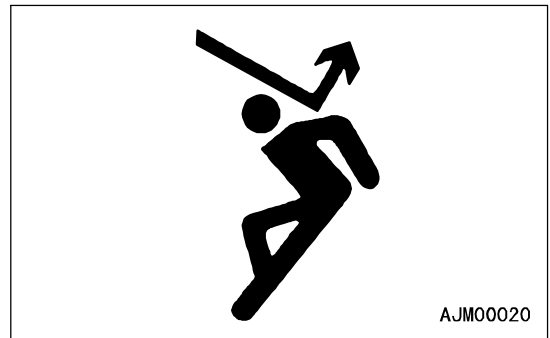

## UNAUTHORIZED MODIFICATION

- Komatsu will not be responsible for any injuries, accidents, product failures or other property damages resulting from modifications made without authorization from Komatsu.
- Any modification made without authorization from Komatsu can create hazards. Before making a modification, consult your Komatsu distributor.

## PRECAUTIONS RELATED TO ATTACHMENTS AND OPTIONS

- Any injuries, accidents, product failures or other property damages resulting from the use of unauthorized attachments or parts will not be the responsibility of Komatsu.
- When installing optional parts or attachments, there may be problems with safety or legal restrictions. Therefore contact your Komatsu distributor for advice.
- When installing and using optional attachments, read the instruction manual for the attachment, and the general information related to attachments in this manual.

## PRECAUTIONS WHEN RUNNING ENGINE INSIDE BUILDING

The engine exhaust gas contains substances that may damage your health or even cause death. Start or operate the engine in a place where there is good ventilation. If the engine or machine must be operated inside a building or under ground, where the ventilation is poor, take steps to ensure that the engine exhaust gas is removed and that ample fresh air is brought in.

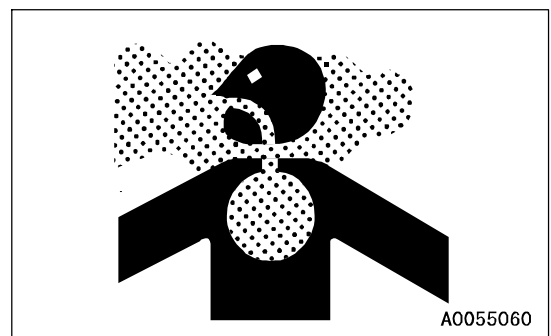

# PRECAUTIONS FOR OPERATION

## PRECAUTIONS FOR JOBSITE

### INVESTIGATE AND CONFIRM JOBSITE CONDITIONS

On the jobsite, there are various hidden dangers that may lead to personal injury or death. Before starting operations, always check the following to confirm that there is no danger on the jobsite.

- When carrying out operations near combustible materials such as thatched roofs, dry leaves or dry grass, there is a hazard of fire, so be careful when operating.
- Check the terrain and condition of the ground at the worksite, and determine the safest method of operation. Do not operate where there is a hazard of landslides or falling rocks.
- If water lines, gas lines, or high-voltage electrical lines may be buried under the worksite, contact each utility and identify their locations. Be careful not to sever or damage any of these lines.
- Take necessary measures to prevent any unauthorized person from entering the operating area.
- In particular, if you need to operate on a road, protect pedestrian and cars by designating a person for worksite traffic duty or by installing fences around the worksite.
- When traveling or operating in water or on soft ground, check the water depth, speed of the current, bedrock, and shape of the ground beforehand and avoid any place that will obstruct travel.

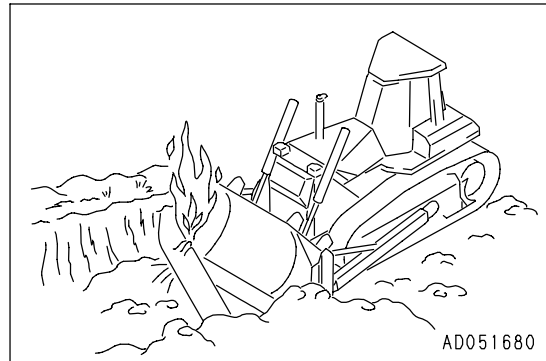

### WORKING ON LOOSE GROUND

- Avoid traveling or operating your machine too close to the edge of cliffs, overhangs, and deep ditches. The ground may be weak in such areas. If the ground should collapse under the weight or vibration of the machine, there is a hazard that the machine may fall or tip over. Remember that the soil after heavy rain or blasting or after earthquakes is weak in these areas.
- When working on embankments or near excavated ditches, there is a hazard that the weight and vibration of the machine will cause the soil to collapse. Before starting operations, take steps to ensure that the ground is safe and to prevent the machine from rolling over or falling.

**DO NOT GO CLOSE TO HIGH-VOLTAGE CABLES**

Do not travel or operate the machine near electric cables. There is a hazard of electric shock, which may cause serious personal injury or death. On jobsites where the machine may go close to electric cables, always do as follows.

- Before starting work near electric cables, inform the local power company of the work to be performed, and ask them to take the necessary action.
- Even going close to high-voltage cables can cause electric shock, which may cause serious burns or even death. Always maintain a safe distance (see the table on the right) between the machine and the electric cable. Check with the local power company about safe operating procedure before starting operations.
- To prepare for any possible emergencies, wear rubber shoes and gloves. Lay a rubber sheet on top of the seat, and be careful not to touch the chassis with any exposed part of your body.
- Use a signalman to give warning if the machine approaches too close to the electric cables.
- When carrying out operations near high voltage cables, do not let anyone near the machine.
- If the machine should come too close or touch the electric cable, to prevent electric shock, the operator should not leave the operator’s compartment until it has been confirmed that the electricity has been shut off.  
Also, do not let anyone near the machine.

Voltage of Cables	Safety Distance
100V - 200V	Over 2 m (7 ft)
6,600V	Over 2 m (7 ft)
22,000V	Over 3 m (10 ft)
66,000V	Over 4 m (14 ft)
154,000V	Over 5 m (17 ft)
187,000V	Over 6 m (20 ft)
275,000V	Over 7 m (23 ft)
500,000V	Over 11 m (36 ft)

**ENSURE GOOD VISIBILITY**

This machine is equipped with mirrors to ensure good visibility, but even then there are places that cannot be seen from the operator’s seat, so be careful when operating.

When traveling or carrying out operations in places with poor visibility, it is impossible to check for obstacles in the area around the machine and to check the condition of the jobsite. This leads to danger of serious personal injury or death. When traveling or carrying out operations in places with poor visibility, always observe the following.

- Position a signalman if there are areas where the visibility is not good.
- Only one signalman should give signals.
- When working in dark places, turn on the working lamp and front lamps installed to the machine, and set up additional lighting in the work area if necessary.
- Stop operations if the visibility is poor, such as in mist, snow, rain, or dust.
- When checking the mirrors installed to the machine, remove all dirt and adjust the angle of the mirror to ensure good visibility.

**CHECKING SIGNS AND SIGNALMAN'S SIGNALS**

- Set up signs to inform of road shoulders and soft ground. If the visibility is not good, position a signalman if necessary. Operators should pay careful attention to the signs and follow the instructions from the signalman.
- Only one signalman should give signals.
- Make sure that all workers understand the meaning of all signals and signs before starting work.

**BEWARE OF ASBESTOS DUST**

Asbestos dust in the air can cause lung cancer if it is inhaled. There is danger of inhaling asbestos when working on jobsites handling demolition work or work handling industrial waste. Always observe the following.

- Spray water to keep down the dust.
- Do not use compressed air.
- If there is danger that there may be asbestos dust in the air, always operate the machine from an upwind position, and make sure that all workers operate on the upwind side.
- All workers should use anti-dust masks.
- Do not allow other persons to approach during the operation.
- Always observe the rules and regulations for the work site and environmental standards.

This machine does not use asbestos, but there is a danger that imitation parts may contain asbestos, so always use genuine Komatsu parts.

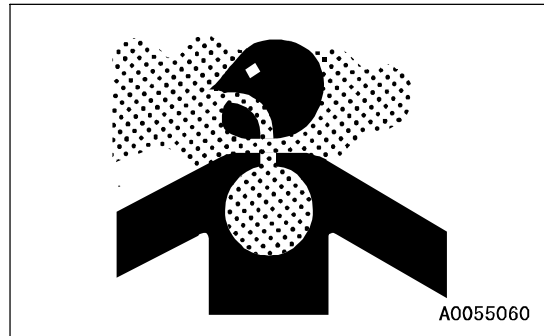

## STARTING ENGINE

### USE WARNING TAGS

If there is any "DANGER! Do NOT operate!" warning tag displayed, it means that someone is carrying out inspection and maintenance of the machine. If the warning sign is ignored and the machine is operated, there is danger that the person carrying out inspection or maintenance may be caught in the rotating parts or moving parts and suffer serious personal injury or death. Do not start the engine or touch the levers.

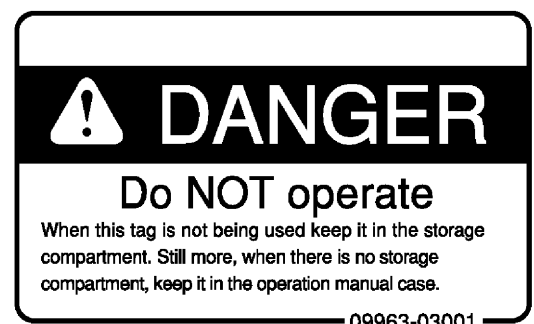
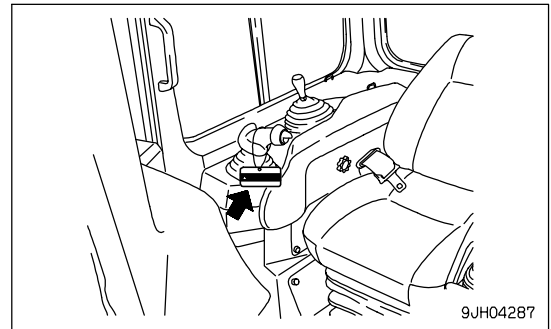

### CHECKS BEFORE STARTING ENGINE

Carry out the following checks before starting the engine at the beginning of the day's work to ensure that there is no problem with the operation of the machine. If this inspection is not carried out properly problems may occur with the operation of the machine, and there is danger that this may lead to serious personal injury or death.

- Remove all dirt from the surface of the window glass to ensure a good view.
  - Be sure to carry out "WALK-AROUND CHECK (PAGE 3-74)".
  - Remove all dirt from the surface of the lens of the front lamps and working lamps, and check that they light up correctly.
  - Check the coolant level, fuel level, and oil level in engine oil pan, check for clogging of the air cleaner, and check for damage to the electric wiring.
  - Check that there is no mud or dust accumulated around the movable parts of any pedals, and check that the pedals work properly.
  - Adjust the operator's seat to a position where it is easy to carry out operations, and check that there is no damage or wear to the seat belt or mounting clamps.
  - Check that the gauges work properly, check the angle of the mirror, and check that the control levers are all at the Neutral position.
  - Before starting the engine, check that work equipment lock lever (1) and parking brake lever (2) are in LOCK position (L).
  - Adjust the mirror so that the rear of the machine can be seen easily from the operator's seat.
- For details of the adjustment procedure, see "ADJUST MIRROR (PAGE 3-89)".
- Check that there are no persons or obstacles above, below, or in the area around the machine.

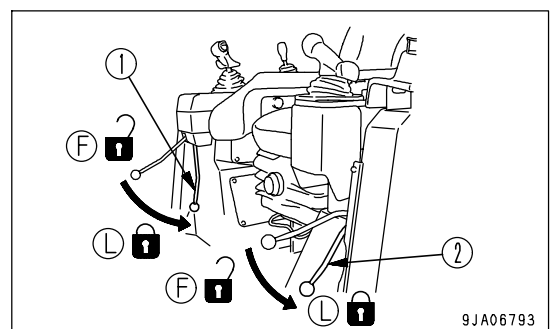



**PRECAUTIONS WHEN STARTING**

- Start and operate the machine only while seated.
- When starting the engine, sound the horn as a warning.
- Do not allow anyone apart from the operator to ride on the machine.
- Do not attempt to start the engine by short-circuiting the engine starting circuit. This may cause fire, serious personal injury or death.

**PRECAUTIONS IN COLD AREAS**

- Carry out the warming-up operation thoroughly. If the machine is not thoroughly warmed up before the control levers are operated, the reaction of the machine will be slow, and this may lead to unexpected accidents.
- If the battery electrolyte is frozen, do not charge the battery or start the engine with a different power source. There is a hazard that this will ignite the battery and cause the battery to explode. Before charging or starting the engine with a different power source, melt the battery electrolyte and check that there is no leakage of electrolyte before starting.

**STARTING WITH BOOSTER CABLES**

If any mistake is made in the method of connecting the booster cables, it may cause the battery to explode, so always do as follows.

- Always wear safety goggles and rubber gloves when starting the engine with booster cable.
- When connecting a normal machine to a problem machine with booster cables, always use a normal machine with the same battery voltage as the problem machine.
- When starting with a booster cable, carry out the starting operation with two workers (one worker sitting in the operator’s seat and the other working with the battery).
- When starting from another machine, do not allow the two machines to touch.
- When connecting the booster cables, turn the starting switch to the OFF position for both the normal machine and problem machine. There is a hazard that the machine will move when the power is connected.
- Be sure to connect the positive (+) cable first when installing the booster cables. Disconnect the negative (-) cable (ground side) first when removing them.
- When removing the booster cables, be careful not to let the booster cable clips touch each other or to let the clips touch the machine.
- For details of the starting procedure when using booster cables, see "STARTING ENGINE WITH BOOSTER CABLE (PAGE 3-145)" in the OPERATION section.

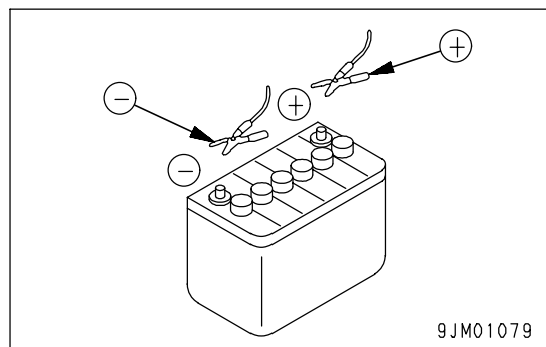
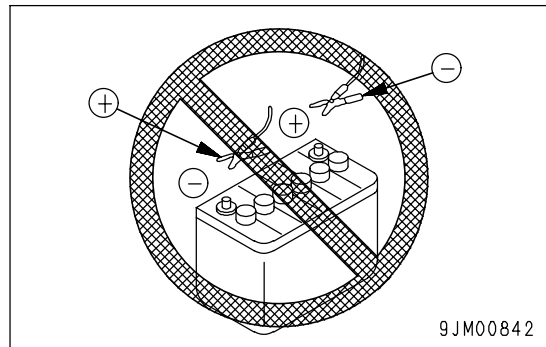

## OPERATION

### CHECKS BEFORE OPERATION

If the checks before starting are not carried out properly, the machine will be unable to display its full performance, and there is also danger that it may lead to serious personal injury or death.

When carrying out the checks, move the machine to a wide area where there are no obstructions, and pay careful attention to the surrounding area. Do not allow anyone near the machine.

- Always wear the seatbelt. There is danger that you may be thrown out of the operator's seat and suffer serious injury when the brakes are applied suddenly.
- Check the operation of travel, steering and brake systems, and work equipment control system.
- Check for any problem in the sound of the machine, vibration, heat, smell, or gauges; check also that there is no leakage of oil or fuel.
- If any problem is found, carry out repairs immediately.

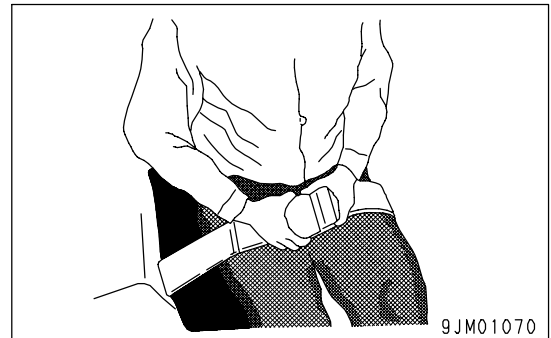

### PRECAUTIONS WHEN TRAVELING IN FORWARD OR REVERSE

- Lock the cab door and windows securely, both when they are open and when they are closed.
- Do not allow anyone apart from the operator to ride on the machine.
- If there are any persons in the area around the machine, there is danger that they may be hit or caught by the machine, and this may lead to serious personal injury or death. Always observe the following before traveling.
  - Always operate the machine only when seated.
  - Before moving off, check again that there is no person or obstruction in the surrounding area.
  - Before moving, sound the horn to warn people in the surrounding area.
  - Check that the backup alarm (alarm buzzer when machine travels in reverse) works properly.
  - If there is an area to the rear of the machine which cannot be seen, position a signalman.

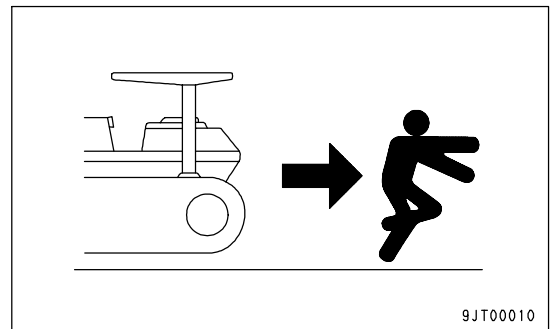

Always be sure to carry out the above precautions even when the machine is equipped with mirrors.

**PRECAUTIONS WHEN TRAVELING**

- Never turn the starting switch key to the OFF position when the machine is traveling. If the engine stops when the machine is traveling, it may become impossible to operate the steering, and this may cause serious personal injury or death. If the engine stops, depress the brake pedal immediately to stop the machine.
- When traveling or carrying out operations, always keep a safe distance from people, structures, or other machines to avoid coming into contact with them.
- When traveling the machine on a flat land, hold the work equipment at height (A) of 40 cm to 50 cm (16 in to 20 in) above the ground. If that height is not maintained between the work equipment and the ground, the work equipment may get stuck in the ground and tip over.

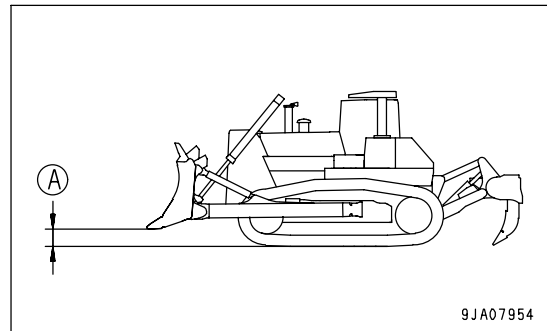

- Avoid traveling over obstacles when possible. If the machine has to travel over an obstacle, keep the work equipment close to the ground and travel at low speed. There is more danger of the machine tipping over to the left or right than tipping over to the front or rear, so do not travel over obstacles which make the machine tilt strongly to the left or right sides.
- When traveling on rough ground, travel at low speed and do not operate the steering suddenly. There is danger that the machine may turn over. The work equipment may hit the ground surface and cause the machine to lose its balance, or may damage the machine or structures in the area.
- When using the machine, to prevent personal injury caused by damage to the work equipment or by the machine overturning due to overloading, do not exceed the permitted performance of the machine or the maximum permitted load for the structure of the machine.
- When passing over bridges or structures, check first that the structure is strong enough to support the weight of the machine.
- When operating in tunnels, under bridges, under electric wires, or other places where the height is limited, operate slowly and be extremely careful not to let the machine body or work equipment hit anything.

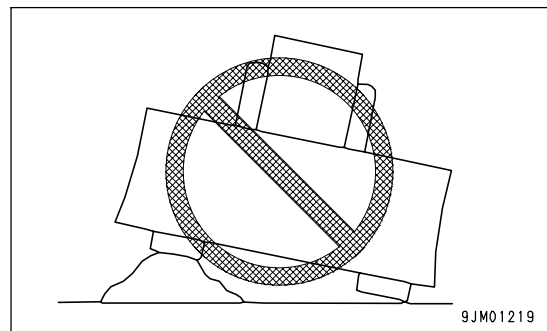

### TRAVELING ON SLOPES

To prevent the machine from tipping over or slipping to the side, always do as follows.

- Keep the work equipment approx. 20 to 30 cm (8 to 12 in) above the ground. In case of emergency, lower the work equipment to the ground immediately to help stop the machine.
- Always travel straight up or down a slope. Traveling at an angle or across the slope is extremely dangerous.
- Do not turn on slopes or travel across slopes. Always go down to a flat place to change the position of the machine, then travel on to the slope again.
- Travel on grass, fallen leaves, or wet steel plates with low speed. Even with slight slopes there is a hazard that the machine may slip.
- When traveling downhill, never shift gear or place the transmission at neutral. It is dangerous not to use the braking force of the engine. Always place the transmission in a low gear before starting to travel downhill.
- Depress the brake or use the braking effect of the engine as necessary.

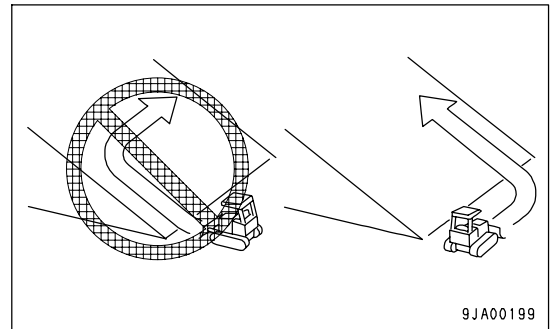

### PRECAUTIONS WHEN OPERATING

- When using the machine, to prevent personal injury caused by damage to the work equipment or by the machine overturning due to overloading, do not exceed the permitted performance of the machine or the maximum permitted load for the structure of the machine.
- Be careful not to approach too close to the edge of cliffs. When making embankments or landfills, or when dropping soil over a cliff, dump one pile, then use the next pile of soil to push the first pile.
- The load suddenly becomes lighter when the soil is pushed over a cliff or when the machine reaches the top of a slope. When this happens, there is danger that the travel speed will suddenly increase, so be sure to reduce the speed.
- If the machine moves with only either side of the blade loaded, its tail may swing. Take care.

### METHOD OF USING BRAKES

- When the machine is traveling, do not rest your foot on the brake pedal. If you travel with your foot resting on the pedal, the brake will always be applied, and this will cause the brakes to overheat and fail.
- Do not depress the brake pedal repeatedly if not necessary.
- When traveling downhill, use the braking force of the engine.

**TRAVELING ON SNOW-COVERED OR FROZEN SURFACES**

- Snow-covered or frozen surfaces are slippery, so be extremely careful when traveling or operating the machine, and do not operate the levers suddenly. Even a slight slope may cause the machine to slip, so be particularly careful when working on slopes.
- With frozen ground surfaces, the ground becomes soft when the temperature rises, and this may cause the machine to tip over or make it impossible for the machine to escape.
- If the machine enters deep snow, there is a hazard that it may tip over or become buried in the snow. Be careful not to leave the road shoulder or to get trapped in a snow drift.
- When clearing snow, the road shoulder and objects placed beside the road are buried in the snow and cannot be seen. There is a hazard of the machine tipping over or hitting covered objects, so always carry out operations carefully.
- When traveling on snow-covered slopes, never apply the foot brake suddenly. Reduce the speed and use the engine as a brake while applying the foot brake intermittently (depress the brake intermittently several times). If necessary, lower the work equipment to the ground to stop the machine.

**PARKING MACHINE**

- Park the machine on firm, level ground.
- Select a place where there is no hazard of landslides, falling rocks, or flooding.
- Lower the work equipment completely to the ground.
- When leaving the machine, set work equipment lock lever (1) to the LOCK position and parking brake lever (2) to the LOCK position (L), and stop the engine.
- Always close the operator's cab door, and use the key to lock all the equipment in order to prevent any unauthorized person from moving the machine. Always remove the key, take it with you, and leave it in the specified place.

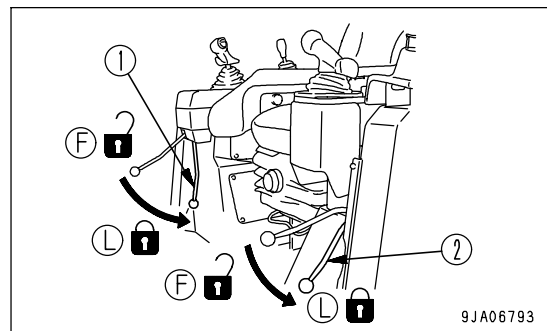

- If it is necessary to park the machine on a slope, always do as follows.
  - Set the work equipment on the downhill side and dig it into the ground.
  - In addition, put blocks under the tracks to prevent the machine from moving.

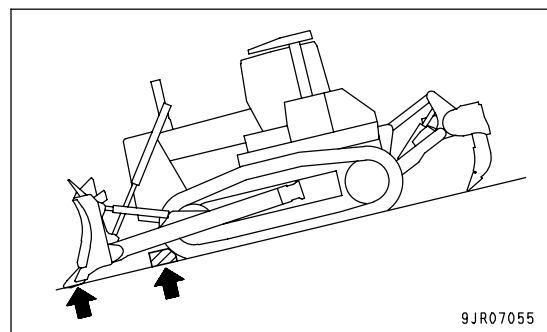

## TRANSPORTATION

When the machine is transported on a trailer, there is danger of serious personal injury or death during transportation. Always do as follows.

- Always check the machine dimensions carefully. Depending on the work equipment installed, the machine weight, transportation height, and overall length may differ.
- Check beforehand that all bridges and other structures on the transportation route are strong enough to withstand the combined weight of the transporter and the machine being transported.
- The machine can be divided into parts for transportation, so when transporting the machine, please contact your Komatsu distributor to have the work carried out.

## LOADING AND UNLOADING

When loading or unloading the machine, mistaken operation may bring the hazard of the machine tipping over or falling, so particular care is necessary. Always do as follows.

- Perform loading and unloading on firm, level ground only. Maintain a safe distance from the edge of the road or cliff.
  - Always use ramps of adequate strength. Be sure that the ramps are wide, long, and thick enough to provide a safe loading slope. Take suitable steps to prevent the ramps from moving out of position or coming off.
  - Be sure the ramp surface is clean and free of grease, oil, ice and loose materials. Remove dirt from machine-tracks. On a rainy day, in particular, be extremely careful since the ramp surface is slippery.
  - Run the engine at low idling and drive the machine slowly at low speed.
  - When on the ramps, do not operate any lever except for the travel lever.
  - Never correct your steering on the ramps. If necessary, drive off the ramps, correct the direction, then enter the ramps again.
  - The center of gravity of the machine will change suddenly at the joint between the ramps and the track or trailer, and there is danger of the machine losing its balance. Travel slowly over this point.
  - When loading or unloading to an embankment or platform, make sure that it has suitable width, strength, and grade.
  - For machines equipped with a cab, always lock the door after boarding the machine. If this is not done, the door may suddenly open during transportation.
- Refer to "TRANSPORTATION (PAGE 3-129)".

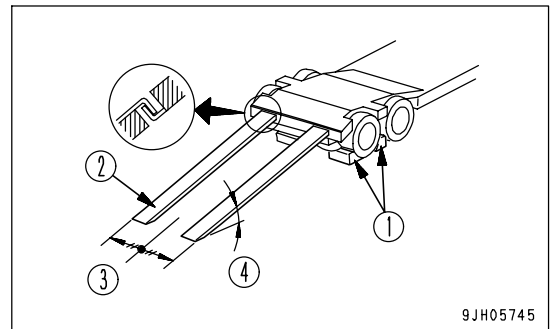

- (1) Blocks
- (2) Ramp
- (3) Centerline of trailer
- (4) Angle of ramps: Max. 15°

## TOWING

### PRECAUTIONS WHEN TOWING

Always use the correct towing equipment and towing method. Any mistake in the selection of the wire rope or towing bar or in the method of towing a disabled machine may lead to serious personal injury or death.

For details of the procedure for towing, see the "METHOD OF TOWING MACHINE (PAGE 3-141)"

- Always confirm that the wire rope or drawbar used for towing has ample strength for the weight of the machine being towed.
- Never use a wire rope which has cut strands (A), reduced diameter (B), or kinks (C). There is danger that the rope may break during the towing operation.
- Always wear leather gloves when handling wire rope.
- Never tow a machine on a slope.
- During the towing operation, never stand between the towing machine and the machine being towed.

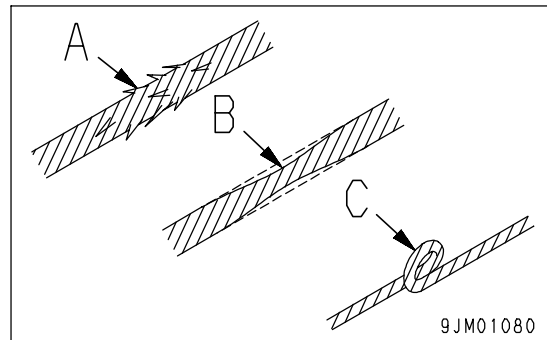

## PRECAUTIONS FOR MAINTENANCE

### PRECAUTIONS BEFORE STARTING INSPECTION AND MAINTENANCE

#### DISPLAY WARNING TAG DURING INSPECTION AND MAINTENANCE

Always display the "DANGER! Do NOT operate" warning tag during the inspection and maintenance. If there is any "DANGER! Do NOT operate!" warning tag displayed, it means that someone is carrying out inspection and maintenance of the machine. If the warning sign is ignored and the machine is operated, there is danger that the person carrying out inspection or maintenance may be caught in the rotating parts or moving parts and suffer serious personal injury or death. Do not start the engine or touch the levers.

- If necessary, put up signs around the machine also.  
Warning tag part number: 09963-03001  
When not using this warning tag, keep it in the toolbox.  
If there is no toolbox, keep it in the pocket for the Operation and Maintenance Manual

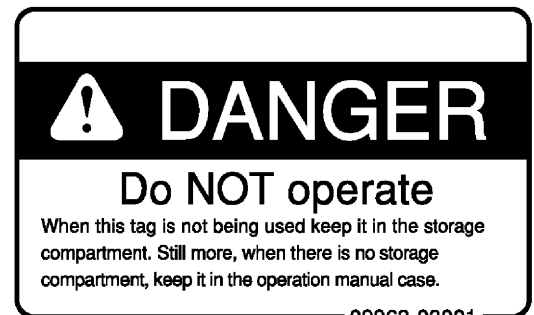
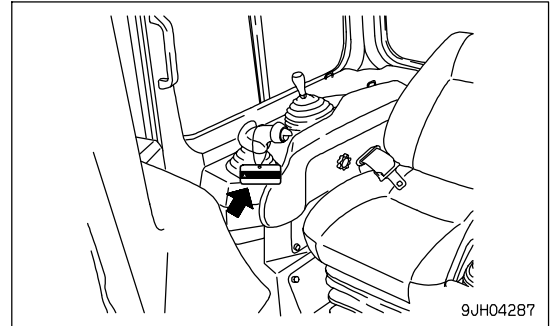

#### KEEP WORKPLACE CLEAN AND TIDY

Do not leave hammers or other tools lying around in the work place. Wipe up all grease, oil, or other substances that will cause you to slip. Always keep the work place clean and tidy to enable you to carry out operations safely. If the work place is not kept clean and tidy, there is the danger that you will trip, slip, or fall over and injure yourself.

#### SELECT SUITABLE PLACE FOR INSPECTION AND MAINTENANCE

- Stop the machine on firm, level ground.
- Select a place where there is no hazard of landslides, falling rocks, or flooding.

#### ONLY AUTHORIZED PERSONNEL

Do not allow any unauthorized personnel into the area when servicing the machine. If necessary, employ a guard.

#### APPOINT LEADER WHEN WORKING WITH OTHERS

When repairing the machine or when removing and installing the work equipment, appoint a leader and follow his instructions during the operation.



**STOP ENGINE BEFORE CARRYING OUT INSPECTION AND MAINTENANCE**

- Lower the work equipment completely to the ground and stop the engine before performing any inspection and maintenance.

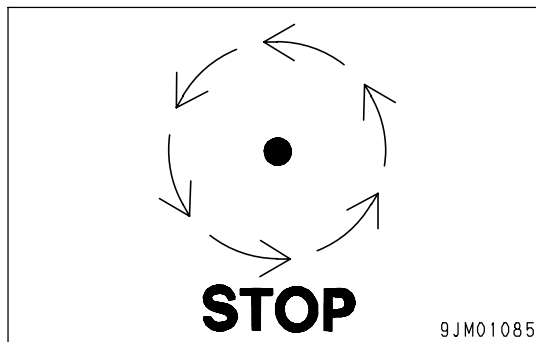

- Turn the starting switch to the ON position, operate the work equipment control lever to the RAISE and LOWER position 2 or 3 times repeatedly to release the remaining pressure in the hydraulic circuit, then set parking brake lever (1) and work equipment lock lever (2) to the LOCK position (L).

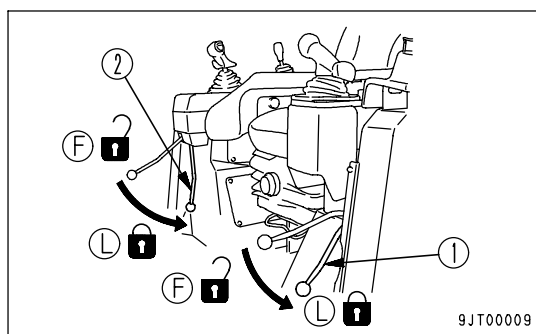

- Put blocks under the track to prevent the machine from moving.

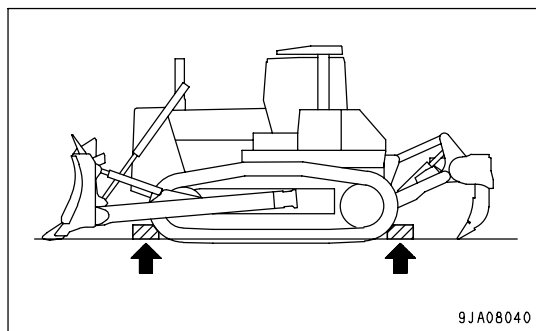

**TWO WORKERS FOR MAINTENANCE WHEN ENGINE IS RUNNING**

To prevent personal injury, do not carry out maintenance with the engine running. If maintenance must be carried out with the engine running, carry out the operation with at least two workers and do as follows.

- One worker must always sit in the operator's seat and be ready to stop the engine at any time. All workers must maintain contact with the other workers.
- When carrying out operations near the fan, fan belt, or other rotating parts, there is a hazard of being caught in the parts, so be careful not to come close.
- Never drop or insert tools or other objects into the fan, fan belt, or other rotating parts. There is danger that they may contact the rotating parts and break or be sent flying.

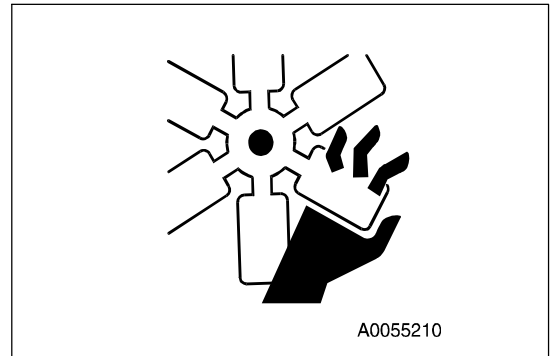

- Set work equipment lock lever (1) and parking brake lever (2) to the LOCK position (L) to prevent the work equipment from moving.
- Do not touch any control levers. If any control lever must be operated, give a signal to the other workers to warn them to move to a safe place.

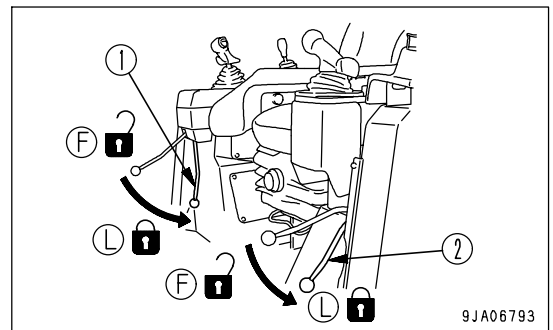
**INSTALLING, REMOVING, OR STORING ATTACHMENTS**

- Appoint a leader before starting removal or installation operations for attachments.
- Place attachments that have been removed from the machine in a stable condition so that they do not fall. And take steps to prevent unauthorized persons from entering the storage area.

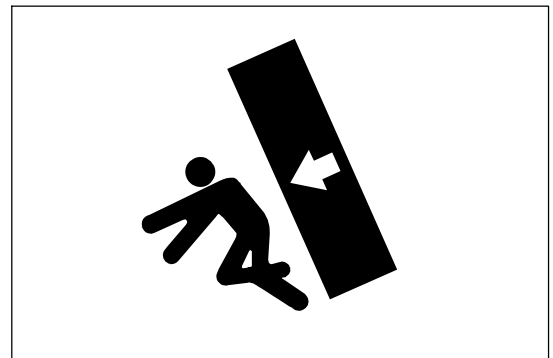
**PRECAUTIONS WHEN WORKING AT HIGH PLACES**

When working at high places, use a step ladder or other stand to ensure that the work can be carried out safely.

**PRECAUTIONS WHEN WORKING UNDER MACHINE OR WORK EQUIPMENT**

- Make sure the hoists or jacks you use are in good repair and strong enough to handle the weight of the component. Never use jacks at places where the machine is damaged, bent, or twisted. Never use frayed, twisted or pinched wire rope. Never use bent or distorted hooks.
- It is extremely dangerous to work under the machine if the track shoes are lifted off the ground and the machine is supported only with the work equipment. If any of the control levers is touched by accident, or there is damage occurring to the hydraulic piping, the work equipment or the machine will suddenly drop. This is extremely dangerous. Never work under the work equipment or the machine.
- If it is necessary to raise the work equipment or the machine and then go under it to carry out inspection or maintenance, support the work equipment and machine securely with blocks and stands strong enough to support the weight of the work equipment and machine.  
If the work equipment and machine are not supported, there is a hazard that they may come down and that this may lead to serious personal injury or death.
- Never use concrete blocks for supports. They can collapse under even light loads.

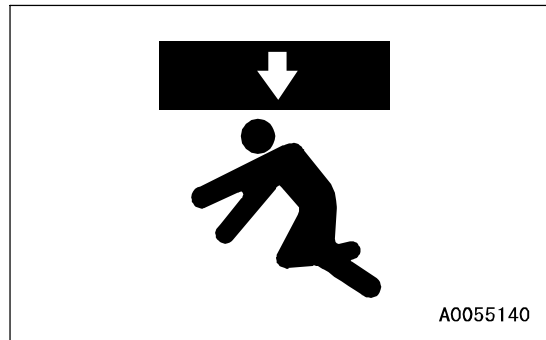

**PROPER TOOLS**

Use only tools suited to the task and be sure to use the tools correctly. Using damaged, deformed, or low quality tools, or making improper use of the tools may cause serious personal injury.

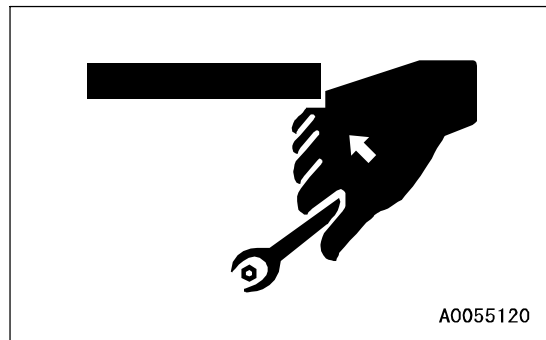

## PRECAUTIONS FOR INSPECTION AND MAINTENANCE

### PRECAUTIONS WHEN WELDING

Welding operations must always be carried out by a qualified welder and in a place equipped with proper equipment. There is a hazard of gas, fire, or electrocution when carrying out welding, so never allow any unqualified personnel to carry out welding.

### HANDLING BATTERY

Before inspecting or handling the battery, turn the key in the starting switch to the OFF position.

- **Danger of battery exploding**

When the battery is being charged, flammable hydrogen gas is generated and may explode. In addition, the battery electrolyte includes dilute sulphuric acid. Any mistake in handling may cause serious personal injury, explosion, or fire, so always observe the following.

- Do not use or charge the battery if the battery electrolyte is below the LOWER LEVEL mark. This will cause explosion. Always carry out periodic inspection of the battery electrolyte level, and add distilled water (or commercially available battery filler solution) to the UPPER LEVEL mark.
- Do not smoke or bring any flame close to the battery.
- Hydrogen gas is generated when the battery is being charged, so remove the battery from the machine, take it to a well-ventilated place, remove the battery caps, then carry out the charging.
- After charging, tighten the battery caps securely.

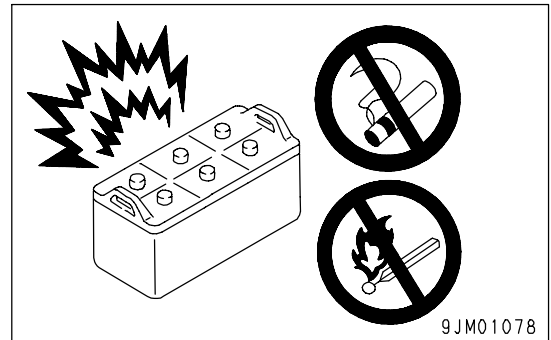

- **Danger from dilute sulphuric acid**

When the battery is being charged, flammable hydrogen gas is generated and may explode. In addition, the battery electrolyte includes dilute sulphuric acid. Any mistake in handling may cause serious personal injury, explosion, or fire, so always observe the following.

- When handling the battery, always wear protective goggles and rubber gloves.
- If battery electrolyte gets into your eyes, immediately wash your eyes with large amounts of fresh water. After that, get medical attention immediately.
- If battery electrolyte gets on your clothes or skin, wash it off immediately with large amounts of water.

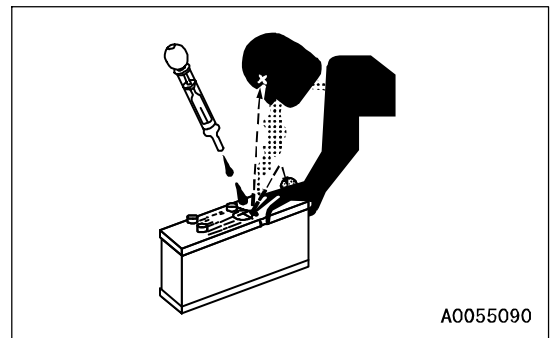

- **Removing battery cables**

Before repairing the electrical system or carrying out electric welding, turn the starting switch OFF. Wait for approx. 1 minute, then remove the negative (-) battery cable to stop the flow of electricity.

**• Danger of sparks**

There is hazard that sparks will be generated, so always observe the following.

- Do not let tools or other metal objects make any contact between the battery cables. Do not leave tools lying around near the battery.
- When removing the battery cables, remove the ground cable (negative (-) cable) first. When installing, connect the positive (+) cable first, then connect the ground. Tighten the battery cable terminals securely.
- Secure the battery firmly in the specified position.

**PRECAUTIONS WHEN USING HAMMER**

When using a hammer, pins may fly out or metal particles may be scattered. This may lead to serious personal injury or death. Always do as follows.

- When hitting pins or bucket teeth, there is a hazard that broken pieces might be sent flying and injure people in the surrounding area. Always check that there is no one in the surrounding area.
- If hard metal parts such as pins, bucket teeth, cutting edges, or bearings are hit with a hammer, there is a hazard that pieces might be scattered and cause serious personal injury or death. Always wear safety glasses and gloves.
- If the pin is hit with strong force, there is a hazard that it may fly out and injure people in the surrounding area. Do not allow anyone to enter the surrounding area.

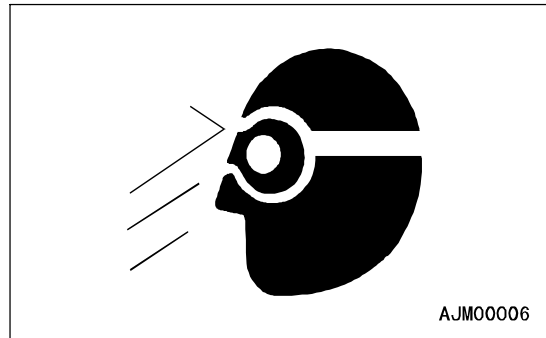

**PRECAUTIONS WITH HIGH-TEMPERATURE COOLANT**

To prevent burns from boiling water or steam spurting out when checking or draining the coolant, wait for the coolant to cool down to a temperature where the radiator cap can be touched by hand. Then loosen the cap slowly to release the pressure inside the radiator, and remove the cap.

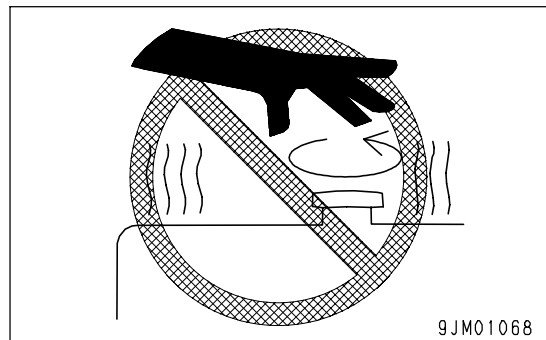

**PRECAUTIONS WITH HIGH-TEMPERATURE OIL**

To prevent burns from hot oil spurting out or from touching high-temperature parts when checking or draining the oil, wait for the oil to cool down to a temperature where the cap or plug can be touched by hand. Then loosen the cap or plug slowly to release the internal pressure and remove the cap or plug.

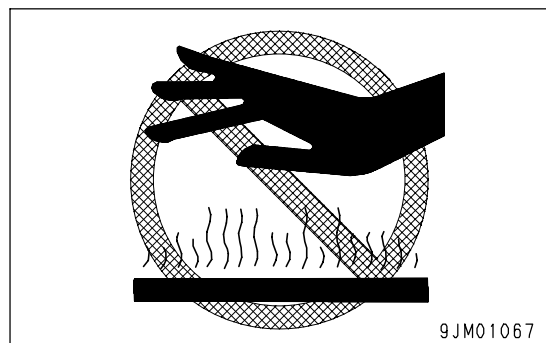

**PRECAUTIONS WITH HIGH-PRESSURE OIL**

The hydraulic system is always under internal pressure. In addition, the fuel piping is also under internal pressure when the engine is running and immediately after the engine is stopped. When carrying out inspection or replacement of the piping or hoses, check that the internal pressure in the circuit has been released. If this is not done, it may lead to serious personal injury or death. Always do as follows.

- Do not carry out inspection or replacement operations when the system is still under pressure.  
For details of the procedure for releasing the pressure, see "PROCEDURE FOR BLEEDING AIR IN HYDRAULIC SYSTEM (PAGE 4-45)".
- If there is any leakage from the piping or hoses, the surrounding area will be wet, so check for cracks in the piping and hoses and for swelling in the hoses.

When carry out inspection, wear safety glasses and leather gloves.

- There is a hazard that high-pressure oil leaking from small holes may penetrate your skin or cause loss of sight if it contacts your skin or eyes directly. If you are hit by a jet of high-pressure oil and suffer injury to your skin or eyes, wash the place with clean water, and consult a doctor immediately for medical attention.

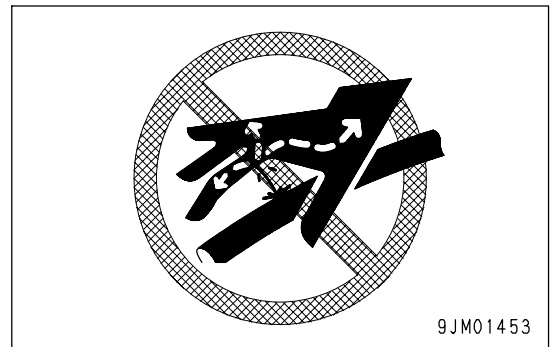
**PRECAUTIONS WITH HIGH-PRESSURE FUEL**

When the engine is running, high-pressure is generated in the engine fuel piping. When carrying out inspection or maintenance of the fuel piping system, stop the engine and wait for at least 30 seconds to allow the internal pressure to go down before starting the operation.

**HANDLING HIGH-PRESSURE HOSES AND PIPING**

- If oil or fuel leaks from high-pressure hoses or piping, it may cause fire or misoperation, and lead to serious personal injury, or death. If the hose or piping mounts are loose or oil or fuel is found to be leaking from the mount, stop operations and tighten to the specified torque.

If any damaged or deformed hoses or piping are found, please consult your Komatsu distributor.

Replace the hose if any of the following problems are found.

- Damaged hose or deformed hydraulic fitting.
- Frayed or cut covering or exposed reinforcement wire layer.
- Covering swollen in places.
- Twisted or crushed movable portion.
- Foreign material embedded in covering.

**NOISE**

When carrying out maintenance of the engine and you are exposed to noise for long periods of time, wear ear covers or ear plugs while working.

If the noise from the machine is too loud, it may cause temporary or permanent hearing problems.

**PRECAUTIONS WITH HIGH-PRESSURE GREASE WHEN ADJUSTING TRACK TENSION**

- Grease is pumped into the track tension adjustment system under high pressure.  
If the specified procedure for maintenance is not followed when making adjustment, grease drain plug (1) may fly out and cause serious injury or property damage.
- When loosening grease drain plug (1) to loosen the track tension, never loosen it more than one turn. Loosen the grease drain plug slowly.
- Never put your face, hands, feet, or any other part of your body close to grease drain plug (1).

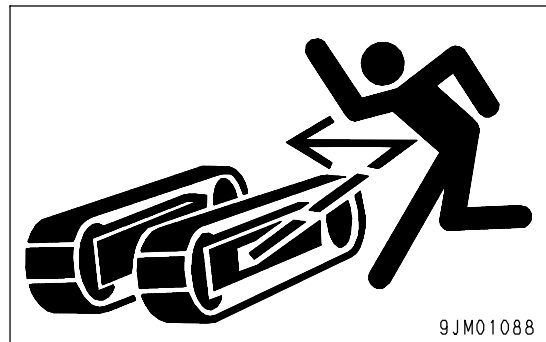
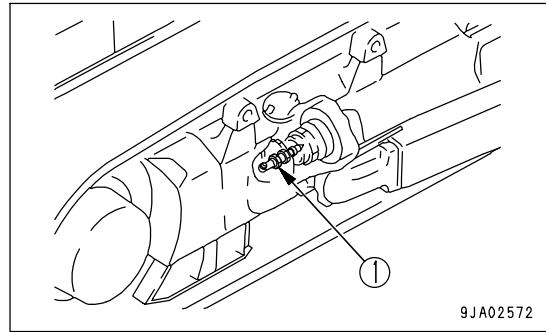

**DO NOT DISASSEMBLE RECOIL SPRING**

Never disassemble the recoil spring assembly. The recoil spring assembly has a powerful spring that acts to reduce the impact on the idler. If it is disassembled by mistake, the spring may shoot out and cause serious personal injury or death.

It is necessary to disassemble the recoil spring assembly, always ask your Komatsu distributor to carry out the operation.

**HANDLING ACCUMULATOR AND GAS SPRING**

This machine is equipped with an accumulator. Even after the engine stops, if the work equipment control lever is operated soon after stop of the engine in the direction to lower the work equipment, the work equipment goes down under its own weight.

After stopping the engine, set the parking brake lever and the work equipment lock lever to the LOCK position. The accumulator and gas spring are charged with high-pressure nitrogen gas. If the accumulator is handled mistakenly, it may cause an explosion that could lead to serious personal injury or death. For this reason, always observe the following precautions.

- Do not disassemble the accumulator.
- Do not bring it near flame or dispose of it in fire.
- Do not make holes in it, weld it, or use a cutting torch.
- Do not hit or roll the accumulator, or subject it to any impact.
- When disposing of the accumulator, the gas must be released. Please contact your Komatsu distributor to have this work performed.



**PRECAUTIONS WITH COMPRESSED AIR**

- When carrying out cleaning with compressed air, there is a hazard of serious personal injury caused by flying dust or particles.
- When using compressed air to clean the filter element or radiator, wear safety glasses, anti-dust mask, gloves, and other protective equipment.

**MAINTENANCE OF AIR CONDITIONER**

- If air conditioner refrigerant gets into your eyes, it may cause loss of sight; if it contacts your skin, it may cause frostbite. Never loosen any parts of the cooling circuit.

**DISPOSING OF WASTE MATERIALS**

To prevent pollution, pay careful attention to the method of disposing of waste materials.

- Always put oil drained from your machine in containers. Never drain oil directly onto the ground or dump into the sewage system, rivers, the sea, or lakes.
- Obey appropriate laws and regulations when disposing of harmful objects such as oil, fuel, coolant, solvent, filters, and batteries.

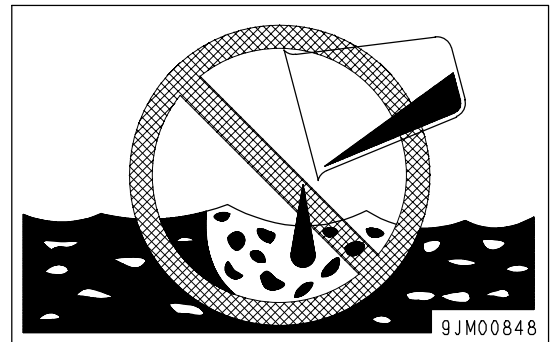
**METHOD OF SELECTING WINDOW WASHER FLUID**

Use an ethyl alcohol base washer liquid.

Methyl alcohol base washer liquid may irritate your eyes, so do not use it.

**PERIODIC REPLACEMENT OF SAFETY CRITICAL PARTS**

- To enable this machine to be used safely for a long period, always carry out periodic replacement of safety critical parts that have a particularly close relation to safety, such as hoses and the seatbelt.  
For details of the replacement of safety critical parts, see "PERIODIC REPLACEMENT OF SAFETY CRITICAL PARTS (PAGE 4-16)".
- The material of these components naturally changes over time, and repeated use causes deterioration, wear, and fatigue. As a result, there is a hazard that these components may fail and cause serious personal injury or death. It is difficult to judge the remaining life of these components from external inspection or the feeling when operating, so always replace them at the specified interval.
- Replace or repair safety-critical parts if any defect is found, even when they have not reached the specified replacement time.





# OPERATION

## **WARNING**

Please read and make sure that you understand the SAFETY section before reading this section.

---

# GENERAL VIEW

## GENERAL VIEW OF MACHINE

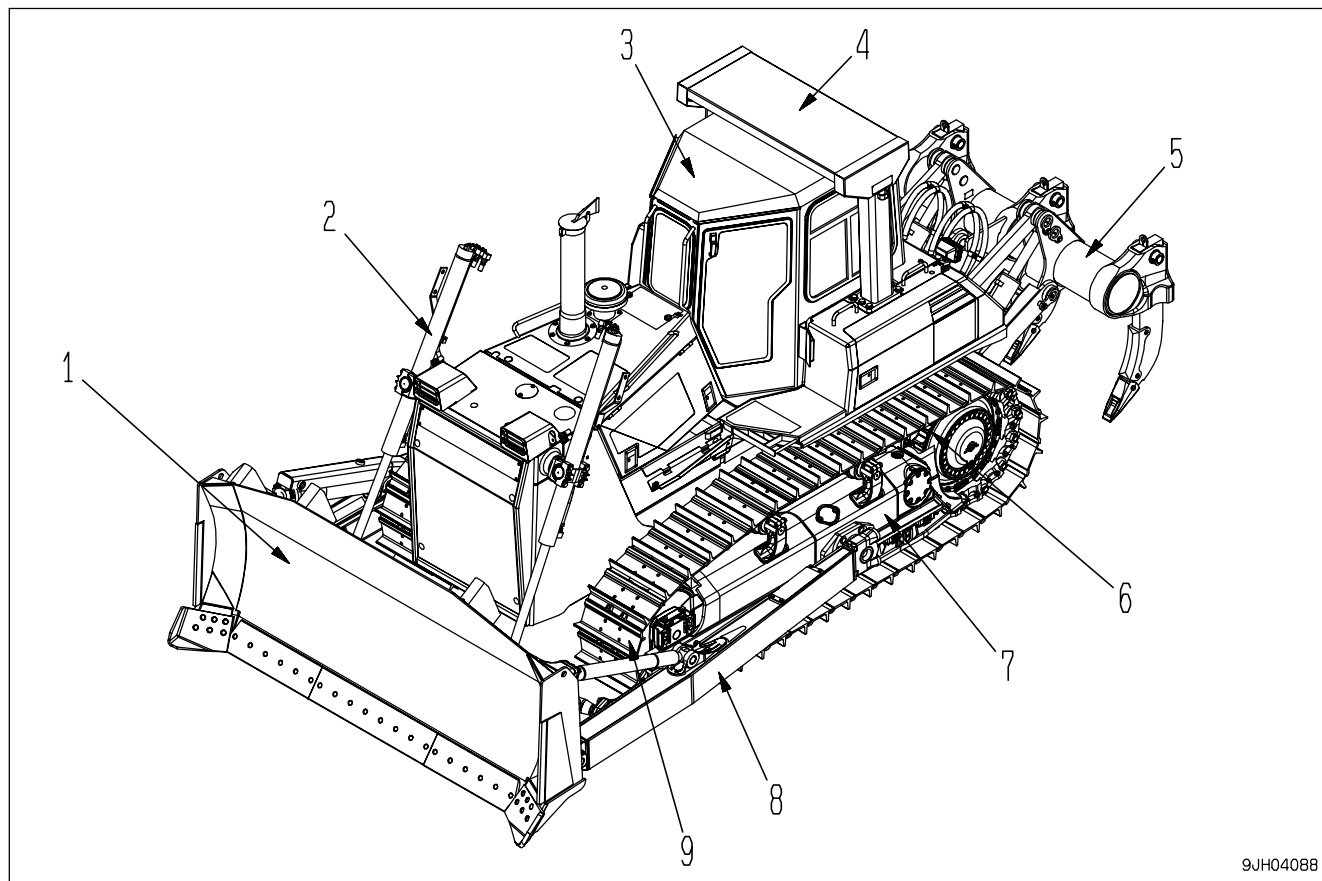

9JH04088

- |                         |                 |
|-------------------------|-----------------|
| (1) Blade               | (6) Sprocket    |
| (2) Blade lift cylinder | (7) Track frame |
| (3) Cab                 | (8) Frame       |
| (4) ROPS guard          | (9) Track shoe  |
| (5) Ripper              |                 |

GENERAL VIEW OF CONTROLS AND GAUGES

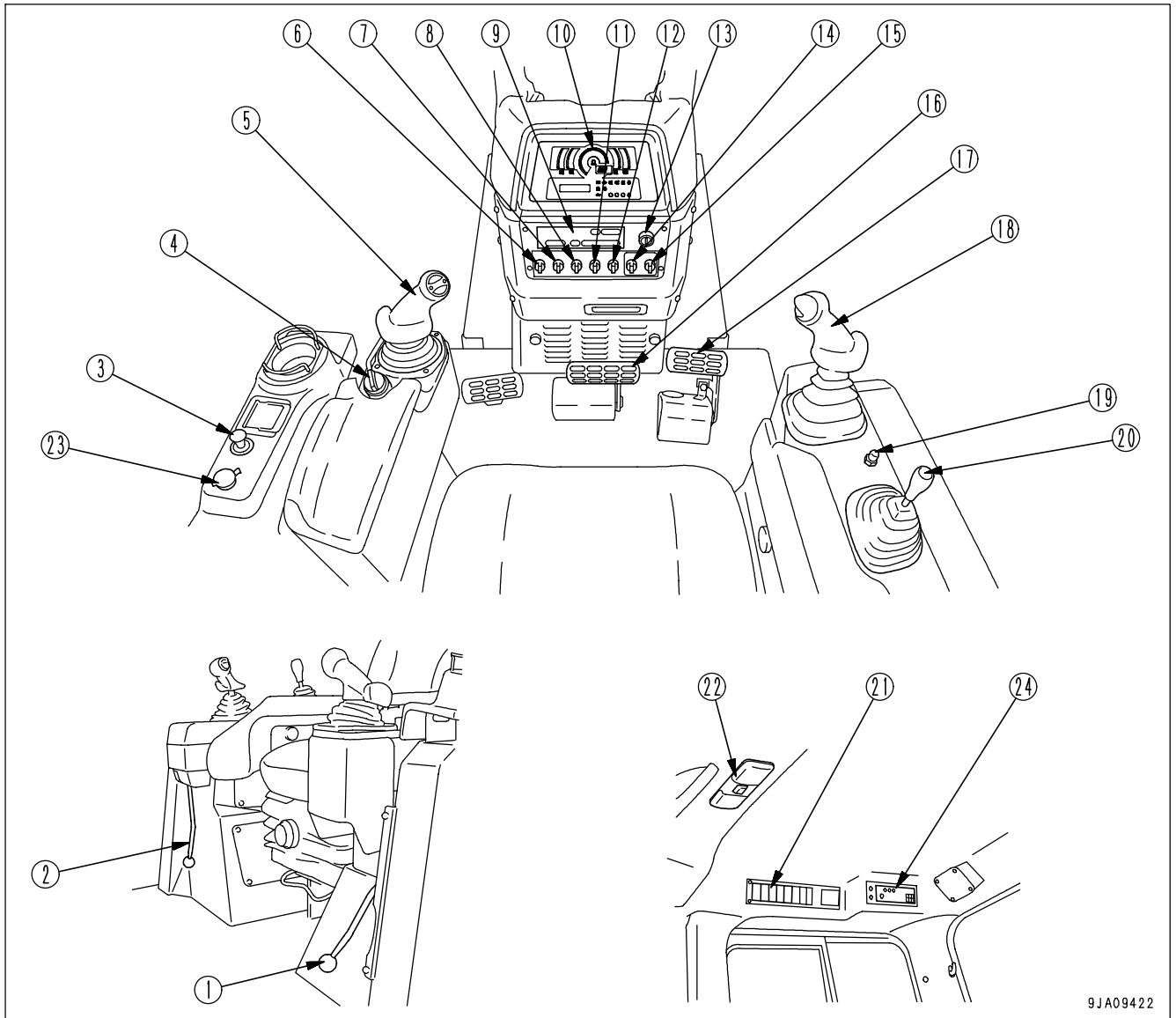

9JA09422

- |   |                               |
|---|-------------------------------|
| (1) Parking brake lever                                     | (13) Starting switch          |
| (2) Work equipment lock lever                               | (14) Information switch       |
| (3) Cigarette lighter (24V)                                 | (15) Buzzer cancel switch     |
| (4) Fuel control dial                                       | (16) Brake pedal              |
| (5) Steering, forward-reverse, gear shift lever             | (17) Deceleration pedal       |
| (6) Auto shift down switch                                  | (18) Blade control lever      |
| (7) Preset mode switch                                      | (19) Horn switch              |
| (8) Head lamp switch  | (20) Ripper control lever     |
| (9) Air conditioner panel or heater panel                   | (21) Wiper switch             |
| (10) Display panel A<br>(Speed range display, Engine speed) | (22) Room lamp switch         |
| (11) Rear lamp switch                                       | (23) Accessory socket (12V)   |
| (12) Fan rotation selector switch                           | (24) Car stereo (If equipped) |

## FRONT PANEL

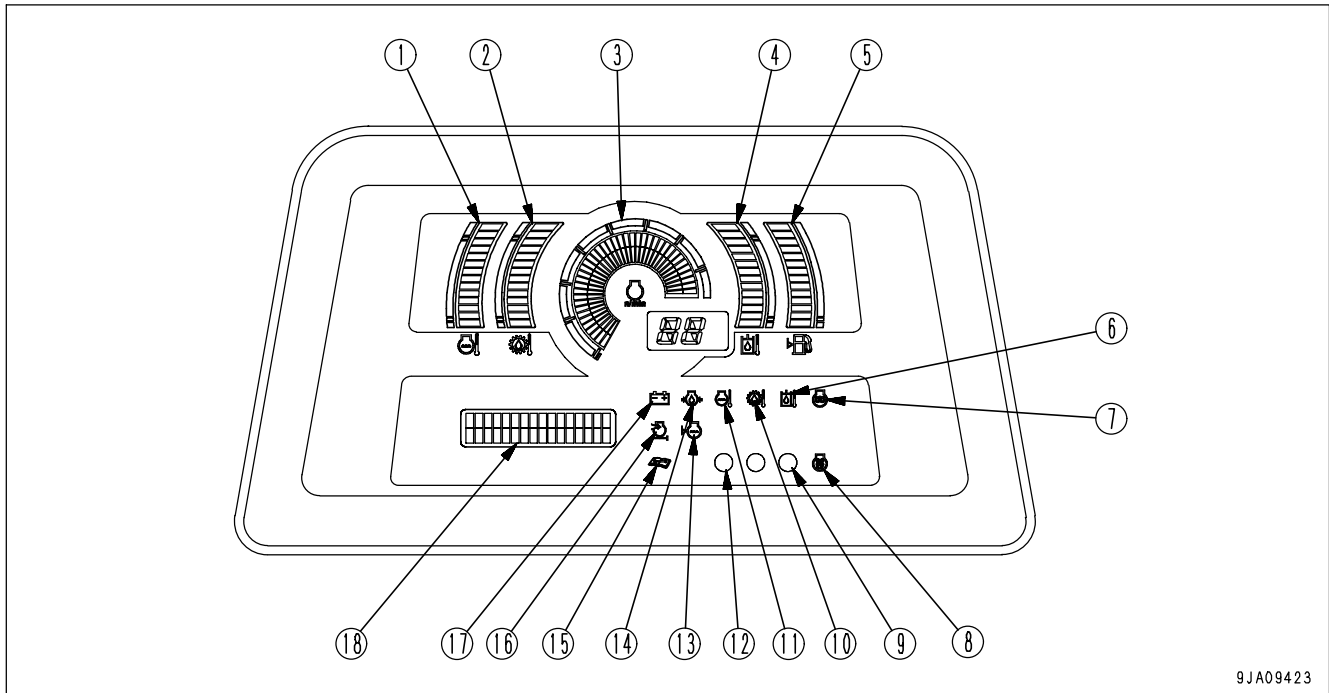

9JA09423

- |  |  |
|--|--|
| (1) Engine coolant temperature gauge                       | (10) Power train oil temperature caution lamp        |
| (2) Power train oil temperature gauge                      | (11) Engine coolant temperature caution lamp         |
| (3) Display panel A<br>(Speed range display, Engine speed) | (12) Fan operation confirmation lamp                 |
| (4) Hydraulic oil temperature gauge                        | (13) Radiator coolant level caution lamp             |
| (5) Fuel level gauge                                       | (14) Engine oil pressure caution lamp                |
| (6) Hydraulic oil temperature caution lamp                 | (15) Maintenance caution lamp                        |
| (7) Engine pre-heating pilot lamp                          | (16) Air cleaner clogging caution lamp (If equipped) |
| (8) Cooling fan reverse rotation pilot lamp                | (17) Battery charge circuit caution lamp             |
| (9) Warning lamp   | (18) Display panel B (Multi-information)             |

# EXPLANATION OF COMPONENTS

The following is an explanation of devices needed for operating the machine.

To perform suitable operations correctly and safely, it is important to completely understand methods of operating the equipment, and the meanings of the displays.

## FRONT PANEL

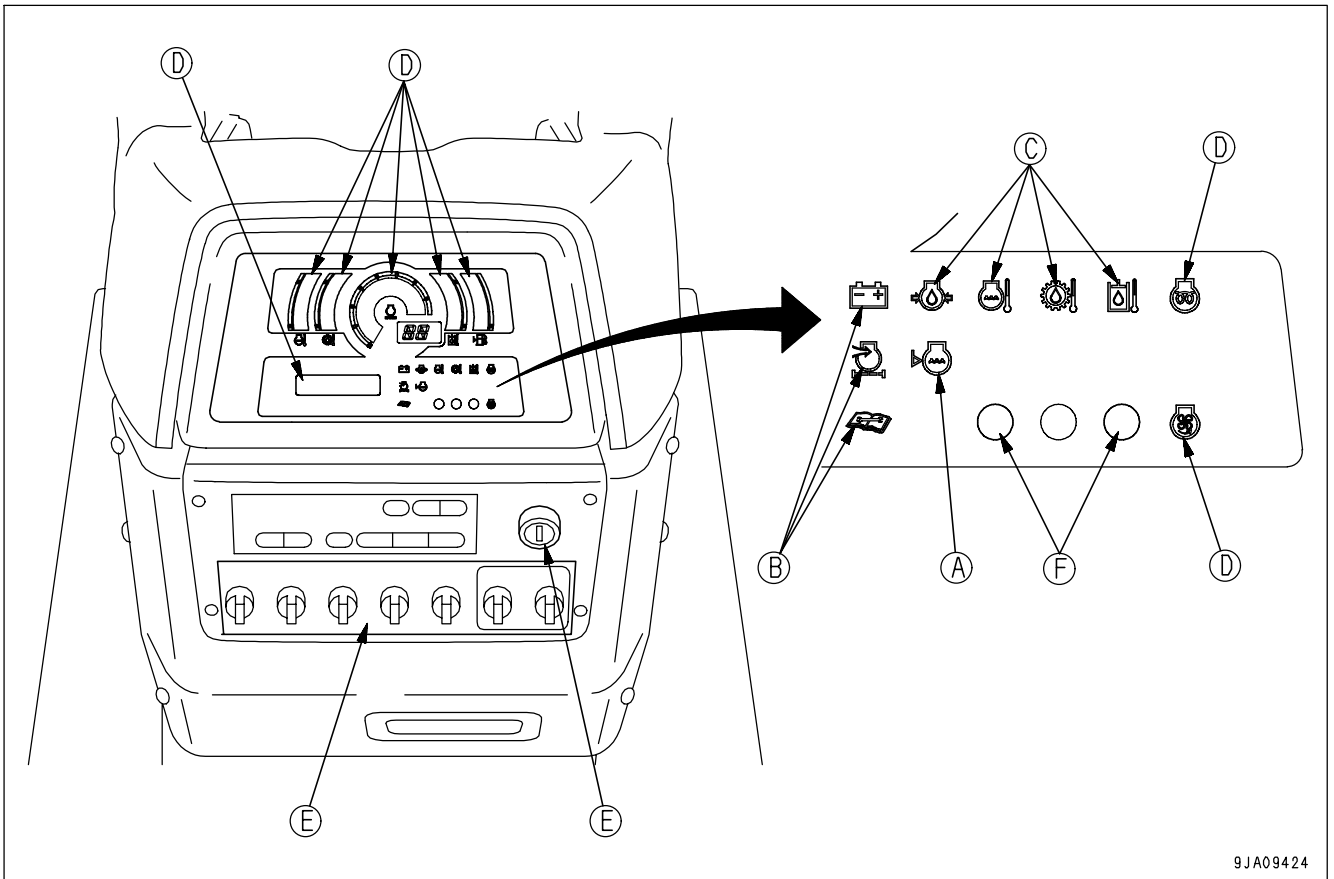

9JA09424

- (A) Check monitor group
- (B) Caution items
- (C) Emergency caution items
- (D) Meter group
- (E) Switches
- (F) Lamps

(A) Check monitor group (for details, see "CHECK MONITOR GROUP (PAGE 3-7)")

Before the engine is started, the basic items among the check before starting items that must be checked are displayed.

If there is any abnormality, the caution lamp for the location of the abnormality flashes.

#### NOTICE

**When carrying out checks before starting, do not simply rely on the monitor. Always refer to the periodic maintenance items or "OPERATION (PAGE 3-74)" to carry out the checks.**

(B) Caution items (for details, see "CAUTION ITEMS (PAGE 3-9)")



### CAUTION

**If the caution lamp for any of these items flashes, check and repair the appropriate item as soon as possible.**

These are items which need to be observed when the engine is running. If any problem occurs, the item needing immediate repair is displayed. If there is any problem, the problem location on the caution lamp will flash.

(C) Emergency caution items (for details, see "EMERGENCY CAUTION ITEMS (PAGE 3-11)")



### CAUTION

**If the caution lamp for any of these items flashes, stop the engine immediately or run it at low idling, and take the following action.**

This displays the abnormal items that action must be taken on immediately the engine is running.

If there is any abnormality, the monitor showing the location of the abnormality will flash and the alarm buzzer will sound.

(D) Meter group (for details, see "METER GROUP (PAGE 3-13)")

This consists of the preheating pilot lamp, power train oil temperature gauge, engine water temperature gauge, hydraulic oil temperature gauge, fuel gauge, dual/single selector display lamp, display panel A (speed range display, engine speed) and display panel B (multi-information).

(E) Switches (for details, see "SWITCHES (PAGE 3-18)".)

These consist of the starting switch, buzzer cancel switch, front lamp switch, rear lamp switch, auto shift down switch, Preset mode switch, information switch, and Fan rotation selector switch.

(F) Lamps (for details, see "LAMPS (PAGE 3-22)".)

These consist of the warning lamp and Fan operation confirmation lamp.

## CHECK MONITOR GROUP

### NOTICE

- When performing the check before starting, do not rely only on these monitors. Always refer to "OPERATION (PAGE 3-74)" to perform these checks.
- Park the machine on level ground and then check the monitor lamps.
- Confirm that monitor lamps light up about 2 seconds after the starting switch is turned to the ON position. If any monitor lamp does not light, contact your Komatsu distributor to inspect and repair.

### REMARK

- When the starting switch is turned to the ON position, before starting the engine, the caution lamps flash for 2 seconds, the warning lamps light up for 2 seconds, and the alarm buzzer sounds for 2 seconds.
- The caution lamps cannot be checked for any malfunction until at least 5 seconds after the engine has been stopped.

This displays the basic items among the check before starting items that must be checked before starting the engine. If there is any abnormality, the caution lamp for that location will flash.

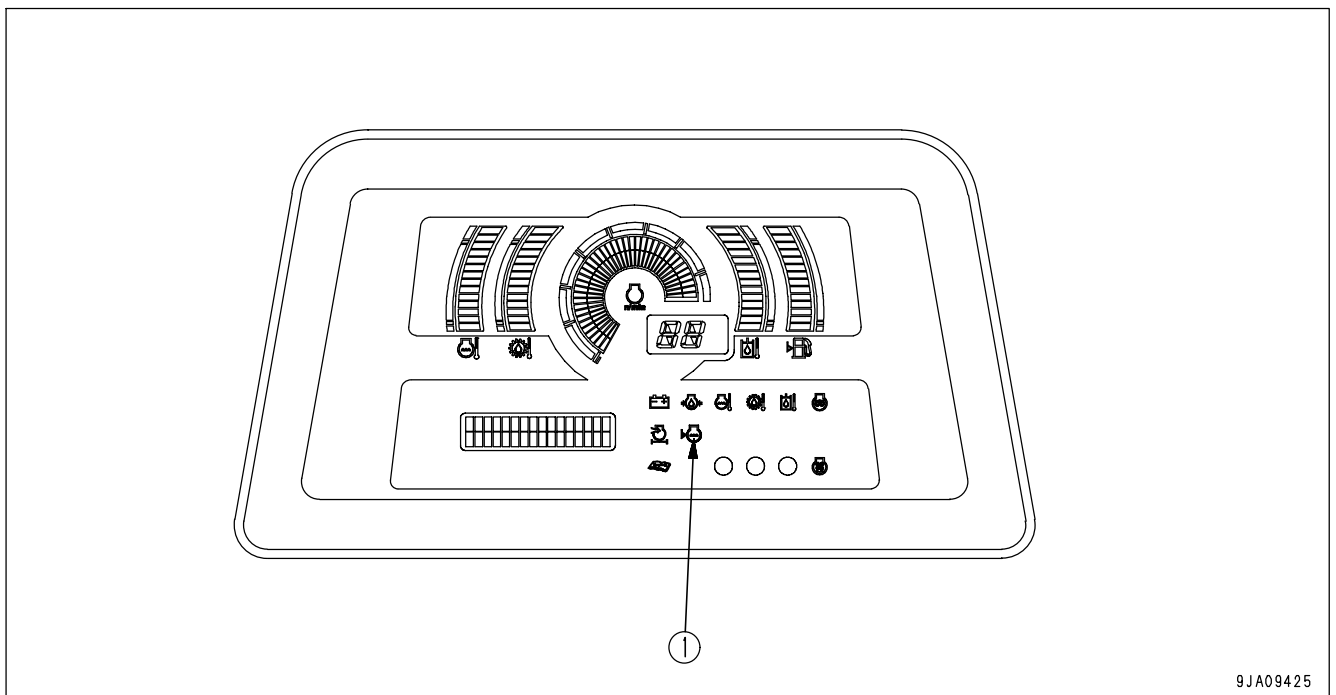

9JA09425

- (1) Radiator coolant level caution lamp



**RADIATOR COOLANT LEVEL CAUTION LAMP**

This lamp (1) warns the operator that the level of the cooling water in the radiator has gone down.

If the lamp flashes, check the level of the cooling water in the main radiator, and add water.

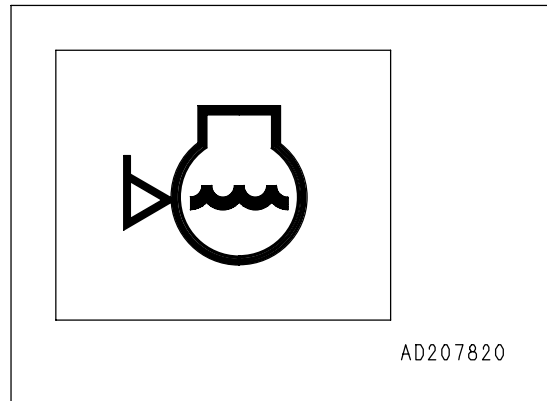

CAUTION ITEMS



If these caution lamps flash, check and repair the appropriate location as soon as possible.

NOTICE

- Park the machine on level ground and check the monitor lamps.
- Confirm that monitor lamps light up about 2 seconds after the starting switch is turned to the ON position. If any monitor lamp does not light, contact your Komatsu distributor to inspect and repair.

These are items which need to be observed when the engine is running. If any problem occurs, the item needing immediate repair is displayed. If there is any problem, the problem location on the caution lamp will flash.

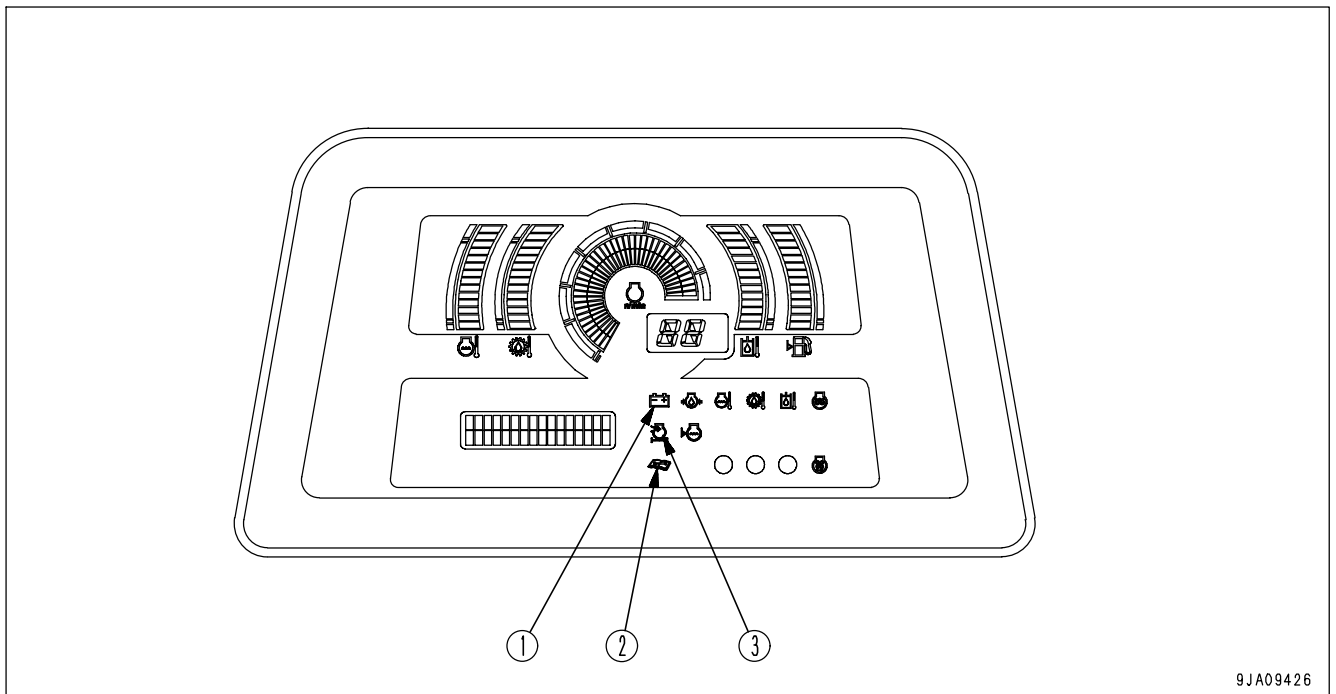

- |   |   |
|---|---|
| (1) Battery charge circuit caution lamp | (3) Air cleaner clogging caution lamp (If equipped) |
| (2) Maintenance caution lamp            |   |

**BATTERY CHARGE CIRCUIT CAUTION LAMP**

This lamp (1) indicates a problem in the charging system while the engine is running.

If the monitor lamp flashes, check the V-belt tension. If any problem is found, see "OTHER TROUBLE (PAGE 3-147)".

**REMARK**

This lamp may light up momentarily when the engine is started or when the engine is stopped. It does not indicate a problem.

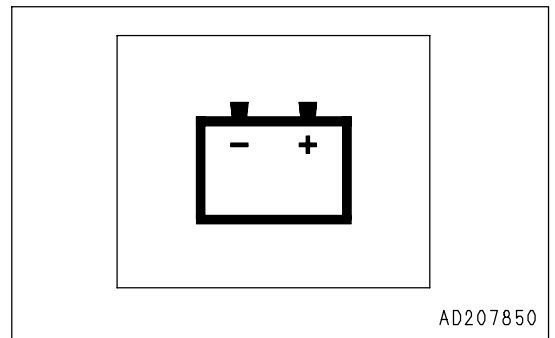

**MAINTENANCE CAUTION LAMP**

This lamp (2) begins to flash 30 hours before the next replacement time and lights up when the replacement time has passed.

After replacing the indicated filter or oil displayed on display panel B (multi-information), reset the interval. For details, see "METHOD OF USING MAINTENANCE MODE (PAGE 3-26)".

The lamp goes out.

**REMARK**

This lamp continues to flash or remains lighted for about 30 seconds after the engine starting switch is turned to the ON position.

The lamp goes off after the engine starts up.

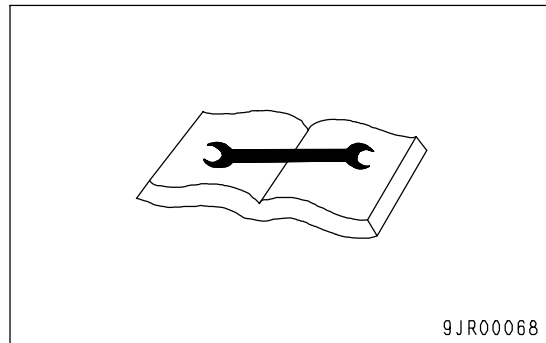
**AIR CLEANER CLOGGING CAUTION LAMP**

(If equipped)

Lamp (3) warns operator that the air cleaner is clogged.

If it flashes, stop the engine, check and clean the air cleaner.

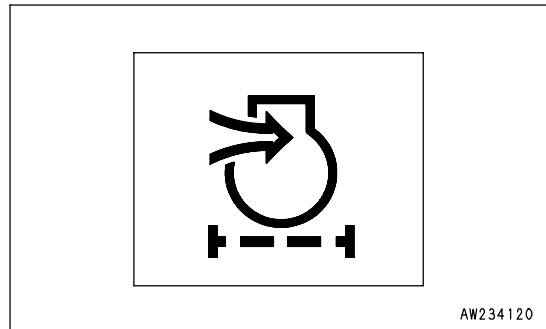

**EMERGENCY CAUTION ITEMS**

**! CAUTION**

If any of the caution lamps begins to flash, stop the engine or reduce the engine speed to low idle immediately and check the trouble spot for necessary actions.

These items must be monitored when the engine is running. If there is any problem, the caution lamp for the location of the problem and warning lamp (A) flash, and the alarm buzzer sounds intermittently. Take the necessary action immediately.

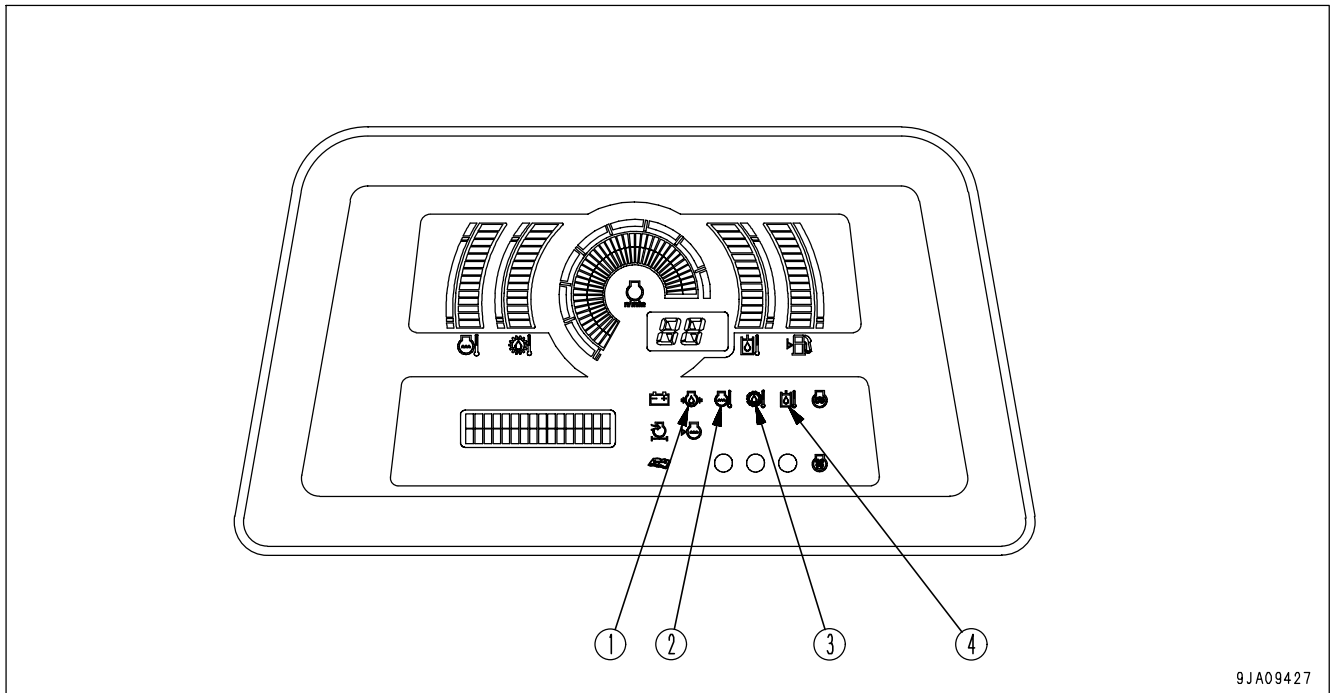

9JA09427

- (1) Engine oil pressure caution lamp
- (2) Engine coolant temperature caution lamp
- (3) Power train oil temperature caution lamp
- (4) Hydraulic oil temperature caution lamp

**ENGINE OIL PRESSURE CAUTION LAMP**

This lamp (1) indicates low engine oil pressure. If the monitor lamp flashes, stop the engine and check it immediately.

**REMARK**

The alarm buzzer sounds, when the starting switch is turned to ON immediately after the engine oil has been changed. It does not indicate a problem.

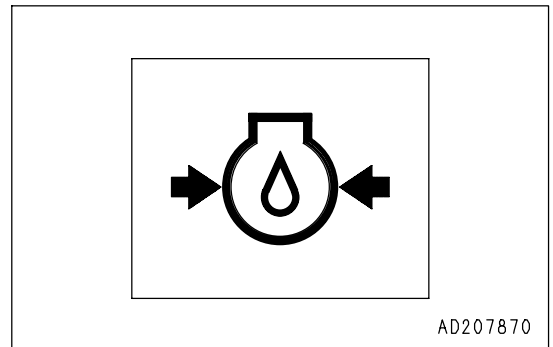

AD207870

**ENGINE COOLANT TEMPERATURE CAUTION LAMP**

This lamp (2) indicates a rise in the coolant temperature.  
When the monitor lamp flashes, run the engine at low idle speed until green range of the engine coolant temperature gauge lights.

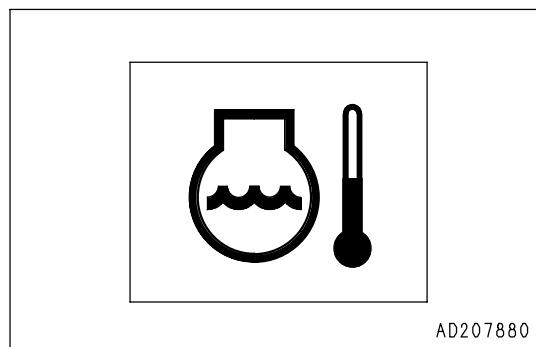
**POWER TRAIN OIL TEMPERATURE CAUTION LAMP**

Lamp (3) warns operator that the torque converter outlet port oil temperature has risen.  
If it flashes, run the engine at low idling until the power train oil temperature gauge goes down to the green range.

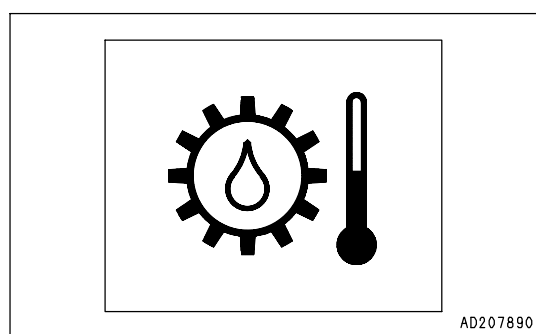
**HYDRAULIC OIL TEMPERATURE CAUTION LAMP**

Lamp (4) indicates a rise in the hydraulic oil temperature.  
When the monitor lamp flashes, stop the machine and run the engine at the low idling speed until oil temperature falls.

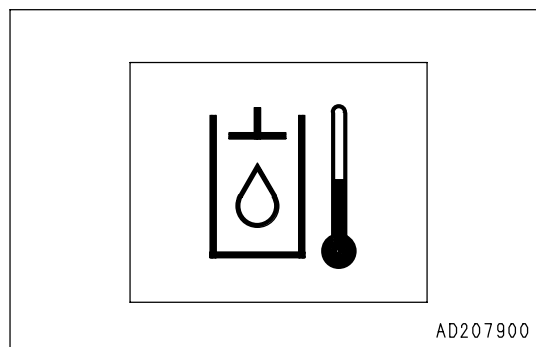

**METER GROUP****NOTICE**

When the engine is stopped, turn that the starting switch to the ON position and check that the gauge or monitor for the engine water temperature gauge, power train oil temperature gauge, and fuel gauge light up.

If they do not light up, please contact your Komatsu distributor for repairs.

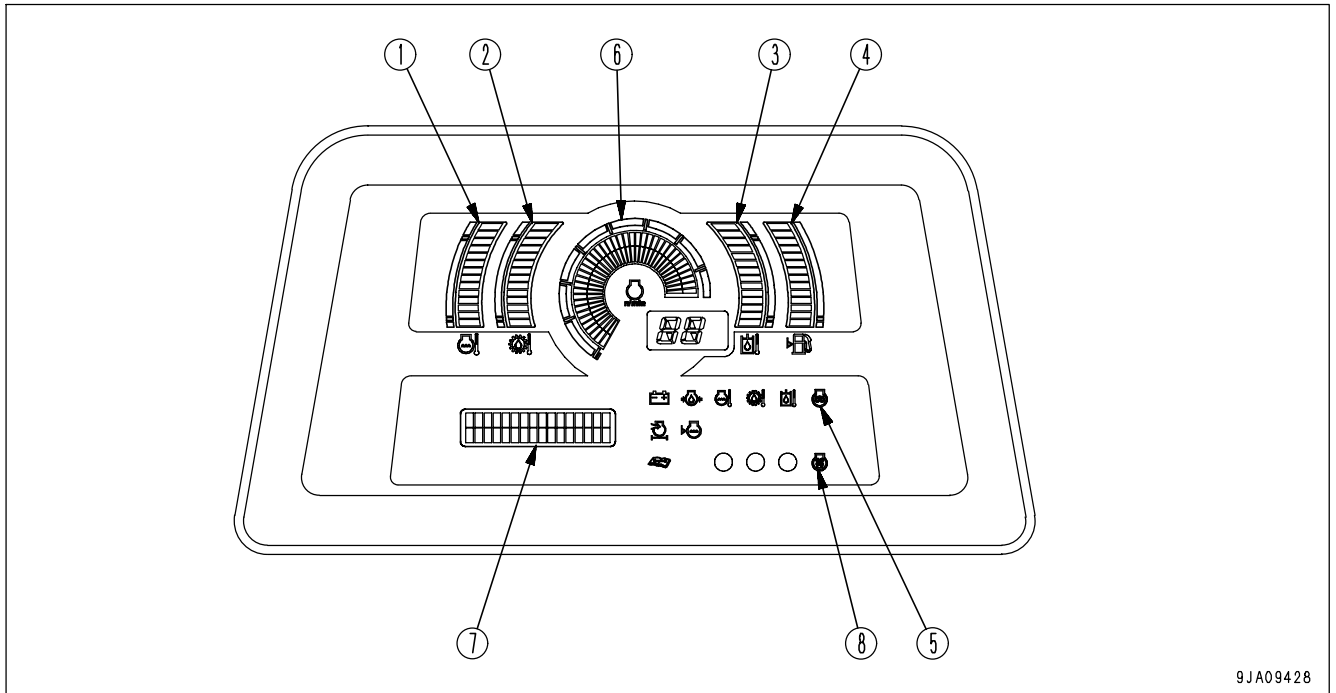

9JA09428

- |                                       |   |
|---------------------------------------|---|
| (1) Engine coolant temperature gauge  | (6) Display panel A                         |
| (2) Power train oil temperature gauge | (Speed range display, engine speed)         |
| (3) Hydraulic oil temperature gauge   | (7) Display panel B (Multi-information)     |
| (4) Fuel level gauge                  | (8) Cooling fan reverse rotation pilot lamp |
| (5) Engine pre-heating pilot lamp     |   |

## ENGINE COOLANT TEMPERATURE GAUGE

### NOTICE

If the coolant temperature gauge often enters red range (C), check the radiator for clogging.

Gauge (1) indicates temperature of the engine coolant.

If the temperature is normal during operation, green range (B) will light.

If red range (C) lights during operation, move the fuel control dial to lower engine speed to approx. 3/4 of the full speed, and run until the coolant temperature enters green range (B).

During operation, if red range (C) lights, engine coolant temperature monitor flashes and the alarm buzzer sounds, stop the machine and run at low idle until coolant temperature enters green range (B).

(A): White range

(B): Green range

(C): Red range

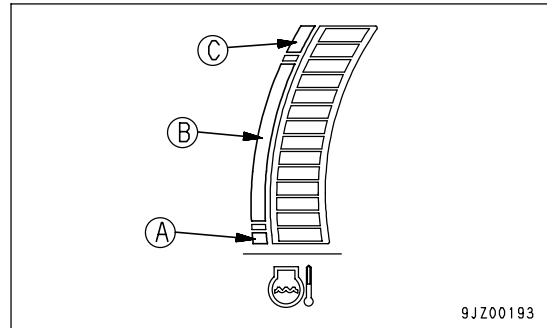

## POWER TRAIN OIL TEMPERATURE GAUGE

### NOTICE

If the power train oil temperature gauge often enters red range (C), shift down one speed range to reduce the load on the power train when operating.

Gauge (2) indicates the torque converter outlet oil temperature.

If the temperature is normal during operation, green range (B) will light.

If red range (C) lights up during operation, move the fuel control dial to lower engine speed to approx. 3/4 of the full speed, reduce the load and run until the oil temperature enters green range (B).

If red range (C) lights up, the power train oil temperature caution lamp flashes and the alarm buzzer sounds during operations, stop the machine, and run the engine at low idling until the oil temperature goes down to green range (B).

(A): White range

(B): Green range

(C): Red range

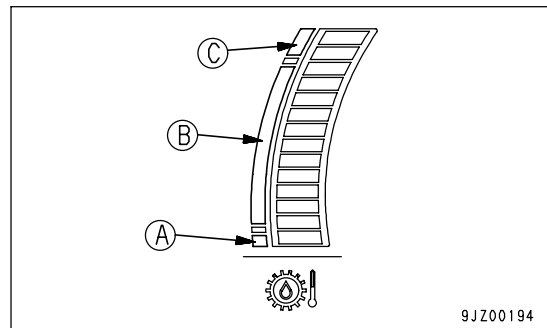

**HYDRAULIC OIL TEMPERATURE GAUGE**

Gauge (3) indicates the hydraulic oil temperature.

If the temperature is normal during operation, green range (B) will light.

If red range (C) lights up during operation, move the fuel control dial to lower engine speed to approx. 3/4 of the full speed, reduce the load and run until the oil temperature enters green range (B).

- (A): White range
- (B): Green range
- (C): Red range

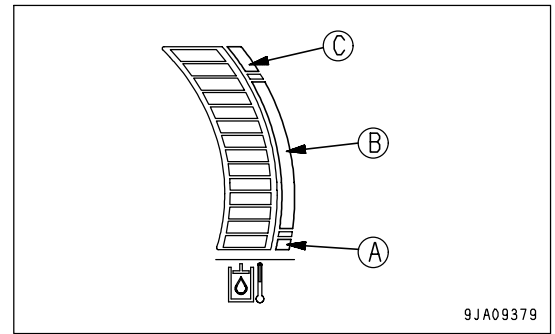

**FUEL LEVEL GAUGE**

Gauge (4) fuel level in the fuel tank.

During normal operation, the green range (B) should be lit.

If red range (A) lights up during operation, add fuel immediately. If this is not done, the engine speed will become irregular or an error display will be shown on the monitor.

- (A): Red range
- (B): Green range

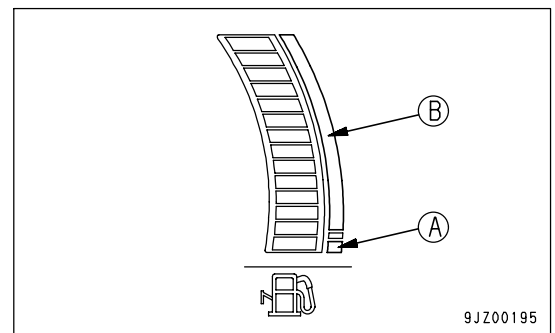

**REMARK**

- The display is not proportional to the amount of fuel remaining.
- If only the red range (A) lights up, there is less than 60 liters (15.85 US gal) of fuel remaining.

**ENGINE PRE-HEATING PILOT LAMP**

Lamp (5) indicates that engine is being pre-heated by the electrical heater during cold weather.

The engine controller detects the coolant temperature and automatically actuates pre-heating in low temperatures when starting the engine.

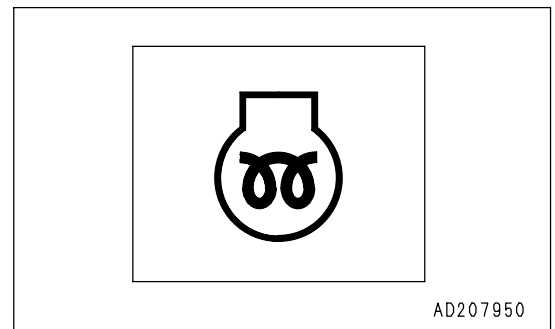



**DISPLAY PANEL A (speed range display, engine speed)**

Meter (6) displays the transmission speed range being used on the machine and engine speed.

- The travel direction (A) and speed range (B) are displayed in the center of the speed range display.

(A) F: FORWARD

R: REVERSE

N: Neutral

P: Parking brake lever at LOCK position

(B) 1: 1st

2: 2nd

3: 3rd

Example: F1 is displayed for FORWARD 1st

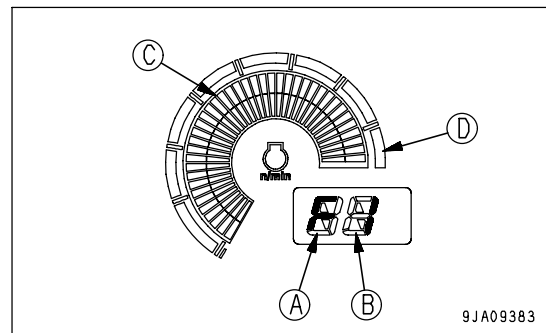

- Bar graph (C) around the outside of the display shows the engine speed.

If the bar graph reaches red range (D) during operation, take action to reduce the engine speed. Always keep the bar graph in the green range.

**DISPLAY PANEL B (multi-information)**

The top and bottom lines in display panel B (multi-information) display information related to the condition of the machine.

The content of the display is divided into "OPERATING MODE" and "MAINTENANCE MODE". Use the buzzer cancel switch to switch between the operating mode and maintenance mode.

For details of switching the mode, see "BUZZER CANCEL SWITCH (PAGE 3-19)".

**OPERATING MODE (default screen)**

Use this mode when operating the machine.

**REMARK**

When the starting switch is turned from the OFF position to the ON position, display panel B (multi-information) always displays the operating mode.

The following information is displayed by the operating mode.

Top line (A): Action code

If any problem occurs on the machine, an action code is displayed. If an action code appears, take the applicable action. For details, see "OTHER TROUBLE (PAGE 3-147).

This displays various types of filter or oil replacement intervals have been reached.

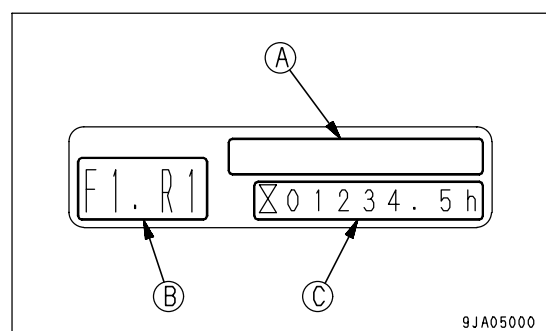

Bottom line, left (B): Preset mode

When the preset mode switch is ON, the selected preset mode is displayed.

For details of selecting the preset mode, see "GEARSHIFTING OPERATION USING PRESET MODE FUNCTION (PAGE 3-106)".

Bottom line, right (C): Service meter or engine speed

Use the information switch to switch the display between the service meter and engine speed. For details of switching the display, see "INFORMATION SWITCH (PAGE 3-21)".

**Service meter**

This displays the total number of hours that the machine has been operated. Use the display to determine the intervals for periodic maintenance.

While the engine is running, the service meter advances, even if the machine is not being operated.

While the engine is running, the hourglass mark at the side of the meter flashes to show that the meter is advancing.

The meter advances 0.1h for every 6 minutes that the engine is running, regardless of the engine speed.

**Maintenance mode**

This displays various types of information related to maintenance of the machine.

The maintenance mode is displayed by continuing to turn the information switch in the ◊ direction for 2.5 seconds.

For details, see "METHOD OF USING MAINTENANCE MODE (PAGE 3-26)".

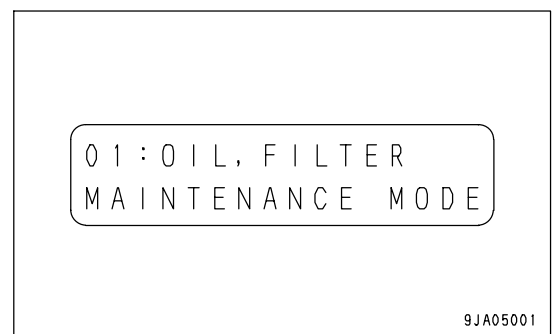

**COOLING FAN REVERSE ROTATION PILOT LAMP**

After the starting switch is turned to the ON position and the fan rotation selector switch is turned to the CLN position, this lamp (8) lights up. If the engine is started when lamp (8) is lighted up, the fan will rotate in the reverse direction.

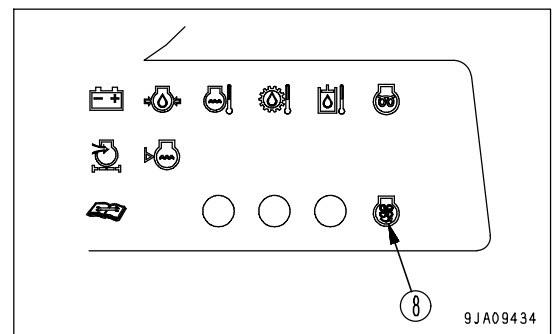

## SWITCHES

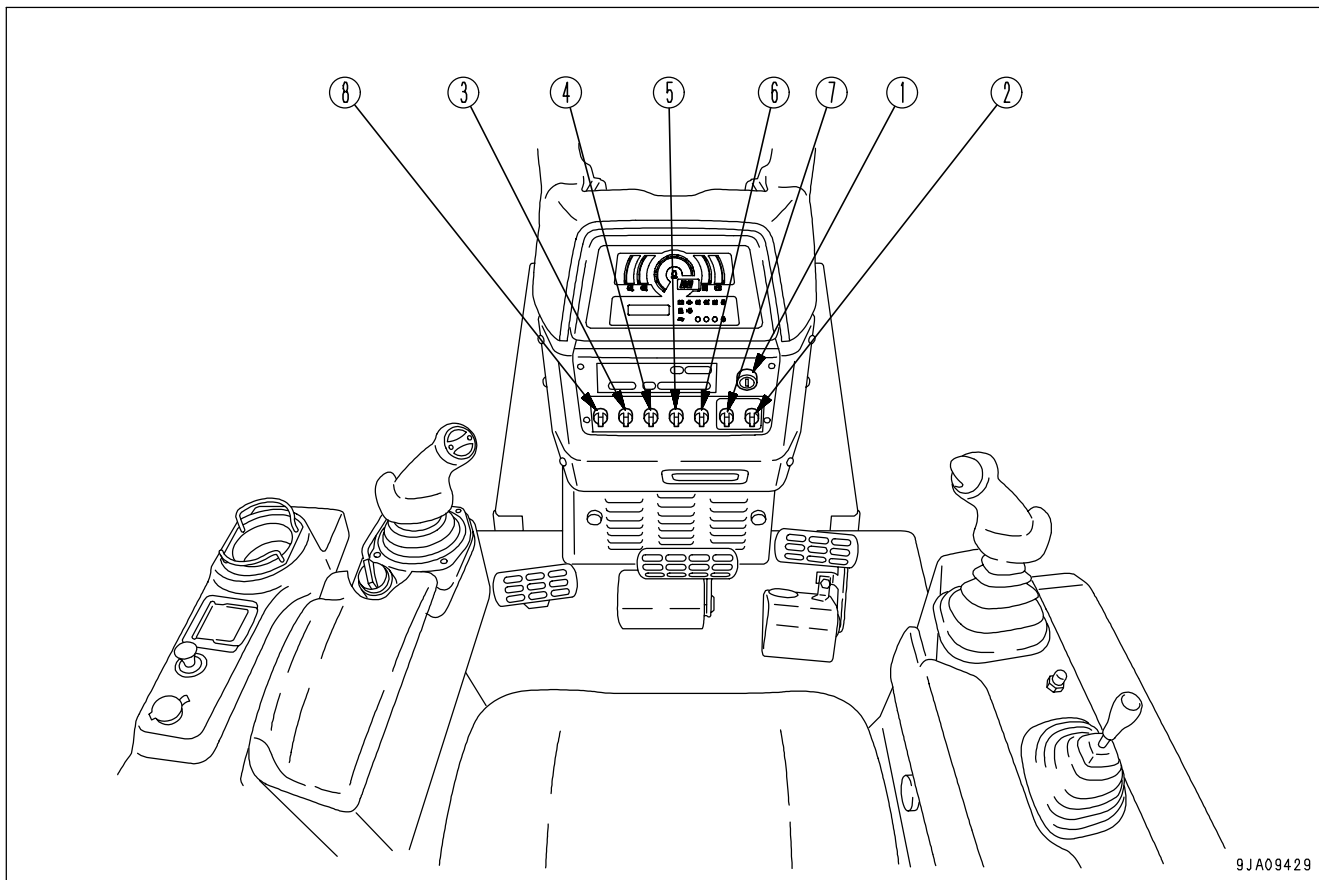

9JA09429

- |                          |                                  |
|--------------------------|----------------------------------|
| (1) Starting switch      | (5) Rear lamp switch             |
| (2) Buzzer cancel switch | (6) Fan rotation selector switch |
| (3) Preset mode switch   | (7) Information switch           |
| (4) Head lamp switch     | (8) Auto shift down switch       |

## STARTING SWITCH

This switch (1) is used to start or stop the engine.

## (A): OFF position

At this position, the starting switch key can be inserted and removed. When the switch is turned to this position, all the electric circuits are turned off and the engine stops.

## (B): ON position

In this position, electric current flows in the charging and lamp circuits.

Keep the starting switch key at the ON position while the engine is running.

## (C): START position

This is the position to start the engine. Hold the key at this position while cranking the engine. Release the key immediately after the engine has been started. The key will return to ON position (B) when released.

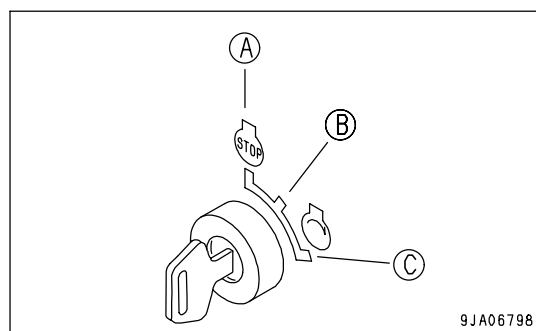

9JA06798

**BUZZER CANCEL SWITCH**

This switch (2) is used to operate control panel B (multi-information) or to stop the alarm buzzer.

When the switch is released, it returns automatically to the center position.

- **When display panel B (multi-information) is in operation mode**
  - When the alarm buzzer sounds, turn this switch to the right and the buzzer stops sounding.
  - If the switch is held at the ◊ position for at least 2.5 seconds, the display switches to the maintenance mode.

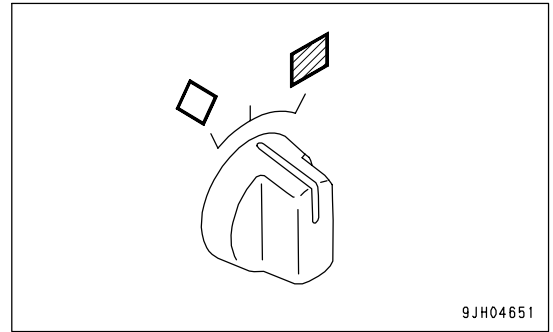

9JH04651

- **When display panel B (multi-information) is in the maintenance mode**

■ position: Cancel or reset to operation mode

◊ position: Confirms selection or selected item

For details, see "METHOD OF USING DISPLAY PANEL B (Multi-information) (PAGE 3-24)".

**PRESET MODE SWITCH**

Turn the switch (3) to the right to set the desired transmission speed range before starting (F1-R1,F1-R2,F2-R1,F2-R2) .

○ (OFF) position: Manual mode

┆ (ON) position: Preset mode

For details, see "GEARSHIFTING OPERATION USING PRESET MODE FUNCTION (PAGE 3-106)".

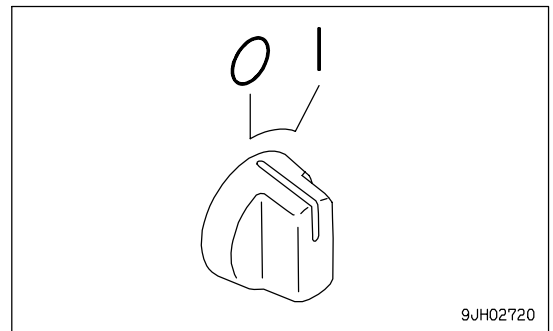

9JH02720

**HEAD LAMP SWITCH**

This switch (4) lights up when the front lamp and panel lamp light up.

○ (OFF) position: Lights out

┆ (ON) position: Lights on

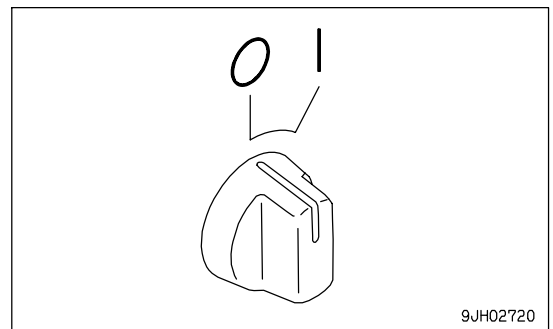

9JH02720

**REAR LAMP SWITCH**

This switch (5) lights up when the rear lamp and panel lamp light up.

- (OFF) position: Lights out
- ┆ (ON) position: Lights on

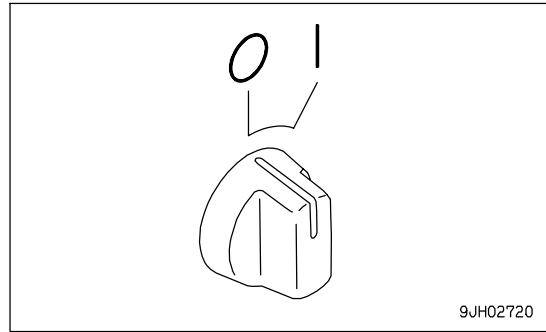
**FAN ROTATION SELECTOR SWITCH**

When this switch (6) is turned to the CLN position, the fan can be set to the cleaning mode.

When the hand is withdrawn, the switch automatically returns to the ○ position.

When the cleaning mode is selected, the cooling fan reverse rotation pilot lamp lights up.

If the switch is turned to the CLN position when the fan is in the cleaning mode, the fan will return to the normal mode and the cooling fan reverse pilot lamp will go out.

The cleaning mode is used to dust off the radiator.

In the cleaning mode, the fan keeps turning at the fullest speed.

Operate the fan rotation selector switch when the engine starting switch key is in the ON position and the engine is at a standstill.

For the cleaning procedures, see "CLEANING AND INSPECTION OF FINS OF RADIATOR, OIL COOLER AND AFTER COOLER (PAGE 4-35)".

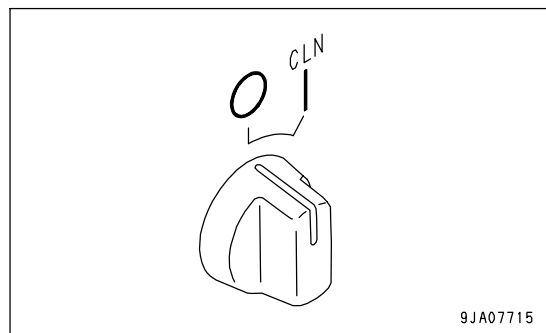
**REMARK**

- Even if you try to operate the fan rotation selector switch while the engine is running, it does not respond to the operation. Instead the fan operation confirmation lamp begins to flash, telling you that the fan rotation speed cannot be switched.  
The switch returns to the normal mode when the engine is stopped or the engine starting switch key is turned to the OFF position.
- When the fan rotation selector switch is in the cleaning mode, the machine cannot be operated.

**INFORMATION SWITCH**

This switch (7) is used to operate display panel B (multi-information).

When the switch is released, it returns automatically to the center position.

- **When display panel B (multi-information) is in the operation mode**

turn the switch to < or > to switch the display to service meter or engine speed.

- **When display panel B (multi-information) is in the maintenance mode**

It is used to move between sub modes, between items, to move the cursor, or to change values.

For details, see "METHOD OF USING DISPLAY PANEL B (Multi-information) (PAGE 3-24)".

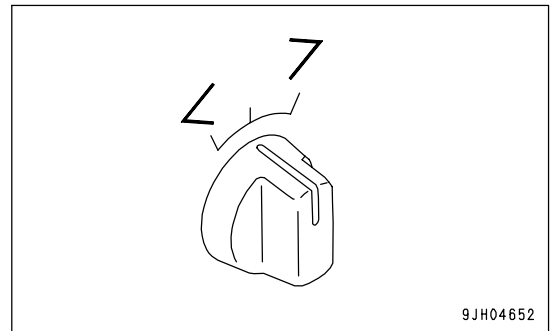

9JH04652

**AUTO SHIFT DOWN SWITCH**

When this switch (8) is operated to the right, if the travel speed drops because of the load conditions when traveling, the transmission automatically shifts to low speed.

○ (OFF) position: Automatic operation canceled

┆ (ON) position: Automatically shifts down to low speed

For details, see "AUTO DOWN SHIFT OPERATION (PAGE 3-109)".

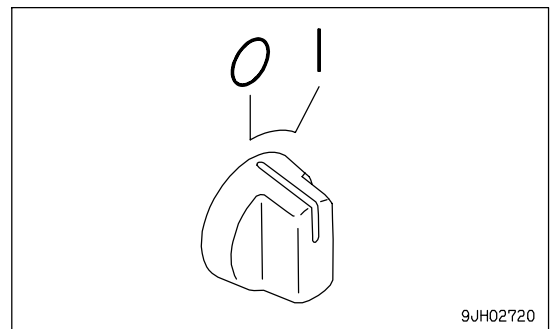

9JH02720

LAMPS

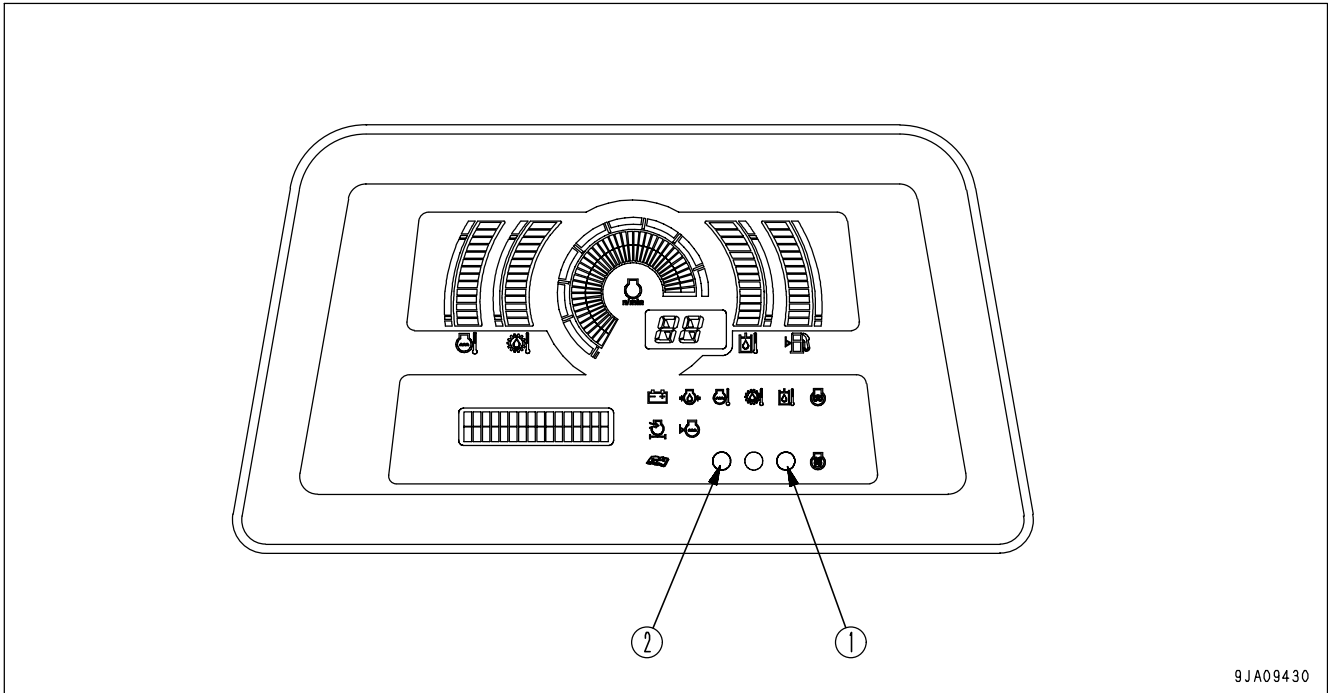

9JA09430

(1) Warning lamp

(2) Fan operation confirmation lamp

WARNING LAMP

(Red)

NOTICE

If alarm buzzer sounds, stop work immediately and perform inspection and maintenance of the appropriate point.

This lamp (1) flashes when the caution lamp flashes and when an action code is displayed on display panel B (multi-information).

When the caution lamp (C) of an emergency warning item flashes, or when the part of an action code is displayed, the alarm buzzer sounds continuously at the same time.

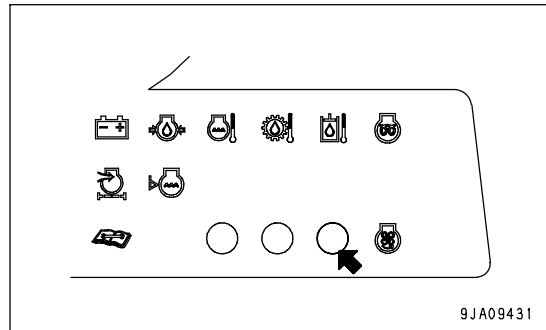

9JA09431

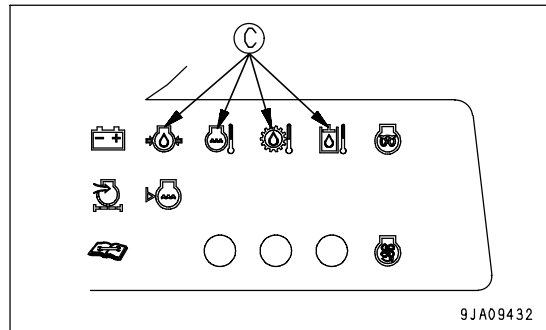

9JA09432

**FAN OPERATION CONFIRMATION LAMP**

(Orange)

If the starting switch is at the ON position when this lamp (2) is out, and the engine is started, the fan will rotate in the normal direction. If the fan rotation selector switch is turned to the CLN position when the engine is running, this lamp (2) will flash for 3 seconds to show that the direction of rotation of the fan has not changed.

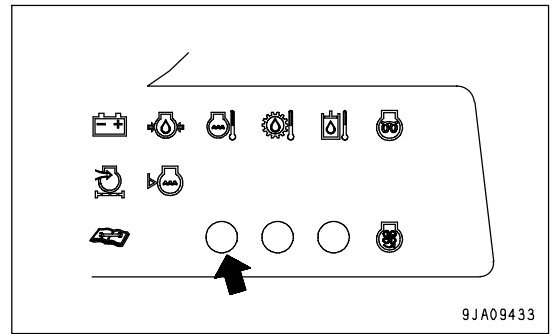



**METHOD OF USING DISPLAY PANEL B (Multi-information)**

To switch from the operation mode to the maintenance mode, turn the buzzer cancel switch to the ◊ position and hold it there for at least 2.5 seconds. The screen will switch to the maintenance mode.

On the first screen, the oil and filter maintenance mode is displayed.

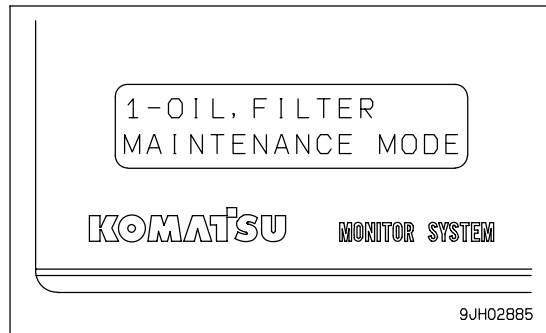
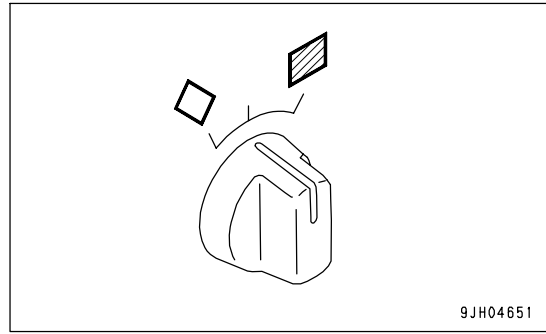

**EXPLANATION OF MODES AND CONTROLS**

The maintenance mode has the following 4 sub modes.

Sub mode	Function	Reference items
Oil/filter maintenance mode	Oil or filter replacement time is displayed	METHOD OF USING MAINTENANCE MODE(3-26 PAGE)
PM clinic auxiliary mode	Engine speed or hydraulic circuit pressure is displayed	METHOD OF USING PM CLINIC AUXILIARY MODE(3-28 PAGE)
Fault code display mode	Fault codes for electronic control related parts are displayed	METHOD OF USING FAULT CODE DISPLAY MODE(3-29 PAGE)
Adjustment mode	Adjusts monitor brightness, etc.	METHOD OF USING USER ADJUST MODE(3-30 PAGE)

Use information switch (1) and buzzer cancel switch (2) to operate each mode.

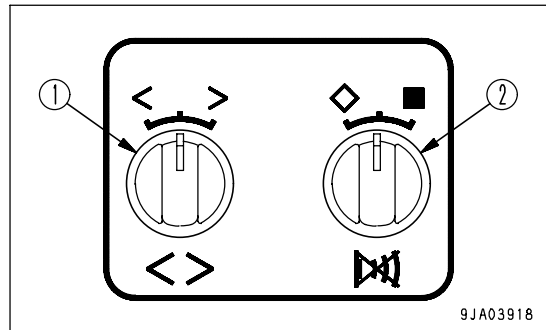

METHOD OF SELECTING MODES

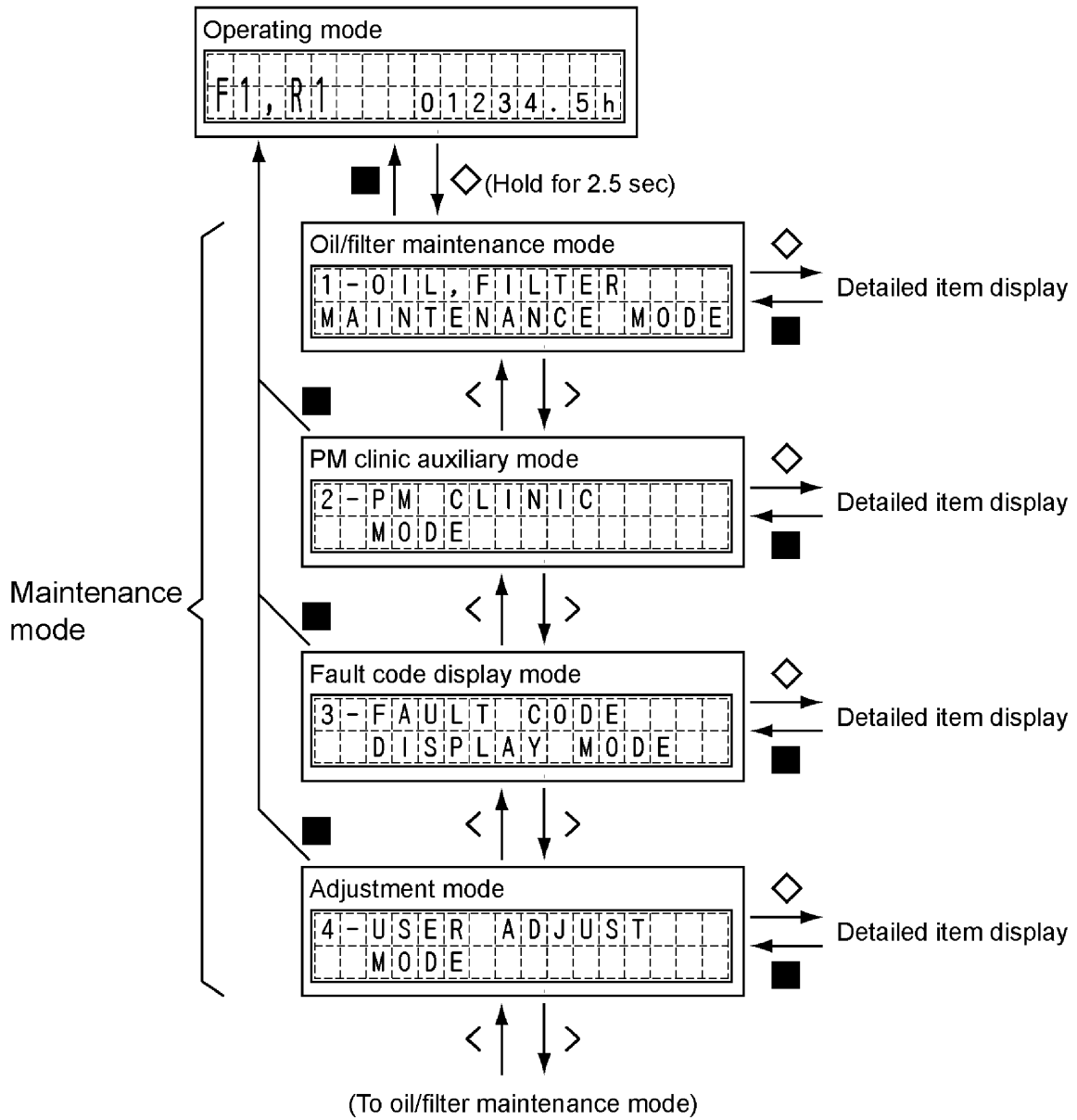

## METHOD OF USING MAINTENANCE MODE

## NOTICE

This function is only a guideline. If dirty oil or filters are found during daily maintenance, replace them immediately.

If the controllers or monitor panel are replaced, the timer for this function will not work properly. Contact your Komatsu distributor for replacement.

The maintenance mode shows the replacement interval for the oil filters and oil on the monitor.

The content of the display is as follows.

- (1) The item is displayed.
- (2) The time remaining until replacement is displayed.
- (3) The number of times that replacement has been made until now is displayed.

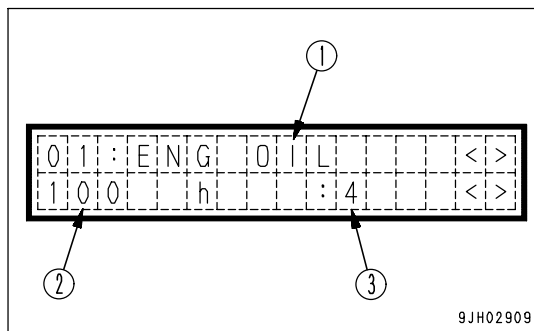

The display items can be displayed in order by operating the information switch to the left or right (<, >).

Code	Display	Item	Time to 1st replacement	Time to 2nd and following replacements
01	ENG OIL	Engine oil	500h	500h
02	ENG FILT	Engine oil filter	500h	500h
03	FUEL FILT	Fuel main filter	1000h	1000h
04	HYD FILT	Hydraulic oil filter	250h	2000h
06	CORR RES	Corrosion resistor	1000h	1000h
07	DAMP OIL	Damper oil	2000h	2000h
08	FNL OIL	Final drive oil	250h	1000h
10	HYD OIL	Hydraulic oil	250h	2000h
12	HSS FILT	HSS charge filter (*)	0	0
19	POWL OIL	Power train oil	250h	1000h
20	POWL FILT	Power train oil filter	250h	500h
41	F.PRE-FLT	Fuel pre-filter	500h	500h

(\*) Although the marked item is displayed, it is not used with this machine.

When the oil or filter has been replaced, select the applicable item, then operate the buzzer cancel switch to  $\diamond$ .

A question asking if the replacement history is to be updated is displayed.

Use the information switches (<, >) to select YES, then turn the buzzer cancel switch to  $\diamond$ . The number of times of replacement increases by 1 and the replacement time is also reset.

When this is done, if the maintenance caution lamp does not go out, there is another item close to the replacement time, so check the situation.

**REMARK**

To return to the maintenance mode, operate the buzzer cancel switch to  $\blacksquare$ .

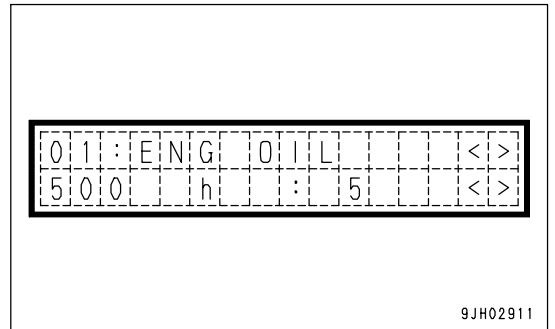
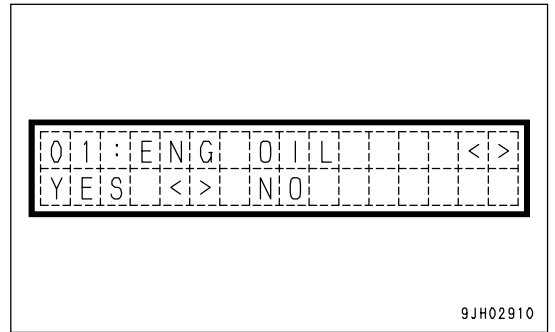

METHOD OF USING PM CLINIC AUXILIARY MODE

**CAUTION**

When moving the work equipment or setting the transmission to the travel position for carrying out measurements, check carefully that the situation is safe.

The PM clinic auxiliary mode displays the engine speed, hydraulic oil pressure, and other items on display panel B. Display panel B (Multi-information) displays the item on the top line (1) and the measured value on the bottom line (2).

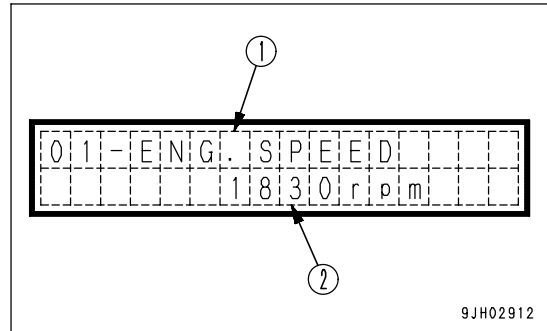

The display items consist of the six items in the table below. The items can be selected by operating the information switch (<, >).

Display	Item	Measured Value
01-ENG SPEED	Engine revolution	Revolution (rpm)
02-COOLANT TEMP.	Engine cooling water temperature	Temperature (°C)
03-ENG OIL PRESS.	Engine oil pressure	Pressure (kPa)
05-BOOST PRESS.	Engine boost pressure	Pressure (kPa)
06-BOOST TEMP.	Engine boost temperature	Temperature (°C)
07-T/C TEMP.	Power train oil temperature	Temperature (°C)
08-HYD TEMP.	Hydraulic oil temperature	Temperature (°C)
09-HYD PRESS.1	Hydraulic pressure	Pressure (MPa)
13-BATTERY VOLT.	Battery voltage	Voltage (mV)

**REMARK**

- Items such as the engine speed fluctuate and are difficult to see during the measurement. In such cases, operate the buzzer cancel switch to ◊. This makes it possible to hold the display of the value.
- To cancel this mode, operate the buzzer cancel switch again to ◊.
- To return to the maintenance mode, operate the buzzer cancel switch to ■.

**METHOD OF USING FAULT CODE DISPLAY MODE**

**NOTICE**

The fault items observed by this function are connected with the electronic control, so even if a fault code is not displayed, there is probably some problem with the machine. If the operator feels any problem with the machine, the machine should be stopped immediately and checked.

When any disconnection or short circuit in any sensor is detected, the location and fault code are displayed by a 6-digit code on display panel B (multi-information). When contacting your Komatsu distributor, inform your distributor of the code at the same time.

If the failure observation function has not determined the condition of the machine, the display is as shown in the diagram on the right.

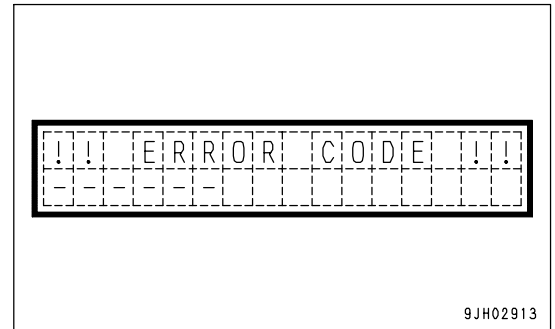

With this function, existing failures can be displayed up to a maximum of 20 items.

If multiple failures are occurring, the display automatically changes every 2 seconds, so check the code (1).

The display is shown repeatedly.

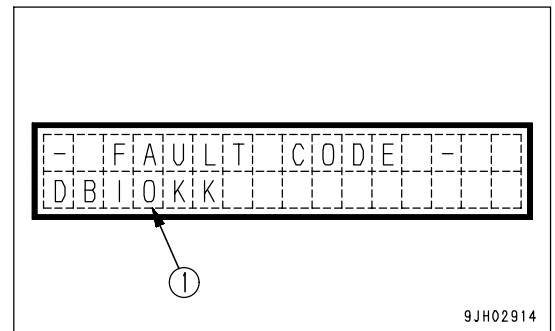

**REMARK**

To return to the maintenance mode, operate the buzzer cancel switch to ■.

**METHOD OF USING USER ADJUST MODE**

With the user adjust mode, the brightness of the panel screen backlighting and the contrast of the liquid crystal panel can be changed, or the cooling fan can be set to maximum speed to clean the radiator when it is clogged. These are displayed on display panel B.

1. Adjusting backlighting of liquid crystal display

- 1) The diagram on the right is the mode for adjusting the brightness of the backlighting of the liquid crystal panel. This display will be switched to the screen brightness adjustment display, if the alarm buzzer cancellation switch is turned to the  $\diamond$  position.

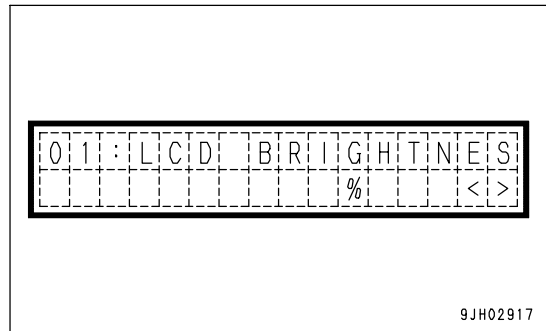

- 2) The brightness can be adjusted by operating the information switch. The higher the number, the brighter the screen becomes; the lower the number, the darker the screen becomes.
  - > position: Number increases
  - < position: Number decreases

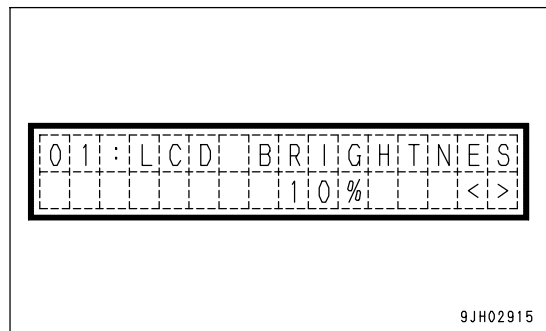

- 3) The brightness of the backlight for the LCD gauges may be held constant by turning the alarm buzzer cancellation switch to the  $\diamond$  position.

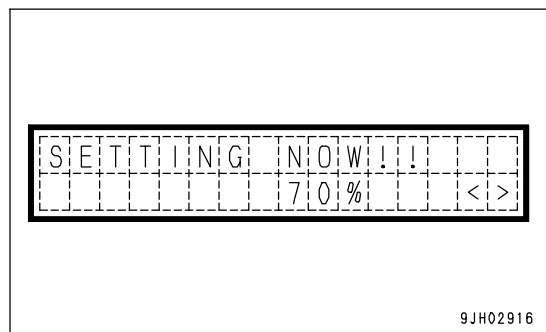

**REMARK**

- To return to the maintenance mode, operate the buzzer cancel switch to  $\blacksquare$ .
- The brightness of the backlighting of the monitor panel differs according to whether the front lamp is lit or not. Entering this mode when the front lamps are lit makes it possible to adjust the brightness when the front lamps are lit. In the same way, entering this mode when the front lamps are not lit makes it possible to adjust the brightness when the front lamps are not lit.

2. Adjusting backlighting of display panel B (multi-information)

1) The diagram on the right is the mode for adjusting the brightness of the backlighting of the display panel B (multi-information).

On the screen, operate the buzzer cancel switch to  $\diamond$  to switch to the screen for adjusting the brightness.

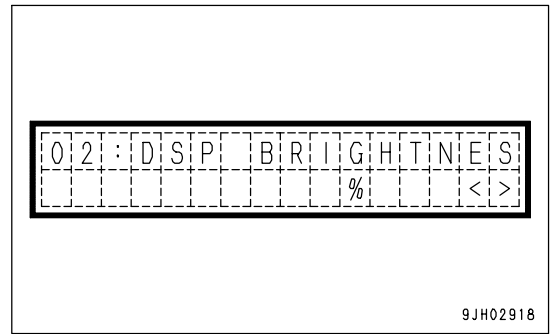

2) The brightness can be adjusted by operating the information switch.

The higher the number, the brighter the screen becomes; the lower the number, the darker the screen becomes.

> position: Number increases

< position: Number decreases

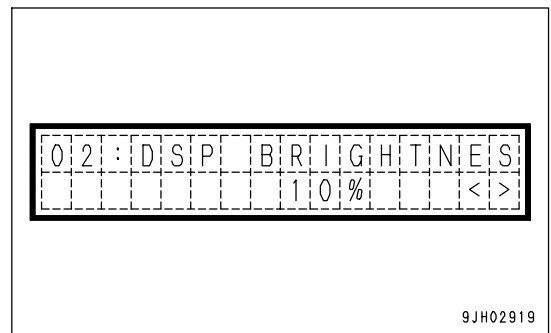

3) When the buzzer cancel switch is operated to  $\diamond$ , the brightness of the display panel B (multi-information) backlighting is set.

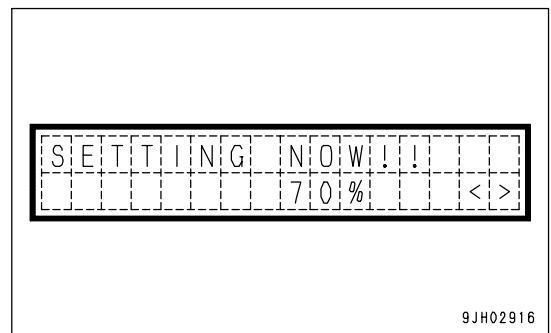

**REMARK**

- To return to the maintenance mode, operate the buzzer cancel switch to  $\blacksquare$ .
- The brightness of the backlighting of the monitor panel differs according to whether the front lamp is lit or not. Entering this mode when the front lamps are lit makes it possible to adjust the brightness when the front lamps are lit. In the same way, entering this mode when the front lamps are not lit makes it possible to adjust the brightness when the front lamps are not lit.



3. Adjusting contrast of liquid crystal display panel B (multi-information)

1) The diagram on the right is the mode for adjusting the contrast of the liquid crystal display panel B (multi-information).

On this screen, operate the buzzer cancel switch to ◇ to switch to the screen to adjust the contrast.

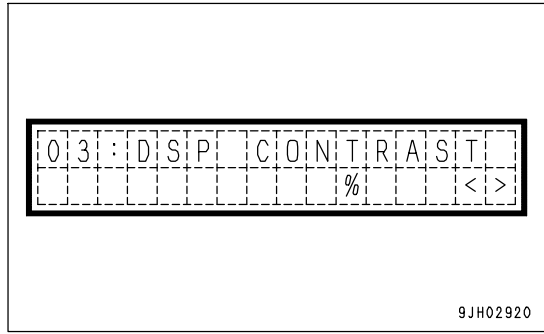

9JH02920

2) The contrast can be adjusted by operating the information switch.

The higher the number, the deeper the screen becomes; the lower the number, the lighter the screen becomes.

> position: Number increases

< position: Number decreases

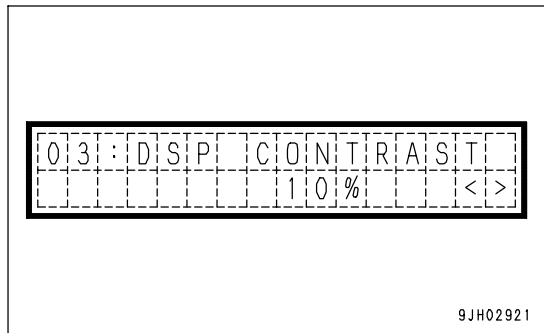

9JH02921

3) When the buzzer cancel switch is operated to ◇, the contrast of the liquid crystal display panel B (multi-information) is set.

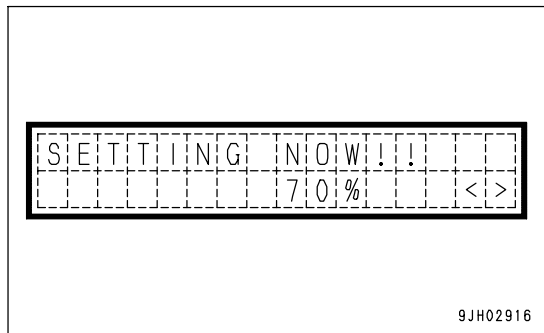

9JH02916

4. Mode to rotate cooling fan at maximum speed

The diagram on the right is the mode for rotating the cooling fan at maximum speed. On this screen, operate the buzzer cancel switch to ◇ to rotate the cooling fan at the maximum speed.

Note that this mode is effective only when the display in the diagram on the right is being given. After leaving this mode, the screen returns to the normal mode.

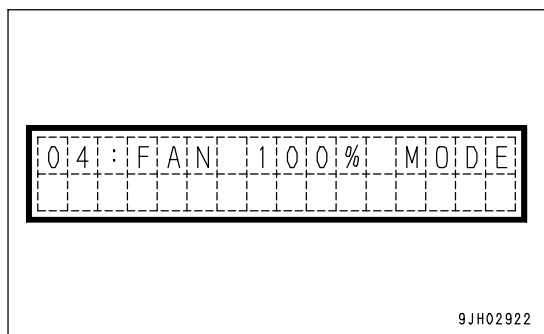

9JH02922

REMARK

- To return to the maintenance mode, operate the buzzer cancel switch to ■.
- The brightness of the backlighting of the monitor panel differs according to whether the front lamp is lit or not. Entering this mode when the front lamps are lit makes it possible to adjust the brightness when the front lamps are lit. In the same way, entering this mode when the front lamps are not lit makes it possible to adjust the brightness when the front lamps are not lit.

SWITCHES

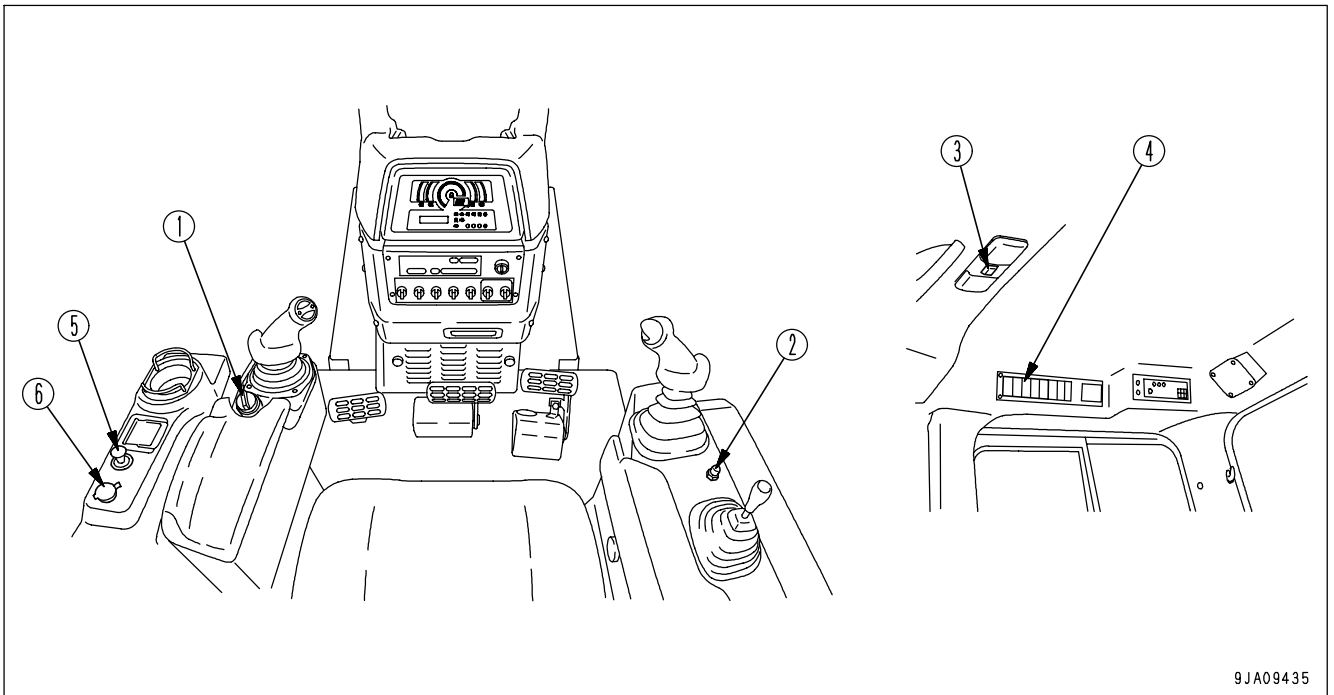

9JA09435

- (1) Fuel control dial
- (2) Horn switch
- (3) Room lamp switch
- (4) Wiper switch
- (5) Cigarette lighter (24V)
- (6) Accessory socket (12V)

FUEL CONTROL DIAL

Dial (1) is used to control the engine speed and output.

- (a) Low idling position: Turn fully to the left
- (b) High idling position: Turn fully to the right

REMARK

To stop the engine, turn the starting switch to the OFF position.

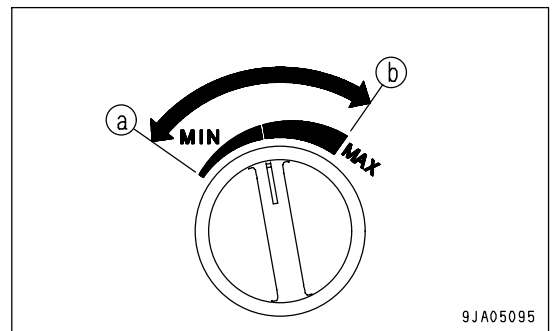

9JA05095

HORN SWITCH

The horn sounds when the button (2) at the rear of the blade control lever at the right side of the operator's seat is pressed.

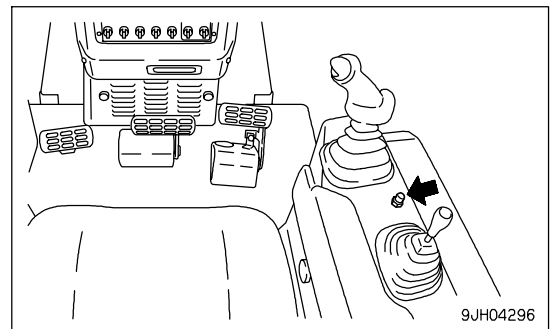

9JH04296

**ROOM LAMP SWITCH**

This (3) illuminates the room lamp.

- (A) ON position: Lamps light up
- (B) OFF position: Lamps are out

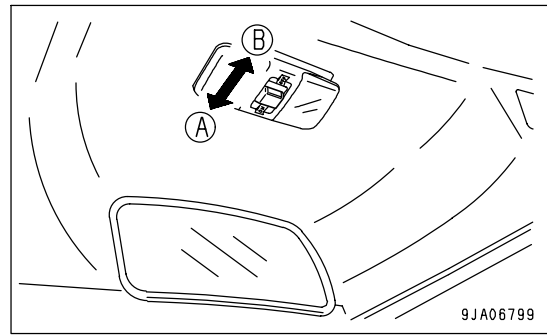

**WIPER SWITCH**

This (4) activates the wipers.

The wiper switches are as follows:

- (A): Left door (LH)
- (B): Front window (FF)
- (C): Right door (RH)
- (D): Rear window (RR)
- (E): Wiper intermittent operation switch (INT)

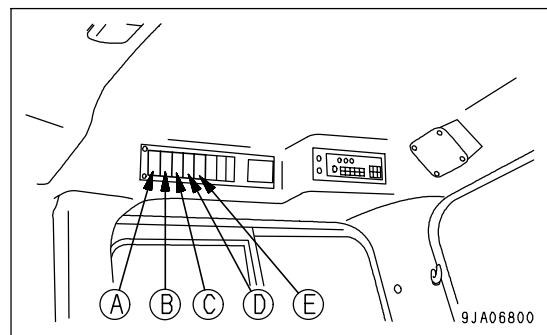

This is also used as the window washer switch.

The switch is operated as follows.

- Wiper only
  - (J) ON position: Wiper is operated
  - (K) OFF position: Wiper stops

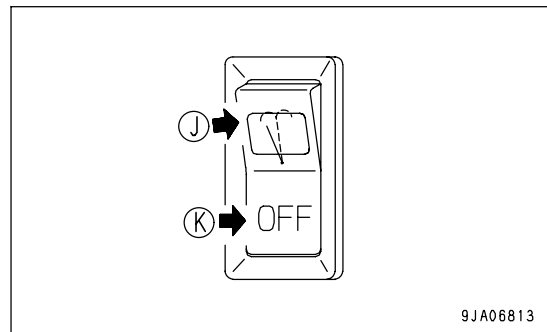

- Wiper and window washer
  - If this is kept pressed to the ON position (J) while the wiper is working, water will be sprayed out.

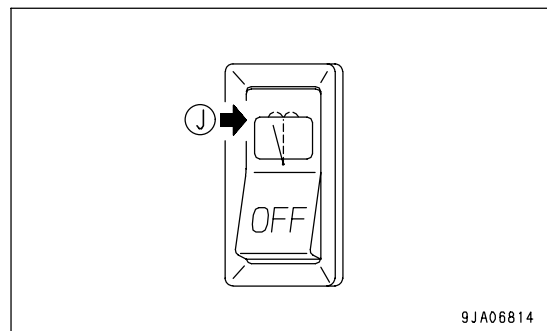

- Only wind washer  
If this is kept to the OFF position (K), water will be sprayed out.

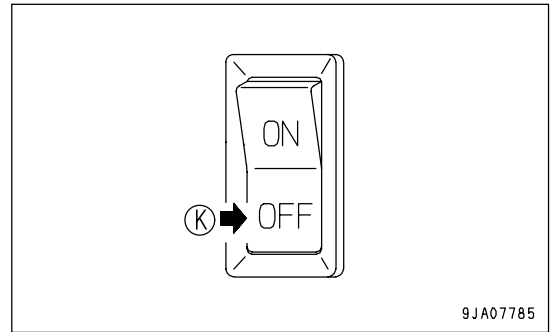

- Wiper intermittent operation switch  
When this switch is turned to the ON position (J) to start the wiper moving, the wiper works once in every four seconds.

**REMARK**

When the wiper intermittent operation switch is ON position (J), if the wiper switch for each window is turned ON position (J), the wiper will move intermittently.

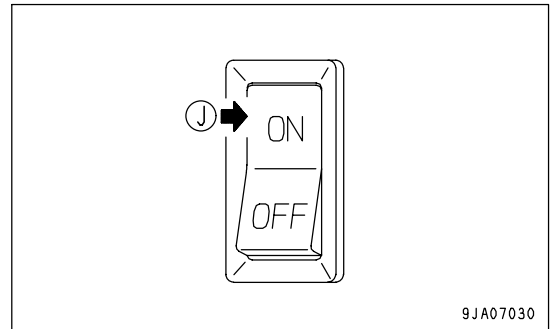

**REMARK**

When installing the cab, check the colors of the washer tank and window washer hoses, and be sure to connect correctly.

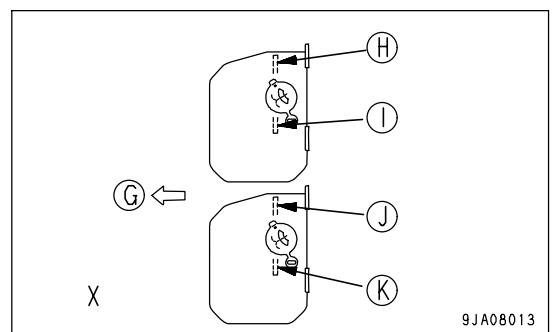
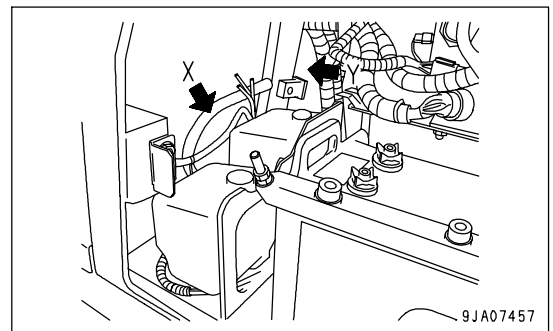

- |                                |                         |
|--------------------------------|-------------------------|
| (G) Machine Front              | (J) Right Door (red)    |
| (H) Left Door (blue)           | (K) Rear Window (black) |
| (I) Front Window (transparent) |                         |

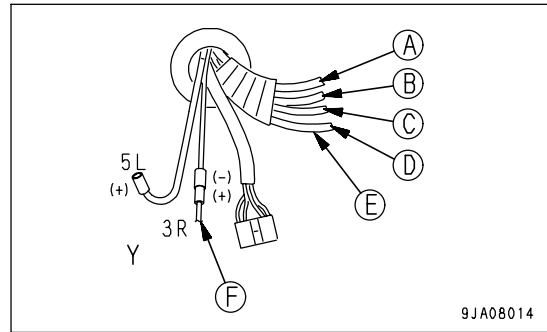

- (A) Red --- Right Door
- (B) Blue --- Left Door
- (C) Black --- Rear Window
- (D) Transparent --- Front Window
- (E) Washer Tube
- (F) From fuse box
- Red (backup power)

**CIGARETTE LIGHTER**

This (5) is used to light cigarettes.

When the cigarette lighter is pushed in, it will return to its original position after a few seconds, so take it out to light your cigarette. If the cigarette lighter is removed, the socket can be used as a power source.

**NOTICE**

This cigarette lighter is 24V. Do not use it as the power supply for 12V equipment. This will cause failure of the equipment. The capacity of the cigarette lighter is 120W (24V x 5A).

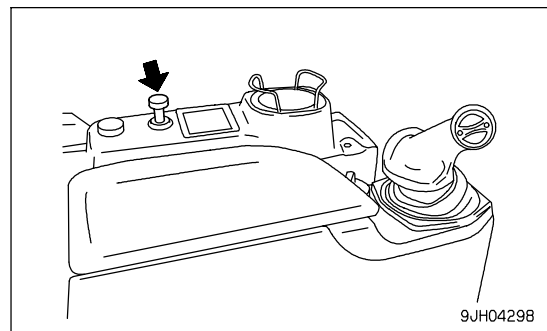

**ACCESSORY SOCKET**

This (6) is used as the power source for a wireless or other 12V equipment.

Accessory socket capacity: 60W (12V x 5A)

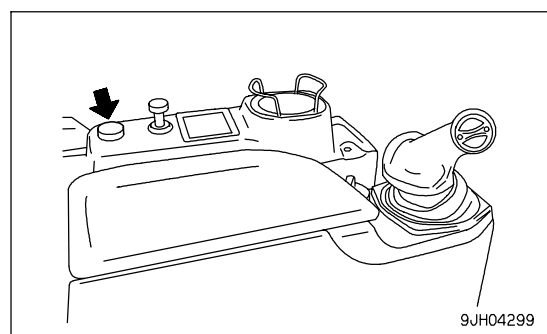

**CONTROL LEVERS AND PEDALS**

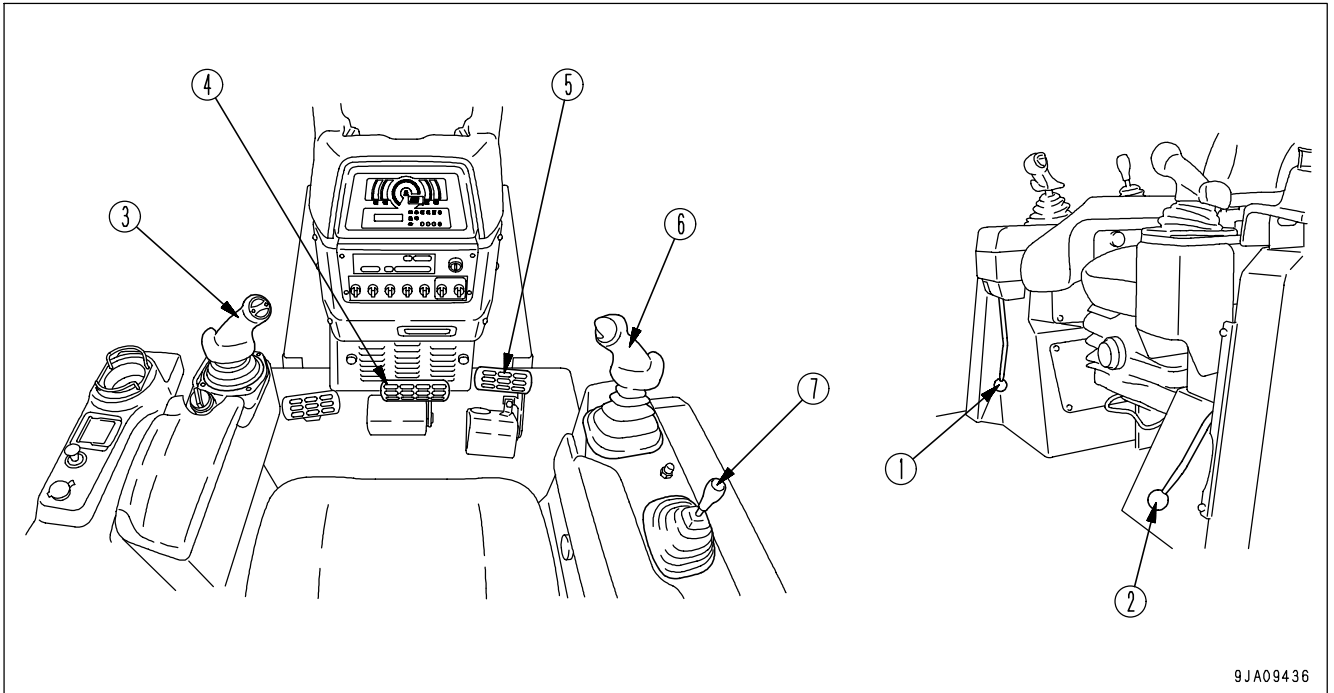

9JA09436

- |   |                          |
|---|--------------------------|
| (1) Work equipment lock lever                   | (5) Deceleration pedal   |
| (2) Parking brake lever                         | (6) Blade control lever  |
| (3) Steering, forward-reverse, gear shift lever | (7) Ripper control lever |
| (4) Brake pedal                                 |                          |

**WORK EQUIPMENT LOCK LEVER**

**! WARNING**

- When leaving the operator's compartment, set the work equipment lock lever securely to the LOCK position. If the work equipment lock lever is not at the LOCK position and the control levers are touched by mistake, it may lead to serious personal injury.
- If the work equipment lock lever is not set securely to the LOCK position, the work equipment may move and cause serious injury. Check that it is in the position shown in the diagram.
- When parking the machine or when carrying out maintenance, always lower the work equipment to the ground, then set the work equipment lock lever to the LOCK position.

This lever (1) serves as a locking device for the blade control lever and ripper control lever.

- (L) LOCK position: Work equipment does not move even when work equipment control lever is operated
- (F) FREE position: Work equipment moves according to operation of work equipment control lever

**REMARK**

When starting the engine, to ensure safety, always set the work equipment lock lever to the LOCK position.

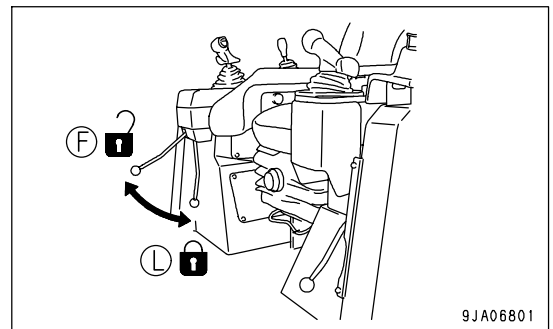

9JA06801

## PARKING BRAKE LEVER

### WARNING

- When parking the machine, always set the parking brake lever in the LOCK position.
- If the parking brake lever is operated, the brake is applied, even when the machine is traveling.  
The machine will suddenly stop, so this is dangerous. For this reason, do not operate the parking brake lever when the machine is moving, except in emergencies.

This lever (2) is the control lever for the parking brake.

(L) LOCK position: Parking brake is applied

(F) FREE position: Parking brake is released

#### REMARK

- Before moving the parking brake lever to the LOCK position, return the steering, forward-reverse, gear shift lever to the NEUTRAL position.
- When starting the engine, if the parking brake lever is not in the LOCK position, the limit switch is actuated and it is impossible to start the engine.

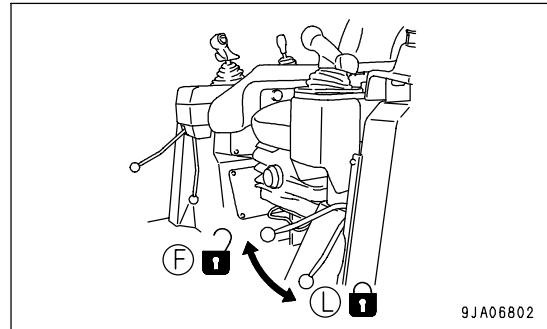

## STEERING, FORWARD-REVERSE, GEAR SHIFT LEVER

This control lever (3) serves to change forward or reverse direction of machine travel, steer the machine to the right or left, change the traveling speed and make a counter-rotation.

#### • Forward-reverse shifting

Position (a): FORWARD

Position (b): REVERSE

Position N: Neutral

Move to the front to drive forward; move to the rear to drive in reverse.

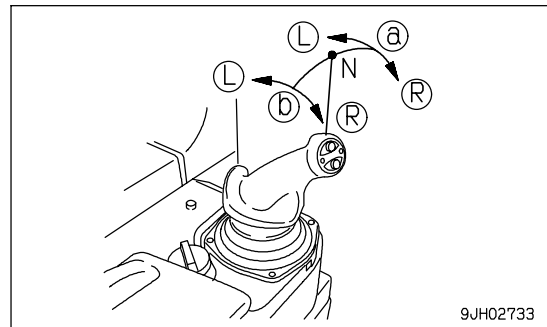

#### • Steering

Position (L): Left turn

Position (R): Right turn

With the lever moved to the front or rear, operate the lever partially to the left or right to turn the machine. The machine will turn gradually in the same direction as the lever is operated.

If the lever is moved fully to the left or right, the machine will turn in a small radius.

#### REMARK

When moving the joystick lever, and the lever is released, it will return to (a) or (b) and the machine will travel in a straight line.

### • Gear shifting

When the steering, directional, and gearshift lever is at the FORWARD or REVERSE position and switch (c) or switch (d) is pushed, the transmission speed will change.

UP switch (c): Each time the switch is pressed, the transmission will shift up one speed.

DOWN switch (d): Each time the switch is pressed, the transmission will shift down one speed.

For details of the maximum speed in each speed range, see "SPECIFICATIONS (PAGE 5-2)".

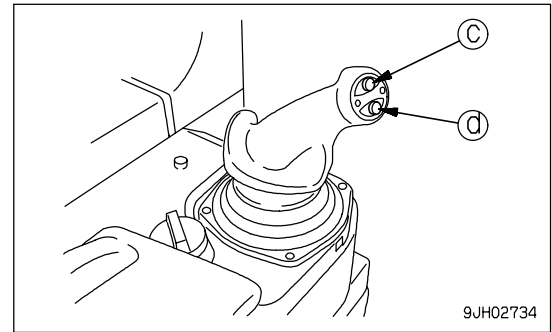

9JH02734

### REMARK

The speed range being used is displayed on panel A on the monitor panel according to the gearshift operation.

<Example>

Neutral: N is displayed on the display panel.

FORWARD 2nd: F2 is displayed on the display panel.

REVERSE 3rd: R3 is displayed on the display panel.

When the parking brake lever is locked, P is displayed.

- For details of the method of shifting gears according to the shift mode, see the "SHIFTING GEARS (PAGE 3-105)". Shift mode selection means that the selected speed range is displayed at the NEUTRAL position (N) before starting.

### • Operating counter-rotation turn



## WARNING

When operating the counter-rotation turn, if the load on the left and right is not balanced, the machine may make a pivot turn, so check the ground conditions and be careful not to hit any obstacles when carrying out the operation.

With the lever in the N position, move the lever partially in the direction of turn. The left and right tracks will rotate in opposite directions, and the machine will make a slow counter-rotation turn. If the lever is moved further, the speed of the counter-rotation turn will increase.

(R): Right counter-rotation turn

(L): Left counter-rotation turn

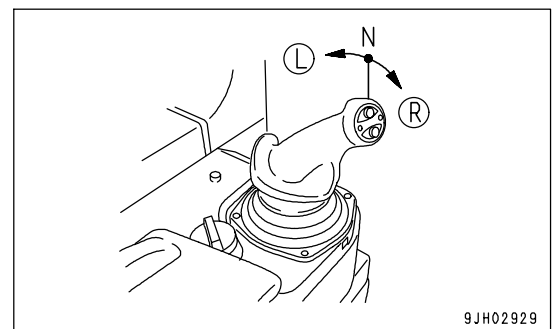

9JH02929



**BRAKE PEDAL****WARNING**

Do not place your foot on this pedal unnecessarily.

Depress the pedal (4) to apply the right and left brakes.

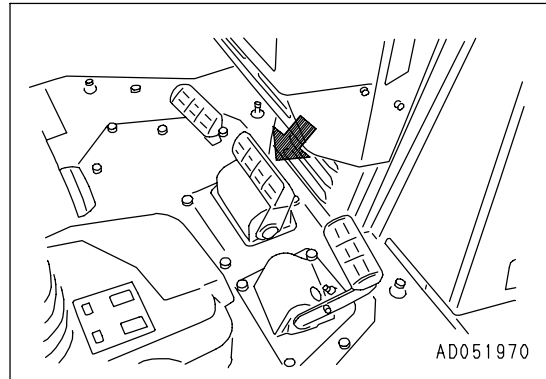
**DECELERATOR PEDAL****WARNING**

- Do not rest your foot on the pedal if you are not using it.
- When passing over the top of a slope or when dumping soil from a cliff, the load on the machine will suddenly be reduced and the travel speed will increase. This situation is dangerous, so use the decelerator pedal to reduce the travel speed of the machine

This pedal (5) is used when reducing the engine speed or stopping the machine.

When switching between forward and reverse, or when stopping the machine, use this pedal to reduce speed.

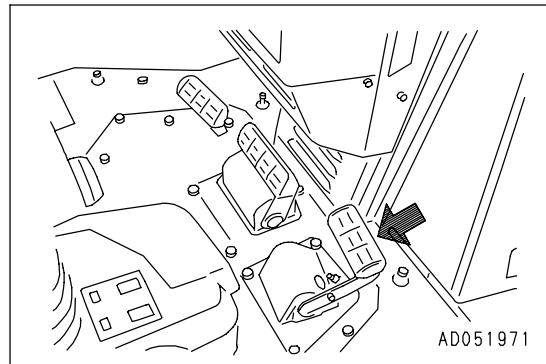

**BLADE CONTROL LEVER**

**POWER TILDOZER**

This lever (6) is used to lift or tilt the blade.

- Lifting control

- (a) RAISE:
- (b) HOLD: Blade is stopped and held in this position.
- (c) LOWER:
- (d) FLOAT: Blade will move freely according to external force.

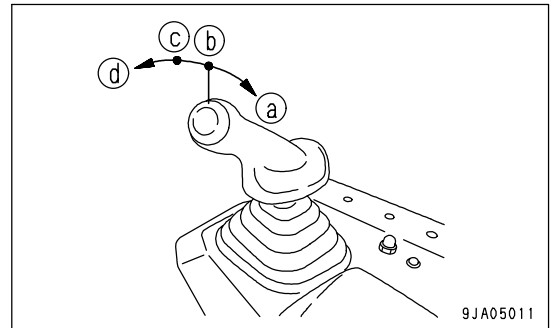

**REMARK**

- If the lever is in the FLOAT position, even when it is released, it does not return to the HOLD position, so return it by hand.
- If the engine is stopped when the control lever is in the FLOAT position, the lever is returned automatically to the HOLD position.
- In low temperatures, it may take a short time for the blade control lever to be held in the FLOAT position, so hold the lever in position for at least 1 second.

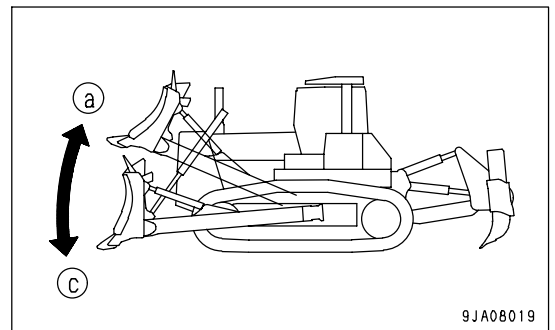

- Tilting control

- (b) HOLD: Blade is stopped and held in this position.
- (e) LEFT TILT
- (f) RIGHT TILT

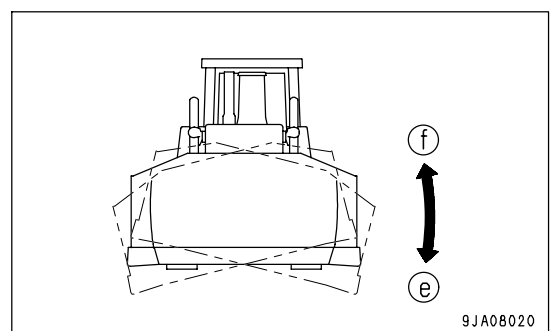
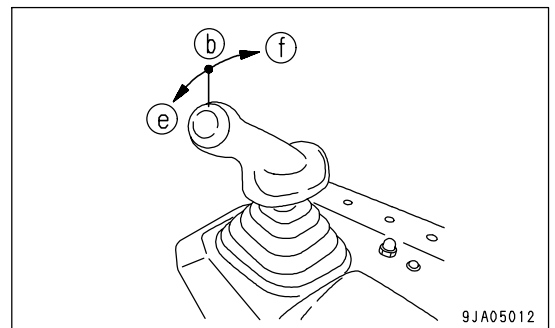

**ANGLE DOZER**

This lever (6) is used to lift the blade.

- Lifting control

- (a) RAISE:
- (b) HOLD: Blade is stopped and held in this position.
- (c) LOWER:
- (d) FLOAT: Blade will move freely according to external force.

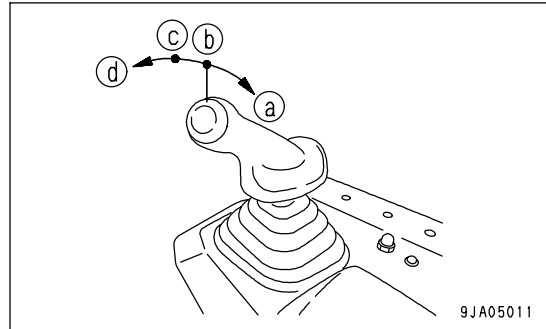

9JA05011

**REMARK**

- If the lever is in the FLOAT position, even when it is released, it does not return to the HOLD position, so return it by hand.
- If the engine is stopped when the control lever is in the FLOAT position, the lever is returned automatically to the HOLD position.
- In low temperatures, it may take a short time for the blade control lever to be held in the FLOAT position, so hold the lever in position for at least 1 second.

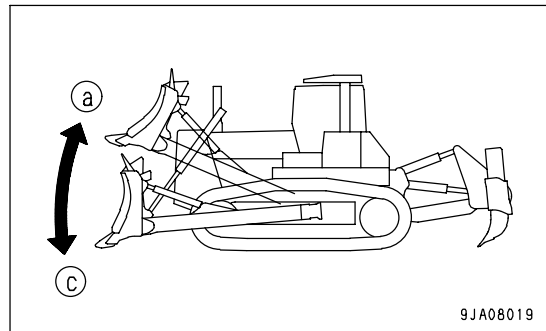

9JA08019

**RIPPER CONTROL LEVER**

This lever (7) is used to operate the ripper.

**FIXED MULTI-SHANK RIPPER SPECIFICATION**

- (a) RAISE
- (b) HOLD: Ripper is stopped and held in the same position.
- (c) LOWER

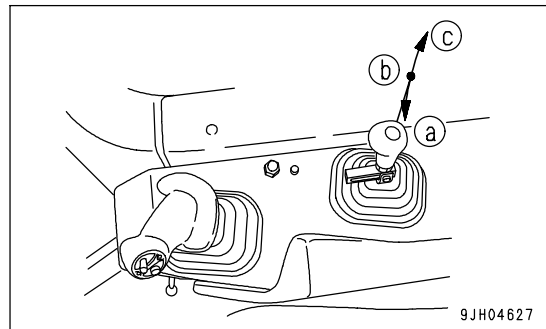

9JH04627

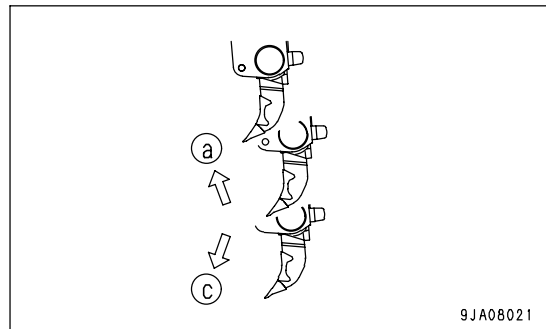

9JA08021

VARIABLE MULTI-SHANK RIPPER SPECIFICATION

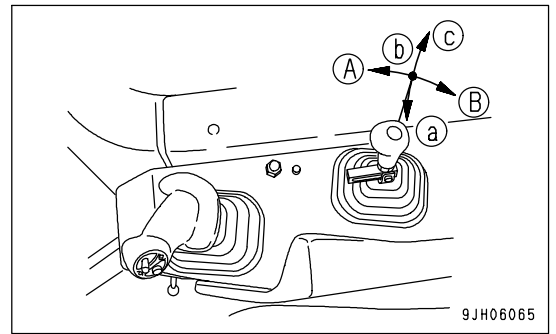

- Lift operation
- (a) RAISE
- (b) HOLD: Ripper is stopped and held in the same position.
- (c) LOWER

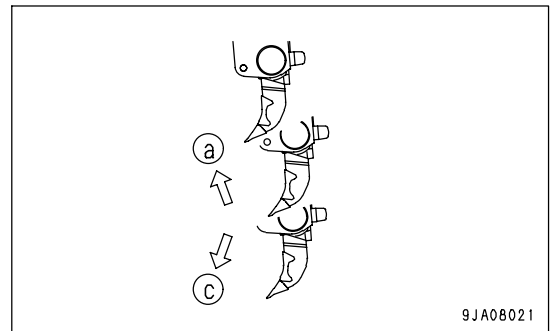

- Tilt operation
- (A) Tilt in
- (B) Tilt back

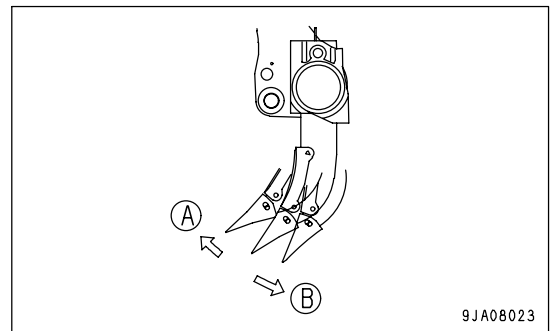

## FUSE

### NOTICE

Before replacing a fuse, be sure to turn starting switch to the OFF position.

The fuses protect the electrical equipment and wiring from burning out.

If the fuse becomes corroded, or white powder can be seen, or the fuse is loose in the fuse holder, replace the fuse.

Replace the fuse with another of the same capacity.

- Chassis

When opening the battery cover, you can see fuse box (A) and (B) and circuit breaker (1) for the main power source.

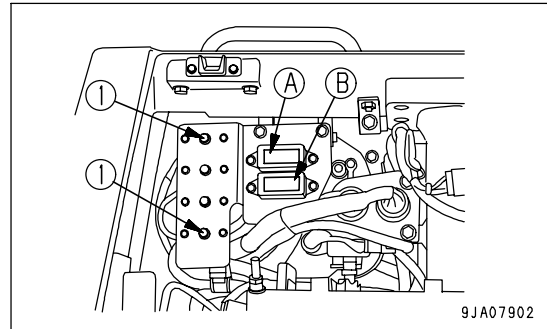

When opening the air conditioner filter cover, you can see circuit breaker (2).

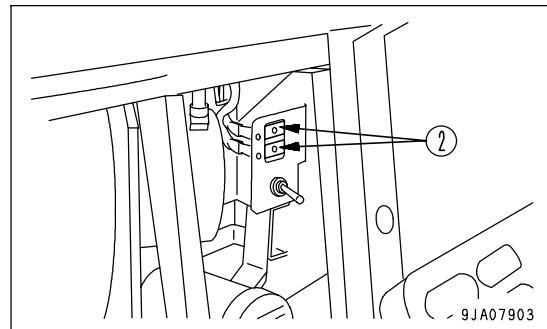

- Cab (machines equipped with cab)

Fuse box (C) is installed in the overhead panel.

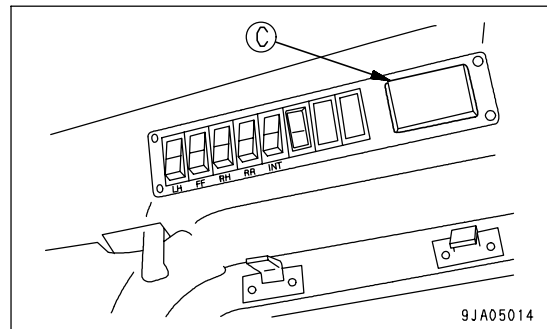

FUSE CAPACITY AND CIRCUIT NAME

Fuse box (A)

No.	Fuse capacity	Circuit
1	30A	Spere power source
2	20A	Horn, Intake air heater
3	20A	Head lamp
4	20A	Rear lamp
5	20A	Controller continuous power

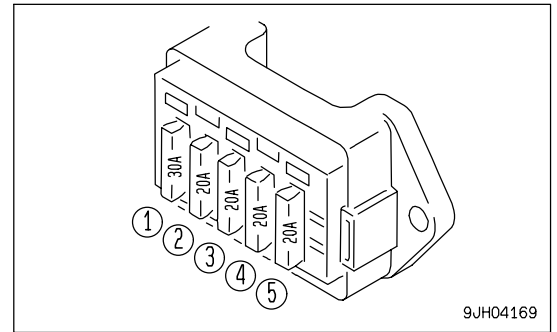

9JH04169

Fuse box (B)

No.	Fuse capacity	Circuit
(1)	20A	Engine starting switch
(2)	30A	Transmission Steering controller
(3)	30A	Backup alarm (Reverse travel alarm buzzer)
(4)	30A	Air conditioner
(5)	5A	Accessory power

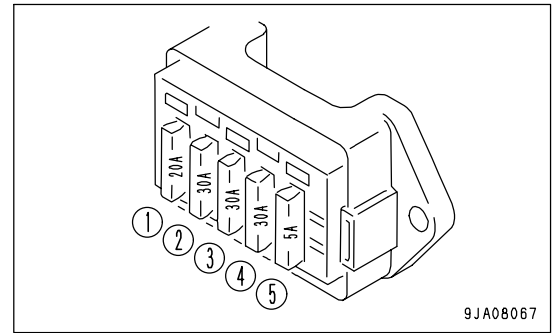

9JA08067

Fuse box (C)

No.	Fuse capacity	Circuit
(1)	10A	Radio memory
(2)	20A	Radio, lamp, cigarette lighter
(3)	20A	Heated wire glass (If equipped)
(4)	10A	Rear wiper
(5)	10A	Front wiper
(6)	10A	Left and right door wiper

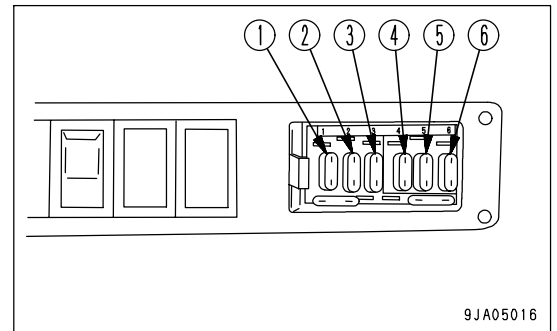

9JA05016

## CIRCUIT BREAKER FOR MAIN POWER SUPPLY

- When the engine starting motor does not work after turning the engine starting switch key to the ON position, open up the battery cover on the machine's left rear to check circuit breaker (1) and (4).
- If there is a surge of current, the circuit breaker shuts off the circuit to protect the electrical components and wiring from damage.
- Turn the starting switch to the OFF position and reset the circuit breaker.

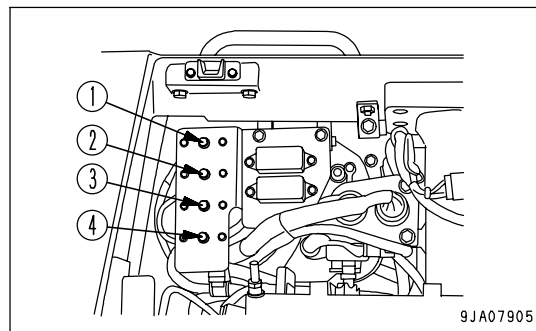

- When resetting the electrical circuit after it has been shut off, press the reset button 5 to 10 minutes after the circuit has been shut off. When the electrical circuit has been shut off, the operation of the reset button is heavier than when the circuit is normal. The height of the reset button is the same, regardless of whether the circuit has been shut off or has been reset, so make note of the effort of the reset button when resetting the circuit.
- Do not keep the circuit breaker reset button longer than necessary.
- If the starting motor does not work even when the circuit breaker has been reset, contact your Komatsu distributor.

No	Fuse capacity	Circuit
(1)	105A	Main power source
(2)	30A	Continuous power for engine controller
(3)	105A	Intake air heater
(4)	30A	Continuous power source

**CIRCUIT BREAKER**

- If the starting switch does not work even when the starting switch is turned to the ON position, open the recirculated air filter cover to gain access to the circuit breaker.
- If excessive current flows through the circuit breaker, it cuts off the electric circuit to prevent damage to the electrical components and wiring.
- To restore the electric circuit after it has been cut off, push in reset button (3). (This springs out when the circuit is cut off.)  
If the electric circuit is normal, reset button (3) will stay pushed in. If it comes out immediately when it is pushed in, the electric circuit must be checked.

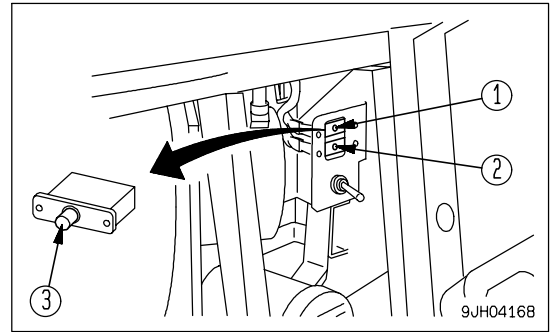

Circuit breakers (1) and (2) also act as reset button (3).

No	Fuse capacity	Circuit
(1)	20A	Starting switch
(2)	20A	Air conditioner

**REMARK**

The circuit breaker is a device installed in electric circuits where a large current flows. It is installed to protect the electric circuit. It protects the electric components and wiring from damage caused by an abnormal current in the same way as a normal fuse. After repairing and restoring the location of the abnormality, there is no need to replace the breaker. It can be used again.

**ELECTRIC POWER TAKE-OUT ADAPTER**

**NOTICE**

The power for the cigarette lighter is 24V. Do not use it as the power source for 12V equipment.

The cigarette lighter socket (1) can be used as a power source for 24V equipment and the accessory socket (2) can be used for 12V equipment.

- Capacity of cigarette lighter : 120W (24V x 5A)
- Capacity of accessory socket : 60W (12V x 5A)

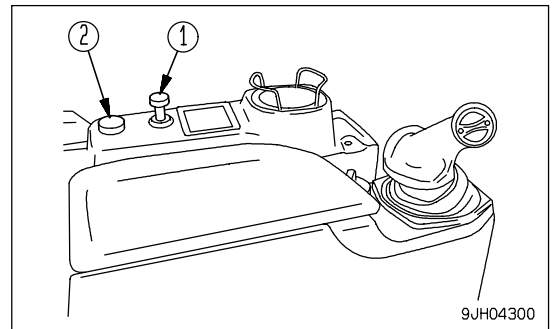



## CAP WITH LOCK

Lock-type caps are available for the radiator water filler cap, hydraulic tank oil filler cap, and fuel tank filler cap. For details of the locations of the caps with locks, see "LOCKING (PAGE 3-125)".

Use the starting switch key to open and close the locks on the caps.

## METHOD OF OPENING RADIATOR CAP AND FUEL CAP

(If equipped)

### OPENING THE CAP

1. Insert the key. Make sure that you have inserted the key fully (1) before turning it. If the key is turned when only partially inserted, it may break.

(L) : Lock position

(F) : Open position

(A) : working angle of key 180°

(B) : 45°

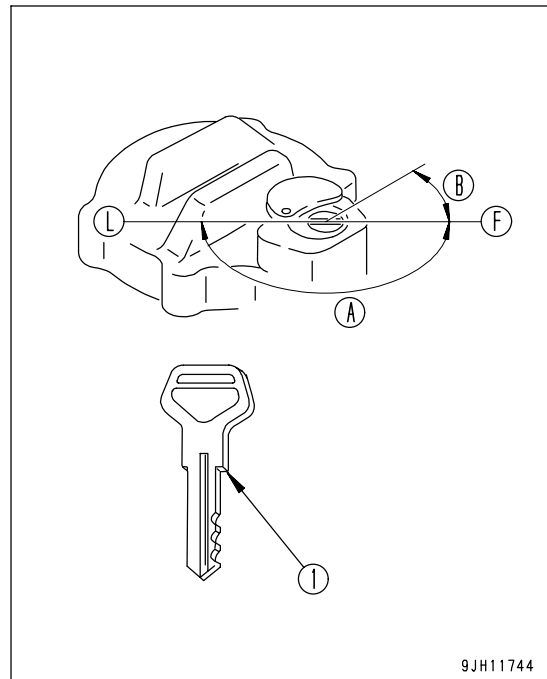

2. Turn the key counterclockwise to align the match mark (2) on the cap with the rotor groove, then turn the cap slowly. When a click is heard, the lock is released, enabling the cap to be opened.

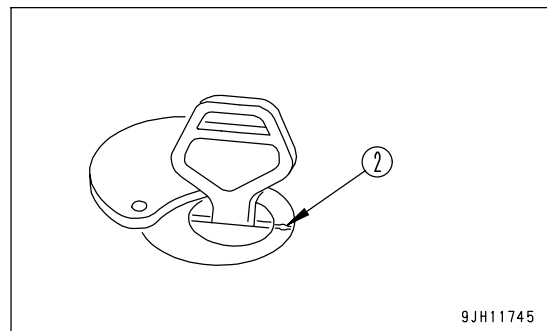

### LOCKING THE CAP

1. Turn the cap into place.
2. Turn the key clockwise and take the key out.

**METHOD OF OPENING AND CLOSING HYDRAULIC CAP**

The method of opening or closing hydraulic cap is as follows.

**OPENING THE CAP**

1. Insert the key. Make sure that you have inserted the key fully (1) before turning it. If the key is turned when only partially inserted, it may break.

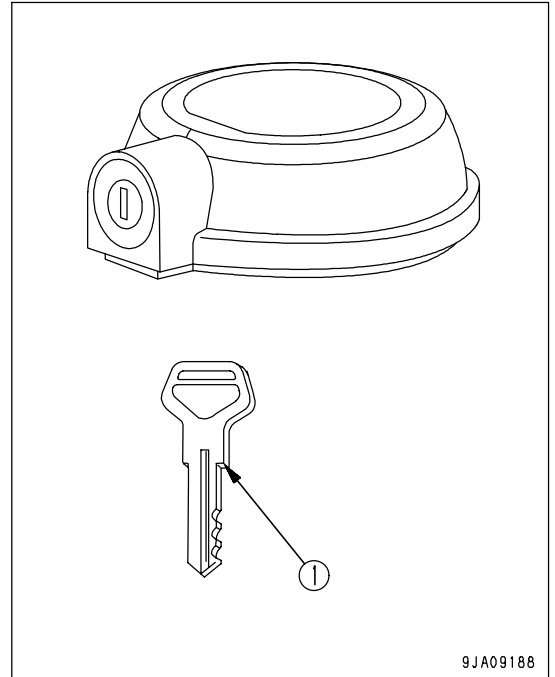

2. Turn the key counterclockwise 180° in direction (A). The cap can then be opened.

(A): Open

(B): Lock

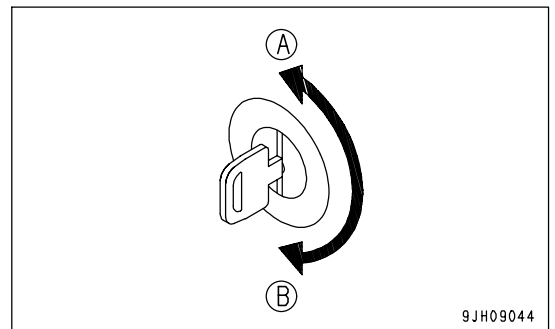
**LOCKING THE CAP**

1. Insert the key.
2. Turn the key clockwise in direction (B), then remove the key.

**DOOR - OPEN LOCK**

Use this when your want to keep the door held open.

1. Push the door against door catch (1). The door will be held by the door catch.

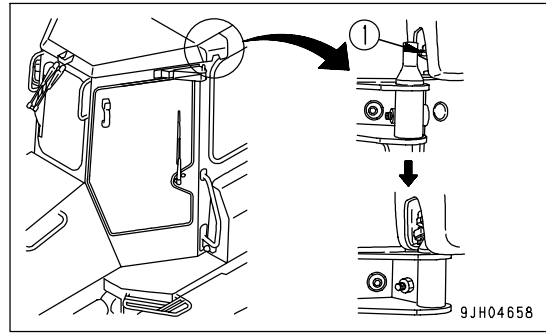

2. To release the door, move lever (2) inside the cab forward. This will release the catch.

**NOTICE**

- When keeping the door open, fix it securely to the catch.
- Always close the door when traveling or carrying out operations. Leaving the door open will cause the door to break.
- Keep the door locked open securely. The door may swing closed because of the vibration.

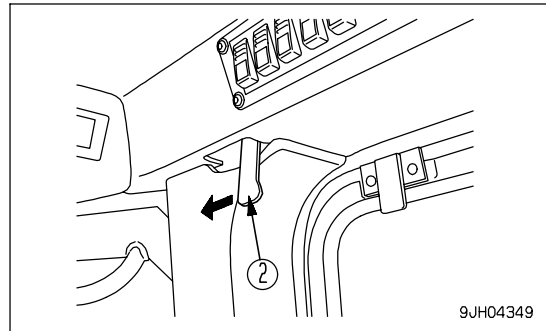

**SASH GLASS INTERMEDIATE LOCK**

When working with the cab sash glass open, use this lock to prevent the glass from chattering.

- When the lever is in the FREE position (F), the glass can be opened or closed.
- When the lever is in the LOCK position (L), the glass is held in position.

**NOTICE**

Always close the window when traveling or carrying out operations. Leaving the window open will cause the window to break.

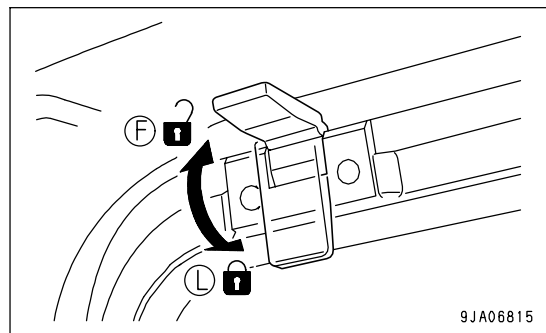
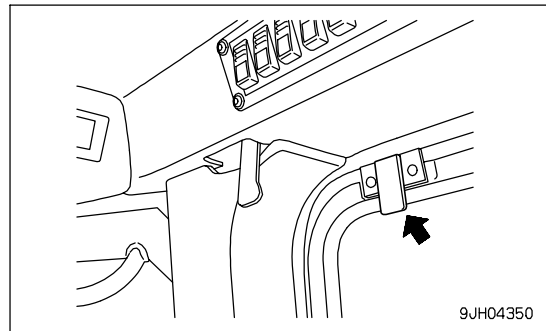

## DOOR POCKET

This is inside the left and right doors. Use it for storing the Operation and Maintenance Manual or other things.

Do not put heavy tools or other heavy objects in it.

If the pocket is dirty, turn 4 clips (1), then remove the pocket and rinse it.

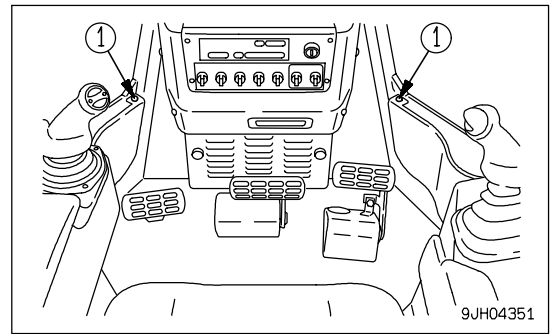

## ASHTRAY

This is on the left side of the operator's seat.

Always make sure that you extinguish the cigarette before closing the lid.

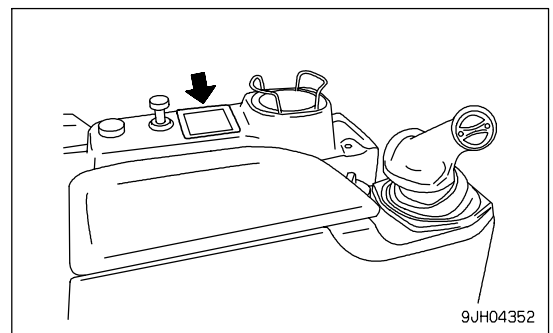

## TOOL BOX

This is on the inside when you open the battery cover on the left side of the machine.

Store the tools in this box.

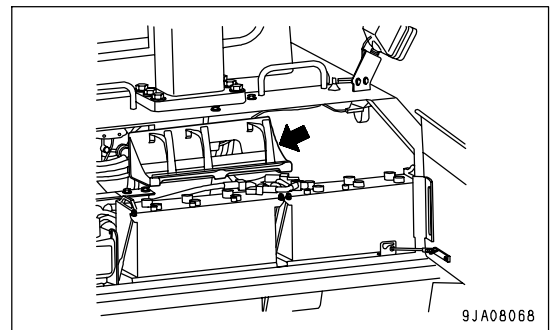

**CAR STEREO, HANDLING**

(Machine equipped with cab) (If equipped)

**EXPLANATION OF COMPONENTS**

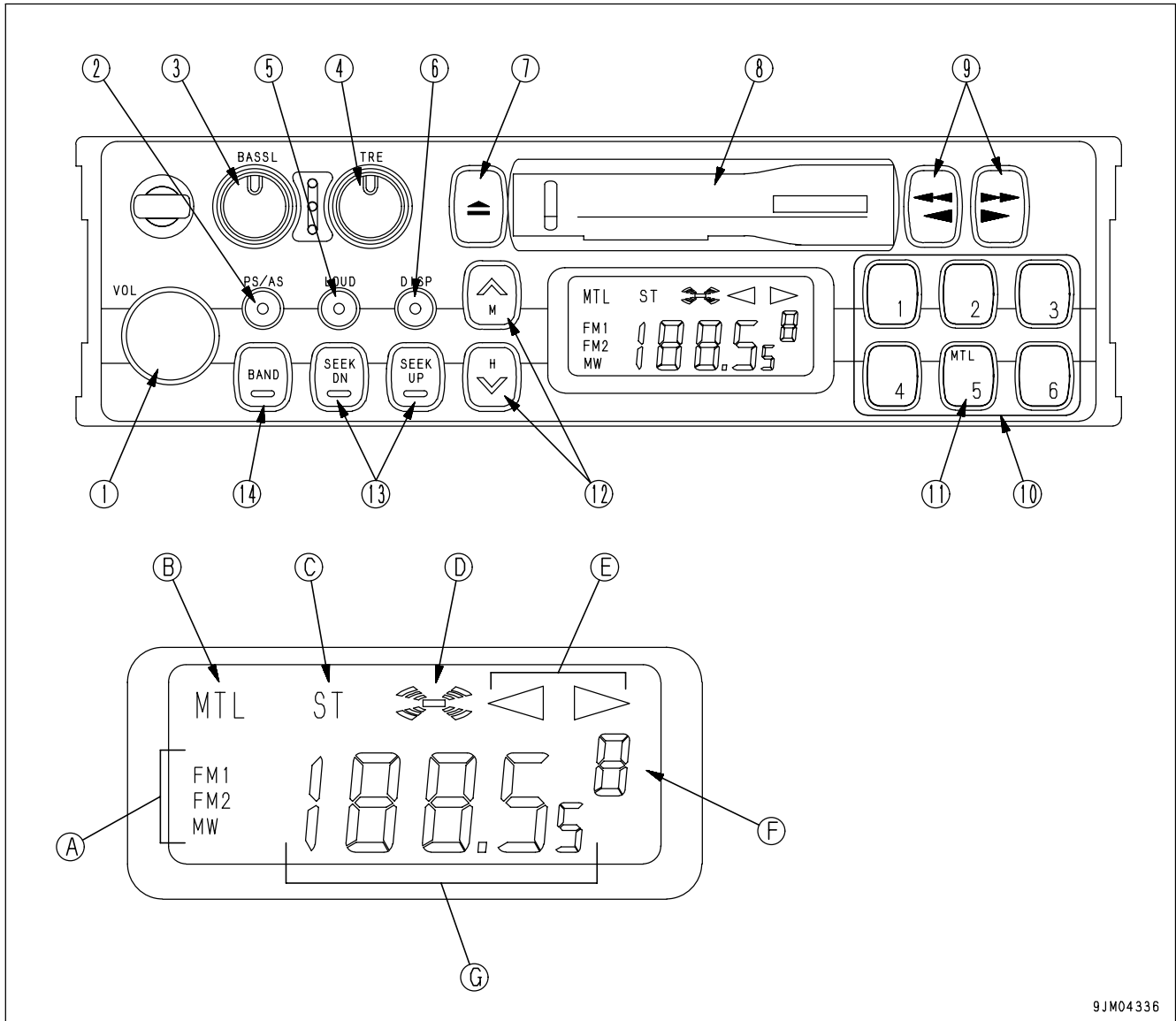

9JM04336

- |  |                                  |
|--|----------------------------------|
| (1) Power switch/volume                | (8) Cassette door                |
| (2) Auto-store/preset scan button      | (9) Fast forward, rewind buttons |
| (3) Bass control knob                  | (10) Preset buttons              |
| (4) Treble control knob                | (11) Metal tape button           |
| (5) Loudness button                    | (12) Manual tuning buttons       |
| (6) Time/radio display selector button | (13) Seek tuning buttons         |
| (7) Tape eject button                  | (14) Band selector button        |
| (A) Band display                       | (E) Tape direction display       |
| (B) Metal tape display                 | (F) Preset channel display       |
| (C) FM stereo reception display        | (G) Time/frequency display       |
| (D) Loudness display                   |                                  |

**POWER SWITCH/VOLUME**

Turn this knob (1) to the right until it clicks to turn the power on.  
Turn it further to increase the volume.

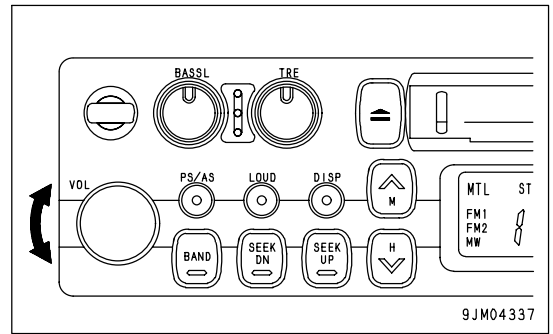

**AUTO-STORE/PRESET SCAN BUTTON**

Use this button (2) to actuate the preset scan and auto-store functions.

- Auto-store  
Each time this button is pressed for more than 2 seconds while in radio reception, this auto-store function automatically starts to search for the desired station within a receivable band, and memorize the frequency in the preset memory. During this scanning process, the frequency shown in the right side of display continues to change. This indicates that each frequency is memorized in the auto-store.

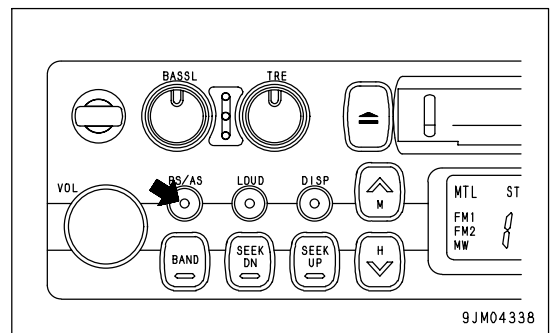

**REMARK**

The auto-store function cannot be used when the channel display is flashing.

When the display is flashing, the preset scan function is being used.

- Preset scan  
If this button is pressed for less than 0.5 second while in radio reception, programs from the six preset stations in the same band will be broadcast one after another for 5 seconds each, starting from No. 1 through No. 6 stations consecutively.  
When the desired station is found, press the button again. This stops the preset scan tuning process and switches to ordinary broadcasting. The same process will be repeated continuously until the button is pressed again.

**BASS CONTROL KNOB**

Turn this button (3) to the left to reduce the low tones; turn it to the right to emphasize the low tones.

- Direction (a): Low tone reduced
- Direction (b): Low tone emphasized

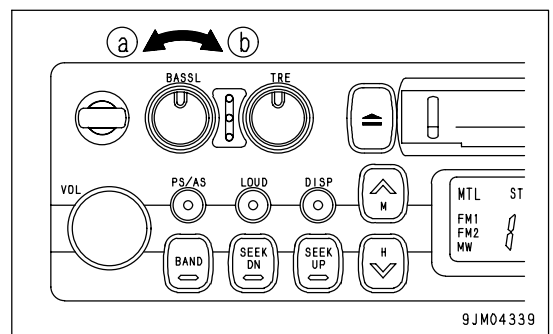

**TREBLE CONTROL KNOB**

Turn this button (4) to the left to reduce the low tones; turn it to the right to emphasize the high tones.

Direction (a): High tone reduced

Direction (b): High tone emphasized

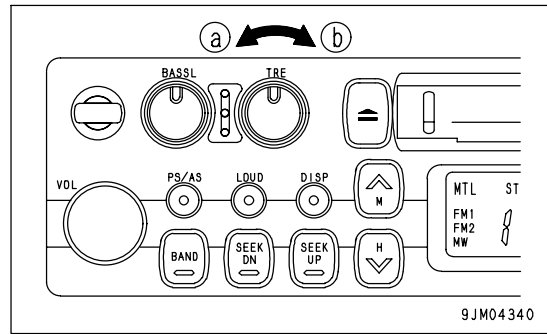

**LOUDNESS BUTTON**

This button (5) is used when playing at low volume. It makes it possible to hear more easily by emphasizing the low tone when the low tones are weak.

Push button: Actuated (ON)

Push button again: Canceled (OFF)

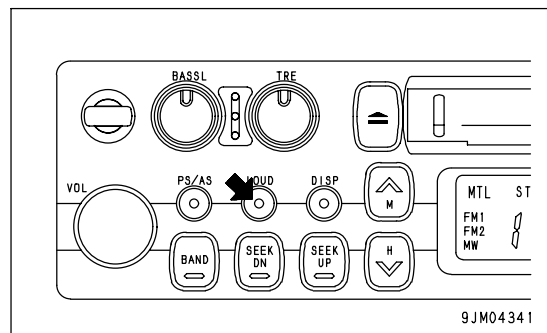

**TIME/RADIO DISPLAY SELECTOR BUTTON**

This button (6) is used to switch between the "Radio/tape display" and the "Time display".

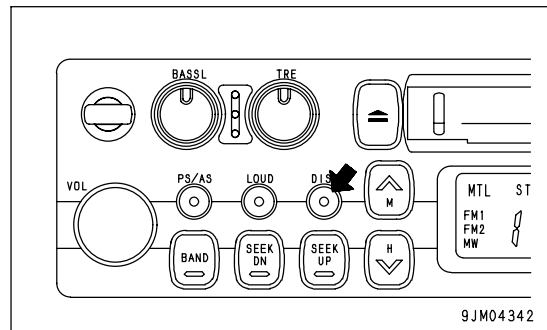

- Correcting the time

Press the button to set the time display.

(A) Correcting hour:

Keep the DISP button pressed and press the bottom (H) of the TUNING button to correct the hour.

(B) Correcting minute:

Keep the DISP button pressed and press the top (M) of the TUNING button to correct the minute.

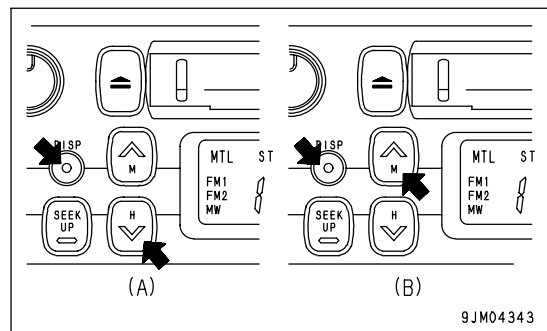

**TAPE EJECT BUTTON**

This button (7) is used to stop the tape and to eject the cassette. When this button is pressed, the tape is ejected and the radio plays.

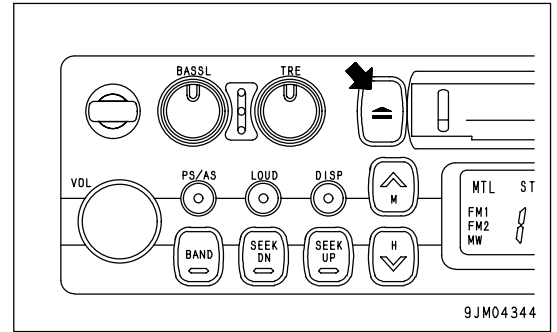

**CASSETTE DOOR**

Set the cassette with the exposed portion of the tape on the right side and insert it through the cassette door (8).

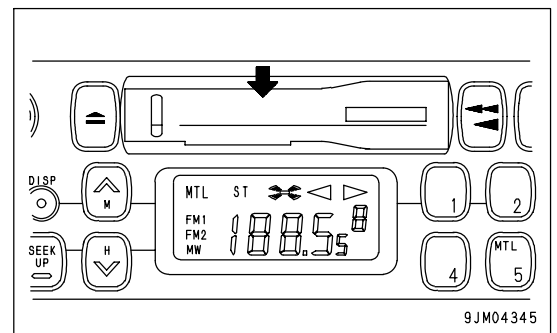

**FAST FORWARD, REWIND BUTTONS**

These buttons (9) are used to fast-forward or rewind the tape.

- Fast-forward/rewind

If you press the button pointing in the same direction as the lighted arrow indicating the direction of play, the tape will be fast-forwarded; if you press the button pointing in the opposite direction, the tape will rewind.

To stop the tape, lightly press the button that is not locked. The fast-forward or rewind operation will be canceled.

If the fast-forward and rewind buttons are pressed at the same time, the tape will change sides.

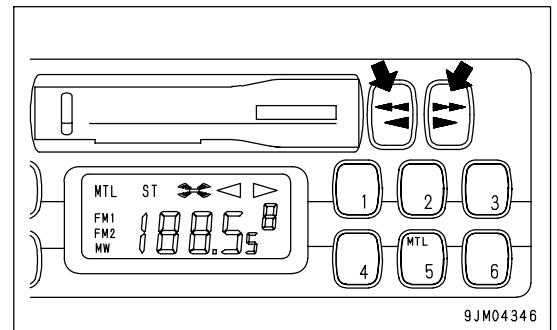

**PRESET BUTTONS**

These buttons (10) are used to call up the broadcast station frequencies preset in memory for each of buttons No. 1 to No. 6. It is possible to preset 18 stations (FM: 12; AM: 6) with these buttons.

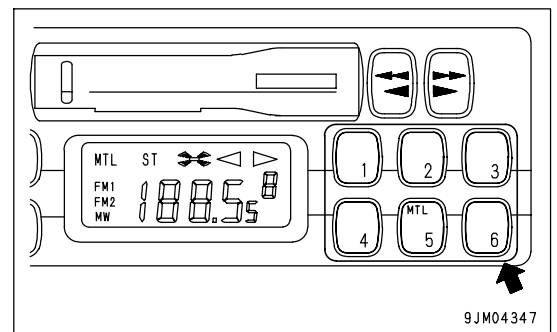



**METAL TAPE BUTTON**

(used also for preset button No. 5)

This button (11) is used when playing a metal or chrome tape. This button is also used for preset button No. 5. When it is pressed, "MTL" appears on the display.

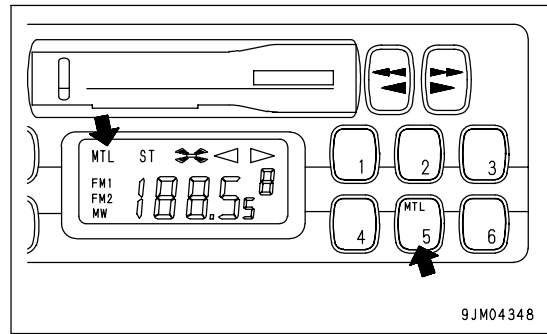

**MANUAL TUNING BUTTONS**

These buttons (12) are used for manual tuning.

When "TUN ^" button is pressed, the frequency goes up; when "TUN v" button is pressed, the frequency goes down. If the button is pressed down and held, the frequency will change continuously.

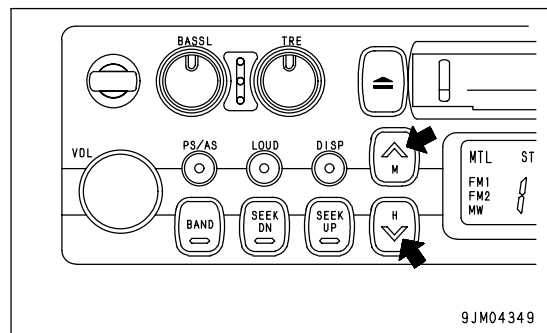

**SEEK TUNING BUTTONS**

These buttons (13) are used to seek tuning.

When the "SEEK UP" button is pressed, the search automatically goes up; when the "SEEK DN" button is pressed, the search automatically goes down.

When the next station that can be received is found, it automatically stops.

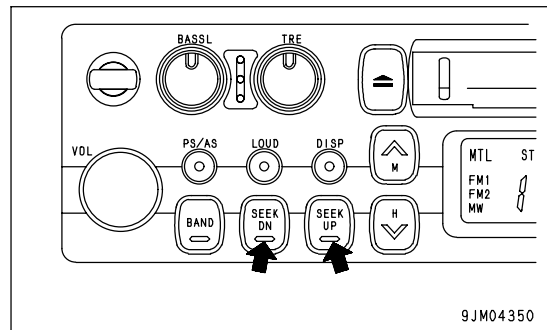

**BAND SELECTOR BUTTON**

When this button (14) is pressed, the band is switched between FM1, FM2, and MW (AM). The band is shown on the display.

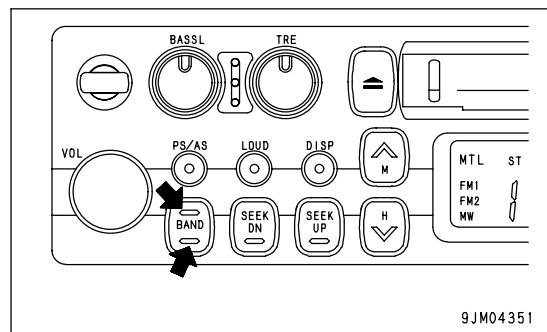

**METHOD OF OPERATION**

**METHOD OF SETTING PRESET BUTTONS**

It is possible to preset 6 MW (AM) stations and 12 FM stations (FM1: 6 stations, FM2: 6 stations).

**REMARK**

If you are playing the cassette, press the tape eject button to stop the tape.

**METHOD OF AUTO PRESET**

1. Use band selector button (1) to select MW (AM), FM1 or FM2.
2. Press auto-store/preset scan button (2) for less than 0.5 second.
3. The preset scan tuning function automatically searches for the desired station within the same band and can memorize as many as 6 stations in the preset memory.

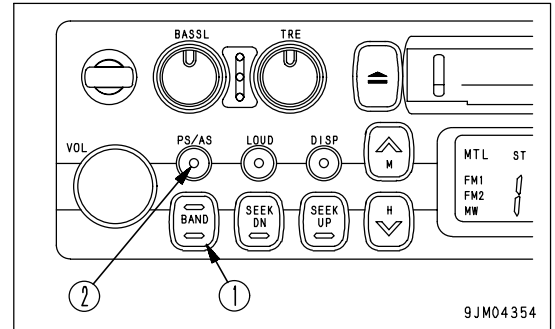

**METHOD OF MANUAL PRESET**

1. Use band selector button (1) to select MW (AM), FM1 or FM2.
2. Press manual tuning buttons (2) or seek tuning buttons (3).
3. Press preset button (4) of the number to be preset for 2 seconds while the frequency display is being shown on the display. (The preset channel and frequency are displayed and the presetting is completed).
4. Repeat the steps explained in Item 2 and 3 above to preset other stations to the subsequent numbers.
5. If you want to preset a station in the other bands, follow the steps explained in Item 1 through 4 above.

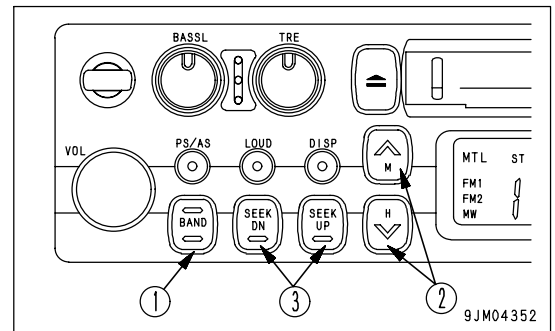

**REMARK**

- Also, use Steps 2 and 3 when changing the setting of a preset switch to another station.
- When the power is disconnected, such as when the battery is replaced, all the settings are deleted, so preset the stations again.

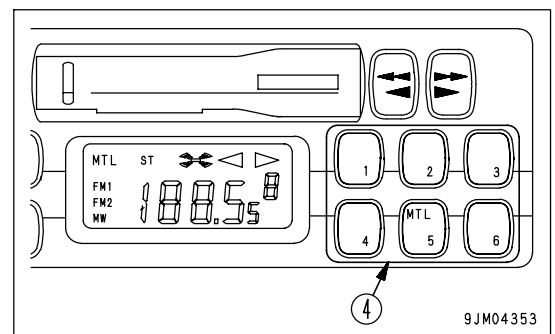

**LISTENING TO RADIO**

1. Turn the starting switch ON, then turn power switch (1) ON.
2. Use band selector button (2) to select MW (AM), FM1 or FM2.
3. Select the station with the preset buttons (3).

**REMARK**

In case you do not promptly remember the number assigned to a certain preset station, press auto-store/preset scan button (4) for less than 0.5 second. The preset 6 stations will broadcast one after another for 5 seconds each. When the desired station broadcasts, press the button again and scan tuning stops.

4. If you want to tune in to a station that is not preset, use either seek tuning button (5) or manual tuning button (6).
5. Adjust the volume, balance, and tone as desired.
6. When turning the radio OFF, turn power switch (1) to the left until it clicks.

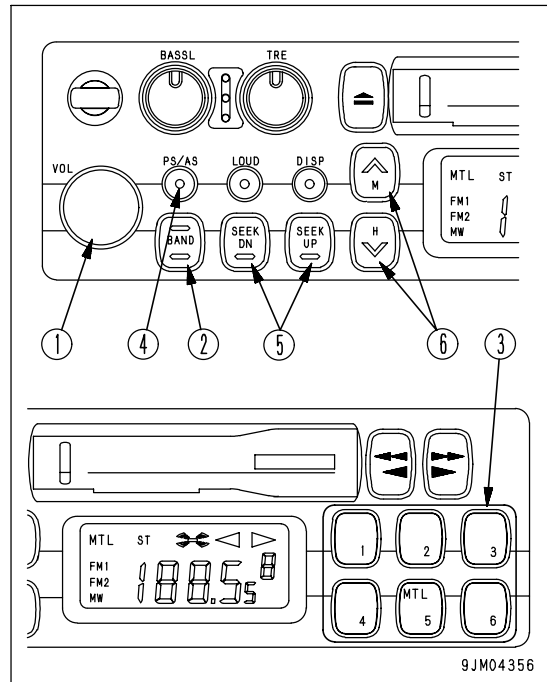

**REMARK**

- To switch to the radio when listening to a cassette, press the cassette eject button to stop the tape.
- If you insert a cassette when listening to the radio, the tape will start to play.

**LISTENING TO A CASSETTE TAPE**

1. Turn the starting switch ON, then turn power switch (1) ON.
2. Set the cassette with the exposed portion of the tape on the right side and push it past the cassette door. The tape will automatically start playing.

If the arrow indicating the direction of play is pointing to the right, the top side is being played; if the arrow is pointing to the left, the bottom side is being played.

When the tape reaches the end, it is automatically reversed and the other side starts to play.

3. When finished with the tape, press the cassette eject button to eject the tape and automatically switch to the radio.

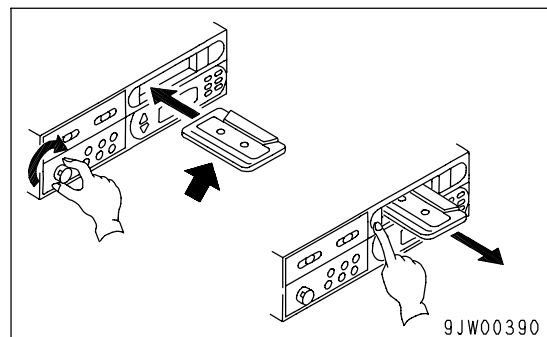
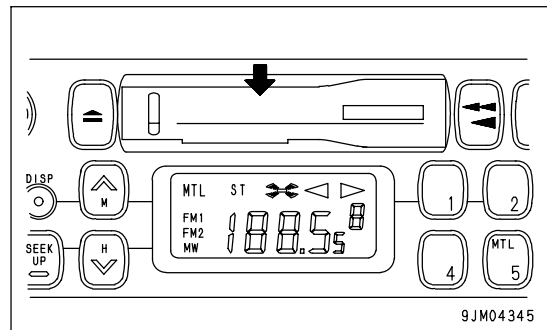

**REVERSING TAPE**

When listening to the tape, press both FAST FORWARD, REWIND buttons (A) and (B) at the same time lightly.

When this is done, the tape direction display will be reversed.

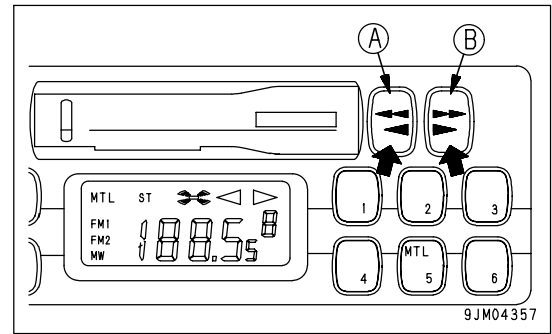
**PRECAUTION WHEN USING****WARNING**

- If a voltage greater than the specified voltage is input, it may cause fire, electrocution, or other failure. Never input any voltage other than the specified voltage.
- Places inside the radio are under high voltage. Do not remove the cover.
- Do not carry out any modifications. This may cause fire, electrocution, or other failure.
- If the sound cannot be heard, nothing is displayed, or any other problem occurs, turn off the power switch and ask your Komatsu distributor to make repairs without delay.

- Stow the antenna when traveling in places with low overhead clearance.
- To ensure safety during operations, keep the volume at a level where it is possible to hear other machines.
- If water gets inside the speaker case or radio (auto tuning), it may cause a serious problem, take care not to let water get in these items.
- Do not wipe the scales or buttons with solvent such as benzene or thinner. Wipe with a dry soft cloth. If the dirt cannot be removed easily, soak the cloth with alcohol.

**NOTICE****Handling cassette tape**

- Clean the tape head approx. once a month with a commercially available head cleaning tape.
- Do not leave the tape any place where it is exposed to direct sunlight, any place that is excessively dusty, or any place where there is a magnetic field.
- Do not use 120-minute tapes. The tape is thin and it easily gets caught up inside the machine.
- If the tape is slack, it easily gets caught up inside the machine. Use a pencil to wind in the tape to remove any slack.
- Do not use any cassette tape if the label has started to come off. It may cause defective rotation, or it may be impossible to get the tape out of the machine.

**AIR CONDITIONER, HANDLING**

(Machine equipped with cab)

**GENERAL LOCATIONS AND FUNCTION OF CONTROL PANEL**

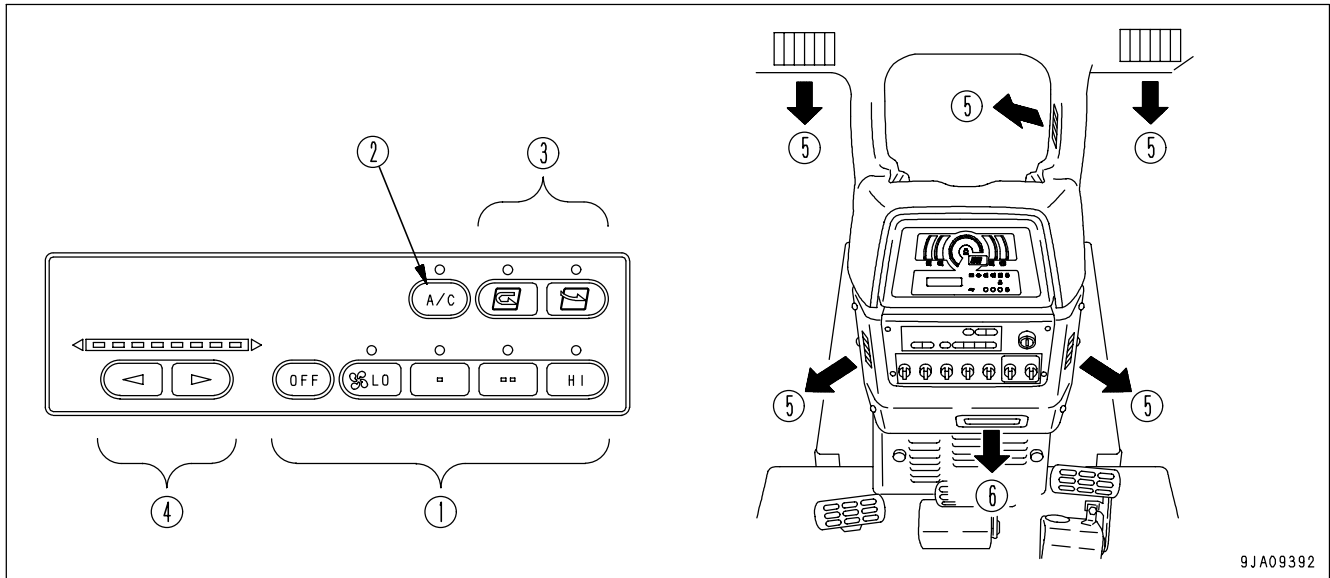

- (1) Fan switch
- (2) Air conditioner switch
- (3) Fresh/recirc selector switch
- (4) Temperature control switch
- (5) Defroster
- (6) Air flow to foot

**FAN SWITCH**

This switch (1) can be used to adjust the airflow in four stages. It also acts as the main switch for the air conditioner. When the OFF switch is pressed, the fan stops. When the switch is pressed, the indicator lamp above the switch lights up to display the airflow.

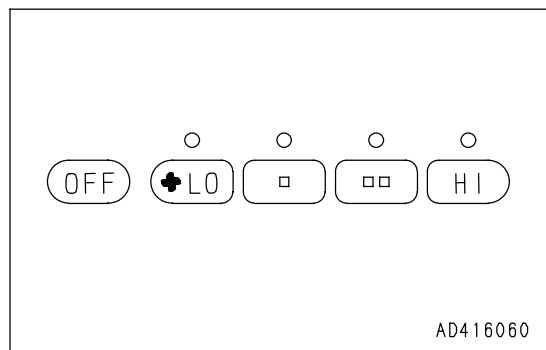

**AIR CONDITIONER SWITCH**

This switch (2) is used to start or stop the cooling or dehumidifying function. When the fan switch is turned ON and the air conditioner switch is pressed, the indicator lamp above the switch lights up. When the switch is pressed again, the switch is turned OFF and the indicator lamp goes out.

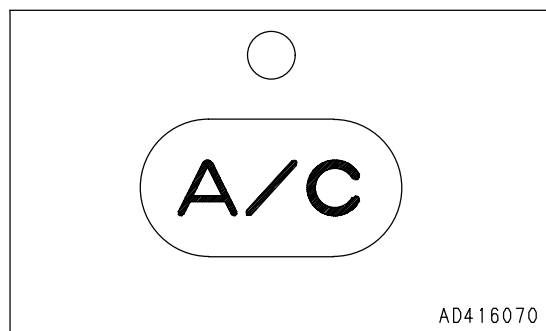

**FRESH/RECIRC SELECTOR SWITCH**

This switch (3) is used to select between recirculation of the air inside the cab or intake of fresh air from outside.

When the switch is pressed, indicator lamp (A) at the top of the switch lights up.

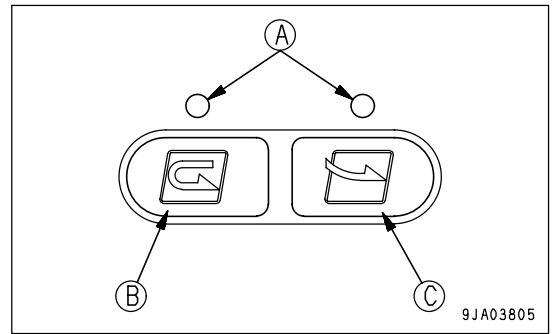

**Recirculation of air inside cab**

Press this switch (B) to use only the air inside the cab. Use this position to carry out rapid heating or cooling of the cab or when the outside air is dirty.

**Intake of fresh air from outside**

Press this switch (C) to carry out heating or cooling with fresh air taken in from the outside. Use this position when fresh air is taken in from outside the cab, or when removing the mist from the cab windows.

**REMARK**

When fresh air is taken into the cab, air pressure in the cab increases, which prevents the dust from entering. When neither heating nor cooling is needed, bring in clean fresh air, with your preferred air flow, to prevent dust from entering the cab.

**TEMPERATURE CONTROL SWITCH**

This switch (4) can be used to adjust the temperature steplessly between low temperature and high temperature.

The temperature level indicator lamps (A) light up to display the temperature of the air coming from the vents.

The more blue lamps on, the lower the temperature is.

The color of the indicator lamp (A) changes while the switch is being pressed.

When the temperature reaches the desired level, release the switch to set the temperature.

The settings for each mode are retained in memory even when the starting switch is turned OFF.

However, in the following cases, the settings must be reset.

- When the machine has been out of use for more than 7 days
- When the battery voltage is extremely low
- When there has been abnormal interference from outside
- When the fan switch is turned OFF (the setting is not kept in memory with only the air conditioner switch)

If the air conditioner is used in the FRESH position, the inside of the cab will be pressurized and this will prevent the entry of dust.

The higher the position of the fan switch, the more effective the pressurizing becomes.

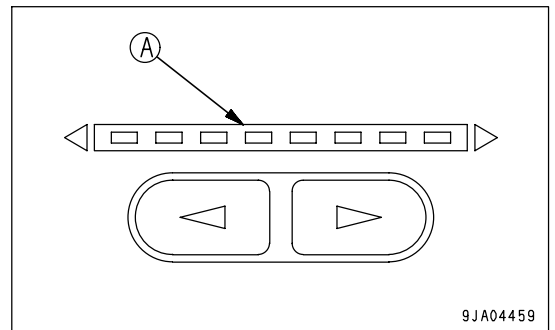

**METHOD OF OPERATION**

Switch		Fan switch	Air conditioner switch	Temperature control switch	FRESH/RECIRC selector switch
Cooling	Rapid	HI	ON	All blue	RECIRC
	Normal	HI - LO	ON	More than half are blue	FRESH
Dehumidifying, heating		HI - LO	ON	More than half are red	FRESH
Heating	Rapid	HI	OFF	All red	RECIRC
	Normal	HI - LO	OFF	More than half are red	FRESH
Defroster		HI	ON	More than half are red	FRESH
Ventilation or pressurizing		HI - LO	OFF	All blue	FRESH

When defrosting, set the temperature control switch so that all lamps are red. This will improve defrosting and demisting.

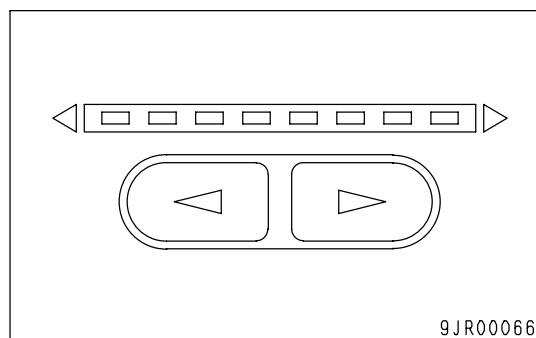

9JR00066

**WHEN NOT USING THE AIR CONDITIONER REGULARLY**

Run the air conditioner in cooling or dehumidification + heating mode for several minutes from time to time to prevent the loss of the oil film in various parts of the compressor.

**REMARK**

If the temperature inside the cab is low, the air conditioner may not work. In such cases, use the recirculated air to warm up the inside of the cab, then turn the air conditioner switch on. The air conditioner will be run.

**COOL BOX**

When the cooling is being used, this can be used for keeping drinks and other things cool.

When the heating is being used, it can be used to keep things warm.

When not using the box, close the grill.

Do not use the cool box for things which smell or leak water or break easily.

Do not use it as a holder for tools or other small objects.

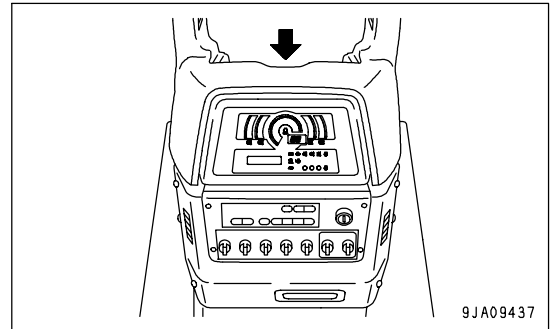
**PRECAUTIONS WHEN USING****PRECAUTIONS WHEN USING THE COOLING**

- If you smoke when using the air conditioner in the RECIRC mode, your eyes may start to itch or burn. Ventilate the cab ever so often to remove the smoke.
  - When using the air conditioner for a long period of time, carry out ventilation process at least once every hour.
- When using the air conditioner, it is recommended for health reasons, that it should only feel slightly cooler (5 or 6 °C (9 or 10.8°F) lower than the outside temperature) when you enter the cab. Therefore, adjust the temperature to a suitable level.

**SET SO THAT COLD AIR DOES NOT DIRECTLY BLOW ONTO THE GLASS SURFACE**

- If the vents (left and right) in the middle of the dashboard are turned so that cold air blows directly on the cab door glass, moisture may condense on the outside of the cab door glass and reduce the visibility. (This occurs particularly in high temperatures.)  
If this happens, close the louvers of the vent and change the direction to prevent the cold air from blowing directly on the surface of the glass.



## INSPECTION DURING OFF-SEASON

Even during the off-season, run the compressor at low speed for several minutes once a week to prevent the loss of the oil film on the lubricated parts of the compressor.

(Run the engine at low speed and set to a mid-range temperature when carrying out this operation.)

### REMARK

When the ambient temperature is low, if the compressor is suddenly run at high speed, it may cause failure of the compressor. Note that the system is set so that the compressor will not run when the cooler switch is turned on, if the ambient temperature is less than 2 to 6.5°C (35.6 to 43.7°F).

## PROCEDURE FOR REPLACING RECEIVER

Replace the receiver once every 2 years.

After replacing the receiver, add compressor oil. Turn the receiver at an angle and measure the oil remaining inside the receiver, then add the same amount of oil (Denso Oil 6) to fill the receiver.

### REMARK

- The replacement interval may become shorter depending on the conditions during use.
- If the receiver is used when the moisture absorption limit of the desiccant has been exceeded, the refrigerant circuit may become blocked and cause the compressor to break down.

## PRECAUTIONS WHEN REPLACING RECEIVER

- If the receiver is left for more than 15 minutes with the blind cover removed, the moisture in the air will be absorbed, and this will reduce the life of the desiccant. If you remove the blind cover, connect the piping quickly, evacuate the system and fill with refrigerant.
- When removing the refrigerant from the refrigerant circuit, release it gradually from the low pressure side to prevent oil from flowing out.

## CHECK COMPRESSOR BELT TENSION AND REFRIGERANT (GAS) LEVEL

If the compressor belt is loose, or the refrigerant level is low, cooling is not carried out efficiently.

For details, see "WHEN REQUIRED (PAGE 4-21)".

## CLEANING AIR FILTER

If the air filter for the FRESH or RECIRC air intake becomes clogged, the cooling or heating capacity will drop.

To prevent this, clean the air filter with compressed air once a week.

For details of the cleaning method, see "WHEN REQUIRED (PAGE 4-21)".

**HANDLING HEATER**

(Machine equipped with cab) (If equipped)

**METHOD OF OPERATION**

Switch	Fan switch	Humidity control switch	RECIRC/FRESH selector switch
Rapid heating	HI	All red	RECIRC
Ventilation or pressurization	HI - LO	All blue	FRESH

**TO HEAT QUICKLY**

If the switch is operated as follows, the cab can be heated quickly.

- Set fan switch (1) to H1, humidity control switch (2) to All red, and RECIRC/FRESH selector switch (3) to RECIRC.
- Set blower switch (2) to position 3 (HIGH).

**NOTICE**

If the heating is run continuously for a long time using only recirculated internal air, the air in the cab will become dirty. After the cab warms up, always turn RECIRC/FRESH selector switch (3) to the FRESH position. In this position, the inside of the cab is pressurized, and this prevents the entry of dust.

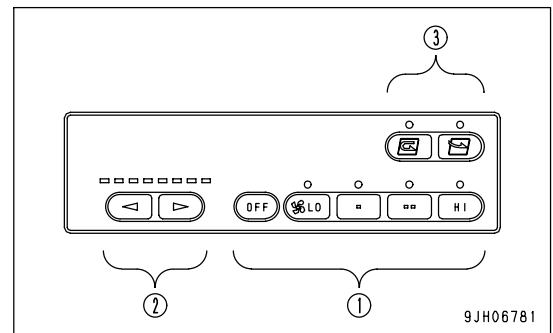

**NORMAL USE**

Set each switch to the desired position.

**CLEANING AIR FILTER**

If the RECIRC or FRESH air filters are clogged, the heating capacity will drop.

Clean the air filter once a week with compressed air.

For details of the method of cleaning, see "WHEN REQUIRED (PAGE 4-21)".

### EXTERNAL POWER SOURCE TYPE ENGINE PREHEATING HEATER

For cold weather (ambient temperature -30°C (-22°F))

This preheater is used as a starting aid when it is difficult to start the engine because of the cold temperature. It is used even when the ambient temperature is above -20°C (-4°F) in seasons where the temperature goes down to -20°C (-4°F).

Using an external power source (single phase, AC200 - 240V) to heat up the engine coolant and the oil in the engine oil pan and power train oil pan will make it easier to start the engine.

#### PROCEDURE FOR SETTING UP EXTERNAL POWER SOURCE

1. When using this engine preheating heater, it is necessary to provide the following external power source.  
For details, see Step 3.
2. It is necessary to make locally the cable used to bring the electricity above to the input socket (receptacle) installed to the machine from the external power source.  
For details of the manufacturing procedure, see Section 4.
3. The external power source input cable is the electric cable to bring the electricity from the local AC power supply to the input socket on the machine. Connect it as shown in the diagram below to operate the electric heater.

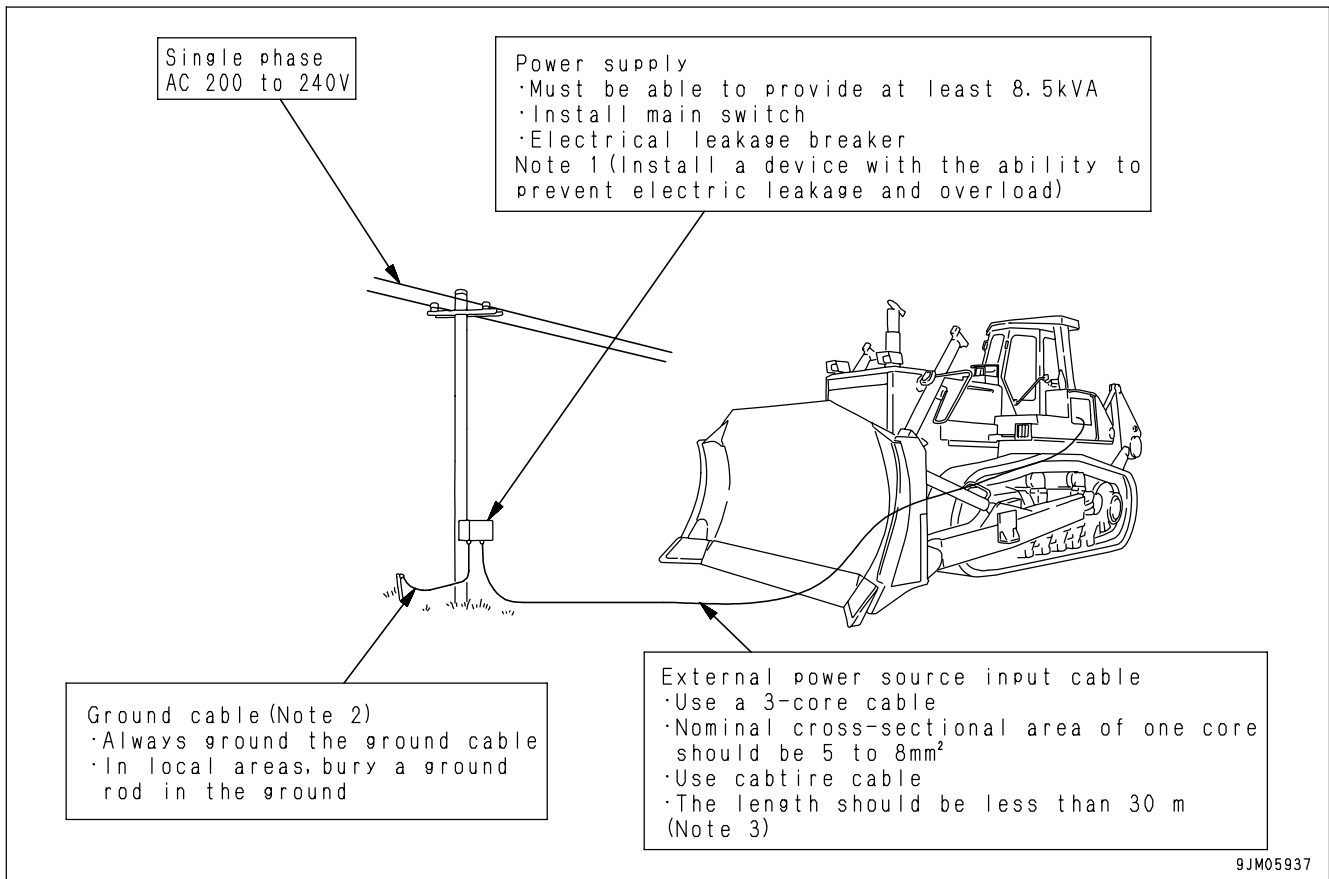

9JM05937

**REMARK**

- The electric leakage breaker is installed to prevent danger of electrocution if the electrical supply leaks to the machine.
- The ground cable is connected to the ground for the same reason.
- This is to prevent any drop in voltage.

4. Manufacturing external power source input cable

The external power source input cable must be manufactured locally to match the local conditions. This does not mean that any cable can be used.

Manufacture the cable as follows.

1) For the wiring, purchase three-core chloroprene sheath cab tire cable locally.

- The nominal cross-sectional area of one core should be 5 to 8 mm<sup>2</sup> (0.0078 to 0.0124 in<sup>2</sup>).
- For the voltage resistance function, it should be able to withstand 3000 volts for 1 minute.
- To prevent any drop in voltage, make the length less than 30 m (98 ft 5 in).

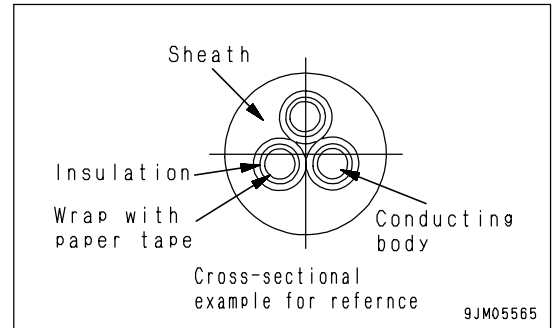

2) Connect the chassis input side plug (shipped as individual part) 175-06-37871 to the tip of the cable.

- The plug has three contacts and each contact is marked with a symbol. Connect each of the 3 core wires of the cable to its respective contact.
- When connecting, solder each core wire to its contact.
- To prevent short-circuiting through the conductor, insulate the soldered portion with a rubber tube or tape.
- Always use part No. 175-06-37871 for the plug.

If any other plug is used, it will be impossible to connect to the external power input receptacle.

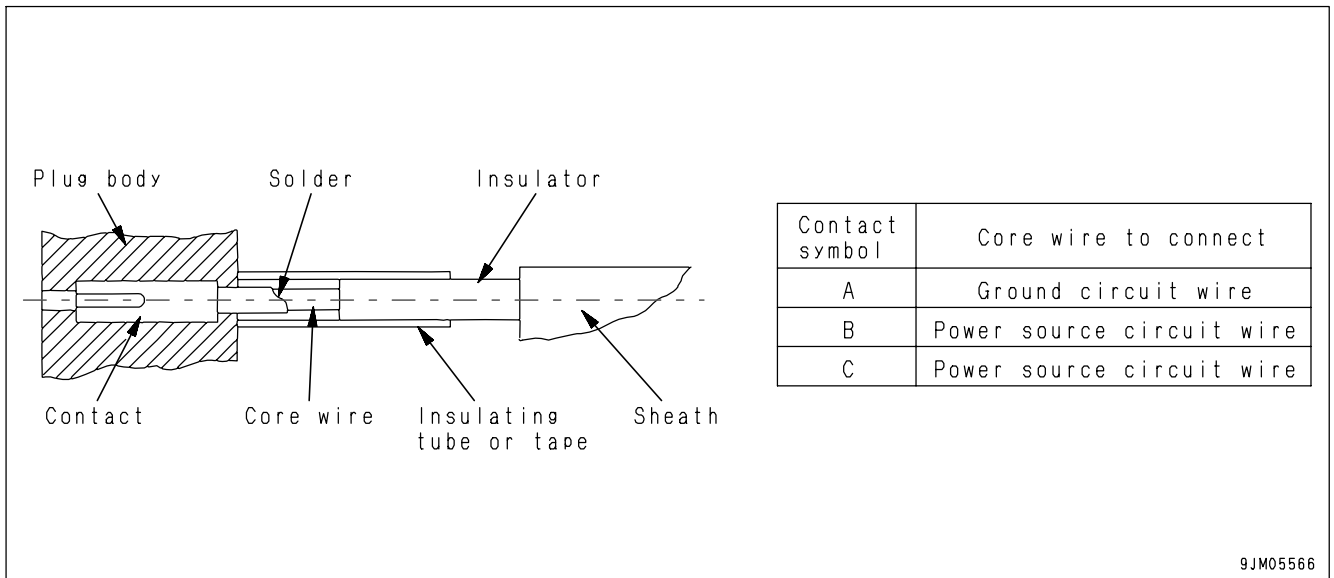

- 3) Modify the other end of the cable so that it can be connected to the power supply equipment. When the modification of the connection is finished, the external power source input cable is completed.

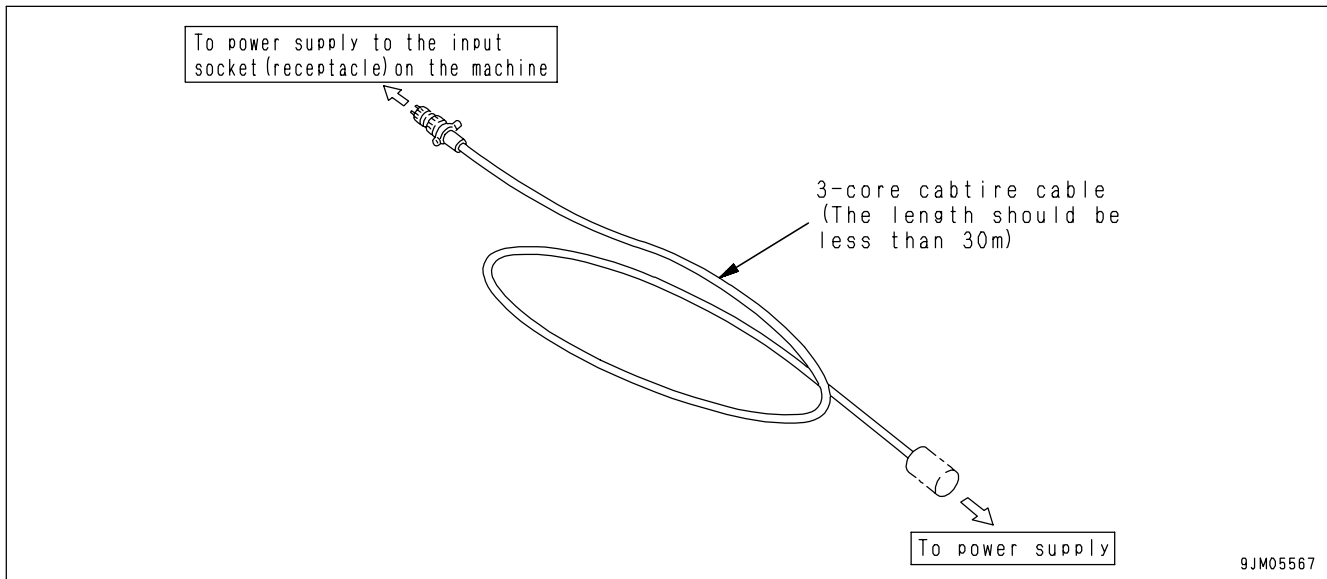

#### 5. Establishing power supply

### **WARNING**

When setting up the power supply equipment, follow all the related laws and regulations in that country and use an authorized contractor.

- 1) Power supply equipment is needed to use this preheater. The power supply equipment is used to supply AC voltage sent from the transformer substation or generator to the preheater. It must have a structure that enables the external power source input cable to be connected easily.
- 2) The shape, size, and method of setting up depend on the local area, but make the specifications as follows. Note that there is no switch or safety device provided on the machine.

- Specifications for power supply equipment
  - Type of output electricity: Single-phase alternating current
  - Output voltage: 200 - 240 volts (V)
  - Supply capacity: 8.5 kilovolt amperes (kVA)
  - Main switch: Yes
  - Electric leakage breaker: Yes
  - Ground circuit: Yes
- System diagram, overall wiring diagram (for reference when carrying out the work)
- System diagram for external power supply type engine preheater

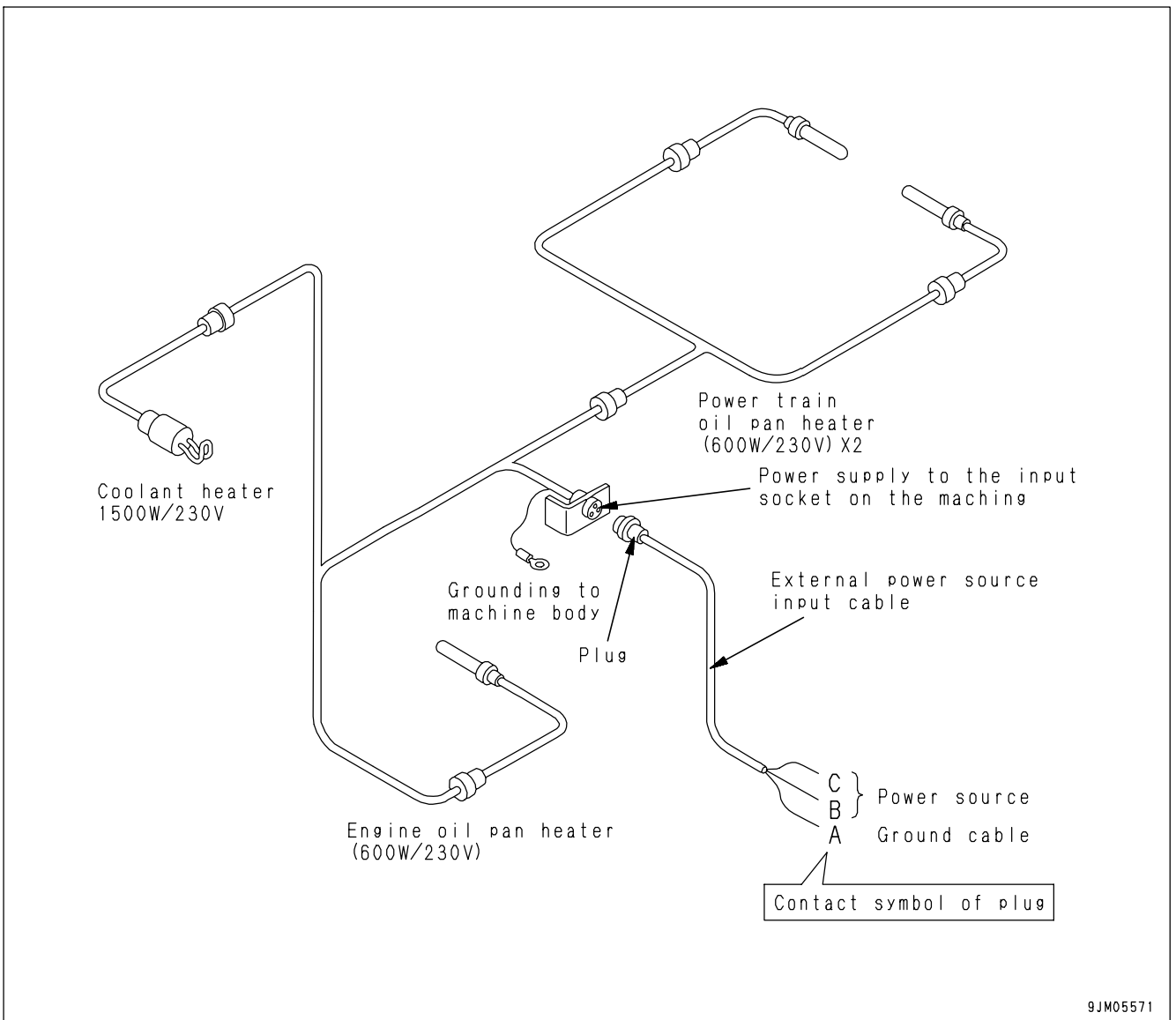

- Overall wiring diagram for external power supply type engine preheater

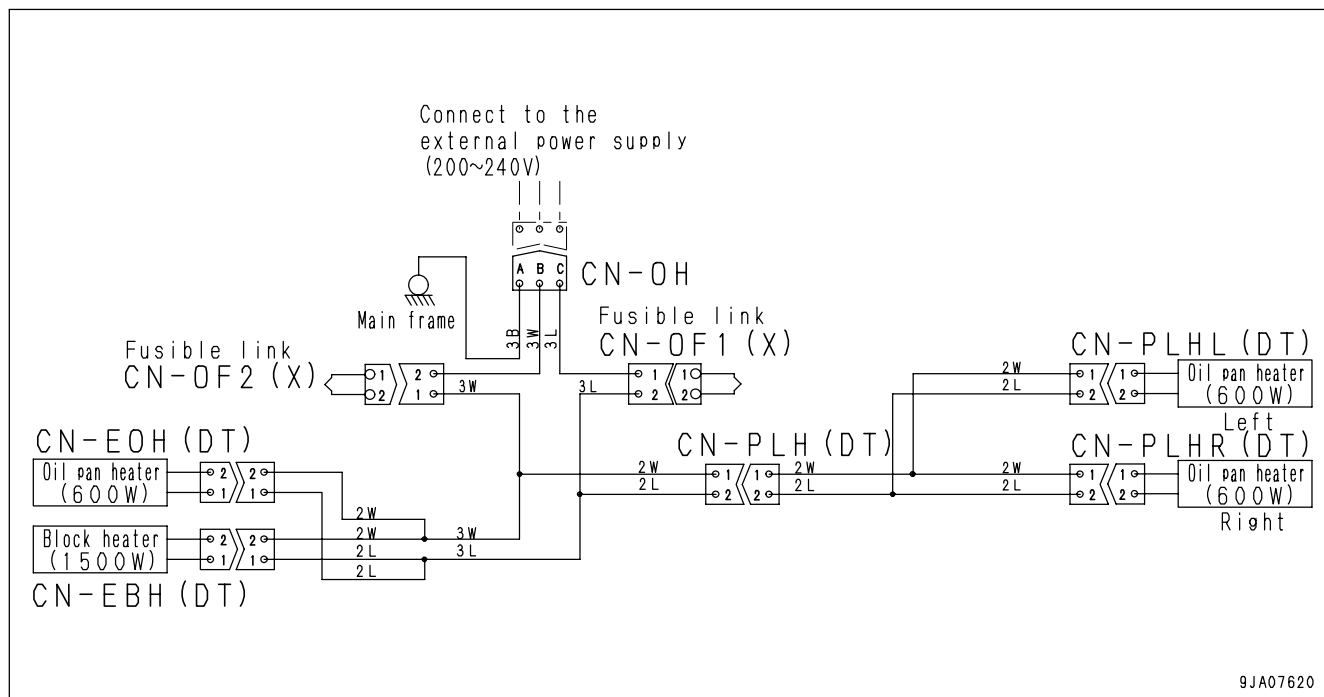

## HANDLING PROCEDURE

Use this engine preheating heater in a season when the ambient temperature goes down below - 20°C (4°F), or when it is difficult to start the cold engine though the ambient temperature stays above - 20°C (4°F).

### NOTICE

For details of the oil to use, see "RECOMMENDED FUEL, COOLANT, AND LUBRICANT (PAGE 4-12)".

Method of operating



## WARNING

- Always lower the work equipment completely to the ground.
- Always wipe off any oil or fuel on the engine preheating heater or nearby parts.
- Always remove dry leaves or other flammable materials accumulated inside the engine room.
- Always check that the engine oil and engine coolant are at the specified level.
- Before passing electricity through the preheater, check that there is no damage to the covering of the wires. If any damage is found, replace or repair the wire.



## WARNING

- Before connecting the cable, check that the power switch is at the OFF position.
- Check that the grounding wiring is properly grounded before turning the power switch ON.

1. After completing operations with the machine, park the machine near the power supply facility (in a place where the external power input cable will reach the power supply). This will make it possible to use the preheater when starting the engine the next time.

### NOTICE

- Park the machine on level ground.
- Take action to prevent the track shoes from freezing and sticking to the ground surface.
- Covering the machine will make it easier to start the engine.



2. Turn the power for the engine preheating heater on several hours before starting the engine to warm up the coolant and oil in the engine oil pan.

1) Connect the power supply to the input socket on the machine with a cable.

The input socket on the machine is inside the battery cover on the left side of the machine.

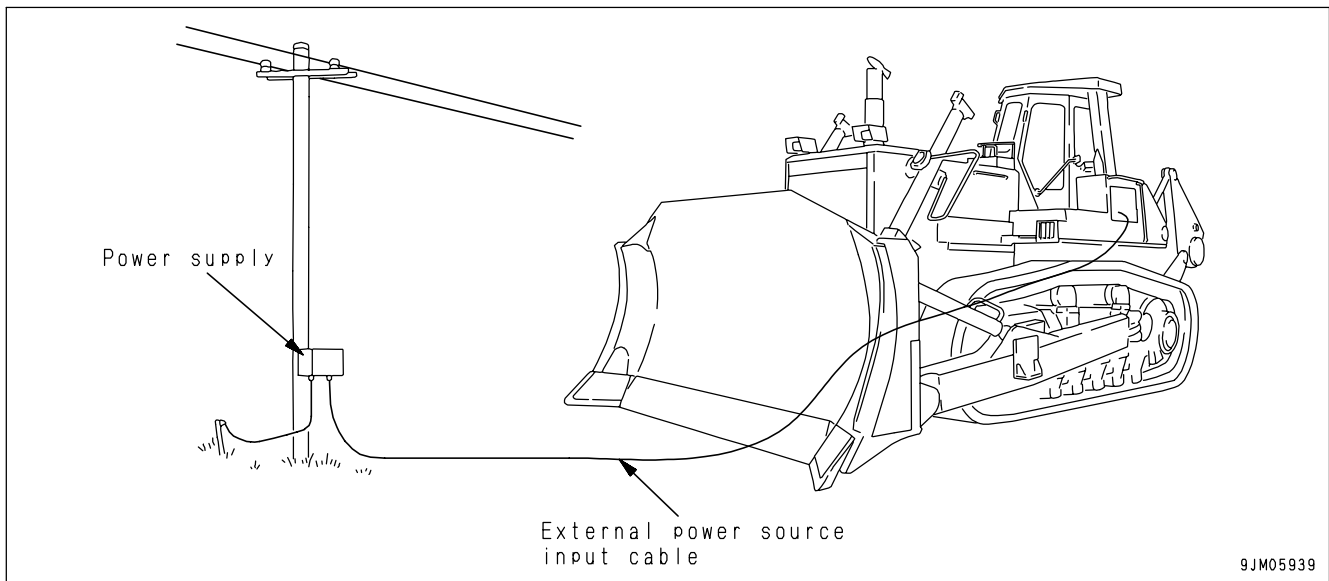
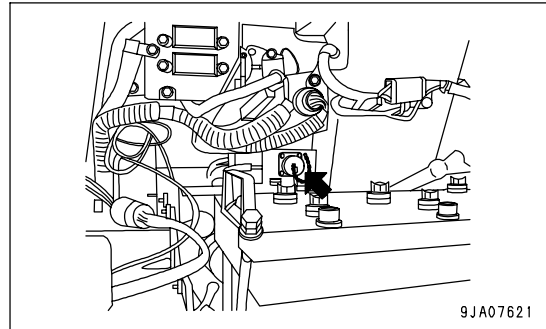

2) Use the standby switch (if available) or the power switch (main switch) on the power supply equipment to start the supply of electricity.

- Before connecting the cable, check that the power switch is at the OFF position.
- Check that the grounding wiring is properly grounded before turning the power switch ON.

3. The time to keep the electricity on differs according to the ambient temperature and the type of oil being used.

Ambient temperature	Type of oil	Min. ON time for electricity
-30°C (-22°F)	SAE 10W	Min. 2 hours

- If the ambient temperature is below - 15°C (5°F), turn on the electricity immediately after stopping the engine on the previous day to maintain the engine temperature.
- The above table shows the standard values. If the weather conditions at the jobsite are unusual, it is effective to investigate the normal conditions that match the area, and use that as the standard.

#### NOTICE

- For details of the starting operation when the ambient temperature is below 0°C (32°F), see "STARTING IN COLD WEATHER (PAGE 3-94)".
- If the ambient temperature is above 0°C (32°F), do not pass electricity through the system. The oil temperature will rise and this will cause deterioration of the oil.
- If the ambient temperature is below - 20°C (- 4°F), and the engine has been stopped for more than two hours, use this engine preheating heater to maintain the temperature.

4. When the preheating operation is finished, turn off the power switch, disconnect the cable, and screw a protective cap in the input receptacle on the machine.
5. Start the engine.

#### NOTICE

**Do not start the engine while the electricity is turned on. Always turn the power switch OFF before starting the engine. If the engine is started with the electricity still turned on, it will cause failure of the coolant heater.**

## OPERATION

### CHECK BEFORE STARTING ENGINE, ADJUST

#### WALK-AROUND CHECK

Before starting the engine, walk around the machine and look at the underside of chassis for anything unusual like loose bolts and nuts, leakage of fuel, oil and coolant. Also check the condition of the work equipment and the hydraulic system.

Also check for loose wiring, play, and collection of dust at places that reach high temperature.



#### WARNING

- Leakage of oil or fuel, or accumulation of flammable material around high temperature parts, such as the engine muffler or turbocharger, may cause fire.  
Check carefully, and if any abnormality is found, repair it or contact your Komatsu distributor.
- Do not get on or off the machine from the rear. Using this position is dangerous because it is easy to slip and you cannot be seen from the operator's compartment. Always use the handrail and step at the side when getting on or off the machine.

If the machine is at an angle, reposition it level before checking.

Perform the following inspections and cleaning every day before starting engine for the day's work.

1. Check for damage, wear, play in work equipment, cylinders, linkage, hoses  
Check for cracks, excessive wear, play in work equipment, cylinders, linkage, and hoses. If any abnormality is found, repair it.
2. Remove dirt and debris from around the engine, battery, and radiator  
Check for dirt accumulated around the engine or radiator. Also check for flammable material (dry leaves, twigs, grass, etc.) accumulated around the battery, engine muffler, turbocharger, or other high temperature engine parts. If any dirt or flammable materials are found, remove them.
3. Check for coolant and oil leakage around the engine  
Check for oil leakage from the engine and coolant leaks from the cooling system. If any abnormality is found, repair it.
4. Check for leakage from fuel line.  
Check that there is no leakage of fuel or damage to the hoses and tubes. If any problem is found, carry out repairs.
5. Check for leakage of oil from power train case, final drive case, hydraulic tank, hose, joints  
Check that there is no oil leakage. If any abnormality is found, repair the place where the oil is leaking.  
Check for leakage of oil from the undercover. Check the ground for traces of oil leakage.
6. Check the undercarriage (track, sprocket, idler, guard) for damage, wear, loose bolts, or leakage of oil from rollers  
If any damage, wear, or oil leakage is found, repair the problem and tighten the bolts.
7. Check for damage to handrail and loose bolts  
Repair any damage and tighten any loose bolts.

8. Check for damage to gauges, lamps on the instrument panel, and loose bolts  
Check for damage to the panel, gauges, and lamps. Replace any damaged parts. Clean off any dirt on the surface.
9. Check for damage to seat belt and mounting clamps  
Check that there is no abnormality in the seat belt or mounting clamps. If there is any damage, replace with new parts.

## CHECK BEFORE STARTING

Always check the items in this section before starting the engine each day.

### CHECK OIL LEVEL IN ENGINE OIL PAN, ADD OIL



## WARNING

Parts and oil are at high temperature immediately after the engine is stopped and may cause serious burns. Wait for the oil temperature to go down before performing this operation.

1. Open the engine side cover on the left side of the chassis.
2. Remove dipstick (G), and wipe the oil off with a cloth.
3. Fully insert dipstick (G) into filler pipe, then remove it.

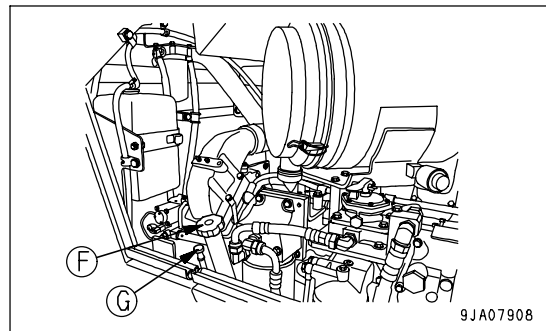

4. The oil level should be between the H and L marks on dipstick (G).  
If the oil level is below the L mark, add engine oil through oil filler (F).

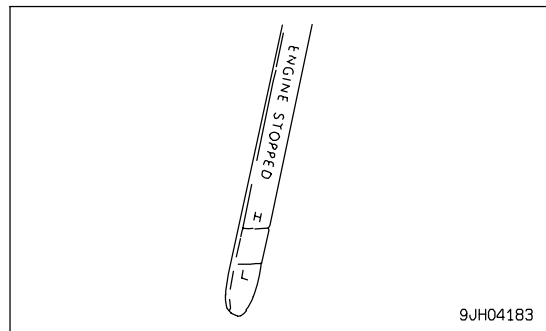

5. If the oil is above the H mark, drain the excess engine oil from drain plug (1), and check the oil level again.
6. If the oil level is correct, tighten the oil filler cap securely and close the engine side cover.

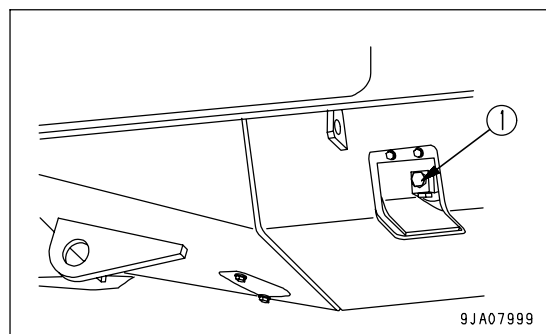

### REMARK

- When checking the oil level after the engine has been operated, wait for at least 15 minutes after stopping the engine before checking.
- If the machine is at an angle make it horizontal before checking.
- When adding oil, remove the dipstick from the holder to release the air inside the crankcase.

## CHECK COOLANT LEVEL, ADD COOLANT

**WARNING**

- Normally, do not open the radiator cap. When checking the coolant level, check the sub-tank when the engine is cold.
- Do not remove the cap when the radiator coolant is hot. Boiling coolant may spurt out. After the coolant temperature goes down, turn the cap slowly to release the pressure, then remove it.

1. Open the engine side cover on the left side of the chassis, and check that the coolant is between the FULL and LOW marks on sub-tank (1). If the coolant level is low, add coolant to the FULL level through the coolant filler port in sub-tank (1).

**REMARK**

The coolant may overflow from the sub-tank drain hose. This is no problem. It occurs because too much coolant has been added.

2. After adding coolant, tighten the cap securely.

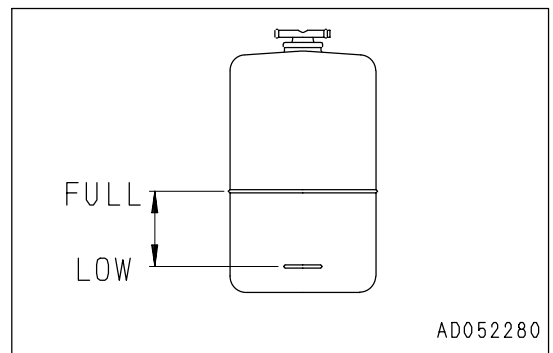
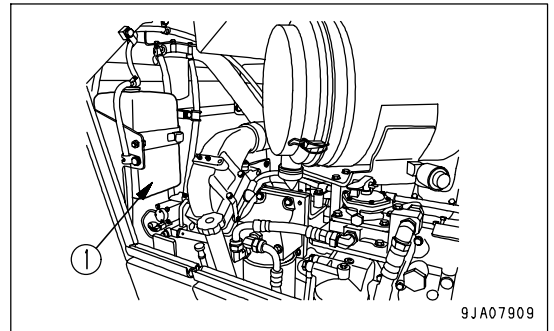

3. If the sub tank is empty, first check for leakage of water, then remove radiator cap (2) and check that the coolant water is above the bottom surface of the strainer (3) as shown in the diagram on the right. Add water if the level is low.
4. After adding coolant, close the engine side cover.

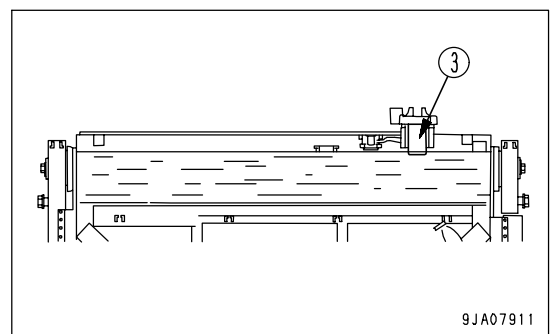
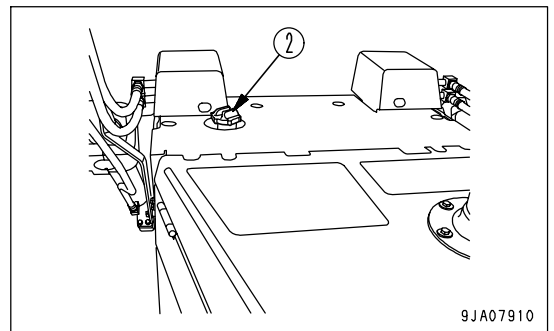

**CHECK DUST INDICATOR**

The dust indicator is located on the air cleaner bracket inside the engine room. It is a safety device to warn when the air cleaner element is clogged.

For the filter element cleaning method, see "CHECK, CLEAN AND REPLACE AIR CLEANER ELEMENT (PAGE 4-25)".

1. Check for the yellow piston overlapping the red zone on the dust indicator (1).
2. If the yellow piston has already moved into the red area (7.5 kPa), either clean the filter element or replace it with new one immediately.

For cleaning the filter element, refer to the section, "CHECK, CLEAN AND REPLACE AIR CLEANER ELEMENT (PAGE 4-25)", in this manual.

3. After checking, cleaning, and replacing, press the knob of dust indicator (1) to return the yellow piston to its original position.
  - In environments where the rubber deteriorates quickly or the surface becomes damaged (in direct sunlight, dusty areas, etc.), replace before it becomes dirty and it becomes difficult to judge the condition.

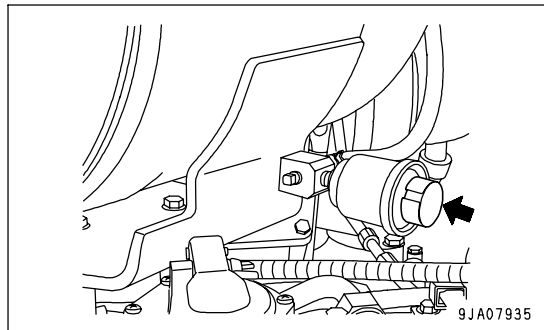
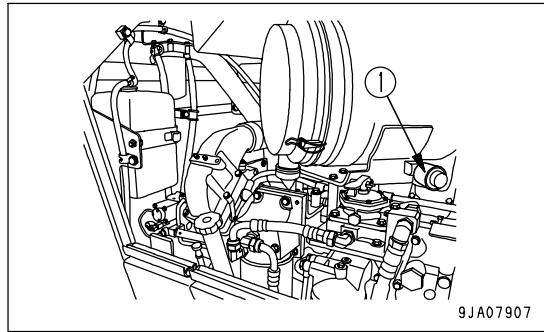

**CHECK, DRAIN WATER SEPARATOR**

The water separator serves to separate moisture mixed in the fuel.

1. Open up the engine side cover and inspection cover on the machine's left side.  
The water separator is in one piece with fuel pre-filter (1) and located in the lower part.
2. Through transparent cap (2), a water level and sediments, if any, can be seen. When water and sediments have accumulated, put a container beneath drain hose (3).
3. Loosen plug (4) to drain water and sediments.
4. When draining is finished, be sure to screw in plug (4).

Specified tightening torque: 0.2 to 0.45 Nm (0.02 to 0.046 kgm, 0.1 to 0.3 lbft)

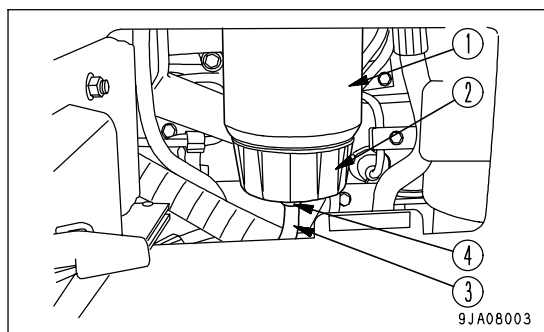
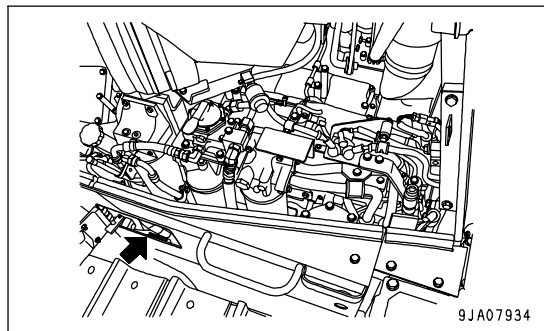

## CHECK OIL LEVEL IN POWER TRAIN CASE, ADD OIL

**WARNING**

The parts and oil are at high temperature after the engine is stopped, and may cause serious burns. Wait for the temperature to go down before starting the operation.

1. Remove dipstick (G), and wipe the oil off with a cloth.
2. Fully insert dipstick (G) into filler pipe, then remove it.
3. Check that the oil level is between the top and bottom marks on dipstick (G).  
If the oil level is below the bottom mark, add oil through the dipstick holder.

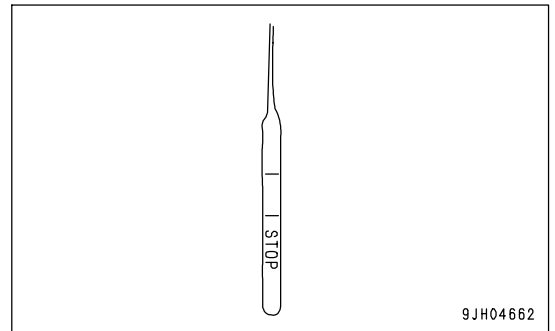
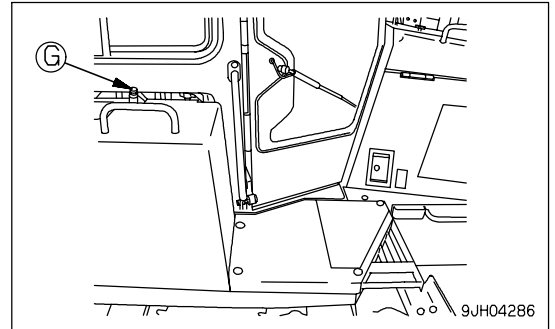

4. If the oil is above the top line, remove drain cover (1) at the right side at the bottom surface of the power train case, loosen drain plug (2), drain the excess oil, then check the oil level again.
5. If the oil level is correct, tighten the oil filter cap securely.

**REMARK**

- If the machine is at an angle, reposition it to level before checking.
- When checking the oil level after the engine has been operated, allow the engine to cool for 15 minutes before checking.

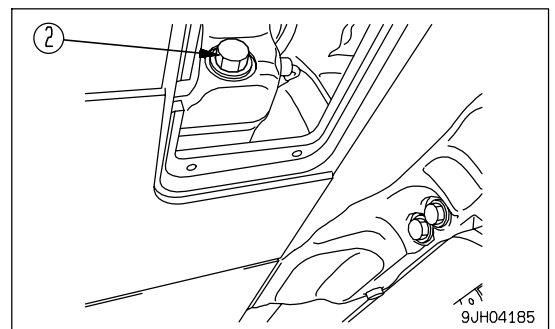
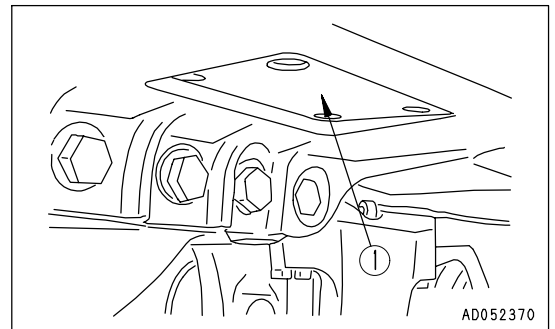



CHECK OIL LEVEL IN HYDRAULIC TANK, ADD OIL

**WARNING**

- When removing the oil filler cap, oil may spurt out, so stop the engine and wait for the oil temperature to go down, then push the cap down to release the internal pressure before removing the cap carefully.
- If oil has been added to above the H mark, stop the engine and wait for the hydraulic oil to cool down. Then remove drain plug (P), loosen drain valve (1), and drain the excess oil.

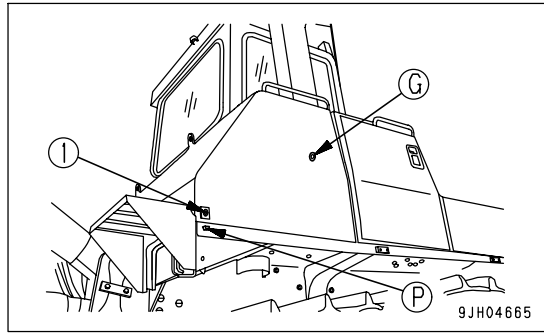

NOTICE

- Check the oil level when the oil is at low temperature. If the oil is at high temperature, the oil level will be higher.
- Do not add oil if the oil level is above the H line. This may damage the oil circuit and cause the oil to spurt out.

1. Lower blade to the ground and stop the engine. Wait for 5 minutes before checking oil level. Oil level should be between the H and L in sight gauge (G).

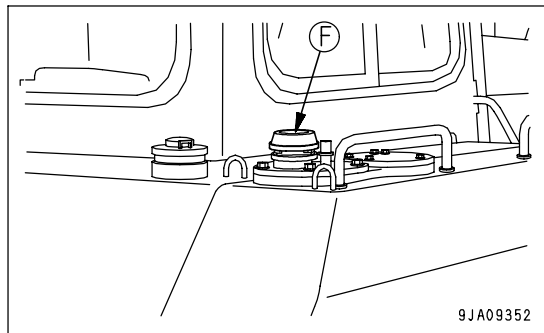

REMARK

When inspecting, if the machine is at an angle, move it to a level place to carry out the check.

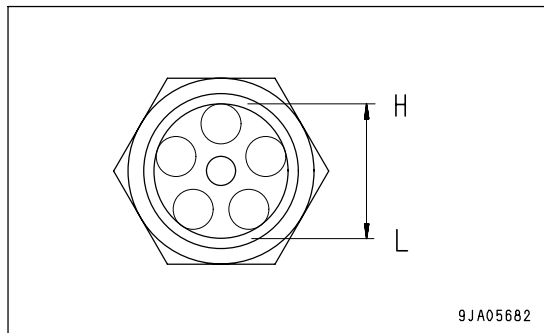

2. If the level is below the L mark, add oil through oil filler (F) as follows.

- 1) Push down cap of oil filler (F) to release the air and remove the internal pressure.
- 2) Keep cap pushed down, turn it slowly counterclockwise, then remove cap.
- 3) Refill the specified quantity of oil through oil filler (F).
- 4) Install cap.

When installing cap to the tank, push it down, then turn it clockwise.

REMARK

If the cap is not installed correctly, it will cause leakage of oil.

When installing the cap, press the cap down, and turn it until it is securely in contact with the stopper.

The cap is the lock addition type.

About handling method of cap with the lock, see "CAP WITH LOCK (PAGE 3-48)".

## CHECK ELECTRIC WIRING

**WARNING**

- If fuses are frequently blown or if there is a short circuit in the electrical wiring, locate the cause and repair or contact your Komatsu distributor.
- Accumulation of flammable material (dead leaves, twigs, grass, etc.) around the battery may cause fire, so always check and remove such material.
- Keep the top surface of the battery clean and check the breather hole in the battery cap. If it is clogged with dirt or dust, wash the battery cap to clear the breather hole.

Check for damage and wrong capacity of the fuse and any sign of disconnection or short circuit in the electric wiring. Check also for loose terminals and tighten any loose parts.

Check the wiring of the "battery", "starting motor" and "alternator" carefully in particular.

Always check if there is any accumulation of flammable material around the battery, and remove such flammable material.

Please contact your Komatsu distributor for investigation and correction of the cause.

**CHECKING WITH MACHINE MONITOR**

1. Turn starting switch (1) to the ON position (B).
2. Check that all the monitors and gauges light up for approx. 2 seconds and the alarm buzzer sounds for approx. 2 seconds.

**REMARK**

If the lamps do not light up, there may be a failure or disconnection in the monitor, please contact your Komatsu distributor.

**NOTICE**

Do not simply use the monitor to carry out the check before starting. Always carry out the check before starting according to the procedure on the following pages.

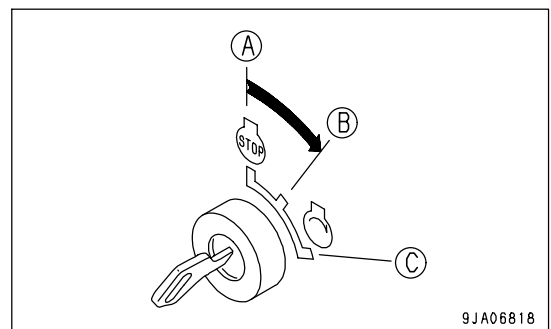
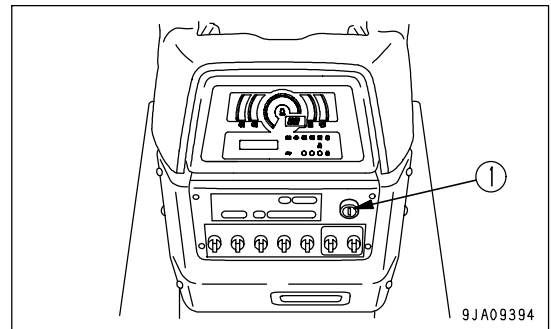

## CHECK FUEL LEVEL, ADD FUEL

**WARNING**

When adding fuel, never let the fuel overflow. This may cause a fire. If the fuel is spilt, wipe it off completely.

1. Turn the starting switch to the ON position and check the fuel level with fuel gauge (G) on the monitor panel.  
After checking, turn the switch back to the OFF position.

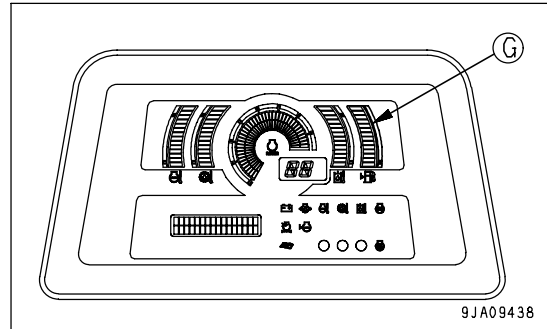

2. After completing work, fill the fuel tank through fuel filler port (F).
3. After adding fuel, tighten the cap securely.  
Fuel capacity: 490 liters (129.46 US gal)

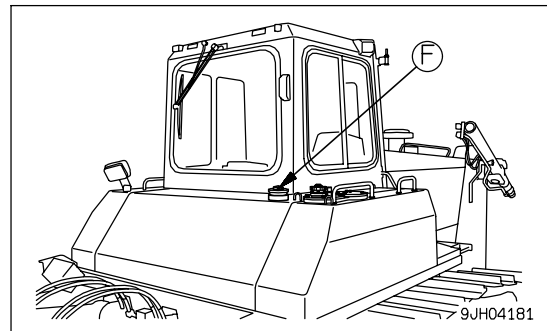
**REMARK**

- When dozing on a grade, make sure there is plenty of fuel in the tank so that the engine fuel line does not become aerated.
- If breather hole (1) on the cap is clogged, the pressure in the tank will drop and fuel will not flow.  
Clean the hole from time to time.

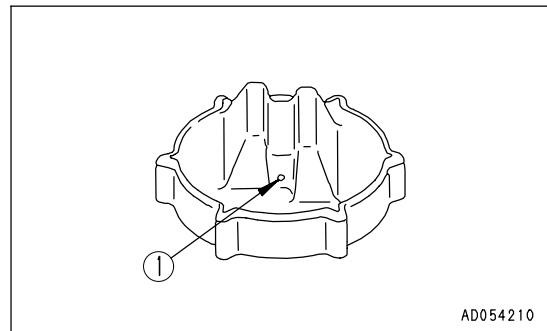

**DRAIN WATER AND SEDIMENT IN FUEL TANK**

- Prepare a container to catch the fuel that is drained.
- 1. Open drain valve(1) at the bottom of the tank to drain sediment and water accumulated on the bottom, together with fuel.  
At this time, take care not pour fuel over yourself.
- 2. When clear fuel comes out, close drain valve (1).

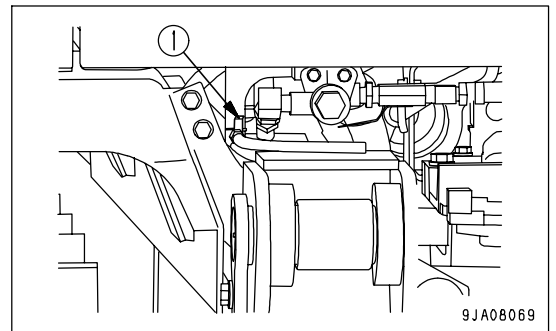
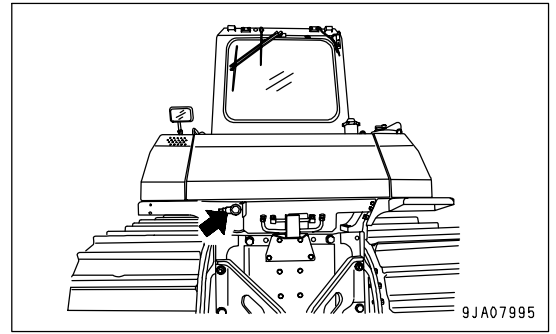

## CHECK BRAKE PEDAL TRAVEL

**WARNING**

If the brake pedal stroke is not 69 to 79 mm (2.7 to 3.1 in) (below 69 mm or over 79 mm), the brake and steering force is too strong or insufficient. If the stroke is 80 mm (3.2 in) or longer, adjust it.

1. Depress the brake pedal all the way until it stops.
2. Measure pedal stroke (A) at the pedal center so that it is somewhere between 69 mm to 79 mm (2.7 in to 3.1 in).
3. When this value exceeds 80 mm (3.2 in), or the brake fails to work, please contact your Komatsu distributor for adjustment.

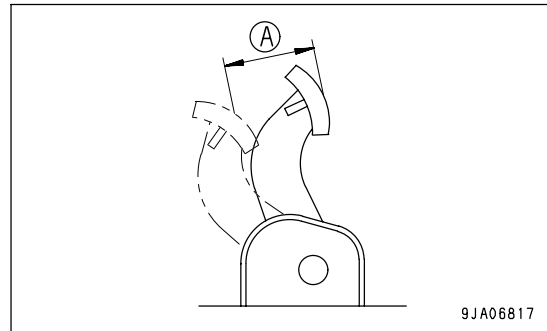

## CHECK THAT LAMPS LIGHT UP

1. Turn starting switch to the ON position (B).

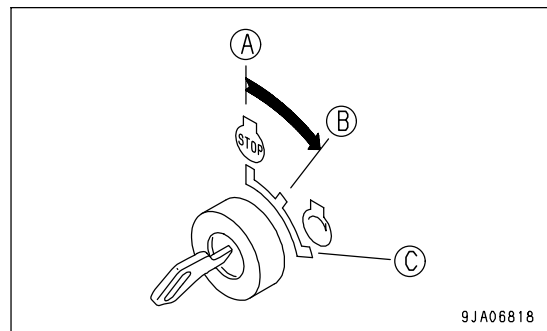

2. Turn the front lamp switch to the I (ON) position and check that the front lamp light up.

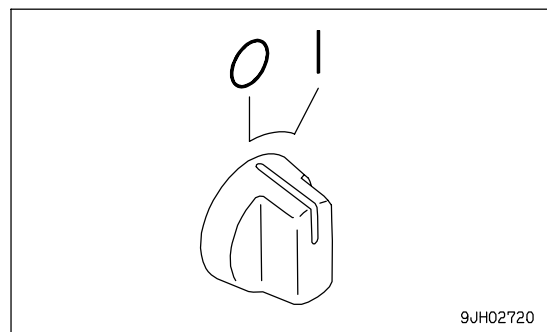

3. Turn the rear lamp switch to the I (ON) position and check that the rear lamps on the left and right fenders light up. If the lamps do not light, check for a broken bulb or disconnected wire, contact your Komatsu distributor for repairs.

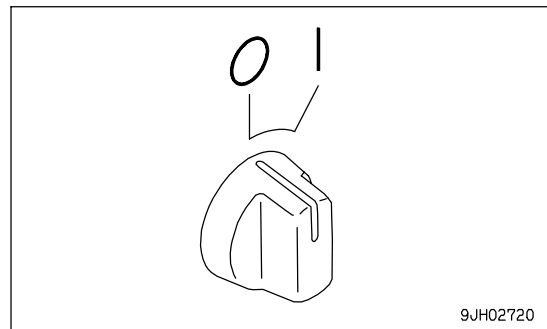

**CHECK HORN SOUND**

Check that the horn sounds. If it does not sound at all or the sound is extremely feeble, a defect or broken wire is suspected, ask your Komatsu distributor for possible repairs.

1. Turn starting switch to the ON position (B).

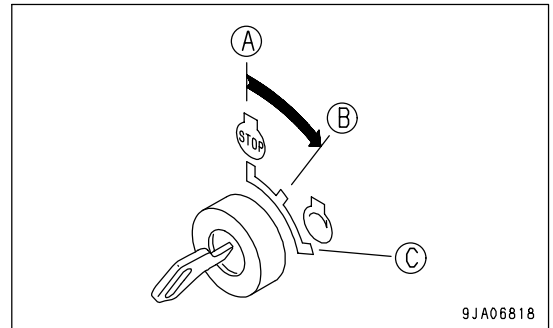

2. Push the horn switch and check that the horn sounds.

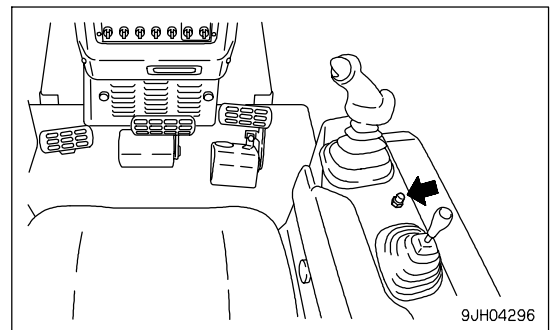

**CHECK OF OPERATION OF BACKUP ALARM**

Check that the backup alarm sounds normally. If it does not, a defect or broken wire is suspected, ask your Komatsu distributor for possible repairs.

1. Turn starting switch to the ON position (B).

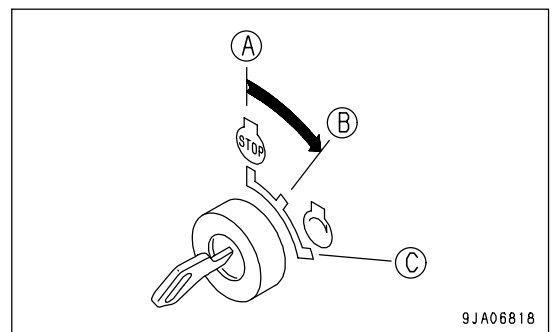

2. Set the steering, forward-reverse, gear shift lever in the REVERSE position (R).

The alarm must sound immediately at this time. The alarm keeps sounding until the steering, forward-reverse, gear shift lever is set to the NEUTRAL position (N) or FORWARD position (F).

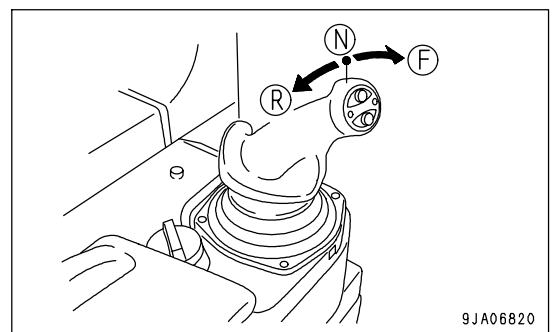

## ADJUSTMENT

### ADJUST OPERATOR'S SEAT



## WARNING

When adjusting the position of the operator's seat, always set the lock lever to the LOCK position to prevent any accidental contact with the control levers.

- Always adjust the operator's seat before starting each operation or when the operators change shift.
- When adjusting the seat, put your back against the backrest and adjust to a position where the brake pedal can be fully depressed.

#### (A) Fore-and-aft adjustment

Pull lever (1), set the seat to a position where it is easy to operate, then release the lever.

Fore-aft adjustment: 160 mm (6.3 in) (8 stages)

#### (B) Weight and height adjustment of seat

- Turn knob (2) under the seat so that weight adjustment indicator (3) displays the green range. The height can be adjusted by turning the knob (2) while the green range is displayed.
- Turn the knob clockwise to raise the seat and turn the knob counterclockwise to lower the seat.

Height adjustment range: stepless, 75 mm (3 in)

Weight adjustment range: 50 to 130 kg (110 to 237 lb)

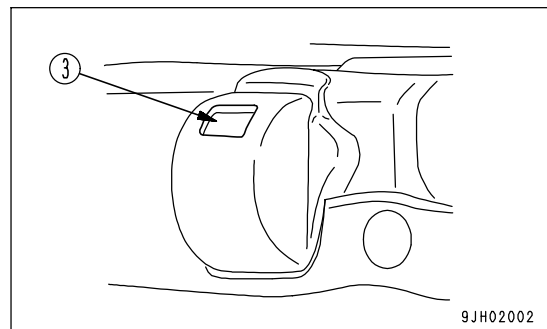
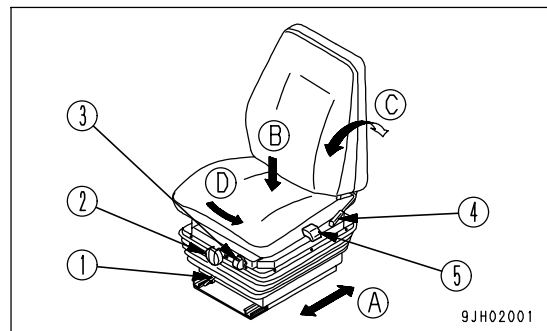

#### (C) Adjust reclining angle

#### REMARK

When the seat is pushed forward, the available reclining angle becomes greater; when the seat is pushed back, the available reclining angle becomes smaller. When moving the backrest, return the backrest to its original position before moving the seat.

Pull lever (4) up, set the backrest to the desired position, then release the lever.

(D) Adjusting direction of seat

Pull up lever (5) to unlock the seat. The seat can then be turned 15° to the right.

After changing the direction of the seat, return the lever securely to lock the seat.

- Change the direction of the seat to the right for the ease of operation of the ripper.

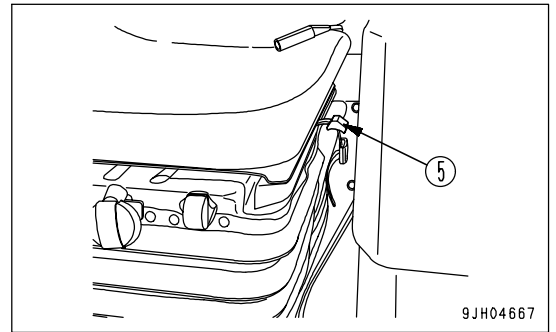



## FASTENING AND REMOVING SEAT BELT

**WARNING**

- Before fastening the seat belt, inspect the securing brackets and belt for abnormal conditions. Replace any worn or damaged seat belt or the securing brackets.
- Even no problem can be seen with the belt, always replace the seatbelt once every three years. The date of manufacture is given on the rear side of the belt.
- Adjust and fasten the seat belt before operating the machine.
- Always use the seat belt when operating the machine.
- Fit the seat belt across your lap without twisting.

Check that the bolts of the clamp securing the belt to the chassis are not loose. Tighten them if they are loose. The tightening torque for the mounting bolt is  $24.5 \pm 4.9$  Nm ( $2.5 \pm 0.5$  kgm,  $18.1 \pm 3.6$  lbft). If the belt surface is scratched or frayed or if the fittings are broken or deformed, replace the seat belt unit.

## FASTENING AND REMOVING SEAT BELT

1. Sit on the seat, depress the brake pedal fully, and adjust the seat so that your back is pressed against the backrest.
2. After adjusting the seat position, adjust tether belt (1). Tense the tether belt and install it when there is no one sitting on the seat.
3. Sit on the seat and hold tongue (4) connected to wind-in mechanism (2) and pull out the belt slowly so that the belt will cover your abdomen sufficiently.
4. Insert tongue (4) in buckle (3) until it clicks. The belt is pulled back into wind-in mechanism (2) until it is fitted to your abdomen. The belt is locked under this condition and cannot be extended anymore. Fit the belt to your abdomen without twisting it.

**REMARK**

If the belt is locked before the tongue is inserted in the buckle, let it return to the wind-in mechanism, then repeat the above procedure from the start.

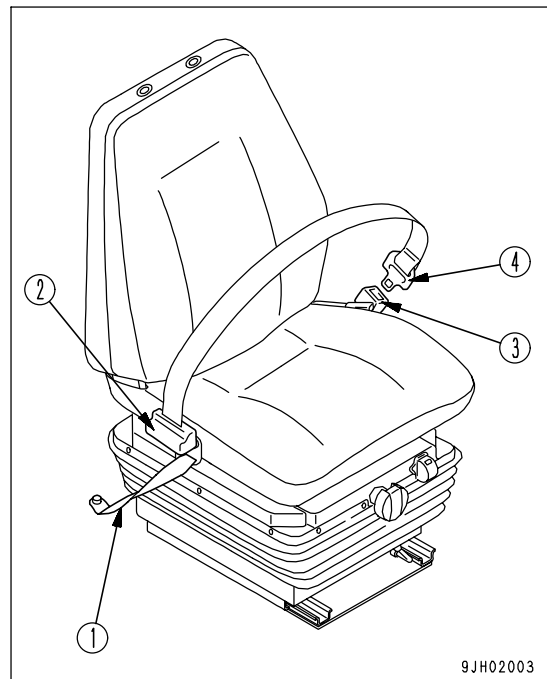

9JH02003

5. Pull the belt to check that it is securely locked in position.
6. When removing the belt, press the red button on buckle (3). The belt will automatically retract.

## ADJUST MIRROR

**WARNING**

Be sure to adjust the mirrors before starting work. If they are not adjusted properly, you cannot secure the visibility and may be injured or may injure someone seriously.

Loosen nut (1) of the mirror and adjust the mirror to a position where it gives the best view from the operator's seat.

In particular, be sure to adjust the mirror so that people at the rear left or right of the machine can be seen clearly.

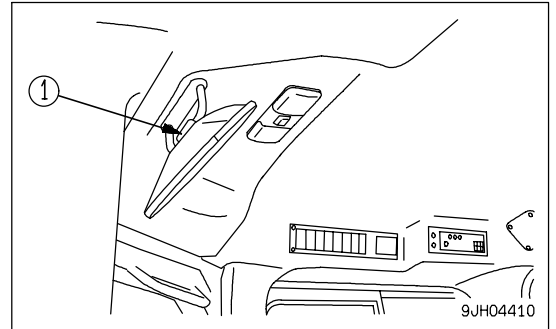

## ADJUST LEFT CONSOLE BOX

**WARNING**

- Before adjusting the position of the left console box, always set the parking brake lever to the LOCK position.
- After adjusting the position of the left console box, push and pull the console box to the front and rear to check that it is locked and cannot move. If it is not locked properly, the console box may suddenly move during operations, causing misoperation of the steering, forward-reverse, gear shift lever, and resulting in failure.

The left console box can be adjusted by 90 mm (3.5 in) in 9 stages to the front or rear. Adjust it to the most suitable position to match the adjustment of the operator's seat.

1. Pull up lock lever (2) at the rear of console box (1) at the left side of the operator's seat, and set the lock lever to the FREE position.

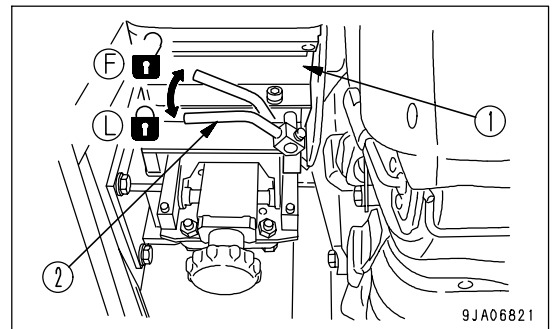
**NOTICE**

Do not grip the steering, forward-reverse, gear shift lever when removing console box (1). There is danger that the lever may break.

2. With the lock lever (2) pulled up, use your other hand to grip the front of console box (1), then move it to the front or rear with your left and right hands.
3. Move console box (1) to the desired position until a click is heard. Then pull up lock lever (2) and release it. Lock lever (2) automatically returns to LOCK position (L).

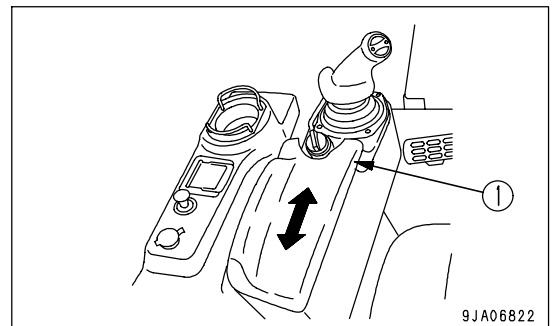

**ADJUST ARMREST**

The height of the armrests on the right and left sides of the operator's seat can be adjusted according to the following procedure. After adjusting the operator's seat, adjust the armrest height properly.

**ADJUST ARMREST (RIGHT)**

Armrest (1) on the right side of the operator's seat can be adjusted in 3 stages: up 30 mm (1.2 in), standard height (center), or down 25 mm (1.0 in).

- 1. Loosen knob (2) (2 places).

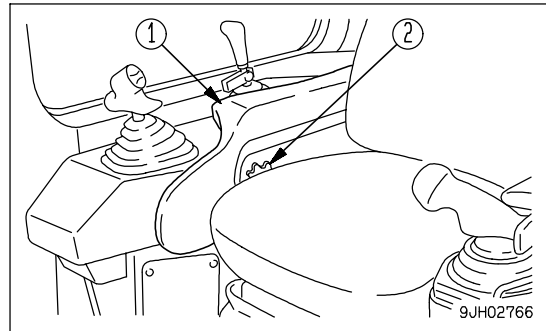

- 2. Move the armrest on the operator's seat to the front, then align the position of the 3 holes ((A), (B),(C)).
- 3. Return the armrest to the rear.
- 4. Tighten knob (2) securely.

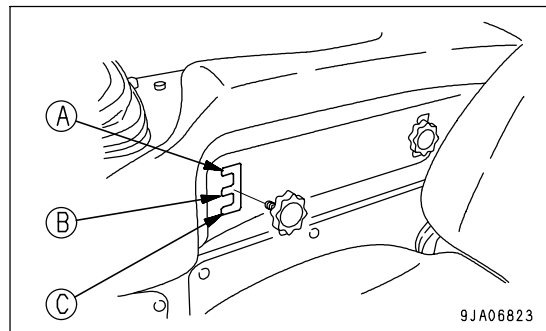

**ADJUST ARMREST (LEFT)**

The armrest on the left side of the operator's compartment can be adjusted to 2 heights.

It is possible to adjust the standard height up 30 mm (1.2 in) or down 30 mm (1.2 in) gradually.

The joystick moves as a unit.

Turn up/down left adjustment knob (1) to adjust the height. Turn the knob to adjust as follows.

Turn **CLOCKWISE** to move **DOWN**

Turn **COUNTERCLOCKWISE** to move **UP**

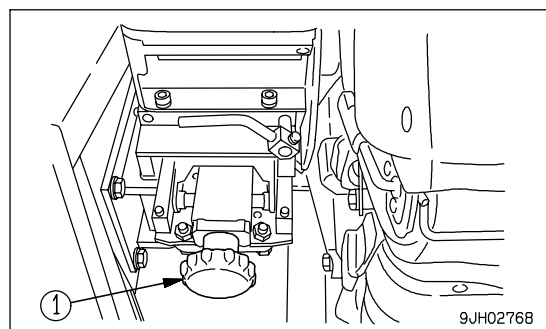

**OPERATION AND CHECK BEFORE STARTING ENGINE**

**⚠ WARNING**

- When starting the engine, check and make sure the work equipment lock lever (4) and parking brake lever (1) are secured in the LOCK position.  
If the control levers are not locked and they are touched by accident when starting the engine, the work equipment may move unexpectedly, and this may lead to a serious injury or death.
- When standing up from the operator's seat, always set the work equipment lock lever (4) and parking brake lever (1) to the LOCK position, regardless of whether the engine is running or stopped.

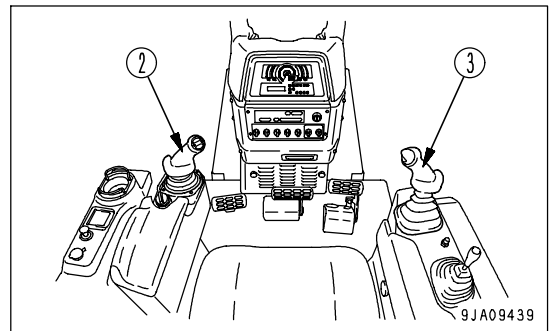
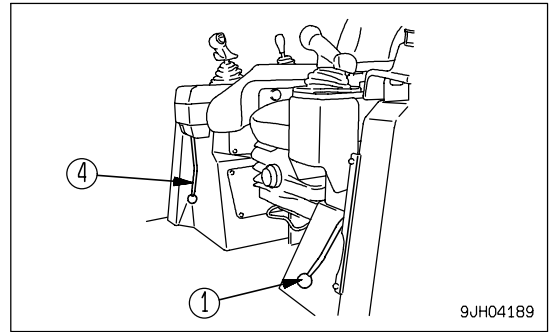

1. Check that parking brake lever (1) is in the LOCK position (L).

**REMARK**

If this parking brake lever is not in the LOCK position, the engine will not start.

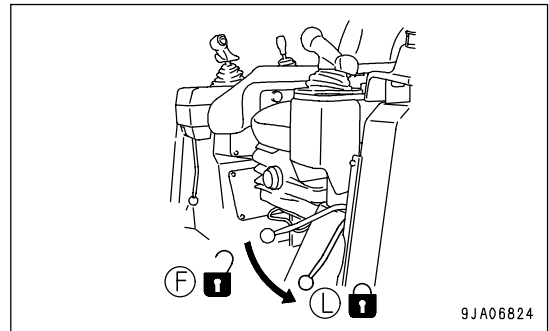

2. Check that steering, forward-reverse, gear shift lever (2) is in the N (neutral) position.

**REMARK**

- The engine cannot be started if steering, forward-reverse, gear shift lever (2) is not in the N (neutral) position.
- If steering, forward-reverse, gear shift lever (2) is in FORWARD or REVERSE, the letter P on display panel A will flash.

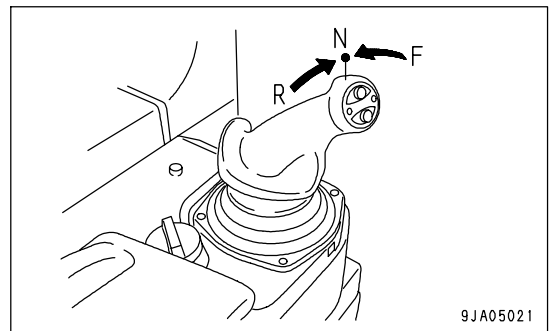

3. Lower the blade to the ground to check that blade control lever (3) is in HOLD position (b).

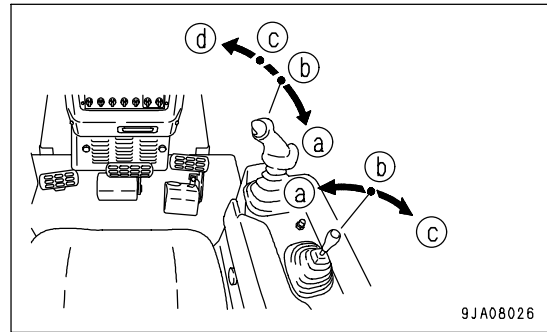

4. Check that the ripper is lowered to the ground.
5. Check that the work equipment lock lever (4) is LOCK position (L).

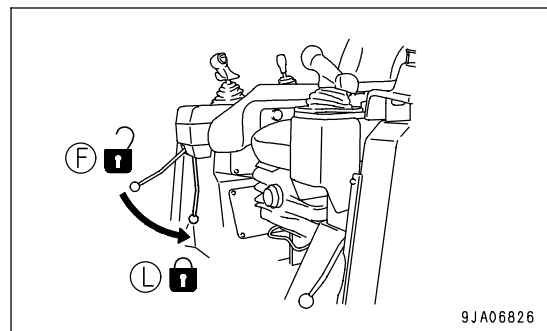

## STARTING ENGINE

### NORMAL STARTING

#### WARNING

- Sit down in the operator's seat before starting the engine.
- Do not attempt to start the engine by short-circuiting the engine starting circuit. Such an act may cause serious bodily injury or fire.
- Check that there are no persons or obstacles in the surrounding area, then sound the horn and start the engine.
- Exhaust gas is toxic. When starting the engine in confined spaces, be particularly careful to ensure good ventilation.

#### NOTICE

- Do not crank the starting motor continuously for more than 20 seconds. If the engine does not start, wait for at least 2 minutes, then repeat the procedure from Step 2.
- Before starting the engine, check that the fuel control dial is in the low idling (MIN) position.
- On this machine, to protect the turbocharger, a turbo protect function is provided. In cold weather, even if fuel control dial (1) is moved immediately after starting the engine, the engine speed may not change for several seconds.
- If the fuel control dial is in the FULL position, the engine will accelerate suddenly and cause damage to the engine parts, so set it to an intermediate or low speed position.

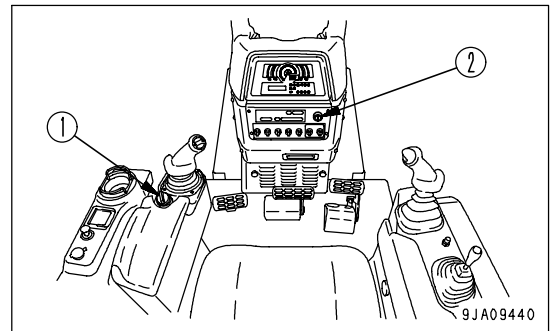

1. Turn fuel control dial (1) to the low idling (MIN) position. If it is in the high idling (MAX) position, be sure to turn it to the low idling (MIN) position.

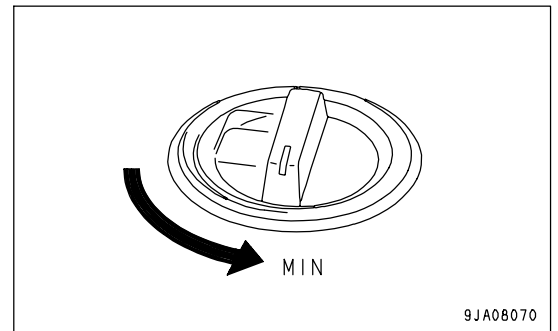

2. Insert the key into starting switch (2) and turn the key to the START position (C). The engine will start.

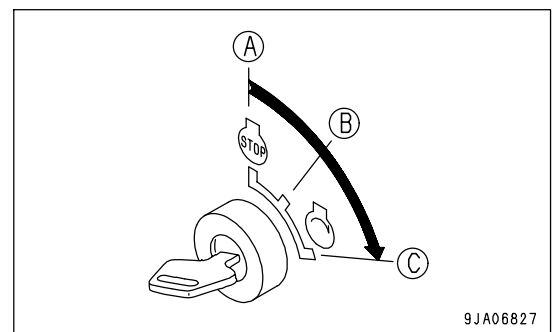

3. When the engine starts, release the key in starting switch (2).  
The key will return automatically to the ON position (B).

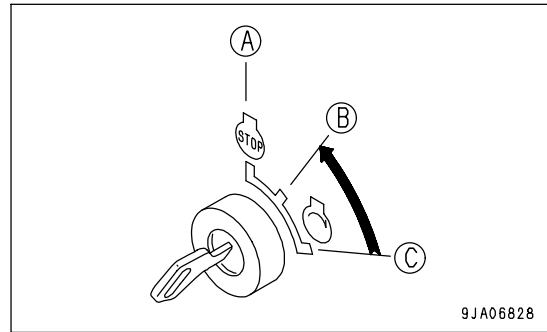

## STARTING IN COLD WEATHER

### WARNING

- Start the engine only after sitting down in the operator's seat.
- Do not attempt to start the engine by short-circuiting the engine starting circuit. Such an act may cause a serious bodily injury or fire.
- Check that there are no persons or obstacles in the surrounding area, then sound the horn and start the engine.
- Never use starting aid fluids as they may cause explosions.
- Exhaust gas is toxic. When starting the engine in confined spaces, be particularly careful to ensure good ventilation.

### NOTICE

- Do not crank the starting motor continuously for more than 20 seconds. If the engine does not start, wait for at least 2 minutes, then repeat the procedure from Step 2.
- Before starting the engine, check that the fuel control dial is in the low idling (MIN) position.
- On this machine, to protect the turbocharger, a turbo protect function is provided. In cold weather, even if fuel control dial (1) is moved immediately after starting the engine, the engine speed may not change for several seconds.
- If the fuel control dial is in the FULL position, the engine will accelerate suddenly and cause damage to the engine parts, so set it to an intermediate or low speed position.

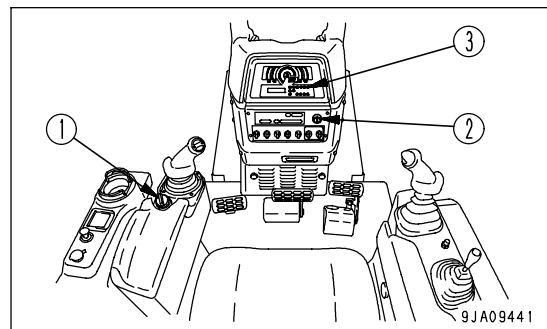

1. Turn fuel control dial (1) to the low idling (MIN) position. If it is in the high idling (MAX) position, be sure to turn it to the low idling (MIN) position.

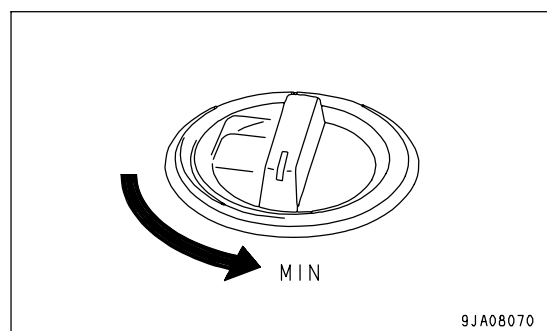

2. Insert the key into starting switch (2) and turn the key to the ON position (B).

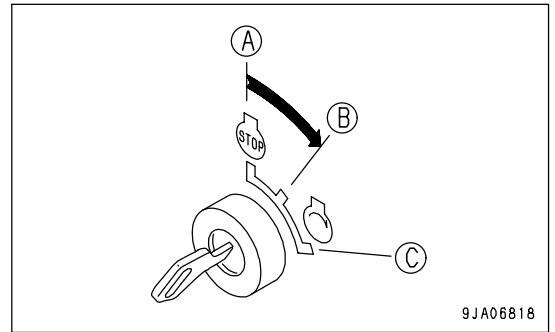

3. Check that engine pre-heating pilot lamp (3) on the monitor panel lights up.  
 4. Maintain the key in the on position until the pre-heating pilot lamp (3) goes off.

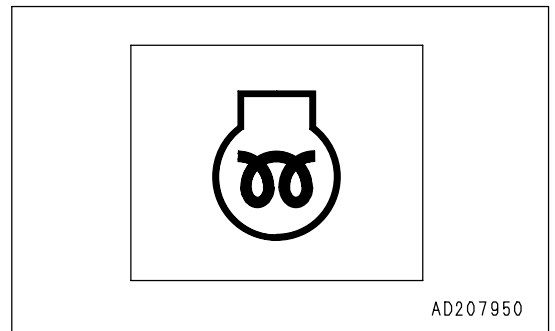

5. When preheating pilot lamp (3) goes off, turn the key of ignition switch (2) to the START position (C) to crank the engine.

The time that preheating pilot lamp (3) stays on changes according to the ambient temperature as shown in the table below.

Ambient temperature	Pre-heat time
-5°C to -10°C (23°F to 14°F)	20 to 27 seconds
-10°C to -20°C (14°F to -4°F)	27 to 40 seconds
-20°C to -30°C (-4°F to -22°F)	40 seconds

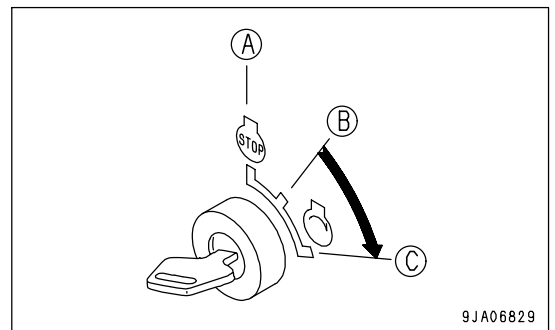

6. When the engine starts, release the key in starting switch (2). The key will return automatically to the ON position (B).

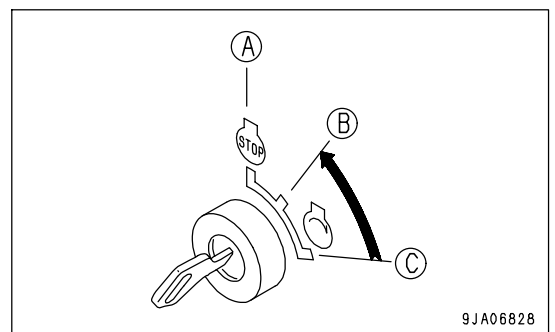

**REMARK**

Immediately after starting the engine, run at idle. While running the engine, release the decelerator pedal and do not operate the work equipment.

Guideline for idle time

- Cold weather: At least 15 seconds
- 1st start after changing engine oil or engine oil filter: 20 seconds



7. When the engine rotation stabilizes, return to the low idle (MIN) position of fuel control dial (1) and then carry out the warming-up operation.

**REMARK**

- Regardless of the ambient temperature, if the key in starting switch (2) is turned from OFF position to left, preheating pilot lamp (3) will light up and preheating will start. (Preheating continues while the starting switch is held at the left.)

For the details of the preheating time, see the table in Step 5.

- While preheating is being carried out, the preheating pilot lamp (3) lights up to show that preheating is being carried out.
- If the engine does not start with the above operation, wait for about 2 minutes, and repeat steps 3. And 4.
- The relationship between the actuation time of the turbo protect function and the engine coolant temperature is as follows.

Even if the fuel control dial is operated within the time given below, the engine speed will not change.

**Turbo protect function**

The turbo protect function is a function to protect the turbocharger by keeping the engine speed at less than 1000 rpm immediately after the engine is started.

- When the turbo protect function is actuated, the engine speed is held at less than 1000 rpm, regardless of the position of the fuel control dial.
- When the turbo protect function is actuated, the engine speed is held at less than 1000 rpm, even if the fuel control dial is operated.
- When the turbo protect function is canceled, the engine speed is set to the speed for the position of the fuel control dial.
- The relationship between the length of time of actuating the turbo protect function and the temperature of the engine coolant is as shown in the table.

Coolant temperature	Turbocharger protection time (sec.)
Above +10°C (50°F)	0
+10°C to -10°C (50°F to 14°F)	Varies within a range of 0 to 20 seconds
Below -10°C (14°F)	20

## OPERATIONS AND CHECKS AFTER STARTING ENGINE



### WARNING

- If there has been any Emergency stop, abnormal actuation or trouble, turn the starting switch key to the OFF position.
- If the work equipment is operated without sufficiently warming the machine up, response of the work equipment to movement of the control lever will be slow, and the work equipment may not respond as the operator desires, so always perform the warming-up operation. Particularly in cold areas, be sure the warming-up operation is completed.

## BREAKING IN THE NEW MACHINE

### NOTICE

Your Komatsu machine has been thoroughly adjusted and tested before shipment from the factory. However, operating the machine under full load before breaking the machine in can adversely affect the performance and shorten the machine life.

Be sure to break in the machine for the initial 100 hours (as indicated on the service meter).

Make sure that you fully understand the content of this manual, and pay careful attention to the following points when breaking in the machine.

- Run the engine at idle for 15 seconds after starting it. During this time, do not operate the control levers or fuel control dial.
- Idle the engine for 5 minutes after starting it up.
- Avoid operation with heavy loads or at high speeds.
- Immediately after starting the engine, avoid sudden starts, sudden acceleration, unnecessary sudden stops, and sudden changes in direction.

## WARMING UP OPERATIONS

### NOTICE

- Do not perform operations or suddenly operate the levers when the hydraulic oil is at a low temperature. Always perform the warming-up operation until the hydraulic oil temperature monitor displays the green range. This will help extend the machine life.

Do not suddenly accelerate the engine before the machine reaches full operating temperature.

- Do not run the engine at low or high idle for more than 20 minutes. This will cause oil leaks from the turbocharger oil supply piping.

If it is necessary to run the engine at idling, apply a load from time to time or run the engine at a mid-range speed.

- If engine oil pressure caution lamp (3) flashes or the buzzer sounds intermittently, stop the engine and check for the cause.

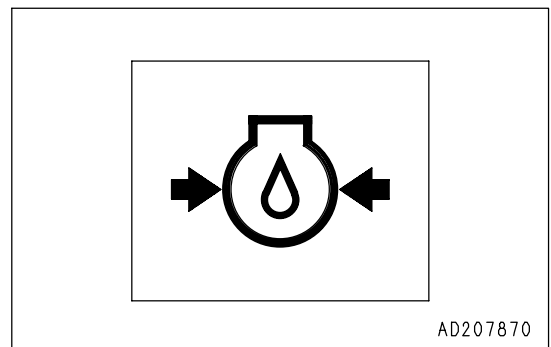
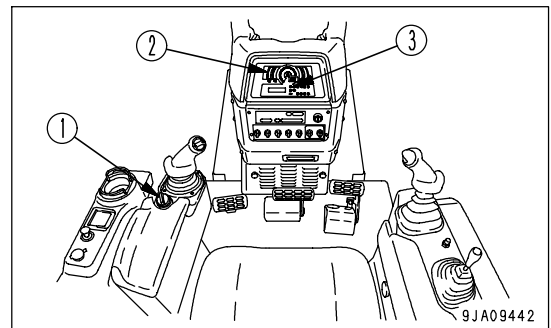

1. Turn fuel control dial (1) to the center position between low idling (MIN) and high idling (MAX) positions and run the engine at a mid-range speed for 5 minutes under no load.
2. After warm-up is completed, check gauges and caution lamps for proper operation. If any problem is found, repair it. Continue to run the engine under a light load until engine coolant temperature gauge indicator (2) is within the green range (B).  
(A): White range  
(B): Green range  
(C): Red range

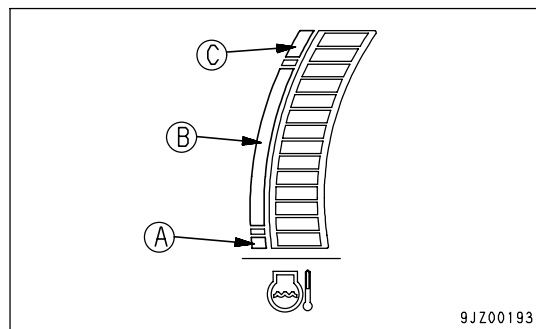
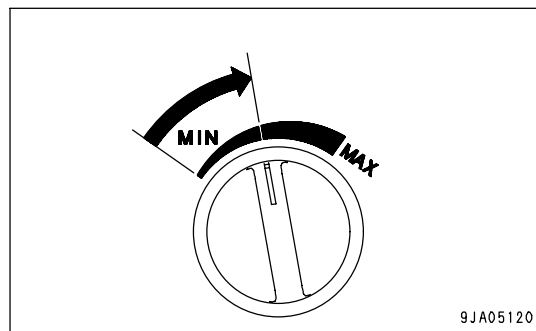

3. Check for abnormal exhaust gas color, noise, or vibration. If any problem is found, contact your Komatsu distributor.

## STARTING IN COLD WEATHER

(Ambient temperature below 10°C (50°F))

### (AUTOMATIC WARMING-UP OPERATION)

This machine is equipped with an automatic warming-up device.

- When the engine is started, if the engine coolant temperature is low (below 30 °C (86 °F)), the warming-up operation is carried out automatically.
- The automatic warming-up operation is canceled if the engine coolant temperature reaches the specified temperature (30 °C (86 °F)) or if the warming-up operation is continued for 10 minutes. If the engine coolant temperature or hydraulic oil temperature are low after the automatic warming-up operation, warm the engine up further as follows.

### NOTICE

- Do not perform operations or suddenly operate the levers when the hydraulic oil is at a low temperature. Always perform the warming-up operation until the hydraulic oil temperature monitor displays the green range. This will help extend the machine life.  
Do not suddenly accelerate the engine before the machine reaches full operating temperature.
- Do not run the engine at low or high idle for more than 20 minutes. This will cause oil leaks from the turbocharger oil supply piping.  
If it is necessary to run the engine at idling, apply a load from time to time or run the engine at a mid-range speed.
- If engine oil pressure caution lamp (3) flashes or the buzzer sounds intermittently, stop the engine and check for the cause.

1. Turn fuel control dial (1) to the center position between LOW IDLE (MIN) and HIGH IDLE (MAX) and run the engine at medium speed for about 5 minutes with no load.

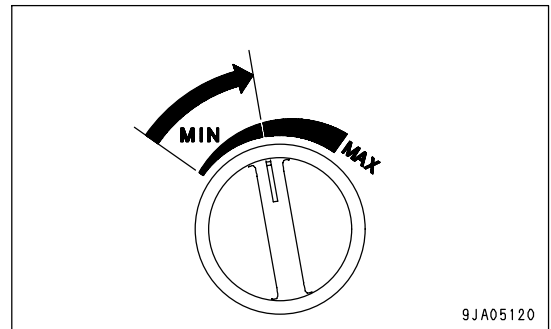
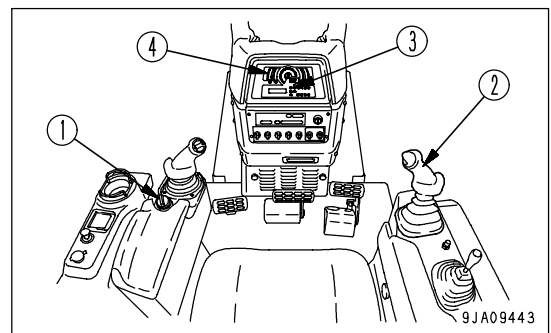

2. Blade control lever (2) to the full RAISE position, then hold the lever in position, and operate slowly to the left tilt relief and right tilt relief positions for 5 minutes.
3. Finally, operate blade control lever (4) and ripper control lever to operate the blade and ripper cylinders several times. If the oil temperature in the work equipment is not properly raised, there will be a time lag in the response of the work equipment and steering.
4. After warm-up is completed, check gauges and caution lamps for proper operation. If any problem is found, repair it. Continue to run the engine under a light load until engine coolant temperature gauge indicator (4) is within the green range (B).  
 (A): White range  
 (B): Green range  
 (C): Red range

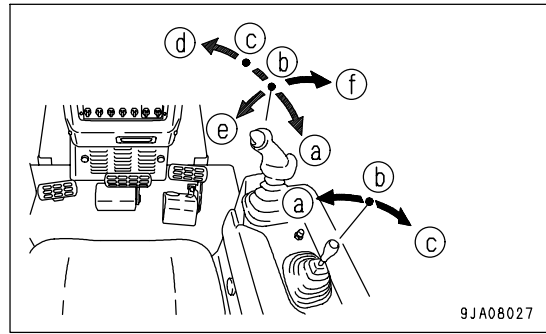

- |           |                |
|-----------|----------------|
| (a) RAISE | (d) FLOAT      |
| (b) HOLD  | (e) LEFT TILT  |
| (c) LOWER | (f) RIGHT TILT |

**REMARK**

If the power train oil temperature is not raised sufficiently, it will take longer to accelerate to the maximum speed.

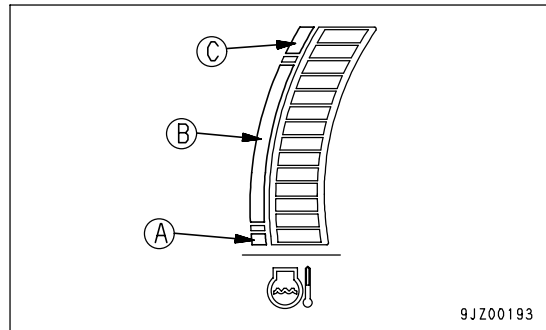

5. Check for abnormal exhaust gas color, noise, or vibration. If any problem is found, contact your Komatsu distributor.

## STOPPING ENGINE

### NOTICE

If the engine is stopped without allowing it to cool down, there is danger that the service life of various parts of the engine will be reduced. Except in emergencies, never stop the engine suddenly.

If the engine overheats, do not stop it suddenly. Run it at low speed to allow it to cool down gradually, then stop it.

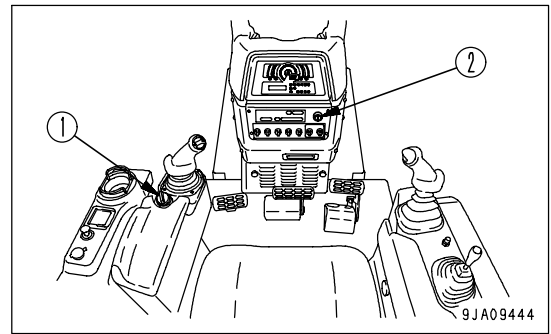

1. Lower the work equipment to the ground.
2. Turn fuel control dial (1) in the low idling (MIN) positions and run the engine at low idling speed for 5 minutes to allow the engine to gradually cool down.

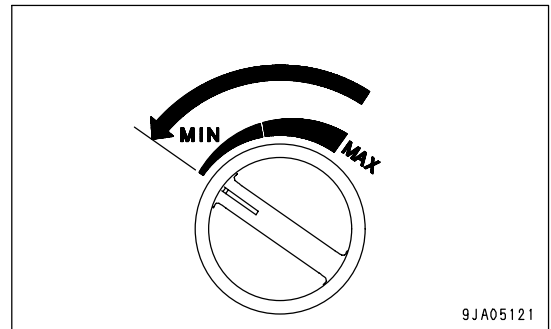

3. Turn the key in ignition switch (2) to the OFF position (A).  
The engine will stop

### REMARK

- When engine starting switch (2) key is turned to the OFF position, the engine stops, but the machine's main power source is not turned off immediately. This is a time lag provided for the controller to memorize the operation status and then terminate the system. While this process continues, the main power is maintained. The power holding time varies depending on the operation condition.
- Also when the cooling fan is used for a cleaning purpose, the machine's main power source is not turned off immediately, even if engine starting switch (2) key is turned to the OFF position. This time lag is provided to protect the hydraulic circuit, and in this case, the machine's main power is maintained for seven seconds.

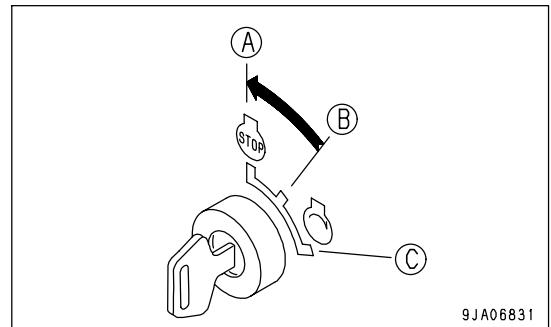

4. Remove the key from starting switch (2).

# MACHINE OPERATION

## MOVING MACHINE

### WARNING

- Before moving the machine, check that the area around the machine is safe, and always sound the horn before moving.  
Do not allow anyone to enter the area around the machine.  
The rear of the machine is a blind spot, so be extremely careful when traveling in reverse.
- When moving the machine down a slope, always keep brake pedal (8) depressed, even after releasing parking brake lever (1).
- When moving the machine up a steep slope, turn fuel control dial (5) to high idling (MAX) position and run the engine at full speed, and keep brake pedal (8) and decelerator pedal (6) depressed. Then operate steering, directional, and gearshift lever (4) from the N (neutral) position to the direction of travel and slowly release brake pedal (8). When the travel speed rises, slowly release decelerator pedal (6).

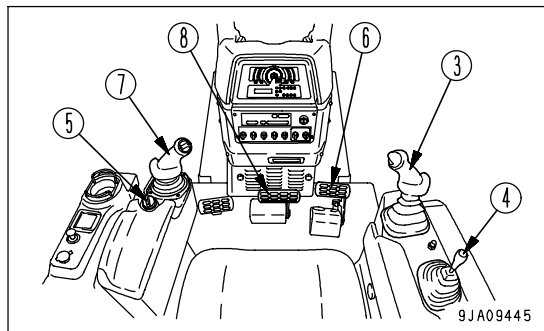
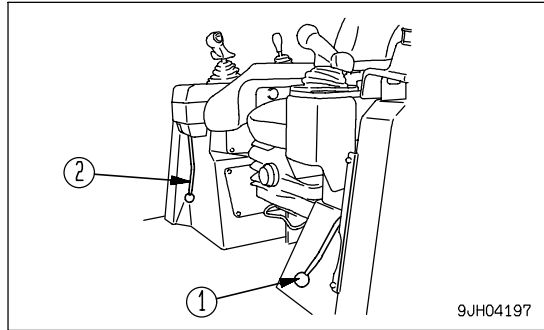

### CAUTION

If parking brake lever (1) is operated to the FREE position when the cooling fan is rotating in the reverse direction, the machine cannot be started up while a letter, "N" is shown in flashing on display A. Stop the engine once and start it up again so that the cooling fan rotates in the normal direction.

1. Operate parking brake lever (1) to the FREE (F) position.

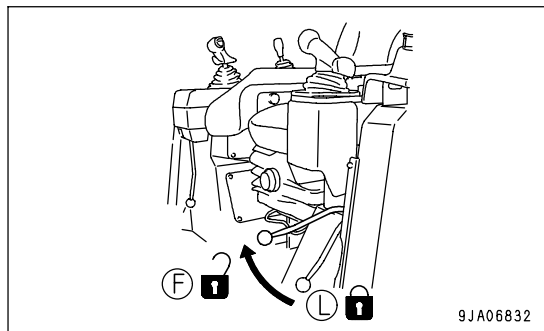

2. Operate blade control lever (3) and work equipment lock lever (2) of ripper control lever (4) to FREE (F) position.

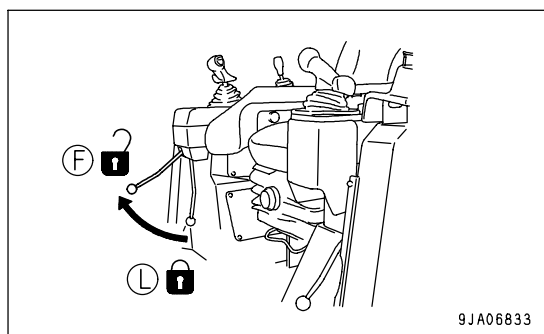

3. Operate blade control lever (3) and ripper control lever (4) to the RAISE (a) position so that the blade will rise above the ground by 40 cm to 50 cm (15.8 in to 19.7 in) and the ripper will rise to the upper limit.

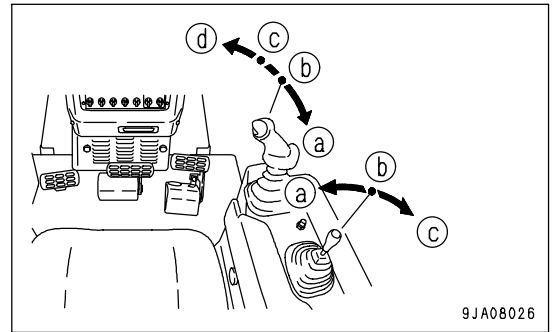

4. Turn fuel control dial (5) to the full speed (MAX) position, raise the engine speed, and fully depress decelerator pedal (6).

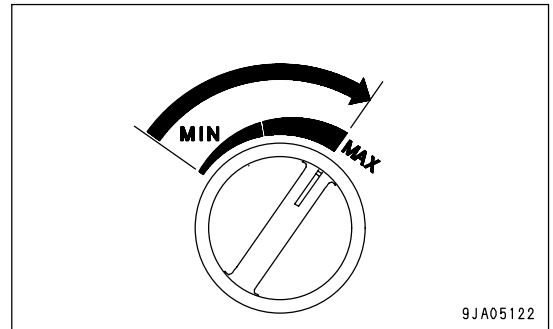

5. Move joystick to the F (FORWARD) or R (REVERSE) position, gradually release decelerator pedal (6) and allow the machine to move.

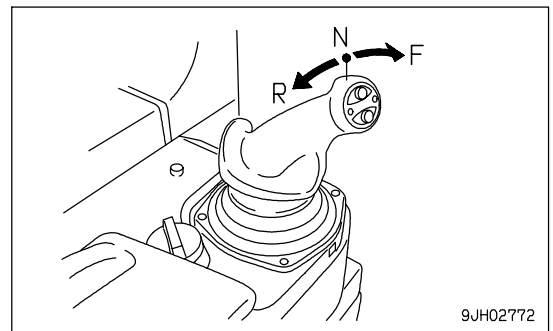

#### REMARK

Check that the backup alarm sounds when steering, forward-reverse, gear shift lever is placed in REVERSE position. If the alarm does not sound, please contact your Komatsu distributor.



### STOPPING MACHINE

#### WARNING

- Avoid stopping suddenly. Give yourself ample room when stopping.
- When stopping the machine, select flat hard ground and avoid dangerous places. If it is unavoidably necessary to park the machine on a slope, place the parking brake lever (1) in the LOCK position and insert blocks underneath the track shoes. As an additional safety measure, thrust the blade into the ground.
- If the work equipment control lever is touched by accident, the work equipment may suddenly move, and may cause damage, serious injury, or death. Before leaving the operator's seat, always secure work equipment lock lever (2) in the LOCK position.

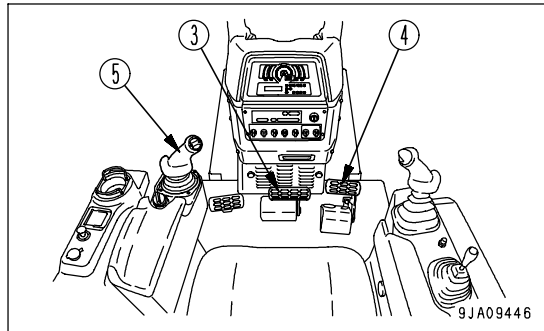
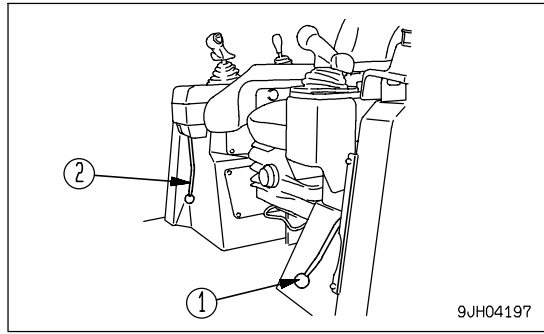

1. Depress brake pedal (3) to apply the brake.

#### NOTICE

If the brake is depressed when the engine speed or travel speed is high, the brake disc may make a slipping sound. Normally, depress decelerator pedal (4) to reduce the engine speed and travel speed before depressing the brake.

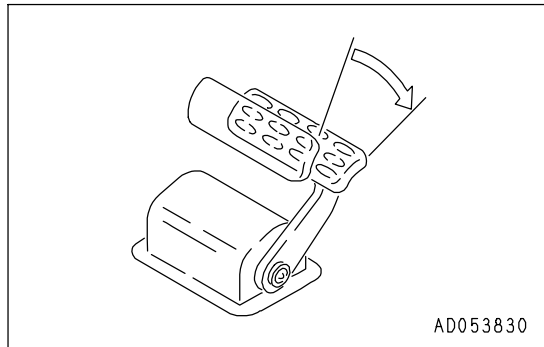

2. Set joystick (5) in the neutral position.

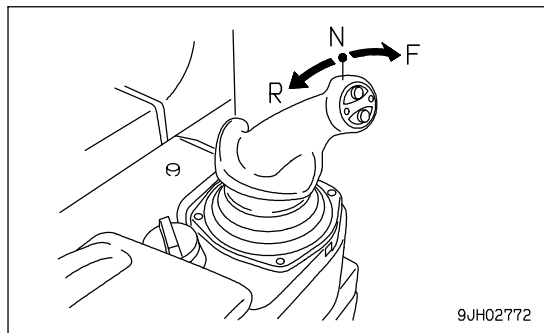

**SHIFTING GEARS**

The machine does not have to be stopped to shift gears.

1. Move steering, forward-reverse, gear shift lever (1) to the desired gear position to shift gears.

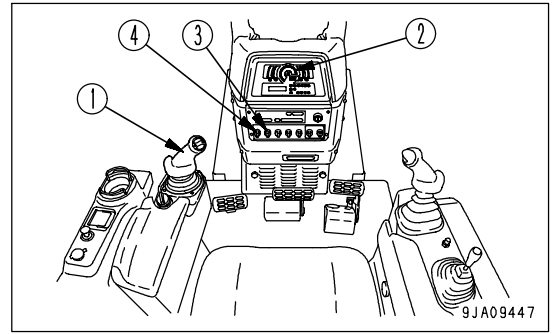

**GEARSHIFTING OPERATION**

Press switch (a) or (b) to shift gears.

Up switch (a): Each time switch is pressed, transmission shifts up 1 range

Down switch (b): Each time switch is pressed, transmission shifts down 1 range

There are 3 forward and 3 reverse speed ranges.

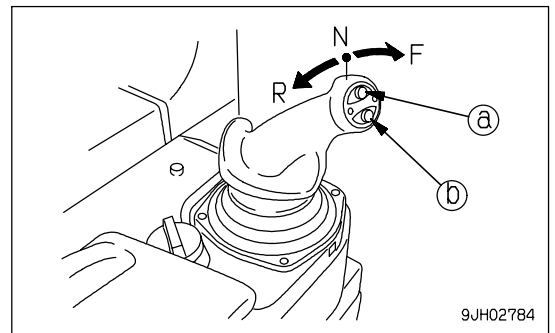

- When the lever is moved to the forward (to set to FORWARD) from the N position, the transmission shifts to F1. If the UP switch is pressed once when the transmission is in F1, the transmission shifts to F2. If the UP switch is pressed once when the transmission is in F2, the transmission shifts to F3. If the DOWN switch is pressed once when the transmission is in F3, the transmission shifts to F2. If the DOWN switch is pressed once when the transmission is in F2, the transmission shifts to F1.
- When the lever is moved to the rear (to set to REVERSE) from the N position, the transmission shifts to R1. If the UP switch is pressed once when the transmission is in R1, the transmission shifts to R2. If the UP switch is pressed once when the transmission is in R2, the transmission shifts to R3. If the DOWN switch is pressed once when the transmission is in R3, the transmission shifts to R2. If the DOWN switch is pressed once when the transmission is in R2, the transmission shifts to R1,

For details of the maximum speed in each speed range, see "SPECIFICATIONS (PAGE 5-2)".

**REMARK**

The speed range in use is displayed on the panel display according to the gearshift operation.

For example:

- Neutral: N is displayed on the display panel A (2)
- FORWARD 2nd: F2 is displayed on the display panel A (2)
- REVERSE 3rd: R3 is displayed on the display panel A (2)
- When the parking brake lever is locked, P is displayed.

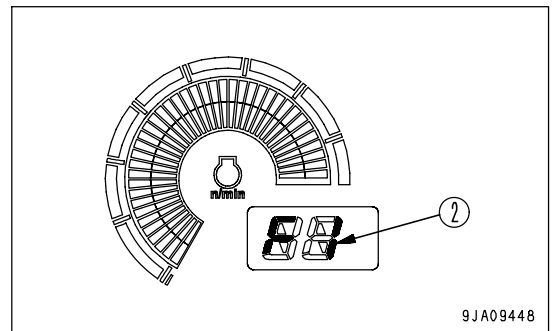

## GEARSHIFTING OPERATION USING PRESET MODE FUNCTION

If the preset mode function is used, the speed ranges used when the machine travels in forward and reverse can be preset as desired.

- F1-R1 mode
- F1-R2 mode
- F2-R1 mode
- F2-R2 mode

1. Set joystick (1) to the N position.

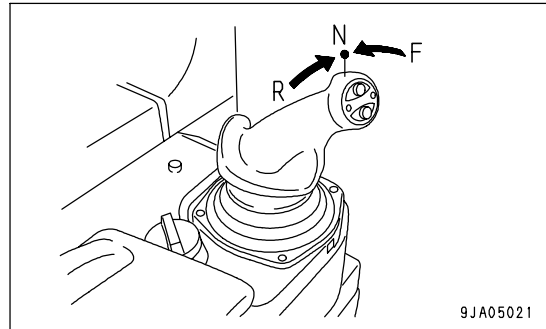

2. When preset mode switch (3) is set to the I position (ON), the function is actuated.

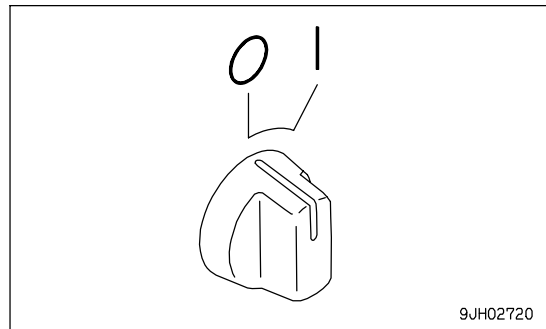

3. When the preset mode function is actuated, [F1-R1] is displayed at the left side of the bottom line of display panel B (multi-information) on the monitor panel, and the [F1-R1] mode is set.

### REMARK

When preset mode switch (3) is set to the ON position (a), the default [F1-R1] mode is set.

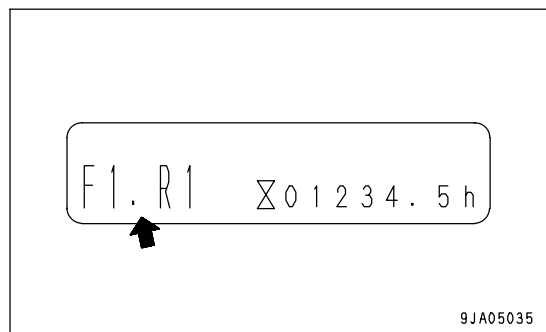

4. If it is desired to select another mode, press up switch (a) or down switch (b) on steering, directional, and speed lever (1) and display the desired mode on control panel B (multi-information).

The types of mode and method of selection are as follows.

up	up	up
[F1-R1] →	[F1-R2] →	[F2-R1] →
←	←	←
[F2-R2]		
down	down	down

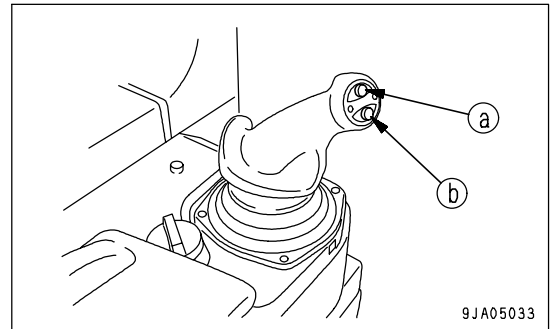

- Shift operation when [F1-R1] mode is set  
 When the preset mode switch is turned ON, the [F1-R1] mode is set by default.  
 After that, if the steering, directional, and speed lever is operated forward (forward travel operation), the transmission is shifted to F1.  
 If it is operated back (reverse travel operation), the transmission is shifted to R1.
  
- Shift operation when [F1-R2] mode is set  
 When the steering, directional, and speed lever is in the N position, if the up switch is pressed once, the mode is set to [F1-R2] mode. After that, if the steering, directional, and speed lever is operated forward (forward travel operation), the transmission is shifted to F1. If it is moved back (reverse travel operation), the transmission is shifted to R2.
  
- Shift operation when [F2-R1] mode is set  
 When the steering, directional, and speed lever is in the N position, if the up switch is pressed Twice, the mode is set to [F2-R1] mode. After that, if the steering, directional, and speed lever is operated forward (forward travel operation), the transmission is shifted to F2. If it is moved back (reverse travel operation), the transmission is shifted to R1.
  
- Shift operation when [F2-R2] mode is set  
 When the steering, directional, and speed lever is in the N position, if the up switch is pressed three times, the mode is set to [F2-R2] mode. After that, if the steering, directional, and speed lever is operated forward (forward travel operation), the transmission is shifted to F2. If it is moved back (reverse travel operation), the transmission is shifted to R2.

**REMARK**

Even when the mode is set to [F1-R1] mode, [F1-R2] mode, [F2-R1] mode, or [F2-R2] mode, it is possible to switch to the desired speed range simply by operating the up switch or down switch.

For example, when the mode is set to [F1-R2] mode, if the steering, directional, and speed lever is moved forward (forward travel operation), the transmission is shifted to F1, but if up switch (a) is pressed once with the lever pushed forward, the transmission is shifted to F2; if it is pressed twice, the transmission is shifted to F3. If the down switch (b) is pressed once when the transmission is in F3, the transmission is shifted to F2; if it is pressed twice, the transmission is shifted to F1.

If the steering, directional, and speed lever is moved back (reverse travel operation), the transmission is shifted to R2, but if up switch (a) is pressed once with the lever pulled back, the transmission is shifted to R3; if down switch (b) is pressed once, the transmission is shifted to R1.

However, the mode remains in the [F1-R2] mode. If the steering, directional, and speed lever is returned to the N position and operated forward again (forward travel operation), the transmission is shifted to F1. If it is moved back (reverse travel operation), the transmission is shifted to R2.

**AUTO DOWN SHIFT OPERATION**

If the travel speed drops because of the load conditions when traveling, this function automatically down shifts to a lower speed range.

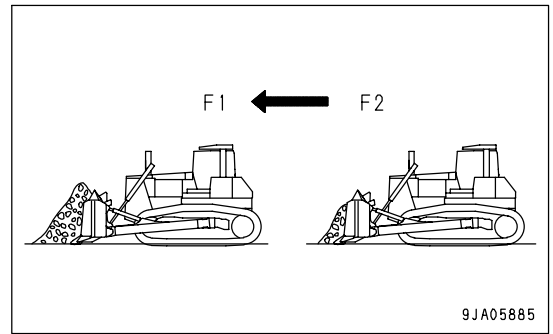

1. The function is actuated when auto shift down switch (4) on the front panel is set to I position (ON).

- (OFF) position: Canceled
- I (ON) position: Actuated

The transmission is automatically shifted down F2→ F1, F3 → F2, R2 → R1, R3 → R2.

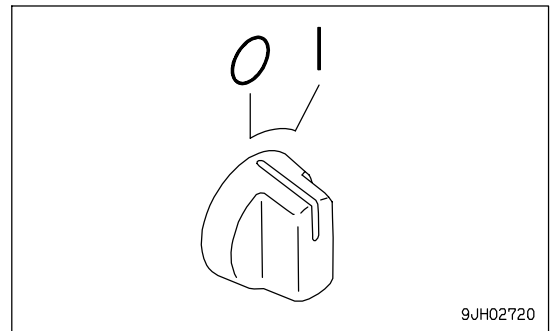

**REMARK**

When the preset mode is being actuated, the system is set so that it does not shift up after the auto shift down has been actuated. If it is desired to shift up, operate the up switch manually. However, the preset mode remains set. If the steering, directional, and speed lever is returned to the N position and then operated again to the forward or reverse position, the preset speed range is again selected.

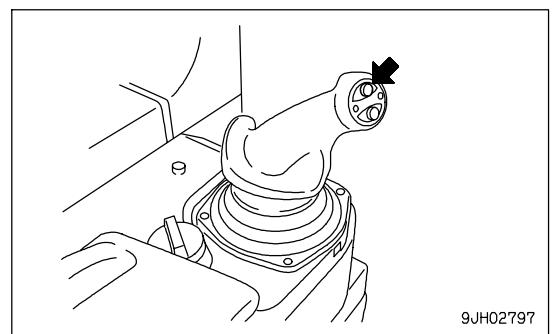
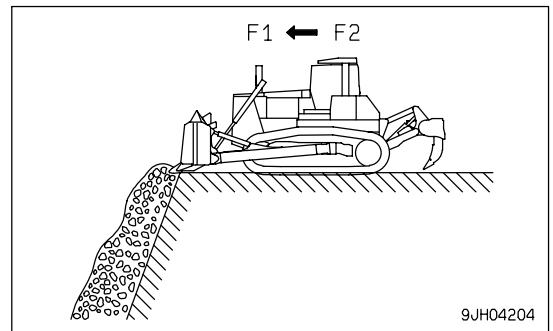

### SHIFTING BETWEEN FORWARD AND REVERSE

#### **WARNING**

When switching between FORWARD and REVERSE, first check that the direction of travel is safe.

#### **CAUTION**

There is no need to stop the machine even when switching between FORWARD and REVERSE.

To increase safety, operator comfort, and the life of the transmission, leave the engine running at full speed, and always depress the decelerator pedal to lower the engine speed.

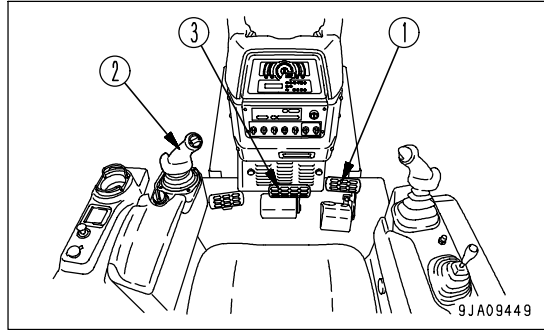

1. Depress decelerator pedal (1) to reduce the engine speed.

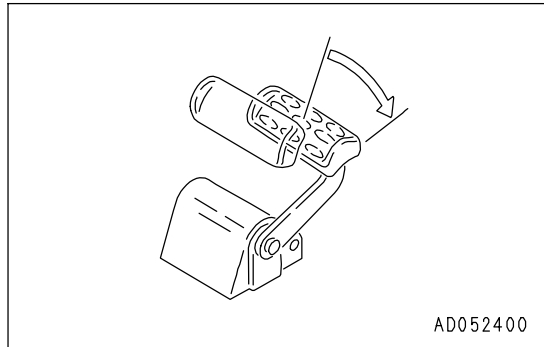

2. Move joystick (2) to the neutral position, reduce the speed, then depress brake pedal (3) and stop the machine.

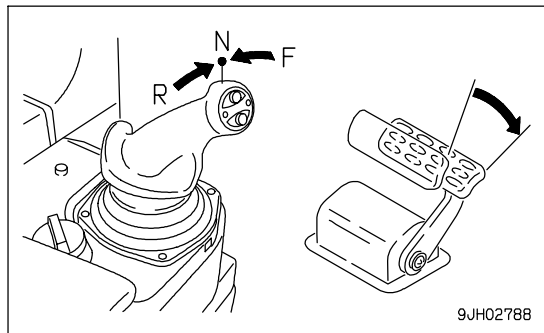

3. After depressing decelerator pedal (1), move steering, forward-reverse, gear shift lever (2) to the desired position.

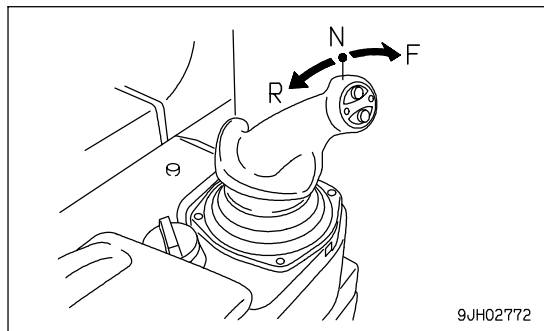

4. Release decelerator pedal (1) and raise the engine speed.

**REMARK**

Check that the backup alarm sounds when steering, forward-reverse, gear shift lever is placed in REVERSE position. If the alarm does not sound, please contact your Komatsu distributor.

**REMARK**

When the joystick is placed in REVERSE, the backup alarm will sound.

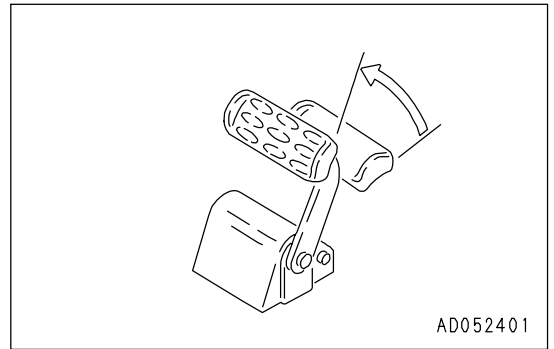



### STEERING MACHINE

#### **WARNING**

- Avoid as much as possible turning the machine on a slope.  
The machine will tend to slip sideways. Particular care should be taken on soft or clay soil.
- Never make a pivot turn at high speed.

### NORMAL TURNING

#### **WARNING**

When performing a counterrotation turn, the feeling of operation when your head is facing the rear is different from the feeling if you are facing the front. Never carry out a counterrotation turn while facing the rear.

To turn the machine while traveling, incline steering, forward-reverse, gear shift lever (1) in the direction of the turn.

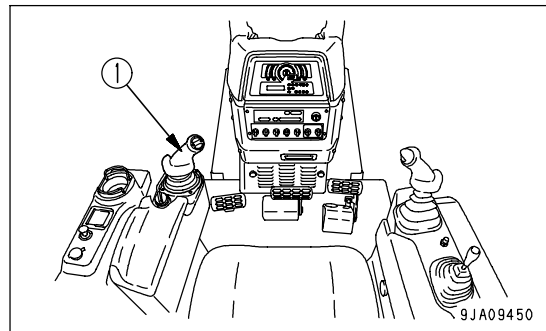

### TURNING LEFT WHILE TRAVELING FORWARD

#### NOTICE

If the lever is moved partially to the forward or reverse position and then is moved in the direction of turn, the machine may carry out a counterrotation turn, so operate the lever fully to the forward or reverse position.

If steering, forward-reverse, gear shift lever (1) is moved to the FORWARD position (F) and moved partially to the left (L), the machine will start to turn gradually. After that, the lever can be moved further towards the end of its travel to set the desired turning radius.

#### REMARK

To turn gradually to the right while traveling forward, if the steering, forward-reverse, gear shift lever (1) is operated to the FORWARD position (F) and moved slowly to the right, the machine will start to turn gradually. After that, the lever can be moved further towards the end of its travel to set the desired turning radius.

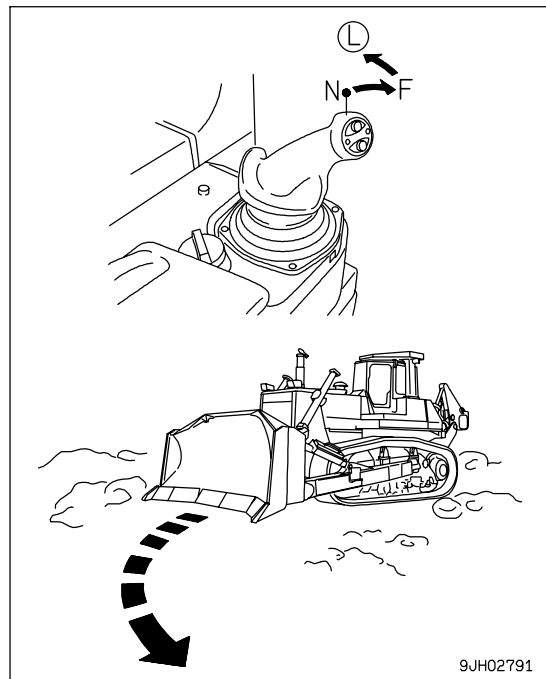

**WHEN MAKING PIVOT TURN TO LEFT WHILE TRAVELING**

**NOTICE**

When carrying out a counterrotation turn, if the load is not equal on the left and right sides, the machine may carry out a pivot turn, so check the ground conditions and be careful not to hit any obstacles.

With steering, forward-reverse, gear shift lever (1) in the N position, operate the lever partially to the left (L). The left and right tracks will rotate in opposite directions, and the machine will make a slow counterrotation turn. If the lever is moved further, the speed of the counterrotation turn will increase.

**REMARK**

When making a right counterrotation turn, move the steering, forward-reverse, gear shift lever (1) to the right (R) in the same way.

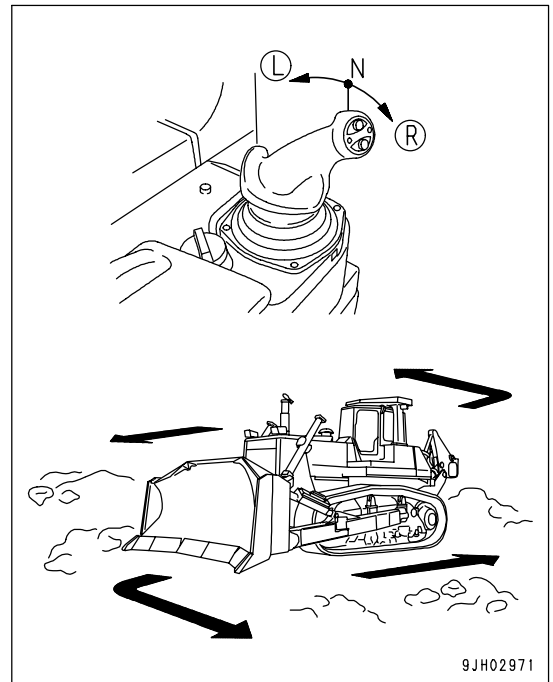

9JH02971

**TURNING WHILE DESCENDING A SLOPE**

**WHEN TURNING TO THE LEFT GRADUALLY WHILE TRAVELING FORWARD**

If steering, forward-reverse, gear shift lever (1) is moved to the FORWARD position (F) and moved partially to the left (L), the machine will start to turn gradually. After that, the lever can be moved further towards the end of its travel to set the desired turning radius.

**REMARK**

To turn gradually to the right while traveling forward, if the steering, forward-reverse, gear shift lever (1) is operated to the FORWARD position (F) and moved slowly to the right, the machine will start to turn gradually. After that, the lever can be moved further towards the end of its travel to set the desired turning radius.

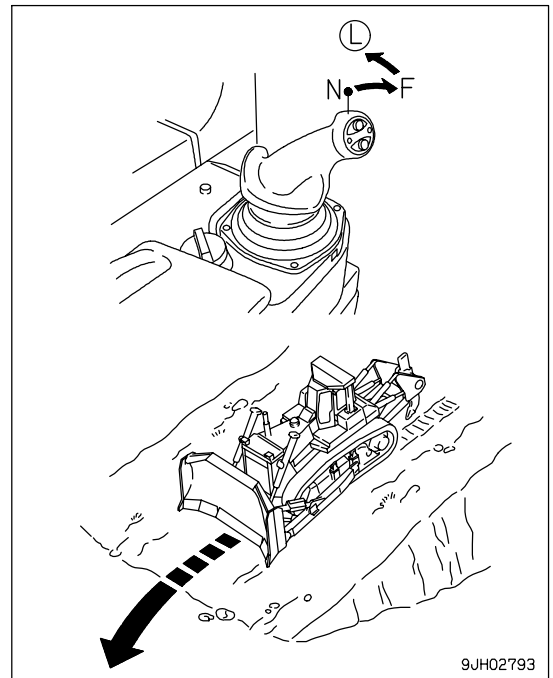

9JH02793

## PRECAUTIONS FOR OPERATION

### PAY ATTENTION TO GAUGES

If the red range of the power train oil temperature gauge lights up during operation, reduce the load and wait for the temperature to go down.

### PERMISSIBLE WATER DEPTH

When operating in water, always keep top surface of the track frame above the surface of the water.

Also, be careful that the engine cooling fan will not come in contact with water. The fan can be damaged.

(A): Permissible water depth line

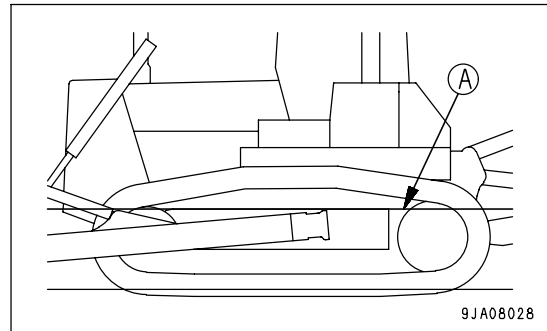

### PRECAUTIONS WHEN TRAVELING FOR A LONG TIME

Avoid operating the machine at high speed for a long time, otherwise the temperature of hydraulic oil sharply rises, and that can cause oil leakage from the track rollers or final drive and lower durability.

If there is no way to avoid operating the machine at high speed for a long time, stop the machine every one hour for 30 minutes and let the track rollers and final drive cool off before starting up the machine again.

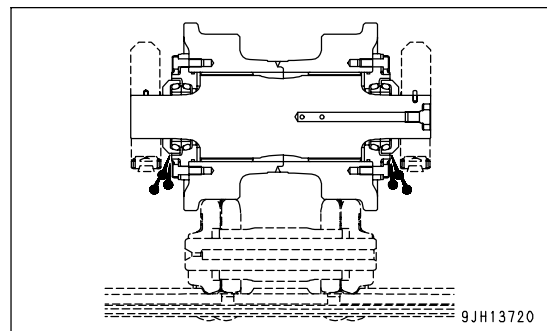

### PRECAUTIONS WHEN TRAVELING UP OR DOWN HILLS

#### METHOD OF USING DECELERATOR PEDAL

When stepping on the decelerator pedal while going uphill, climbing ability will be reduced and the machine will stop. Furthermore, the engine may stall.

#### USE ENGINE AS BRAKE

When going downhill, move steering, forward-reverse, gear shift lever into low speed to run engine at slow speed and travel down slope using the engine as a brake.

Do not move the steering, forward-reverse, gear shift lever to the NEUTRAL position.

When traveling down hills of more than 15°, shift down to 1st speed (R1 or F1).

#### BRAKING WHEN TRAVELING DOWNHILL

While descending a slope using the engine as a brake, also apply the brakes.

Failure to brake may result in overrunning, causing engine trouble.

## PRECAUTIONS WHEN OPERATING BLADE

### METHOD OF USING BLADE LIFT CYLINDER

Do not carry out back grading operations with the cylinder fully extended. There is high risk that an excessive load will be brought to bear on the cylinder.

## PRECAUTIONS ON SLOPES

### BE CAREFUL OF FUEL LEVEL

- If the fuel level in the fuel tank becomes low when the machine is working on slopes, the engine may suck in air because of the angle of the machine or the swaying of the machine. This may make the engine stop, so be careful not to let the fuel level in the fuel tank become too low.
- When working on slopes where the angle of the machine is more than 20°, if the 2nd level of the fuel gauge lights up, add fuel immediately.

(A): Red range

(B): Green range

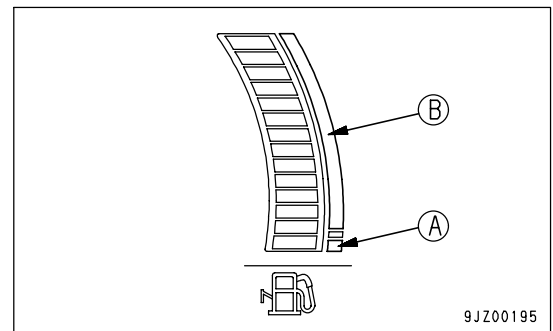

### BE CAREFUL OF OIL LEVEL

When operating machine on sloped areas of more than 20°, fill all appropriate components with oil to H level.

### PRECAUTIONS WHEN ENGINE STOPS ON SLOPES

If the engine stops while working or traveling on a hill, immediately depress the brake pedal to bring the machine to a complete stop.

### METHOD OF USING BRAKES

The following actions cause premature damage to the brakes, so avoid such operations.

- Using emergency brake at full speed
- Using brake with engine running at full speed in first gear (F1, R1) (Machine stall condition)

### REMARK

Always depress the decelerator pedal to lower the engine speed before actuating the brakes.

### IT IS PROHIBITED TO KEEP THE DOOR OPEN DURING OPERATIONS

Always keep the door closed when traveling or carrying out operations.

If the door is open, there is danger of damage from obstacles or strong vibration.

### IT IS PROHIBITED TO MODIFY THE CAB GLASS IN ANY WAY THAT WILL OBSTRUCT THE VIEW

- For safety reasons, do not install anything on the cab glass that will obstruct the view.
- Always keep the glass clean to ensure safety during operations.

**PRECAUTIONS FOR BLIND SPOTS CAUSED BY CAB AND ROPS STRUCTURES****WARNING**

The cab stay and ROPS stay cause blind spots.

When operating, always be sure to check carefully that there is no obstacle or worker in the surrounding area.

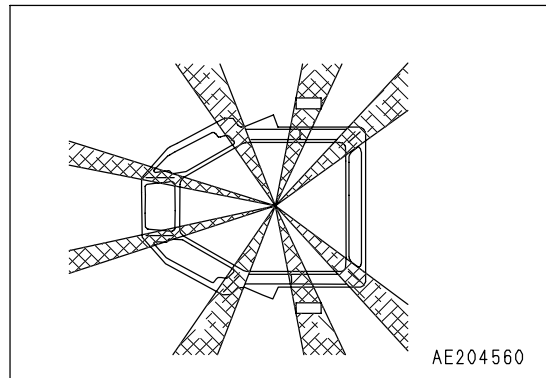

## WORK POSSIBLE USING BULLDOZER

In addition to the following, it is possible to further increase the range of applications by using various attachments.

### DOZING

A bulldozer digs and transports dirt in a forward direction. Slope excavation can always be most effectively carried out by proceeding from the top downward.

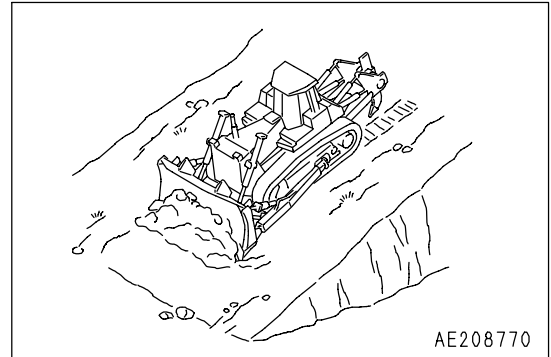

### CUTTING INTO HARD OR FROZEN GROUND OR DITCHING

For digging and ditch excavation of hard or frozen ground tilt the blade. Even hard ground can be dug effectively by a tilted or angled blade.

If the ground is harder, use a ripper attachment for better efficiency.

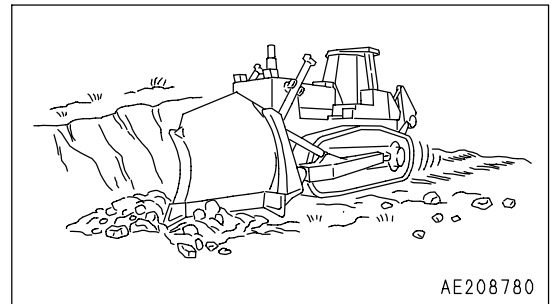

### FELLING TREES, REMOVING STUMPS

#### NOTICE

**Do not up root trees or stumps or fell trees by angling or tilting the blade.**

For trees with a diameter of 10 to 30 cm (3.9 to 11.8 in), raise the blade high and push 2 or 3 times to fell the tree.

Next, travel in reverse, and dig the corner of the blade into the ground to cut and dig up the roots.

When doing this, never hit the tree at high speed or apply shock to fell the tree.

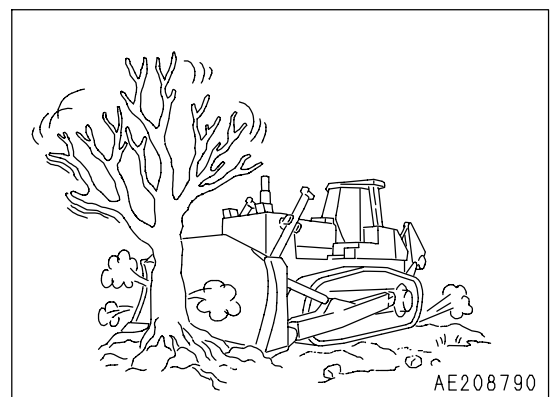

## PUSHER OPERATIONS

- When carrying out pusher operations, always install a pusher plate.
- When approaching the other machine, depress the decelerator pedal to reduce the engine speed and approach slowly. After coming into contact, raise the travel speed slowly and push with full power.

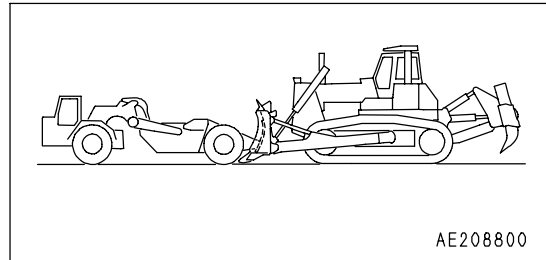

## SMOOTHING

### NOTICE

**Avoid smoothing on rocky or stony ground. It can damage the blade.**

When finishing the ground surface to a smooth finish after digging or filling operations, keep a full load of soil in the blade and operate the blade up or down in small movements while traveling forward. When leveling windrows or ruts left by the tracks, set the blade to the FLOAT position, travel at low speed in reverse and drag the blade over the ground surface.

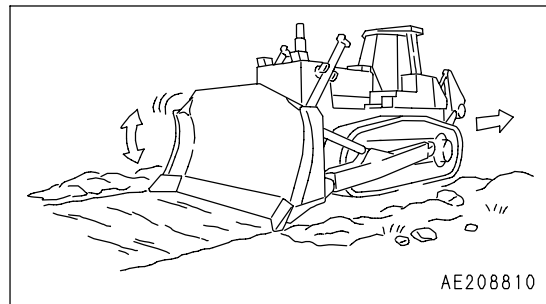

## ADJUSTING POSTURE OF WORK EQUIPMENT



### WARNING

When adjusting, it is dangerous if the work equipment is moved by mistake. Set the work equipment in a safe condition, then stop the engine and lock the work equipment securely with the work equipment lock lever.

## BLADE ADJUSTMENT

### TILTING THE TILTDOZER

#### NOTICE

The maximum tilt is 750 mm (29.6 in) for the EX specification machine and 500 mm (19.7 in) for the PX specification machine. When tilting, make sure that it does not exceed 750 mm (29.6 in) for the EX specification machine or 500 mm (19.7 in) for the PX specification machine.

If the maximum tilt is exceeded, excessive force will be brought to bear on all parts, and this will damage the machine.

If the blade control lever is operated, the following tilt amount can be obtained.

Right side: 410 mm (16.2 in)

Left side: 410 mm (16.2 in)

If more tilt is required, do as follows.

Use bar handle (2) installed to the left brace to turn brace (1) and change length (L) of the brace. This makes it possible to obtain a maximum tilt of 750 mm (29.6 in) for the EX specification machine and 500 mm (19.7 in) for the PX specification machine.

- Standard distance between joints (L): 1287 mm (50.7 in)

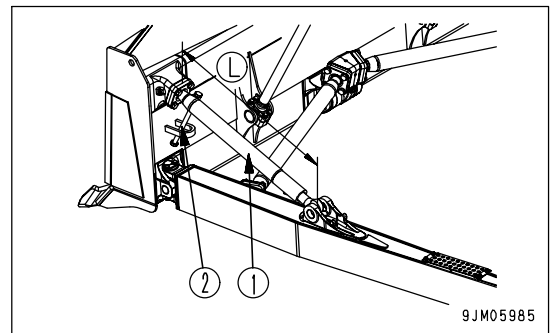

### ADJUSTING SHIM IN BLADE CYLINDER CAP

Set standard shim amount (A) at the blade cylinder cap at 4 mm (0.16 in).

Remove a shim as the cap and cylinder securing ball wear.

Adequate clearance amount: 0.2 mm - 0.5 mm (0.008 in to 0.02 in)

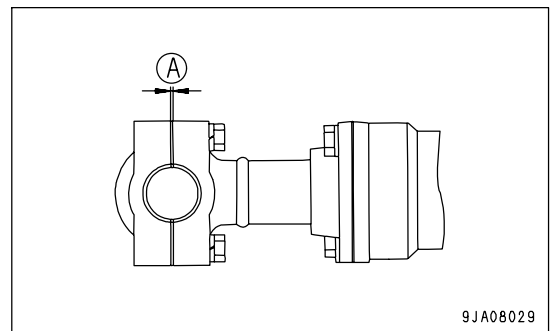



## ADJUSTING DIGGING ANGLE

(PX Specifications)

It is possible to change the digging angle (A) of the blade by removing cap (1) and bolt (2) installed between the blade and tilt cylinder or brace (3), or replacing with optional parts.

This is extremely effective in improving the earth rolling function of the blade on soft ground without using the tilt cylinder to change the left and right tilt.

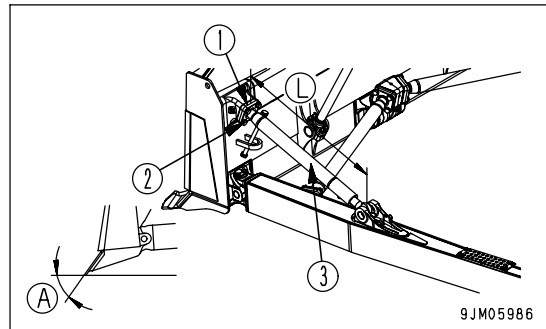

### 1. When replacing with optional cap (1) and bolts (2)

Digging angle (A): 55° -> 52.5°

Part numbers for replacement parts

- Cap (1): 154-929-3210 (2 caps/machine)
- Bolt (2): 01011-82420 (8 bolts/machine)

### 2. When removing cap (1) installed to standard machine

Digging angle (A): 55° -> 50.5°

Prepare the following parts for bolts (2) and replace.

- Bolt (2): 01010-82490 (8 bolts/machine)

## REMARK

It is possible to change digging angle (A) of the blade by a range of  $\pm 5^\circ$  by changing the length (L) of the brace and tilt cylinder.

However, the more the digging angle is changed, the more the change becomes in the amount of tilt on the left and right sides provided by the tilt cylinder.

## ADJUSTING BRACE

**WARNING**

If maintenance is carried out with the engine running, always have one worker sitting in the operator's seat while another worker carries out the maintenance. Both workers must mutually confirm the safety during the operation.

An adjustment of the brace can easily be made by, after starting up the engine, tilting the blade to the right and left through a fine control of the blade control lever and turning brace handle (1) while lifting and lowering the blade.

(A): 300mm - 400mm (11.8 in - 15.7 in)

- When extending the brace

It is easy to carry out the adjustment if the blade is set on top of a block and the brace handle is turned.

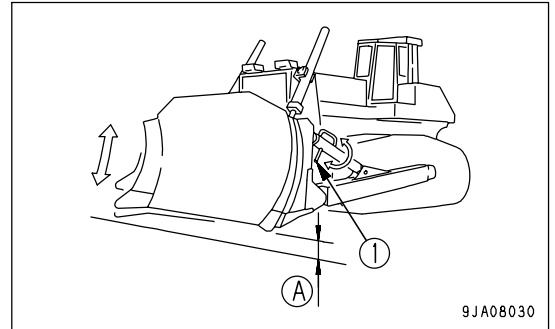
**REMARK**

When operated in this way, the blade is tilted, so the handle gradually becomes heavier. When this happens, return the blade from the tilt position to the horizontal position and turn the handle again according to the procedure given above.

**SHIM ADJUSTMENT**

Adjust the thickness of shim so that the ball joint play (6 points) in the axial direction (shown by the arrow) does not exceed 1 mm (0.04 in).

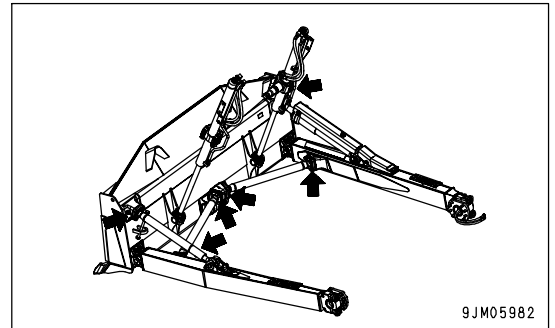

1. Remove shim (1) and tighten bolts (2) to eliminate the ball joint play.
2. Measure clearance "A" and remove bolts (2).
3. Adjust the thickness of shim (1) to  $(A + 0.5) - (A + 1)$  mm, then tighten bolt (2).
4. Confirm that ball joint can move smoothly after tightening bolts.

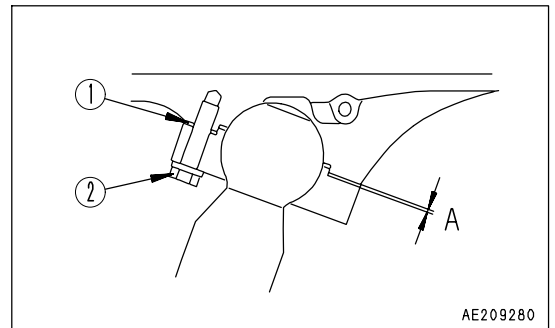

## ADJUSTING RIPPER

### ADJUSTING DIGGING DEPTH

Mounting pin holes are provided in the shank and these are used according to the desired digging depth. For normal use, use the bottom hole, and when particularly deep digging is needed, use the top hole.

1. Place a pointed object on the tip of pin (1), then hit with a hammer to remove from the opposite side.
2. Remove pin (2) and change the position of the shank hole.
3. Insert pin (1) partially by hand then knock it in with a hammer.
  - The pin is made of one piece, so insert it partially by hand then knock it in with a hammer.

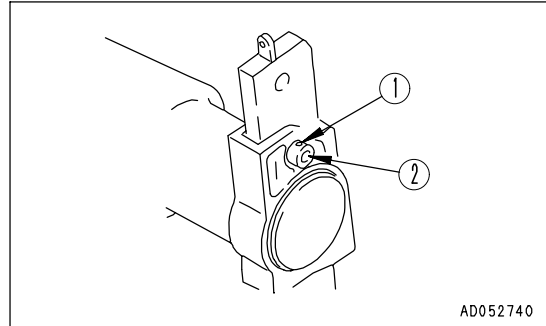

### REPLACING POINT AND PROTECTOR

To protect the shank, if the protector and point installed to the tip are worn, replace them.

Place a pin remover on the pin marked by the arrow, then hit with a hammer to remove from the opposite side.

#### REMARK

The pin is a unitized type, so insert the pin partially by hand, then knock it in fully with a hammer.

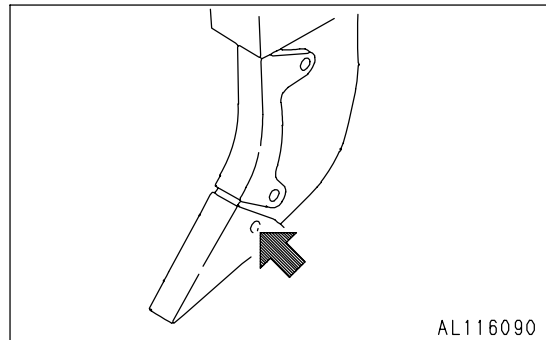

**PARKING MACHINE**

**! WARNING**

- Avoid stopping suddenly. Give yourself ample room when stopping.
- When stopping the machine, select flat hard ground and avoid dangerous places. If it is unavoidably necessary to park the machine on a slope, place the parking brake lever (4) in the LOCK position and insert blocks underneath the track shoes. As an additional safety measure, thrust the blade into the ground.
- If the work equipment control lever is touched by accident, the work equipment may suddenly move, and may cause damage, serious injury, or death. Before leaving the operator's seat, always secure work equipment lock lever (7) in the LOCK position.

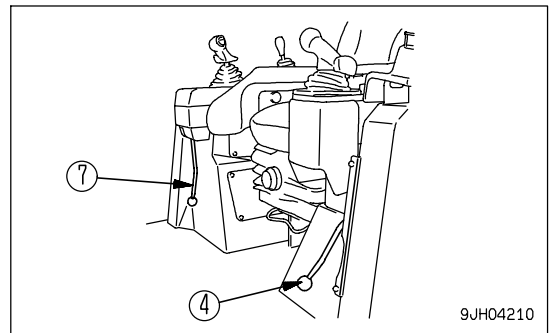
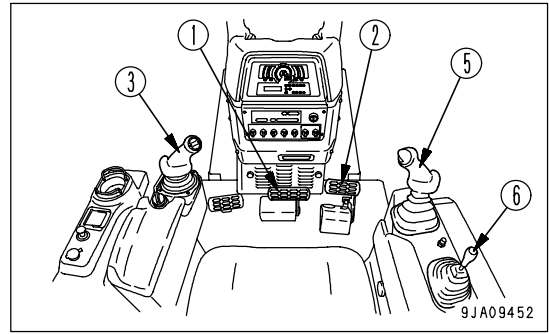

1. Depress brake pedal (1) to stop the machine.

**NOTICE**

If the brake pedal is depressed when the engine speed or machine travel speed is high, the brake disc may produce a slipping sound. When depressing the brake pedal, usually depress decelerator pedal (2) to reduce the engine speed and machine travel speed.

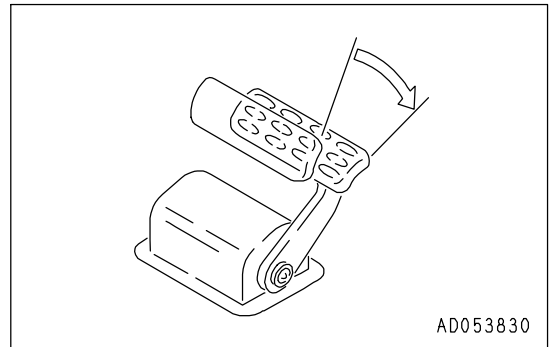

2. Place joystick (3) at the neutral position and set the speed range to 1st.

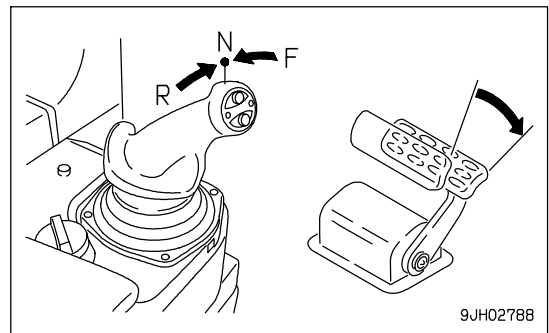

3. Operate parking brake lever (4) to the LOCK (L) position.

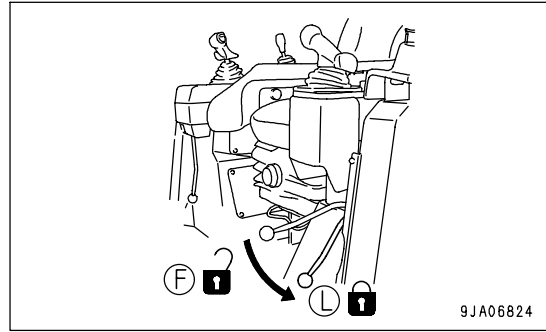

4. Operate blade control lever (5) and ripper control lever (6) to the LOWER (c) position to lower the blade and ripper to the ground.

5. Operate blade control lever (5) and ripper control lever (6) to the HOLD (b) position.

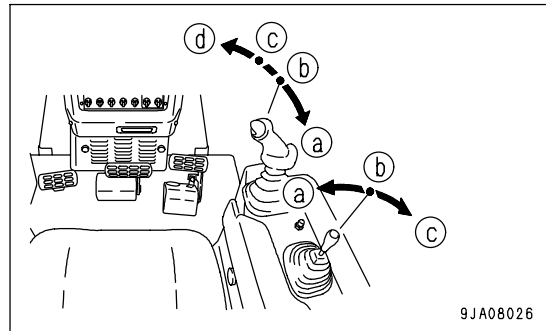

6. Operate blade control lever (5) and work equipment lock lever (7) of ripper control lever (6) to the LOCK (L) position.

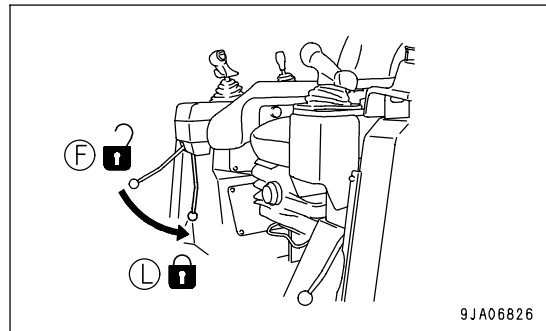

## CHECK AFTER FINISHING WORK

### BEFORE STOPPING ENGINE

Use the meters and caution lamps to check the engine coolant temperature, engine oil pressure, fuel, and power train oil temperature.

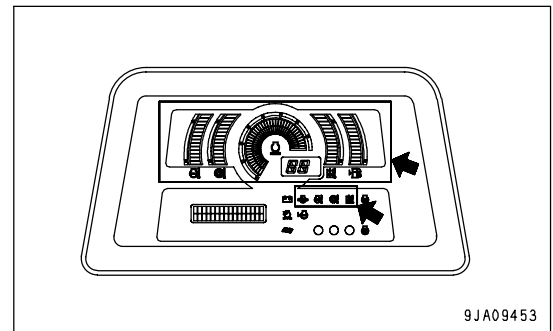

### AFTER STOPPING ENGINE

1. Walk around the machine and check the work equipment, machine exterior, and undercarriage, also check for any leakage of oil or coolant. If any problems are found, repair them.
2. Fill the fuel tank.
3. Check the engine compartment for paper and debris. Clean out any paper and debris to avoid a fire hazard.
4. Remove any mud affixed to the undercarriage.

### LOCKING

To prevent vandalism, there are locks in the following places.

Places that can be locked with the starting switch key.

- Right and left engine side cover (1)  
(left side: 2 places, right side: 2 places)
- Cab door opener (3)
- Cap with lock (4)
  - Radiator cap (if equipped)
  - Fuel tank cap (if equipped)
  - Hydraulic oil tank cap
- Battery inspection cover (2)
- Rear cover (5)

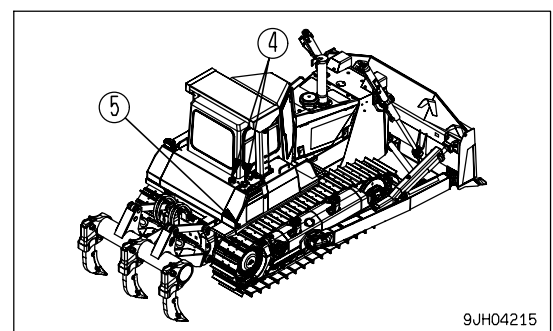
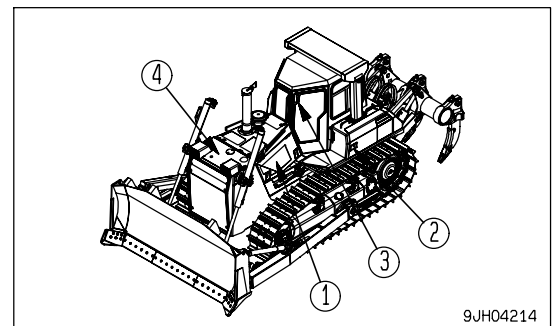

## TIPS FOR LONGER UNDERCARRIAGE LIFE

Undercarriage life greatly varies depending on operation method, inspection and maintenance. For most efficient operation, keep the following point in mind.

### OPERATION METHOD

- Select the track shoe that best suits the type of soil to be encountered in service.  
Consult your Komatsu distributor when selecting track shoes.
- Do not allow shoe slippage to occur during operation. If slippage occurs, reduce load to the blade until slipping stops.
- Avoid sudden starts, acceleration or stops, unnecessary high speeds and sharp turns.
- Always operate machine in a straight line whenever possible. When making turns, be careful not to allow the machine to stay to one side, so operation in both turning directions can be done properly. Make turns with the largest possible radius.
- Prior to operation, clear boulders and obstacles to prevent machine from riding over them while operating.
- On a slope, operate the machine parallel to the inclination of the slope. Do not operate across the slope. Also when stopping the machine on a slope, the machine should face the top of the slope.
- When ground inclines to the left or right during digging operations, do not continue to dig with the incline. Move the machine back to level ground and start to dig again.
- Do not force the machine to carry out work that exceeds its working capability. Such work includes cases where the idler or sprocket come off the ground when the machine meets obstacles that resist the power of the machine during dozing or ripping operations.

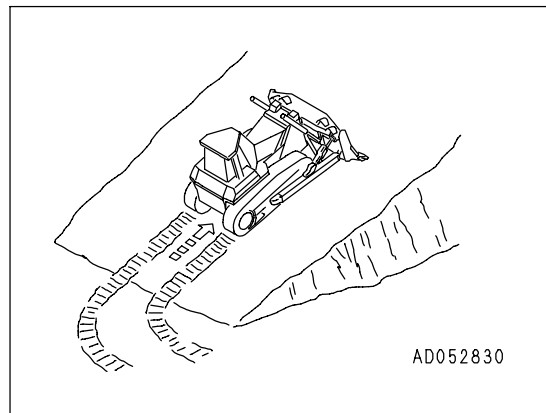

### INSPECTION AND ADJUSTMENT

- Properly adjust track tension.  
Tension should be measured at clearance (A) shown in the diagram - usually 20 to 30 mm (0.8 to 1.2 in) at this point. For rocky terrain, tighten tracks slightly. In clay or sandy areas, slightly loosen them. (For inspection and adjustment procedures, refer to "CHECK TRACK SHOE TENSION, ADJUST (PAGE 4-29)").
- Check idler rollers for oil leakage as well as for loose bolts and nuts. If any trouble is detected, repair immediately.
- Check the clearance between the idler guide plate and the track frame. If clearance (B) increases, idler may develop side motion and tracks may come off. (For inspection and adjustment procedures, refer to "ADJUST IDLER CLEARANCE (PAGE 4-32)").

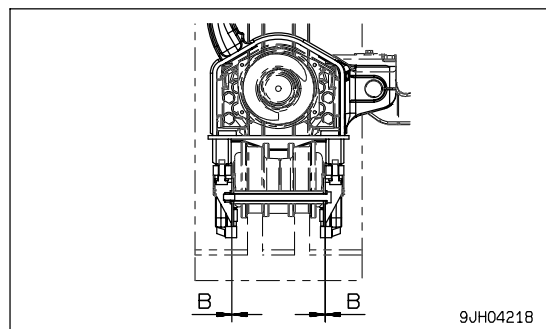
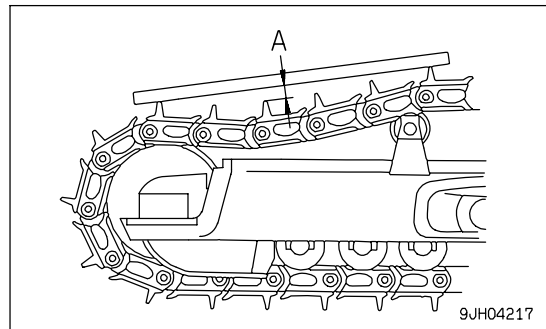

**INSPECTION AND REPAIR**

Frequent inspection and prompt repair will reduce repair costs.

The following items for inspection will serve as a guide to maintenance service of each undercarriage part. Perform periodical inspection and contact the Komatsu distributor in your area when machine has approached repairable limits and reversing limits.

**MEASURING LINK PITCH**

1. Insert a wooden block between track shoe and sprocket to take up the slack in track shoes.

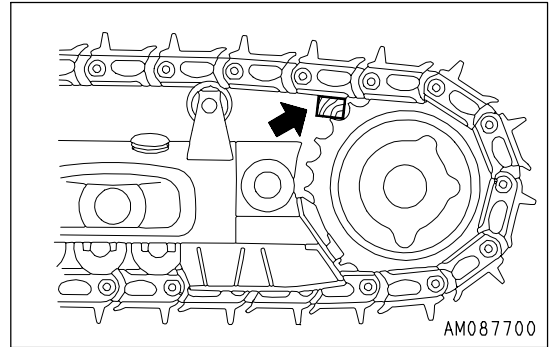

2. Measure the pitch length (L) of 4 links at a straight portion at least 2 links from master pin (A). Divide this measurement by four to obtain the link pitch.

- Basic link pitch (P): 216.3 mm (8.5 in)
- Link pitch limit for turning bushing: 219.3 mm (8.6 in)

There is no link window on the master link.

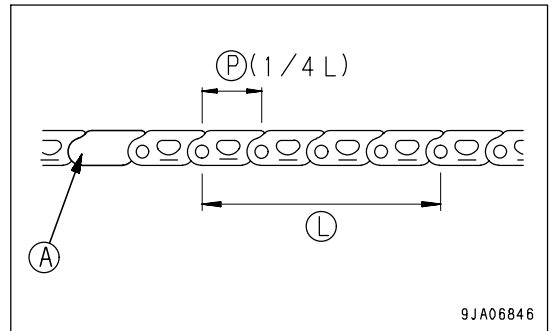

**REMARK**

The measured value under decimal of link pitch is different from the basic value depending upon the precision of measure or the tolerance of product even if it isn't worn out.

Don't judge it's worn out too soon, do it with the trend of measured value after that.

**MEASURING HEIGHT OF GROUSER**

- After taking up slack in track shoes, measure height at center of shoe as shown below.

Standard height (h): 72 mm (2.8 in)

Repair limits: 25 mm (1.0 in)

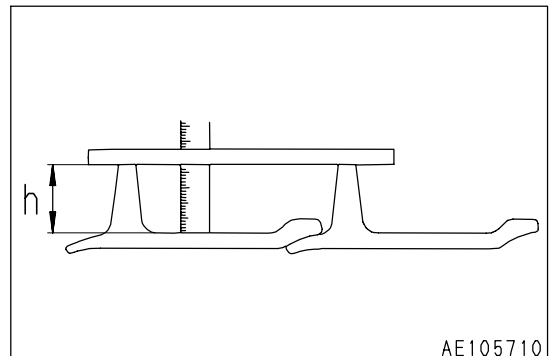



**MEASURING OUTSIDE DIAMETER OF TRACK ROLLER**

1. Measure height (size C) of link tread as shown.
2. Stop machine at position where link tread, whose size C has been measured completely, contacts roller tread. Then measure size B.

3. Calculate outside diameter of tread (size A)

$$A = (B - C) \times 2$$

Standard size (A): 222 mm (8.7 in)

Repair limits: 182 mm (7.2 in) (Single roller)

182 mm (7.2 in) (Double roller)

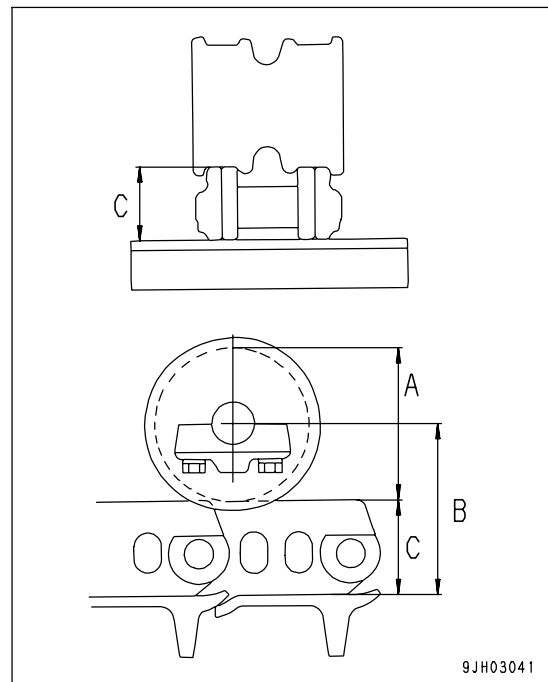

# TRANSPORTATION

When transporting the machine, observe all related laws and regulations, and be careful to assure safety.

## TRANSPORTATION MEANS

When transporting the machine, see "SPECIFICATIONS (PAGE 5-2)" for the weight and dimensions of the machine, and select the optimum method of transportation.

Note that the specifications (weight and dimensions) differ according to the kind of track shoe and blade.

## REMOVING CAB

(Machine equipped with cab) (If equipped)

If it is necessary to remove the cab for transportation, disconnect the washer hoses, cab wiring, and washer motor wiring before removing the cab.

1. Pull the grommet portion in towards the cab from the hole in the machine cover, then remove.
2. Disconnect 4 washer hoses and the wiring (single wires x 2, 4-pin plug x 1) from the socket.
  - After removing, cover the washer hoses with a vinyl bag to prevent any dirt or dust from entering.
  - Before removing the cab, measure the clearance between the cab and each lever (joystick and blade control lever, etc.). Note the measurements to use as a standard when installing the cab again.

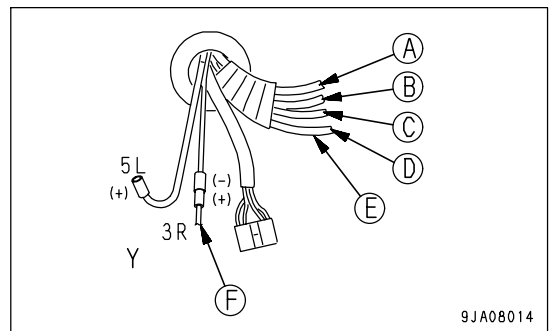
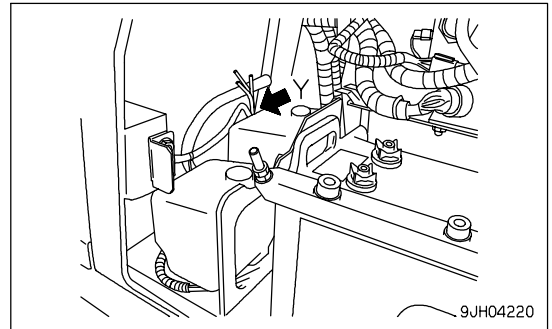

- (A) Red --- Right Door
- (B) Blue --- Left Door
- (C) Black --- Rear Window
- (D) Transparent --- Front Window
- (E) Washer Tube
- (F) From fuse box Red (backup power)

## INSTALLATION OF CAB

(Machine equipped with cab) (If equipped)

Install the cab parts in the opposite order to removal.

Connect all parts that were disconnected.

1. Lower the cab slowly on top of the floor frame.
2. Align the cab with the floor frame, then install bolts and washers in holes (A) - (U).  
Do not screw the bolts in fully. Screw them in 3 or 4 turns.
3. Tighten the bolts in holes (N) - (U) fully.  
Tighten in the order (N), (U), (Q), (R), (O), (T), (P), (S).
4. Tighten the bolts, (A) to (M), completely.

If there are any unclear points about removing or installing the cab, please contact your Komatsu distributor.

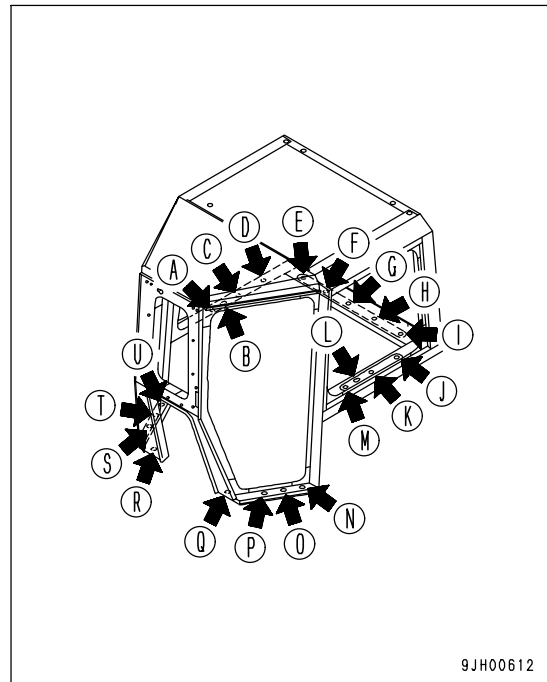

9JH00612

## INSTALLATION OF ROPS

### NOTICE

ROPS is an important component for ensuring safety. Always tighten the mounting bolts securely to the specified tightening torque.

Tightening torque: 824 - 1030 Nm (84 - 105 kgm, 607.6 - 759.5 lbft)

## LOADING, UNLOADING WORK

**WARNING**

- Since loading and unloading of the machine is dangerous, be extremely careful.
- When loading or unloading the machine, operate it slowly with the engine speed low and the transmission in the 1st gear.
- Use ramps having sufficient width, length, thickness, and strength. Install them securely and set their angle to 15° or less. If the ramps are deflected appreciably, reinforce them with blocks.
- Perform the loading work of the machine on firm, level ground. Secure sufficient distance between the shoulder of the road and the trailer.
- Remove mud from the undercarriage of the machine so that the machine will not slip sideways on the ramps. In addition, remove water, snow, ice, grease, oil, etc. from the ramps.
- Never steer the machine on the ramps, since steering on the ramps can cause the machine to tip over. If it is necessary to change the travel direction, return to the ground or to the bed of the trailer, then change the travel direction.
- The center of gravity of the machine shifts suddenly at the border between the ramps and trailer, and the machine is unbalanced and becomes dangerous. Accordingly, pass the border slowly.

When loading or unloading, always use ramps or a platform. Proceed as follows.

**LOADING WORK**

1. Load and unload on firm level ground only.

Maintain a safe distance from the edge of a road.

2. Apply the trailer brakes securely and put blocks (1) under the tires to hold the trailer in position. Set gap (3) between ramps (2) to match the distance between the left and right tracks, and keep angle (4) to a maximum of 15°.

If ramps (2) bend appreciably under the weight of the machine, put wooden block (5) under the ramps to support them.

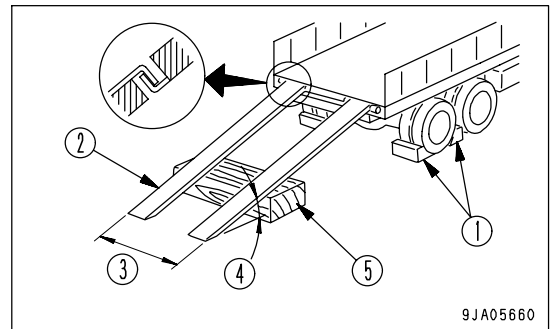

3. Start the engine.

Warm the engine up fully.

4. Set parking brake lever to the FREE position (F).
5. Set the transmission in the 1st gear and run the engine at low idle.
6. Set the travel direction toward the ramps and drive slowly.
7. The center of gravity of the machine shifts suddenly at the border between the ramps and trailer, and the machine is unbalanced and becomes dangerous. Accordingly, pass the border slowly.
8. Stop the machine at the specified position on the trailer.

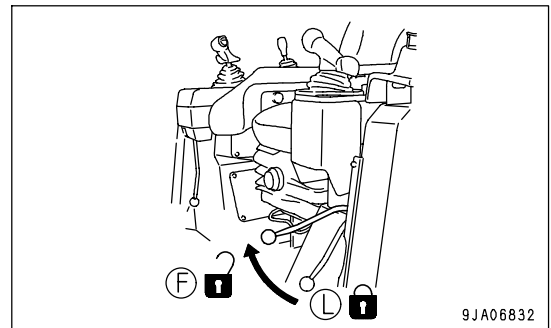

**SECURING MACHINE**

**NOTICE**

Be sure to lower the car radio antenna to the stow position (if the machine is equipped with a cab).

Load the machine onto a trailer as follows:

1. Lower the work equipment slowly.  
(When transporting with work equipment installed)
2. Set the work equipment lock lever to the LOCK position (L) securely.  
(When transporting with work equipment installed)

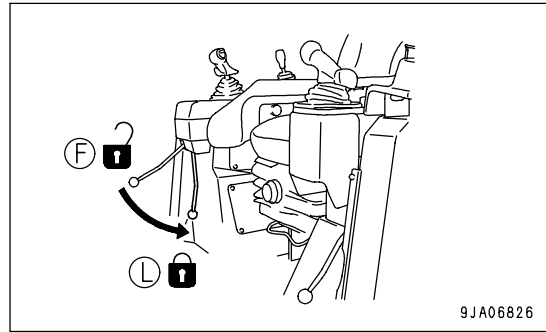

3. Set the parking brake lever to the LOCK position (L) securely.
4. Stop the engine, then remove the key from the starting switch.

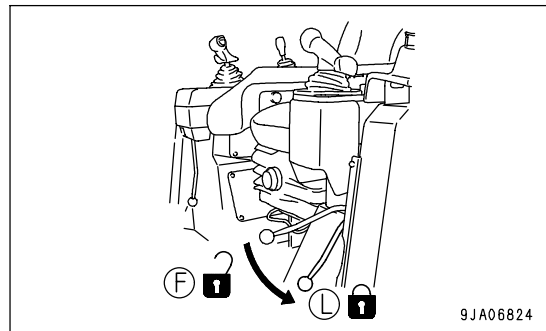

5. Fix the machine as explained below so that it will not move during transportation.

In particular, fix the machine securely to prevent it from slipping sideways.

- 1) Put blocks (1) in front and behind the track shoes of both sides.
- 2) Set up chain or wire, following (A) or (B).
  - A: Secure chain or wire around the track shoes.
  - B: Secure chain or wire through the holes of track links.
- 3) Protect the wire from contacting directly with angular parts of the machine, by inserting pads.

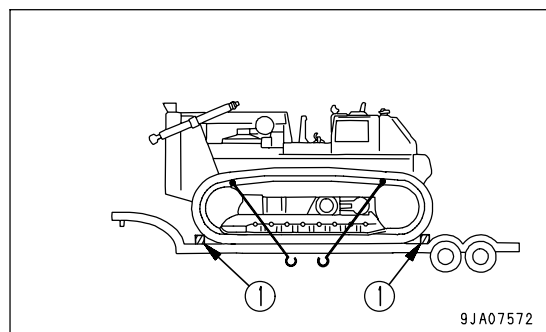
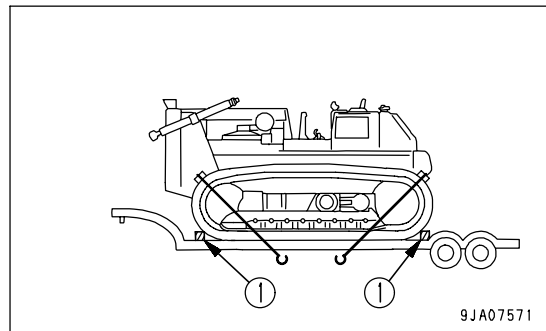

- 4) Secure the attachment at two places with a chain or wire rope.

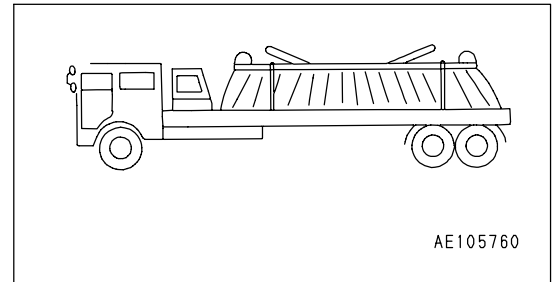

**UNLOADING WORK**

1. Load and unload on firm level ground only. Maintain a safe distance from the edge of a road.
2. Apply the trailer brakes securely and put blocks (1) under the tires to hold the trailer in position. Set gap (3) between ramps (2) to match the distance between the left and right tracks, and keep angle (4) to a maximum of 15°.
- If ramps (2) bend appreciably under the weight of the machine, put wooden block (5) under the ramps to support them.
3. Remove the chains and wire ropes fastening the machine.

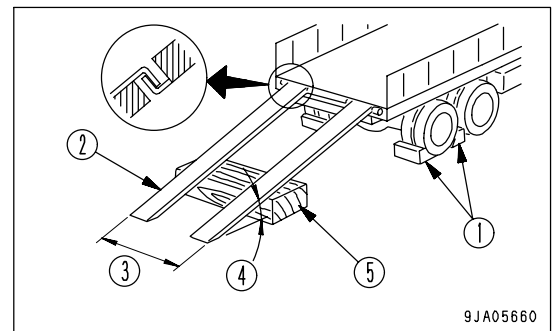

4. Start the engine.  
Warm the engine up fully.
5. Set main work equipment lock lever to FREE position (F), and raise the work equipment.  
(When transporting with work equipment installed)

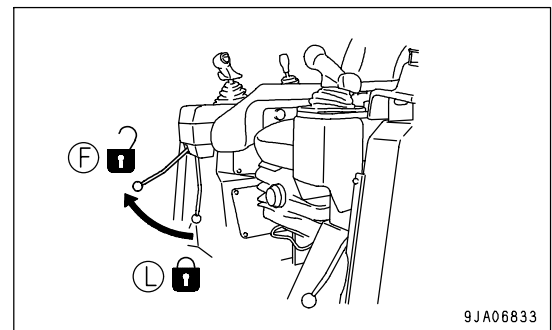

6. Set parking brake lever to the FREE position (F).
7. Set the transmission in the 1st gear and run the engine at low idle.
8. Set the travel direction toward the ramps and drive slowly.
9. The center of gravity of the machine shifts suddenly at the border between the ramps and trailer, and the machine is unbalanced and becomes dangerous. Accordingly, pass the border slowly.
10. Drive down the ramps slowly and carefully until the machine leaves the ramps perfectly.

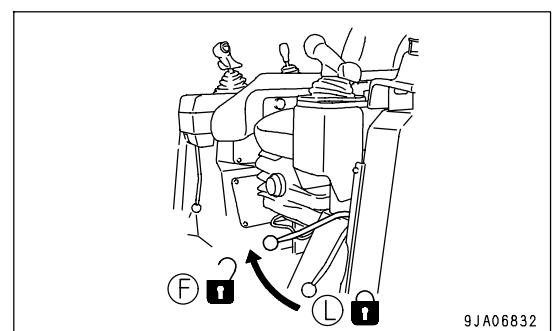

## METHOD OF LIFTING MACHINE



### WARNING

- The person using the crane to carry out lifting operations must be a qualified crane operator.
- Never carry out lifting operations if any person is on the machine being lifted.
- Always use a wire rope that has ample strength for the weight of the machine being lifted.
- Keep the machine horizontal when lifting it.
- When carrying out lifting operations, set the work equipment lock lever and parking brake lever to the LOCK position to prevent the machine or work equipment from moving unexpectedly.
- Never enter the area under or around a raised machine.
- There is danger of the machine losing its balance.

Use the procedure below to set the machine in the proper posture and use the lifting equipment when lifting the machine.

### NOTICE

This method of lifting applies to the standard specification machine.

The method of lifting differs according to the attachments and options installed.

For details of the procedure for machines that are not the standard specification, please consult your Komatsu distributor.

For weight, see "SPECIFICATIONS (PAGE 5-2)".

When lifting the machine, stop it on a level place, then observe the following procedure.

1. Stop the engine and set the parking brake lever to the LOCK position (L) securely.

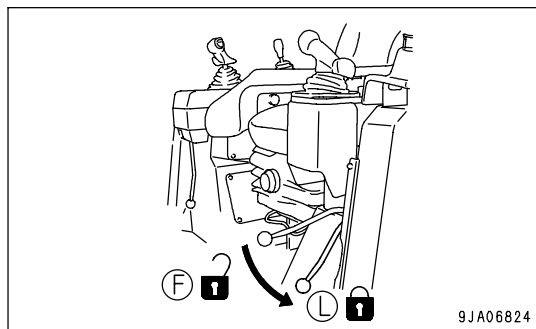

2. Set the work equipment lock lever to the LOCK position (L) securely.

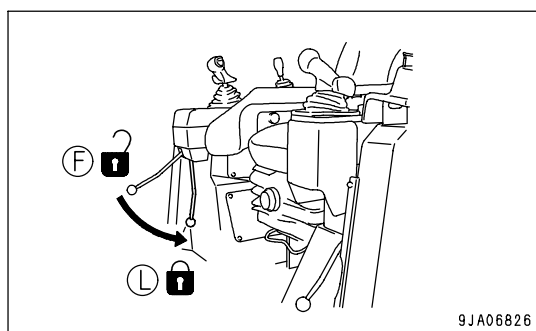

3. Install wire ropes, slings, etc. matched to the weight of the machine to the lifting points as shown in the diagram on the right.

**NOTICE**

- Use protectors to prevent the wire rope from being cut on sharp corners and to prevent the wire rope from cutting into the machine bodywork.
- When using a spreader bar, select an ample width to prevent contact with the machine.

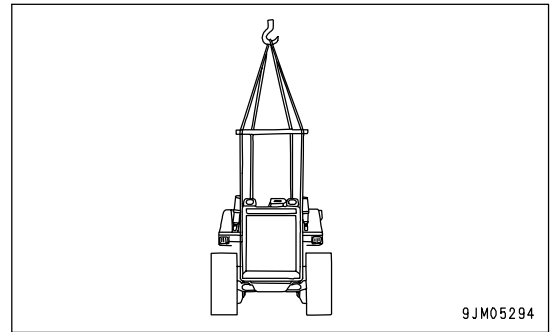

4. After setting the wire ropes, lift up the machine and stop at 100 to 200 mm (3.9 to 7.9 in) above the ground, and check that the wire ropes are not slack and the machine is level, then lift up slowly.

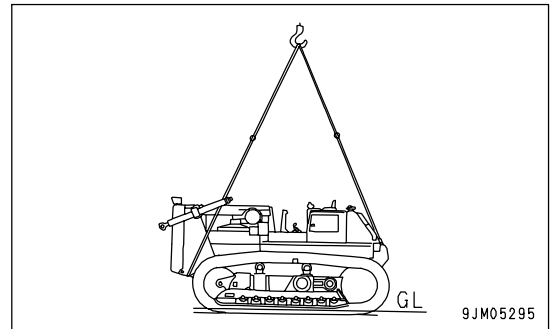
**PRECAUTIONS FOR TRANSPORTATION****WARNING**

Determine the route for transporting the machine by taking into account the width, height and weight of the machine.

Obey all state and local laws governing the weight, width and length of a load. Observe all regulations governing wide loads.

**TRAVELING ON ROADS**

- When traveling on paved roads, use flat shoes to protect their surface.  
Even when travelling a short distance, always place boards to protect the road surface.

**REMARK**

Note that the asphalt road becomes soft in summer.



## COLD WEATHER OPERATION

### PRECAUTIONS FOR LOW TEMPERATURE

If the temperature becomes low, it becomes difficult to start the engine, and the coolant may freeze, so do as follows.

#### FUEL AND LUBRICANTS

Change to oil with low viscosity for all components. For details of the specified viscosity, see "RECOMMENDED FUEL, COOLANT, AND LUBRICANT (PAGE 4-12)".

#### COOLANT



### WARNING

- Antifreeze is toxic. Be careful not to get it into your eyes or on your skin. If it should get into your eyes or on your skin, wash it off with large amounts of fresh water and see a doctor at once.
- When changing the coolant or when handling coolant containing antifreeze that has been drained when repairing the radiator, please contact your Komatsu distributor or request a specialist company to carry out the operation. Antifreeze is toxic. Do not let it flow into drainage ditches or spray it onto the ground surface.
- Antifreeze is flammable. Do not bring any flame close. Do not smoke when handling antifreeze.

#### NOTICE

Please use Komatsu genuine supercoolant (AF-NAC) for the coolant. As a basic rule, we do not recommend the use of any coolant other than Komatsu genuine supercoolant.

For details on the amount of antifreeze mixture and on when to change the coolant, see "CLEAN INSIDE OF COOLING SYSTEM (PAGE 4-21)".

**BATTERY**

 **WARNING**

- The battery generates flammable gas. Do not bring fire or sparks near the battery.
- Battery electrolyte is dangerous. If it gets in your eyes or on your skin, wash it off with a large amount of water and consult a doctor.
- Battery electrolyte dissolves paint. If it gets on the bodywork, wash it off immediately with water.
- If the battery electrolyte is frozen, do not charge the battery or start the engine with a different power source. There is danger that the battery may explode.
- Battery electrolyte is toxic. Do not let it flow into drainage ditches or spray it on to the ground surface.

When the ambient temperature drops, the capacity of the battery will also drop. If the battery charge ratio is low, the battery electrolyte may freeze. Maintain the battery charge as close as possible to 100%. Insulate it against cold temperature to ensure the machine can be started easily the next morning.

Measure the specific gravity and calculate the rate of charge from the following conversion table.

Charging Rate (%)	Electrolyte Temperature	20°C (68°F)	0°C (32°F)	-10°C (14°F)	-20°C (-4°F)
	100		1.28	1.29	1.30
90		1.26	1.27	1.28	1.29
80		1.24	1.25	1.26	1.27
75		1.23	1.24	1.25	1.26

- As the battery capacity drastically drops in low temperatures, cover or remove the battery from the machine, store the battery in a warm place, and install it again the next morning.
- If the electrolyte level is low, add distilled water in the morning before beginning work. Do not add water after the day's work to prevent diluted electrolyte in the battery from freezing during the night.

**AFTER COMPLETION OF WORK**

To prevent mud, water, or the undercarriage from freezing and making it impossible for the machine to move on the following morning, observe the following precautions.

- Remove all the mud and water from the machine body. In particular, wipe the hydraulic cylinder rods clean to prevent damage to the seal caused by mud, dirt, or drops of water on the rod from getting inside the seal.
- Park the machine on hard, dry ground.  
If this is impossible, park the machine on boards.  
The boards prevent the tracks from freezing to the ground, and allow the machine to be moved the next morning.
- Open the drain valve and drain any water collected in the fuel system to prevent it from freezing.
- Fill the fuel tank to capacity. This minimizes moisture condensation in the tank when the temperature drops.

**AFTER COLD WEATHER**

When the season changes and the weather becomes warmer, do as follows.

- Replace the fuel and oil for all parts with oil of the viscosity specified.  
For details, see "RECOMMENDED FUEL, COOLANT, AND LUBRICANT (PAGE 4-12)".

## LONG-TERM STORAGE

### BEFORE STORAGE

When keeping in long-term storage (more than one month), store as follows.

- Clean and wash all parts, then store the machine indoors. If the machine has to be stored outdoors, select level ground and cover the machine with a sheet.
- Completely fill the fuel tank. This prevents moisture from collecting.
- Lubricate and change the oil before storage.
- Apply a thin coat of grease to metal surface of the hydraulic piston rods and the idler adjusting rods.
- Disconnect the negative terminals of the battery and cover it or remove it from the machine and store it separately.
- Place all control levers in the neutral position, set the work equipment lock lever and parking brake lever in the LOCK position, and set the fuel control dial to the low idling position.
- To prevent rust, fill with Komatsu genuine supercoolant (AF-NAC) to give a density of at least 30% for the engine coolant.

### DURING STORAGE



#### WARNING

If it is necessary to perform the rust-prevention operation while the machine is indoors, open the doors and windows to improve ventilation and prevent gas poisoning.

- During storage, operate and move the machine for a short distance once a month so that a new film of oil will coat moving parts. At the same time, also charge the battery.
- Before operating the work equipment, wipe the grease off the hydraulic piston rod.
- If the machine is equipped with an air conditioner, operate the air conditioner for 3 to 5 minutes once a month to lubricate all parts of the air conditioner compressor. Always run the engine at low idle when doing this. In addition, check the refrigerant level twice a year.

### AFTER STORAGE

#### NOTICE

If the machine has been stored without carrying out the monthly rust-prevention operation, consult your Komatsu distributor before using it.

When using the machine after long-term storage, do as follows before using it.

- Wipe off the grease from the hydraulic cylinder rods.
- Add oil and grease at all lubrication points.
- When the machine is stored for a long period, moisture in the air will mix with the oil. Check the oil before and after starting the engine. If there is water in the oil, change all the oil.

## TROUBLESHOOTING

### AFTER RUNNING OUT OF FUEL

When starting the engine again after running out of fuel, fill with fuel, then bleed the air from the fuel system before starting the engine.

Always watch the fuel level and be careful not to run out of fuel.

If the engine has stopped because of lack of fuel, it is necessary to use the priming pump to bleed the air completely from the fuel circuit.

### PROCEDURE FOR BLEEDING AIR



#### CAUTION

- This engine consists of higher precision parts than on the conventional fuel injection pump and nozzle, so if dirt gets in, it will cause problems. If there is any dirt stuck to the fuel line, use fuel to wash it off completely.
- Be careful when opening the air bleed plug at the fuel filter head and the air bleeder of the supply pump. The system is still under pressure and fuel may spurt out.

1. Fill the fuel tank with fuel.
2. Loosen air bleed plug (A), (B) at the fuel filter head (1).
3. Loosen wing nut (4) holding lever (3) of priming pump (2).
4. Push in lever (3) repeatedly.

Check that bubbles come out with the fuel from air bleed plug (A).

5. Wrap sealing tape around air bleed plug (A) before tightening it.
6. Operate the priming pump again and check that no more bubbles come out with the fuel from air bleed plug (B).
7. Tighten air bleed plug (B).

Tightening torque: 4.9 to 6.9 Nm (0.5 to 0.7 kgm , 3.6 to 5.1 lbft)

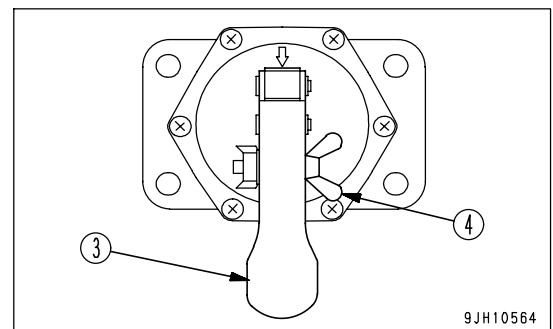
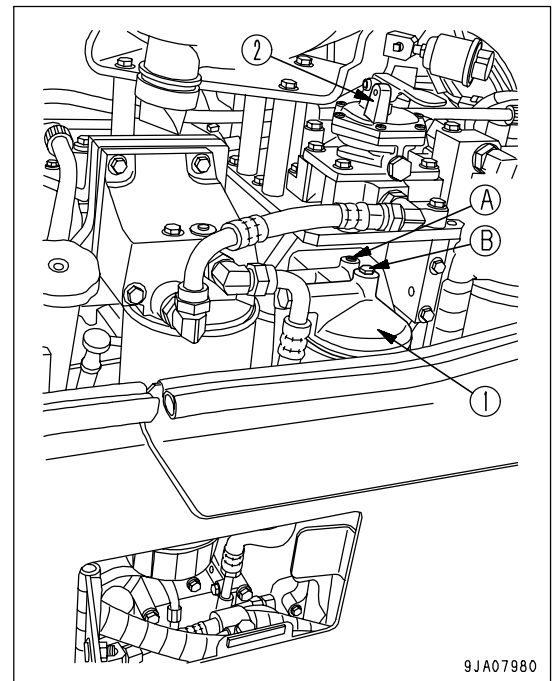

8. Loosen air bleeder (5) of the supply pump.
9. Push the lever (3) of the priming pump (2) repeatedly (approx. 90 to 100 times) until no more bubbles come out with the fuel from air bleeder (5), then tighten air bleeder (5).  
Tightening torque: 4.9 to 6.9 Nm (0.5 to 0.7 kgm , 3.6 to 5.1 lbft)
10. Continue pumping until it becomes hard to operate priming pump (2) and an overflow valve releasing sound (like a squeak) is continuously heard.

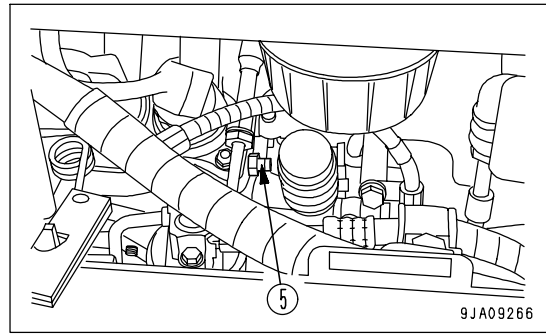

11. Tighten wing nut (4) securely to lock lever (3) in position.  
Target tightening torque: 11.8 Nm  
(1.2 kgm, 8.7 lbft)

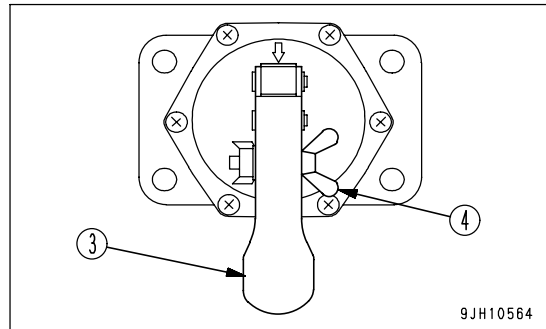

12. Turn the key in the starting switch to the START position and start the engine.  
When doing this, do not crank the starting motor continuously for more than 20 seconds. If the engine does not start, wait for at least 2 minutes, then try again. Perform this operation a maximum of 4 times.
13. If the engine does not start, repeat the procedure from Step 2.

## METHOD OF TOWING MACHINE



### WARNING

Serious injury or death could result if a disabled machine is towed incorrectly or if there is a mistake in the selection or inspection of the wire rope.

- If the engine does not start, put blocks under the track to prevent the machine from moving, then release the brake. If blocks are not use, there is danger that the machine may move suddenly.
- Always check that the wire rope used for towing has ample strength for the weight of the machine being towed.
- Never use a wire rope which has cut strands (A), reduced diameter (B), or kinks (C). There is danger that the rope may break during the towing operation.
- Always wear leather gloves when handling wire rope.
- Never tow a machine on a slope.
- During the towing operation, never stand between the towing machine and the machine being towed.
- Operate the machine slowly and be careful not to apply any sudden load to the wire rope.

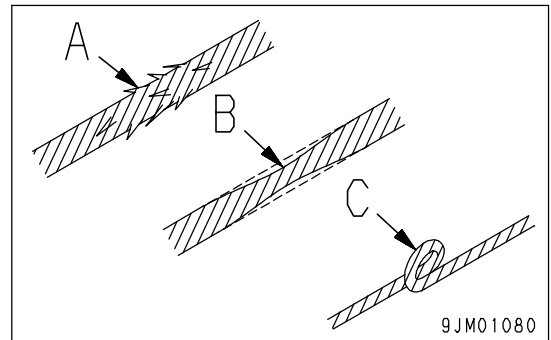

### NOTICE

The maximum towing capacity for this machine is 205,800 N (21,000 kg).  
Always carry out towing operations within the maximum towing capacity.

For details of the method of towing, please contact your Komatsu distributor.

- If the engine stops or the oil pressure in the brake circuit lowers because of a trouble in the hydraulic system, the brake works and the machine cannot move. To move the machine in this case, the oil pressure in the brake circuit must be heightened to the specified level with a special device. Ask your Komatsu distributor.
- Moving a machine by towing is only used to move it to a place where it is possible to carry out inspection and maintenance. It is not intended for moving the machine long distances. Do not use this method for towing the machine for long distances.
- If it is impossible to operate the steering and brakes of the machine being towed, do not let anyone ride on the machine.
- Keep the angle of the towing line to the minimum. Operate the machine so that the angle does not become greater than 30° from the straight line.

If the machine sinks in mud and cannot get out under its own power, or if being used to tow a heavy object, fit the wire to the towing hook as shown in the diagram on the right, or in the case of machines with a drawbar, fit the wire to the drawbar pin when towing.

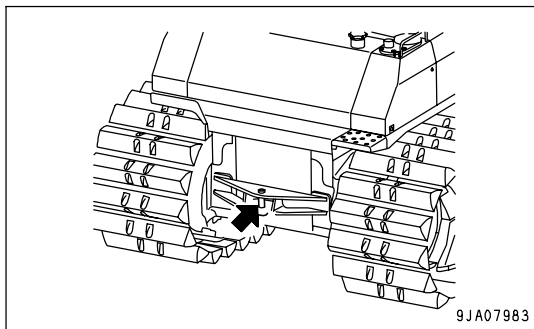
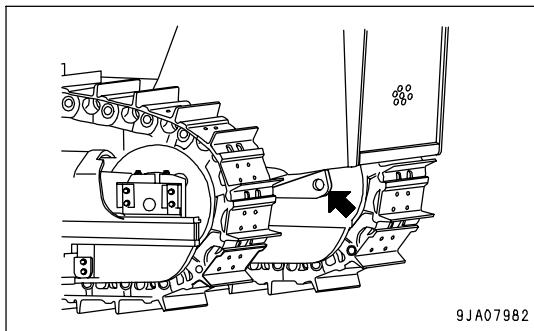

## IF BATTERY IS DISCHARGED

### WARNING

- It is dangerous to charge a battery when mounted on a machine. Make sure that it is dismantled before charging.
- When checking or handling the battery, stop the engine and turn the starting switch key to the OFF position.
- The battery generates hydrogen gas, so there is a hazard of explosion. Do not bring lighted cigarettes near the battery, or do anything that will cause sparks.
- Battery electrolyte is dilute sulfuric acid, and it will attack your clothes and skin. If it gets on your clothes or on your skin, immediately wash it off with a large amount of water. If it gets in your eyes, wash it out with fresh water and consult a doctor.
- When handling batteries, always wear safety glasses and rubber gloves.
- When removing the battery, first disconnect the cable from the ground (normally the negative (-) terminal). When installing, install the positive (+) terminal first.  
If a tool touches the positive terminal and the chassis, there is danger that it will cause a spark, so be extremely careful.
- If the terminals are loose, there is danger that the defective contact may generate sparks that will cause an explosion.
- When removing or installing the terminals, check which is the positive (+) terminal and which is the negative (-) terminal.

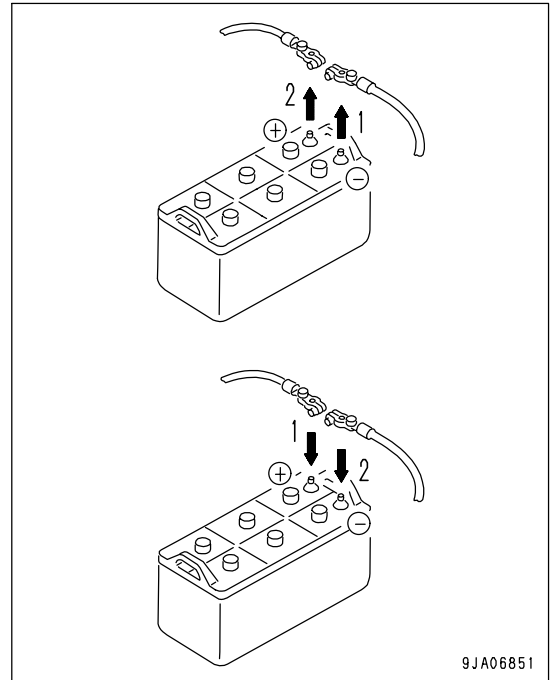

## REMOVE AND INSTALL BATTERY

- Before removing the battery, remove the ground cable (normally connected to the negative (-) terminal).  
If any tool touches between the positive terminal and the chassis, there is a hazard of sparks being generated.
- When installing the battery, connect the ground cable last.
- When replacing the battery, secure it with battery hold-down.  
Tightening torque: Tightening battery terminal: 9.8 to 14.7 Nm (1 to 1.5 kgm, 7.2 to 10.8 lbft)

## REMOVAL, INSTALLATION OF BATTERY CABLE

1. Open the battery cover (1).
2. Remove tray (2).
3. Before removing the battery, remove the ground cable (normally connected to the negative (-) terminal). If any tool touches between the positive terminal and the chassis, there is danger of sparks being generated. Loosen the nut of the terminal and remove the wires from the battery.
4. When installing the battery, connect the ground cable last.  
Insert the hole of the terminal on the battery and tighten the nut.  
Tightening torque: 9.8 to 19.6 Nm (1 to 2 kgm, 7.2 to 14.5 lbft)
5. Close the cover.

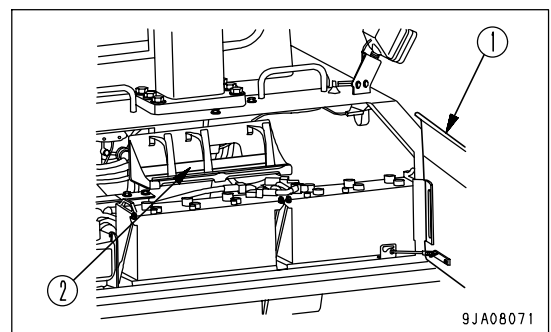



## PRECAUTIONS FOR BATTERY CHARGING

When charging the battery, if the battery is mistakenly handled, there is danger of explosion. Follow the precautions in "OTHER TROUBLE (PAGE 3-147)" and the instructions given in the charger manual, and always do as follows.

- Set the voltage of the charger to match the voltage of the battery to be charged. If the correct voltage is not selected, the charger may overheat and cause an explosion.
- Connect the positive (+) charger clip of the charger to the positive (+) terminal of the battery, then connect the negative (-) charger clip of the charger to the negative (-) terminal of the battery. Be sure to attach the clips securely.
- Set the charging current to 1/10 of the value of the rated battery capacity; when carrying out rapid charging, set it to less than the rated battery capacity.  
If the charger current is too high, the electrolyte will leak or dry up, and this may cause the battery to catch fire and explode.
- If the battery electrolyte is frozen, do not charge the battery or start the engine with a different power source. There is a danger that this will ignite the battery electrolyte and cause the battery to explode.
- Do not use or charge the battery if the battery electrolyte level is below the LOWER LEVEL line. This may cause an explosion. Check the battery electrolyte level periodically and add distilled water to bring the electrolyte level to the UPPER LEVEL line.

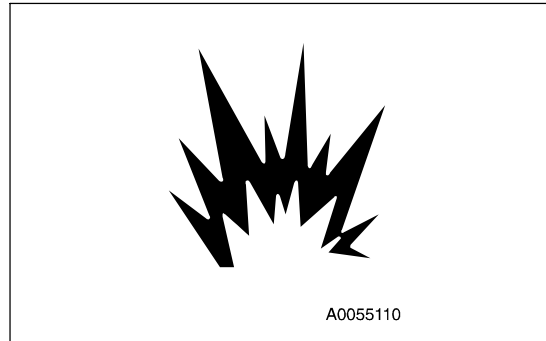

## STARTING ENGINE WITH BOOSTER CABLE

When starting the engine with a booster cable, do as follows.

### PRECAUTIONS WHEN CONNECTING AND DISCONNECTING BOOSTER CABLE

#### WARNING

- When connecting the cables, never contact the positive (+) and negative (-) terminals.
- When starting the engine with a booster cable, wear safety glasses and rubber gloves.
- Be careful not to let the normal machine and problem machine contact each other. This prevents sparks from generating near the battery which could ignite the hydrogen gas given off by the battery.
- Make sure that there is no mistake in the booster cable connections. The final connection is to the engine block of the problem machine, but sparks will be generated when this is done, so connect to a place as far as possible from the battery.
- When disconnecting the booster cable, take care not to bring the clips in contact with each other or with the machine body.

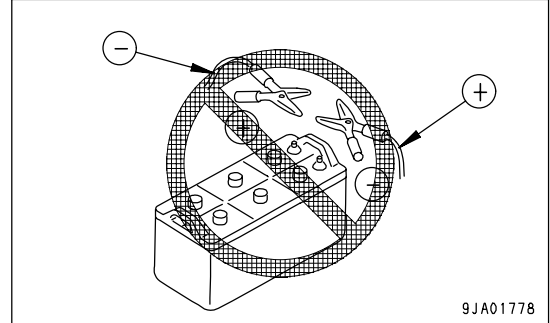

### NOTICE

- The starting system for this machine uses 24V. For the normal machine, also use a 24V battery.
- The size of the booster cable and clip should be suitable for the battery size.
- The battery of the normal machine must be the same capacity as that of the engine to be started.
- Check the cables and clips for damage or corrosion.
- Make sure that the cables and clips are firmly connected.
- Check that the work equipment lock levers and parking brake levers of both machine are in the LOCK position.
- Check that each lever is in the NEUTRAL position.

### CONNECTING THE BOOSTER CABLE

Keep the starting switch of the normal machine and problem machine in the OFF position. Connect the booster cable as follows, in the order of the numbers marked in the diagram.

1. Remove the tray.
2. Connect the clip of booster cable (A) to the positive (+) terminal of battery (C) on the problem machine.
3. Connect the clip at the other end of booster cable (A) to the positive (+) terminal of battery (D) on the normal machine.
4. Connect the clip of booster cable (B) to the negative (-) terminal of battery (D) on the normal machine.
5. Connect the clip at the other end of booster cable (B) to engine block (E) on the problem machine.

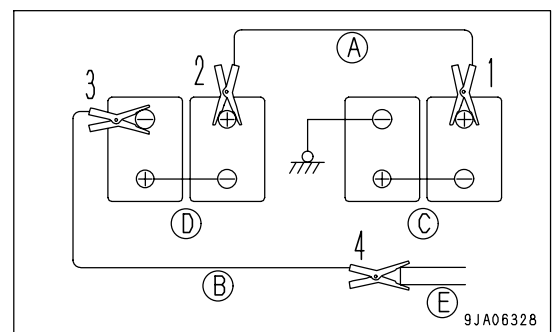

## STARTING ENGINE

**WARNING**

Always check that the work equipment lock lever and Parking brake lever is set to the LOCK position, regardless of whether the machine is working normally or has failed. Check also that all the control levers are in the HOLD or NEUTRAL position.

1. Make sure the clips are firmly connected to the battery terminals.
  2. Start engine of the normal machine and run it at high idle speed.
  3. Turn the starting switch of the problem machine to the START position and start the engine.
- If the engine doesn't start at first, try again after 2 minutes or so.

**DISCONNECTING THE BOOSTER CABLE**

After the engine has started, disconnect the booster cables in the reverse of the order in which they were connected.

1. Remove the clip of booster cable (B) from engine block (E) on the problem machine.
2. Remove the clip of booster cable (B) from the negative (-) terminal of battery (D) on the normal machine.
3. Remove the clip of booster cable (A) from the positive (+) terminal of battery (D) on the normal machine.
4. Remove the clip of booster cable (A) from the positive (+) terminal of battery (C) on the problem machine.
5. Install the tray.

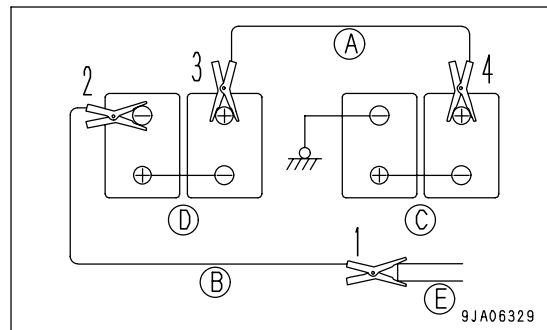

## OTHER TROUBLE

## ELECTRICAL SYSTEM

- ( ): Always contact your Komatsu distributor when dealing with these items.
- In cases of problems or causes which are not listed below, contact your Komatsu distributor for repairs.

Problem	Main cause	Remedy
Lamp does not glow brightly even when the engine runs at high speed	• Defective wiring	( • Check, repair loose terminals, disconnections Check fuses and diodes in fuse box)
Lamp flickers while engine is running	• Defective adjustment of fan belt tension	• Adjust fan belt tension For details, see EVERY 250 HOURS SERVICE
Charge lamp does not go out even when engine is running	• Defective alternator • Defective wiring	( • Replace) ( • Check, repair Check fuse, diode in fuse box)
Abnormal noise is generated from alternator	• Defective alternator	( • Replace)
Starting motor does not turn when starting switch is turned to ON	• Defective wiring • Insufficient battery charge	( • Check, repair) • Charge
Pinion of starting motor keeps going in and out	• Insufficient battery charge	• Charge
Starting motor turns engine sluggishly	• Insufficient battery charge • Defective starting motor	• Charge ( • Replace)
Starting motor disengages before engine starts	• Defective wiring • Insufficient battery charge	( • Check, repair) • Charge
Preheating monitor lamp does not light up (When the temperature of the engine cooling water exceed 20°C (68°F), this condition is normal)	• Defective wiring • Defective timer • Defective monitor • Disconnection in glow plug	( • Check, repair) ( • Replace) ( • Replace) ( • Replace)
Air conditioner operation is defective	• Blown fuse • Insufficient battery charge • Defective air conditioner switch • Defective blower switch • Defective compressor	( • Check, repair) • Charge ( • Replace air conditioner switch) ( • Replace blower switch) ( • Replace)

**MONITOR PANEL**

When an error code appears on the display panel B (multi-information), take appropriate remedies based upon the table below.

- (1): Display panel B
- (2): Warning lamp (red)

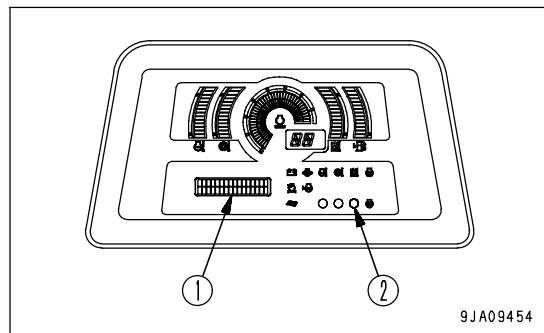

**REMARK**

If different kinds of failures occur at the same time, their failure codes are arranged in the order of seriousness in the display. The order of seriousness in this case is E04, E03, E02 and E01, starting from the most serious one.

Table of action codes

Action code	Method of displaying problem	Example of content of problem	Action to be carried out by operator
E01	<ul style="list-style-type: none"> <li>• Shows only action code</li> </ul>	<ul style="list-style-type: none"> <li>• Backup alarm does not sound</li> <li>• Fan always rotates at maximum speed</li> </ul>	<ul style="list-style-type: none"> <li>• Automatic functions stop or some functions stop, but operations can be carried out</li> <li>• Please ask your Komatsu distributor to carry out repairs.</li> </ul>
E02	<ul style="list-style-type: none"> <li>• Action code is displayed</li> <li>• Warning lamp flashes</li> <li>• Alarm buzzer sounds</li> </ul>	<ul style="list-style-type: none"> <li>• Does not shift up or down</li> <li>• Exhaust gas color is poor in low temperatures</li> <li>• Problem with engine oil pressure sensor</li> </ul>	<ul style="list-style-type: none"> <li>• Stop engine, then start again. Operations can be carried out without limiting functions. However, it is necessary for operator to be careful.</li> <li>• Please ask your Komatsu distributor to carry out repairs</li> </ul>
CALL E03	<ul style="list-style-type: none"> <li>• Action code is displayed</li> <li>• Warning lamp flashes</li> <li>• Alarm buzzer sounds</li> </ul>	<ul style="list-style-type: none"> <li>• Problem with engine boost pressure</li> <li>• Limit on speed ranges that can be used</li> <li>• Engine does not run at full speed</li> <li>• Excessive transmission shock</li> <li>• Steering ability is poor</li> </ul>	<ul style="list-style-type: none"> <li>• Move to a safe place</li> <li>• Please ask your Komatsu distributor to carry out repairs</li> </ul>
CALL E04	<ul style="list-style-type: none"> <li>• Action code is displayed</li> <li>• Warning lamp flashes</li> <li>• Alarm buzzer sounds</li> </ul>	<ul style="list-style-type: none"> <li>• Impossible to control engine</li> <li>• Impossible to travel</li> <li>• Machine stops</li> </ul>	<ul style="list-style-type: none"> <li>• Stop immediately.</li> <li>• Please ask your Komatsu distributor to carry out repairs</li> </ul>

Note: If a problem display appears on display panel B, check the fault code. For details, see "METHOD OF USING FAULT CODE DISPLAY MODE (PAGE 3-29)".

When contacting your Komatsu distributor, please give the fault code also.

**CHASSIS**

- ( ): Always contact your Komatsu distributor when dealing with these items.
- In cases of problems or causes which are not listed below, contact your Komatsu distributor for repairs.

Problem	Main causes	Remedy
Oil pressure in torque converter fails to rise	<ul style="list-style-type: none"> <li>• Improper tightening of oil pipe, pipe joint, air leaking in or oil leaking out because of damage</li> <li>• Wear, scuffing of gear pump</li> <li>• Insufficient oil in power train case</li> <li>• Clogged oil filter element strainer in power train case</li> </ul>	<ul style="list-style-type: none"> <li>• Check, repair</li> <li>( • Check, replace)</li> <li>• Add oil to the specified level. For details, see CHECK BEFORE STARTING</li> <li>• Clean. For details, see EVERY 500 HOURS SERVICE</li> </ul>
Torque converter is overheats	<ul style="list-style-type: none"> <li>• Clogged radiator</li> <li>• Engine water temperature is high</li> <li>• Clogged oil cooler</li> <li>• Oil pressure too low</li> <li>• Lack of flow of lubricant caused by wear of power train gear pump</li> </ul>	<ul style="list-style-type: none"> <li>• Clean radiator core</li> <li>• See ENGINE related parts</li> <li>( • Clean or replace)</li> <li>• Go to "Oil pressure in torque converter fails to rise"</li> <li>( • Replace gear pump)</li> </ul>
Torque converter oil temperature gauge dose not work	<ul style="list-style-type: none"> <li>• Defective oil temperature gauge</li> <li>• defective contact in wiring connection</li> </ul>	<ul style="list-style-type: none"> <li>( • Replace oil temperature gauge)</li> <li>( • Check, repair)</li> </ul>
Lacks drawber pull (machine dose not pick up speed)	<ul style="list-style-type: none"> <li>• Lack of engine horsepower</li> <li>• Oil pressure in torque converter is too low</li> </ul>	<ul style="list-style-type: none"> <li>• See ENGINE related parts</li> <li>• Go to " Oil pressure in torque converter fails to rise"</li> </ul>
Machine will not move off when joystick is placed at FORWARD	<ul style="list-style-type: none"> <li>• Insufficient oil in power train case</li> <li>• Transmission oil pressure does not rise</li> <li>• Defective lever wiring</li> <li>• Parking brake lever is at LOCK position</li> </ul>	<ul style="list-style-type: none"> <li>• Add oil to specified level. For details, see CHECK BEFORE STARTING</li> <li>• Go to oil pressure in torque converter fails to rise</li> <li>( • Check, repair)</li> <li>• Set to FREE position</li> </ul>
Dose not steer even when steering is operated	<ul style="list-style-type: none"> <li>• Parking brake lever is at LOCK position</li> <li>• Defective lever wiring</li> <li>• Abnormality HSS pump</li> <li>• Abnormality HSS motor</li> </ul>	<ul style="list-style-type: none"> <li>• Set to FREE position</li> <li>( • Check, repair)</li> <li>( • Check, replace)</li> <li>( • Check, replace)</li> </ul>
Machine doesn't stop when brake pedal are depressed	<ul style="list-style-type: none"> <li>• Defective brake adjustment</li> </ul>	<ul style="list-style-type: none"> <li>( • Adjust linkage)</li> <li>( • Check brake pressure)</li> </ul>

Problem	Main causes	Remedy
Track comes off	<ul style="list-style-type: none"> <li>• Track is too loose</li> </ul>	<ul style="list-style-type: none"> <li>• Adjust track tension. For details, see WHEN REQUIRED</li> </ul>
Sprocket develops abnormal wear	<ul style="list-style-type: none"> <li>• Track is too loose or too tight</li> </ul>	<ul style="list-style-type: none"> <li>• Adjust track tension. For details, see WHEN REQUIRED</li> </ul>
Machine does not travel in straight line	<ul style="list-style-type: none"> <li>• Abnormality HSS valve, HSS motor</li> </ul>	( • Replace)
Blade rises too slowly or does not rise at all (or blade tilts too slowly)	<ul style="list-style-type: none"> <li>• Lack of hydraulic oil</li> <li>• Defective hydraulic pump</li> <li>• Work equipment lock lever is at LOCK position</li> </ul>	<ul style="list-style-type: none"> <li>• Add oil to specified level. For details, see EVERY 250 HOURS SERVICE</li> <li>• Check</li> <li>• Set to FREE position</li> </ul>
Ripper moves too slowly, does not move	<ul style="list-style-type: none"> <li>• Lack of hydraulic oil</li> <li>• Defective hydraulic pump</li> <li>• Work equipment lock lever is at LOCK position</li> </ul>	<ul style="list-style-type: none"> <li>• Add oil to specified level. For details, see EVERY 250 HOURS SERVICE</li> <li>• Check</li> <li>• Set to FREE position</li> </ul>
Insufficient force of ripper	<ul style="list-style-type: none"> <li>• Leakage from piping</li> </ul>	( • Tighten)

## ENGINE

- ( ): Always contact your Komatsu distributor when dealing with these items.
- In cases of problems or causes which are not listed below, contact your Komatsu distributor for repairs.

Problem	Main causes	Remedy
Engine oil pressure monitor flashes when engine speed is raised after completion of warm-up	<ul style="list-style-type: none"> <li>• Engine oil pan oil level is low (sucking in air)</li> <li>• Clogged oil filter cartridge</li> <li>• Defective tightening of oil pipe joint, oil leakage from damaged part</li> <li>• Defective monitor panel</li> </ul>	<ul style="list-style-type: none"> <li>• Add oil to specified level, see CHECK BEFORE STARTING</li> <li>• Replace cartridge, see EVERY 500 HOURS SERVICE</li> <li>( • Check, repair)</li> <li>( • Replace)</li> </ul>
Steam is emitted from top part of radiator (pressure valve)	<ul style="list-style-type: none"> <li>• Coolant level low, water leakage</li> <li>• Dirt or scale accumulated in cooling system</li> </ul>	<ul style="list-style-type: none"> <li>• Add coolant, repair, see CHECK BEFORE STARTING</li> <li>• Change coolant, clean inside of cooling system, see WHEN REQUIRED</li> <li>• Clean or repair, see WHEN REQUIRED</li> </ul>
Engine water temperature monitor remains alight altitude operation)	<ul style="list-style-type: none"> <li>• Clogged radiator fins or damaged fins</li> <li>• Defective thermostat</li> <li>• Loose radiator filler cap (high altitude operation)</li> <li>• Defective monitor panel</li> </ul>	<ul style="list-style-type: none"> <li>( • Replace thermostat)</li> <li>• Tighten cap or replace packing</li> <li>( • Replace)</li> </ul>
Engine does not start when starting motor is turned	<ul style="list-style-type: none"> <li>• Lack of fuel</li> <li>• Air in fuel system</li> <li>• No fuel in fuel filter</li> <li>• Starting motor cranks engine sluggishly</li> <li>• Defective valve compression</li> </ul>	<ul style="list-style-type: none"> <li>• Add fuel, see CHECK BEFORE STARTING</li> <li>• Repair place where air is sucked in</li> <li>( • Replace pump or nozzle)</li> <li>• See ELECTRICAL SYSTEM</li> <li>( • Adjust valve clearance)</li> </ul>
Exhaust gas is white or blue	<ul style="list-style-type: none"> <li>• Too much oil in oil pan</li> <li>• Improper fuel</li> </ul>	<ul style="list-style-type: none"> <li>• Add oil to specified level, see CHECK BEFORE STARTING</li> <li>• Change to specified fuel</li> </ul>
Exhaust gas occasionally turns black	<ul style="list-style-type: none"> <li>• Clogged air cleaner element</li> <li>• Defective nozzle</li> <li>• Defective compression</li> <li>• Defective turbocharger</li> </ul>	<ul style="list-style-type: none"> <li>• Clean or replace, see WHEN REQUIRED</li> <li>( • Replace nozzle)</li> <li>( • Adjust valve clearance)</li> <li>( • Clean or replace, turbocharger)</li> </ul>
Combustion noise occasionally makes breathing sound	<ul style="list-style-type: none"> <li>• Defective nozzle</li> <li>• Lack of fuel (in Air)</li> </ul>	<ul style="list-style-type: none"> <li>( • Replace nozzle)</li> <li>• Add fuel</li> </ul>
Abnormal noise generated (combustion or mechanical)	<ul style="list-style-type: none"> <li>• Low grade fuel being used</li> <li>• Overheating</li> <li>• Damage inside muffler</li> <li>• Excessive valve clearance</li> </ul>	<ul style="list-style-type: none"> <li>• Change to specified fuel</li> <li>• See item "Indicator of water temperature gauge is in red range on right side of gauge".</li> <li>( • Replace muffler)</li> <li>( • Adjust valve clearance)</li> </ul>
Monitor displays error code	Please contact your Komatsu distributor	
Alarm buzzer sounds		
Engine horsepower lowered suddenly (Engine is running in duration mode)		





# MAINTENANCE

 **WARNING**

Please read and make sure that you understand the SAFETY section before reading this section.

---

## GUIDE TO MAINTENANCE

Do not perform any inspection and maintenance operation that is not found in this manual.  
Stop the machine on flat hard ground when performing inspections and maintenance.

### CHECK SERVICE METER:

Check the service meter reading every day to see if the time has come for any necessary maintenance to be performed.

### KOMATSU GENUINE REPLACEMENT PARTS:

Use Komatsu genuine parts specified in the Parts Book as replacement parts.

### KOMATSU GENUINE OILS:

For lubrication of the machine, use the Komatsu genuine lubricants. Moreover use oil of the specified viscosity according to the ambient temperature.

### ALWAYS USE CLEAN WASHER FLUID:

Use automobile window washer fluid, and be careful not to let any dirt get into it.

### CLEAN OIL AND GREASE:

Use clean oil and grease. Also, keep the containers of the oil and grease clean. Keep foreign materials away from oil and grease.

### CHECKING FOREIGN MATERIALS IN DRAINED OIL:

After oil is changed or filters are replaced, check the old oil and filters for metal particles and foreign materials. If large quantity of metal particles or foreign materials are found, always report to the person in charge, and carry out suitable action.

### FUEL STRAINER:

If your machine is equipped with a fuel strainer, do not remove it while fueling.

### WELDING INSTRUCTIONS:

- Cut off power. Wait for approx. one minute after turning off the engine starting switch key, and then disconnect the negative (-) terminal of the battery.
- When carrying out welding repairs on the floor frame, remove all connectors from the machine controller. There is danger of damage to the controller.
- Do not apply more than 200 V continuously.
- Connect grounding cable within 1 m (3.3 ft) of the area to be welded. If grounding cable is connected near instruments, connectors, etc., the instruments may malfunction.
- If a seal or bearing happens to come between the part being welded and grounding point, change the grounding point to avoid such parts.
- Do not use the area around the work equipment pins or the hydraulic cylinders as the grounding point.

### DO NOT DROP THINGS INSIDE MACHINE:

- When opening inspection windows or the oil filler port of the tank to carry out inspection, be careful not to drop nuts, bolts, or tools inside the machine.  
If such things are dropped inside the machine, it may cause damage and/or malfunction of the machine, and will lead to failure. If you drop anything inside the machine, always remove it immediately.
- Do not put unnecessary things in your pockets. Carry only things which are necessary for inspection.

**DUSTY WORKSITES:**

When working at dusty worksites, do as follows:

- Inspect the dust indicator more frequently to see if the air cleaner is clogged.  
Clean the air cleaner element at a shorter interval than specified.  
On machines equipped with an air cleaner clogging monitor, the check can be carried out with the monitor.
- Clean the radiator core frequently to avoid clogging.
- Clean and replace the fuel filter frequently.
- Clean electrical components, especially the starting motor and alternator, to avoid accumulation of dust.
- When inspecting or changing the oil, move the machine to a place that is free of dust to prevent dirt from getting into the oil.

**AVOID MIXING OILS:**

If a different brand or grade of oil has to be added, drain the old oil and replace all the oil with the new brand or grade of oil. Never mix different brand or grade of oil.

**PRECAUTIONS FOR OPENING AND CLOSING ENGINE SIDE COVER:**

- When standing on track to open the engine side cover, adopt a standing position, hold the side cover with both thumbs, and open it slowly with your other fingers.

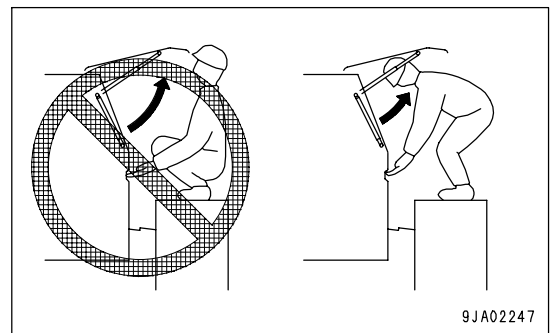

**LOCKING THE INSPECTION COVER:**

Lock inspection cover securely into position with the lock bar. If inspection or maintenance is performed with inspection cover not locked in position, there is a danger that it may be suddenly blow shut by the wind and cause injury to the worker.

**HYDRAULIC SYSTEM-AIR BLEEDING:**

After repairing or replacing hydraulic equipment or after removing the hydraulic piping, it is necessary to bleed the air from the circuit. For details, see "PROCEDURE FOR BLEEDING AIR IN HYDRAULIC SYSTEM (PAGE 4-45)".

**PRECAUTIONS WHEN INSTALLING HYDRAULIC HOSES:**

- When removing parts at locations where there are O-rings or gasket seals, clean the mounting surface, and replace with new parts.  
When doing this, be careful not to forget to assemble the O-rings and gaskets.
- When installing the hoses, do not twist them or bend them sharply. If they are installed so, their service life will be shortened extremely and they may be damaged.

**CHECKS AFTER INSPECTION AND MAINTENANCE WORK:**

If you forget to perform the checks after inspection and maintenance, unexpected problems may occur, and this may lead to serious injury or property damage. Always do the following:

- Checks after operation (with engine stopped)
  - Have any inspection and maintenance points been forgotten?
  - Have all inspection and maintenance items been performed correctly?
  - Have any tools or parts been dropped inside the machine? It is particularly dangerous if parts are dropped inside the machine and get caught in the lever linkage mechanism.
  - Are there any leakage of coolant or oil? Have all nuts and bolts been tightened?
- Checks when engine is running
  - For the checks when the engine is running, see "TWO WORKERS FOR MAINTENANCE WHEN ENGINE IS RUNNING (PAGE 2-29)" in the SAFETY section, and take care of safety sufficiently.
  - Check that the inspected and maintained parts work normally.
  - Raise the engine speed and check for fuel leakage and oil leakage.

**FUEL AND LUBRICANTS TO MATCH THE AMBIENT TEMPERATURE:**

Select the fuel and lubricants to match the ambient temperature.

For details, see "RECOMMENDED FUEL, COOLANT, AND LUBRICANT (PAGE 4-12)".

## OUTLINE OF SERVICE

- Always use Komatsu genuine parts for replacement parts, grease or oil.
- When changing the oil or adding oil, do not mix different types of oil. When changing the type of oil, drain all the old oil and fill completely with the new oil. Always replace the filter at the same time. (There is no problem if the small amount of oil remaining in the piping mixes with the new oil.)
- Unless otherwise specified, when the machine is shipped from the factory, it is filled with the oil and coolant listed in the table below.

Item	Type
Engine oil pan	Engine oil EO15W40DH (Komatsu genuine parts)
Power train case Final drive case Damper case	Power train oil TO30 (Komatsu genuine parts)
Hydraulic tank	Power train oil TO10 (Komatsu genuine parts)
Radiator	Supercoolant AF-NAC (Density: 30% or above) (Komatsu genuine parts)

## HANDLING OIL, FUEL, COOLANT, AND PERFORMING OIL CLINIC

### OIL

- Oil is used in the engine and hydraulic equipment under extremely severe conditions (high temperature, high pressure), and deteriorates with use.  
Always use oil that matches the grade and maximum and minimum ambient temperatures recommended in the Operation and Maintenance Manual. Even if the oil is not dirty, always change the oil at the specified interval.
- Oil corresponds to blood in the human body, always be careful when handling it to prevent any impurities (water, metal particles, dirt, etc.) from getting in.  
The majority of problems with the machine are caused by the entry of such impurities.  
Take particular care not to let any impurities get in when storing or adding oil.
- Never mix oils of different grades or brands.
- Always add the specified amount of oil.  
Having too much oil or too little oil are both causes of problems.
- If the oil in the work equipment is not clear, there is probably water or air getting into the circuit. In such cases, please contact your Komatsu distributor.
- When changing the oil, always replace the related filters at the same time.
- We recommend you have an analysis made of the oil periodically to check the condition of the machine. For those who wish to use this service, please contact your Komatsu distributor.
- When using commercially available oil, it may be necessary to reduce the oil change interval.  
We recommend that you use the Komatsu oil clinic to carry out a detailed checks of the characteristics of the oil.

## FUEL

- To prevent the moisture in the air from condensing and forming water inside the fuel tank, always fill the fuel tank after completing the day's work.
- The fuel pump is a precision instrument, and if fuel containing water or dirt is used, it cannot work properly.
- Be extremely careful not to let impurities get in when storing or adding fuel.
- Always use the fuel specified for the temperature in the Operation and Maintenance Manual.
  - If the fuel is used at temperatures lower than the specified temperature (particularly at temperatures below -15 °C (5°F), the fuel will solidify.
  - If the fuel is used at temperatures higher than the specified temperature, the viscosity will drop, and this may result in problems such as a drop in output.
- Before starting the engine, or when 10 minutes have passed after adding fuel, drain the sediment and water from the fuel tank.
- If the engine runs out of fuel, or if the filters have been replaced, it is necessary to bleed the air from the circuit.
- If there is any foreign material in the fuel tank, wash the tank and fuel system.

## NOTICE

**Always use diesel oil for the fuel.**

**To ensure good fuel consumption characteristics and exhaust gas characteristics, the engine mounted on this machine uses an electronically controlled high-pressure fuel injection device. This device requires high precision parts and lubrication, so if low viscosity fuel with low lubricating ability is used, the durability may drop markedly.**

## COOLANT AND WATER FOR DILUTION

- The coolant has the important function of preventing corrosion as well as preventing freezing. Even in the areas where freezing is not an issue, the use of antifreeze coolant is essential. Komatsu machines are supplied with Komatsu Supercoolant (AF-NAC). Komatsu Supercoolant (AF-NAC) has excellent anticorrosion, antifreeze and cooling properties and can be used continuously for 2 years or 4000 hours. As a basic rule, we do not recommend the use of any coolant other than Komatsu genuine supercoolant (AF-NAC). If you use another coolant, it may cause serious problems such as corrosion of the engine and parts of the cooling system that use light metals such as aluminum.
- When using Komatsu Supercoolant (AF-NAC), there is no need to use a corrosion resistor. For details, see "CLEAN INSIDE OF COOLING SYSTEM (PAGE 4-21)".
- When diluting the antifreeze coolant, use distilled water or tap water (soft water). Natural water, such as a river water or well water (hard water), contains large amounts of minerals (calcium, magnesium, etc.), and this makes it easier for scale to form inside the engine or radiator. Once scale is deposited inside the engine or radiator, it is extremely difficult to remove. It also causes overheating due to poor heat exchange, so when you dilute the coolant, we recommend that you use water with an overall hardness of less than 100 PPM.
- When using antifreeze, always observe the precautions given in the Operation and Maintenance Manual.
- Antifreeze coolant is flammable, so be sure to keep it away from flame.
- The ratio of Supercoolant (AF-NAC) to water differs according to the ambient temperature. For details of the ratio when mixing, see "CLEAN INSIDE OF COOLING SYSTEM (PAGE 4-21)". Even in areas where it is not necessary to prevent freezing, use Supercoolant (AF-NAC) at a mixing ratio of at least 30% to prevent corrosion of the cooling system. Supercoolant (AF-NAC) may be supplied in premix. In this case, never add diluting water.
- If the engine overheats, wait for the engine to cool before adding coolant.
- If the coolant level is low, it will cause overheating, and will also cause problems with corrosion due to air entering the coolant.

**GREASE**

- Grease is used to prevent seizure and noises at the joints.
- This construction equipment is used under heavy-duty conditions. Always use the recommended grease and follow the change intervals and recommended ambient temperatures given in this Operation and Maintenance Manual.
- The nipples not included in the MAINTENANCE section are nipples used when overhauling, so they do not need grease.  
If any part becomes stiff or generates noise after being used for a long time, grease it.
- Always wipe off all of the old grease that is pushed out when greasing.  
Be particularly careful to wipe off the old grease in places where sand or dirt sticking in the grease would cause wear of the rotating parts.

**CARRYING OUT KOWA (Komatsu Oil Wear Analysis)**

KOWA is a maintenance service that makes it possible to prevent machine failures and downtime. With KOWA, the oil is periodically sampled and analyzed. This enables early detection of wear of the machine drive parts and other problems.

We strongly recommend you to use this service. The oil analysis is carried out at actual cost, so the cost is low, and the results of the analysis are reported together with recommendations which will reduce repair costs and machine downtime.

**KOWA ANALYSIS ITEMS**

- Measurement of density of metal wear particles  
This uses an ICP (Inductively Coupled Plasma) analyzer to measure the density of iron, copper, and other metal wear particles in the oil.

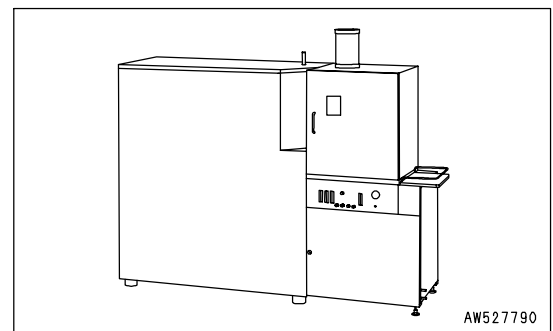

- Measurement of quantity of particles  
This uses a PQI (Particle Quantifier Index) measurer to measure the quantity of iron particles of 5µm or more, enabling early detection of failures.

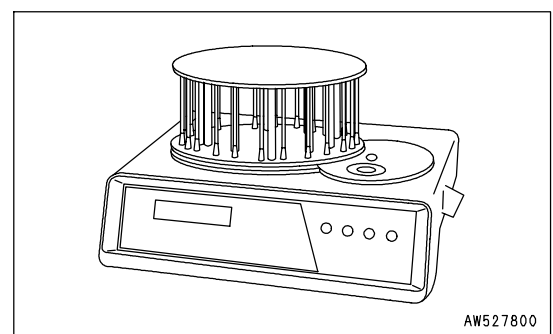

- Others  
Measurements are made of items such as the ratio of water in the oil, density of the antifreeze coolant, ratio of fuel in the oil, and dynamic viscosity, enabling a highly precise diagnosis of the machine's health.



### OIL SAMPLING

- Sampling interval
  - 250 hours: Engine
  - 500 hours: Other components
- Precautions when sampling
  - Make sure that the oil is well mixed before sampling.
  - Perform sampling at regular fixed intervals.
  - Do not perform sampling on rainy or windy days when water or dust can get into the oil.

For further details of KOWA, please contact your Komatsu distributor.

### STORING OIL AND FUEL

- Keep indoors to prevent any water, dirt, or other impurities from getting in.
- When keeping drum cans for a long period, put the drum on its side so that the filler port of the drums is at the side to prevent moisture from being sucked in.  
If drums have to be stored outside, cover them with a waterproof sheet or take other measures to protect them.
- To prevent any change in quality during long-term storage, be sure to use in the order of first in - first out (use the oldest oil or fuel first).

### FILTERS

- Filters are extremely important safety parts. They prevent impurities in the fuel and air circuits from entering important equipment and causing problems.  
Replace all filters periodically. For details, see the Operation and Maintenance Manual.  
However, when working in severe conditions, replace the filters at shorter intervals according to the oil and fuel (sulfur content) being used.
- Never try to clean the filters (cartridge type) and use them again. Always replace with new filters.
- When replacing oil filters, check if any metal particles are attached to the old filter. If any metal particles are found, contact your Komatsu distributor.
- Do not open packs of spare filters until just before they are to be used.
- Always use Komatsu genuine filters.

### RELATING TO ELECTRIC SYSTEM

- It is extremely dangerous if the electrical equipment becomes wet or the covering of the wiring is damaged. This will cause an electrical short circuit and may lead to malfunction of the machine. Do not wash the inside of the operator's cab with water. When washing the machine, be careful not to let water get into the electrical components.
- Service relating to the electric system is checking fan belt tension, checking damage or wear to the fan belt and checking battery fluid level.
- Never install any electric components other than those specified by Komatsu.
- External electro-magnetic interference may cause malfunction of the control system controller, before installing a radio receiver or other wireless equipment, contact your Komatsu distributor.
- Be careful to keep the electric system free of water when washing the machine or when it rains.
- When working at the seashore, carefully clean the electric system to prevent corrosion.
- When installing electrical equipment, connect it to the special power source connector.  
Do not connect the optional power source to the fuse, starting switch, or battery relay.

## HANDLING HYDRAULIC SYSTEM

- During operations and after completion of operations, the hydraulic equipment is at a high temperature. During operations, it is also under high pressure, so when carrying out inspection and maintenance of hydraulic related equipment, be careful of the following points.
  - Stop the machine on flat ground, lower the work equipment completely to the ground, and carry out the operation so that there is no pressure on the cylinder circuits.
  - Always stop the engine.
  - Immediately after stopping operations, the hydraulic oil and lubricating oil is at high temperature and high pressure, so wait for the oil temperature to go down before starting maintenance.  
Even after the temperature has gone down, some parts may still be under internal pressure, so when loosening plugs, bolts, or hose connections, do not stand directly in front of the parts, and loosen slowly to release the internal pressure before removing.
  - When carrying out inspection and maintenance of the hydraulic circuit, always release the air in the hydraulic tank to remove the internal pressure.
- Inspection and maintenance include checking the hydraulic system for oil level, replacement of filter elements and replacement of hydraulic oil.
- If high-pressure hoses have been removed, check that there is no damage to the O-rings. If any damage is found, replace the O-ring.
- It is necessary to bleed the air from the circuits when the hydraulic filter element or strainer have been replaced or washed, or when hydraulic equipment has been repaired or replaced, or when the hydraulic piping has been removed.
- The accumulator is charged with high-pressure nitrogen gas, and it is extremely dangerous if it is handled incorrectly. For details of the method of handling, see "CHECKING CHARGE PRESSURE OF NITROGEN GAS IN ACCUMULATOR (FOR CONTROL CIRCUIT) (PAGE 4-70)".

## WEAR PARTS LIST

Replace wear parts such as the filter element or cutting edge at the time of periodic maintenance or before they reach the wear limit. The wear parts should be replaced correctly in order to ensure more economic use of the machine. When replacing parts, always use Komatsu genuine parts.

As a result of our continuous efforts to improve product quality, the part number may change, so inform your Komatsu distributor of the machine serial number and check for the latest part number when ordering parts.

## WEAR PARTS LIST

The parts in parentheses are to be replaced at the same time.

Item	Part No.	Part Name	Weight (kg(lb))	Q'ty	Replacement frequency			
Engine oil filter	600-211-1340	Cartridge	-	1	Every 500 hours service			
Transmission filter	154-49-71990 (07000-12130)	Element (O-ring)	- -	1 (1)				
Fuel pre-filter	600-319-3440	Cartridge	-	1				
Fuel main filter	600-319-3550	Cartridge	-	1	Every 1000 hours service			
Corrosion resistor	600-411-1151	Cartridge	-	1				
Hydraulic tank breather element	20Y-60-21410	Element	-	1	Every 2000 hours service			
Hydraulic oil filter	207-60-71181 (07000-15195)	Element (O-ring)	- -	1 (1)				
Air cleaner	600-185-5100	Element assembly	-	1	-			
Blade	D85EX Semi-U dozer	154-70-11314	Cutting edge	52.9 (117)	1	-		
		154-71-43190	Cutting edge	41.5 (92)	2			
		(154-71-41270)	(Bolt)	-	(20)			
		(01643-21845)	(Washer)	-	(20)			
		(154-70-22270)	(Nut)	-	(20)			
		150-70-21346	End bit (right)	26.2 (58)	1			
		150-70-21356	End bit (left)	26.2 (58)	1			
		(154-71-41270)	(Bolt)	-	(12)			
		(01643-21845)	(Washer)	-	(12)			
		(154-70-22270)	(Nut)	-	(12)			
		D85EX Straight tilt dozer	154-70-11314	Cutting edge	52.9 (117)		1	-
			154-81-11191	Cutting edge	39.0 (86)		2	
	(154-71-41270)		(Bolt)	-	(20)			
	(01643-21845)		(Washer)	-	(20)			
	(154-70-22270)		(Nut)	-	(20)			
	150-70-21346		End bit (right)	26.2 (58)	1			
	150-70-21356		End bit (left)	26.2 (58)	1			
	(154-71-41270)		(Bolt)	-	(12)			
	(01643-21845)		(Washer)	-	(12)			
	(154-70-22270)		(Nut)	-	(12)			
	D85PX		154-70-11314	Cutting edge	52.9 (117)	3	-	
			(154-71-41270)	(Bolt)	-	(24)		
		(01643-21845)	(Washer)	-	(24)			
		(154-70-22270)	(Nut)	-	(24)			
150-70-21346		End bit (right)	26.2 (58)	1				
150-70-21356		End bit (left)	26.2 (58)	1				
(154-71-41270)		(Bolt)	-	(12)				
(01643-21845)		(Washer)	-	(12)				
(154-70-22270)		(Nut)	-	(12)				

Item	Part No.	Part Name	Weight (kg(lb))	Q'ty	Replacement frequency
Ripper (Fixed multi-shank ripper) (Variable multi-shank ripper)	D85	154-78-31330	12.9 (28.44)	3	-
	EX	175-78-31230	15 (33.08)	3	
	(09244-02508)	Protector Point (Pin)	-	(9)	

**NOTICE**

**When handling parts that weigh more than 25 kg (55 lb), remember that they are heavy objects, and take the necessary care.**

## RECOMMENDED FUEL, COOLANT, AND LUBRICANT

- Komatsu genuine oils are adjusted to maintain the reliability and durability of Komatsu construction equipment and components.

In order to keep your machine in the best conditioner for long periods of time, it is essential to follow the instructions in this Operation and Maintenance Manual.

- Failure to follow these recommendations may result in shortened life or excess wear of the engine, power train, cooling system, and/or other components.
- Commercially available lubricant additives may be good for the machine, but they may also cause harm. Komatsu does not recommend any commercially available lubricant additive.
- Use the oil recommended according to the ambient temperature in the chart below.
- Specified capacity means the total amount of oil including the oil in the tank and the piping. Refill capacity means the amount of oil needed to refill the system during inspection and maintenance.
- When starting the engine in temperatures below 0°C (32°F), be sure to use the recommended multi-grade oil, even if the ambient temperature may become higher during the course of the day.
- If the machine is operated at a temperature below -20°C (-4°F), a separate device is needed, so consult your Komatsu distributor.
- When the fuel sulfur content is less than 0.2%, change the engine oil according to the period inspection table given in this Operation and Maintenance Manual.

If the fuel sulfur content is more than 0.2%, change the oil according to the following table.

Sulfur content (%)	Oil change interval
Less than 0.2 %	500 hours
0.2 to 0.5 %	250 hours
0.5 and up	Not recommendable (*)

\* If these fuels are used, there is danger that serious trouble may occur because of early deterioration of the engine oil or early wear of the internal parts of the engine. If the local situation makes it necessary to use these fuels, always remember the following.

- 1) Be sure to check Total Basic Number (TBN) of oil frequently by TBN handy checker etc., and change oil based on the result.
- 2) Always be aware that oil change interval is extremely shorter than standard.
- 3) Be sure to carry out periodic engine inspection by distributor's expert since change interval of periodic replacement parts and overhaul interval are also shorter.

USE OF FUEL, COOLANT AND LUBRICANTS ACCORDING TO AMBIENT TEMPERATURE

Reservoir	Fluid Type	Ambient Temperature									Recommended Komatsu Fluids
		-22	-4	14	32	50	68	86	104	122 °F	
		-30	-20	-10	0	10	20	30	40	50 °C	
Engine oil pan	Engine oil	(Note.1)									Komatsu EOS0W30
		(Note.1)									Komatsu EOS5W40
		(Note.5)									Komatsu EO10W30DH
		(Note.5)									Komatsu EO15W40DH
		(Note.5)									Komatsu EO30DH
Damper case Idler (each)	Power train oil (Note.2)	(Note.5)									TO30
Power train case	Power train oil	(Note.5)									TO10
		(Note.5)									TO30
Final drive case (each)	Power train oil	(Note.5)									TO30
Hydraulic system	Power train oil	(Note.5)									TOS5W30
		(Note.5)									TO10
	Hydraulic oil	(Note.5)									HO46-HM
		(Note.5)									Komatsu EO10W30DH
Grease fitting	Hyper grease (Note.3)	(Note.5)									G2-T, G2-TE
		(Note.5)									G2-LI
Cooling system	Supercoolant AF-NAC (Note.4)	(Note.5)									G2-LI-S
		(Note.5)									AF-NAC
Fuel tank	Diesel fuel	(Note.5)									ASTM Grade No.1-D S15 ASTM Grade No.1-D S500
		(Note.5)									ASTM Grade No.2-D S15 ASTM Grade No.2-D S500

• ASTM: American Society of Testing and Material

		Engine oil pan	Damper case	Idler (each)	Power train oil pan (incl. transmission, torque converter and bevel gear cassettes)	Final drive case (each)	Hydraulic system	Fuel tank	Cooling system
Specified amount	liter	44	1.6	0.35	90	(EX)26 (PX)36	(EX)120 (PX)106	490	58
	US gal	11.62	0.42	0.09	23.78	(EX)6.87 (PX)9.51	(EX)31.70 (PX)28.01	129.46	15.32
Refill capacity	liter	38	1.6	0.35	60	(EX)26 (PX)36	71	-	-
	US gal	10.04	0.42	0.09	15.85	(EX)6.87 (PX)9.51	18.76	-	-

**NOTICE**

Always use diesel oil for the fuel.

To ensure good fuel consumption characteristics and exhaust gas characteristics, the engine mounted on this machine uses an electronically controlled high-pressure fuel injection device. This device requires high precision parts and lubrication, so if low viscosity fuel with low lubricating ability is used, the durability may drop markedly.

Note 1: HTHS ( High-Temperature High-Shear Viscosity 150°C), specified by ASTM D4741 must be equal to or higher than 3.5 mPa-S. Komatsu EOS0W30 and EOS5W40 are the most suitable oils.

Note 2: Powertrain oil has different properties from engine oil. Be sure to use the recommended oils.

Note 3: Hyper grease (G2-T, G2-TE) has a high performance.

When it is necessary to improve the lubricating ability of the grease in order to prevent squeaking of pins and bushings, the use of G2-T or G2-TE is recommended.

Note 4: Supercoolant (AF-NAC)

1) Coolant has the important function of anticorrosion as well as antifreeze.

Even in the areas where freezing is not an issue, the use of antifreeze coolant is essential.

Komatsu machines are supplied with Komatsu Supercoolant (AF-NAC). Komatsu Supercoolant (AF-NAC) has excellent anticorrosion, antifreeze and cooling properties and can be used continuously for 2 years or 4000 hours. Komatsu Supercoolant (AF-NAC) is strongly recommended wherever available.

2) For details of the ratio when diluting super coolant with water, see "CLEAN INSIDE OF COOLING SYSTEM (PAGE 4-21)".

When the machine is shipped from the factory, it may be filled with coolant containing 30% or more Supercoolant (AF-NAC). In this case, no adjustment is needed for temperatures down to -10°C (14°F). (never dilute with water)

3) To maintain the anticorrosion properties of Supercoolant (AF-NAC), always keep the density of Supercoolant between 30% and 68%.

Note 5: In this range, preheating with a starting aid is necessary.

**RECOMMENDED BRANDS, RECOMMENDED QUALITY FOR PRODUCTS OTHER THAN KOMATSU GENUINE OIL**

When using commercially available oils other than Komatsu genuine oil, consult your Komatsu distributor.

# STANDARD TIGHTENING TORQUES FOR BOLTS AND NUTS

## TORQUE LIST



If nuts, bolts, or other parts are not tightened to the specified torque, it will cause looseness or damage to the tightened parts, and this will cause failure of the machine or problems with operation.  
Always pay careful attention when tightening parts.

Unless otherwise specified, tighten the metric nuts and bolts to the torque shown in the table below.  
If it is necessary to replace any nut or bolt, always use a Komatsu genuine part of the same size as the part that was replaced.

Thread diameter of bolt (a)(mm)	Width across flats (b)(mm)	Tightening torque					
		Target value			Service limit		
		Nm	kgm	lbft	Nm	kgm	lbft
6	10	13.2	1.35	9.8	11.8-14.7	1.2-1.5	8.7-10.8
8	13	31	3.2	23.1	27-34	2.8-3.5	20.3-25.3
10	17	66	6.7	48.5	59-74	6.0-7.5	43.4-54.2
12	19	113	11.5	83.2	98-123	10.0-12.5	72.3-90.4
14	22	177	18	130.2	157-196	16.0-20.0	115.7-144.7
16	24	279	28.5	206.1	245-309	25.0-31.5	180.8-227.8
18	27	382	39	282.1	343-425	35.0-43.5	253.2-314.6
20	30	549	56	405.0	490-608	50.0-62.0	361.7-448.4
22	32	745	76	549.7	662-829	67.5-84.5	488.2-611.2
24	36	927	94.5	683.5	824-1030	84.0-105.0	607.6-759.5
27	41	1320	135.0	976.5	1180-1470	120.0-150.0	868.0-1085.0
30	46	1720	175.0	1265.8	1520-1910	155.0-195.0	1121.1-1410.4
33	50	2210	225.0	1627.4	1960-2450	200.0-250.0	1446.6-1808.3
36	55	2750	280.0	2025.2	2450-3040	250.0-310.0	1808.3-2242.2
39	60	3280	335.0	2423.1	2890-3630	295.0-370.0	2133.7-2676.2

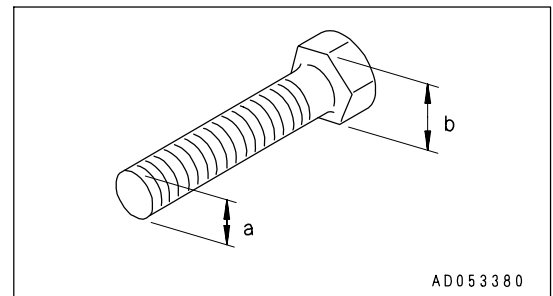

Apply the following table for Hydraulic Hose.

Nominal- No. of threads (a)	Width across flats (b) mm	Tightening torque					
		Target valve			Permissible range		
		Nm	kgm	lbft	Nm	kgm	lbft
9/16 -18UNF	19	44	4.5	32.5	34 - 54	3.5 - 5.5	25.3 - 39.8
11/16 -16UN	22	74	7.5	54.2	54 - 93	5.5 - 9.5	39.8 - 68.7
13/16 -16UN	27	103	10.5	75.9	84 - 132	8.5 - 13.5	61.5 - 97.6
1 -14UNS	32	157	16.0	115.7	128 - 186	13.0 - 19.0	94.0 - 137.4
1 3/16 -12UN	36	216	22.0	159.1	177 - 245	18.0 - 25.0	130.2 - 180.8

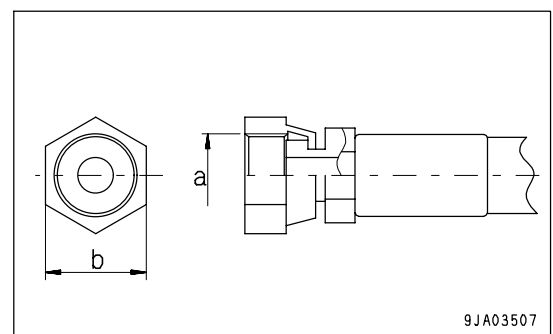



## PERIODIC REPLACEMENT OF SAFETY CRITICAL PARTS

For using the machine safely for an extended period of time, you are required to periodically replace the safety (critical and fire prevention) related parts listed in the table of important parts on the following page.

Material quality of these parts can change as time passes and they are likely to wear out or deteriorate. However, it is difficult to determine the extent of wear or deterioration at the time of periodic maintenance. Hence, it is required to replace them with new ones regardless of their condition after a certain period of usage. This is important to ensure that these parts maintain their full performance at all times.

Furthermore, should anything abnormal be found on any of these parts, replace it with a new one even if the periodic replacement time for the part has not yet arrived.

If any of the hose clamps show deterioration like deformation or cracking, replace the clamps at the same time as the hoses.

Also perform the following checks with hydraulic hoses which need to be replaced periodically. Tighten all loose clamps and replace defective hoses, as required.

When replacing hoses, always replace O-rings, gaskets, and other such parts at the same time.

Have your Komatsu distributor replace the critical parts.

### SAFETY CRITICAL PARTS

Replace wear parts such as the filter element or air cleaner element at the time of periodic maintenance or before they reach the wear limit. The wear parts should be replaced correctly in order to ensure more economic use of the machine. When replacing parts, always use Komatsu genuine parts.

As a result of our continuous efforts to improve product quality, the part number may change, so inform your Komatsu distributor of the machine serial number and check for the latest part number when ordering parts.

NO.	Periodic Replacement Parts	Q'ty	Replacement Interval
1	Fuel hose (Fuel tank to fuel strainer)	2	Every 2 years or every 4000 hours of service meter reading whichever comes earlier
2	Fuel hose (Fuel strainer to hand priming pump)	1	
3	Fuel hose (Hand priming pump to pre-filter)	1	
4	Fuel hose (Pre-filter to feed pump)	1	
5	Fuel hose (supply pump to fuel tank)	1	
6	Fuel hose (Nozzle to fuel tank)	2	
7	Hydraulic hose between torque converter oil cooler and power train assembly	2	
8	Hydraulic hose between power train pump and power train filter	1	
9	Hydraulic hose between power train filter and branching-off block	1	
10	Hydraulic hose between branching-off block and steering case	1	
11	Hydraulic hose between power train lubrication pump and steering case	1	
12	Power train hydraulic pressure sensing hose assembly	1	
13	Hydraulic hose between HSS pump and work equipment valve	2	
14	Hydraulic hose between HSS motor and work equipment valve	2	
15	Hydraulic hose between work equipment valve and hydraulic tank	1	
16	Hydraulic hose between HSS pump and drain relay block (P/L)	1	
17	Hydraulic hose between HSS motor and drain relay block (P/L)	1	
18	Hydraulic hose between cooling fan pump and drain relay block (P/L)	1	
19	Hydraulic hose between drain relay block (P/L) and hydraulic tank	1	
20	Hydraulic hose between cooling fan pump and self- pressure decompression valve	1	
21	Hydraulic hose between self- pressure decompression valve and cooling fan motor	3	

NO.	Periodic Replacement Parts	Q'ty	Replacement Interval
22	Hydraulic hose between cooling fan motor and hydraulic tank	5	Every 2 years or every 4000 hours of service meter reading whichever comes earlier
23	Hydraulic hose between oil cooler bypass valve and hydraulic oil cooler	1	
24	Hydraulic hose between PPC branching-off block and work equipment valve	2	
25	Hydraulic hose between PPC branching-off block and cooling fan pump	1	
26	Hydraulic hose between PPC branching-off block and work equipment lock valve	2	
27	Hydraulic hose between self- pressure decompression valve and drain relay block (ROPS)	1	
28	Hydraulic hose between work equipment valve and drain relay block (ROPS)	1	
29	Hydraulic hose between self- pressure decompression valve and PPC branching- off block	1	
30	Hydraulic hose between PPC lock valve and blade PPC valve	1	
31	Hydraulic hose between PPC lock valve and ripper PPC valve	1	
32	Hydraulic hose between blade PPC valve and work equipment valve	4	
33	Hydraulic hose between ripper PPC valve and work equipment valve (rigid type multi-shank ripper)	2	
34	Hydraulic hose between ripper PPC valve and work equipment valve (variable type multi-shank ripper)	4	
35	Hydraulic hose between blade PPC valve and drain relay block (ROPS)	1	
36	Hydraulic hose between ripper PPC valve and drain relay block (ROPS)	1	
37	Hydraulic hose between work equipment valve and ripper relay block (rigid type multi-shank ripper)	2	
38	Hydraulic hose between work equipment valve and ripper relay block (variable type multi-shank ripper)	4	
39	Hydraulic hose between ripper relay block and ripper cylinder (rigid type multi-shank ripper)	4	
40	Hydraulic hose between ripper relay block and ripper cylinder (variable type multi-shank ripper)	8	
41	Hydraulic hose between work equipment valve and blade tilt relay cover	2	
42	Hydraulic hose between right pivot shaft end face cover and straight frame relay tube	2	
43	Hydraulic hose between straight frame relay tube and blade tilt cylinder	2	
44	Hydraulic hose between work equipment valve and blade lift relay tube	2	
45	Hydraulic hose between radiator guard head and lift cylinder	4	
46	Hydraulic hose between drain relay block (ROPS) and hydraulic tank	1	
47	Safety seat belt	1	
48	Clamp for high pressure hose	1S	Every 8000 hours of service meter reading
49	Fuel splash prevention cap	1S	

# MAINTENANCE SCHEDULE CHART

## MAINTENANCE SCHEDULE CHART

### INITIAL 250 HOURS SERVICE (ONLY AFTER THE FIRST 250 HOURS)

REPLACE POWER TRAIN OIL FILTER ELEMENT .....	4- 58
CHANGE OIL IN POWER TRAIN CASE, CLEAN STRAINERS (POWER TRAIN STRAINER, SCAVENGING PUMP STRAINER) .....	4- 59
CHANGE OIL IN FINAL DRIVE CASE .....	4- 62
CHANGE OIL IN HYDRAULIC TANK, REPLACE HYDRAULIC OIL FILTER ELEMENT AND CLEAN HYDRAULIC TANK STRAINER .....	4- 67

### WHEN REQUIRED

CLEAN INSIDE OF COOLING SYSTEM .....	4- 21
CHECK, CLEAN AND REPLACE AIR CLEANER ELEMENT .....	4- 25
CHECK TRACK SHOE TENSION, ADJUST .....	4- 29
CHECK AND TIGHTEN TRACK SHOE BOLTS .....	4- 31
ADJUST IDLER CLEARANCE .....	4- 32
REVERSE AND REPLACE END BITS AND CUTTING EDGES .....	4- 34
CLEANING AND INSPECTION OF FINS OF RADIATOR, OIL COOLER AND AFTER COOLER .....	4- 35
CLEAN FUEL TANK STRAINER .....	4- 38
CLEAN STEERING CLUTCH CASE BREATHER .....	4- 38
CHECK UNDERCARRIAGE OIL .....	4- 39
CLEAN AIR CONDITIONER AIR FILTER (FRESH/RECIRC FILTER) .....	4- 40
CHECK, ADJUST AIR CONDITIONER .....	4- 40
GREASE DOOR HINGE .....	4- 42
CHECK DOOR LATCH .....	4- 42
CHECK DOOR LOCK STRIKER .....	4- 42
REPLACE DOOR DAMPER .....	4- 43
CHECK WINDOW WASHER FLUID LEVEL, ADD FLUID .....	4- 43
REPLACE WIPER BLADE .....	4- 44
PROCEDURE FOR BLEEDING AIR IN HYDRAULIC SYSTEM .....	4- 45
LUBRICATING .....	4- 45

**CHECK BEFORE STARTING**

**EVERY 250 HOURS SERVICE**

LUBRICATING ----- 4- 47  
 CHECK ALTERNATOR DRIVE BELT TENSION, ADJUST ----- 4- 49  
 CHECK LEVEL OF BATTERY ELECTROLYTE ----- 4- 50  
 CHECK BRAKE PERFORMANCE ----- 4- 52  
 CHECK OIL LEVEL IN DAMPER CASE, ADD OIL ----- 4- 53

**EVERY 500 HOURS SERVICE**

CHANGE OIL IN ENGINE OIL PAN, REPLACE ENGINE OIL FILTER CARTRIDGE ----- 4- 54  
 REPLACE FUEL PRE-FILTER CARTRIDGE ----- 4- 55  
 REPLACE POWER TRAIN OIL FILTER ELEMENT ----- 4- 58  
 CHECK OIL LEVEL IN FINAL DRIVE CASE, ADD OIL ----- 4- 58

**EVERY 1000 HOURS SERVICE**

CHANGE OIL IN POWER TRAIN CASE, CLEAN STRAINERS (POWER TRAIN STRAINER, SCAVENGING PUMP STRAINER) ----- 4- 59  
 REPLACE HYDRAULIC TANK BREATHER ELEMENT ----- 4- 61  
 CHANGE OIL IN FINAL DRIVE CASE ----- 4- 62  
 CHECK, CLEAN FUEL STRAINER ----- 4- 62  
 REPLACE FUEL MAIN FILTER CARTRIDGE ----- 4- 63  
 CHECK ALL TIGHTENING POINTS OF ENGINE EXHAUST PIPE CLAMPS ----- 4- 66  
 REPLACE CORROSION RESISTOR CARTRIDGE ----- 4- 66

**EVERY 2000 HOURS SERVICE**

CHANGE OIL IN HYDRAULIC TANK, REPLACE HYDRAULIC OIL FILTER ELEMENT AND CLEAN HYDRAULIC TANK STRAINER ----- 4- 67  
 CHANGE OIL IN DAMPER CASE, CLEAN DAMPER BREATHER ----- 4- 68  
 CHECK PIVOT BEARING OIL LEVEL, ADD OIL ----- 4- 69  
 CHECKING CHARGE PRESSURE OF NITROGEN GAS IN ACCUMULATOR (FOR CONTROL CIRCUIT) ----- 4- 70  
 CHECK ALTERNATOR ----- 4- 72  
 CHECK ENGINE VALVE CLEARANCE, ADJUST ----- 4- 72

**EVERY 4000 HOURS SERVICE**

REPLACE ACCUMULATOR (FOR CONTROL CIRCUIT ) ----- 4- 73  
 CHECK WATER PUMP ----- 4- 73  
 CHECK STARTING MOTOR ----- 4- 73  
 CHECKING FOR LOOSENESS OF HIGH-PRESSURE CLAMP, HARDENING OF RUBBER ----- 4- 74  
 CHECKING FOR MISSING FUEL SPRAY PREVENTION CAP, HARDENING OF RUBBER ----- 4- 74  
 CHECK MAIN FRAME, WORK EQUIPMENT (BLADE, RIPPER) ----- 4- 75

**EVERY 8000 HOURS SERVICE**

REPLACE HIGH-PRESSURE PIPING CLAMPS ----- 4- 76  
 REPLACE FUEL SPLAY PREVENTION CAPS ----- 4- 76

## SERVICE PROCEDURE

### INITIAL 250 HOURS SERVICE (ONLY AFTER THE FIRST 250 HOURS)

Perform the following maintenance only after the first 250 hours.

- Replace power train oil filter element
- Change power train case oil and wash strainer (power train pump strainer, scavenging pump strainer)
- Change oil in final drive case
- Change oil in hydraulic tank, replace hydraulic oil filter element, clean hydraulic tank strainer

For details of the methods of maintenance, see EVERY 500 HOURS SERVICE, EVERY 1000 SERVICE, EVERY 2000 HOURS SERVICE.

**WHEN REQUIRED**

**CLEAN INSIDE OF COOLING SYSTEM**

 **WARNING**

- Immediately after the engine is stopped, the cooling water is at high temperature and the radiator is under high internal pressure. If the radiator cap is removed in this condition and the water is drained, it may cause burns. To prevent this, wait for the temperature to go down, then turn the cap slowly to release the internal pressure.
- Start the engine and clean the inside of the cooling system.. When standing up or leaving the operator's seat, set the work equipment lock lever and parking brake lever to the LOCK position.
- For details when starting the engine, see "CHECK BEFORE STARTING ENGINE, ADJUST (PAGE 3-74)" and "STARTING ENGINE (PAGE 3-93)".
- If the undercover is removed, there is danger of touching the fan.  
Never enter the area at the rear of the machine when the engine is running.

Stop the machine on level ground when cleaning or changing the coolant.

Clean the inside of the cooling system, change the coolant according to the table below.

Antifreeze coolant	Interval for cleaning inside of cooling system and changing antifreeze coolant	Precautions for use
Komatsu supercoolant (AF-NAC)	Every two years or every 4000 hours whichever comes first	1*

\*1: When using Komatsu Supercoolant (AF-NAC), there is no need to use a corrosion resistor. When no corrosion resistor is used, use the special cover (600-411-9000). Please consult your Komatsu distributor about the method of installing.  
When using corrosion resistor, use Komatsu genuine corrosion resistor. If you use another corrosion resistor, it may cause serious problems such as corrosion of the engine and parts of the cooling system that use light metals such as aluminum.

The coolant has the important function of preventing corrosion as well as preventing freezing. Even in the areas where freezing is not an issue, the use of antifreeze coolant is essential. Komatsu machines are supplied with Komatsu Supercoolant (AF-NAC). Komatsu Supercoolant (AF-NAC) has excellent anticorrosion, antifreeze and cooling properties and can be used continuously for 2 years or 4000 hours. As a basic rule, we do not recommend the use of any coolant other than Komatsu genuine supercoolant (AF-NAC). If you use another coolant, it may cause serious problems such as corrosion of the engine and parts of the cooling system that use light metals such as aluminum.

To maintain the anticorrosion properties of Supercoolant (AF-NAC), always keep the density of Supercoolant between 30% and 68%.

When deciding the ratio of antifreeze to water, check the lowest temperature in the past, and decide from the mixing table given below.

It is actually better to estimate and temperature about 10°C (18°F) lower when deciding the mixing ratio.

The mixing ratio depends on the ambient temperature, but it should always be a minimum of 30% by volume (antifreeze/total amount of coolant x 100).

Even in areas where it is not necessary to prevent freezing, use Supercoolant (AF-NAC) at a mixing ratio of at least 30% to prevent corrosion of the cooling system.

The freezing temperature of undiluted antifreeze is -15°C (5°F). Do not store undiluted antifreeze at a temperature of below -15°C (5°F).

Mixing rate of water and antifreeze

Min. atmospheric temperature	°C	-10	-15	-20	-25	-30	-35	-40
	°F	14	5	-4	-13	-22	-31	-40
Amount of antifreeze	liter	17.4	20.9	23.8	26.7	29.0	31.3	33.6
	US gal	4.60	5.52	6.28	7.05	7.66	8.27	8.89
Amount of water	liter	40.6	37.1	34.2	31.3	29.0	26.7	24.4
	US gal	10.72	9.81	9.04	8.27	7.66	7.05	6.44
Volume ratio (%)		30	36	41	46	50	54	58

 **WARNING**

- Antifreeze is flammable, so keep it away from flame.  
Antifreeze is toxic. When open the drain valve, be careful not to get water containing antifreeze on you. If it gets in your eyes, flush your eyes with large amount of fresh water and see a doctor at once.
- When changing the coolant or draining the coolant from the radiator before carrying out repairs, ask a specialist company to handle any coolant containing antifreeze, or contact your Komatsu distributor. Antifreeze is toxic, so never pour it into drainage water ditches or drain it onto the ground surface.

Use antifreeze and appropriate water for diluting (for details, see "COOLANT AND WATER FOR DILUTION (PAGE 4-6)")

We recommend use of an antifreeze density gauge to control the mixing proportions.

Prepare a container whose capacity is larger than the specified coolant volume to catch drained coolant.

Prepare a hose to supply antifreeze coolant and water.

1. Stop the engine, wait for the coolant to cool completely, then turn valve (2) of corrosion resistor (1) to the Close stopper position.

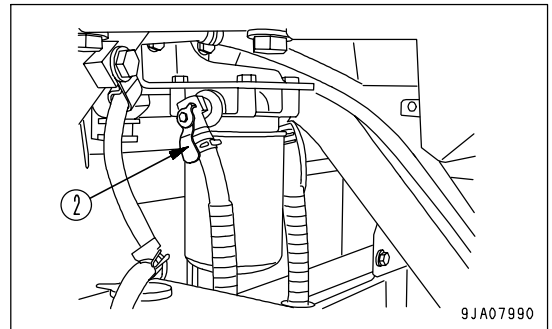
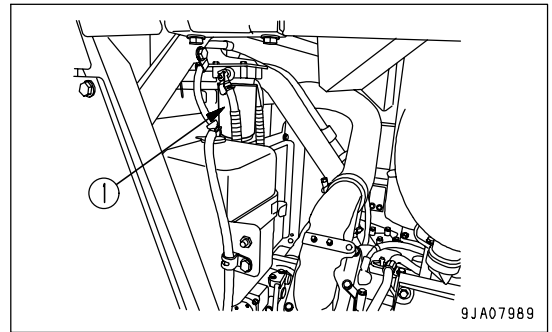

2. Turn main radiator cap (3) slowly, and remove.

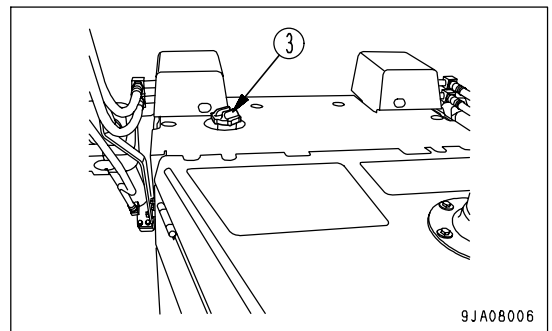

3. Prepare a container to catch the coolant, pull out hose (4) of the main radiator at the bottom front right of the machine, then open drain valve (5) and drain the water.
4. Open the drain valve (6) in the water pump piping on the right side of the engine, and drain the water.
5. After draining, close up drain valve (5), (6) and pour in clean water up to the vicinity of the water filler.
6. After the radiator is filled with water, start the engine and run it at low idle. After the water temperature rises above 90°C (194 °F), run the engine for approx. 10 minutes.
7. Stop the engine and open drain valve (5), (6) to drain the water.
8. After draining the water, clean the cooling system with cleaning agent.  
For the cleaning method, see the instructions for the cleaning agent.

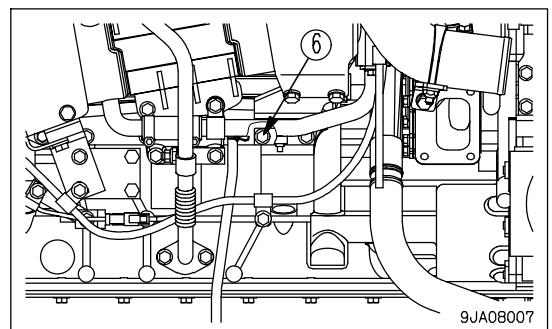
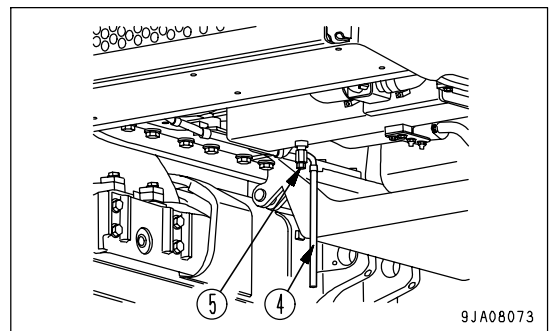



9. Replace the corrosion resistor, then open each valve (2).

For details of the procedure for replacing the corrosion resistor, see "REPLACE CORROSION RESISTOR CARTRIDGE (PAGE 4-66)".

10. Close drain valve (5), (6).

11. Add coolant mixed with antifreeze until it overflows from the water filler.

Decide the proportions of antifreeze and water according to the table for the mixing rate of water and antifreeze.

12. To remove air in the cooling system, run the engine for 5 minutes at low idle, then for 5 minutes at high idle.

(While doing this, leave the radiator cap removed.)

13. Drain the coolant from sub-tank (7), clean the inside of the sub-tank, then add water until the coolant level is between the FULL and LOW marks.

14. Stop the engine, wait for approx. 3 minutes, then add coolant until the coolant level is near the coolant filler port, and tighten the cap (3). Check the coolant level and add coolant if necessary.

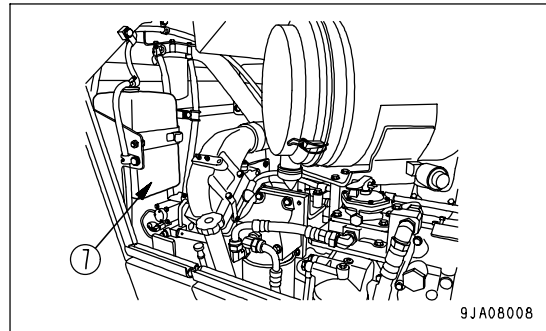

**CHECK, CLEAN AND REPLACE AIR CLEANER ELEMENT**

**! WARNING**

- Always wear protective glasses, dust mask, or other protective equipment.
- When removing the air cleaner element from the air cleaner body, it is dangerous to pull it out by force.  
When working at high places or where the foothold is poor, be careful not to fall because of the reaction when pulling out the outer element.

**CHECKING**

When the yellow piston inside red zone (A) of the dust indicator (1) overlaps the red zone, clean the air cleaner element. After cleaning, press the reset button.

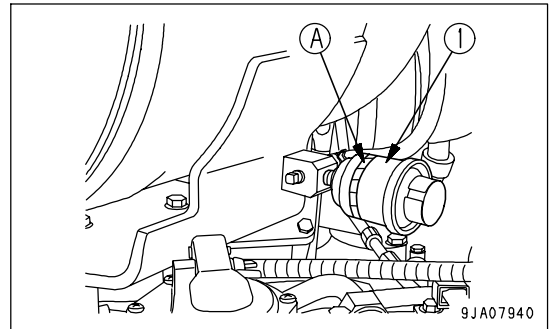

**NOTICE**

Always wait for the yellow piston in the dust indicator to overlap the red zone on the outside before cleaning the element.  
If the element is cleaned frequently before the yellow piston in the dust indicator overlaps the red zone on the outside, the air cleaner will be unable to display its normal performance and the cleaning effect will become poor.  
In addition, the frequency of dust stuck to the element falling inside the inner element during the cleaning operation will increase.

**INSPECTION FOR MACHINES EQUIPPED WITH AIR CLEANER CLOGGING MONITOR**

(If equipped)

If air cleaner clogging monitor (1) of the monitor panel flashes, clean the air cleaner element.

**NOTICE**

Do not clean the air cleaner element until the air cleaner clogging monitor on the monitor panel flashes. If the element is cleaned frequently before the clogging monitor flashes, the air cleaner will not be able to display its performance fully, and the cleaning efficiency will also go down.  
In addition, during the cleaning operation, more dirt stuck to the element will fall inside the inner element.

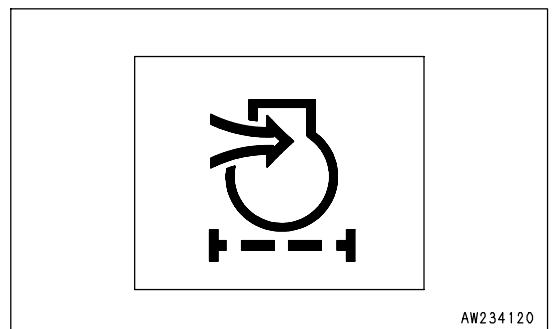
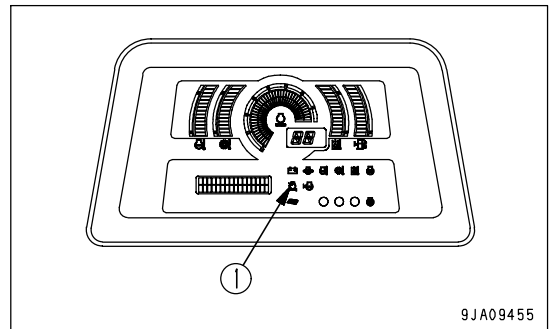

## CLEANING OR REPLACING OUTER ELEMENT

## NOTICE

Before and after cleaning the element, do not leave or keep it in direct sunlight.

1. Open the left engine side cover.
2. Remove three clips (2), then remove cover (3).

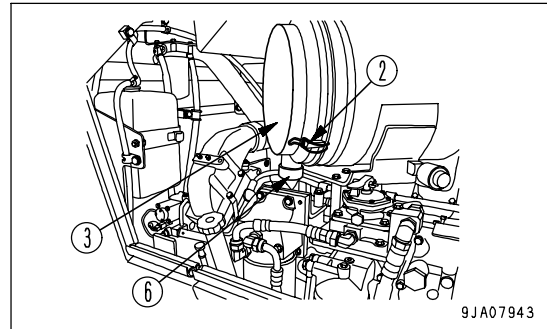

## NOTICE

Never remove inner element (5). If it is removed, dust will enter and cause engine trouble.

3. Remove outer element (4).
4. Hold the outer element, rock it lightly up and down and to the left and right, and rotate the element to the left and right to pull it out.
5. Clean the interior of the air cleaner body, cover (3) and evacuator valve (6).

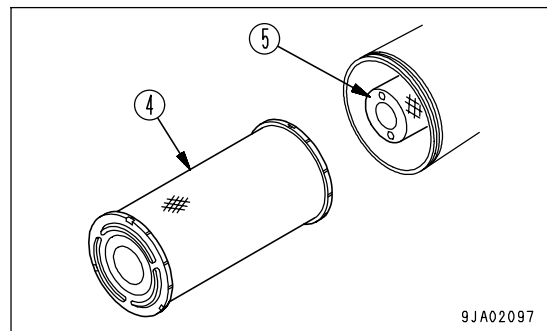

## NOTICE

The inner element must not be used again even after cleaning. When replacing the outer element, replace the inner element at the same time.

6. Direct dry compressed air (Max. 0.69 MPa (7 kg/cm<sup>2</sup>, 99.4 PSI)) from the inside of the outer element along its folds. Then direct the compressed air from the outside along the folds, and again from the inside.
  - 1) Check that the inner element is not loose. If it is loose, insert it securely.
  - 2) Replace any outer element which has been cleaned 6 times or used for 1 year. Replace the inner element at the same time.

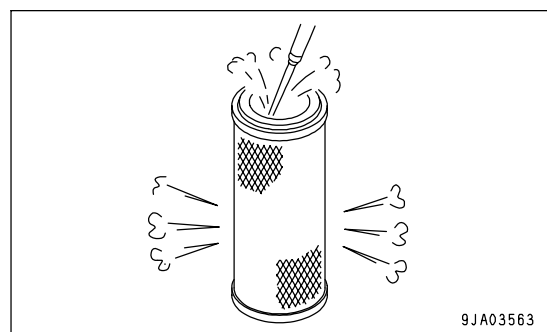

- 3) Even if the outer element has not been cleaned 6 times, if the yellow piston in the dust indicator goes to the 5 kPa position immediately after cleaning (when the engine is running at high idling, replace both the inner and the outer element.

- If small holes or thinner parts are found on the element when it is checked by shining a light through it after cleaning, replace the element.

**NOTICE**

- When cleaning the element, do not hit or beat it against anything.
- Do not use an element whose folds or gasket or seal are damaged.

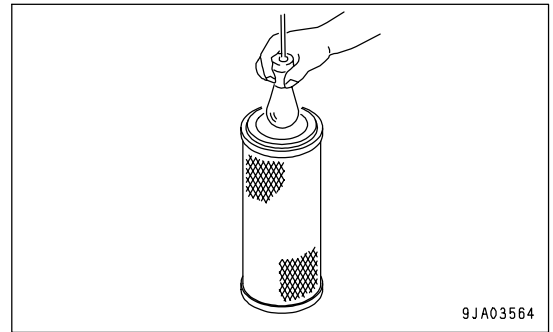

- Before installing the outer element, check that the inner element is fitted securely. If the inner element is not fitted securely, push it in properly.

**CAUTION**

When installing the cover (3), check O-ring (7) and replace it if there are any scratches or damage.

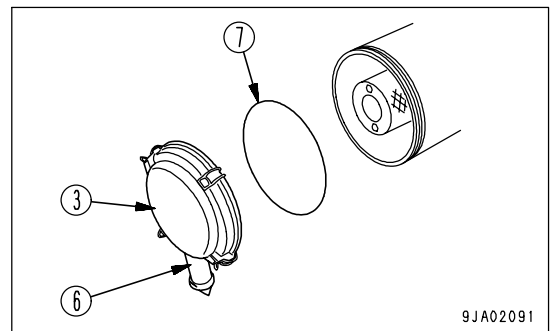

- Set the cleaned outer element in position, then secure cover (3) with mounting clips (2).

- Push the button of dust indicator (1) and return the yellow piston to its original position.

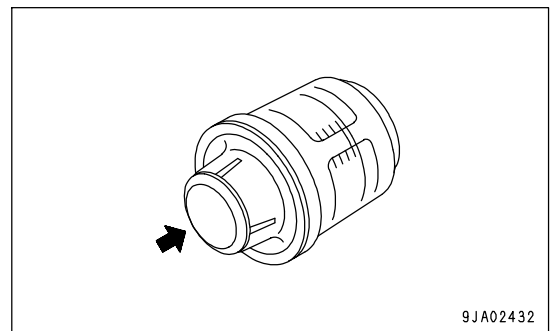

- Close the left engine side cover.

**REPLACING ELEMENT**

1. Open the left engine side cover.
2. Remove three clips (2), then remove cover (3).

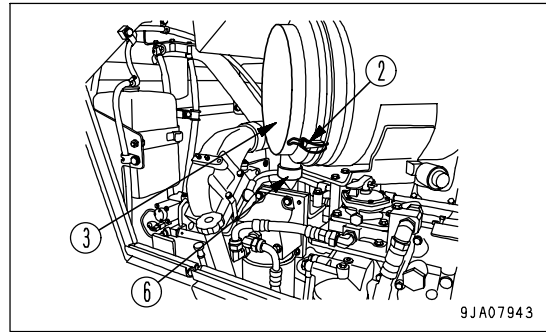

3. Remove outer element (4).  
Do not remove inner element (5) at this time, however.
4. Clean the interior of the air cleaner body, cover (3) and evacuator valve (6).

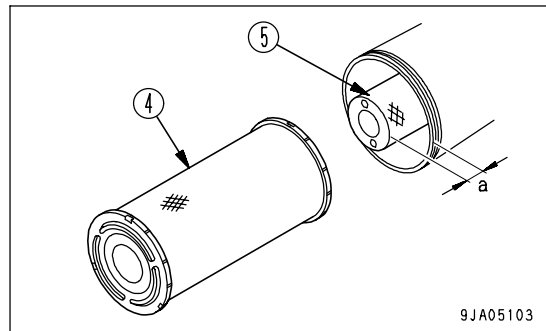

**NOTICE**

If the outer element and cover are installed when the inner element is not installed properly, the outer element may break.

When installation is correct, protrusion "a" of the inner element from the air cleaner body is 35 mm.

5. Remove inner element (5), then quickly install the new inner element.  
Push the inner element in properly and check that it is fitted securely.
6. Set the new outer element (4) in position.
7. Replace O-ring (7) for cover (3) with new one.
8. Set the arrow mark on cover (3) at the top, install to the air cleaner body, then secure with clip (2).

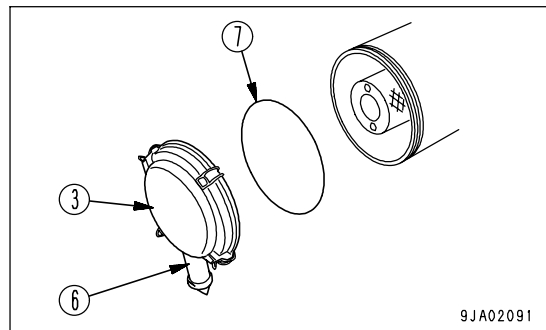

9. Push the button of dust indicator (1) and return the yellow piston to its original position.

**REMARK**

Immediately after a new element has been installed, the yellow piston of the dust indicator may go to the 2nd position, but this does not indicate any abnormality.

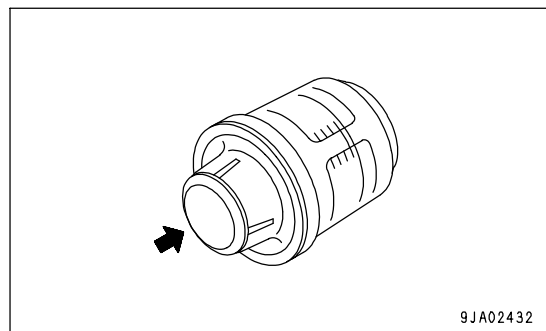

10. Close the left engine side cover.

**CHECK TRACK SHOE TENSION, ADJUST**

The wear of pins and bushings on the undercarriage will vary with the working conditions and types of soil. It is thus necessary to continually inspect the track tension so as to maintain the standard tension.

Carry out the check and adjustment under the same conditions as when operating (on jobsites where the track becomes clogged with mud, measure with the track clogged with mud).

**INSPECTION**

Stop the machine on level ground (machine does not move forward even when brake is not applied), then put a straight rod on top of the carrier roller and idler as shown in the diagram on the right. Check that clearance a between the rod and the grouser is the standard distance.

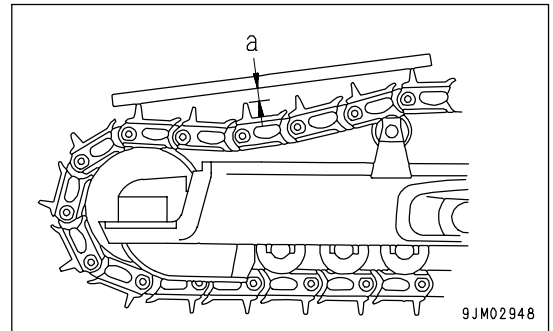

- Standard tension dimension a
  - EX: 20 - 30 mm
  - PX: 10 - 15 mm

If the track tension is not at the standard value, adjust it in the following manner.

**ADJUSTMENT**

**! WARNING**

There is danger of plug (1) flying out under the high internal pressure of the grease. Never loosen plug (1) more than 1 turn. Never loosen any part other than plug (1). Never put your face in the mounting direction of plug (1). If the track tension cannot be loosened with the procedure given here, please contact your Komatsu distributor.

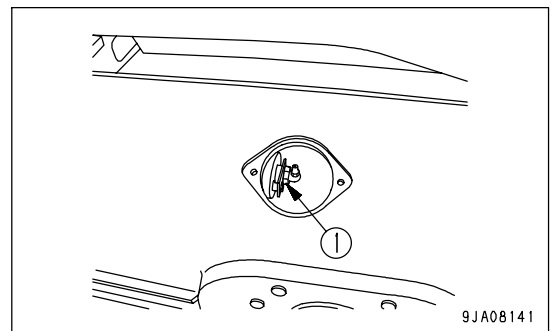

**WHEN INCREASING TENSION**

Prepare a grease pump.

1. Pump in grease through grease fitting (2) with a grease pump.
2. To check that the correct tension has been achieved, move the machine backwards and forwards.
3. Check the track tension again, and if the tension is not correct, adjust it again.

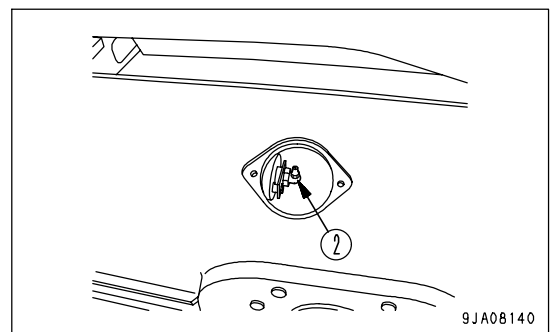

4. Continue to pump in grease until (S) becomes 0 mm. If the tension is still loose, the pin and bushing are excessively worn, so they must be either turned or replaced. Please contact your Komatsu distributor.

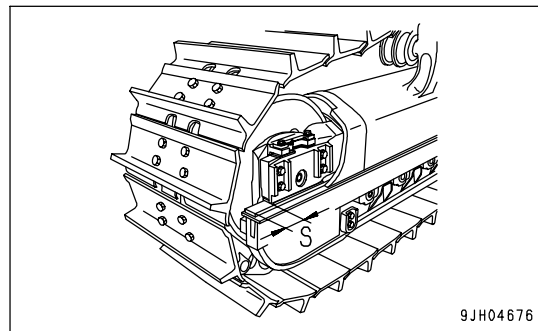

#### WHEN LOOSENING TENSION

### WARNING

It is extremely dangerous to release the grease by any method except the procedure given below. If the track tension is not relieved by this procedure, please contact your Komatsu distributor.

1. Loosen plug (1) gradually to release the grease.
2. When loosening plug (1), turn it a maximum of one turn.
3. If the grease does not come out smoothly, move the machine forwards and backwards a short distance.
4. Tighten plug (1).
5. To check that the correct tension has been achieved, move the machine backwards and forwards.
6. Check the track tension again, and if the tension is not correct, adjust it again.

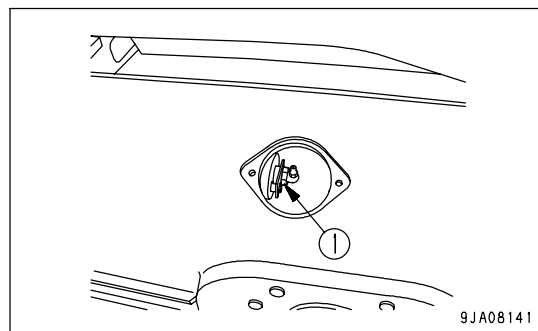

#### WHEN REMOVING TRACK SHOE

### WARNING

Depending on the situation, the operation to remove the track may be extremely dangerous.

Before removing the track, if the procedure "WHEN LOOSENING TENSION (PAGE 4-30)" does not loosen the track tension, contact your Komatsu distributor for repairs.

### CHECK AND TIGHTEN TRACK SHOE BOLTS

If the machine is used with track shoe bolts (1) loose, they will break, so tighten any loose bolts immediately.

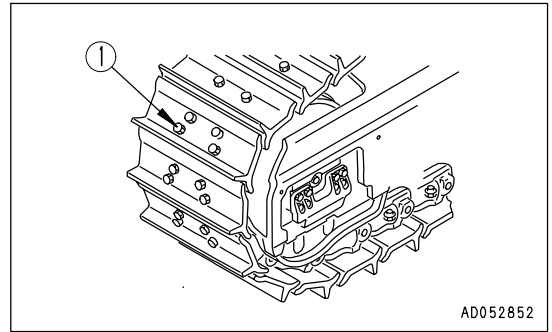

### METHOD OF TIGHTENING (TRACK SHOE BOLTS)

1. First, tighten to the tightening torque below, then check that the nut and shoe are in close contact with the link mating surface.
  - D85EX:  $343 \pm 39$  Nm ( $35 \pm 4$  kgm,  $253.2 \pm 28.9$  lbft)
  - D85PX:  $539 \pm 49$  Nm ( $55 \pm 5$  kgm,  $253.2 \pm 28.9$  lbft)
2. After checking, tighten a further  $120^\circ \pm 10^\circ$ .

### METHOD OF TIGHTENING (MASTER CONNECTING BOLT)

1. First tighten to a tightening torque of  $343 \pm 39$  Nm ( $35 \pm 4$  kgm,  $253 \pm 29$  lbft) then check that the link contact surfaces are in close contact.
2. After checking, tighten a further  $160^\circ$  to  $180^\circ$ .

### ORDER FOR TIGHTENING

Tighten the bolts in the order shown in the diagram on the right.

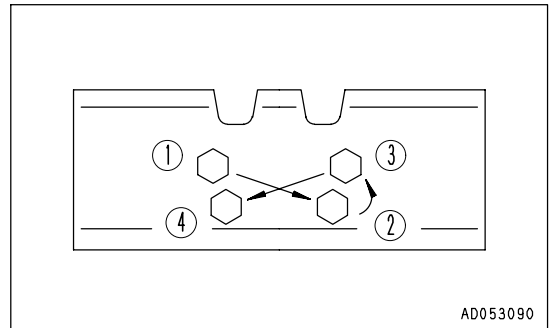



## ADJUST IDLER CLEARANCE

The idler moves forward and backward under external pressure when this happens, side guide and guide plate become worn.

As they become worn, there is side play in the idler, or the idler turns at an angle, causing the track to come off or resulting in uneven wear, so adjust as follows.

### ADJUSTING IN SIDEWAYS DIRECTION

1. Drive the machine for 8 to 12 m (24.4 to 36.6 ft) on flat ground, then measure clearance A (4 places: left, right, inside outside) between the track frame and guide plate.
2. If clearance A is more than 4 mm (0.158 in), remove bolt (1), then take out shim, and adjust to that the clearance on one side is less than 0.5 to 1 mm (0.020 to 0.039 in).

### REMARK

There are two types of shim  
(thickness: 0.5 mm (0.02 in) and 1.0 mm (0.04 in)).

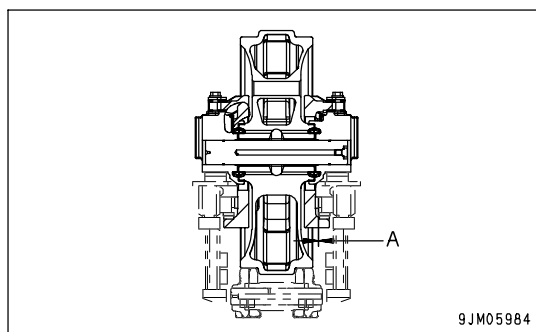
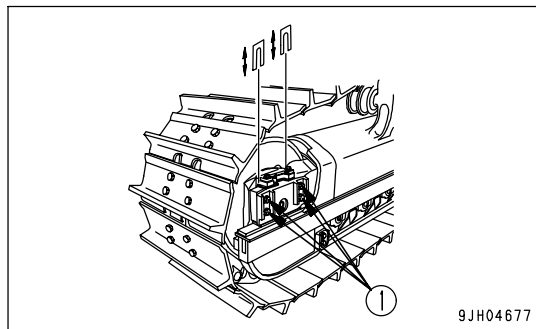

**ADJUSTING IN VERTICAL DIRECTION**

1. To determine the amount of adjustment, measure clearance B, then subtract 2 mm and record the result (amount of adjustment).

**Example**

If clearance B = 5 mm (0.197 in):

Amount of adjustment = 5 - 2 = 3 mm (0.118 in)

2. Loosen bolts (9) (inside, outside: Total 4) to a point where there is no more reaction from the spring.
3. Loosen bolt (1) (inside, outside: Total 8) . When doing this, do not loosen it more than 3 turns.
4. Using a bar, pull up up-down guide (5) to set clearance C to 0, then remove shims of a thickness equal to the amount of adjustment measured in Step 1.
5. After removing shims (7), add them on top of shim (8).

(Left, right, inside, outside: Total 8 places)

When doing this, check that the total thickness of shim (7) and shim (8) is the same after adjustment as it was before adjustment at all places.

Discarding shims or adding shims will result in improper function of the built-in spring.

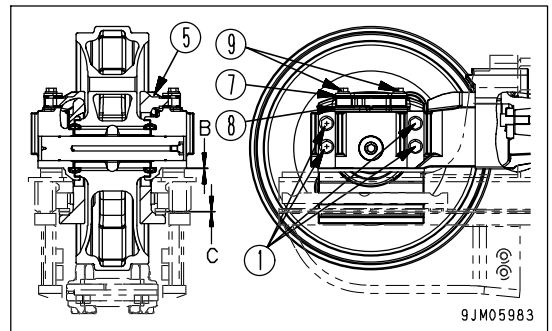
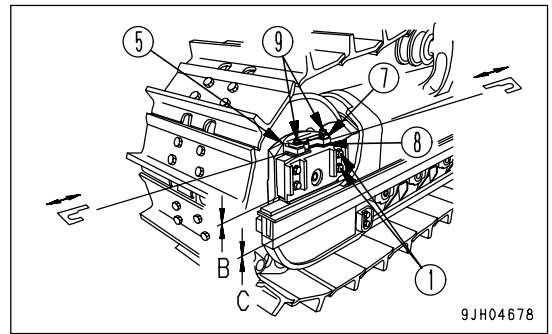

**REMARK**

There are two types of shim thickness: 1 mm (0.039 in) and 2 mm (0.079 in).

## REVERSE AND REPLACE END BITS AND CUTTING EDGES



### WARNING

It is dangerous if the work equipment moves during the turning or replacement operation.

Set the work equipment in a stable condition, set the work equipment lock lever to the LOCK position, then stop the engine.

Reverse or replace the end bits and cutting edges before it is worn out to the blade end.

1. Raise the blade to a proper height, position a block under the frame to prevent the blade from falling.

2. Operate the work equipment lock lever to the LOCK position.

If the cutting edge and the end bit on both sides are worn out, replace with new one.

If the mounting surface is worn, correct it before turning or replacing the end bits.

3. Loosen nut (1) and remove bolt (2). Then remove the cutting edge and the end bit and clean the mounting surface.

4. Reverse or replace the cutting edge and the end bit when worn out.

If bolt (1) and nut (2) are damaged, replace them with new ones at the same time.

5. Install the edge to the blade, then tighten partially. Drop the blade three to five times on to the ground or rock to remove any play in bolt (2), then tighten it to the correct tightening torque. When installing end bit (3), put top surface (4) of the end bit in close contact with stopper (5), then tighten with the bolts.

Tightening torque:  $628 \pm 79$  Nm ( $64 \pm 8$  kgm,  $462 \pm 57.9$  lbft)

6. After several hours of running, retourque the nuts.

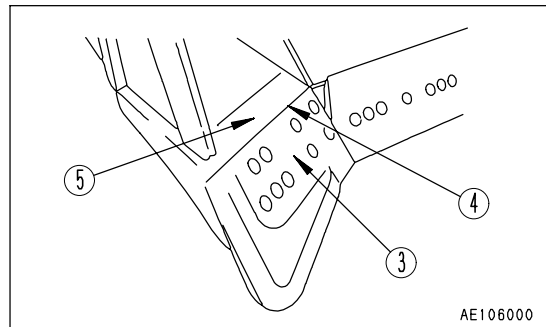
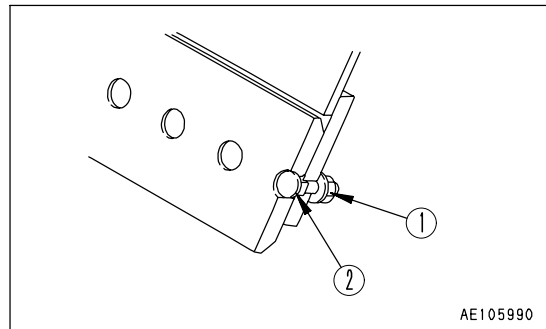

## CLEANING AND INSPECTION OF FINS OF RADIATOR, OIL COOLER AND AFTER COOLER

Carry out this procedure if there is any mud or dirt stuck to the radiator or oil cooler.

### REMARK

Check the hydraulic cooler hoses. If any hose is cracked or hardened by age, replace with a new hose. Also check and tighten all loose hose clamps.

### CLEANING BY ROTATING COOLING FAN IN REVERSE DIRECTION



## WARNING

When cleaning the cooling fan by turning it in the reverse direction, make sure that the parking brake lever is in the LOCK position.

### NOTICE

When rotating the cooling fan in the reverse direction, be extremely careful of flying dust.

Open up the right and left engine side covers and check that no dust and dirt are accumulated inside the engine room.

When the fan operation confirmation lamp is lighted and the fan is turning in the reverse direction, the machine does not move even if the steering - forward and reverse - gearshift lever is operated to any of the forward, reverse and steering positions. This function is designed to protect the radiator.

When stopping the engine when the cooling fan is rotating in the reverse direction, first run the engine at low idling, then stop it.

The dust and dirt stuck to the radiator and cooler can be blown out by rotating the cooling fan in the reverse direction.

1. Turn starting switch (1) to the "OFF" position and stop the engine.
2. Turn starting switch (1) to the "ON" position.
3. Turn fan rotation selector switch (2) to the cleaning (CLN) position.  
Cooling fan reverse rotation pilot lamp (3) lights up.

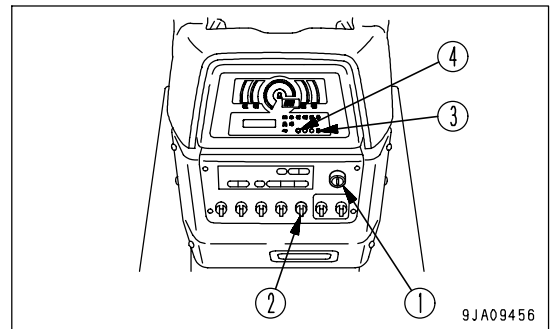

9JA09456

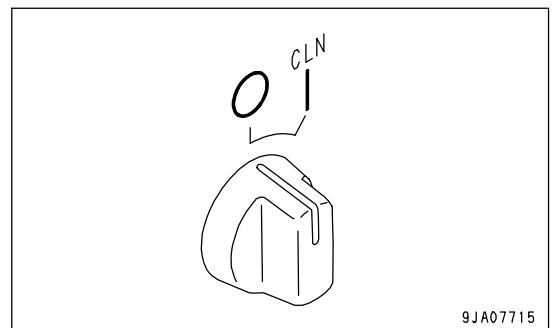

9JA07715

**REMARK**

Even if the fan rotation selector switch is turned while the engine is running, the fan does not change its rotation direction.

Then fan operation confirmation lamp (4) flashes, telling you that the fan rotation cannot be switched.

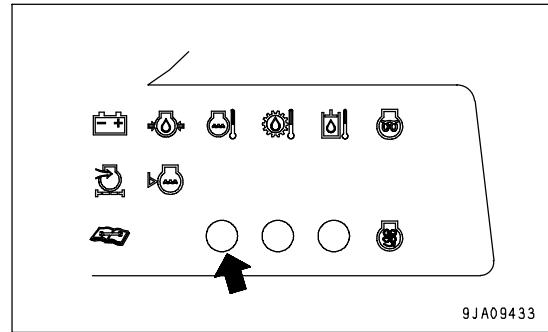

4. Start up the engine by turning engine starting switch key (1).  
The cooling fan begins to turn in the reverse direction.
5. Run the engine at high idle.  
Select the time for running the engine at high idle as follows according to the condition of clogging.  
Normal clogging: 1 to 2 minutes  
Excessive clogging: 2 to 3 minutes
6. After completing the cleaning, run the engine at low idle for approx. 10 seconds.
7. Turn starting switch (1) to the "OFF" position and stop the engine.

**REMARK**

When the cooling fan is turning for cleaning, power cannot be switched off immediately, even if the engine starting switch key is turned to the OFF position in order to protect the hydraulic circuit.

8. Turn starting switch (1) to the "ON" position.
9. Check that fan operation confirmation lamp (3) is unlighted and start up the engine. The cooling fan begins to turn in the normal direction.

**REMARK**

If dirt is caught in the radiator fins, blow with compressed air to clean.

**CLEANING WITH COMPRESSED AIR****WARNING**

- Directing compressed air, pressurized water, or steam directly at your body, or using these and causing dust to fly may cause personal injury. Always wear protective glasses, anti-dust mask, and other protective equipment.
- When carrying out cleaning, always stop the engine and check that the fan is not rotating. If you touch the fan when it is rotating, it will cause serious personal injury.

**NOTICE**

When using compressed air for cleaning, blow it keeping some distance to avoid damaging the fins. Damage on the fins can cause water leakage and overheating. In a dusty job site, check the fins every day, regardless of the maintenance interval.

**CLEANING OF RADIATOR FINS**

1. Remove bolts (1) at the four corners of the radiator grill, then open radiator grill (2).
2. Clean the radiator fins clogged with mud, dust and leaves with compressed air. Steam or water may be used instead of compressed air.

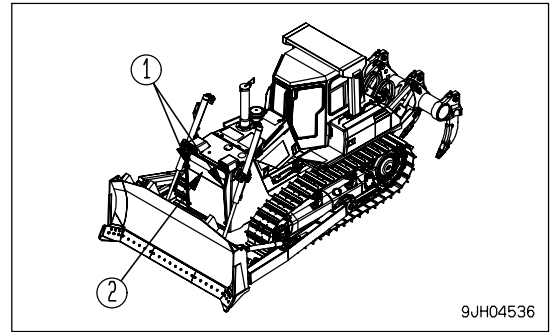

9JH04536

**CLEANING OF OIL COOLER FINS**

1. Open the engine side cover on the right side of the machine.
2. Blow off dirt, dust and dry leaf shreds that clog the oil cooler fins, with compressed air. Steam or water may well be used for this purpose instead of compressed air.

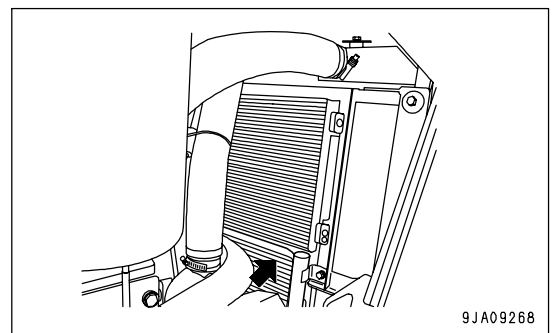

9JA09268

**REMARK**

Check the hydraulic cooler hoses. If any hose is cracked or hardened by age, replace with a new hose. Also check and tighten all loose hose clamps.

**CLEANING OF AFTER-COOLER FINS**

1. Open the engine side cover on the right side of the machine.
2. Blow off dirt, dust and dry leaf shreds that clog the after-cooler fins, with compressed air. Steam or water may well be used for this purpose instead of compressed air.

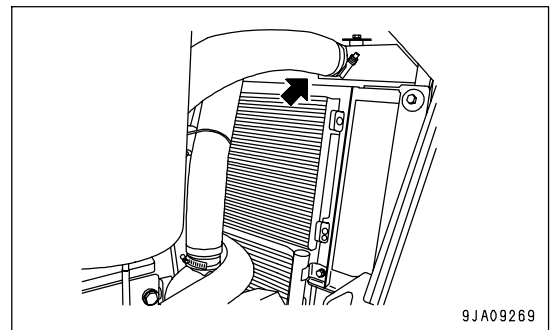

9JA09269

**REMARK**

Check the hydraulic cooler hoses. If any hose is cracked or hardened by age, replace with a new hose. Also check and tighten all loose hose clamps.

### CLEAN FUEL TANK STRAINER

Clean the strainer if there is any dirt collected in it.

Remove the filler cap (1) of the fuel tank and take out strainer.

If the strainer is dirty, clean it with diesel fuel.

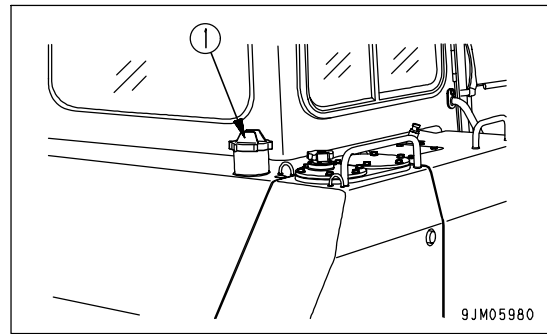

### CLEAN STEERING CLUTCH CASE BREATHER

1. Open the valve cover.
2. Remove the bolts, then remove cover (1).
3. Remove breather (2) at the side of the hydraulic tank, remove the dirt stuck to the breather, then wash it in clean diesel oil or flushing oil.

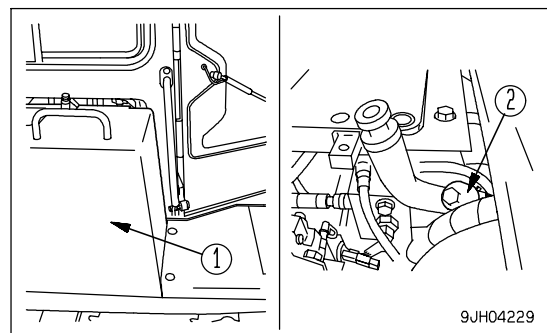

CHECK UNDERCARRIAGE OIL

 **WARNING**

If the oil level in the idler is low, new oil must be added, and the machine body must be inclined in this case. Since this work is dangerous, ask your Komatsu distributor.

**REMARK**

At the idler portion, seal bolt (1) cannot be seen if the side outer cover is not removed.

Stop the machine on level ground, and check for any reduction in the oil at the idler (portion P), track roller (portion Q), and carrier roller (portion R).

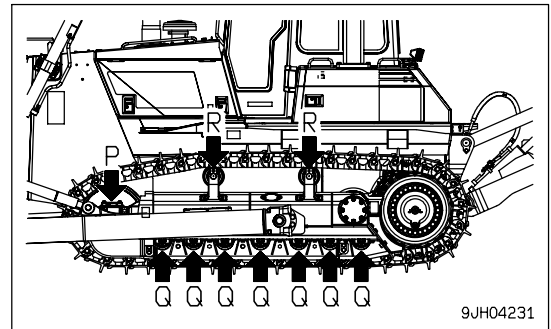

9JH04231

1. Loosen seal bolt (1) slowly and check if oil oozes out from the thread. If oil oozes out, the oil level has not gone down, so tighten the bolt.
2. If no oil comes out even when seal bolt is removed, the oil level is low. Contact your Komatsu distributor for repairs.

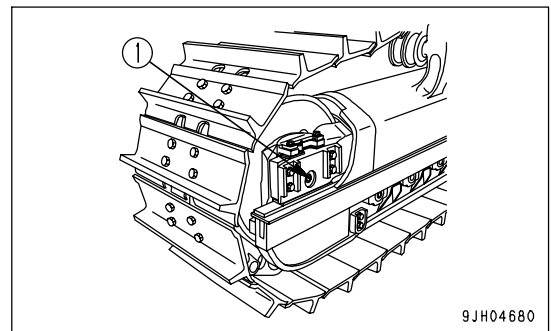

9JH04680

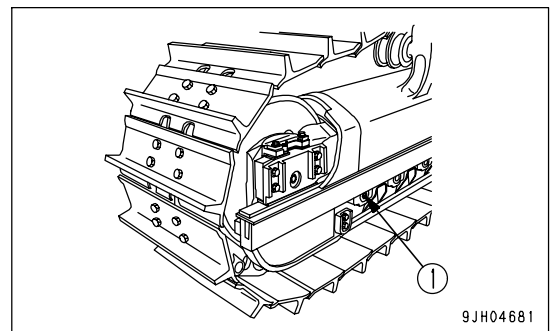

9JH04681

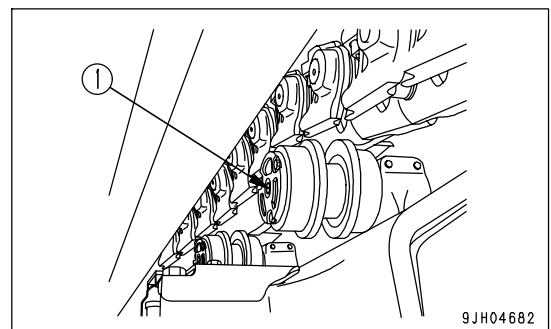

9JH04682



## CLEAN AIR CONDITIONER AIR FILTER (FRESH/RECIRC FILTER)

Clean the air conditioner air filter if it becomes clogged or if there is dirt or oil stuck to it.

In places where there is a lot of dust, clean the air filter once a week. In addition, clean the air conditioner air filter at the same time, when cleaning the engine air cleaner.

1. Open inspection cover (1) on top of the hood, then remove pressure air filter (2).
2. Open inspection cover (3) under the front panel and pull up recirculation air filter (4) to remove it.
3. Clean filters (2) and (4) with compressed air. If there is oil stuck to the filter, or it is extremely dirty, wash it in a neutral agent. After washing it, dry it completely before installing it again.

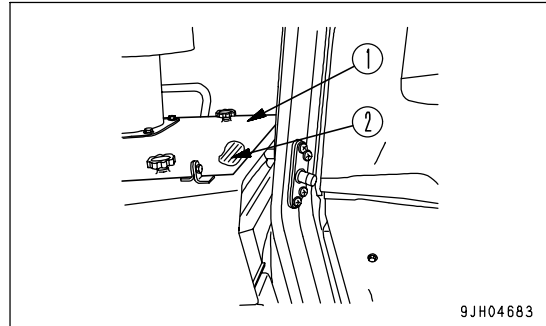

### REMARK

If the filters cannot be cleaned with air or in water, replace them with new ones.

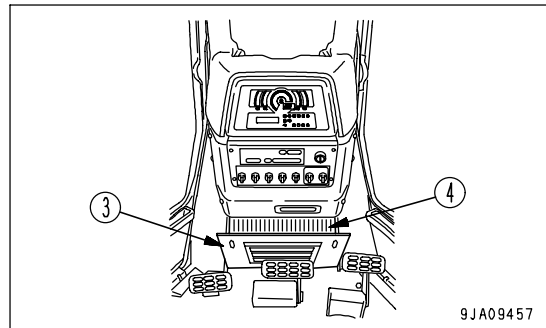

## CHECK, ADJUST AIR CONDITIONER

### CHECKING TENSION OF COMPRESSOR BELT

If the driving belt slackens, it is likely to slip, lowering the cooling efficiency. Depress the mid point between drive pulley (1) and compressor pulley (2) with a thumb (approx. 98 N (10 kg)) every now and then to make sure that deflection amount (A) is approx. 15 mm to 18 mm (0.59 to 0.71 in).

When it is a new belt, elongation is expected in the initial period of use, so be sure to make an adjustment in a few days after the replacement.

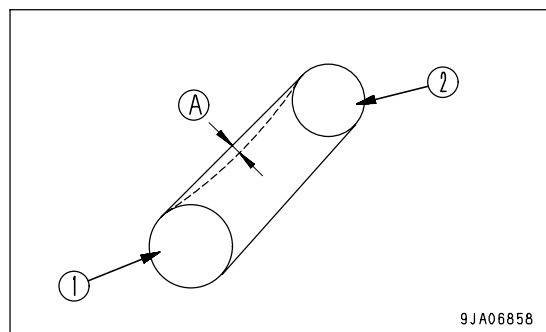

### REMARK

If the V-belt has stretched and there is no more allowance for adjustment, replace the V-belt.

**REPLACE AIR CONDITIONER BELT**

1. Loosen 4 bolts (1) and jack bolt (2), then move compressor (3) to the side.
2. Replace the V-belt.
  - When adjusting the V-belt, do not push the compressor directly with the bar. Use jack bolt (2).
3. Tighten jack bolt (2) and bolts (1), and apply tension to the V-belt. The standard deflection for the belt is approx. 10 mm (0.4 in) when pressed with a finger force of approx. 58.8N (6 kg) at a point midway between the air conditioner compressor pulley and fan pulley.

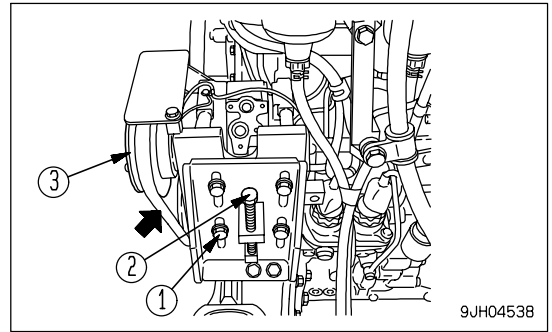

**CHECK LEVEL OF REFRIGERANT**

**! WARNING**  
 If the refrigerant used in the air conditioner gets into your eyes or on your hands, it may cause loss of sight or frostbite. Do not touch the refrigerant. Never loosen any part of the refrigerant circuit. Do not bring any flame close to any point where the refrigerant gas is leaking.

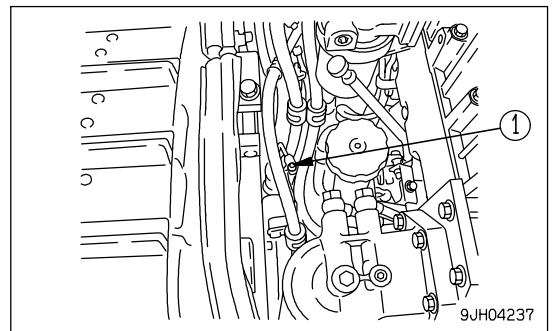

If the level of the refrigerant (gas) is low, the cooling effect will be reduced. Run the engine at high idle, and check the flow of the refrigerant gas (R134a) in the refrigerant circuit through the sight glass (2) (inspection window) of the receiver (1) when the cooler is running at high speed.

- (A) Correct: No bubbles are included in the flow
- (B) Low: Bubbles are included in the flow (bubbles pass continuously)
- (C) None: Colorless, transparent

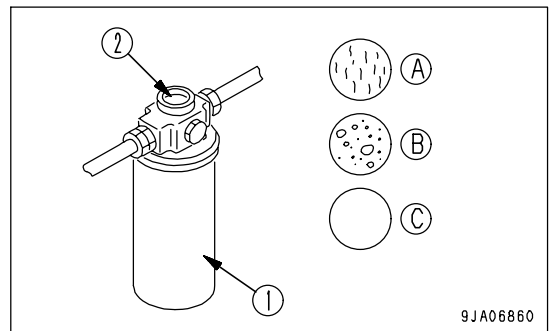

**REMARK**

- When there are bubbles, the refrigerant gas level is low, so contact your refrigerant dealer to have refrigerant added. If the air conditioner is run with the refrigerant gas level low, it will cause damage to the compressor.
- New R134a is used as the refrigerant.

**OPERATING AIR CONDITIONER OFF-SEASON**

Even during the off-season, operate the air conditioner for 3 to 5 minutes once a month to maintain the oil film at all parts of the compressor.

### GREASE DOOR HINGE

If the door makes a squeaking noise when it is opened or closed, spray lubricant in through the split in the hinge bushing.  
If the bushing is worn, replace the hinge.

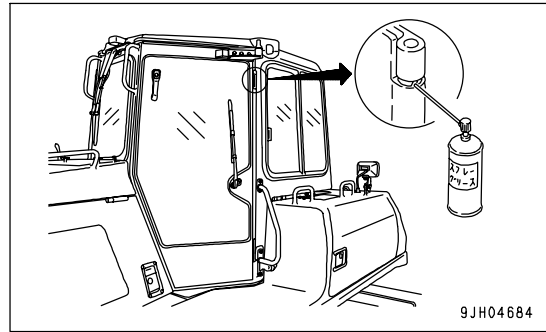

### CHECK DOOR LATCH



It is quite dangerous if the machine suddenly starts to move during the inspection work. Stop the engine and operate the parking brake lever to the LOCK (L) position without fail.

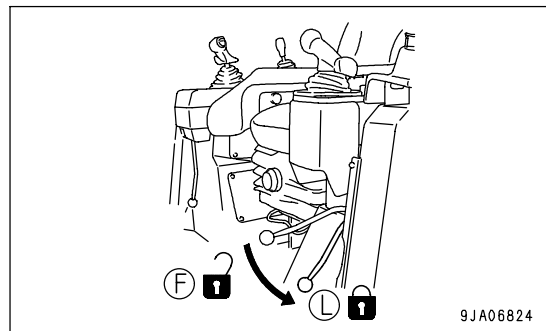

#### Check

Hold the door open-locked, and check that there is still grease inside the latch. If the amount of grease is low or there is no more grease, coat the inside of the latch with grease from portion (1).

#### REMARK

If there is no more grease inside the latch, the movement will become poor because of dust inside the latch, and the handle may be stiff when opening the door.

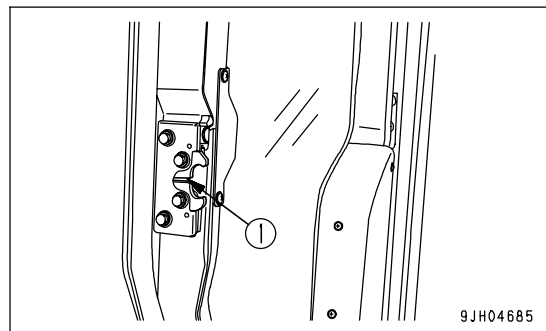

### CHECK DOOR LOCK STRIKER

If wear (A) of the door of lock striker exceeds 0.5 mm (0.02 in), replace the striker. If it is used as it is, the play will increase and this may result in breakage of the hinge or door lock.

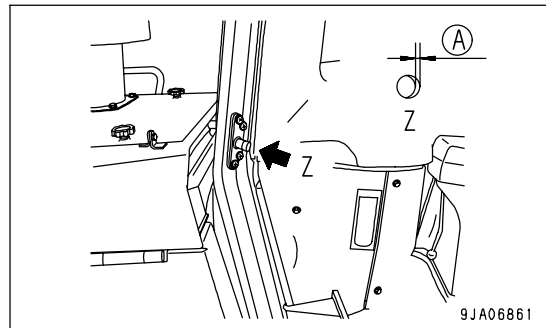

**REPLACE DOOR DAMPER**

If depth (A) of the groove of door damper rubber (1) is less than 2 mm (0.08 in), replace the damper.

There are 4 dampers: 1 each at the top and bottom on the left and right doors.

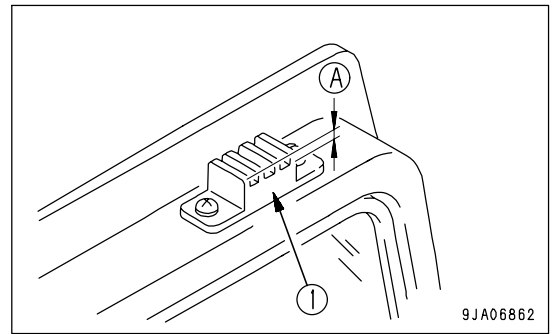

**CHECK WINDOW WASHER FLUID LEVEL, ADD FLUID**

If there is air in the window washer fluid, check the level and add fluid.

Open the battery cover, check the level of the fluid in window washer tank (1), and if it is low, add automobile window washer fluid.

When adding fluid, be careful not to let any dust get in.

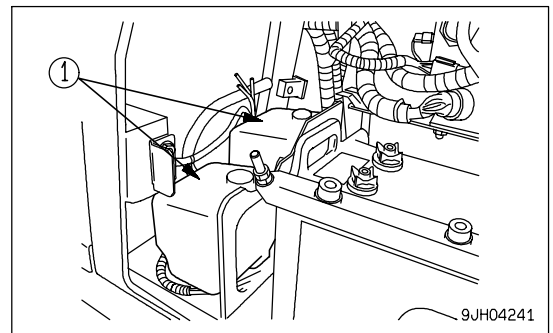

**PROPORTION FOR MIXING FLUID WITH WATER**

The proportion differs according to the ambient temperature, so dilute the washer fluid with water to the following proportions before adding.

Area, season	Proportions	Freezing temperature
Normal	Washer fluid 1/3: water 2/3	-10°C (14°F)
Winter in cold area	Washer fluid 1/2 : water 1/2	-20°C (-4°F)
Winter in extremely cold area	Pure washer fluid	-30°C (-22°F)

There are two types depending on the freezing temperature:

-10°C (14°F) (general use) and -30°C (-22°F) (cold area use), select according to the area and season.

### REPLACE WIPER BLADE

If the blade is damaged, it will not wipe the window clean, so replace the blade.

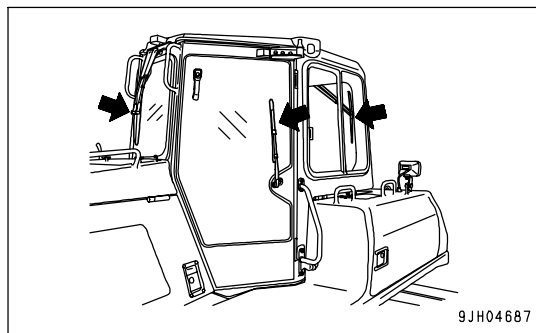

### REPLACEMENT

#### FRONT WIPER

1. It is hooked at portion (A), so move the blade in the direction of the arrow to remove it.
2. Install the new blade and hook it securely.

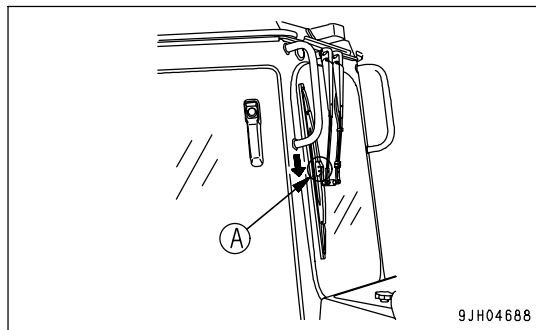

#### REAR WIPER

1. Remove E-ring (1).  
The blade can then be removed.
2. Install a new blade, then install securely with E-ring (1).

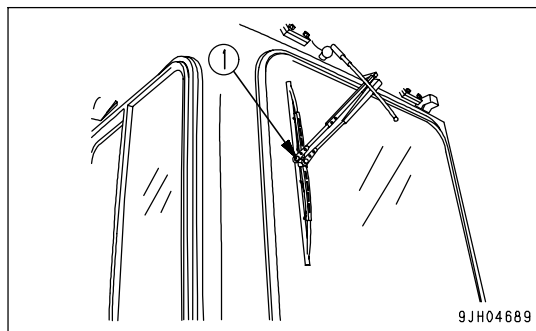

#### DOOR WIPER

1. It is hooked at portion (A), so move the blade in the direction of the arrow to remove it.
2. Install the new blade and hook it securely.

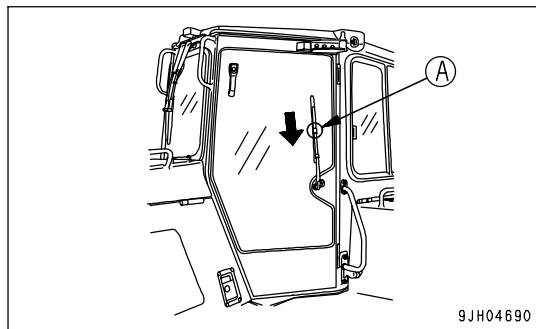

## PROCEDURE FOR BLEEDING AIR IN HYDRAULIC SYSTEM

See "STARTING ENGINE (PAGE 3-93)".

Since the engine must be started and the blade must be operated, see OPERATION.

### NOTICE

If the engine is run at high speed immediately after startup or a cylinder is pushed up to its stroke end, air taken inside the cylinder may cause damage to the piston packing.

#### 1. Bleeding air from cylinders

- 1) Run the engine at low idle, and extend and retract each cylinder 4 to 5 times, taking care that a cylinder is not moved to the end of its stroke. (Stop the cylinder approx. 100 mm (3.9 in) short of its stroke end)
- 2) Next, operate each cylinder 3 to 4 times to the end of its stroke.
- 3) Finally, operate each cylinder 4 to 5 times to the end of its stroke to completely remove the air.

## LUBRICATING

1. Lower the work equipment to the ground, then stop the engine.
2. Add grease through a grease fitting indicated with an arrow on deceleration pedal (1), using a grease pump.
3. After greasing, wipe off any old grease that was pushed out.

Fuel control (1 place)

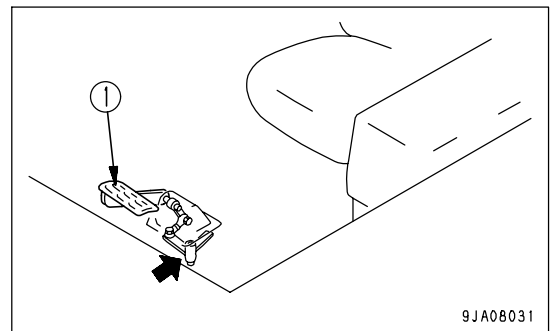

**CHECK BEFORE STARTING**

For details of the following items, see "CHECK BEFORE STARTING (PAGE 3-76)" in the OPERATION section.

- Check oil level in engine oil pan, add oil
- Check coolant level, add coolant
- Check dust indicator
- Check, drain water separator
- Check oil level in power train case, add oil
- Check oil level in hydraulic tank, add oil
- Check electric wiring
- Checking with machine monitor
- Check fuel level, add fuel
- Drain water and sediment in fuel tank
- Check brake pedal travel
- Check that lamps light up
- Check horn sound
- Check of operation of backup alarm

## EVERY 250 HOURS SERVICE

### LUBRICATING

1. Lower the work equipment to the ground, then stop the engine.
2. Using a grease pump, pump in grease through the grease fittings shown by arrows.
3. After greasing, wipe off any old grease that was pushed out.

(1) Blade lift cylinder support yoke (4 places)

**REMARK**

These are at the front and rear of the left and right cylinders.

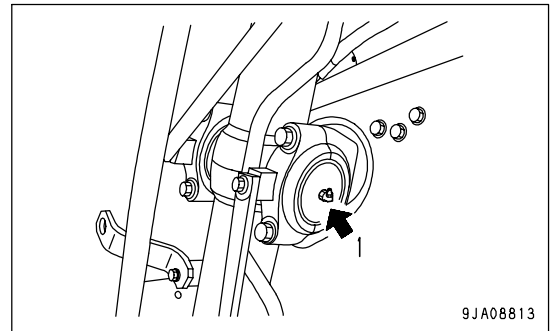

(2) Blade lift cylinder support shaft (2 places)

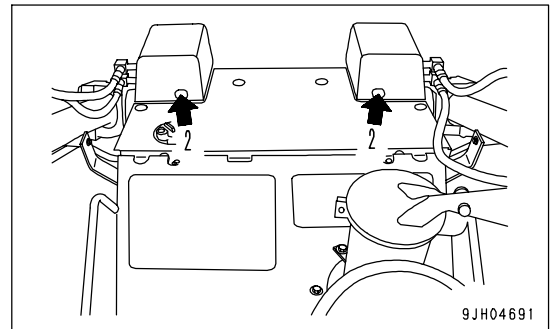

(3) Blade arm ball joint (4 places)

(4) Brace screw (2 places)

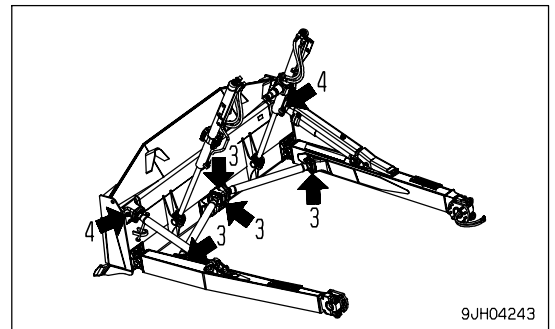

(5) Ripper lift cylinder bottom pin (2 places)

(6) Ripper lift cylinder rod end pin (2 places)

(7) Ripper arm pin (front) (6 places)

(8) Ripper arm pin (rear) (6 places)

- (5) - (8) indicate the greasing points for the fixed multi-shank ripper specification.

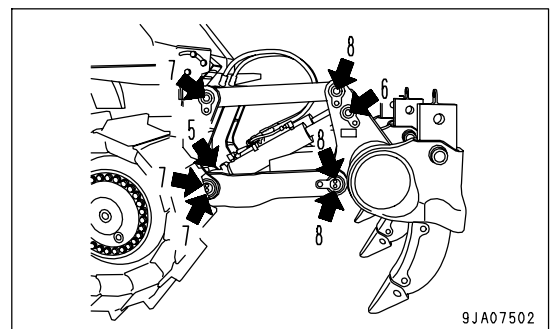



- (9) Ripper arm pin (front) (2 places)
- (10) Ripper arm pin (rear) (2 places)
- (11) Lift cylinder bottom pin (2 places)
- (12) Lift cylinder head pin (2 places)
- (13) Tilt cylinder bottom pin (2 places)
- (14) Tilt cylinder head pin (2 places)

- (9) - (14) indicate the greasing points for the variable multi-shank ripper specification.

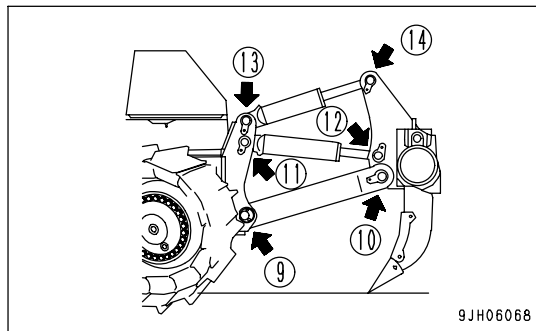

- (15) Equalizer bar side shaft (2 places)

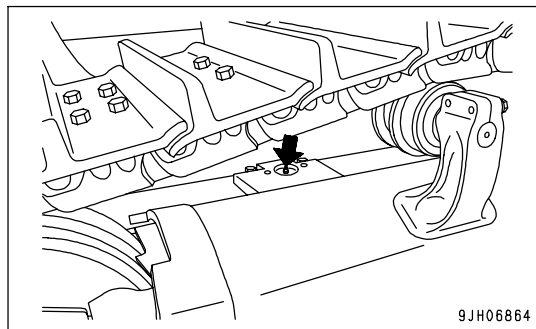

- (16) Suspension (Equalizer bar center shaft) (1 place)

- 1) Carry out greasing of the suspension (equalizer bar center shaft) through the grease fittings marked by arrows.
- 2) Pump the greasing lever up and down 3 to 5 times.

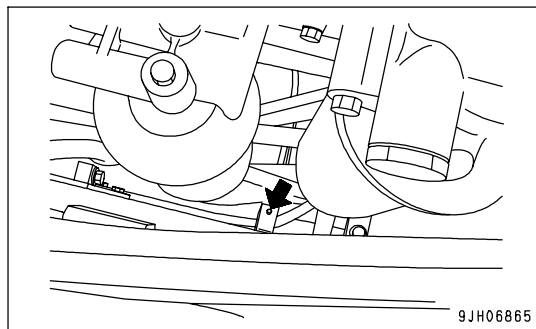

## CHECK ALTERNATOR DRIVE BELT TENSION, ADJUST

### CHECKING

Depress a belt at a mid point between drive pulley (1) and alternator pulley (2) with a thumb to apply 98 N (10 kg) - pressure, and when deflection amount (A) remains between 13 mm and 16 mm (0.51 in and 0.63 in), the deflection is within the standard value.

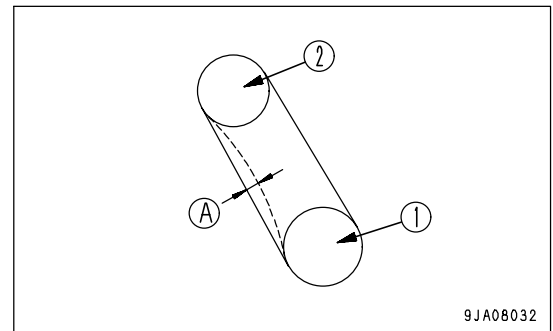

### ADJUSTING

1. Remove cap (1), loosen bolt (4), nut (2) and (5), and adjust the belt tension by turning nut (6).
2. After the tension adjustment, tighten nut (2) and (5), install cap (1) and secure alternator (3).

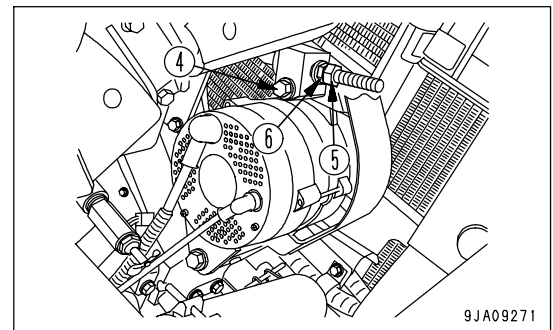
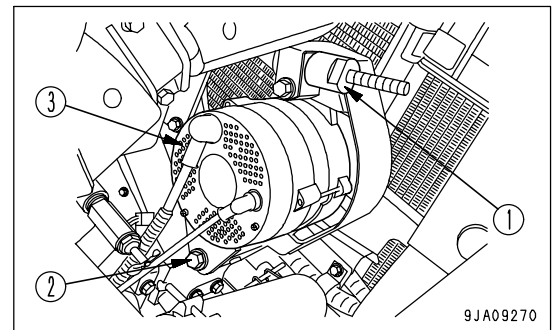

### REMARK

- Check each pulley for breakage and wear of the V-groove. In particular, check that the V-belt does not touch the bottom of the V-groove.
- If any abnormality is found, ask your Komatsu distributor for replacement of the pulley.
- If the V-belt is so lengthened that it cannot be adjusted any more or if it has any cuts or cracks, replace it.
- When adjusting the V-belt, do not press the alternator directly with a bar, but put a wood piece, etc. in-between them.
- If the V-belt has been replaced with a new part, there will be initial elongation, so inspect and adjust it again after one-hour of operation.

## CHECK LEVEL OF BATTERY ELECTROLYTE

Carry out this procedure before operating the machine.



### WARNING

- Do not use the battery if the battery electrolyte level is below the LOWER LEVEL line. This will accelerate deterioration of the inside of the battery and reduce the service life of the battery. In addition, it may cause an explosion.
- The battery generates flammable gas and there is danger of explosion, do not bring fire or sparks near the battery.
- Battery electrolyte is dangerous. If it gets in your eyes or on your skin, wash it off with a large amount of water and consult a doctor.
- When adding distilled water to the battery, do not allow the battery electrolyte to go above the UPPER LEVEL line. If the electrolyte level is too high, it may leak and cause damage to the paint surface or corrode other parts.

### NOTICE

If there is a fear that the battery water may freeze after refilling with purified water (e.g. commercially available replenishment water for a battery), do the replenishment before the day's work on the next day.

Inspect the battery electrolyte level at least once a month and follow the basic safety procedures given below.

Open battery cover on the left side of the machine.

### WHEN CHECKING ELECTROLYTE LEVEL FROM SIDE OF BATTERY

If it is possible to check the electrolyte level from the side of the battery, check as follows.

1. Use a wet cloth to clean the area around the electrolyte level lines and check that the electrolyte level is between the UPPER LEVEL (U.L.) and LOWER LEVEL (L.L.) lines.  
If the battery is wiped with a dry cloth, static electricity may cause a fire or explosion.

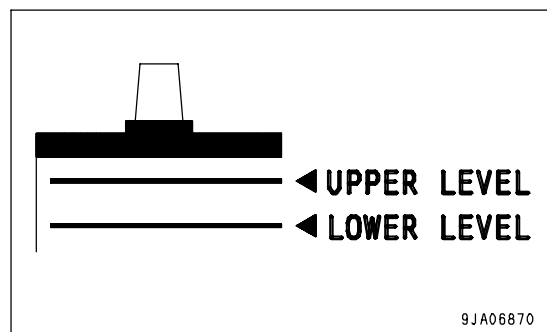

2. If the electrolyte level is below the midway point between the U.L and L.L lines, remove cap (1) and add distilled water to the U.L line.
3. After adding distilled water, tighten cap (1) securely.

### REMARK

If distilled water is added to above the U.L. line, use a syringe to lower the level to the U.L. line. Neutralize the removed fluid with baking soda (sodium bicarbonate), then flush it away with a large amount of water or consult your Komatsu distributor or battery maker.

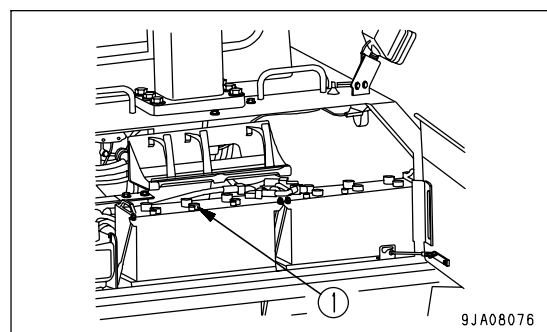

**WHEN IT IS IMPOSSIBLE TO CHECK ELECTROLYTE LEVEL FROM SIDE OF BATTERY**

If it is impossible to check the electrolyte level from the side of the battery, or there is no display of the UPPER LEVEL line on the side of the battery, check as follows.

1. Open the battery cover on the left side of the machine body.
2. Remove tray (1).
3. Remove cap (2) at the top of the battery, look through the water filler port (3), and check the electrolyte surface. If the electrolyte does not reach the sleeve (4), add purified water (e.g. commercially available replenishment water for a battery) so that the level reaches the bottom of the sleeve (UPPER LEVEL line) without fail.
  - (A) Suitable level: Electrolyte level is up to bottom of sleeve, so surface tension causes electrolyte surface to bulge and poles appear bent.
  - (B) Low: Electrolyte level is not up to bottom of sleeve, so poles appear straight and not bent.
4. After adding distilled water, tighten cap (2) securely.

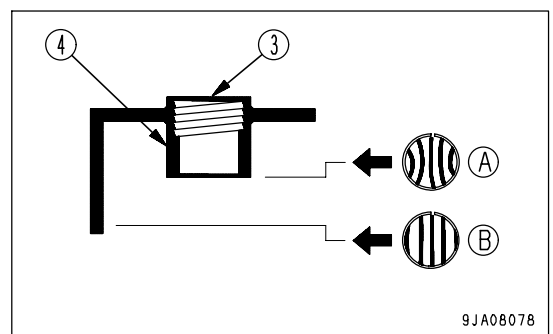
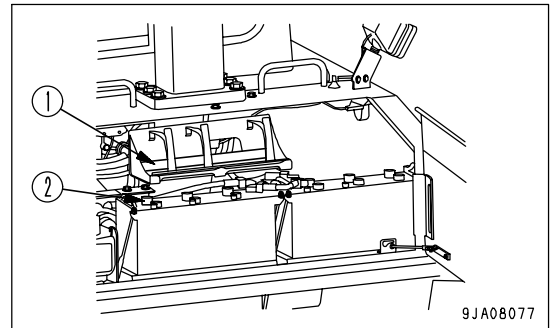

**REMARK**

If water is added to above the bottom tip of the sleeve, use a pipette to remove electrolyte. Neutralize the removed electrolyte with sodium bicarbonate, then flush it away with a large amount of water. If necessary, contact your Komatsu distributor or your battery maker.

**WHEN IT IS POSSIBLE TO USE INDICATOR TO CHECK ELECTROLYTE LEVEL**

If it is possible to use an indicator to check the electrolyte level, follow the instructions given.

## CHECK BRAKE PERFORMANCE

**WARNING**

If the machine moves during the following operation, please contact your Komatsu distributor for repairs immediately.

**NOTICE**

Do not place the joystick in the 1st speed position.  
Otherwise, it will cause damage to the machine.

Before starting the engine, check that the area around the machine is safe, then do as follows:

1. Start the engine.
2. After completing the warm-up operation, set fuel control dial (3) to the SLOW position.
3. Operate work equipment lock lever (1) to the FREE (F) position, and then operate blade control lever (6) and ripper control lever (7) to raise the blade and ripper.  
Hold work equipment lock lever (1) in the FREE (F) position.
4. Hold parking brake lever (2) in the FREE (F) position.
5. Depress brake pedal (5), set joystick (4) in FORWARD, then press the shift up button to enter 2nd speed.
6. Operate fuel control dial (3) and gradually raise the engine speed to full throttle. (Keep the brake pedal depressed.)
7. Check that the machine does not move. This indicates that brake performance is normal.

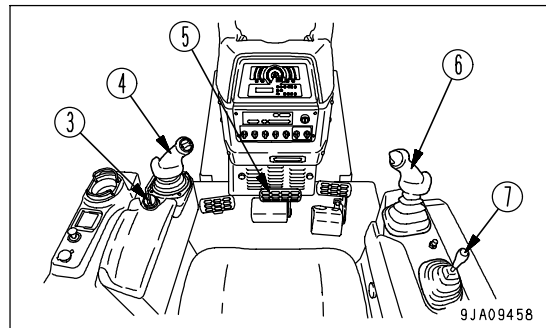
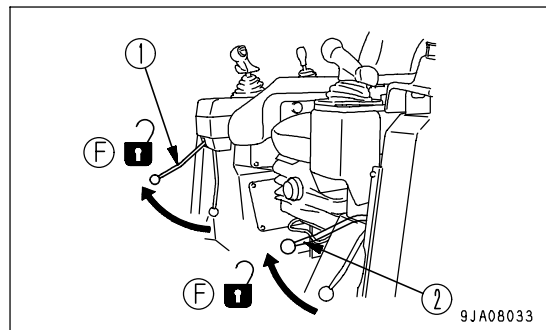

**CHECK OIL LEVEL IN DAMPER CASE, ADD OIL**

1. Open the engine side cover on the left side of the chassis.
2. Remove dipstick (G) and wipe the oil off with a cloth.
3. Fully insert dipstick (G) into filler pipe, then remove it.

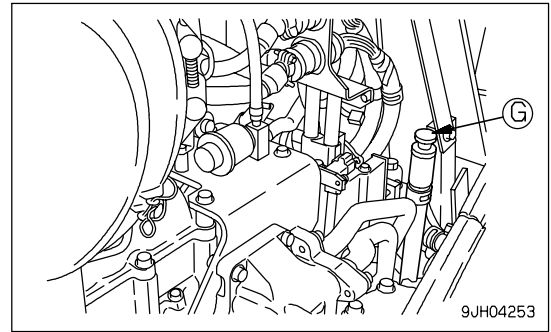

9JH04253

4. The oil on the oil level gauge (G) should be between the H mark and L mark.  
If the oil is below the L mark, add oil through the dipstick guide.

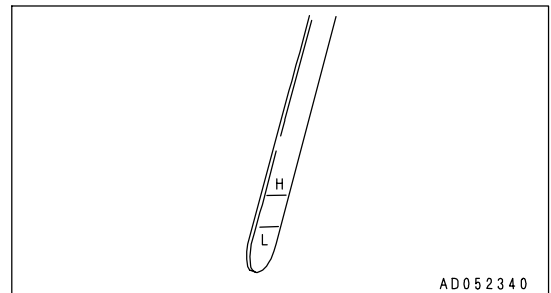

AD052340

5. If the oil is above the H mark, open inspection cover (2) in the center of the bottom face of the power train case, drain the excess oil from drain plug (P) of the engine damper which can be seen towards the front of the machine from the inspection window, then check the oil level again.

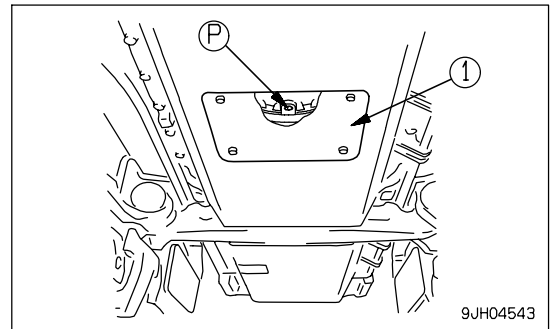

9JH04543

**REMARK**

- Check the oil level while the engine is stopped.
- If the machine is inclined, set it in a level position before checking the oil level.

**EVERY 500 HOURS SERVICE**

Maintenance for every 250 hours should be performed at the same time.

**CHANGE OIL IN ENGINE OIL PAN, REPLACE ENGINE OIL FILTER CARTRIDGE**

(including engine by-pass filter cartridge)

**WARNING**

Parts and oil are at high temperature immediately after the engine is stopped and may cause serious burns. Wait for the oil temperature to go down before performing this operation.

- Refill capacity: 38 liters (10.04 US gal)
  - Prepare a socket wrench and filter wrench.
1. Open cover (1) at the front left under the machine and put a container directly underneath to catch the drained oil.
  2. Loosen drain plug (P) (with a slit) slowly to avoid getting oil on yourself, and drain the oil.
  3. Check the drained oil, if there is excessive metal particles or foreign material, contact your Komatsu distributor.
  4. Install drain plug (P).
5. Open up the engine side cover on the left side of the machine.
  6. Remove bottom side cover (2).
  7. Using a filter wrench, turn filter cartridge (3) counterclockwise to remove it.
  8. Clean the filter holder, fill the new filter cartridge with clean oil, coat the thread and packing portion of the new filter cartridge with oil (or coat thinly with grease), then install.
  9. When installing the filter cartridge, bring the packing surface into contact with the filter holder, then tighten a further 3/4 to 1 turn.
  10. After replacing the filter cartridge, add oil through oil filler (F) until the oil level is between the H and L marks on the dipstick (G).
  11. Run the engine at idle for a short time, then stop the engine, and check that the oil level is between the H and L marks on the dipstick. For details, see "CHECK OIL LEVEL IN ENGINE OIL PAN, ADD OIL (PAGE 3-76)".

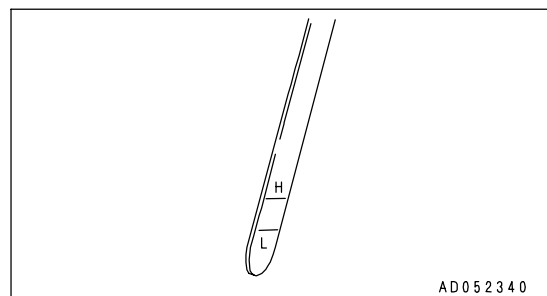
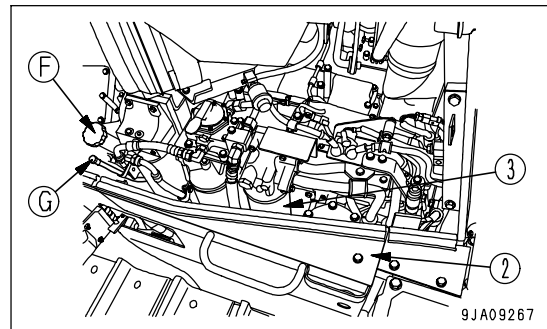
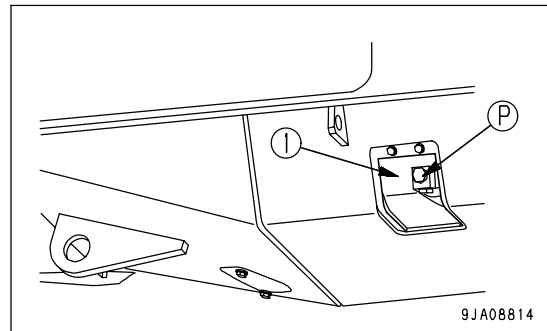

## REPLACE FUEL PRE-FILTER CARTRIDGE



### WARNING

- After the engine has been operated, all parts are at high temperature, so do not replace the filter immediately. Wait for all parts to cool down before starting the operation.
- High pressure is generated inside the engine fuel piping system when the engine is running. When replacing the filter, wait for at least 30 seconds after stopping the engine to let the internal pressure go down before replacing the filter.
- Do not bring any fire or flame close.

### NOTICE

- Genuine Komatsu fuel filter cartridges use a special filter that has highly efficient filtering ability. When replacing the filter cartridge, always use a genuine Komatsu part.
- The common rail fuel injection system used on this machine consists of more precise parts than the conventional injection pump and nozzle. If any part other than a genuine Komatsu filter cartridge is used, dust or dirt may get in and cause problems with the injection system. Always avoid using substitute parts.
- When carrying out inspection or maintenance of the fuel system, pay more attention than normal to the entry of dirt. If dirt is stuck to any part, use fuel to wash it off completely.

Prepare a filter wrench and a container to catch the fuel.

1. Close valve (1) at the bottom of the fuel tank.

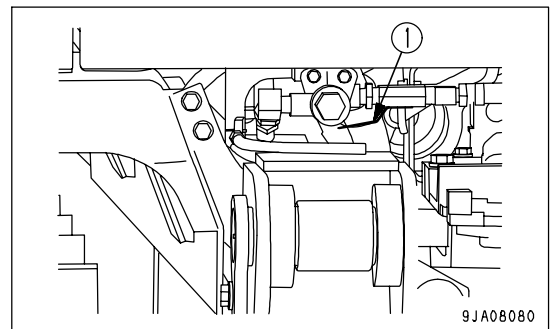



2. Set the container to catch the fuel under the filter cartridge (2).
3. Loosen drain valve (3), then drain all the water and sediment in the transparent cap (4) and also the fuel accumulated in filter cartridge (2).
4. Using a filter wrench, turn transparent cap (4) to the left to remove it. (This cap is used again.)
5. Using a filter wrench, turn filter cartridge (2) counterclockwise to remove it.

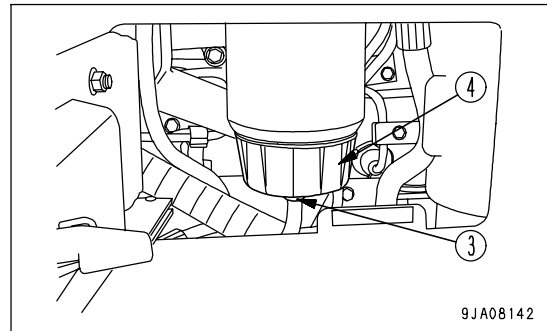
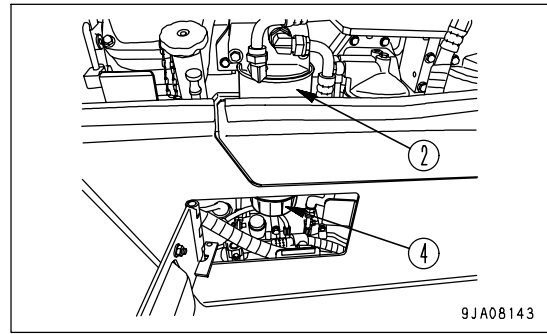

6. Remove seal (5) from transparent cap (4), then clean the cap. If transparent cap (4) is damaged, replace it with a new part.
7. Coat new seal (5) with clean fuel or oil, then install it to transparent cap (4).
8. Install transparent cap (3) to new filter cartridge (2).
  - Tightening torque for transparent cap:  
10.0 Nm (1.0 kgm, 7.2 lbft)
9. Check that the drain valve (3) at the bottom of transparent cap (4) is tightened securely.
  - Tightening torque: 0.2 - 0.45Nm ( 0.02 -0.046 kgm, 0.1 - 0.3 lbft)

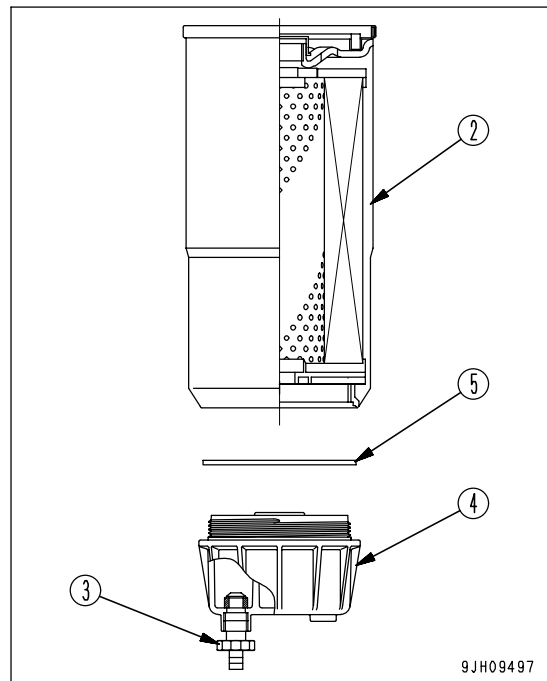

10. Clean the filter holder, fill the new filter cartridge with clean fuel, coat the packing surface thinly with oil, then install to the filter holder.

NOTICE

- When adding fuel, do not remove cap (B). Always add fuel from the 8 small holes (A) on the dirty side.
- After adding fuel, remove cap (B) and install the fuel filter.
- Always fill with clean fuel. Be careful not to let any dirt or dust get into the fuel. In particular, center portion is the clean side, so do not remove cap (B) when adding fuel. Be careful not to let dirt or dust get into center portion on the clean side.

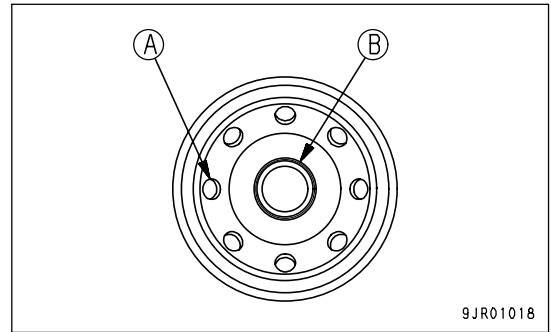

11. When installing, tighten until the packing surface contacts the seal surface of the filter holder, then tighten it 3/4 of a turn.

If the filter cartridge is tightened too far, the packing will be damaged and this will lead to leakage of fuel. If the filter cartridge is too loose, fuel will also leak from the packing, so always tighten the correct amount.

- When tightening with a filter wrench, be extremely careful not to dent or damage the filter.

12. Open valve (1) at the bottom of the fuel tank.

13. After replacing the filter cartridge, start the engine and run it at low idling for 10 minutes.

Check that there is no oil leakage from the filter seal surface or mounting surface of the transparent cap. If any oil leakage is found, check the tightening condition of the filter cartridge. If there is still oil leakage, repeat Steps 1 - 5 to remove the filter cartridge, then check the packing surface for damage or embedded foreign material. If any problem is found, replace the cartridge with a new part and repeat Steps 6 - 13 to install it.

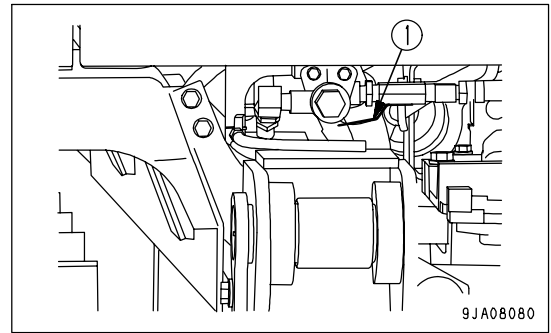

## REPLACE POWER TRAIN OIL FILTER ELEMENT



### WARNING

- Immediately after the engine is stopped, the oil and parts are at high temperature, and may cause burns. To prevent this, wait for the temperature to go down before starting the operation.
- Before opening the filter cases, depress the brake pedal several times to release the pressure, then lock the brake pedal. If there is still pressure inside the filter, oil may spurt out.

1. Open the engine side cover on the left of the machine.

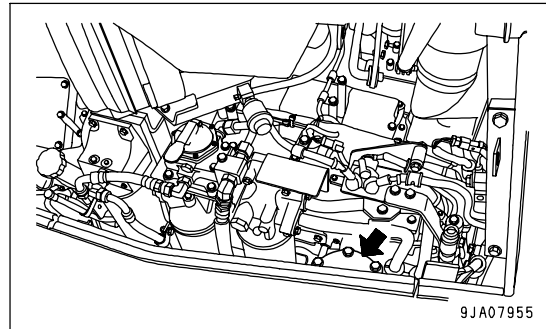

2. Remove bolts (1) and cover (2) is lifted up, then take out element (3).
  3. Clean inside of the case and the removed parts, then install a new element.
- Replace the O-ring with a new one.

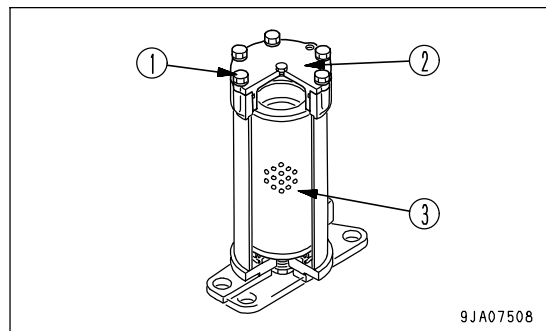

## CHECK OIL LEVEL IN FINAL DRIVE CASE, ADD OIL



### WARNING

There is danger that oil may spurt out under internal pressure, so stand to the side, and gradually turn the plug to release internal pressure before removing the plug.

1. Place the machine on a horizontal place.
2. Remove oil level plug (G) and check whether the final drive case is filled with oil to lower edge of the plug hole.
3. If the oil level is low, add oil through oil level plug (G).  
Before removing the oil level plug (G), remove all the mud and dirt from around the plug, and be careful not to let any dirt or mud get in when adding oil.

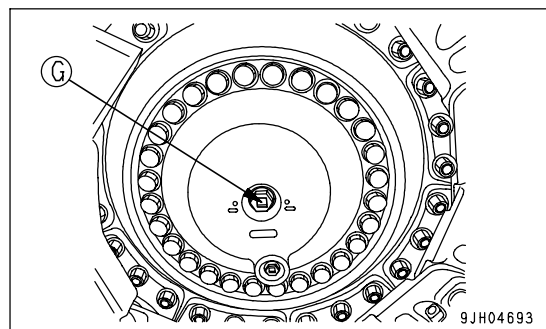

### EVERY 1000 HOURS SERVICE

Maintenance for every 250 and 500 hours service should be carried out at the same time.

### CHANGE OIL IN POWER TRAIN CASE, CLEAN STRAINERS (POWER TRAIN PUMP STRAINER, SCAVENGING PUMP STRAINER)



#### WARNING

- The oil is at high temperature immediately after operations, so wait for the temperature to go down before starting the operation.
- The undercover is heavy. Do not go directly under the cover when opening or closing it. When removing bolts (5), carry out the operation at the rear of the point immediately under the cover so that it is possible to escape at any time.  
Prepare the following.

- Refill capacity: 60 liters (15.85 US gal)
1. Remove drain cover (1) at the bottom Right of the power train case, then loosen drain plug (P) and drain the oil.  
Do not remove drain plug (P).
  2. After draining the oil, tighten drain plug (P).

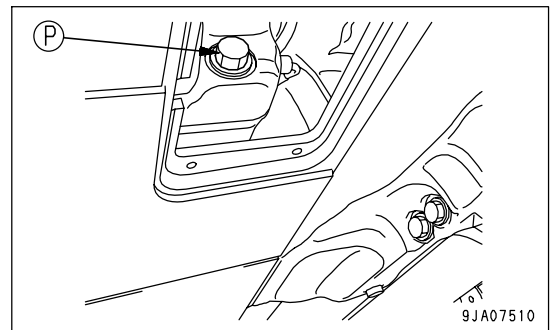
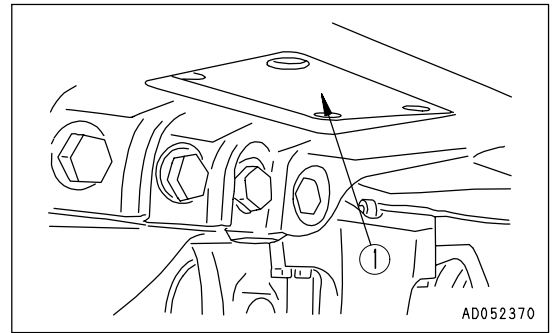

3. Remove inspection cover (2) in the undercover at the bottom rear of the machine as follows.
  - 1) Remove 2 bolts (3) at the Right of machine.
  - 2) Hold cover (2) in position and gradually remove 2 bolts (4) at the Left of machine. (Rain water may flow out when doing this.)

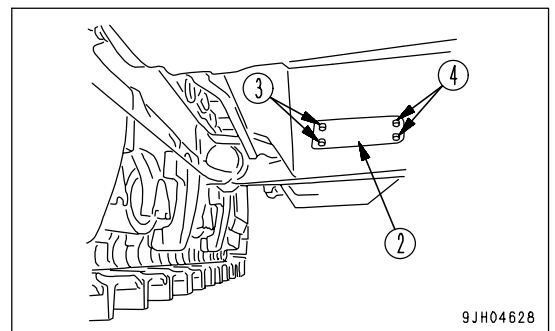

- 3) Lower cover (2) slowly and open it. (The right side of the cover has a hinge.)  
The strainer can be seen at portion P at the top.  
(A): Machine's right side

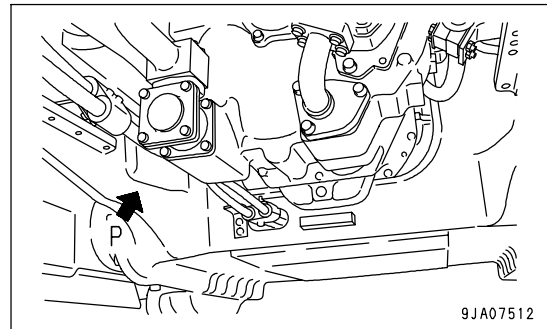
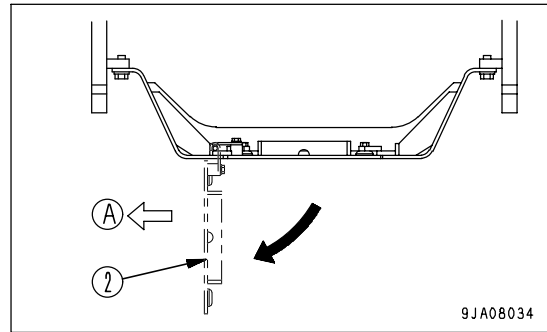

4. Remove drain plug (P2) in the strainer cover, and drain the oil (approx. 4 liters (1.06 US gal)) collected inside the piping.
5. Loosen mounting bolt (5) of the power train strainer, then remove cover (6).
6. Remove spring (7), then remove strainer (8).
7. Remove any dirt stuck to strainer (8), then wash it in clean diesel oil or flushing oil. Wash the removed parts and the inside of the case at the same time.
8. Loosen mounting bolt (9) of the scavenging pump strainer, then remove cover (10).
9. Remove strainer (11).

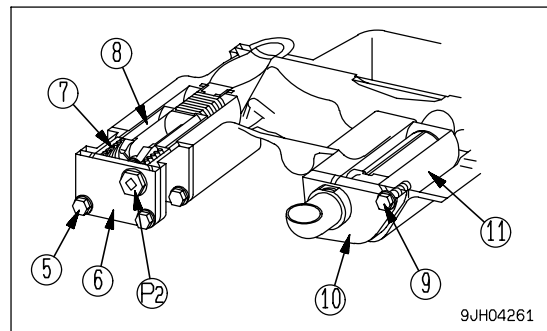

10. Remove any dirt stuck to strainer (11), then wash it in clean diesel oil or flushing oil. Wash the removed parts and the inside of the case at the same time.
11. Install the strainers in their original position.
12. After installing, replace the element in the power train oil filter. For details, see "REPLACE POWER TRAIN OIL FILTER ELEMENT (PAGE 4-58)".
13. Refill the specified quantity of oil through oil filler (F).
14. After filling with oil, check that the oil is at the specified level. For details, see "CHECK OIL LEVEL IN POWER TRAIN CASE, ADD OIL (PAGE 3-79)".  
If the spring or strainer are damaged, replace them with a new part.

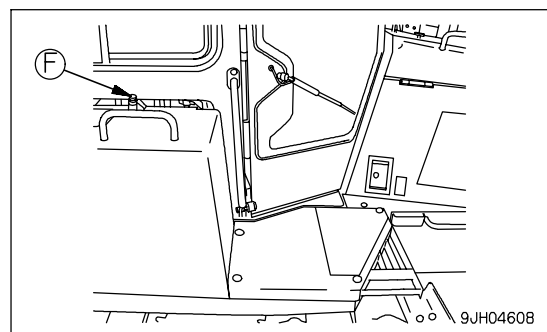

REPLACE HYDRAULIC TANK BREATHER ELEMENT

**! WARNING**

- The parts and oil are at high temperature immediately after the engine is stopped, and may cause burns. Wait for the temperature to go down before starting the work.
- When removing the oil filler cap, oil may spurt out, so push the cap down to release the internal pressure, then remove the cap carefully.

1. Push down cap (1) of oil filler (F) to release the air and remove the internal pressure.
2. Keep cap (1) pushed down, turn it slowly counterclockwise, then remove cap (1).

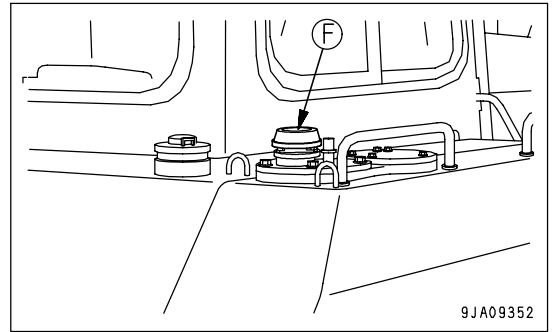

3. Remove ring (2) from inside the lip of cap (1).
4. Remove valve (3).
5. Replace filter element (4).

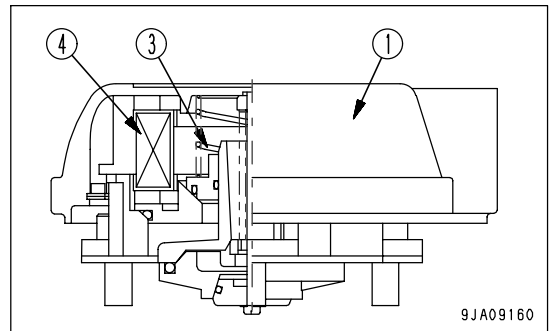

6. Install valve (3) and ring (2) in their original positions.
7. Install cap (1).  
When installing cap (1) to the tank, push it down, then turn it clockwise.

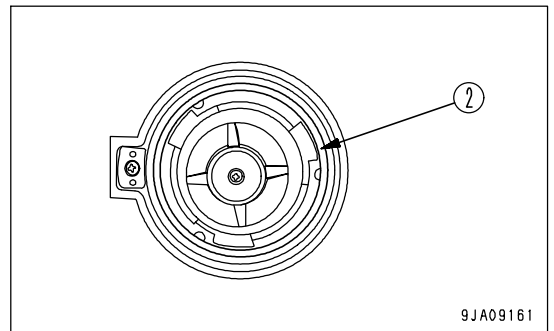

**REMARK**

If the cap is not installed correctly, it will cause leakage of oil.

When installing the cap, press the cap down, and turn it until it is securely in contact with the stopper.

The cap is the lock addition type.

About handling method of cap with the lock, see "CAP WITH LOCK (PAGE 3-48)".

## CHANGE OIL IN FINAL DRIVE CASE



### WARNING

- The oil is at high temperature immediately after the machine has been operated. Wait for the oil to cool down before starting the operation.
- There is danger that oil spouts out due to the internal pressure. When removing the plug, work from the side, turn the plug slowly to release the internal pressure, and remove it carefully.

#### Refill capacity:

D85EX : (each) 26 liters (6.87US gal)

D85PX : (each) 36 liters (9.51US gal)

1. Stop the machine so that drain plug (H) is directly at the bottom.
2. After removing oil filler/level plug (G), remove drain plugs (H) and (1), drain the oil, then tighten the plug again.
3. Add the replacement amount of oil through the hole of plug (G).
4. After adding oil, check that the oil is up to to the specified level.  
For details, see "CHECK OIL LEVEL IN FINAL DRIVE CASE, ADD OIL (PAGE 4-58)".

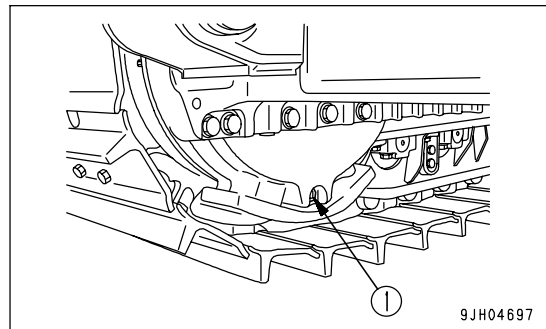
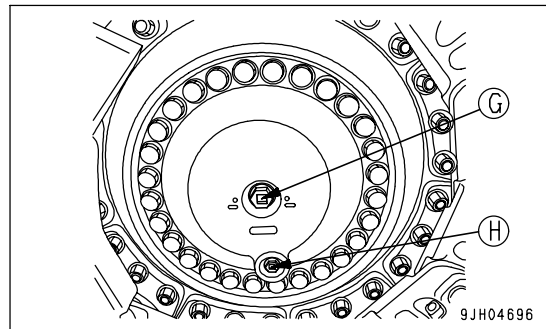

## CHECK, CLEAN FUEL STRAINER

1. Close fuel supply valve (1), then remove strainer cap (2).  
The strainer forms one unit with the strainer cap.
2. Remove any dirt stuck to the strainer, then wash in clean diesel fuel or flushing oil. If the strainer is damaged, replace it.
3. After checking and cleaning, set the strainer in the case, then tighten cap (2).
4. After installing, open fuel supply valve (1).

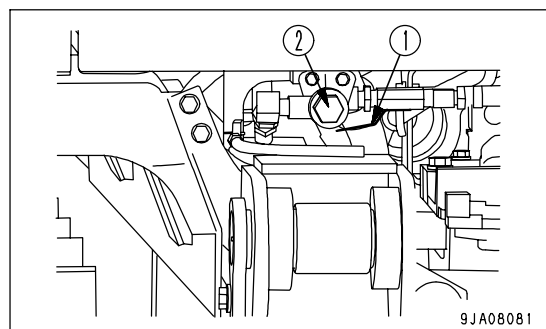

## REPLACE FUEL MAIN FILTER CARTRIDGE

Carry out this operation after carrying out the maintenance in the "REPLACE FUEL PRE-FILTER CARTRIDGE (PAGE 4-55)" for every 500 hours.

### WARNING

- After the engine has been operated, all parts are at high temperature, so do not replace the filter immediately. Wait for all parts to cool down before starting the operation.
- High pressure is generated inside the engine fuel piping system when the engine is running. When replacing the filter, wait for at least 30 seconds after stopping the engine to let the internal pressure go down before replacing the filter.
- Do not bring any fire or flame close.
- Be careful when opening the air bleed plug in the fuel filter head. It is still under pressure, so fuel may spurt out.

### NOTICE

- Genuine Komatsu fuel filter cartridges use a special filter that has highly efficient filtering ability. When replacing the filter cartridge, always use a genuine Komatsu part.
- The common rail fuel injection system used on this machine consists of more precise parts than the conventional injection pump and nozzle. If any part other than a genuine Komatsu filter cartridge is used, dust or dirt may get in and cause problems with the injection system. Always avoid using substitute parts.
- When carrying out inspection or maintenance of the fuel system, pay more attention than normal to the entry of dirt. If dirt is stuck to any part, use fuel to wash it off completely.

Prepare a filter wrench and a container to catch the fuel.

1. Close valve (1) at the bottom of the fuel tank.

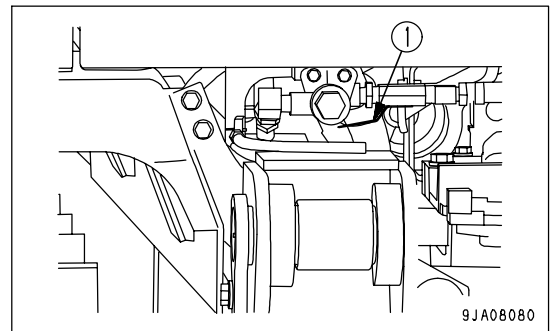

2. Set the container to catch the fuel under the filter cartridge (2).
3. Using a filter wrench, turn filter cartridge (2) counterclockwise to remove it.

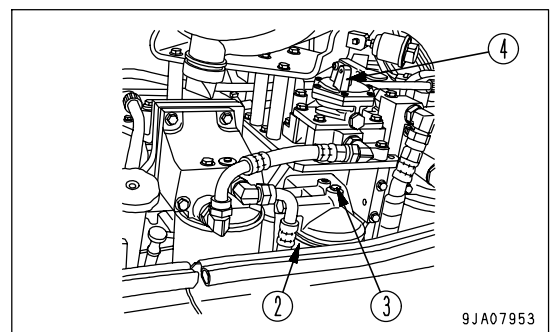



- Clean the filter holder, coat the packing surface of the new filter cartridge thinly with oil, then install the filter cartridge to the filter holder.

**NOTICE**

- Do not fill the new filter cartridge with fuel.
- Remove cap (B) and install the filter cartridge.

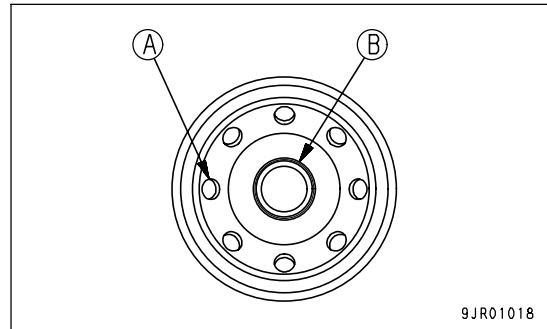

- When installing, tighten until the packing surface contacts the seal surface of the filter holder, then tighten it 3/4 of a turn.

If the filter cartridge is tightened too far, the packing will be damaged and this will lead to leakage of fuel. If the filter cartridge is too loose, fuel will also leak from the packing, so always tighten the correct amount.

- Open valve (1) at the bottom of the fuel tank.

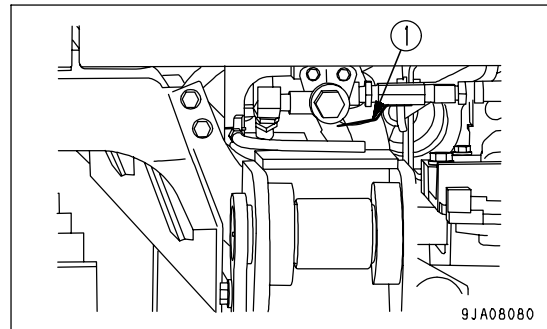

- After completing the replacement of filter cartridge (2), bleed the air.

Bleed the air as follows:

- Add fuel to the fuel tank until full (to FULL mark on the fuel gauge).

9. Loosen air bleed plug (3) at the fuel main filter head.
10. Loosen wing nut (6) of lever (5) of priming pump (4).
11. Push in lever (5) repeatedly.  
Check that bubbles come out with the fuel from air bleed plug (3).
12. Tighten air bleed plug (3).  
Tightening torque: 4.9 to 6.9 Nm (0.5 to 0.7 kgm , 3.6 to 5.1 lbft)
13. Tighten wing nut (6) securely to lock lever (5) in position.  
Target tightening torque: 2 to 3 Nm  
(0.2 to 0.3 kgm , 1.4 to 2.2 lbft)

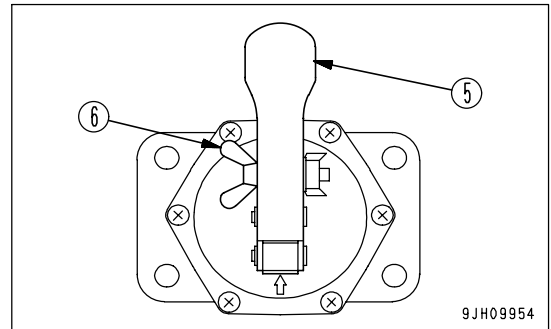
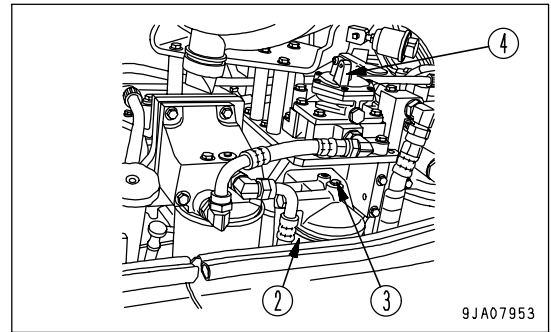

14. After replacing the filter cartridge, start the engine and run it at low idling for 10 minutes.  
Check the filter seal surface for oil leakage. If any leakage of oil is found, check the tightening condition of the filter cartridge. If there is still leakage of oil, repeat Steps 1 - 3 to remove the cartridge, then check the cartridge. If there is any damage to the packing surface or embedded foreign material, replace the cartridge with a new part and repeat the procedure for Steps 4 - 14.

## CHECK ALL TIGHTENING POINTS OF ENGINE EXHAUST PIPE CLAMPS

Please ask your Komatsu distributor to check the tightening of the clamps between the air cleaner - turbocharger - aftercooler - engine.

## REPLACE CORROSION RESISTOR CARTRIDGE



### WARNING

If the engine has been operated, all parts will be at a high temperature, so never try to replace the cartridge immediately after stopping the engine.

Always wait for the engine and other parts to cool down.

- Container to catch drained coolant
  - Prepare a filter wrench for fuel filter element.
1. Turn valve (2) of corrosion resistor (1) as far as the CLOSE stopper.
  2. Set a container to catch the coolant under the cartridge.
  3. Using a filter wrench, turn cartridge (3) to the left to remove it.
  4. Clean the filter holder, coat the packing surface and thread of the new cartridge with oil, then install it to the filter holder.
  5. When installing, tighten until the packing surface contacts the seal surface of the filter holder, then tighten it up 2/3 of a turn. If the filter cartridge is tightened too far, the packing will be damaged and this will lead to leakage of coolant. If the filter cartridge is too loose, coolant will also leak from the packing, so always tighten to the correct amount.
  6. Turn valve (2) of the cartridge to the OPEN position.
  7. After replacing the cartridge, start the engine and check for any coolant leakage from the filter seal surface. If there is any leakage, check if the cartridge is tightened properly.

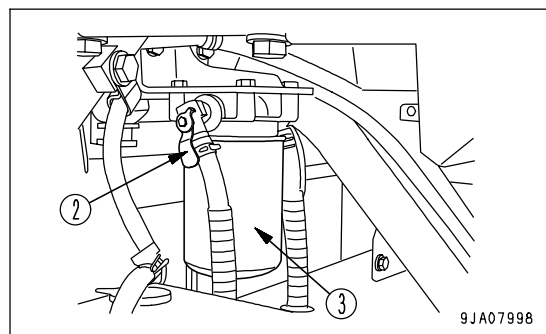
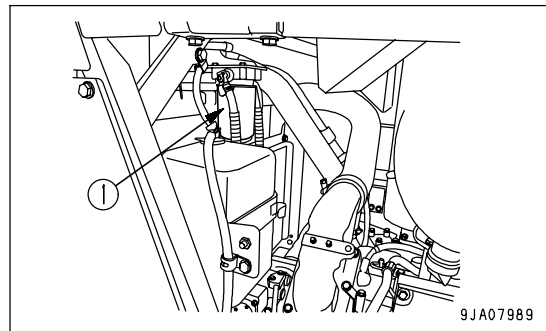

### EVERY 2000 HOURS SERVICE

Maintenance for every 250, 500 and 1000 hours service should be carried out at the same time.

### CHANGE OIL IN HYDRAULIC TANK, REPLACE HYDRAULIC OIL FILTER ELEMENT AND CLEAN HYDRAULIC TANK STRAINER



#### WARNING

- The parts and oil are at high temperature immediately after the engine is stopped, and may cause burns. Wait for the temperature to go down before starting the work.
- When removing the oil filler cap, oil may spurt out, so push the cap down to release the internal pressure, then remove the cap carefully.

- Refill capacity: 71 liters (18.76 US gal)

1. Lower the work equipment to the ground, then stop the engine.
2. Push down cap of oil filler (F) to release the air and remove the internal pressure.
3. Keep cap pushed down, turn it slowly counterclockwise, then remove cap.

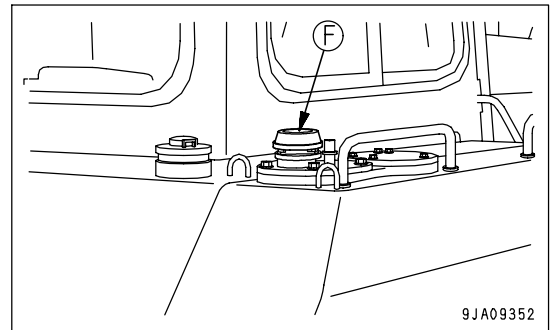

4. Remove drain plug (1) at the bottom of the tank and loosen drain valve (2). After draining the oil, tighten drain plug (1) and drain valve (2). When loosening drain valve (1), be careful not to get oil on yourself.

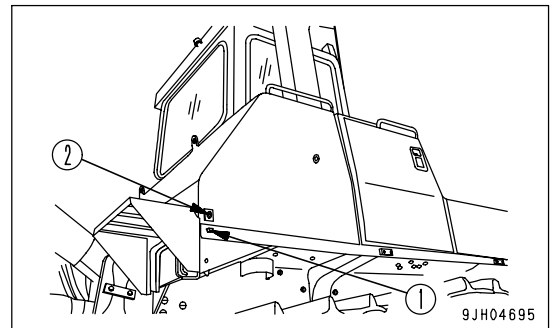

5. Remove bolts (3), then remove cover (4) and take out the element.
6. Clean the inside of case and removed parts and install a new element.

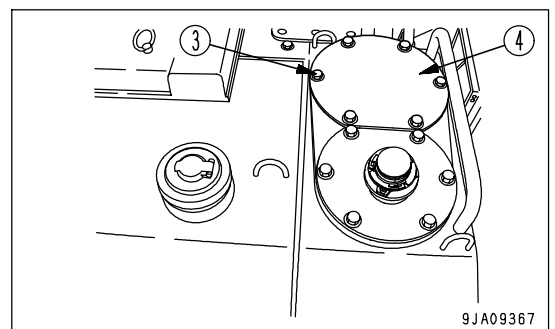

7. Remove bolts (5), then remove cover (6) and take out the strainer.
8. Wash the strainer in clean diesel oil or flushing oil.
9. Install the strainer to its original position.

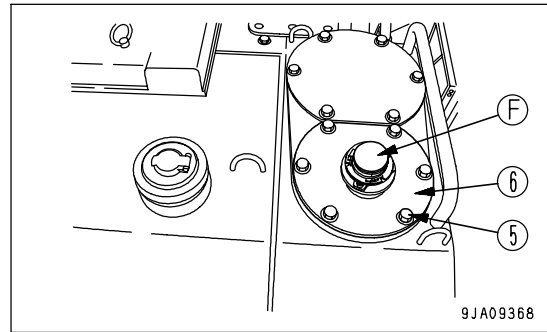

10. Add the refill amount of engine oil through oil filler port (F), then install the cap. When installing cap to the tank, push it down, then turn it clockwise.

**REMARK**

If the cap is not installed correctly, it will cause leakage of oil.

When installing the cap, press the cap down, and turn it until it is securely in contact with the stopper.

11. After adding oil, check that the oil is at the specified level. For details, see "CHECK OIL LEVEL IN HYDRAULIC TANK, ADD OIL (PAGE 3-80)".

**CHANGE OIL IN DAMPER CASE, CLEAN DAMPER BREATHER**

**WARNING**

- The oil is at high temperature immediately after the machine has been operated. Wait for the oil to cool down before carrying out maintenance.
- The undercover is heavy, so do not go directly under the cover when opening or closing it. When removing bolts (2) and (3), carry out the operation at the rear of the point immediately under the cover so that it is possible to escape at any time.

Refill capacity: 1.6 liters (0.42 US gal)

1. Open the engine side cover on the left of the machine; you can see dipstick (G).

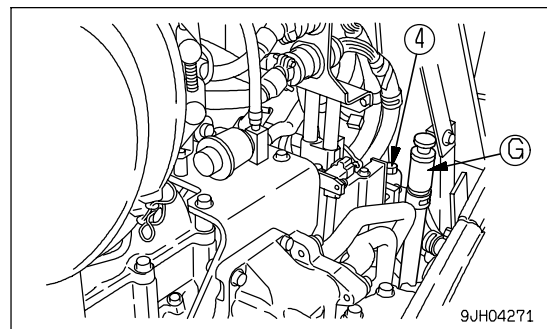

- Remove the undercover (1) at the bottom rear of the chassis as follows.

(A): Machine's right side

- Remove 2 bolts (2) at the Right of machine.
- Hold cover (1) in position and gradually remove 2 bolts (3) at the Left of machine. (Rain water may flow out when doing this.)
- Lower cover (1) slowly to open it. (There is a hinge on the right side of the cover.)

Drain plug (P) can be seen at the top.

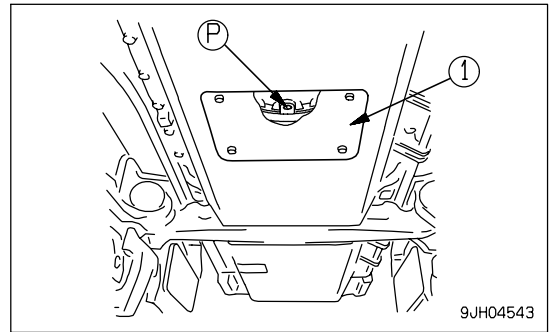

- Remove dipstick (G), then remove drain plug (P) and drain the oil.

After draining the oil, tighten drain plug (P).

- Add oil through the holder of dipstick (G). After adding the oil, insert dipstick (G).
- Wipe away dust around the breather (4).
- Remove breather (4).
- Remove any dirt or dust stuck to breather (4), then wash with clean diesel oil or flushing oil. If it cannot be cleaned completely, replace with a new part.
- Install the breather (4).
- Then close cover (1).

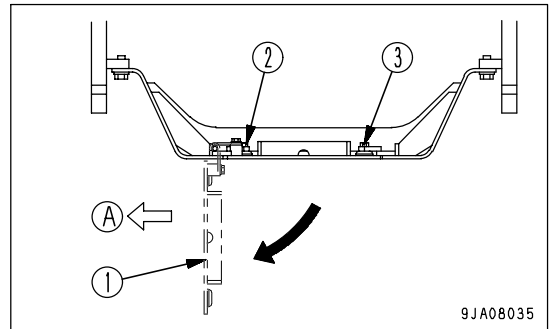

**CHECK PIVOT BEARING OIL LEVEL, ADD OIL**

- Remove plug (1).

When removing plug (1), be careful not to let dirt or dust get it.

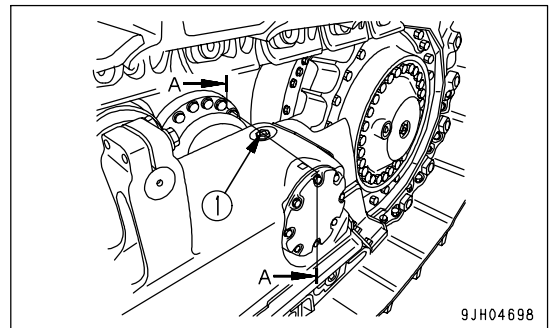

- Check that oil is at oil level (A). If not, refill with oil through oil filler plug (1). (The oil should be TO30 (SAE 30) irrespective of an atmospheric temperature.)

(B): 25mm (1 in)

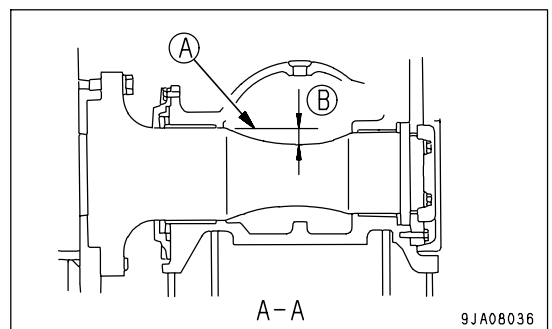

## CHECKING CHARGE PRESSURE OF NITROGEN GAS IN ACCUMULATOR (FOR CONTROL CIRCUIT)

### WARNING

The accumulator is charged with high-pressure nitrogen gas, so mistaken operation may cause an explosion, which will lead to serious injury or damage. When handling the accumulator, always do as follows.

- The pressure in the hydraulic circuit cannot be completely removed. When removing the hydraulic equipment, do not stand in the direction that the oil spurts out when carrying out the operation. In addition, loosen the bolts slowly when carrying out the operation.
- Do not disassemble the accumulator.
- Do not bring it near flame or dispose of it in fire.
- Do not make holes in it or weld it.
- Do not hit it, roll it, or subject it to any impact.
- When disposing of the accumulator, the gas must be released. Please contact your Komatsu distributor to have this work carried out.

### FUNCTION OF ACCUMULATOR

The accumulator stores the pressure in the control circuit. Even after the engine is stopped, the control circuit can be operated, so the following actions are possible.

- If the control lever is operated in the direction to lower the work equipment, it is possible for the work equipment to go down under its own weight.
- The pressure in the hydraulic circuit can be released.

The accumulator is installed to the position shown in the diagram on the right.

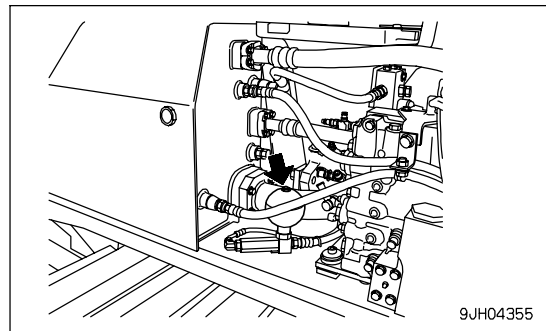

### CHECKING FUNCTION OF ACCUMULATOR

Replace the accumulator every 2 years or every 4000 hours, whichever comes sooner.

Check the nitrogen gas charge pressure as follows.

1. Stop the machine on firm, level ground.
2. Operate the parking brake lever to LOCK position (L).

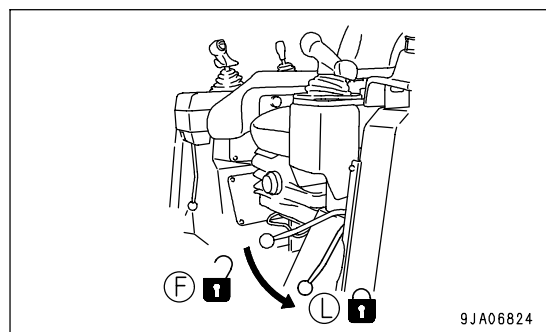

3. Raise the work equipment (blade) to the maximum height.

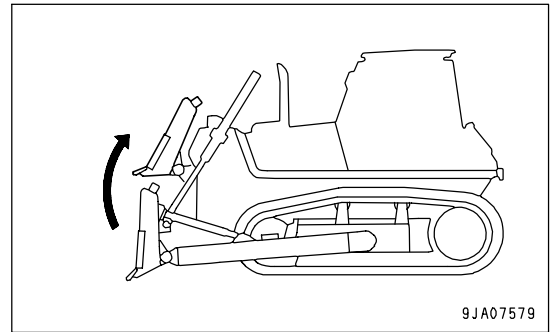

**NOTICE**

Carry out the following procedure for lowering the blade to the ground within 15 seconds after stopping the engine. When the engine is stopped, the pressure inside the accumulator gradually goes down, so this inspection can be carried out only immediately after the engine is stopped.

4. While holding the work equipment at the highest position, turn the engine starting switch key to OFF position (A).
5. Turn the engine starting switch key to ON position (B).

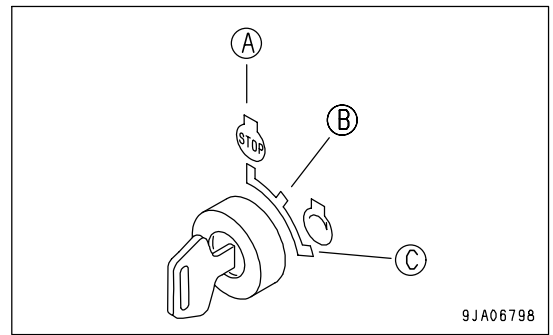

6. Turn the work equipment lock lever to FREE position (F).
7. Operate the blade control lever fully in the direction to lower the blade.

**REMARK**

Check that the area around the machine is safe, then operate the blade control lever to the LOWER position.

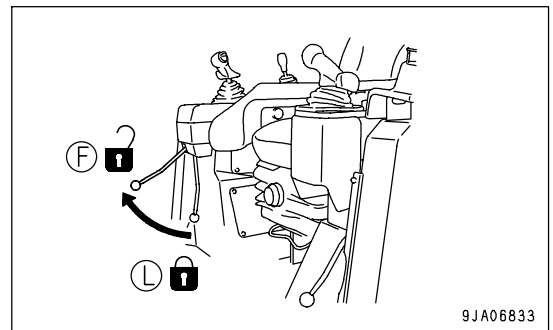

8. Check that the work equipment goes down to the ground under its own weight.
9. This completes the inspection.

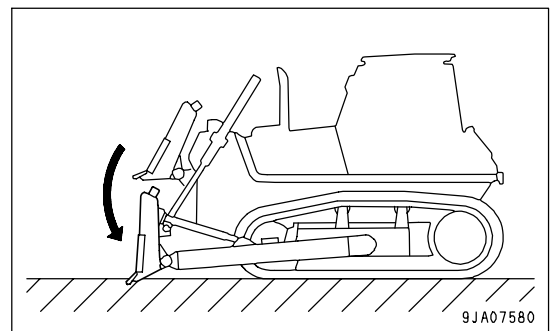

**NOTICE**

If the nitrogen gas charge pressure in the accumulator is low and operations are continued, it will become impossible to release the remaining pressure inside the hydraulic circuit if a failure occurs on the machine.



In the following cases, the charge pressure of the accumulator has gone down. Please contact your Komatsu distributor.

- Work equipment does not go down
- Stops while going down

## METHOD OF RELEASING PRESSURE IN HYDRAULIC CIRCUIT

### NOTICE

Finish the steps of operating the blade control lever to the front and back, and to the right and left, to each stroke end within 15 seconds after the engine has stopped. After the engine stops, pressure inside the accumulator begins to gradually go down, so the pressure cannot be released except right after the engine stops.

1. Lower the work equipment and stop the engine.
2. Turn the starting switch to the ON position.
3. Set the work equipment lock lever to the FREE position.
4. Operate the blade control lever fully to the front, rear, left, and right to release the pressure from the hydraulic circuit.

When releasing the pressure from the hydraulic ripper circuit, operate the ripper control lever fully to the left and right (in the case of the fixed multi-shank ripper) or to the front, rear, left, and right (in the case of the variable multi-shank ripper).

5. Set the work equipment lock lever to the LOCK position.

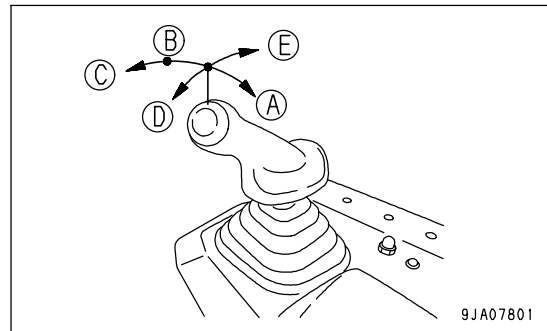

- (A) RAISE
- (B) LOWER
- (C) FLOAT
- (D) LEFT TILT
- (E) RIGHT TILT

## CHECK ALTERNATOR

Contact your Komatsu distributor to have the alternator checked.

If the engine is started frequently, have this inspection carried out every 1000 hours.

## CHECK ENGINE VALVE CLEARANCE, ADJUST

Special tools are needed for inspection and maintenance, so contact your Komatsu distributor.

## EVERY 4000 HOURS SERVICE

Maintenance for every 250, 500, 1000 and 2000 hours service should be carried out at the same time.

### REPLACE ACCUMULATOR (FOR CONTROL CIRCUIT)



#### WARNING

The accumulator is charged with high-pressure nitrogen gas, so mistaken operation may cause an explosion, which will lead to serious injury or damage. When handling the accumulator, always do as follows.

- The pressure in the hydraulic circuit cannot be completely removed. When removing the hydraulic equipment, do not stand in the direction that the oil spurts out when carrying out the operation. In addition, loosen the bolts slowly when carrying out the operation.
- Do not disassemble the accumulator.
- Do not bring it near flame or dispose of it in fire.
- Do not make holes in it or weld it.
- Do not hit it, roll it, or subject it to any impact.
- When disposing of the accumulator, the gas must be released. Please contact your Komatsu distributor to have this work carried out.

If operations are continued after the performance of the accumulator has dropped, it will be impossible to release the remaining pressure in the hydraulic circuit if there should be a failure on the machine. Please ask your Komatsu distributor to replace the accumulator.

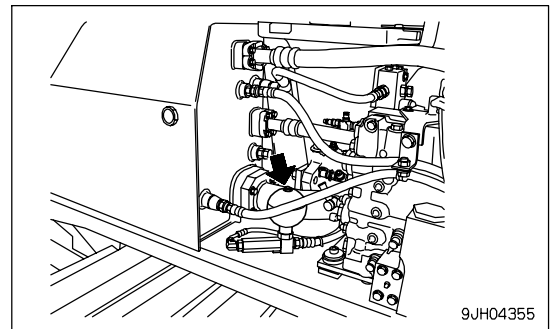

### CHECK WATER PUMP

Check the water pump and its relative parts for water leak, and if anything abnormal is found, call on your Komatsu distributor for repairs or replacement.

### CHECK STARTING MOTOR

Contact your Komatsu distributor to have the starting motor checked.

If the engine is started frequently, have this inspection carried out every 1000 hours.

**CHECKING FOR LOOSENESS OF HIGH-PRESSURE CLAMP, HARDENING OF RUBBER**

Check visually and touch with your fingers to check that there are no loose bolts or hardening of rubber parts at clamps (1) to (15). If there is any looseness or hardened rubber, contact your Komatsu distributor for replacement.

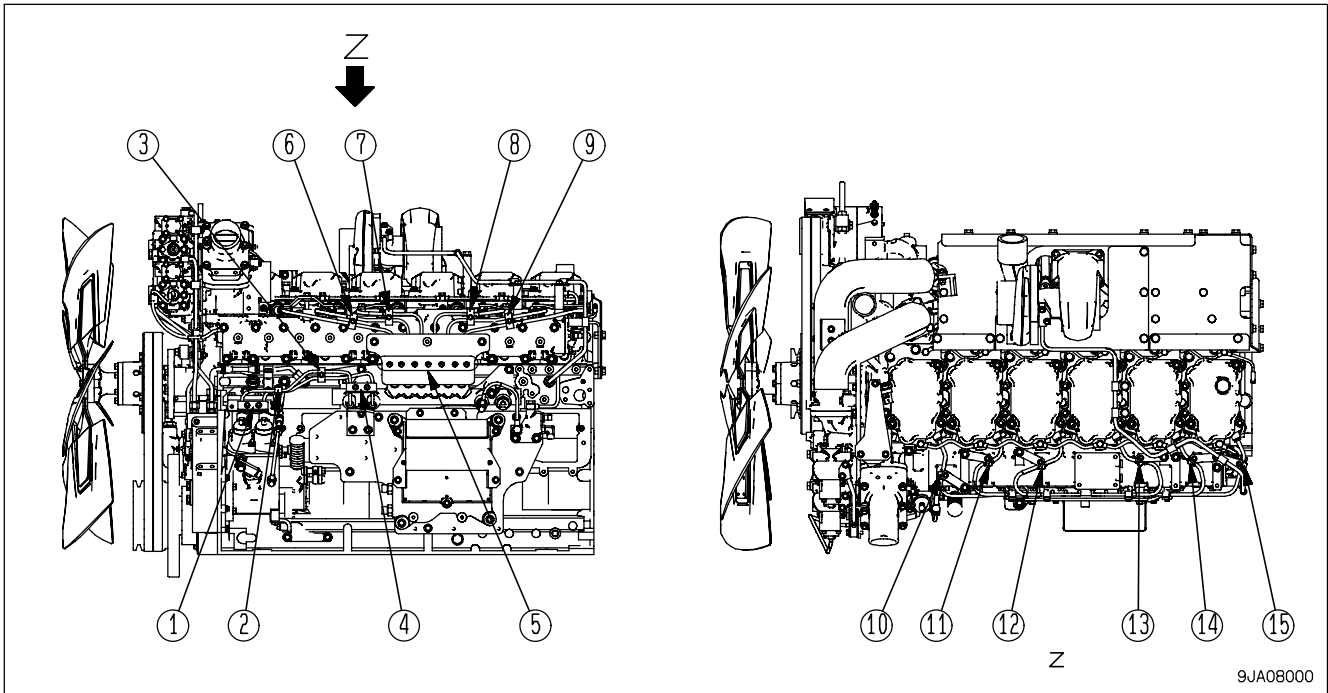

**NOTICE**

If the engine continues to be used when there are loose bolts, hardened rubber, or missing parts, there is danger of damage or breakage occurring due to vibration and wear at the connections of high-pressure piping. Always check that the proper high-pressure piping clamps are correctly installed.

**CHECKING FOR MISSING FUEL SPRAY PREVENTION CAP, HARDENING OF RUBBER**

Fuel spray prevention caps (1) - (16) and fuel spray prevention cover (17) are protective parts installed to prevent fire caused by fuel leaking and spraying out on to high temperature parts of the engine. Check visually that there are no missing caps or loose bolts, and feel with your finger to check that the rubber has not hardened. If there is any problem, the problem part must be replaced. Contact your Komatsu distributor for part replacement.

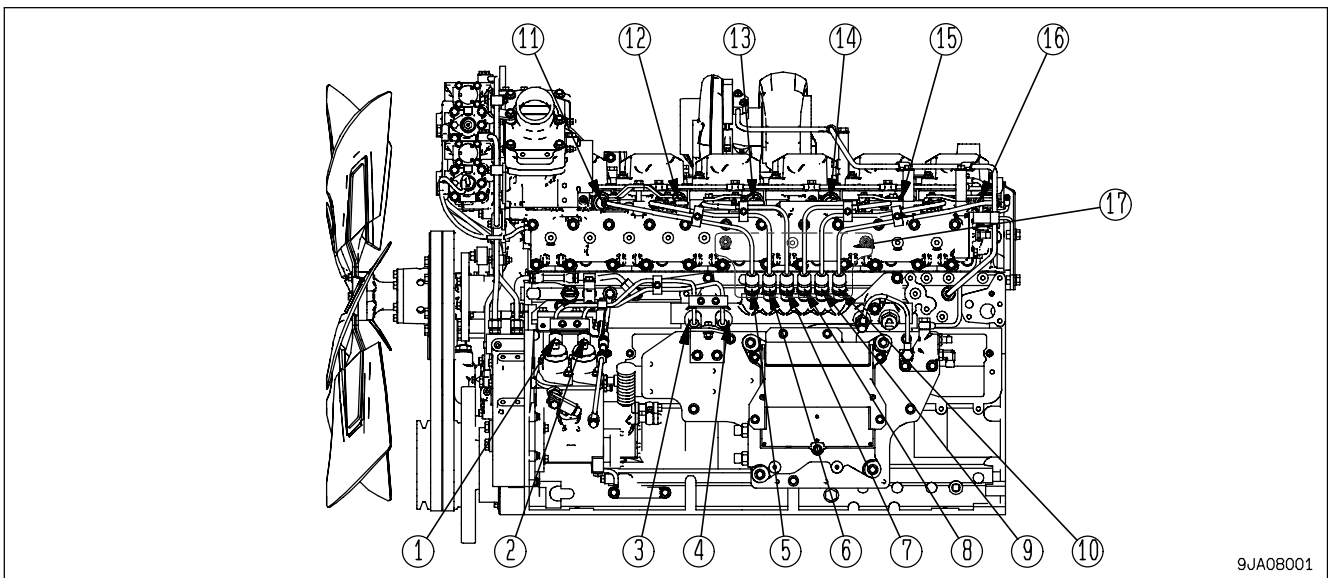

**CHECK MAIN FRAME, WORK EQUIPMENT (BLADE, RIPPER)**

Check after the first 4000 hours, and every 1000 hours after that.

- Preparation

Wipe off all the mud that is stuck around portions (A) - (L) of the work equipment and frame to make it easier to carry out the check.

- Visual check

Carefully check the base material of the steel casting and welding at portions (A) - (L), and check that there is no damage.

If any cracks or other damage is found, repair them.

Contact your Komatsu distributor for details of the repair procedure.

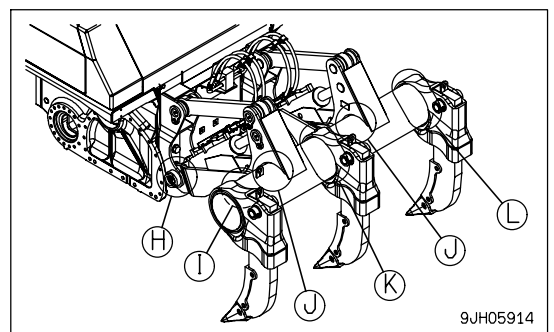
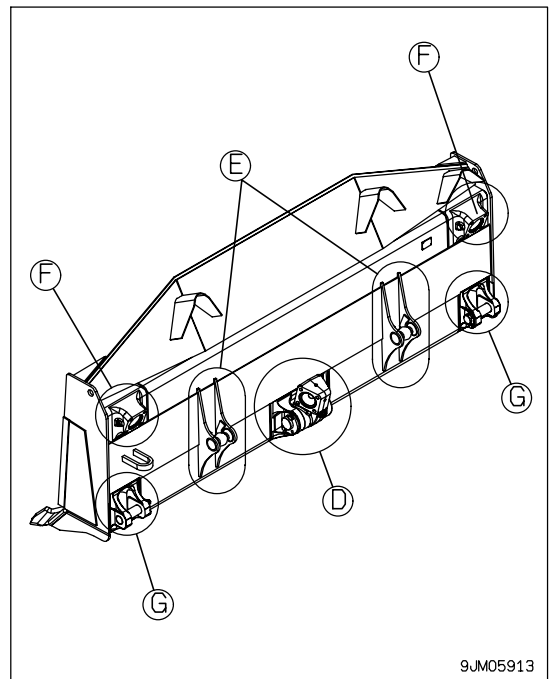
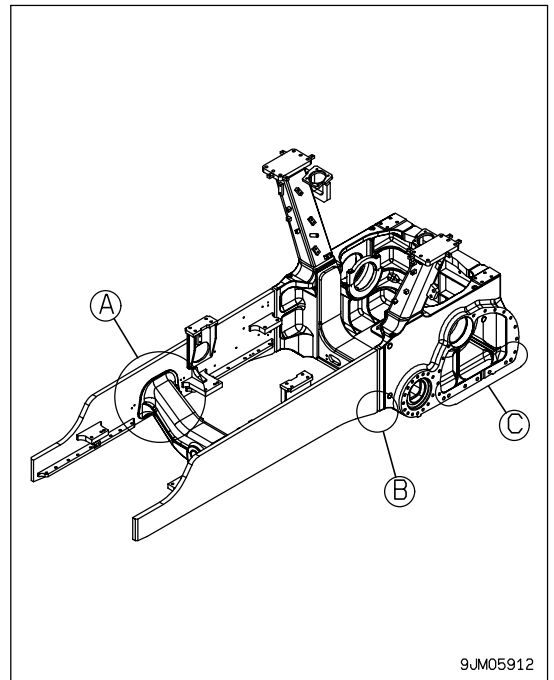

**EVERY 8000 HOURS SERVICE**

Maintenance for every 250, 500, 1000, 2000, and 4000 hours service should be carried out at the same time.

**REPLACE HIGH-PRESSURE PIPING CLAMPS**

Contact your Komatsu distributor to have the engine high-pressure clamps replaced.

**REPLACE FUEL SPLAY PREVENTION CAPS**

Contact your Komatsu distributor to have the fuel spray prevention cap replaced.

# **SPECIFICATIONS**

# SPECIFICATIONS

Item	Unit	D85EX-15E0	D85PX-15E0
		Semi-U tilt dozer	Straight tilt dozer
Operating weight (without operator)	kg (lb)	28,100 (61,961)(*1)	27,650 (60,968)(*2)
Blade unit weight (including cylinder)	kg (lb)	3,575 (7,883)	3,343 (7,371)
Ripper unit weight(Multi ripper)	kg (lb)	2,500 (5,513)	-
Drawbar unit weight	kg (lb)	-	90 (198)
Name of engine	-	KOMATSU SAA6D125E-5 diesel engine	
Engine horsepower	kW(HP)/rpm	197 (264)/1,900	
A Overall length	mm (ft in)	7,255 (23'10")	6,065 (19'11")
B Overall height	mm (ft in)	3,324 (10'11")	3,361 (11')
C Overall width	mm (ft in)	3,635 (11'11")	4,365 (14'4")
Travel speed (1st/2nd/3rd)	Forward	km/h (MPH)	3.3/6.1/10.1 (2.1/3.8/6.3)
	Reverse	km/h (MPH)	4.4/8.0/13.0 (2.7/5.0/8.1)

\*1: Semi-U tilt dozer, multi-shank ripper, ROPS cab, air conditioner

\*2: Straight tilt dozer, drawbar, ROPS cab, and air conditioner

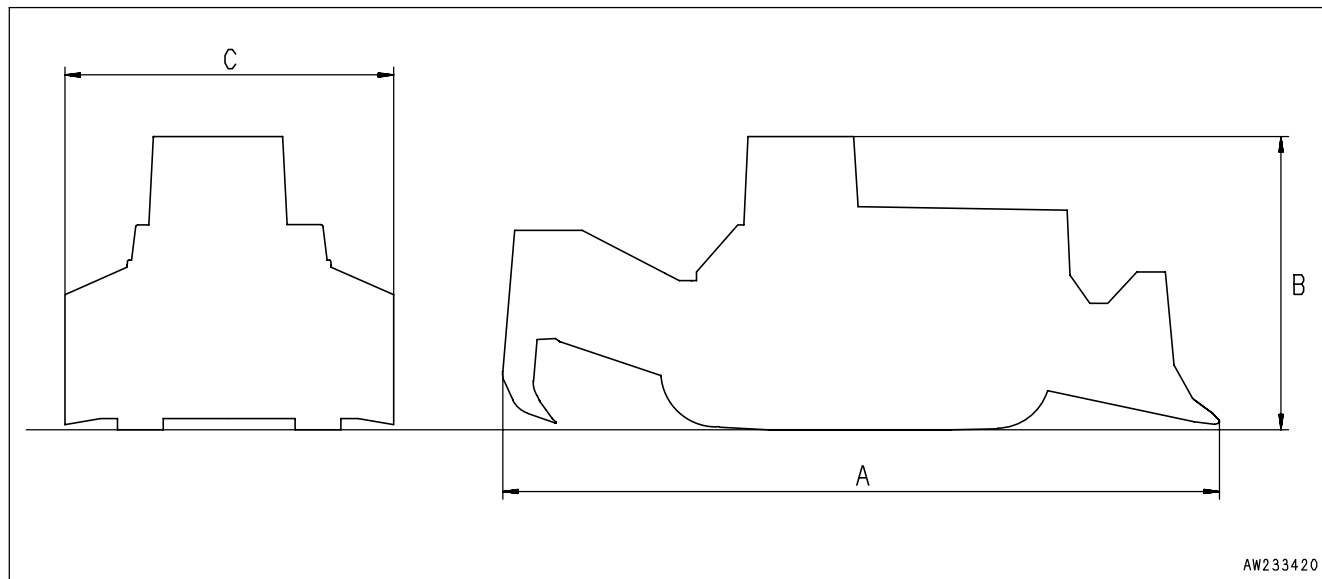

# ATTACHMENTS, OPTIONS

 **WARNING**

Please read and make sure that you understand the SAFETY section before reading this section.

---



## GENERAL PRECAUTIONS

### PRECAUTIONS RELATED TO SAFETY

If attachments or options other than those authorized by Komatsu are installed, this will not only affect the life of the machine, but will also cause problems with safety.

When installing attachments not listed in this Operation and Maintenance Manual, contact your Komatsu distributor first.

If you do not contact Komatsu, we cannot accept any responsibility for any accidents or failures.



### WARNING

#### General precautions

- Read the instruction manual for the attachment carefully, and do not use the machine before you understand the operation method completely.

If you lose the instruction manual, be sure to order another copy from your Komatsu distributor.

- To prevent serious personal injury caused by misoperation, place your foot on the pedal only when operating the pedal.

#### Precautions for removal and installation

When removing or installing an attachment, observe the following items and work safely.

- Select a firm, level surface when installing or removing an attachment.
- When working in cooperation with one or more other workers, decide signs and observe them when carrying out the operation.
- When carrying a heavy part (25 kg (55 lb) or more), use a crane.
- When removing a heavy part, always place a support in position before removing it.

When lifting a load with a crane, be particularly careful of the center of gravity.

- It is dangerous to carry out operations when the load has been raised by a crane. Always lower the load onto a stand and check that it is safe.
- When leaving an attachment removed or installing it, place it in a stable position to prevent it from falling over.
- Never go under a load raised by a crane.

Always stand in a place which is safe even if the load should fall.

#### NOTICE

Qualifications are required to operate a crane. Never allow the crane to be operated by an unqualified person.

For details of removal and installation operations, contact your Komatsu distributor.

## SELECTION OF TRACK SHOE

Select suitable track shoes to match the operating conditions.

### METHOD OF SELECTING SHOES

If a wider shoe than necessary is used, the load on the track will increase, and this will cause the shoes to bend, links to crack, pins to break, shoe bolts to come loose, and various other problems.

Category	Use	Precautions when using
A	Bedrock, normal soil	This shoe can be used for a wide range of work from crushed rock to general civil engineering work such as reclamation of residential land. There is no particular limit to its use.
B	Normal soil	Use this shoe for general soil, such as where the main work is scraper work and pusher work, reclaiming land for golf courses, or stripping the overburden for coal mines. This shoe cannot be used on bedrock. On jobsites where there are rocks in the soil, be careful to avoid letting the machine mount the rocks.
C	Soft soil	Use this shoe on soft ground where the shoe in category B sinks into the ground. Do not use this shoe on jobsites where there are rocks in the soil.
D	Extremely soft ground (swamp)	<ul style="list-style-type: none"> <li>• With A, B, or C, use these shoes only in places where the machine sinks.</li> <li>• These shoes cannot be used on rough ground where there are large obstacles such as boulders or fallen trees.</li> <li>• Travel at Hi or Mi speed only on flat ground, and if it is impossible to avoid going over obstacles, shift down and travel at half speed in Lo.</li> </ul>

#### REMARK

- Use heavy single shoes for machines operating in category A (rocky ground).
- Using heavy single shoes in categories B or C will help to improve the wear life.

	D85EX-15E0		D85PX-15E0	
	Specifications	Category	Specifications	Category
Standard	560mm Single	A	910mm Swamp	D
Option	610mm Single	B	---	---
Option	660mm Single	C	---	---
Option	560mm Heavy single	A	---	---
Option	610mm Heavy single	B	---	---
Option	660mm Heavy single	C	---	---

# PROCEDURE FOR SELECTING RIPPER POINT

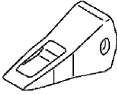
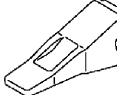
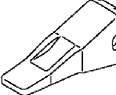
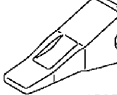
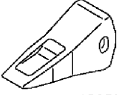
Procedure①	Install standard point (A)					
Procedure② Check wear	Is wear rapid? <ul style="list-style-type: none"> <li>Yes → Is there a high proportion of quartz in rock?                         <ul style="list-style-type: none"> <li>Yes (more than 70%) (Whole point wears uniformly) → Install point (B)</li> <li>No (less than 70%) Excessive generation of heat from point (only tip of point wears) → Install point (C)</li> </ul> </li> <li>No → Install point (A)</li> </ul>					
Procedure③ Check for cracks or breakage	Dose point break when impact force is applied? <ul style="list-style-type: none"> <li>Yes → Install point (A)</li> <li>No → Install point (A)</li> </ul> Dose point break when impact force is applied? <ul style="list-style-type: none"> <li>Yes → Install point (E)</li> <li>No → Install point (C)</li> </ul>					
Typical rock	Hardness	Soft ←→ Hard	Soft ←→ Medium hard	Soft ←→ Medium hard ←→ Hard		
	Type of rock	General rock	Sandstone	Basalt, andesite, granite, chert		
	Features	—	<ul style="list-style-type: none"> <li>Very high proportion of quartz (70 - 95%), point wears rapidly</li> </ul>	<ul style="list-style-type: none"> <li>Fairly high proportion of quartz (40 - 70%)</li> <li>Dose not form seams or layers, so there is excessive generation of heat from the point, the tip wears rapidly, and ripping is difficult</li> </ul>		
Suitable point	Features	Point (A) <ul style="list-style-type: none"> <li>Symmetrical shape</li> <li>Yellow</li> <li>Short (can be turned and used)</li> </ul>	Point (B) <ul style="list-style-type: none"> <li>Non-symmetrical shape</li> <li>Yellow</li> <li>Long</li> </ul>	Point (C) <ul style="list-style-type: none"> <li>Non-symmetrical shape</li> <li>Red</li> <li>Long</li> </ul>	Point (D) <ul style="list-style-type: none"> <li>Symmetrical shape</li> <li>Red</li> <li>Long (can be turned and used)</li> </ul>	Point (E) <ul style="list-style-type: none"> <li>Symmetrical shape</li> <li>Red</li> <li>Short (can be turned and used)</li> </ul>
	Shape	 AD053700	 AD053710	 AD053710	 AD053710	 AD053700
	Part No.	175-78-31230	175-78-34131	175-78-34141	175-78-31293	175-78-31232

# HANDLING TRIMMING DOZER

## GENERAL VIEW

### GENERAL VIEW OF MACHINE

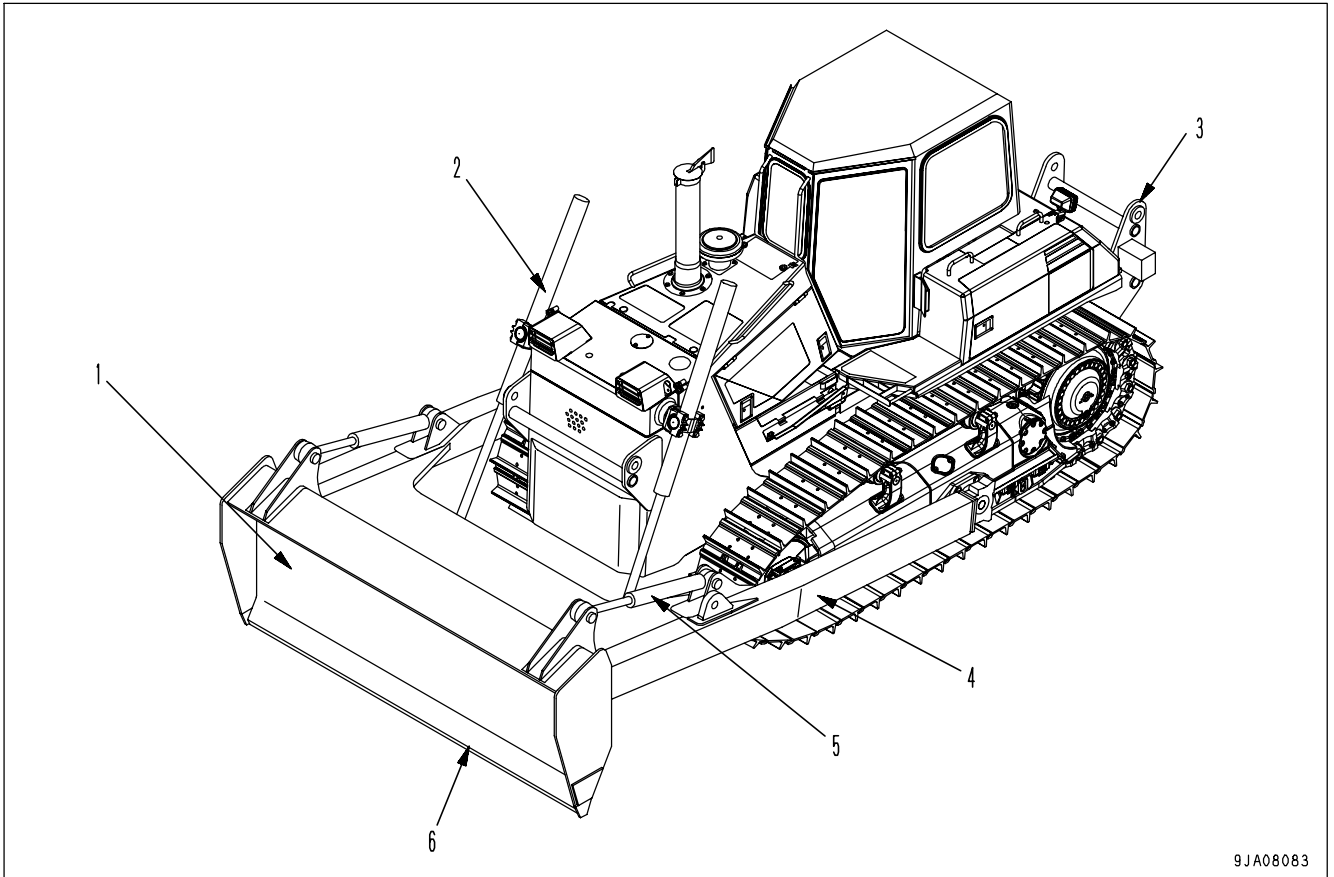

- |                   |                       |
|-------------------|-----------------------|
| (1) Blade         | (4) Frame             |
| (2) Lift cylinder | (5) Trimming cylinder |
| (3) Rear guard    | (6) Cutting edge      |

## EXPLANATION OF COMPONENTS

The following is an explanation of devices needed for operating the machine.

To perform suitable operations correctly and safely, it is important to completely understand methods of operating the equipment, and the meanings of the displays.

## CONTROL LEVERS AND PEDALS

### WORK EQUIPMENT LOCK LEVER



#### WARNING

When standing up from the operator's seat, lower the blade to the ground and set the work equipment lock lever securely to the LOCK position. If the work equipment is not locked securely, there is danger of serious injury if the blade control lever is touched by mistake.

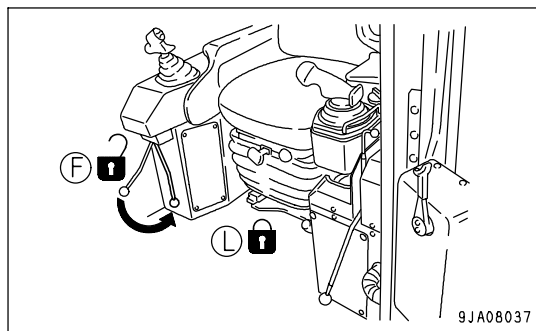

The work equipment lock lever also serves as a locking device for the blade control lever. When it is operated to the LOCK (L) position, the trimming dozer operation is locked.

#### REMARK

When starting up the engine, be sure to operate the work equipment lock lever to the LOCK (L) position for safety.

### BLADE CONTROL LEVER

Use the blade control lever to operate the trimming dozer.

- (a) RAISE:
- (b) HOLD: Blade is stopped and held in this position.
- (c) LOWER:
- (d) FLOAT: Blade will move freely according to external force.
- (A) Tilted forward: Blade is tilted forward
- (B) Tilted back: Blade is tilted back

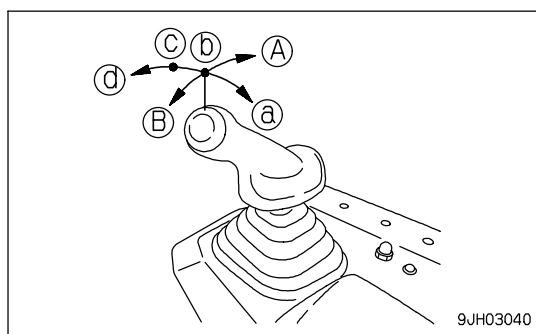

#### CAUTION

- Do not use this machine for dozing operations or digging operations.
- Do not operate the machine in forward or reverse with the machine jacked up by the blade.

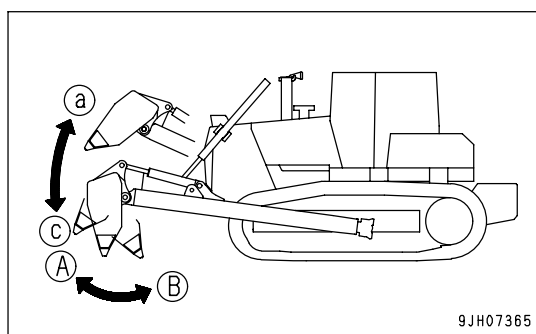

**MAINTENANCE**

**MAINTENANCE SCHEDULE CHART**

**EVERY 250 HOURS SERVICE**

LUBRICATING -----	6-	8
CHECK OIL LEVEL IN HYDRAULIC TANK, ADD OIL -----	6-	8

**EVERY 2000 HOURS SERVICE**

CHANGE OIL IN HYDRAULIC TANK, REPLACE HYDRAULIC OIL FILTER ELEMENT AND CLEAN HYDRAULIC TANK STRAINER -----	6-	9
---	----	---

## SERVICE PROCEDURE

### EVERY 250 HOURS SERVICE

#### LUBRICATING

1. Lower the work equipment to the ground, then stop the engine.
2. Using a grease pump, pump in grease through the grease fittings shown by arrows.
3. After greasing, wipe off any old grease that was pushed out.

- (1) Frame shaft (2 places)
- (2) Support shaft (2 places)  
(hydraulic cylinder for trimming)
- (3) Piston rod (2 places)  
(hydraulic cylinder for trimming)

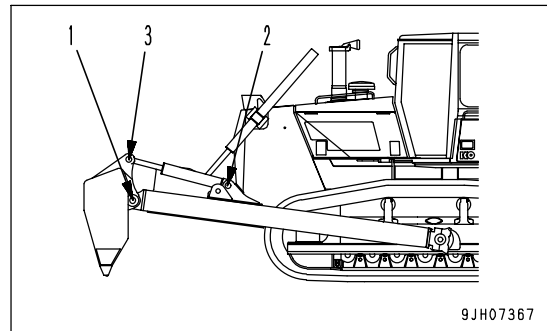

#### CHECK OIL LEVEL IN HYDRAULIC TANK, ADD OIL

Stop the machine at a level place, lower the blade perpendicularly to the ground, stop the engine, then carry out inspection.

#### REMARK

For details of the procedure for checking and adding oil, see "CHECK OIL LEVEL IN HYDRAULIC TANK, ADD OIL (PAGE 3-80)" in the Operation and Maintenance Manual for the D85EX-15E0 bulldozer.

**EVERY 2000 HOURS SERVICE**

Carry out the maintenance for EVERY 250 HOURS SERVICE at the same time.

**CHANGE OIL IN HYDRAULIC TANK, REPLACE HYDRAULIC OIL FILTER ELEMENT AND CLEAN HYDRAULIC TANK STRAINER****WARNING**

- The oil is at high temperature immediately after the machine has been operated. Wait for the oil to cool down before changing the oil.
- When removing the oil filler cap (F), push the cap down to release the internal pressure, then remove the cap carefully.

- Refill capacity: 71 liters (18.76 US gal)

1. Lower the blade to the ground, stop the engine, then move the blade to the front and rear.
2. Push down cap of oil filler (F) to release the air and remove the internal pressure.
3. Keep cap pushed down, turn it slowly counterclockwise, then remove cap.

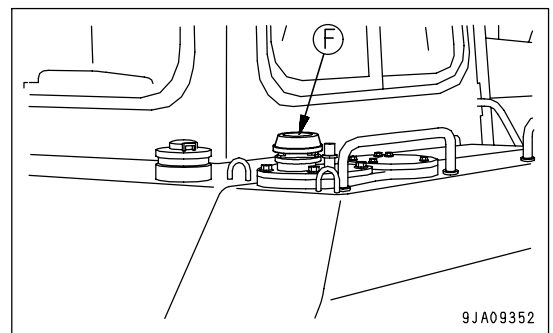

4. Remove drain plug (1) at the bottom of the tank and loosen drain valve (2). After draining the oil, tighten drain plug (1) and drain valve (2). When loosening drain valve (1), be careful not to get oil on yourself.

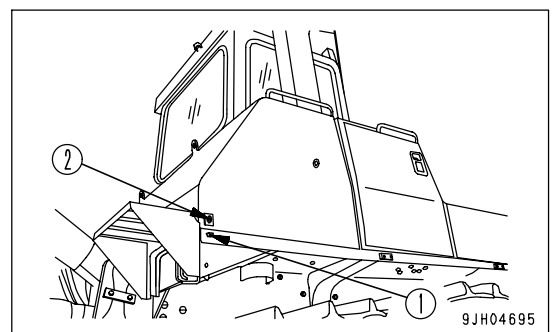

5. Remove bolts (3), then remove cover (4) and take out the element.
6. Clean the inside of case and removed parts and install a new element.

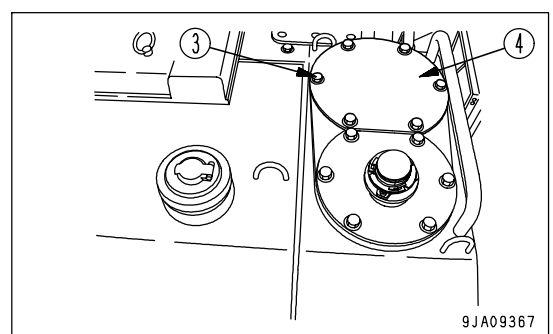



7. Remove bolts (5), then remove cover (6) and take out the strainer.
8. Wash the strainer in clean diesel oil or flushing oil.
9. Install the strainer to its original position.

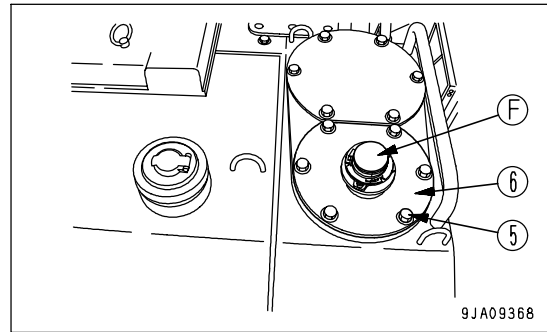

10. Add the refill amount of engine oil through oil filler port (F), then install the cap.  
When installing cap to the tank, push it down, then turn it clockwise.

**REMARK**

If the cap is not installed correctly, it will cause leakage of oil.

When installing the cap, press the cap down, and turn it until it is securely in contact with the stopper.

11. After adding oil, check that the oil is at the specified level. For details, see "CHECK OIL LEVEL IN HYDRAULIC TANK, ADD OIL (PAGE 3-80)" in the Operation and Maintenance Manual for the D85EX-15E0 bulldozer.

**SPECIFICATIONS**

	Item	Unit	D85EX-15E0 Trimming dozer
	Weight of bare machine (*1)	kg (lb)	3,810 (8,401)
	Operating weight (*2)	kg (lb)	25,860 (57,021)
	Hydraulic equipment		
	Pump type		Force-feed plunger pump type
	Hydraulic oil		Engine oil CD SAE10W
	Hydraulic oil amount	ℓ (US gal)	106 (28.01)
A	Overall length	mm (ft in)	6,690 (21' 11")
B	Overall height	mm (ft in)	3,045 (10' 0")
C	Overall width	mm (ft in)	3,410 (11' 2")
D	Blade forward tilt angle	°	35
E	Blade rear tilt angle	°	35

\*1: Includes blade cylinder, trimming cylinder.

\*2: Includes air conditioner, counterweight.

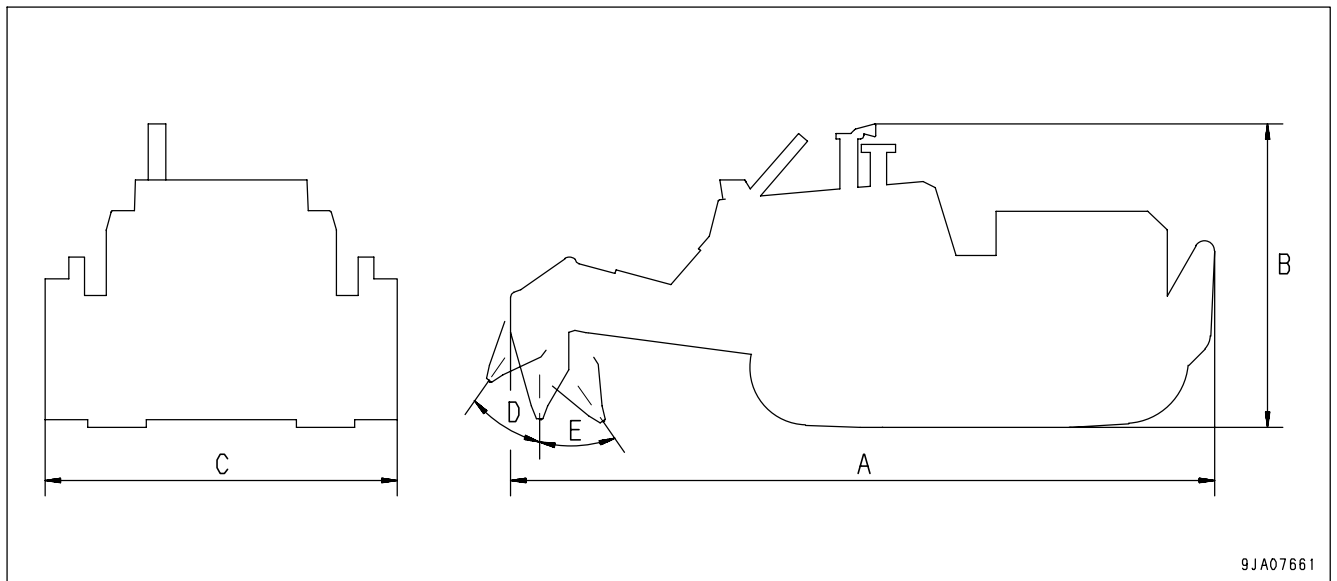

## HANDLING MACHINES EQUIPPED WITH KOMTRAX

- KOMTRAX is a machine management system that uses wireless communications.
- A contract with your Komatsu distributor is necessary before the KOMTRAX system can be used. Any customers desiring to use the KOMTRAX system should consult their Komatsu distributor.
- The KOMTRAX equipment is a wireless device using radio waves, so it is necessary to obtain authorization and conform to the laws of the country or territory where the machine equipped with KOMTRAX is being used. Always contact your Komatsu distributor before selling or exporting any machine equipped with KOMTRAX.
- When selling or exporting the machine or at other times when your Komatsu distributor considers it necessary, it may be necessary for your Komatsu distributor to remove the KOMTRAX equipment or to carry out action to stop communications.
- If you do not obey the above precautions, neither Komatsu nor your Komatsu distributor can take any responsibility for any problem that is caused or for any loss that results.

## BASIC PRECAUTIONS



### WARNING

- Never disassemble, repair, modify, or move the communications terminal, antenna, or cables. This may cause failure or fire on the KOMTRAX equipment or the machine itself. (Your Komatsu distributor will carry out removal and installation of KOMTRAX.)
- Do not allow cables or cords to become caught; do not damage or pull cables or cords by force. Short circuits or disconnected wires may cause failure or fire on the KOMTRAX equipment or the machine itself.
- For anyone wearing a pacemaker, make sure that the communications antenna is at least 22 cm (8.7 in) from the pacemaker. The radio waves may have an adverse effect on the operation of the pacemaker.

## NOTICE

- Even when the key in the starting switch of the KOMTRAX system is at the OFF position, a small amount of electric power is consumed. When putting the machine into long-term storage, take the action given in "LONG-TERM STORAGE (PAGE 3-138)".
- Please contact your Komatsu distributor before installing a top guard or other attachment that covers the cab roof.
- Be careful not to get water on the communications terminal or wiring.

## REMARK

- The KOMTRAX system uses wireless communications, so it cannot be used inside tunnels, underground, inside buildings, or in mountain areas where radio waves cannot be received. Even when the machine is outside, it cannot be used in areas where the radio signal is weak or in areas outside the wireless communication service area.
- There is absolutely no need to inspect or operate the KOMTRAX communications terminal, but if any abnormality is found, please consult your Komatsu distributor.

INDEX

<A>			
ADJUSTING POSTURE OF WORK EQUIPMENT -----	3-119		
AIR CONDITIONER, HANDLING -----	3- 60		
ASHTRAY -----	3- 51		
<B>			
BEFORE READING THIS MANUAL -----	1- 2		
<C>			
CAP WITH LOCK -----	3- 48		
CAR STEREO, HANDLING -----	3- 52		
CHECK BEFORE STARTING ENGINE, ADJUST -----	3- 74		
CIRCUIT BREAKER -----	3- 47		
CIRCUIT BREAKER FOR MAIN POWER SUPPLY -----	3- 46		
COLD WEATHER OPERATION -----	3-136		
AFTER COLD WEATHER -----	3-137		
AFTER COMPLETION OF WORK -----	3-137		
PRECAUTIONS FOR LOW TEMPERATURE -----	3-136		
CONTROL LEVERS AND PEDALS -----	3- 37		
<D>			
DOOR - OPEN LOCK -----	3- 50		
DOOR POCKET -----	3- 51		
<E>			
ELECTRIC POWER TAKE-OUT ADAPTER -----	3- 47		
EXPLANATION OF COMPONENTS -----	3- 5		
EXTERNAL POWER SOURCE TYPE			
ENGINE PREHEATING HEATER -----	3- 66		
<F>			
FRONT PANEL -----	3- 5		
FUSE -----	3- 44		
<G>			
GENERAL PRECAUTIONS -----	6- 2		
PRECAUTIONS RELATED TO SAFETY -----	6- 2		
GENERAL PRECAUTIONS COMMON TO OPERATION AND MAINTENANCE -----	2- 10		
DO NOT GET CAUGHT IN WORK EQUIPMENT -----	2- 14		
FIRE PREVENTION -----	2- 12		
PRECAUTIONS BEFORE STARTING OPERATION -----	2- 10		
PRECAUTIONS RELATED TO ATTACHMENTS AND OPTIONS -----	2- 15		
PRECAUTIONS RELATED TO PROTECTIVE STRUCTURES -----	2- 15		
PRECAUTIONS WHEN GETTING ON OR OFF MACHINE -----	2- 13		
PRECAUTIONS WHEN RUNNING ENGINE INSIDE BUILDING -----	2- 15		
PREPARATIONS FOR SAFE OPERATION -----	2- 10		
UNAUTHORIZED MODIFICATION -----	2- 15		
GENERAL VIEW -----	3- 2		
GENERAL VIEW OF CONTROLS AND GAUGES -----	3- 3		
GENERAL VIEW OF MACHINE -----	3- 2		
GUIDE TO MAINTENANCE -----	4- 2		
<H>			
HANDLING HEATER -----	3- 65		
HANDLING MACHINES EQUIPPED WITH KOMTRAX -----	6- 12		
HANDLING TRIMMING DOZER -----	6- 5		
EXPLANATION OF COMPONENTS -----	6- 6		
GENERAL VIEW -----	6- 5		
MAINTENANCE -----	6- 7		
SPECIFICATIONS -----	6- 11		
<I>			
IMPORTANT SAFETY INFORMATION -----	1- 3		
INTENDED USE -----	1- 4		
GENERAL VIEW AND DIRECTIONS OF MACHINE -----	1- 4		
USE OF MACHINE -----	1- 4		
VISIBILITY FROM OPERATOR'S SEAT -----	1- 5		
<L>			
LOCATION OF PLATES, TABLE TO ENTER SERIAL NO. AND DISTRIBUTOR -----	1- 6		
ADDITIONAL EPA NAMEPLATE -----	1- 7		
BLADE SERIAL NO. PLATE POSITION -----	1- 7		

ENGINE SERIAL NO. PLATE POSITION -----	1- 6	AND MAINTENANCE -----	2- 31
PRODUCT IDENTIFICATION NUMBER (PIN)/MACHINE SERIAL NO. PLATE -----	1- 6	PRECAUTIONS FOR OPERATION -----	2- 16
RIPPER SERIAL NO. PLATE POSITION -----	1- 7	OPERATION -----	2- 21
SERVICE METER POSITION -----	1- 8	PRECAUTIONS FOR JOBSITE -----	2- 16
TABLE TO ENTER SERIAL NO. AND DISTRIBUTOR -----	1- 8	STARTING ENGINE -----	2- 19
LONG-TERM STORAGE -----	3-138	TOWING -----	2- 26
AFTER STORAGE -----	3-138	TRANSPORTATION -----	2- 25
BEFORE STORAGE -----	3-138	PROCEDURE FOR SELECTING RIPPER POINT -----	6- 4
DURING STORAGE -----	3-138	<R>	
<M>		RECOMMENDED FUEL, COOLANT, AND LUBRICANT -----	4- 12
MAINTENANCE SCHEDULE CHART -----	4- 18	RECOMMENDED BRANDS, RECOMMENDED QUALITY FOR PRODUCTS OTHER THAN KOMATSU GENUINE OIL -----	4- 14
MAINTENANCE SCHEDULE CHART -----	4- 18	USE OF FUEL, COOLANT AND LUBRICANTS ACCORDING TO AMBIENT TEMPERATURE -----	4- 13
<O>		<S>	
OPERATION -----	3- 74	SAFETY -----	2- 2
CHECK AFTER FINISHING WORK -----	3-125	SAFETY LABELS -----	2- 5
LOCKING -----	3-125	POSITIONS OF SAFETY PICTOGRAMS -----	2- 5
MACHINE OPERATION -----	3-102	SAFETY LABELS -----	2- 6
OPERATIONS AND CHECKS AFTER STARTING ENGINE -----	3- 97	SASH GLASS INTERMEDIATE LOCK -----	3- 50
PARKING MACHINE -----	3-123	SELECTION OF TRACK SHOE -----	6- 3
PRECAUTIONS FOR OPERATION -----	3-114	METHOD OF SELECTING SHOES -----	6- 3
SHIFTING BETWEEN FORWARD AND REVERSE -----	3-110	SERVICE PROCEDURE -----	4- 20
SHIFTING GEARS -----	3-105	CHECK BEFORE STARTING -----	4- 46
STARTING ENGINE -----	3- 93	EVERY 1000 HOURS SERVICE -----	4- 59
STEERING MACHINE -----	3-112	EVERY 2000 HOURS SERVICE -----	4- 67
STOPPING ENGINE -----	3-101	EVERY 250 HOURS SERVICE -----	4- 47
WORK POSSIBLE USING BULLDOZER -----	3-117	EVERY 4000 HOURS SERVICE -----	4- 73
OUTLINE OF SERVICE -----	4- 5	EVERY 500 HOURS SERVICE -----	4- 54
HANDLING HYDRAULIC SYSTEM -----	4- 9	EVERY 8000 HOURS SERVICE -----	4- 76
HANDLING OIL, FUEL, COOLANT, AND PERFORMING OIL CLINIC -----	4- 5	INITIAL 250 HOURS SERVICE (ONLY AFTER THE FIRST 250 HOURS) -----	4- 20
RELATING TO ELECTRIC SYSTEM -----	4- 8	WHEN REQUIRED -----	4- 21
<P>		SPECIFICATIONS -----	5- 2
PERIODIC REPLACEMENT OF SAFETY CRITICAL PARTS -----	4- 16	STANDARD TIGHTENING TORQUES FOR BOLTS AND NUTS -----	4- 15
SAFETY CRITICAL PARTS -----	4- 16	TORQUE LIST -----	4- 15
PRECAUTIONS FOR MAINTENANCE -----	2- 27	SWITCHES -----	3- 33
PRECAUTIONS BEFORE STARTING INSPECTION AND MAINTENANCE -----	2- 27	<T>	
PRECAUTIONS FOR INSPECTION		TIPS FOR LONGER UNDERCARRIAGE LIFE -----	3-126

## INDEX

---

TOOL BOX -----	3- 51
TRANSPORTATION -----	3-129
INSTALLATION OF CAB -----	3-130
INSTALLATION OF ROPS -----	3-130
LOADING, UNLOADING WORK -----	3-131
METHOD OF LIFTING MACHINE -----	3-134
PRECAUTIONS FOR	
TRANSPORTATION -----	3-135
REMOVING CAB -----	3-129
TRANSPORTATION MEANS -----	3-129
TRAVELING ON ROADS -----	3-135
TROUBLESHOOTING -----	3-139
AFTER RUNNING OUT OF FUEL -----	3-139
IF BATTERY IS DISCHARGED -----	3-143
METHOD OF TOWING MACHINE -----	3-141
OTHER TROUBLE -----	3-147
 <W>	
WEAR PARTS LIST -----	4- 10
WEAR PARTS LIST -----	4- 10

D85EX-15E0, D85PX-15E0 BULLDOZER

---

Form No. TEN00277-01

---