

Operation & Maintenance Manual

HYDRAULIC
EXCAVATOR

PC400-8 **PC400LC-8**
PC450-8 **PC450LC-8**

SERIAL NUMBERS

PC400-70290
PC450-70290 and up

ecot3

WARNING

Unsafe use of this machine may cause serious injury or death. Operators and maintenance personnel must read this manual before operating or maintaining this machine. This manual should be kept near the machine for reference and periodically reviewed by all personnel who will come into contact with it.

NOTICE

Komatsu has Operation & Maintenance Manuals written in some other languages. If a foreign language manual is necessary, contact your local distributor for availability.

KOMATSU

FOREWORD

CALIFORNIA

Proposition 65 Warning

Diesel engine exhaust and some of its constituents are known to the State of California to cause cancer, birth defects, and other reproductive harm.

CALIFORNIA

Proposition 65 Warning

Battery posts, terminals and related accessories contain lead and lead compounds, chemicals known to the State of California to cause cancer and birth defects or other reproductive harm.

Wash hands after handling.

BEFORE READING THIS MANUAL

This manual gives details of the operation and methods of inspection and maintenance for this machine that must be obeyed in order to use the machine safely. Most accidents are caused by the failure to follow fundamental safety rules for the operation and maintenance of machines.

Read, understand and follow all precautions and warnings in this manual and on the machine before performing operation and maintenance. Failure to do so may result in serious injury or death.

Komatsu cannot predict every circumstance that might involve a potential hazard when the machine is used. Therefore, the safety messages in this manual and on the machine may not include all possible safety precautions. If you carry out any operation, inspection, or maintenance under conditions that are not described in this manual, understand that it is your responsibility to take the necessary precautions to ensure safety. In no event should you or others engage in the prohibited uses or actions described in this manual. Improper operation and maintenance of the machine can be hazardous and could result in serious injury or death.

If you sell the machine, be sure to give this manual to the new owner together with the machine.

Always keep this Operation and Maintenance Manual in the location shown on the right so that all relevant personnel can read it at any time.

Storage location for the Operation and Maintenance Manual:
magazine box on the left side of the operator's seat.

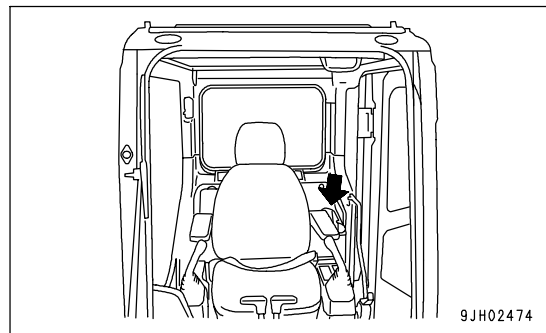

If this manual is lost or damaged, contact your distributor immediately to arrange for its replacement. For details regarding the machine serial No. you will need to provide your Komatsu distributor, see "YOUR MACHINE SERIAL NUMBERS AND DISTRIBUTOR (PAGE 1-8)".

This manual uses the international units (SI) for units of measurement. For reference, units that have been used in the past are given in ().

The explanations, values, and illustrations in this manual have been prepared based on the latest information available as of the date of its publication. Continuing improvements in the design of this machine may lead to additional changes that are not reflected in this manual. Consult Komatsu or your Komatsu distributor for the latest available information concerning your machine or with questions regarding information contained in this manual.

- The numbers in circles in the illustrations correspond to the numbers in () in the text.

(For example: ① → (1))



Komatsu delivers machines that comply with all applicable regulations and standards of the country to which it has been shipped. If this machine has been purchased in another country, it may lack certain safety devices and specifications that are necessary for use in your country. If there is any question about whether your product complies with the applicable standards and regulations of your country, consult Komatsu or your Komatsu distributor before operating the machine.

SAFETY INFORMATION

To enable you to use the machine safely, and to prevent injury to operators, service personnel or bystanders, the precautions and warnings included in this manual and the safety signs attached to the machine must always be followed.

To identify important safety messages in the manual and on the machine labels, the following signal words are used.

The "Safety Alert Symbol" identifies important safety messages on machines, in manuals, and elsewhere. When you see this symbol, be alert to the risk of personal injury or death. Follow the instructions in the safety message.

- | | |
|--|--|
|  DANGER | This signal word indicates an imminently hazardous situation which, if not avoided, will result in death or serious injury. |
|  WARNING | This signal word indicates a potentially hazardous situation which, if not avoided, could result in death or serious injury. |
|  CAUTION | This signal word indicates a potentially hazardous situation exists which, if not avoided, may result in minor or moderate injury. |

The following signal words are used to alert you to information that must be followed to avoid damage to the machine.

- | | |
|----------------|--|
| NOTICE | This precaution is given where the machine may be damaged or the service life reduced if the precaution is not followed. |
| REMARKS | This word is used for information that is useful to know. |

INTRODUCTION

USE OF MACHINE

This Komatsu machine is designed to be used mainly for the following work:

- Digging work
- Leveling work
- Ditching work
- Loading work
- Demolition work

See the section "RECOMMENDED APPLICATIONS (PAGE 3-165)" for further details.

DIRECTIONS OF MACHINE

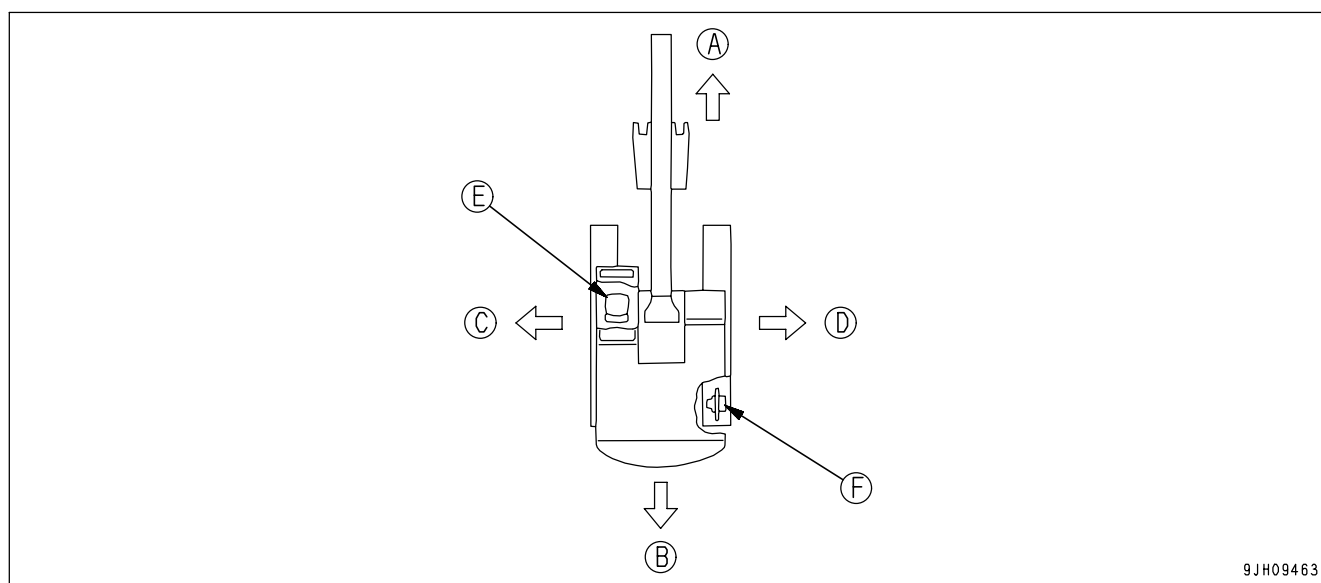

(A) Front

(B) Rear

(C) Left

(D) Right

(E) Operator's seat

(F) Sprocket

In this manual, the terms front, rear, left, and right refer to the travel direction as seen from the operator's seat when the operator's seat is facing the front and the sprocket is at the rear of the machine.

VISIBILITY FROM OPERATOR'S SEAT

The visibility standards (ISO 5006) for this machine require a view shown in the diagram below.

PROXIMITY VISIBILITY

The visibility of this machine in the area 1 m from the outside surface of the machine at a height of 1.5 m is shown in the diagram below. The hatched area (A) shows the area where the view is blocked by part of the machine when mirrors or other aids to visibility are installed as standard. Please be fully aware that there are places that cannot be seen when operating the machine.

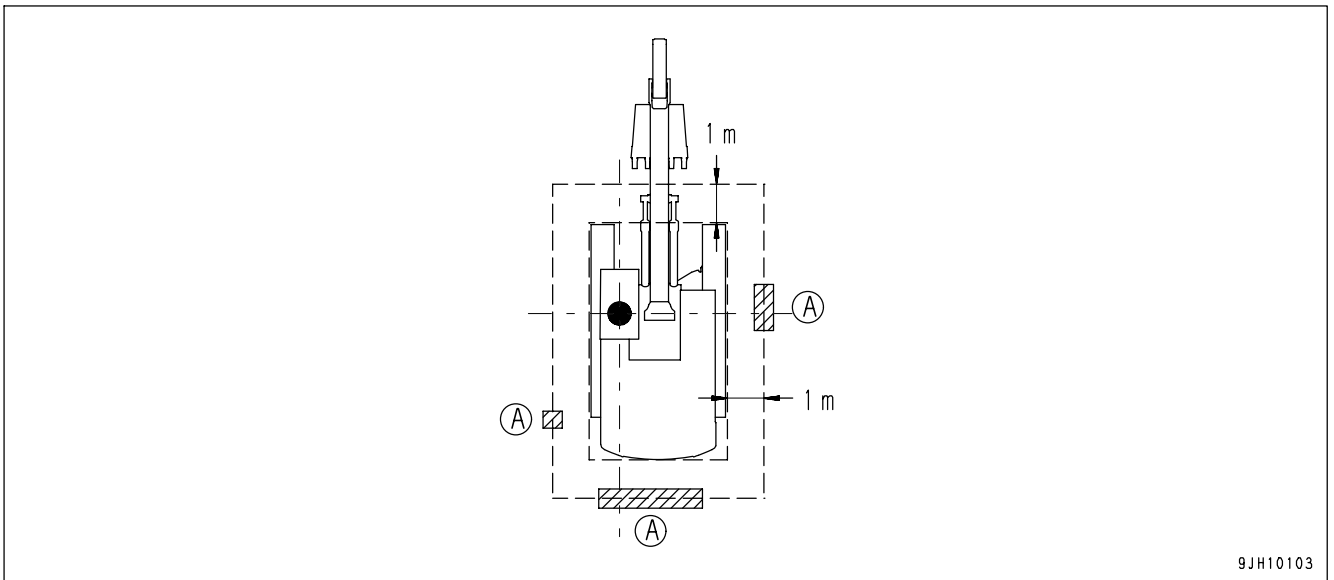

(If equipped rear view camera)

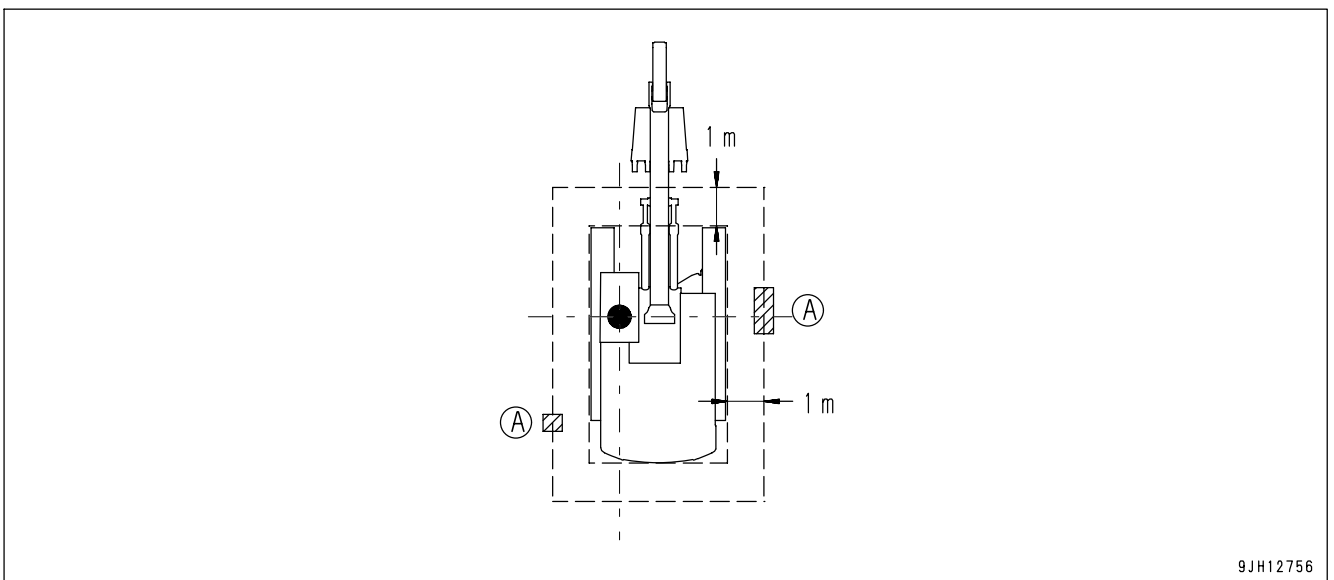

12M CIRCUMFERENCE VISIBILITY

The visibility at a radius of 12 m from the machine is as shown in the diagram below. The hatched areas (B) show the areas where the view is blocked when mirrors or other aids to visibility are installed as standard. Please be fully aware that there are places that cannot be seen when operating the machine.

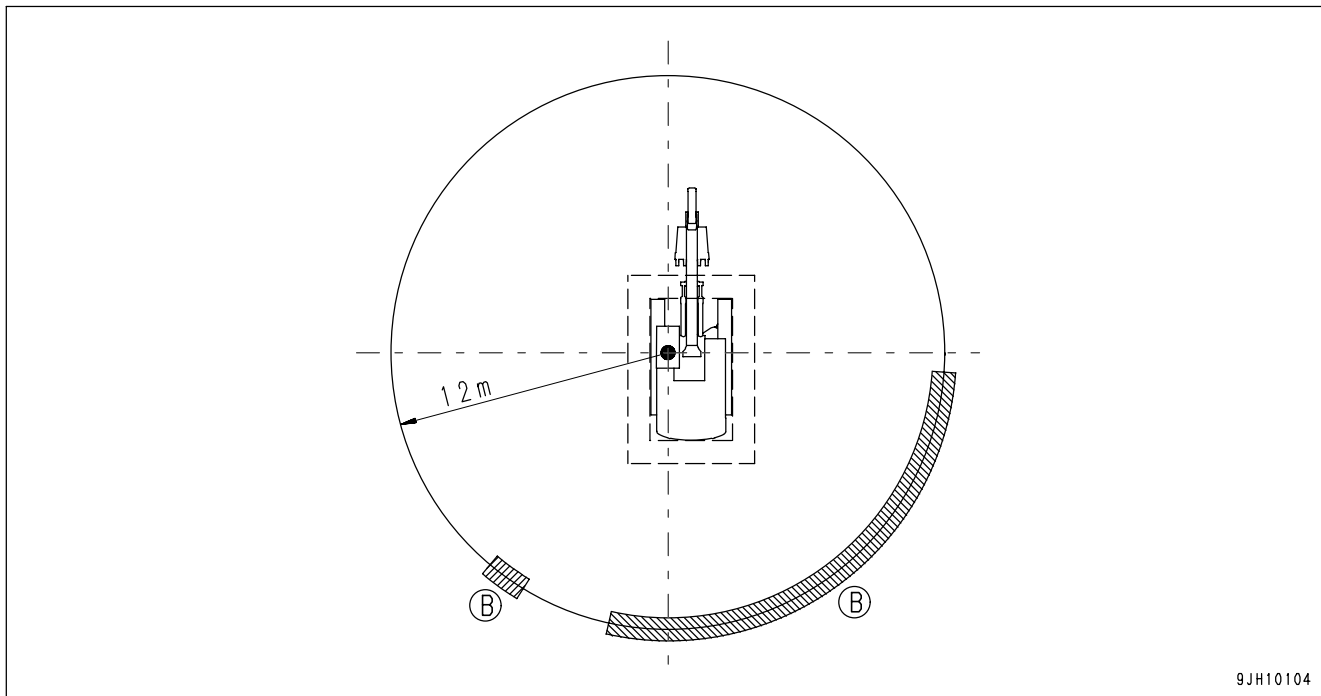

(If equipped rear view camera)

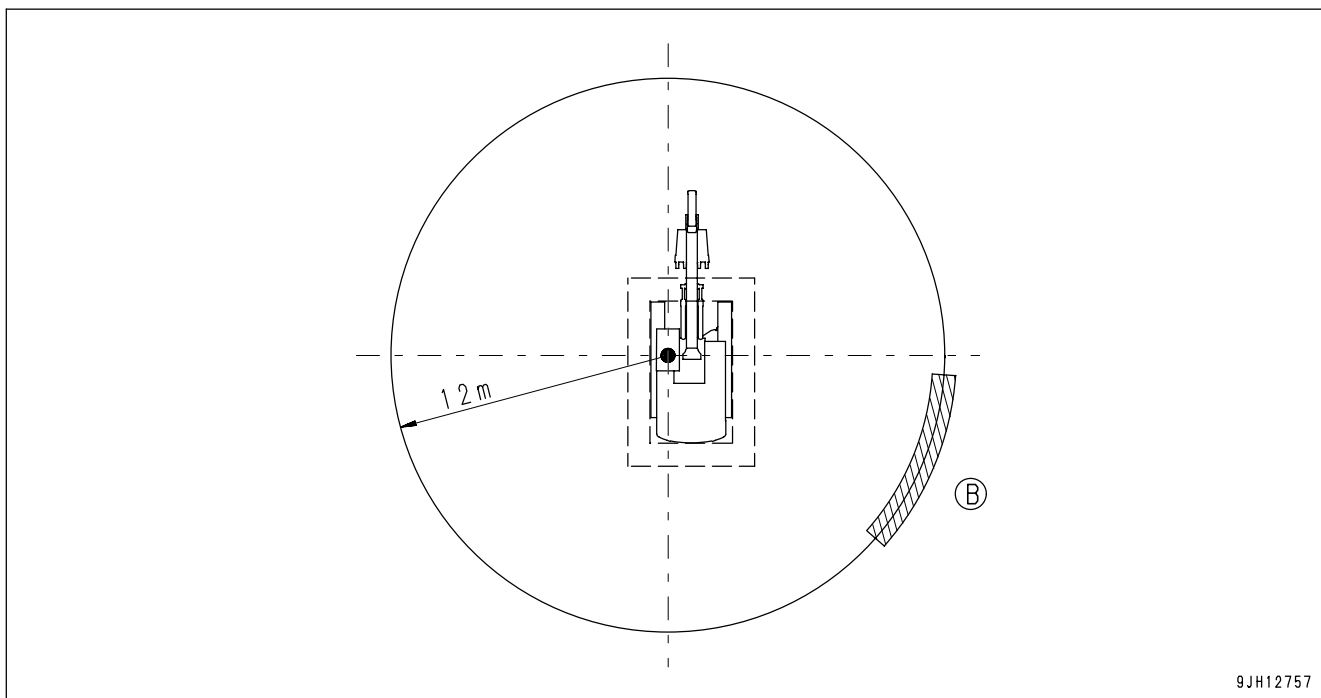

PRODUCT INFORMATION

When requesting service or ordering replacement parts, please inform your Komatsu distributor of the following items.

PRODUCT IDENTIFICATION NUMBER (PIN)/MACHINE SERIAL NO. PLATE

On the bottom right of the operator's cab

The design of the nameplate differs according to the territory.

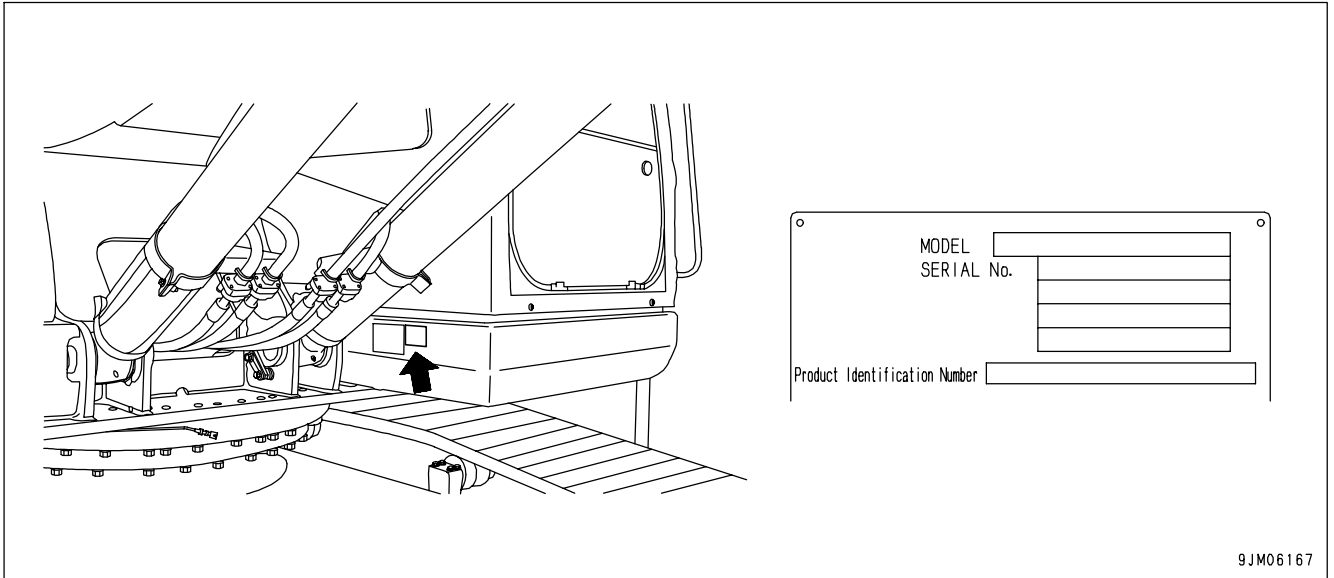

EPA REGULATIONS, ENGINE NUMBER PLATE

On the upper side of the engine cylinder head cover.

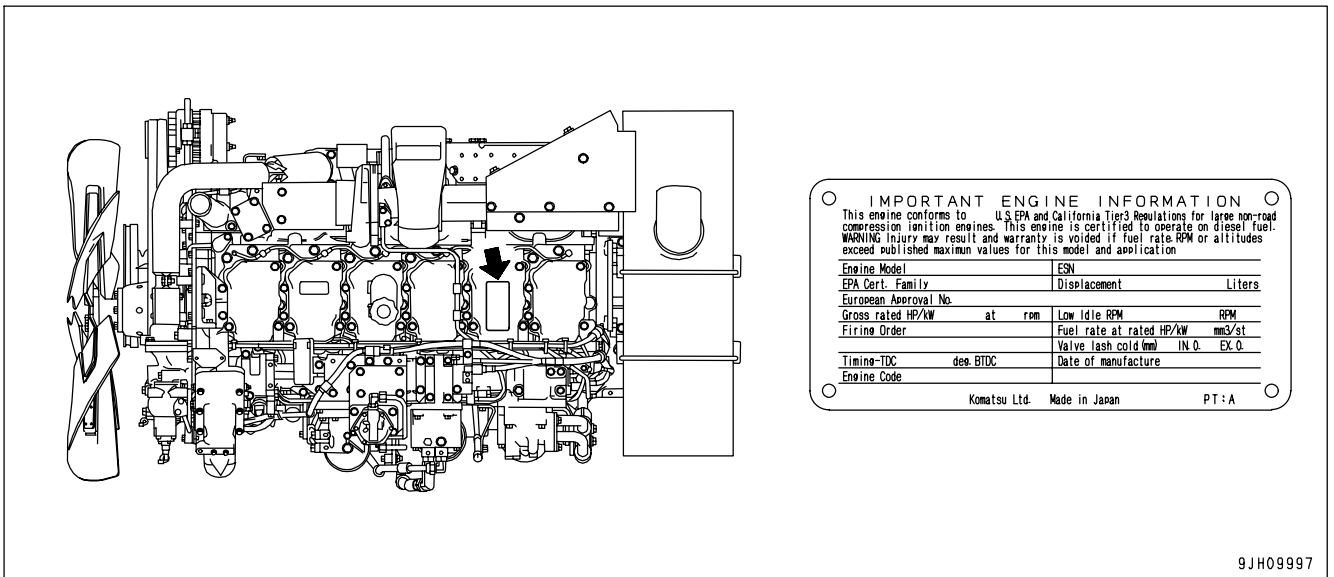

EPA: Environmental Protection Agency, U.S.A.

SERVICE METER LOCATION

On top of the machine monitor

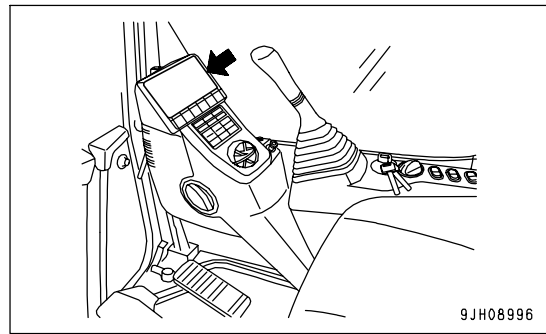

YOUR MACHINE SERIAL NUMBERS AND DISTRIBUTOR

Machine serial No.	
Engine serial No.	
Product identification number (PIN)	
Distributor name	
Address	-----

Service Personnel	-----
Phone/Fax	-----

CONTENTS

FOREWORD ----- 1- 1

 BEFORE READING THIS MANUAL ----- 1- 2

 SAFETY INFORMATION ----- 1- 3

 INTRODUCTION ----- 1- 4

 USE OF MACHINE ----- 1- 4

 DIRECTIONS OF MACHINE ----- 1- 4

 VISIBILITY FROM OPERATOR'S SEAT ----- 1- 5

 PRODUCT INFORMATION ----- 1- 7

 PRODUCT IDENTIFICATION NUMBER (PIN)/MACHINE SERIAL NO. PLATE ----- 1- 7

 EPA REGULATIONS, ENGINE NUMBER PLATE ----- 1- 7

 SERVICE METER LOCATION ----- 1- 8

 YOUR MACHINE SERIAL NUMBERS AND DISTRIBUTOR ----- 1- 8

SAFETY ----- 2- 1

 SAFETY ----- 2- 2

 SAFETY LABELS ----- 2- 5

 LOCATION OF SAFETY LABELS ----- 2- 5

 SAFETY LABELS ----- 2- 6

 GENERAL PRECAUTIONS COMMON TO OPERATION AND MAINTENANCE ----- 2- 12

 PRECAUTIONS BEFORE STARTING OPERATION ----- 2- 12

 PREPARATIONS FOR SAFE OPERATION ----- 2- 12

 FIRE PREVENTION ----- 2- 14

 PRECAUTIONS WHEN GETTING ON OR OFF MACHINE ----- 2- 15

 DO NOT GET CAUGHT IN WORK EQUIPMENT ----- 2- 17

 PRECAUTIONS RELATED TO PROTECTIVE STRUCTURES ----- 2- 17

 PROTECTION AGAINST FALLING, FLYING, INTRUDING OBJECTS ----- 2- 17

 UNAUTHORIZED MODIFICATION ----- 2- 18

 PRECAUTIONS RELATED TO ATTACHMENTS AND OPTIONS ----- 2- 18

 PRECAUTIONS RELATED TO CAB GLASS ----- 2- 18

 PRECAUTIONS WHEN RUNNING ENGINE INSIDE BUILDING ----- 2- 18

 PRECAUTIONS FOR OPERATION ----- 2- 19

 PRECAUTIONS FOR JOBSITE ----- 2- 19

 STARTING ENGINE ----- 2- 21

 OPERATION ----- 2- 23

 TRANSPORTATION ----- 2- 31

 TOWING ----- 2- 32

 LIFTING OBJECTS WITH BUCKET ----- 2- 33

 PRECAUTIONS FOR MAINTENANCE ----- 2- 34

 PRECAUTIONS BEFORE STARTING INSPECTION AND MAINTENANCE ----- 2- 34

 PRECAUTIONS FOR INSPECTION AND MAINTENANCE ----- 2- 38

OPERATION ----- 3- 1

 MACHINE VIEW ILLUSTRATIONS ----- 3- 2

 OVERALL MACHINE VIEW ----- 3- 2

 CONTROLS AND GAUGES ----- 3- 3

 DETAILED CONTROLS AND GAUGES ----- 3- 5

 MONITORING SYSTEM ----- 3- 5

 SWITCHES ----- 3- 70

 CONTROL LEVERS AND PEDALS ----- 3- 75

 SUN ROOF ----- 3- 78

 WINDSHIELD ----- 3- 78

EMERGENCY ESCAPE HAMMER	3- 84
DOOR LOCK	3- 84
CAP WITH LOCK	3- 85
DRINK BOX	3- 87
MAGAZINE BOX	3- 87
ASHTRAY	3- 87
AIR CONDITIONER CONTROLS	3- 88
RADIO	3-101
AUXILIARY ELECTRIC POWER	3-106
FUSE	3-107
FUSIBLE LINK	3-108
CONTROLLER	3-108
TOOL BOX	3-109
GREASE PUMP HOLDER	3-109
FIRE EXTINGUISHER	3-109
MACHINE OPERATIONS AND CONTROLS	3-110
BEFORE STARTING ENGINE	3-110
STARTING ENGINE	3-129
AFTER STARTING ENGINE	3-132
STOPPING THE ENGINE	3-143
MACHINE OPERATION	3-144
STEERING THE MACHINE	3-148
SWINGING	3-150
WORK EQUIPMENT CONTROLS AND OPERATIONS	3-151
WORKING MODE	3-153
PROHIBITED OPERATIONS	3-155
GENERAL OPERATION INFORMATION	3-160
TRAVELING ON SLOPES	3-162
ESCAPE FROM MUD	3-164
RECOMMENDED APPLICATIONS	3-165
BUCKET REPLACEMENT AND INVERSION	3-167
PARKING MACHINE	3-171
MACHINE INSPECTION AFTER DAILY WORK	3-172
LOCKING	3-173
TRANSPORTATION	3-174
TRANSPORTATION PROCEDURE	3-174
LOADING AND UNLOADING WITH TRAILER	3-175
LIFTING MACHINE	3-184
TRANSPORTATION POSTURE	3-186
PROCEDURE FOR INCREASING OR REDUCING TRACK FRAME GAUGE	3-188
COLD WEATHER OPERATION	3-190
COLD WEATHER OPERATION INFORMATION	3-190
AFTER DAILY WORK COMPLETION	3-192
AFTER COLD WEATHER SEASON	3-192
LONG TERM STORAGE	3-193
BEFORE STORAGE	3-193
DURING STORAGE	3-193
AFTER STORAGE	3-194
STARTING MACHINE AFTER LONG-TERM STORAGE	3-194
TROUBLES AND ACTIONS	3-195

RUNNING OUT OF FUEL	3-195
PHENOMENA THAT ARE NOT FAILURES	3-196
TOWING THE MACHINE	3-197
LIGHTWEIGHT TOWING HOLE	3-198
SEVERE JOB CONDITION	3-198
DISCHARGED BATTERY	3-199
OTHER TROUBLE	3-203
MAINTENANCE	4- 1
MAINTENANCE INFORMATION	4- 2
OUTLINE OF SERVICE	4- 4
HANDLING OIL, FUEL, COOLANT, AND PERFORMING OIL CLINIC	4- 4
ELECTRIC SYSTEM MAINTENANCE	4- 7
WEAR PARTS	4- 8
WEAR PARTS LIST	4- 8
RECOMMENDED FUEL, COOLANT, AND LUBRICANT	4- 9
RECOMMENDED BRANDS, RECOMMENDED QUALITY FOR PRODUCTS OTHER THAN KOMATSU GENUINE OIL	4- 11
TIGHTENING TORQUE SPECIFICATIONS	4- 12
TIGHTENING TORQUE LIST	4- 12
SAFETY CRITICAL PARTS	4- 13
SAFETY CRITICAL PARTS LIST	4- 14
MAINTENANCE SCHEDULE	4- 15
MAINTENANCE SCHEDULE CHART	4- 15
MAINTENANCE INTERVAL FOR HYDRAULIC BREAKER	4- 17
MAINTENANCE PROCEDURE	4- 18
INITIAL 1000 HOURS MAINTENANCE (ONLY AFTER THE FIRST 1000 HOURS) WHEN REQUIRED	4- 18
CHECK BEFORE STARTING	4- 46
EVERY 50 HOURS MAINTENANCE	4- 47
EVERY 250 HOURS MAINTENANCE	4- 48
EVERY 500 HOURS MAINTENANCE	4- 53
EVERY 1000 HOURS MAINTENANCE	4- 66
EVERY 2000 HOURS MAINTENANCE	4- 73
EVERY 4000 HOURS MAINTENANCE	4- 80
EVERY 5000 HOURS MAINTENANCE	4- 82
EVERY 8000 HOURS MAINTENANCE	4- 84
SPECIFICATIONS	5- 1
SPECIFICATIONS	5- 2
ATTACHMENTS AND OPTIONS	6- 1
GENERAL PRECAUTIONS FOR SAFETY	6- 2
PRECAUTIONS WHEN SELECTING	6- 2
READ THE INSTRUCTION MANUAL THOROUGHLY	6- 2
PRECAUTIONS WHEN REMOVING OR INSTALLING	6- 2
PRECAUTIONS WHEN USING	6- 2
BUCKET WITH HOOK	6- 3
HOOK CONDITION	6- 3
PROHIBITED OPERATIONS	6- 3
MACHINE READY FOR ATTACHMENT	6- 4
LOCATIONS	6- 4
HYDRAULIC CIRCUIT	6- 8

ATTACHMENT REMOVAL AND INSTALLATION	6- 13
ATTACHMENT OPERATIONS	6- 17
LONG TERM STORAGE	6- 18
SPECIFICATIONS	6- 18
HANDLING THE ELECTRIC PRIMING PUMP	6- 19
BLEEDING AIR FROM FUEL CIRCUIT	6- 19
ATTACHMENT GUIDE	6- 22
ATTACHMENT COMBINATIONS	6- 22
TRACK SHOES SELECTION	6- 24
RECOMMENDED ATTACHMENT OPERATIONS	6- 25
HYDRAULIC BREAKER	6- 25
HANDLING MACHINES EQUIPPED WITH KOMTRAX	6- 29
BASIC PRECAUTIONS	6- 29
INDEX	7- 1

SAFETY

WARNING

Please read and make sure that you fully understand the precautions described in this manual and the safety labels on the machine. When operating or servicing the machine, always follow these precautions strictly.

SAFETY

SAFETY LABELS	2- 5
LOCATION OF SAFETY LABELS	2- 5
SAFETY LABELS	2- 6
GENERAL PRECAUTIONS COMMON TO OPERATION AND MAINTENANCE	2- 12
PRECAUTIONS BEFORE STARTING OPERATION	2- 12
ENSURING SAFE OPERATION	2- 12
UNDERSTANDING THE MACHINE	2- 12
PREPARATIONS FOR SAFE OPERATION	2- 12
PRECAUTIONS REGARDING SAFETY-RELATED EQUIPMENT	2- 12
INSPECTING MACHINE	2- 12
WEAR WELL-FITTING CLOTHES AND PROTECTIVE EQUIPMENT	2- 12
KEEP MACHINE CLEAN	2- 13
PRECAUTIONS INSIDE OPERATOR'S COMPARTMENT	2- 13
PROVIDE FIRE EXTINGUISHER AND FIRST AID KIT	2- 13
IF ANY PROBLEM IS FOUND	2- 13
FIRE PREVENTION	2- 14
ACTION IF FIRE OCCURS	2- 14
PRECAUTIONS TO PREVENT FIRE	2- 14
PRECAUTIONS WHEN GETTING ON OR OFF MACHINE	2- 15
USE HANDRAILS AND STEPS WHEN GETTING ON OR OFF MACHINE	2- 15
NO JUMPING ON OR OFF MACHINE	2- 16
NO PEOPLE ON ATTACHMENTS	2- 16
PRECAUTIONS WHEN STANDING UP FROM OPERATOR'S SEAT	2- 16
PRECAUTIONS WHEN LEAVING MACHINE	2- 16
EMERGENCY EXIT FROM OPERATOR'S CAB	2- 16
DO NOT GET CAUGHT IN WORK EQUIPMENT	2- 17
PRECAUTIONS RELATED TO PROTECTIVE STRUCTURES	2- 17
PROTECTION AGAINST FALLING, FLYING, INTRUDING OBJECTS	2- 17
UNAUTHORIZED MODIFICATION	2- 18
PRECAUTIONS RELATED TO ATTACHMENTS AND OPTIONS	2- 18
PRECAUTIONS RELATED TO CAB GLASS	2- 18
PRECAUTIONS WHEN RUNNING ENGINE INSIDE BUILDING	2- 18

PRECAUTIONS FOR OPERATION	2- 19
PRECAUTIONS FOR JOBSITE	2- 19
INVESTIGATE AND CONFIRM JOBSITE CONDITIONS	2- 19
WORKING ON LOOSE GROUND	2- 19
DO NOT GO CLOSE TO HIGH-VOLTAGE CABLES	2- 20
ENSURE GOOD VISIBILITY	2- 20
CHECKING SIGNS AND SIGNALMAN'S SIGNALS	2- 20
BEWARE OF ASBESTOS DUST	2- 21
STARTING ENGINE	2- 21
USE WARNING TAGS	2- 21
INSPECTION AND MAINTENANCE BEFORE STARTING ENGINE	2- 22
PRECAUTIONS WHEN STARTING ENGINE	2- 22
PRECAUTIONS IN COLD AREAS	2- 22
STARTING WITH BOOSTER CABLES	2- 23
OPERATION	2- 23
CHECKS BEFORE OPERATION	2- 23
PRECAUTIONS WHEN TRAVELING IN FORWARD OR REVERSE AND SWINGING	2- 24
PRECAUTIONS WHEN TRAVELING	2- 25
TRAVELING ON SLOPES	2- 26
OPERATING ON SLOPES	2- 27
PROHIBITED OPERATIONS	2- 27
TRAVELING ON SNOW-COVERED OR FROZEN SURFACES	2- 29
PARKING MACHINE	2- 30
TRANSPORTATION	2- 31
LOADING AND UNLOADING	2- 31
TOWING	2- 32
PRECAUTIONS WHEN TOWING	2- 32
LIFTING OBJECTS WITH BUCKET	2- 33
PRECAUTIONS FOR LIFTING OPERATIONS	2- 33

PRECAUTIONS FOR MAINTENANCE	2- 34
PRECAUTIONS BEFORE STARTING INSPECTION AND MAINTENANCE	2- 34
DISPLAY WARNING TAG DURING INSPECTION AND MAINTENANCE	2- 34
KEEP WORKPLACE CLEAN AND TIDY	2- 34
SELECT SUITABLE PLACE FOR INSPECTION AND MAINTENANCE	2- 34
ONLY AUTHORIZED PERSONNEL	2- 34
APPOINT LEADER WHEN WORKING WITH OTHERS	2- 34
STOP ENGINE BEFORE CARRYING OUT INSPECTION AND MAINTENANCE	2- 35
TWO WORKERS FOR MAINTENANCE WHEN ENGINE IS RUNNING	2- 36
INSTALLING, REMOVING, OR STORING ATTACHMENTS	2- 36
PRECAUTIONS WHEN WORKING AT HIGH PLACES	2- 36
PRECAUTIONS WHEN WORKING UNDER MACHINE OR WORK EQUIPMENT	2- 37
PROPER TOOLS	2- 37
PRECAUTIONS FOR INSPECTION AND MAINTENANCE	2- 38
PRECAUTIONS WHEN WELDING	2- 38
HANDLING BATTERY	2- 38
PRECAUTIONS WHEN USING HAMMER	2- 39
PRECAUTIONS WITH HIGH-TEMPERATURE COOLANT	2- 39
PRECAUTIONS WITH HIGH-TEMPERATURE OIL	2- 39
PRECAUTIONS WITH HIGH-PRESSURE OIL	2- 40
PRECAUTIONS WITH HIGH-PRESSURE FUEL	2- 40
HANDLING HIGH-PRESSURE HOSES AND PIPING	2- 40
PRECAUTIONS FOR HIGH VOLTAGE	2- 41
NOISE	2- 41
PRECAUTIONS WITH HIGH-PRESSURE GREASE WHEN ADJUSTING TRACK TENSION	2- 41
DO NOT DISASSEMBLE RECOIL SPRING	2- 42
HANDLING ACCUMULATOR AND GAS SPRING	2- 42
PRECAUTIONS WITH COMPRESSED AIR	2- 42
MAINTENANCE OF AIR CONDITIONER	2- 42
DISPOSING OF WASTE MATERIALS	2- 43
METHOD OF SELECTING WINDOW WASHER FLUID	2- 43
PERIODIC REPLACEMENT OF SAFETY CRITICAL PARTS	2- 43

SAFETY LABELS

The following warning signs and safety labels are used on this machine.

- Be sure that you fully understand the correct position and content of labels.
- To ensure that the content of labels can be read properly, be sure that they are in the correct place and always keep them clean. When cleaning them, do not use organic solvents or gasoline. These may cause the labels to peel off.
- There are also other labels in addition to the warning signs and safety labels. Handle those labels in the same way.
- If the labels are damaged, lost, or cannot be read properly, replace them with new ones. For details of the part numbers for the labels, see this manual or the actual label, and place an order with Komatsu distributor.

LOCATION OF SAFETY LABELS

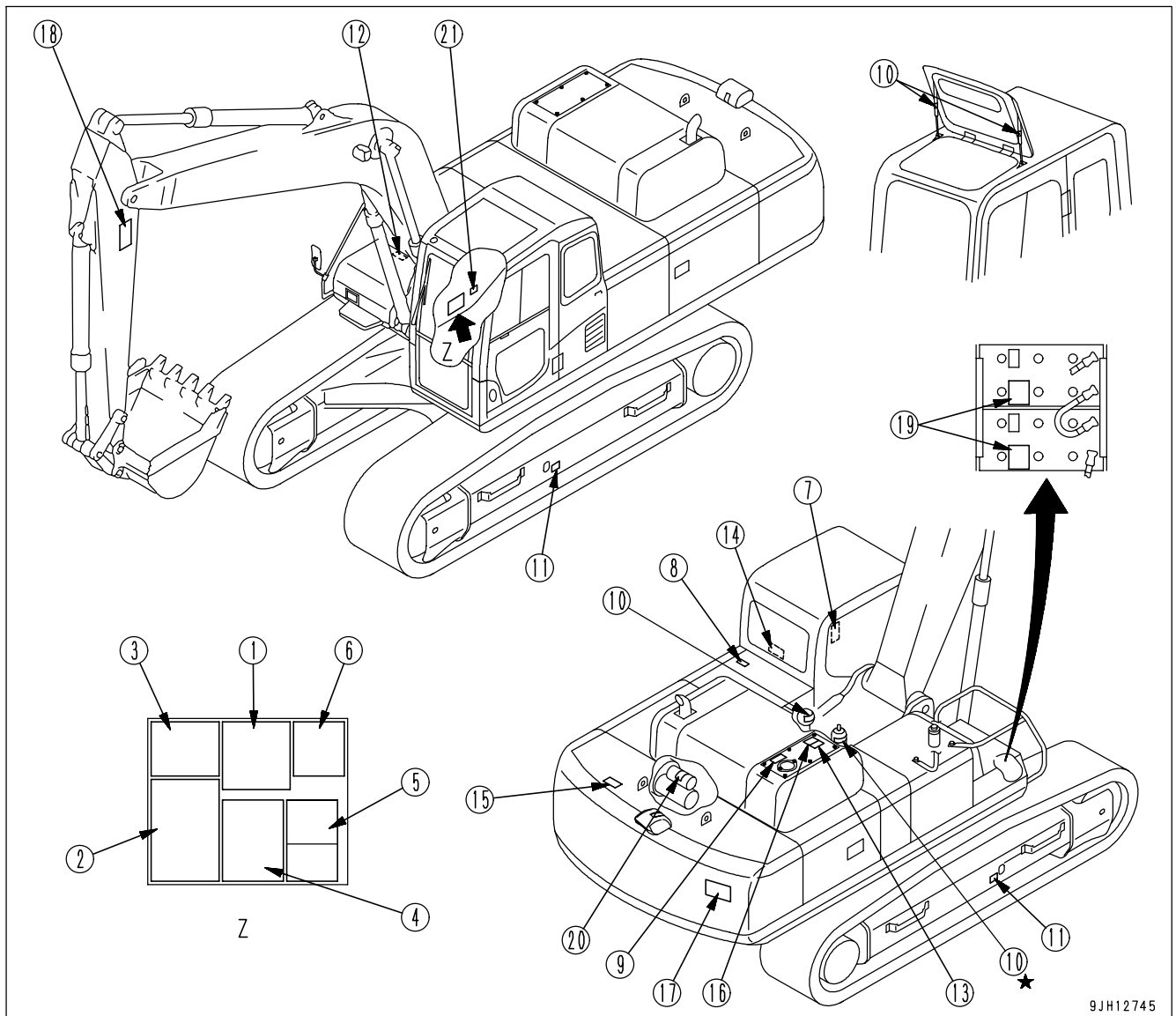

★: if equipped

SAFETY LABELS

- (1) Caution before operating or maintaining machine
(09651-03001)

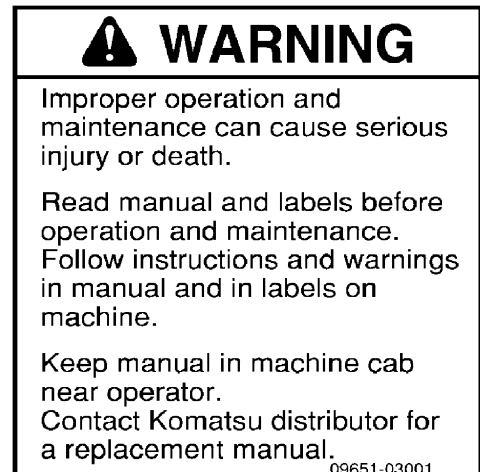

- (2) Caution before operating (09802-03000)

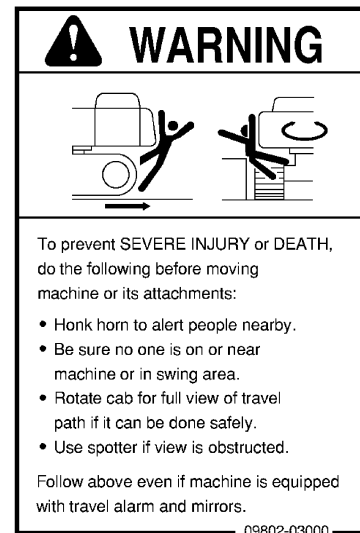

- (3) Caution for leaving operator's seat (09654-03001)



(4) Caution for going close to electric cables (09801-03001)

DANGER

Hazardous voltage hazard.
 Serious injury or death can occur if machine or attachments are not kept safe distance away from electric lines.

VOLTAGE		SAFE DISTANCE
LOW VOLTAGE	100V 200V	2m
	6.600V	2m
	22.000V	3m
SPECIAL HIGH VOLTAGE	66.000V	4m
	154.000V	5m
	187.000V	6m
	275.000V	7m
	500.000V	11m

09801-03001

(5) Caution for operating pattern (09822-03000)

WARNING

In order to prevent an accident resulting in injury or death caused by error-operation, confirm the machine motion and indicated operating pattern, when operating machines. Pay attention to the circumference and operate slowly when confirming the machine motion.

ISO pattern

09822-03000

- (6) Caution when opening or closing front window
(09839-03000)

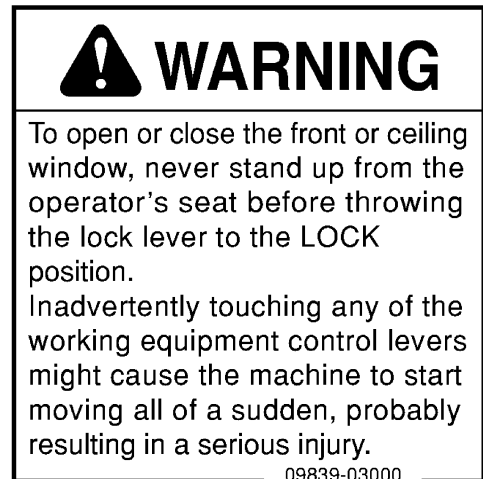

- (7) Caution when stowing front window (09803-03000)

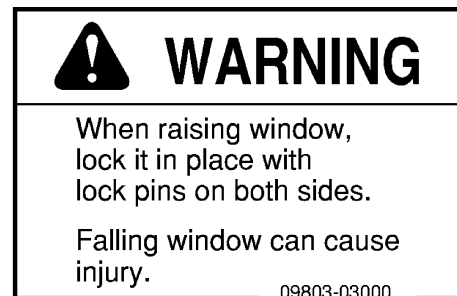

- (8) Caution for high-temperature hydraulic oil (09653-03001)



- (9) Caution with high-temperature coolant (09668-03001)

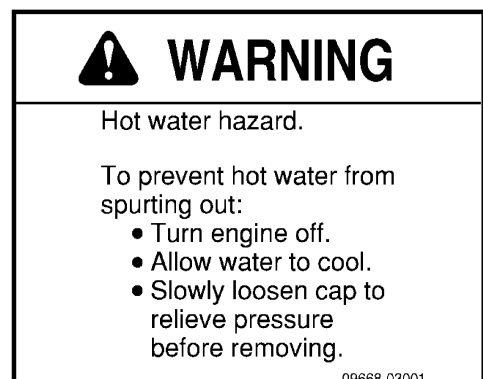

(10) Caution for handling accumulator and gas spring
(09659-53000)



(11) Caution for adjusting track tension (09657-03003)



(12) Caution for handling cable (09808-03000)

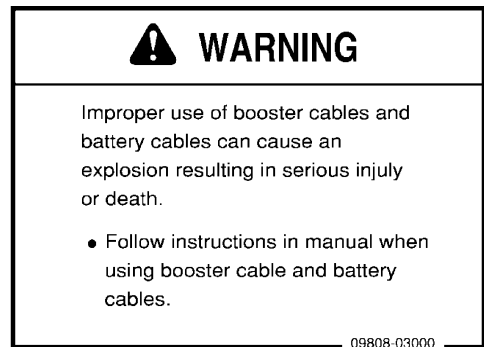

(13) Stopping rotation for inspection and maintenance
(09667-03001)

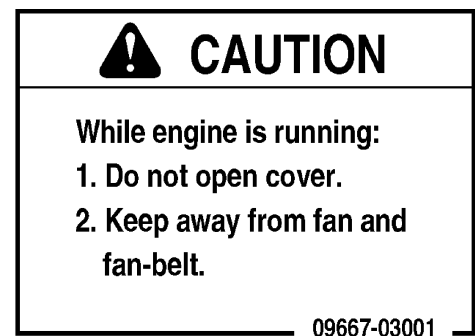

(14) Emergency escape (09844-00050)

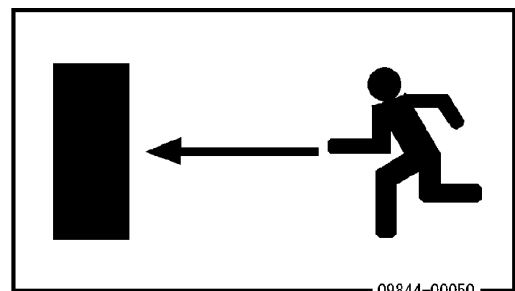

(15) Caution against falling (09805-23000)



(16) Caution against falling (09805-13000)



(17) Prohibited to enter within swing range (09133-23000)



(18) Beware of work equipment (09134-A1681)



Sign indicates a hazard of being hit by the working device of the machine.

Keep away from machine during operation.

(19) Caution when handling battery (14X-98-11370)

 **WARNING**

EXPLOSIVE GASES

- Cigarettes flames or sparks could cause battery to explode.
- Always shield eyes and face from battery.
- Do not charge or use booster cables or adjust post connections without proper instruction and training.
- Keep vent caps tight and level.

POISON CAUSES SEVERE BURNS
Contains sulfuric acid

- Avoid contact with skin eyes or clothing.
- In event of accident flush with water and call a physician immediately.
- Keep out of reach of children.

14X-98-11370

(20) Jump start prohibited (09842-A0481)



Start the engine only after sitting down in the operator's seat.

Do not attempt to start the engine by short-circuiting the engine starting circuit. Such an act may cause a serious bodily injury or fire.

(21) Caution when swinging or traveling in reverse (22B-00-21290)
(If equipped)

 **WARNING**

When swinging or backing up excavator, press button to change display mode on monitor so you can see rear and side of machine. Before moving, look around and at mirror and monitor to confirm that no one is around the machine. Failure to do so can result in serious injury or death.

22B-00-21290

GENERAL PRECAUTIONS COMMON TO OPERATION AND MAINTENANCE

Mistakes in operation, inspection, or maintenance may result in serious personal injury or death. Before carrying out operation, inspection, or maintenance, always read this manual and the safety labels on the machine carefully and obey the warnings.

PRECAUTIONS BEFORE STARTING OPERATION

ENSURING SAFE OPERATION

- Only trained and authorized personnel can operate and maintain the machine.
- Follow all safety, precautions, and instructions in this manual when operating or performing inspection or maintenance on the machine.
- If you are not feeling well, or if you are under the influence of alcohol or medication, your ability to safely operate or repair your machine may be severely impaired, putting yourself and everyone else on your job site in danger.
- When working with another operator or with the person on the worksite traffic duty, discuss the content of the operation beforehand and use the determined signals when carrying out the operation.

UNDERSTANDING THE MACHINE

Before operating the machine, read this manual thoroughly. If there are any places in this manual that you do not understand, ask the person in charge of safety to give an explanation.

PREPARATIONS FOR SAFE OPERATION

PRECAUTIONS REGARDING SAFETY-RELATED EQUIPMENT

- Be sure that all guards, covers, cameras, and mirrors are in their proper position. Have them repaired immediately if they are damaged.
- Understand the method of use of safety features and use them properly.
- Never remove any safety features. Always keep them in good operating condition.

INSPECTING MACHINE

Check the machine before starting operations. If any abnormality is found, do not operate the machine until repairs of the problem location have been completed.

WEAR WELL-FITTING CLOTHES AND PROTECTIVE EQUIPMENT

- Do not wear loose clothes or any accessories. If these catch on the control levers or protruding parts, there is danger that it may cause the machine to move unexpectedly.
- Always wear a hard hat and safety shoes. If the nature of the work requires it, wear safety glasses, mask, gloves, ear plugs, and safety belt when operating or maintaining the machine.
- If you have long hair and it hangs out from your hard hat, there is a hazard that it may get caught up in the machine, so tie your hair up and be careful not to let it get caught.
- Check that all protective equipment functions properly before using it.

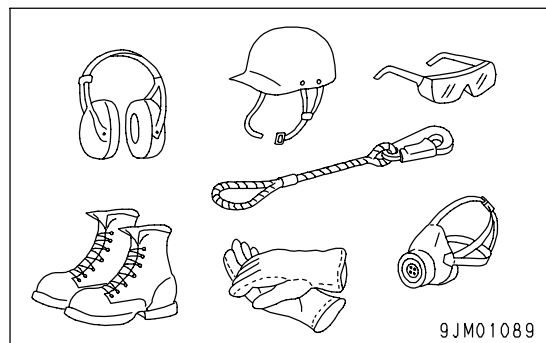

9JM01089

KEEP MACHINE CLEAN

- If you get on or off the machine or carry out inspection and maintenance when the machine is dirty with mud or oil, there is a hazard that you will slip and fall. Wipe off any mud or oil from the machine. Always keep the machine clean.
- If water gets into the electrical system, there is a hazard that it will cause malfunctions or misoperation. If there is any misoperation, there is danger that the machine may move unexpectedly and cause serious personal injury or death. When washing the machine with water or steam, do not allow the water or steam to come into direct contact with electrical components.

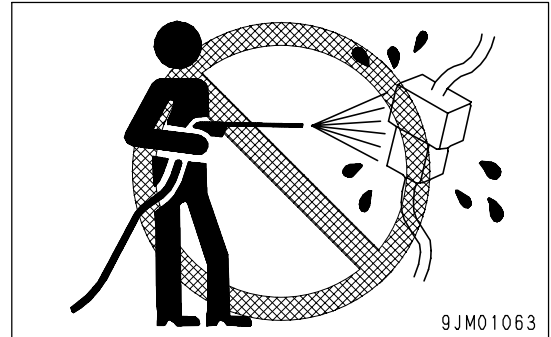
**PRECAUTIONS INSIDE OPERATOR'S COMPARTMENT**

- When entering the operator's compartment, always remove all mud and oil from the soles of your shoes. If you operate the pedal with mud or oil affixed to your shoes, your foot may slip and this may cause a serious accident.
- Do not leave tools or a machine parts lying around inside the operator's compartment. If tools or parts get into the control devices, it may obstruct operation and cause the machine to move unexpectedly, resulting in serious personal injury or death.
- Do not stick suction pads to the window glass. Suction pads act as a lens and may cause fire.
- Do not use a cell phone when driving or operating the machine. This may lead to mistakes in operation, which could cause serious personal injury or death.
- Never bring any dangerous objects such as flammable or explosive items into the operator's compartment.

PROVIDE FIRE EXTINGUISHER AND FIRST AID KIT

Always follow the precautions below to prepare for action if any injury or fire should occur.

- Be sure that fire extinguishers have been provided and read the labels to ensure that you know how to use them in emergencies.
- Carry out periodic inspection and maintenance to ensure that the fire extinguisher can always be used.
- Provide a first aid kit in the storage point. Carry out periodic checks and add to the contents if necessary.

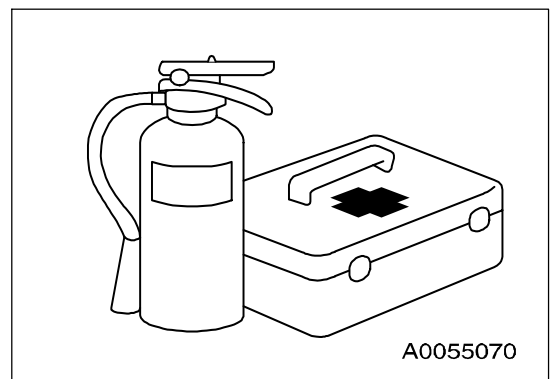
**IF ANY PROBLEM IS FOUND**

If you find any problems in the machine during operation or maintenance (noise, vibration, smell, incorrect gauges, smoke, oil leakage, etc., or any abnormal display on the warning devices or monitor), report to the person in charge and have the necessary action taken. Do not operate the machine until the problem has been corrected.

FIRE PREVENTION

ACTION IF FIRE OCCURS

- Turn the start switch OFF to stop the engine.
- Use the handrails and steps to get off the machine.
- Do not jump off the machine. There is the danger of falling and suffering serious injury.

PRECAUTIONS TO PREVENT FIRE

• Fire caused by fuel, oil, antifreeze, or window washer fluid

Do not bring any flame or fire close to flammable substances such as fuel, oil, antifreeze, or window washer fluid. There is danger that they may catch fire. To prevent fire, always observe the following:

- Do not smoke or use any flame near fuel or other flammable substances.
- Stop the engine before adding fuel.
- Do not leave the machine when adding fuel or oil.
- Tighten all fuel and oil caps securely.
- Be careful not to spill fuel on overheated surfaces or on parts of the electrical system.
- After adding fuel or oil, wipe up any spilled fuel or oil.
- Put greasy rags and other flammable materials into a safe container to maintain safety at the workplace.
- When washing parts with oil, use a non-flammable oil. Do not use diesel oil or gasoline. There is danger that they may catch fire.
- Do not weld or use a cutting torch to cut any pipes or tubes that contain flammable liquids.
- Determine well-ventilated areas for storing oil and fuel. Keep the oil and fuel in the determined place and do not allow unauthorized persons to enter.
- When carrying out grinding or welding work on the machine, move any flammable materials to a safe place before starting.

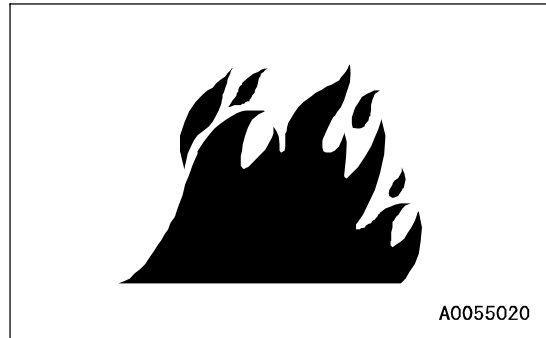

• Fire caused by accumulation of flammable material.

- Remove any dry leaves, chips, pieces of paper, coal dust, or any other flammable materials accumulated or affixed around the engine, exhaust manifold, muffler, or battery, or inside the undercovers.
- To prevent fires spreading from sparks or burning particles from other fires, remove any flammable materials such as dry leaves, chips, pieces of paper, coal dust, or any other flammable materials accumulated around the cooling system (radiator, oil cooler) or inside the undercover.

• Fire coming from electric wiring

Short circuits in the electrical system can cause fire. To prevent fire, always observe the following.

- Keep all electric wiring connections clean and securely tightened.
- Check the wiring every day for looseness or damage. Tighten any loose connectors or wiring clamps. Repair or replace any damaged wiring.

- **Fire coming from piping**

Check that all the hose and tube clamps, guards, and cushions are securely fixed in position.

If they are loose, they may vibrate during operation and rub against other parts. There is danger that this may lead to damage to the hoses and cause high-pressure oil to spurt out, leading to fire, serious personal injury or death.

- **Explosion caused by lighting equipment**

- When checking fuel, oil, battery electrolyte, or coolant, always use lighting with anti-explosion specifications.
- When taking the electrical power for the lighting from the machine itself, follow the instructions in this manual.

PRECAUTIONS WHEN GETTING ON OR OFF MACHINE

USE HANDRAILS AND STEPS WHEN GETTING ON OR OFF MACHINE

To prevent personal injury caused by slipping or falling off the machine, always do as follows.

- Use the handrails and steps marked by arrows in the diagram on the right when getting on or off the machine.

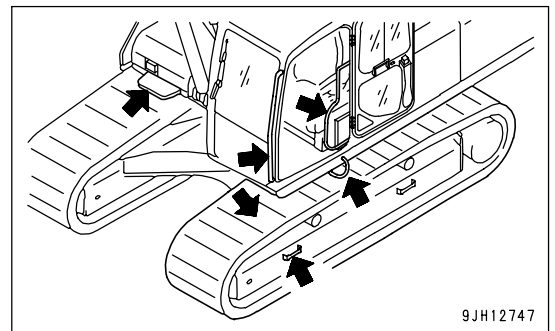

9JH12747

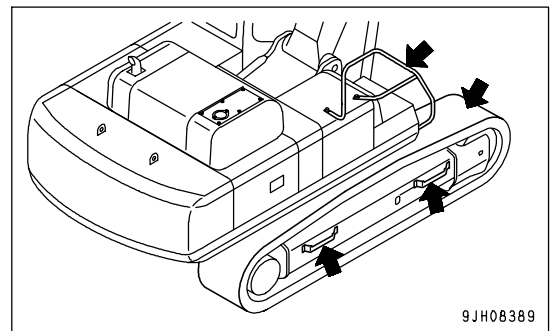

9JH08389

- Always face the machine and maintain at least three-point contact (both feet and one hand, or both hands and one foot) with the handrail and steps to ensure that you support yourself.

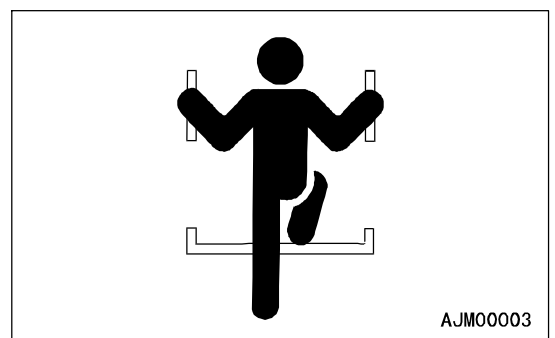

AJM00003

- Before getting on or off the machine, check the handrails and steps, and if there is any oil, grease, or mud on them, wipe it off immediately. In addition, repair any damage and tighten any loose bolts.
- Do not grip the control levers or lock lever when getting on or off the machine.
- Never climb on the engine hood or covers where there are no non-slip pads.
- Do not get on or off the machine while holding tools in your hand.
- The collapsible type side mirror can turn, so do not grab hold of it as a handrail.

NO JUMPING ON OR OFF MACHINE

- Never jump on or off the machine. Never get on or off a moving machine.
- If the machine starts to move when there is no operator on the machine, do not jump on to the machine and try to stop it.

NO PEOPLE ON ATTACHMENTS

Never let anyone ride on the work equipment or other attachments. There is a hazard of falling and suffering serious personal injury or death.

PRECAUTIONS WHEN STANDING UP FROM OPERATOR'S SEAT

Before standing up from the operator's seat, such as when opening or closing the front window or ceiling window, when removing or installing the bottom window, or adjusting the position of the seat, always lower the work equipment completely to the ground, set lock lever (1) to the lock position (L), and stop the engine.

If the control levers are touched by mistake, the machine may suddenly move and cause serious personal injury or death.

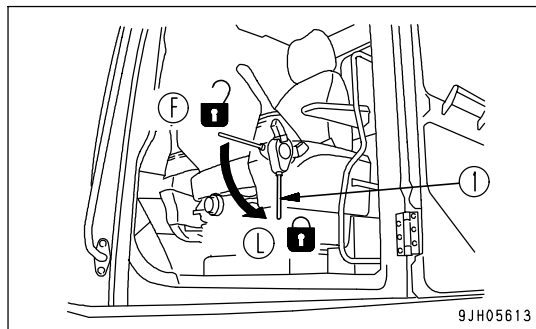
**PRECAUTIONS WHEN LEAVING MACHINE**

If the proper procedures are not taken when parking the machine, the machine may suddenly move off by itself, and this may lead to serious personal injury or death. Always do the following.

- When leaving the machine, always lower the work equipment completely to the ground, set lock lever (1) to the lock position (L), and stop the engine.
- In addition, lock all parts, always take the key with you and leave it in the specified place.

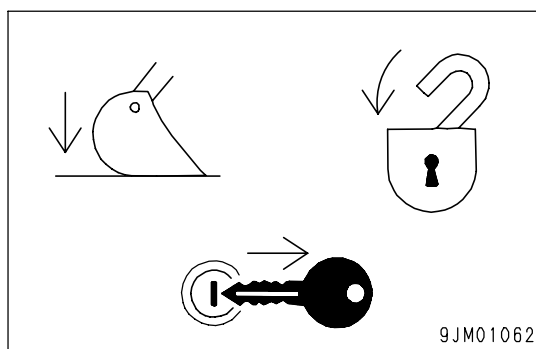
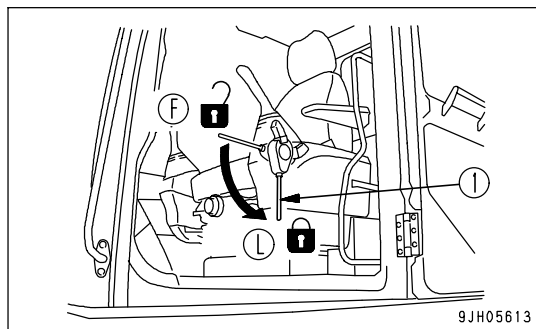
**EMERGENCY EXIT FROM OPERATOR'S CAB**

- If it should be impossible to open the door of the cab, break the window glass with the hammer supplied and use the window as an emergency escape.
For details, see "EMERGENCY ESCAPE HAMMER (PAGE 3-84)" in this volume.
- When escaping, remove all the pieces of glass from the window frame first and be careful not to cut yourself on the glass. Be careful also not to slip on the broken pieces of glass on the ground.

DO NOT GET CAUGHT IN WORK EQUIPMENT

The clearance in the area around the work equipment changes according to the movement of the link. If you get caught, you may suffer serious personal injury or death. Do not allow anyone to come close to any rotating or extending/retracting portion.

PRECAUTIONS RELATED TO PROTECTIVE STRUCTURES

The operator's compartment is equipped with a structure (ROPS, FOPS) to protect the operator by absorbing the impact energy. If the machine weight (mass) exceeds the certified value (shown on the ROLL-OVER PROTECTIVE STRUCTURE (ROPS) CERTIFICATION plate), ROPS will not be able to fulfill its function. Do not increase machine weight beyond the certified value by modifying the machine or by installing attachments to the machine. Also, if the function of the protective equipment is impeded, the protective equipment will not be able to protect the operator, and the operator may suffer injury or death. Always observe the following.

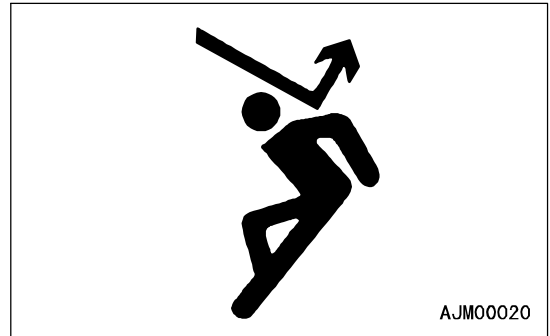

- If the machine is equipped with a protective structure, do not remove the protective structure and carry out operations without it.
- If the protective structure is welded, or holes are drilled in it, or it is modified in any other way, its strength may drop. Consult your Komatsu distributor before carrying out any modifications.
- If the protective structure is damaged or deformed by falling objects or by rolling over, its strength will be reduced and it will not be able to fulfill its function properly. In such cases, always contact your Komatsu distributor for advice on the method of repair.
- Even if the protective structure is installed, always fasten your seat belt properly when operating the machine. If you do not fasten your seatbelt properly, it cannot display its effect.

PROTECTION AGAINST FALLING, FLYING, INTRUDING OBJECTS

On jobsites where there is a hazard that falling objects, flying objects, or intruding objects may hit or enter the operator's cab, consider the operating conditions and install the necessary guards to protect the operator.

- When operating on jobsites, such as mines or quarries, where there is a hazard of falling rocks, install FOPS and a front guard, and always keep all the windows and doors closed when operating. In addition, always check that there is no one except the operator in the surrounding area. They may be hit by falling objects or flying objects.
- When carrying out demolition or breaker operations, install a front guard and always keep all the windows closed when operating. In addition, always check that there is no one except the operator in the surrounding area. They may be hit by falling objects or flying objects.
- If, furthermore, the machine is used for standard operations, it is also necessary to install additional guards, depending on the prevailing conditions at the jobsite.

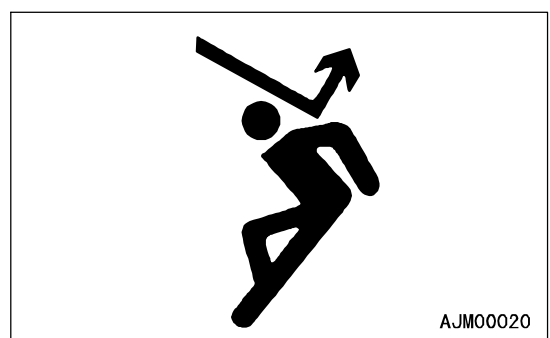
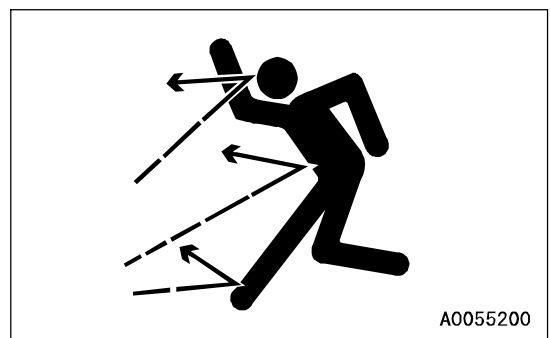

In such a case, do not operate the machine without an additional guard. Be sure to consult with your Komatsu distributor about necessary guards.

UNAUTHORIZED MODIFICATION

- Komatsu will not be responsible for any injuries, accidents, product failures or other property damages resulting from modifications made without authorization from Komatsu.
- Any modification made without authorization from Komatsu can create hazards. Before making a modification, consult your Komatsu distributor.

PRECAUTIONS RELATED TO ATTACHMENTS AND OPTIONS

- Any injuries, accidents, product failures or other property damages resulting from the use of unauthorized attachments or parts will not be the responsibility of Komatsu.
- When installing optional parts or attachments, there may be problems with safety or legal restrictions. Therefore contact your Komatsu distributor for advice.
- Depending on type of combination of work equipment, there is hazard that the work equipment may hit the cab or other parts of the machine. During operation, an interference of the work equipment with the machine may cause a serious personal injury. Before using unfamiliar work equipment, check there is hazard of interference, and operate within not contact.
- When installing and using optional attachments, read the instruction manual for the attachment, and the general information related to attachments in this manual.

PRECAUTIONS RELATED TO CAB GLASS

- If the cab glass is broken during operations, stop operations and repair the cab glass immediately.
- If the cab glass on the work equipment side is broken, there is a hazard that the operator may be directly hit or caught in the work equipment. If the glass is broken, stop operations immediately and replace the glass.
- The ceiling window is made of plastic, so if it is scratched, the visibility will become poor and there is danger that it may break. If it is scratched, replace it with the new part as soon as possible. If the window is scratched and is not replaced, there is danger that any rocks falling on it will cause it to break, leading to injury to the operator.

PRECAUTIONS WHEN RUNNING ENGINE INSIDE BUILDING

The engine exhaust gas contains substances that may damage your health or even cause death. Start or operate the engine in a place where there is good ventilation. If the engine or machine must be operated inside a building or under ground, where the ventilation is poor, take steps to ensure that the engine exhaust gas is removed and that ample fresh air is brought in.

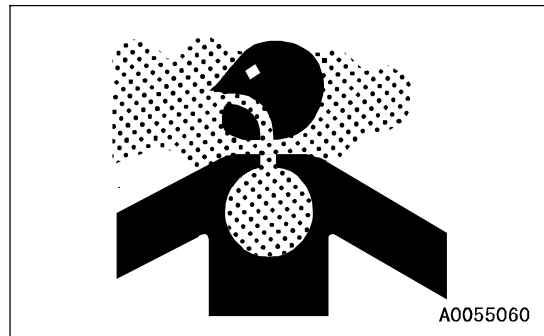

PRECAUTIONS FOR OPERATION

PRECAUTIONS FOR JOBSITE

INVESTIGATE AND CONFIRM JOBSITE CONDITIONS

On the jobsite, there are various hidden dangers that may lead to personal injury or death. Before starting operations, always check the following to confirm that there is no danger on the jobsite.

- When carrying out operations near combustible materials such as thatched roofs, dry leaves or dry grass, there is a hazard of fire, so be careful when operating.
- Check the terrain and condition of the ground at the worksite, and determine the safest method of operation. Do not operate where there is a hazard of landslides or falling rocks.
- If water lines, gas lines, or high-voltage electrical lines may be buried under the worksite, contact each utility and identify their locations. Be careful not to sever or damage any of these lines.
- Take necessary measures to prevent any unauthorized person from entering the operating area.
- In particular, if you need to operate on a road, protect pedestrian and cars by designating a person for worksite traffic duty or by installing fences around the worksite.
- When traveling or operating in water or on soft ground, check the water depth, speed of the current, bedrock, and shape of the ground beforehand and avoid any place that will obstruct travel.

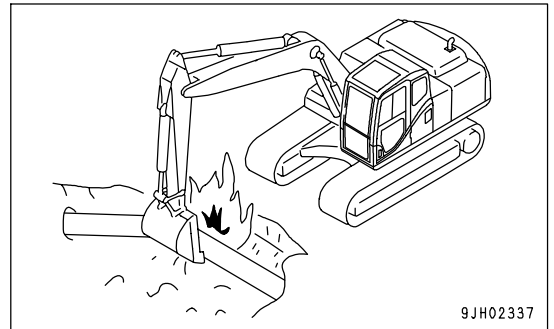

WORKING ON LOOSE GROUND

- Avoid traveling or operating your machine too close to the edge of cliffs, overhangs, and deep ditches. The ground may be weak in such areas. If the ground should collapse under the weight or vibration of the machine, there is a hazard that the machine may fall or tip over. Remember that the soil after heavy rain or blasting or after earthquakes is weak in these areas.
- When working on embankments or near excavated ditches, there is a hazard that the weight and vibration of the machine will cause the soil to collapse. Before starting operations, take steps to ensure that the ground is safe and to prevent the machine from rolling over or falling.

DO NOT GO CLOSE TO HIGH-VOLTAGE CABLES

Do not travel or operate the machine near electric cables. There is a hazard of electric shock, which may cause serious personal injury or death. On jobsites where the machine may go close to electric cables, always do as follows.

- Before starting work near electric cables, inform the local power company of the work to be performed, and ask them to take the necessary action.

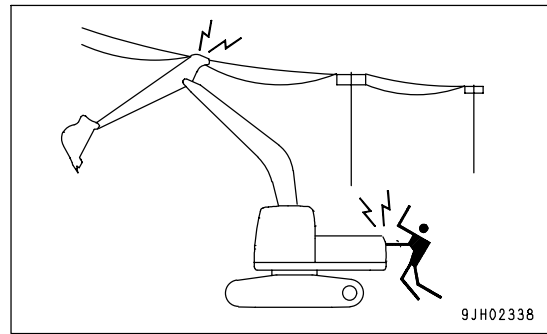

- Even going close to high-voltage cables can cause electric shock, which may cause serious burns or even death. Always maintain a safe distance (see the table on the right) between the machine and the electric cable. Check with the local power company about safe operating procedure before starting operations.
- To prepare for any possible emergencies, wear rubber shoes and gloves. Lay a rubber sheet on top of the seat, and be careful not to touch the chassis with any exposed part of your body.
- Use a signalman to give warning if the machine approaches too close to the electric cables.

Voltage of Cables	Safety Distance
100V - 200V	Over 2 m (7 ft)
6,600V	Over 2 m (7 ft)
22,000V	Over 3 m (10 ft)
66,000V	Over 4 m (14 ft)
154,000V	Over 5 m (17 ft)
187,000V	Over 6 m (20 ft)
275,000V	Over 7 m (23 ft)
500,000V	Over 11 m (36 ft)

- When carrying out operations near high voltage cables, do not let anyone near the machine.
- If the machine should come too close or touch the electric cable, to prevent electric shock, the operator should not leave the operator’s compartment until it has been confirmed that the electricity has been shut off. Also, do not let anyone near the machine.

ENSURE GOOD VISIBILITY

This machine is equipped with mirrors and cameras to ensure good visibility, but even then there are places that cannot be seen from the operator’s seat, so be careful when operating.

When traveling or carrying out operations in places with poor visibility, it is impossible to check for obstacles in the area around the machine and to check the condition of the jobsite. This leads to danger of serious personal injury or death. When traveling or carrying out operations in places with poor visibility, always observe the following.

- Position a signalman if there are areas where the visibility is not good.
- Only one signalman should give signals.
- When working in dark places, turn on the working lamp and front lamps installed to the machine, and set up additional lighting in the work area if necessary.
- Stop operations if the visibility is poor, such as in mist, snow, rain, or dust.
- When checking the mirrors installed to the machine, remove all dirt and adjust the angle of the mirror to ensure good visibility.
- If the machine is equipped with cameras, clean off any dirt from the lens and make sure that the camera gives a clear view.

CHECKING SIGNS AND SIGNALMAN'S SIGNALS

- Set up signs to inform of road shoulders and soft ground. If the visibility is not good, position a signalman if necessary. Operators should pay careful attention to the signs and follow the instructions from the signalman.
- Only one signalman should give signals.
- Make sure that all workers understand the meaning of all signals and signs before starting work.

BEWARE OF ASBESTOS DUST

Asbestos dust in the air can cause lung cancer if it is inhaled. There is danger of inhaling asbestos when working on jobsites handling demolition work or work handling industrial waste. Always observe the following.

- Spray water to keep down the dust.
- Do not use compressed air.
- If there is danger that there may be asbestos dust in the air, always operate the machine from an upwind position, and make sure that all workers operate on the upwind side.
- All workers should use anti-dust masks.
- Do not allow other persons to approach during the operation.
- Always observe the rules and regulations for the work site and environmental standards.

This machine does not use asbestos, but there is a danger that imitation parts may contain asbestos, so always use genuine Komatsu parts.

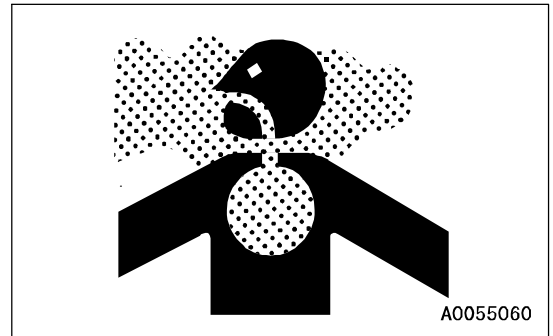
**STARTING ENGINE****USE WARNING TAGS**

If there is any "DANGER! Do NOT operate!" warning tag displayed, it means that someone is carrying out inspection and maintenance of the machine. If the warning sign is ignored and the machine is operated, there is danger that the person carrying out inspection or maintenance may be caught in the rotating parts or moving parts and suffer serious personal injury or death. Do not start the engine or touch the levers.

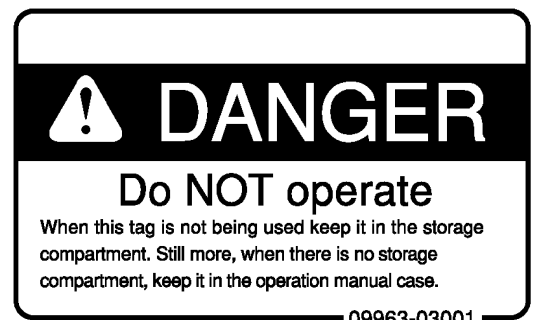
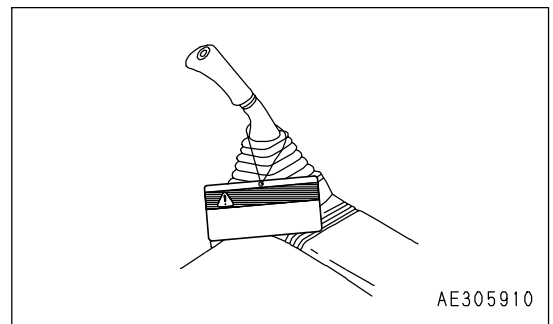

INSPECTION AND MAINTENANCE BEFORE STARTING ENGINE

Carry out the following checks before starting the engine at the beginning of the day's work to ensure that there is no problem with the operation of the machine. If this inspection is not carried out properly problems may occur with the operation of the machine, and there is danger that this may lead to serious personal injury or death.

- Remove all dirt from the surface of the window glass to ensure a good view.
- Carry out the "Walk-around Checks (PAGE 3-110)".
- Remove all dirt from the surface of the lens of the front lamps and working lamps, and check that they light up correctly.
- Check the coolant level, fuel level, and oil level in engine oil pan, check for clogging of the air cleaner, and check for damage to the electric wiring.
- Check that there is no mud or dust accumulated around the movable parts of any pedals, and check that the pedals work properly.
- Adjust the operator's seat to a position where it is easy to carry out operations, and check that there is no damage or wear to the seat belt or mounting clamps.
- Check that the gauges work properly, check the angle of the mirror, and check that the control levers are all at the Neutral position.
- Before starting the engine, check that lock lever (1) is in LOCK position (L).
- Adjust the mirrors so that the rear of the machine can be seen clearly from the operator's seat.
When adjusting, see "Rearview Mirrors (PAGE 3-121)".
- If the machine is equipped with cameras, adjust the angle so that the surrounding area can be seen clearly from the operator's seat.
For details when adjusting, see "Adjusting Angle of Rear View Camera (PAGE 3-124)".
- Check that there are no persons or obstacles above, below, or in the area around the machine.

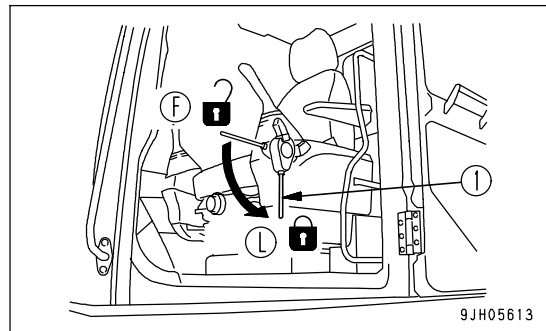

PRECAUTIONS WHEN STARTING ENGINE

- Start and operate the machine only while seated.
- When starting the engine, sound the horn as a warning.
- Do not allow anyone apart from the operator to ride on the machine.
- Do not attempt to start the engine by short-circuiting the engine starting circuit. This may cause fire, serious personal injury or death.

PRECAUTIONS IN COLD AREAS

- Carry out the warming-up operation thoroughly. If the machine is not thoroughly warmed up before the control levers or control pedals are operated, the reaction of the machine will be slow or the machine may move in a way not expected by the operator. Particularly in cold weather, be sure to carry out the warming-up operation thoroughly.
- If the battery electrolyte is frozen, do not charge the battery or start the engine with a different power source. There is a hazard that this will ignite the battery and cause the battery to explode.
Before charging or starting the engine with a different power source, melt the battery electrolyte and check that there is no leakage of electrolyte before starting.

STARTING WITH BOOSTER CABLES

If any mistake is made in the method of connecting the booster cables, it may cause the battery to explode, so always do as follows.

- Always wear safety goggles and rubber gloves when starting the engine with booster cable.
- When connecting a normal machine to a problem machine with booster cables, always use a normal machine with the same battery voltage as the problem machine.
- When starting with a booster cable, carry out the starting operation with two workers (one worker sitting in the operator's seat and the other working with the battery).
- When starting from another machine, do not allow the two machines to touch.
- When connecting the booster cables, turn the starting switch to the OFF position for both the normal machine and problem machine. There is a hazard that the machine will move when the power is connected.
- Be sure to connect the positive (+) cable first when installing the booster cables. Disconnect the negative (-) cable (ground side) first when removing them.
- When removing the booster cables, be careful not to let the booster cable clips touch each other or to let the clips touch the machine.
- For details of the starting procedure when using booster cables, see "Starting Engine with Booster Cables (PAGE 3-201)" in the OPERATION section.

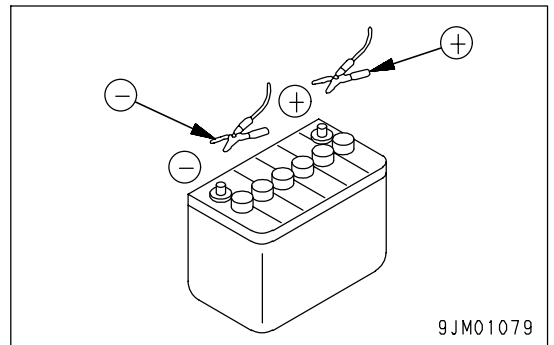
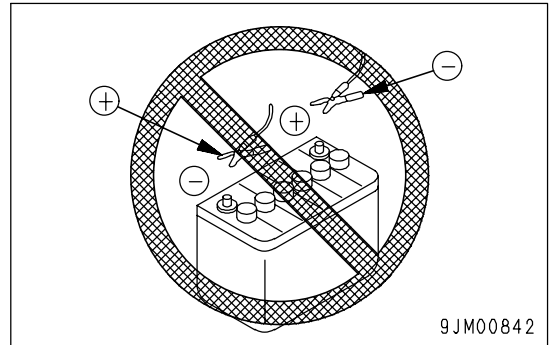

OPERATION

CHECKS BEFORE OPERATION

If the checks before starting are not carried out properly, the machine will be unable to display its full performance, and there is also danger that it may lead to serious personal injury or death.

When carrying out the checks, move the machine to a wide area where there are no obstructions, and pay careful attention to the surrounding area. Do not allow anyone near the machine.

- Always wear the seatbelt. There is danger that you may be thrown out of the operator's seat and suffer serious injury when the brakes are applied suddenly.
- Check that the movement of the machine matches the display on the control pattern card. If it does not match, replace it immediately with the correct control pattern card.
- Check the operating condition of the machine, work equipment, arm, boom, travel, and swing system.
- Check for any problem in the sound of the machine, vibration, heat, smell, or gauges; check also that there is no leakage of oil or fuel.
- If any problem is found, carry out repairs immediately.

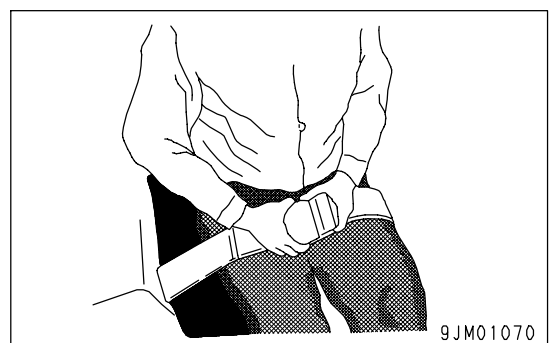

PRECAUTIONS WHEN TRAVELING IN FORWARD OR REVERSE AND SWINGING

- When traveling, drive with sprocket (1) at the rear of the machine. If sprocket (1) is at the front, the operation of the travel levers will be the opposite of the actual direction of travel, so there is a hazard that the machine may travel in an unexpected direction, leading to serious injury or death.
- Always lock all the door and windows of the operator's compartment in position (open or closed).
On jobsites where there is a hazard of flying objects or of objects entering the operator's compartment, check that all the door and windows are securely closed.
- Do not allow anyone apart from the operator to ride on the machine.
- If there are any persons in the area around the machine, there is danger that they may be hit or caught by the machine, and this may lead to serious personal injury or death. Always observe the following before traveling.
 - Always operate the machine only when seated.
 - Before moving off, check it again that there is no person or obstacle in the surrounding area.
 - Before starting to move, sound the horn to warn people in the surrounding area.
 - Check that the travel alarm and other alarms work properly.
 - If there is an area to the rear of the machine that cannot be seen, position a signalman. Swing slowly and be extremely careful not to hit any person or object.

Always be sure to carry out the above precautions even when the machine is equipped with mirrors and cameras.

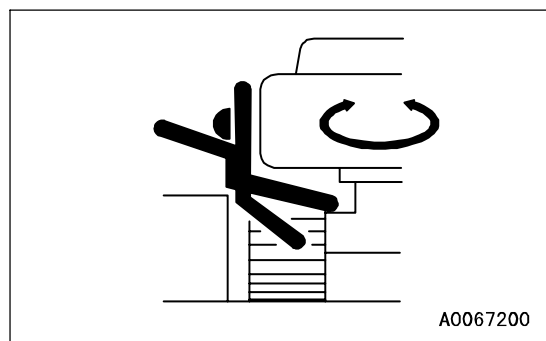
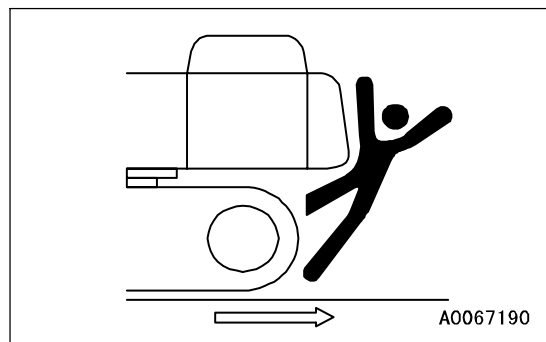
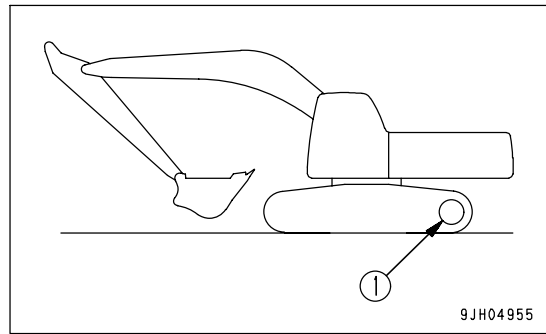

PRECAUTIONS WHEN TRAVELING

- When traveling or carrying out operations, always keep a safe distance from people, structures, or other machines to avoid coming into contact with them.
- When traveling on the level ground, keep the work equipment approximately 40 to 50 cm above the ground. Otherwise, the work equipment may contact to the ground and the machine may be turned over.
- If the view to the right side is poor, raise the boom to ensure better visibility.
- For machines equipped with an auto-deceleration system, always turn the auto-deceleration switch OFF when traveling on rough ground or steep slopes. If the machine is operated with the auto-deceleration system ON, the engine speed will rise and the machine travel speed may suddenly become faster.
- Avoid traveling over obstacles when possible. If the machine has to travel over an obstacle, keep the work equipment close to the ground and travel at low speed. There is more danger of the machine tipping over to the left or right than tipping over to the front or rear, so do not travel over obstacles which make the machine tilt strongly to the left or right sides.
- When traveling on rough ground, travel at low speed and do not operate the steering suddenly. There is danger that the machine may turn over. The work equipment may hit the ground surface and cause the machine to lose its balance, or may damage the machine or structures in the area.
- When using the machine, to prevent personal injury caused by damage to the work equipment or by the machine overturning due to overloading, do not exceed the permitted performance of the machine or the maximum permitted load for the structure of the machine.
- When passing over bridges or structures, check first that the structure is strong enough to support the weight of the machine.
- When operating in tunnels, under bridges, under electric wires, or other places where the height is limited, operate slowly and be extremely careful not to let the machine body or work equipment hit anything.

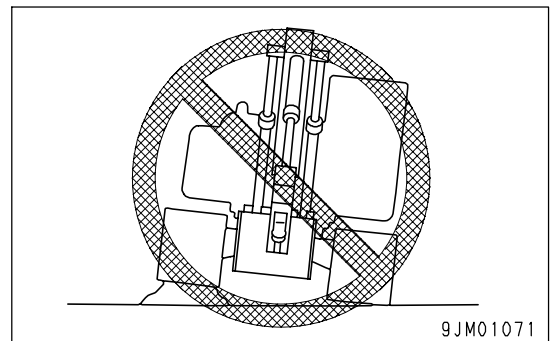
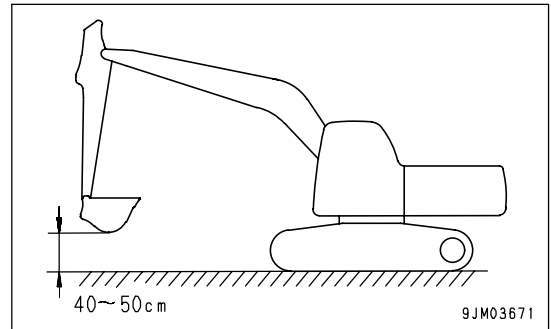

TRAVELING ON SLOPES

To prevent the machine from tipping over or slipping to the side, always do as follows.

- Keep the work equipment approx. 20 to 30 cm (8 to 12 in) above the ground. In case of emergency, lower the work equipment to the ground immediately to help stop the machine.
- When travel up slopes, set the operator's cab facing uphill, when travel down slopes, set the operator's cab facing downhill. Always check the firmness of the ground under the front of the machine when traveling.

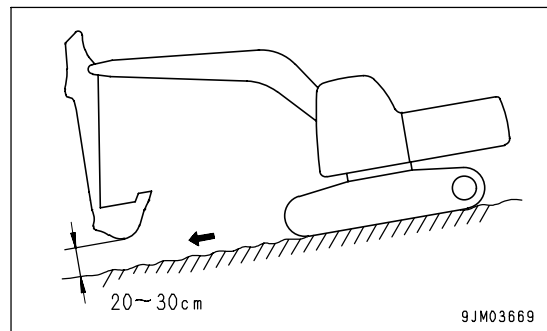
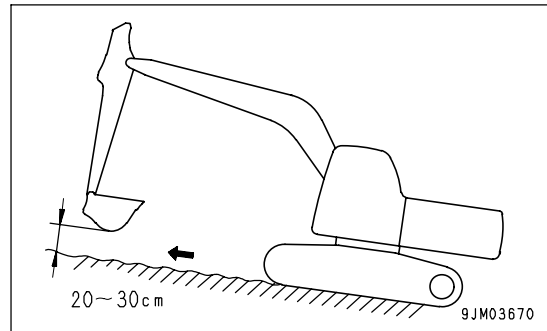

- When traveling up a steep slope, extend the work equipment to the front to improve the balance, keep the work equipment approximately 20 to 30 cm (8 to 12 in) above the ground, and travel at low speed.

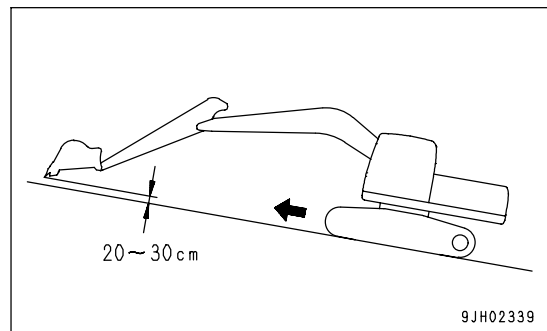

- When traveling downhill, lower the engine speed, keep the travel lever close to the neutral position, and travel at low speed.
- Always travel straight up or down a slope. Traveling at an angle or across the slope is extremely dangerous.
- Do not turn on slopes or travel across slopes. Always go down to a flat place to change the position of the machine, then travel on to the slope again.

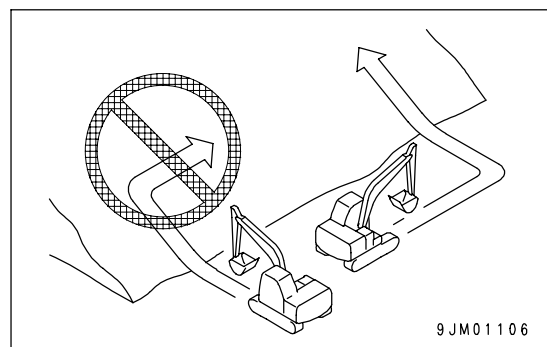

- Do not travel on a slope covered with the steel plates. Even with slight slopes there is a hazard that the machine may slip.
- Travel on grass or fallen leaves with low speed. Even with slight slopes there is a hazard that the machine may slip.
- If the engine stops when the machine is traveling on a slope, move the control levers immediately to the neutral position and start the engine again.

OPERATING ON SLOPES

- When working on slopes, there is a hazard that the machine may lose its balance and turn over when the swing or work equipment are operated. This may lead to serious injury or property damage, so always provide a stable place when carrying out these operations, and operate carefully.
- Do not swing the work equipment from the uphill side to the downhill side when the bucket is loaded. This operation is dangerous, and may cause the machine to tip over.
- If the machine has to be used on a slope, pile the soil to make a platform (A) that will keep the machine as horizontal as possible.
- Do not work on a slope covered with the steel plates. Even with slight slopes there is a hazard that the machine may slip.

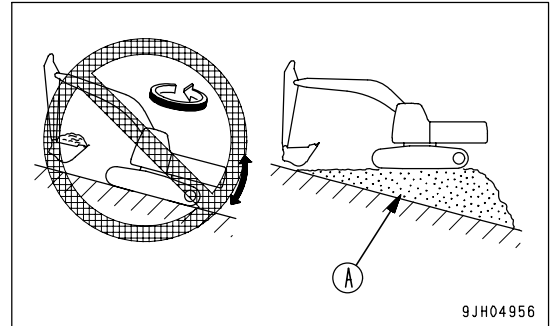
**PROHIBITED OPERATIONS**

If the machine rolls over or falls, or the ground at the working point collapses, or a structure being demolished collapses, it may lead to serious personal injury or death. Always observe the following.

- Never dig the work face under an overhang. There is a hazard that rocks may fall or that the overhang may collapse and fall on top of the machine.

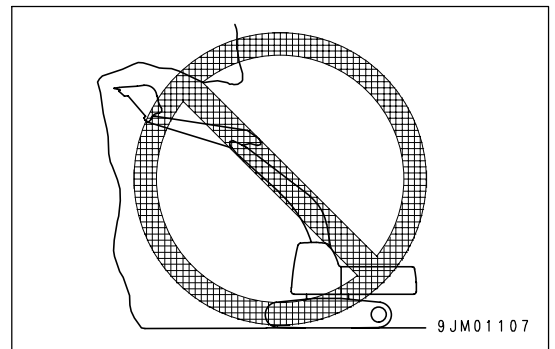

- Do not excavate too deeply under the front of the machine. The ground under the machine may collapse and cause the machine to fall.

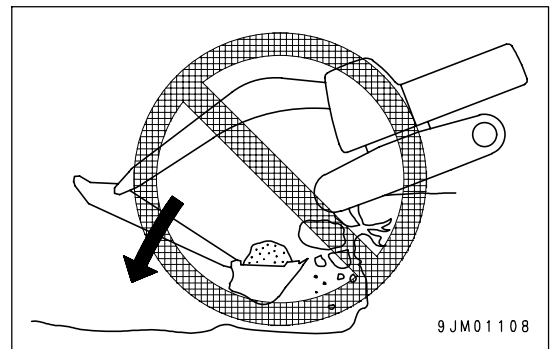

- To make it easier to escape if there is any problem, set the tracks at right angles to the road shoulder or cliff with the sprocket at the rear when carrying out operations.

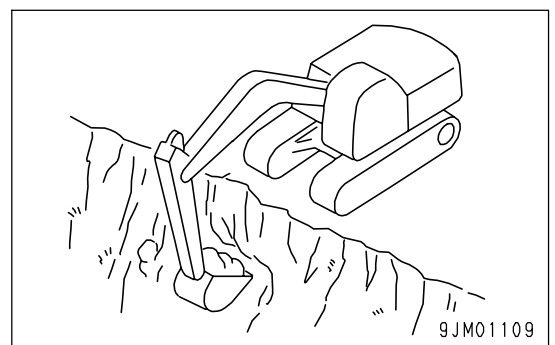

- When carrying out demolition work, do not carry out demolition work under the front of the machine. This makes the ground unstable, and there is a hazard of the machine falling.

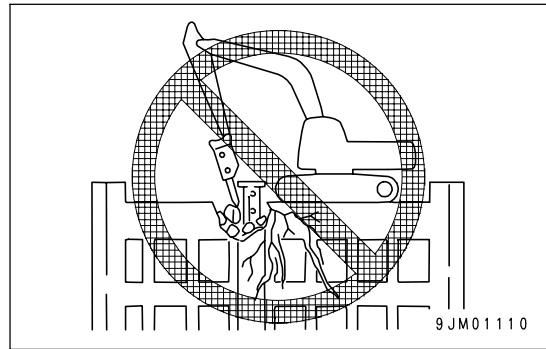

- When carrying out demolition work, do not carry out demolition work above your head. There is a hazard of broken parts falling or of the building collapsing and causing serious injury or death.

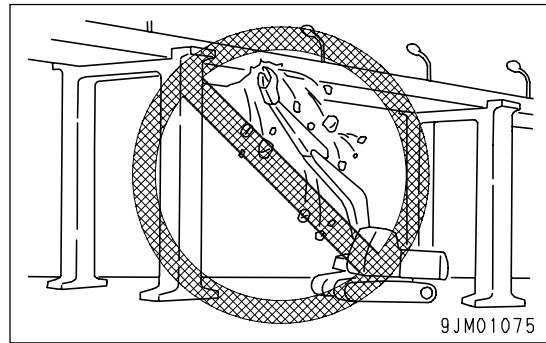

- When carrying out demolition work, do not use the impact force of the work equipment for breaking work. There is a hazard of damage to the work equipment and also a hazard of serious personal injury or death being caused by flying pieces of broken materials, or of the machine tipping over due to reaction from the impact.

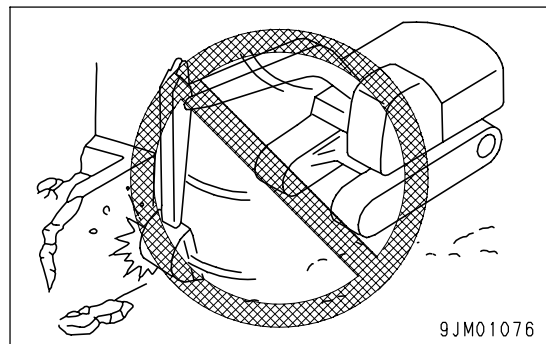

- Do not pass the bucket over the heads of other workers or over the operator's seat of dump trucks or other hauling equipment. There is danger that the load may spill or the bucket may hit the dump truck and cause serious personal injury or death.
- When working on or from the top of buildings or other structures, check the strength and the structure before starting operations. There is a hazard of the building collapsing and causing serious injury or damage.
- Generally speaking, the machine is more liable to overturn when the work equipment is at the side than when it is at the front or rear.
- When using a breaker or other heavy work equipment, there is a hazard of the machine losing its balance and tipping over. When operating on flat ground as well as on slopes.
 - Do not suddenly lower, swing, or stop the work equipment.
 - Do not suddenly extend or retract the boom cylinder. There is a hazard that impact will cause the machine to tip over.

- In the operation using the fork or grapple, do not attempt to pick up an object with their tips.
There is a danger of damage to the machine or personal injury, as the picked - up object can easily slip off.

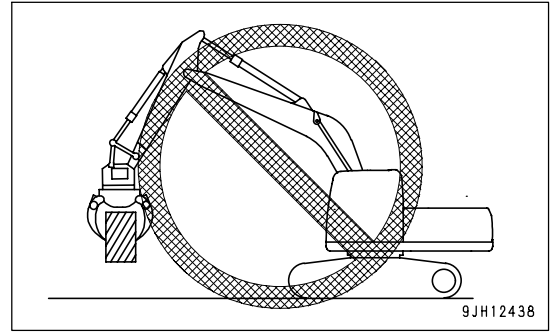

TRAVELING ON SNOW-COVERED OR FROZEN SURFACES

- Snow-covered or frozen surfaces are slippery, so be extremely careful when traveling or operating the machine, and do not operate the levers suddenly. Even a slight slope may cause the machine to slip, so be particularly careful when working on slopes.
- With frozen ground surfaces, the ground becomes soft when the temperature rises, and this may cause the machine to tip over or make it impossible for the machine to escape.
- If the machine enters deep snow, there is a hazard that it may tip over or become buried in the snow. Be careful not to leave the road shoulder or to get trapped in a snow drift.
- When clearing snow, the road shoulder and objects placed beside the road are buried in the snow and cannot be seen. There is a hazard of the machine tipping over or hitting covered objects, so always carry out operations carefully.

PARKING MACHINE

- Park the machine on firm, level ground.
- Select a place where there is no hazard of landslides, falling rocks, or flooding.
- Lower the work equipment completely to the ground.

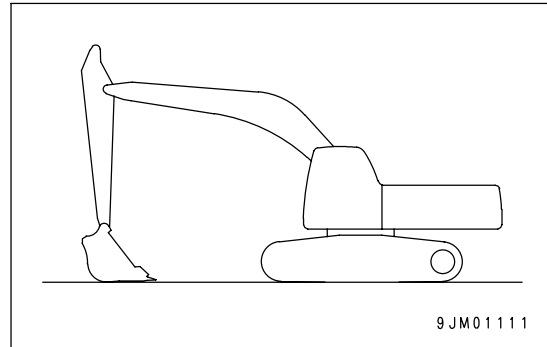

- When leaving the machine, set lock lever (1) to the LOCK position (L), then stop the engine.
- Always close the operator's cab door, and use the key to lock all the equipment in order to prevent any unauthorized person from moving the machine. Always remove the key, take it with you, and leave it in the specified place.

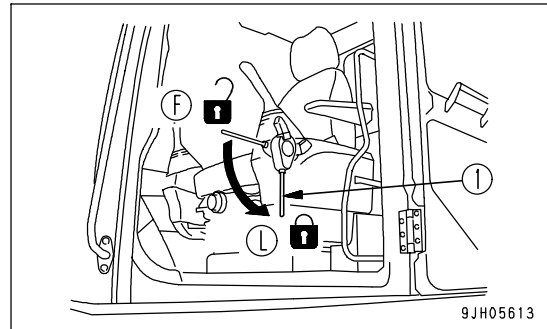

- If it is necessary to park the machine on a slope, always do as follows.
 - Set the work equipment on the downhill side and dig it into the ground.
 - In addition, put blocks under the tracks to prevent the machine from moving.

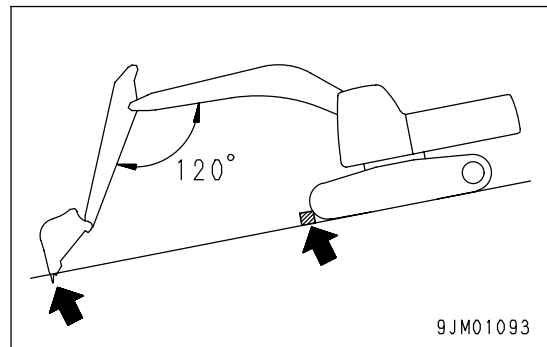

TRANSPORTATION

When the machine is transported on a trailer, there is danger of serious personal injury or death during transportation. Always do as follows.

- Always check the machine dimensions carefully. Depending on the work equipment installed, the machine weight, transportation height, and overall length may differ.
- Check beforehand that all bridges and other structures on the transportation route are strong enough to withstand the combined weight of the transporter and the machine being transported.
- The machine can be divided into parts for transportation, so when transporting the machine, please contact your Komatsu distributor to have the work carried out.

LOADING AND UNLOADING

When loading or unloading the machine, mistaken operation may bring the hazard of the machine tipping over or falling, so particular care is necessary. Always do as follows.

- Perform loading and unloading on firm, level ground only. Maintain a safe distance from the edge of the road or cliff.
- Never use the work equipment to load or unload the machine. There is danger that the machine may fall or tip over.
- Always use ramps of adequate strength. Be sure that the ramps are wide, long, and thick enough to provide a safe loading slope. Take suitable steps to prevent the ramps from moving out of position or coming off.
- Be sure the ramp surface is clean and free of grease, oil, ice and loose materials. Remove dirt from machine-tracks. On a rainy day, in particular, be extremely careful since the ramp surface is slippery.
- For machines equipped with an auto-deceleration device, always turn the auto-deceleration switch OFF. If the machine is operated with the auto-deceleration system ON, there is danger that the engine speed will suddenly rise, the machine will suddenly move off, or the machine travel speed will become faster.
- Run the engine at low idling and drive the machine slowly at low speed.
- When on the ramps, do not operate any lever except for the travel lever.
- Never correct your steering on the ramps. If necessary, drive off the ramps, correct the direction, then enter the ramps again.
- The center of gravity of the machine will change suddenly at the joint between the ramps and the track or trailer, and there is danger of the machine losing its balance. Travel slowly over this point.
- When loading or unloading to an embankment or platform, make sure that it has suitable width, strength, and grade.
- When swinging the upper structure on the trailer, the trailer is unstable, so pull in the work equipment and swing slowly.
- For machines equipped with a cab, always lock the door after boarding the machine. If this is not done, the door may suddenly open during transportation.

Refer to "TRANSPORTATION (PAGE 3-174)".

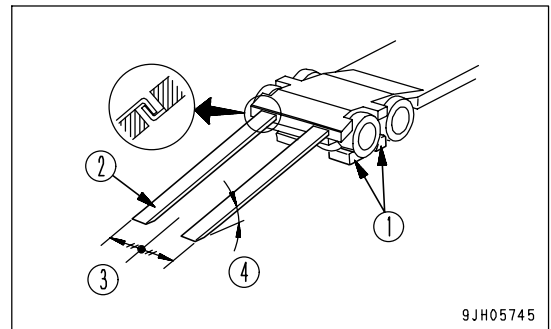

- (1) Blocks
- (2) Ramp
- (3) Centerline of trailer
- (4) Angle of ramps: Max. 15°

9JH05745

TOWING

PRECAUTIONS WHEN TOWING

Always use the correct towing equipment and towing method. Any mistake in the selection of the wire rope or towing bar or in the method of towing a disabled machine may lead to serious personal injury or death.

For towing, see "TOWING THE MACHINE (PAGE 3-197)".

- Always confirm that the wire rope or drawbar used for towing has ample strength for the weight of the machine being towed.
- Never use a wire rope which has cut strands (A), reduced diameter (B), or kinks (C). There is danger that the rope may break during the towing operation.
- Always wear leather gloves when handling wire rope.
- Never tow a machine on a slope.
- During the towing operation, never stand between the towing machine and the machine being towed.

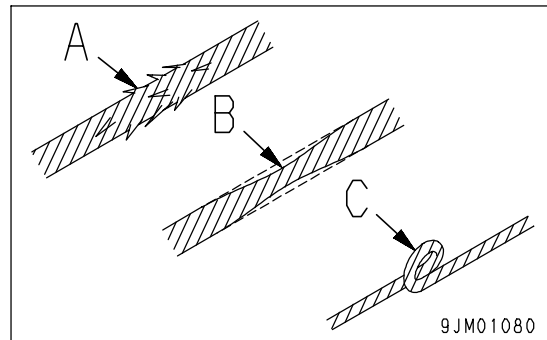

LIFTING OBJECTS WITH BUCKET

PRECAUTIONS FOR LIFTING OPERATIONS

- Do not carry out lifting work on slopes, soft ground, or other places where the machine is not stable.
- Use wire rope that conforms to the specified standard.
- Determine the signals to be used and place a signaller in position.
- To prevent the danger of contact with a raised load or the danger from a falling load, do not allow any worker inside the area.
- It is dangerous if a raised load hits any person or structure. When operating the swing or work equipment, always check carefully that the surrounding area is safe.
- Do not start, swing, or stop the machine suddenly. There is a hazard that the lifted load will swing.
- Do not use the work equipment or swing to pull the load in any direction. There is danger that the hook may break and the load come off, causing the work equipment to move suddenly and cause personal injury.
- Do not leave the operator's seat when there is a raised load.

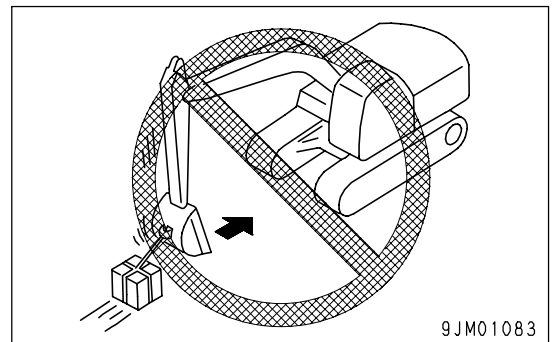
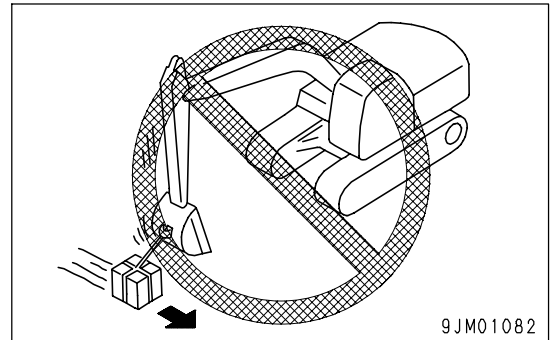

PRECAUTIONS FOR MAINTENANCE

PRECAUTIONS BEFORE STARTING INSPECTION AND MAINTENANCE

DISPLAY WARNING TAG DURING INSPECTION AND MAINTENANCE

If there is any "DANGER! Do NOT operate!" warning tag displayed, it means that someone is carrying out inspection and maintenance of the machine. If the warning sign is ignored and the machine is operated, there is danger that the person carrying out inspection or maintenance may be caught in the rotating parts or moving parts and suffer serious personal injury or death. Do not start the engine or touch the levers.

- If necessary, put up signs around the machine also.

Warning tag part number: 09963-03001

When not using this warning tag, keep it in the toolbox.

If there is no toolbox, keep it in the pocket for the Operation and Maintenance Manual

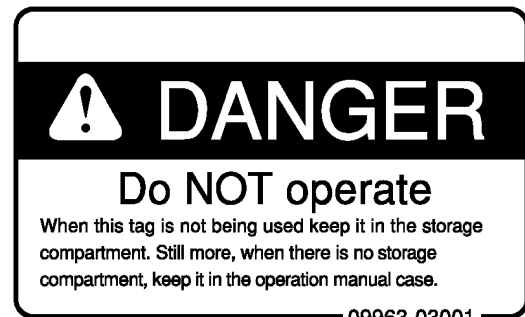
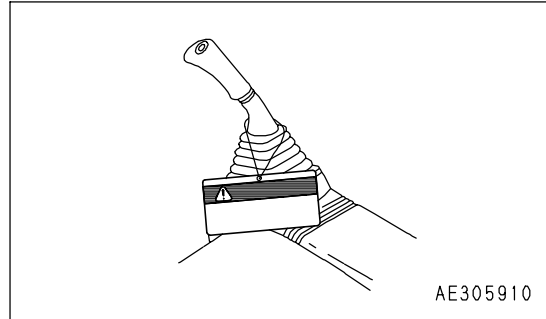

KEEP WORKPLACE CLEAN AND TIDY

- Do not leave hammers or other tools lying around in the work place. Wipe up all grease, oil, or other substances that will cause you to slip. Always keep the work place clean and tidy to enable you to carry out operations safely. If the work place is not kept clean and tidy, there is the danger that you will trip, slip, or fall over and injure yourself.
- When cleaning the ceiling window which is made of organic glass (polycarbonate), use tap water and avoid use of organic solvents for cleaning. An organic solvent like benzene, toluene or methanol can invite a chemical reaction like dissolution and decomposition on the window glass, deteriorating polycarbonate in use.

SELECT SUITABLE PLACE FOR INSPECTION AND MAINTENANCE

- Stop the machine on firm, level ground.
- Select a place where there is no hazard of landslides, falling rocks, or flooding.

ONLY AUTHORIZED PERSONNEL

Do not allow any unauthorized personnel into the area when servicing the machine. If necessary, employ a guard.

APPOINT LEADER WHEN WORKING WITH OTHERS

- When repairing the machine or when removing and installing the work equipment, appoint a leader and follow his instructions during the operation.

STOP ENGINE BEFORE CARRYING OUT INSPECTION AND MAINTENANCE

- Lower the work equipment completely to the ground and stop the engine before performing any inspection and maintenance.

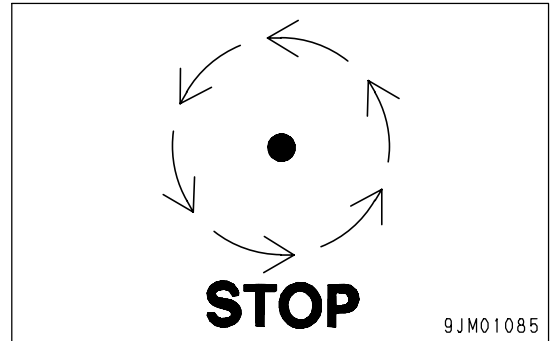

- Turn the starting switch to the ON position. Operate the work equipment control lever back and forth, left and right at the full stroke 2 to 3 times to eliminate the remaining internal pressure in the hydraulic circuit, and then move lock lever (1) to the LOCK position (L).
- Check that the battery relay is off and main power is not conducted. (Wait for approx. one minute after turning off the engine starting switch key and press the horn switch. If the horn does not sound, it is not activated.)

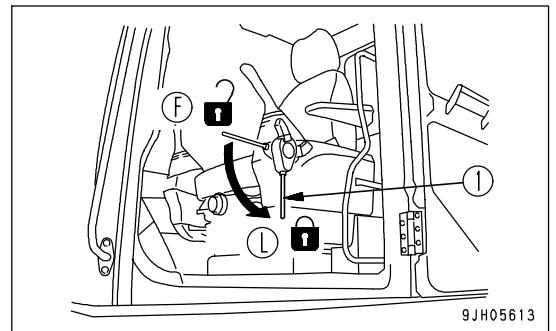

- Put blocks under the track to prevent the machine from moving.

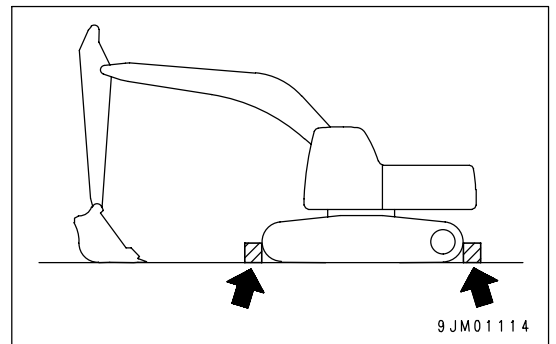

TWO WORKERS FOR MAINTENANCE WHEN ENGINE IS RUNNING

To prevent personal injury, do not carry out maintenance with the engine running. If maintenance must be carried out with the engine running, carry out the operation with at least two workers and do as follows.

- One worker must always sit in the operator’s seat and be ready to stop the engine at any time. All workers must maintain contact with the other workers.
- When carrying out operations near the fan, fan belt, or other rotating parts, there is a hazard of being caught in the parts, so be careful not to come close.
- Never drop or insert tools or other objects into the fan, fan belt, or other rotating parts. There is danger that they may contact the rotating parts and break or be sent flying.

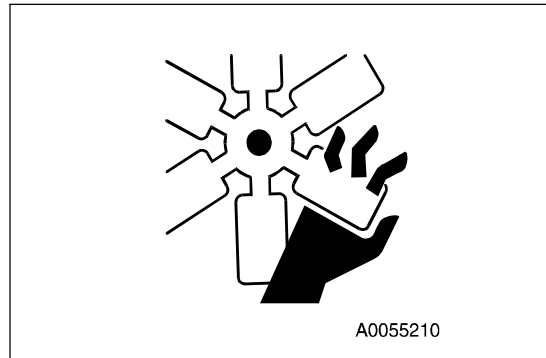

- Release the residual pressure from the hydraulic system, and place Lock lever (1) to its LOCK position. For releasing of the residual oil pressure, see the "METHOD OF RELEASING PRESSURE IN HYDRAULIC CIRCUIT (PAGE 4-78)".
- Do not touch the control levers or pedals. If it is necessary to operate the control levers or pedals, always give a signal to your fellow workers and have them move to a safe place.

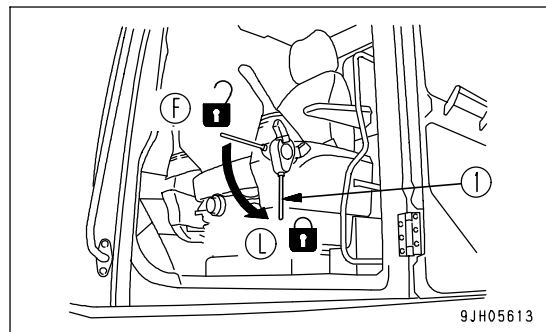

INSTALLING, REMOVING, OR STORING ATTACHMENTS

- Appoint a leader before starting removal or installation operations for attachments.
- Place attachments that have been removed from the machine in a stable condition so that they do not fall. And take steps to prevent unauthorized persons from entering the storage area.



PRECAUTIONS WHEN WORKING AT HIGH PLACES

When working at high places, use a step ladder or other stand to ensure that the work can be carried out safely.

PRECAUTIONS WHEN WORKING UNDER MACHINE OR WORK EQUIPMENT

- Make sure the hoists or jacks you use are in good repair and strong enough to handle the weight of the component. Never use jacks at places where the machine is damaged, bent, or twisted. Never use frayed, twisted or pinched wire rope. Never use bent or distorted hooks.
- It is extremely dangerous to work under the machine if the track shoes are lifted off the ground and the machine is supported only with the work equipment. If any of the control levers is touched by accident, or there is damage occurring to the hydraulic piping, the work equipment or the machine will suddenly drop. This is extremely dangerous. Never work under the work equipment or the machine.
- If it is necessary to raise the work equipment or the machine and then go under it to carry out inspection or maintenance, support the work equipment and machine securely with blocks and stands strong enough to support the weight of the work equipment and machine.
If the work equipment and machine are not supported, there is a hazard that they may come down and that this may lead to serious personal injury or death.
- Never use concrete blocks for supports. They can collapse under even light loads.

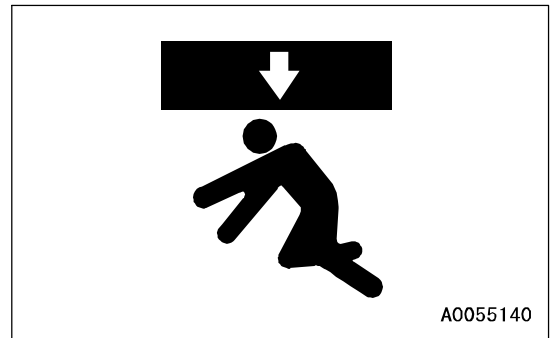
**PROPER TOOLS**

Use only tools suited to the task and be sure to use the tools correctly. Using damaged, deformed, or low quality tools, or making improper use of the tools may cause serious personal injury.

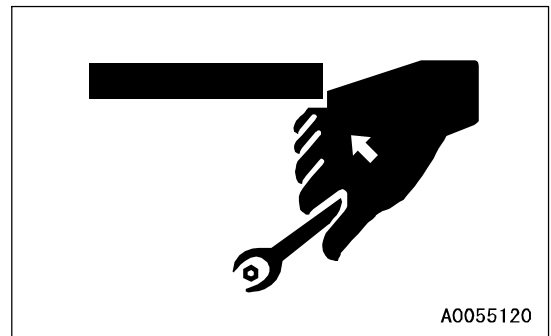

PRECAUTIONS FOR INSPECTION AND MAINTENANCE

PRECAUTIONS WHEN WELDING

Welding operations must always be carried out by a qualified welder and in a place equipped with proper equipment. There is a hazard of gas, fire, or electrocution when carrying out welding, so never allow any unqualified personnel to carry out welding.

HANDLING BATTERY

Before inspecting or handling the battery, turn the key in the starting switch to the OFF position.

- **Danger of battery exploding**

When the battery is being charged, flammable hydrogen gas is generated and may explode. In addition, the battery electrolyte includes dilute sulphuric acid. Any mistake in handling may cause serious personal injury, explosion, or fire, so always observe the following.

- Do not use or charge the battery if the battery electrolyte is below the LOWER LEVEL mark. This will cause explosion. Always carry out periodic inspection of the battery electrolyte level, and add distilled water (or commercially available battery filler solution) to the UPPER LEVEL mark.
- Do not smoke or bring any flame close to the battery.
- Hydrogen gas is generated when the battery is being charged, so remove the battery from the machine, take it to a well-ventilated place, remove the battery caps, then carry out the charging.
- After charging, tighten the battery caps securely.

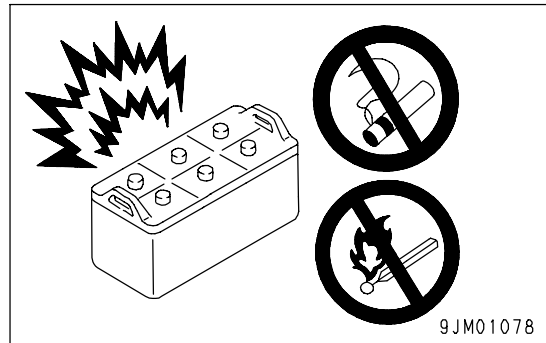

- **Danger from dilute sulphuric acid**

When the battery is being charged, flammable hydrogen gas is generated and may explode. In addition, the battery electrolyte includes dilute sulphuric acid. Any mistake in handling may cause serious personal injury, explosion, or fire, so always observe the following.

- When handling the battery, always wear protective goggles and rubber gloves.
- If battery electrolyte gets into your eyes, immediately wash your eyes with large amounts of fresh water. After that, get medical attention immediately.
- If battery electrolyte gets on your clothes or skin, wash it off immediately with large amounts of water.

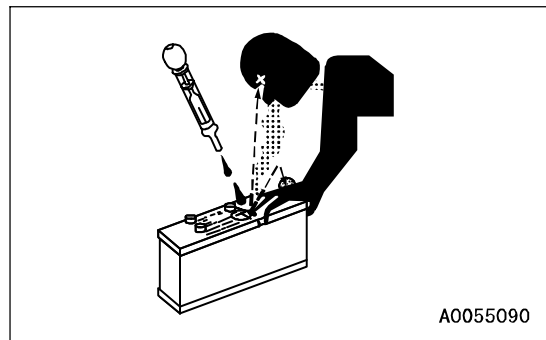

- **Removing battery cables**

Before repairing the electrical system or carrying out electric welding, turn the starting switch OFF. Wait for approx. 1 minute, then remove the negative (-) battery cable to stop the flow of electricity.

- **Danger of sparks**

There is hazard that sparks will be generated, so always observe the following.

- Do not let tools or other metal objects make any contact between the battery cables. Do not leave tools lying around near the battery.
- When removing the battery cables, remove the ground cable (negative (-) cable) first. When installing, connect the positive (+) cable first, then connect the ground. Tighten the battery cable terminals securely.
- Secure the battery firmly in the specified position.

PRECAUTIONS WHEN USING HAMMER

When using a hammer, pins may fly out or metal particles may be scattered. This may lead to serious personal injury or death. Always do as follows.

- When hitting pins or bucket teeth, there is a hazard that broken pieces might be sent flying and injure people in the surrounding area. Always check that there is no one in the surrounding area.
- If hard metal parts such as pins, bucket teeth, cutting edges, or bearings are hit with a hammer, there is a hazard that pieces might be scattered and cause serious personal injury or death. Always wear safety glasses and gloves.
- If the pin is hit with strong force, there is a hazard that it may fly out and injure people in the surrounding area. Do not allow anyone to enter the surrounding area.

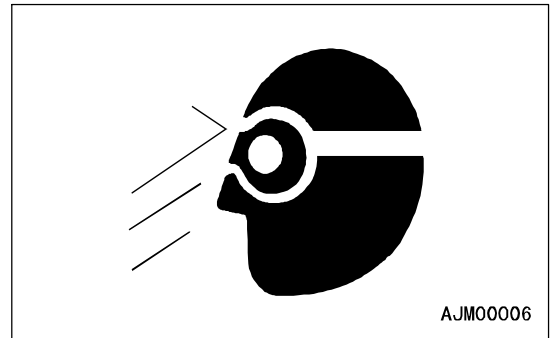

PRECAUTIONS WITH HIGH-TEMPERATURE COOLANT

To prevent burns from boiling water or steam spurting out when checking or draining the coolant, wait for the coolant to cool down to a temperature where the radiator cap can be touched by hand. Then loosen the cap slowly to release the pressure inside the radiator, and remove the cap.

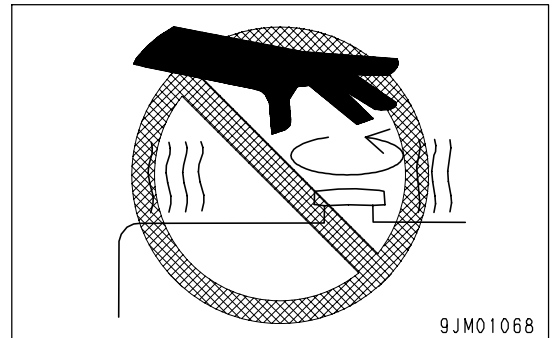

PRECAUTIONS WITH HIGH-TEMPERATURE OIL

To prevent burns from hot oil spurting out or from touching high-temperature parts when checking or draining the oil, wait for the oil to cool down to a temperature where the cap or plug can be touched by hand. Then loosen the cap or plug slowly to release the internal pressure and remove the cap or plug.

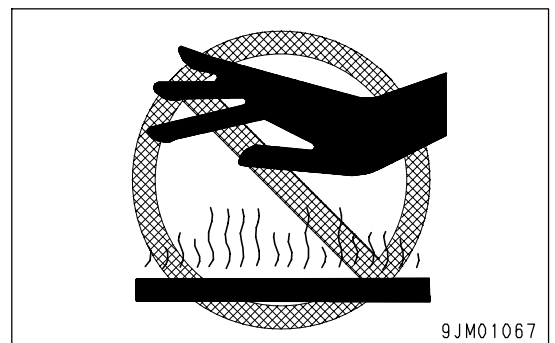

PRECAUTIONS WITH HIGH-PRESSURE OIL

The hydraulic system is always under internal pressure. In addition, the fuel piping is also under internal pressure when the engine is running and immediately after the engine is stopped. When carrying out inspection or replacement of the piping or hoses, check that the internal pressure in the circuit has been released. If this is not done, it may lead to serious personal injury or death. Always do as follows.

- Do not carry out inspection or replacement work with the circuit under pressure.

Always release the pressure before starting. For details, see "METHOD OF RELEASING PRESSURE IN HYDRAULIC CIRCUIT (PAGE 4-78)".

- If there is any leakage from the piping or hoses, the surrounding area will be wet, so check for cracks in the piping and hoses and for swelling in the hoses.

When carry out inspection, wear safety glasses and leather gloves.

- There is a hazard that high-pressure oil leaking from small holes may penetrate your skin or cause loss of sight if it contacts your skin or eyes directly. If you are hit by a jet of high-pressure oil and suffer injury to your skin or eyes, wash the place with clean water, and consult a doctor immediately for medical attention.

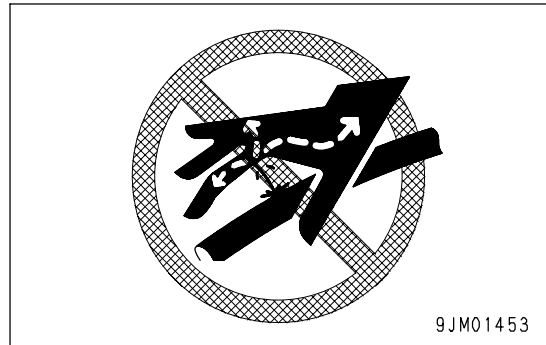
**PRECAUTIONS WITH HIGH-PRESSURE FUEL**

When the engine is running, high-pressure is generated in the engine fuel piping. When carrying out inspection or maintenance of the fuel piping system, stop the engine and wait for at least 30 seconds to allow the internal pressure to go down before starting the operation.

HANDLING HIGH-PRESSURE HOSES AND PIPING

- If oil or fuel leaks from high-pressure hoses or piping, it may cause fire or misoperation, and lead to serious personal injury, or death. If the hose or piping mounts are loose or oil or fuel is found to be leaking from the mount, stop operations and tighten to the specified torque.

If any damaged or deformed hoses or piping are found, please consult your Komatsu distributor.

Replace the hose if any of the following problems are found.

- Damaged hose or deformed hydraulic fitting.
- Frayed or cut covering or exposed reinforcement wire layer.
- Covering swollen in places.
- Twisted or crushed movable portion.
- Foreign material embedded in covering.

PRECAUTIONS FOR HIGH VOLTAGE

When the engine is running and immediately after it is stopped, high voltage is generated inside the engine controller and the engine injector, and there is danger of electrocution. Never touch the inside of the controller or the engine injector portion.

If it is necessary to touch the inside of the controller or the engine injector portion, please contact your Komatsu distributor.

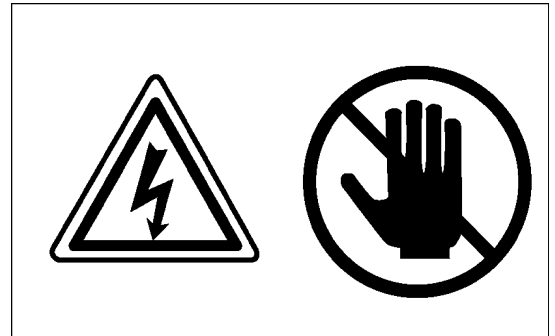
**NOISE**

When carrying out maintenance of the engine and you are exposed to noise for long periods of time, wear ear covers or ear plugs while working.

If the noise from the machine is too loud, it may cause temporary or permanent hearing problems.

PRECAUTIONS WITH HIGH-PRESSURE GREASE WHEN ADJUSTING TRACK TENSION

- Grease is pumped into the track tension adjustment system under high pressure.

If the specified procedure for maintenance is not followed when making adjustment, grease drain plug (1) may fly out and cause serious injury or property damage.

- When loosening grease drain plug (1) to loosen the track tension, never loosen it more than one turn. Loosen the grease drain plug slowly.
- Never put your face, hands, feet, or any other part of your body close to grease drain plug (1).

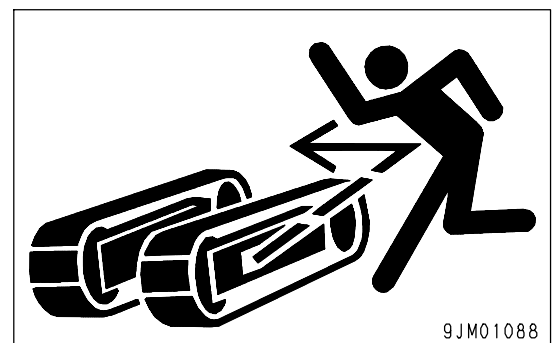
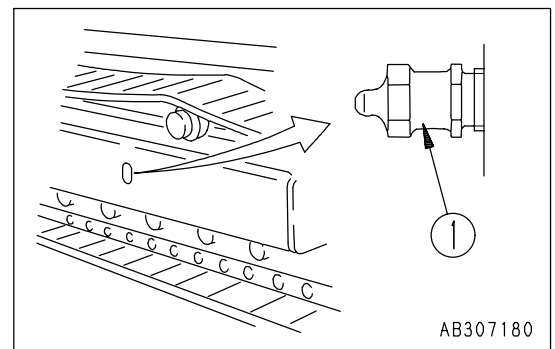

DO NOT DISASSEMBLE RECOIL SPRING

Never disassemble the recoil spring assembly. The recoil spring assembly has a powerful spring that acts to reduce the impact on the idler. If it is disassembled by mistake, the spring may shoot out and cause serious personal injury or death.

It is necessary to disassemble the recoil spring assembly, always ask your Komatsu distributor to carry out the operation.

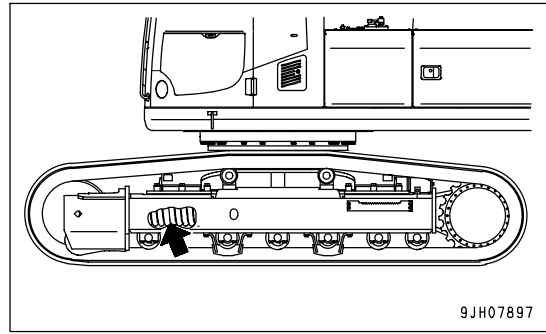

HANDLING ACCUMULATOR AND GAS SPRING

This machine is equipped with an accumulator. Even after the engine stops, the work equipment control levers can be operated for a short time in the LOWER direction to allow the work equipment to go down under its own weight. After stopping the engine, set the lock lever to the LOCK position.

The accumulator and gas spring are charged with high-pressure nitrogen gas. If the accumulator is handled mistakenly, it may cause an explosion that could lead to serious personal injury or death. For this reason, always observe the following precautions.

- Do not disassemble the accumulator.
- Do not bring it near flame or dispose of it in fire.
- Do not make holes in it, weld it, or use a cutting torch.
- Do not hit or roll the accumulator, or subject it to any impact.
- When disposing of the accumulator, the gas must be released. Please contact your Komatsu distributor to have this work performed.



PRECAUTIONS WITH COMPRESSED AIR

- When carrying out cleaning with compressed air, there is a hazard of serious personal injury caused by flying dust or particles.
- When using compressed air to clean the filter element or radiator, wear safety glasses, anti-dust mask, gloves, and other protective equipment.

MAINTENANCE OF AIR CONDITIONER

- If air conditioner refrigerant gets into your eyes, it may cause loss of sight; if it contacts your skin, it may cause frostbite. Never loosen any parts of the cooling circuit.

DISPOSING OF WASTE MATERIALS

To prevent pollution, pay careful attention to the method of disposing of waste materials.

- Always put oil drained from your machine in containers. Never drain oil directly onto the ground or dump into the sewage system, rivers, the sea, or lakes.
- Obey appropriate laws and regulations when disposing of harmful objects such as oil, fuel, coolant, solvent, filters, and batteries.

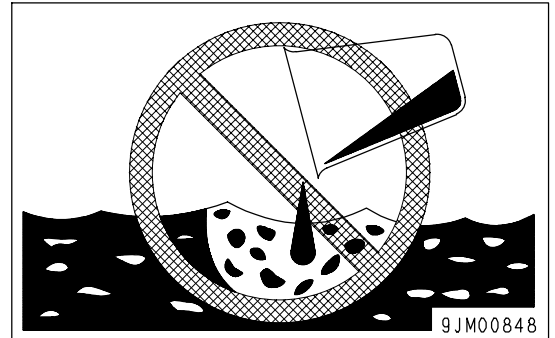
**METHOD OF SELECTING WINDOW WASHER FLUID**

Use an ethyl alcohol base washer liquid.

Methyl alcohol base washer liquid may irritate your eyes, so do not use it.

PERIODIC REPLACEMENT OF SAFETY CRITICAL PARTS

- To enable this machine to be used safely for a long period, always carry out periodic replacement of safety critical parts that have a particularly close relation to safety, such as hoses and the seatbelt.
For details of the replacement of safety critical parts, see "SAFETY CRITICAL PARTS (PAGE 4-13)".
- The material of these components naturally changes over time, and repeated use causes deterioration, wear, and fatigue. As a result, there is a hazard that these components may fail and cause serious personal injury or death. It is difficult to judge the remaining life of these components from external inspection or the feeling when operating, so always replace them at the specified interval.
- Replace or repair safety-critical parts if any defect is found, even when they have not reached the specified replacement time.

OPERATION

WARNING

Please read and make sure that you understand the SAFETY section before reading this section.

MACHINE VIEW ILLUSTRATIONS

OVERALL MACHINE VIEW

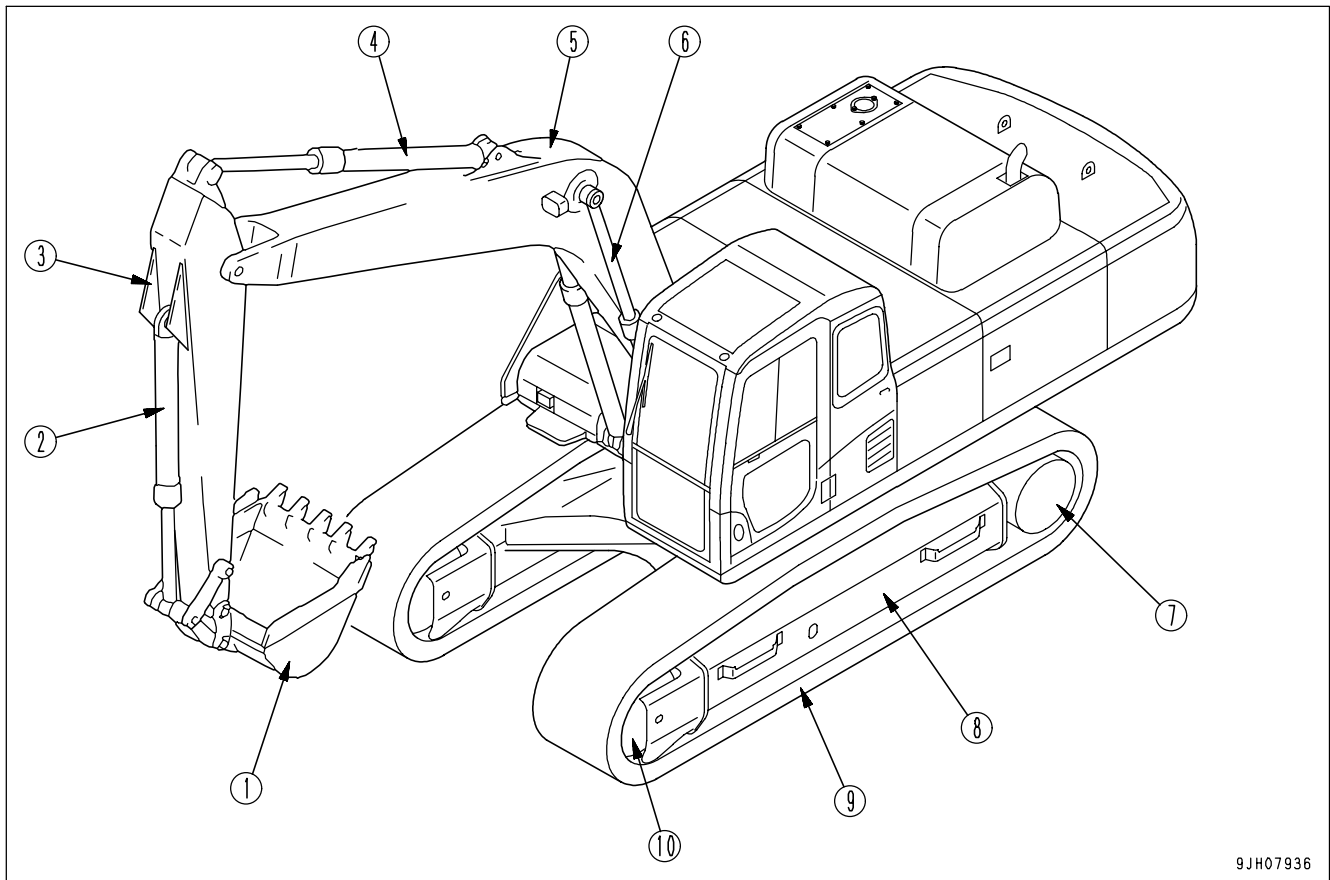

9JH07936

- | | |
|---------------------|-------------------|
| (1) Bucket | (6) Boom cylinder |
| (2) Bucket cylinder | (7) Sprocket |
| (3) Arm | (8) Track frame |
| (4) Arm cylinder | (9) Track shoe |
| (5) Boom | (10) Idler |

CONTROLS AND GAUGES

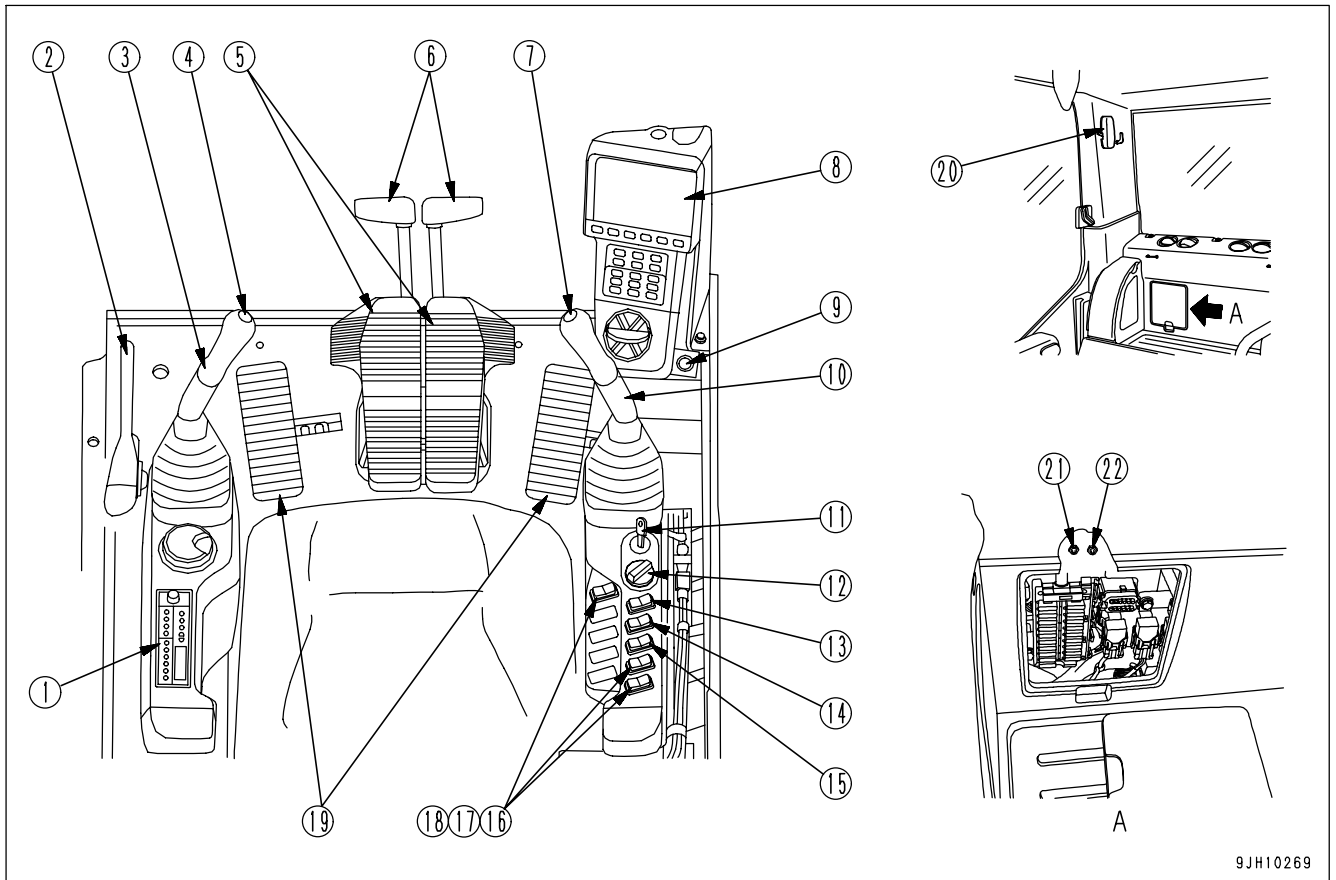

9JH10269

- | | |
|---|---|
| (1) Radio | (13) Lamp switch |
| (2) Lock lever | (14) Swing lock switch |
| (3) Left work equipment control lever | (15) Machine push-up switch |
| (4) One-touch power max. switch | (16) Heated operator seat switch (if equipped) |
| (5) Travel pedals | (17) Large capacity airflow air conditioner blower switch (if equipped) |
| (6) Travel levers | (18) Revolving warning lamp switch (if equipped) |
| (7) Horn switch | (19) Attachment control pedal (if equipped) |
| (8) Machine monitor | (20) Room lamp switch |
| (9) Cigarette lighter | (21) Emergency pump drive switch |
| (10) Right work equipment control lever | (22) Swing parking brake release switch |
| (11) Starting switch | |
| (12) Fuel control dial | |

Machine monitor

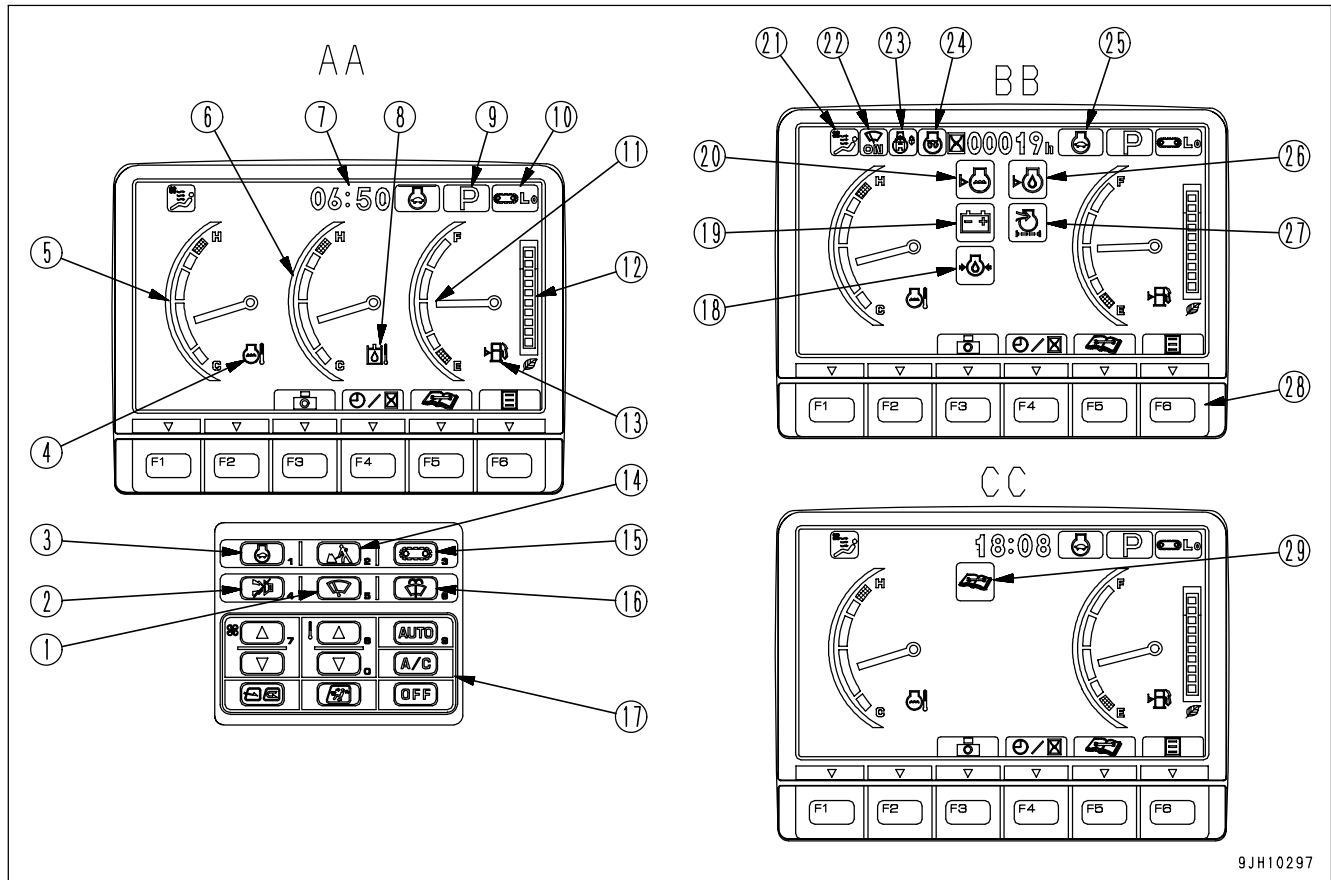

9JH10297

AA: Screen for standard

BB: Screen with all lamps lighted up

CC: Maintenance time warning screen

- | | |
|--|---|
| (1) Wiper switch | (16) Window washer switch |
| (2) Buzzer cancel switch | (17) Air conditioner control switch |
| (3) Auto-deceleration switch | (18) Engine oil pressure monitor |
| (4) Engine coolant temperature monitor | (19) Charge level monitor |
| (5) Engine coolant temperature gauge | (20) Radiator coolant level monitor |
| (6) Hydraulic oil temperature gauge | (21) Air conditioner monitor |
| (7) Service meter, Clock | (22) Wiper monitor |
| (8) Hydraulic oil temperature monitor | (23) Swing lock monitor |
| (9) Working mode monitor | (24) Engine pre-heating monitor or One-touch power max. monitor |
| (10) Travel speed monitor | (25) Auto-deceleration monitor |
| (11) Fuel gauge | (26) Engine oil level monitor |
| (12) ECO gauge | (27) Air cleaner clogging monitor |
| (13) Fuel level monitor | (28) Function switches (F1 to F6) |
| (14) Working mode selector switch | (29) Maintenance interval monitor |
| (15) Travel speed selector switch | |

DETAILED CONTROLS AND GAUGES

The following is an explanation of devices needed for operating the machine.

To perform suitable operations correctly and safely, it is important to completely understand methods of operating the equipment, and the meanings of the displays.

MONITORING SYSTEM

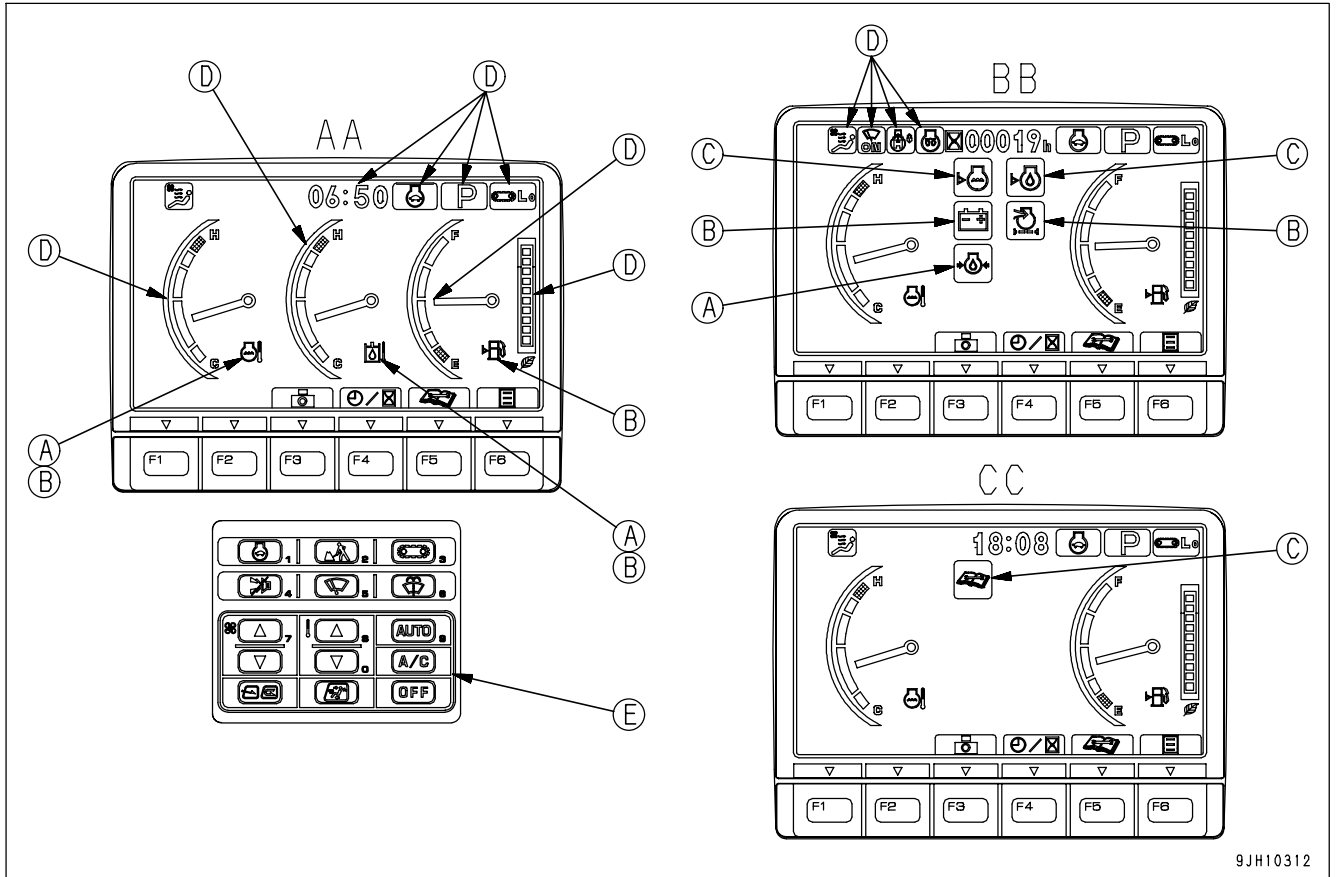

9JH10312

- AA: Screen for standard
- BB: Screen with all lamps lighted up
- CC: Maintenance time warning screen

- (A) Emergency monitors
- (B) Caution monitors
- (C) Basic check monitors
- (D) Meter display portion, pilot display
- (E) Monitor switches portion

REMARK

One of the features of liquid crystal display panels is that there may be black spots (spots that do not light up) or white spots (spots that stay lighted up) on the screen. If there are fewer than 10 black or white spots, this is not a failure or a defect.

Basic Operation of Machine Monitor

Starting Engine When Situation is Normal

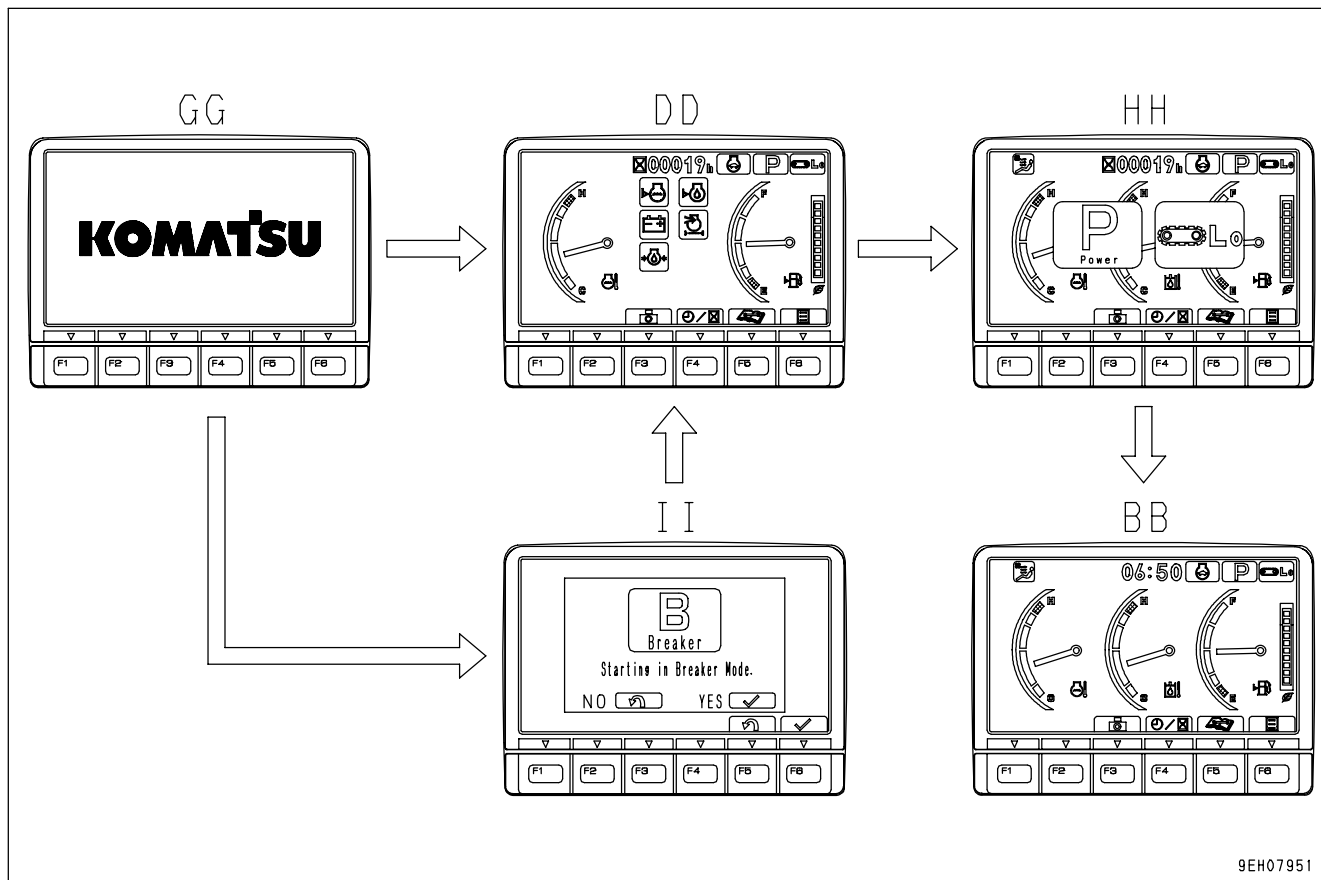

9EH07951

- When the starting switch is turned to the ON position, the opening screen GG is displayed.
- After the opening screen GG is displayed for 2 seconds, the screen switches to the check before starting screen DD.
- After the check before starting screen DD is displayed for 2 seconds, the screen switches to the working mode/travel mode display screen HH.
- After the working mode/travel mode display screen HH is displayed for 2 seconds, the screen switches to standard screen BB.
- If the working mode when the engine is started is B mode, the opening screen GG is displayed for 2 seconds, and the screen then switches to the breaker mode confirmation screen II.

When starting in B mode, press switch F6. If you do not want to start B mode, press switch F5. In this case, the system starts with E mode.

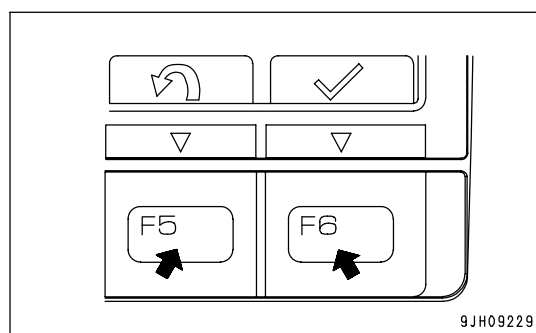

9JH09229

REMARK

When the engine is started, the battery voltage may suddenly drop depending on the temperature and the battery condition. If this happens, the display on the machine monitor may momentarily go out, but this does not indicate any abnormality.

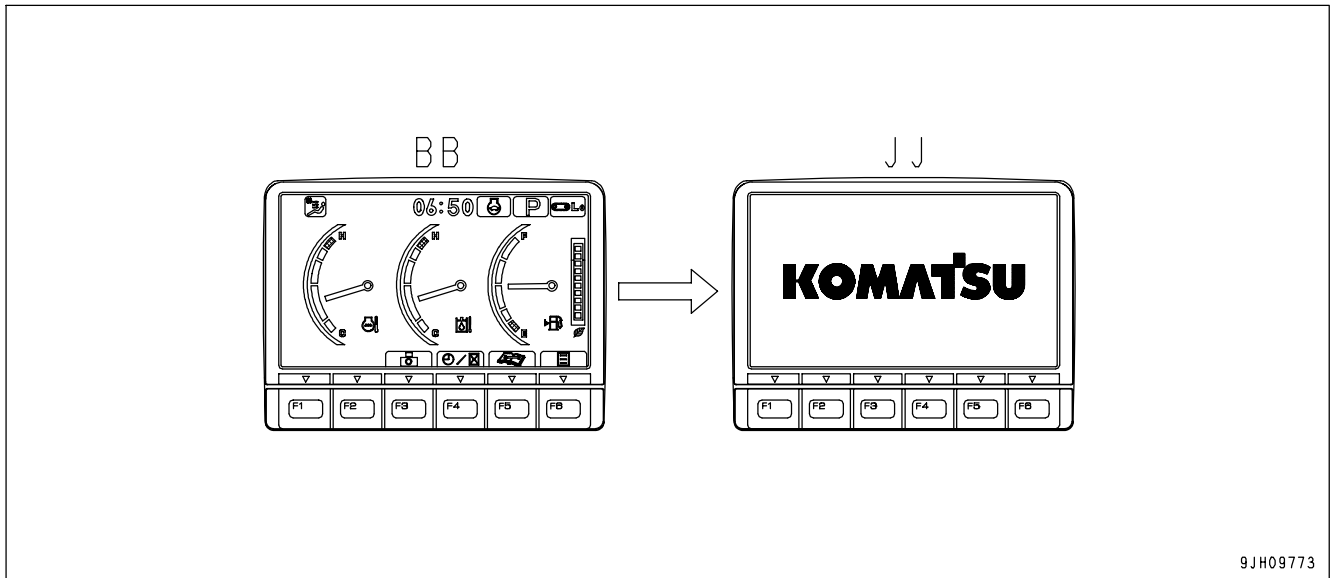
Stopping Engine When Situation is Normal

- When the starting switch is turned to the OFF position, ending screen JJ is displayed for 5 seconds, then the display goes out.

If There Is Abnormality When Starting Engine

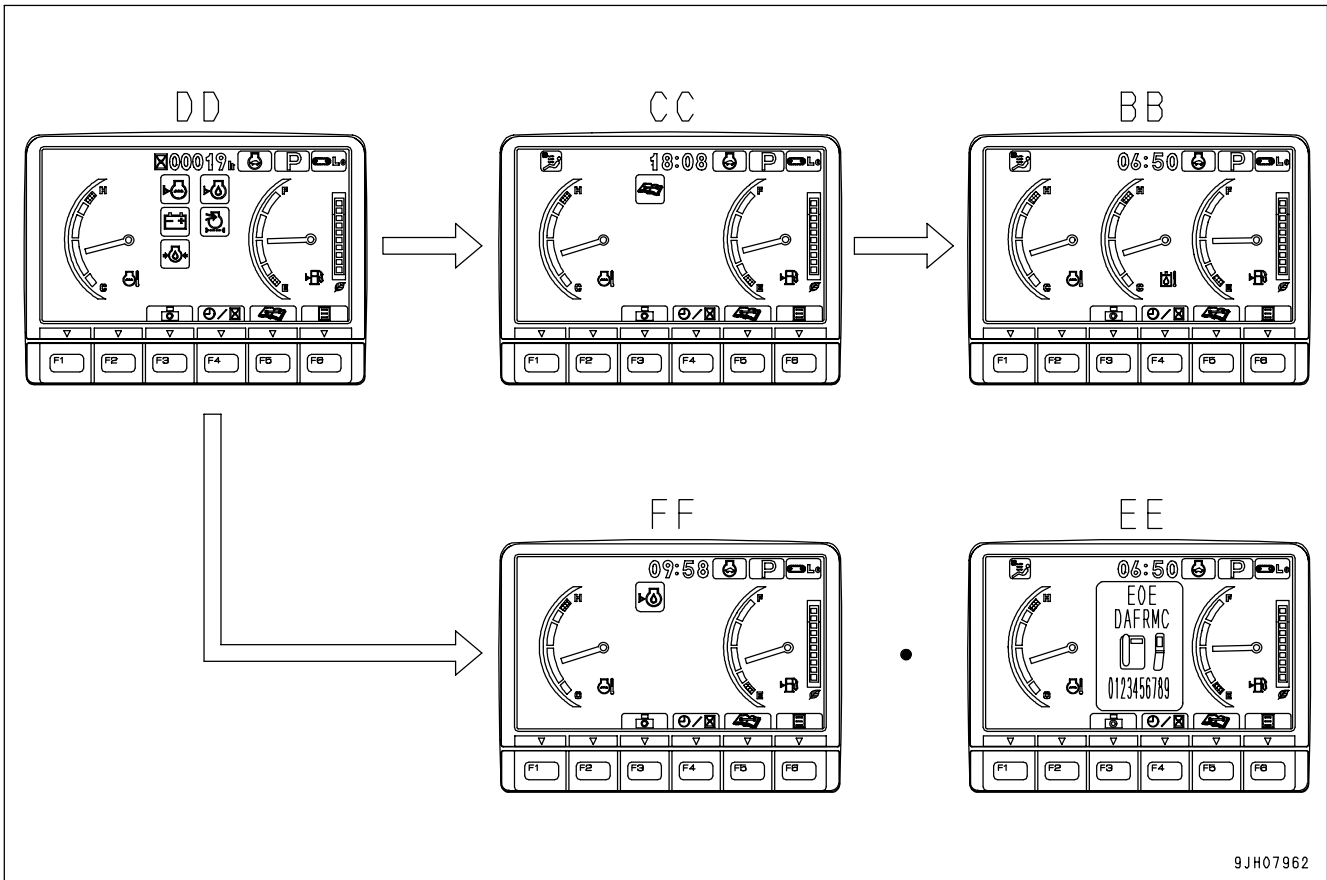

9JH07962

- If there is any abnormality when starting the engine, the check before starting screen DD changes to the maintenance interval warning screen CC, warning screen FF, or error screen EE.
- After displaying the check before starting screen DD for 2 seconds, the screen changes to the maintenance interval warning screen CC.
- After displaying the maintenance interval warning screen CC for 30 seconds, the screen returns to the standard screen BB.
- After displaying the check before starting screen DD for 2 seconds, the screen changes to the warning screen FF or error screen EE.

If Any Abnormality Occurs During Operation

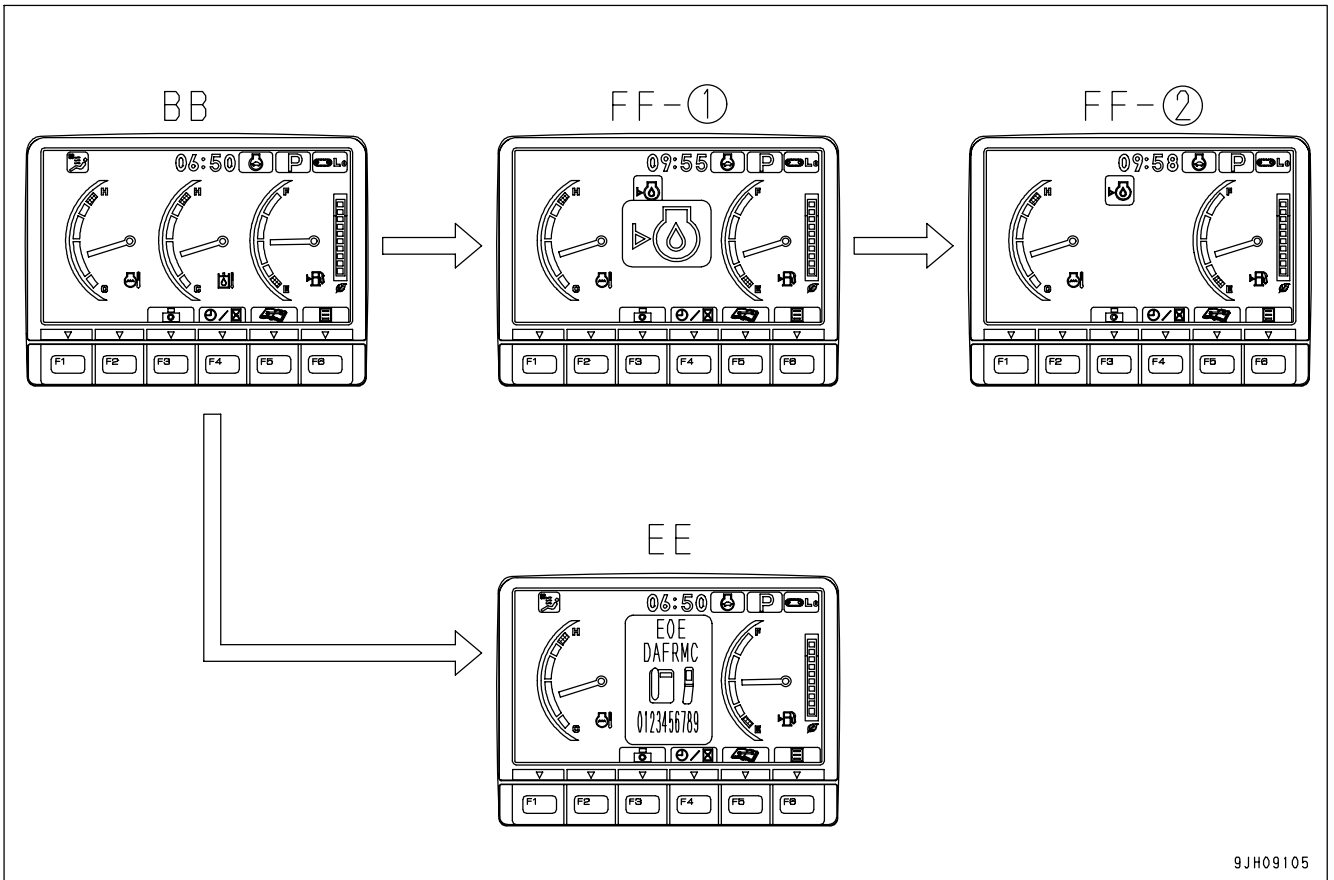

- If any abnormality occurs during operation, the standard screen BB changes to warning screen FF-(1) or the error screen EE.
- After displaying warning screen FF-(1) for 2 seconds, the screen automatically changes to warning screen FF-(2).

REMARK

The colors lighting up the monitors related to the emergency stop items, caution items, and basic check items are as follows.

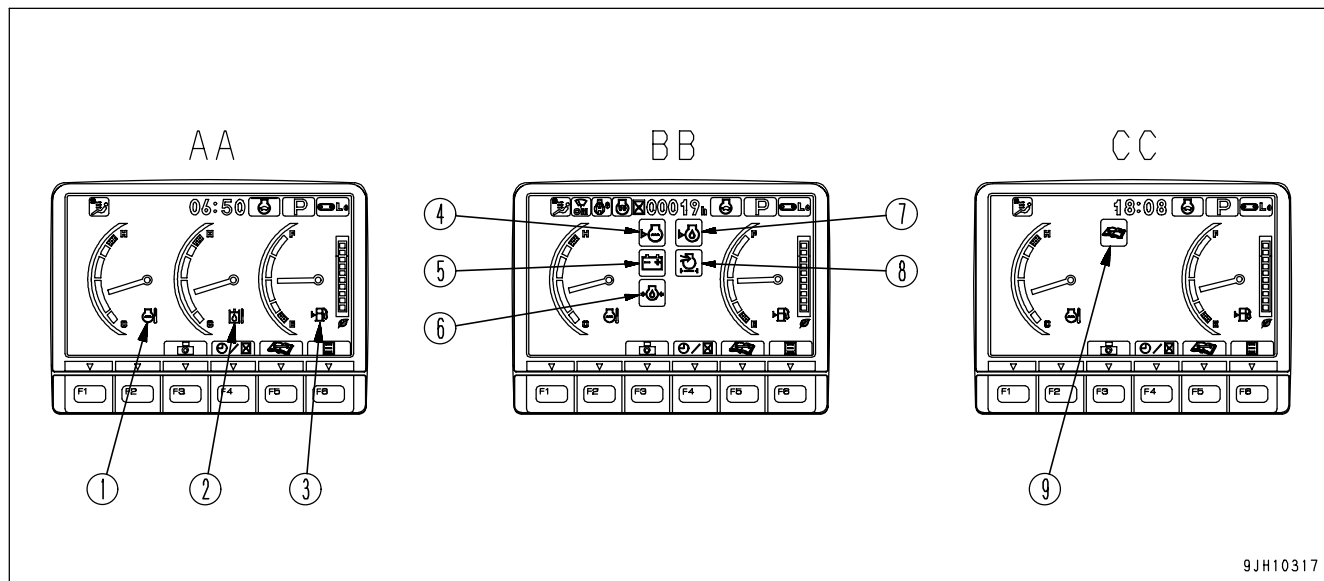

9JH10317

AA: Screen for standard

BB: Screen with all lamps lighted up

CC: Maintenance time warning screen

	Type of monitor	Color when monitor lights up		
		When normal	When abnormal	At low temperature
(1)	Engine coolant temperature monitor	Blue	Red	White
(2)	Hydraulic oil temperature monitor	Blue	Red	White
(3)	Fuel level monitor	Blue	Red	-
(4)	Radiator coolant level monitor	OFF	Red	-
(5)	Charge level monitor	OFF	Red	-
(6)	Engine oil pressure monitor	OFF	Red	-
(7)	Engine oil level monitor	OFF	Red	-
(8)	Air cleaner clogging monitor	OFF	Red	-
(9)	Maintenance interval monitor	OFF	Red	-

Emergency Monitors

! CAUTION

If the monitor lights up red, stop the engine immediately or run at low idle, check applicable location, then perform necessary actions.

These items should be observed while the engine is running. If there is a problem, the monitor for the abnormal location lights up red and buzzer sounds, perform action immediately.

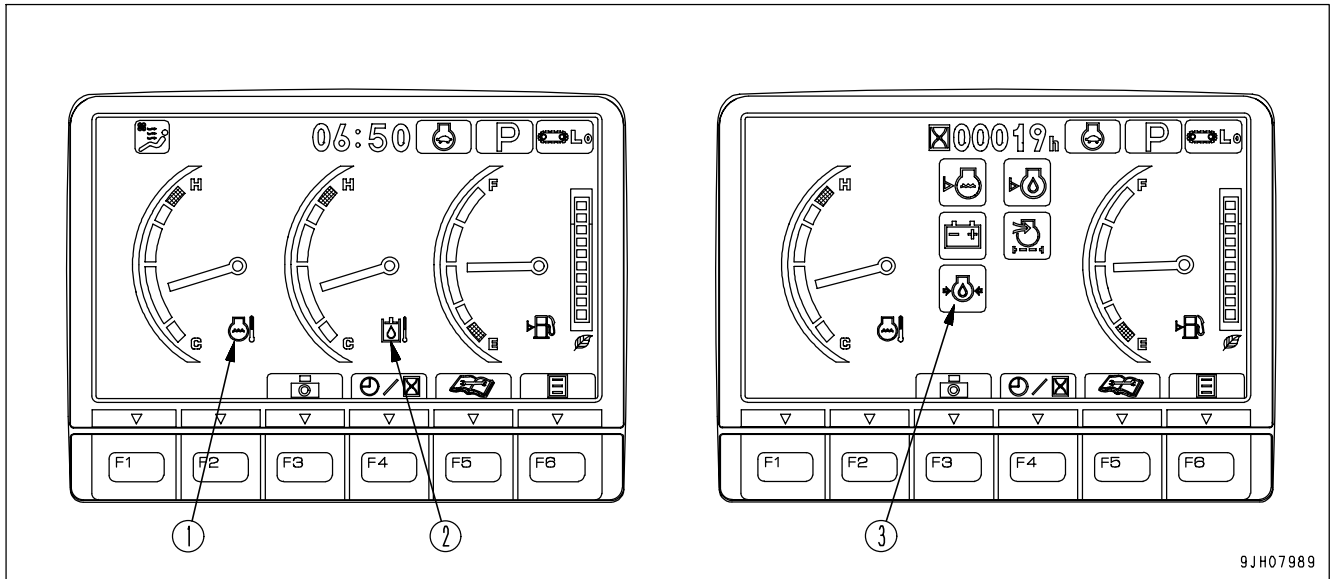

- (1) Engine coolant temperature monitor
- (2) Hydraulic oil temperature monitor
- (3) Engine oil pressure monitor

Engine Coolant Temperature Monitor

Monitor (1) warns operator that the engine coolant temperature has risen.

If the engine coolant temperature becomes abnormally high, the monitor shows abnormal display (C). The overheat prevention system is automatically actuated and the engine speed drops. Stop operations and run the engine at low idling until monitor (1) shows normal display (B).

- Display (A) at low temperatures: Monitor background (D) is white
- Display (B) at correct temperatures: Monitor background (D) is blue
- Display (C) when condition is abnormal: Monitor background (D) is red

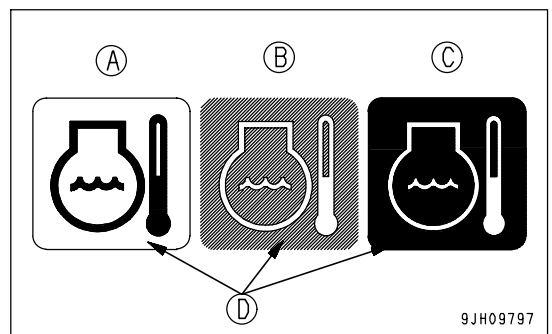

Hydraulic Oil Temperature Monitor

This monitor (2) warns the operator that the hydraulic oil temperature has risen.

If the hydraulic oil temperature becomes abnormally high, abnormality display (C) is shown.

Stop operations and stop the engine or run it at low idling until the monitor changes to normal display (B).

Display (A) at low temperatures: Monitor background (D) is white
 Display (B) at correct temperatures: Monitor background (D) is blue

Display (C) when condition is abnormal: Monitor background (D) is red

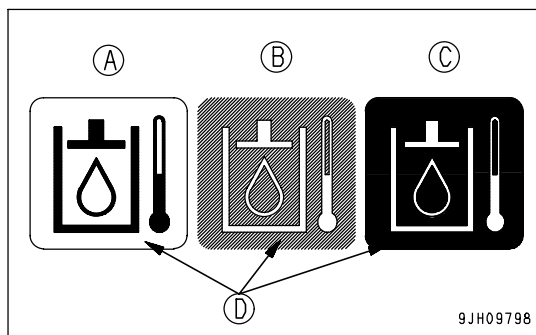

Engine Oil Pressure Monitor

Monitor (3) lights up red if the engine lubrication oil pressure goes below normal level. If monitor lights up red, stop the engine immediately, check the lubrication system and level of oil in the engine oil pan.

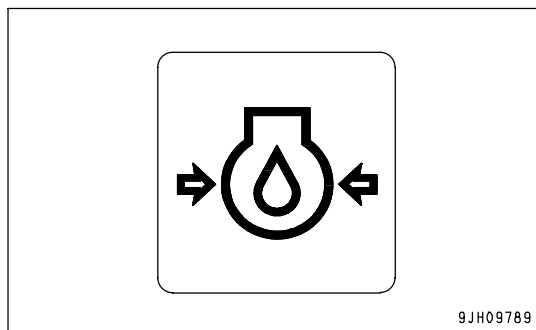

Caution Monitors



If the warning monitor lights up red, stop operations as soon as possible and perform inspection and maintenance of the applicable location. If the warning is ignored, it may lead to failure.

These are items that should be observed while the engine is running. If any abnormality occurs, the screen displays the item that needs immediate action.

If there is an abnormality, the monitor for the abnormal location lights up red.

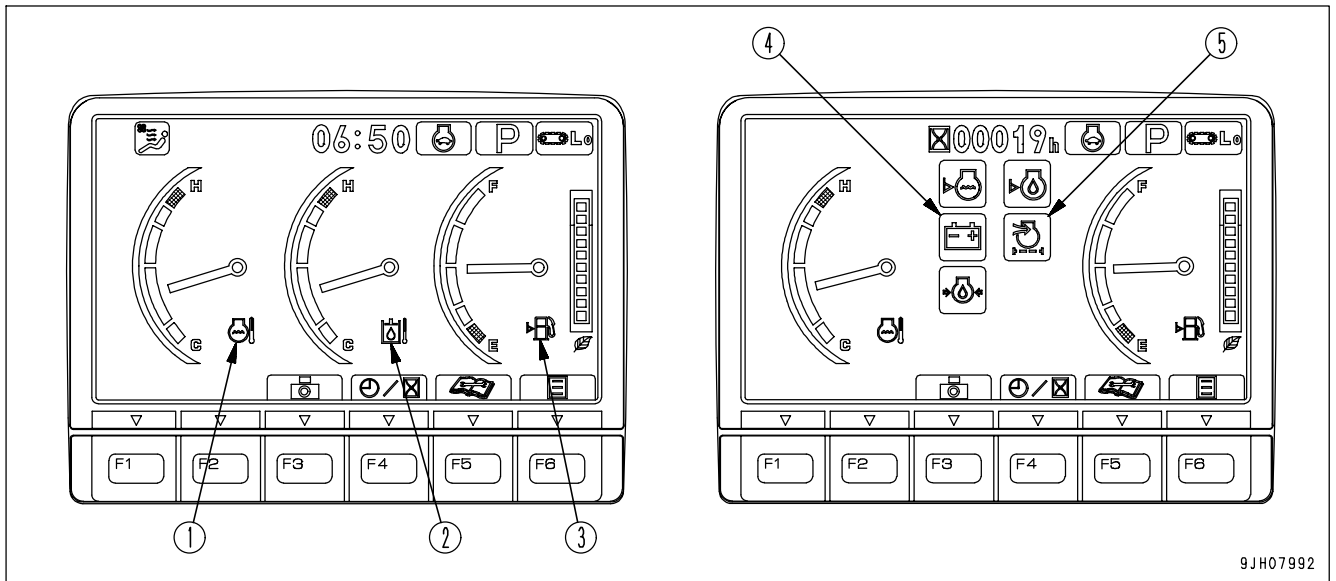

- (1) Engine coolant temperature monitor
- (2) Hydraulic oil temperature monitor
- (3) Fuel level monitor
- (4) Charge level monitor
- (5) Air cleaner clogging monitor

Engine Coolant Temperature Monitor

If this monitor (1) shows low-temperature display (A), carry out the warm-up operation. For details, see "Engine Warm Up (PAGE 3-133)".

Monitor (1) will show normal display (B), so carry out the warm-up operation for the engine.

Display (A) at low temperatures: Monitor background (D) is white
 Display (B) at correct temperatures: Monitor background (D) is blue

Display (C) when condition is abnormal: Monitor background (D) is red

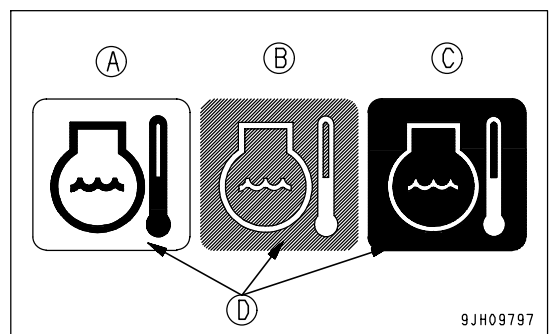

Hydraulic Oil Temperature Monitor

If this monitor (2) shows low-temperature display (A), carry out the warm-up operation. For details, see "Hydraulic Equipment Warm Up (PAGE 3-135)".

Carry out the warm-up operation for the hydraulic equipment until monitor (2) shows normal display (B).

Display (A) at low temperatures: Monitor background (D) is white

Display (B) at correct temperatures: Monitor background (D) is blue

Display (C) when condition is abnormal: Monitor background (D) is red

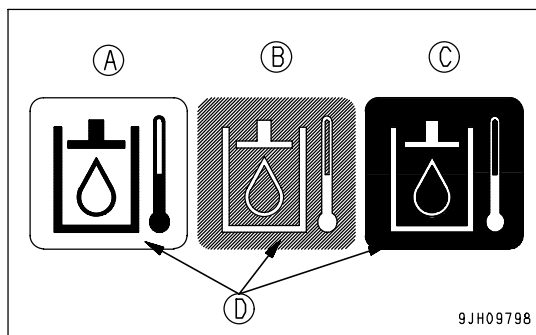

Fuel Level Monitor

This monitor (3) lights up to warn that the operator that the level in the fuel tank is low.

When the remaining fuel level reaches approx. 80 liters (21.14 US gal), the monitor lamp lights up red, so add fuel as soon as possible.

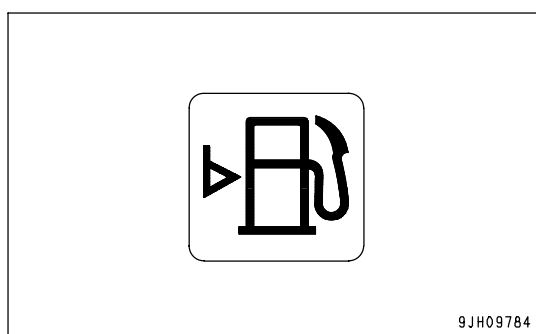

Charge Level Monitor

This monitor (4) warns the operator that there is an abnormality in the charging system when the engine is running.

If the battery is not being charged properly while the engine is running, monitor lights up red.

If monitor lights up red, check the V-belt for looseness. If any abnormality is found, perform the necessary actions. For details, see "OTHER TROUBLE (PAGE 3-203)".

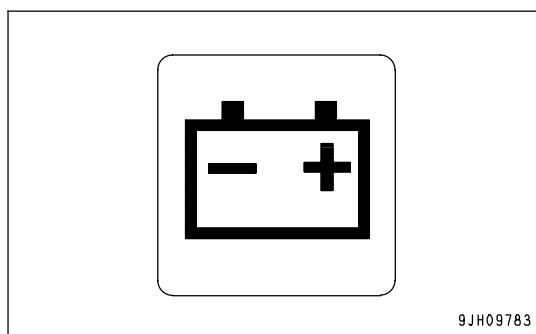

Air Cleaner Clogging Monitor

This monitor (5) warns the operator that the air cleaner is clogged. If it lights up red, stop the engine and inspect and clean the air cleaner.

For details of checking and cleaning the air cleaner, see "CHECK, CLEAN AND REPLACE AIR CLEANER ELEMENT (PAGE 4-19)".

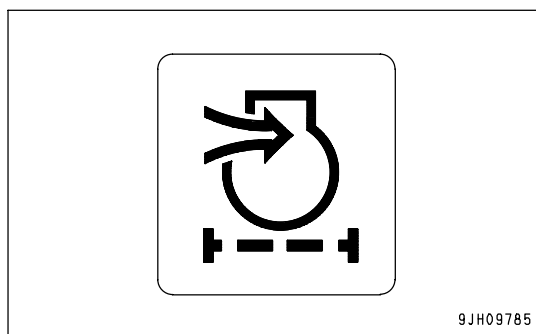

Basic Check Monitors



These monitors do not guarantee the condition of the machine.

Do not simply rely on the monitor when carrying out checks before starting (daily inspection). Always get off the machine and check each item directly.

Displays basic items among the check before starting items that must be checked before starting the engine. If there is any abnormality, monitor for the location of abnormality will light up.

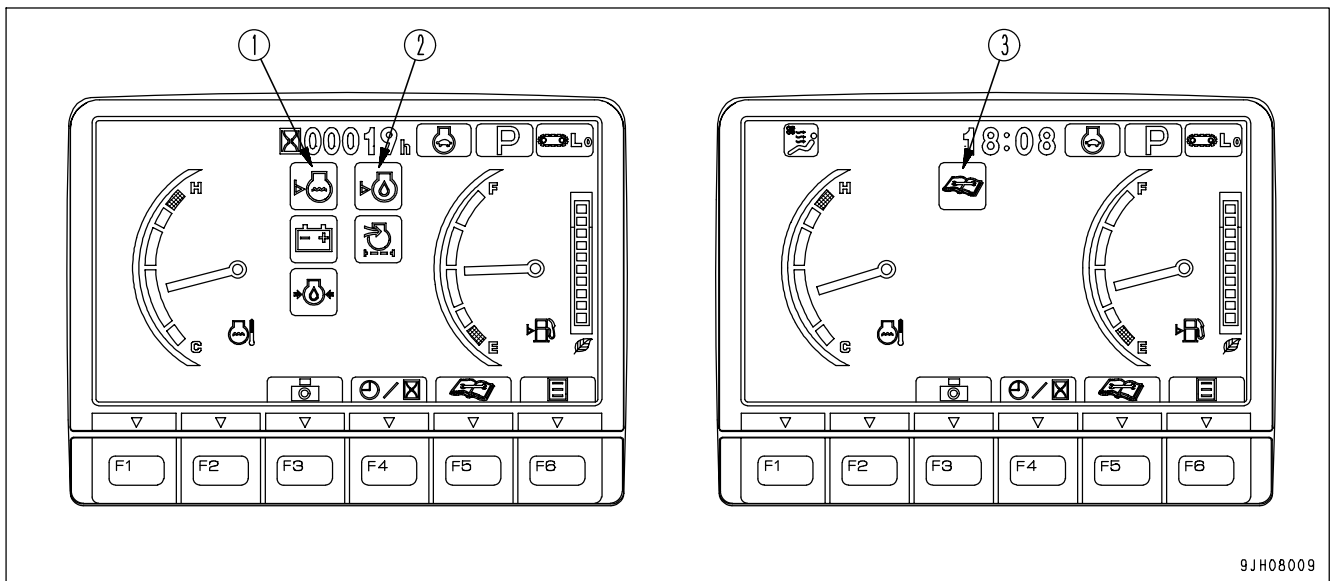

- (1) Radiator coolant level monitor
- (2) Engine oil level monitor

- (3) Maintenance interval monitor

Radiator Coolant Level Monitor

Monitor (1) warns the operator that there has been a drop in the radiator coolant level.

If the radiator coolant is low, the lamp lights up red, so check coolant level in the radiator and subtank, and add coolant.

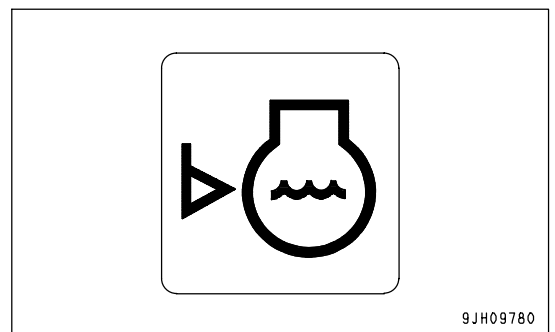

Engine Oil Level Monitor

Monitor (2) warns the operator that the oil level in the engine oil pan has dropped.

If oil level in the engine oil pan is low, the lamp lights up red, so check the oil level, and add oil.

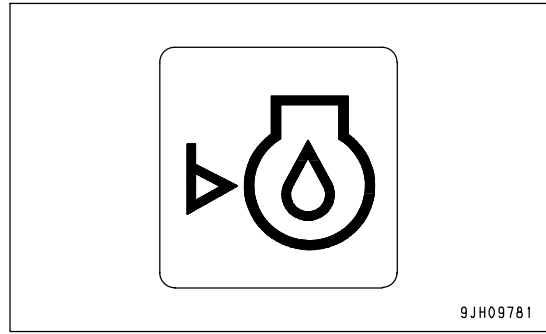

Maintenance Interval Monitor

This monitor (3) lights up when the maintenance time gets close and remains lighted after the maintenance time has already passed.

- Lighted yellow: The maintenance time is due within 30 hours.
- Lighted red: The maintenance time has already passed.

This monitor lights up when the starting switch is turned to the ON position. It goes off after 30 seconds and the display changes to the normal screen.

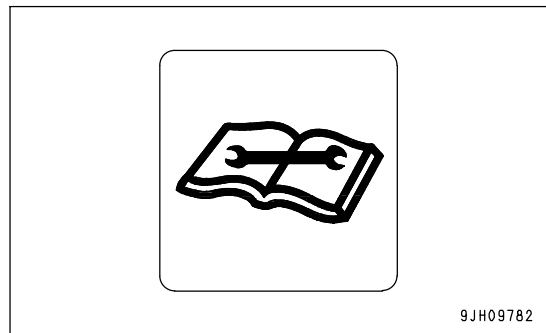

REMARK

- For details of the method of confirming the maintenance interval, see "Maintenance Selector Switch (PAGE 3-41)".
- If it is desired to change settings for the maintenance interval, have your Komatsu distributor change the settings.

Meter Display Portion

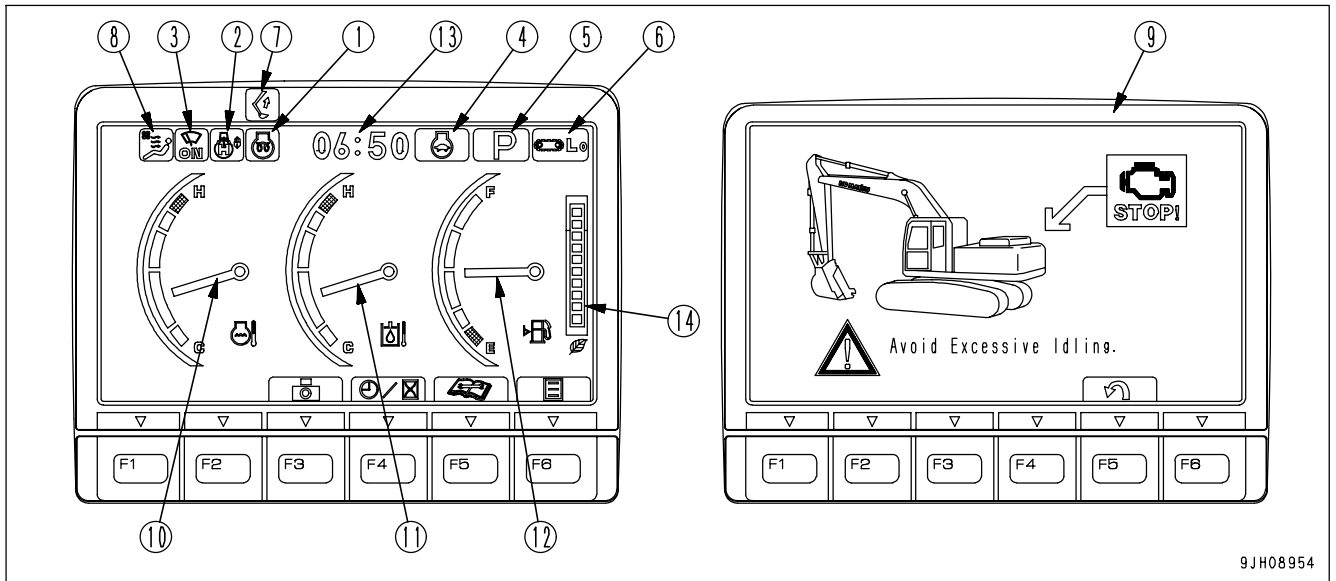

Pilot display

- (1) Engine pre-heating monitor
- (2) Swing lock monitor
- (3) Wiper monitor
- (4) Auto-deceleration monitor
- (5) Working mode monitor
- (6) Travel speed monitor
- (7) One-touch power max. monitor
- (8) Air conditioner monitor
- (9) Idle stop guidance

Gauge and Meter

- (10) Engine coolant temperature gauge
- (11) Hydraulic oil temperature gauge
- (12) Fuel gauge
- (13) Service meter, clock
- (14) ECO gauge

Pilot Display

- The pilot display at the top of the screen consists of the pilot lamps to confirm the actuation of each function.
- When the starting switch is turned ON, the pilot lamp lights up when the display items are functioning.

Engine Pre-heating Monitor

This monitor (1) lights up when the engine preheating electric heater is actuated. When the ambient temperature is low and the starting switch is set to the ON position, the lamp lights up, and when the preheating is completed, it goes out.

The preheating time differs according to the ambient temperature.

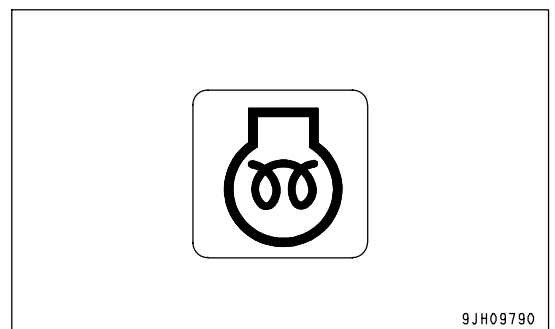

9JH09790

Swing Lock Monitor

This monitor (2) informs the operator that the swing lock is being actuated.

Actuated: Lights up

When the swing lock switch is turned ON (ACTUATED), the monitor lamp lights up.

This lamp lights up when the swing parking brake release switch is set to the FREE position.

- For details of the positions of the swing parking brake release switch, see "CONTROLS AND GAUGES (PAGE 3-3)".

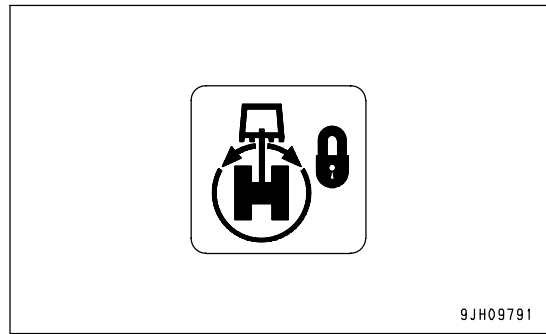

REMARK

The swing motor is equipped with a disc brake that mechanically stops the rotation. When the swing lock monitor is lighted up, the brake remains applied.

Wiper Monitor

Monitor (3) indicates operating status of the wiper.

The monitor display when wiper switch is operated, as follows.

When ON lights up: Wiper moves continuously

When INT lights up: Wiper moves intermittently

OFF: Wiper stops

- For details of the positions of the wiper switch, see "CONTROLS AND GAUGES (PAGE 3-3)".



Auto-deceleration Monitor

Monitor (4) shows if the auto-deceleration is being actuated.

The monitor display when auto-deceleration switch is operated, as follows.

Auto-deceleration monitor ON: Auto-deceleration actuated

Auto-deceleration monitor OFF: Auto-deceleration canceled

- For details of the positions of the auto-deceleration switch, see "CONTROLS AND GAUGES (PAGE 3-3)".

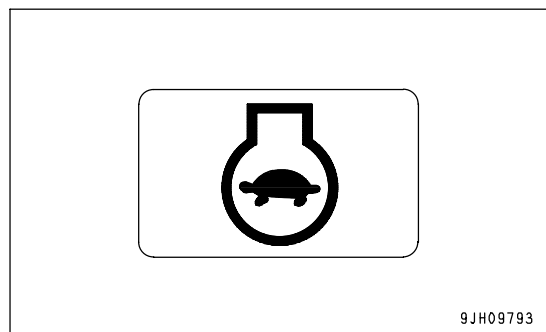

Working Mode Monitor

This monitor (5) displays the setting of the working mode.

The monitor display is as follows according to the operation of the working mode switch.

P: P mode (for heavy-load operations)

E: E mode (for operations with emphasis on fuel consumption)

L: L mode (for fine control operations)

B: B mode (for breaker operations)

ATT: ATT mode (for crusher operations)

- For details of the positions of the working mode switch, see "CONTROLS AND GAUGES (PAGE 3-3)".

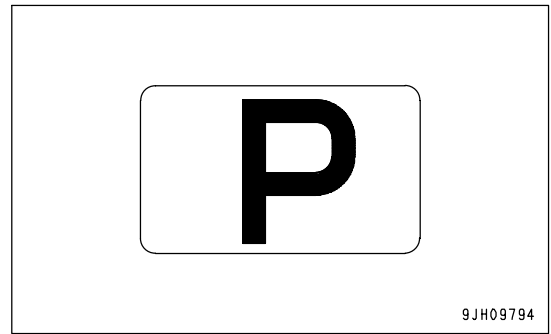
**Travel Speed Monitor**

This monitor (6) shows the setting for the travel speed.

The monitor display is as follows according to the operation of the travel speed selector switch.

Lo: Low-speed travel

Mi: Mid-range speed travel

Hi: High-speed travel

- For details of the positions of the travel speed selector switch, see "CONTROLS AND GAUGES (PAGE 3-3)".

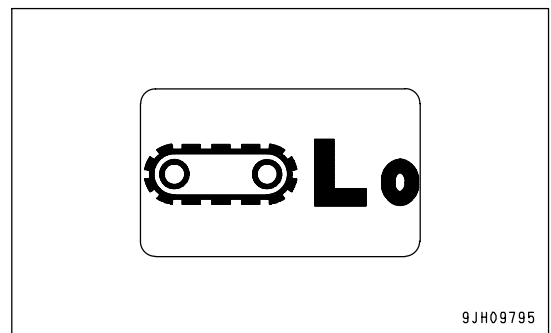
**One-Touch Power Max. Monitor**

This monitor (7) shows if the one-touch power max. function is being actuated.

The monitor display when the knob switch on the left control lever is operated is as follows. (The actual monitor display is shown at the position of preheating monitor (1).)

Monitor lights up: Digging power is increased while knob switch is kept pressed.

- For details of the positions of the knob switch, see "CONTROLS AND GAUGES (PAGE 3-3)".

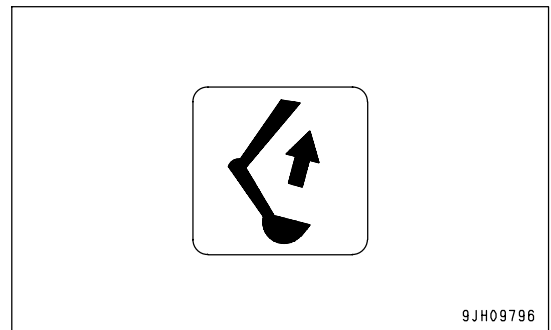
**REMARK**

Only when the working mode is P or E mode, the power is increased while the knob switch is being pressed. Even if the knob switch continues to be pressed, the power increase is finished after 8.5 seconds.

Monitor goes out: Power max function stopped

Air Conditioner Monitor

This monitor (8) displays the working status of the air conditioner.

Monitor lighted up: Air conditioner ON

Monitor off: Air conditioner OFF

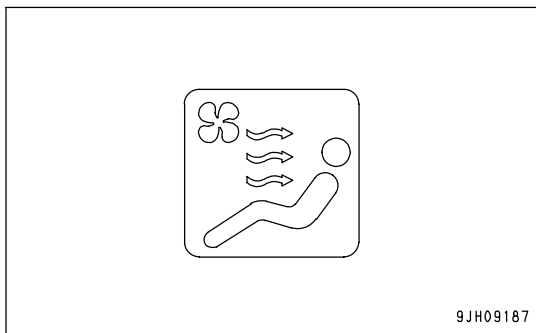

Idle Stop Guidance

If the levers are not operated for more than five minutes, and the engine is idling, the idling stop message is displayed on the monitor. When waiting for work or stopping work for a short periods, stop the engine to reduce unnecessary fuel consumption.

- The idling stop message screen returns to the standard screen any lever is operated again or when function switch F5 (Back) is pressed.

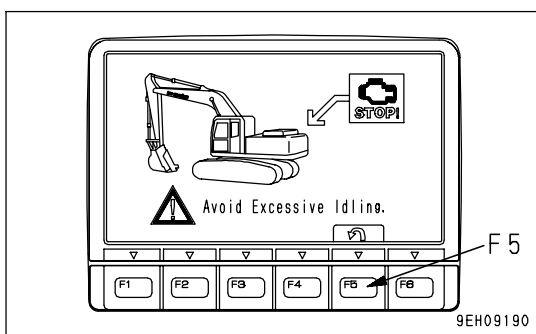

Gauges and Meter

Engine Coolant Temperature Gauge

This meter (10) shows the engine coolant temperature.

During normal operations, the indicator should be in the green range. If the indicator goes beyond red range (A) during operations, the overheat prevention system is actuated.

- (A) - (B): Red range
- (A) - (C): Green range
- (C) - (D): White range

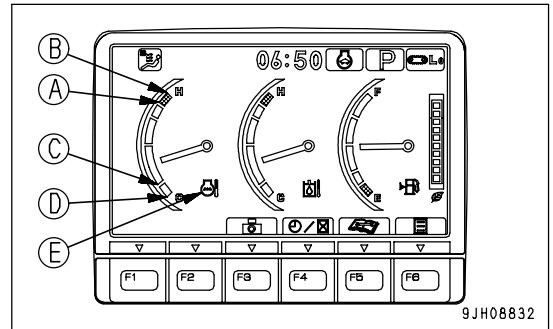

The overheat prevention system is actuated as follows.

Red range (A) position: Engine coolant temperature monitor (E) shows abnormality display

Red range (B) position: Engine speed changes to low idling, engine coolant temperature monitor (E) shows abnormality display, alarm buzzer sounds at same time

The overheat prevention system continues to work until the indicator enters the green range.

When the engine is started, if the indicator is at position (C), engine coolant temperature monitor (E) shows the low-temperature display.

If this happens, carry out the warm-up operation. For details, see "Engine Warm Up (PAGE 3-133)".

Display (G) at low temperatures: Monitor background (K) is white

Display (H) at correct temperatures: Monitor background (K) is blue

Display (J) when condition is abnormal: Monitor background (K) is red

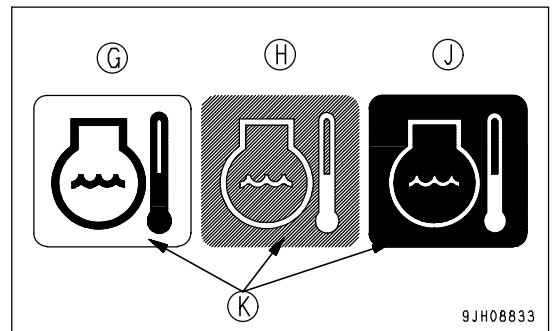

Hydraulic Oil Temperature Gauge

This meter (11) shows the hydraulic oil temperature.

During normal operations, the indicator should be in the green range.

If the indicator enters the red range (A) during operations, the hydraulic oil temperature is 102°C (215.6°F) or more. Run the engine at low idling or stop it and wait for the hydraulic oil temperature to go down.

- (A) - (B): Red range
- (A) - (D): Green range
- (D) - (C): White range

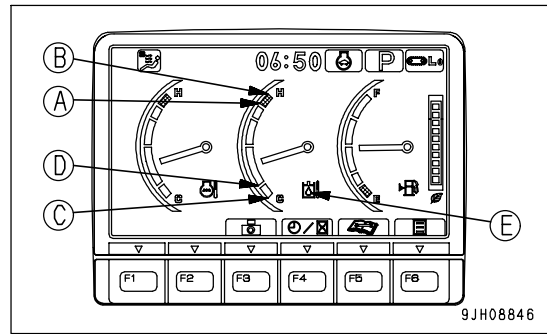

REMARK

When the indicator reaches red range (A), the hydraulic oil temperature is as follows.

Red range (A) position: 102°C (215.6°F) or more

Red range (B) position: 105°C (221°F) or more

When the indicator is in red range (A) - (B), hydraulic oil temperature monitor (E) shows the abnormality display.

When the engine is started, if the indicator is at position (C) and the hydraulic oil temperature is 20°C (68°F), hydraulic oil temperature monitor (E) shows the low-temperature display. If this happens, carry out the warm-up operation. For details, see "Hydraulic Equipment Warm Up (PAGE 3-135)".

Display (G) at low temperatures: Monitor background (K) is white

Display (H) at correct temperatures: Monitor background (K) is blue

Display (J) when condition is abnormal: Monitor background (K) is red

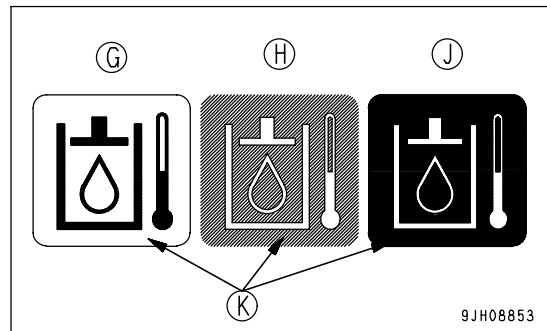

Fuel Gauge

This meter (12) shows the amount of fuel remaining in the fuel tank. During normal operations, the indicator should be in the green range.

If the indicator starts to enter red range (A) during operation, there is less than 110 liters (29.06 US gal) of fuel remaining, so carry out inspection and add fuel.

- (A) - (B): Indicates red range
- (A) - (C): Indicates green range

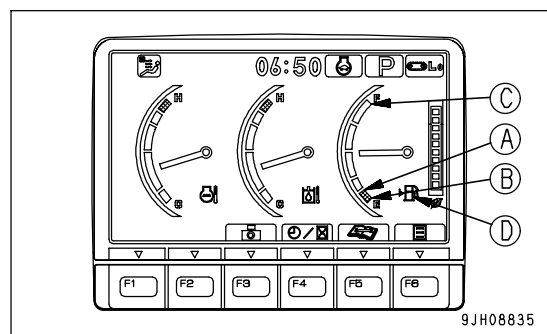

REMARK

When the indicator reaches red range (B), there is less than 80 liters (21.14 US gal) of fuel remaining.

When the indicator is in the red range (B), fuel level monitor (D) lights up red.

The correct fuel level may not be displayed for a short time when the starting switch is turned ON, but this is not an abnormality.

Service Meter, Clock

This meter (13) shows the total hours of operation of the machine or the present time.

When the engine is running, the service meter advances even if the machine is not moving. The service meter advances 1 for every hour that the machine is working, regardless of the engine speed.

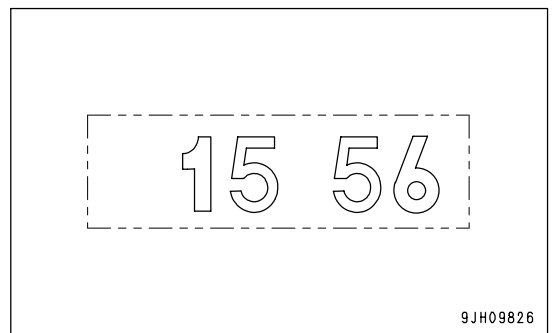
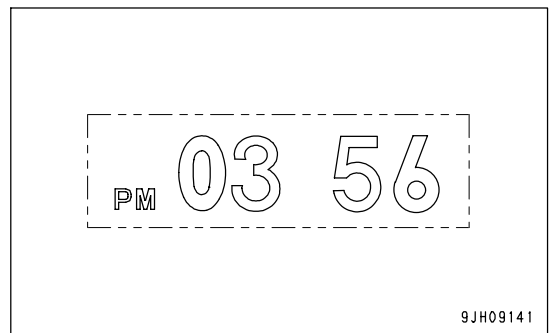
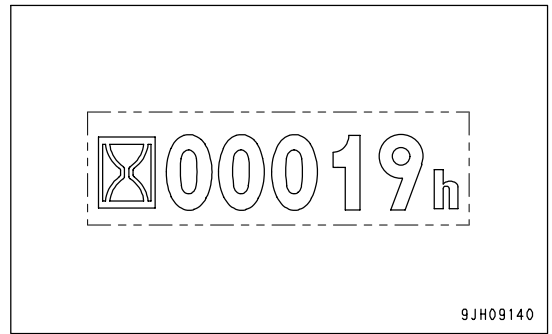

- When the standard screen is being displayed, if function switch F4 is pressed, it is possible to switch between the clock display and the service meter display.
- Clock display (12-hour or 24-hour displays are available)
To set or correct the time, press function switch F6 (user mode switch).

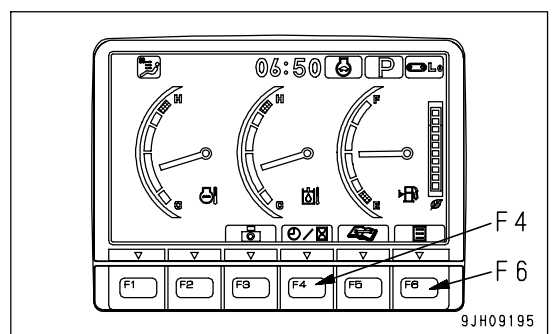

ECO Gauge

This gauge (14) shows the working load status.

When the gauge is in green range A, the work load is light to medium. When the gauge is in orange range B, the load is heavy.

- When the gauge enters the orange range, there is no abnormality on the machine, but to protect the environment, reduce the engine output to a point where there is no adverse effect on the operation. Generally, carry out energy-saving operations in the green range. Reducing the frequency of travel also helps to save energy. Consider the best way of saving energy.

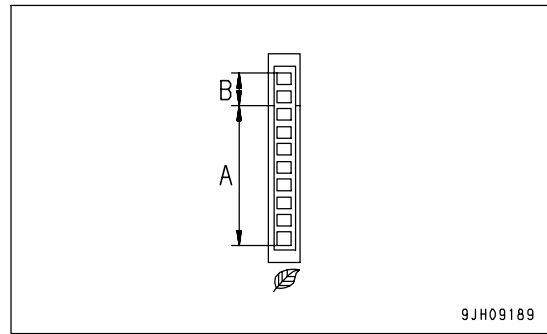

Monitor Switches Portion

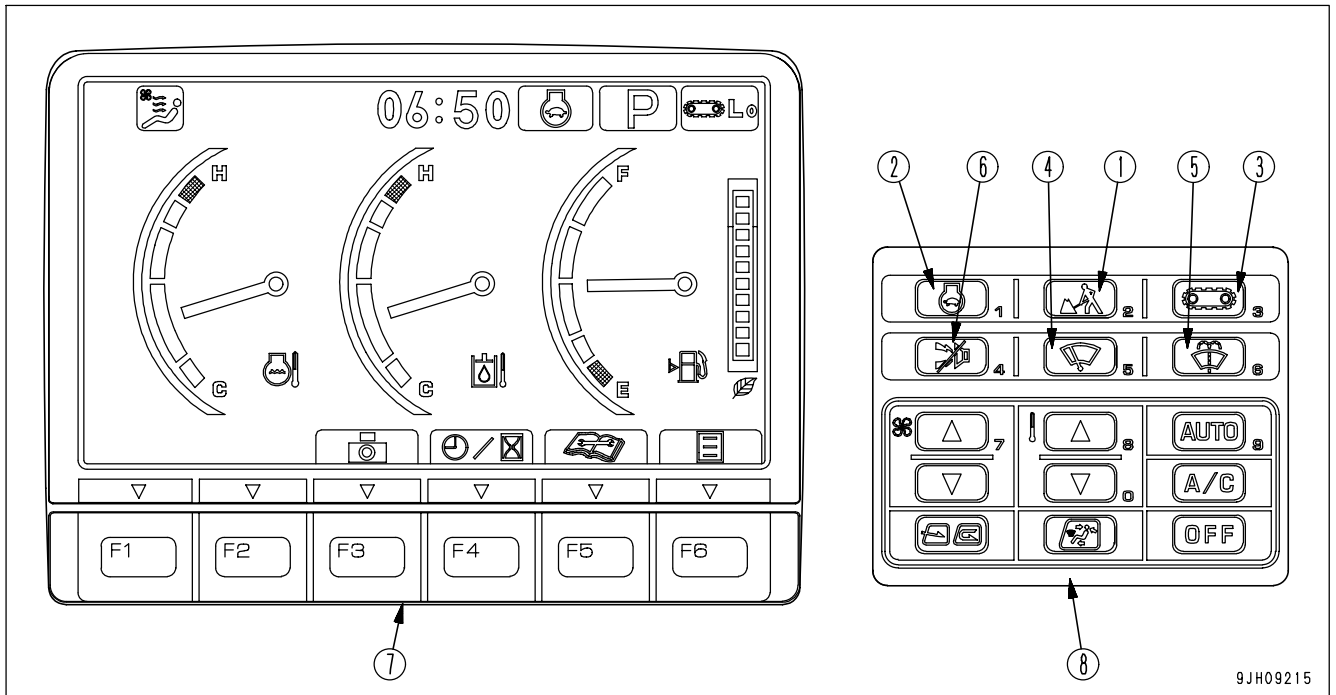

9JH09215

- | | |
|----------------------------------|----------------------------|
| (1) Working mode selector switch | (5) Window washer switch |
| (2) Auto-deceleration switch | (6) Buzzer cancel switch |
| (3) Travel speed selector switch | (7) Function switches |
| (4) Wiper switch | (8) Air conditioner switch |

Working Mode Selector Switch

Use this switch (1) to set the movement or power of the work equipment.

The operation becomes easier if the mode is selected to match the content of the operation.

P mode: For heavy-load operations

E mode: For operation with emphasis on fuel consumption

L mode: For fine control operations

B mode: For breaker operations

ATT mode: For double-acting circuit attachment, such as crusher (attachment-ready machines)

- When the monitor first appears, it is automatically set to the mode in use when it was started the previous time.
- Press switch (1) to display the working mode selection screen. For each set mode, the pilot monitor at the top right of the monitor display shows P, E, L, B, ATT.

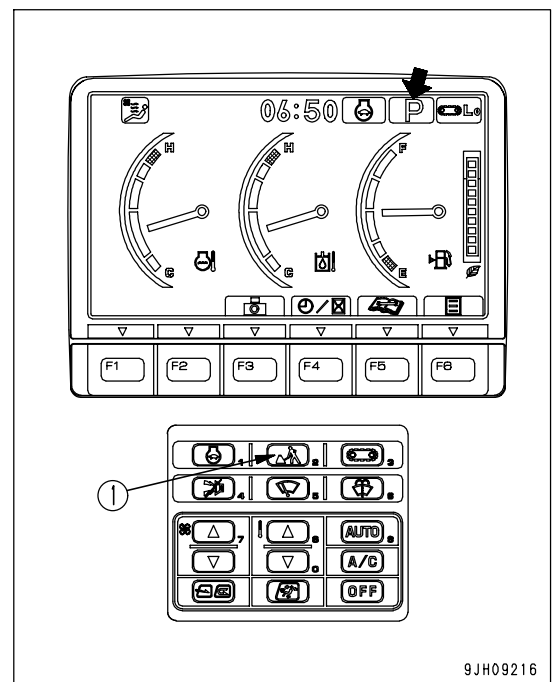

9JH09216

- For machines ready for attachment, the attachment mode is added to the display.
For details of the method for handling machines ready for attachment, see the ATTACHMENTS AND OPTIONS Section.
- When the monitor starts up, if the working mode setting is B mode, the confirmation message on the right is displayed and the buzzer sounds.
- When starting up and staying in B mode, always press function switch F6 (Yes).
If you press F5 (No), the system starts up in E mode.

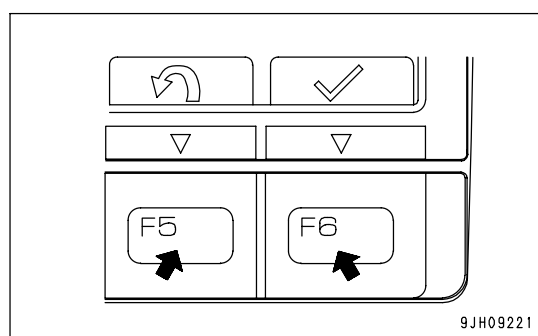
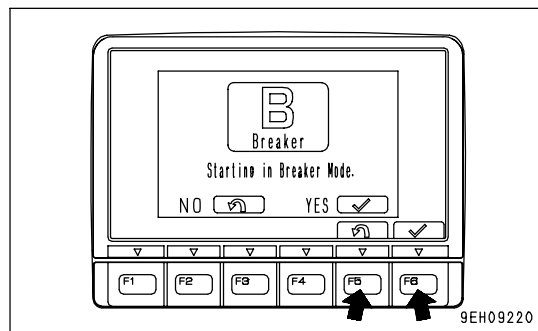

- If you want to have automatic setting of the P, E, L, B or ATT mode when starting (optional default setting), please ask your Komatsu distributor to change the setting.

Procedure for operation

1. If working mode selector switch (1) is pressed, the Working Mode screen is displayed on the monitor.
2. Press function switches F3 or F4 at the bottom of the screen or working mode selector switch (1) to change the mode selection one at a time.
 - If no switch is touched for more than five seconds, the selected working mode is automatically set as the working mode and the screen changes to Steps 3 and Steps 4.

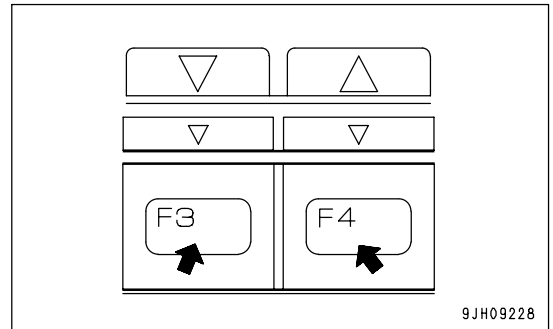
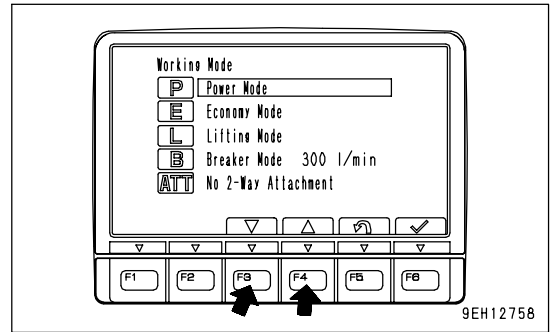

REMARK

To return to the standard screen without changing the working mode, press function switch F5.

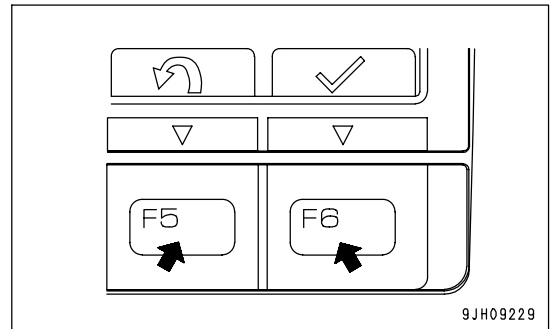

3. After selecting the desired mode, press function switch F6 and the mode is displayed in the center of the monitor display. (Example: If power mode is selected: P)
4. After two seconds, the pilot monitor display at the top right of the screen is highlighted in orange.

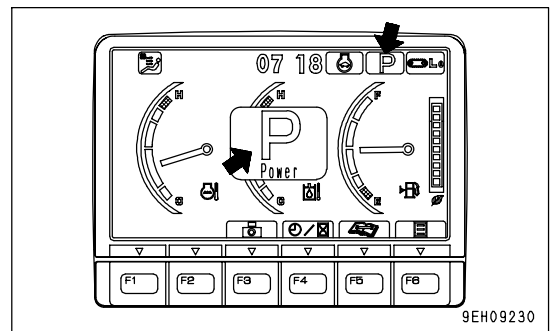

- After two seconds, the screen returns to the standard screen. The monitor display highlighted in orange in Steps 4 returns to blue.

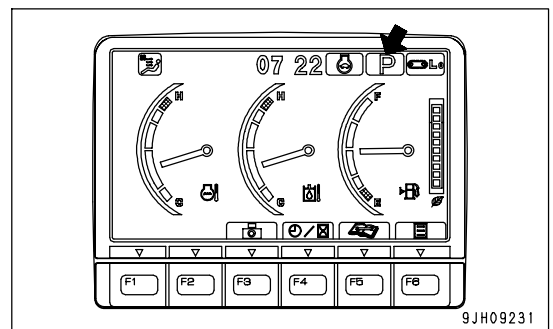

REMARK

When setting the working mode to B mode, to ensure safety, the buzzer sounds and at the same time, the message in the illustration on the right is displayed. When setting to the breaker mode, always press function switch F6.

- If function switch F5 is pressed, the breaker mode is not set, and the screen returns to working mode selection screen.

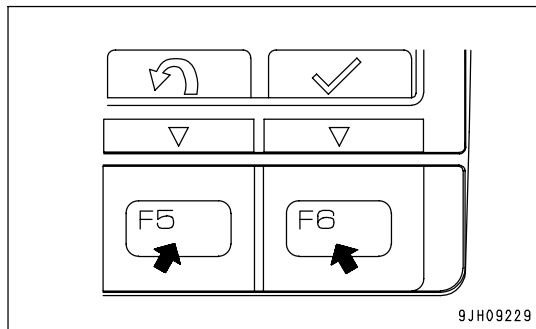
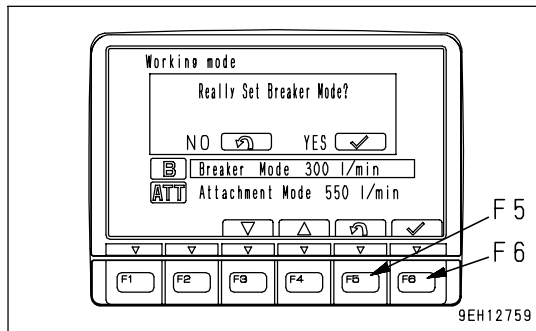

NOTICE

When using the breaker, set to B mode. If B mode is not used, there is danger that the breaker may break.

Auto-deceleration Switch

If the control levers are at neutral, this switch (2) automatically lowers the engine speed and turns on the function to reduce fuel consumption.

Auto-deceleration monitor ON: Auto-deceleration ON

Auto-deceleration monitor OFF: Auto-deceleration OFF

Each time the switch is pressed, the auto-deceleration is switched between ON and OFF.

- Auto-deceleration function

When the auto-deceleration function is ON, if the work equipment and travel levers are returned to the N position, the engine speed will drop after 4 seconds from the operating speed to idling speed.

This makes it possible to reduce fuel consumption.

If any lever is operated when the machine is in this condition, engine speed will return to the previous operating speed to make it possible to perform operations.

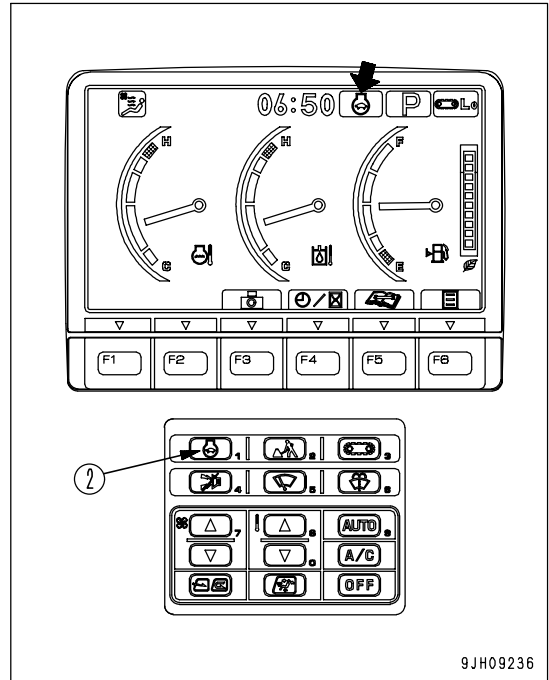

9JH09236

1. When auto-deceleration switch (2) is pressed and the auto-deceleration function is turned ON, the mode is displayed in the center of the monitor display, and after two seconds, the screen returns to the standard screen.

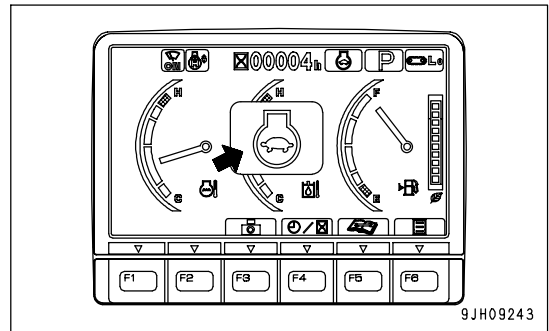

9JH09243

2. On the standard screen, the Auto-deceleration monitor lights up.
(When the auto-deceleration is OFF, it does not light up.)

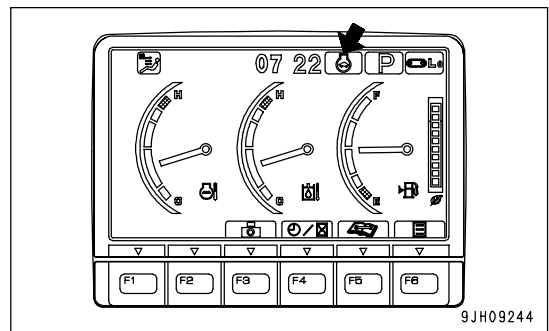

9JH09244

Travel Speed Selector Switch

WARNING

- When loading or unloading from a trailer, always travel at low speed (with travel speed selector switch (3) at the Lo position). Never operate travel speed selector switch (3) while loading or unloading.
- If the travel speed is switched between Hi and Lo when the machine is traveling, the machine may deviate to one side, even when traveling in a straight line.
Stop the machine before switching the travel speed.

Switch (3) is used to set the travel speed to 3 stages.

- Lo lights up : Low-speed travel
- Mi lights up : Medium-speed travel
- Hi lights up : Hi-speed travel

When the engine is started, the speed is automatically set to Lo. Each time that the switch is pressed, the display changes Lo → Mi → Hi → Lo in turn.

Even if the travel speed is set to high-speed (Hi) or a mid-range speed (Mi), when traveling on soft ground or uphill, and travel power is needed, the system automatically shifts down to low speed travel (Lo). There is no need to operate the switch. In this case, the pilot monitor on the monitor display stays lighted up at Hi (high-speed) or Mi (mid-range speed).

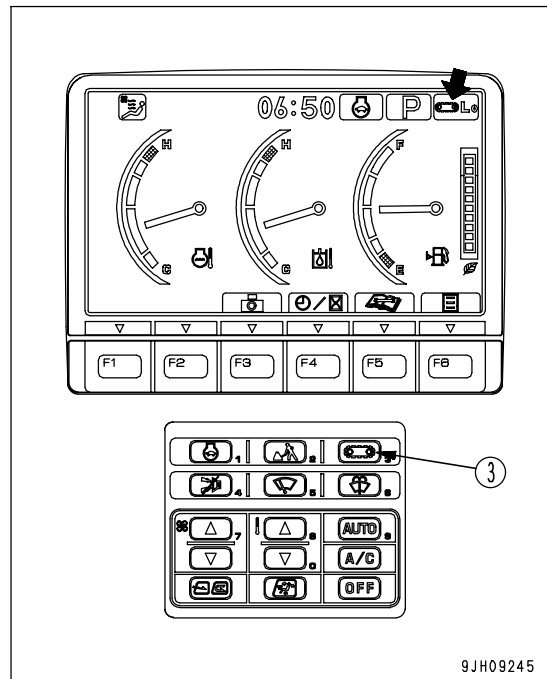

9JH09245

REMARK

Each time travel speed selector switch (3) is switched, the mode is displayed on the monitor display, and after two seconds, the screen returns to the standard screen.

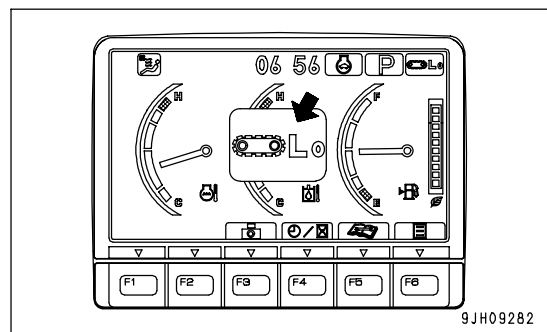

9JH09282

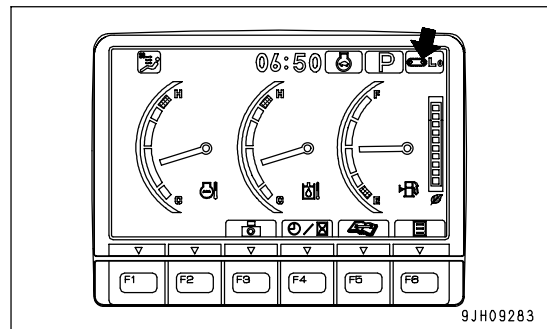

9JH09283

Wiper Switch

This switch (4) actuates the front window wiper.

Each time the switch is pressed, it changes ON → INT → stop (OFF).

Wiper monitor INT lighted up: Wiper operates intermittently

Wiper monitor ON lighted up: Wiper operates continuously

Wiper monitor OFF: Wiper stops

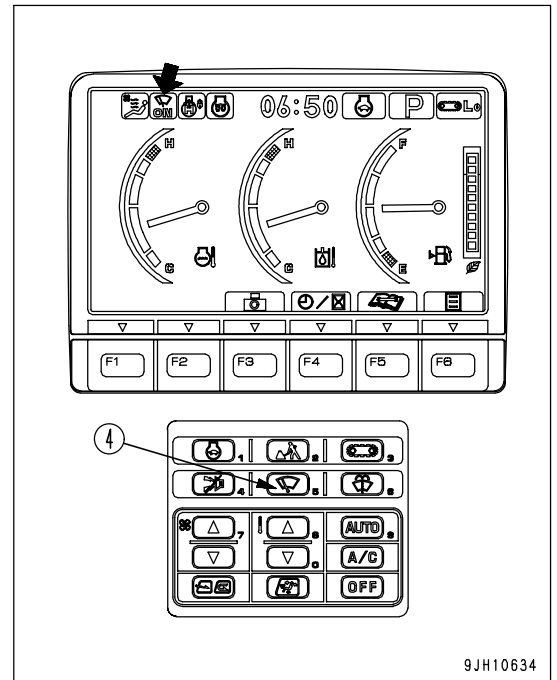

REMARK

Each time wiper switch (4) is pressed, the mode is displayed in the center of the monitor display, and after two seconds, the screen returns to the standard screen.

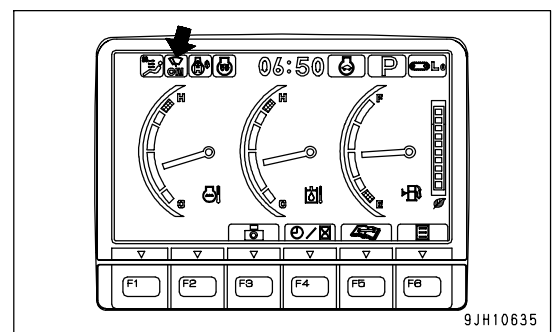
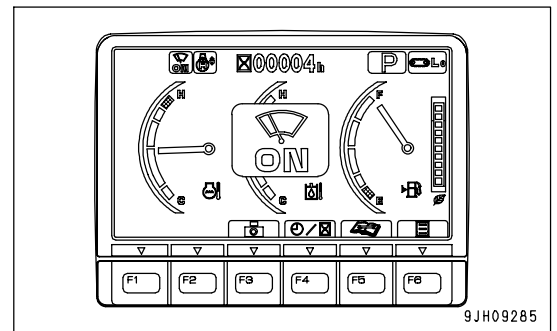

Window Washer Switch

This switch (5) is kept continuously pressed, window washer fluid is sprayed out on the front glass. When the switch is released, the spray stops.

- If switch (5) is kept pressed when the wiper is stopped, the window washer fluid will spray, and at the same time, the wiper will be actuated continuously. When switch (5) is released, the wiper will continue to operate for 2 cycles, then stop.
- If the wiper is moving intermittently and switch (5) is kept pressed continuously, window washer fluid will spray, and at the same time, the wiper will be actuated continuously. When switch (5) is released, the wiper will continue to operate for 2 cycles, then return to intermittent operation.

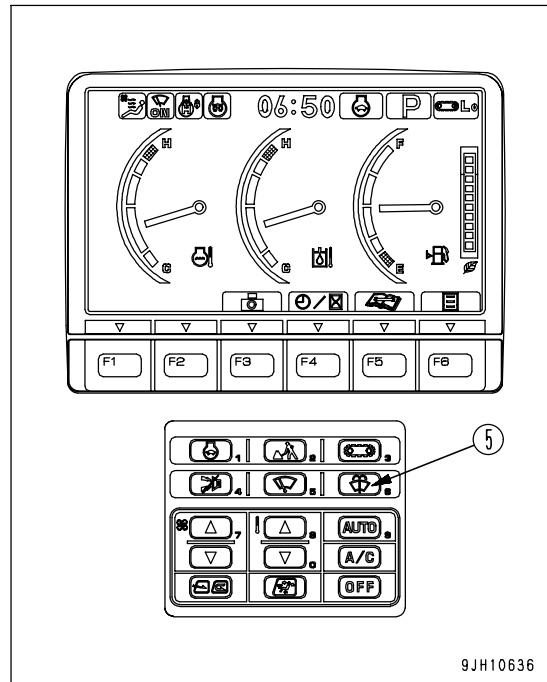

Buzzer Cancel Switch

When this switch (6) is pressed, the warning buzzer for the abnormal warning item stops.

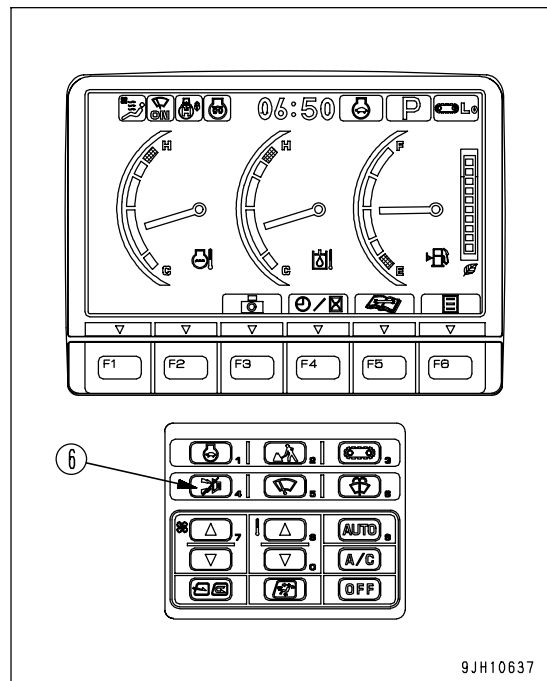

Function Switches

Function switches (7) consist of 6 switches (F1 to F6). The function of each switch differs according to the content of each screen.

When the monitor display shows the standard screen, the functions are displayed as follows.

- F3: Camera screen selector switch (if equipped)
- F4: Service meter/time display selector switch
- F5: Maintenance mode switch
- F6: User mode switch
- F1 and F2 are auxiliary switches for expanded functions.

For explanation of each switch, see "Handling Function Switches (PAGE 3-34)".

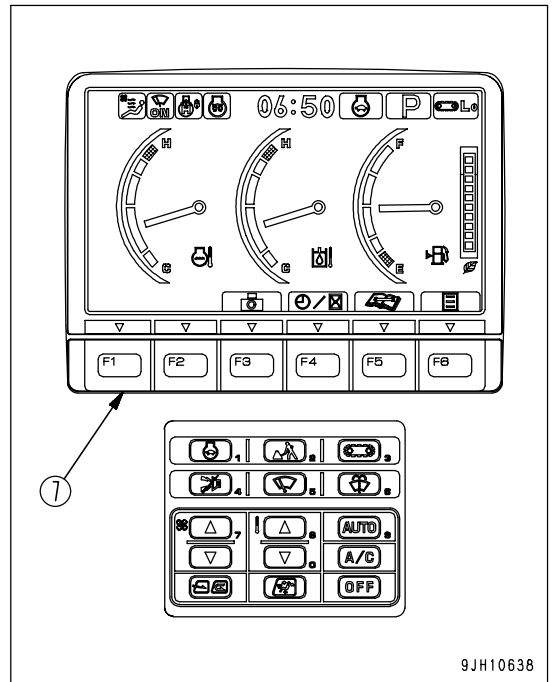

9JH10638

Air Conditioner Switch

The air conditioner switches (8) consist of 9 switches.

For explanation of each switch, see "AIR CONDITIONER CONTROLS (PAGE 3-88)".

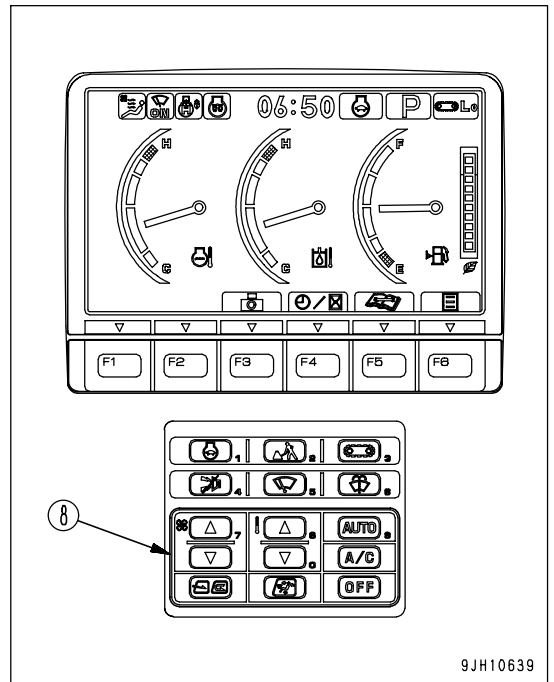

9JH10639

Handling Function Switches

- The function switches (A) at the bottom of the monitor display consist of 6 switches (F1 - F6). The function of each switch differs according to the content of each screen.
- The function of switches (A) on each screen can be confirmed by guidance icons (B) displayed on top of each switch.
- If there is no display in guidance icon (B), even if switch (A) is pressed, it will not function.
- Even if guidance icon (B) is pressed, it will not function. Press switch (A) immediately below the guidance icon display to operate the function.

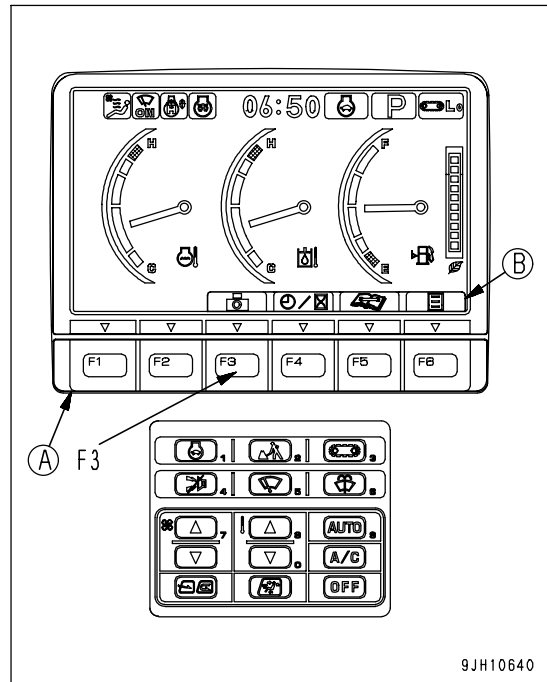

The operation of the function switches if the initial screen is the standard screen is as follows.

Camera Screen Selector Mode Switch

On machines with a camera, press switch F3 to switch to the camera screen display.

- On machines not equipped with a camera, the guidance icon on top of switch F3 is not displayed.
Even if switch F3 is pressed, the screen will not switch to the camera screen display.
- A maximum of three cameras can be installed.
- If you want to install a camera, please consult your Komatsu distributor.

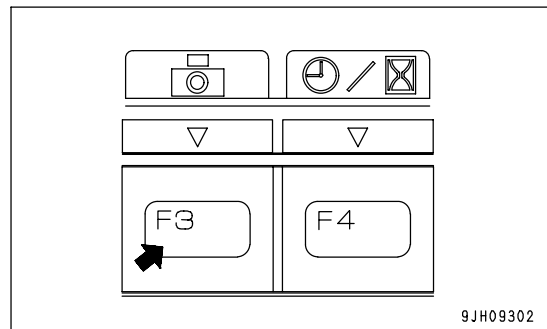

Operations on Camera 1 Image Display Screen

The following explanation describes the method of operation when it is desired to display only one camera screen on the monitor.

- On the standard screen, if switch F3 is pressed, the image display screen is displayed.

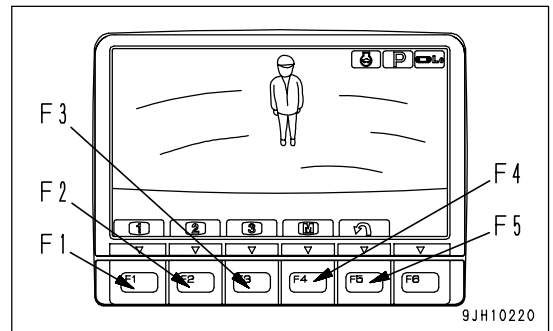

- Press switch F1 to display all the screens for images from the No. 1 camera.
- Press switch F2 to display all the screens for images from the No. 2 camera.

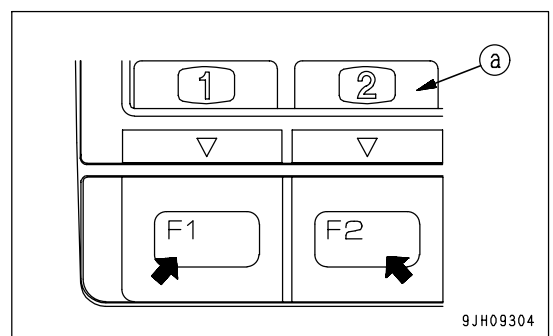

- Press switch F3 to display all the screens for images from the No. 3 camera.

REMARK

If the machine is not equipped with a No. 2 camera or No. 3 camera, guidance icons (a), (b) and (c) are not displayed.

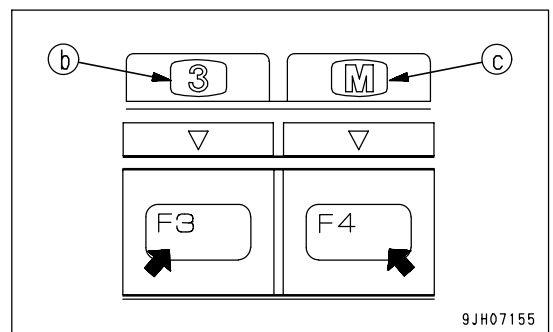

- Press switch F5 to return to the standard screen.

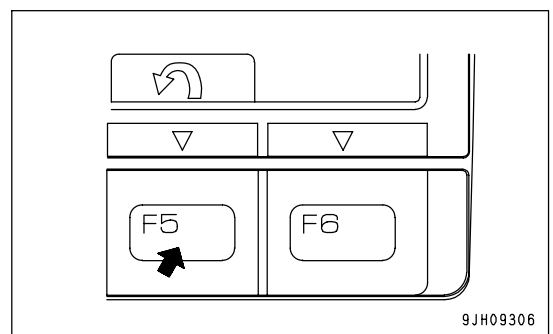

Operation of Image Display Screen When Two Camera Screens are Shown Simultaneously.

The following explanation describes the method of operation when it is desired to display two camera screens at the same time on the monitor.

- On the No. 1 camera image display screen, if switch F4 is pressed, No. 1 camera image (d) and No. 2 camera image (e) are displayed.
- Even if three cameras are installed, only the images from the No. 1 camera and No. 2 camera can be displayed at the same time.
- When two screens are displayed at the same time, the display changes more slowly than when only one screen is displayed.

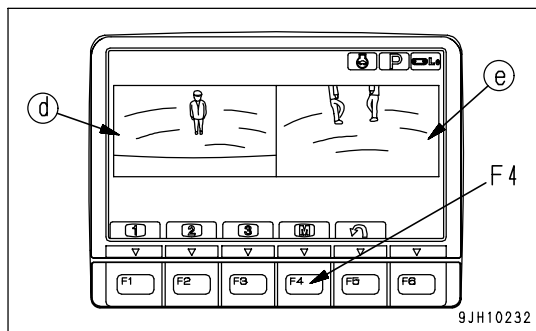

- Press switch F5 to return to the standard screen.

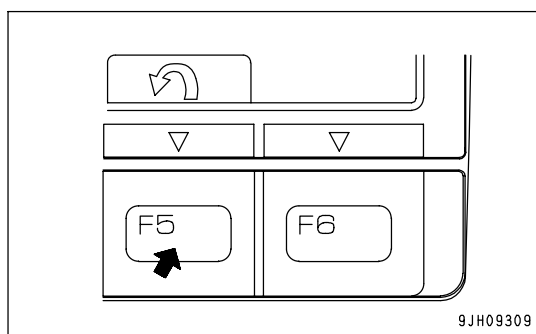

Other Mode Operations When Displaying Camera Image

- Even during the camera display, it is possible to operate other modes.

- The air conditioner can be operated.

If the air conditioner switch is operated, the screen switches to the air conditioner control screen. If the screen switches to the air conditioner control screen, press switch F6 to return to the camera image screen. In addition, if no operation is carried out for 5 seconds after the screen switches to the air conditioner control screen, the screen automatically returns to the camera image screen.

For details of the operation of the air conditioner, see "AIR CONDITIONER CONTROLS (PAGE 3-88)".

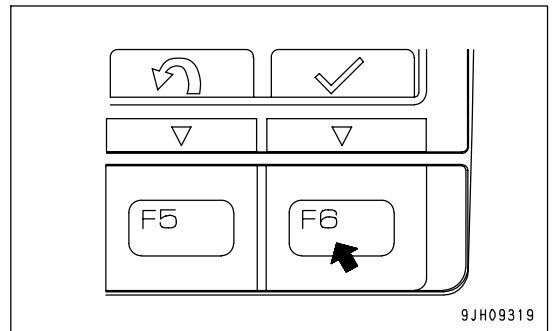
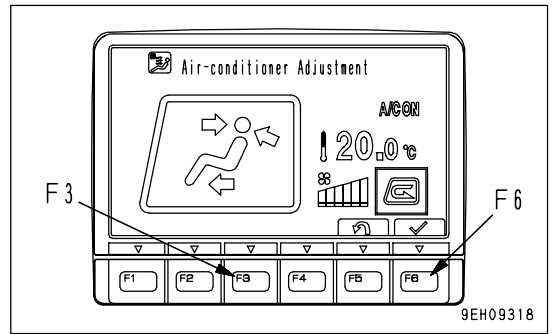

- It is possible to change the working mode by pressing the working mode selector switch.

For details of the working mode selector switch, see "Working Mode Selector Switch (PAGE 3-25)".

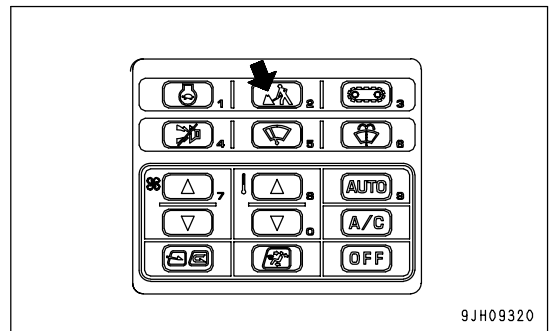

If the working mode is changed, the screen returns to the standard screen.

Press switch F3 again to return to the camera image display.

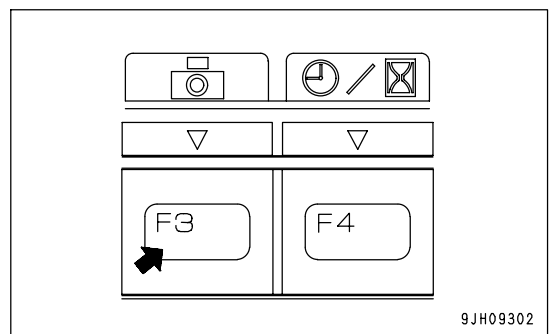

- Press the travel speed selector switch to change the travel speed mode.
For details of the travel speed selector switch, see "Travel Speed Selector Switch (PAGE 3-30)".

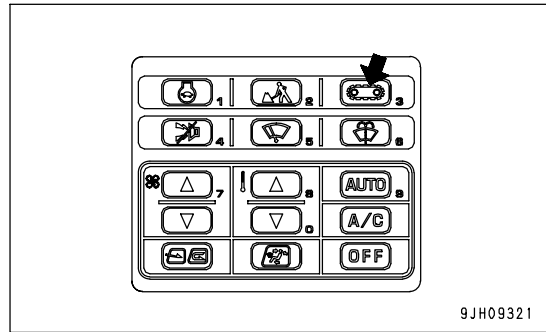

When the travel speed mode is changed, the screen returns to the standard screen. To display the camera image, press switch F3 again.

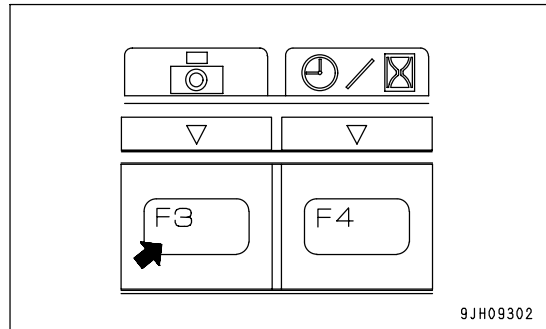

- Press the auto-deceleration switch to turn the auto-deceleration function ON/OFF.

Even if the auto-deceleration switch is pressed, the camera image display screen does not switch to another screen.

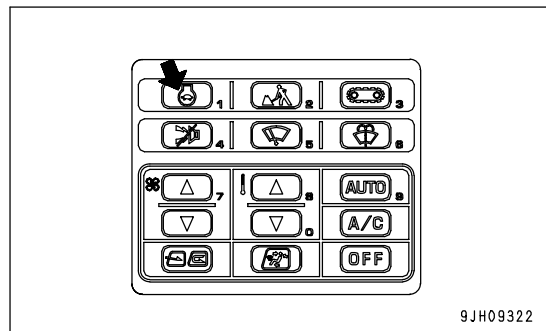

- It is possible to press the buzzer cancel switch to stop the alarm buzzer for the warning item where there is an abnormality.

Even if the buzzer cancel switch is pressed, the camera image display screen does not switch to another screen.

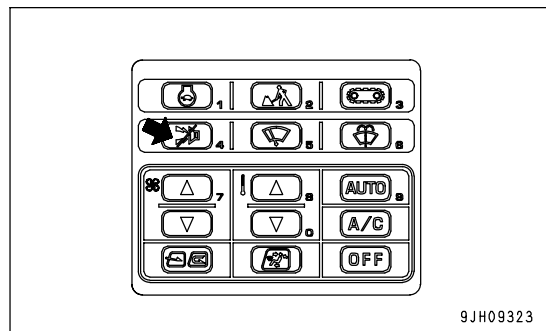

- Press the wiper switch and washer switch to operate the wipers and washer.

Even if the wiper switch or washer switch is pressed, the camera image display screen does not switch to another screen.

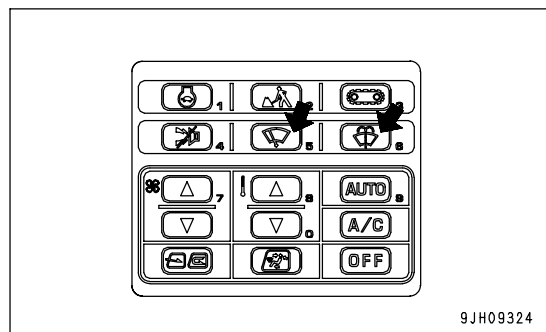

Action When Warning is Generated When Displaying Camera Image

- If an error or alarm occurs while the camera image is being displayed, the error monitor or alarm monitor is displayed at the top left of the screen and flashes.

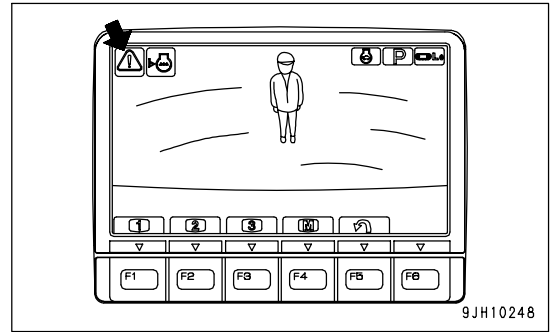

9JH10248

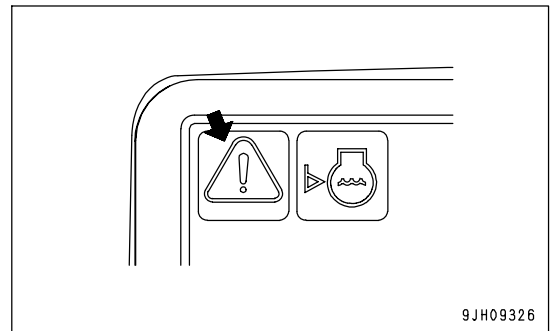

9JH09326

- If the error monitor or alarm monitor is displayed, press switch F6, return to the standard screen, and check the content of the error or alarm display.

When the error monitor is flashing, if no lever is operated for more than 10 seconds, the screen automatically returns to the standard screen.

When the screen returns to the standard screen, the error monitor at the top left of the screen goes out and the error or alarm is displayed in the center of the screen.

- If an error monitor is displayed, move the machine, set it in a safe posture, then have inspection carried out immediately.

For details of the content of the warning displays, see "Basic Check Monitors (PAGE 3-15)", "Caution Monitors (PAGE 3-13)", "Emergency Monitors (PAGE 3-11)" and "TROUBLES AND ACTIONS (PAGE 3-195)".

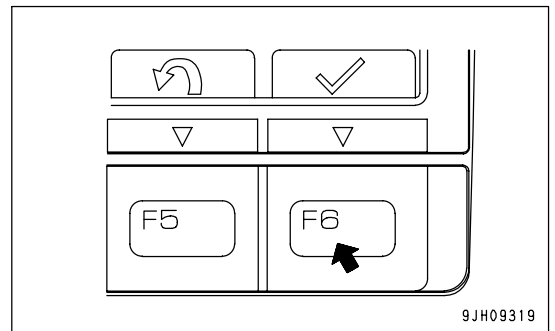

9JH09319

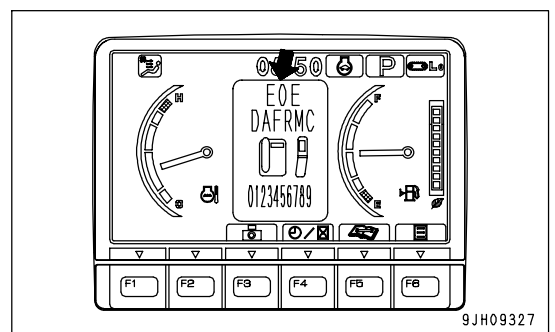

9JH09327

Service Meter/Clock Display Selector Switch

On the standard screen, it is possible to press switch F4 to switch the service meter and clock display at the top of the monitor display.

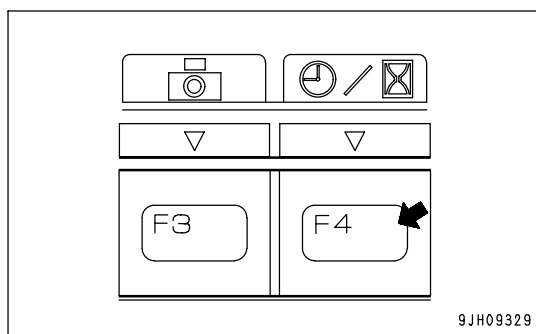
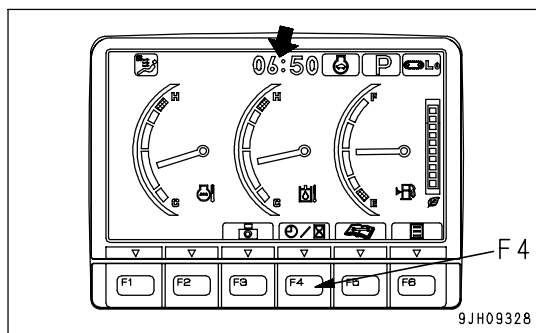

- When the time is being displayed, press switch F4 to switch to the service meter display.
When the service meter is being displayed, press switch F4 to switch to the time display.

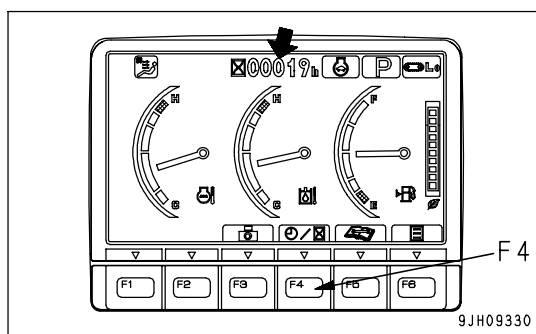

Maintenance Selector Switch

When switch F5 is pressed on the standard screen, the monitor display screen switches to the maintenance mode screen.

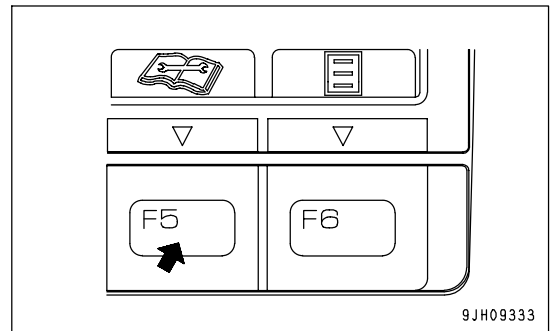
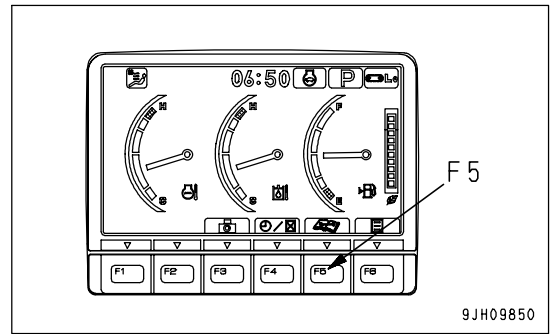

The items on the maintenance display are as follows.

a	b
Engine oil change	500
Engine oil filter change	500
Fuel main filter change	1000
Fuel pre-filter change	500
Hydraulic oil filter change	1000
Hydraulic tank breather change	500
Damper case service	1000
Final drive oil change	2000
Swing machinery oil change	1000
Hydraulic oil change	5000

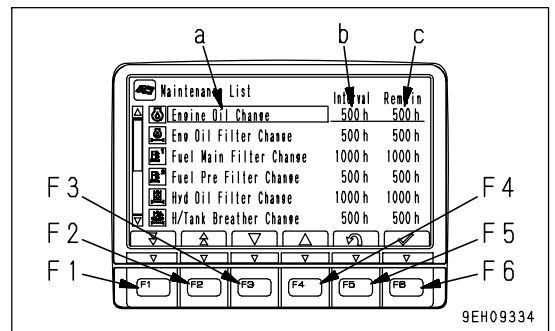

- a: Maintenance items
- b: Default maintenance interval settings (h)
- c: Time remaining until maintenance (h)

Operations on Maintenance List Screen

On the maintenance list screen, it is possible to carry out the following operations with switches F1 to F6.

- F1: Displays next page. When on the last page, it displays the first page.
- F2: Displays previous page. When on the first page, it displays the last page.
- F3: Moves to next item (1 line down). When on the last line, it moves to the first line on the next page.
- F4: Moves to previous item (1 line up). When on the first line, it moves to the last line on the previous page.
- F5: Returns to standard screen.
- F6: If this switch is kept pressed, the screen changes to the screen for resetting the remaining time for the selected item (item highlighted in yellow).

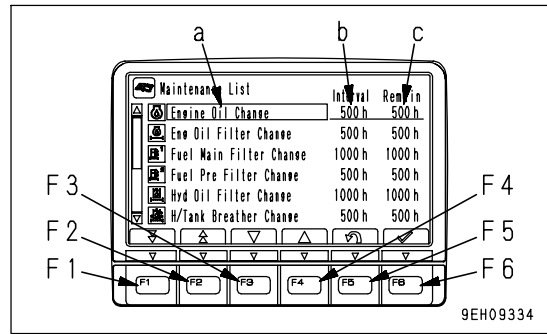

REMARK

When resetting the remaining time, keep switch F6 pressed for at least 1.5 seconds. If switch F6 is not kept pressed for at least 1.5 seconds, the switch operating sound can be heard, but the screen does not switch to the screen for resetting the remaining time.

- If no switch is operated for 30 seconds on the maintenance list screen, the screen automatically returns to the standard screen.
- On the maintenance list screen, if the time remaining until maintenance for any item is less than 30 hours, the remaining time display is highlighted in yellow. If the time remaining until maintenance becomes 0 hours, the remaining time display is highlighted in red.
- If you want to change the setting for the maintenance interval, please consult your Komatsu distributor.

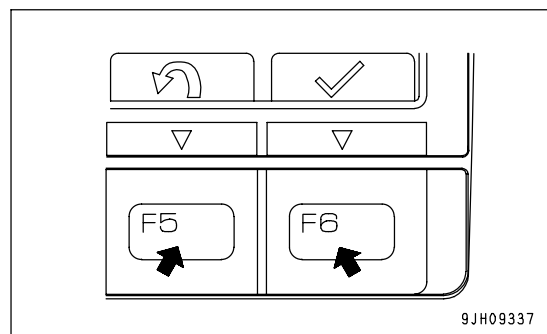
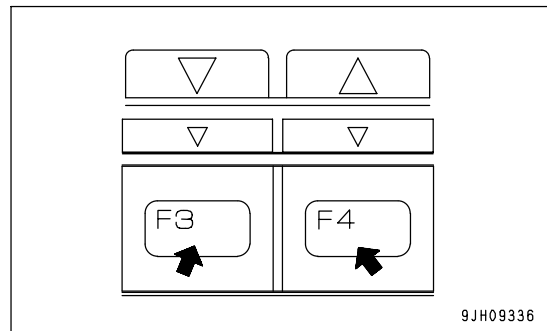
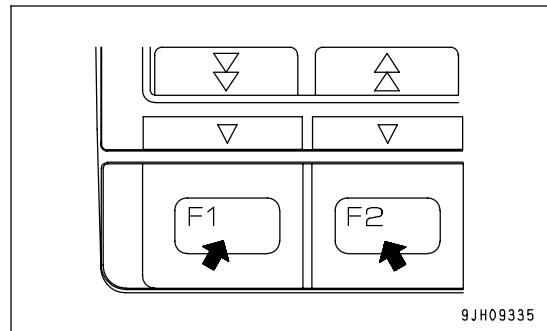

Operations on Maintenance Interval Reset Screen

On the maintenance list screen, if switch F6 is kept pressed for at least 1.5 seconds, the screen changes to the maintenance time reset screen.

Reset the remaining time on this screen.

1. Press switch F6 when the reset screen is in the condition shown in the diagram on the right. The screen switches to the reconfirmation screen.

REMARK

- It is desired to cancel the reset, press switch F5. The screen returns to the maintenance list screen.
- On the reset screen, if no switch is operated for more than 30 seconds, the screen automatically switches to the maintenance list screen.

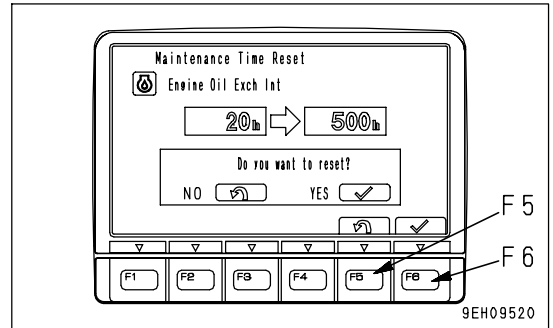

2. The reconfirmation screen shown on the right is displayed.
3. If switch F6 is pressed again, the remaining time is reset and the screen switches to the maintenance list screen.

REMARK

- It is desired to cancel the reset, press switch F5. The screen returns to the maintenance list screen.
- On the reconfirmation screen, if no switch is operated for more than 30 seconds, the screen automatically switches to the maintenance list screen.

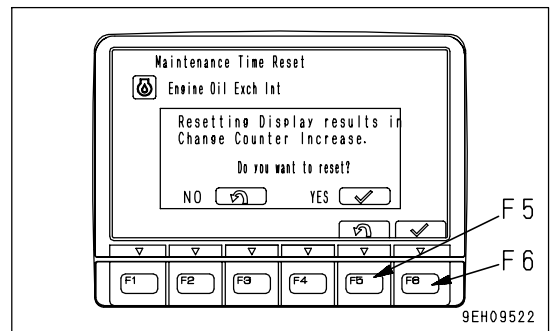

User Mode Selector Switch

When the switch F6 is pressed, the monitor display screen switches to the setting mode screen for the machine.

- On the User Menu screen, it is possible to carry out the following operations with switches F3 to F6.

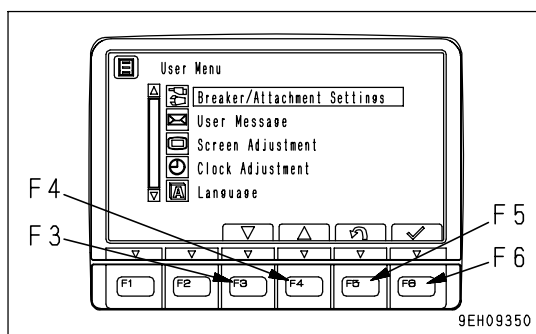
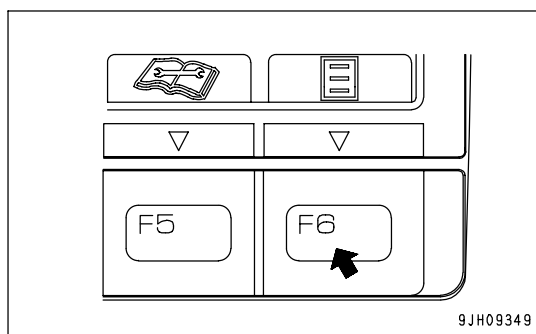
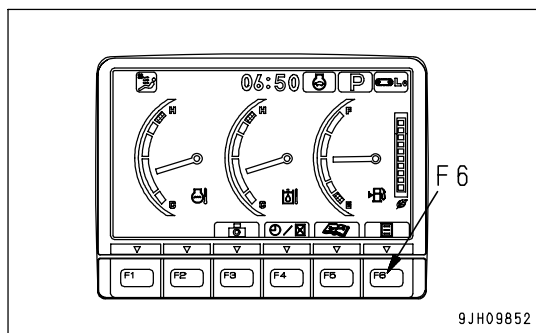

F3: Moves to next item (1 line down). When on the last line, it moves to the first line on the next page.

F4: Moves to previous item (1 line up). When on the first line, it moves to the last line on the previous page.

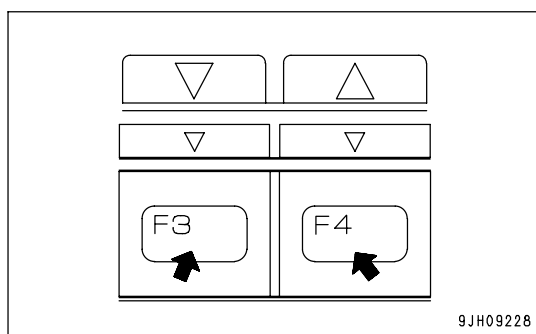

F5: Returns to standard screen.

F6: Switches to setting screen for selected item.

- If no switch is operated for 30 seconds on the user menu screen, the screen automatically returns to the previous screen.

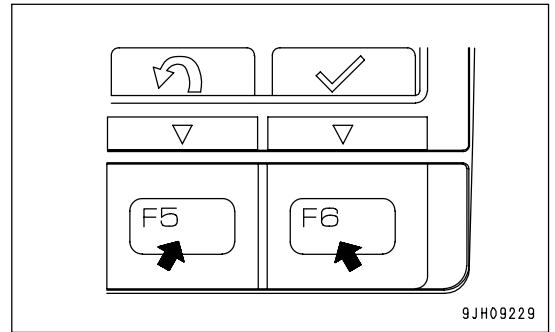

- The following items can be set.

- a: Breaker/attachment setting
(machines ready for installation of attachment)
- b: Message display
(machines equipped with KOMTRAX)
- c: Screen adjustment
- d: Clock adjustment
- e: Language selection
- f: Economy mode adjustment

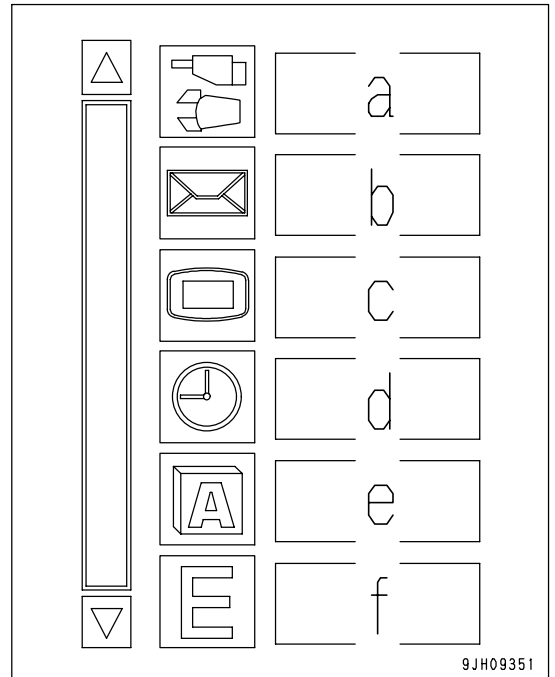

The operation for setting a to f is as follows.

Breaker/Attachment Setting

- On machines ready for attachment, it is possible on the breaker/attachment setting menu to adjust the oil flow in B mode and ATT mode to match the attachment.
For machines that have no attachment, the breaker/attachment setting mode is not displayed.

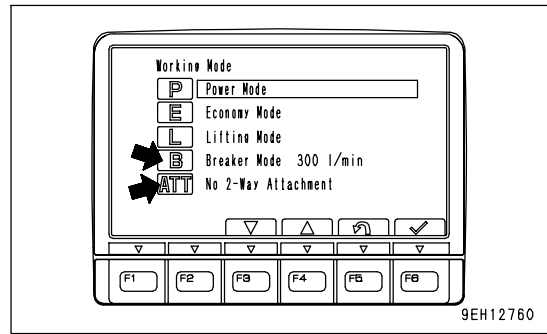

Changing Breaker Mode Setting

1. On the standard screen, press switch F6.

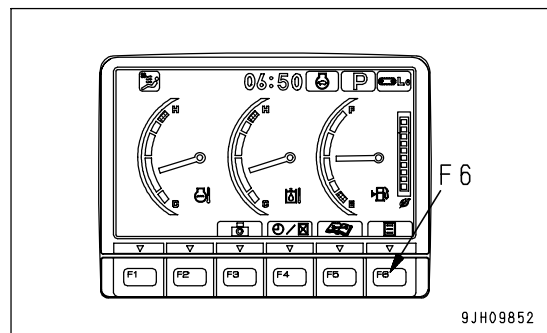

2. Select Breaker/Attachment Settings on the user menu, then press switch F6.

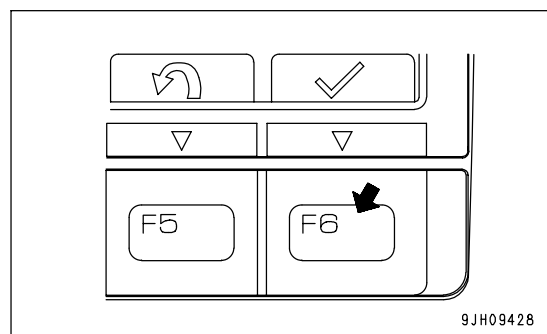
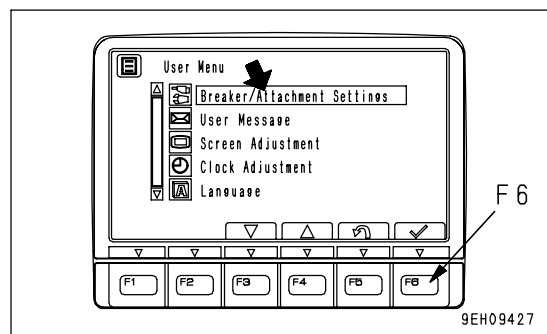

3. On the working mode selection screen shown on the right, select B Breaker and press switch F6.

- On the working mode selection screen shown on the right, it is possible to carry out the following operations with switches F3 to F6.

- F3: Moves to next item (1 line down).
- F4: Moves to previous item (1 line up).
- F5: Returns to user menu screen.
- F6: Switches to setting screen for selected item.

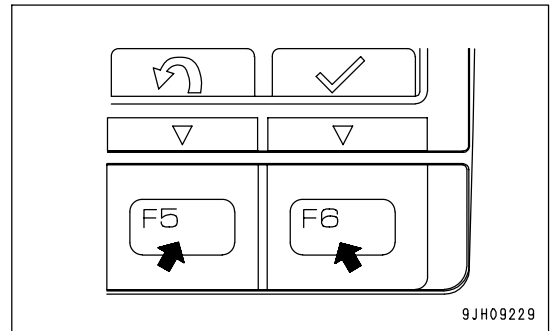
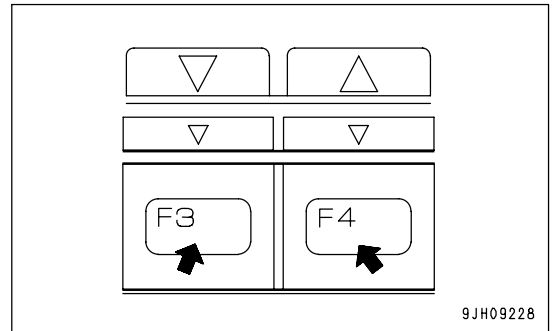
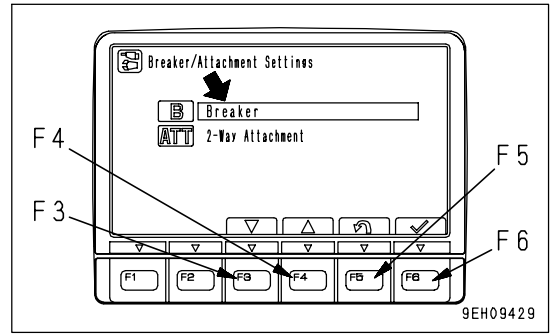

4. The screen switches to the Breaker Select Menu.

- Breaker setting selection menu
In breaker Select (a), the oil flow to be set in B mode can be set to one of two set values.
- Breaker flow setting menu
In the breaker flow setting (b), the oil flow to be set in B mode can be changed.

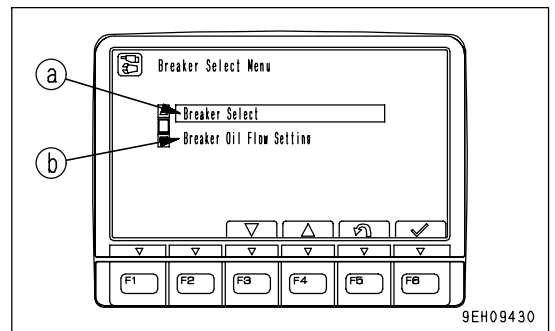

On the Breaker Select Menu screen, it is possible to carry out the following operations with switches F3 - F6.

- F3: Moves to next item (1 line down).
- F4: Moves to previous item (1 line up).
- F5: Returns to previous screen.
- F6: Switches to setting screen for selected item.

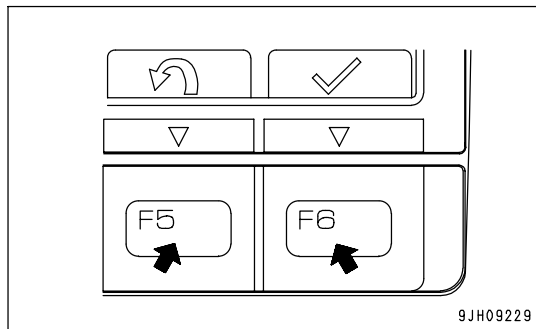
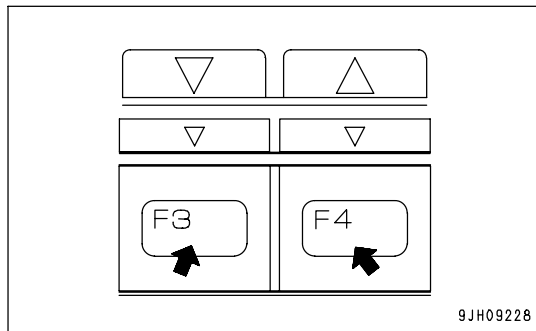

Changing breaker setting selection

1. Select breaker setting selection (a) on the breaker setting menu screen, then press switch F6.

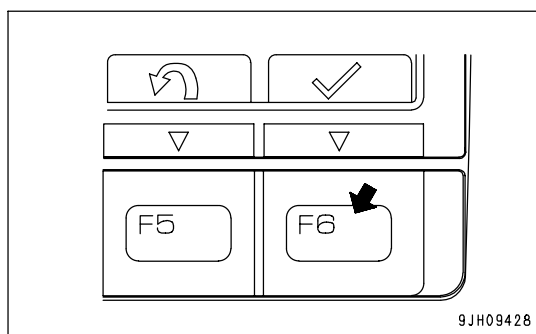
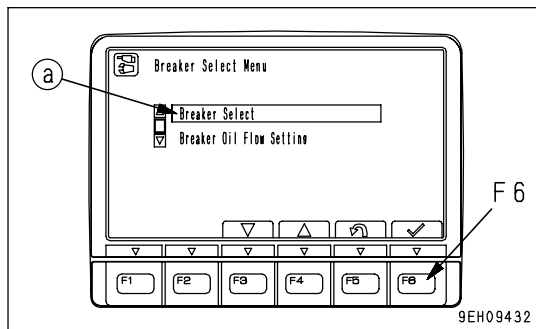

2. On the Breaker Select screen, select one of the two set values for the oil flow, then press switch F6.

- The default values for the flow setting are both set to 300 liter/min, as shown in the illustration on the right. To select the oil flow setting, follow the procedure given in "Changing breaker flow setting (PAGE 3-50)".
- The present oil flow set for B mode is marked with a B in front of the item name as shown in the illustration on the right.

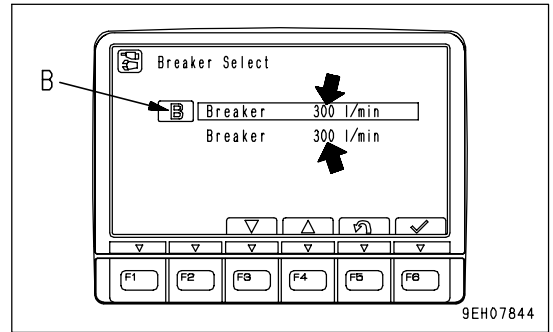

- On the Breaker Select Menu and breaker setting selection menu, it is possible to carry out the following operations with switches F3 - F6.

- F3: Moves to next item (1 line down).
- F4: Moves to previous item (1 line up).
- F5: Returns to previous screen.
- F6: Switches to setting screen for selected item.

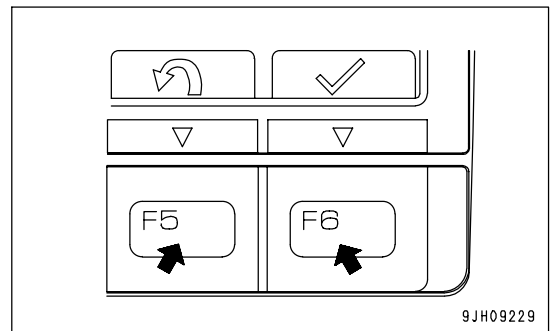
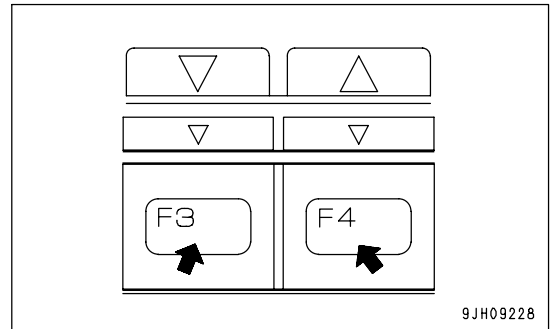

Changing breaker flow setting

1. Select breaker flow setting (b) on the Breaker Select Menu screen, then press switch F6.

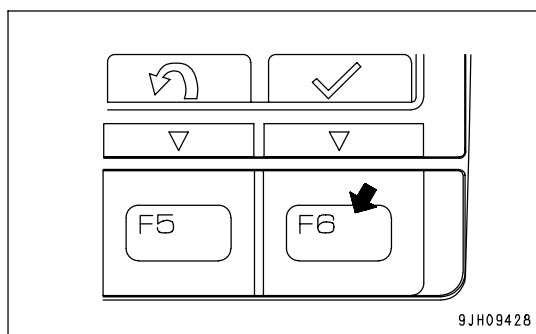
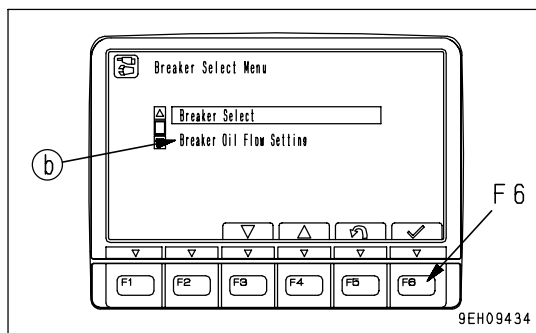

2. On the Breaker Oil Flow Setting screen, select one of the two set values for the oil flow, then press switch F6.

- The default values for the oil flow setting are both set to 300 liter/min, as shown in the illustration on the right. The present oil flow set for B mode is marked with B in front of the item name as shown in the illustration on the right.

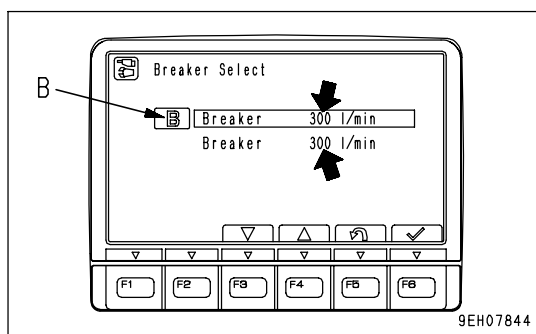

- On the Breaker Select Menu and Breaker Oil Flow Setting screen, it is possible to carry out the following operations with switches F3 - F6.

- F3: Moves to next item (1 line down).
- F4: Moves to previous item (1 line up).
- F5: Returns to previous screen.
- F6: Switches to setting screen for selected item.

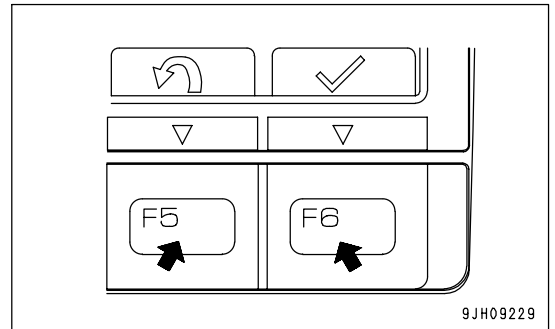
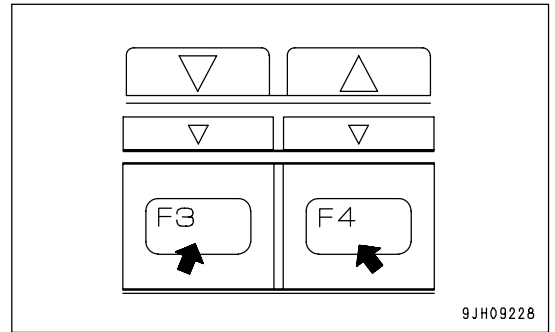

3. On the Breaker Oil Flow Setting screen, change the set oil flow.

- After using switches F3 or F4 to change to a suitable oil flow, press switch F6 to accept the change in the oil flow and return to the previous screen.
- When switch F5 is pressed, no change is made in the oil flow and the screen returns to the previous screen.

- (X): Present oil flow setting
- (Y): Min. adjusted oil flow
- (Z): Max. adjusted oil flow

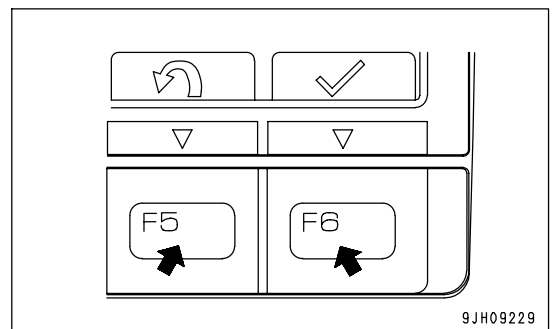
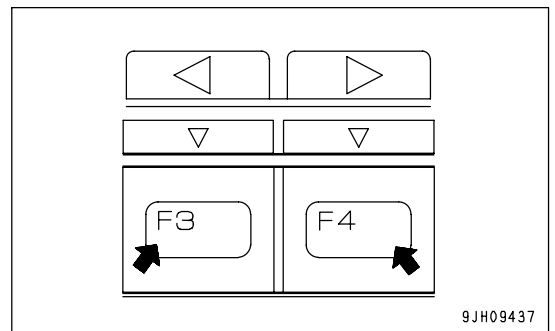
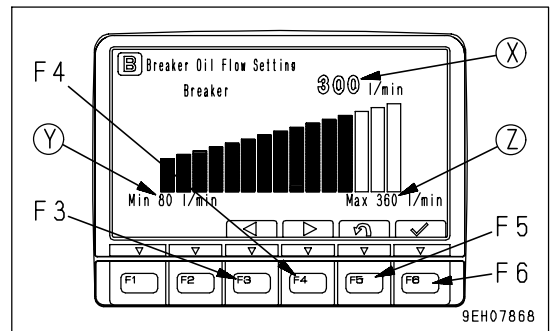

Changing Attachment Mode Setting

1. On the standard screen, press switch F6.

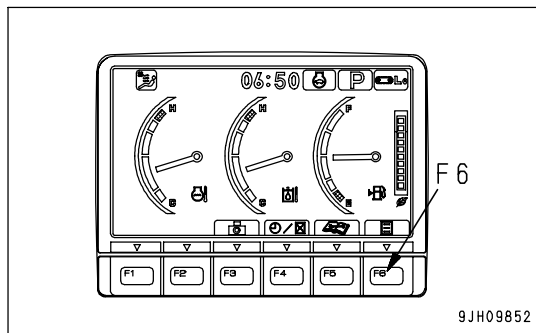

2. Select Breaker/Attachment Settings on the user menu, then press switch F6.

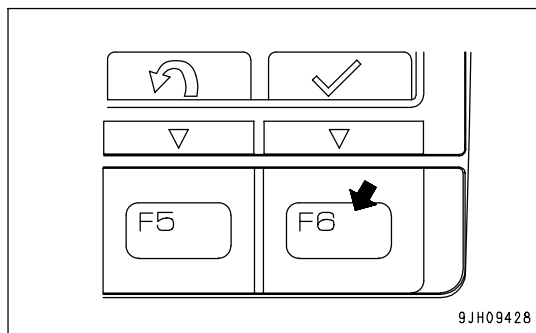
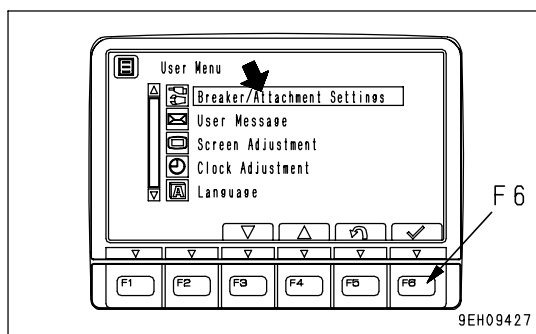

3. On the working mode selection screen shown on the right, select ATT 2-Way Attachment, then press switch F6.

- On the working mode selection screen shown on the right, it is possible to carry out the following operations with switches F3 to F6.

- F3: Moves to next item (1 line down).
- F4: Moves to previous item (1 line up).
- F5: Returns to user menu screen.
- F6: Switches to setting screen for selected item.

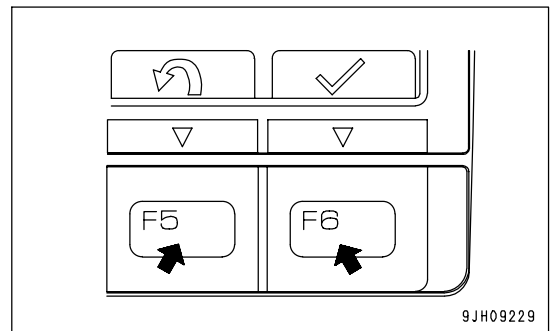
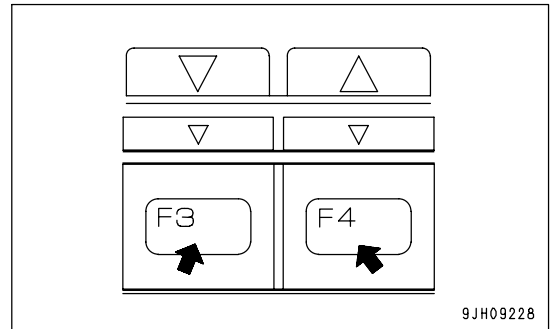
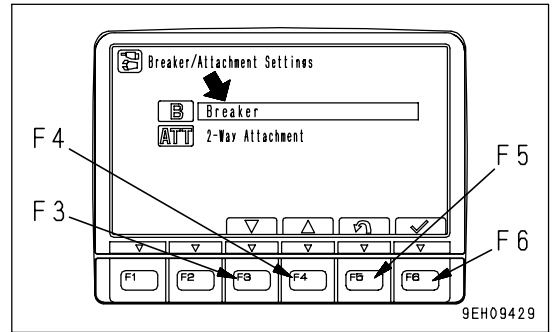

4. The screen switches to the 2-Way Attachment Select menu.

- 2-Way Attachment Select menu
In 2-Way Attachment Select (a), the oil flow to be set in ATT mode can be set to one of two set values.
- 2-Way Attachment Oil Flow Setting menu
In 2-Way Attachment Oil Flow Setting (b), it is possible to change the oil flow set for the ATT mode.

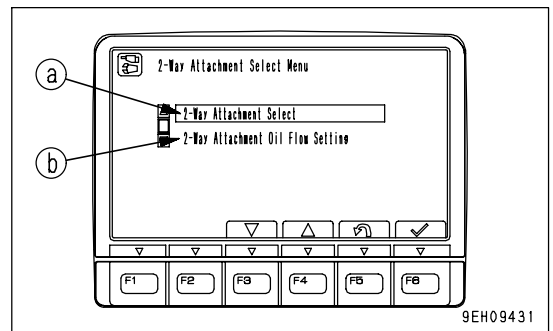

On the 2-Way Attachment Select Menu screen, it is possible to carry out the following operations with switches F3 - F6.

- F3: Moves to next item (1 line down).
- F4: Moves to previous item (1 line up).
- F5: Returns to previous screen.
- F6: Switches to setting screen for selected item.

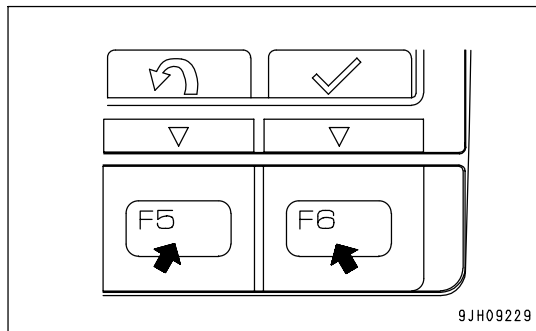
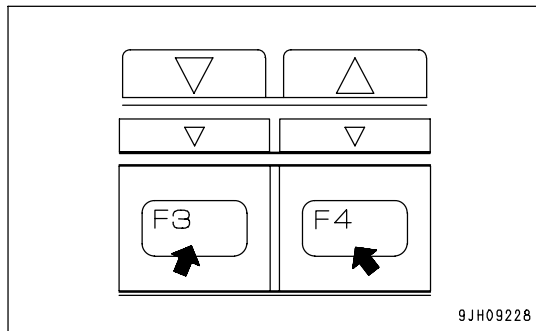

Changing attachment setting selection

1. Select attachment setting selection (a) on the attachment setting menu screen, then press switch F6.

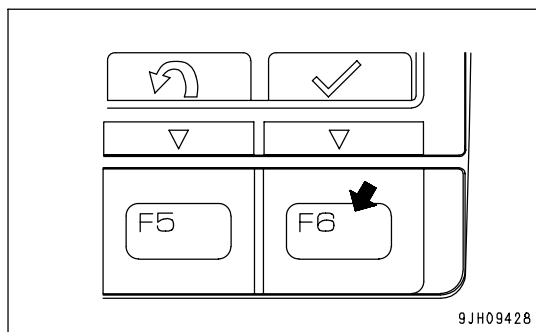
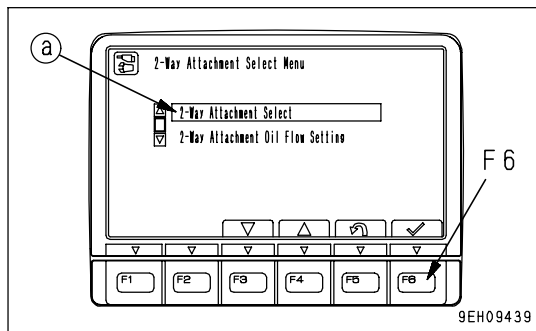

2. On the 2-Way Attachment Select Menu, select one of the two set values for the oil flow, then press switch F6.

- The default values for the oil flow setting are both set to 550 liters/min, as shown in the illustration on the right. To change the oil flow setting, follow the procedure given in "Changing attachment flow setting (PAGE 3-56)".
- The present oil flow set for ATT mode is marked with ATT in front of the item name as shown in the illustration on the right.

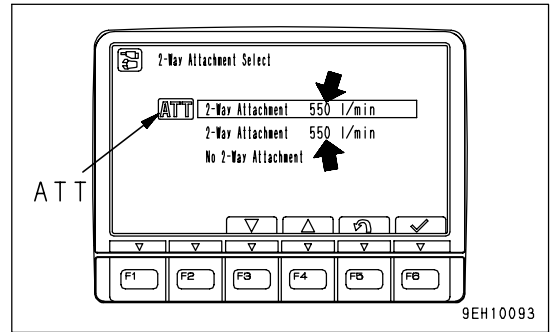

- If No 2-Way Attachment is selected, it becomes impossible to select the attachment mode on the working mode selection screen.

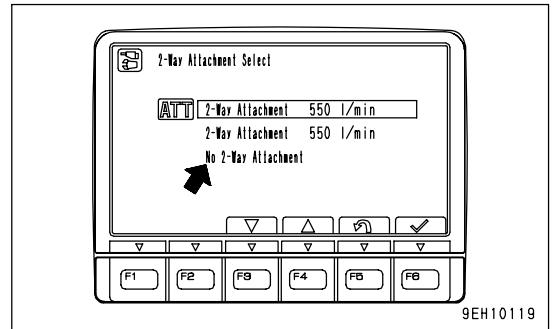

On the working mode selection screen, it is not possible to select No 2-Way Attachment.

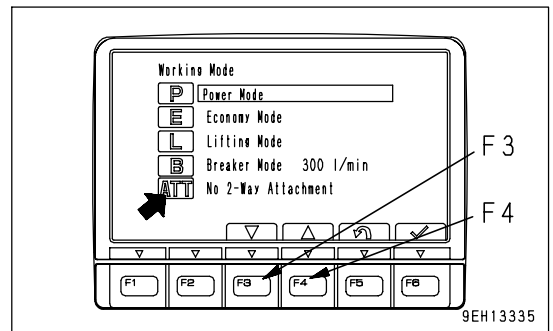

- On the 2-Way Attachment Select Menu screen and 2-way attachment select menu, it is possible to carry out the following operations with switches F3 - F6.

- F3: Moves to next item (1 line down).
- F4: Moves to previous item (1 line up).
- F5: Returns to previous screen.
- F6: Switches to setting screen for selected item.

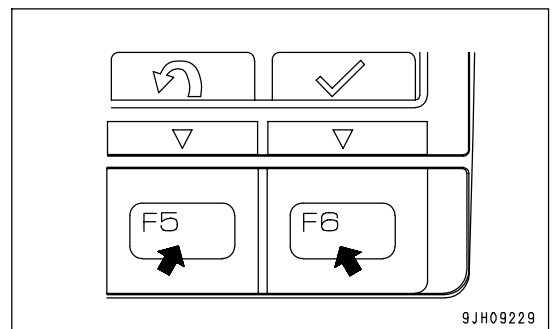
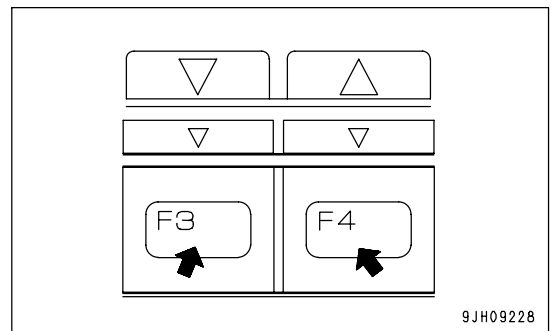

Changing attachment flow setting

1. Select 2-Way Attachment Oil Flow Setting (b) on the 2-Way Attachment Select menu screen, then press switch F6.

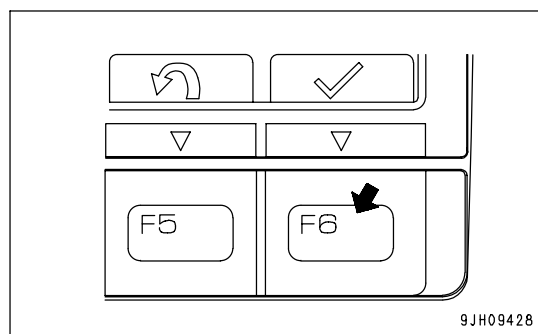
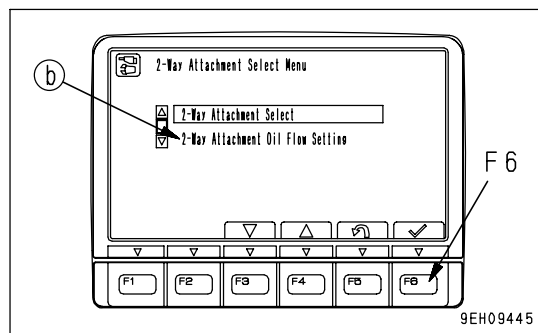

2. On the 2-Way Attachment Select Oil Flow Setting screen, select one of the two set values for the oil flow, then press switch F6.

- The default values for the oil flow setting are both set to 550 liters/min, as shown in the illustration on the right. The present oil flow set for ATT mode is marked with ATT in front of the item.
- "No 2-Way Attachment" cannot be selected

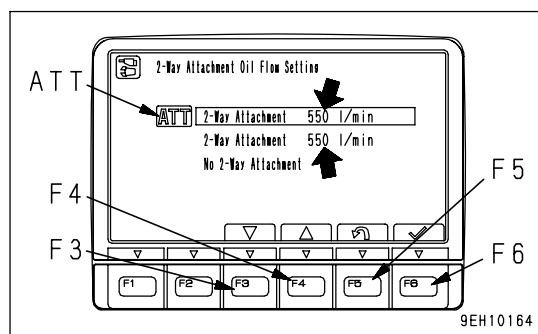

- On the 2-Way Attachment Select Menu screen and 2-Way Attachment Select Menu screen, it is possible to carry out the following operations with switches F3 - F6.

- F3: Moves to next item (1 line down).
- F4: Moves to previous item (1 line up).
- F5: Returns to previous screen.
- F6: Switches to setting screen for selected item.

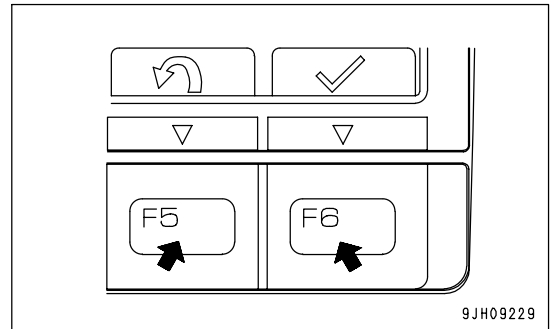
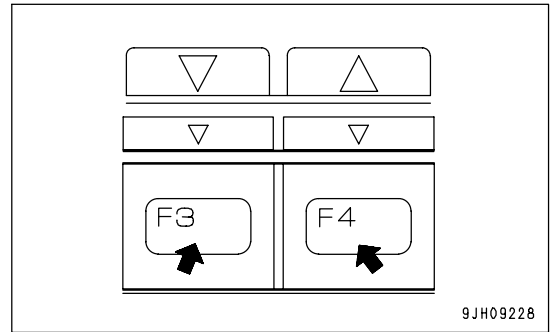

- On the 2-Way Attachment Oil Flow Setting menu, it is possible to change the oil flow setting.

- After using switches F3 or F4 to change to a suitable oil flow, press switch F6 to accept the change in the oil flow and return to the previous screen.
- When switch F5 is pressed, no change is made in the oil flow and the screen returns to the previous screen.

- (X): Present oil flow setting
- (Y): Min. adjusted oil flow
- (Z): Max. adjusted oil flow

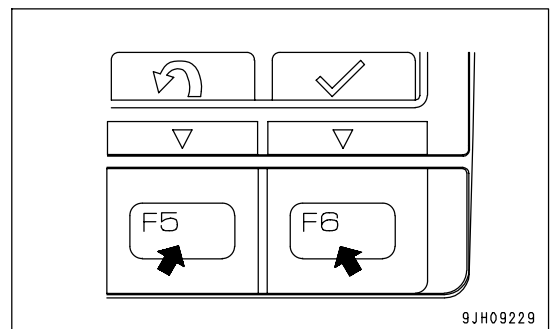
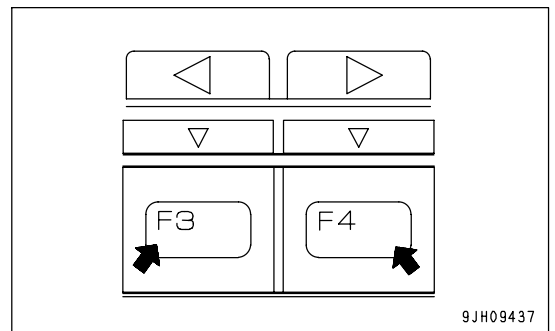
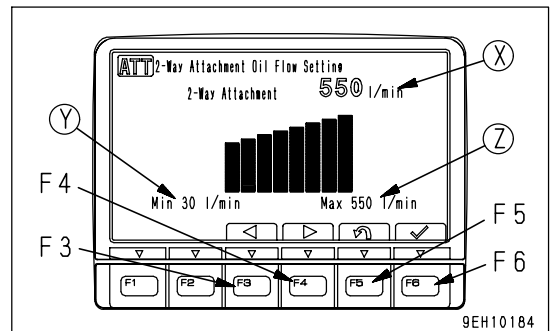

Message Display

(Machines equipped with KOMTRAX)

On machines equipped with KOMTRAX, it is possible to see the messages from your Komatsu distributor on this message display menu.

REMARK

At present, there is no territory where it is possible to use the message service.

In territories where it is not possible to use the message service, the message display menu functions as follows.

1. On the standard screen, press switch F6.

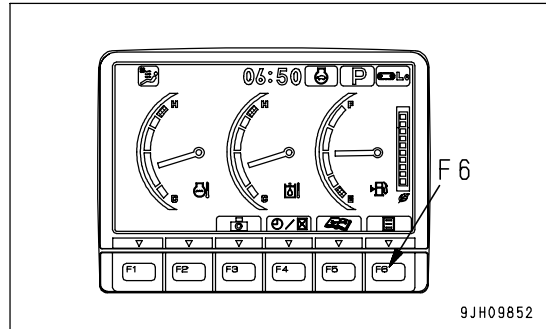

2. Select "User Message" on the User Menu, then press switch F6.

- If you press switch F5, the screen returns to the user menu screen.

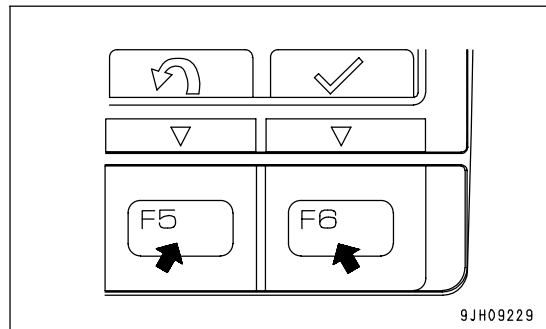
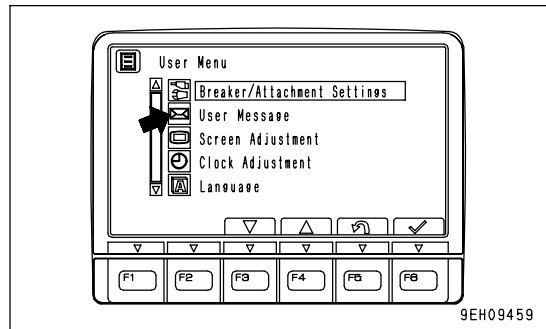

3. "No message" is displayed on the screen.
Press switch F5 to return to the standard screen.

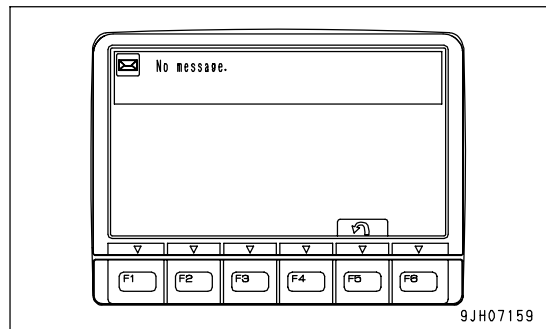

Adjusting Screen

Use this screen adjustment menu to adjust the brightness, contrast, and back light of the screen.

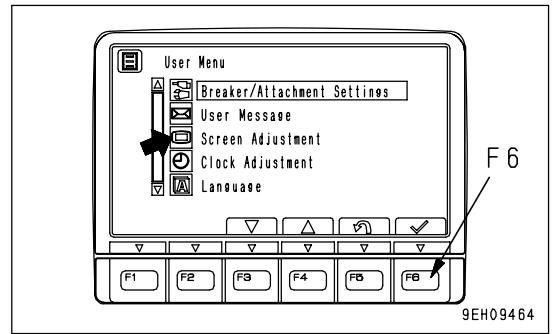

1. On the standard screen, press switch F6.

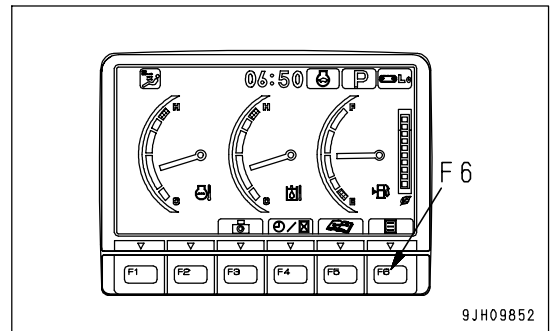

2. Select screen adjustment on the user menu, then press switch F6. The screen switches to the selection menu screen for screen adjustment.

- On machines equipped with cameras, it is possible to adjust the brightness, contrast, and back light of the cameras screen on this menu.

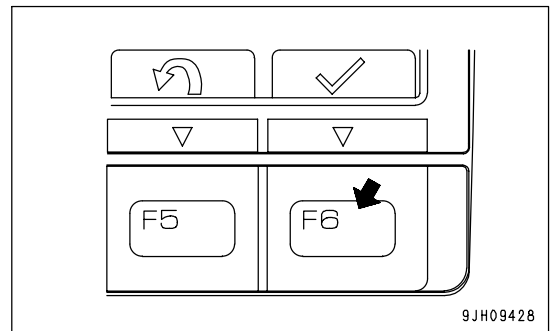

3. Select item to be adjusted (a) or (b) from the selection menu screen for screen adjustment, then press switch F6. The screen switches to the setting screen for the selected item.

- (a): Standard screen adjustment
- (b): Camera screen adjustment

- On the mode selection screen shown on the right, it is possible to carry out the following operations with switches F3 to F6.

- F3: Moves to next item (1 line down).
- F4: Moves to previous item (1 line up).
- F5: Returns to user menu screen.
- F6: Switches to setting screen for selected item.

REMARK

If the machine is not equipped with a camera, the selection menu for screen adjustment is not displayed.
 If screen adjustment is selected from the user menu, the adjustment screen in Step 4 is displayed.

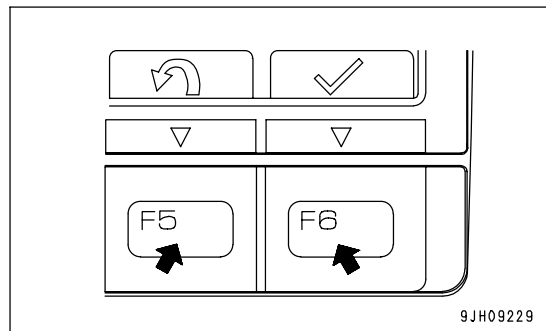
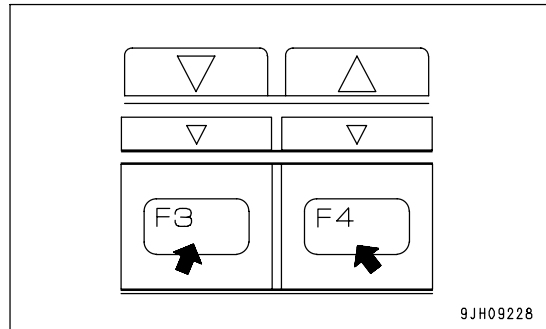
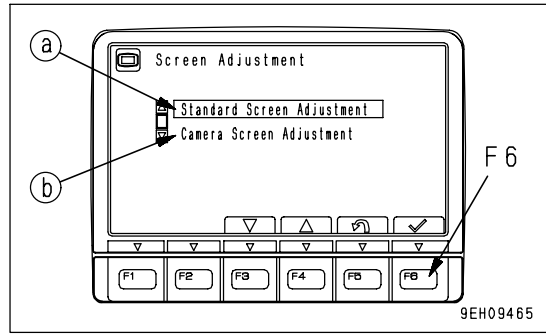

4. Use switches F2 to F6 to adjust the brightness, contrast, and back light of the selected screen.

- 1) Adjustment screen for standard screen
 - If the light switch is at night mode ON, and the standard screen is adjusted, it is possible to adjust the brightness of the monitor screen (night mode).
 - If the light switch is at day mode ON or OFF, and the standard screen is adjusted, it is possible to adjust the brightness of the monitor screen (day mode).

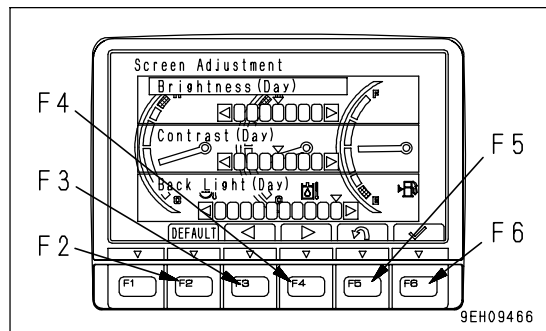

- 2) Adjusting camera screen
 - The background when adjusting the camera image is the image for the No. 1 camera.
 - When displaying the camera screen, the screen may become dark if the image is on snow. In such cases, we recommend adjustment of the screen.

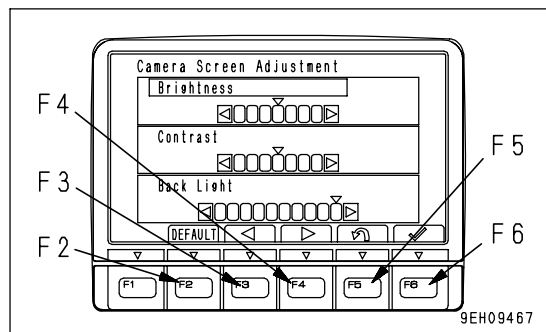

On the screen for Items 1) and 2), it is possible to carry out the following operations with switches F2 to F6.

- F2: Resets all adjusted values to default value
- F3: Indicator of selected item moves 1 segment to left.
- F4: Indicator of selected item moves 1 segment to right.
- F5: Returns to user menu.
- F6: Accepts change and switches to next item setting.

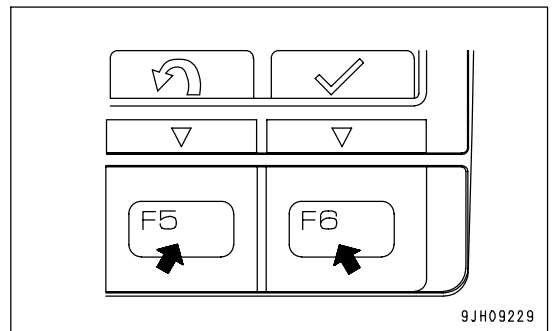
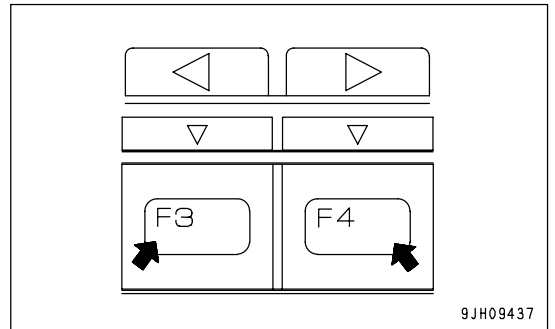
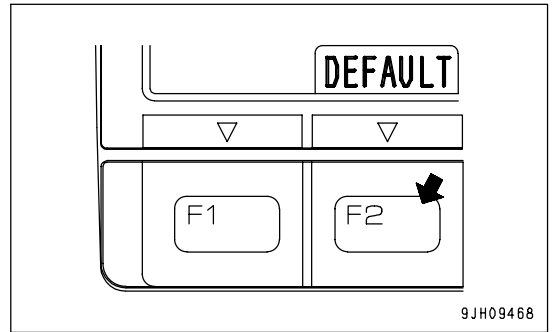

Clock Adjustment

On this clock adjustment menu, it is possible to change the setting of the clock displayed on the pilot monitor of the standard display.

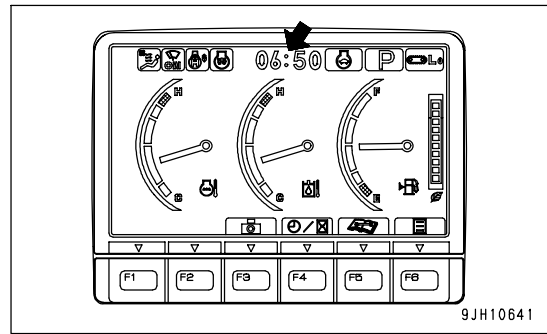

1. On the standard screen, press switch F6.

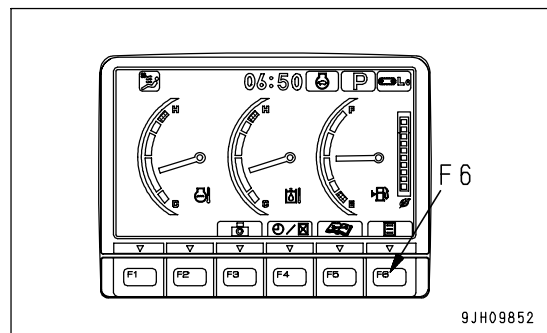

2. Select "Clock Adjustment" on the user menu, then press switch F6. The screen switches to the time adjustment selection menu screen.

- The following three items can be changed.
 - (a) Clock setting
 - (b) 12/24 hour display mode
 - (c) Daylight saving time

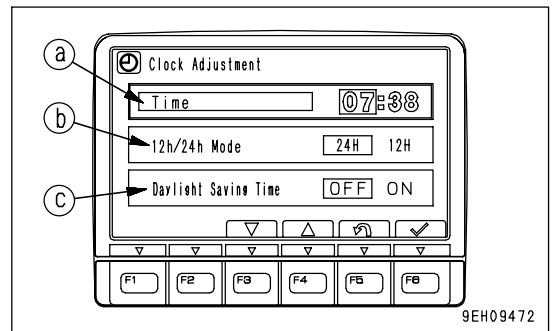
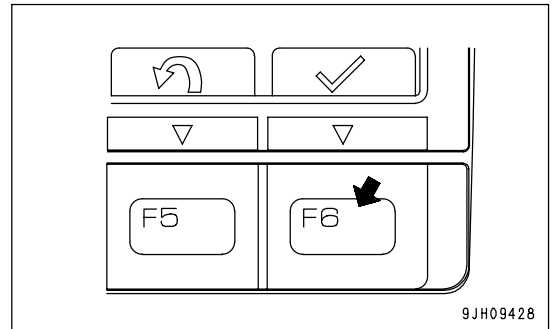
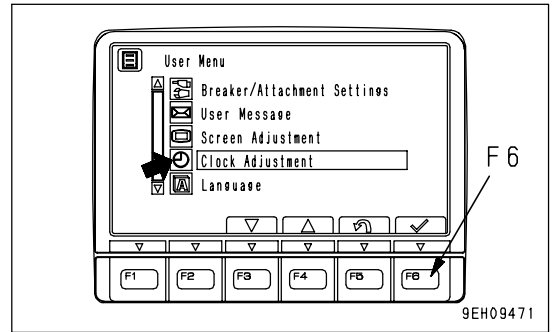

3. On the clock adjustment selection screen, it is possible to carry out the following operations with switches F3 to F6.

• Time

Adjust the hour setting.

1) If "Time" (a) is not highlighted in yellow, press switch F6 to highlight "Time" (a) in yellow. When this is done, hour display (b) changes to orange.

Adjust hour display (b) with the switches as follows. If it is not necessary to change the hour setting, press switch F6.

F3: Time advances 1 hour.

F4: Time goes back 1 hour.

F5: Cancels change and returns to user menu.

F6: Accepts change and goes to setting for minutes.

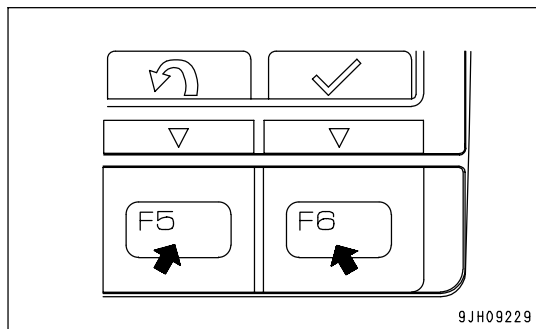
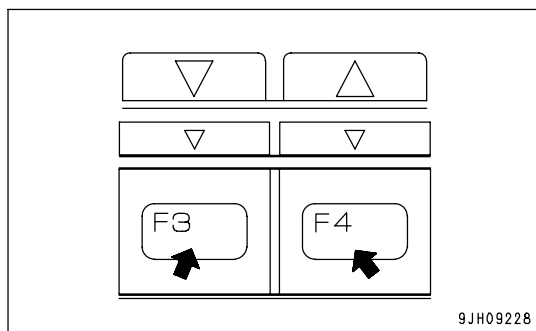
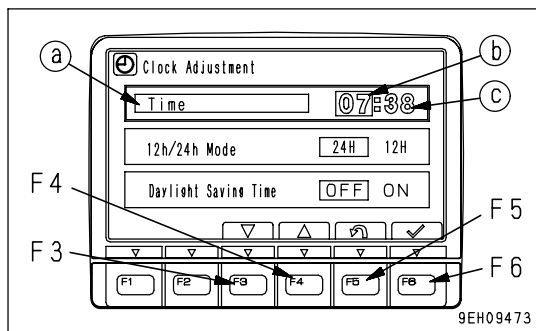

2) When minute display (c) is highlighted in orange, operate the switches as follows to adjust minute display (c).
 If it is not necessary to change the minute setting, press switch F6. If the time has been changed, always press switch F6.

- F3: Time advances 1 minute.
- F4: Time goes back 1 minute.
- F5: Cancels change and returns to user menu.
- F6: Accepts change and goes to setting for 12/24 hour display mode.

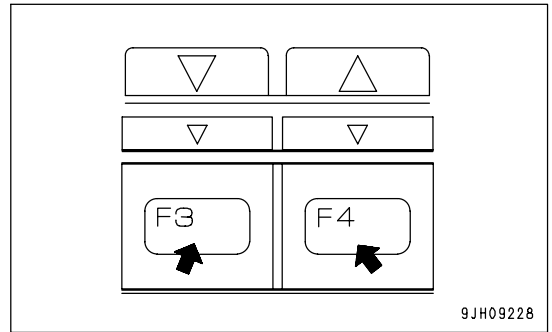

9JH09228

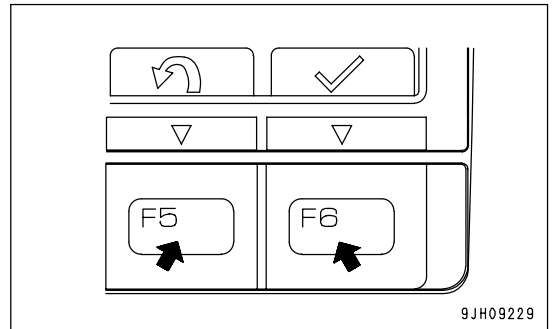

9JH09229

- 12h/24h Mode
 Choose either a 12-hour display (am/pm) or a 24-hour display.

- (b): 24-hour display
- (c): 12-hour display (am/pm)

- 1) If "12h/24h Mode" (a) is not highlighted in yellow, press switch F6 to highlight "12h/24h Mode" (a) in yellow.
- 2) Change the "12h/24h mode" with the switches as follows.

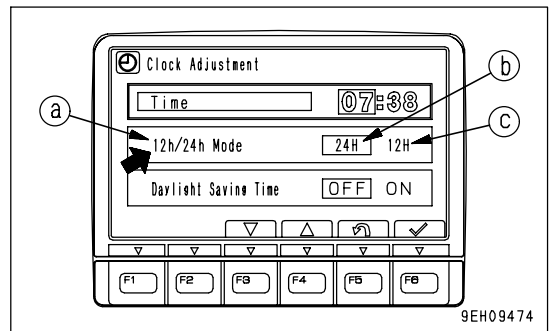

9EH09474

The selected display mode (b) or (c) is highlighted in green.

- F3: Moves 1 item to left.
- F4: Moves 1 item to right.
- F5: Cancels change and returns to user menu.
- F6: Accepts change and goes to setting for "Daylight Saving Time".

If the setting has been changed, always press switch F6.

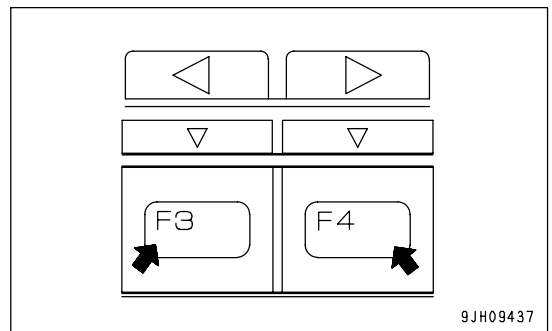

9JH09437

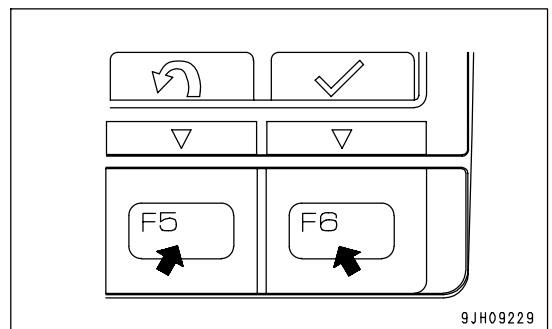

9JH09229

- Daylight Saving Time (Summer time)

1) If daylight saving time is turned ON (a), the clock display becomes 1 hour earlier. If daylight saving time is turned OFF (b), the clock display returns to the set time.

The selected display mode is highlighted in green.

2) Change the daylight saving time with the switches as follows.

F3: Moves 1 item to left.

F4: Moves 1 item to right.

F5: Cancels change and returns to user menu.

F6: Accepts change and goes to setting for "Time".

If the setting has been changed, always press switch F6.

REMARK

Daylight saving time or summer time means moving the clock forward 1 hour to take advantage of the fact that the sun rises early in summer. This system is used in many countries during the summer.

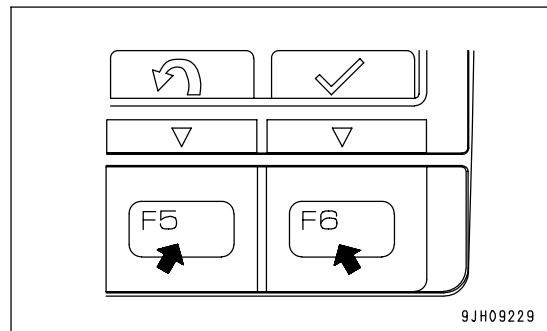
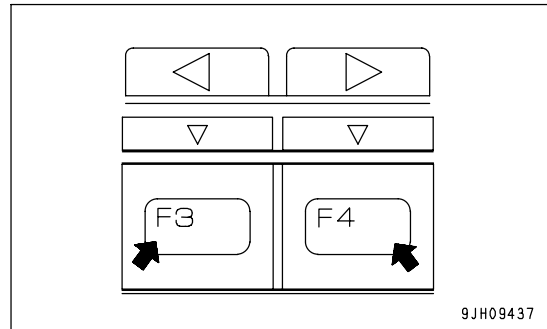
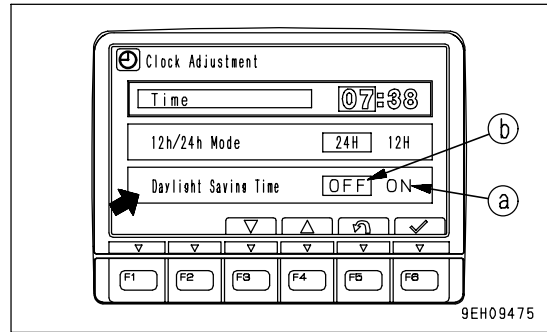

Language Selection

On this language selection menu, it is possible to select the language used on the monitor display.

- The languages that can be selected are as follows.
 Japanese, English, Chinese, French, Spanish, Portuguese, Italian, German, Russian, Turkish, Indonesian, Thai

1. On the standard screen, press switch F6.

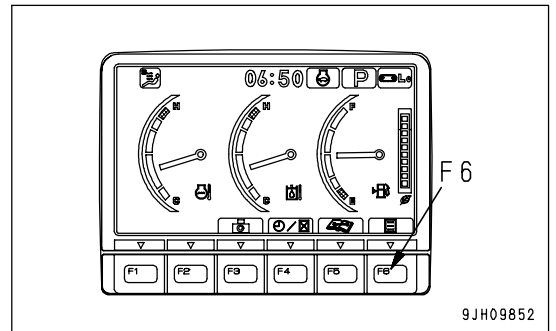

2. Select "Language" on the user menu, then press switch F6.
 The screen switches to the language selection menu screen.

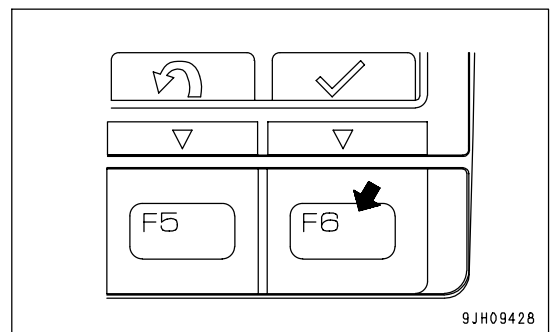
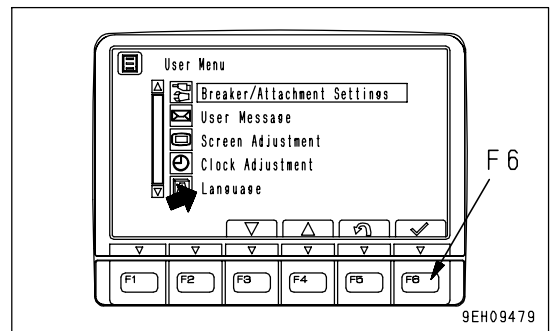

3. Select the language to use for the display, then press switch F6. The screen display changes to the selected language.

- On the language selection screen, it is possible to carry out the following operations with switches F3 to F6.

F3: Moves to item below.

F4: Moves to item above.

F5: Cancels change and returns to user menu screen.

F6: Accepts change and returns to user menu screen.

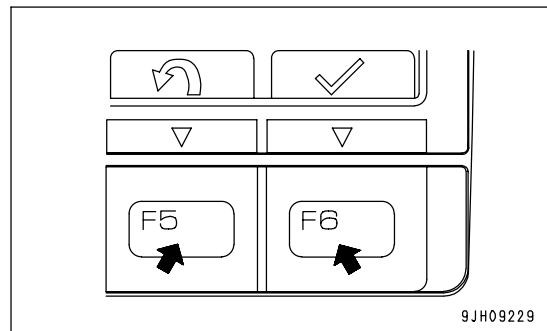
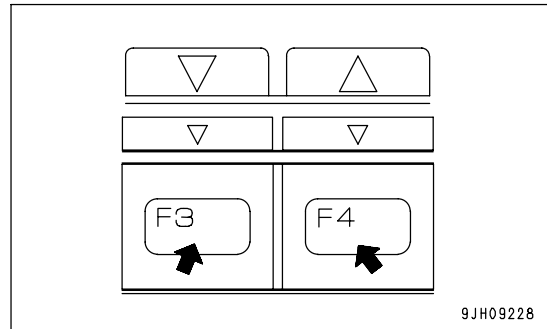
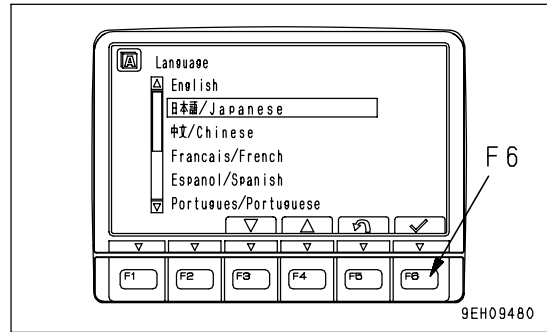

Adjusting Economy Mode

With this economy mode, the engine output can be adjusted to improve the fuel consumption in E mode.

1. On the standard screen, press switch F6.

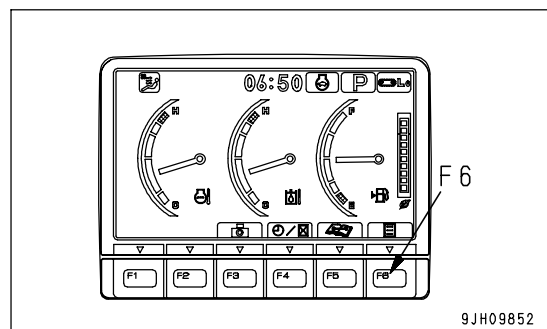

2. Select "Economy Mode Adjustment" on the user menu, then press switch F6.
The screen switches to the economy mode adjustment selection menu screen.

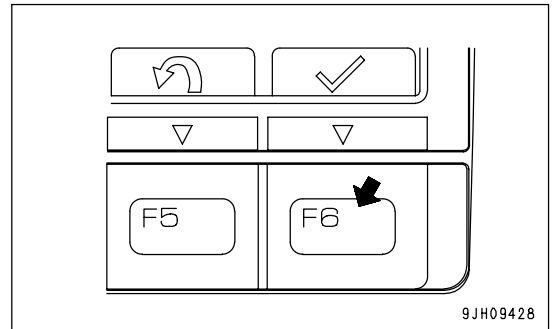
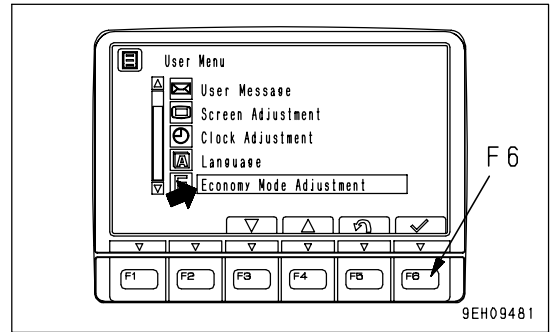

3. Select the desired E mode from the economy mode adjustment selection menu.
The levels that can be set are as follows.
E0: Default
E1: Economy Adjustment 1
E2: Economy Adjustment 2
E3: Economy Adjustment 3

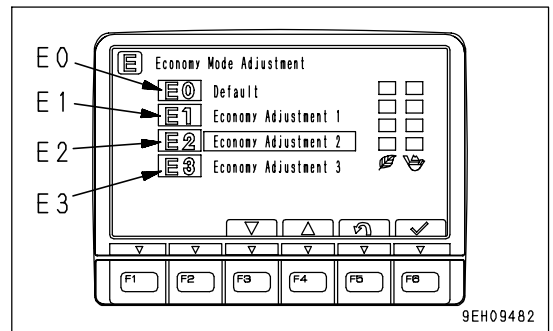

- The higher the selection is made from E0 to E3, the better the fuel consumption becomes, but the production is reduced accordingly.
- When the machine is shipped, it is set to E0.
- On the Economy Mode Adjustment menu screen, it is possible to carry out the following operations with switches F3 - F6.

- F3: Moves to item below.
- F4: Moves to item above.
- F5: Cancels change and returns to user menu screen.
- F6: Accepts change and returns to user menu screen.

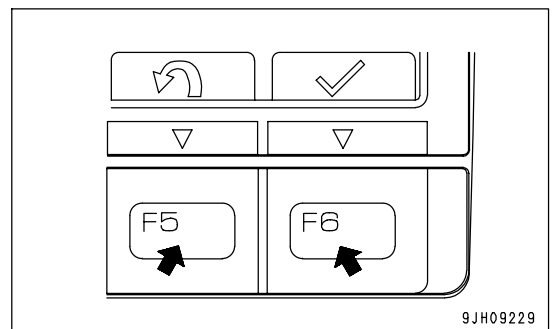
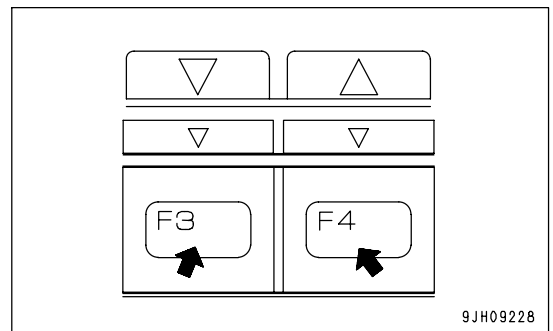

SWITCHES

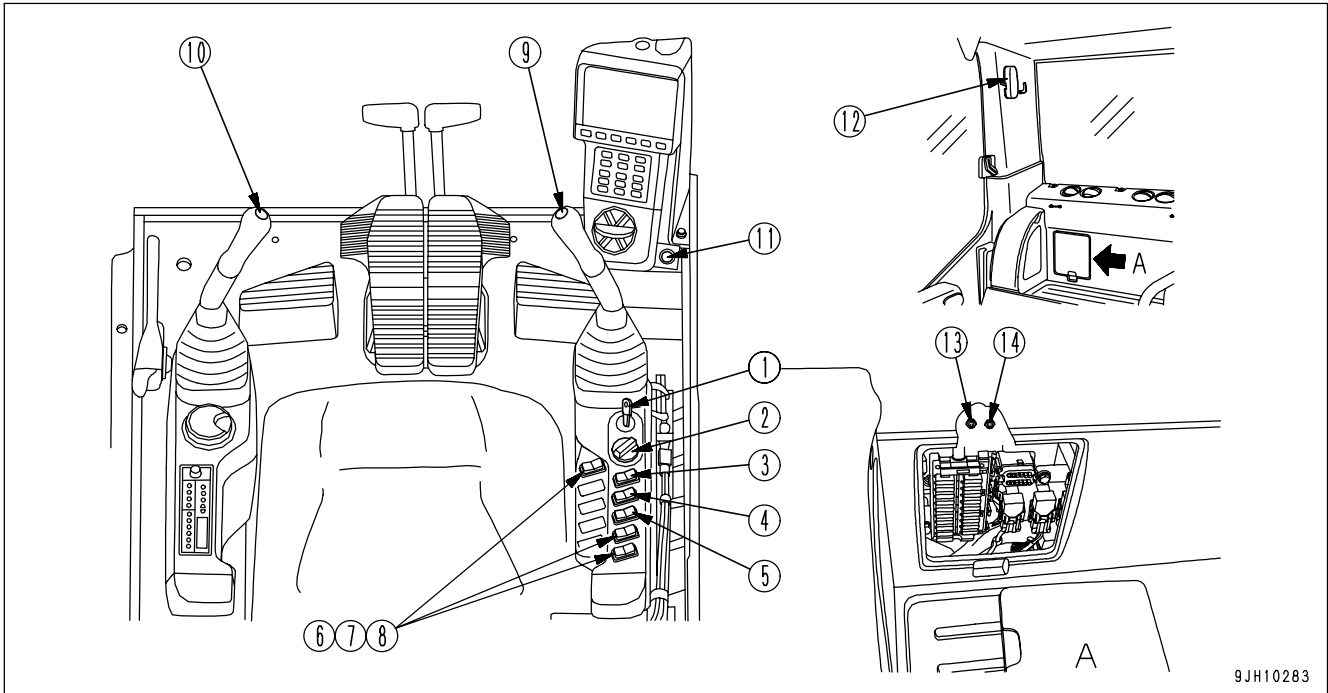

- | | |
|--|---|
| (1) Starting switch | (8) Revolving warning lamp switch (if equipped) |
| (2) Fuel control dial | (9) Horn switch |
| (3) Lamp switch | (10) One-touch power max. switch |
| (4) Swing lock switch | (11) Cigarette lighter |
| (5) Machine push-up switch | (12) Room lamp switch |
| (6) Heated operator seat switch (if equipped) | (13) Emergency pump drive switch |
| (7) Large capacity airflow air conditioner blower switch (if equipped) | (14) Swing parking brake release switch |

Starting Switch

Starting switch (1) is used to start or stop the engine.

(A): OFF position

The key can be inserted or withdrawn. Switches for the electrical system (except room lamp), are all turned off and the engine is stopped.

(B): ON position

Electric current flows through the charging and lamp circuits. Keep starting switch key in the ON position while the engine is running.

(C): START position

This is the engine-start position. Keep the key at this position during cranking. Immediately after starting the engine, release the key. It will automatically return to the ON position (B).

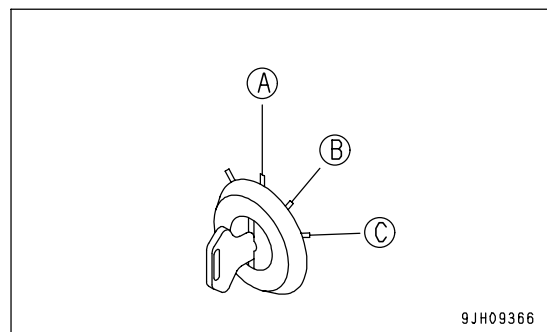

Fuel Control Dial

Dial (2) adjusts the engine speed and output.

- (a) Low idling (MIN): Turned fully to the left
 (b) Full speed (MAX): Turned fully to the right

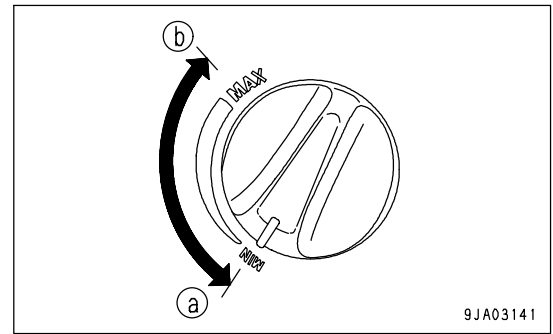
**Lamp Switch**

This switch (3) is used to light up the working lamp and monitor lighting.

- (a) Night position: Lamps light up and monitor illumination is set to night mode
 (b) Day position: Lamps light up and monitor illumination is set to day mode
 (c) OFF position: Lamps go out.
 (The monitor illumination is set to day mode.)

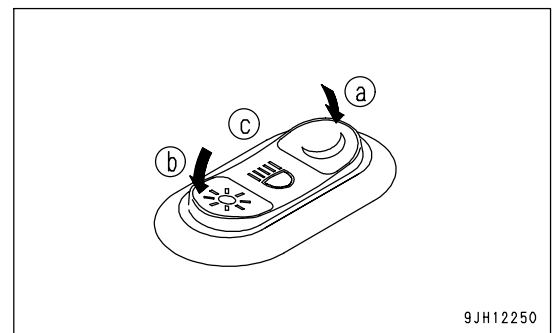
**Swing Lock Switch****WARNING**

- When not using the swing operation, e.g. when traveling, put the swing lock switch to the ON position.
- On slopes, even when the swing lock switch is at the ON position, the weight of the work equipment may cause the upper structure to swing if the swing control lever is operated in the downhill direction.

This switch (4) is used to lock the upper structure so that it cannot swing.

- (a) ON position (actuated): The swing lock is always applied, and the upper structure will not swing even if the swing is operated. In this condition, the swing lock lamp lights up.
 (b) OFF position (canceled): The swing lock is released, when operating the swing control lever, allowing the upper structure to swing.

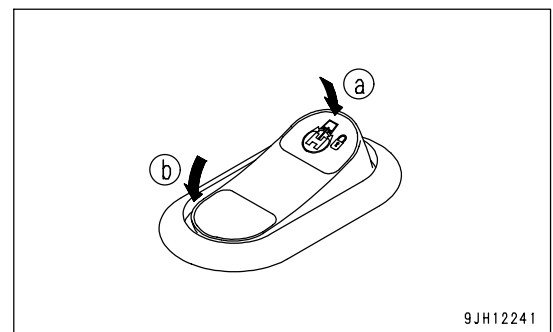

Machine Push-up Switch

This switch (5) is used to switch the safety valve set pressure at the head end of the boom cylinder to two levels.

(a) Low-pressure setting: The boom thrust force is weak, so the swaying of the chassis is small during digging operations, and digging operations can be carried out smoothly. This is used for general digging operations on normal ground, soft rock, or blasted rock.

(b) High-pressure setting: The thrusting force of the boom becomes more powerful, so it is easy to escape from soft ground.

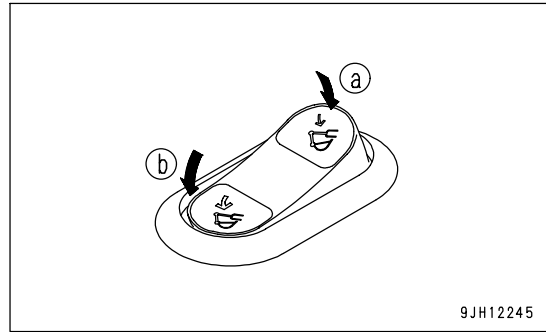

Heated operator seat switch

(If equipped)

This switch (6) is used to switch on the heated seat.

(a) ON: seat heated

(b) OFF: seat not heated

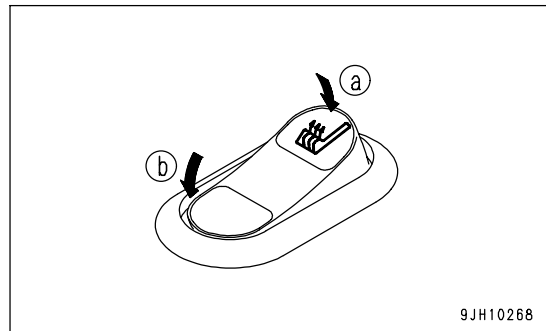

Large Capacity Airflow Air Conditioner Blower Switch

(If equipped)

When this switch (7) is pressed, the additional blower motor is actuated and the air flow from the air conditioner vents increases.

(a) ON: Large-capacity air conditioner blower is actuated

(b) OFF: Large-capacity air conditioner blower is stopped

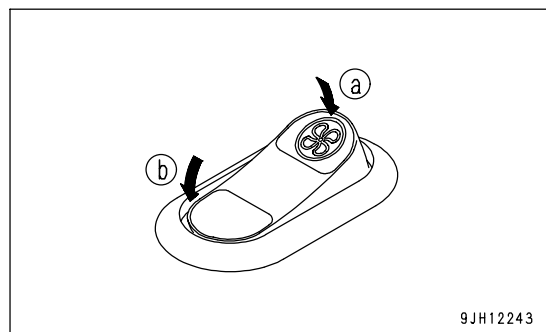

Revolving Warning Lamp Switch

(If equipped)

Use this switch (8) to light up the yellow rotating lamp on top of the cab.

(a) ON: Lamps light up

(b) OFF: Lamps go off

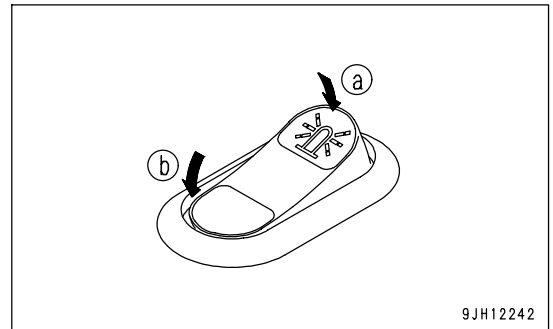
**Horn Switch**

Use this switch (9) to sound the horn.

Press the switch on the right work control lever to sound the horn.

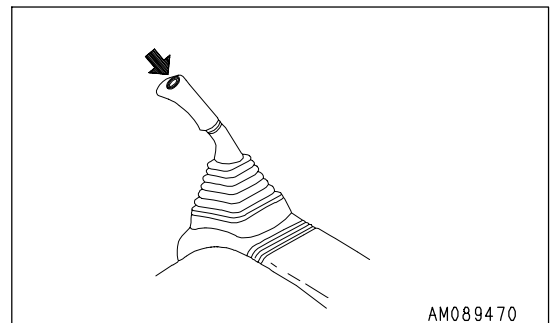
**One-Touch Power Max. Switch**

This switch (10) on the left work equipment control lever is used to actuate the power max functions.

Press once (single click) and keep the switch pressed. The one-touch power max. function is actuated for a maximum of 8.5 seconds at P and E mode.

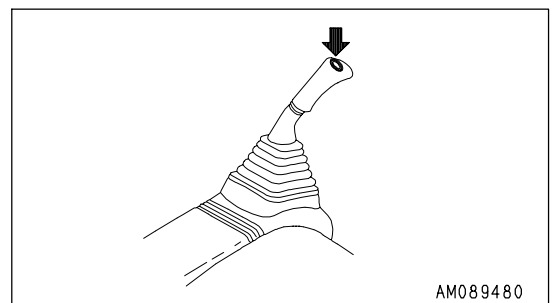
**Cigarette Lighter**

This switch (11) is used when lighting cigarettes.

When the cigarette lighter is pushed in, it will return to its original position after several seconds, so pull it out to use it.

If the cigarette lighter is removed, the socket can be used as an 85W (24V x 3.5A) power source.

NOTICE

This cigarette lighter is for 24V. Do not use it as the power source for 12V equipment.

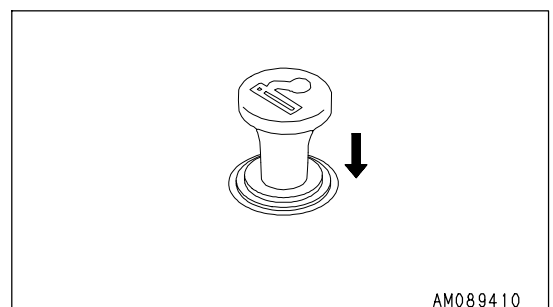

Room Lamp Switch

NOTICE

It is possible to turn on the interior cab room lamp even when starting switch is in the OFF position, do not forget to turn it off.

Use this switch (12) to light up the room lamp.

- (a) ON position: Lamp lights up
- (b) OFF position: Lamp goes out

The room lamp lights up even when the starting switch is at the OFF position

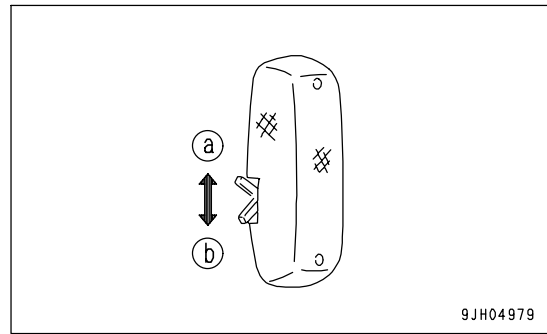

Emergency Pump Drive Switch

NOTICE

- This switch is provided to enable you to carry out operation temporarily, when any problem occurs on the pump control system. Do not use it except in emergency. Furthermore, remove the cause of the problem immediately.
- If this switch is depressed and moved to the EMERGENCY position by mistake, thereby engaging the machine in the work, while the machine is in normal condition, an "E02" mark is shown in the display.
If "E02" is displayed during the work, check that the switch is in the NORMAL position.

This switch (13) is used to make it possible to carry out operations temporarily if any problem should occur in the pump control system (when the display shows "E02").

- (a) EMERGENCY: When abnormal (move switch up)
- (b) NORMAL: When normal (move switch down)

If the display shows "E02", move the switch up to make it possible to carry out work.

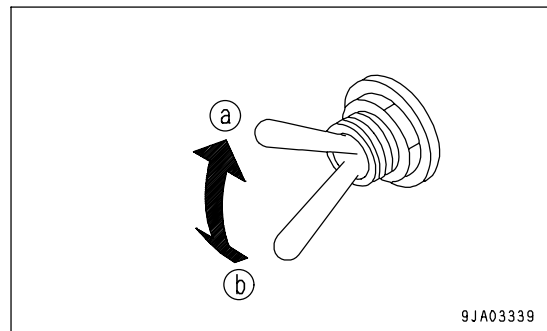

Swing Parking Brake Release Switch

NOTICE

This switch makes it possible to perform swing operations for a short even when there is a problem in the swing parking brake electric system. DO NOT use this switch except in emergencies. Repair the problem as soon as possible.

This switch (14) is used to make it possible to carry out operations temporarily if any problem should occur in the swing parking brake system (when the upper structure does not swing but the display does not show "E03").

- (a) FREE: When abnormal (move switch up)
- (b) NORMAL: When normal (move switch down)

- If the display does not show "E03", move the switch up to FREE position (a) to make it possible to carry out work.
- When the switch is moved to FREE position (a), the swing lock monitor flashes.

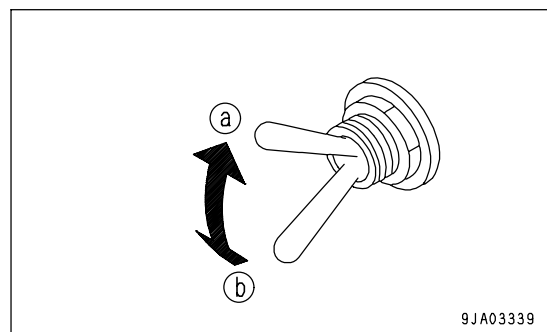

CONTROL LEVERS AND PEDALS

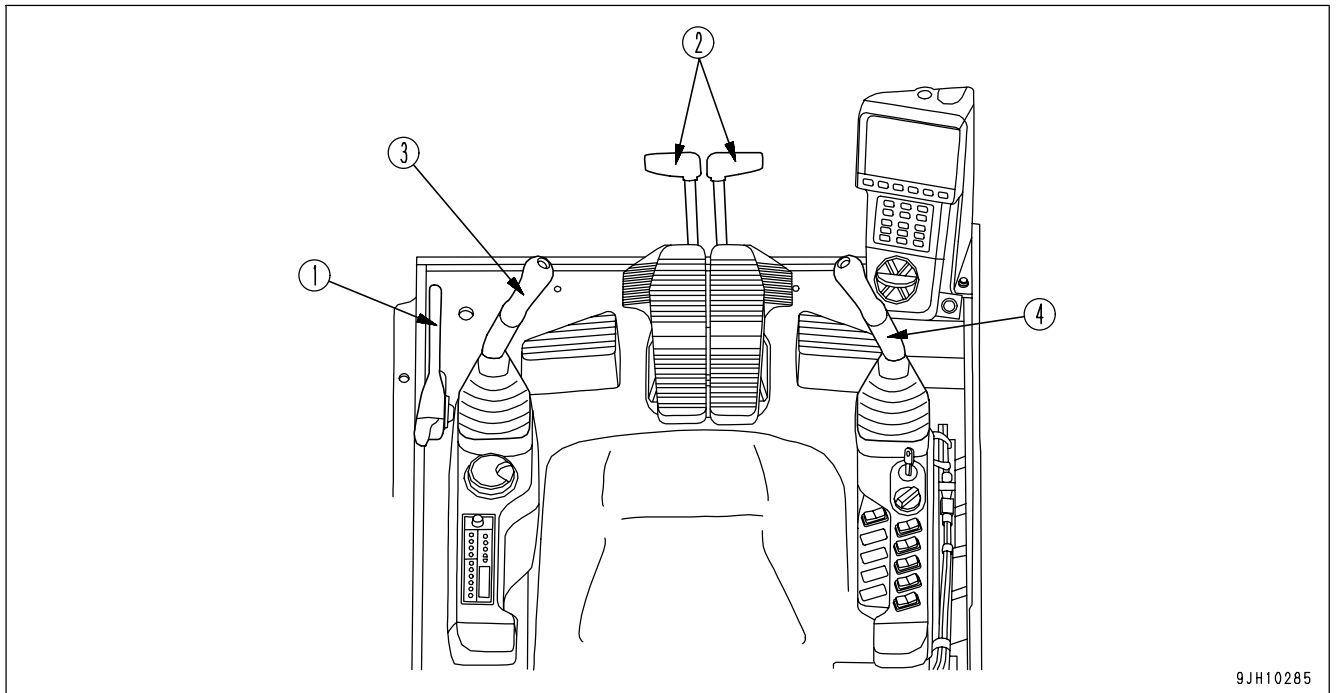

9JH10285

- | | |
|--|---|
| (1) Lock lever | (3) Left work equipment control lever
(with auto-deceleration system) |
| (2) Travel levers
(with pedal and auto-deceleration system) | (4) Right work equipment control lever
(with auto-deceleration system) |

Lock Lever

**WARNING**

- When leaving the operator's compartment, set the lock lever securely to the LOCK position. If the lock lever is not at the LOCK position and the control levers or control pedals are touched by mistake, it may lead to serious personal injury.
- Check that the condition of the lever is as shown in the diagram.
- When pulling the lock lever up, be careful not to touch the work equipment control lever.
When pushing the lock lever down, be careful not to touch the work equipment control lever.

This lever (1) is a device to lock the work equipment, swing, travel, and attachment (if equipped) control levers.

(L) LOCK position: Even when levers or attachment control pedal (if equipped) are operated, machine does not move

(F) FREE position: Machine moves according to operation of levers or attachment control panel (if equipped)

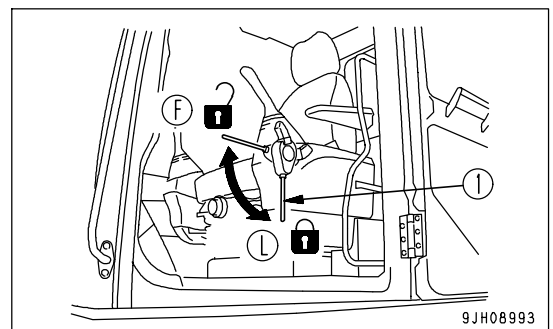

9JH08993

REMARK

This lock lever is of hydraulic lock type. Accordingly, when it is in the lock position (L), the control levers or control pedals move but the machine does not move.

Travel Levers

! WARNING

- Do not rest your foot on the pedal during operations. If the pedal is depressed by mistake, the machine may suddenly move and cause a serious accident. Be extremely careful when operating the pedal for travel or steering operations. When you are not using the pedal, do not rest your foot on it.
- If the track frame is facing the rear, the direction of travel operations will be reversed when the travel lever is operated. (The machine will travel forward when operated in reverse, and in reverse when operated forward; the left and right directions will also be reversed.)
- When operating the travel levers, check if the track frame is facing the front or the rear. (If the sprocket is at the rear, the track frame is facing the front.)

This lever (2) is used to change the direction of travel between forward and reverse. () shows the pedal operation.

- (a) FORWARD: The lever is pushed forward
(The pedal is angled forward)
- (b) REVERSE: The lever is pulled back
(The pedal is angled back)
- N (Neutral): The machine stops

REMARK

If the lever is shifted to the FORWARD or REVERSE position from the Neutral position, the alarm sounds to warn that the machine is starting to move.

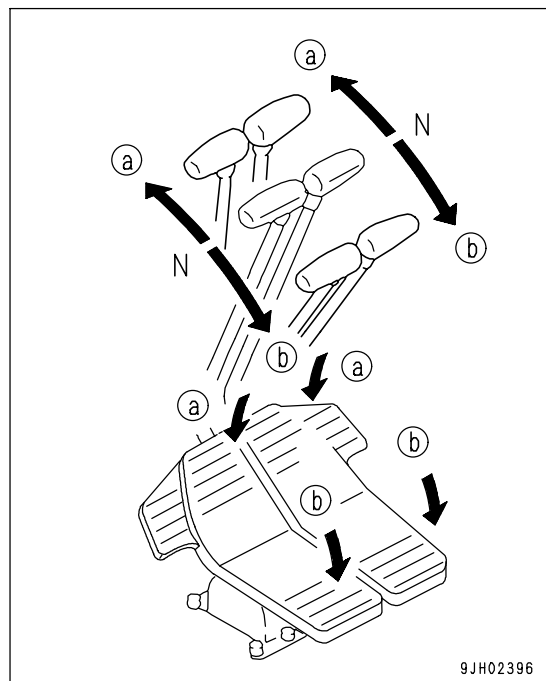

9JH02396

Work Equipment Control Lever

Left work equipment control lever (3) is used to operate the arm and upper structure.

Arm operation

- (a) Arm OUT
- (b) Arm IN

Swing operation

- (c) Swing to right
- (d) Swing to left

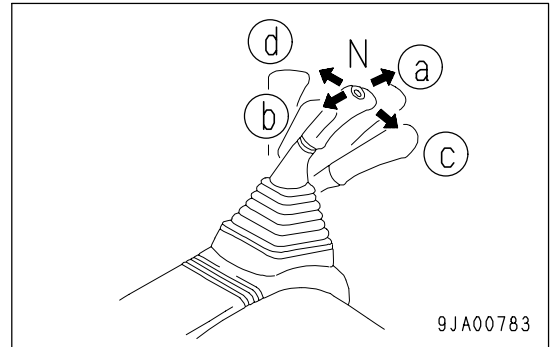

N (Neutral) : The upper structure and arm are held in position and do not move.

Right work equipment control lever (4) is used to operate the boom and bucket.

Boom operation

- (a) RAISE
- (b) LOWER

Bucket operation

- (c) DUMP
- (d) CURL

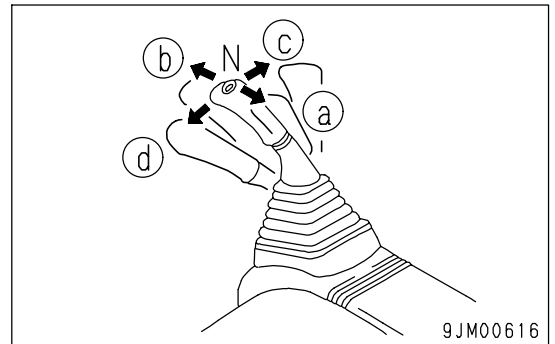

N (Neutral) : The boom and bucket are held in position and do not move.

SUN ROOF

(PC400, PC400LC only)

WARNING

When leaving the operator's seat, set the lock lever securely to the LOCK position.

If the lock lever is at the FREE position and the control levers or control pedals is touched by mistake, this may lead to a serious accident.

Opening

1. Set the lock lever (1) securely to the LOCK position (L).

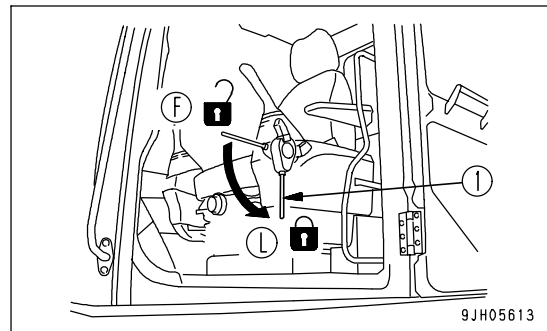

2. Push up lock (A) in the front center of the roof window and check that the lock is released. Then hold grip (B) and push up the roof window.

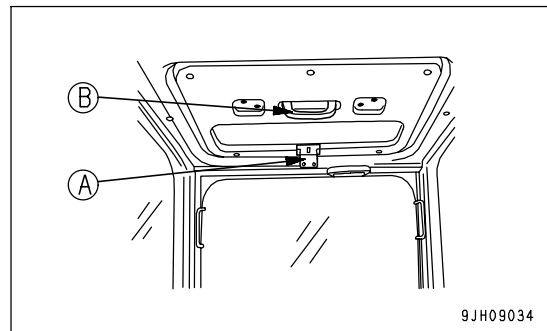

Closing

Hold grasping grip (B), lower the ceiling window, and apply lock (A). If the lock cannot be applied, open the ceiling window, then pull it in again and apply the lock.

WINDSHIELD

WARNING

- When opening or closing the front window, bottom window, or door, always set the lock lever to the LOCK position. If the lock lever is at the FREE position and the control levers or control pedals is touched by mistake, this may lead to a serious accident.
- When opening or closing the front window, stop the machine on horizontal ground, lower the work equipment completely to the ground, stop the engine, then carry out the operation.
- When opening the front window, hold the grip securely with both hands, pull up, and do not let go until the automatic lock catch is locked.
- When closing the front window, the window will move quicker under its own weight. Hold the grips securely with both hands when closing it.

It is possible to stow (pull up) the front window in the roof of the operator's compartment.

Opening

1. Stop the machine on level ground, lower the work equipment completely to the ground, then stop the engine.
2. Set the lock lever (1) securely to the LOCK position (L).

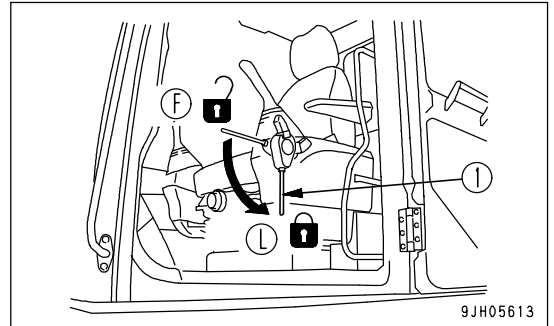

3. Check that the wiper blade is stowed in the right stay.

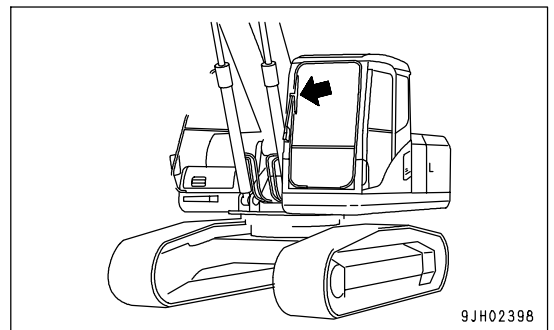

4. Hold 2 grips (A) on the left and right top sides of the front window, and pull the 2 levers (B) to release the locks at the top of the front window. The top of the front window will come out.

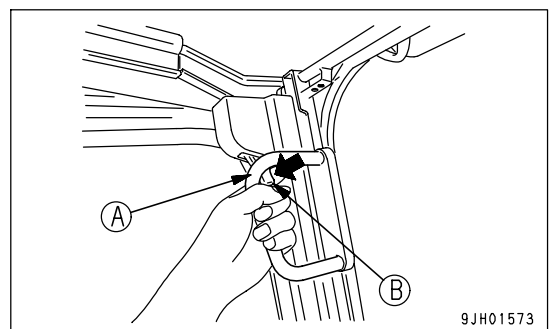
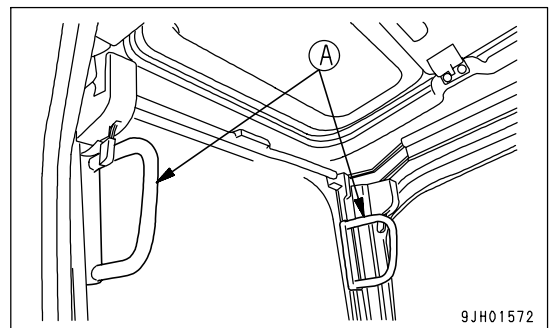

5. Hold lower knob (C) with your left hand from inside the operator's cab, and with your right hand, grip top knob (D), pull it up, and push it against lock catch (E) at the rear of the cab securely to lock the window.

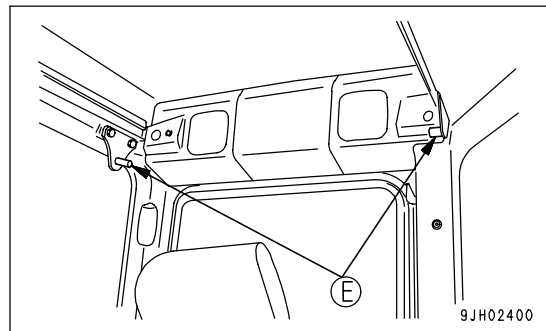
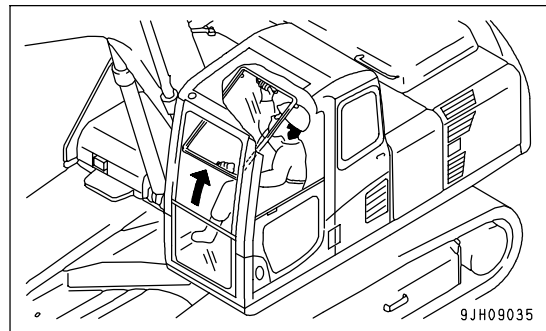
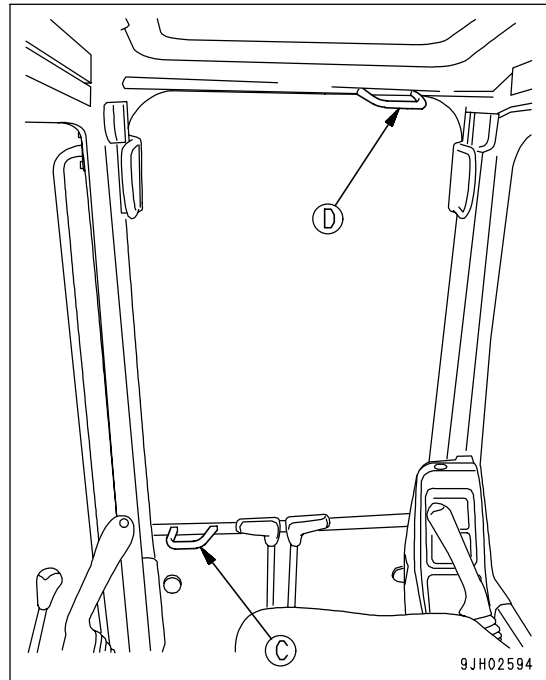

6. Check that lever (B) is securely at the LOCK position.

- The lock is engaged if the arrow on lock case (F) matches the position of the arrow on lever (B). Check visually.
- If the arrow on lock case (F) does not match the position of the arrow on lever (B), the lock is not engaged. Repeat the operation in Step 5 to engage the lock.

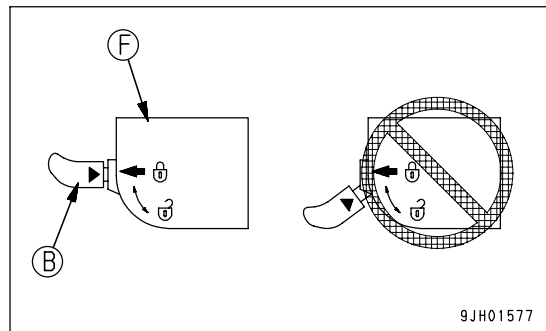

Closing

**WARNING**

When closing the window, lower it slowly and be careful not to get your hand caught.

1. Stop the machine on level ground, lower the work equipment completely to the ground, then stop the engine.
2. Set the lock lever (1) securely to the LOCK position (L).

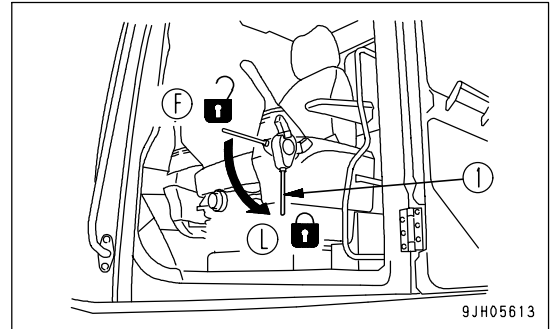

3. Grip left and right handles (A), and pull down lever (B) to release the lock.

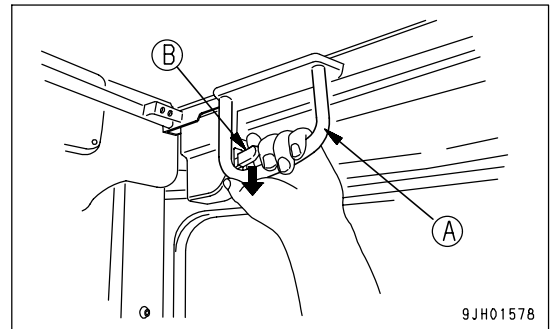

4. Grip handle (C) at the bottom of the front window with your left hand and handle (D) at the top with your right hand, push to the front, then lower slowly.

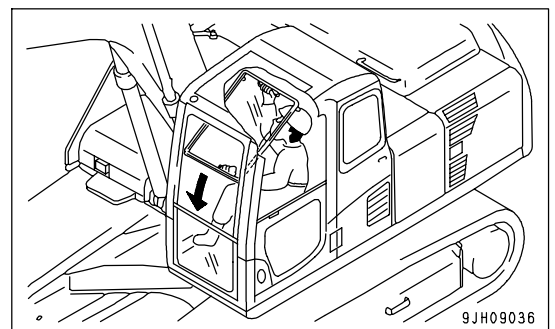
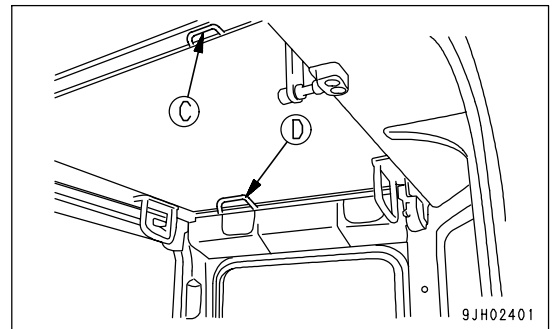

5. When the bottom of the window reaches the top of the bottom window, push the top of the window to the front to push it against left and right lock catches (G) and engage the lock.

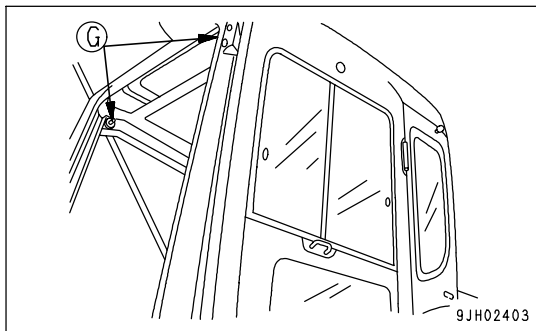

6. Check that lever (B) is securely at the LOCK position.

- The lock is engaged if the arrow on lock case (F) matches the position of the arrow on lever (B). Check visually.
- If the arrow on lock case (F) does not match the position of the arrow on lever (B), the lock is not engaged. Repeat the operation in Step 5 to engage the lock.

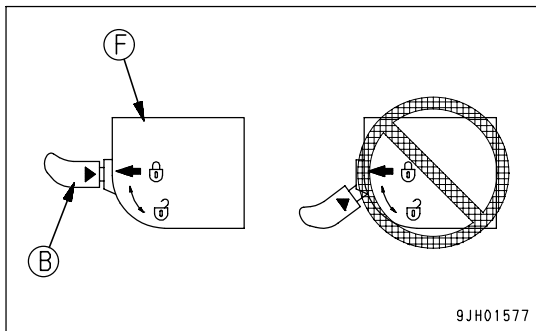

Removing Lower Windshield

1. Open the front window, then hold grip (1), pull up, and remove the bottom window.

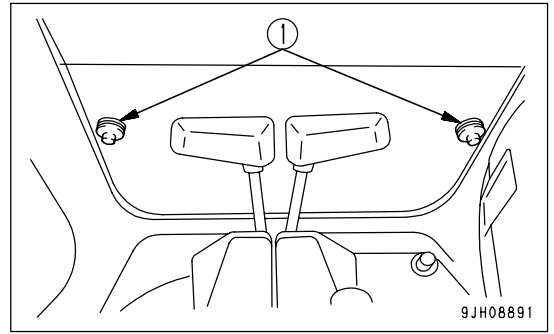

- If sand or dust is collected at the bottom of the front window, it will be difficult to remove the window. In addition, when stowing, the sand and dust stuck to the glass will be carried inside the cab. To prevent this, clean area (A) before removing.

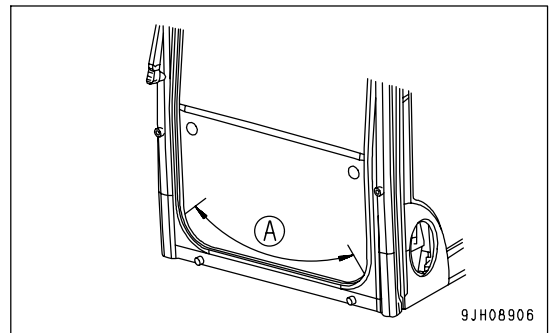

2. After removing the lower windshield, store it at the right rear of the operator's cab, and set lever (2) to lock position (B) to hold it securely in position.
3. When removing it, set lever (2) to release position (C), hold the glass with both hands, and pull it up.

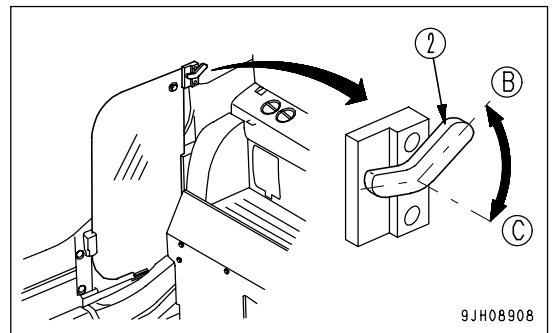

EMERGENCY ESCAPE HAMMER

CAUTION

- If it is necessary to break the window glass with the hammer, be extremely careful not to injure yourself on the flying pieces of broken glass.
- To prevent injury, remove the broken pieces of glass remaining in the frame before escaping through the window. Be careful also not to slip on the broken pieces of glass.

If it should become impossible to open the cab door for any reason, and it is necessary to make an emergency escape from the operator's compartment, use hammer (A) to escape.

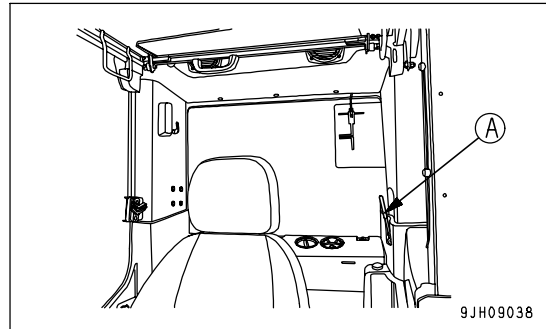

To escape from the operator's cab, use hammer (A) to break the glass and escape through the window.

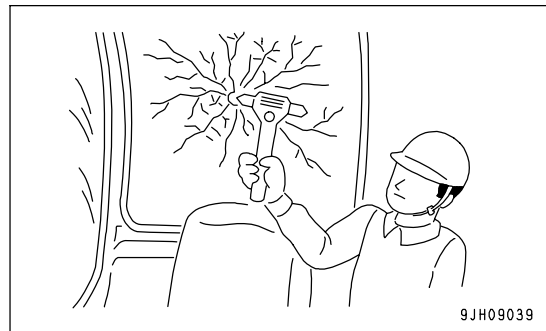

DOOR LOCK

WARNING

- Before releasing the door lock, always stop the machine on flat ground.
- Never release the door lock on a slope. The door may suddenly close and cause injury.
- When releasing the door lock, do not extend your body or hands outside the machine and do not put your hands on the door frame. The door may suddenly close and cause injury.

Use the door lock to fix the door in position after opening it.

1. Push the door against catch (1) to lock it in position.
2. When closing the door, push down the lever (2) on the left of the operator's seat to release the catch.
3. When attaching the door in position, lock it firmly to the catch.

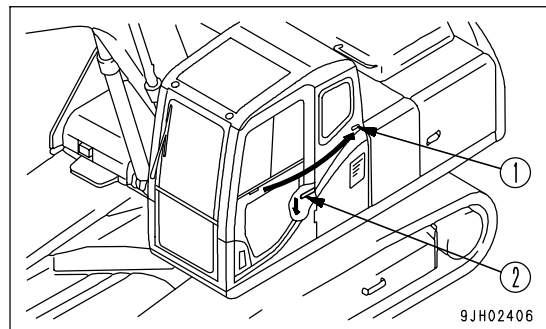

CAP WITH LOCK

Use the starting switch key to open and close the locks on the caps and covers.

For details of the locations of the caps and covers with locks, see "LOCKING (PAGE 3-173)".

Insert the key as far as it will go to the shoulder (A). If the key is turned before it is inserted all the way, it may break.

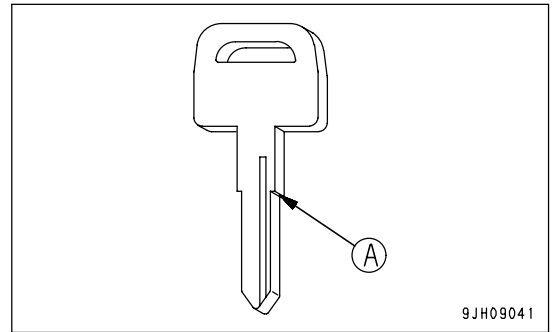

9JH09041

Opening and Closing Caps with Lock

Opening the Cap

1. Insert the key into the key slot.
2. Turn the key clockwise, align the key groove with mark (1) on the cap, then open the cap.

Position (A): OPEN

Position (B): LOCK

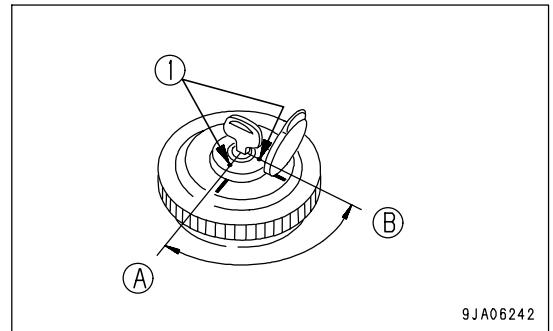

9JA06242

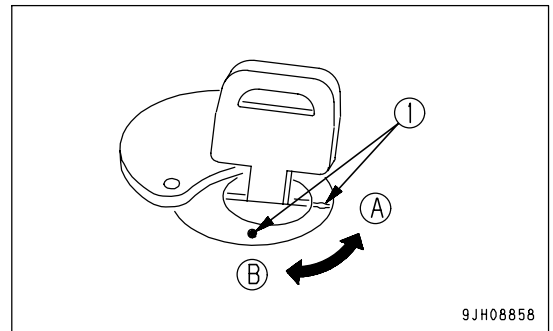

9JH08858

Locking the Cap

1. Turn the cap until tight, then insert the key into the key slot.
2. Turn the starting switch key to LOCK position (B), then remove the key.

Opening and Closing Cover with Lock

Opening the Cover (Locked Cover)

1. Insert the key into the key slot.
 2. Turn the key counterclockwise and open the cover by pulling the cover grip.
- (A): Open
 (B): Lock

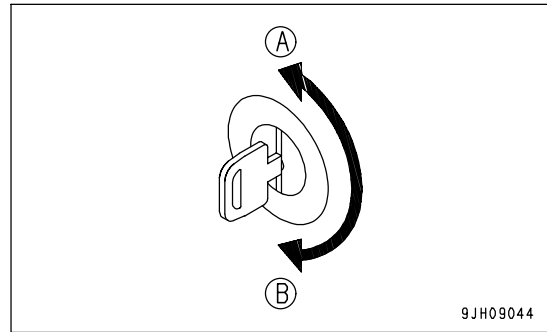

Locking the Cover

1. Close the cover and insert the key into the key slot.
2. Turn the key clockwise and take the key out.

DRINK BOX

- This is on the right side at the rear of the operator's seat. It keeps drinks and other things hot or cold.
- Hot or cold air blows into the box according to the setting of the air conditioner.

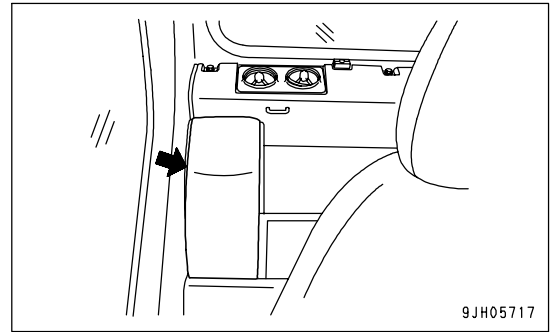

MAGAZINE BOX

(The cup holder is provided separately at the front of the magazine box.)

Located on left side of the operator's seat.

Keep the Operation and Maintenance Manual in this box so that it can be taken out and read whenever necessary.

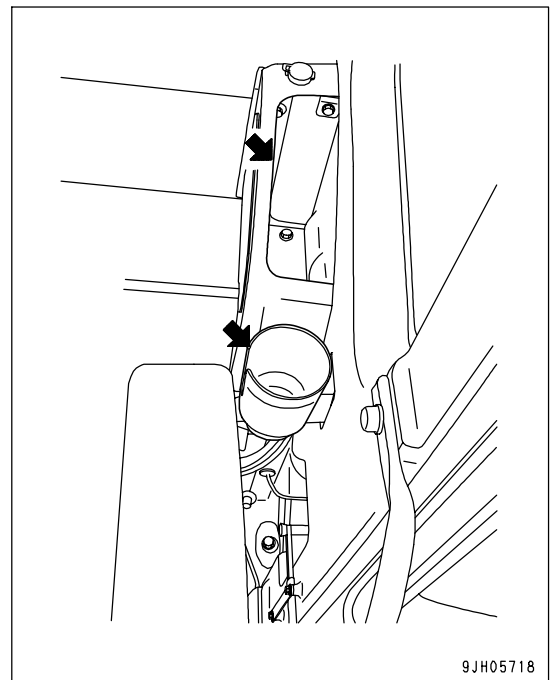

ASHTRAY

This is on top of the console box on the left side of the operator's seat.

Always put out your cigarette before putting it in the ashtray and be sure to close the lid.

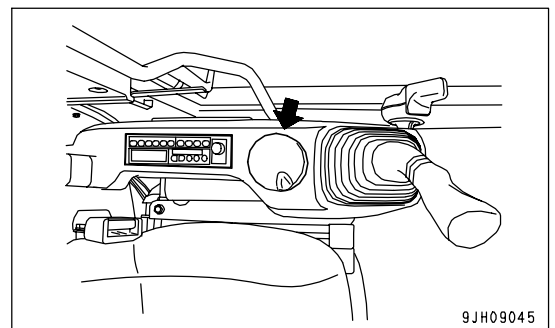

AIR CONDITIONER CONTROLS

Air Conditioner Control Panel

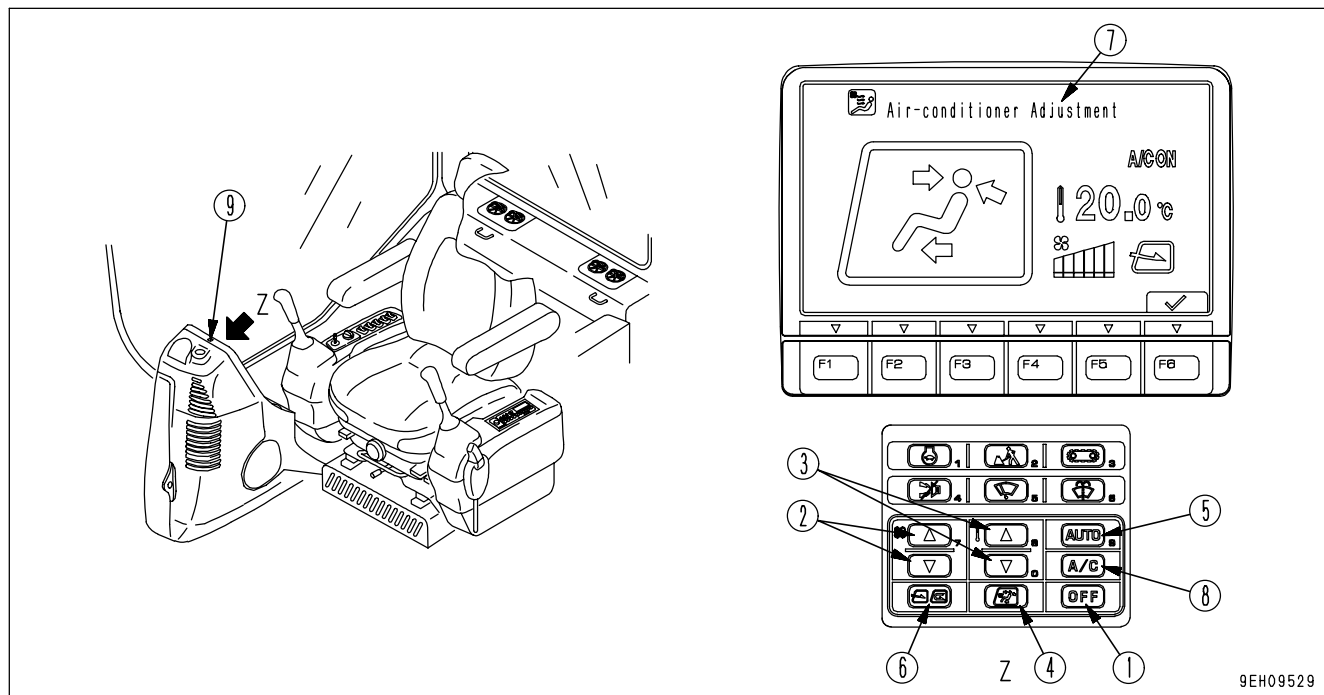

- (1) OFF switch
- (2) Fan switch
- (3) Temperature control switch
- (4) Vent selector switch
- (5) Auto switch
- (6) FRESH/RECIRC selector switch
- (7) Display monitor
- (8) Air conditioner switch
- (9) Sunlight sensor

OFF Switch

Switch (1) is used to stop the fan and air conditioner.

REMARK

Even if this switch (1) is pressed, the monitor screen does not switch to the air conditioner adjustment screen.

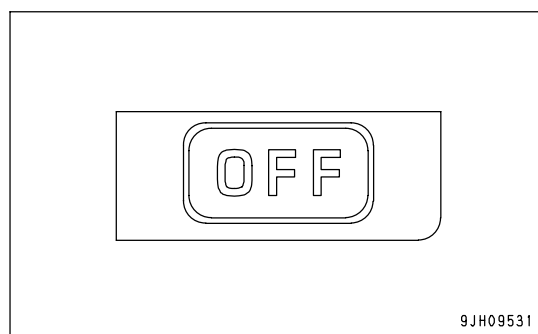

Fan Switch

Switch (2) is used to adjust the air flow.

The air flow can be adjusted to six levels.

- Press the \triangle switch to increase the air flow; press the ∇ switch to decrease the air flow.
- During auto operation, the air flow is automatically adjusted.

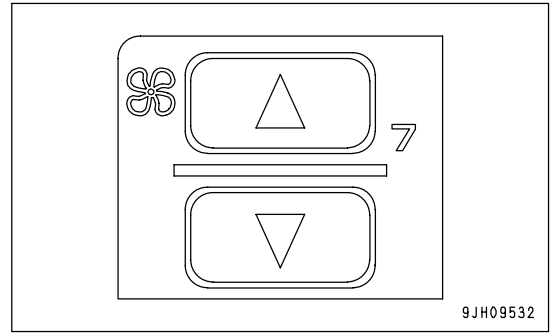

Monitor display and air flow

A: Liquid crystal display

B: Air flow

a: Air flow "low"

b: Air flow "medium 1"

c: Air flow "medium 2"

d: Air flow "medium 3"

e: Air flow "medium 4"

f: Air flow "high"

A	B
	a
	b
	c
	d
	e
	f

Temperature Control Switch

Switch (3) is used to control temperature inside the cab. The temperature can be set between 18°C (64.4°F) and 32°C (89.6°F).

- Press the \triangle switch to raise the set temperature; press the ∇ switch to lower the set temperature.
- The temperature is generally set at 25°C (77°F).
- The temperature can be set in stages of 0.5°C (0.9°F).

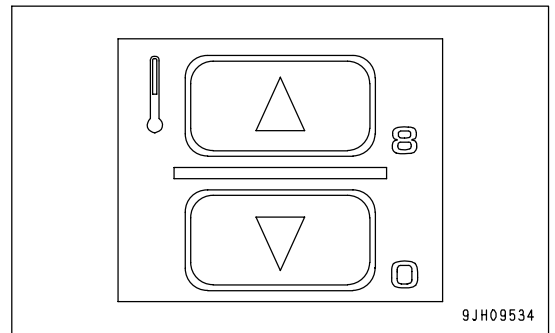

<Monitor display and the function>

Monitor display °C	Set temperature
18.0	Max. cooling
18.5 to 31.5	Adjusts temperature inside cab to set temperature
32.0	Max. heating

REMARK

If the mode is set to auto mode and the temperature setting is set to 18.0 °C (64.4 °F) or 32.0 °C (89.6 °F), the air flow from the fan is always set to HIGH and does not change even when the set temperature is reached.

Vent Selector Switch

Switch (4) is used to select the vents.

- When switch (4) is pressed, the display on monitor display (7) switches and air blows out from the vents displayed.
- During automatic operation, the vents are automatically selected.

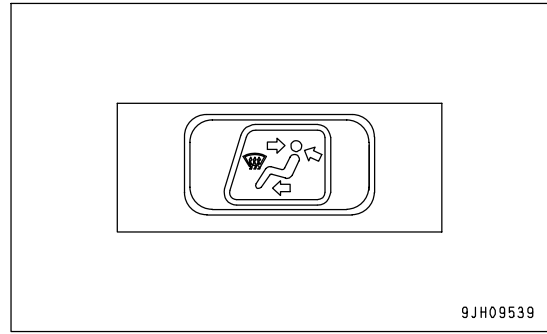

- (A): Rear vent (4 places)
- (B1): Face vent (1 place)
- (C): Foot vent (1 place)
- (D): Front window glass vent (2 place)
- (B2): Front window glass vent (1 place)

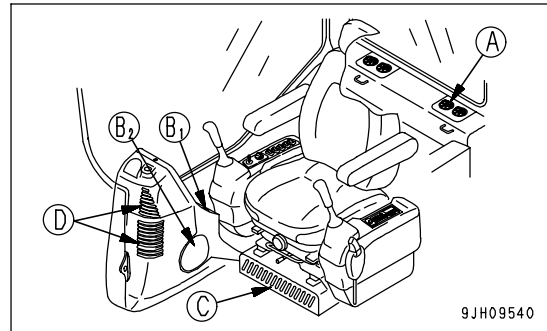

Liquid crystal display	Vent mode	Vent				Remarks
		Ⓐ	Ⓑ	Ⓒ	Ⓓ	
	Front vent		○			Cannot be selected for automatic operation
	Front and rear vents	○	○			—
	Front, rear and foot vents	○	○	○		—
	Foot vent			○		—
	Foot vent Defroster vent			○	○	Cannot be selected for automatic operation
	Defroster vent				○	Cannot be selected for automatic operation

Note 1: Air blows out from vents marked ○

Auto Switch

With switch (5), the air flow, vents, and air source (RECIRC/FRESH) are automatically selected according to the set temperature.

- Press switch (5), then use temperature control switch (3) to set the temperature, and run the air conditioner under automatic control.
- When switching from automatic operation to manual operation, it is possible to use the switches to select the vents and air source (RECIRC/FRESH).

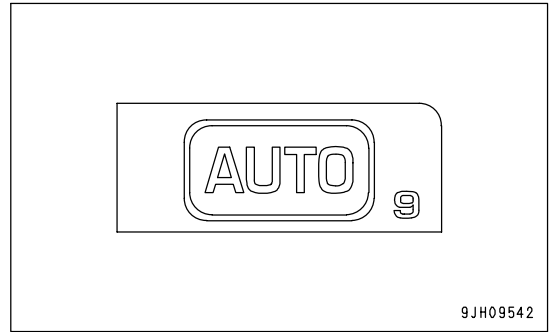

9JH09542

REMARK

When Auto Mode is selected, if the set temperature is set to 18.0 °C (64.4 °F) or 32.0 °C (89.6 °F), the air flow is always set to High, but this is not a problem.

FRESH/RECIRC Selector Switch

Switch (6) is used to switch the air source between recirculation of the air inside the cab and intake of fresh air from the outside.

- During automatic operation, the selection of inside air (RECIRC) and outside air (FRESH) is performed automatically.

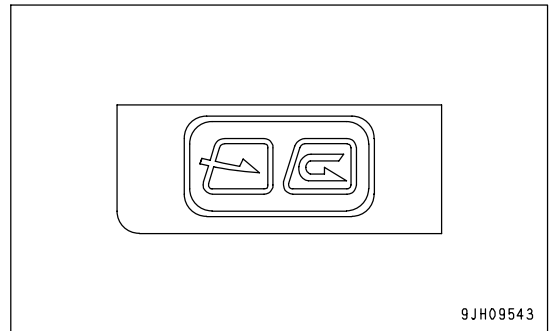

9JH09543

RECIRC	Outside air is shut off and only air inside the cab is circulated. Use this setting to perform rapid cooling of the cab or when outside air is dirty.
FRESH	Outside air is taken into the cab. Use this setting to take in fresh air when performing demisting.

Display Monitor

Monitor (7) displays the status of temperature setting (a), air flow (b), and vents (c).

- When OFF switch (1) is pressed, the display of temperature setting (a) and air flow (b) goes out, and operation stops.

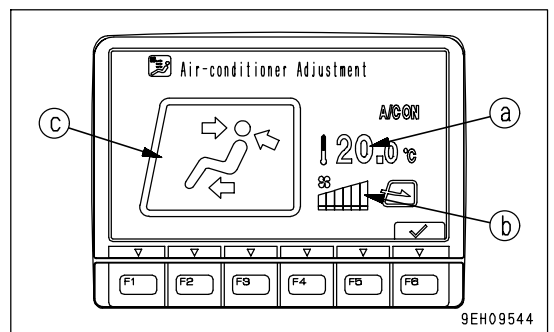

9EH09544

Air Conditioner Switch

Switch (8) is used to turn the air conditioner (cooling, dehumidifying, heating) ON or OFF.

- Press air conditioner switch (8) when the fan is operating (when display (b) is shown on the display monitor). The air conditioner is switched ON and starts to work. Press the switch again to stop the air conditioner.
- Air conditioner cannot be operated while the fan is off.

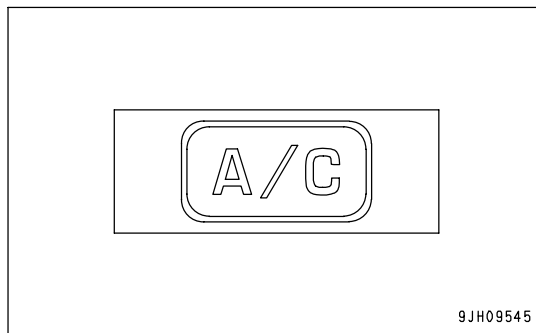

Sunlight Sensor

This sensor (9) automatically adjusts the flow of air from the vents to match the strength of the sun's rays. In addition, it automatically detects changes in the temperature inside the cab caused by changes in the strength of the sun's rays beforehand and automatically adjusts the temperature.

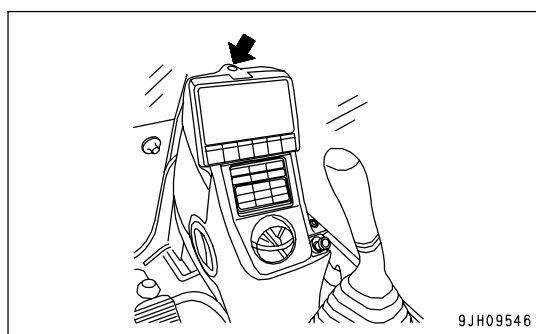

Method of Operation

The air conditioner can be operated automatically or manually. Select the method of operation as desired.

Automatic Operation

1. Turn auto switch (5) ON.
 - The monitors for the set temperature (a) and air flow (b) are also displayed.

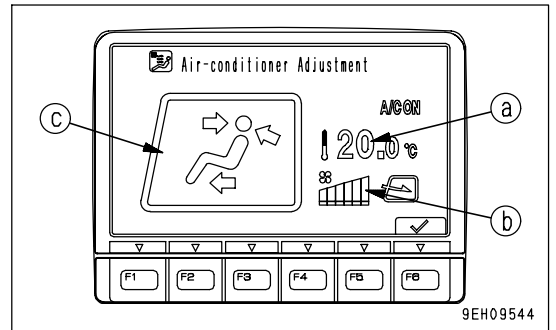
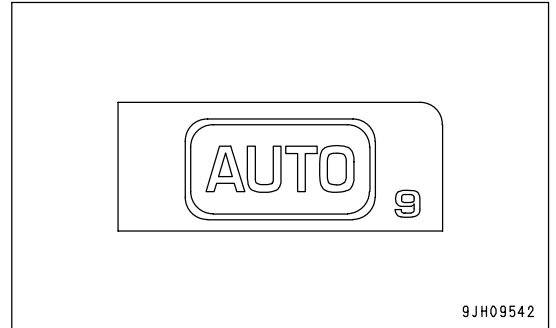

2. Use temperature set switch (3) to set to the desired temperature. The air flow, combination of vents, and selection of fresh or recirculated air is automatically selected according to the set temperature, and the air conditioner is operated automatically to provide the set temperature.

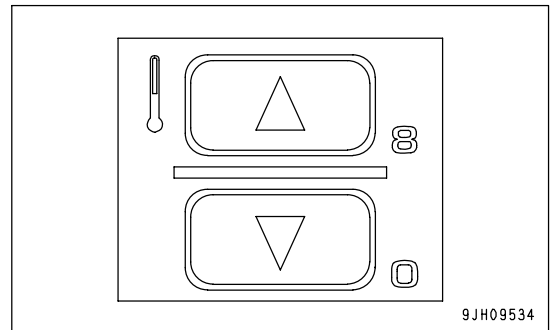

REMARK

When vent display monitor (c) displays (d) or (e), and engine coolant temperature is low, the air flow is automatically limited to prevent cold air from blowing out.

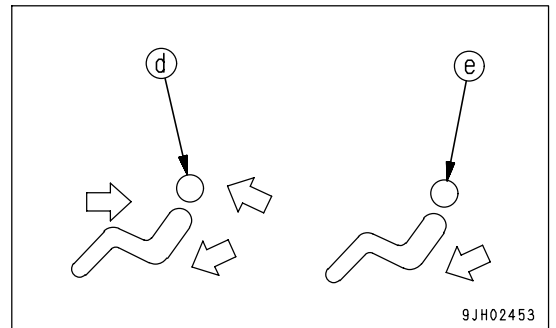

Stopping Automatic Operation

Press OFF switch (1). Operation stops.

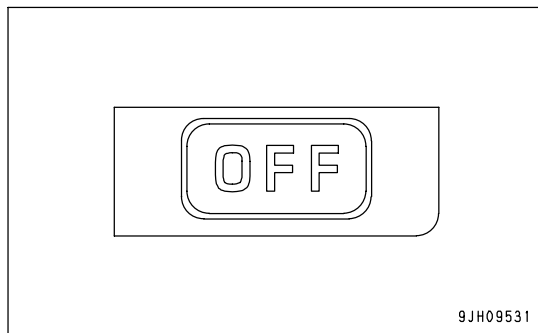

Manual Operation

1. Press fan switch (2) and adjust the air flow. When doing this, check that temperature setting (a) and air flow (b) are displayed on monitor (7).

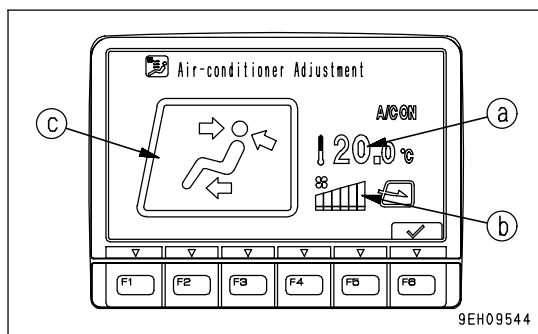
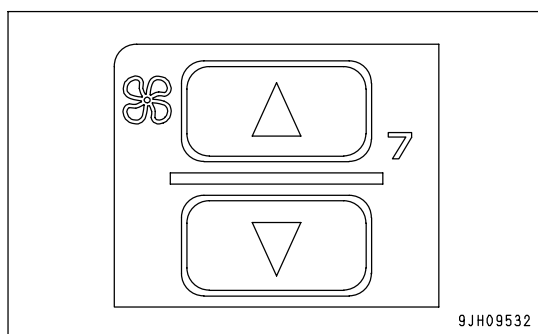

2. Turn air conditioner switch (8) ON.

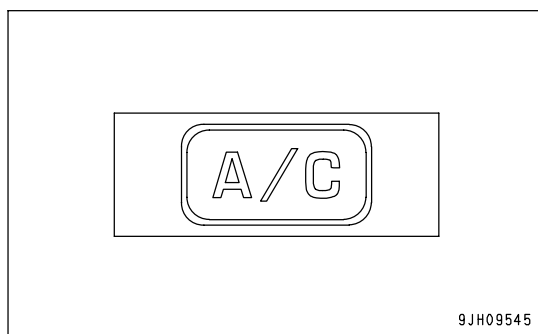

3. Press temperature setting switch (3) and adjust temperature inside the cab.

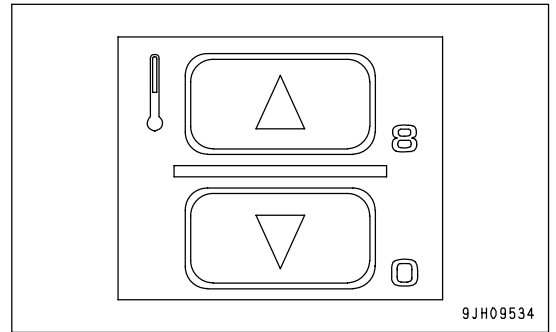

4. Press vent selector switch (4) and select the desired vents. When this is done, the display for vent (c) of the display monitor changes according to the selection.

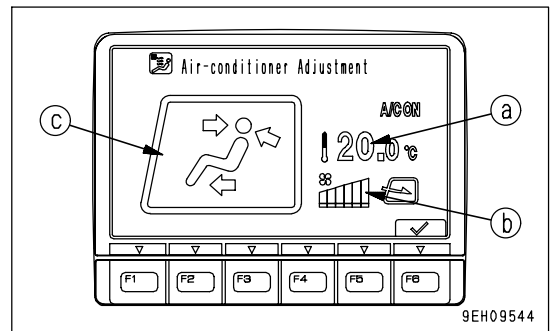
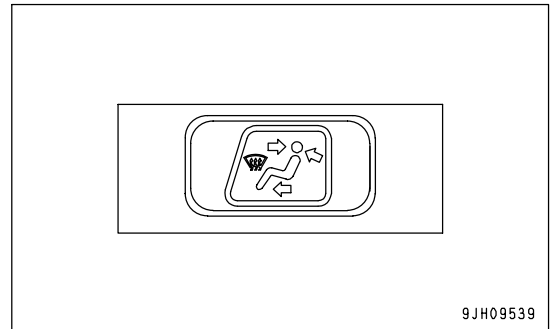

5. Press RECIRC/FRESH selector switch (6) and select recirculation of the air inside the cab (RECIRC) or intake of fresh air from outside (FRESH).

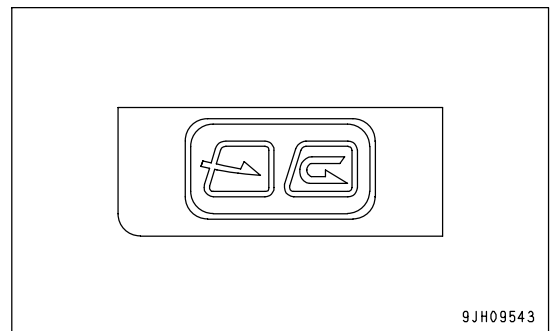

Stopping Manual Operation

Press OFF switch (1). Operation stops.

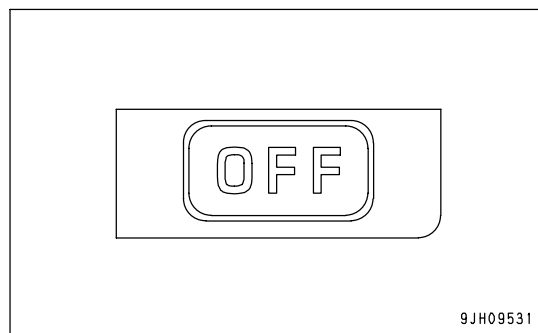

Operation with Cold Air to Face and Warm Air to Feet

To operate with cold air blowing to the face and warm air blowing to the feet, set as follows.

1. Press fan switch (2) and adjust the air flow. When doing this, check that temperature setting (a) and air flow (b) are displayed on monitor (7).

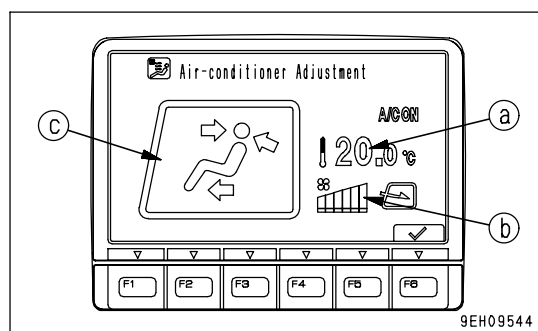
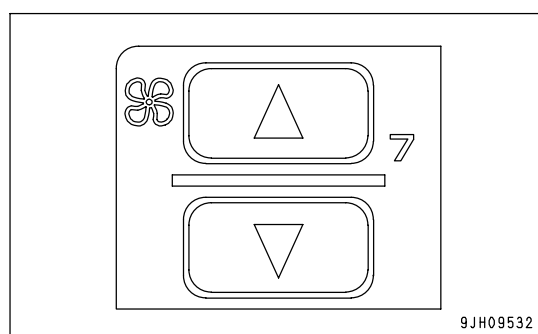

2. Press vent selector switch (4) and set the vent display on the display monitor to the display shown in the diagram on the right.

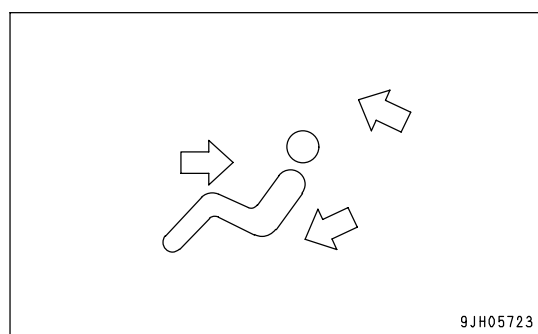

3. Turn air conditioner switch (8) ON.

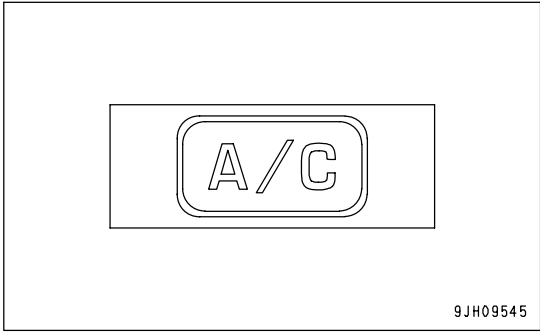

4. Adjust fan switch (2), temperature setting switch (3) and RECIRC/FRESH selector switch (6) to the desired positions.

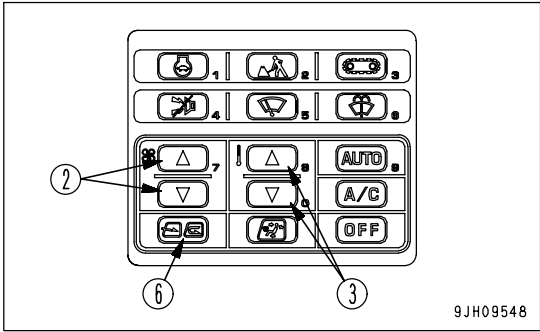

Defroster Operation

1. Press fan switch (2) and adjust the air flow. When doing this, check that temperature setting (a) and air flow (b) are displayed on monitor (7).

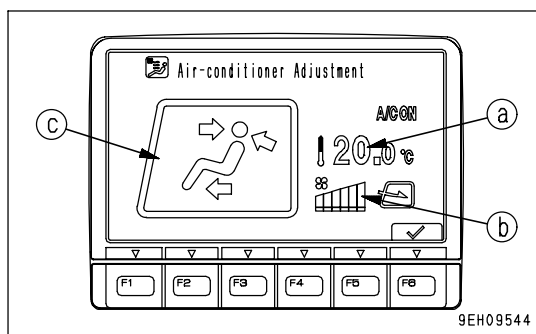
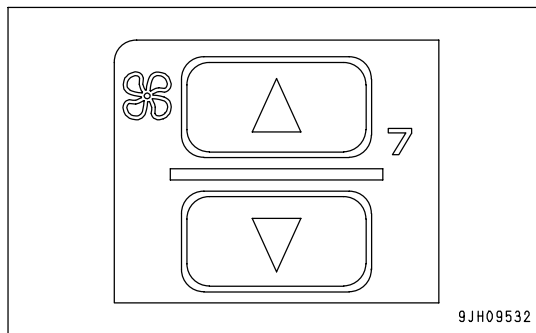

2. Press vent selector switch (4) and set vent display on the display monitor to (f) or (g) as shown in diagram on the right.

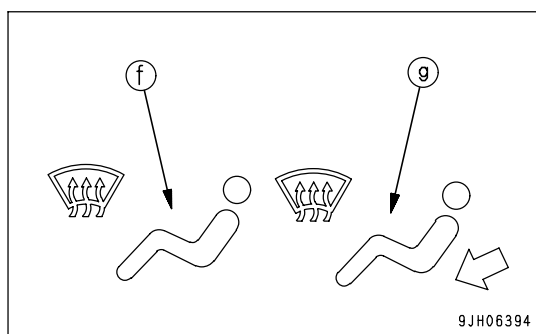
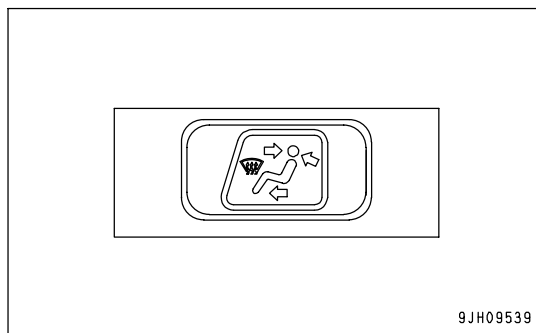

3. Press RECIRC/FRESH selector switch (6) and set it to take in fresh air.

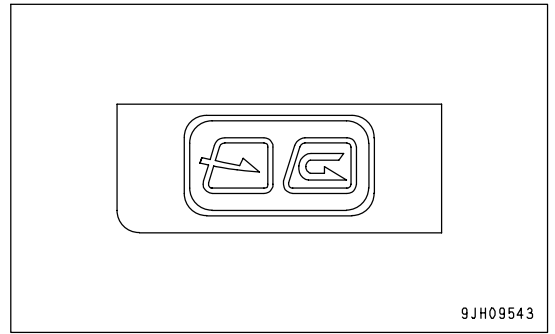

4. Press temperature setting switch (3) and set temperature on the display (7) monitor to maximum heating.

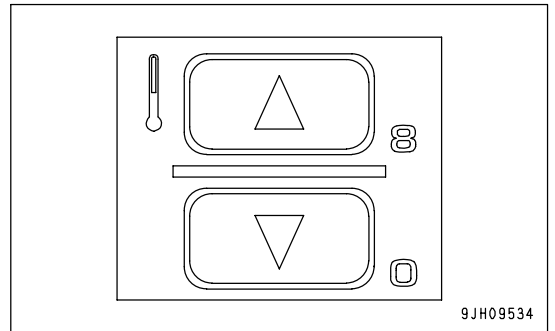

5. Adjust vents (A), (B1), and (B2) so that the air blows onto the window glass.
(Vents (C) and (D) are fixed and cannot be adjusted.)

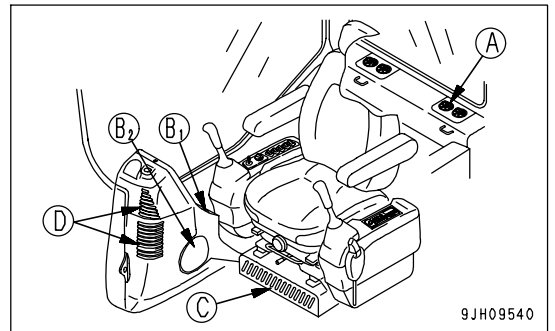

When operating in the rainy season or when it is desired to remove the mist from the window glass or to dehumidify the air, turn air conditioner switch (8) ON.

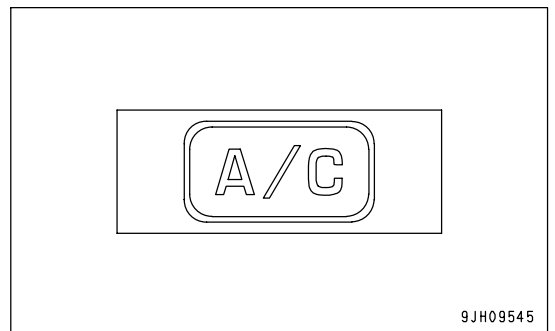

Use Air Conditioner with Care

NOTICE

- When running the air conditioner, always start with the engine running at low speed. Never start the air conditioner when the engine is running at high speed. It will cause failure of the air conditioner.
- If water gets into the control panel or sunlight sensor, it may lead to unexpected failure, be careful not to let water get on these parts. In addition, never bring any flame near these parts.
- For the auto function of the air conditioner to work properly, always keep the sunlight sensor clean and do not leave anything around the sunlight sensor that may interfere with its sensor function.

Ventilation

- When running the air conditioner for a long time, turn the lever to the FRESH position once an hour to carry out ventilation and cooling.
- If you smoke when the air conditioner is on, the smoke may start to hurt your eyes, so open the window and turn the lever to FRESH for a while to remove the smoke while continuing the cooling.

Temperature Control

When the cooler is on, set the temperature so that it feels slightly cool when entering the cab (5 or 6 °C (9 or 10.8 °F) lower than the outside temperature). This temperature difference is considered to be the most suitable for your health, so always be careful to adjust the temperature properly.

Inspection and maintenance of Air Conditioner Equipped Machine

- When carrying out inspection and maintenance on machines equipped with an air conditioner, carry out the inspection and maintenance according to the chart. For details, see "CHECK AND MAINTENANCE AIR CONDITIONER (PAGE 4-39), CHECK AIR CONDITIONER COMPRESSOR BELT TENSION, ADJUST (PAGE 4-52), CLEAN AIR CONDITIONER FRESH/RECIRC FILTERS (PAGE 4-64)".
- When the air conditioner is not being used every day, to prevent loss of the film of oil at various parts, run at the engine at low speed from time to time and carry out cooling or dehumidifying heating for several minutes.
- If the temperature inside the cab is low, the air conditioner may not work. In this case, circulate fresh air to warm the inside of the cab. When the air conditioner switch is turned ON, the air conditioner will work.
- If any abnormality is detected in any equipment or sensor used on the air conditioner, "A/C Controller Error" is displayed on the air conditioner monitor screen. If "A/C Controller Error" is displayed, please ask your Komatsu distributor to carry out inspection and repair.

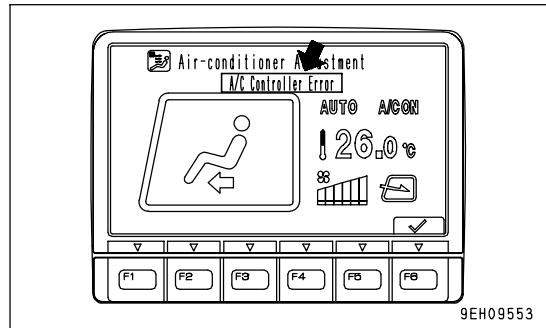

RADIO

Control Panel

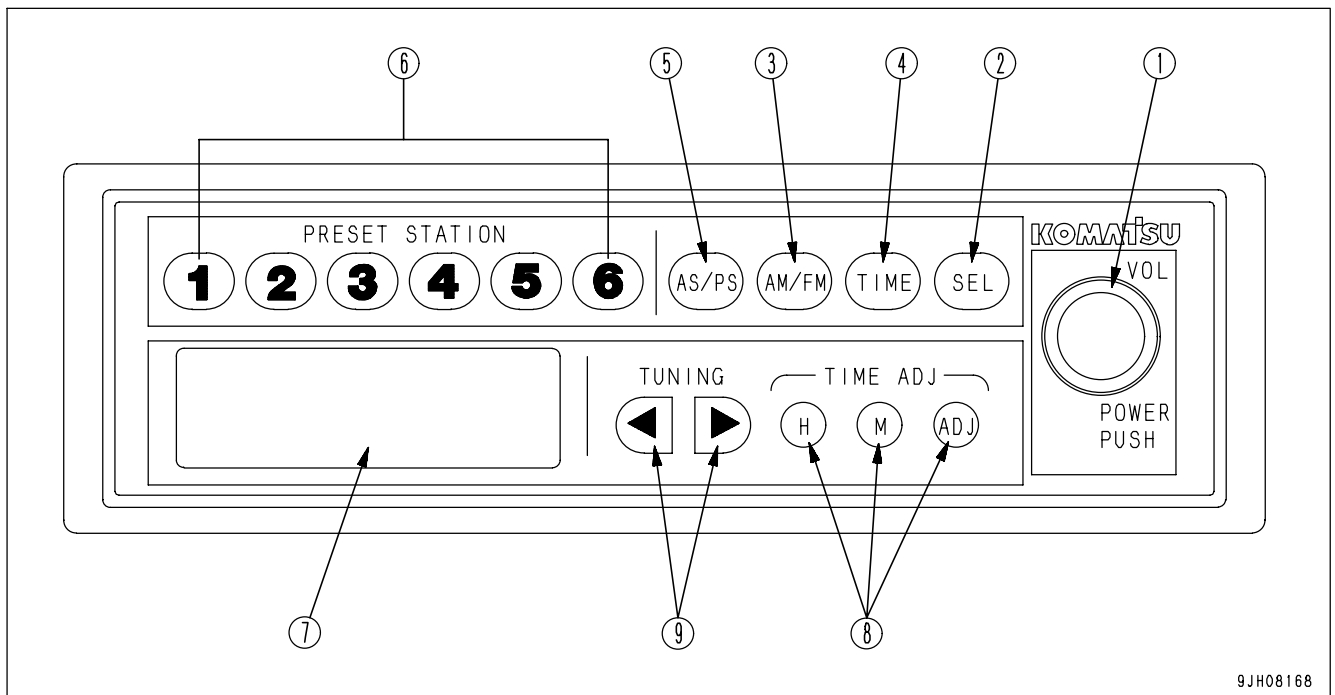

9JH08168

- | | |
|---|--|
| (1) Power switch, Volume control knob, Balance control knob | (5) AS/PS button |
| (2) SEL button | (6) Preset station buttons (1,2,3,4,5,6) |
| (3) FM/AM selection button | (7) Display |
| (4) Display selection button | (8) Time reset button |
| | (9) Tuning button |

Power switch, Volume control knob, Balance control knob

Press this knob (1) to turn the power for the radio on. The frequency is displayed on display (7). Press the knob again to turn the power off.

Turn the knob clockwise to increase the volume; press counterclockwise to reduce the volume. The range for the volume is VOL 0 - VOL 40.

SEL button

Each time this button (2) is pressed, the mode changes as follows: VOL (volume) → BAS (bass) → TRE (treble) → BAL (balance). The mode is displayed on display (7). For details of each mode, see "Method of Operating Mode (PAGE 3-104)".

FM/AM Selection Button (AM/FM)

Press this button (3) to select the desired band.

Each time the button is pressed, the band changes FM → AM → FM . . .

Display Selection Button (TIME)

On this machine, priority is given to the frequency display. When the frequency is being displayed, press button (4) and the display will show the present time for 5 seconds. After 5 seconds pass, the display returns automatically to the frequency display. If any button other than TIME ADJ (H, M, ADJ) is pressed within 5 seconds, the display returns to the frequency display. For details of the method of adjusting the time, see "Setting Correct Time (PAGE 3-104)".

AS/PS button

This button (5) actuates the auto store and preset scan functions.

- Auto store

If this button is kept pressed for at least 2 seconds during radio reception, it will automatically search for six available AM and FM stations each, starting with the lowest frequency and going up to the highest frequency. These frequencies can then be saved in the preset memory.

- Preset scan

If this button is pressed within 2 seconds, it is possible to select one of the already preset stations. Wait for 6 sec. after pressing the button and then press the button again to select the next preset station. If it is impossible to receive the preset frequency, the selection advances after 1 second to the next preset station.

Preset Station Buttons (1, 2, 3, 4, 5, 6)

If this button (6) has been used to decide which stations to preset, it is possible to select the desired station at a touch. It is possible to preset 6 stations each for both AM and FM.

For details of the method of presetting the stations, see "Method of Setting with Preset Button (PAGE 3-103)".

REMARK

The preset button can be used to save the frequency manually. To save the frequency automatically, use the Auto store button.

Display

This display (7) shows the reception band, frequency, preset No., and time.

Time Reset Button

Use this button (8) when adjusting the time. For details of the method of adjusting the time, see "Setting Correct Time (PAGE 3-104)".

H: Hour

M: Minute

ADJ: Sets to 00 minutes

Tuning Button (TUNING)

Use this button (9) to change the frequency.

For further details, see "Method of Tuning (PAGE 3-103)"

Controls of Radio

Method of Setting with Preset Button

1. Press power switch (1) and display the frequency on display (7).
2. Use tuning button (9) to set to the desired frequency. There are two methods for tuning: auto tuning and manual tuning.
3. With the display (7) showing the desired frequency, keep the desired Preset button No pressed for at least 1.5 seconds. The reception sound will disappear, but when the presetting operation (saving to memory) is completed, the sound will appear again and the Preset No and frequency will be shown on the display to show that the presetting operation has been completed.

After completing the presetting, press Preset button (6) and release it within approx. 1.5 seconds. This will make it possible to receive the channel preset to that button. One channel each for AM and FM can be preset to each Preset button.

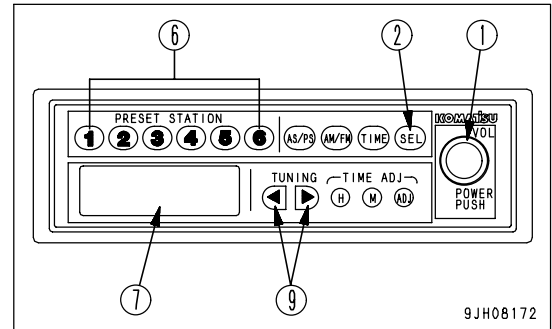

REMARK

It is also possible to save to the Preset button by using the auto store button.

Method of Tuning

1. Press power switch (1) and display the frequency on display (7).
2. Use tuning button (9) to set to the desired frequency. There are two methods for tuning: auto tuning and manual tuning.

- Manual tuning

Press tuning button (9) until the frequency is displayed on display (7).

< button: Frequency moves down

> button: Frequency moves up

When the frequency reaches the top or bottom frequency, it automatically continues as follows: Top → Bottom, or Bottom → Top.

- Auto tuning

Press tuning button (9) for at least 3 seconds. When a station is picked up, the tuning automatically stops. To search for the next station, press the tuning button again for at least 3 seconds.

< button: Frequency moves down

> button: Frequency moves up

If this button is pressed during auto tuning, the auto tuning will be cancelled and the setting will return to the frequency in use before the button was pressed.

Method of Operating Mode

- (BAS) Bass adjustment: When button (2) is pressed, BAS is displayed on display (7). If knob (1) is turned clockwise within 5 seconds, the bass sound is emphasized. If the knob is turned counterclockwise, the bass sound is reduced.
- (TRE) Treble adjustment: When button (2) pressed, TRE is displayed on display (7). If knob (1) is turned clockwise within 5 seconds, the treble sound is emphasized. If the knob is turned counterclockwise, the treble sound is reduced.
- (BAL) Balance adjustment: When button (2) is pressed, BAL is displayed on display (7). If knob (1) is turned clockwise within 5 seconds, the sound from the right speaker is increased. If the knob is turned counterclockwise, the sound from the left speaker is increased. When it is set to BAL 0, the sound from the left and right speakers is balanced.

REMARK

With each mode, the display is returned automatically to its original setting after 5 seconds.

Setting Correct Time

1. Press display selector button (4) to display the time.
After 5 seconds, the display will return to the frequency display and the time cannot be corrected. If this happens, press display selector button (4) again.
2. Press time adjustment button (8) to select Hour or Minute.
 - H button: Adjusts the hour (each time the button is pressed, the time advances by one hour)
 - M button: Adjusts the minute (each time the button is pressed, the time advances by one minute)
 - If the H or M button is kept pressed, the time will advance continuously until the button is released.
 - ADJ button: When the ADJ button is pressed, the time is reset as follows.
 - When display is 00 - 05 minutes, time is returned to 00 min. 00 sec. (No change in hour)
(10:05 → 10:00)
 - When display is 55 - 59 minutes, time is advanced to 00 min. 00 sec. (Hour advances)
(10:59 → 11:00)
 - When display is 06 - 54 minutes, time cannot be reset. (Time stays same)
(10:26 → 10:26)

Use the H, M, and ADJ buttons to set to the correct time.

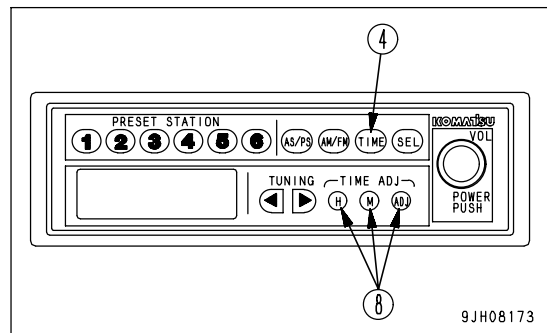

Antenna

Before transporting the machine putting it inside a building, stored the antenna to prevent any interference. Stow the antenna as follows.

1. Loosen antenna mounting bolt (1) and store the antenna at position (A).
2. Tighten bolt(1).

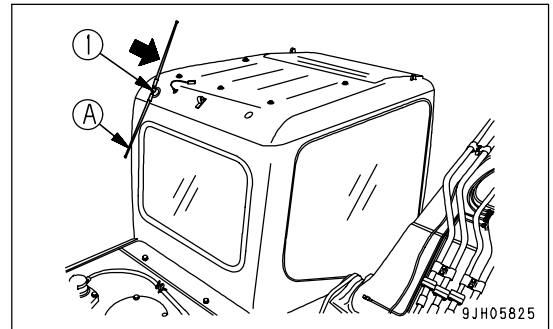
**Use Radio with Care**

- To ensure safety, always keep the sound to a level where it is possible to hear outside sounds during operation.
- If water gets into the speaker case or radio, it may lead to an unexpected failure, so be careful not to get water on the equipment.
- Do not wipe the scales or buttons with solvent such as benzene or thinner. Wipe with a dry soft cloth. If the dirt cannot be removed easily, soak the cloth with alcohol.
- When the battery is replaced, the settings for the preset buttons are all cleared, so set them again.

AUXILIARY ELECTRIC POWER

24V Power Source

NOTICE

**Do not use this as the power supply for 12V equipment.
It will cause failure of the equipment.**

Pull out the connector plug for taking out electric power from the rear side of the panel.

Maximum usable electric power is 85 W (24 V x 3.5 A).

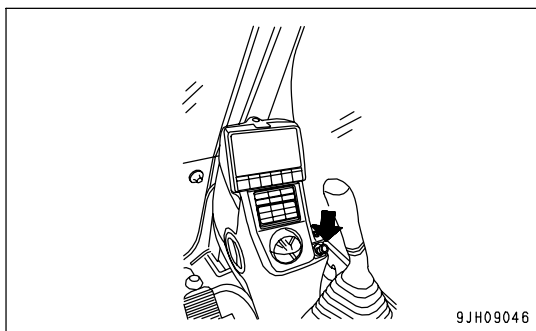

12V Power Source

(If equipped)

This power source can be used up to a capacity of 60W (12V x 5A).

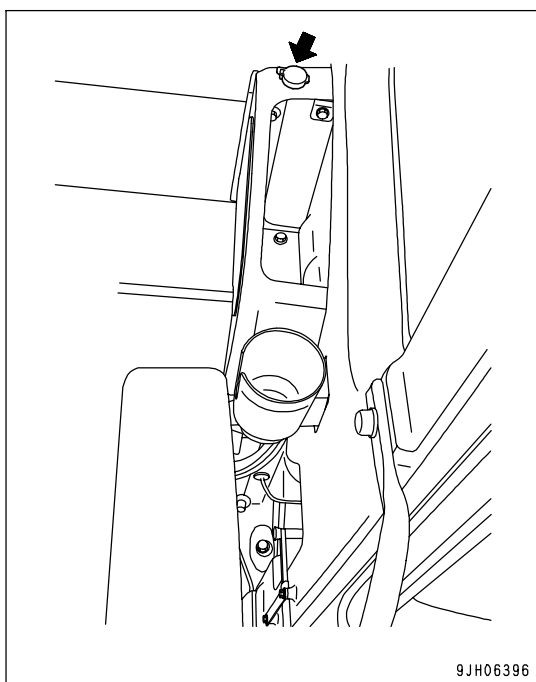

FUSE

NOTICE

Before replacing a fuse, be sure to turn off the starting switch.

- The fuse holder is at the rear right of the operator's seat.
- The fuses protect the electrical equipment and wiring from burning out.
- If the fuse becomes corroded, or white powder can be seen, or the fuse is loose in the fuse holder, replace the fuse.
- Replace the fuse with another of the same capacity.

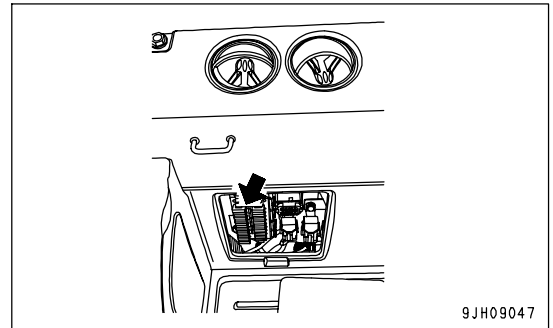

Fuse Capacities and Circuit Names

No.	Fuse capacity	Name of circuit
(1)	10A	Working lamp relay, hazard switch
(2)	30A	Electromagnetic valve
(3)	10A	PPC hydraulic lock solenoid
(4)	10A	Window washer, cigarette lighter
(5)	10A	Horn
(6)	10A	Auto pre heater
(7)	10A	Rotating lamp
(8)	20A	Working lamp, rear lamp
(9)	10A	Radio, speaker, left knob switch
(10)	20A	Spere
(11)	20A	Air conditioner unit
(12)	10A	Spere
(13)	10A	Headlamp
(14)	10A	Optional power source (1)
(15)	20A	Optional power source (2), travel alarm, 12V power port, heated air suspension seat
(16)	10A	Radio backup, room lamp
(17)	20A	Monitor (normal power source), stating switch, pomp controller
(18)	10A	Electric priming pump
(19)	30A	Engine controller
(20)	5A	Engine controller ACC

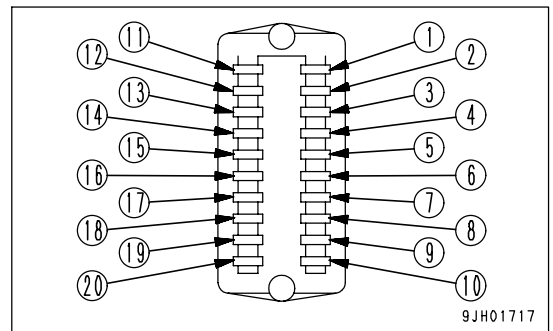

FUSIBLE LINK

If the starting motor does not turn when the starting switch is turned to the START position, there is probably a disconnection in fusible link (1) or (2). Open the battery box cover on the right side of the chassis, then check and replace the fusible link.

(1): Fusible link for 24V power supply

(2): Fusible link for 24V permanent power supply

Fusible link (2) is taped to the nearby wiring harness. When carrying out inspection or replacement, check the wiring harness number.

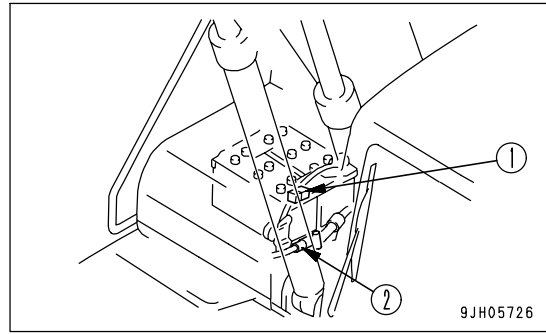

REMARK

A fusible link refers to the large-sized fuse wiring installed in the high current flow portion of the circuit to protect electrical components and wiring from burning, in the same way as an ordinary fuse.

CONTROLLER

Controller installed.

NOTICE

- Be careful not to get water, mud, or juice on the controller. This will cause failure.
- The engine controller has been given moisture prevention treatment, so there is no problem if rain gets on it, but do not spray it with water when washing the machine.
- If any abnormality occurs in the controller, do not disassemble it yourself. Contact your Komatsu distributor for repairs.

- Engine controller
Open the front engine hood. It is under the fuel pre-filter.

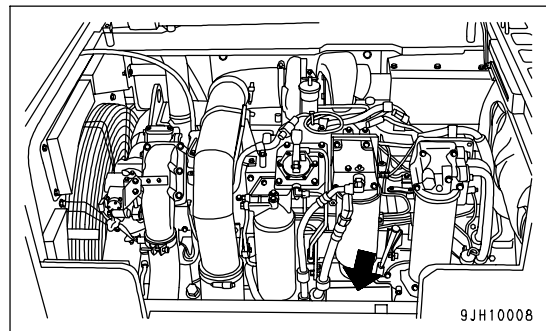

- Pump controller
This is on the right side at the rear of the operator's seat.

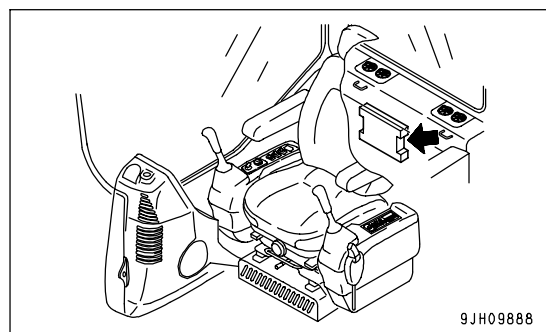

TOOL BOX

Store the tools in this box.

This is inside of the battery box cover on the right side of the machine.

NOTICE

When putting large objects in the toolbox, make sure that they do not contact the battery. This may cause damage to the battery.

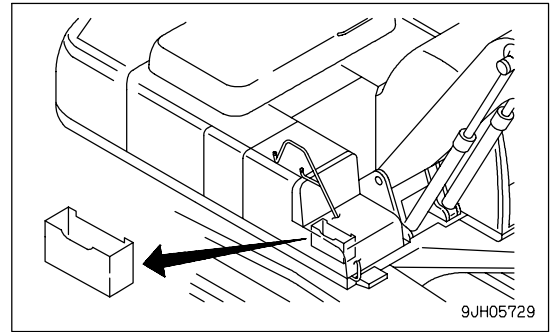

GREASE PUMP HOLDER

This is inside the door at the rear right of the machine. When not using the grease gun, fit it in this holder.

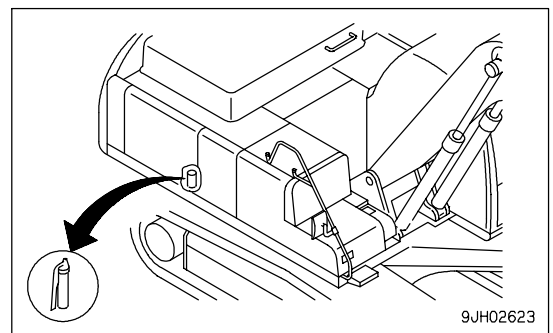

FIRE EXTINGUISHER

(If equipped)

A fire extinguisher is prepared at the rear part inside the operator's cab.

The directions are described on the nameplate affixed to it. Just in case, carefully read and grasp them beforehand.

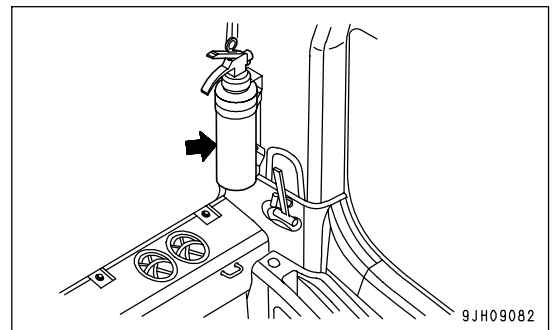

MACHINE OPERATIONS AND CONTROLS

BEFORE STARTING ENGINE

Walk-around Checks

Before starting the engine, walk around the machine and look at the underside of chassis for anything unusual like loose bolts and nuts, leakage of fuel, oil and coolant. Also check the condition of the work equipment and the hydraulic system.

Also check for loose wiring, play, and collection of dust at places that reach high temperature.



WARNING

Remove any flammable materials from around the battery, engine, muffler, turbocharger, or other high temperature engine parts. Leakage of fuel or oil will cause the machine to catch fire. Check carefully, be sure to repair any problem, or contact your Komatsu distributor.

Perform the following inspections and cleaning every day before starting engine for the day's work.

1. Check for damage, wear, play in work equipment, cylinders, linkage, hoses
Check for cracks, excessive wear, play in work equipment, cylinders, linkage, and hoses. If any problem is found, repair it.
2. Remove dirt and debris from around the engine, battery, and radiator.
Check for dirt accumulated around the engine and radiator. Also check for flammable material (dry leaves, twigs, etc.) around the battery, engine muffler, turbocharger, or other high temperature engine parts. If any dirt or flammable materials are found, remove them.
For the method of removing dirt from the radiator, see "CLEAN AND INSPECT RADIATOR FINS, OIL COOLER FINS, AFTERCOOLER FINS AND CONDENSER FINS (PAGE 4-62)".
3. Check for coolant and oil leakage around the engine
Check for oil leakage from the engine and coolant leaks from the cooling system. If any problem is found, repair it.
4. Check for oil leakage from hydraulic equipment, hydraulic tank, hoses, and joints
Check for oil leakage. If any problem is found, repair the area where oil is leaking.
5. Check the undercarriage (track, sprocket, idler, guard) for damage, wear, loose bolts, or leakage of oil from rollers.
If any problem is found, repair it.
6. Check for problems in handrails, steps, loose bolts.
If any problem is found, repair it. Tighten any loose bolts.
7. Check for problem in gauges, monitor.
Check for problem in the gauges and monitor in the operator's cab. If any problem is found, replace the parts.
Clean off any dirt from the surface.
8. Clean, check rear view mirror
Check that there is no damage to the rear view mirror. If it is damaged repair. Clean the surface of the mirror and adjust the angle so that the area at the rear can be seen from the operator's seat.

9. Seat belt and mounting clamps
Check for damage or wear to the seat belt and mounting clamps. If there is any damage, replace with new parts.
10. Check bucket with hook (if equipped) for damage.
Check for damage to the hook, guide, and hook mount. If any problem is found, contact your Komatsu distributor for repairs.
11. Check, clean rear-view monitor
Check that there is no problem with the rear-view monitor. If any problem is found, contact your Komatsu distributor and ask for repairs to be carried out.

Checks Before Starting

Always check the items in this section before starting the engine each day.

Drain Water And Sediment from Fuel Tank

1. Set a container under the drain hose to catch the drained fuel.
2. Turn drain valve (1) to the OPEN (O) position and drain all the sediment and water accumulated at the bottom together with the fuel.
3. When clean fuel comes out, turn drain valve (1) to the CLOSE (S) position.

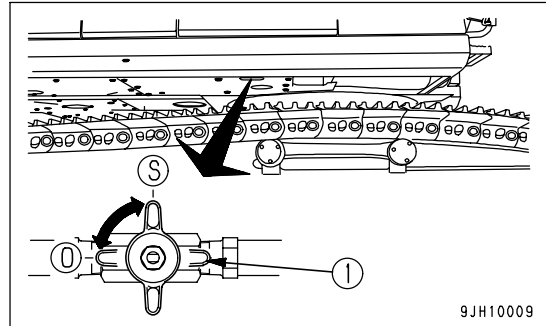

Check Oil Level in Hydraulic Tank, Add Oil

! WARNING

- The parts and oil are at high temperature immediately after the engine is stopped, and may cause burns. Wait for the temperature to go down before starting the work.
- When removing the oil filler cap, turn it slowly to release the internal pressure, then remove it.

1. Set the work equipment in the posture shown in the diagram on the right, then check the oil level and add oil if necessary.
2. If the work equipment is not in the condition shown in the diagram on the right, start the engine, run the engine at low speed, retract the arm and bucket cylinder rods fully, then lower the boom, set the bucket teeth in contact with the ground, and stop the engine.
3. Within 15 seconds after stopping the engine, move each control lever (for work equipment and travel) to the full stroke in all directions to release the internal pressure.
4. Check sight gauge (G). The oil level should be between the H and L marks.
5. If the level is below the L mark, add oil through oil filler (F) at the top of the hydraulic tank.

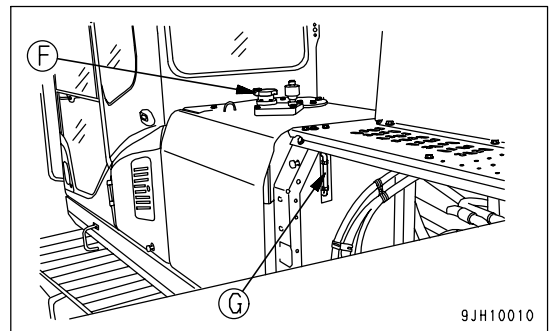
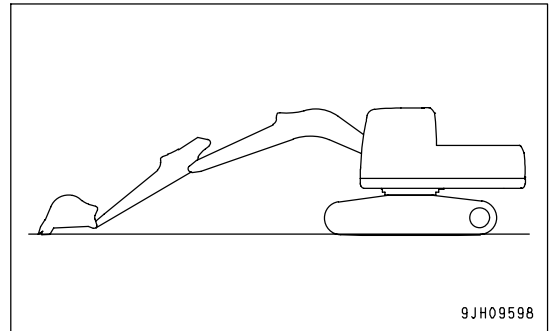

REMARK

The oil level will vary depending upon the oil temperature. Accordingly, use the following as a guide:

- Before starting operation: Between H and L levels (Oil temperature 10 to 30°C (50 to 86°F))
- Normal operation: Around H level (Oil temperature 50 to 80°C (122 to 176°F))

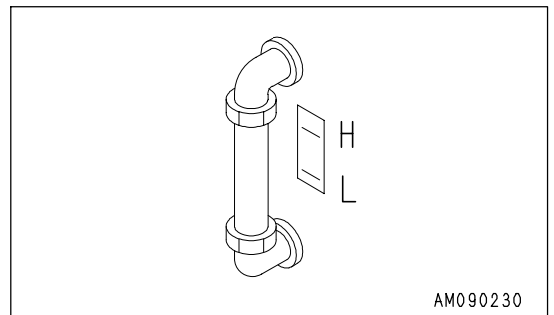

NOTICE

Do not add oil above the H line. This will damage the hydraulic circuit or cause the oil to spurt out.

If oil has been refilled, exceeding the H level, swing the upper structure until drain plug (P) beneath the hydraulic tank comes between the right and left track shoes and stop the engine. Wait for the oil to cool down sufficiently, then remove cover (1) and drain the excess oil through drain plug (P).

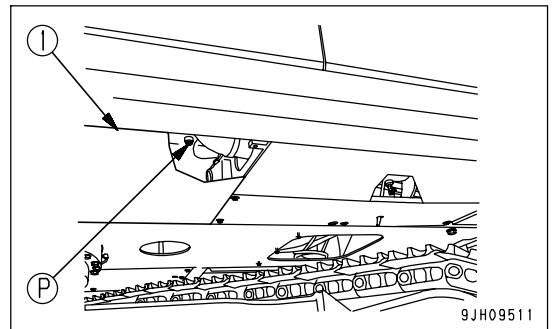

Check Oil Level in Engine Oil Pan, Add Oil

**WARNING**

Parts and oil are at high temperature immediately after the engine is stopped and may cause serious burns. Wait for the oil temperature to go down before performing this operation.

1. Open the front engine hood.
2. Remove dipstick (G), and wipe the oil off with a cloth.
3. Fully insert dipstick (G) into filler pipe, then remove it.

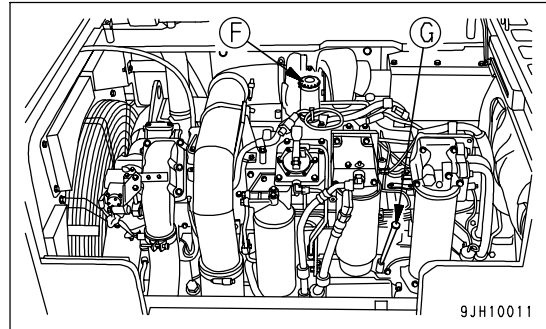

4. The oil level should be between the H and L marks on dipstick (G).
If the oil level is below the L mark, add oil through oil filler port (F).

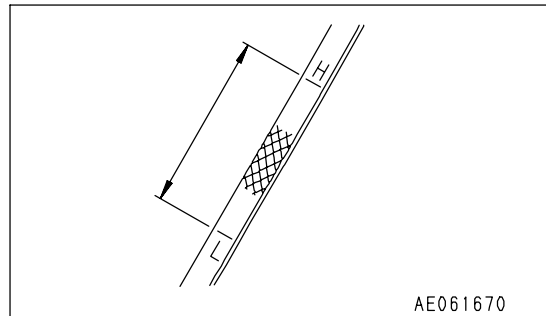

5. If the oil is above the H mark on the gauge, remove cover (1), drain the excess oil from drain valve (P) at the bottom of the engine oil pan, then check the oil level again.
6. If oil level is correct, securely tighten the oil filler cap and close the engine hood.

REMARK

When checking the oil level after the engine has been operated, wait for at least 15 minutes after stopping the engine before checking.

If the machine is at an angle, make it horizontal before checking.

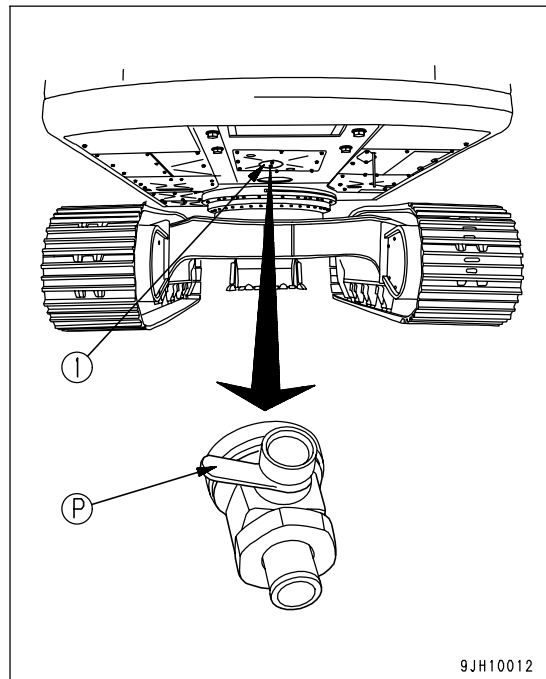

Check for Water and Sediment in Water Separator, Drain Water

1. Open the front engine hood.
2. The water separator forms one unit with fuel pre-filter (1).

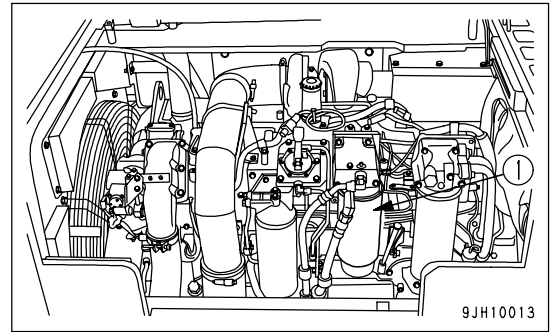

3. It is possible to judge the water level and amount of sediment by looking through transparent cap (2). If there is any water or sediment collected at the bottom, set a container to catch the drain water under drain hose (3).
4. Loosen drain valve (4) and drain the water.
5. When fuel starts to drain from drain hose (3), tighten drain valve (4) immediately.
Tightening torque: 0.2 to 0.45 Nm (0.02 to 0.046 kgm, 0.1 to 0.3 lbft)

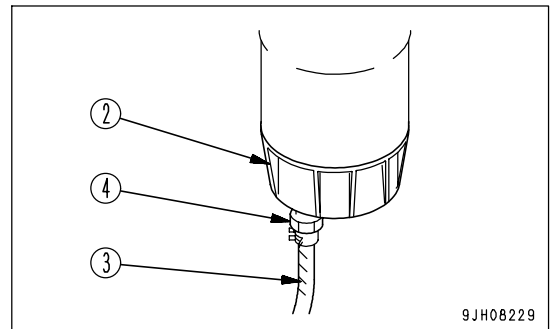

Check Coolant Level, Add Coolant

WARNING

- Do not open the radiator cap unless necessary. When checking the coolant, always wait for the engine to cool down and check the sub tank.
- Immediately after the engine is stopped, the coolant is at a high temperature and the radiator is under high internal pressure. If the cap is removed to check the coolant level in this condition, there is a hazard of burns. Wait for the temperature to go down, then turn the cap slowly to release the pressure and remove it carefully.

1. Open the rear engine hood and check that the cooling water level is between the FULL and LOW marks on the sub-tank (1). If the water level is low, add water through the water filler of sub-tank (1) to the FULL level.
2. After adding coolant, tighten the cap securely.
3. If the sub-tank becomes empty, there is probably water leakage. After checking, repair any abnormality immediately. If no abnormality is found, check the level of the water in the radiator. If it is low, add Supercoolant (AF-NAC) of the same density as the Supercoolant in the radiator, then add Supercoolant to the sub-tank.

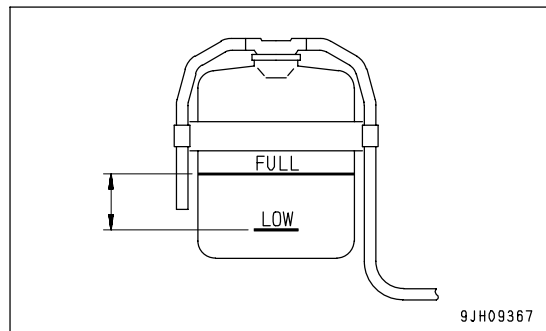
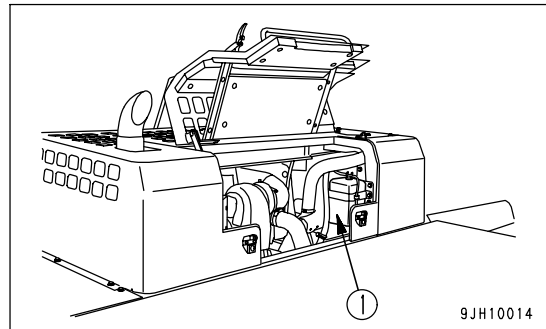

Check Electric Wiring

CAUTION

- If fuses are frequently blown or if there are traces of short-circuiting on the electrical wiring, promptly ask your Komatsu distributor to locate the cause and make the repair.
- Keep the top surface of the battery clean and check the breather hole in the battery cap. If it is clogged with dirt or dust, wash the battery cap to clear the breather hole.

Check that there is no damage to the fuses; that fuses of the specified capacity are used; that there is no disconnection or trace of short-circuiting in the electric wiring and no damage to the covering. Check also that there is no loosened terminals. If any, tighten them.

Moreover, pay particular attention to the electric wiring when checking the battery, engine starting motor and alternator.

Be sure to check that there is no inflammable material accumulated around the battery. If any is found, remove immediately.

Check Fuel Level, Add Fuel

WARNING

When adding fuel, never spill the fuel or let it overflow. It will cause fire.
 If any fuel has spilled, wipe it up completely. If fuel has spilled over soil or sand, remove that soil or sand.
 Fuel is highly flammable and dangerous. Never bring flames near fuel.

1. Turn the engine starting switch to the ON position and check the fuel level gauge (1) on the monitor panel for fuel level. After checking, turn the switch back to the OFF position.

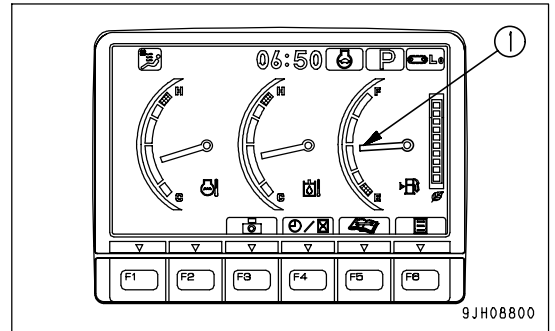

2. If fuel is found to be low, unscrew fuel filler cap (F) on the fuel tank and add fuel through the filler port until float gauge (G) comes up to the highest point.

Fuel tank capacity: 650 liters (171.73 US gal)

Position of tip (a) of float gauge (G) when fuel tank is full:
 Approx 50 mm (2 in)

3. After adding fuel, push float gauge (G) straight down with fuel filler cap (F). Be careful not to get float gauge (G) caught in the tab of fuel filler cap (F), and tighten fuel filler cap (F) securely.

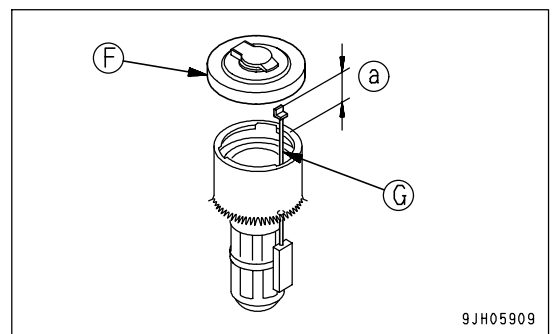
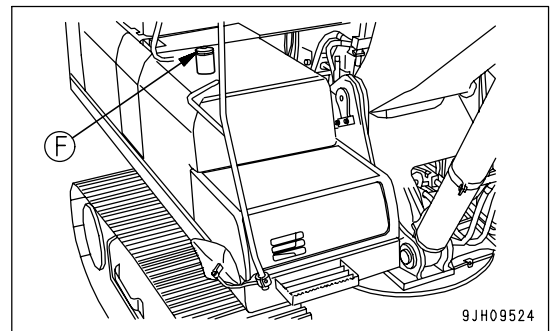

REMARK

If breather hole (3) on the cap is clogged, the pressure in the tank will drop and fuel will not flow. Clean the hole from time to time.

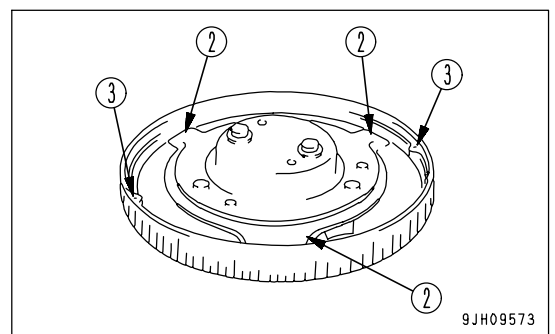

Check Working Lamp Switch

Check that the working lamps and lamps inside the instruments light up properly. Check also that there is no dirt or damage.

If any lamp does not light up, the bulb is probably blown up or there is a disconnection, so ask your Komatsu distributor to carry out repairs.

1. Turn the starting switch to the ON position.
2. Turn the lamp switch ON (night mode (a), and day mode (b)) and check that the working lamp lights up.

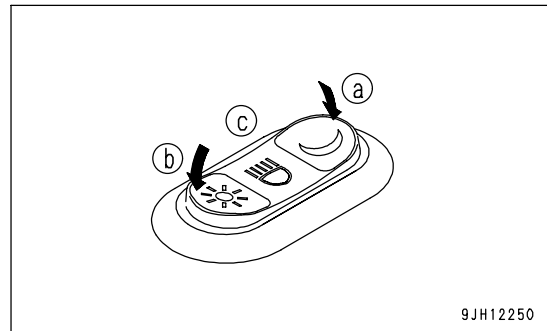
**Check Function of Horn**

1. Turn the starting switch to the ON position.
2. Confirm that the horn sounds immediately when the horn button is pressed.

If the horn does not sound, contact your Komatsu distributor for repair.

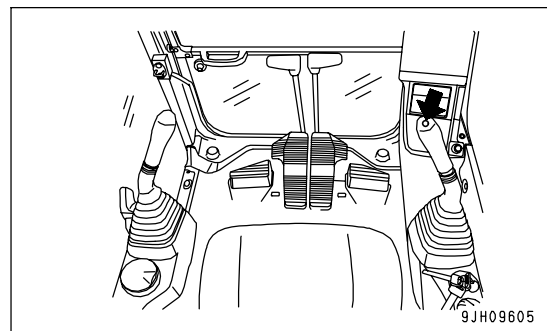

Adjustment

Seat Adjustment



WARNING

When adjusting the position of the operator's seat, always set the lock lever to the LOCK position to prevent any accidental contact with the control levers.

- Always adjust the operator's seat before starting each operation or when the operators change shift.
- Adjust the operator's seat so control levers and switches can be operated freely and easily with the operator's back against the backrest.

(A) Fore-and-aft adjustment

Pull lever (1) up, set the seat to the desired position, then release the lever.

Fore-and-aft adjustment: 160 mm (6.3 in) (16 stages)

(B) Adjusting reclining

REMARK

The seat can be reclined more when the seat is pushed to the front. The amount of reclining decreases as the seat is pushed back, so when moving the seat back, return the seatback to the upright position.

Pull up lever (2) and set the backrest to a position that is comfortable for operation, then release the lever.

Sit with your back against the seat backrest when adjusting. If your back is not against the backrest, the backrest may suddenly move forward.

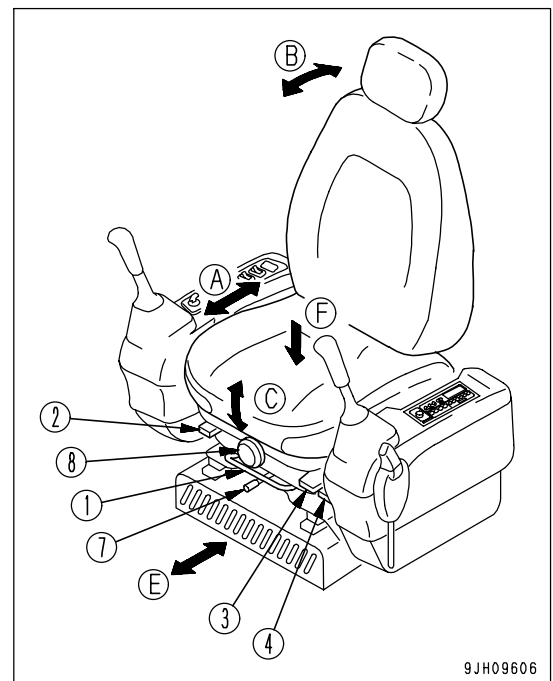

9JH09606

(C) Adjusting seat tilt

- Forward tilt

Push lever (3) down to adjust angle of the front of seat. (4 stages)

- To raise the angle at front of the seat, keep the lever pushed down and apply your weight to the rear of seat.
- To lower the angle at front of the seat, keep the lever pushed down and apply your weight to the front of seat.

- Rear tilt

Pull lever (4) up to adjust angle of the rear of seat. (4 stages)

- To raise the angle at rear of the seat, keep lever (3) pulled up, and stand up slightly to remove your weight from the seat.
- To lower the angle at rear of the seat, keep lever (3) pulled up, and apply your weight to the seat.

Amount of tilt: Up 13°, down 13°

- Adjusting seat height

It is possible to move the seat up or down by combining adjustments forward tilt and rear tilt.

After setting the forward tilt or rear tilt to the desired height, operate the opposite part to set the seat horizontal then secure in position.

Height adjustment: 60 mm (2.4 in)

(D) Adjusting armrest height

The height of armrest (5) can be adjusted up or down by changing the position of adjustment bolt (6) at the rear of the armrest.

Armrest height adjustment: 33 mm (1.3 in)

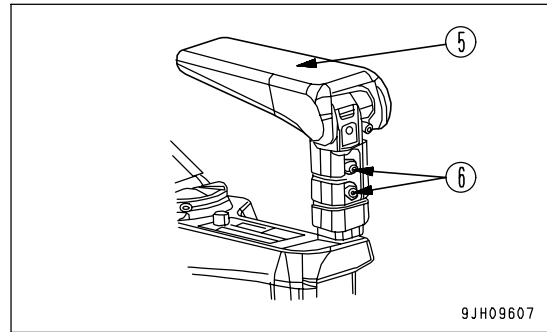
**(E) Overall fore-and-aft adjustment of seat**

Move lever (7) to right, set to the desired position, then release the lever. In this case, the operator's seat, left and right control levers, and lock lever all slide together.

Fore-and-aft adjustment: 180 mm (7.1 in) (9 stages)

(F) Adjusting suspension

Turn knob (8) to the right to make the suspension harder, or to the left to make the suspension softer. Adjust the reading of the dial to match the operator's weight and select the optimum suspension.

REMARK

To obtain the optimum adjustment, turn the knob (8) so that the indicator of the weight display (kg) in the transparent portion of knob (8) is the same as the operator's weight.

(G) Adjusting suspension

(air suspension seat (if equipped))

Push switch (9) to make the suspension harder.

Pull switch (9) to release the air and make the suspension softer.

(The sound of air being released can be heard.)

Range of adjustment for operator's weight: 60-150 kg

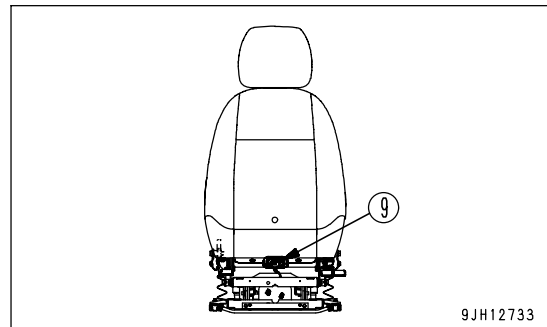
**(H) Heated seat**

Turn the heated seat switch ON to warm the seat cushion and the seat back.

Rearview Mirrors

! WARNING

- Be sure to adjust the mirrors before starting work. If they are not adjusted properly, you cannot secure the visibility and may be injured or may injure someone seriously.
- When adjusting the angle of the mirror over the counterweight, provide a secure scaffold using a step ladder and then carry out the work. Do not do the work standing on the counterweight, as there is always the danger of a serious injury due to falling-off from the machine.

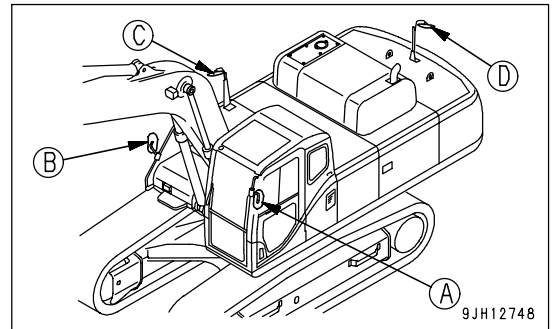

Mirror (A)

Adjust the mirror mount so that it is possible to see people at the rear left of the machine.

- Install the side view mirror in the location indicated in the figure at right.
- (L): 60 mm (2.4 in)
- Fix mirror securing stay (1) the way the side view mirror stretches outward to the maximum.
- If the side view mirror does not move smoothly when adjusting its angle, loosen mirror securing bolt (2) and mirror securing stay bolt (3).

Tightening torque of bolt (2): 7.85 - 9.81 Nm
(0.8 - 1.0 kgm, 5.8 - 7.2 lbft)

- When adjusting the side view mirror angle, make an adjustment so that the side of the machine comes into view on the mirror as shown in the figure at right.

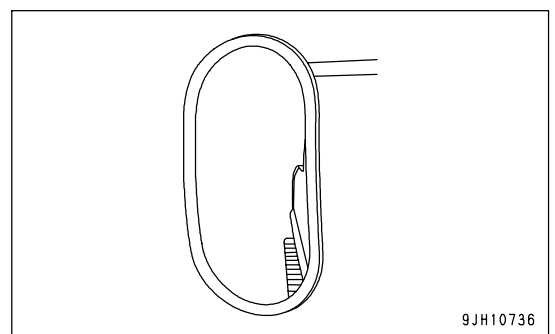
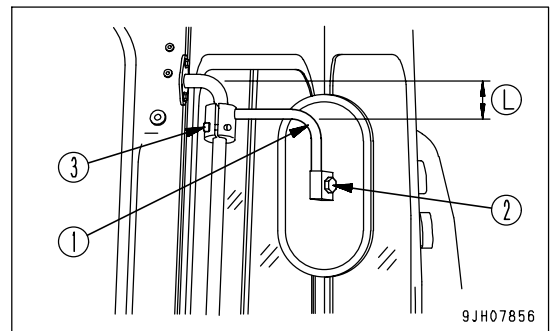

Mirror (B)

Adjust the mirror mount so that it is possible to see people at the rear right of the machine.

- Install the side view mirror in the location indicated in the figure at right.
- If the side view mirror does not move smoothly when adjusting its angle, loosen mirror securing screw (4) and mirror securing stay bolt (5).

(M): 40 mm (1.6 in)

Tightening torque of screw (4): 1.96 - 2.94 Nm

(0.2 - 0.3 kgm, 1.4 - 2.2 lbft)

- When adjusting the side view mirror angle, make an adjustment so that the side of the machine comes into view on the mirror as shown in the figure at right.

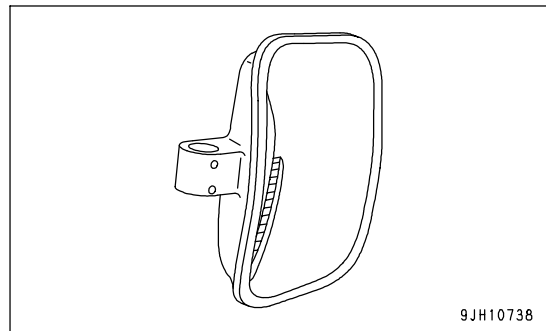
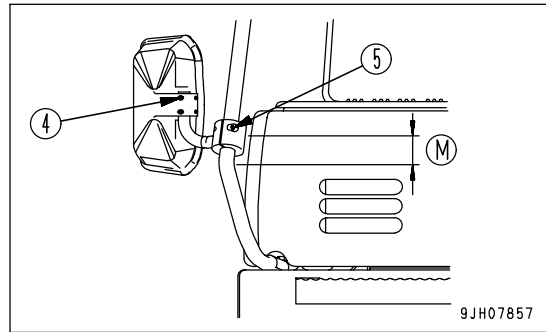

Mirrors (C), (D)

(If equipped)

Adjust the side view mirrors so that people around 1 m away from the machine can be seen.

(W): 1 m (3 ft 3 in)

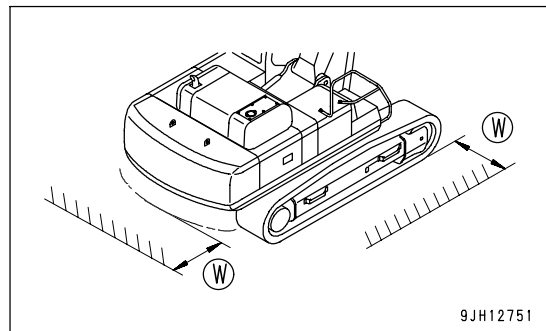

- If side view mirror (C), (D) does not move smoothly when adjusting its angle, loosen mirror securing screw (6).

Tightening torque of screw (6): 3.1 - 3.5 Nm

(0.31 - 0.35 kgm , 2.2 - 2.6 lbft)

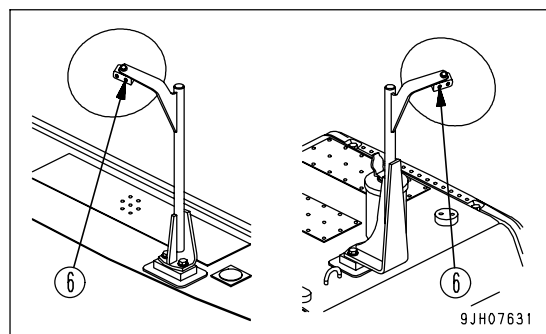

- When installing mirrors (C) and (D), make sure to leave clearance (V) to prevent contact between the mirror and mirror stay.
(V): Min. 10 mm (0.4 in)

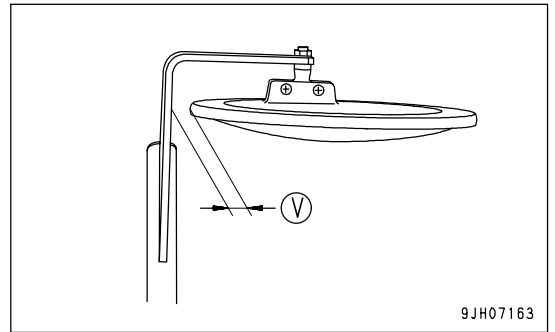

Adjusting Angle of Rear View Camera

WARNING

- Be sure to adjust the camerae before starting work. If they are not adjusted properly, you cannot secure the visibility and may be injured or may injure someone seriously.
- When adjusting the angle of the camera over the counterweight, provide a secure scaffold using a step ladder and then carry out the work. Do not do the work standing on the counterweight, as there is always the danger of a serious injury due to falling-off from the machine.

If the image on the monitor is not aligned correctly, remove cover (1) and adjust the mounting angle (A) of the rear view camera. Amount of adjustment of angle (A): Within a range of 35°-80°

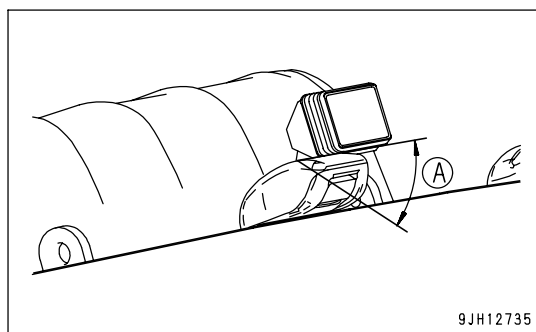
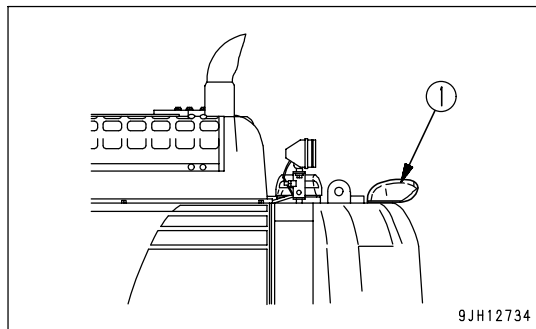

1. When removing cover (1), insert a flat-headed screwdriver into the hole of cover (2), push the tooth on the inside, and remove the cover.
2. Remove 2 bolts (3).
3. Remove cover (1).

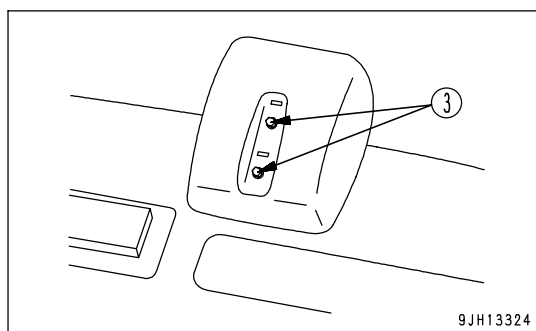
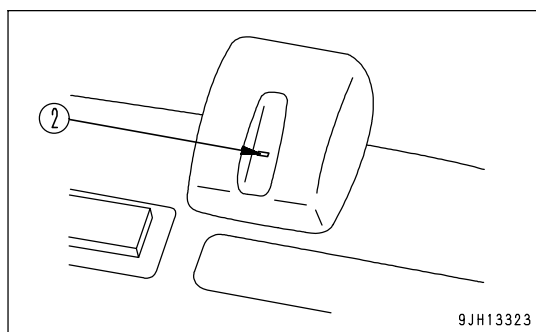

- Loosen mounting bolt (4) of the camera and adjust mounting angle (A) of the camera so that the center line of mounting bolt (4) is aligned with fourth-from-bottom scale (B).

REMARK

Part of the machine is shown on the monitor screen.

- After adjusting, tighten bolt (4).

Tightening torque: 3-5 Nm (0.3-0.5 kgm, 2.2-3.6 lbft)

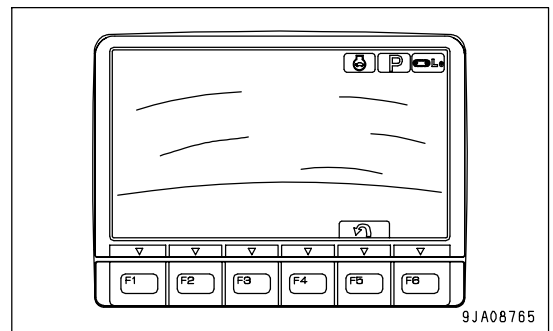
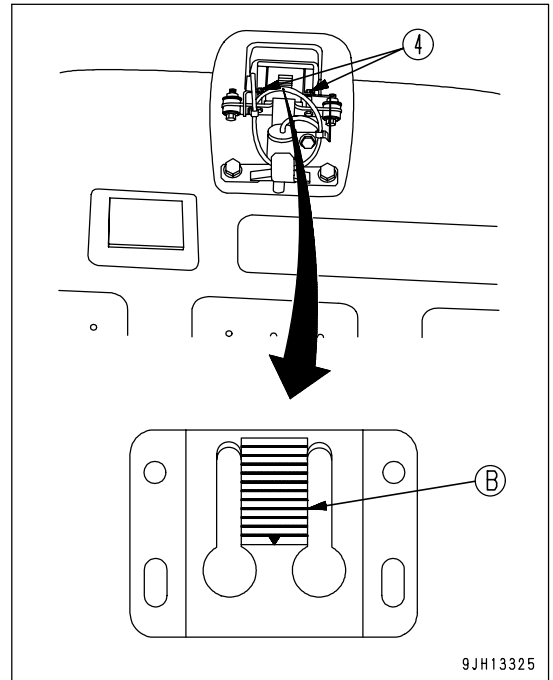

- Install covers (1) and (2).

Seat Belt



WARNING

- Before fitting the seat belt, check that there is no problem in the belt mount bracket or mounting belt. If it is worn or damaged, replace the seat belt.
- Even if no problem can be seen in the belt, replace the seat belt every 3 years. The date of manufacture of the belt is shown on the back of the belt.
- Always wear the seat belt during operations.
- Fit the seat belt so that it is not twisted.

Fastening and Removing

This seat belt has a wind-in device, so it is not necessary to adjust the length.

Fastening Seat Belt

Hold grip (2) and pull the belt out from wind-in device (1), check that the belt is not twisted, then insert tongue (3) into buckle (4) securely.

When doing this, pull the belt lightly to check that it is properly locked.

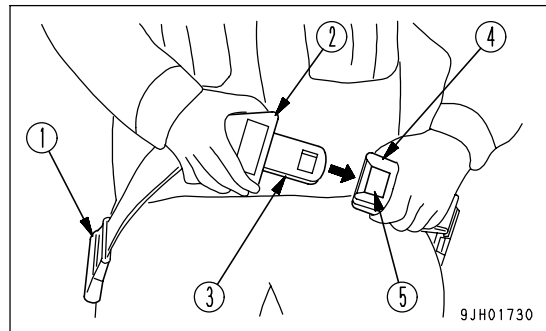

Removing Belt

Press button (5) in buckle (4), and remove tongue (3) from buckle (4).

The belt is automatically wound in, hold grip (2) and return the belt slowly to wind-in device (1).

Operations Before Starting Engine

WARNING

When starting the engine, check that the lock lever is securely at the LOCK position. If the lock lever is not locked securely and the control levers or control pedal are touched when the engine is started, the machine may move unexpectedly, and this may lead to serious personal injury.

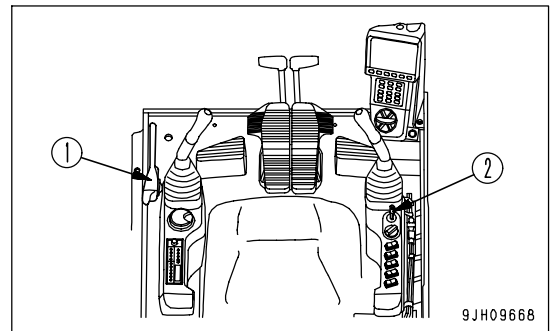

1. Check that lock lever (1) is at the LOCK position (L).
2. Check that each control lever and control pedal is at the Neutral position.
If the control levers and control pedal are not being touched, they will be at the Neutral position.

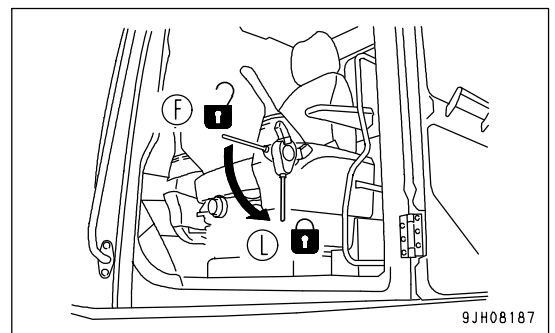

3. Insert the key in starting switch (2), turn the key to the ON position (B), then carry out the following checks.

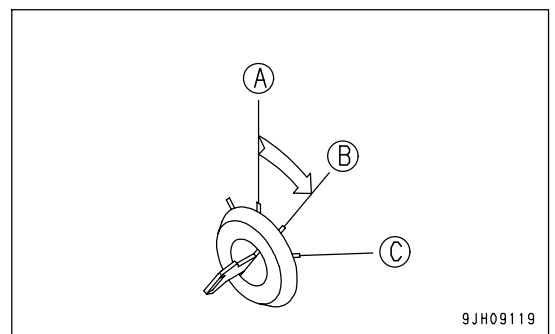

- If a password has been set, the input display screen will be displayed on the monitor screen.
After inputting the password, press Enter switch F6 (3).

REMARK

Contact your Komatsu distributor for details of the method of setting, changing, or cancelling the password.

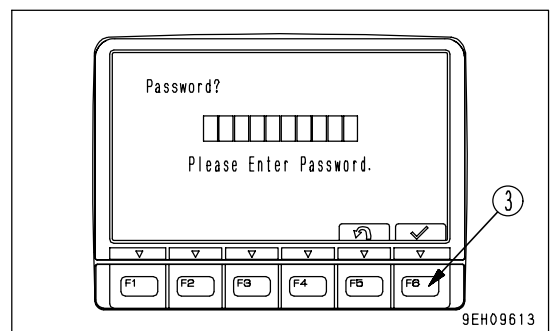

1) The buzzer sounds for approx. 2 seconds, then the monitor or meter lights up for approx. 2 seconds.

- Radiator coolant level monitor (4)
- Charge level monitor (5)
- Engine oil pressure monitor (6)
- Engine oil level monitor (7)
- Air cleaner clogging monitor (8)
- Engine coolant temperature gauge (9)
- Engine coolant temperature monitor (10)
- Fuel gauge (11)
- Fuel level monitor (12)

If any monitor does not light up or the buzzer does not sound, there is probably a failure in the monitor, so please contact your Komatsu distributor for repairs.

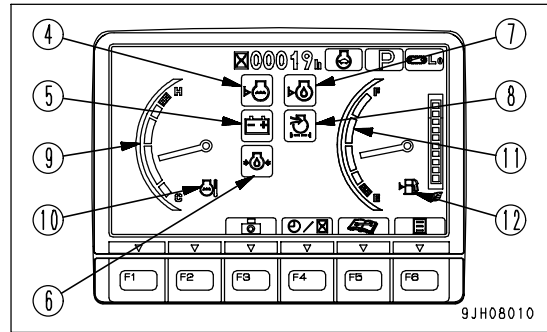

2) After approx. 2 seconds, the screen will change to the working mode/travel speed display monitor. Next, it will switch to the standard screen.

- Engine coolant temperature gauge (9)
- Engine coolant temperature monitor (10)
- Fuel gauge (11)
- Fuel level monitor (12)
- Hydraulic oil temperature gauge (13)
- Hydraulic oil temperature monitor (14)

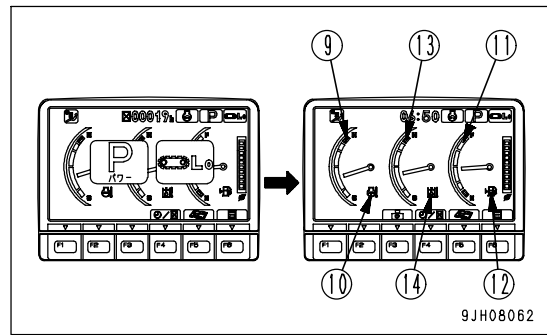

3) If the hydraulic oil temperature gauge goes out and caution lamp (15) stays lighted up red, perform inspection immediately for the item which is lighted up red.

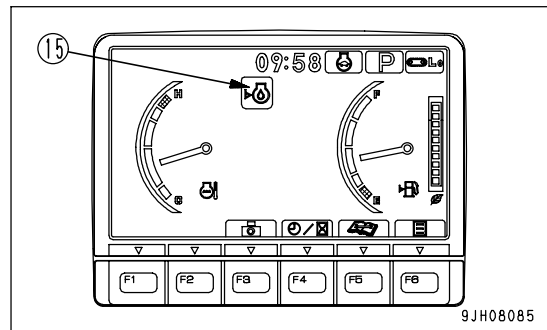

4) If the maintenance interval has passed, maintenance interval monitor (16) lights up for 30 seconds. Press maintenance switch F5 (17), check the item, and carry out maintenance immediately.

For details of the method of checking the maintenance interval, see "Maintenance Selector Switch (PAGE 3-41)" in the explanation for each component.

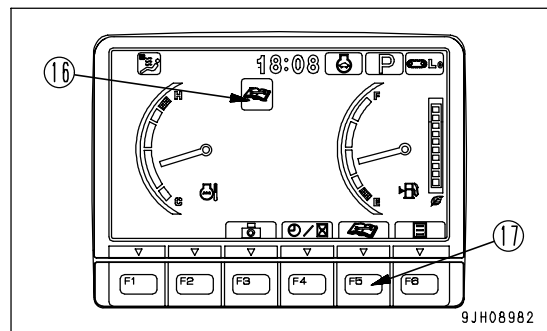

STARTING ENGINE

**WARNING**

- Start the engine only after sitting down in the operator's seat.
- Do not attempt to start the engine by short-circuiting the engine starting circuit. Such an act may cause a serious bodily injury or fire.
- Check that there are no persons or obstacles in the surrounding area, then sound the horn and start the engine.
- Never use starting aid fluids as they may cause explosions.
- Exhaust gas is toxic. When starting the engine in confined spaces, be particularly careful to ensure good ventilation.

NOTICE

- Before starting the engine, check that fuel control dial (2) is at the low idling (MIN) position. If the fuel control dial is at the full speed (MAX) position, the engine will accelerate suddenly and cause damage to the engine parts.
- Do not keep the key in starting switch (3) at the START position continuously for more than 20 seconds.
If the engine does not start, wait for at least 2 minutes, then start again from the beginning.
- After the engine starts, wait for the engine oil pressure monitor to go out. Do not touch the control levers or control pedal while the engine oil pressure monitor is lighted up.

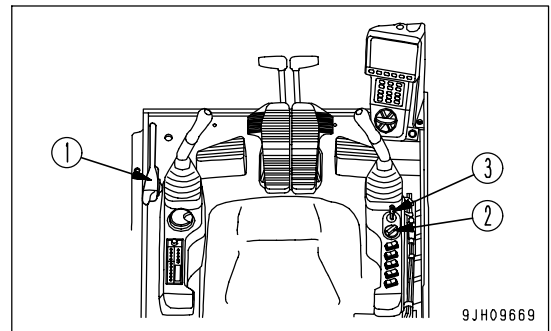

This machine is equipped with an engine automatic preheating device that functions to start the engine preheating automatically.

If the ambient temperature is low, the preheating monitor will light up when the key in starting switch (3) is turned to the ON position to inform the operator that preheating has been started automatically.

1. Check the lock lever (1) is in the LOCK position (L). If the lock lever is in the FREE position (F), the engine does not start.

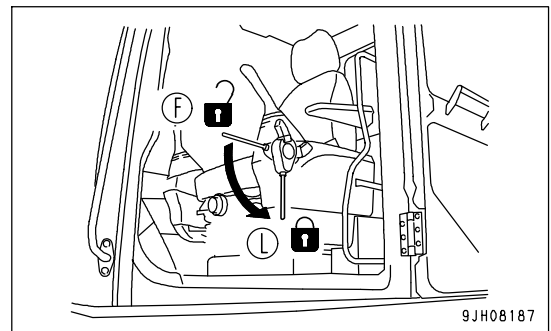

2. Set fuel control dial (2) to the low idling (MIN) position.

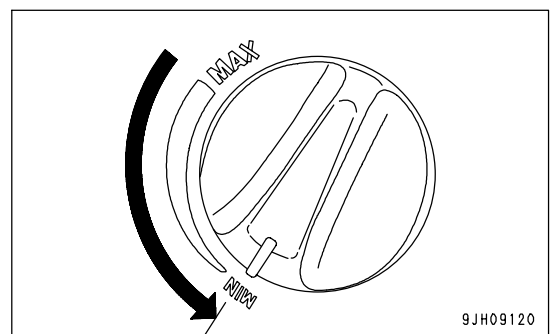

3. Turn the key in starting switch (3) to ON position (B).

If the ambient temperature is low, the preheating monitor lights up and automatic preheating is carried out. Keep the key in starting switch (3) at the ON position (B) until the preheating monitor goes out.

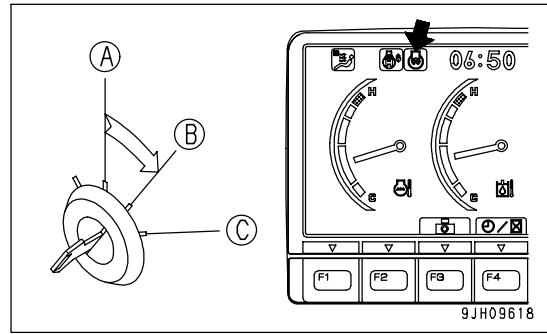

The time that the preheating monitor stays lighted up depends on the ambient temperature as shown in the table on the right.

Ambient temperature	Lighting time
-4 °C to -20 °C (24.8 °F to -4.0 °F)	5 seconds to 40 seconds
-20.0 °C (4.0 °F) or less	40 seconds

4. If the preheating monitor does not light up, or it lights up and then goes out to inform that the engine preheating has been completed, turn the key in starting switch (3) to the START position (C) and start the engine.

REMARK

If the ambient temperature is low, the engine may not start even when the key in the starting switch (3) is kept at the START position for 20 seconds. If this happens, wait for at least 2 minutes, then start again from the beginning.

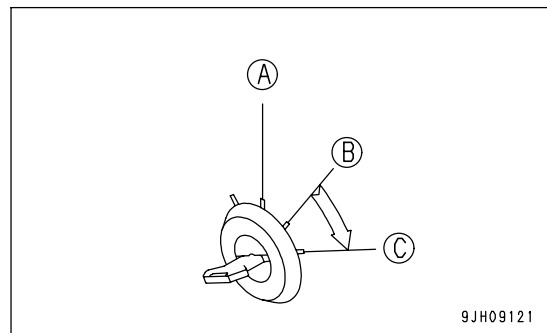

5. After the engine starts, release the key in starting switch (3). The key will automatically return to the ON position (B).

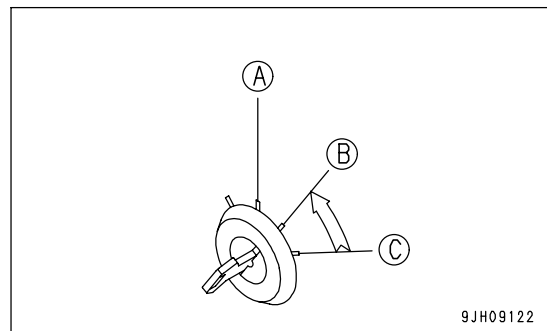

6. Even if the engine starts, wait for the engine oil pressure monitor to go out. Do not touch the control levers or control pedal while the engine oil pressure monitor is lighted up.

NOTICE

If the engine oil pressure monitor does not go out even after 4 to 5 seconds have passed, stop the engine immediately. Check the oil level, check for leakage of oil, and take the necessary action.

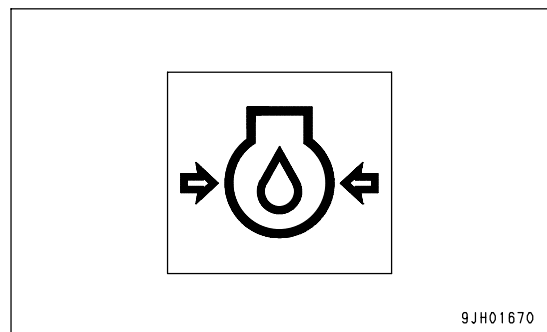

REMARK

Regardless of the ambient temperature, it is possible to start the engine preheating manually.

1. Turn the key in starting switch (3) to the left from OFF position (A). The preheating monitor lights up and engine preheating starts.
(Preheating continues while the key in starting switch (3) is held at the left position.)
2. The preheating monitor starts lighting about 30 seconds after preheating starts and then goes off in about 10 seconds.
3. After the preheating monitor goes off, turn the key in starting switch (3) to START position (C). The engine will start.

If the engine cannot be started with the above procedure, wait for at least two minutes, then start again from Step 1.

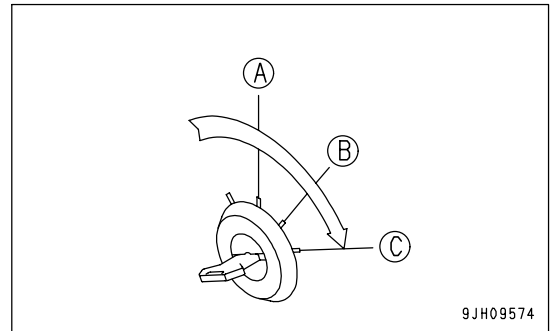
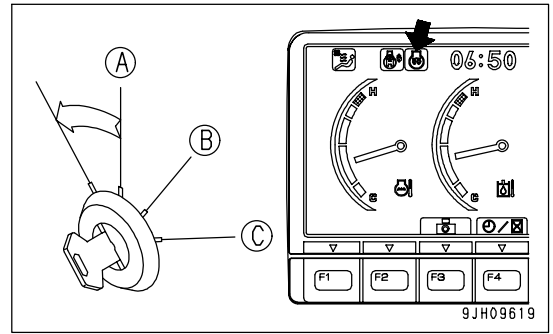

Turbo protect function

The turbo protect function is a function to protect the turbocharger by keeping the engine speed at less than 1000 rpm immediately after the engine is started.

- When the turbo protect function is actuated, the engine speed is held at less than 1000 rpm, regardless of the position of the fuel control dial.
- When the turbo protect function is actuated, the engine speed is held at less than 1000 rpm, even if the fuel control dial is operated.
- When the turbo protect function is canceled, the engine speed is set to the speed for the position of the fuel control dial.
- The relationship between the length of time of actuating the turbo protect function and the temperature of the engine coolant is as shown in the table.

Coolant temperature	Turbo protect time (sec.)
Above 10°C (50°F)	0
10 to -10°C (50 to -14°F)	Change 0 to 20
below -10°C (14°F)	20

AFTER STARTING ENGINE

**WARNING**

- To stop the engine in emergencies or when the actuation of the engine is abnormal or there is any other trouble, turn the key in the starting switch to the OFF position.
- Do not carry out operations or operate the levers or pedal suddenly while the hydraulic oil is at low temperature. Always carry out the warm-up operation for the hydraulic equipment until the hydraulic oil temperature monitor displays the correct temperature.

(When the hydraulic oil temperature is low, the low temperature display shown on the right is given.)

(A) Display when temperature is correct: Monitor background (C) is blue

(B) Display when temperature is low: Monitor background (C) is white

- If the warm-up operation for the hydraulic equipment is not carried out thoroughly, and the machine is moved, the reaction of the control levers and pedals will be slow and the movement may not be what the operator intended. Always warm up the hydraulic equipment. In particular, in cold areas, always warm up the hydraulic equipment thoroughly.

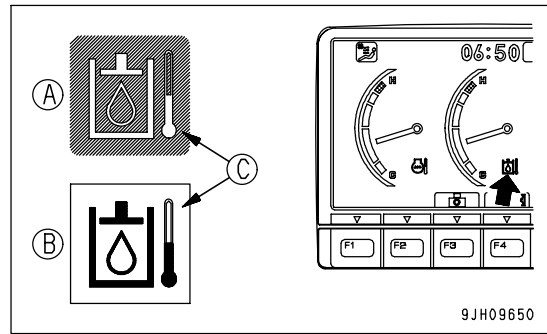

There are two types of warm-up operation: warm up the engine and warm up the hydraulic equipment. In addition, depending on the environment, the method of carrying out the warm-up operation may differ, so carry out the warm-up operation according to the items given in the appropriate section.

(When only the engine is warmed up, the hydraulic equipment is not warmed up, so always carry out the warm-up operation for the hydraulic equipment separately from the warm-up operation for the engine. Warm up the hydraulic equipment thoroughly ensures that the hydraulic oil is warmed up and that warm hydraulic oil circulates in all the control circuits.)

Breaking-in the New Machine

NOTICE

Your Komatsu machine has been thoroughly adjusted and tested before shipment from the factory. However, operating the machine under full load before breaking the machine in can adversely affect the performance and shorten the machine life. Be sure to break in the machine for the initial 100 hours (as indicated on the service meter).

Make sure that you fully understand the content of this manual, and pay careful attention to the following points when breaking in the machine.

- Run the engine at idle for 15 seconds after starting it. During this time, do not operate the control levers or fuel control dial.
- Idle the engine for 5 minutes after starting it up.
- Avoid operation with heavy loads or at high speeds.
- Immediately after starting the engine, avoid sudden starts, sudden acceleration, unnecessary sudden stops, and sudden changes in direction.

Engine Warm Up

NOTICE

- Do not accelerate the engine suddenly until the warm-up operation has been completed.
- Do not run the engine at low idling or high idling under no load for more than 20 minutes. This will have an adverse effect on the environment, and will also have an adverse effect on the internal structure of the engine. If it is necessary to run the engine at idling for more than 20 minutes, apply a load from time to time or run at a mid-range speed.

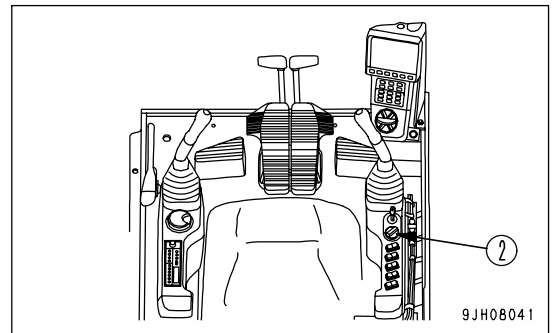

After the engine starts, do not start operating the machine immediately. First, carry out the following operations and checks.

1. This machine is equipped with an automatic engine warm-up system, so if the engine water temperature is below 30 °C after the engine is started, the engine warm-up operation starts automatically. When the engine automatic warm-up operation starts, the engine speed is maintained at a speed higher than the normal low idling speed. If the engine water temperature goes above 30 °C or if the warm-up operation has been continued for more than 10 minutes, the automatic warm-up operation is cancelled and the engine speed drops to the normal low idling speed.

2. Check that engine coolant temperature monitor (1) displays the correct temperature.

If it displays low temperature, use the procedure in Step 3 to carry out additional warm up of the engine until the monitor displays the correct temperature.

- (A) Display when temperature is correct: Monitor background (C) is blue
- (B) Display when temperature is low: Monitor background (C) is white

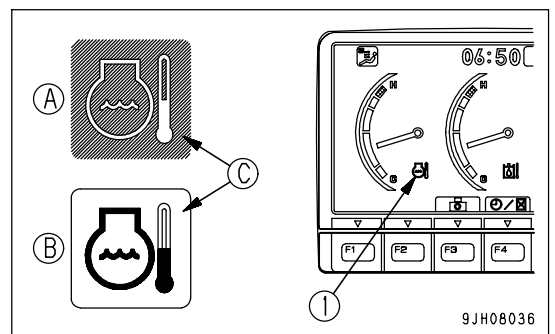

- Turn fuel control dial (2) to a point midway between low idling (MIN) and full speed (MAX), run the engine under no load at a mid-range speed until engine coolant temperature monitor (1) displays the correct temperature.

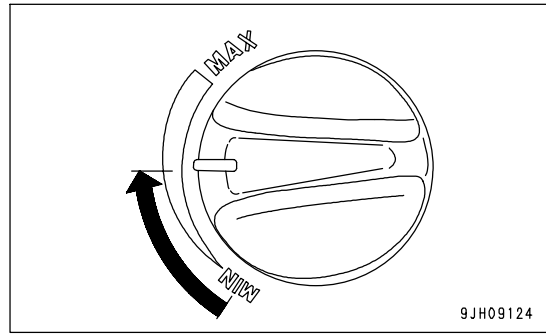

- Display when temperature is correct: Monitor background (C) is blue
- Display when temperature is low: Monitor background (C) is white

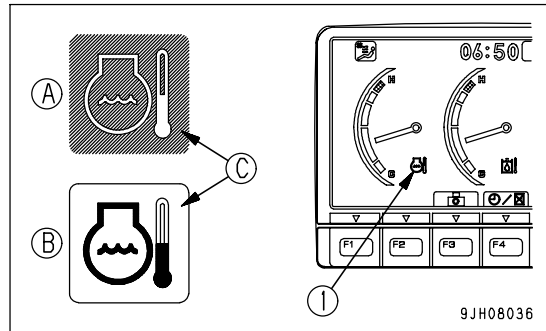

If the engine coolant temperature monitor displays the correct temperature, the engine warm-up operation is completed.

After checking that the engine coolant temperature monitor displays the correct temperature, carry out the warm-up operation for the hydraulic equipment.

NOTICE

Canceling automatic warm-up operation

If it becomes necessary in an emergency to cancel the automatic warm-up operation or to lower the engine speed to low idle, do as follows.

- Turn fuel control dial (2) to the full speed (MAX) position and hold it for 3 seconds.

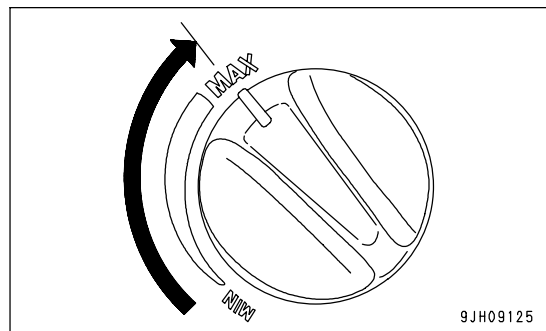

- When fuel control dial (2) is returned to the low idle (MIN) position, the engine speed will drop.

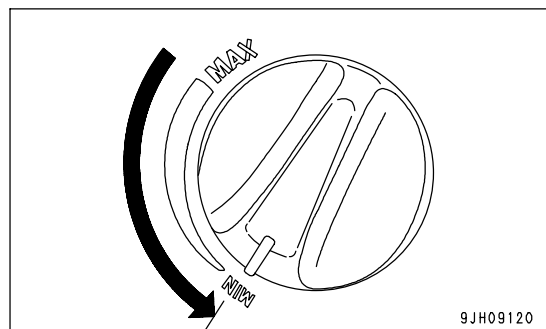

Hydraulic Equipment Warm Up

! WARNING

- Before carrying out the warming-up operation for the hydraulic equipment, turn the swing lock switch ON, check on the monitor that the swing lock is actuated, then start the warming-up operation.
- When warming up the hydraulic equipment, check that there is no person or obstacle in the surrounding area, then sound the horn and start the operation.
- Carry out the warming-up operation for the hydraulic equipment until the hydraulic oil temperature monitor displays the correct temperature. (When the hydraulic oil temperature is low, the low temperature display shown in the diagram on the right is given.)
 (A) Display when temperature is correct: Monitor background (C) is blue
 (B) Display when temperature is low: Monitor background (C) is white
- The warming-up operation for the hydraulic equipment is necessary not only for the circuit between the pump and cylinders and between the pump and motor, but also for the control circuits. Do not carry out the operation just for one cylinder or motor, or the operation just in one direction. Carry out the operation in all directions for all the work equipment (boom, arm, bucket), swing, travel, and attachment (if equipped).

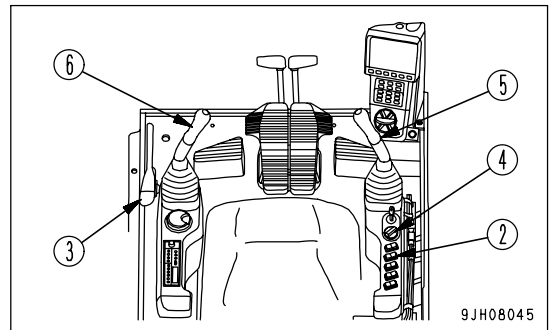
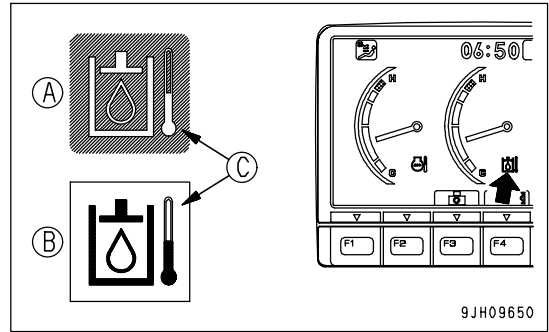

1. Check that engine coolant temperature monitor (1) displays the correct temperature.

(A) Display when temperature is correct: Monitor background (C) is blue

(B) Display when temperature is low: Monitor background (C) is white

If it displays low temperature, carry out additional warm up of the engine until engine coolant temperature monitor (1) displays the correct temperature.

For details of the procedure, see "Engine Warm Up (PAGE 3-133)".

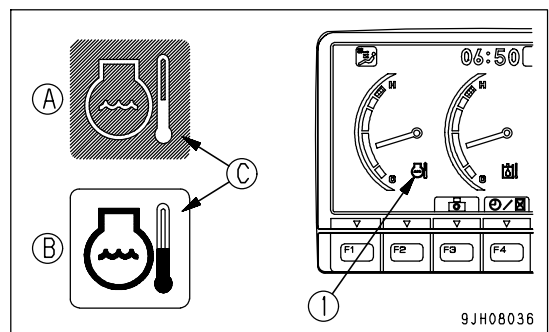

- Turn swing lock switch (2) ON and check that the swing lock monitor lights up.

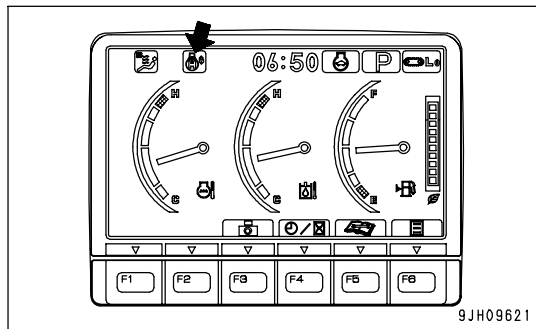

- To complete the warm-up operation of the hydraulic equipment more quickly, set the working mode to P mode (heavy-duty mode).
For details of the procedure for setting the working mode, see "Working Mode Selector Switch (PAGE 3-25)".

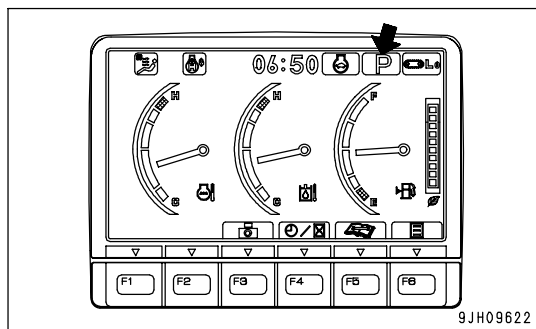

- Move lock lever (3) slowly to the FREE position (F), then raise the bucket from the ground.

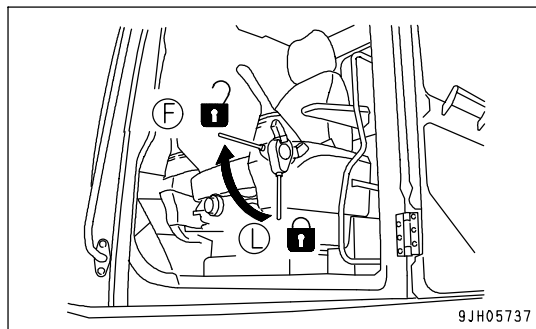

- Turn fuel control dial (4) to a point midway between low idling (MIN) and full speed (MAX).

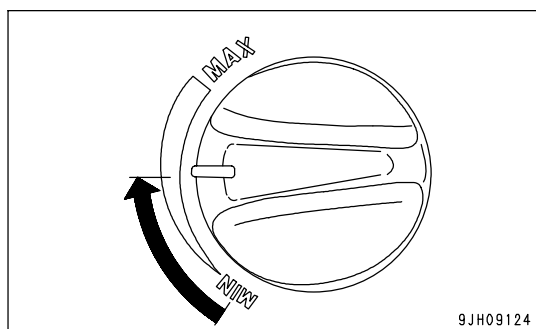

NOTICE

When the work equipment is retracted, take care that it does not interfere with the machine body or ground.

6. Move right work equipment control lever (5) slowly in the direction to pull in the bucket (D). Operate the lever to the end of its travel and hold it in position for 30 seconds.
7. Move right work equipment control lever (5) slowly in the direction to push out the bucket (C). Operate the lever to the end of its travel and hold it in position for 30 seconds.
8. Next, move left work equipment control lever (6) slowly in the direction to pull in the arm (B). Operate the lever to the end of its travel and hold it in position for 30 seconds.
9. Move left work equipment control lever (6) slowly in the direction to push out the arm (A). Operate the lever to the end of its travel and hold it in position for 30 seconds.
10. Repeat the operation in Steps 6 to 9 for 5 minutes.

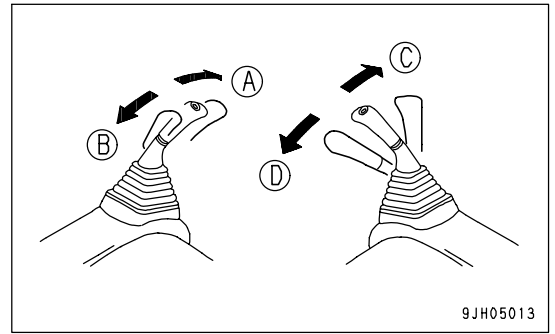

11. Check that hydraulic oil temperature monitor (7) is displaying the correct temperature.
If the hydraulic oil temperature monitor is not displaying the correct temperature (it is displaying low temperature), repeat Steps 6 to 10 until the display is the correct temperature.

- (A) Display when temperature is correct: Monitor background (C) is blue
- (B) Display when temperature is low: Monitor background (C) is white

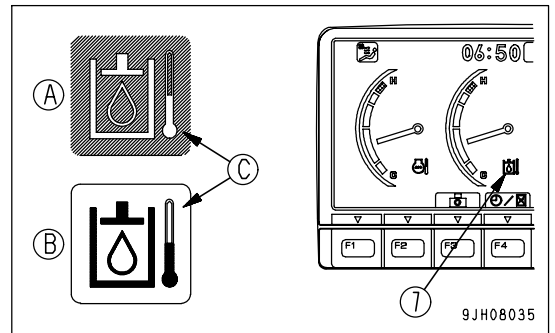

12. Check that engine coolant temperature monitor (1) displays the correct temperature.

- (A) Display when temperature is correct: Monitor background (C) is blue
- (B) Display when temperature is low: Monitor background (C) is white

If it displays low temperature, carry out additional warm up of the engine until engine coolant temperature monitor (1) displays the correct temperature.

For details of the procedure, see "Engine Warm Up (PAGE 3-133)".

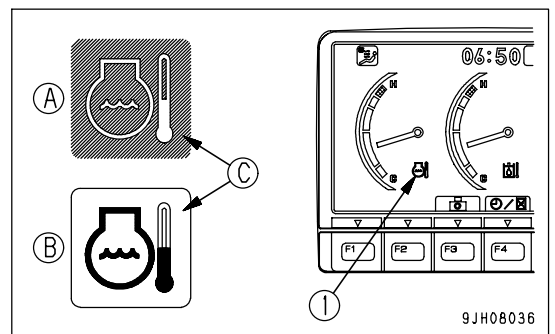

13. Check that the hydraulic oil temperature monitor and engine coolant temperature monitor are displaying the correct temperature, then check that all the gauges and caution monitors on the machine monitor are in the following status.

- Radiator coolant level monitor (8): OFF
- Charge level monitor (9): OFF
- Engine oil pressure monitor (10): ON
- Engine oil level monitor (11): OFF
- Air cleaner clogging monitor (12): OFF
- Engine preheating lamp (13): OFF
- Engine water temperature gauge (14): Indicator in green range
- Engine coolant temperature monitor (1): Displays correct temperature
- Hydraulic oil temperature gauge (15): Displays green range
- Hydraulic oil temperature monitor (7): Displays correct temperature
- Fuel gauge (16): Displays green range
- Fuel level monitor (17): Display is correct level

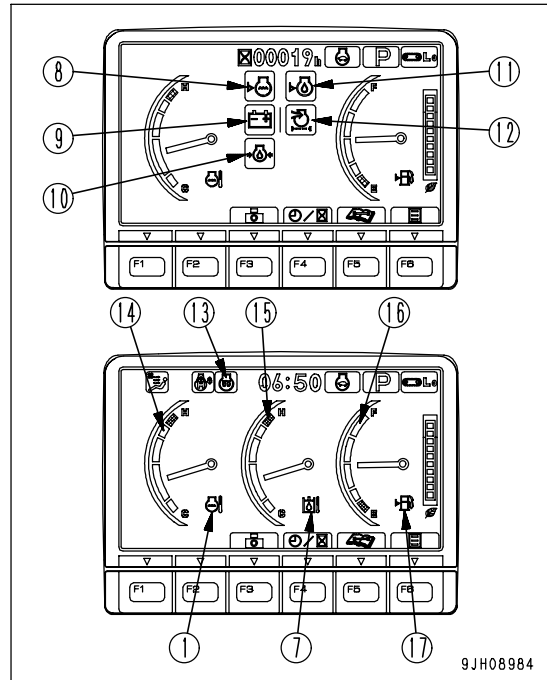

14. Check for abnormal exhaust gas color, noise, or vibration. If any problem is found, contact your Komatsu distributor.

In cold temperatures [ambient temperature below 0 °C (32 °F)], even when the hydraulic oil temperature monitor displays the correct temperature, carry out additional Step 15 to warm up all the hydraulic equipment.

15. Turn fuel control dial (4) to the full speed (MAX) position, repeat Steps 6 to 9 for 3 to 5 minutes, then check again that the hydraulic oil temperature monitor is displaying the correct temperature.

If it is not displaying the correct temperature, repeat Steps 6 to 9 for 3 to 5 minutes until hydraulic oil temperature monitor (7) displays the correct temperature.

(A) Display when temperature is correct: Monitor background (C) is blue

(B) Display when temperature is low: Monitor background (C) is white

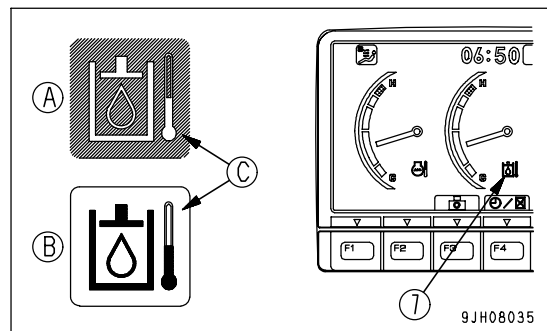
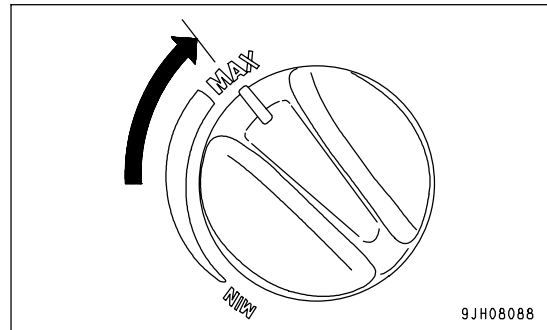

For both normal temperatures and cold temperatures, carry out the following operation.

16. Check that fuel control dial (4) is at a point midway between low idling (MIN) and full speed (MAX).

If it is not at the midway position, set it to the midway position and run the engine at a mid-range speed before operating.

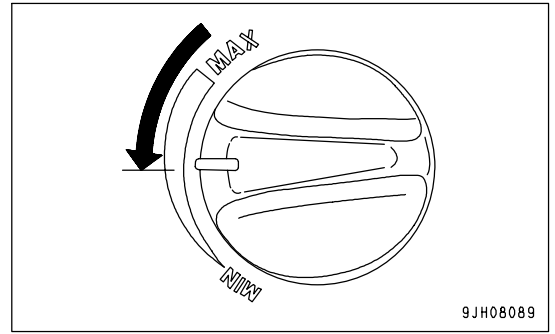

9JH08089

17. Before starting operations, repeat the following operations slowly 3 to 5 times to circulate warm oil through the control circuits.

- Boom operation RAISE (E) ↔ LOWER (F)
- Arm operation IN (B) ↔ OUT (A)
- Bucket operation CURL (D) ↔ DUMP (C)

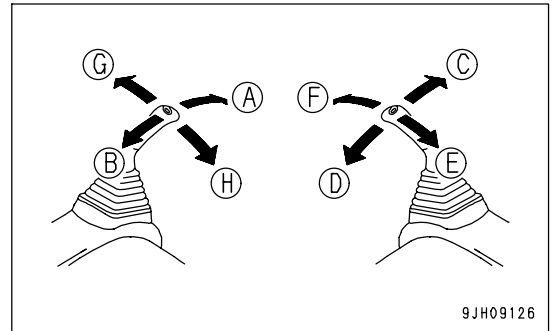

9JH09126

When carrying out swing operations, release swing lock switch (2), check that swing lock monitor (19) goes out, then operate the swing.

- Swing operation Left (G) ↔ Right (H)

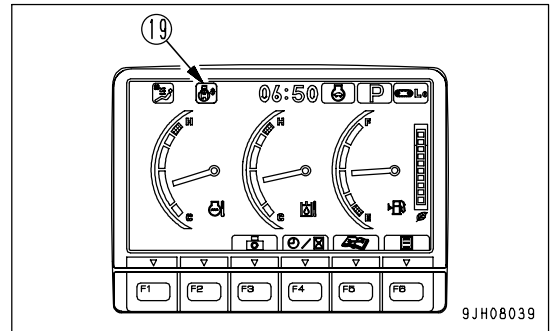

9JH08039

- Travel (Lo) operation FORWARD (A) ↔ REVERSE (B)

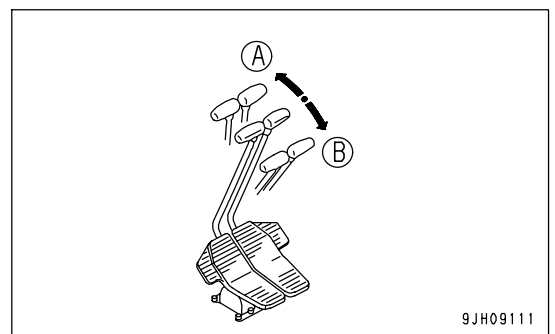

9JH09111

For attachment operations (if equipped), change the working mode to the attachment mode.

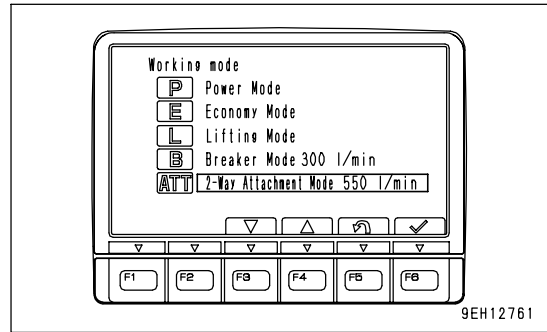

- Attachment operation One way (A) ↔ Other way (B)

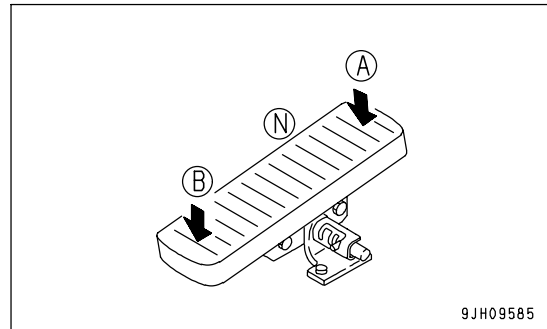

18. Check that hydraulic oil temperature monitor (7) is displaying the correct temperature.

If the hydraulic oil temperature monitor is not displaying the correct temperature (it is displaying low temperature), repeat Steps 6 to 10 until the display is the correct temperature.

- (A) Display when temperature is correct: Monitor background (C) is blue
- (B) Display when temperature is low: Monitor background (C) is white

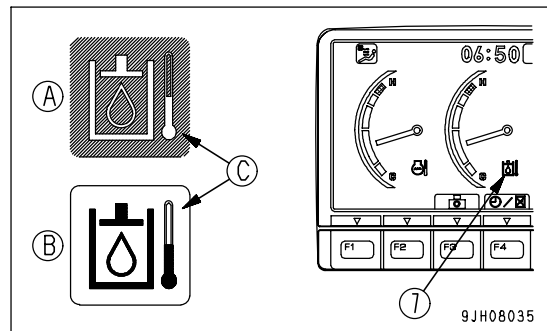

If the hydraulic oil temperature monitor displays the correct temperature, the hydraulic equipment warm-up operation is completed.

After confirming that the hydraulic oil temperature monitor displays the correct temperature, carry out the following procedure.

Operation After Completion Of Warm-Up Operation

1. Check that hydraulic oil temperature monitor (7) displays the correct temperature.

- (A) Display when temperature is correct: Monitor background (C) is blue
- (B) Display when temperature is low: Monitor background (C) is white

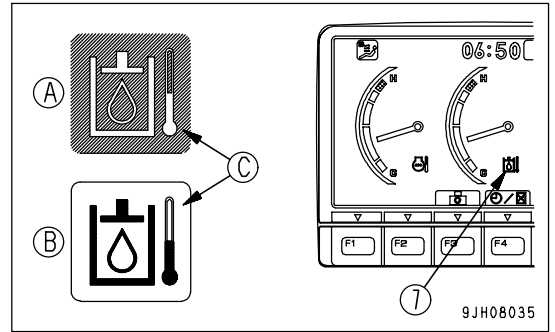

2. Push working mode selector switch (20) of the machine monitor to select the working mode to be used.

For details of the procedure for selecting the working mode, see "Working Mode Selector Switch (PAGE 3-25)".

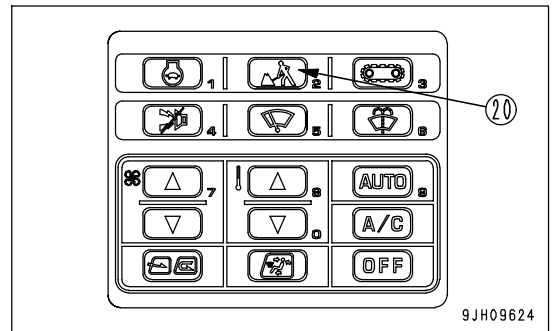

• Working mode monitor display

1) P mode

For heavy-duty operations

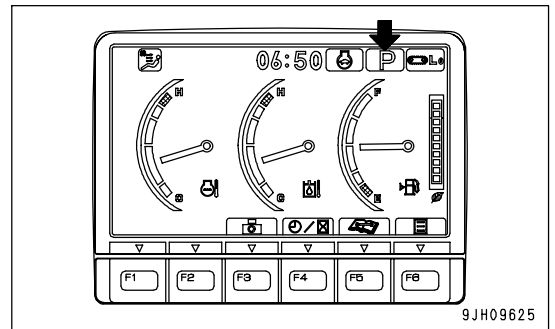

2) E mode

For operations with emphasis on fuel economy

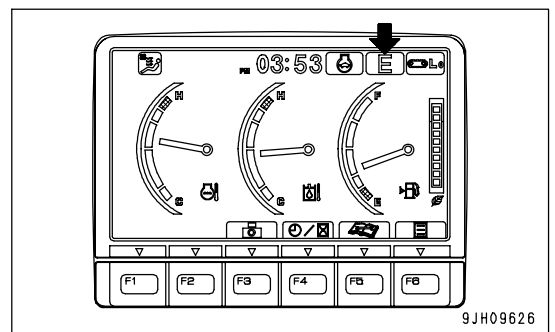

3) L mode

For operations requiring fine control

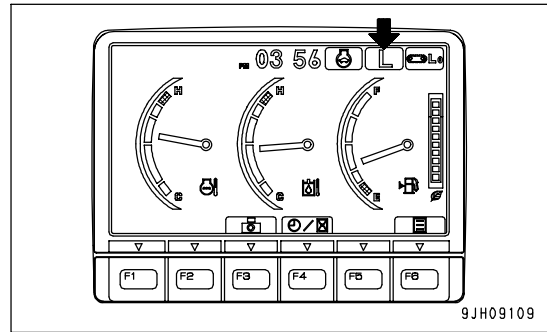

4) B mode

For breaker operations

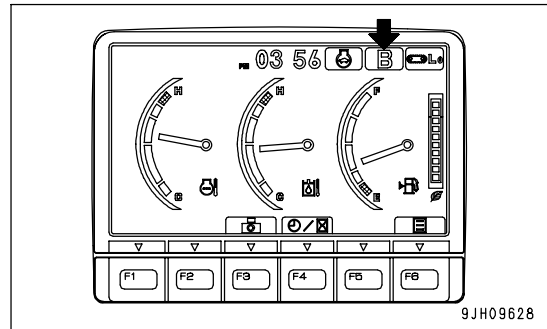

5) ATT mode

For operations with crusher or other double-acting action attachment

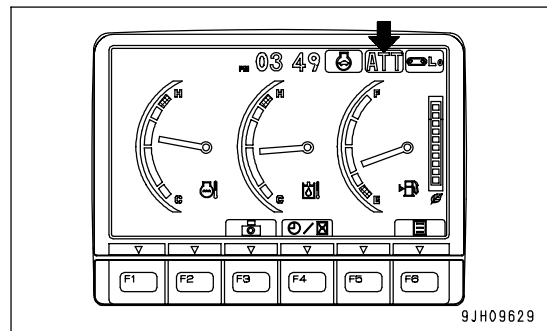

STOPPING THE ENGINE

NOTICE

If the engine is stopped abruptly, service life of component parts of the engine may be considerably reduced. Do not stop the engine abruptly except in an emergency. If the engine has overheated, do not try to stop it abruptly but run it at medium speed to allow it to cool down gradually, and then stop it.

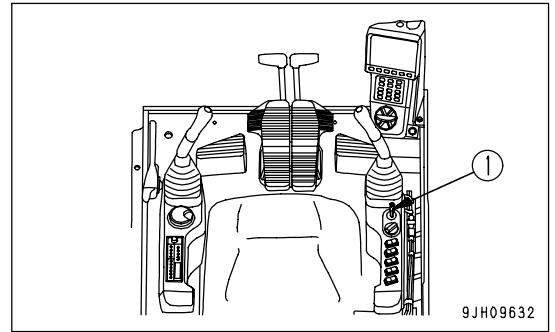

1. Run the engine at low idle for about 5 minutes to cool down gradually.
2. Turn the key in starting switch (1) to the OFF position (A) and stop the engine.
3. Remove the key from starting switch (1).

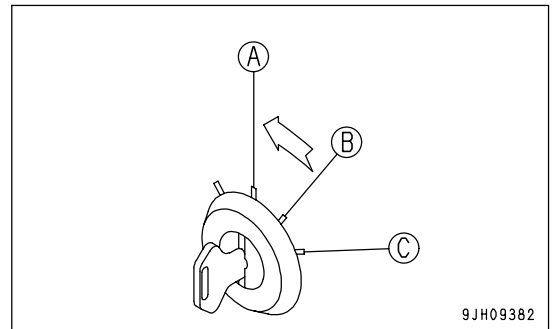

MACHINE OPERATION

! WARNING

- Before operating the travel levers or travel pedals, check the direction of the track frame. If the track frame is facing the rear (if the sprocket is at the front), the machine moves in the opposite direction from the operation of the travel levers or travel pedals (front and rear travel is reversed, left and right steering is reversed).
- Before starting the machine off, check that the area around the machine is safe, and sound the horn.
- Do not allow anyone to enter the area around the machine.
- Clear any obstacles from the travel path.
- There is a blind spot at the rear of the machine, so be particularly careful when traveling in reverse.
- If the travel levers or travel pedals is operated when the auto deceleration is being actuated, the engine speed will suddenly rise, so be careful when operating.
- When traveling, check that the alarm sounds normally.

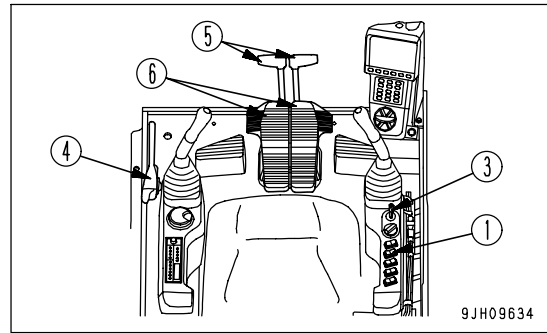

Preparations for Moving the Machine

1. Set swing lock switch (1) to the ON (actuated) position and confirm that swing lock monitor lamp (2) lights up.

- (a): ON position
- (b): OFF position

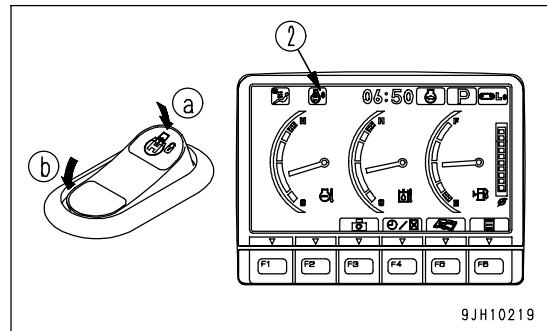

2. Turn fuel control dial (3) towards the full speed (MAX) position to increase the engine speed.

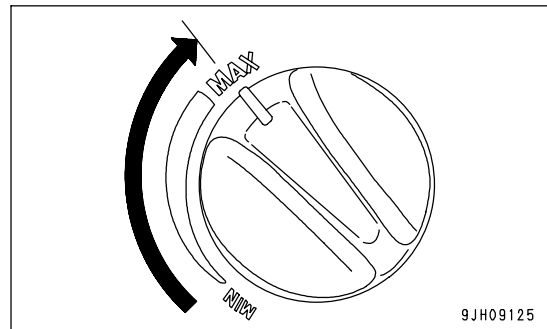

Moving Machine Forward

1. Set lock lever (4) in the FREE position (F), fold the work equipment, and raise it 40 to 50 cm (16 to 20 in) from the ground.
 - If the work equipment blocks the view and it is difficult to travel in safety, raise the work equipment to a greater height.

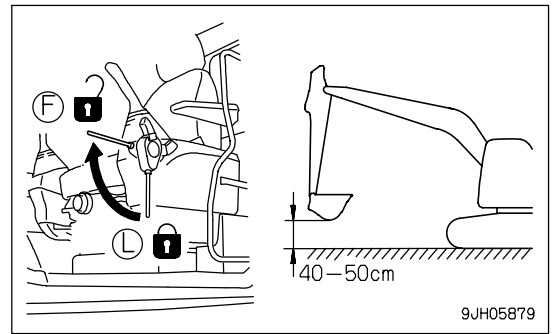

2. Operate the right and left travel levers (5), or the right or left travel pedals (6) as follows:

- When sprocket (A) is situated at the rear of the machine; Start the machine either by pushing lever (5) forward slowly or by stepping on the front part of pedal (6) slowly.

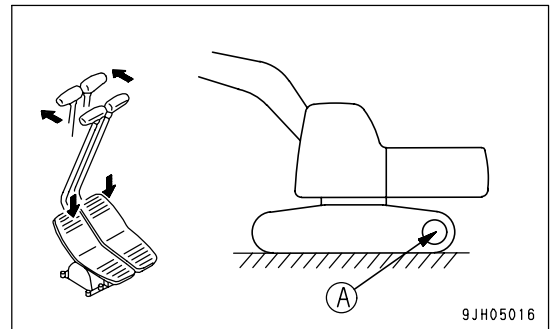

- When sprocket is situated at the front of the machine; Start the machine either by pulling lever (5) back slowly or by stepping on the rear part of pedal (6) slowly.

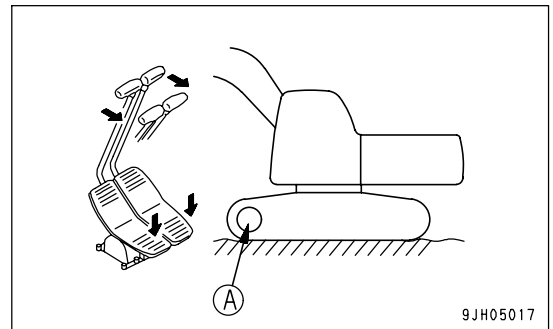

3. Check that the travel alarm sounds properly. If the travel alarm does not sound, please contact your Komatsu distributor for repair.

REMARK

In cold temperatures, if the machine travel speed is not normal, thoroughly perform the warming-up operation. In addition, if the undercarriage is clogged with mud and the machine travel speed is not normal, remove the soil and mud from the undercarriage.

Moving Machine Backward

1. Set lock lever (4) in the FREE position (F), fold the work equipment, and raise it 40 to 50 cm (16 to 20 in) from the ground.

- If the work equipment blocks the view and it is difficult to travel in safety, raise the work equipment to a greater height.

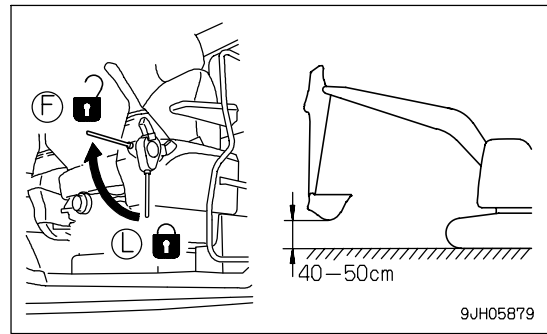

2. Operate the right and left travel levers (5), or the right or left travel pedals (6) as follows:

- When sprocket (A) is at the rear of the machine:
Slowly pull the levers (5) backward, or slowly depress the rear part of the pedals (6) to move the machine backward.

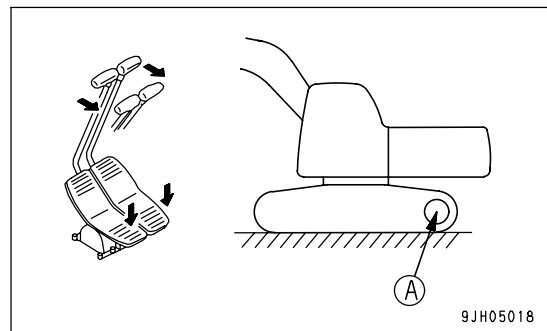

- When sprocket (A) is at the front of the machine:
Slowly push the levers (5) forward, or slowly depress the front part of the pedals (6) to move the machine backward.

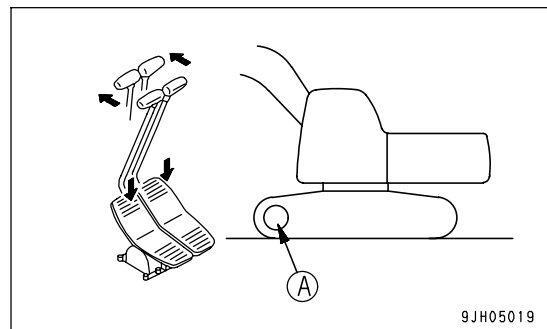

3. Check that the travel alarm sounds properly. If the travel alarm does not sound, please contact your Komatsu distributor for repair.

REMARK

In cold temperatures, if the machine travel speed is not normal, thoroughly perform the warming-up operation. In addition, if the undercarriage is clogged with mud and the machine travel speed is not normal, remove the soil and mud from the undercarriage.

Stopping Machine

Avoid stopping suddenly. Give yourself ample room when stopping.

1. Put the left and right travel levers (1) in the neutral position, then stop the machine.

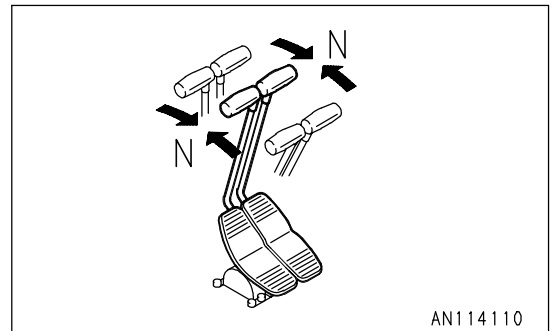
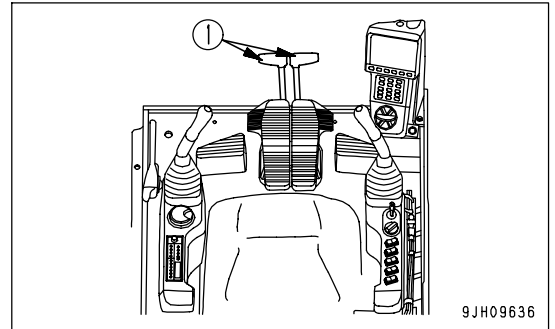

STEERING THE MACHINE

Steering

 **WARNING**

Before operating the travel levers or travel pedals, check the direction that the track frame is facing (the position of the sprocket). When the sprocket is at the front, the direction of operation of the travel levers or control pedals is the opposite from the direction of movement of the machine.

Use the travel levers to change direction.
 Avoid sudden changes of direction as much as possible.
 Especially when performing counter-rotation (spin turn), stop the machine before turning.
 Operate two travel levers (1) as follows.

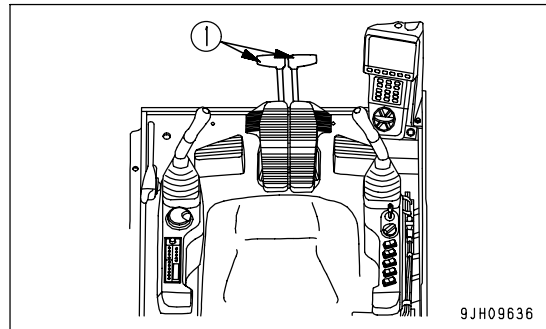

Steering the Machine when Stopped

When turning to the left:
 Push the right travel lever forward to turn to the left when traveling forward; and pull it back to turn left when traveling in reverse.
 (A): Forward left turn
 (B): Reverse left turn

REMARK
 When turning to the right, operate the left travel lever in the same way.

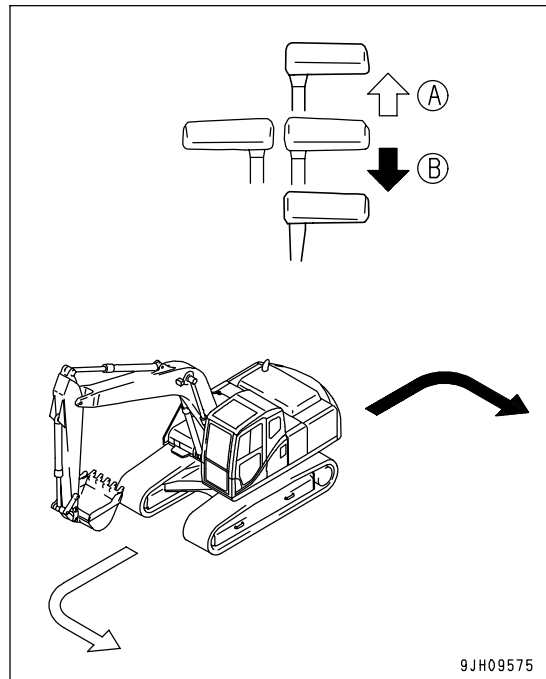

Changing Direction of the Machine

When turning to the left:

If the left travel lever is returned to the neutral position, the machine will turn to the left.

(A): Forward left turn

(B): Reverse left turn

REMARK

When turning to the right, operate the right travel lever in the same way.

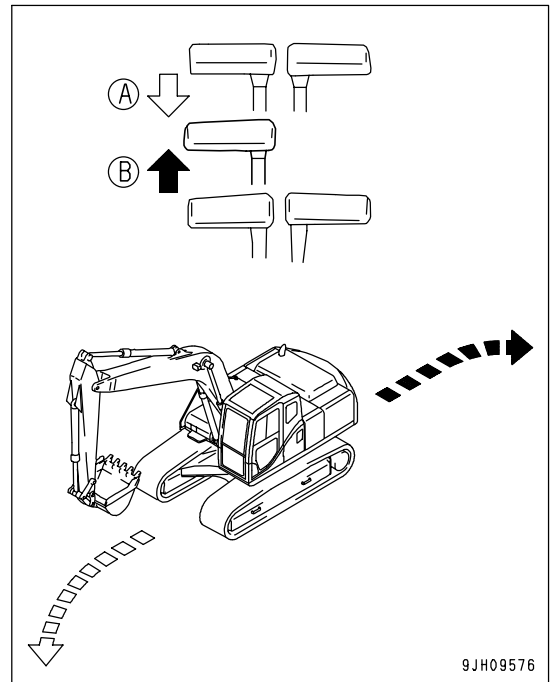

9JH09576

Counter-rotation Turn (Spin Turn)

When using counter-rotation (spin turn) to turn left, pull the left travel lever back and push the right travel lever forward.

REMARK

When using counter-rotation to turn right, pull the right travel lever back and push the left travel lever forward.

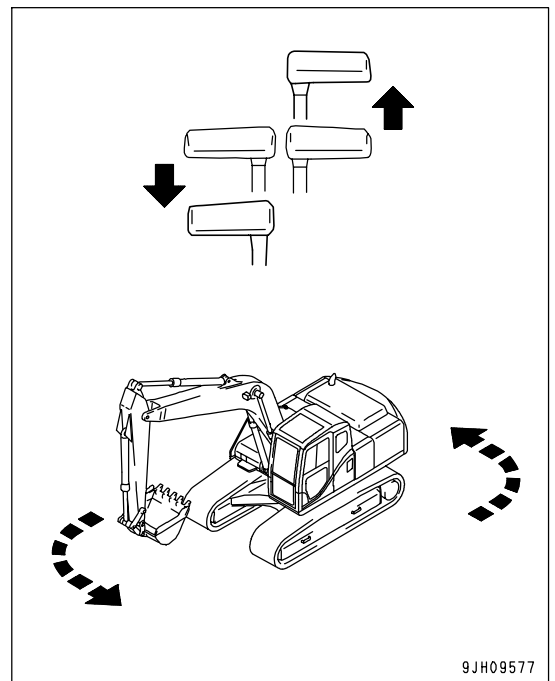

9JH09577

SWINGING

! WARNING

- The tail of the machine extends outside the tracks. Before operating the swing, check that the area around the machine is safe.
- If the lever is operated when the engine speed has been lowered by the auto-deceleration function, the engine speed will suddenly rise, operate the levers carefully.

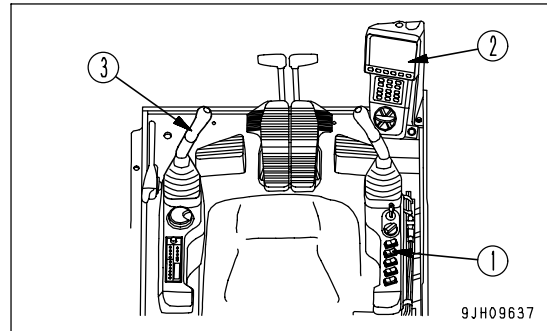

1. Before starting the swing operation, turn swing lock switch (1) OFF and check that swing lock monitor (2) has gone out.
 - (a): ON position
 - (b): OFF position

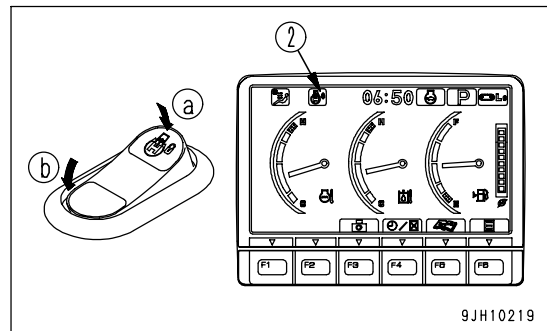

2. Operate left work equipment control lever (3) to swing the upper structure.
 - (A): Left swing
 - (B): Right swing

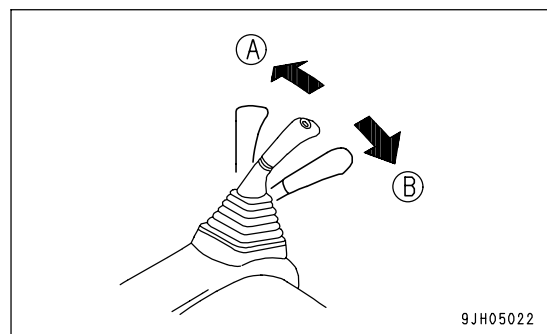

3. When not using the swing, turn swing lock switch (1) ON. Check that swing lock monitor (2) lights up.
 - (a): ON position
 - (b): OFF position

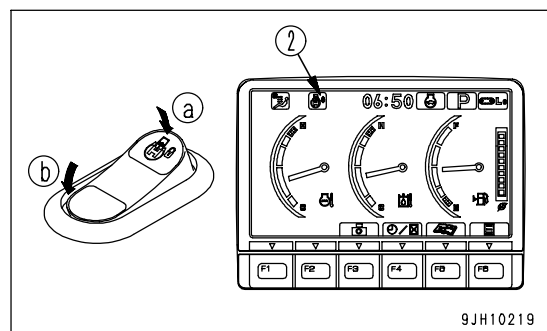

WORK EQUIPMENT CONTROLS AND OPERATIONS

**WARNING**

If the lever is operated when the engine speed has been lowered by the auto-deceleration function, the engine speed will suddenly rise, operate the levers carefully.

Use the control levers to operate the work equipment.

Note that when the levers are released, they return to the HOLD position and the work equipment is held in that position.

- Arm control

Move the left work equipment control lever to the front or rear to operate the arm.

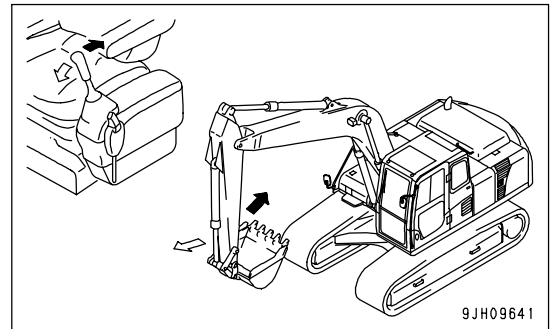

- Swing control

Move the left work equipment control lever to the left or right to swing the upper structure.

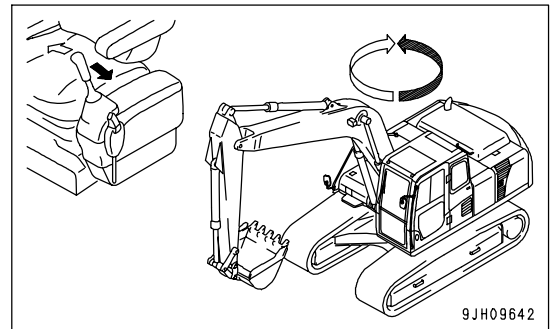

- Boom control

Move the right work equipment control lever to the front or rear to operate the boom.

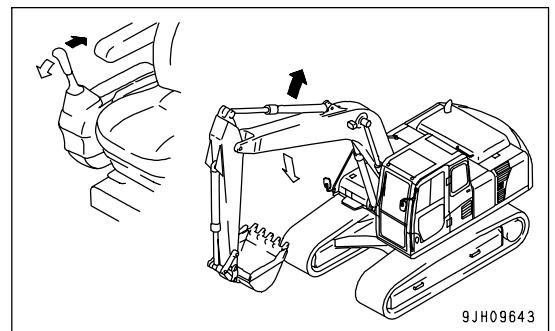

- Bucket control

Move the right work equipment control lever to the left or right to operate the bucket.

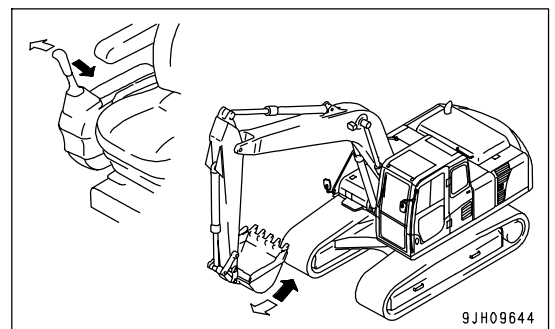

If the work equipment control levers are returned to the neutral position when the machine is stopped, even if the fuel control dial is set to FULL, the auto-deceleration mechanism will act to reduce the engine speed to a mid-range speed.

REMARK

The control circuit on this machine is equipped with an accumulator. Even if the engine is stopped, if the starting switch key is turned to the ON position within 15 seconds after stopping the engine, and the lock lever is set to the FREE position, it is possible to use the lever operation to lower the work equipment to the ground.

This procedure can also be used for releasing the remaining pressure in the hydraulic cylinder circuits or for lowering the boom after loading the machine onto a trailer.

WORKING MODE

Working Mode

Use working mode selector switch (1) to select the working mode that matches the operating conditions or purpose. This will make it possible to carry out operations efficiently.

Use the following procedure to select the most efficient working mode.

When the starting switch is turned ON, the working mode is set to the mode that was in operation when the starting switch was last turned OFF.

Use the working mode switch to set the mode to the most efficient mode to match the type of work.

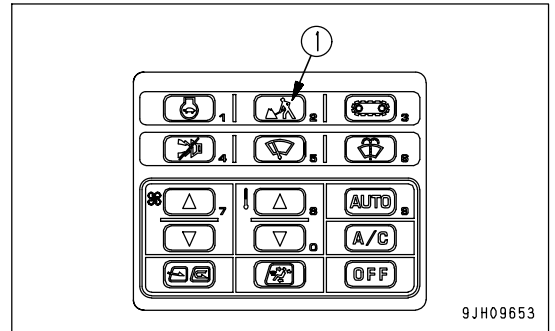

Working mode	Applicable operations
P mode	Normal digging or loading operations (operations with emphasis on production)
E mode	Normal digging or loading operations (operations with emphasis on fuel consumption)
L mode	Aligning position (fine control operations)
B mode	Breaker operations
ATT mode	Operations with the crusher or other double-acting action attachment

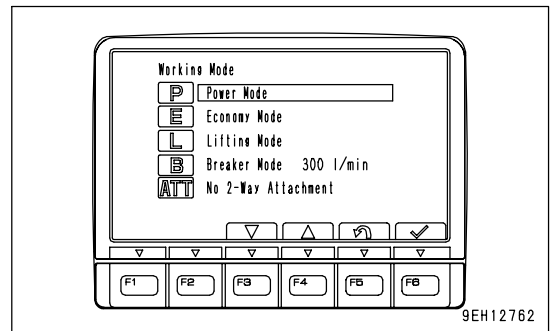

NOTICE

If breaker operations are carried out in a mode other than the breaker mode, there is danger of breakage of the hydraulic equipment. Do not carry out breaker operations in any mode except the breaker mode.

1. If working mode selector switch (1) is pressed, the working mode selection screen is displayed on the monitor.

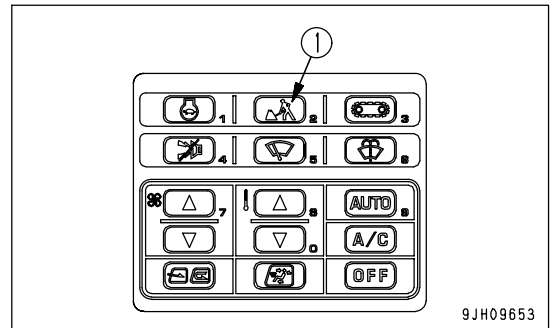

2. Press switches F3 or F4 at the bottom of the screen or the working mode selector switch to select the appropriate mode.

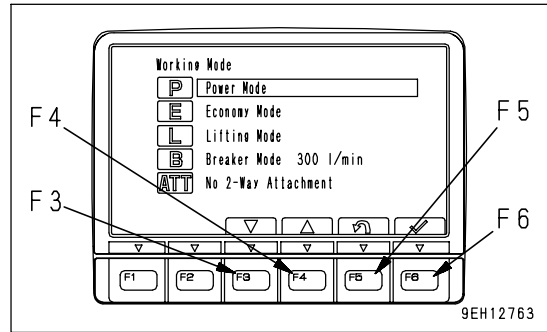

3. After selecting the desired mode, press switch F6 to accept the change. The screen returns to the standard screen.

If switch F5 is pressed, the screen returns to the standard screen without changing the mode.

- If a working mode is selected, and nothing is done for 5 seconds, the selected working mode is automatically accepted and the screen returns to the standard screen.
- If a working mode is selected and working mode switch (1) is kept pressed, the selected mode is accepted and the screen returns to the standard screen.

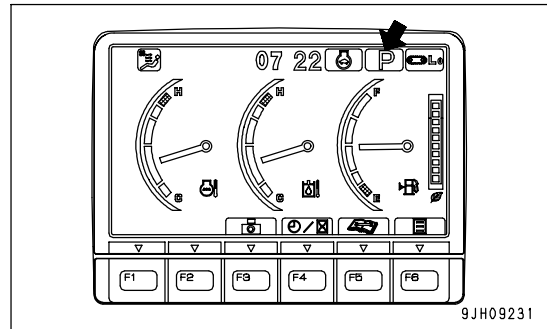

- If the breaker mode is selected, "Really Set Breaker Mode?" is displayed on the screen. To set to the breaker mode, press switch F6. If switch F5 is pressed, the screen returns to the working mode selection screen.

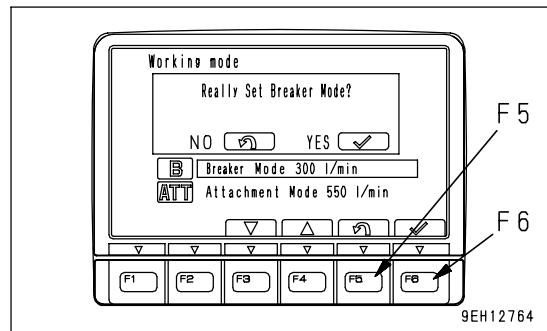

One-Touch Power Max. Switch

The one-touch power max. Switch can be used during operations to increase the power. Make effective use of this function whenever necessary in combination with the working mode.

- Press the left knob switch and keep it pressed. The power is increased as long as the switch is being pressed. However, the increased power is automatically canceled after 8.5 seconds.
- This function is not actuated when the working mode is set to L mode, B mode, or ATT mode.

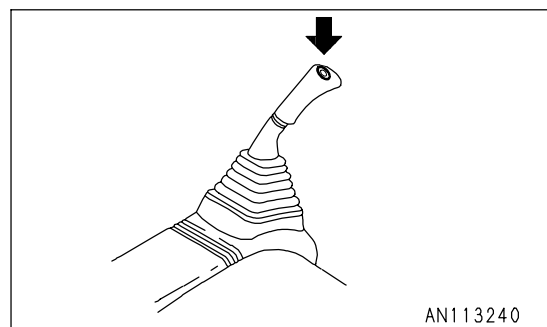

PROHIBITED OPERATIONS



WARNING

- If it is necessary to operate the work equipment control lever when the machine is traveling, stop the machine, then operate the control lever.
- If any lever is operated when the auto-deceleration is being actuated, the engine speed will suddenly increase, so be careful when operating.

Operations Using Swing Force

Do not use the swing force to compact soil or break objects. This is not only dangerous, but will also drastically reduce the life of the machine.

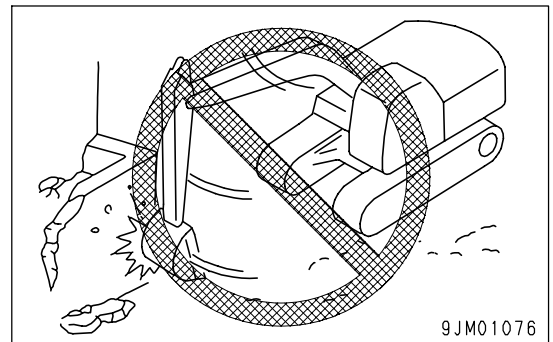

Operations Using Travel Force

Do not dig the bucket into the ground and use the travel force to carry out excavation. This will damage the machine or work equipment.

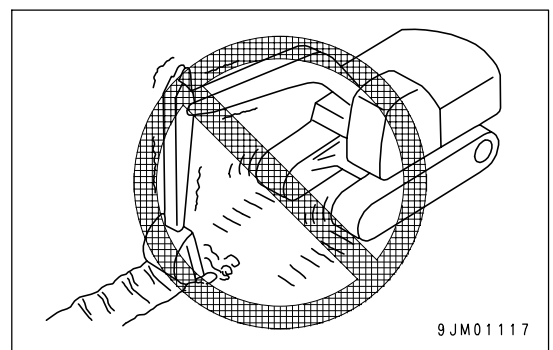

Prohibited to Extend Hydraulic Cylinder to End of Stroke

If the work equipment is used with the cylinder rod operated to its stroke end, and given impact by some external force, the hydraulic cylinders will be damaged, causing personal injury. Avoid operations with the hydraulic cylinder fully retracted or fully extended.

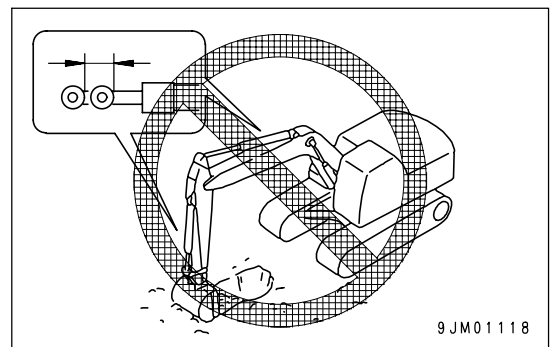

Operations Using Bucket Dropping Force

Do not use the dropping force of the machine for digging, or use the dropping force of the bucket as a pickaxe, breaker, or pile driver. This will drastically reduce the life of the machine.

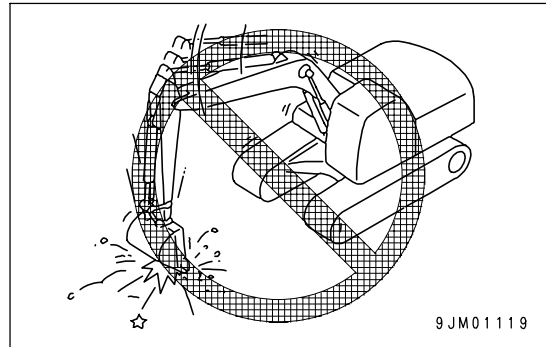

Operations Using Bucket as Lever

Do not use the bucket to lever rocks out. If the back of the bucket contacts the rock behind, the principle of the lever will bring excessive force to bear on the machine or work equipment, and there is danger that this may lead to breakage or damage of the machine.

In such situations, use only the force of the arm and bucket to carry out the digging operation. If any excessive force is brought to bear, the safety valve in the hydraulic system automatically controls the force within the specified range, and this prevents damage to the machine.

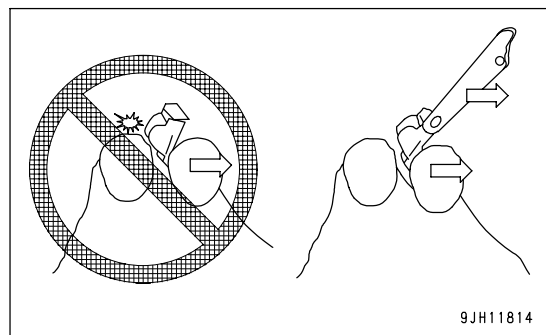

Operations Using Machine Dropping Force

Do not use the dropping force of the machine for digging.

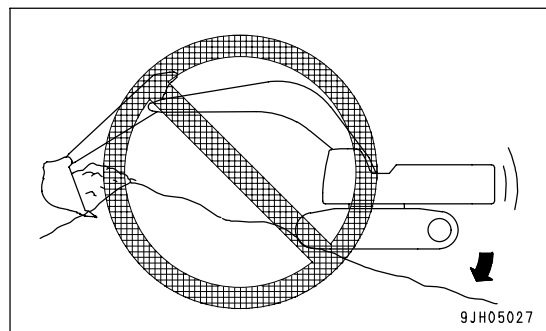
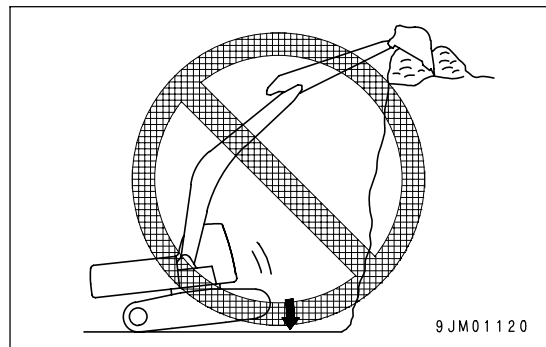

Operations Digging at an Angle without Engaging Teeth

Do not swing the upper structure when digging hard rock at a position higher than the machine if the bucket teeth will not penetrate the rock. The teeth will slip on the rock surface and generate excessive vibration of the machine, and this will lead to cracking of the work equipment or frame.

In addition, if the bucket teeth slip and hit the rock, there will be excessive impact load on the work equipment and frame, and this will reduce the service life of the machine.

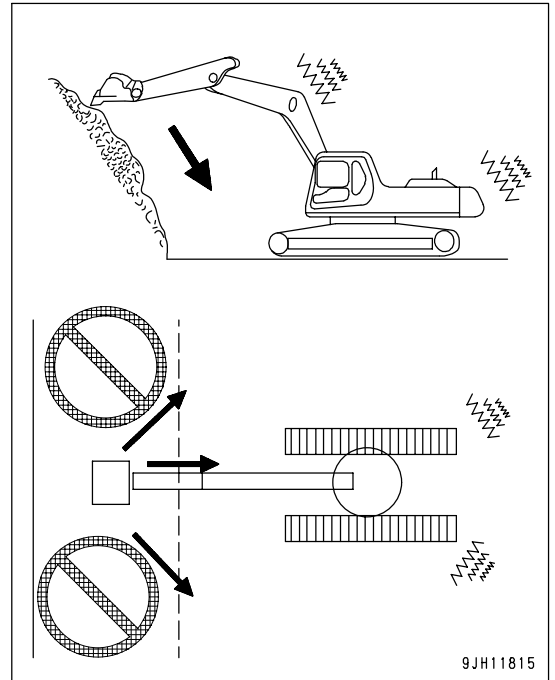

Digging Hard Rocky Ground

Do not attempt to directly excavate hard rocky ground with the work equipment. It is better to excavate it after breaking up by some other means. This will not only save the machine from damage but will make for better economy.

Operations When Machine is Not Stable

Do not carry out operations when the machine is not in a stable position. This will generate a twisting load on the frame and other parts and will reduce the service life of the machine.

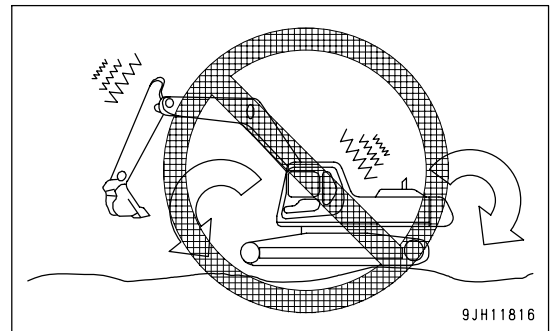

When carrying out operations in such a place, pile soil under the front of the track or take other measures to stabilize the machine before starting the operation.

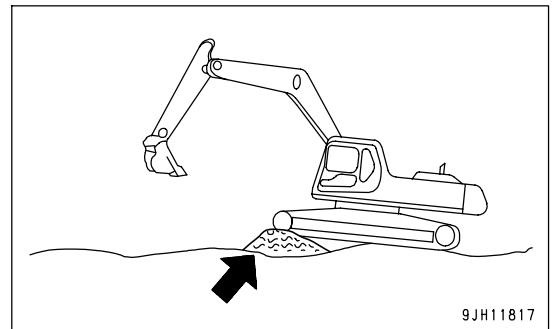

Swinging or Traveling When Rock Is on Top of Track Assembly

Do not swing the upper structure or travel if there is in the rock on top of the track assembly. It will contact the undercover or frame and cause damage. In the worst case, it may cause damage to the hydraulic equipment and result in a serious breakdown.

During operations, always check that there is no rock, pieces of rock, or mud on top of the track assembly.

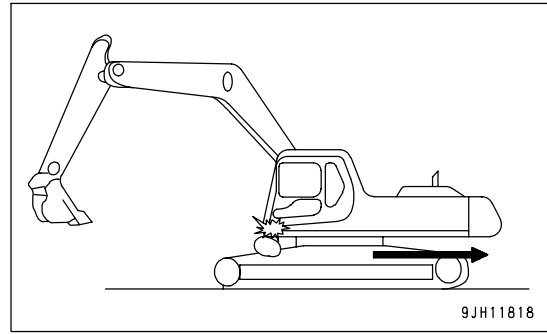

Sudden Lever or Pedal Shifting High Speed Travel

- (1) Do not operate the levers and pedals suddenly or take any other action to move the machine quickly.
- (2) Do not operate the levers or pedals suddenly from FORWARD (A) to REVERSE (B) (or from REVERSE (B) to FORWARD (A)).
- (3) Do not operate the levers or pedals suddenly (do not release them suddenly) to stop the machine when traveling at high speed.

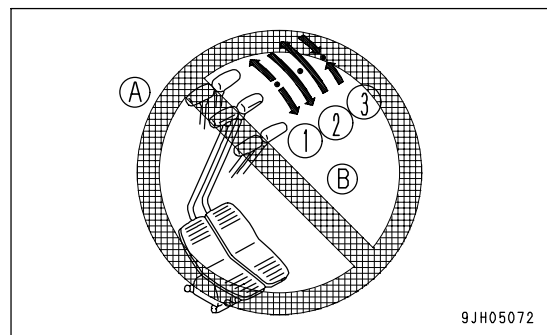

High-Speed Travel Operations on Rough Ground

Do not travel at high speed on rough ground or rocks. Each time the machine travels over rough parts of the ground surface, the thrusting load on the machine will increase and reduce the service life of the machine.

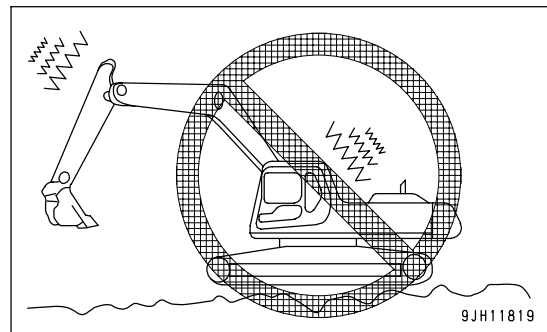

To protect the machine when traveling on rough ground or on rocks, there is a cushion structure in the idler (1), so set the idler facing in the direction of travel and travel at low speed.

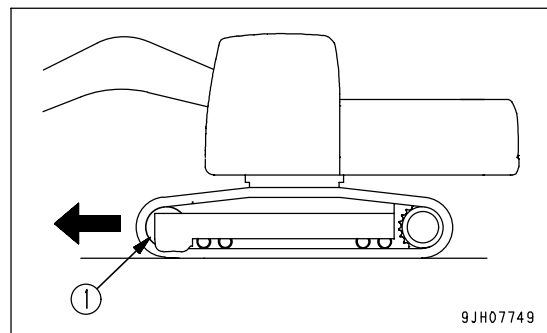

Long-Time Continuous Travel Operations

Do not travel continuously at high speed for 1.5 hours or more. The lubricating oil inside the track rollers and final drive will rise to a high temperature, and there is danger that this will cause damage to the oil seal or leakage of oil.

When traveling continuously for a long time, stop the machine for 30 minutes every 1.5 hours to allow the lubricating oil inside the track rollers and final drive to cool down.

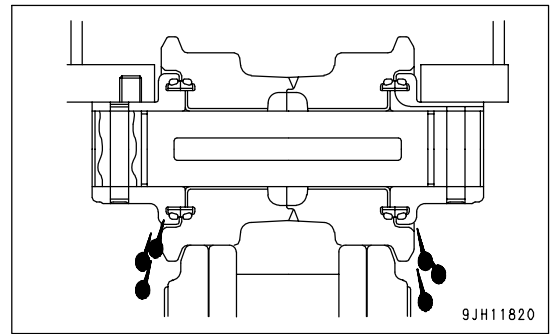

GENERAL OPERATION INFORMATION

Traveling

Traveling over boulders, tree stumps, or other obstacles will cause a big shock to the chassis (and in particular to the tracks), and this will cause damage to the machine. For this reason, always remove any obstacles or travel around them, or take other steps to avoid traveling over such obstacles as far as possible.

If there is no way to avoid traveling over an obstacle, reduce the travel speed, keep the work equipment close to the ground, and try to travel so that the center of the track passes over the obstacle.

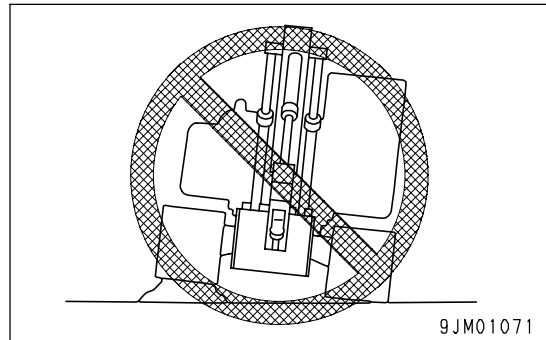

High Speed Travel

On uneven roadbeds such as rock beds or uneven roads with large rocks, travel at Lo speed. When traveling at high speed, set the idler in the forward direction.

- Press travel speed selector switch (1) to switch the travel speed. The travel speed (Lo, Mi, Hi) is displayed on the travel speed monitor (2).

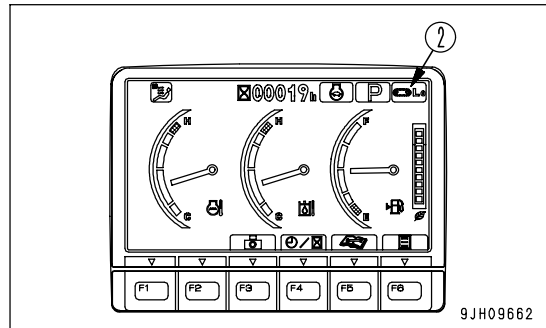
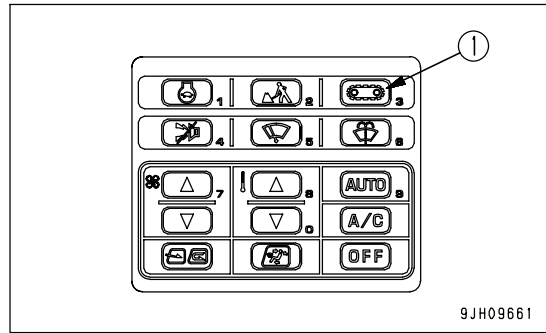

Permissible Water Depth**NOTICE**

When driving the machine out of water, if the angle of the machine exceeds 15°, the rear of the upper structure will go under water, and water will be thrown up by the cooling fan. This may cause the fan to break.

Be extremely careful when driving the machine out of water.

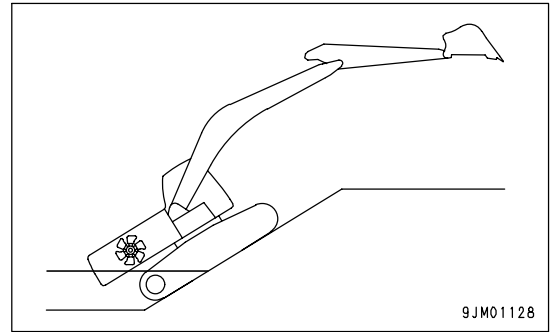

Do not drive the machine in water deeper than the center of carrier roller (1).

Supply grease to the parts which have been under water for a long time until the used grease is projected out of the bearings (around the bucket pin, in particular).

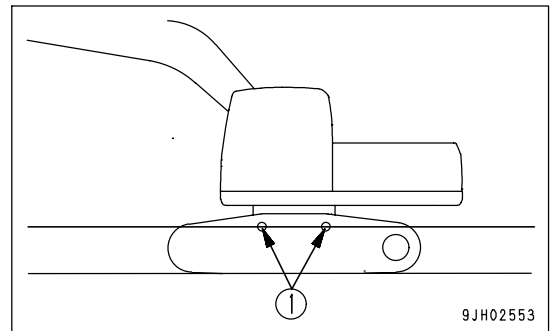

TRAVELING ON SLOPES

! WARNING

- Turning or operating the work equipment when working on slopes may cause the machine to lose its balance and turn over, so avoid such operations.
It is particularly dangerous to swing downhill when the bucket is loaded. If such operations have to be performed, pile soil to make a platform (A) on the slope so the machine is kept horizontal during operation.
- Do not work on a slope covered with the steel plates. Even with slight slopes there is a hazard that the machine may slip.
- Do not travel up or down steep slopes. There is a danger that the machine may turn over.
- When traveling, raise the bucket approx. 20 to 30 cm (8 to 12 in) from the ground.
Do not travel downhill in reverse.
- Never turn on slopes or travel across slopes.
Always go down to a flat place to perform these operations. It may be longer, but it will ensure safety.
- Always operate or travel in such a way that it is possible to stop safely at any time if the machine slips or becomes unstable.
- When traveling uphill, if the shoes slip or it is impossible to travel uphill using only the force of the tracks, do not use the pulling force of the arm to help the machine travel uphill. There is danger that the machine may turn over.

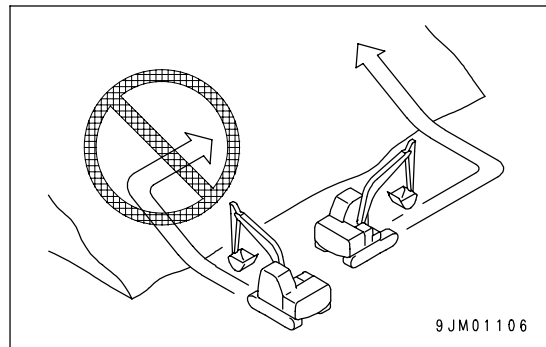
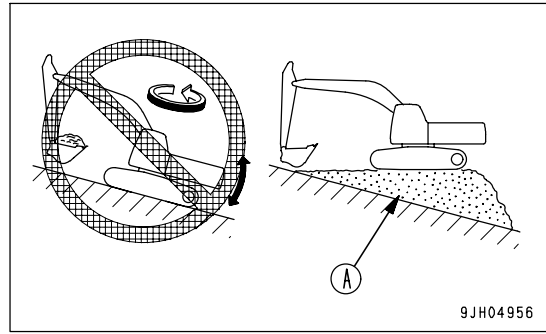

1. When traveling down steep hills, use the travel lever and fuel control dial to keep the travel speed low. When traveling down a steep hill of more than 15°, set the work equipment to the posture shown in the diagram on the right, and lower the engine speed.

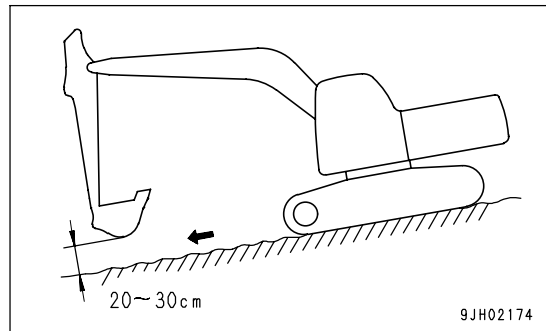

2. When traveling up a steep hill of more than 15°, set the work equipment to the posture shown in the diagram on the right.

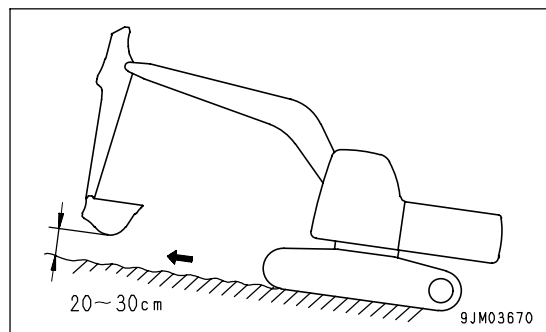

- When traveling up a steep slope, extend the work equipment to the front to improve the balance, keep the work equipment approximately 20 to 30 cm (8 to 12 in) above the ground, and travel at low speed.

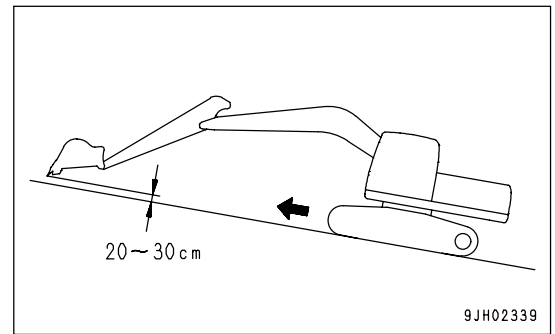

Traveling Downhill

Put the travel lever in the neutral position. This will cause the brake to be automatically applied.

Engine Stopped on Slope

If the engine stops when traveling uphill, move the travel levers to the neutral position, lower the bucket to the ground, stop the machine, then start the engine again.

Cab Doors on Slope

- If the engine stops when the machine is on a slope, never use the left work equipment control lever to carry out swing operations. The upper structure will swing under its own weight.
- Do not open or close the door when the machine is on a slope. The operating effort may suddenly change. Always keep the door locked in position when it is open and when it is closed.

ESCAPE FROM MUD

Always operate carefully to avoid getting stuck in mud. If the machine does get stuck in mud, do as follows to get the machine out.

- Place the machine push-up switch at high-pressure set position (b). This will increase the pushing power of the boom and make it easier to escape.

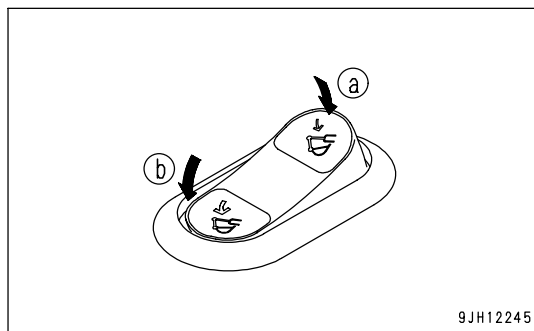

9JH12245

Track on One Side Stuck

NOTICE

When using the boom or arm to raise the machine, always have the bottom of the bucket in contact with the ground. The angle between the boom and arm should be 90° to 110°.

The same applies when using the bucket installed in the reverse direction.

When only one side is stuck in mud, use the bucket to raise the track, then lay boards or logs and drive the machine out.

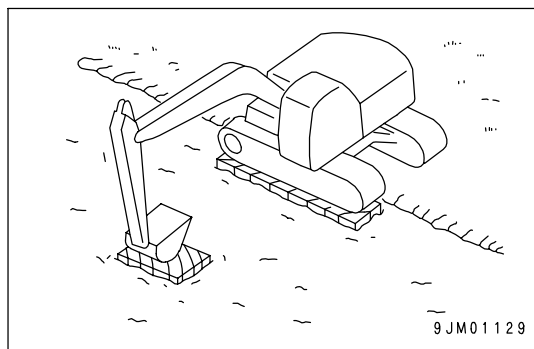

9JM01129

Tracks on Both Sides Stuck

When the tracks on both sides are stuck in mud and they slip, making it impossible for the machine to move, lay boards or logs as explained above, and dig the bucket into the ground in front. Then pull in the arm as in normal digging operations and put the travel levers in the FORWARD position to pull the machine out.

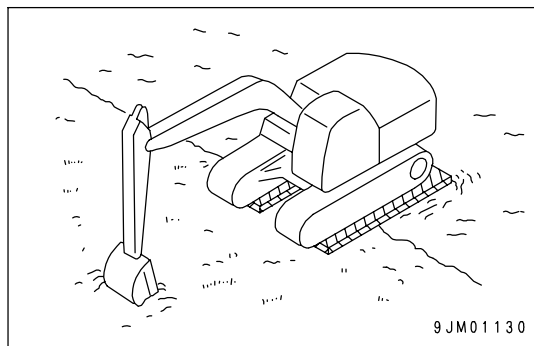

9JM01130

RECOMMENDED APPLICATIONS

In addition to the following, it is possible to further increase the range of applications by using various attachments.

Backhoe Work

A backhoe is suitable for excavating areas that are lower than the machine.

When the condition of the machine is as shown in the diagram on the right (angle between [bucket cylinder and link] and [arm cylinder and arm] is 90°), the maximum excavation force is obtained from the pushing force of each cylinder.

When excavating, use this angle effectively to optimize your working efficiency.

The range for excavating with the arm is from a 45° angle away from the machine to a 30° angle towards the machine.

There may be some differences depending on the excavation depth, but try to stay within the above range rather than operating the cylinder to the end of its stroke.

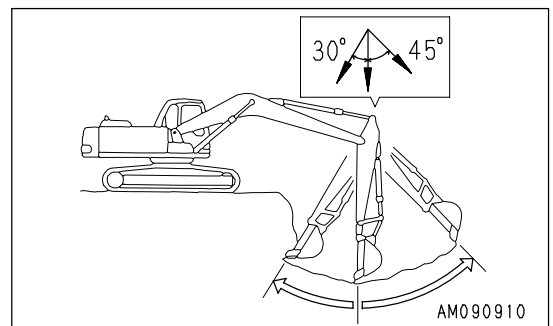
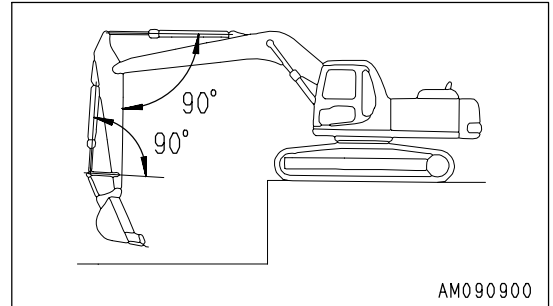

Shovel Work

NOTICE

The rock bucket (PC 400: if equipped, PC 450: standard) interferes with the arm, so it cannot be reversed to carry out excavation to the front.

A shovel is suitable for excavating at a position higher than the machine. Shovel work is performed by attaching the bucket in the reverse direction.

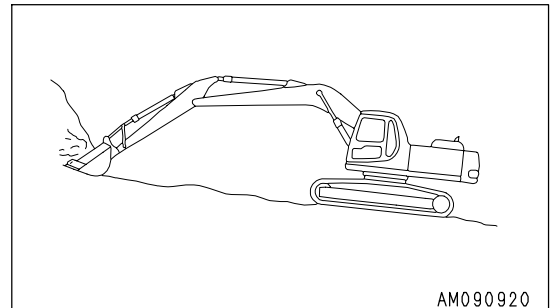

Ditching Work

Ditching work can be performed efficiently by attaching a bucket which matches the digging operation and then setting the tracks parallel to the line of the ditch to be excavated.

To excavate a wide ditch, first dig both sides and then finally remove the center portion.

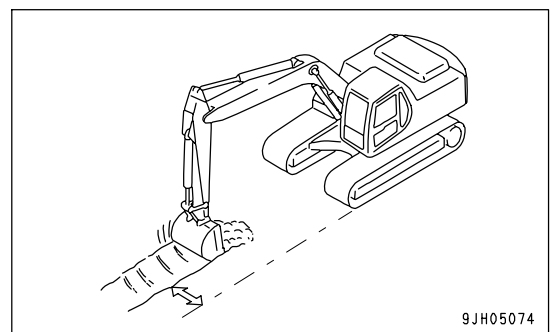

Loading Work

In places where the swing angle is narrow, work efficiency can be enhanced by locating the dump truck in a place easily visible to the operator.

Loading is easier and capacity greater if you begin from the front of the dump truck body than if loading is done from the side.

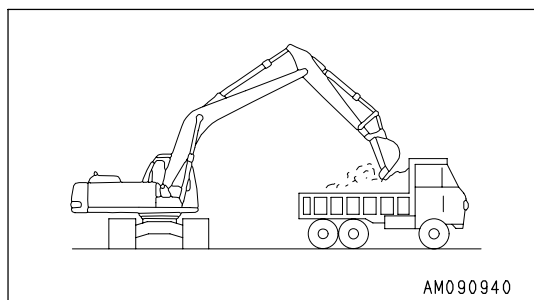

BUCKET REPLACEMENT AND INVERSION



WARNING

- When pins are knocked in with a hammer, pieces of metal may fly and cause serious injury. When carrying out this operation, always wear goggles, hard hat, gloves, and other protective equipment.
- When the bucket is removed, place it in a stable condition.
- If pins are hit with a strong force, there is a hazard that the pin may fly out and injure people in the surrounding area. Make sure that there is no one in the surrounding area before starting the operation.
- When removing the pins, do not stand behind the bucket. In addition, be extremely careful not to put your foot under the bucket while standing at the side for the work.
- When removing or inserting pins, be extremely careful not to get your fingers caught.
- Never insert your fingers into the pin holes when aligning the holes.

Stop the machine on a firm and flat surface and do the work. When performing joint work, appoint a lead and follow that person's instructions and signals.

Replacement

1. Place the bucket in contact with a flat surface.

REMARK

When removing the pins, place the bucket so that it is in light contact with the ground.

If the bucket is lowered strongly to the ground, the resistance will be increased and it will be difficult to remove the pins.

NOTICE

After removing the pins, make sure that mud or sand does not get on them. Dust seals are fitted at both ends of the bushings, be careful not to damage them.

2. Remove the double nut on the stopper bolt for arm pin (A) and link pin (B), remove the bolt, pull out arm pin (A) and link pin (B), and then remove the bucket.
3. Align the arm (5) with holes (1) of the replacement bucket and the link (6) with holes (2), then insert grease-coated pins (A) and (B) into hole (1) and hole (2) respectively.

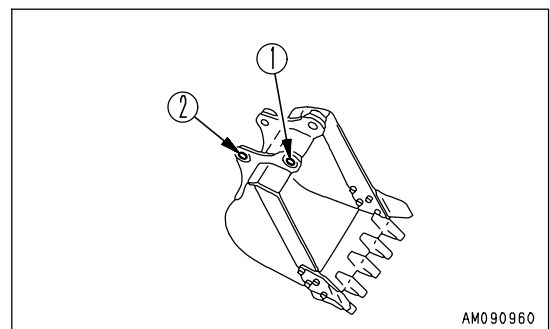
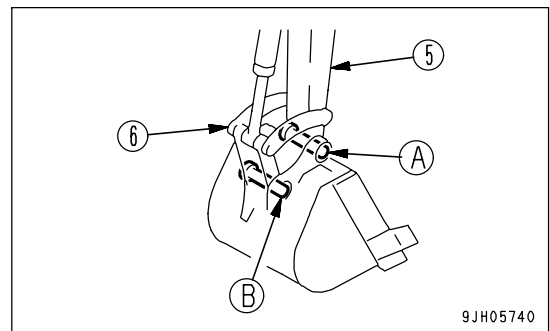

REMARK

When installing the bucket, for arm pin portion (A), fit O-ring (3) to bucket (4) in the position shown in the diagram on the right. After inserting the pin, fit it in the standard groove.

For link pin portion (B), install the bucket with O-ring (3) fitted in the standard groove.

4. Install the stopper bolts and nuts for each pin, then grease the pin.

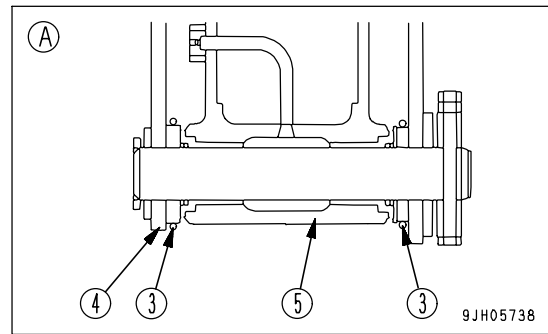
**REMARK**

- Lubricate with grease thoroughly until the grease comes out from the end face.
- When replacing the bucket, replace the dust seal if it has been damaged. If a damaged seal is used without being replaced, sand and dirt may enter the pin portion and cause abnormal wear of the pin.

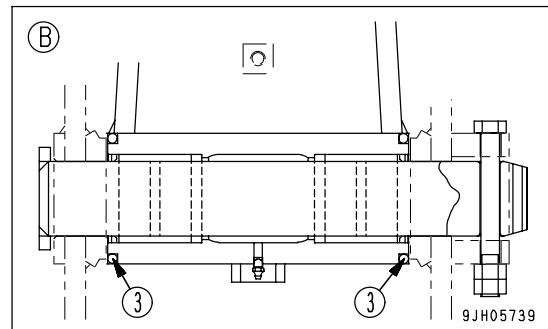

Inversion

NOTICE

The rock bucket (PC 400: if equipped, PC 450: standard) interferes with the arm, so it cannot be reversed to carry out excavation to the front.

1. Place the bucket in contact with a flat surface.

REMARK

When removing the pins, place the bucket so that it is in light contact with the ground.

If the bucket is lowered strongly to the ground, the resistance will be increased and it will be difficult to remove the pins.

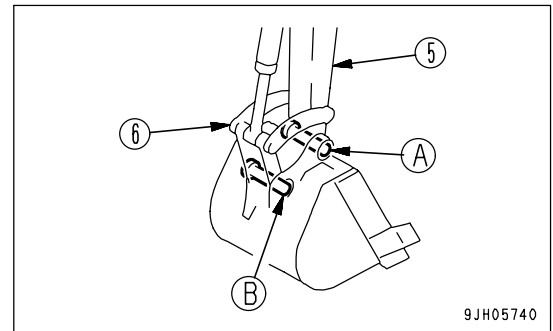

NOTICE

After removing the pins, make sure that mud or sand does not get on them. Dust seals are fitted at both ends of the bushings, be careful not to damage them.

2. Remove the double nut on the stopper bolt for arm pin (A) and link pin (B), remove the bolt, pull out arm pin (A) and link pin (B), and then remove the bucket.

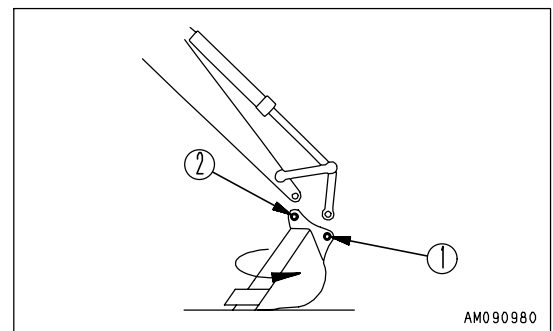

3. After removing the bucket, reverse it.
4. Align arm (5) with replacement bucket hole (1), then align link (6) with hole (2), coat pins (A) and (B) with grease, and install.

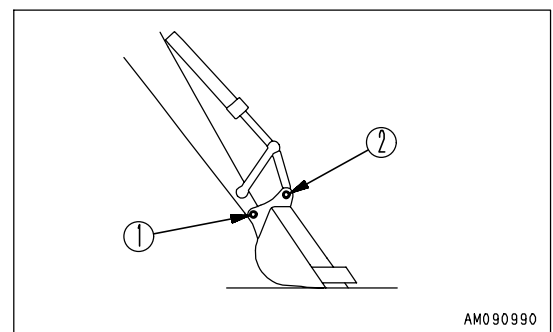

REMARK

When reversing, do not install an O-ring. Keep the O-ring in a safe place until using it next.

5. Install the stopper bolts and nuts for each pin, then grease the pin.

REMARK

- Lubricate with grease thoroughly until the grease comes out from the end face.
- When replacing the bucket, replace the dust seal if it has been damaged. If a damaged seal is used without being replaced, sand and dirt may enter the pin portion and cause abnormal wear of the pin.

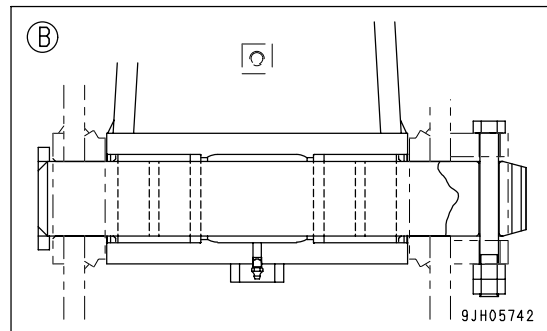
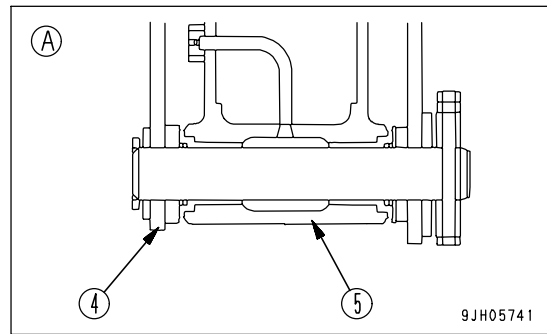

PARKING MACHINE

 **WARNING**

- Avoid stopping suddenly. Give yourself ample room when stopping.
- When stopping the machine, select flat hard ground and avoid dangerous places.

If it is unavoidably necessary to park the machine on a slope, insert blocks underneath the track shoes. As an additional safety measure, thrust the bucket into the ground.

- If the control lever is touched by accident, the machine may move suddenly, and this may lead to a serious accident.

Before leaving the operator's compartment, always set the lock lever securely to LOCK position.

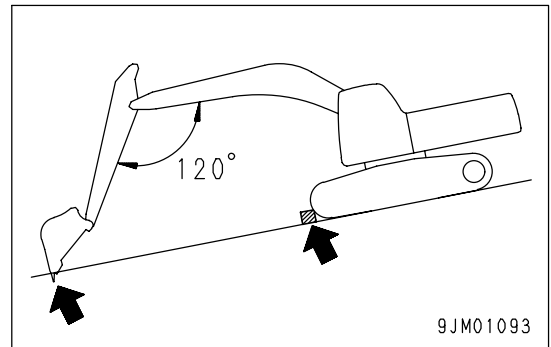

1. Put left and right travel levers (1) in the neutral position.
The machine stops.

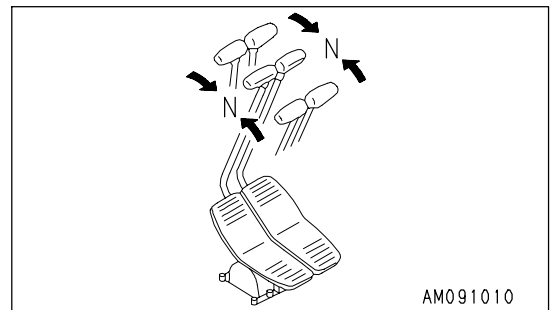
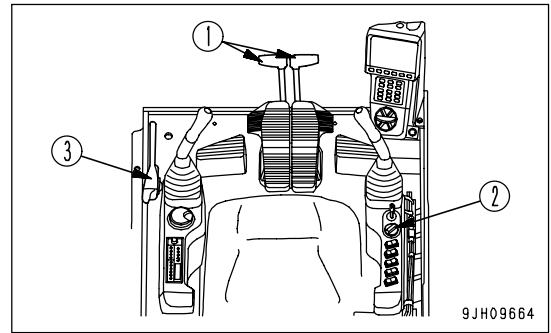

2. Turn fuel control dial (2) to low idling position (MIN) and lower the engine speed.

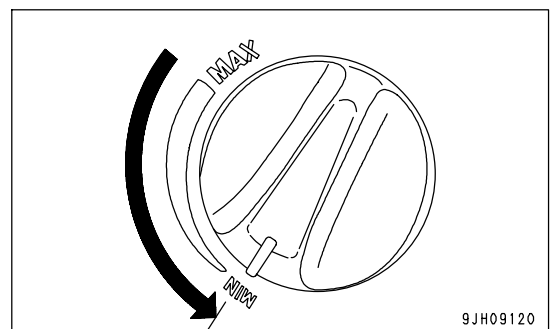

- Lower the bucket horizontally until the bottom touches the ground.

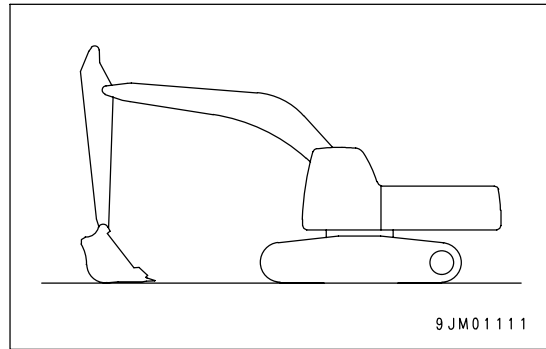

- Set lock lever (3) in the LOCK position (L).

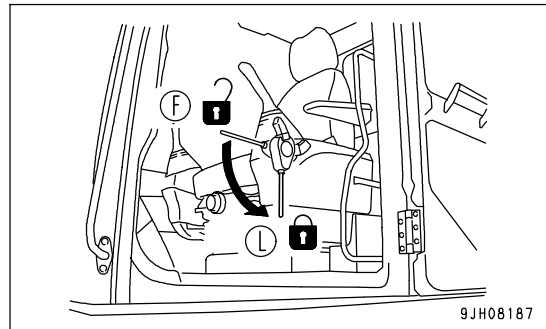

- Check the engine cooling water temperature and engine oil pressure with the machine monitor.

- If the coolant temperature gauge is in the red range, allow it to cool until the indicator enters the green range, then stop the engine. For details of the inspection and action to take, see "TROUBLES AND ACTIONS (PAGE 3-195)".
- If the engine oil pressure monitor lights up, stop the engine immediately. For details of the inspection and action to take, see "TROUBLES AND ACTIONS (PAGE 3-195)".

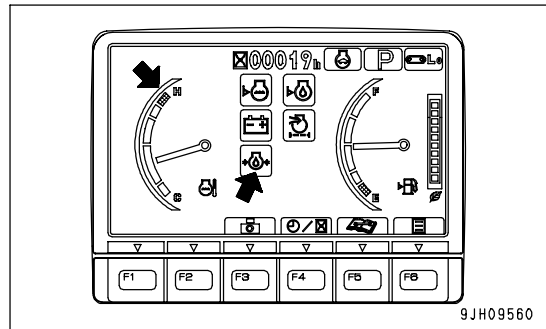

- Stop the engine. For details on the procedure for stopping the engine, see "STOPPING THE ENGINE (PAGE 3-143)".

MACHINE INSPECTION AFTER DAILY WORK

- Walk around the machine and check the work equipment, machine exterior, and undercarriage, also check for any leakage of oil or coolant. If any problems are found, repair them.
- Fill the fuel tank.
- Check the engine compartment for paper and debris. Clean out any paper and debris to avoid a fire hazard.
- Remove any mud affixed to the undercarriage.

LOCKING

Always lock the following places.

- (1) Operator's cab door
Always close the window.
- (2) Fuel tank filler port
- (3) Battery box cover
- (4) Left side door of the machine
- (5) Right side door of the machine
- (6) Hydraulic tank filler port
- (7) Air conditioner FRESH filter intake port
- (8) Engine hood front cover
- (9) Engine hood rear cover

REMARK

Use the starting switch key to lock and unlock all these places.

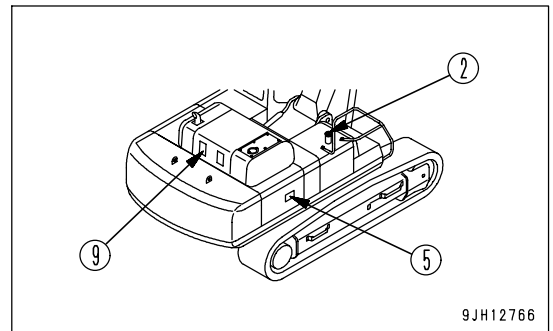
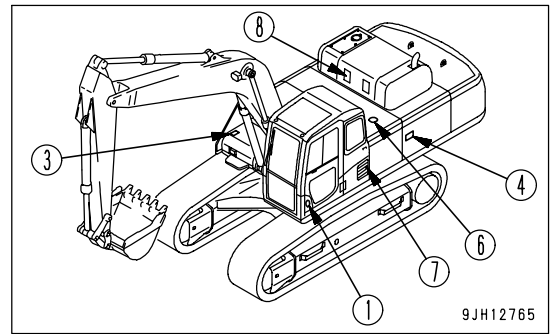

TRANSPORTATION

When transporting the machine, observe all related laws and regulations, and be careful to assure safety.

TRANSPORTATION PROCEDURE

- Select the method of transportation to match the weight and dimensions given in "SPECIFICATIONS (PAGE 5-2)".
Note that the weight and dimensions given in SPECIFICATIONS may differ according to the type of shoe or arm, or other attachments.
- Please consult your Komatsu distributor for details of the procedure for transporting machines with a protective guard installed for the operator's cab.

LOADING AND UNLOADING WITH TRAILER

 **WARNING**

Always obey the following when loading or unloading the machine from a trailer.

- Select firm, level ground when loading or unloading the machine. Maintain a safe distance from the edge of the road.
- Always turn the auto-deceleration switch OFF (cancel).
If the auto-deceleration switch is left ON, the machine may suddenly start moving.
- Always set the travel speed switch to low speed (Lo), run the engine at low idling, and operate the machine slowly when loading or unloading.
- In cold areas, carry out the warming-up operation thoroughly and make sure that the engine speed is stable before carrying out the loading or unloading operation.
- Never correct your steering on the ramps. There is danger that the machine may tip over.
If necessary, drive off the ramps or back on to the trailer and correct the direction.
- It is dangerous to use the work equipment for loading and unloading operations. Always use ramps.
- When on the ramps, do not operate any lever except the travel lever.
- The center of gravity of the machine will change suddenly at the joint between the ramps and the trailer, and there is danger of the machine losing its balance.
Travel slowly over this point.
- If it is necessary to swing the work equipment on the trailer platform, the footing is unstable, so be extremely careful that the machine does not tip over.
If the work equipment is installed to the machine, pull the work equipment in, and operate slowly to prevent the machine from losing its balance.
- Position a flagman to give guidance to prevent the machine from coming off the ramps and to ensure safety in the operation.

Always observe the following regarding the ramps and trailer platform.

- Use ramps with ample width, length, thickness, and strength and install them at a maximum slope of 15°.

When using piled soil, compact the piled soil fully to prevent the slope face from collapsing.
- Clean the machine tracks and ramps before starting in order to prevent the machine from slipping on the ramps.

There is danger of the machine slipping if there is water, snow, grease, oil, or ice on the ramp surface.

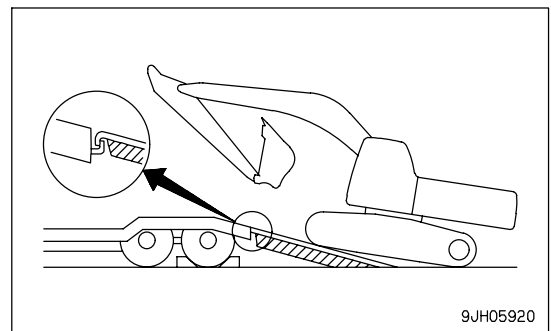
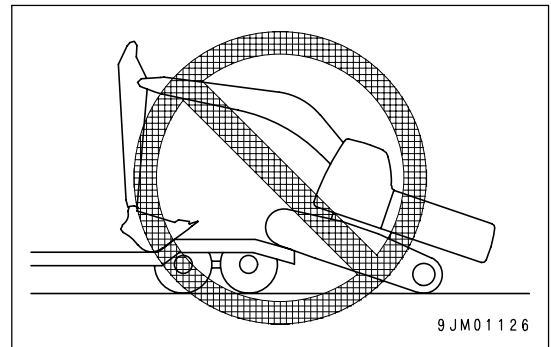

When loading or unloading, always use ramps or a platform. Proceed as follows.

Loading

1. Load and unload on firm level ground only.

Maintain a safe distance from the edge of a road.

2. Apply the trailer brakes securely, then put blocks (1) under the tires to prevent the trailer from moving.

- Set left and right ramps (2) parallel to each other and equally spaced to the left and right of center (3) of the trailer. Make angle of installation (4) a maximum of 15°. If the ramps bend a large amount under the weight of the machine, put blocks under the ramps to prevent them from bending.

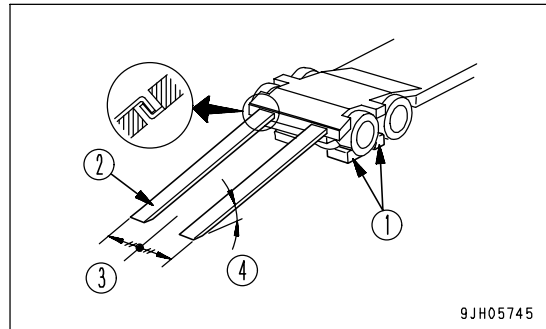

3. Turn the travel speed selector switch to low speed travel (Lo lamp lights up).

- Press travel speed selector switch (5) to switch the travel speed. The travel speed (Lo, Mi, Hi) is displayed on the travel speed monitor (6).

4. Turn auto-deceleration switch (7) OFF and operate the fuel control dial to set the engine speed to low idling.

- Each time auto-deceleration switch (7) is pressed, it switches OFF → ON → OFF in turn.
- When auto-deceleration switch (7) is turned OFF, the auto-deceleration monitor (8) goes out.

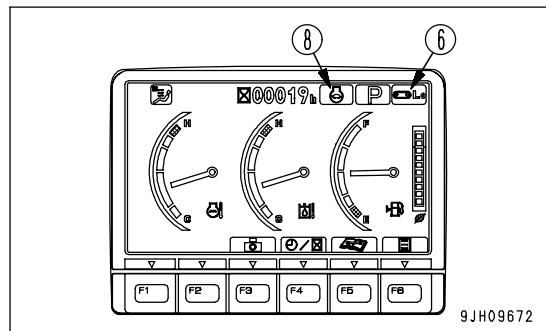
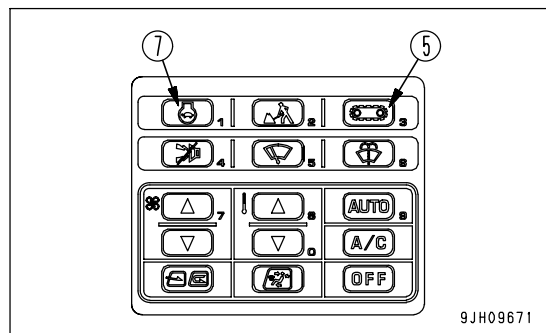

5. Turn the swing lock switch ON to apply the swing lock.

- When the swing lock switch is turned to the ON position, the swing lock monitor (9) lights up.

- (a): ON position
- (b): OFF position

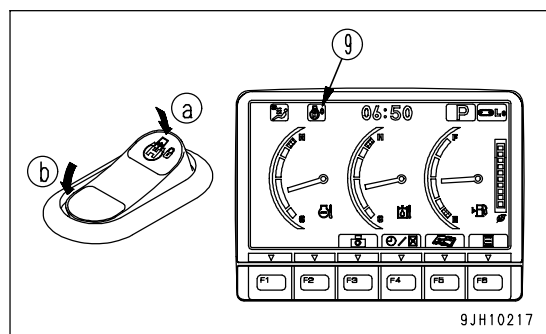

6. If the machine is equipped with work equipment, set the work equipment at the front, and travel forward to load it; if it has no work equipment, travel in reverse to load it.

Follow instructions and signals of a conductor particularly when traveling in reverse.

7. Before moving onto the ramps, make sure that the machine is positioned in a straight line with the ramps and that the centerline of the machine matches that of the trailer.

Align the direction of travel with the ramps and travel slowly.

Lower the work equipment as far as possible without causing interference.

When on the ramps, operate only the travel lever. Do not operate any other lever.

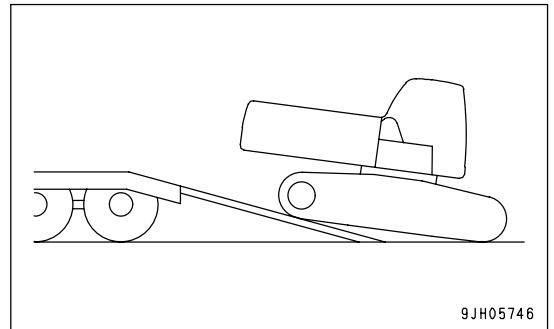
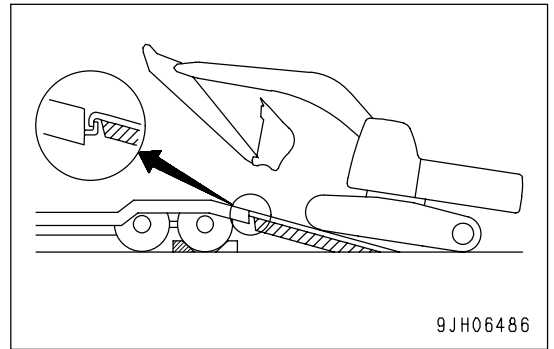

8. When loading or unloading a machine with the work equipment installed, at the point where the tracks are on both the ramps and the ground surface, turn the swing lock switch OFF, then swing the upper structure slowly 180°.

After doing that, drive slowly in reverse and load the machine onto the trailer.

9. Turn the swing lock switch ON to apply the swing lock.

- When the swing lock switch is turned to the ON position, the swing lock monitor (9) lights up.

(a): ON position

(b): OFF position

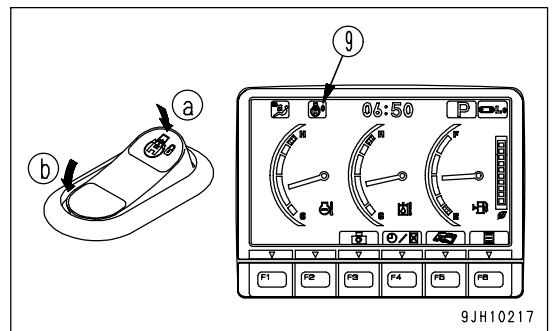
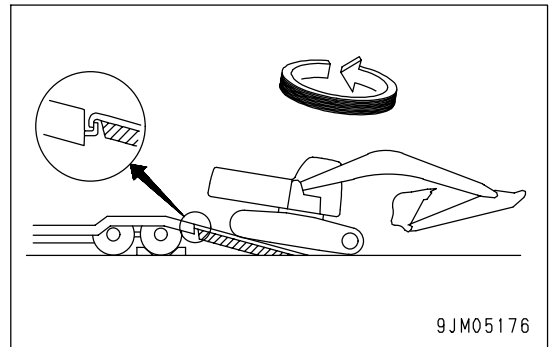

10. When the machine travels over the rear wheels of the trailer, it becomes unstable, drive slowly and carefully. (Never operate the steering.)
11. At the moment the machine passes the rear wheels, it tilts forward, be careful not to let the work equipment hit the trailer body. Drive the machine forward to the specified position, then stop the machine.
12. Lower the work equipment on top of wooden blocks.

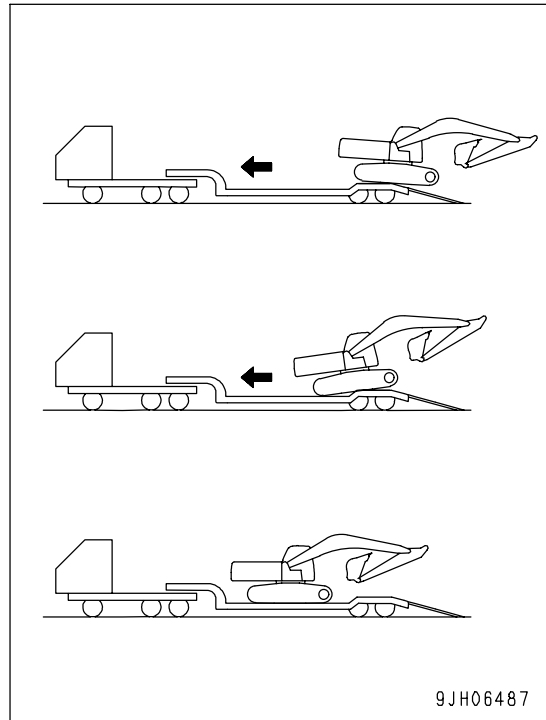

Securing Machine

NOTICE

- Stow the antenna and reassemble the mirrors so that they are within the width of the machine.
- To prevent damage to the bucket cylinder during transportation, fit a wooden block at one end of the bucket cylinder to prevent it from touching the floor.

Load the machine onto a trailer as follows:

1. Extend the bucket and arm cylinders fully, then lower the boom slowly.

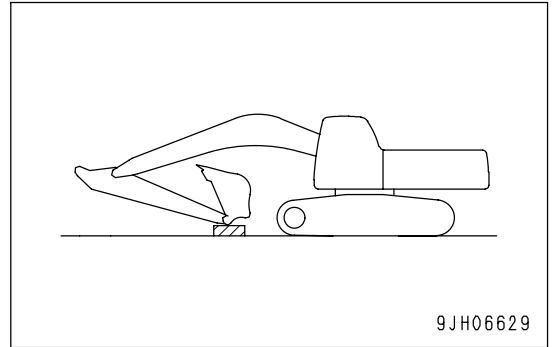

2. Set the lock lever securely to the LOCK position (L).
3. Stop the engine, then remove the key from the starting switch.
4. Close all doors, windows, and covers.
Lock the covers, caps, and doors fitted with locks.

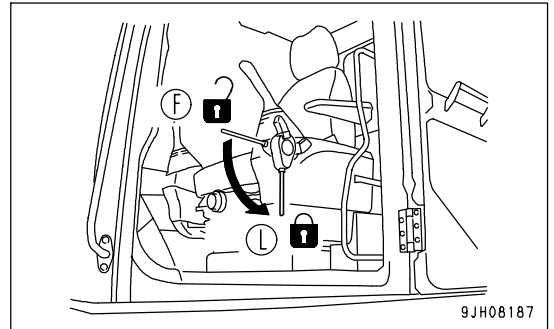

5. Place blocks under both ends of the tracks to prevent the machine from moving during transportation, and secure the machine with chains or wire rope of suitable strength.
Be particularly careful to secure the machine in position so it does not slip to the side.

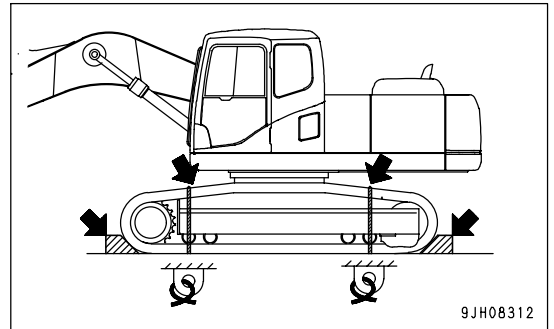

Stowing Radio Antenna

- Loosen bolt (2) of radio antenna (1) at the rear of the cab, lower the antenna, then tighten bolt (2) again to secure radio antenna (1) in position.
- When unloading the machine from the trailer and operating it, follow the opposite procedure from stowing to set radio antenna (1) vertical, then secure it in position with bolt (2).

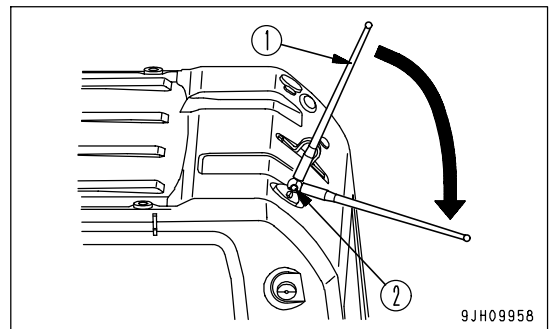

Rearview Mirrors

The mirrors are at the positions shown in the diagram on the right. If they are damaged, or are to be removed for shipment, or are to be installed again, use the following procedure.

- After installing the mirrors, be sure to adjust them, referring to "Rearview Mirrors (PAGE 3-121)".

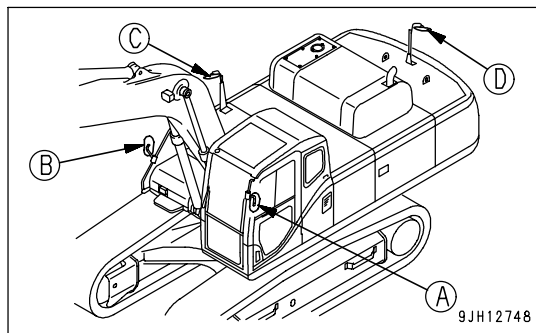

Removal

Mirror (A)

1. Loosen locknut (2) of mirror (1), then remove mirror (1) from support (3).
2. Loosen bolt (4) and remove support (3) and clamp (5) from the handrail.

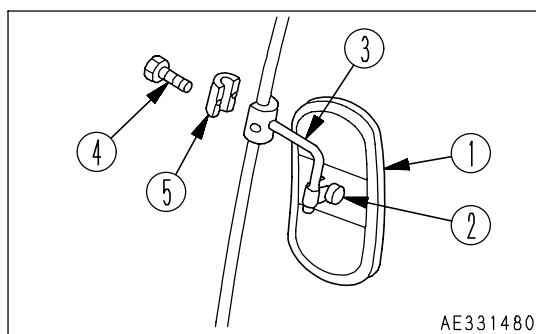

Mirror (B)

3. Loosen mounting bolt (2), then remove mirror (1) from support (3).
4. Loosen bolt (4) and remove support (3) and clamp (5) from the handrail.

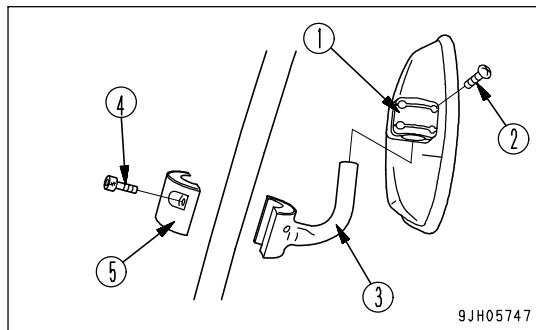

Mirrors (C), (D)

(If equipped)

5. Loosen locknut (2), then remove mirror (1) from bracket (3).
6. Remove bolt (4), then remove bracket (3) from the machine.

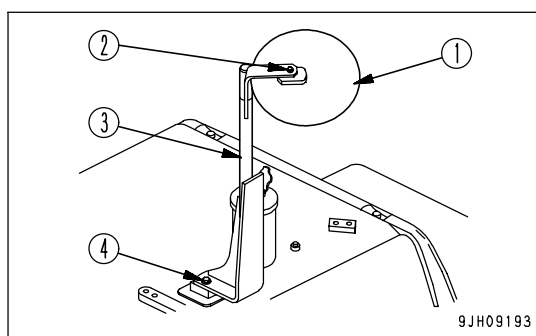

Installation

Mirror (A)

1. Install support (3) and clamp (5) to the handrail, then tighten with bolt (4).
2. Install mirror (1) to bracket (3), then tighten locknut (2).

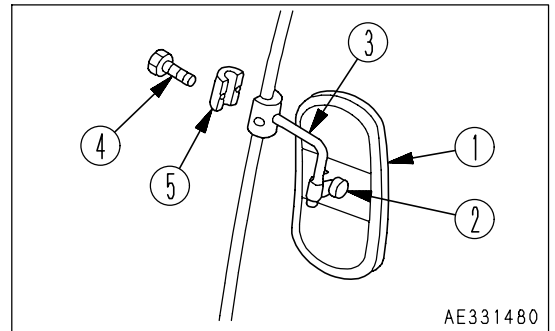

Mirror (B)

3. Install support (3) and clamp (5) to the handrail, then tighten with bolt (4).
4. Install mirror (1) to support (3), then tighten lock bolt (2).

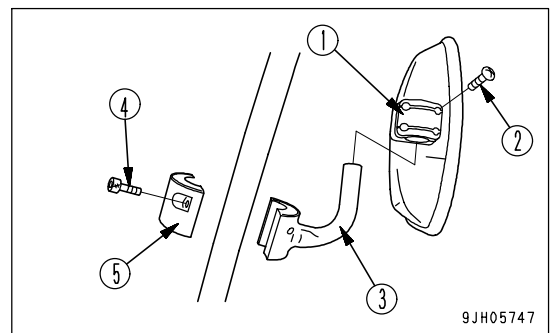

Mirrors (C), (D)

(If equipped)

5. Install bracket (3) to the machine with bolt (4).
6. Install mirror (1) to bracket (3), then tighten locknut (2).

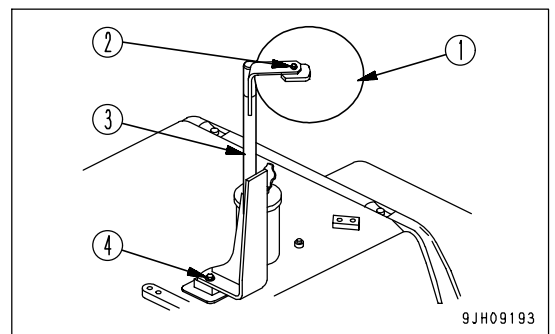

Unloading

1. Load and unload on firm level ground only. Maintain a safe distance from the edge of a road.
2. Apply the trailer brakes securely, then put blocks (1) under the tires to prevent the trailer from moving.
 - Set left and right ramps (2) parallel to each other and equally spaced to the left and right of center (3) of the trailer. Make angle of installation (4) a maximum of 15°. If the ramps bend a large amount under the weight of the machine, put blocks under the ramps to prevent them from bending.

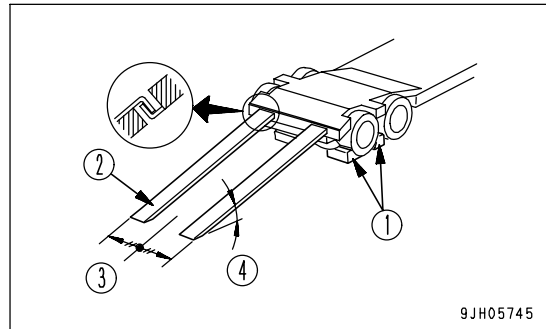

3. Remove the chains and wire ropes fastening the machine.
4. Start the engine.
 - Warm the engine up fully.
5. Set the lock lever to FREE position (F).

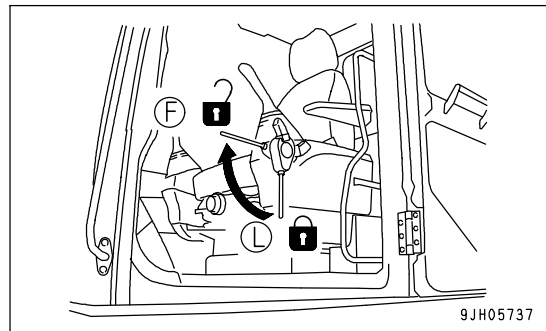

6. Turn the travel speed selector switch to low speed travel (Lo lamp lights up).
 - Press travel speed selector switch (5) to switch the travel speed. The travel speed (Lo, Mi, Hi) is displayed on the travel speed monitor (6).

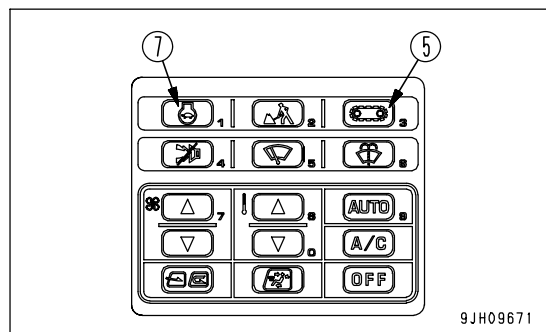

7. Turn auto-deceleration switch (7) OFF and operate the fuel control dial to set the engine speed to low idling.
 - Each time auto-deceleration switch (7) is pressed, it switches OFF → ON → OFF in turn.
 - When auto-deceleration switch (7) is turned OFF, the auto-deceleration monitor (8) goes out.

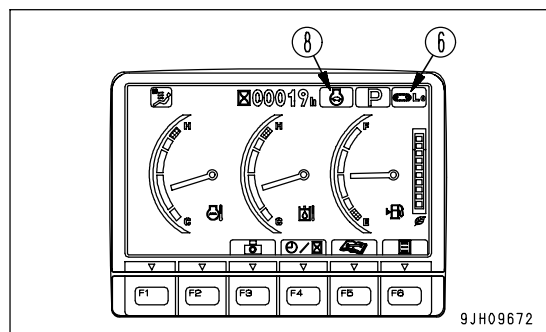

8. Raise the work equipment, pull in the arm under the boom, then move the machine slowly.
9. When the machine is horizontal on top of the rear wheels of the trailer, stop the machine.

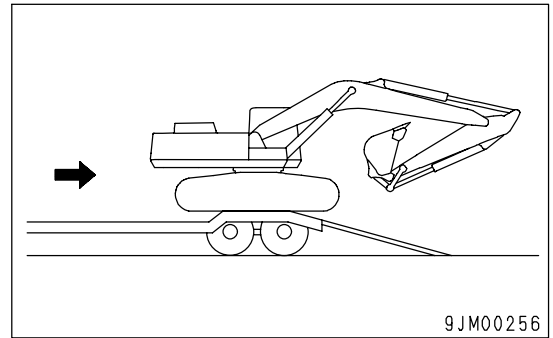
**NOTICE**

- When unloading the machine, always keep the arm and boom at an angle of 90° - 110° .
If the machine is unloaded with the arm pulled in, it will cause damage to the machine.
- When moving onto the ramps, do not thrust the bucket into the ground. This will cause damage to the hydraulic cylinders.

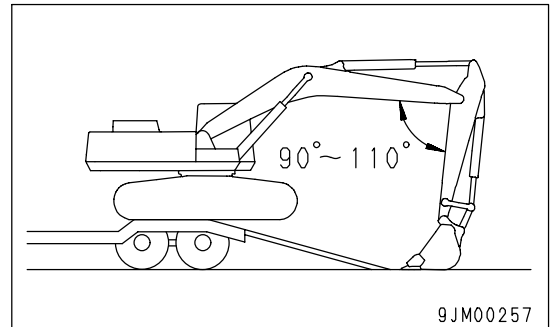

10. When moving from the rear of the trailer on to the ramps, set the angle of the arm and boom to 90° to 110° , lower the bucket to the ground, then move the machine slowly.
11. When moving down the ramps, operate the boom and arm slowly to lower the machine carefully until it is completely off the ramps.

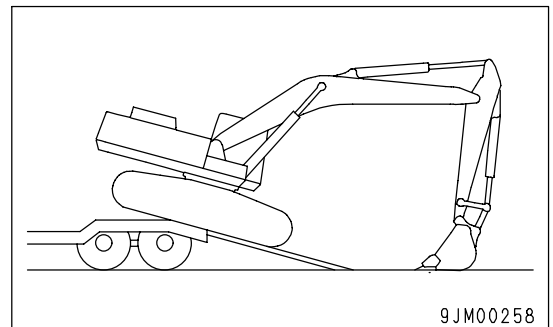

LIFTING MACHINE

**WARNING**

- The operator carrying out the lifting operation using a crane must be a properly qualified crane operator.
- Never raise the machine with any worker on it.
- Always make sure that the wire rope is of ample strength for the weight of this machine.
- When lifting, keep the machine horizontal.
- When carrying out lifting operations, set the lock lever to the LOCK position to prevent the machine from moving unexpectedly.
- Never enter the area under or around a raised machine.

Never try to lift the machine in any posture other than the posture given in the procedure below or using lifting equipment other than in the procedure below.

There is a hazard that the machine may lose its balance.

NOTICE

This method of lifting applies to the standard specification machine.

The method of lifting differs according to the attachments and options installed.

For details of the procedure for machines that are not the standard specification, please consult your Komatsu distributor.

For weight, see "SPECIFICATIONS (PAGE 5-2)".

When lifting the machine, carry out the operation on flat ground as follows.

1. Start the engine, then swing the upper structure so that the work equipment will be on the side of sprocket (1).
2. Extend the bucket cylinder and arm cylinder fully, then lower the work equipment to the ground as shown in the diagram on the right using the boom cylinder.

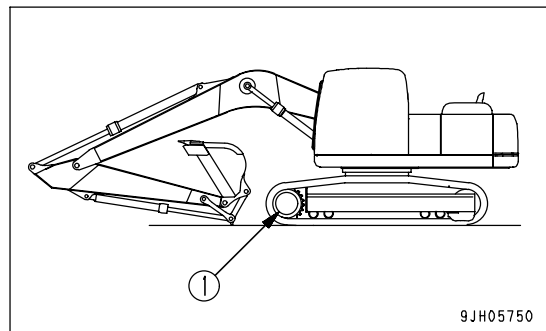

3. Set the lock lever securely to the LOCK position (L).

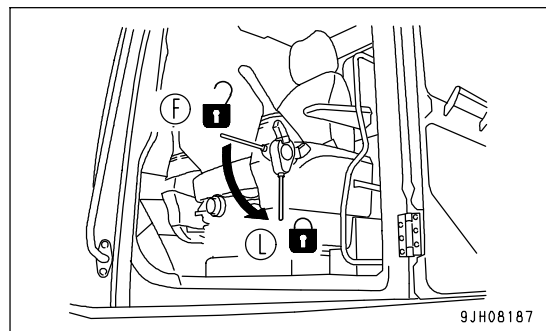

4. Stop the engine, check that there is nothing around the operator's compartment, then get off the machine. Close the cab door and front glass securely.

5. Pass wire ropes between the 1st and 2nd track rollers from the front and between the 1st and 2nd track rollers from the rear. However, for machines equipped with a full roller guard for the track roller, pass the wire rope under the track.
6. Set the lifting angle (A) of the wire rope to 30° to 40°, then lift the machine slowly.
7. After the machine comes off the ground, check the hook condition and the lifting posture, and then lift slowly.

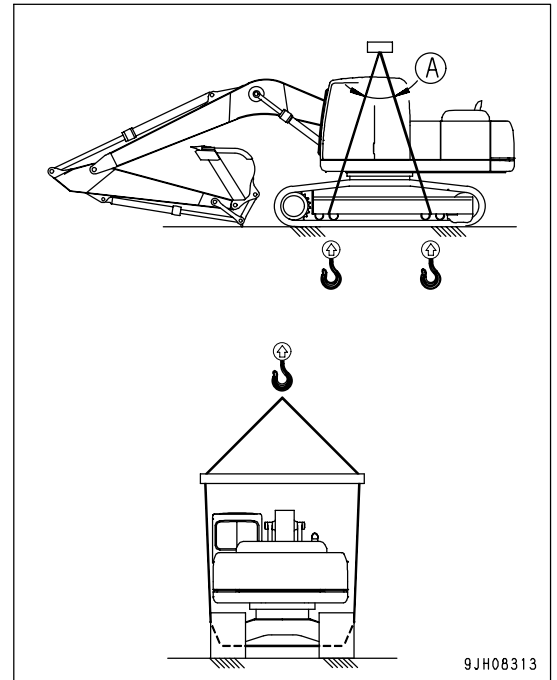

TRANSPORTATION POSTURE

This machine is separated into four kits for transportation: (1) upper structure, (2) cab, (3) work equipment, (4) others. When transporting the machine, please ask your Komatsu distributor to divide the machine up into kits.

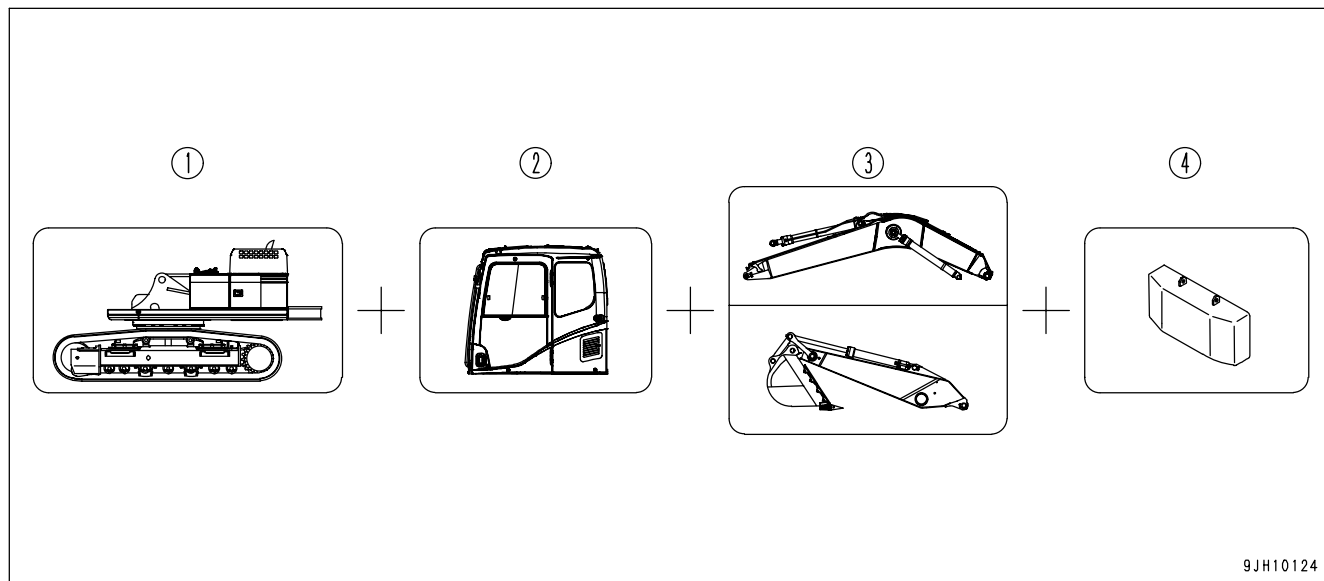

9JH10124

Posture for Each Unit

Upper Structure + Undercarriage

Item	Unit	PC400	PC400LC	PC450	PC450LC
A	mm (ft in)	3,285 (10' 9")	3,285 (10' 9")	3,285 (10' 9")	3,285 (10' 9")
B	mm (ft in)	5,850 (19' 2")	6,015 (19' 9")	5,850 (19' 2")	6,015 (19' 9")
Overall width	mm (ft in)	3,340 (10' 11")	3,440 (11' 3")	3,340 (10' 11")	3,440 (11' 3")
Weight	kg (lb)	24,510 (54,045)	25,510 (55,250)	25,090 (55,323)	26,090 (57,528)

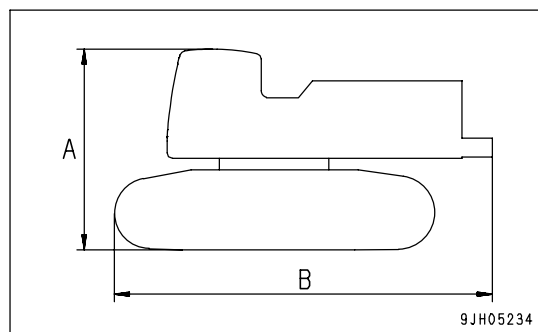

9JH05234

Upper Structure + Undercarriage (without cab)

Item	Unit	PC400	PC400LC	PC450	PC450LC
A	mm (ft in)	3,205 (10' 6")	3,205 (10' 6")	3,205 (10' 6")	3,205 (10' 6")
B	mm (ft in)	5,850 (19' 2")	6,015 (19' 9")	5,850 (19' 2")	6,015 (19' 9")
Overall width	mm (ft in)	3,340 (10' 11")	3,440 (11' 3")	3,340 (10' 11")	3,340 (10' 11")
Weight	kg (lb)	23,940 (52,788)	24,940 (54,993)	24,520 (54,067)	25,520 (56,272)

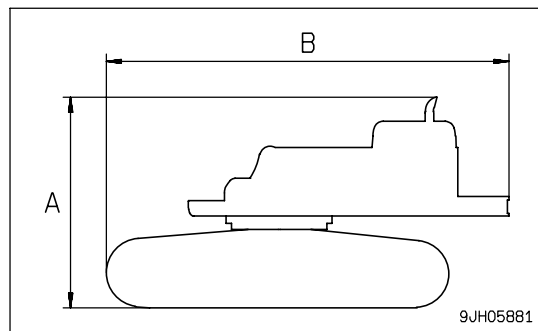

9JH05881

Cab

Item	Unit	PC400, PC400LC	PC450, PC450LC
A	mm (ft in)	1,670 (5' 6")	1,670 (5' 6")
B	mm (ft in)	1,840 (6')	1,840 (6')
Overall width	mm (ft in)	1,000 (3' 3")	1,000 (3' 3")
Weight	kg (lb)	570 (1,257)	570 (1,257)

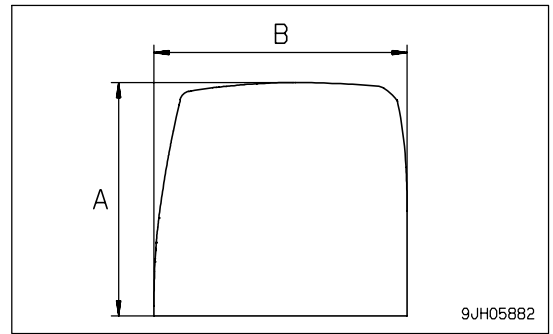

Work Equipment

• Boom

Item	Unit	PC400, PC400LC	PC450, PC450LC
A	mm (ft in)	7,280 (23' 11")	7,280 (23' 11")
B	mm (ft in)	1,730 (5' 8")	1,760 (5' 8")
Overall width	mm (ft in)	985 (3' 3")	985 (3' 3")
Weight	kg (lb)	4,600 (10,143)	4,800 (10,584)

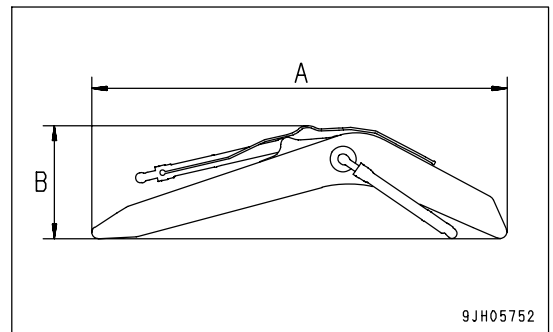

• Arm, Bucket

Item	Unit	PC400, PC400LC	PC450, PC450LC
A	mm (ft in)	4,890 (16' 1")	5,050 (16' 7")
B	mm (ft in)	1,950 (6' 5")	1,950 (6' 5")
Overall width	mm (ft in)	1,630 (5' 4")	1,630 (5' 4")
Weight	kg (lb)	3,400 (7,497)	4,200 (9,216)

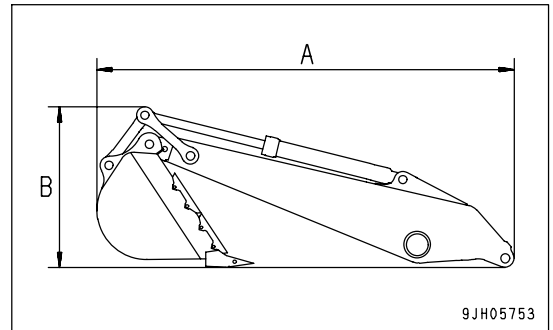

Others

• Counterweight

Item	Unit	PC400, PC400LC	PC450, PC450LC
A	mm (ft in)	1,145 (3' 9")	1,145 (3' 9")
B	mm (ft in)	2,995 (9' 10")	2,995 (9' 10")
C	mm (ft in)	970 (3' 2")	970 (3' 2")
Weight	kg (lb)	9,230 (20,352)	9,230 (20,352)

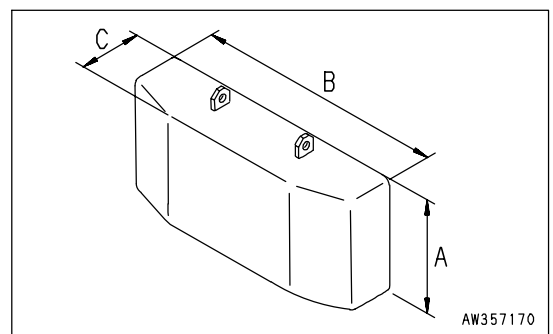

PROCEDURE FOR INCREASING OR REDUCING TRACK FRAME GAUGE

WARNING

- Never use the machine for operations with the track frame retracted.
- Never operate the cylinders suddenly when extending or retracting the track frame gauge width. It is dangerous if they are operated suddenly.
- Stop the machine on firm level ground when extending or retracting the track frame gauge width.

Reducing Track Gauge

1. Remove center frame mounting bolts (1) (front and rear: 9 each) on one side.

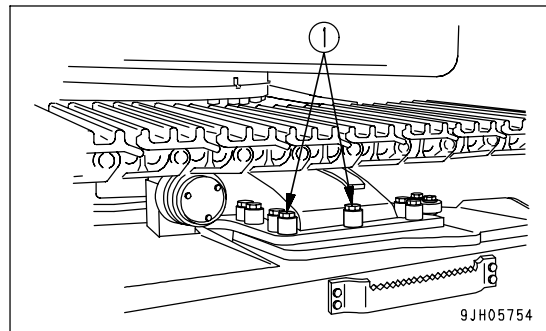

2. Swing the upper structure to the side where the track frame gauge is to be reduced, set it at 90° to track frame (2), then use the work equipment to jack up the track frame.
3. Set blocks (3) (20 to 30 cm (8 to 12 in) wooden blocks) towards the outside of track frame (2), then use the boom cylinder to lower the machine slowly. The track frame (2) will slide and stop when it contacts the stopper.

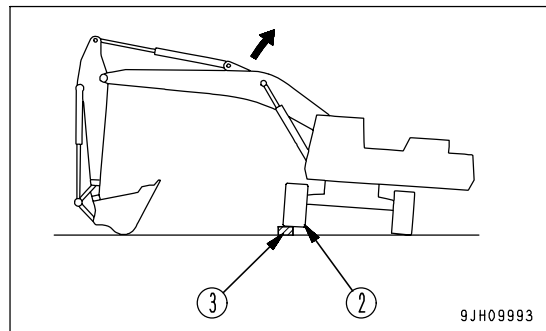

4. Lower the machine slowly to the ground, then install 8 of removed mounting bolts (front and rear: 4 each).
 - Tightening torque: 1520 - 1910 Nm
(155 - 195 kgm, 1121 - 1410 lbft)
5. Follow the same procedure to retract the track frame on the other side.

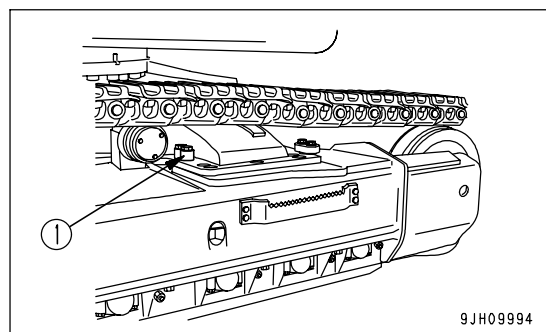

Increasing Track Gauge

1. Remove center frame mounting bolts (1) (front + rear: each 4 bolts) from the front and rear of the track frame on the side to be extended.

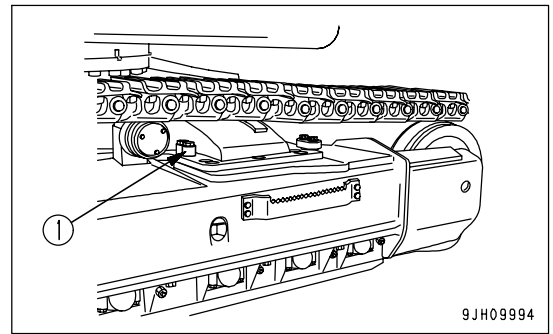

2. Swing the upper structure to the opposite side to where the track frame gauge is to be increased, set it at 90° to track frame (2), then use the work equipment to jack up the track frame.

REMARK

Height (H) of the track frame being raised should be less than 50 mm (2 in). Take care not to raise the track frame so much that the stopper bolt is distorted.

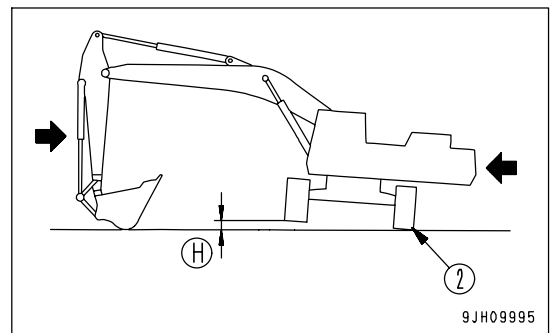

3. Using the arm, pull the machine to the front.
The track frame will slide.
4. Extend the track frame until it comes into contact with the stopper, then lower the machine slowly to the ground. Install bolts (1) (front + rear: each 9 bolts) and tighten to specified torque.
 - Tightening torque: 1520 - 1910 Nm
(155 - 195 kgm, 1121 - 1410 lbft)
5. Follow the same procedure to retract the track frame on the other side.

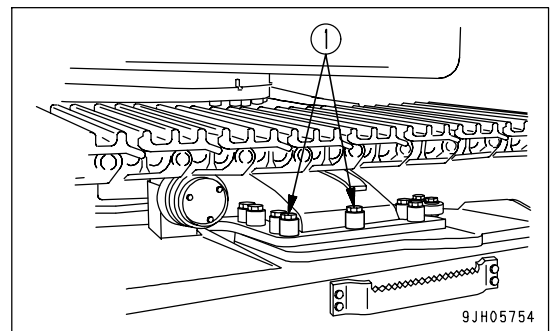

COLD WEATHER OPERATION

COLD WEATHER OPERATION INFORMATION

If the temperature becomes low, it becomes difficult to start the engine, and the coolant may freeze, so do as follows.

Fuel and Lubricants

Change to fuel and oil with low viscosity for all components. For details of the specified viscosity, see "RECOMMENDED FUEL, COOLANT, AND LUBRICANT (PAGE 4-9)".

Cooling System Coolant



WARNING

- Antifreeze is toxic. Be careful not to get it into your eyes or on your skin. If it should get into your eyes or on your skin, wash it off with large amounts of fresh water and see a doctor at once.
- When changing the coolant or when handling coolant containing antifreeze that has been drained when repairing the radiator, please contact your Komatsu distributor or request a specialist company to carry out the operation. Antifreeze is toxic. Do not let it flow into drainage ditches or spray it onto the ground surface.

NOTICE

Please use Komatsu genuine supercoolant (AF-NAC) for the coolant. As a basic rule, we do not recommend the use of any coolant other than Komatsu genuine supercoolant.

The Supercoolant is already diluted with distilled water, so it is not flammable.

For details of the density of the Supercoolant and the interval for changing the coolant, see "CLEAN INSIDE OF COOLING SYSTEM (PAGE 4-25)".

Battery

 **WARNING**

- The battery generates flammable gas. Do not bring fire or sparks near the battery.
- Battery electrolyte is dangerous. If it gets in your eyes or on your skin, wash it off with a large amount of water and consult a doctor.
- Battery electrolyte dissolves paint. If it gets on the bodywork, wash it off immediately with water.
- If the battery electrolyte is frozen, do not charge the battery or start the engine with a different power source. There is danger that the battery may explode.
- Battery electrolyte is toxic. Do not let it flow into drainage ditches or spray it on to the ground surface.

When the ambient temperature drops, the capacity of the battery will also drop. If the battery charge ratio is low, the battery electrolyte may freeze. Maintain the battery charge as close as possible to 100%. Insulate it against cold temperature to ensure the machine can be started easily the next morning.

REMARK

Measure the specific gravity and calculate the charging rate from the following conversion table.

Electrolyte Temperature	20°C (68°F)	0°C (32°F)	-10°C (14°F)	-20°C (-4°F)
Charging Rate (%)				
100	1.28	1.29	1.30	1.31
90	1.26	1.27	1.28	1.29
80	1.24	1.25	1.26	1.27
75	1.23	1.24	1.25	1.26

- As the battery capacity drastically drops in low temperatures, cover or remove the battery from the machine, store the battery in a warm place, and install it again the next morning.
- If the electrolyte level is low, add distilled water in the morning before beginning work. Do not add water after the day's work to prevent diluted electrolyte in the battery from freezing during the night.

AFTER DAILY WORK COMPLETION



WARNING

Performing idle-running of the tracks is dangerous, stay well away from the tracks.

To prevent mud, water, or the undercarriage from freezing and making it impossible for the machine to move on the following morning, observe the following precautions.

- Remove all the mud and water from the machine body. In particular, wipe the hydraulic cylinder rods clean to prevent damage to the seal caused by mud, dirt, or drops of water on the rod from getting inside the seal.
- Park the machine on hard, dry ground.

If this is impossible, park the machine on boards.

The boards prevent the tracks from freezing to the ground, and allow the machine to be moved the next morning.

- Open the drain valve and drain any water collected in the fuel system to prevent it from freezing.
 - Fill the fuel tank to capacity. This minimizes moisture condensation in the tank when the temperature drops.
 - After operation in water or mud, remove water from undercarriage as described below to extend undercarriage service life.
1. Swing 90° with engine at low idle and bring the work equipment to the side of the track.
 2. Jack up the machine until the track is raised slightly from the ground. Rotate the track under no load. Repeat this procedure on both the left and right sides.

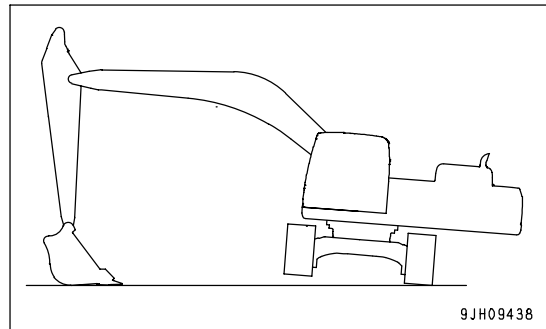

AFTER COLD WEATHER SEASON

When the season changes and the weather becomes warmer, do as follows.

- Replace the fuel and oil for all parts with oil of the viscosity specified.
For details, see "RECOMMENDED FUEL, COOLANT, AND LUBRICANT (PAGE 4-9)".

LONG TERM STORAGE

BEFORE STORAGE

NOTICE

To protect the hydraulic cylinder piston rod while in storage, keep the work equipment in the posture shown at right.

(This prevents rust from developing on the piston rod)

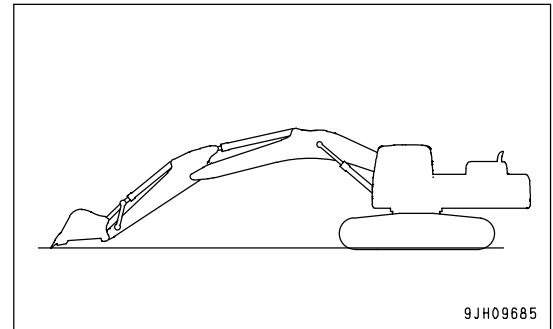

When putting the machine in storage for a long time (more than one month), do as follows.

- Clean and wash all parts, then store the machine indoors. If the machine has to be stored outdoors, select level ground and cover the machine with canvas.
- Completely fill the fuel tank. This prevents moisture from collecting.
- Lubricate and change the oil before storage.
- Coat the exposed portion of the hydraulic cylinder piston rod with grease.
- Disconnect the negative terminals of the battery and cover it or remove it from the machine and store it separately.
- Lock each control lever and pedal with the lock lever and pedal lock.
- Set the stop valve to the LOCK position on machines ready for attachments. Install the blind plugs to the elbows. For details of the LOCK and FREE positions of the stop valve, see "ATTACHMENT REMOVAL AND INSTALLATION (PAGE 6-13)".
- To prevent rust, fill with Komatsu genuine supercoolant (AF-NAC) to give a density of at least 30% for the engine coolant.

DURING STORAGE



WARNING

If it is necessary to perform the rust-prevention operation while the machine is indoors, open the doors and windows to improve ventilation and prevent gas poisoning.

- During storage, operate and move the machine for a short distance once a month so that a new film of oil will coat moving parts. At the same time, also charge the battery.
- When operating the work equipment, wipe off all the grease from the hydraulic cylinder rods.
- If the machine is equipped with an air conditioner, operate the air conditioner for 3 to 5 minutes once a month to lubricate all parts of the air conditioner compressor. Always run the engine at low idle when doing this. In addition, check the refrigerant level twice a year.

AFTER STORAGE

NOTICE

If the machine has been stored without carrying out the monthly rust-prevention operation, consult your Komatsu distributor before using it.

When using the machine after long-term storage, do as follows before using it.

- Wipe off the grease from the hydraulic cylinder rods.
- Add oil and grease at all lubrication points.
- When the machine is stored for a long period, moisture in the air will mix with the oil. Check the oil before and after starting the engine. If there is water in the oil, change all the oil.

STARTING MACHINE AFTER LONG-TERM STORAGE

When starting the engine after long-term storage, carry out the warming-up operation thoroughly. For details, see "Engine Warm Up (PAGE 3-133)".

TROUBLES AND ACTIONS

RUNNING OUT OF FUEL

When starting the engine again after running out of fuel, fill with fuel, then bleed the air from the fuel system before starting the engine.

Always watch the fuel level and be careful not to run out of fuel.

If the engine has stopped because of lack of fuel, it is necessary to use the priming pump to bleed the air completely from the fuel circuit.

Procedure for Bleeding Air



CAUTION

- This engine consists of higher precision parts than on the conventional fuel injection pump and nozzle, so if dirt gets in, it will cause problems. If there is any dirt stuck to the fuel line, use fuel to wash it off completely.
- Be careful when opening the air bleed plug at the fuel filter head. The system is still under pressure and fuel may spurt out.

1. Loosen air bleed plug (A) at the fuel main filter head (1).
2. Loosen wing nut (4) holding lever (3) of priming pump (2).
3. Push in lever (3) repeatedly.

Check that bubbles come out with the fuel from air bleed plug (A).

4. Tighten air bleed plug (A).
Tightening torque: 4.9 to 6.9 Nm (0.5 to 0.7 kgm, 3.6 to 5.1 lbft)
5. Tighten wing nut (4) securely to lock lever (3) in position.
Target tightening torque: 11.8 Nm
(1.2 kgm, 8.7 lbft)

6. Turn the key in the starting switch to the START position and start the engine.

When doing this, do not crank the starting motor continuously for more than 20 seconds. If the engine does not start, wait for at least 2 minutes, then try again. Perform this operation a maximum of 4 times.

7. If the engine does not start, repeat the operation from Step 1.

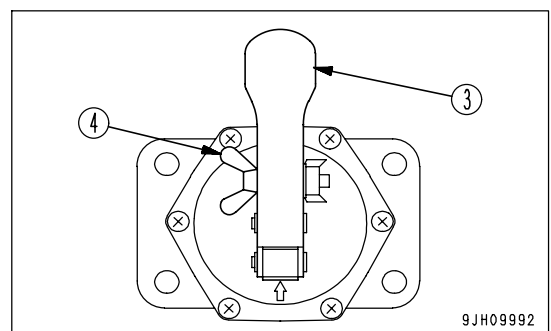
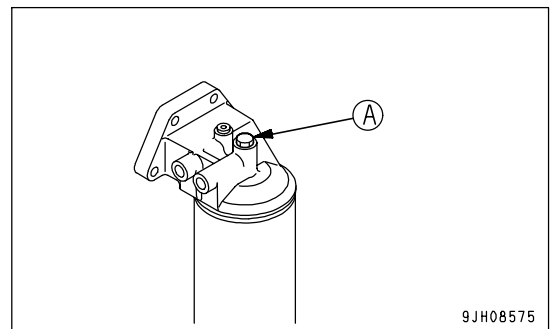
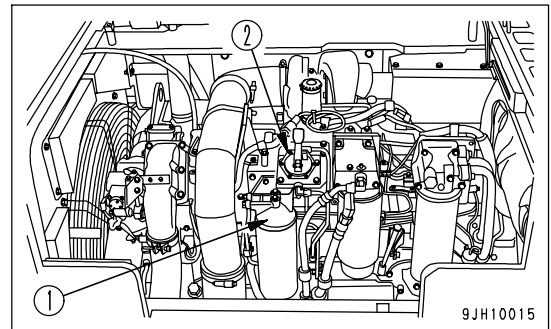

PHENOMENA THAT ARE NOT FAILURES

Note that the following phenomena are not failures:

- When the arm control lever is operated to the IN position and the work equipment is lowered under no load from a high position, the arm speed will drop momentarily when the arm is more or less at the vertical position.
- When the bucket control lever is operated to the CURL position and the work equipment is lowered under no load from a high position, the bucket speed will drop momentarily when the bucket teeth are more or less at the horizontal position.
- The bucket or arm will fluctuate by itself during heavy-duty digging operations.

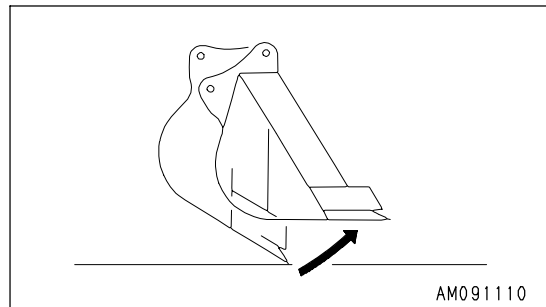
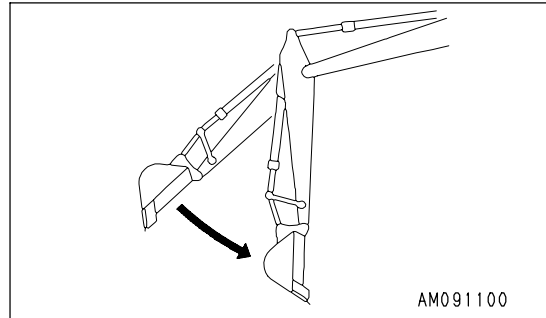

- When starting or stopping the swing, noise will be emitted from the brake valve.
- When going down a steep slope at low speed, a noise will be emitted from the travel motor brake valve.

TOWING THE MACHINE

 **WARNING**

Serious injury or death could result if a disabled machine is towed incorrectly or if there is a mistake in the selection or inspection of the wire rope.

- Always check that the wire rope used for towing has ample strength for the weight of the machine being towed.
- Never use a wire rope which has cut strands (A), reduced diameter (B), or kinks (C). There is danger that the rope may break during the towing operation.
- Always wear leather gloves when handling wire rope.
- Never tow a machine on a slope.
- During the towing operation, never stand between the towing machine and the machine being towed.
- Operate the machine slowly and be careful not to apply any sudden load to the wire rope.

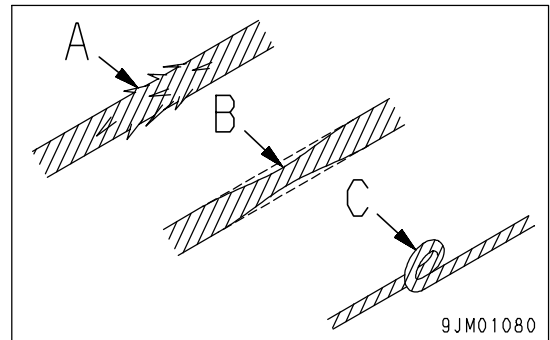
**NOTICE**

The maximum towing capacity for this machine is 303,030N (30,900 kg). Always carry out towing operations within the maximum towing capacity.

- If the machine sinks in mud and cannot get out under its own power, or if the drawbar pull of the excavator is being used to tow a heavy object, use a wire rope as shown in the diagram on the right.
- Place pieces of wood between wire ropes and body to prevent damage to ropes and body.
- Hold the wire rope level and direct it straight to the track frame.
- When towing a machine, travel at a speed of less than 1 km/h for a distance of only a few meters to a place that is suitable for carrying out repairs.

This is for use only in emergencies.

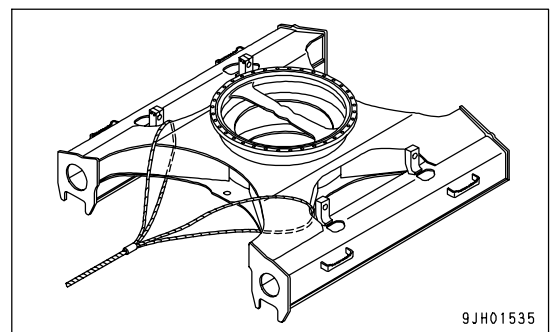
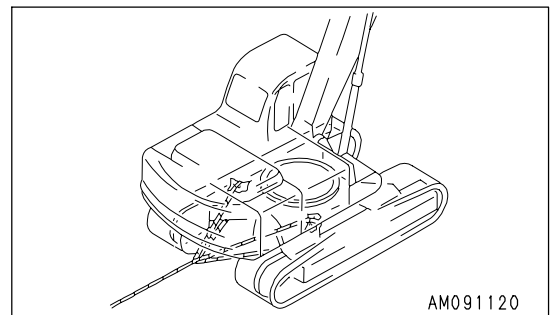

LIGHTWEIGHT TOWING HOLE



WARNING

- The shackle must always be used.
- Hold the wire rope level and direct it straight to the track frame.
- Move the machine slowly and be careful not to apply any sudden load to the wire rope.

There is a hole in the track frame to fit the shackle when towing light objects.

Permissible towing load: Max. 154,000N(16,000 kg)

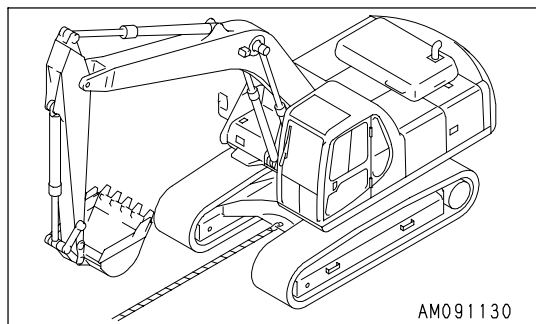

SEVERE JOB CONDITION

- When carrying out digging operations in water, if the work equipment mounting pin goes into the water, carry out greasing every time the operation is carried out.
- For heavy-duty operations and deep digging, carry out greasing of the work equipment mounting pins every time before operation.
After greasing, operate the boom, arm and bucket several times, then grease again.

DISCHARGED BATTERY

WARNING

- It is dangerous to charge a battery when mounted on a machine. Make sure that it is dismantled before charging.
- When checking or handling the battery, stop the engine and turn the starting switch key to the OFF position.
- The battery generates hydrogen gas, so there is a hazard of explosion. Do not bring lighted cigarettes near the battery, or do anything that will cause sparks.
- Battery electrolyte is dilute sulfuric acid, and it will attack your clothes and skin. If it gets on your clothes or on your skin, immediately wash it off with a large amount of water. If it gets in your eyes, wash it out with fresh water and consult a doctor.
- When handling batteries, always wear safety glasses and rubber gloves.
- When removing the battery, first disconnect the cable from the ground (normally the negative (-) terminal). When installing, install the positive (+) terminal first.
If a tool touches the positive terminal and the chassis, there is danger that it will cause a spark, so be extremely careful.
- If the terminals are loose, there is danger that the defective contact may generate sparks that will cause an explosion.
- When removing or installing the terminals, check which is the positive (+) terminal and which is the negative (-) terminal.

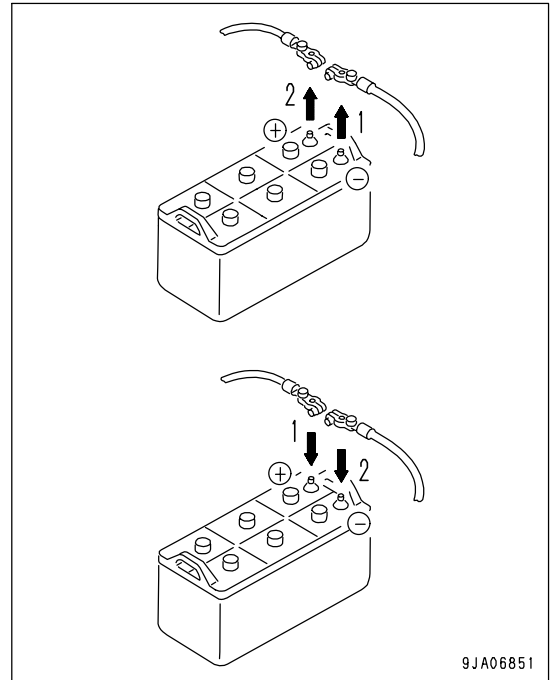

9JA06851

Battery Removal and Installation

- Before removing the battery, remove the ground cable (normally connected to the negative (-) terminal).
If any tool touches between the positive terminal and the chassis, there is a hazard of sparks being generated.
- When installing the battery, connect the ground cable last.
- When replacing the battery, secure it with battery hold-down.
Tightening torque: Tightening battery terminal: 9.8 to 19.6 Nm (1 to 2.0 kgm, 7.2 to 14.8 lbf)

Battery Charges

When charging the battery, if the battery is not handled correctly, there is a hazard that the battery may explode. Always follow the instructions of "DISCHARGED BATTERY (PAGE 3-199)" and the instruction manual accompanying the charger, and do as follows.

- Set the voltage of the charger to match the voltage of the battery to be charged. If the correct voltage is not selected, the charger may overheat and cause an explosion.
- Connect the positive (+) charger clip of the charger to the positive (+) terminal of the battery, then connect the negative (-) charger clip of the charger to the negative (-) terminal of the battery. Be sure to attach the clips securely.
- Set the charging current to 1/10 of the value of the rated battery capacity; when carrying out rapid charging, set it to less than the rated battery capacity.
If the charger current is too high, the electrolyte will leak or dry up, and this may cause the battery to catch fire and explode.
- If the battery electrolyte is frozen, do not charge the battery or start the engine with a different power source. There is a danger that this will ignite the battery electrolyte and cause the battery to explode.
- Do not use or charge the battery if the battery electrolyte level is below the LOWER LEVEL line. This may cause an explosion. Check the battery electrolyte level periodically and add distilled water to bring the electrolyte level to the UPPER LEVEL line.

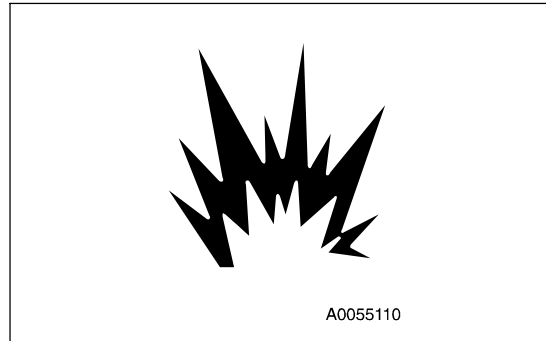

Starting Engine with Booster Cables

When starting the engine with a booster cable, do as follows.

Connecting and Disconnecting Booster Cables



WARNING

- When connecting the cables, never contact the positive (+) and negative (-) terminals.
- When starting the engine with a booster cable, always wear safety glasses.
- Be careful not to let the normal machine and problem machine contact each other. This prevents sparks from generating near the battery which could ignite the hydrogen gas given off by the battery. If hydrogen gas explodes, it could cause serious injury.
- Be careful not to make a mistake when connecting a booster cable. In the last connection (to the upper structure frame), a spark will be caused, connect the cable to a spot as far away from the battery as possible. (Avoid the work equipment, however, because it is not a good conductor)
- When removing the booster cable, exercise good care so that the booster cable clips may not contact each other, or they contact the chassis.

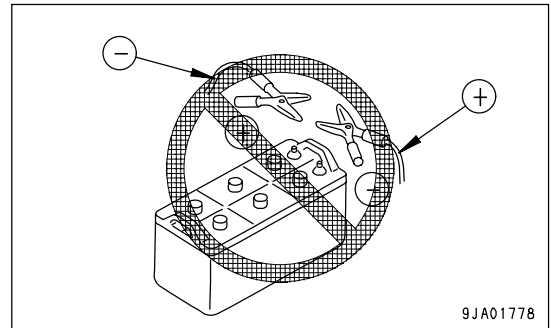

NOTICE

- The starting system for this machine uses 24V. For the normal machine, also use a 24V battery.
- The size of the booster cable and clip should be suitable for the battery size.
- The battery of the normal machine must be the same capacity as that of the engine to be started.
- Check the cables and clips for damage or corrosion.
- Make sure that the cables and clips are firmly connected.
- Check that the lock levers and parking brake levers of both machine are in the LOCK position.
- Check that each lever is in the NEUTRAL position.

Booster Cable Connection

Keep the starting switch of the normal machine and problem machine in the OFF position.

Connect the booster cable as follows, in the order of the numbers marked in the diagram.

1. Connect the clip of booster cable (A) to the positive (+) terminal of battery (C) on the problem machine.
2. Connect the clip at the other end of booster cable (A) to the positive (+) terminal of battery (D) on the normal machine.
3. Connect the clip of booster cable (B) to the negative (-) terminal of battery (D) on the normal machine.
4. Connect the other clip of booster cable (B) to the revolving frame (E) of the problem machine.

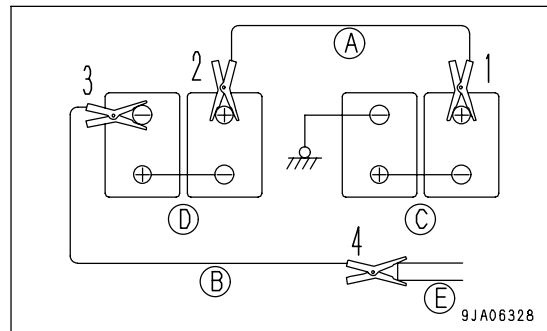

Starting the Engine



WARNING

Always check that the lock lever is set to the LOCK position, regardless of whether the machine is working normally or has failed. Check also that all the control levers are in the neutral position.

1. Make sure the clips are firmly connected to the battery terminals.
2. Start engine of the normal machine and run it at high idle speed.
3. Turn the starting switch of the problem machine to the START position and start the engine.
If the engine doesn't start at first, try again after 2 minutes or so.

Booster Cable Disconnection

After the engine has started, disconnect the booster cables in the reverse of the order in which they were connected.

1. Remove one clip of booster cable (B) from the revolving frame (E) of the problem machine.
2. Remove the clip of booster cable (B) from the negative (-) terminal of battery (D) on the normal machine.
3. Remove the clip of booster cable (A) from the positive (+) terminal of battery (D) on the normal machine.
4. Remove the clip of booster cable (A) from the positive (+) terminal of battery (C) on the problem machine.

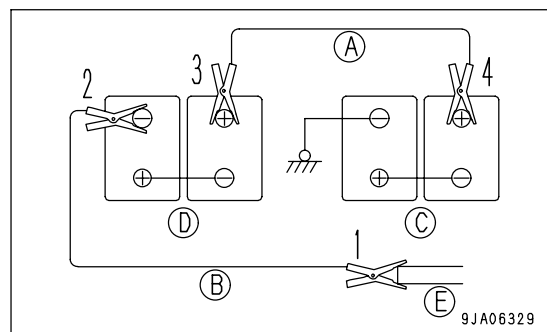

OTHER TROUBLE

Electrical System

- (): Always contact your Komatsu distributor when dealing with these items.
- In cases of problems or causes which are not listed below, contact your Komatsu distributor for repairs.

Problem	Main causes	Remedy
Lamp does not glow brightly even when the engine runs at high speed	<ul style="list-style-type: none"> • Defective wiring, deterioration of battery • Loose fan belt 	<ul style="list-style-type: none"> (• Check, repair loose terminals, disconnections, replace battery) • Check fan belt tension, replace
Lamp flickers while engine is running		
Charge level monitor does not go out even when engine is running	<ul style="list-style-type: none"> • Defective alternator • Defective wiring 	<ul style="list-style-type: none"> (• Replace) (• Check, repair)
Abnormal noise is generated from alternator	<ul style="list-style-type: none"> • Defective alternator 	<ul style="list-style-type: none"> (• Replace)
Starting motor does not turn when starting switch is turned to ON	<ul style="list-style-type: none"> • Defective wiring • Defective starting motor • Insufficient battery charge 	<ul style="list-style-type: none"> (• Check, repair) (• Replace) • Charge
Pinion of starting motor keeps going and out	<ul style="list-style-type: none"> • Insufficient battery charge • Defective safety relay 	<ul style="list-style-type: none"> • Charge (• Replace)
Starting motor turns engine sluggishly	<ul style="list-style-type: none"> • Insufficient battery charge • Defective starting motor 	<ul style="list-style-type: none"> • Charge (• Replace)
Starting motor disengages before engine starts	<ul style="list-style-type: none"> • Defective wiring, defective ring gear pinion • Insufficient battery charge 	<ul style="list-style-type: none"> (• Check, repair) • Charge
Engine pre-heating monitor does not light	<ul style="list-style-type: none"> • Defective wiring • Defective heater relay • Defective monitor 	<ul style="list-style-type: none"> (• Check, repair) (• Replace) (• Replace)
Oil pressure monitor does not light up when engine is stopped (starting switch at ON position)	<ul style="list-style-type: none"> • Defective monitor • Defective caution lamp switch 	<ul style="list-style-type: none"> (• Replace) (• Replace)
Outside of electrical heater is not warm when touched by hand	<ul style="list-style-type: none"> • Defective wiring • Disconnection in electric heater • Defective operation of heater relay switch 	<ul style="list-style-type: none"> (• Check, repair) (• Replace) (• Replace)

Chassis

- (): Always contact your Komatsu distributor when dealing with these items.
- In cases of problems or causes which are not listed below, contact your Komatsu distributor for repairs.

Problem	Main causes	Remedy
Speed of travel, swing, boom, arm, bucket is slow	• Lack of hydraulic oil	• Add oil to specified level, see CHECK BEFORE STARTING
Pump generates abnormal noise (sucking in air)	• Clogged element in hydraulic tank strainer, lack of oil	• Clean, see EVERY 2000 HOURS SERVICE
Excessive rise in hydraulic oil temperature	• Loose fan belt • Dirty oil cooler • Lack of hydraulic oil	• Check fan belt tension, replace • Clean, see EVERY 500 HOURS SERVICE • Add oil to specified level, see CHECK BEFORE STARTING
Track comes off	• Track too loose	• Adjust track tension, see WHEN REQUIRED
Abnormal wear of sprocket		
Boom rises slowly, does not rise	• Lack of hydraulic oil	• Add oil to specified level, CHECK BEFORE STARTING
Does not swing	• Swing lock switch still applied	• Turn swing lock switch OFF

Engine

- (): Always contact your Komatsu distributor when dealing with these items.
- In cases of problems or causes which are not listed below, contact your Komatsu distributor for repairs.

Problem	Main causes	Remedy
Engine oil pressure monitor lights up	<ul style="list-style-type: none"> • Engine oil pan oil level is low (sucking in air) • Clogged oil filter cartridge • Defective tightening of oil pipe, pipe joint, oil leakage from damaged point • Defective engine oil pressure sensor • Defective monitor 	<ul style="list-style-type: none"> • Add oil to specified level, see CHECK BEFORE STARTING • Replace cartridge, see EVERY 500 HOURS SERVICE (• Check, repair) (• Replace sensor) (• Replace monitor)
Steam spurts out from top of radiator (pressure valve)	<ul style="list-style-type: none"> • Coolant level low, leakage of water • Loose fan belt • Dirt or scale accumulated in cooling system 	<ul style="list-style-type: none"> • Check, add coolant, repair, see CHECK BEFORE STARTING • Check fan belt tension, adjust, replace • Change coolant, flush inside of cooling system, see WHEN REQUIRED
Radiator coolant level monitor lights up	<ul style="list-style-type: none"> • Clogged radiator fins or damaged fins • Defective thermostat • Loose radiator filler cap (high-altitude operations) • Defective water level sensor • Defective monitor 	<ul style="list-style-type: none"> • Clean or repair, see EVERY 500 HOURS SERVICE (• Replace thermostat) • Tighten cap or replace packing (• Replace sensor) (• Replace monitor)
Engine does not start when starting motor is turned	<ul style="list-style-type: none"> • Lack of fuel • Air in fuel system • Defective fuel injection pump or defective nozzle • Starting motor cranks engine sluggishly • Engine pre-heating monitor does not light up • Defective compression (defective valve clearance) 	<ul style="list-style-type: none"> • Add fuel, see CHECK BEFORE STARTING • Repair place where air is sucked in, see EVERY 500 HOURS SERVICE (• Replace pump or nozzle) • See ELECTRICAL SYSTEM • See ELECTRICAL SYSTEM (• Adjust valve clearance)
Exhaust gas is white or blue	<ul style="list-style-type: none"> • Too much oil in oil pan • Improper fuel 	<ul style="list-style-type: none"> • Set oil to specified level, see CHECK BEFORE STARTING • Change to specified fuel
Exhaust gas occasionally turns black	<ul style="list-style-type: none"> • Clogged air cleaner element • Defective nozzle • Defective compression • Defective turbocharger 	<ul style="list-style-type: none"> • Clean or replace, see WHEN REQUIRED (• Replace nozzle) (• See defective compression above) (• Clean or replace turbocharger)
Combustion noise occasionally make breathing sound	<ul style="list-style-type: none"> • Defective nozzle 	<ul style="list-style-type: none"> (• Replace nozzle)

Problem	Main causes	Remedy
Abnormal noise generated (combustion or mechanical)	<ul style="list-style-type: none">• Low-grade fuel being used• Overheating • Damage inside muffler• Excessive valve clearance	<ul style="list-style-type: none">• Change to specified fuel• Refer to "Radiator coolant level monitor lights up" as above(• Replace muffler)(• Adjust valve clearance)

Electronic Control System

When the user code is shown on the display portion of the machine monitor, take the respective measures shown in the self-diagnosis chart below.

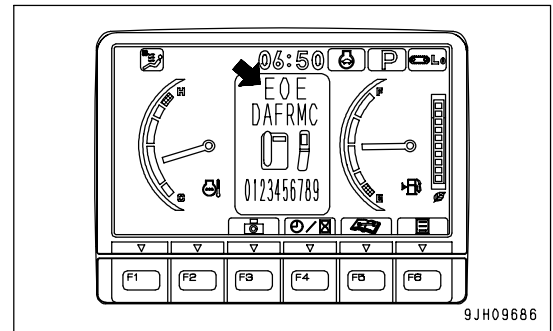

Machine Monitoring System

Monitor display	Failure mode	Action
E02	Pump control system error	When emergency pump drive switch is at the up (emergency) position, normal operations become possible, but have inspection carried out immediately. (*1)
E03	Swing brake system error	Have inspection carried out immediately.
E10	Engine controller power source error Engine controller drive system circuit error (engine stopped)	Have inspection carried out immediately.
E11	Engine controller system error Output reduced to protect engine	Operate machine to a safe posture and have inspection carried out immediately.
E14	Abnormality in throttle system	Operate machine to a safe posture and have inspection carried out immediately.
E15	Engine sensor (coolant temperature, fuel pressure, oil pressure) system error	<p>If a display of "CA2249" or "CA559" appears in the user code screen and yet the machine has not run out of fuel, replace both fuel main filter element and fuel pre-filter element immediately. (*2)</p> <p>If the display of "CA2249" or "CA559" still does not disappear after the replacement, ask your Komatsu distributor for an inspection immediately, even though normal operation of the machine is still possible.</p> <p>On the other hand, if any other code than "CA2249" and "CA559" appears in the user code screen, again ask your Komatsu distributor for an inspection immediately, even though normal operation of the machine is still possible.</p>
E0E	Network error	Operate machine to a safe posture and have inspection carried out immediately.

(*1): For details of handling the emergency pump drive switch, see "Emergency Pump Drive Switch (PAGE 3-74)".

(*2): For the replacement of the fuel main filter element, see "REPLACE FUEL MAIN FILTER CARTRIDGE (PAGE 4-66)" and for the replacement of the fuel pre-filter element, see "REPLACE FUEL PRE-FILTER CARTRIDGE (PAGE 4-55)" respectively.

Point of Contact to Telephone when Error Occurs

If an error screen is displayed on the monitor, the telephone number for the point of contact is displayed at the bottom of the error screen.

REMARK

If no point of contact telephone number has been registered, no telephone number is displayed.

It is necessary to register the telephone number, please ask your Komatsu distributor to carry out the registration.

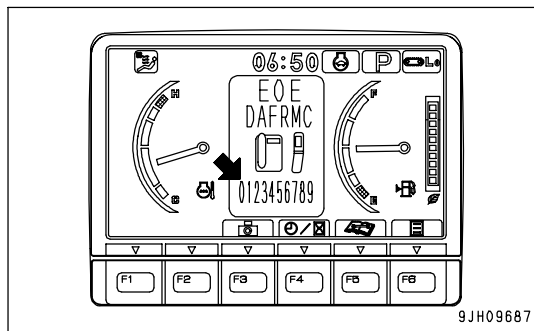

MAINTENANCE

WARNING

Please read and make sure that you understand the SAFETY section before reading this section.

MAINTENANCE INFORMATION

Do not perform any inspection and maintenance operation that is not found in this manual.

Service Meter Reading

Check the service meter reading every day to see if the time has come for any necessary maintenance to be performed.

Komatsu Genuine Replacement Parts

Use Komatsu genuine parts specified in the Parts Book as replacement parts.

Komatsu Genuine Lubricants

For lubrication of the machine, use the Komatsu genuine lubricants. Moreover use oil of the specified viscosity according to the ambient temperature.

Windshield Washer Fluid

Use automobile window washer fluid, and be careful not to let any dirt get into it.

Fresh and Clean Lubricants

Use clean oil and grease. Also, keep the containers of the oil and grease clean. Keep foreign materials away from oil and grease.

Check Drained Oil and Used Filter

After oil is changed or filters are replaced, check the old oil and filters for metal particles and foreign materials. If large quantity of metal particles or foreign materials are found, always report to the person in charge, and carry out suitable action.

Fuel Strainer

If your machine is equipped with a fuel strainer, do not remove it while fueling.

Welding Instructions

- Cut off power. Wait for approx. one minute after turning off the engine starting switch key, and then disconnect the negative (-) terminal of the battery.
- Do not apply more than 200 V continuously.
- Connect grounding cable within 1 m (3.3 ft) of the area to be welded. If grounding cable is connected near instruments, connectors, etc., the instruments may malfunction.
- If a seal or bearing happens to come between the part being welded and grounding point, change the grounding point to avoid such parts.
- Do not use the area around the work equipment pins or the hydraulic cylinders as the grounding point.

Do not Drop Things Inside Machine

- When opening inspection windows or the oil filler port of the tank to carry out inspection, be careful not to drop nuts, bolts, or tools inside the machine.
If such things are dropped inside the machine, it may cause damage and/or malfunction of the machine, and will lead to failure. If you drop anything inside the machine, always remove it immediately.
- Do not put unnecessary things in your pockets. Carry only things which are necessary for inspection.

Dusty Jobsite

When working at dusty worksites, do as follows:

- Clean the radiator fins and other parts of the heat exchange equipment more frequently, and take care not to let the fins become clogged.
- Replace the fuel filter more frequently.
- Clean electrical components, especially the starting motor and alternator, to avoid accumulation of dust.
- When checking and replacing the oil or filters, move the machine to a place where there is no dust and take care to prevent dust from entering the system.

Avoid Mixing Lubricants

If a different brand or grade of oil has to be added, drain the old oil and replace all the oil with the new brand or grade of oil. Never mix different brand or grade of oil.

Locking the Inspection Covers

Lock inspection cover securely into position with the lock bar. If inspection or maintenance is performed with inspection cover not locked in position, there is a danger that it may be suddenly blow shut by the wind and cause injury to the worker.

Hydraulic System - Air Bleeding

When hydraulic equipment has been repaired or replaced, or the hydraulic piping has been removed and installed again, the air must be bled from the circuit. For details, see "BLEEDING AIR FROM HYDRAULIC SYSTEM (PAGE 4-44)".

Hydraulic Hose Installation

- When removing parts at locations where there are O-rings or gasket seals, clean the mounting surface, and replace with new parts.
When doing this, be careful not to forget to assemble the O-rings and gaskets.
- When installing the hoses, do not twist them or bend them sharply. If they are installed so, their service life will be shortened extremely and they may be damaged.

Checks After Inspection and Maintenance Works

If you forget to perform the checks after inspection and maintenance, unexpected problems may occur, and this may lead to serious injury or property damage. Always do the following:

- Checks after operation (with engine stopped)
 - Have any inspection and maintenance points been forgotten?
 - Have all inspection and maintenance items been performed correctly?
 - Have any tools or parts been dropped inside the machine? It is particularly dangerous if parts are dropped inside the machine and get caught in the lever linkage mechanism.
 - Are there any leakage of coolant or oil? Have all nuts and bolts been tightened?
- Checks when operating engine
 - For details of the checks when operating the engine, see "TWO WORKERS FOR MAINTENANCE WHEN ENGINE IS RUNNING (PAGE 2-36)" and pay careful attention to safety.
 - Are the inspection and maintenance items working properly?
 - Is there any leakage of fuel or oil when the engine speed is raised?

OUTLINE OF SERVICE

- Always use Komatsu genuine parts for replacement parts, grease or oil.
- When changing the oil or adding oil, do not mix different types of oil. When changing the type of oil, drain all the old oil and fill completely with the new oil. Always replace the filter at the same time. (There is no problem if the small amount of oil remaining in the piping mixes with the new oil.)
- Unless otherwise specified, when the machine is shipped from the factory, it is filled with the oil and coolant listed in the table below.

Item	Type
Engine oil pan	Engine oil EO15W40DH (Komatsu genuine parts)
Damper case	Powertrain oil TO30 (Komatsu genuine parts)
Swing machinery case	
Final drive case	
Hydraulic oil system	Powertrain oil TO10 (Komatsu genuine parts)
Radiator	Supercoolant AF-NAC (density: 30% or above) (Komatsu genuine parts)

HANDLING OIL, FUEL, COOLANT, AND PERFORMING OIL CLINIC

OIL

- Oil is used in the engine and hydraulic equipment under extremely severe conditions (high temperature, high pressure), and deteriorates with use.
Always use oil that matches the grade and maximum and minimum ambient temperatures recommended in the Operation and Maintenance Manual. Even if the oil is not dirty, always change the oil at the specified interval.
- Oil corresponds to blood in the human body, always be careful when handling it to prevent any impurities (water, metal particles, dirt, etc.) from getting in.
The majority of problems with the machine are caused by the entry of such impurities.
Take particular care not to let any impurities get in when storing or adding oil.
- Never mix oils of different grades or brands.
- Always add the specified amount of oil.
Having too much oil or too little oil are both causes of problems.
- If the oil in the work equipment is not clear, there is probably water or air getting into the circuit. In such cases, please contact your Komatsu distributor.
- When changing the oil, always replace the related filters at the same time.
- We recommend you have an analysis made of the oil periodically to check the condition of the machine. For those who wish to use this service, please contact your Komatsu distributor.
- When using commercially available oil, it may be necessary to reduce the oil change interval.
We recommend that you use the Komatsu oil clinic to carry out a detailed checks of the characteristics of the oil.

FUEL

- To prevent the moisture in the air from condensing and forming water inside the fuel tank, always fill the fuel tank after completing the day's work.
- The fuel pump is a precision instrument, and if fuel containing water or dirt is used, it cannot work properly.
- Be extremely careful not to let impurities get in when storing or adding fuel.
- Always use the fuel specified for the temperature in the Operation and Maintenance Manual.
 - If the fuel is used at temperatures lower than the specified temperature (particularly at temperatures below -15 °C (5°F), the fuel will solidify.
 - If the fuel is used at temperatures higher than the specified temperature, the viscosity will drop, and this may result in problems such as a drop in output.
- Before starting the engine, or when 10 minutes have passed after adding fuel, drain the sediment and water from the fuel tank.
- If the engine runs out of fuel, or if the filters have been replaced, it is necessary to bleed the air from the circuit.
- If there is any foreign material in the fuel tank, wash the tank and fuel system.

NOTICE

Always use diesel oil for the fuel.

To ensure good fuel consumption characteristics and exhaust gas characteristics, the engine mounted on this machine uses an electronically controlled high-pressure fuel injection device. This device requires high precision parts and lubrication, so if low viscosity fuel with low lubricating ability is used, the durability may drop markedly.

COOLANT AND WATER FOR DILUTION

- The coolant has the important function of preventing corrosion as well as preventing freezing. Even in the areas where freezing is not an issue, the use of antifreeze coolant is essential. Komatsu machines are supplied with Komatsu Supercoolant (AF-NAC). Komatsu Supercoolant (AF-NAC) has excellent anticorrosion, antifreeze and cooling properties and can be used continuously for 2 years or 4000 hours. As a basic rule, we do not recommend the use of any coolant other than Komatsu genuine supercoolant (AF-NAC). If you use another coolant, it may cause serious problems, such as corrosion of the engine and aluminum parts of the cooling system.
- When using antifreeze, always observe the precautions given in the Operation and Maintenance Manual.
- The Supercoolant is already diluted with distilled water, so it is not flammable.
- With the Supercoolant (AF-NAC), the density used for the coolant differs according to the ambient temperature. For details of the coolant density, see "CLEAN INSIDE OF COOLING SYSTEM (PAGE 4-25)". Even in areas where it is not considered necessary to prevent freezing, always use Supercoolant (AF-NAC) with a density of over 30% in order to prevent corrosion of the cooling system. Supercoolant (AF-NAC) is diluted with distilled water that does not contain any ions or water-hardening substances. Never dilute the Supercoolant with ordinary water.
- If the engine overheats, wait for the engine to cool before adding coolant.
- If the coolant level is low, it will cause overheating, and will also cause problems with corrosion due to air entering the coolant.

GREASE

- Grease is used to prevent seizure and noises at the joints.
- This construction equipment is used under heavy-duty conditions. Always use the recommended grease and follow the change intervals and recommended ambient temperatures given in this Operation and Maintenance Manual.
- Grease fittings not included in the maintenance section are grease fittings for overhaul, so they do not need grease.
If any part becomes stiff after being used for long time, add grease.
- Always wipe off all of the old grease that is pushed out when greasing.
Be particularly careful to wipe off the old grease in places where sand or dirt sticking in the grease would cause wear of the rotating parts.

CARRYING OUT KOWA (Komatsu Oil Wear Analysis)

KOWA is a maintenance service that makes it possible to prevent machine failures and downtime. With KOWA, the oil is periodically sampled and analyzed. This enables early detection of wear of the machine drive parts and other problems.

We strongly recommend you to use this service. The oil analysis is carried out at actual cost, so the cost is low, and the results of the analysis are reported together with recommendations which will reduce repair costs and machine downtime.

KOWA ANALYSIS ITEMS

- Measurement of density of metal wear particles
This uses an ICP (Inductively Coupled Plasma) analyzer to measure the density of iron, copper, and other metal wear particles in the oil.

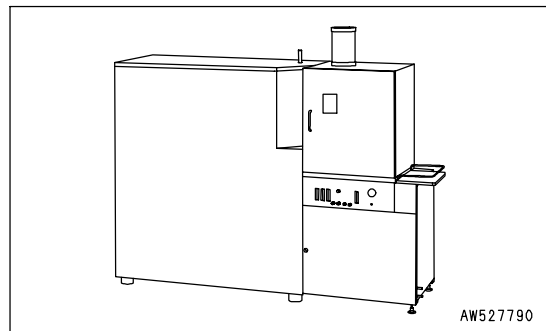

- Measurement of quantity of particles
This uses a PQI (Particle Quantifier Index) measurer to measure the quantity of iron particles of 5µm or more, enabling early detection of failures.

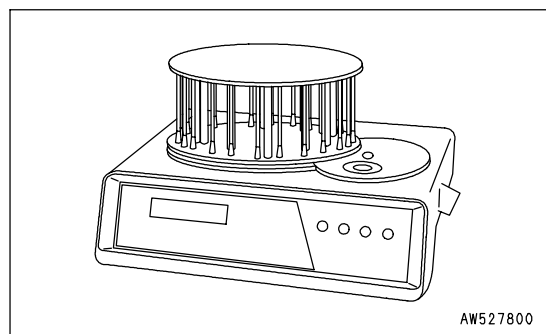

- Others
Measurements are made of items such as the ratio of water in the oil, density of the antifreeze coolant, ratio of fuel in the oil, and dynamic viscosity, enabling a highly precise diagnosis of the machine's health.

OIL SAMPLING

- Sampling interval
 - 250 hours: Engine
 - 500 hours: Other components
- Precautions when sampling
 - Make sure that the oil is well mixed before sampling.
 - Perform sampling at regular fixed intervals.
 - Do not perform sampling on rainy or windy days when water or dust can get into the oil.

For further details of KOWA, please contact your Komatsu distributor.

STORING OIL AND FUEL

- Keep indoors to prevent any water, dirt, or other impurities from getting in.
- When keeping drum cans for a long period, put the drum on its side so that the filler port of the drums is at the side to prevent moisture from being sucked in.
If drums have to be stored outside, cover them with a waterproof sheet or take other measures to protect them.
- To prevent any change in quality during long-term storage, be sure to use in the order of first in - first out (use the oldest oil or fuel first).

FILTERS

- Filters are extremely important safety parts. They prevent impurities in the fuel and air circuits from entering important equipment and causing problems.
Replace all filters periodically. For details, see the Operation and Maintenance Manual.
However, when working in severe conditions, replace the filters at shorter intervals according to the oil and fuel (sulfur content) being used.
- Never try to clean the filters (cartridge type) and use them again. Always replace with new filters.
- When replacing oil filters, check if any metal particles are attached to the old filter. If any metal particles are found, contact your Komatsu distributor.
- Do not open packs of spare filters until just before they are to be used.
- Always use Komatsu genuine filters.

ELECTRIC SYSTEM MAINTENANCE

- It is extremely dangerous if the electrical equipment becomes wet or the covering of the wiring is damaged. This will cause an electrical short circuit and may lead to malfunction of the machine. Do not wash the inside of the operator's cab with water. When washing the machine, be careful not to let water get into the electrical components.
- Service relating to the electric system is checking fan belt tension, checking damage or wear to the fan belt and checking battery fluid level.
- Never install any electric components other than those specified by Komatsu.
- External electro-magnetic interference may cause malfunction of the control system controller, before installing a radio receiver or other wireless equipment, contact your Komatsu distributor.
- When working at the seashore, carefully clean the electric system to prevent corrosion.
- When installing electrical equipment, connect it to the special power source connector.
Do not connect the optional power source to the fuse, starting switch, or battery relay.

WEAR PARTS

Replace wear parts such as the filter element or air cleaner element at the time of periodic maintenance or before they reach the wear limit. The wear parts should be replaced correctly in order to ensure more economic use of the machine. When replacing parts, always use Komatsu genuine parts.

As a result of our continuous efforts to improve product quality, the part number may change, so inform your Komatsu distributor of the machine serial number and check for the latest part number when ordering parts.

WEAR PARTS LIST

The parts in parentheses are to be replaced at the same time.

Item	Part No.	Part Name	Q'ty	Change interval
Fuel pre-filter	600-319-3440	Cartridge (incl. O-ring)	1	Every 500 hours
Engine oil filter	600-211-1340	Cartridge	1	Every 500 hours
Hydraulic tank breather	20Y-60-21470	Element	1	Every 500 hours
Fuel main filter	600-319-3520	Cartridge	1	Every 1000 hours
Hydraulic oil filter	208-60-71123 (07000-15210)	Element (O-ring)	1 (1)	Every 1000 hours
Additional breather for hydraulic tank	421-60-35170	Element	1	Every 1000 hours
Air conditioner RECIRC filter	208-979-7620	Filter	1	Every one year
Air conditioner FRESH filter	17M-911-3530	Element	1	Every one year
Air cleaner	600-185-6100	Element assembly	1	-
Additional filter for breaker (if equipped)	208-970-5121 (07000-12011) (07000-02125)	Element (O-ring) (O-ring)	1 (1) (1)	-
Bucket	208-70-34211 (208-70-34200)	Vertical pin type Tooth (Pin)	5 (5)	-
	208-70-14152 (09244-03036)	Horizontal pin type Tooth (Pin)	5 (5)	
	208-70-34160 208-70-34170	Side cutter type cutter (left)	1	
		cutter (right)	1	
	208-934-7131 113-78-21170 209-939-7110 209-939-7120	Shroud type Shroud	4	
		Pin	8	
		Shim	16	
Shim		8		

RECOMMENDED FUEL, COOLANT, AND LUBRICANT

- Komatsu genuine oils are adjusted to maintain the reliability and durability of Komatsu construction equipment and components.

In order to keep your machine in the best conditioner for long periods of time, it is essential to follow the instructions in this Operation and Maintenance Manual.

- Failure to follow these recommendations may result in shortened life or excess wear of the engine, power train, cooling system, and/or other components.
- Commercially available lubricant additives may be good for the machine, but they may also cause harm. Komatsu does not recommend any commercially available lubricant additive.
- Use the oil recommended according to the ambient temperature in the chart below.
- Specified capacity means the total amount of oil including the oil in the tank and the piping. Refill capacity means the amount of oil needed to refill the system during inspection and maintenance.
- When starting the engine in temperatures below 0°C (32°F), be sure to use the recommended multi-grade oil, even if the ambient temperature may become higher during the course of the day.
- If the machine is operated at a temperature below -20°C (-4°F), a separate device is needed, so consult your Komatsu distributor.
- When the fuel sulfur content is less than 0.2%, change the engine oil according to the period inspection table given in this Operation and Maintenance Manual.

If the fuel sulfur content is more than 0.2%, change the oil according to the following table.

Sulfur content (%)	Oil change interval
Less than 0.2 %	500 hours
0.2 to 0.5 %	250 hours
0.5 and up	Not recommendable (*)

* If these fuels are used, there is danger that serious trouble may occur because of early deterioration of the engine oil or early wear of the internal parts of the engine. If the local situation makes it necessary to use these fuels, always remember the following.

- 1) Be sure to check Total Basic Number (TBN) of oil frequently by TBN handy checker etc., and change oil based on the result.
- 2) Always be aware that oil change interval is extremely shorter than standard.
- 3) Be sure to carry out periodic engine inspection by distributor's expert since change interval of periodic replacement parts and overhaul interval are also shorter.

Reservoir	Fluid Type	Ambient Temperature, degrees Celsius									Recommended Komatsu Fluids
		-22	-4	14	32	50	68	86	104	122°F	
		-30	-20	-10	0	10	20	30	40	50°C	
Engine oil pan	Engine oil	(Note.1)									Komatsu EOS0W30
		(Note.1)									Komatsu EOS5W40
		(Note.1)									Komatsu EO10W30-DH
		(Note.1)									Komatsu EO15W40-DH
		(Note.1)									Komatsu EO30-DH
Swing machinery case Final drive case Damper case	Powertrain oil (Note.2)	(Note.1)									TO30
Hydraulic system	Powertrain oil	(Note.1)									TO10
	Hydraulic oil	(Note.1)									HO46-HM
Grease fitting	Hyper grease (Note.3)	(Note.1)									G2-T, G2-TE
	Lithium EP grease	(Note.1)									G2-LI
Cooling system	Supercoolant AF-NAC (Note.4)	(Note.1)									AF-NAC
Fuel tank	Diesel fuel	(Note.1)									ASTM Grade No.1-D S15 ASTM Grade No.1-D S500
		(Note.1)									ASTM Grade No.2-D S15 ASTM Grade No.2-D S500

• ASTM: American Society of Testing and Material

		Engine oil pan	Swing machinery case	Final drive case (Each)	Damper case	Hydraulic oil system	Cooling system	Fuel tank
Specified capacity	Liter	46	20	10.5	1.07	472	36	650
	US gal	12.15	5.28	2.77	0.28	124.70	9.51	171.73
Refill capacity	Liter	37	20	10.5	1.07	248	36	-
	US gal	9.78	5.28	2.77	0.28	65.2	9.51	-

NOTICE

Always use diesel oil for the fuel.

To ensure good fuel consumption characteristics and exhaust gas characteristics, the engine mounted on this machine uses an electronically controlled high-pressure fuel injection device. This device requires high precision parts and lubrication, so if low viscosity fuel with low lubricating ability is used, the durability may drop markedly.

Note 1: HTHS (High-Temperature High-Shear Viscosity 150°C), specified by ASTM D4741 must be equal to or higher than 3.5 mPa-S. Komatsu EOS0W30 and EOS5W40 are the most suitable oils.

Note 2: Powertrain oil has different properties from engine oil. Be sure to use the recommended oils.

Note 3: Hyper grease (G2-T, G2-TE) has a high performance.

When it is necessary to improve the lubricating ability of the grease in order to prevent squeaking of pins and bushings, the use of G2-T or G2-TE is recommended.

Note 4: Supercoolant (AF-NAC)

1) Coolant has the important function of anticorrosion as well as antifreeze.

Even in the areas where freezing is not an issue, the use of antifreeze coolant is essential.

Komatsu machines are supplied with Komatsu Supercoolant AF-NAC. Komatsu Supercoolant AF-NAC has excellent anticorrosion, antifreeze and cooling properties and can be used continuously for 2 years or 4000 hours.

Komatsu Supercoolant AF-NAC is strongly recommended wherever available.

2) For details of the Supercoolant AF-NAC density, see "CLEAN INSIDE OF COOLING SYSTEM (PAGE 4-25)".

Supercoolant AF-NAC is supplied already diluted. In this case, add the pre-diluted fluid to keep the tank full. (Never dilute the Supercoolant with ordinary water.)

3) To maintain the anticorrosion properties of Supercoolant AF-NAC, always keep the density of Supercoolant between 30% and 68%.

RECOMMENDED BRANDS, RECOMMENDED QUALITY FOR PRODUCTS OTHER THAN KOMATSU GENUINE OIL

When using commercially available oils other than Komatsu genuine oil, consult your Komatsu distributor.

TIGHTENING TORQUE SPECIFICATIONS

TIGHTENING TORQUE LIST



If nuts, bolts, or other parts are not tightened to the specified torque, it will cause looseness or damage to the tightened parts, and this will cause failure of the machine or problems with operation.

Always pay careful attention when tightening parts.

Unless otherwise specified, tighten the metric nuts and bolts to the torque shown in the table below.

If it is necessary to replace any nut or bolt, always use a Komatsu genuine part of the same size as the part that was replaced.

Thread diameter of bolt (a)(mm)	Width across flats (b)(mm)	Tightening torque					
		Target value			Service limit		
		Nm	kgm	lbft	Nm	kgm	lbft
6	10	13.2	1.35	9.8	11.8-14.7	1.2-1.5	8.7-10.8
8	13	31	3.2	23.1	27-34	2.8-3.5	20.3-25.3
10	17	66	6.7	48.5	59-74	6.0-7.5	43.4-54.2
12	19	113	11.5	83.2	98-123	10.0-12.5	72.3-90.4
14	22	172	17.5	126.6	153-190	15.5-19.5	112.1-141
16	24	260	26.5	191.7	235-285	23.5-29.5	170.0-213.4
18	27	360	37	267.6	320-400	33.0-41.0	238.7-296.6
20	30	510	52.3	378.3	455-565	46.5-58.0	336.3-419.5
22	32	688	70.3	508.5	610-765	62.5-78.0	452.1-564.2
24	36	883	90	651	785-980	80.0-100.0	578.6-723.3
27	41	1295	132.5	958.4	1150-1440	118.0-147.0	853.5-1063.3
30	46	1720	175.0	1265.8	1520-1910	155.0-195.0	1121.1-1410.4
33	50	2210	225.0	1627.4	1960-2450	200.0-250.0	1446.6-1808.3
36	55	2750	280.0	2025.2	2450-3040	250.0-310.0	1808.3-2242.2
39	60	3280	335.0	2423.1	2890-3630	295.0-370.0	2133.7-2676.2

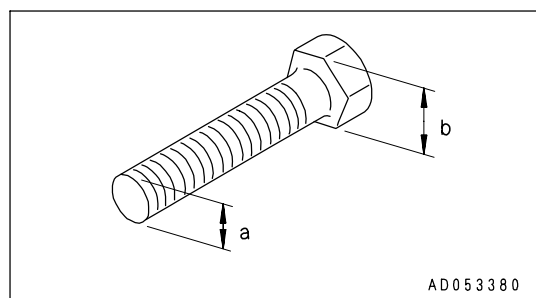

Apply the following table for Hydraulic Hose.

Thread diameter a (mm)	Width across flat b(mm)	Tightening torque [Nm (kgm)]	
		Target value	Permissible range
9/16 -18UNF	19	44 (4.5)	35 - 54 (3.5 - 5.5)
11/16 -16UN	22	74 (7.5)	54 - 93 (5.5 - 9.5)
13/16 -16UN	27	103 (10.5)	84 - 132 (8.5 - 13.5)
1 -14UNS	32	157 (16.0)	128 - 186 (13.0 - 19.0)
1-3/16 -12UN	36	216 (22.0)	177 - 245 (18.0 - 25.0)
*1-7/16-12UN -2B	41	215 (22)	176 - 234 (18 - 24)

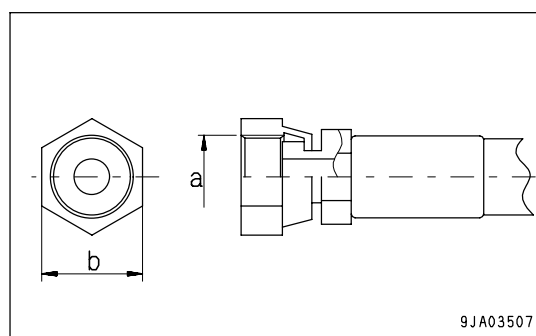

- The torques marked * indicate the tightening torques for the hoses at the top of the swivel joint.

SAFETY CRITICAL PARTS

For using the machine safely for an extended period of time, you must periodically replace the safety critical and fire prevention-related parts listed in the table of important parts.

Material quality of these parts can change as time passes and they are likely to wear out or deteriorate. However, it is difficult to determine the extent of wear or deterioration at the time of periodic maintenance. Hence, it is required to replace them with new ones regardless of their condition after a certain period of usage. This is important to ensure that these parts maintain their full performance at all times.

Furthermore, should anything abnormal be found on any of these parts, replace it with a new one even if the periodic replacement time for the part has not yet arrived.

If any of the hose clamps show deterioration like deformation or cracking, replace the clamps at the same time as the hoses.

Also perform the following checks with hydraulic hoses which need to be replaced periodically. Tighten all loose clamps and replace defective hoses, as required.

When replacing hoses, always replace O-rings, gaskets, and other such parts at the same time.

Have your Komatsu distributor replace the critical parts.

SAFETY CRITICAL PARTS LIST

No.	Safety critical parts for periodic replacement	Q'ty	Replacement interval
1	Fuel hose (fuel tank - block)	1	Every 2 years or 4000 hours, whichever comes sooner
2	Fuel hose (block - fuel pre-filter)	1	
3	Fuel hose (fuel pre-filter - supply pump)	1	
4	Fuel hose (supply pump - engine controller base)	1	
5	Fuel hose (engine controller base - fuel main filter)	1	
6	Over flow hose (supply pump - fuel tank)	1	
7	Spill hose (engine controller base - fuel tank)	1	
8	Pump outlet hose (pump - control valve)	2	
9	Work equipment hose (boom cylinder inlet port)	4	
10	Work equipment hose (bucket cylinder line, boom foot)	2	
11	Work equipment hose (bucket cylinder inlet port)	2	
12	Work equipment hose (bucket cylinder inlet port, 4.0 m arm)	2	
13	Work equipment hose (arm cylinder line, boom foot)	2	
14	Work equipment hose (arm cylinder inlet port)	2	
15	Attachment additional line hose (boom foot)	2	
16	Attachment additional line hose (boom intermediate)	2	
17	Attachment additional line hose (boom top)	2	
18	Swing line hose (swing motor inlet port)	2	
19	Main suction hose	1	
20	Gear pump suction hose	1	
21	Heater hose	2	
22	Travel line hose (control valve - swivel joint)	4	
23	Travel line hose (swivel joint - travel motor)	4	
24	Accumulator (for control circuit)	1	
25	High-pressure piping clamp	10	Every 8000 hours
26	Missing fuel spray prevention cap	12	
27	Seat belt	1	Every 3 years

MAINTENANCE SCHEDULE

If the machine is equipped with a hydraulic breaker, the maintenance schedule for some parts will be different. For details, see "MAINTENANCE INTERVAL FOR HYDRAULIC BREAKER (PAGE 4-17)" to confirm the correct maintenance schedule when carrying out maintenance.

MAINTENANCE SCHEDULE CHART

INITIAL 1000 HOURS MAINTENANCE (ONLY AFTER THE FIRST 1000 HOURS)

CHECK ENGINE VALVE CLEARANCE, ADJUST ----- 4- 79

WHEN REQUIRED

CHECK, CLEAN AND REPLACE AIR CLEANER ELEMENT ----- 4- 19
 CLEAN INSIDE OF COOLING SYSTEM ----- 4- 25
 CHECK AND TIGHTEN TRACK SHOE BOLTS ----- 4- 28
 CHECK AND ADJUST TRACK TENSION ----- 4- 29
 REPLACE BUCKET TEETH (VERTICAL PIN TYPE) ----- 4- 31
 REPLACE BUCKET TEETH (HORIZONTAL PIN TYPE) ----- 4- 34
 REPLACE BUCKED SIDE CUTTER SHROUD ----- 4- 36
 ADJUST BUCKET CREARANCE ----- 4- 37
 CHECK WINDOW WASHER FLUID LEVEL, ADD FLUID ----- 4- 38
 CHECK AND MAINTENANCE AIR CONDITIONER ----- 4- 39
 WASHING WASHABLE FLOOR ----- 4- 40
 CHECK GAS SPRING ----- 4- 43
 BLEEDING AIR FROM HYDRAULIC SYSTEM ----- 4- 44

CHECKS BEFORE STARTING

EVERY 50 HOURS MAINTENANCE

LUBRICATING ----- 4- 47

EVERY 250 HOURS MAINTENANCE

LUBRICATE SWING CIRCLE ----- 4- 48
 CHECK LEVEL OF BATTERY ELECTROLYTE ----- 4- 49
 CHECK FAN BELT, ALTERNATOR BELT TENSION, ADJUST ----- 4- 51
 CHECK AIR CONDITIONER COMPRESSOR BELT TENSION, ADJUST ----- 4- 52

EVERY 500 HOURS MAINTENANCE

LUBRICATING ----- 4- 53
 REPLACE FUEL PRE-FILTER CARTRIDGE ----- 4- 55
 CHECK SWING PINION GREASE LEVEL, ADD GREASE ----- 4- 57
 CHECK OIL LEVEL IN SWING MACHINERY CASE, ADD OIL ----- 4- 58
 CHECK OIL LEVEL IN FINAL DRIVE CASE, ADD OIL ----- 4- 59
 CHANGE OIL IN ENGINE OIL PAN, REPLACE ENGINE OIL FILTER CARTRIDGE ----- 4- 60
 CLEAN AND INSPECT RADIATOR FINS, OIL COOLER FINS, AFTER COOLER FIN AND
 CONDENSER FINS ----- 4- 62
 CLEAN AIR CONDITIONER FRESH/RECIRC FILTERS ----- 4- 64
 REPLACE BREATHER ELEMENT IN HYDRAULIC TANK ----- 4- 65

EVERY 1000 HOURS MAINTENANCE

REPLACE FUEL MAIN FILTER CARTRIDGE ----- 4- 66

REPLACE HYDRAULIC OIL FILTER ELEMENT ----- 4- 69

CHANGE OIL IN SWING MACHINERY CASE ----- 4- 70

CHECK OIL LEVEL IN DAMPER CASE, ADD OIL ----- 4- 71

CHECK ALL TIGHTENING POINTS OF ENGINE EXHAUST PIPE CLAMPS ----- 4- 71

REPLACE HYDRAULIC TANK ADDITIONAL BREATHER ELEMENT ----- 4- 72

CHECK NITROGEN GAS CHARGE PRESSURE IN ACCUMULATOR (FOR BREAKER) ----- 4- 72

EVERY 2000 HOURS MAINTENANCE

CHANGE OIL IN FINAL DRIVE CASE ----- 4- 73

CLEAN HYDRAULIC TANK STRAINER ----- 4- 74

CHECKING CHARGE PRESSURE OF NITROGEN GAS IN ACCUMULATOR (FOR CONTROL CIRCUIT) ----- 4- 75

CHECK ALTERNATOR ----- 4- 79

CHECK ENGINE VALVE CLEARANCE, ADJUST ----- 4- 79

CHECK VIBRATION DAMPER ----- 4- 79

EVERY 4000 HOURS MAINTENANCE

CHECK WATER PUMP ----- 4- 80

CHECK STARTING MOTOR ----- 4- 80

REPLACE ACCUMULATOR (FOR CONTROL CIRCUIT) ----- 4- 80

CHECK FOR LOOSENESS OF HIGH-PRESSURE PIPING CLAMP, HARDENING OF RUBBER ----- 4- 81

CHECK FOR MISSING FUEL SPRAY PREVENTION CAP, HARDENING OF RUBBER ----- 4- 81

EVERY 5000 HOURS MAINTENANCE

CHANGE OIL IN HYDRAULIC TANK ----- 4- 82

EVERY 8000 HOURS MAINTENANCE

REPLACE HIGH-PRESSURE PIPING CLAMP ----- 4- 84

REPLACE FUEL SPRAY PREVENTION CAP ----- 4- 84

MAINTENANCE INTERVAL FOR HYDRAULIC BREAKER

For machine equipped with a hydraulic breaker, the hydraulic oil deteriorates faster than for normal bucket digging operations, so set the maintenance intervals as follows.

- **Replace hydraulic filter element**

On a new machine, replace the element after the first 100 to 150 hours, then carry out further replacement of the element according to the table on the right.

- **Change oil in hydraulic tank**

Change the oil according to the table on the right.

- **Replacing additional filter element for breaker (if equipped)**

Use a guideline of 250 hours for use of the breaker (operating ratio for the breaker: 50 % or more), and replace the element according to the table on the right.

X : Breaker operating ratio (%)

Y : Replacement interval (H)

(A): Hydraulic filter element

(B): Hydraulic oil

(C): Additional filter element

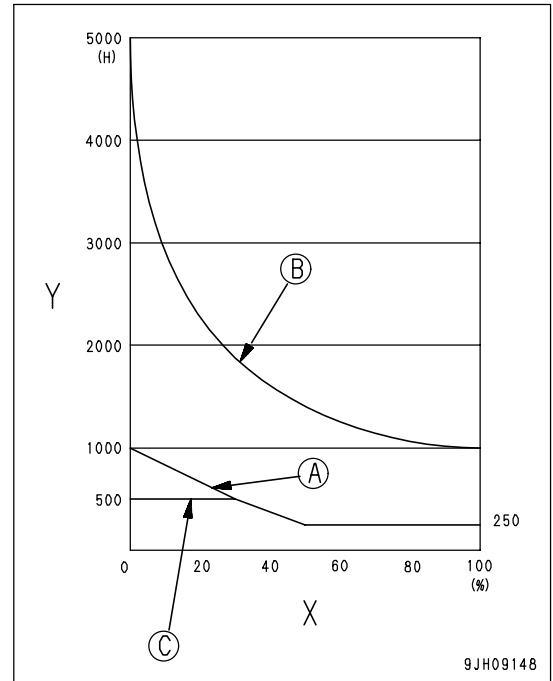

REMARK

Breaker operating ratio 100% means that only the breaker is used

Breaker operating ratio 0% means that the breaker is not used

MAINTENANCE PROCEDURE

INITIAL 1000 HOURS MAINTENANCE (ONLY AFTER THE FIRST 1000 HOURS)

Carry out the following maintenance only after the first 1000 hours of operation on new machines.

- Check engine valve clearance, adjust

Special tools are needed for inspection and maintenance, so contact your Komatsu distributor.

For details of the method of replacing or maintaining, see the section on EVERY 2000 HOURS SERVICE.

WHEN REQUIRED

CHECK, CLEAN AND REPLACE AIR CLEANER ELEMENT

WARNING

- When using compressed air, there is danger of dirt flying and causing personal injury. Always wear protective glasses, dust mask, or other protective equipment.
- When removing the outer element from the air cleaner body, it is dangerous to pull it out by force. When working in high places or where the foothold is poor, be careful not to fall because of the reaction when pulling out the outer element.

NOTICE

- Do not clean the air cleaner element until the air cleaner clogging monitor on the monitor panel light up. If the element is cleaned frequently before the air cleaner clogging monitor light up, the air cleaner will not be able to display its performance fully, and the cleaning efficiency will also go down. In addition, during the cleaning operation, more dirt stuck to the element will fall inside the inner element.
- If inspection, cleaning, or maintenance is carried out with the engine running, dirt will enter the engine and cause damage to the engine. Always stop the engine before carrying out these operations.

Checking

If air cleaner clogging monitor (1) of the monitor panel flashes, clean the air cleaner element.

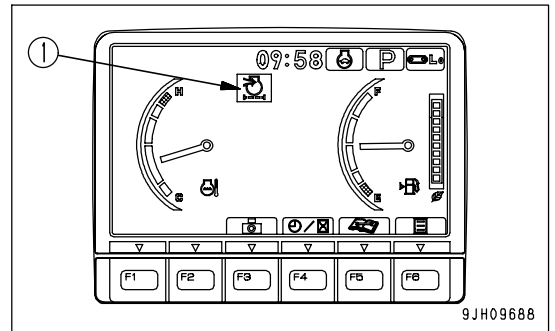

Replacing

- Replace element, O-ring
If the element has been used for one year, or air cleaner clogging monitor (1) on the monitor panel lights up after the element has been cleaned, replace outer element (5), inner element (6), and O-ring (8).
- Replacing vacuator valve
Replace vacuator valve (4) if it is damaged or if the rubber is markedly deformed.

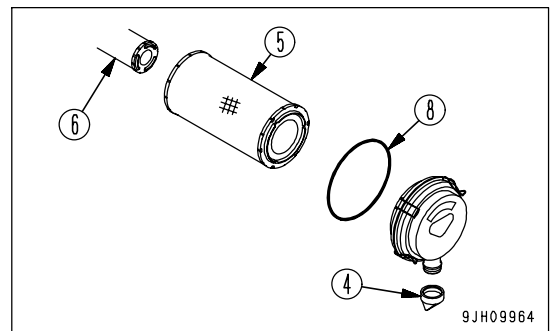

Cleaning Outer Element

NOTICE

Before and after cleaning the element, do not leave or keep it in direct sunlight.

1. Open the right door of the machine, remove 6 hooks (2), then remove cover (3).

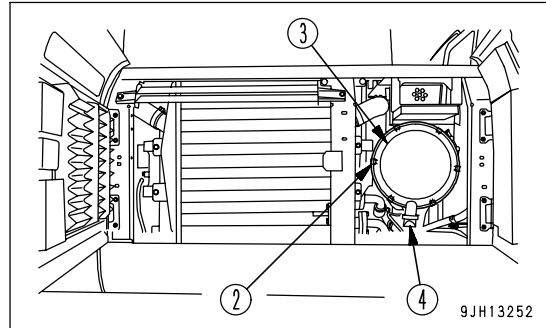

NOTICE

- Never remove the inner element (6). It will allow dirt to enter and cause failure of the engine.
- Do not use a screwdriver or other tool.

2. Hold the outer element (5), rock it lightly up and down and to the left and right, and rotate the element to the left and right to pull it out.
3. When the outer element (5) has been removed, check that the inner element has not come out of position and is not at an angle. If it is at an angle, insert your hand and push it in straight.
4. After removing the outer element (5), cover the inner element (6) with a clean cloth or tape to prevent dirt or dust from entering.
5. Wipe off or brush off the dirt stuck to cover (3) and the inside of the air cleaner body (7).
6. Remove any dirt or dust that is accumulated to evacuator valve (4) installed to cover (3).

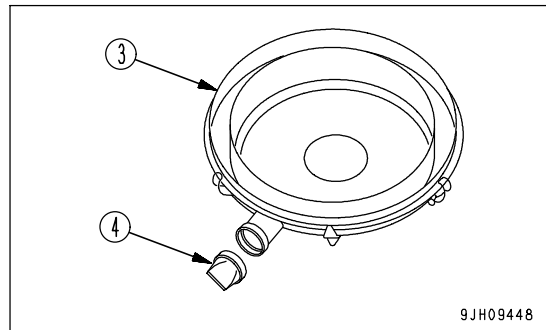
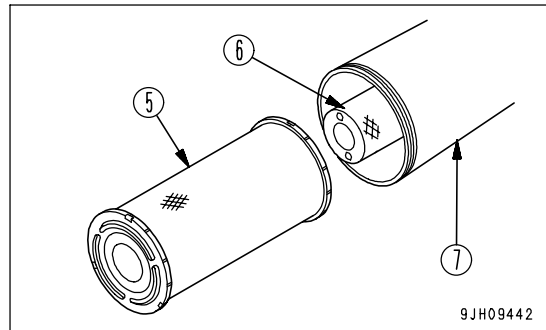

NOTICE

When cleaning the element, do not hit or beat it against anything.

7. Direct dry compressed air (less than 0.69 MPa (7 kg/cm², 99.4 PSI)) to the outer element from inside along its folds, then direct it from outside along its folds and again from inside.
 - 1) Replace the outer element which has been cleaned 6 times repeatedly or used throughout a year. Replace the inner element at the same time.

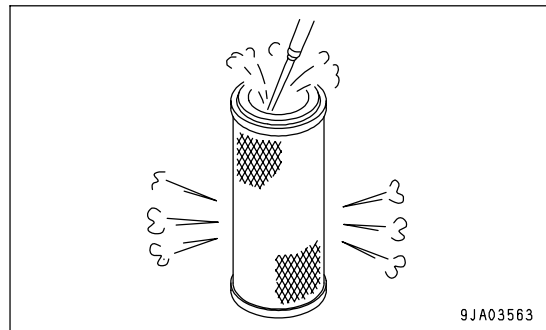

- 2) Replace both inner and outer elements when the air cleaner clogging monitor (1) lights up soon after installing the cleaned outer element even though it has not been cleaned 6 times.

8. If small holes or thinner parts are found on the element when it is checked by shining a light through it after cleaning, replace the element.

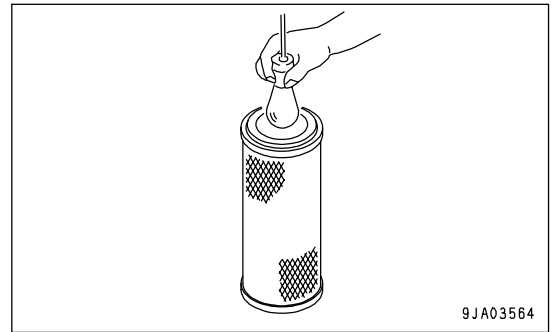

9. Remove the cloth or tape covering inner element (6).

NOTICE

- Do not use an element whose folds or gasket or seal are damaged.
- If the element or O-ring are cleaned and used again after they have been used for more than one year, it will cause problems. Do not use them again.

10. Check that there is no dirt or oil stuck to the seal portion of the new element or cleaned element. Wipe off any dirt or oil.
11. Push the outer element in straight with your hand when installing it to the air cleaner body. If the outer element is held and rocked lightly up and down and to the left and right while pushing it in, the outer element can be inserted easily.

NOTICE

Be sure to install the air cleaner element facing in the correct direction. Install so that the bottom of the air cleaner element cylinder (face where no hole is drilled) (B), (C) is at cover (3) end. If the direction of installation is mistaken, there is danger that it will cause breakage of the air cleaner element or serious damage to the engine.

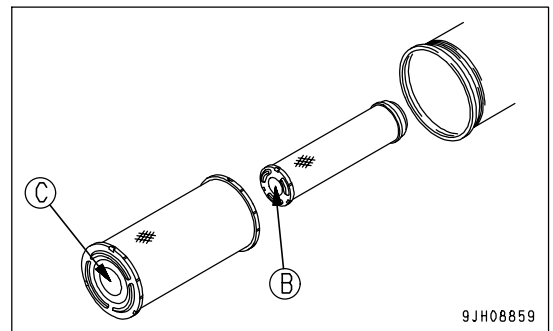

NOTICE

When inserting the element, if the rubber at the tip is swollen or the outer element is not pushed in straight, and cover (3) is assembled by force to hook (2), there is danger that the hook and air cleaner body may be damaged, so be careful when assembling.

12. Install cover (3) as follows.

- 1) Align cover (3) with the element.
- 2) Hook the tip of hook (2) to the protruding part of the air cleaner body and lock it in position.
- 3) When locking hooks (2) in position, apply the hooks in turn on opposite sides (top, bottom, left, right) in the same way as when tightening bolts.
- 4) Always install cover (3) so that the evacuator (4) is facing the ground (A).
- 5) When cover (3) is installed, check that the clearance between the air cleaner body and cover (3) is not too large. If it is too large, install again.

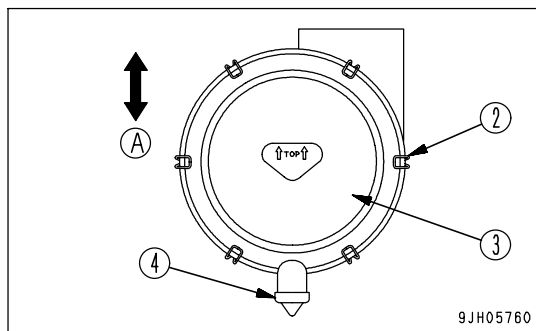
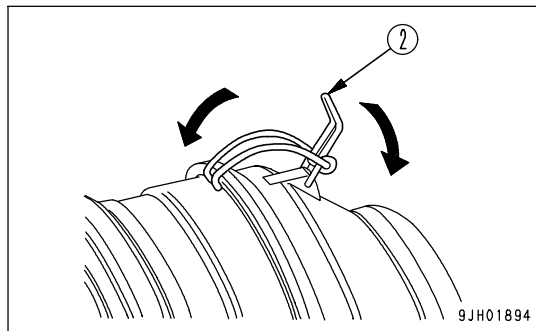

Replacing Element

1. Open the right door of the machine, remove 6 hooks (2), then remove cover (3).

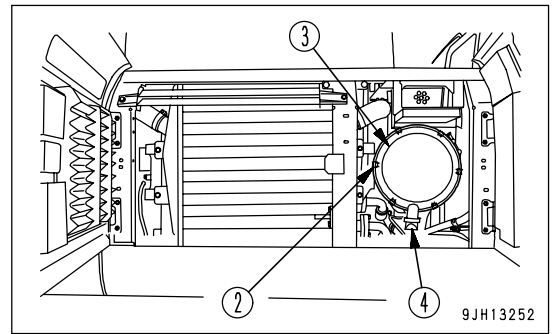

2. Hold the outer element (5), rock it lightly up and down and to the left and right, and rotate the element to the left and right to pull it out.

Do not remove inner element (6) when doing this.

3. When the outer element (5) has been removed, check that the inner element has not come out of position and is not at an angle. If it is at an angle, insert your hand and push it straight.

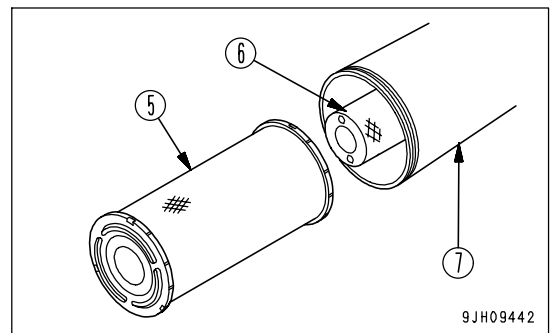

4. Wipe off or brush off the dirt stuck to cover (3) and the inside of the air cleaner body (7).

5. Remove any dirt or dust that is accumulated to evacuator valve (4) installed to cover (3).

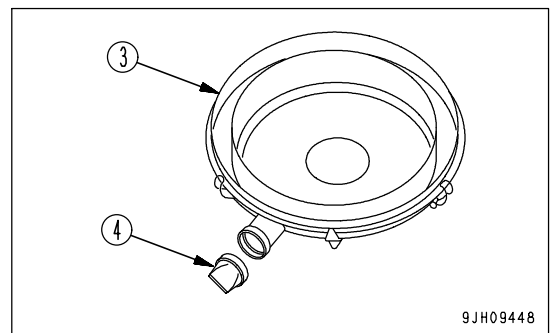

NOTICE

- The inner element must not be cleaned and used again. When replacing the outer element, replace the inner element at the same time.
- If the inner element is not installed properly and the outer element and cover are installed, there is danger that the outer element will be damaged.
- The seal portion on imitation parts lacks precision, and allows the entry of dust, which leads to damage of the engine. Do not use such imitation parts.

6. Remove inner element (6), then quickly install the new inner element.
Insert the inner element securely so that it does not move.

7. Push the new outer element (5) in straight with your hand when installing it to the air cleaner body.
If the element is held and rocked lightly up and down and to the left and right while pushing it in, the element can be inserted easily.

NOTICE

Be sure to install the air cleaner element facing in the correct direction. Install so that the bottom of the air cleaner element cylinder (face where no hole is drilled) (B), (C) is at cover (3) end. If the direction of installation is mistaken, there is danger that it will cause breakage of the air cleaner element or serious damage to the engine.

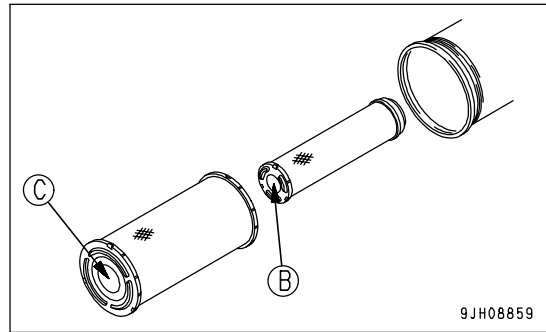

8. Replace O-ring (8) of cover (3) with a new part.

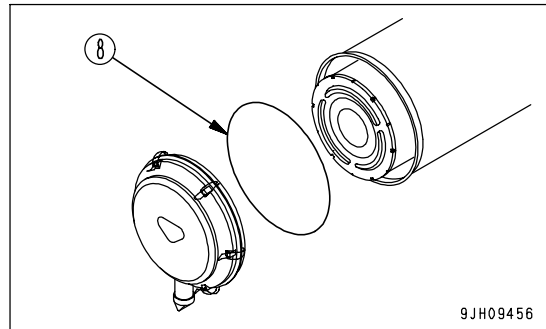

NOTICE

When inserting the element, if the rubber at the tip is swollen or the outer element is not pushed in straight, and cover (3) is assembled by force to hook (2), there is danger that the hook and air cleaner body may be damaged, so be careful when assembling.

9. Install cover (3) as follows.

- 1) Align cover (3) with the element.
- 2) Hook the tip of hook (2) to the protruding part of the air cleaner body and lock it in position.
- 3) When locking hooks (2) in position, apply the hooks in turn on opposite sides (top, bottom, left, right) in the same way as when tightening bolts.
- 4) Always install cover (3) so that the evacuator (4) is facing the ground (A).
- 5) When cover (3) is installed, check that the clearance between the air cleaner body and cover (3) is not too large. If it is too large, install again.

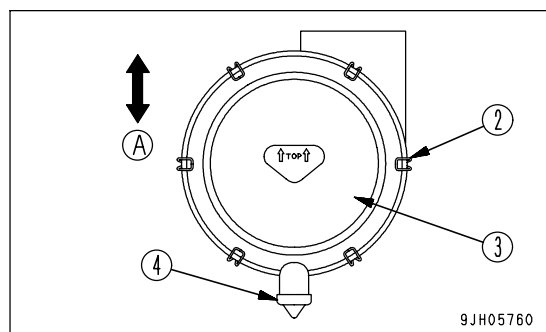
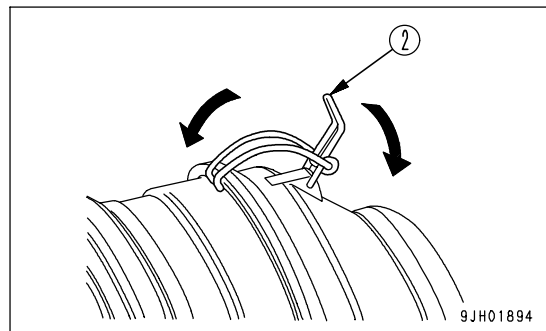

CLEAN INSIDE OF COOLING SYSTEM

 **WARNING**

- Immediately after the engine is stopped, the coolant is at a high temperature and the radiator is under high internal pressure. If the cap is removed to drain the coolant in this condition, there is a hazard of burns. Wait for the temperature to go down, then turn the cap slowly to release the pressure before removing it.
- When starting the engine while cleaning the machine, set the lock lever in the lock position to prevent the machine from moving.
- For details of starting the engine, see "BEFORE STARTING ENGINE (PAGE 3-110)" and "STARTING ENGINE (PAGE 3-129)" in the OPERATION section.
- There is danger of touching the fan if the undercover is left removed.
Never enter behind the machine when the engine is running.

Stop the machine on level ground when cleaning or changing the coolant.

Clean the inside of the cooling system, change the coolant according to the table below.

Antifreeze coolant	Interval for cleaning inside of cooling system and changing antifreeze coolant
Komatsu supercoolant (AF-NAC)	Every two years or every 4000 hours whichever comes first

The coolant has the important function of preventing corrosion as well as preventing freezing. Even in the areas where freezing is not an issue, the use of antifreeze coolant is essential. Komatsu machines are supplied with Komatsu Supercoolant (AF-NAC). Komatsu Supercoolant (AF-NAC) has excellent anticorrosion, antifreeze and cooling properties and can be used continuously for 2 years or 4000 hours. As a basic rule, we do not recommend the use of any coolant other than Komatsu genuine supercoolant (AF-NAC). If you use another coolant, it may cause serious problems, such as corrosion of the engine and aluminum parts of the cooling system.

To maintain the anticorrosion properties of Supercoolant (AF-NAC), always keep the density of Supercoolant between 30% and 68%.

Supercoolant (AF-NAC) is already diluted with distilled water. When using coolant, investigate the lowest temperatures in the past and decide the density for the coolant from the coolant density table below.

When actually deciding the density for the coolant, set it for a temperature 10°C (18°F) below the actual temperature.

The coolant density varies according to the ambient temperature, but it must always be a minimum of 30%.

Coolant density table

Minimum Temp	°C	Above -10	-15	-20	-25	-30	-35	-40	-45	-50
	°F	Above 14	5	-4	-13	-22	-31	-40	-49	-58
Concentration (%)		30	36	41	46	50	54	58	61	64

! WARNING

- Antifreeze is toxic. When open the drain valve, be careful not to get water containing antifreeze on you. If it gets in your eyes, flush your eyes with large amount of fresh water and see a doctor at once.
- When changing the coolant or draining the coolant from the radiator before carrying out repairs, ask a specialist company to handle any coolant containing antifreeze, or contact your Komatsu distributor. Antifreeze is toxic, so never pour it into drainage water ditches or drain it onto the ground surface.

The coolant is already diluted with distilled water. (For details of the distilled water, see "COOLANT AND WATER FOR DILUTION (PAGE 4-5)". Check the density with a coolant tester.

Prepare a container whose capacity is larger than the specified coolant volume to catch drained coolant.
Prepare a hose to use when filling with coolant.

1. Stop the machine on level ground, then stop the engine.
2. Open the cover (1).

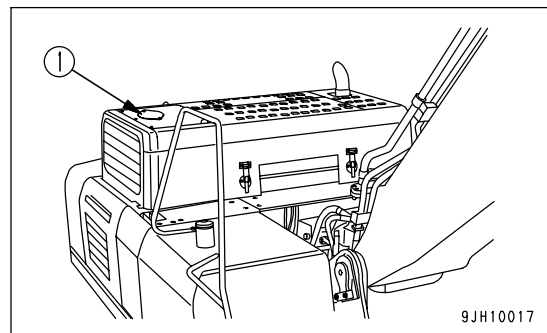

3. Check that the cooling water temperature has gone down enough to make it possible to touch the radiator cap surface by hand, then turn radiator cap (2) slowly until it contacts the stopper to release the pressure.
4. Following this, push radiator cap (2), turn it until it contacts the stopper, then remove it.

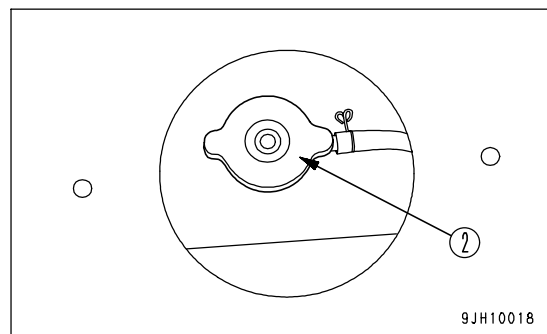

5. Remove drain valve cover (3) on the radiator side and drain valve cover (4) on the engine side.

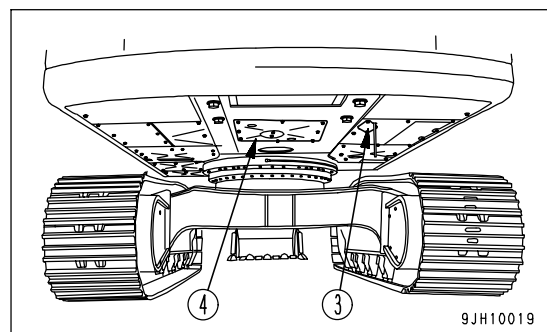

6. Open drain valves (5) and (6), and drain the coolant. Set containers to catch the drained coolant under drain valve (5) on the radiator side and drain valve (6) on the engine site.
7. After draining the antifreeze solution, close drain valve (5), (6), then fill with clean water. After the radiator is filled with water, start and run the engine at low idling speed. After the water temperature rises above 90°C (194°F), run the engine for about 10 minutes.
8. Stop the engine and open drain valves (5), (6) to drain the water.
9. After draining the water, clean the radiator with detergent. For the cleaning method, follow the instruction of detergent.
10. Close drain valve (5) and (6).

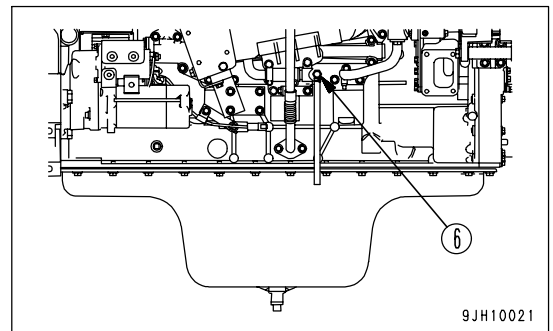
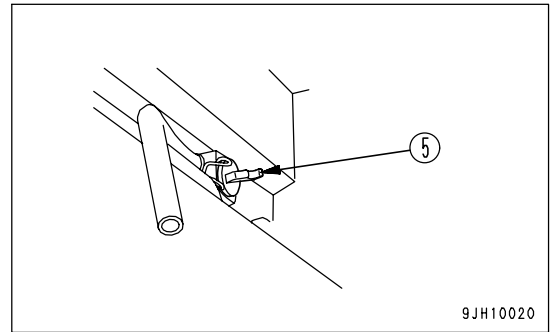

11. Install the covers (3) and (4).
12. Add Supercoolant through the water filler up to the bottom of the filler port.
For details of the Supercoolant density, see the COOLANT DENSITY TABLE.
13. Run the engine at low idling for 5 minutes to remove the air from the water, then run at high idling for 5 minutes.
(Leave radiator cap (2) removed when doing this.)
14. Open the rear engine hood, drain the water from sub-tank (7), wash the inside of the sub-tank, then add water to a point between the FULL and LOW marks.
 - If the sub-tank is extremely dirty and it is difficult to clean, replace it with a new part.
15. Stop the engine, wait for approx. 3 minutes, add Supercoolant up to the bottom of the filler port, then tighten the radiator cap (2).
16. Install cover (1).
17. Close the engine hood.

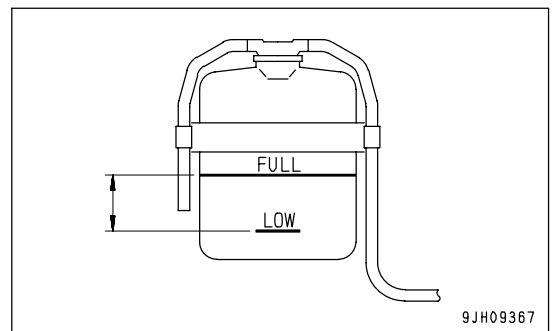
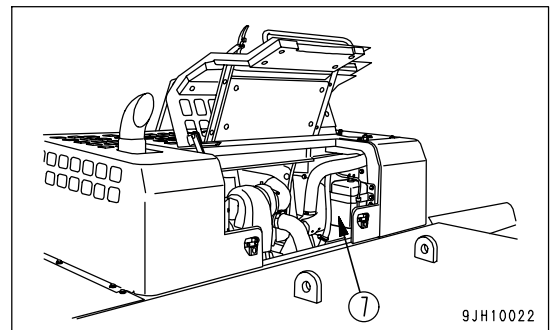

CHECK AND TIGHTEN TRACK SHOE BOLTS

If the machine is used with track shoe bolts (1) loose, they will break, so tighten any loose bolts immediately.

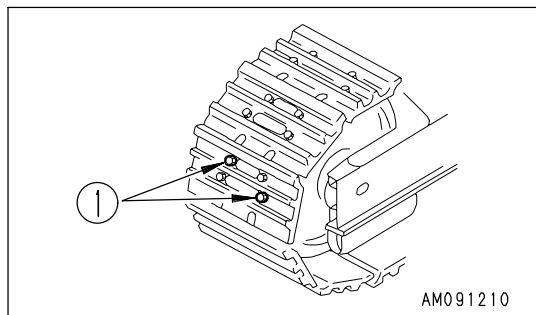

Tightening

1. First, tighten to a tightening torque of 392 ± 39.2 Nm (40 ± 4 kgm, 289.3 ± 28.9 lbft), then check that the nut and shoe are in tight contact with the link mating surface.
2. After checking, tighten a further $120^\circ \pm 10^\circ$.

Order for Tightening

Tighten the bolts in the order shown in the diagram on the right. After tightening, check that the nut and shoe are in close contact with the link mating surface.

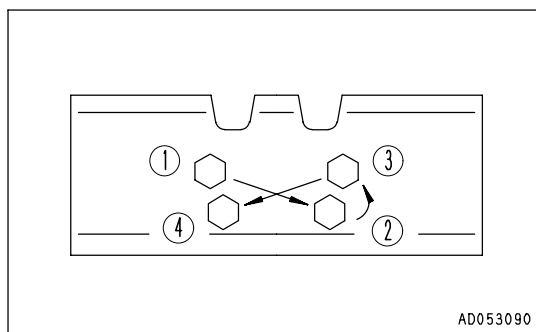

CHECK AND ADJUST TRACK TENSION

Wear on pins and bushings of the undercarriage will vary with working conditions and type of soil, so inspect the track tension every now and then in order to maintain the standard tension.

For carrying out inspection and adjustment of track shoes, park the machine on the flat and solid ground.

Checking

1. Run the engine at low idle, then move the machine forward for a distance equal to the track length on ground, and slowly stop the machine.
2. Put on the track shoe straight wooden bar (3) which stretches from idler (1) to upper carrier roller (2).
3. Measure the maximum deflection between bottom surface of the wooden bar and top surface of the track shoe. Deflection "a" should be 10 - 30 mm (0.4 - 1.2 in).

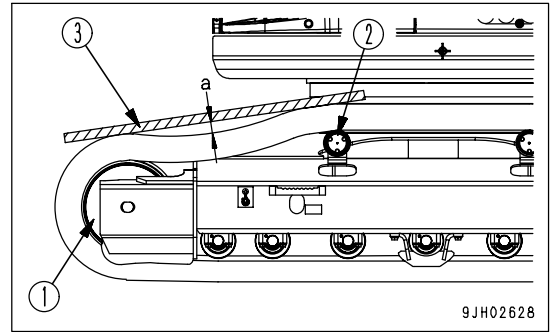

If the track tension is not at the standard value, adjust it in the following manner.

Adjustment

WARNING

There is danger of plug (1) flying out under the high internal pressure of the grease. Never loosen plug (1) more than 1 turn. Never loosen any part other than plug (1). Never put your face in the mounting direction of plug (1). If the track tension cannot be loosened with the procedure given here, please contact your Komatsu distributor.

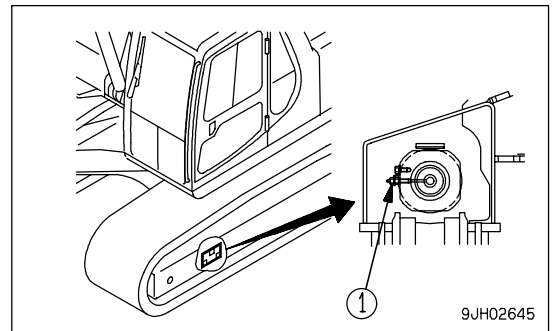

Increasing Track Tension

Prepare a grease pump.

1. Pump in grease through grease fitting (2) with a grease pump. (Grease fitting (2) forms one part with plug (1).)
2. To check if the tension is correct, run the engine at low idle, move the machine slowly forward (by an amount equal to the length of track on ground), then stop the machine.
3. Check the track tension again, and if the tension is not correct, adjust it again.

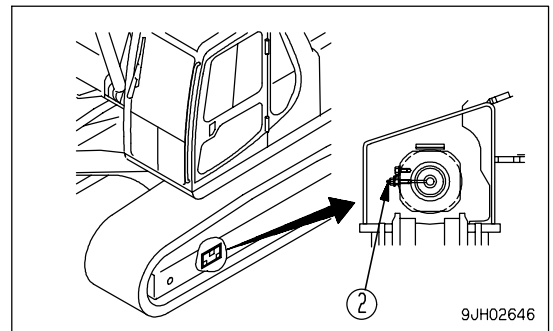

4. Continue to pump in grease until dimension (S) becomes zero (0). If the tension is still loose, the pin and bushing are excessively worn, so they must be either turned or replaced. Please contact your Komatsu distributor for repairs.

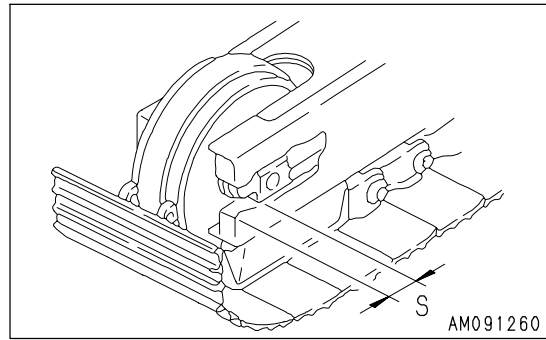

Loosening Track Tension

! WARNING

It is extremely dangerous to release the grease by any method except the procedure given below. If track tension is not relieved by this procedure, contact your Komatsu distributor for repairs.

1. Loosen plug (1) gradually to release the grease.
2. When loosening plug (1), turn it a maximum of one turn.
3. If the grease does not come out smoothly, move the machine forwards and backwards a short distance.
4. Tighten plug (1).
5. To check if the tension is correct, run the engine at low idle, move the machine slowly forward (by an amount equal to the length of track on ground), then stop the machine.
6. Check the track tension again, and if the tension is not correct, adjust it again.

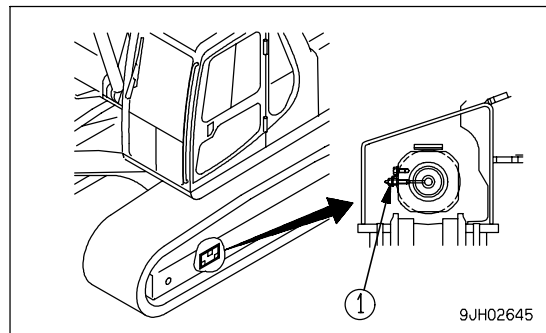

REPLACE BUCKET TEETH (VERTICAL PIN TYPE)

Replace the bucket teeth before the adapter starts to wear.



WARNING

- It is dangerous if the work equipment moves by mistake when the teeth are being replaced.
Set the work equipment in a stable condition, then stop the engine and set the lock lever securely to the LOCK position.
- The pins can be knocked out only with strong force, so there is a hazard that the pin may fly out. Check that there is no one in the surrounding area.
- There is a hazard that fragments will fly during the replacement work, so always wear protective equipment like safety glasses and gloves.

1. To make it possible to knock out pin of tooth (1), put block (5) under the bottom of the bucket, and set so that the bottom surface of the bucket is horizontal.

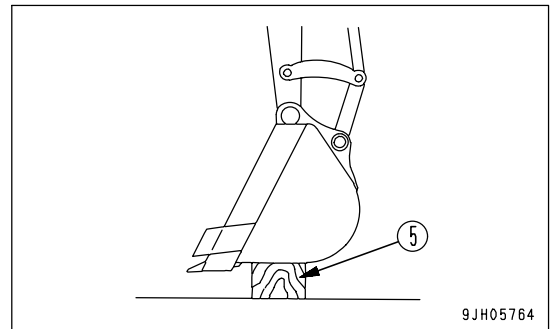

2. Check that the work equipment is in a stable condition, then set the lock lever to the LOCK position (L).

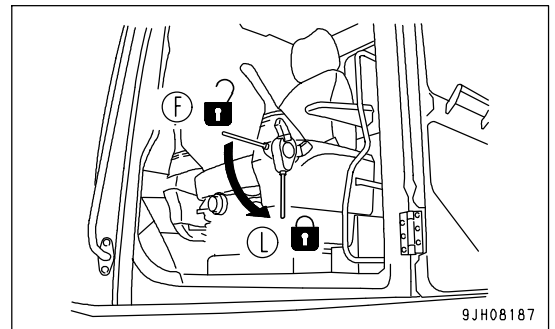

3. Use a hammer and drift to knock out lock pin (2). (If the drift is set against rubber pin lock (3) when it is hit, the rubber pin lock may break. Set it against the back of the pin.)
4. After removing lock pin (2) and rubber pin lock (3), check them.

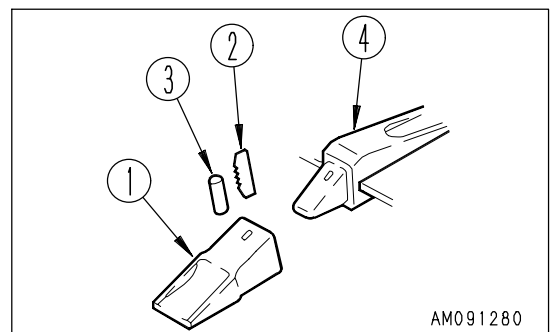

If lock pin (2) and rubber pin lock (3) are used in the condition below, it will cause tooth (1) to come off during operation. Always replace them with new parts.

- The lock pin (2) is too short.
Dimension (B) is 1/3 or more of dimension (A) when locking pin (2) is aligned with bottom face (C).

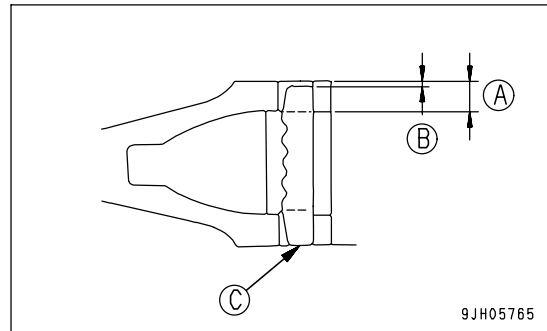

- Rubber (6) of the rubber pin lock is cut and the steel ball is about to come out.

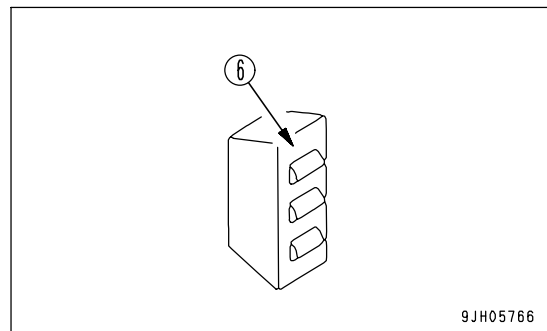

- Steel ball (7) sinks in when it is pushed by hand.

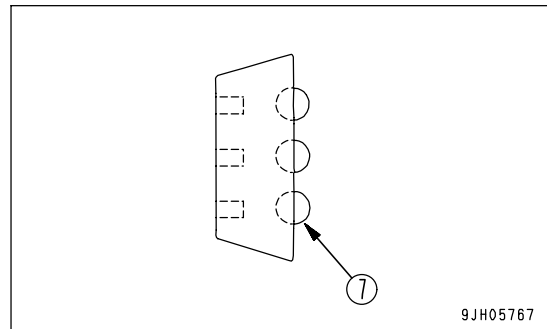

5. Clean the surface of adapter (4) and remove the soil with a knife.

6. Use your hand or a hammer to push rubber pin lock (3) into the hole of the adapter (4).

When doing this, be careful that the rubber pin lock (3) does not fly out from the adapter surface.

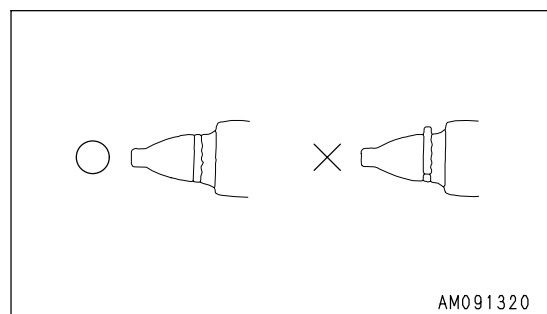

7. Clean the inside of teeth (1), then install it to adapter (4). If there is mud affixed to it or if there are protrusions, the teeth (1) will not enter the adapter properly, and there will not be proper contact at the mating portion.

8. Fit tooth (1) to adapter (4), and confirm that when the pointer is pressed strongly, the rear face of the hole for the pin of the teeth (1) is at the same level as the rear face of the hole for the pin of the adapter (4).

If the rear face of the pin hole of tooth (1) protrudes in front of the rear face of the pin hole of adapter (4), do not knock the pin in.

If this happens, there is something (C) preventing the tooth (1) from fitting completely in adapter (4), locate the problem and remove the obstruction. When tooth (1) fits completely in adapter (4), knock in lock pin (2).

9. Insert lock pin (2) in the pin hole in the tooth (1), and knock it in so that the top surface of lock pin (2) is the same height as the surface of tooth (1).

10. After replacing a bucket tooth, always check the following.

- 1) After the lock pin (2) has been knocked in completely, check that it is secured by the teeth (1) and surface.
- 2) Lightly hit lock pin (2) in the reverse direction from which it was hit in.
- 3) Lightly hit the tip of the teeth (1) from above and below, and hit its sides from right and left.
- 4) Confirm that rubber pin lock (3) and lock pin (2) are set as shown in the figure.

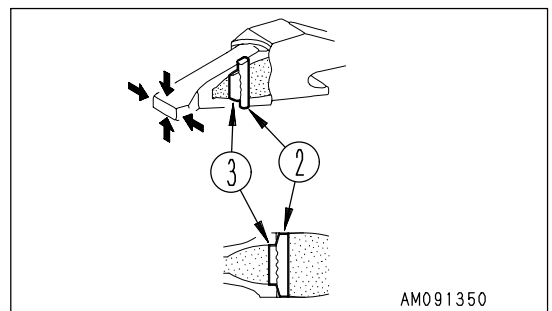
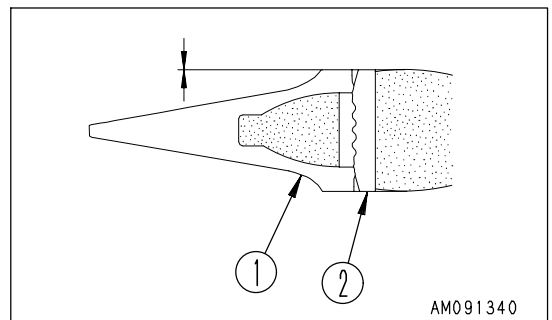
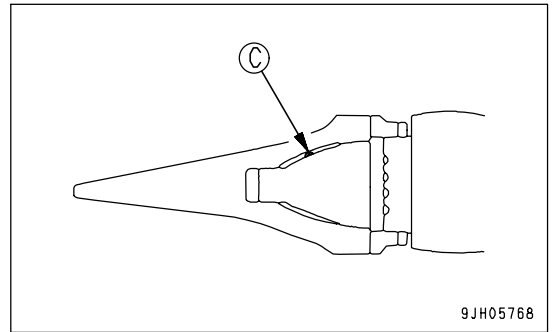

REMARK

If the tooth is turned, the wear will become uniform. This will extend the service life of the tooth and reduce the frequency of replacement.

When replacing the tooth, replace the rubber pin lock and lock pin with new parts at the same time. This will prevent the tooth from falling out.

REPLACE BUCKET TEETH (HORIZONTAL PIN TYPE)

Replace the bucket teeth before the adapter starts to wear.

WARNING

- It is dangerous if the work equipment moves by mistake when the teeth are being replaced.
Set the work equipment in a stable condition, then stop the engine and set the lock lever securely to the LOCK position.
- The pins can be knocked out only with strong force, so there is a hazard that the pin may fly out. Check that there is no one in the surrounding area.
- There is a hazard that fragments will fly during the replacement work, so always wear protective equipment like safety glasses and gloves.

1. To make it possible to knock out pin (1) of tooth (2), put block (5) under the bottom of the bucket, and set so that the bottom surface of the bucket is horizontal.

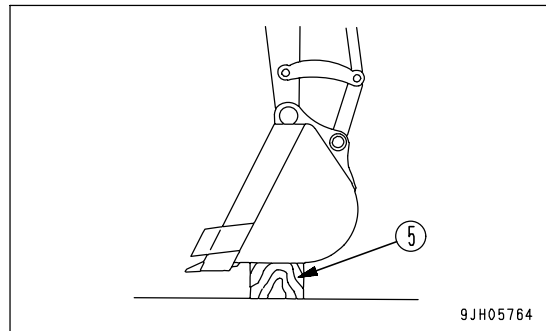

2. Check that the work equipment is in a stable condition, then set the lock lever to the LOCK position (L).

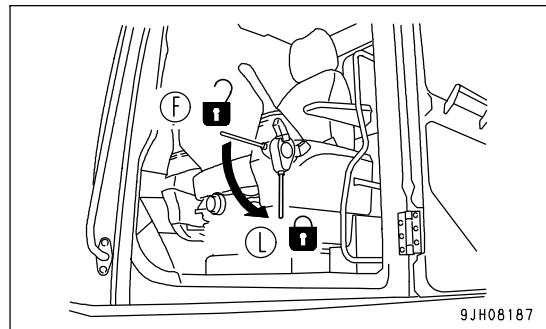

3. Place a bar on the head of pin (1), hit the bar with a hammer to knock out the pin, then remove tooth (2).

REMARK

- If the bucket teeth cannot be safely removed by this method, have your Komatsu distributor replace the bucket teeth.

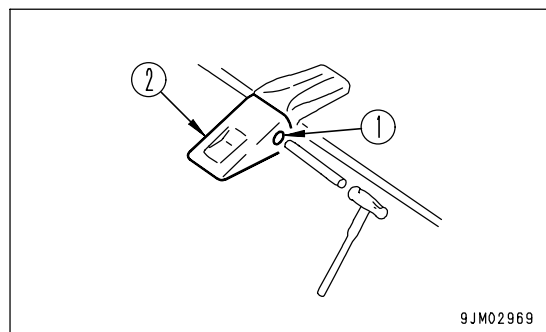

4. Clean the mounting face. Fit a new tooth (2) in the adapter, push in pin (1) partially by hand, then lock it with a hammer to install the tooth to the bucket.

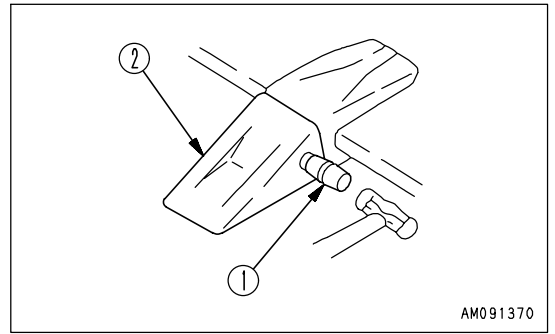

REPLACE BUCKET SIDE CUTTER, SHROUD

WARNING

- It is dangerous if the work equipment is mistakenly moved when replacing the bucket side cutters and shroud.
Set the work equipment in a stable condition, stop the engine, then set lock lever securely to the LOCK position (L).
- As the locking pin is knocked out with force, there is danger that the pin may fly out. Check that there is no one near the machine.
- Broken pieces may fly during the replacement operation, so always wear safety glasses, gloves, or other protective equipment.

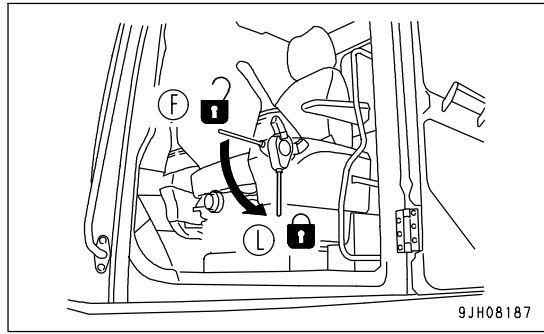

Side Cutters

Loosen mounting bolts (2), then remove side cutter (1). Replace the side cutter, bolts, and nuts with new parts.

Tightening torque for bolts: 3040 to 3630 Nm (310 to 370 kgm, 2,242.2 to 2,676.2 lbf)

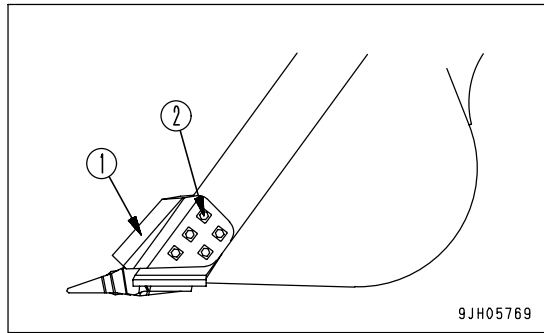

Shroud

1. Place a bar on the head of pin (1), hit the bar with a hammer to knock out the pin, then remove tooth (2).

REMARK

If it cannot be removed by this method, for safety reasons, always contact your Komatsu distributor to have the replacement carried out.

2. Clean the mounting face. Fit a new shroud (2) in the adapter, push in pin (1) partially by hand, then lock it with a hammer to install the tooth to the bucket.

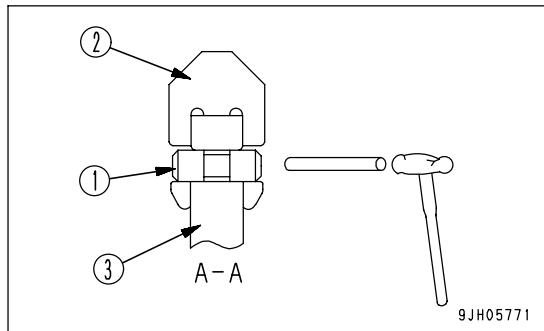
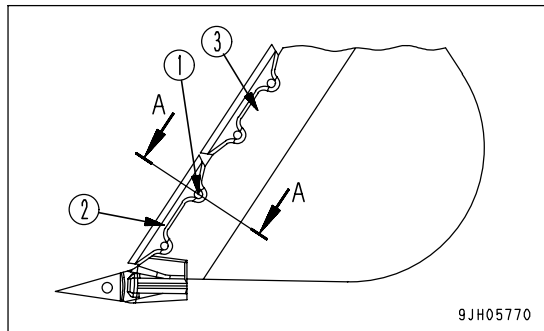

ADJUST BUCKET CLEARANCE

WARNING

It is dangerous if the work equipment is mistakenly moved when adjusting the bucket clearance.

Set the work equipment in a stable condition, stop the engine, then set lock lever securely to the LOCK position (L).

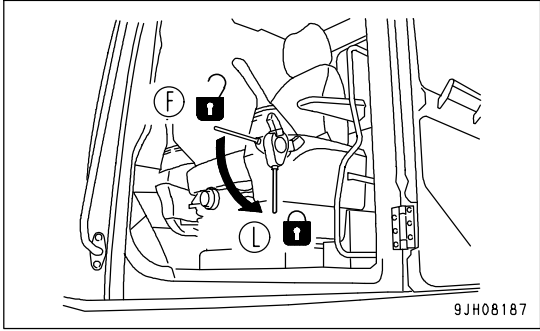

1. Set the work equipment in the position shown in the diagram on the right, then stop the engine and set the lock lever to the LOCK position (L).
2. Shift O-ring (1) and measure the amount of play "a".
Measurement is easier if you move the bucket to one side so that all the play can be measured at one place (the right side in the diagram).
Use a clearance gauge for easy and accurate measurement.
3. Loosen 4 plate mounting bolts (2), and loosen plate (3).
The shim is a split type, so the operation can be carried out without removing the bolts.
4. Remove shim (4) corresponding to the amount of play "a" measured above.

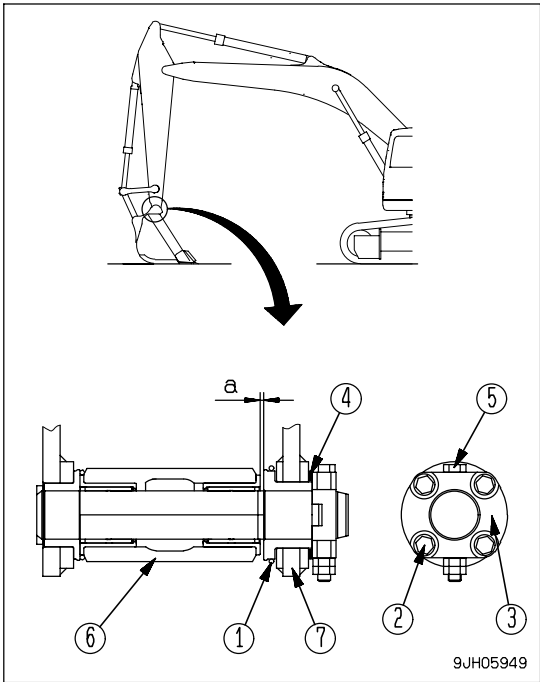

[Example]

In the case of play of 3 mm (0.118 in), remove two 1.0 mm (0.039 in) shims and one 0.5 mm (0.020 in) shim. Play becomes 0.5 mm (0.020 in). For shim (4), two types of 1.0 mm (0.039 in) and 0.5 mm (0.020 in) are used.

When play "a" is smaller than one shim, do not carry out any maintenance.

5. Tighten the four bolts (2).
If the bolts (2) are too stiff to tighten, pull out pin stopper bolt (5) for easier tightening.

- (6) Arm
- (7) Bucket

CHECK WINDOW WASHER FLUID LEVEL, ADD FLUID

If there is air in the window washer fluid, check the level of the fluid in window washer tank (1), and if it is low, add automobile window washer fluid.

The window washer tank (1) is at the rear left of the machine inside the door.

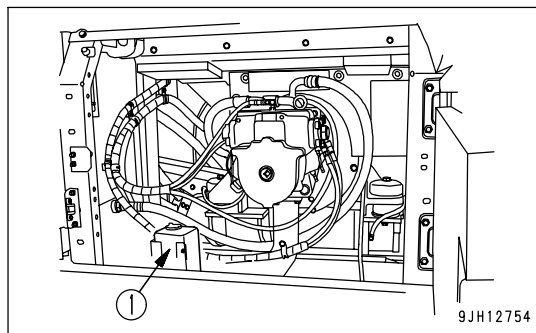

When adding fluid, be careful not to let any dust get in.

There are two types depending on the freezing temperature:

-10°C (14°F) (general use) and -30°C (-22°F) (cold area use), select according to the area and season.

Mixture Ratio of Pure Washer Fluid and Water

The proportion differs according to the ambient temperature, so dilute the washer fluid with water to the following proportions before adding.

(Mixture ratio of washer fluid at -30°C (-22°F) (cold area))

Area, season	Proportions	Freezing temperature
Normal	Washer fluid 1/3: water 2/3	-10°C (14°F)
Winter in cold area	Washer fluid 1/2 : water 1/2	-20°C (-4°F)
Winter in extremely cold area	Pure washer fluid	-30°C (-22°F)

CHECK AND MAINTENANCE AIR CONDITIONER

Check Level of Refrigerant (gas)



WARNING

If the refrigerant used in the air conditioner gets into your eyes or on your hands, it may cause loss of sight or frostbite. Do not touch the refrigerant. Never loosen any part of the refrigerant circuit.

Do not bring any flame close to any point where the refrigerant gas is leaking.

If the level of the refrigerant (gas) is low, the cooling effect will be reduced. Run the engine at high idle, and check the flow of the refrigerant gas (R134a) in the refrigerant circuit through the sight glass (2) (inspection window) of the receiver (1) when the cooler is running at high speed.

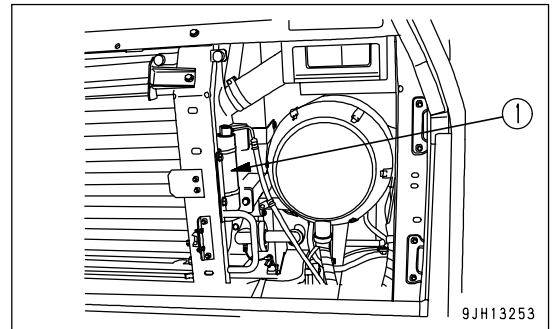

- (A) No bubbles in refrigerant flow: Suitable
- (B) Some bubbles in flow (bubbles pass continuously): Lack of refrigerant
- (C) Colorless, transparent: No refrigerant

REMARK

When there are bubbles, the refrigerant gas level is low, so contact your Komatsu distributors to have refrigerant added. If the air conditioner is run with the refrigerant gas level low, it will cause damage to the compressor.

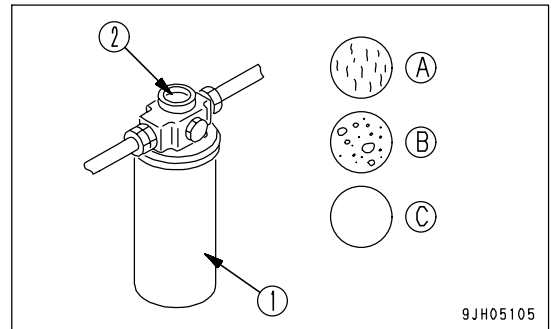

Inspection During Off Season

Even during the off-season, operate the air conditioner for 3 to 5 minutes once a month to maintain the oil film at all parts of the compressor.

Inspection and Maintenance Items

Check, maintenance items	Content of check, maintenance	Guideline for maintenance interval
Refrigerant (gas)	Charge amount	Twice a year (spring, autumn)
Air conditioner condenser	Clogged fins	Every 500 hours
Compressor	Operating condition	Every 4000 hours
V-belt	Damage, tension	Every 250 hours
Blower motor, fan	Operating condition (does it make abnormal noise?)	When required
Control mechanism	Operating condition (does it function normally?)	When required
Piping mounts	Mounting condition, looseness at tightening or connecting portions, leakage of gas, damage	When required

WASH WASHABLE FLOOR



WARNING

- When setting the machine at an angle, use strong blocks to stabilize the machine and be extremely careful when carrying out the operation.
- If the control levers are touched by mistake, the machine may suddenly move, and this may lead to a serious accident. Always set the lock lever securely to the LOCK position before standing up from the operator's seat.

NOTICE

- When carrying out this operation, be careful not to get water on the monitor and connectors inside the operator's cab.
- Never spray water above the pedestal of the operator's seat (2).
- If any water splashes on the surrounding equipment, be sure to wipe it off.

With the washable floor, it is possible to flush out the dirt on the cab floor directly with water.

Washing Washable Floor Mat

1. Stop the machine on horizontal ground, lower the bucket to the ground, and then stop the engine.
2. When washing the floor mat, use a brush to remove the dust, or direct the water onto the mat and wash it with a brush.

Method of Washing

1. Set the machine at an angle.
For details, see "Method of Setting Machine at Angle (PAGE 4-42)"
2. Swing the upper structure slowly so that water drain holes (3) in the cab floor are at a low position.

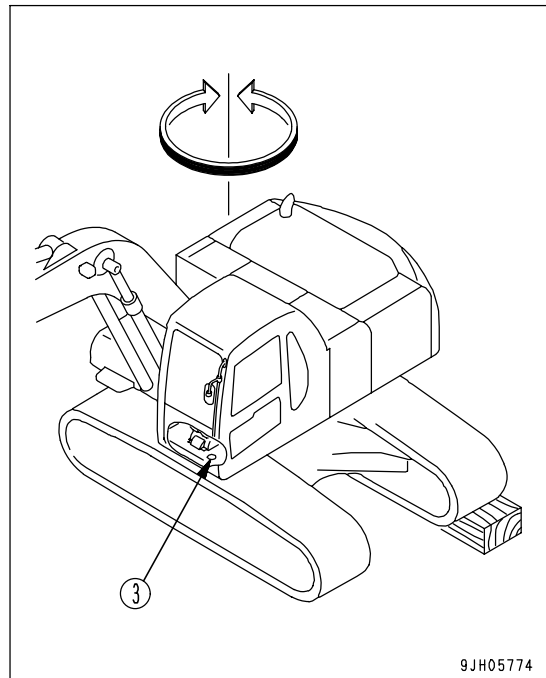

9JH05774

- Lower the work equipment to the ground and set the machine in a stable condition.

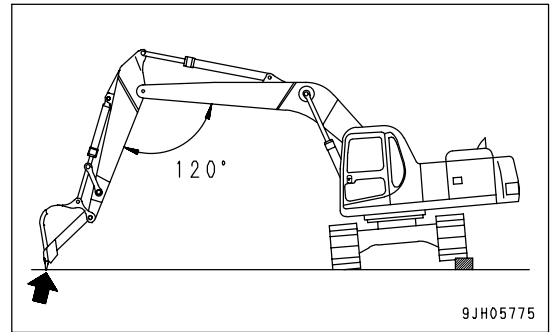

- Set lock lever (1) to LOCK position (L) and stop the engine.

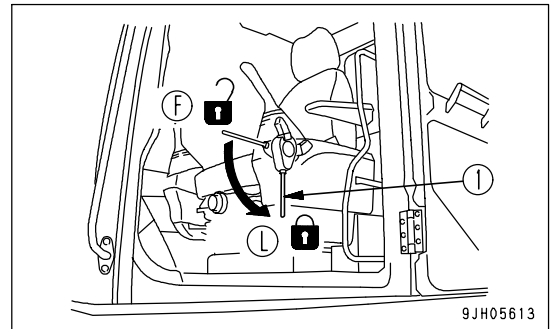

- Remove the floor mat holder plate (4).
- Pull the knob of floor mat holder clip (5) and remove clip (5).
- Remove the floor mat.
- Remove the cap from water drain hole (3).
- Flush out the dirt on the floor directly with water through water drain hole (3).
- After completing the washing operation, install the cap in water drain hole (3).
- Fit the floor mat, then secure it with floor mat holder plate (4).
- Secure the floor mat in position with the floor mat holder clip (5).

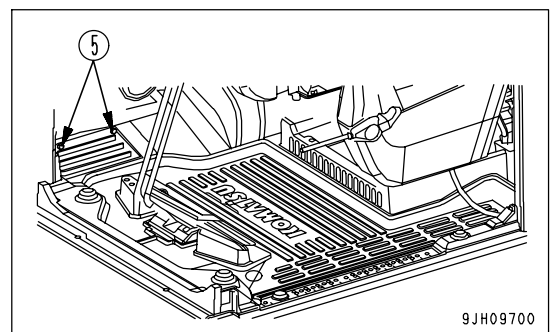
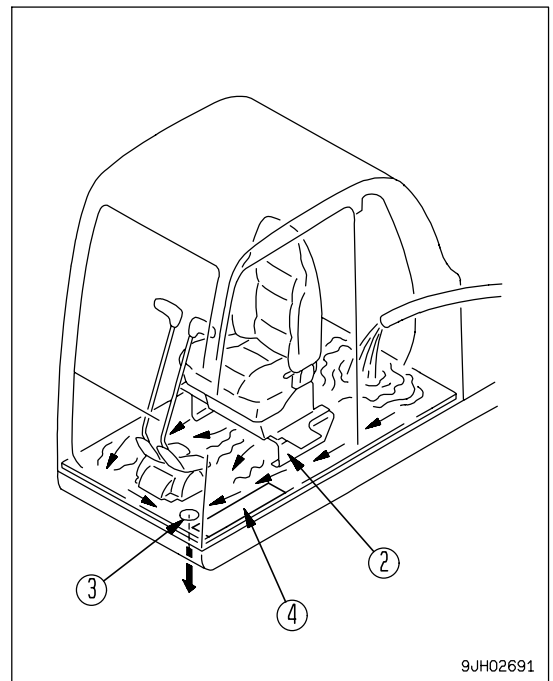

Method of Setting Machine at Angle

Method Using Slope



WARNING

Select a solid and smooth slope.

Always put blocks under the track to prevent the machine from moving, and dig the work equipment into the ground.

1. Stop the machine so that the work equipment is on the downhill side.
2. Put blocks under the track and dig the work equipment into the ground.

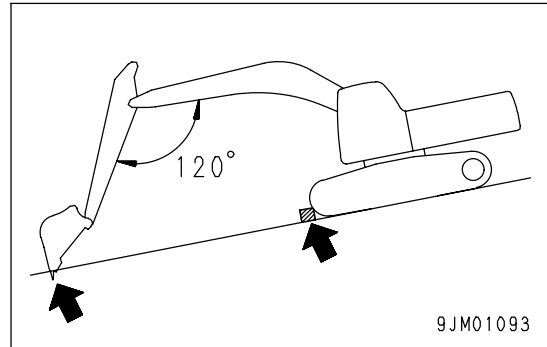

Method Using Block



WARNING

Select a firm flat place.

Put strong blocks under the undercarriage to stabilize the machine and be extremely careful when carrying out the operation.

1. Raise the chassis with the boom and arm.
When doing this, operate the levers slowly.
2. Insert block (5) under the raised track to make the machine stable.

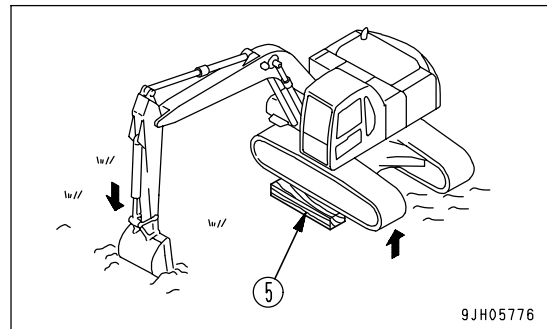

3. Raise the boom slowly and lower the machine.
When doing this, check that the machine is always stable.

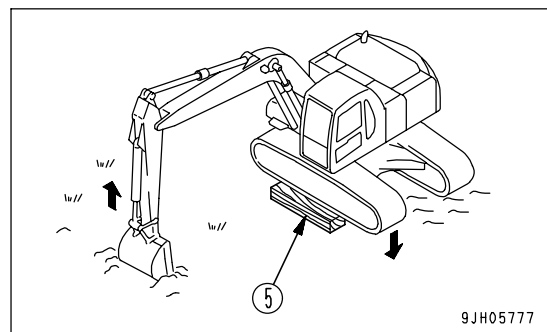

CHECK GAS SPRING



WARNING

The gas spring is charged with high-pressure nitrogen gas, so mistaken operation may cause an explosion, which will lead to serious injury or damage. When handling the gas spring, always do as follows.

- Do not disassemble the gas spring.
- Do not bring it near flame or dispose of it in fire.
- Do not make holes in it or weld it.
- Do not hit it, roll it, or subject it to any impact.
- When disposing of the gas spring, the gas must be released. Please contact your Komatsu distributor to have this work carried out.

The gas springs are located at the cab roof (left, right: two places).

In the following cases, please ask your Komatsu distributor to carry out inspection, repair, and replacement.

- When the sun roof is heavy to open.
- When the sun roof is not held open.
- When oil or gas is found to be leaking from the gas spring.

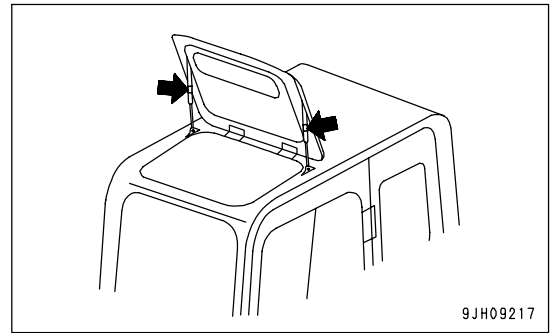

BLEEDING AIR FROM HYDRAULIC SYSTEM

For details, see "STARTING ENGINE (PAGE 3-129)". If it is necessary to refer to the items for starting the engine, moving the machine off, steering, or stopping, see the OPERATION section.

1. Bleeding air from pump

- 1) Loosen air bleeder (1) and check that oil oozes out from the air bleeder.
- 2) If the oil does not ooze out, remove the drain hose from the hydraulic pump case and fill the pump case completely with hydraulic oil through drain port (2).
Hold the removed hose firmly, keeping the mouthpiece higher than the oil level in the hydraulic tank so that oil will not spill out of the hose.
- 3) After completing the air bleed operation, tighten air bleeder (1) and install the drain hose.

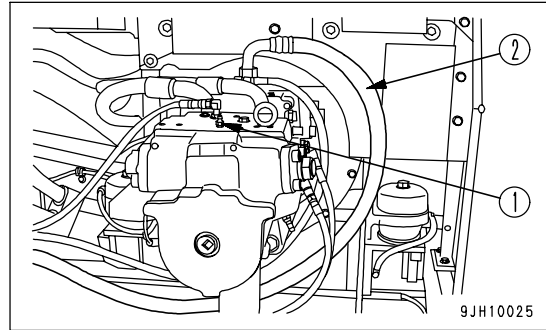

NOTICE

If the drain hose is installed first, oil will spurt out from bleeder hole (1).

If the pump is operated without filling the pump case with hydraulic oil, abnormal heat will be generated and this may cause an unexpected damage to the pump.

2. Starting engine

- Start the engine, referring to "STARTING ENGINE (PAGE 3-129)".
- Run the engine at low idle for 10 minutes after starting, then start operations.

3. Bleeding air from cylinders

- 1) Run the engine at low idle, and extend and retract each cylinder 4 to 5 times, taking care that a cylinder is not moved to the end of its stroke. (Stop the cylinder approx. 100 mm (3.9 in) short of its stroke end)
- 2) Next, operate each cylinder 3 to 4 times to the end of its stroke.
- 3) Finally, operate each cylinder 4 to 5 times to the end of its stroke to completely remove the air.

NOTICE

If the engine is run at high speed immediately after startup or a cylinder is pushed up to its stroke end, air taken inside the cylinder may cause damage to the piston packing.

4. Bleeding air from swing motor

- 1) Run the engine at low idling, loosen hose (3) at port S, and check that oil oozes out from port S hose (3).

NOTICE

Do not operate the swing under any circumstances.

- 2) If oil does not ooze out, stop the engine, remove port S hose (3), and fill the inside of the motor case with hydraulic oil.
- 3) After completely bleeding the air from the swing motor, tighten port S hose (3).
- 4) Run the engine at low idle and slowly swing at least two times uniformly to the left and right. This will automatically bleed the air from the swing circuit.

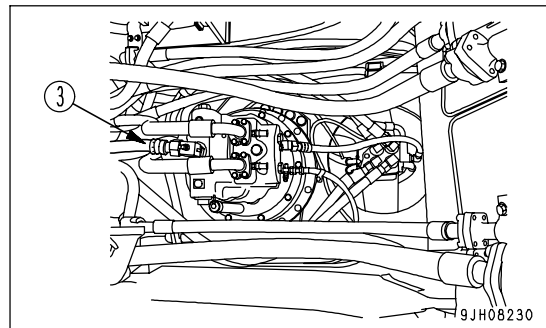

NOTICE

- If the air is not bled from the swing motor, the motor bearings may be damaged.
- When replacing the travel motor safety valve, please contact your Komatsu distributor to have it replaced and to have the air bled.

5. Bleeding air from travel motor

(Bleed the air only when the oil inside the travel motor case has been drained.)

- 1) Run the engine at low idling, loosen air bleeder (4), and tighten it when oil flows out.

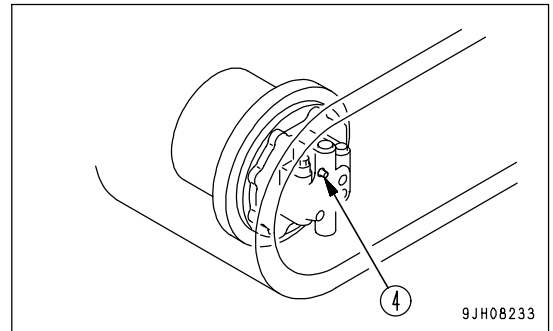

- 2) Run the engine at low idle and swing the work equipment 90° to bring it to the side of the track.
- 3) Jack up the machine until the track is raised slightly from the ground. Rotate the track under no load for 2 minutes. Repeat this procedure on both the left and right sides.

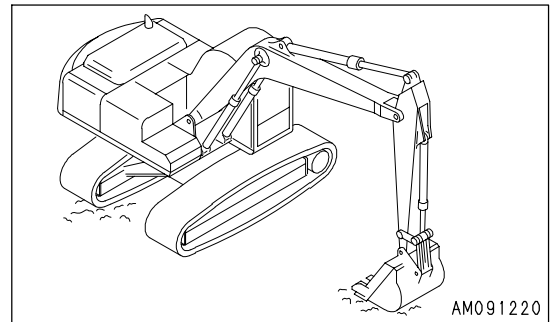

6. Bleeding air from attachment (when installed)

If a breaker or other attachment has been installed, run the engine at low idle and operate the attachment pedal repeatedly (approx. 10 times) until the air has been bled from the attachment circuit.

NOTICE

- If the method of bleeding the air from the attachment itself is specified by the manufacturer, bleed the air according to the specified procedure.
- After completing the air bleeding operation, stop the engine, and leave the machine for 5 minutes before starting operations. This will remove the air bubbles in the oil inside the hydraulic cylinders.
- Check that there is no leakage of oil and wipe off any oil that has been spilled.
- After completing the air bleeding operation, inspect the oil level, and if the oil level is low, add oil.

CHECK BEFORE STARTING

For details of the following items, see "Checks Before Starting (PAGE 3-112)" in the OPERATION section.

- Drain water and sediment from fuel tank
- Check oil level in hydraulic tank, add oil
- Check oil level in engine oil pan, add oil
- Check for water and sediment in water separator, drain water
- Check coolant level, add coolant
- Check electric wiring
- Check fuel level, add fuel
- Check working lamp switch
- Check function of horn

EVERY 50 HOURS MAINTENANCE

LUBRICATING

NOTICE

- If any abnormal noise is generated from any greasing point, carry out greasing regardless of the greasing interval.
- Carry out greasing every 10 hours for the first 50 hours on a new machine.
- After the machine was subjected to jobs in the water, be sure to grease the wet pins.

1. Set the machine to the greasing posture shown on the right, lower the work equipment to the ground, then stop the engine.
2. Using a grease pump, pump in grease through the grease fittings shown by arrows.
3. After greasing, wipe off any old grease that was pushed out.

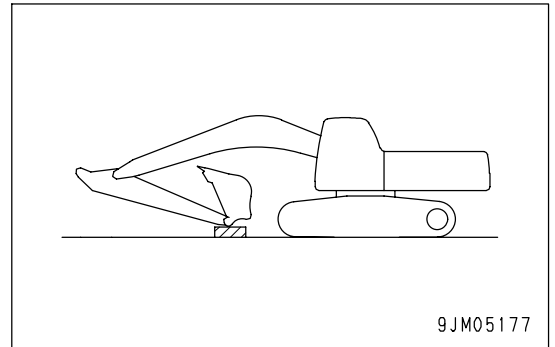

- (1) Arm-Link coupling pin (1 place)
- (2) Arm - Bucket connection pin (1 place)

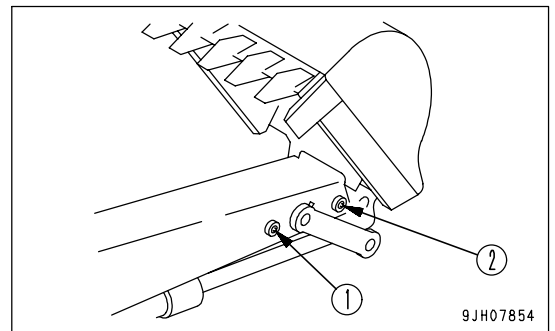

- (3) Link coupling pin (2 places)
- (4) Bucket cylinder rod pin (1 place)
- (5) Bucket-Link coupling pin (1 place)

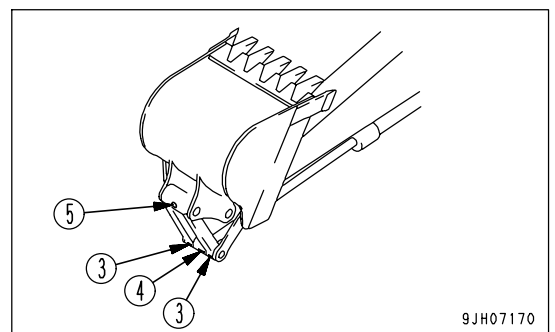

EVERY 250 HOURS MAINTENANCE

Maintenance for every 50 hours service should be carried out at the same time.

LUBRICATE SWING CIRCLE

1. Lower the work equipment to the ground.
2. Using a grease pump, pump in grease through the grease fittings shown by arrows. (2 places)
3. After greasing, wipe off any old grease that was pushed out.

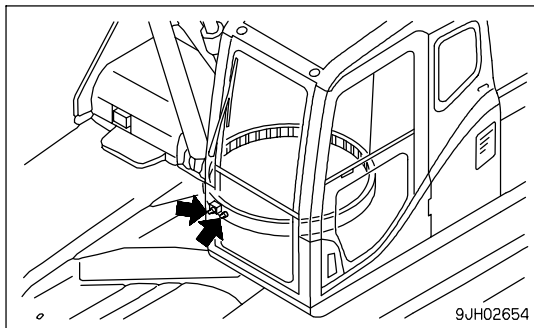

CHECK LEVEL OF BATTERY ELECTROLYTE

Carry out this procedure before operating the machine.



WARNING

- Do not use the battery if the battery electrolyte level is below the LOWER LEVEL line. This will accelerate deterioration of the inside of the battery and reduce the service life of the battery. In addition, it may cause an explosion.
- The battery generates flammable gas and there is danger of explosion, do not bring fire or sparks near the battery.
- Battery electrolyte is dangerous. If it gets in your eyes or on your skin, wash it off with a large amount of water and consult a doctor.

NOTICE

- When adding distilled water to the battery, do not allow the battery electrolyte to go above the UPPER LEVEL line. If the electrolyte level is too high, it may leak and cause damage to the paint surface or corrode other parts.
- When adding distilled water in cold weather, add it before starting operations in the morning to prevent the electrolyte from freezing.

Inspect the battery electrolyte level at least once a month and follow the basic safety procedures given below. Open cover (1) at the front right side of the machine. The battery is inside.

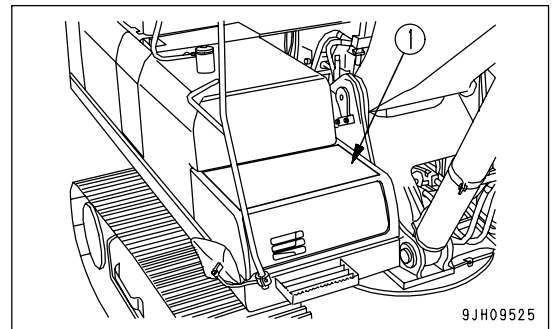

When Checking Electrolyte Level from Side of Battery

If it is possible to check the electrolyte level from the side of the battery, check as follows.

1. Use a wet cloth to clean the area around the electrolyte level lines and check that the electrolyte level is between the UPPER LEVEL (U.L.) and LOWER LEVEL (L.L.) lines. If the battery is wiped with a dry cloth, static electricity may cause a fire or explosion.

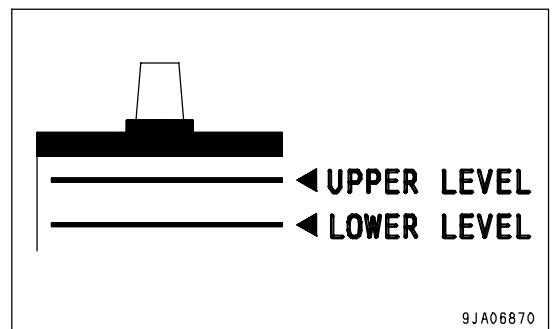

2. If the electrolyte level is below the midway point between the UPPER LEVEL (U.L.) and LOWER LEVEL (L.L.) lines, remove cap (2) and add purified water (e.g. commercially available replenishment water for a battery) to the U.L. line.
3. After adding distilled water, tighten cap (2) securely.

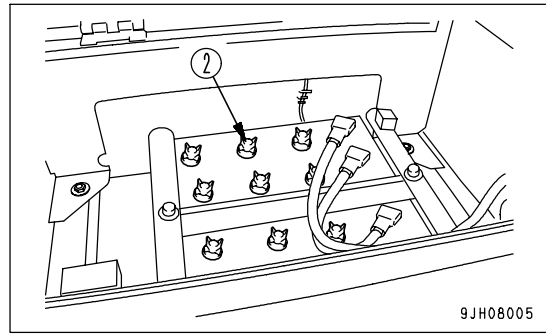

REMARK

If distilled water is added to above the UPPER LEVEL (U.L.) line, use a syringe to lower the level to the UPPER LEVEL (U.L.) line. Neutralize the removed fluid with baking soda (sodium bicarbonate), then flush it away with a large amount of water or consult your Komatsu distributor or battery maker.

When it is Impossible to Check Electrolyte Level from Side of Battery

If it is impossible to check the electrolyte level from the side of the battery, or there is no display of the UPPER LEVEL line on the side of the battery, check as follows.

1. Remove cap (2) at the top of the battery, look through the water filler port (3), and check the electrolyte surface. If the electrolyte does not reach the sleeve (4), add purified water (e.g. commercially available replenishment water for a battery) so that the level reaches the bottom of the sleeve (UPPER LEVEL line) without fail.
 - (A) Suitable level: Electrolyte level is up to bottom of sleeve, so surface tension causes electrolyte surface to bulge and poles appear bent.
 - (B) Low: Electrolyte level is not up to bottom of sleeve, so poles appear straight and not bent.
2. After adding distilled water, tighten cap (2) securely.

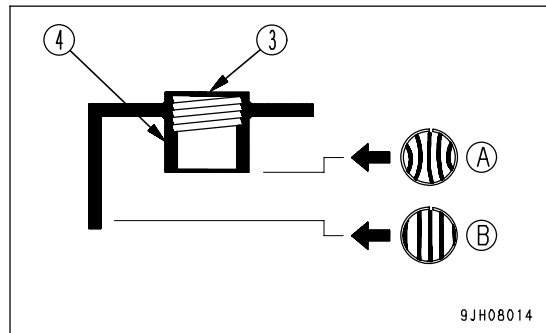
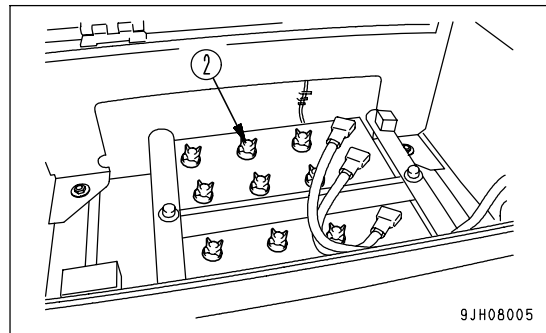

REMARK

If water is added to above the bottom tip of the sleeve, use a pipette to remove electrolyte. Neutralize the removed electrolyte with sodium bicarbonate, then flush it away with a large amount of water. If necessary, contact your Komatsu distributor or your battery maker.

When it is Possible to Use Indicator to Check Electrolyte Level

If it is possible to use an indicator to check the electrolyte level, follow the instructions given.

CHECK FAN BELT, ALTERNATOR BELT TENSION, ADJUST

Inspection

The deflection of the belt should be approx. 13 mm (0.5 in) when pressed with a finger force of approx. 58.8N (6 kg) at mid-point (a) between the alternator pulley and the fan pulley.

- (A): Alternator pulley
- (B): Fan pulley
- (C): Crankshaft pulley

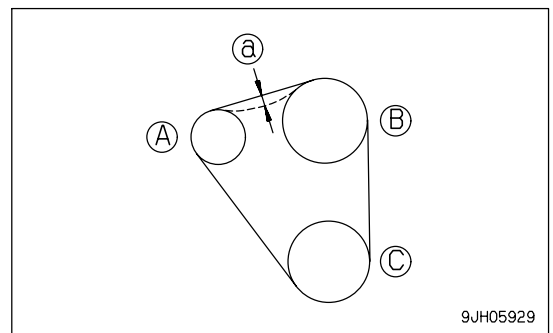
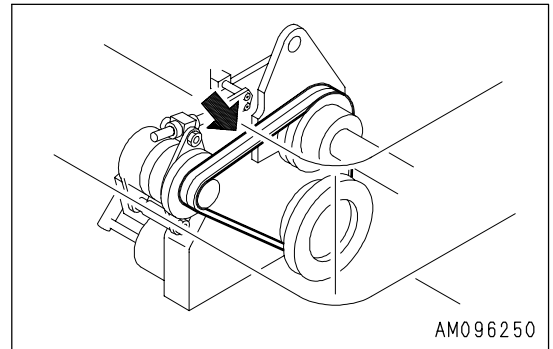

Adjustment

1. Loosen bolts and nuts (1), (2), (3).
Turn nut (4) clockwise to move alternator (5) so that the belt deflects by approx. 13 mm (0.5 in) with applied force of approx. 6 kg (58.8 N).
2. Tighten bolts and nuts (1), (2) and (3) to secure alternator (5).
Tightening torque
Lock nut(1) and (4): $137.2 \pm 53.9 \text{ Nm}$ ($14 \pm 5.5 \text{ kgm}$, $101.3 \pm 39.8 \text{ lbft}$)
Bolt(2): $33.3 \pm 4.9 \text{ Nm}$ ($3.4 \pm 0.5 \text{ kgm}$, $24.6 \pm 3.6 \text{ lbft}$)
Bolt(3): $127.4 \pm 19.6 \text{ Nm}$ ($13 \pm 2 \text{ kgm}$, $94.0 \pm 14.5 \text{ lbft}$)

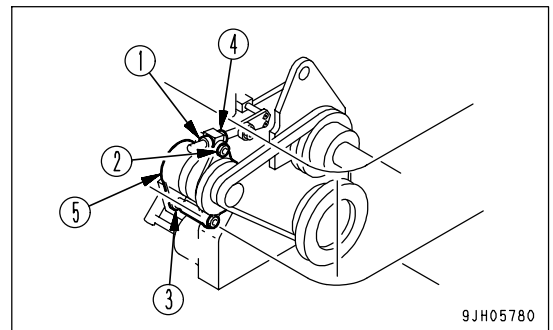

NOTICE

- Check each pulley for damage, wear of the V-groove, and wear of the V-belt. In particular, be sure to check that the V-belt is not touching the bottom of the V-groove.
- In case any of the following occurs, ask the Komatsu distributor in your territory to replace the belts with new ones.
 - The fan belt has elongated, leaving little allowance for adjustment.
 - A cut or crack is found on the belt.
 - Slipping or creaking sound is heard coming from the belt.
- When the new V-belt is set, readjust it after one hour of operation.

CHECK AIR CONDITIONER COMPRESSOR BELT TENSION, ADJUST

Checking

The deflection of the belt should be 14 to 16 mm (0.6 in) when pressed with a finger force of approx. 58.8N (6 kg) at mid-point (a) between the crankshaft pulley and the compressor pulley.

- (A): Compressor pulley
- (B): Crankshaft pulley

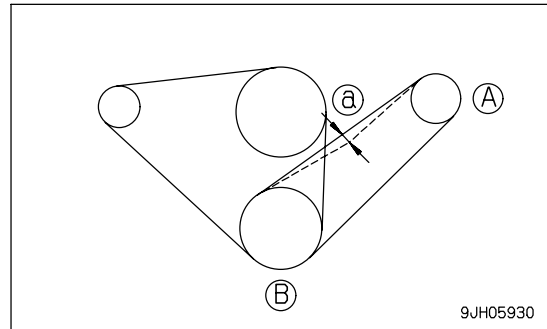

Adjustment

1. Remove guard (1).

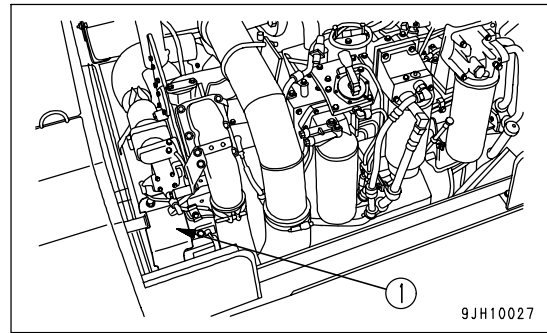

2. Loosen bolt (2) and nut (3).
3. Turn nut (4) clockwise and move compressor (5) so that the deflection of the belt is approx. 14-16 mm (at a force of approx. 6 kg).
4. When the position of the compressor is determined, tighten nut (3) and bolt (2) to lock it in position.

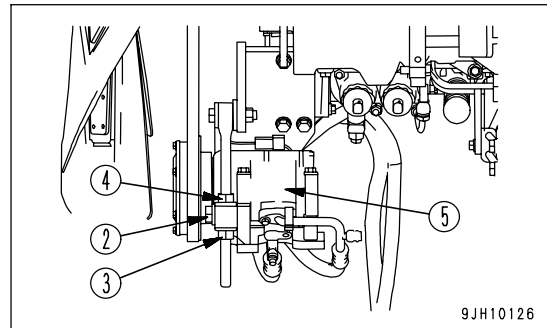

NOTICE

- Check each pulley for damage, wear of the V-groove, and wear of the V-belt. In particular, be sure to check that the V-belt is not touching the bottom of the V-groove.
- In case any of the following occurs, ask the Komatsu distributor in your territory to replace the belts with new ones.
 - The fan belt has elongated, leaving little allowance for adjustment.
 - A cut or crack is found on the belt.
 - Slipping or creaking sound is heard coming from the belt.
- When the new V-belt is set, readjust it after one hour of operation.

EVERY 500 HOURS MAINTENANCE

Maintenance for every 50 and 250 hours service should be carried out at the same time.

LUBRICATING

NOTICE

- If any abnormal noise is generated from any greasing point, carry out greasing regardless of the greasing interval.
- Carry out greasing every 10 hours for the first 50 hours on a new machine.
- After the machine was subjected to jobs in the water, be sure to grease the wet pins.
- When carrying out heavy-duty operations, such as hydraulic breaker operations, carry out the greasing every 100 hours.

1. Set the machine to the greasing posture shown on the right, lower the work equipment to the ground, then stop the engine.
2. Using a grease pump, pump in grease through the grease fittings shown by arrows.
3. After greasing, wipe off any old grease that was pushed out.

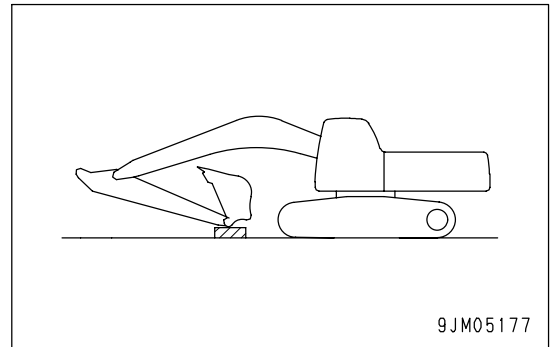

- (1) Boom cylinder rod pin (2 places)
- (2) Arm cylinder foot pin (1 places)

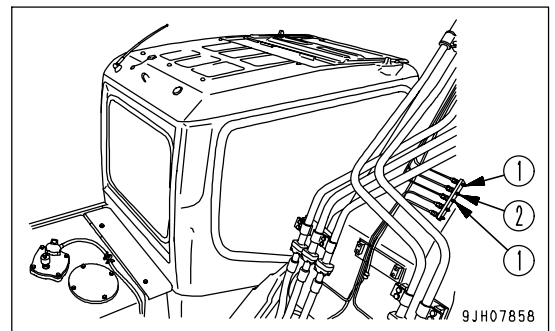

- (3) Boom-Arm coupling pin (1 place)
- (4) Arm cylinder rod end (1 place)
- (5) Bucket cylinder foot pin (1 place)

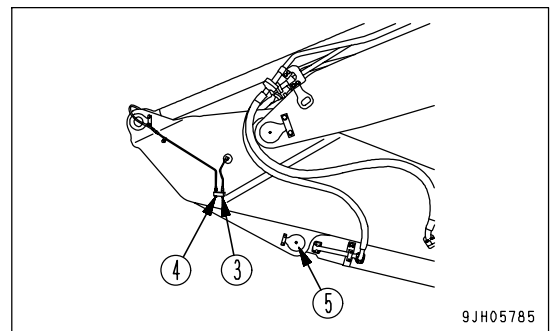

- (6) Boom cylinder foot pin (2 places)

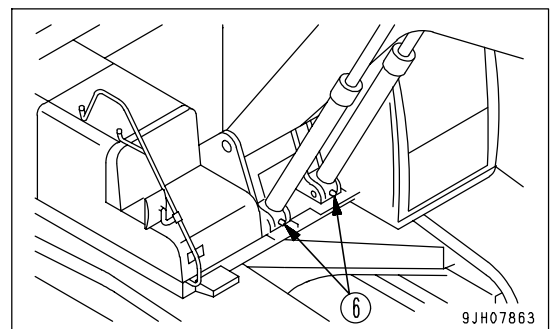

(7) Boom foot pin (2 places)

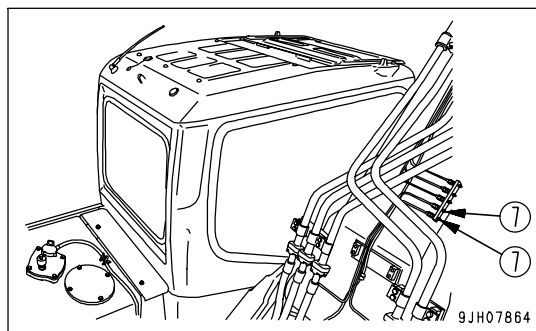

REPLACE FUEL PRE-FILTER CARTRIDGE

! WARNING

- After the engine has been operated, all parts are at high temperature, so do not replace the filter immediately. Wait for all parts to cool down before starting the operation.
- High pressure is generated inside the engine fuel piping system when the engine is running. When replacing the filter, wait for at least 30 seconds after stopping the engine to let the internal pressure go down before replacing the filter.
- Do not bring any fire or flame close.

NOTICE

- Genuine Komatsu fuel filter cartridges use a special filter that has highly efficient filtering ability. When replacing the filter cartridge, always use a genuine Komatsu part.
- The common rail fuel injection system used on this machine consists of more precise parts than the conventional injection pump and nozzle. If any part other than a genuine Komatsu filter cartridge is used, dust or dirt may get in and cause problems with the injection system. Always avoid using substitute parts.
- When carrying out inspection or maintenance of the fuel system, pay more attention than normal to the entry of dirt. If dirt is stuck to any part, use fuel to wash it off completely.
- Prepare a container to catch drain fuel.
- Prepare a filter wrench

1. Turn the valve (1) at the bottom of the fuel tank to the CLOSE position (S).

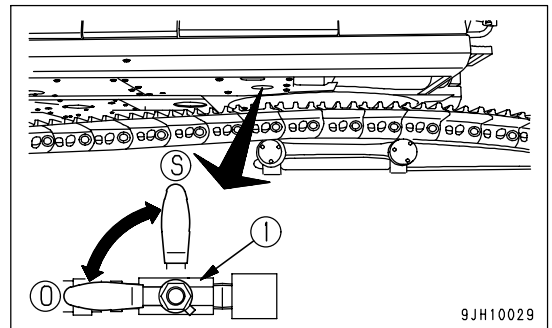

2. Open the front engine hood.
3. Set the container to catch the fuel under the filter cartridge (2).
4. Loosen drain valve (3), then drain all the water and sediment in the transparent cap (4) and also the fuel accumulated in filter cartridge (2).
5. Using a filter wrench, turn transparent cap (4) to the left to remove it. (This cap is used again.)
6. Using a filter wrench, turn filter cartridge (2) counterclockwise to remove it.

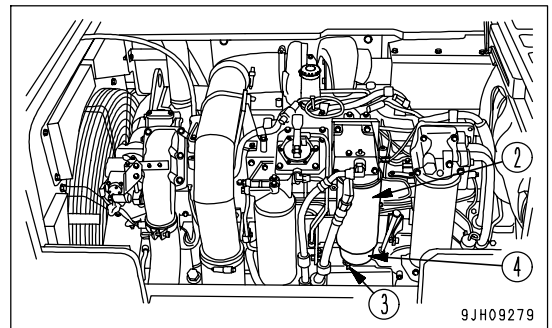

7. Remove seal (5) from transparent cap (4), then clean the cap. If transparent cap (4) is damaged, replace it with a new part.
8. Coat new seal (5) with clean fuel or oil, then install it to transparent cap (4).
9. Install transparent cap (3) to new filter cartridge (2).
 - Tightening torque for transparent cap: 10.0 Nm (1.0 kgm, 7.2 lbft)
10. Check that the drain valve (3) at the bottom of transparent cap (4) is tightened securely. Tightening torque: 0.2 - 0.45Nm (0.02 -0.046 kgm, 0.1 - 0.3 lbft)

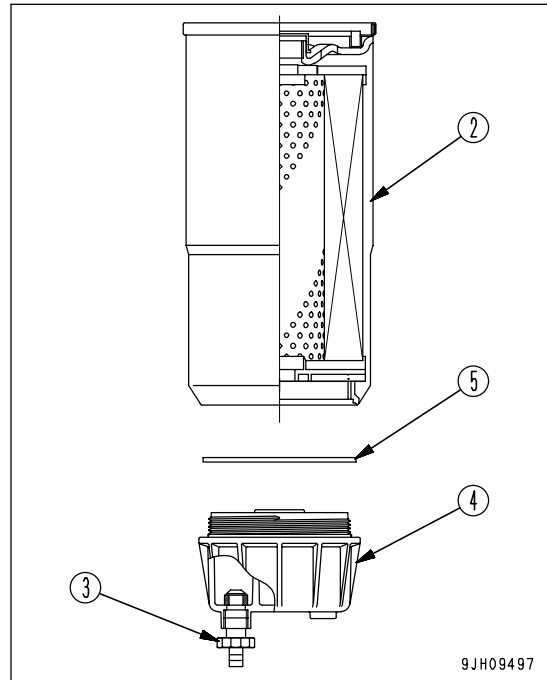

11. Clean the filter holder, fill the new filter cartridge with clean fuel, coat the packing surface thinly with oil, then install to the filter holder.

NOTICE

- When adding fuel, do not remove cap (B). Always add fuel from the 8 small holes (A) on the dirty side.
- After adding fuel, remove cap (B) and install the fuel filter.
- Always fill with clean fuel. Be careful not to let any dirt or dust get into the fuel. In particular, center portion is the clean side, so do not remove cap (B) when adding fuel. Be careful not to let dirt or dust get into center portion on the clean side.

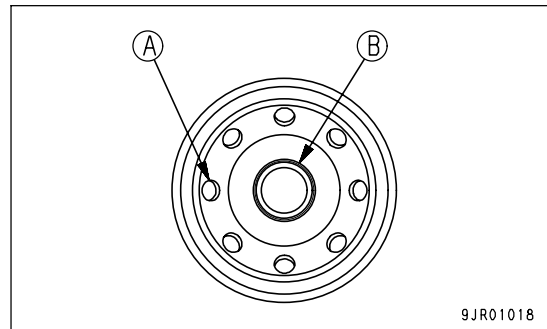

12. When installing, tighten until the packing surface contacts the seal surface of the filter holder, then tighten it 3/4 of a turn. If the filter cartridge is tightened too far, the packing will be damaged and this will lead to leakage of fuel. If the filter cartridge is too loose, fuel will also leak from the packing, so always tighten the correct amount.
 - When tightening with a filter wrench, be extremely careful not to dent or damage the filter.

13. Turn the valve (1) at the bottom of the fuel tank to the OPEN position (O).

14. After replacing the filter cartridge, start the engine and run it at low idling for 10 minutes.

Check for leakage of fuel from the filter seal surface and transparent cap mounting. If any fuel is leaking, check the tightening of the filter cartridge. If there is still fuel leakage, repeat Steps 1 - 6 to remove the filter cartridge, and if any damage or embedded foreign material in the packing surface is found, replace it with a new cartridge and repeat Steps 7 - 14 to install it.

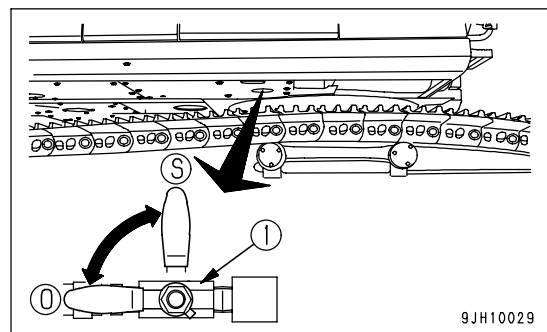

CHECK SWING PINION GREASE LEVEL, ADD GREASE

- Prepare a scale.
- 1. Swing 3 times each to the left and right, then stop the machine.
- 2. Remove bolts (1) (2 bolts) on the top of the revolving frame and remove cover (2).

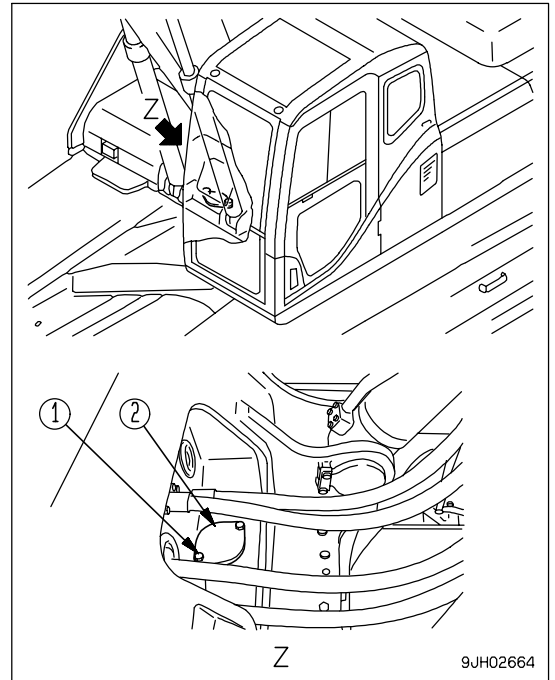

- 3. Insert scale (3) through inspection and maintenance hole (A) into the grease, and check that height (S) of the grease is at least 54 mm (2.1 in). If the grease level is low, add grease.
- 4. Check if the grease is milky white. If it is milky white, it is necessary to change the grease. Please contact your Komatsu distributor.

The total amount of grease is 33 liters (29.7 kg) [8.7 US gal (65 lb)].

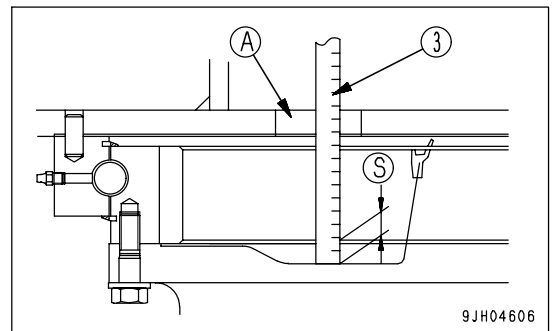

- 5. Install cover (2) with bolts (1).

CHECK OIL LEVEL IN SWING MACHINERY CASE, ADD OIL

! WARNING

Parts and oil are at high temperature immediately after the engine is stopped and may cause serious burns. Wait for the oil temperature to go down before performing this operation.

1. Remove dipstick (G) and wipe the oil from the dipstick with a cloth.
2. Fully insert dipstick (G) into the filler pipe.
3. Pull out dipstick (G) and check that the oil level is between the (H) and (L) marks on the dipstick.
4. If the oil does not reach the L mark on dipstick (G), add engine oil through dipstick insertion hole.
When refilling, remove bleeding plug (1).
5. If the oil level is above the (H) mark on dipstick (G), loosen drain valve (P) and drain the excess oil.
 - When draining the oil, first pull hose (2) out from inspection hole (B), then turn the drain valve to the OPEN position.
6. After checking oil level or adding oil, insert the dipstick into the hole and install air bleeding plug (1).

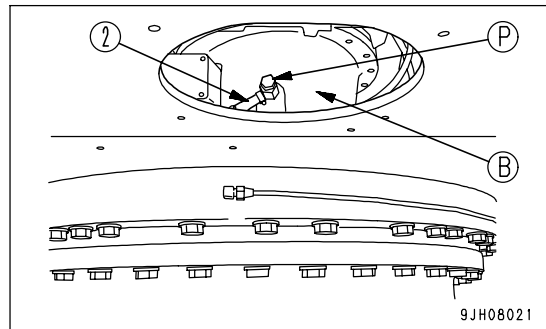
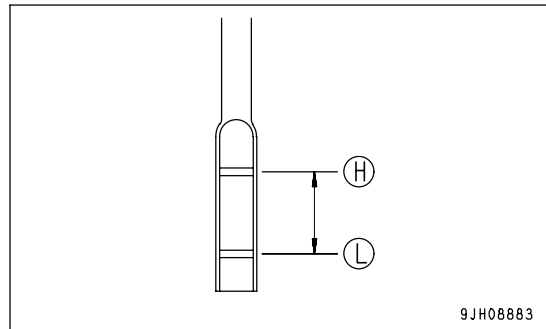
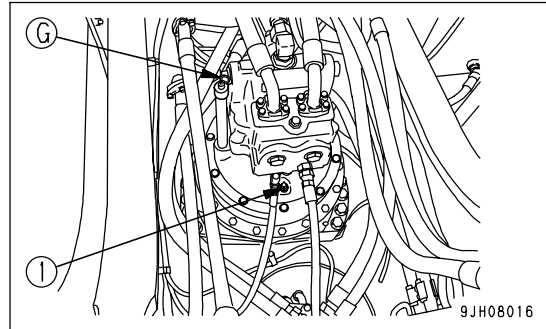

CHECK OIL LEVEL IN FINAL DRIVE CASE, ADD OIL

! WARNING

- The parts and oil are at high temperature immediately after the engine is stopped, and may cause serious burns. Wait for the temperature to go down before starting the operation.
- If there is still pressure remaining inside the case, the oil or plug may fly out.
Loosen the plug slowly to release the pressure.

- Prepare a handle.
 1. Set the TOP mark at the top, with the UP mark and plug (P) perpendicular to the ground surface.
 2. Remove plug (F) using the handle. When the oil level reaches a point 10 mm (0.4 in) below the bottom of the plug hole, the correct amount of oil has been added.
 3. If the oil level is too low, install plug (F), operate the travel levers, and drive forward or in reverse to rotate the sprocket one turn. Then repeat Step 2 to check again.
 4. If the oil level is low, add oil through the hole of plug (F). Add oil until oil overflows from the hole of plug (F).
 5. After checking, install plug (F).
Tightening torque for plugs (F): 68.6 ± 9.8 Nm (7 ± 1 kgm, 50.6 ± 7.2 lbf)

REMARK
There are two plugs (F). Add oil through the one easier to fill oil and through which no internal gears are to be seen.

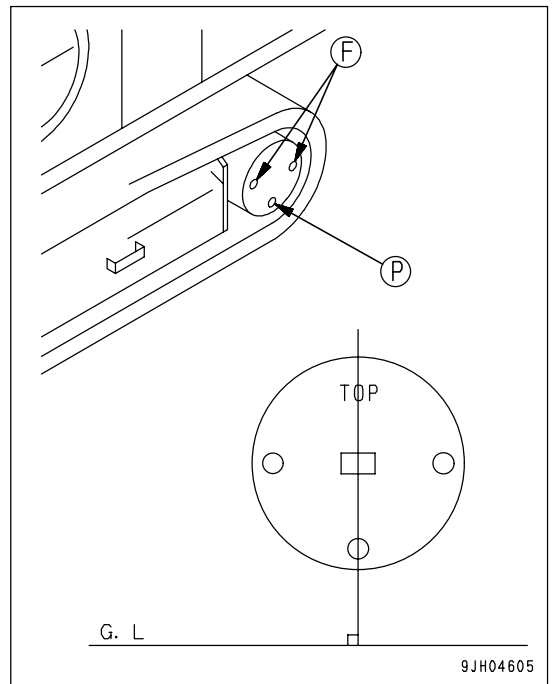

9JH04605

CHANGE OIL IN ENGINE OIL PAN, REPLACE ENGINE OIL FILTER CARTRIDGE

! WARNING

Parts and oil are at high temperature immediately after the engine is stopped and may cause serious burns. Wait for the oil temperature to go down before performing this operation.

- Refill capacity: 37 liters (9.78 US gal)
- Prepare a filter wrench
 1. Remove cover (1) under the machine and put a container under drain valve (P) to catch the drained oil.
 2. To prevent getting oil on yourself, lower the lever of drain valve (P) slowly, drain the oil, then raise the lever to close the valve.

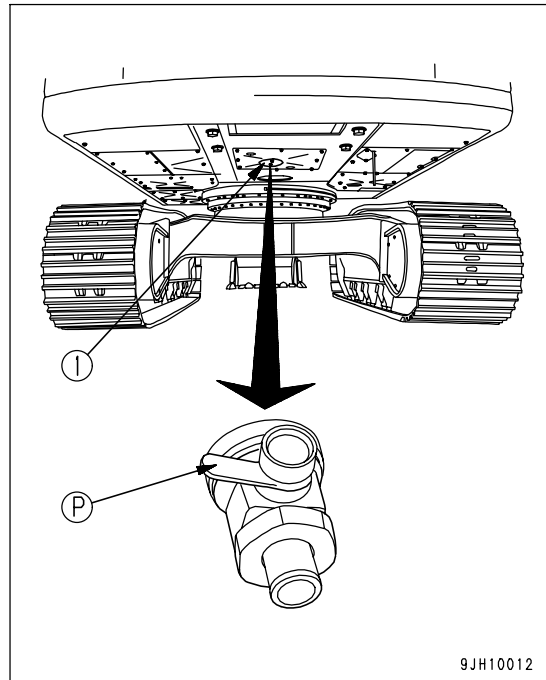

9JH10012

3. Open the front engine hood.
4. Using a filter wrench, turn filter cartridge (2) counterclockwise to remove it.

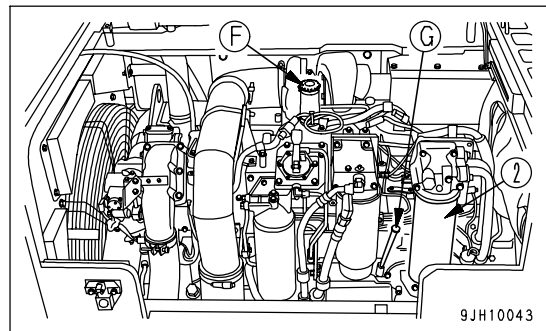

9JH10043

5. Clean the filter holder, fill the new filter cartridge with clean oil, coat the thread and packing surface of the new filter cartridge with clean oil (or coat it thinly with grease), then install it to the filter holder.

REMARK

Check that there is no old packing stuck to the filter holder. If there is any old packing stuck to the filter, it will cause leakage of oil.

6. When installing, tighten until the packing surface contacts the seal surface of the filter holder, then tighten it a further 3/4 to 1 turn.

7. After replacing the filter cartridge, add oil through oil filler port (F) so that the oil level is between the H and L marks on dipstick (G).
8. Run the engine at idle for a short time, then stop the engine, and check that the oil level is between the H and L marks on the dipstick. For details, see "Check Oil Level in Engine Oil Pan, Add Oil (PAGE 3-114)".
9. Install cover (1).

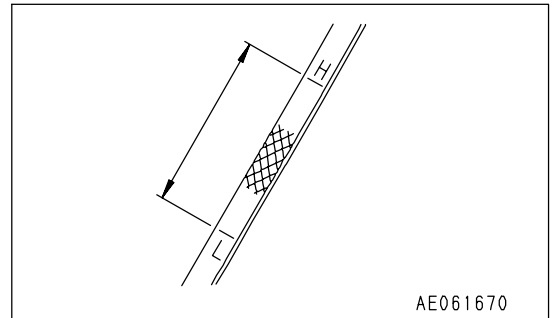

CLEAN AND INSPECT RADIATOR FINS, OIL COOLER FINS, AFTERCOOLER FINS AND CONDENSER FINS

! WARNING

If compressed air, high-pressure water, or steam hits your body directly or dirt is sent flying by the compressed air, high-pressure water, or steam, there is danger of personal injury. Always wear protective glasses, dust mask, and other protective equipment.

NOTICE

When using compressed air for cleaning, blow it keeping some distance to avoid damaging the fins. Damage on the fins can cause water leakage and overheating. In a dusty job site, check the fins every day, regardless of the maintenance interval.

1. Remove cover (1).

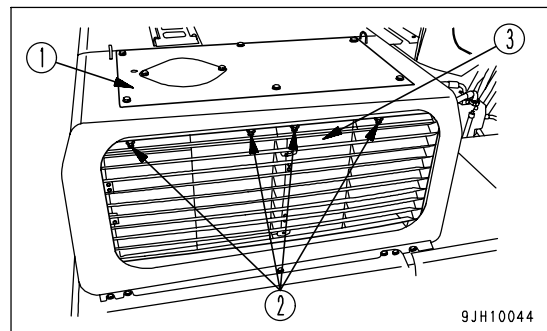

2. Loosen screw (2) and pull up net (3).
3. Clean net (3). (it is to be installed again, as instructed in the step 8.)
4. Remove 5 bolts (4), then move bracket (5) to the side and make a gap between radiator fins (6) and oil cooler fins (7).
5. Inspect the front and rear of radiator fins (6), oil cooler fins (7), after-cooler fins (8) and condenser fins (9) for dirt, dust, dry leaves, etc. Blow them away with compressed air, if any. Steam or water may be used instead of compressed air.
6. Check the rubber hose. Replace with a new one if the hose is found to have cracks or to be hardened by aging. In addition, check the hose clamps for looseness.

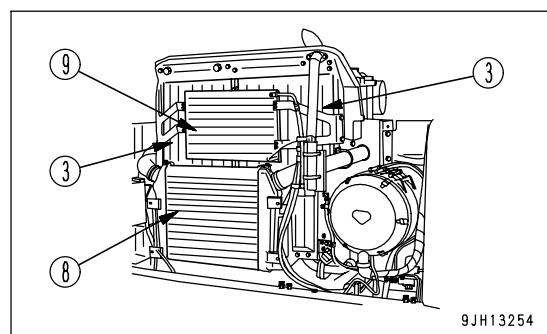
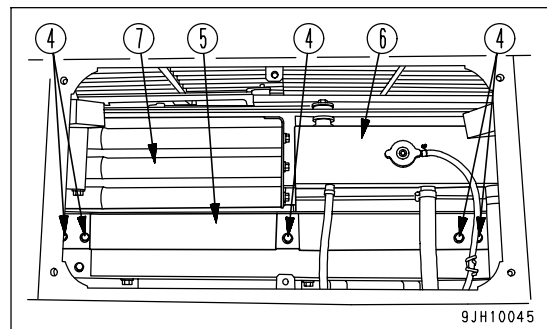

7. Remove undercover (10) and blow the mud, dirt, and leaves that have been cleaned off to the outside.
8. Push in cleaned net (3) back to the original place and secure it with screw (2).
9. Secure bracket (5) with bolt (4).
10. Remove the cover (1) and undercover(10).

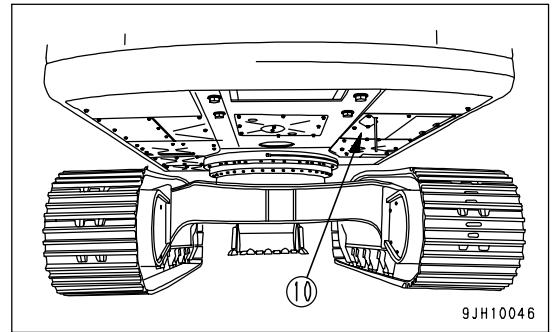

CLEAN AIR CONDITIONER FRESH/RECIRC FILTERS



WARNING

If compressed air scattered around dust and debris, there is danger of injury. Always wear protective equipment such as protective glasses and mask.

NOTICE

As a guideline, the filters should be cleaned every 500 hours, but on dusty jobsites, clean the filters more frequently.

REMARK

If the filter becomes clogged, the air flow will be reduced, and there will be an abnormal noise from the air conditioner unit.

Cleaning Recirculated Air Filter

1. Remove wing bolts (1) from the inspection window at the bottom rear left on the inside of the operator's cab, then take out the recirculated air filter.
2. Clean the filter with compressed air. If there is oil on the filter, or if the filter is extremely dirty, wash it in a neutral agent. After rinsing it in water, dry it thoroughly before using it again.
Replace the filter with a new part every year. If the clogging of the filter cannot be removed by blowing with air or washing in water, replace the filter immediately.
 - The RECIRC filter must be installed facing in the correct direction. Install it so that the projecting part faces the front of the machine.

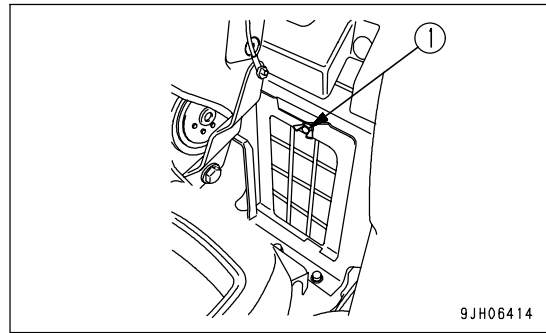

Cleaning Fresh Air Filter

1. Use the starting switch key to open cover (2) at the rear left of the operator's cab, then open cover (2) by hand and remove filter (3) inside the cover.
2. Clean the filter with compressed air. If there is oil on the filter, or if the filter is extremely dirty, wash it in a neutral agent. After rinsing it in water, dry it thoroughly before using it again.
Replace the filter with a new part every year. If the clogging of the filter cannot be removed by blowing with air or washing in water, replace the filter immediately.
3. After cleaning, return filter (3) to its original position and close the cover. Use the starting switch key to lock the cover. Do not forget to remove the starting switch key.

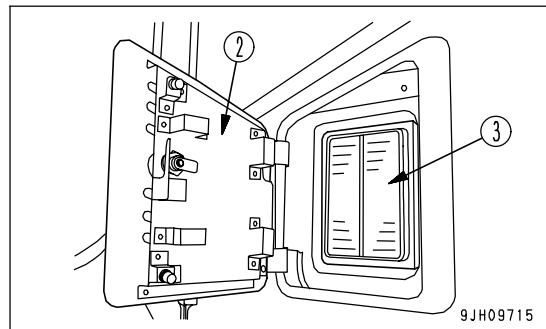

REMARK

The FRESH filter must be installed facing in the correct direction. When installing, insert the long (L) end of filter (3) into the filter case first. If the short (S) end is installed first, cover (2) will not close.

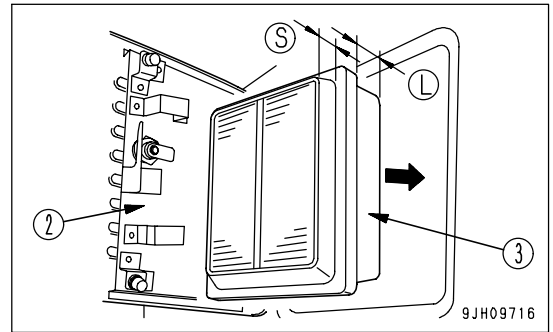

REPLACE BREATHER ELEMENT IN HYDRAULIC TANK

! WARNING

- The parts and oil are at high temperature immediately after the engine is stopped, and may cause burns. Wait for the temperature to go down before starting the work.
- When removing the oil filler cap, turn it slowly to release the internal pressure, then remove it.

1. Remove the cap of oil filler (F) at the top of the hydraulic tank.

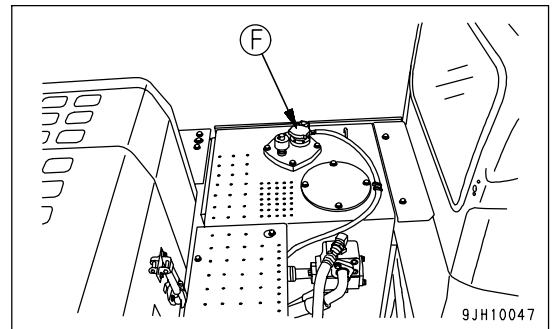

2. Replace element (1) inside the cap.

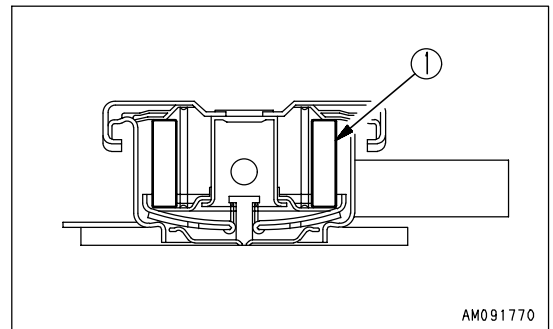

EVERY 1000 HOURS MAINTENANCE

Maintenance for every 50, 250 and 500 hours should be carried out at the same time.

REPLACE FUEL MAIN FILTER CARTRIDGE

WARNING

- After the engine has been operated, all parts are at high temperature, so do not replace the filter immediately. Wait for all parts to cool down before starting the operation.
- High pressure is generated inside the engine fuel piping system when the engine is running. When replacing the filter, wait for at least 30 seconds after stopping the engine to let the internal pressure go down before replacing the filter.
- Do not bring any fire or flame close.
- Be careful when opening the air bleed plug in the fuel filter head. It is still under pressure, so fuel may spurt out.

NOTICE

- Genuine Komatsu fuel filter cartridges use a special filter that has highly efficient filtering ability. When replacing the filter cartridge, always use a genuine Komatsu part.
 - The common rail fuel injection system used on this machine consists of more precise parts than the conventional injection pump and nozzle. If any part other than a genuine Komatsu filter cartridge is used, dust or dirt may get in and cause problems with the injection system. Always avoid using substitute parts.
 - When carrying out inspection or maintenance of the fuel system, pay more attention than normal to the entry of dirt. If dirt is stuck to any part, use fuel to wash it off completely.
- Prepare a container to catch drain fuel.
 - Prepare a filter wrench

1. Turn the valve (1) at the bottom of the fuel tank to the CLOSE position (S).

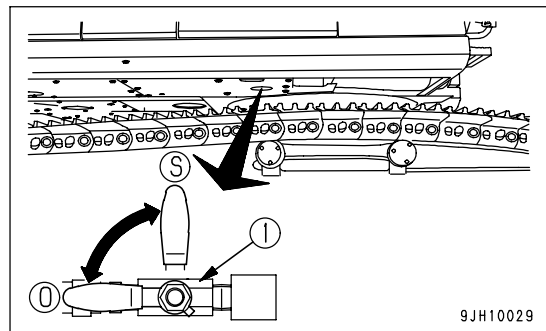

2. Open the front engine hood.
3. Set the container to catch the fuel under the filter cartridge (2).
4. Using a filter wrench, turn filter cartridge (2) counterclockwise to remove it.

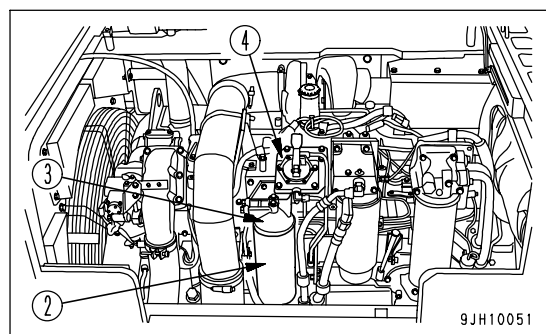

5. Clean the filter holder, coat the packing surface of the new filter cartridge thinly with oil, then install the filter cartridge to the filter holder.

NOTICE

- Do not fill the new filter cartridge with fuel.
- Remove cap (B) and install the filter cartridge.

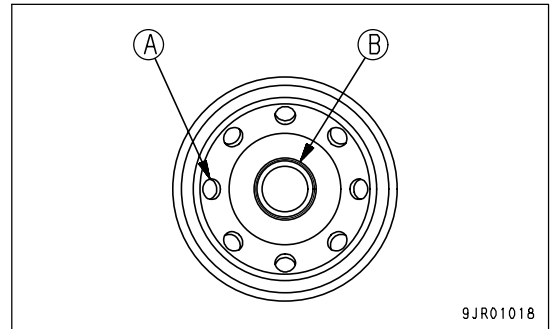

6. When installing, tighten until the packing surface contacts the seal surface of the filter holder, then tighten it 3/4 of a turn.

If the filter cartridge is tightened too far, the packing will be damaged and this will lead to leakage of fuel. If the filter cartridge is too loose, fuel will also leak from the packing, so always tighten the correct amount.

7. Turn the valve (1) at the bottom of the fuel tank to the OPEN position (O).

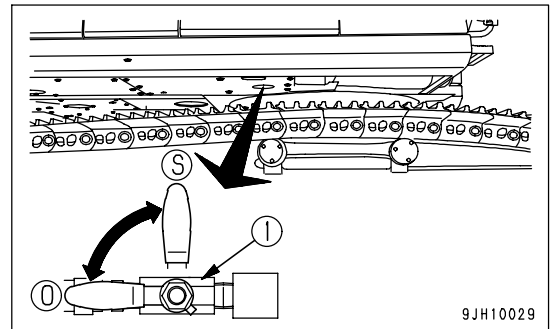

8. After completing the replacement of filter cartridge (2), bleed the air.

Bleed the air as follows:

9. Add fuel to the fuel tank until full (to FULL mark on the fuel gauge).
10. Loosen air bleed plug (C) at the fuel main filter head (3).
11. Loosen wing nut (6) holding lever (5) of priming pump (4).
12. Push in lever (5) repeatedly.
Check that bubbles come out with the fuel from air bleed plug (C).
13. Tighten air bleed plug (C).
Tightening torque: 4.9 to 6.9 Nm (0.5 to 0.7 kgm, 3.6 to 5.1 lbft)
14. Tighten wing nut (6) securely to lock lever (5) in position.
Target tightening torque: 11.8 Nm (1.2 kgm, 8.7 lbft)

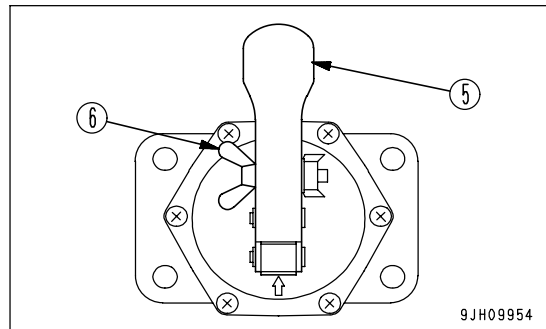
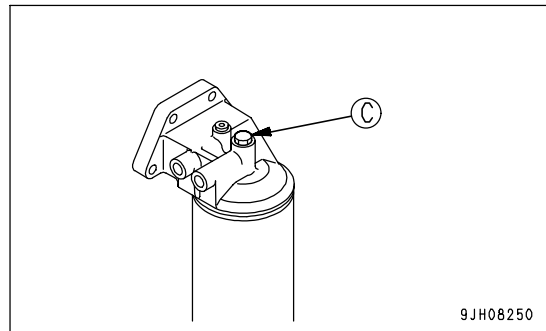
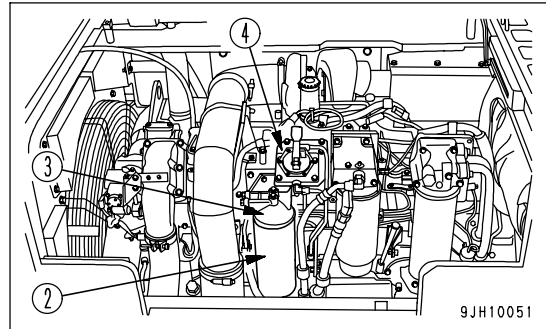

15. After replacing the filter cartridge, start the engine and run it at low idling for 10 minutes.
Check for leakage of fuel from the filter seal surface. If any fuel is leaking, check the tightening of the filter cartridge. If there is still fuel leakage, repeat Steps 1 - 4 to remove the filter cartridge, and if any damage or embedded foreign material in the packing surface is found, replace it with a new cartridge and repeat Steps 5 - 15 to install it.

REPLACE HYDRAULIC OIL FILTER ELEMENT

WARNING

- The parts and oil are at high temperature immediately after the engine is stopped, and may cause burns. Wait for the temperature to go down before starting the work.
- When removing the oil filler cap, turn it slowly to release the internal pressure, then remove it.

NOTICE

If the machine is equipped with a hydraulic breaker, the hydraulic oil will deteriorate much faster than during normal bucket operations. For details, see "MAINTENANCE INTERVAL FOR HYDRAULIC BREAKER (PAGE 4-17)" when carrying out maintenance.

1. Set the work equipment on the hard and flat ground in the maintenance posture as shown in the figure, then lower it to the ground and stop the engine.

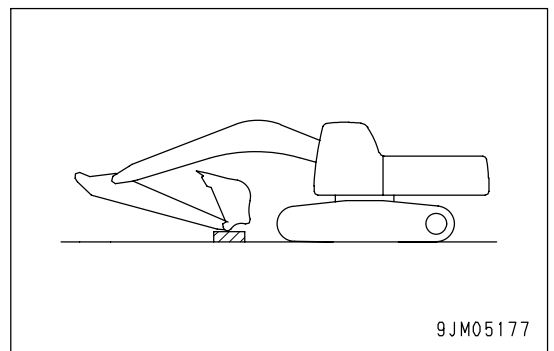

2. Remove the cap from oil filler (F), and release the internal pressure.
3. Loosen 4 bolts, then remove cover (1).
When doing this, the cover may fly out under the force of spring (2), hold the cover down when removing the bolts.
4. After removing spring (2), valve (3) and strainer (4), take out element (5).
 - Inspect the bottom of the filter case for dirt, and remove it, if any. Take good care then not to let fall the dirt into the hydraulic tank.

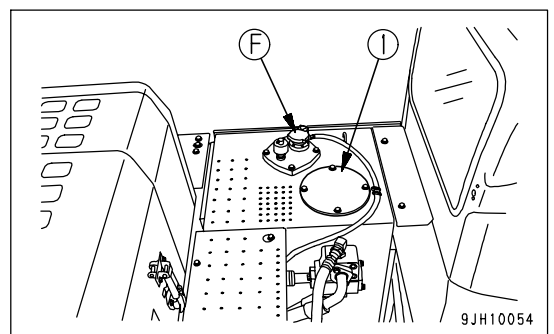

REMARK

If the mounting bolts of cover (1) loosened in Step 3 are left for approx. 5 minutes, the internal pressure inside the case will be released, so if the element is removed when the oil in the element has drained out, the amount of dripping oil will be reduced.

5. Clean the removed parts in flushing oil.
6. Install the new element in the place where old element (5) was installed.
7. Set valve (3), strainer (4) and spring (2) on top of the element.
8. Set cover (1) in position, push it down by hand, and install the cover with the mounting bolts.
9. Screw in the oil filler cap and install the cover.
10. To bleed the air, start the engine according to "STARTING ENGINE (PAGE 3-129)" and run the engine at low idle for 10 minutes.
11. Stop the engine.

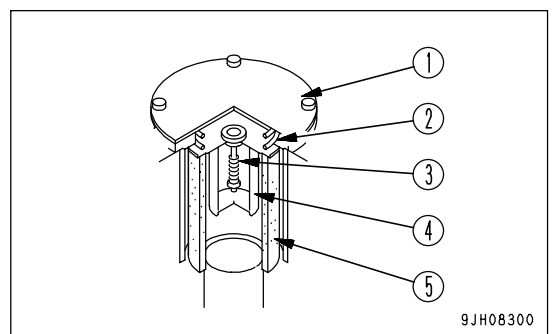

REMARK

Operate the machine after halting for more than 5 minutes to eliminate bubbles in the oil inside the tank.

12. Check for oil leakage and wipe off any spilled oil.

CHANGE OIL IN SWING MACHINERY CASE



WARNING

Parts and oil are at high temperature immediately after the engine is stopped and may cause serious burns. Wait for the oil temperature to go down before performing this operation.

- Refill capacity: 20 liters (5.28 US gal)

1. Remove cover (A) of the inspection hole.
(Only demolition specification machine)

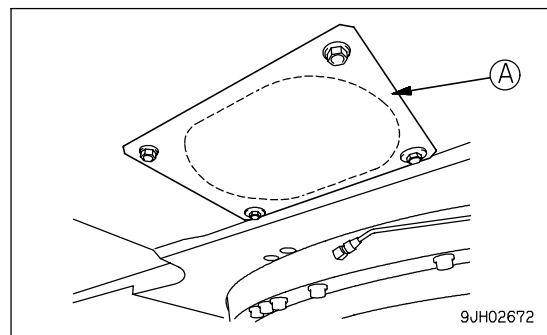

2. Set a container under drain valve (P) under the machine body to catch the oil.
3. Loosen drain valve (P) under the body, drain the oil, then tighten the drain valve again.

- When draining the oil, first pull hose (2) out from inspection hole (B), then turn the drain valve to the OPEN position.

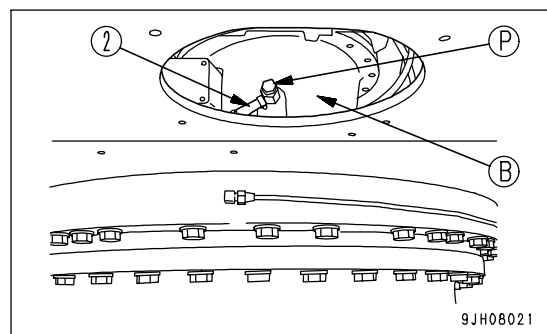

4. Remove dipstick (G) and air bleeding plug (1).
5. Add the replacement amount of oil through the insertion guide for dipstick (G).
6. Check the oil level. For details, see "CHECK OIL LEVEL IN SWING MACHINERY CASE, ADD OIL (PAGE 4-58)".
7. Install air bleed plug (1).

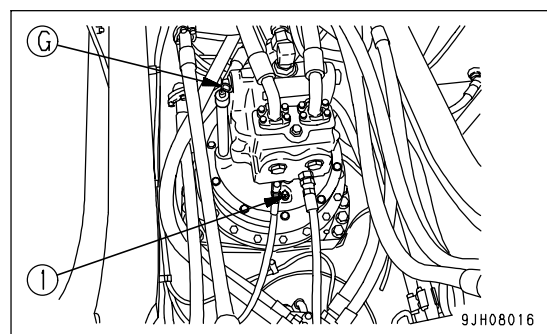

CHECK OIL LEVEL IN DAMPER CASE, ADD OIL



WARNING

Parts and oil are at high temperature immediately after the engine is stopped and may cause serious burns. Wait for the oil temperature to go down before performing this operation.

NOTICE

Park the machine on flat ground and stop the engine. After waiting for more than 30 minutes after stopping the engine, check the oil level.

1. Open the door on the left side of the machine.
2. Remove plug (P) and check that the oil is up to near the bottom of the plug hole. If the oil level is low, remove cap (F) and add oil through the oil filler port to the bottom of the hole of plug (P).

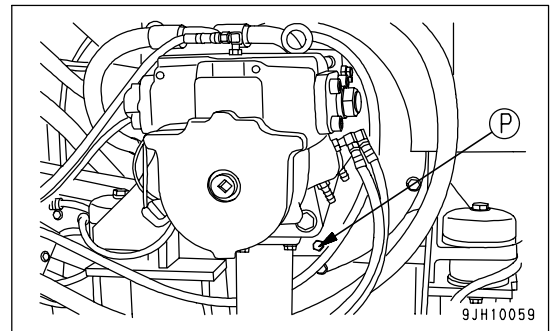

NOTICE

If excess oil is supplied, drain it to the specified amount to avoid overheating.

3. Install plug (P) and cap (F).
4. Close the door.

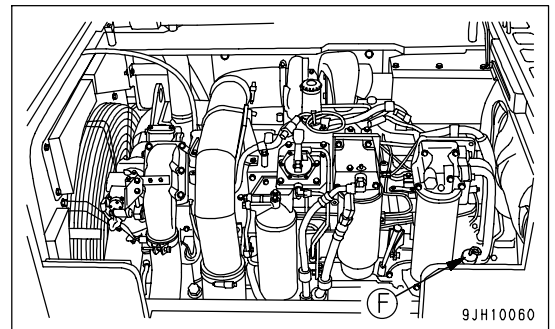

CHECK ALL TIGHTENING POINTS OF ENGINE EXHAUST PIPE CLAMPS

Please ask your Komatsu distributor to check the tightening of the clamps between the air cleaner - turbocharger - aftercooler - engine.

REPLACE HYDRAULIC TANK ADDITIONAL BREATHER ELEMENT

! WARNING

- The parts and oil are at high temperature immediately after the engine is stopped, and may cause burns. Wait for the temperature to go down before starting the work.
- When removing the oil filler cap, turn it slowly to release the internal pressure, then remove it.

1. Remove nut (2) of breather assembly (1) at the top of the hydraulic tank, then remove cover (3).
2. Replace filter element (4) with a new element.
3. Install cover (3) and nut (2).

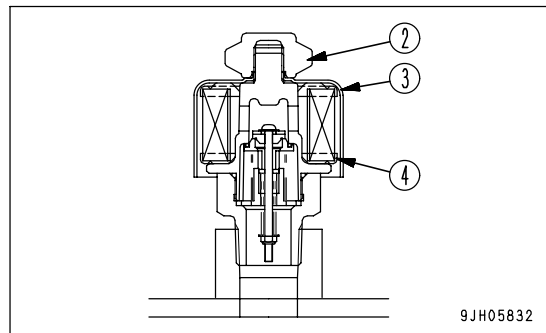
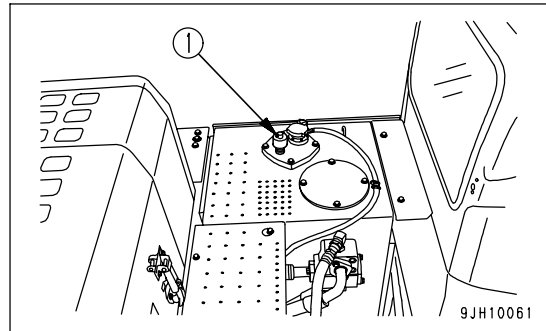

CHECK NITROGEN GAS CHARGE PRESSURE IN ACCUMULATOR (for breaker)

(If equipped)

A special tool is needed for inspecting and charging with nitrogen gas.
 Have your Komatsu distributor inspect and charge the accumulator.

EVERY 2000 HOURS MAINTENANCE

Maintenance for every 50, 250, 500 and 1000 hours service should be carried out at the same time.

CHANGE OIL IN FINAL DRIVE CASE



WARNING

- The parts and oil are at high temperature immediately after the engine is stopped, and may cause serious burns. Wait for the temperature to go down before starting the operation.
- If there is still pressure remaining inside the case, the oil or plug may fly out.
Loosen the plug slowly to release the pressure.

- Refill capacity: each 10.5 liters (2.77 US gal)
- Prepare a handle.

1. Set the TOP mark at the top, with the TOP mark and plug (P) perpendicular to the ground surface.
2. Set a container under plug (P) to catch the oil.
3. Remove plugs (P) and (F) with the handle and drain the oil.

REMARK

Check the O-rings in the plugs for damage. If necessary, replace with new ones.

4. Tighten plug (P).
5. Add oil through the hole of plug (F).
6. When oil begins to overflow from the plug (F) hole, install plug (F).

Tightening torque of plugs (P) and (F):

$68.6 \pm 9.8 \text{ Nm}$ ($7 \pm 1 \text{ kgm}$, $50.6 \pm 7.2 \text{ lbft}$)

REMARK

There are two plugs (F). Add oil through the one easier to fill oil and through which no internal gears are to be seen.

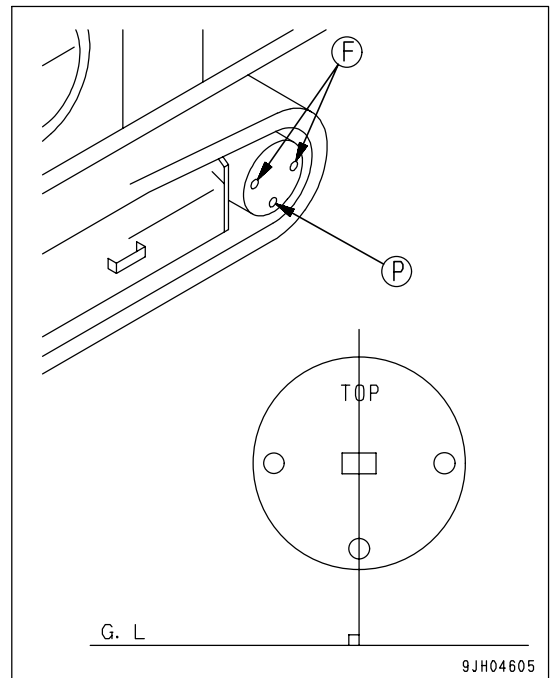

CLEAN HYDRAULIC TANK STRAINER

! WARNING

- The parts and oil are at high temperature immediately after the engine is stopped, and may cause burns. Wait for the temperature to go down before starting the work.
- When removing the oil filler cap, turn it slowly to release the internal pressure, then remove it.

1. Remove the cap from oil filler (F), and release the internal pressure.
2. Remove 4 bolts, then remove cover (1). When doing this, cover (1) may fly out under the force of spring (2), so keep the cover pressed down while removing the bolts.
3. Hold the top of rod (3) and pull up to remove spring (2) and strainer (4).
4. Remove all the dirt stuck to strainer (4), then wash it in flushing oil. If strainer (4) is damaged, replace it with a new part.
5. When installing, insert strainer (4) into protruding part (5) of the tank, and assemble.
6. Assemble so that the protruding part at the bottom of cover (1) holds spring (2), then tighten with the bolt.

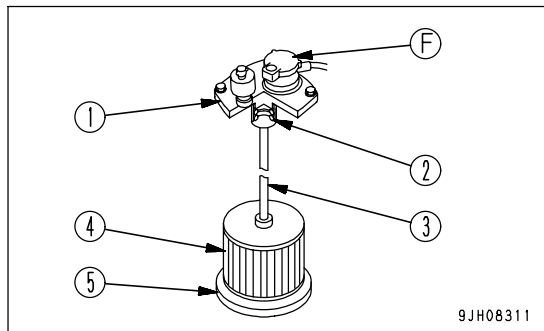
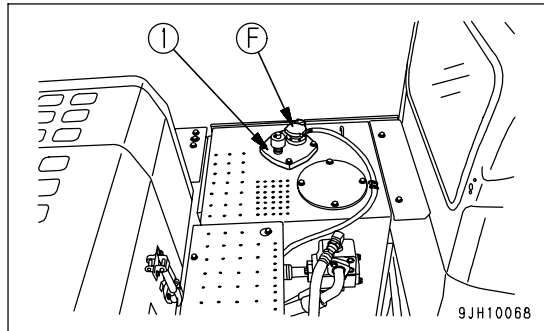

CHECKING CHARGE PRESSURE OF NITROGEN GAS IN ACCUMULATOR (FOR CONTROL CIRCUIT)



WARNING

The accumulator is charged with high-pressure nitrogen gas, so mistaken operation may cause an explosion, which will lead to serious injury or damage. When handling the accumulator, always do as follows.

- The pressure in the hydraulic circuit cannot be completely removed. When removing the hydraulic equipment, do not stand in the direction that the oil spurts out when carrying out the operation. In addition, loosen the bolts slowly when carrying out the operation.
- Do not disassemble the accumulator.
- Do not bring it near flame or dispose of it in fire.
- Do not make holes in it or weld it.
- Do not hit it, roll it, or subject it to any impact.
- When disposing of the accumulator, the gas must be released. Please contact your Komatsu distributor to have this work carried out.

NOTICE

If the nitrogen gas charge pressure in the accumulator is low and operations are continued, it will become impossible to release the remaining pressure inside the hydraulic circuit if a failure occurs on the machine.

FUNCTION OF ACCUMULATOR

The accumulator stores the pressure in the control circuit. Even after the engine is stopped, the control circuit can be operated, so the following actions are possible.

- If the control lever is operated in the direction to lower the work equipment, it is possible for the work equipment to go down under its own weight.
- The pressure in the hydraulic circuit can be released.

The accumulator is installed to the position shown in the diagram on the right.

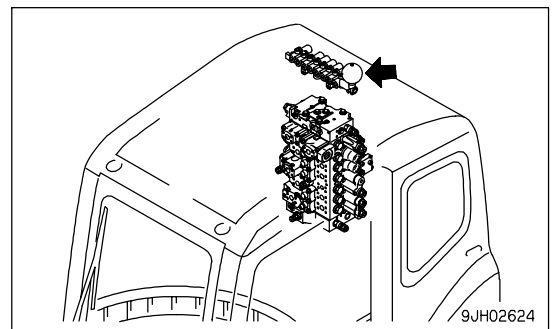

CHECKING FUNCTION OF ACCUMULATOR

CAUTION

When carrying out the inspection, check first that there is no person or obstacle in the surrounding area.

Check the nitrogen gas charge pressure as follows.

1. Stop the machine on firm, level ground.
2. Hold the work equipment in the maximum reach posture (arm fully out, bucket fully dumped) at a height (A) 1.5 m (4 ft 11 in) from the ground.

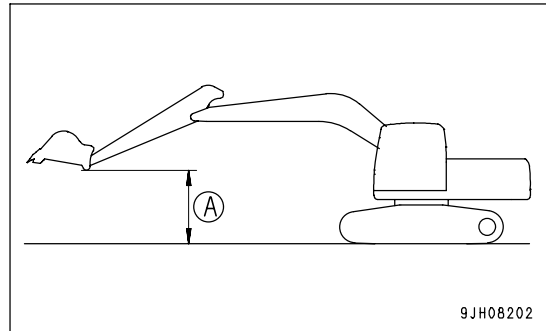

Carry out Steps 3 - 5 within 15 seconds.

When the engine is stopped, the pressure in the accumulator gradually goes down. For this reason, the check can only be carried out immediately after the engine is stopped.

3. Keep the work equipment at the maximum reach, turn the starting switch to the OFF position (A), and stop the engine.

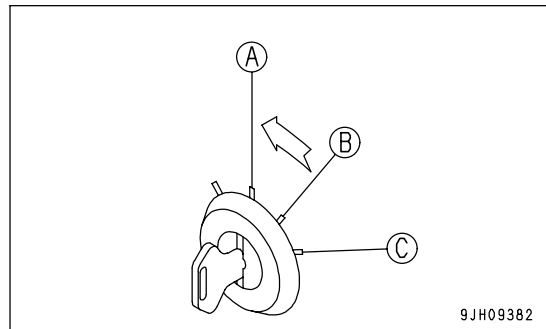

4. Turn the starting switch to the ON position (B).

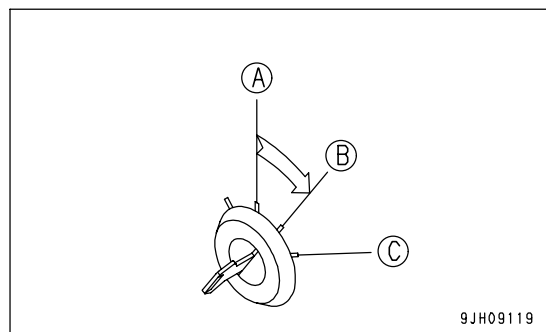

5. With the lock lever at the FREE position (F), operate the work equipment control levers fully in the LOWER direction and check that the work equipment is lowered to the ground.

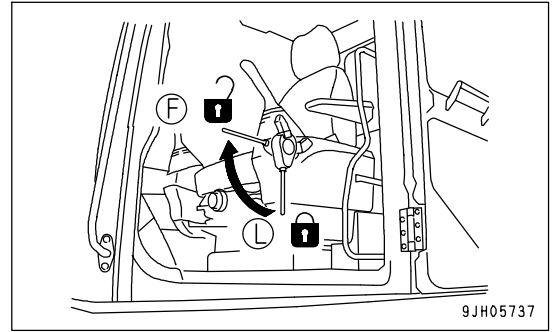

6. If the work equipment goes down under its weight and contacts the ground, the accumulator is normal.
 If the work equipment does not go down or stops in midway, the charged pressure of the gas in the accumulator for the hydraulic circuit has probably dropped.
 Please contact your Komatsu distributor for inspection.

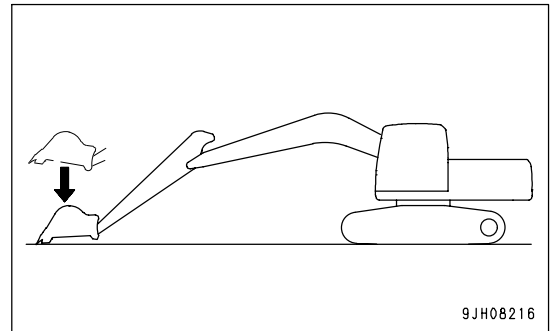

7. This completes the inspection. After completion of the inspection, set the lock lever to the LOCK position and turn the starting switch to the OFF position.

METHOD OF RELEASING PRESSURE IN HYDRAULIC CIRCUIT

1. Place the work equipment on the ground. Close the crusher attachment jaws, etc.
2. Operate the work equipment lock lever to the LOCK position.
3. Insert the lock pin for the attachment control pedal in position (c) where it is possible to operate the pedal.
(If equipped)

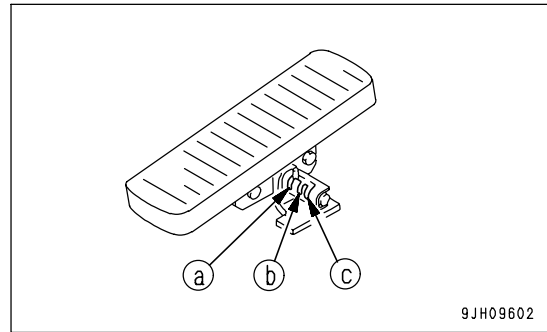

Carry out Steps 4 - 6 within 15 seconds.

When the engine is stopped, the pressure in the accumulator gradually goes down. For this reason, the release can only be carried out immediately after the engine is stopped.

4. Stop the engine.
5. Turn the starting switch to the ON position (B).

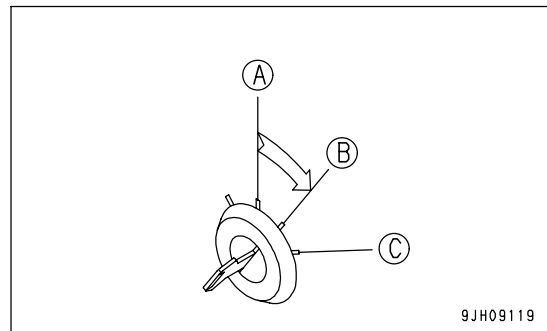

6. Set lock lever to FREE position (F), then operate the work equipment control levers and the attachment control pedal (if equipped) fully to the front, rear, left, and right to release the pressure in the control circuit.

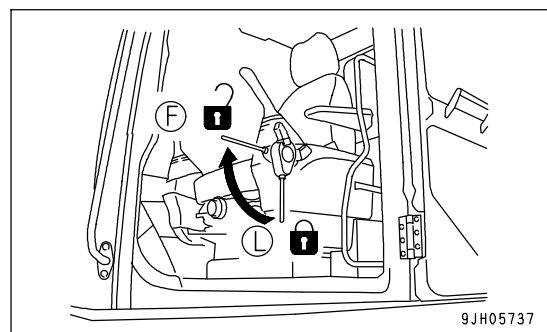

7. Set the lock lever to the LOCK position, then turn the starting switch to the OFF position.
8. Insert the lock pin in position (a) so that the attachment control pedal cannot be operated.
(If equipped)

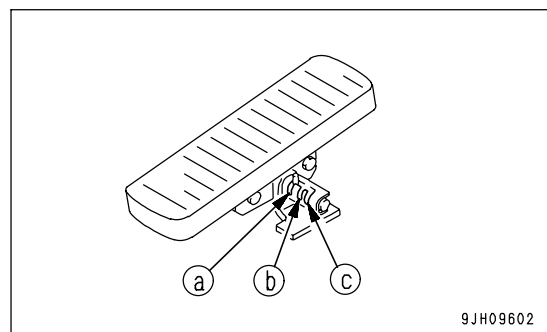

CHECK ALTERNATOR

Contact your Komatsu distributor to have the alternator checked.

If the engine is started frequently, have this inspection carried out every 1000 hours.

CHECK ENGINE VALVE CLEARANCE, ADJUST

Special tools are needed for inspection and maintenance, so contact your Komatsu distributor.

CHECK VIBRATION DAMPER

Check that there are no cracks or peeling in the outside surface of the rubber.

If any cracks or peeling are found, contact your Komatsu distributor to have the parts replaced.

EVERY 4000 HOURS MAINTENANCE

Maintenance for every 50, 250, 500, 1000 and 2000 hours service should be carried out at the same time.

CHECK WATER PUMP

Since the pulley may have play, oil may leak, water may leak, contact your Komatsu distributor for inspection, overhaul or replacement.

CHECK STARTING MOTOR

Contact your Komatsu distributor to have the starting motor checked.

If the engine is started frequently, have this inspection carried out every 1000 hours.

REPLACE ACCUMULATOR (FOR CONTROL CIRCUIT)

Replace the accumulator every 2 years or every 4000 hours, whichever comes sooner.



WARNING

The accumulator is charged with high-pressure nitrogen gas, so mistaken operation may cause an explosion, which will lead to serious injury or damage. When handling the accumulator, always do as follows.

- The pressure in the hydraulic circuit cannot be completely removed. When removing the hydraulic equipment, do not stand in the direction that the oil spurts out when carrying out the operation. In addition, loosen the bolts slowly when carrying out the operation.
- Do not disassemble the accumulator.
- Do not bring it near flame or dispose of it in fire.
- Do not make holes in it or weld it.
- Do not hit it, roll it, or subject it to any impact.
- When disposing of the accumulator, the gas must be released. Please contact your Komatsu distributor to have this work carried out.

If operations are continued after the performance of the accumulator has dropped, it will be impossible to release the remaining pressure in the hydraulic circuit if there should be a failure on the machine. Please ask your Komatsu distributor to replace the accumulator.

The accumulator is installed to the position shown in the diagram on the right.

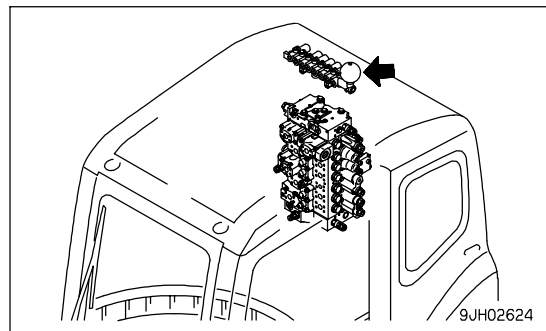

CHECK FOR LOOSENESS OF HIGH-PRESSURE PIPING CLAMP, HARDENING OF RUBBER

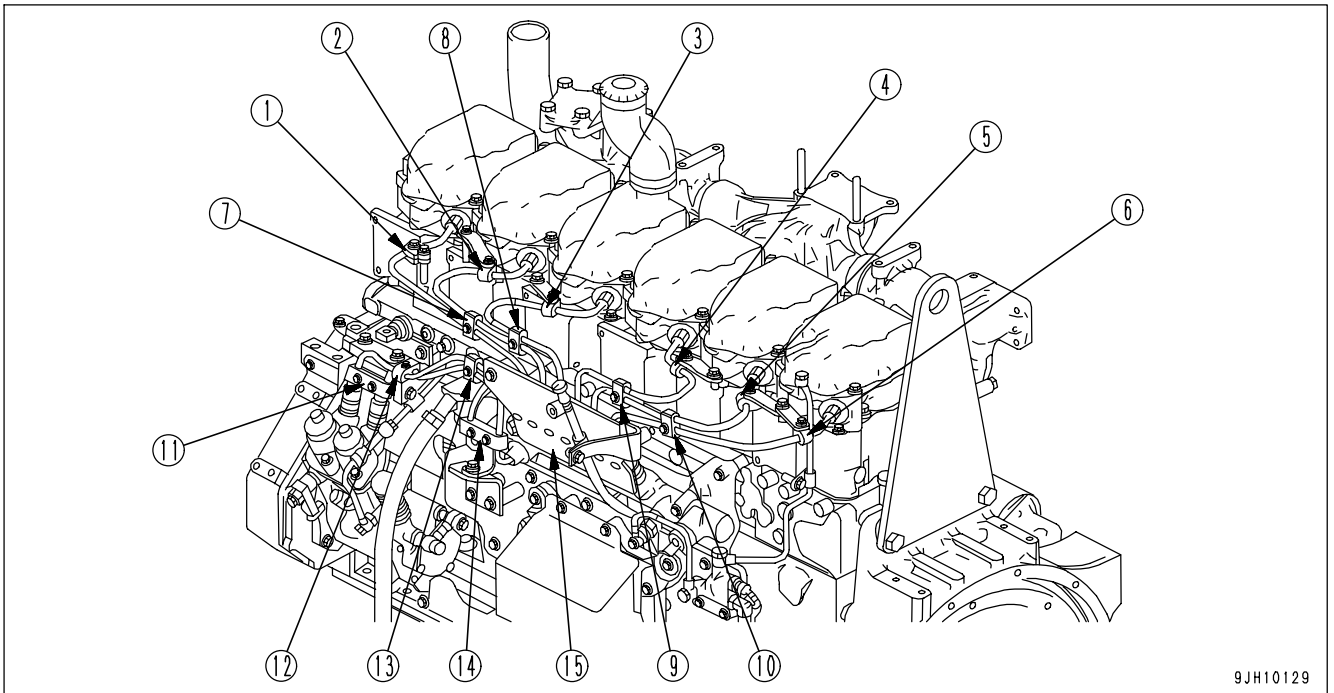

9JH10129

Check visually and touch with your fingers to check that there are no loose bolts or hardening of rubber parts at clamps (1) to (15). If there is any looseness or hardened rubber, contact your Komatsu distributor for replacement.

CHECK FOR MISSING FUEL SPRAY PREVENTION CAP, HARDENING OF RUBBER

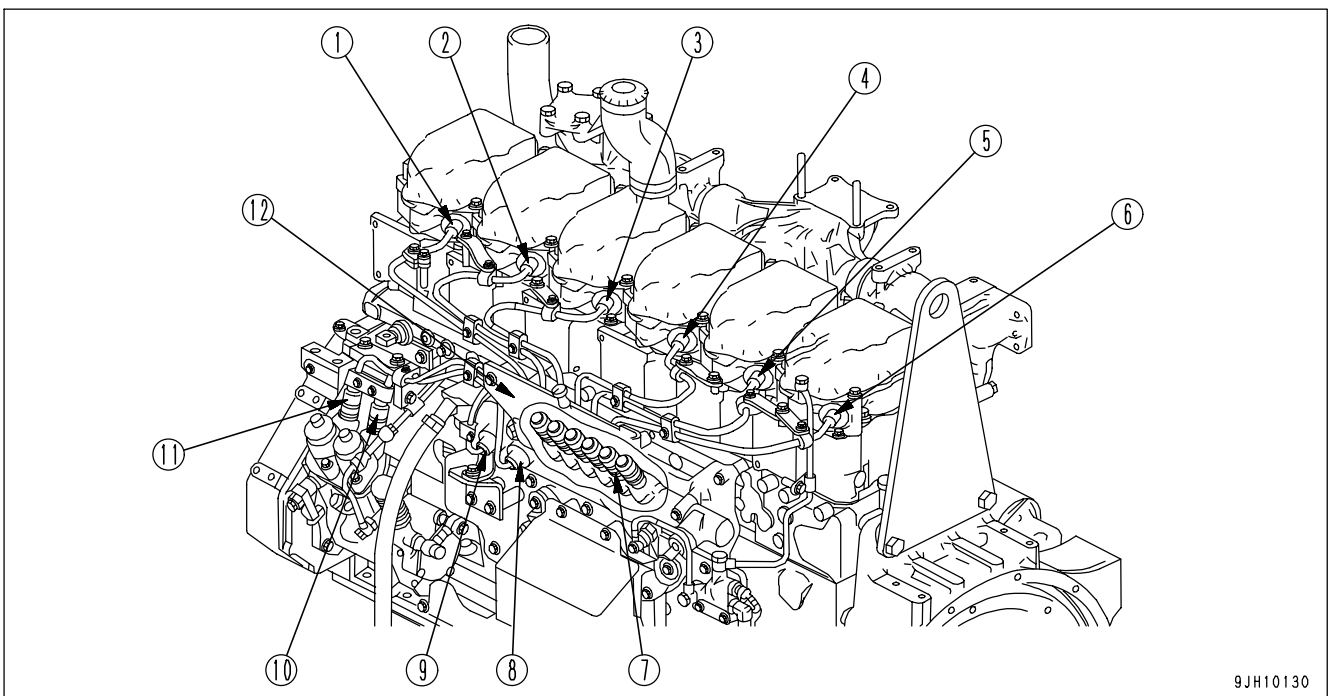

9JH10130

Check for any missing fuel spray prevention caps (1) to (11) or fuel spray prevention cover (12), and check also for any hardened rubber portions. If there are any missing caps or cover or the rubber is hardened, please contact your Komatsu distributor for repairs.

EVERY 5000 HOURS MAINTENANCE

Maintenance for every 50, 250, 500 and 1000 hours service should be carried out at the same time.

CHANGE OIL IN HYDRAULIC TANK



WARNING

- The parts and oil are at high temperature immediately after the engine is stopped, and may cause burns. Wait for the temperature to go down before starting the work.
- When removing the oil filler cap, turn it slowly to release the internal pressure, then remove it.

NOTICE

If the machine is equipped with a hydraulic breaker, the hydraulic oil will deteriorate much faster than during normal bucket operations. For details, see "MAINTENANCE INTERVAL FOR HYDRAULIC BREAKER (PAGE 4-17)" when carrying out maintenance.

- Refill capacity: 248 liters (65.52 US gal)
 - Prepare a handle (for the socket wrench).
1. Swing the upper structure so that hydraulic tank drain plug (P) and drain plug (A) at the bottom of the pump suction tube are in the middle between the left and right tracks.
 2. Retract the arm and bucket cylinders, then lower the boom and put the teeth in contact with the ground.
 3. Set the lock lever to the LOCK position and stop the engine.

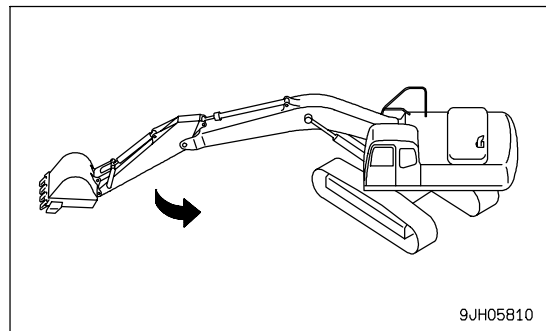

4. Remove the cap of oil filler port (F) at the top of the hydraulic tank.

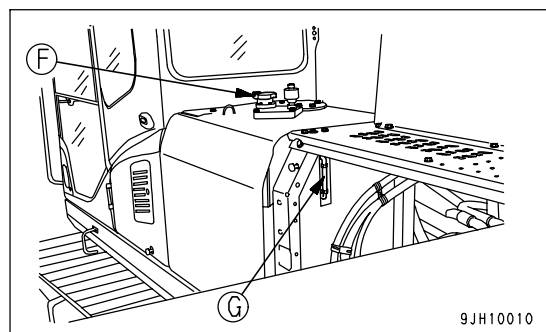

5. Remove the undercover(1) and (2).
6. Set the oil container under the drain plug under the machine. Using the handle, remove drain plug (P), (A) and drain the oil. Check the O-ring installed to plug (P), (A), and if it is damaged, replace the O-ring. After draining the oil, tighten drain plug (P), (A).

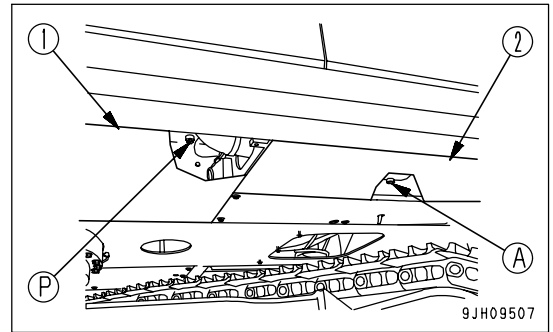

- Tightening torque of drain plug (P) and (A)
58.8 to 78.5 Nm (6 to 8 kgm, 43.3 to 57.9 lbft)
 - When removing drain plug (P), (A), be careful not to get oil on yourself.
 - First, remove drain plug (P) at the bottom of the tank, then remove drain plug (A) at the suction tube. If they are removed in this order, almost the same amount of oil can be drained.
7. Add the replacement amount of oil through oil filler (F). Check that the oil level is between the H and L lines on the sight gauge (G).
For details of oil level check, see "Check Oil Level in Hydraulic Tank, Add Oil (PAGE 3-113)".
 8. Install the undercover (1) and (2).
 9. Bleed the air from the hydraulic circuit.
For details of the method of bleeding the air from the hydraulic circuit, see "BLEEDING AIR FROM HYDRAULIC SYSTEM (PAGE 4-44)".

EVERY 8000 HOURS MAINTENANCE

Maintenance for every 50, 250, 500, 1000, 2000 and 4000 hours service should be carried out at the same time.

REPLACE HIGH-PRESSURE PIPING CLAMP

Contact your Komatsu distributor to have the engine high-pressure clamps replaced.

REPLACE FUEL SPRAY PREVENTION CAP

Contact your Komatsu distributor to have the fuel spray prevention cap replaced.

SPECIFICATIONS

SPECIFICATIONS

Item	Unit	PC400-8	PC400LC-8	PC450-8	PC450LC-8
Operating weight	kg (lb)	41,740 (92,037)	42,740 (94,242)	43,320 (95,521)	44,320 (97,726)
Bucket capacity	m ³ (cu.yd)	1.9 (2.5)			
Name of engine	-	KOMATSU SAA6D125E-5 deisel engine			
Rated horsepower of engine	kW (HP)/rpm	257 (345) /1,900			
A Overall length	mm (ft in)	11,940 (39' 2")	11,940 (39' 2")	12,040 (39' 6")	12,040 (39' 6")
B Overall height	mm (ft in)	3,635 (11' 11")	3,635 (11' 11")	3,660 (12')	3,660 (12')
C Overall width	mm (ft in)	3,340 (10' 11")	3,440 (11' 3")	3,340 (10' 11")	3,340 (10' 11")
D Track shoe width	mm (ft in)	600 (1' 12")	700 (2' 4")	600 (1' 12")	600 (1' 12")
E Height of cab	mm (ft in)	3,285 (10' 9")	3,285 (10' 9")	3,285 (10' 9")	3,285 (10' 9")
F Radius of upper structure	mm (ft in)	3,645 (11' 12")	3,645 (11' 12")	3,645 (11' 12")	3,645 (11' 12")
G Overall length of track	mm (ft in)	5,055 (16' 7")	5,385 (17' 8")	5,055 (16' 7")	5,385 (17' 8")
H Tumbler center distance	mm (ft in)	4,020 (13' 2")	4,350 (14' 3")	4,020 (13' 2")	4,350 (14' 3")
Min. ground clearance	mm (ft in)	555 (1' 10")	550 (1' 10")	555 (1' 10")	550 (1' 10")
Traveling speed (Lo/Mi/Hi)	km/h (MPH)	3.0/4.0/5.5 (1.9/2.5/3.4)			
Swing speed	rpm	9.1			

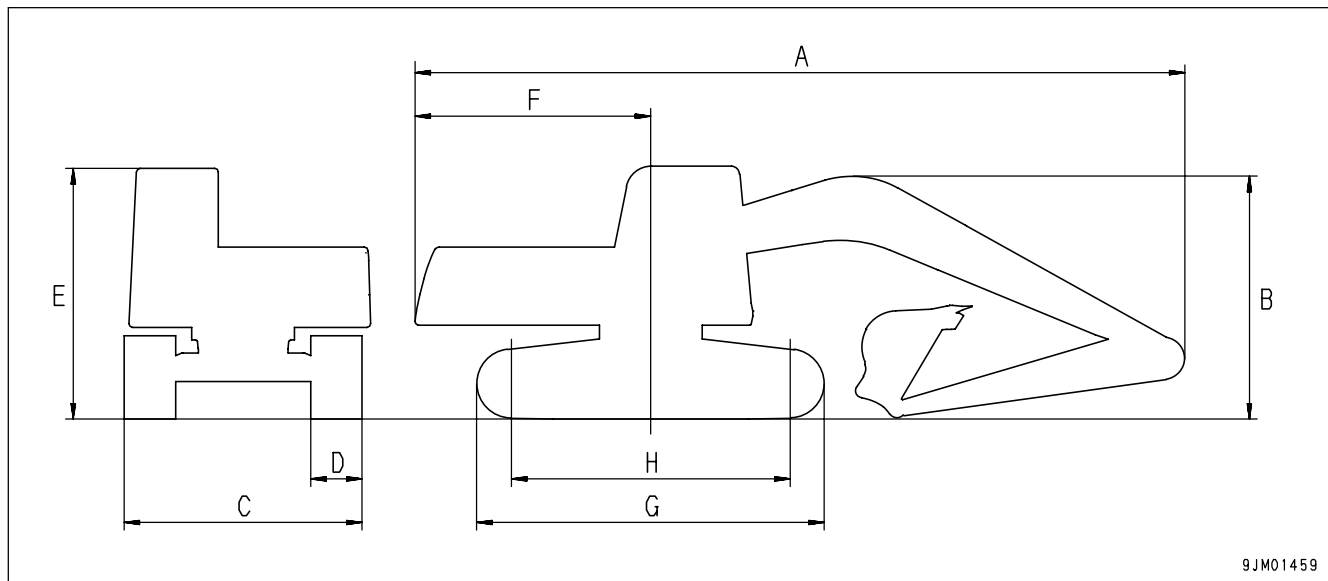

9JM01459

	Working ranges	Unit	PC400-8	PC400LC-8	PC450-8	PC450LC-8
A	Max. digging reach	mm (ft in)	12,025 (39' 5")	12,025 (39' 5")	12,005 (39' 5")	12,005 (39' 5")
B	Max. digging depth	mm (ft in)	7,820 (25' 8")	7,820 (25' 8")	7,790 (25' 7")	7,790 (25' 7")
C	Max. digging height	mm (ft in)	10,915 (35' 10")	10,915 (35' 10")	10,925 (35' 10")	10,925 (35' 10")
D	Max. vertical wall digging depth	mm (ft in)	6,870 (22' 6")	6,870 (22' 6")	6,600 (21' 8")	6,600 (21' 8")
E	Max. dumping height	mm (ft in)	7,565 (24' 10")	7,565 (24' 10")	7,625 (25')	7,625 (25')
F	Min. dump height	mm (ft in)	2,890 (9' 6")	2,890 (9' 6")	2,920 (9' 7")	2,920 (9' 7")
G	Max. digging reached at ground level	mm (ft in)	11,820 (38' 9")	11,820 (38' 9")	11,800 (38' 9")	11,800 (38' 9")

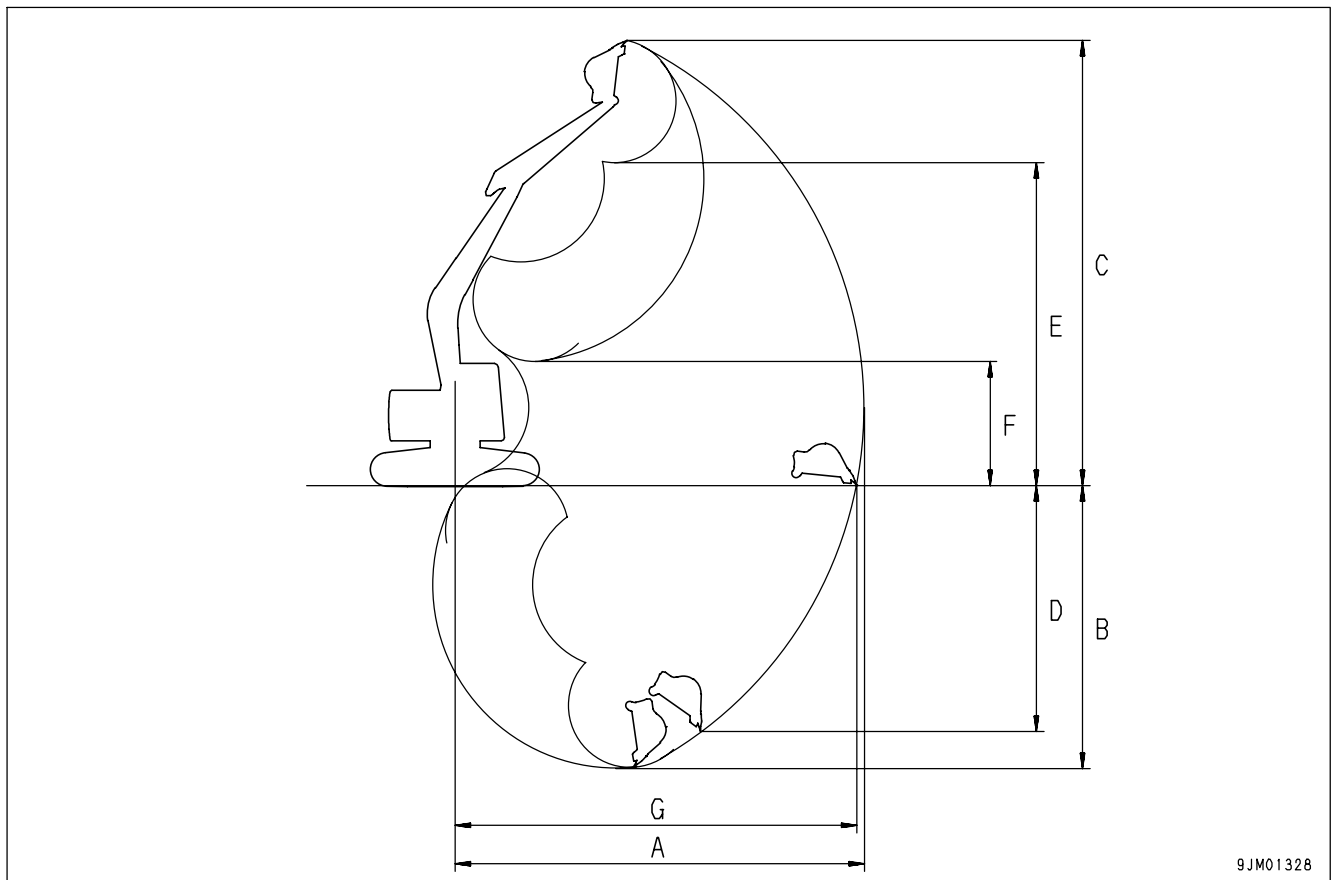

9JM01328

ATTACHMENTS, OPTIONS

WARNING

Please read and make sure that you understand the SAFETY section before reading this section.

GENERAL PRECAUTIONS FOR SAFETY

When installing attachments or options to the machine, it is necessary to pay attention to safety. Please obey the following precautions strictly when selecting, installing, or using attachments or options.

PRECAUTIONS WHEN SELECTING

- Please consult your Komatsu distributor before installing attachments or options to the machine. Depending on the type of attachment or option, it may be necessary to install a front guard, overhead guard, or other safety structure to the machine. There may also be problems of the attachment or option hitting the operator's cab.
- Install only attachments or options authorized by Komatsu. Komatsu cannot accept any responsibility for any accident, damage, or failure caused by the use of attachments or options not authorized by Komatsu.

READ THE INSTRUCTION MANUAL THOROUGHLY

- Before installing or using any attachment or option, make sure that you thoroughly read and understand the instruction manuals for the machine and the attachment or option.
- If you lose the instruction manual or it is damaged, always obtain a new copy from the attachment manufacturer or your Komatsu distributor.

PRECAUTIONS WHEN REMOVING OR INSTALLING

When removing or installing the attachment or option, obey the following precautions, and take care to ensure safety during the operation.

- Carry out the removal and installation operation on a flat, firm ground surface.
- When the operation is carried out by two or more workers, choose the leader and follow his instructions.
- Use a crane when handling heavy objects (more than 25 kg (55 lb)). (The crane must be operated by a qualified operator.)
- Never go under a load raised by the crane.
- Do not carry out operations with the load kept raised by the crane. Always use a stand to prevent the load from falling.
- When removing a heavy part, consider the balance after it is removed. To prevent the machine from tipping over, set a support in position if necessary before removing the part.
- Before installing or after removing the attachment or option, set it in a stable condition to prevent it from falling over.
- For details of the removal or installation operation, please consult your Komatsu distributor.

PRECAUTIONS WHEN USING

When long or heavy work equipment is installed, remember the following precautions. Before starting operations, move the machine to a safe place and carry out a test operation to make sure that you fully understand the movement, center of gravity, and working range of the machine.

- Do not swing the work equipment if the machine is at an angle. If the work equipment is swung with the machine at an angle, there is danger that the machine will tip over.
- Always maintain a safe distance from obstacles in the surrounding area when operating. If long work equipment is installed, the working range becomes larger.
- If heavy work equipment is installed, pay careful attention to the following precautions.
 - The swing overrun (the distance the work equipment moves before completely stopping after the swing brake is applied) will be greater. There is danger of hitting objects if the swing overrun is miscalculated, so allow extra space to the swing position when swinging.
 - The hydraulic drift of the work equipment (the amount of the work equipment moves down under its own weight when it is stopped in a raised position) also becomes greater. Do not stop the work equipment in a raised position; always lower it to the ground.
 - Do not swing, lower, or stop the work equipment suddenly. There is danger that the machine may tip over.
 - Do not suddenly extend or retract the boom cylinder. The shock may cause the machine to tip over.

BUCKET WITH HOOK

HOOK CONDITION

Check that there is no damage to the hook, stopper, or hook mount. If there is any problem, contact your Komatsu distributor.

PROHIBITED OPERATIONS

Operations with Care

- When carrying out lifting operations, reduce the engine speed and use the L mode (for fine-control operations).
- Depending on the posture of the work equipment, there is the danger that the wire or load may slip off the hook. Always be careful to maintain the correct hook angle to prevent this from happening.
- Never travel the machine while lifting a load.
- If the bucket with hook is turned and used for operations, it will hit the arm during dumping operations, be careful when using it.
- If you are planning to newly install a hook, contact your Komatsu distributor.

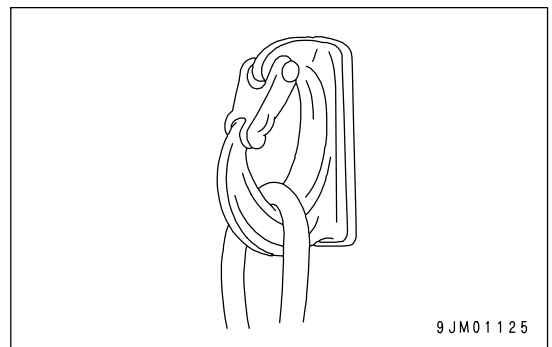
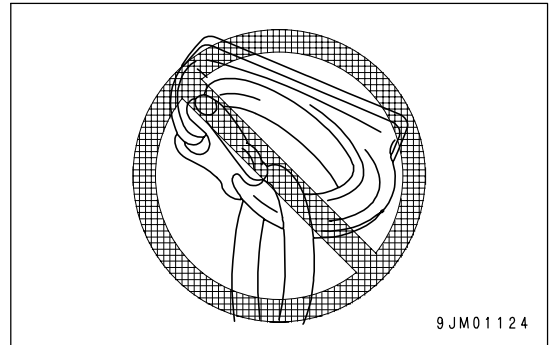

MACHINE READY FOR ATTACHMENT

LOCATIONS

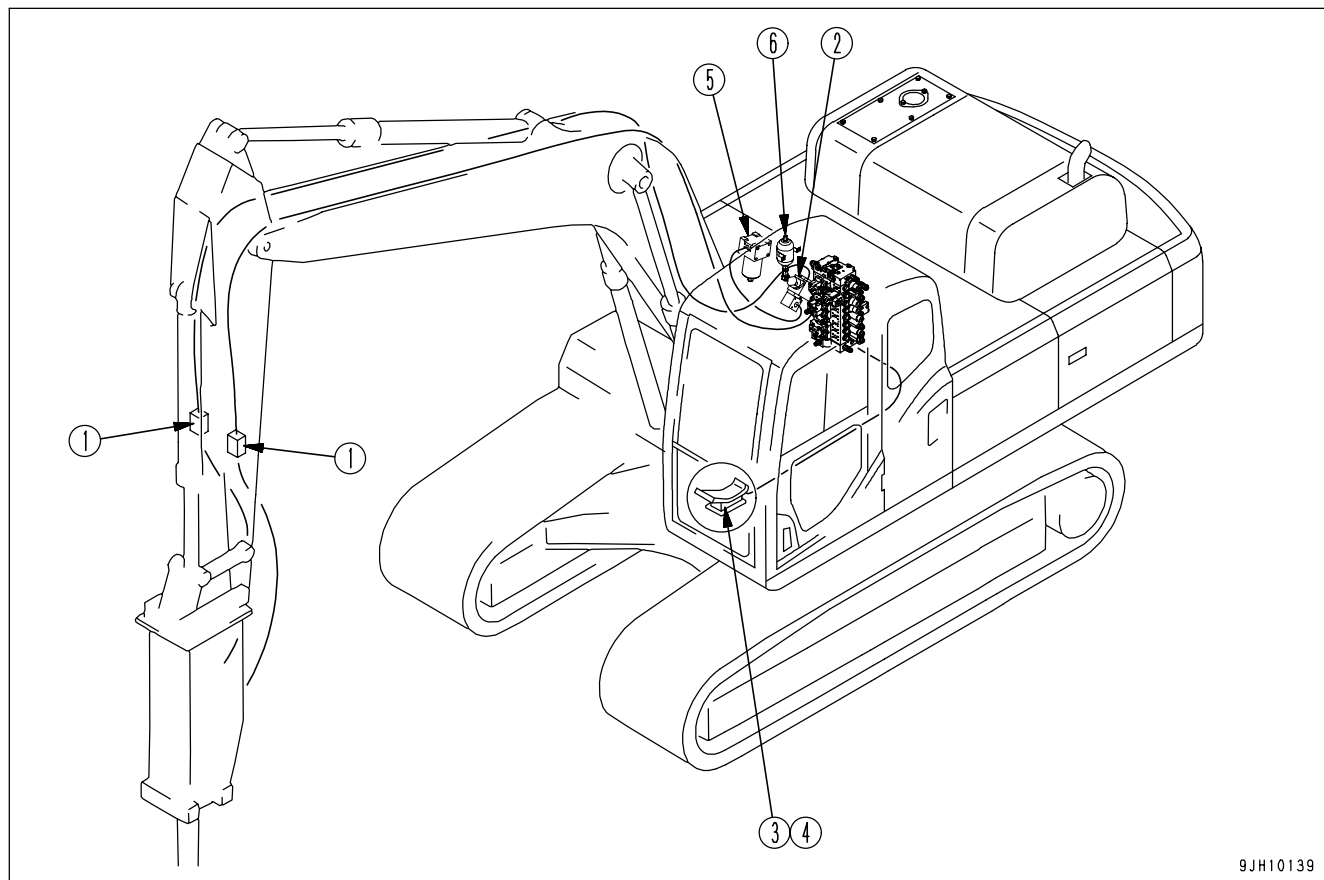

9JH10139

- | | |
|------------------------------|---|
| (1) Stop valve | (4) Lock pin |
| (2) Selector valve | (5) Breaker circuit additional oil filter |
| (3) Attachment control pedal | (6) Accumulator |

Stop Valve

This valve (1) stops the flow of the hydraulic oil.

(F) FREE: Hydraulic oil flows.

(L) LOCK: Hydraulic oil stops.

When removing or installing attachments, set this valve to the LOCK position.

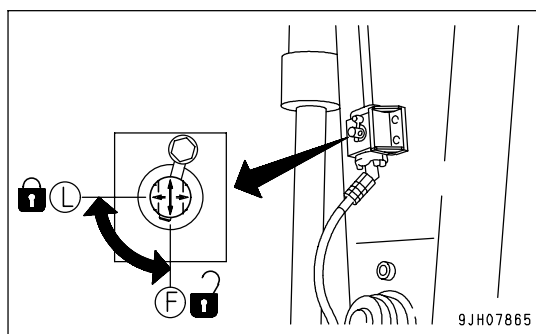

9JH07865

Selector Valve

This valve (2) switches the flow of hydraulic oil. It is automatically switched according to the selected working mode. It is necessary to switch the working mode to match the attachment that is installed. For details of switching the working mode, see "HYDRAULIC CIRCUIT (PAGE 6-8)".

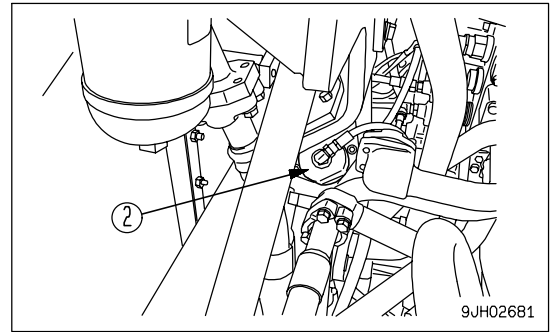

NOTICE

If a service circuit from the attachment maker has been added, the return circuit may not switch automatically.

Attachment Control Pedal



WARNING

Do not carry out operations with your foot on the pedal. If the pedal is depressed by mistake, the attachment may suddenly move and cause a serious accident. Lock the pedal with the lock pin when you are not operating the attachment.

This pedal (3) is used to control the attachment. When the front, center (neutral), and rear of the pedal are depressed, the movement of the attachment is as follows.

Hydraulic breaker

Front of pedal (A): Actuated

Center of pedal (N): Stopped

Rear of pedal (B): Stopped

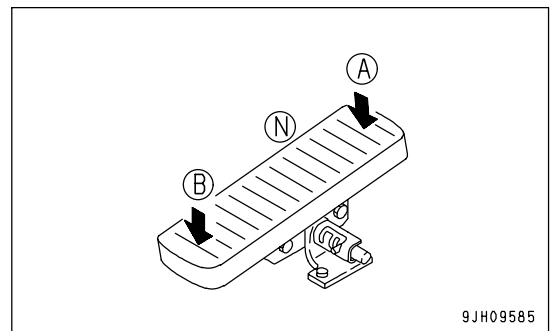

Regarding other attachments, hold a meeting with the attachment maker at the time of installation to confirm the operation of the pedal and attachment before using it.

Lock Pin

This pin (4) locks the control pedal.

Position (a): Locked

Position (b): Only front of pedal can be operated to full position
(rear is locked)

Position (c): Both front and rear of pedal can be operated to
full position

- When not using the attachment, set the lock pin to position (a).
- When using a breaker, select B mode on the monitor and set the lock pin to position (b).
- When using a Crasher, select P or E mode on the monitor and set the lock pin to position (c).

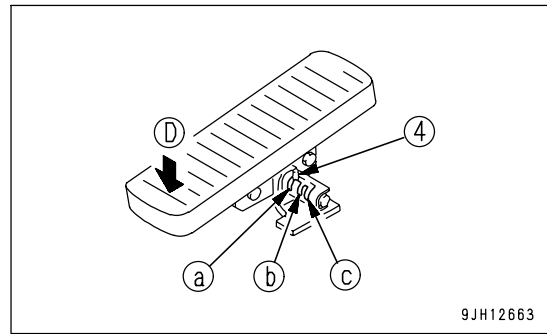
**NOTICE**

- When using the breaker, if the lock pin is set to position (c) and the pedal is operated in direction (D), it will cause damage or defective operation of the breaker. To prevent this, when using the breaker, always set the lock pin to position (b).
- Before changing the position of the lock pin, stop the engine.

Breaker Circuit Additional Oil Filter

This filter (5) prevents deterioration of the hydraulic oil when using a breaker.

Oil only flows when B mode is selected on the monitor.

NOTICE

Always install an additional filter in the return circuit on machines equipped with a hydraulic breaker.

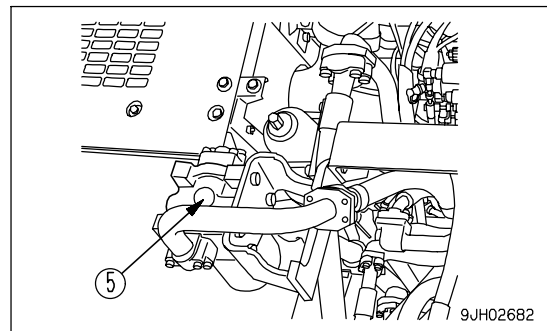

Accumulator



WARNING

The accumulator is charged with high-pressure nitrogen gas, so mistaken operation may cause an explosion, which will lead to serious injury or damage. When handling the accumulator, always do as follows.

- The pressure in the hydraulic circuit cannot be completely removed. When removing the hydraulic equipment, do not stand in the direction that the oil spurts out when carrying out the operation. In addition, loosen the bolts slowly when carrying out the operation.
- Do not disassemble the accumulator.
- Do not bring it near flame or dispose of it in fire.
- Do not make holes in it or weld it.
- Do not hit it, roll it, or subject it to any impact.
- When disposing of the accumulator, the gas must be released. Please contact your Komatsu distributor to have this work carried out.

This accumulator (6) is installed to reduce the peak pressure in the hydraulic circuit when a breaker is used. Normally, do not touch it.

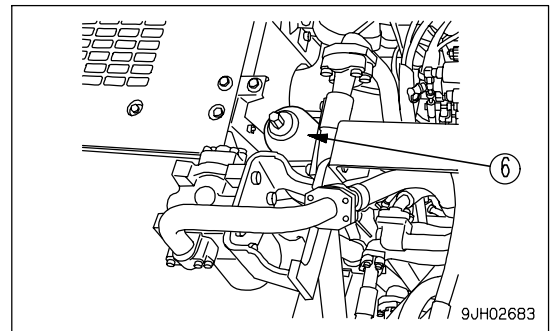

NOTICE

On machines equipped with a breaker, it is necessary to install an accumulator to the breaker piping to match the model number of the breaker manufacturer. If no accumulator is installed and the breaker is operated, the service life of the machine will be reduced. For questions about the breaker, please contact your Komatsu distributor.

For details, see "CHECK NITROGEN GAS CHARGE PRESSURE IN ACCUMULATOR (for breaker) (PAGE 4-72)" or "CHECKING CHARGE PRESSURE OF NITROGEN GAS IN ACCUMULATOR (FOR CONTROL CIRCUIT) (PAGE 4-75)".

HYDRAULIC CIRCUIT

NOTICE

- It is necessary to return the return circuit directly to the return filter when a breaker is used, so use only the B mode. Do not use any other mode.
- When the machine is shipped from the factory, the standard set pressure of the safety valve in the service valve is set as follows:
 When B mode is selected: 21.6 MPa (220 kg/cm², 3,124 PSI)
 When P or E mode is selected: 24.5 MPa (250 kg/cm², 3,550 PSI).
 The set pressure may have to be adjusted depending on the attachment. In such cases, please ask your Komatsu distributor to carry out the adjustment.

Switching Hydraulic Circuit

- Depending on the type of attachment, set the working mode on the monitor as follows.
- The set pressure of the safety valve in the service valve and the hydraulic circuit switch is according to the working mode selected.

Attachment	Working mode	Hydraulic circuit	Set pressure of safety valve in service valve
Breaker or other attachment with one-way circuit	B mode	Return circuit automatically switched so that it does not pass through control valve	When shipped from factory : 21.6 MPa (220 kg/cm ² , 3124 PSI)
Crusher or other attachment with two-way circuit	P mode or E mode	Return circuit automatically switched so that it passes through control valve	When shipped from factory : 24.5 MPa (250 kg/cm ² , 3550 PSI)

Adjusting Oil Flow

Depending on the attachment, it is necessary to change the oil flow in the service circuit. For details of setting the oil flow, see "ATTACHMENT OPERATIONS (PAGE 6-17)".

Switching Between Breaker and General Attachment

- If an attachment is installed as an option, and the mode is set to B mode:
 - (1) The system is set to the breaker operation circuit (1-way circuit).
 - (2) The hydraulic oil flowing to the breaker circuit flows to the additional filter for the breaker.
 - (3) The relief pressure valve is set to low pressure.
 Set pressure when machine is shipped from factory: 21.6 MPa (220 kg/cm², 3,124 PSI)
 - (4) It is possible to use the selector mode to adjust the maximum oil flow.
- If an attachment is installed as an option, and the mode is set to P or E mode:
 - (1) The system is set to the crusher operation circuit (2-way circuit).
 - (2) The hydraulic oil flowing to the crusher circuit does not flow to the additional filter for the breaker.
 - (3) The relief pressure valve is set to high pressure.
 Set pressure when machine is shipped from factory: 24.5 MPa (250 kg/cm², 3,550 PSI)
 - (4) It is possible to use the selector mode to adjust the maximum oil flow.

Hydraulic Circuit Connection

When connecting the attachment, connect the hydraulic circuit as follows.

1. Remove blind plug (1) at the end of the stop valve piping.
(Two spots on the left and right)
Be careful not to lose or damage any part that has been removed.

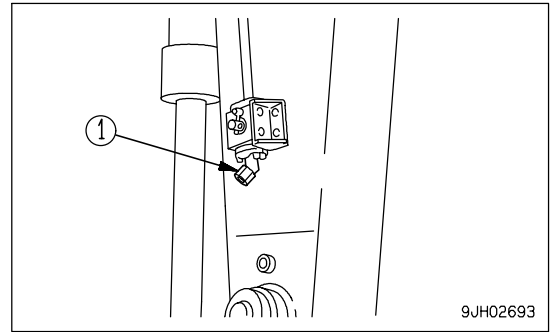

2. Connect attachment piping (2) provided by the attachment maker to the part from which the plug was removed Step 1.
For the mouthpiece size and accumulator add-on, the action to take differs according to the attachment manufacturer, so please consult your Komatsu distributor.

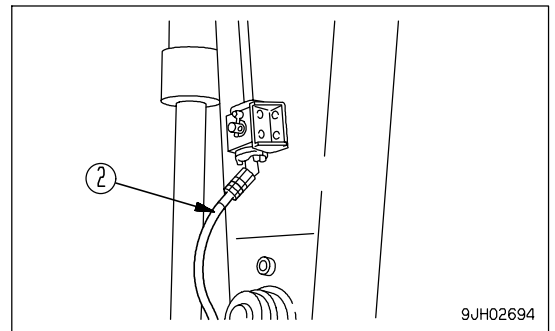

Oil Flow Path

The direction of operation of the pedal and the path of the oil flow is as shown in the diagram below.

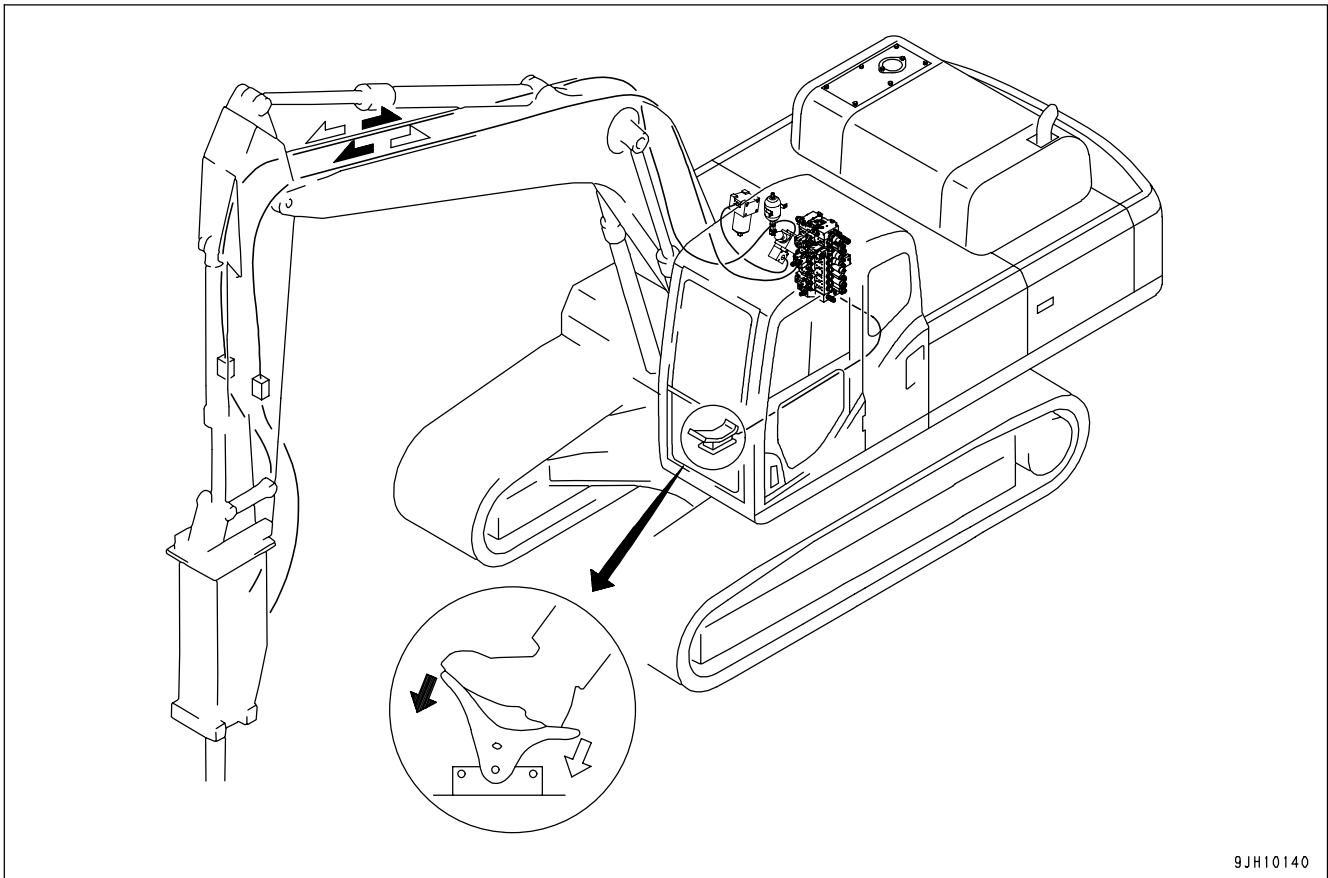

When the front of the pedal is depressed, oil flows to the piping on the left side of the work equipment; when the rear of the pedal is depressed, oil flows to the piping on the right side of the work equipment. (When a breaker is installed, only the front of the pedal can be used.)

Replace Additional Breaker Filter Element

WARNING

- The parts and oil are at high temperature after the engine is stopped, and may cause serious burns. Wait for the temperature to go down before cleaning the engine breather.
- When using compressed air, there is a hazard that dirt may be blown up and cause serious injury. Always use safety glasses, dust mask, or other protective equipment.

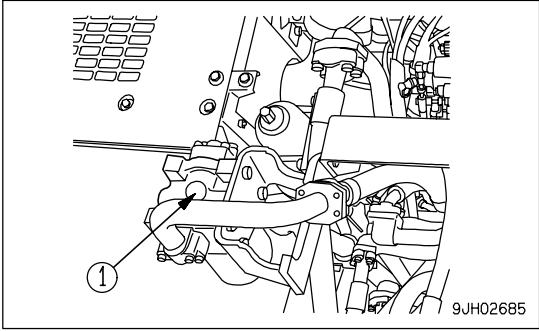

NOTICE

For details of the replacement interval for the element, see "MAINTENANCE INTERVAL FOR HYDRAULIC BREAKER (PAGE 4-17)".

- Prepare a container to catch the oil.
1. Lower the work equipment to the ground and stop the engine.

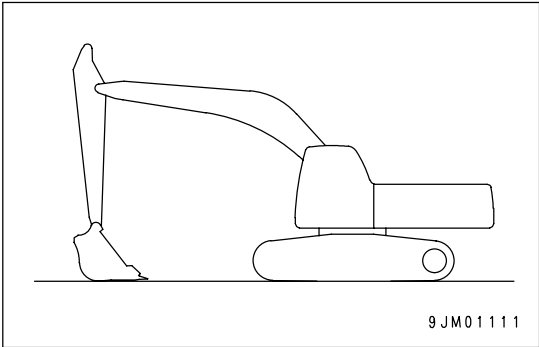

2. Turn the starting switch to the ON position (B), then set the lock lever to the FREE position (F).
3. After carrying out Step 2, operate each work equipment control lever and attachment control pedal fully to the front, rear, left, and right 2 or 3 times within 15 seconds to release the internal pressure in the hydraulic circuit.

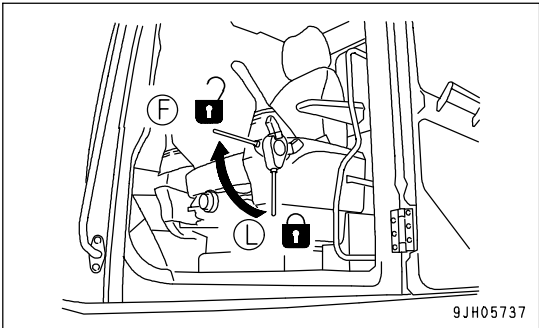
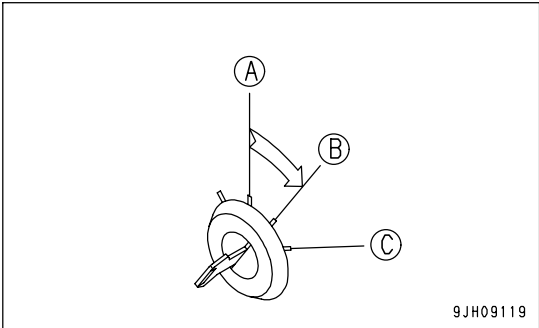

4. Set the lock lever to LOCK position (L).

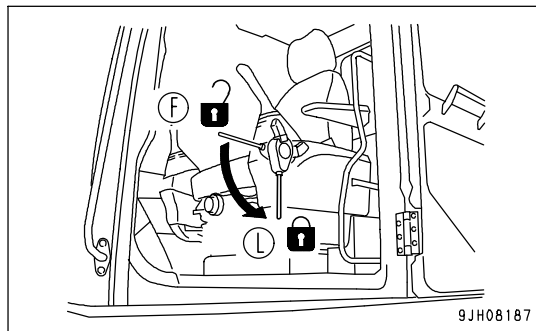

5. Loosen slowly oil filler cap (F) on top of the hydraulic tank to eliminate the internal pressure in the hydraulic circuit.

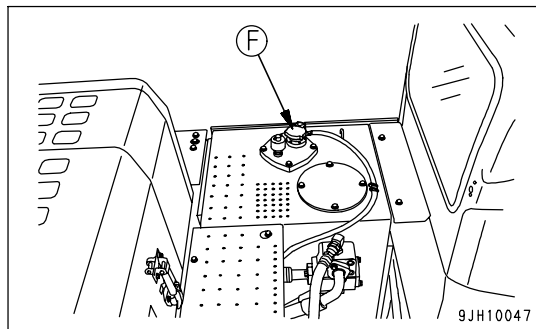

6. Place a container under the filter element to catch the oil.

7. Set a container in position to catch the drained oil, then remove plug (1) and drain the oil accumulated in filter case (2).

8. Turn filter case (2) to the left, remove it, then take out element (3).

9. Clean the removed parts, then install new element (3).

- Element (3) must be installed facing in the correct direction. Set direction (Y) with the holes in it facing up, and insert the hole in element (3) on the protruding portion inside filter head (4).

10. Install new O-ring (5) to filter case (2), then screw filter case (2) into filter head (4). When the top of filter case (2) comes into contact with the filter head, tighten it at least a further 1/2 turns.

11. Clean plug (1), then fit a new O-ring (6) to plug (1).

12. Install plug (1) to filter case (2).

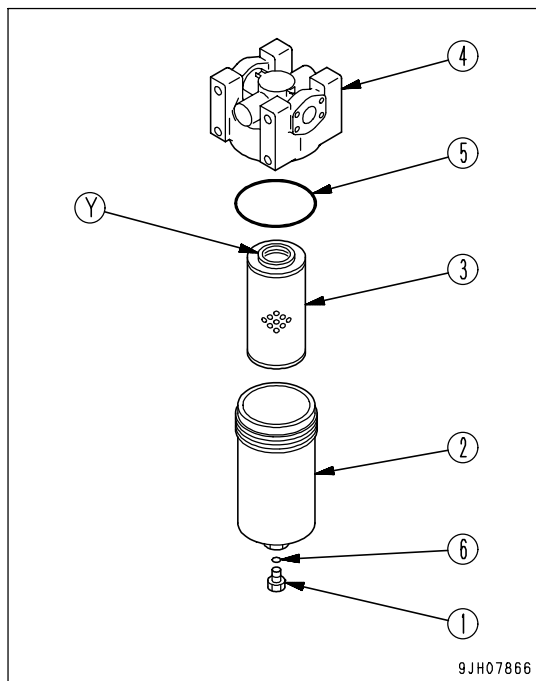

ATTACHMENT REMOVAL AND INSTALLATION

Attachment Removal

1. Lower the attachment to the ground and stop the engine.
2. Turn the starting switch to the ON position (B), then set the lock lever to the FREE position (F).
3. After carrying out Step 2, operate each work equipment control lever and attachment control pedal fully to the front, rear, left, and right 2 or 3 times within 15 seconds to release the internal pressure in the hydraulic circuit.

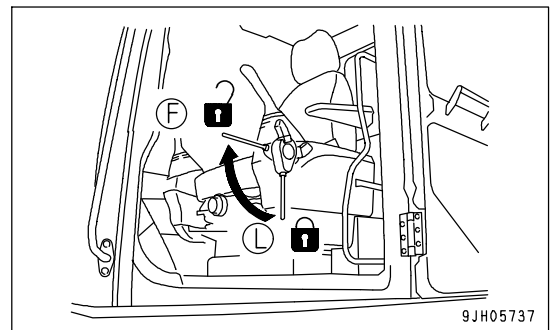
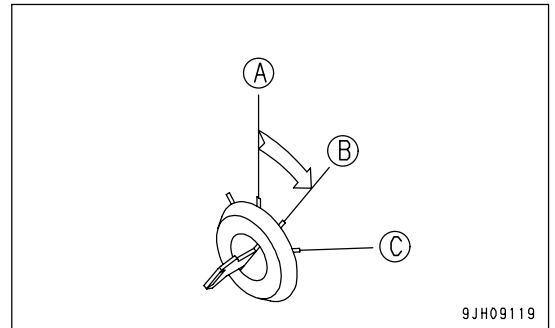

4. Set the lock lever to LOCK position (L).

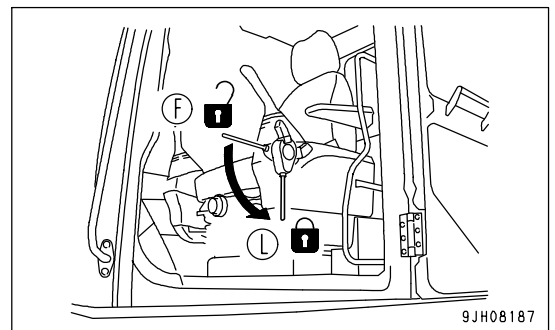

5. Loosen slowly oil filler cap (F) on top of the hydraulic tank to eliminate the internal pressure in the hydraulic circuit.

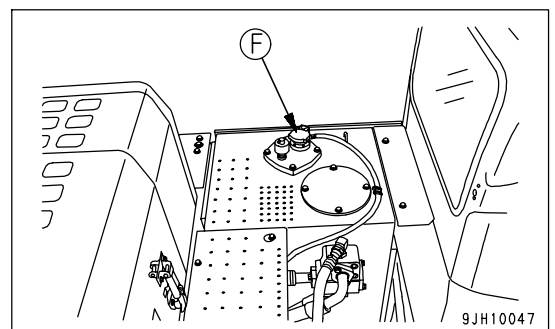

6. After checking that the oil has cooled down, turn the rotor on the stop valve installed to the piping for the inlet port and outlet port on the side face of the arm to the LOCK position (L).

7. Remove the hoses on the attachment side. Install the plugs to the two outlets.

The plugs are used to prevent the attachment from incorrect operation caused by mixing in of foreign matter. After the plugs are correctly installed, store the attachment.

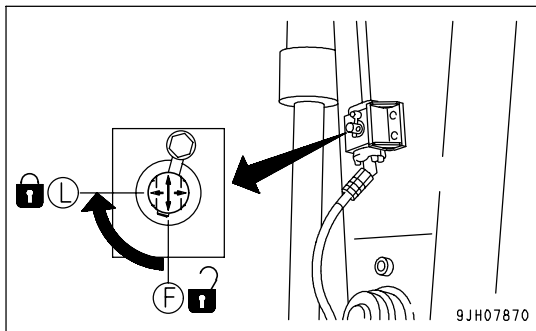

8. Pull out the mounting pins (2 places), remove the attachment, then install the bucket.

For details of the procedure for installing the bucket, see "BUCKET REPLACEMENT AND INVERSION (PAGE 3-167)".

9. After installing the bucket, check the oil level in the hydraulic tank.

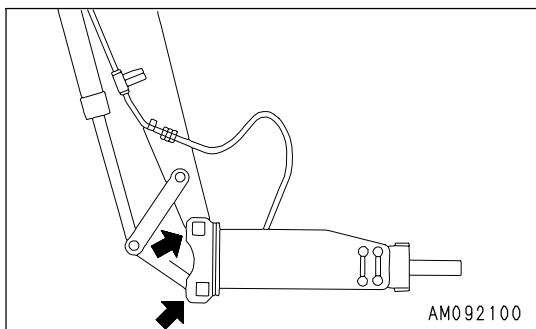

Attachment Installation

1. Remove the bucket.

For bucket dismounting procedure, see "BUCKET REPLACEMENT AND INVERSION (PAGE 3-167)".

2. Place the attachment in a horizontal position, then install to the arm with pin (A) and then pin (B).

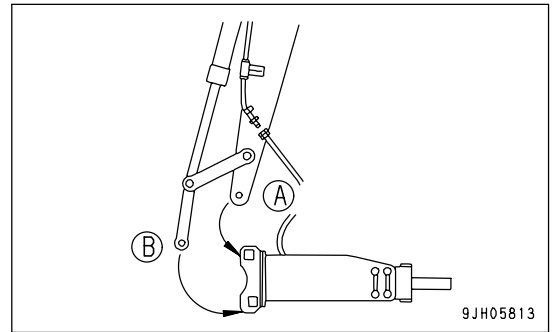

3. Lower the attachment to the ground and stop the engine.
4. Turn the starting switch to the ON position (B), then set the lock lever to the FREE position (F).
5. After carrying out Step 4, operate each work equipment control lever and attachment control pedal fully to the front, rear, left, and right 2 or 3 times within 15 seconds to release the internal pressure in the hydraulic circuit.

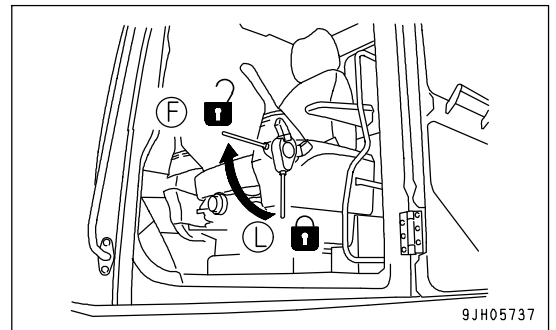
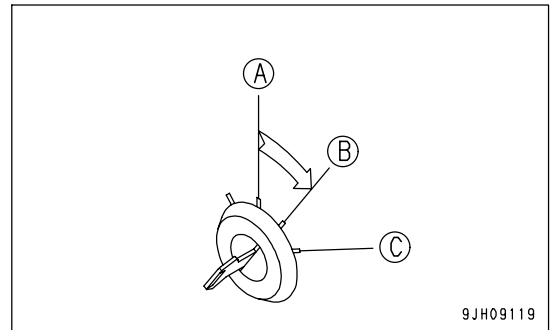

6. Set the lock lever to LOCK position (L).

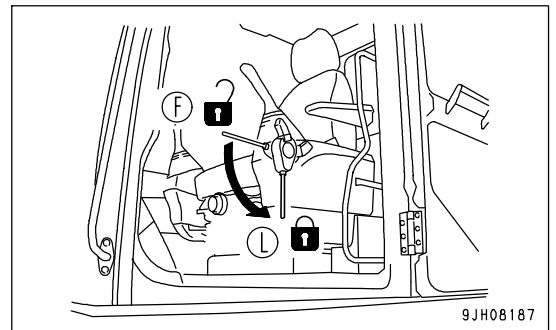

7. Loosen slowly oil filler cap (F) on top of the hydraulic tank to eliminate the internal pressure in the hydraulic circuit.

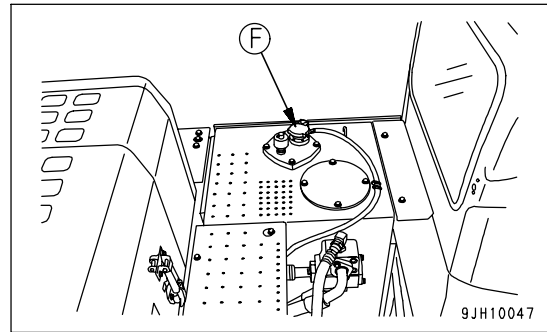

8. After confirming low oil temperature, remove the plug from the outlet and inlet port respectively.

Take care that no dust, mud etc. adheres to the hose mousepiece portions.

If O-ring is damaged, replace it with a new one.

9. Connect the hose at the attachment side.

When doing this, check the direction of flow of the oil and be careful not to make any mistake.

10. Turn the rotor on the stop valve installed to the piping for the inlet port and outlet port on the side face of the arm to the FREE position (F).

11. After installing the attachment, check the oil level in the hydraulic tank.

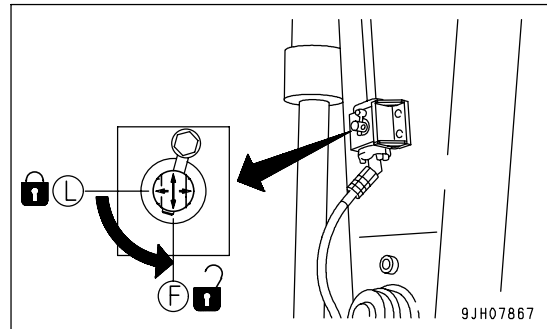

ATTACHMENT OPERATIONS



WARNING

- If the pedal is operated when the auto-deceleration is being actuated and the engine speed has dropped, the engine speed will suddenly rise, so be careful when operating.
- If you leave your foot resting on the pedal and depress the pedal by mistake, there is danger that the attachment may suddenly move and cause serious personal injury. If you do not need to operate the pedal, do not rest your foot on the pedal.
- When the attachment is not being used, set the lock pin of the pedal to the LOCK position to prevent the pedal from being operated.

The method of operating the attachment is as follows.

When Using Breaker

NOTICE

When carrying out breaker operations, use the breaker mode. If the breaker mode is not used, the breaker may be damaged.

With the working mode set to B mode, insert the lock pin in front-only FREE position (b). Press the front of the pedal to operate the breaker.

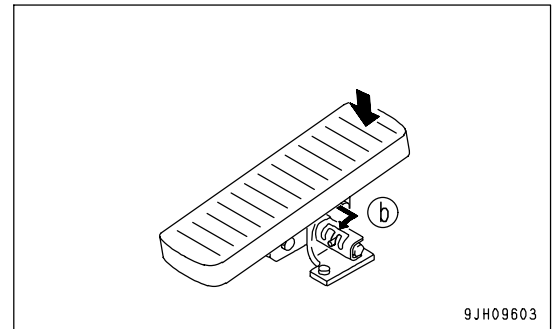

1. Set the working mode to B mode.

When switching the working mode, see "Working Mode Selector Switch (PAGE 3-25)".

2. When it is required to change the setting like a flow rate, see "Changing Breaker Mode Setting (PAGE 3-46)".

Precautions when using

- Check that the stop valve is at the FREE position.
- Check that the working mode is B mode.
For details of the path of the oil, see "HYDRAULIC CIRCUIT (PAGE 6-8)".
- When considering whether it is necessary to install an accumulator for the attachment circuit, contact the attachment manufacturer and then decide.
- For other precautions when handling the breaker, follow the instruction manual from the breaker manufacturer and use the breaker correctly.
- The deterioration of the hydraulic oil when using the breaker is much faster than for normal operations, so reduce the maintenance interval for the hydraulic oil and element.
For details, see "MAINTENANCE INTERVAL FOR HYDRAULIC BREAKER (PAGE 4-17)".

When Using General Attachment Such as Crusher

With the working mode set to P mode or E mode, set the lock pin to FREE position (c) for both the front and rear, and depress the front or rear of the pedal to actuate the attachment.

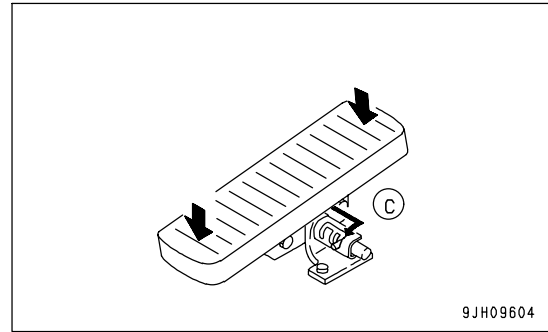

1. Set the working mode to P mode or E mode.

When switching the working mode, see "Working Mode Selector Switch (PAGE 3-25)".

2. When it is required to change the setting like a flow rate, see "Changing Attachment Mode Setting (PAGE 3-52)".

Precautions when using

- Check that the stop valve is at the FREE position.
- Check that the working mode is P mode or E mode.

For details of the path of the oil, see "HYDRAULIC CIRCUIT (PAGE 6-8)".

- For other precautions related to the handling of attachment, follow the explanation in the operation manual provided by the attachment manufacturer to operate the attachment correctly.

LONG TERM STORAGE

If the equipment is not to be used for a long time, do as follows.

- Set the stop valve in the LOCK condition.
- Fit a plug at the tip of the stop valve piping.
- Set the lock pin at the LOCK position.

If there is no breaker or general attachment installed, operating the pedal may cause overheating and other problems.

SPECIFICATIONS

Hydraulic specifications

- Max. flow at merge: 275 x 2 liters / min.
- Safety valve relief set pressure for service valve
 - A port: 21.6 MPa (220 kg/cm², 3,120 PSI) (except B mode)
 - B port: 24.5 MPa (250 kg/cm², 3,550 PSI) (except B mode)
- Safety valve cracking pressure for service valve
 - A port: 17.2 MPa (175 kg/cm², 2,490 PSI) (except B mode)
 - B port: 20.1 MPa (205 kg/cm², 2,910 PSI) (except B mode)
- Safety valve relief set pressure for service valve: 21.6 MPa (220 kg/cm², 3,120 PSI) (B mode)
- Safety valve cracking pressure for service valve: 17.2 MPa (175 kg/cm², 2,490 PSI) (B mode)

HANDLING THE ELECTRIC PRIMING PUMP

BLEEDING AIR FROM FUEL CIRCUIT

This machine is equipped with an electric priming pump to bleed the air from the fuel circuit. In the following cases, use the procedure below to bleed the air.

- When fuel filter has been replaced
- When engine has run out of fuel
- When water is drained from the fuel pre-filter
- When the additional water separator is inspected, checked, and drained of water
- When starting the engine for the first time after replacing the supply pump or modifying the piping or any other parts



WARNING

When using the electric priming pump, do not loosen the air bleed plug for the fuel circuit. When the electric priming pump is operated, pressure is applied to the fuel circuit, so if the air bleed plug is loosened, fuel will spurt out and create a dangerous situation.

1. Turn the key in starting switch (1) to the OFF position (A).

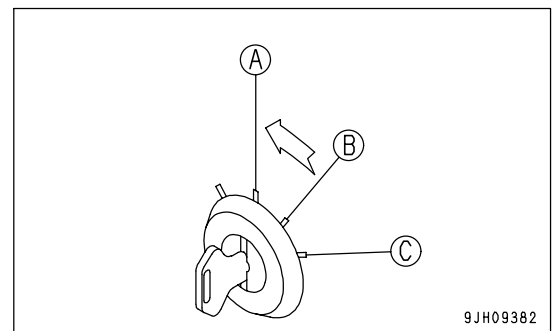

2. Turn the valve (1) at the bottom of the fuel tank to the OPEN position (O).

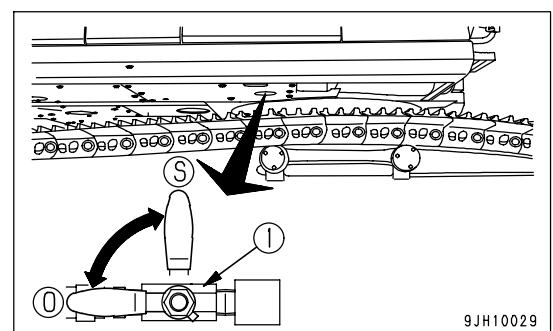

3. Open the front engine hood.
4. Turn the air bleed valve (2) to the open position (O).

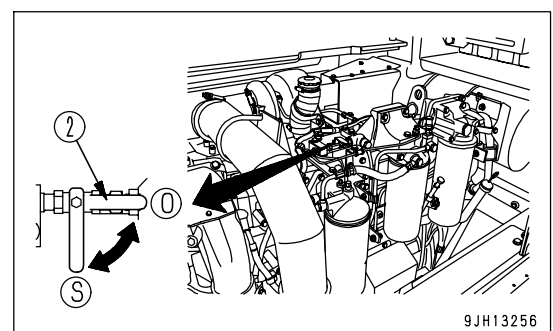

5. Turn electric priming pump switch (3) to the ON position (A). Lamp (4) flashes and the electric priming pump starts. Release electric priming pump switch (3). Switch (3) will return automatically to the original position (N).

REMARK

- While lamp (4) is flashing, the electric priming pump is actuated for 30 seconds and then stops for 10 seconds. This action is repeated until lamp (4) goes out.
- If this switch is turned to the OFF position (B) when the lamp is flashing, the lamp will go out and the electric priming pump will stop.
- When the lamp is flashing, the electric priming pump will stop, but this does not indicate any abnormality.

6. When the specified time (approx. 7 minutes) has passed, lamp (4) automatically goes out and the electric priming pump stops.

REMARK

When there is no fuel in the fuel system, there is a possibility that air entered the fuel circuit is not completely bled by priming once.

If one of the following cases applies, tilt the electric priming pump switch to ON position (A) again to activate the electric priming pump.

- The engine has come to a halt due to fuel exhaustion.
- The fuel hose or tube has been maintained or replaced.
- The electric priming pump has been maintained or replaced.

7. When the lamp goes out, the air bleed operation is completed.
8. Turn air bleed valve (2) to the closed position (S).

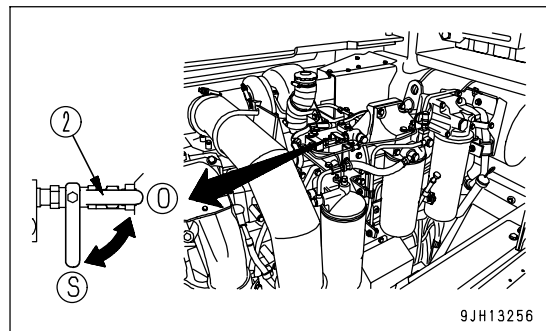
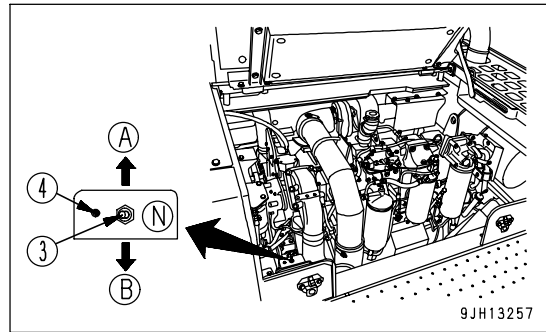

9. Start the engine.

If the engine does not start, the probable reason is that the air has not been completely bled.

Do as follows, then start the engine again.

- 1) Check that the air bleed valve is closed.
- 2) Turn electric priming pump switch (3) ON position (A).
- 3) Try to start the engine while the electric priming pump is in operation. If the engine still does not start, wait for approx. 2 minutes, and then repeat steps 2) and 3).
- 4) After the engine has started, run the engine for approx. 5 minutes to bleed air from the fuel system completely.

NOTICE

Do not keep the starting motor rotating continuously for more than 20 seconds.

If the engine will not start, wait for at least 2 minutes before trying to start the engine again.

ATTACHMENT GUIDE



WARNING

- Please read the instruction manual for the attachment and the sections of this manual related to attachments and options.
- When installing any attachment or option, there may be problems with safety, so please contact your Komatsu distributor before installing.
- Installing attachments or options without consulting your Komatsu distributor may not only cause problems with safety, but may also have an adverse effect on the operation of the machine and the life of the equipment.
- Any injuries, accidents, or damage resulting from the use of unauthorized attachments or options will not be the responsibility of Komatsu.

ATTACHMENT COMBINATIONS



WARNING

Depending on the type or combination of work equipment, there is danger that the work equipment may hit the cab or machine body.

When using unfamiliar work equipment for the first time, check before starting if there is any danger of interference, and operate with caution.

PC400, PC400LC

This table lists the combination of attachments which can be installed to the long arm (standard), short arm and extension arm.

○: Can be used

△: Can be used only for light duty work

×: Cannot be used

NOTICE

- When the long arm is equipped, if the bucket is pulled in to the machine body, the arm interferes with the body. Operate the long arm carefully.
- When the boom is fully lowered during oblique digging, the boom interferes with the undercarriage. Operate the boom carefully.

Categories of use

For general digging: Digging or loading sand, gravel, clay etc.

For light duty digging: Digging or loading dry, uncaked earth and sand, mud etc.

For loading work: Loading dry, loose earth and sand

- For digging or loading hard soil or soft rock, it is recommended that the strengthened bucket with high durability and high wear resistance be employed.

The items marked * are for when the side cutter is installed.

Bucket name	Bucket Capacity m ³ (cu.yd)	Opening width mm (ft in)	Use	Standard boom 7,000 mm (22' 12")					HD boom 7,000 mm (22' 12")
				Standard arm 3.4 m (11' 2")	Short arm 2.9 m (9' 6")	Ultra short arm 2.4 m (7' 10")	Semi-long arm 4.0 m (13' 1")	Long arm 7.8 m (25' 7")	HD arm 3.4 m (11' 2")
*Narrow	1.3 (1.7)	1,120 (3' 8")	Narrow digging	○	○	○	○	○	×
*Narrow	1.6 (2.1)	1,270 (4' 2")	Narrow digging	○	○	○	△	△	×
*Standard	1.9 (2.5)	1,475 (4' 10")	General digging	○	○	○	×	×	×
*Light-duty work	2.1 (2.7)	1,565 (5' 2")	Loading	△	△	△	×	×	×
Light-duty work	2.2 (2.9)	1,715 (5' 8")	Loading	△	△	△	×	×	×
*Rock	1.9 (2.5)	1,625 (5' 4")	Digging soft rock	○	○	○	×	×	○
*Rock	2.1 (2.7)	1,745 (5' 9")	Digging soft rock	△	△	△	×	×	△
Ripper	1.1 (1.4)	1,250 (4' 1")	Digging rock	○	○	○	×	×	○
Single-shank ripper	-	-	Ripping rock	○	○	○	×	×	○

PC450, PC450LC

This is the combination table for attachments installed to the standard HD arm.

○: Can be used

△: Can be used only for light duty work

×: Cannot be used

NOTICE

When the boom is fully lowered during oblique digging, the boom interferes with the undercarriage. Operate the boom carefully.

The items marked * are for when the side cutter is installed.

Name	Capacity m ³ (cu.yd)	Opening width mm (ft in)	Use	Standard arm 3.4m (11 ft 2 in)
*Rock (standard) bucket	1.9 (2.5)	1,625 (5' 4")	General digging	○
*Rock (large) bucket	2.1 (2.7)	1,745 (5' 9")	For large-scale digging	○
Ripper bucket	1.1 (1.4)	1,250 (4' 1")	Digging rock	○
Single-shank ripper	-	-	Ripping rock	○

TRACK SHOES SELECTION

Select the appropriate track shoe to match the operating conditions.

Selection

Check the category from the usage table below and select the track shoe from the table at the bottom.

- Use category B is for wide shoes. There are limits for the use of wide shoes, so check carefully when using. Investigate the conditions of use carefully and consider the situation to select the most suitable track shoe.
- When selecting the shoe width, shoe possible that will cause no problem within the range for flotation and ground contact pressure of the machine. If a larger width of the necessary is used, there will be a greater load on the track shoe, and this will cause problems such as bending of the track shoes, cracking of the links, breakage of pins, and loosening of shoe bolts.

Category	Use	Precautions for use
A	Rocky ground, riverbeds, normal soil	• On rough ground where there are large obstacles such as boulders or fallen trees, travel at Lo speed.
B	Normal soil, soft ground	• These shoes cannot be used on rough ground where there are large obstacles such as boulders or fallen trees. • Travel at Hi speed and Mi speed only on flat ground, and if it is impossible to avoid going over obstacles, shift down and travel at half speed in Lo.
C	Paved road surface	• Be careful on slopes. Flat shoes have low gradeability.

	PC400		PC450		PC400LC		PC450LC	
	Specifications	Category	Specifications	Category	Specifications	Category	Specifications	Category
Standard	600 mm Triple	A	600 mm Triple	A	700 mm Triple	B	600 mm Triple	A
Option	700 mm Triple	B	700 mm Triple	B	600 mm Triple	A	700 mm Triple	B
Option	800 mm Triple	B			800 mm Triple	B		
Option	700 mm Flat	C			700 mm Flat	C		

RECOMMENDED ATTACHMENT OPERATIONS

Below described are instructions which must be followed without fail when doing the work using a hydraulic excavator equipped with an attachment.

NOTICE

Select the optimum model of attachment for a hydraulic excavator on which it is to be mounted.

- Depending on machine models of hydraulic excavator, the kind of attachments or the model of specific attachments that can be mounted will vary. Hence, consult your Komatsu distributor for the selection of optimum attachments.

HYDRAULIC BREAKER

Main Applications

- Crushed rock
- Demolition work
- Road construction

This attachment can be used for a wide range of applications including demolition of buildings, breaking up road surfaces or slag, tunnel work, rock crushing and breaking operations in quarries.

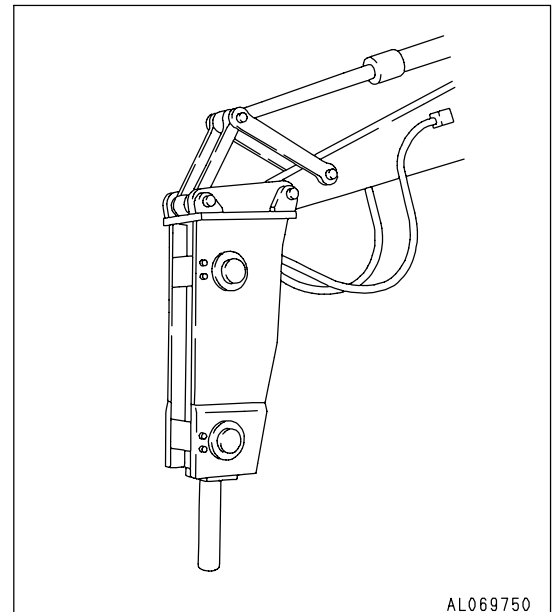

Keep the chisel pushed perpendicularly against the impact surface when carrying out breaking operations.

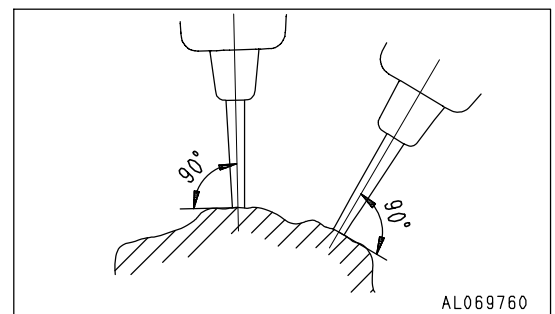

When applying impact, push the chisel against the impact surface and operate so that the chassis rises approx. 5 cm (2 in) off the ground. Do not let the machine come further off the ground than this amount.

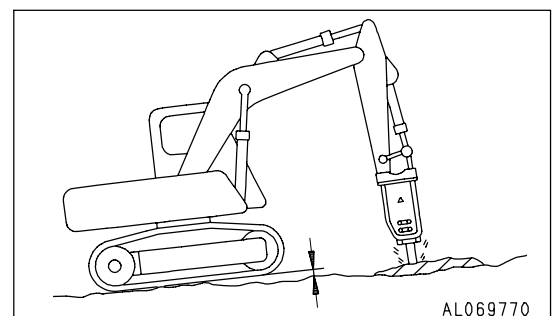

When applying continuous impact to the same impact surface, if the chisel does not penetrate or break the surface within 1 minute, change the point of impact and carry out breaking operations closer to the edge.

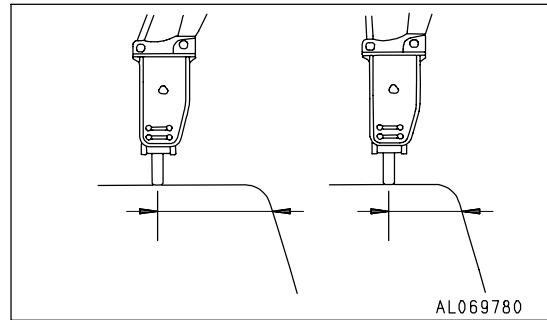

The direction of penetration of the chisel and the direction of the breaker body will gradually move out of line with each other, always adjust the bucket cylinder to keep them aligned.

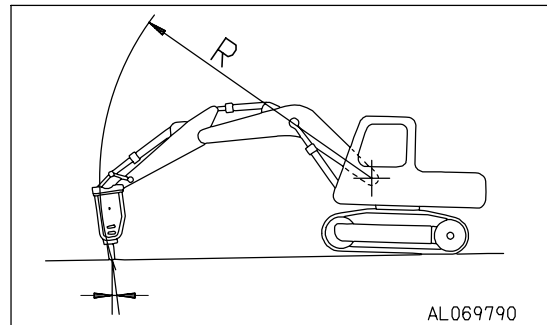

Always keep the chisel pressed against the impact surface properly to prevent using the impact force when there is no resistance.

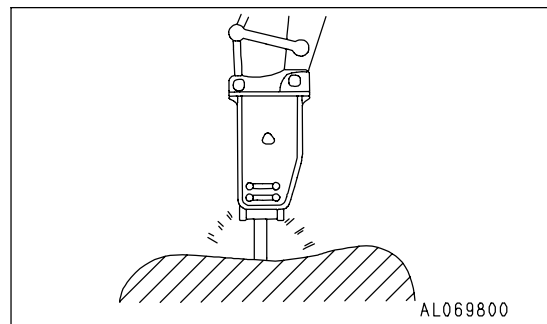

Prohibited Works

To ensure that the machine has a long life, and to ensure that operations are carried out in safety, do not operate the machine in any of the following ways.

- Do not operate all cylinders to the end of their strokes. Always leave approx. 5 cm (2 in) to spare.

Using the mount to gather in pieces of rock

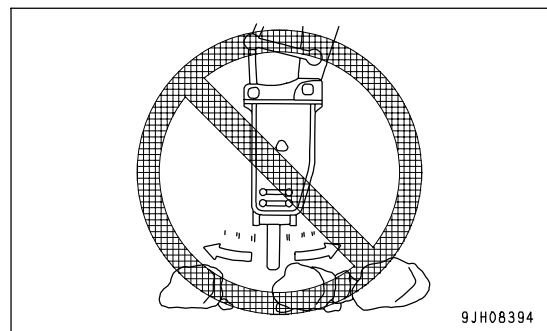

Operations using the swing force

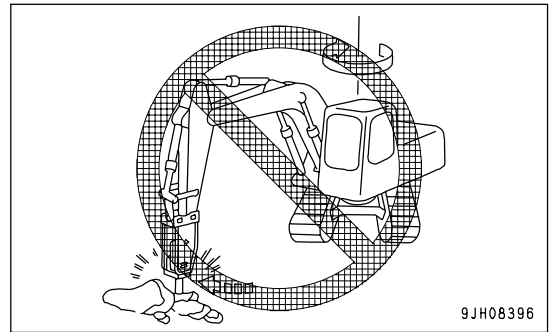

Moving the chisel while carrying out impacting operations

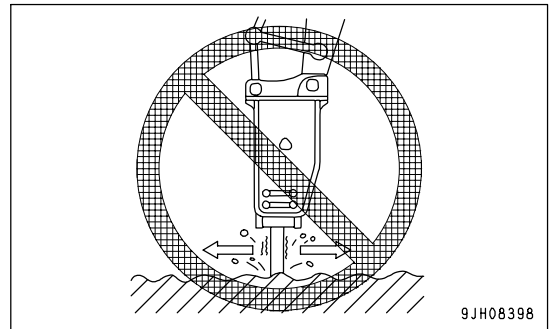

Holding the chisel horizontal or pointed up when carrying out impacting operations

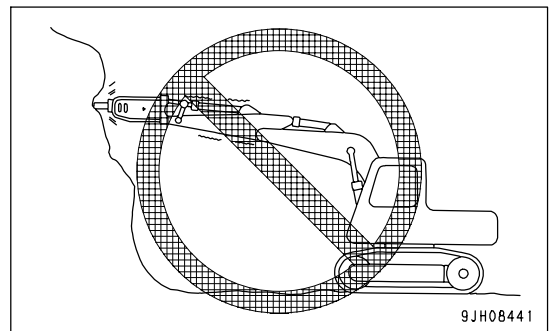

Twisting the chisel when it has penetrated the rock

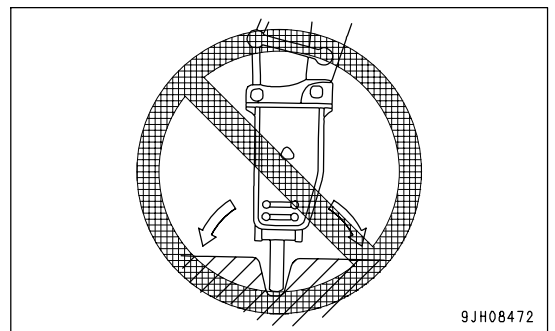

Pecking operations

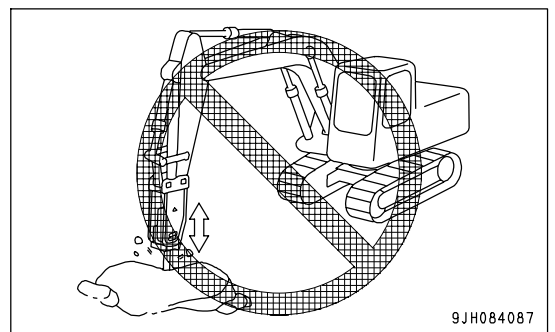

Extending the bucket cylinder fully and thrusting to raise the machine off the ground

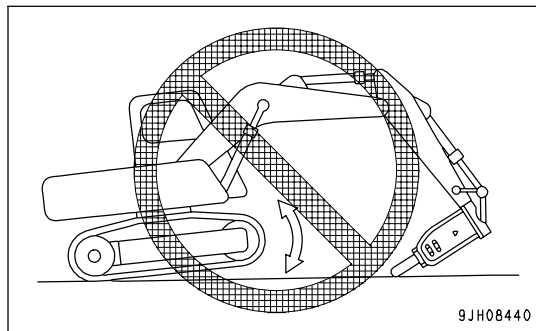

Greasing

Supply grease in the correct position.

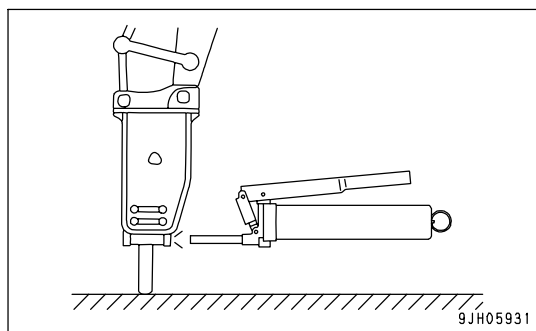

NOTICE

If the breaker is greased in an improper posture, it is filled with more grease than necessary. As a result, soil and sand will enter the hydraulic circuit and can damage the hydraulic components, while the breaker is in use. Therefore, be sure to grease the breaker, holding it in the right posture.

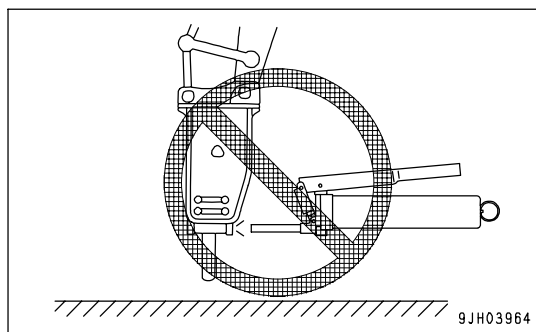
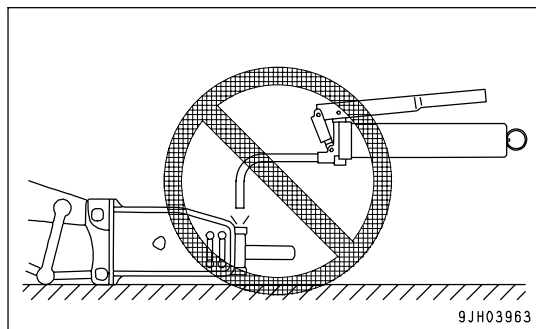

HANDLING MACHINES EQUIPPED WITH KOMTRAX

- KOMTRAX is a machine management system that uses wireless communications.
- A contract with your Komatsu distributor is necessary before the KOMTRAX system can be used. Any customers desiring to use the KOMTRAX system should consult their Komatsu distributor.
- The KOMTRAX equipment is a wireless device using radio waves, so it is necessary to obtain authorization and conform to the laws of the country or territory where the machine equipped with KOMTRAX is being used. Always contact your Komatsu distributor before selling or exporting any machine equipped with KOMTRAX.
- When selling or exporting the machine or at other times when your Komatsu distributor considers it necessary, it may be necessary for your Komatsu distributor to remove the KOMTRAX equipment or to carry out action to stop communications.
- If you do not obey the above precautions, neither Komatsu nor your Komatsu distributor can take any responsibility for any problem that is caused or for any loss that results.

BASIC PRECAUTIONS



WARNING

- Never disassemble, repair, modify, or move the communications terminal, antenna, or cables. This may cause failure or fire on the KOMTRAX equipment or the machine itself. (Your Komatsu distributor will carry out removal and installation of KOMTRAX.)
- Do not allow cables or cords to become caught; do not damage or pull cables or cords by force. Short circuits or disconnected wires may cause failure or fire on the KOMTRAX equipment or the machine itself.
- For anyone wearing a pacemaker, make sure that the communications antenna is at least 22 cm (8.7 in) from the pacemaker. The radio waves may have an adverse effect on the operation of the pacemaker.

NOTICE

- Even when the key in the starting switch of the KOMTRAX system is at the OFF position, a small amount of electric power is consumed. When putting the machine into long-term storage, take the action given in "LONG TERM STORAGE (PAGE 3-193)".
- Please contact your Komatsu distributor before installing a top guard or other attachment that covers the cab roof.
- Be careful not to get water on the communications terminal or wiring.

REMARK

- The KOMTRAX system uses wireless communications, so it cannot be used inside tunnels, underground, inside buildings, or in mountain areas where radio waves cannot be received. Even when the machine is outside, it cannot be used in areas where the radio signal is weak or in areas outside the wireless communication service area.
- There is absolutely no need to inspect or operate the KOMTRAX communications terminal, but if any abnormality is found, please consult your Komatsu distributor.

INDEX

<A>		GENERAL PRECAUTIONS COMMON	
AFTER STARTING ENGINE -----	3-132	TO OPERATION AND MAINTENANCE ----	2- 12
AIR CONDITIONER CONTROLS -----	3- 88	DO NOT GET CAUGHT IN WORK	
ASHTRAY -----	3- 87	EQUIPMENT -----	2- 17
ATTACHMENT GUIDE -----	6- 22	FIRE PREVENTION -----	2- 14
ATTACHMENT COMBINATIONS -----	6- 22	PRECAUTIONS BEFORE STARTING	
AUXILIARY ELECTRIC POWER -----	3-106	OPERATION -----	2- 12
		PRECAUTIONS RELATED TO	
BEFORE READING THIS MANUAL -----	1- 2	ATTACHMENTS AND OPTIONS -----	2- 18
BEFORE STARTING ENGINE -----	3-110	PRECAUTIONS RELATED TO	
BUCKET REPLACEMENT AND		CAB GLASS -----	2- 18
INVERSION -----	3-167	PRECAUTIONS RELATED TO	
BUCKET WITH HOOK -----	6- 3	PROTECTIVE STRUCTURES -----	2- 17
HOOK CONDITION -----	6- 3	PRECAUTIONS WHEN GETTING	
PROHIBITED OPERATIONS -----	6- 3	ON OR OFF MACHINE -----	2- 15
<C>		PRECAUTIONS WHEN RUNNING	
CAP WITH LOCK -----	3- 85	ENGINE INSIDE BUILDING -----	2- 18
COLD WEATHER OPERATION -----	3-190	PREPARATIONS FOR SAFE	
AFTER COLD WEATHER SEASON -----	3-192	OPERATION -----	2- 12
AFTER DAILY WORK COMPLETION ----	3-192	PROTECTION AGAINST FALLING,	
COLD WEATHER OPERATION		FLYING, INTRUDING OBJECTS -----	2- 17
INFORMATION -----	3-190	UNAUTHORIZED MODIFICATION -----	2- 18
CONTROL LEVERS AND PEDALS -----	3- 75	GENERAL PRECAUTIONS FOR	
CONTROLLER -----	3-108	SAFETY -----	6- 2
CONTROLS AND GAUGES -----	3- 3	PRECAUTIONS WHEN REMOVING	
<D>		OR INSTALLING -----	6- 2
DETAILED CONTROLS AND GAUGES ----	3- 5	PRECAUTIONS WHEN SELECTING ----	6- 2
DIRECTIONS OF MACHINE -----	1- 4	PRECAUTIONS WHEN USING -----	6- 2
DOOR LOCK -----	3- 84	READ THE INSTRUCTION MANUAL	
<E>		THOROUGHLY -----	6- 2
ELECTRIC SYSTEM MAINTENANCE -----	4- 7	GREASE PUMP HOLDER -----	3-109
EMERGENCY ESCAPE HAMMER -----	3- 84	<H>	
EPA REGULATIONS, ENGINE NUMBER		HANDLING MACHINES EQUIPPED	
PLATE -----	1- 7	WITH KOMTRAX -----	6- 29
ESCAPE FROM MUD -----	3-164	BASIC PRECAUTIONS -----	6- 29
<F>		HANDLING OIL, FUEL, COOLANT, AND	
FIRE EXTINGUISHER -----	3-109	PERFORMING OIL CLINIC -----	4- 4
FUSE -----	3-107	HANDLING THE ELECTRIC PRIMING	
FUSIBLE LINK -----	3-108	PUMP -----	6- 19
<G>		BLEEDING AIR FROM FUEL	
GENERAL OPERATION INFORMATION ---	3-160	CIRCUIT -----	6- 19
		<I>	
		INTRODUCTION -----	1- 4

<L>		MAINTENANCE SCHEDULE CHART ----	4- 15
LIFTING MACHINE -----	3-184	MONITORING SYSTEM -----	3- 5
LOADING AND UNLOADING WITH TRAILER -----	3-175	<O>	
LOCKING -----	3-173	OUTLINE OF SERVICE -----	4- 4
LONG TERM STORAGE -----	3-193	<P>	
AFTER STORAGE -----	3-194	PARKING MACHINE -----	3-171
BEFORE STORAGE -----	3-193	PRECAUTIONS FOR MAINTENANCE ----	2- 34
DURING STORAGE -----	3-193	PRECAUTIONS BEFORE STARTING INSPECTION AND MAINTENANCE ----	2- 34
STARTING MACHINE AFTER LONG-TERM STORAGE -----	3-194	PRECAUTIONS FOR INSPECTION AND MAINTENANCE -----	2- 38
<M>		PRECAUTIONS FOR OPERATION -----	2- 19
MACHINE INSPECTION AFTER DAILY WORK -----	3-172	LIFTING OBJECTS WITH BUCKET ----	2- 33
MACHINE OPERATION -----	3-144	OPERATION -----	2- 23
MACHINE OPERATIONS AND CONTROLS -----	3-110	PRECAUTIONS FOR JOBSITE -----	2- 19
MACHINE READY FOR ATTACHMENT ----	6- 4	STARTING ENGINE -----	2- 21
ATTACHMENT OPERATIONS -----	6- 17	TOWING -----	2- 32
HYDRAULIC CIRCUIT -----	6- 8	TRANSPORTATION -----	2- 31
LOCATIONS -----	6- 4	PROCEDURE FOR INCREASING OR REDUCING TRACK FRAME GAUGE ----	3-188
LONG TERM STORAGE -----	6- 18	PRODUCT IDENTIFICATION NUMBER (PIN)/MACHINE SERIAL NO. PLATE ----	1- 7
SPECIFICATIONS -----	6- 18	PRODUCT INFORMATION -----	1- 7
MACHINE VIEW ILLUSTRATIONS -----	3- 2	PROHIBITED OPERATIONS -----	3-155
OVERALL MACHINE VIEW -----	3- 2	<R>	
MAGAZINE BOX -----	3- 87	RADIO -----	3-101
MAINTENANCE INFORMATION -----	4- 2	RECOMMENDED APPLICATIONS -----	3-165
MAINTENANCE PROCEDURE -----	4- 18	RECOMMENDED ATTACHMENT OPERATIONS -----	6- 25
CHECK BEFORE STARTING -----	4- 46	HYDRAULIC BREAKER -----	6- 25
EVERY 1000 HOURS MAINTENANCE -----	4- 66	RECOMMENDED FUEL, COOLANT, AND LUBRICANT -----	4- 9
EVERY 2000 HOURS MAINTENANCE -----	4- 73	RECOMMENDED BRANDS, RECOMMENDED QUALITY FOR PRODUCTS OTHER THAN KOMATSU GENUINE OIL -----	4- 11
EVERY 250 HOURS MAINTENANCE ---	4- 48	<S>	
EVERY 4000 HOURS MAINTENANCE -----	4- 80	SAFETY -----	2- 2
EVERY 50 HOURS MAINTENANCE ----	4- 47	SAFETY CRITICAL PARTS -----	4- 13
EVERY 500 HOURS MAINTENANCE ---	4- 53	SAFETY CRITICAL PARTS LIST -----	4- 14
EVERY 5000 HOURS MAINTENANCE -----	4- 82	SAFETY INFORMATION -----	1- 3
EVERY 8000 HOURS MAINTENANCE -----	4- 84	SAFETY LABELS -----	2- 5
INITIAL 1000 HOURS MAINTENANCE (ONLY AFTER THE FIRST 1000 HOURS) -----	4- 18	SERVICE METER LOCATION -----	1- 8
WHEN REQUIRED -----	4- 19	SPECIFICATIONS -----	5- 2
MAINTENANCE SCHEDULE -----	4- 15	STARTING ENGINE -----	3-129
MAINTENANCE INTERVAL FOR HYDRAULIC BREAKER -----	4- 17	STEERING THE MACHINE -----	3-148

INDEX

STOPPING THE ENGINE	3-143
SUN ROOF	3- 78
SWINGING	3-150
SWITCHES	3- 70
<T>	
TIGHTENING TORQUE LIST	4- 12
TIGHTENING TORQUE SPECIFICATIONS	4- 12
TOOL BOX	3-109
TRANSPORTATION	3-174
TRANSPORTATION POSTURE	3-186
TRANSPORTATION PROCEDURE	3-174
TRAVELING ON SLOPES	3-162
TROUBLES AND ACTIONS	3-195
DISCHARGED BATTERY	3-199
LIGHTWEIGHT TOWING HOLE	3-198
OTHER TROUBLE	3-203
PHENOMENA THAT ARE NOT FAILURES	3-196
RUNNING OUT OF FUEL	3-195
SEVERE JOB CONDITION	3-198
TOWING THE MACHINE	3-197
<U>	
USE OF MACHINE	1- 4
<V>	
VISIBILITY FROM OPERATOR'S SEAT ---	1- 5
<W>	
WEAR PARTS	4- 8
WEAR PARTS LIST	4- 8
WINDSHIELD	3- 78
WORK EQUIPMENT CONTROLS AND OPERATIONS	3-151
WORKING MODE	3-153
<Y>	
YOUR MACHINE SERIAL NUMBERS AND DISTRIBUTOR	1- 8

PC400-8, PC400LC-8, PC450-8, PC450LC-8 HYDRAULIC EXCAVATOR

Form No. TEN00336-01

©2009 KOMATSU
All Rights Reserved
Printed in Japan 09-09
