

# Operation & Maintenance Manual

# PC4000-6

## HYDRAULIC MINING SHOVEL

**SERIAL NUMBERS PC4000-6 8172**

This material is proprietary to Komatsu Mining Germany GmbH and is not to be reproduced, used, or disclosed except in accordance with written authorization from Komatsu Mining Germany GmbH.

It is our policy to improve our products whenever it is possible and practical to do so. We reserve the right to make changes or improvements at any time without incurring any obligation to install such changes on products sold previously.

Due to this continuous program of research and development, revisions may be made to this publication. It is recommended that customers contact their distributor for information on the latest revision.

Copyright 2006 Komatsu  
Printed in U.S.A.  
Komatsu Mining Germany



# **1. INTRODUCTION**

## **1.1 CONTENTS OF THE BINDER**

Assembled in this file are the Operation- and Maintenance Manuals for your KOMATSU Mining Shovel.

## 1.2 DIVISION OF THE BINDER

**Part 1:**

Operation Manual

**Part 2:**

Maintenance Manual

**Part 3:**

Depending on the volume of Part 3 a second Binder "Volume 2" is being delivered with the Shovel. This Binder contains the General Assembly Procedure Manual for the Shovel, Specification Booklet, Service Literature for the Power Unit (Diesel Engine or Electric Motor) and for Special Equipment. The Electrical- and Hydraulic Diagrams are attached in the pocket of the front cover.

**Refer to the -TABLE OF CONTENTS VOLUME 2 BINDER- for details.**

**Read the Manuals before You Start the Engine.**

Before operating the machine, familiarize yourself with its instruments and controls.

**Observe the instructions in these manuals for:**

- your Personal SAFETY
- Operating SAFETY, and
- READY and EFFICIENT PERFORMANCE of your KOMATSU Shovel.

Periodic preventive inspections and maintenance are the surest means of keeping the machine in proper working order. Prompt detection and correction of minor irregularities, and immediate replacement of worn out or broken parts will prevent failures and avoid expenses.

Replace damaged graphics and symbols.

Observe safety precautions to prevent injury and damage.

If you have any questions concerning this literature please contact

**Komatsu Mining Germany GmbH**

Service Information  
Department 8151.30  
P.O. Box 18 03 61  
D - 40570 Düsseldorf  
GERMANY

## 1.3 DESIGNATED USE OF THE SHOVEL

This machine has been manufactured in accordance with advanced and up-to-date technology standards including recognized safety rules. Nevertheless, its use may constitute a risk to life and limb of the user or of third parties, or cause damage to the machine and to other material property.

The machine must only be used in technically perfect condition in accordance with its designated use and the instructions set out in the operation manual. Only trained safety-conscious operators who are fully aware of the risks involved should operate the machine. Any functional disorders, especially those affecting the safety of the machine, should, therefore, be rectified immediately.

The hydraulic Shovel is designed exclusively for excavating, i.e. excavation of bulk material and natural soil structure (e.g. earth, clay, sand and stones ashore and off-shore). Observe local and national safety regulations. Special conditions at the worksite require additional safe working precautions, follow your company's safety instructions. Short traveling distances for changing the working site are considered as part of the designated use of the Shovel.

Using the Shovel for purposes other than those mentioned above (such as object handling and use as a transport vehicle) is considered contrary to its designated use. The manufacturer/supplier cannot be held liable for any damage resulting from such use. The risk of such misuse lies entirely with the user.

---

---

**▲ WARNING**

---

---

**Special use of the Shovel beyond its designated use, e.g. object handling operations, require written agreement from the manufacturer and retrofitment of the Shovel with respective safety related equipment before such special applications are permitted.**

---

---

## 1.4 DELIVERY OF THE SHOVEL

The Shovel is being delivered disassembled into its main components.

**For assembling the Shovel refer to the  
"General Assembly Procedure Manual"  
in Volume 2 Service Literature Binder.**

---

**⚠ WARNING**

---

- **Improper assembling of the Shovel can cause serious accidents with personal injury or death.**
  - **Personnel entrusted with work on the machine must have read the Assembly Manual, the Operation- and Maintenance Manual and in particular the section on safety before beginning work. Reading the instructions after work has begun is too late. If there are any questions concerning safe assembling procedure, contact your local Komatsu Service Organization.**
- 

Prior to first operation, inspect the Shovel thoroughly with the Service Engineer responsible for the erection of the machine. Check all fluid levels according to the Lubrication and Maintenance Schedule.

Damages and defects caused by incorrect operation and maintenance are not covered by the manufacturers guarantee.

**NOTICE**

**If the Shovel is equipped with a fire suppression system, make sure that the system is ready for operation.**

**SPARE PARTS**

For your spare part orders refer to the Parts Catalogue.

In order to keep your Shovel in first-class operating condition use only genuine spare and wear parts.

The use of any part other than the genuine part releases the KOMATSU MINING GERMANY GmbH from any guarantee.

**SERVICE**

For all questions related to your Shovel please contact your local Service Center.

In all your written or phoned inquiries please indicate the model and serial number of your Shovel.

## 1.5 EXPLANATION OF ABBREVIATIONS

<b>ABB</b>	<b>Definition</b>
A	Ampere
AC	Alternating Current
API	American Petroleum Institute
cSt	Centistoke
°C	Degree Celsius
CENSE	Engine Monitoring System
CLS	Central Lubrication System
DC	Direct Current
DIN	German Institute for Standardization
EBL	Electronic Bucket Levelling System
ECM	Electronic Control Module (Engine)
FGPS	Front Guard Protective Structure
FOPS	Falling-Object Protective Structure
GL	Gear Lubricant
h	hours of operation
HPF	High Pressure Filter (Hydraulic Oil)
HT	High Tension
LED	Light Emitting Diode
LT	Low Tension
N	Newton
Nm	Newton meter
QSK	Type of Engine Fuel System
PLC	Programmable Logic Controller
PM	Planned Maintenance
ppm	parts per million
PTO	Power Take-Off (Pump Distributor Gear)
SLS	Swing circle pinion Lubrication System
V	Volt
VHMS	Vehicle Health Monitoring System
1/min	Revolutions Per Minute (RPM)



## 1.6 TABLE OF CONTENTS

<b>1. INTRODUCTION .....</b>	<b>3</b>
1.1 CONTENTS OF THE BINDER .....	4
1.2 DIVISION OF THE BINDER .....	5
1.3 DESIGNATED USE OF THE SHOVEL .....	6
1.4 DELIVERY OF THE SHOVEL .....	7
1.5 EXPLANATION OF ABBREVIATIONS .....	8
1.6 TABLE OF CONTENTS .....	9
<b>2. SAFETY .....</b>	<b>15</b>
2.1 SAFETY INSTRUCTIONS .....	16
2.1.1 WARNINGS AND SYMBOLS .....	16
2.1.2 BASIC OPERATION AND DESIGNATED USE OF THE HYDRAULIC MINING SHOVEL ..	16
2.1.3 ORGANIZATIONAL MEASURES .....	17
2.1.4 SELECTION AND QUALIFICATION OF PERSONNEL - BASIC RESPONSIBILITIES .....	19
2.1.5 SAFETY INSTRUCTIONS GOVERNING SPECIFIC OPERATIONAL PHASES .....	20
2.1.6 WARNING OF SPECIAL DANGERS .....	23
2.1.7 TRANSPORTING AND TOWING -RECOMMISSIONING .....	25
2.1.8 SPECIAL SAFETY EQUIPMENT .....	25
2.1.9 SAFETY HARNESS IN CONFORMITY WITH EN 361 (EUROPEAN STANDARD) .....	29
<b>3. OPERATION .....</b>	<b>37</b>
3.1 FOREWORD .....	38
3.2 CONSTRUCTION OF THE SHOVEL .....	39
3.2.1 OVERALL VIEW .....	39
3.2.2 SUPERSTRUCTURE .....	40
3.2.3 HYDRAULICALLY OPERATED ACCESS LADDER .....	50
3.2.4 EMERGENCY ESCAPE LADDER .....	54
3.2.5 EMERGENCY ENGINE SHUTDOWN FROM GROUND MAN OR OPERATOR WARNING SYSTEM .....	56
3.2.6 OPERATOR'S CAB WITH INTEGRATED FALLING OBJECT PROTECTIVE STRUCTURE (FOPS) .....	58
3.2.7 UNDERCARRIAGE .....	69
3.2.8 WORKING ATTACHMENT .....	70
3.2.9 DIESEL ENGINE TYPE SDA 16V160 .....	72
3.2.10 ENGINE OIL MANAGEMENT SYSTEM .....	74

<b>3.3</b>	<b>OPERATOR'S CAB - CONTROLS</b> .....	<b>78</b>
3.3.1	CONTROLS WITH BACKHOE ATTACHMENT .....	78
3.3.2	SAFETY CIRCUIT FOR CONTROLS .....	79
3.3.3	CONTROLS WITH BOTTOM DUMP BUCKET ATTACHMENT .....	82
3.3.4	SAFETY CIRCUIT FOR CONTROLS .....	83
3.3.5	AUTOMATIC FLOAT POSITION FOR BOOM AND STICK .....	85
3.3.6	OPERATOR'S CONSOLE .....	87
3.3.7	INTERFACE PANEL FOR DIAGNOSTICS AND CONTROLS FOR HEATING AND AIR CONDITIONING .....	93
<b>3.4</b>	<b>VEHICLE HEALTH MONITORING SYSTEM VHMS – HEALTH MONITOR</b> .....	<b>96</b>
3.4.1	INITIALIZATION SCREEN NO. 0.0 .....	96
3.4.2	OPERATOR INFORMATION SCREEN NO. 1.1 .....	96
3.4.3	STANDARD MONITOR 1 (NO. 1.2) .....	97
3.4.4	TABLE OF ALL TOP MESSAGES PROVIDED BY THE SYSTEM .....	111
3.4.5	TABLE OF AVAILABLE INSTRUCTION MESSAGES .....	120
<b>3.5</b>	<b>OPERATING THE HEATER, VENTILATION AND AIR CONDITIONING</b> .....	<b>122</b>
3.5.1	A - HEATING .....	123
3.5.2	B - COOLING .....	123
3.5.3	COMBINED OPERATION OF AIR CONDITIONING AND HEATING .....	123
3.5.4	AUXILIARY HEATER FOR OPERATOR'S CAB .....	125
<b>3.6</b>	<b>POWER HOUSE</b> .....	<b>126</b>
3.6.1	EMERGENCY ENGINE SHUTDOWN SWITCHES .....	127
3.6.2	MAINTENANCE SAFETY SWITCH AND BATTERY MAIN SWITCHES .....	129
3.6.3	CENTRAL CONTROL AND FILTER PANEL .....	131
<b>3.7</b>	<b>ELECTRICAL EQUIPMENT IN CAB BASE</b> .....	<b>134</b>
3.7.1	STANDARD COMPONENTS IN CAB BASE .....	135
3.7.2	SWITCH BOARD (X2) IN CAB BASE .....	137
3.7.3	COMPONENTS OF ELECTRICAL PRE-HEATING SYSTEM LOCATED IN THE CAB BASE 147	
<b>3.8</b>	<b>CHECKS BEFORE STARTING THE ENGINE</b> .....	<b>154</b>
<b>3.9</b>	<b>STARTING THE ENGINE</b> .....	<b>160</b>
3.9.1	STARTING PROCEDURE .....	163
3.9.2	ENGINE WARM-UP .....	167
3.9.3	HYDRAULIC OIL WARM-UP .....	167
<b>3.10</b>	<b>MOVING THE SHOVEL</b> .....	<b>169</b>
3.10.1	TRAVEL CONTROL WITH FOOT PEDALS .....	169
3.10.2	TRAVELLING INSTRUCTIONS .....	172
<b>3.11</b>	<b>SLEWING AND BRAKING THE SUPERSTRUCTURE</b> .....	<b>173</b>
3.11.1	SLEWING THE SUPERSTRUCTURE .....	173
3.11.2	BRAKING THE SUPERSTRUCTURE .....	175
3.11.3	SLEW PARKING BRAKE .....	176

<b>3.12</b>	<b>WORKING WITH THE ATTACHMENT .....</b>	<b>178</b>
3.12.1	MACHINES EQUIPPED WITH "EURO" CONTROL SYSTEM .....	178
3.12.2	MACHINES EQUIPPED WITH "KMG" CONTROL SYSTEM .....	179
3.12.3	BOTTOM DUMP BUCKET .....	180
3.12.4	DROP BALL OPERATION .....	181
3.12.5	COMBINED OPERATION CYCLES .....	184
<b>3.13</b>	<b>WORKING INSTRUCTIONS .....</b>	<b>186</b>
3.13.1	STABILITY OF THE SHOVEL .....	186
3.13.2	SHOVEL OPERATION .....	186
<b>3.14</b>	<b>PARKING THE SHOVEL .....</b>	<b>189</b>
<b>3.15</b>	<b>STOPPING THE ENGINE .....</b>	<b>190</b>
3.15.1	RELIEVE PRESSURE IN THE HYDRAULIC SYSTEM .....	193
<b>3.16</b>	<b>OPERATION OF THE LUBRICATION SYSTEM .....</b>	<b>194</b>
3.16.1	CENTRAL LUBRICATION SYSTEM "CLS" .....	194
3.16.2	SWING CIRCLE PINION LUBRICATION SYSTEM "SLS" .....	196
<b>3.17</b>	<b>FIRE DETECTION AND SUPPRESSION SYSTEM .....</b>	<b>198</b>
3.17.1	HIGH LEVEL ALARM "FIRE" .....	201
3.17.2	ENGINE SHUT-DOWN THROUGH FUEL SHUT-OFF SOLENOID VALVE .....	201
3.17.3	ACTUATION MODES OF THE FIRE SUPPRESSION SYSTEM .....	201
3.17.4	INDICATION OF OPERATIONAL MODES AT CONTROL MODULE, AFTER AUTOMATIC ACTUATION OF THE FIRE SUPPRESSION SYSTEM .....	203
3.17.5	LOCATION OF THE EXTINGUISHING AGENT TANK ASSEMBLIES AND EXPELLANT GAS CARTRIDGES ON POWER HOUSE ROOF .....	205
<b>3.18</b>	<b>TRANSFER PUMP FOR HYDRAULIC OIL .....</b>	<b>206</b>
3.18.1	OPERATING THE TRANSFER PUMP .....	207
3.18.2	FUNCTIONS OF THE TRANSFER PUMP .....	209
<b>3.19</b>	<b>CENTRAL REFILLING SYSTEM .....</b>	<b>212</b>
3.19.1	SYSTEMS CONNECTED TO THE REFILLING SYSTEM .....	213
3.19.2	OPERATING THE HYDRAULIC SERVICE ARM .....	215
3.19.3	RECEIVER PANEL WITH MONITOR BOX .....	217
3.19.4	REFILLABLE GREASE CONTAINERS OF THE CENTRAL LUBRICATION SYSTEM AND SWING CIRCLE PINION LUBRICATION SYSTEM .....	223
<b>3.20</b>	<b>WORK ON THE LOADER ATTACHMENT .....</b>	<b>226</b>
<b>3.21</b>	<b>TRANSPORTATION AND LIFTING OF THE SHOVEL .....</b>	<b>227</b>
3.21.1	DISASSEMBLING OF THE SHOVEL .....	227
3.21.2	TRANSPORTATION AND LIFTING .....	227
<b>3.22</b>	<b>RETRIEVAL PROCEDURE .....</b>	<b>228</b>
<b>3.23</b>	<b>SHOVEL STORAGE .....</b>	<b>229</b>
3.23.1	PREPARING FOR STORAGE .....	229
3.23.2	ONE MONTH REPETITIVE SERVICE PERIOD .....	230

3.23.3	SIX MONTH REPETITIVE SERVICE PERIOD .....	230
3.23.4	PREPARING FOR OPERATION .....	231
<b>3.24</b>	<b>TROUBLE SHOOTING .....</b>	<b>232</b>
3.24.1	ENGINE .....	232
3.24.2	HYDRAULIC SYSTEM .....	233
3.24.3	FINAL DRIVES AND SWING MACHINERY .....	234
3.24.4	CRAWLER TRACKS .....	234
<b>4.</b>	<b>MAINTENANCE .....</b>	<b>235</b>
4.1	FOREWORD .....	236
4.2	PRECAUTIONS FOR MAINTENANCE .....	237
4.3	FUEL AND LUBRICANTS .....	239
4.4	FILLING CAPACITIES .....	241
4.5	STANDARD TORQUE LIST .....	242
4.6	LUBRICATION AND MAINTENANCE SCHEDULE .....	243
4.6.1	INITIAL SERVICING .....	243
4.6.2	PERIODIC SERVICING INTERVALS .....	243
4.6.3	PERIODIC SERVICING SCHEDULE .....	244
4.6.4	EXTENDED SERVICE INTERVALS FOR ENGINES EQUIPPED WITH ENGINE OIL MANAGEMENT SYSTEM .....	251
4.6.5	MAINTENANCE OF THE ENGINE .....	253
4.7	WHEN NECESSARY .....	254
4.7.1	ENGINE AIR CLEANER SERVICE .....	255
4.7.2	SWING CIRCLE TOOTHING LUBRICATION .....	259
4.7.3	AUTOMATIC LUBRICATION SYSTEMS FILL GREASE BARRELS .....	261
4.7.4	TRACK ROLLERS AND GUIDE WHEELS - REPLACE FLOATING SEALS .....	265
4.8	EVERY 10 OPERATING HOURS OR DAILY .....	266
4.8.1	WALK-AROUND INSPECTION .....	267
4.8.2	AIR CLEANER - CLEAN PRE-CLEANER .....	277
4.8.3	RADIATOR - CHECK COOLANT LEVEL .....	279
4.8.4	TRACK GROUPS - CLEAN .....	279
4.8.5	FUEL SYSTEM WATER SEPARATOR - DRAIN WATER .....	281
4.9	EVERY 50 OPERATING HOURS OR WEEKLY .....	282
4.9.1	SWING MACHINERY AND MOTOR ADAPTER HOUSINGS - CHECK OIL LEVELS .....	283
4.9.2	TRAVEL GEARS, BRAKE HOUSINGS AND MOTOR ADAPTER HOUSINGS - CHECK OIL LEVELS .....	287
4.9.3	FINAL DRIVE HOUSINGS - CHECK OIL LEVEL .....	289
4.9.4	PTO (PUMP DISTRIBUTOR GEAR) AND OIL RESERVOIR - CHECK OIL LEVEL .....	291
4.9.5	HYDRAULIC ACCESS LADDER - CHECK SAFETY SENSOR .....	293
4.9.6	HYDRAULIC OIL COOLERS - INSPECT AND CLEAN IF NECESSARY .....	295

<b>4.10</b>	<b>EVERY 250 OPERATING HOURS OR MONTHLY</b>	<b>296</b>
4.10.1	AIR CONDITIONING COMPRESSOR - CHECK DRIVE BELT TENSION	297
4.10.2	UNDERCARRIAGE PIN CONNECTIONS - LUBRICATE	299
4.10.3	SIGNAL HORN COMPRESSOR - LUBRICATE	299
4.10.4	HYDRAULIC OIL COOLER FAN BEARING HOUSINGS - CHECK FOR LEAKAGE AND CLEAN BREATHER FILTER	299
4.10.5	RADIATOR FAN BEARING HOUSING - CHECK FOR LEAKAGE AND CLEAN BREATHER FILTER	299
4.10.6	AUTOMATIC LUBRICATION SYSTEMS - CLEAN IN-LINE GREASE FILTER	301
4.10.7	CAB AIR CLEANER - CLEAN OR REPLACE FILTER ELEMENT	305
4.10.8	WINDSHIELD WASHER SYSTEM - CHECK FLUID LEVEL	307
4.10.9	AIR CONDITIONING FOR OPERATOR'S CAB - CHECK REFRIGERANT LEVEL	309
<b>4.11</b>	<b>EVERY 500 OPERATING HOURS OR MONTHLY</b>	<b>310</b>
4.11.1	BATTERIES - CHECK FLUID LEVEL	311
4.11.2	FLEXIBLE DRIVE COUPLING - CHECK OIL LEVEL	313
4.11.3	PTO (PUMP DISTRIBUTOR GEAR) MAIN PUMP DRIVE SHAFT HOUSINGS - CHECK OIL LEVEL	315
4.11.4	FUEL TANK - DRAIN CONDENSATION	317
4.11.5	CRAWLER TRACK - INSPECTION	319
<b>4.12</b>	<b>EVERY 1000 OPERATING HOURS OR EVERY 6 MONTH</b>	<b>324</b>
4.12.1	HIGH STRENGTH BOLT CONNECTIONS	325
4.12.2	HYDRAULIC SYSTEM - FILTER SERVICE	367
4.12.3	PTO (PUMP DISTRIBUTOR GEAR), SWING MACHINERY AND TRAVEL GEARS - OIL SAMPLE ANALYSIS	379
4.12.4	SIGNAL HORN COMPRESSOR - CLEAN AND LUBRICATE	381
4.12.5	HYDRAULIC TRACK TENSIONING SYSTEM - CHECK ACCUMULATORS	383
4.12.6	WATER FILTER - REPLACE FILTER CARTRIDGE	385
4.12.7	HYDRAULIC OIL COOLER - INSPECT AND LUBRICATE DOOR HINGES	387
4.12.8	MACHINERY HOUSE DOORS - INSPECT AND LUBRICATE DOOR HINGES	389
<b>4.13</b>	<b>EVERY 2000 OPERATING HOURS OR YEARLY</b>	<b>390</b>
4.13.1	HYDRAULIC SYSTEM - CHANGE OIL, REPLACE SUCTION STRAINERS AND PULSATION DAMPER	391
4.13.2	EMERGENCY ESCAPE LADDER - INSPECTION	403
<b>4.14</b>	<b>EVERY 3000 OPERATING HOURS HOWEVER AT LEAST ONCE A YEAR</b>	<b>404</b>
4.14.1	SWING MACHINERY AND MOTOR ADAPTER HOUSING - CHANGE OIL	405
4.14.2	TRAVEL GEARS, BRAKE AND MOTOR ADAPTER HOUSINGS - CHANGE OIL	413
4.14.3	FINAL DRIVE HOUSINGS - CHANGE OIL	417
4.14.4	PTO (PUMP DISTRIBUTOR GEAR) - CHANGE OIL	419
<b>4.15</b>	<b>FIRE PREVENTION</b>	<b>420</b>
<b>4.16</b>	<b>WELD REPAIRS</b>	<b>422</b>
4.16.1	PROTECTIVE MEASURES BEFORE STARTING WELD REPAIRS ON THE UNDERCARRIAGE	425
4.16.2	PROTECTIVE MEASURES BEFORE STARTING WELD REPAIRS ON THE LOADER ATTACHMENT	427
4.16.3	PROTECTIVE MEASURES BEFORE STARTING WELD REPAIRS ON THE	

SUPERSTRUCTURE ..... 429

4.16.4 AFTER FINISHING THE WELD REPAIRS ON THE SUPERSTRUCTURE ..... 430

## **2. SAFETY**

## 2.1 SAFETY INSTRUCTIONS

### 2.1.1 WARNINGS AND SYMBOLS

The following signs and designations are used in the manual to designate in-structions of particular importance.

**⚠ WARNING**

Refers to orders and prohibitions designed to prevent injury or extensive damage.

**⚠ CAUTION**

Refers to special information and/or orders and prohibitions directed towards preventing damage.

**NOTICE**

Refers to special information on how to use the machine most efficiently.

### 2.1.2 BASIC OPERATION AND DESIGNATED USE OF THE HYDRAULIC MINING SHOVEL

Refer to "DESIGNATED USE OF THE SHOVEL" on page 6 for details.

**⚠ WARNING**

The use of the Shovel for object handling operations without the respective safety related equipment is not allowed.



### 2.1.3 ORGANIZATIONAL MEASURES

- The Operation,- Lubrication and Maintenance Manual must always be at hand at the place of use of the machine, e. g. by stowing them in the box provided for such purpose.
- In addition to the Operation,- Lubrication and Maintenance Manual, observe and instruct the user in all other generally applicable legal and other mandatory regulations relevant to accident prevention and environmental protection.  
These compulsory regulations may also deal with the handling of hazardous substances, issuing and/or wearing of personal protective equipment, or traffic regulations.
- The Operation,- Lubrication and Maintenance Manual must be supplemented by instructions covering the duties involved in supervising and notifying special organizational features, such as job organization, working sequences or the personnel entrusted with the work.
- Personnel entrusted with work on the machine must have read the Operation,- Lubrication and Maintenance Manual and in particular the chapter on safety before beginning work. Reading the instructions after work has begun is too late. This applies especially to persons working only occasionally on the machine, e. g. during setting up or maintenance.
- Check - at least from time to time - whether the personnel is carrying out the work in compliance with the Operation,- Lubrication and Maintenance Manual and paying attention to risks and safety factors.
- For reasons of security, long hair must be tied back or otherwise secured, garments must be close-fitting and no jewellery - such as rings - may be worn. Injury may result from being caught up in the machinery or from rings catching on moving parts.
- Use protective equipment wherever required by the circumstances or by law.
- Observe all safety instructions and warnings attached to the machine.
- See to it that safety instructions and warnings attached to the machine are always complete and perfectly legible.
- In the event of safety-relevant modifications or changes in the behaviour of the machine during operation, stop the machine immediately and report the malfunction to the competent authority/person.
- Never make any modifications, additions or conversions which might affect safety without the supplier's approval. This also applies to the installation and adjustment of safety devices and valves as well as to welding work on load-bearing elements.
- Spare parts must comply with the technical requirements specified by the manufacturer. Spare parts from original equipment manufacturers can be relied to do so.

- Replace hydraulic hoses within stipulated and appropriate intervals even if no safety-relevant defects have been detected.
- Adhere to prescribed intervals or those specified in the Operation,- Lubrication and Maintenance Manual for routine checks and inspections.
- For the execution of maintenance work, tools and workshop equipment adapted to the task on hand are absolutely indispensable.
- The personnel must be familiar with the location and operation of fire extinguishers.
- Observe all fire-warning and fire-fighting procedures.

## **2.1.4 SELECTION AND QUALIFICATION OF PERSONNEL - BASIC RESPONSIBILITIES**

- Any work on and with the machine must be executed by reliable personnel only. Statutory minimum age limits must be observed.
- Employ only trained or instructed staff and set out clearly the individual responsibilities of the personnel for operation, set-up, maintenance and repair.
- Make sure that only authorized personnel works on or with the machine.
- Define the machine operator's responsibilities - also with regard to observing traffic regulations - giving the operator the authority to refuse instructions by third parties that are contrary to safety.
- Do not allow persons to be trained or instructed or persons taking part in a general training course to work on or with the machine without being permanently supervised by an experienced person.
- Work on the electrical system and equipment of the machine must be carried out only by a skilled electrician or by instructed persons under the supervision and guidance of a skilled electrician and in accordance with electrical engineering rules and regulations.
- Work on chassis, brake and steering systems must be performed by skilled personnel only which has been specially trained for such work.
- Work on the hydraulic system must be carried out only by personnel with special knowledge and experience of hydraulic equipment.

## 2.1.5 SAFETY INSTRUCTIONS GOVERNING SPECIFIC OPERATIONAL PHASES

### STANDARD OPERATION

- Avoid any operational mode that might be prejudicial to safety.
- Before beginning work, familiarize yourself with the surroundings and circumstances of the site, such as obstacles in the working and travelling area, the soil bearing capacity and any barriers separating the construction site from public roads.
- Take the necessary precautions to ensure that the machine is used only when in a safe and reliable state.  
Operate the machine only if all protective and safety-oriented devices, such as re-movable safety devices, emergency shut-off equipment, sound-proofing elements and exhausters, are in place and fully functional.
- Check the machine at least once per working shift for obvious damage and defects. Report any changes (incl. changes in the machine's working behaviour) to the competent organization/person immediately. If necessary, stop the machine immediately and lock it.
- In the event of malfunctions, stop the machine immediately and lock it. Have any defects rectified immediately.
- Start the machine from the driver's seat only.
- During start-up and shut-down procedures always watch the indicators in accordance with the Operation,- Lubrication and Maintenance Manual.
- Before starting up or setting the machine in motion, make sure that nobody is at risk.
- Before starting work or travelling with the machine, check that the braking, steering, signalling and lighting systems are fully functional.
- Before setting the machine in motion always check that the accessories have been safely stowed away.
- When travelling on public roads, ways and places always observe the valid traffic regulations and, if necessary, make sure beforehand that the machine is in a condition compatible with these regulations.
- In conditions of poor visibility and after dark always switch on the lighting system.
- Persons accompanying the driver must be seated on the passenger seat provided for this purpose.
- When crossing underpasses, bridges and tunnels or when passing under overhead lines always make sure that there is sufficient clearance.

- Always keep at a distance from the edges of building pits and slopes.
- Avoid any operation that might be a risk to machine stability.
- Never travel across slopes; always keep the working equipment and the load close to the ground, especially when travelling downhill.
- On sloping terrain always adapt your travelling speed to the prevailing ground conditions. Never change to a lower gear on a slope but always before reaching it.
- Before leaving the driver's seat always secure the machine against inadvertent movement and unauthorized use.

### **SPECIAL WORK IN CONJUNCTION WITH UTILIZATION OF THE MACHINE AND MAINTENANCE AND REPAIRS DURING OPERATION; DISPOSAL OF PARTS AND CONSUMABLES**

- Observe the adjusting, maintenance and inspection activities and intervals set out in the Operation,- Lubrication and Maintenance Manual, including information on the replacement of parts and equipment. These activities may be executed by skilled personnel only.
- Brief operating personnel before beginning special operations and maintenance work, and appoint a person to supervise the activities.
- In any work concerning the operation, conversion or adjustment of the machine and its safety-oriented devices or any work related to maintenance, inspection and repair, always observe the start-up and shut-down procedures set out in the Operation,- Lubrication and Maintenance Manual and the information on maintenance work.
- Ensure that the maintenance area is adequately secured.
- If the machine is completely shut down for maintenance and repair work, it must be secured against inadvertent starting by:
  - locking the principal control elements and removing the ignition key and/or
  - attaching a warning sign to the main switch
- Carry out maintenance and repair work only if the machine is positioned on stable and level ground and has been secured against inadvertent movement and buckling.
- To avoid the risk of accidents, individual parts and large assemblies being moved for replacement purposes should be carefully attached to lifting tackle and secured. Use only suitable and technically perfect lifting gear and suspension systems with adequate lifting capacity. Never work or stand under suspended loads.

- 
- The fastening of loads and the instructing of crane operators should be entrusted to experienced persons only. The marshaller giving the instructions must be within sight or sound of the operator.
  - For carrying out overhead assembly work always use specially designed or otherwise safety-oriented ladders and working platforms. Never use machine parts as a climbing aid. Wear a safety harness when carrying out maintenance work at greater heights.  
Keep all handles, steps, handrails, platforms, landings and ladders free from dirt, snow and ice.
  - Clean the machine, especially connections and threaded unions, of any traces of oil, fuel or preservatives before carrying out maintenance/repair. Never use aggressive detergents. Use lint-free cleaning rags.
  - Before cleaning the machine with water, steam jet (high-pressure cleaning) or detergents, cover or tape up all openings which - for safety and functional reasons - must be protected against water, steam or detergent penetration. Special care must be taken with electric motors and switchgear cabinets.
  - Ensure during cleaning of the machine that the temperature sensors of the fire-warning and fire-fighting systems do not come into contact with hot cleaning agents as this might activate the fire-fighting system.
  - After cleaning, remove all covers and tapes applied for that purpose.
  - After cleaning, examine all fuel, lubricant, and hydraulic fluid lines for leaks, loose connections, chafe marks and damage. Any defects found must be rectified without delay.
  - Always tighten any screwed connections that have been loosened during maintenance and repair.
  - Any safety devices removed for set-up, maintenance or repair purposes must be refitted and checked immediately upon completion of the maintenance and repair work.
  - Ensure that all consumables and replaced parts are disposed of safely and with minimum environmental impact.

## 2.1.6 WARNING OF SPECIAL DANGERS

### ELECTRIC ENERGY

- Use only original fuses and circuit breakers with the specified current rating. Switch off the machine immediately if trouble occurs in the electrical system.
- When working with the machine, maintain a safe distance from overhead electric lines. If work is to be carried out close to overhead lines, the working equipment must be kept well away from them. Caution, danger! Check out the prescribed safety distances.
- If your machine comes into contact with a live wire
  - do not leave the machine
  - drive the machine out of the hazard zone
  - warn others against approaching and touching the machine
  - have the live wire de-energized
  - do not leave the machine until the damaged line has been safely de-energized.
- Work on the electrical system or equipment may only be carried out by a skilled electrician himself or by specially instructed personnel under the control and supervision of such electrician and in accordance with the applicable electrical engineering rules.
- If provided for in the regulations, the power supply to parts of machine, on which inspection, maintenance and repair work is to be carried out must be cut off.  
Before starting any work, check the de-energized parts for the presence of power and ground or short-circuit them in addition to insulating adjacent live parts and elements.
- The electrical equipment of the machine is to be inspected and checked at regular intervals. Defects such as loose connections or scorched cables must be rectified immediately.
- Necessary work on live parts and elements must be carried out only in the presence of a second person who can cut off the power supply in case of danger by actuating the emergency shut-off or main power switch. Secure the working area with a red-and-white safety chain and a warning sign. Use insulated tools only.
- Before starting work on high-voltage assemblies and after cutting out the power supply, the feeder cable must be grounded and components such as capacitors short-circuited with a grounding rod.

## **GAS, DUST, STEAM AND SMOKE**

- Operate internal combustion engines and fuel operated heating systems only on adequately ventilated premises. Before starting the machine on enclosed premises, make sure that there is sufficient ventilation.  
Observe the regulations in force at the respective site.
- Carry out welding, flame-cutting and grinding work on the machine only if this has been expressly authorized, as there may be a risk of explosion and fire.
- Special care must be taken before welding, flame-cutting and grinding operations are carried out on the counterweight. The filling of the counterweight chambers can create explosive gases which will accumulate in the chambers of the counterweight. These gases must be expelled before welding, flame-cutting and grinding operations are carried out on the counterweight. Danger of explosion.  
Follow the instructions given in PARTS & SERVICE NEWS No. AH04518 for expelling the gases from the counterweight chambers.
- Before carrying out welding, flame-cutting and grinding operations, clean the machine and its surroundings from dust and other inflammable substances and make sure that the premises are adequately ventilated (risk of explosion).

## **HYDRAULIC AND PNEUMATIC EQUIPMENT**

- Work on hydraulic equipment may be carried out only by persons having special knowledge and experience in hydraulic systems.
- Check all lines, hoses and screwed connections regularly for leaks and obvious damage. Repair damage immediately. Splashed oil may cause injury and fire.
- Depressurize all system sections and pressure pipes (hydraulic system, compressed-air system) to be removed in accordance with the specific instructions for the unit concerned before carrying out any repair work.
- Hydraulic and compressed-air lines must be laid and fitted properly. Ensure that no connections are interchanged. The fittings, lengths and quality of the hoses must comply with the technical requirements.

## **NOISE**

- During operation, all sound baffles must be closed.
- Always wear the prescribed ear protectors.



## **OIL, GREASE AND OTHER CHEMICAL SUBSTANCES**

- When handling oil, grease and other chemical substances, observe the product-related safety regulations.
- Be careful when handling hot consumable (risk of burning or scalding).

### **2.1.7 TRANSPORTING AND TOWING -RECOMMISSIONING**

- The machine must be towed, loaded and transported only in accordance with the Operation,- Lubrication and Maintenance Manual.
- For towing the machine observe the prescribed transport position, admissible speed and itinerary.
- Use only appropriate means of transport and lifting gear of adequate capacity.
- The recommissioning procedure must be strictly in accordance with the Operation,- Lubrication and Maintenance Manual.

### **2.1.8 SPECIAL SAFETY EQUIPMENT**

#### **SAFETY HARNESS IN CONFORMITY WITH EN 361 (EUROPEAN STANDARD)**

The safety harness should only be used together with connectors according to EN 354, and fall arrest according to EN 355, or fall protection devices according to EN 360.

**Refer to page page 29 in this section for more information.**

## **FALLING-OBJECT PROTECTIVE STRUCTURE "FOPS" FOR OPERATOR'S CAB.**

The Shovel must be equipped with a falling object protective structure "FOPS" if it is used for applications where there is a risk of falling material.

The "FOPS" structure shall comply with EN 474.

## **FRONT GUARD PROTECTIVE STRUCTURE "FGPS" FOR OPERATOR'S CAB**

The Shovel must be equipped with a front guard protective structure "FGPS" if it is used for applications where there is a risk of hitting objects from the front.

## **OBJECT HANDLING**

Object handling operations are not allowed. If the Shovel is used for object handling applications it must be equipped with the respective safety devices.

## **LIGHTING**

The Shovel must only be operated when the operator has sufficient visibility in relation to the work area. Disturbing shady areas or dazzling effects must be avoided.

If necessary, the Shovel must be retrofitted with lighting equipment (working lights) in order to ensure sufficient visibility conditions.

## **WARNING BEACON**

The Shovel can be retrofitted with a warning beacon which is fitted on the cab roof by means of a magnetic bracket.

## **NOTICE**

**The above-mentioned special safety devices can be ordered as accessories together with the Shovel.**

**They are also available as a field package for installation through our service organization.**

This page left intentionally blank

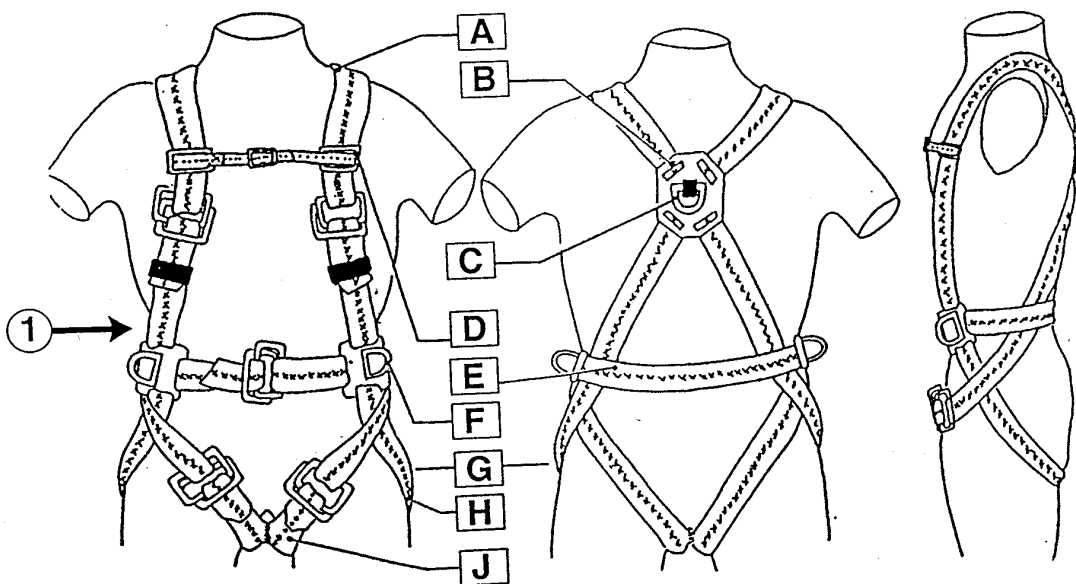
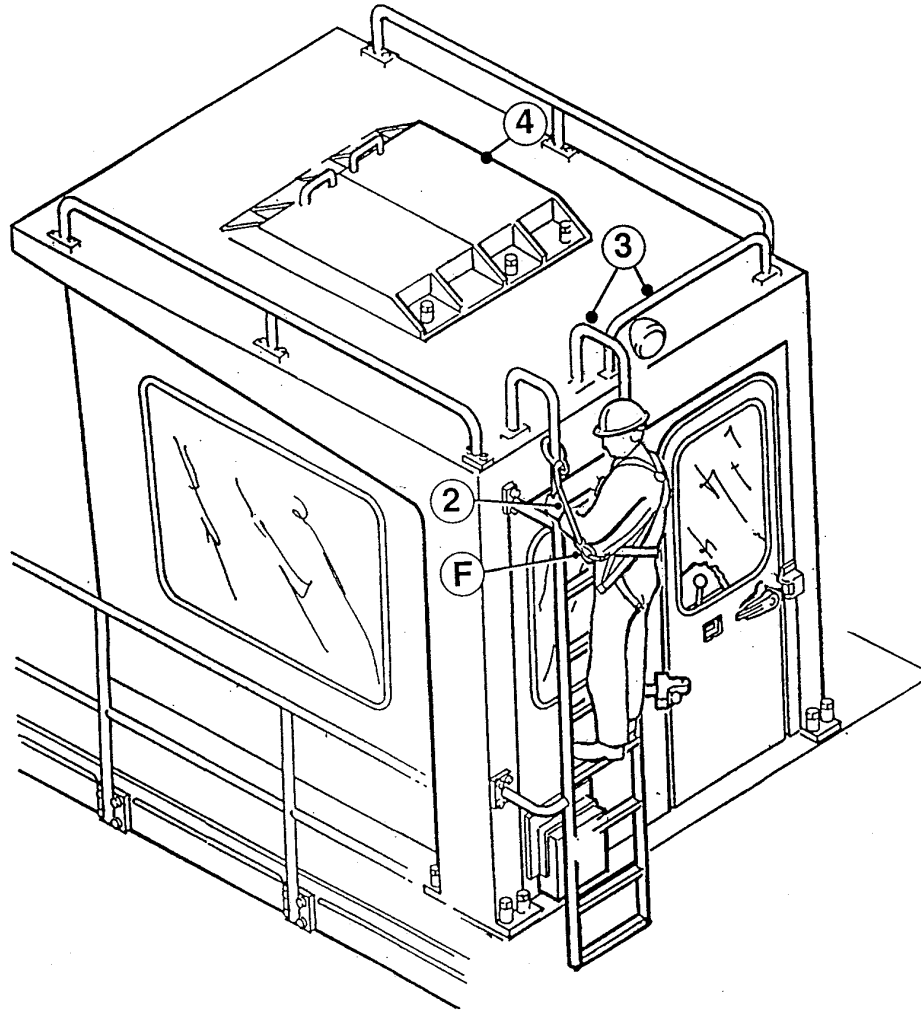

Z 20885

## 2.1.9 SAFETY HARNESS IN CONFORMITY WITH EN 361 (EUROPEAN STANDARD)

---

---

 **WARNING**

---

---

Always use the Safety Harness (1) in conjunction with strap type Fall Absorber (2), illust. (Z 20885) before mounting onto the loader attachment or other unsecured places of the Shovel.

---

---

### NOTICE

- The Safety Harness is located in the Cabinet of the Operator's Cab.
- The illustration (Z 20885) shows a typical use of the safety harness. Shovels with new type Operator's cab are not equipped with ladder (3), because the air conditioner unit of the new type cab is located on the back wall of the cab.

### Legend for illustration Z 20885

- (1) Safety Harness according to EN 361
- (2) Strap-Type Fall Absorber according to DIN EN 355
- (3) Ladder to cab roof and railings (attachment points)
- (4) Protection hoods for roof mounted air conditioning, if so equipped
- (A) Shoulder Strap
- (B) Back Plate
- (C) Catching Hook
- (D) Shoulder-Strap Fixing
- (E) Belly Strap
- (F) Holding Hook
- (G) Hold-Back Hook
- (H) Pelvis Strap
- (J) Leg Strap

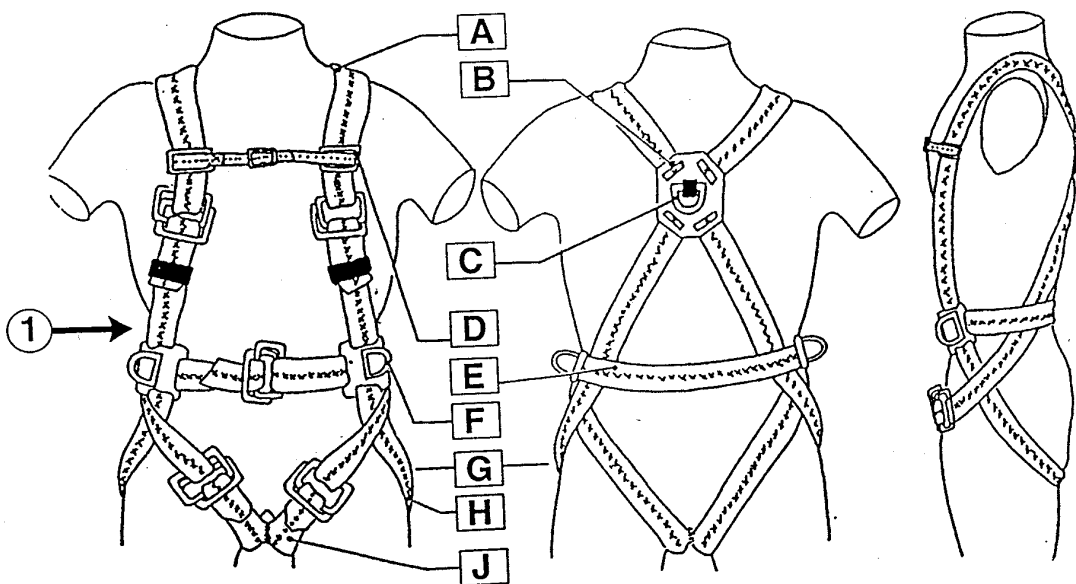
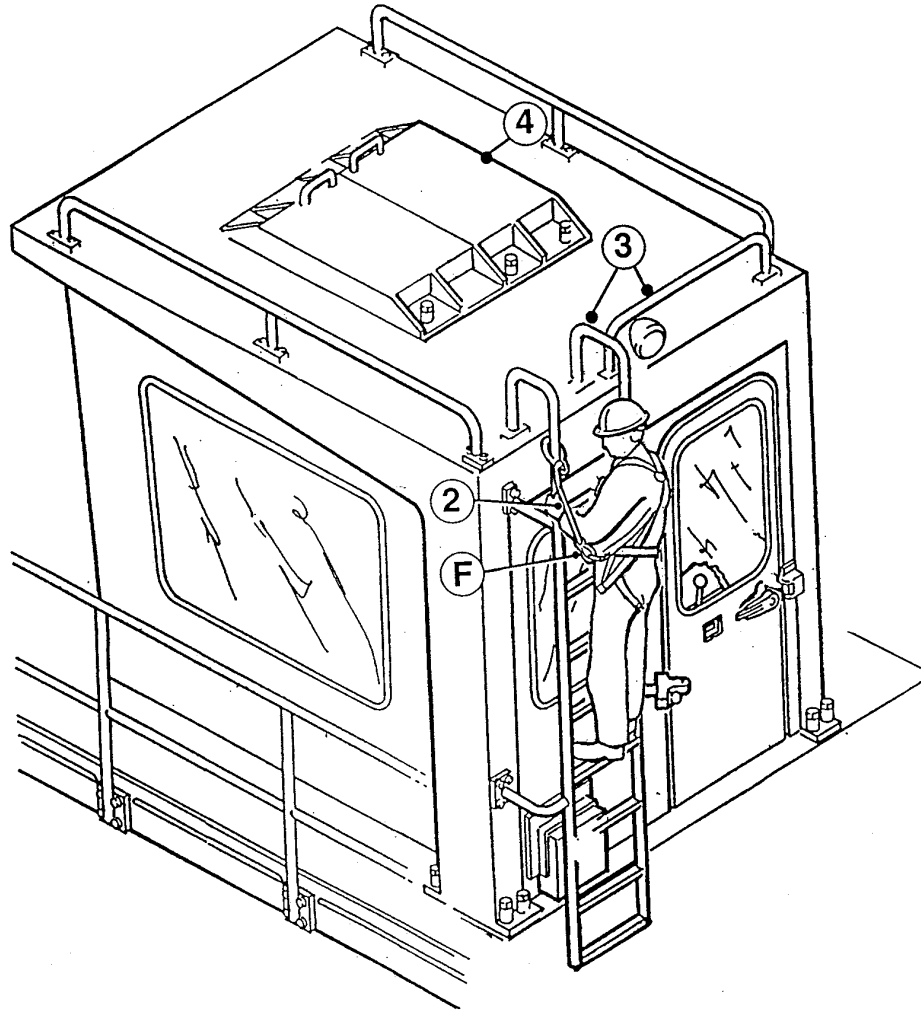

Z 20885

## INSTRUCTIONS FOR USE

Open the lock, lift the harness by the catch hook (C), the blue straps (leg straps J) are below. The harness is being put on just like a jacket. Pull the belly strap (E) through the lock, as shown on the illustration, and secure it.

By closing the breast strap, you avoid the shoulder straps to side-slip. Bring the leg straps (J) around the legs to the front, pull them in, as shown in the illustration, and tighten them. Adapt the harness to body form, seeing to perfect fit, in particular that the catching hook (C) be in the center of the back.

The safety harness should belong to its wearer personally.

The safety harness should only be used together with connectors acc. to EN 354, and fall arrest acc. to EN 355, or fall protection devices acc. to EN 360.

The attachment point for the safety harness should be above the wearer, and the carrying capacity of the attachment point should be sufficient to correspond with the minimum carrying capacity acc. to EN 795.

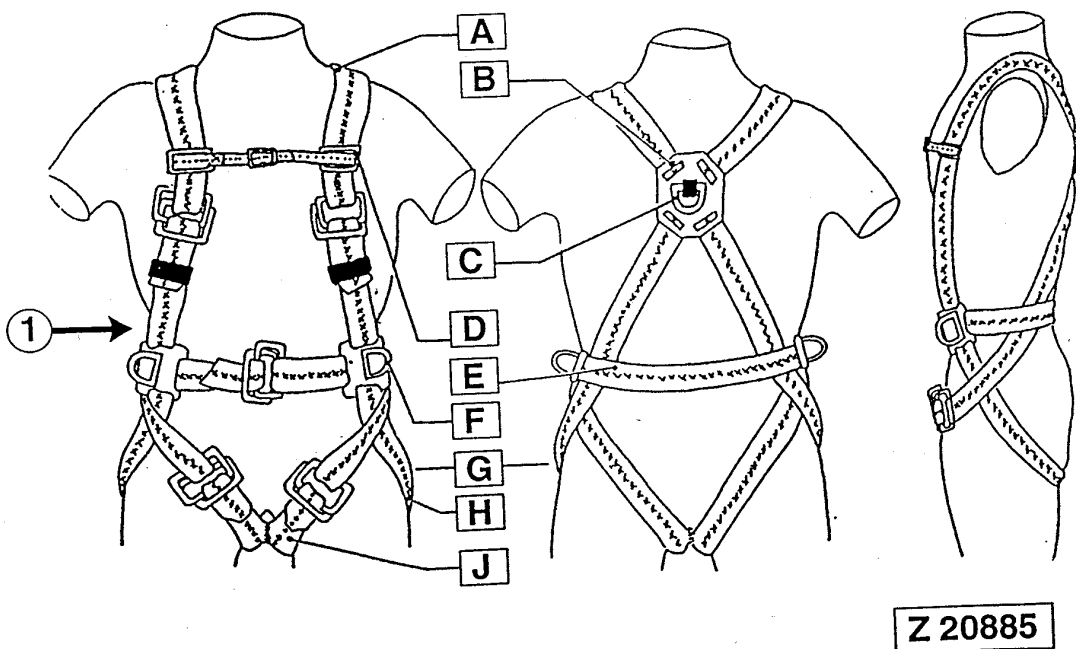
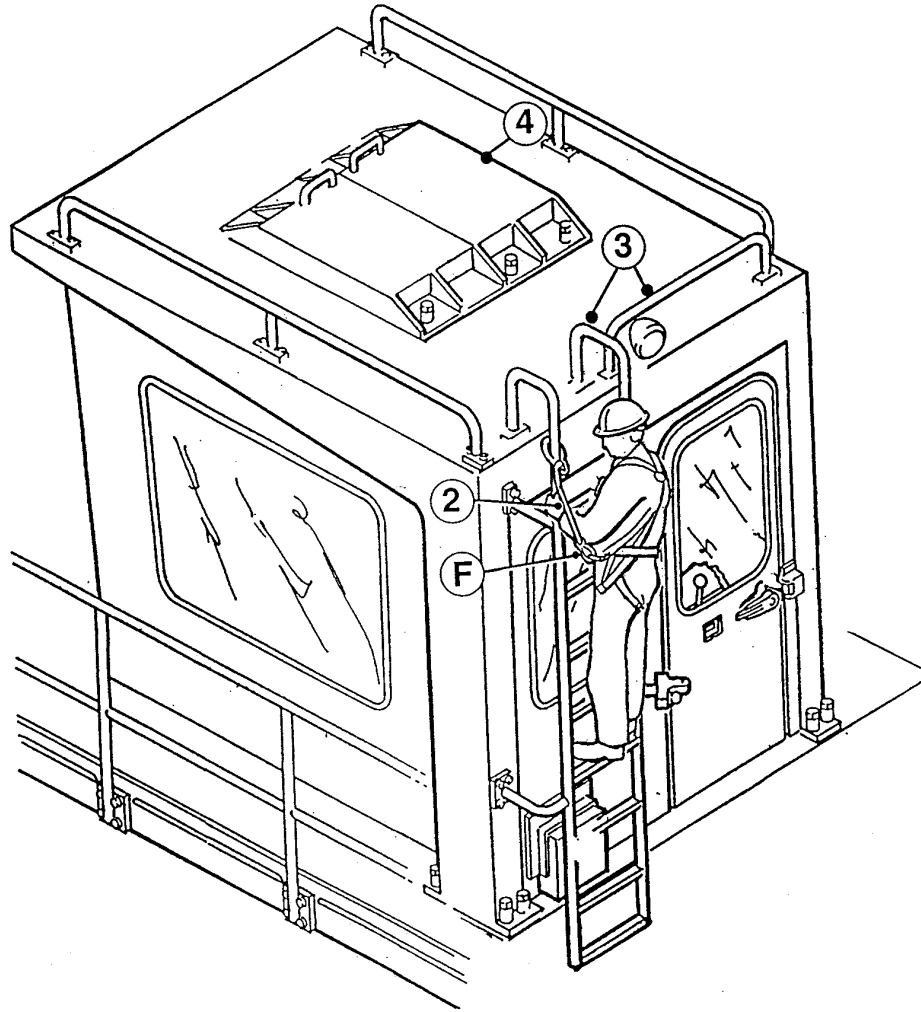

Z 20885



## **PRIOR TO USING THE HARNESS (1), THE WEARER SHALL**

- Carry out a visual check of the system or component; correct functioning and perfect working order have to be assured.
- Make sure that the recommendations for use with other components of the system be observed in conformity with the instructions for use.

The system or component must no longer be used, if there are any doubts in respect

of its safe condition. The equipment has to be inspected by the manufacturer or by a qualified person.

It is essential for safety reasons that a fall protection system or system component

which has already been subjected to fall be removed from service and sent back to the manufacturer or an authorized qualified repair shop for maintenance and renewed testing.

Fall protection systems have to be treated with care and to be kept clean and ready for use. It has to be warned against bringing the systems into contact with acids or other caustic liquids and gases, oils, detergents, or sharp-edged objects.

Should the harness have become wet during use or cleaning, do not dry near a fire or other sources of heat, but rather in a natural way in not too warm rooms. Keep the harness freely suspended or loosely rolled up.

When using the fall protection systems, the pertaining safety regulations in force and the "Rules for Use of Personal Fall Arrest Systems" have to be observed for protection against danger.

At least every 12 months, the safety harness and its components have to be inspected by a competent person authorized by the manufacturer and maintained, if the manufacturer considers it necessary.

## **RECOMMENDATIONS FOR USE OF THE HOLDING HOOKS AND HOLD-BACK HOOKS OF THE SAFETY HARNESS (1),**

During the holding function, the connectors may only be placed around a mast or other construction between the two holding hooks, so that free fall is limited to max.0.5 m.

It should be strictly seen to it that the connector be not slung around constructions with too small diameter or sharp edges.

With the lateral holding hooks, work may only be carried out on horizontal or almost horizontal surfaces (roofs). The connectors have to be adjusted in such a way that the area, where danger of falling down prevails, cannot be reached.

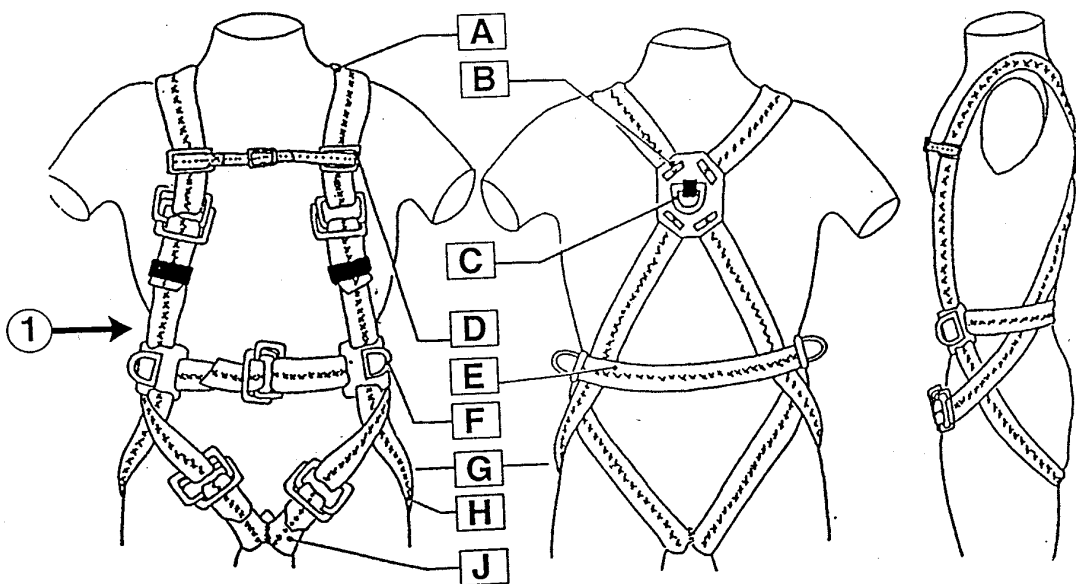
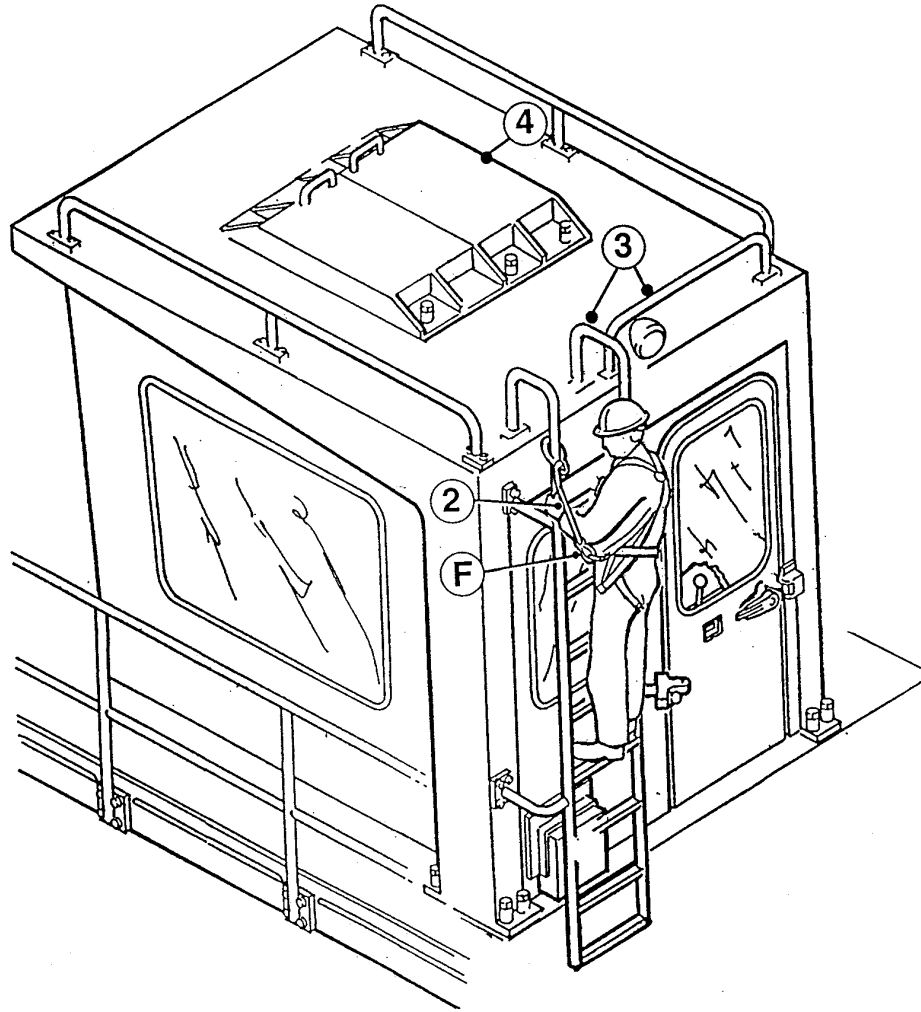

Z 20885

## INSTRUCTIONS FOR USE

Strap-Type Fall Absorber acc. to DIN EN 355 (Type E.K.N.-BFD)

### Use

Within a fall-arrest system, the strap-type fall absorber (2) has to be used in conjunction with a safety harness (1) acc. to DIN EN 361. The maximum length including the safety rope must not exceed 2.0 m. For longer ropes, a rope-shortening device has to be applied in addition.

Fix the rope to the attachment point and attach the strap-type fall absorber to the catching hook in the back of the safety harness. The attachment point should be above the wearer and its minimum carrying capacity should be 10 KN, acc. to DIN EN 795.

The strap-type fall absorber and the safety rope must not be damaged, e.g. never pull

them over sharp edges nor get them burnt by welding sparks.

### Storing and maintenance

The strap-type fall absorber has to be kept dry in an airy and shady room. It must not be exposed to acids, caustic chemicals, nor to an aggressive atmosphere, and contact with oils has to be avoided. If the strap-type fall absorber is dirty, it may be cleaned with a little water and a light-duty detergent. Dry it in a shady place (nowhere near fire or other sources of heat). Protect it from sharp-edged objects.

### Inspection

Prior to use, all parts have to be inspected for safe condition and damages. At least once a year, the strap-type fall absorber has to be tested by a competent person. A damaged or used strap-type fall absorber has to be removed from service immediately. The strap-type fall absorber must not be changed in any way. Repair work has to be done by the



# **3. OPERATION**

## 3.1 FOREWORD

This Operation Manual contains the instructions for correct operation of your KOMATSU Shovel. It should always be ready for use in the Operator's cab.

---

---

**⚠ WARNING**

---

---

**The information in this manual does not replace any safety rules or laws used in your area.**

---

---

Special safety regulations are given in the rules for the prevention of accidents. It is your responsibility to observe these rules.

**Carefully read the Safety Instructions → See "SAFETY" on page 15.**

Before operating the machine, familiarize yourself with its instruments and controls.

Observe the instructions in this manual for:

- your Personal SAFETY
- Operating SAFETY, and
- READY and EFFICIENT PERFORMANCE of your KOMATSU Shovel.

---

---

**⚠ WARNING**

---

---

**Improper operation of this machine can cause injury or death.**

---

---

### NOTICE

**Optional equipment and accessories are available. Disregard the instructions for equipment not on your Shovel.**

## 3.2 CONSTRUCTION OF THE SHOVEL

### 3.2.1 OVERALL VIEW

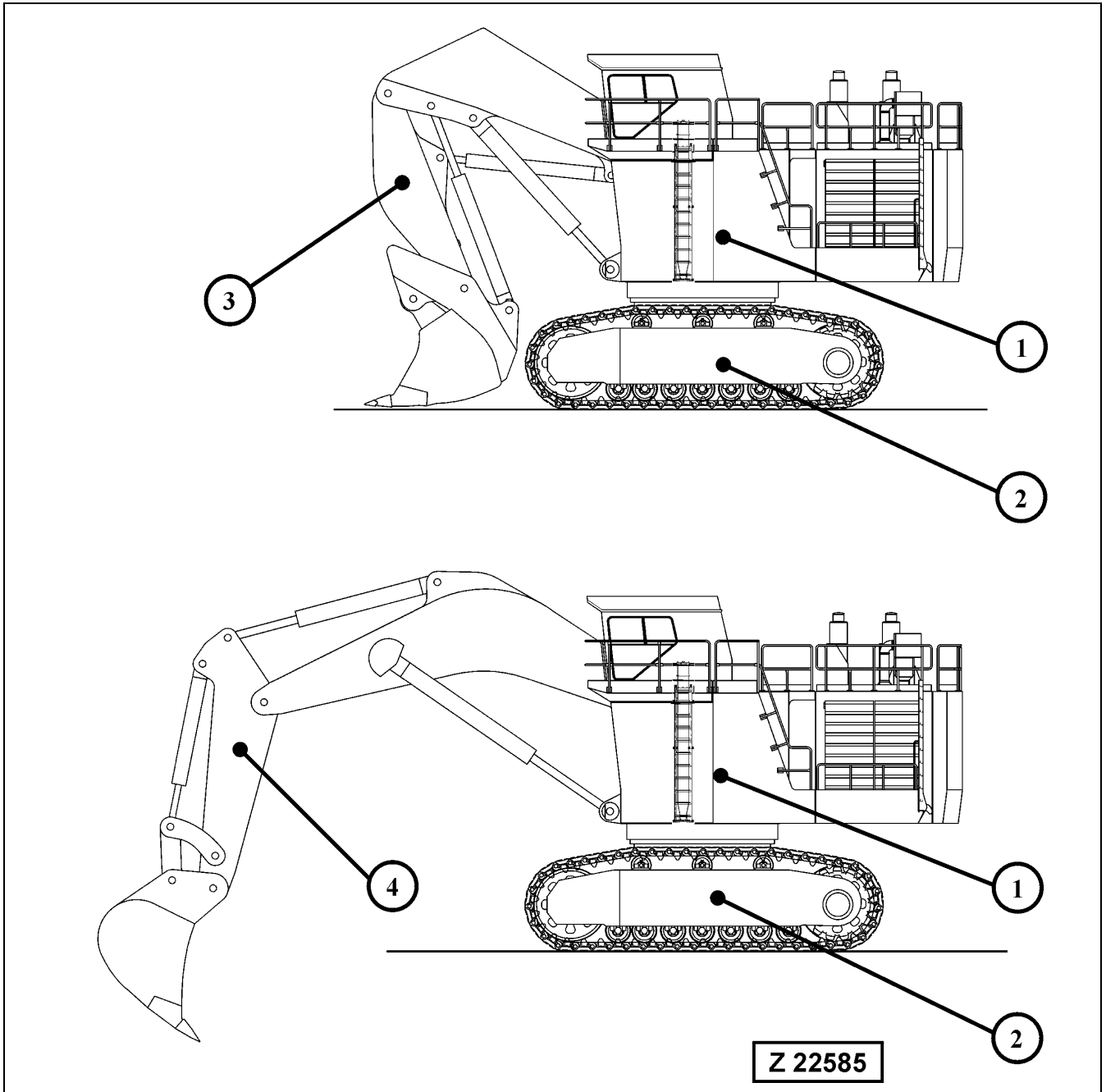

#### Legend for illustration Z 22585

- (1) Superstructure
- (2) Undercarriage
- (3) Bottom dump bucket attachment
- (4) Backhoe attachment

### 3.2.2 SUPERSTRUCTURE

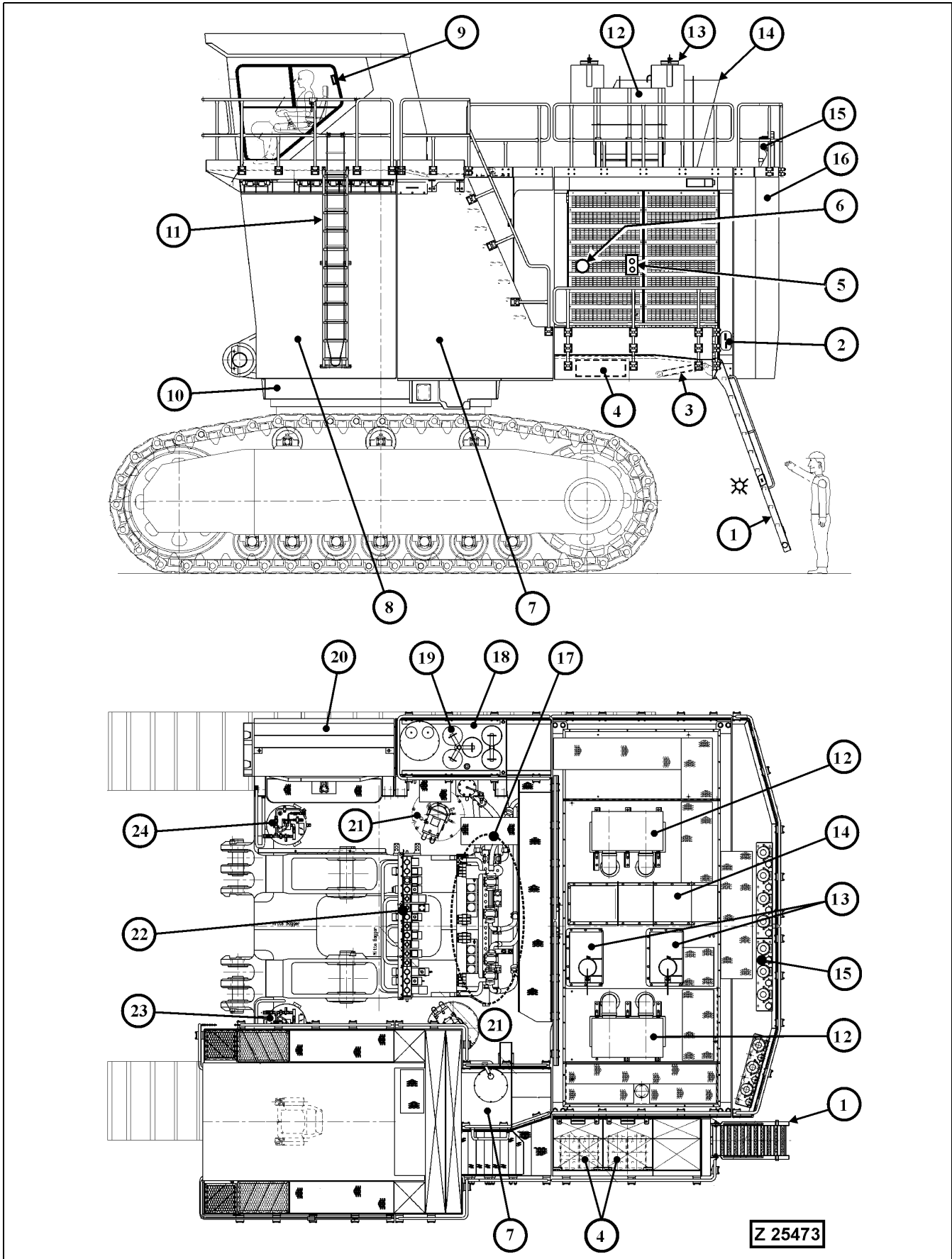



**Legend for illustration Z25473**

(1) Hydraulically operated access ladder, see page 50 for more information.

(2) Battery main switches

**NOTICE**

**After switching OFF the main key switch in the Operator's cab, wait at least 3 minutes before switching OFF the battery main switches. The Vehicle Health Monitoring System (VHMS) needs this period for saving data. If batteries are switched OFF before this time period is over, data will be lost.**

(3) Lift cylinder for access ladder

(4) Location of batteries below the catwalk

(5) Control switch for access ladder

(6) Emergency engine shut down switch

=====  **CAUTION** =====

**Never stop the engine from a full load except in case of emergency.**

**If a hot engine is shut down without previous idling period of three to five minutes, the temperature in certain engine parts rising sharply after the cooling system ceases to function. The resulting thermal stress, especially in the turbochargers, may cause serious damage.**

=====

(7) Fuel tank

(8) Cab base, contains the electronic components of the VHMS system and the electrical switch boards.

(9) Sliding window of operator's cab, see page 54 for more information

(10) Swing circle guard

(11) Emergency escape ladder, see page 54 for more information.

(12) Engine air cleaners

(13) Exhaust mufflers

(14) Air duct

(15) Extinguishing agent tank assemblies, only on machines equipped with a fire detection, actuation and suppression system.

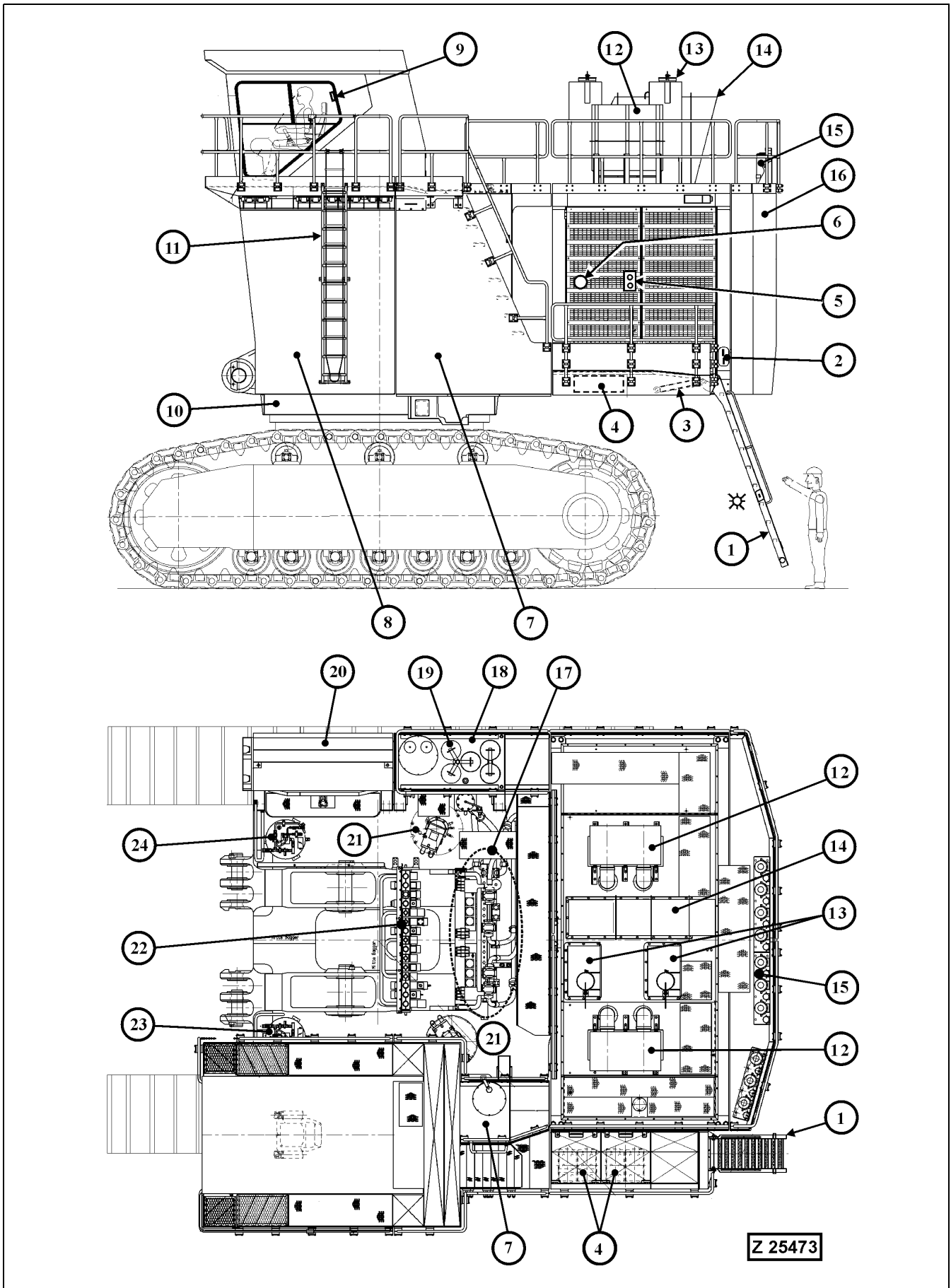

**Legend for illustration Z25473 (continued)**

- (16) Counter weight

**▲ WARNING**

**The chambers of the counterweight are filled with a mixture of concrete, granulated ore and steel pellets. This mixture can create explosive gases which will accumulate in the chambers of the counterweight. Before any welding, flame-cutting, grinding or drilling procedures are carried out on the counterweight it is vital to expel these gases from the counterweight chambers. Failure to properly expel the gases from the counterweight chambers can result in an explosion with serious personal injury or death. Follow the instructions given in PARTS & SERVICE NEWS No. AH04518 for expelling the gases from the counterweight chambers.**

- (17) Main control valves with high pressure in-line filters
- (18) Hydraulic oil reservoir
- (19) Return oil filters
- (20) Hydraulic oil cooler
- (21) Swing machinery
- (22) Distributor manifold
- (23) Swing circle pinion Lubrication System (SLS)
- (24) Central Lubrication System (CLS)

### Machinery House

### View A

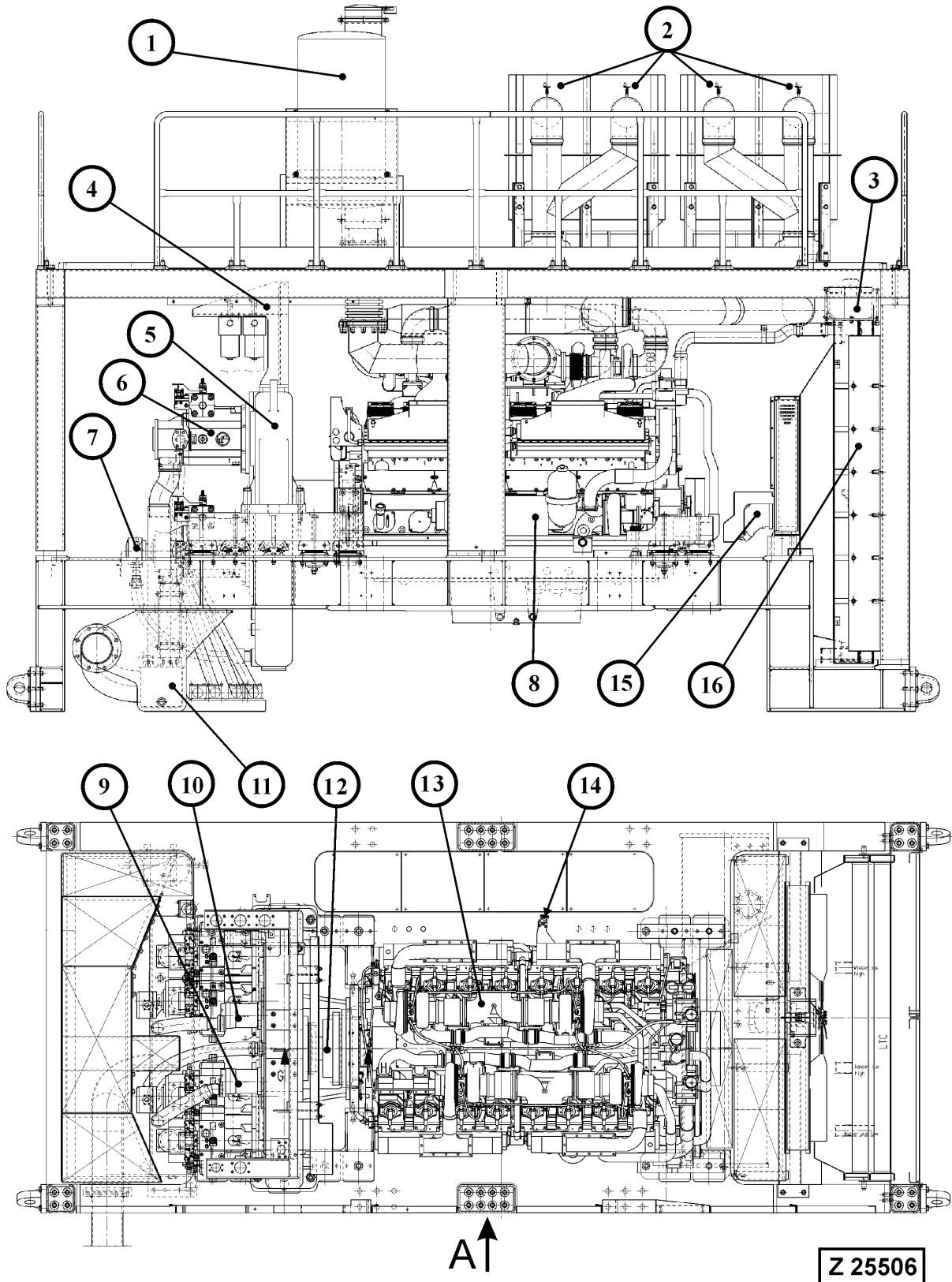

**Legend for illustration Z25506**

- (2) Engine air cleaners
- (1) Exhaust muffler
- (3) Expansion tank for radiator
- (4) Central control and filter carrier
- (5) Pump distributor gear (PTO)
- (6) Main hydraulic pumps
- (7) Auxiliary piggyback hydraulic pumps
- (8) Eliminator filter
- (9) Hydraulic pump for radiator fan drive
- (10) Hydraulic pump for hydraulic oil cooler fan drive
- (11) Suction oil reservoir
- (12) Flexible coupling, oil filled
- (13) Diesel engine
- (14) Engine oil filler tube
- (15) Hydraulic motor for radiator fan drive
- (16) Coolant radiator

Main Hydraulic Oil Reservoir

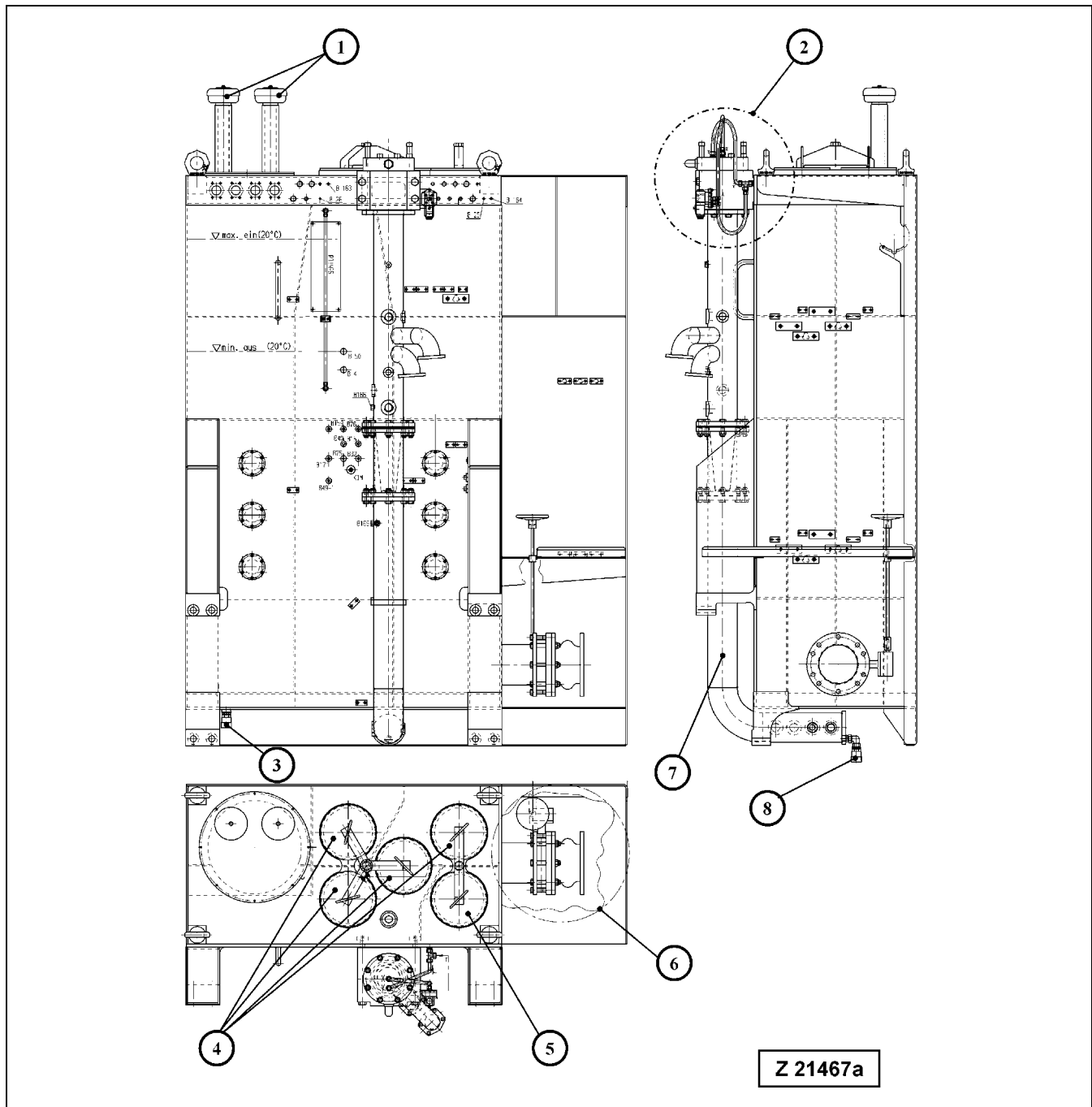

Legend for illust. Z 21467a

- |   |                                      |
|---|--------------------------------------|
| (1) Breather filter                             | (5) Leakage oil filter               |
| (2) Back-pressure valve, temperature controlled | (6) Main shut-off slider             |
| (3) Drain coupling, main oil reservoir          | (7) Collector pipe for return oil    |
| (4) Return oil filters                          | (8) Drain coupling on collector pipe |

**Hydraulic Oil Cooler**

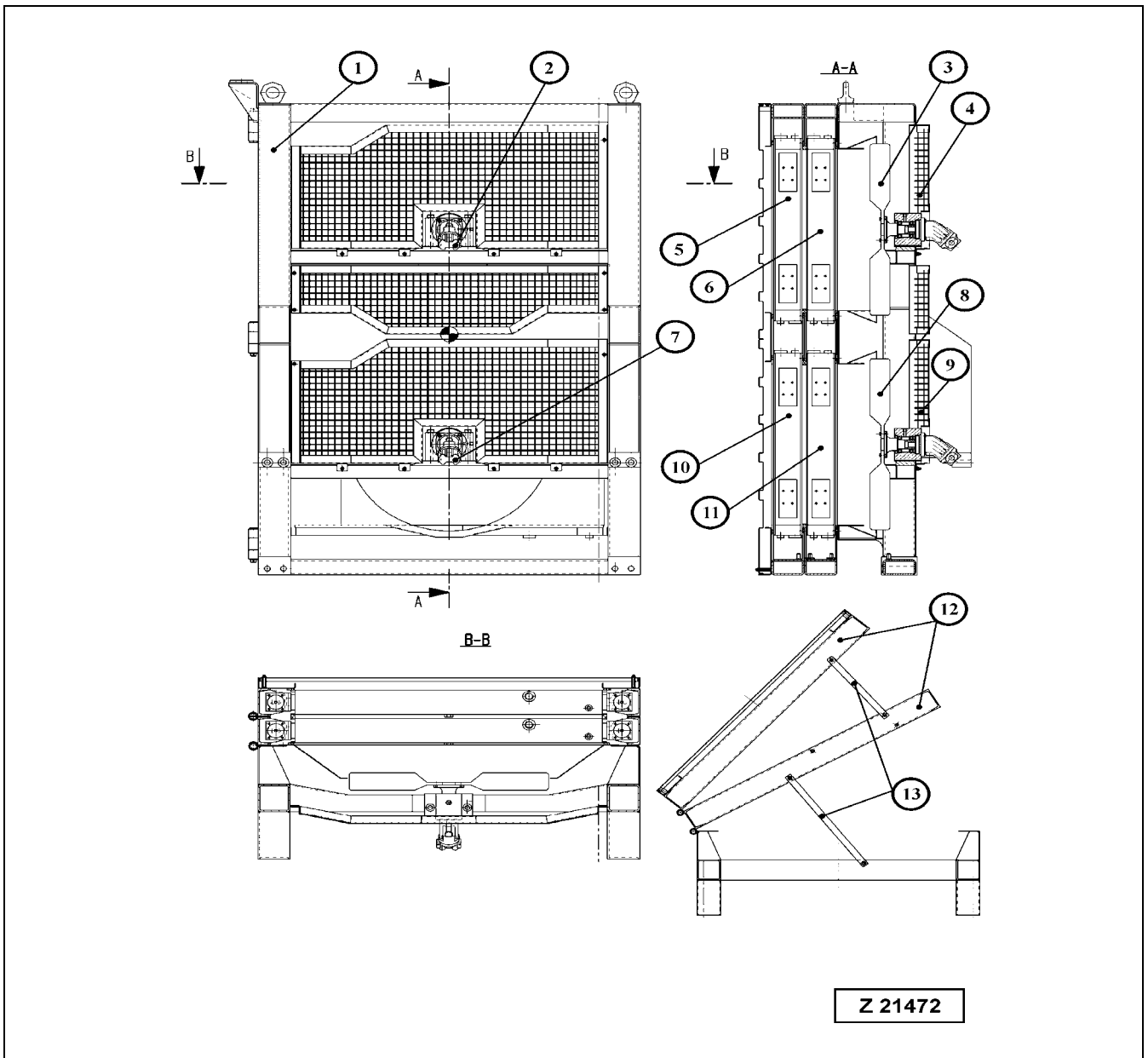

**Legend for illust. Z 21472**

- |     |                               |      |                                 |
|-----|-------------------------------|------|---------------------------------|
| (1) | Cooler frame                  | (8)  | Lower fan                       |
| (2) | Hydraulic motor for upper fan | (9)  | Fan guard                       |
| (3) | Upper fan                     | (10) | Front section of lower cooler   |
| (4) | Fan guard                     | (11) | Rear section of lower cooler    |
| (5) | Front section of upper cooler | (12) | Hinged cooler carriers          |
| (6) | Rear section of upper cooler  | (13) | Locking rods for cooler carrier |
| (7) | Hydraulic motor for lower fan |      |                                 |

**Fuel Tank**

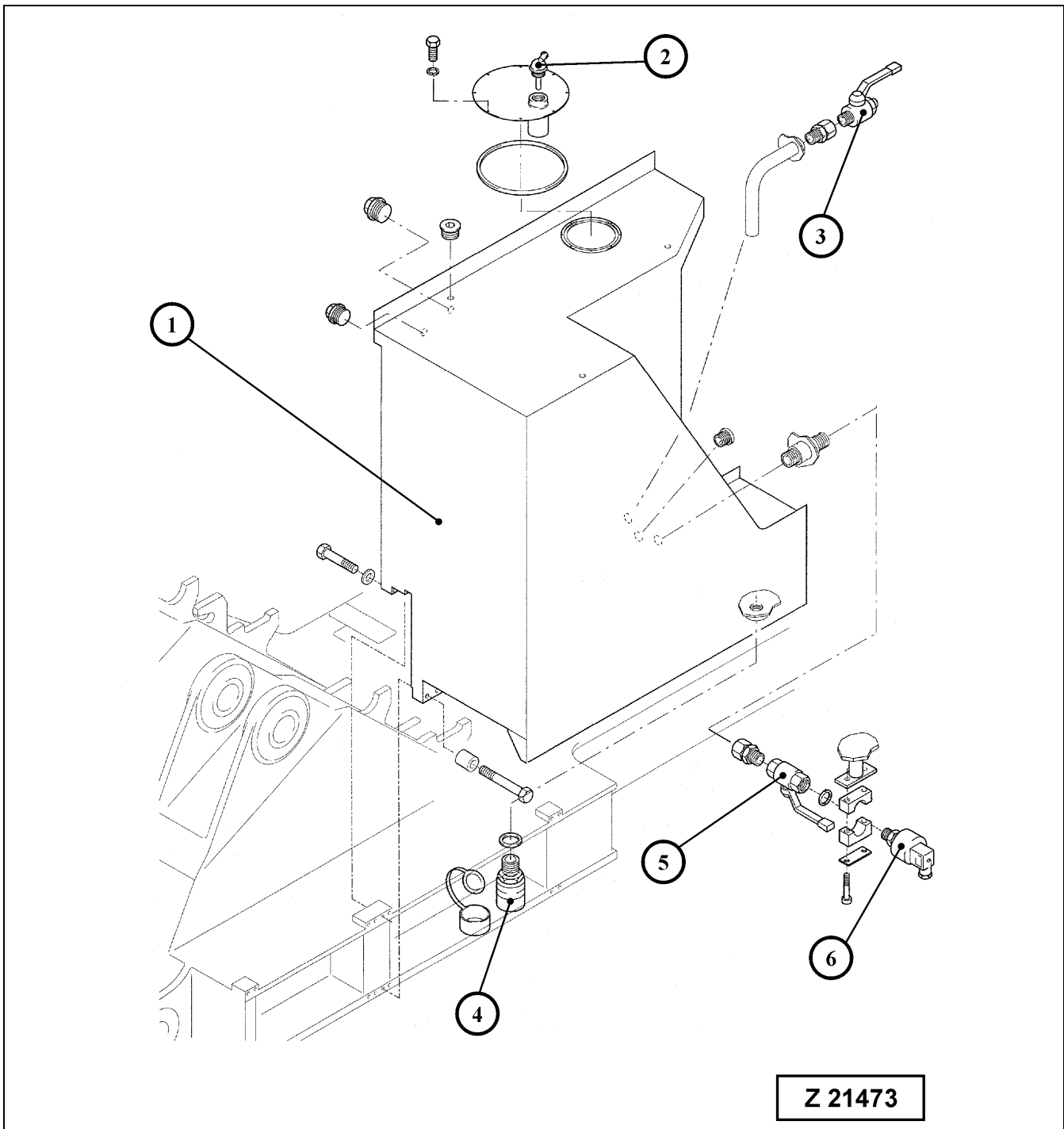

**Legend for illust. Z 21473**

- |     |                    |     |                                       |
|-----|--------------------|-----|---------------------------------------|
| (1) | Fuel tank          | (4) | Drain coupling                        |
| (2) | Breather valve     | (5) | Shut-off cock for pressure transducer |
| (3) | Fuel shut-off cock | (7) | Pressure transducer for fuel level    |



**Counterweight**

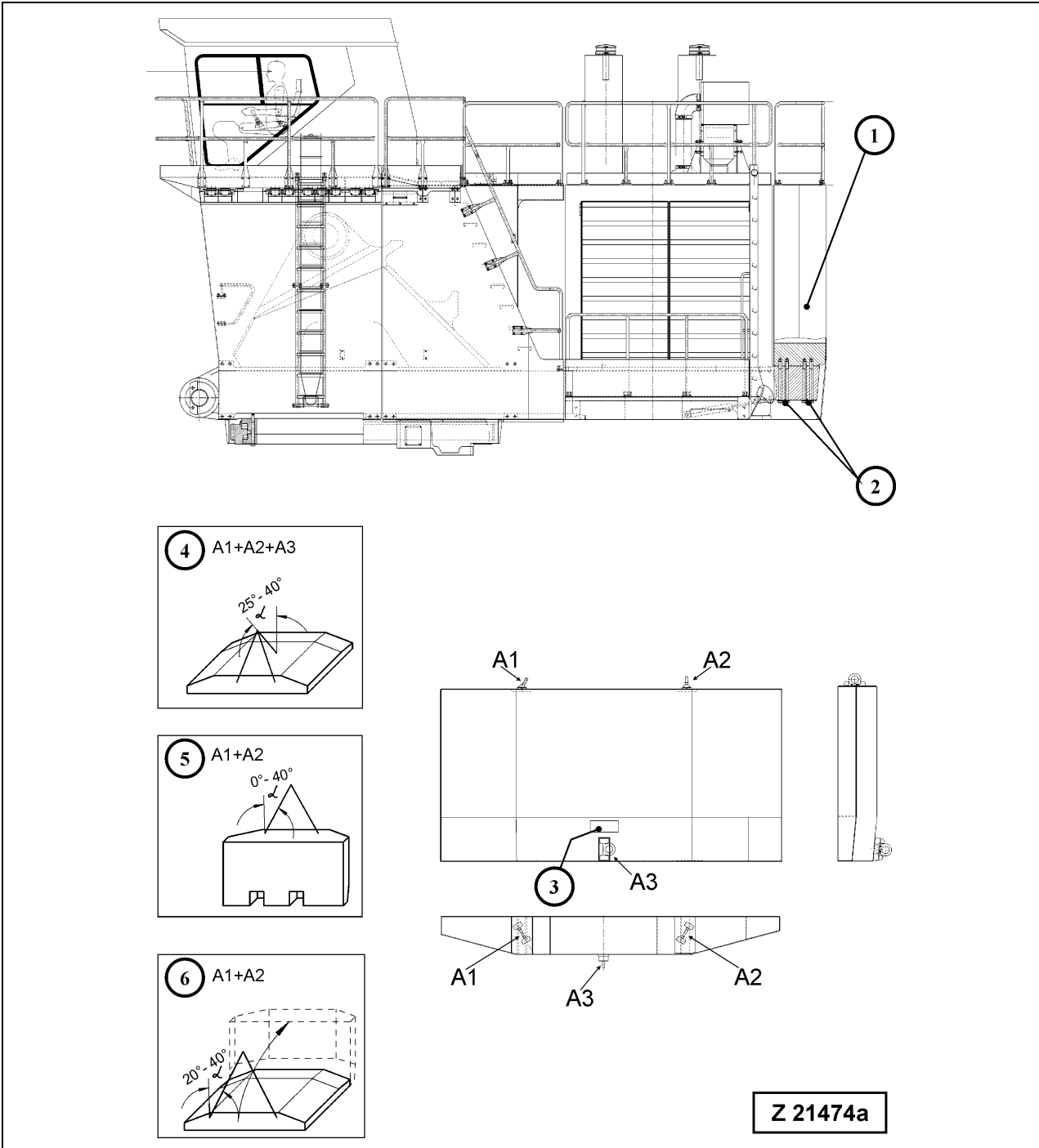

**Legend for illust. Z 21474a**

- |     |   |     |  |
|-----|---|-----|--|
| (1) | Counter weight, 37000 kg  | (4) | Fastening points for horizontal transport          |
| (2) | Mounting bolts, Qty 16, size M42, quality grade 10.9. Tightening torque 4950 Nm | (5) | Fastening points for vertical transport            |
| (3) | Instruction label   | (6) | Fastening points for raising up the counter weight |

### 3.2.3 HYDRAULICALLY OPERATED ACCESS LADDER

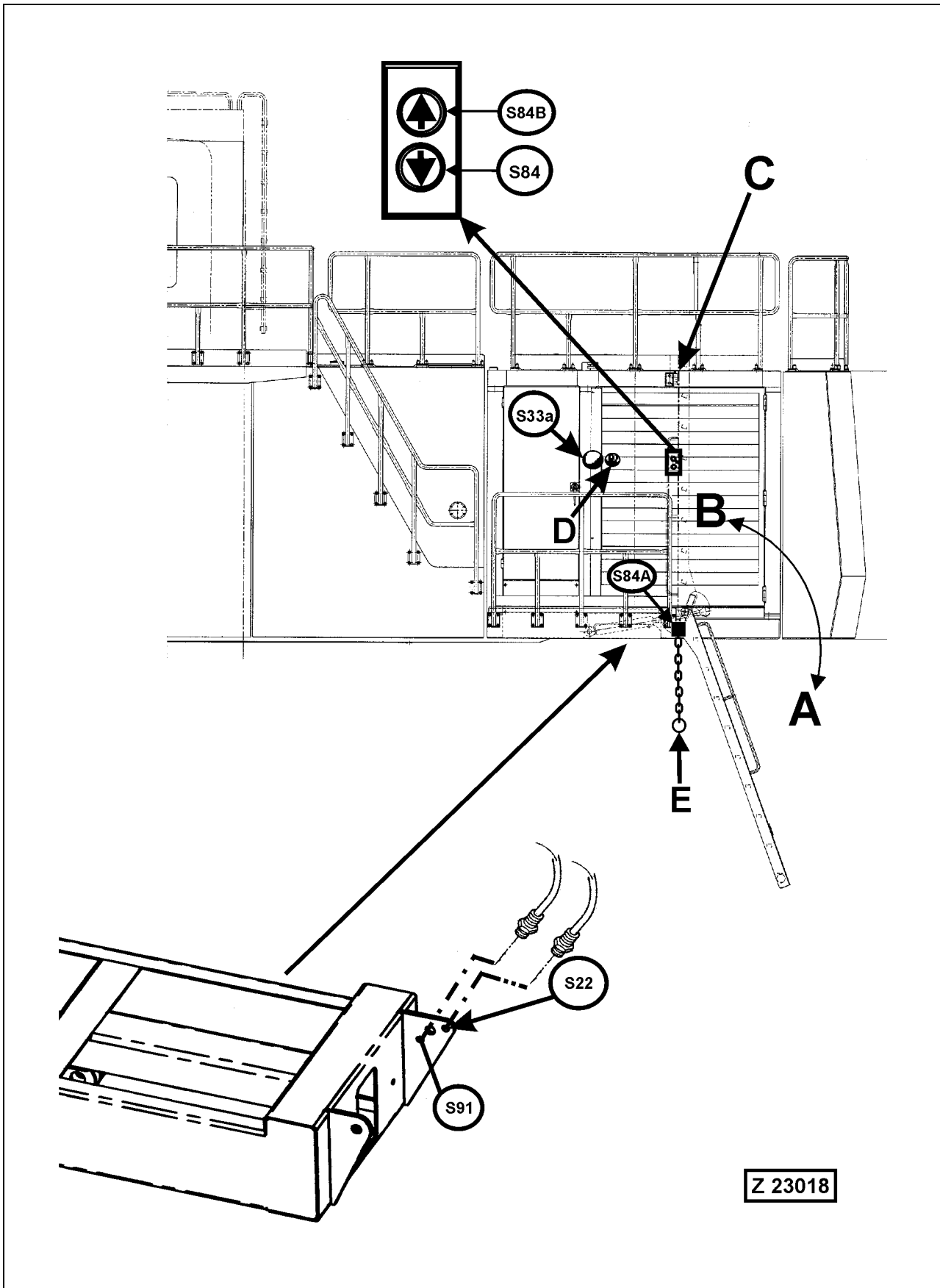

**Legend for illustration Z 23018**

- (A) Access ladder in lowered position
- (B) Access ladder in upper position (Working position)
- (C) Stop bar
- (D) Manual actuator for fire suppression system (if so equipped)
- (E) Pull chain for emergency lowering of the access ladder

**CAUTION**

**Use this chain only in emergency cases, when the Operator does not respond to other communication signals.**

- (S84) Ladder control switch for lowering the ladder
- (S84B) Ladder control switch for lifting the ladder
- (S84A) Safety switch for emergency lowering of the access ladder. When the chain (E) is being pulled down with the engine running, the pilot control system is made inoperative, preventing further movements of the Shovel.
- (S22) Safety sensor, located on ladder pivot bracket  
Function of sensor (S22): Cut out of the pilot control system and actuation of the hydraulic swing brake with the ladder in lowered position.
- (S91) Monitor and control sensor  
Function of sensor (S91):  
This sensor monitors the ladder position and controls the moving speed of the ladder. In case the sensor (S22) fails to function properly, the sensor (S91) prevents unintended movement of the ladder.
- (S33a) Emergency shutdown switch for engine

**Operating the hydraulic Access Ladder**

**WARNING**

- **Make sure the moving range of the ladder is clear of all persons before raising the ladder. Stop raising the ladder by releasing the control switch (S84B) if there are any obstacles within the moving range of the ladder.**
- **Mount the ladder only in completely lowered position. Entering the ladder in any other position can result in serious injury or death.**
- **DO NOT lift persons with the hydraulic access ladder. Death or serious injury can result.**
- **DO NOT lift objects (tools) with the hydraulic access ladder.**

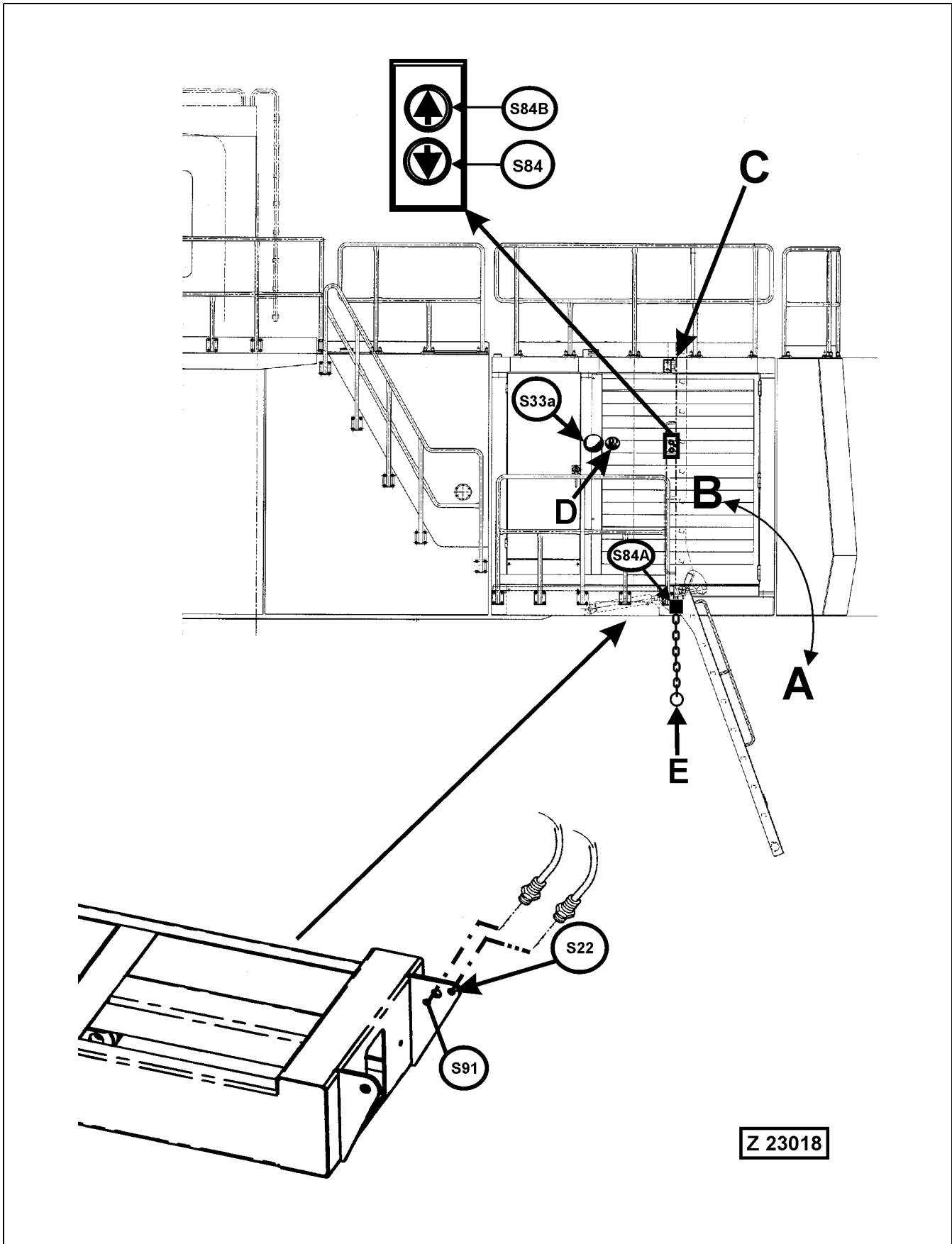

**Operating the hydraulic Access Ladder, illust. (Z 23018)****Raise the ladder**

Enter the Shovel with ladder in fully lowered position (A).

Start the engine.

**For starting procedure → See "STARTING THE ENGINE" on page 160.**

Go back to the ladder control switch (S84B) at the radiator door.

Raise the ladder by pressing button (S84B) until the ladder contacts the stop bar (C) in position (B).

**Lowering the ladder**

Stop the engine.

**For stopping procedure → See "STOPPING THE ENGINE" on page 190.**

Lower the ladder by pressing push button (S84). If necessary, slightly push the ladder until it starts moving down by its own weight.

---

---

**⚠ WARNING**

---

---

- **Make sure the moving range of the ladder is clear of all persons before lowering the ladder.**
  - **Enter the ladder only after the ladder is in fully lowered position (A).**
- 
- 

**NOTICE**

**Check safety sensor of access ladder for correct function after every 50 operating hours or once a week. Refer to Maintenance Section 4, for checking procedure.**

### 3.2.4 EMERGENCY ESCAPE LADDER

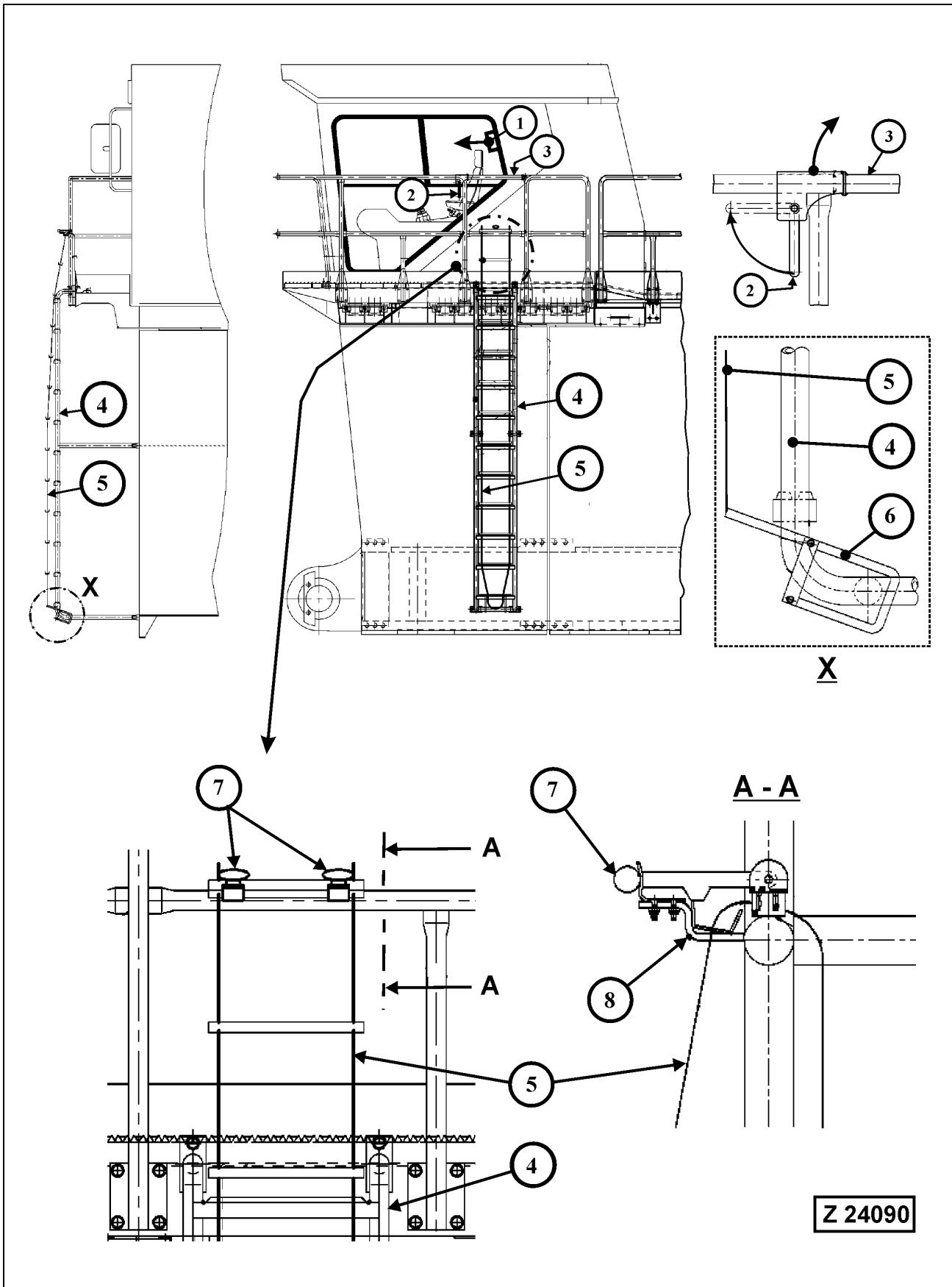

**Legend for illust. Z24090**

- (1) Sliding window, serves also for emergency exit
- REMARK**  
If the operator's cab is equipped with external metal sun visors, disengage the four catches and push out the sun visor panel.
- (2) Release lever for hinged railing bar (3)
- (3) Hinged railing bar
- (4) Rigidly mounted emergency escape ladder. The rigidly mounted emergency escape ladder with rope ladder extension provides the means to go down to the ground.
- (5) Rope ladder. The upper end of the rope ladder is fixed onto the lower rung of the rigid escape ladder (4) by means of the fasteners (6), see detail (X). The lower end of the rope ladder is fixed on brackets (8) and secured with rubber fasteners (7), see section (A-A).
- (6) Hooks for fastening the rope ladder onto the rigid ladder (4)
- (7) Rubber fasteners for rope ladder in lifted position
- (8) Bracket for rope ladder in lifted position. The lower rung of the rope ladder is hooked up into the brackets (8)

**Using the emergency escape ladder**

In case of emergency with normal walkways obstructed use escape ladder (4) and (5) for leaving the machine. Proceed as follows:

1. Move up lever (2) and pull out.
2. Open the hinged railing bar (3).
3. Unhook fasteners (7) and take out rope ladder rung from brackets (8).
4. Let the rope ladder fall down to the ground. The upper end of the rope ladder is fixed onto the lower rung of the rigid ladder (4).
5. Use the rigid ladder (4) and then the rope ladder (5) for leaving the shovel.

### 3.2.5 EMERGENCY ENGINE SHUTDOWN FROM GROUND MAN OR OPERATOR WARNING SYSTEM

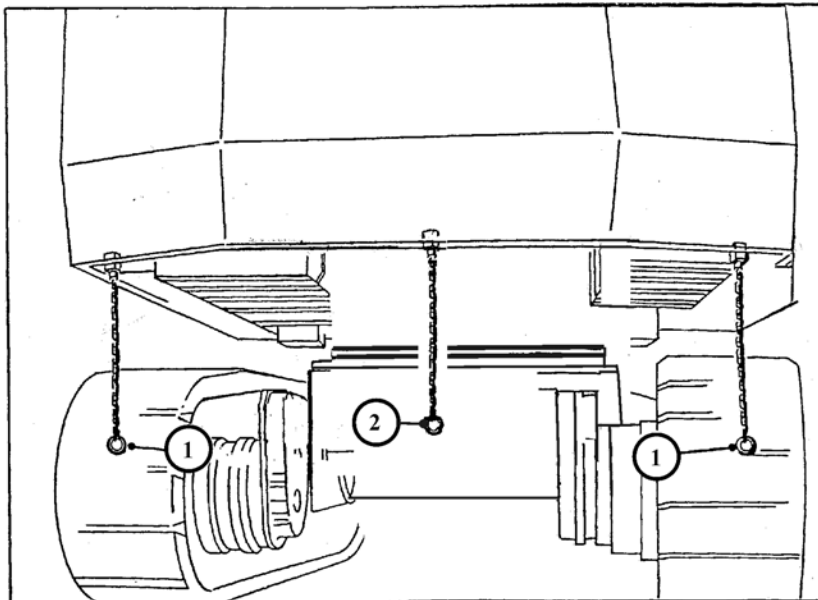
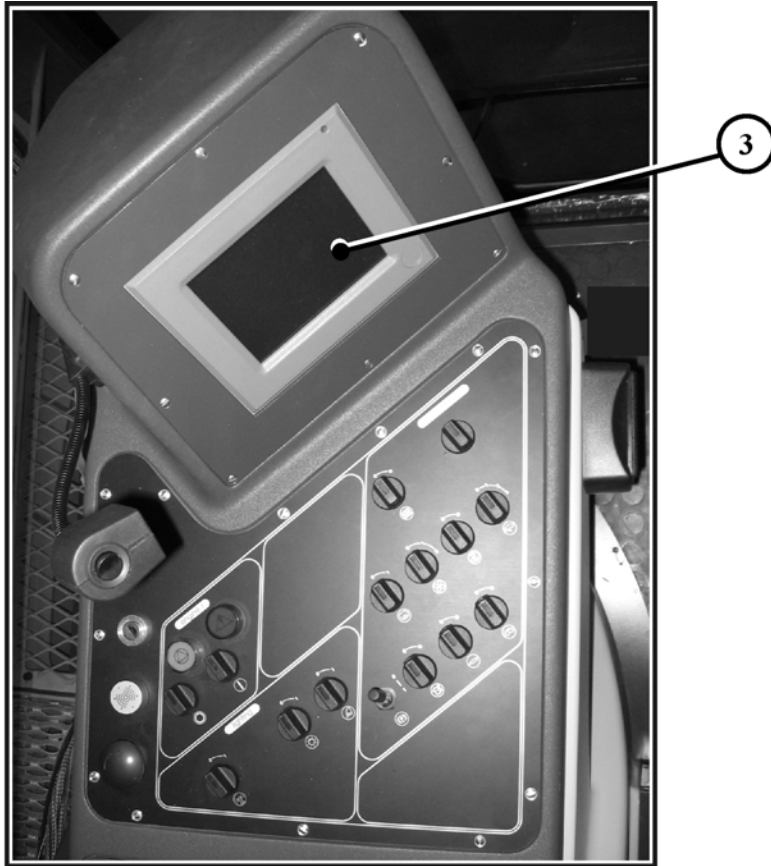

Z 25443



## Emergency Engine Shutdown System actuated from Ground Man (special equipment)

### Legend for illust. Z25443

- (1) Actuating chains for emergency shut down of the engine. To stop the engine, pull down one of the chains (1).
- (2) Actuating chain for hydraulically operated service arm.
- (3) Health monitor on the instrument panel in the Operator's cab. When one of the chains (1) is being pulled down from ground man, the engine will be stopped and the following message will be displayed on the health monitor (3):  
**Engine shut down has been actuated from ground man.**

---

---

**▲ CAUTION**

---

---

**Never stop the engine from a full load except in case of emergency.**

**If a hot engine is shut down without previous idling period of three to five minutes, the temperature in certain engine parts rising sharply after the cooling system ceases to function. The resulting thermal stress, especially in the turbochargers, may cause serious damage.**

---

---

## Operator Warning System (special equipment)

This system is used to inform the Operator that someone wants to enter the Shovel or to draw the Operator's attention to special circumstances requiring his action.

### Legend for illust. Z25443

- (1) Actuating chains for pull switches of the Operator warning system
- (2) Actuating chain for hydraulically operated service arm.
- (3) Health monitor on the instrument panel in the Operator's cab. When one of the chains (1) is being pulled down the following message will be displayed on the health monitor (3):  
**Warning: Pull switch from ground man actuated.**

As soon as a chain (1) is being pulled down, the above message will be displayed informing the Operator that someone wants his attention. In such a case, the Operator should stop work until he has received the ground man's request.

### 3.2.6 OPERATOR'S CAB WITH INTEGRATED FALLING OBJECT PROTECTIVE STRUCTURE (FOPS)

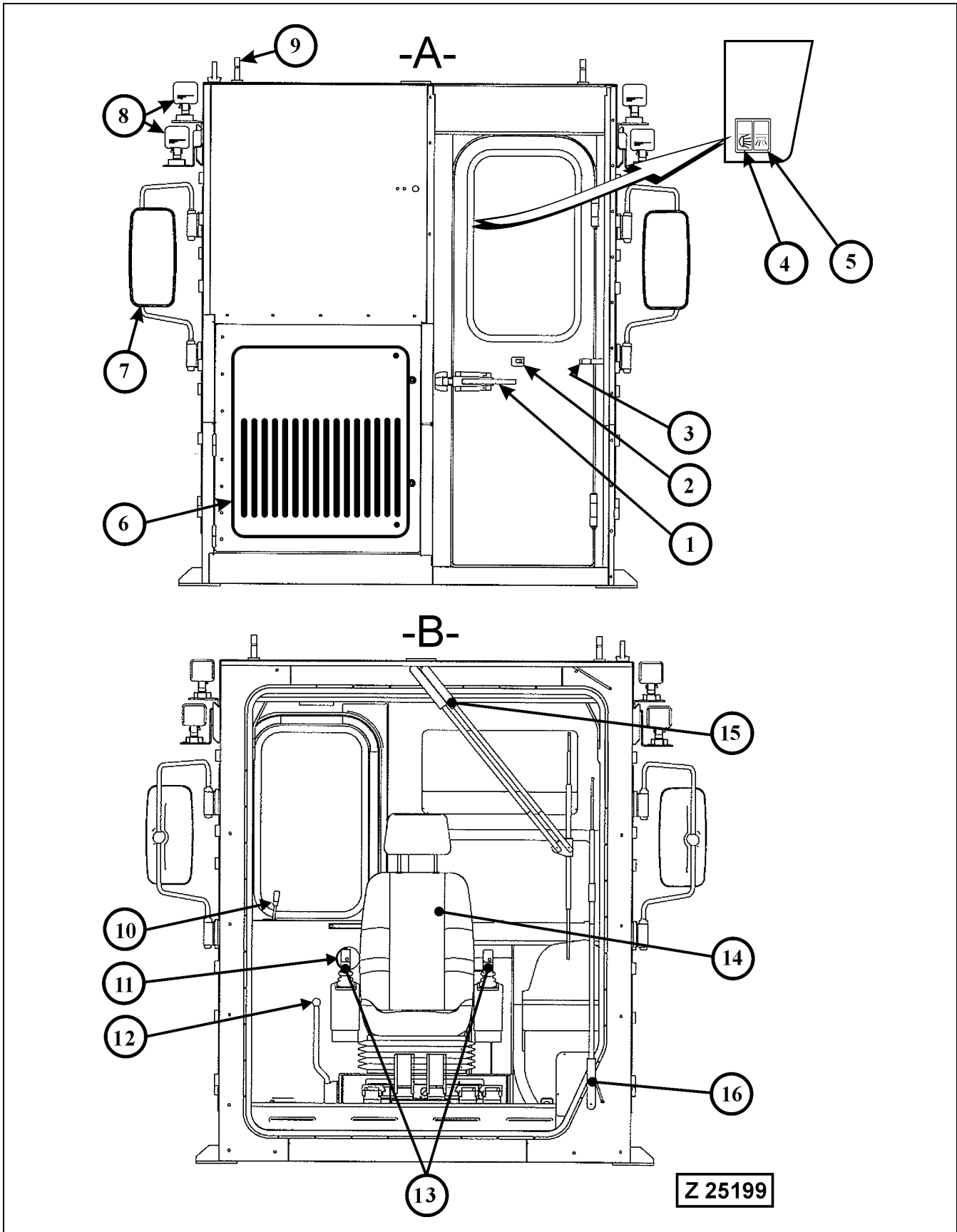

**Legend for illust. Z 25199****NOTICE**

The Operator's cab is equipped with an integrated Falling Object Protective Structure (FOPS) that meets the requirements of ISO 3449. Any modifications on the steel structure of the cab are inadmissible. Repairs on the FOPS must only be carried out by specialists having the authorization for repair work on Falling Object Protective Structures and in accordance with the manufacturer's repair instructions.

**A Rear View of Operator's Cab**

- (1) Door handle
- (2) Door latch (with door fully opened)
- (3) Door locking pin, engages into latch (2) when the cab door is fully opened.
- (4) Light switch for access area lighting
- (5) Light switch for interior cab lighting
- (6) Air conditioner door
- (7) Outside Mirrors with integrated heaters, both mirrors are adjusted electrically via a control switch on the instrument panel. Refer to page 87 for more information.
- (8) Main Working Lights
- (9) Adapter for Warning Beacon

**B Front View of Operator's Cab**

- (10) Release lever for door lock (2 - 3)
- (11) Door opener push button
- (12) Safety lock lever, see page 61 for more information
- (13) Control levers for working attachment, see page 78 for more information.
- (14) Operator's Seat, refer to page page 67 for more information.
- (15) Upper windshield wiper
- (16) Lower windshield wiper

**CAUTION**

**Make sure the cab door is always closed when working with the Shovel.**

**Lock the door in open position by engaging latch (2) into locking pin (3).**

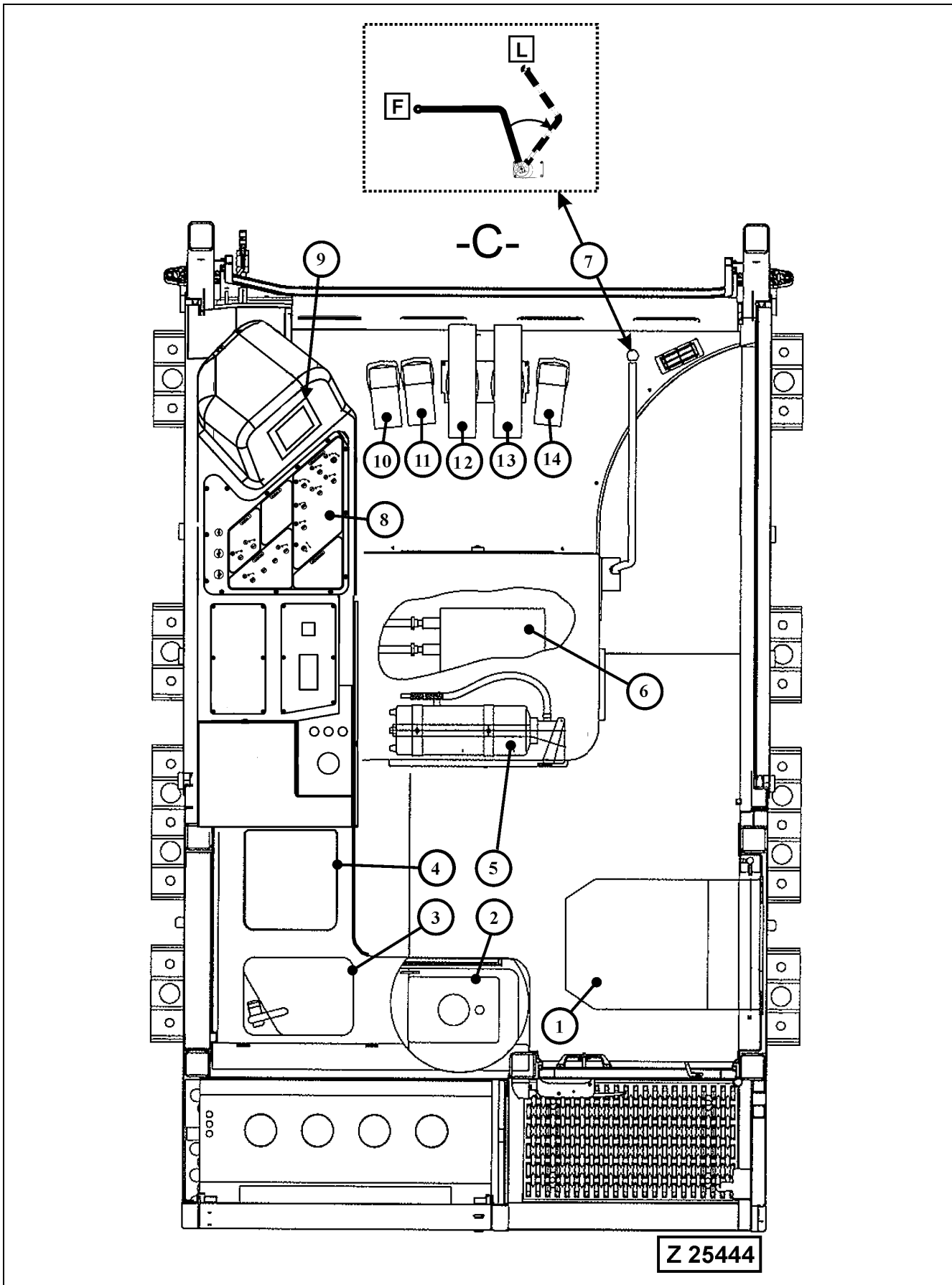

**Legend for illustration Z25444****C Top View of Operator's Cab**

- (1) Co-driver's seat, refer to page 68 for more information
- (2) Windshield washer reservoir, refer to page 63 for more information.
- (3) Washbasin with water tap
- (4) Refrigerator box
- (5) Portable fire extinguisher located behind the Operator's seat. Make sure the fire extinguisher is always charged and ready for use.
- (6) Heater unit located in the seat base
- (7) Safety lock lever.
  - This lever locks the controls for working equipment, swing and travel drive when placed in the fully rear position (L).
  - Start the engine with lock lever in LOCKED position (L). Thereafter set the lock lever to free position (F) in order to enable operation of the hydraulic control system.

---

---

** WARNING**

---

---

**Before leaving the operator's cab set the safety lock lever to LOCK position (L). If the controls are not locked, and they are touched inadvertently, this may lead to a serious accident.**

---

---

- (8) Instrument panel, see page 89 for more information.
- (9) Monitor of the **Vehicle Health Monitoring System -VHMS-**, see page 96 for more information.
- (10) Pedal for closing the bottom dump bucket (Face shovel only)
- (11) Pedal for opening the bottom dump bucket (Face shovel only)
- (12) Travel control pedal, left track forward - reverse
- (13) Travel control pedal, right track forward - reverse
- (14) Swing brake pedal

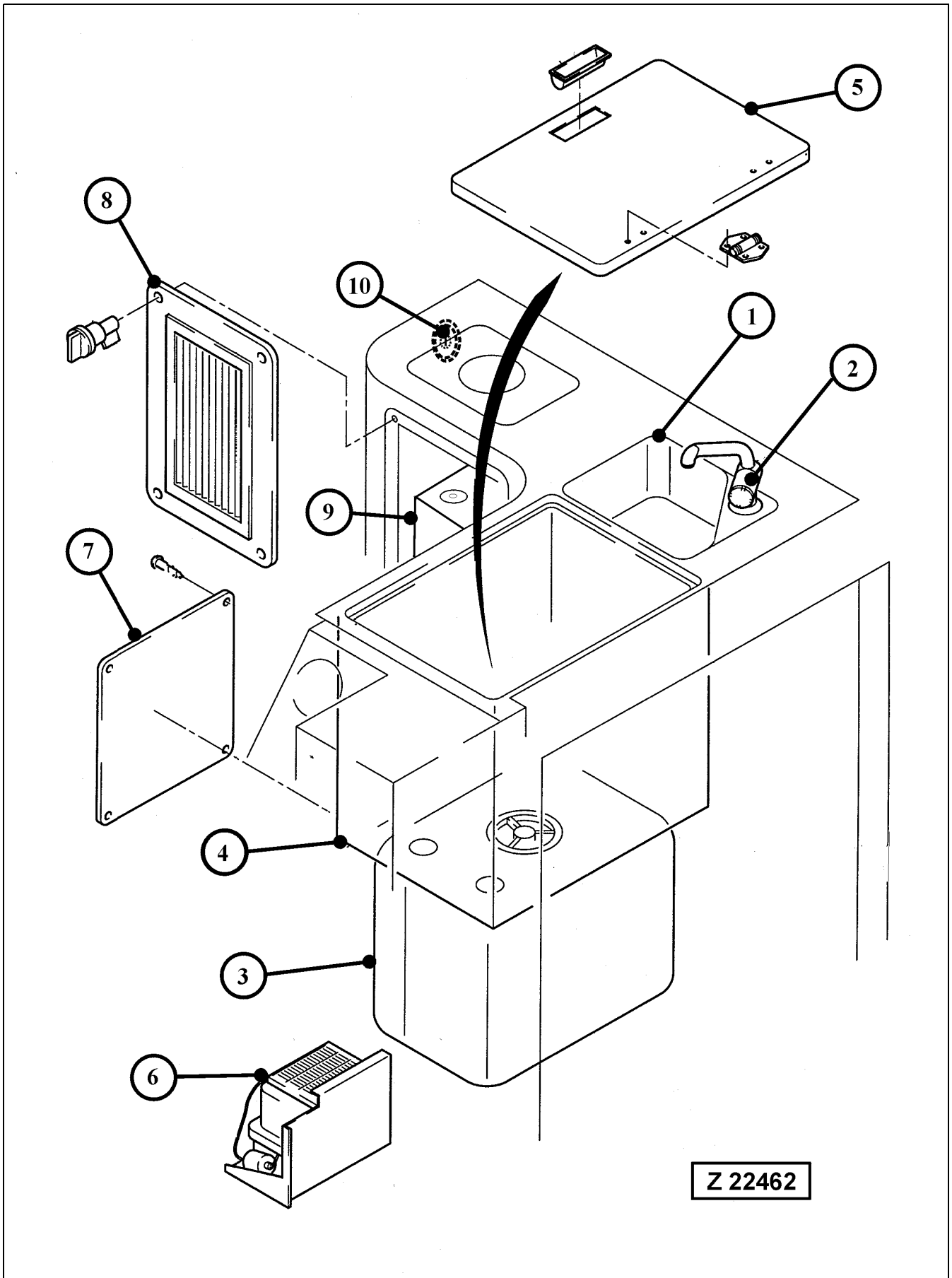

## Operator's Cab - Hand Wash Sink and Refrigerator Box

### Legend for illust. Z 22462

- (1) Hand wash sink
- (2) Water-tap

---

---

 **WARNING**

---

---

**No drinking water.  
Use for hand washing only**

---

---

- (3) Water tank for hand wash sink. The capacity of the water tank is 50 liters. The tank has to be filled via the adapter on the service arm. Refer to page 212 for more information.
- (4) Refrigerator box
- (5) Refrigerator box cover
- (6) Refrigerator unit
- (7) Access cover for water tank (3) and refrigerator unit (6)
- (8) Access cover for windshield washer reservoir
- (9) Windshield washer reservoir. The water reservoir is accessible after removing the cover (8). The reservoir has a capacity of 7 liters.
- (10) Filler cap lockable. To fill the water tank (3) unlock cap (10) using the key provided and remove. Be sure to lock the cap after filling the water tank.

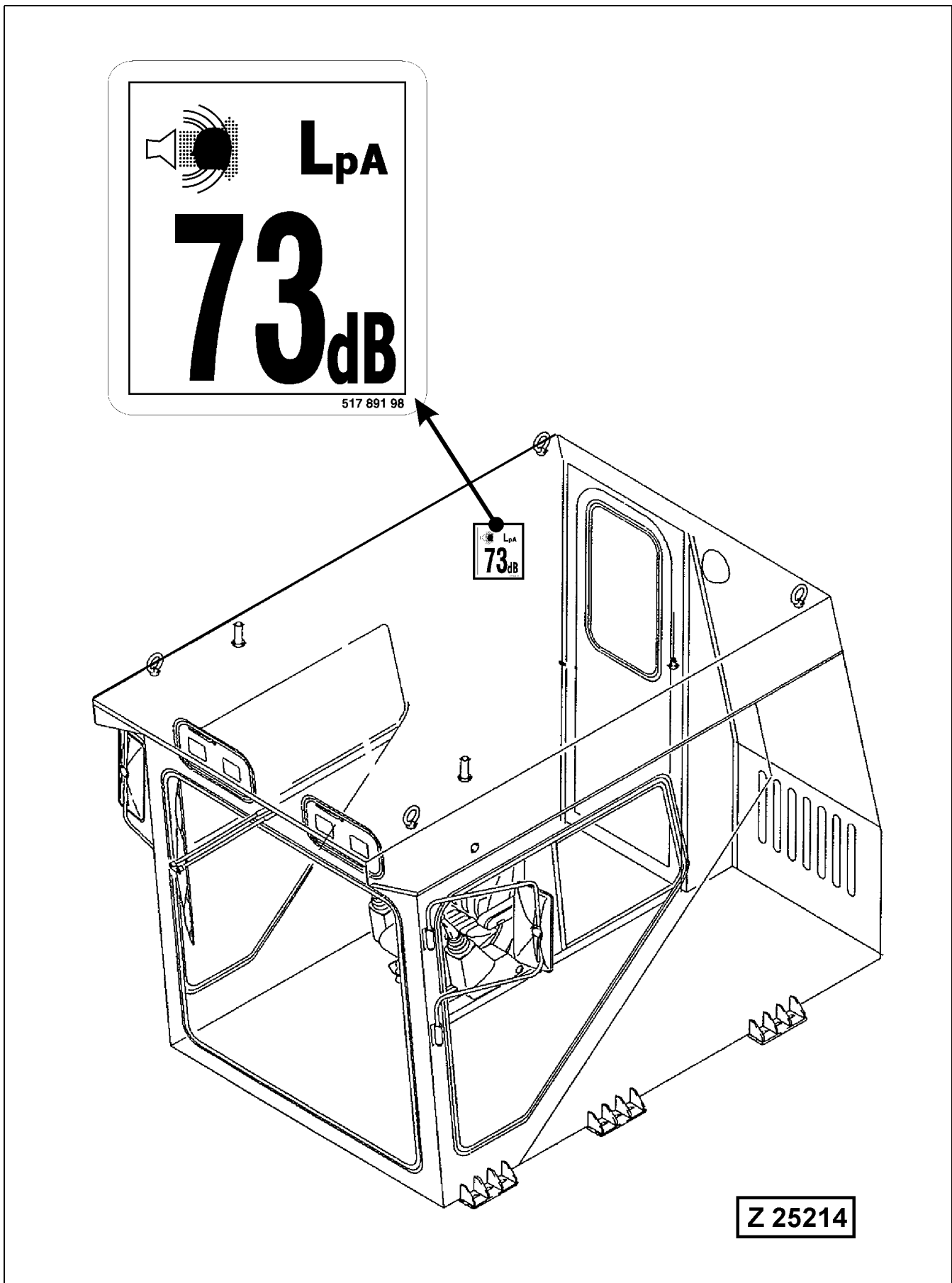



**Sound Pressure Level in the Operator's Cab**

The sound pressure level in the operator's cab is 73 dB(A), measured according to ISO6396 (Dynamic test method).

The sound pressure value is also shown on the decal affixed in the operator's cab, see illustration Z25214.

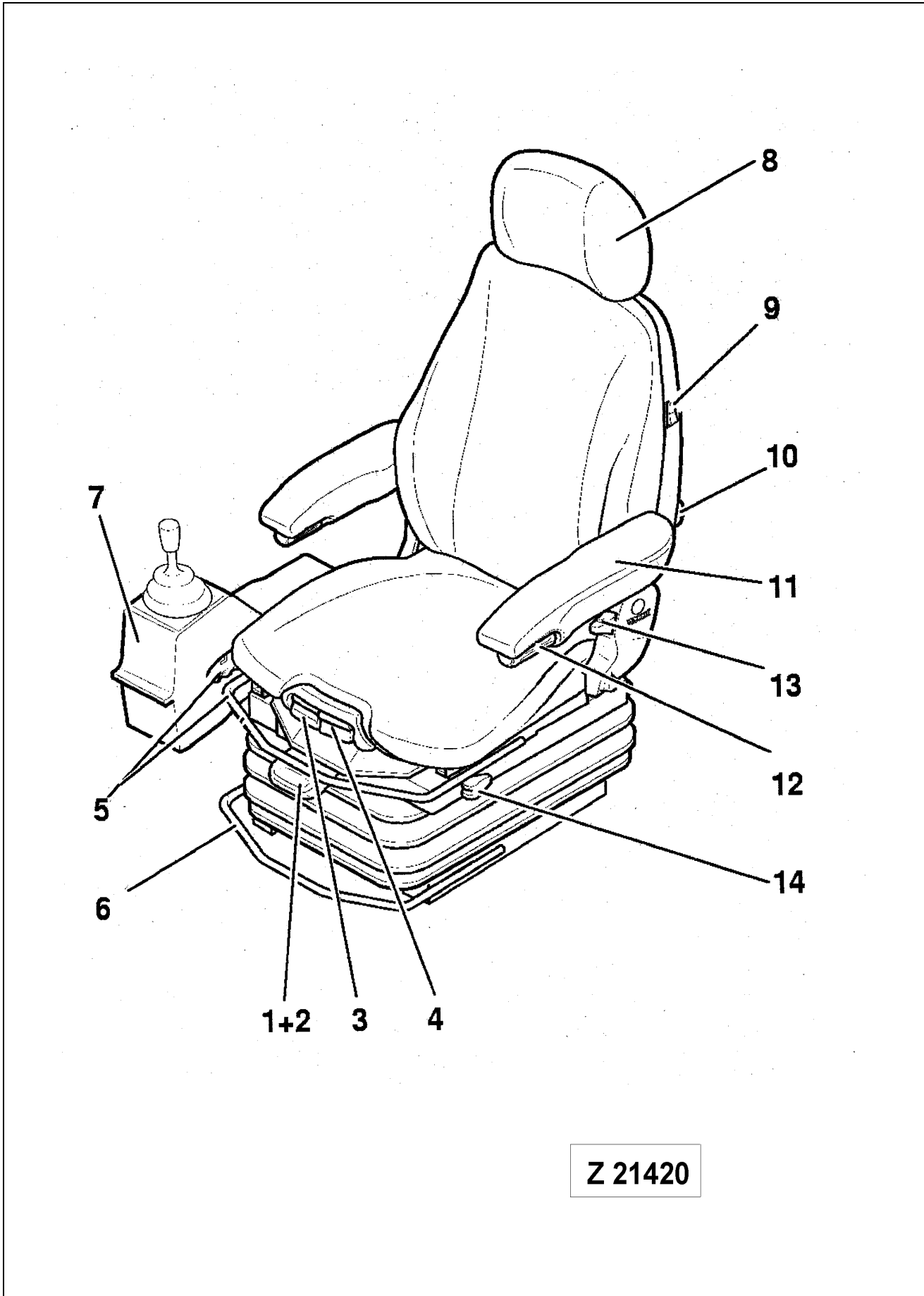

## Operator's Seat Adjustment

Before operating the Shovel adjust the seat and mirrors for Operators maximum comfort, visibility, and complete control of the Shovel.

### Legend for illust. (Z 21420):

- (1) Seat suspension adjustment (firm to soft ride)
- (2) Height adjustment
- (3) Seat depth adjustment
- (4) Seat cushion tilt adjustment
- (5) Fore/aft adjustment
- (6) Not used on this model
- (7) Control lever carrier
- (8) Headrest (optional)
- (9) Seat heater switch (optional)
- (10) Lumbar support adjustment
- (11) Armrest, foldable
- (12) Armrest adjustment
- (13) Backrest adjustment
- (14) Fore/aft isolator  
Seat belt (not shown)

---

---

**⚠ WARNING**

---

---

- **Use seat belt in accordance with the local safety regulations and laws.**
  - **Check condition and fastening of the seat belt. Replace any worn or damaged part of the seat belt system.**
  - **To ensure proper functioning of the seat belt replace the seat belt and securing parts after every three years.**
- 
- 

### REMARK

For more Information, refer to the separate Operating Instruction Manual "AIR SUSPENSION SEAT" in volume 2 binder.

## Co-driver's Seat

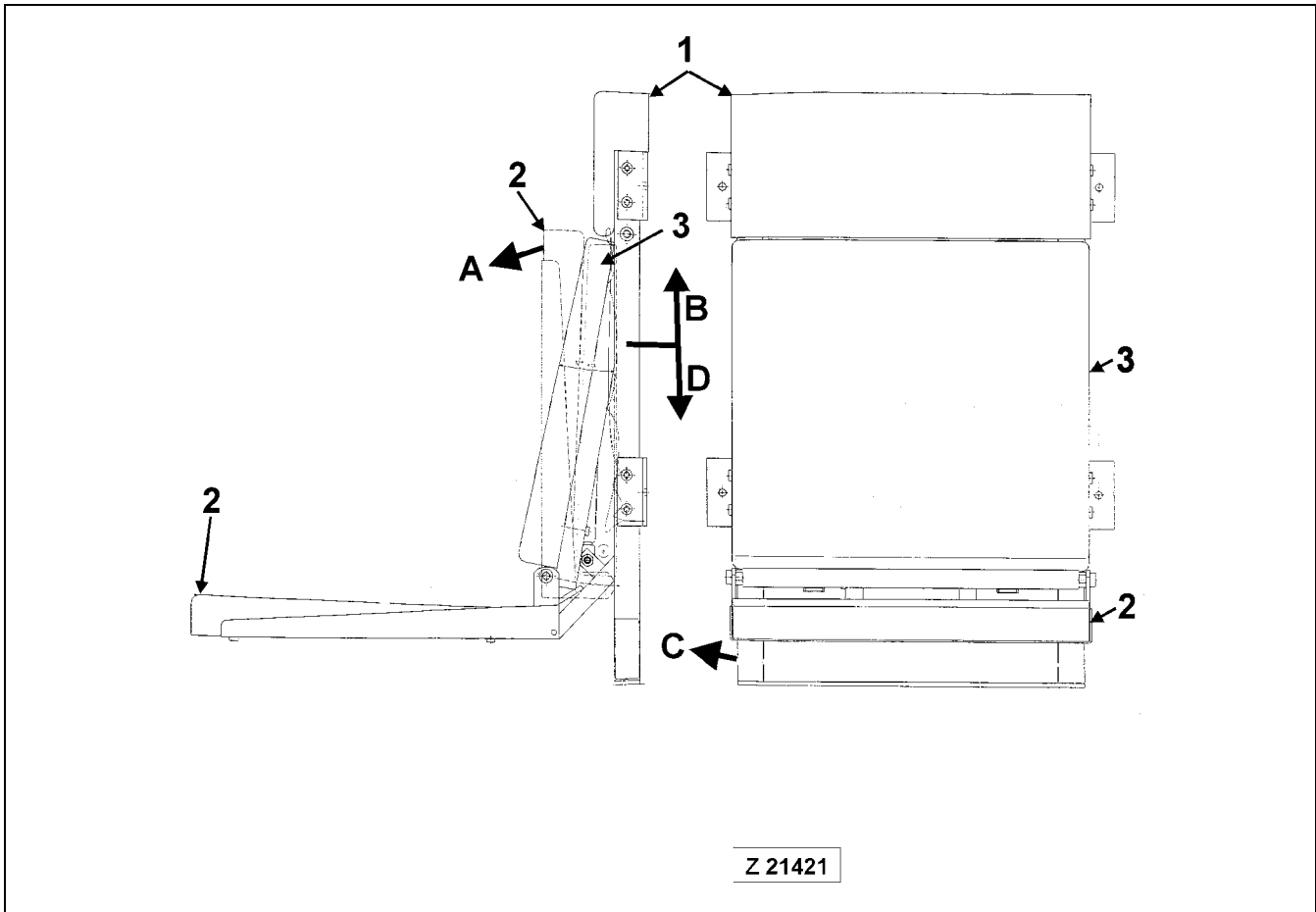

### Legend for illust. Z 21421

- |                           |               |
|---------------------------|---------------|
| (1) Seat suspension frame | (3) Back rest |
| (2) Folding seat          |               |

### Adjust Seat Position

A - Fold down seat to sitting position. The seat will automatically move up when released.

B - To swing the seat out, towards the front, first lift seat suspension frame (1) and then swing seat to the front; facing the wind-shield.

C - Swing seat to stop position.

D - With the seat in its final stop position lower seat suspension frame (1). The seat suspension frame (1) must engage into stop blocks mounted in the seat carrier.

### REMARK

Be sure to secure the seat in its home position and swung out position by lowering suspension frame (1) into the stop blocks of the seat carrier.

### 3.2.7 UNDERCARRIAGE

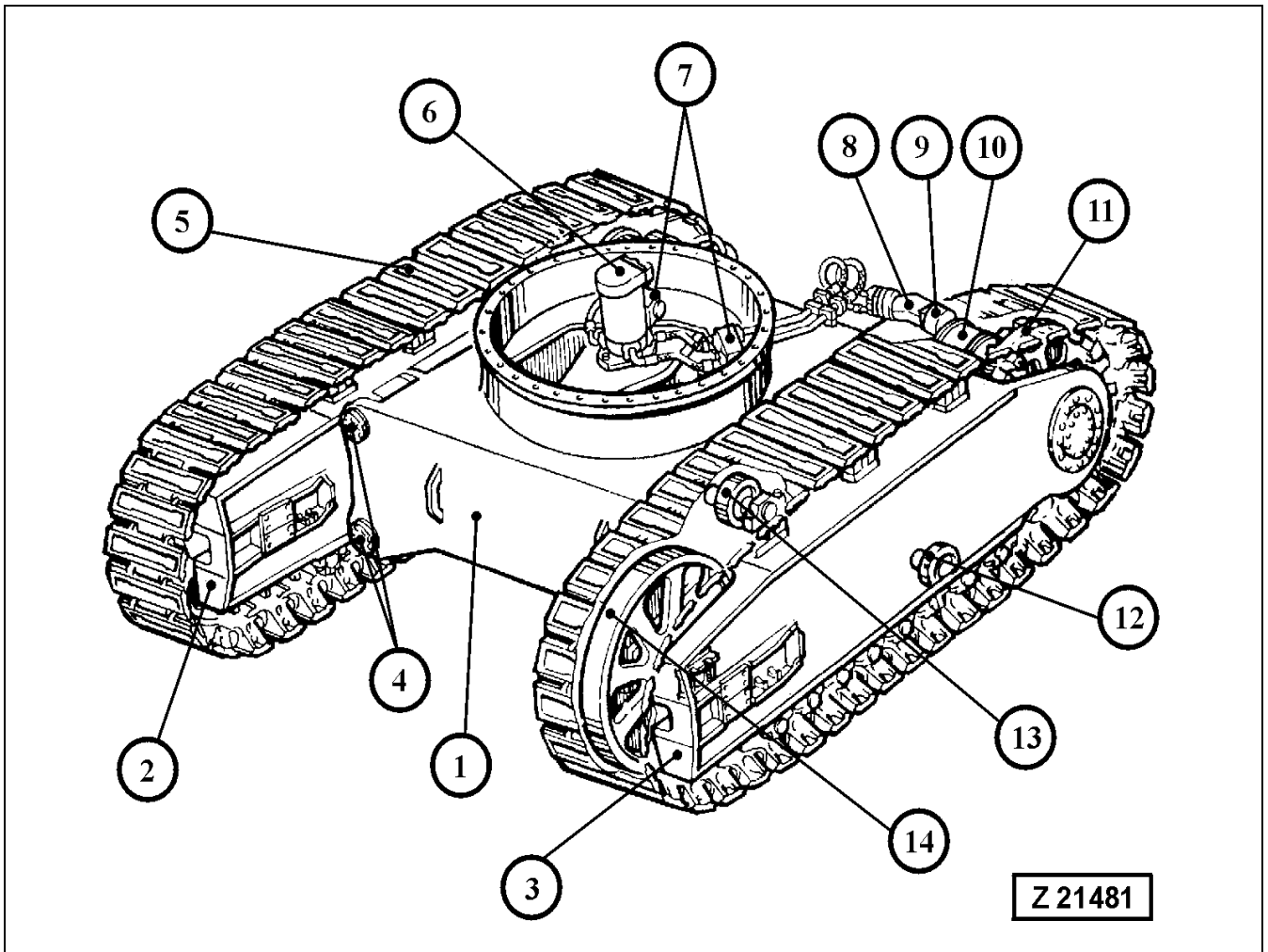

Legend for illustration Z 21481

- |     |  |      |                |
|-----|--|------|----------------|
| (1) | Center frame                                     | (8)  | Travel motor   |
| (2) | Crawler carrier, RH                              | (9)  | Parking brake  |
| (3) | Crawler carrier, LH                              | (10) | Travel gear    |
| (4) | Connecting pins, crawler carrier to center frame | (11) | Drive sprocket |
| (5) | Crawler track                                    | (12) | Track roller   |
| (6) | Swivel joint                                     | (13) | Carrier roller |
| (7) | Brake valves                                     | (14) | Guide wheel    |

### 3.2.8 WORKING ATTACHMENT

#### Loader attachment with bottom dump bucket

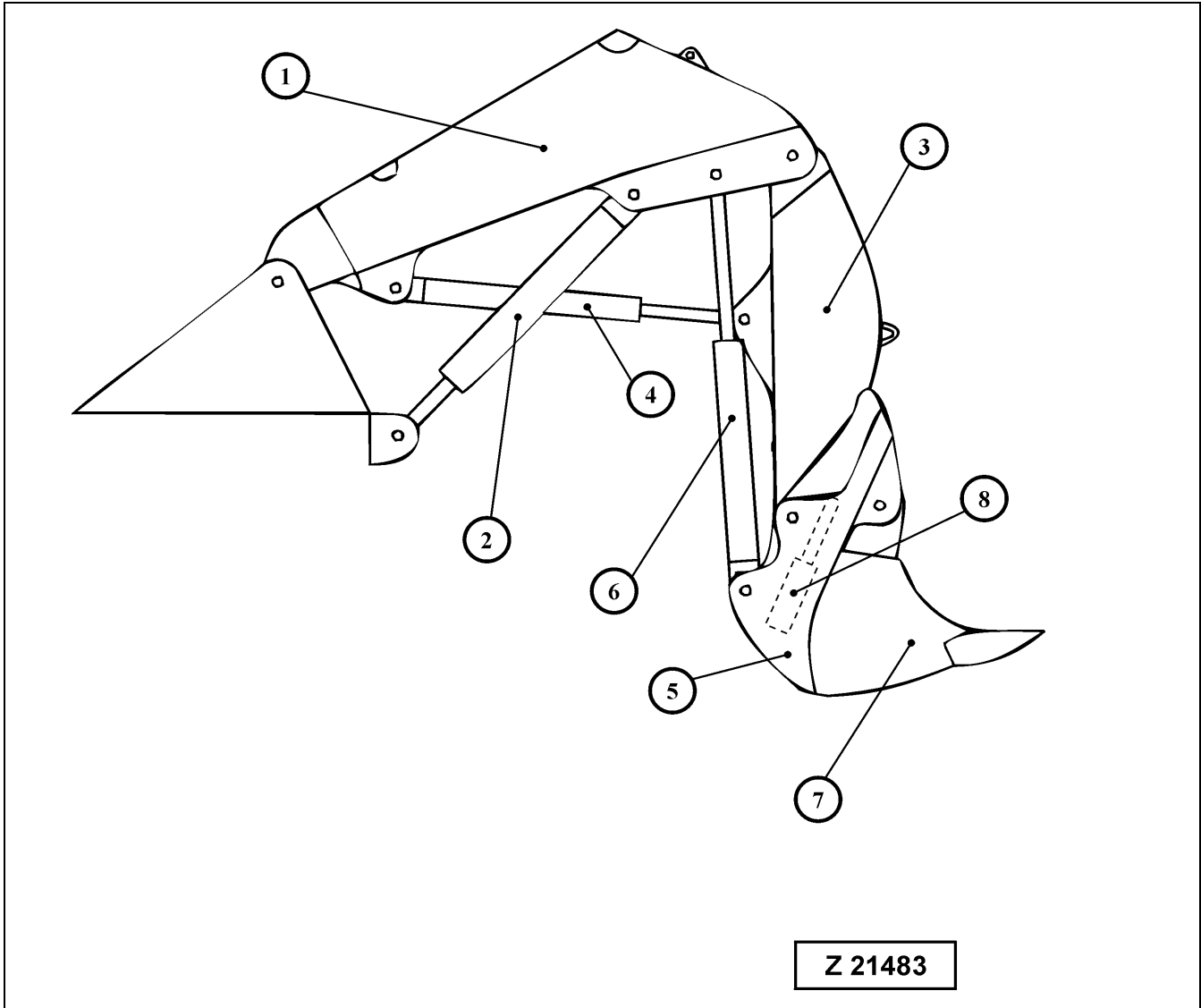

**Legend for illustration Z 21483**

- |                     |                                      |
|---------------------|--------------------------------------|
| (1) Boom            | (5) Bucket wall                      |
| (2) Boom cylinders  | (6) Bucket cylinders                 |
| (3) Stick           | (7) Bucket bowl                      |
| (4) Stick cylinders | (8) Bowl opening - closing cylinders |

**Loader attachment with backhoe bucket**

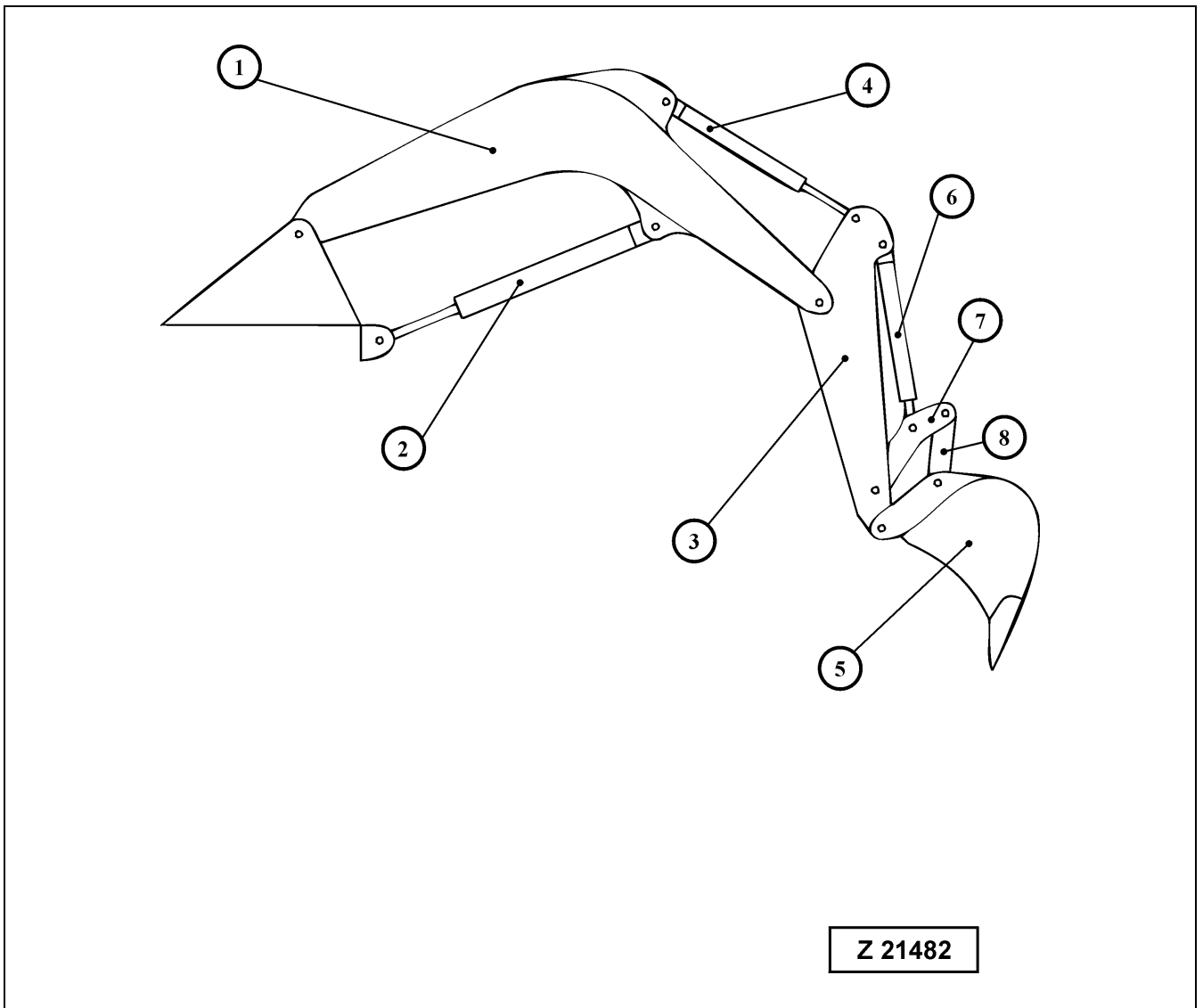

**Legend for illustration Z 21482**

- |                     |                      |
|---------------------|----------------------|
| (1) Boom            | (5) Backhoe bucket   |
| (2) Boom cylinders  | (6) Bucket cylinders |
| (3) Stick           | (7) Link             |
| (4) Stick cylinders | (8) Rod              |

**3.2.9 DIESEL ENGINE TYPE SDA 16V160**

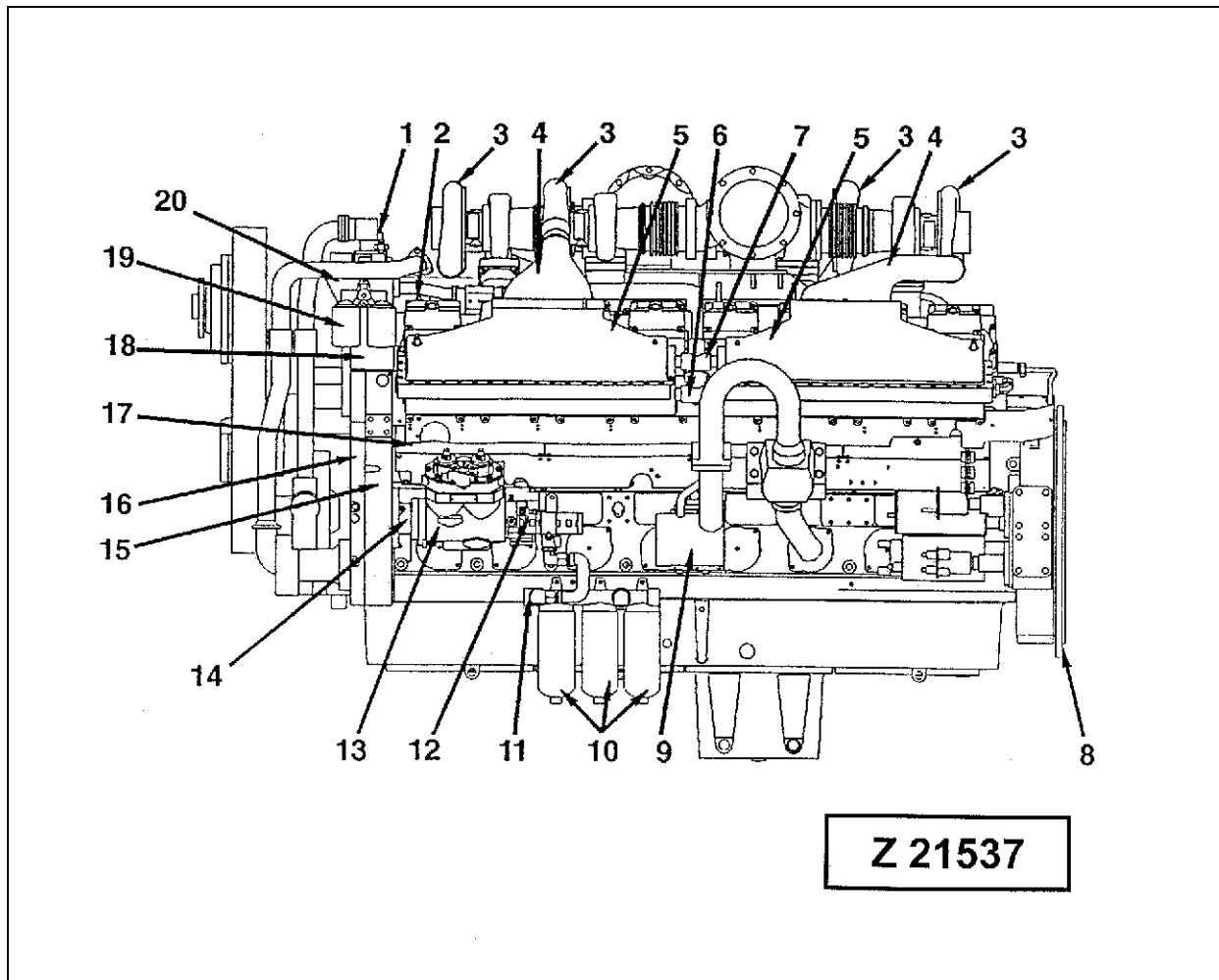

**Legend for illustration Z 21537, engine left side view**

- |      |                                 |      |                            |
|------|---------------------------------|------|----------------------------|
| (1)  | LTA water outlet connection     | (11) | Fuel filter head           |
| (2)  | Rocker lever cover              | (12) | Fuel pump                  |
| (3)  | Turbocharger                    | (13) | Air compressor (Not used)  |
| (4)  | Air crossover connection        | (14) | Accessory drive            |
| (5)  | Aftercooler assemblies          | (15) | Front gear housing         |
| (6)  | Aftercooler water inlet tube    | (16) | Front gear cover           |
| (7)  | Aftercooler water outlet tube   | (17) | Cam follower cover         |
| (8)  | Flywheel housing                | (18) | Thermostat housing support |
| (9)  | Electronic control module (ECM) | (19) | Coolant filters            |
| (10) | Fuel filter                     | (20) | Thermostat housing         |



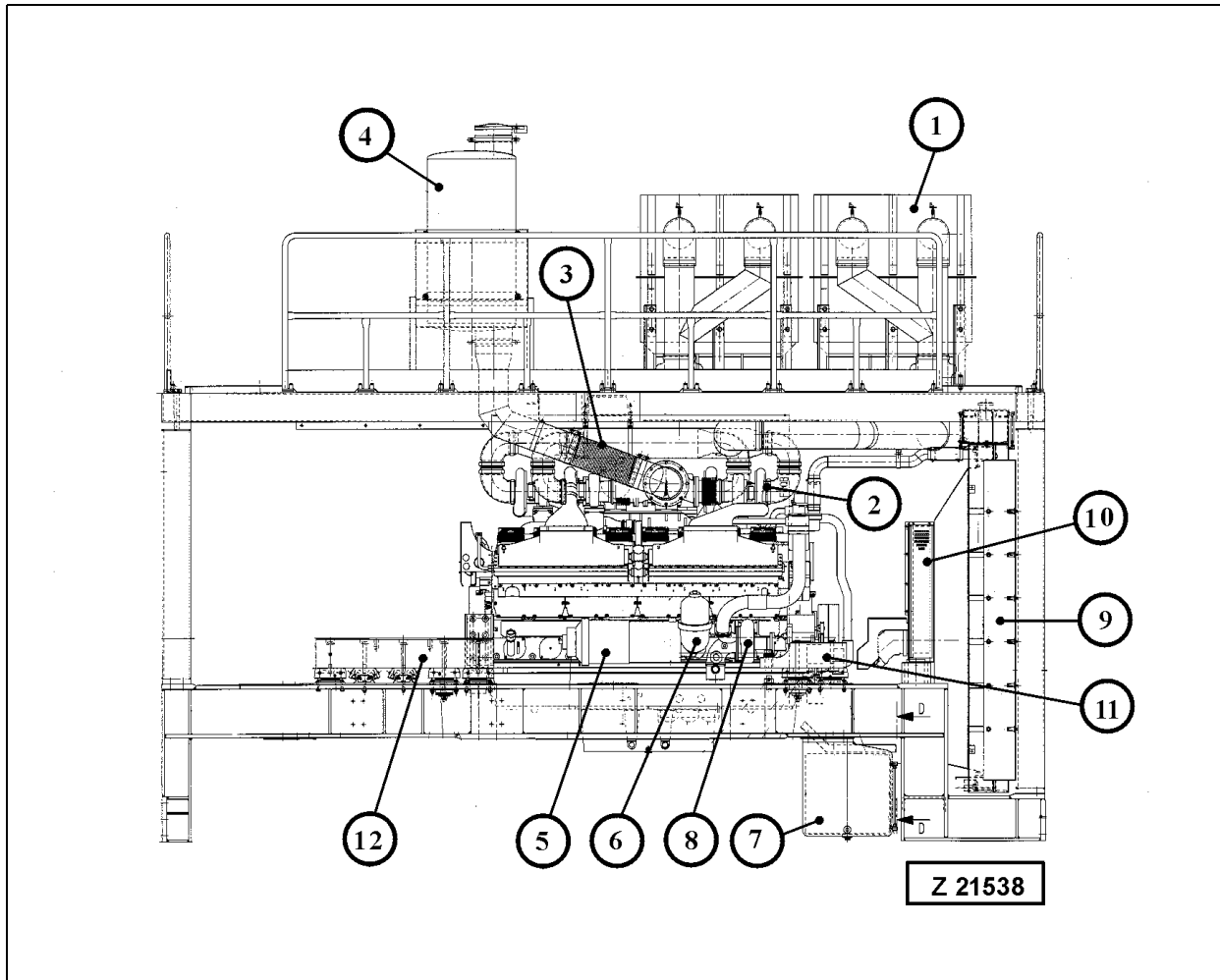

#### Legend for illustration Z 21538, engine right side

- |     |                                     |      |                            |
|-----|-------------------------------------|------|----------------------------|
| (1) | Engine air cleaners                 | (7)  | Engine oil reserve tank *) |
| (2) | Turbocharger                        | (8)  | Water pump                 |
| (3) | Flexible exhaust hose               | (9)  | Coolant radiator           |
| (4) | Muffler                             | (10) | Radiator fan guard         |
| (5) | Eliminator oil filtration system *) | (11) | Engine bearing front       |
| (6) | Oil cleaning centrifuge *)          | (12) | Engine bearing rear        |

\*) These units are part of the Komatsu engine oil management system which combines the automatic engine oil supply system "**Reserve**" and the oil burning system "**Centinel**" in connection with the "**Eliminator**" oil filtration system.

### 3.2.10 ENGINE OIL MANAGEMENT SYSTEM

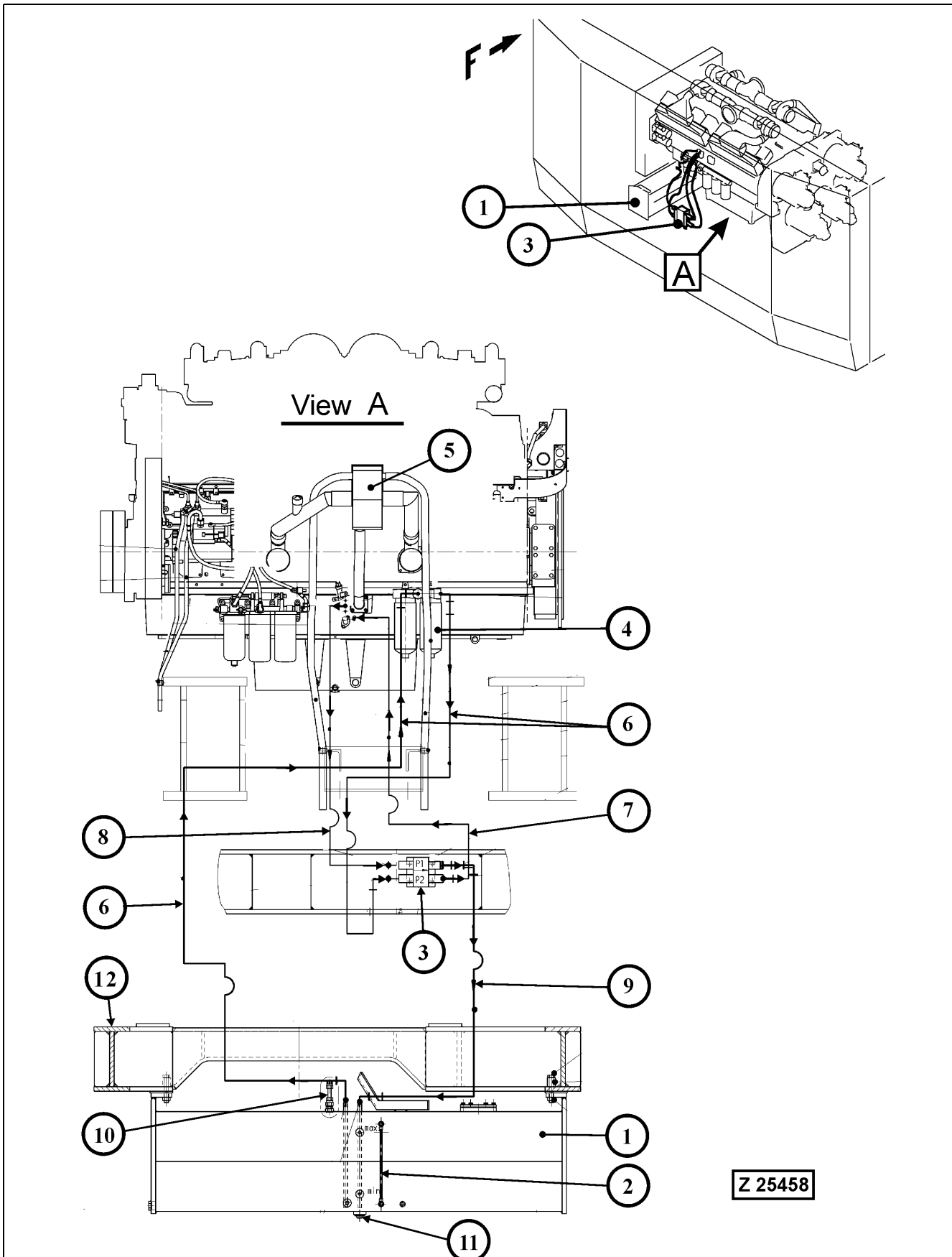

### Engine Oil Management System

The engine oil management system combines the automatic engine oil supply system "**Reserve**" and the oil burning system "**Centinel**" in connection with the "**Eliminator**" oil filtration system.

#### Reserve System Oil Flow Schematic, illustration Z25458

- (1) Reserve oil tank, usable contents 457 liters. Refilling interval, approx. 400 - 500 operating hours
- (2) Oil level sight gauge. Check oil level in the reserve tank before starting the engine. If necessary refill reserve tank via service arm adapter, refer to page 212 for more information.
- (3) Pumping unit, located on the side member of the power frame. The pump unit works automatically as soon as the engine speed is above 300 RPM. The pump unit consists of a pumping element for feeding oil from tank (1) into the engine oil pan via lines (6), oil filters (4) and line (7). The second pumping element withdraws oil from the engine oil pan and feeds it back into the reserve tank via line (8 and 9) when the oil level in the oil pan exceeds the maximum running oil level. This function maintains a favorable engine oil level. The combined operation of the pumping elements provides constant circulation of oil between the engine sump and reserve tank (1) increasing the total volume of working oil. This maintains the oil quality over longer periods. Oil drawn off by the Centinel burn system is also replaced through the supply system "Reserve".
- (4) Oil filter of the supply system. Replace both filter elements after every 400 - 500 operating hours.
- (5) Crankcase breather filter
- (6) Suction lines
- (7) Oil supply line from pump (3) to engine oil pan
- (8) Withdrawal oil line from oil pan to pump (3)
- (9) Oil feed-back line to reserve tank (1)
- (10) Reserve tank breather filter
- (11) Oil drain plug
- (12) Power frame side member

**Oil Burning System "Centinel" combined with Oil Supply System "Reserve"**

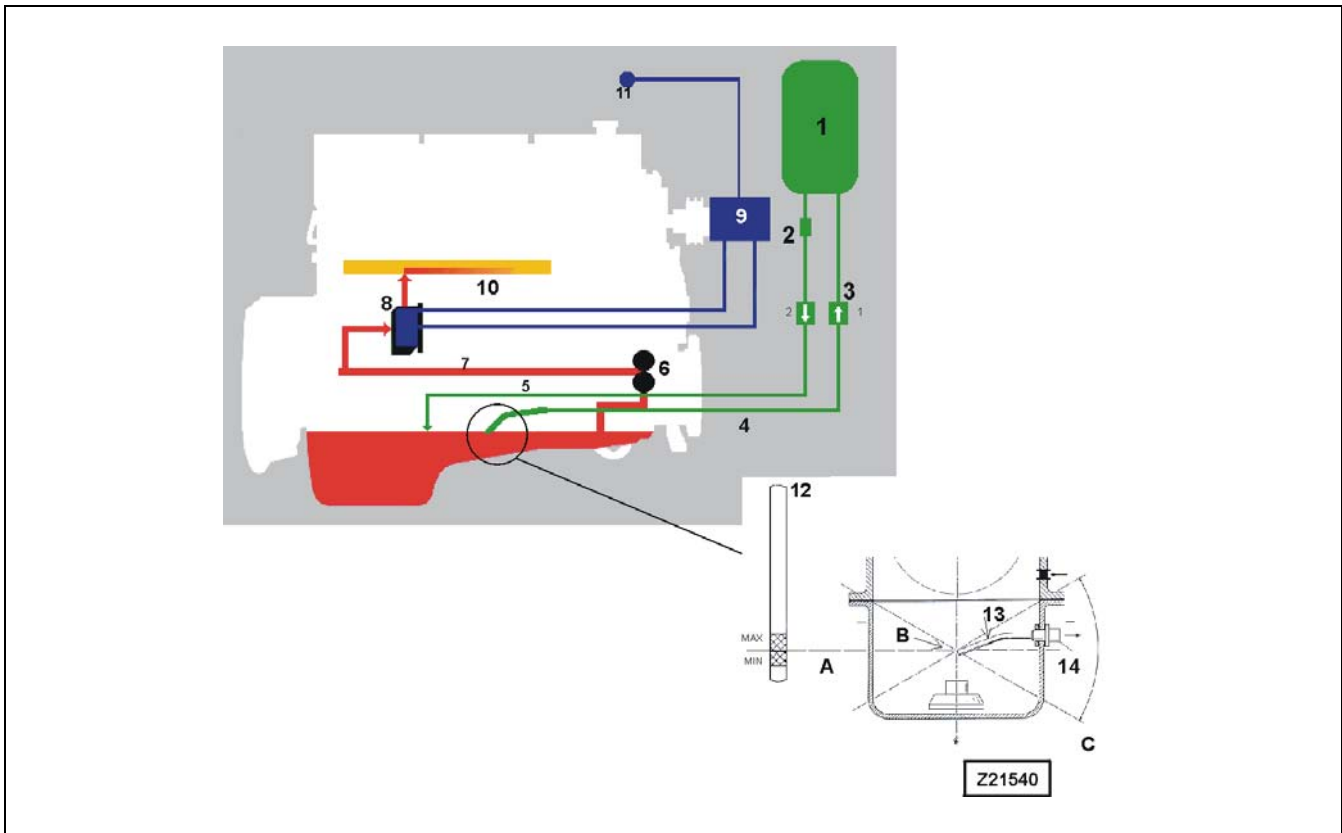

**Legend for illust. Z 21473 (schematic illustration)**

- |                                     |  |
|-------------------------------------|--|
| (1) Engine oil reserve tank         | (10) Fuel/lube oil blend                   |
| (2) Oil filter                      | (11) System malfunction indicator          |
| (3) Pump unit                       | (12) Oil level gauge                       |
| (4) Suction oil to reserve tank     | (13) Oil withdrawal tube                   |
| (5) Supply oil from tank to oil pan | (14) Withdrawal adapter plate              |
| (6) Engine oil pump                 | (A) Oil level with engine running          |
| (7) Main oil rifle                  | (B) Control point for filling / withdrawal |
| (8) Oil control valve               | (C) Roll or tilt oil level                 |
| (9) Centinel Control Module (CCM)   |  |

**Brief description of system function**

The "Centinel" system is a continuous oil replacement system of electromechanical design and can extend oil and filter change intervals through continuous oil exchange. This is accomplished by injecting engine oil at a controlled rate, proportional to fuel consumed, into the fuel system for consumption. Make-up oil is introduced into the engine by the oil supply system "Reserve", maintaining an optimal engine oil level.

## Eliminator Engine Oil Filtration System

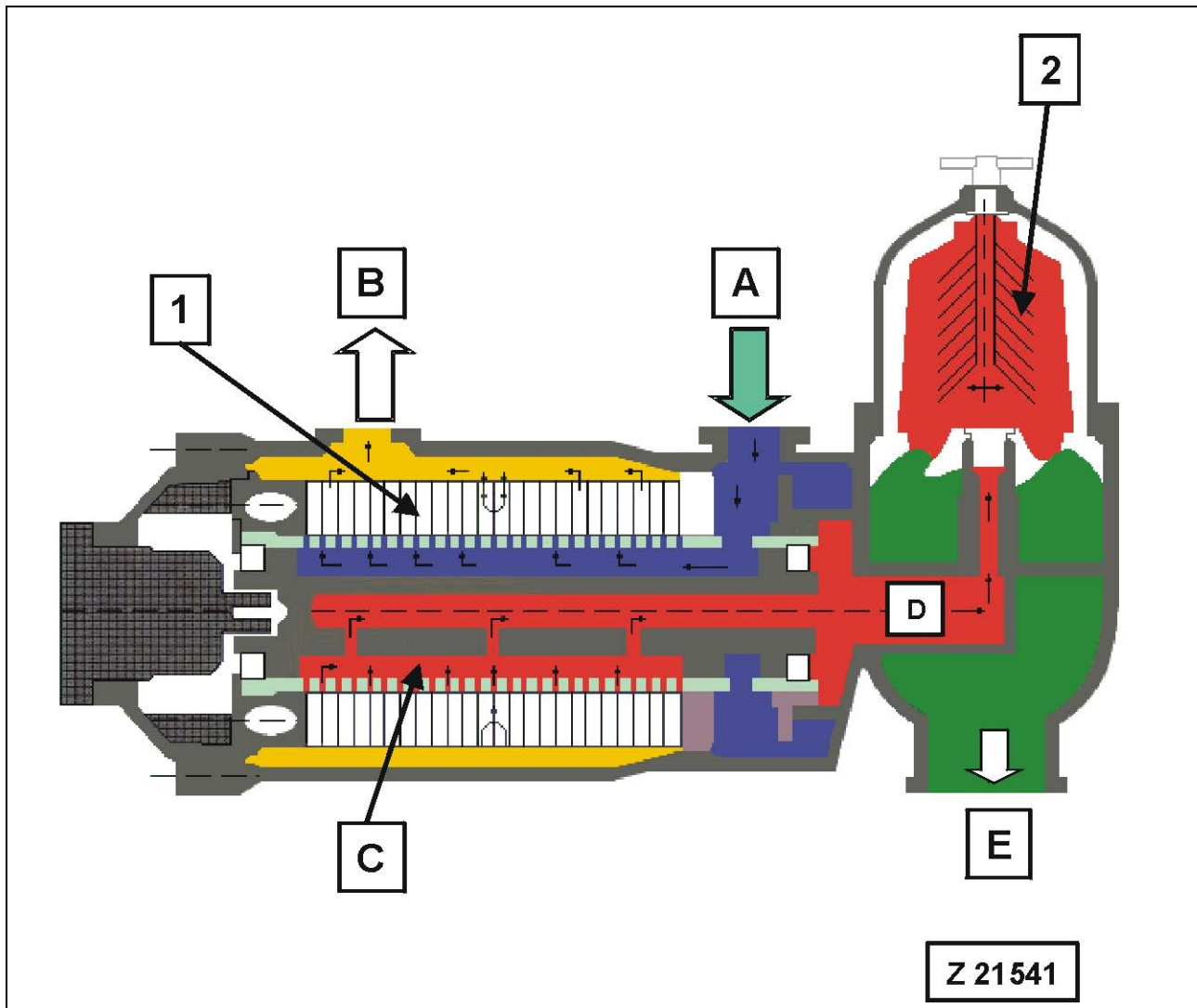

### Legend for illust. Z 21541 (schematic illustration)

- |     |  |     |   |
|-----|--|-----|---|
| (A) | Oil inlet from engine (100%)               | (E) | Oil flow to engine oil pan (5%)   |
| (B) | Oil outlet to engine (95%)                 | (1) | Stainless steel filter removes particles as small as 20 $\mu\text{m}$   |
| (C) | Backflush oil (5%) for cleaning the filter | (2) | Centrifugal separator removes particles up to a size of 2 $\mu\text{m}$ |
| (D) | Oil flow to centrifuge (5%)                |     |   |

### REMARK

Refer to the Service Bulletin "Eliminator Filter" filed in volume 2 binder for all operation and maintenance instructions.

### 3.3 OPERATOR'S CAB - CONTROLS

#### 3.3.1 CONTROLS WITH BACKHOE ATTACHMENT

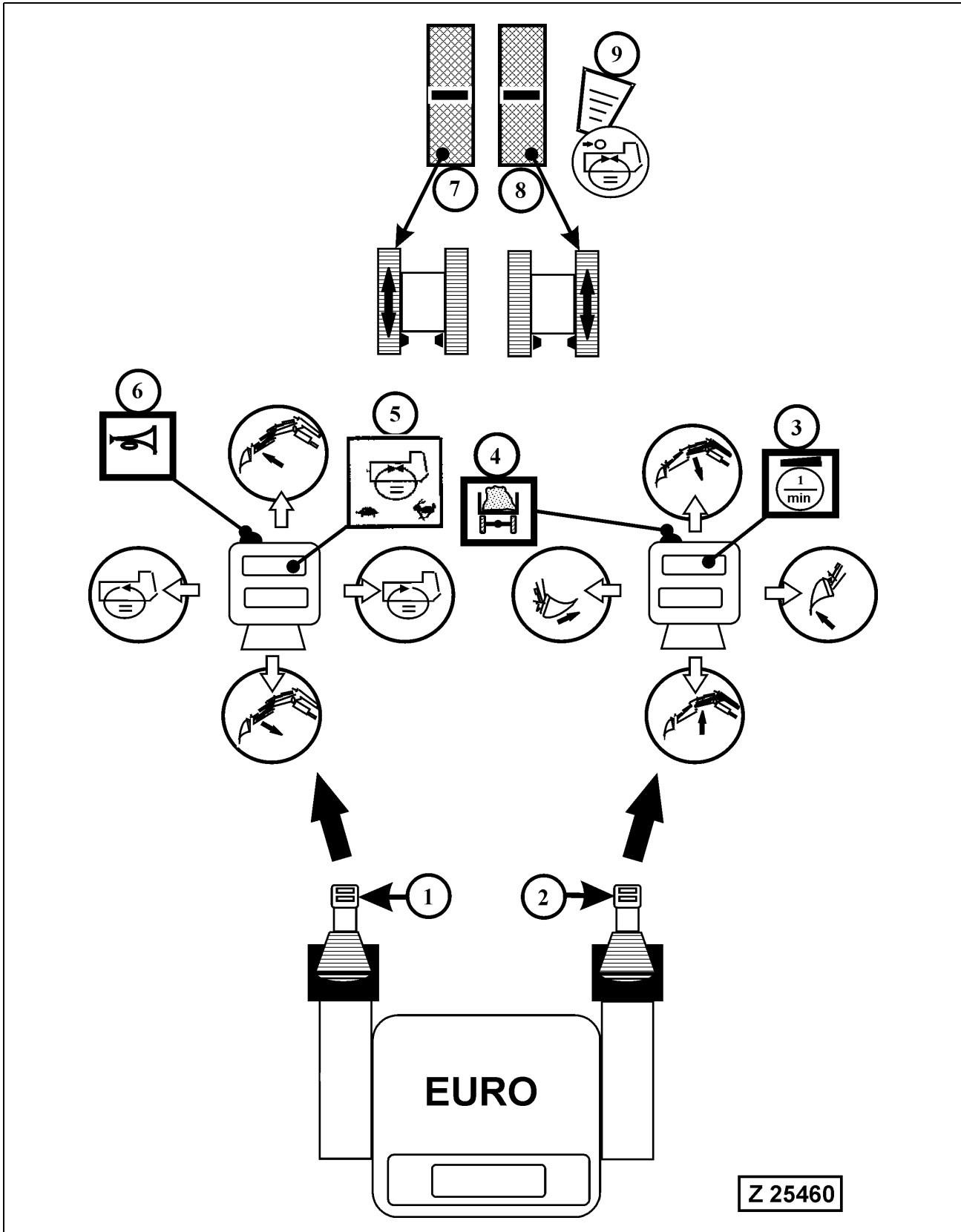

Z 25460

## HYDRAULIC CONTROL SYSTEM

There are two control patterns of levers (1 and 2) available:

- "EURO" control pattern and
- "KMG" (Komatsu Mining Germany) control pattern

Your Shovel is equipped with the **EURO** control pattern for levers (1 and 2).

**For more information → See "WORKING WITH THE ATTACHMENT" on page 178.**

---

### WARNING

---

- **Wrong operation of the controls can cause mechanical break-down, property damage, injury or death.**
  - **Observe the Safety Instructions → See "SAFETY" on page 15.**
  - **Before starting the engine / motor, make sure you know the location and function of each control.**
  - **Always sit in the Operator's seat when operating this machine.**
- 

### 3.3.2 SAFETY CIRCUIT FOR CONTROLS

(Pilot control system cut-out and actuation of swing parking brake)

This system is controlled through the safety lock lever at the operator's seat, the retractable access ladder and the service arm of the refilling system. It prevents movements of the Shovel and its attachment as long as the safety lock lever is in the upper locked position and/or the retractable ladder is in the lowered position or when the service arm of the central refilling system is in its lowered position.

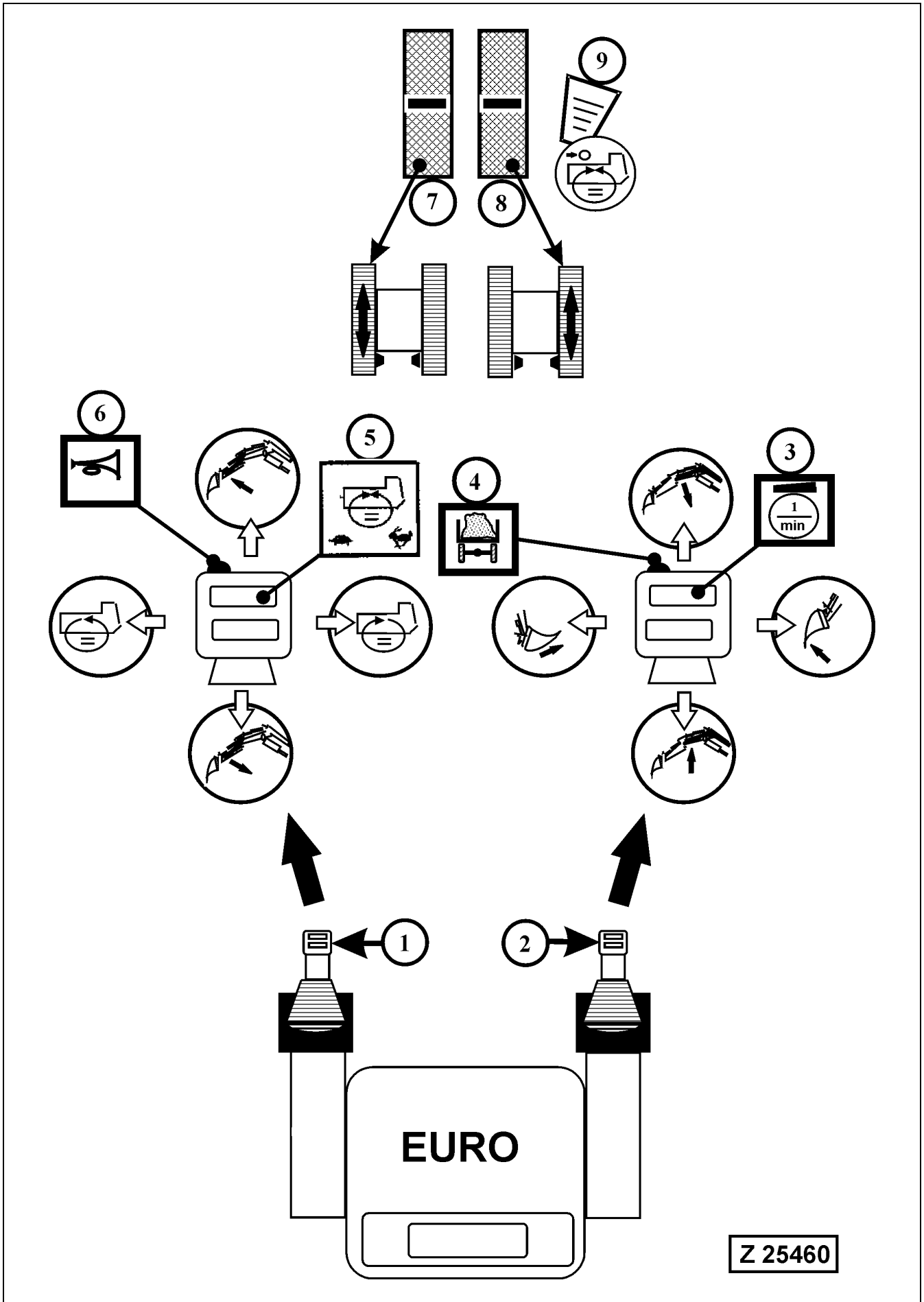



## EURO Control Pattern

### Legend for illustration Z25460

- (1) Control lever for stick and swing machinery
- (2) Control lever for boom and bucket
- (3) Toggle switch for engine speed selection  
Low idle – High idle
- (4) Push button for Truck counter number 1 (TR1)  
For counting loaded trucks press this button. The total number of trucks loaded is shown on the VHMS monitor field TR1, refer to page 96 for more information. A second truck counter switch is located on the control panel, refer to page 89 for more information.

#### NOTICE

**The push button (4) has a second function. When the Vehicle Health Monitoring System is switched to the PM CLINIC group within the SERVICE MENU, selected PM CLINIC data can be frozen by pushing button (4). Frozen data can then be stored in the PM CLINIC MEMORY. For more information refer to the SERVICE MANUAL VHMS-System.**

- (5) Swing speed switch. This switch has two positions:
  - Left side down - Normal swing speed.
  - Right side down - Increased swing speed.

It is recommended to use the higher swing speed for slewing angles greater than 90°.

- (6) Signal horn button
- (7) Travel control pedal, left track forward - reverse
- (8) Travel control pedal, right track forward - reverse
- (9) Slew brake pedal

**For more information see page 178.**

### 3.3.3 CONTROLS WITH BOTTOM DUMP BUCKET ATTACHMENT

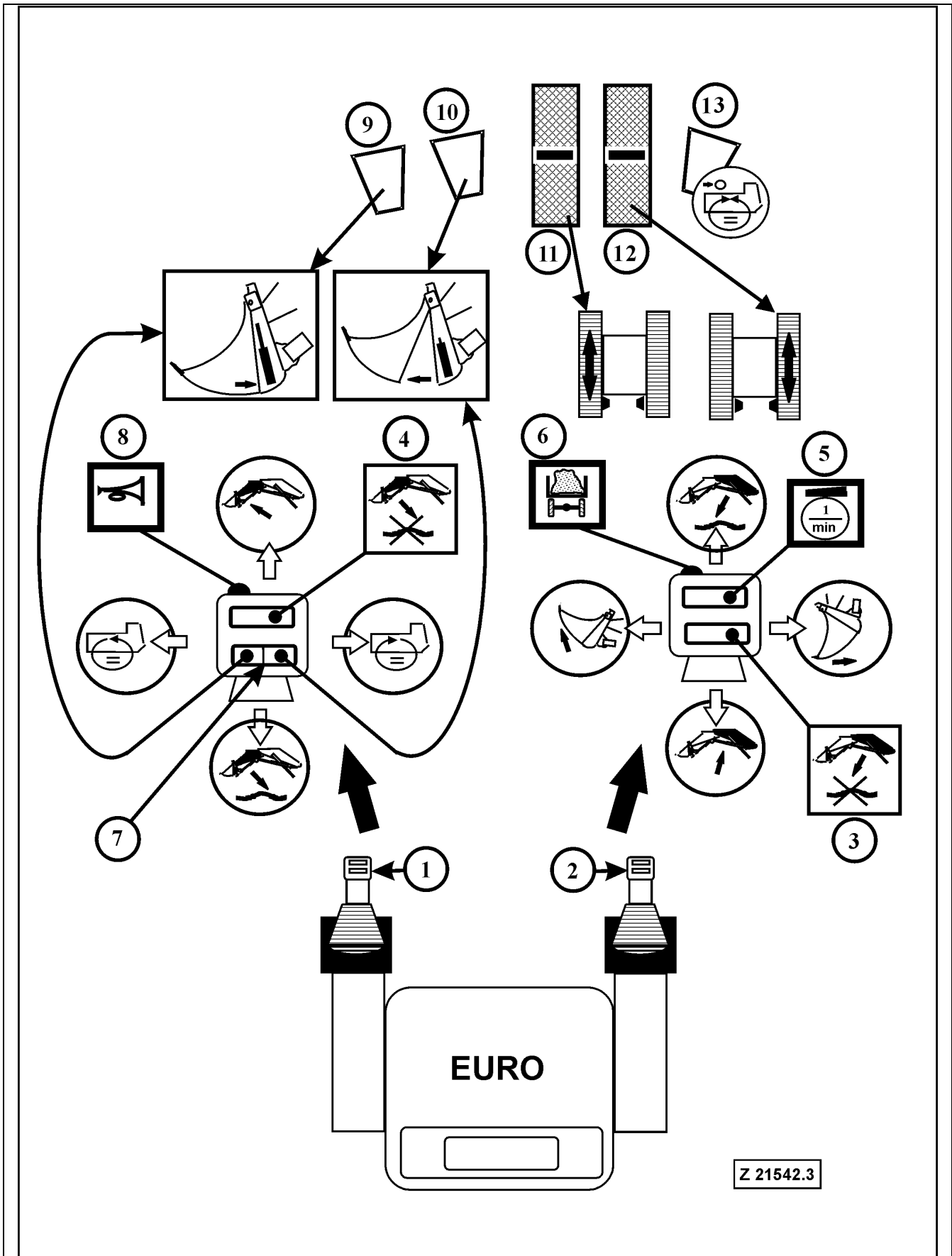

## HYDRAULIC CONTROL SYSTEM

There are two control patterns of levers (1 and 2) available:

- "EURO" control pattern and
- "KMG" (Komatsu Mining Germany) control pattern

Your Shovel is equipped with the **EURO** control pattern for levers (1 and 2).

**For more information → See "WORKING WITH THE ATTACHMENT" on page 178.**

---

---

### WARNING

---

---

- **Wrong operation of the controls can cause mechanical break-down, property damage, injury or death.**
  - **Observe the Safety Instructions → See "SAFETY" on page 15.**
  - **Before starting the engine / motor, make sure you know the location and function of each control.**
  - **Always sit in the Operator's seat when operating this machine.**
- 
- 

### 3.3.4 SAFETY CIRCUIT FOR CONTROLS

(Pilot control system cut-out and actuation of swing parking brake)

This system is controlled through the safety lock lever at the operator's seat, the retractable access ladder and the service arm of the refilling system. It prevents movements of the Shovel and its attachment as long as the safety lock lever is in the upper locked position and/or the retractable ladder is in the lowered position or when the service arm of the central refilling system is in its lowered position.

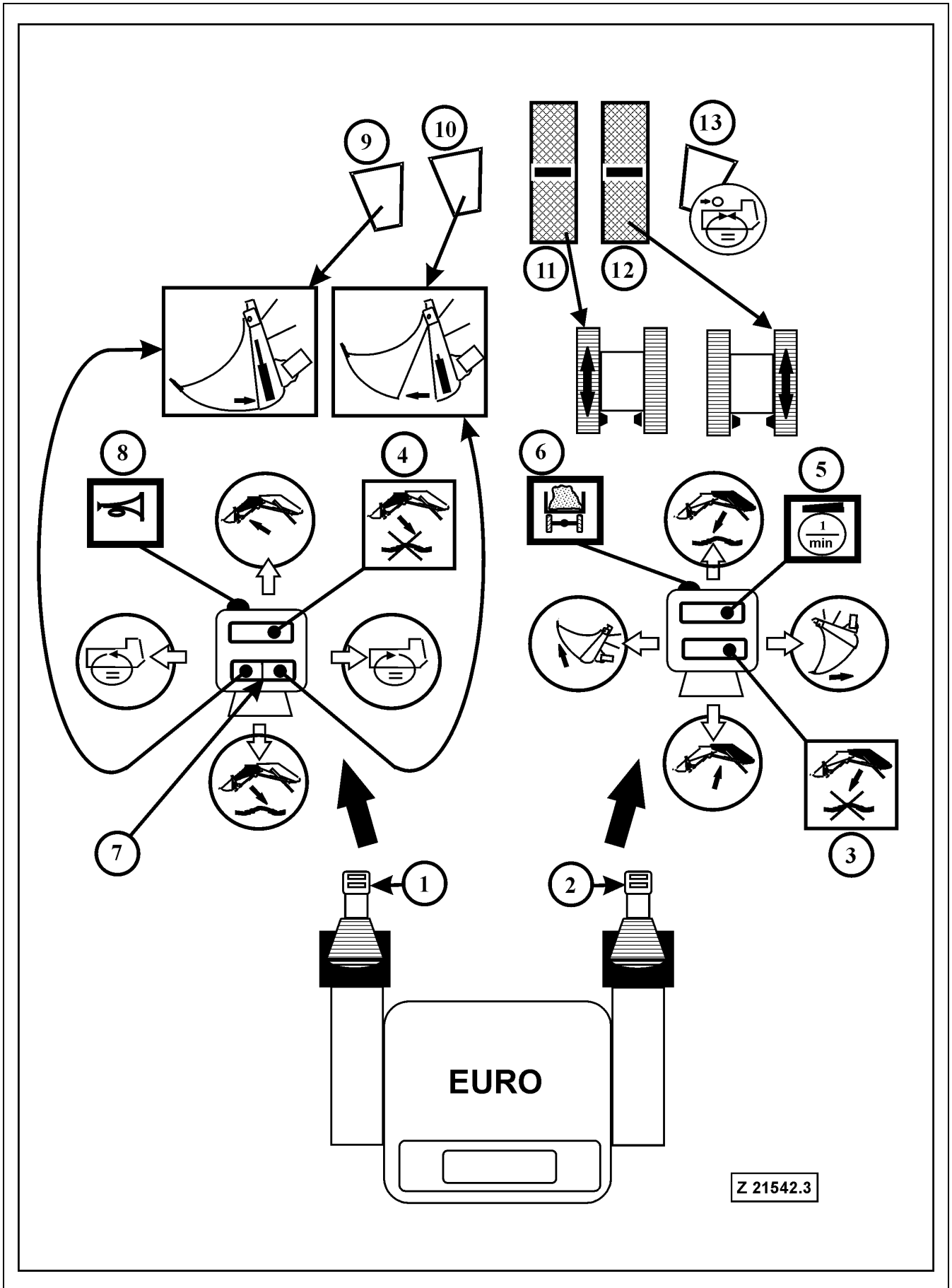

## EURO Control Pattern

### Legend for illustration Z21542.3

- (1) Control lever for stick and swing machinery
- (2) Control lever for boom and bucket
- (3) Push button for deactivation of boom float position
- (4) Push button for deactivation of stick float position
- (5) Toggle switch for engine speed selection  
Low idle – High idle
- (6) Push button for Truck counter number 1 (TR1)  
For counting loaded trucks press this button. The total number of trucks loaded is shown on the VHMS monitor field TR1, refer to page 96 for more information. A second truck counter switch is located on the control panel, refer to page 89 for more information.

#### NOTICE

**The push button (6) has a second function. When the Vehicle Health Monitoring System is switched to the PM CLINIC group within the SERVICE MENU, selected PM CLINIC data can be frozen by pushing button (6). Frozen data can then be stored in the PM CLINIC MEMORY. For more information refer to the SERVICE MANUAL VHMS-System.**

- (7) Toggle switch for opening and closing the bottom dump bucket.

#### REMARK

Opening and closing of the bottom dump bucket can be carried out either with switch (7) or pedals (9 and 10).

- (8) Signal horn button
- (9) Pedal for closing the bottom dump bucket
- (10) Pedal for opening the bottom dump bucket
- (11) Travel control pedal, left track forward - reverse
- (12) Travel control pedal, right track forward - reverse
- (13) Slew brake pedal

### 3.3.5 AUTOMATIC FLOAT POSITION FOR BOOM AND STICK

The Shovel operates automatically with the float position for boom and stick activated.

That means the lowering movement of boom and stick is always done in the float position. To deactivate the float position, press button (3) for boom and/or (4) for stick, and keep depressed as long as the float position shall be deactivated. When releasing the buttons the float position is activated again.

**For more information → See "WORKING WITH THE ATTACHMENT" on page 178.**

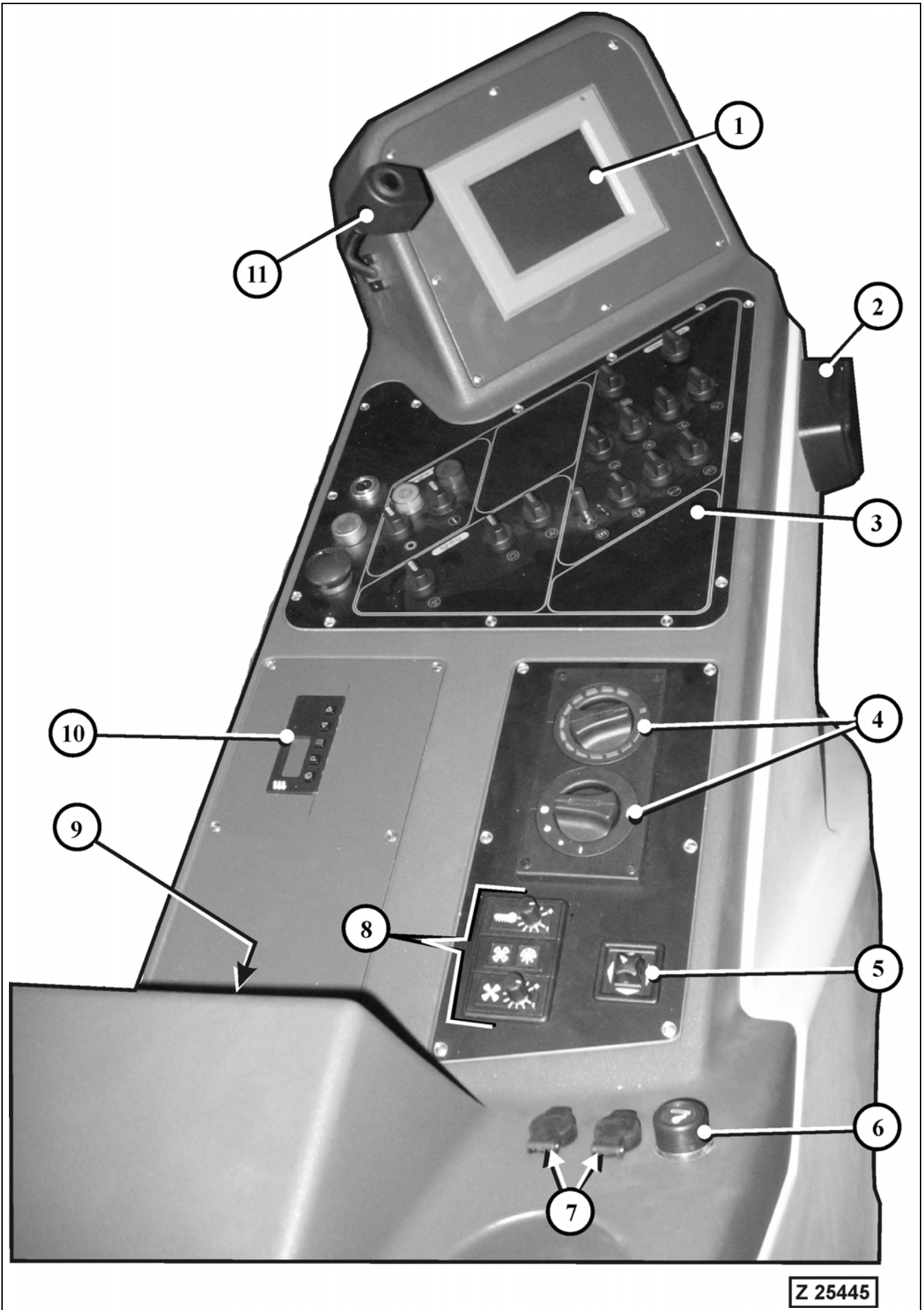

### 3.3.6 OPERATOR'S CONSOLE

#### Legend for illustration Z25445

- (1) Monitor of the **Vehicle Health Monitoring System**  
**>VHMS<**

The monitor (1) displays the condition of the machine, the maintenance status, and messages for the operator and service man, and is also used to input the necessary data.

The surface of the monitor screen is equipped with touch switches to switch the screen and input the data.

**For more information → See "VEHICLE HEALTH MONITORING SYSTEM VHMS – HEALTH MONITOR" on page 96.**

- (2) Ashtray
- (3) Switch board, refer to next page for description of components
- (4) Cab heater controls, see page 93 for more information
- (5) Switch for left and right mirror adjustment
- (6) Cigarette lighter
- (7) Plug sockets, 24V DC
- (8) Air conditioner control panel, see page 93 for more information
- (9) Radio location
- (10) Control module for engine-independent auxiliary cab heater (special equipment), see page 122 for more information.
- (11) Switch board lighting with flexible arm

---

**⚠ CAUTION**

---

**Make sure the cab door is always closed when working with the Shovel.**

**Secure the door in open position with the locking device provided.**

---

---

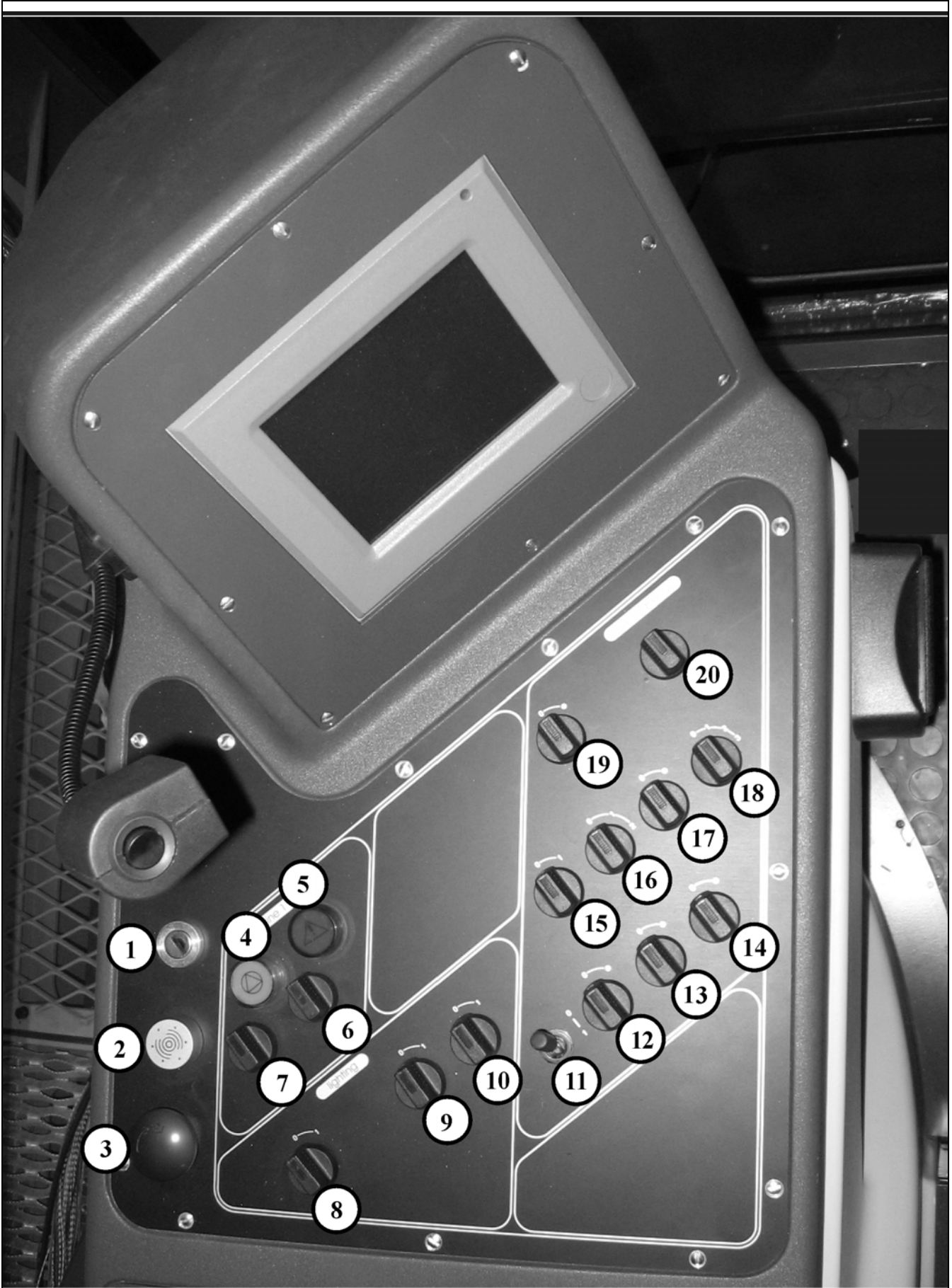

Z 25446



## Switch Board

### Legend for illustration Z25446

- (1) Key operated main switch

**CAUTION**

**After switching OFF main switch (1), wait at least 3 minutes before switching OFF the battery main switches. VHMS needs this period for saving data. If batteries are switched OFF before this time period is over, data will be lost.**

- (2) Acoustic warning signal

This signal sounds for approximately 1 second when a fault message appears on the VHMS screen.

**CAUTION**

**In case of too low hydraulic oil level this signal sounds continuously. Shut down the Shovel, locate and correct the cause immediately. Fill up hydraulic oil to the correct level. For the correct checking procedure → See "CHECKS BEFORE STARTING THE ENGINE" on page 154.**

- (3) Strike button, emergency shut down of the engine and pilot control system cut out.

**WARNING**

**In case of emergency push in this button to stop the Diesel engine and to cut out the pilot control circuit. DO NOT use for normal stopping procedure.**

For releasing the switch, turn and pull-up the strike button.

- (4) Engine WARNING lamp (Yellow). This lamp is used to monitor engine out-of-range condition, in case the VHMS Monitor fails to function. When this lamp illuminates, the engine can still be operated until end of shift, but it can lose some system features which sometimes results in power loss (derate condition). Inform Service about the engine problem.
- (5) Engine STOP lamp (Red). This lamp is used to monitor engine out-of-range condition, in case the VHMS Monitor fails to function. When this lamp illuminates, stop the engine operation in a safe manner immediately. The engine monitoring system CENSE or the electronic control module ECM will initiate automatic engine shutdown due to serious engine problem. Inform Service about the engine failure.
- (6) Rotary switch "Engine START"
- (7) Rotary switch "Engine STOP"
- (8) Switch for warning beacon on cab roof
- (9) Switch for interior illumination

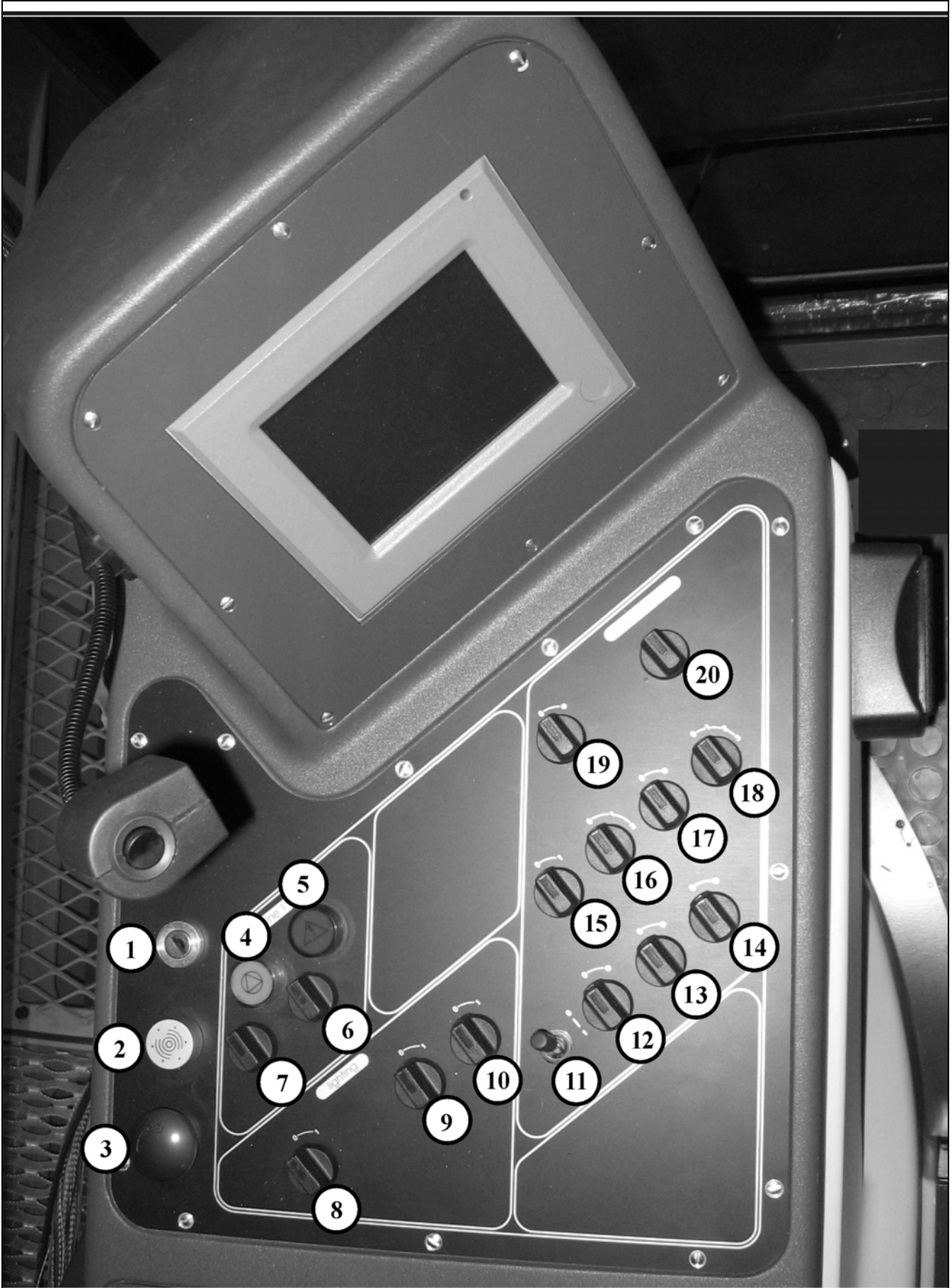

Z 25446

## Switch Board (continued)

### Legend for illustration Z25446

- (10) Switch for main working lights
- (11) Toggle switch, swing parking brake
  - 0 - Parking brake released - UP
  - 1 - Parking brake applied - DOWN.

### ▲ CAUTION

**The parking brake should only be applied with superstructure at complete standstill, except in case of emergency. Refer to page 176 for more information.**

- (12) Enable switch for hydraulic service arm operation. Set this switch to ON position "1" before lowering the service arm. With this switch in ON position, the pilot control system is made inoperative and the hydraulic swing brake is applied. After completion of replenishment procedure, swing back the service arm to its home position and set switch (12) to OFF position "0".
- (13) Switch, manual actuation of central lubrication system
- (14) Switch, windshield washer
- (15) Switch, mirror heating
- (16) Switch, cab ventilation blower. Blower runs with low speed, even with switch in -0- position. (Cab pressurizing prevents ingress of dust).
- (17) Switch, manual actuation of swing ring gear pinion lubrication system
- (18) Switch for upper and lower windshield wiper
  - 0 - Off
  - 1 - Interval stage
  - 2 - Slow stage
  - 3 - Fast stage
- (19) Switch for Truck counter number 2 (TR2). For counting loaded trucks rotate this switch. The total number of trucks loaded is shown on the VHMS monitor field TR2, refer to page 96 for more information. The push button for Truck counter number 1 (TR1) is located on the RH control lever.
- (20) Swing speed switch.
  - 0 - Normal swing speed.
  - 1 - Increased swing speed.
 It is recommended to use the higher swing speed for slewing angles greater than 90°.

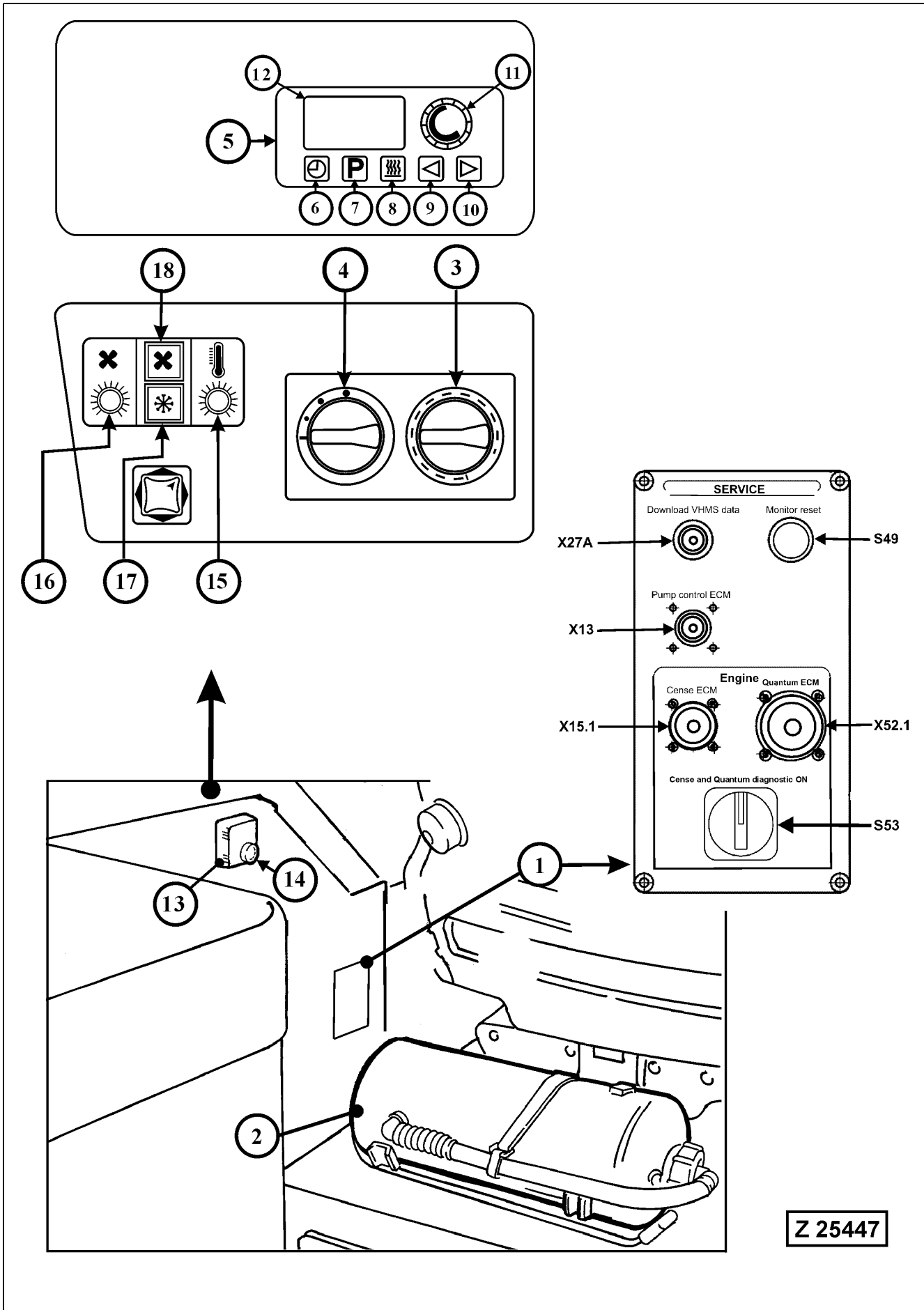

### 3.3.7 INTERFACE PANEL FOR DIAGNOSTICS AND CONTROLS FOR HEATING AND AIR CONDITIONING

#### Legend for illust. (Z25447)

- (1) Interface panel on rear operator's console
- (X27A) Data link connector for download of VHMS memory data
- (S49) Reset button for VHMS monitor
- (X13) Data link connector for Electronic Tool connection to the electronic pump control system MC7
- (X15.1) Data link connector for Electronic Tool connection to the ECM of the engine monitoring system CENSE
- (X52.1) Data link connector for Electronic Tool connection to the ECM of the engine control system QUANTUM
- (S53) Enable switch for Cense and Quantum diagnostic. For download of engine data and for programming the Cense and Quantum ECM stop the engine and set main key switch to off position, then turn on switch (S53). For checking active fault codes of the engine via service lamps H94, H95 and H96 located on switch board (X2) in the cab base use the same procedure described above. Refer to page 141 for more information.
- (2) Portable fire extinguisher. Observe the local Fire Prevention Regulations in regard to number, size and location of portable fire extinguishers. Make sure the fire extinguisher is always charged and ready for use.
- (3) Cab heating control
- (4) Cab heating blower control

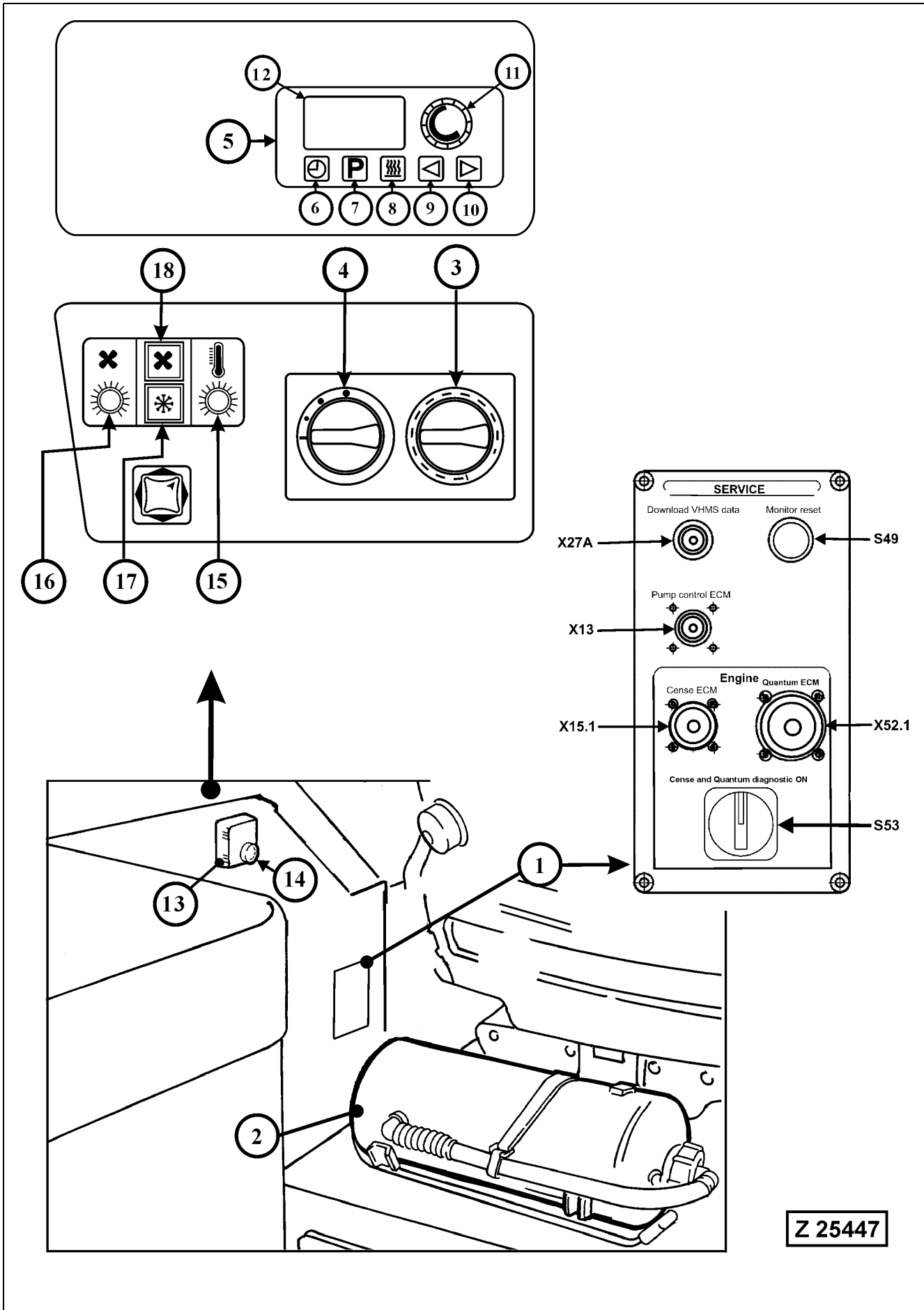

## Interface Panel for Diagnostics and Controls for Heating and Air Conditioning (continued)

### Legend for illust. Z25447

- (5) Control module for the engine independent auxiliary cab heater (if so equipped). This module is used for switching ON and OFF the auxiliary cab heater during operation of the shovel with the Diesel engine running, and for pre-selection of heater start times and duration of heating periods. For detailed setting instructions of the control module refer to the separate operating instruction sheet in volume 2 binder.
  - (6) Button for actual time indication
  - (7) Button for preselection of heating time
  - (8) Button for heating indication
  - (9) Button for settings backwards
  - (10) Button for settings forward
  - (11) Not used
  - (12) Display shows the operating condition of the auxiliary cab heater
  - (13) Thermostat for engine independent auxiliary cab heater (if so equipped).  
This unit is used to maintain a desired temperature in the cab during standstill periods of the shovel. For operation of the auxiliary cab heater, power supply must be provided by an external power source. The battery main switches and the pre-heating system main switch must be in ON position. See section PRE-HEATING SYSTEMS on page 147 and section OPERATING THE HEATER; VENTILATION AND AIR CONDITIONING on page 122 for more information. The fuel shut-off cock for the water heater HYDRONIC must be in open position, see page 125 for more information. Activate the heater with control module (5).
  - (14) Temperature selector button
  - (15) Air conditioner temperature control knob
- REMARK**
- To lower the cab air temperature (maximum cooling output) rotate the control knob to the left ( - ) sign. To reduce cooling output rotate the knob to the right ( + ) sign.
- (16) Air conditioner blower control knob
  - (17) Indicator light, air conditioning ON
  - (18) Indicator light, air conditioning blower ON

## 3.4 VEHICLE HEALTH MONITORING SYSTEM VHMS – HEALTH MONITOR

### 3.4.1 INITIALIZATION SCREEN NO. 0.0

The Monitor of the **Vehicle Health Monitoring System "VHMS"** illust. (Z 21569) displays the condition of the machine, the maintenance status, and messages for the operator and service man, and is also used to input the necessary data. The surface of the monitor screen is equipped with touch switches to switch the screen and input the data.

#### Sequence of Displays

When the main key switch is turned ON, the initialization screen (No. 0.0) is displayed for approx. 5 seconds. This screen shows also the selected system language.

#### REMARK

If the ambient temperature of the monitor is below -10°C, the screen remains dark until the internal heater has warmed up the screen to operating temperature. If the ambient temperatures goes above +60°C the screen becomes dark (back light is turned off to protect the screen).

When the temperature returns to operating range, the display will appear again, so carry out operations according to the machine monitor. A reset button for the monitor is located on the Operator's console, see illustration (Z 25447) on page 93.

#### REMARK

The system offers two languages, for example ENGLISH – GERMAN, according to Customer request. Changing of the present language can be carried out in the main group SETTINGS of the SERVICE MENU. Refer to the SERVICE MANUAL VHMS-SYSTEM for more information.



### 3.4.2 OPERATOR INFORMATION SCREEN NO. 1.1

The second display (No. 1.1), illust. (Z 21570) is of general information for the operator.

Press the touch switch "NEXT" on the screen surface for display of the standard monitor 1, (No. 1.2).

#### REMARK

The colored Graphic Flow Chart (Z 21568) attached in the pocket of the front cover gives an overall view of the menu structure, the menu availability for the operator and for the service staff, as well as the automatic functions of the system. The numbering (0.0, 1.1, 1.2 and so on) of the monitors in this chart is also used on all monitor pictures in this section. Use this chart for menu control in connection with the description on the following pages.

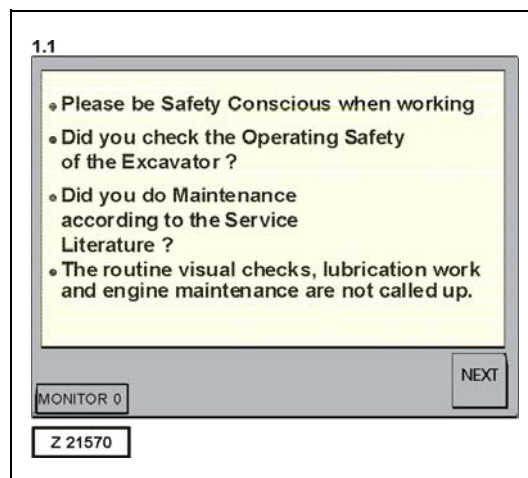



### 3.4.3 STANDARD MONITOR 1 (NO. 1.2)

See illust. (Z 21571)

Displayed items:

**LH column**

- **Date**
- **Time**
- °C = Ambient temperature
- h = Operating hours (SMR)
- TR1 = Truck counter 1
- TR2 = Truck counter 2
- 1/min = Engine speed (RPM)
- **Monitor No. 1.**

**Gauges**

- FUEL LEVEL
- HYDRAULIC OIL TEMPERATURE
- COOLANT TEMPERATURE
- OIL PRESSURE ENGINE

**Color Definition**

Blue	Normal operating range
Yellow	Warning range
Red	Serious trouble, act immediately. Engine derate or shutdown may happen.

**REMARK**

When the pointer of a gauge moves into a yellow or red range, there will be in most cases an automatic message display informing the operator in plain text about the failure and the necessary action to be taken. For a typical display see 1.2.5 Automatic Message.

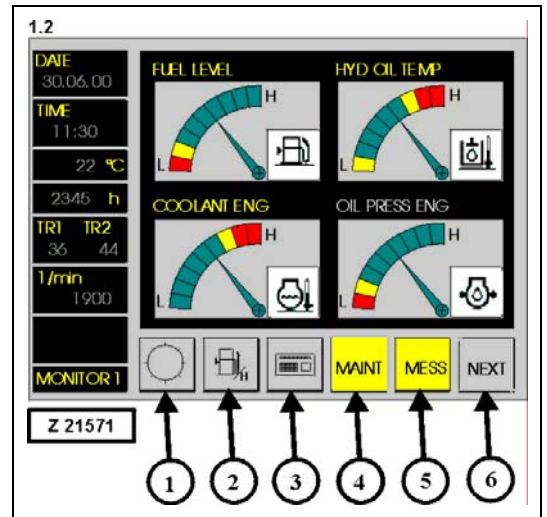

**Touch Switches**

<b>1</b>	"Brightness" This button switches to Brightness and Contrast setting screen, for details see picture No. 1.2.1.
<b>2</b>	"Fuel Consumption" This button switches to Fuel consumption screen, for details see picture No. 1.2.2.
<b>3</b>	"Settings Operator" This button switches to Settings for Operator, User ID and Truck counter resetting screen, for details see picture No. 1.2.3.
<b>4</b>	"Maintenance" This button switches to the Maintenance Monitor. The color of this switch changes to yellow when Maintenance is due, for details see Maintenance Monitor No. 1.2.4.
<b>5</b>	"Message" This button switches to Failure Message history screen for the operator. The color of this switch changes to yellow when a current message is available in the Failure Message history for the operator. The button remains yellow as long as the cause for the message exists, even if the message was canceled. For details see Failure Message screen (for Operator) No. 1.2.5.
<b>6</b>	"Monitor selection" This button switches to the next Monitor in the following order: Monitor 1 >2 >3 >1 and so on, see pictures No. 1.2, 1.3 and 1.4.

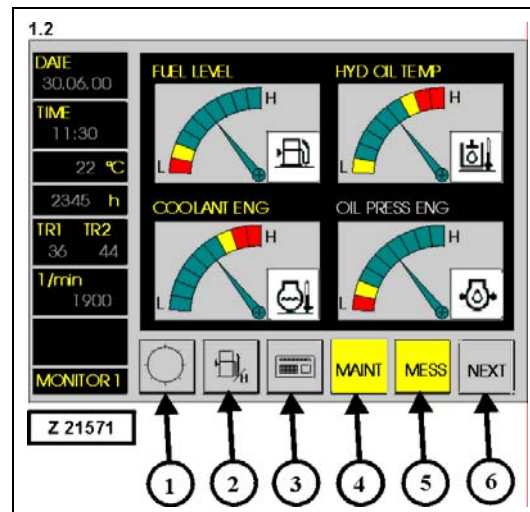

**Expansion Monitor 2 (No. 1.3)**

See illust. (Z 21572)

Displayed items:

**LH column**

Same as Standard Monitor 1

**Gauges**

- ENGINE OIL TEMPERATURE
- PTO OIL TEMPERATURE
- BOARDNET VOLTAGE
- CHARGING AMPERE

**Touch Switches**

Same as Standard Monitor 1

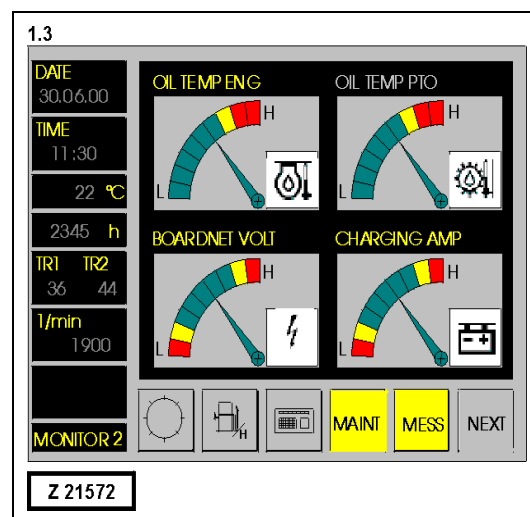

## Expansion Monitor 3 (No. 1.4)

See illust. (Z 21573)

Displayed items:

### LH column

Same as Standard Monitor 1

- Gauges:
- HYDRAULIC OIL LEVEL
- ENGINE OIL LEVEL
- GREASE LEVEL **CENTRAL LUBRICATION SYSTEM (CLS)**
- GREASE LEVEL **SWING RING GEAR LUBRICATION SYSTEM (SLS)**

### Touch Switches

Same as Standard Monitor 1

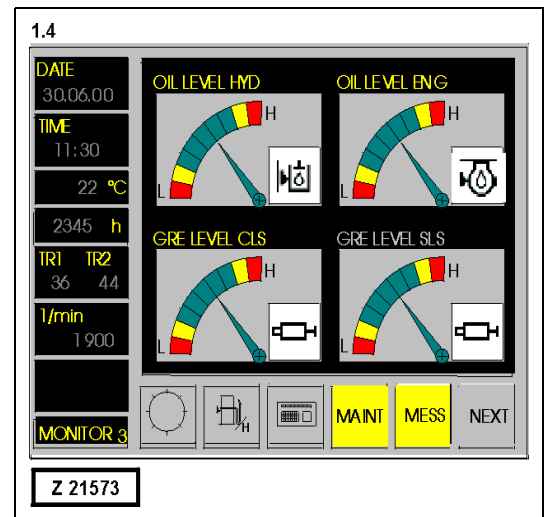

## Brightness and Contrast Setting Screen (No. 1.2.1)

See illust. (Z 21574)

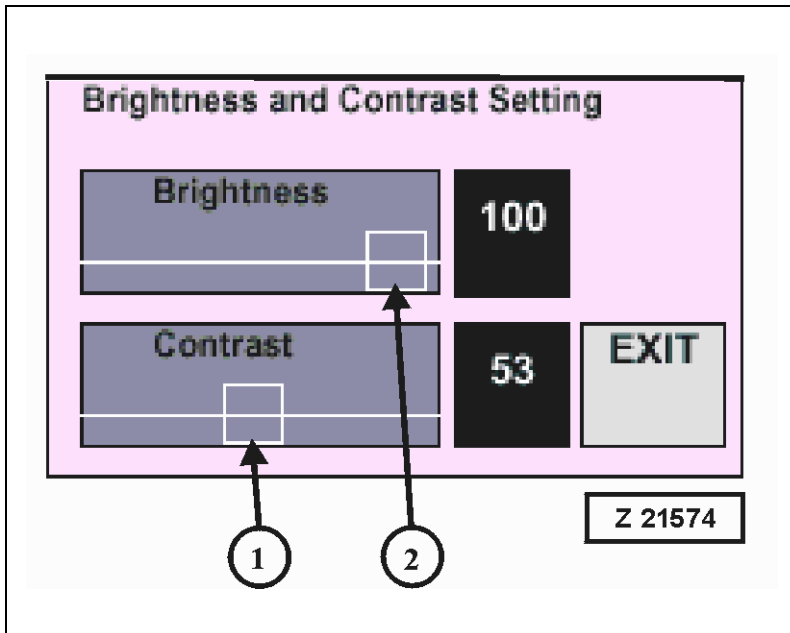

When the brightness button is pressed, the screen No. 1.2.1 is displayed. If this screen is not touched within 5 seconds, it will disappear and the original screen will be displayed.

- (1) Contrast control slide:  
To adjust the contrast of the screen, press the desired position on the slide bar.
- (2) Brightness control slide:  
To adjust the brightness of the screen, press the desired position on the slide bar.

## Fuel Consumption Screen (No. 1.2.2)

See illust. (Z 21575)

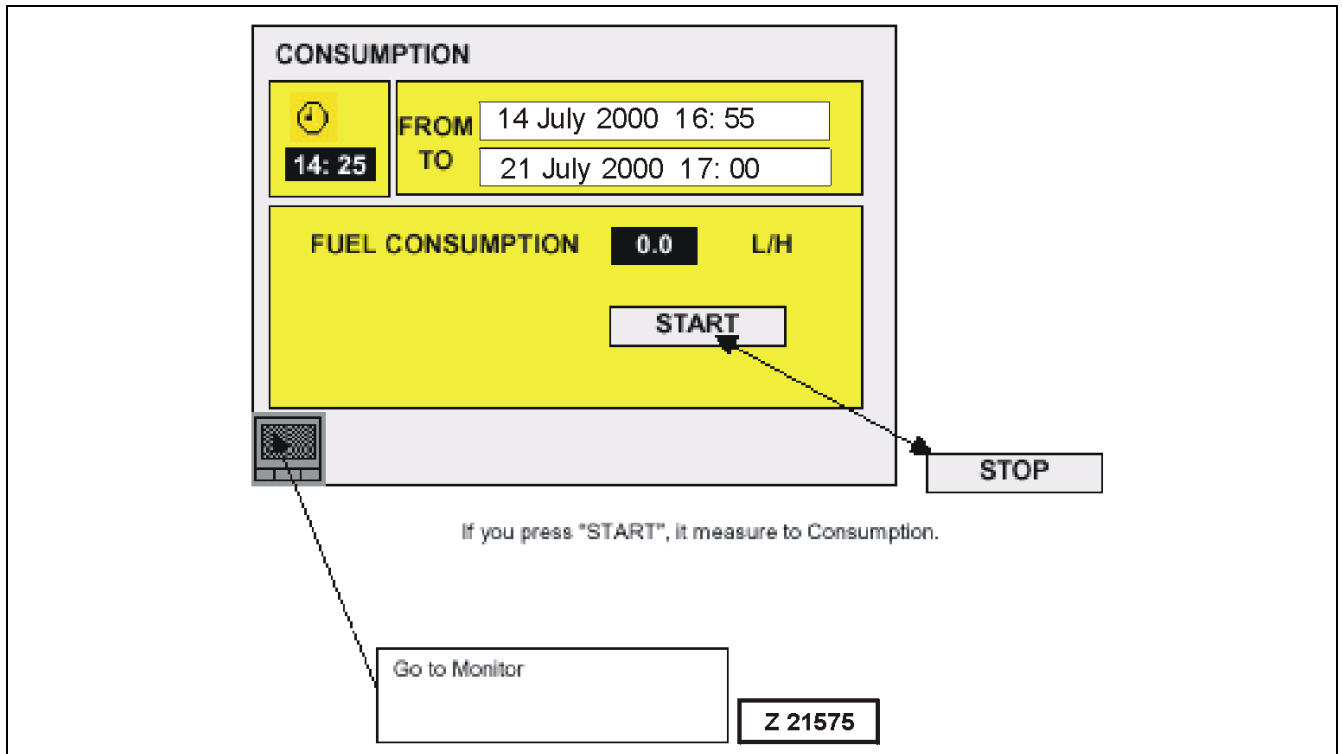

When the fuel consumption button (2) is pressed, the screen No. 1.2.2 is displayed. The last data are displayed in each field on the screen. Pushing the "START" button will erase them and "TO" and "FUEL CONSUMPTION" fields are changed to blank. If you want to start fuel consumption measurement, push the "START" button. The Date and local Time will be inserted into the "FROM" field. The "START" button changes to "STOP" button. Push the (Go to Monitor) button to go back to the Standard Monitor 1.

When the time period for fuel consumption measurement is over, for example after 4 days, select the CONSUMPTION Screen from any of the three Monitors No. 1.2, 1.3 or 1.4 by pushing the fuel consumption button (2). The displayed consumption screen shows the starting date and time of fuel consumption measurement. Push the "STOP" button. The current date and time is inserted into the "TO" field and the average fuel consumption calculated during the time period "FROM – TO" is inserted into the "FUEL CONSUMPTION" field.

- **Clock symbol:** current time
- **FROM:** date and time when the "START" button is pushed
- **TO:** date and time when the "STOP" button is pushed
- **FUEL CONSUMPTION:** Average consumption data between Start and Stop.

Push the (Go to Monitor) button to go back to the Standard Monitor 1.

**Settings for Operator, Screen (No. 1.2.3), see illust. (Z 21576)**

When the button -Settings for Operator is pressed, the screen No. 1.2.3 is displayed.

**Entry of the Operator identification number (USER ID button):**

In the selection menu for settings (1.2.3) appears on the right side of the button "USER ID" the actual eleven-digit Operator identification number. The use of the button "USER ID" branches into the setting mode for the Operator identification number, see illust. (Z 21578).

Without prior entry, 0 is predetermined as identification number.

To distinguish Operators, it is possible to enter a eleven-digit Operator identification number. To this effect, the Clear-button puts the cursor onto the first position (left side). Data entry may be started via the number buttons.

If eleven numbers were entered each further entry will be ignored. Using the Enter-button the identification number will be taken over and branched back to the selection menu (1.2.3).

**Resetting the Truck Counter:**

Press the button "Reset Truck Counter 1" the display changes to "YES – NO" decision screen, picture (Z 21577). When pressing the "YES" button the counter 1 will be reset to zero. Truck counter 2 is reset in the same way.

**REMARK**

There are two hidden touch switches on the SETTING for Operator screen, see (1) and (2) illust. (Z 21576). These switches are used by service personnel for entering the Service Menu. To enter the Service Menu, first press the lower button (1) and then the upper button(2).

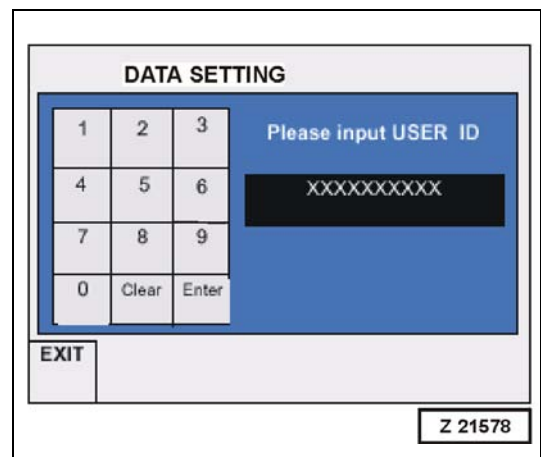
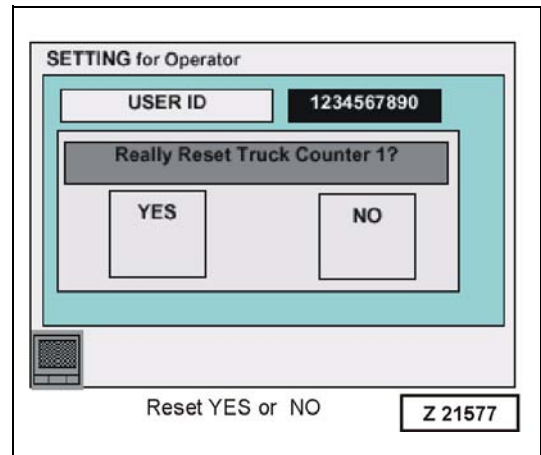
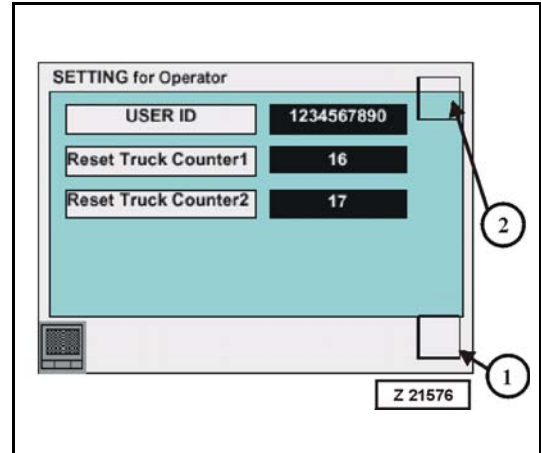

### Maintenance Monitor 1.2.4

The Maintenance Monitor can be selected from the Standard monitor 1 and from the expansion monitors 2 and 3 by pressing the Maintenance button (4). The color of this button changes to yellow when maintenance is due. The color will change to red when maintenance is overdue.

The maintenance monitor is shown at six different operating hour readings, see pictures (Z 21579A to F).

#### Color definition of Periodic Maintenance text:

The five periodic maintenance intervals are listed in text form with a colored background. The colors have the following significance:

**Grey** - Maintenance still not due the displayed hours at the right side of the text are greater than 48 h before the next maintenance is due.

**Yellow** - Maintenance is due the displayed hours are equal or smaller than 48 h before the next maintenance or, numbers smaller or equal to 48 h with a minus sign indicating that the maintenance is already overrun. The total number of hours in the yellow range is 96, divided in 48 hours with a positive value and 48 hours with a negative value.

**Red** - Maintenance is overdue hour numbers with a negative value go further into the minus range indicating that the limit for the periodic maintenance is exceeded.

#### Examples of Maintenance Monitor displays:

Illust. Z 21579A: 2050 Operating hours

All five periodic maintenance intervals on the screen are gray. No maintenance required.

Illust. Z 21579B: 2220 Operating hours

The Periodic 250 h Maintenance field is yellow indicating that this maintenance has to be carried out. The number of hours displayed is less than 48. All other maintenance fields having hour numbers greater than 48 h and are still gray.

Illust. Z 21579C: 2980 Operating hours

The 250 h, 500 h, 1000 h and 3000 h maintenance is due. The 2000 h maintenance has been carried out at 2000 operating hours and there are 1020 h left until the next 2000 h maintenance becomes necessary.

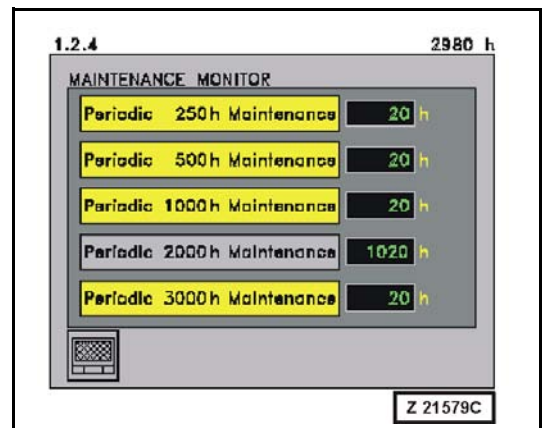
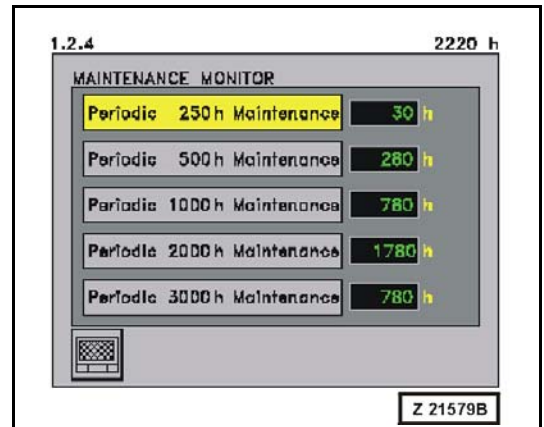
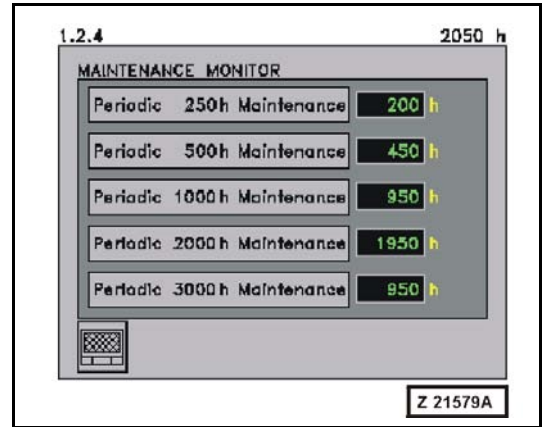

### Maintenance Monitor 1.2.4 (continued)

Illust. Z 21579D: 3050 Operating hours  
 The 250 h, 500 h, 1000 h and 3000 h maintenance has not been carried out within the yellow time period so the background color has changed to red, indicating that the limit for these maintenance items is exceeded by 50 h

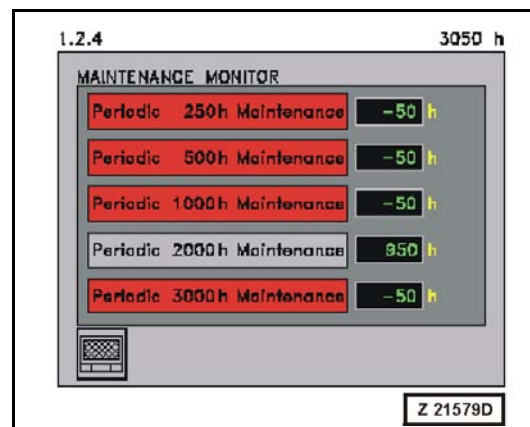

**WARNING**  
**Inform Service about the present maintenance display. Maintenance is urgently required.**

The 2000 h maintenance has been carried out at 2000 operating hours and was confirmed in the Service Menu. There are 950 h left until the next 2000 h maintenance becomes necessary.

Illust. Z 21579E: 3100 Operating hours  
 The 250 h, 500 h, 1000 h and 3000 h maintenance has been carried out at 3100 operating hours and was confirmed in the Service Menu. The background color has changed to gray.

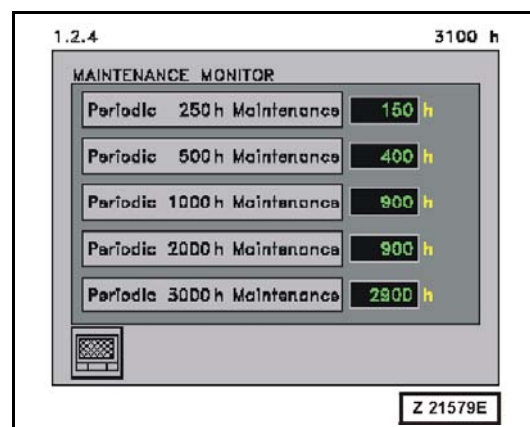

Illust. Z 21579F: 3550 Operating hours  
 The 250 h, maintenance has been carried out at 3250 and at 3500 operating hours. The periodic 500 h maintenance which was also due at 3500 operating hours was not carried or not confirmed in the Service Menu so the background color changed to red. Inform Service for carrying out the 500 h maintenance. On pressing the key it is possible to return to the monitor 1.

**Peculiarities to be observed:**

Higher maintenance also include lower maintenance. (Lower maintenance must also be carried out!) Exception: On performance of the 3000 h maintenance it is not necessary to also carry out the 2000 h maintenance. The maintenance cycles are rigidly linked to the running time meter. Maintenance may be confirmed max. 48 h prior to elapsing the maintenance cycle. Only running time hours are taken into consideration (No minutes or seconds). On initial start-up any maintenance is indicated with gray.

**NOTICE**

**The routine visual checks and inspections after every 10 and 50 operating hours are not called up on the Maintenance Monitor. Carry out these checks and inspections according to the MAINTENANCE section 4 in this manual. The engine maintenance has to be carried out according to the separate Engine Operation and Maintenance Manual filed in this binder.**

**REMARK**

On new machines an INITIAL SERVICING after the first 250 and 1000 operating hours is required, in addition to the periodic maintenance intervals displayed on the monitor. Carry out all maintenance items according to the MAINTENANCE section 4 in this Manual.

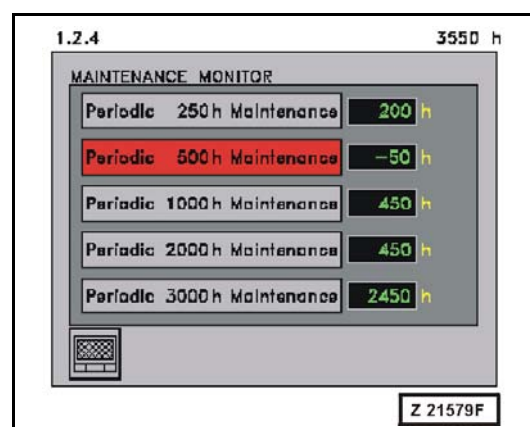



## **Maintenance confirmation through Service Personnel**

Maintenance indicated with yellow or red background color should be confirmed through Service Personnel in the Service Menu subsequent to the execution of the maintenance. With the confirmation the actual value maintenance number is increased by 1. Thus, the length of the maintenance cycle is added to the display value and the gray color will appear in the maintenance display.

The button in the Service Menu used for maintenance confirmation then turns gray instead of yellow and is then without any function. The confirmation of the maintenance generates a corresponding message present for 1 second and is then stored.

For more information of maintenance confirmation refer to the Service Manual "VHMS" System.

### 1.2.5 Failure Message (for Operator)

#### Failure history for Operator

The Failure Message history screen illustration (Z 21580) can be selected from the Standard monitor 1 and from the expansion monitors 2 and 3 by pressing the "Message" button. The color of this button changes to yellow when a current message is available in the failure message history for the operator.

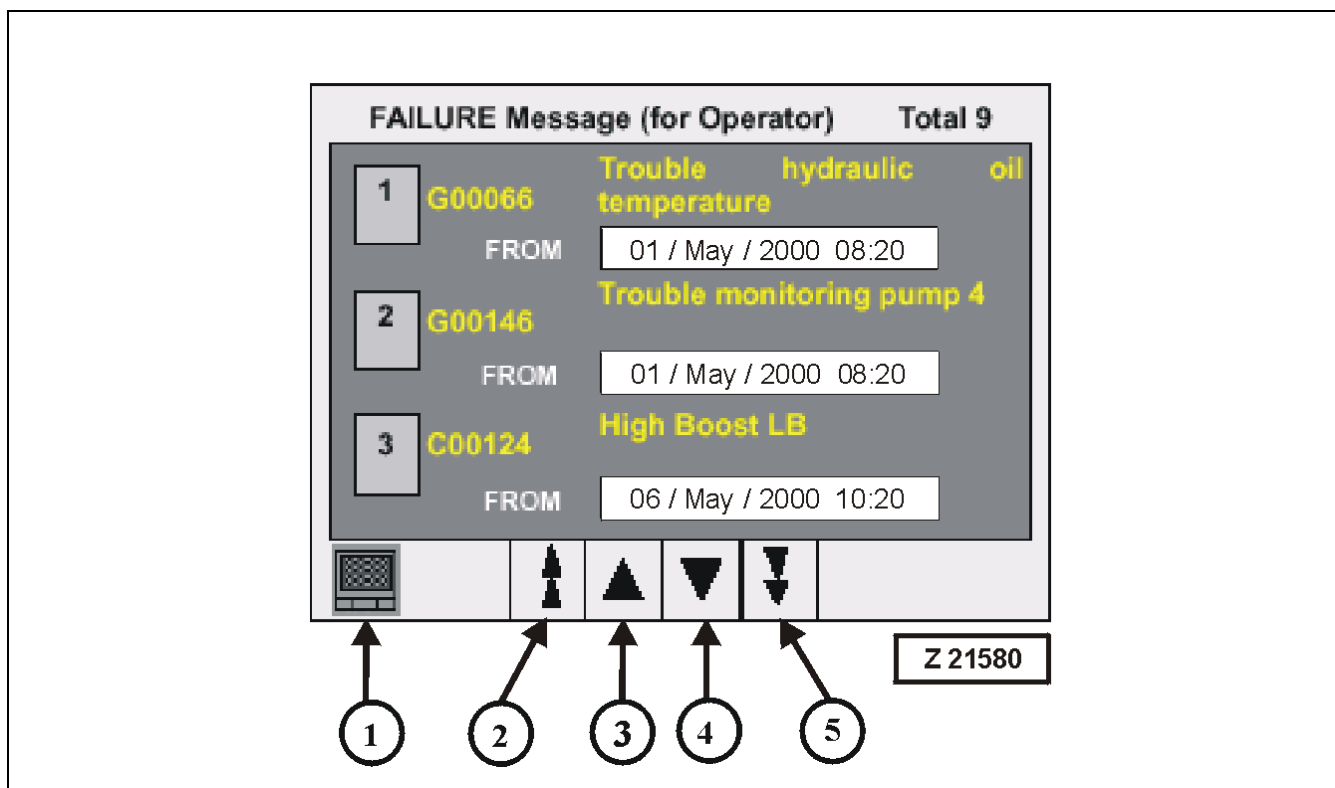

#### Legend for illust. (Z 21580)

(1)	Standard monitor display button, switches back to the Monitor previously displayed.
2	Quick scroll up button, replaces all three messages with three previous messages
3	Scroll up button, shifts single messages
4	Scroll down button, shifts single messages
5	Quick scroll down button, replaces all three messages with three following messages

When the cause for a message listed in the failure history has gone, the message will be removed from the failure history for operator and the time and date is added to the already stored message in the memory of the Failure History for Service.

### Automatic Messages

If a failure or an information condition occurs during operation, the present display is automatically replaced by a message in text. If there are several messages at the same time, the system starts rolling up of all present messages and the present display. Each message is being displayed a few seconds. The message text informs the operator about the type of failure and the action to be taken. Carry out the action given on the screen.

### REMARK

The headings of automatic messages have a background color indicating the severity of the condition as follows:

<b>RED</b>	Severe - act immediately. See illust. (Z 21581) for a typical message with red background.
<b>YELLOW</b>	Caution - inform service, work can be continued. See illust. (Z 21582) for a typical message with yellow background.
<b>GREEN</b>	Information. See illust. (Z 21583) for a typical message with green background.

### Automatic Messages

Example of a message with red background color of the top message, see illust. (Z 21581).

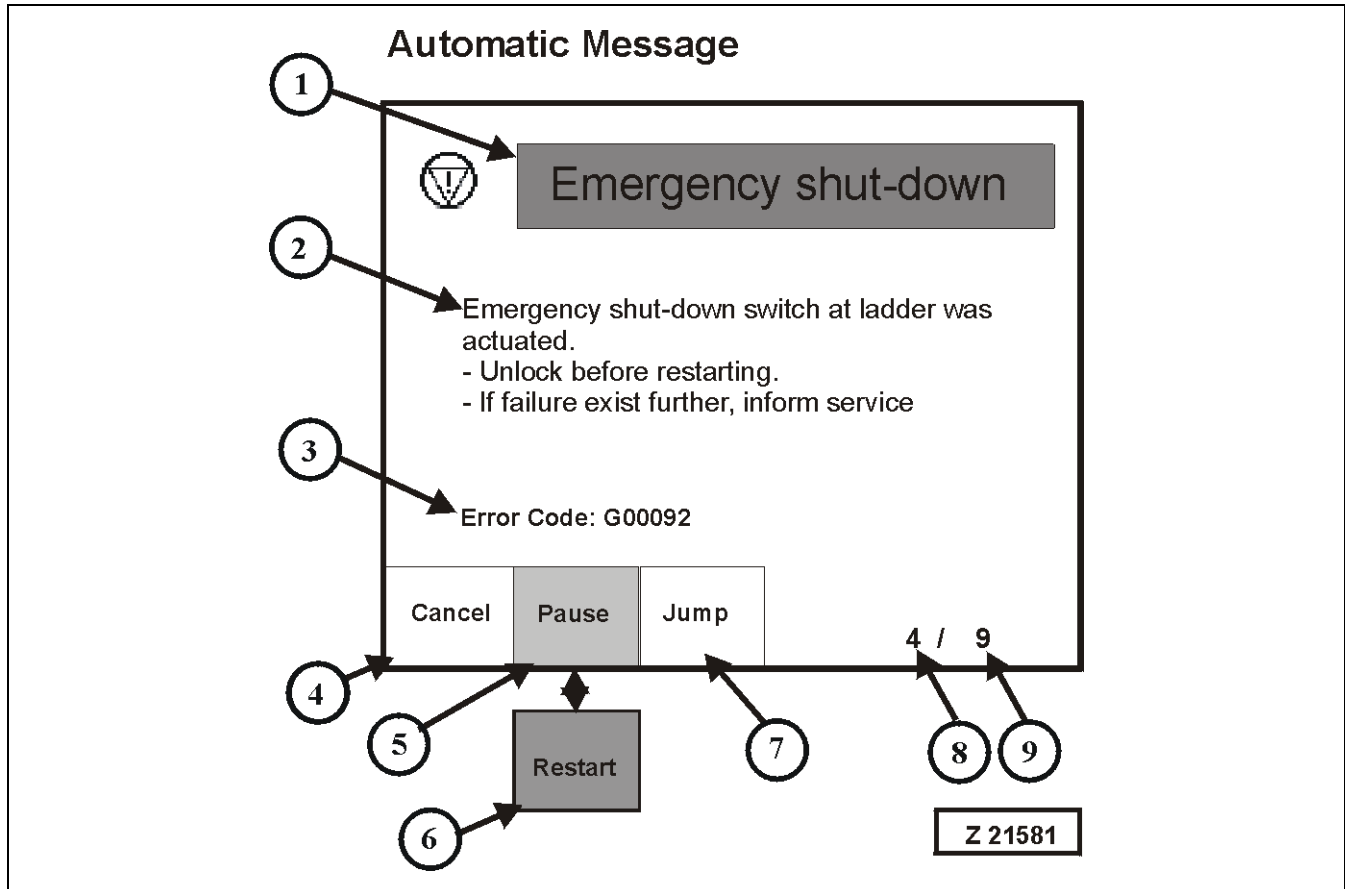

Legend for illust. (Z 21581) and (Z 21582)

1	Top message: Type of failure
2	Instruction message: Follow the displayed instructions
3	Message number (Error code): G = Shovel generated message C = engine 1 generated message
4	Cancel button: When this button is pressed, the displayed current message disappears and is listed in the failure history for operator. The message will be displayed again when a different Operator Identification number (ID) is entered.
5	Pause button (green): When this button is pressed, automatic rolling up of messages is stopped and the displayed message will be frozen on the screen for two minutes. The button changes to Restart (red). New message will overwrite the frozen message.

### Automatic Messages

Legend for illust. (Z 21581) and (Z 21582) continued

6	Restart button (red): This button restarts automatic roll up of current messages.
7	Jump button: This button switches to the last displayed menu, normally the Standard Monitor 1. After two minutes the display jumps automatically back to the last displayed Automatic Message and rolling up of messages starts again. If a menu select button was activated during the two minutes standard Monitor display period, the display will also jump back to Automatic Message when the two minutes are over. New message will overwrite any menu display and rolling up of messages starts again.
8	Order of occurrence of message now being displayed
9	Total number of existing messages

Example of a message with yellow background color of the top message, see illust. (Z 21582).

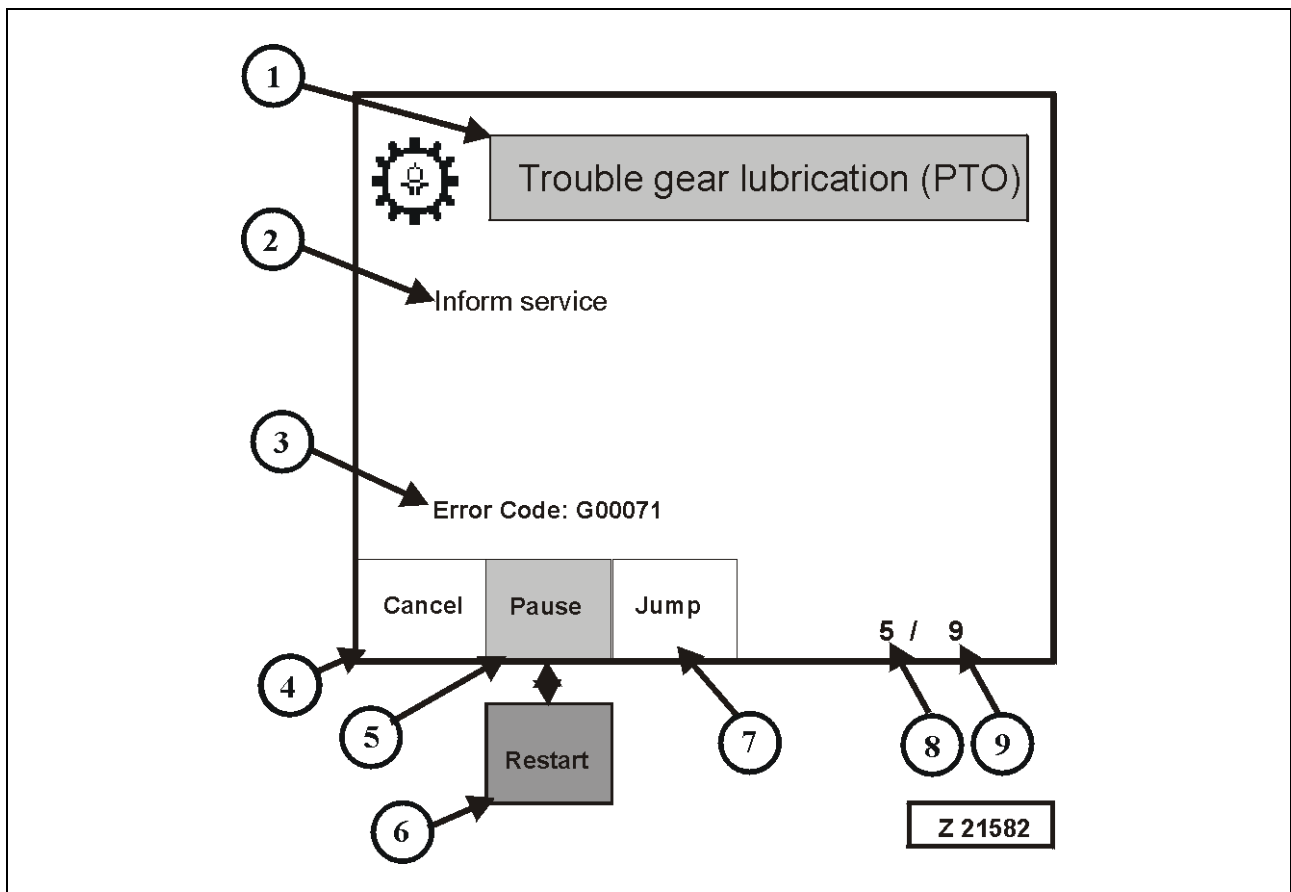

### Automatic Messages

Example of an information message with green background color of the top message, see illust. (Z 21583).

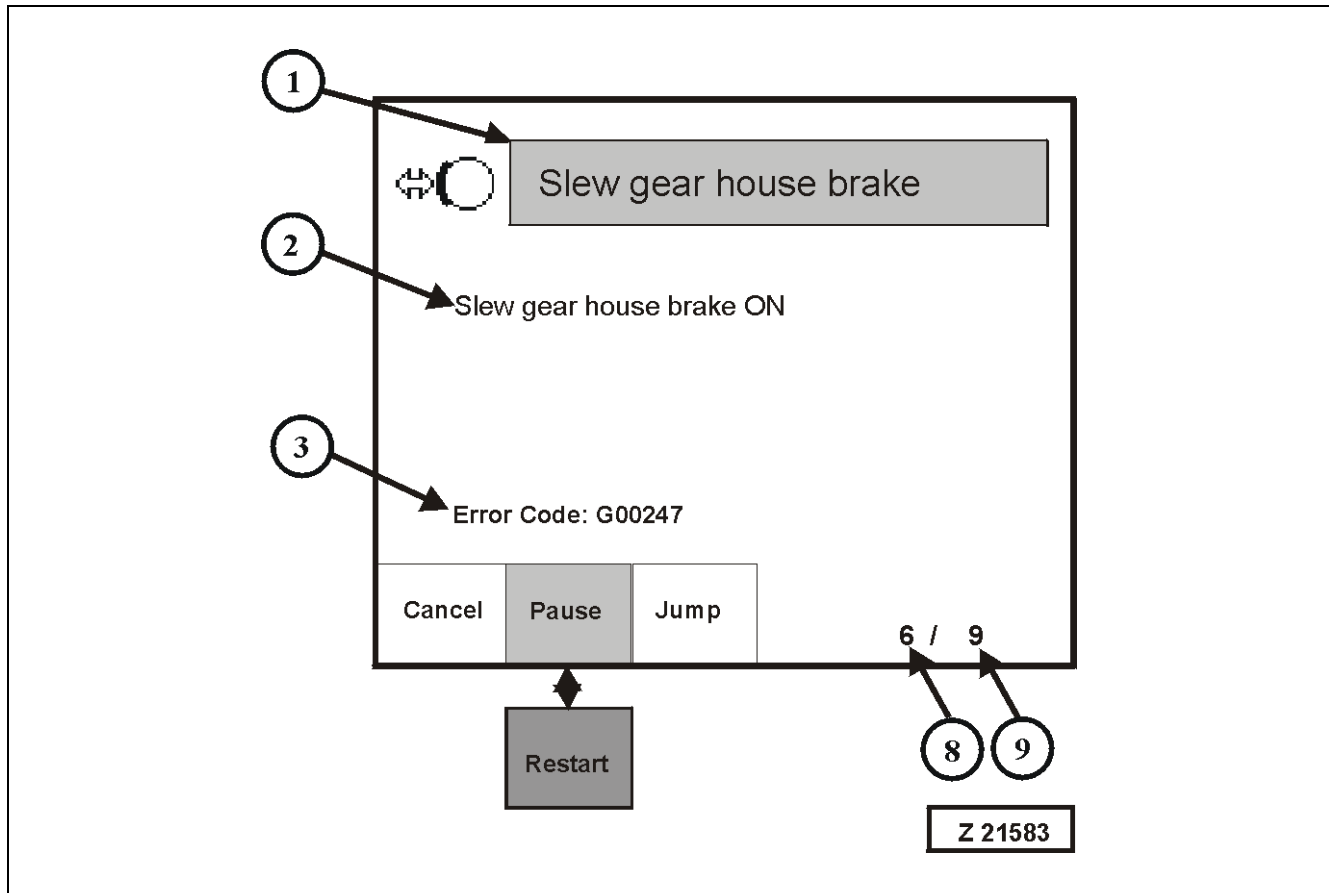

#### Legend for illust. (Z 21583)

1	Top message: Type of information
2	Explanation of condition
3	Message number (Error code): G = Shovel generated message C = engine 1 generated message
8	Order of occurrence of message now being displayed
9	Total number of existing messages

#### REMARK

All messages available in the system are listed up on the following pages.

#### NOTICE

The message number G00169\*) indicates two trouble conditions, either return oil filter trouble or return oil strainer trouble. Refer to instruction message number 17 on page 120 for more information.

### 3.4.4 TABLE OF ALL TOP MESSAGES PROVIDED BY THE SYSTEM

#### NOTICE

The Instruction Messages belonging to the TOP Messages are listed in a separate Table. The number shown in the Instruction Message column indicates the applying Instruction Message for the TOP Message.

ErrorCode (Message number) G = Shovel C = Engine 1	Color code of TOP Message: 0 = RED 1 = YELLOW 2 = GREEN	Instruction Message Number. Refer to separate Table	TOP Message with colored background
			REMARK Messages w/o color code are not displayed. These messages are stored in the history memory only.
G00001	0	1	Trouble Shut-Off (gate) valve
G00002	2	37	Test speed 1800 rpm
G00003	1	38	Trouble pump controller
G00005	1	39	Low hydraulic oil level
G00007	0	2	Trouble hydraulic oil level
G00008	0	3	Trouble HPF 1
G00009	0	3	Trouble HPF 2
G00010	0	3	Trouble HPF 3
G00011	0	3	Trouble HPF 4
G00012	1	17	CLS grease level too low
G00013	1	17	SLS grease level too low
G00020	0	4	Trouble Shut-Off (gate) valve (Start blocked)
G00021	0	5	Trouble monitoring HPF 1
G00022	0	5	Trouble monitoring HPF 2
G00023	0	5	Trouble monitoring HPF 3
G00024	0	5	Trouble monitoring HPF 4
G00060	0	6	Fire in the power house
G00061	0	2	Trouble monitoring, engine speed too low
G00062	0	2	Trouble monitoring, engine speed too high
G00063	0	2	Trouble monitoring hydraulic oil temp
G00064	0	2	Trouble monitoring hydraulic oil level
G00065	1	2	Very low hydraulic oil level
G00066	0	7	Trouble hydraulic oil temperature
G00067	1	2	Trouble battery voltage too high
G00069	1	2	Trouble monitoring oil temp gear (PTO)
G00070	1	2	Trouble oil temperature gear (PTO)

<b>ErrorCode (Message number) G = Shovel C = Engine 1</b>	<b>Color code of TOP Message: 0 = RED 1 = YELLOW 2 = GREEN</b>	<b>Instruction Message Number. Refer to separate Table</b>	<b>TOP Message with colored background</b>  <b>REMARK</b> Messages w/o color code are not displayed. These messages are stored in the history memory only.
G00071	1	2	Trouble gear lubrication (PTO)
G00072			Trouble monitoring hydraulic oil level
G00073			Trouble monitoring remote engine oil level
G00074			Trouble monitoring grease pressure (central)
G00075			Trouble monitoring grease pressure (swing)
G00076			Trouble monitoring pressure suction tank
G00077			Trouble monitoring grease level (central)
G00078			Trouble monitoring grease level (swing)
G00079			Trouble monitoring pressure oil cooler
G00080			Trouble monitoring pressure preload valve
G00081	0	7	Trouble lubrication system
G00090	0	8	Trouble power supply
G00091	0	9	Pilot control cut out
G00092	0	10	Emergency shut-down at access ladder
G00093	0	10	Emergency shut-down at valve block
G00094	0	10	Emergency shut-down at hydraulic control panel
G00095	0	10	Emergency shut-down in cab
G00096	0	14	Pilot control cut out
G00104	1	15	Trouble battery current
G00105	1	16	Trouble battery charging current too low
G00140	1	17	Trouble monitoring X1-Pressure
G00141	1	17	Trouble monitoring X2-Pressure
G00142	1	17	Trouble monitoring pump support pressure X4
G00143			Trouble monitoring pump 1
G00144			Trouble monitoring pump 2
G00145			Trouble monitoring pump 3
G00146			Trouble monitoring pump 4
G00147	1	17	Trouble monitoring gear lubrication (PTO)
G00148	1	17	Trouble monitoring fuel level
G00149			Trouble monitoring ambient temperature



<b>ErrorCode (Message number) G = Shovel C = Engine 1</b>	<b>Color code of TOP Message: 0 = RED 1 = YELLOW 2 = GREEN</b>	<b>Instruction Message Number. Refer to separate Table</b>	<b>TOP Message with colored background</b>  <b>REMARK</b> Messages w/o color code are not displayed. These messages are stored in the history memory only.
G00151	1	17	Trouble monitoring gear (PTO) oil filter
G00152	1	17	Trouble monitoring oil filter pump lubric
G00153	1	17	Trouble monitoring oil filter pump contr
G00154	1	17	Trouble monitoring return oil filter
G00155	1	17	Trouble monitoring leak oil filter
G00157	1	17	Trouble monitoring oil filter radiator
G00158	1	17	Trouble monitoring oil filter fan drive oil cooler
G00159	1	17	Trouble monitoring breather filter
G00160	1	17	Trouble monitoring engine air cleaner
G00161	1	17	Trouble monitoring battery voltage
G00162	1	17	Trouble monitoring charging-/discharging current
G00163	1	17	Trouble monitoring pilot control
G00164	1	17	Trouble air cleaner
G00165	1	17	Trouble breather filter hydraulic oil tank
G00166	1	17	Trouble oil filter gear (PTO)
G00167	1	17	Trouble oil filter pump lubrication
G00168	1	17	Trouble oil filter pump control
G00169*)	1	17	Trouble return oil filter hydraulic oil tank
G00170	1	17	Trouble leak oil filter hydraulic oil tank
G00171	1	17	Trouble oil filter fan drive oil cooler
G00172	1	17	Trouble oil filter fan drive radiator
G00173	1	18	Trouble monitoring swing gear house brake
G00174	1	19	Trouble monitoring travel gear house brake
G00175	1	19	Trouble travel gear house brake
G00176	1	17	Trouble battery voltage
G00177	1	17	Trouble battery charging circuit
G00178	1	17	Trouble battery charging current to high
G00179	1	17	Trouble control pressure X1
G00180	1	17	Trouble pilot pressure X2 too low
G00181	1	17	Trouble pilot pressure X2 too high
G00183	1	17	Trouble pump support pressure X4

<b>ErrorCode (Message number) G = Shovel C = Engine 1</b>	<b>Color code of TOP Message: 0 = RED 1 = YELLOW 2 = GREEN</b>	<b>Instruction Message Number. Refer to separate Table</b>	<b>TOP Message with colored background</b>  <b>REMARK</b> Messages w/o color code are not displayed. These messages are stored in the history memory only.
G00184	1	20	Central lubrication system empty
G00185	1	20	Trouble central lubrication system
G00186	1	20	Trouble central lubrication system
G00187	1	20	Swing gear lubrication system empty
G00188	1	20	Trouble swing gear ubrication system
G00189	1	20	Trouble swing gear lubrication system
G00240	2	21	Trouble hydraulic oil temperature
G00242	2	22	Engine already running
G00243	2	23	Fill up fuel tank
G00245	0	24	Engine shutdown from ground
G00246	2	25	Hydraulic oil temperature
G00247	2	26	Swing gear house brake
G00249	1	27	Hydraulic oil temperature
G00251	2	28	VHMS is by-passed
G00252	0	10	Emergency shut-down at access ladder
G00253	0	10	Emergency shut-down at valve block
G00254	0	10	Emergency shut-down at hydraulic control panel
G00255	0	10	Emergency shut-down in cab
G00256	2	0	Operator warning system
G00257	2	30	Hydraulic oil temperature
G00417	1	2	Can not connect to PLC
G00419	1	2	Source voltage error
G00420	1	2	Connector sel error
G00421	1	2	Farm sys error
G00422	1	2	Can-net sys (J1939)
G00423	1	2	Application sys error
G00424	1	2	Hot short ckt in buzzer
G00425	1	2	Settings impossible to take over into the PLC
G00491	1	2	Communication failure CGC - VHMS Controller
MFAO			Manual Trigger

<b>ErrorCode (Message number) G = Shovel C = Engine 1</b>	<b>Color code of TOP Message: 0 = RED 1 = YELLOW 2 = GREEN</b>	<b>Instruction Message Number. Refer to separate Table</b>	<b>TOP Message with colored background</b>  <b>REMARK</b> Messages w/o color code are not displayed. These messages are stored in the history memory only.
C00112	1	35	Timing Fueling Mismatch
C00113			Timing Act Shorted High
C00115	1	34	Speed Signal Lost
C00116	1	35	Timing Rail Press Ckt Failed High
C00117	1	35	Timing Rail Press Ckt Failed Low
C00118			Fuel Pump Press Ckt Failed High
C00119			Fuel Pump Press Ckt Failed Low
C00121			1 Eng Speed Signal Lost
C00122	1	40	LB Boost Ckt Failed High
C00123	1	40	LB Boost Ckt Failed Low
C00124			High Boost LB
C00125			Low Boost LB
C00126			High Boost RB
C00127			Low Boost RB
C00128			RB Boost Ckt Failed High
C00129			RB Boost Ckt Failed Low
C00135			Oil Press Ckt Failed High
C00136			Pre Filter Oil Press Ckt Failed High
C00137			Pre Filter Oil Press Ckt Failed Low
C00141			Oil Press Ckt Failed Low
C00143	0	33	Low Oil Press
C00144			Coolant Temp Ckt Failed High
C00145			Coolant Temp Ckt Failed Low
C00151	0	33	High Coolant Temp
C00153			LBF IMT Ckt Failed High
C00154			LBF IMT Ckt Failed Low
C00155	0	33	High IMT LBF
C00156			LBR IMT Ckt Failed High
C00157			LBR IMT Ckt Failed Low
C00158	1	32	High IMT LBR
C00159			RBF IMT Ckt Failed High

<b>ErrorCode (Message number) G = Shovel C = Engine 1</b>	<b>Color code of TOP Message: 0 = RED 1 = YELLOW 2 = GREEN</b>	<b>Instruction Message Number. Refer to separate Table</b>	<b>TOP Message with colored background</b>  <b>REMARK</b> Messages w/o color code are not displayed. These messages are stored in the history memory only.
C00161			RBF IMT Ckt Failed Low
C00162	1	32	High IMT RBF
C00163			RBR IMT Ckt Failed High
C00164			RBR IMT Ckt Failed Low
C00165	0	32	High IMT RBR
C00212			Oil Temp Ckt Failed High
C00213			Oil Temp Ckt Failed Low
C00214	1	31	High Oil Temp
C00221			Ambient Air Press Failed High
C00222			Ambient Air Press Failed Low
C00223			CORS Burn Valve Open Circuit
C00231			Coolant Press Ckt Failed High
C00232			Coolant Press Ckt Failed Low
C00233	0	33	Low Coolant Press
C00252			Oil Level Signal Invalid
C00253	1	33	Oil Level Low
C00254	0	34	FSOV Open Cicuit
C00259	1	31	FSOV Mech Stuck Open
C00261	0	33	High Fuel Temp
C00263			Fuel Temp Ckt Failed High
C00265			Fuel Temp Ckt Failed Low
C00299			Hot Shutdown
C00316			Fuel Pump Open Circuit
C00318			Fuel Pump Mech Stuck
C00343			ECM Hardware Issue Non Mission Disabling
C00346			ECM Software / Hardware Failure
C00423	1	35	Timing Press Incorrect
C00426			J1939 Broadcast Data Missing
C00427			J1939 Datalink Can Not Transmit
C00441			Low Battery Voltage
C00442			High Battery Voltage

<b>ErrorCode (Message number) G = Shovel C = Engine 1</b>	<b>Color code of TOP Message: 0 = RED 1 = YELLOW 2 = GREEN</b>	<b>Instruction Message Number. Refer to separate Table</b>	<b>TOP Message with colored background</b>  <b>REMARK</b> Messages w/o color code are not displayed. These messages are stored in the history memory only.
C00451	1	40	Rail Press Ckt Failed High
C00452	1	40	Rail Press Ckt Failed Low
C00455	1	31	Rail Actuator Open Ckt
C00467	1	35	Desired Timing Not Achieved
C00468	1	40	Desired Rail Press not Achieved
C00514	1	40	Rail Actuator Mech Stuck
C00527			Dual Output A Shorted High or Open Ckt
C00529			Dual Output B Shorted High or Open Ckt
C00553	1	31	Rail Press OOR High
C00554	1	40	Rail Press Incorrect
C00555	0	33	High Blowby Press
C00612	1	31	High Oil Filter Rest
C00616			High Turbo Comp Inlet Temp LBR
C00621			Low Power #1 LB
C00622			Low Power #2 LB
C00623			Low Power #3 LB
C00624			Low Power #4 LB
C00625			Low Power #5 LB
C00626			Low Power #6 LB
C00627			Low Power #7 LB
C00628			Low Power #8 LB
C00631			Low Power #1 RB
C00632			Low Power #2 RB
C00633			Low Power #3 RB
C00634			Low Power #4 RB
C00635			Low Power #5 RB
C00636			Low Power #6 RB
C00637			Low Power #7 RB
C00638			Low Power #8 RB
C00641	0	32	High Exh Temp #1 LB
C00642	0	32	High Exh Temp #2 LB

<b>ErrorCode (Message number) G = Shovel C = Engine 1</b>	<b>Color code of TOP Message: 0 = RED 1 = YELLOW 2 = GREEN</b>	<b>Instruction Message Number. Refer to separate Table</b>	<b>TOP Message with colored background</b>  <b>REMARK</b> Messages w/o color code are not displayed. These messages are stored in the history memory only.
C00643	0	32	High Exh Temp #3 LB
C00644	0	32	High Exh Temp #4 LB
C00645	0	32	High Exh Temp #5 LB
C00646	0	32	High Exh Temp #6 LB
C00647	0	32	High Exh Temp #7 LB
C00648	0	32	High Exh Temp #8 LB
C00651	0	32	High Exh Temp #1 RB
C00652	0	32	High Exh Temp #2 RB
C00653	0	32	High Exh Temp #3 RB
C00654	0	32	High Exh Temp #4 RB
C00655	0	32	High Exh Temp #5 RB
C00656	0	32	High Exh Temp #6 RB
C00657	0	32	High Exh Temp #7 RB
C00658	0	32	High Exh Temp #8 RB
C00661			High Power #1 LB
C00662			High Power #2 LB
C00663			High Power #3 LB
C00664			High Power #4 LB
C00665			High Power #5 LB
C00666			High Power #6 LB
C00667			High Power #7 LB
C00668			High Power #8 LB
C00671			Exh Temp Ckt Failed Low #1 LB
C00672			Exh Temp Ckt Failed Low #2 LB
C00673			Exh Temp Ckt Failed Low #3 LB
C00674			Exh Temp Ckt Failed Low #4 LB
C00675			Exh Temp Ckt Failed Low #5 LB
C00676			Exh Temp Ckt Failed Low #6 LB
C00677			Exh Temp Ckt Failed Low #7 LB
C00678			Exh Temp Ckt Failed Low #8 LB

<b>ErrorCode (Message number) G = Shovel C = Engine 1</b>	<b>Color code of TOP Message: 0 = RED 1 = YELLOW 2 = GREEN</b>	<b>Instruction Message Number. Refer to separate Table</b>	<b>TOP Message with colored background</b>  <b>REMARK</b> Messages w/o color code are not displayed. These messages are stored in the history memory only.
C00694			LBR Turbo Comp Inlet Temp Sesnor Ckt Failed High
C00695			LBR Turbo Comp Inlet Temp Sesnor Ckt Failed Low
C00711			High Power #1 RB
C00712			High Power #2 RB
C00713			High Power #3 RB
C00714			High Power #4 RB
C00715			High Power #5 RB
C00716			High Power #6 RB
C00717			High Power #7 RB
C00718			High Power #8 RB
C00719			Blowby Press Ckt Failed High
C00721			Exh Temp Ckt Failed Low #1 RB
C00722			Exh Temp Ckt Failed Low #2 RB
C00723			Exh Temp Ckt Failed Low #3 RB
C00724			Exh Temp Ckt Failed Low #4 RB
C00725			Exh Temp Ckt Failed Low #5 RB
C00726			Exh Temp Ckt Failed Low #6 RB
C00727			Exh Temp Ckt Failed Low #7 RB
C00728			Exh Temp Ckt Failed Low #8 RB
C00729			Blowby Press Ckt Failed Low
C00753			Cam Sync Error
C00777			Ambient Derate Error
C00783	0	32	Rapid Rise in LBF IMT
C02154			Post Oil Filter Press Ckt Failed High
C02155			Post Oil Filter Press Ckt Failed Low
C02157	0	32	Rapid Rise in LBR IMT
C02158	0	32	Rapid Rise in RBF IMT
C02159	0	32	Rapid Rise in RBR IMT

### 3.4.5 TABLE OF AVAILABLE INSTRUCTION MESSAGES

#### NOTICE

**TOP Messages and applying Instruction Messages are always displayed together.**

Message No.	Instruction Message
0	
1	Engine stopped because of main Shut-Off (gate) valve. - Open the Shut-Off (gate) valve. - If failure exist further, inform service.
2	Inform service.
3	Stop the engine. - Inform service.
4	Start blocked because of main Shut-Off (gate) valve. - Open the Shut-Off (gate) valve. - If failure exist further, inform service.
5	Start blocked. - Inform service.
6	The fire suppression system has been actuated. - Inform the fire brigade. - Evacuate endangered persons. - Fight the fire. - Inform service.
7	Bucket motion switched off. - Inform service.
8	Circuit breaker F13 switch on. - If failure exist further, inform service.
9	Ladder end switch or seat contact open. - If failure exist further, inform service.
10	Emergency shut-down switch was actuated. - Unlock before restarting. - If failure exist further, inform service.
11	Engine switched off by Maintenance safety switch in the engine room. - Unlock before restarting. - If failure exist further, inform service.
12	
13	
14	Enable switch for refilling arm active. - If failure exist further, inform service.
15	Load of the batteries too high. - Inform service.
16	Batteries are not being charged. - Inform service.
17*)	Inform service till end of shift and then press cancel button.  <b>NOTICE</b> <b>The message number G00169 indicates two trouble conditions, either return oil filter restriction or restriction of the return oil strainer in the return oil collector pipe. To find out the unit which caused the fault message, check the LED number H74 on the Programmable Logic Controller (E6) located on the main switch board (X2) in the cab base, see page 143. If the LED H74 is OFF, the return oil filters in the oil tank are restricted and need to be replaced. If the LED H74 is ON, the return oil strainer in the return oil collector pipe is restricted and needs to be replaced. Refer to page 391 in the maintenance section 4 for servicing instructions.</b>



Message No.	Instruction Message
18	Swing gear house brake OFF - Inform service till end of shift and then press cancel button.
19	Travel gear house brake OFF - Inform service till end of shift and then press cancel button.
20	Inform service and then press cancel button.
21	Hydraulic oil far below operating temperature ! - Pre-heat hydraulic oil or warm up at low idle speed and reduced power.
22	Engine runs (starter motor inactive).
23	A fuel reserve only is still in the tank. - Order tanker.
24	Engine shutdown has been actuated from ground man.
25	Hydraulic oil below operating temperature. - Operate with reduced power !
26	Swing gear house brake ON
27	Hydraulic oil overheat - engine power derated
28	The VHMS is by-passed. - Reset by-pass switch.
29	Engine shutdown by key switch before proper engine cool down. - Before you switch off the engine, cool down the engine at low idle speed for 2 - 3 minutes.
30	Hydraulic oil far below operating temperature ! Pre-heat hydraulic oil or warm up at low idle speed and reduced power.
31	Continue shift but advise service.
32	Stop engine call service.
33	Derate active continue to work. Later shutdown possible. Inform service.
34	Call service because of shutdown.
35	Interrupt work and inform service about "Speed Derate".
36	Continue work until next PM (Schedule work for next PM)
37	Switch Test speed in cab base forces the engine to run constantly 1800 rpm.
38	If failure exist further, inform service.
39	Inform service if attachment in defined position.
40	Continue to work and inform service about "Power Derate"

# 3.5 OPERATING THE HEATER, VENTILATION AND AIR CONDITIONING

## Legend for illustration Z25448

- (1) Switch, cab ventilation blower.
- (2) Heater and air conditioning control panel
- (3) Cab heating control
- (4) Cab heating blower control
- (5) Control module for the engine independent auxiliary cab heater (if so equipped).  
This module is used for switching ON and OFF the auxiliary cab heater during operation of the shovel with the Diesel engines running, and for pre-selection of heater start times and duration of heating periods with engines off. For detailed setting instructions of the control module refer to the separate operating instruction sheet in volume 2 binder.
- (6) Button for actual time indication
- (7) Button for preselection of heating time
- (8) Button for heating indication
- (9) Button for settings backwards
- (10) Button for settings forward
- (11) Not used
- (12) Display shows the operating condition of the heater
- (13) Thermostat for engine independent cab heater (if so equipped).  
This unit is used to maintain a desired temperature in the cab during standstill periods of the shovel. The battery main switches and the pre-heating system main switch must be in ON position. See page 147 for more information. The fuel shut-off cock for the water heater HYDRONIC must be in open position, see page 125 for more information. Activate the heater with control module (5).
- (14) Temperature selector button (if so equipped)
- (15) Air conditioner temperature control knob. To lower the cab air temperature (maximum cooling output) rotate the control knob to the left (-) sign. To reduce cooling output rotate the knob to the right (+) sign.
- (16) Air conditioner blower control knob
- (17) Indicator light, air conditioning ON
- (18) Indicator light, air conditioning blower ON

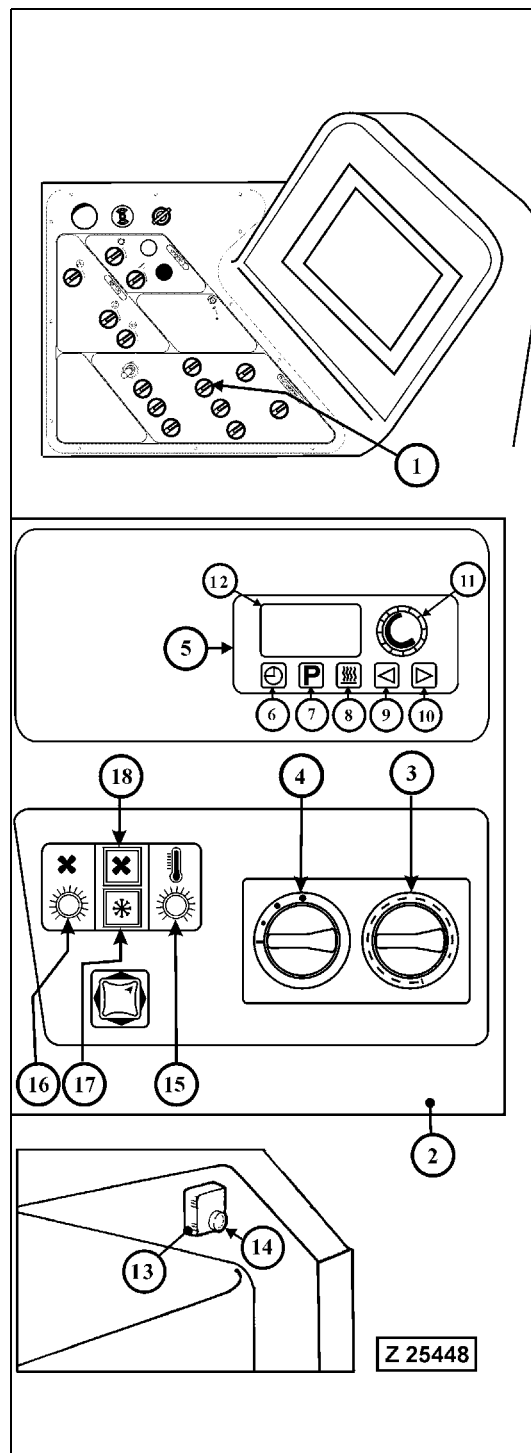

### 3.5.1 A - HEATING

1. Set temperature control (3) to desired stage.
2. Set blower control (4) to desired stage.

### 3.5.2 B - COOLING

1. Set blower switch (16) to high stage.
2. Rotate the air conditioner control knob (15) to the desired temperature level.

#### NOTICE

When the air-conditioning is in operation the door and windows should be closed to ensure maximum cooling performance.

#### CAUTION

On rainy days with high atmospheric humidity select high fan speed to prevent ice build up at the evaporator. If icing occurs, select low cooling output with control knob (15) and run blower (16) with high speed. After de-icing of the evaporator operate the air conditioner at medium cooling output.

#### NOTICE

- If the Shovel has been exposed to the sun for a long period it is recommended to ventilate the cab thoroughly by opening doors or windows until the hot air is expelled.
- The air conditioner should be operated at least 30 minutes once a month. This operation will keep seals from drying out, causing possible damage to the compressor and / or system due to loss of refrigerant. For more information, refer to the separate Manual "AIR CONDITIONING" in volume 2 binder.
- The blower switch (1) for cab pressurizing should be in position "0". Otherwise too much hot air will be sucked into the operator's cab.

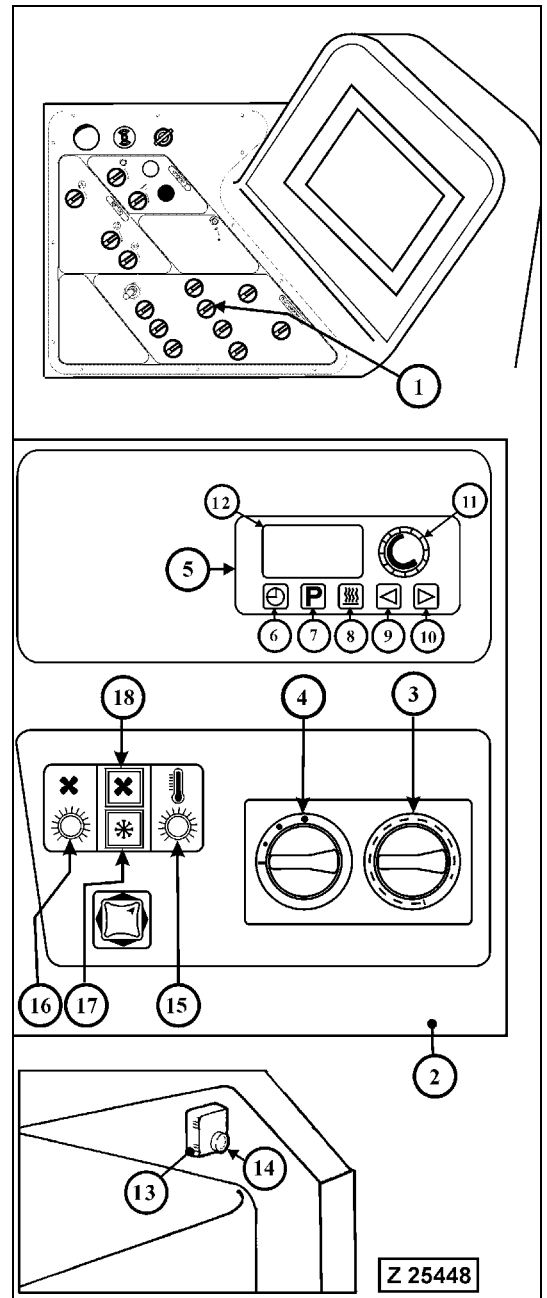

### 3.5.3 COMBINED OPERATION OF AIR CONDITIONING AND HEATING

Mainly on wet and rainy days, if no or little heating is desired, it is possible to dehumidify (to dry) the cabin air by using the air conditioner and heater. To do this, select intermediate control positions.

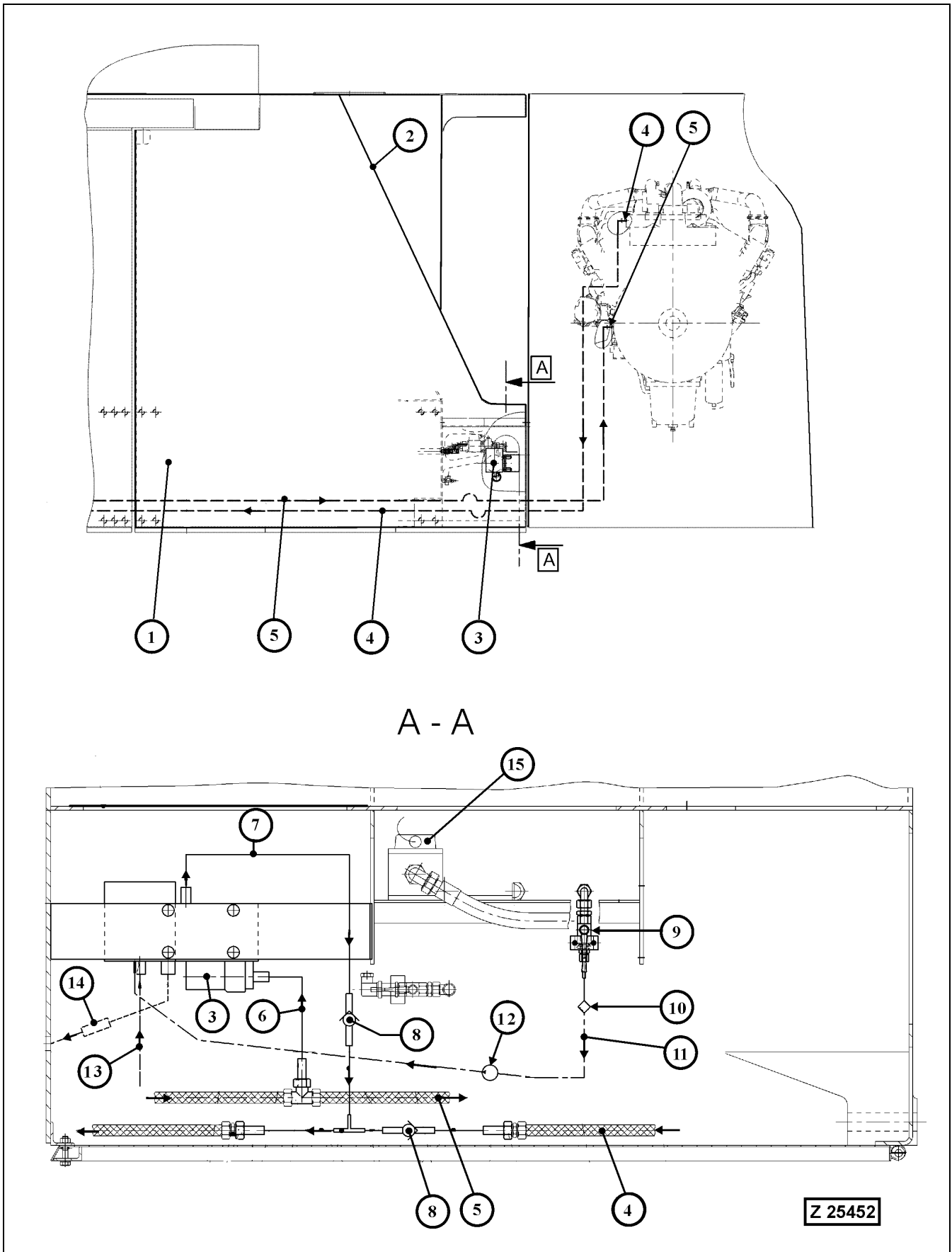

### 3.5.4 AUXILIARY HEATER FOR OPERATOR'S CAB

#### Special Equipment

#### REMARK

The auxiliary cab heater is located in the compartment below the stair to the operator's cab. View A-A shows the arrangement of components and the flow of water, fuel and air.

#### Legend for illustration Z25452

- (1) Fuel tank
- (2) Stair to operator's cab
- (3) Heater unit HYDRONIC 10, refer to the separate operation manual HYDRONIC 10 for all operating and maintenance instructions. The manual is filed in volume 2 binder.
- (4) Water supply line from engine to cab heater
- (5) Water return line
- (6) Water line to auxiliary heater
- (7) Hot water line from auxiliary heater to cab heater
- (8) Check valve
- (9) Fuel shut off-cock for fuel supply to heater (3)
- (10) Fuel strainer
- (11) Fuel supply line
- (12) Fuel dosing pump
- (13) Combustion air intake line
- (14) Exhaust muffler
- (15) Fuel shut-off solenoid valve

#### Operation

To activate the heater (3), open fuel shut off-cock (9). Select the desired heating stage with the control module (5) shown on page 122.

#### REMARK

During the warm season the fuel shut-off cock (9) should be closed.

### 3.6 POWER HOUSE

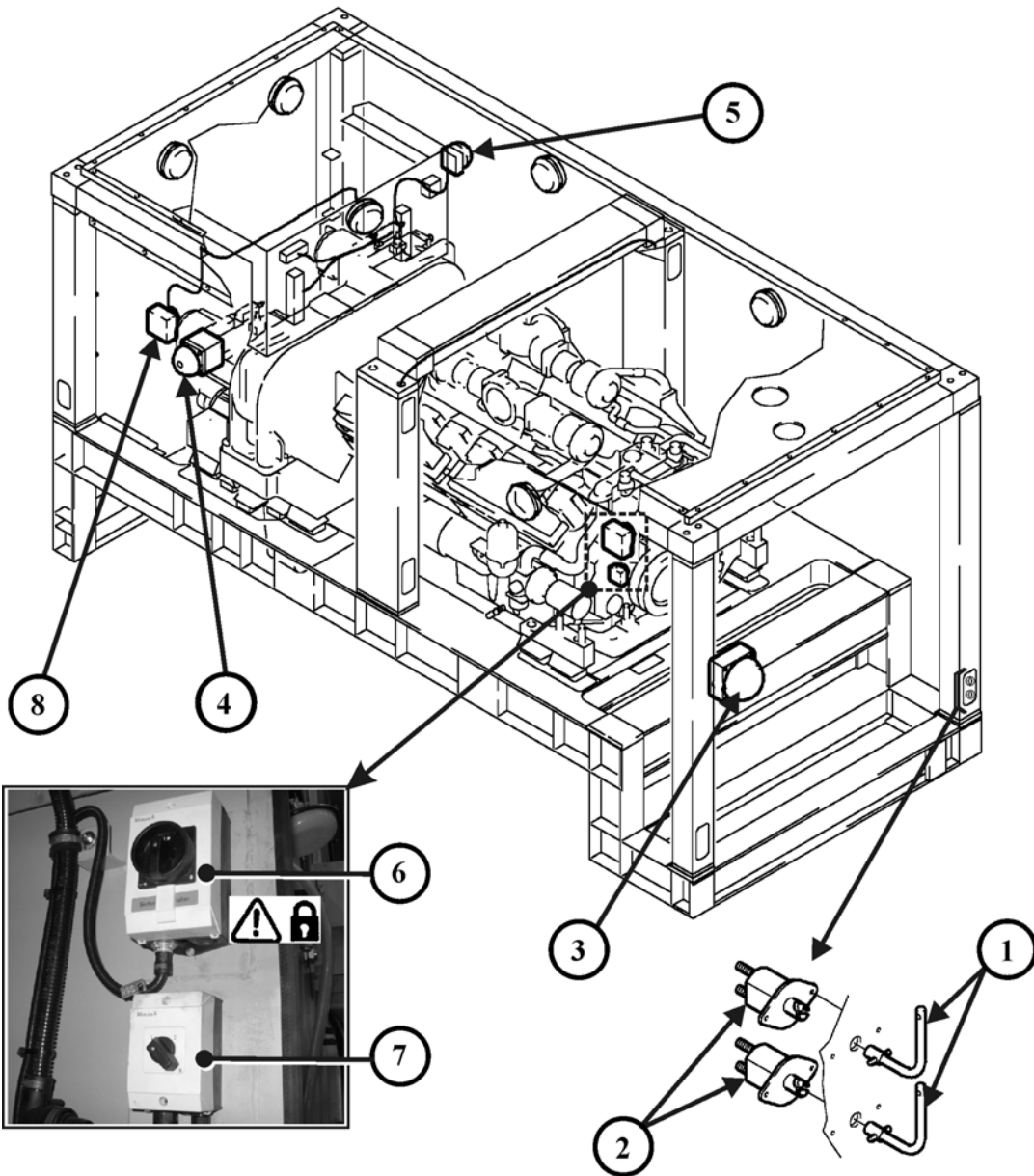
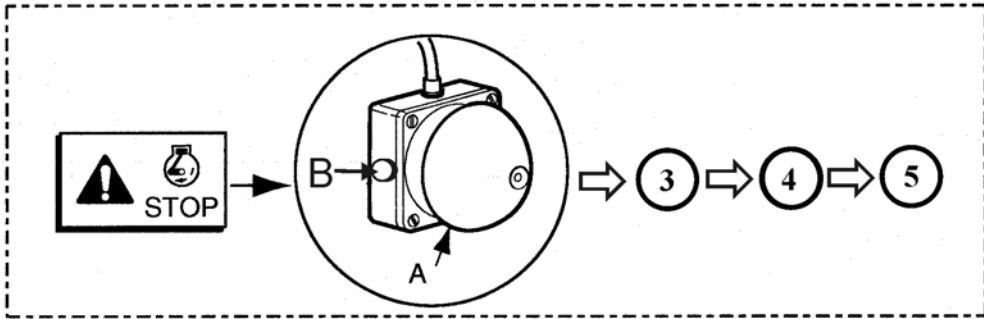

Z 25359

### 3.6.1 EMERGENCY ENGINE SHUTDOWN SWITCHES

#### Legend for illustration Z25359

- (1) Battery main switch keys

#### NOTICE

**After switching OFF the main key switch in the Operator's cab, wait at least 3 minutes before switching OFF the battery main switches. The Vehicle Health Monitoring System (VHMS) needs this period for saving data. If batteries are switched OFF before this time period is over, data will be lost.**

- (2) Battery main switches (S2 and S3)
- (3) Emergency engine shutdown switch (S33a) on radiator door
- (4) Emergency engine shutdown switch (S33b) on rear power house door
- (5) Emergency engine shutdown switch (S33c) in pump compartment on the central control and filter carrier
- (6) Maintenance safety switch (S58) for start prevention of the Diesel engine, see next page for more information
- (7) Light switch (S15) on front door for interior power house lighting
- (8) Light switch (S15a) on rear door for interior power house lighting
- (A) Push button of emergency shutdown switches (3, 4 and 5) for stopping the engine
- (B) Release button for emergency shut down switch (if so equipped)

#### WARNING

- In case of emergency push in the button (A) to stop the engine.
- Never stop the engine from a full load except in case of emergency. If a hot engine is shut down without previous idling period of three to five minutes, the temperature in certain engine parts rising sharply after the cooling system ceases to function. The resulting thermal stress, especially in the turbochargers, may cause serious damage.

#### NOTICE

- For restarting, first push in release button (B). On switches without release button (B) pull out button (A) and then start the engine in the normal way at the control panel in the operator's cab. The engine can not be started with button (A) in depressed position.
- When one of the Shutdown switches (3 - 5) is activated, the VHMS display informs the Operator by a corresponding message.

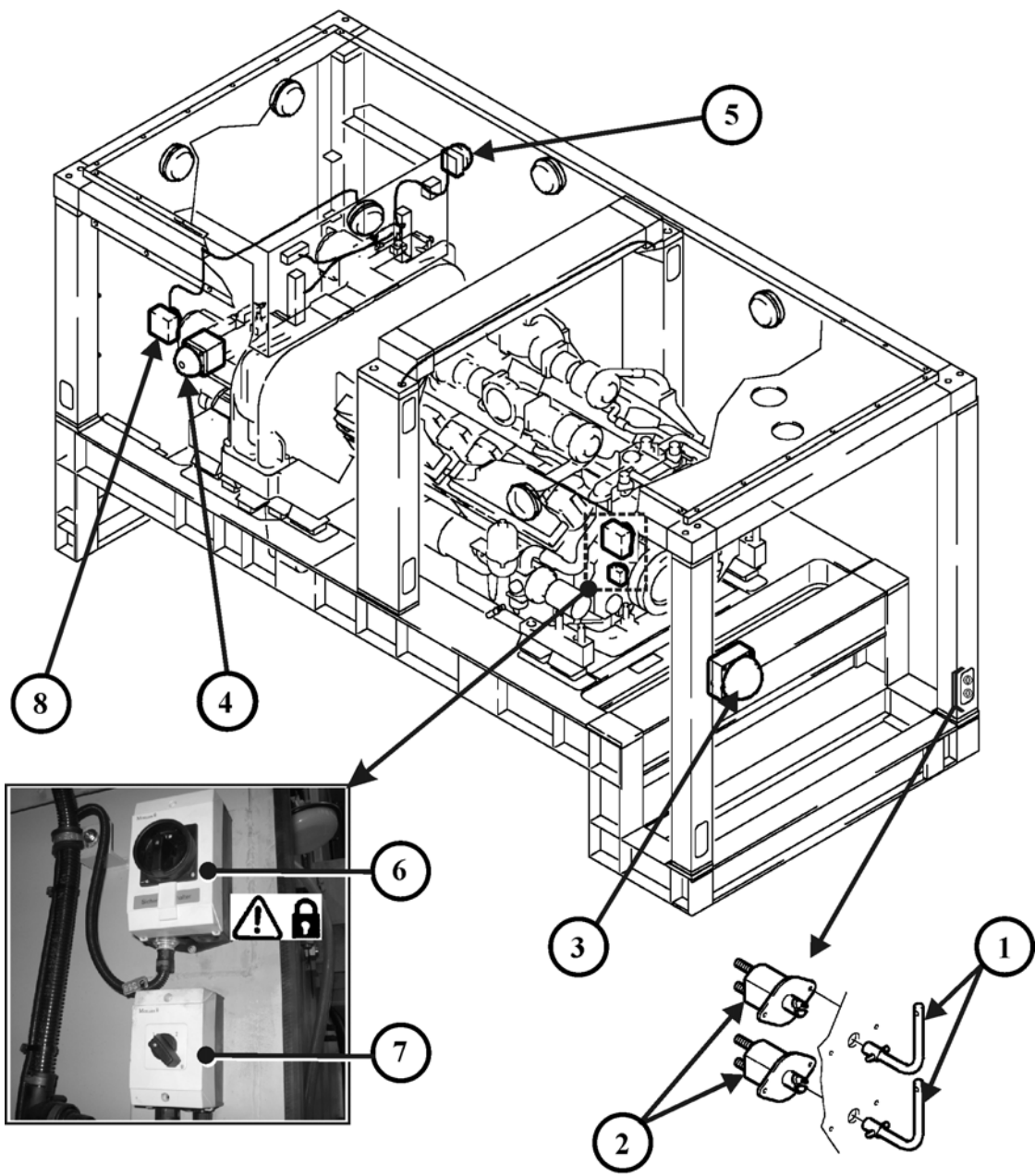
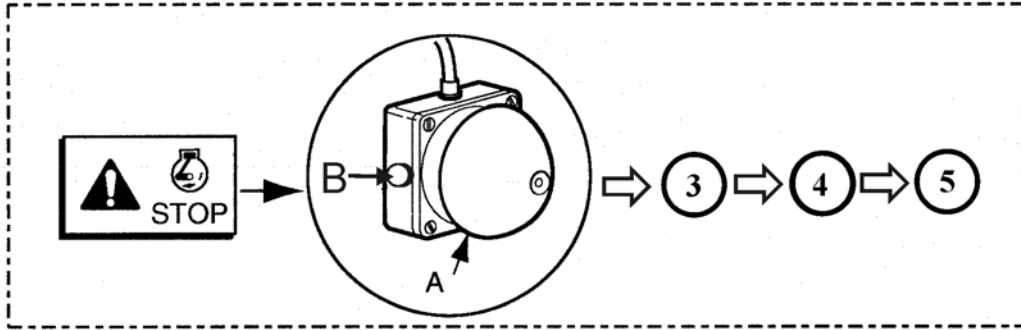

Z 25359



### 3.6.2 MAINTENANCE SAFETY SWITCH AND BATTERY MAIN SWITCHES

#### Legend for illustration Z25359

- (6) Maintenance safety switch (S58) for start prevention of the Diesel engine. This switch is located inside the power house, next to the front door.

**WARNING**

Before beginning any maintenance operations set the safety switch (6) to -0- position to prevent starting of the engine during maintenance. Secure this position by inserting a padlock into the holes of the safety switch. Up to three padlocks can be attached.

**WARNING**

- Before working on the batteries or any other part of the electrical system remove both battery main switch keys (1).
- Batteries give off highly inflammable gas! Never allow sparks or open flame near the batteries!
- Avoid spilling any electrolyte on hands or clothing. Repair or replace all broken wires immediately. All terminals must be clean and securely fastened; never paint connections.
- DO NOT short across or ground any terminals of the batteries.

**CAUTION**

Make sure that all machinery house doors are securely closed before starting the engine and during operation of the shovel.

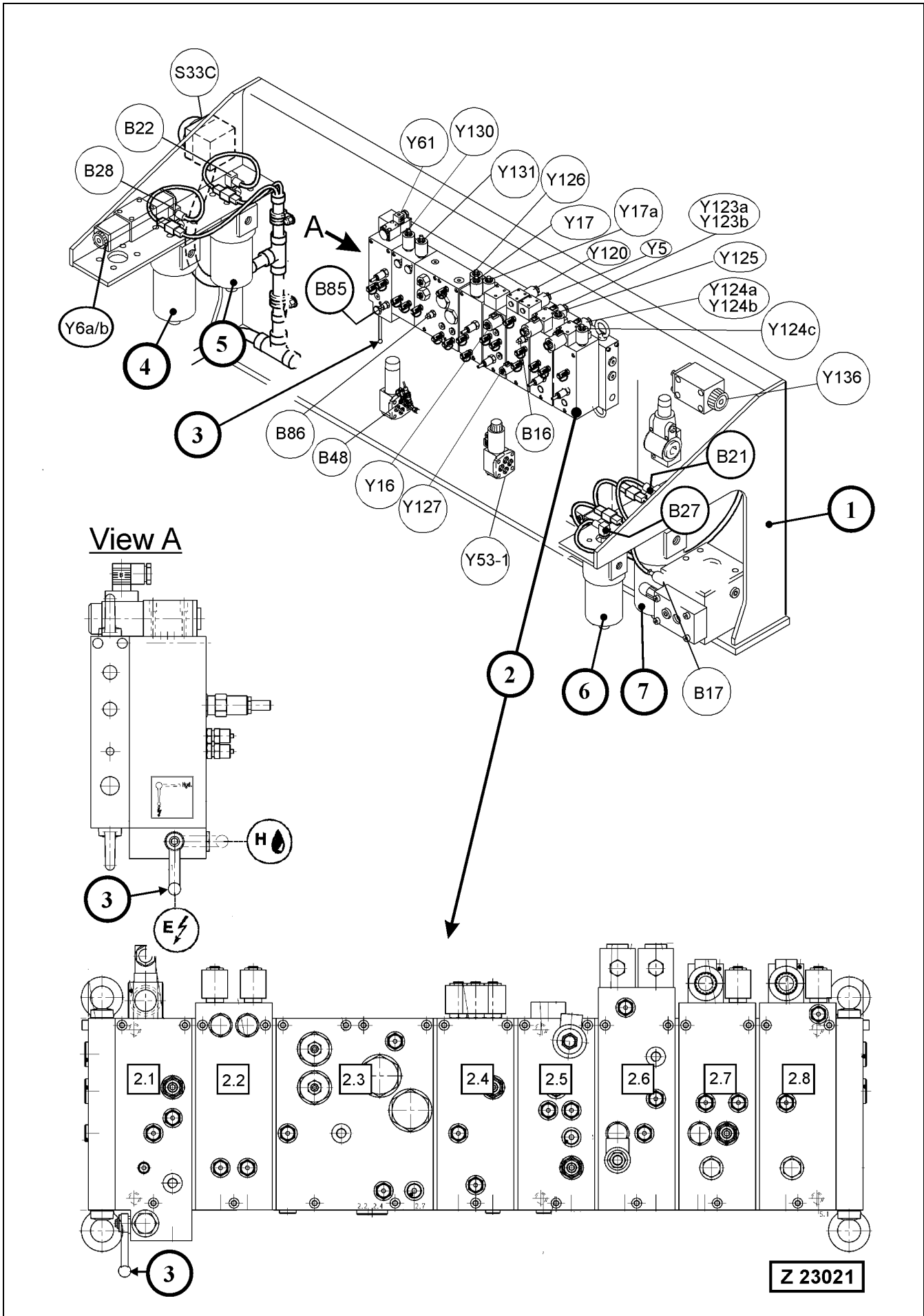

### 3.6.3 CENTRAL CONTROL AND FILTER PANEL

#### Legend for illustration Z 23021

- (1) Central control and filter panel
- (2) Valve bank
  - (2.1) Valve block, pump load limiting circuit
  - (2.2) Valve block, fixed pump 1 and 3 for swing
  - (2.3) Valve block, pilot oil circuit
  - (2.4) Valve block, pump control circuit
  - (2.5) Valve block, travel circuit
  - (2.6) Valve block, swing circuit
  - (2.7) Valve block, hydraulic access ladder circuit
  - (2.8) Valve block, hydraulic swing down service arm circuit
- (3) Change over valve lever for operation modes of pump control system.  
Lever Positions:  
E - Electronic operation mode (normal operation mode)  
H - Hydraulic operation mode (e.g. for testing purposes)

#### REMARK

The standard operation mode of the pump control system is the Electronic Operation Mode.

For testing purposes the pump control system can be changed to the hydraulic operation mode. In case of a failure in the electronic control system use the hydraulic operation mode to continue operation.

- (4) Pressure oil filter for hydraulic oil cooler fan drive circuit
- (5) Pressure oil filter for pump control and pilot oil circuit
- (6) Pressure oil filter for PTO gear lubrication circuit
- (7) Pressure oil filter for engine radiator fan drive circuit

#### Pressure Switches

- (B16) Swing brake
- (B17) PTO lubrication oil
- (B21) Radiator fan drive oil filter
- (B22) Pump control and pilot oil filter
- (B27) PTO lubrication oil filter
- (B28) Oil cooler fan drive oil filter
- (B48) Travel parking brake
- (B85) Pump control oil pressure X1
- (B86) Pilot oil pressure X2

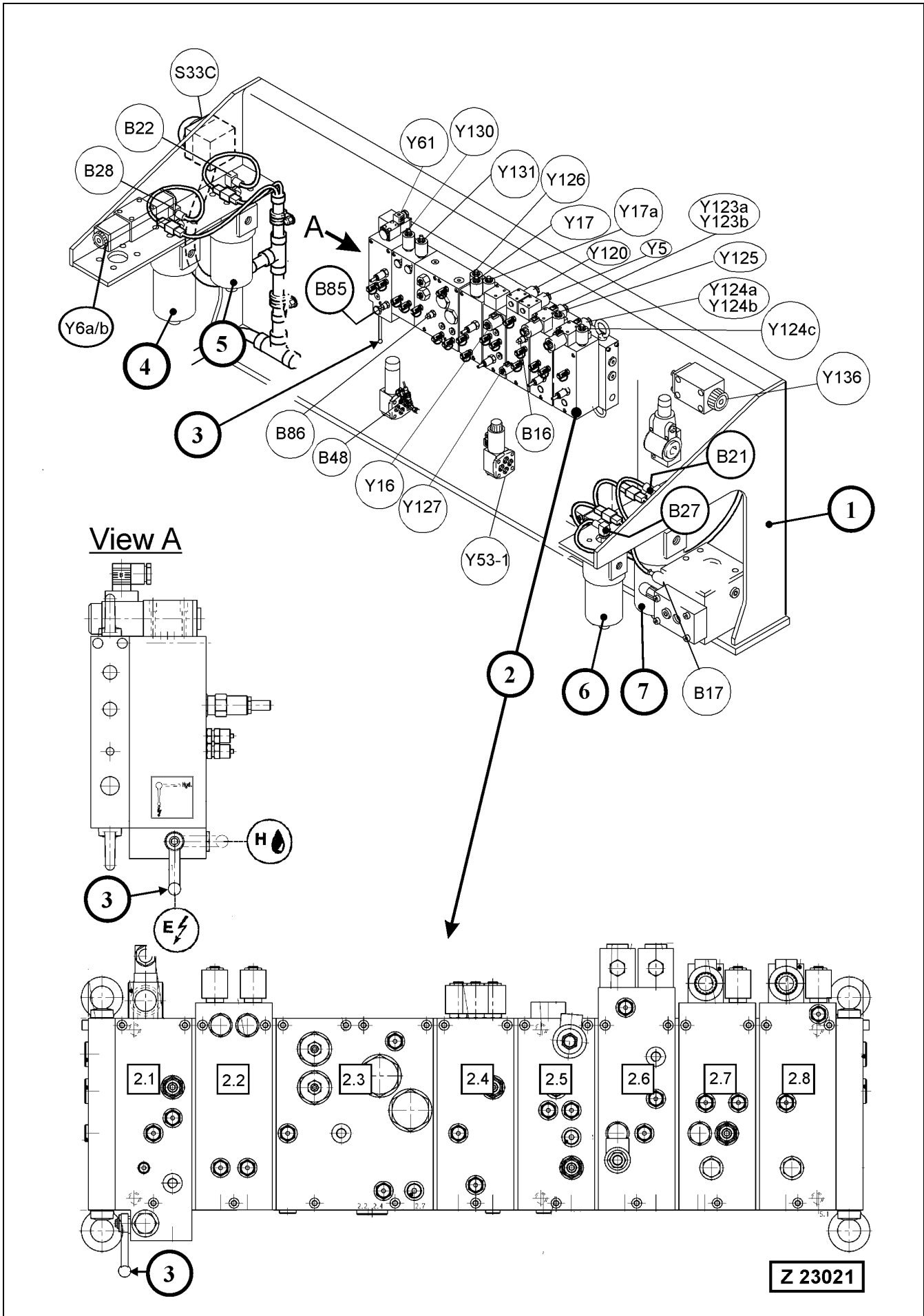

**Legend for illustration Z 23021 (continued)****Solenoid Valves**

(Y5))	Swing parking brake operating pressure
(Y6a)	Oil cooler fan RPM control minimum speed
(Y6b)	Oil cooler fan RPM control medium speed
(Y16)	Travel parking brake operating pressure
(Y17)	Pump idle time control system
(Y17a)	Pump 1/2 Qmax control (reduced delivery with too cold oil)
(Y53.1)	Reduced pre-load pressure of PTO gear oil cooler
(Y61)	Pump 1 - 4 control pressure (X1)
(Y120)	Hydraulic swing brake operating pressure
(Y123a)	Access ladder raise
(Y123b)	Access ladder lower
(Y124a)	Service arm raise
(Y124b)	Service arm lower
(Y124c)	Service arm lock/enable valve
(Y125)	Service arm fast speed
(Y126)	Flow reduction pump 1
(Y127)	Proportional swing brake pressure
(Y130)	Fixed pump 1 (max. flow with X1 = 45 bar)
(Y131)	Fixed pump 3 (max. flow with X1 = 45 bar)
(Y136)	Engine radiator fan speed control

**REMARK**

Refer to the Service Manual of the Excavator for testing and adjustment procedures.

### 3.7 ELECTRICAL EQUIPMENT IN CAB BASE

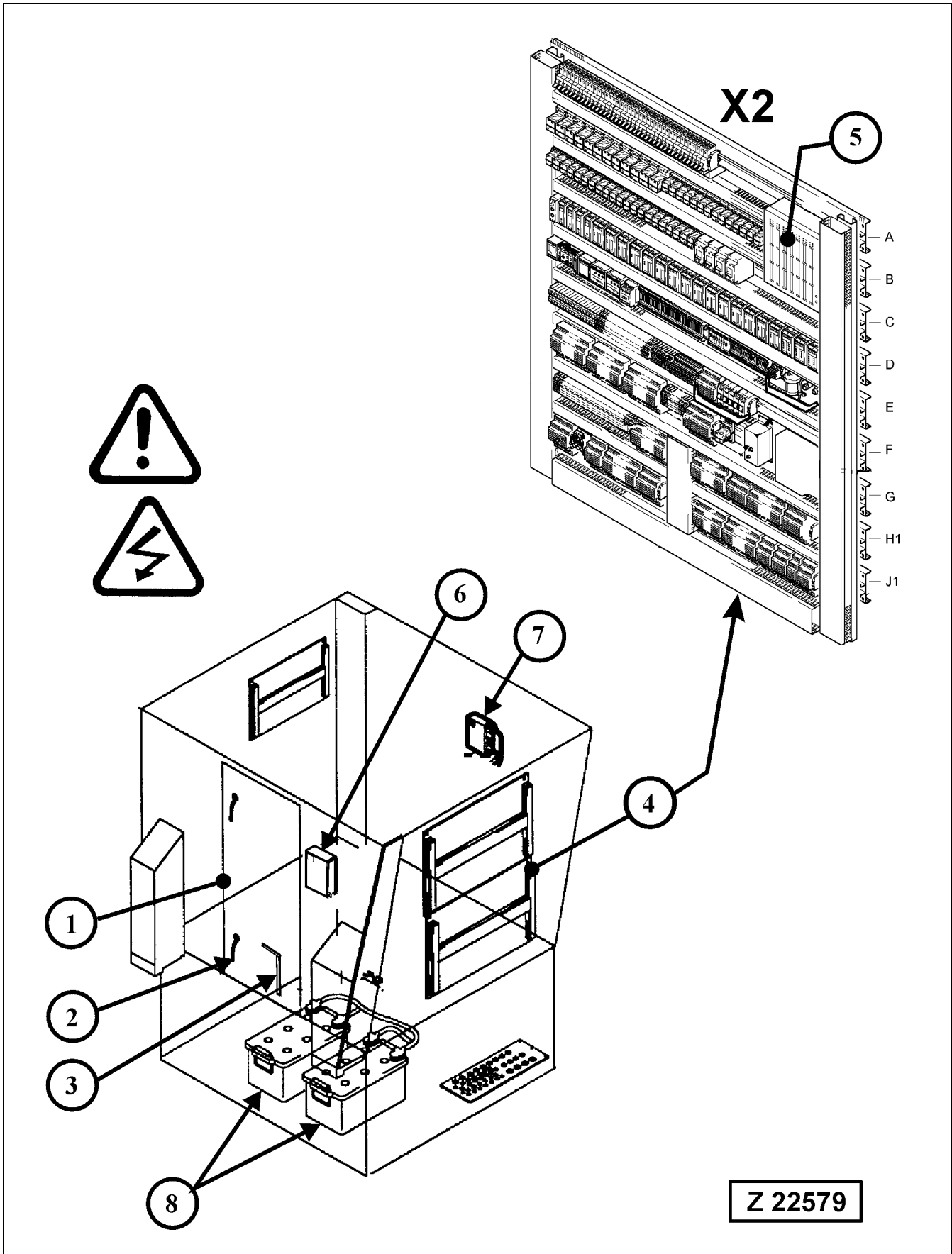

### 3.7.1 STANDARD COMPONENTS IN CAB BASE

#### REMARK

On shovels with electrical pre-heating systems there are additional components in the cab base. Refer to page 147 for more information.

---



---

#### WARNING

---



---

The cab base contains batteries which are located in a compartment below the floor plate. Batteries emit highly explosive gas! Sparks or flame can cause the gas to explode.

- DO NOT smoke or use open flame when entering the cab base.
  - DO NOT weld or grind near the batteries.
  - DO NOT short across or ground any terminals of the batteries.
  - On removal always disconnect the ground (-) cables first. when reinstalling the batteries connect the positive (+) cables first.
- 
- 

---



---

#### WARNING

---



---

- The cab base may contain high tension electrical appliances. Access to the cab base for authorized service staff only.
  - All cables of the 24V DC board net system are of blue color. All other cable colors indicate a higher voltage: DO NOT touch these cables and their terminals and connected components. Always contact authorized Electricians having the permission to work on medium and high voltage systems.
- 
- 

#### Legend for illustration Z 22579

- |     |  |
|-----|--|
| (1) | Cab base door. Keep the door always locked, access to the cab base for authorized personnel only.                |
| (2) | Door handles   |
| (3) | Lock rod for locking the cab base door in open position  |
| (4) | Main switch board (X2), refer to page 137 for switch board components.   |
| (5) | Programmable logic controller (PLC)  |
| (6) | Controller of the VHMS system  |
| (7) | Electronic pump control module (MC7)   |
| (8) | Back-up batteries for the programmable logic controller (PLC). The battery box is located below the floor plate. |

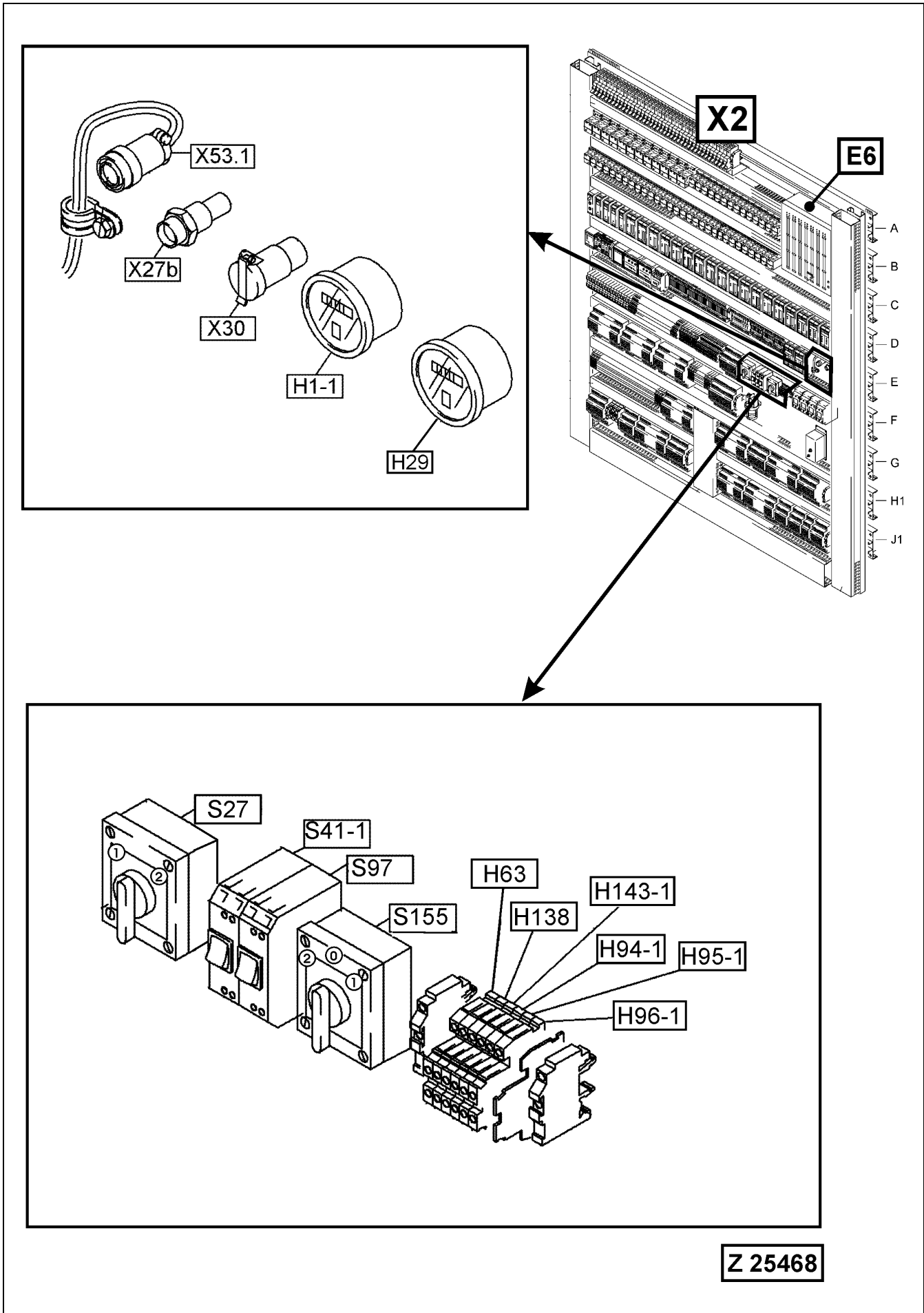



## 3.7.2 SWITCH BOARD (X2) IN CAB BASE

Legend for illustration Z25468

### Switches

- (S27) Emergency By-pass switch for the shutdown function of the PLC (E6). If an automatic shutdown is initiated by Shovel systems, with a dangerous situation for man or machine, which needs the Shovel to be operable to over-come the dangerous situation, actuate this switch to override the shutdown function of the system and to enable a restart of the Diesel engine.

#### NOTICE

- **This switch can not override engine initiated shutdowns.**
  - **As soon as the immediate situation of danger is over, shutdown the unit. Correct the fault that caused the shut down and re-set the Emergency By-pass switch (S27).**
- (S41.1) Switch for constant engine speed adjustment to 1800/min (rated speed) for testing purposes
- (S97) Switch for upload of new program to VHMS controller (E46), refer to VHMS Service Manual for more information.

### Service Switch for "QMIN" and "QMAX" Control of the Main Hydraulic Pumps

#### CAUTION

**The Service switch (S155) is used for testing and adjusting procedures of the hydraulic system and should only be operated through authorized service personnel**

- (S155) Service switch for Qmin/Qmax position of main hydraulic pumps.

Switch positions:

- 0 - Normal operating position
- 1 - Qmax position. The main pumps remain in maximum delivery position.
- 2 - Qmin position. The main pumps remain in Qmin position, i.e. minimum oil delivery to the hydraulic system.

#### NOTICE

**Make sure that the switch (S155) is switched off as soon as the testing and adjusting procedures of the hydraulic system are finished.**

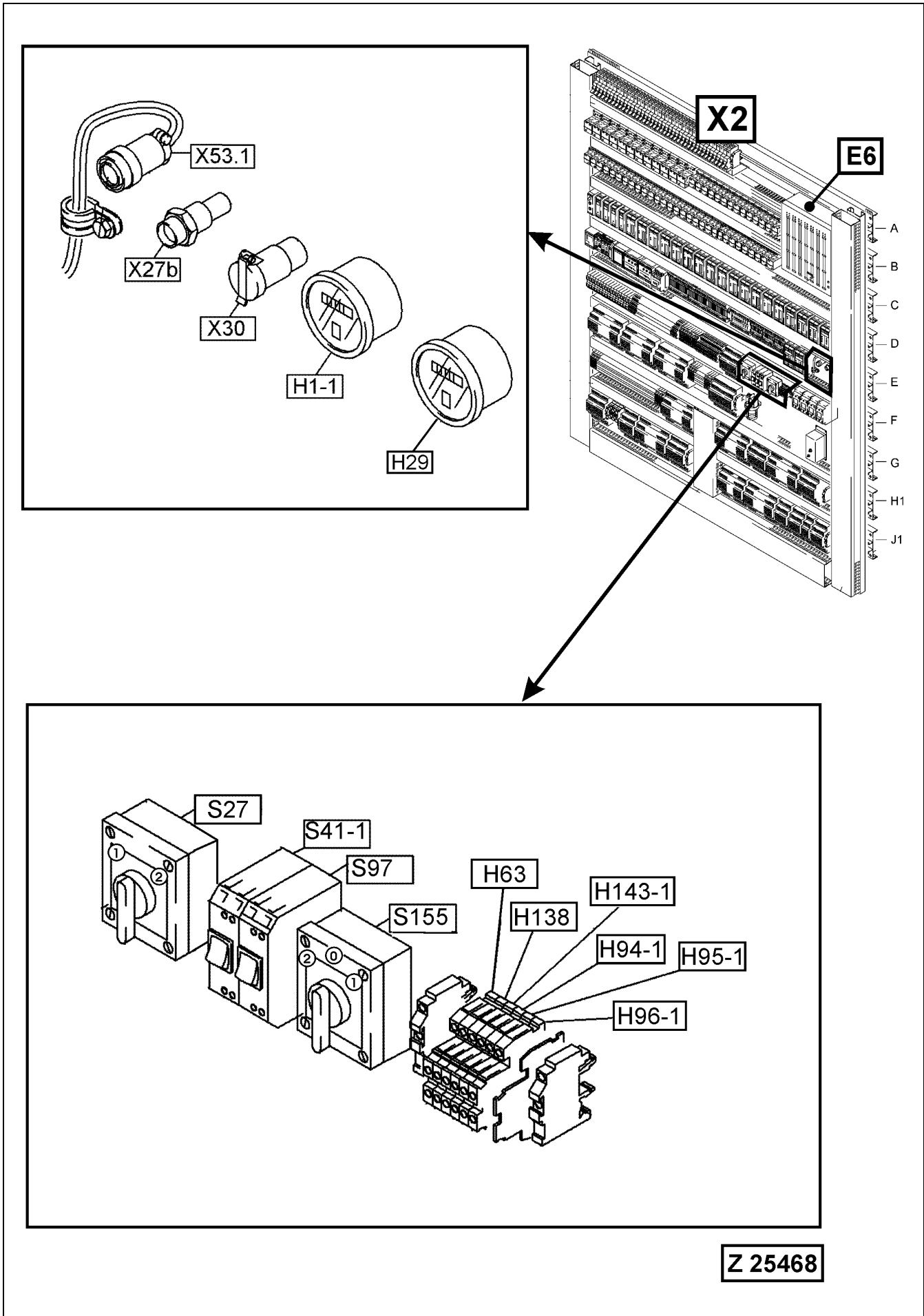

## Legend for illustration Z25468

### Service Indicator Lights

- (H94.1) Engine STOP lamp red. This lamp flashes out fault codes of the QUANTUM electronic engine control system. See heading **-Checking active diagnostic fault codes-** for more information.
- (H95.1) Engine WARNING lamp yellow. This lamp flashes out fault codes of the CENSE electronic engine monitoring system.
- (H96.1) Engine FLUID lamp white. The engine PROTECTION system will illuminate the FLUID lamp when an abnormal condition occurs
- (H63) Electronic pump control module (MC7) active and program information
- (H138) This light pulses if there is a failure in the electronic pump control module (MC7)
- (H143.1) Monitoring light of the automatic engine oil supply system "Reserve"
- Steady light: oil is pumped from engine oil pan to reserve oil tank.
  - Regular blinking: oil is pumped from reserve oil tank to engine oil pan.
  - Irregular blinking: oil is pumped in both directions, oil level in engine oil pan is correct.

### NOTICE

**If the indicator light (H143.1) is off with the engine running, there is a failure in the reserve systems. Have the reserve systems checked and repaired through authorized service personnel.**

### Other Components

- (E6) Programmable Logic Controller (PLC) of the VHMS system.
- (X53.1) Connector for Modular Mining System (MMS) service processor
- (X27B) Connector for program upload to the VHMS controller
- (X30) Plug socket 24 Volt
- (H1-1) Hour meter engine running
- (H29) Hour meter traveling operation

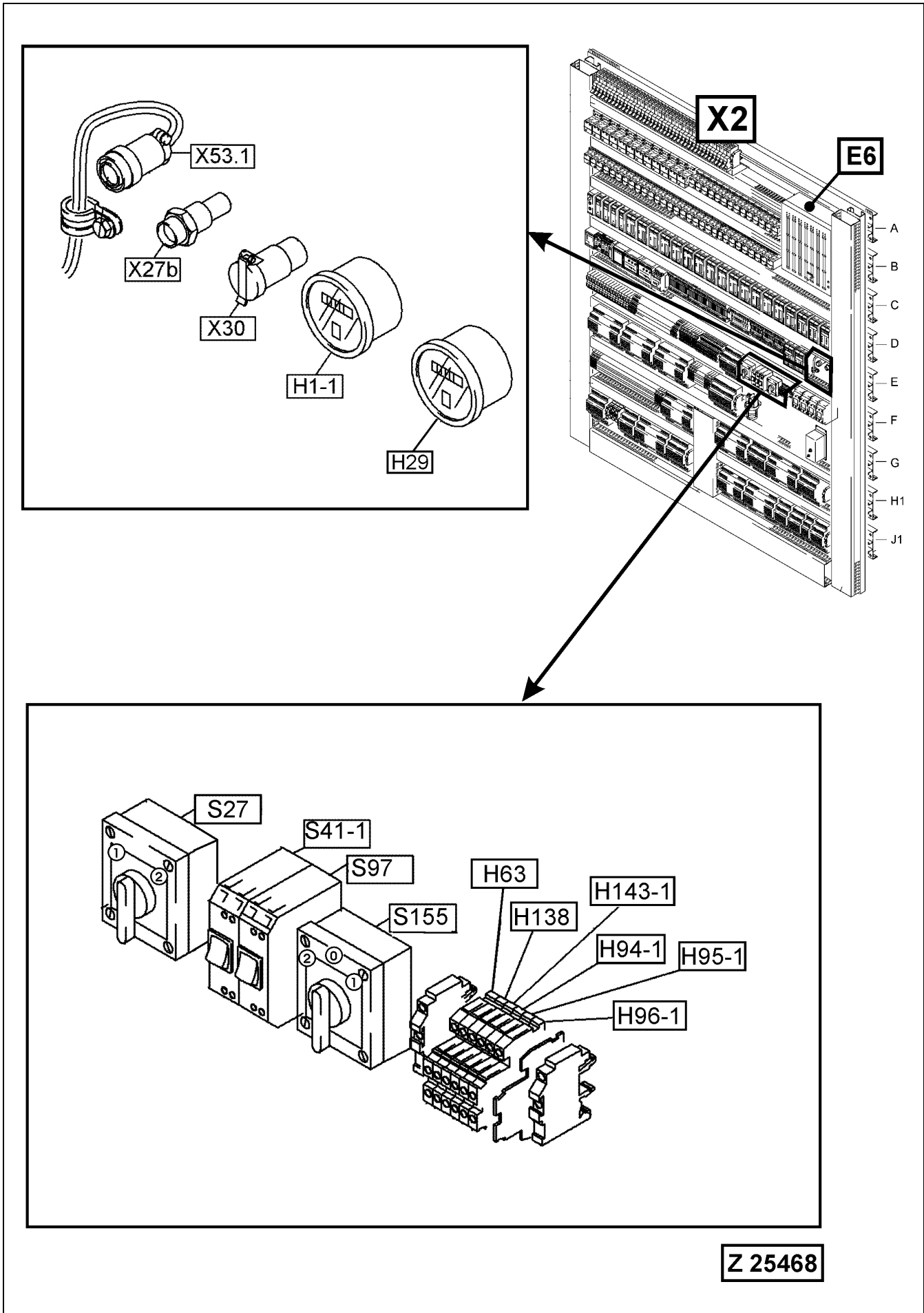

## Checking active diagnostic Fault Codes of the engine control system QUANTUM and of the engine monitoring system CENSE

### REMARK

With the engine diagnostic enable switch in ON position, the three indicator lamps (H94.1) STOP, (H95.1) WARNING, and (H96.1) FLUID will illuminate together for approximately five seconds; then all three lamps will be turned off at the same time if no faults are present.

If active faults are present, then fault code flashout will start if the engine diagnostic switch is ON and the engine is off. QUANTUM faults will be flashed out on the red STOP indicator lamp and CENSE faults will be flashed out on the yellow WARNING indicator lamp. The white FLUID lamp will remain on as long as a fault condition is present.

### To check for active fault codes proceed as follows:

1. Stop the engine and turn the Excavator main key switch to OFF position.
2. Turn the engine diagnostic enable switch to ON position. The diagnostic switch is located on the operator console, see page 93 for more information.
3. All active QUANTUM faults are flashed out first on the red STOP indicator lamp (H94.1). After all QUANTUM fault codes are flashed out, the active CENSE fault codes will be flashed out on the yellow WARNING indicator lamp (H95.1 ).  
The fault code flash out will begin with the first active QUANTUM fault. The first digit will be flashed out (0.3 seconds between each flash), followed by a 1 second delay; then the second digit will be flashed out, followed by the third digit. There will be a 2 second delay before the next fault is flashed out. Once all QUANTUM fault codes are flashed out, CENSE fault codes will start to flash out on the yellow WARNING indicator lamp (H95.1). The same timing sequence, described above, is used for the CENSE faults. Once all faults have been displayed, there will be a 3 second delay before the fault code flashout begins again.

---

---

### CAUTION

---

---

**Active faults MUST be corrected as soon as possible.  
Contact your Komatsu dealer for repair.**

---

---

### REMARK

For more information, refer to the separate Engine Operation and Maintenance Manual filed in volume 2 binder.

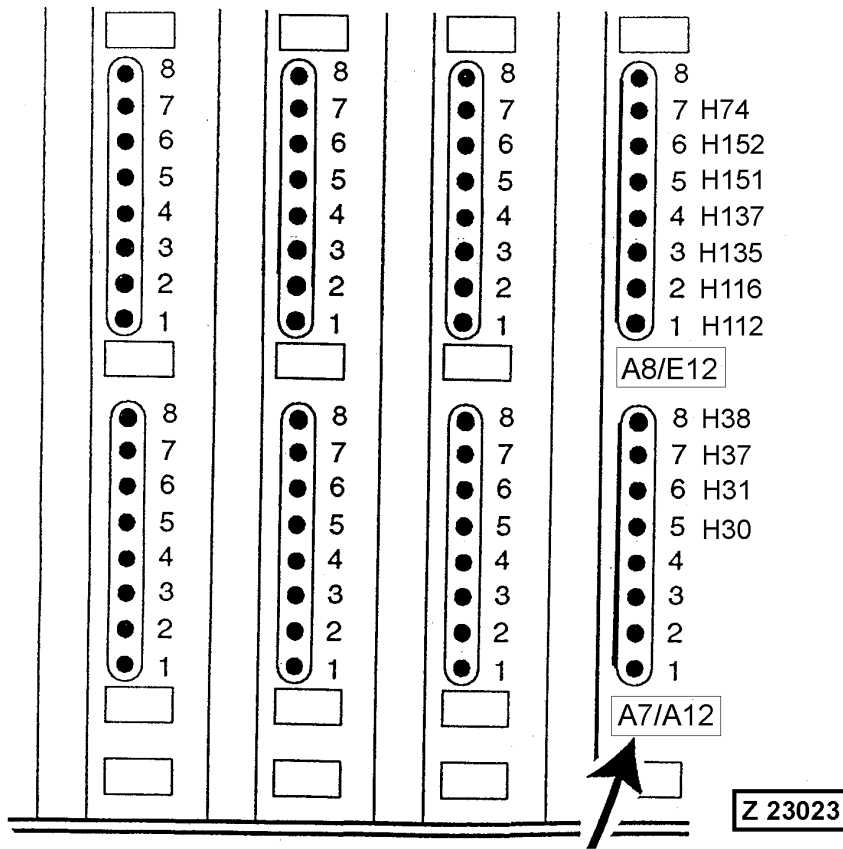
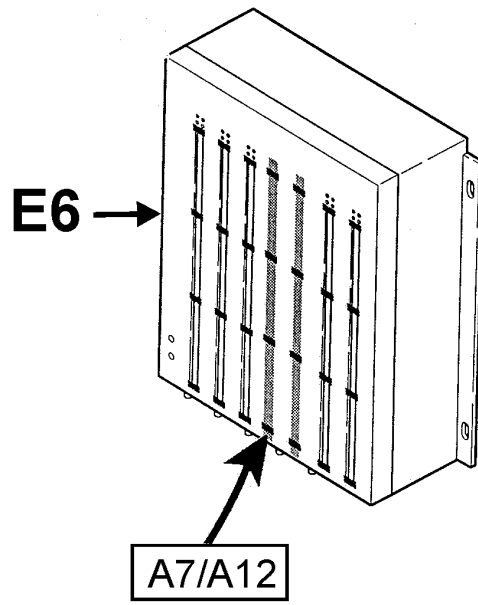

## Emergency Indication of Operating Conditions

The VHMS system is equipped with an emergency indication via LED's on the Programmable Logic Controller "PLC" (E6), illust. (Z 22588).

In case of a malfunction of the health monitor in the operator's cab, the LED's in the fourth column (A7/A12 and A8/E12) of the "PLC" indicating failures in vital operating systems of the Shovel.

The following faults are indicated:

Fault	LED No.
The VHMS system is by-passed (By-pass switch S27 actuated)	H30
Start of engine blocked, resp. engine shifted to low idle speed by one or more of the four high pressure filters.  <b>NOTICE</b> <b>The LED "H31" monitors all four high pressure filters. Refer to page 145 for description of the diagnostic codes flashed out by LED "H31".</b>	H31
Start of engine blocked, resp. engine shut down, due to closed main shut-off (gate) valve hydraulic tank	H37
Faulty monitor channel for hydraulic oil temperature	H38
Oil strainer in the return oil collector pipe restricted.  <b>NOTICE</b> <b>If the message number G00169 &gt;Trouble return oil filter hydraulic oil tank&lt; is displayed on the VHMS screen, there are two possible trouble conditions, either return oil filter restriction or restriction of the return oil strainer in the return oil collector pipe. To find out the unit which caused the fault message, check the LED number H74 . If the LED H74 is OFF, the return oil filters in the oil tank are restricted and need to be replaced. If the LED H74 is ON, the return oil strainer in the return oil collector pipe is restricted and needs to be replaced. Refer to page 391 in the maintenance section 4 for servicing instructions.</b>	H74
Faulty monitor channel engine speed	H112
Emergency shut down switch actuated	H116
Engine shutdown from ground man	H135
Hydraulic oil level too low	H137
VHMS Controller trouble	H151
VHMS Display trouble	H152

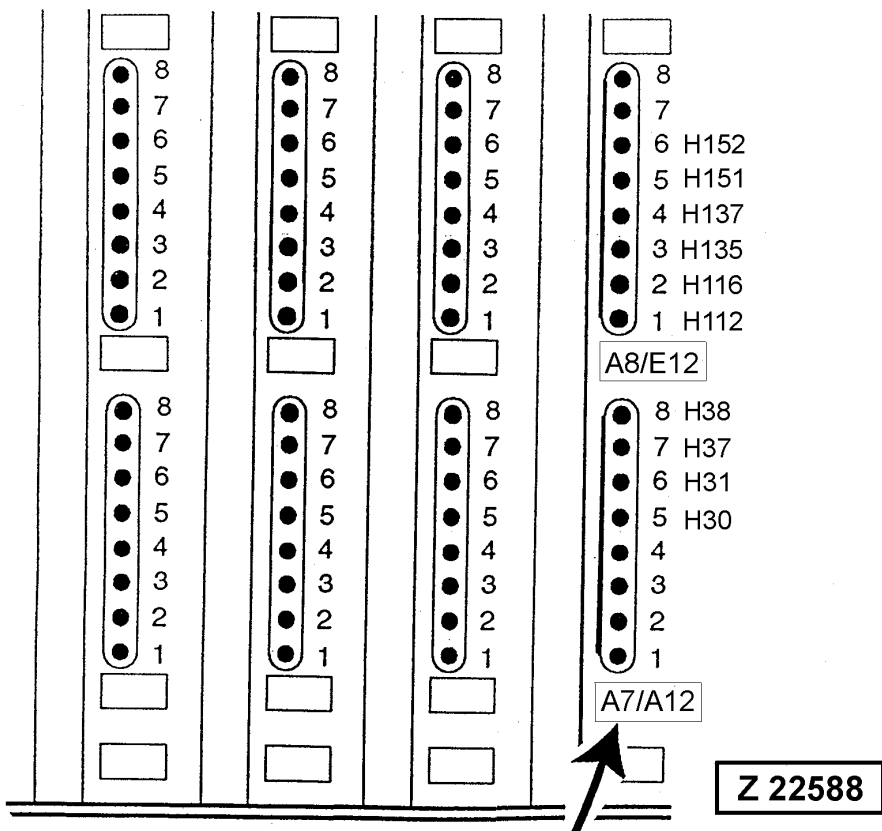
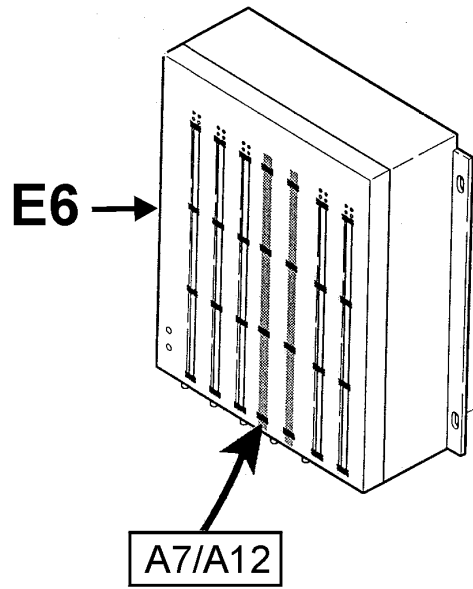



### High Pressure Filter "HPF" Identification Codes of LED H31

The LED "H31", illust. (Z 22588), monitors all four high pressure filters of the four main pumps. If a failure condition of a high pressure filter occurs, the LED "H31" will begin flashing out a diagnostic code for identification of the concerned filter. If more than one filter send a failure signal at the same time, the LED will always show the diagnostic code of that filter with the lowest number.

#### High Pressure Filter "HPF" Number:

Code HPF #1	1	1	1	1				
Code HPF #2	1	2	1	2	1	2		
Code HPF #3	1	2	3	1	2	3	1	
Code HPF #4	1	2	3	4	1	2	3	4
	0.5s	0.5s	0.5s	0.5s	0.5s	0.5s	0.5s	2s

#### Example: Identification Code for High Pressure Filter #4:

When the differential pressure switch of high pressure filter #4 sends the signal "Filter restricted, the LED H31 will flash four times at regular intervals of 0.5 seconds and then after two seconds pause time will start again flashing four times at regular intervals of 0.5 seconds and so on.

The number of the four 0.5 seconds interval flashing groups corresponds to the number of the high pressure filters.

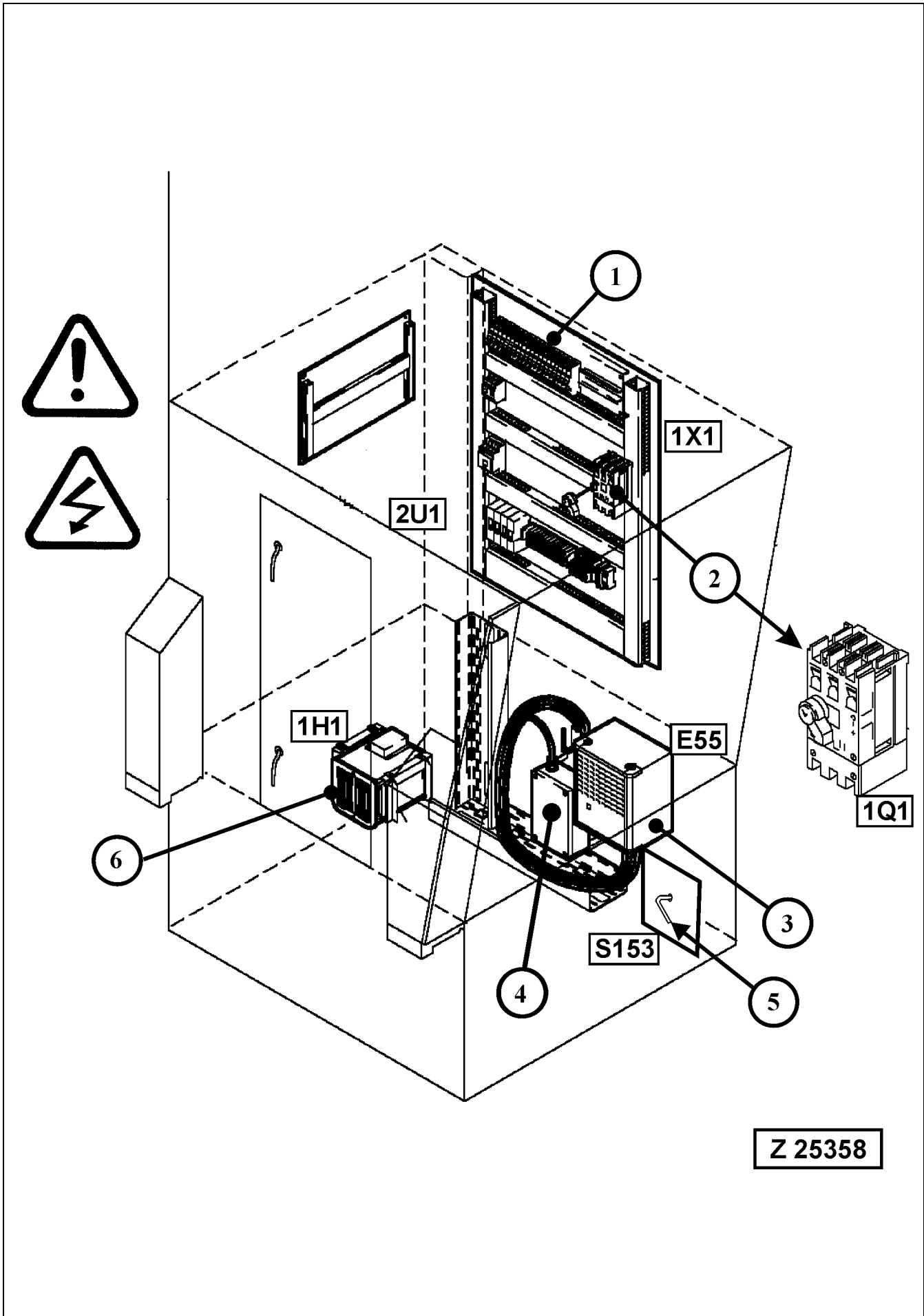

### 3.7.3 COMPONENTS OF ELECTRICAL PRE-HEATING SYSTEM LOCATED IN THE CAB BASE

---

---

**⚠ WARNING**

---

---

**The cab base contains high tension electrical appliances. Access to the cab base for authorized service staff only.**

---

---

#### General

The preheating system is a special equipment and can be installed in the factory or locally at site. Power supply to the preheating system must be provided through an external power source. The following description applies to a typical preheating system as it is delivered ex works.

#### The following systems are equipped with heaters:

- Engine cooling system
- Engine lubricating system
- Hydraulic system (main and suction oil reservoir)
- PTO (pump distributor gear)
- Storage batteries

#### REMARK

The auxiliary heater unit in the cab base (6), illust. Z25358 and the battery charger (3) are also connected to the external power supply.

#### Legend for illustration Z25358

- (1) Main switch board (1X1) for the preheating systems, located in the cab base
- (2) Main switch (1Q1) for all system heaters
- (3) Battery charger (E55)
- (4) Fuse box with circuit breaker F76 - 125A for battery charger
- (5) Key switch (S153) for battery charger (3)
- (6) Heater unit for cab base

---

---

**⚠ WARNING**

---

---

**Be sure to switch off main switch (2) and to disconnect power supply cable before working on any part of the heating system.**

---

---

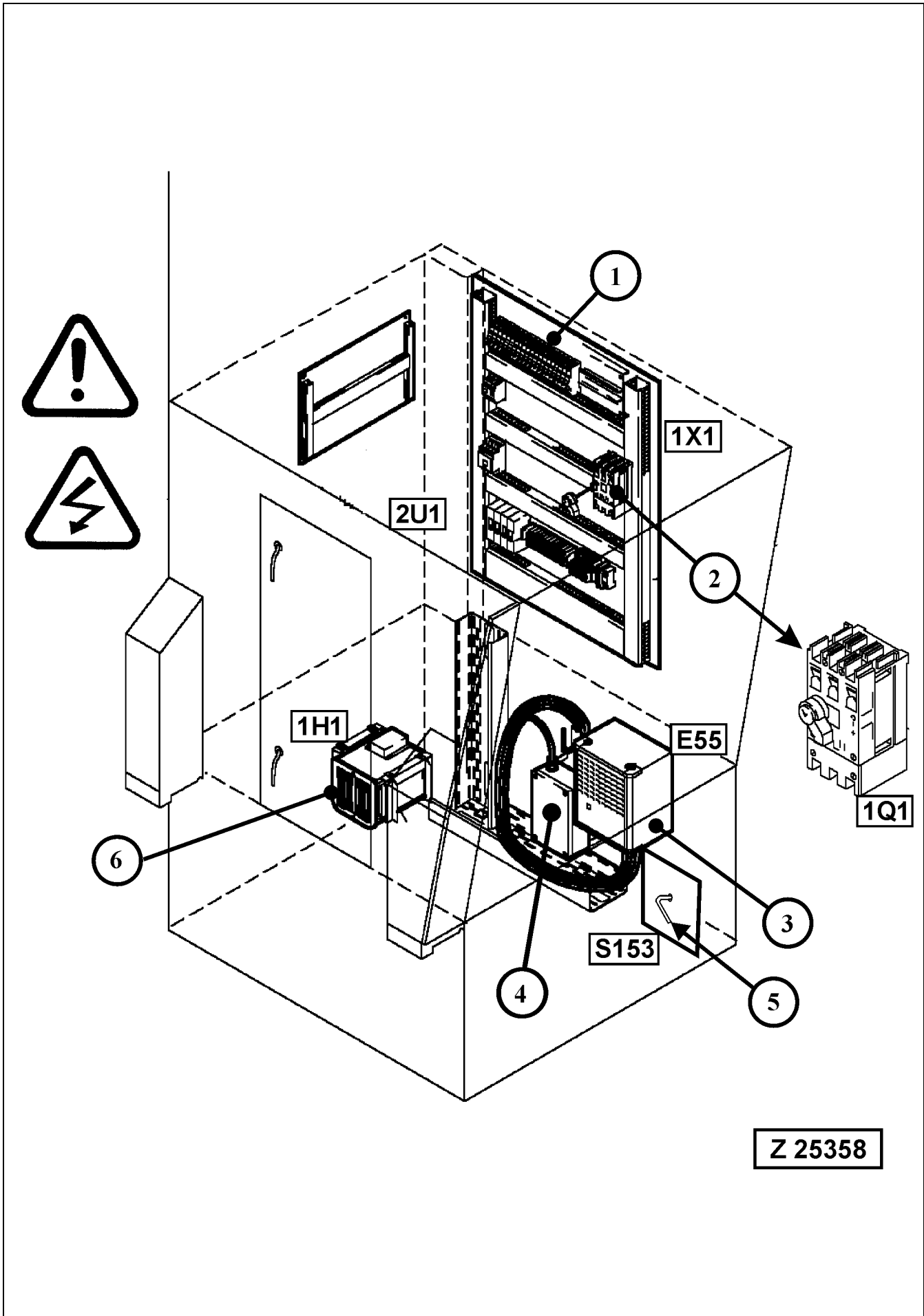

## **Components of Electrical Preheating System in Cab Base (continued)**

### **Operating the Preheating System**

Use the preheating system during stand-still periods e.g. over night and low ambient temperatures.

The heating system should be energized as soon as the engine is shut down. This allows the heating system to maintain the desired temperature with the use of minimum power.

The preheating systems for hydraulic oil and engine coolant are equipped with additional control boxes with separate ON/OFF switches. See following pages for more information.

### **Battery Charger (3)**

Power supply to the battery charger is provided by the generator set or an external power source connected to the plug socket at the cab stairway. The batteries of the shovel are charged by the battery charger (3). The battery charger is switched ON and OFF with main switch (5) and the switch on the front panel of the battery charger. For operating instructions refer to the separate Users Manual "MASTERVOLT" battery charger filed in volume 2 binder.

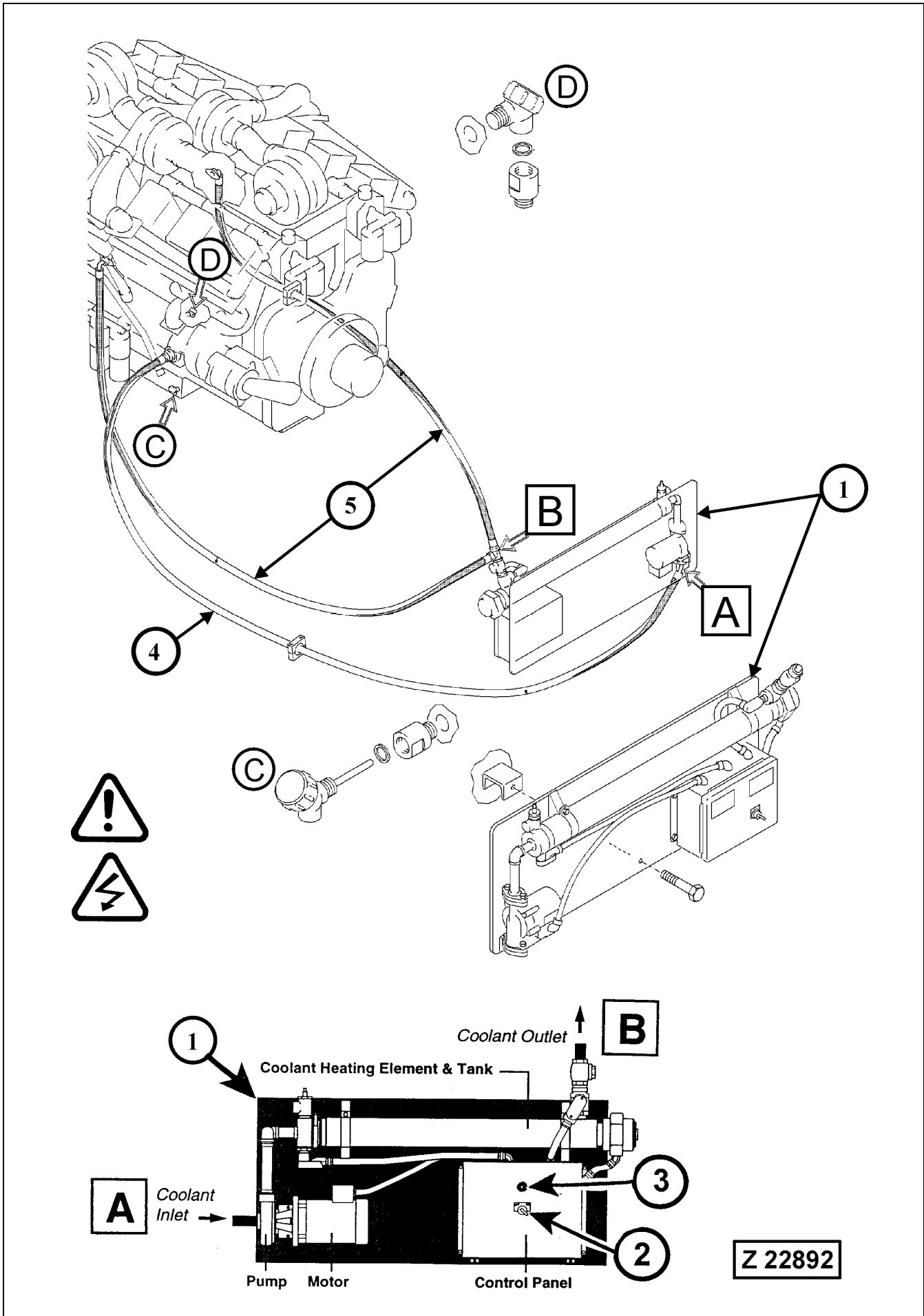

## Pre-heating System (continued)

### Engine Coolant and Engine Oil Heatings

#### REMARK

Use the heating system during stand-still periods e.g. over night and low ambient temperatures. The heating system should be energized as soon as the engine is stopped. This allows the heating system to maintain the desired temperature with the use of minimum power.

#### Legend for illustration Z 22892

- (1) Coolant heating system, installed on LH side member of the main frame.
- (2) Switch, coolant heater ON/OFF.
- (3) Indicator light, coolant heating ON,
- (4) Coolant hose from engine to coolant heater
- (5) Coolant hoses, preheated coolant to the engine.
- (A) Coolant inlet
- (B) Coolant outlet
- (C) Engine oil heater installed in the engine oil pan
- (D) Thermostat for engine oil heater installed in the engine oil pan

#### REMARK

The engine oil reserve tank is also equipped with a heater element and thermostat, see next page for details.

To activate the coolant heating, set main switch (1Q1) on the switch board in cab base to ON position. The coolant heating can then be switched on with switch (2) on the control panel. The lamp (3) illuminates with coolant heating ON.

#### NOTICE

**Before starting the shovel engine, switch OFF the coolant heater.**

#### REMARK

For more information about the coolant heating system, refer to the manufacturer's manual -KIM HOTSTART Coolant Heating System- delivered with the heating system.

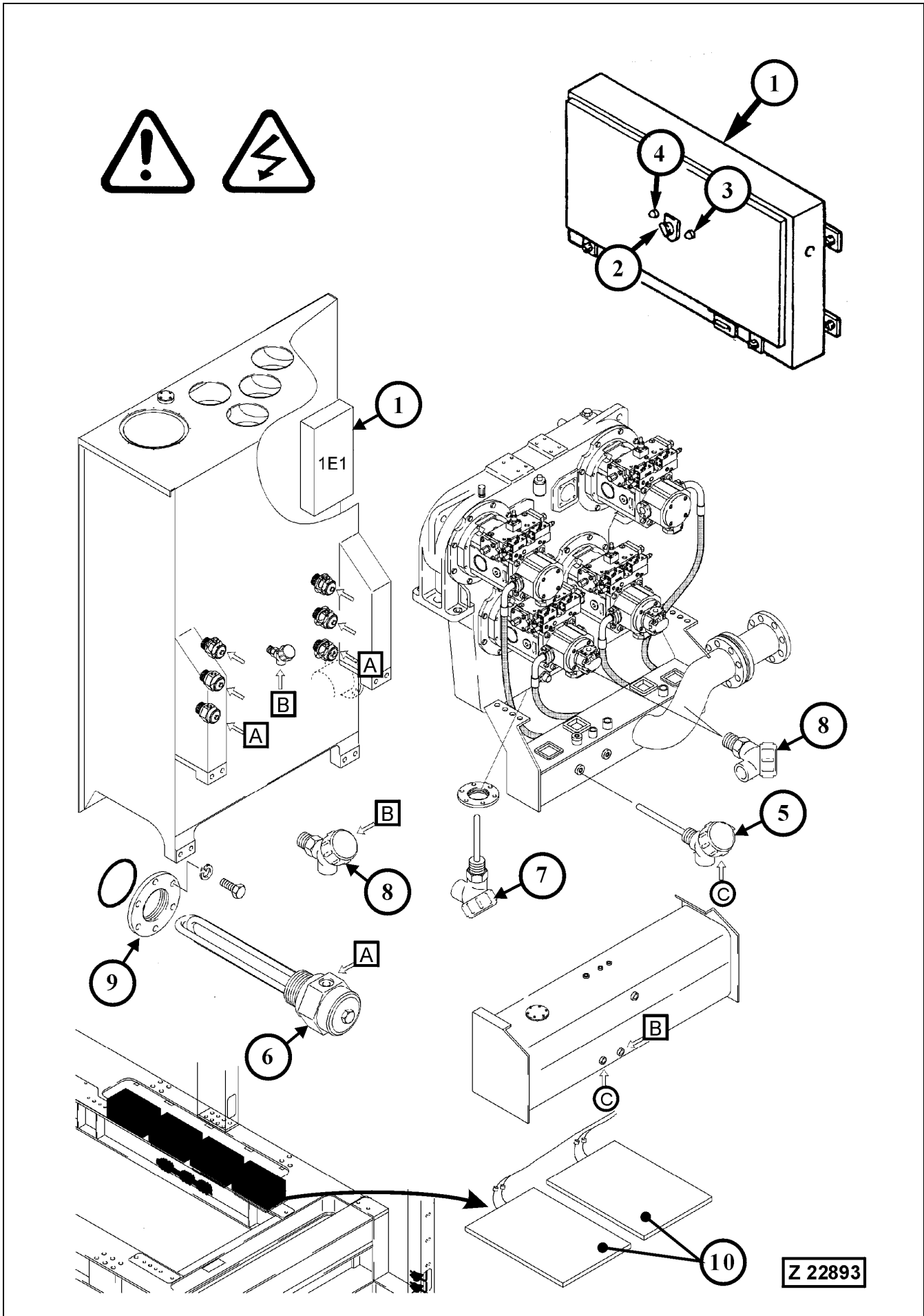



## Pre-heating System (continued)

### Heaters for Hydraulic Oil Reservoirs, PTO Housing, Engine Oil Reserve Tank and Batteries, illustration Z 22893

- (1) Junction box for hydraulic oil heating
- (2) Switch, hydraulic oil heating ON / OFF.
- (3) Warning light red, heating system failure,
- (4) Indicator light green, hydraulic oil heating ON.
- (5) Immersion heaters installed in the suction oil reservoir and engine oil reserve tank
- (6) Immersion heaters installed in the main hydraulic oil reservoir
- (7) Immersion heater installed in the PTO (pump distributor gear)
- (8) Thermostats installed in the main oil reservoir, suction oil reservoir, PTO (pump distributor gear) and in the engine oil reserve tank
- (9) Adapter flange for heater element
- (10) Heater plates for batteries

#### REMARK

The batteries are located below the rear walkway floor plates in the engine room.

- (A) Location of immersion heaters (6) at the main oil reservoir
- (B) Location of thermostats (8) at the main oil reservoir and engine oil reserve tank
- (C) Location of immersion heaters (5) at the suction oil reservoir and engine oil reserve tank

### 3.8 CHECKS BEFORE STARTING THE ENGINE

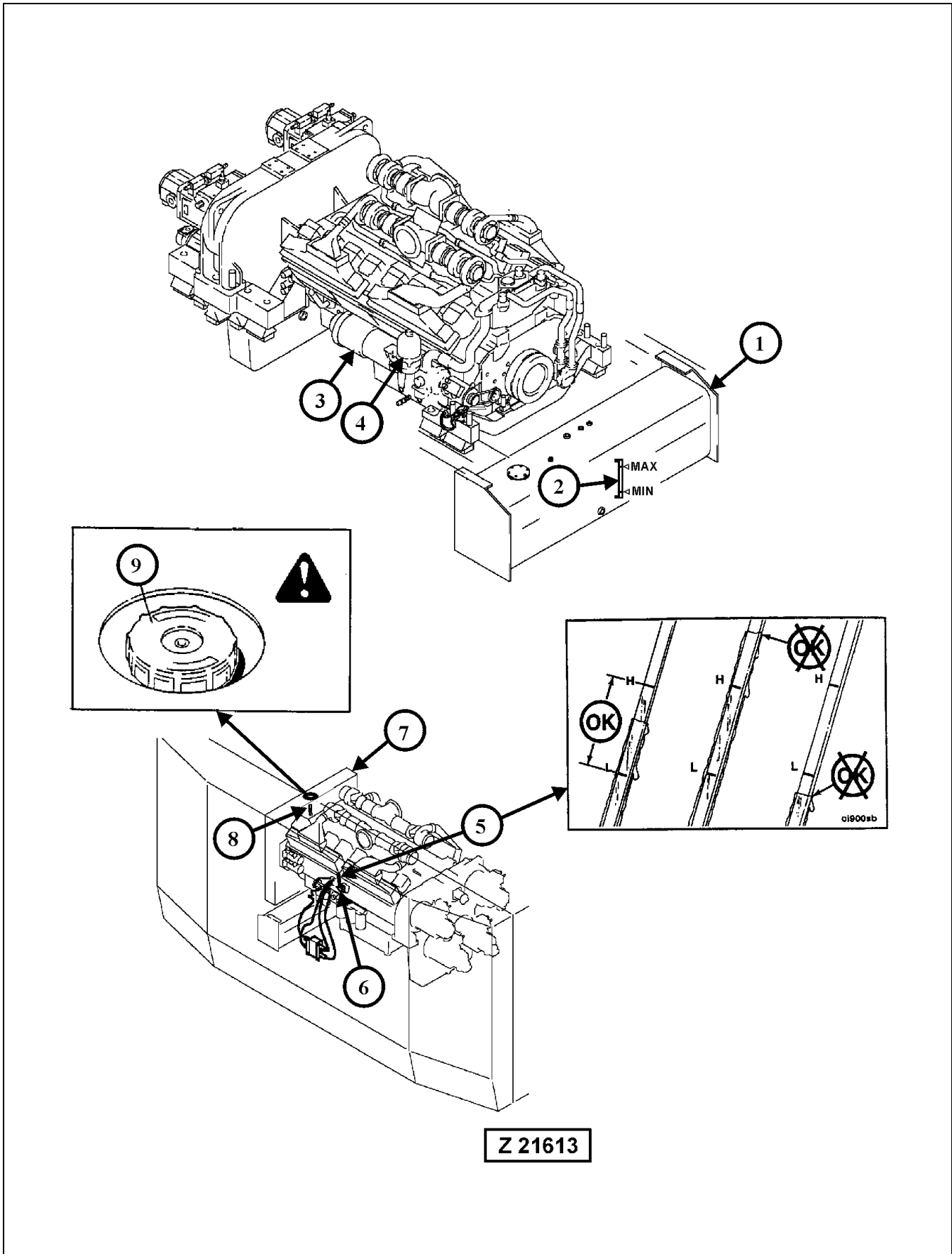

---

---

**CAUTION**

---

---

**Before starting the Engine, make sure that no one will be endangered when starting the Engine.**

---

---

## CHECK THE FOLLOWING ITEMS

### Legend for illustration Z 21613

- (1) Engine oil reserve tank of the RESERVE system
- (2) Sight gauge reserve tank oil level
- (3) Eliminator engine oil filtration system
- (4) Centrifugal separator for engine oil
- (5) Engine oil pan dipstick oil level gauge
- (6) Oil filler tube for engine oil pan
- (7) Engine coolant radiator
- (8) Coolant sight gauge on radiator
- (9) Radiator pressure cap

### 1. WALK-AROUND INSPECTION

Make a "Walk-around" inspection of the Shovel. Refer to Maintenance Section 4. for the daily inspection items.

### 2. Engine oil level in reserve tank and engine oil pan

Check oil level with Shovel standing on level ground. Check oil level in reserve tank (1) on sight gauge (2). The oil level is correct when it is between the MAX and MIN mark on the sight gauge. If necessary add engine oil via service arm connector.

**For more information → See "CENTRAL REFILLING SYSTEM" on page 212.**

Check oil level in engine oil pan with the dipstick oil gauge (5). For accurate readings, the oil level should not be checked until the oil has settled into the oil pan after the engine has been shut down (about 5 minutes).

### REMARK

The oil level in the engine oil pan can vary between the MIN and MAX marking on gauge (5) depending on the operating condition of the reserve system when the engine was stopped. With sufficient oil in the reserve tank and with the reserve system in proper working order, there is no need to fill the engine oil pan even with the oil level at the MIN mark on gauge (5). If the oil level is below the MIN marking on the gauge, corrective action must be taken. Fill the reserve tank and check the reserve system. The function of the reserve system is monitored by an indicator light located on the "X2" switch board in the cab base. See page 137 for more information.

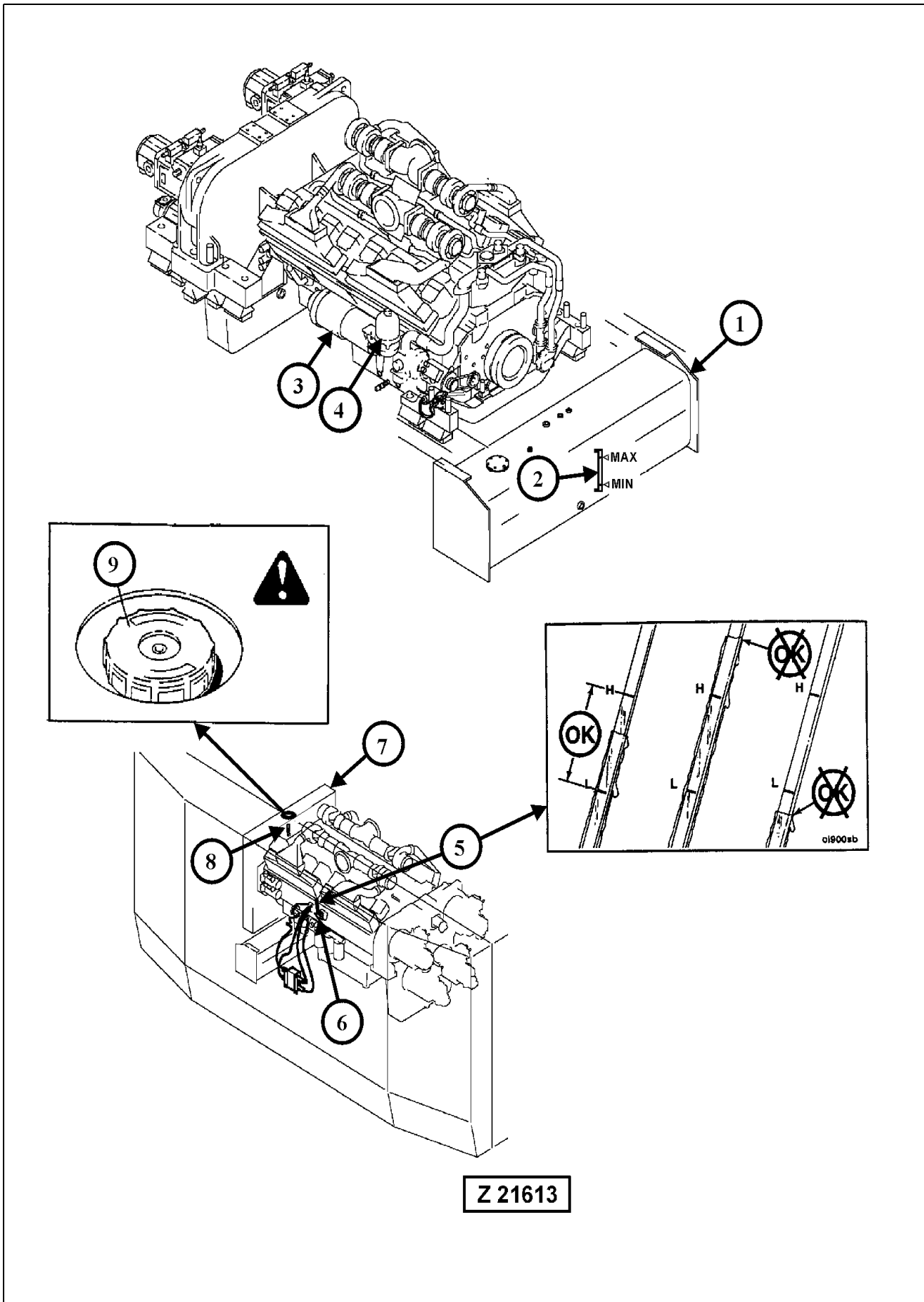

### 3. Coolant level

---

**▲ WARNING**

---

**DO NOT** remove the radiator pressure cap (9), illust. Z21613 from a hot engine. Wait until the temperature is below 50°C before removing the pressure cap (9). Failure to do so can result in personal injury from heated coolant spray or steam. Turn the radiator cap (9) slowly counterclockwise to the safety stop to allow the pressure to escape, then continue to turn until cap is free to be removed.

---

The coolant level should be in the upper field of the sight gauge (8). If necessary add coolant.

**REMARK**

Refer to the Engine Manual for the correct coolant composition.

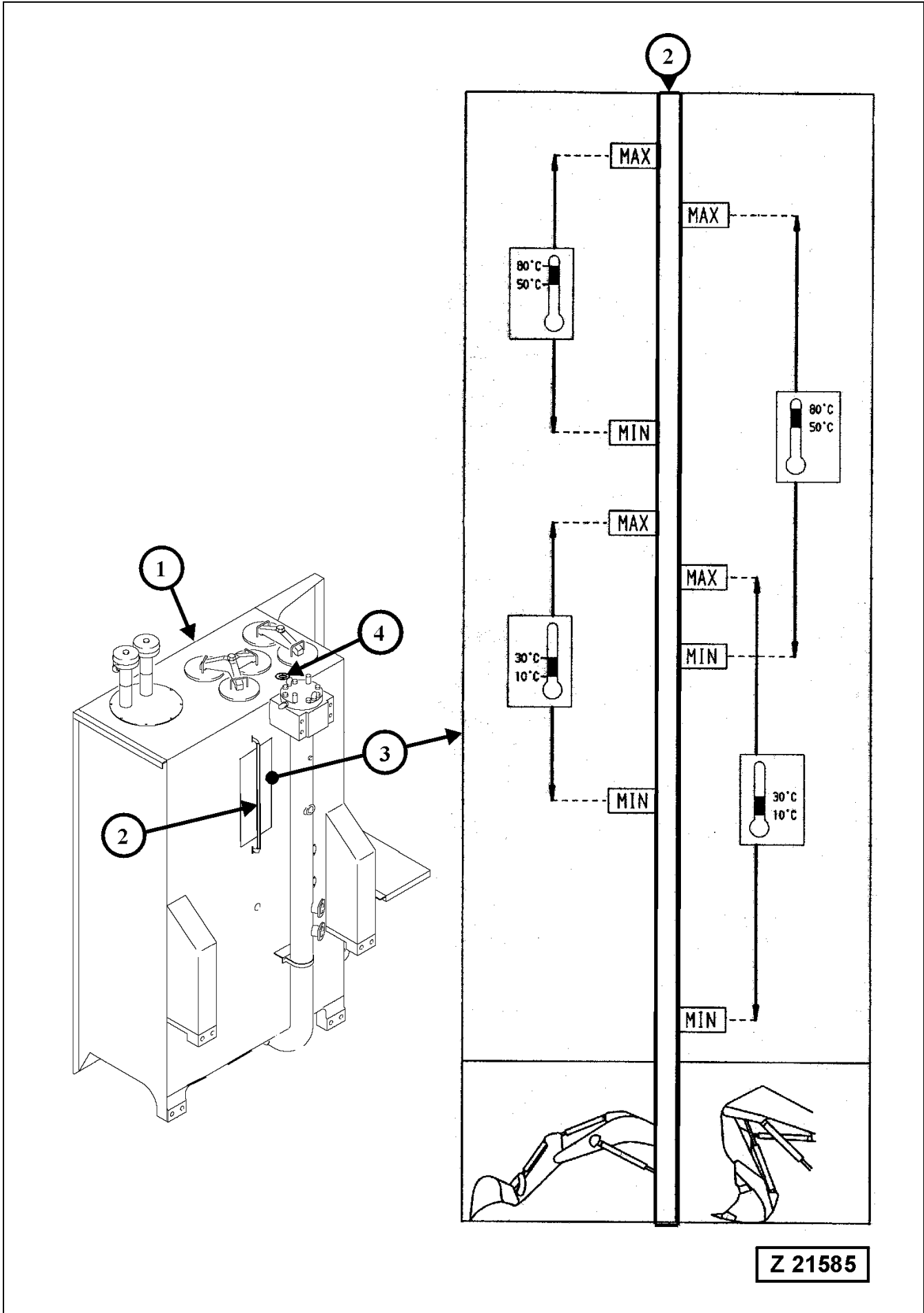

## 4. Hydraulic System - Check Oil Level

### General Information

The hydraulic oil level in the main oil reservoir fluctuates depending on the oil temperature and the position of the loader attachment (hydraulic cylinders retracted / extended).

### Legend for illustration Z 21585

- (1) Main hydraulic oil reservoir
- (2) Hydraulic oil level sight gauge
- (3) Oil level plate
- (4) Oil filler plug

For checking the oil level lower the attachment (backhoe or bottom dump bucket) onto the ground in a position as shown in the illustration Z 21585.

Depending on type of attachment and the present oil temperature, select the applying oil level range on plate (3). Be sure to use the correct marking on oil level plate (3).

Add hydraulic oil as necessary.

## Machinery House Doors

---

---

**▲ CAUTION**

---

---

**Make sure that all machinery house doors are securely closed before starting the engine and remain closed during operation of the shovel.**

---

---

## Operator's Seat Adjustment

Before operating the Shovel adjust the seat and mirrors for Operators maximum comfort, visibility, and complete control of the Shovel.

---

---

**▲ CAUTION**

---

---

**Use seat belt in accordance with the local safety regulations and laws.**

---

---

### 3.9 STARTING THE ENGINE

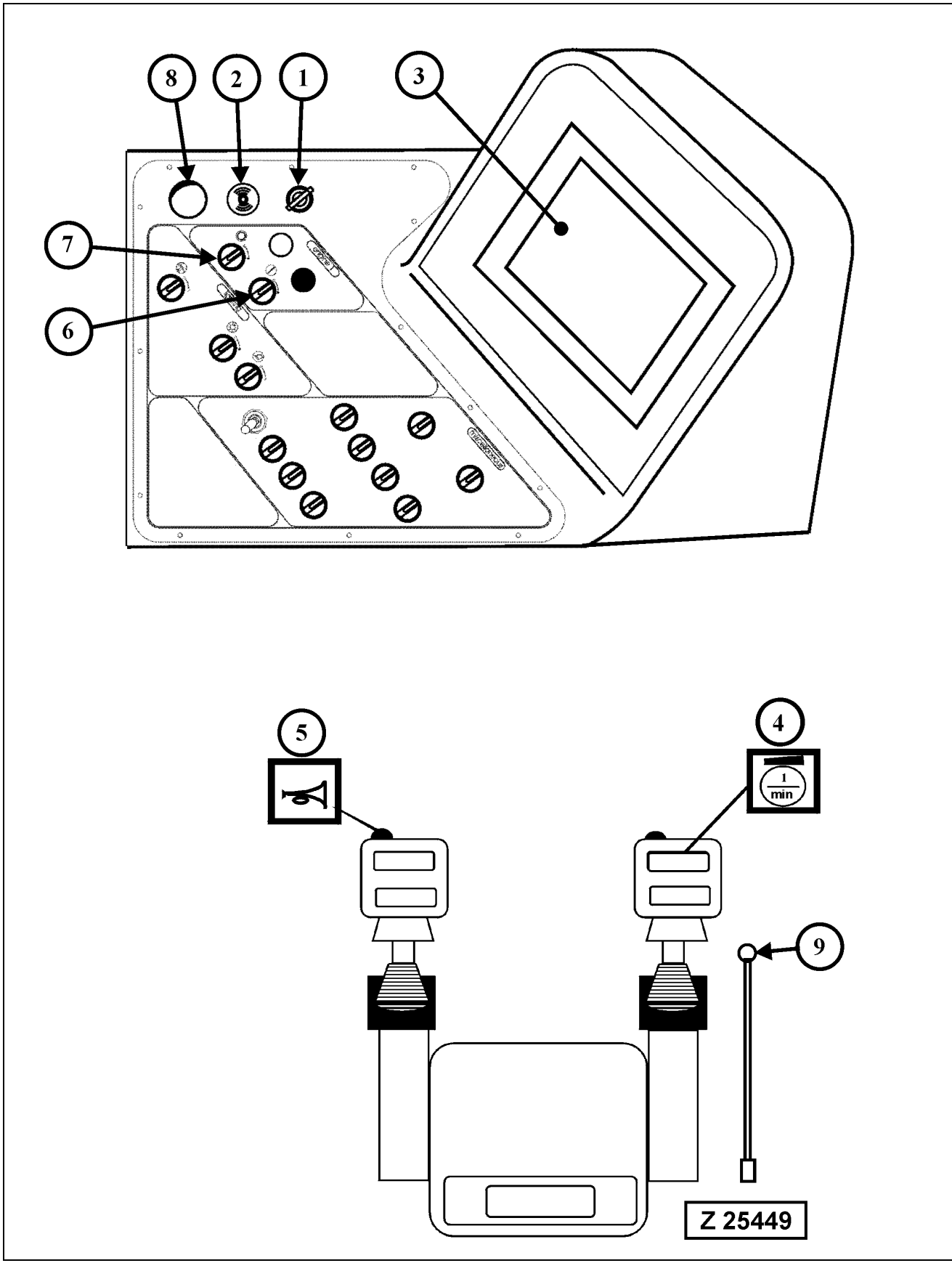



**NOTICE**

- Before starting read the Engine Operation Manual. Observe the instructions for starting the Engine.

---

---

**⚠ WARNING**

---

---

- After repairs on the Diesel engine or starter motors, make sure that the ground cables are correctly connected before starting the engine. Loose or missing ground cables can cause fire, serious injury or death.
  - Start the engine from the operator's seat only. Never attempt to start the engine by shorting across starter terminals. This can cause fire, serious injury or death.
  - Before each starting make sure that all controls are in neutral position.
  - Be sure to sound the signal horn before starting to make your intention clear.
- 
- 

---

---

**⚠ CAUTION**

---

---

Before starting the engine and again before starting work, pay attention to the hydraulic oil temperature. Refer to paragraph "Hydraulic Oil Warm-up" in this section.

---

---

**Legend for illustration Z25449**

- (1) Key operated main switch
- (2) Acoustic warning signal
- (3) Health monitor
- (4) Engine speed selector switch
  - Low idle - High idle
- (5) Signal horn button
- (6) Rotary switch - engine start
- (7) Rotary switch - engine stop
- (8) Strike button - emergency engine shutdown and cut out of pilot control system
- (9) Safety lock lever

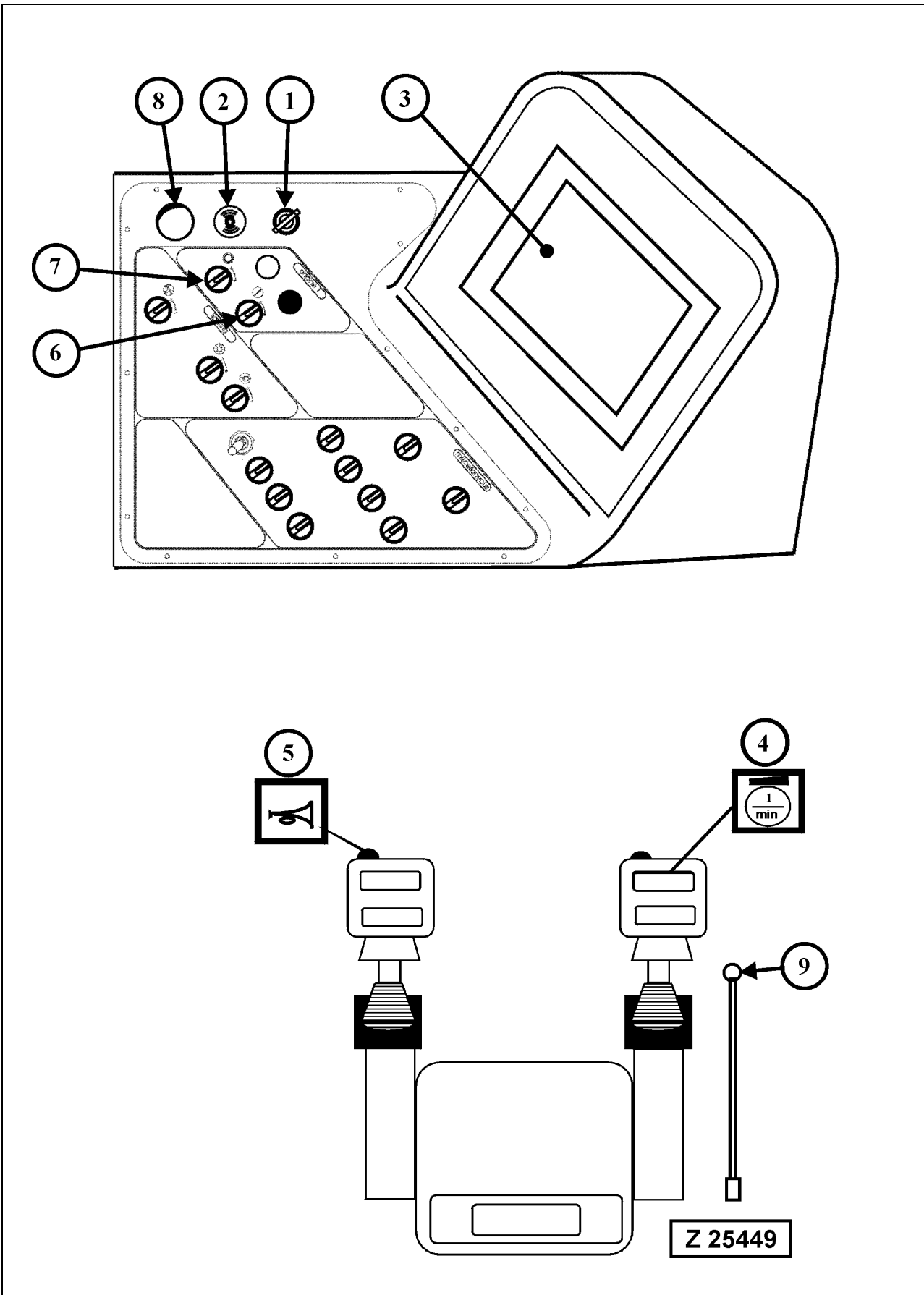

### 3.9.1 STARTING PROCEDURE

1. Insert battery main switch keys and turn to operating position, refer to section 3.6 for the location of the battery main switches.

#### REMARK

Start the engine with the safety lock lever (9) illust. Z25449 in the fully rear LOCKED position. When the engine is running move the safety lock lever fully to the front in FREE position.

2. Insert key into main switch (1) and turn to operating position.

#### NOTICE

**The warning buzzer (2) must give an acoustic test signal. If the buzzer fails to function, corrective action must be taken.**

3. Observe health monitor (3). Normally the initialization screen is displayed on the monitor.

**For more information → See "VEHICLE HEALTH MONITORING SYSTEM VHMS – HEALTH MONITOR" on page 96.**

4. Set toggle switch (4) to low idle speed position.
5. Sound the signal horn (5).
6. Start the engine by turning starter switch (6).

#### REMARK

The engine is equipped with a prelubrication system which is activated by the starter switch (6). Turning and holding the switch in the start position sends current to the prelubrication starter solenoid which then pre lubricates the engine. This solenoid timer prevents current from flowing to the conventional starting motor until adequate oil pressure has been achieved in the cam oil rifle. After a subsequent 3 second delay, current is then directed to the conventional starting motors for cranking the engine.

#### Cold Weather Starting Aid

##### Controlled Ether Injection

The electronic control module (ECM) of the engine controls ether injection into the intake manifold while cranking if the engine is below a calibrated minimum coolant temperature or intake manifold temperature value. It will continue to inject ether until a calibrated maximum engine speed has been reached. For more information refer to Engine Manual page 1-16.

#### NOTICE

**Never operate the starter longer than 30 seconds at a time in order to avoid damage. If the engine does not start within the first 30 seconds, wait 2 minutes before cranking again.**

7. As soon as the engine is running, check health monitor display (3), for information.

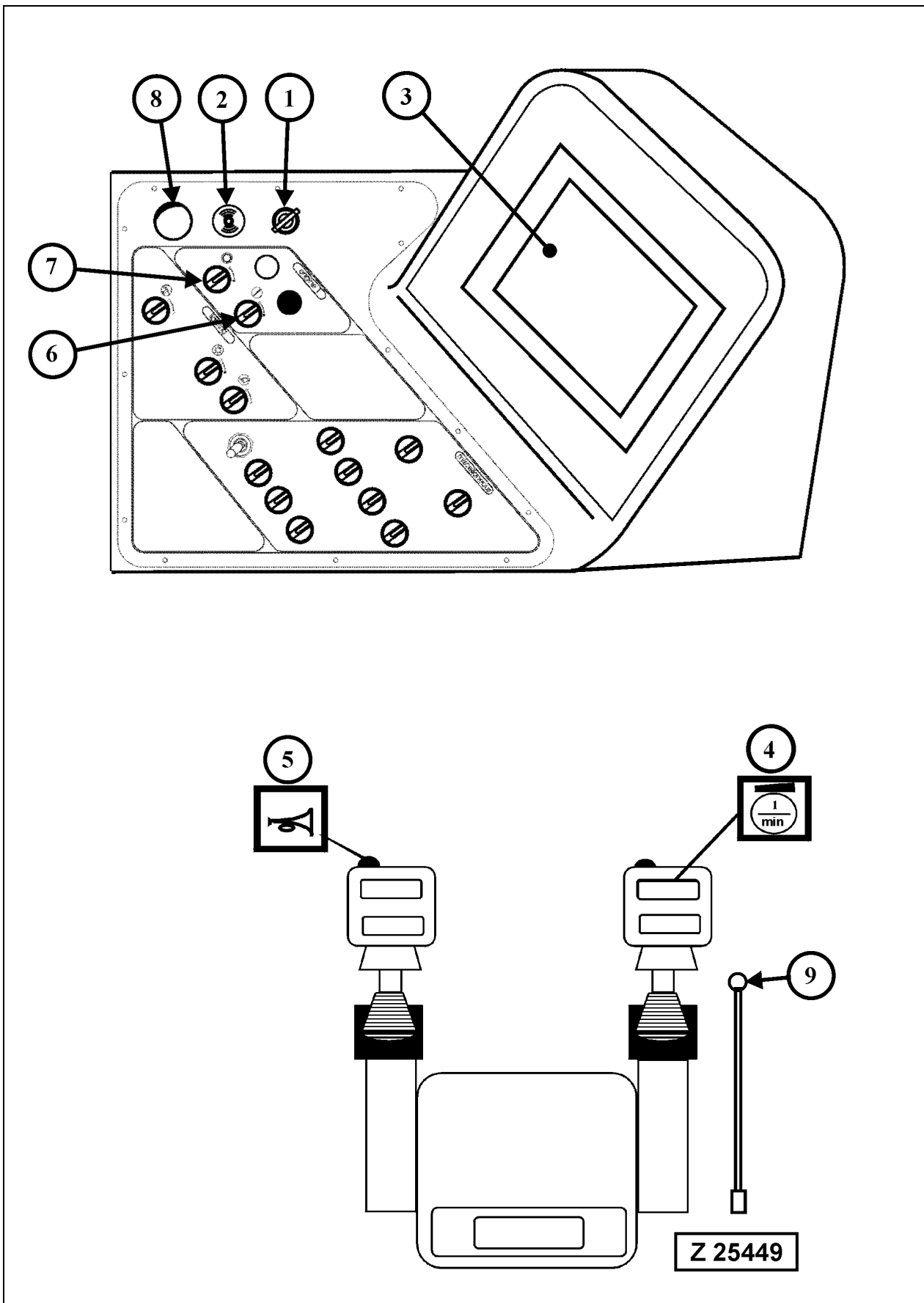

**After starting observe the following**

The VHMS System monitors the Shovel's functions and provides information about the appropriate operational data.

If a FAULT message is displayed on screen (3), the acoustic warning signal (2) will sound simultaneously for approximately 1 second. In such a case proceed according to the instructions of the displayed message.

Warning buzzer (2) will sound continuously when the hydraulic oil level is too low. In this case, stop the engine, locate and correct the cause immediately. Fill up hydraulic oil to the correct level.

8. After warming up of the engine, the speed can be increased by setting switch (4) to high idle speed position.

**NOTICE**

**DO NOT idle the engine for excessively long periods. Long periods of idling, more than 10 minutes, can damage the engine because combustion chamber temperature drop so low the fuel will not burn completely. This will cause carbon to clog the injector spray holes and piston rings and can cause the valves to stick.**

---

---

**⚠ CAUTION**

---

---

**Never let the engine run with disconnected batteries. This may cause alternator damage.**

---

---

**Emergency By-pass Switch for the Shut-down Function of the Programmable Logic Controller**

The emergency by-pass switch is located on the "X2" switch board in the cab base compartment and marked with "S27". If an automatic shutdown is initiated by Shovel systems, with a dangerous situation for man or machine, which needs the Shovel to be operable to over-come the dangerous situation, actuate this switch to override the shutdown function of the system and to enable a restart of the Diesel engine.

**NOTICE**

**This switch can not override engine initiated shutdowns.**

---

---

**⚠ CAUTION**

---

---

**As soon as the immediate situation of danger is over, shut down the unit. Correct the fault that caused the shut down and re-set the Emergency By-pass switch.**

---

---

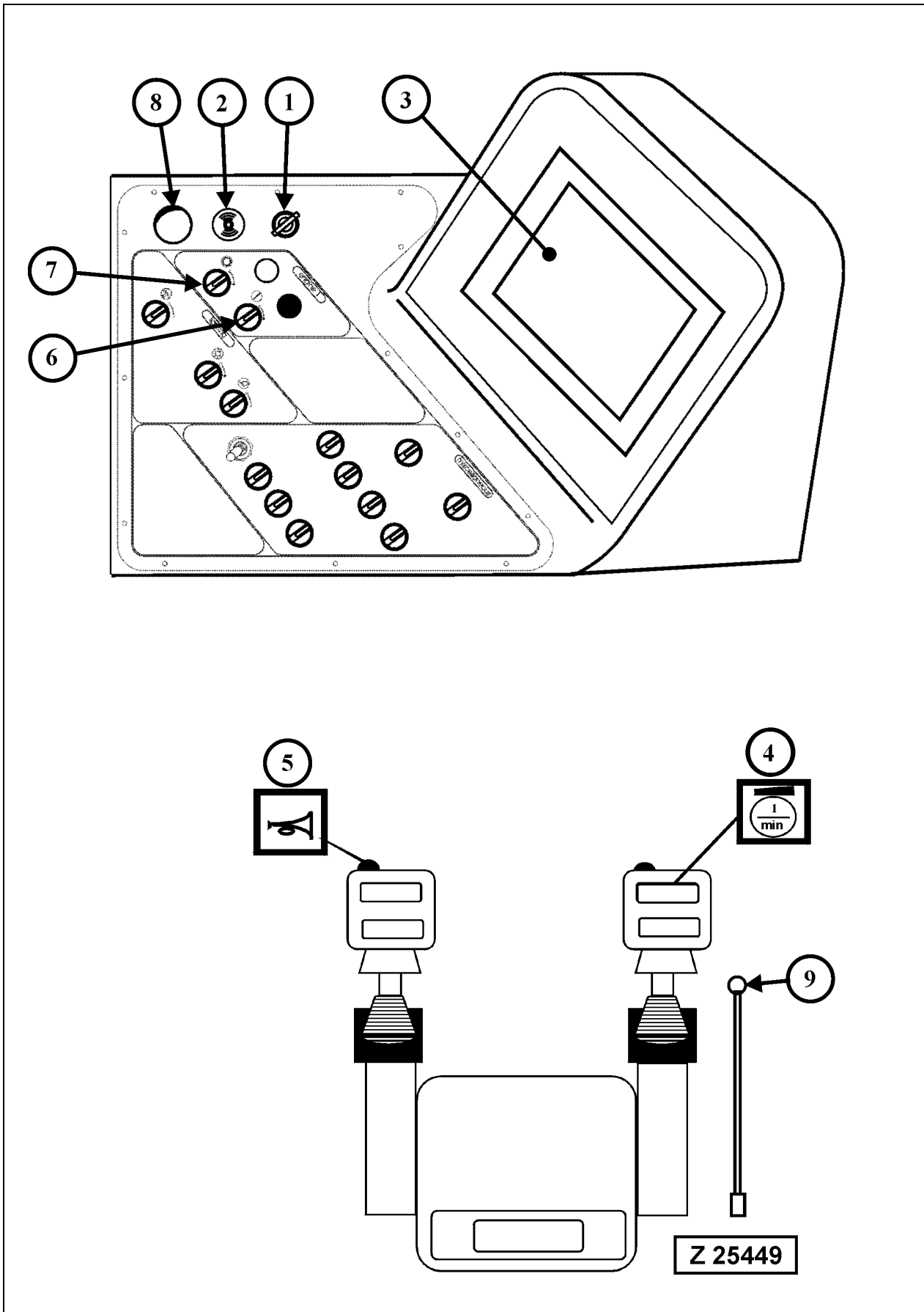

### 3.9.2 ENGINE WARM-UP

After starting let the engine run for a warm-up period before increasing the engine speed. This is necessary to avoid piston and bearing seizure.

Refer to the engine operation and maintenance manual for more information.

### 3.9.3 HYDRAULIC OIL WARM-UP

---

---

**CAUTION**

**On machines WITHOUT hydraulic oil pre-heating system:  
DO NOT start the engine if the ambient temperature (oil temperature) is below the starting temperature shown in column "1" of the hydraulic oil viscosity chart in this section.**

**On machines WITH hydraulic oil pre-heating system:  
Before starting the engine, warm-up the hydraulic oil to the starting temperature shown in column "1" of the hydraulic oil viscosity chart.**

---

---

#### REMARK

With hydraulic oil too cold, corresponding messages will be displayed on the health monitor (3). Follow the instructions given by message text.

The Shovel is equipped with a "½ Qmax control circuit for cold oil" which limits the main pumps oil delivery to approximately 50% of the total capacity as long as the oil temperature has not reached the minimum operating temperature shown in column "2" of the Viscosity and Temperature Chart on next page.

The pumps will move to maximum delivery position as soon as the minimum operating temperature of the hydraulic oil is obtained.

During the warm-up period, complete several operating cycles of all hydraulic movements without load. Avoid operation against limit stops. (high pressure build up).

Work can be started when the minimum operating temperature shown in column "2" of the viscosity chart is obtained.

## HYDRAULIC OIL VISCOSITY AND TEMPERATURE CHART

Rated viscosity at 40° C of hydraulic oil grade:	Starting temperature (max. 1000 cSt) -1-	Operating range (100 - 10 cSt) -2-
ISO VG	°C	°C
HLP 22	-20	8 - 55
HLP 32	-14	16 - 70
HLP 46	-6	25 - 80
HLP 68	0	32 - 85
HLP 100	+5	39 - 85

### NOTICE

The starting and operating temperatures in the above chart depend on the hydraulic oil viscosity grade used in the system. See decal in the operator's cab for viscosity grade of the factory oil filling.

#### For example:

Hydraulic system filled with VG 22 viscosity grade oil.

1. Lowest permissible starting temperature (oil temperature):  
- 20x C, see column "1"
2. Operating temperature:  
min. + 8x C  
max. + 55° C, see column "2"



### 3.10 MOVING THE SHOVEL

#### 3.10.1 TRAVEL CONTROL WITH FOOT PEDALS

**NOTICE**

Travelling directions with cab in normal working and travel position i.e. cab above idler wheel. Counter weight above drive sprockets.

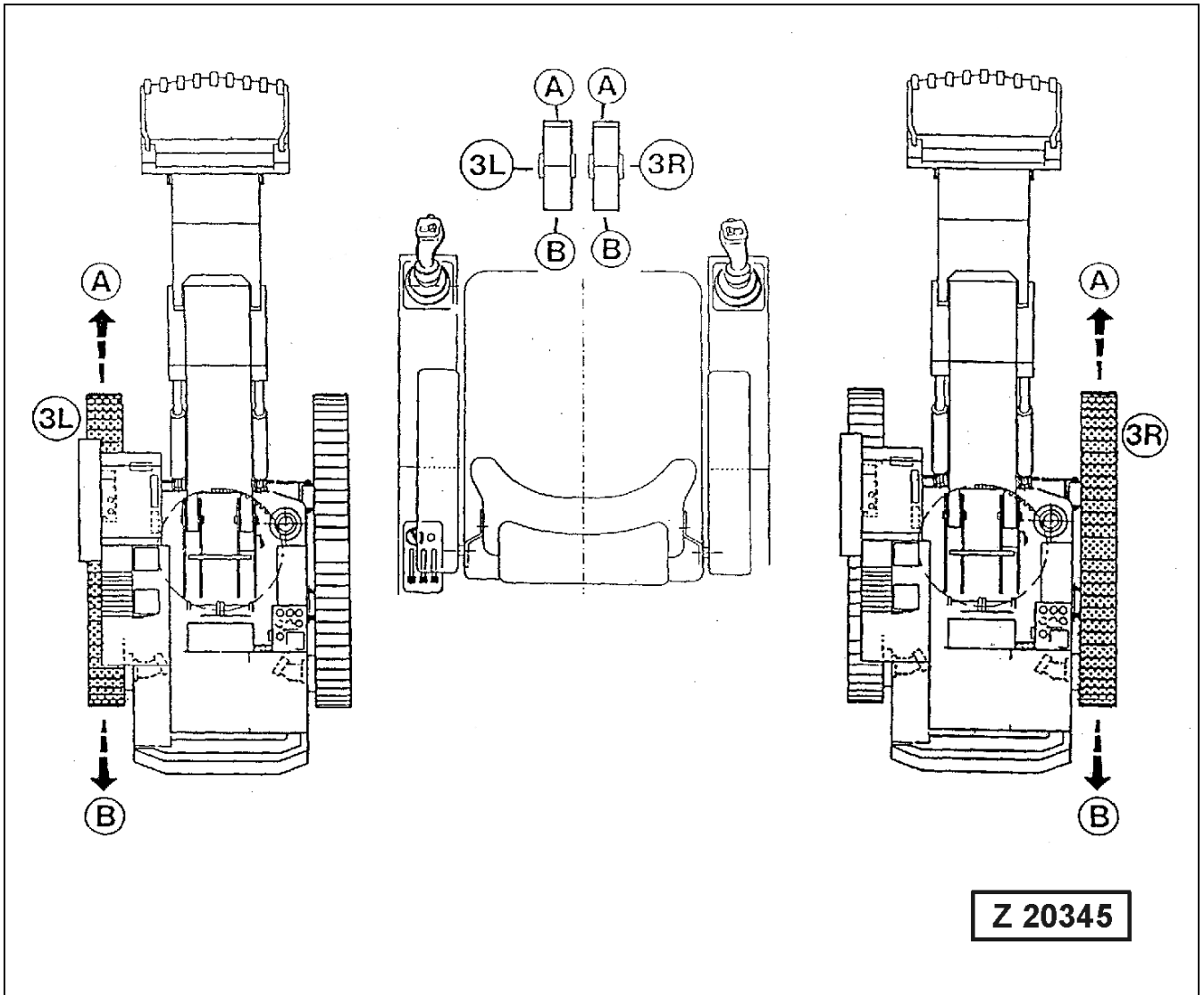

**Legend for illustration Z 20345**

- (3L) Left pedal, inside
- A Left track forward
- B Left track reverse

- (3R) Right pedal, inside
- A Right track forward
- B Right track reverse

**WARNING**

Be sure to sound the signal horn before starting to drive to make your intention clear.

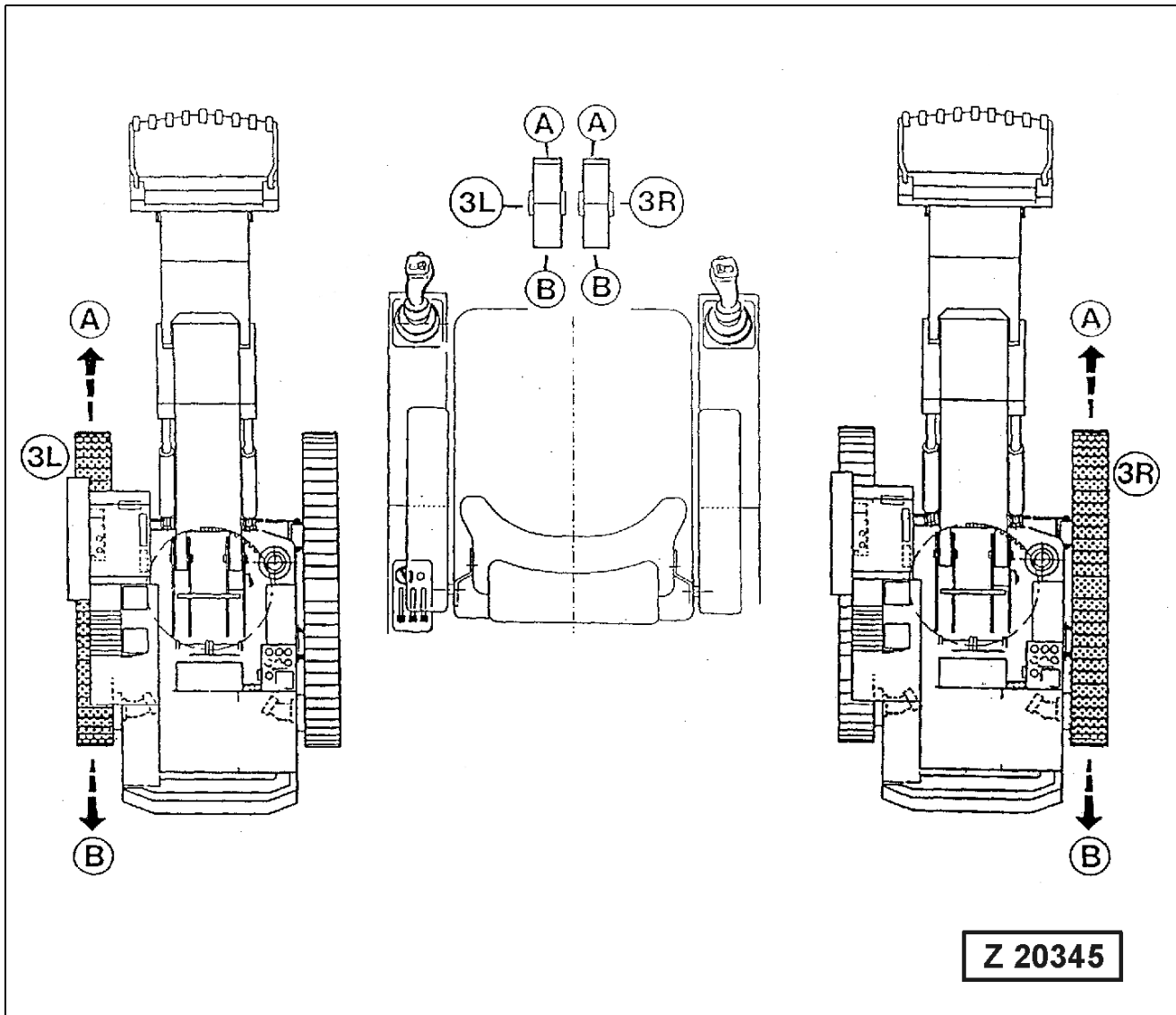

Regulate travel speed by depressing the pedals more or less. Apply swing circle brake as necessary.

On machines with two-speed range travel drive, select normal or fast speed range according to ground conditions.

For braking the machine release pedals (3L and 3R)

**DO NOT** reduce engine speed for braking, otherwise travel motors and gears could be damaged.

---

---

**▲ WARNING**

---

---

- Travelling on a grade requires special care. Plan your work so that the Shovel travels up- and downhill parallel to the grade. The superstructure must be parallel with the undercarriage and the working attachment must face to the front in travel direction. The travel gears must be at the rear in the direction of travel.
  - **DO NOT** use the **FAST TRAVEL SPEED RANGE** when travelling on a grade.
  - For maximum stability carry the bucket as close to ground level as possible. Operate the travel control pedals sensitively. Avoid jerky acceleration and deceleration of travel motions. Travel speed must be conform to the ground conditions.
- 
- 

**NOTICE****Two Speed Range Travel Drive**

If the Shovel is equipped with a Two Speed Range travel drive, always use the low speed range when travelling on a slope .

**Never go downhill with fast speed range engaged.**

**The low travel speed range must also be used during cornering.**

**PARKING BRAKE**

The Shovel is equipped with spring loaded disk type parking brakes. These brakes engaging and releasing automatically. They are arranged between the hydraulic motors and travel gears. When the motor/engine is running the parking brakes are automatically released by pilot oil pressure. With the motor/engine at standstill the parking brakes are engaged.

**TRAVEL ALARM / BACK-UP ALARM**

(Special equipment)

The Shovel can be equipped with one of the above alarm systems. The back-up alarm will sound at reverse travel. The travel alarm will sound at forward and reverse travel.

### 3.10.2 TRAVELLING INSTRUCTIONS

- Never travel the Shovel without first making certain that no one will be endangered.
- Be sure to sound the signal horn before starting to drive to make your intention clear.
- Before travelling long distances swing the superstructure parallel to the undercarriage and apply the swing brake.
- When travelling over inclines and gradients raise the working attachment only to such a height, that the bucket has sufficient ground clearance.
- Do not travel crossways to slope.
- Whenever possible operate the Shovel with the sprockets to the rear in the direction of travel.
- On steep terrain make sure that the final drives are at the rear in relation to travel direction.
- Before travelling over a bridge find out whether its bearing capacity is sufficient for the operating weight of the Shovel.
- Check for sufficient clearance and use a spotter.
- Pay attention to high voltage lines. On rough terrain observe movement of the boom.
- Travel speed must conform to local conditions so that the Shovel can be stopped at any time.
- Change travelling direction only after the machine is stopped.
- In order to avoid damage to track rollers and links, never turn the undercarriage over ditches and troughs.
- When working attachment is removed, the reduced stability of the Shovel has to be considered during travelling or slewing and when basic boom is operated. The stability can be improved, when the final drives are positioned opposite to counterweight.
- Observe permissible tilt angle of the Diesel engine when travelling uphill or downhill (superstructure must be in line with the undercarriage). Refer to Engine Operation Manual for the respective data.

# 3.11 SLEWING AND BRAKING THE SUPERSTRUCTURE

## 3.11.1 SLEWING THE SUPERSTRUCTURE

### MACHINES WITH "EURO" CONTROL

Legend for illustration Z25450

- "L" CCW- Lever (1) to the left "L"
- "N" Neutral position
- "R" CW- Lever (1) to the right "R"

**REMARK**

The slew speed can be increased by activating the slew speed switch (2). For smooth and efficient slewing operation, use the higher slew speed only for slewing angles greater than 90°.

**WARNING**

- Be sure everyone is in the clear before slewing the superstructure.
- Never swing or position the attachment or load over persons or vehicle cabs.
- Never allow anyone to walk or work under the Shovel or load while the Shovel is operating.

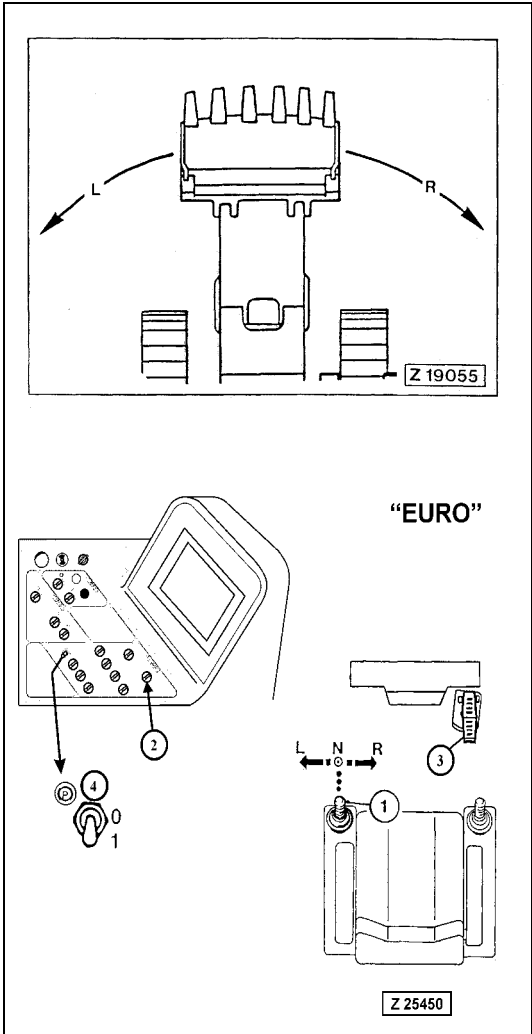

**MACHINES WITH "KMG" CONTROL**

**Legend for illustration Z25451**

- "L" CCW- Lever (2) to the left "L"
- "N" Neutral position
- "R" CW- Lever (2) to the right "R"

**REMARK**

The slew speed can be increased by activating the slew speed switch (5). For smooth and efficient slewing operation, use the higher slew speed only for slewing angles greater than 90°.

**WARNING**

- Be sure everyone is in the clear before slewing the superstructure.
- Never swing or position the attachment or load over persons or vehicle cabs.
- Never allow anyone to walk or work under the Shovel or load while the Shovel is operating.

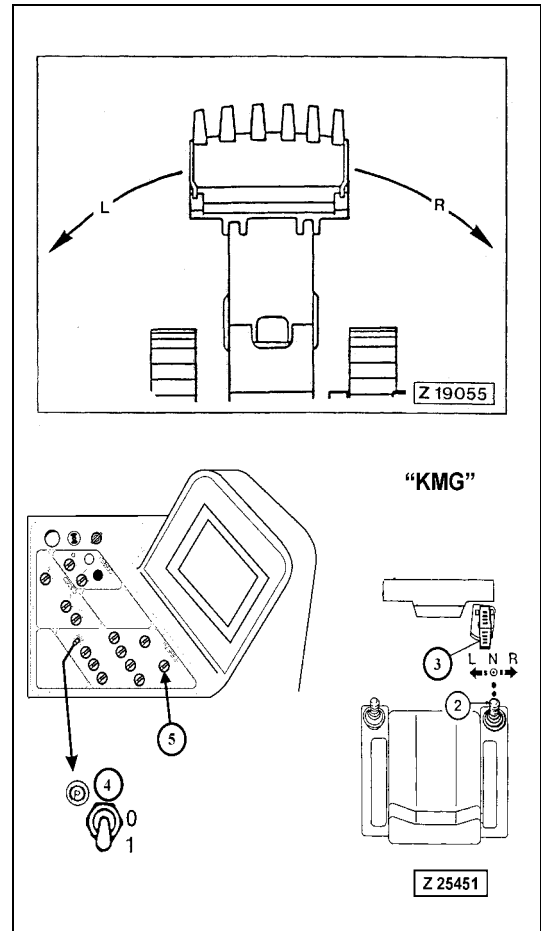

### 3.11.2 BRAKING THE SUPERSTRUCTURE

Braking of the superstructure from a slewing movement is carried out first by returning the control lever (1) or (2) to the neutral position (N).

This procedure can be shortened by depressing pedal (3).

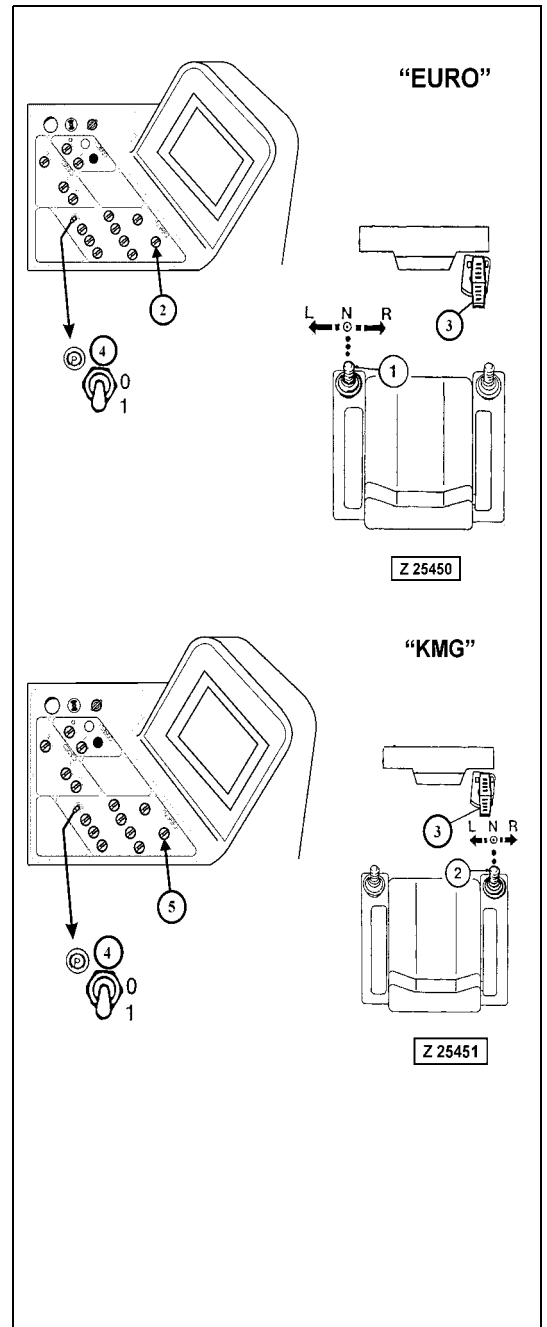

### 3.11.3 SLEW PARKING BRAKE

The parking brake for the slew gears is a spring loaded disk type brake. This brake is switched ON and OFF with toggle switch (4).

#### NOTICE

The slew parking brake must only be applied with the Superstructure at complete standstill. Applying the parking brake with superstructure still slewing may result in severe damage to the brake.

#### WARNING

- Use the slew parking brake only in an emergency situation for stopping the rotating superstructure.
- If the parking brake has been used for emergency stopping, it is necessary to shut down the Excavator and to have the parking brake of each swing gear inspected and repaired if necessary. Contact your Komatsu dealer for support.

#### SWITCH POSITIONS

- "0" Parking brake OFF
- "1" Parking brake ON

#### APPLYING THE PARKING BRAKE

Pull out toggle switch (4) against spring force and move down to position "1".

#### RELEASING THE PARKING BRAKE

Move up toggle switch (4) to position "0". In this position the switch is automatically pulled down by spring force.

#### NOTICE

Be sure to release the parking brake before slewing the superstructure.

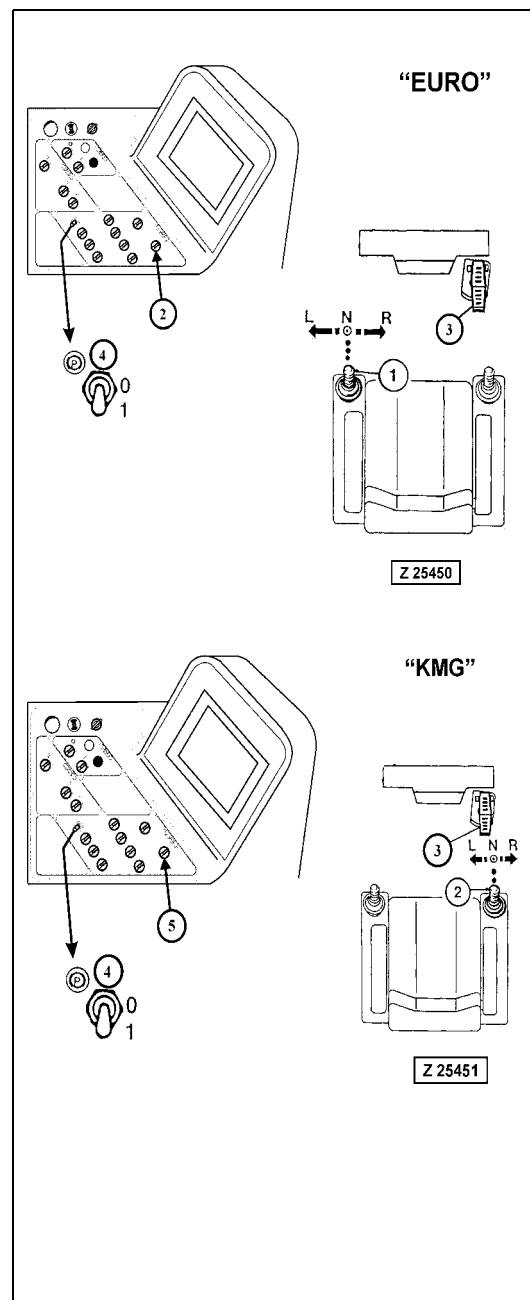



### **Hydraulic Slew Brake actuated by hydraulic access Ladder and Service Arm of Central Refilling System**

The hydraulic slew brake will be applied automatically when the access ladder and/or the service arm of the central refilling system is not in its completely lifted position.

### **IMPORTANT INSTRUCTIONS FOR SLEWING THE SUPERSTRUCTURE**

---

---

**▲ WARNING**

---

---

- **DO NOT swing over persons or over the unprotected cab of a truck.**
  - **DO NOT level the ground in front of the Shovel by turning superstructure back and forth.**
  - **DO NOT jump off the rotating superstructure.**
  - **Never swing against the wall of a pit. First raise the attachment out of the pit and then start rotating the superstructure.**
  - **Start digging only after finishing the slewing operation.**
- 
-

# 3.12 WORKING WITH THE ATTACHMENT

## 3.12.1 MACHINES EQUIPPED WITH "EURO" CONTROL SYSTEM

**NOTICE**

The illustrations show a typical construction of control stand and working attachment. However, the shown operation - and working movements apply to this machine.

### BACKHOE

- |                     |                                  |
|---------------------|----------------------------------|
| LH control lever(1) | RH control lever (2)             |
| E Extending stick   | A Lowering boom                  |
| F Retracting stick  | B Lifting boom                   |
|                     | C Filling bucket (roll back)     |
|                     | D Emptying bucket (roll forward) |

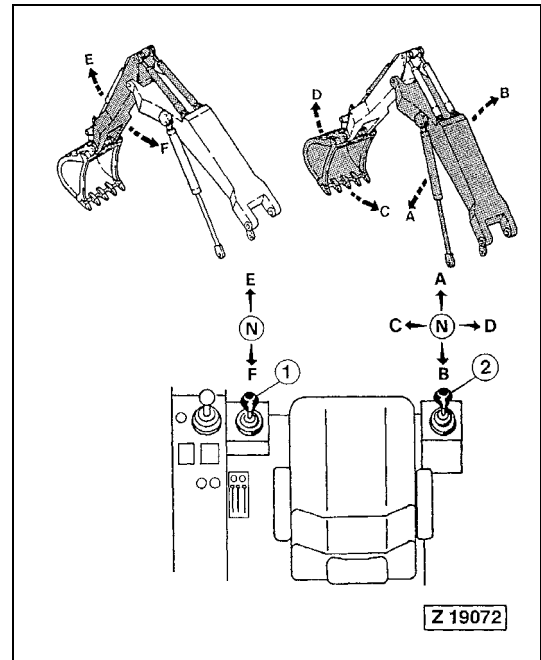

### FACE SHOVEL

- |                      |                                 |
|----------------------|---------------------------------|
| LH control lever (1) | RH control lever (2)            |
| E Extending stick    | A Lowering boom                 |
| F Retracting stick   | B Lifting boom                  |
|                      | C Filling bucket (roll forward) |
|                      | D Emptying bucket (roll back)   |

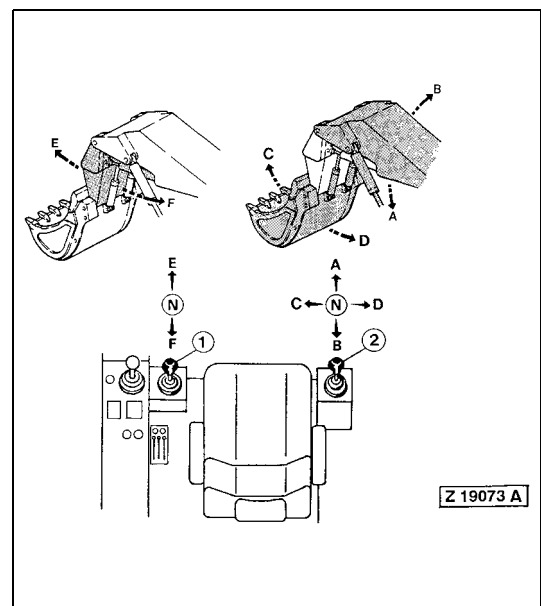

**NOTICE**

The raised working attachment can also be lowered with the ENGINE at standstill. If, for example, the engine stalls with the working attachment in a raised position, lowering of the working attachment is possible by moving control lever (2) to position (A). The necessary oil pressure for shifting the spools of the main control valves is provided by a pressure accumulator in the pilot oil circuit. After stopping the engine, relieve the pressure in the hydraulic system.

For more information → See "STOPPING THE ENGINE" on page 190.

### 3.12.2 MACHINES EQUIPPED WITH "KMG" CONTROL SYSTEM

**NOTICE**

The illustrations show a typical construction of control stand and working attachment. However, the shown operation - and working movements apply to this machine.

**BACKHOE**

- |                                  |                        |
|----------------------------------|------------------------|
| L.H. control lever (1)           | R.H. control lever (2) |
| A Lowering boom                  | E Extending stick      |
| B Lifting boom                   | F Retracting stick     |
| C Filling bucket (roll back)     |                        |
| D Emptying bucket (roll forward) |                        |

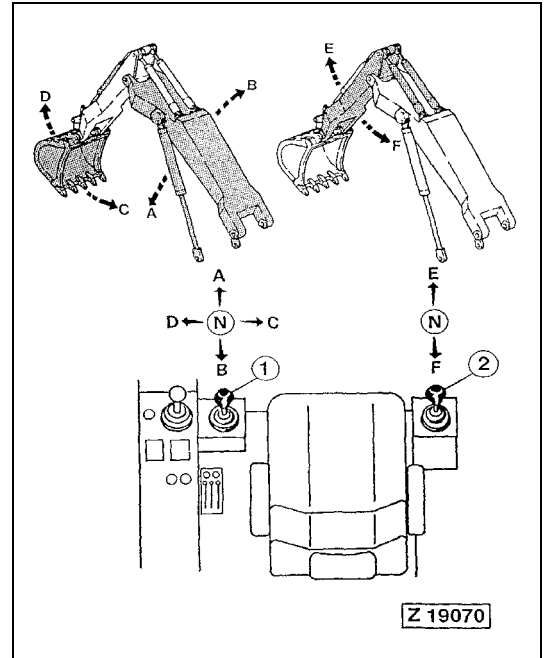

**FACE SHOVEL**

- |                                 |                        |
|---------------------------------|------------------------|
| L.H. control lever (1)          | R.H. control lever (2) |
| A Lowering boom                 | E Extending stick      |
| B Lifting boom                  | F Retracting stick     |
| C Emptying bucket (roll back)   |                        |
| D Filling bucket (roll forward) |                        |

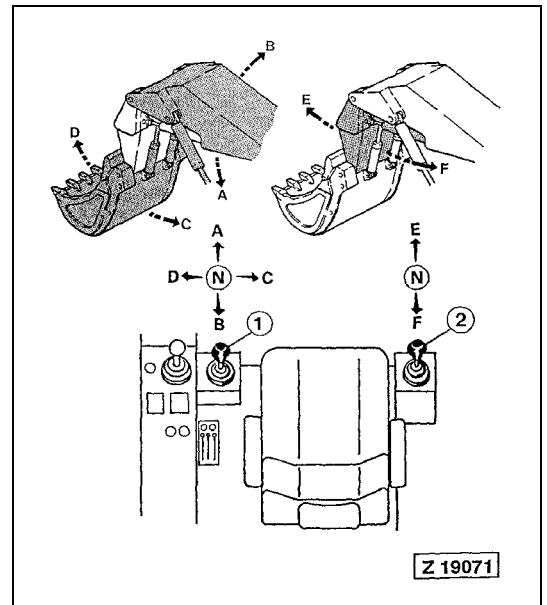

**NOTICE**

The raised working attachment can also be lowered with the engine at standstill. If, for example, the engine stalls with the working attachment in a raised position, lowering of the working attachment is possible by moving control lever (1) to position (A). The necessary oil pressure for shifting the spools of the main control valves is provided by a pressure accumulator in the pilot oil circuit. After stopping the engine, relieve the pressure in the hydraulic system.

For more information → See "STOPPING THE ENGINE" on page 190.

### 3.12.3 BOTTOM DUMP BUCKET

**NOTICE**

The illustration shows a typical construction of control stand and working attachment.

However, the shown operation- and working movements apply to this machine.

#### OPERATING THE BUCKET CLAM

- G Closing the bottom dump bucket:  
Depress LH pedal (4)
- H Opening the bottom dump bucket:  
Depress RH pedal (5)

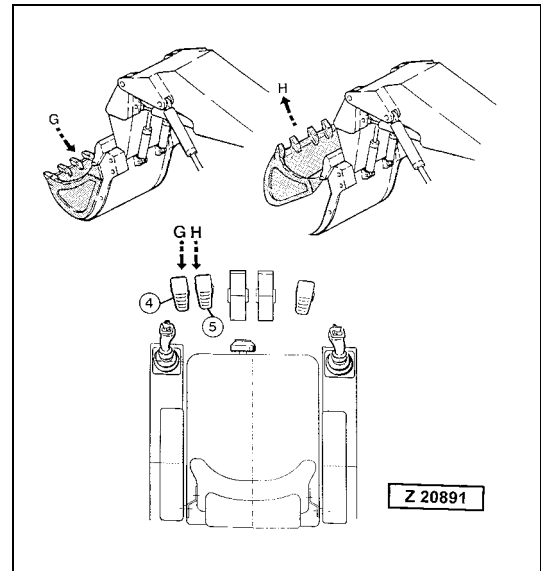

**CAUTION**

As soon as the bucket is completely closed, release pedal (4). Otherwise the pressure relief valve of the bucket closing circuit will open resulting in unnecessary loading of the hydraulic system.

**CAUTION**

DO NOT use the bucket clam for loosening or removing anchored rocks or other solid objects (illust. Z 19984 and Z 19985), since such operations may result in severe damage to the clam pivot bearings.

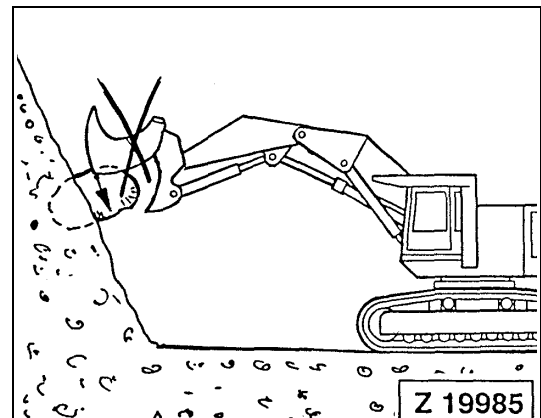
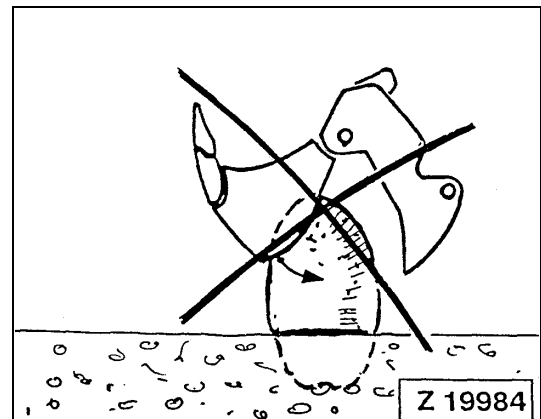

### 3.12.4 DROP BALL OPERATION

#### **WARNING**

- Make sure all safety devices are correctly installed on your machine.
- Always walk-around and look for hazards before you operate your machine in the work area.
- Consult the supervisor of the job site for instructions concerning safe operation in the work area.
- Know the rules for movement of people and machines on the job site. Follow the instructions of the supervisor.
- Before starting drop ball operation, clear area of other persons and sound the signal horn. Stop drop ball operation when other persons approaching to the work area.
- The drop ball must never be placed loosely in the bucket. Always pick-up the drop ball at its greatest circumference, see detail (A) in the illustration number (6).
- When lifting the drop ball, make sure the back wall of the bucket remains in a vertical position, see detail (B) in illustration no. (7). The ball drop height is reached, when the bucket is on a level with the cab roof.
- With the drop ball lifted, never tilt back the bucket beyond the vertical position (B), otherwise the drop ball could roll over and fall on the Shovel.
- Before leaving the Shovel locate the drop ball on a safe place. DO NOT leave the drop ball in the bucket.

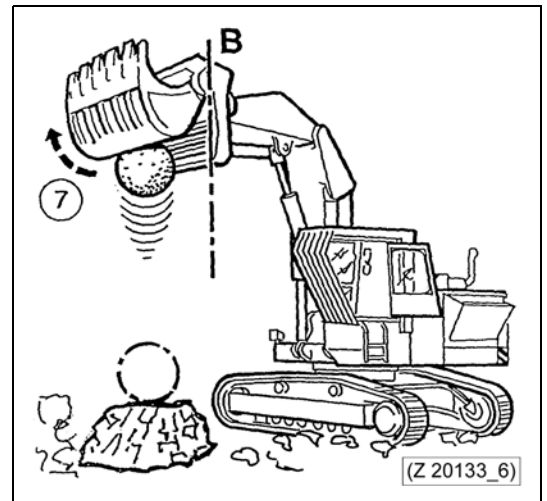
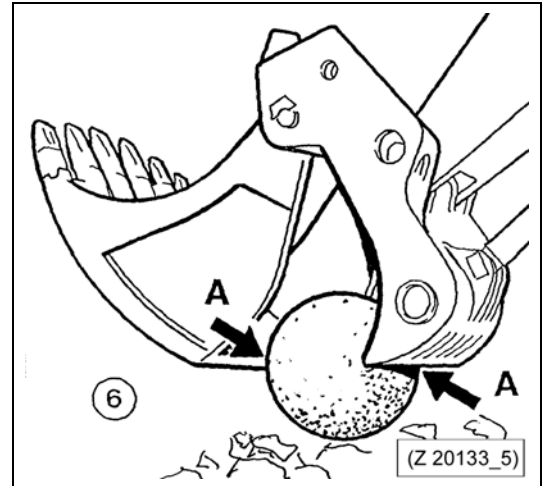

**SAFETY DEVICES (SPECIAL EQUIPMENT)**

**Legend for illustration Z 20133\_1**

- (1) Front splinter guard for operator's cab
- (2) Protection screen for lubrication system, slew gear and working lights (if so equipped)
- (3) Cylinder piston rod guard
- (4) Slew ring guard
- (5) Reinforcement ledges on bucket wall and clam edges

**NOTICE**  
 More information regarding safety devices for drop ball operation on request.

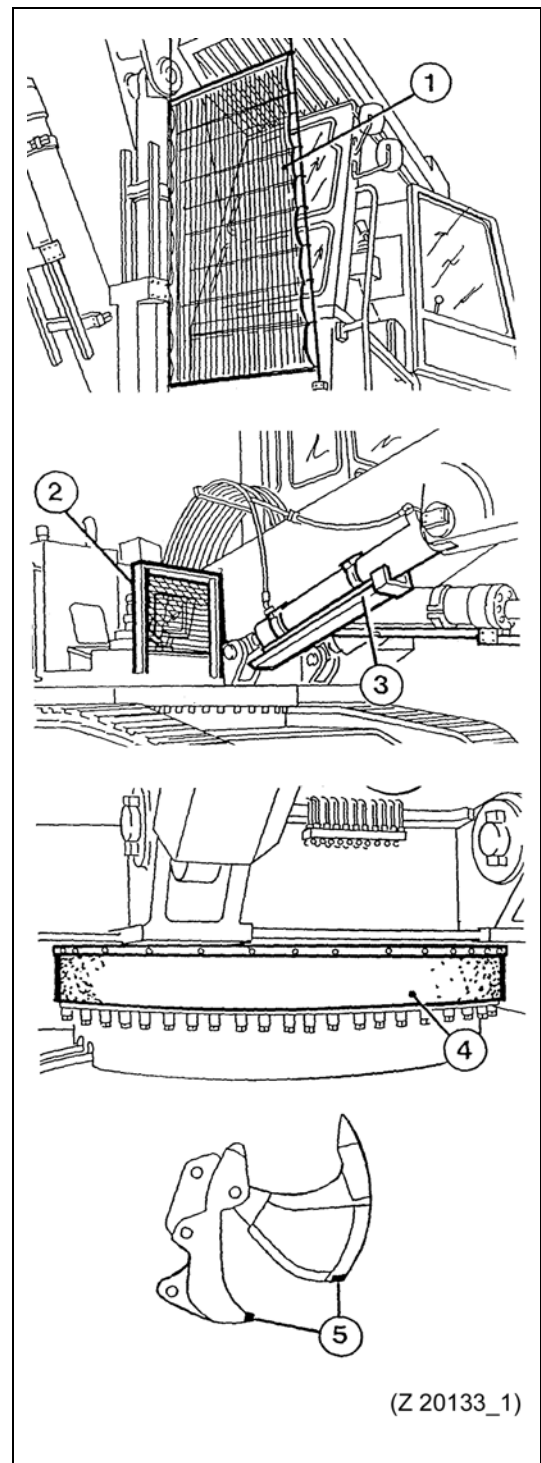

**Legend for illustration Z 20133\_5**

- (6) Pick-up position of the drop ball  
 A - Greatest circumference of the drop ball

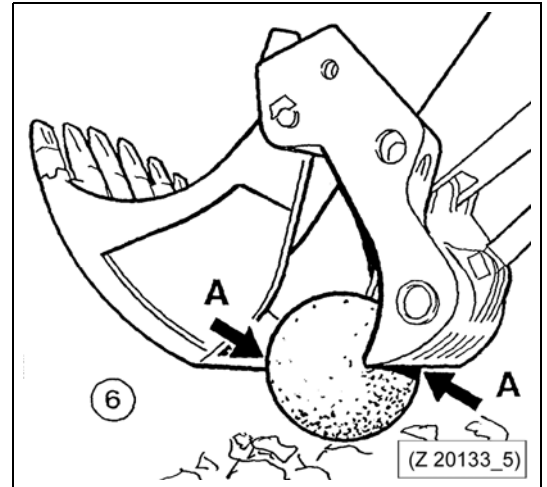
**Legend for illustration Z 20133\_6**

- (7) Drop height, level with cab roof  
 B - Back wall of the bucket in vertical position

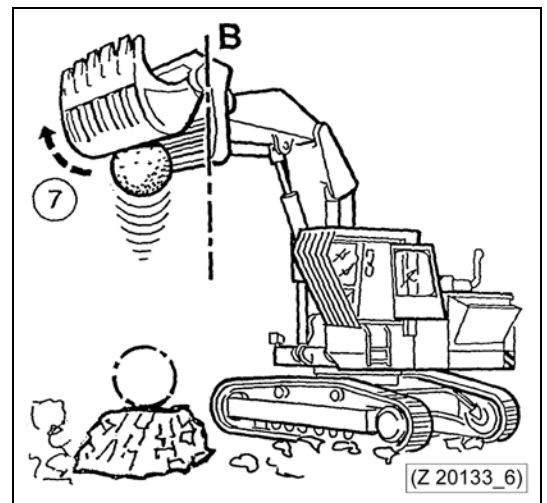
**WORKING HINTS**

Place the rock to be crushed on a solid and level ground with the impact surface in a horizontal position.

If so equipped lift up the cab front guard (1). The roof mounted beacon will then automatically switch on for warning other persons.

Change the impact surface of the rock by 90°, if after two to three drops the rock is not being crushed.

### 3.12.5 COMBINED OPERATION CYCLES

With each of the control levers, two operation cycles can be initiated simultaneously. In order to obtain efficient operation, always select intermediate control lever positions in relation to work load.

**NOTICE**

The illustration shows a typical Shovel.

The movements shown in the illustration are controlled:

- at KMG control system with L.H. lever
- at EURO control system with R.H. lever

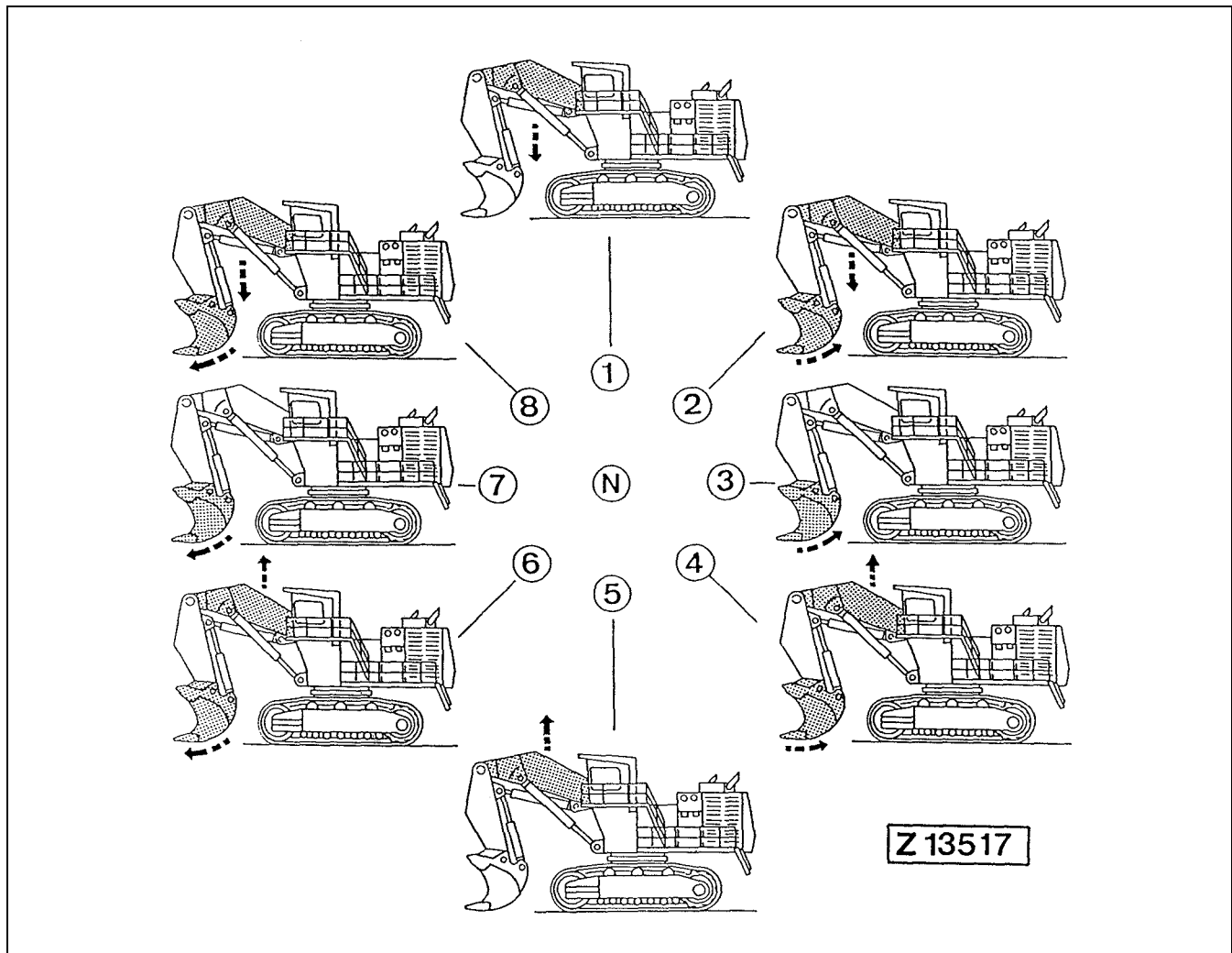

**Legend for illustration Z 13517**

- |     |                                   |     |                                  |
|-----|-----------------------------------|-----|----------------------------------|
| (N) | Neutral position                  | (5) | Raising boom                     |
| (1) | Lowering boom                     | (6) | Raising boom and filling bucket  |
| (2) | Lowering boom and emptying bucket | (7) | Filling bucket                   |
| (3) | Emptying bucket                   | (8) | Lowering boom and filling bucket |
| (4) | Raising boom and emptying bucket  |     |                                  |



**NOTICE**

The illustration shows a typical Shovel.

The movements shown in the illustration are controlled:

- at KMG control system with R.H. lever
- at EURO control system with L.H. lever

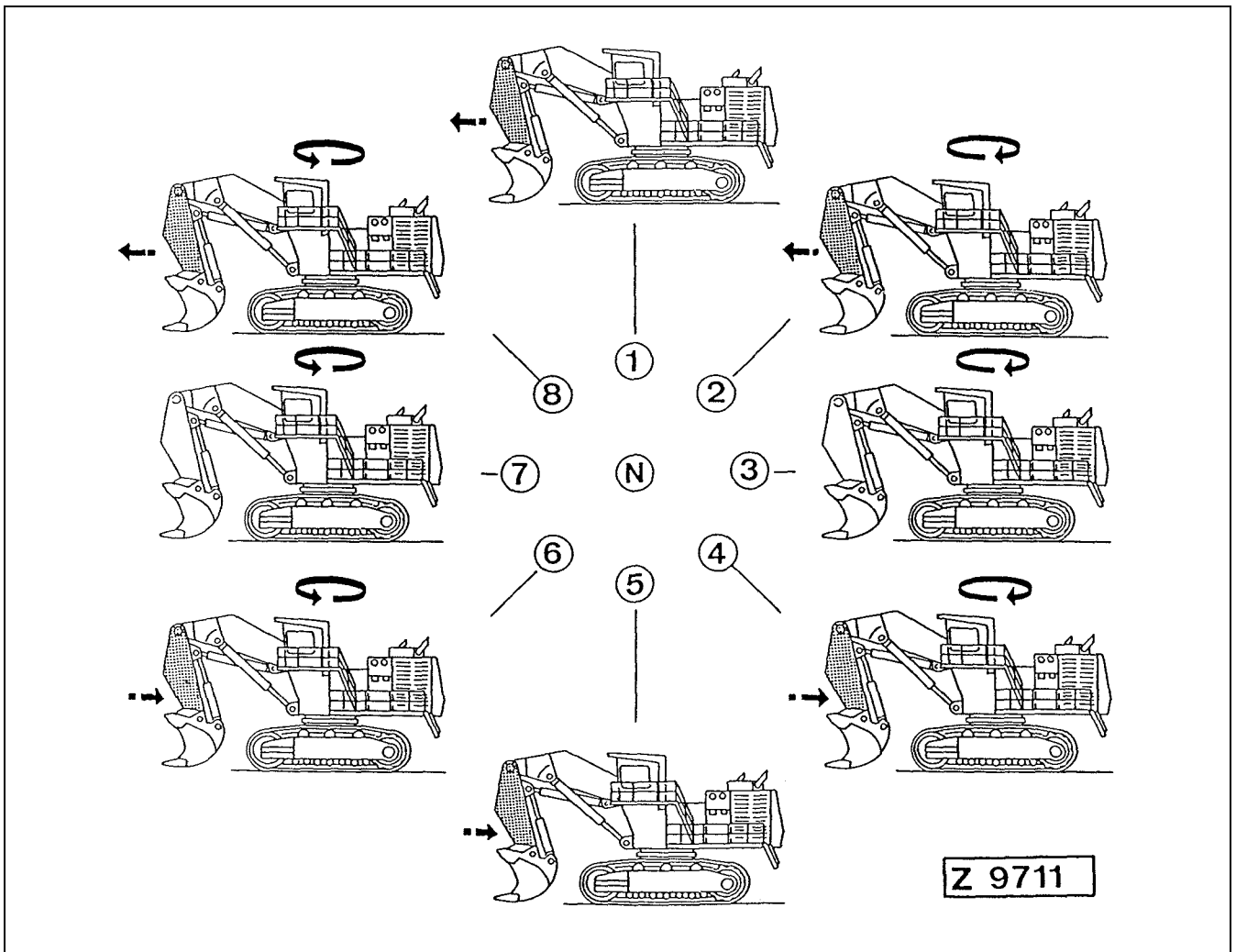
**Legend for illustration Z 9711)**

- |     |   |     |  |
|-----|---|-----|--|
| (N) | Neutral position  | (5) | Retracting stick                         |
| (1) | Extending stick (away from machine)                         | (6) | Retracting stick and slewing to the left |
| (2) | Extending stick and slewing to the right                    | (7) | Slewing to the left                      |
| (3) | Slewing to the right  | (8) | Extending stick and slewing to the left  |
| (4) | Retracting stick (towards machine) and slewing to the right |     |  |

## 3.13 WORKING INSTRUCTIONS

### 3.13.1 STABILITY OF THE SHOVEL



#### WARNING

**Before beginning work prepare a suitable Shovel base, to ensure adequate stability for safe working of the Shovel.**

The stability of the Shovel is determined according to DIN 24087, and is based on a level ground.

The Shovel must therefore be operated in such away, that its stability is always ensured and the danger of tipping over is avoided.

When slewing the superstructure take in account, that the stability of the Shovel is being reduced when the superstructure (bucket) is turning in a transverse direction to the undercarriage.

Avoid working with the crawler tracks across the slope, as this reduces stability and increases the tendency for the Shovel to slide or to tip over.

In the following a few Examples of Operating and Working Conditions which can reduce the Stability of the Shovel:

- Overloading of the Shovel (Bucket overfilled).
- Ground conditions such as loose sand or wet soil (possibility of a cave-in).
- Jerky acceleration or deceleration of working- and travel motions.
- Operating on a slope.

### 3.13.2 SHOVEL OPERATION

- When working with the loader attachment, switch-off the fast speed range (if equipped).
- Do not operate control levers jerkily.
- Do not work below overhanging rocks or earth masses.
- Always keep a safe distance to the edge of an excavation where bank cave-ins are possible.
- Operation on a grade requires special care. Plan your work so that the Shovel travels uphill and downhill parallel to the grade. Bear in mind, that the Shovel's stability is reduced when operating on a slope.
- Always keep the Shovel under control.
- Know the Shovel's limits - and do not exceed them.

**CAUTION**

**DO NOT "Sweep" with the loader attachment, illust. (Z 10369), as this may result in severe damage on slew gear components.**

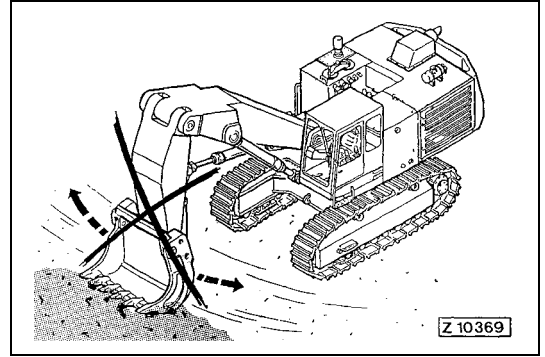

**CAUTION**

**DO NOT use the bucket clam for loosening or removing anchored rocks or other solid objects (illust. Z 19984 and Z 19985), since such operations may result in severe damage to the clam pivot bearings.**

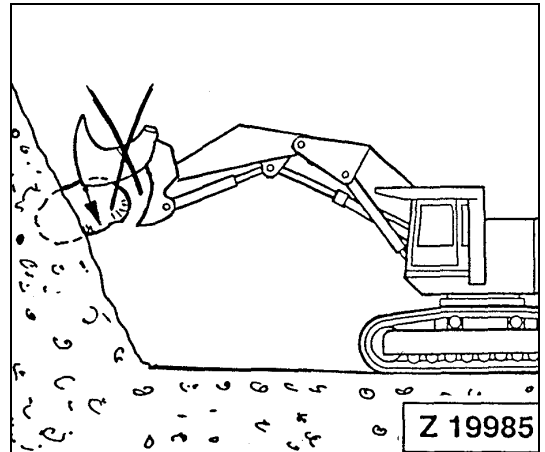

**WARNING**

**Be careful not to spill the load. When the bucket is fully loaded, do not raise the boom fully. If the boom is raised fully, the load can spill to the rear and cause danger to the operator.**

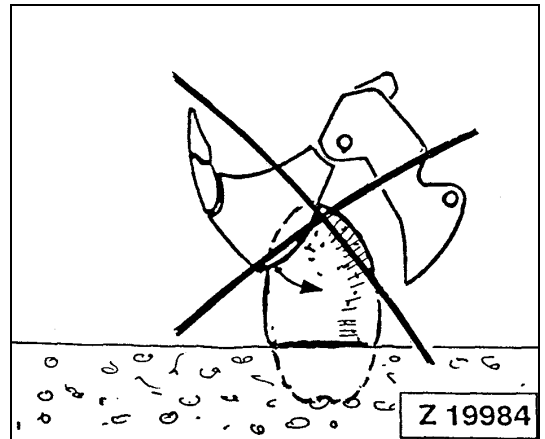

**Precautions when operating hydraulic cylinders to end of stroke**

Do not operate the hydraulic cylinders of the working attachment to the end of their strokes. This will bring excessive force onto the inner stoppers of the cylinders and will reduce the lifetime of the cylinders.

To prevent this, move the control levers to neutral position before the cylinders reach their end of stroke.

- When working with the bucket in the longitudinal direction, the final drives should be in the rear position illust. (Z 0144), for the following reasons:

- The travel motors and travel gears are protected from falling rocks etc.
- When the Shovel is operated on muddy ground and the tracks are covered with mud, the sprocket runs on a clean track when backing up.

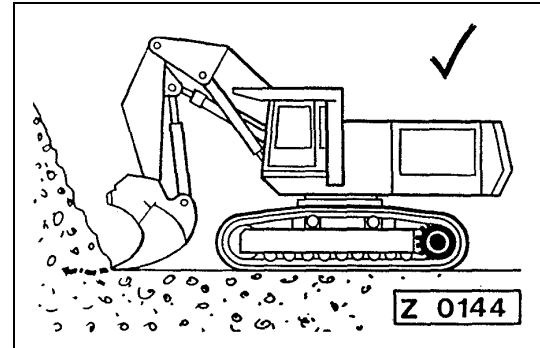

- When working with the loader in a cross direction to the track group, be sure that the track is not raised off the ground, illust. (Z 20978). This can cause the track to set-off from the rollers when it is lowered down on the ground. Also the flanges of the track rollers and the track shoes can be bent by the excessive load.

- **Loading Trucks:**

Position the truck as closely as possible to the Shovel.  
Do not swing the attachment over unprotected driver cabs.  
Swing the attachment at a sufficient height over the loading platform  
Distribute material evenly on loading platform.  
Do not overload the truck.

- Remove sticky material from the bucket.
- Always keep the Shovel as close as possible to the work area. Short boom trips - high efficiency.
- When turning into a pit, the rotating motion must not be stopped by the walls of the pit.
- Only a bucket with a complete set of teeth and cutting edges in good condition ensures efficient performance.
- Loosen hard material and rocks with the bucket, not with the stick crowding thrust.
- Correct bucket size and properly adjusted equipment prevents overloading and ensures maximum operating efficiency of the Shovel.

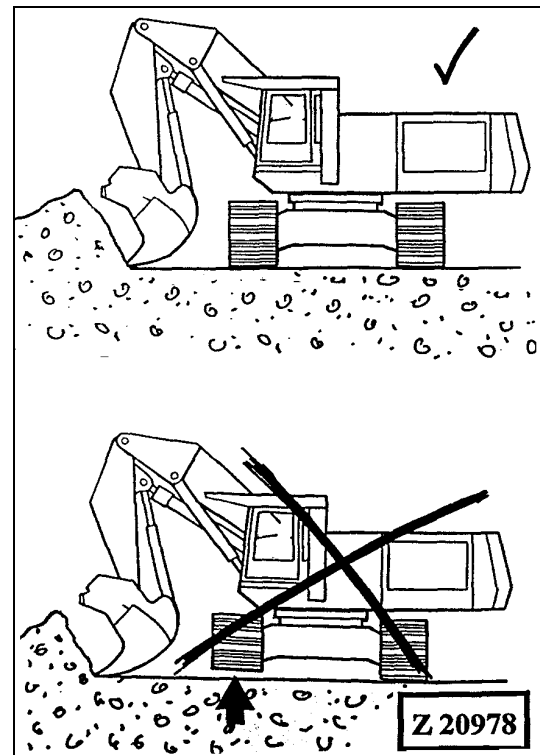

## 3.14 PARKING THE SHOVEL

Park the machine at a safe place on level and solid ground.

- Lower the working attachment onto the ground in a position as shown on the oil level plate at the hydraulic oil reservoir.
- Stop the engine and relieve the pressure in the hydraulic system, see "STOPPING THE ENGINE" on page 190 for more information.
- Move the safety lock lever fully to the rear in locked position.

### **WARNING**

**DO NOT leave the Operator's Cab when the engine is running.**

### NOTICE

After switching OFF the main key switch in the Operator's cab, wait at least 3 minutes before switching OFF the battery main switches. The Vehicle Health Monitoring System (VHMS) needs this period for saving data. If batteries are switched OFF before this time period is over, data will be lost.

- Be sure to lock the operator's cab door before leaving the Shovel.
- If the Shovel has to be parked on steep terrain, the track groups must be secured with wedges.
- Before leaving the Shovel make sure that the parked machine does not impair local requirements, have consideration for other mining traffic.

## CLEANING THE TRACK GROUPS

Under working conditions with excessive material build up on the crawler components, cleaning of the crawlers is very important to prevent damage.

Material build up on guide wheels, drive sprockets and tracks can lead to over tensioning of the tracks, resulting in severe damage to these components.

If there is danger of frost, the tracks must also be cleaned.

### NOTICE

Use a suitable cleaning device for removing dirt, mud and debris from the tracks, rollers, guide wheels and sprockets.

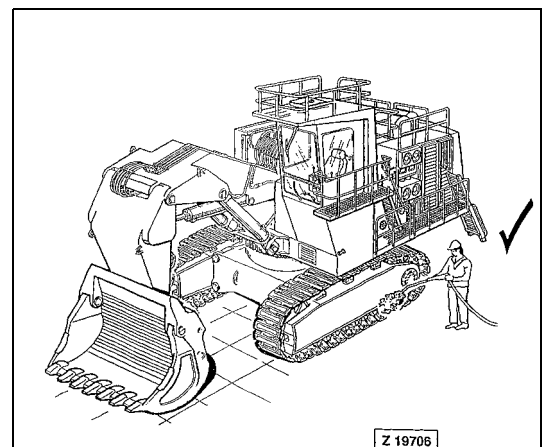

### 3.15 STOPPING THE ENGINE

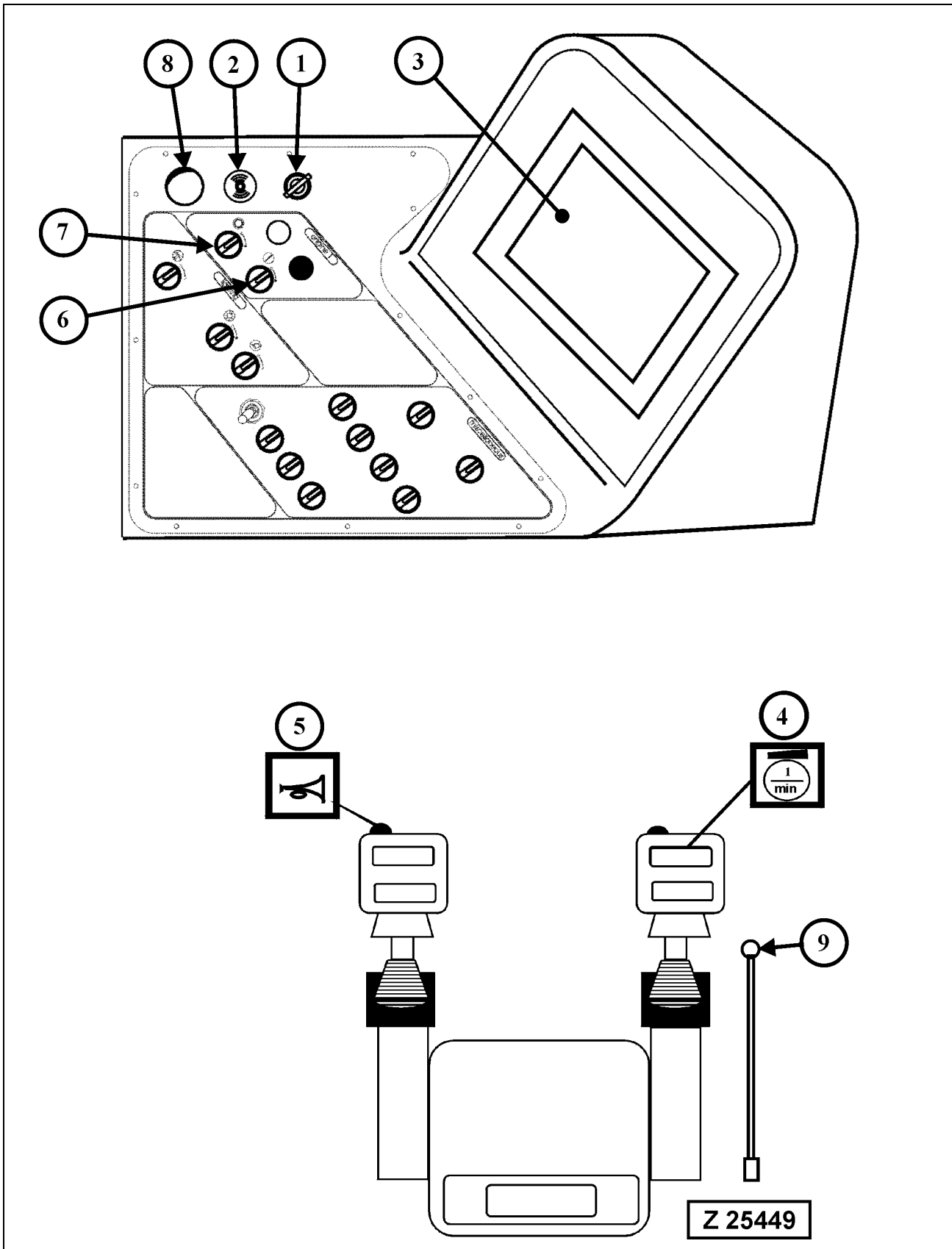

---

---

**⚠ CAUTION**

---

---

Never stop the engine from full load except in case of emergency.

Before shutting down run the engine at idling speed for approximately 5 minutes. This cooling down period prevents heat accumulation and thermal stress, especially in the turbochargers.

---

---

---

---

**⚠ CAUTION**

---

---

For EMERGENCY SHUTDOWN of the Engine, use STRIKE BUTTON (8).

Additional emergency shut-down switches are located on the power house. For more information → See "POWER HOUSE" on page 126.

---

---

#### Stopping procedure, illustration Z25449

1. Park the Shovel at a safe place on level and solid ground.

**For more information → See "PARKING THE SHOVEL" on page 189.**

2. Deposit the working attachment onto the ground, proceed as follows:
  - **A - Backhoe Attachment**  
Lower the backhoe attachment fully extended onto the ground as shown on the oil level plate at the main hydraulic oil reservoir.
  - **B - Bottom Dump Bucket Attachment**  
Lower the bottom dump bucket attachment onto the ground with the stick fully retracted and with the bucket resting completely flat on the ground. This position is shown on the oil level plate at the main hydraulic oil reservoir.

The positions A or B are necessary to prevent unintentional movement of the working attachment when the pressure in the hydraulic system is relieved, and for correct checking of the hydraulic oil level.

3. Move all controls into neutral position.
4. Set toggle switch (4) to low idle speed position. Let the engine idle for about five minutes without load.
5. Turn switch (7) clockwise to stop position. When the engine has come to standstill, relieve the pressure in the hydraulic system.

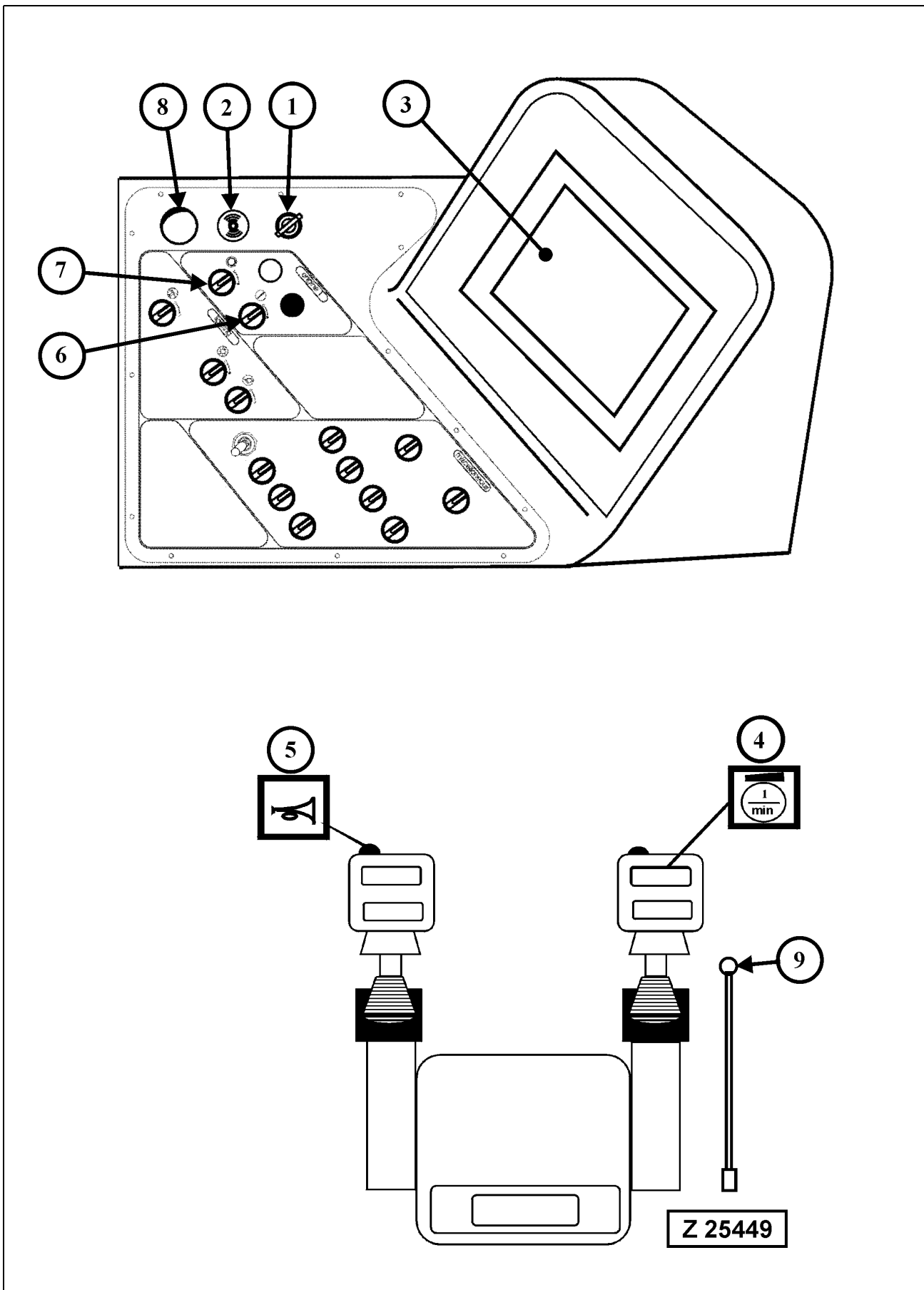



### 3.15.1 RELIEVE PRESSURE IN THE HYDRAULIC SYSTEM

---

---

**▲ WARNING**

---

---

With the engine at standstill and main switch (1) in ON position, move all controls for working attachment and crawlers several times through all shift positions to relieve the pressure in the hydraulic system. The necessary oil pressure for shifting the spools of the main control valves is provided by a pressure accumulator in the pilot oil circuit.

---

---

**NOTICE**

The pressure accumulator in the pilot oil circuit serves also for lowering a raised working attachment to the ground with the engine at standstill. If, for example, the engine stalls with the working attachment in a raised position, lowering of the working attachment is possible by operating the respective control lever.

6. Set main switch key (1) to "0" position and remove.

**NOTICE**

After switching OFF the main key switch in the Operator's cab, wait at least 3 minutes before switching OFF the battery main switches. The Vehicle Health Monitoring System (VHMS) needs this period for saving data. If batteries are switched OFF before this time period is over, data will be lost.

7. Set safety lock lever (9) fully to the rear in LOCKED position.

8. Switch off the battery main switches and remove keys.

## 3.16 OPERATION OF THE LUBRICATION SYSTEM

### 3.16.1 CENTRAL LUBRICATION SYSTEM "CLS"

The central lubrication system works automatically as soon as the engine is running at high idle speed.

The VHMS System monitors the function of the central lubrication system.

Trouble conditions of the lubrication system are indicated through fault messages on health monitor (3).

#### Legend for illustration Z25453

- (1) Switch, manual actuation of central lubrication system
- (2) Switch, manual actuation of slew ring gear lubrication system
- (3) Health monitor

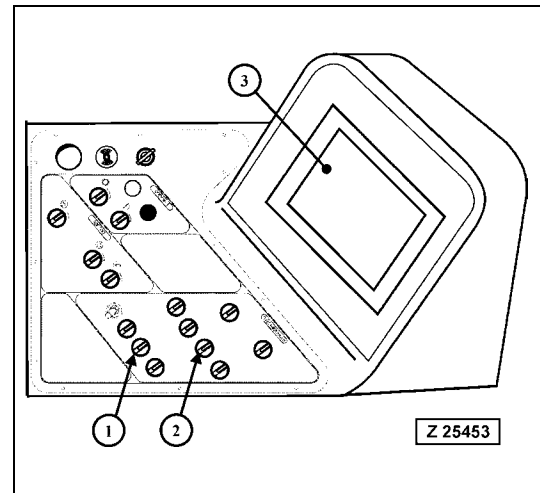

#### Manual actuation of the central lubrication system

Manual actuation of the lubrication system overrides the adjusted pause time (factory setting 15 minutes). The lubrication cycle starts after a pressure build up time of 1 to 2 minutes. Thereafter the monitoring time of 10 minutes starts. The complete lubrication cycle takes approximately 12 minutes. After this period the lubrication cycle counter adds one lubrication cycle to the memory. For display of the cycle counter reading use the service menu of the VHMS system.

#### REMARK

The start of a manually actuated lubrication cycle can be delayed by up to 10 minutes if the system is in the monitoring time period of a previous automatic lubrication cycle.

#### **CAUTION**

**If the central lubrication system fails to work for a period longer than four hours an automatic bucket motion cut off can happen depending on the installed VHMS soft ware. Repair the system as soon as possible.**

## ADJUSTMENTS OF THE CENTRAL LUBRICATION SYSTEM

The following adjustments can be made in the service menu of the VHMS system, under menu point 4.8.1:

### Level 4: Service Menu / Settings 4.8.1

- \*PAUSE TIME
- \*MONITORING TIME
- \*PRESSURE RELIEF TIME
- \*LUBE CYCLE COUNTER

Refer to Service Manual VHMS system for description of adjustment procedure.

### Repairs on the Central Lubrication System with the Engine running or with the Engine OFF and Main Switch Key in ON position

If repairs under the above conditions have been carried out it is necessary to reset the control circuit of the lubrication system by actuating the rotary switch (1), illust. (Z25453) for a full lube cycle.

If this manually actuated lube cycle is not being carried out, the fault message "LUBE SYSTEM FAILURE" will remain on the health monitor (3).

Resetting of the lube system control circuit can also be done by shutting down the engine and switching OFF the main switch key.

### NOTICE

For more information regarding inspection, trouble shooting and maintenance of the lubrication system, refer to the separate manual LUBRICATION SYSTEMS in volume 2 binder.

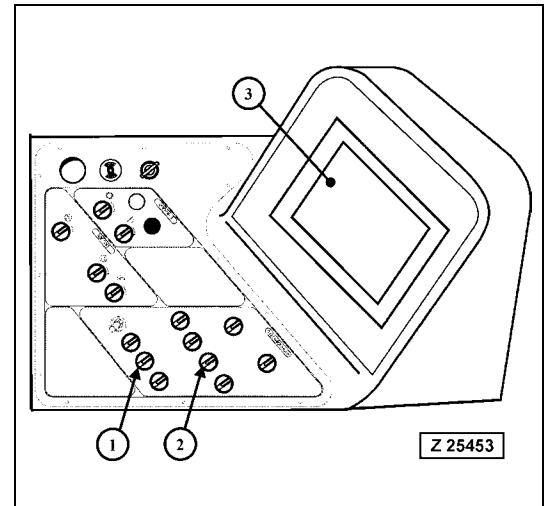

### 3.16.2 SWING CIRCLE PINION LUBRICATION SYSTEM "SLS"

This system works automatically as soon as the engine is running at high idle speed.

The VHMS System monitors the function of the swing circle lubrication system.

Trouble conditions of the lubrication system are indicated through fault messages on health monitor (3).

#### Legend for illustration Z25453

- (1) Switch, manual actuation of central lubrication system
- (2) Switch, manual actuation of swing circle lubrication system
- (3) Health monitor

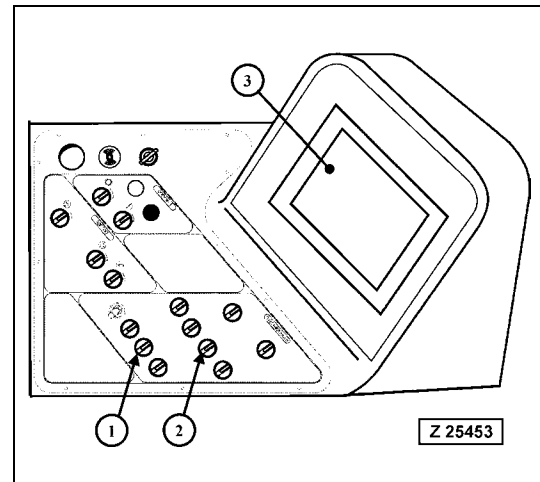

#### Manual actuation of the swing circle lubrication system

Manual actuation of the lubrication system overrides the adjusted pause time (factory setting 15 minutes). The lubrication cycle starts after a pressure build up time of 1 to 2 minutes. Thereafter the monitoring time of 10 minutes starts. The complete lubrication cycle takes approximately 12 minutes. However, since the swing circle lubrication system works only during slewing of the superstructure also the monitoring time elapses only during the slewing movement. This is the reason why the total monitoring time usually lasts longer than the adjusted 10 minutes. After elapsing of the monitoring time the lubrication cycle counter adds one lubrication cycle to the memory. For display of the cycle counter reading use the service menu of the VHMS system.

#### REMARK

The start of a manually actuated lubrication cycle can be delayed by up to 10 minutes if the system is in the monitoring time period of a previous automatic lubrication cycle.

#### **CAUTION**

**If the swing circle lubrication system fails to work for a period longer than four hours an automatic bucket motion cut off can happen depending on the installed VHMS software. Repair the system as soon as possible.**

## SWING CIRCLE LUBRICATION SYSTEM "SLS"

**Repairs on the swing circle lubrication system with the Engine running or with the Engine OFF and Main Switch Key in ON position**

If repairs under the above conditions have been carried out it is necessary to reset the control circuit of the lubrication system by actuating the rotary switch (2), illust. (Z25453) for a full lube cycle.

If this manually actuated lube cycle is not being carried out, the fault message "LUBE SYSTEM FAILURE" will remain on the health monitor (3).

Resetting of the lube system control circuit can also be done by shutting down the engine and switching OFF the main switch key.

### NOTICE

**For more information regarding inspection, trouble shooting and maintenance of the lubrication system, refer to the separate manual LUBRICATION SYSTEMS in volume 2 binder.**

## ADJUSTMENTS OF THE SWING CIRCLE-LUBRICATION SYSTEM

The following adjustments can be made in the service menu of the VHMS system, under menu point 4.8.1:

### Level 4: Service Menu / Settings 4.8.1

- \*PAUSE TIME
- \*MONITORING TIME
- \*PRESSURE RELIEF TIME
- \*LUBE CYCLE COUNTER

Refer to Service Manual VHMS system for description of adjustment procedure.

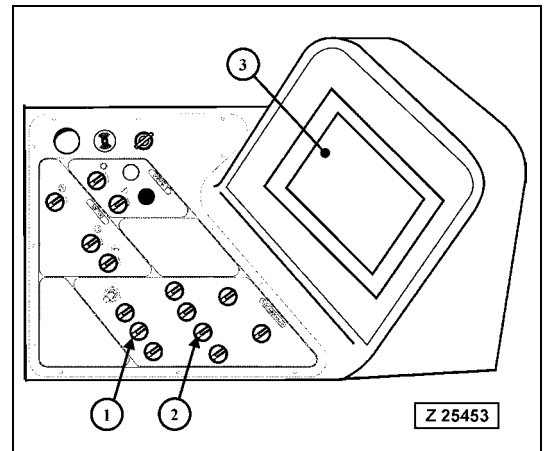

# 3.17 FIRE DETECTION AND SUPPRESSION SYSTEM

(Special Equipment)

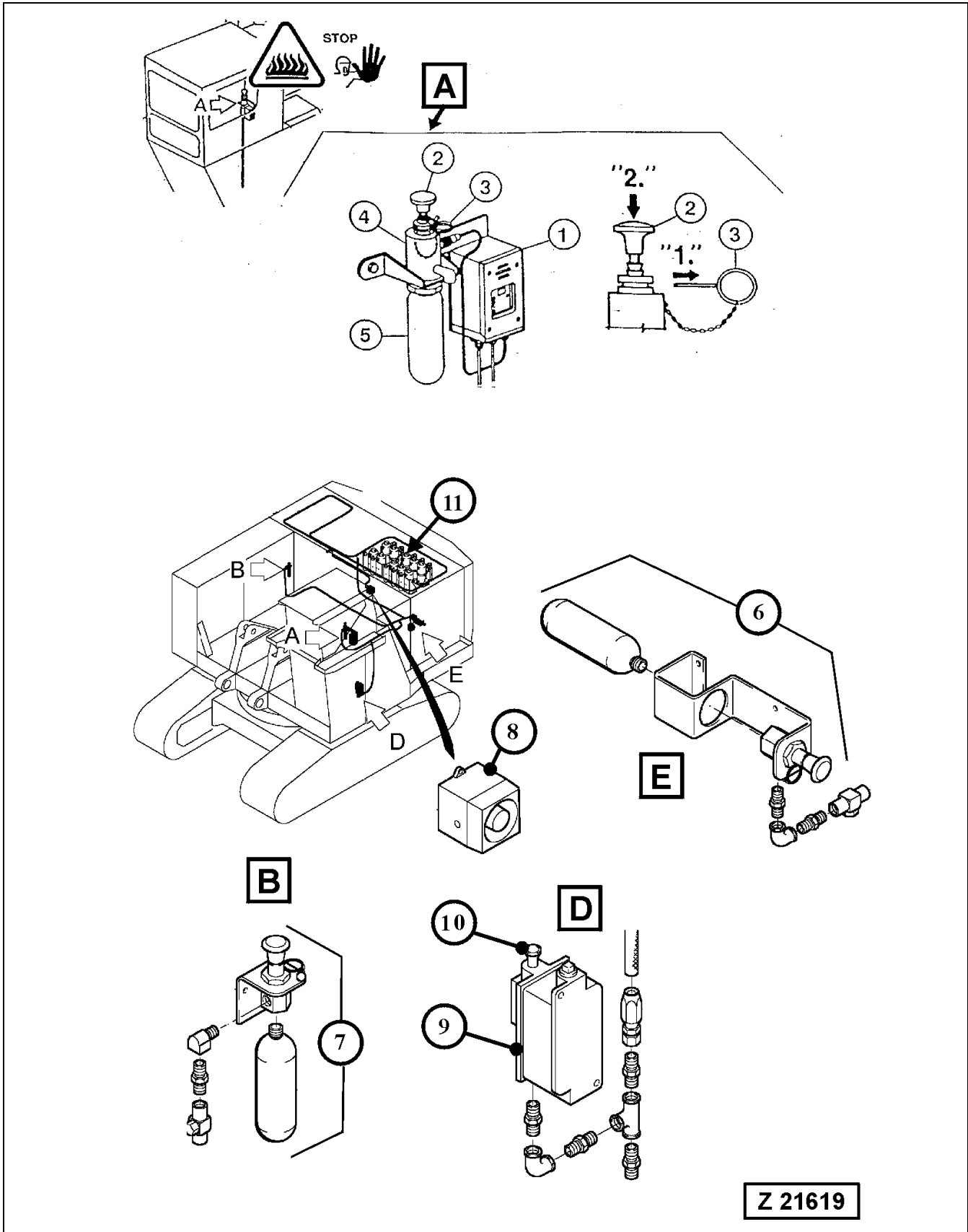

---

## FIRE DETECTION AND SUPPRESSION SYSTEM

---

### WARNING

---

**Before operating the Shovel make sure the Fire Detection, Actuation and Suppression system is operative.**

**Carry out inspection and maintenance according to the separate manuals "Fire Detection and Actuation System" and "Fire Suppression System" in volume 2 Binder.**

---

---

### CAUTION

---

**This section covers only such information necessary for the operator to understand operation of the fire detection and actuation system.**

**All other information i.e. placing the system in service, daily inspection, functional tests, maintenance and trouble shooting are contained in the separate manuals.**

---

#### Legend for illustration Z 21619

- (A) Control module with manual/automatic actuator in the Operator's cab
- (1) Control module, refer to the separate Manual "CHECKFIRE SC ELECTRIC DETECTION AND ACTUATION SYSTEM" for all information concerning - Operational Modes, Daily Inspection, Maintenance and System Conditions -.
- (2) Strike button, manual actuation
- (3) Ring pin
- (4) Manual / automatic actuator
- (5) LT-5-R cartridge
- (6) Manual actuator switch at the radiator door
- (7) Manual actuator switch at the rear power house door
- (8) High level alarm on operator's cab
- (9) Pressure switch - DPST located in the cab base. This switch shuts off the engine immediately when the fire detection system has a fire detected. The reset plunger (10) moves out into its upper position. When the fire suppression system has been recharged, push in the reset plunger.
- (10) Reset plunger, be sure to push in this plunger as soon as the fire suppression system has been recharged after actuation of the system.
- (11) Fire extinguishing tanks on power house roof

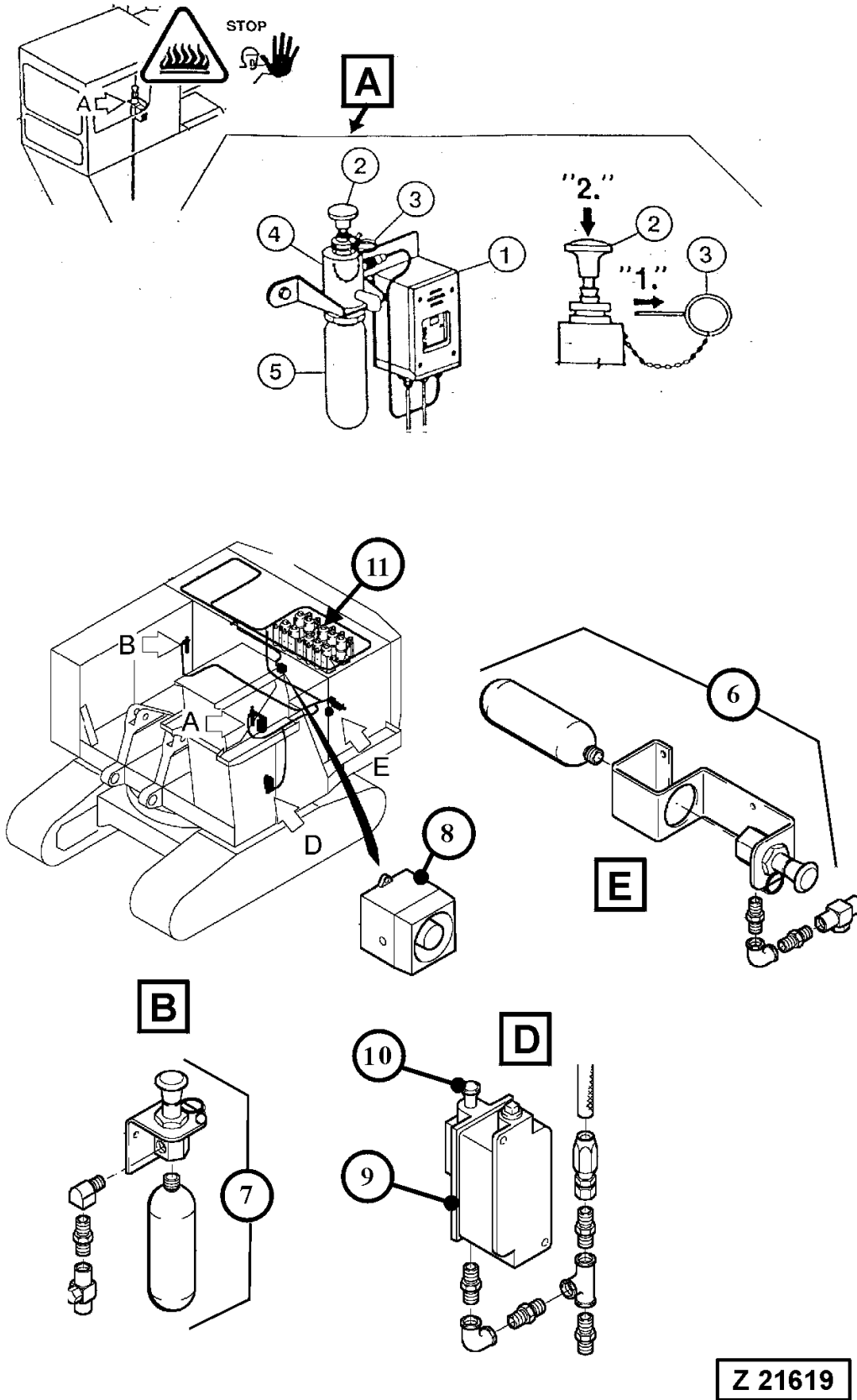



### 3.17.1 HIGH LEVEL ALARM "FIRE"

The high level alarm (8), illust. Z 21619 will sound approximately 15 seconds before discharge of the fire suppression system in case of automatic actuation of the system. Act according to the circumstances and the applying safety regulations. Evacuate area to lessen risk of injury from flames.

### 3.17.2 ENGINE SHUT-DOWN THROUGH FUEL SHUT-OFF SOLENOID VALVE

The fuel shut-off solenoid valve for the engine is actuated through pressure switch (9), illust. Z 21619.

When the fire detection system detects a fire, the valve will be closed shutting-off fuel supply to the engine (Shut-down of the engine).

### 3.17.3 ACTUATION MODES OF THE FIRE SUPPRESSION SYSTEM

#### MANUAL ACTUATION

Via strike button (2) in operator's cab or strike button of switches (6) on radiator door and (7) at the rear power house door.

---

---

**▲ WARNING**

---

---

**Manual actuation will result in immediate system discharge which may obscure vision. Make certain the Shovel is stopped safely before manually actuating the system. Manual actuation will bypass all auxiliary shutdown and alarm functions.**

---

---

#### NOTICE

**For manual actuation via switches (4, 6 or 7), pull ring (3) and strike button (2).**

#### AUTOMATIC ACTUATION

Via detection wires routed through the engine - and hydraulic pump compartments.

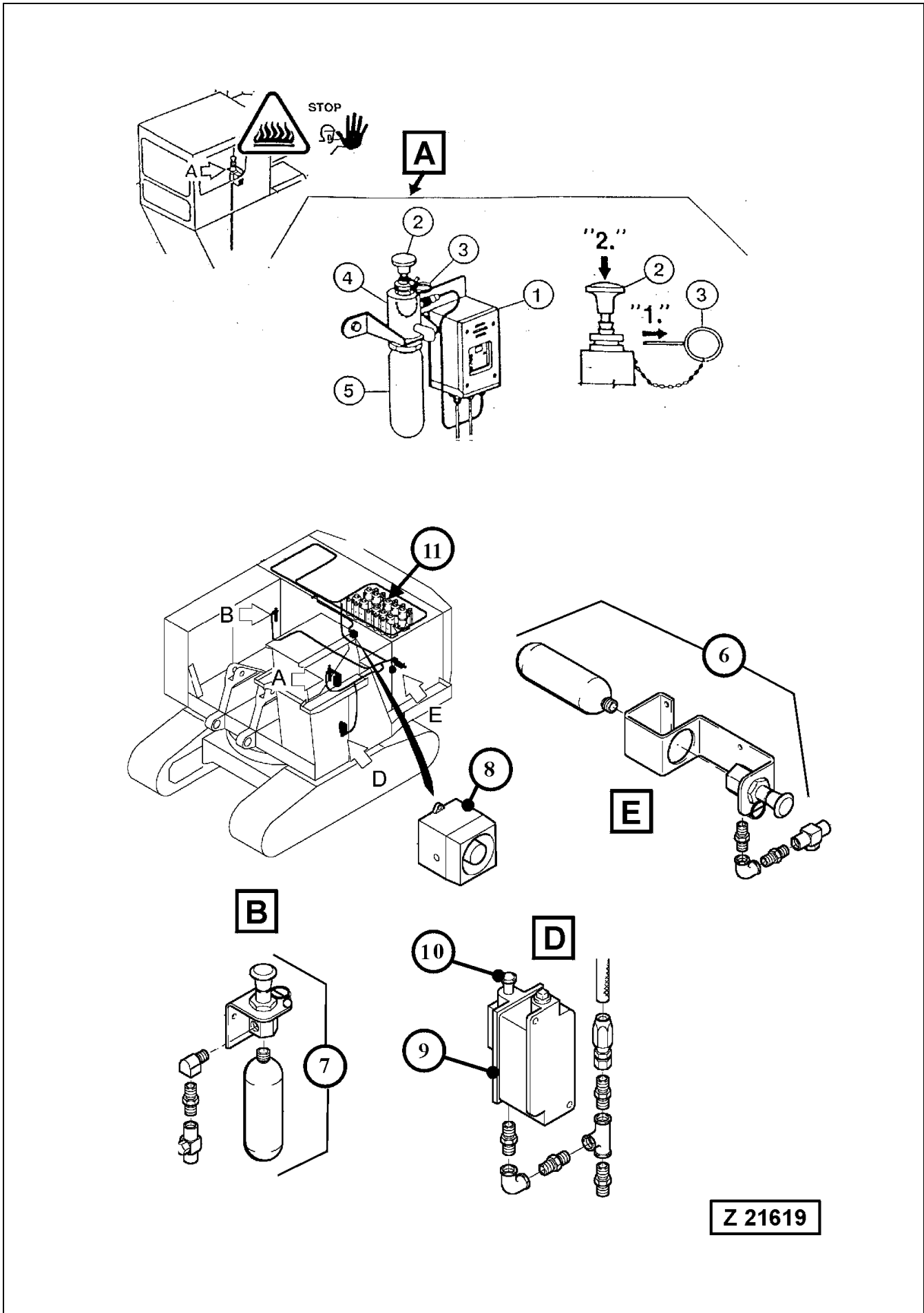

### **3.17.4 INDICATION OF OPERATIONAL MODES AT CONTROL MODULE, AFTER AUTOMATIC ACTUATION OF THE FIRE SUPPRESSION SYSTEM**

Alarm to Shutdown Period - The RED alarm LED and the audio alarm will pulse at a rate of 2 times per second.

Shutdown to Discharge Period - The RED alarm LED and the audio alarm pulses "on" four times per second.

#### **Timer Setting (factory adjustment)**

- Alarm to Shutdown: 5 seconds
- Shutdown to Discharge: 10 seconds

---

---

#### **▲ WARNING**

---

---

##### **In Case of Fire**

- Act according to the circumstances and the applying safety regulations.
  - Evacuate area to lessen risk of injury from flames, heat, hazardous vapours, explosions, or other hazards that may be created.
  - Evacuate endangered Persons.
  - Inform the fire brigade.
  - Fight the fire.
- 
- 

---

---

#### **▲ CAUTION**

---

---

**For continued protection, the Detection and Actuation System and the Fire Suppression System must be recharged through authorized Service Personnel immediately after operation.**

---

---

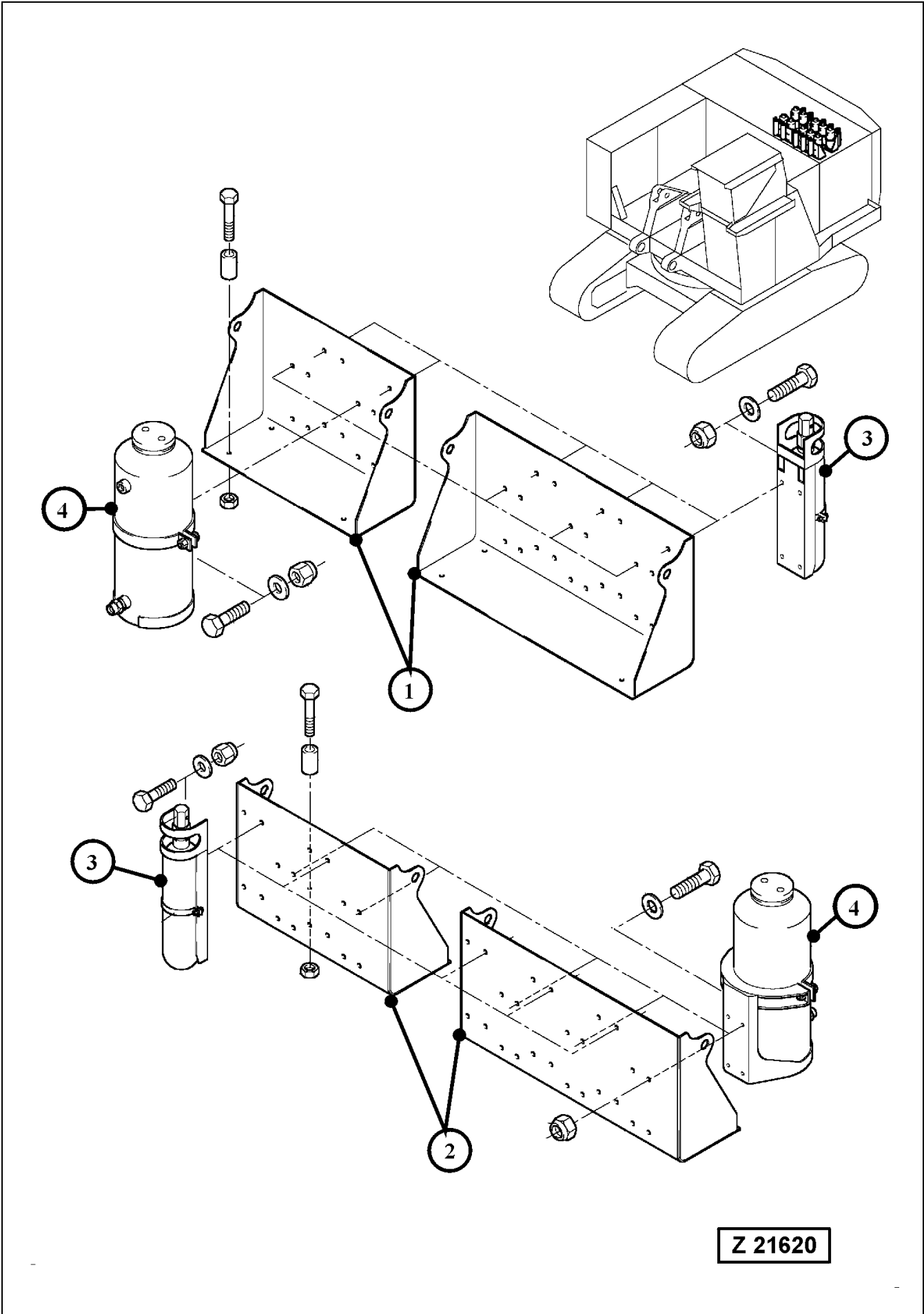

### 3.17.5 LOCATION OF THE EXTINGUISHING AGENT TANK ASSEMBLIES AND EXPELLANT GAS CARTRIDGES ON POWER HOUSE ROOF

#### Legend for illustration Z 21620

- (1) Rear mounting bracket for the Extinguishing agent tank assemblies and Expellant gas cartridges
- (2) Front mounting bracket for the Extinguishing agent tank assemblies and Expellant gas cartridges
- (3) Expellant gas cartridges
- (4) Extinguishing agent tank assemblies

#### REMARK

Check Extinguishing agent tank assemblies (4) and Expellant gas cartridges (3) for good condition and proper mounting. Check filling level of Extinguishing agent tank assemblies (4) according to the instructions in the separate Inspection and Maintenance manual "A-101 VEHICLE FIRE SUPPRESSION SYSTEM".

When checking the filling level, make sure the extinguishing powder is not compacted. Stir up the extinguishing powder with a suitable stick until it is in a free flowing condition.

# 3.18 TRANSFER PUMP FOR HYDRAULIC OIL

(SPECIAL EQUIPMENT)

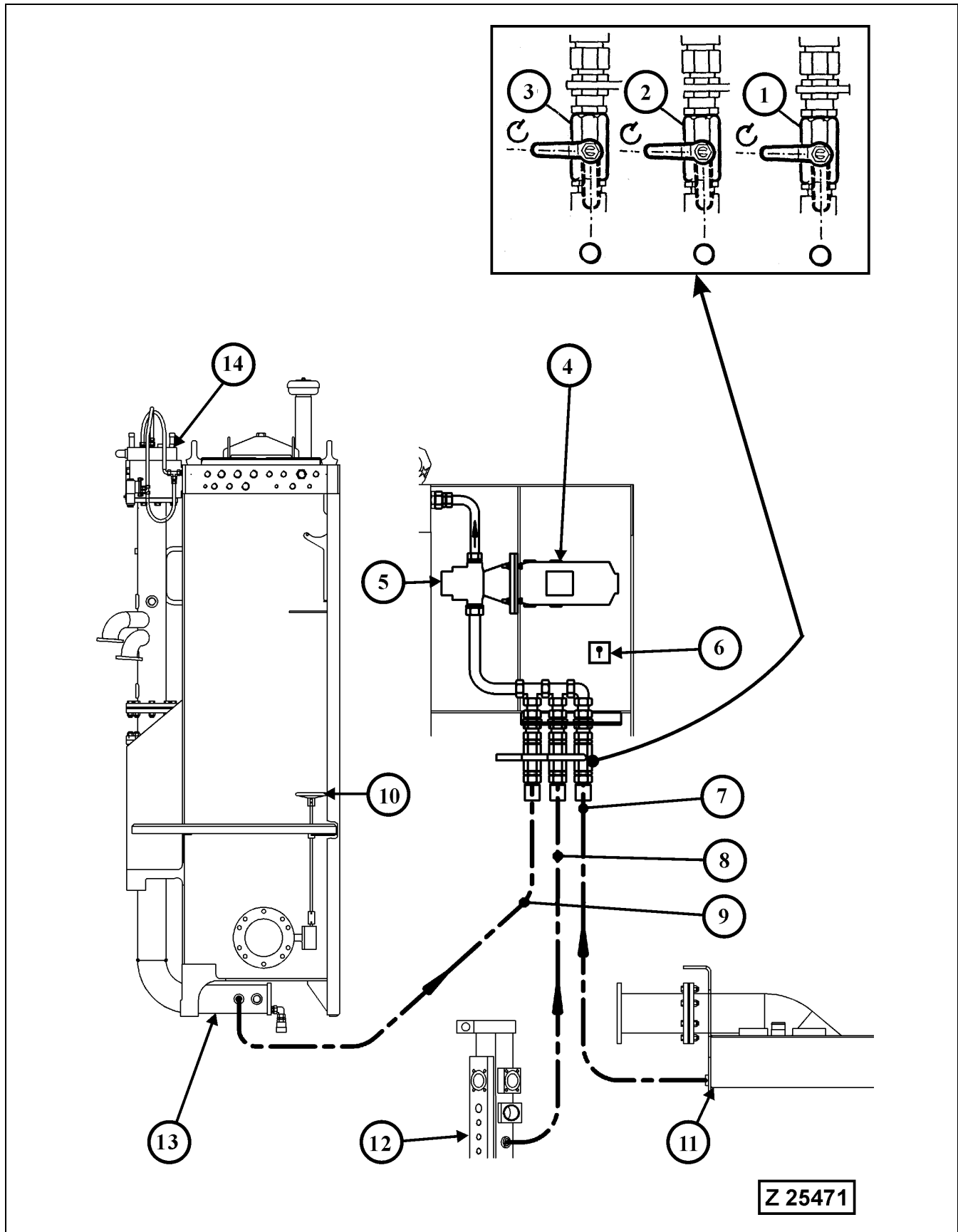

### 3.18.1 OPERATING THE TRANSFER PUMP

Legend for illust. Z25471

#### REMARK

The illustration shows the transfer pump arrangement viewed from center of the platform.

- (1) Cock for suction oil reservoir (11)
- (2) Cock for return oil collector pipe (12)
- (3) Cock for back-pressure valve pipe (13)
  - C - Closed
  - O - Open
- (4) Electric motor of the transfer pump
- (5) Transfer pump
- (6) Operating switch (S35) for transfer pump (4)

#### REMARK

A Level switch (B111) at the oil reservoir turns off the transfer pump (4) when the oil level in the main oil reservoir has reached maximum permissible height. The pump will be switched on again when the oil level sinks below the maximum height.

- (7) Suction line to suction oil reservoir (11)
- (8) Suction line to return oil collector pipe (12)
- (9) Suction line to back-pressure valve pipe (13)
- (10) Hand wheel of main shut-off valve between suction oil reservoir and main oil reservoir
  - To OPEN the valve turn hand wheel (10) CCW to the stop.
  - To CLOSE the valve turn hand wheel (10) CW to the stop.

A proximity switch located on the gearbox of the shut-off valve monitors the valve position. With the valve not fully open a corresponding message will be displayed on the screen in the Operator's cab.

#### CAUTION

**Before starting the engine make sure the shut-off valve is completely open by turning hand wheel (10) fully to the left (CCW).**

- (11) Suction oil reservoir
- (12) Return oil collector pipe in front of main control valves
- (13) Back-pressure valve pipe
- (14) Back-pressure valve

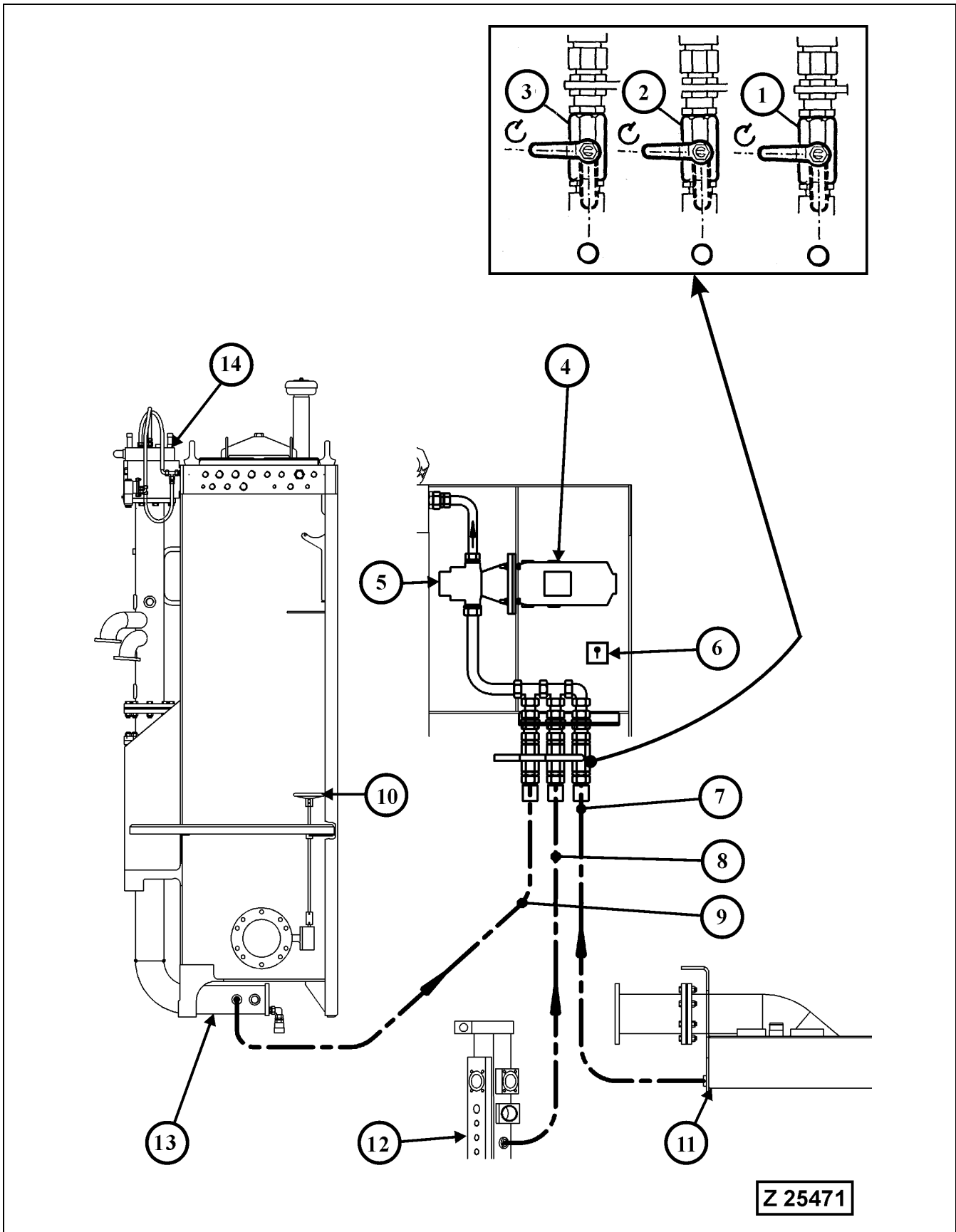



### 3.18.2 FUNCTIONS OF THE TRANSFER PUMP

**A** - Transfusing oil from the suction oil reservoir (11), illustration Z25471 into the main oil reservoir. Necessary for evacuation of the suction oil reservoir, when changing the hydraulic oil (main oil reservoir will be evacuated via service arm connector, see page 212 for details). Before servicing the main hydraulic pumps it is advisable to empty the suction oil reservoir partially.

**B** - Transfusing oil from return oil collector pipe (12) and back-pressure valve pipe (13) into main oil reservoir. Necessary when changing the hydraulic oil and prior to servicing the high pressure filters or the main control valves (oil return system).

---



---

#### CAUTION

---



---

**Before operating the transfer pump, lower the attachment to the ground with the stick fully retracted and the bucket fully rolled back. Shut down the engines.**

---



---

#### NOTICE

**During normal operation the valves (1, 2 and 3) must be in closed position -C-.**

#### **A - Pumping the oil from the Suction Oil Reservoir (11) into the Main Oil Reservoir**

1. Close main valve (10).
2. Open cock (1), position -O-.

#### REMARK

In order to prevent build-up of a vacuum in the suction system, open the vent plugs on the suction port of each main hydraulic pump.

3. Switch on pump (4) with switch (6).  
A level switch turns off transfer pump (4) when the oil level in the main reservoir has reached maximum height. The pump will be switched on again when the oil level sinks below the maximum level. When changing the hydraulic oil, be sure to evacuate the main oil reservoir via the service arm connector simultaneously with the transfusion procedure. Otherwise the level switch would switch off the transfer pump preventing overfilling of the main oil reservoir.
4. When the suction oil reservoir is empty or after completion of the maintenance job switch off transfer pump (4) with switch (6). Close cock (1), position -C- and open main valve (10).
5. With the main shut-off valve (10) open, the suction oil reservoir will be filled with oil from the main oil reservoir. Let the vent plugs on the main pump suction ports open to allow the air to escape from the suction oil reservoir and hoses.

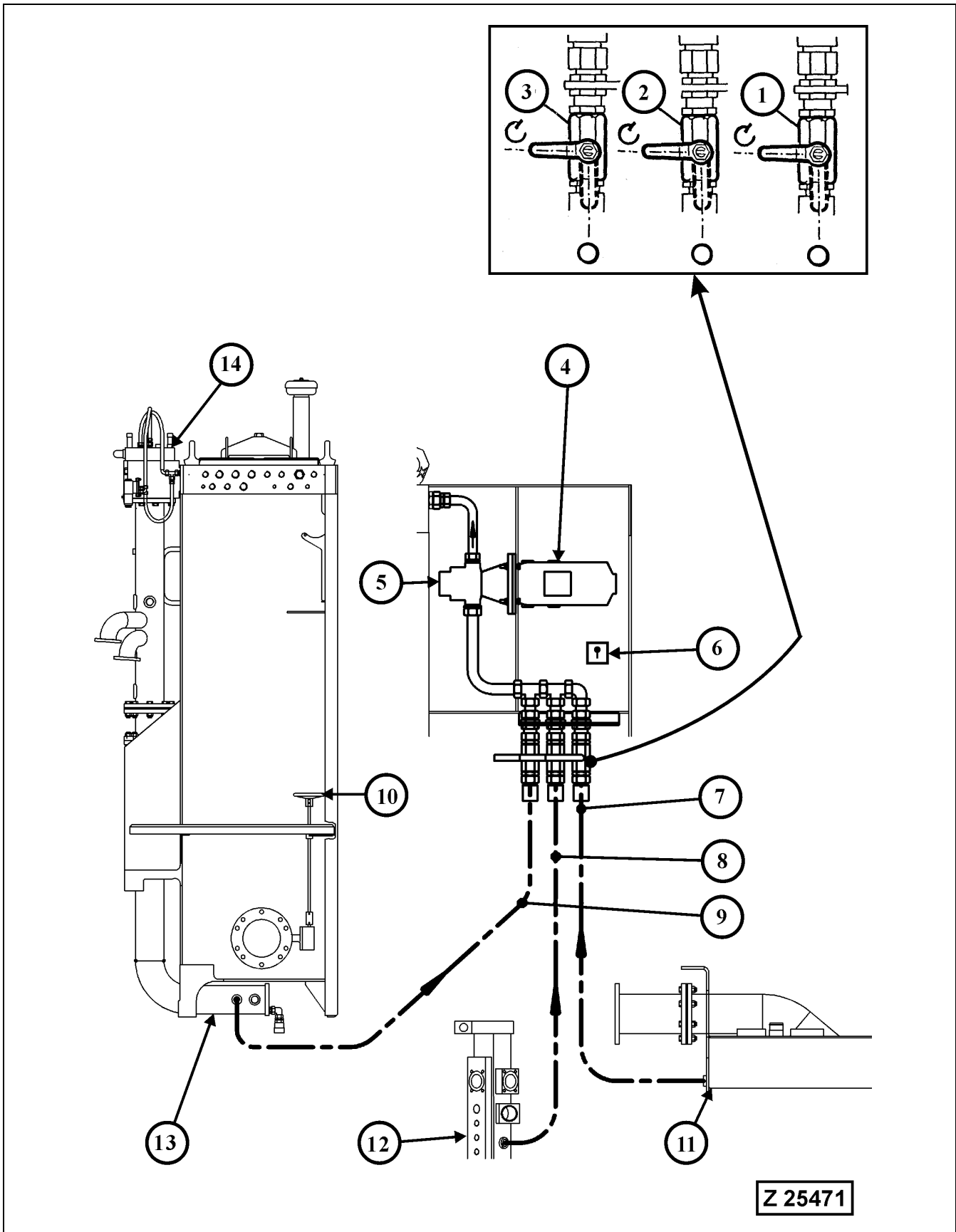

**A - Pumping the oil from the Suction Oil Reservoir (11) into the Main Oil Reservoir (continued)**

6. The suction oil reservoir and the suction hoses are filled, when bubble free oil flows out at the vent plug openings on each main pump. Install vent plugs and tighten securely.
7. Check oil level in all main pump housings and vent the hydraulic pumps according to page 399 in the Maintenance Section 4.
8. Check oil level in the main reservoir. Fill up with new hydraulic oil as necessary.
9. Start the engine and run without load to allow trapped air to be removed from the hydraulic system.

---

**⚠ CAUTION**

---

**DO NOT start the engine when the suction oil reservoir is empty.**

---

---

**B - Pumping the Oil from the Return Oil Collector Pipe (12) and back-pressure valve pipe (13) into the Main Reservoir**

1. To empty the collector pipe (12), open cock (2).
2. Switch on pump with switch (6).
3. Observe oil level sight gauge at the main oil reservoir. As soon as the oil level remains constant the return oil collector pipe is empty. Now switch off the transfer pump (4) and close cock (2).
4. To empty the back-pressure valve pipe (13), open cock (3).
5. Switch on pump with switch (6).
6. Observe oil level sight gauge at the main oil reservoir. As soon as the oil level remains constant the back-pressure valve pipe is empty. Now switch off the transfer pump (4) and close cock (3).

---

**⚠ CAUTION**

---

**DO NOT start the engine during servicing.**

---

---

# 3.19 CENTRAL REFILLING SYSTEM

(Special Equipment)

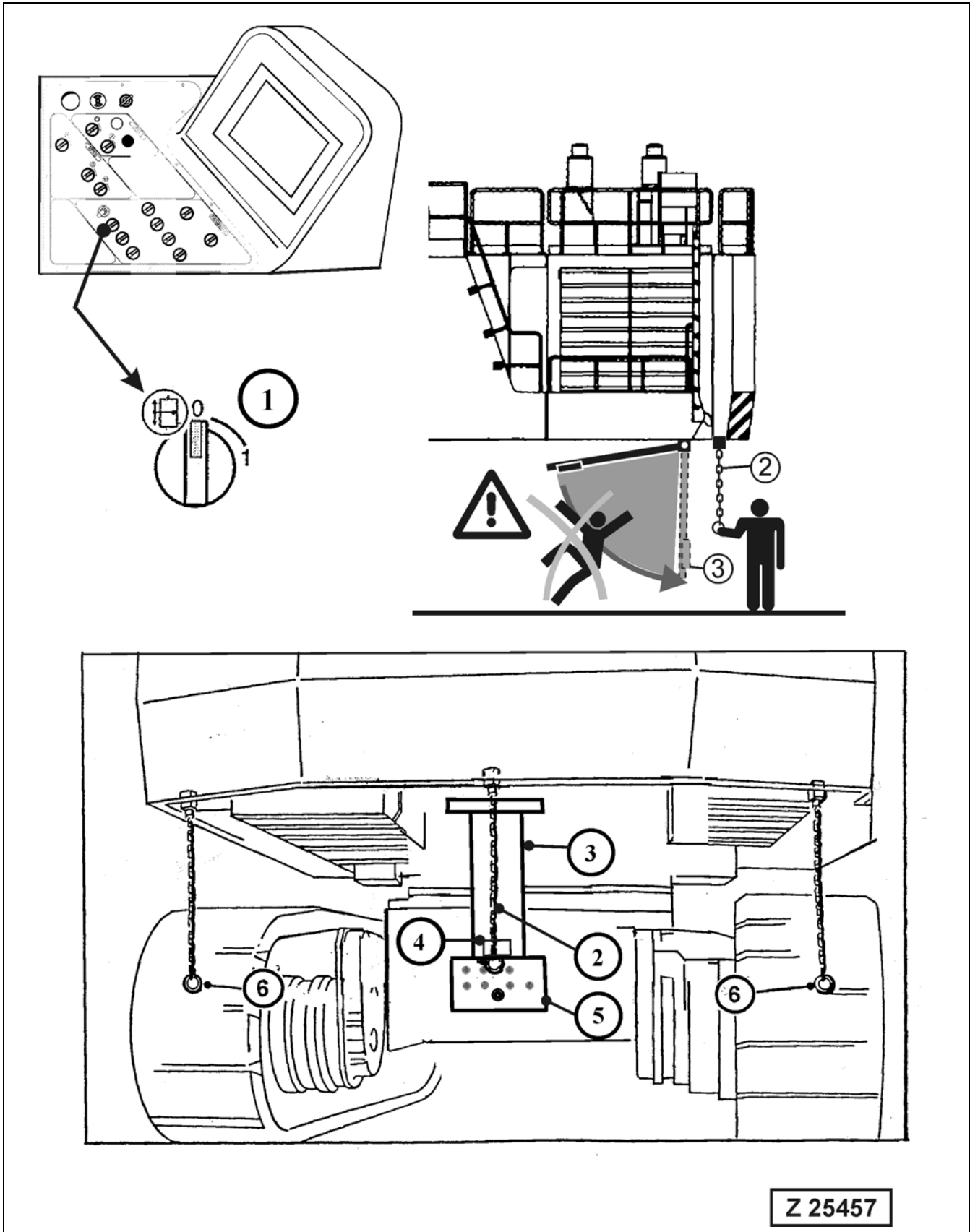

### 3.19.1 SYSTEMS CONNECTED TO THE REFILLING SYSTEM

The following systems are connected to the receiver panel (5) of service arm (3), illust. (Z25457):

- Fuel Tank
- Water Tank for Hand Wash Sink in the Operator's Cab
- Engine oil reserve Tank of the RESERVE System
- Engine Oil Pan
- Engine Coolant Radiator
- Main Hydraulic Oil Reservoir
- Central Lubrication System (CLS)
- Swing circle pinion Lubrication System (SLS)

#### Legend for illustration Z25457

- (1) Enabling switch for hydraulic service arm operation
- (2) Actuating chain for lowering and lifting of hydraulic service arm (3)
- (3) Service arm, hydraulically operated
- (4) Monitoring and control box
- (5) Receiver panel
- (6) Actuating chains for Operator Warning System or Emergency Shutdown of the Engine.

#### Operation of the hydraulic Service Arm

---

---

**⚠ WARNING**

---

---

- **Never enter, or allow anyone else to enter the moving range of the service arm (3). Death or serious injury can result.**
  - **DO NOT loosen any connections on the hydraulic circuit of the service arm. The circuit is under pressure. Lower the service arm completely before carry out any work on the hydraulic circuit.**
- 
- 

#### REMARK

With Enabling switch (1) in ON position "1" and/or Service Arm (3) not in fully lifted home position, the pilot control system is inoperative i.e. no Shovel movement possible.

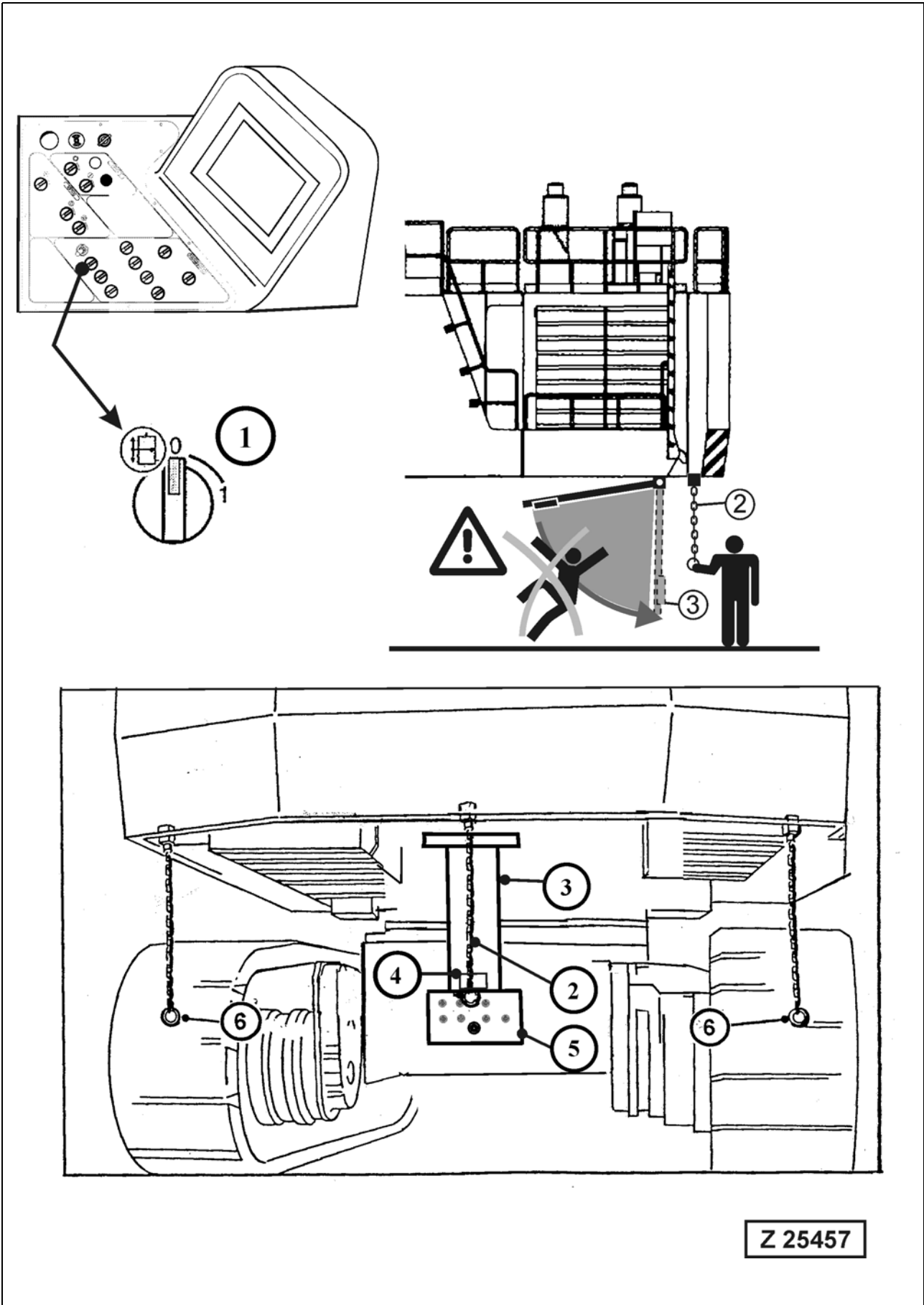

### 3.19.2 OPERATING THE HYDRAULIC SERVICE ARM

#### A - Diesel Engine OFF

The Service Arm can only be lowered.

Proceed as follows:

1. Turn main key switch to ON position.
2. Turn enabling switch (1), illust. (Z25457) to ON position "1".
3. For lowering the Service Arm (3) pull down chain (2).
4. Release chain (2) when arm (3) is in fully lowered position.

#### REMARK

To stop lowering movement of the Service Arm in any position release chain (2).

5. Before leaving the Shovel turn enabling switch (1) to OFF position "0" and remove the main switch key.

#### B - Diesel Engine running

Control the Service Arm as follows:

1. Turn enabling switch (1), illust. (Z25457) to ON position "1".
2. To lower the service arm (3) pull chain (2) and hold until the service arm is in fully lowered position. For reversing moving direction of service arm release the chain (2) to stop service arm movement and then pull chain (2) again.
3. To lift the service arm pull chain (2) and hold until the service arm is completely lifted into its home position.

#### NOTICE

**Be sure the Service Arm is completely lifted to its home position otherwise the proximity sensor in the guide frame of the service arm will not release the pilot control system.**

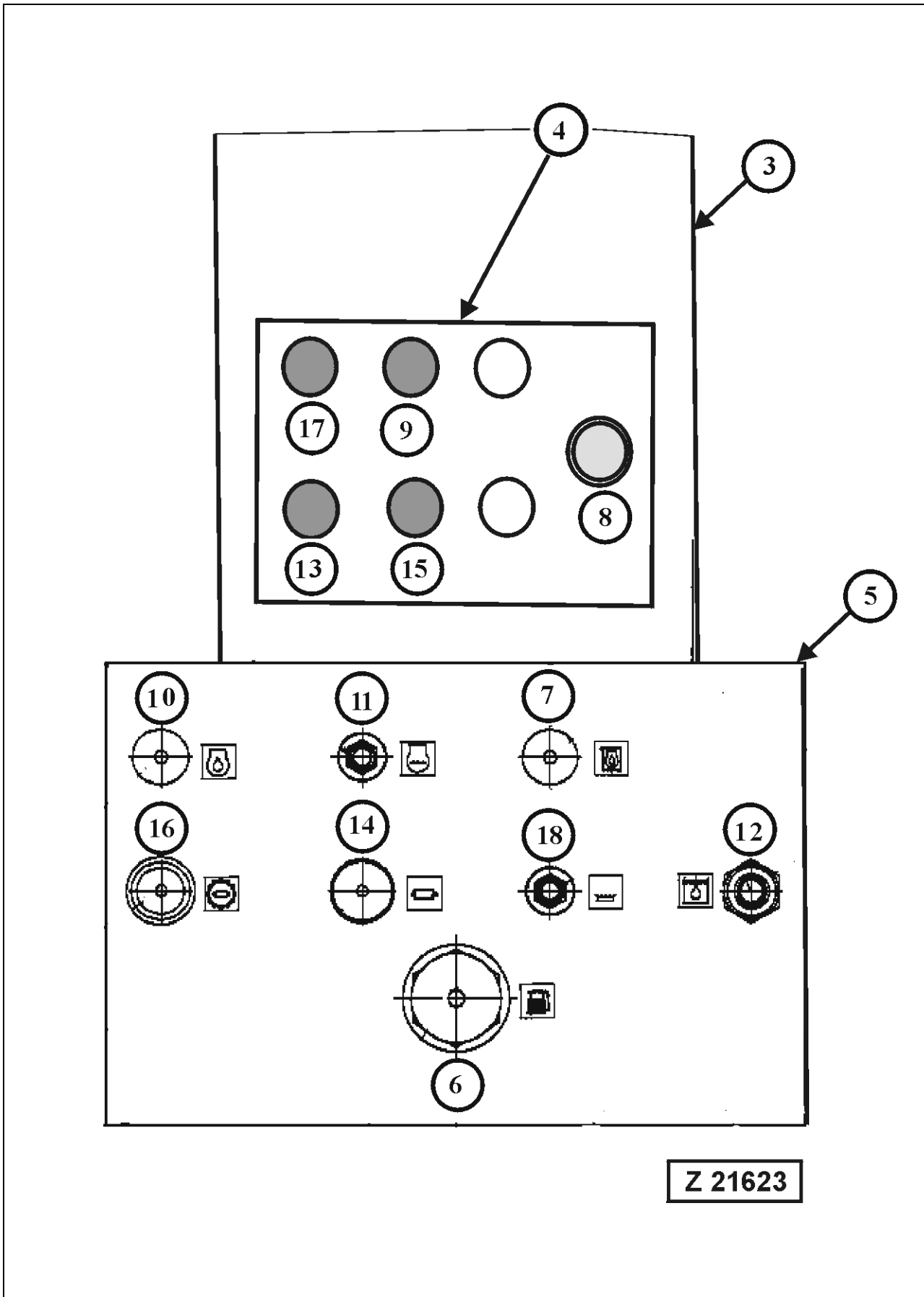



### 3.19.3 RECEIVER PANEL WITH MONITOR BOX

Legend for illustration Z 21623:

3	Service arm, hydraulically operated
4	Monitoring and control box
5	Receiver panel
6	Fuel filling adapter  <b>REMARK</b> The fuel nozzle cut-out pressure should be adjusted to 0,38 bar. If this pressure is too low for filling the fuel tank up to the correct level, gradually increase the cut-out pressure until the pressure is sufficient for filling up to the correct level The maximum flow rate should not exceed 680 liter per minute.
7	Filling adapter for engine oil reserve tank of the reserve system
8	Push button for testing lamps (9, 13, 15 and 17). Push the button, all lamps must light up. If a lamp does not light up, corrective action must be taken.
9	Indicator light, engine oil reserve tank full.
10	Engine oil evacuation and filling adapter connected to the engine oil pan. Monitor oil level at level gauge.
11	Radiator coolant draining and filling adapter. Monitor coolant level at radiator filler neck.

#### NOTICE

The two-loop type engine cooling system is equipped with two radiators. One radiator for the engine crankcase and cylinder heads and one radiator for the low temperature after-cooler (LTA) system. The radiators are connected with a pipe on the bottom side. This pipe contains a check valve which allows coolant flow from rear engine radiator to the front LTA radiator only. For draining the coolant from the front mounted LTA radiator, it is necessary to open the shut-off cock in the draining/filling hose line just below the radiators. Refer to the engine Operation and Maintenance Manual in part 3 of this binder for the maintenance instructions of the cooling system.

#### CAUTION

Be sure to close the shut-off cock on the bottom side of the radiators as soon as the maintenance of the cooling system is finished.

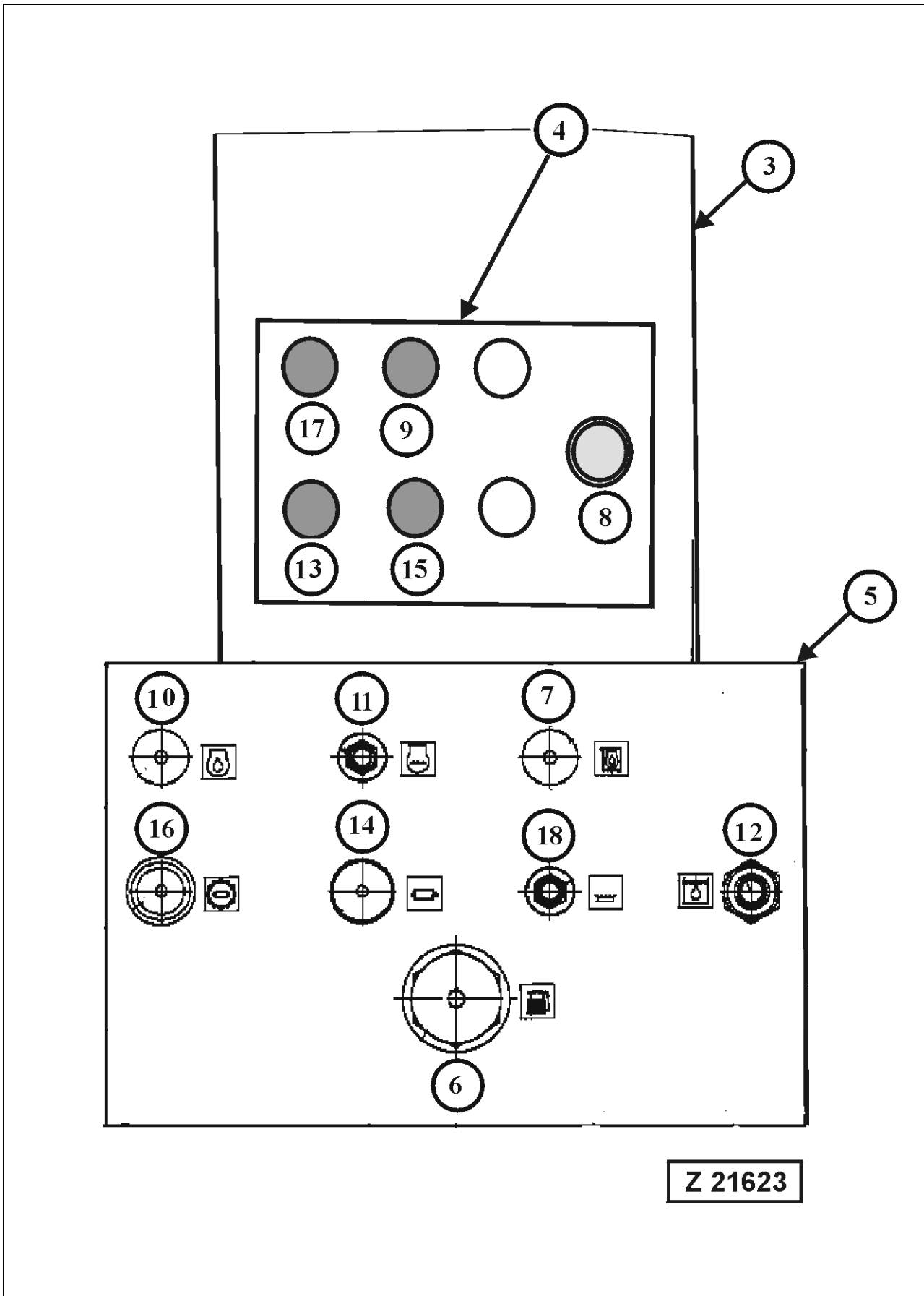

**Legend for illustration Z 21623**

12	Adapter for evacuation and filling of the main hydraulic oil reservoir. After the oil is completely evacuated, drain the oil from suction oil reservoir, collector pipe and back-pressure valve pipe. Refer to maintenance section, item hydraulic oil change for draining procedure. Open the shut-off valve between main oil reservoir and suction oil reservoir. Fill the hydraulic reservoir and observe indicator lamp (13).
13	Indicator lamp lights up when the hydraulic oil level in the reservoir is correct. Recheck hydraulic oil level at the sight gauge before operating the machine.
14	Adapter for filling the grease barrel of the Central Lubrication System (CLS). Before filling the grease barrel make sure the grease filter in the filling line is not obstructed.
15	Indicator light, grease barrel of Central lubrication System FULL.
16	Adapter for filling the grease barrel of the Swing circle pinion Lubrication System (SLS). Before filling the grease barrel make sure the grease filter in the filling line is not obstructed.
17	Indicator light, grease barrel of Swing circle pinion Lubrication System FULL.

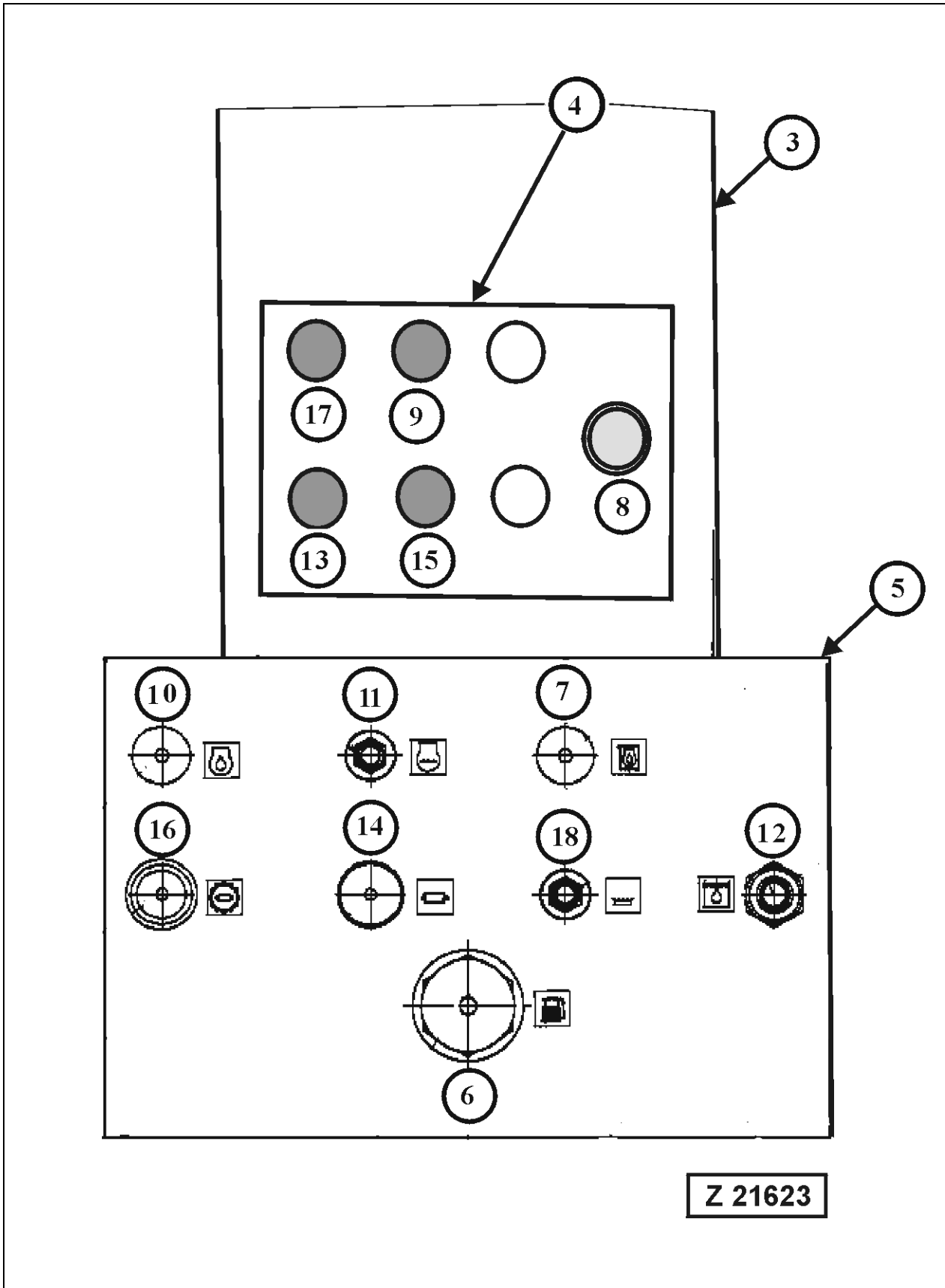

## RECEIVER PANEL WITH MONITOR BOX

### Legend for illust. Z 21623

18	Adapter for filling the water tank in the Operator's cab. The water tank has a capacity of 50 liters. The filling line of the water tank is equipped with a drain cock. Before filling the water tank, drain the old water by opening this drain cock. Close the drain cock and fill in 50 liters of clear water.
----	---

### NOTICE

**If freezing temperatures are expected, drain the water from the filling line by opening the drain cock. Switch on the engine-independent auxiliary cab heater during standstill periods to prevent freezing of the water in the cab water tank.**

### ⚠ WARNING

- **DO NOT drink the water from the water-tap in the Operator's cab.**
- **Use for hand washing only.**

### REMARK

The overflow line of the hand wash sink and water tank must not be obstructed. The overflow line is routed inside the cab base through a hole in the base floor to the outside. Excess water will flow through this line to the outside just below the cab base.

### Refilling Procedure:

### REMARK

Refer to Maintenance section 4, for the correct lubricant specifications and filling capacities.

For Engine Lubricants and Coolants refer to the separate Engine Operation & Maintenance Manual in volume 2 Binder.

1. Connect supply lines to the respective adapters.
2. Monitor the respective fluid/lubricant level at the indicator lights (9, 13, 15 and 17).
3. After finishing the refilling operation, cover the adapters with the protection caps provided and swing back hydraulic service arm (3) to its home position.

### ⚠ CAUTION

**Recheck fluid levels before operating the machine.**

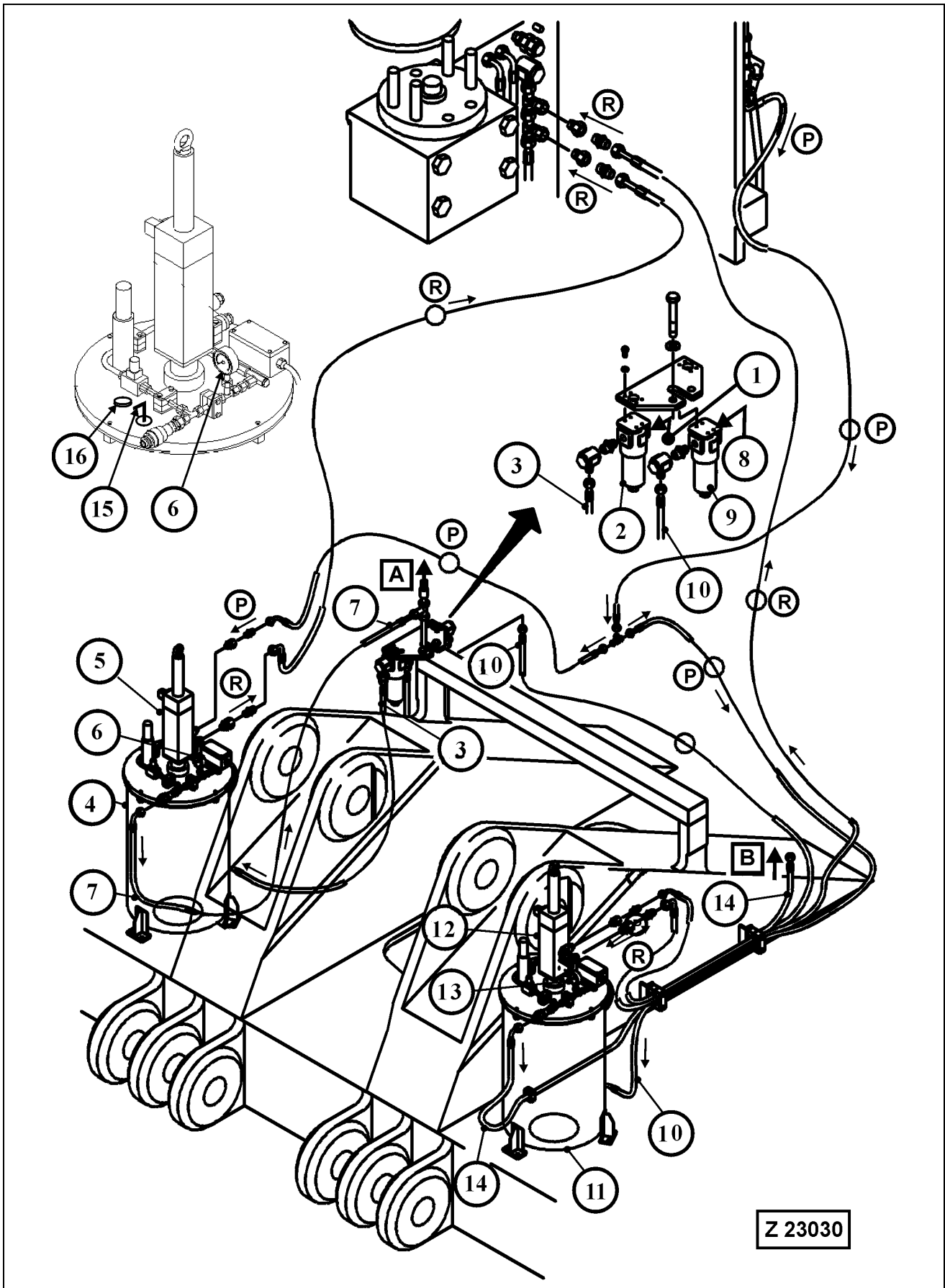

### 3.19.4 REFILLABLE GREASE CONTAINERS OF THE CENTRAL LUBRICATION SYSTEM AND SWING CIRCLE PINION LUBRICATION SYSTEM

#### Legend for illustration Z 23030

- (A) Grease supply line to the injectors for lubrication of the loader attachment, swing circle bearing and swing machinery pinion bearing
- (B) Grease supply line to the injectors for lubrication of the swing circle tooth-  
ing
- (P) Pressure oil supply from pilot oil circuit to hydraulically driven grease  
pumps (5 and 12)
- (R) Return oil to main hydraulic oil reservoir
- (1) Grease refilling line from service arm adapter to grease filter (2) of the cen-  
tral lubrication system
- (2) Grease filter for central lubrication system. Before filling the grease con-  
tainer make sure the filter is not obstructed. Service the filter element  
according to the instructions in the maintenance section 4, item no. 4.8.
- (3) Grease refilling line from grease filter (2) to grease container (4) of the cen-  
tral lubrication system
- (4) Grease container of the central lubrication system
- (5) Hydraulically driven grease pump
- (6) Grease pressure gauge
- (7) Grease supply line to the injectors of the central lubrication system, see  
(A).
- (8) Grease refilling line from service arm adapter to grease filter (9) of the  
swing circle pinion lubrication system
- (9) Grease filter for swing circle pinion lubrication system. Before filling the  
grease container make sure the filter is not obstructed. Service the filter  
element according to the instructions in the maintenance section 4, item  
no. 4.8.
- (10) Grease refilling line from grease filter (9) to grease container (11) of the  
swing circle pinion lubrication system
- (11) Grease container of the swing circle pinion lubrication system
- (12) Hydraulically driven grease pump
- (13) Grease pressure gauge
- (14) Grease supply line to the injectors of the swing circle pinion lubrication  
system, see (B).
- (15) Grease level gauge. Check grease level in both containers at regular inter-  
vals.
- (16) Breather filter

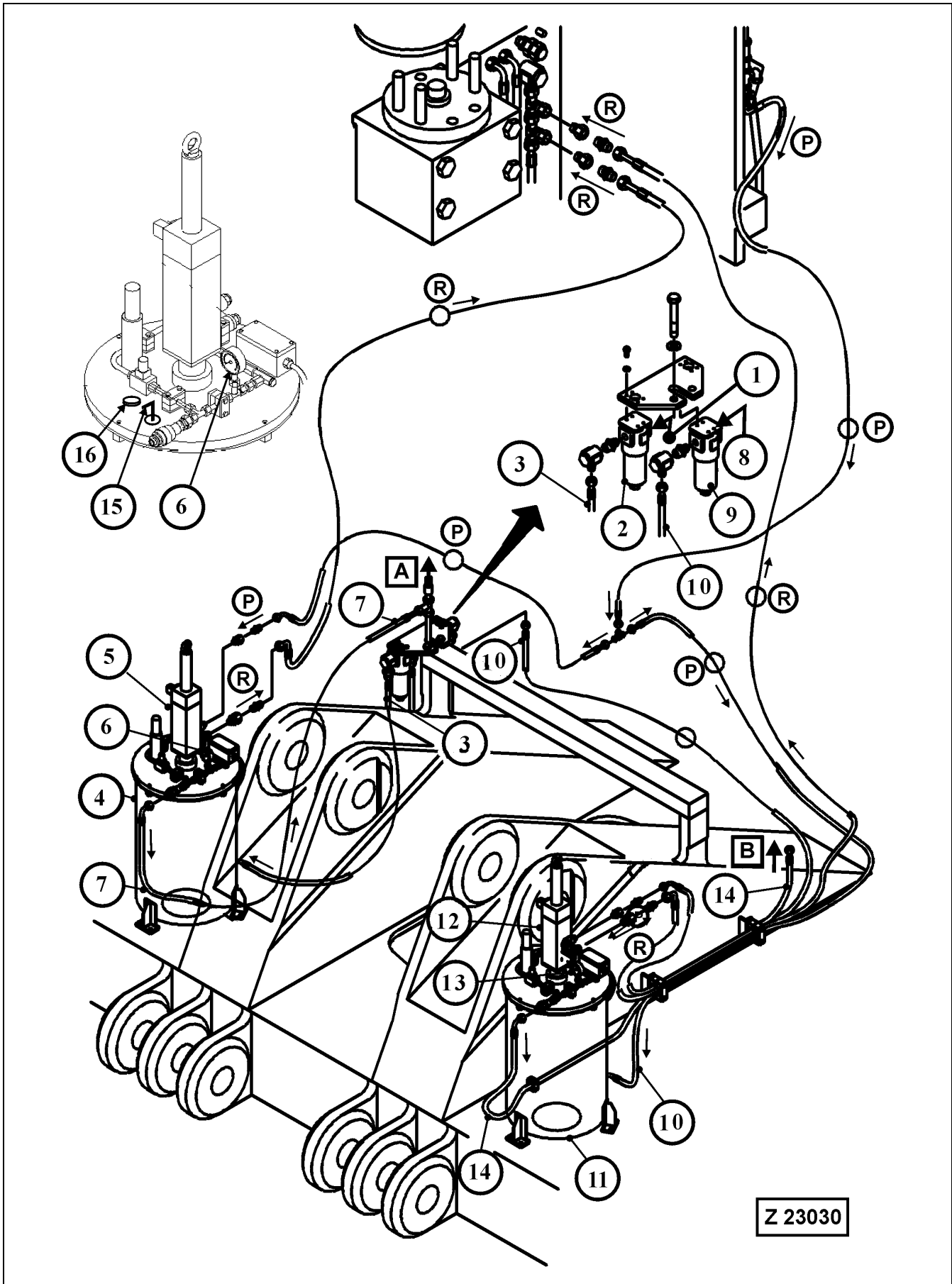



## Refilling the Grease Containers of the Automatic Lubrication Systems

Refill the respective grease container, when the Fault message

- "Central lube system grease container empty"
- or
- "Swing circle lube system grease container empty"

is being displayed on the VHMS monitor.

---

---

**▲ CAUTION**

---

---

**The central lubrication system and the swing circle pinion lubrication system have to be filled with different types of grease. Select the correct greases according to the Lubricant Charts in volume 2 binder.**

---

---

As soon as a grease container is filled up to the correct level the corresponding indicator lamp (15 or 17), illust. (Z 21623) lights up.

In order to ensure proper operation of the lubrication systems carry out the periodic maintenance of the grease filters (2 and 9), illust. (Z 23030). Refer to maintenance section 4, item no. 4.8. Periodic inspection of the grease pumps (5 and 12) at least once a year is advisable.

After finishing the refilling operation, cover the adapters with the protection caps provided.

Carry out a test-run of the lubrication systems by actuating the switches on the instrument panel.

---

## 3.20 WORK ON THE LOADER ATTACHMENT

---

### WARNING

---

- **Work on the loader attachment must be carried out only by personnel with special knowledge of the Shovel. Improper working on the attachment can cause severe accidents with personal injury.**
  - **If you are not sure how to carry out the work on the attachment contact your local Komatsu Service Station for support.**
- 

### OBSERVE THE FOLLOWING INSTRUCTIONS

- Wear safety clothing, goggles, respirator and other safety devices, whenever working conditions make this necessary.
- Provide hoists of sufficient capacity to lift heavy units. Refer to the separate Assembly Procedure Manual, filed in volume 2 binder, for weight specifications. Be sure to observe the safety instructions in the Assembly Procedure Manual when working on the loader attachment.
- Before working on the loader attachment lower it to the ground, stop the engine and cycle all hydraulic control levers to relieve all pressure before disconnecting hydraulic lines.

**For more information → See "STOPPING THE ENGINE" on page 190**

- Lifting gear, tools and other suspension systems must be in good condition and of sufficient lifting capacity.
- Be sure hydraulic cylinders and attachment components are properly supported from hoist and securely fastened before removing supporting pins.
- Floors must be clean and dry. After draining operations be sure all spillage is cleaned up.

## 3.21 TRANSPORTATION AND LIFTING OF THE SHOVEL

---

---

**⚠ WARNING**

---

---

**Before Disassembling, Lifting or Transporting this Shovel contact your local Komatsu Service Station for all the necessary instructions for safe and economic disassembling, lifting and transportation procedures of your Shovel.**

---

---

### 3.21.1 DISASSEMBLING OF THE SHOVEL

The Shovel is being transported disassembled into its main components.

---

---

**⚠ WARNING**

---

---

**Disassembling of the Shovel must be carried out only by personnel with special knowledge of the Shovel. Improper disassembling procedures can cause severe accidents with personal injury.**

---

---

The sequence of disassembly can be derived from the Assembly Procedure Manual, filed in volume 2 binder. Disassembling is basically the reverse order of the assembling procedure.

### 3.21.2 TRANSPORTATION AND LIFTING

The transport dimensions and weights of the Shovel's components are listed in the Assembly Procedure Manual, filed in volume 2 binder.

Observe the operating permits of the low loader used for transportation. They contain the permissible load, loading width and height.

---

---

**⚠ WARNING**

---

---

- **Observe the federal, state and local laws and regulations for transportation of heavy units. Know the safety rules and laws before you transport this Shovel.**
  - **Make sure the low loader and the components of the Shovel are equipped with the correct safety devices.**
  - **Secure the Shovel and all components transported on the low loader against movement.**
- 
-

---

## 3.22 RETRIEVAL PROCEDURE

---

**▲ WARNING**

---

- Before starting retrieval measures, inform the responsible safety department.
  - Check for fuel or oil spillage.
  - Observe the local fire prevention- and safety regulations.
- 

---

**▲ CAUTION**

---

Contact your local Komatsu service station for all the necessary instructions for safe and economic retrieval procedures of your Shovel

---

**NOTICE**

Select the sequence of retrieval steps with regard to the stability of the Shovel. It must be prevented that the removal of main components impairs the stability of the Shovel

The Assembly Procedure Manual in volume 2 binder contains information of component weights and instructions for correct lifting procedures.

## 3.23 SHOVEL STORAGE

### GENERAL

Storage periods up to 30 days require no special preservation when the unit is stored in a protected place. When the Shovel is placed in storage for 30 days or more follow the procedure below.

#### NOTICE

**The description below includes special equipment which may not be installed in your machine.**

### 3.23.1 PREPARING FOR STORAGE

1. Clean the Shovel thoroughly, lubricate all points according to the lubrication chart. Move the machine to a protected place or cover the Shovel with a tarpaulin. Retract all hydraulic cylinders as far as possible. Cover the protruding piston rods with grease.
2. Refer to Engine Operation and Maintenance Manual for Engine storage procedure.
3. Fill up cooling system with anti-freeze and coolant. Observe instructions in the Engine Manual.
4. Service the engine air cleaner.
5. Drain condensation from fuel tank and fill the fuel tank with a mixture of 90% Diesel fuel and 10% protection oil, e.g. Shell Ensis 20.
6. Seal the engine air intake, exhaust outlet, electrical components, fuel tank ventilation and breather on the hydraulic oil reservoir to prevent dirt and moisture from entering.
7. Remove the batteries and store them in a cool, dry place (0 to 10° C) to minimize self discharge. Be sure the batteries are fully charged. Never allow batteries to run down below  $\frac{3}{4}$  full charge.
8. Loosen all drive belts.
9. Repaint areas that have paint damage with a good quality paint. Grease all machined unpainted surfaces with good quality grease to prevent rust.
10. Drain condensation from hydraulic oil reservoir. If necessary, add hydraulic oil.
11. Attach a tag to the instrument panel to indicate what work has been done.

### 3.23.2 ONE MONTH REPETITIVE SERVICE PERIOD

1. Service the engine according to the engine manual.
2. Check coolant level and cooling systems for leakage.
3. Check all oil levels according to the lubrication chart.
4. Drain condensation from fuel tank and hydraulic oil reservoir.
5. Operate air conditioning for approx. ½ hour.

### 3.23.3 SIX MONTH REPETITIVE SERVICE PERIOD

1. Perform steps 1 through 4 of the one month repetitive service period.
2. Lubricate Shovel according to lubrication chart (manual lubrication only).
3. Completely fill the fuel tank.
4. Check hydraulic system and all gear boxes for leakage. If necessary - fill up the units with the specified lubricant. Repaint surfaces that have paint damage.
5. Prepare the engine for operation according to the engine manual. Tighten all drive belts. Install fully charged batteries. Make sure the alternator is correctly connected.
6. Remove coverings from engine air intake, exhaust outlet, electrical components, fuel tank ventilation and breathers on the hydraulic reservoir.
7. Start the engine and run at low idle a few minutes to allow distribution of lubricating oil. DO NOT increase engine speed until normal oil pressure and temperature are reached.
8. Operate heater unit and air conditioning.
9. Operate the central lubricating system and slew ring gear lubrication system. Check the lubrication results at the respective lubrication points.
10. Carry out several complete working cycles with the loader attachment.
11. Stop the engine, observe the cooling down period. Install all coverings which have been removed according to step 6. Service the engine according to the engine manual. Lubricate all machined surfaces. Remove Batteries and store as described under "Preparing for Storage". Loosen all drive belts. Fill up the fuel tank.

### 3.23.4 PREPARING FOR OPERATION

1. Remove grease from all machined unpainted surfaces (piston rods).
2. Install fully charged batteries.
3. Remove all coverings.
4. Fill up fuel tank with an approved Diesel fuel.
5. Check cooling system for leaks, loose connections and coolant level. Check mixture ratio of antifreeze, refer to the engine manual for details.
6. Service the engine according to the engine manual. Tighten all drive belts. Make sure the alternator is correctly connected.
7. Carry out the maintenance according to the lubrication and maintenance manual of the Shovel.
8. Start the engine and run at low idle speed until the normal oil pressure and temperature are reached. DO NOT place the Shovel under load before the normal values are indicated.
9. If the engine is misfiring or loss of power is evident, check the fuel system for restriction or loose parts.
10. Carry out several complete working cycles. Check the function of special equipments (central lubricating system, swing circle pinion lubricating system, fire detection and suppression system etc.).

## 3.24 TROUBLE SHOOTING

### GENERAL

The following charts list a number of the most common problems encountered in operation. Some of the faults may be due to careless handling or operation, improper maintenance or the use of lubricating oils other than specified. The "Probable Cause" column is formulated in such a way as to imply the answer to particular failure. For repairs requiring expert knowledge and tools, consult authorized service personnel.

### 3.24.1 ENGINE

Problem	Probable cause
Engine will not start	<ul style="list-style-type: none"> <li>● Fuel tank empty or filter clogged</li> <li>● Fuel supply system air-bound or clogged</li> <li>● Fuel filters not sealed properly</li> <li>● Engine speed control system defective</li> <li>● Cold starting aid, fluid container empty</li> </ul>
Uneven engine operation	<ul style="list-style-type: none"> <li>● Fuel filters clogged</li> <li>● Air in fuel system</li> <li>● Engine speed governor defective</li> </ul>
Engine overheats	<ul style="list-style-type: none"> <li>● Coolant supply insufficient</li> <li>● Fan belt slipping</li> <li>● Coolant passages in cooling system clogged with dirt or scale</li> <li>● Radiator air passages clogged with dirt</li> <li>● Exhaust pipe or muffler restricted</li> <li>● Thermostat defective</li> </ul>
Engine does not develop full power	<ul style="list-style-type: none"> <li>● Air cleaner clogged</li> <li>● Fuel filters clogged</li> <li>● Exhaust pipe or muffler restricted</li> <li>● Engine speed control system incorrectly adjusted</li> <li>● Valve (s) faulty</li> <li>● Fuel lines restricted</li> <li>● Turbocharger faulty, or inoperative</li> </ul>
Loss of oil pressure	<ul style="list-style-type: none"> <li>● Oil filter (s) clogged</li> <li>● Low oil level</li> <li>● Poor quality oil</li> <li>● Oil pressure switch defective</li> <li>● Oil pump filter screen clogged</li> <li>● Dirt in regulating valve</li> <li>● Crankshaft, connecting rod or camshaft bearing (s) worn excessively.</li> </ul>

### NOTICE

Refer to the engine manual for more detailed information.



### 3.24.2 HYDRAULIC SYSTEM

Problem	Probable cause
Poor hydraulic system performance	<ul style="list-style-type: none"> <li>● Hydraulic oil not at operating temperature.</li> <li>● Engine speed too low.</li> <li>● Reservoir low on oil</li> <li>● Restrictions in lines</li> <li>● Cooling circuit, pump control system and/or pilot control circuit defective.</li> <li>● Internal leakage (control blocks, valves or power units.)</li> <li>● Pressure lines twisted or kinked</li> <li>● Spool not in full stroke.</li> <li>● Relief valve defective, or out of adjustment.</li> <li>● Worn cylinders.</li> <li>● Defective hydraulic pump.</li> </ul>
Excessive oil temperature	<ul style="list-style-type: none"> <li>● Low oil level</li> <li>● Incorrect viscosity or type of oil</li> <li>● Hydr. oil cooler clogged with dirt.</li> <li>● Oil cooler fan defective or wrong speed.</li> <li>● Cooling circuit defective</li> <li>● Pump control system defective</li> <li>● Spool not in full stroke.</li> <li>● Internal leakage (control blocks, valves or power units)</li> <li>● Worn pump components</li> <li>● Job conditions (high temperature of materials being handled)</li> </ul>
Jerky motion of power cylinders	<ul style="list-style-type: none"> <li>● Piston rod bent</li> <li>● Piston sticking</li> <li>● Inside diameter of cylinder tube partially increased or scored</li> <li>● Air in control circuit</li> <li>● Oil too cold</li> <li>● Valve spool sticking, centering springs defective</li> <li>● Pump and/or engine control system defective</li> <li>● Valve of power circuit defective</li> </ul>
Noise when slewing	<ul style="list-style-type: none"> <li>● Insufficient lubrication of slew ring gear and/or slewing connection.</li> <li>● Slewing connection mounting bolts loose</li> <li>● Drive pinion worn</li> <li>● Slew gear bearings worn</li> <li>● Sun gear or planetary pinions worn</li> <li>● High pressure circuit valves defective</li> <li>● Anti-cavitation valves sticking</li> </ul>
Excessive oil foaming	<ul style="list-style-type: none"> <li>● Air in hydraulic system</li> <li>● Poor quality oil</li> <li>● Excessive by-passing of oil over relief valves</li> <li>● Pressure hoses badly twisted or kinked</li> <li>● Restricted oil flow due to foreign matter</li> <li>● Breather on the reservoir clogged.</li> <li>● Relief valve improperly adjusted</li> </ul>

### 3.24.3 FINAL DRIVES AND SWING MACHINERY

Noisy operation	<ul style="list-style-type: none"> <li>● Incorrect lubricant or oil level too low</li> <li>● Bearings scored or damaged.</li> <li>● Sun gear teeth excessively worn or damaged</li> <li>● Bearings of planetary pinions worn</li> </ul>
-----------------	---

### 3.24.4 CRAWLER TRACKS

Excessive track wear	<ul style="list-style-type: none"> <li>● Wrong track tension</li> <li>● Track roller loose or out of alignment</li> <li>● Track shoes loose</li> <li>● Track links stuck</li> <li>● Worn drive sprocket</li> </ul>
Excessive wear on drive sprocket	<ul style="list-style-type: none"> <li>● Wrong track tension</li> <li>● Track links (pins/bores) Excessively worn</li> <li>● Sprocket, rollers and guide wheel out of alignment</li> </ul>

# **4. MAINTENANCE**

## 4.1 FOREWORD

This section contains instructions for the correct care and maintenance of your machine.

### NOTICE

**Since this section covers also special equipment and accessories, you may find illustrations and descriptions which do not apply to your machine.**

### DEFINITIONS

#### Service point

Unit or system where the prescribed maintenance work has to be performed (e.g. engine, hydraulic, PTO etc.).

#### Service intervals

Number of operating hours after which the maintenance work has to be performed (e.g. "Every 10 Operating Hours", at 10, 20, 30 etc.; "Every 250 Operating Hours", at 250, 500, 750 etc.).

### GENERAL RECOMMENDATIONS

Thoroughly clean all grease fittings, caps and plugs before lubricating.

Seals must be replaced when oil drain plugs and oil level plugs have been opened.

Fill-up fuel tank at the end of the shift to prevent condensation of moisture.

It is recommended to carry-out oil change in assemblies when they are still at operating temperature to speed up draining.



#### **WARNING**

**Avoid direct contact of hot oil with your skin. Hot oil can cause personal injury.**

## 4.2 PRECAUTIONS FOR MAINTENANCE

- Before starting any lubrication or maintenance work read the Fundamental Safety Instructions on page 16.
- Park the Shovel at a safe place on level ground. Proceed according to the instructions on page 189 "Parking the Shovel". Lower the attachment flat onto the ground. Move all control levers to neutral position.
- Stop the engine and move all control levers through their shift positions to relieve the pressure in the hydraulic system. Refer to page 190 "Stopping the Engine" for detailed description of the stopping procedure.
- Before any maintenance work is started, set the maintenance safety switch to 0 position. Refer to page 129 for location of the maintenance safety switch. In the 0 position the engine can not be started. Secure this position by inserting a padlock into the holes of the switch. Up to three padlocks can be attached to the holes provided.
- A warning plate "CAUTION MACHINE MAINTENANCE" must be fixed in the Operator's cab before any lubrication or maintenance work is started.

### NOTICE

**Some checks and adjustments can only be done with the engine running. For such jobs two men are necessary. Thereby, the controls must not be left unattended, while the other man carries out checks and adjustments.**

**The man in the operator's seat must keep constant visual contact with the other one and they must agree on suitable communication signals before they start their work.**

- Block the machine to prevent machine movement
- Always use safety devices to block hydraulic cylinders. Never rely on the machine hydraulic system to hold when working on the loader attachment. A hydraulic line or cylinder could fail or someone could accidentally strike the control levers causing the loader to fall.
- Relieve all pressure in the hydraulic system before servicing the hydraulic system.
- Oily cloth and inflammable material must be removed from the machine. Clean the excavator before starting maintenance work.
- Switch-off battery main switch and remove key, before working on the electrical system.
- Wear safety clothing, goggles, respirator and other safety devices, whenever working conditions make this necessary. Observe the local safety rules.
- Never allow unauthorized persons access to the machine during lubrication and maintenance work.

- After servicing, remove oily cloth, inflammable material and all tools from the machine.
- Clean the Excavator with a steam jet, especially after servicing fuel system, engine and hydraulic system.

**NOTICE**

- **For cleaning the Excavator and its components use only fresh water with a salt content of less than 0.05%.**
- **For cleaning the headlights, DO NOT use steam jet, high pressure cleaning device or strong water jet.**
- **Be sure to reinstall safety devices, guards or shields after adjusting and/or servicing the machine.**

## 4.3 FUEL AND LUBRICANTS

Lubrication Point	Lubricant	Ambient Temperature °C	Viscosity Grades		Quality Grades DIN/API
Engine Oil Coolant Fuel	Refer to "Engine Operation and Maintenance Manual" for Specifications.				
Hydraulic System	Hydraulic oil "HLP or "HLPD" with ZINC anti-wear additives *1)	- 25 to + 15	22	-	DIN-51524 T.2 - HLP
		-15 to + 25	32	or 32 - 68	
		-10 to + 30	46		
		- 5 to + 35	68		
		+ 5 to + 50	100	-	
Travel gears, Final drives and Swing machinery	Hydraulic oil "HLP"	- 40 to + 10	HLP T32		DIN 51524. T.2 - HLP
	Gear oil "CLP" *2)	-15 to + 50	CLP 220		DIN 51517 3 - CLP
Brake housings and Motor adapter housings of Travel Gears	Engine oil	all	SAE 10		
	or Hydraulic oil		HLP 22 or HLP 32		DIN 51524T.2 - HLP
PTO (Pump distributor gear)	Hydraulic oil "HLP"	- 40 to + 10	HLP T32		DIN 51524. T.2 - HLP
	Gear oil "CLP" *2)	-15 to + 50	CLP 150		DIN 51517 3 - CLP
Fan bearing housings of Radiator and Hydraulic oil cooler	Gear oil "CLP"		CLP 150		DIN 51517 3 - CLP

**NOTICE**

- \*1) DO NOT mix up ZINC-FREE Hydraulic oils with Hydraulic oils containing Zinc. DO NOT mix up Mineral Hydraulic oils with Synthetic Hydraulic oils. Mixing of the above oils, will result in diminishing of anti wear properties and oxidation stability of the oil. Quick plugging of the oil filters in the hydraulic system is to be expected.
- \*2) Refer to the chart "Gear Oils" in part 3 of this binder for the released gear oil qualities and viscosity grades.
- The lubricating instructions in this book refer to the recommended grade specifications. Damages caused by using lubricants other than specified are not covered by the manufacturer's guarantee.

Lubrication Point	Lubricant	Ambient Temperature °C	Viscosity Grades	Quality Grades
				DIN/API
Grease Fittings (manual lubrication)	Multi-Purpose Grease "MPG"	Refer to the Lubricant Chart in Part 3 of Volume 2 Binder for the recommended Multi-Purpose Greases. The part numbers of recommended Multi-Purpose Greases are listed in the Parts Catalog .		
Central Lubrication System				
Swing Circle Teeth (manual lubrication)	Adhesive Lubricant	Refer to Lubricant Chart for Swing circle open Gear lubrication in Volume 2 Binder for the recommended Adhesive Lubricants. The part numbers of the recommended Adhesive Lubricants are listed in the Parts Catalog .		
Swing Circle Pinion Lubrication System				
Track rollers, Carrier rollers and Idler wheels	Gear oil "CLP" or "API"	-	CLP 220 SAE 90	DIN 51517 3 CLP API GL 5
Flexible coupling	Engine oil "API"	-	SAE 15W-40	API CD+SF
Air conditioning system	Refrigerant		R 134a <b>CAUTION:</b> The Air Conditioning is prepared for Refrigerant "R134a" only. Observe Note below.	
Refrigerant compressor	Special oil See Note below.			

**NOTICE**  
**The Air Conditioning must be filled with refrigerant "R134a" through authorized Service Specialists only. DO NOT use refrigerant "R12", otherwise serious damage on system components could occur. The lubrication oil for the refrigerant compressor must be compatible with "R134a" refrigerant.**



## 4.4 FILLING CAPACITIES

Unit or System	Liter (approx.)
Engine cooling system	475.0
Engine oil pan	290.0
Engine oil reserve tank	580.0 (457.0 Refill)
Fuel tank	6400.0
Hydraulic oil reservoir	3900,0
Hydraulic system	5900.0
Flexible coupling between engine and PTO	1.3
PTO (Pump distributor gear)	150.0
Swing machinery (Manufacturer L&S), each	42.0
● Motor adapter housing	0.6
Swing machinery (Manufacturer Siebenhaar), each	60.0
● Motor adapter housing	*1)
● Brake housing	*1)
Travel gears, each	155.0
● Motor adapter housing	0.6
● Brake housing	0.5
Drive shaft housing, final drives, each	145.0
Track rollers, each	2.4
Guide wheels, each	2.9
Support rollers, each	4.0
Fan bearing housing of radiator	*2)
Fan bearing housings of hydraulic oil cooler	*2)
Water tank for hand wash sink in Operator's cab	50.0
Water tank for windshield washer system	7.0

**REMARK**

Capacities listed above are approximate values.  
 For proper checking use level plugs, dipsticks, and inspection openings, provided for this purpose.

\*1) Fill up to level gauge marking.

\*2) Fill up to lower edge of level plug opening.

## 4.5 STANDARD TORQUE LIST

Bolt dia.	Wrench size [mm]	Tightening torque		
		Nm		
		lbs.ft.		
		Quality grades		
		8.8	10.9	12.9
M 10	17	43	63	73
		32	47	54
M 12	19	74	108	127
		54.6	80	94
M 14	22	118	173	202
		87	128	149
M 16	24	179	265	310
		132	196	229
M 18	27	255	360	425
		188	265	313
M20	30	360	510	600
		265	376	443
M 22	32	485	690	810
		358	509	597
M 24	36	620	880	1030
		457	649	760
M 27	41	920	1310	1530
		679	966	1128
M 30	46	1250	1770	2080
		922	1305	1534
M 33	50	1690	2400	2800
		1246	1770	2065
M 36	55	2170	3100	3600
		1600	2286	2655
M 39	60	2800	4000	4700
		2065	2950	3466

Insert all bolts lubricated with MPG, KP2K

## 4.6 LUBRICATION AND MAINTENANCE SCHEDULE

### 4.6.1 INITIAL SERVICING

#### AFTER THE FIRST 250 OPERATING HOURS

Change oil in Swing machinery, travel gears and PTO (pump distributor gear). Thereafter every 3000 hours, but at least once a year. An oil sample analysis should be made every 1000 operating hours.

Hydraulic system: Replace return oil filter elements and leakage oil filter element. Inspect return oil strainers. Thereafter every 1000 operating hours.

#### AFTER THE FIRST 250 AND 1000 OPERATING HOURS

Check tightening torque of high strength bolt connections. Thereafter every 1000 hours. (The swing circle connection bolts need only to be checked after the first 1000 operating hours in accordance with PARTS & SERVICE NEWS No. AH00511 filed in volume 2 binder).

#### NOTICE

**The above initial service is of vital importance for proper operation and long service life of the machine.**

### 4.6.2 PERIODIC SERVICING INTERVALS

All following intervals of time between services are based on average operating conditions. Under unusually severe conditions of operation, reduce the interval of time between services.

#### NOTICE

**The periodic servicing intervals are also displayed on the maintenance monitor of the VHMS system.**

**Carry out the maintenance work of indicated service intervals according to this maintenance section.**

**4.6.3 PERIODIC SERVICING SCHEDULE**

<b>Service Intervals</b>	<b>Service Point</b>	<b>Service</b>	<b>See</b>
<b>When necessary</b>	Engine Air Cleaners	Maintenance	page 255
	Swing circle tothing	Immediately apply grease if bare spots are visible	page 259
	Automatic lubrication systems	Replace or fill grease containers Clean or replace filter elements	page 261
	Track rollers	If leakage occurs replace floating seals and fill with GL SAE 90 EP or ISO VG CLP 220	page 265
	Carrier rollers		
	Guide wheels		
	Cold starting aid	Replace fluid cartridge The fluid cartridge is located on the LH air cleaner carrier.	(1)
<b>Every 10 operating hours or daily</b>	Shovel	Walk-around inspection	page 267
	Working attachment	Check grease injectors of automatic lubrication system. Lubricate backhoe bucket linkage.	page 271
	Swing circle	Check grease injectors of automatic lubrication system.	page 275
	Air cleaner	Clean pre-cleaner	page 277
	Radiator	Check coolant level	page 279
	Track groups	Clean, esp. in winter	page 279
	Fuel system water separator	Drain water	page 281
	Engine	Check oil level	(1)
	Eliminator filter	Maintenance check	(4)
<b>Every 50 operating hours or weekly</b>	Swing machinery and Motor adapter housings	Check oil levels	page 283
	Travel gears, Brake housings and Motor adapter housings	Check oil levels	page 287
	Final drives	Check oil level	page 289
	PTO (Pump distributor gear)	Check oil level	page 291
	Hydraulic access ladder	Check safety sensor	page 293
	Hydraulic oil cooler and radiator	Check and clean as necessary	page 295

- (1) Perform maintenance according to separate Engine Operation an Maintenance Manual filed in volume 2 binder.
- (2) Perform inspections according to the separate Manual "FIRE DETECTION AND ACTUATION SYSTEM" filed in volume 2 binder.
- (4) Perform maintenance according to separate Service Bulletin " Eliminator Filter" filed in volume 2 binder.

Service Intervals	Service Point	Service	See
<b>Every 250 operating hours or monthly</b>	Refrigerant compressor	Check drive belt tension	page 297
	Undercarriage pin connections	Lubricate	page 299
	Signal horn compressor	Lubricate	page 299
	Oil cooler fan bearing housings and Radiator fan bearing housing	Check for leakages and clean breather filters	page 299
	Automatic lube systems	Clean in-line grease screens	page 301
	Cab, air filter	Clean or replace filter element	page 305
	Windshield washer reservoir	Check fluid level	page 307
	Air conditioning for Operator's cab	Inspection	page 309
	Engine	Maintenance	(1)
	Fire suppression system	Inspection	(2)
	Eliminator filter	Maintenance check	(4)
<b>Every 500 operating hours or quarterly</b>	Batteries	Check fluid level	page 311
	Flexible Coupling	Check oil level	page 313
	Pump drive shaft housings	Check oil level	page 315
	Fuel tank	Drain condensation	page 317
	Track groups	Inspection	page 319
	Fire detection and actuation system	Maintenance	(2)

- (1) Perform maintenance according to separate Engine Operation and Maintenance Manual filed in volume 2 binder.
- (2) Perform inspections according to the separate Manuals "FIRE DETECTION AND ACTUATION SYSTEM" and "FIRE SUPPRESSION SYSTEM" filed in volume 2 binder.
- (4) Perform maintenance according to separate Service Bulletin "Eliminator Filter" filed in volume 2 binder.

**CAUTION**

Carry out initial service according to item 4.6.1.

Service Intervals	Service Point	Service	See
<b>Every 1000 operating hours or every 6 months</b>	High strength bolt connections	Check for correct tightening torque and security	page 325
	Hydraulic system	Replace return and pressure filter elements Clean or replace high pressure filter elements Replace breather filter elements Drain sediments	page 367
	PTO (Pump distributor gear) Swing machinery and Travel gears	Oil sample analysis	page 379
	Signal horn compressor	Clean and lubricate	page 381
	Hydraulic track tensioning system	Check pressure accumulators	page 383
	Water filter for hand wash sink in Operator's cab	Replace carbon filter cartridge	page 385
	Hydraulic oil cooler doors and machinery house doors	Inspect and lubricate door hinges	page 387
	Engine	Maintenance	(1)
	Fire suppression system	Maintenance	(2)
	Air conditioning	Inspect the complete system	(3)
	Eliminator filter	Maintenance check	(4)

- (1) Perform maintenance according to separate Engine Operation an Maintenance Manual filed in volume 2 binder.
- (2) Perform inspections according to the separate Manual "FIRE SUPPRESSION SYSTEM" filed in volume 2 binder.
- (3) Perform inspections according to the separate Manual "OPERATING INSTRUCTIONS AC" filed in volume 2 binder.
- (4) Perform maintenance according to separate Service Bulletin "Eliminator Filter" filed in volume 2 binder.

**CAUTION**

**Carry out initial service according to item 4.6.1.**

Service Intervals	Service Point	Service	See
<b>Every 2000 operating hours or yearly.</b>	Hydraulic system	Change oil (*) Replace suction strainers (*) Replace pulsation damper	page 391
	Emergency escape ladder	Inspect	page 403
	Fire detection and actuation system	Maintenance	(3)
<b>Every 3000 operating hours however at least once a year.</b>	Swing machinery and Motor adapter housings	Change oil	page 405
	Travel gears, Brake housings and Motor adapter housings	Change oil	page 413
	Final drives (Drive shaft housings)	Change oil	page 417
	PTO (Pump distributor gear)	Change oil	page 419
	Engine	Maintenance	(1)

- (\*) The hydraulic oil change intervals can be extended for a further time period, when an oil sample analysis shows a positive result. When extending the oil change interval, it is necessary to carry out an oil sample analysis after every 1000 operating hours. However, it is recommended to change the hydraulic oil after 6000 operating hours at the latest.

**REMARK**

The pulsation damper of the hydraulic oil cooler circuit must be replaced after every 2000 operating hours.

- (1) Perform maintenance according to separate Engine Operation an Maintenance Manual filed in volume 2 binder.
- (2) Perform inspections according to the separate Manual "FIRE SUPPRESSION SYSTEM" filed in volume 2 binder.

**NOTICE**

- **The Lubrication oil Pump for Pump Distributor Gear Lubrication should be replaced with a new pump after every 5000 operating hours.**
- **To ensure proper functioning of the seat belt replace the seat belt and securing parts after every three years.**

Lubrication Chart

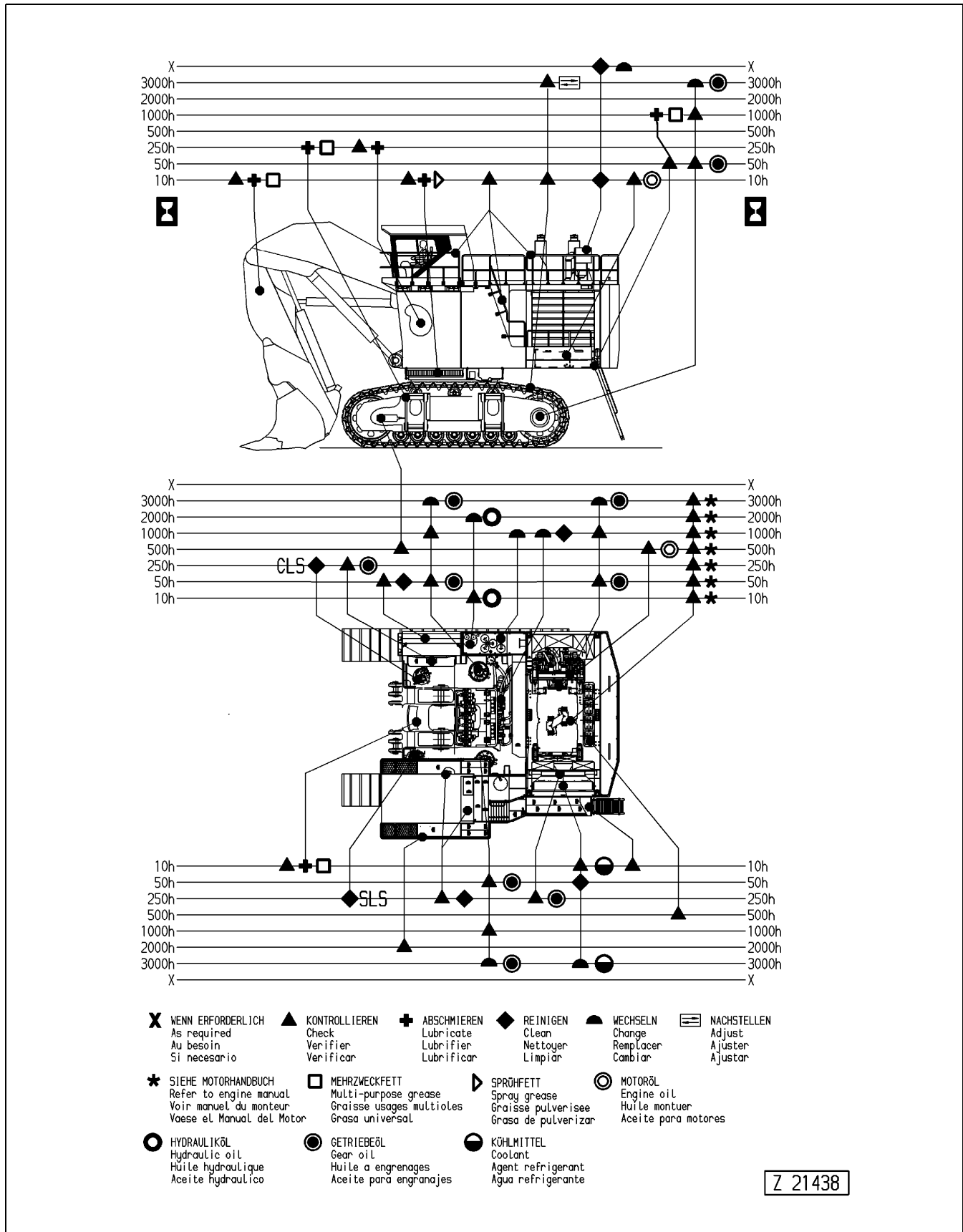

Z 21438



## REPLACEMENT OF HYDRAULIC HOSE LINES

Hydraulic Hose lines are subjected to natural aging. Hence, their usable lifetime is limited to maximum 6 years.

---

---

**⚠ CAUTION**

---

---

**The maximum permissible storage time of hydraulic hose lines is 2 years. This storage period is part of the usable lifetime and must be considered when a new hose line is being installed. If, for example, a hose line with a one year storage time shall be installed, the remaining service life of the hose line is 5 years. The production year and the ordering number of the hydraulic hose lines is stamped on the hose fittings.**

---

---

All hydraulic hose lines of the Shovel have to be replaced after every 6 years at the latest, even if there are no visible damages.

---

---

**⚠ WARNING**

---

---

**Repairs on hydraulic hoses and hose lines are not allowed. Use ONLY GENUINE KMG Replacement Hydraulic Hose Lines.**

---

---

## INSPECTION OF HYDRAULIC HOSE LINES

Inspect all hoses, hose lines and fittings periodically. Check for leaks and damages. Replace damaged parts without delay. Hydraulic fluid escaping under pressure can cause serious injuries and fire break out.

Some examples of faults on hydraulic hoses requiring replacement of the concerned part:

- Damages on the outer layer (e.g. chafed spots, cuts or scratches).
- Brittle top layers. Flaws on the hose material
- Distortion of the hose line (strong deviation from the original shape) under pressurized and pressureless conditions or when bended, e.g. disintegration of hose layers or blisterings.
- Leaks
- Detachment of hose and fitting. Damaged hose fitting.

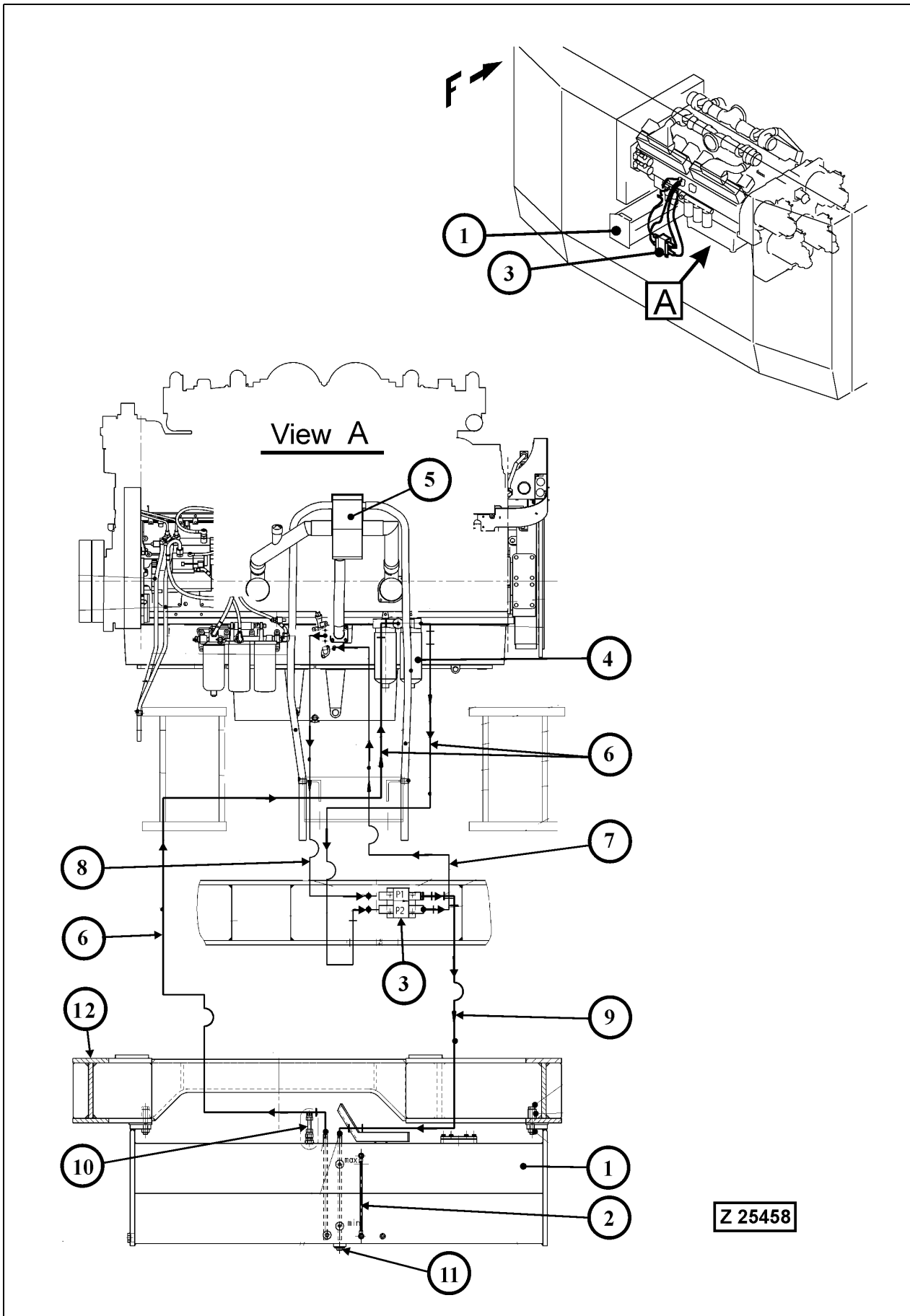

## 4.6.4 EXTENDED SERVICE INTERVALS FOR ENGINES EQUIPPED WITH ENGINE OIL MANAGEMENT SYSTEM

### REMARK

The engine oil management system of the engine combines the automatic engine oil supply system "**Reserve**" and the oil burning system "**Centinel**" in connection with the "**Eliminator**" oil filtration system.

### Reserve System Oil Flow Schematic, illustration Z25458

- (1) Reserve oil tank, usable contents 457 liters. Refilling interval, approx. 400 - 500 operating hours
- (2) Oil level sight gauge. Check oil level in the reserve tank before starting the engine. If necessary refill reserve tank via service arm adapter, refer to page 213 for more information.
- (3) Pumping unit, located on the side member of the power frame.
- (4) Oil filter of the supply system. Replace both filter elements after every 400 - 500 operating hours.
- (5) Crankcase breather filter
- (6) Suction lines
- (7) Oil supply line from pump (3) to engine oil pan
- (8) Withdrawal oil line from oil pan to pump (3)
- (9) Oil feed-back line to reserve tank (1)
- (10) Reserve tank breather filter
- (11) Oil drain plug
- (12) Power frame side member

### Servicing Intervals

- **Every 10 operating hours**

Check oil level in engine oil reserve tank (1) on sight gauge (2). Keep oil level between MIN and MAX mark on the gauge. Check also the oil level in the engine oil pan.

### REMARK

The oil level in the engine oil pan can vary between the MIN and MAX marking on the oil level gauge depending on the operating condition of the reserve system when the engine was stopped.

With sufficient oil in the reserve tank and with the reserve system in proper working order, there is no need to fill the engine oil pan even with the oil level at the MIN mark on the gauge. If the oil level is below the MIN marking on the gauge, corrective action must be taken. Fill the reserve tank and check the reserve system. The function of pumping unit (3) is monitored by an indicator light located on the "X2" switch board in the cab base.

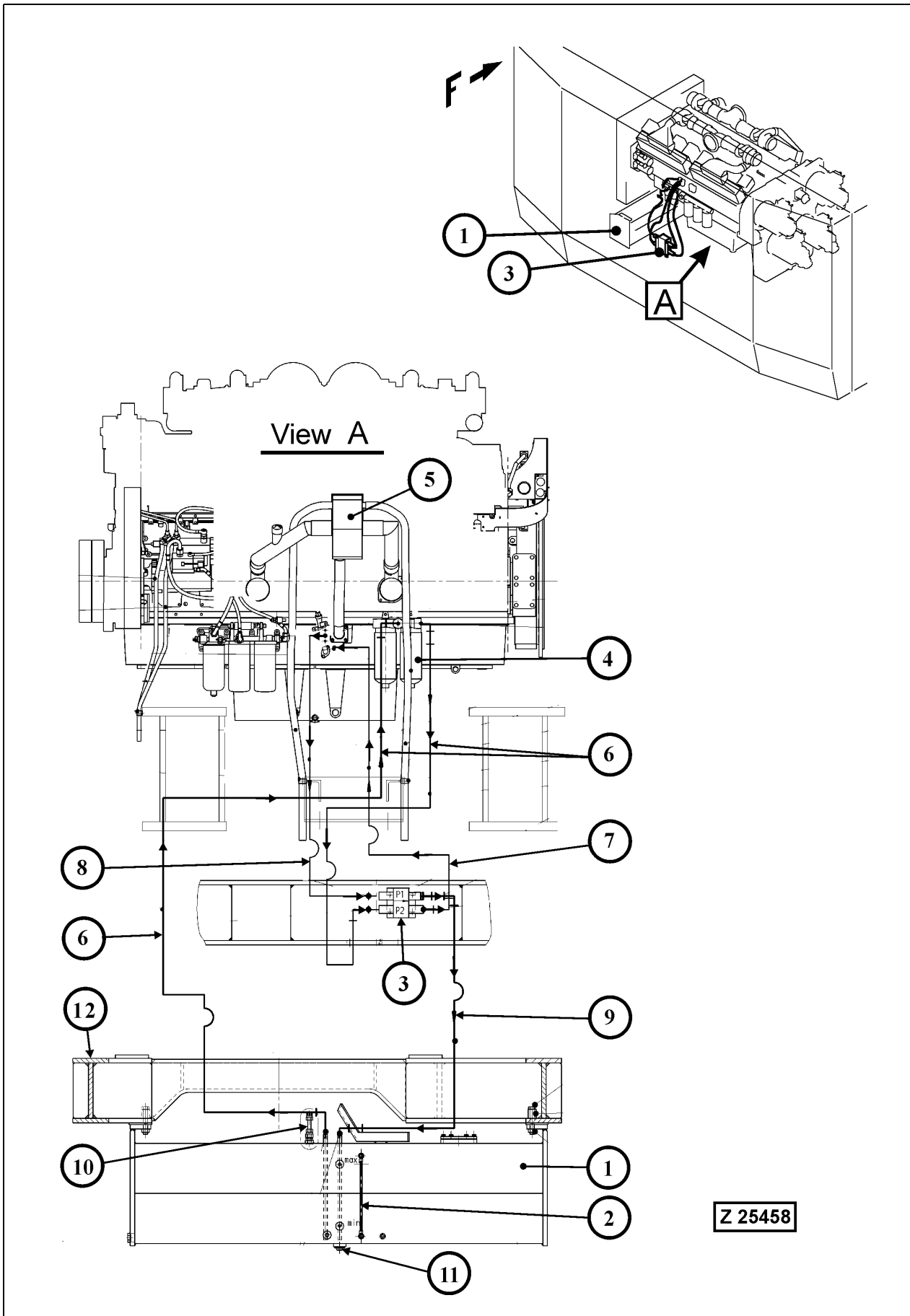

## Extended Service Intervals for Engines equipped with Engine Oil Management System

- **Every 400 to 500 operating hours**

The reserve tank contents of engine oil is sufficient for 400 to 500 hours of operation depending on operating conditions and environmental factors. Fill the reserve tank via the service arm. Use engine oil according to the specifications in the Engine Operation and Maintenance Manual. Change both oil filter cartridges (4) and clean breather filter (10).

- **Every 4000 operating hours**

Change engine oil. Drain the oil from engine oil pan and from engine oil reserve tank. It is recommended to change the oil when the oil level in the reserve tank is near the minimum level.

### NOTICE

**After the engine oil has been drained from the engine oil pan and from the reserve tank, fill engine oil pan and reserve tank via the swing down service arm. The service arm receiver panel has two connectors for filling of engine oil, one connector for the engine oil pan and one connector for the reserve tank.**

**DO NOT use the oil in the reserve tank to fill the engine oil pan after an oil change.**

**See section "CENTRAL REFILLING SYSTEM" on page 212 for more information.**

Refer also to the Engine Operation and Maintenance Manual for oil change procedure and oil specifications.

### REMARK

Service the Eliminator Oil Filtration System according to the separate Service Bulletin "**Eliminator Filter**" filed in volume 2 Binder.

## 4.6.5 MAINTENANCE OF THE ENGINE

---

---

 **CAUTION**

---

---

**All maintenance has to be carried out in accordance with the separate Engine Operation and Maintenance Manual.**

---

---

# 4.7 WHEN NECESSARY

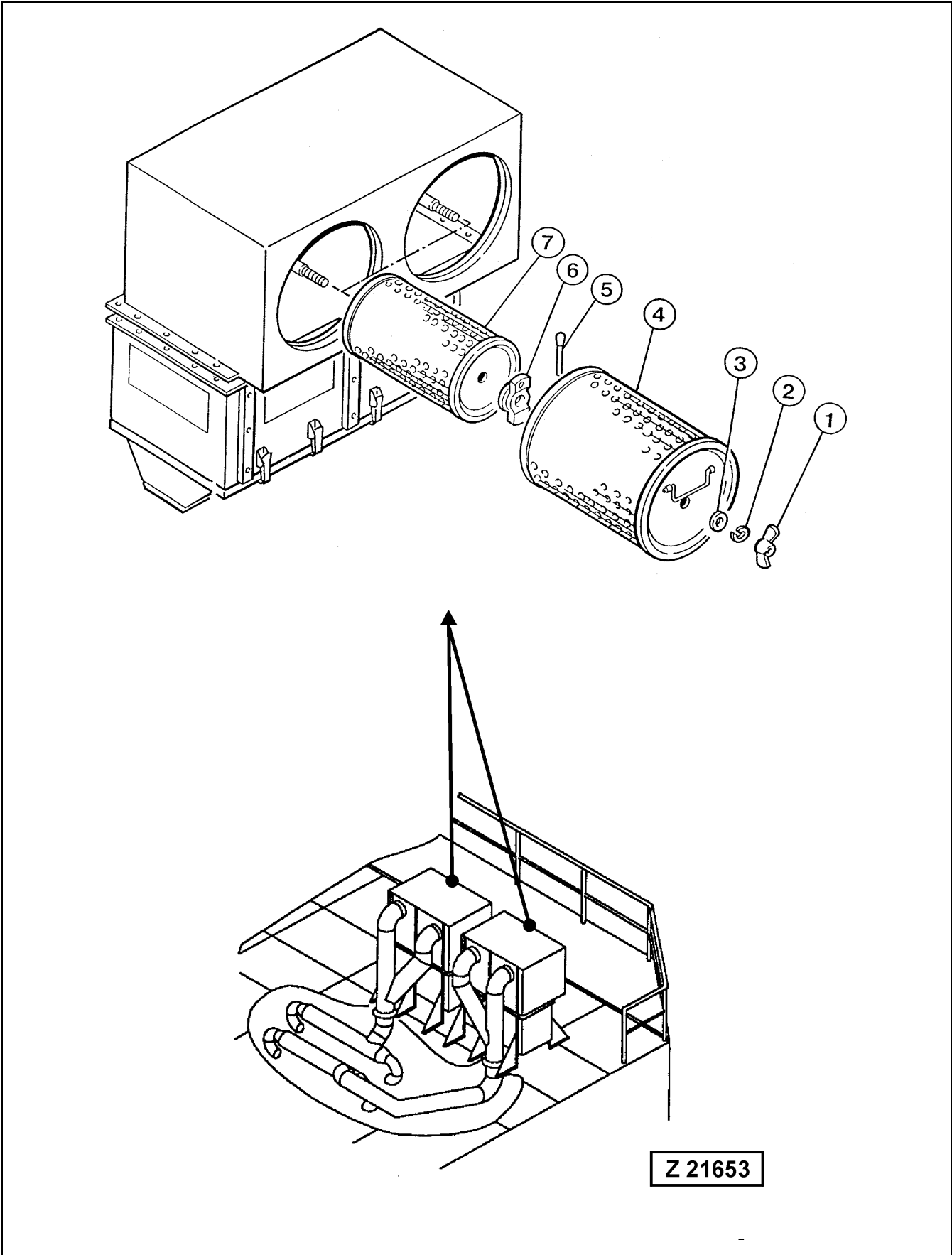

## 4.7.1 ENGINE AIR CLEANER SERVICE

### Servicing the Engine Air Cleaners

#### NOTICE

Before servicing the filter elements clean dust cups of the pre-cleaners.

Servicing the main filter elements, illust. Z 21653:

---

---

**CAUTION**

---

---

**Never service air cleaner while engine is running.**

**Clean main filter elements as soon as the fault message "Air cleaner element restricted" is displayed on the VHMS monitor.**

**Replace elements after 6 cleanings or annually, whichever occurs first.**

---

---

1. Remove elements in sequence of reference numbers (1 to 4).
2. Clean and check resp. replace main filter element.  
Wipe out filter housing with a clean cloth.
3. Element cleaning methods:  
Clean main element by one of the following methods.  
Compressed air or washing:  
Compressed air is recommended when element will be re-used immediately because a washed element must be dried before re-use.

#### **Compressed air:**

Direct air through element in the direction opposite to normal air flow through the element. Move nozzle up and down while rotating element. Keep nozzle at least one inch from pleated paper. Maximum air pressure to prevent damage of element is 100 P.S.I. (6 bar).

#### **Washing:**

1. Soak element 15 minutes or more in cleaning solution. See package for full instructions.
2. Rinse until water is clear maximum water pressure 40 P.S.I. (2,5 bar).
3. Air-dry or use warm flowing air, max. 160° F (+70° C). Do not use compressed air or light bulbs.

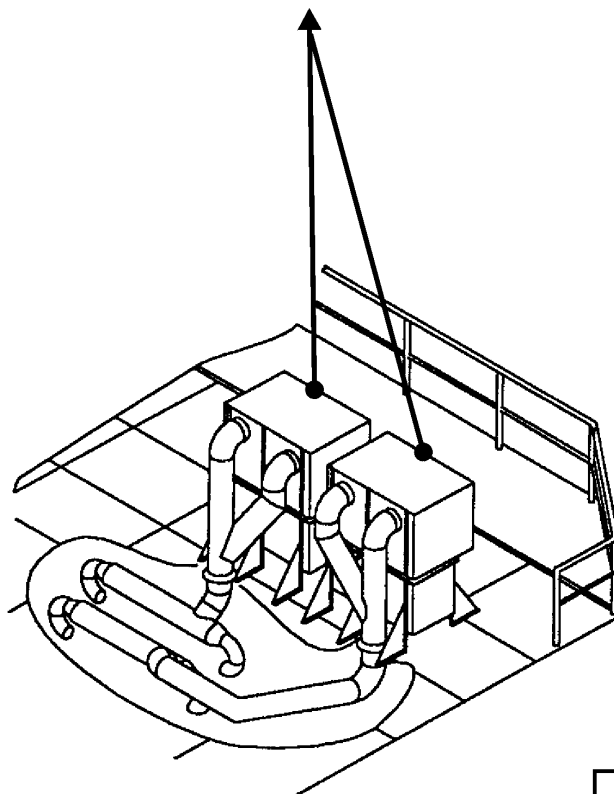
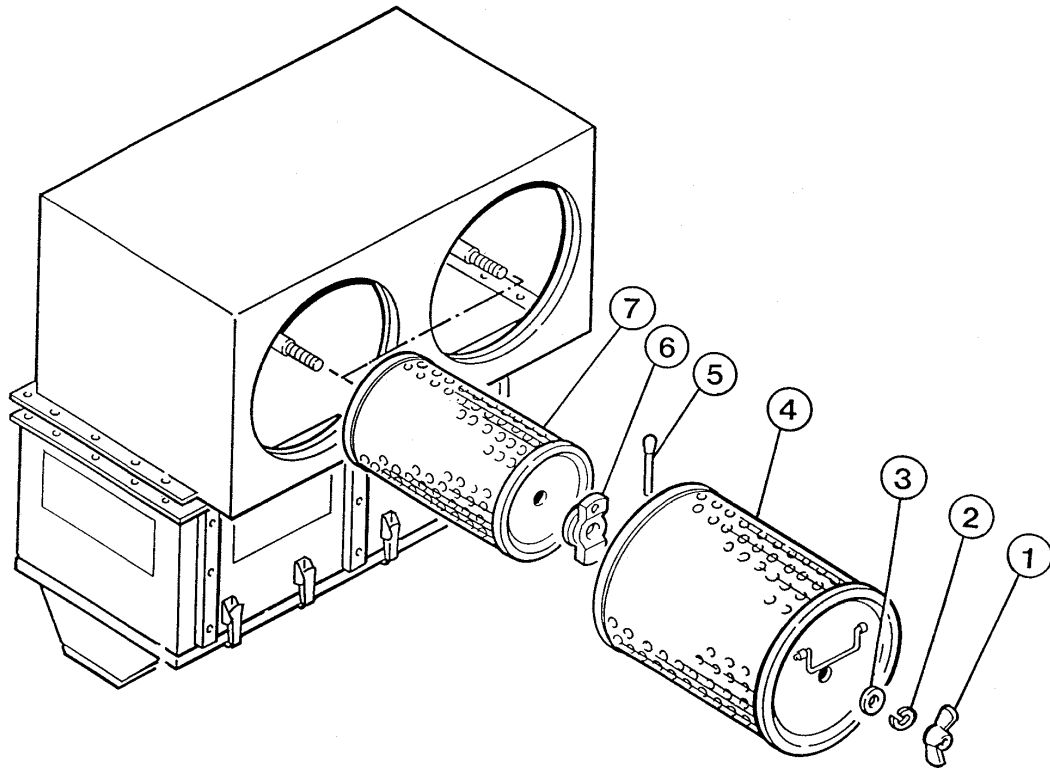

Z 21653



**NOTICE**

**Before installing main elements (4) check service indicator (6) of safety element (7).**

**If a red signal is shown, replace safety element (7).**

**Clean indicator (6) then suck on the outer side of the indicator to reset signal to green indication.**

4. Install main filter elements (4).

**NOTICE**

- **If the fault message "Air cleaner element restricted" is again displayed after installation of a new main filter element the safety-filter element has also to be replaced.**
- **If faulty service or a defect has been detected while servicing the main filter element also the safety filter element has to be replaced.**
- **After having the main filter element cleaned three-times or replaced also the safety filter element has to be replaced.**

**Replacing the safety filter element (7):**

1. Remove element in sequence of ref. no. (1 to 7).
2. Cover air intake opening.
3. Install new safety filter element (7).

---

---

**▲ WARNING**

---

---

**The safety filter element may not be cleaned and re-used**

---

---

4. Remove cover from air intake opening.
5. Install safety and main filter element, take care service indicator (6) is correctly secured by cotter pin (5).

**General Service Tips**

The air cleaners should be inspected periodically to maintain maximum engine protection and maximum service life. These inspections should include the following points.

1. Inspect the air transfer duct between the air cleaner and the engine to be sure all clamps are tight, all flange joints are tight, and there are no cracks in the ducting.
2. Air cleaner mounting bolts and clamps must be tight to hold the air cleaner securely.
3. Check the dust caup to make sure it is sealing 360° around the air cleaner body.
4. Automatic dust unloader valve (if so equipped) must be in place, not inverted or damaged, and free from obstruction.

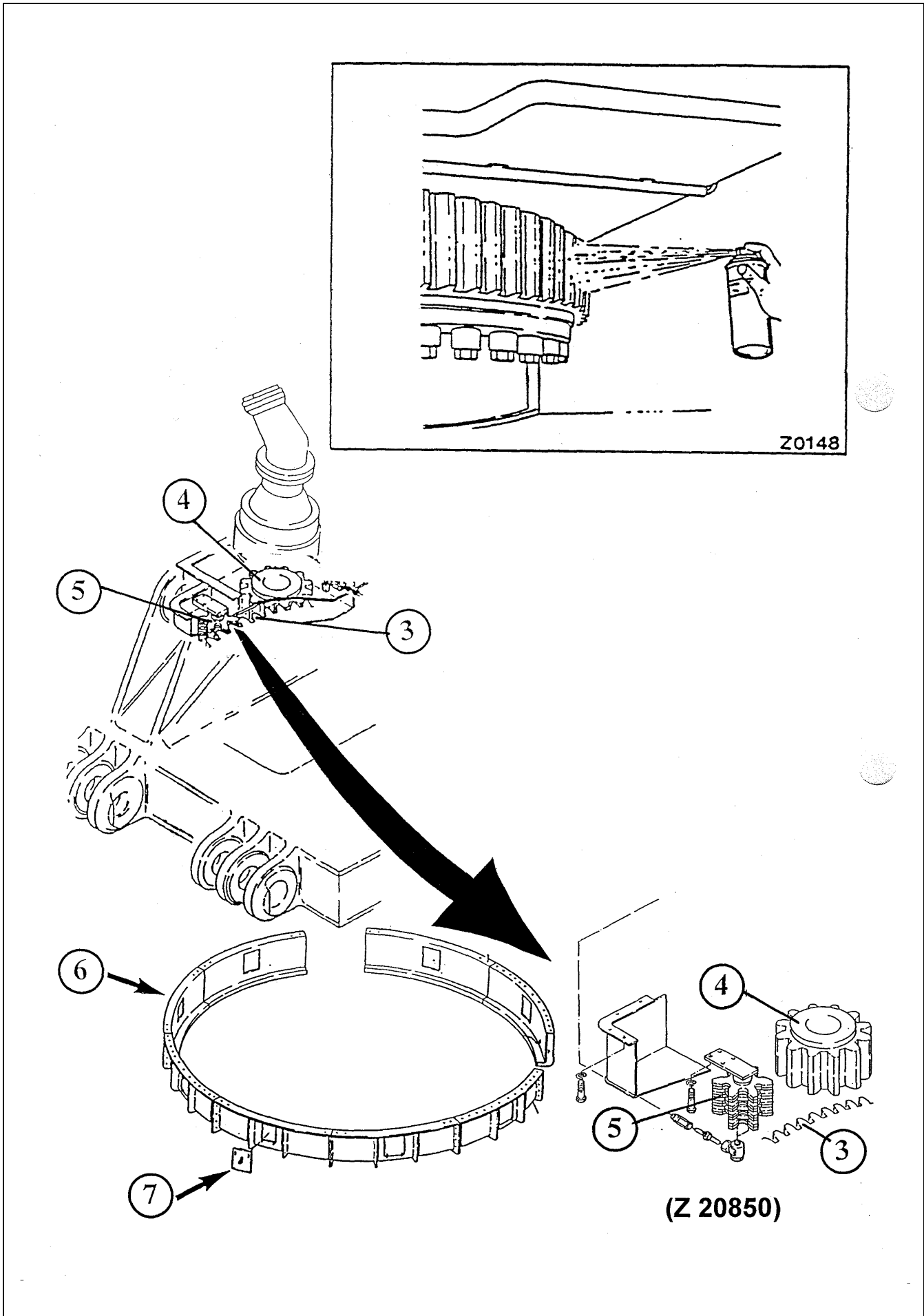

## 4.7.2 SWING CIRCLE TOOTHING LUBRICATION

See illustration Z 20850

All teeth of the gear ring (3) must be completely covered with grease.

### NOTICE

- If the machine is equipped with gear ring guard (6), remove covers (7) for swing circle teeth inspection.
- If the automatic lubrication system of the swing circle tothing fails to function for more than four operating hours, bucket motion cut-off will occur. Repair the lubrication system as soon as possible to prevent damage to the gear ring, drive pinion (4) and lubrication pinion (5). As an interim measure lubricate the tothing with special adhesive spray grease, illust. (Z 0148) or spread type adhesive grease as specified in the Parts Catalog. The spread type grease can be applied, for example, with a brush.
- Make sure that the multi-purpose grease of the swing circle bearing does not come in contact with the teeth of the swing circle because this will diminish lubrication capability of the swing circle teeth lubricant. If necessary remove excessive multi-purpose grease from the swing circle above the dust seal ring.

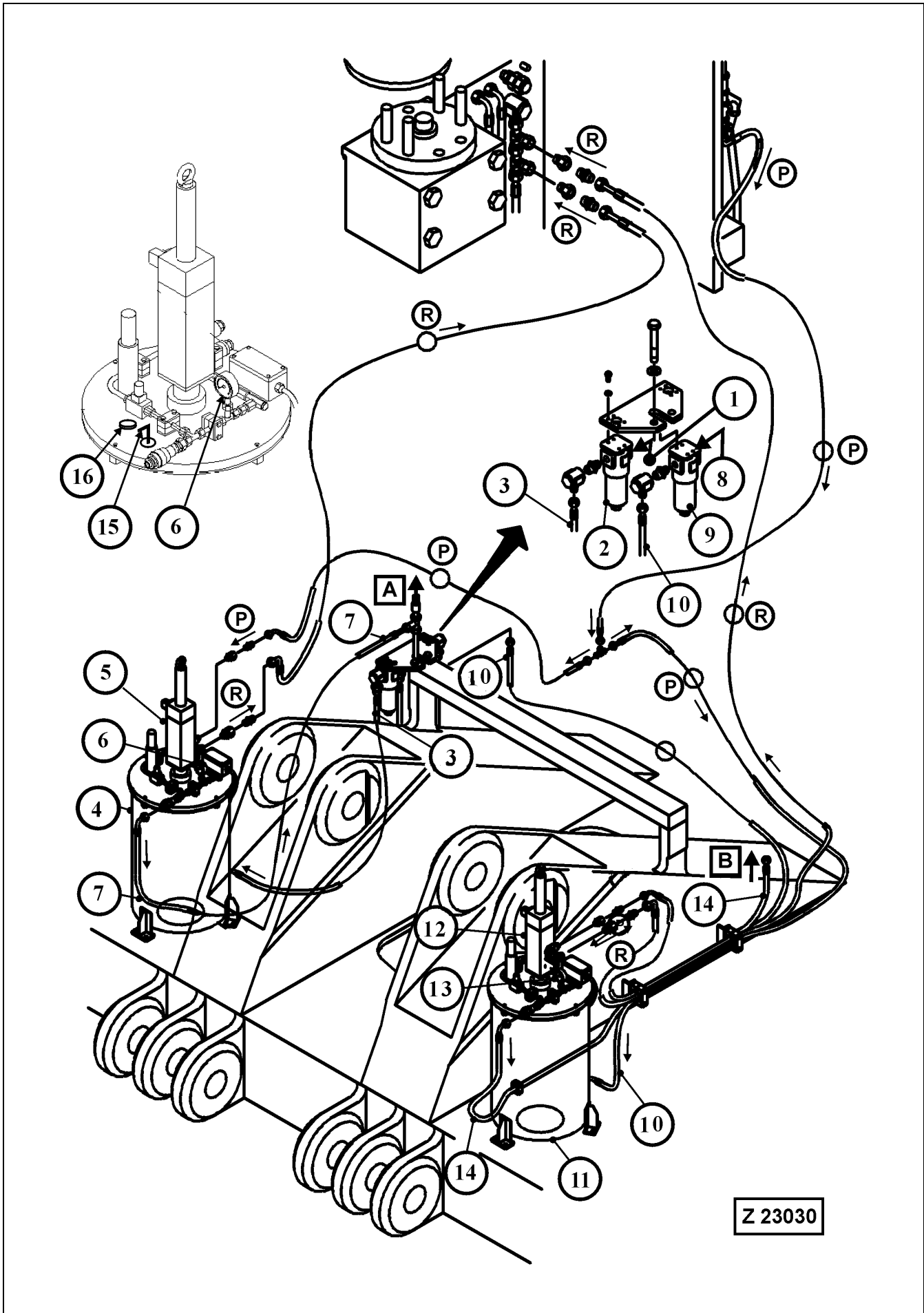

### 4.7.3 AUTOMATIC LUBRICATION SYSTEMS FILL GREASE BARRELS

Fill the grease barrels of the Central Lubrication System and Swing circle pinion Lubrication System when the corresponding message "grease barrel empty" is displayed on the health monitor. Make sure the grease filters in the filling line are not obstructed. If necessary service the Grease Filters.

#### Legend for illustration Z 23030

- (A) Grease supply line to the injectors for lubrication of the loader attachment, swing circle bearing and swing machinery pinion bearing
- (B) Grease supply line to the injectors for lubrication of the swing circle tooth-  
ing
- (P) Pressure oil supply from pilot oil circuit to hydraulically driven grease  
pumps (5 and 12)
- (R) Return oil to main hydraulic oil reservoir
- (1) Grease refilling line from service arm adapter to grease filter (2) of the cen-  
tral lubrication system
- (2) Grease filter for central lubrication system.
- (3) Grease refilling line from grease filter (2) to grease container (4) of the cen-  
tral lubrication system
- (4) Grease container of the central lubrication system
- (5) Hydraulically driven grease pump
- (6) Grease pressure gauge
- (7) Grease supply line to the injectors of the central lubrication system, see  
(A).
- (8) Grease refilling line from service arm adapter to grease filter (9) of the  
swing circle pinion lubrication system
- (9) Grease filter for swing circle pinion lubrication system.
- (10) Grease refilling line from grease filter (9) to grease container (11) of the  
swing circle pinion lubrication system
- (11) Grease container of the swing circle pinion lubrication system
- (12) Hydraulically driven grease pump
- (13) Grease pressure gauge
- (14) Grease supply line to the injectors of the swing circle pinion lubrication  
system, see (B).
- (15) Grease level gauge. Check grease level in both containers at regular inter-  
vals.
- (16) Breather filter

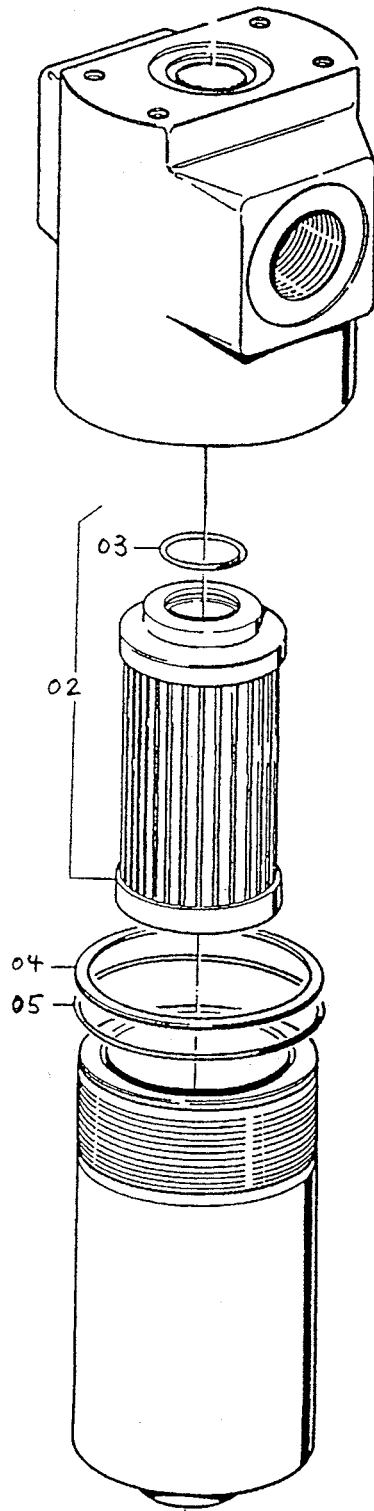

(Z 20718)

r

**Service the Grease Filters for Refillable Grease Containers of the Central Lubrication System and Swing circle pinion Lubrication System, illust. Z 20718**

1. Screw off filter case.
2. Remove element assy. (02) and clean. Take care not to contaminate the "Clean" inside of the element when flushing.

**NOTICE**

**Carefully inspect elements for damage. Always install new elements if ruptures or other damages are found.**

3. Inspect O-rings (03 and 05) and back-up ring (04). Replace if necessary.
4. Fill filter case half way up with the specified grease.
5. Installation sequence vice versa. Take care for proper position of filter element (02).

**NOTICE**

**Replace element (02) after three cleanings or after every 5000 operating hours, whichever occurs first.**

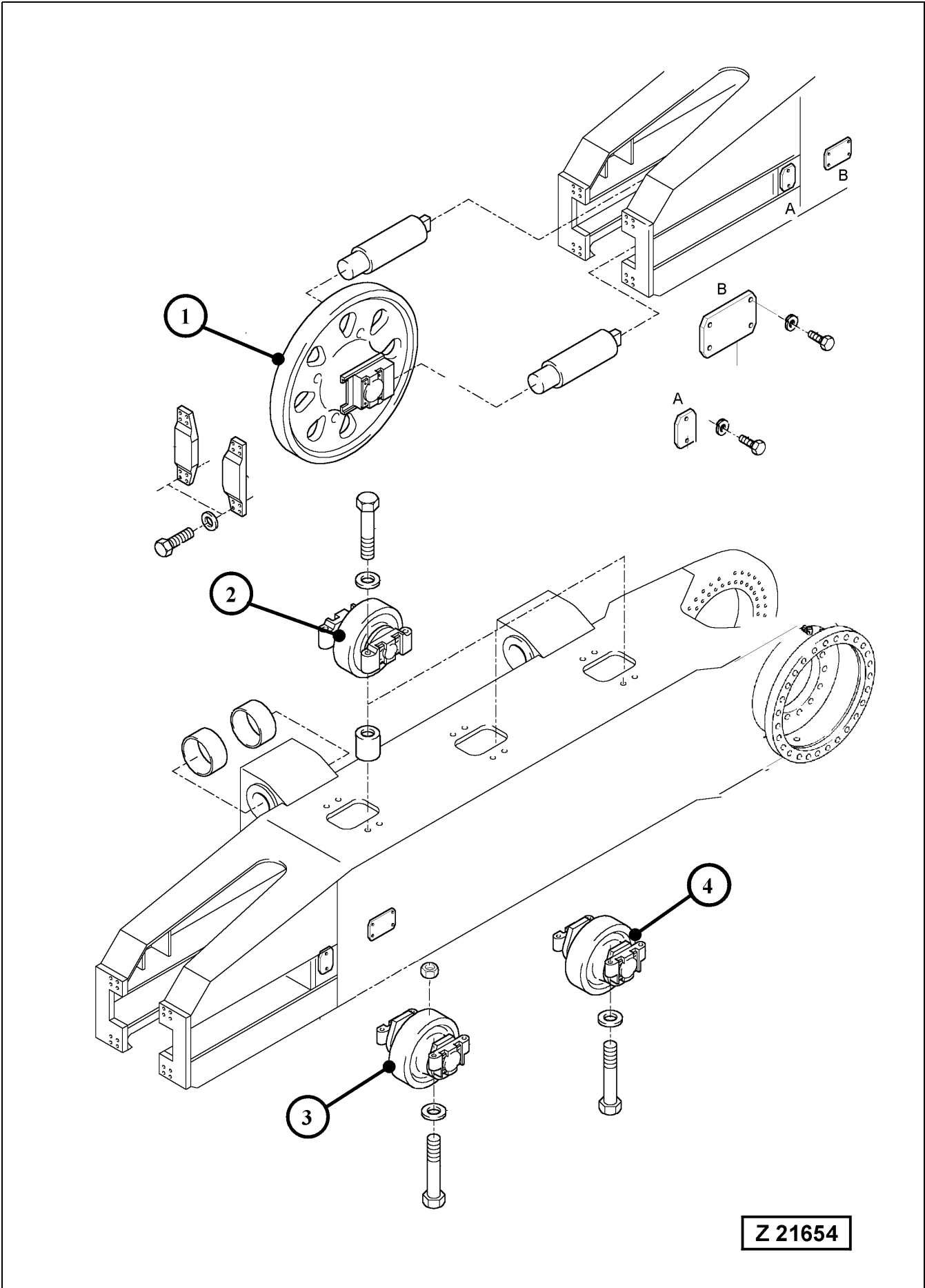

Z 21654



## 4.7.4 TRACK ROLLERS AND GUIDE WHEELS - REPLACE FLOATING SEALS

### Legend for illustration Z 21654

- (1) Guide wheel, if leakage occurs. replace floating seal. Refer to repair manual for replacement procedure.
- (2) Carrier roller, if leakage occurs. replace floating seal. Refer to repair manual for replacement procedure.
- (3) Front track roller mounted to side frame with bolts and self-locking nuts, if leakage occurs. replace floating seal. Refer to repair manual for replacement procedure.
- (4) Track rollers mounted to side frame with bolts only, if leakage occurs. replace floating seal. Refer to repair manual for replacement procedure.m

# 4.8 EVERY 10 OPERATING HOURS OR DAILY

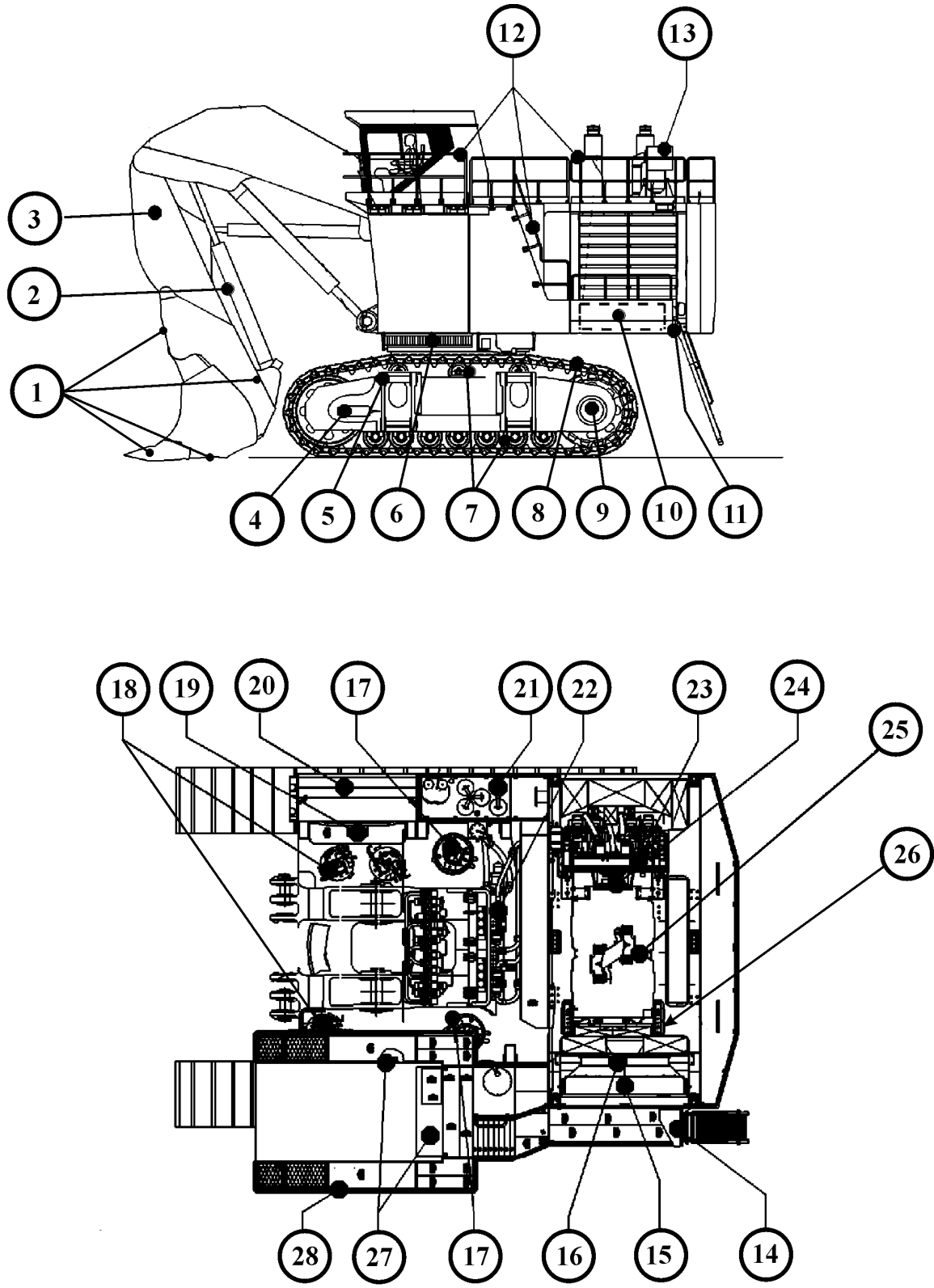

Z 25475

## 4.8.1 WALK-AROUND INSPECTION

### Legend for illustration Z25475

- (1) Check condition of the loader bucket. Both loader bucket versions, bottom dump bucket and backhoe bucket are equipped with wear protection packages as specified in the contract. These wear packages protect the base body of the bucket from premature wear and tear. Therefore it is important to check the condition of the wear protection elements regularly. Worn or damaged protection elements should be replaced at an early stage in order to prevent damage to the base body of the bucket. In case the bucket base is already weakened, reconditioning measures will be necessary. Contact your Komatsu dealer for support.
- (2) Hydraulic cylinders. Check cylinders, hydraulic lines and connections for leakage and damage.
- (3) Working attachment. Check overall condition. Inspect for loose or missing securing parts.
- (4) Check guide wheels for leakage.
- (5) Check connecting pins, center frame - crawler carrier for proper mounting. Inspect for loose or missing securing parts.
- (6) Check swing circle tothing for adequate lubrication.
- (7) Check track rollers and carrier rollers for leakage.

### NOTICE

**If leakage is found on guide wheels or rollers inspect the floating seals of the respective unit, replace if necessary. Fill the unit with the correct gear lubricant.**

- (8) Check track pad connection pins for wear and security.
- (9) Check final drives for leakage.
- (10) Check oil level in engine oil reserve tank of the automatic engine oil supply system "RESERVE"
- (11) Check condition, fastening and security of access ladder.
- (12) Check condition, fastening and security of all walk-ways, steps, railings and hand rails.
- (13) Check condition and fastening of engine air cleaner.
- (14) Check operation of hydraulic access ladder.
- (15) Check radiator coolant level. Check cooling system for leakage, damaged hoses and connections.
- (16) Check housing of radiator fan bearing for leakage. Check fan guards and coverings for correct installation, good condition and security.
- (17) Check swing machinery for leakage.

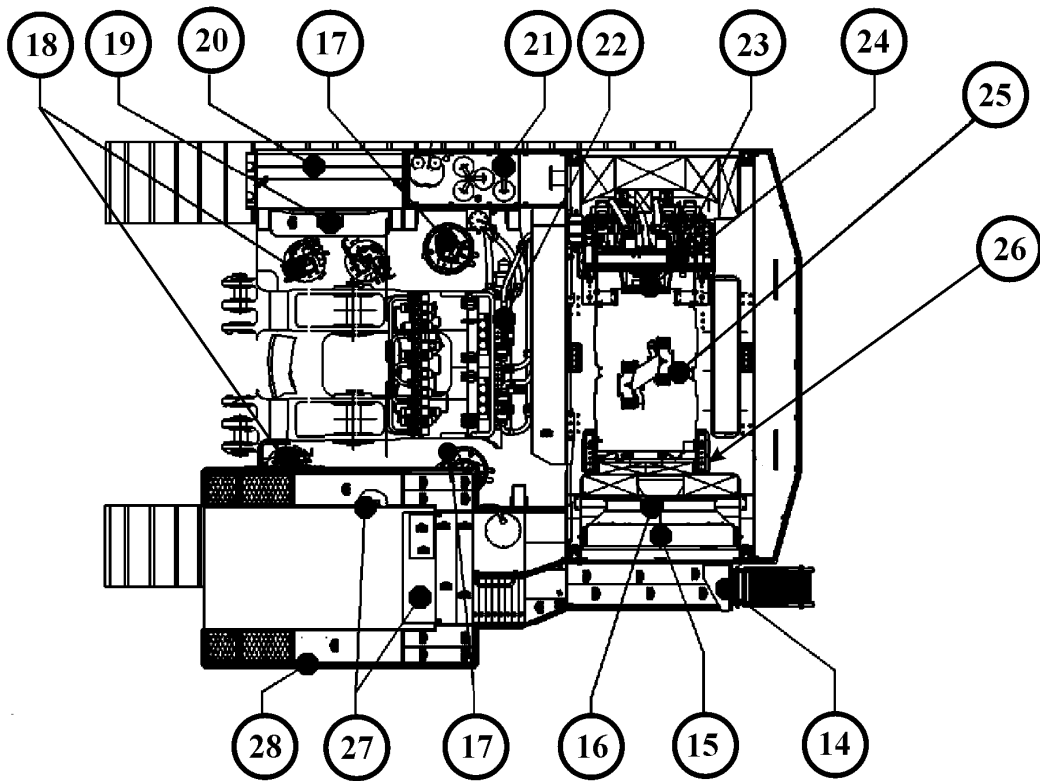
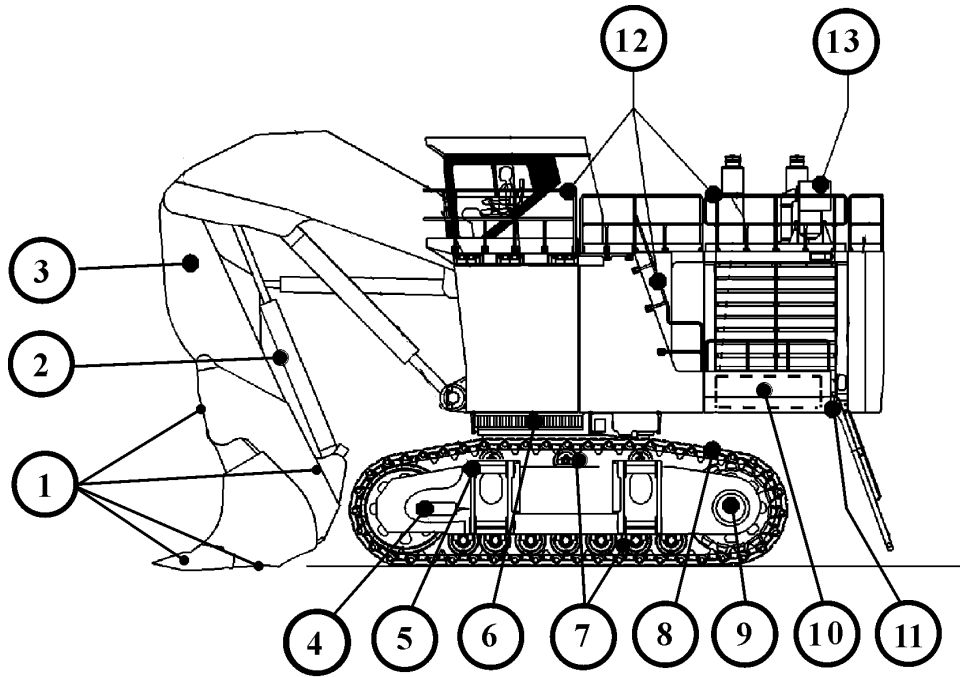

Z 25475

**Legend for illustration Z25475**

- (18) Check automatic lubrication systems for leakage, damaged hoses and connections.
- (19) Check housing of oil cooler fan bearing for leakage. Check fan guards and coverings for correct installation, good condition and security.
- (20) Check hydraulic oil cooler for plugged cores.
- (21) Check hydraulic oil level. Check hydraulic oil reservoir for leakage, damaged hoses and connections.
- (22) Check condition and fastening of control valves.
- (23) Check PTO and hydraulic pumps for leakage, damaged hoses and connections.
- (24) Check flexible coupling between engine and PTO for leakage.
- (25) Check engine for good condition and security. Check for oil and fuel leakages.
- (26) Engine mounts, check for good condition and correct fastening.
- (27) Operator's cab air conditioning and air filter, check hoses for leakages and loose connections.
- (28) Emergency escape ladder, check condition and fastening.

---

---

**⚠ CAUTION**

---

---

**If any damages, failures or wrong condition, have been found during the inspection, corrective action must be taken.**

---

---

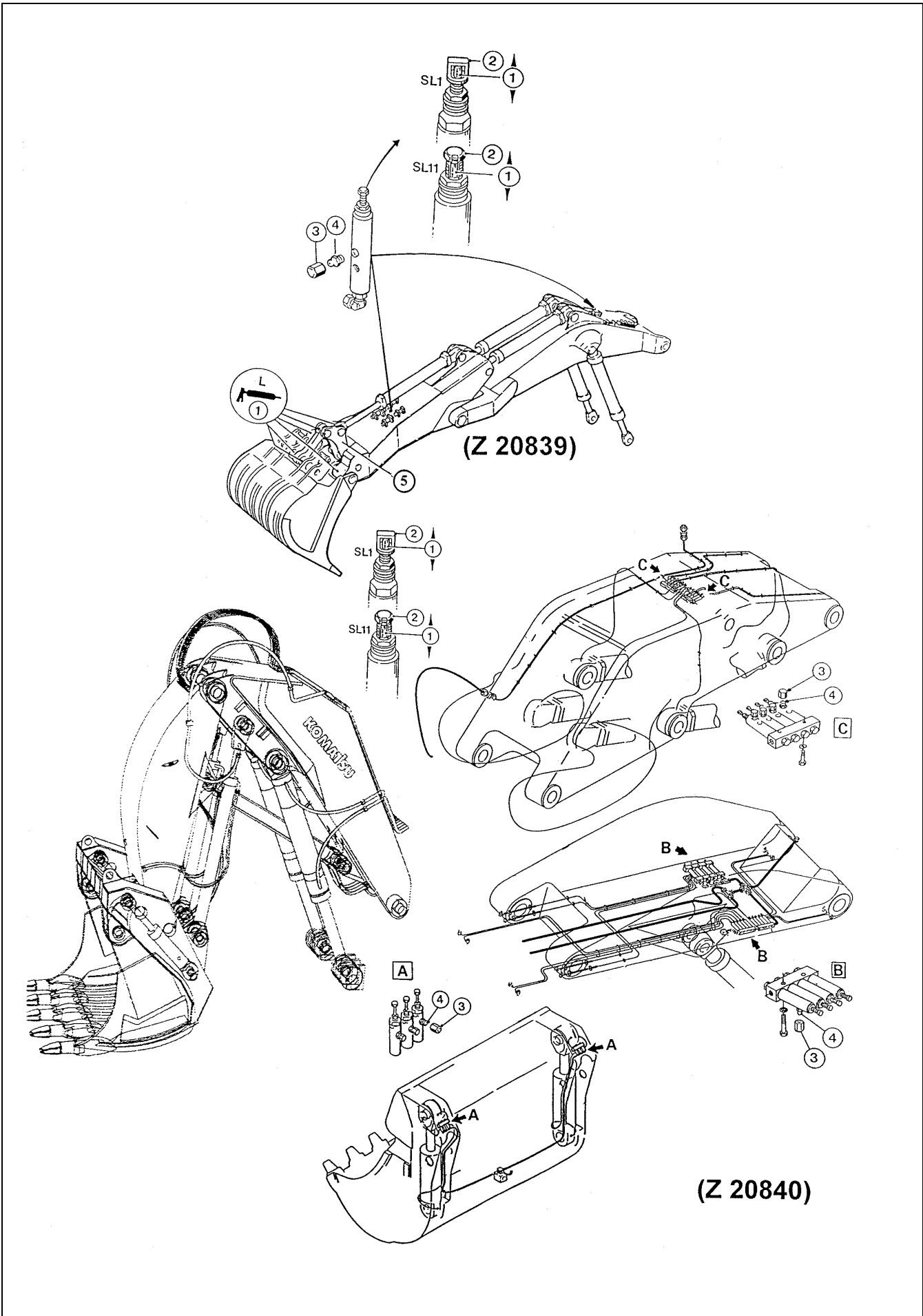

## CHECK GREASE INJECTORS FOR PROPER OPERATION

### NOTICE

There are two types of grease injectors installed “SL1” and “SL11” injectors, see illust. (Z 20840).

### Legend for illustration Z 20840

- A Injectors on bottom dump bucket
- B Injectors on stick
- C Injectors on boom
- (1) Indicator stem for visual indication of injector operation
- (2) Output adjusting screw
- (3) Protection cap
- (4) Grease fitting
- (5) Grease fittings on backhoe bucket linkage

### REMARK

Backhoe bucket linkage must be lubricated manually, if not connected to the central lubrication system.

Check operation of all grease injectors (A, B and C) by visually watching the cycle indicator stem (1) while operating the central lubrication system manually. Stem (1) must move in and out once a complete lubrication cycle.

If a cycle indicator (1) does not move during a lubrication cycle, grease supply to the lubrication point of the concerned injector is interrupted.

Refer to next page for corrective action.

Carry out same checks on the injectors for swing circle, see next page.

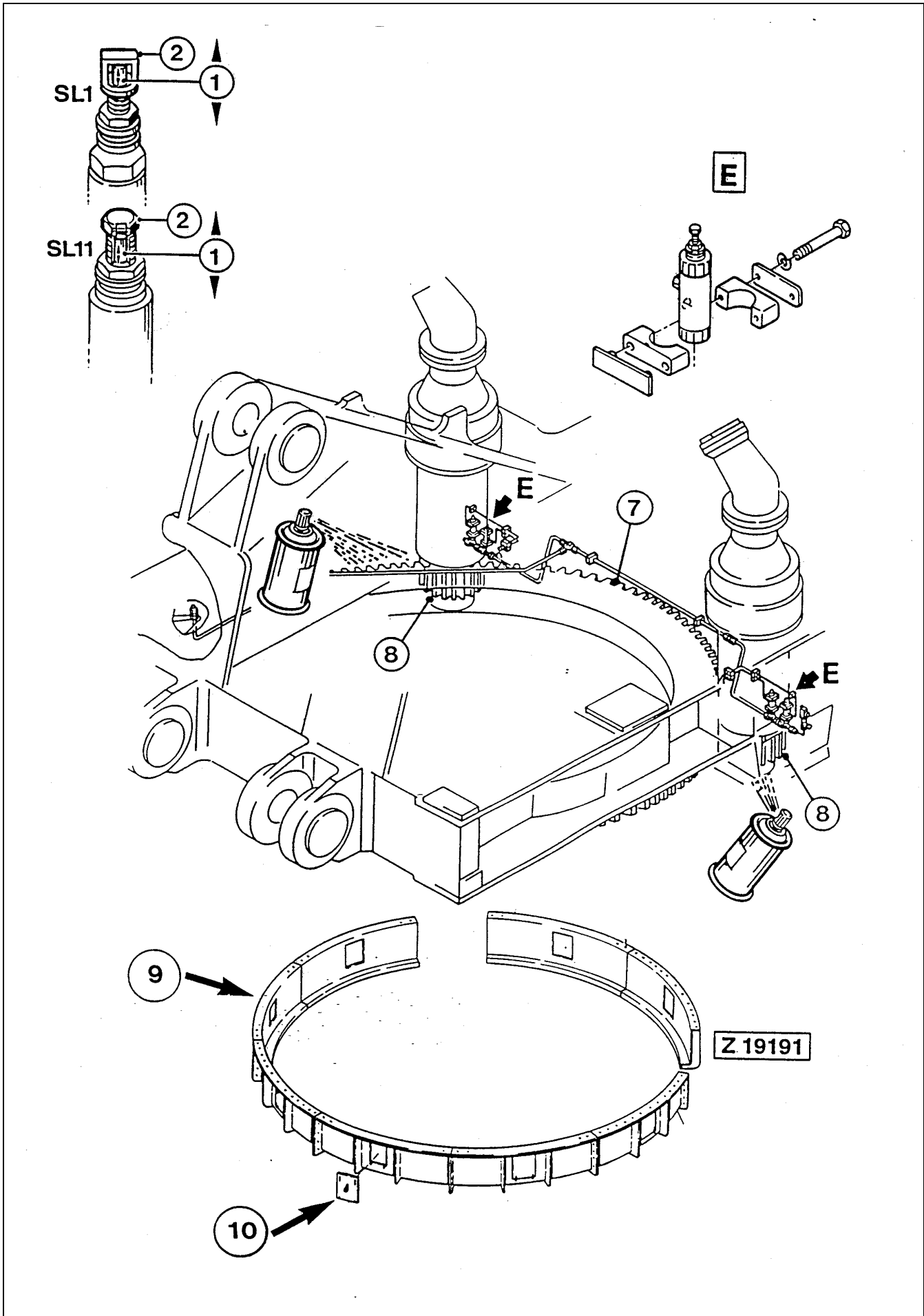



## CHECK GREASE INJECTORS

### Legend for illustration Z 19191

- E Injectors for swing circle teeth lubrication
- (1) Indicator stem for visual indication of injector operation
- (2) Output adjusting screw
- (7) Swing circle
- (8) Swing machinery drive pinion
- (9) Swing circle guard
- (10) Inspection cover for swing circle teeth

Check operation of injectors "E" .  
If necessary lubricate manually, using spray grease.

## CORRECTIVE ACTIONS

1. Check to make sure grease supply through inlet line is provided.
2. Disconnect the outlet line of the respective injector.
3. Operate the central lubrication system manually.
  - A -  
If now the injector works, i.e. cycle indicator stem (1) moves in and out the disconnected line or the grease passage at the lubrication point is damaged or blocked by foreign matter. Repair as necessary.
  - B -  
If the injector does not work, i.e. cycle indicator stem (1) stationary, replace the respective injector.
4. Operate the central lubrication system and re-check operation of the grease injectors.

### NOTICE

**If the failure is caused through a defective central lubrication system, manually lubricate at grease fittings (4) after removal of caps (3).**

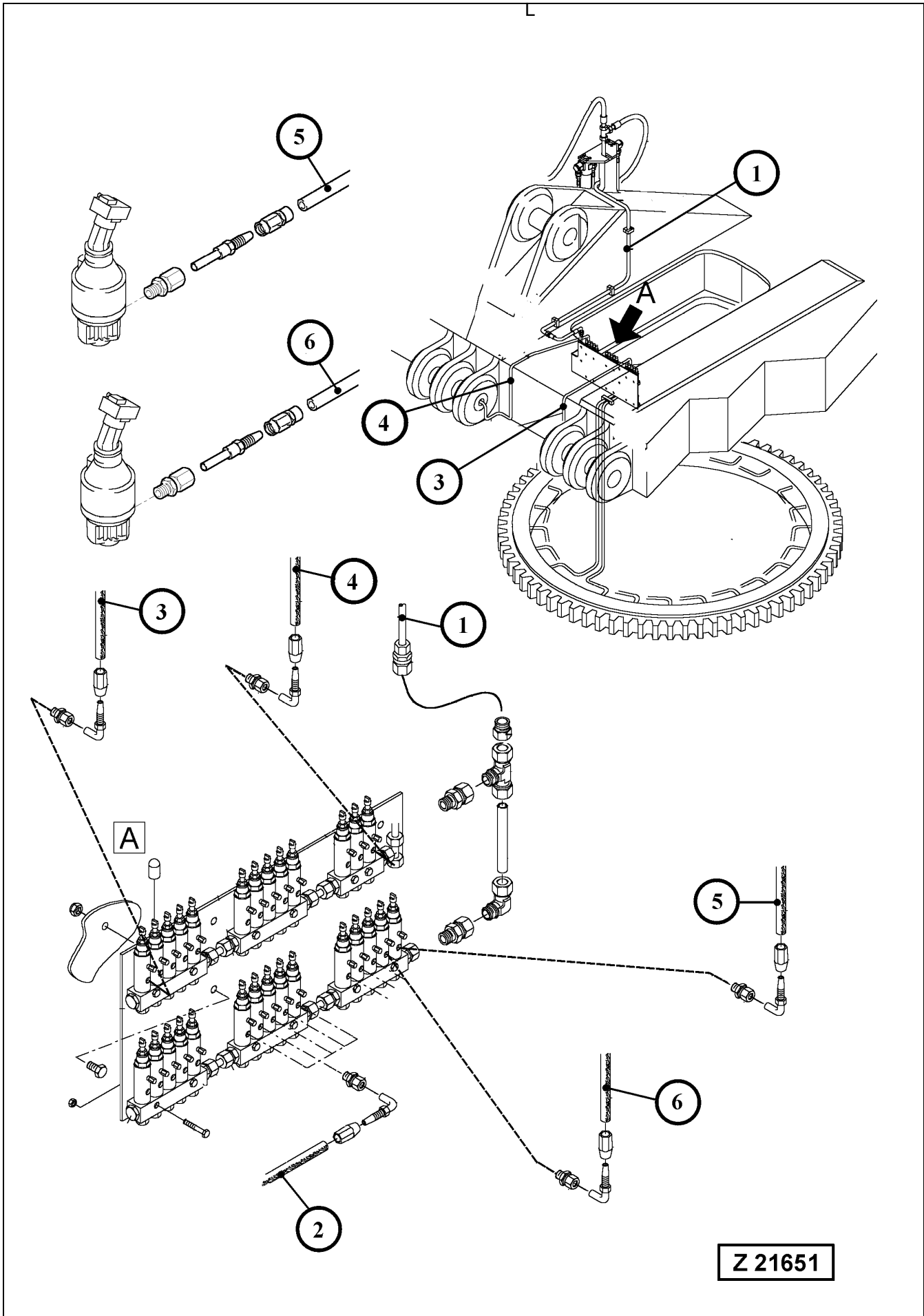

## CHECK GREASE INJECTORS

### Legend for illustration Z 21651

- A        Injectors for lubrication of swing circle bearing, boom cylinder foot bearings and swing machinery pinion bearings
- (1)       Grease supply line to injectors (A)
- (2)       Grease supply lines to swing circle bearing lube connectors
- (3)       Grease supply line to LH boom cylinder foot bearing
- (4)       Grease supply line to RH boom cylinder foot bearing
- (5)       Grease supply line to RH swing machinery pinion bearing
- (6)       Grease supply line to LH swing machinery pinion bearing

Check operation of injectors "A" as described on previous page.

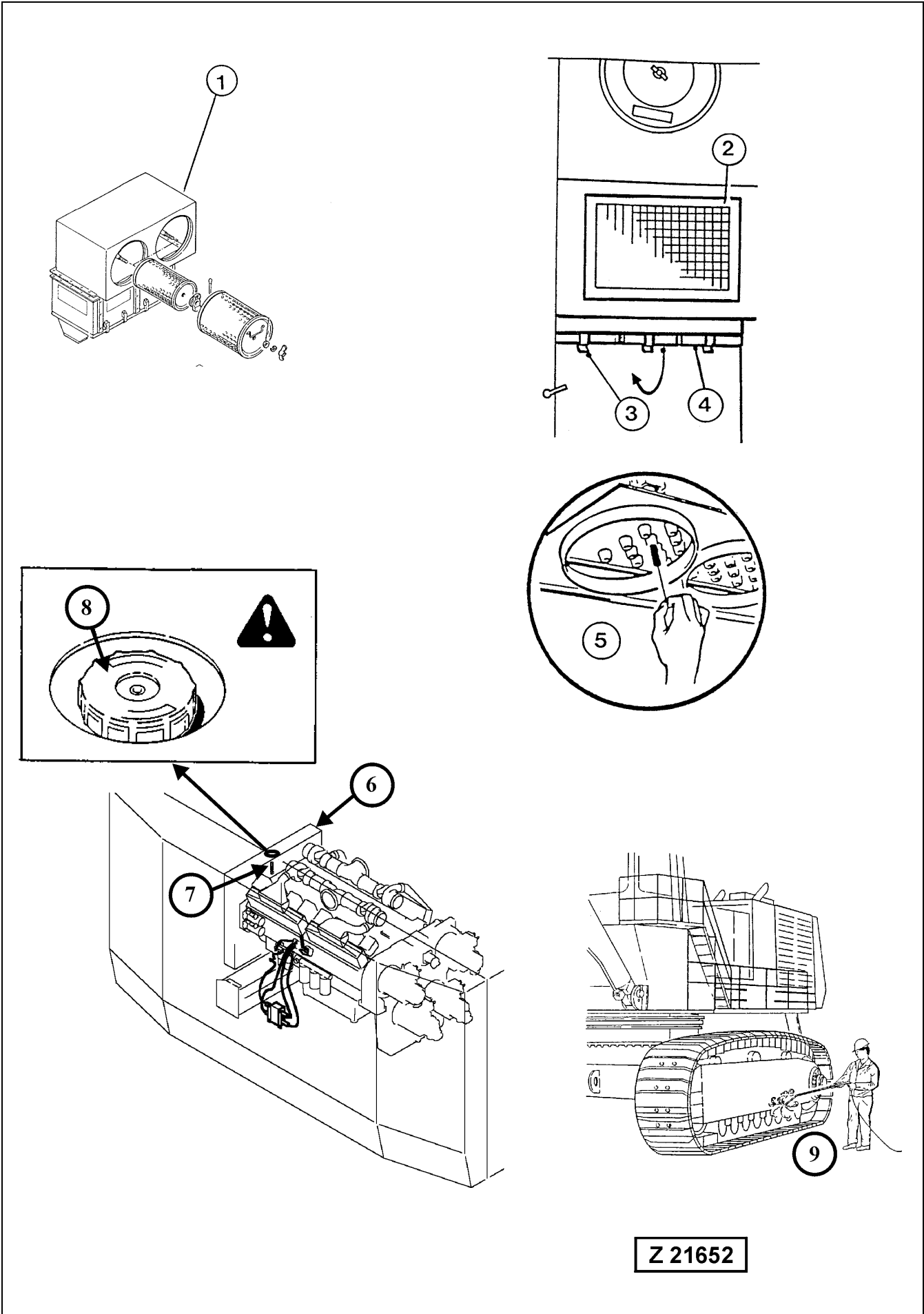

## 4.8.2 AIR CLEANER - CLEAN PRE-CLEANER

### Clean dust cups of pre-cleaners

#### Legend for illust. Z 21652:

- (1) Roof mounted air cleaner units
- (2) Air intake screen
- (3) Clamps
- (4) Dust cups
- (5) Jet tubes

1. Provide suitable container for collecting the dust before opening the dust cups (4).
2. Loosen the clamps and swing down dust cups (4).
3. Remove dust from pre-cleaner dust cups.
4. Check condition of the dust cup gaskets and replace if necessary.
5. Swing back dust cups (4) to closed position and secure with the clamps provided.
6. Check air cleaner mounting parts for tight fit and security.

#### **NOTICE**

**When operating the machine under very dusty conditions, check pre-cleaner jet tubes (5) for plugging. Dust plugging of tubes can be removed with a stiff fiber brush.**

**Never clean tubes with compressed air unless both the primary and safety elements are installed in the air cleaner. Do not steam-clean tubes.**

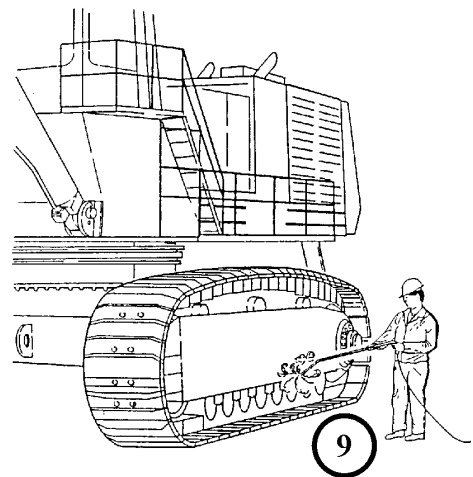
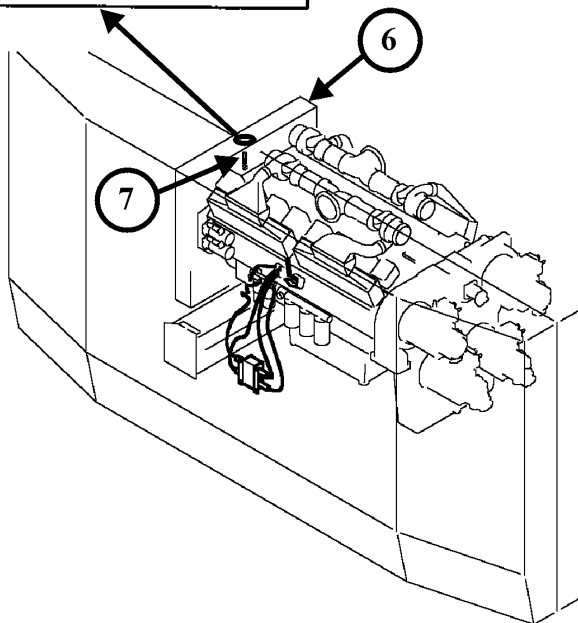
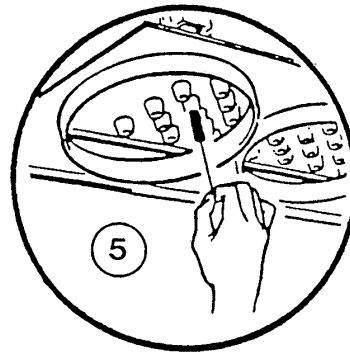
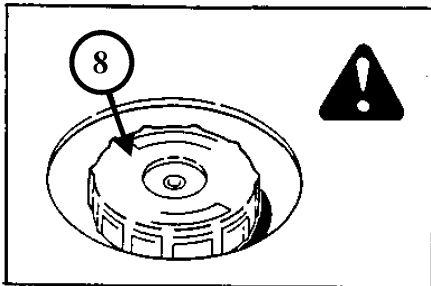
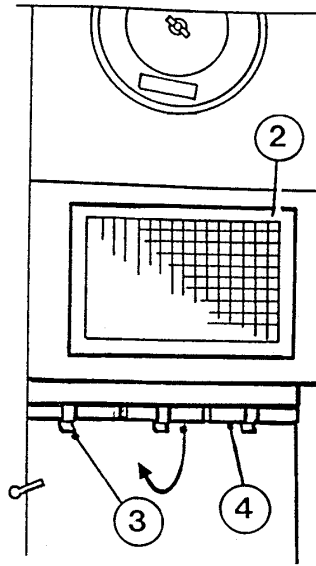
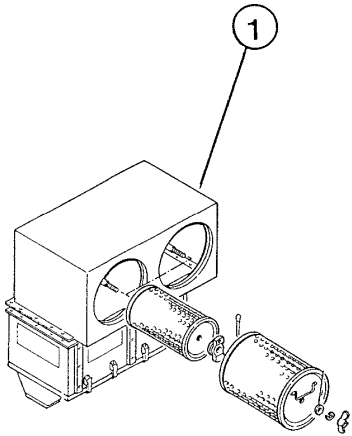

Z 21652

### 4.8.3 RADIATOR - CHECK COOLANT LEVEL

#### Legend for illustration Z 21652

- (6) Radiator
- (7) Coolant level sight gauge
- (8) Radiator pressure cap

---

---

**▲ WARNING**

---

---

**DO NOT** remove the radiator pressure cap (8) from a hot engine. Wait until the temperature is below 50°C before removing the pressure cap (8). Failure to do so can result in personal injury from heated coolant spray or steam. Turn the radiator cap (8) slowly counterclockwise to the safety stop to allow the pressure to escape, then continue to turn until cap is free to be removed.

---

---

The coolant level should be in the upper field of the sight gauge (7). If necessary add coolant.

#### **REMARK**

Refer to the Engine Operation and Maintenance Manual for the correct coolant composition.

### 4.8.4 TRACK GROUPS - CLEAN

See (9), illustration Z 21652

Clean track groups especially during the cold season.

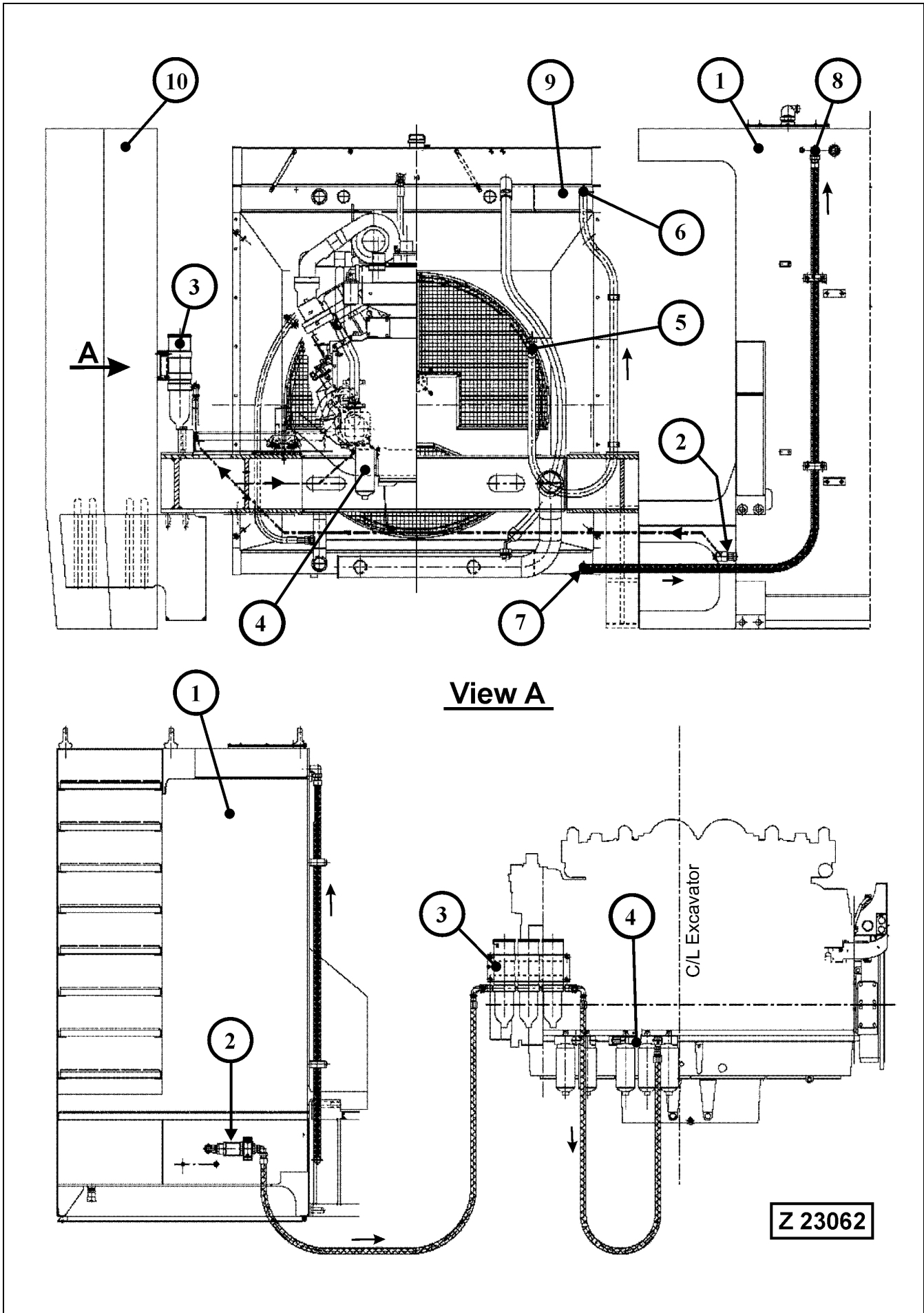

**View A**

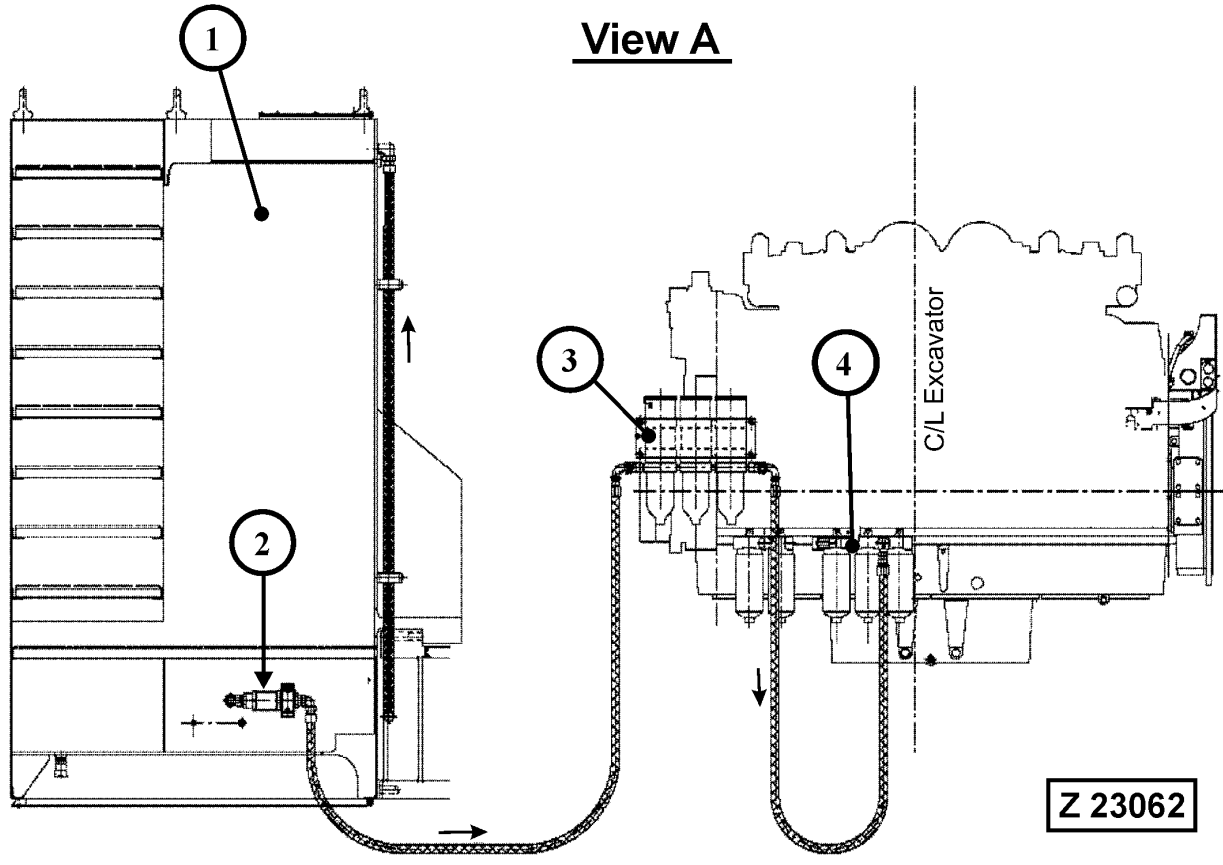

Z 23062



## 4.8.5 FUEL SYSTEM WATER SEPARATOR - DRAIN WATER

Legend for illustration Z 23062

- (1) Fuel tank
- (2) Fuel shut-off solenoid valve. This solenoid valve cuts-off fuel supply to the engine when the stop switch on the instrument panel is actuated.
- (3) Water separator filter
- (4) Engine fuel filters
- (5) Return fuel from engine
- (6) Fuel inlet to fuel cooler segment of the radiator
- (7) Fuel outlet from fuel cooler segment of the radiator
- (8) Return fuel to tank
- (9) Fuel cooler segment of the radiator
- (10) Counterweight

### Draining Water

Frequency of water draining is determined by the contamination of the fuel. Inspect or drain the collection bowl of water daily or as necessary. The collection bowl must be drained before contaminants reach the top of the turbine.

Refer to separate Instruction booklet -Fuel Filter/Water Separator- filed in volume 2 binder for draining procedure.

### Filter Element Replacement

Frequency of element replacement is determined by the contamination of the fuel. Replace the elements after every 500 operating hours, if power loss is noticed or annually, which ever comes first. Refer to separate Instruction booklet -Fuel Filter/Water Separator- filed in volume 2 binder for replacement procedure.

# 4.9 EVERY 50 OPERATING HOURS OR WEEKLY

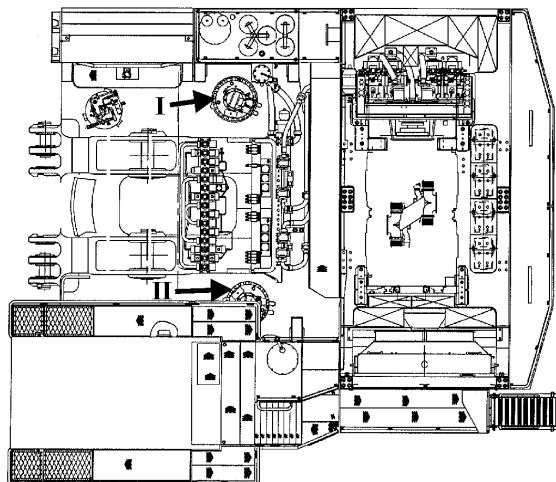
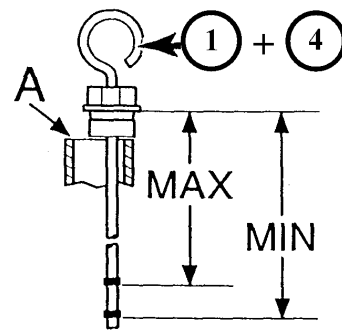
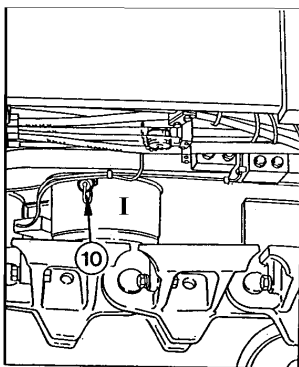
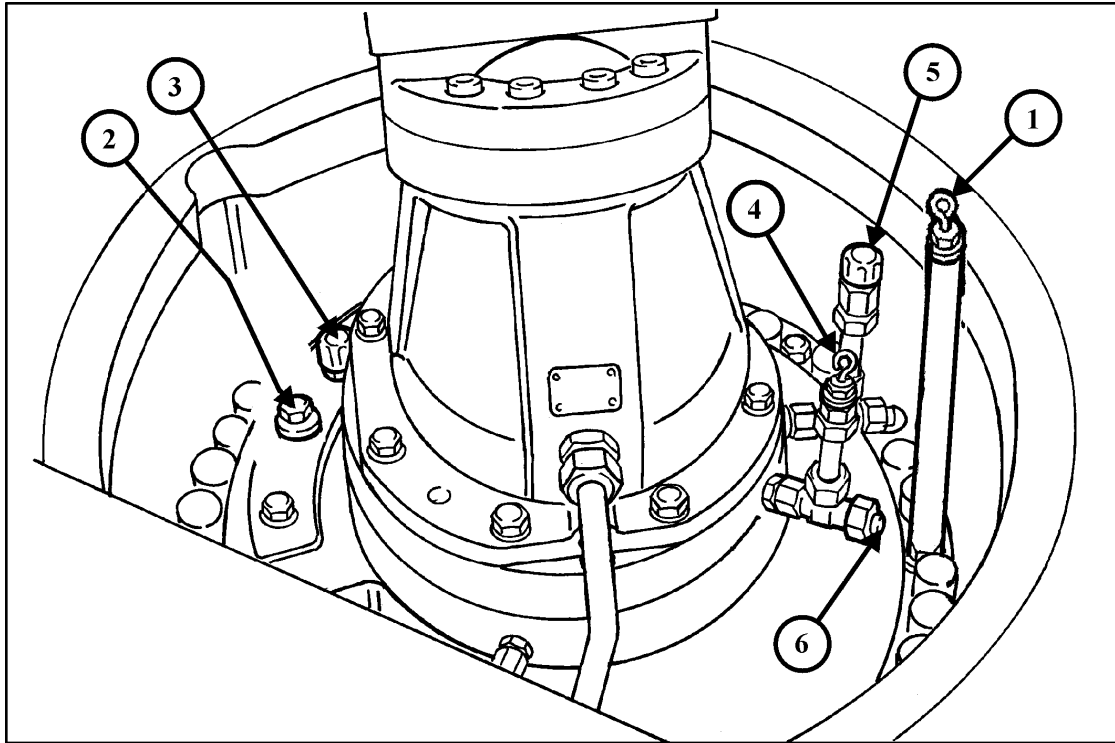

Z 22895

## 4.9.1 SWING MACHINERY AND MOTOR ADAPTER HOUSINGS - CHECK OIL LEVELS

### REMARK

The machine can be equipped either with a swing machinery of manufacturer "L&S" or of manufacturer "Siebenhaar". Refer to the data plate on each swing machinery housing to find out the manufacturer of the swing machinery.

### Swing Machinery manufactured by "L&S"

I Swing machinery RH

II Swing machinery LH

### Legend for illustration Z22895

Swing machinery

- (A) Position of oil level gauge for checking the oil levels
- (1) Oil level gauge
- (2) Oil filler plug
- (3) Breather filter
- (10) Drain coupling or evacuation nozzles for Wiggins system

Motor Adapter Housing

- (4) Oil level gauge and filler opening. This opening can also be used for connecting a suction pump when changing the oil.
- (5) Breather filter
- (6) Oil drain plug

### CHECK SWING MACHINERY OIL LEVEL

Remove oil level gauge (1), illustration Z22895 and wipe it clean. Insert the gauge but DO NOT screw in, see detail "A". Remove the gauge. The oil level should be at the upper mark of gauge (1). If necessary add the specified gear oil through filler opening (2). Remove breather filter (3). Blow out with compressed air from inside to outside and reinstall.

### CHECK MOTOR ADAPTER HOUSING OIL LEVEL

Remove oil level gauge (4) and wipe it clean. Insert the gauge but DO NOT screw in, see detail "A". Remove the gauge. The oil level should be at the upper mark of gauge (4). If necessary add the specified oil through filler opening (4). Remove breather filter (5). Blow out with compressed air from inside to outside and reinstall.

C

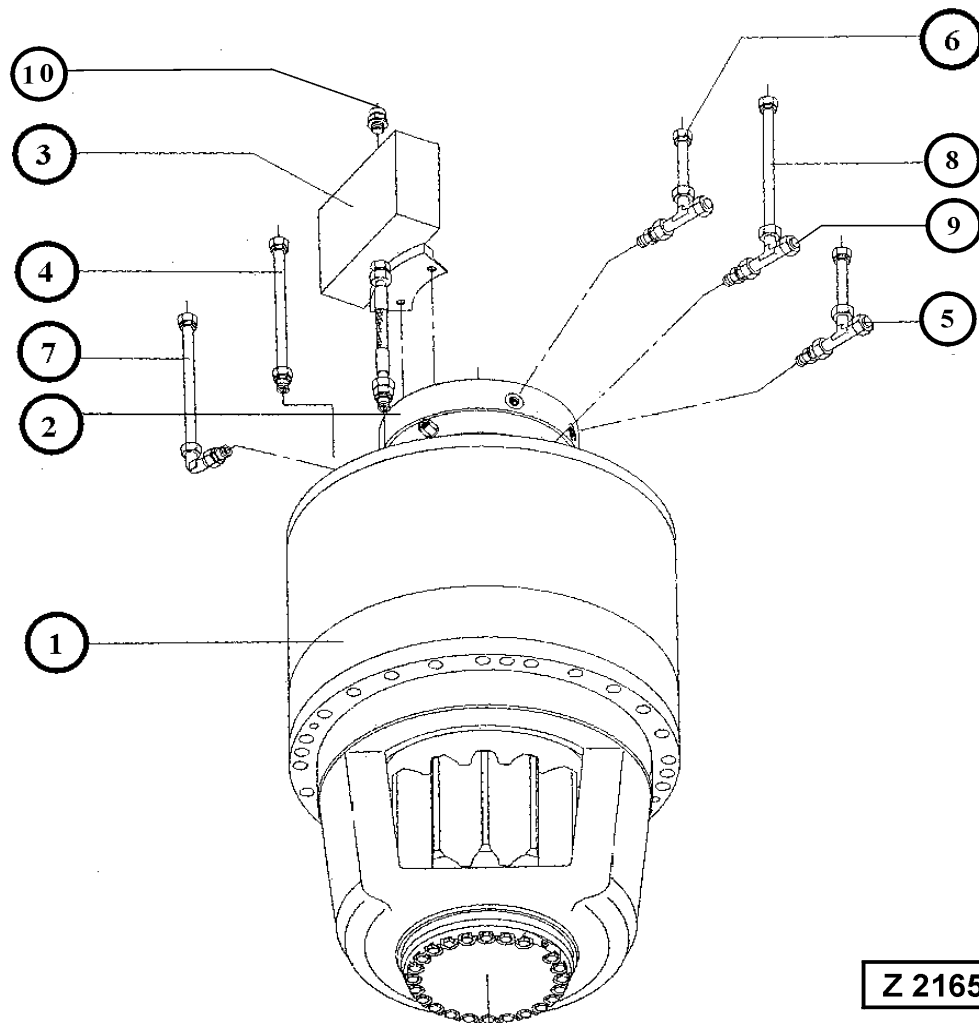
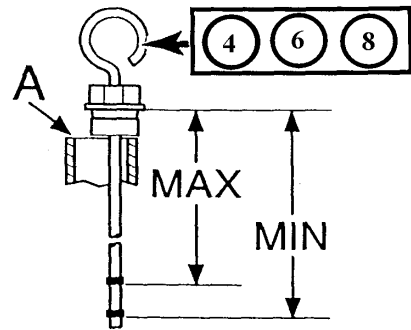
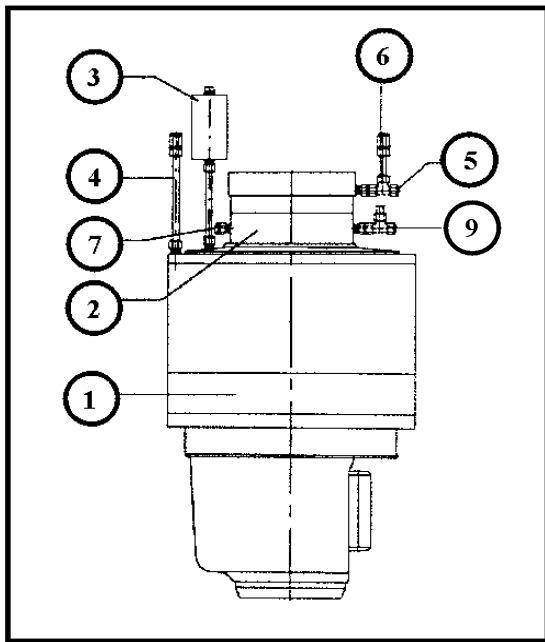

Z 21656

**Swing Machinery manufactured by "Siebenhaar"****Legend for illustration Z 21656**

- (A) Position of oil level gauge for checking the oil levels
- (1) Swing machinery
- (2) Brake housing
- (3) Compensator oil tank for swing machinery
- (4) Oil level gauge for swing machinery
- (5) Oil drain plug for motor adapter housing
- (6) Oil level gauge for motor adapter housing
- (7) Breather filter for brake housing
- (8) Oil level gauge for brake housing
- (9) Oil drain plug for brake housing
- (10) Breather filter

**CHECK SWING MACHINERY OIL LEVEL**

Remove oil level gauge (4) and wipe it clean. Insert the gauge but DO NOT screw in, see detail "A". Remove the gauge. The oil level should be at the upper mark of gauge (4). If necessary add the specified gear oil through filler pipe. Remove breather filter (10). Blow out with compressed air from inside to outside and reinstall.

**CHECK BRAKE HOUSING OIL LEVEL**

Remove oil level gauge (8) and wipe it clean. Insert the gauge but DO NOT screw in, see detail "A". Remove the gauge. The oil level should be at the upper mark of gauge (8).  
If necessary add the specified oil through filler opening.  
Remove breather filter from pipe (7). Blow out with compressed air from inside to outside and reinstall.

**CHECK MOTOR ADAPTER HOUSING OIL LEVEL**

Remove oil level gauge (6) and wipe it clean. Insert the gauge but DO NOT screw in, see detail "A". Remove the gauge. The oil level should be at the upper mark of gauge (6). If necessary add the specified oil through filler opening.

**NOTICE**

**Swing machinery, Brake- and Motor adapter housings have to be filled with different types of oil. Refer to page 239 for the correct oil specifications.**

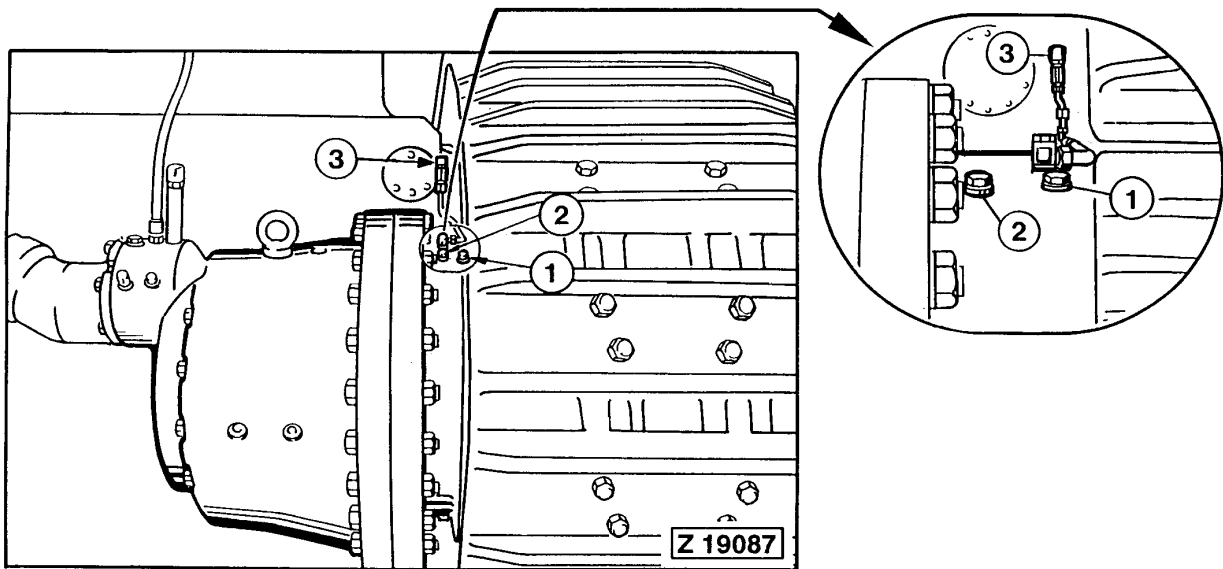
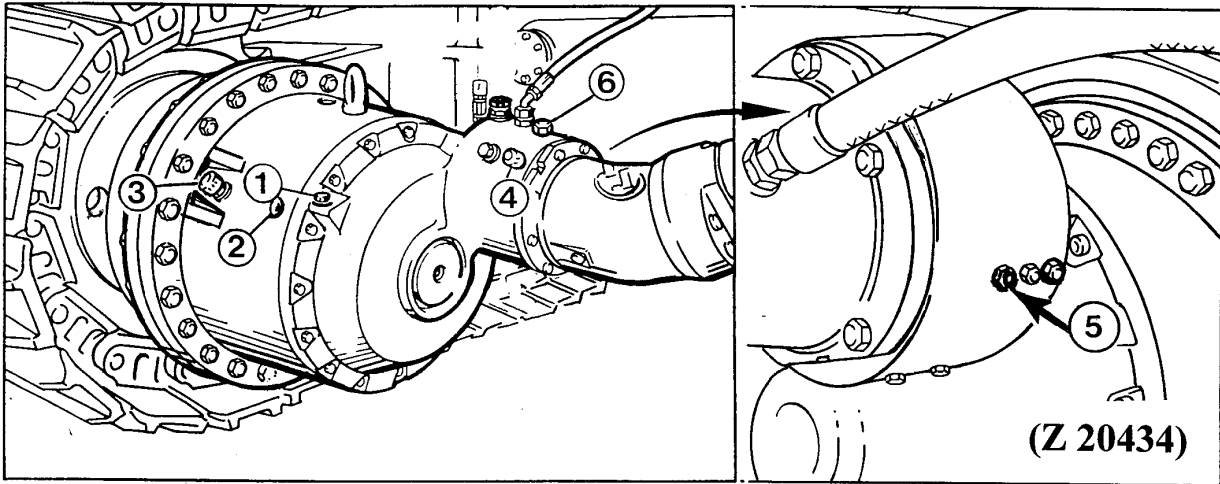

## 4.9.2 TRAVEL GEARS, BRAKE HOUSINGS AND MOTOR ADAPTER HOUSINGS - CHECK OIL LEVELS

### Legend for illustration Z 20434

#### Travel Gears

- (1) Oil level gauge
- (2) Oil filler plug
- (3) Breather filter

#### **REMARK**

The breather filters for the travel gears are mounted inside the center frame and connected with extension hoses.

#### Motor Adapter Housings

- (4) Breather filter. The bore of the breather filter is also used as a level and filler opening.

#### **REMARK**

The breather filters for the motor adapter housings are mounted inside the center frame and connected with extension hoses.

#### Brake housings

- (5) Oil level plug
- (6) Oil filler plug

### **CHECK TRAVEL GEAR OIL LEVEL**

Remove oil level gauge (1) and wipe it clean. Screw in the gauge and remove again. Oil level should be at the upper mark of gauge (1). If necessary add oil through filler opening (2).

### **CHECK MOTOR ADAPTER HOUSING OIL LEVEL**

Check oil level by removing breather filter line connector on port (4). Oil level should be at lower edge of opening (4). If necessary, add oil through the filler opening. Screw in breather filter line connector into port (4).

### **CHECK BRAKE HOUSING OIL LEVEL**

Check oil level by removing oil level plugs (5). Oil level should be at lower edge of openings (5). Add oil through filler openings (6) if necessary and install plugs (5) and (6).

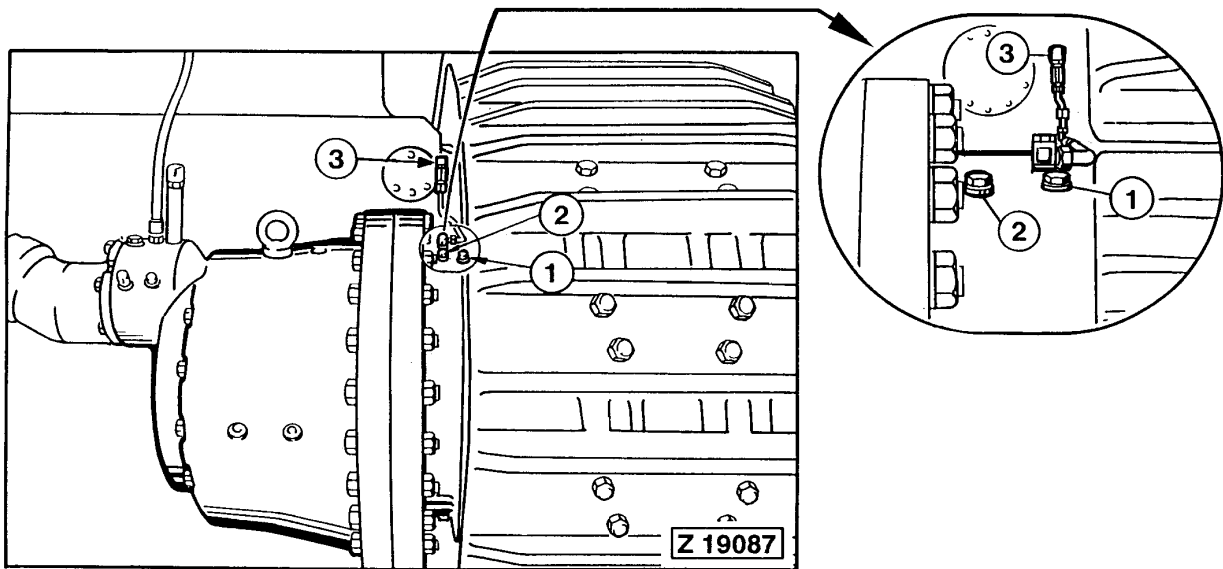
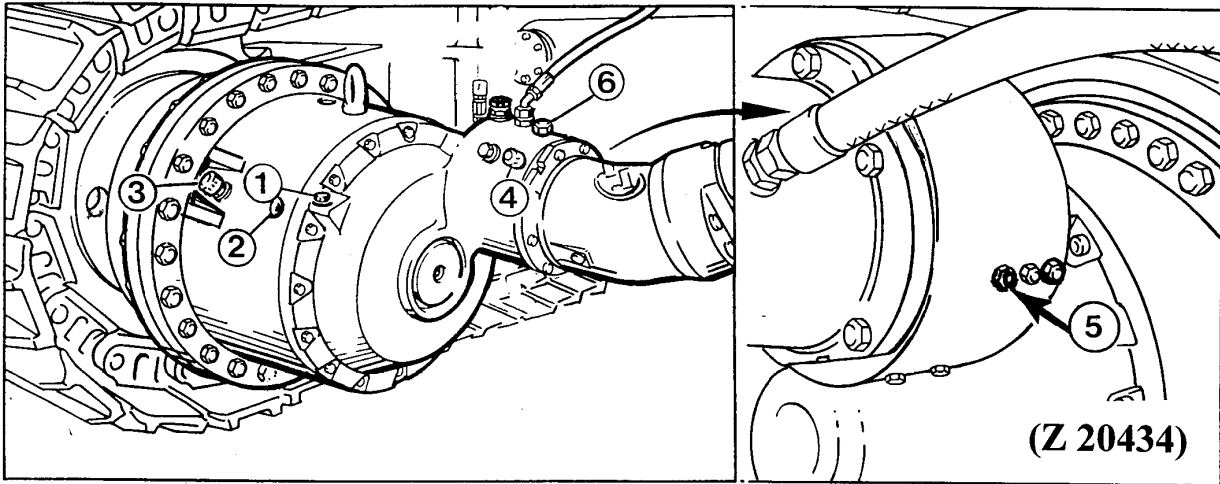



### 4.9.3 FINAL DRIVE HOUSINGS - CHECK OIL LEVEL

(Drive Shaft Housings)

#### Legend for illustration Z 19087

- (1) Oil level gauge
- (2) Oil filler plug
- (3) Breather filter

#### REMARK

The breather filters for the final drives are mounted inside the center frame and connected with extension hoses.

Check oil level by removing oil level gauge (1).  
Oil level must be between upper and lower mark on gauge (1).

If necessary top up fresh oil through filler opening (2) up to the upper (max.) mark on gauge (1).

#### CHECK BREATHER FILTERS

Check the six breather filters located inside the center frame, of the travel gears, motor adapter housings and final drives, for restriction. If necessary, remove breather filters, blow out with compressed air from inside to outside and reinstall.

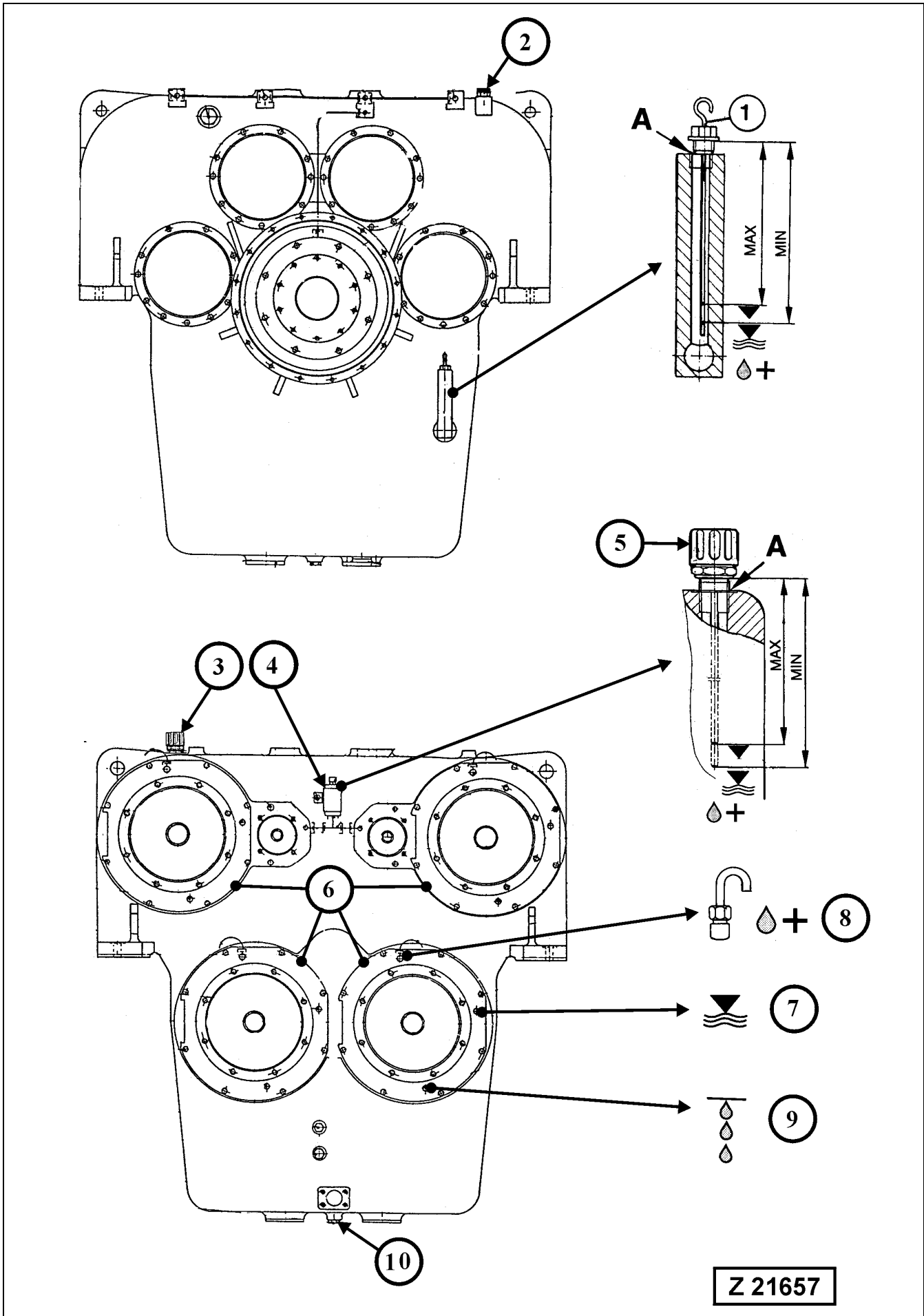

## 4.9.4 PTO (PUMP DISTRIBUTOR GEAR) AND OIL RESERVOIR - CHECK OIL LEVEL

### Legend for illustration Z 21657

- (1) Oil level gauge
- (2) Oil filler plug
- (3) Breather filter
- (4) Oil collector reservoir for secondary oil pump drive shaft housings
- (5) Breather filter with oil level gauge
- (6) Main pump drive shaft housings
- (7) Oil level plug of main pump drive shaft housing
- (8) Oil filler plug with breather pipe of main pump drive shaft housing
- (9) Oil drain plug of main pump drive shaft housing
- (10) Oil drain plug of PTO gear

### CHECK OIL LEVEL OF PTO GEAR

1. Unscrew level gauge (1) and wipe it clean.
2. Insert gauge (1), but DO NOT screw in, see detail (A).
3. Remove level gauge and read the oil level. The oil level should be between the "MIN" and "MAX" mark. If necessary, add oil through filler opening (2) up to the "MAX" mark on gauge (1).

#### NOTICE

**If the oil level is above the "MAX" mark, drain the oil down until the oil level is at the "MAX" mark. Too much oil in the pump distributor gear will cause aeration of the oil.**

4. Insert gauge (1) and tighten securely. Remove breather filter (3). Blow out with compressed air from inside to outside and reinstall.

### CHECK OIL LEVEL OF OIL COLLECTOR RESERVOIR (4)

Remove breather filter with oil level gauge (5). The oil level should be between the "MIN" and "MAX" mark. If necessary, add oil through the level gauge opening. Clean the breather filter and install.

#### NOTICE

**If oil starts dropping out at breather (5), check oil seals of secondary pump drive shafts for damage.**

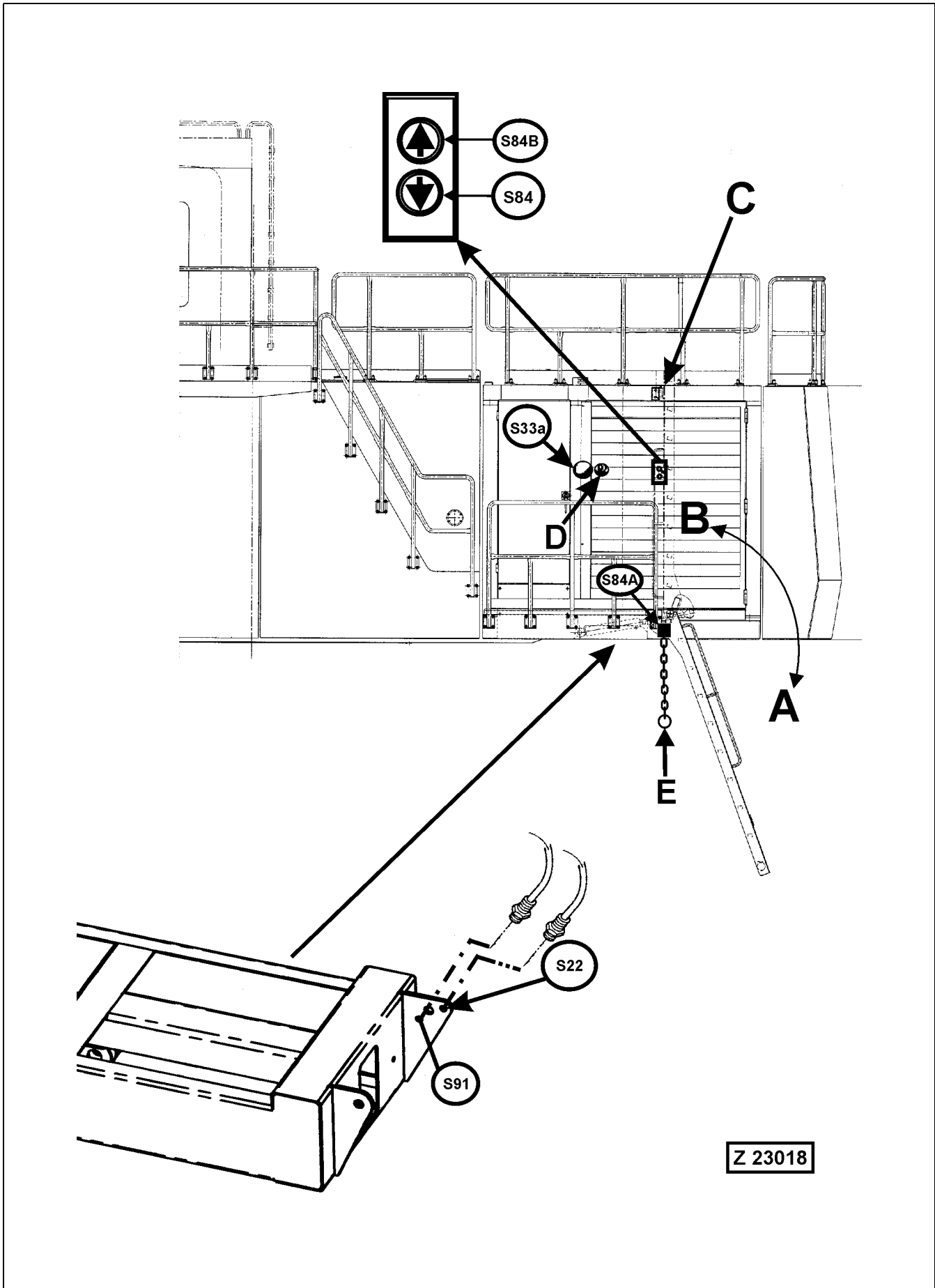

## 4.9.5 HYDRAULIC ACCESS LADDER - CHECK SAFETY SENSOR

### Legend for illustration Z 23018

- (A) Access ladder in lowered position
- (B) Access ladder in upper position (Working position)
- (C) Stop bar
- (D) Manual actuator for fire suppression system (if so equipped)
- (E) Pull chain for emergency lowering of the access ladder

**CAUTION**

**Use this chain only in emergency cases, when the Operator does not respond to other communication signals.**

- (S84) Ladder control switch for lowering the ladder
- (S84B) Ladder control switch for lifting the ladder
- (S84A) Safety switch for emergency lowering of the access ladder. When the chain (E) is being pulled down with the engine running, the pilot control system is made inoperative, preventing further movements of the Shovel.
- (S22) Safety sensor, located on ladder pivot bracket  
Function of sensor (S22): Cut out of the pilot control system and actuation of the hydraulic swing brake with the ladder in lowered position.
- (S91) Monitor and control sensor  
Function of sensor (S91):  
This sensor monitors the ladder position and controls the moving speed of the ladder. In case the sensor (S22) fails to function properly, the sensor (S91) prevents unintended movement of the ladder.
- (S33a) Emergency shutdown switch for engine

### Check Safety Sensor (S22) as follows:

With the ladder completely lowered (position A) start the engine.  
Hold an iron part (screw driver) in front of sensor (S22).  
The ladder must not start to move.  
If the ladder starts to move, immediately remove the iron part from the sensor.

**WARNING**

- Inform the Service Staff about the malfunction of the ladder sensor.
- DO NOT operate the Shovel before the failure has been eliminated and the sensors function properly.

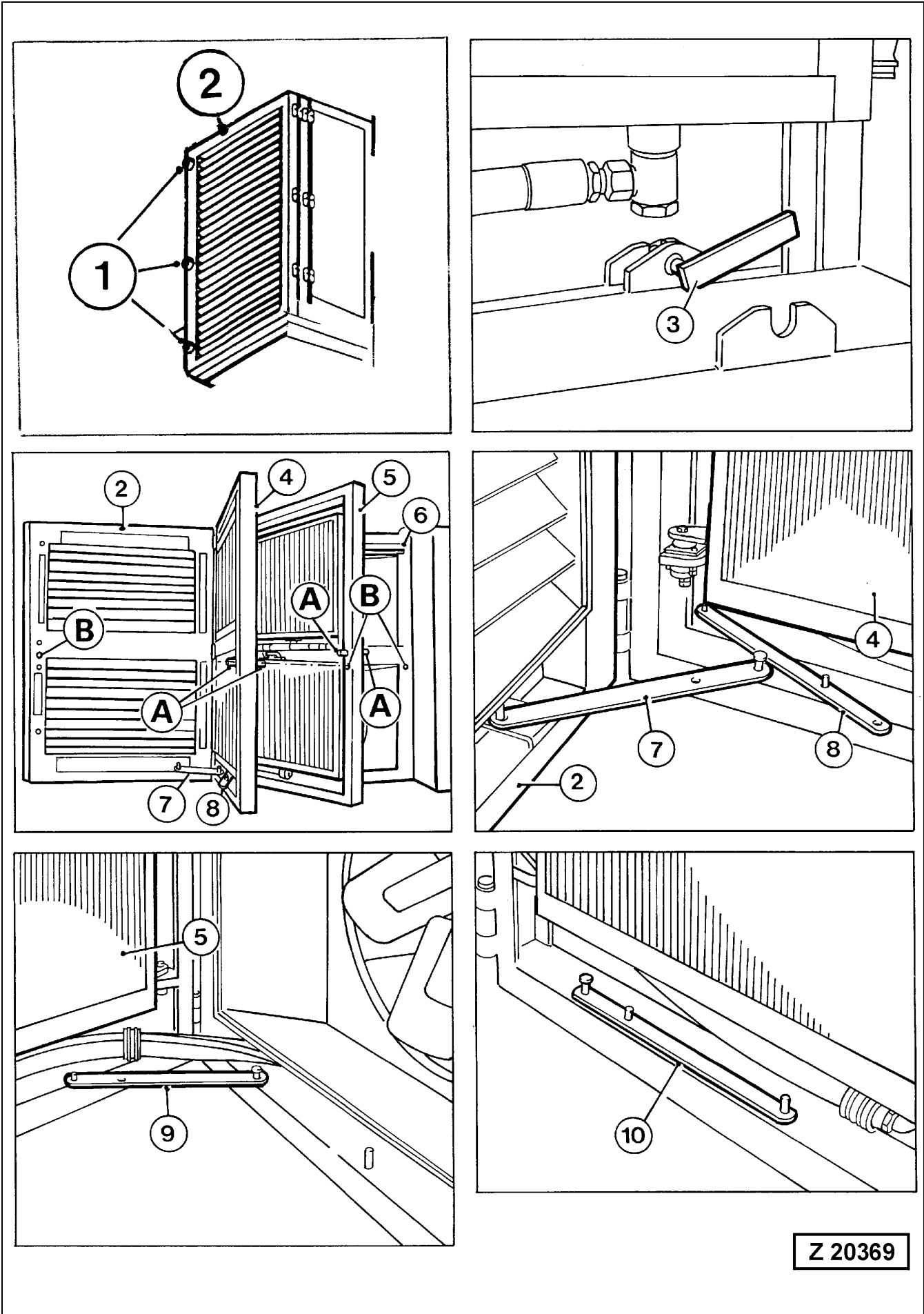

## 4.9.6 HYDRAULIC OIL COOLERS - INSPECT AND CLEAN IF NECESSARY

See illustration Z 20369

---

**⚠ WARNING**

---

- Provide adequate working platform for safe access to the hydraulic oil coolers.
- Before removing mounting bolts (1) of the hydraulic oil cooler door (2) check to make sure that all door hinges are in good condition and properly fastened on their carrier frames. If cracks are found at the welded joints of the hinges, **DO NOT** remove mounting bolts (1) otherwise the cooler door may become detached and fall off. Danger of accidents. Have the damage repaired as soon as possible.

- 
1. Loosen mounting bolts (1).
  2. Open door (2).

**REMARK**

Details (A and B) in the illustration show LH hinged oil coolers. The description below applies also to RH hinged oil coolers.

3. Loosen fasteners (3) and swing out oil coolers (4 and 5).
4. Secure door (2) and oil coolers (4 and 5) with locking bars (7, 8 and 9).
5. Clean the oil coolers with compressed air. Direct the air flow from inside to outside.
6. After cleaning, swing back the oil coolers to their home position.

**PROCEED AS FOLLOWS**

- Disengage locking bars (7, 8 and 9) and fix them in storage position (10).
- Swing back inner cooler (5). Take care guide pin (A) fits into hole (B) of main frame (6). Secure cooler (5) with fastener (3).
- Swing back outer cooler (4); observe (A - B) and secure with fastener (3).
- Close door (2); observe (B - A). Install mounting bolts (1) and tighten securely.

**NOTICE**

**When cleaning the oil coolers, inspect also laying and fastening of the hydraulic oil lines.**

### 4.10 EVERY 250 OPERATING HOURS OR MONTHLY

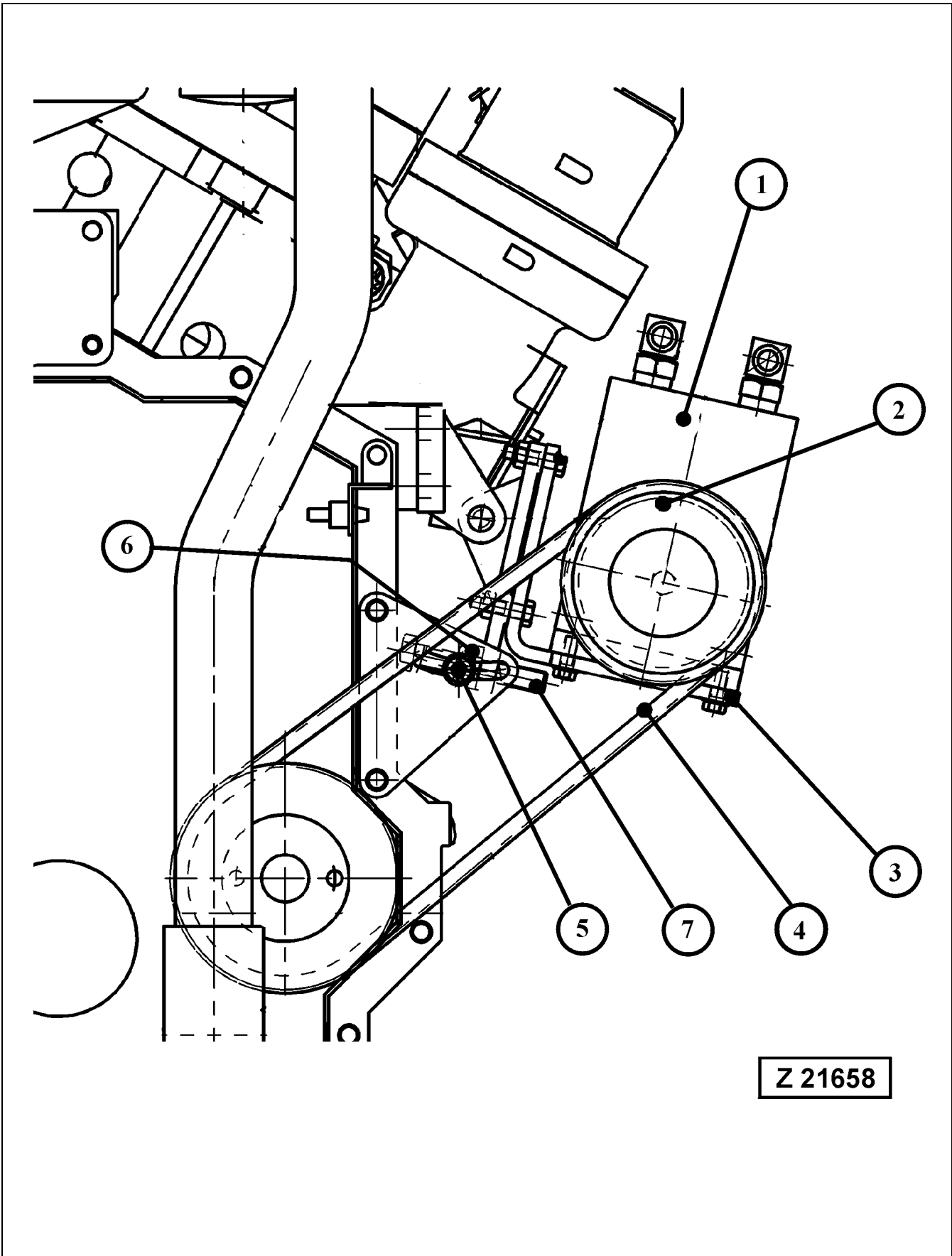



## 4.10.1 AIR CONDITIONING COMPRESSOR - CHECK DRIVE BELT TENSION

### WARNING

Be sure to set the maintenance safety switch to 0 position before to start the checking procedure. Refer to page 129 for the location of the maintenance safety switch. In the 0 position the engine can not be started. Secure this position by inserting a padlock into the holes of the switch. Up to three padlocks can be attached to the holes provided.

#### Legend for illustration Z21658

- (1) Refrigerant compressor
- (2) Electromagnetic clutch
- (3) Compressor carrier
- (4) Drive belts
- (5) Clamping bolt
- (6) Lock nut
- (7) Adjusting bolt for belt tension

#### Check tension of each belt

Remove the drive belt guard.

The tension is correct if the belt can be depressed with 110 N (25 lb) force approximately 15 to 20 mm midway between the belt pulleys.

Excessive belt tension causes undue wear on the bearings. After a new belt has been in use for approximately 20 minutes, check the tension and adjust again if necessary.

#### NOTICE

**Always replace the belts in complete sets.**

#### Adjust belt tension

1. Loosen clamping bolt (5)
2. Loosen lock nut (6)
3. Turn adjusting bolt (7) until correct belt deflection is obtained.  
Tighten lock nut (6)
4. Tighten clamping bolt (5) and check the belt adjustment.
5. Install the drive belt guard.

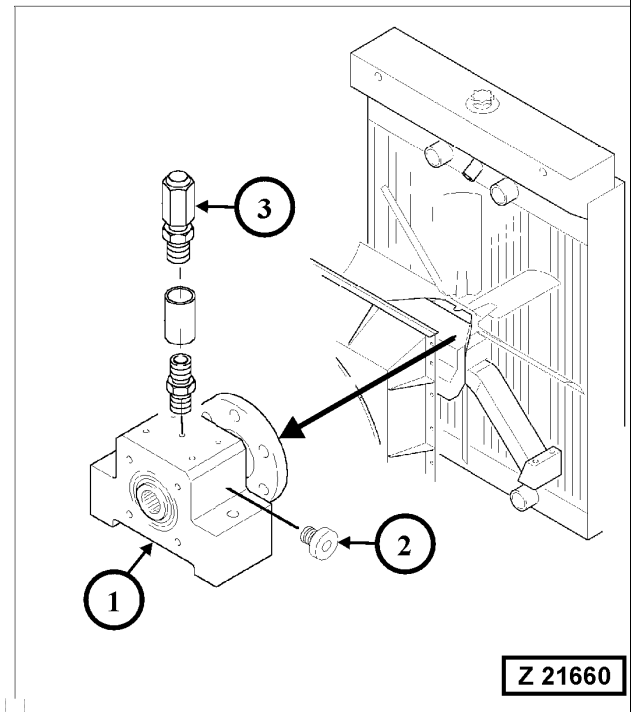
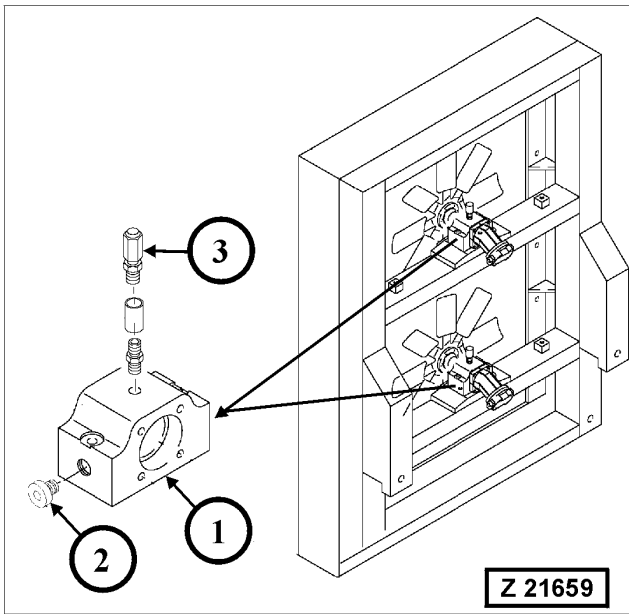
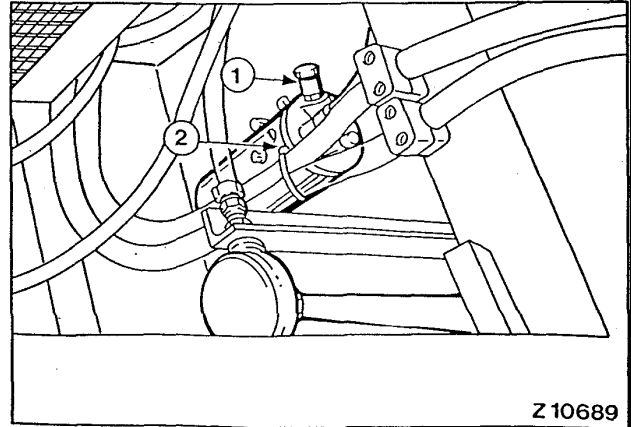
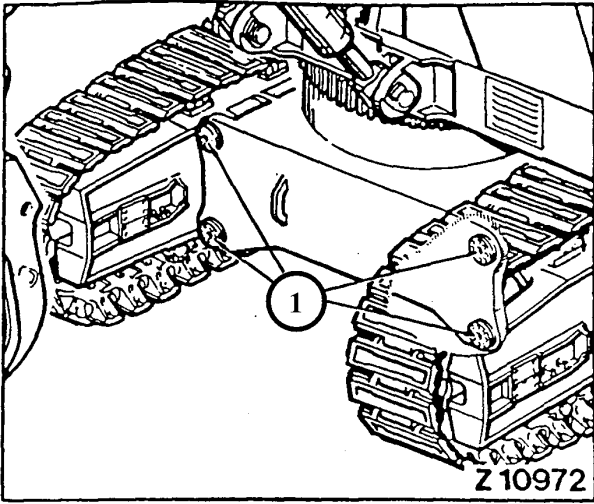

### **4.10.2 UNDERCARRIAGE PIN CONNECTIONS - LUBRICATE**

See illustration Z 10972

Lubricate the pin connections via grease fittings (1) at center section (16 fittings; front, rear and from inside).

### **4.10.3 SIGNAL HORN COMPRESSOR - LUBRICATE**

See illustration Z 10689

The compressor (2) is located in the cab base.

Fill several drops of thin oil into the lubricator (1).

The oil must be free from resin and acid and must have the lowest solidifying-point possible (below - 40° C).

#### **NOTICE**

**If the Shovel is equipped with a second signal horn there is also a second compressor which has to be lubricated in the same way as the first one.**

### **4.10.4 HYDRAULIC OIL COOLER FAN BEARING HOUSINGS - CHECK FOR LEAKAGE AND CLEAN BREATHER FILTER**

See illustration Z 21659

Check housings (1) for leakage. If leakage is found, check the oil level in the bearing housing. Remove oil level plug (2). The oil level should be at lower edge of the opening. If necessary add oil through the breather filter adapter pipe. Clean breather filter (3) with compressed air from inside to outside and install plug (2) and breather filter (3). Oil loss of the bearing housing indicates worn or damaged seal rings. To prevent damage to the fan bearings, install new seal rings.

### **4.10.5 RADIATOR FAN BEARING HOUSING - CHECK FOR LEAKAGE AND CLEAN BREATHER FILTER**

See illustration Z 21660

Check housing (1) for leakage. If leakage is found, check the oil level in the bearing housing. Remove oil level plug (2). The oil level should be at lower edge of the opening. If necessary add oil through the breather filter adapter pipe. Clean breather filter (3) with compressed air from inside to outside and install plug (2) and breather filter (3). Oil loss of the bearing housing indicates worn or damaged seal rings. To prevent damage to the fan bearings, install new seal rings.

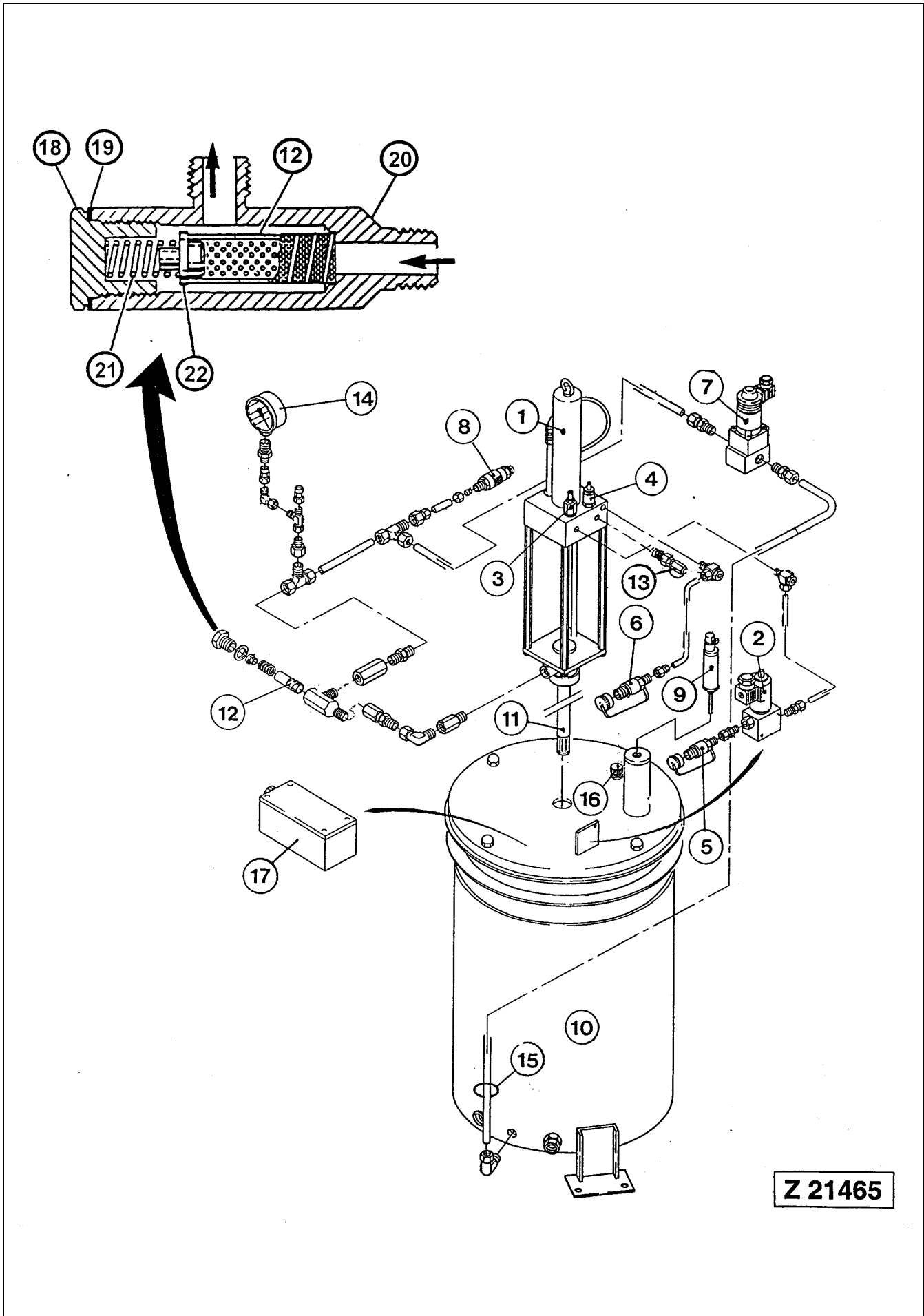

## 4.10.6 AUTOMATIC LUBRICATION SYSTEMS - CLEAN IN-LINE GREASE FILTER

### Legend for illustration Z 21465

- (1) Grease pump drive (Hydraulic cylinder)
- (2) Solenoid valve (Oil pressure supply)
- (3) Flow control valve
- (4) Pressure reducing valve
- (5) Hydraulic oil supply line (Pilot pressure)
- (6) Hydraulic oil return line
- (7) Vent valve (Solenoid valve, de-energized open to barrel)
- (8) Grease supply line to injectors
- (9) Lubricant level indication, (Sonar sending and receiver principal)
- (10) Grease barrel
- (11) Pump mechanism
- (12) Grease filter element
- (13) Hydraulic pressure test plug (Operating pressure)
- (14) Grease pressure gauge (Operating pressure)
- (15) Vent line to barrel
- (16) Breather
- (17) Electrical terminal box

### Components of In-Line-Grease-Filter:

- (12) Filter element
- (18) Plug screw
- (19) Packing ring
- (20) Filter housing
- (21) Spring
- (22) Spring guide

---

---

### WARNING

---

---

**Before servicing stop the engine/motor and remove ignition key in order to prevent operation of the system. Be sure to vent system pressure before removing plug (18).**

---

---

A blocked filter can disintegrate under pressure and damage the automatic lube system.

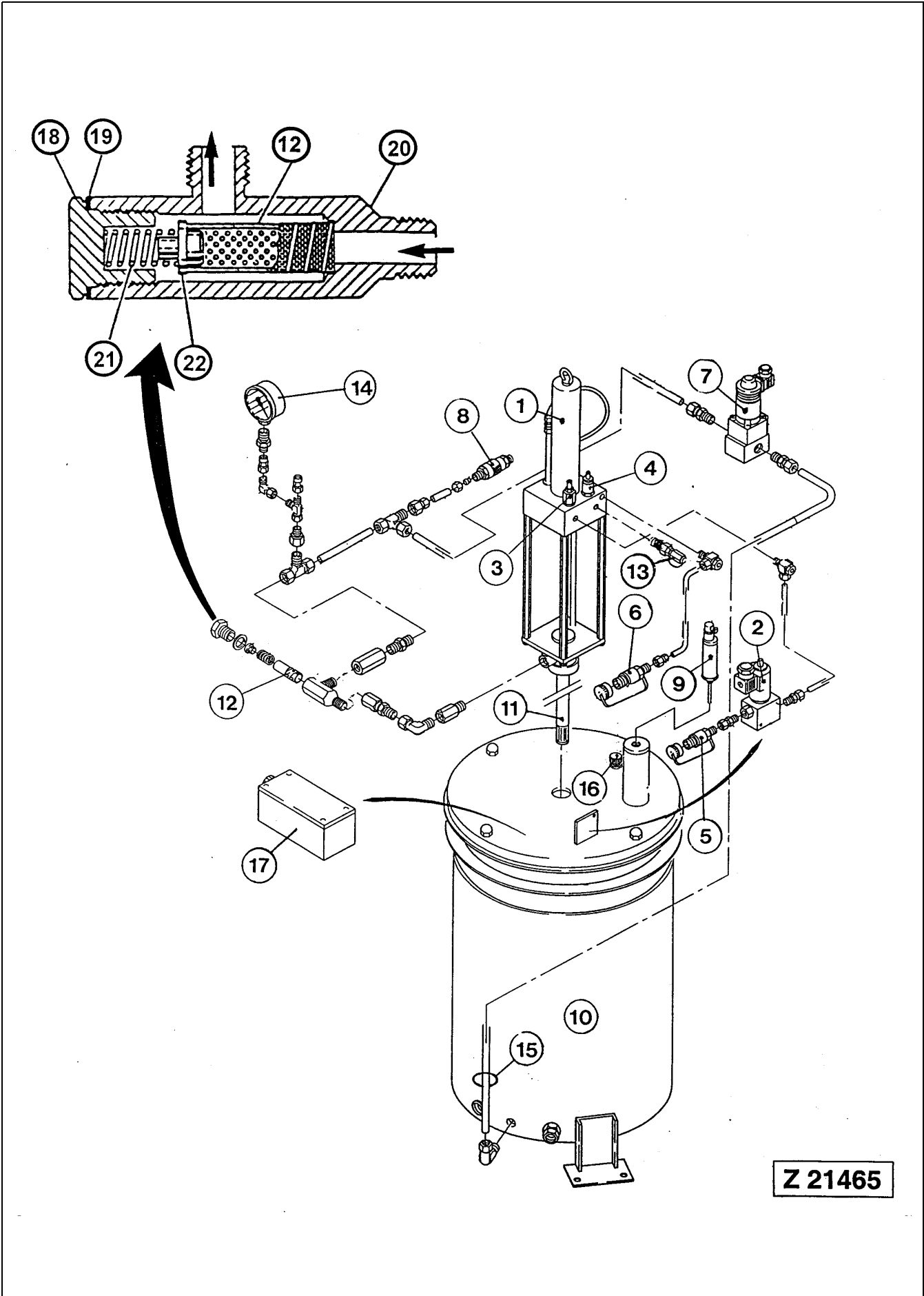

Z 21465

**Service the in-line grease filter as follows:**

1. Unscrew plug (18), illustration Z 21465, using 36 mm width wrench and remove packing ring (19).
2. Take out spring (21), spring guide (22) and element (12).
3. Clean all parts and inspect for damage. Replace as necessary.
4. Assemble all parts according to the illustration. Make sure all sealing surfaces are clean. Take care for proper position of spring guide (22).
5. Install plug screw (18) with new packing ring (19) and tighten with a wrench.

**Check breather filter (16)**

Check condition and fastening of breather filter (16). If necessary clean the breather filter with compressed air. For removal of the breather filter it is necessary to lift off the container cover. Make sure the breather filter mounting nut inside the cover is securely tightend before lowering the cover onto the container.

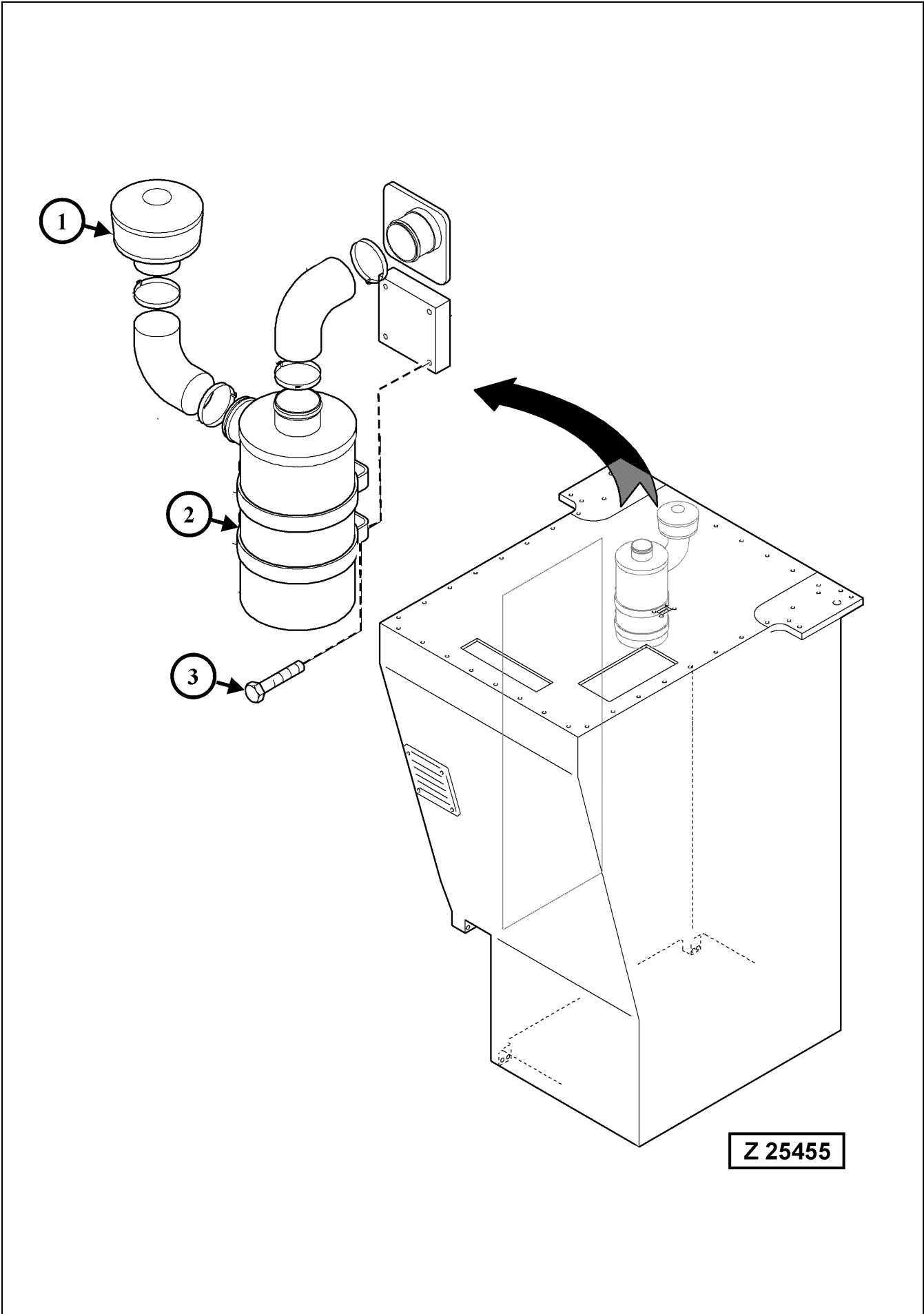



## 4.10.7 CAB AIR CLEANER - CLEAN OR REPLACE FILTER ELEMENT

### Legend for illustration Z25455(

- (1) Pre-cleaner
- (2) Air cleaner housing located on cab base
- (3) Air cleaner mounting bolts

### Clean pre-cleaner dust bowl

1. Check the dust level in bowl (1), if the level is near the Max. marking remove and clean the dust bowl.
2. Install dust bowl and cover.
3. Check condition of the hose and hose clamps and replace if necessary.

### REMARK

When operating the machine under very dusty conditions, check pre-cleaner in shorter intervals.

### Clean and inspect main filter element

1. Remove element from housing (2).
2. Clean and check resp. replace filter element. Wipe out filter housing with a clean cloth.
3. Element cleaning methods:  
Clean main element by one of the following methods. Compressed air or washing. Compressed air is recommended when element will be re-used immediately because a washed element must be dried before re-use.

### Compressed air:

Direct air through element in the direction opposite to normal air flow through the element. Move nozzle up and down while rotating element. Keep nozzle at least one inch from pleated paper. Maximum air pressure to prevent damage of element is 100 P.S.I. (6 bar).

### Washing:

Soak element 15 minutes or more in cleaning solution. See package for full instructions. Rinse until water is clear maximum water pressure 40 P.S.I. (2,5 bar). Air-dry or use warm flowing air, max. 160° F (+70° C). Do not use compressed air or light bulbs.

### Replace element after 6 cleaning or annually, whichever occurs first.

4. Install filter element and bottom cover. Make sure all connections are correctly fitted and tight.

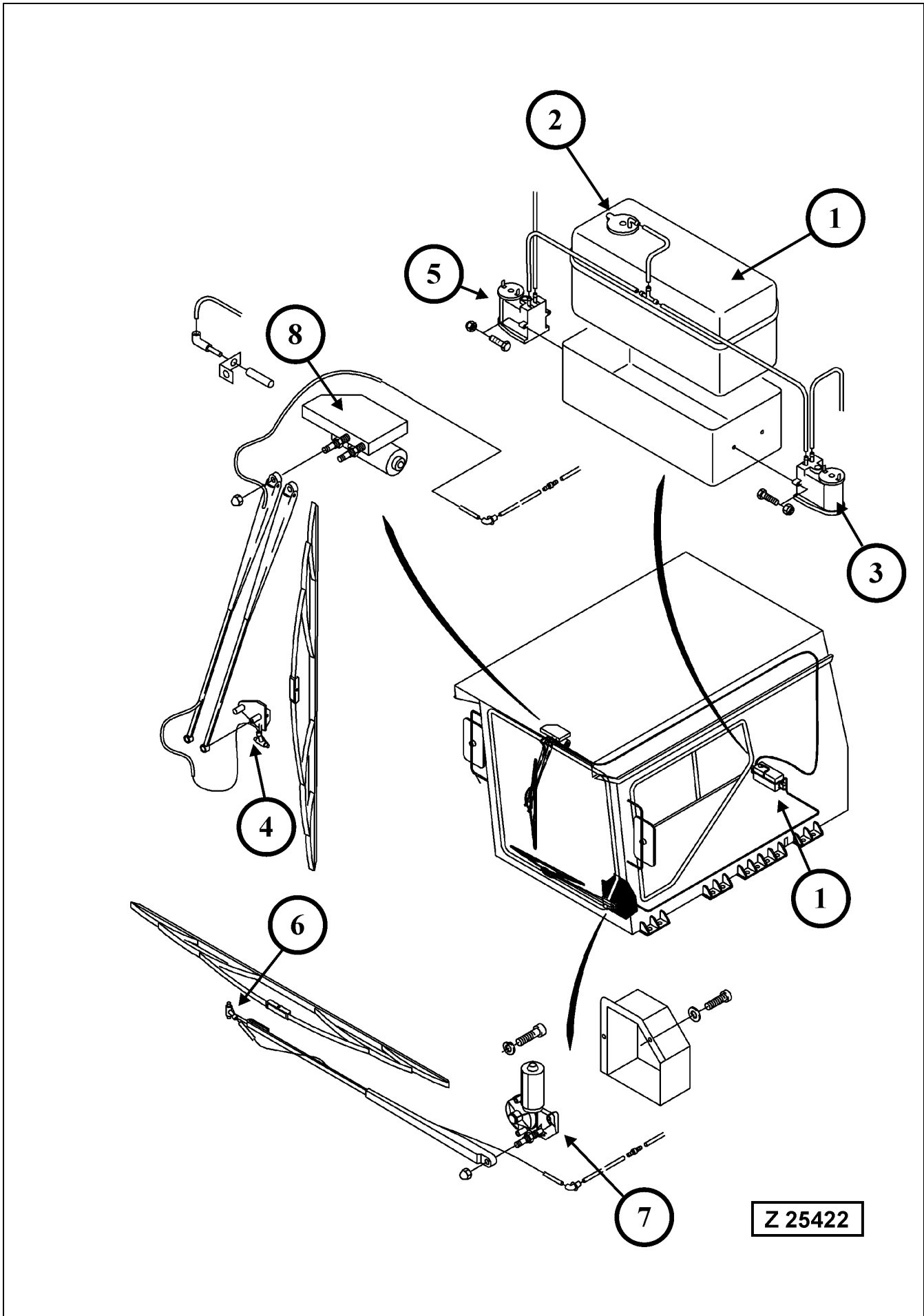

## 4.10.8 WINDSHIELD WASHER SYSTEM - CHECK FLUID LEVEL

### Legend for illustration Z 25422

- (1) Water reservoir for windshield washer
- (2) Filler cap with suction line
- (3) Water pump for windshield washer
- (4) Upper washer nozzle for windshield
- (5) Water pump for windshield washer
- (6) Lower washer nozzle for windshield
- (7) Wiper motor for lower windshield wiper
- (8) Wiper motor for upper windshield wiper

Fill the water reservoir (1) with clear water, add anti-freeze and cleaning agent as necessary. Filling capacity of the water reservoir is 7 liters.

Check washer and wiper system for tightness and carry out a functional test of both systems.

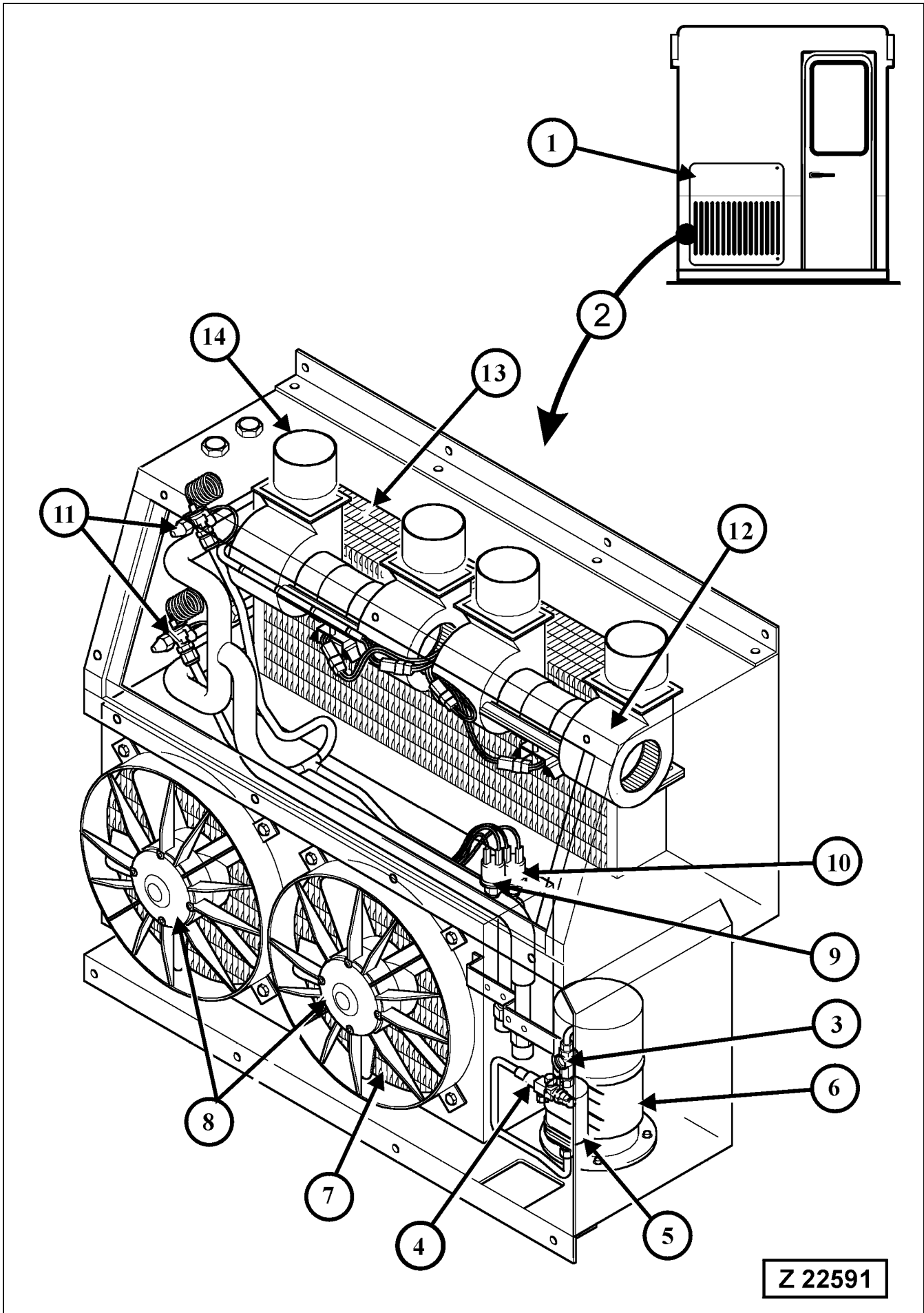

## 4.10.9 AIR CONDITIONING FOR OPERATOR'S CAB - CHECK REFRIGERANT LEVEL

### Legend for illustration Z 22591

- (1) Air conditioner door with filter mat
- (2) Air conditioner unit
- (3) Sight glass for checking refrigerant filling
- (4) Shut-off valve on dryer cartridge
- (5) Dryer cartridge
- (6) Refrigerant collector reservoir
- (7) Condenser
- (8) Condenser blower
- (9) Low pressure switch
- (10) High pressure switch
- (11) Expansion valves
- (12) Evaporator blower
- (13) Evaporator
- (14) Cool air outlets

### Checking the refrigerant level:

Switch on air conditioning equipment and run at maximum capacity for approx. 5 minutes.

Observe inspection glass (3). A refrigerant flow loaded with bubbles or foam indicates a lack of refrigerant. In this case well equipped refrigeration specialists must check the circuit for tightness and must add the missing quantity or refrigerant. If more than 200 grams per year are lost, the oil level of the refrigerant compressor must also be checked. This is a special procedure and must be carried out by refrigeration specialists only. Isolated small bubbles in the inspection glass may be neglected.

Even with an absolutely tight equipment a certain amount of refrigerant is lost through the walls of the hoses.

Therefore a small annual replenishment of the refrigerant quantity is normal.

The dryer cartridge (5) must be replaced after every 1000 operating hours or once a year by refrigeration specialists.

Clean the filter mats of condenser (7) and evaporator (13).

### REMARK

Servicing of the air conditioning systems is restricted to workshops especially equipped for this purpose. Refer to the separate booklet "AIR CONDITIONING" in Service Literature Binder – Volume 2 for more information.

# 4.11 EVERY 500 OPERATING HOURS OR MONTHLY

-A-

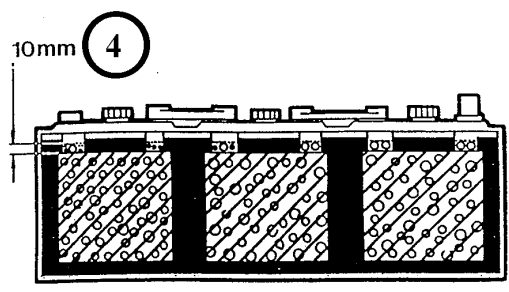
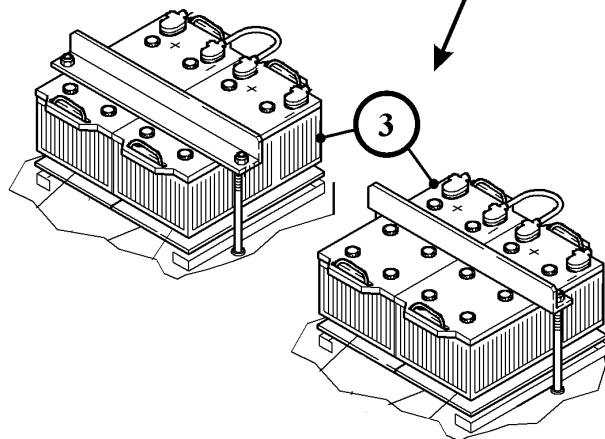
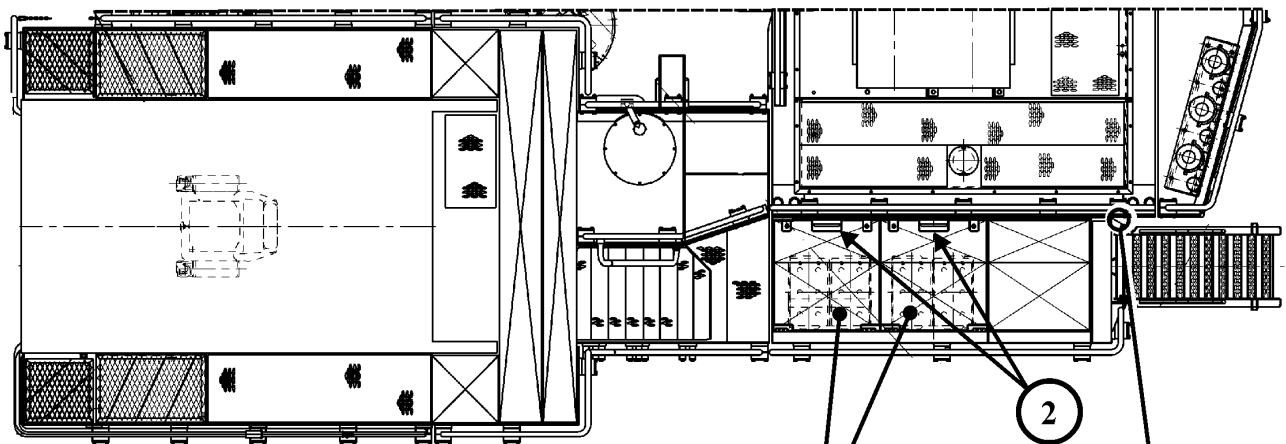

Z 25474

## 4.11.1 BATTERIES - CHECK FLUID LEVEL

See illustration Z25474

A - Top view of access area

---

---

**⚠ WARNING**

---

---

- Batteries give off highly inflammable gas! Never allow sparks or open flame near the batteries!
  - Avoid spilling any electrolyte on hands or clothing. Repair or replace all broken wires immediately. All terminals must be clean and securely fastened; never paint connections.
  - DO NOT short across or ground any terminals of the batteries.
- 
- 

Check electrolyte level:

**NOTICE**

The batteries are located below the walkway floor in two separate boxes. To get access to the batteries remove floor plate fastening bolts and open the hinged floor plates.

Secure the open floor plates against falling down with the safety chains provided.

1. Remove the two battery main switch keys (1).
2. Open floor plates (2).
3. Check electrolyte level (4) of batteries (3).
4. If necessary remove filler and breather caps and top up with clean distilled water.
5. See that contact surfaces of battery terminals are bright. Clean if necessary and apply some vaseline to the terminal posts.

---

---

**⚠ WARNING**

---

---

- Care must be taken that the batteries are not overfilled as the electrolyte will expand and overflow when the temperature rises.
  - On removal always disconnect the ground (-) cables first. When re-installing the batteries connect the positive (+) cables first.
- 
-

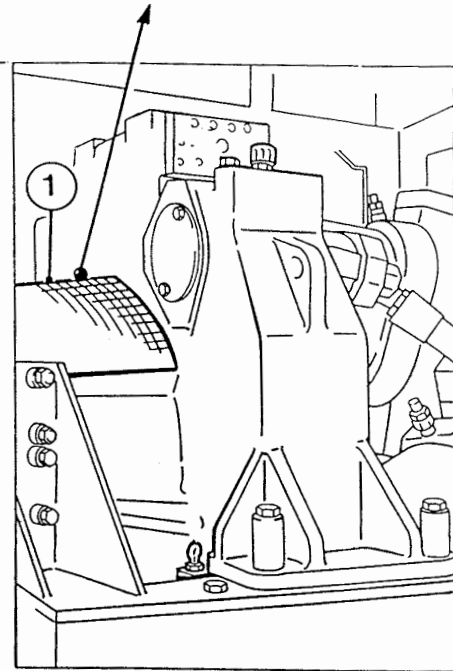
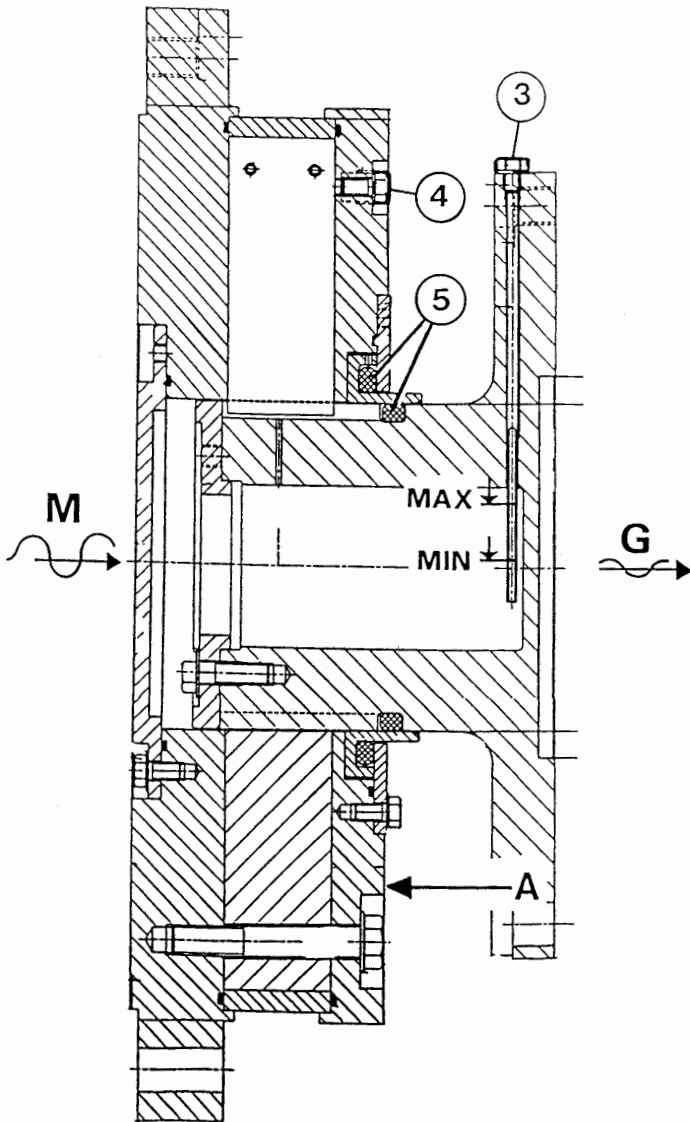
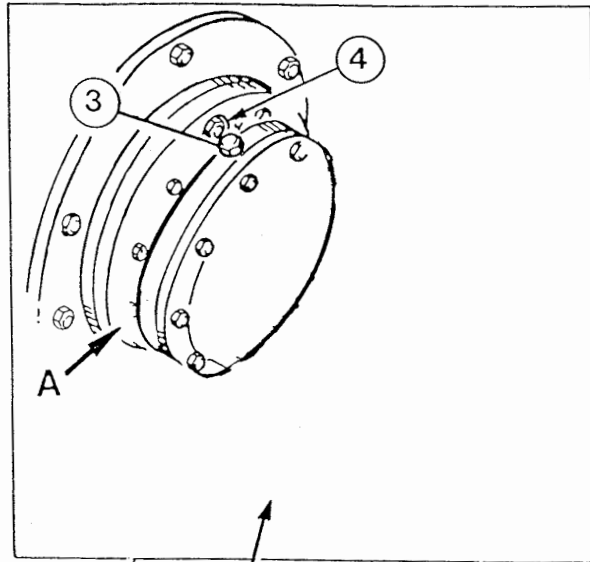
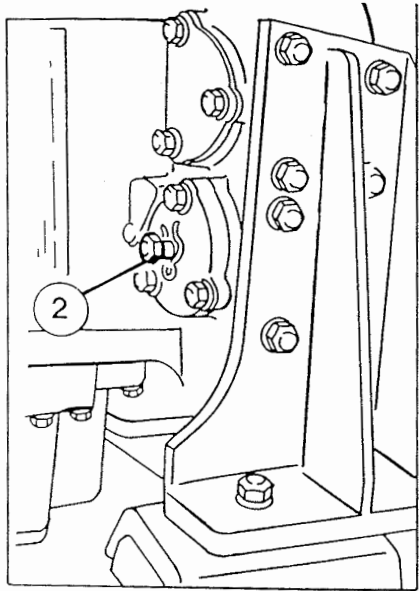

(Z 20703)



## 4.11.2 FLEXIBLE DRIVE COUPLING - CHECK OIL LEVEL

See illustration Z 20703

### NOTICE

**The Engine must be out of operation for approximately 30 minutes before checking the oil level. This period is necessary for settling of the oil in the lower part of the coupling housing.**

1. Remove guard (1).
2. Turn flexible coupling by using barring device (2) to bring oil level gauge (3) in its uppermost (12 o'clock) position.

### REMARK

To use the barring device, remove the clip and push the device shaft toward the flywheel. The barring device must be rotated counterclockwise to turn the flywheel (flexible coupling) in the direction of normal rotation.

3. Unscrew gauge (3), wipe it clean and insert into the gauge opening.  
DO NOT screw in. Pull out gauge (3) and read the oil level.
4. If necessary add oil through gauge opening to bring the oil level up to the "MAX" mark on gauge (3). To speed-up the filling procedure, remove bleeder screw (4) and warm up the oil to approximately +30°C.
5. Insert gauge (3) with packing ring and bleeder screw (4) with packing ring and tighten securely.
6. Check area (A) for leakage. If oil leakage is found (radial traces of oil), O-rings (5) must be checked for damage and replaced if necessary.
7. Install guard (1).

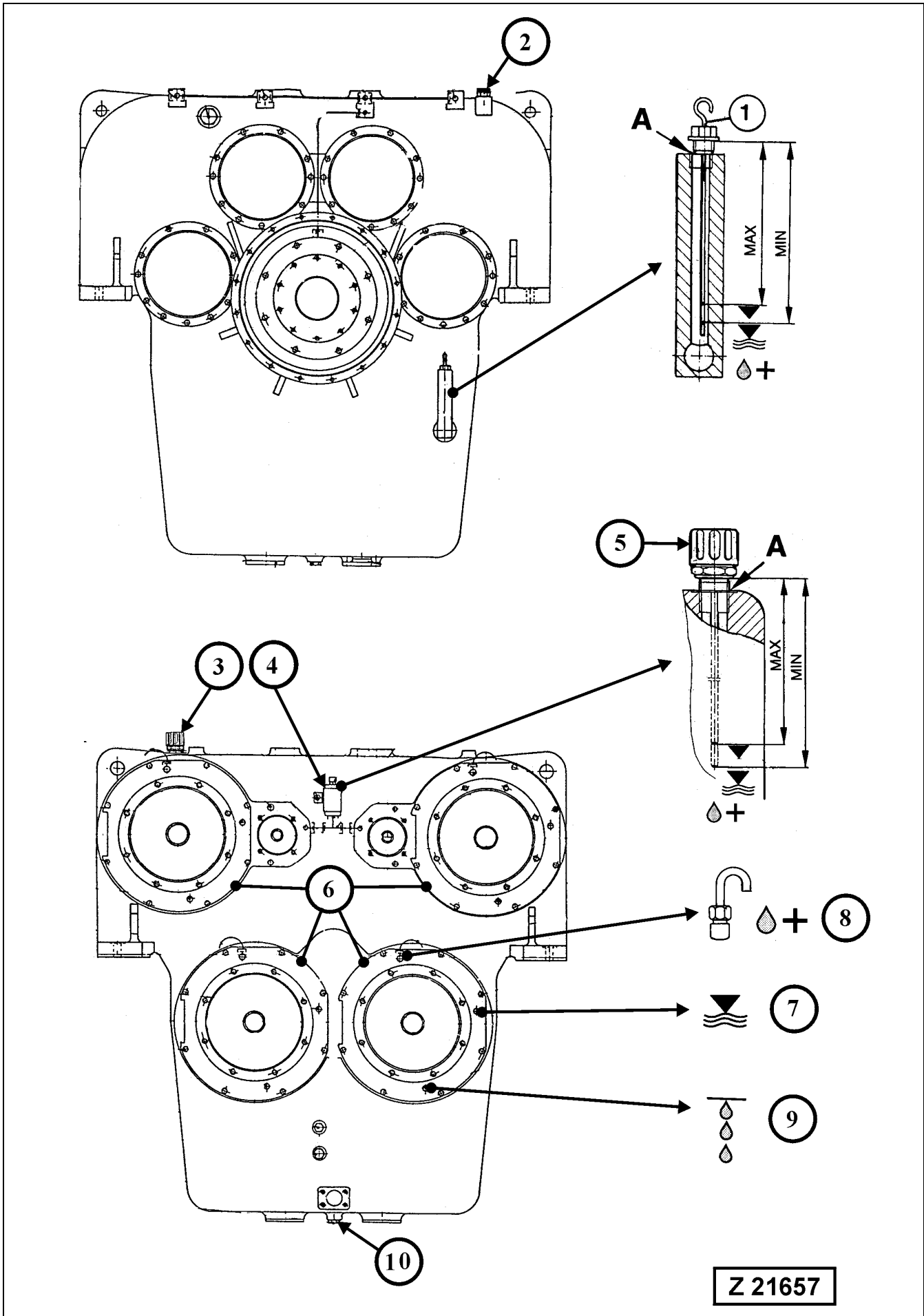

### 4.11.3 PTO (PUMP DISTRIBUTOR GEAR) MAIN PUMP DRIVE SHAFT HOUSINGS - CHECK OIL LEVEL

#### Legend for illustration Z 21657

- (1) Oil level gauge
- (2) Oil filler plug
- (3) Breather filter
- (4) Oil collector reservoir for secondary oil pump drive shaft housings
- (5) Breather filter with oil level gauge
- (6) Main pump drive shaft housings
- (7) Oil level plug of main pump drive shaft housing
- (8) Oil filler plug with breather pipe of main pump drive shaft housing
- (9) Oil drain plug of main pump drive shaft housing
- (10) Oil drain plug of PTO gear

#### CHECK OIL LEVEL OF ALL MAIN PUMP DRIVE SHAFT HOUSINGS

The Oil level should be at the lower edge of level plug opening (7). If necessary remove filler plug with breather pipe (8) and add Gear Oil through the filler opening up to the level opening (7).

Re-install plugs (7 and 8) and tighten securely.

If pump removal becomes necessary, drain the drive shaft housing oil by removing drain plug (9). Be sure to fill the drive shaft housing up to the filler opening (7) after mounting of the pump.

#### NOTICE

**If oil starts dropping out at one of the breather pipes (8), the oil seal ring of the respective pump drive shaft must be checked and replaced if necessary.**

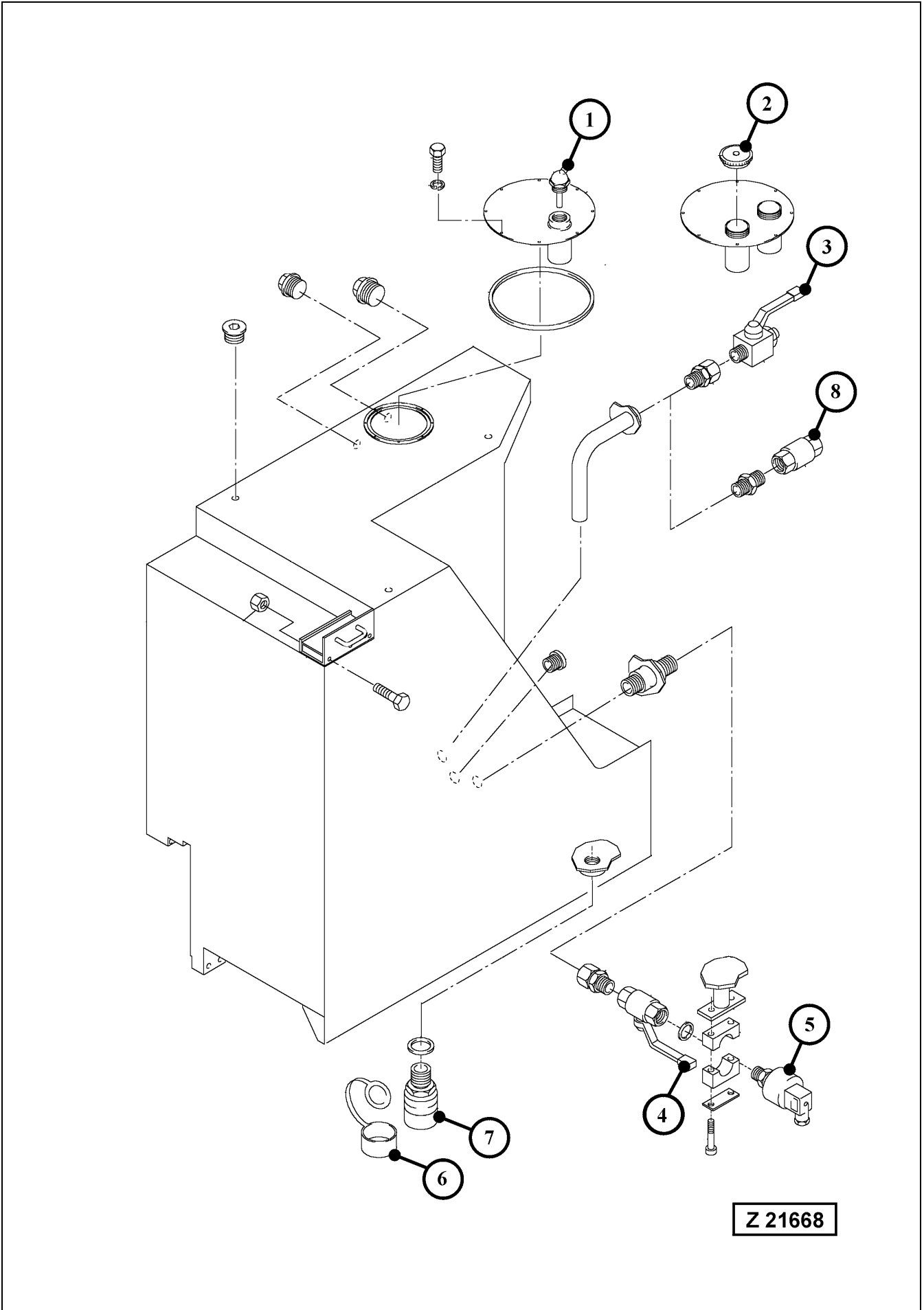

## 4.11.4 FUEL TANK - DRAIN CONDENSATION

### Legend for illust. Z 21668

- (1) Fuel tank breather valve on machines with central refilling system
- (2) Fuel filler caps on machines without central refilling system
- (3) Main fuel shut-off cock on machines without automatic fire suppression system
- (4) Shut-off cock for fuel pressure transducer (5). Close this cock when replacing pressure transducer (5).
- (5) Fuel pressure transducer
- (6) Protection cap
- (7) Drain coupling
- (8) Connector for fuel shut-off solenoid valve on machines with automatic fire suppression system

---

---

 **WARNING**

---

---

**DO NOT smoke or use an open flame when working around inflammable fuels.**

---

---

### DRAIN CONDENSATION AS FOLLOWS

1. Provide adequate working platform in order to ensure safe access to the tank bottom.
2. Connect drain hose to coupling (7). Collect outflowing sediments in a suitable container.
3. When servicing the fuel system, close main fuel shut-off cock (3).

### REMARK

On machines with automatic fire suppression system, the fuel shut-off solenoid valve connected to adapter (8) will automatically shut-off fuel supply to the engine when the engine is stopped.

4. After finishing the fuel system maintenance open cock (3) and vent the fuel system according to the Engine Maintenance Manual. Check to make sure all fuel lines and connections are tight and in good condition.

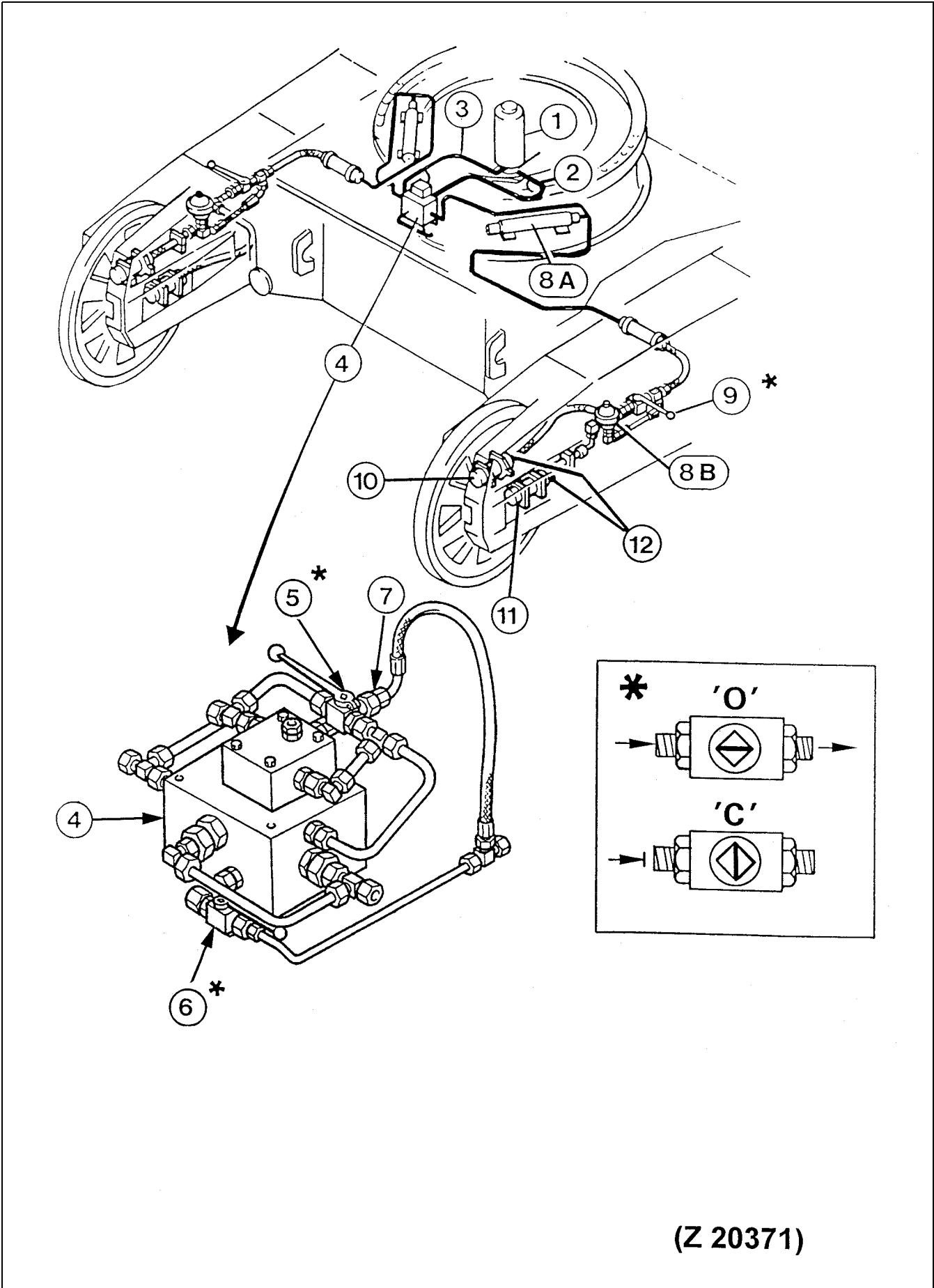

(Z 20371)

## 4.11.5 CRAWLER TRACK - INSPECTION

### CHECK ADJUSTING RANGE OF GUIDE WHEELS

(Track retensioning range)

#### GENERAL

The hydraulic track tensioning system, illust. Z 20371 maintains automatically the correct track tension. The pilot pressure oil of the travel brake release circuit is used, to pressurize the four adjusting cylinders (10) and (11). The resulting force moves the guide wheels toward the front, until the correct track tension is obtained. External forces acting upon the guide wheels are absorbed through the pressure accumulators (8A) and (8B).

#### Legend for illust. Z 20371:

- (1) Rotary distributor
- (2) Supply line, pilot pressure from travel brake release circuit
- (3) Return oil line (leakage oil)
- (4) Valve block
- (5) Pressure relief cock for hydraulic track tensioning system.  
"C" - Closed (Normal working position)  
"O" - Open
- (6) Shut-off cock in supply line  
"O" - Open (Normal working position)  
"C" - Closed
- (7) Two stage pilot pressure operated relief valve
- (8A) Pressure accumulator, high pressure (150 bar)
- (8B) Pressure accumulator, low pressure (31 bar)
- (9) Shutoff cocks, RH & LH  
"O" - Open (Normal working position)  
"C" - Closed
- (10) Track adjusting cylinders, inner
- (11) Track adjusting cylinders, outer
- (12) Test connectors and vent valves

#### WARNING

**Before working on the hydraulic track tensioning system, relieve all pressure in the system by opening cock (5), position 'O'. After finishing the service work close the pressure relief cock (5), position 'C'.**

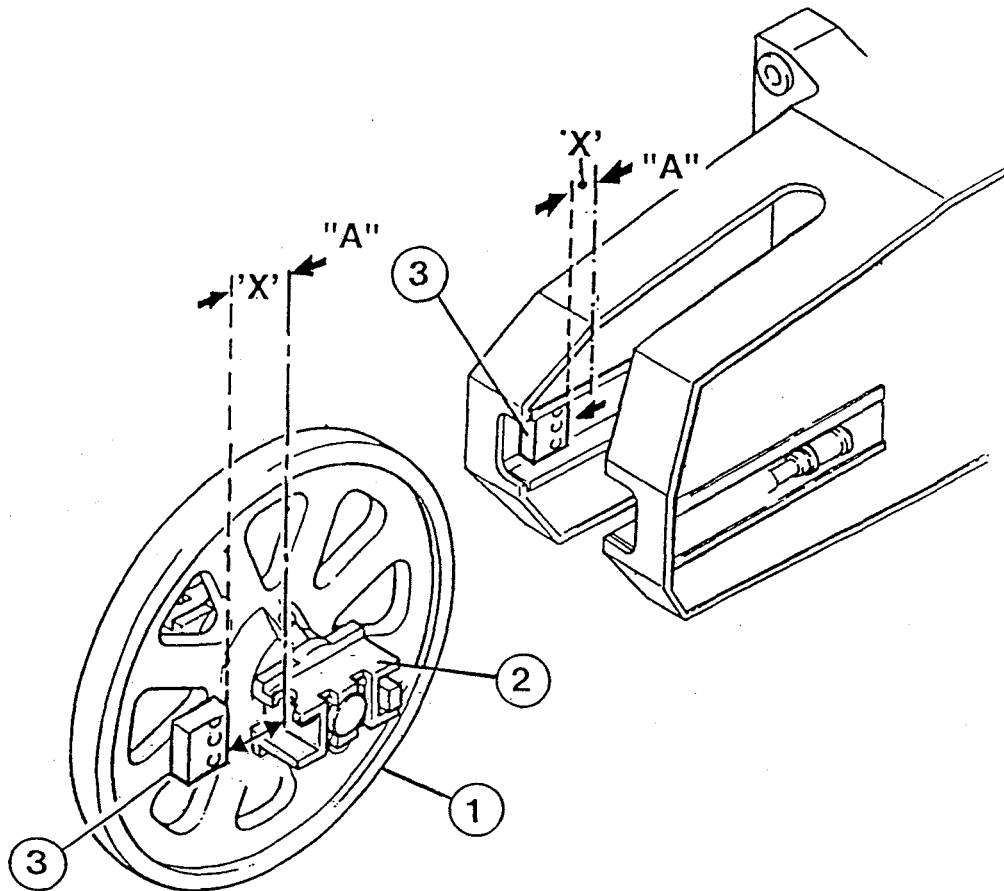
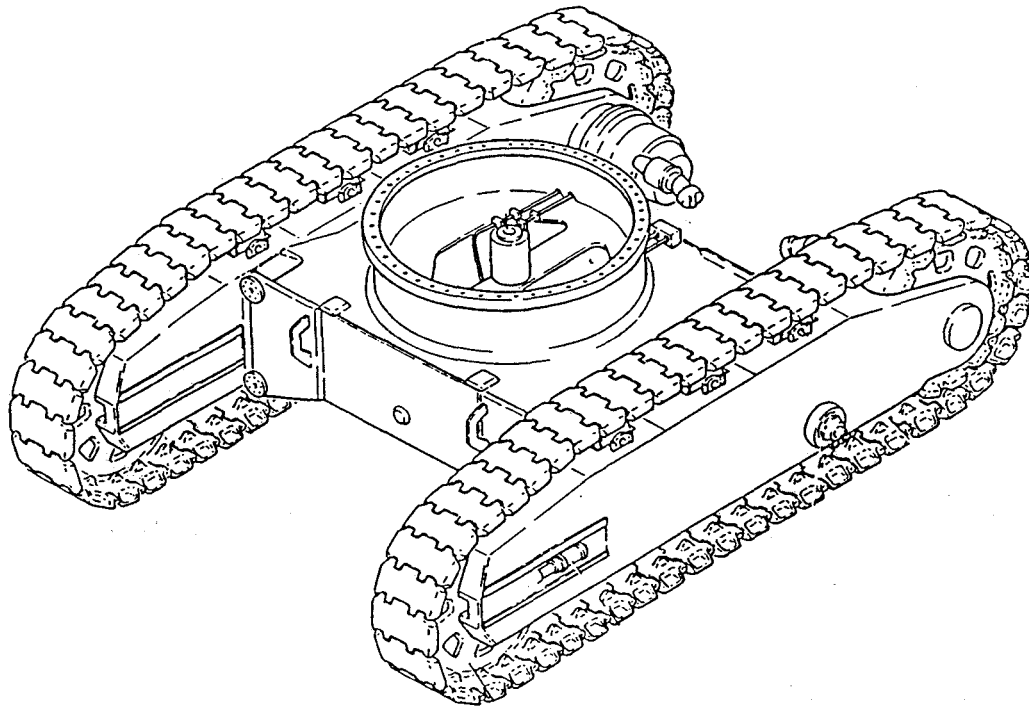

Z 20015



## CHECK ADJUSTING RANGE FOR GUIDE WHEELS

### Legend for illustration Z 20015

- (1) Guide wheel
- (2) Slide block
- (3) Stop plate

“X” Adjusting range for track tension

The adjusting range for track tension is the distance “X” between guide wheel slide block (2) and stop plate (3). Depending on lengthening of the track the slide block (2) may come in contact with stop plate (3). In such a case, it must be ensured that the track does not become too loose. Depending on track condition, the removal of one track pad will restore the adjusting range “X”. If necessary contact our Service Department for more information.

---

---

**⚠ WARNING**

---

---

**Before working on the track adjusting system, relieve all pressure in the system by opening the pressure relief cock (5), see illust. Z 20371 on previous page.**

---

---

### NOTICE

- If removal of a track pad becomes necessary, it must be done on both tracks in order to maintain the same length of both tracks.
- During operation, the pressure relief cock (5) must always be in CLOSED position. Open cock (5) for pressure relieve prior servicing any part of the system, e.g. removal of a track pad.

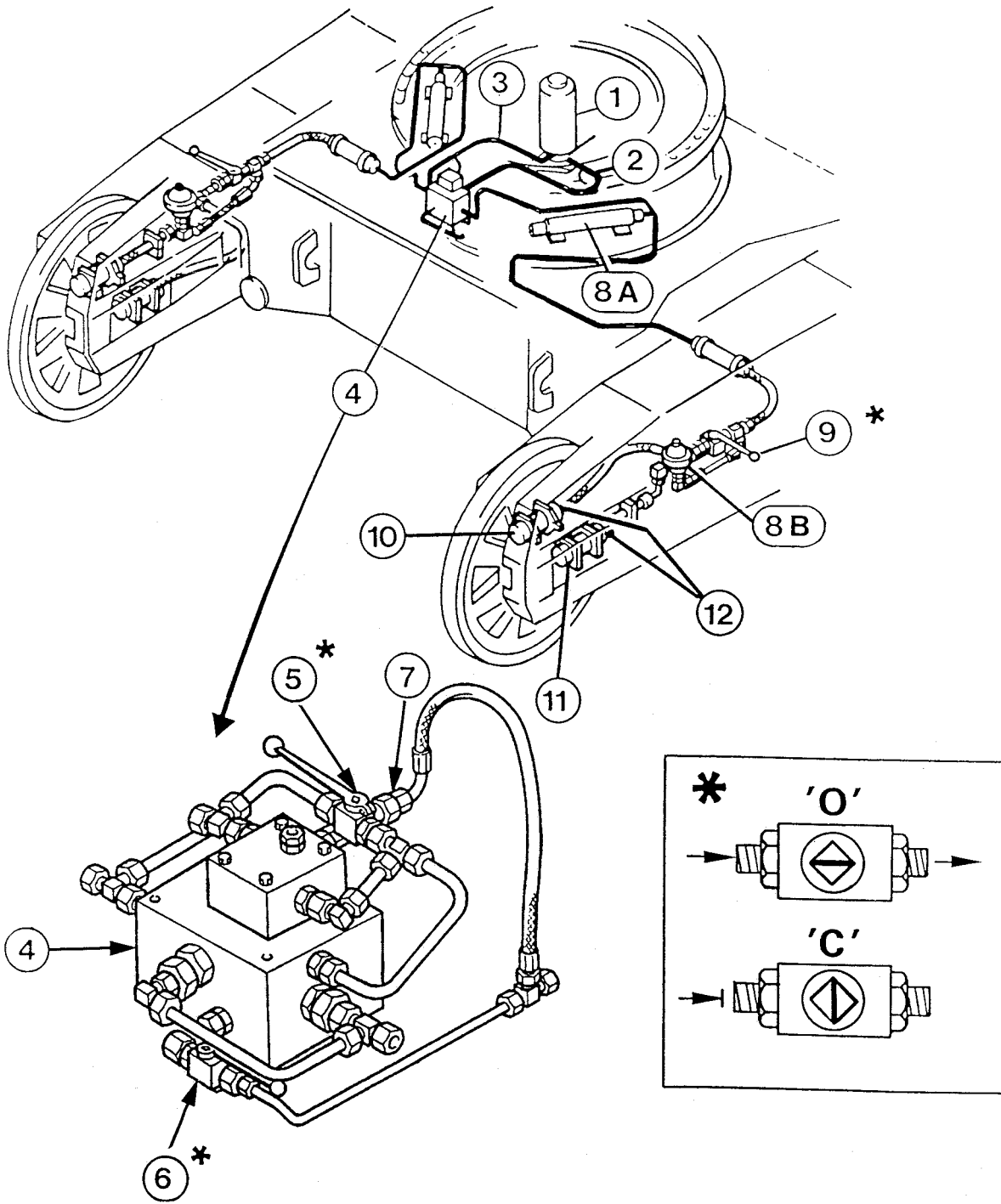

(Z 20371)

## CHECK ADJUSTING RANGE FOR GUIDE WHEELS

### NOTICE

The cocks (9), illust. Z 20371 must always be in OPEN position. Close only in such cases, when the adjusting cylinders (10 and 11) must remain under pressure while servicing other components of the system.

### Bleeding the System

1. Make sure pressure relief cock (5) illust. Z 20371 is in closed position "C"; and shutoff cocks (6 and 9) are in open position "O".
2. Start the engine/motor.
3. Slowly open vent valves (12) on all four adjusting cylinders until bubble free oil flows out. Close the vent valves (12).
4. Move the machine forward and reverse to distribute tension.
5. Check adjusting range "X" according to Illust. (Z 20015) on previous page.
6. Check the complete system for leakages.

### NOTICE

Further track group inspection and wear measurement procedures should be carried out according to the Parts and Service News Bulletin No. AH02521 filed in volume 2 binder.

# 4.12 EVERY 1000 OPERATING HOURS OR EVERY 6 MONTH

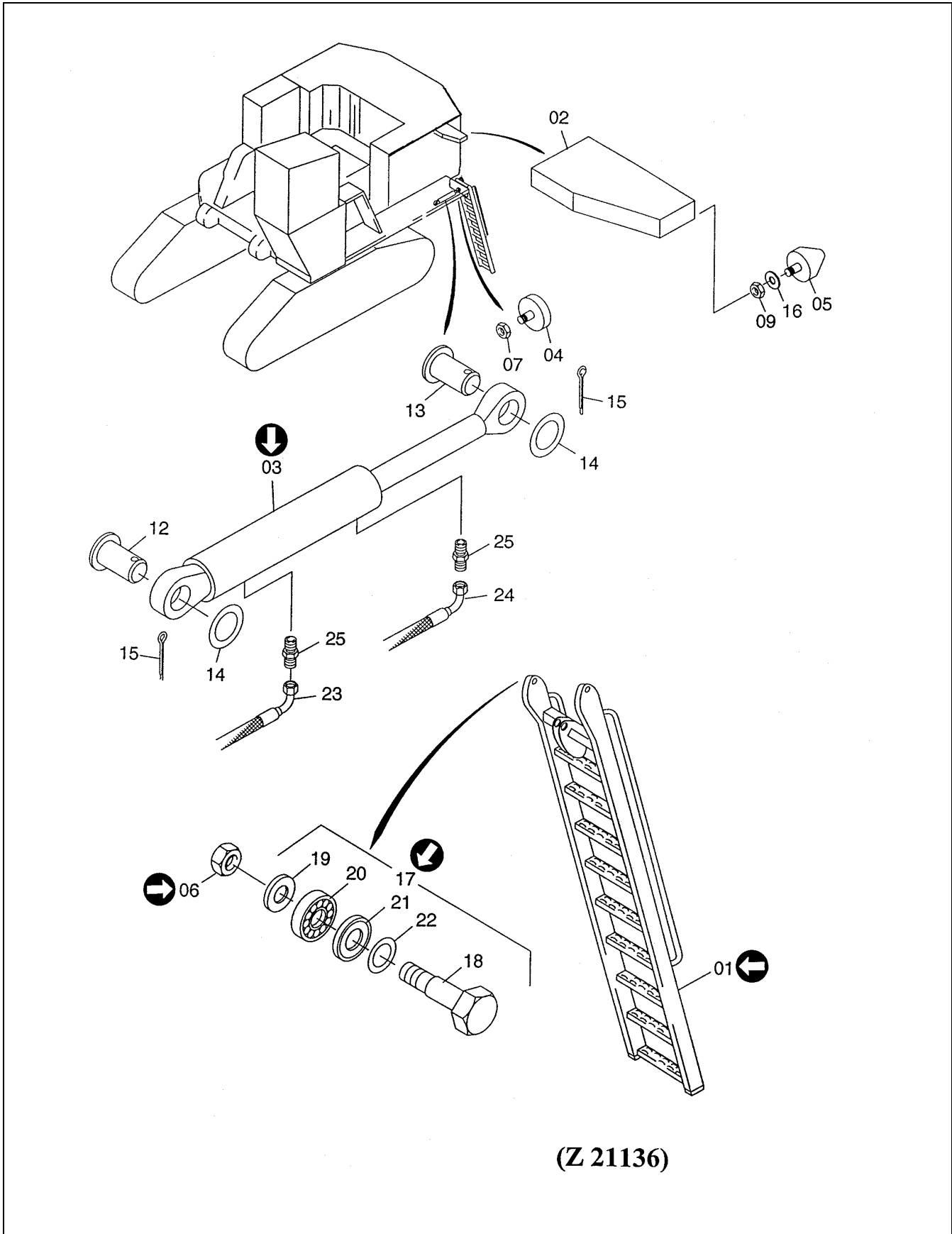

## 4.12.1 HIGH STRENGTH BOLT CONNECTIONS

Check high-strength bolt connections for correct tightening torque. Check securing elements for damage and looseness. If any damages, failures or wrong conditions are found, corrective action must be taken.

### NOTICE

- If the torque load is not stated otherwise refer to standard torque chart I for torque data.
- Bolts inserted with Multi-Purpose Grease MPG, KP2K on thread and head.

---

---

### CAUTION

---

---

When selecting the tightening torque observe quality grade and bolt size

---

---

### Hydraulic Access Ladder, illust. Z 21136

- (01) Hinged ladder
- (03) Ladder lifting cylinder
- (06) Self locking nut
- (17) Ladder bearing assembly

Check condition and fastening of hinged ladder (01), bearing assembly (17) and hydraulic cylinder (03).  
Make sure the self locking nuts (06) are correctly tightened and have not lost their clamping torque.

### Tightening Torque of Self Locking Nuts (06):

- New nut: 440 Nm
- Used nut: 350 Nm

### Clamping Torque of Self Locking Nuts (06):

- New nut: 106 Nm
- Used nut: 12 Nm minimum

Lubricate both eyes of hydraulic cylinder (03). Make sure both pivot pins (12 and 13) are properly secured with cotter pins (15). Check hydraulic lines (23 and 24) for leakage and damage. Replace as necessary.

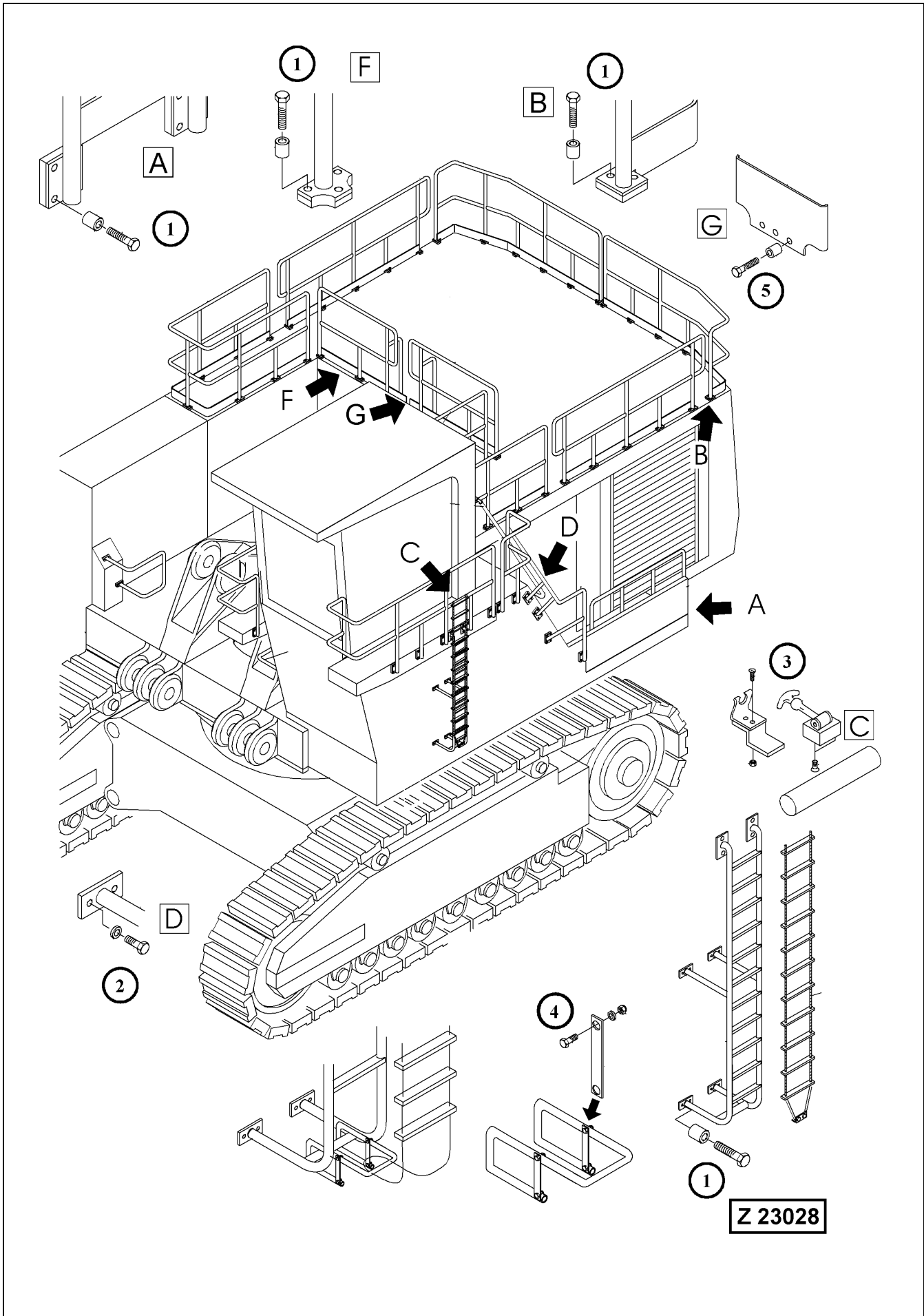

## High-Strength Bolt Connections (continued)

Check fastening and condition of railings (A, B, C, D, F and G), illust. Z 23028

Reference No.:	Bolt size mm	Grade	SW * mm	Tightening torque Nm	Qty.
(1)	M12	8.8	19	74	214
(2)	M12	8.8	19	74	4
(3)	M4	8.8	7		8
(4)	M5	8.8			4
(5)	M10	8.8	17	43	3

\* SW = Wrench size

### REMARK

Detail (C) shows the bracket for attaching the emergency escape rope ladder.

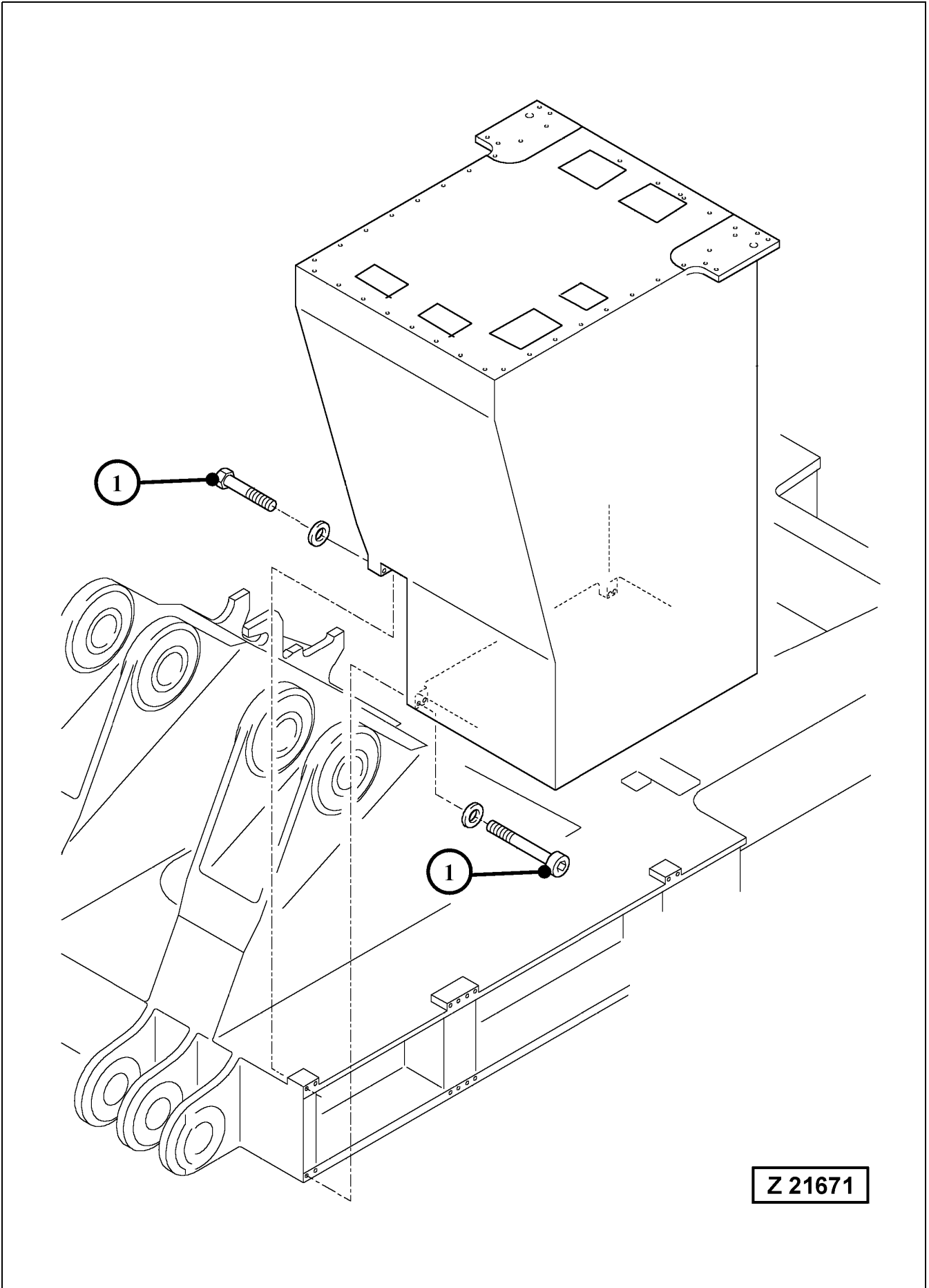



---

**High-Strength Bolt Connections (continued)****Check fastening and condition of cab base, illust. Z 21671**

<b>Reference No.:</b>	<b>Bolt size mm</b>	<b>Grade</b>	<b>SW * mm</b>	<b>Tightening torque Nm</b>	<b>Qty.</b>
(1)	M36	10.9	55	3100	8

\* SW = Wrench size

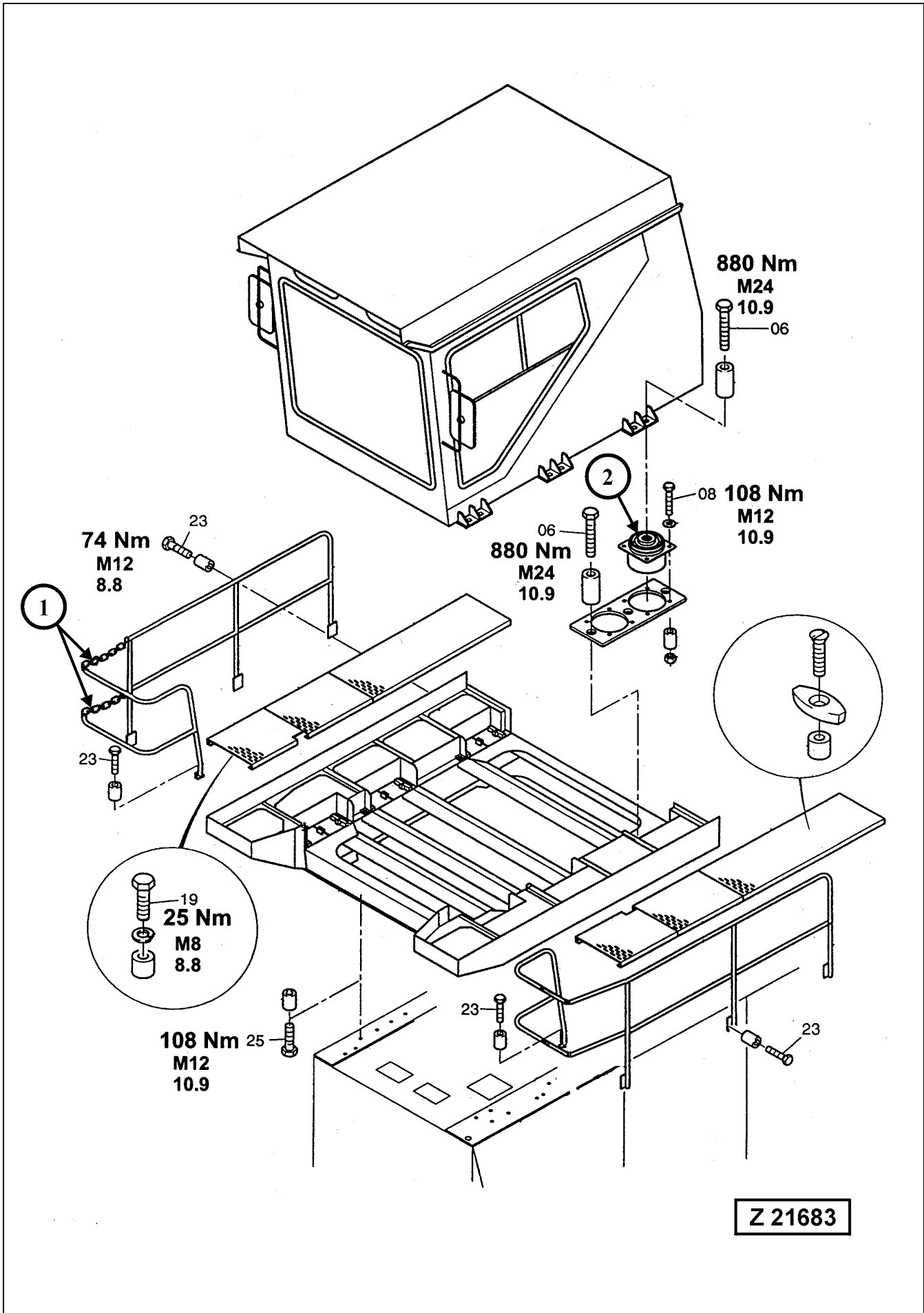

## High-Strength Bolt Connections (continued)

### Check mounting of Operator's cab, illust. Z 21683

- Check tightening torque of mounting bolts as indicated in the illustration.
- Re-tighten loose mounting bolts and replace missing or damaged bolts.
- Check condition and fastening of safety chains (1).
- Check the silicone oil filled viscous mounts (2) for leakage and signs of fatigue.

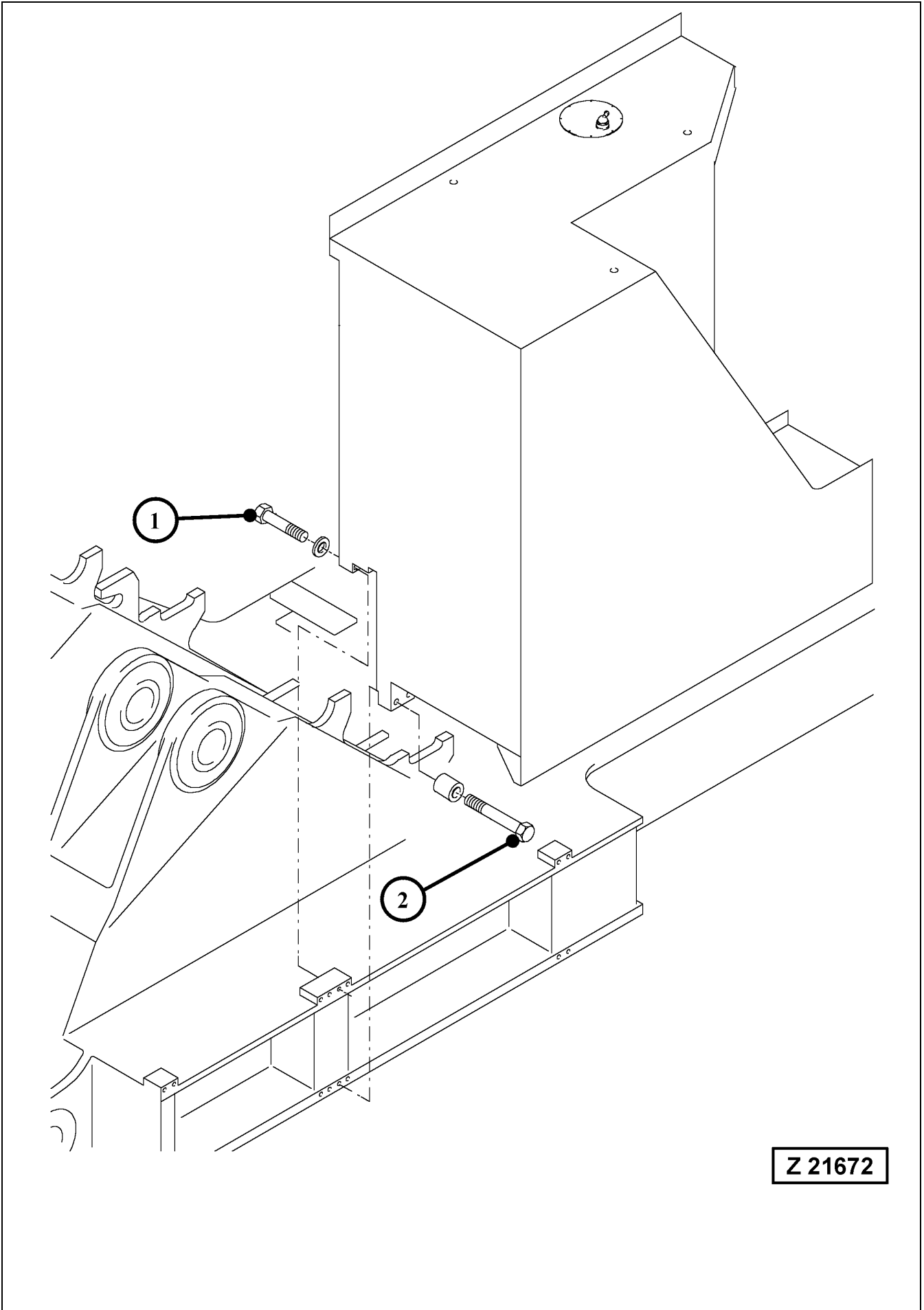

Z 21672

**High-Strength Bolt Connections (continued)****Check fastening and condition of fuel tank, illust. Z 21672**

<b>Reference No.:</b>	<b>Bolt size mm</b>	<b>Grade</b>	<b>SW * mm</b>	<b>Tightening torque Nm</b>	<b>Qty.</b>
(1)	M30	10.9	46	1770	4
(2)	M30	10.9	46	1770	4

\* SW = Wrench size

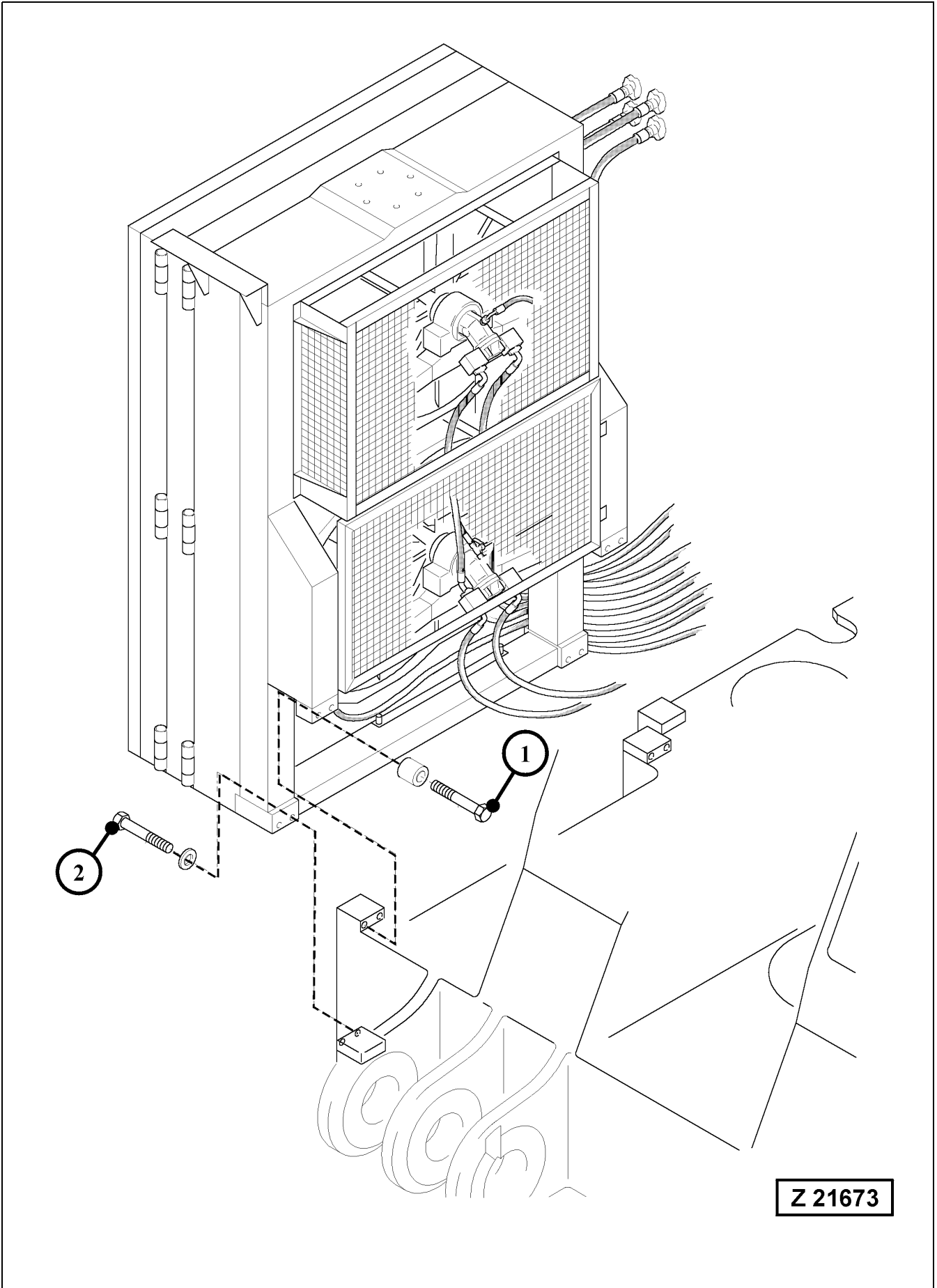

**High-Strength Bolt Connections (continued)**

Check fastening and condition of hydraulic oil cooler,  
illust. Z 21673

Reference No.:	Bolt size mm	Grade	SW * mm	Tightening torque Nm	Qty.
(1)	M30	10.9	46	1770	4
(2)	M30	10.9	46	1770	4

\* SW = Wrench size

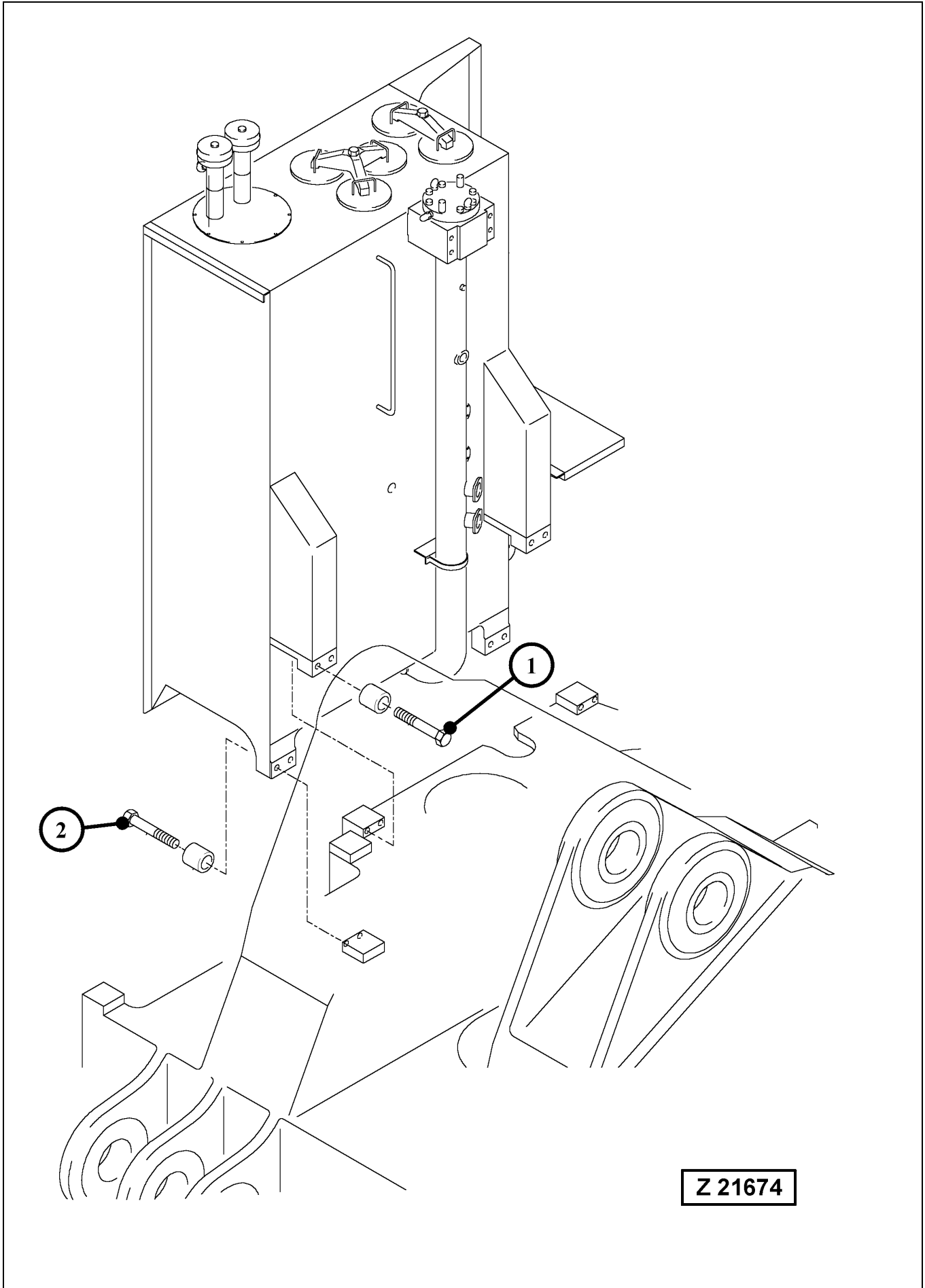

Z 21674



**High-Strength Bolt Connections (continued)**

Check fastening and condition of hydraulic oil tank,  
illust. Z 21674

Reference No.:	Bolt size mm	Grade	SW * mm	Tightening torque Nm	Qty.
(1)	M30	10.9	46	1770	4
(2)	M30	10.9	46	1770	4

\* SW = Wrench size

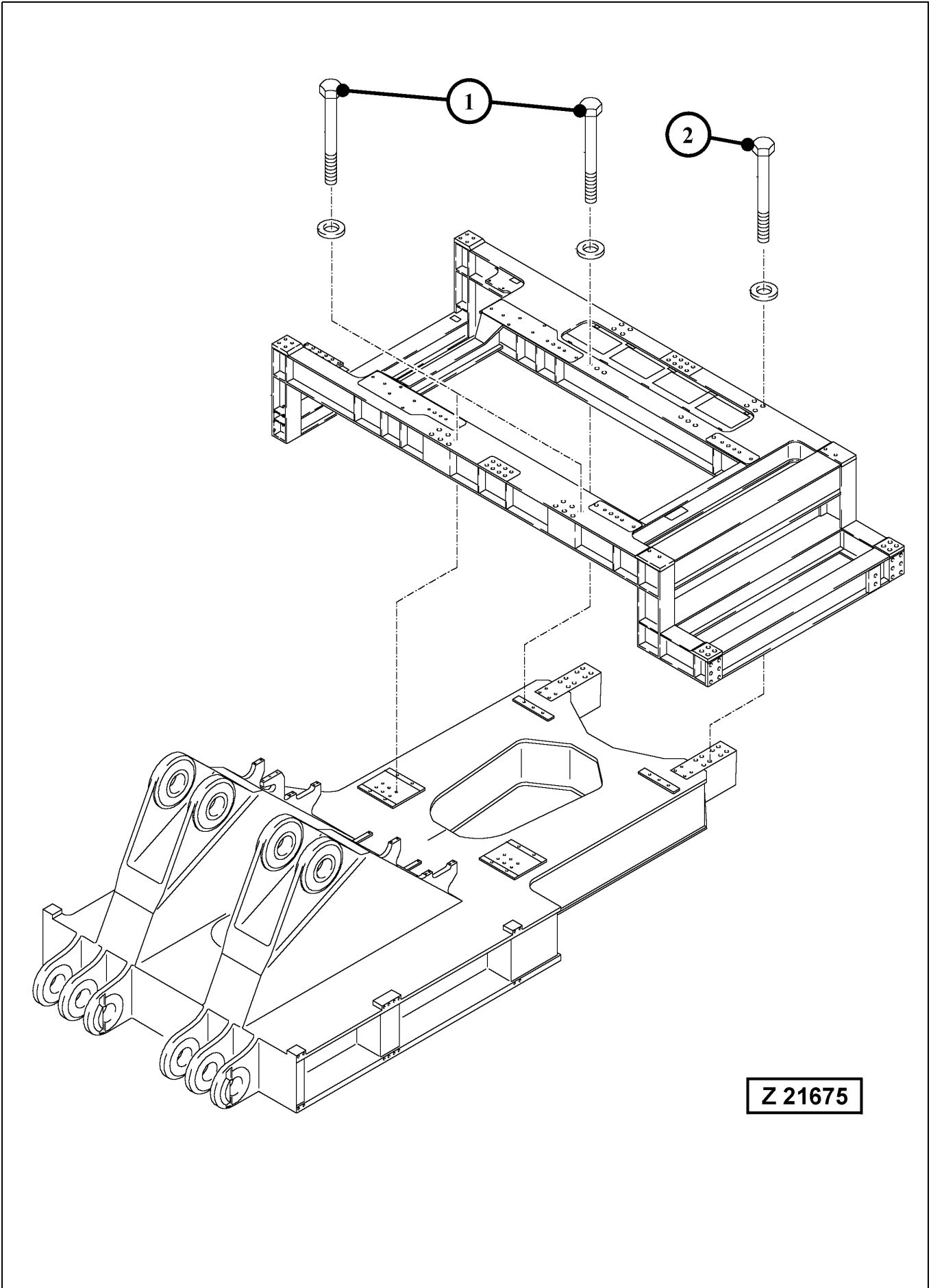

Z 21675

**High-Strength Bolt Connections (continued)****Check mounting of power frame, illust. Z 21675**

<b>Reference No.:</b>	<b>Bolt size mm</b>	<b>Grade</b>	<b>SW * mm</b>	<b>Tightening torque Nm</b>	<b>Qty.</b>
(1)	M30	10.9	46	1770	18
(2)	M30	10.9	46	1770	8

\* SW = Wrench size

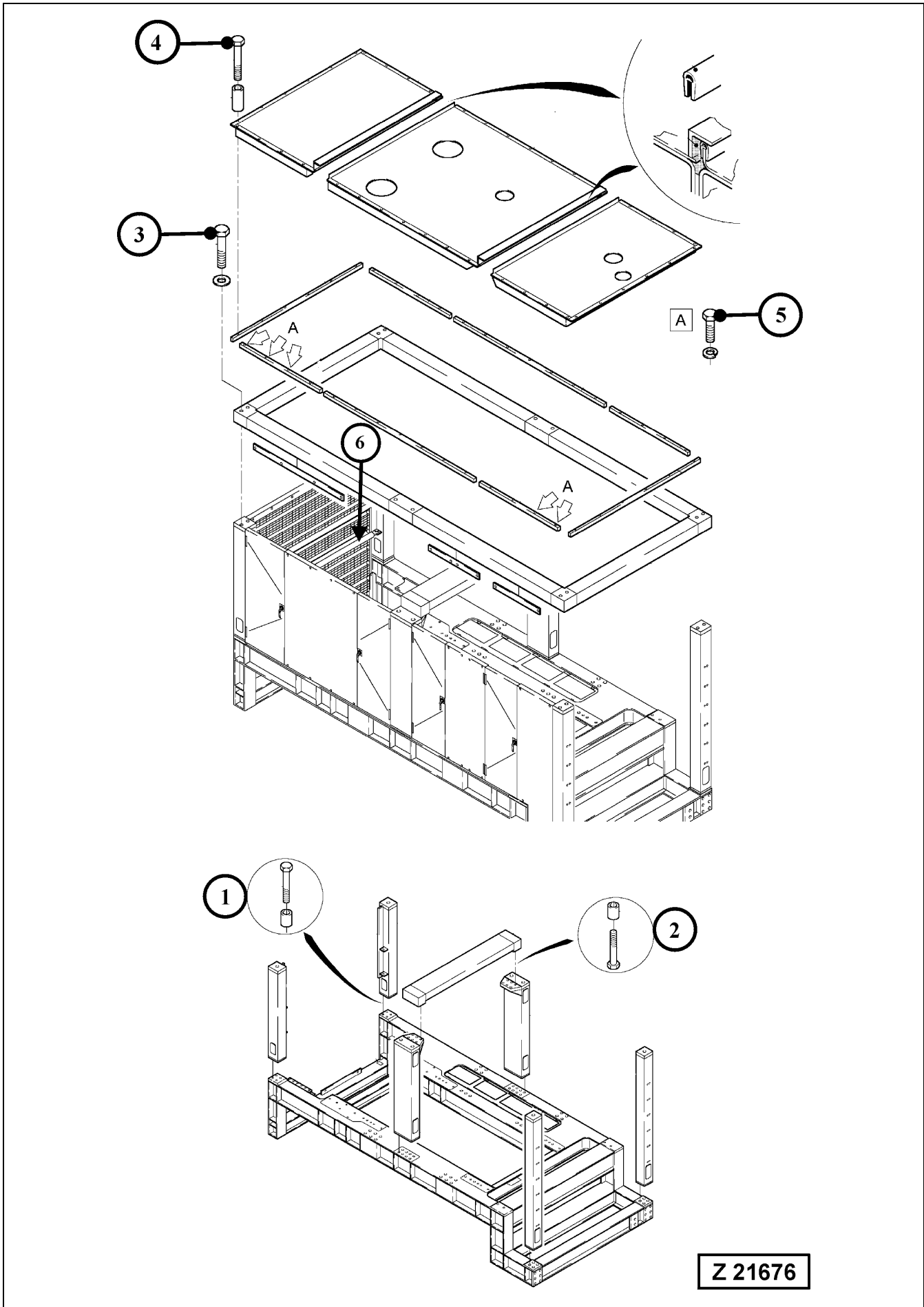

Z 21676

## High-Strength Bolt Connections (continued)

Machinery house, check mounting of posts and cross member. Check roof frame and roof elements for proper mounting and good condition, illust. Z 21676

Reference No.:	Bolt size mm	Grade	SW * mm	Tightening torque Nm	Qty.
(1)	M30	10.9	46	1770	32
(2)	M24	10.9	36	880	12
(3)	M36	10.9	55	3100	12
(4)	M12	8.8	19	74	37
(5)	M12	10.9	19	108	5

\* SW = Wrench size

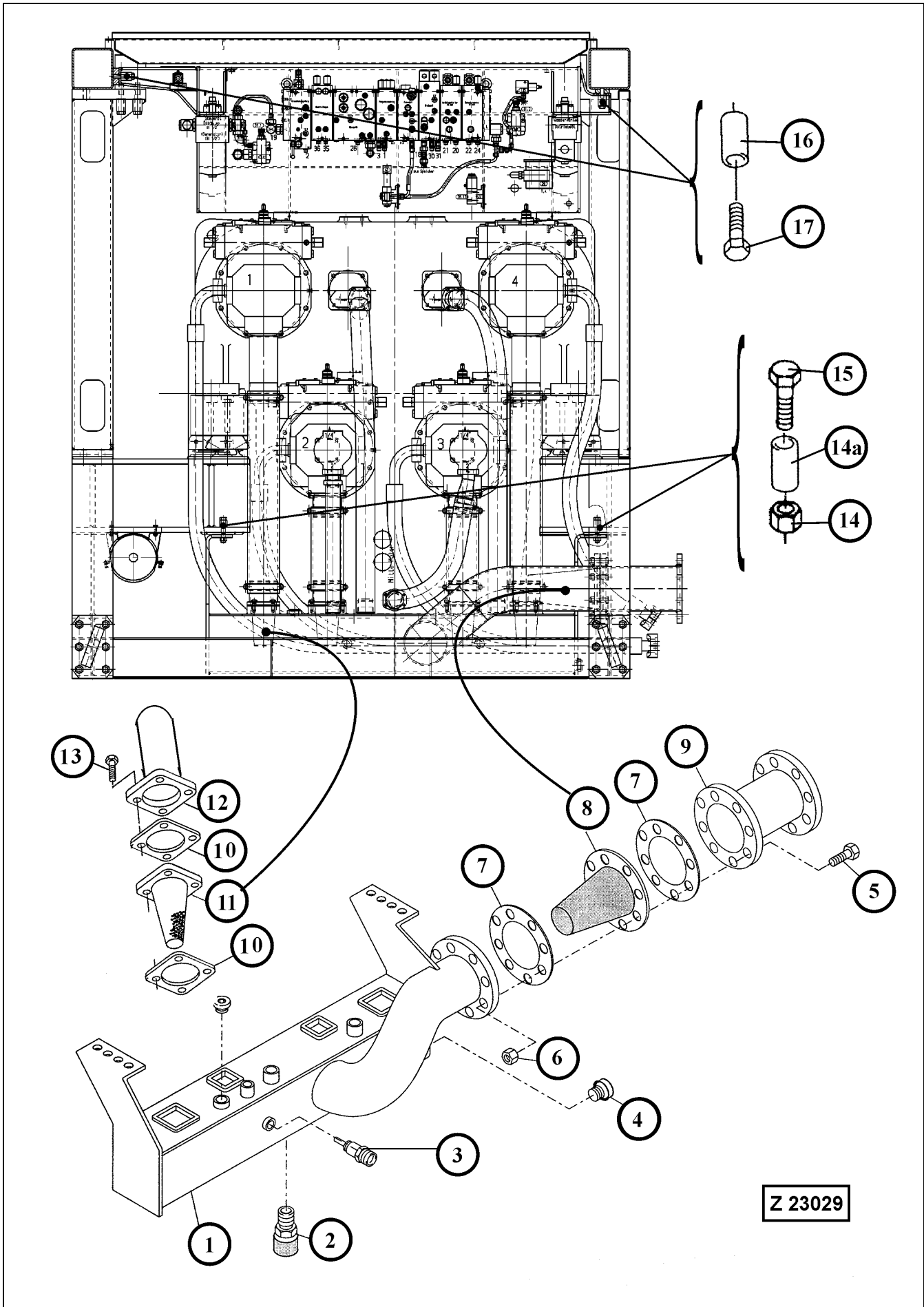

## High-Strength Bolt Connections (continued)

Check mounting and security of central control and filter panel and of the suction oil tank, illustration Z 23029

Legend for illustration (Z 23029):

Reference No.:	Bolt size mm	Grade	SW * mm	Tightening torque Nm	Qty.
(1) Suction oil reservoir					
(2) Drain coupling					
(3) Pressure switch					
(4) Plug					
(5) Bolt	M20	8.8	30	360	8
(6) Nut					
(7) Gaskets					
(8) Main suction oil strainer					
(9) Intermediate pipe					
(10) Gaskets					
(11) Suction oil strainer, one for each main pump					
(12) Suction hose connector pipe					
(13) Bolt	M16	8.8	24	179	16
(14) Lock nuts					
(14a) Resilient sleeve					
(15) Bolt	M20	10.9	30	510	8
(16) Resilient sleeve					
(17) Bolt	M18	10.9	27	360	6

\* SW = Wrench size

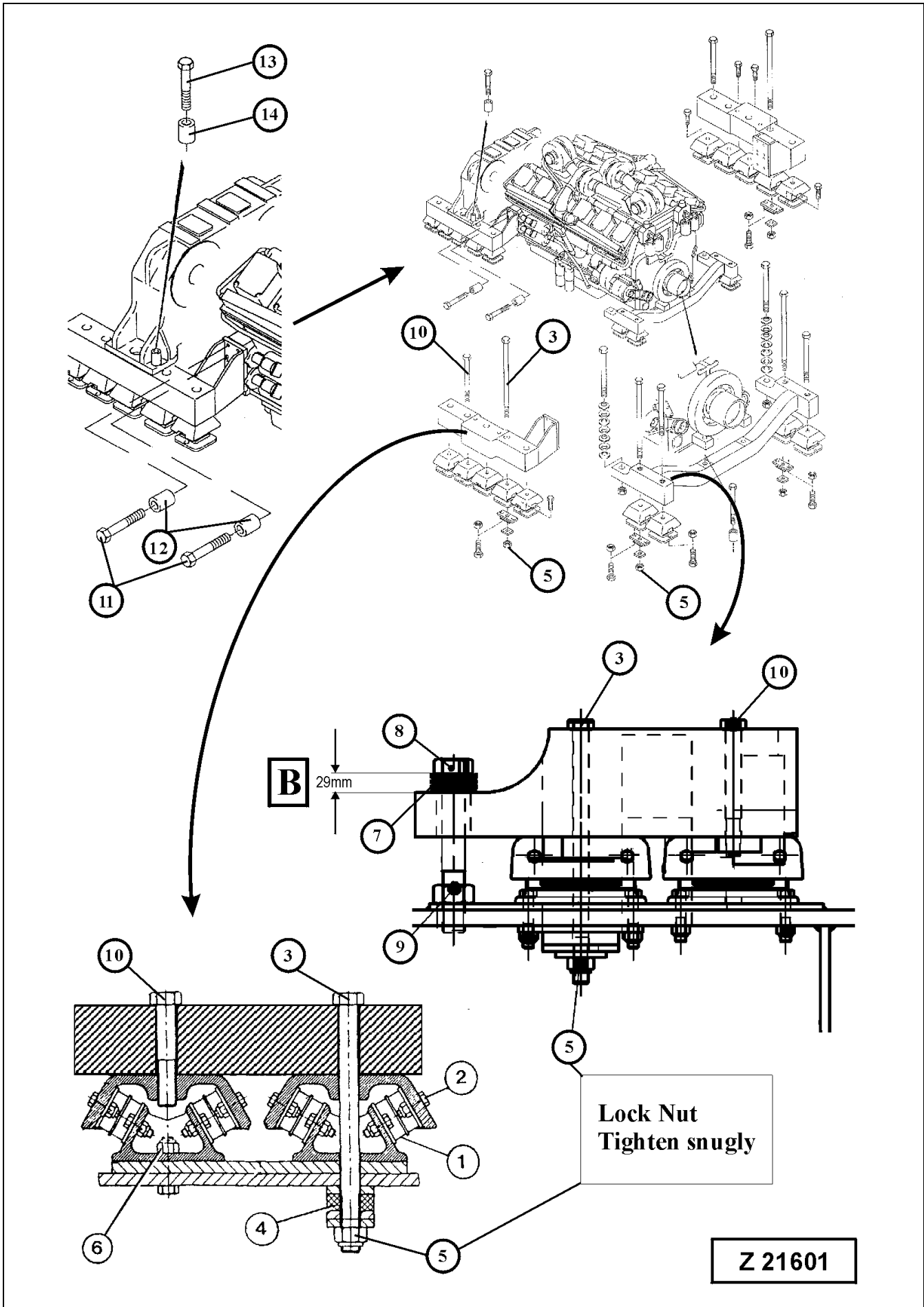



## High-Strength Bolt Connections (continued)

### Check mounting and security of Diesel engine and pump distributor gear, illust. Z 21601

- Check all flexible bearings (1) for engine and pump distributor gear.
  - Check the flexible bearings for damage and signs of fatigue. Make sure that there is no contact between the upper and lower metal brackets of the flexible bearings (1). Replace the bearings if necessary.  
After new flexible bearings have been installed, check distance (B) on both torque supports.

#### NOTICE

**All flexible bearings (1) and all rubber-bounded metal bars (4) should be replaced during engine overhaul.**

- Check distance (B) between torque support and stop bolt (8).
  - With setting of the flexible engine bearings (1) the distance (B) increases and must be adjusted. To do this, loosen lock nut (9) and tighten stop bolt (8) until the correct distance (B) is obtained. Tighten lock nut (9) and recheck distance (B).  
If new flexible engine bearings (1) have been installed, replace also cup springs (7) and adjust distance (B) to 29 mm.
- Check tie bolts (3) on front and rear carrier units for looseness.
  - Check to make sure that the self locking retainer nuts (5) are tight and that there is no gap between nut and rubber-bounded metal bar (4).  
If necessary retighten retainer nuts (5) snugly.  
Check rubber-bounded metal bars (4) for signs of fatigue and damage.  
Replace as necessary.

#### NOTICE

- **Check all bolt connections for correct tightening torque.**
- **Check condition of engine carrier and brackets. If any damages, failures or wrong condition are found, corrective action must be taken.**

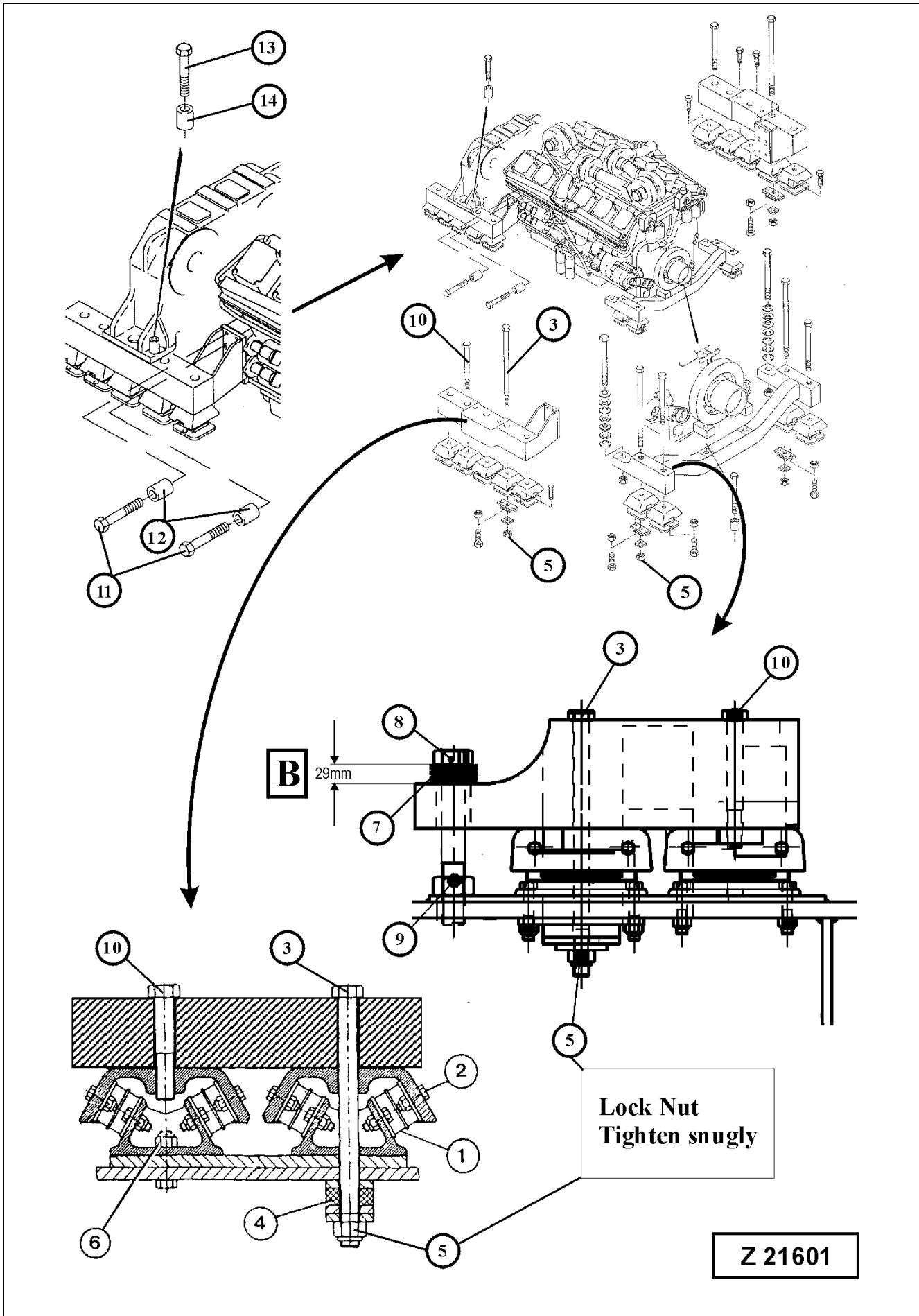

## High-Strength Bolt Connections (continued)

Check mounting and security of Diesel engine and pump distributor gear, illust. Z 21601

Legend for illustration (Z 21601):

Reference No.:	Bolt size mm	Grade	SW * mm	Tightening torque Nm	Qty.
(1) Flexible bearing					14
(2) Bolt w/self locking nut	M10	8.8	17	43	112
(3) Tie bolt	M24	10.9	36	snugly	4
(4) Rubber bounded metal bar					4
(5) Self locking nut	M24	8.0	36	snugly	4
(6) Bolt w/self locking nut	M16	10.9	24	265	20
(7) Cup springs					14
(8) Stop bolt	M36	10.9	55	to distance "B"	2
(9) Lock nut	M36	10.0	55		2
(10) Bolt	M24	10.9	36	880	10
(11) Bolt	M20	10.9	30	510	16
(12) Resilient sleeve					16
(13) Bolt	M30	10.9	46	1770	4
(14) Resilient sleeve					4

\* SW = Wrench size

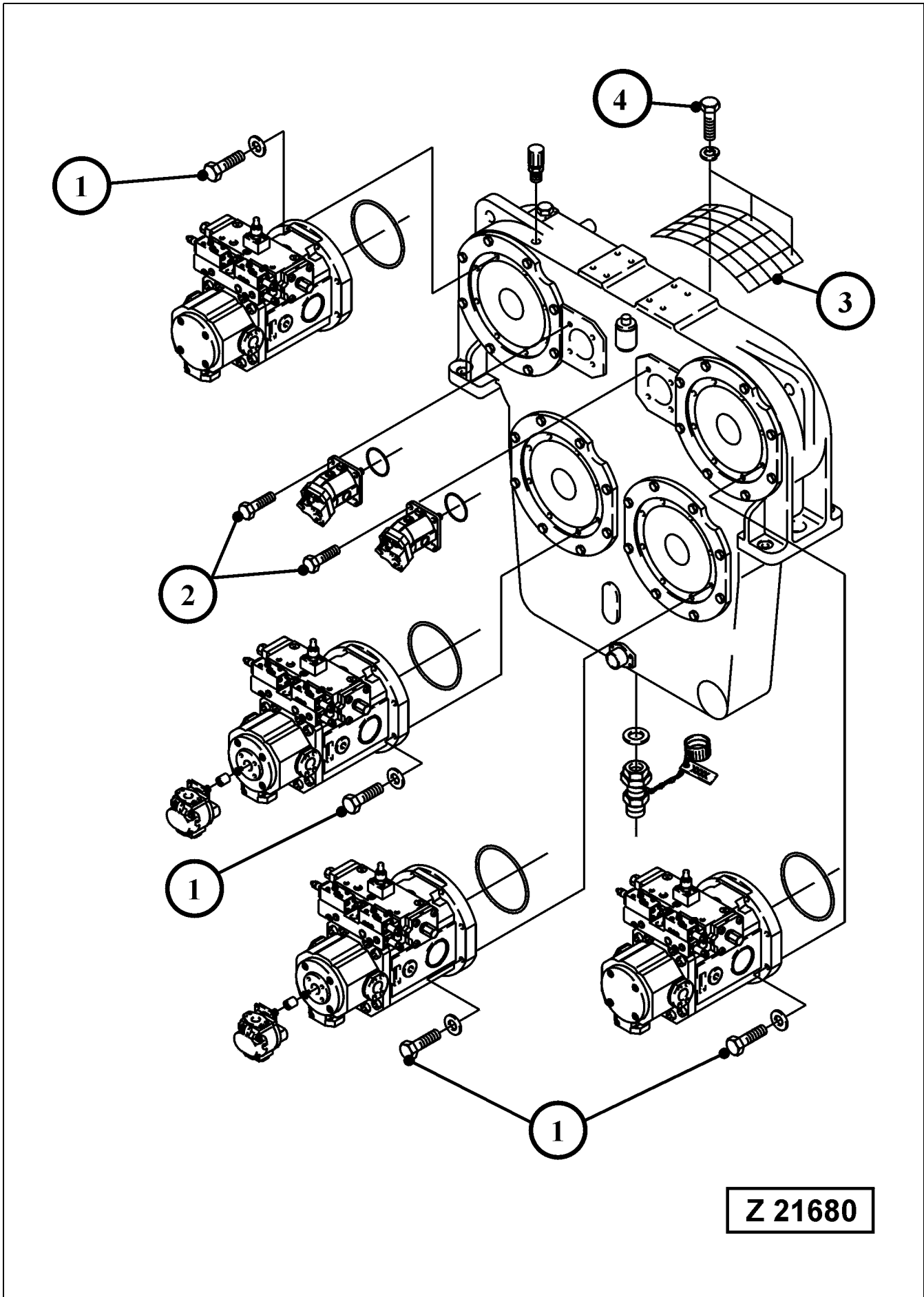

### High-Strength Bolt Connections (continued)

Check condition and fastening of the hydraulic pumps,  
illust. Z 21680

Reference No.:	Bolt size mm	Grade	SW * mm	Tightening torque Nm	Qty.
(1)	M20	10.9	30	510	32
(2)	M16	10.9	24	265	8
(3)	Guard for flex- ible coupling				1
(4)	M8	8.8	15	20	3

\* SW = Wrench size

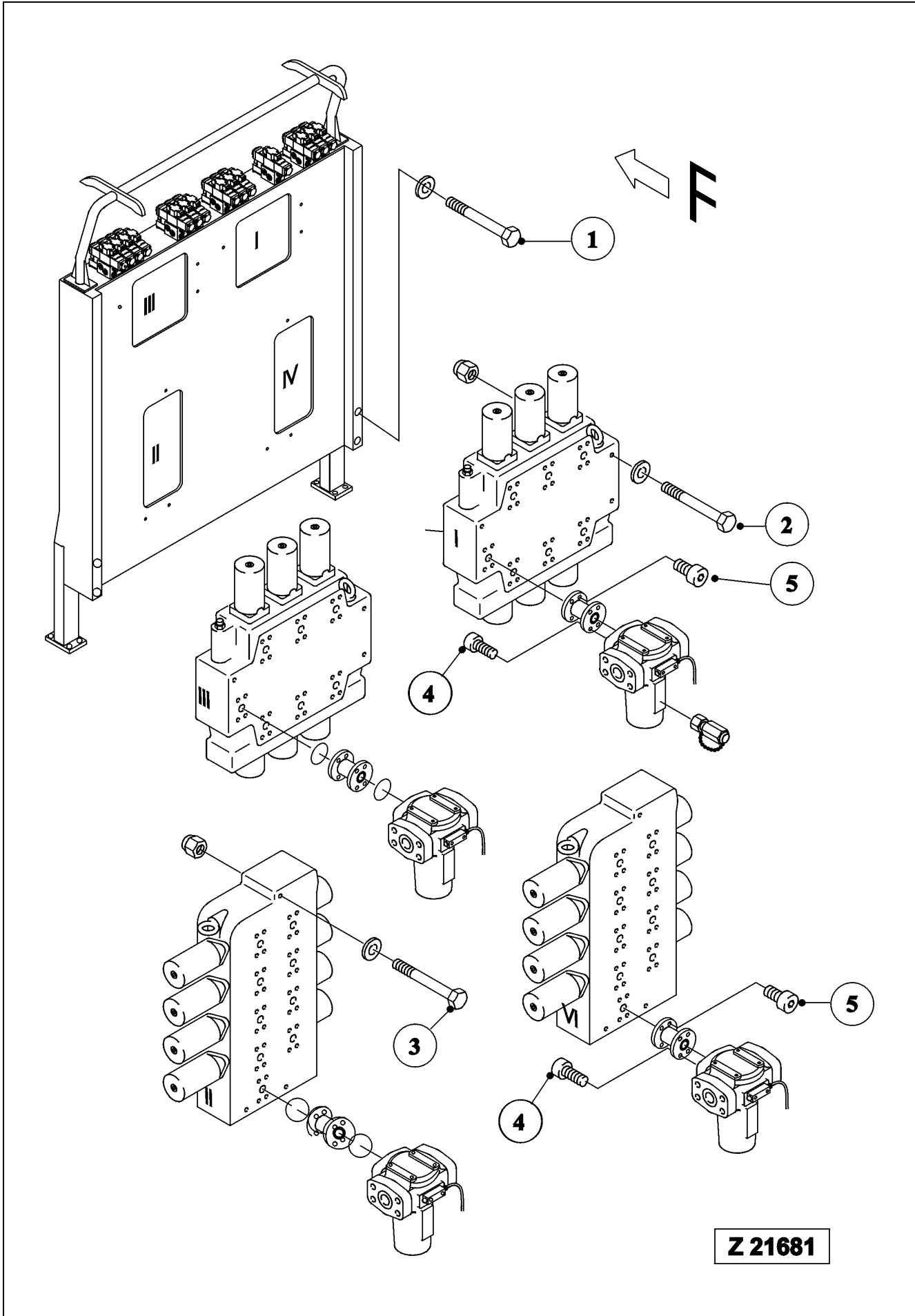

**Z 21681**

**High-Strength Bolt Connections (continued)**

Check condition and fastening of main control valves and high pressure filters, illust. Z 21681

Reference No.:	Bolt size mm	Grade	SW * mm	Tightening torque Nm	Qty.
(1)	M24	10.9	36	880	4
(2)	M16	10.9	24	265	6
(3)	M16	10.9	24	265	6
(4)	M20	10.9	30	510	16
(5)	M16	10.9	24	265	16

\* SW = Wrench size

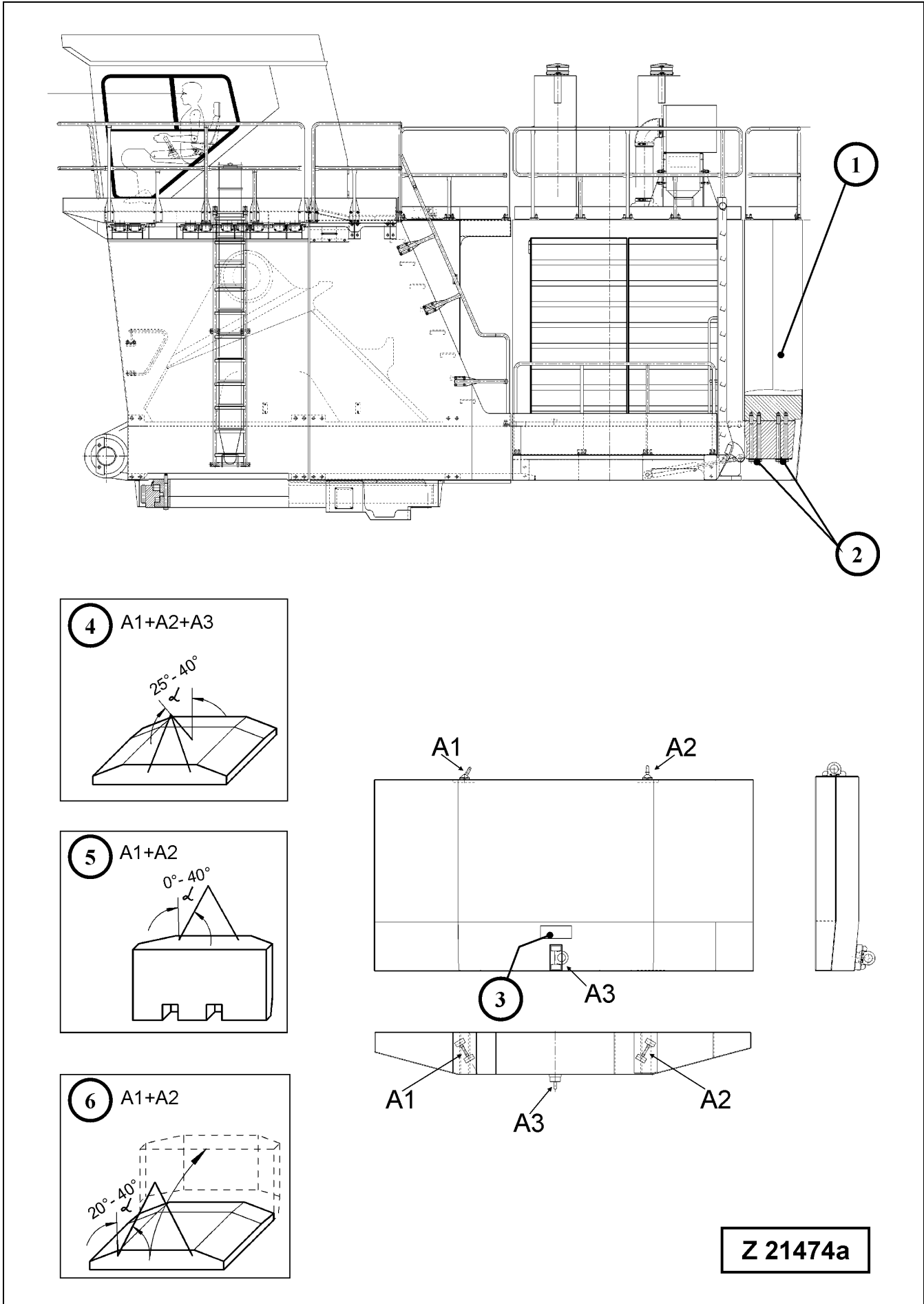



**High-Strength Bolt Connections (continued)**

**Check tightening torque of the counterweight mounting bolts (2), illustration Z 21474a**

Reference No.:	Bolt size mm	Grade	SW * mm	Tightening torque Nm	Qty.
(1) Counter weight					
(2) Mounting bolts	M42	10.9	65	4950	16
(3) Instruction label					
(4) Fastening points for horizontal transport					
(5) Fastening points for vertical transport					
(6) Fastening points for raising up the counter weight					

\* SW = Wrench size

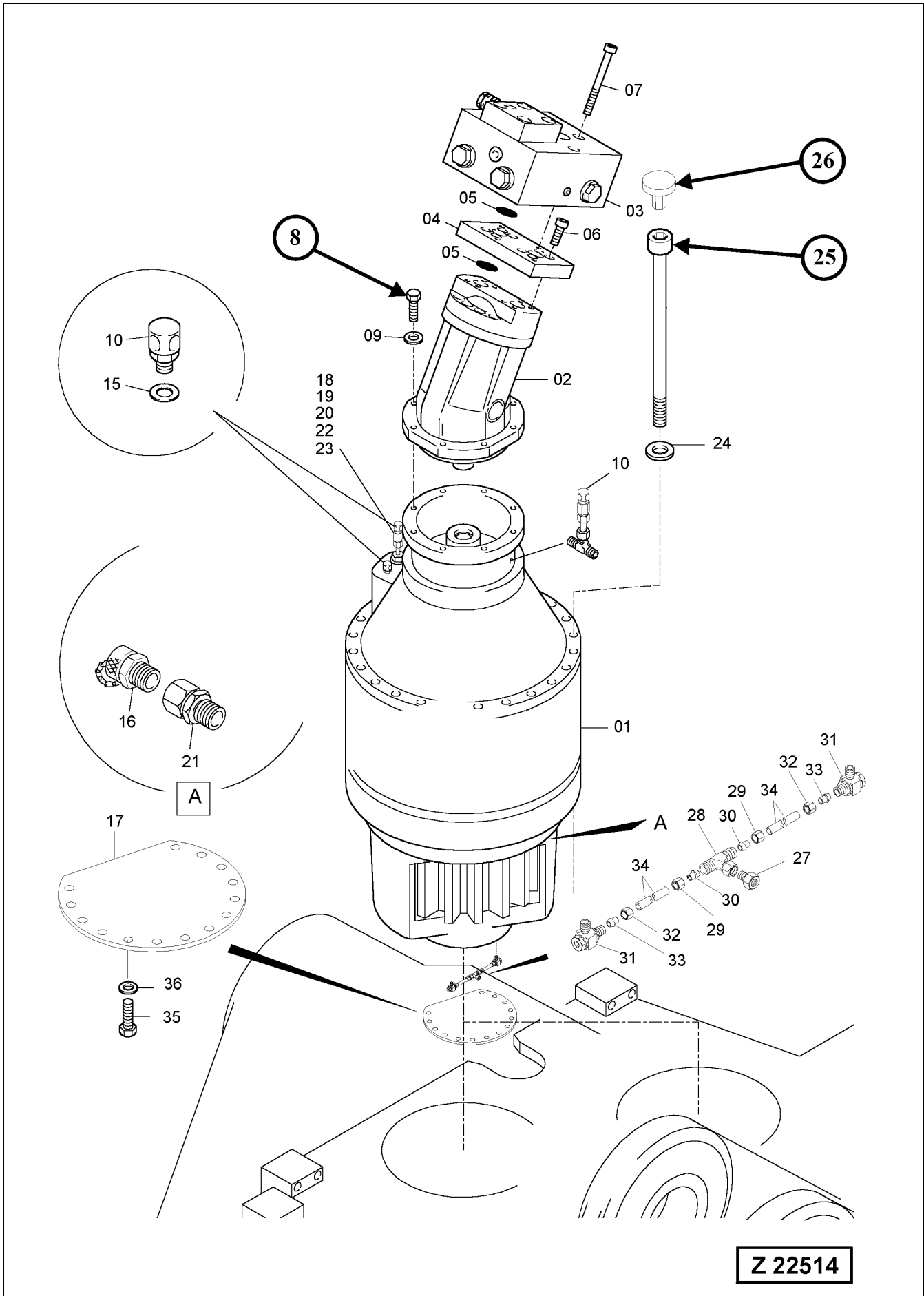

Z 22514

## High-Strength Bolt Connections (continued)

Check condition and fastening of both swing gears (01) and swing motors (02), illust. Z 22514

Reference No.:	Bolt size mm	Grade	SW * mm	Tightening torque Nm	Qty. **
(8)	M 16	10.9	24	265	16
(25)	M 24	12.9	19	1030	68

\* SW = Wrench size

\*\* Quantity for both swing gears

### REMARK

After checking and retightening of swing gear mounting bolts (25), attach protection caps (26) onto the bolt heads.

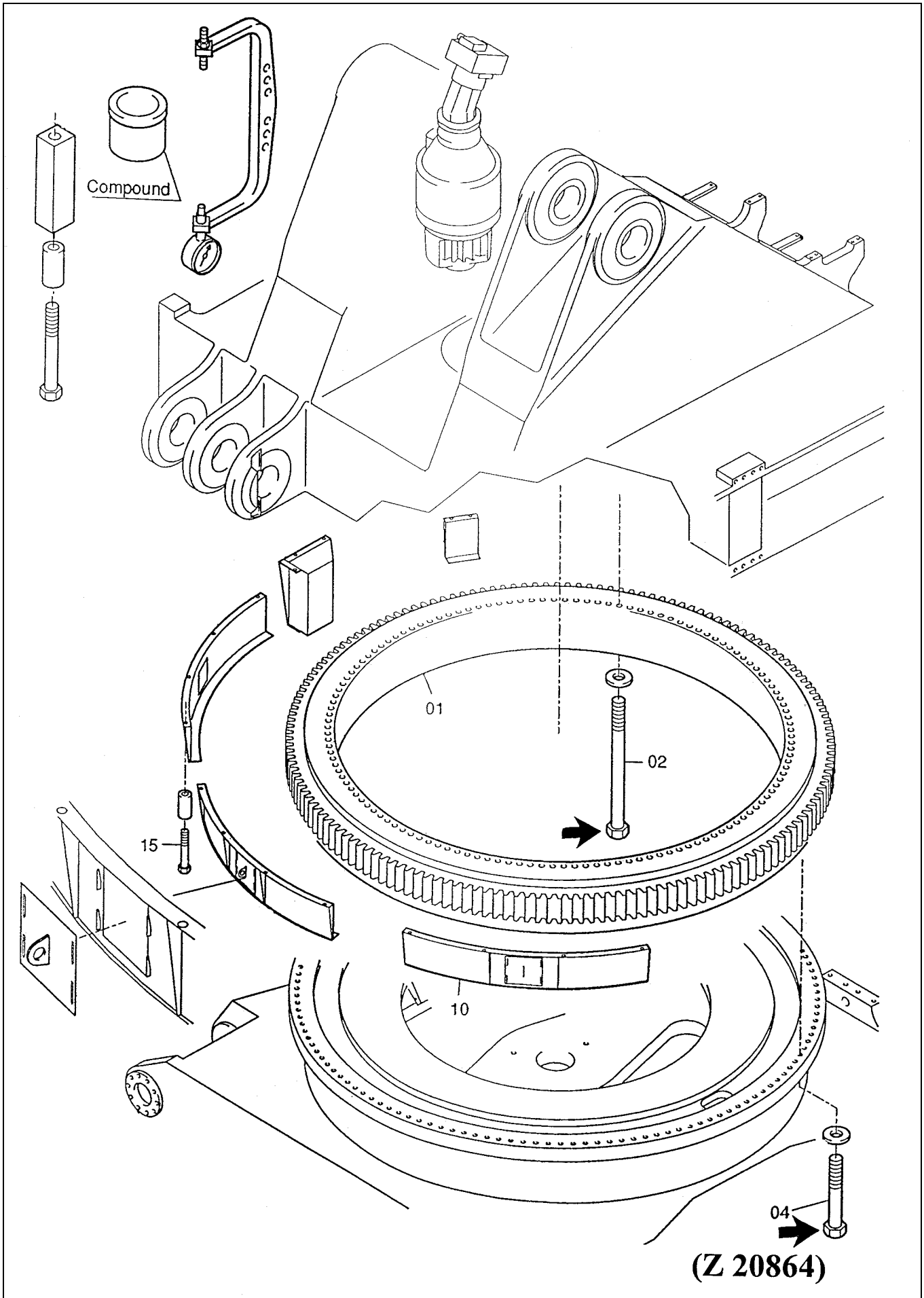

## High-Strength Bolt Connections (continued)

### Swing circle, illust. Z 20864

Check tightening torque of inner and outer mounting bolts (02 and 04) according to PARTS & SERVICE NEWS, No. AH00511.

#### **NOTICE**

**Checking/retightening of swing circle mounting bolts is only necessary after the first 1000 operating hours.**

Check condition and fastening of swing circle guard (10) and bolts (15).

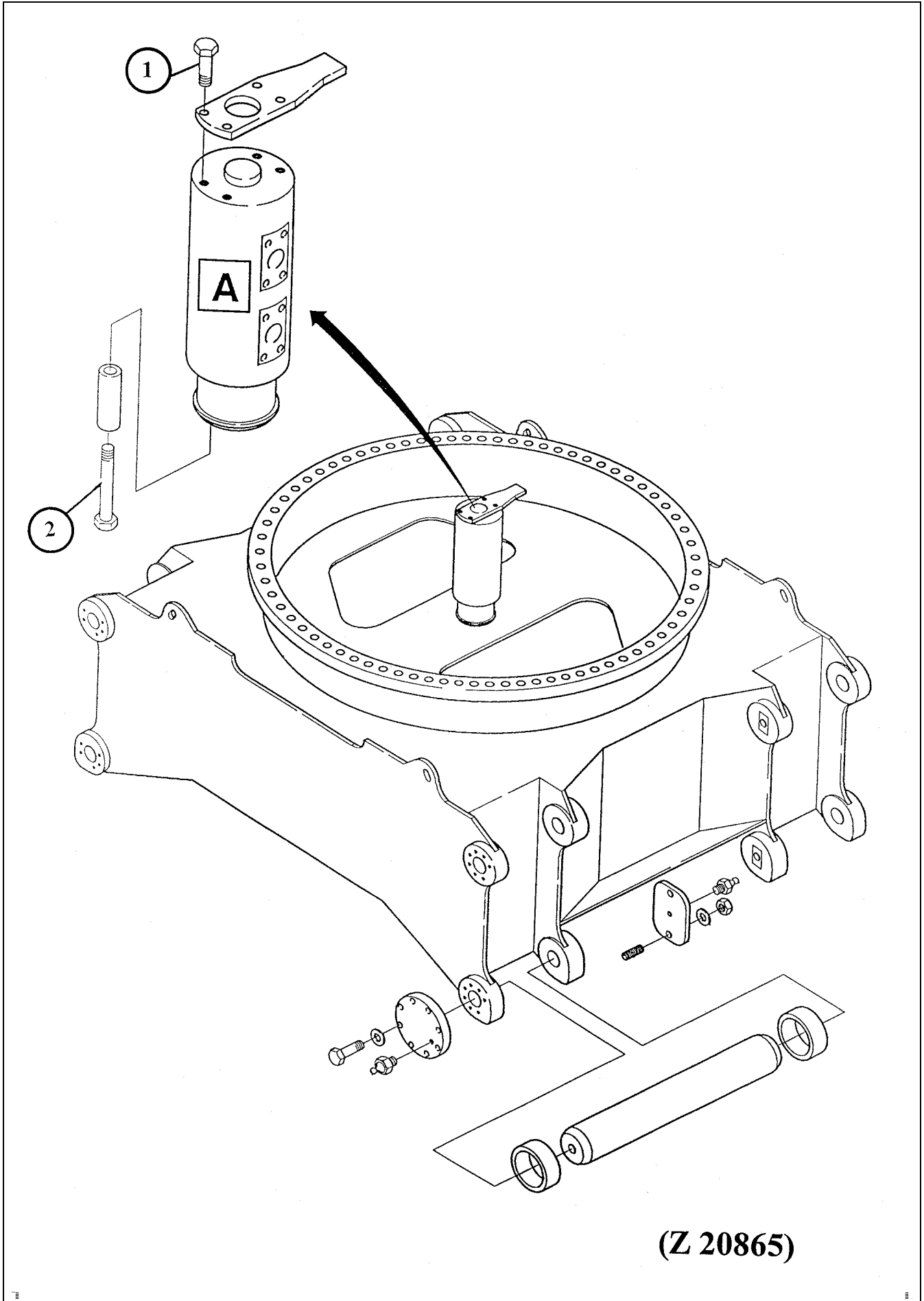

**(Z 20865)**

**High-Strength Bolt Connections (continued)**

Check condition and fastening of swivel joint (A),  
illust. Z 20865

Reference No.:	Bolt size mm	Grade	SW * mm	Tightening torque Nm	Qty.
(1)	M 16	8.8	24	179	4
(2)	M 16	10.9	24	265	8

\* SW = Wrench size

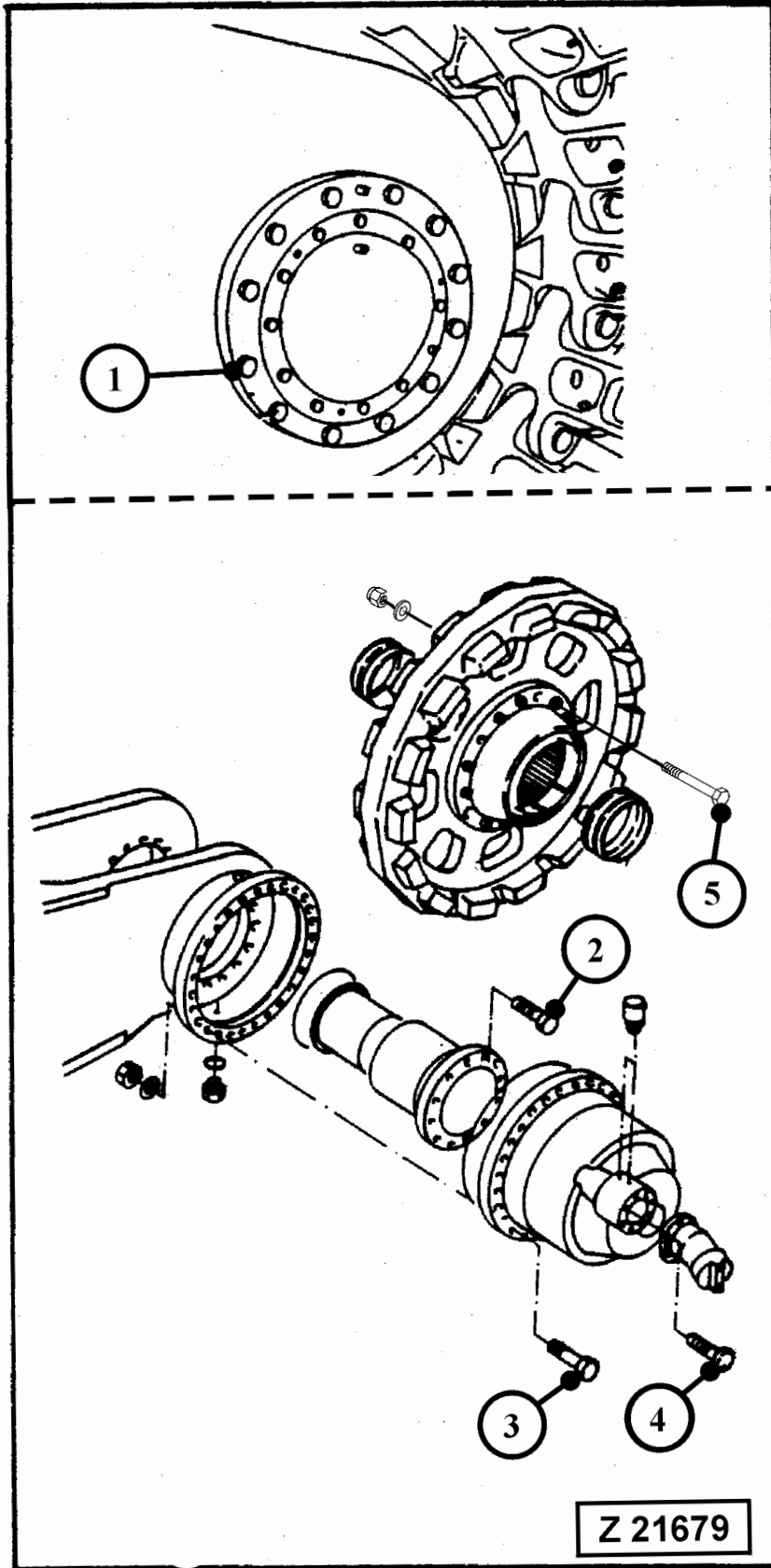



## High-Strength Bolt Connections (continued)

Check condition and fastening of travel gear and sprocket,  
illust. Z 21679

Reference No.:	Bolt size mm	Grade	SW * mm	Tightening torque Nm	Qty.
(1) see NOTICE below	M 30	8.8	46	1250	24
(2)	M 30	8.8	46	1250	24
(3)	M 36	10.9	55	3100	72
(4)	M20	8.8	30	360	16
(5)	M 36	10.9	55	3100	12

\* SW = Wrench size

### NOTICE

If bolt connections (1) have been found loose, it is necessary  
to check also the inner bolts (2) for looseness.

For this purpose the travel gear assy has to be removed.

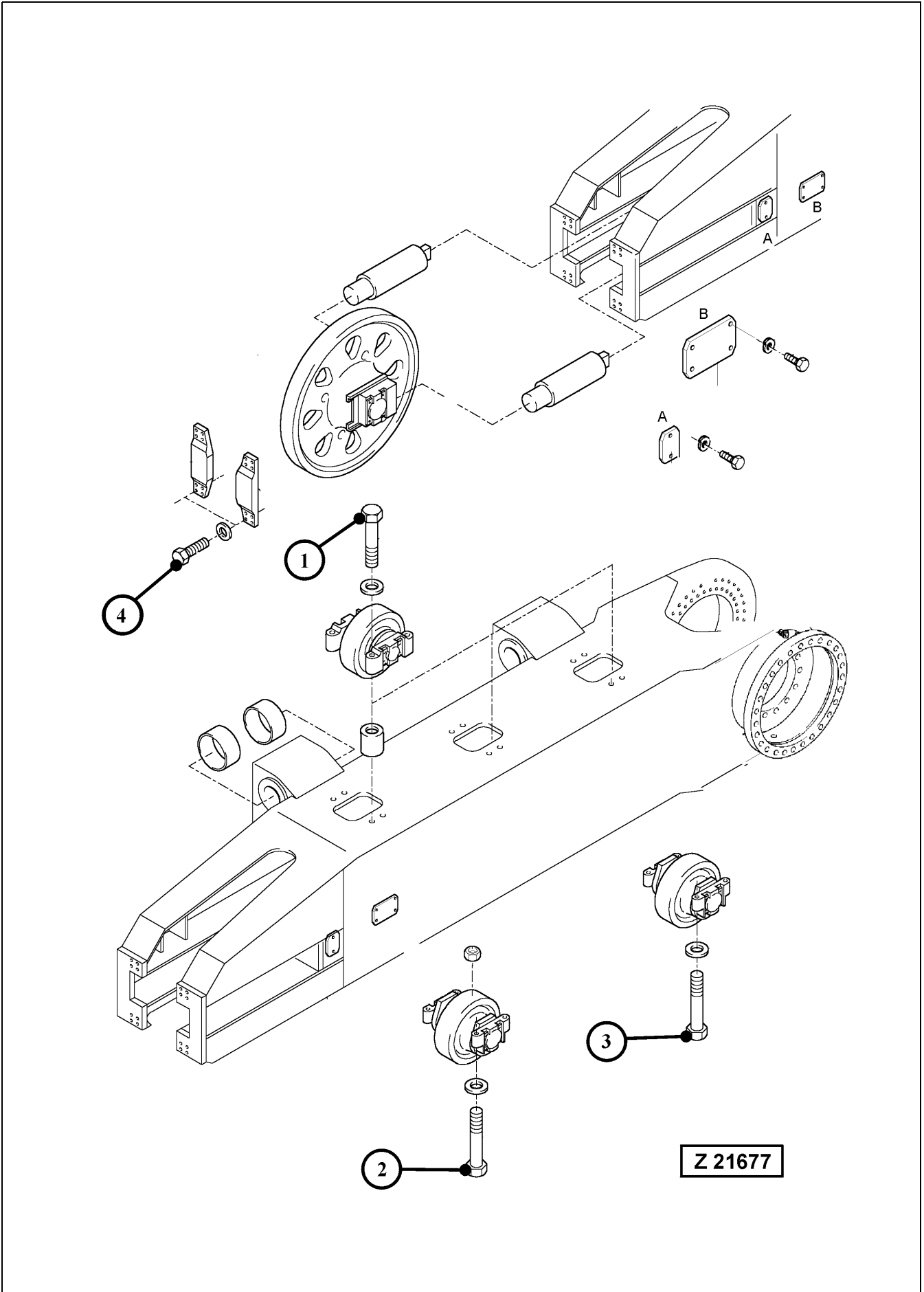

## High-Strength Bolt Connections (continued)

Check condition and fastening of track rollers and carrier rollers, illust. Z 21677

Reference No.:	Bolt size mm	Grade	SW * mm	Tightening torque Nm	Qty.
(1)	M 30	10.9	46	1770	24
(2)	M 30	10.9	46	1770	8
(3)	M 30	10.9	46	1770	48
(4)	M20	10.9	30	510	32

\* SW = Wrench size

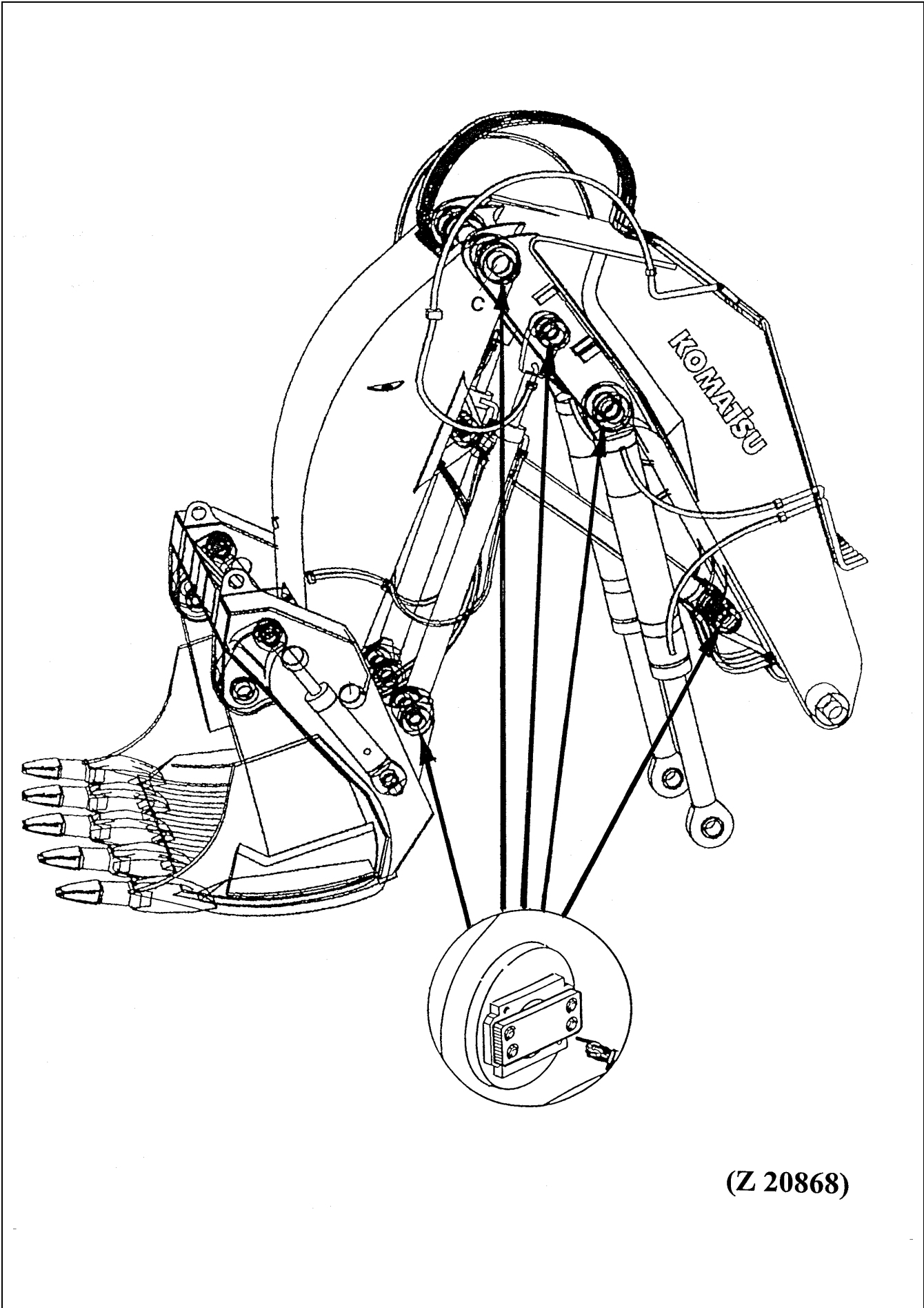

(Z 20868)

**High-Strength Bolt Connections (continued)**

Loader attachment, check condition and fastening of pin  
retainer plates and bolts, illust. Z 20868

Reference No.:	Bolt size mm	Grade	SW * mm	Tightening torque Nm	Qty.
Retainer bolts	M 16	8.8	24	179	32

\* SW = Wrench size

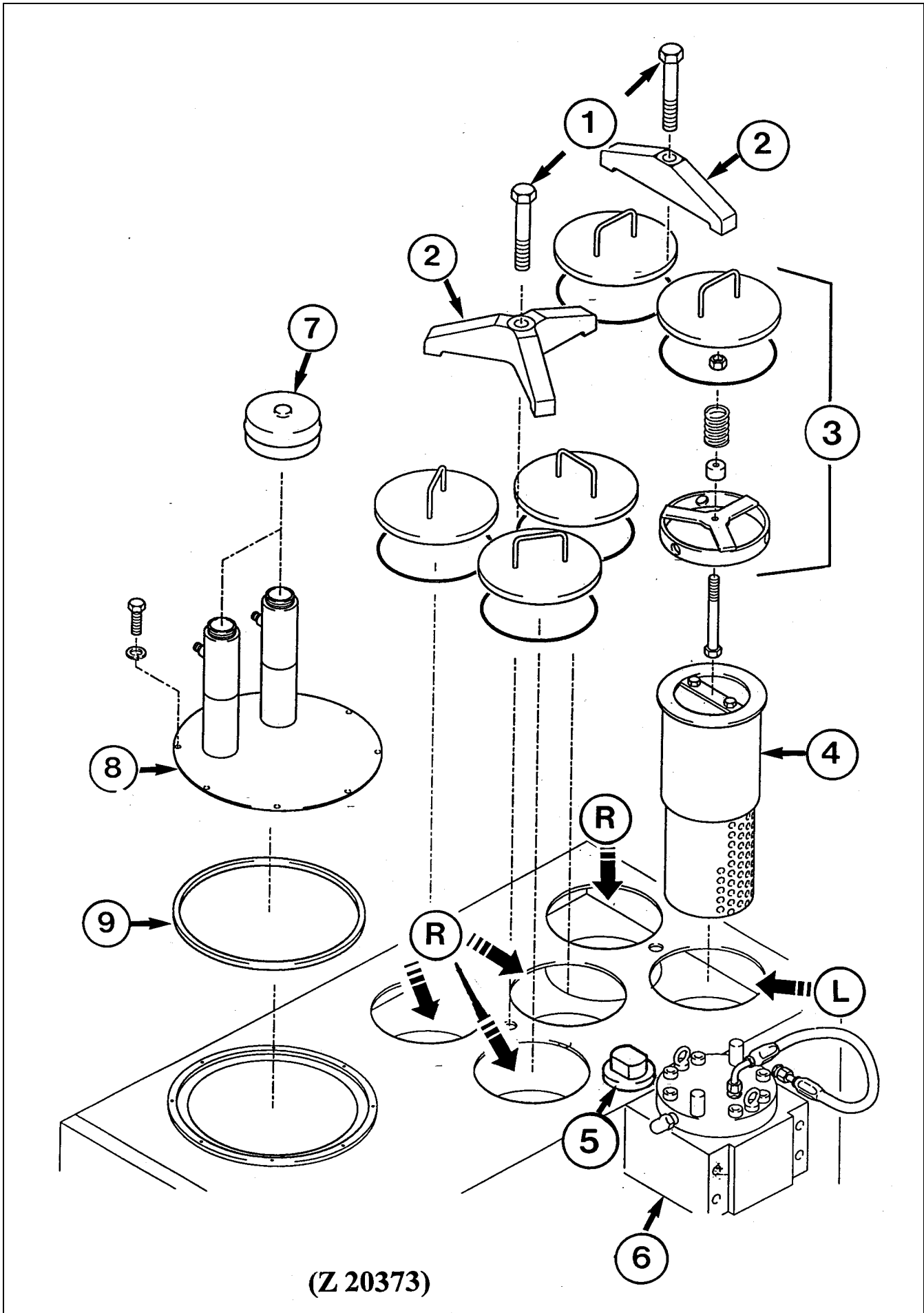

## 4.12.2 HYDRAULIC SYSTEM - FILTER SERVICE

### Legend for illust. Z 20373

R	Return of filter location
L	Leakage oil filter location
(1)	Mounting bolt
(2)	Filter cover retainer
(3)	Filter cover assy
(4)	Return- and leakage filter unit, see next page for details
(5)	Oil filler plug
(6)	Back-pressure valve
(7)	Breather filter
(8)	Cover
(9)	Gasket

### NOTICE

The description of the hydraulic filters appears in the following sequence:

- Return- and Leakage oil filters
- Breather filter
- High pressure filters
- Pressure filters on central control and filter frame (see the following pages)

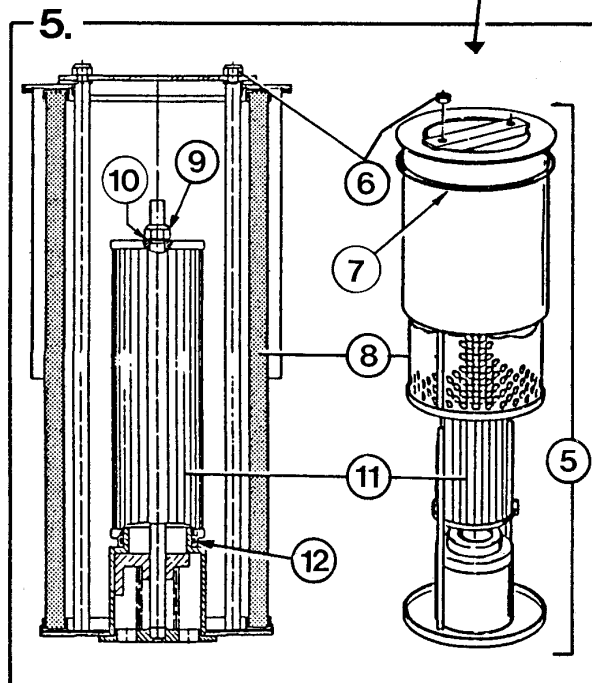
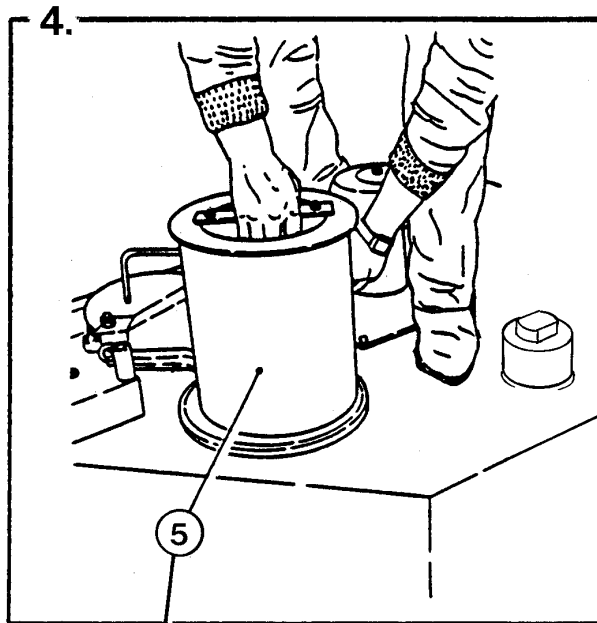
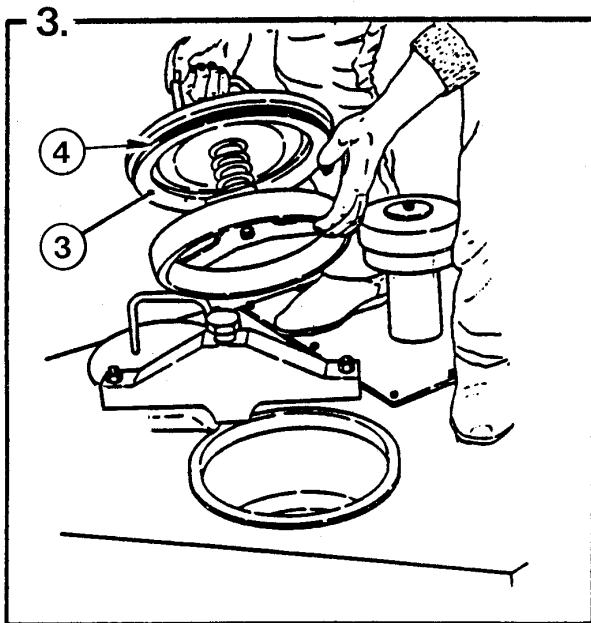
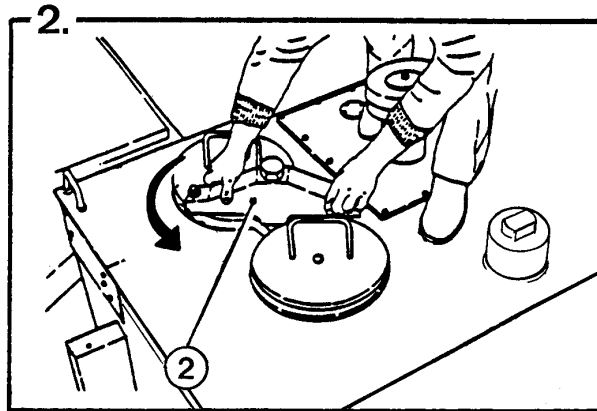
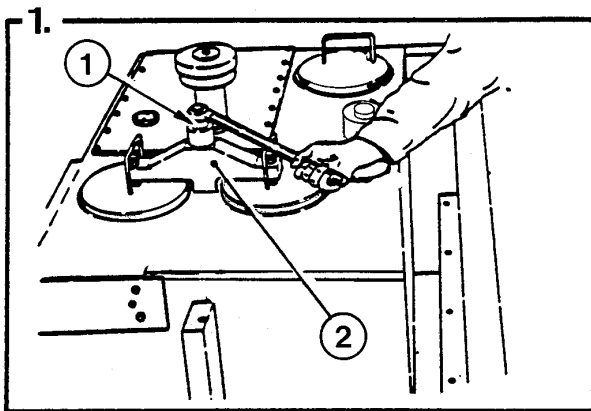

Z 19336



## FILTER SERVICE

- Replace return oil filter elements
- Replace leakage oil filter element
- Check filter screens

### Follow the steps shown in illust. Z 19336:

1. Loosen bolt (1).
2. Turn retainer (2).
3. Remove cover assy (3). Inspect O-ring (4) and replace if necessary.
4. Lift out element assy (5).
5. Disassemble filter assy (5) in sequence of ref. nos. (6 to 12)
6. Discard element (8)
7. Inspect screen (11) and clean if necessary.

### NOTICE

**Take care not to contaminate the clean inside of the screen when flushing.**

8. Inspect screen (11) and O-ring (12) for damage replace if necessary.  
Install screen (11) use new sealing washer (10) and self locking nut (9).
9. Reassemble filter assy (5) with new element (8) according to step 5.  
Use new self locking nuts (6).
10. Install filter assy use new gasket (7).  
Torque bolt (1) to 850 Nm.

### NOTICE

- **After each repair of the hydraulic system the elements (8) should be replaced after about 50 operating hours.**
- **The filter elements must also be replaced when the fault message "Filter restriction" is displayd on the VHMS monitor.**
- **Replace screens (11) every 5000 operating hours at the latest.**

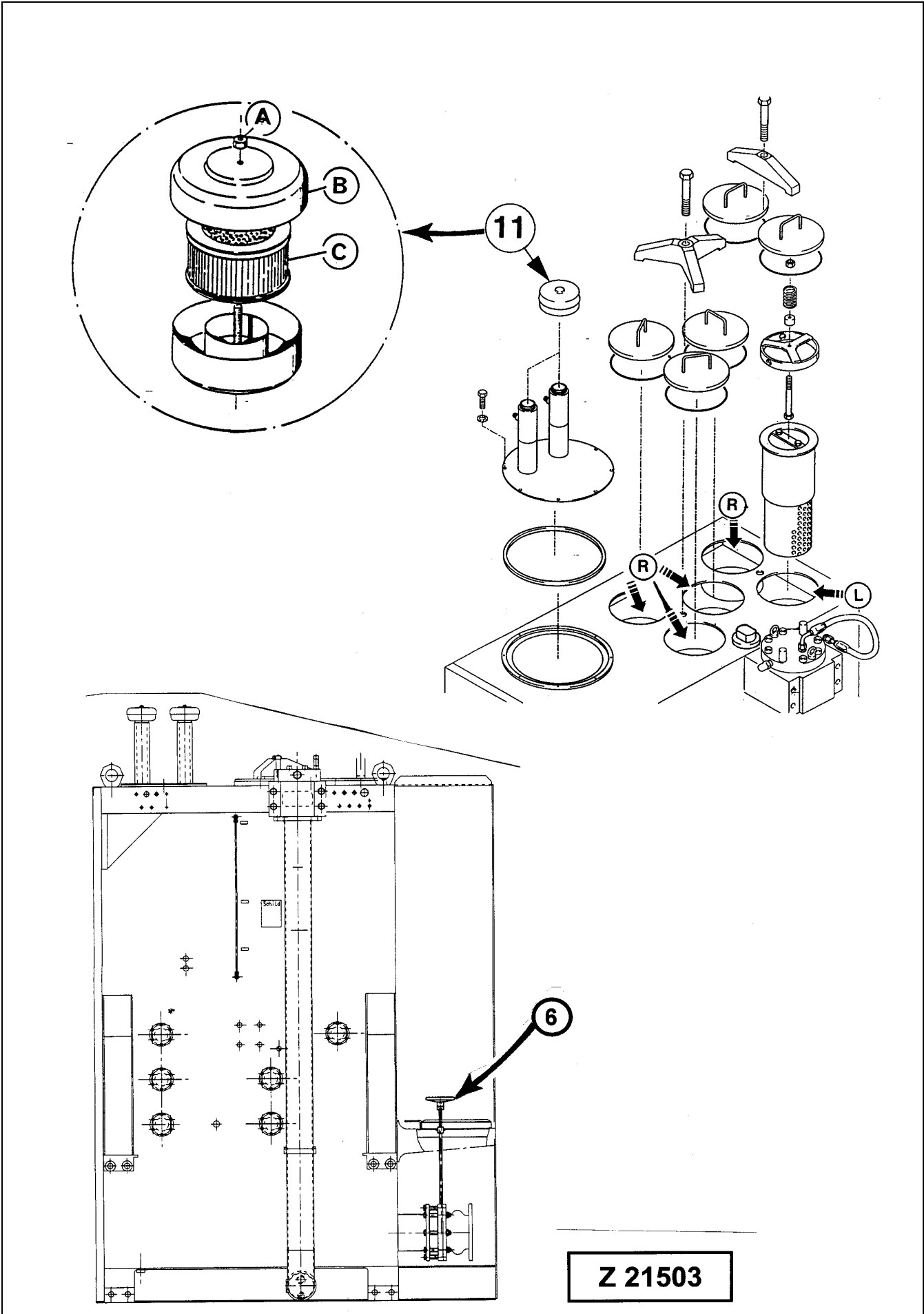

## **FILTER SERVICE**

- Replace breather filter element
- Drain water and sediments from hydraulic oil tank

### **Legend for illust. Z 21503**

- (6) Hand wheel of main shut-off valve located between suction oil tank and main oil tank
- To open the valve, turn hand wheel (6) CCW to the stop
  - To close the valve, turn hand wheel CW to the stop

A proximity switch located on the gearbox of the shut-off valve monitors the valve position. With the valve not fully open, a corresponding message will be displayed on the VHMS monitor in the operator's cab.

#### **REMARK**

Before starting the engine, make sure the valve (6) is completely open.

- (11) Breather filter

### **Replace Element (C) of Breather Filter (11).**

1. Remove nut (A).
2. Remove cover (B).
3. Remove filter element (C).
4. Insert new filter element and reassemble the breather filter (15).

### **Drain Water and Sediments**

Drain water and sediments with machine standing on level ground and when machine was out of operation for some time.

Refer to Operation section 3.18 for evacuation procedure.

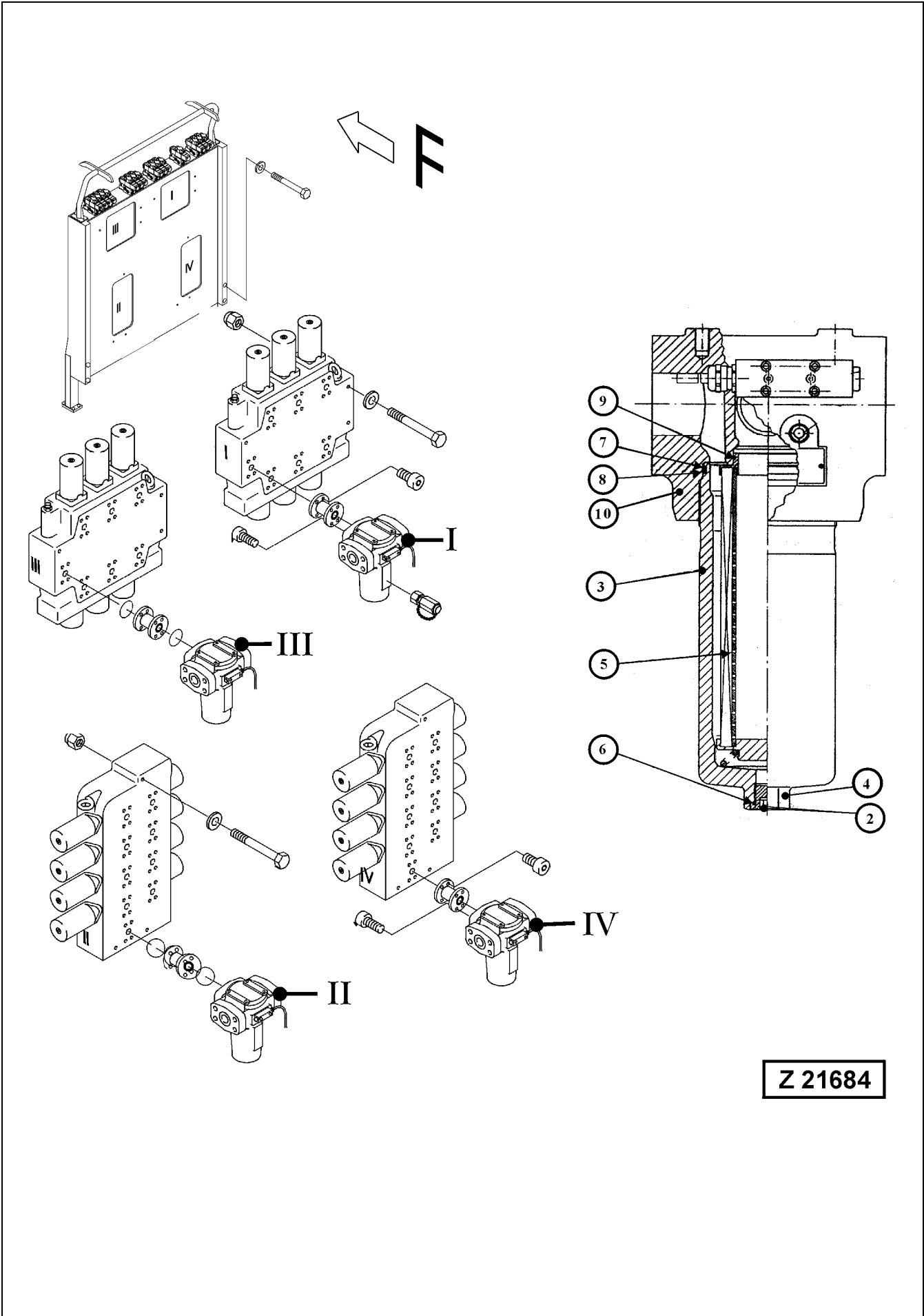

Z 21684

## FILTER SERVICE

### High Pressure Filters "HPF", illustration Z 21684

#### NOTICE

- The filter reference numbers correspond to the numbering of main pumps and control valves.
- If a fault message "Trouble HPF ...." is displayed on the VHMS monitor, the engine will be shifted automatically to low idle speed. The fault message "Trouble HPF ...." indicates a restricted high pressure filter. Stop work and inform Service staff about the fault message.

#### Legend for illustration Z 21684

- I HPF for pump I
- II HPF for pump II
- III HPF for pump III
- IV HPF for pump IV
- (2) Drain plug
- (3) Filter case
- (4) Hexagon
- (5) Filter element
- (6) Packing ring
- (7) O-ring
- (8) Back-up ring
- (9) O-ring
- (10) Filter header

#### Clean or replace high pressure filter elements:

1. Place working attachment on the ground and shut-off the engine.  
Relieve pressure in the hydraulic system with several movements of the control levers.
2. Place a suitable container below the filter in order to collect outflowing oil.
3. Remove plug (2) and drain the oil.
4. Screw off filter case (3).
5. Remove element (5) and clean. Take care not to contaminate the "Clean" inside of the element when flushing.

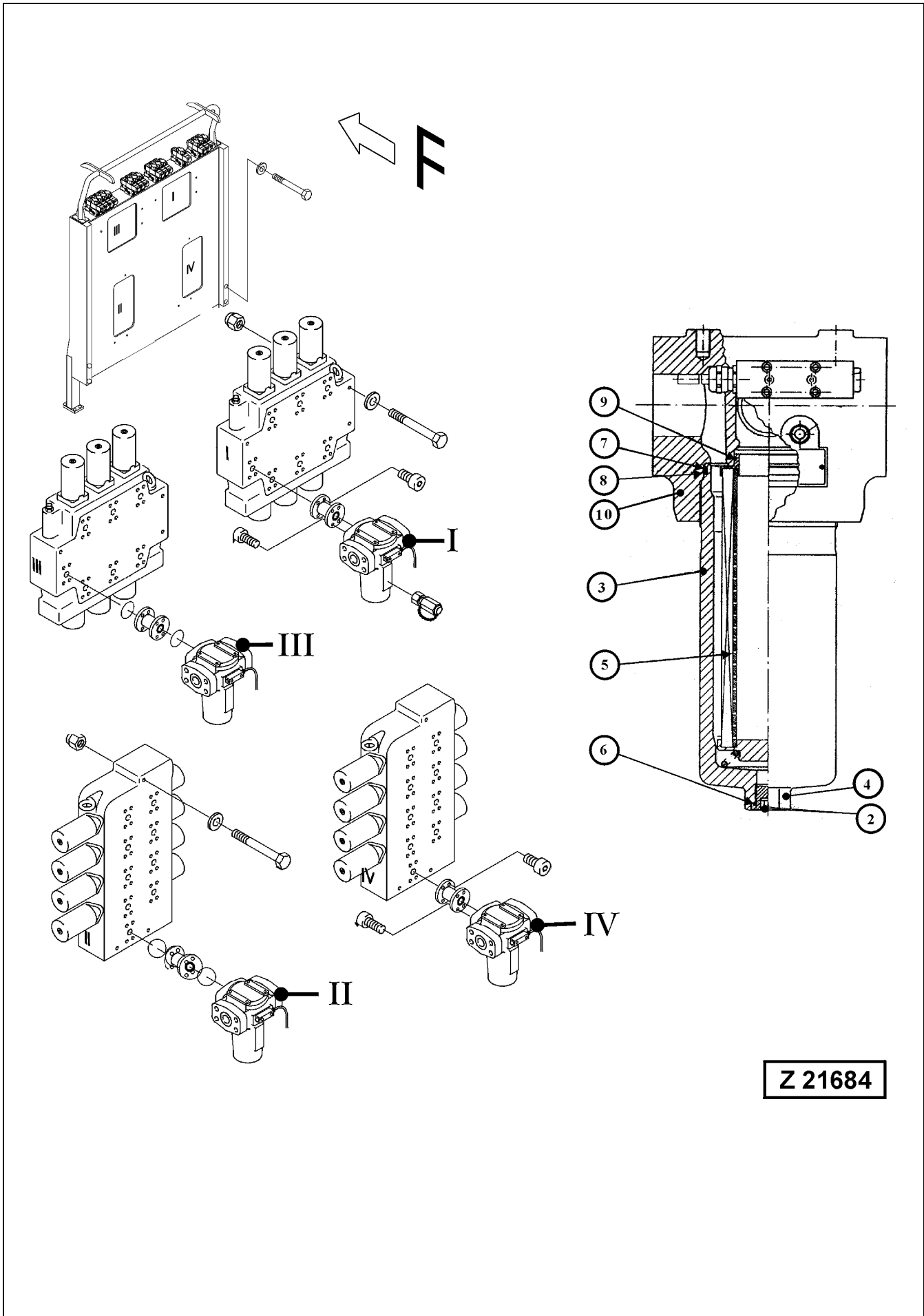

Z 21684

## FILTER SERVICE

### High Pressure Filters "HPF", illustration Z 21684

#### NOTICE

**Carefully inspect elements for damage. Always install new elements if ruptures or other damages are found.**

6. Inspect O-rings (7 and 9) and back-up ring (10). Replace if necessary.
7. Install drain plug (2) with new packing ring (6). Fill filter case (3) half way up with clean hydraulic oil and re-assemble the filter. Make sure element (5) is properly seated in the filter head.
8. After short operating period check filter units for leakage.

---

---

**▲ CAUTION**

---

---

**In case filter element (5) is soiled by metal chips, examine hydraulic pump for damages. Install new element (5).**

---

---

#### NOTICE

**If after cleaning of the filter element, the message "Trouble HPF ...." is displayed again, replace the filter element.**

**Replace elements (5) after three cleanings or after every 5000 operating hours, whichever occurs first.**

**After pump repairs all high pressure filter elements must be replaced.**

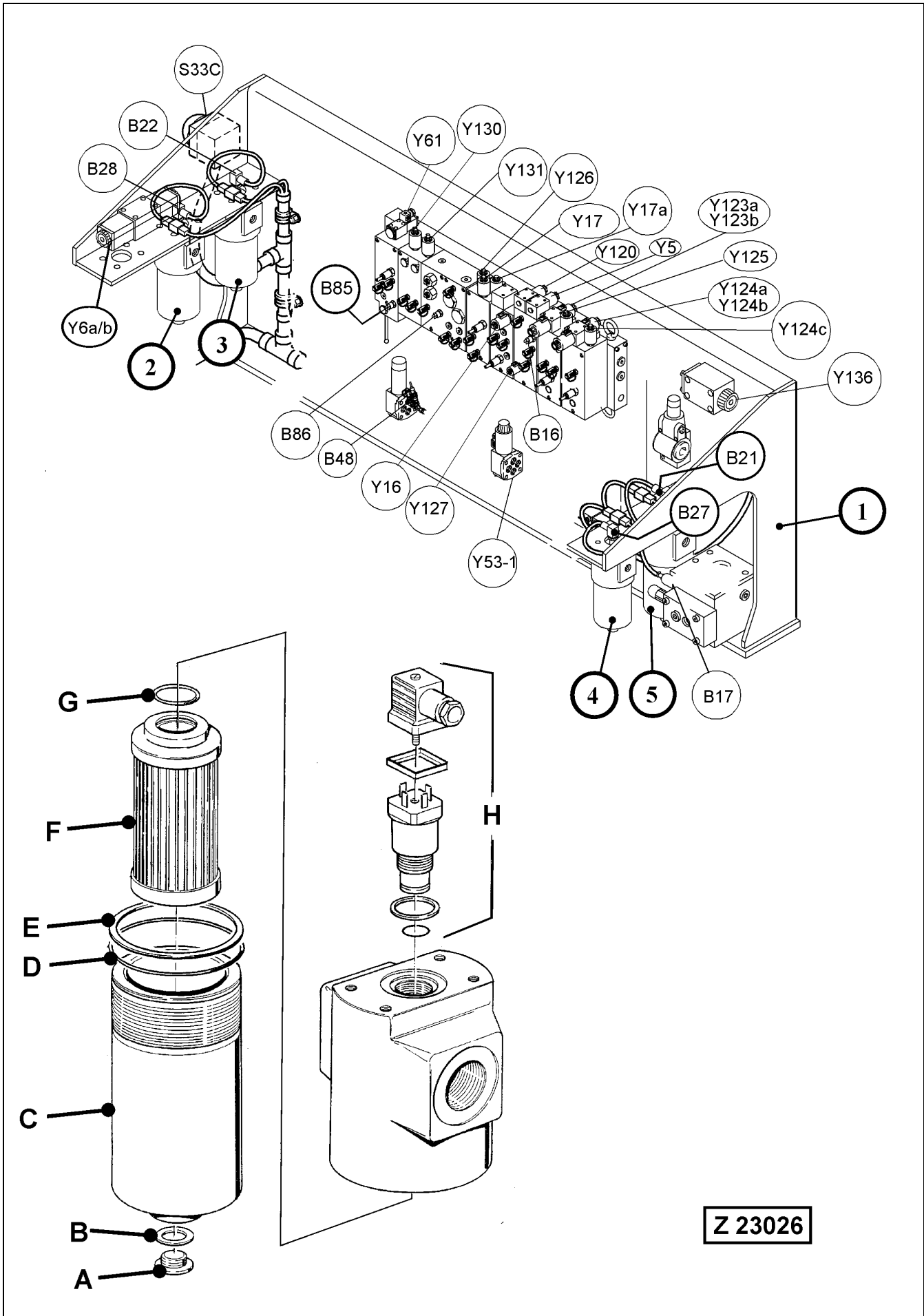



## FILTER SERVICE

### Replace Pressure Oil Filter Elements, illust. Z 23026

#### NOTICE

If a fault message "Trouble oil filter...." is displayed, stop the engine and replace element of the respective pressure filter.

#### Legend for illust. Z 23026

- (1) Central control and filter carrier
- (2) Pressure oil filter, hydraulic oil cooler fan drive
- (3) Pressure oil filter, pump regulation and pilot circuit
- (4) Pressure oil filter, PTO gear lubrication
- (5) Pressure oil filter, engine radiator fan drive

#### Replace filter element (F) as follows:

1. Place working attachment on the ground and shut-off the engine.  
Relieve pressure in the hydraulic system with several movements of the control levers.
2. Place a suitable container below the filter in order to collect outflowing oil.
3. Remove plug (A) and drain the oil.
4. Unscrew case (C) of the respective filter and clean the filter case.
5. Discard element (F) with O-ring (G).
6. Inspect O-ring (D) and back-up ring (E), replace if necessary.
7. Install drain plug (A) with new packing ring (B).
8. Lubricate the thread at the filter head and at filter case (C) with multi-purpose grease K2K.
9. Insert a new element (F) with new O-ring (G).
10. Fill the case (C) half way up with clean hydraulic oil.
11. Screw the case (C) into the head and tighten.
12. After short operating period check filter for leakage.
13. Check restriction indicator (H) for proper mounting and good condition.

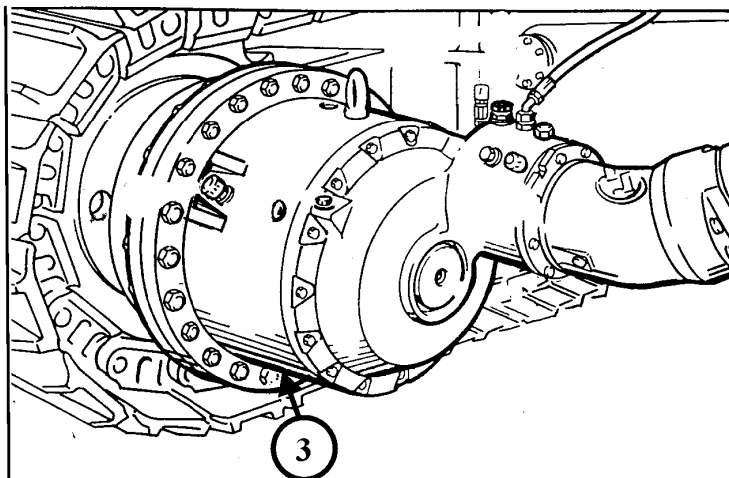
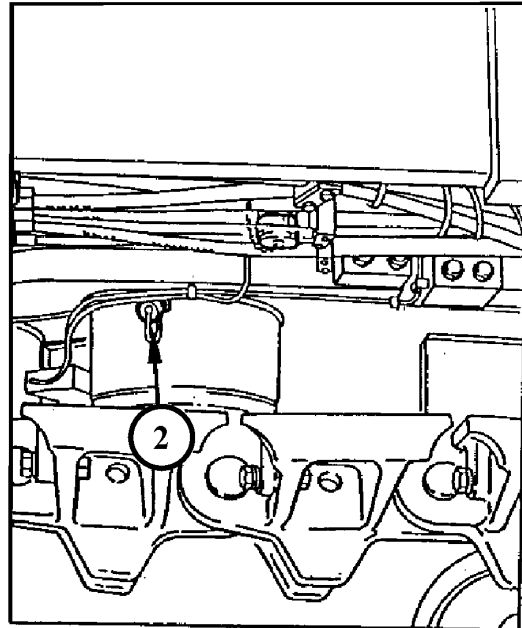
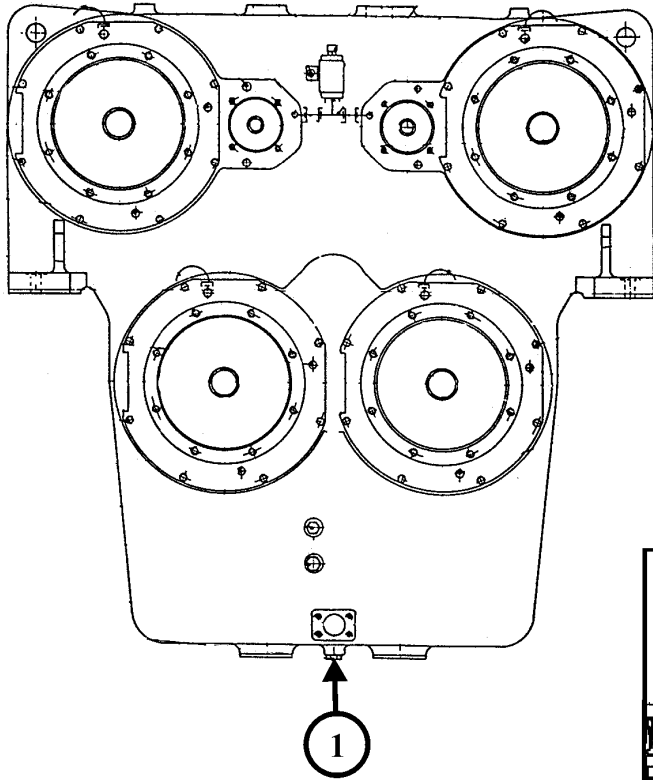

Z 21686

### 4.12.3 PTO (PUMP DISTRIBUTOR GEAR), SWING MACHINERY AND TRAVEL GEARS - OIL SAMPLE ANALYSIS

The oil sample analysis gives information about the grade of contamination and aging of the gear oils. Refer to the tables below for limits of contamination.

#### Oil drain plugs, illustration Z 21686

- (1) PTO (Pump distributor gear)
- (2) Swing machinery (RH and LH)
- (3) Travel gear (RH and LH)

#### PTO (PUMP DISTRIBUTOR GEAR)

(Oil contamination)

Element		Normal	Increased		Critical
Iron	<	100 ppm	100 -300 ppm	>	300 ppm
Copper	<	10 ppm	10 - 20 ppm	>	20 ppm
Chromium	<	5 ppm	5 - 15 ppm	>	15 ppm
Silicon	<	40 ppm	40 - 60 ppm	>	60 ppm

#### SWING MACHINERY AND TRAVEL GEARS

(Oil contamination)

Element		Normal	Increased		Critical
Iron	<	400 ppm	400 -700 ppm	>	700 ppm
Copper	<	25 ppm	25 - 60ppm	>	60 ppm
Chromium	<	5 ppm	5 - 15 ppm	>	15 ppm
Silicon	<	40 ppm	40 - 60 ppm	>	60 ppm

**NOTICE**

If the grade of contamination approaches to the “critical” values in the above tables, change the gear oil. However, the regular oil changes must be carried out every 3000 operating hours or once a year, whichever occurs first.

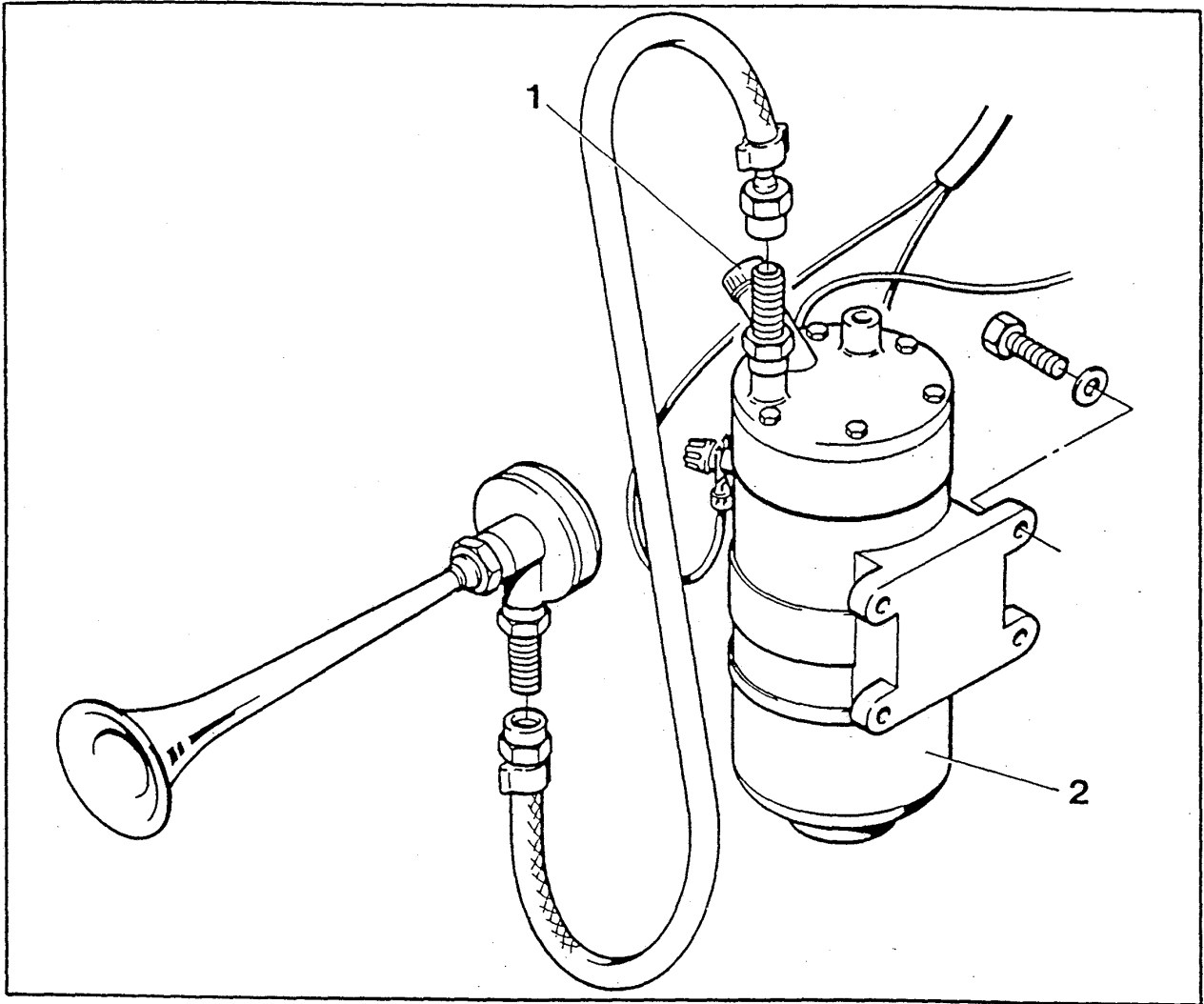

Z9543

#### **4.12.4 SIGNAL HORN COMPRESSOR - CLEAN AND LUBRICATE**

See illustration Z 9543

Unscrew collector protection cap (2).

If the fins of the collector are very strongly blackened or coated with verdigris, clean them with emery cloth.

Unscrew ball bearing cover and fill it half way up with grease.

Install removed parts.

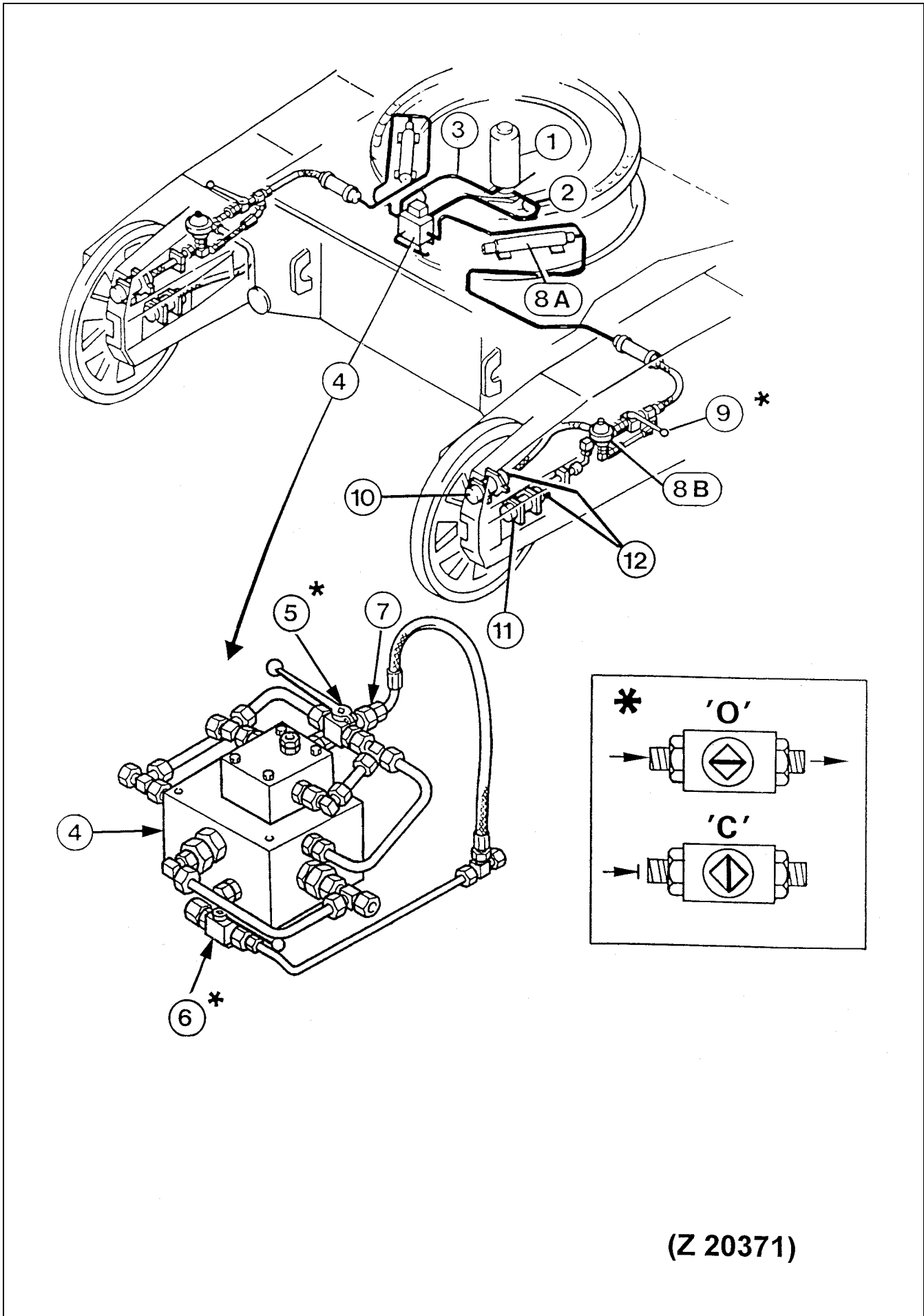

(Z 20371)

## 4.12.5 HYDRAULIC TRACK TENSIONING SYSTEM - CHECK ACCUMULATORS

### WARNING

Before working on any part of the hydraulic track tensioning system relieve all pressure in the system by opening pressure relief cock (5), illustration Z 20371.

### NOTICE

For checking the charging pressure a special testing and filling device must be used. This device can be ordered from your Komatsu Dealer.

The testing and filling procedure of the pressure accumulators has to be carried out in accordance with Parts & Service News No. AH01531A.

### Legend for illust. Z 20371:

- (1) Rotary distributor
- (2) Supply line, pilot pressure from travel brake release circuit
- (3) Return oil line (leakage oil)
- (4) Valve block
- (5) Pressure relief cock for hydraulic track tensioning system.  
     "C" - Closed (Normal working position)  
     "O" - Open
- (6) Shut-off cock in supply line  
     "O" - Open (Normal working position)  
     "C" - Closed
- (7) Two stage pilot pressure operated relief valve
- (8A) Pressure accumulator, high pressure (150 bar)
- (8B) Pressure accumulator, low pressure (31 bar)
- (9) Shutoff cocks, RH & LH  
     "O" - Open (Normal working position)  
     "C" - Closed
- (10) Track adjusting cylinders, inner
- (11) Track adjusting cylinders, outer
- (12) Test connectors and vent valves

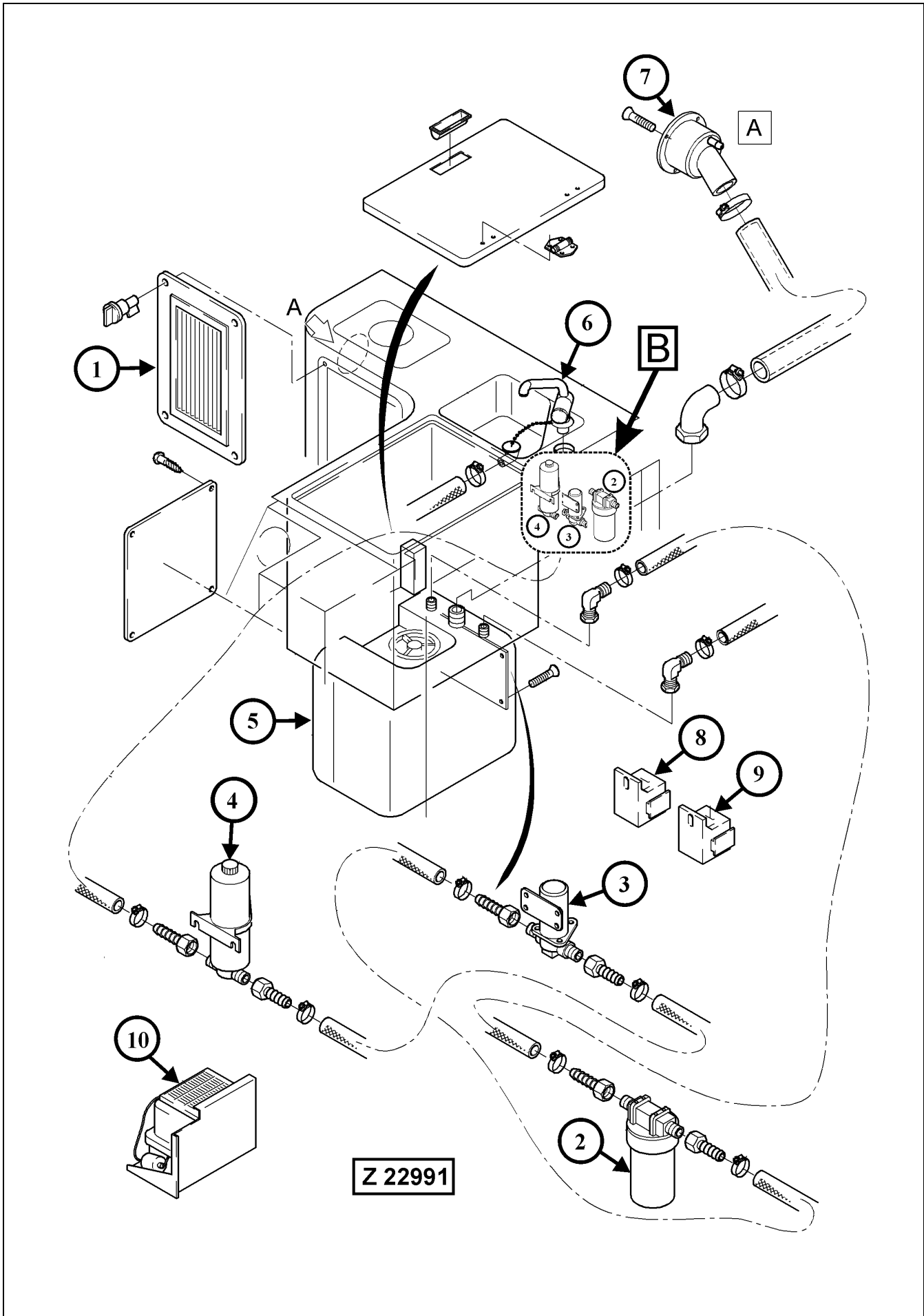



## 4.12.6 WATER FILTER - REPLACE FILTER CARTRIDGE

### Legend for illust. Z22991

- (A) Location of filler neck for water tank (5)
- (B) Location of water filter (2), pump (3) and pressure compensation tank (4).
- (1) Access cover for water filter compartment
- (2) Water filter
- (3) Water pump
- (4) Pressure compensation tank
- (5) Water tank
- (6) Water tap
- (7) Filler neck for water tank
- (8) Relay
- (9) Circuit breaker 7,5 A
- (10) Refrigerator

### Replace filter cartridge of water filter (2) as follows:

1. Open water tap (6) and drain all water from tank (5). Remove access cover (1). Depress red pressure relief button on filter header (if so equipped) to relieve pressure.
2. Unscrew bottom of housing. Remove large O-ring, wipe clean of lubricant and set aside. Remove used cartridge and discard. Rinse out bottom of housing and fill about 1/3 full with water. Add about 2 tablespoons of bleach and scrub cap and bottom of housing with nonabrasive sponge or cloth. Rinse thoroughly.
3. Lubricate O-ring with clean petroleum jelly (Vaseline). Place O-ring back into groove and smooth into place with finger. Insert new cartridge over stand pipe in bottom of housing. Cartridges with tapered ends need to be specifically installed with the tapered end toward the threads of the housing.
4. Screw bottom of housing onto cap and hand tighten. DO NOT over-tighten. Make sure cap standpipe slips into cartridge. Fill water tank (5) with 50 liters of clear water. Depress pressure relief button (if so equipped) to release trapped air.
5. Open water tap (6) and flush the new filter cartridge for a minimum of 5 minutes. The water must be completely clear before closing the tap.

---

---

 **WARNING**

---

---

**DO NOT drink the water of the cab water system.  
The cab water system is not constructed as a drinking water system.**

---

---

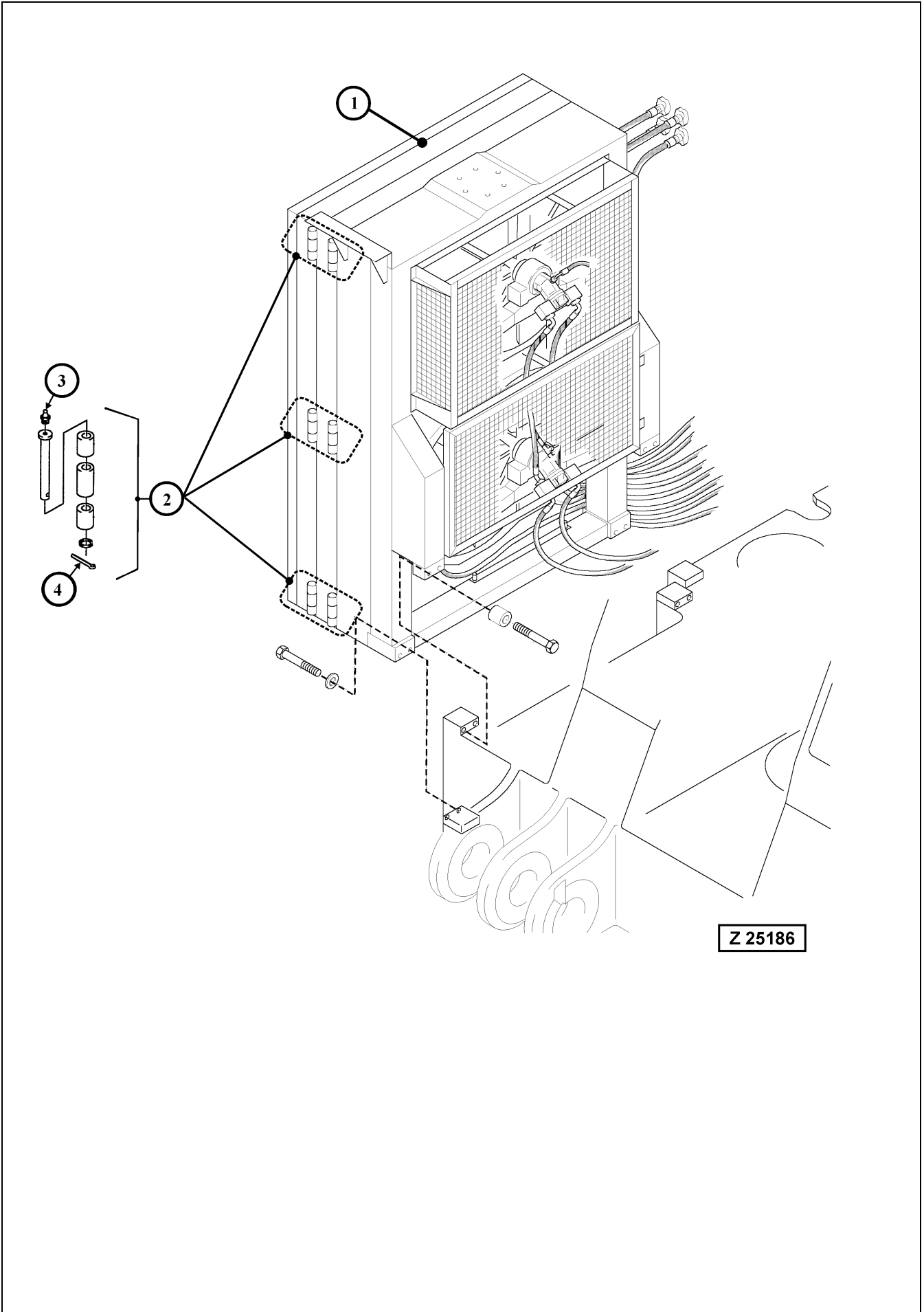

## 4.12.7 HYDRAULIC OIL COOLER - INSPECT AND LUBRICATE DOOR HINGES

---

---

**⚠ WARNING**

---

---

- Provide adequate working platform for safe access to the hydraulic oil coolers.
  - Check all door hinges (2) for good condition and proper fastening to their carrier frames. If cracks or distortion at the weld area of the hinges are found corrective action must be taken. **DO NOT** attempt to open the cooler doors before the damage has been repaired otherwise the cooler door may become detached and fall off. Danger of accidents.
- 
- 

### Legend for illust. Z25186

- (1) Hydraulic oil cooler
- (2) Cooler hinges
- (3) Grease fitting
- (4) Cotter pin

- Lubricate all cooler hinges (2) at grease fittings (3).
- Check to make sure that the hinge pins are properly secured with cotter pins (4).

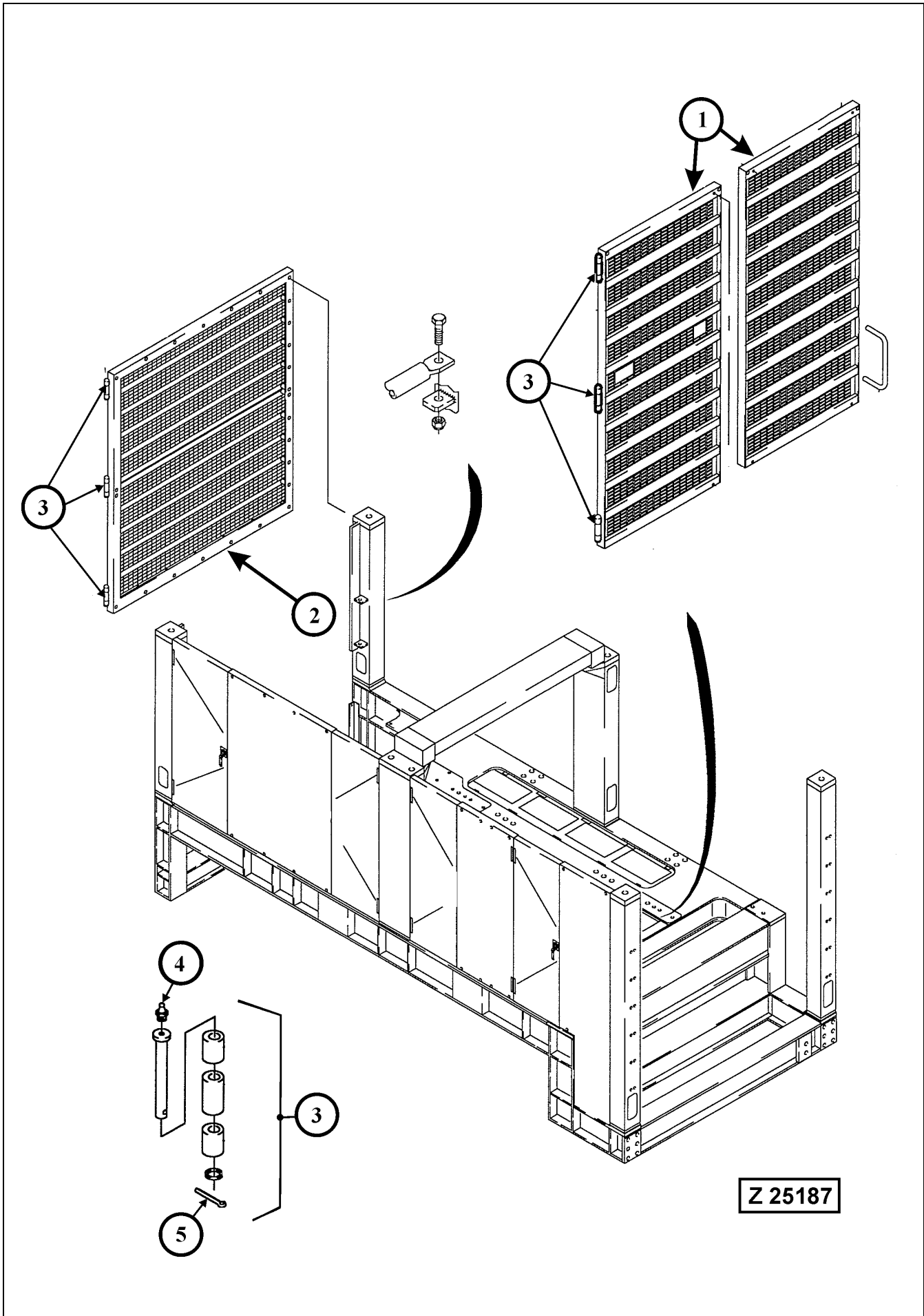

## 4.12.8 MACHINERY HOUSE DOORS - INSPECT AND LUBRICATE DOOR HINGES

---

---

 **WARNING**

---

---

- Provide adequate working platform for safe access to the rear machinery house door (2).
  - Check all door hinges (3) for good condition and proper fastening to their carrier frames. If cracks or distortion at the weld area of the hinges are found corrective action must be taken.
- 
- 

### Legend for illust. Z25187

- (1) Front doors of machinery house
  - (2) Rear door of machinery house
  - (3) Door hinges
  - (4) Grease fitting
  - (5) Cotter pin
- Lubricate all door hinges (3) at grease fittings (4).
  - Check to make sure that the hinge pins are properly secured with cotter pins (5).

# 4.13 EVERY 2000 OPERATING HOURS OR YEARLY

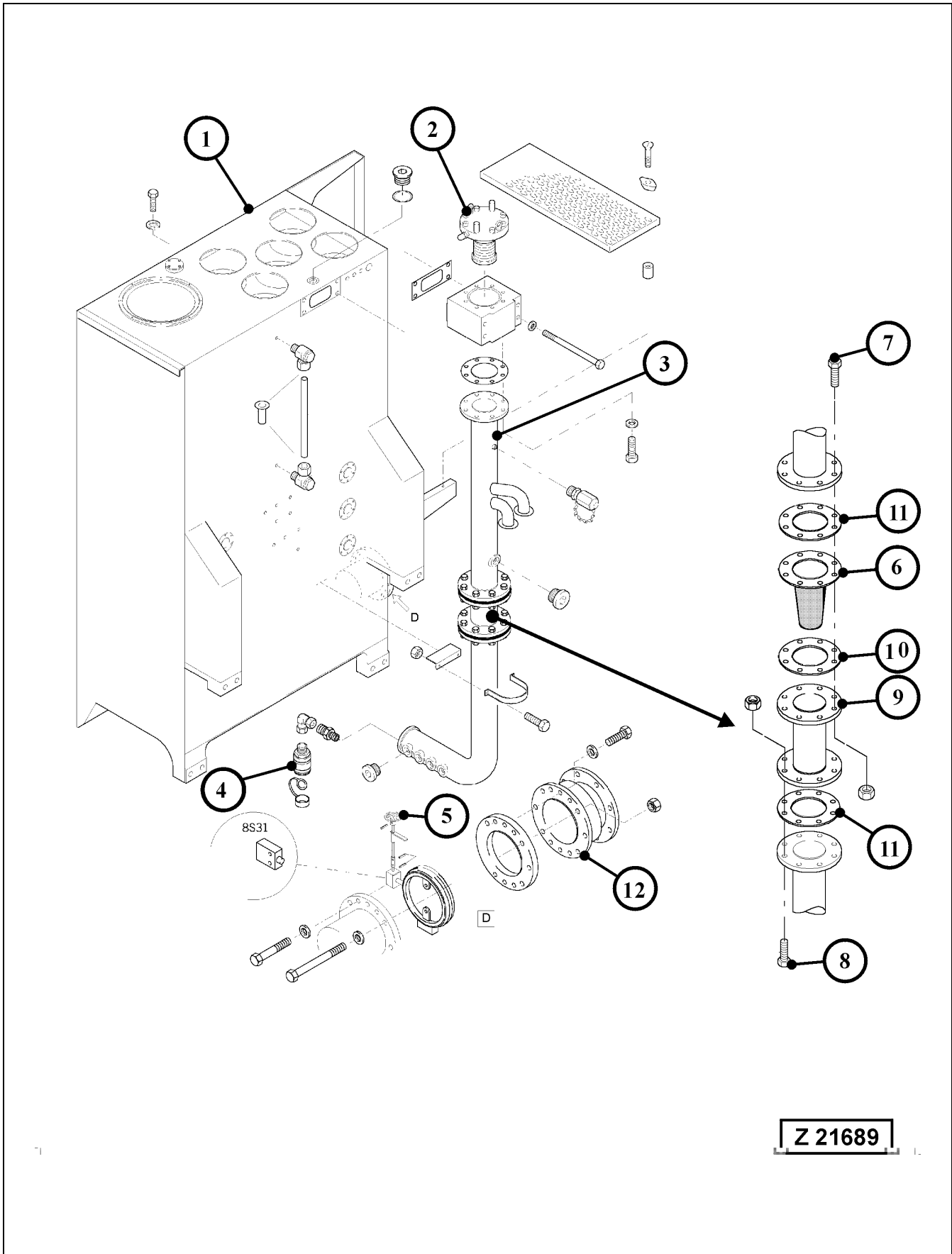

### 4.13.1 HYDRAULIC SYSTEM - CHANGE OIL, REPLACE SUCTION STRAINERS AND PULSATION DAMPER

#### NOTICE

The hydraulic oil change intervals can be extended for a further time period, when an oil sample analysis shows a positive result. When extending the oil change interval, it is necessary to carry out an oil sample analysis after every 1000 operating hours.

However, it is recommended to change the hydraulic oil after 6000 operating hours at the latest.

The pulsation damper must be replaced after every 2000 operating hours.

#### Legend for illust. Z 21689

- (1) Main oil reservoir
- (2) Back-pressure valve
- (3) Return oil collector pipe
- (4) Drain coupling
- (5) Hand wheel of main shut-off valve
- (6) Return oil strainer
- (7) Bolt
- (8) Bolt
- (9) Intermediate pipe
- (10) Gasket
- (11) Gaskets
- (12) Compensator

Evacuate main hydraulic oil reservoir according to section **Central Refilling System** on page 212.

On machines **without transfer pump** for hydraulic oil attach drain hose (part of tool set) to coupling (4) and drain oil from return oil collector pipe (3). Drain also the oil from return oil manifold, see illustration Z 21690 and from suction oil reservoir, see illustration Z 21691A.

On machines **with transfer pump** for hydraulic oil, proceed according to page 206.

#### REMARK

Replace return oil strainer (6), illustration Z 21689 after major repairs on the hydraulic system and after every 6000 operating hours. Use new gaskets (10 and 11).

With hydraulic oil reservoir empty, service the return oil filters and inspect the reservoir for sediments. Clean the reservoir if necessary.

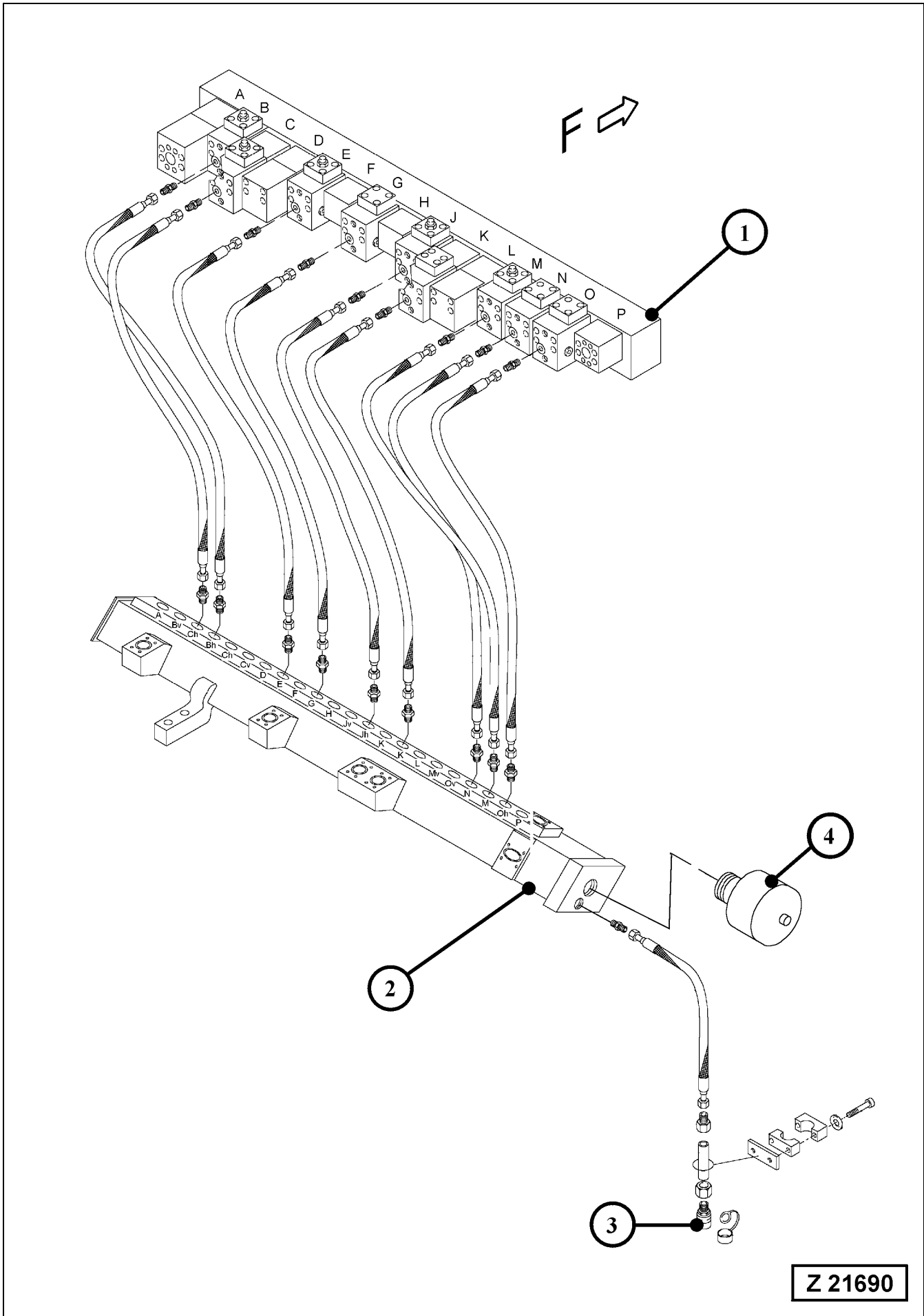



## **HYDRAULIC SYSTEM - CHANGE OIL, REPLACE SUCTION STRAINERS AND PULSATION DAMPER**

### **Legend for illust. Z 21690**

- (1) Distributor manifold
- (2) Return oil collector manifold
- (3) Drain coupling
- (4) Pulsation damper

Attach drain hose (part of tool set) to coupling (3) and drain oil from return oil collector manifold (2). Remove pulsation damper (4) and install new pulsation damper with new O-ring.

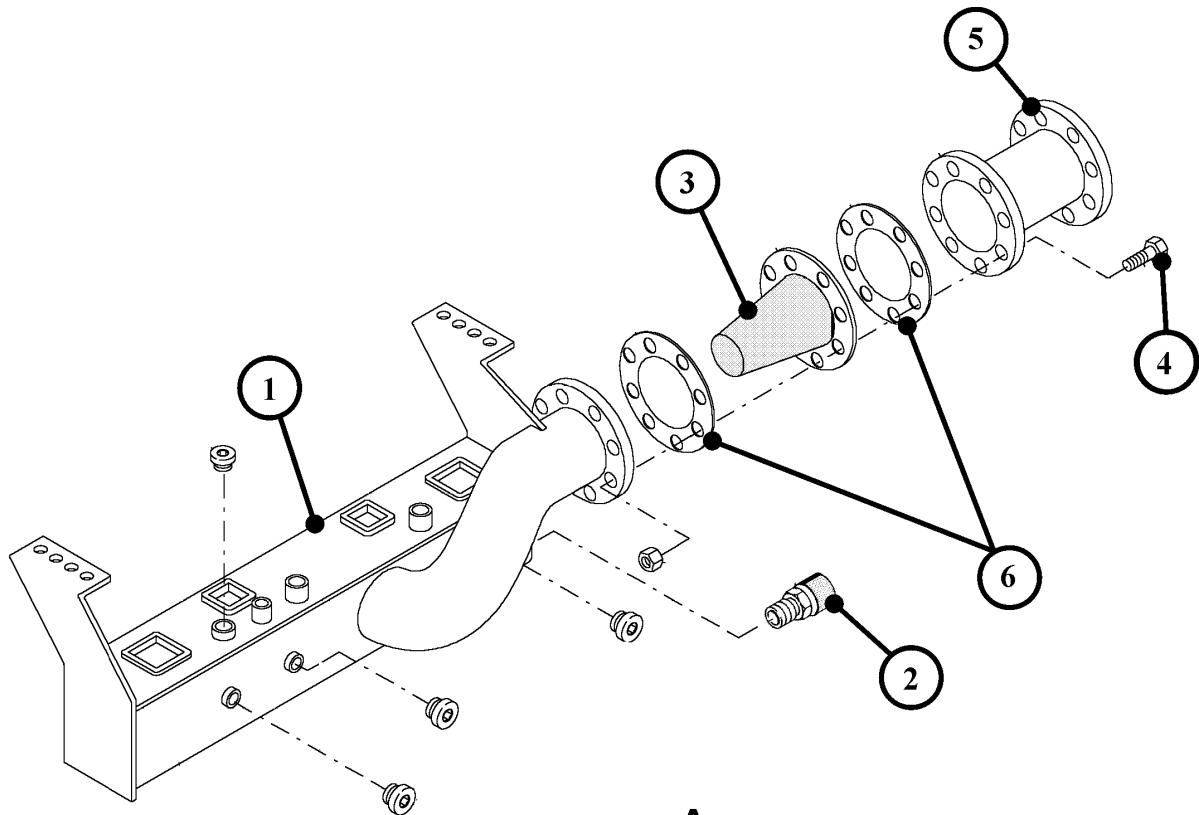

-A-

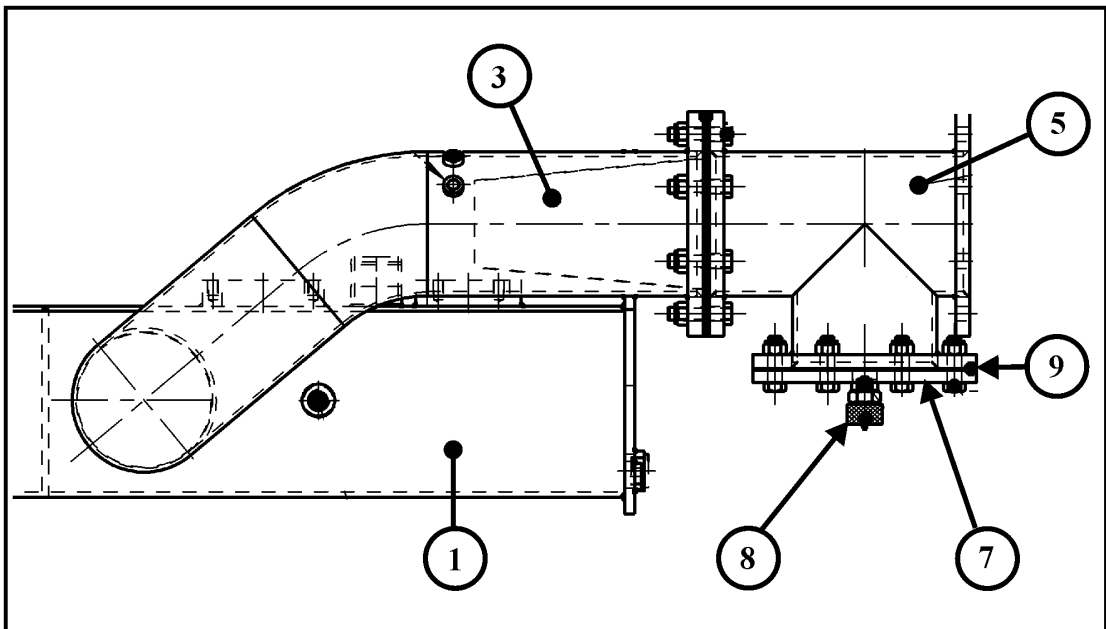

Z 21691A

## HYDRAULIC SYSTEM - CHANGE OIL, REPLACE SUCTION STRAINERS AND PULSATION DAMPER

### Legend for illust. Z 21691A

- (1) Suction oil reservoir
- (2) Drain coupling
- (3) Suction oil strainer
- (4) Bolts
- (5) Intermediate pipe

#### REMARK

On the bottom of the intermediate pipe there is a cover for inspection of strainer (3), see detail (A).

- (6) Gaskets
- (7) Inspection cover
- (8) Drain coupling
- (9) Gasket

### Replace suction strainer (3)

Attach drain hose (part of tool set) to coupling (2) and drain oil from suction oil reservoir. Remove intermediate pipe (5) and strainer (3). Install new strainer (3) with new gaskets (6).

#### REMARK

For inspection of strainer (3) between oil changes proceed as follows:

1. Close main shut-off valve (5), illustration Z21689.
2. Attach drain hose to coupling (8), illustration Z21691A and drain the oil from intermediate pipe (5).
3. Inspect strainer (3) and replace if necessary.
4. Install cover (7) using a new gasket (9).
5. Open main shut-off valve.
6. Bleed the air from suction oil reservoir according to the instructions on page 401.

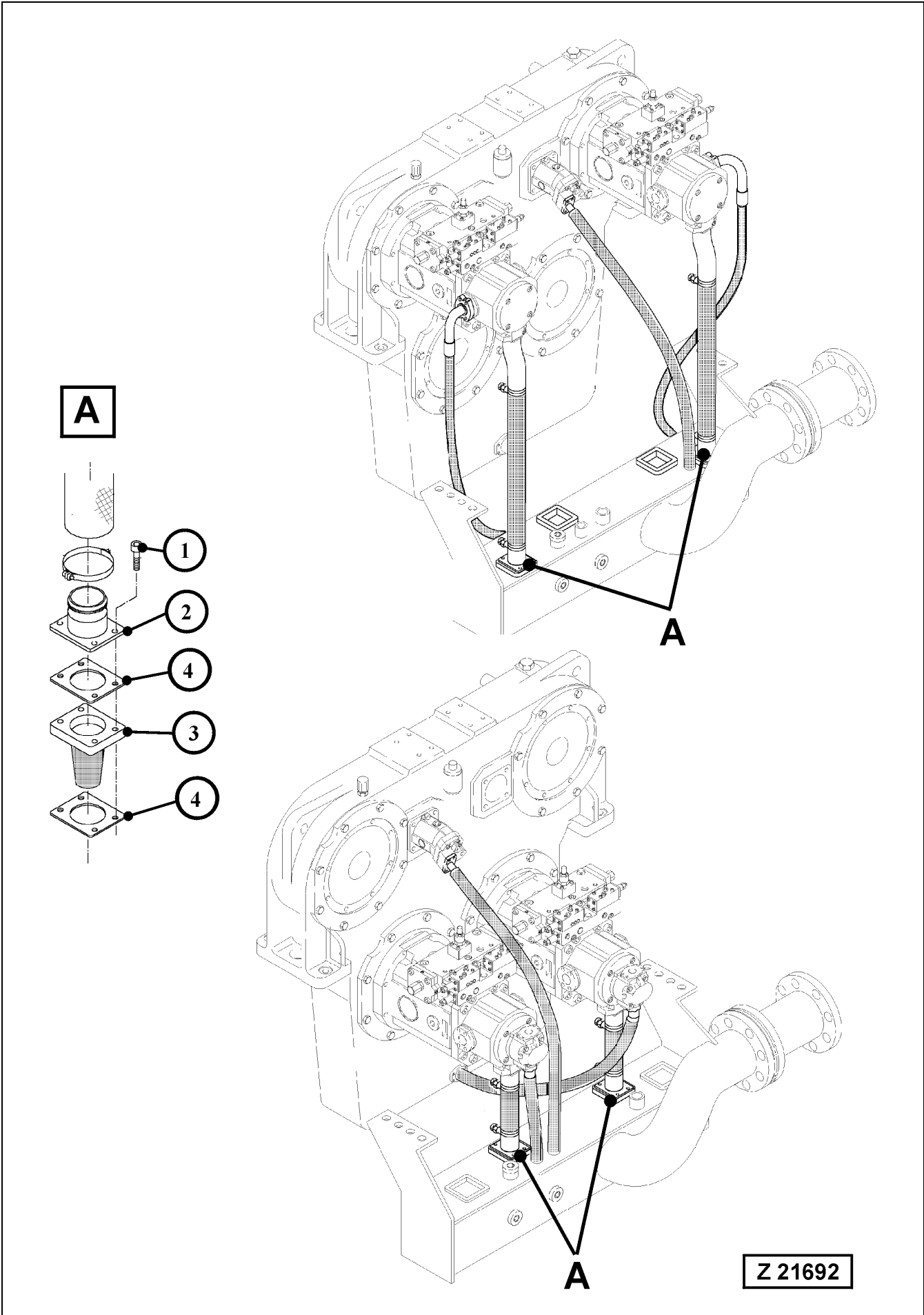

## **HYDRAULIC SYSTEM - CHANGE OIL, REPLACE SUCTION STRAINERS AND PULSATION DAMPER**

### **Legend for illust. Z 21692**

- (A) Location of main pump suction strainers
- (1) Bolts
- (2) Suction hose flange
- (3) Suction screen
- (4) Gaskets

### **Replace suction oil strainers of the four main pumps**

1. Remove bolts (1)
2. Move away suction hose with flange (2).
3. Remove strainer (3) with gaskets (4) and discard.
4. Install new strainer (3) with new gaskets (4).
5. Locate flange (2) above the strainer and tighten bolts (1).
6. Check to make sure that the hose clamps of the suction hoses are in good condition and properly fitted.

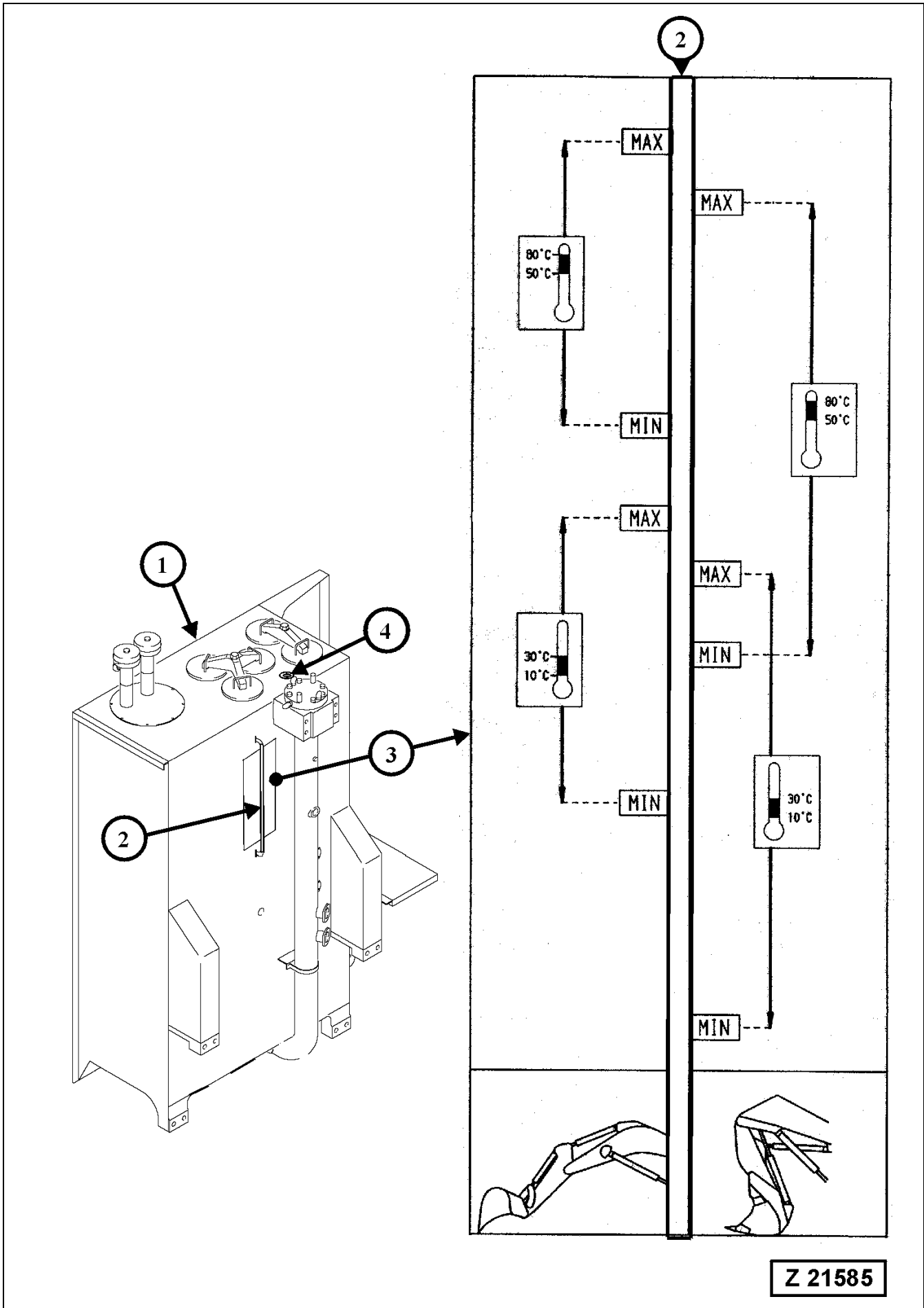

Z 21585

## HYDRAULIC SYSTEM - CHANGE OIL, REPLACE SUCTION STRAINERS AND PULSATION DAMPER

### FILLING THE HYDRAULIC SYSTEM

1. Make sure main shut-off valve is in open position and all connections are securely tightened.

#### REMARK

Select hydraulic oil viscosity grade according to ambient temperatures.

If the new hydraulic oil has a different viscosity grade compared with the drained oil it is necessary to enter the new viscosity grade into the appropriate "**Service SETTINGS**" group of the VHMS Menu Control.

2. On machines equipped with Central Refilling System fill main hydraulic oil reservoir according to section "Central Refilling System" on page 212.  
On machine without central refilling system fill main oil reservoir through opening (4), illustration Z 21585. Depending on type of attachment and the present oil temperature, select the applying oil level range on plate (3). Be sure to use the correct marking on oil level plate (3).

#### Legend for illustration Z 21585

- |     |                                 |
|-----|---------------------------------|
| (1) | Main hydraulic oil reservoir    |
| (2) | Hydraulic oil level sight gauge |
| (3) | Oil level plate                 |
| (4) | Oil filler plug                 |

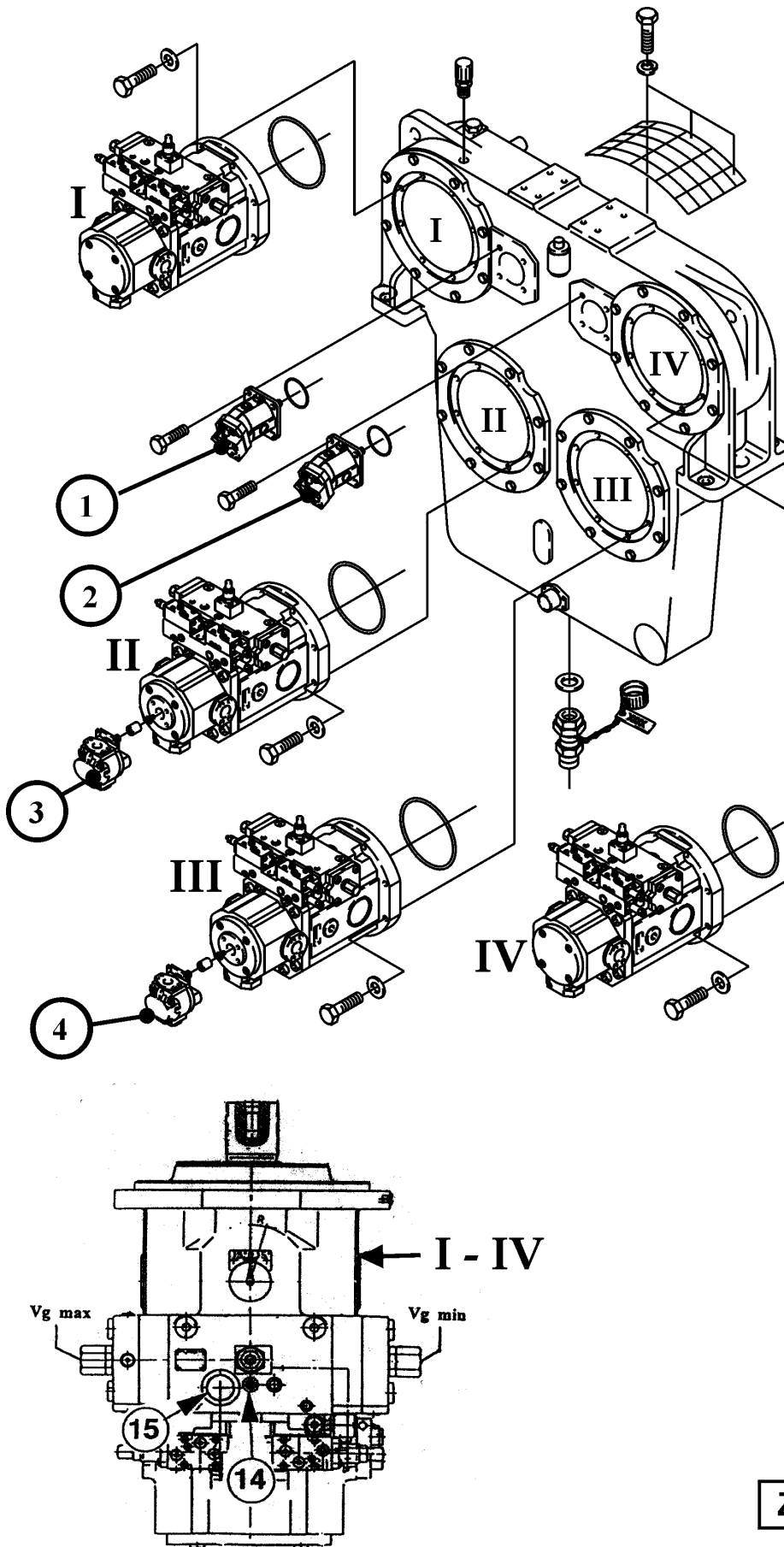

Z 21693



## HYDRAULIC SYSTEM - CHANGE OIL, REPLACE SUCTION STRAINERS AND PULSATION DAMPER

### Bleed air from all Hydraulic Pumps and check the Oil Level in the four Main Pump Housings

Legend for illust. Z 21693

- I - IV Main hydraulic pumps (swash plate type)
- (1) Axial piston pump for hydraulic oil cooler fan drive
- (2) Axial piston pump for engine coolant radiator fan drive
- (3) Piggy-back gear pump for pump regulation and pilot oil circuit
- (4) Piggy-back gear pump for PTO gear lubrication system
- (14) Oil level and filler plug of main pump housing
- (15) Port of leakage oil return line

### Bleeding air from pumps (1 - 4) and main pumps (I - IV)

Bleeding air from the hydraulic pumps and complete filling of the suction oil reservoir and the suction lines is essential, to prevent damages caused by air in the suction system (cavitation).

Proceed as follows:

1. Open vent plug on top of pumps (1 and 2). Close the vent plugs as soon as bubble-free oil flows out.
2. Open vent plug (13), illust. Z22513 on the suction port of gear pumps (3 and 4) and wait until bubble-free oil flows out. Then tighten vent plug (13).
3. Open vent plug (13) on the pump suction port of all four main pumps. As soon as bubble free oil flows out tighten vent plug (13).

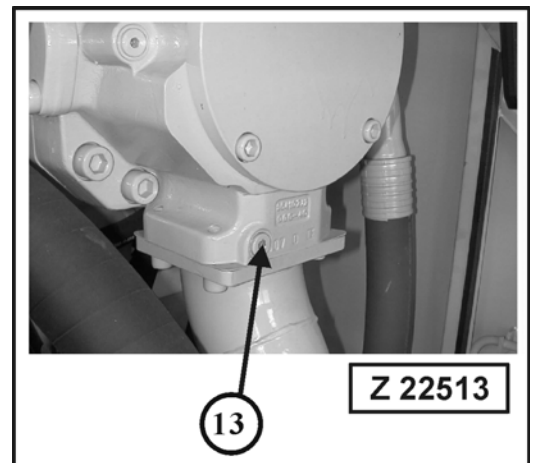

### Check oil level in main pump housings (I - IV)

1. Remove level and filler plug (14), illust. Z 21693. The oil level in the pump housing must reach the lower edge of the opening.
2. If necessary add hydraulic oil up to the lower edge of the filler opening.
3. Insert level and filler plug (14) and tighten securely.

#### NOTICE

- **Make sure the main pump housings are correctly filled, otherwise the pump drive shaft bearings could be damaged due to lack of lubrication.**
- **Check hydraulic oil level.**
- **Check the whole hydraulic system for leakages.**

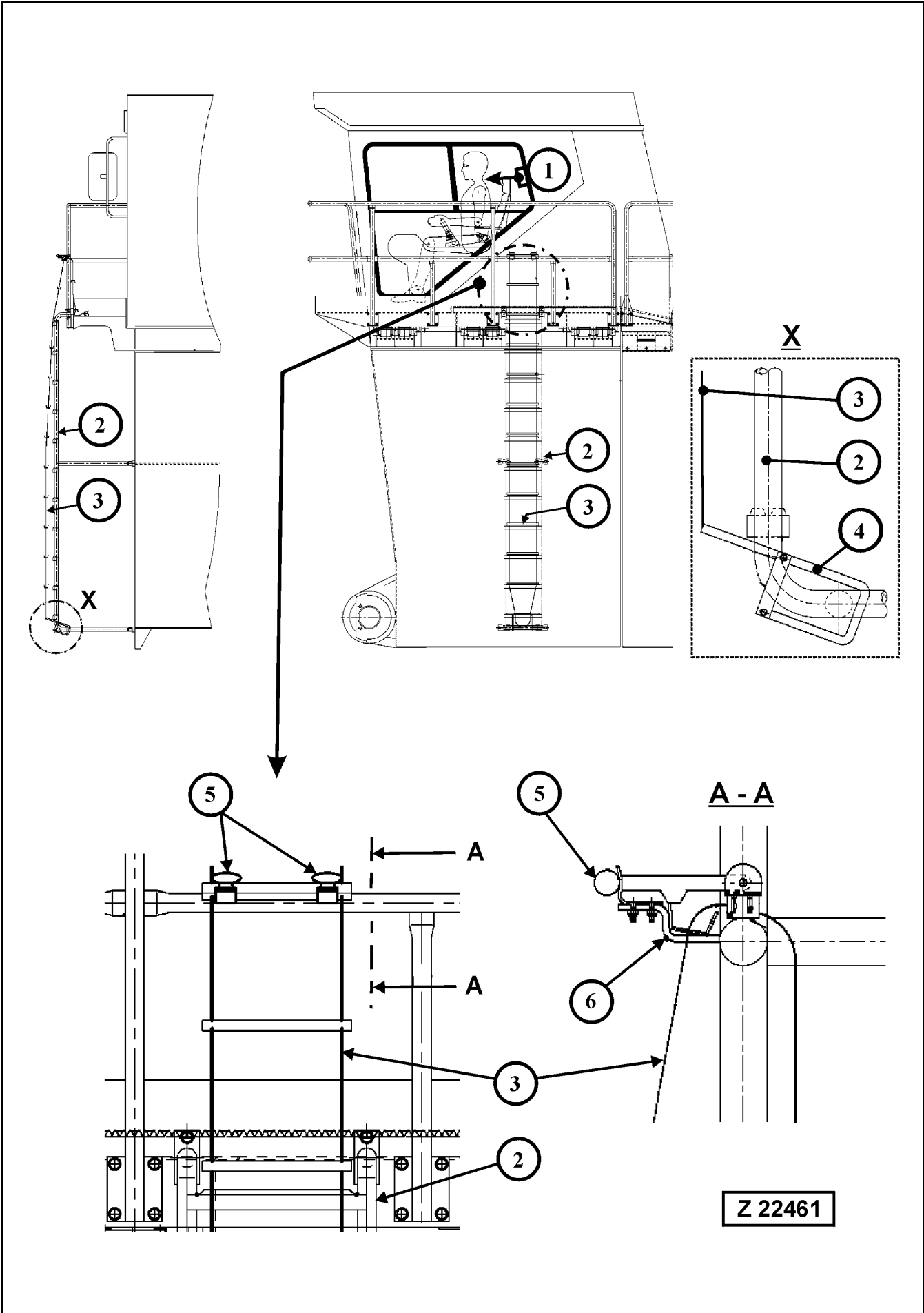

### 4.13.2 EMERGENCY ESCAPE LADDER - INSPECTION

See illustration Z 22461

(1)	Sliding window, serves also for emergency exit
(2)	Rigidly mounted emergency escape ladder
(3)	Rope ladder. The upper end of the rope ladder is fixed onto the lower rung of the rigid escape ladder (2) by means of the fasteners (4), see detail (X). The lower end of the rope ladder is fixed on brackets (6) and secured with rubber fasteners (5), see section (A-A).
(4)	Hooks for fastening the rope ladder onto the rigid ladder (2)
(5)	Rubber fasteners for rope ladder in lifted position
(6)	Bracket for rope ladder in lifted position. The lower rung of the rope ladder is hooked up into the brackets (6)
(1)	Sliding window, serves also for emergency exit

Check rigidly mounted emergency escape ladder (2) for good condition and proper fastening.

Check rope ladder (3) for good condition and proper fastening.

If any damage or bad condition is found replace the concerned parts without delay.

# 4.14 EVERY 3000 OPERATING HOURS HOWEVER AT LEAST ONCE A YEAR

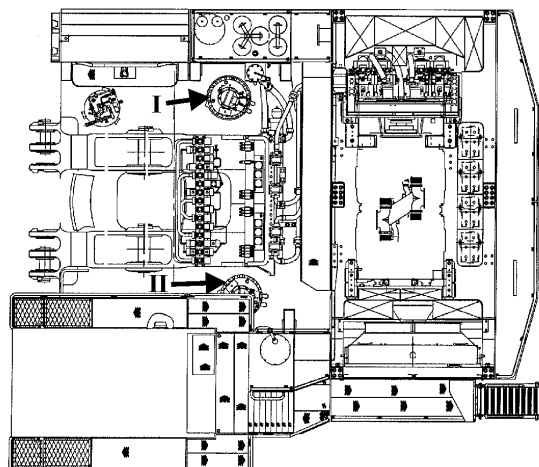
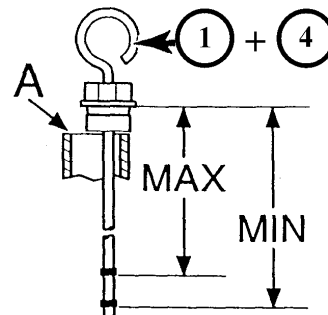
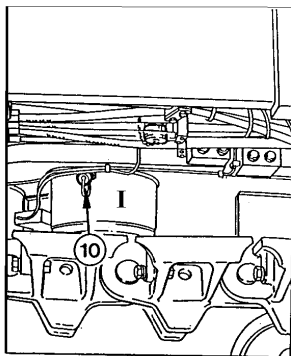
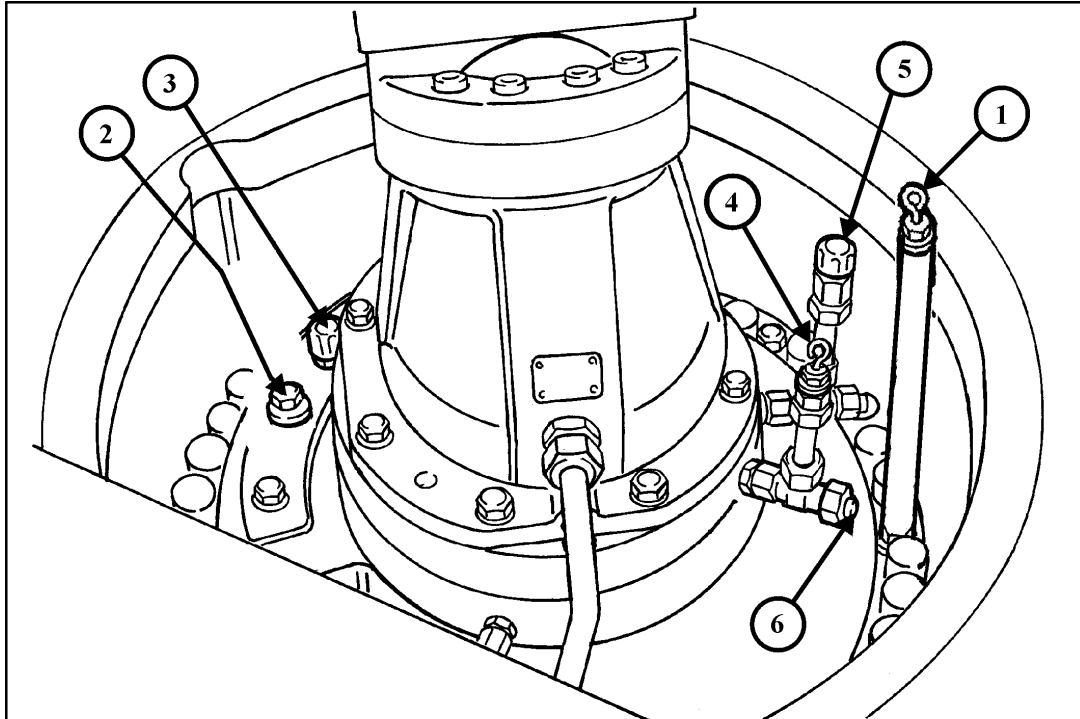

Z 22895

## 4.14.1 SWING MACHINERY AND MOTOR ADAPTER HOUSING - CHANGE OIL

### REMARK

The machine can be equipped either with a swing machinery of manufacturer "L&S" or of manufacturer "Siebenhaar". Refer to the data plate on each swing machinery housing to find out the manufacturer of the swing machinery.

### Swing Machinery manufactured by "L&S"

I Swing machinery RH

II Swing machinery LH

### I Legend for illustration Z22882

#### Swing gears

- (A) Position of oil level gauge for checking the oil levels
- (1) Oil level gauge
- (2) Oil filler plug
- (3) Breather filter
- (10) Drain couplings or evacuation nozzles for Wiggins system

#### Motor Adapter Housing

- (4) Oil level gauge and filler opening. This opening can also be used for connecting a suction pump when changing the oil.
- (5) Breather filter
- (6) Oil drain plug

### Swing Gears, change oil:

1. Use adequate working platform for draining the oil. Place receptacles of sufficient capacity (approx. 100 liter) below drain couplings (10). Attach drain hose (part of tool set) to drain coupling (10). Remove parts (1, 2 and 3) to speed up draining. On swing gears with evacuation nozzle (10), use the Wiggins system for changing the oil.
2. Clean breather filter (3) with compressed air from inside to outside and re-install.
3. After the oil is completely drained, flush the gear with the regular gear oil. Remove drain hose from coupling (10) and attach the protection cap onto the drain coupling.
4. Fill gear housing through filler opening (2) up to the "MAX" mark on level gauge (1) with fresh oil and re-install plug (2).
5. For checking the oil level insert the level gauge (1) but DO NOT screw in, see detail (A).
6. After short operating period check oil level and housings for leaks.

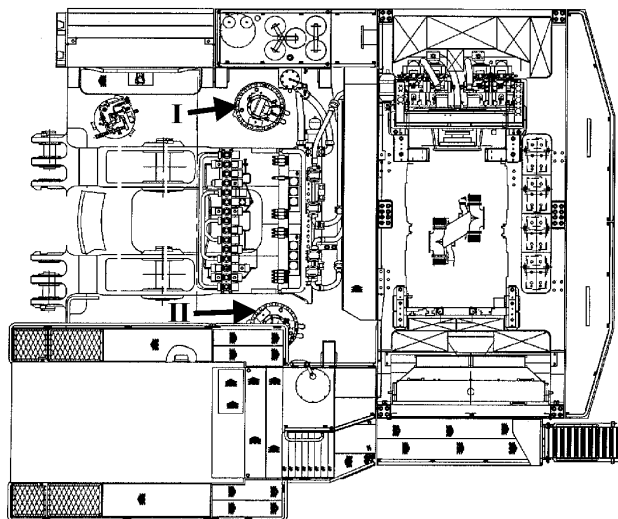
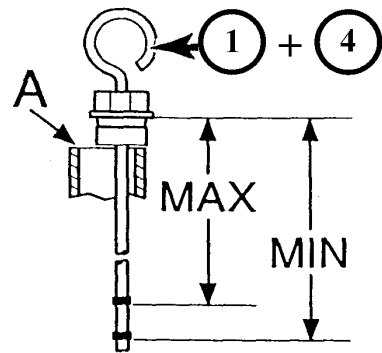
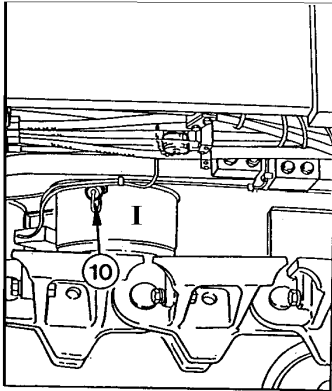
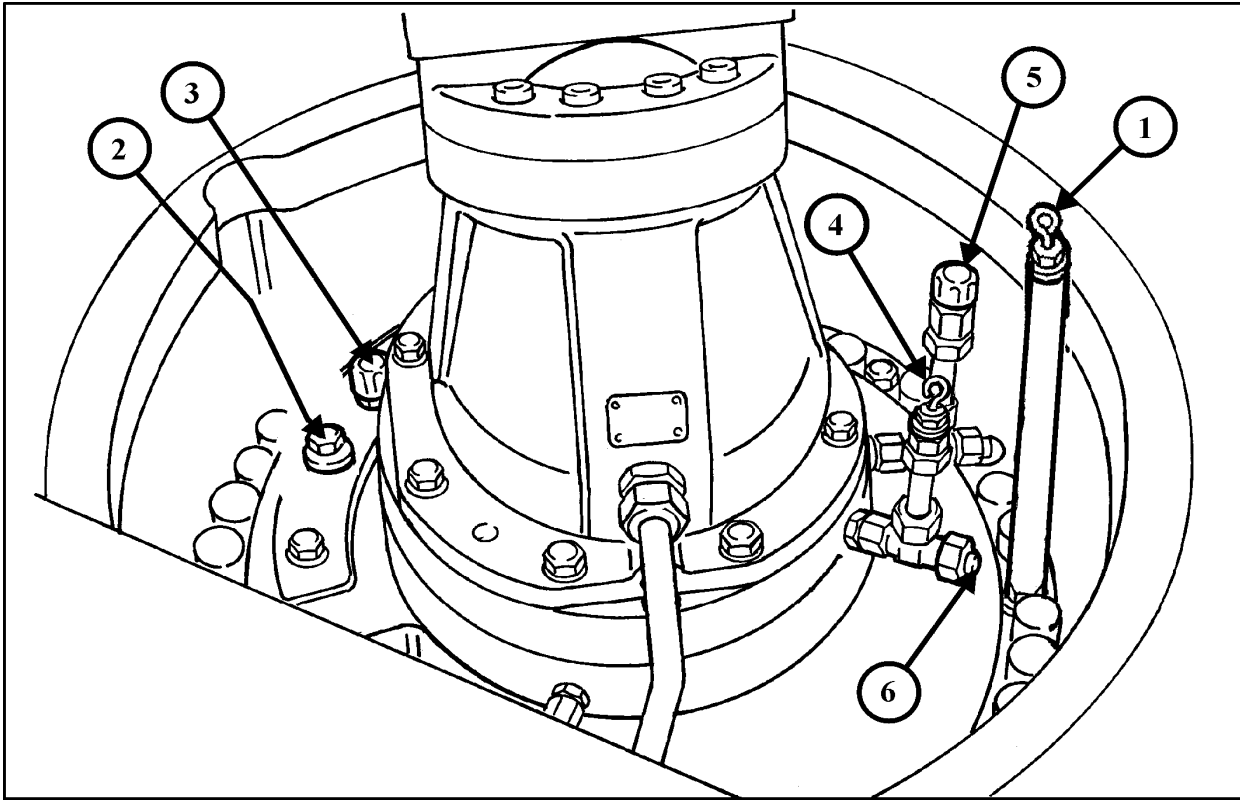

Z 22895

**MOTOR ADAPTER HOUSING - CHANGE OIL (L&S)**

1. Remove level gauge (4) and breather filter (5). Insert the hose of a suction pump into the gauge pipe (4) until the hose end just touches the bottom of the T-union. Place the oil outlet hose of the suction pump into a receptacle. Switch on the pump and completely suck off the oil from the motor housing. If a suction pump is not available, place a receptacle below drain plug (6).  
Remove plug (6) and drain the oil completely.
2. Clean breather filter (5) with compressed air from inside to outside and re-install.
3. If removed, install drain plug (6) and fill-up gear oil through filler opening (4), up to the "MAX" mark on level gauge (4) and install the level gauge.
4. After short operating period check oil level and housing for leaks.

**NOTICE**

**For checking the oil level insert the level gauge (4) but DO NOT screw in, see detail (A).**

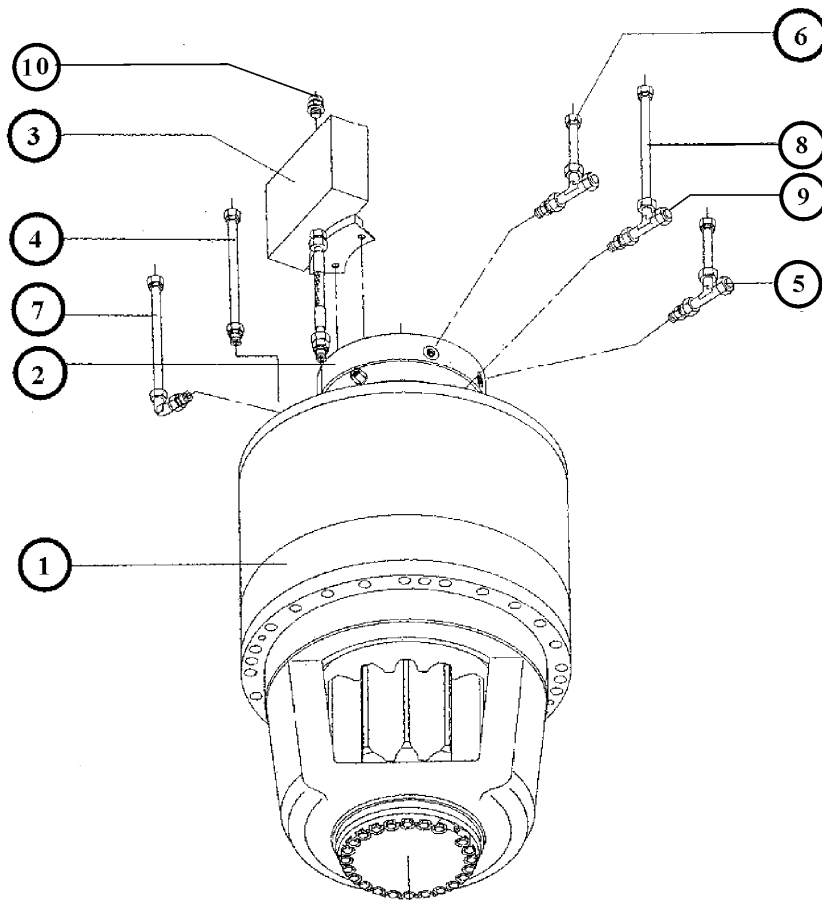
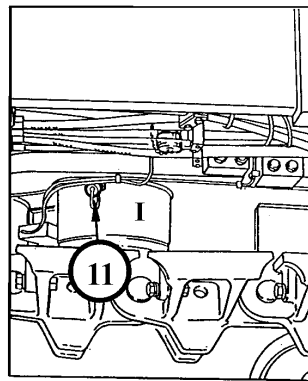
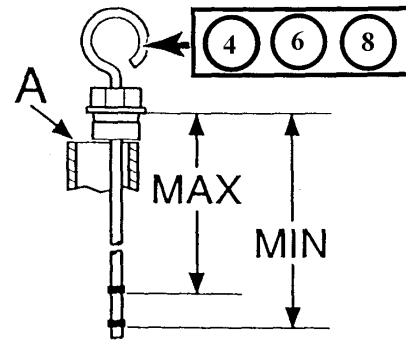
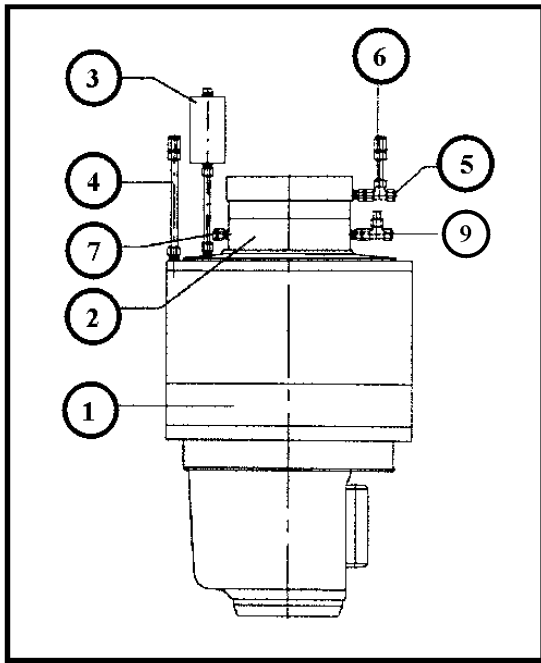

Z 21694



## **SWING MACHINERY MANUFACTURED BY "SIEBENHAAR"**

### **Legend for illustration Z 21694**

- (A) Position of oil level gauge for checking the oil levels
- (1) Swing machinery (RH and LH)
- (2) Brake housing
- (3) Compensator oil tank for swing machinery
- (4) Oil level gauge for swing machinery
- (5) Oil drain plug for motor adapter housing
- (6) Oil level gauge for motor adapter housing
- (7) Breather filter for brake housing
- (8) Oil level gauge for brake housing
- (9) Oil drain plug for brake housing
- (10) Breather filter
- (11) Drain coupling or evacuation nozzle for Wiggins system

### **SWING MACHINERY - CHANGE OIL (SIEBENHAAR)**

1. Use adequate working platform for draining the oil. Place receptacles of sufficient capacity (approx. 100 liter) below each drain coupling (11). Attach drain hose (part of tool set) to drain coupling (11). Remove parts (4 and 10) to speed up draining.
2. Clean breather filter (10) with compressed air from inside to outside and re-install.
3. After the oil is completely drained, flush the gear with the regular gear oil.
4. Remove drain hose from coupling (11) and attach the protection cap onto the drain coupling.
5. Fill gear housing through filler opening up to the "MAX" mark on level gauge (4) with fresh oil and re-install oil filler plug.

### **NOTICE**

**For checking the oil level insert the level gauge (4) but DO NOT screw in, see detail (A).**

6. After short operating period check oil level and housings for leaks.

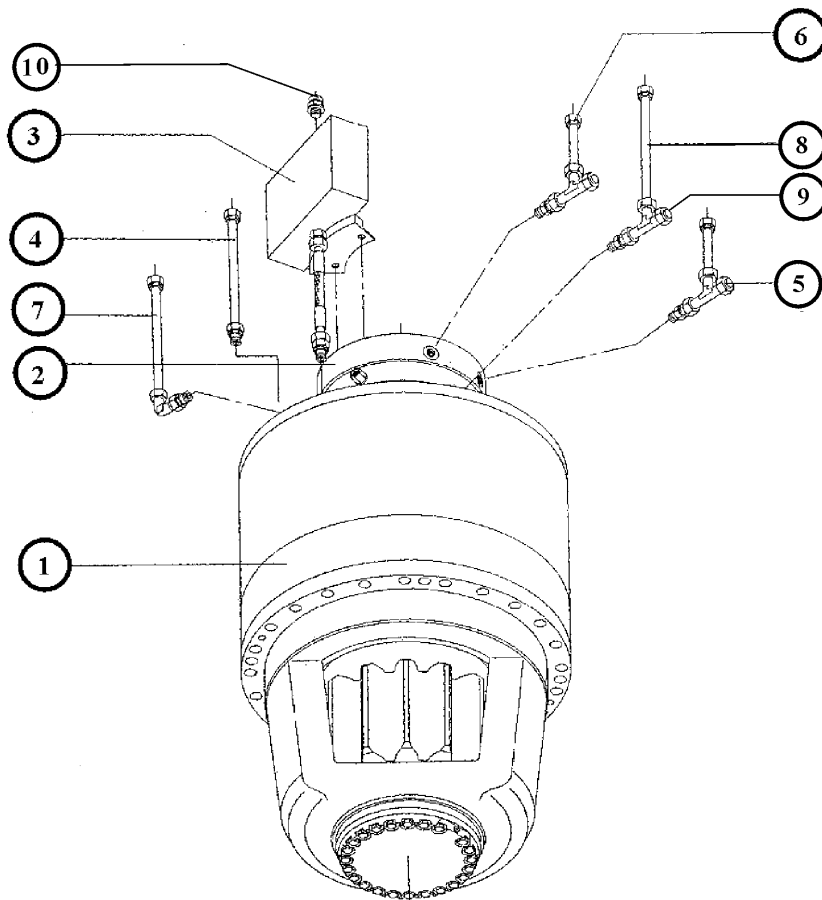
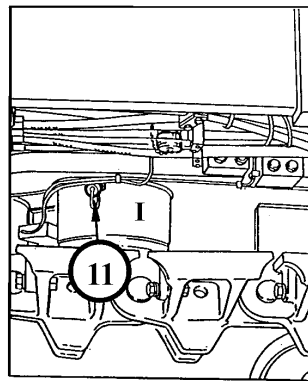
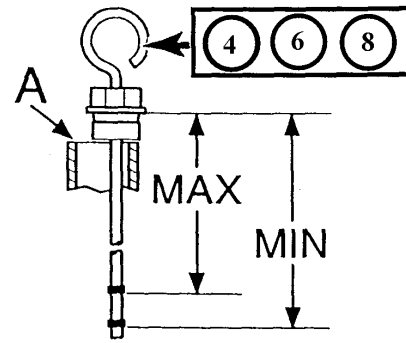
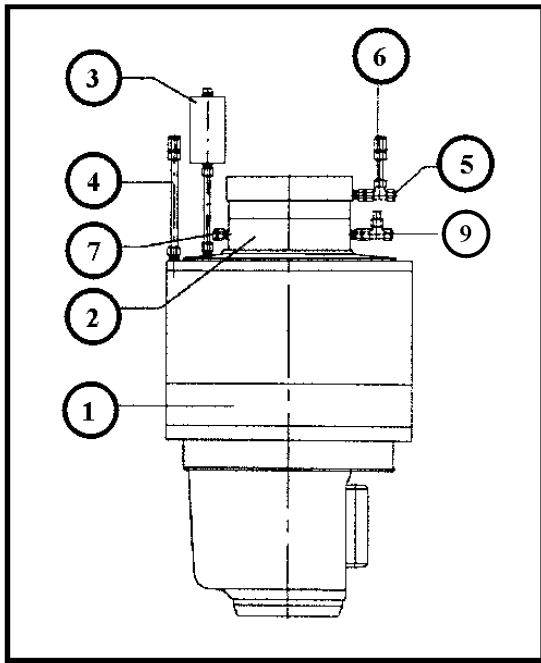

Z 21694

**Brake Housing - Change Oil (Siebenhaar)**

1. Remove level gauge (8), illustration Z 21694, drain plug (9) and breather filter (7). Drain the oil into a receptacle of approx. 5 liter capacity.
2. Clean breather filter (7) with compressed air from inside to outside and re-install.
3. Install drain plug (9) and fill-up engine or hydraulic oil through filler opening, up to the "MAX" mark on level gauge (8) and install the level gauge.
4. After short operating period check oil level and housing for leaks.

**NOTICE**

**Be sure to fill the brake housing and motor adapter housing with engine oil or hydraulic oil as specified on page 239.**

**Motor Adapter Housing - Change Oil**

1. Remove level gauge (6) and drain plug (5). Drain the oil into a receptacle of approx. 5 liter capacity.
2. Install drain plug (5) and fill-up engine or hydraulic oil through filler opening, up to the "MAX" mark on level gauge (6) and install the level gauge.
3. After short operating period check oil level and housing for leaks.

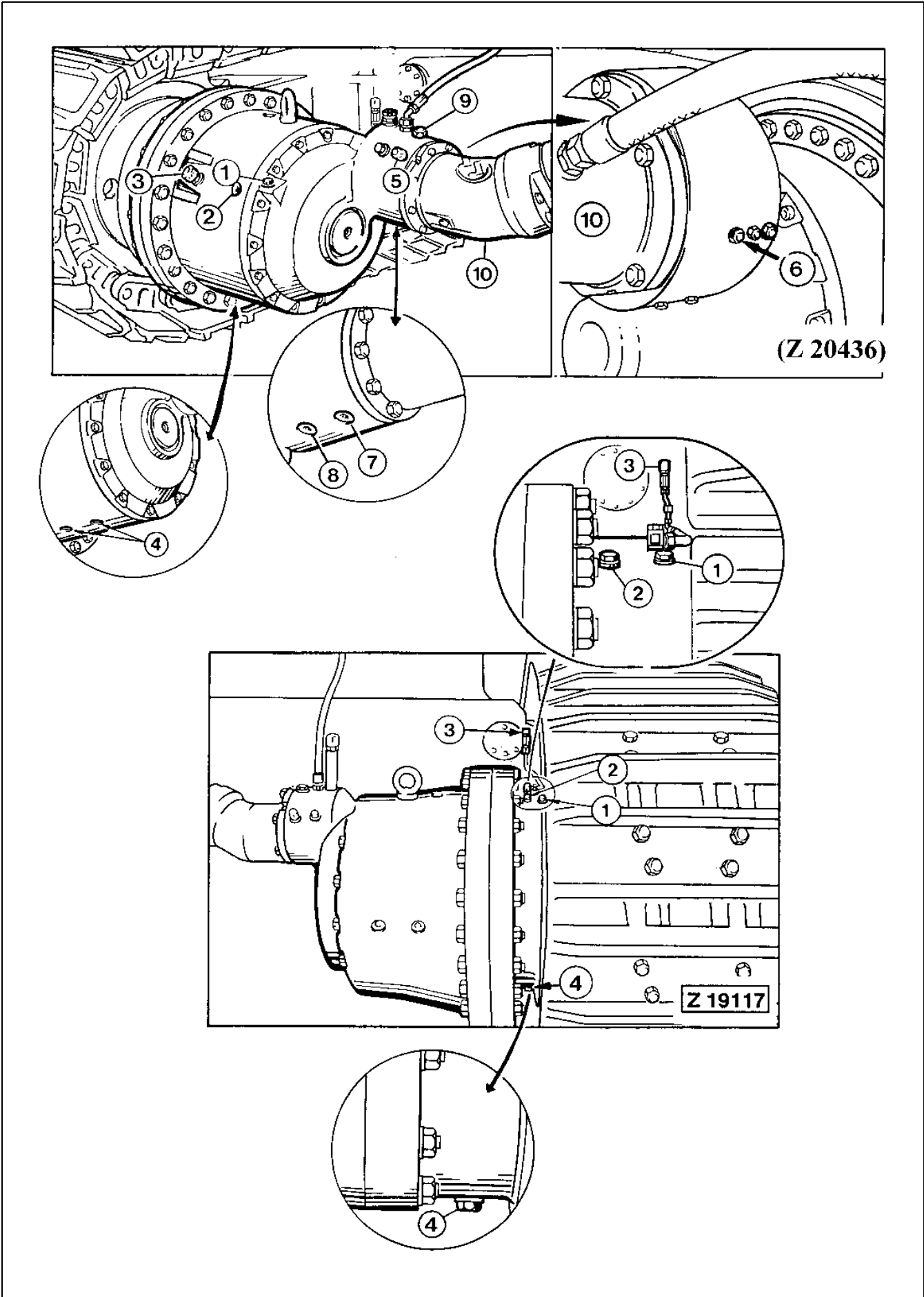

## 4.14.2 TRAVEL GEARS, BRAKE AND MOTOR ADAPTER HOUSINGS - CHANGE OIL

### Legend for illustration Z 20436

- (1) Oil level gauge for travel gear
- (2) Oil filler plug
- (3) Adapter for breather filter hose line
- (4) Drain plugs
- (5) Breather filter for motor adapter housing. The bore of the breather filter is also used as a level and filler opening.
- (6) Oil level plug for brake housing
- (7) Oil drain plug for motor adapter housing
- (8) Oil drain plug for brake housing
- (9) Oil filler plug for brake housing
- (10) Hydraulic motor

### TRAVEL GEARS - CHANGE OIL

#### REMARK

The breather filters for the travel gears are mounted inside the center frame and connected with extension hoses.

1. Remove drain plugs (4), filler plug (2) and oil level gauge (1). Check breather filter, mounted inside center frame, and clean as necessary.
2. After the oil is completely drained, flush the gear with the regular gear oil and reinstall drain plugs (4).
3. Fill the gear with fresh oil through filler opening (2) up to the "Max" mark on oil level gauge (1).
4. Install filler plug (2) and gauge (1).
5. After short operating period check gears for leakage.

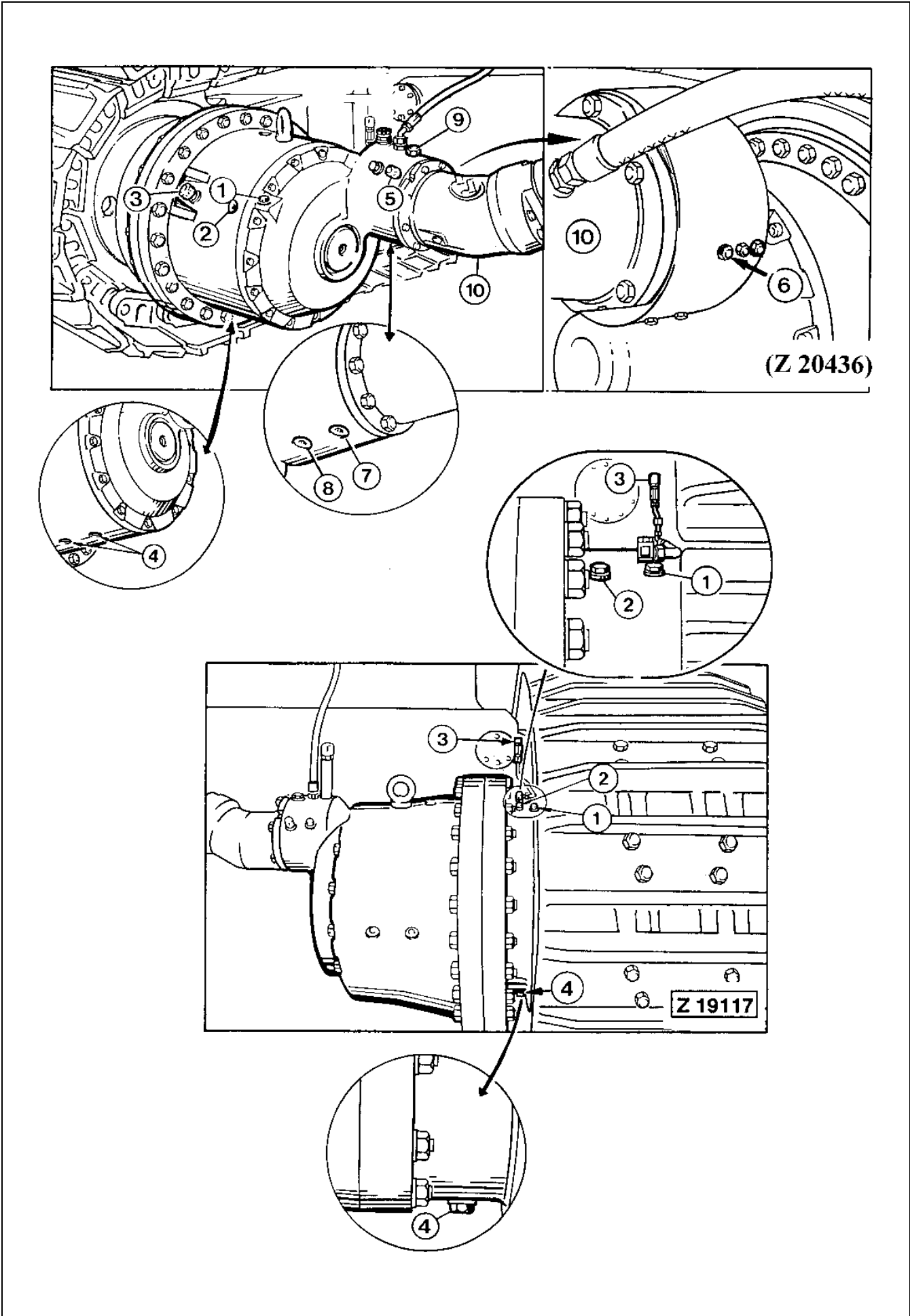

## **BRAKE HOUSINGS - CHANGE OIL**

See illustration Z 20436

---

---

**▲ CAUTION**

---

---

**The brakes must be released for changing the oil.**

---

---

1. Place wedges at front and rear side of both crawlers.
2. Start the engine and lower the bucket onto the ground.
3. Have a second person for control in the operator's cab.
4. Change the oil. Remove parts (6, 8 and 9) and drain the oil. Install plug (8) and fill in fresh oil up to level opening (6). Install plugs (5 and 6).
5. Shut down the engine.

### **NOTICE**

**Be sure to fill the brake housings and motor adapter housings with engine oil or hydraulic oil as specified on page 239.**

## **MOTOR ADAPTER HOUSINGS - CHANGE OIL**

1. Remove parts (5 and 7) and drain the oil completely.
2. Check breather filter, mounted inside center frame, and clean as necessary.
3. Install drain plug (7) and fill-up oil to level opening (5). Reconnect breather filter hose line to level and filler opening (5).

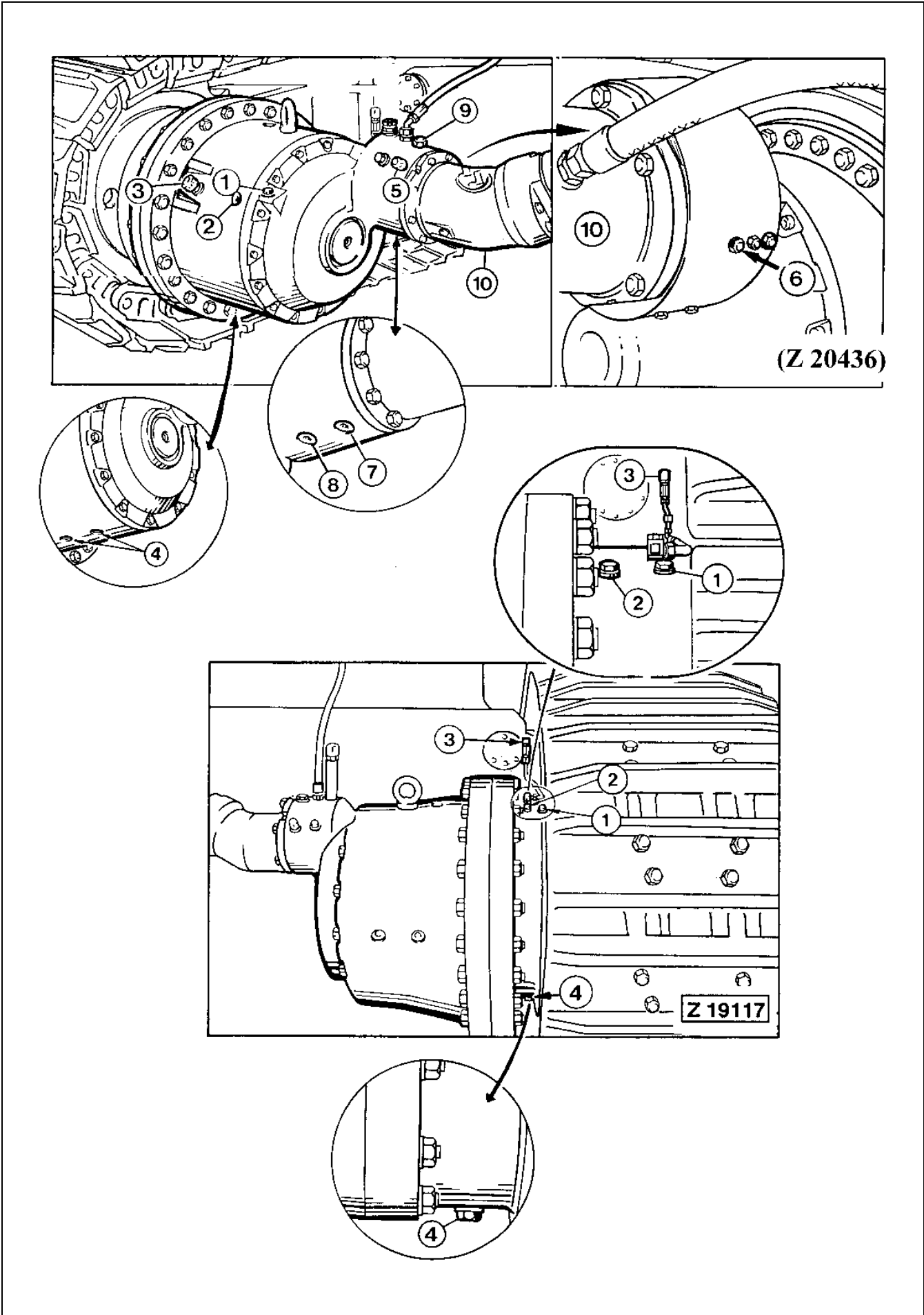



### **4.14.3 FINAL DRIVE HOUSINGS - CHANGE OIL**

See illustration Z 19117

1. Remove drain plug (4), filler plug (2) and oil level gauge (1) and drain the lubricating oil.
2. Check breather filter (3), mounted inside center frame, and clean as necessary.
3. After the oil is completely drained, install the cleaned drain plug (4) and tighten securely.
4. Fill in new oil up to the "MAX" marking on oil level gauge (1).
5. Clean filler plug (2) and reinstall.
6. After short operating period check oil level and gear for leaks.

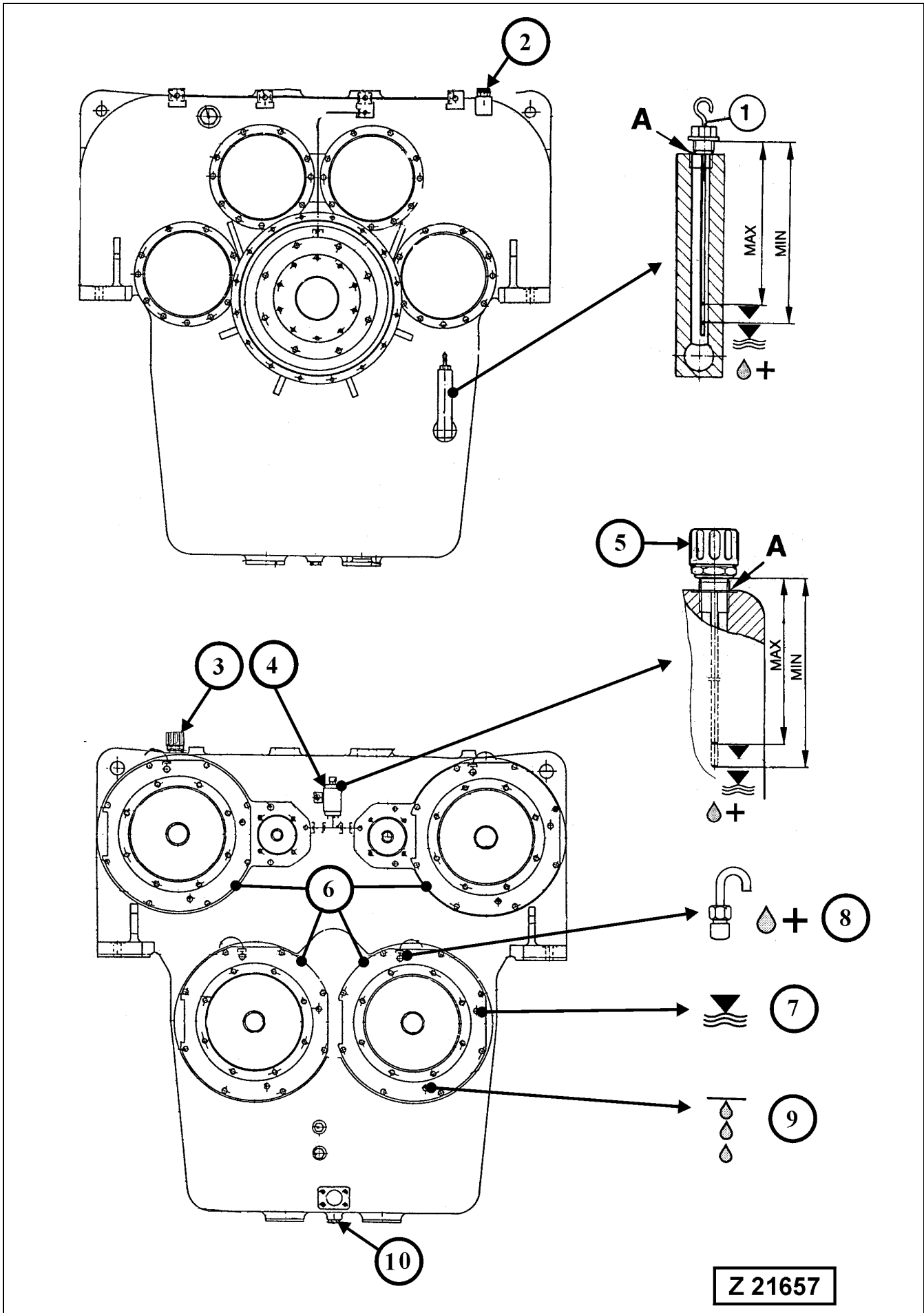

#### 4.14.4 PTO (PUMP DISTRIBUTOR GEAR) - CHANGE OIL

##### Legend for illustration Z 21657

- (1) Oil level gauge
- (2) Oil filler plug
- (3) Breather filter
- (4) Oil collector reservoir for secondary oil pump drive shaft housings
- (5) Breather filter with oil level gauge
- (6) Main pump drive shaft housings
- (7) Oil level plug of main pump drive shaft housing
- (8) Oil filler plug with breather pipe of main pump drive shaft housing
- (9) Oil drain plug of main pump drive shaft housing
- (10) Oil drain plug of PTO gear

##### Gear Oil Viscosity

Select gear oil viscosity grade according to ambient temperatures.

If the new gear oil has a different viscosity grade compared with the drained oil it is necessary to enter the new viscosity grade into the appropriate "**Service SETTINGS**" group of the VHMS Menu Control.

##### Change the Oil

1. Remove drain plug (10).
2. Remove gauge (1) and filler plug (2).
3. Remove breather filter (3), blow out with compressed air from inside to outside and re-install.
4. After the oil is completely drained, flush the gear with the regular gear oil and reinstall drain plug (10).
5. Fill in new oil through opening (2) up to the "MAX" mark on gauge (1). DO NOT screw in gauge (1) for checking the oil level, see detail (A).
6. Re-install parts (1 and 2).
7. After short operating period, check oil level and housing for leakage.

# 4.15 FIRE PREVENTION

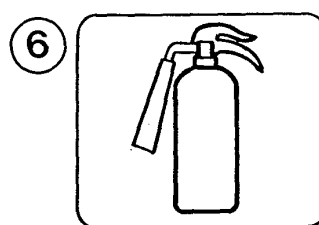
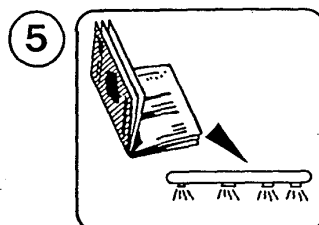
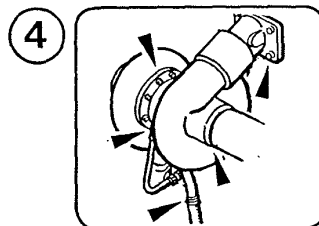
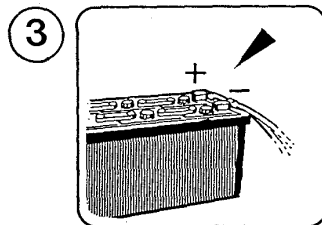
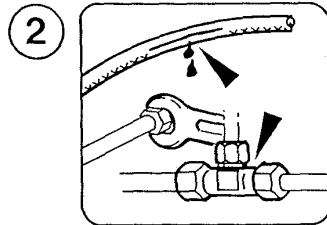
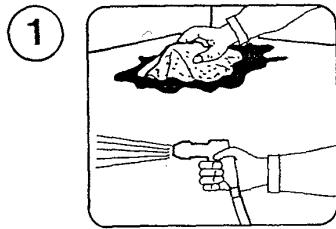

Z 19360

## PRECAUTIONS

See illustration Z 19360

In order to prevent risks of possible fire break out observe the following items:

1. Keep the Shovel clean, especially from inflammable materials.  
Clean the Shovel after servicing the hydraulic system, engine and fuel system by means of a steam jet.
2. Clean engine compartment, hydraulic pump compartment and service platform of the superstructure.  
Thereafter check fuel lines, engine oil lines and hydraulic oil lines for leakage, loose fastenings and damage.  
If any leakage, damage or loose fastening is found, corrective action must be taken immediately.
3. Check all electrical cables, terminals and connections for loose fastenings, damage and wear.  
Replace or repair defective or worn parts without delay.
4. Check the turbocharger for correct mounting and tight exhaust, intake and lube oil connections.  
Carry out all necessary repairs without delay.
5. **On machines equipped with a fire detection, actuation and suppression system:**  
Refer to the manufacturers service manuals in part 3 of the Service Literature Binder for correct maintenance and inspection of the systems.  
When checking the filling level of the dry chemical tanks, make sure that the extinguishing powder (Ansul FORAY dry chemical agent) is not compacted.  
Stir up the extinguishing powder with a suitable stick until it is in a free flowing condition.

### NOTICE

**When cleaning the power house take care the heat detection sensors do not come in contact with hot steam or other hot agent. Otherwise the fire suppression system may be triggered.**

6. Make sure fire extinguishers are charged and ready for use.

### NOTICE

**After cleaning lubricate all lubrication points by means of central lube system or manually.  
Lubricate slew ring gear after drying by means of the automatic lube system or manually.**

# 4.16 WELD REPAIRS

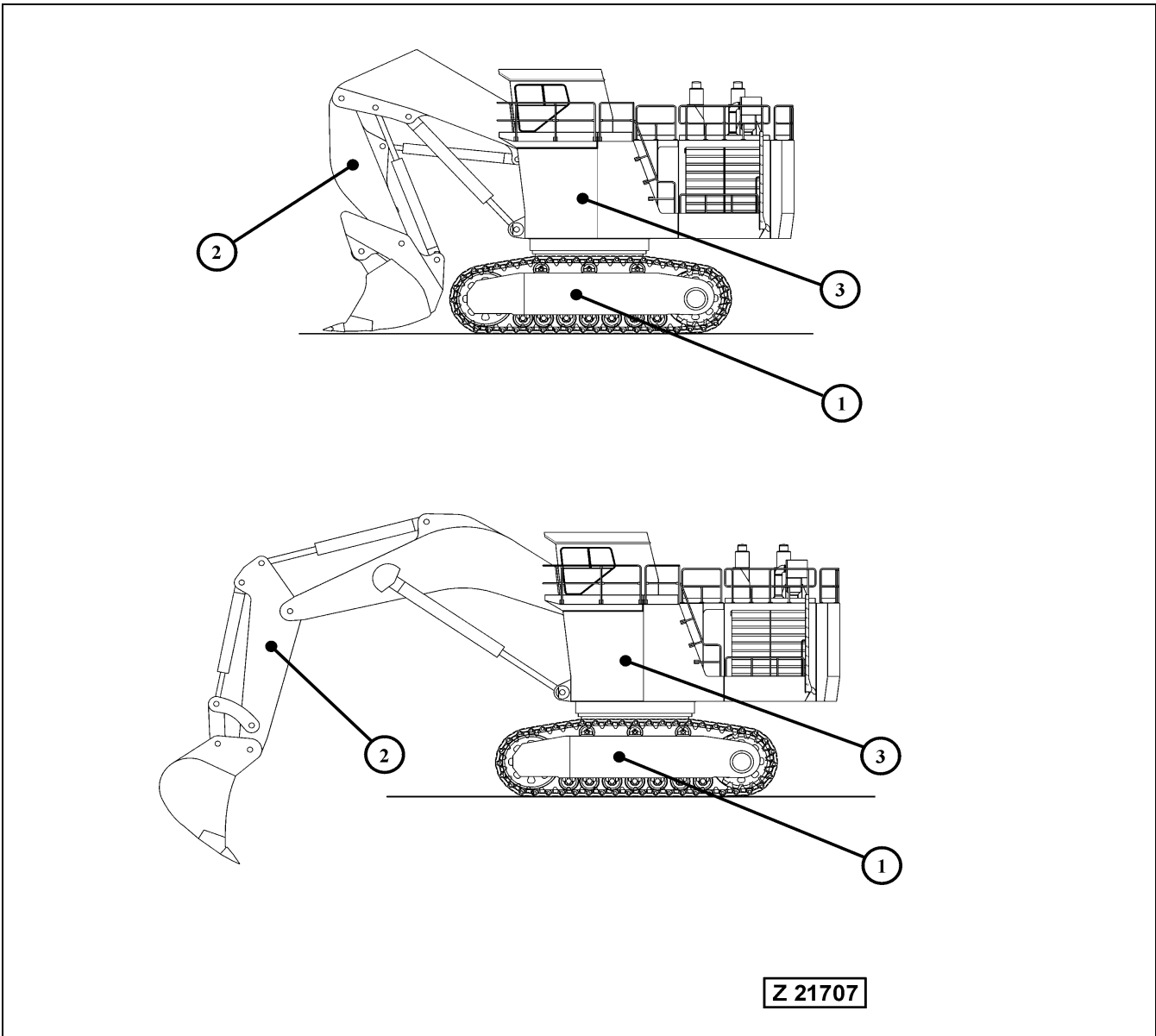

**CAUTION**

Before carry out weld repairs, contact our Service Department in order to avoid improper welding procedures. Weld repairs can cause severe damage to an entire structure if performed incorrectly. If cracks are found in the steel construction of your Shovel, please inform our Service Department as soon as possible. Attach suitable information material (photos, catalog drawings etc.) showing the location and nature of the crack.

## GENERAL INFORMATION

Welding operations can cause damage to electronic components. (Computers, Control Units, Sensors etc.), in case the welding current goes through these units. Therefore protective measures are necessary before any weld repair is started.

## GENERAL PROTECTIVE MEASURES

- A. Observe the prevailing safety and fire prevention regulations.
- Before any weld repair is started, a survey should be made of the area and all safety considerations satisfied such as fuel tanks, oil lines, electrical cables and synthetic materials.
- B. Attach the welding ground directly to the part that is being repaired. Do not allow welding current to go through bearings. Welding current could arc the bearings, resulting in severe damage to the bearing.

## WELD REPAIRS ON MAJOR COMPONENTS OF THE SHOVEL

### COUNTERWEIGHT

---

**▲ WARNING**

---

The chambers of the counterweight are filled with a mixture of concrete, granulated ore and steel pellets. This mixture can create explosive gases which will accumulate in the chambers of the counterweight. Before any welding, flame-cutting, grinding or drilling procedures are carried out on the counterweight it is vital to expel these gases from the counterweight chambers. Failure to properly expel the gases from the counterweight chambers can result in an explosion with serious personal injury or death.

Follow the instructions given in **PARTS & SERVICE NEWS** No. AH04518 for expelling the gases from the counterweight chambers.

---

### Legend for illustration Z 21707

- (1) Undercarriage, refer to page 425 for protective measures.
- (2) Loader attachment, refer to page 427 for protective measures.
- (3) Superstructure, refer to page 429 for protective measures.

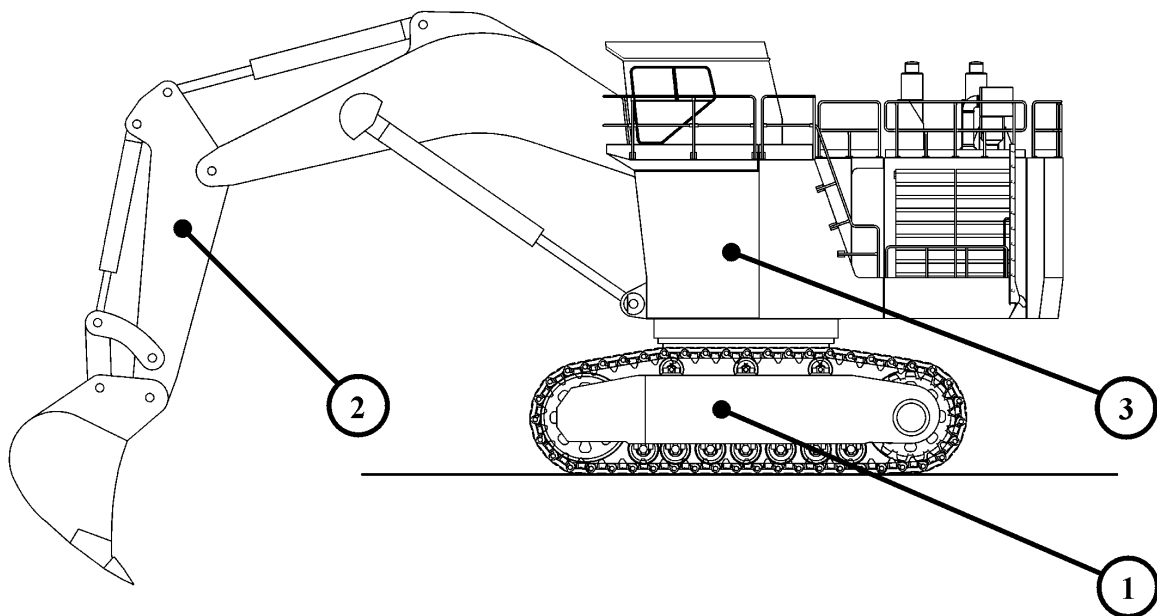
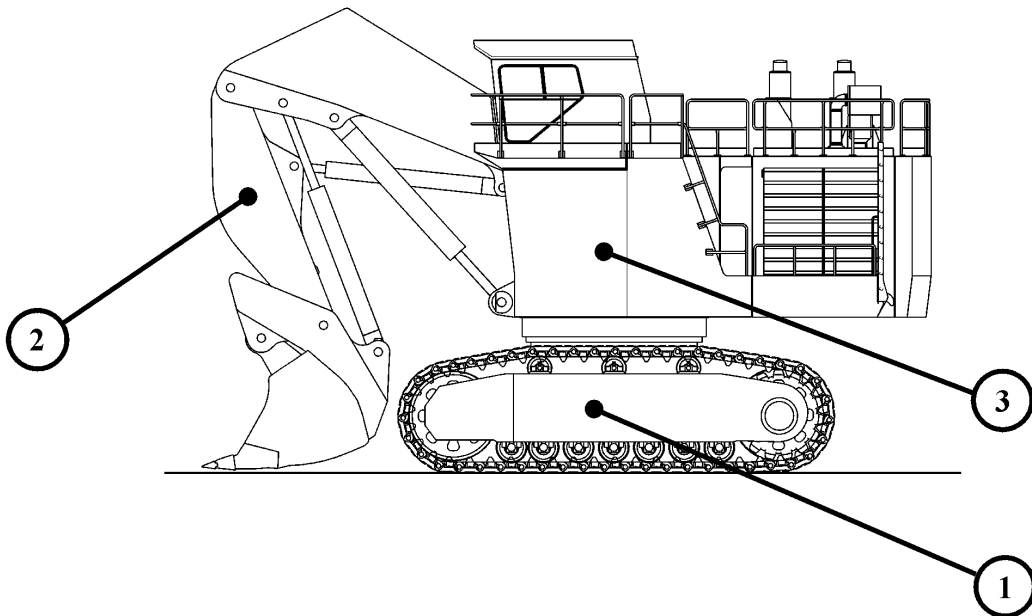

Z 21707



### **4.16.1 PROTECTIVE MEASURES BEFORE STARTING WELD REPAIRS ON THE UNDERCARRIAGE**

On standard Shovels there are no special protective measures necessary.

However, the general protective measures (A and B) must be observed.

On Shovels with a power unit (generator set) mounted to the undercarriage, all electrical connections between the Shovel and the power unit have to be disconnected.

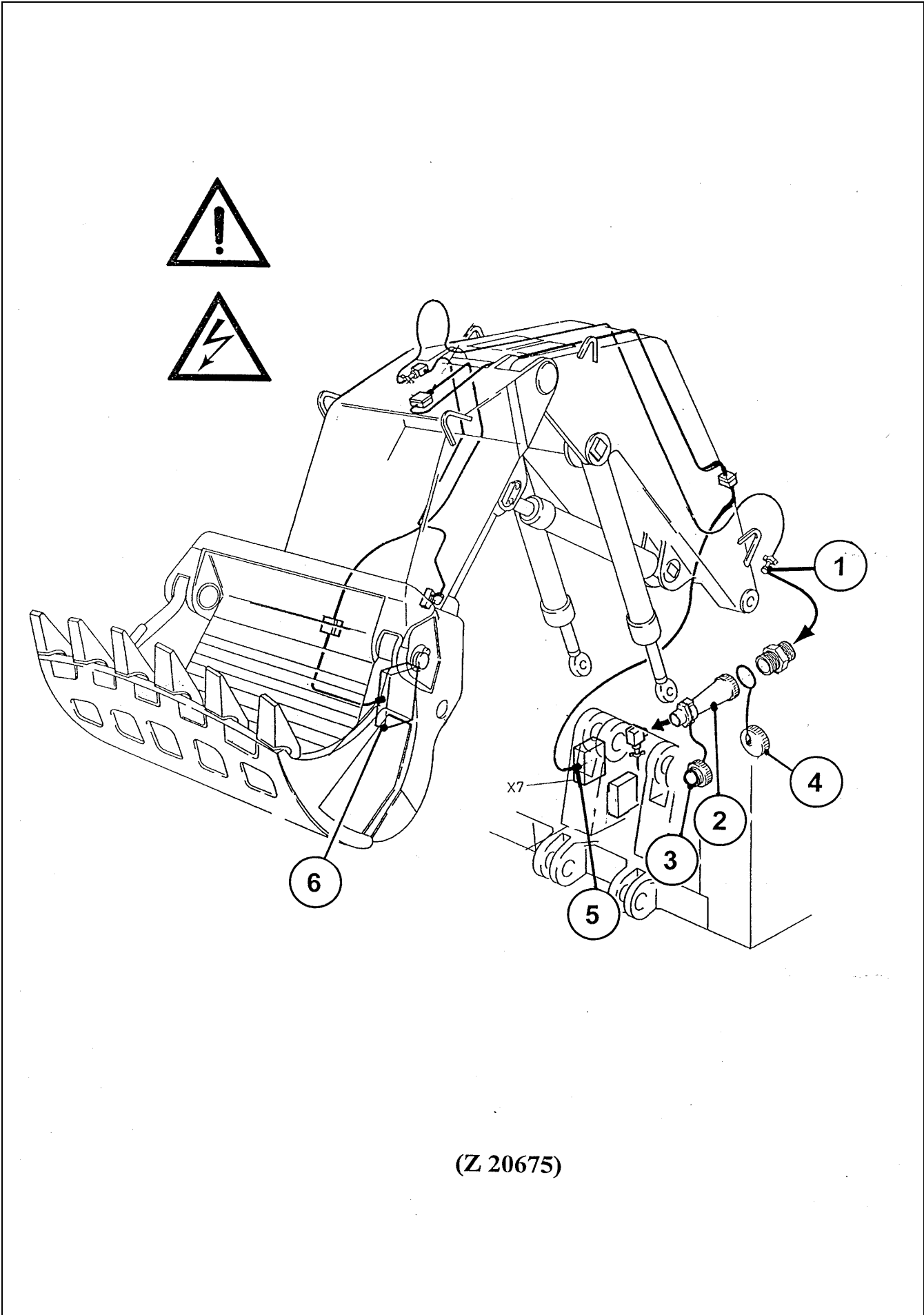

(Z 20675)

## 4.16.2 PROTECTIVE MEASURES BEFORE STARTING WELD REPAIRS ON THE LOADER ATTACHMENT

### Legend for illustration Z 20675

- (1) Electrical cable connector of the end-line pressure switch for the central lubrication system
- (2) Plug socket
- (3) Protection cap for (2)
- (4) Protection cap for (1)
- (5) Switch box of the electronic bucket levelling system "EBL", (Special Equipment)
- (6) Bucket position detector box for the "EBL" system (Special Equipment)

### NOTICE

**If weld repairs have to be carried out on the Loader Attachment (Bucket, Stick and/or Boom) disconnect the end line pressure switch cable connector (1) from socket (2) and close the openings with caps (3 and 4).**

**If the Shovel is equipped with an electronic Bucket Levelling System, disconnect also the cable connector on switch box (5).**

**Be sure to disconnect electrical connections of working lights and other electrical equipment mounted on the loader attachment.**

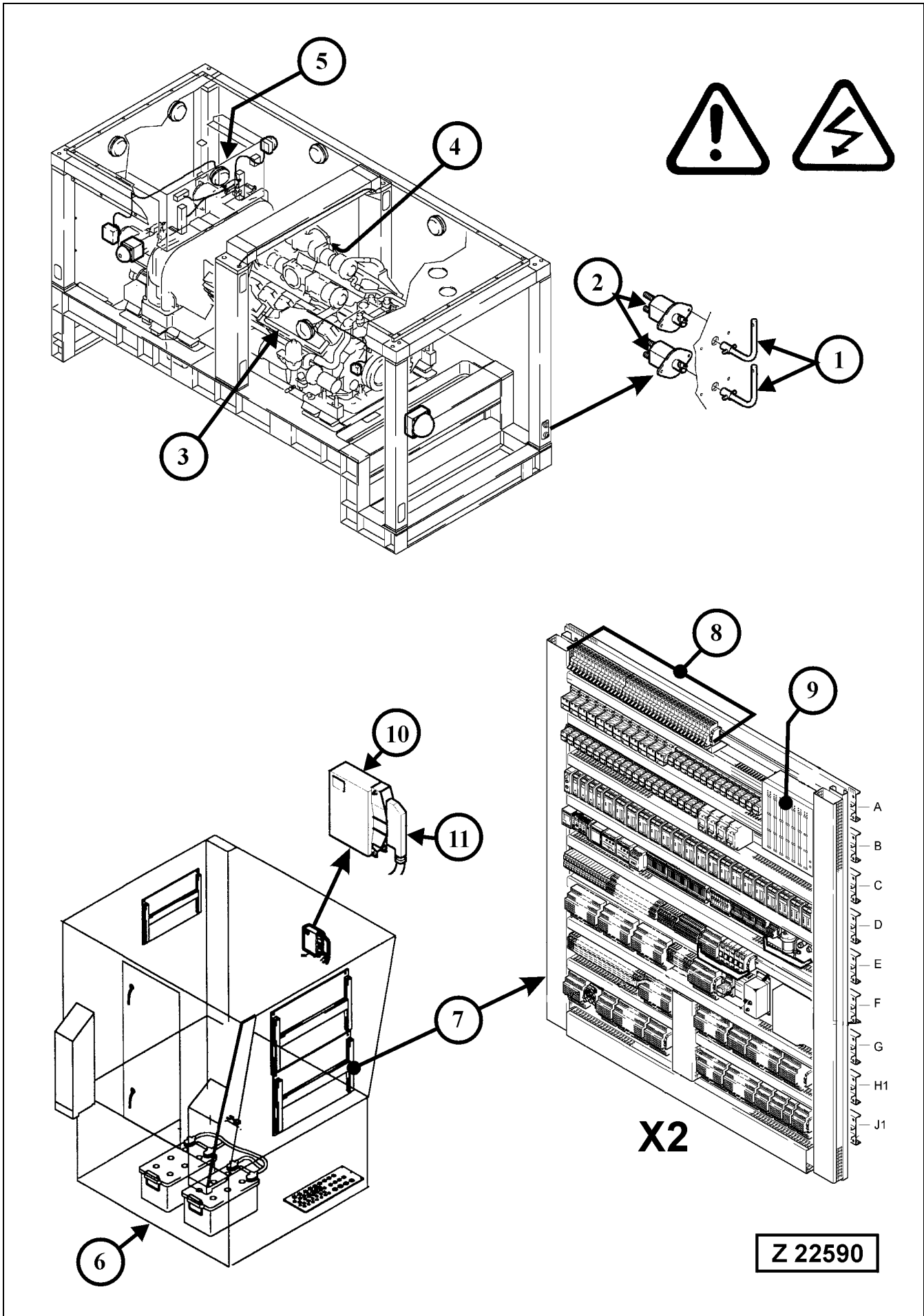

### 4.16.3 PROTECTIVE MEASURES BEFORE STARTING WELD REPAIRS ON THE SUPERSTRUCTURE

#### Legend for illustration Z 22590

- (1) Battery main switch keys
- (2) Battery main switches
- (3) Diesel engine
- (4) Interface harness connectors located on left engine side near the flywheel housing.
- (5) Central control and filter carrier
- (6) Cab base
- (7) Main switch board "X2"
- (8) Circuit breakers
- (9) Programmable logic controller (PLC)
- (10) Electronic pump control module MC7
- (11) Wiring harness connector

1. Remove battery main switch keys (1).
2. Disconnect the 21-pin and 31-pin interface harness connectors (4) on the engine.
3. Switch off all circuit breakers (8) on switch board (7).
4. Disconnect all plugs on the programmable logic controller (9).
5. Remove the wiring harness connector (11) from electronic pump control module MC7 (10).
6. Attach the welding ground directly to the part that is being repaired. Do not allow welding current to go through bearings. Welding current could arc the bearings, resulting in severe damage to the bearing.
7. Observe the prevailing safety and fire prevention regulations. Before any weld repair is started, a survey should be made of the area and all safety considerations satisfied such as fuel tanks, oil lines, electrical cables and synthetic materials.

#### NOTICE

- **DO NOT carry out weld repairs on engine (3), on the central control and filter panel (4) and on the cab base (6). Contact your local Komatsu dealer if such repairs are necessary.**
- **Be sure to isolate Electronic Components of Special Equipment e.g. Air Conditioning, Generator Set, Pre-heating systems etc.**

#### **4.16.4 AFTER FINISHING THE WELD REPAIRS ON THE SUPERSTRUCTURE**

After finishing the weld repairs connect all cable connectors which have been disconnected and switch on all circuit breakers. When all electrical connections are established insert the battery main switch keys.

---

<b>1. INTRODUCTION .....</b>	<b>3</b>
1.1 CONTENTS OF THE BINDER .....	4
1.2 DIVISION OF THE BINDER .....	5
1.3 DESIGNATED USE OF THE SHOVEL .....	6
1.4 DELIVERY OF THE SHOVEL .....	7
1.5 EXPLANATION OF ABBREVIATIONS .....	8
1.6 TABLE OF CONTENTS .....	9
<b>2. SAFETY .....</b>	<b>15</b>
2.1 SAFETY INSTRUCTIONS .....	16
2.1.1 WARNINGS AND SYMBOLS .....	16
2.1.2 BASIC OPERATION AND DESIGNATED USE OF THE HYDRAULIC MINING SHOVEL ..	16
2.1.3 ORGANIZATIONAL MEASURES .....	17
2.1.4 SELECTION AND QUALIFICATION OF PERSONNEL - BASIC RESPONSIBILITIES .....	19
2.1.5 SAFETY INSTRUCTIONS GOVERNING SPECIFIC OPERATIONAL PHASES .....	20
2.1.6 WARNING OF SPECIAL DANGERS .....	23
2.1.7 TRANSPORTING AND TOWING -RECOMMISSIONING .....	25
2.1.8 SPECIAL SAFETY EQUIPMENT .....	25
2.1.9 SAFETY HARNESS IN CONFORMITY WITH EN 361 (EUROPEAN STANDARD) .....	29
<b>3. OPERATION .....</b>	<b>37</b>
3.1 FOREWORD .....	38
3.2 CONSTRUCTION OF THE SHOVEL .....	39
3.2.1 OVERALL VIEW .....	39
3.2.2 SUPERSTRUCTURE .....	40
3.2.3 HYDRAULICALLY OPERATED ACCESS LADDER .....	50
3.2.4 EMERGENCY ESCAPE LADDER .....	54
3.2.5 EMERGENCY ENGINE SHUTDOWN FROM GROUND MAN OR OPERATOR WARNING SYSTEM .....	56
3.2.6 OPERATOR'S CAB WITH INTEGRATED FALLING OBJECT PROTECTIVE STRUCTURE (FOPS) .....	58
3.2.7 UNDERCARRIAGE .....	69
3.2.8 WORKING ATTACHMENT .....	70
3.2.9 DIESEL ENGINE TYPE SDA 16V160 .....	72
3.2.10 ENGINE OIL MANAGEMENT SYSTEM .....	74
3.3 OPERATOR'S CAB - CONTROLS .....	78
3.3.1 CONTROLS WITH BACKHOE ATTACHMENT .....	78
3.3.2 SAFETY CIRCUIT FOR CONTROLS .....	79

3.3.3	CONTROLS WITH BOTTOM DUMP BUCKET ATTACHMENT .....	82
3.3.4	SAFETY CIRCUIT FOR CONTROLS .....	83
3.3.5	AUTOMATIC FLOAT POSITION FOR BOOM AND STICK .....	85
3.3.6	OPERATOR'S CONSOLE .....	87
3.3.7	INTERFACE PANEL FOR DIAGNOSTICS AND CONTROLS FOR HEATING AND AIR CONDITIONING .....	93
<b>3.4</b>	<b>VEHICLE HEALTH MONITORING SYSTEM VHMS – HEALTH MONITOR .....</b>	<b>96</b>
3.4.1	INITIALIZATION SCREEN NO. 0.0 .....	96
3.4.2	OPERATOR INFORMATION SCREEN NO. 1.1 .....	96
3.4.3	STANDARD MONITOR 1 (NO. 1.2) .....	97
3.4.4	TABLE OF ALL TOP MESSAGES PROVIDED BY THE SYSTEM .....	111
3.4.5	TABLE OF AVAILABLE INSTRUCTION MESSAGES .....	120
<b>3.5</b>	<b>OPERATING THE HEATER, VENTILATION AND AIR CONDITIONING .....</b>	<b>122</b>
3.5.1	A - HEATING .....	123
3.5.2	B - COOLING .....	123
3.5.3	COMBINED OPERATION OF AIR CONDITIONING AND HEATING .....	123
3.5.4	AUXILIARY HEATER FOR OPERATOR'S CAB .....	125
<b>3.6</b>	<b>POWER HOUSE .....</b>	<b>126</b>
3.6.1	EMERGENCY ENGINE SHUTDOWN SWITCHES .....	127
3.6.2	MAINTENANCE SAFETY SWITCH AND BATTERY MAIN SWITCHES .....	129
3.6.3	CENTRAL CONTROL AND FILTER PANEL .....	131
<b>3.7</b>	<b>ELECTRICAL EQUIPMENT IN CAB BASE .....</b>	<b>134</b>
3.7.1	STANDARD COMPONENTS IN CAB BASE .....	135
3.7.2	SWITCH BOARD (X2) IN CAB BASE .....	137
3.7.3	COMPONENTS OF ELECTRICAL PRE-HEATING SYSTEM LOCATED IN THE CAB BASE 147	
<b>3.8</b>	<b>CHECKS BEFORE STARTING THE ENGINE .....</b>	<b>154</b>
<b>3.9</b>	<b>STARTING THE ENGINE .....</b>	<b>160</b>
3.9.1	STARTING PROCEDURE .....	163
3.9.2	ENGINE WARM-UP .....	167
3.9.3	HYDRAULIC OIL WARM-UP .....	167
<b>3.10</b>	<b>MOVING THE SHOVEL .....</b>	<b>169</b>
3.10.1	TRAVEL CONTROL WITH FOOT PEDALS .....	169
3.10.2	TRAVELLING INSTRUCTIONS .....	172
<b>3.11</b>	<b>SLEWING AND BRAKING THE SUPERSTRUCTURE .....</b>	<b>173</b>
3.11.1	SLEWING THE SUPERSTRUCTURE .....	173
3.11.2	BRAKING THE SUPERSTRUCTURE .....	175
3.11.3	SLEW PARKING BRAKE .....	176
<b>3.12</b>	<b>WORKING WITH THE ATTACHMENT .....</b>	<b>178</b>
3.12.1	MACHINES EQUIPPED WITH "EURO" CONTROL SYSTEM .....	178
3.12.2	MACHINES EQUIPPED WITH "KMG" CONTROL SYSTEM .....	179
3.12.3	BOTTOM DUMP BUCKET .....	180



3.12.4	DROP BALL OPERATION .....	181
3.12.5	COMBINED OPERATION CYCLES .....	184
<b>3.13</b>	<b>WORKING INSTRUCTIONS .....</b>	<b>186</b>
3.13.1	STABILITY OF THE SHOVEL .....	186
3.13.2	SHOVEL OPERATION .....	186
<b>3.14</b>	<b>PARKING THE SHOVEL .....</b>	<b>189</b>
<b>3.15</b>	<b>STOPPING THE ENGINE .....</b>	<b>190</b>
3.15.1	RELIEVE PRESSURE IN THE HYDRAULIC SYSTEM .....	193
<b>3.16</b>	<b>OPERATION OF THE LUBRICATION SYSTEM .....</b>	<b>194</b>
3.16.1	CENTRAL LUBRICATION SYSTEM "CLS" .....	194
3.16.2	SWING CIRCLE PINION LUBRICATION SYSTEM "SLS" .....	196
<b>3.17</b>	<b>FIRE DETECTION AND SUPPRESSION SYSTEM .....</b>	<b>198</b>
3.17.1	HIGH LEVEL ALARM "FIRE" .....	201
3.17.2	ENGINE SHUT-DOWN THROUGH FUEL SHUT-OFF SOLENOID VALVE .....	201
3.17.3	ACTUATION MODES OF THE FIRE SUPPRESSION SYSTEM .....	201
3.17.4	INDICATION OF OPERATIONAL MODES AT CONTROL MODULE, AFTER AUTOMATIC ACTUATION OF THE FIRE SUPPRESSION SYSTEM .....	203
3.17.5	LOCATION OF THE EXTINGUISHING AGENT TANK ASSEMBLIES AND EXPELLANT GAS CARTRIDGES ON POWER HOUSE ROOF .....	205
<b>3.18</b>	<b>TRANSFER PUMP FOR HYDRAULIC OIL .....</b>	<b>206</b>
3.18.1	OPERATING THE TRANSFER PUMP .....	207
3.18.2	FUNCTIONS OF THE TRANSFER PUMP .....	209
<b>3.19</b>	<b>CENTRAL REFILLING SYSTEM .....</b>	<b>212</b>
3.19.1	SYSTEMS CONNECTED TO THE REFILLING SYSTEM .....	213
3.19.2	OPERATING THE HYDRAULIC SERVICE ARM .....	215
3.19.3	RECEIVER PANEL WITH MONITOR BOX .....	217
3.19.4	REFILLABLE GREASE CONTAINERS OF THE CENTRAL LUBRICATION SYSTEM AND SWING CIRCLE PINION LUBRICATION SYSTEM .....	223
<b>3.20</b>	<b>WORK ON THE LOADER ATTACHMENT .....</b>	<b>226</b>
<b>3.21</b>	<b>TRANSPORTATION AND LIFTING OF THE SHOVEL .....</b>	<b>227</b>
3.21.1	DISASSEMBLING OF THE SHOVEL .....	227
3.21.2	TRANSPORTATION AND LIFTING .....	227
<b>3.22</b>	<b>RETRIEVAL PROCEDURE .....</b>	<b>228</b>
<b>3.23</b>	<b>SHOVEL STORAGE .....</b>	<b>229</b>
3.23.1	PREPARING FOR STORAGE .....	229
3.23.2	ONE MONTH REPETITIVE SERVICE PERIOD .....	230
3.23.3	SIX MONTH REPETITIVE SERVICE PERIOD .....	230
3.23.4	PREPARING FOR OPERATION .....	231

<b>3.24</b>	<b>TROUBLE SHOOTING</b>	<b>232</b>
3.24.1	ENGINE	232
3.24.2	HYDRAULIC SYSTEM	233
3.24.3	FINAL DRIVES AND SWING MACHINERY	234
3.24.4	CRAWLER TRACKS	234
<b>4.</b>	<b>MAINTENANCE</b>	<b>235</b>
<b>4.1</b>	<b>FOREWORD</b>	<b>236</b>
<b>4.2</b>	<b>PRECAUTIONS FOR MAINTENANCE</b>	<b>237</b>
<b>4.3</b>	<b>FUEL AND LUBRICANTS</b>	<b>239</b>
<b>4.4</b>	<b>FILLING CAPACITIES</b>	<b>241</b>
<b>4.5</b>	<b>STANDARD TORQUE LIST</b>	<b>242</b>
<b>4.6</b>	<b>LUBRICATION AND MAINTENANCE SCHEDULE</b>	<b>243</b>
4.6.1	INITIAL SERVICING	243
4.6.2	PERIODIC SERVICING INTERVALS	243
4.6.3	PERIODIC SERVICING SCHEDULE	244
4.6.4	EXTENDED SERVICE INTERVALS FOR ENGINES EQUIPPED WITH ENGINE OIL MANAGEMENT SYSTEM	251
4.6.5	MAINTENANCE OF THE ENGINE	253
<b>4.7</b>	<b>WHEN NECESSARY</b>	<b>254</b>
4.7.1	ENGINE AIR CLEANER SERVICE	255
4.7.2	SWING CIRCLE TOOTHING LUBRICATION	259
4.7.3	AUTOMATIC LUBRICATION SYSTEMS FILL GREASE BARRELS	261
4.7.4	TRACK ROLLERS AND GUIDE WHEELS - REPLACE FLOATING SEALS	265
<b>4.8</b>	<b>EVERY 10 OPERATING HOURS OR DAILY</b>	<b>266</b>
4.8.1	WALK-AROUND INSPECTION	267
4.8.2	AIR CLEANER - CLEAN PRE-CLEANER	277
4.8.3	RADIATOR - CHECK COOLANT LEVEL	279
4.8.4	TRACK GROUPS - CLEAN	279
4.8.5	FUEL SYSTEM WATER SEPARATOR - DRAIN WATER	281
<b>4.9</b>	<b>EVERY 50 OPERATING HOURS OR WEEKLY</b>	<b>282</b>
4.9.1	SWING MACHINERY AND MOTOR ADAPTER HOUSINGS - CHECK OIL LEVELS	283
4.9.2	TRAVEL GEARS, BRAKE HOUSINGS AND MOTOR ADAPTER HOUSINGS - CHECK OIL LEVELS	287
4.9.3	FINAL DRIVE HOUSINGS - CHECK OIL LEVEL	289
4.9.4	PTO (PUMP DISTRIBUTOR GEAR) AND OIL RESERVOIR - CHECK OIL LEVEL	291
4.9.5	HYDRAULIC ACCESS LADDER - CHECK SAFETY SENSOR	293
4.9.6	HYDRAULIC OIL COOLERS - INSPECT AND CLEAN IF NECESSARY	295
<b>4.10</b>	<b>EVERY 250 OPERATING HOURS OR MONTHLY</b>	<b>296</b>
4.10.1	AIR CONDITIONING COMPRESSOR - CHECK DRIVE BELT TENSION	297

4.10.2	UNDERCARRIAGE PIN CONNECTIONS - LUBRICATE .....	299
4.10.3	SIGNAL HORN COMPRESSOR - LUBRICATE .....	299
4.10.4	HYDRAULIC OIL COOLER FAN BEARING HOUSINGS - CHECK FOR LEAKAGE AND CLEAN BREATHER FILTER .....	299
4.10.5	RADIATOR FAN BEARING HOUSING - CHECK FOR LEAKAGE AND CLEAN BREATHER FILTER .....	299
4.10.6	AUTOMATIC LUBRICATION SYSTEMS - CLEAN IN-LINE GREASE FILTER .....	301
4.10.7	CAB AIR CLEANER - CLEAN OR REPLACE FILTER ELEMENT .....	305
4.10.8	WINDSHIELD WASHER SYSTEM - CHECK FLUID LEVEL .....	307
4.10.9	AIR CONDITIONING FOR OPERATOR'S CAB - CHECK REFRIGERANT LEVEL .....	309
<b>4.11</b>	<b>EVERY 500 OPERATING HOURS OR MONTHLY .....</b>	<b>310</b>
4.11.1	BATTERIES - CHECK FLUID LEVEL .....	311
4.11.2	FLEXIBLE DRIVE COUPLING - CHECK OIL LEVEL .....	313
4.11.3	PTO (PUMP DISTRIBUTOR GEAR) MAIN PUMP DRIVE SHAFT HOUSINGS - CHECK OIL LEVEL .....	315
4.11.4	FUEL TANK - DRAIN CONDENSATION .....	317
4.11.5	CRAWLER TRACK - INSPECTION .....	319
<b>4.12</b>	<b>EVERY 1000 OPERATING HOURS OR EVERY 6 MONTH .....</b>	<b>324</b>
4.12.1	HIGH STRENGTH BOLT CONNECTIONS .....	325
4.12.2	HYDRAULIC SYSTEM - FILTER SERVICE .....	367
4.12.3	PTO (PUMP DISTRIBUTOR GEAR), SWING MACHINERY AND TRAVEL GEARS - OIL SAMPLE ANALYSIS .....	379
4.12.4	SIGNAL HORN COMPRESSOR - CLEAN AND LUBRICATE .....	381
4.12.5	HYDRAULIC TRACK TENSIONING SYSTEM - CHECK ACCUMULATORS .....	383
4.12.6	WATER FILTER - REPLACE FILTER CARTRIDGE .....	385
4.12.7	HYDRAULIC OIL COOLER - INSPECT AND LUBRICATE DOOR HINGES .....	387
4.12.8	MACHINERY HOUSE DOORS - INSPECT AND LUBRICATE DOOR HINGES .....	389
<b>4.13</b>	<b>EVERY 2000 OPERATING HOURS OR YEARLY .....</b>	<b>390</b>
4.13.1	HYDRAULIC SYSTEM - CHANGE OIL, REPLACE SUCTION STRAINERS AND PULSATION DAMPER .....	391
4.13.2	EMERGENCY ESCAPE LADDER - INSPECTION .....	403
<b>4.14</b>	<b>EVERY 3000 OPERATING HOURS HOWEVER AT LEAST ONCE A YEAR .....</b>	<b>404</b>
4.14.1	SWING MACHINERY AND MOTOR ADAPTER HOUSING - CHANGE OIL .....	405
4.14.2	TRAVEL GEARS, BRAKE AND MOTOR ADAPTER HOUSINGS - CHANGE OIL .....	413
4.14.3	FINAL DRIVE HOUSINGS - CHANGE OIL .....	417
4.14.4	PTO (PUMP DISTRIBUTOR GEAR) - CHANGE OIL .....	419
<b>4.15</b>	<b>FIRE PREVENTION .....</b>	<b>420</b>
<b>4.16</b>	<b>WELD REPAIRS .....</b>	<b>422</b>
4.16.1	PROTECTIVE MEASURES BEFORE STARTING WELD REPAIRS ON THE UNDERCARRIAGE .....	425
4.16.2	PROTECTIVE MEASURES BEFORE STARTING WELD REPAIRS ON THE LOADER ATTACHMENT .....	427
4.16.3	PROTECTIVE MEASURES BEFORE STARTING WELD REPAIRS ON THE SUPERSTRUCTURE .....	429
4.16.4	AFTER FINISHING THE WELD REPAIRS ON THE SUPERSTRUCTURE .....	430

