

Operation & Maintenance Manual

MX502

HYDRAULIC EXCAVATOR

SERIAL NUMBERS **MX50 7038** and up

This material is proprietary to Komatsu America Corp. and is not to be reproduced, used, or disclosed except in accordance with written authorization from Komatsu America Corp.

It is our policy to improve our products whenever it is possible and practical to do so. We reserve the right to make changes or improvements at any time without incurring any obligation to install such changes on products sold previously.

Due to this continuous program of research and development, revisions may be made to this publication. It is recommended that customers contact their distributor for information on the latest revision.

Copyright 2004 Komatsu
Printed in U.S.A.
Komatsu America Corp.

March 2004

FOREWORD

CALIFORNIA

Proposition 65 Warning

Diesel engine exhaust and some of its constituents are known to the State of California to cause cancer, birth defects, and other reproductive harm.

CALIFORNIA

Proposition 65 Warning

Battery posts, terminals and related accessories contain lead and lead compounds, chemicals known to the State of California to cause cancer and birth defects or other reproductive harm.

Wash hands after handling.

FOREWORD

This manual provides rules and guidelines which will help you use this machine safely and effectively. The precautions in this manual must be followed at all times when performing operation and maintenance. Most accidents are caused by the failure to follow fundamental safety rules for the operation and maintenance of machines. Accidents can be prevented by knowing beforehand conditions that may cause a hazard when performing operation and maintenance.



WARNING

Operators and maintenance personnel must always do as follows before beginning operation or maintenance.

- Always be sure to read and understand this manual thoroughly before performing operation and maintenance.
- Read the safety messages given in this manual and the safety labels affixed to the machine thoroughly and be sure that you understand them fully.

Keep this manual at the storage location for the Operation and Maintenance Manual given below, and have all personnel read it periodically.

If this manual has been lost or has become dirty and cannot be read, request a replacement manual immediately from Komatsu or your Komatsu distributor.

If you sell the machine, be sure to give this manual to the new owners together with the machine.

Komatsu delivers machines that comply with all applicable regulations and standards of the country to which it has been shipped. If this machine has been purchased in another country or purchased from someone in another country, it may lack certain safety devices and specifications that are necessary for use in your country. If there is any question about whether your product complies with the applicable standards and regulations of your country, consult Komatsu or your Komatsu distributor before operating the machine.

Storage location for the Operation and Maintenance Manual:
Pocket on inside of cover of toolbox under operator's seat

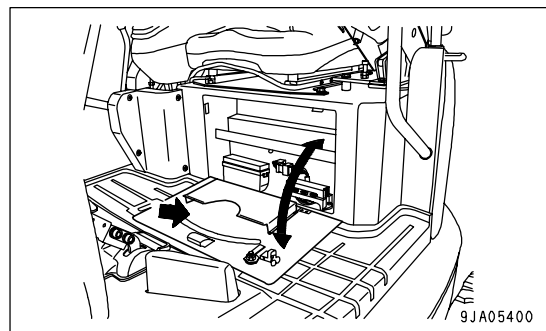

EMISSION CONTROL WARRANTY**EMISSION CONTROL WARRANTY STATEMENT (APPLIES TO CANADA ONLY)****1. Products Warranted**

Komatsu America International Company, Komatsu Mining Systems Inc. and Komatsu Utility Corporation (collectively "Komatsu") produce and/or market products under brand names of Komatsu, Dresser, Dressta, Haulpak and Galion. This emissions warranty applies to new engines bearing the Komatsu name installed in these products and used in Canada in machines designed for industrial off-highway use. This warranty applies only to these engines produced on or after January 1, 2000. This warranty will be administered by Komatsu distribution in Canada.

2. Coverage

Komatsu warrants to the ultimate purchaser and each subsequent purchaser that the engine is designed, built and equipped so as to conform, at the time of sale by Komatsu, with all U.S. Federal emission regulations applicable at the time of manufacture and that it is free from defects in workmanship or material which would cause it not to meet these regulations within five years or 3,000 hours of operation, whichever occurs first, as measured from the date of delivery of the engine to the ultimate purchaser.

3. Limitations

Failures, other than those resulting from defects in materials or workmanship, are not covered by this warranty. Komatsu is not responsible for failures or damage resulting from what Komatsu determines to be abuse or neglect, including, but not limited to: operation without adequate coolant or lubricants; over fueling; over speeding; lack of maintenance of lubricating, cooling or intake systems; improper storage, starting, warm-up, run-in or shutdown practices; unauthorized modifications of the engine. Komatsu is also not responsible for failures caused by incorrect fuel or by water, dirt or other contaminants in the fuel. Komatsu is not responsible for non-engine repairs, "downtime" expense, related damage, fines, all business costs or other losses resulting from a warrantable failure.

KOMATSU IS NOT RESPONSIBLE FOR INCIDENTAL OR CONSEQUENTIAL DAMAGES.

This warranty, together with the express commercial warranties, are the sole warranties of Komatsu. **THERE ARE NO OTHER WARRANTIES, EXPRESS OR IMPLIED, OR OF MERCHANTABILITY OR FITNESS FOR A PARTICULAR PURPOSE.**

GARANTIE SUR LE CONTRÔLE DES ÉMISSIONS**ÉNONCÉ DE GARANTIE SUR LE CONTRÔLE DES ÉMISSIONS (APPLICABLE AU CANADA SEULEMENT):****1. Produits garantis:**

Komatsu America International Company, Komatsu Mining Systems Inc. et Komatsu Utility Corporation (collectivement Komatsu) produisent et/ou font la mise en marché de produits portant les noms de marque Komatsu, Dresser, Dressta, Haulpak et Galion. Cette garantie sur les émissions s'applique à tous les nouveaux moteurs portant le nom Komatsu, installés dans ces produits et utilisés au Canada dans des machines conçues pour utilisation industrielle non-roulière. Cette garantie s'applique seulement sur les moteurs produits à partir du 1er Janvier 2000. Cette garantie sera administrée par la distribution de Komatsu au Canada.

2. Couverture:

Komatsu garantit à l'acheteur ultime et chaque acheteur subséquent que le moteur est conçu, construit et équipé en toute conformité, au moment de la vente par Komatsu, avec toutes les Réglementations fédérales américaines sur les émissions applicables au moment de la fabrication et qu'il est exempt de défauts de construction ou de matériaux qui auraient pour effet de contrevenir à ces réglementations en dedans de 5 ans ou 3000 heures d'opération, mesuré à partir de la date de livraison du moteur au client ultime.

3. Limitations:

Les bris, autres que ceux résultant de défauts de matériaux ou de construction, ne sont pas couverts par cette Garantie. Komatsu n'est pas responsable pour bris ou dommages résultant de ce que Komatsu détermine comme étant de l'abus ou négligence, incluant mais ne se limitant pas à: l'opération sans lubrifiants ou agent refroidissants adéquats; la suralimentation d'essence; la survitesse; le manque d'entretien des systèmes de lubrification, de refroidissement ou d'entrée; de pratiques non-propices d'entreposage, de mise en marche, de réchauffement, de conditionnement ou d'arrêt; les modifications non-autorisées du moteur. De plus, Komatsu n'est pas responsable de bris causés par de l'essence inadéquate ou de l'eau, des saletés ou autres contaminants dans l'essence. Komatsu n'est pas responsable des réparations non-relées au moteur, des dépenses encourues suite aux temps d'arrêts, des dommages relatifs, amendes, et de tout autre coût d'affaires ou autres pertes résultant d'un bris couvert par la garantie.

KOMATSU N'EST PAS RESPONSABLE DES INCIDENTS OU DOMMAGES CONSÉQUENTS.

Cette garantie, ainsi que les garanties expresses commerciales, sont les seules garanties de Komatsu. **IL N'Y A AUCUNE AUTRE GARANTIE, EXPRESSE OU SOUS-ENTENDUE, MARCHANDABLE OU PROPICE A UNE UTILISATION PARTICULIÈRE.**

INFORMATION IMPORTANTE SUR LE MOTEUR
 CE MOTEUR EST CONFORME AUX NORMES AMÉRICAINES DE L'EPA (ANNÉE DU MODÈLE) ET DE LA CALIFORNIE POUR LES MOTEURS LARGES NON-ROUTIERS À IGNITION PAR COMPRESSION. CE MOTEUR EST CERTIFIÉ POUR OPÉRER À ESSENCE DIESEL.

AVERTISSEMENT
 DES BLESSURES PEUVENT RÉSULTER ET LA GARANTIE S'ANNULER SI LES RPM DU TAUX D'ESSENCE OU L'ALTITUDE EXCÈDENT LES VALEURS MAXIMALES PUBLIÉES POUR CE MODÈLE ET SON APPLICATION.

IMPORTANT ENGINE INFORMATION
 THIS ENGINE CONFORMS TO YYYY MODEL YEAR U.S. EPA REGULATION AND THE CALIFORNIA REGULATIONS LARGE NON ROAD COMPRESSION IGNITION ENGINES. THIS ENGINE IS CERTIFIED TO OPERATE ON DIESEL FUEL.

WARNING
 INJURY MAY RESULT AND WARRANTY IS VOIDED IF FUEL RATE RPM OR ALTITUDES EXCEED PUBLISHED MAXIMUM VALUES FOR THIS MODEL AND APPLICATION.

ENGINE MODEL	SERIAL NO.	DISPLACEMENT	LITERS
ENGINE FAMILY			
EXHAUST EMISSION CONTROL SYSTEM		FIRING ORDER	1 - 5 - 3 - 6 - 2 - 4
ADV. LOAD OUTPUT	Kw (HP)	RPM	
VALVE LASH COLD (mm)	IN. EX.	FUEL RATE AT ADV.	mm ³ /STROKE
IDLE SPEED	RPM	FAMILY EMISSION LIMIT	
INITIAL INJECTION TIMING	DEG. BTDC	DATE OF MANUFACTURE	
KOMATSU LTD. MADE IN JAPAN			

MODÈLE DU MOTEUR

FAMILLE DU MOTEUR

SYSTÈME DE CONTRÔLE DES ÉMISSIONS D'ÉCHAPPEMENT

CHARGE DE SORTIE ADV.

PORTÉE DE VALVE À FROID (mm)

VITESSE STATIQUE

RÉGLAGE DE L'ALLUMAGE - INJECTION INITIALE

DEG. BTDC

NO. SÉRIE

DÉPLACEMENT

LITRES

SÉQUENCE DE MISE À FEU

mm³/BAITTEMENT

TAUX D'ESSENCE À ADV.

LIMITE D'ÉMISSION DE LA FAMILLE

DATE DE FABRICATION

KOMATSU LTD. FABRIQUÉ AU JAPON

ENGINE DATAPLATE - ENGLISH / FRENCH



SAFETY INFORMATION

To enable you to use this machine safely, safety precautions and labels are given in this manual and affixed to the machine to give explanations of situations involving potential hazards and of the methods of avoiding such situations.

Signal words

The following signal words are used to inform you that there is a potential hazardous situation that may lead to personal injury or damage.

In this manual and on machine labels, the following signal words are used to express the potential level of hazard.

- | | |
|--|---|
|  DANGER | Indicates an imminently hazardous situation which, if not avoided, will result in death or serious injury. |
|  WARNING | Indicates a potentially hazardous situation which, if not avoided, could result in death or serious injury. |
|  CAUTION | Indicates a potentially hazardous situation which, if not avoided, may result in minor or moderate injury. This word is used also to alert against unsafe practices that may cause property damage. |

Example of safety message using signal word

 WARNING
When standing up from the operator's seat, always place the safety lock lever in the LOCK position. If you accidentally touch the control levers when they are not locked, this may cause a serious injury or death.

Other signal words

In addition to the above, the following signal words are used to indicate precautions that should be followed to protect the machine or to give information that is useful to know.

NOTICE This word is used for precautions that must be taken to avoid actions which could shorten the life of the machine.

REMARKS This word is used for information that is useful to know.

- Safety labels

Safety labels are affixed to the machine to inform the operator or maintenance worker on the spot when carrying out operation or maintenance of the machine that may involve hazard.

This machine uses "Safety labels using words" and "Safety labels using pictograms" to indicate safety procedures.

Example of safety label using words

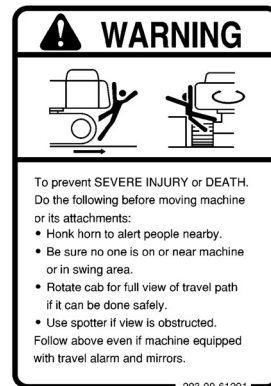

Part No.

Safety labels using pictogram

Safety pictograms use a picture to express a level of hazardous condition equivalent to the signal word. These safety pictograms use pictures in order to let the operator or maintenance worker understand the level and type of hazardous condition at all times. Safety pictograms show the type of hazardous condition at the top or left side, and the method of avoiding the hazardous condition at the bottom or right side. In addition, the type of hazardous condition is displayed inside a triangle and the method of avoiding the hazardous condition is shown inside a circle.



Part No.

Komatsu cannot predict every circumstance that might involve a potential hazard in operation and maintenance. Therefore, the safety messages in this manual and on the machine may not include all possible safety precautions. If any procedures or actions not specifically recommended or allowed in this manual are used, it is your responsibility to take the necessary steps to ensure safety.

In no event should you engage in prohibited uses or actions described in this manual.

The explanations, values, and illustrations in this manual were prepared based on the latest information available at that time. Continuing improvements in the design of this machine can lead to changes in detail which may not be reflected in this manual. Consult Komatsu or your Komatsu distributor for the latest available information of your machine or for questions regarding information in this manual.

The numbers in circles in the illustrations correspond to the numbers in () in the text. (For example: ① -> (1))

INTRODUCTION

This Komatsu machine is designed to be used mainly for the following work:

- Digging work
- Leveling work
- Ditching work
- Loading work
- Demolition work

See the section "WORK POSSIBLE USING COMPACT HYDRAULIC EXCAVATOR (PAGE 3-78)" for further details.

DIRECTIONS OF MACHINE

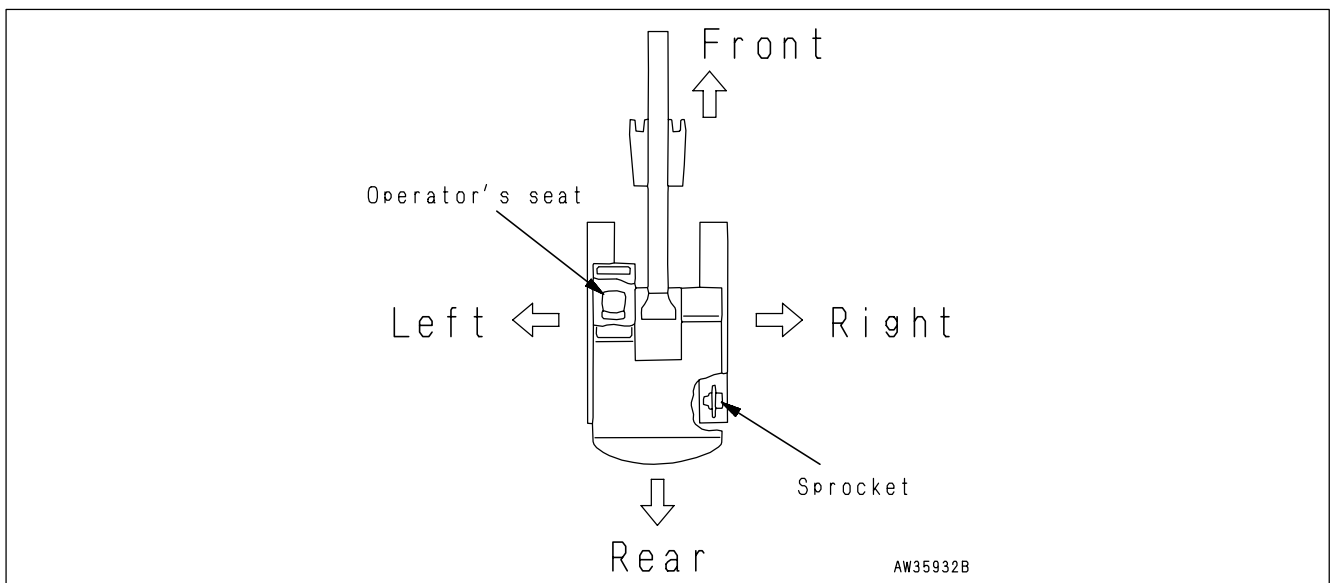

In this manual, the terms front, rear, left, and right refer to the travel direction as seen from the operator's seat when the operator's seat is facing the front and the sprocket is at the rear of the machine.

PRODUCT INFORMATION

When requesting service or ordering replacement parts, please inform your Komatsu distributor of the following items.

PRODUCT IDENTIFICATION NUMBER (PIN)/MACHINE SERIAL NO. PLATE

On the left front of the frame.

The design of the nameplate differs according to the territory.

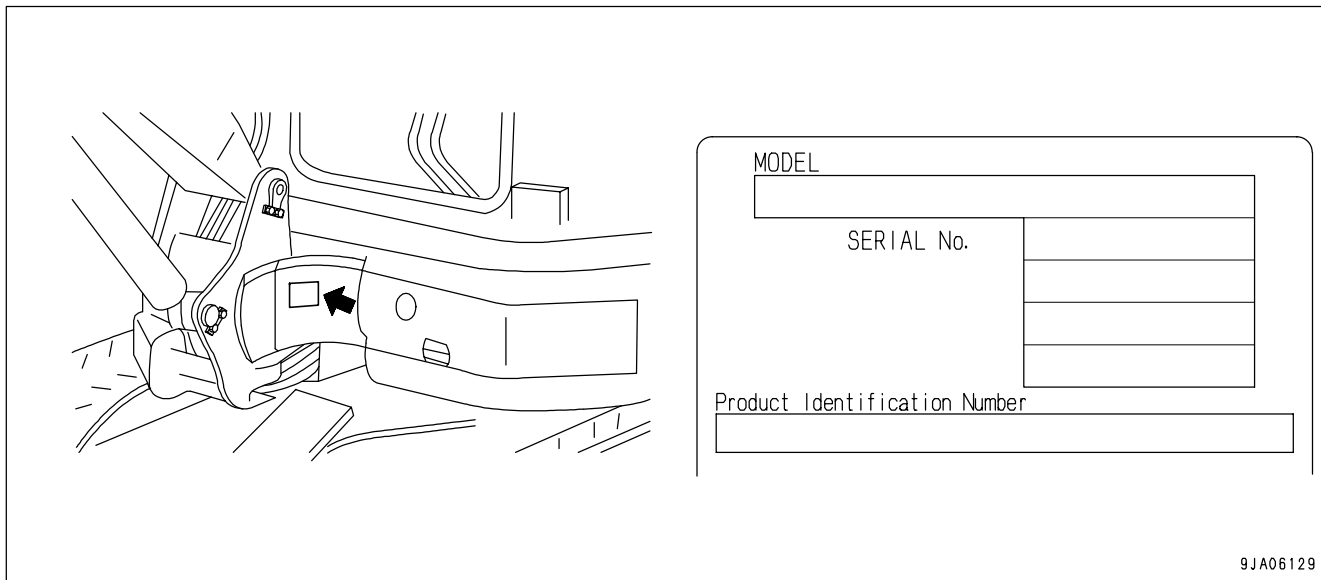

ENGINE SERIAL NUMBER PLATE AND ITS LOCATION

This is stuck on the intake manifold.

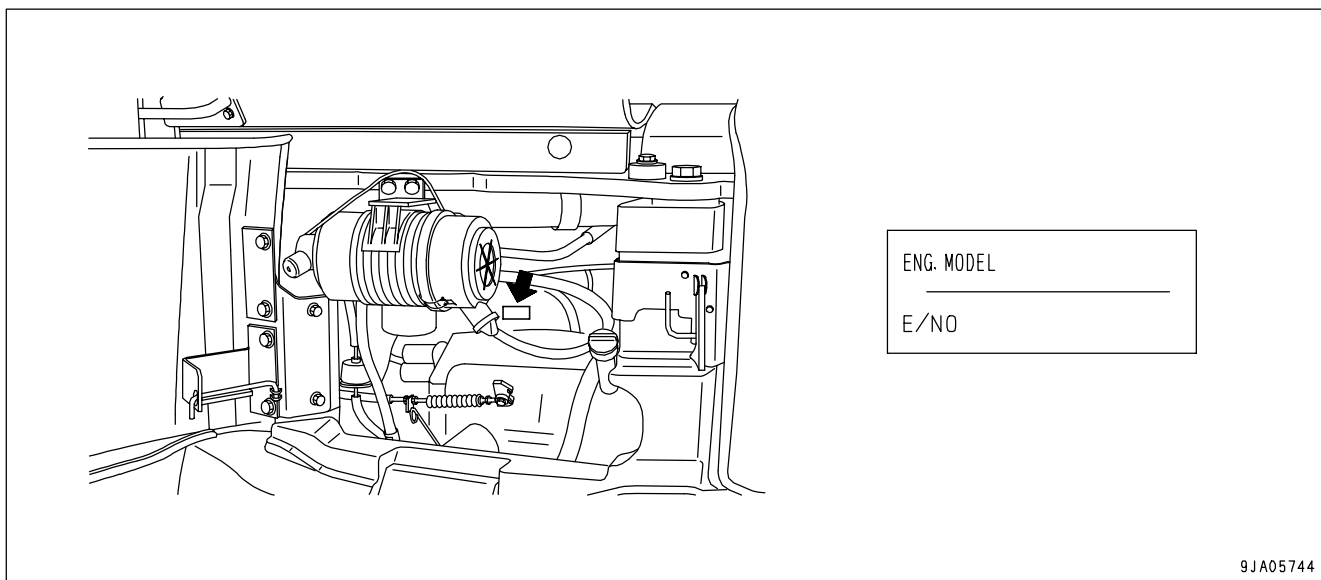

EMISSION CONTROL INFORMATION LABEL AND ITS LOCATION

This is stuck on the inside right side of the counterweight.

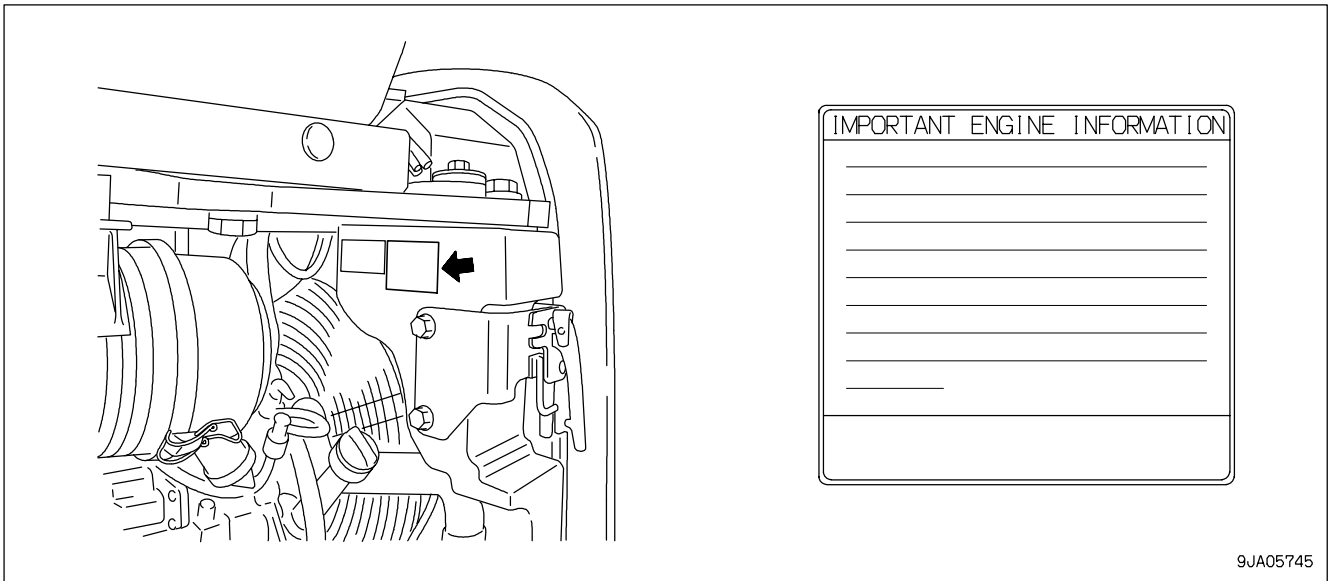

EPA: Environmental Protection Agency, U.S.A.

SERVICE METER LOCATION

On top of the machine monitor

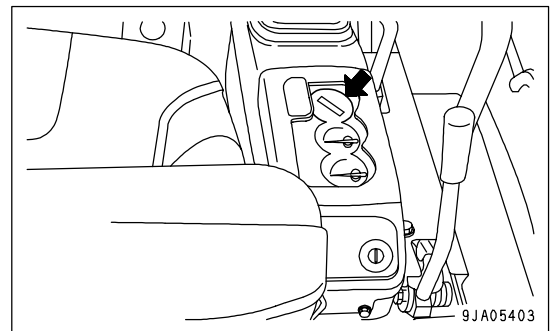

YOUR MACHINE SERIAL NUMBERS AND DISTRIBUTOR

Machine serial No.	
Engine serial No.	
Product identification number (PIN)	
Distributor name	
Address	-----

Service Personnel	-----
Phone/Fax	-----

CONTENTS

FOREWORD	1- 1
FOREWORD	1- 2
SAFETY INFORMATION	1- 5
INTRODUCTION	1- 7
DIRECTIONS OF MACHINE	1- 7
PRODUCT INFORMATION	1- 8
PRODUCT IDENTIFICATION NUMBER (PIN)/MACHINE SERIAL NO. PLATE	1- 8
ENGINE SERIAL NUMBER PLATE AND ITS LOCATION	1- 8
EMISSION CONTROL INFORMATION LABEL AND ITS LOCATION	1- 9
SERVICE METER LOCATION	1- 9
YOUR MACHINE SERIAL NUMBERS AND DISTRIBUTOR	1- 10
SAFETY	2- 1
SAFETY INFORMATION	2- 2
SAFETY LABELS	2- 4
LOCATION OF SAFETY LABELS	2- 4
SAFETY LABELS	2- 5
SAFETY INFORMATION	2- 10
SAFETY MACHINE OPERATION	2- 19
STARTING ENGINE	2- 19
OPERATION	2- 21
TRANSPORTATION	2- 27
BATTERY	2- 28
TOWING	2- 30
LIFTING OBJECTS WITH BUCKET	2- 31
SAFETY MAINTENANCE INFORMATION	2- 32
OPERATION	3- 1
MACHINE VIEW ILLUSTRATIONS	3- 2
OVERALL MACHINE VIEW	3- 2
CONTROLS AND GAUGES	3- 3
DETAILED CONTROLS AND GAUGES	3- 4
MONITORING SYSTEM	3- 4
SWITCHES	3- 12
CONTROL LEVERS AND PEDALS	3- 16
WINDSHIELD	3- 22
SLIDING DOOR	3- 26
SLIDING WINDOW	3- 26
EMERGENCY ESCAPE HAMMER	3- 27
COVER WITH LOCK	3- 28
ENGINE REAR COVER	3- 29
COOLING COVER	3- 29
MUD COVER	3- 30
METHOD OF OPENING (TILTING) FLOOR	3- 31
FUSE	3- 36
BLOCK FUSE	3- 37
AUXILIARY ELECTRIC POWER	3- 38
OPERATION MANUAL STORAGE	3- 39
TOOL BOX	3- 39
GREASE GUN HOLDER	3- 39
ASHTRAY	3- 39

MACHINE OPERATIONS AND CONTROLS -----	3- 40
BEFORE STARTING ENGINE -----	3- 40
STARTING ENGINE -----	3- 54
AFTER STARTING ENGINE -----	3- 58
STOPPING THE ENGINE -----	3- 61
MACHINE OPERATION -----	3- 62
STEERING THE MACHINE -----	3- 67
SWINGING -----	3- 69
WORK EQUIPMENT CONTROLS AND OPERATIONS -----	3- 70
PROHIBITED OPERATIONS -----	3- 72
GENERAL OPERATION INFORMATION -----	3- 74
TRAVELING ON SLOPES -----	3- 75
ESCAPE FROM MUD -----	3- 77
WORK POSSIBLE USING COMPACT HYDRAULIC EXCAVATOR -----	3- 78
BUCKET REPLACEMENT -----	3- 80
PARKING MACHINE -----	3- 81
CHECK AFTER SHUT OFF ENGINE -----	3- 82
MACHINE INSPECTION AFTER DAILY WORK -----	3- 82
LOCKING -----	3- 83
RUBBER SHOES AND ROAD LINERS -----	3- 84
TRANSPORTATION -----	3- 89
TRANSPORTATION PROCEDURE -----	3- 89
LOADING AND UNLOADING WITH TRAILER -----	3- 90
LIFTING MACHINE -----	3- 96
COLD WEATHER OPERATION -----	3- 99
COLD WEATHER OPERATION INFORMATION -----	3- 99
CAB HEATER IN COLD WEATHER -----	3-100
AFTER DAILY WORK COMPLETION -----	3-101
AFTER COLD WEATHER SEASON -----	3-101
LONG TERM STORAGE -----	3-102
BEFORE STORAGE -----	3-102
DURING STORAGE -----	3-103
AFTER STORAGE -----	3-103
TROUBLES AND ACTIONS -----	3-104
RUNNING OUT OF FUEL -----	3-104
PHENOMENA THAT ARE NOT FAILURES -----	3-104
TOWING THE MACHINE -----	3-105
SEVERE JOB CONDITION -----	3-105
DISCHARGED BATTERY -----	3-106
OTHER TROUBLE -----	3-110
MAINTENANCE -----	4- 1
MAINTENANCE INFORMATION -----	4- 2
LUBRICANTS, COOLANT AND FILTERS -----	4- 4
HANDLING OIL, FUEL, COOLANT, AND PERFORMING OIL CLINIC -----	4- 4
ELECTRIC SYSTEM MAINTENANCE -----	4- 6
HANDLING HYDRAULIC SYSTEM -----	4- 7
WEAR PARTS -----	4- 8
WEAR PARTS LIST -----	4- 8
LUBRICANTS, FUEL AND COOLANT SPECIFICATIONS -----	4- 9
TIGHTENING TORQUE SPECIFICATIONS -----	4- 13

TIGHTENING TORQUE LIST	4- 13
SAFETY CRITICAL PARTS	4- 14
SAFETY CRITICAL PARTS LIST	4- 14
MAINTENANCE SCHEDULE	4- 15
MAINTENANCE SCHEDULE CHART	4- 15
MAINTENANCE INTERVAL FOR HYDRAULIC BREAKER	4- 16
MAINTENANCE PROCEDURE	4- 17
WHEN REQUIRED	4- 17
CHECK BEFORE STARTING	4- 45
EVERY 500 HOURS MAINTENANCE	4- 46
EVERY 1000 HOURS MAINTENANCE	4- 55
EVERY 2000 HOURS MAINTENANCE	4- 57
SPECIFICATIONS	5- 1
SPECIFICATIONS	5- 2
ATTACHMENTS AND OPTIONS	6- 1
ATTACHMENTS AND OPTIONS - GENERAL INFORMATION	6- 2
SAFETY FIRST	6- 2
ATTACHMENT INSTALLATION	6- 3
BUCKET WITH HOOK	6- 4
PROHIBITED OPERATIONS	6- 4
AIR CONDITIONER	6- 5
CONTROL PANEL AND COMPONENTS	6- 5
AIR CONDITIONER CONTROLS	6- 6
AIR CONDITIONER MAINTENANCE	6- 7
WINDSHIELD WASHER	6- 11
WINDSHIELD WASHER OPERATION	6- 11
CHECK WINDOW WASHER FLUID LEVEL, ADD FLUID	6- 11
MACHINE READY FOR ATTACHMENT	6- 12
LOCATIONS	6- 12
HYDRAULIC CIRCUIT	6- 14
ATTACHMENT OPERATIONS	6- 16
LONG TERM STORAGE	6- 17
SPECIFICATIONS	6- 17
CHANGING MACHINE CONTROL PATTERN (IF PATTERN CHANGE VALVE EQUIPPED)	6- 18
CONTROL PATTERN CHANGE PROCEDURE	6- 18
MACHINE CONTROL PATTERNS	6-19
ATTACHMENT GUIDE	6- 20
ATTACHMENT COMBINATIONS	6- 20
RECOMMENDED ATTACHMENT OPERATIONS	6- 21
HYDRAULIC BREAKER	6- 21
INDEX	7- 1

SAFETY

WARNING

Please read and make sure that you fully understand the precautions described in this manual and the safety labels on the machine. When operating or servicing the machine, always follow these precautions strictly.

SAFETY INFORMATION

SAFETY LABELS	2- 4
LOCATION OF SAFETY LABELS	2- 4
SAFETY LABELS	2- 5
 SAFETY INFORMATION	
Safety Rules	2- 10
If Abnormalities are Found	2- 10
Working Wear and Personal Protective Items	2- 10
Fire Extinguisher and First Aid Kit	2- 10
Safety Equipment	2- 11
Keep Machine Clean	2- 11
Keep Operator's Compartment Clean	2- 11
Leaving Operator's Seat with Lock	2- 11
Handrails and Steps	2- 12
Mounting and Dismounting	2- 12
No Persons on Attachments	2- 12
Burn Prevention	2- 13
Fire Prevention and Explosion Prevention	2- 13
Action if Fire Occurs	2- 14
Windshield Washer Fluid	2- 14
Falling Objects, Flying Objects and Intruding Objects Prevention	2- 15
Cautions Related to ROPS (Rollover Protection System)	2- 15
Attachment Installation	2- 16
Attachment Combinations	2- 16
Cab Widow Glasses	2- 16
Unauthorized Modifications	2- 16
Safety at Jobsite	2- 16
Working on Loose Ground	2- 16
Distance to High Voltage Cables	2- 17
Ensure Good Visibility	2- 17
Ventilation for Enclosed Area	2- 17
Signalman's Signal and Signs	2- 18
Emergency Exit from Operator's Cab	2- 18
Asbestos Dust Hazard Prevention	2- 18

SAFETY MACHINE OPERATION	2- 19
STARTING ENGINE	2- 19
Checks Before Starting Engine	2- 19
Safety Rules for Starting Engine	2- 20
Starting Engine in Cold Weather	2- 20
OPERATION	2- 21
Checks Before Operation	2- 21
Safety Rules for Changing Machine Directions	2- 21
Safety Rules for Traveling	2- 22
Traveling on Slopes	2- 23
Operations on Slopes	2- 24
Prohibited Operations	2- 24
Operations on Snow	2- 26
Parking Machine	2- 26
TRANSPORTATION	2- 27
Loading and Unloading	2- 27
Shipping the Machine	2- 27
BATTERY	2- 28
Battery Hazard Prevention	2- 28
Starting Engine with Booster Cables	2- 29
TOWING	2- 30
Safety Rules for Towing	2- 30
LIFTING OBJECTS WITH BUCKET	2- 31
Safety Rules for Lifting Objects	2- 31
SAFETY MAINTENANCE INFORMATION	2- 32
Warning Tag	2- 32
Keep Work Place Clean and Tidy	2- 32
Appoint Leader when Working with Others	2- 32
Stop Engine Before Carrying Out Maintenance	2- 33
Cautions for Opening (Tilting) Floor	2- 34
Two Workers for Maintenance when Engine is Running	2- 35
Proper Tools	2- 35
Personnel	2- 35
Attachments	2- 36
Work Under the Machine	2- 36
Noise	2- 36
When Using Hammer	2- 36
Welding Works	2- 36
Removing Battery Terminals	2- 37
Safety First when Using High-pressure Grease to Adjust Track Tension	2- 37
Do Not Disassemble Recoil Springs	2- 37
Safety Rules for High-pressure Oil	2- 37
Safety Handling High-pressure Hoses	2- 38
Waste Materials	2- 38
Air Conditioner Maintenance	2- 38
Compressed Air	2- 38
Periodic Replacement of Safety Critical Parts	2- 38

SAFETY LABELS

The following warning signs and safety labels are used on this machine.

- Be sure that you fully understand the correct position and content of labels.
- To ensure that the content of labels can be read properly, be sure that they are in the correct place and always keep them clean. When cleaning them, do not use organic solvents or gasoline. These may cause the labels to peel off.
- There are also other labels in addition to the warning signs and safety labels. Handle those labels in the same way.
- If the labels are damaged, lost, or cannot be read properly, replace them with new ones. For details of the part numbers for the labels, see this manual or the actual label, and place an order with Komatsu distributor.

LOCATION OF SAFETY LABELS

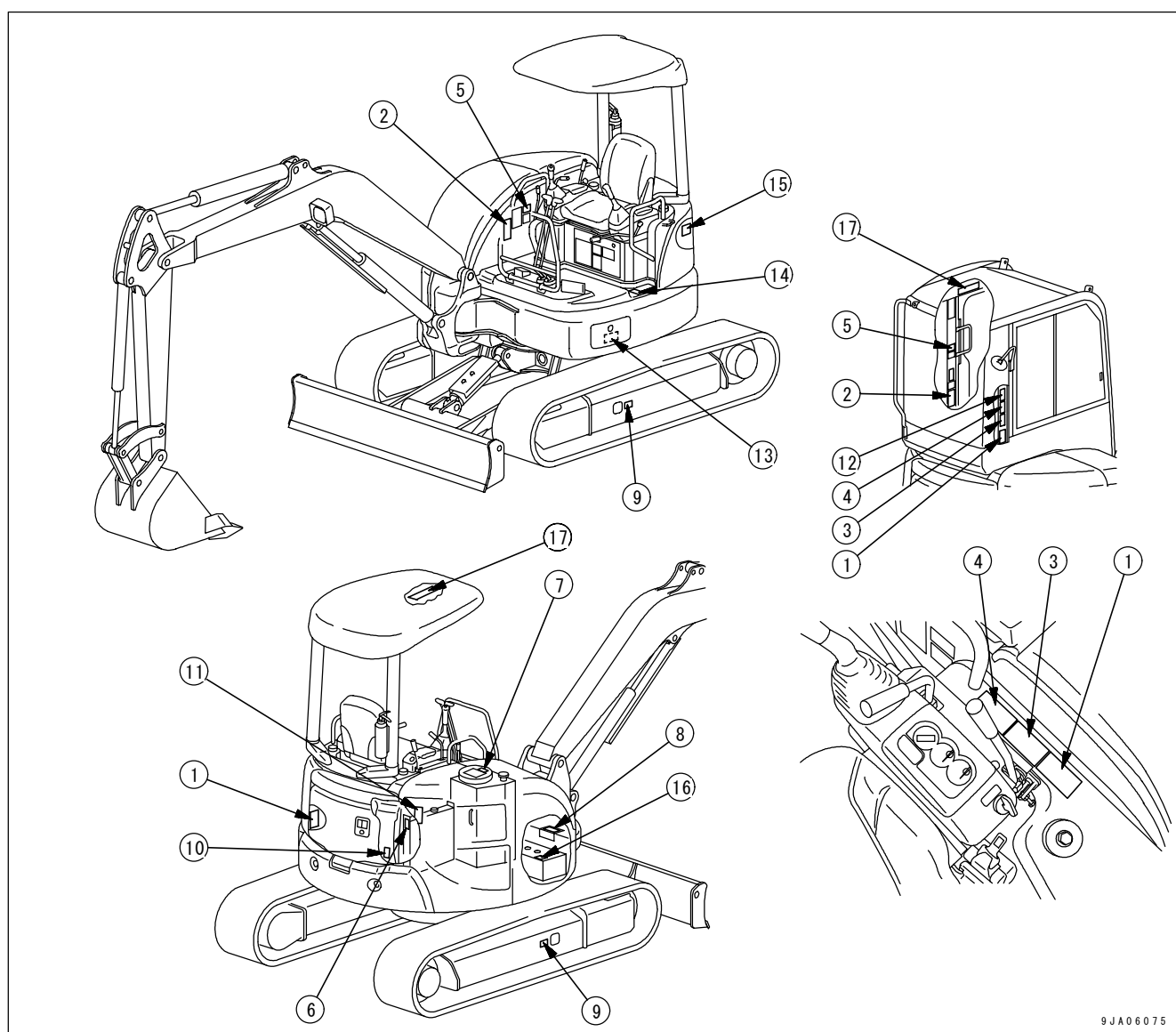

SAFETY LABELS

- (1) Precautions for operation, inspection and maintenance
(22F-98-17371)



- (2) Precautions for before operation (22L-98-22160)

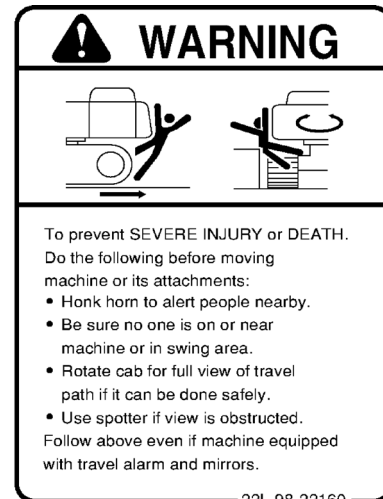

- (3) Warning for leaving operator's seat (09654-03001)



(4) Warnings for high voltage (09801-03001)

⚠ DANGER



Hazardous voltage hazard.
Serious injury or death can occur if machine or attachments are not kept safe distance away from electric lines.

VOLTAGE		SAFE DISTANCE
LOW VOLTAGE	100V 200V	2m
	6,600V	2m
	22,000V	3m
SPECIAL HIGH VOLTAGE	66,000V	4m
	154,000V	5m
	187,000V	6m
	275,000V	7m
	500,000V	11m

09801-03001

(5) Precautions for operating pattern (22J-98-1A630)

⚠ WARNING

THIS MACHINE IS EQUIPPED WITH A CONTROL PATTEAN SELECTOR VALVE. TO PREVENT PERSONAL INJURY CAUSED BY MISTAKEN OPERATION, ALWAYS CHECK THAT THE MOVEMENT OF THE MACHINE MATCHES THE PATTERN SHOWN ON THE CONTROL PATTERN CARD BEFORE STARTING OPERATIONS.

- WHEN CHECKING THE MOVEMENT OF THE MACHINE, CHECK THAT THE SURROUNDING AREA IS SAFE AND OPERATE THE MACHINE SLOWLY.
- IF THE MOVEMENT DOSE NOT MATCH THE CONTROL PATTERN CARD, REPLACE THE CARD WITH THE CARD SHOWING THE CORRECT CONTROL PATTERN.

ALWAYS DO AS FOLLOWS WHEN CHANGING THE CONTROL PATTERN.

- LOWER THE WORK EQUIPMENT TO THE GROUND, STOP THE ENGINE, AND SET THE SAFETY LOCK LEVER TO THE LOCK POSITION. THEN CHENGE THE CONTROL PATTERN.
- DO NOT RISK SERIOUS BODILY INJURY OR DEATH.

22J-98-1A630

(6) Precautions for high-temperature cooling water (20M-98-83250)

⚠ WARNING

Hot water hazard.
To prevent hot water from spurting out:

- Turn engine off.
- Allow water to cool.
- Slowly loosen cap to relieve pressure before removing.

20M-98-83250

(7) Precautions for high-temperature hydraulic oil (22F-98-21660)



(8) Precautions for handling electric wires (09808-03000)

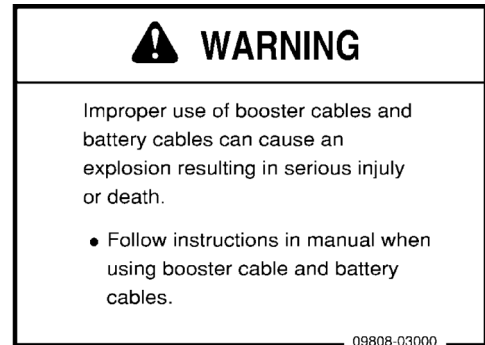

(9) Precautions for check and adjust track tension (09657-03003)

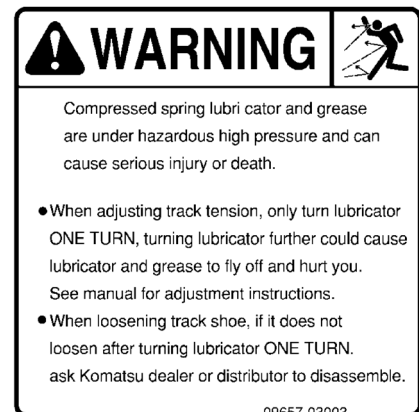

(10) Caution when opening while engine is running (09667-03001)

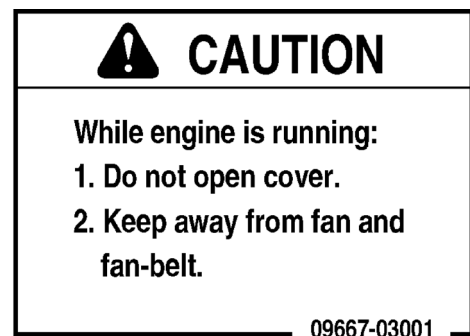

(11) Prohibited to enter range of swing (22F-98-21610)

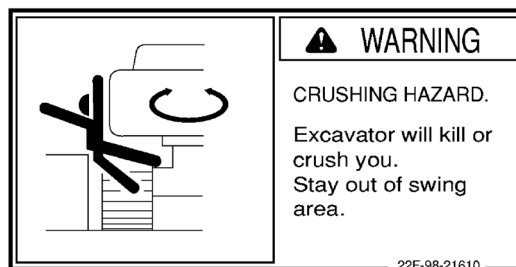

(12) Precautions for stowage (09803-03000)
(Machines equipped with cab)

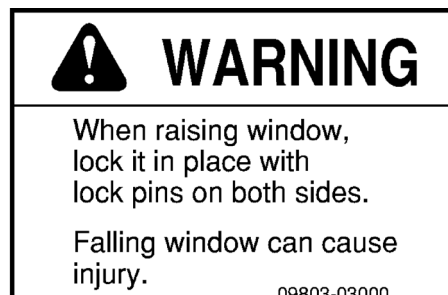

(13) Caution when changing operating pattern (22F-98-21640)



(14) Caution for lock pin when opening floor (22F-98-21630)

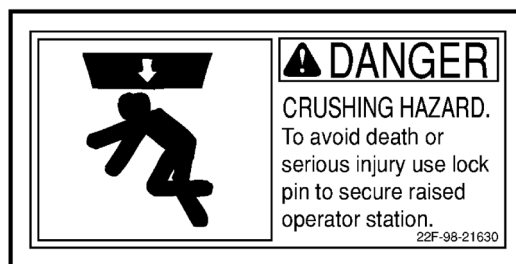

(15) Caution when closing floor (22F-98-21620)

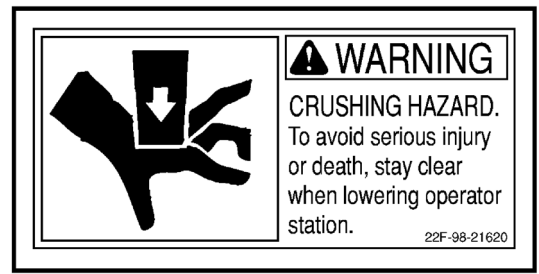

(16) Precaution for handling battery (09664-30002)

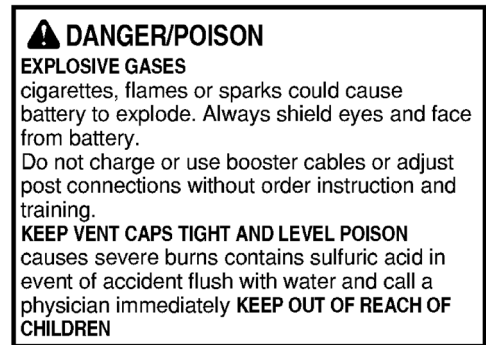

(17) Precaution for handling ROPS (22M-98-21941)

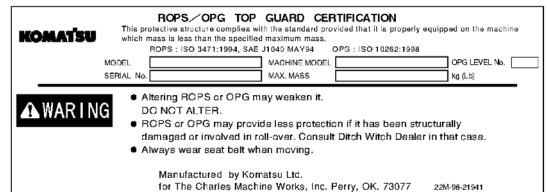

SAFETY INFORMATION

SAFETY RULES

- Only trained and authorized personnel can operate and maintain the machine.
- Follow all safety rules, precautions and instructions when operating or performing maintenance on the machine.
- If you are under the influence of alcohol or medication, your ability to safely operate or repair your machine may be severely impaired putting yourself and everyone else on your jobsite in danger.
- When working with another operator or with a person on worksite traffic duty, be sure that all personnel understand all hand signals that are to be used.

IF ABNORMALITIES ARE FOUND

If you find any abnormality in the machine during operation or maintenance (noise, vibration, smell, incorrect gauges, smoke, oil leakage, etc., or any abnormal display on the warning devices or monitor), report to the person in charge and have the necessary action taken. Do not operate the machine until the abnormality has been corrected.

WORKING WEAR AND PERSONAL PROTECTIVE ITEMS

- Do not wear loose clothing and accessories. There is a hazard that they may catch on control levers or other protruding parts.
- If you have long hair and it hangs out from your hard hat, there is a hazard that it may get caught up in the machine, so tie your hair up and be careful not to let it get caught.
- Always wear a hard hat and safety shoes. If the nature of the work requires it, wear safety glasses, mask, gloves, ear plugs, and safety belt when operating or maintaining the machine.
- Check that all protective equipment functions properly before using it.

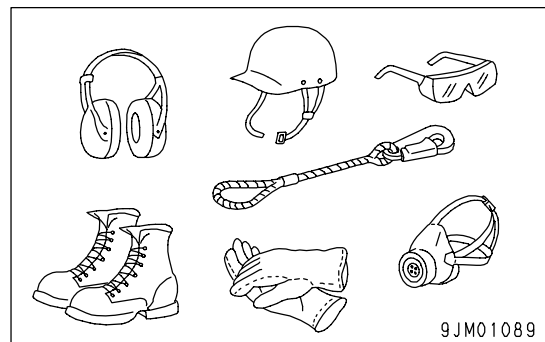

FIRE EXTINGUISHER AND FIRST AID KIT

Always follow the precautions below to prepare for action if any injury or fire should occur.

- Be sure that fire extinguishers have been provided and read the labels to ensure that you know how to use them in emergencies.
- Carry out periodic inspection and maintenance to ensure that the fire extinguisher can always be used.
- Provide a first aid kit at the storage point. Carry out periodic checks and add to the contents if necessary.

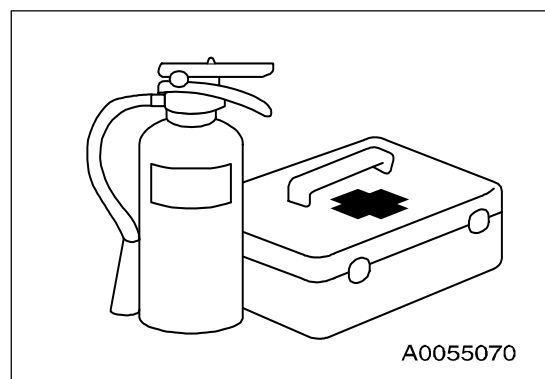

SAFETY EQUIPMENT

- Be sure that all guards and covers are in their proper position. Have guards and covers repaired immediately if they are damaged.
- Understand the method of use of safety features and use them properly.
- Never remove any safety features. Always keep them in good operating condition.

KEEP MACHINE CLEAN

- If water gets into the electrical system, there is a hazard that it will cause malfunctions or misoperation. Do not use water or steam to wash the electrical system (sensors, alternator, starting motor, solenoid valves, connectors).
- If inspection and maintenance is carried out when the machine is still dirty with mud or oil, there is a hazard that you will slip and fall, or that dirt or mud will get into your eyes. Always keep the machine clean.
- When washing the machine with the floor open (tilted), cover with vinyl to prevent water from getting into the electrical system.

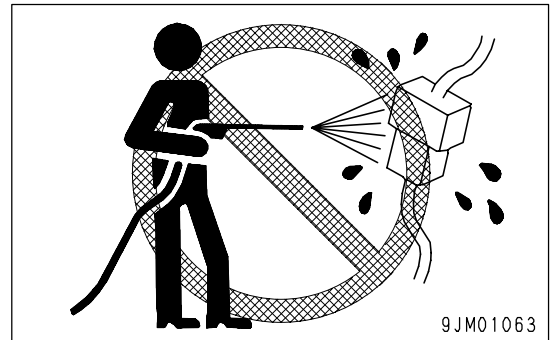
**KEEP OPERATOR'S COMPARTMENT CLEAN**

- When entering the operator's compartment, always remove all mud and oil from the soles of your shoes. If you operate the pedal with mud or oil affixed to your shoes, your foot may slip and this may cause a serious accident.
- Do not leave parts or tools lying around the operator's compartment.
- Do not stick suction pads to the window glass. Suction pads act as a lens and may cause fire.
- Do not use cellular telephones inside the operator's compartment when driving or operating the machine.
- Never bring any dangerous objects such as flammable or explosive items into the operator's compartment.

LEAVING OPERATOR'S SEAT WITH LOCK

- Before standing up from the operator's seat (such as when opening or closing the front window or roof window, or when removing or installing the bottom window, or when adjusting the operator's seat), lower the work equipment completely to the ground, set safety lock lever (1) securely to the LOCK position (L), then stop the engine. If you accidentally touch the levers when they are not locked, there is a hazard that the machine may suddenly move and cause serious injury or property damage.

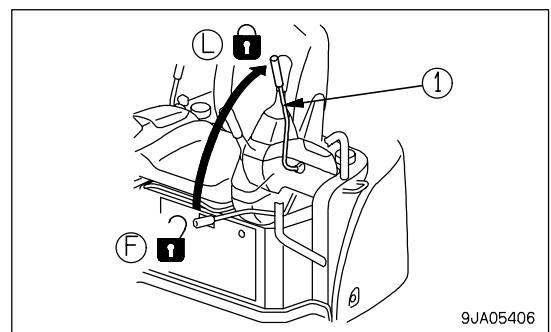

- When leaving the machine, always lower the work equipment and blade completely to the ground, set safety lock lever (1) to LOCK position (L), then stop the engine. Use the key to lock all the equipment. Always remove the key, take it with you, and keep it in the specified place.

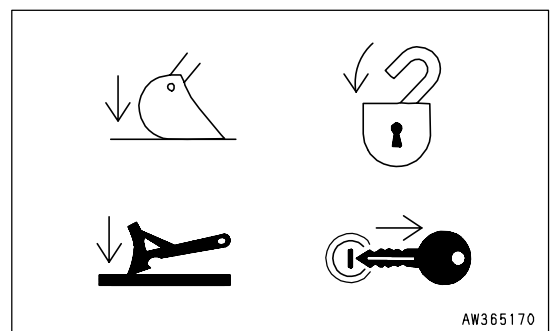

HANDRAILS AND STEPS

To prevent personal injury caused by slipping or falling off the machine, always do as follows.

- Use the handrails and steps marked by arrows in the diagram on the right when getting on or off the machine.

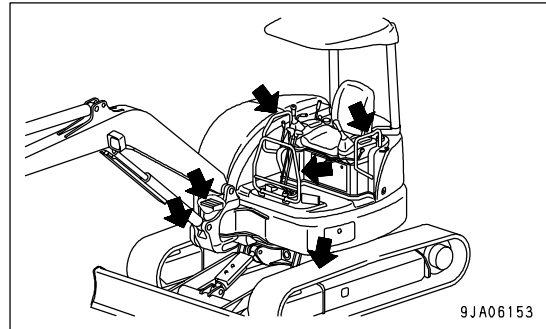

- machine equipped with cab

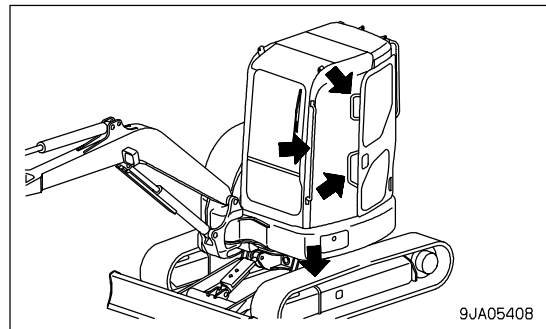

- To ensure safety, always face the machine and maintain three-point contact (both feet and one hand, or both hands and one foot) with the handrails and steps (including the track shoe) to ensure that you support yourself.
- Do not grip the control levers when getting on or off the machine.
- Never climb on the engine hood or covers where there are no non-slip pads.
- Before getting on or off the machine, check the handrails and steps (including the track shoe). If there is any oil, grease, or mud on the handrails or steps (including the track shoe), wipe it off immediately. Always keep these parts clean. Repair any damage and tighten any loose bolts.
- Do not get on or off the machine while holding tools in your hand.

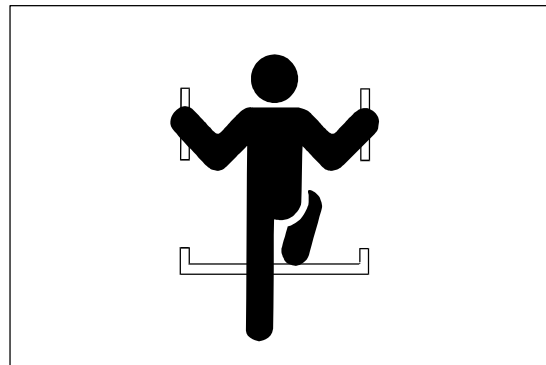

MOUNTING AND DISMOUNTING

- Never jump on or off the machine. Never get on or off a moving machine.
- If the machine starts to move when there is no operator on the machine, do not jump on to the machine and try to stop it.

NO PERSONS ON ATTACHMENTS

Never let anyone ride on the work equipment, or other attachments. There is a hazard of falling and suffering serious injury.

BURN PREVENTION**Hot coolant**

- To prevent burns from hot water or steam spurting out when checking or draining the coolant, wait for the water to cool to a temperature where it is possible to touch the radiator cap by hand before starting the operation. Even when the coolant has cooled down, loosen the cap slowly to relieve the pressure inside the radiator before removing the cap.

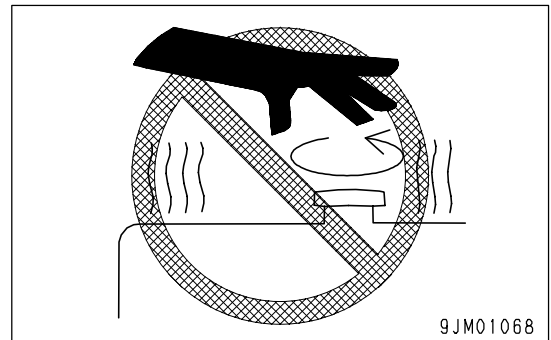

9JM01068

Hot oil

- To prevent burns from hot oil spurting out when checking or draining the oil, wait for the oil to cool to a temperature where it is possible to touch the cap or plug by hand before starting the operation. Even when the oil has cooled down, loosen the cap or plug slowly to relieve the internal pressure before removing the cap or plug.

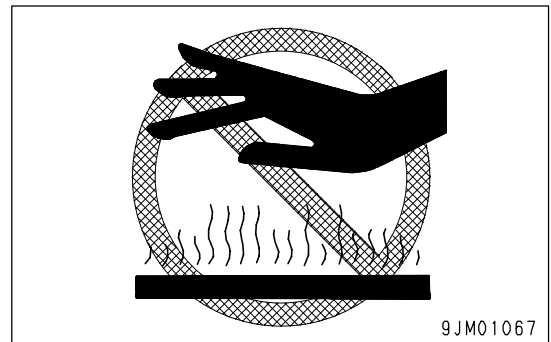

9JM01067

FIRE PREVENTION AND EXPLOSION PREVENTION**• Fire caused by fuel or oil**

Fuel, oil, antifreeze, and window washer liquid are particularly flammable and can be hazardous. To prevent fire, always observe the following:

- Do not smoke or use any flame near fuel or oil.
- Stop the engine before refueling.
- Do not leave the machine while adding fuel or oil.
- Tighten all fuel and oil caps securely.
- Do not spill fuel on overheated surfaces or on parts of the electrical system.
- Use well-ventilated areas for adding or storing oil and fuel.
- Keep oil and fuel in the determined place and do not allow unauthorized persons to enter.
- After adding fuel or oil, wipe up any spilled fuel or oil.
- When carrying out grinding or welding work on the chassis, move any flammable materials to a safe place before starting.
- When washing parts with oil, use a non-flammable oil. Diesel oil and gasoline may catch fire, so do not use them.
- Put greasy rags and other flammable materials into a safe container to maintain safety at the work place.
- Do not weld or use a cutting torch to cut any pipes or tubes that contain flammable liquids.



A0055020

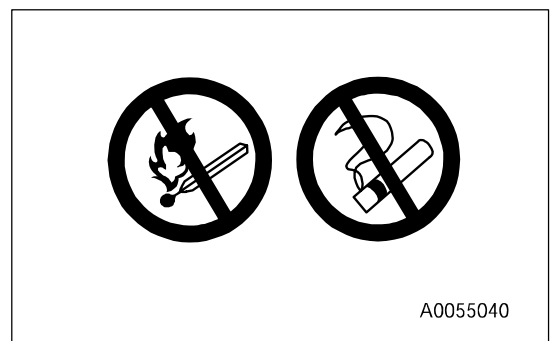

A0055040

- **Fire caused by accumulation of flammable material.**

Remove any dry leaves, chips, pieces of paper, dust, or any other flammable materials accumulated or affixed around the engine, exhaust manifold, muffler, or battery, or inside the undercovers.

- **Fire coming from electric wiring**

Short circuits in the electrical system can cause fire.

- Always keep electric wiring connections clean and securely tightened.
- Check the wiring every day for looseness or damage. Tighten any loose connectors or wiring clamps. Repair or replace any damaged wiring.

- **Fire coming from hydraulic line**

Check that all the hose and tube clamps, guards, and cushions are securely fixed in position.

If they are loose, they may vibrate during operation and rub against other parts. This may lead to damage to the hoses, and cause high-pressure oil to spurt out, leading to fire damage or serious injury.

- **Explosion caused by lighting equipment**

- When checking fuel, oil, battery electrolyte, window washer fluid, or coolant, always use lighting with anti-explosion specifications. If such lighting equipment is not used, there is danger of explosion that may cause serious injury.
- When taking the electrical power for the lighting from the machine itself, follow the instructions in this manual.

ACTION IF FIRE OCCURS

If a fire occurs, escape from the machine as follows.

- Turn the start switch OFF to stop the engine.
- Use the handrails and steps to get off the machine.

WINDSHIELD WASHER FLUID

Use an ethyl alcohol base washer liquid.

Methyl alcohol base washer liquid may irritate your eyes, so do not use it.

FALLING OBJECTS, FLYING OBJECTS AND INTRUDING OBJECTS PREVENTION

On jobsites where there is a hazard that falling objects, flying objects, or intruding objects may hit or enter the operator's cab, consider the operating conditions and install the necessary guards to protect the operator.

- When carrying out demolition or breaker operations, install a front guard and use a laminated coating sheet on the front glass.
- When working in mines or quarries where there is a hazard of falling rock, install FOPS (Falling Objects Protective Structure) and a front guard, and use a laminated coating sheet on the front glass.
- When carrying out the above operations, always close the front window. In addition, always ensure that bystanders are a safe distance away and are not in hazard from falling or flying objects.
- The above recommendations assume that the conditions are for standard operations, but it may be necessary to add additional guards according to the operating conditions on the jobsite. Always contact your Komatsu distributor for advice.

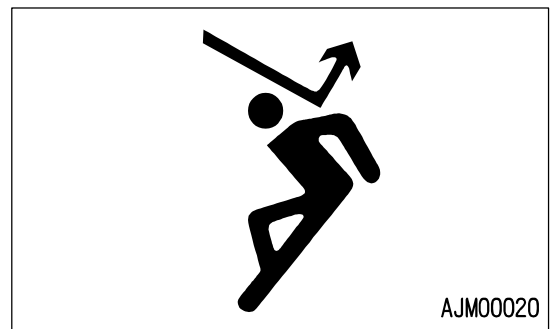
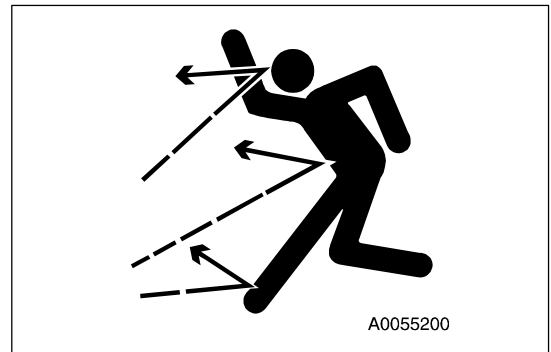

CAUTIONS RELATED TO ROPS (ROLLOVER PROTECTION SYSTEM)

- ROPS is a structure designed to protect an operator who is wearing a seatbelt if the machine should roll over. It supports the weight of the machine when it rolls over and also absorbs the impact energy.
- If ROPS is modified, its strength may be reduced. When modifying, consult your Komatsu distributor.
- If ROPS is damaged or deformed by falling objects or by rolling over, its strength will be reduced and it will not be able to fulfill its function properly. In such cases, always Komatsu contact your distributor for advice of the method of repair.

Even if ROPS is installed, always fasten your seat belt properly when operating the machine. If you do not use your fasten your seat belt properly, it cannot display its effect.

Prohibition of removal of ROPS canopy

- Never remove the ROPS canopy under any circumstances. If the machine should roll over, this will lead to to serious personal injury.
- When removing the ROPS canopy for transportation or any other reason, always consult your Komatsu distributor beforehand.

ATTACHMENT INSTALLATION

- When installing optional parts or attachments, there may be problems with safety or legal restrictions. Therefore contact your Komatsu distributor for advice.
- Any injuries, accidents, or product failures resulting from the use of unauthorized attachments or parts will not be the responsibility of Komatsu.
- When installing and using optional attachments, read the instruction manual for the attachment, and the general information related to attachments in this manual.

ATTACHMENT COMBINATIONS

Depending on the type or combination of work equipment, there is a hazard that the work equipment may hit the cab or other parts of the machine. Before using unfamiliar work equipment, check if there is any hazard of interference, and operate with caution.

CAB WINDOW GLASSES

If the cab glass on the work equipment side is broken, there is a hazard that the work equipment may contact the operator's body directly. Stop operation immediately and replace the glass.

UNAUTHORIZED MODIFICATIONS

Any modification made without authorization from Komatsu can create hazards. Before making a modification, consult your Komatsu distributor.

- Komatsu will not be responsible for any injuries, accidents, product failures or other property damages resulting from modifications made without authorization from Komatsu.

SAFETY AT JOBSITE

Before starting operations, thoroughly check the area for any unusual conditions that could be dangerous.

- When carrying out operations near combustible materials such as thatched roofs, dry leaves or dry grass, there is a hazard of fire, so be careful when operating.
- Check the terrain and condition of the ground at the worksite, and determine the safest method of operation. Do not carry out operations at places where there is a hazard of landslides or falling rocks.
- If water lines, gas lines, or high-voltage electrical lines may be buried under the worksite, contact each utility and identify their locations. Be careful not to sever or damage any of these lines.
- Take necessary measures to prevent any unauthorized person from entering the operating area.
- In particular, if you need to operate on a road, protect pedestrian and cars by designating a person for worksite traffic duty or by installing fences around the worksite.
- When traveling or operating in shallow water or on soft ground, check the shape and condition of the bedrock, and the depth and speed of flow of the water before starting operations.

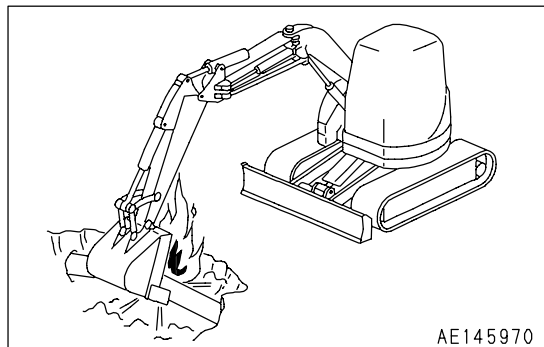

WORKING ON LOOSE GROUND

- Avoid traveling or operating your machine too close to the edge of cliffs, overhangs, and deep ditches. The ground may be weak in such areas. If the ground should collapse under the weight or vibration of the machine, there is a hazard that the machine may fall or tip over. Remember that the soil after heavy rain or blasting or after earthquakes is weak in these areas.
- When working on embankments or near excavated ditches, there is a hazard that the weight and vibration of the machine will cause the soil to collapse. Before starting operations, take steps to ensure that the ground is safe and to prevent the machine from rolling over or falling.

DISTANCE TO HIGH VOLTAGE CABLES

Do not travel or operate the machine near electric cables. There is a hazard of electric shock, which may cause serious injury or property damage. On jobsites where the machine may go close to electric cables, always do as follows.

- Before starting work near electric cables, inform the local power company of the work to be performed, and ask them to take the necessary action.

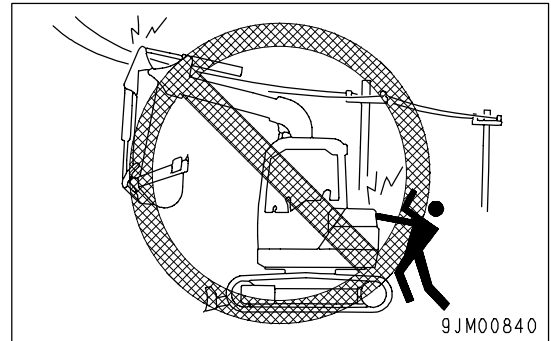

- Even going close to high-voltage cables can cause electric shock, which may cause serious burns or even death. Always maintain a safe distance (see the table on the right) between the machine and the electric cable. Check with the local power company about safe operating procedure before starting operations.
- To prepare for any possible emergencies, wear rubber shoes and gloves. Lay a rubber sheet on top of the seat, and be careful not to touch the chassis with any exposed part of your body.
- Use a signalman to give warning if the machine approaches too close to the electric cables.
- When carrying out operations near high voltage cables, do not let anyone come close to the machine.
- If the machine should come too close or touch the electric cable, to prevent electric shock, the operator should not leave the operator's compartment until it has been confirmed that the electricity has been shut off. Also, do not let anyone come close to the machine.

Voltage of Cables	Safety Distance
100 V - 200 V	Over 2 m (7 ft)
6,600 V	Over 2 m (7 ft)
22,000 V	Over 3 m (10 ft)
66,000 V	Over 4 m (14 ft)
154,000 V	Over 5 m (17 ft)
187,000 V	Over 6 m (20 ft)
275,000 V	Over 7 m (23 ft)
500,000 V	Over 11 m (36 ft)

ENSURE GOOD VISIBILITY

- Check for any persons or obstacles in the area around the machine and check the conditions of the jobsite to ensure that operations and travel can be carried out safely. Always do as follows.
 - When working in dark places, turn on the working lamp and front lamps installed to the machine, and set up additional lighting in the work area if necessary.
 - Stop operations if the visibility is poor, such as in mist, snow, rain, or dust.

VENTILATION FOR ENCLOSED AREA

Exhaust fumes from the engine can kill.

- If it is necessary to start the engine within an enclosed area, or when handling fuel, flushing oil, or paint, open the doors and windows to ensure that adequate ventilation is provided to prevent gas poisoning.

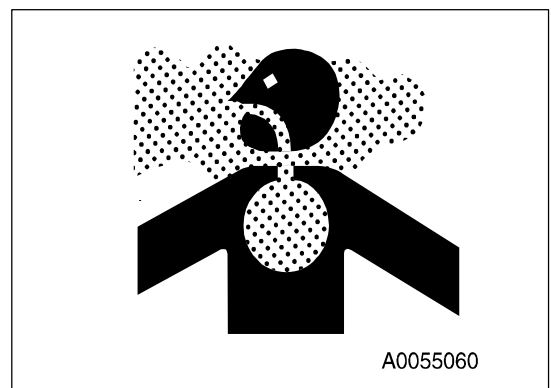

SIGNALMAN'S SIGNAL AND SIGNS

- Set up signs to inform of road shoulders and soft ground. If the visibility is not good, position a signalman if necessary. Operators should pay careful attention to the signs and follow the instructions from the signalman.
- Only one signalman should give signals.
- Make sure that all workers understand the meaning of all signals and signs before starting work.

EMERGENCY EXIT FROM OPERATOR'S CAB

If for any reason, it becomes impossible to open the cab door, use the hammer supplied to break the window and use it as an emergency escape.

For details, see "EMERGENCY ESCAPE HAMMER (PAGE 3-27)" in this manual.

- When escaping, remove all the pieces of glass from the window frame first and be careful not to cut yourself on the glass. Be careful also not to slip on the broken pieces of glass on the ground.

ASBESTOS DUST HAZARD PREVENTION

Asbestos dust in the air can cause lung cancer if it is inhaled. There is danger of inhaling asbestos when working on jobsites handling demolition work or work handling industrial waste. Always observe the following.

- Spray water to keep down the dust when cleaning. Do not use compressed air for cleaning.
- If there is danger that there may be asbestos dust in the air, always operate the machine from an upwind position. All workers should use an approved respirator.
- Do not allow other persons to approach during the operation.
- Always observe the rules and regulations for the work site and environmental standards.

This machine does not use asbestos, but there is a danger that imitation parts may contain asbestos, so always use genuine Komatsu parts.

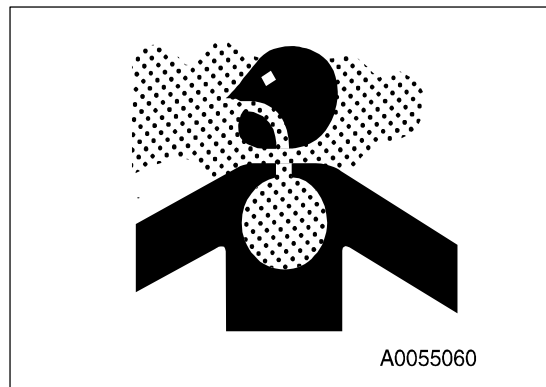

SAFETY MACHINE OPERATION

STARTING ENGINE

If there is a warning tag hanging from the work equipment control lever, do not start the engine or touch the levers .

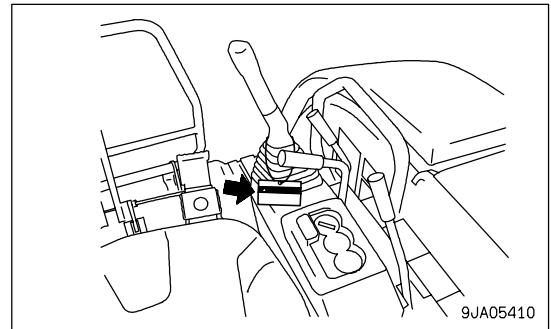

CHECKS BEFORE STARTING ENGINE

Carry out the following checks before starting the engine at the beginning of the day's work.

- Remove all dirt from the surface of the window glass to ensure a good view.
- Remove all dirt from the surface of the lens of the front lamps and working lamps, and check that they light up correctly.
- Check the coolant level, fuel level, and oil level in engine oil pan, check for clogging of the air cleaner, and check for damage to the electric wiring.
- Adjust the operator's seat to a position where it is easy to carry out operations, and check that there is no damage or wear to the seat belt or mounting clamps.
- Check that the gauges work properly, check the angle of the lights and working lamps, and check that the control levers are all at the neutral position.
- Before starting the engine, check that the safety lock lever is at the LOCK position.
- Adjust the angle of the rearview mirror so that viewed from the operator's seat, the rear lower part of the machine (whose view is usually blocked by the engine hood) can be clearly seen. For this adjustment, see the section of "Rearview Mirrors (PAGE 3-49)" in this manual.
- Check that there are no persons or obstacles above, below, or in the area around the machine.

- Do as follows to check that the floor is fixed securely in position. If it is not fixed securely in position, it may cause serious personal injury.
 - Open the engine rear cover and check that floor tilt lock bolts (1) (5 places) are securely tightened. (4 places for cab specification)
 - If there is any up-down play in the floor frame or any gap at (A) (normal: 0 mm), lock bolt (1) may be broken or loose, so check lock bolts (1).

If any abnormality is found, always carry out repairs or ask your Komatsu distributor to carry out repairs.

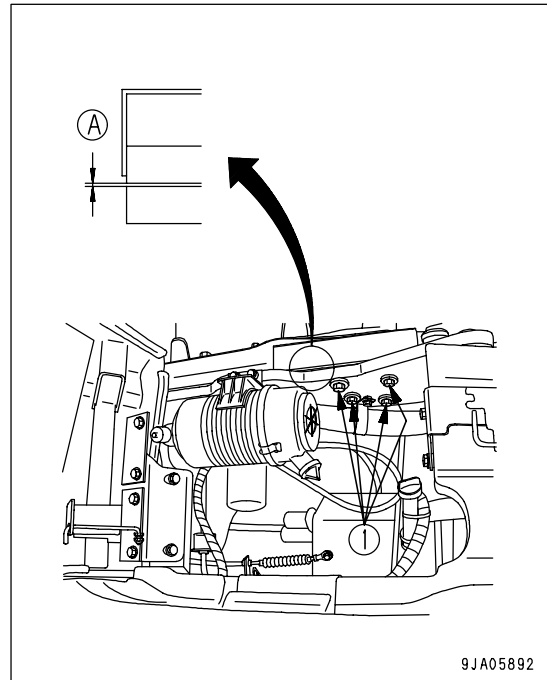

SAFETY RULES FOR STARTING ENGINE

- Start and operate the machine only while seated.
- Do not attempt to start the engine by short-circuiting the engine starting circuit. Such an act may cause a serious bodily injury or fire.
- When starting the engine, sound the horn as a warning.
- Do not allow anyone apart from the operator to ride on the machine.

STARTING ENGINE IN COLD WEATHER

- Carry out the warming-up operation thoroughly. If the machine is not thoroughly warmed up before the control levers are operated, the reaction of the machine will be slow, and this may lead to unexpected accidents.
- If the battery electrolyte is frozen, do not charge the battery or start the engine with a different power source. There is a hazard that this will ignite the battery and cause the battery to explode. Before charging or starting the engine with a different power source, melt the battery electrolyte and check that there is no leakage of electrolyte before starting.

OPERATION

CHECKS BEFORE OPERATION

When carrying out the checks, move the machine to a wide area where there are no obstructions, and operate slowly. Do not allow anyone near the machine.

- Fit the seat belt (if equipped) securely.
- Check that the movement of the machine matches the display on the control pattern card. If it does not match, replace it immediately with the correct control pattern card.
- Check the operation of the gauges and equipment, and check the operation of the bucket, arm, boom, travel system, swing system, and steering system.
- Check for any abnormality in the sound of the machine, vibration, heat, smell, or gauges; check also that there is no leakage of oil or fuel.
- If any abnormality is found, carry out repairs immediately.

SAFETY RULES FOR CHANGING MACHINE DIRECTIONS

- Before traveling, position the upper structure so that the sprocket is at the rear of the operator's cab. If the sprocket is at the front of the operator's cab, the machine makes a movement reverse to the control lever movement (for example, forward becomes reverse, and left becomes right). Be careful to avoid such a reverse movement of the machine.
- Before travelling, check again that there is no one in the surrounding area, and that there are no obstacles.
- Before travelling, sound the horn to warn people in the area.
- Always operate the machine only when seated.
- Do not allow anyone apart from the operator to ride on the machine.
- If there is an area to the rear of the machine which cannot be seen, position a signal person. Take special care not to hit other machines or people when turning or swinging the machine.
- For machines equipped with a travel alarm, check that the alarm works properly.
- Always lock the door and windows of the operator's compartment in position (open or closed).

On jobsites where there is a hazard of flying objects or of objects entering the operator's compartment, check that the door and windows are securely closed.

Always be sure to carry out the above precautions even when the machine is equipped with mirrors.

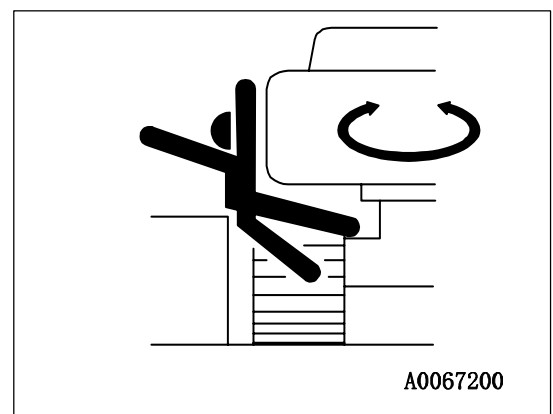
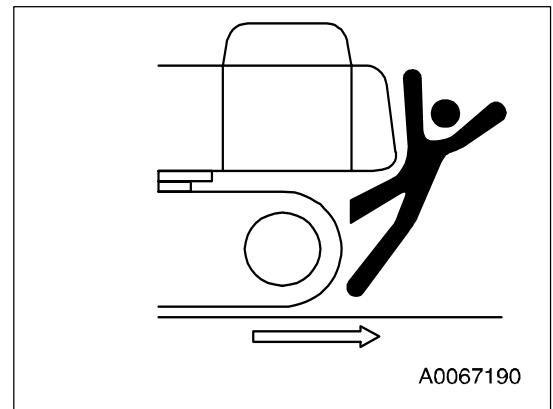
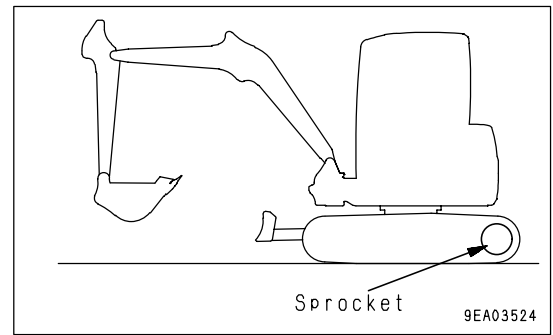

SAFETY RULES FOR TRAVELING

- It is dangerous to drive too fast, or to start suddenly, stop suddenly, or to turn sharply.
- When traveling on flat ground, keep the work equipment 40 to 50 cm (16 to 20 in) high above the ground.
- When traveling on rough ground, travel at low speed and do not operate the steering suddenly. There is danger that the machine may turn over. The work equipment may hit the ground surface and cause the machine to lose its balance, or may damage the machine or structures in the area.

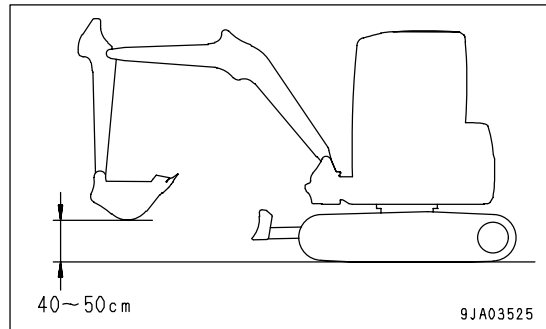

- Avoid traveling over obstacles when possible. If the machine has to travel over an obstacle, keep the work equipment close to the ground and travel at low speed. Never travel over obstacles which make the machine tilt strongly to one side.
- When traveling or carrying out operations, always keep a safe distance from people, structures, or other machines to avoid coming into contact with them.
- When passing over bridges or structures, check first that the structure is strong enough to support the weight of the machine. When traveling on public roads, check first with the relevant authorities and follow their instructions.

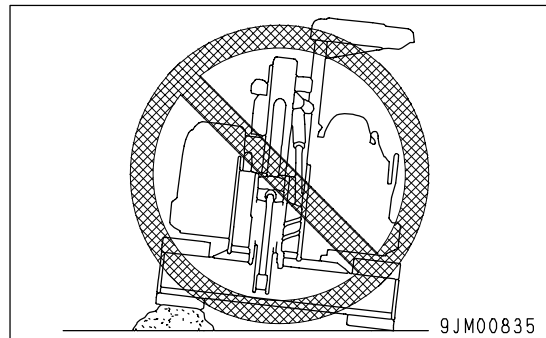

- When operating in tunnels, under bridges, under electric wires, or other places where the height is limited, operate slowly and be extremely careful not to let the work equipment hit anything.
- For machines with the canopy specification, when the work equipment is operated to the maximum left boom swing with the work equipment in the minimum swing posture, soil may spill from the bucket and fall on to the floor. Be extremely careful when operating in this posture.

TRAVELING ON SLOPES

To prevent the machine from tipping over or slipping to the side, always do as follows.

- Keep the work equipment approx. 20 to 30 cm (8 to 12 in) above the ground. In case of emergency, lower the work equipment to the ground immediately to help stop the machine.
- When travel up slopes, set the operator's cab facing uphill, when travel down slopes, set the operator's cab facing downhill. Always check the firmness of the ground under the front of the machine when traveling.

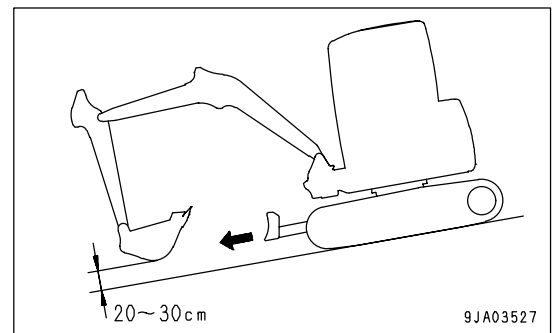
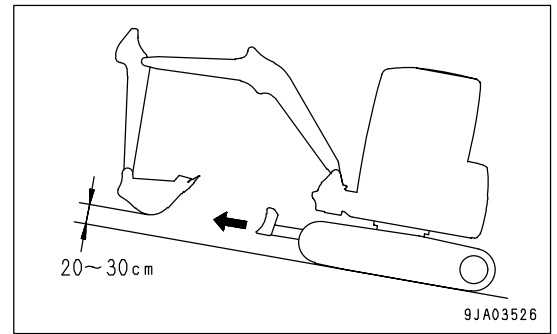

- When traveling up a steep slope, extend the work equipment to the front to improve the balance, keep the work equipment approximately 20 to 30 cm (8 to 12 in) above the ground, and travel at low speed.

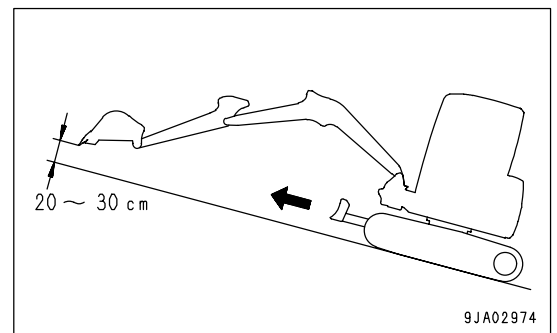

- When traveling downhill, lower the engine speed, keep the travel lever close to the neutral position, and travel at low speed. When traveling down a slope with a grade of more than 15°, set the machine with the sprocket (1) at the downhill end and the work equipment in the posture shown in the diagram on the right, then lower the engine speed and travel downhill.

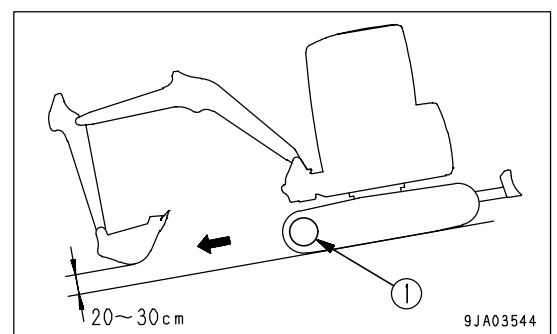

- Always travel straight up or down a slope. Traveling at an angle or across the slope is extremely dangerous.
- Do not turn on slopes or travel across slopes. Always go down to a flat place to change the position of the machine, then travel on to the slope again.
- Travel on grass, fallen leaves, or wet steel plates with low speed. Even with slight slopes there is a hazard that the machine may slip.
- If the engine stops when the machine is traveling on a slope, move the control levers immediately to the neutral position and start the engine again.

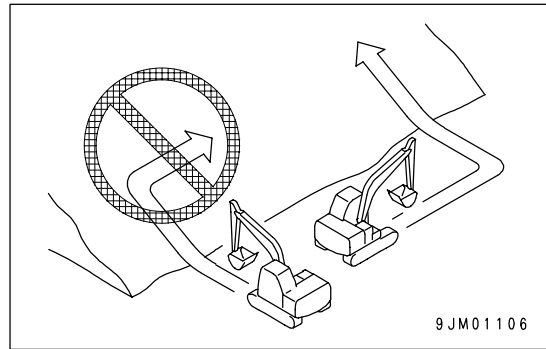

9JM01106

OPERATIONS ON SLOPES

- When working on slopes, there is a hazard that the machine may lose its balance and turn over when the swing or work equipment are operated. This may lead to serious injury or property damage, so always provide a stable place when carrying out these operations, and operate carefully.
- Do not swing the work equipment from the uphill side to the downhill side when the bucket is loaded. This operation is dangerous, and may cause the machine to tip over.
- If the machine has to be used on a slope, pile the soil to make a platform that will keep the machine as horizontal as possible.

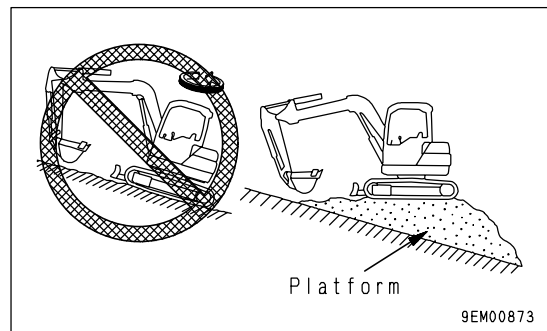

9EM00873

PROHIBITED OPERATIONS

- Never dig the work face under an overhang. There is a hazard that rocks may fall or that the overhang may collapse and fall on top of the machine.

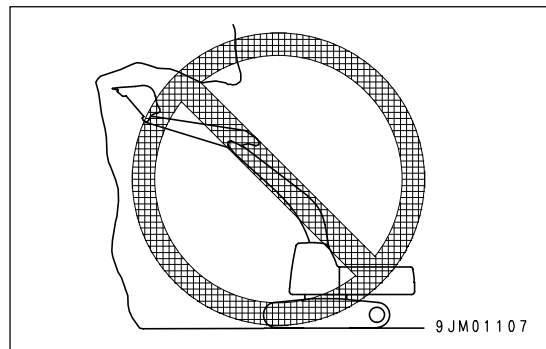

9JM01107

- Do not excavate too deeply under the front of the machine. The ground under the machine may collapse and cause the machine to fall.

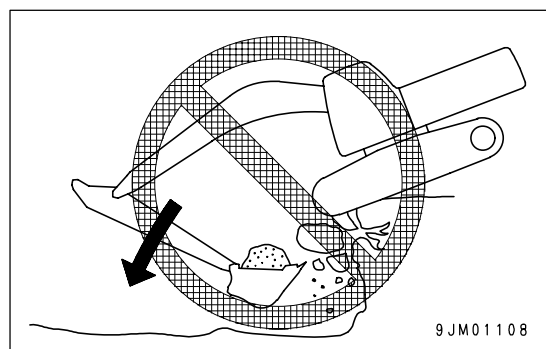

9JM01108

- To make it easier to escape if there is any problem, set the tracks at right angles to the road shoulder or cliff with the sprocket at the rear when carrying out operations.

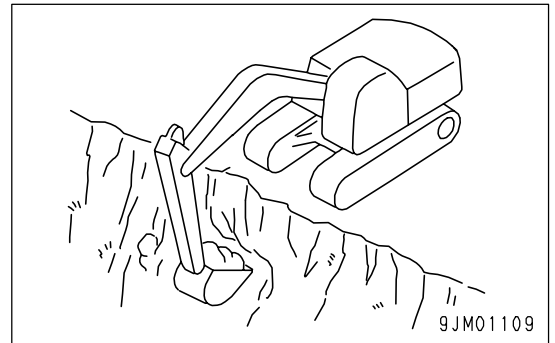

- Do not carry out demolition work under the machine. There is a hazard that the machine may become unstable and tip over.
- When working on or from the top of buildings or other structures, check the strength and the structure before starting operations. There is a hazard of the building collapsing and causing serious injury or damage.

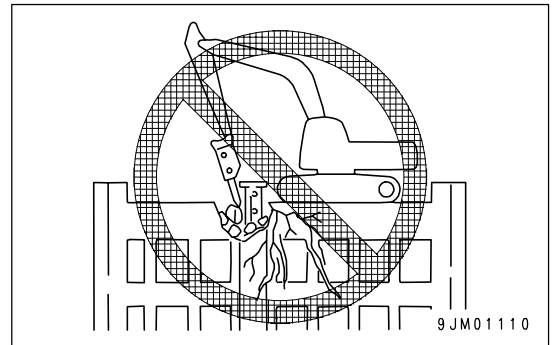

- When carrying out demolition work, do not carry out demolition above your head. There is a hazard of broken parts falling or of the building collapsing and causing serious injury or property damage.

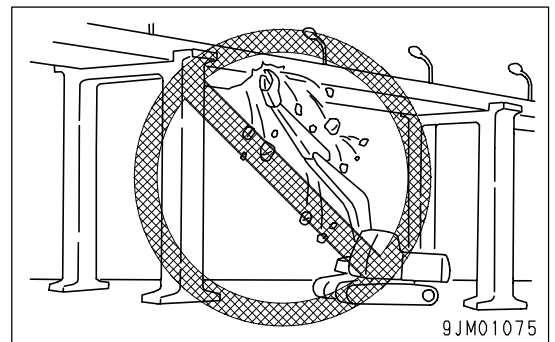

- Do not use the impact force of the work equipment for breaking work. There is a hazard of damage to the work equipment, or a hazard of serious personal injury being caused by flying pieces of broken materials, or of the machine tipping over due to reaction from the impact.
- Generally speaking, the machine is more liable to overturn when the work equipment is at the side than when it is at the front or rear.

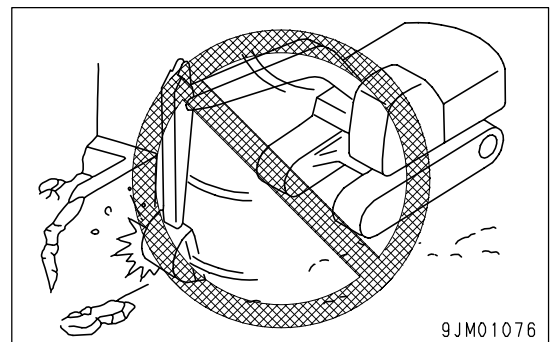

- When using a breaker or other heavy work equipment, there is a hazard of the machine losing its balance and tipping over. When operating on flat ground as well as on slopes.
 - Do not suddenly lower, swing, or stop the work equipment.
 - Do not suddenly extend or retract the boom cylinder. There is a hazard that impact will cause the machine to tip over.
- Do not pass the bucket over the head of other workers or over the operator's seat of dump trucks or other hauling equipment. The load may spill or the bucket may hit the dump truck and cause serious injury or property damage.

OPERATIONS ON SNOW

- Snow-covered or frozen surfaces are slippery, so be extremely careful when traveling or operating the machine, and do not operate the levers suddenly. Even a slight slope may cause the machine to slip, so be particularly careful when working on slopes.
- With frozen ground surfaces, the ground becomes soft when the temperature rises, and this may cause the machine to tip over.
- If the machine enters deep snow, there is a hazard that it may tip over or become buried in the snow. Be careful not to leave the road shoulder or to get trapped in a snow drift.
- When clearing snow, the road shoulder and objects placed beside the road are buried in the snow and cannot be seen. There is a hazard of the machine tipping over or hitting covered objects, so always carry out operations carefully.

PARKING MACHINE

- Park the machine on firm, level ground.
- Select a place where there is no hazard of falling rocks or landslides, or of flooding if the land is low.
- Lower the work equipment and blade completely to the ground.

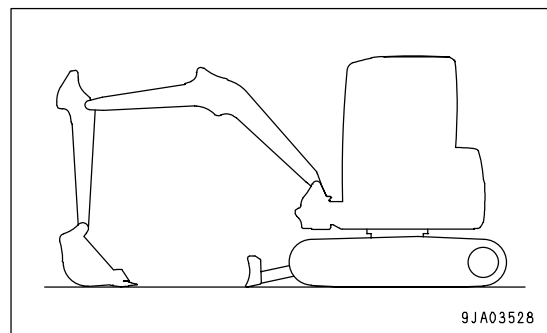

- When leaving the machine, set safety lock lever (1) to the LOCK position (L), then stop the engine.

REMARK

For machines equipped with a cab, there is only a safety lock lever on the left.

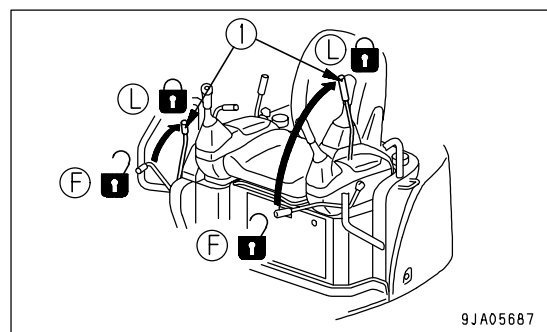

- Always close the operator's cab door, and use the key to lock all the equipment in order to prevent any unauthorized person from moving the machine. Always remove the key, take it with you, and leave it in the specified place.
- If it is necessary to park the machine on a slope, always do as follows.
 - Set the bucket on the downhill side, then dig it into the ground.
 - Put blocks under the tracks to prevent the machine from moving.

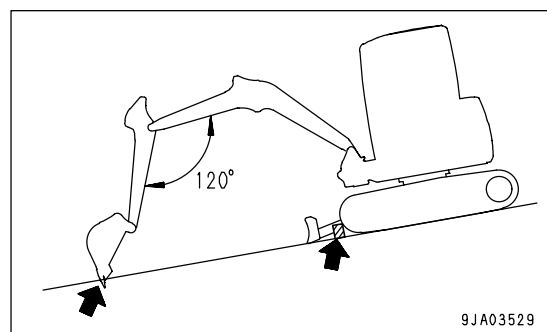

TRANSPORTATION

LOADING AND UNLOADING

When loading or unloading the machine, mistaken operation may bring the hazard of the machine tipping over or falling, so particular care is necessary. Always do as follows.

- Perform loading and unloading on firm, level ground only. Maintain a safe distance from the edge of the road or cliff.
 - Never use the work equipment to load or unload the machine. There is danger that the machine may fall or tip over.
 - Always use ramps of adequate strength. Be sure that the ramps are wide, long, and thick enough to provide a safe loading slope. Take suitable steps to prevent the ramps from moving out of position or coming off.
 - Be sure the ramp surface is clean and free of grease, oil, ice and loose materials. Remove dirt from machine-tracks. On a rainy day, in particular, be extremely careful since the ramp surface is slippery.
 - If the machine is equipped with auto-deceleration, always turn the switch OFF (cancel) before starting the operation. If the machine is operated with the auto-deceleration switch ON (actuate), there is danger that the engine speed may suddenly increase, causing the machine to suddenly start and the travel speed to increase.
 - Run the engine at low idling, set to low speed, and operate the machine slowly when loading or unloading.
 - Never correct your steering on the ramps. If necessary, drive off the ramps, correct the direction, then enter the ramps again.
 - When on the ramps, do not touch any other parts.
 - The center of gravity of the machine will change suddenly at the joint between the ramps and the track or trailer, and there is danger of the machine losing its balance. Travel slowly over this point.
 - When loading or unloading to an embankment or platform, make sure that it has suitable width, strength, and grade.
 - When swinging the upper structure on the trailer, the trailer is unstable, so pull in the work equipment and swing slowly. And turn swing lock switch ON to apply swing lock after loading machine.
 - For machines equipped with a cab, always lock the door after boarding the machine. If this is not done, the door may suddenly open during transportation.
- Refer to "TRANSPORTATION (PAGE 3-89)".

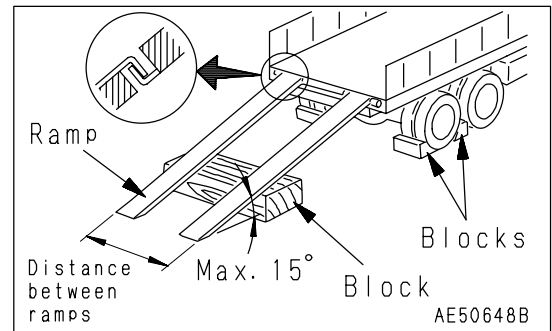

SHIPPING THE MACHINE

When shipping the machine on a trailer, do as follows.

- The weight, transportation height, and overall length of the machine differ according to the work equipment, so be sure to confirm the dimensions.
- When passing over bridges or structures on private land, check first that the structure is strong enough to support the weight of the machine. When traveling on public roads, check first with the relevant authorities and follow their instructions.
- For details of the shipping procedure, see "TRANSPORTATION (PAGE 3-89)" in the OPERATION section.

BATTERY

BATTERY HAZARD PREVENTION

Battery electrolyte contains sulphuric acid, and batteries generate flammable hydrogen gas, which may explode. Mistaken handling can lead to serious injury or fire. For this reason, always observe the following precautions.

- Do not use or charge the battery if the battery electrolyte level is below the LOWER LEVEL line. This may cause an explosion. Always check the battery electrolyte level periodically and add distilled water to bring the electrolyte level to the UPPER LEVEL line.
- When working with batteries, always wear safety glasses and rubber gloves.
- Never smoke or use any flame near the battery.

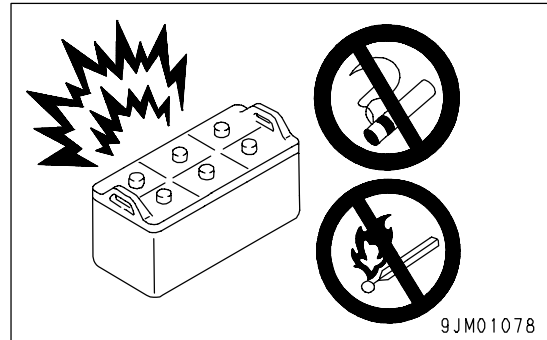

- If you spill acid on your clothes or skin, immediately flush the area with large amount of water.
- If acid gets into your eyes, flush them immediately with large amount of water and seek medical attention.

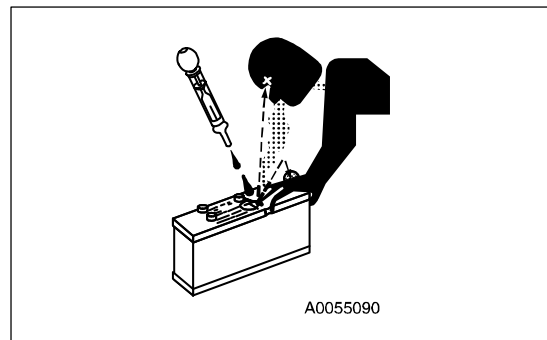

- Before working with batteries, turn the starting switch to the OFF position.

As there is a hazard that sparks will be generated, always do as follows.

- Do not let tools or other metal objects make any contact between the battery terminals. Do not leave tools or other metal objects on top of the battery.
- Always disconnect the negative (-) terminal (ground side) first when removing the battery; when installing the battery, connect the positive (+) terminal first, and connect the ground last. Tighten the battery terminals securely.
- Flammable hydrogen gas is generated when the battery is charged, so remove the battery from the chassis, take it to a well-ventilated place, and remove the battery caps before charging it.
- Tighten the battery caps securely. If any battery cap is damaged, replace it immediately.
- Install the battery securely to the determined place. When doing this, be careful not to let the clamps contact the terminals.
- Make sure that the cover on top of the battery covers the battery completely. Do not let it roll back. If the cover is damaged, replace it immediately.
- If there is salt on the battery terminals, wash with water of a temperature of approx. 40°C (104°F), then dry completely and remove with a wire brush.

STARTING ENGINE WITH BOOSTER CABLES

If any mistake is made in the method of connecting the booster cables, it may cause the battery to explode, so always do as follows.

- When starting with a booster cable, carry out the starting operation with two workers (one worker sitting in the operator's seat and the other working with the battery).
- When starting from another machine, do not allow the two machines to touch.
- When connecting the booster cables, turn the starting switch OFF for both the normal machine and problem machine. There is a hazard that the machine will move when the power is connected.
- Be sure to connect the positive (+) cable first when installing the booster cables. Disconnect the negative (-) cable (ground side) first when removing them.
- When removing the booster cables, be careful not to let the booster cable clips touch each other or to let the clips touch the machine.
- Always wear safety goggles and rubber gloves when starting the engine with booster cables.
- When connecting a normal machine to a problem machine with booster cables, always use a normal machine with the same battery voltage as the problem machine.
- For details of the starting procedure when using booster cables, see "Starting Engine with Booster Cables (PAGE 3-108)" in the OPERATION section.

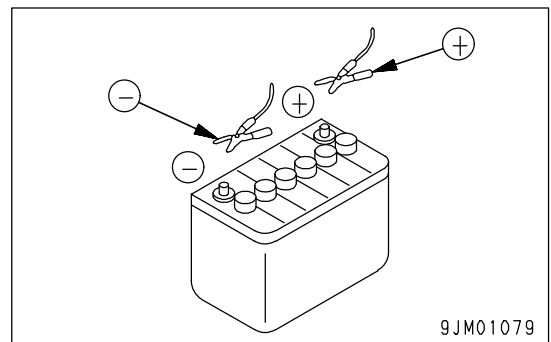
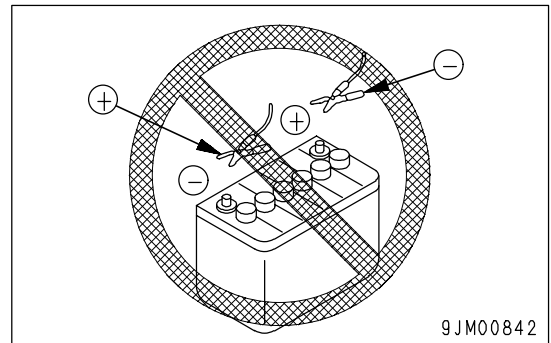

TOWING

SAFETY RULES FOR TOWING

Serious injury or death could result if a disabled machine is towed incorrectly or if there is a mistake in the selection or inspection of the wire rope.

For towing, see "TOWING THE MACHINE (PAGE 3-105)".

- Always wear leather gloves when handling wire rope.
- Fix the wire rope to the track frame.
- During the towing operation, never stand between the towing machine and the machine being towed.
- Never tow a machine on a slope.

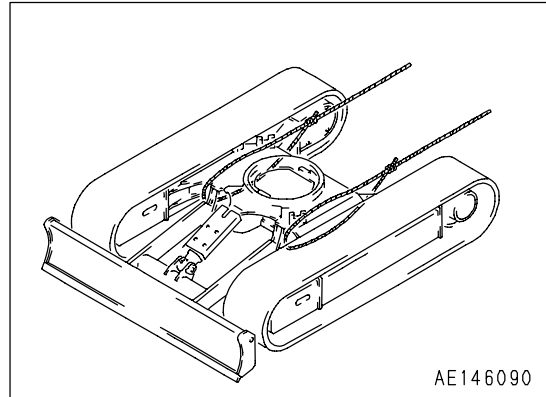

- Never use a wire rope which has cut strands (A), reduced diameter (B), or kinks (C). There is danger that the rope may break during the towing operation.

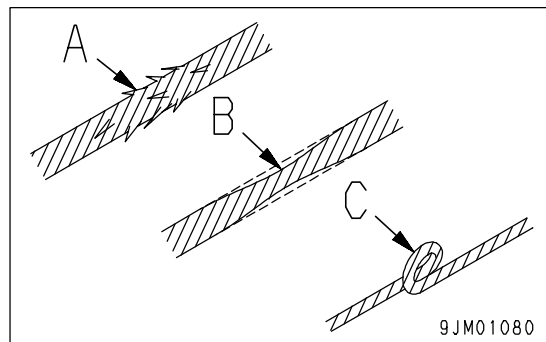

LIFTING OBJECTS WITH BUCKET

SAFETY RULES FOR LIFTING OBJECTS

- Do not carry out lifting work on slopes, soft ground, or other places where the machine is not stable.
- Use wire rope that conforms to the specified standard.
- Do not exceed the specified lifting load.

For details of the maximum lifting load permitted for this machine, see "BUCKET WITH HOOK (PAGE 6-4)".

- It is dangerous if a raised load hits any person or structure. When operating the swing or work equipment, always check carefully that the surrounding area is safe.
- Do not operate the swing or work equipment suddenly. There is danger that it will cause the load to sway.
- Do not use 2 machines to cooperate to lift the same load. This is dangerous.
- Do not use the work equipment or swing to pull the load in any direction. There is danger that the hook may break and the load come off, causing the work equipment to move suddenly and cause personal injury.
- Do not leave the operator's seat when there is a raised load.

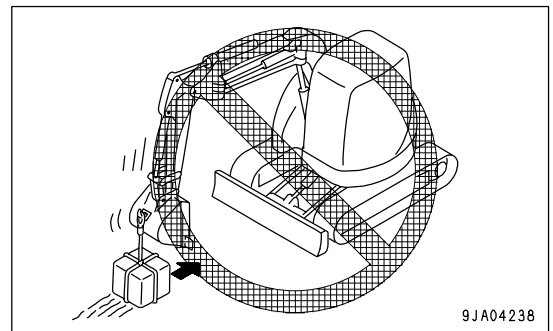
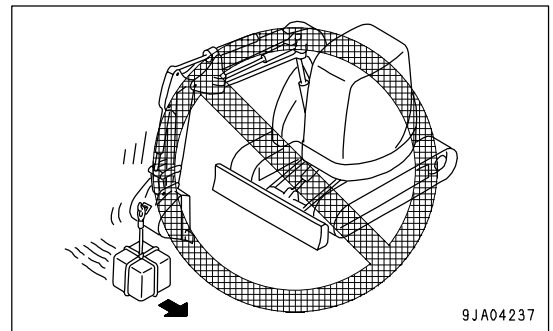

SAFETY MAINTENANCE INFORMATION

WARNING TAG

- Always attach the "DO NOT OPERATE" warning tag to the work equipment control lever in the operator's cab to alert others that you are performing service or maintenance on the machine. Attach additional warning tags around the machine if necessary. Warning tag Part No. 09963-03001
Keep this warning tag in the tool box while it is not used. If there is no toolbox, keep the tag in the operation manual pocket.
- If others start the engine, or touch or operate the work equipment control lever while you are performing service or maintenance, you could suffer serious injury or property damage.

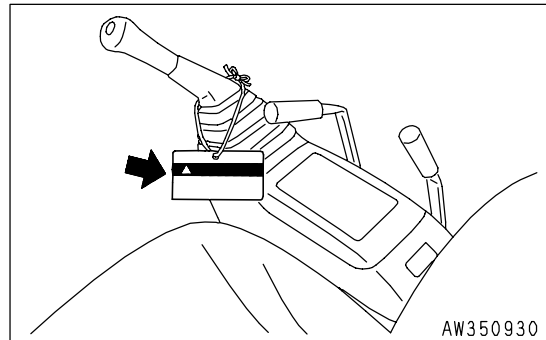

KEEP WORK PLACE CLEAN AND TIDY

- Park the machine on firm, level ground.
- Select a place where there is no hazard of falling rocks or landslides, or of flooding if the land is low.
- Lower the work equipment and blade completely to the ground.

APPOINT LEADER WHEN WORKING WITH OTHERS

When repairing the machine or when removing and installing the work equipment, appoint a leader and follow his instructions during the operation.

When working with others, misunderstandings between workers can lead to serious accidents.

STOP ENGINE BEFORE CARRYING OUT MAINTENANCE

- Stop the machine on firm, level ground.
- Select a place where there is no hazard of falling rocks or landslides, or of flooding if the land is low.
- Lower the work equipment and blade completely to the ground.

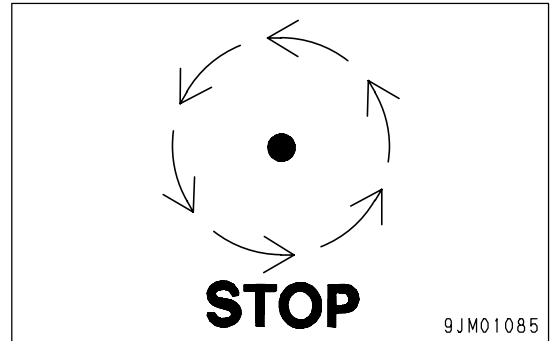

- Place the work equipment control lever to the neutral position, set safety lock lever (1) to LOCK position (L), then stop the engine.

REMARK

For machines equipped with a cab, there is only a safety lock lever on the left.

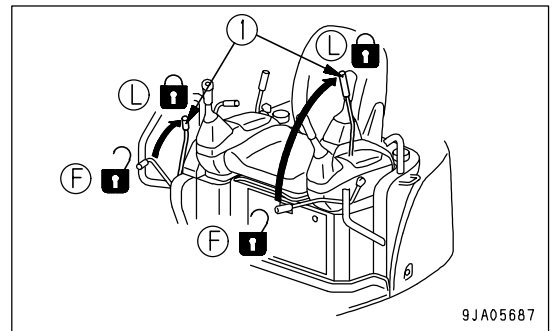

- Put blocks under the track to prevent the machine from moving.

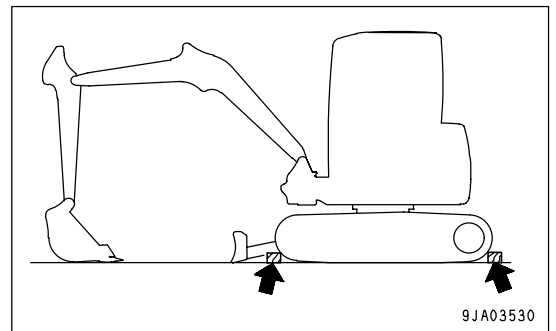

CAUTIONS FOR OPENING (TILTING) FLOOR

When opening (tilting) the cab or floor, see Section "METHOD OF OPENING (TILTING) FLOOR (PAGE 3-31)" for details.

Precautions when parking machine

- Park the machine on firm, level ground.
- Select a place where there is no hazard of falling rocks or landslides, or of flooding if the land is low.
- Lower the work equipment and blade completely to the ground.

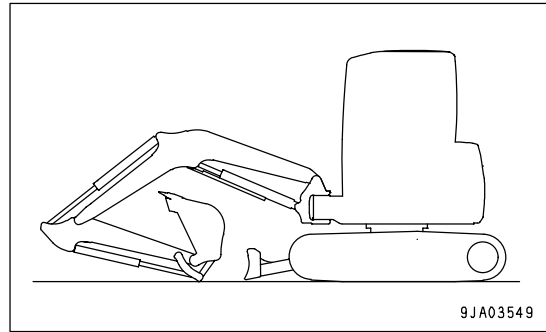
**Precautions when opening or closing**

- Do not open the floor when the machine is on a slope or when there is strong wind. This may lead to serious personal injury.
- Never open the floor when the engine is running, or when the door on the cab specification machine is open, or when the safety lock lever is at the FREE position. This is extremely dangerous.
- Immediately after the engine is stopped, the parts and oil are at a high temperature, and will cause burns. Check that the temperature in the engine room has gone down before starting the operation to open the floor.
- Do not get on or off the operator's seat during the floor opening operation. You may fall and suffer serious personal injury.

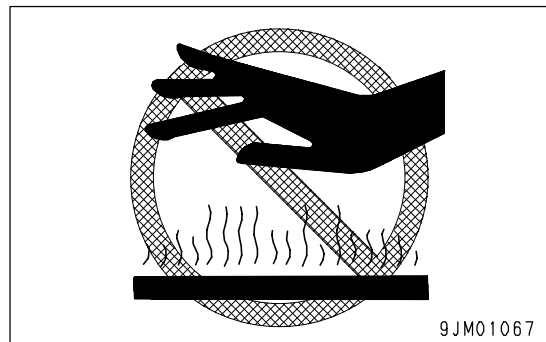
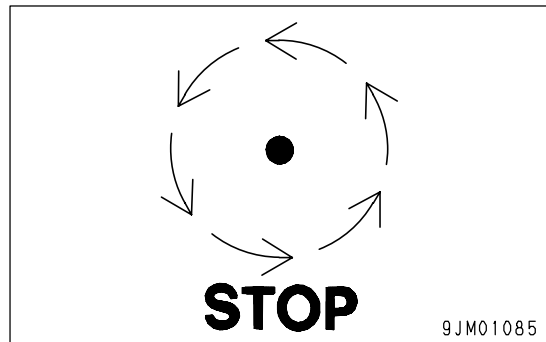

TWO WORKERS FOR MAINTENANCE WHEN ENGINE IS RUNNING

To prevent injury, do not carry out maintenance with the engine running. If maintenance must be carried out with the engine running, carry out the operation with at least two workers and do as follows.

- One worker must always sit in the operator's seat and be ready to stop the engine at any time. All workers must maintain contact with the other workers.

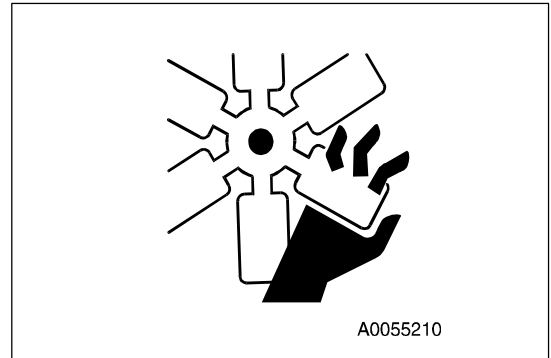

- Set safety lock lever (1) to the LOCK position (L).

REMARK

For machines equipped with a cab, there is only a safety lock lever on the left.

- When carrying out operations near the fan, fan belt, or other rotating parts, there is a hazard of being caught in the parts, so be careful not to come close.
- Do not touch any control levers. If any control lever must be operated, give a signal to the other workers to warn them to move to a safe place.
- Never drop or insert tools or other objects into the fan or fan belt. Parts may break or be sent flying.

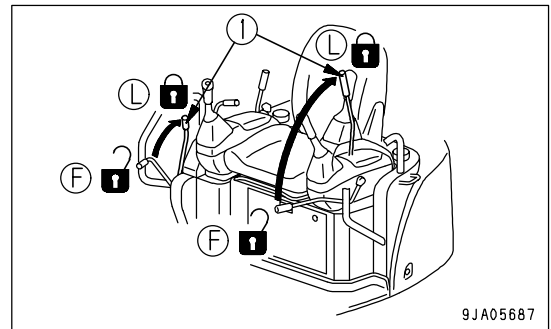
**PROPER TOOLS**

Use only tools suited to the task and be sure to use the tools correctly. Using damaged, low quality, faulty, makeshift tools or improper use of the tools could cause serious personal injury.

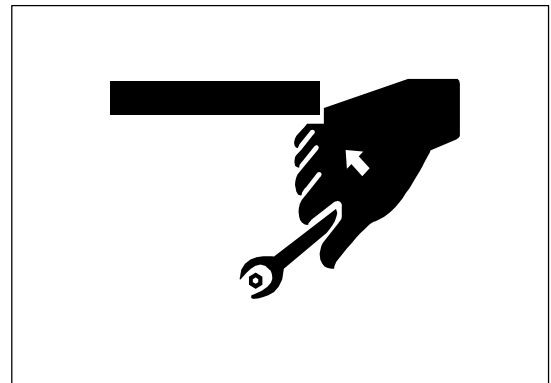
**PERSONNEL**

Only authorized personnel can service and repair the machine. Do not allow unauthorized personnel into the area. If necessary, employ an observer.

ATTACHMENTS

- Appoint a leader before starting removal or installation operations for attachments.
- Place attachments that have been removed from the machine in a stable condition so that they do not fall. And take steps to prevent unauthorized persons from entering the storage area.

**WORK UNDER THE MACHINE**

- If it is necessary to go under the work equipment or the machine to carry out service and maintenance, support the work equipment and machine securely with blocks and stands strong enough to support the weight of the work equipment and machine.
- It is extremely dangerous to work under the machine if the track shoes are lifted off the ground and the machine is supported only with the work equipment. If any of the control levers is touched by accident, or there is damage occurring to the hydraulic piping, the work equipment or the machine will suddenly drop. This is extremely dangerous. Never work under the work equipment or the machine.

**NOISE**

When carrying out maintenance of the engine and you are exposed to noise for long periods of time, wear ear covers or ear plugs while working.

If the noise from the machine is too loud, it may cause temporary or permanent hearing problems.

WHEN USING HAMMER

When using a hammer, pins may fly out or metal particles may be scattered. This may lead to serious injury. Always do as follows.

- If hard metal parts such as pins, bucket teeth, cutting edges, or bearings are hit with a hammer, there is a hazard that pieces might be scattered and cause injury. Always wear safety goggles and gloves.
- When hitting pins or bucket teeth, there is a hazard that broken pieces might be sent flying and injure people in the surrounding area. Always check that there is no one in the surrounding area.
- There is a hazard that the pin hit with strong force may fly out and injure people in the surrounding area.

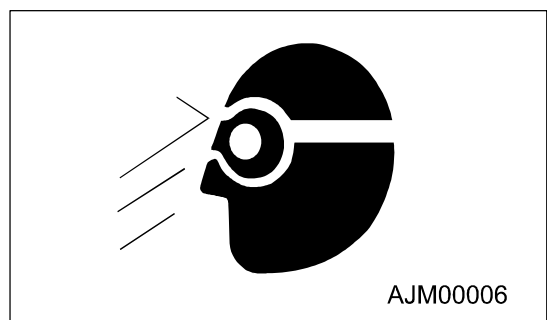
**WELDING WORKS**

Welding operations must always be carried out by a qualified welder and in a place equipped with proper equipment. There is a hazard of gas, fire, or electrocution when carrying out welding, so never allow any unqualified personnel to carry out welding.

REMOVING BATTERY TERMINALS

When repairing the electrical system or when carrying out electrical welding, remove the negative (-) terminal of the battery to prevent the flow of current.

SAFETY FIRST WHEN USING HIGH-PRESSURE GREASE TO ADJUST TRACK TENSION

- Grease is pumped into the track tension adjustment system under high pressure.

If the specified procedure for maintenance is not followed when making adjustment, grease drain plug (1) may fly out and cause serious injury or property damage.

- When loosening grease drain plug (1) to loosen the track tension, never loosen it more than one turn. Loosen the grease drain plug slowly.
- Never put your face, hands, feet, or any other part of your body close to grease drain plug (1).

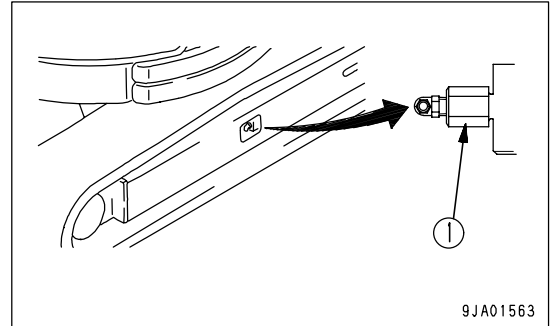

DO NOT DISASSEMBLE RECOIL SPRINGS

Never attempt to disassemble the recoil spring assembly. It contains a spring under high pressure which serves as a shock absorber for the idler. If it is disassembled by mistake, the spring will fly out and cause serious injury. When it becomes necessary to disassemble it, ask your Komatsu distributor to do the work.

SAFETY RULES FOR HIGH-PRESSURE OIL

The hydraulic system is always under internal pressure. When inspecting or replacing piping or hoses, always check that the pressure in the hydraulic circuit has been released. If the circuit is still under pressure, it will lead to serious injury, so always do as follows.

- Always release the pressure before starting any inspection or replacement operation.
- If there is any leakage from the piping or hoses, the surrounding area will be wet, so check for cracks in the piping and hoses and for swelling in the hoses.

When carry out inspection, wear safety glasses and leather gloves.

- There is a hazard that high-pressure oil leaking from small holes may penetrate your skin or cause blindness if it contacts your eyes directly. If you are hit by a jet of high-pressure oil and suffer injury to your skin or eyes, wash the place with clean water, and consult a doctor immediately for medical attention.

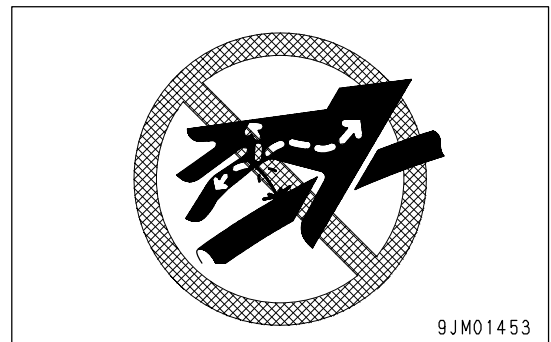

SAFETY HANDLING HIGH-PRESSURE HOSES

- If oil or fuel leaks from high-pressure hoses, it may cause fire or defective operation, which may lead to serious injury. If any loose bolts are found, stop work and tighten to the specified torque. If any damaged hoses are found, stop operations immediately and contact your Komatsu distributor.

Replace the hose if any of the following problems are found.

- Damaged hose, deformed mouthpiece, damaged O-ring
- Frayed or cut covering or exposed reinforcement wire layer
- Covering swollen in places
- Twisted or crushed movable portion of hose
- Foreign material embedded in covering

WASTE MATERIALS

To prevent pollution, pay careful attention to the method of disposing of waste materials.

- Always put oil drained from your machine in containers. Never drain oil directly onto the ground or dump into the sewage system, rivers, the sea, or lakes.
- Obey appropriate laws and regulations when disposing of harmful objects such as oil, fuel, coolant, solvent, filters, and batteries.

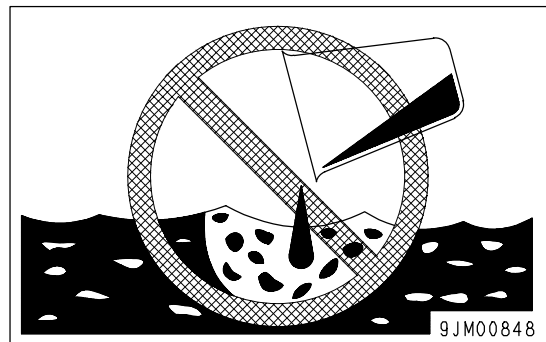
**AIR CONDITIONER MAINTENANCE**

If air conditioner refrigerant gets into your eyes, it may cause blindness; if it touches your skin, it may cause frostbite. Never touch refrigerant.

COMPRESSED AIR

- When carrying out cleaning with compressed air, there is a hazard of serious injury caused by flying particles.
- When using compressed air to clean elements or the radiator, always wear safety goggles, dust mask, gloves, and other protective equipment.

PERIODIC REPLACEMENT OF SAFETY CRITICAL PARTS

- To enable the machine to be used safely for long periods, be particularly careful to periodically replace the seatbelt, hoses, and other parts which have a close relationship to safety.

See Replacing critical parts: SAFETY CRITICAL PARTS (PAGE 4-14)

- The material of these components naturally changes over time, and repeated use causes deterioration, wear, and fatigue. As a result, there is a hazard that these components may fail and cause serious injury or death. It is difficult to judge the remaining life of these components from external inspection or the feeling when operating, so always replace them at the specified interval.
- Replace or repair safety-critical parts if any defect is found, even when they have not reached the time specified interval.

OPERATION

WARNING

Please read and make sure that you understand the SAFETY section before reading this section.

MACHINE VIEW ILLUSTRATIONS

OVERALL MACHINE VIEW

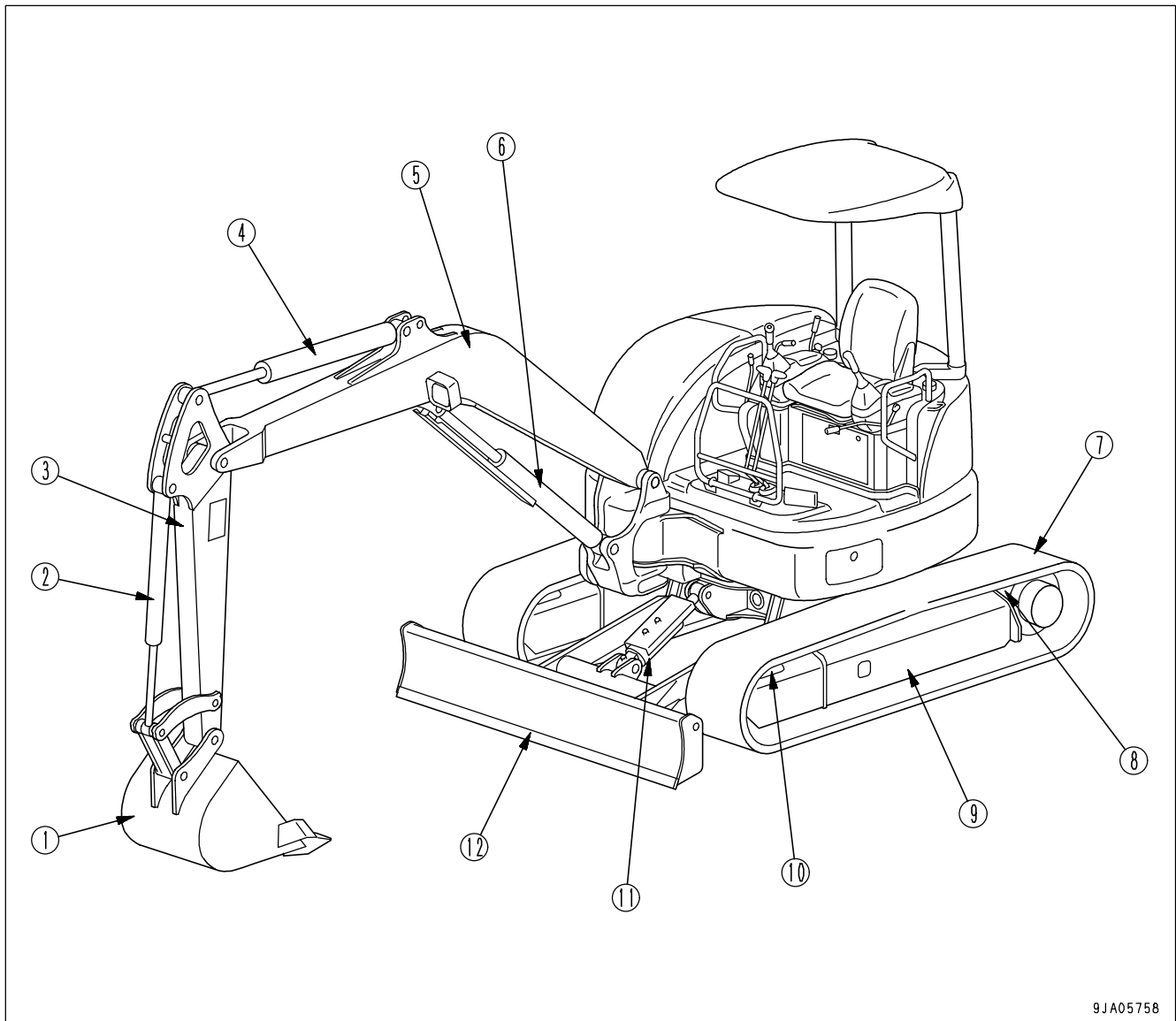

9JA05758

- | | |
|---------------------|---------------------|
| (1) Bucket | (7) Track shoe |
| (2) Bucket cylinder | (8) Sprocket |
| (3) Arm | (9) Track frame |
| (4) Arm cylinder | (10) Idler |
| (5) Boom | (11) Blade cylinder |
| (6) Boom cylinder | (12) Blade |

CONTROLS AND GAUGES

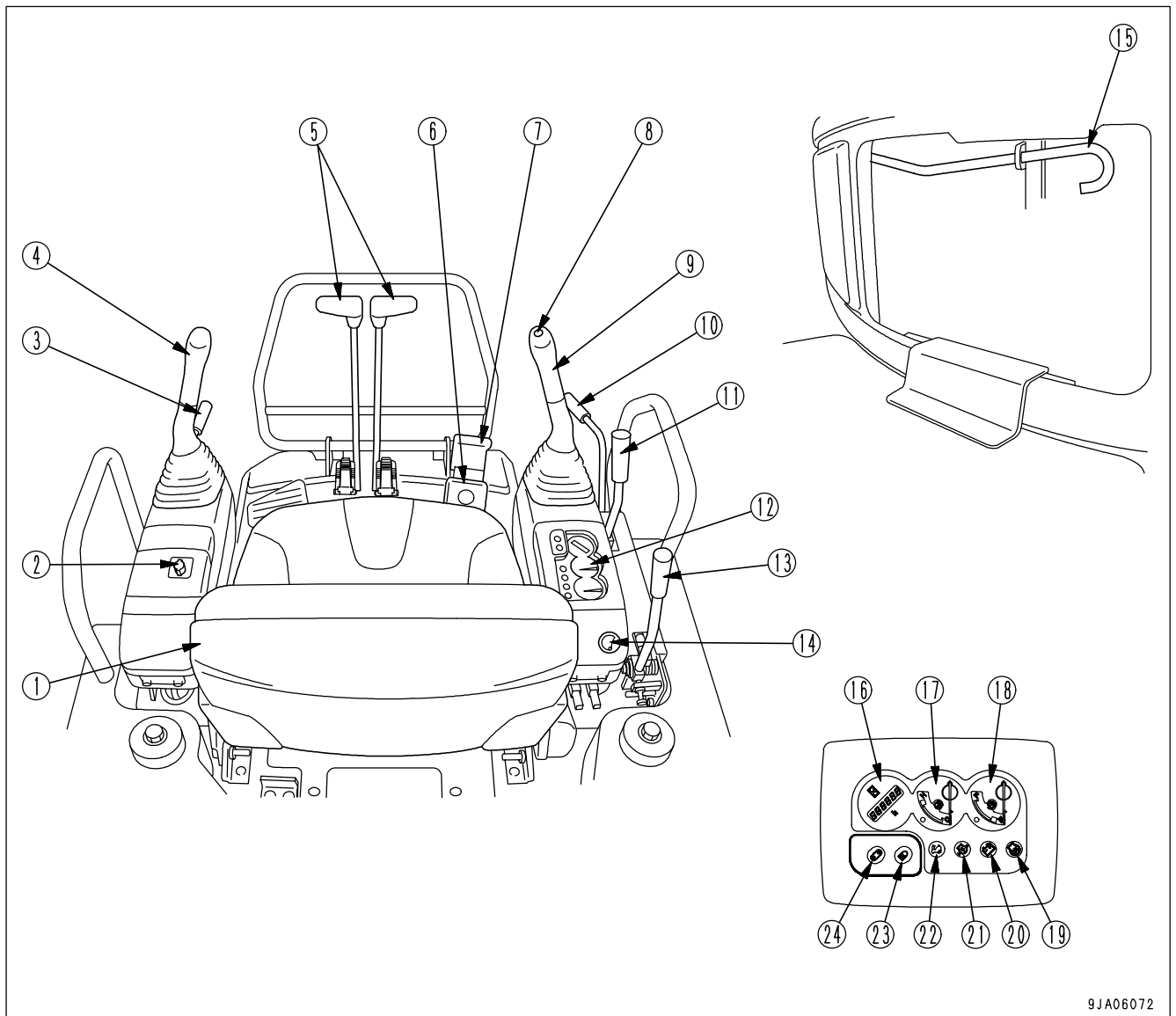

9JA06072

- | | |
|--|---------------------------------------|
| (1) Operator's seat | (13) Fuel control lever |
| (2) Heater switch (cab specification machine) | (14) Starting switch |
| (3) Safety lock lever (left) | (15) Floor lock cancel lever |
| (4) Left work equipment control lever | (16) Service meter |
| (5) Travel Levers (with pedals) | (17) Engine coolant temperature gauge |
| (6) Boom swing control pedal | (18) Fuel gauge |
| (7) Pedal lock | (19) Engine pre-heating monitor |
| (8) Horn switch | (20) Charge level monitor |
| (9) Right work equipment control lever | (21) Engine oil pressure monitor |
| (10) Safety lock lever (right)
(canopy specification machine) | (22) Travel speed boost monitor |
| (11) Blade control lever | (23) Lamp switch |
| (12) Machine monitor | (24) Travel speed selector switch |

DETAILED CONTROLS AND GAUGES

The following is an explanation of the devices needed for operating the machine.

To perform suitable operations correctly and safely, it is important to completely understand the methods of operating equipment and meanings of the displays.

MONITORING SYSTEM

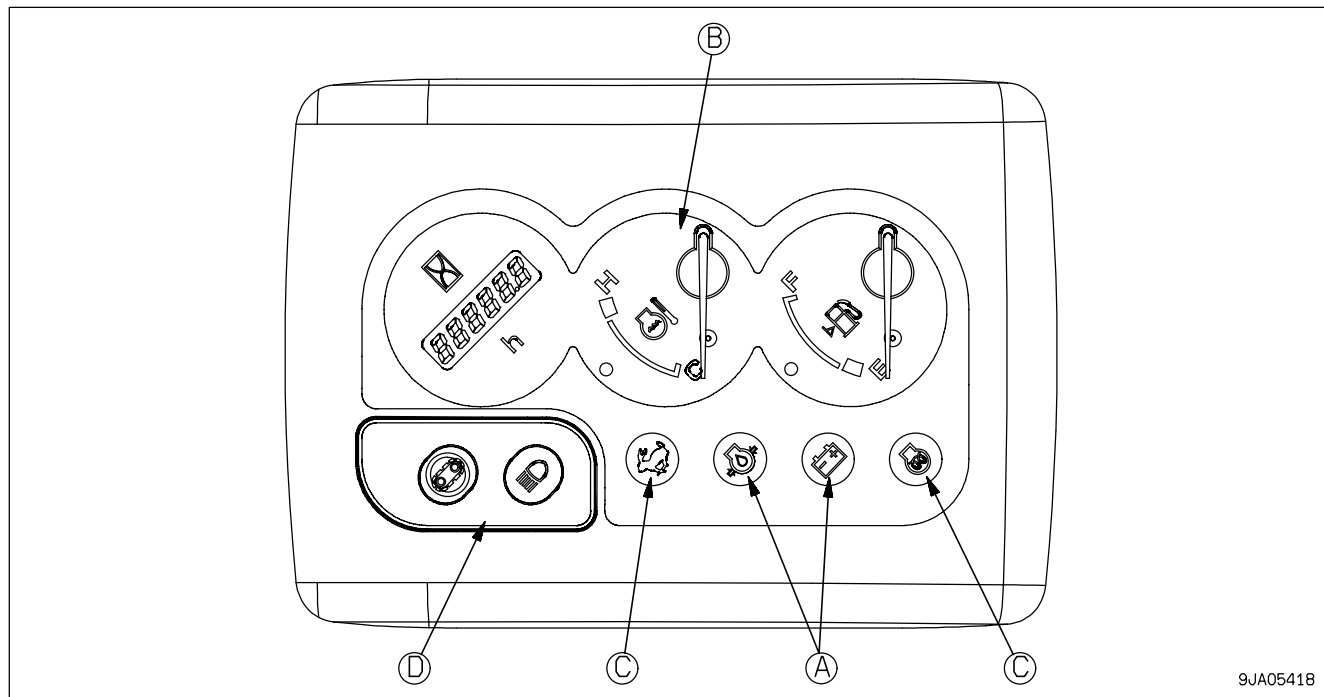

9JA05418

- (A) Emergency monitors
- (B) Meter display portion

- (C) Pilot lamps
- (D) Monitor switches portion

Emergency Monitors

CAUTION

If the monitor flashes or the buzzer sounds, stop the engine immediately or run it at low idling, then inspect the problem point immediately and repair the problem.

These are items which need to be observed when the engine is running. If there is any abnormality, the abnormal location on the monitor will lights up and the buzzer will sound. Carry out the necessary repairs immediately.

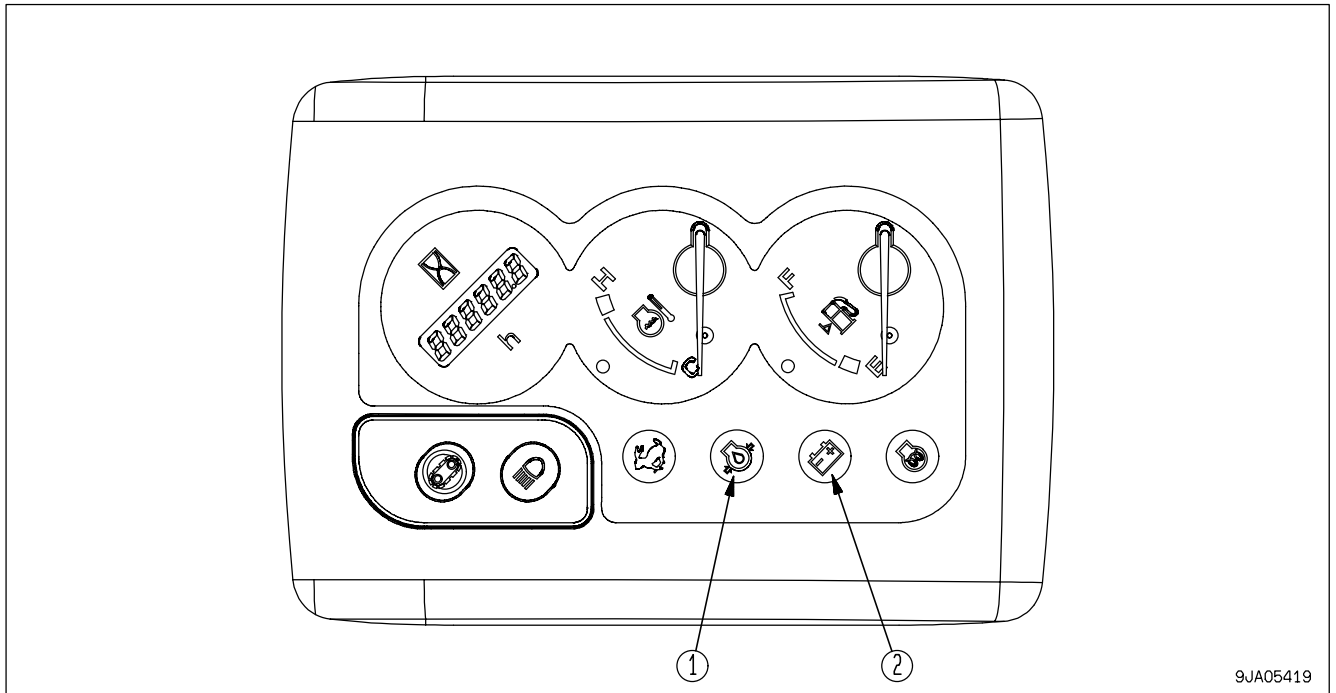

(1) Engine oil pressure monitor

(2) Charge level monitor

Engine Oil Pressure Monitor

This monitor (1) flashes and the buzzer sounds if the engine and lubricating oil pressure goes below the specified level. If the monitor flashes, stop the engine and carry out inspection. For details, see Section "OTHER TROUBLE (PAGE 3-110)".

REMARK

While the starting switch is ON, the lamp will remain lit and will go off once the engine is started.

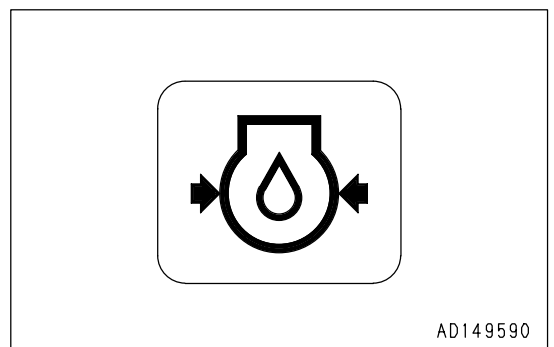

AD149590

Charge Level Monitor

If there is an abnormality in the charging when the engine is running, this monitor (2) flashes and the buzzer sounds.

If the monitor flashes, stop the engine and check the V-belt tension. If any abnormality is found, see Section "OTHER TROUBLE (PAGE 3-110)".

REMARK

While the starting switch is ON, the lamp will remain lit and will go off once the engine is started.

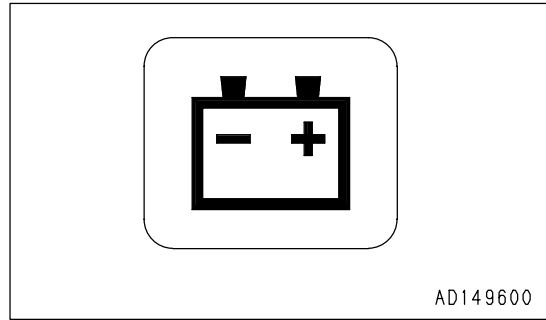

Meter Display Portion

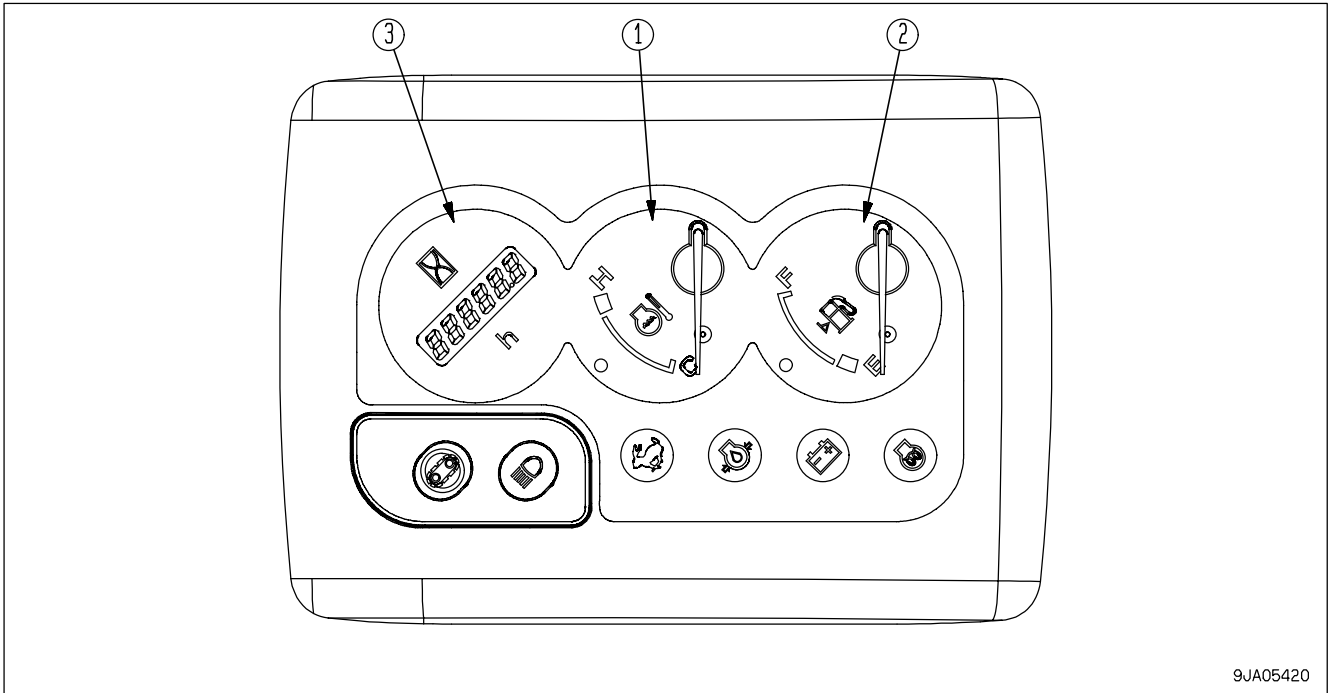

9JA05420

- (1) Engine coolant temperature gauge
- (2) Fuel gauge
- (3) Service meter

Engine Coolant Temperature Gauge

This meter (1) shows the engine coolant temperature. During operation, the indicator should be in range (A). If the indicator enters red range (B) during operation, pilot lamp (C) flashes and the buzzer sounds at the same time. If this happens, run the engine at low idling and wait until pilot lamp (C) goes out and the indicator goes down to range (A).

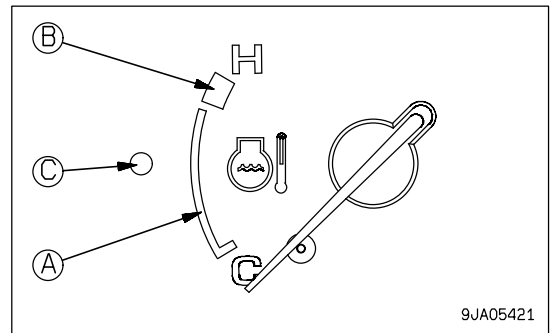

9JA05421

Fuel Gauge

This meter (2) shows the fuel level in the fuel tank. F indicates that the tank is full. E indicates that the fuel level is low. If the fuel level goes below 4.5 liters (1.19 US gal), the indicator enters red range (A), and at the same time, pilot lamp (B) flashes. If the indicator enters red range (A) or pilot lamp (B) flashes, check the fuel level and add fuel.

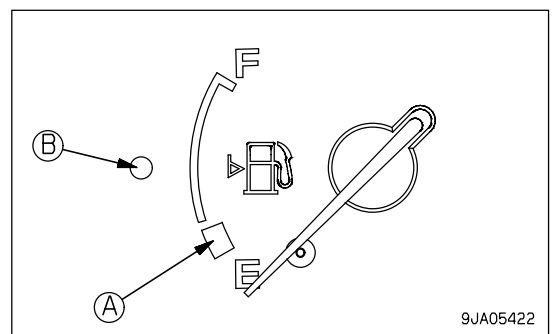

9JA05422

The correct level may not be displayed for a short time after the starting switch is turned to the ON position, but this is not an abnormality.

Service Meter

This meter (3) shows the total time that the machine has been operated.

Use this display to manage the specified service intervals.

If the engine is running, the service meter advances even if the machine is not being operated.

The meter advances 0.1 for every 1/10 hours (6 minutes) of engine operation, regardless of the engine speed.

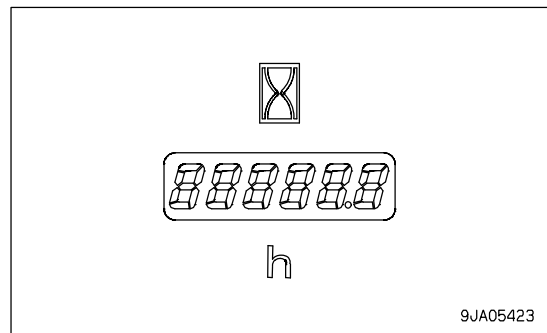

Pilot Lamps

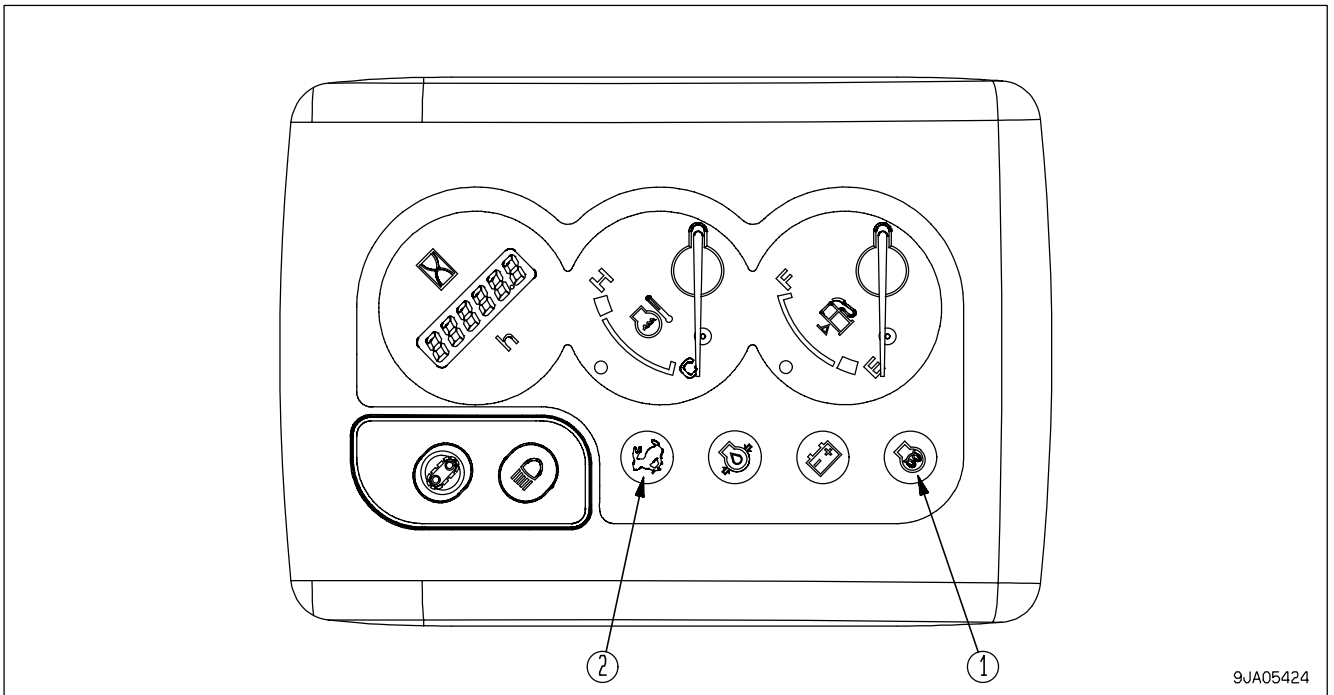

9JA05424

(1) Engine pre-heating monitor

(2) Travel speed boost monitor

Engine Pre-heating Monitor

This monitor (1) flashes when the starting switch is set to the HEAT position. After approx. 18 seconds, the buzzer sounds and the monitor goes out.

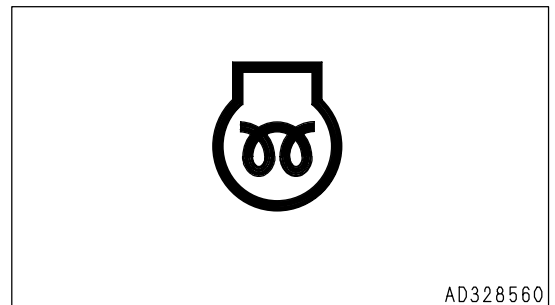

AD328560

Travel Speed Boost Monitor

This monitor (2) lights up when the speed range selector switch is at high speed. When the speed range is low speed, the monitor goes out.

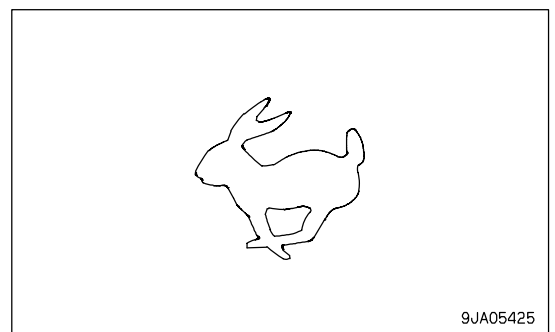

9JA05425

REMARK

When traveling at high speed, if the machine travels on soft ground or up a slope and the load increases, the travel is automatically switched to low speed travel, but the travel speed boost monitor displays stays lighted up.

Monitor Switches Portion

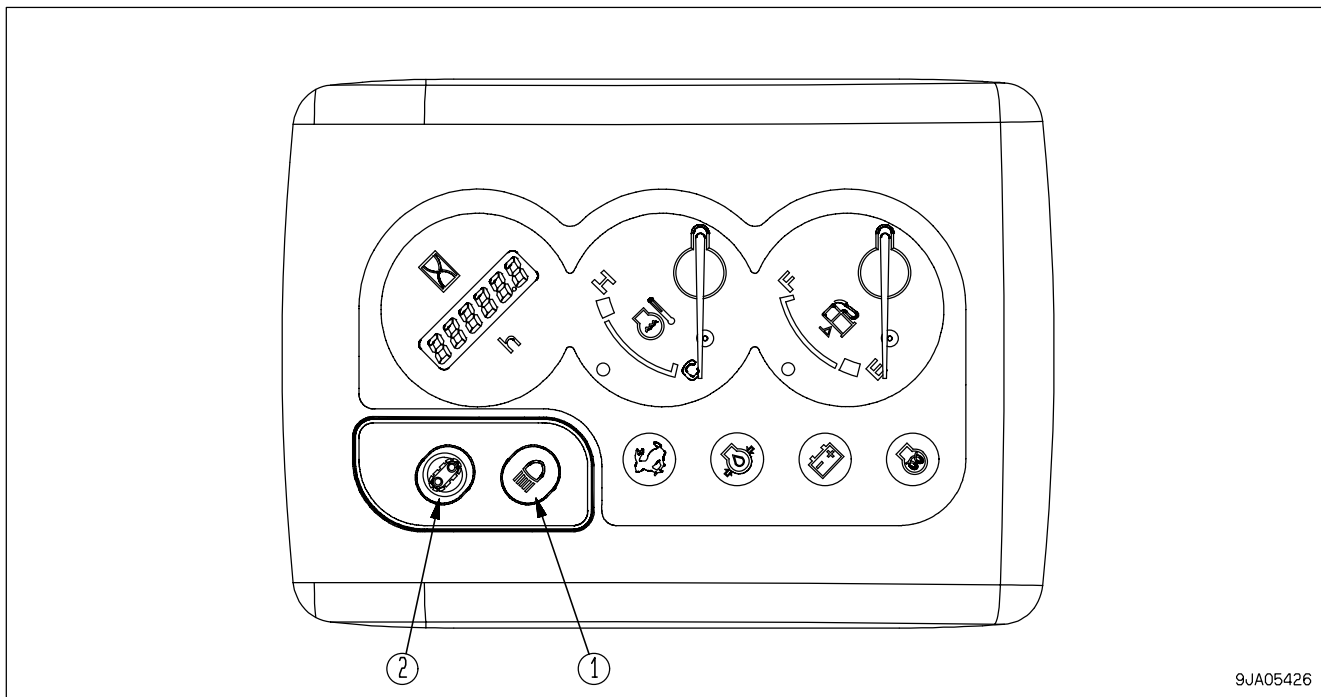

(1) Lamp switch

(2) Travel speed selector switch

Lamp Switch

Use this switch (1) to turn on the headlamps and the lamp inside the machine monitor.

Each time the switch is pressed, it is switched between ON and OFF.

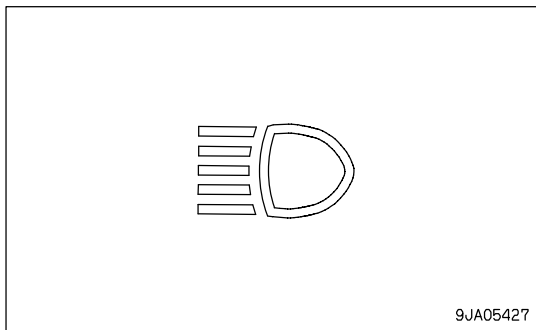

Travel Speed Selector Switch



WARNING

- When loading or unloading from a trailer, always travel at low speed. Never operate the travel speed selector switch during the loading or unloading operation.
- If the travel speed is switched between Hi and Lo when the machine is traveling, the machine may deviate to one side, even when traveling in a straight line.
Stop the machine before switching the travel speed.

Use this switch (2) to switch the travel speed to low speed or high speed.

Each time the switch is pressed, it is switched between low speed and high speed.

When the machine is traveling at high speed, the travel speed boost monitor lights up.

REMARK

- When the engine is started, the travel speed is automatically set to low speed.
- When traveling at high speed, if the machine travels on soft ground or up a slope and the load increases, the travel is automatically switched to low speed travel, so there is no need to operate the switch. The travel speed boost monitor displays stays lighted up.
When the load is reduced, the travel system returns to high speed travel.

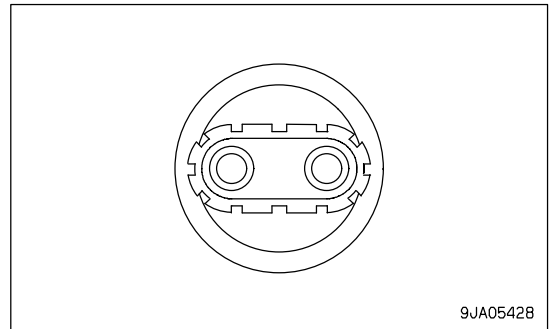

SWITCHES

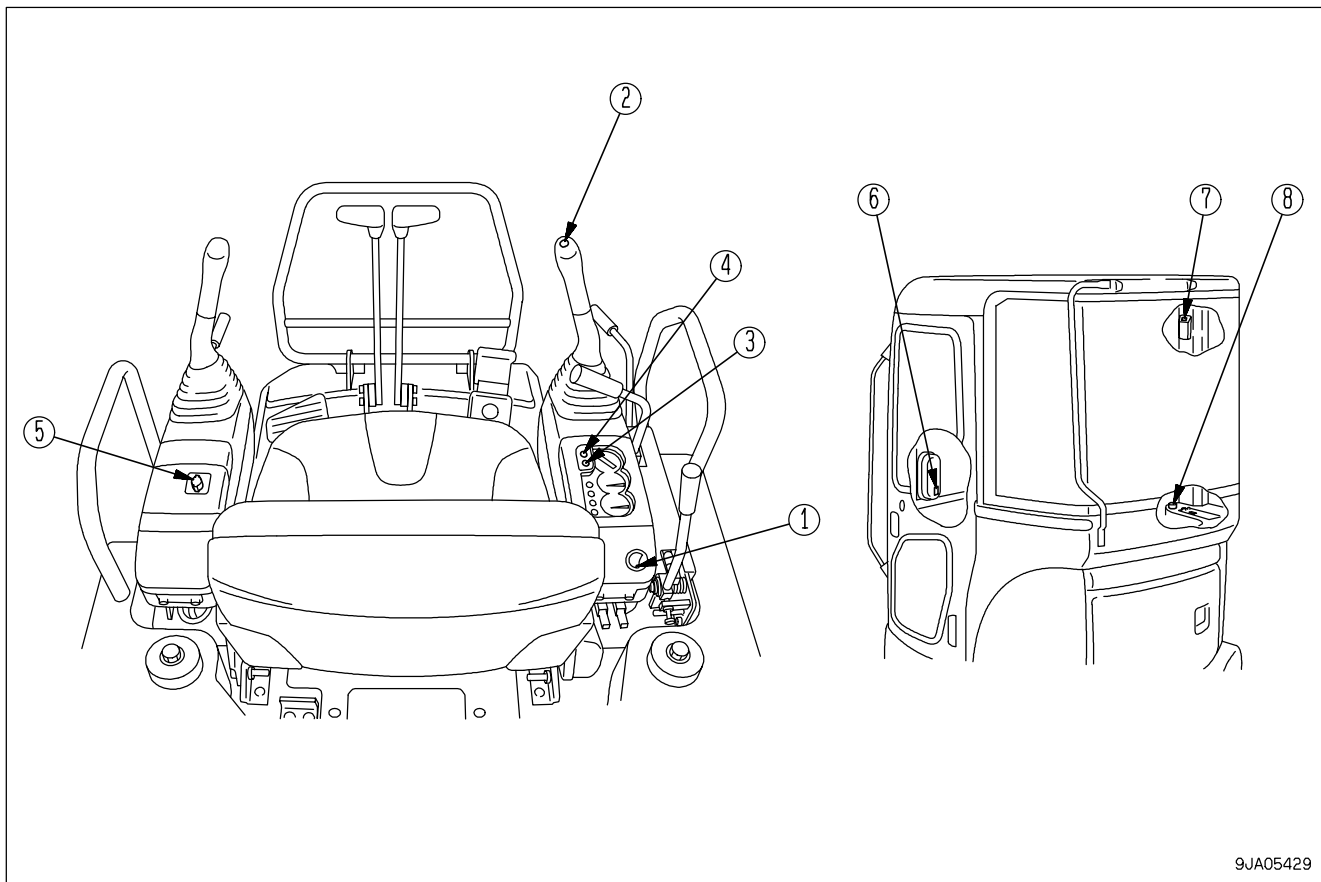

- (1) Starting switch
- (2) Horn switch
- (3) Lamp switch
- (4) Travel speed selector switch
- (5) Cab heater switch
(Machines equipped with cab)
- (6) Windshield wiper switch
(Machines equipped with cab)
- (7) Room lamp switch
(Machines equipped with cab)
- (8) Cigarette lighter
(Machines equipped with cab)

Starting Switch

This switch (1) is used to start or stop the engine.

OFF position

The key can be inserted or withdrawn. The switches for the electric system are all turned off and the engine is stopped.

ON position

Electric current flows in the charging and lamp circuits. Keep the starting switch key at the ON position while the engine is running.

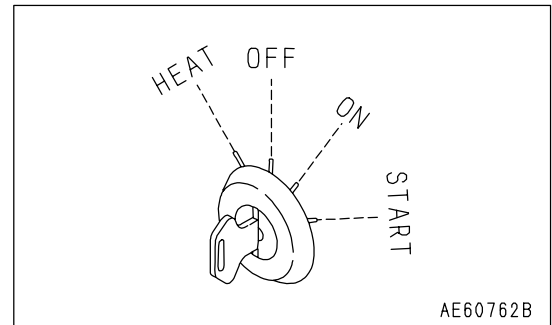
**START position**

This is the engine-start position. Keep the key at this position during cranking. Immediately after starting the engine, release the key. It will automatically return to the ON position.

HEAT (preheat) position

When starting the engine in cold weather, turn the key to this position. When the key is set to the HEAT position, the preheating monitor lights up. Keep the key at this position until the preheating monitor goes out.

When the preheating monitor goes out, release the key.

When the key is released, it will return to the OFF position, so turn it immediately to START and start the engine.

Horn Switch

Press switch (2) at the center of the knob of the right work equipment lever to sound the horn.

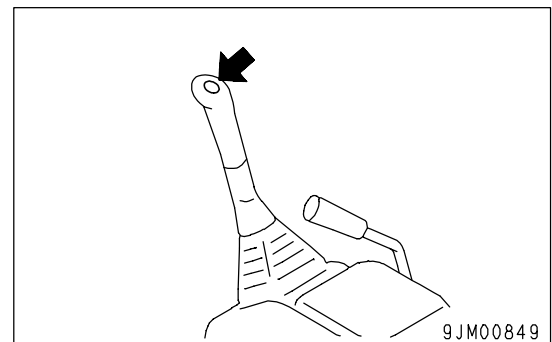
**Lamp Switch**

Use this switch (3) to turn on the headlamps and the lamp inside the machine monitor.

For details, see MONITOR SWITCHES, Section "Lamp Switch (PAGE 3-10)".

Travel Speed Selector Switch

Use this switch (4) to switch the travel speed to low speed or high speed.

For details, see MONITOR SWITCHES, Section "Travel Speed Selector Switch (PAGE 3-11)".

Cab Heater Switch

(Machines equipped with cab)

This switch (5) is used to heat the operator’s compartment. The flow rate of the hot air can be set to two levels.

- Position 0: Off
- Position 1: Weak
- Position 2: Strong

Hot water from the engine is used to carry out heating, so heating is possible when the engine cooling water is hot.

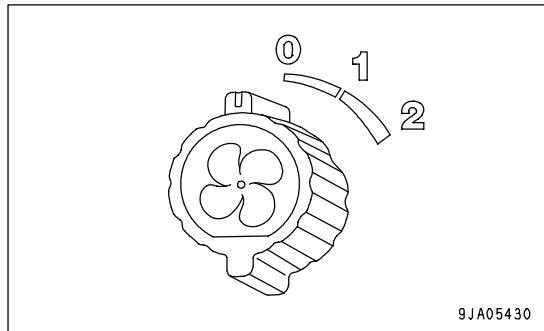

9JA05430

Windshield Wiper Switch

(Machines equipped with cab)

This switch (6) actuates the front window wiper.

This is also used as the window washer switch.

The switch is operated as follows.

- Wiper only
 - When the switch is set to position (B), the wiper is actuated.
 - Position (A): Wiper stopped
 - Position (B): Wiper actuated

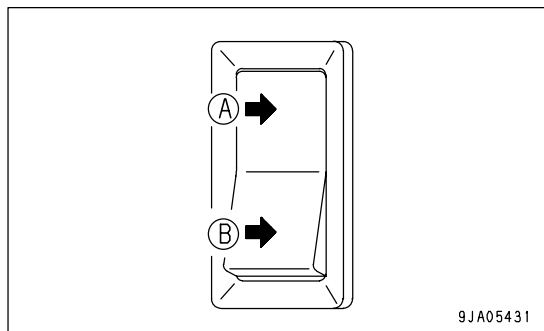

9JA05431

- Wiper and window washer
 - When the wiper is working and the switch is kept pushed to position (B), washer fluid is sprayed out.
 - When the switch is released, it returns, and only the wiper operates.

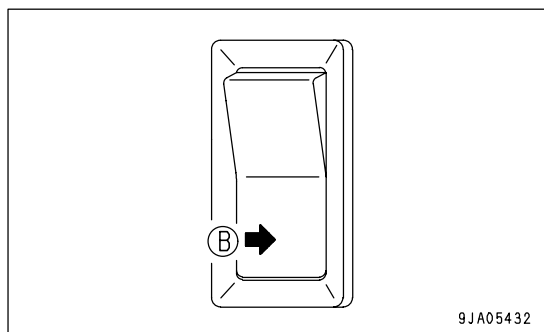

9JA05432

REMARK

Be careful of the following when operating the window washer.

- Do not keep the switch pushed in to the washer spray position for more than 10 seconds continuously.
- Do not press the switch to the washer spray position if the washer fluid tank is empty.

Room Lamp Switch

(Machines equipped with cab)

This switch (7) is used to turn on the room lamp.

Position (A): Lights off

Position (B): Lights up

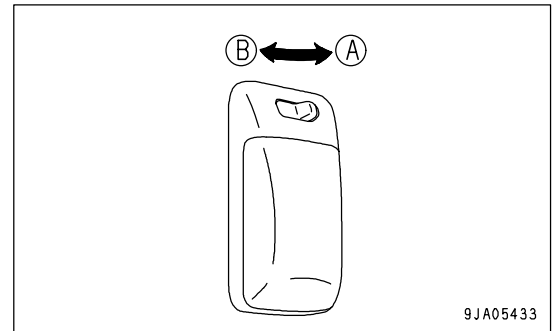
**Cigarette Lighter**

(Machines equipped with cab)

This lighter (8) is used to light cigarettes.

When the cigarette lighter is pushed in, it will return to its original position after a few seconds, so take it out to light your cigarette.

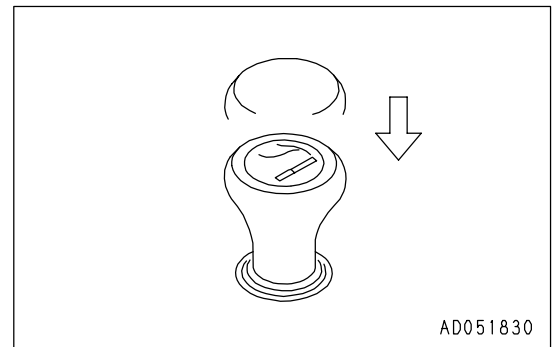

CONTROL LEVERS AND PEDALS

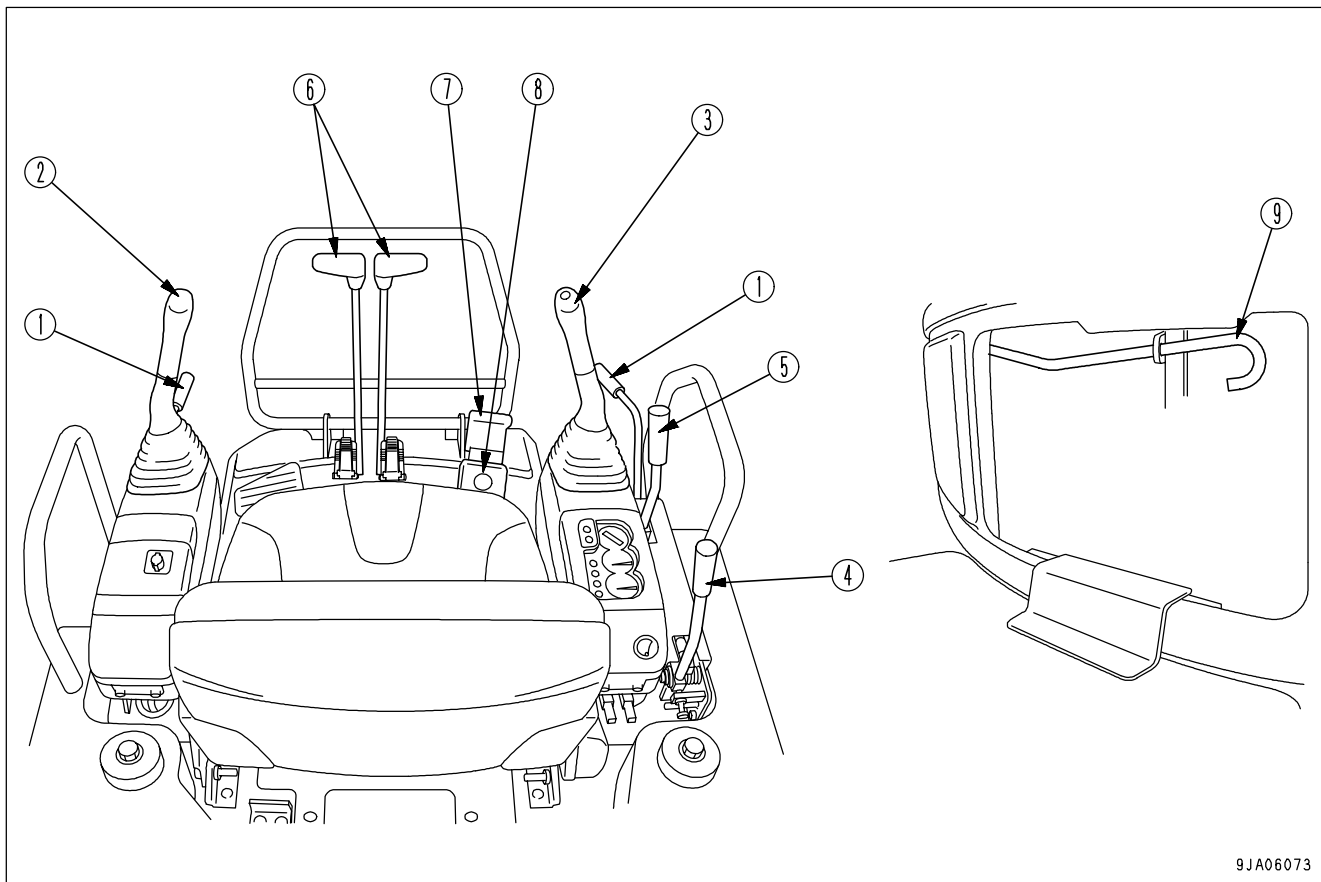

9JA06073

- | | |
|--|---|
| (1) Safety lock lever
(Machine equipped with cab: left side only) | (5) Blade control lever |
| (2) Left work equipment control lever | (6) Travel levers (with pedals) |
| (3) Right work equipment control lever | (7) Pedal lock (for boom swing control pedal) |
| (4) Fuel control lever | (8) Boom swing control pedal |
| | (9) Floor lock cancel lever |

Safety Lock Lever

**WARNING**

- When leaving the operator's compartment, set the safety lock lever securely to the LOCK position (L). If the safety lock lever is not at the LOCK position (L) and the control levers are touched by mistake, it may lead to serious personal injury.
- If the safety lock lever is not set securely to LOCK position (L), it may cause serious personal injury. Always check that the lever is at LOCK position (L).
- When pulling the safety lever up, be careful not to touch the work equipment control lever.
- When pushing the safety lever down, be careful not to touch the work equipment control lever.

This lever (1) is a device to lock the operation of the work equipment, swing, travel, and attachment.

When the lever is pulled up, it is set to LOCK position (L).

This safety lock lever is a hydraulic lock type, so even when it is at LOCK position (L), the control levers and pedals move, but the work equipment and the machine do not move.

REMARK

- If the safety lock lever on either the left or right is not at LOCK position (L), the engine will not start.
- Check that the safety lock lever is at LOCK position (L) before operating the starting switch.
- If the engine stops when the safety lock lever is at FREE position (F), operate the safety lock lever to LOCK position (L) before operating the starting switch.

Machine equipped with canopy

(F): Free

(L): Lock

When the left lever is pulled up, the lever stand springs up and is locked.

When the right lever is pulled up, the lever stand does not move, but it is locked.

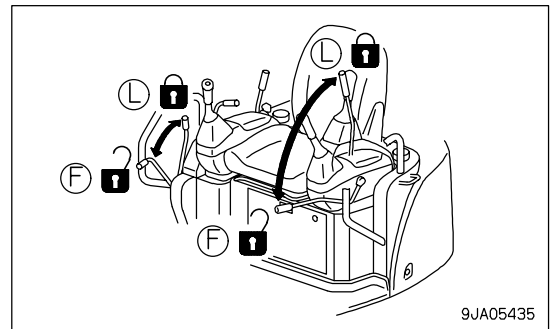
**REMARK**

The engine can be started even when the right lever is at the FREE position (F).

Machine equipped with cab

(F): Free

(L): Lock

When the left lever is pulled up, the lever stand springs up and is locked.

REMARK

For machines equipped with a cab, there is only a safety lock lever on the left.

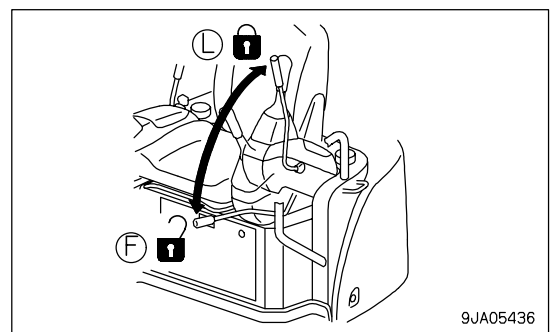

Work Equipment Control Lever

! WARNING

- The operating pattern is set to the standard operating pattern (ISO pattern).
- When changing the operating pattern, please contact your Komatsu distributor.
- The method of using operating patterns other than the ISO pattern is given in the ATTACHMENT AND OPTIONS section. Always read and understand the contents before operating the machine.
- When changing the operating pattern, change the operating plate at the same time to the operating plate that matches the movement of the machine.

The place to attach the operating plate is on the right side of the operator's cab.

A: Canopy specification

B: Cab specification

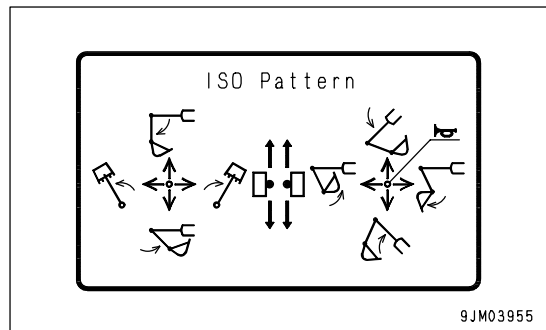
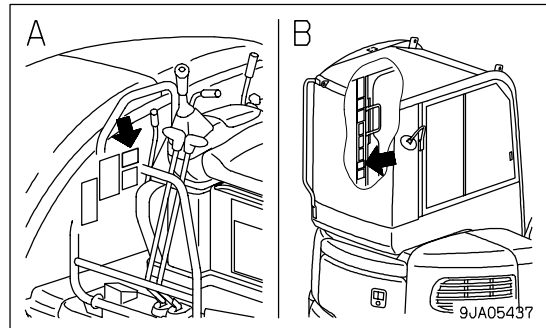

This left work equipment control lever (2) is used to operate the arm and upper structure.

Swing operation

- (a) Swing to right
- (b) Swing to left

Arm operation

- (c) Arm IN
- (d) Arm OUT

N (Neutral): The upper structure and arm are held in that position when they come to a stop and do not move.

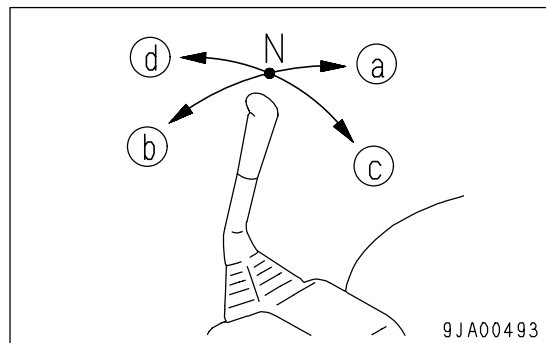

This right work equipment control lever (3) is used to operate the arm and upper structure.

Boom operation

- (e) RAISE
- (f) LOWER

Bucket operation

- (g) DUMP
- (h) CURL

N (Neutral): The boom and bucket are held in that position when they come to a stop and do not move.

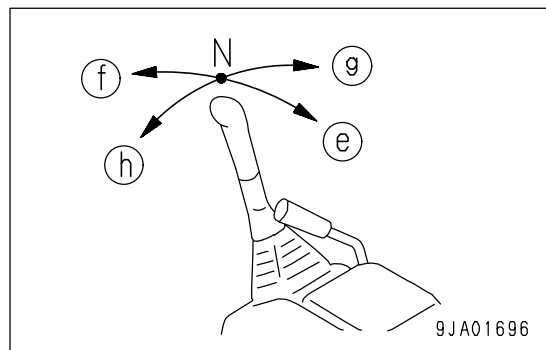

Fuel Control Lever

This lever (4) is used to control the engine speed and output.

(a) Low idling: Push the lever fully.

(b) High idling: Pull the lever fully.

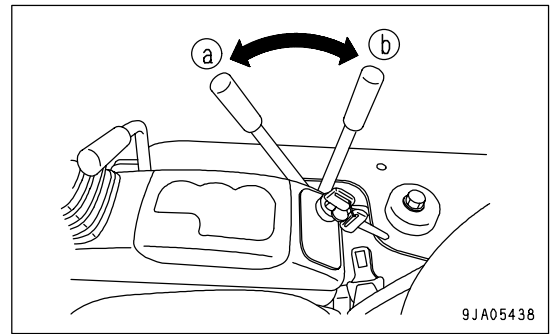
**Blade Control Lever****NOTICE**

When digging operations using the blade are continued for more than one hour, pay careful attention to the rise in the water temperature.

This lever (5) is used to control the blade.

(a) Lower

(b) Raise

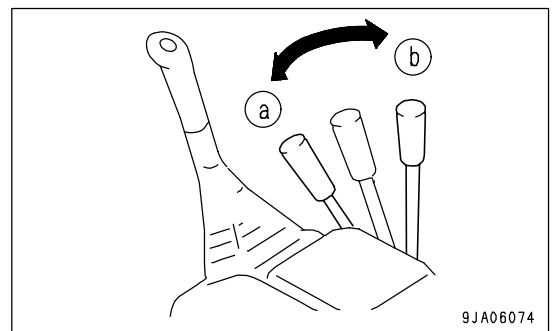

Travel Levers (with Pedals)

WARNING

- Do not put your foot on the pedal unless the machine is traveling. If you leave your foot on the pedal and press it by mistake, the machine will move suddenly, and this may lead to a serious accident. Do not rest a foot on the pedal except when traveling or steering the machine, using the pedal.
- If the track frame is facing the rear, the direction of travel operations will be reversed.
When operating the travel levers, check if the track frame is facing the front or the rear.
(If sprocket (A) is at the rear, the track frame is facing the front.)
- Take good care when traveling or steering the machine, using the pedal.
- When getting in or out of the operator's compartment, there is danger that your toes may catch on the travel pedal, so always fold back the pedal so that it cannot be operated.

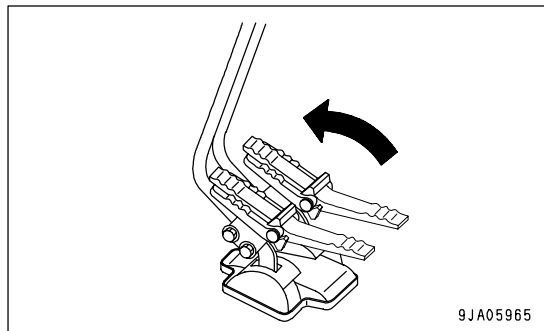
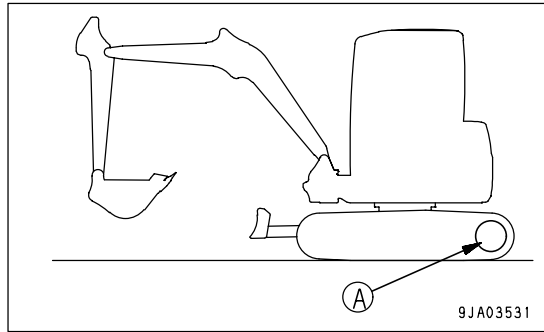

This lever (6) is used to change the direction of travel.

(): This indicates operation of the pedal.

(a) FORWARD: This lever is pushed forward
(The pedal is angled forward)

(b) REVERSE: The lever is pulled back
(The pedal is angled back)

N (Neutral): The machine stops

When operating the pedal, first sit in the operator's seat, then fold out the pedal.

After finishing pedal operations, fold back the pedal while still seated in the operator's seat.

REMARK

If the lever is shifted to the advance or reverse position from the neutral position, the alarm sounds to warn that the machine is starting to advance.

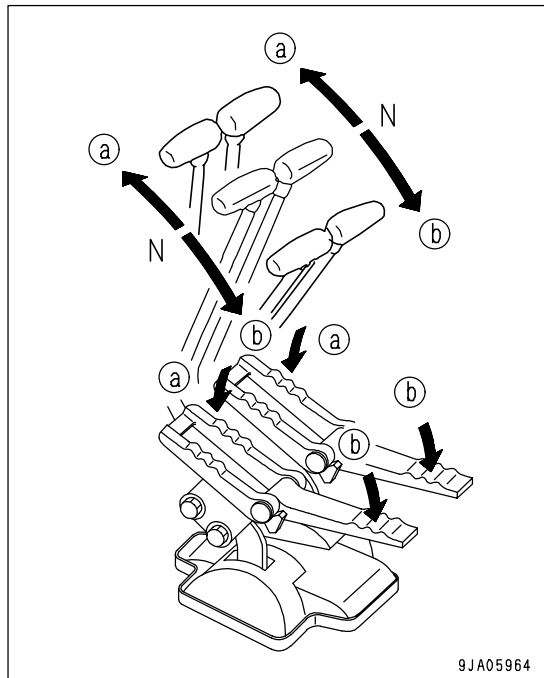

Pedal Lock

(For boom swing control pedal)



When boom swing operation is not required, lock the boom with the pedal lock. If the operation pedal is accidentally pressed while it is not lock, a serious accident or injury.

This pedal (7) is used to lock the boom swing pedal.
The pedal is locked by fitting the plate over the pedal.

(F): Free

(L): Lock

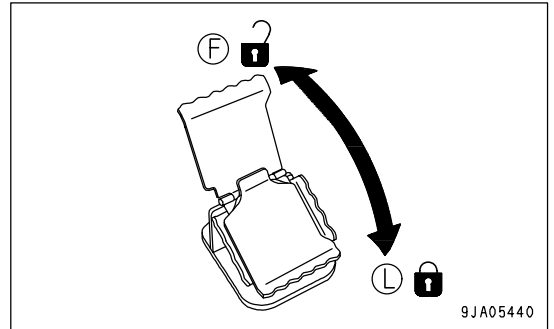

Boom Swing Control Pedal

This pedal (8) swings the boom to the left and right.

(a): Right swing

(b): Left swing

N (Neutral): Boom is stopped and held in this position.

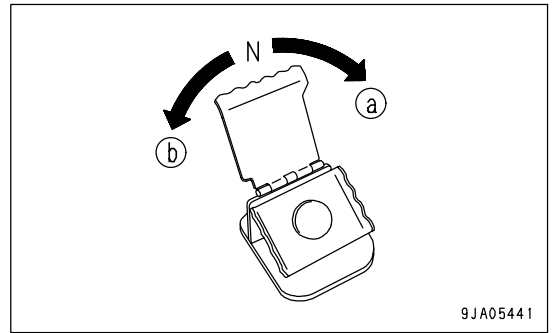

Floor Lock Cancel Lever



Always observe the warning and caution items when opening or closing the floor. If the operation is carried out mistakenly, it may lead to serious personal injury.

- Do not open or close the floor on slopes.
- Do not open or close the floor when there is a strong wind.

When opening or closing the floor, pull this lever (9) to FREE (F) position to release the lock.

Open or close the floor while pulling this lever (9).

After opening or closing the floor, release lever (9). It will return automatically to LOCK position (L).

(F): Free

(L): Lock

When opening (tilting) the cab or floor, see Section "METHOD OF OPENING (TILTING) FLOOR (PAGE 3-31)" for details.

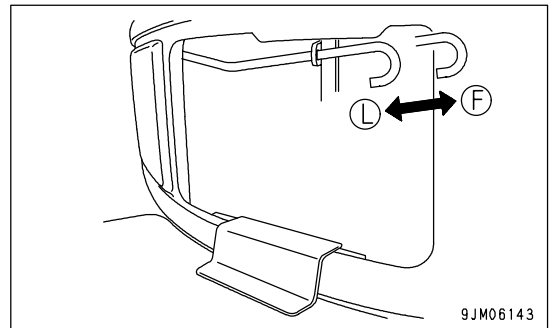

WINDSHIELD

(Machines equipped with cab)

WARNING

- When opening or closing the front window, bottom window, or door, always set the safety lock lever to the LOCK position. If the control levers are not locked and they are touched by accident, this may lead to a serious accident.
- When opening or closing the window at the front of the cab, stop the machine on horizontal ground, lower the work equipment completely to the ground, stop the engine, then carry out the operation.
- When opening the front window, hold the grip securely with both hands, pull up, and do not let go until the automatic lock catch is locked.
- When closing the front window, hold the handle with your both hands and close it firmly.

It is possible to stow (pull up) the front window in the roof of the operator's compartment. The front window (bottom) can be removed and stored at the rear inside the cab.

Opening

1. Stop the machine on level ground, lower the work equipment completely to the ground, then stop the engine.
2. Lock the safety lock lever (1) securely.

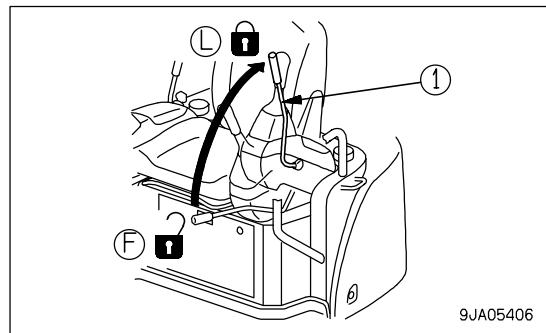

3. Grip knobs (A) on the left and right in the center of the front window, keep lock lever (B) pressed down with your thumb, then pull left and right knobs (A) to release the lock.

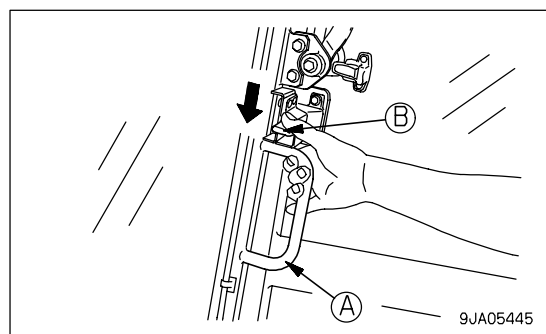
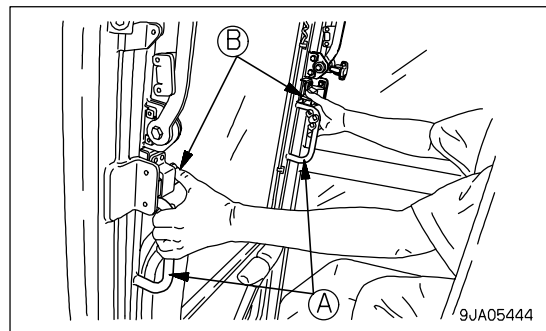

4. Grip left and right knobs (A) and pull the front window up diagonally.

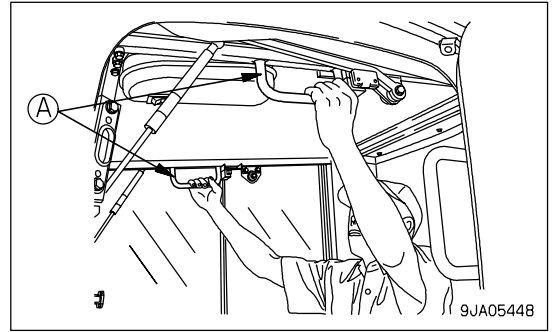

5. When it will move no further to the rear, push up knobs (A) to lock securely.

When pushing up, check that lock lever (B) moves in lock release direction (F), then returns in the lock direction (L). Push up knobs (A) to lock securely.

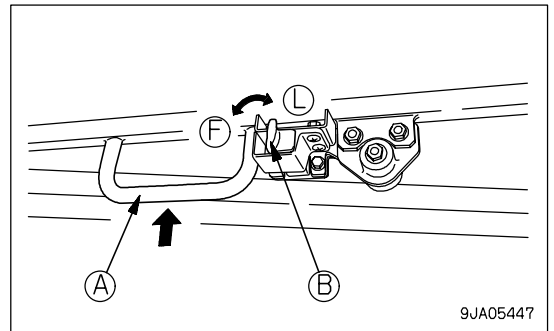
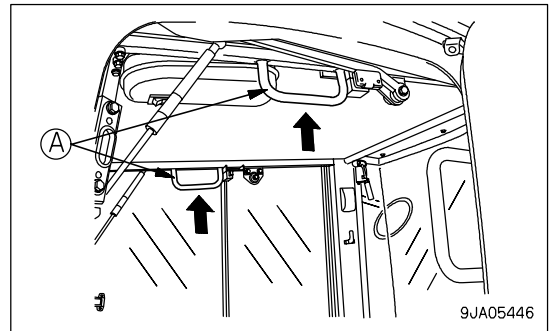

Closing

WARNING

When closing the window, lower it slowly and be careful not to get your hand caught.

1. Stop the machine on level ground, lower the work equipment completely to the ground, then stop the engine.
2. Lock the safety lock lever (1) securely.

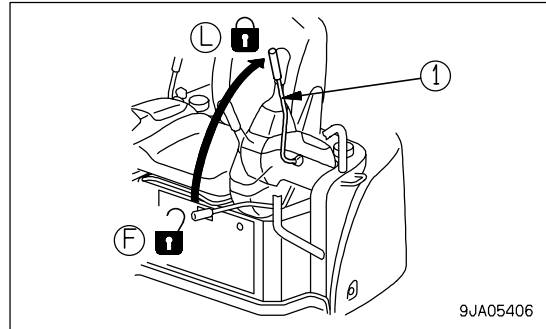

3. Hold left and right knobs (A), then push lock lever (B) with your thumb to the front and pull knobs (A) down to release the lock.
4. Grip left and right knobs (A) and slowly lower the front window diagonally to the front.

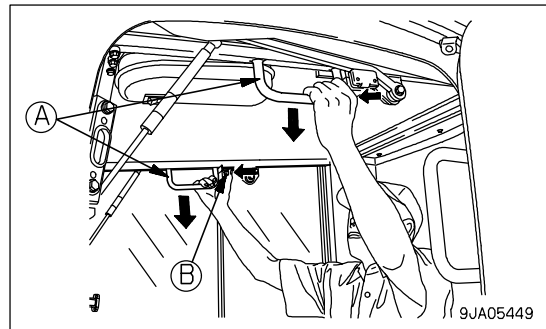

5. When the bottom of the window reaches the top of the bottom window, push left and right knobs (A) to the front, and push against left and right stoppers (C) to engage the lock.

When pushing to the front, check that lock lever (B) moves in lock release direction (F), then returns in the lock direction (L). Push knobs (A) to the front to lock securely.

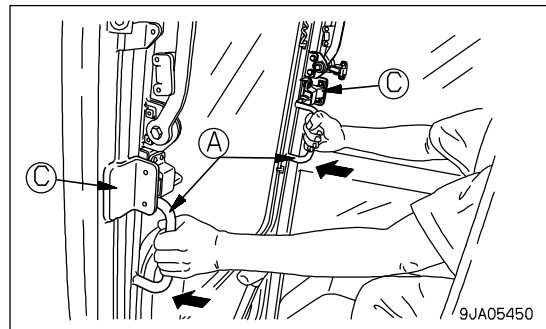

REMARK

To check that the lock is applied, check that lock (D) is in front of stopper (C).

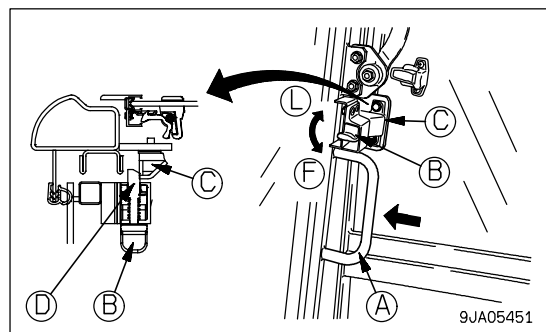

Removing Lower Windshield

1. Open the front window, then hold grip (A), pull up, and remove the bottom window.

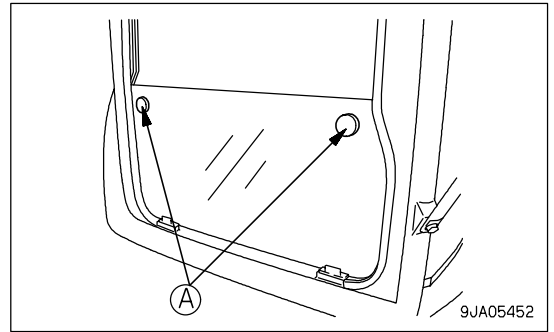

2. After removing the lower window, stow it in left and right brackets (B) at the rear of the operator's cab.

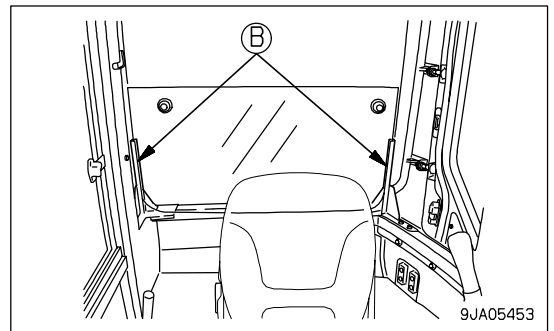

Installing Lower Windshield

With the front window open, install the bottom part of the front window.

1. Open the front window, then hold grip (A), pull up, and remove the bottom window.

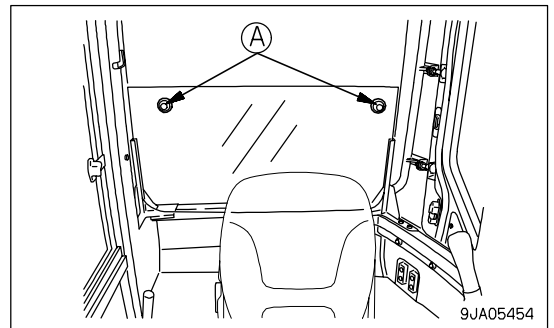

2. Install the lower window and push it down securely.

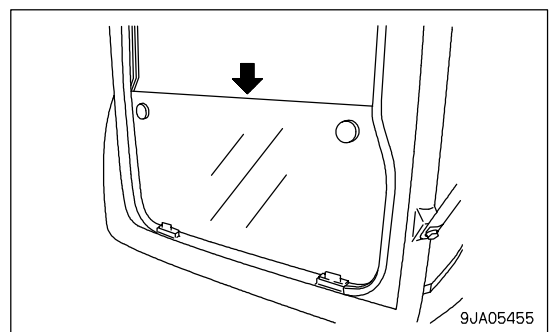

SLIDING DOOR

(Machines equipped with cab)

CAUTION

- Be sure to check that the sliding door is locked in position both when it is open and when it is closed.
- Always stop the machine on level ground when opening or closing the door.
If the door is opened or closed on a slope, there is danger that the operating effort will suddenly change. Do not open or close the door on slopes.
- When opening or closing the door, always use door handle (1) and knob (2).
- Be careful not to get your hands caught between the front pillar or center pillar.
- If there is anyone inside the cab, call out to that person before opening or closing the door.

NOTICE

Always clean the step at the entrance to the cab and take action to prevent snow or mud from accumulating. If snow accumulates, it may freeze and make it impossible to open the door.

Door Lock

When closing the door, pull the handle back to remove lock (3), then pull the door to the front.

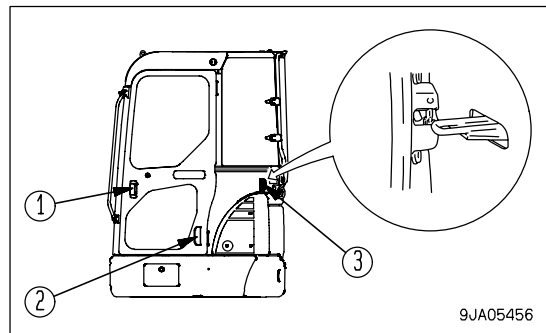

SLIDING WINDOW

(Machines equipped with cab)

CAUTION

Do not put your head or hands out of the window when traveling or during operations.

The window on the right side of the cab can be opened.

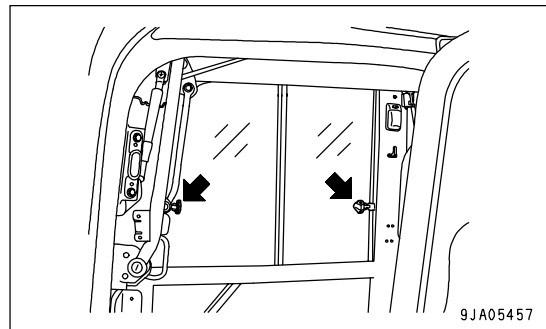

EMERGENCY ESCAPE HAMMER

(Machines equipped with cab)

**CAUTION**

- If it is necessary to break the window glass with the hammer, be extremely careful not to injure yourself on the flying pieces of broken glass.
- To prevent injury, remove the broken pieces of glass remaining in the frame before escaping through the window. Be careful also not to slip on the broken pieces of glass.

In case it becomes impossible to open the door, a hammer (1) to be used for escape from the cab is installed.

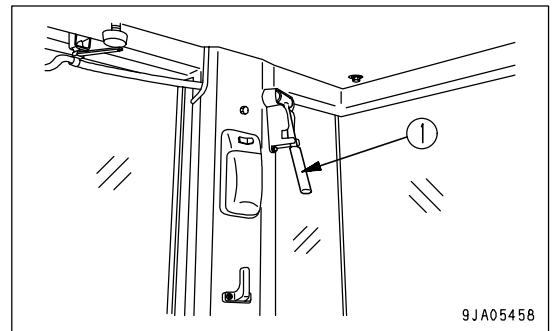

When escaping, break the window glass with hammer (1).

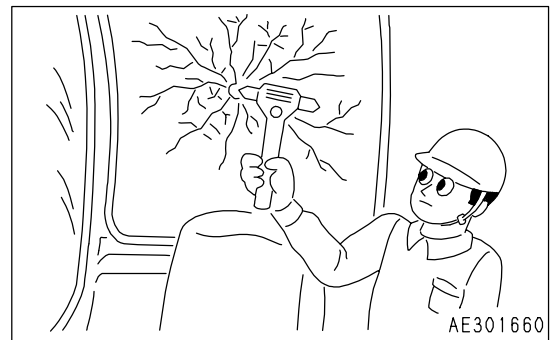

COVER WITH LOCK

Opening and Closing Covers with Lock

Use the starting switch key to open or close the cover with the lock. For details of the position of the cover with the lock, see Section "LOCKING (PAGE 3-83)".

Insert the key securely (6 mm (0.236 in) from the root of the key), then turn it. If it is turned when partially inserted, the key may break.

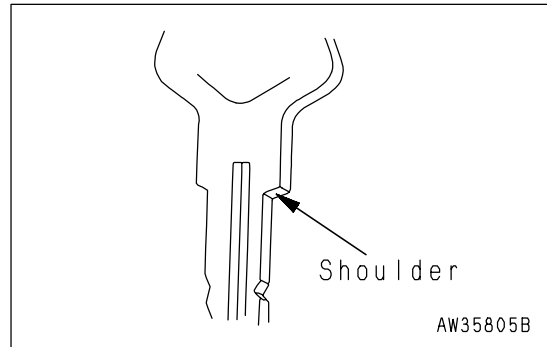

In Case of Tool Box and Cab Door

When Opening

1. Insert the key into the key slot.
2. Turn the key counterclockwise and pull the cover or doorknob to open.

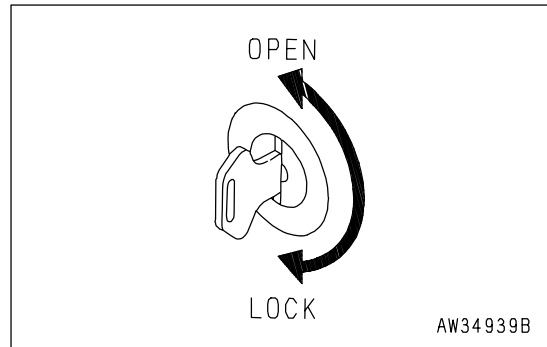

When Locking

1. Close the cover and insert the key into the key slot.
2. Turn the key clockwise and take the key out.

In Case of Engine Rear Cover and Dirt Cover

When Opening

1. Insert the key into the key slot.
2. Turn the key clockwise and open the cover.

When Locking

1. Close the cover and insert the key into the key slot.
2. Turn the key counterclockwise and take the key out.

ENGINE REAR COVER

 **CAUTION**

When carrying out inspection and service inside the engine rear cover, always open the cover fully until it is secured in position by the rod.

NOTICE

- Except when opening the cover, always keep it locked.
- When it is locked, opening knob (1) of the cover does not move.

1. Release lock (1) of the cover.

(For details of the method of opening and closing the cover with the lock, see Section "In Case of Engine Rear Cover and Dirt Cover (PAGE 3-28)".

2. Pull opening knob (2) of the cover and open engine rear cover (3).

3. Pull engine rear cover (3) and open it fully. Cover (3) is secured in position by rod (4).

4. When closing engine rear cover (3), lift up rod (4) and close cover (3) slightly. When the rod comes out from the groove, close the cover.

Push cover (3) in to lock it.

5. Lock the cover.

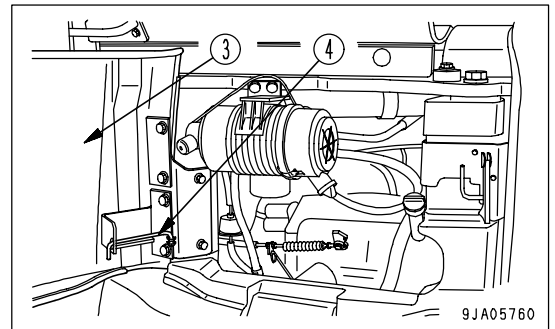
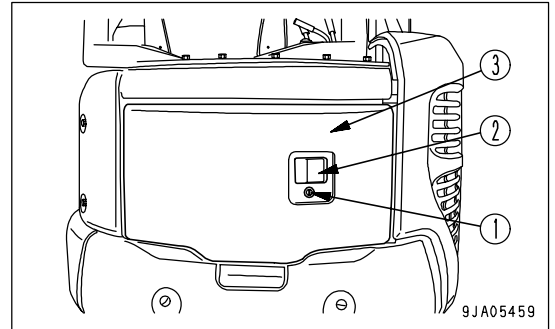

COOLING COVER

 **CAUTION**

When carrying out inspection and maintenance inside the cooling cover, open the engine rear cover, then open the cooling cover.

- Always open the engine rear cover fully to a point where it is held in position by the rod.
- Always secure the cooling cover in position with the rod.

1. Open engine rear cover (1) until it is secured in position.

(For details, see Section "ENGINE REAR COVER (PAGE 3-29)".)

2. Pull cover opening lever (2) and open cooling cover (3).

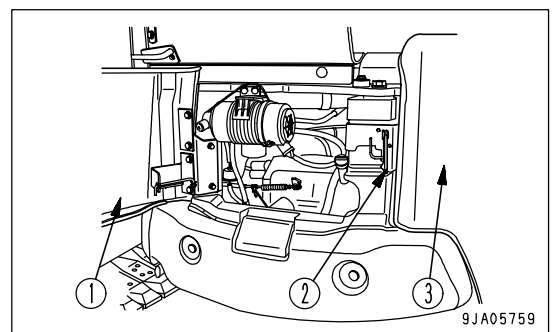

3. Pull cooling cover (3) to open it, then set rod (4) in the LOCK position (L) to hold cover (3) in position.
4. When closing cooling cover (3), set rod (4) to the FREE position (F), then close the cover.
When closing, pull opening lever (2), then close cover (3), lower opening lever (2), and lock it in position.
5. Close engine rear cover (1).
(For details, see Section "ENGINE REAR COVER (PAGE 3-29)".)
6. Lock the cover.

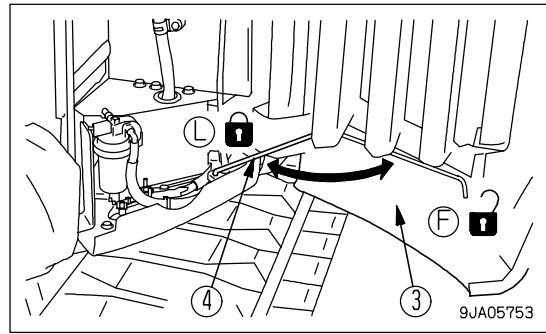

MUD COVER

! WARNING

- Never climb on top of the cover. There is danger that you may slip and fall.
- When carrying out inspection and maintenance inside the cover, always open the cover fully and check that it is secured in position by the support lever.

NOTICE

Always keep the hood locked except when opening it.
Check the direction of the key slot in the opening knob to check that it is locked.

1. Release lock (1) of the cover.
(For details of the method of opening and closing the cover with the lock, see Section "In Case of Engine Rear Cover and Dirt Cover (PAGE 3-28)".)
2. Push opening knob (1) of the dirt cover to release the lock, then open cover (2).

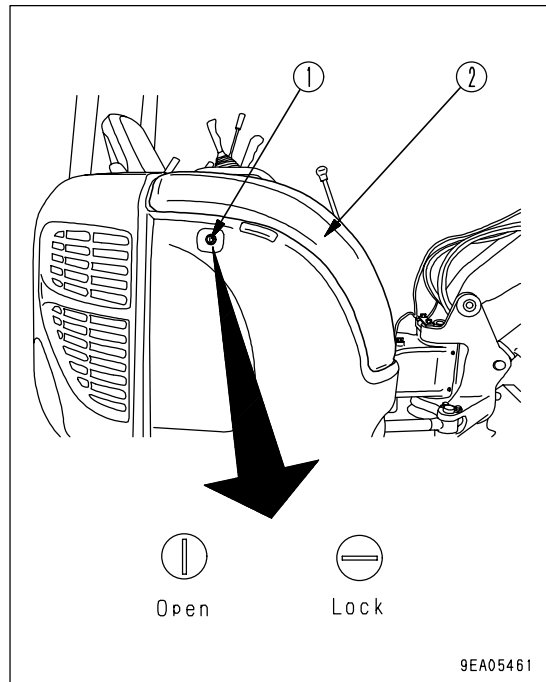

3. When dirt cover (2) is opened fully, it is secured in position by support lever (3).
After opening dirt cover (2), check that cover (2) is secured in position by support lever (3).
4. When closing dirt cover (2), pull up support lever (3) slightly, hold cover (2), lower it slowly, then push cover (2) in to lock it.
5. Lock the cover.

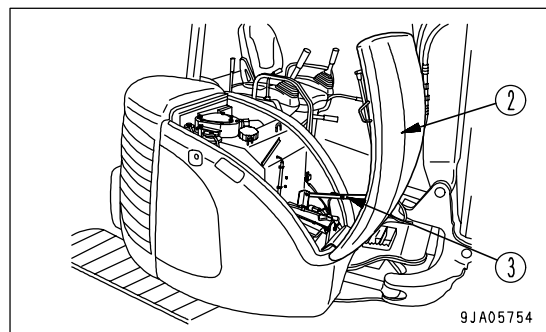

METHOD OF OPENING (TILTING) FLOOR

WARNING

Always observe the warning and caution items when opening or closing the floor. If the operation is carried out mistakenly, it may lead to serious personal injury.

- Do not open or close the floor on slopes.
- Do not open or close the floor when there is a strong wind.
- Do not enter the floor area or the inside of the cab when the floor is open.
- Do not start the engine when the floor is open.
- If there is any breakage or abnormality in the lock when the floor is opened, stop the operation and ask your Komatsu distributor to carry out repairs.
- Do not remove the canopy. There is danger that the floor may suddenly come up.
- Do not remove the floor mounting bolts (1). There is danger that the floor may suddenly come up.

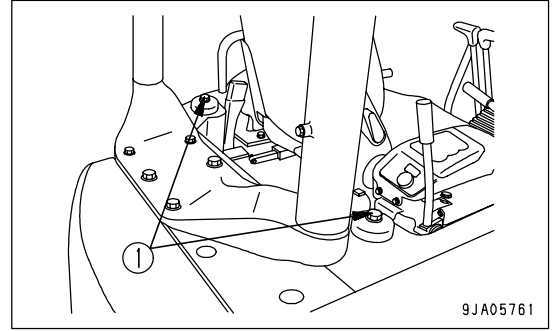

Before starting the opening (tilting) operation of the floor, read the precautions related to safety and maintenance in Section "CAUTIONS FOR OPENING (TILTING) FLOOR (PAGE 2-34)".

When Opening (tilt open)

1. Lower the blade.
2. Extend the bucket and arm cylinders fully, then lower the boom slowly.

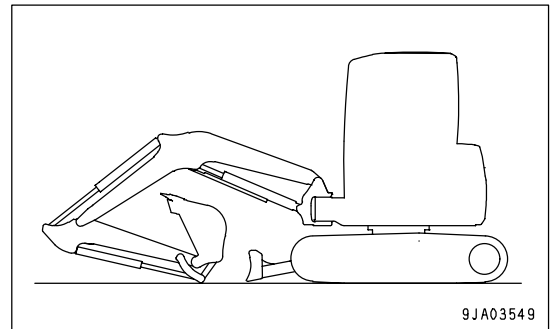

3. Set the safety lock lever to the LOCK position, then stop the engine.

REMARK

For machines equipped with a cab, there is only a safety lock lever on the left.

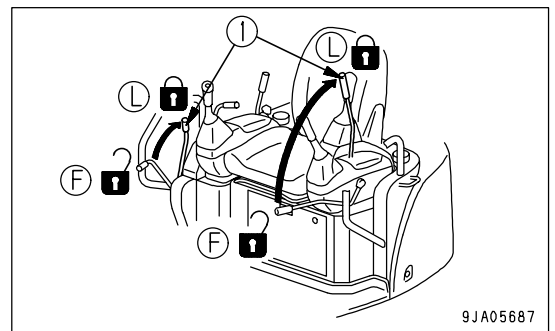

4. Fit blocks securely under the track to prevent the machine from moving.

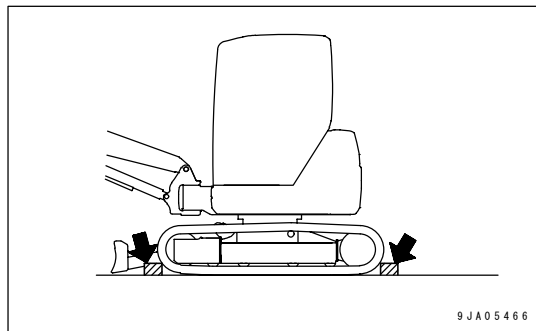

5. Remove bolts (2) (M10 x 3), then remove triangular cover (3).

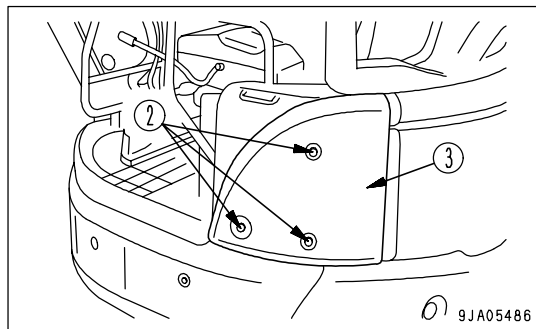

6. Loosen floor tilt lock bolts (4) (M14 x 2).
Bolts (4) have a structure that prevents them from falling out.

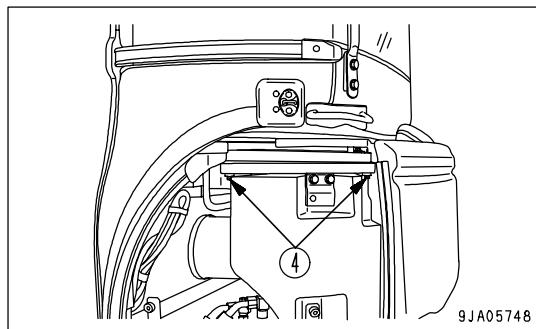

7. Open engine rear cover (5) fully and secure it in position.
(For details of the method of opening and closing the cover with the lock, see Section "In Case of Engine Rear Cover and Dirt Cover (PAGE 3-28)".)

8. Loosen floor tilt lock bolts (6) (M14).

Number of floor tilt lock bolts (6): Canopy specification: 5
Cab specification: 4

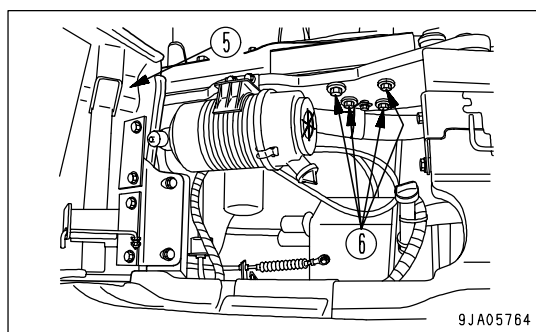

Bolts (6) have a structure that prevents them from falling out.

9. Close engine rear cover (5).

10. Open inspection window (7), use your left hand to pull floor lock release lever (8) in the direction of the arrow (to the rear) while holding knob (9) with your right hand and pushing it up in the direction of the arrow (approx 45°).

The canopy or cab form one unit with the floor and rise up together with the floor.

NOTICE

- If the floor does not come up, release lever (8) is not in the release position.
Pull knob (9) back with your right hand, then repeat the above procedure again.
- When opening or closing the floor, do not let any part of your body enter the area under the floor.

REMARK

The floor opening operation is assisted by a gas cylinder, so when the ambient temperature is low, the operating effort increases.

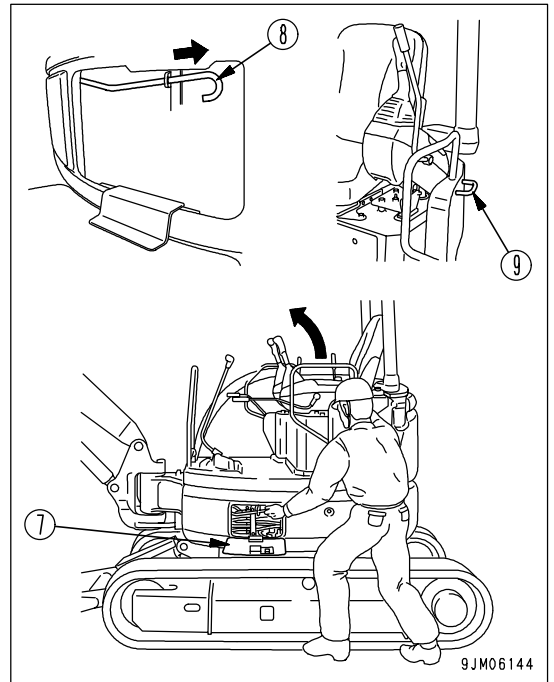

11. After the floor rises, push knob (9) up until lock pin (10) fits in the lock groove (12) of lock plate (11).

When lock pin (10) moves to lock groove (12), the 1st stage lock is completed.

12. Insert the second lock pin (13) securely into lock hole (14) from the inside.

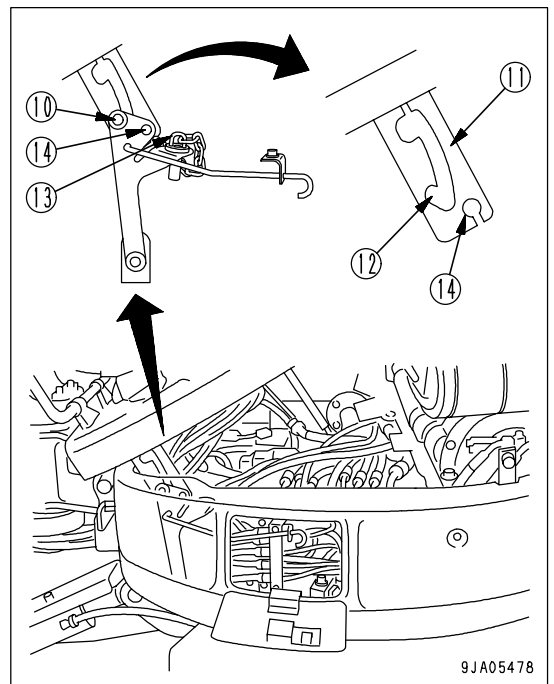

13. Turn until the stopper hook at the top of lock pin (13) catches securely on pin (15) in the insertion portion.

NOTICE

Check that lock pin (13) is hooked to pin (15) and does not come out.

This completes the 2nd stage lock, and the operation to open the floor is completed.

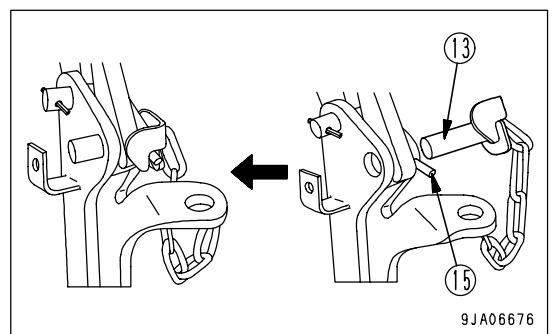

When Closing (tilt close)

NOTICE

Before closing the floor, check that there is no damage or abnormality in the wiring or piping inside the floor.
If any damage or abnormality is found, please ask your Komatsu distributor to carry out repairs.

1. Remove lock pin (13) and insert it in storage hole (16).

REMARK

If lock pin (13) does not come out, do as follows.

Machine equipped with canopy: Hold knob (9) and raise while removing lock pin.

Machine equipped with cab: Hold knob (9) and lower while removing lock pin.

2. Use your left hand to pull floor lock release lever (8) in the direction of the arrow (to the rear) while holding knob (9) with your right hand and pulling it down in the direction of the arrow (approx 45°).

NOTICE

- Lower slowly and check that there is no damage or catching of the wiring or piping.
- When opening or closing the floor, do not let any part of your body enter the area under the floor.

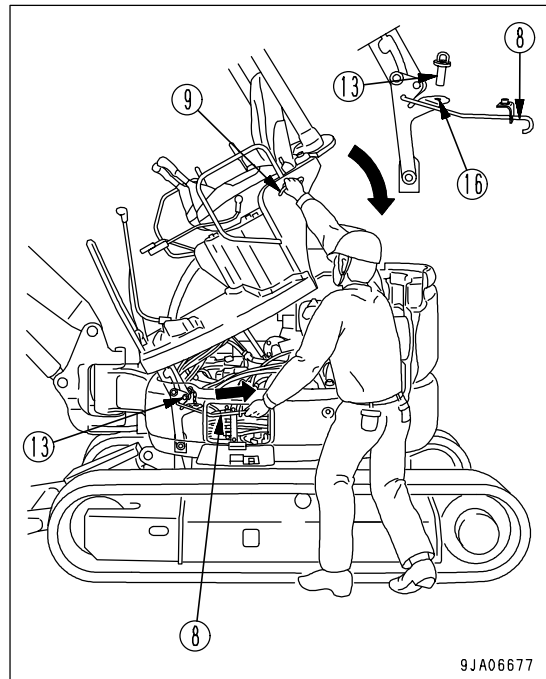

3. Open engine rear cover (5) fully and secure it in position.
(For details of the method of opening and closing the cover with the lock, see Section "In Case of Engine Rear Cover and Dirt Cover (PAGE 3-28)".)
4. Tighten floor tilt lock bolts (6) (M14).

Number of floor tilt lock bolts (6): Canopy specification: 5
Cab specification: 4

Tightening torque: 156.8 to 196 N·m (16 to 20 kgf·m, 115.7 to 144.7 lbft)

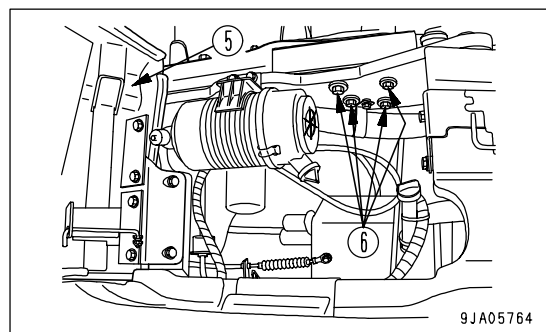

REMARK

If any bolt (6) is damaged, replace it with a genuine Komatsu part of the same size.

5. Tighten floor tilt lock bolts (4) (M14 x 2).

Tightening torque: 156.8 to 196 N·m (16 to 20 kgf·m, 115.7 to 144.7 lbft)

REMARK

If bolt (4) is damaged, replace it with a genuine Komatsu part of the same size.

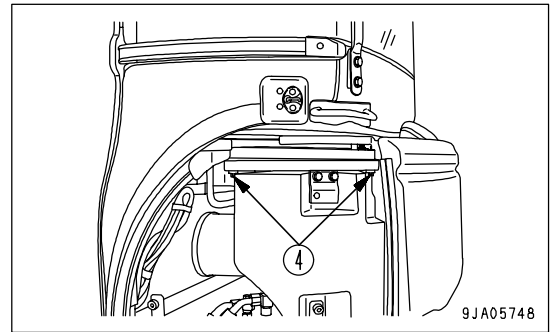

6. Close engine rear cover (5).
7. Install triangular cover (3) with bolts (2) (M10 x 3).

This completes the operation for closing the floor.

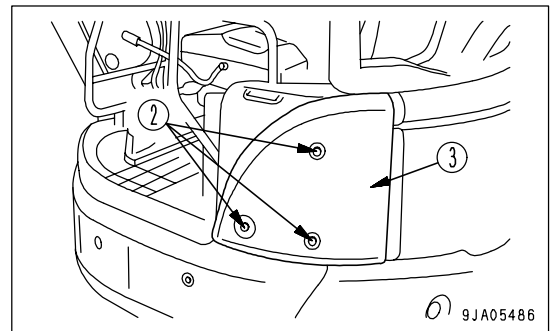

FUSE

NOTICE

Before replacing a fuse, be sure to turn off the starting switch.

The fuses protect the electrical equipment and wiring from burning out.

If the fuse becomes corroded, or white powder can be seen, or the fuse is loose in the fuse holder, replace the fuse.

Replace the fuse with another of the same capacity.

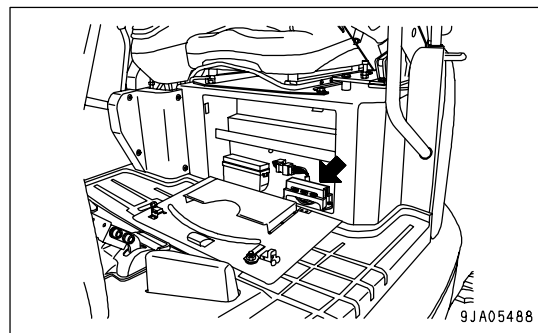

Fuse Capacities and Circuit Names

No.	Fuse capacity		Name of circuit
	Canopy specification	Cab specification	
(1)	30A		Engine stop solenoid
(2)	10A		PPC solenoid, horn, fuel pump, safety relay
(3)	10A		Monitor panel, buzzer, speed boost solenoid
(4)	10A		If equipped
(5)	10A	20A	Heater, travel alarm buzzer air conditioner (Cab specification)
(6)	-	20A	Room lamp, radio, windshield wiper, window washer
(7)	10A		Monitor panel, controller, radio (Cab specification)
(8)	10A	20A	Working lamp
(9)	-		-
(10)	-		-
(11)	30A		Spare
(12)	10A	20A	Spare
(13)	10A		Spare

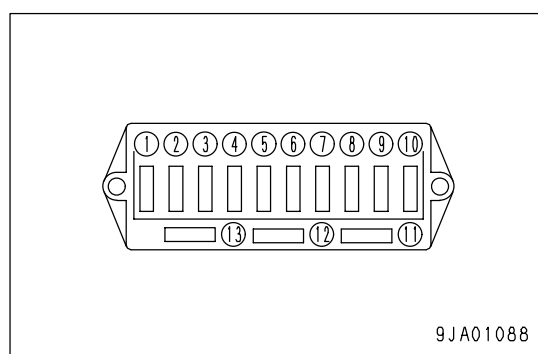

BLOCK FUSE

If the starting motor does not turn even when the starting switch is turned to the ON position, block fuse (1) is probably blown, so open the cover at the right side of the machine and check or replace the fuse.

This is at the top surface of the battery.

For details of the method of opening and closing the cover on the right side of the machine, see "MUD COVER (PAGE 3-30)".

REMARK

A block fuse is a large fuse wire installed to the circuit where a large-capacity current is flowing. It acts in the same way as a normal fuse to protect the electrical equipment and wiring from burning out under abnormal current.

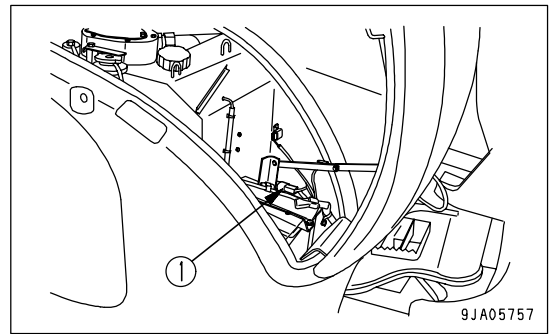

AUXILIARY ELECTRIC POWER

NOTICE

When installing electrical not supplied by Komatsu, use 12V specification with a maximum of 120W (equivalent to 10A). If equipment is to be installed with a capacity greater than this, please contact your Komatsu distributor.

Connector (1) for electrical power supply for options is at the following place.

Machine equipped with canopy

- Connector (1) (connector No.CN-F9) is at the rear of the box for the right work equipment control lever. There are two connectors: the one on the right (outside) is the power supply for the option.

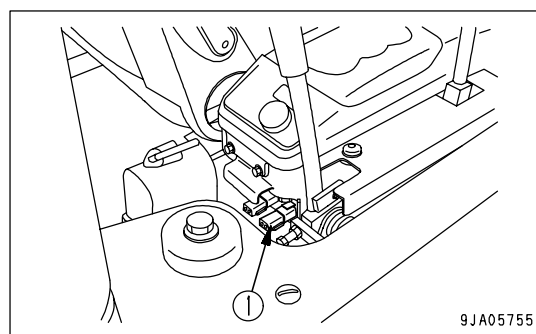

Machine equipped with cab

- The connector (connector No.CN-F8) is inside the cover of the stay on the right side of the cab. Always consult your Komatsu distributor before using it.

The connector types are shown in the table below.

	M type housing (2 poles)		Terminal		
	Body	Rear holder	AVS 0.5	M. AVS0.85 - 2	M. AVS3
Ditch Witch part No.	455-780	455-781	455-782	455-783	455-784

OPERATION MANUAL STORAGE

NOTICE

Except when opening the cover for some reason, always keep the cover locked.

This is under the operator's seat.

There is a box for keeping the Operation and Maintenance Manual in the rear of the operator's seat backrest.

Keep the Operation and Maintenance Manual in the box so that it can be seen at any time.

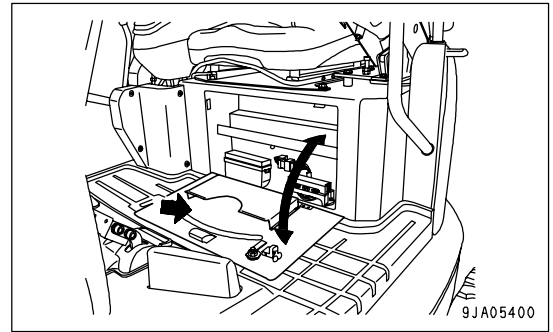

TOOL BOX

NOTICE

Except when opening the cover for some reason, always keep the cover locked.

Store the tools in this box.

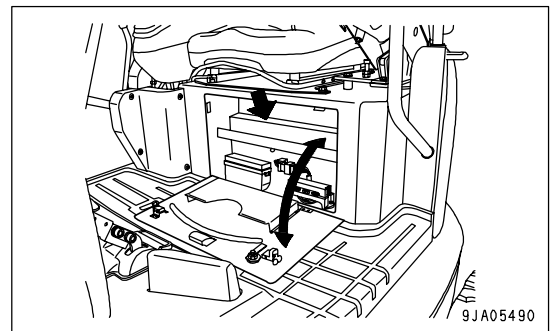

GREASE GUN HOLDER

This is in front of the fuel tank. When not using the grease gun, insert it in this holder.

Close the handle of the grease gun and stow it with the handle facing the front of the machine.

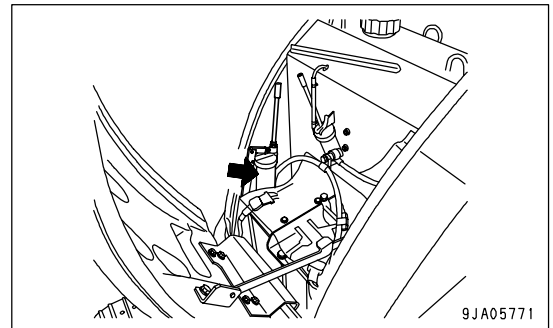

ASHTRAY

(Machines equipped with cab)

This is on the right side of the operator's compartment.

It is a magnetic type, so it can be fitted at any suitable place.

Always check that the cigarette is out before closing the lid.

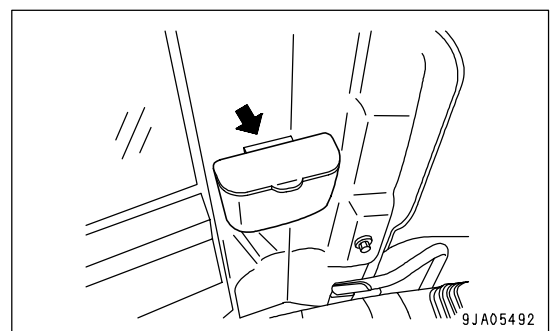

MACHINE OPERATIONS AND CONTROLS

BEFORE STARTING ENGINE

Walk-around Checks

Before starting the engine, look around the machine and under the machine to check for loose nuts or bolts, or leakage of oil, fuel, or coolant, and check the condition of the work equipment and hydraulic system. Check also for loose wiring, play, and accumulation of dust in places which reach high temperatures.



WARNING

- When carrying out inspection and maintenance, always open the engine rear cover and the dirt cover to a point where the cover is secured by the stopper.
For the cooling cover, set the rod to the LOCK position to secure it in position.
- Remove any flammable material accumulated around the battery and around the engine muffler and other high-temperature parts around the engine. Leakage of fuel and oil will cause fire on the machine. Check thoroughly and repair any abnormalities or contact your Komatsu distributor.
- Check that the floor is securely held in position by bolts (1). If it is not held securely in position, this may cause serious personal injury.

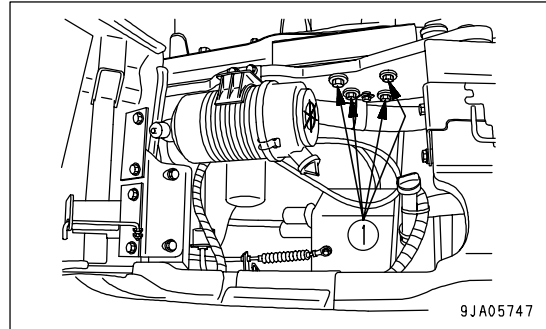

If the machine is at an angle, reposition it level before checking.

Carry out the following inspections and cleaning every day before starting the engine for the day's work.

1. Check for damage, wear, play in work equipment, cylinders, linkage, and hoses.
Check that there are no cracks, excessive wear, or play in the work equipment, cylinders, linkage, or hoses. If any abnormality is found, repair it.
2. Remove dirt and dust from around engine, battery, and radiator
Check that there is no dirt or dust accumulated around the engine or radiator. Check also that there is no flammable material (dry leaves, twigs, etc.) accumulated around the engine muffler or high temperature parts of the engine, or around the battery. Remove all dirt, dust, and flammable materials.
3. Check for leakage of water or oil around engine
Check that there is no leakage of oil from the engine or leakage of water from the cooling system. If any abnormality is found, repair it.
4. Check for oil leakage from hydraulic equipment, hydraulic tank, hoses, joints
Check that there is no oil leakage. If any abnormality is found, repair the place where the oil is leaking.
5. Check of the undercarriage parts
Check track shoe, sprocket, idler, guard for damage, wear, loose bolts, or leakage of oil from rollers, etc. Repair them if any trouble is found.
6. Check of the handrails and steps
Check the handrails and steps for any damage or loosened bolts, and repair the damaged part and tighten the loosened bolts, if any.

7. Check for abnormality in gauges and monitor

Check that there is no abnormality in the gauges and monitor in the operator's cab. If any abnormality is found, replace the parts. Clean off any dirt on the surface.

8. Checking window for damage and displacement

Check the window for any damage or displacement. If it is found broken or displaced, repair it. In particular, repairs must be made immediately, once stopping the machine, if the window is broken or displaced during operation. Do not attempt to continue to operate the machine without repair.

9. Checking and cleaning rear view mirror

Check the rear view mirror for any abnormality, and replace it with new one, if it is damaged. Keep the mirror surface clean and adjust the angle so that the lower part of the machine at the rear (a portion whose view is blocked by the engine hood) can be seen from the operator's seat.

10. Seat belt and mounting clamps

Check that there is no abnormality in the seat belt or mounting clamps. If there is any damage, replace with new parts.

11. Inspection of floor tilt lock bolts

- Open the engine rear cover and check that floor tilt lock bolts (1) are securely tightened.
Canopy specification: 5 places
Cab specification: 4 places
If any bolt is loose, tighten it.
- If there is any up-down play in the floor frame or any gap at (A) (normal: 0 mm), lock bolt (1) may be broken or loose, so check lock bolts (1).

If any abnormality is found, always carry out repairs or ask your Komatsu distributor to carry out repairs.

When tightening any loose bolts, tighten also the 2 bolts inside the triangular cover on the left side of the machine.

For details of the procedure for tightening, see Method of opening or closing floor, "When Closing (tilt close) (PAGE 3-34)".

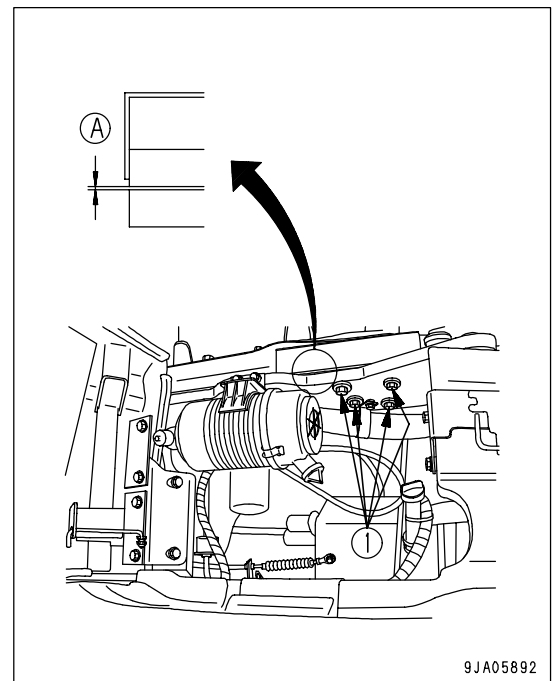

12. Check bucket with hook (if equipped) for damage.

Check that there is no damage to the hook, guide, or hook mount. If any abnormality is found, please contact your Komatsu distributor for repair.

Checks Before Starting

Always check the items in this section before starting the engine each day.

Check Coolant Level, Add Coolant



WARNING

- Do not open the radiator cap unless necessary. When checking the coolant, always wait for the engine to cool down and check the sub tank.
- Immediately after the engine is stopped, the coolant is at a high temperature and the radiator is under high internal pressure. If the cap is removed to check the coolant level in this condition, there is a hazard of burns. Wait for the temperature to go down, then turn the cap slowly to release the pressure before removing it.

1. Open the engine rear cover and cooling cover. For details, see Section "COOLING COVER (PAGE 3-29)".
2. Check that the coolant level is between the FULL and LOW range on sub tank (1). If the water level is low, add coolant through the water filler port of sub tank (1) to the FULL line.
3. After adding coolant, tighten the cap securely.
4. If the sub tank is empty, check for leakage of water, then check the radiator water level. Add coolant to the radiator if necessary, then add coolant to the sub tank.

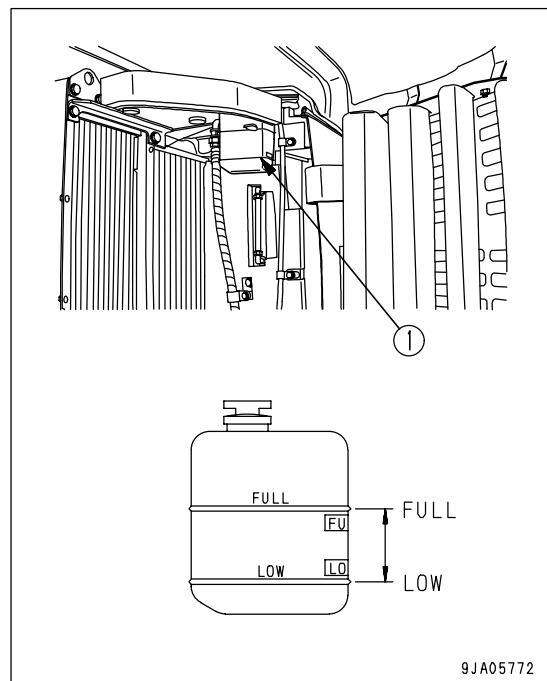

Check Oil Level in Engine Oil Pan, Add Oil

**WARNING**

Engine parts and oil are at high temperature immediately after the engine is stopped, and will cause serious burns. Wait for the temperature to cool down before starting the operation.

**CAUTION**

When carrying out inspection and service inside the engine rear cover, always open the cover fully until it is secured in position by the rod.

REMARK

- If the machine is at an angle, reposition it to level before checking.
- When checking the oil level after the engine has been operated, allow the engine to cool for 15 minutes before checking.

1. Open the engine rear cover.
2. Remove dipstick (G) and wipe the oil off with a cloth.
3. Completely insert dipstick (G) into the oil filler pipe, then remove it and check the oil level.

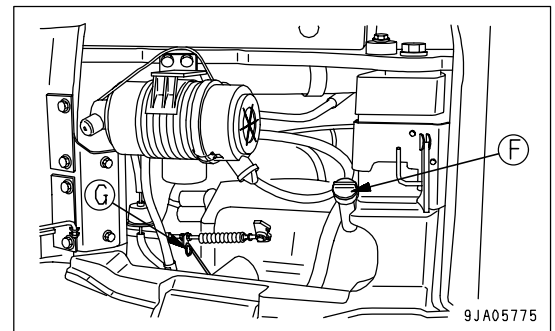

4. The oil level should be between the H and L marks on dipstick (G).
If the oil level is below the L mark, add oil through oil filler (F).

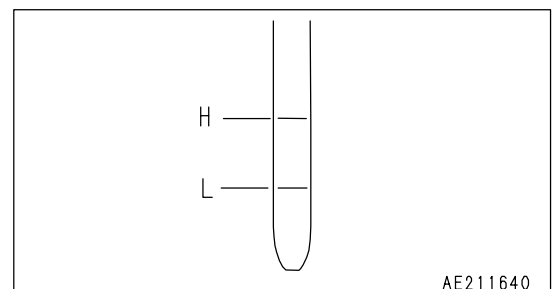

5. If the oil is above the H mark, drain the excess engine oil from drain plug (P), and check the oil level again.
6. If the oil level is correct, tighten the oil filler, then close the engine rear cover.

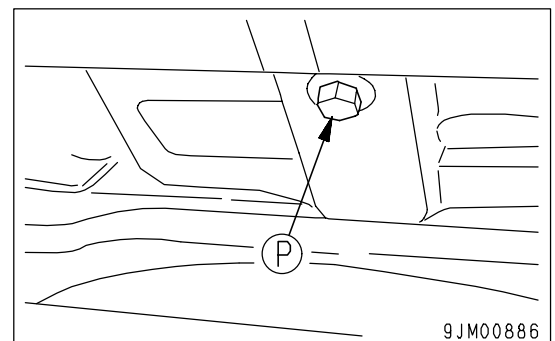

Check Fuel Level, Add Fuel

 **WARNING**

When adding fuel, never spill the fuel or let it overflow. It will cause fire.

If any fuel has spilled, wipe it up completely. If fuel has spilled over soil or sand, remove that soil or sand.

Fuel is highly flammable and dangerous. Never bring flames near fuel.

1. Insert the key in starting switch (1), and turn in to the ON position to light up the monitor.
2. Check the fuel level with fuel gauge (2). If the fuel level is low, open the dirt cover and add fuel through fuel filler port (F) while checking level gauge (G).
Fuel capacity: 65 liters (17.17 US gal)
3. After adding fuel, tighten the cap securely.

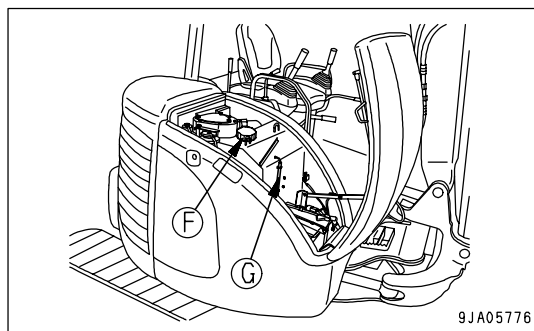
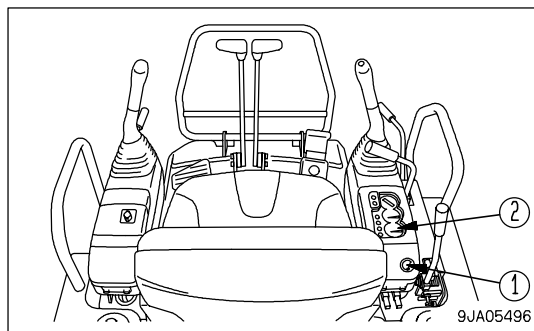
**NOTICE**

If breather hole (3) in the cap is clogged, the pressure in the tank will drop and fuel may not flow. Clean the hole from time to time and check that breather hole (3) is not clogged.

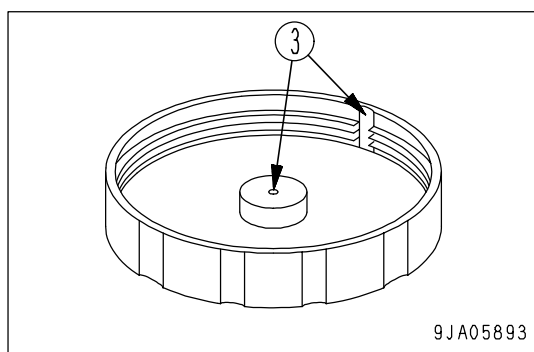

Check Oil Level in Hydraulic Tank, Add Oil

WARNING

- The parts and oil are at high temperature after the engine is stopped, and may cause burns. Wait for the temperature to go down before starting the work.
- When removing the oil filler cap, turn it slowly to release the internal pressure, then remove it.

1. If the work equipment is not in the condition shown in the diagram on the right, start the engine, run the engine at low speed, retract the arm and bucket cylinder rods fully, then lower the boom, set the bucket teeth in contact with the ground, and stop the engine.
2. Open the engine rear cover and cooling cover. For details, see Section "COOLING COVER (PAGE 3-29)".

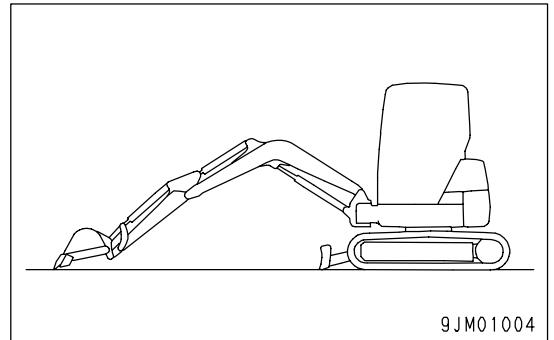

3. Confirm that the oil level is between the H and L marks of sight gauge (G).

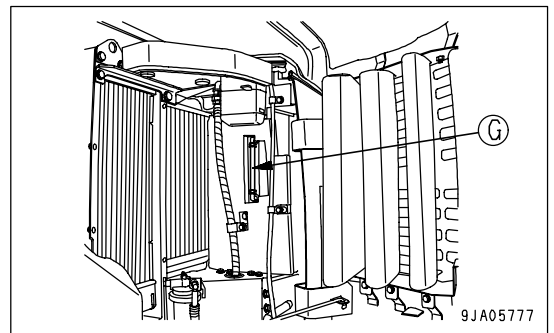

NOTICE

Do not add oil above the H line. This will damage the hydraulic circuit or cause the oil to spurt out.

If oil has been added above the H level, stop the upper structure so that the drain plug (P) under the hydraulic tank will be between both tracks, and stop the engine and wait for the hydraulic oil to cool down, then drain the excess oil from drain plug (P).

4. If the oil level is below the L mark, open the dirt cover, move the cover on top of oil filler port (F), then add oil through oil filler port (F).

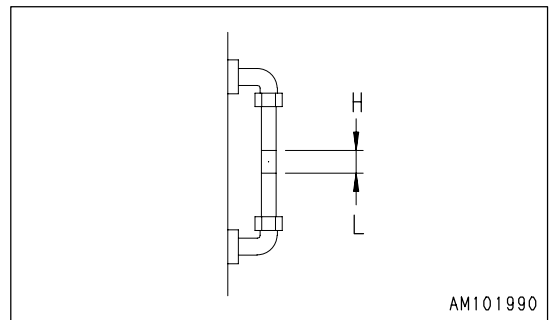

REMARK

The oil level will vary depending upon the oil temperature.

Accordingly, use the following as the guide:

- Before operation: around L level
(Oil temperature 10 to 30°C (50 to 86°F))
- Normal operation: around H level
(Oil temperature 50 to 80°C (122 to 176°F))

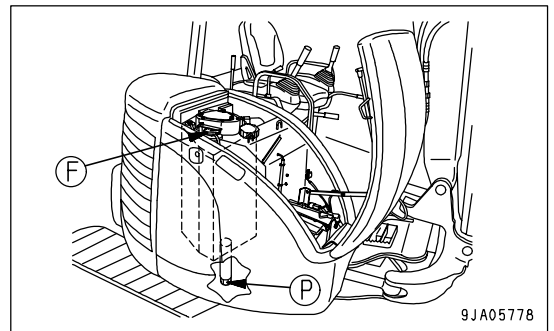

5. Extend the boom, arm, and bucket cylinder fully as shown in the diagram on the right, remove the oil filler cap, then install the cap and pressurize the inside of the tank.

NOTICE

Be sure to pressurize the hydraulic tank. If it is not pressurized, the pump will suck in air, and this will adversely affect the equipment.

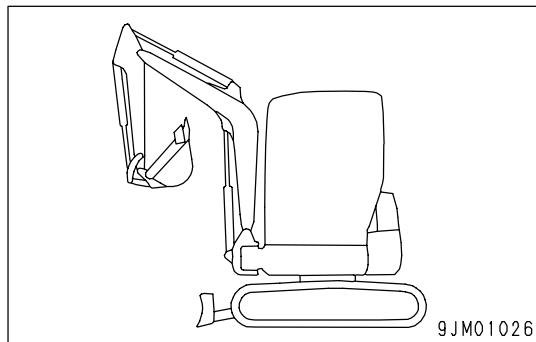

Check Dust Indicator

1. Open the engine rear cover.
2. Check that the red piston has not appeared in the transparent portion of dust indicator (1).
3. If the red piston has appeared, clean or replace the element immediately.

For details of the method of cleaning the element, see "CHECK, CLEAN AND REPLACE AIR CLEANER ELEMENT (PAGE 4-17)".

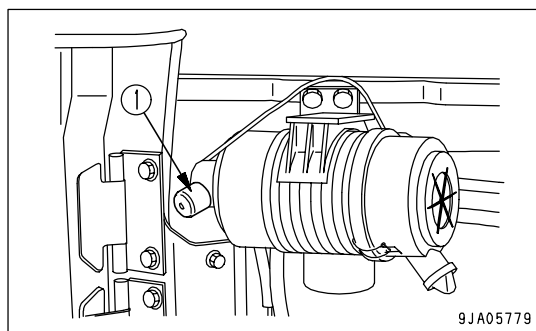

4. After checking, cleaning, and replacing, press the knob of dust indicator (1) to return the red piston to its original position.

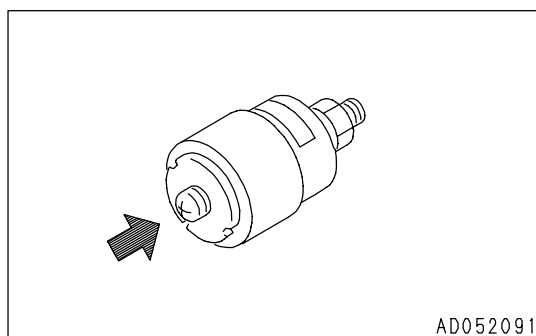

Check Water Separator

If red ring (1) of the water separator is at the bottom of case (2), there is no water.

If the ring (1) is floating, there is water up to the bottom of the ring, so drain the water as follows.

1. Open the engine rear cover and cooling cover. For details, see Section "COOLING COVER (PAGE 3-29)".
2. Set handle (3) to CLOSED position (A).
3. Loosen drain plug (4), drain the accumulated water until red ring (1) reaches the bottom, then tighten plug (4).
4. Set handle (3) to OPEN position (B).
5. Drain any water or sediment from the fuel tank. For details, see "DRAIN WATER AND SEDIMENT FROM FUEL TANK (PAGE 4-27)".

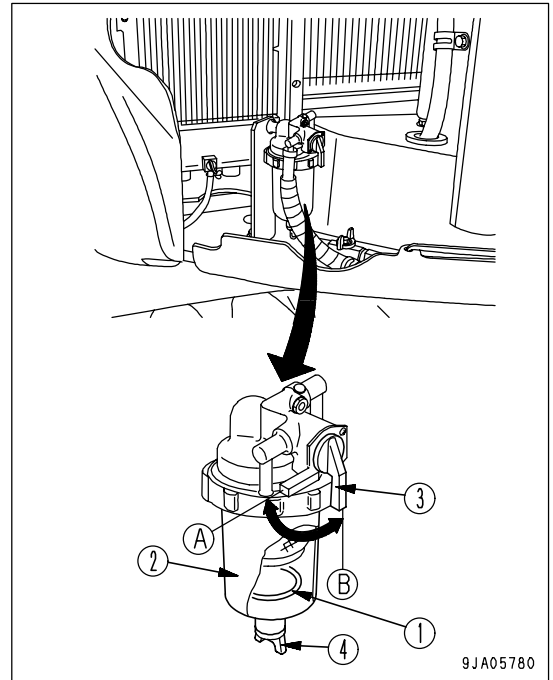

Check Electric Wiring



WARNING

- If the fuses frequently blow or if there are traces of short circuits on the electrical wiring, locate the cause immediately and carry out repairs, or contact your Komatsu distributor for repairs.
- Keep the top surface of the battery clean and check the breather hole in the battery cap. If it is clogged with dirt or dust, wash the battery cap to clean the breather hole.

Check that there is no damage to the fuse, that a fuse of the specified capacity is being used, that there are no signs of any disconnection, breakage, or short circuit in the electric wiring, check for any loose terminals, and tighten any loose terminals that are found.

Be particularly careful to check the wiring for the battery, starting motor, and alternator.

In addition, if any flammable material is accumulated around the battery, remove it.

For troubleshooting and repairs, contact your Komatsu distributor.

Check Function of Horn

1. Turn the starting switch to the ON position.
2. Confirm that the horn sounds immediately when the horn button is pressed.
If the horn does not sound, please contact your Komatsu distributor for repair.

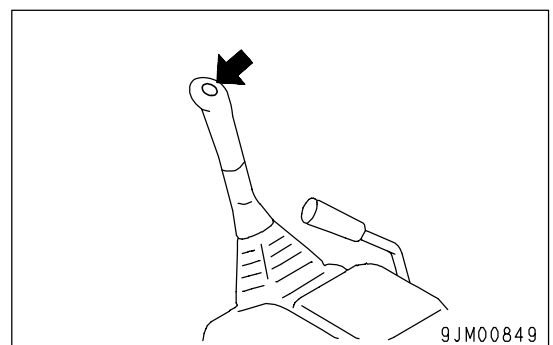

Adjustment



WARNING

- Adjust the seat position before starting operations or after changing the operator.
- Adjust the seat so that the control levers and switches can be operated freely and easily with the operator back against the backrest.

Seat Adjustment

(A) Fore-and-aft adjustment

The seat can move forward and backward.

Move lever (1) to the upper, set the operator's seat at the desired position, then release the lever.

Amount for fore-and-aft adjustment: 140 mm (5.5 in)

Adjust the position of the operator's seat to match the operation. For example, when carrying out deep digging operations, slide the seat to the front to improve the view below the front of the machine.

(B) Adjusting reclining

Pull up lever (2) and set the seat back to a position which is comfortable for operation, then release the lever.

Sit with your back against the seat back when adjusting. If your back is not touching the seat back, the seat back may suddenly move forward.

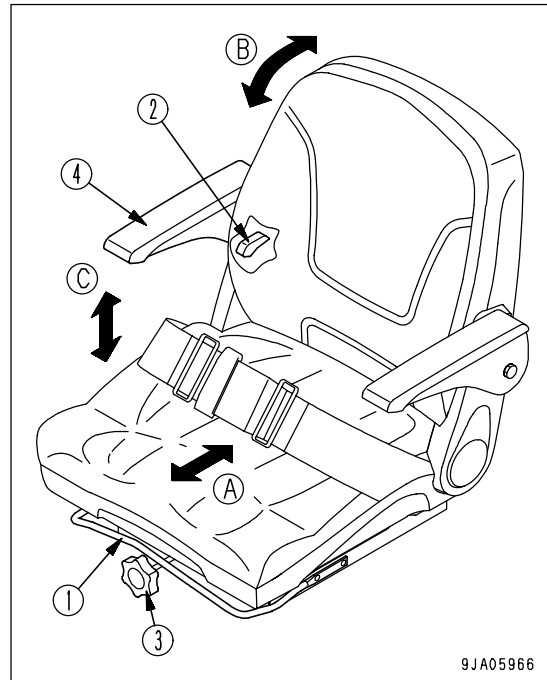

(C) Adjusting suspension

Turn knob (3) under the seat and adjust to the desired position.

The weight can be adjusted to 50 to 120 kg (110 to 265 lb).

If you want to make the seat softer, turn the weight adjustment to a lower weight; if you want to make the seat harder, adjust to a higher weight. When operating on uneven surfaces, adjust the seat to a harder setting.

(D) Armrest

Armrest (4) can be made to spring up by hand approx. 90°.

Rearview Mirrors

Adjust the angle so that the area behind the operator's compartment can be seen clearly.

- Machine equipped with canopy

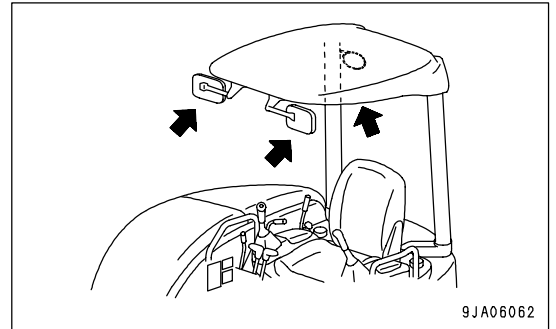

- Machine equipped with cab

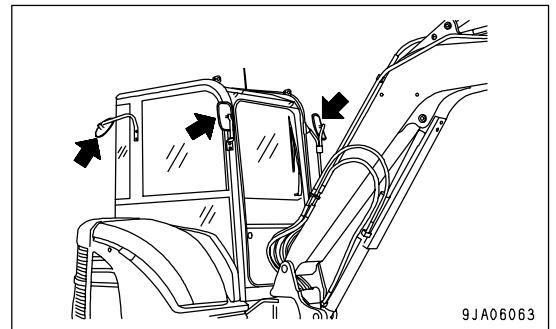

Seat Belt



WARNING

- Before fastening the seat belt, check that there is no abnormality in the securing brackets or belt. If there is any wear or damage, replace.
- Even if there appears to be no abnormality in the seat belt, replace the seat belt once every 3 years. The date of manufacture is woven on the reverse side of the belt.
- Adjust and fasten the seat belt before operating the machine.
- Always use the seat belt when operating the machine.
- Do not use the seat belt with either half of the belt twisted.

Check the mounting bolts of the belt fitting on the machine body for looseness, and re-tighten them if necessary. The tightening torque for the mounting bolt is 24.5 ± 4.9 N·m (2.5 ± 0.5 kgf·m, 18.1 ± 3.6 lbf·ft).

If the belt surface is scratched or frayed or if the fittings are broken or deformed, replace the seat belt unit.

Fastening and Removing

1. Adjust the seat so that the operator still feels that there is sufficient knee room when fully depressing the pedal while seated, with the operator's back against the backrest.
2. After adjusting the seat position, sit in the seat. Grip buckle (1) and tongue (2) in each hand and insert tongue (2) into buckle (1). Confirm by pulling the belt that the tongue is securely locked to the buckle.
3. When removing the belt, raise the tip of buckle (1) lever to release it.

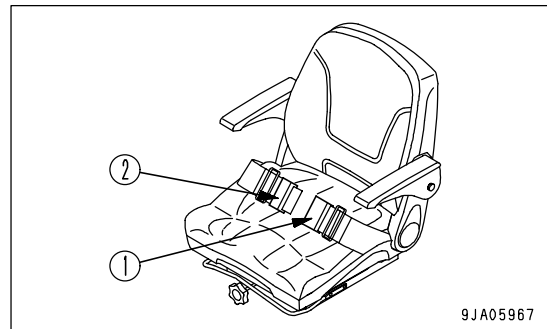

Fasten belt along your body without kinking it. Adjust the lengths of the belt on the tongue sides.

Seat Belt Adjustment

Shortening

Pull the free end of the belt on either the buckle body or tongue side.

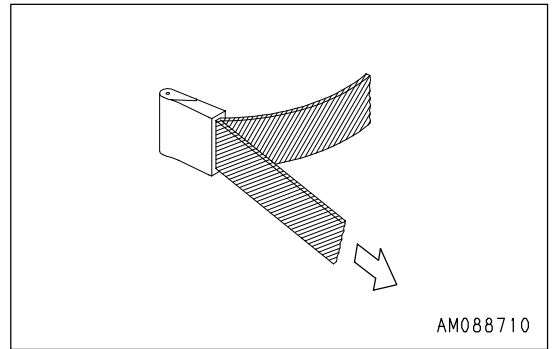

Lengthening

Pull the belt while holding it at a right angle to the buckle or tongue.

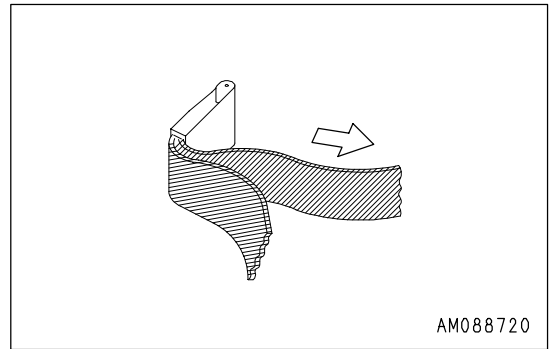

Operations Before Starting Engine

! WARNING

When standing up from the operator's seat, always set the safety lock lever to the LOCK position, regardless of whether the engine is running or stopped.

1. Check that safety lock lever (1) is at the LOCK position (L).

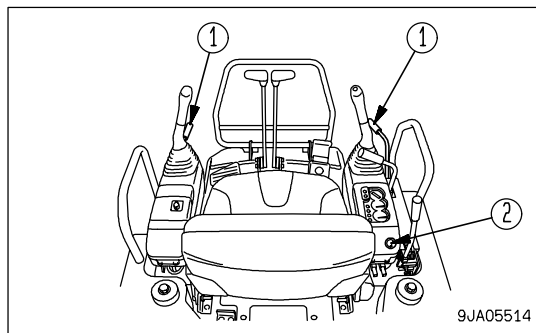

REMARK

If the safety lock lever on either the left or right is not at LOCK position (L), the engine will not start.

Machine equipped with canopy

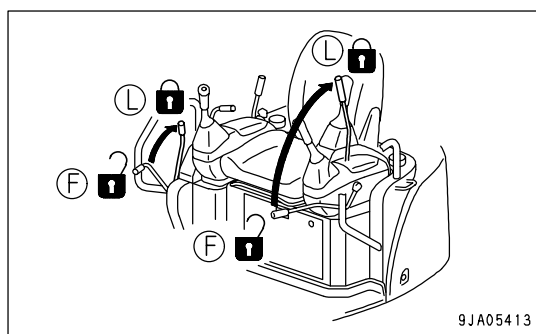

Machine equipped with cab

REMARK

For machines equipped with a cab, there is only a safety lock lever on the left.

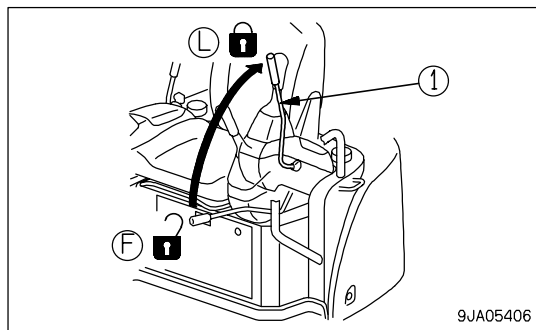

2. Check the position of each levers.

3. Insert the key in starting switch (2), turn the key to the ON position, then carry out the following checks.

- 1) The buzzer sounds for approx. 1 second, then the monitors and gauges light up for approx. 3 seconds.
 - Preheating monitor (3)
 - Charge monitor (4)
 - Engine oil pressure monitor (5)
 - Engine coolant temperature caution lamp (6)
 - Fuel level caution lamp (7)
 - Travel speed boost monitor (8)

If a monitor or gauge does not light up or the buzzer does not sound, there is probably a blown fuse or disconnection in the monitor, so contact your Komatsu distributor for repairs.

After approx. 3 seconds, only the following monitors stay lighted up. The other monitors go out.

- Charge monitor (4)
 - Engine oil pressure monitor (5)
- 2) Press lamp switch (9) and check that the working lamp lights up. If it does not light up, there is probably a blown bulb or disconnection, so contact your Komatsu distributor for repairs.

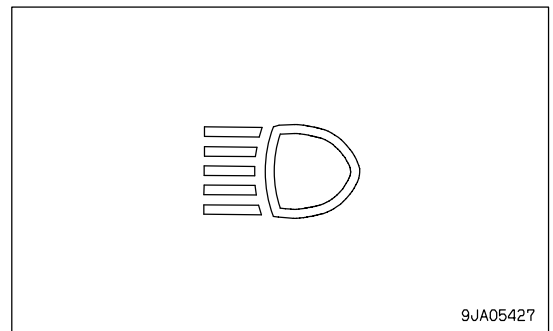
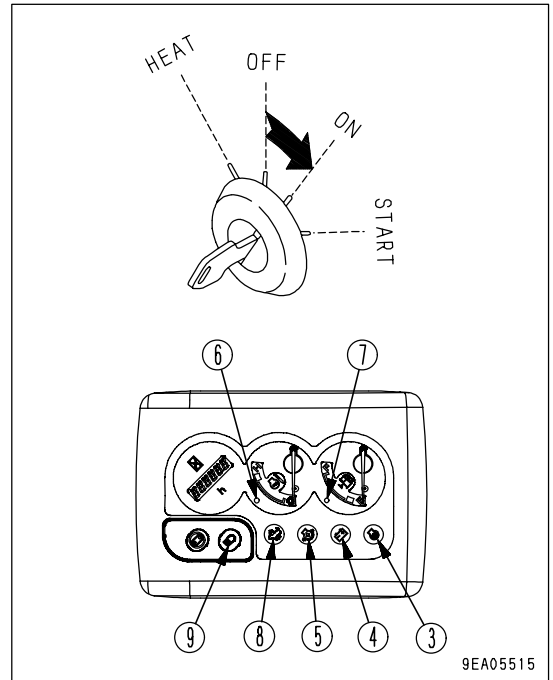

- 3) Press horn switch (10) to confirm that the horn will sound.

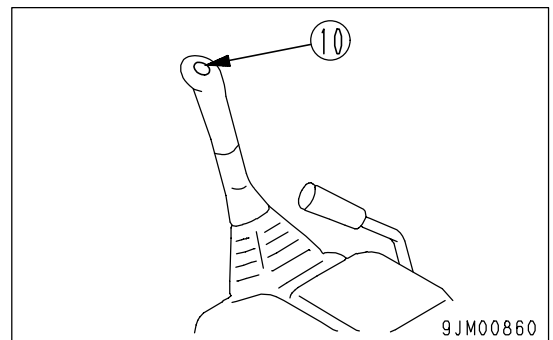

STARTING ENGINE

Normal Starting

WARNING

- Start the engine only after sitting down in the operator's seat.
- Do not attempt to start the engine by short-circuiting the engine starting circuit. Such an act may cause serious bodily injury or fire.
- Check that there are no persons or obstacles in the surrounding area, then sound the horn and start the engine.
- Exhaust gas is toxic. When starting the engine in confined spaces, be particularly careful to ensure good ventilation.

NOTICE

Do not keep the starting motor rotating continuously for more than 20 seconds.

If the engine does not start, wait for at least one minute, then try again.

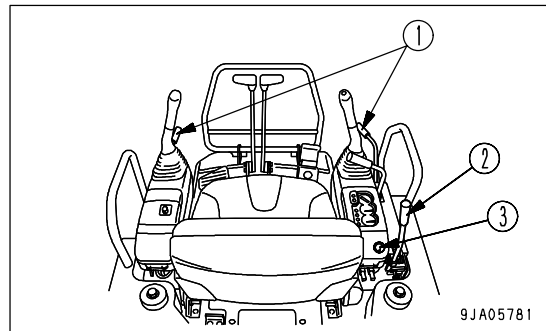

1. Check the safety lock lever (1) is at the LOCK position (L). If the safety lock lever is in the FREE position (F), the engine does not start.

REMARK

For machines equipped with a cab, there is only a safety lock lever on the left.

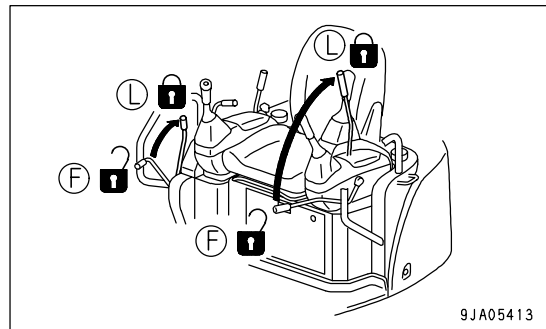

2. Pull fuel control lever (2) to position (B) midway between low idling position (A) and the full position.

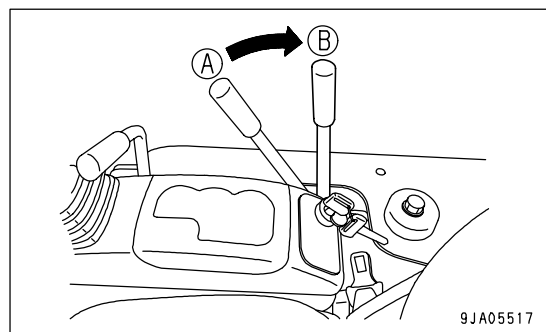

3. Turn the key in starting switch (3) to the START position. The engine will start.

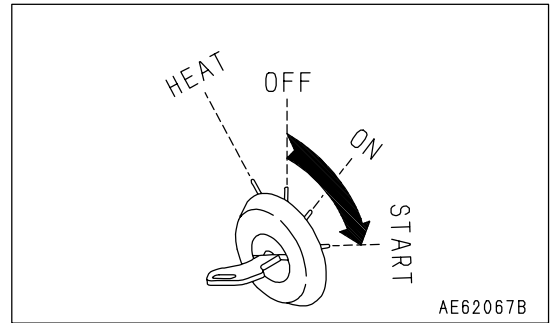

4. When the engine start, release the key in the starting switch (3). The key will return automatically to the ON position.

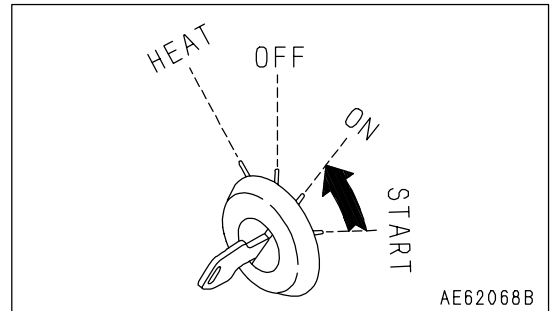

Starting Engine in Cold Weather



WARNING

- Start the engine only after sitting down in the operator's seat.
- Do not attempt to start the engine by short-circuiting the engine starting circuit. Such an act may cause a serious bodily injury or fire.
- Check that there are no persons or obstacles in the surrounding area, then sound the horn and start the engine.
- Never use starting aid fluids as they may cause explosions.
- Exhaust gas is toxic. When starting the engine in confined spaces, be particularly careful to ensure good ventilation.

NOTICE

Do not keep the starting motor rotating continuously for more than 20 seconds.

If the engine does not start, wait for at least one minute, then repeat the operation from Step 3.

When starting in low temperatures, do as follows.

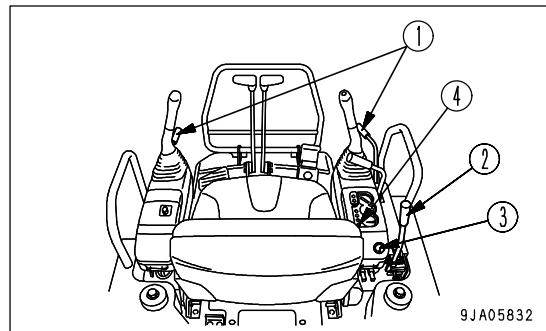

1. Check the safety lock lever (1) is at the LOCK position (L). If the safety lock lever is in the FREE position (F), the engine does not start.

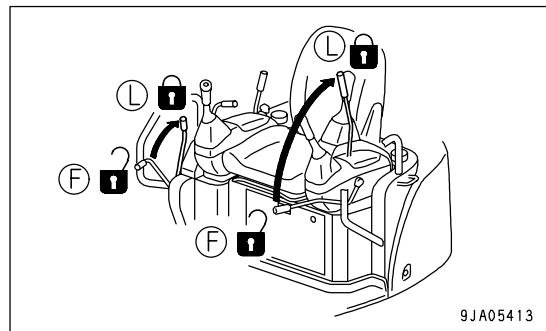

REMARK

For machines equipped with a cab, there is only a safety lock lever on the left.

2. Pull fuel control lever (2) to FULL position (B).

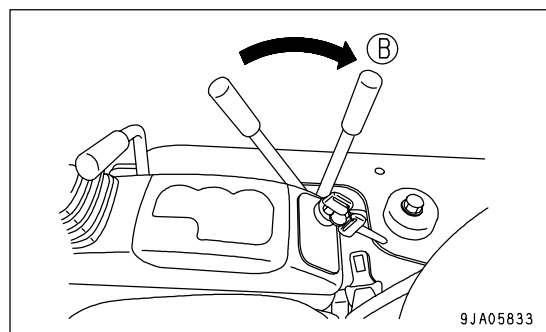

- Hold the key in starting switch (3) at the HEAT position and check that the buzzer sounds and preheating monitor (4) lights up, and that preheating monitor (4) flashes after that. After approx. 18 seconds, the buzzer sounds and preheating monitor (4) goes out to indicate that the preheating is completed.

REMARK

The monitor and gauge also light up when the key is at the HEAT position, but this does not indicate any abnormality.

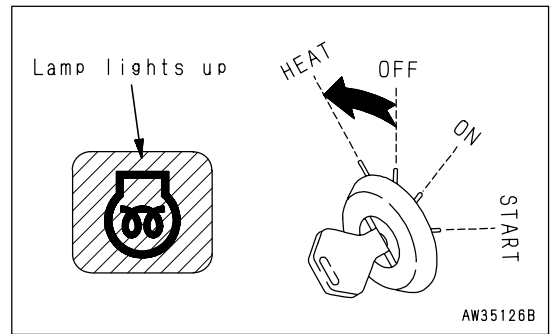

- When pre-heating monitor (4) goes off, turn the key in starting switch (3) to the START position to start the engine.

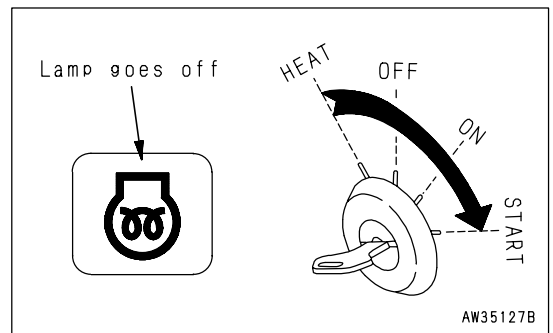

- When the engine starts, release the key in starting switch (3). The key will return automatically to the ON position.

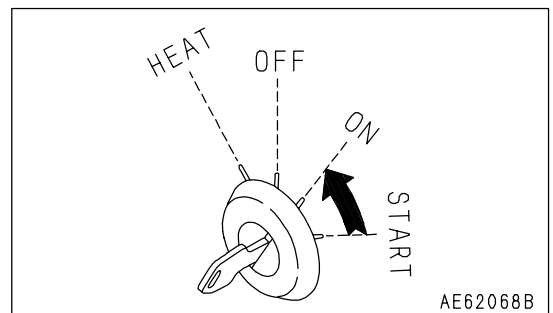

AFTER STARTING ENGINE



WARNING

- Emergency stop
If there has been any abnormal actuation or trouble, turn the starting switch key to the OFF position.
- If the work equipment is operated without warming the machine up sufficiently, the response of the work equipment to the movement of the control lever will be slow, and the work equipment may not move as the operator desires, so always carry out the warming-up operation. Particularly in cold areas, be sure to carry out the warming-up operation fully.

Breaking-in the New Machine



CAUTION

Your Komatsu machine has been thoroughly adjusted and tested before shipment. However, operating the machine under severe conditions at the beginning can adversely affect the performance and shorten the machine life.

Be sure to break-in the machine for the initial 100 hours (as indicated by the service meter).

During break-in operations, follow the precautions described in this manual.

- Idle the engine for 5 minutes after starting it up.
- Avoid operation with heavy loads or at high speeds.
- Immediately after starting the engine, avoid sudden starts, sudden acceleration, unnecessary sudden stops, and sudden changes in direction.

Warming-up Operation

NOTICE

- When the hydraulic oil is at a low temperature, do not carry out operations or move the lever suddenly. Always carry out the warming-up operation. This will help to extend the machine life.
- Do not suddenly accelerate the engine before the warming-up operation is completed.
Do not run the engine at low idling or high idling continuously for more than 20 minutes.

After starting the engine, do not immediately start operations. First, carry out the following operations and checks.

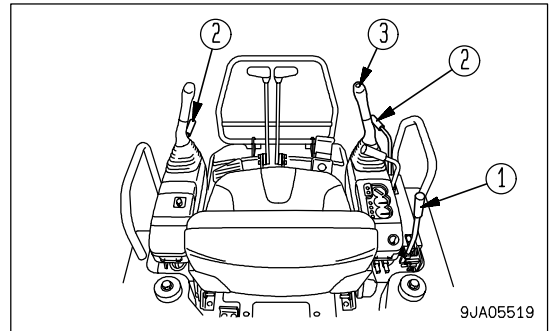

1. Pull fuel control lever (1) from low idling (position A) to midway position (B) between full speed and low idling to raise the engine speed to a mid-range speed, then run under no load for approx. 5 minutes.

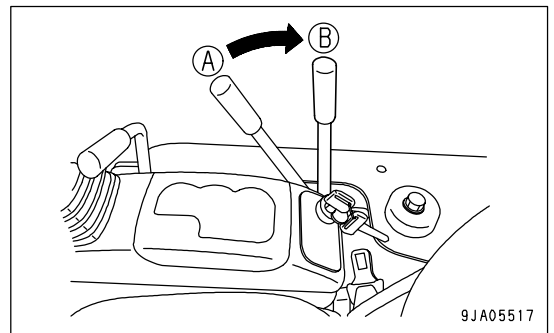

REMARK

When the ambient temperature is below 0°C (32°F), keep the fuel control lever close to the 1/4 position when carrying out the warming-up operation.

2. Set safety lock lever (2) to the FREE position, and raise the bucket from the ground.

Machine equipped with canopy

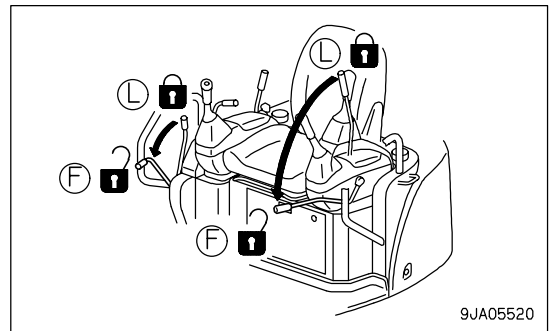

Machine equipped with cab

REMARK

For machines equipped with a cab, there is only a safety lock lever on the left.

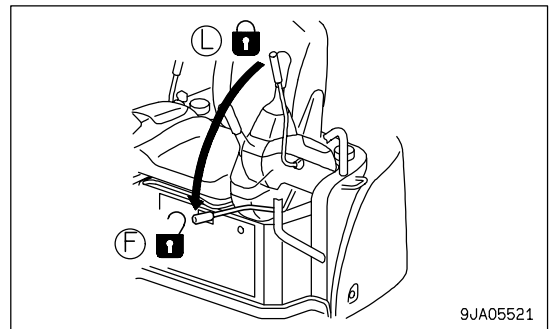

3. Operate right work equipment control lever (3) slowly, pull the bucket into the stop position, and hold it there for 5 minutes.

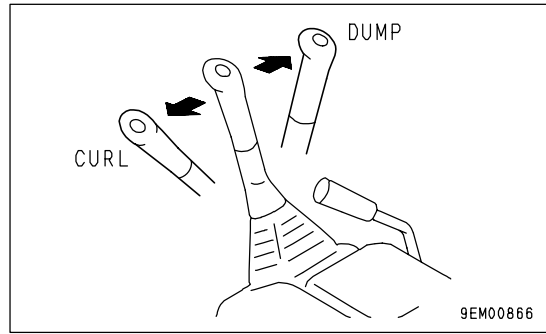

4. After carrying out the warming-up operation, check that each gauge and monitor is in the following condition. If any abnormality is found, carry out maintenance and repair.

- Engine coolant temperature gauge (4): Indicator is in correct range
- Fuel gauge (5): Indicator is in correct range
- Engine oil pressure monitor (6): Monitor is off
- Charge monitor (7): Monitor is off

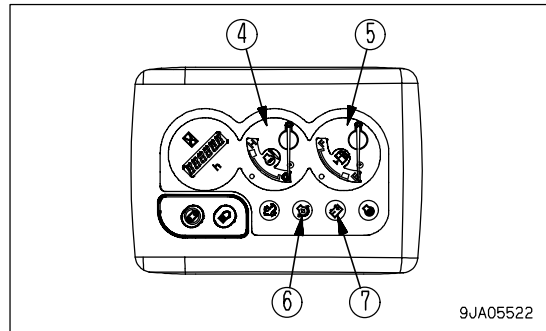

5. Check that there is no abnormal exhaust gas color, noise or vibration. If any abnormality is found, contact your Komatsu distributor.

6. Set safety lock lever (2) to the LOCK position, then check that the machine does not move even when the levers and pedals are operated.

- 1) The work equipment and swing do not move when the left and right work equipment control levers are operated.
- 2) The machine does not travel when the left and right travel levers are operated.
- 3) The blade does not move when the blade control lever is operated.
- 4) The boom swing does not move when the boom swing control pedal is operated.

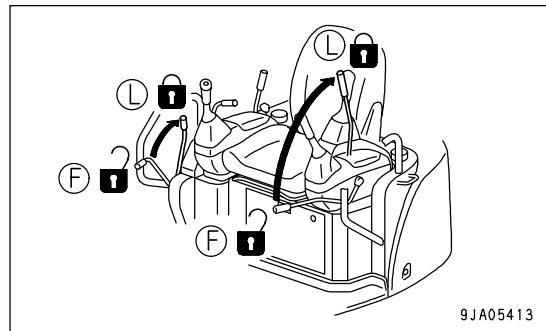

STOPPING THE ENGINE

NOTICE

If the engine is stopped abruptly, service life of component parts of the engine may be considerably reduced. Hence do not stop the engine abruptly except in an emergency. If the engine has overheated, do not try to stop it abruptly but run it at medium speed to allow it to cool down gradually, and then stop it.

1. Run the engine at low idling for about 5 minutes to cool down gradually.

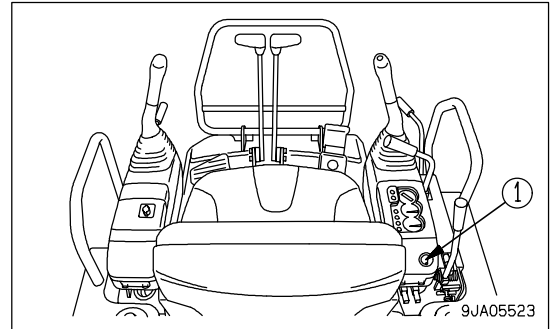

2. Turn the key of starting switch (1) to the OFF position to stop the engine.
3. Remove the key from starting switch (1).

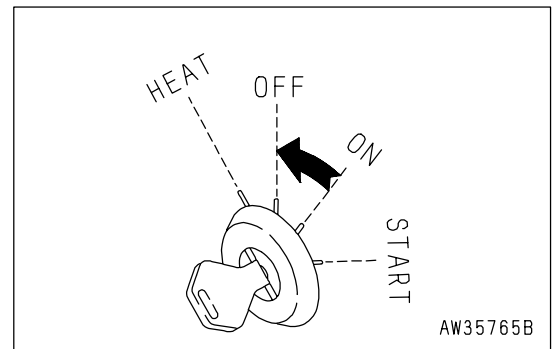

MACHINE OPERATION

**WARNING**

- Before operating the travel levers, check the direction of the track frame. If the sprocket is at the front, the operation of the travel levers is reversed.
- When moving off, check that the area around the machine is safe, and sound the horn before moving.
- Clear all personnel from the machine and the area.
- Clear all obstructions from the path of the machine.
- Check that the travel alarm works properly.

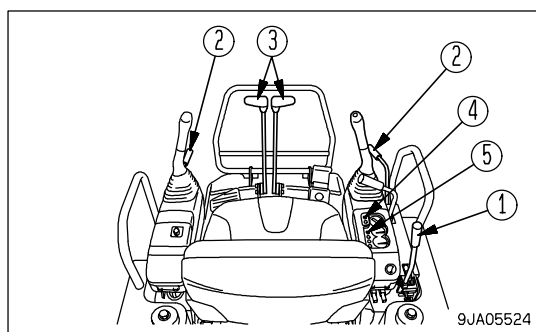
**Preparations for Moving the Machine Off**

1. Pull fuel control lever (1) towards the high idling position to increase the engine speed.
(B): High idling

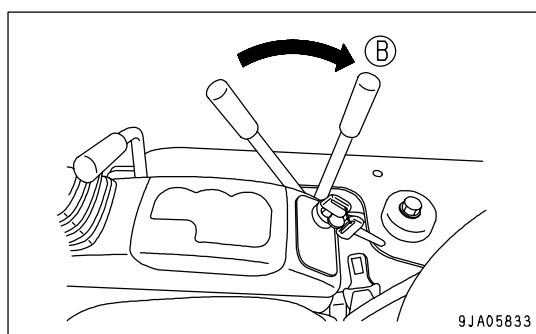

Moving Machine Forward

1. Set safety lock lever (2) to the FREE position, then raise the work equipment 40 to 50 cm (1.6 to 2.0 in) from the ground.

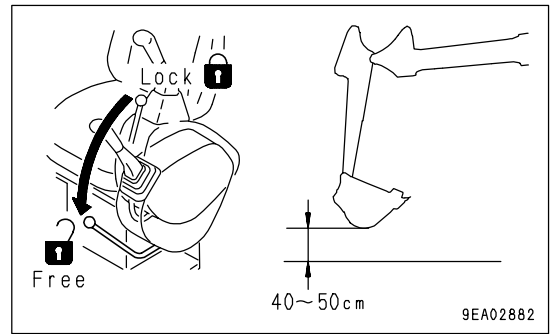

2. Raise the blade.
3. Operate the both travel levers (3) as explained below.
 - When the sprocket (A) is at the rear of the machine.
Push levers (3) forward slowly to move the machine off.

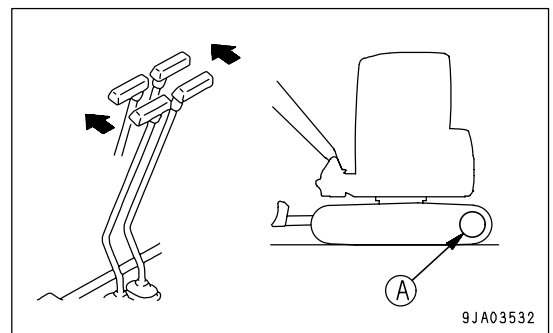

- When the sprocket (A) is at the front of the machine.
Pull levers (3) backward slowly to move the machine off.

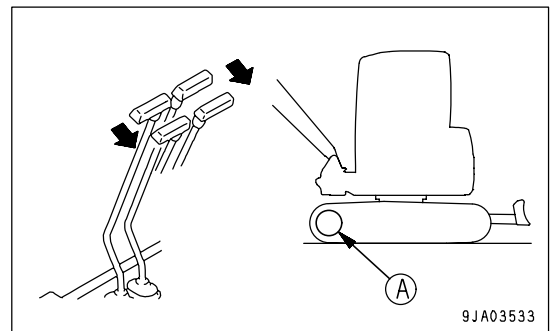

4. Switch the travel speed as follows.
 - When the travel speed selector switch (4) is pressed, the travel speed can be switched between high speed and low speed.
Each time the switch is pressed, the travel speed is switched between low speed and high speed.

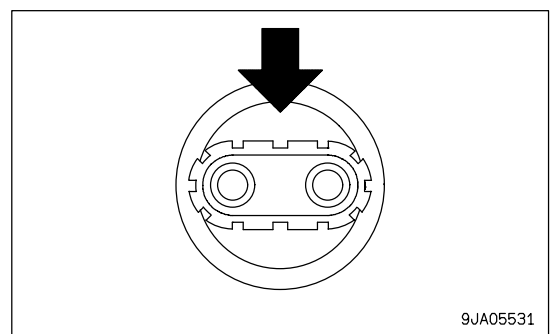

- When the machine is traveling at high speed, travel speed boost monitor (5) lights up.
For details of the travel speed values, see Section "SPECIFICATIONS (PAGE 5-2)".

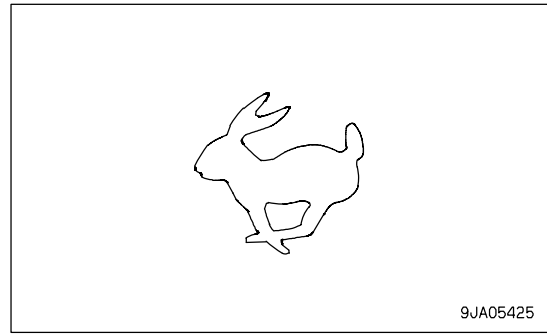

REMARK

- When the engine is started, the travel speed is automatically set to low speed.
- When traveling at high speed, if the machine travels on soft ground or up a slope and the load increases, the travel is automatically switched to low speed travel, so there is no need to operate the switch. The travel speed boost monitor displays stays lighted up.
When the load is reduced, the travel system returns to high speed travel.

5. Check that the travel alarm sounds.

If the alarm does not sound, please contact your Komatsu distributor for repairs.

Moving Machine Backward

1. Set safety lock lever (2) to the FREE position, then raise the work equipment 40 to 50 cm (1.6 to 2.0 in) from the ground.

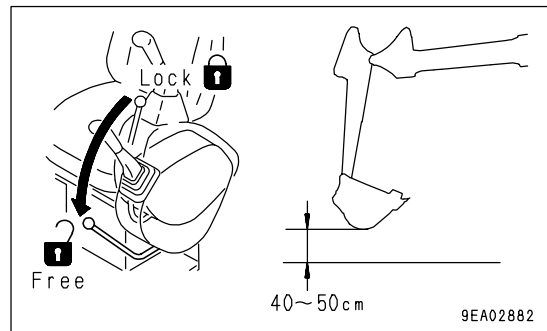

2. Raise the blade.

3. Operate the both travel levers (3) as explained below.

- When the sprocket (A) is at the rear of the machine.
Pull levers (3) backward slowly to move the machine off.

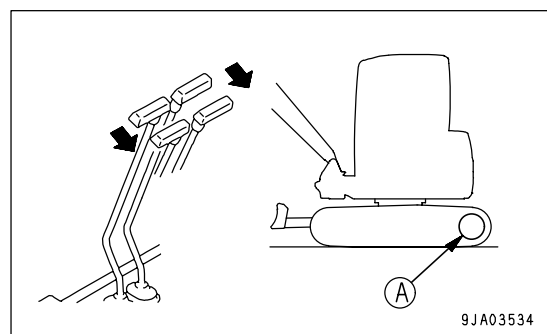

- When the sprocket (A) is at the front of the machine.
Push levers (3) forward slowly to move the machine off.

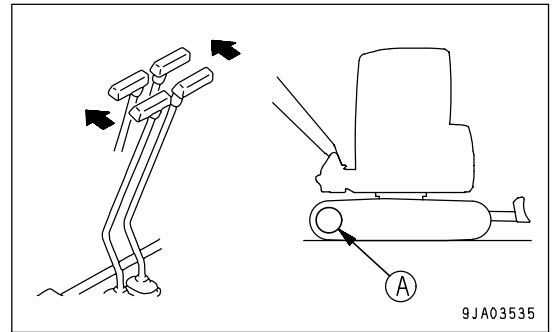

4. Switch the travel speed as follows.

- When the travel speed selector switch (4) is pressed, the travel speed can be switched between high speed and low speed.
Each time the switch is pressed, the travel speed is switched between low speed and high speed.

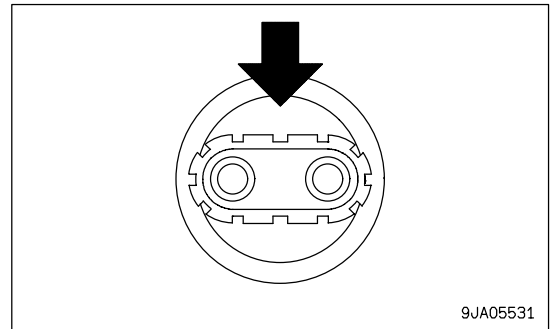

- When the machine is traveling at high speed, travel speed boost monitor (5) lights up.
For details of the travel speed values, see Section "SPECIFICATIONS (PAGE 5-2)".

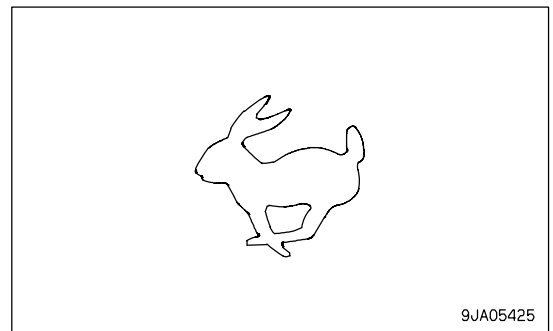

REMARK

- When the engine is started, the travel speed is automatically set to low speed.
- When traveling at high speed, if the machine travels on soft ground or up a slope and the load increases, the travel is automatically switched to low speed travel, so there is no need to operate the switch. The travel speed boost monitor displays stays lighted up.
When the load is reduced, the travel system returns to high speed travel.

5. Check that the travel alarm sounds.

If the alarm does not sound, please contact your Komatsu distributor for repairs.

Stopping Machine



Avoid stopping suddenly. Give yourself ample room when stopping.

1. Put the left and right travel levers (1) in the NEUTRAL position, then stop the machine.

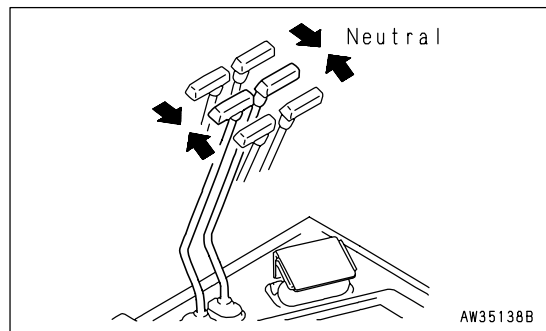
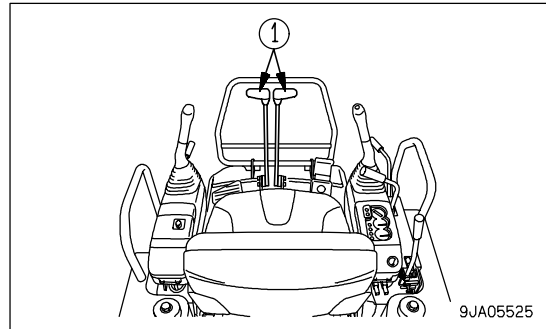

STEERING THE MACHINE

Steering



WARNING

Before operating the travel levers, check the direction of the track frame (the position of the sprocket). If the sprocket is at the rear, the machine moves in the reverse direction to the operation of the travel levers.

REMARK

When traveling at high speed, if the load increases, the automatic travel speed shifting function automatically shifts the transmission to low speed and the machine travels slowly. When the load decreases, it automatically returns the transmission to high speed travel.

Use the travel levers to change direction.

Avoid sudden changes of direction as far as possible. In particular, when carrying out counter-rotation (spin turn), stop the machine first before turning.

Operate two travel levers (1) as follows.

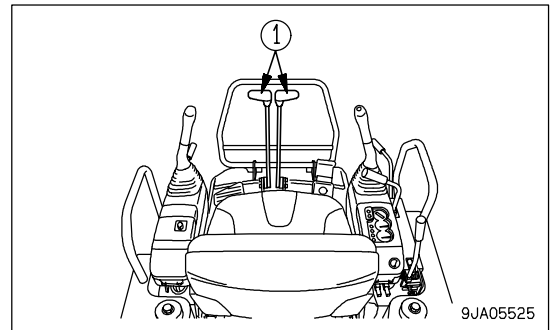

Steering the Machine when Stopped

When turning to the left:

Push the right travel lever forward to travel left when traveling forward; and pull it back to turn left when traveling in reverse.

REMARK

When turning to the right, operate the left travel lever in the same way.

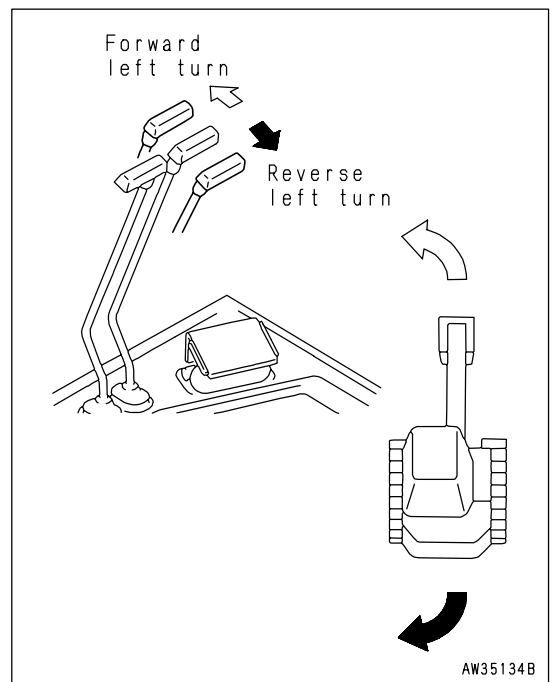

Changing Direction of the Machine

When turning to the left:

If the left travel lever is returned to the neutral position, the machine will turn to the left.

REMARK

When turning to the right, operate the right travel lever in the same way.

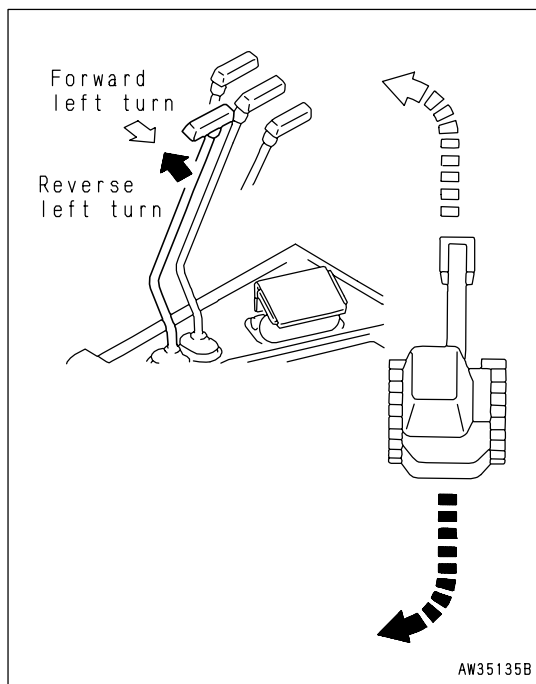

Counter-rotation Turn (Spin Turn)

When using counter-rotation (spin turn) to turn left, pull the left travel lever back and push the right travel lever forward.

REMARK

When using counter-rotation (spin turn) to turn right, pull the right travel lever back and push the left travel lever forward.

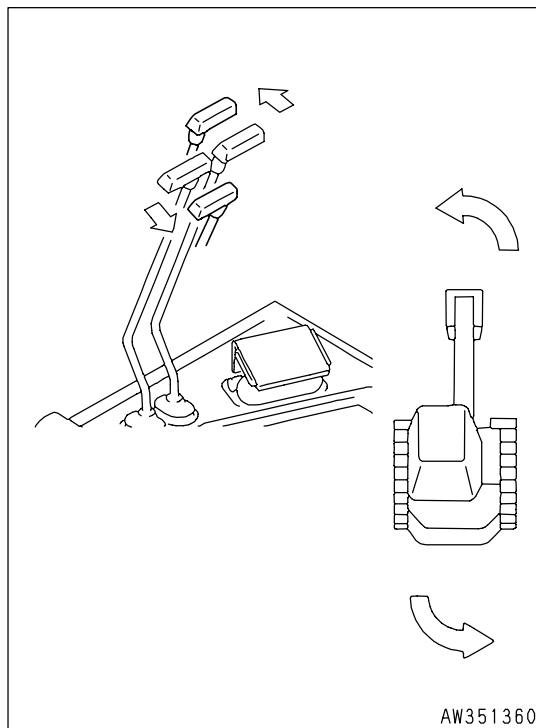

SWINGING

**WARNING**

When operating the swing, check that the area around the machine is safe.

1. Operate left work equipment control lever (1) to swing the upper structure.
2. When not using the swing, set left work equipment control lever (1) to the N position.
The swing holding brake will be applied.

REMARK

- When using the swing on a slope, run the engine at low idling and operate the swing lever extremely slowly.
Be particularly careful to avoid sudden movement when the bucket is loaded.
- When the bucket is loaded and the left work equipment control lever is operated, the swing holding brake is released, so the upper structure may swing momentarily, but this is not an abnormality.

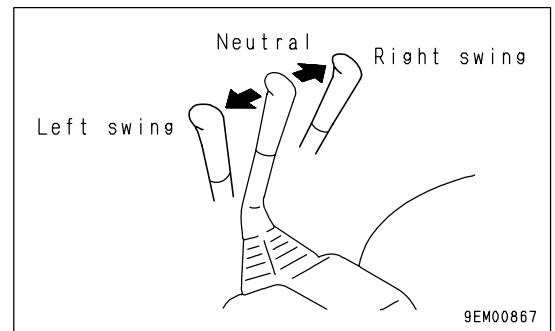
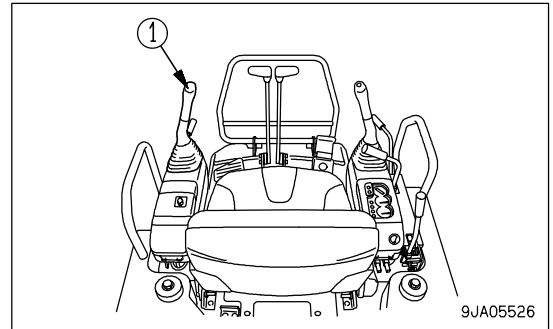

WORK EQUIPMENT CONTROLS AND OPERATIONS**WARNING**

For operation modes other than the standard one (ISO pattern), refer to the chapter of **ATTACHMENTS AND OPTIONS** in this manual.

Use the control levers to operate the work equipment.

Note that when the levers are released, they return to the HOLD position and the work equipment is held in that position.

- Arm control

Move the left work equipment control lever to the front or rear to operate the arm.

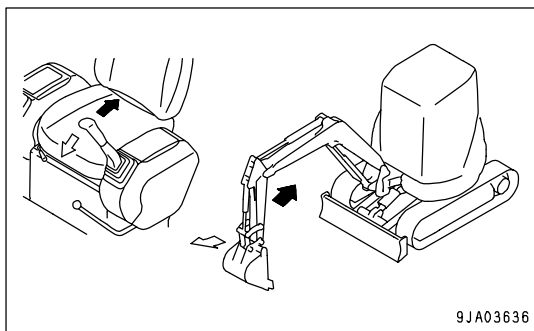

- Swing control

Move the left work equipment control lever to the left or right to swing the upper structure.

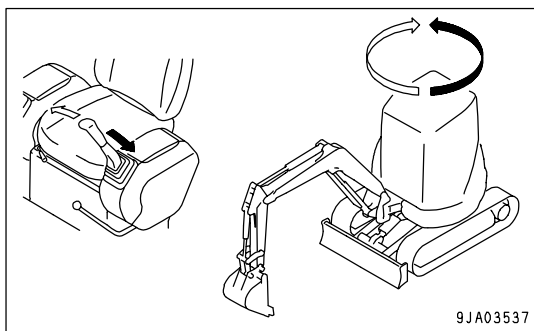

- Boom control

Move the right work equipment control lever to the front or rear to operate the boom.

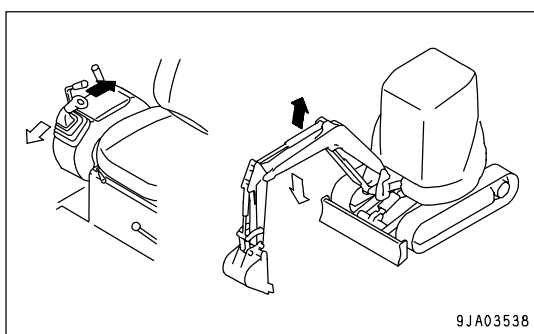

- Bucket control

Move the right work equipment control lever to the left or right to operate the bucket.

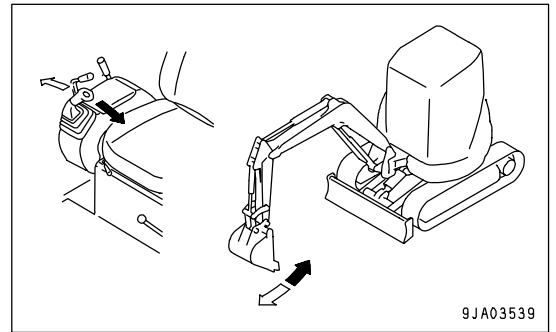

- Boom swing operation

The boom swing operation can be carried out with the boom swing control pedal.

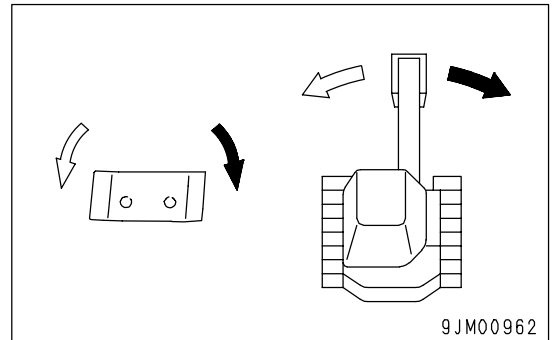

- Blade control

Move the lever on the right side of the operator's seat to the front or rear to operate the blade.

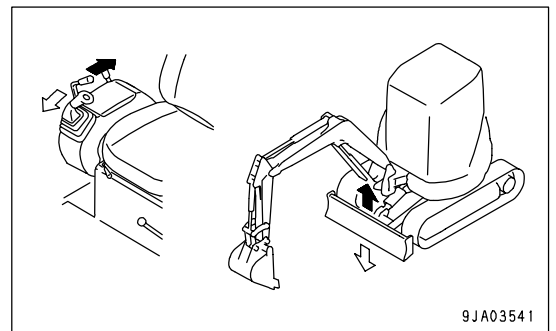

PROHIBITED OPERATIONS

! WARNING

Do not attempt to operate the work equipment control lever, while the machine is traveling.

Operations Using Swing Force

Do not use the swing force to compact soil or break earth mounds or walls.

When swinging, do not dig the bucket teeth into the soil. These operations will damage the work equipment.

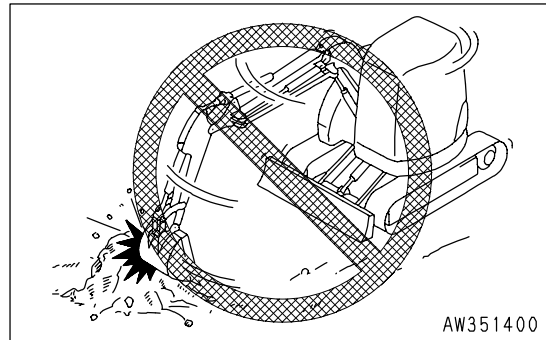

Operations Using Travel Force

Do not dig the bucket into the ground and use the travel force to carry out excavation. This will damage the machine or work equipment.

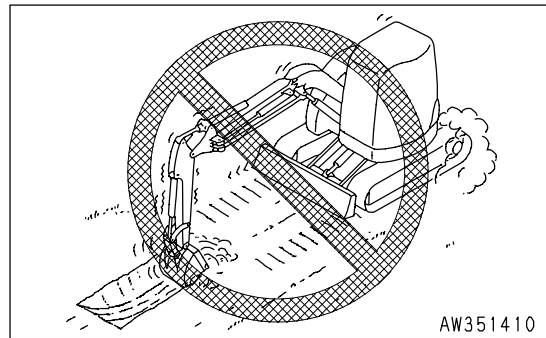

Prohibition of Operations Using Hydraulic Cylinders to Stroke Ends

When operating the cylinder, do not operate it to the end of its stroke. Always leave a small margin.

If the cylinder is operated to the end of its stroke, force will be brought to bear on the cylinder, and this may cause damage to the pins, boom, arm, and frame.

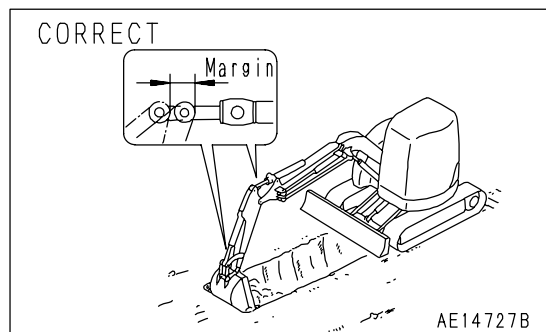

Digging Hard Rocky Ground

It is better to excavate hard rocky ground after breaking it up by some other means. This will not only reduce damage to the machine but make for better economy.

Operations Using Bucket Dropping Force

Do not use the dropping force of the machine for digging, or use the dropping force of the bucket as a pickaxe, breaker, or pile driver. This will markedly reduce the life of the machine.

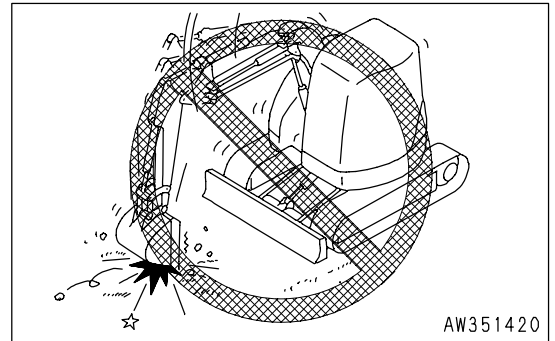

Operations Using Machine Dropping Force

It is prohibited to carry out digging operations using the dropping force of the machine.

When excavating hard rock bed, use some other method to break the rock into small pieces before excavating. This avoids damage to the machine and also is more economical.

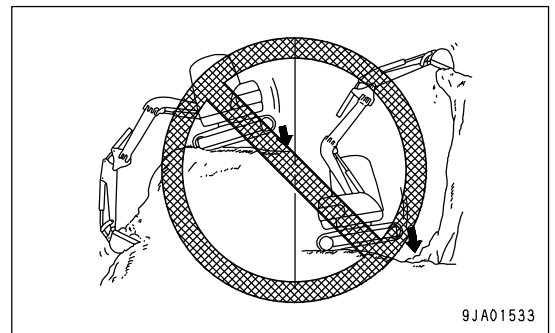

Prohibition of Lifting Operation

It is prohibited to use this machine for lifting operations. However, this prohibition is removed only in the case where the special lifting hook is installed.

For details, see "BUCKET WITH HOOK (PAGE 6-4)".

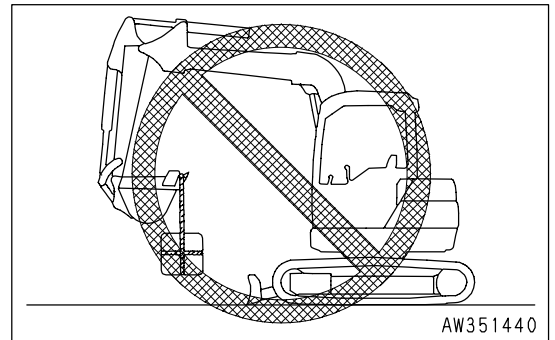

Support Blade on Both Sides

When using the blade as an outrigger, never support the machine with only one end of the blade.

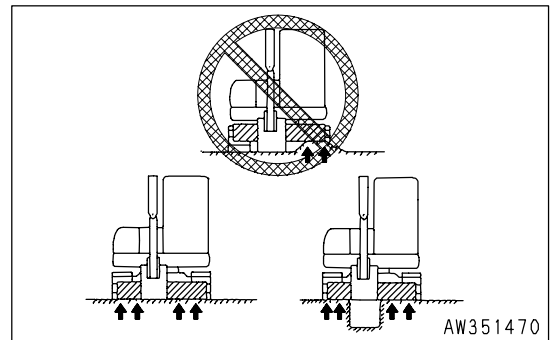

GENERAL OPERATION INFORMATION

Traveling

Traveling over boulders, tree stumps, or other obstacles will cause a big shock to the chassis (and in particular to the tracks), and this will cause damage to the machine. For this reason, always remove any obstacles or travel around them, or take other steps to avoid traveling over such obstacles as far as possible.

If there is no way to avoid traveling over an obstacle, reduce the travel speed, keep the work equipment close to the ground, and try to travel so that the center of the track passes over the obstacle.

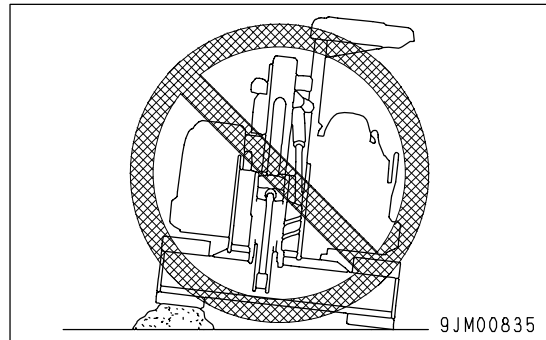

Folding in Work Equipment

When folding in the work equipment to the travel or transportation posture, be careful not to let the bucket hit the blade.

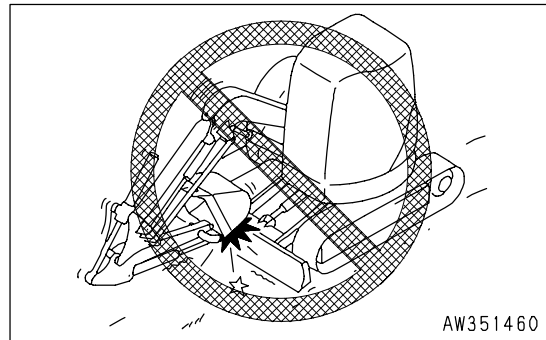

Avoid Hitting Blade

Be careful not to hit the blade against rocks or boulders. This will cause premature damage to the blade or cylinders.

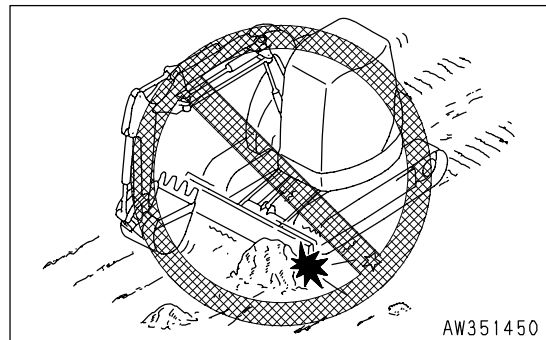

Blade During Backhoe Operations

When carrying out deep digging operations with the blade at the front, be careful not to let the boom cylinder hit the blade. Always position the blade at the back unless it is needed at the front.

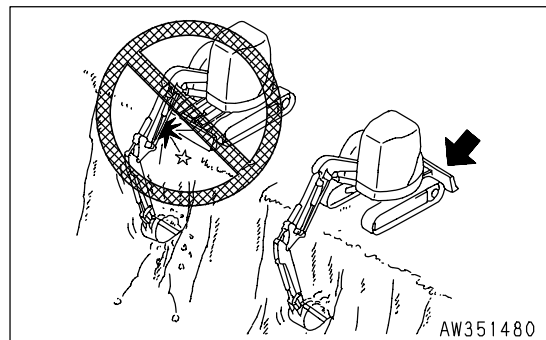

Permissible Water Depth

CAUTION

When driving the machine out of water, if the angle of the machine exceeds 15°, the rear of the upper structure will go under water, and water will be thrown up by the radiator fan. This may cause the fan to break. Be extremely careful when driving the machine out of water.

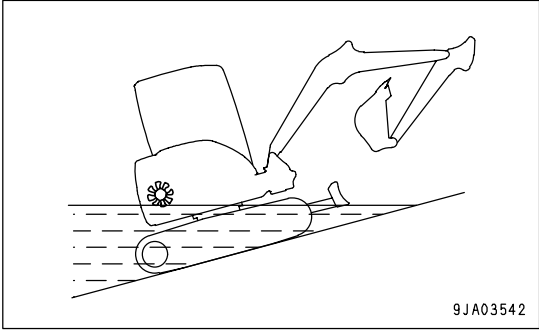

Do not immerse the machine in water by more than the permissible depth (under center of carrier roller (1)).

In addition, for parts that have been immersed in water for a long time, pump in grease until the old grease comes out from the bearings. (Around the bucket pins)

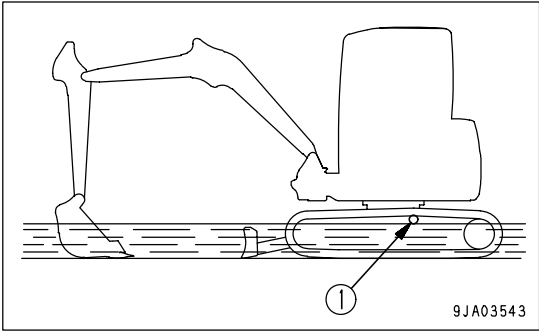

TRAVELING ON SLOPES

WARNING

- Turning or operating the work equipment when working on slopes may cause the machine to lose its balance and turn over, so avoid such operations. It is particularly dangerous to swing downhill when the bucket is loaded. If such operations have to be carried out, pile soil to make a platform on the slope so that the machine can be kept horizontal when operating.
- Do not travel up or down steep slopes. There is danger that the machine may turn over.
- When traveling, raise the bucket approx. 20 to 30 cm (8 to 12 in) from the ground. Do not travel downhill in reverse.
- Never turn on slopes or travel across slopes. Always go down to a flat place to perform these operations. It may be longer, but it will ensure safety.
- Always operate or travel in such a way that it is possible to stop safely at any time if the machine slips or becomes unstable.
- When traveling uphill, if the shoes slip or it is impossible to travel uphill using only the force of the tracks, do not use the pulling force of the arm to help the machine travel uphill. There is danger that the machine may turn over.

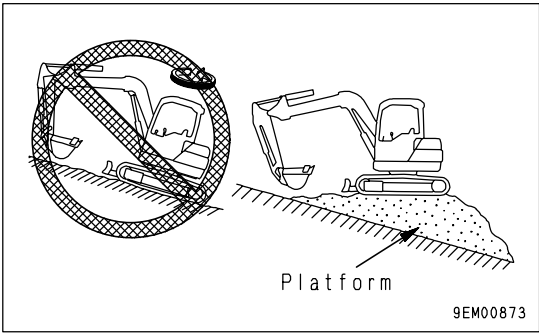
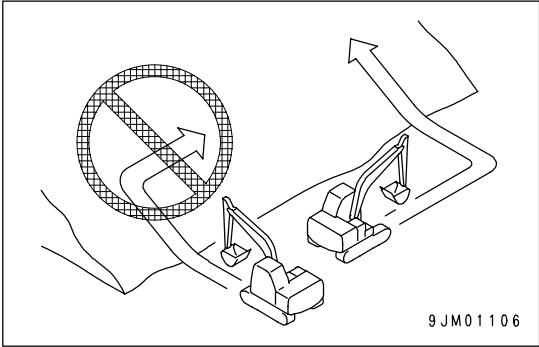

1. When traveling down steep hills, use the travel lever and fuel control lever to keep the travel speed low.
When traveling down a steep hill of more than 15°, set the work equipment to the posture shown in the diagram on the right, and lower the engine speed.

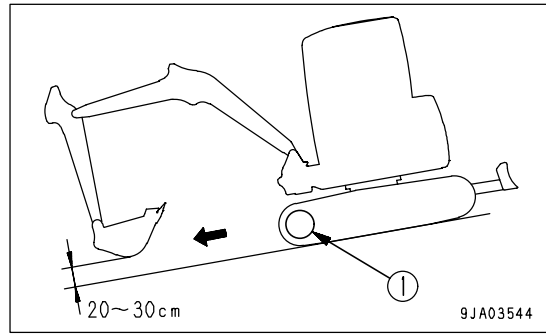

REMARK

Travel down fills with the sprocket (1) side down.
If the machine travels down with the sprocket (1) side up, the track tends to become loose, and that can cause skipping pitches.

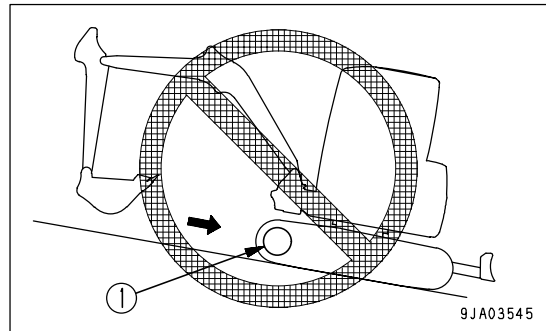

2. When traveling up a steep hill of more than 15°, set the work equipment to the posture shown in the diagram on the right.

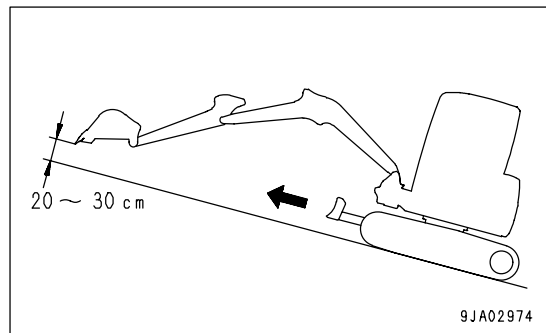

Traveling Downhill

Put the travel lever in the neutral position. This will cause the brake to be automatically applied.

Engine Stopped on Slope

If the engine stops when traveling uphill, move the travel levers to the neutral position, lower the bucket to the ground, stop the machine, then start the engine again.

Cab Doors on Slope

- If the engine stops when the machine is on a slope, never use the left work equipment control lever to carry out swing operations. The upper structure will swing under its own weight.
- Do not open or close the sliding door (cab specifications) on slopes when traveling or operating. The operating effort may change suddenly.
Always keep the sliding door locked.
- Take good care when opening or closing the sliding door (the cab specification). There is the danger that it will likely gain momentum due to its own weight and open or shut suddenly.

ESCAPE FROM MUD

Always operate carefully to avoid getting affixed in mud. If the machine does get affixed in mud, do as follows to get the machine out.

Stuck One Side of Track

NOTICE

When using the boom or arm to raise the machine, always have the bottom of the bucket in contact with the ground. (Never push with the teeth.) The angle between the boom and arm should be 90° to 110° .

When only one side is affixed in mud, use the bucket to raise the track, then lay boards or logs and drive the machine out.

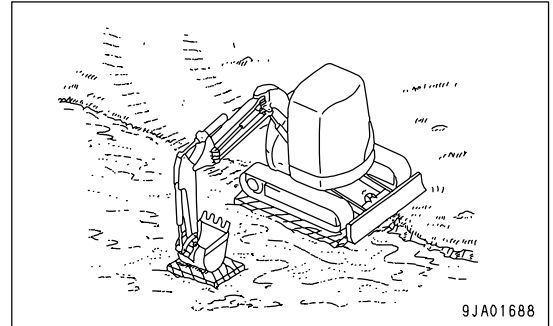

Stuck Both Sides of Tracks

If the track on both sides are in mud and the machine slips and cannot move, use the procedure given above to lay logs or timber. dig the bucket into the ground at the front, operate the arm in the same way as when digging, and set the travel lever to FORWARD to pull the machine out.

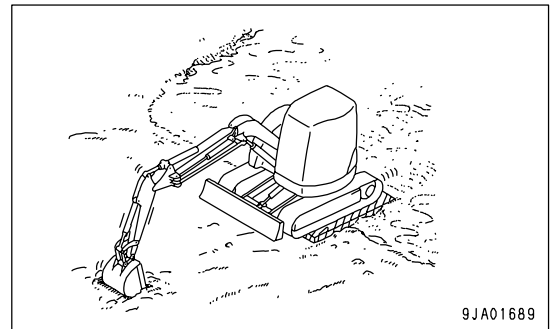

WORK POSSIBLE USING COMPACT HYDRAULIC EXCAVATOR

In addition to the following, it is possible to further increase the range of applications by using various attachments.

Backhoe Work

This is suitable for excavating places lower than the machine.

When work equipment is in condition shown in diagram on right
Bucket cylinder and link

When the center line of arm cylinder and arm foot pin is at 90°, the push-out digging force of each cylinder is the maximum.

Make the optimum use of this angle during digging operations to increase the operating efficiency.

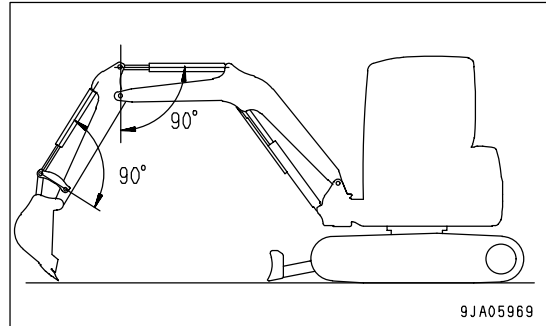

The range for excavating with the arm is from a 45° angle away from the machine to a 30° angle toward the machine.

There may be some differences depending on the digging depth, not try to keep within the above range rather than operating to the end of the cylinder stroke.

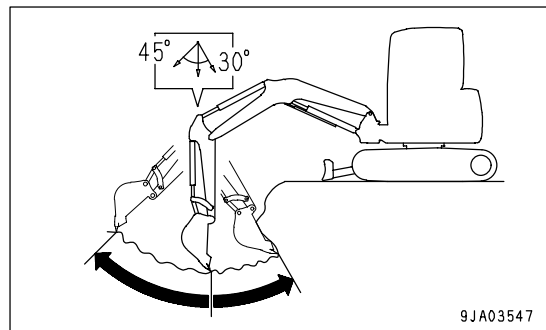

Ditching Work

Ditching work can be performed efficiently by attaching a bucket which matches the digging operation and then setting the tracks parallel to the line of the ditch to be excavated.

To excavate a wide ditch, first dig both sides and then finally remove the center portion.

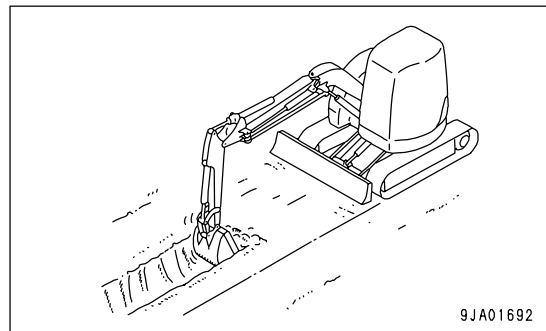

Loading Work

In places where the swing angle is small, work efficiency can be enhanced by locating the dump truck in a place easily visible to the operator.

Loading dump trucks is easier and the loading capacity is greater if the hydraulic excavator loads from the rear of the dump truck rather than from the side.

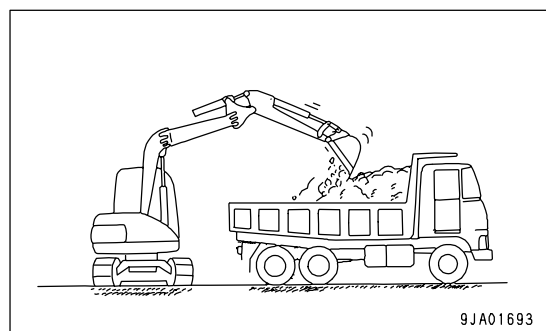

Smoothing Work

When refilling after excavation and when smoothing the ground surface, use the blade.

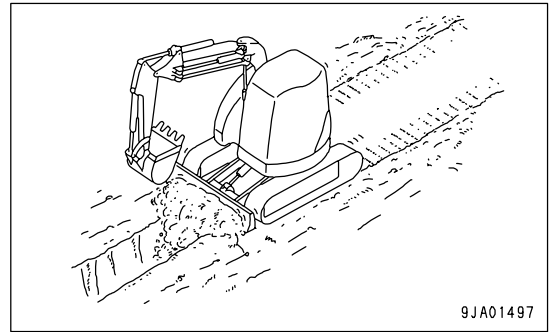
**Side Ditching Work**

The machine can be used for side ditching in a confined worksite by combining the swing and boom swing operations.

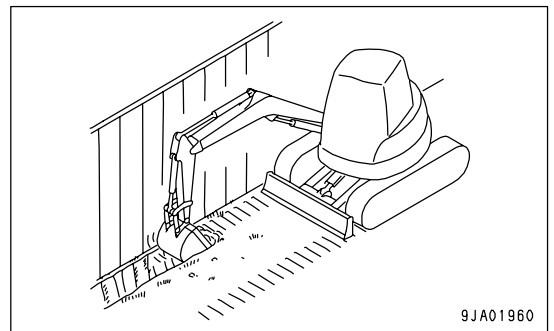

BUCKET REPLACEMENT



WARNING

- When pins are knocked in with a hammer, pieces of metal may fly and cause serious injury. When carrying out this operation, always wear goggles, hard hat, gloves, and other protective equipment.
- When the bucket is removed, place it in a stable condition.
- If pins are hit with a strong force, there is a hazard that the pin may fly out and injure people in the surrounding area. Make sure that there is no one in the surrounding area before starting the operation.
- When removing the pins, do not stand behind the bucket. In addition, be extremely careful not to put your foot under the bucket while standing at the side for the work.
- When removing or inserting pins, be extremely careful not to get your fingers caught.
- Never insert your fingers into the pin holes when aligning the holes.

NOTICE

After removing the pins, make sure that mud or sand does not get on them. Dust seals are fitted at both ends of the bushings, so be careful not to damage them.

Stop the machine on a firm and flat surface and do the work. When performing joint work, appoint a conductor and follow that person's instructions and signals.

1. Place the bucket in contact with a flat surface, then pull out pins (A) and (B).

REMARK

- When removing the pins, place the bucket so that it is in light contact with the ground. If the bucket is lowered strongly to the ground, the resistance will be increased and it will be difficult to remove the pins.
- When removing the pin, check the number of shims used to adjust the play. This is necessary when assembling again.

2. Align the arm with holes (1) and the link with holes (2), then coat with grease and install pins (A) and (B).

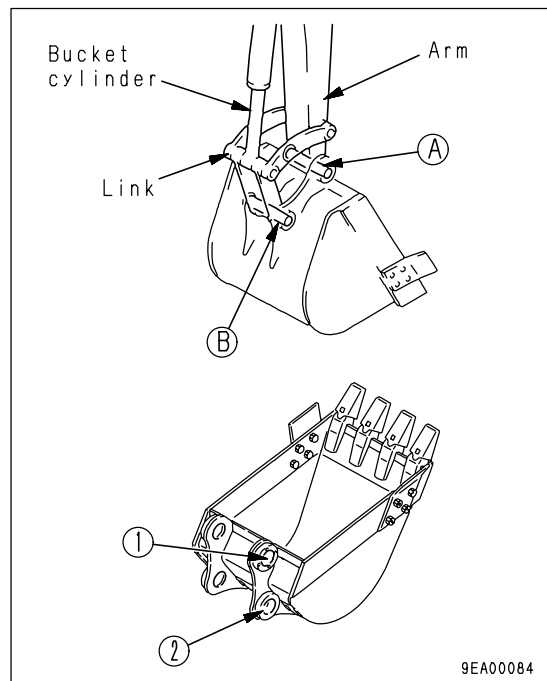

REMARK

- When installing the bucket, the O-rings are easily damaged, so fit the O-rings on the boss of the arm end as shown in the diagram. When knocking the pin, move the O-ring down to the regular groove.
- Check that the shims used to adjust the play have been inserted.

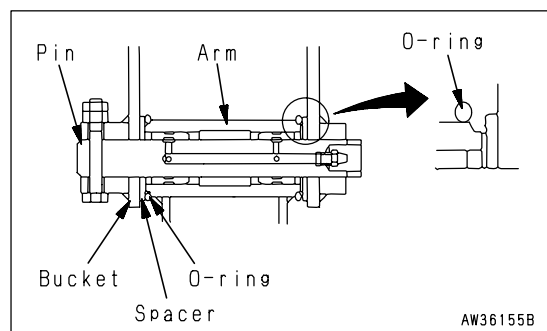

3. Install the stopper bolts and nuts for each pin, then grease the pin.

PARKING MACHINE

⚠ WARNING

- Avoid stopping suddenly. Give yourself ample room when stopping.
- Park the machine on the firm, level ground.
 Avoid parking the machine on slopes.
 If it is unavoidably necessary to park the machine on a slope, put blocks under the tracks and dig the work equipment into the ground surface to stop the machine from moving.
- If the control levers are touched by accident, the work equipment or machine may move suddenly, and this may lead to a serious accident.
 Before standing up from the operator's seat, always set the safety lock lever securely to the LOCK position.
- Set the blade on the downhill side and lower it to the ground.

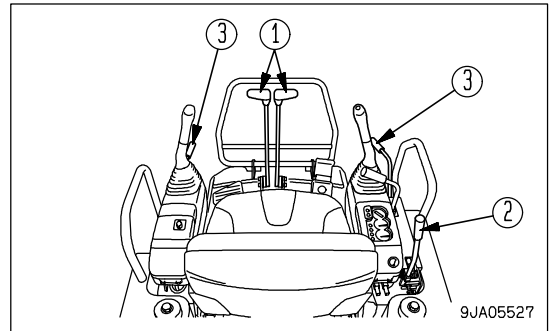
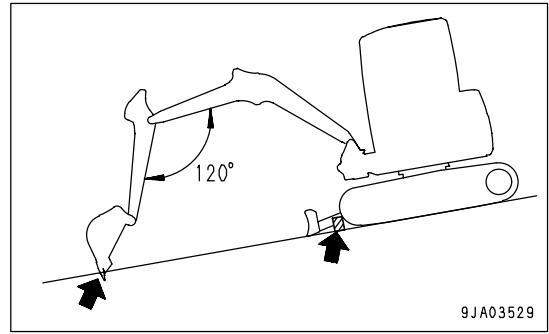

1. Put the left and right travel levers (1) in the NEUTRAL position, then stop the machine.

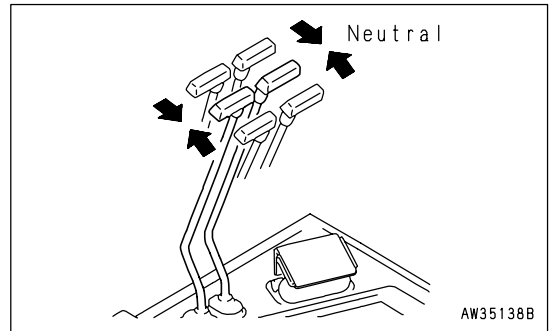

2. Lower fuel control lever (2) to low idling position (A) to reduce the engine speed.

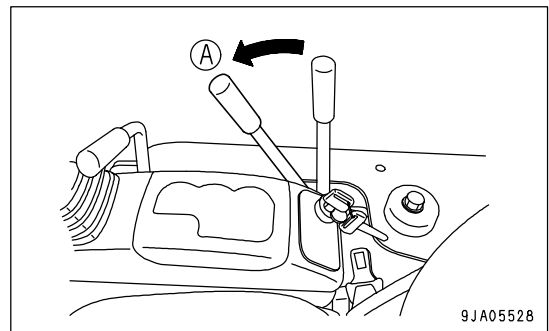

3. Lower the bucket horizontally until the bottom touches the ground.
4. Lower the blade to the ground.

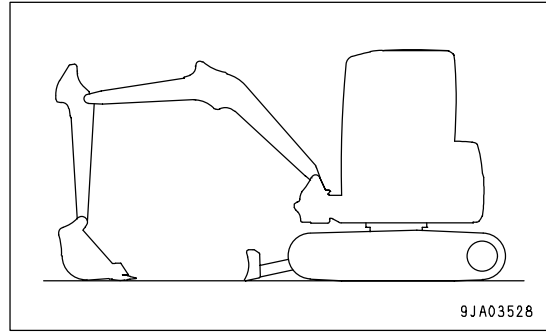

5. Set safety lock lever (3) in the LOCK position.

REMARK

For machines equipped with a cab, there is only a safety lock lever on the left.

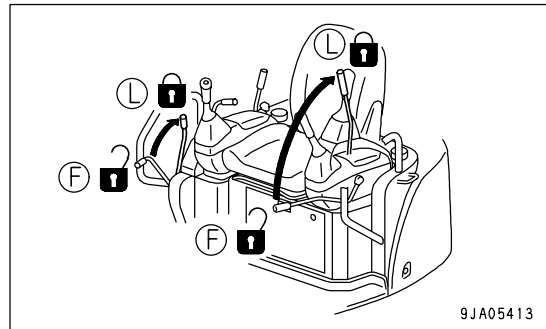

CHECK AFTER SHUT OFF ENGINE

Check the engine coolant temperature (1), engine oil pressure (2), and fuel level (3) on the machine monitor.

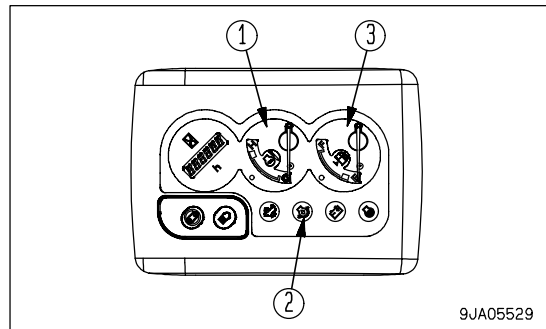

MACHINE INSPECTION AFTER DAILY WORK

1. Walk around the machine and check the work equipment, machine exterior, and undercarriage, also check for any leakage of oil or coolant. If any abnormalities are found, repair them.
2. Fill the fuel tank.
3. Check the engine compartment for paper and debris. Clean out any paper and debris to avoid a fire hazard.
4. Remove any mud affixed to the undercarriage.

LOCKING

Always lock the following places.

- (1) Operator's cab door (machines equipped with cab)
Always close the windows.
- (2) Engine rear cover
- (3) Dirt cover
- (4) Operation and Maintenance Manual, toolbox cover

For details of locking, see Section "Opening and Closing Covers with Lock (PAGE 3-28)".

REMARK

Use the starting switch key to open and close all these places.

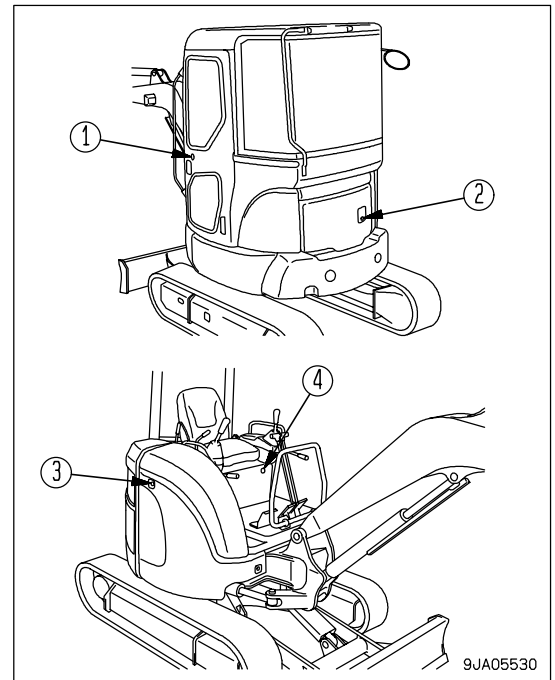

RUBBER SHOES AND ROAD LINERS

(Machine equipped with rubber shoe or road liner)

Rubber Shoes and Road Liners Information

Rubber shoes and road liner have excellent properties that are not found in steel shoes. However, if they are used in the same way as steel shoes, full use cannot be made of their advantages.

Be sure to operate without straining the rubber shoes in a way that matches the condition of the jobsite and the nature of the work.

Comparison Among Rubber Shoes

	Rubber shoe	Road liner	Steel shoe
Little vibration	◎	◎	△
Smooth travel (No creaks)	◎	○	○
Little noise	◎	◎	△
No damage to paved surface	◎	◎	△
Easy to handle	◎	△	△
Easily damage	△	○	◎
Strong drawber pull	◎	◎	◎

◎: Excellent

○: Good

△: Average

Considering the properties of the material used, rubber shoes and road liners offer various advantages. However, their weak point is lack of strength. Therefore, it is important to understand the advantages of rubber shoes and road liners, and to follow the precautions regarding handling and prohibited work. This will extend the life of the rubbershoes and road liners and will enable the machine to display the advantages of rubber shoes and road liners to the maximum. Before using rubber shoes and road liner, always read "Using Rubber Shoes and Road Liners (PAGE 3-85)".

Warranty for Rubber Shoes and Road Liners

It is important to inspect and maintain the tracks at the correct tension. Furthermore, these shoes must not be used near objects where they are likely to suffer damage, such as the corners of steel plates, U-shaped ditch liners, blocks, on crushed rock or the sharp edges of rocks, iron beams, or scrap iron.

Any damage resulting from the customer's mistaken use of the machine shall not be included in the scope of the warranty.

Using Rubber Shoes and Road Liners

Prohibited Works

Do not carry out the following types of work.

- Carrying out operations and steering on crushed rock, extremely rough hard rock, steel beams, scrap iron, or near the edges of steel plates will cause damage to the rubber shoes and road liners.
- In places such as river beds where there are large numbers of large and small boulders, the stones may get caught and damage the rubber shoes and road liners or make the shoes come off. If dozing operations are carried out when the shoes are slipping, this will reduce the life of the rubber shoes and road liner.
- Be careful not to get oil, fuel, or chemical solvent on the rubber shoes and road liners. If such a substance should get on the shoes, remove it immediately. Furthermore, do not travel on road surfaces where oil has collected.
- When putting the machine into long-term storage (3 months or more), store the machine indoors where it is protected from direct sunlight or rain.
- Do not use the machine in high-temperature areas, such as areas where there is burning wood, steel plates that have been left under the hot sun, or places where asphalt has been laid.
- Do not move the machine with the crawler on one side raised using the work equipment. This will cause damage to the rubber shoes and may cause the rubber shoes to come off.
- When the rubber parts of the road liner are so worn or broken that the head of the mounting bolts are scratched, replace the shoe immediately. If the bolt heads are broken, the bolt cannot be removed.
- When installing road liners, always install them to all links on both sides. If they are installed to only one part of the links, their durability will be greatly reduced.

Long Life Operations

Be careful of the following points when carrying out work.

- Avoid carrying out counterrotation turns on concrete surfaces. There is danger that the concrete surface will scrape off the rubber from the shoe.
- Avoid making sudden changes in direction. This may cause premature wear or damage to the rubber shoes and road liners.
- Avoid operating the steering when traveling over places where there is a big difference in height. When traveling over obstacles or places where there is a difference in height, drive the machine at right angles to the obstacle to prevent the shoes from coming off.
- If the machine has been raised using the bucket, lower it slowly.
- Avoid doing work with materials that produce oil when crushed (soya beans, corn, or remains of vegetables squeezed for oil); or wash the machine after use.
- Avoid handling materials that will attack the adhesion of the steel core, such as salt, ammonium sulphate, potassium chloride, potassium sulphate, or calcium superphosphate; or wash the machine after use.
- The adhesion of the core will be attacked by salt, so avoid using the machine in coastal areas.
- When handling salt, sugar, wheat, or soya beans, if there is any deep cut in the rubber shoes and road liners, these substances may get into the lugs or cut portion of the rubber. Always repair the rubber before use.
- Do not carry out work that involves scraping against walls or concrete embankments.
- Rubber shoes and road liners slip extremely easily on snow or frozen roads. Be careful not to slip when traveling or working on slopes.
- The properties of rubber shoes and road liners change when working in extremely cold places, and this will reduce the life of the rubber shoes and road liners.
- Because of the properties of rubber, use the rubber shoes within a range of -25°C to $+55^{\circ}\text{C}$ (-13°F to $+131^{\circ}\text{F}$).
- Because of the properties of rubber, use the road liners within a range of -25°C to $+65^{\circ}\text{C}$ (-13°F to $+149^{\circ}\text{F}$).
- When carrying out bucket operations, be careful not to damage the rubber shoes and road liners with the bucket.

- Always maintain the rubber shoes at the proper tension to prevent them from coming off. If the tension is low, the rubber shoes will come off under the following conditions. Even if the tension is correct, be extremely careful when carrying out operations.

1. Avoid operating the steering when traveling over curbs, rocks, or places where there is a big difference in height (more than approx. 20 cm (8 in)). When traveling over such objects, always travel at right angles to the object.

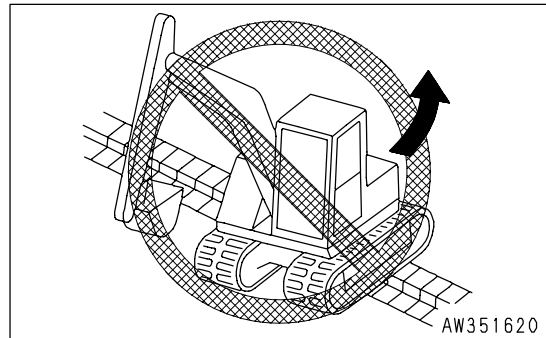

2. When traveling in reverse up a slope, do not turn when moving from flat ground onto the slope. If it is necessary to turn on slopes, be sure to turn gradually.

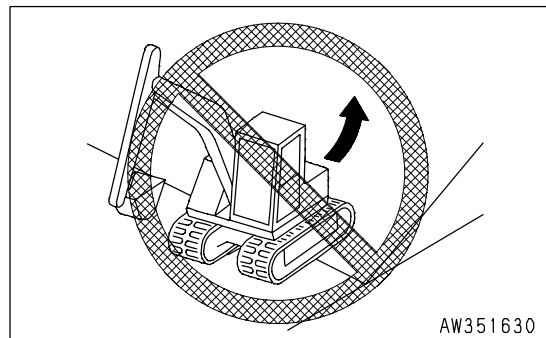

3. Avoid traveling along the edge of slopes or on rough ground with the track on one side raised (with the machine tilting at an angle of more than approx. 10°) and with the track on the other side on flat ground. To avoid damage to the rubber shoes and road liners, travel with the tracks on both sides on flat ground.

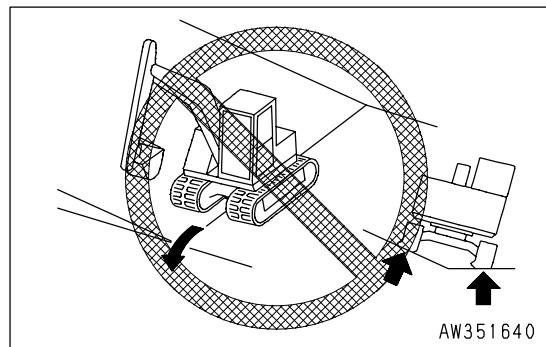

4. If the machine is operated as explained in 1 to 3 above, the rubber shoes are slackened. Do not steer the machine in the positions shown in the figure.

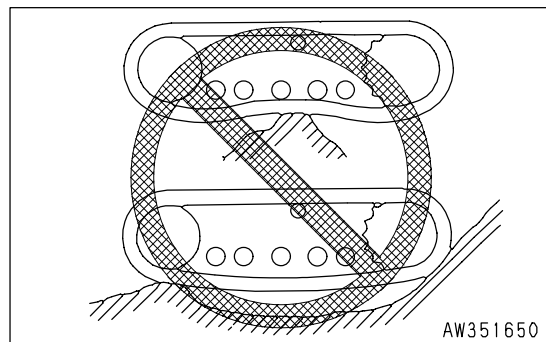

Mechanism of rubber shoe coming off track

- 1) When traveling over an obstacle, a gap is formed between the track roller and the rubber shoe. In this condition, the rubber shoe may come off.

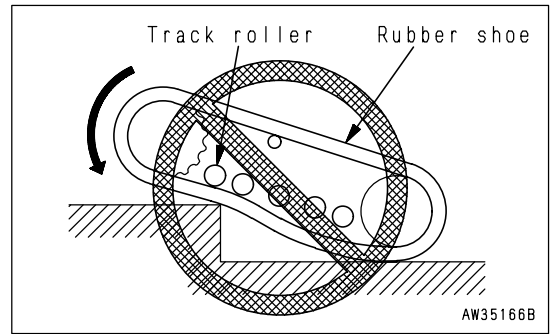

- 2) Furthermore, if the machine travels in reverse, a gap is formed between the track roller, idler, and rubber shoe.

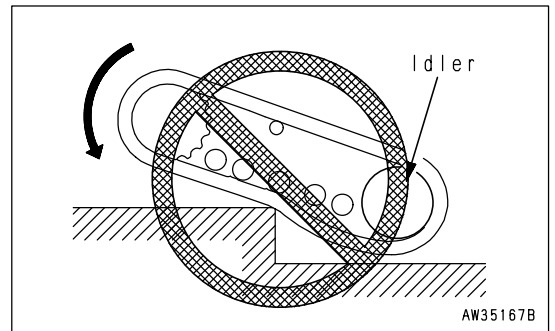

- When turning in a condition where the rubber shoe cannot move to the side because of the object it is passing over, or because of some other object.
- When the rubber shoe has moved out of alignment and the idler or track roller are not aligned with the core.

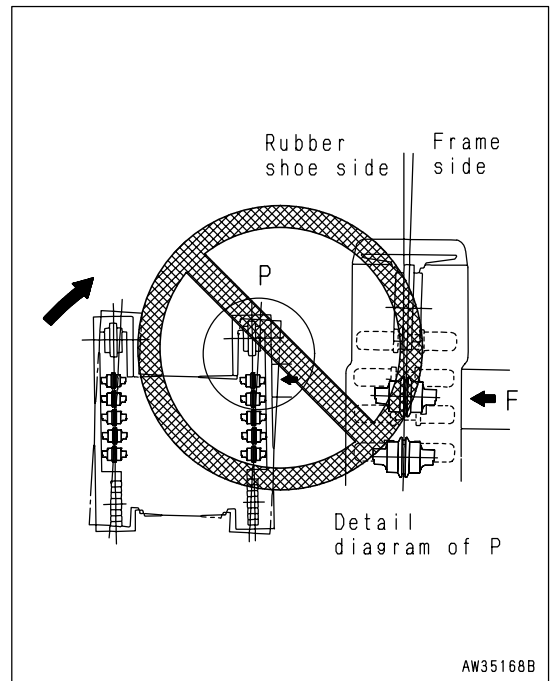

- If the machine travels in reverse in this condition, the rubber shoe will come off.

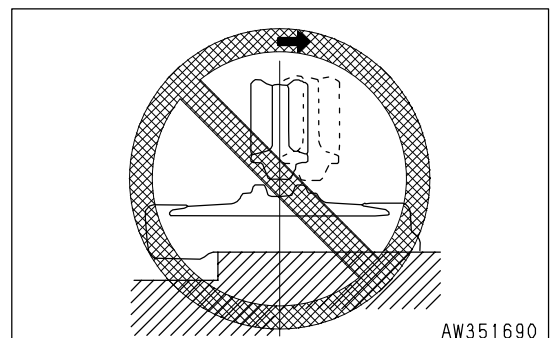

- If the machine is turned in this condition, the rubber shoe will come off.

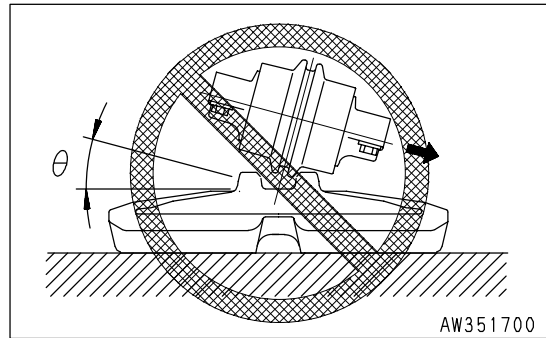

TRANSPORTATION

When transporting the machine, observe all related laws and regulations, and be careful to assure safety.

TRANSPORTATION PROCEDURE

As a basic rule, transport the machine by trailer.

Select the trailer to match the weight and dimensions given in "SPECIFICATIONS (PAGE 5-2)".

Note that the value for the weight and transportation dimensions given in SPECIFICATIONS may differ according to the type of shoe or type of arm or other attachments.

LOADING AND UNLOADING WITH TRAILER

**WARNING**

- When loading or unloading, check that travel speed boost monitor (1) is off, and always travel at low speed.
If the monitor is on, the speed is set to high-speed travel, so press travel speed selector switch (2).
Monitor (1) goes out and the speed is shifted to low-speed travel.
- Always keep the one-touch deceleration switch (if equipped) at the OFF position during loading or unloading operations.
- When loading or unloading, run the engine at low speed, travel at low speed, and operate slowly.
- When loading or unloading the machine, park the trailer on a flat firm road surface.
Keep ample distance between the road shoulder and the machine.
- Use ramps with ample width, length, thickness, and strength, and install them at a maximum slope of 15°.
When using piled soil, compact the piled soil fully to prevent the slope face from collapsing.
- Remove the mud from the undercarriage to prevent the machine from slipping to the side on the ramps.
Remove any water, snow, grease, oil, or other substances stuck to the ramps.
- Never change the direction of travel when the machine is on the ramps. There is danger that the machine may tip over.
Return the machine to the road surface or the trailer platform, then change the direction of travel.
- It is dangerous to use the work equipment for the loading or unloading operation.
- Never operate any lever other than the travel lever on the ramps.
- The center of gravity of the machine will change suddenly at the joint between the ramps and the truck or trailer, and there is a hazard of the machine losing its balance. Travel slowly over this point.
- When swinging the upper structure on the trailer or truck, the machine is unstable, so pull in the work equipment and swing slowly.
- On machines with the cab specification, always check that the sliding door is locked in position, both when it is open and when it is closed. If the door is open or closed on the ramps or on the platform of the trailer, there is danger that the operating effort will suddenly change. Do not open or close the door on the ramps or trailer platform.

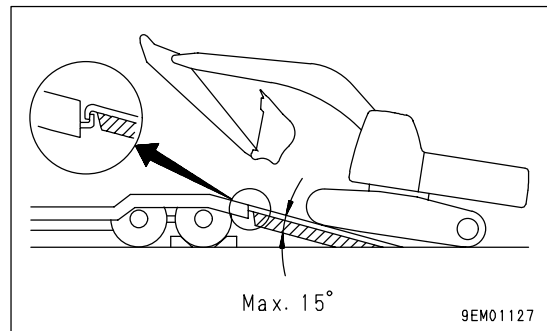
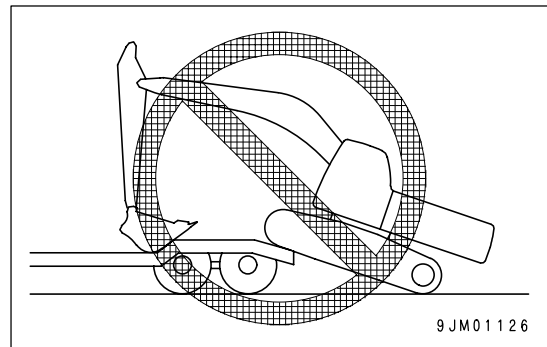
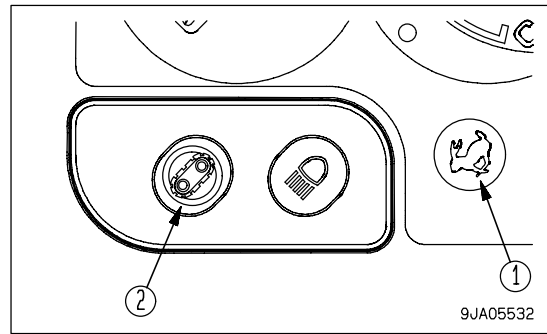

When loading or unloading, always use ramps or a platform and carry out the operation as follows.

Loading

1. Load and unload on firm level ground only.
 Maintain a safe distance from the edge of a road.
2. Properly apply the brakes on the trailer and put blocks under the tires to ensure that the trailer does not move.
 Make the slope of the ramps a maximum of 15°.

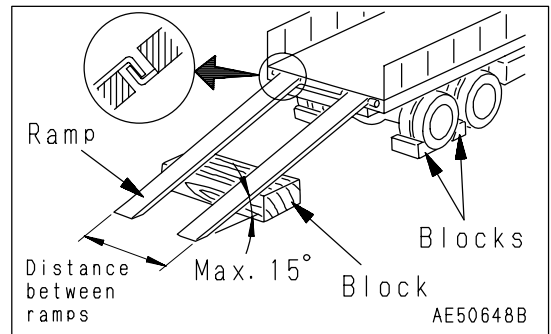

3. Set fuel control lever to the low idling position (A).

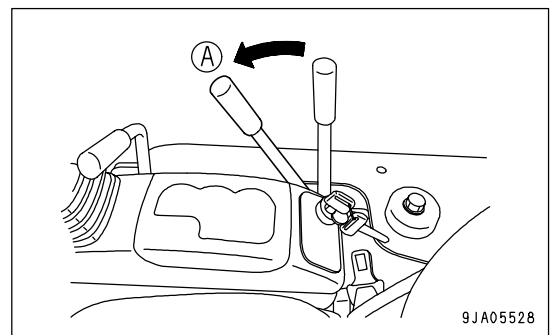

4. Check that the travel speed boost monitor is off.

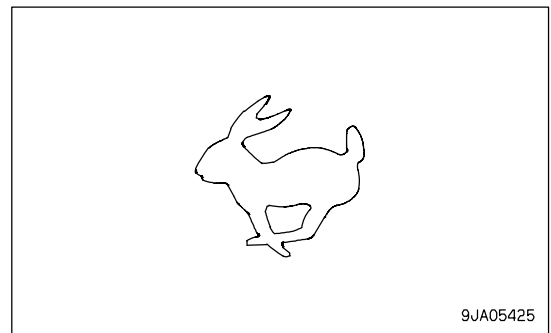

If the monitor is on, the speed is set to high speed travel, so press the travel speed selector switch.
 The monitor goes out and the speed is shifted to low speed travel.

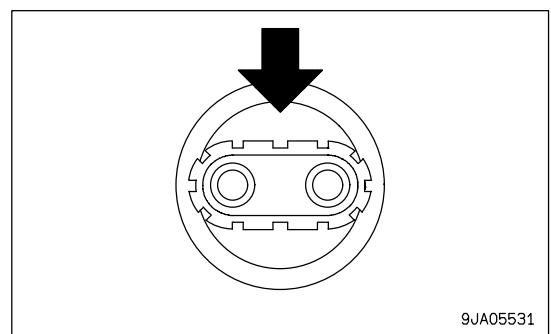

5. When loading, set the work equipment at the front and the blade at the rear, with the undercarriage and upper structure set parallel.
6. Before moving onto the ramps, make sure that the machine is positioned in a straight line with the ramps and that the centerline of the machine matches that of the trailer.
Align the direction of travel with the ramps and travel slowly.
Lower the work equipment as far as possible without causing interference.
When on the ramps, operate only the travel lever. Do not operate any other lever.
7. Stop the machine at the specified place, then swing the upper structure slowly 180°.

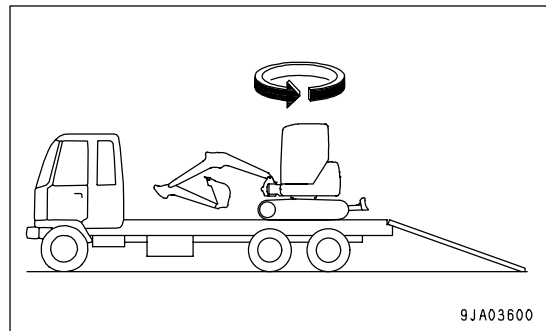
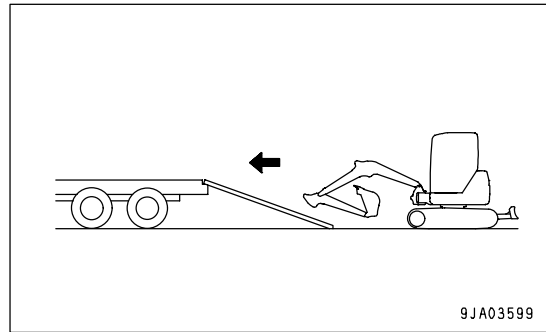

8. Load the machine at the specified position on the trailer or truck.

Securing Machine

After placing the machine on the specified position of the trailer, secure it according to the following procedure.

NOTICE

To prevent damage to the bucket cylinder during transportation, fit a wooden block at one end of the bucket cylinder to prevent it from touching the floor.

1. Lower the blade.
2. Extend the bucket and arm cylinders fully, then lower the boom slowly.
3. Stop the engine, then remove the key from the starting switch.
4. Secure control levers with the safety lock lever.

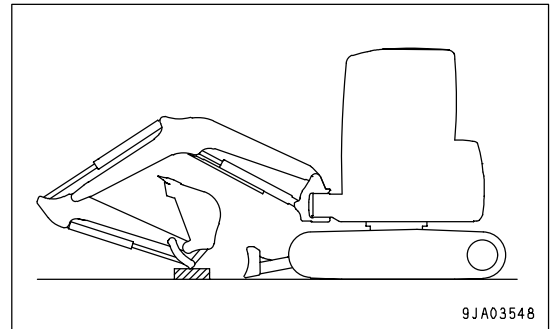

REMARK

For machines equipped with a cab, there is only a safety lock lever on the left.

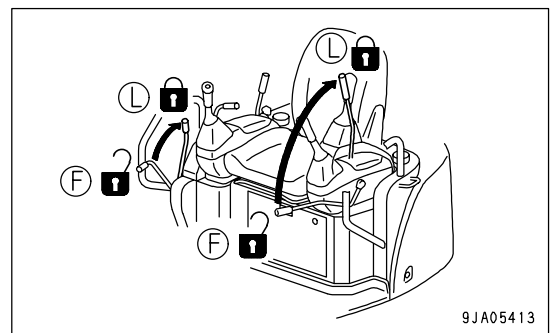

5. Lock the sliding door (cab specification) and covers with locks. See Section "Opening and Closing Covers with Lock (PAGE 3-28)".

NOTICE

Do not use the hole at the back of the track frame for towing or lifting the machine.

6. Place blocks under both ends of the tracks to prevent the machine from moving during transportation, and secure the machine with chains or wire rope of suitable strength. Be particularly careful to secure the machine in position so it does not slip to the side.

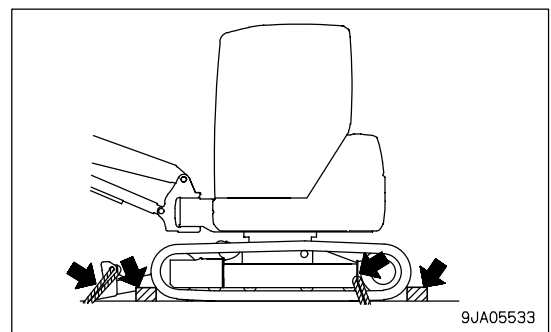

When securing with a chain or wire rope, use the hole at the rear of the track frame and the hole in the blade side plate.

Unloading

1. Load and unload on firm level ground only. Maintain a safe distance from the edge of a road.
2. Properly apply the brakes on the trailer and put blocks under the tires to ensure that the trailer does not move.
Make the slope of the ramps a maximum of 15°.
3. Remove the chains and wire ropes fastening the machine.
4. Start the engine.
Warm the engine up fully.

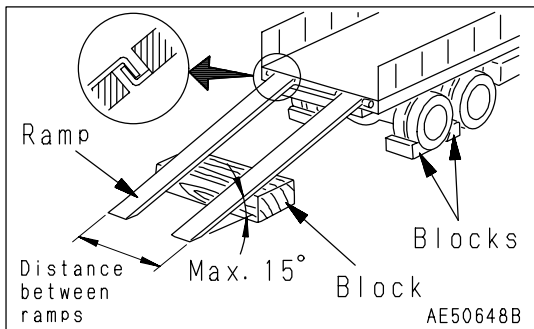

5. Check that the travel speed boost monitor is off.

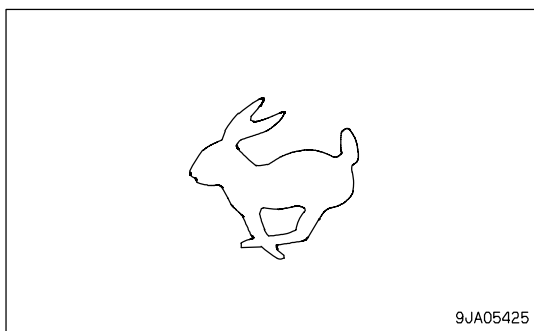

If the monitor is on, the speed is set to high speed travel, so press the travel speed selector switch.
The monitor goes out and the speed is shifted to low speed travel.

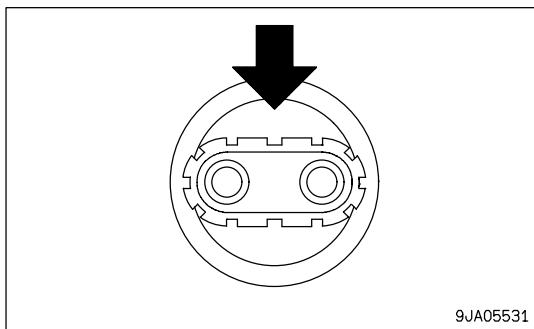

6. Set the safety lock lever to the FREE position.

Machine equipped with canopy

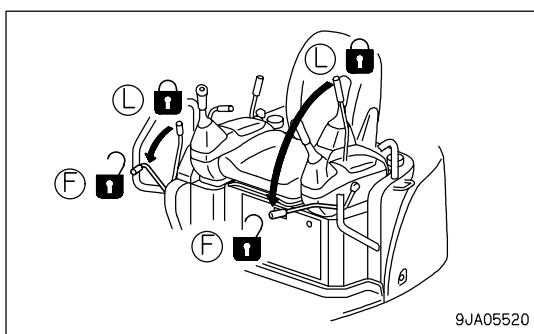

Machine equipped with cab

REMARK

For machines equipped with a cab, there is only a safety lock lever on the left.

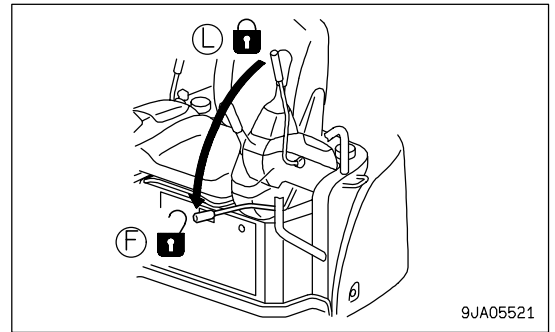

- 7. Set fuel control lever to the low idling position (A).
- 8. Raise the blade.

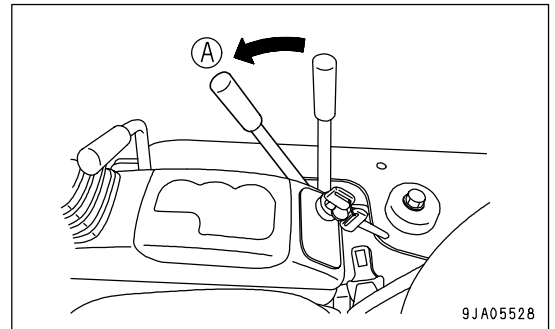

- 9. Raise the work equipment, align the direction of travel with the ramp, and travel slowly.
Lower the work equipment as far as possible without causing interference.
When on the ramps, operate only the travel lever. Do not operate any other lever or pedal.

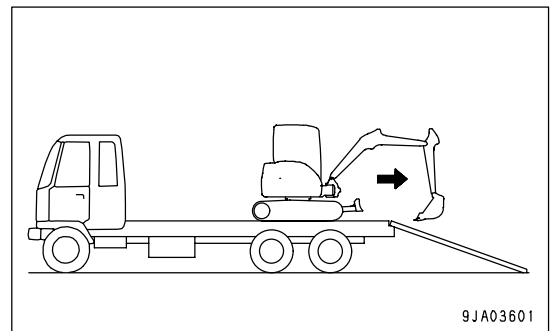

LIFTING MACHINE

**WARNING**

- The operator carrying out the lifting operation using a crane must be a properly qualified crane operator.
- Never raise the machine with any worker on it.
- Always make sure that the wire rope is of ample strength for the weight of this machine.
- Never lift the machine with the upper structure swung to the side. Always set the upper structure parallel to the undercarriage before lifting.
- When lifting, keep the machine horizontal.
- Never go under the machine when it is raised.
- Never try to lift the machine in any posture other than the posture given in the procedure below or using lifting equipment other than in the procedure below.

There is a hazard that the machine may lose its balance.

**CAUTION**

- It is prohibited to use the 4 hooks on the top of the cab to lift the machine. This will damage the cab.
- It is prohibited to use the transportation holes in the track frame to lift the machine. This will damage the track frame.

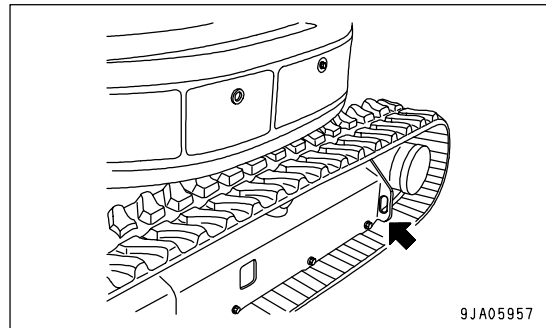
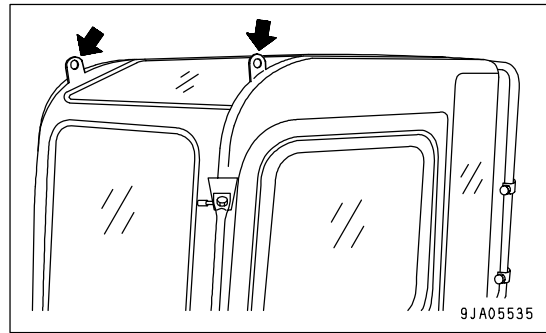
**NOTICE**

- For the details on the machine weight, see the section of "SPECIFICATIONS (PAGE 5-2)".
- The lifting procedure applies to machines with standard specifications.

The method of lifting differs according to the attachments and options actually installed. In such cases, please contact your Komatsu distributor for information.

When lifting the machine, carry out the operation on flat ground as follows.

1. Start the engine, then swing the upper structure so that the work equipment is at sprocket (1) end with the track frame and upper structure set parallel.
2. Raise the blade fully.
3. Extend the bucket cylinder, arm cylinder, and boom cylinder fully.
4. When the boom swing has been operated to the left or right, operate the boom swing pedal to set the boom parallel to the track frame, then set the pedal lock to the LOCK position.

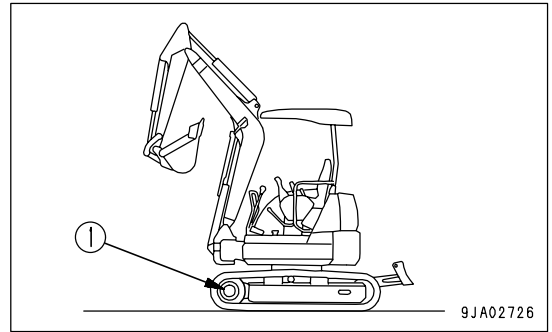

5. Operate the safety lock lever to the LOCK position.

REMARK

For machines equipped with a cab, there is only a safety lock lever on the left.

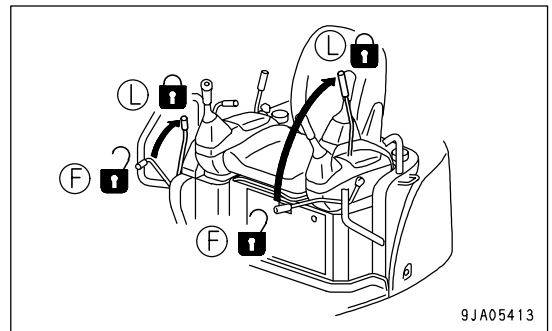

6. Stop the engine, check that there is nothing around the operator's compartment, then get off the machine.
For cab specification machines, close the cab door and front glass securely.
7. Install shackles to the lifting holes (2 places) on both ends of the blade, then install the wire ropes.

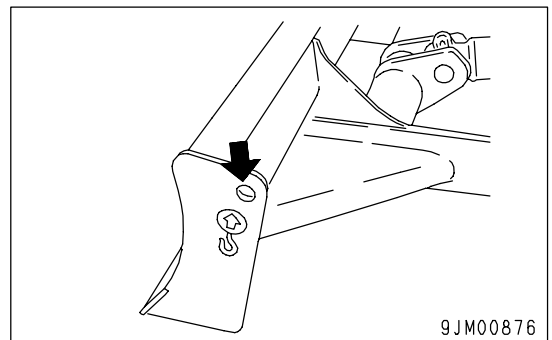

8. Pass the wire rope through the bracket on the boom (see diagram on right).

NOTICE

- Be sure to use the three brackets.
Do not lift the machine with the boom or the upper structure swung.
- Be careful not to get the hoses caught.

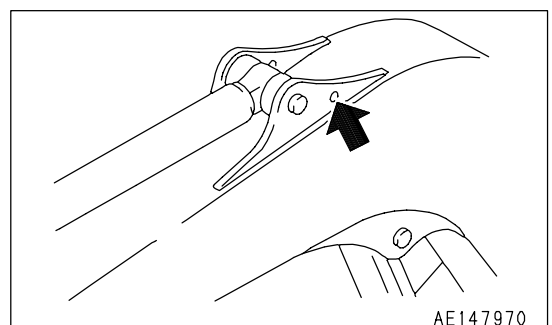

9. Set the lifting angle of the wire rope to 30° to 40° , then lift the machine slowly.
10. After the machine comes off the ground, check the hook condition and the lifting posture, and then lift slowly.

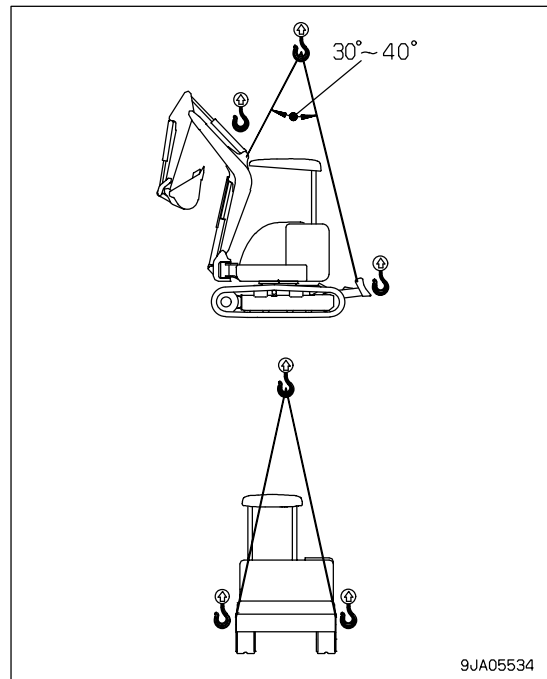

COLD WEATHER OPERATION

COLD WEATHER OPERATION INFORMATION

If the temperature becomes low, it becomes difficult to start the engine, and the coolant may freeze, so do as follows.

Fuel and Lubricants

Change to fuel and oil with low viscosity for all components. For details of the specified viscosity, see "LUBRICANTS, FUEL AND COOLANT SPECIFICATIONS (PAGE 4-9)".

Cooling System Coolant



WARNING

- Antifreeze is toxic. Be careful not to get it into your eyes or on your skin. If it should get into your eyes or on your skin, wash it off with large amounts of fresh water and see a doctor at once.
- When changing the coolant or when handling coolant containing antifreeze that has been drained when repairing the radiator, please contact your Komatsu distributor. Antifreeze is toxic, so do not let it flow into drainage ditches or spray it on to the ground surface.
- Antifreeze is flammable, so do not bring any flame close. Do not smoke when handling antifreeze.

NOTICE

- Never use methanol, ethanol, or propanol-based antifreeze.
- Never use any water-leakage prevention agent or any antifreeze containing such an agent.
- Do not mix different types of antifreeze.

For details of the antifreeze mixture when changing the coolant, see "CLEAN INSIDE OF COOLING SYSTEM (PAGE 4-22)".

Use a Permanent Antifreeze (ethylene glycol mixed with corrosion inhibitor, antifoam agent, etc.) meeting the standard requirements as shown below. With permanent antifreeze, no change of coolant is required for a year. If it is doubtful that an available antifreeze meets the standard requirements, ask the supplier of that antifreeze for information.

Standard requirements for permanent antifreeze

- SAE J1034
- FEDERAL STANDARD O-A-548D

REMARK

In areas where permanent antifreeze is not available, it is possible to use antifreeze whose main component is ethylene glycol and does not contain any corrosion inhibitor. (Such antifreeze can be used for the winter season only.) However, in such a case, the coolant must be changed twice a year (spring and fall), so use permanent antifreeze when possible.

Battery

WARNING

- The battery generates flammable gas, so do not bring fire or sparks near the battery.
- Battery electrolyte is dangerous. If it gets in your eyes or on your skin, wash it off with a large amount of water and consult a doctor.
- Battery electrolyte dissolves paint. If it gets on the bodywork, wash it off immediately with water.
- If the battery electrolyte is frozen, do not charge the battery or start the engine with a different power source. There is danger that the battery may explode.
- Battery electrolyte is toxic, so do not let it flow into drainage ditches or spray it on to the ground surface.

When the ambient temperature drops, the capacity of the battery will also drop. If the battery charge ratio is low, the battery electrolyte may freeze. Maintain the battery charge as close as possible to 100%, and insulate it against cold temperature so that the machine can be started easily the next morning.

REMARK

Measure the specific gravity and calculate the rate of charge from the following conversion table.

Temperature (°C) \ Charging Rate (%)	20	0	-10	-20
100	1.28	1.29	1.30	1.31
90	1.26	1.27	1.28	1.29
80	1.24	1.25	1.26	1.27
75	1.23	1.24	1.25	1.26

- As the battery capacity drops markedly in low temperatures, cover the battery or remove it from the machine, keep it in a warm place, and install it again the next morning.
- If the electrolyte level is low, add distilled water in the morning before beginning work. Do not add the water after the day's work so as to prevent fluid in the battery from freezing during the night.

CAB HEATER IN COLD WEATHER

(Machines equipped with cab)

If the ambient temperature drops, use the operator's cab heater.

When using the heater, turn valve (1) on the water manifold counterclockwise to open it.

When leaving the heater unused for a long time, turn valve (1) clockwise to close it.

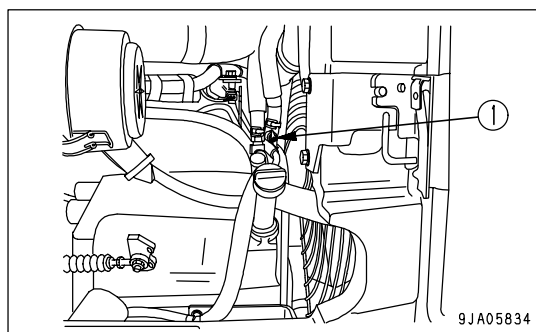

AFTER DAILY WORK COMPLETION



WARNING

- Performing idle-running of the tracks is dangerous, so stay well away from the tracks.

To prevent mud, water, or the undercarriage from freezing and making it impossible for the machine to move on the following morning, always observe the following precautions.

- Remove all the mud and water from the machine body. In particular, wipe the hydraulic cylinder rod clean to prevent damage to the seal caused by mud or dirt on the rod surface getting inside the seal together with drops of water.
- Park the machine on hard, dry ground.
If this is impossible, park the machine on wooden boards.
The boards help protect the tracks from being frozen in soil so the machine can move next morning.
- Open the drain valve and drain any water collected in the fuel system to prevent it from freezing.
- After operation in water or mud, remove water from undercarriage as described below to extend undercarriage service life.
 1. Swing 90° with engine at low idling and bring the work equipment to the side of the track.
 2. Jack up the machine until the track is raised slightly from the ground. Rotate the track under no load. Repeat this procedure on both the left and right sides.

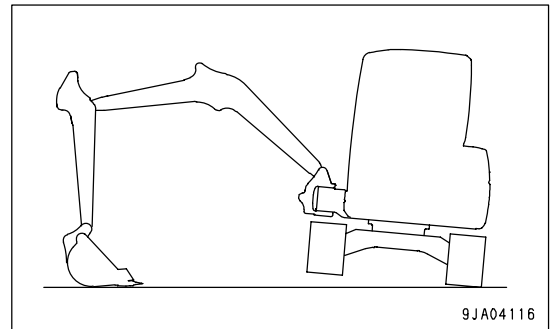

AFTER COLD WEATHER SEASON

When season changes and the weather becomes warmer, do as follows.

- Replace the fuel and oil for all parts with oil of the viscosity specified.
For details, see "LUBRICANTS, FUEL AND COOLANT SPECIFICATIONS (PAGE 4-9)".

LONG TERM STORAGE

BEFORE STORAGE

NOTICE

To protect the hydraulic cylinder piston rod while in storage, keep the work equipment in the posture shown at right.

(This prevents rust from developing on the piston rod)

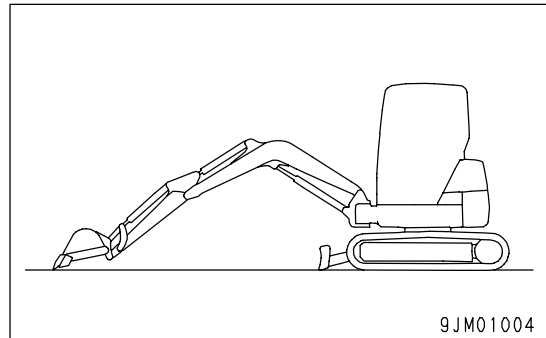

When keeping in long-term storage (more than one month), store as follows.

- Clean and wash all parts, then store the machine indoors. If the machine has to be stored outdoors, select level ground and cover the machine with a sheet.
- Fill the fuel tank to prevent moisture from accumulating.
- Completely fill the fuel tank, lubricate and change the oil before storage.
- Apply a thin coat of grease to the metal surface of the hydraulic piston rods.
- Disconnect the negative terminals of the battery and cover it, or remove it from the machine and store it separately.
- Lock each control lever and pedal with the safety lock lever and pedal lock.
- Set the stop valve to the LOCK position on machines ready for attachments. Install the blind plugs to the elbows.
- Set the selector valve on the machines which can install attachments to the "Crusher or general attachment" position.

DURING STORAGE



WARNING

When it is necessary to perform the rust-preventive operation while the machine is indoors, open the doors and windows to improve ventilation and prevent gas poisoning.

- During storage, always operate the machine once a month so that a new film of oil will be coated over movable parts and component surfaces. At the same time, also charge the battery.
- When operating the work equipment, wipe off all the grease from the hydraulic cylinder rod.
- If the machine is equipped with an air conditioner, operate it for 3 to 5 minutes once a month to lubricate each portion of its compressor. Be sure to idle the engine at low speed for this purpose. Also, check the quantity of refrigerant twice a year.

AFTER STORAGE

NOTICE

If the machine has been stored without the monthly rust prevention operation, consult your Komatsu distributor for service.

When using the machine after long-term storage, do as follows before using it.

- Wipe off the grease from the hydraulic cylinder rods.
- Add oil and grease at all lubrication points.
- When the machine is stored for a long period, moisture in the air can contaminate the oil over time. Check the oil for presence of water before and after starting the engine. If there is water in the oil, change the oil.

TROUBLES AND ACTIONS

RUNNING OUT OF FUEL

When starting the engine after running out of fuel, fill with fuel and bleed the air from the fuel system before starting. For details of bleeding the air, see "Air Bleeding (PAGE 4-51)".

PHENOMENA THAT ARE NOT FAILURES

Note that the following phenomena are not failures:

- When the arm control lever is operated to the IN position and the work equipment is lowered under no load from a high position, the arm speed will drop momentarily when the arm is more or less at the vertical position.

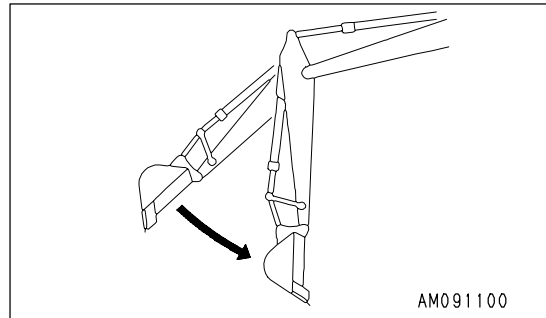

- When the bucket control lever is operated to the CURL position and the work equipment is lowered under no load from a high position, the bucket speed will drop momentarily when the bucket teeth are more or less at the horizontal position.

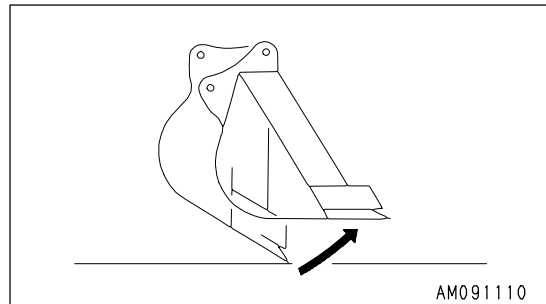

- When starting or stopping the swing, noise will be emitted from the brake valve.
- When going down a steep slope at low speed, a noise will be emitted from the travel motor brake valve.

TOWING THE MACHINE



WARNING

- When towing the machine, use a wire rope that has ample strength for the weight of the machine that is being towed.
- Do not apply a sudden load to the wire rope.

When the machine is stuck in soft ground and cannot escape under its own power, or when towing a heavy machine, pass the wire rope through the front of the track frame as shown in the diagram on the right before carrying out towing.

Places pieces of wood between the wire ropes and the body to prevent the wire ropes from damaging the body.

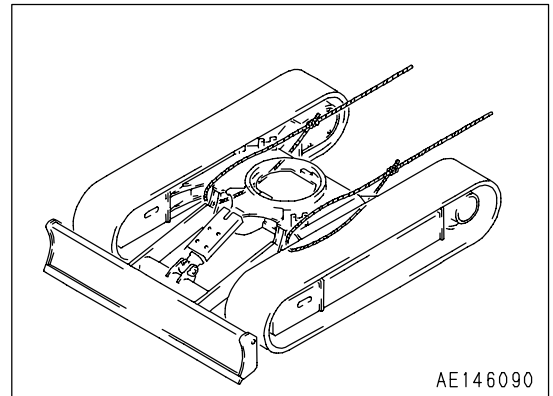

SEVERE JOB CONDITION

- When digging in water, if the water gets on to the work equipment mounting pins, add grease to bucket links (A), (B), (C), (D) and (E) for each operation.
- When carrying out heavy duty digging and deep digging operations, add grease to bucket links (A), (B), (C), (D) and (E) (total: 5 places) before each operation. After greasing, operate the bucket several times, then add grease again.

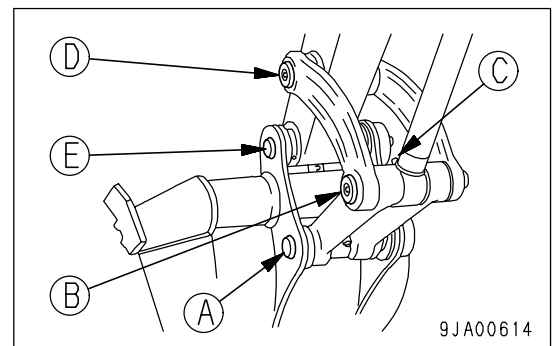

DISCHARGED BATTERY

**WARNING**

- It is dangerous to charge a battery when mounted on a machine. Make sure that it is dismantled before charging.
 - When checking or handling the battery, stop the engine and turn the starting switch key to the OFF position.
 - The battery generates hydrogen gas, so there is a hazard of explosion. Do not bring lighted cigarettes near the battery, or do anything that will cause sparks.
 - Battery electrolyte is dilute sulphuric acid, and it will attack your clothes and skin. If it gets on your clothes or on your skin, immediately wash it off with a large amount of water. If it gets in your eyes, wash it out with fresh water and consult a doctor.
 - When handling batteries, always wear protective goggles and rubber gloves.
 - When removing the battery, first disconnect the cable from the ground (normally the negative (-) terminal). When installing, install the positive (+) terminal first.
- If a tool touches the positive terminal and the chassis, there is danger that it will cause a spark, so be extremely careful.
- If the terminals are loose, there is danger that the defective contact may generate sparks that will cause an explosion.
 - When removing or installing the terminals, check which is the positive (+) terminal and which is the negative (-) terminal.

When removing, disconnect the cable from the ground terminal first.

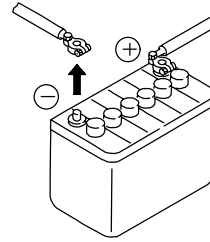

When installing, connect the cable to the positive (+) terminal first.

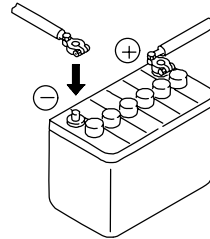

9EA00023

Battery Removal and Installation

NOTICE

After securing the battery, check that it does not move. If it moves, tighten it again securely.

- Before removing the battery, remove the ground cable (normally connected to the negative (-) terminal).
If any tool touches between the positive terminal and the chassis, there is a hazard of sparks being generated.
- When installing the battery, connect the ground cable last.
- Install the battery securely to the determined place. When doing this, be careful not to let the clamps contact the terminals.
- When replacing the battery, fix the battery securely with battery clamp (1).
Tightening torque for mounting bolt (2):
4.90 to 5.88 N·m (0.5 to 0.6 kgf·m, 3.6 to 4.3 lbft)
- Make sure that the cover on top of the battery covers the battery completely. Do not let it roll back.
If the cover is damaged, replace it immediately.
- If there is salt on the battery terminals, wash with water of a temperature of approx. 40°C (104°F), then dry completely and remove with a wire brush.

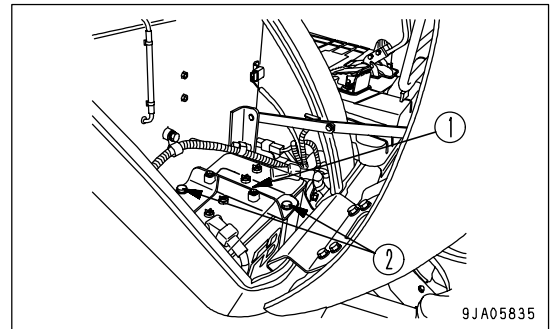

Battery Charges

When charging the battery, if the battery is not handled correctly, there is a hazard that the battery may explode. Always follow the instructions of "DISCHARGED BATTERY (PAGE 3-106)" and the instruction manual accompanying the charger, and do as follows.

- Flammable hydrogen gas is generated when the battery is charged, so remove the battery from the chassis, take it to a well-ventilated place, and remove the battery caps before charging it.
- Tighten the battery caps securely. If any battery cap is damaged, replace it immediately.
- Set the voltage of the charger to match the voltage of the battery to be charged. If the correct voltage is not selected, the charger may overheat and cause an explosion.
- Connect the positive (+) charger clip of the charger to the positive (+) terminal of the battery, then connect the negative (-) charger clip of the charger to the negative (-) terminal of the battery. Be sure to fix the clips securely.
- Set the charging current to 1/10 of the value of the rated battery capacity; when carrying out rapid charging, set it to less than the rated battery capacity.
If the charger current is too high, the electrolyte will leak or dry up, and this may cause the battery to catch fire and explode.
- If the battery electrolyte is frozen, do not charge the battery or start the engine with a different power source. There is a hazard that this will ignite the battery electrolyte and cause the battery to explode.
- Do not use or charge the battery if the battery electrolyte level is below the LOWER LEVEL line. This may cause an explosion. Always check the battery electrolyte level periodically and add distilled water to bring the electrolyte level to the UPPER LEVEL line.

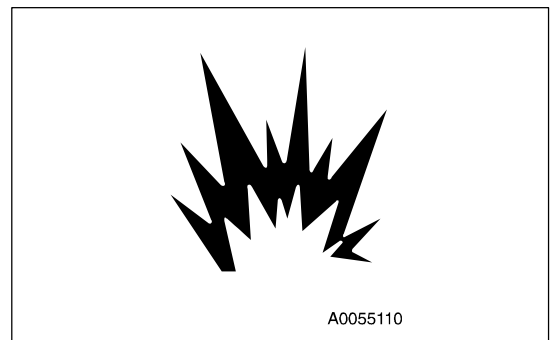

Starting Engine with Booster Cables

When starting the engine with a booster cable, do as follows:

Connecting and Disconnecting Booster Cables



WARNING

- When connecting the cables, never contact the positive (+) and negative (-) terminals.
- When starting the engine with a booster cable, always wear safety glasses.
- Be careful not to let the normal machine and problem machine contact each other. This prevents sparks from generating near the battery which could ignite the hydrogen gas given off by the battery. If hydrogen gas explodes, it could cause serious injury.
- Be careful not to make a mistake when connecting a booster cable. In the last connection (to the upper structure frame), a spark will be caused, so connect the cable to a spot as far away from the battery as possible. (Avoid the work equipment, however, because it is not a good conductor)
- When removing the booster cable, exercise good care so that the booster cable clips may not contact each other, or they contact the chassis.

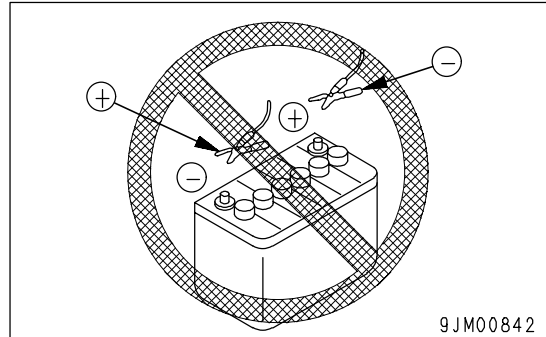

NOTICE

- The size of the booster cable and clip should be suitable for the battery size.
- The battery of the normal machine must be the same capacity as that of the engine to be started.
- Check the cables and clips for damage or corrosion.
- Make sure that the cables and clips are firmly connected.
- Check that the safety lock levers and parking brake levers of both machines are in the LOCK position.
- Check that each lever is in the NEUTRAL position.

Booster Cable Connection

Keep the starting switch of the normal machine and problem machine in the OFF position.

Connect the booster cable as follows, in the order of the numbers marked in the diagram.

1. Connect one clip of booster cable (A) to the positive (+) terminal of the problem machine.
2. Connect the other clip of booster cable (A) to the positive (+) terminal of the normal machine.
3. Connect one clip of booster cable (B) to the negative (-) terminal of the normal machine.
4. Connect the other clip of booster cable (B) to the engine block of the problem machine.

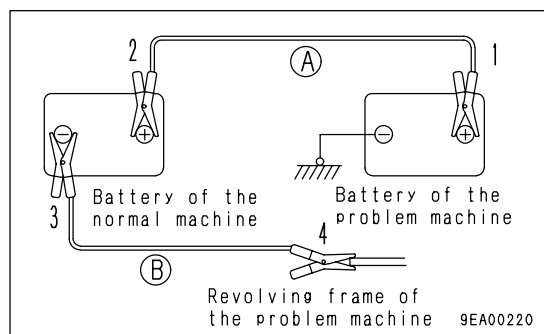

Starting the Engine

 **CAUTION**

Always check that the safety lock lever is set to the LOCK position, regardless of whether the machine is working normally or has failed. Check also that all the control levers are at the HOLD or neutral position.

1. Make sure the clips are firmly connected to the battery terminals.
 2. Start the engine of the normal machine and keep it running at high idle.
 3. Turn the starting switch of the problem machine to the START position and start the engine.
- If the engine doesn't start at first, try again after 2 minutes or so.

Booster Cable Disconnection

After the engine has started, disconnect the booster cables in reverse order of connection.

1. Remove one clip of booster cable (B) from the engine block of the problem machine.
2. Remove the other clip of booster cable (B) from the negative (-) terminal of the normal machine.
3. Remove one clip of booster cable (A) from the positive (+) terminal of the normal machine.
4. Remove the other clip of booster cable (A) from the positive (+) terminal of the problem machine.

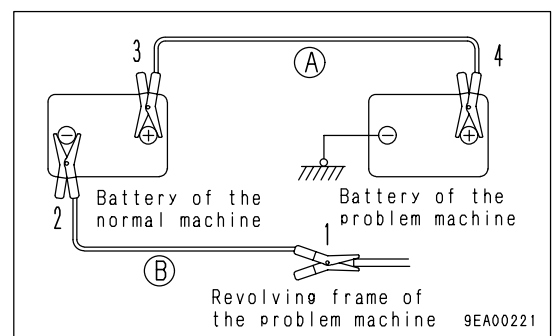

OTHER TROUBLE

Electrical System

- (): Always contact your Komatsu distributor when dealing with these items.
- In cases of abnormalities or causes which are not listed below, contact your Komatsu distributor for repairs.

Problem	Main causes	Remedy
Lamp dose not glow brightly even when the engine runs at high speed	<ul style="list-style-type: none"> • Defective wiring • Defective adjustment of fan belt tension • Blown fuse 	<ul style="list-style-type: none"> (• Check, repair loose terminals, disconnections) • Adjust fan belt tension For details, see EVERY 500 HOURS SERVICE <ul style="list-style-type: none"> • Replace
Lamp flickers while engine is running		
Charge level monitor dose not go out even when engine is running	<ul style="list-style-type: none"> • Defective alternator • Defective wiring 	<ul style="list-style-type: none"> (• Replace) (• Check, repair)
Abnormal noise is generated from alternator	<ul style="list-style-type: none"> • Defective alternator 	<ul style="list-style-type: none"> (• Replace)
Starting motor dose not turn when starting switch is turned to ON	<ul style="list-style-type: none"> • Defective wiring • Insufficient battery charge • Blown fuse 	<ul style="list-style-type: none"> (• Check, repair) • Charge • Replace
Starting motor pinion repeatedly moves in and out (makes rattling sound)	<ul style="list-style-type: none"> • Insufficient battery charge 	<ul style="list-style-type: none"> • Charge
Starting motor turns engine sluggishly	<ul style="list-style-type: none"> • Insufficient battery charge • Defective starting motor 	<ul style="list-style-type: none"> • Charge (• Replace)
Starting motor disengages before engine starts	<ul style="list-style-type: none"> • Defective wiring • Insufficient battery charge 	<ul style="list-style-type: none"> (• Check, repair) • Charge
Pre-heating monitor dose not lights	<ul style="list-style-type: none"> • Defective wiring • Defective monitor 	<ul style="list-style-type: none"> (• Check, repair) (• Replace)
Oil pressure monitor dose not light up when engine is stopped (starting switch at ON position)	<ul style="list-style-type: none"> • Defective monitor • Defective oil pressure switch 	<ul style="list-style-type: none"> (• Replace) (• Replace)

Chassis

- (): Always contact your Komatsu distributor when dealing with these items.
- In cases of abnormalities or causes which are not listed below, contact your Komatsu distributor for repairs.

Problem	Main causes	Remedy
Speed of travel, swing, boom, arm, bucket is slow	<ul style="list-style-type: none"> • Lack of hydraulic oil 	<ul style="list-style-type: none"> • Add oil to specified level, see CHECK BEFORE STARTING
Pump generates abnormal noise	<ul style="list-style-type: none"> • Clogged element in hydraulic tank strainer 	<ul style="list-style-type: none"> • Clean, see EVERY 2000 HOURS SERVICE
Excessive rise in hydraulic oil temperature	<ul style="list-style-type: none"> • Lack of hydraulic oil • Loose fan belt • Clogged radiator fins, oil cooler fins 	<ul style="list-style-type: none"> • Add oil to specified level, see CHECK BEFORE STARTING • Adjust fan belt tension, EVERY 500 HOURS SERVICE • Clean or repair. For details, see EVERY 500 HOURS SERVICE
Track comes off	<ul style="list-style-type: none"> • Track too loose 	<ul style="list-style-type: none"> • Adjust track tension, see WHEN REQUIRED
Abnormal wear of sprocket		

Engine

- (): Always contact your Komatsu distributor when dealing with these items.
- In cases of abnormalities or causes which are not listed below, contact your Komatsu distributor for repairs.

Problem	Main causes	Remedy
Engine oil pressure monitor flashes (buzzer sounds at same time)	<ul style="list-style-type: none"> • Engine oil pan oil level is low (sucking in air) • Clogged oil filter cartridge • Defective tightening of oil pipe joint, oil leakage from damaged part • Defective engine oil pressure sensor 	<ul style="list-style-type: none"> • Add oil specified level, see CHECK BEFORE STARTING • Replace cartridge, see EVERY 500 HOURS SERVICE (• Check, repair) (• Replace sensor)
Steam is emitted from top part of radiator (pressure valve)	<ul style="list-style-type: none"> • Coolant level low, water leakage • Loosen fan belt • Dirt or scale accumulated in cooling system 	<ul style="list-style-type: none"> • Add coolant, repair, see CHECK BEFORE STARTING • Adjust fan belt tension, see EVERY 500 HOURS SERVICE • Change coolant, clean inside of cooling system, see WHEN REQUIRED
Engine coolant temperature gauge indicator is in red range (at same time, pilot lamp flashes and buzzer sounds)	<ul style="list-style-type: none"> • Clogging radiator fin or damaged fin • Defective thermostat • Loosen radiator filler cap (high altitude operation) • Defective water level sensor 	<ul style="list-style-type: none"> • Clean or repair, see EVERY 500 HOURS SERVICE (• Replace thermostat) • Tighten cap or replace packing (• Replace sensor)
Even when engine is run for a long time, engine coolant temperature gauge indicator does not enter correct range	<ul style="list-style-type: none"> • Defective thermostat • Monitor defective 	<ul style="list-style-type: none"> (• Replace thermostat) (• replace monitor)
Even when coolant temperature gauge indicator is in correct range, pilot lamp flashes	<ul style="list-style-type: none"> • Defective thermostat 	<ul style="list-style-type: none"> (• Replace thermostat)
Engine does not start when starting motor is turned	<ul style="list-style-type: none"> • Lack of fuel • Air in fuel system • Water in fuel system • Defective fuel injection pump or nozzle • Starting motor cracks engine sluggishly • Engine pre-heating monitor does not lights up • Defective compression <ul style="list-style-type: none"> • Defective valve clearance 	<ul style="list-style-type: none"> • Add fuel, see CHECK BEFORE STARTING • Repair place where air is sucked in, see EVERY 500 HOURS SERVICE • Drain water from system, see WHEN REQUIRED and CHECK BEFORE STARTING (• Replace pump or nozzle) • See ELECTRICAL SYSTEM • See ELECTRICAL SYSTEM (• Adjust valve clearance)
Exhaust gas is whiter or blue	<ul style="list-style-type: none"> • Too mach oil in oil pan • Improper fuel 	<ul style="list-style-type: none"> • Add oil specified level, see CHECK BEFORE STARTING • Change to specified fuel

Problem	Main causes	Remedy
Exhaust gas occasionally turns black	<ul style="list-style-type: none"> • Clogging air cleaner element • Defective nozzle • Defective compression 	<ul style="list-style-type: none"> • Clean or replace, see WHEN REQUIRED (• Replace nozzles) (• See defective compression above)
Combustion noise occasionally makes breathing sound	<ul style="list-style-type: none"> • Defective nozzle 	<ul style="list-style-type: none"> (• Replace nozzle)
Abnormal noise generated (combustion or mechanical)	<ul style="list-style-type: none"> • Low grade fuel being used • Overheating • Damage inside muffler • Excessive valve clearance 	<ul style="list-style-type: none"> • Change to specified fuel • See red range of engine coolant temperature gauge lights up as above • Replace muffler (• Adjust valve clearance)

MAINTENANCE

WARNING

Please read and make sure that you understand the SAFETY section before reading this section.

MAINTENANCE INFORMATION

Do not carry out any inspection and maintenance operation that is not found in this manual.

Service Meter Reading

Check the service meter reading every day to see if the time has come for any necessary maintenance to be performed.

Komatsu Genuine Replacement Parts

Use Komatsu genuine parts specified in the Parts Book as replacement parts.

Komatsu Genuine Lubricants

Use Komatsu genuine oils and grease. Choose oils and grease with proper viscosities specified for ambient temperature.

Windshield Washer Fluid

Use automobile window washer fluid, and be careful not to let any dirt get into it.

Fresh and Clean Lubricants

Use clean oil and grease. Also, keep the containers of the oil and grease clean. Keep foreign materials away from oil and grease.

Check Drained Oil and Used Filter

After oil is changed or filters are replaced, check the old oil and filters for metal particles and foreign materials. If large quantity of metal particles or foreign materials are found, always report to the person in charge, and carry out suitable action.

Fuel Strainer

If your machine is equipped with a fuel strainer, do not remove it while fueling.

Welding Instructions

- Turn off the engine ignition switch.
- Do not apply more than 200 V continuously.
- Connect grounding cable within 1 m (3.3 ft) of the area to be welded. If grounding cable is connected near instruments, connectors, etc., the instruments may malfunction.
- If a seal or bearing happens to come between the part being welded and grounding point, change the the grounding point to avoid such parts.
- Do not use the area around the work equipment pins or the hydraulic cylinders as the grounding point.

Do not Drop Things Inside Machine

- When opening inspection windows or the oil filler port of the tank to carry out inspection, be careful not to drop nuts, bolts, or tools inside the machine.
If such things are dropped inside the machine, it may cause damage and/or malfunction of the machine, and will lead to failure. If you drop anything inside the machine, always remove it immediately.
- Do not put unnecessary things in your pockets. Carry only things which are necessary for inspection.

Dusty Jobsite

When working at dusty worksites, do as follows:

- Inspect the air cleaner clogging monitor frequently to see if the air cleaner is clogged.
Clean the air cleaner element at a shorter interval than specified.
- Clean the radiator core frequently to avoid clogging.

- Clean and replace the fuel filter frequently.
- Clean electrical components, especially the starting motor and alternator, to avoid accumulation of dust.
- When inspecting or changing the oil, move the machine to a place that is free of dust to prevent dirt from getting into the oil.

Avoid Mixing Lubricants

If a different brand or grade of oil has to be added, drain the old oil and replace all the oil with the new brand or grade of oil. Never mix different brand or grade of oil.

Cover on Right Side of the Machine

If the cover on the right side of the machine is fully opened and the boom is swung to the right, there is danger that the boom may hit the cover and break it.

If the boom must be swung to the right with the cover open, set the cover so that it is half-open.

Locking the Inspection Covers

Lock inspection cover securely into position with the lock bar. If inspection or maintenance is performed with inspection cover not locked in position, there is a hazard that it may suddenly be blown shut by the wind and cause injury to the worker.

Hydraulic System - Air Bleeding

After repairing or replacing the hydraulic equipment or after removing the hydraulic piping, it is necessary to bleed the air from the circuit. For details, see "CHANGE OIL IN HYDRAULIC TANK, CLEAN STRAINER (PAGE 4-57)".

Hydraulic Hose Installation

- When removing parts at locations where there are O-rings or gasket seals, clean the mounting surface, and replace with new parts.
When doing this, be careful not to forget to assemble the O-rings and gaskets.
- When installing the hoses, do not twist or bend them into loops with a small radius.
This will cause damage to the hose and drastically reduce its service life.

Checks After Inspection and Maintenance Works

If you forget to perform the checks after inspection and maintenance, unexpected problems may occur, and this may lead to serious injury or property damage. Always do the following:

- Checks after operation (with engine stopped)
 - Have any inspection and maintenance points been forgotten?
 - Have all inspection and maintenance items been performed correctly?
 - Have any tools or parts been dropped inside the machine? It is particularly dangerous if parts are dropped inside the machine and get caught in the lever linkage mechanism.
 - Is there any coolant or oil leaks?
Have all nuts and bolts been tightened?
- Checks when operating engine
 - For details of the checks when operating the engine, see "TWO WORKERS FOR MAINTENANCE WHEN ENGINE IS RUNNING (PAGE 2-35)" and pay careful attention to safety.
 - Are the inspection and maintenance items working properly?
 - Is there any leakage of fuel or oil when the engine speed is raised?

Use of Fuel and Lubricants According to Ambient Temperature

It is necessary to decide the type of fuel and lubricants according to the ambient temperature.

For details, see Section "LUBRICANTS, FUEL AND COOLANT SPECIFICATIONS (PAGE 4-9)".

LUBRICANTS, COOLANT AND FILTERS

HANDLING OIL, FUEL, COOLANT, AND PERFORMING OIL CLINIC

Oil

- Oil is used in the engine and hydraulic equipment under extremely severe conditions (high temperature, high pressure), and deteriorates with the use.

Always use oil that matches the grade and maximum and minimum ambient temperatures recommended in the Operation and Maintenance Manual. Even if the oil is not dirty, always change the oil after the specified interval.

- Oil corresponds to blood in the human body, so always be careful when handling it to prevent any impurities (water, metal particles, dirt, etc.) from getting in.

The majority of problems with machines are caused by the entry of such impurities.

Take particular care not to let any impurities get in when storing or adding oil.

- Never mix oils of different grades or brands.
- Always add the specified amount of oil.

Having too much oil or too little oil are both causes of problems.

- If the oil in the work equipment is not clear, there is probably water or air getting into the circuit. In such cases, please contact your Komatsu distributor.
- When changing the oil, always replace the related filters at the same time.
- We recommend you have an analysis made of the oil periodically to check the condition of the machine. For those who wish to use this service, please contact your Komatsu distributor.
- When using commercially available oil, it may be necessary to shorten the oil change interval. For this reason, we recommend making full use of the Komatsu oil clinic.

Fuel

- After completing the day's operations, fill the fuel tank to force out any air containing moisture. This will prevent the moisture from condensing and mixing with the fuel.
- The fuel pump is a precision instrument, and if fuel containing water or dirt is used, it cannot work properly.
- Be extremely careful not to let impurities get in when storing or adding fuel.
- Always use the fuel specified in the Operation and Maintenance Manual. Fuel may congeal depending on the temperature when it is used (particularly in low temperature below -15°C (5 °F)). It is necessary to use the fuel that is suitable for the temperature.
- Before starting the engine, or when 10 minutes have passed after adding fuel, drain the sediment and water from the fuel tank.
- If the engine runs out of fuel, or if the filters have been replaced, it is necessary to bleed the air from the circuit.
- If there is any foreign material in the fuel tank, wash the tank and fuel system.

Cooling System Coolant

- River water contains large amount of calcium and other impurities, so if it is used, scale will stick to the engine and radiator, and this will cause defective heat exchange and overheating.

Do not use water that is not suitable for drinking.

- When using antifreeze, always observe the precautions given in the Operation and Maintenance Manual.
- Komatsu machines are supplied with Komatsu original anti-freeze in the coolant when the machine is shipped. This anti-freeze is effective in preventing corrosion of the cooling system. The anti-freeze can be used continuously for two years or 4000 hours. Therefore, it can be used as it is even in hot areas.
- Antifreeze is flammable, so be extremely careful not to expose it to flame or fire.
- The proportion of anti-freeze to water differs according to the ambient temperature. For details of the mixing proportions, see "CLEAN INSIDE OF COOLING SYSTEM (PAGE 4-22)".
- If the engine overheats, wait for the engine to cool before adding coolant.

- If the coolant level is low, it will cause overheating and will also cause problems with corrosion from the air in the coolant.

Grease

- Grease is used to prevent twisting and noise at the joints.
- This construction equipment is used under heavy-duty conditions. Always use the recommended grease and follow the change intervals and recommended ambient temperatures given in this Operation and Maintenance Manual.
- The nipples not included in the maintenance section are nipples for overhaul, so they do not need grease. If any part becomes stiff after being used for long time, add grease.
- Always wipe off all of the old grease that is pushed out when greasing. Be particularly careful to wipe off the old grease in places where sand or dirt sticking in the grease would cause wear of the rotating parts.

Carrying Out KOWA (Komatsu Oil Wear Analysis)

The oil clinic samples the oil periodically and analyzes it. This is a preventive maintenance service, which provides early discovery of abnormal parts and wear of the drive parts of the machine. This then makes it possible to ensure prevention of failures and reduction in downtime.

Komatsu’s long years of experience and rich supply of accumulated data make it possible to accurately determine the condition of your machine. This enables us to locate the problems and to recommend suitable and timely repair methods.

The oil clinic charges the customer only the actual costs, and provides an immediate report of the results of the analysis and recommendations for action to take. This low-cost service can save you high costs and inconvenience in the future, so we strongly recommend you to avail yourself of this service.

KOWA Analysis Items

- Analysis of metal wear particles
This uses an ICP (Inductively Coupled Plasma) analyzer to measure the density of metal wear particles in the oil.

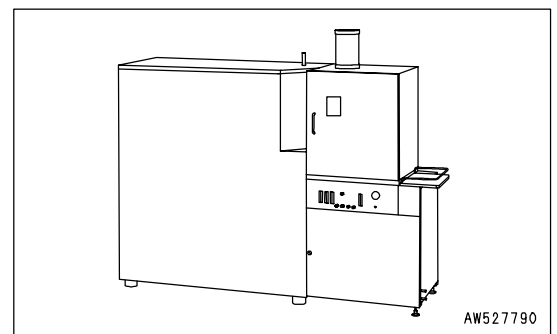

- Measurement of particle quantity
This uses a PQI (Particle Quantifier Index) machine to measure the quantity of large iron particles in the oil.

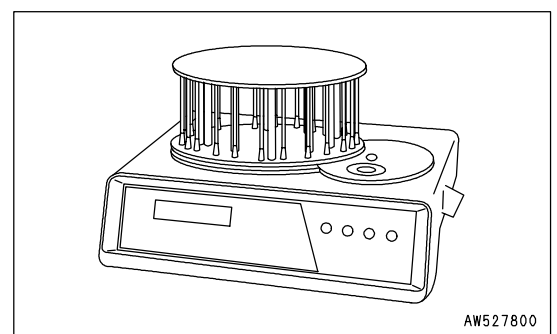

- Others
Measurements are made of items such as the ratio of water or fuel in the oil, and the dynamic viscosity.

Oil Sampling

- Collection interval
Every 500 hours: Engine and components other than engine
- Precautions when sampling
 - Make sure that the oil is well mixed before sampling.
 - Carry out sampling regularly at fixed intervals.
 - Do not carry out sampling on rainy or windy days when water or dust can get into the oil.

For further details of KOWA, please contact your Komatsu distributor.

Oil and Fuel Storage

- Keep indoors to prevent any water, dirt, or other impurities from getting in.
- When keeping drum cans for a long period, put the drum on its side so that the filler port of the drums is at the side to prevent moisture from being sucked in.
If drums have to be stored outside, cover them with a waterproof sheet or take other measures to protect them.
- To prevent any change in quality during long-term storage, be sure to use in the order of first in - first out (use the oldest oil or fuel first).

Filters

- Filters are extremely important safety parts. They prevent impurities in the fuel and air circuits from entering important equipment and causing problems.
Replace all filters periodically. For details, see the Operation and Maintenance Manual.
However, when working in severe conditions, replace the filters at shorter intervals according to the oil and fuel (sulfur content) being used.
- Never try to clean the filters (cartridge type) and use them again. Always replace with new filters.
- When replacing oil filters, check if any metal particles are affixed to the old filter. If any metal particles are found, contact your Komatsu distributor.
- Do not open packs of spare filters until just before they are to be used.
- Always use Komatsu genuine filters.

ELECTRIC SYSTEM MAINTENANCE

- It is extremely dangerous if the electrical equipment becomes wet or the covering of the wiring is damaged. This will cause an electrical short circuit and may lead to malfunction of the machine. Do not wash the inside of the operator's cab with water. When washing the machine, be careful not to let water get into the electrical components.
- Service relating to the electric system is checking fan belt tension, checking damage or wear to the fan belt and checking battery fluid level.
- Never install any electric components other than those specified by Komatsu.
- External electro-magnetic interference may cause malfunction of the control system controller, so before installing a radio receiver or other wireless equipment, please contact your Komatsu distributor.
- When working at the seashore, carefully clean the electric system to prevent corrosion.
- When installing an operator's cab cooler or any other electrical equipment, connect it to an independent power source connector. The cables to supply power to the optional equipment must never be connected to the fuse, starting switch, or battery relay.

HANDLING HYDRAULIC SYSTEM

- Hydraulic equipment is at a high temperature during operations and immediately after operations. During operations, it is also under high pressure, so be careful of the following points when carrying out inspection and maintenance of hydraulic-related equipment.
 - Stop the machine on level ground, lower the bucket completely to the ground, and set so that there is no pressure on the cylinder circuits.
 - Always stop the engine.
 - Immediately after the engine is stopped, the hydraulic oil and lubricants are at a high temperature and high pressure. Wait for the temperature to go down before starting the maintenance operation. Even when the temperature goes down, the circuits may be under internal pressure, so when loosening plugs, screws, or hose connections, do not stand directly in front. Loosen gradually to release the internal pressure before removing.
 - Always release the air in the hydraulic tank to remove the internal pressure before carrying out inspection and maintenance of the hydraulic circuit.
- Inspection and maintenance works include checking the hydraulic system for oil level, replacement of filter elements and replacement of hydraulic oil.
- If high-pressure hoses have been removed, check that there is no damage to the O-rings. If any damage is found, replace the O-ring.
- It is necessary to bleed the air from the circuits when the hydraulic filter element or strainer have been replaced or washed, or when hydraulic equipment has been repaired or replaced, or when the hydraulic piping has been removed.

WEAR PARTS

Replace wear parts such as the filter element or air cleaner element at the time of periodic maintenance or before they reach the wear limit. The wear parts should be replaced correctly in order to ensure more economic use of the machine. When replacing parts, always use Komatsu genuine parts.

As a result of our continuous efforts to improve product quality, the part number may change, so inform your Komatsu distributor of the machine serial number and check for the latest part number when ordering parts.

WEAR PARTS LIST

The parts in parentheses are to be replaced at the same time.

Item	Part No.	Part Name	Q'ty	Replacement frequency	
Engine oil filter	451-251	Cartridge	1	EVERY 500 HOURS	
Fuel filter	457-777	Cartridge	1	EVERY 500 HOURS	
Hydraulic filter	457-769	Element	1	EVERY 1000 HOURS	
Water separator	457-771	Element	1	-	
Air cleaner	Single type	457-772	Element	1	-
	Double type	457-772	Element (Outer)	1	-
452-368		Element (Inner)	1		
Standard bucket (vertical pin)	458-053	Tooth	4	-	
	(454-141)	(Pin)	(4)		
	(453-260)	(Lock)	(4)		
	452-034	Cuttet (left)	1	-	
	452-035	Cutter (right)	1		
	(456-665)	(Bolt)	(8)		
(457-460)	(Nut)	(8)			

LUBRICANTS, FUEL AND COOLANT SPECIFICATIONS

RESERVOIR	KIND OF FLUID	AMBIENT TEMPERATURE									
		-22 -30	-4 -20	14 -10	32 0	50 10	68 20	86 30	104 40	122°F 50°C	
Engine oil pan	Engine oil					SAE 30					
				SAE 10W							
				SAE 10W-30							
				SAE 15W-40							
Final drive case					SAE 30						
Hydraulic system					SAE 10W						
					SAE 10W-30						
					SAE 15W-40						
Fuel tank		Diesel fuel				ASTM D975 No.2					
					*1						
Grease fitting	Grease	HYPER WHITE GREASE									
Cooling system	Water	Add antifreeze									

*1: ASTM D975 No.1

		Engine oil pan	Final drive case (each)	Hydraulic system	Fuel tank	Cooling system
Specified capacity	Liters	8.0	0.8	55	65	7.3
	US gal	2.11	0.21	14.53	17.17	1.93
Refill capacity	Liters	7.4	0.8	20	-	-
	US gal	1.96	0.21	5.28	-	-

REMARK

- When fuel sulphur content is less than 0.5%, change oil in the oil pan according to the periodic maintenance hours described in this manual.
Change oil according to the following table if fuel sulphur content is above 0.5%.
- When starting the engine with an atmospheric temperature of lower than 0°C (32°F), be sure to use engine oil of SAE10W, SAE10W-30 and SAE15W-40, even though the atmospheric temperature goes up to 10°C (50° F) more or less during the day.
- Use API classification CD as engine oil and if API classification CC, reduce the engine oil change interval to half.
- There is no problem if single grade oil is mixed with multigrade oil (SAE10W-30, 15W-40), but be sure to add single grade oil that matches the temperature range in the table.
- We recommend Komatsu genuine oil which has been specifically formulated and approved for use in engine and hydraulic work equipment applications.

Specified capacity: Total amount of oil including oil for components and oil in piping.

Refill capacity: Amount of oil needed to refill system during normal inspection and maintenance.

ASTM: American Society of Testing and Material

SAE: Society of Automotive Engineers

API: American Petroleum Institute

Fuel sulphur content	Change interval of oil in engine oil pan
0.5 to 1.0%	1/2 of regular interval
Above 1.0%	1/4 of regular interval

No.	Supplier	Engine Oil [CD or CE] SAE10W, 30, 40 10W30, 15W40 (The 15W40 oil marked * is CE.)	Gear Oil [GL-4 or GL-5] SAE80, 90, 140	Grease [Lithium-Base] NLGI No.2	Anti-freeze Coolant [Ethylene Glycol Base] Permanent Type
1	KOMATSU	EO10-CD EO30-CD EO10-30CD EO15-40CD	GO90 GO140	G2-LI G2-LI-S	AF-ACL AF-PTL AF-PT(Winter, one season type)
2	AGIP	Diesel sigma S super dieselmulti- grade *Sigma turbo	Rotra MP	GR MU/EP	-
3	AMOCO	*Amoco 300	Multi-purpose gear oil	PYKON premium grease	-
4	ARCO	*Arcofleet S3 plus	Arco HD gear oil	Litholine HEP 2 Arco EP moly D	-
5	BP	Vanellus C3	Gear oil EP Hypogear EP	Energrease LS-EP2	Antifreeze
6	CALTEX	*RPM delo 400 RPM delo 450	Universal thuban Universal thuban EP	Marfak all purpose 2 Ultra-duty grease 2	AF engine coolant
7	CASTROL	*Turbomax *RX super CRD	EP EPX Hypoy Hypoy B Hypoy C	MS3 Spheerol EPL2	Anti-freeze
8	CHEVRON	*Delo 400	Universal gear	Ultra-duty grease 2	-
9	CONOCO	*Fleet motor oil	Universal gear lubricant	Super-sta grease	-
10	ELF	Multiperformance 3C Performance 3C	-	Tranself EP Tranself EP type 2	Glacelf
11	EXXON (ESSO)	Essolube D3 *Essolube XD-3 *Essolube XD-3 Extra *Esso heavy duty Exxon heavy duty	Gear oil GP Gear oil GX	Beacon EP2	All season coolant
12	GULF	Super duty motor oil *Super duty plus	Multi-purpose gear lubricant	Gulfcrown EP2 Gulfcrown EP special	Antifeeze and coolant
13	MOBIL	Delvac 1300 *Delvac super 10W-30, 15W-40	Mobilube GX Mobilube HD	Mobilux EP2 Mobilgease 77 Mobilgrease special	-

No.	Supplier	Engine Oil [CD or CE] SAE10W, 30, 40 10W30, 15W40 (The 15W40 oil marked * is CE.)	Gear Oil [GL-4 or GL-5] SAE80, 90, 140	Grease [Lithium-Base] NLGI No.2	Anti-freeze Coolant [Ethylene Glycol Base] Permanent Type
14	PENNZOIL	*Superme duty fleet motor oil	Multi-purpose 4092 Multi-purpose 4140	Multi-purpose white grease 705 707L White-bearing grease	Anti-freeze and summer coolant
15	PETROFIN E	FINA kappa TD	FINA potonic N FINA potonic NE	FINA marson EPL2	FINA tamidor
16	SHELL	Rimura X	Spirax EP Spirax heavy duty	Albania EP grease	-
17	SUN	-	Sunoco GL5 gear oil	Sunoco ultra prestige 2EP Sun prestige 742	Sunoco antifreeze and summer coolant
18	TEXACO	*Ursa super plus Ursa premium	Multigear	Multifak EP2 Starplex 2	Coda 2055 startex antifreeze coolant
19	TOTAL	Rubia S *Rubia X	Total EP Total Transmission TM	Multis EP2	Antigal/antifreeze
20	UNION	*Guardol	MP gear lube LS	Unoba EP	-
21	VEEDOL	*Turbostar *Diesel star MDC	Multigear Multigear B Multigear C	-	Antifreeze

TIGHTENING TORQUE SPECIFICATIONS

TIGHTENING TORQUE LIST



If nuts, bolts, or other parts are not tightened to the specified torque, it will cause looseness or damage to the tightened parts, and this will cause failure of the machine or problems with operation.

Always pay careful attention when tightening parts.

Unless otherwise specified, tighten the metric nuts and bolts to the torque shown in the table below. If it is necessary to replace any nut or bolt, always use a Komatsu genuine part of the same size as the part that was replaced.

Thread diameter of bolt (a)(mm)	Width across flats (b)(mm)	Tightening torque					
		Target value			Service limit		
		N·m	kgf·m	lbft	N·m	kgf·m	lbft
6	10	13.2	1.35	9.8	11.8-14.7	1.2-1.5	8.7-10.8
8	13	31	3.2	23.1	27-34	2.8-3.5	20.3-25.3
10	17	66	6.7	48.5	59-74	6.0-7.5	43.4-54.2
12	19	113	11.5	83.2	98-123	10.0-12.5	72.3-90.4
14	22	172	17.5	126.6	153-190	15.5-19.5	112.1-141
16	24	260	26.5	191.7	235-285	23.5-29.5	170.0-213.4
18	27	360	37	267.6	320-400	33.0-41.0	238.7-296.6
20	30	510	52.3	378.3	455-565	46.5-58.0	336.3-419.5
22	32	688	70.3	508.5	610-765	62.5-78.0	452.1-564.2
24	36	883	90	651	785-980	80.0-100.0	578.6-723.3
27	41	1295	132.5	958.4	1150-1440	118.0-147.0	853.5-1063.3
30	46	1720	175.0	1265.8	1520-1910	155.0-195.0	1121.1-1410.4
33	50	2210	225.0	1627.4	1960-2450	200.0-250.0	1446.6-1808.3
36	55	2750	280.0	2025.2	2450-3040	250.0-310.0	1808.3-2242.2
39	60	3280	335.0	2423.1	2890-3630	295.0-370.0	2133.7-2676.2

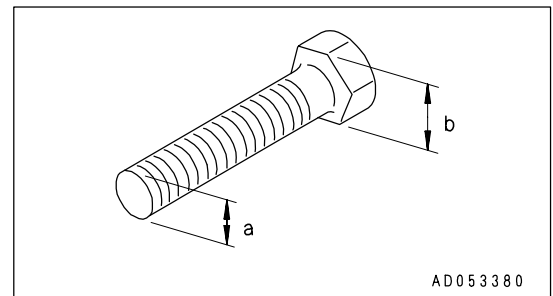

Apply the following table for Hydraulic Hose.

Nominal - No. of threads (a)	Width across flats (b) (mm)	Tightening torque					
		Target value			Permissible range		
		N·m	kgf·m	lbft	N·m	kgf·m	lbft
9/16 -18UNF	19	44	4.5	32.5	35 - 63	3.5 - 6.5	25.3 - 47.0
11/16 -16UN	22	74	7.5	54.2	54 - 93	5.5 - 9.5	39.8 - 68.7
13/16 -16UN	27	103	10.5	75.9	84 - 132	8.5 - 13.5	61.5 - 97.6
1 -14UNS	32	157	16.0	115.7	128 - 186	13.0 - 19.0	94.0 - 137.4
13/16 -12UN	36	216	22.0	159.1	177 - 245	18.0 - 25.0	130.2 - 180.8

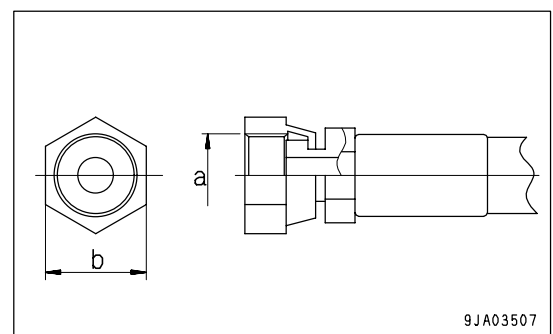

SAFETY CRITICAL PARTS

To ensure safety at all times when operating or driving the machine, the user of the machine must always carry out periodic maintenance. In addition, to further improve safety, please contact your Komatsu distributor for periodic replacement of parts related to safety and fire prevention in the "SAFETY CRITICAL PARTS LIST".

Material quality of these parts can change as time passes and they are likely to wear out or deteriorate. However, it is difficult to determine the extent of wear or deterioration at the time of periodic maintenance. Hence it is required to replace them with new ones irrespective of their conditions after a certain period of usage. This is important to ensure that these parts maintain their full performance at all the time.

Furthermore, should anything abnormal be found on any of these parts, replace it with a new one even if the periodic replacement time for the parts has not yet arrived.

If any of the hose clamps show deterioration like deformation or crack, replace such a defective clamp with a new one together with a defective hose.

Also carry out the following checks with hydraulic hoses which need not be replaced periodically. Tighten a loosened clamp again or replace a defective hose, as such abnormality requires.

When replacing the hoses, always replace the O-rings, gaskets, and other such parts at the same time.

Ask your Komatsu distributor to replace the critical parts.

SAFETY CRITICAL PARTS LIST

No.	Safety critical parts for periodic replacement	Q'ty	Replacement interval
1	Fuel hose (fuel tank - water separator)	1	Every 2 years or 4000 hours, whichever comes sooner
2	Fuel hose (water separator - feed pump)	1	
3	Fuel hose (feed pump - fuel filter)	1	
4	Fuel hose (fuel filter - injection pump)	1	
5	Fuel hose (fuel filter - fuel tank)	1	
6	Spill hose (fuel filter - injection pump)	1	
7	Spill hose (between nozzles)	2	
8	Spill hose (nozzle - injection pump)	1	
9	Spill cap	1	
10	Hydraulic hose (main pump suction)	2	
11	Hydraulic hose (main pump delivery)	4	
12	Hydraulic hose (boom cylinder)	4	
13	Hydraulic hose (arm cylinder)	4	
14	Hydraulic hose (bucket cylinder)	4	
15	Hydraulic hose (swing cylinder)	2	
16	Seat belt	1	Every 3 years

MAINTENANCE SCHEDULE

If the machine is equipped with a hydraulic breaker, the maintenance schedule for some parts will be different. For details, see "MAINTENANCE INTERVAL FOR HYDRAULIC BREAKER (PAGE 4-16)" to confirm the correct maintenance schedule when carrying out maintenance.

MAINTENANCE SCHEDULE CHART

WHEN REQUIRED

CHECK, CLEAN AND REPLACE AIR CLEANER ELEMENT	4- 17
CLEAN INSIDE OF COOLING SYSTEM	4- 22
CHECK LEVEL OF BATTERY ELECTROLYTE	4- 25
CLEAN WATER SEPARATOR ELEMENT	4- 27
DRAIN WATER AND SEDIMENT FROM FUEL TANK	4- 27
CHECK AND TIGHTEN TRACK SHOE BOLTS (Machine equipped with road liner, steel shoe)	4- 28
CHECK AND ADJUST TRACK TENSION (Machine equipped with road liner, steel shoe)	4- 29
CHECK, RUBBER SHOES OR ROAD LINERS (Machine equipped with rubber shoes, road liner)	4- 31
CHECK AND ADJUST RUBBER SHOE TENSION (Machine equipped with rubber shoes)	4- 33
REPLACE RUBBER SHOES (Machine equipped with rubber shoes)	4- 35
REPLACE ROAD LINERS (Machine equipped with road liner)	4- 37
REPLACE BUCKET TEETH	4- 38
CHECK WINDOW WASHER FLUID LEVEL, ADD FLUID	4- 41
CHECK, CLEAN AND LUBRICATE CAB SLIDE DOOR RAIL AND ROLLER	4- 42
LUBRICATING	4- 42
BLEEDING AIR FROM HYDRAULIC SYSTEM	4- 43

CHECKS BEFORE STARTING

EVERY 500 HOURS MAINTENANCE

LUBRICATING	4- 46
CHANGE OIL IN ENGINE OIL PAN, REPLACE ENGINE OIL FILTER CARTRIDGE	4- 49
REPLACE FUEL FILTER CARTRIDGE	4- 50
CHECK OIL LEVEL IN FINAL DRIVE CASE, ADD OIL	4- 52
CLEAN AND INSPECT RADIATOR FINS AND OIL COOLER FINS	4- 53
CHECK AND ADJUST COOLING FAN BELT TENSION	4- 54

EVERY 1000 HOURS MAINTENANCE

REPLACE HYDRAULIC OIL FILTER ELEMENT	4- 55
CHANGE OIL IN FINAL DRIVE CASE	4- 56
CHECK ENGINE VALVE CLEARANCE, ADJUST	4- 56

EVERY 2000 HOURS MAINTENANCE

CHANGE OIL IN HYDRAULIC TANK, CLEAN STRAINER	4- 57
CHECK ALTERNATOR, STARTING MOTOR	4- 59

MAINTENANCE INTERVAL FOR HYDRAULIC BREAKER

For machine equipped with a hydraulic breaker, the hydraulic oil deteriorates faster than for normal bucket digging operations, so set the maintenance intervals as follows.

- **Replace hydraulic filter element**

On a new machine, replace the element after the first 100 to 150 hours, then carry out further replacement of the element according to the table on the right.

- **Change oil in hydraulic tank**

Change the oil according to the table on the right.

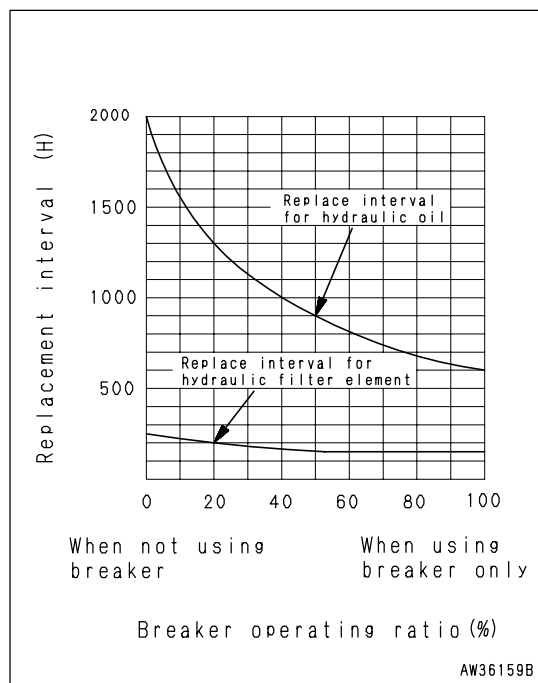

MAINTENANCE PROCEDURE

WHEN REQUIRED

CHECK, CLEAN AND REPLACE AIR CLEANER ELEMENT



WARNING

- If inspection, cleaning, or maintenance is carried out with the engine running, dirt will get into the engine and damage it. Always stop the engine before carrying out these operations.
- When using compressed air, there is danger that dirt may be blown around and cause serious injury. Always use safety glasses, dust mask, and other protective equipment.

Machines Equipped with Singel Element

Checking

1. Open the engine rear cover.
2. If the dust indicator (1) shows red, clean the air cleaner element.

NOTICE

Do not clean the air cleaner element before the red piston in dust indicator (1) appears.

If the air cleaner element is cleaned frequently before the red piston in the dust indicator appears, the air cleaner cannot provide the proper performance and the cleaning efficiency is lowered.

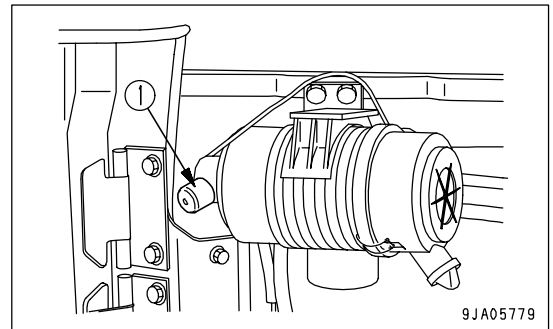

Cleaning or Replacing Element

1. Open the engine rear cover.
2. Remove clips (2), then remove dust cup (3).

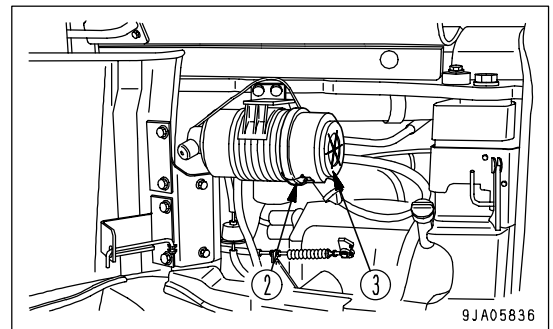

3. Take out element (4) and cover the air connector at the end of the air cleaner body with a clean cloth or tape.
4. Clean the inside of the air cleaner body, dust cap (3), and vacuator valve (5).

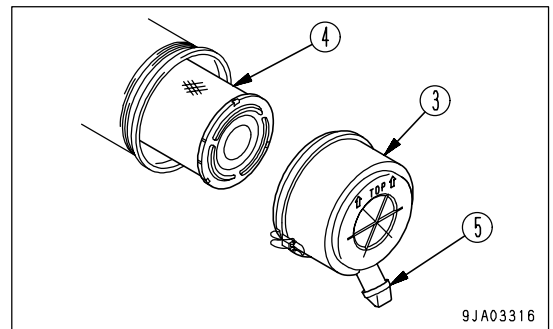

5. Direct dry compressed air (Max. 0.69 MPa (7 kgf/cm², 99.4 PSI)) from the inside of the outer element along its folds. Then direct the compressed air from the outside along the folds, and again from the inside.

- 1) Replace the element which has been cleaned 5 times repeatedly or used throughout a year.
- 2) Replace element when the dust indicator red piston appears soon after installing the cleaned element even though it has not been cleaned 6 times.

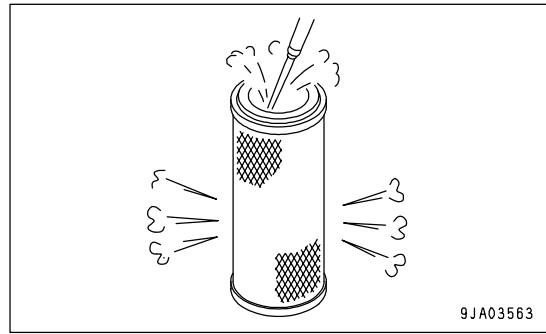

6. If small holes or thinner parts are found on the element when it is checked by shining a light through it after cleaning, replace the element.

NOTICE

When cleaning the element, do not hit it or beat it against something.
Do not use an element whose folds or gasket or seal are damaged.
Wrap unused element and store them in a dry place.

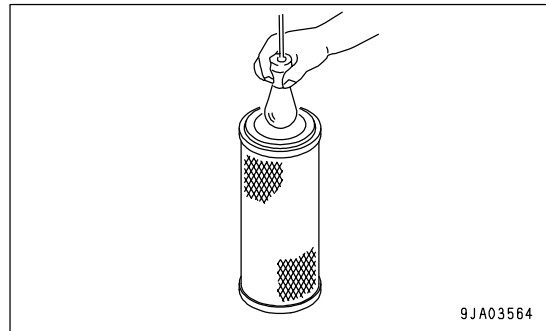

7. Remove the cloth or adhesive tape used to cover the air connector inside the air cleaner body.
8. Install cleaned element (4) or a new element.
9. Set dust cup (3) with the arrow pointing up, then set it to the air cleaner body and secure it with clip (2).

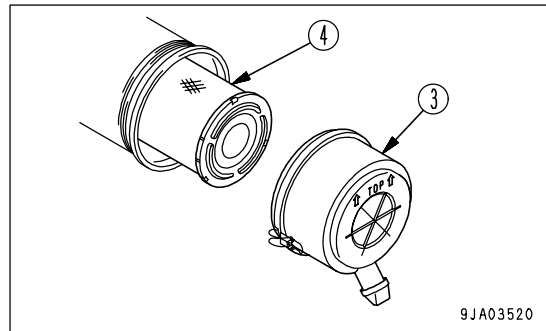

10. Press the button of dust indicator (1) to return the red piston to its original position.

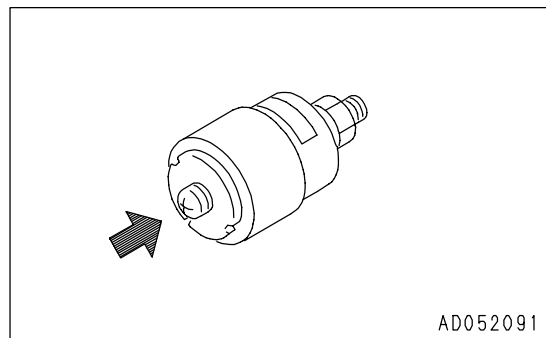

Machines Equipped with Double Element

Checking

1. Open the engine rear cover.
2. If the dust indicator (1) shows red, clean the air cleaner element.

NOTICE

Do not clean the air cleaner element before the dust indicator becomes red. If the element is cleaned frequently before the dust indicator becomes red, the performance of the air cleaner is diminished and the cleaning effect is lowered. In addition, dust sticking to the element falls into the inner element each time the element is cleaned.

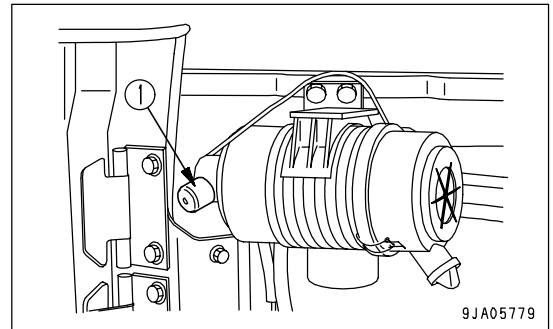

Cleaning Outer Element

1. Open the engine rear cover.
2. Remove clips (2), then remove dust cup (3).

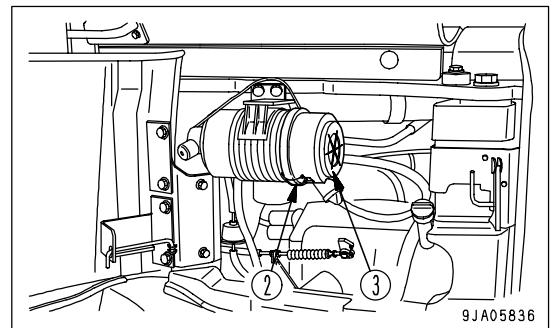

NOTICE

Never remove inner element (5). If it is removed, dust will enter and cause engine trouble.

3. Remove outer element (4).

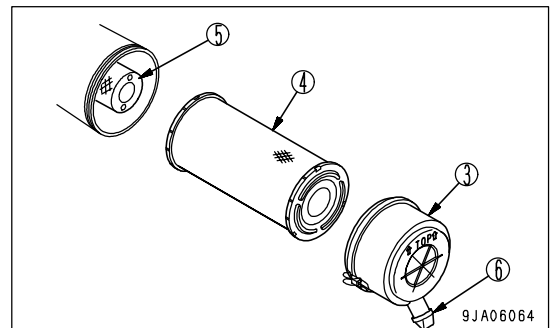

4. Clean dust cup (3) and vacuator valve (6) inside the air cleaner body.

NOTICE

The inner element must not be used again even after its cleaning. When replacing the outer element, replace the outer element at the same time.

5. Direct dry compressed air (Max. 0.69 MPa (7 kgf/cm², 99.4 PSI)) from the inside of the outer element along its folds. Then direct the compressed air from the outside along the folds, and again from the inside.

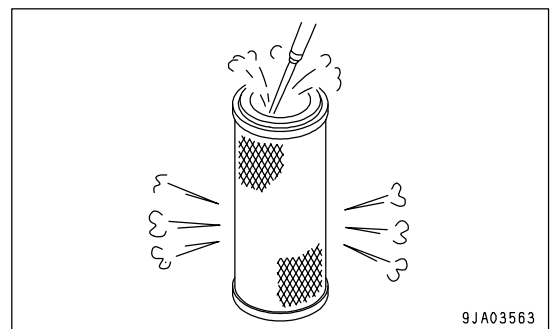

- 1) Replace the outer element which has been cleaned 5 times repeatedly or used throughout a year. Replace the inner element at the same time.
- 2) Even if the outer element has not been cleaned 5 times, if the dust indicator immediately displays red after cleaning, replace both the inner and outer elements.

6. If small holes or thinner parts are found on the element when it is checked by shining a light through it after cleaning, replace the element.

NOTICE

When cleaning the element, do not hit it or beat it against something.
 Do not use an element whose folds or gasket or seal are damaged.
 Wrap unused element and store them in a dry place.

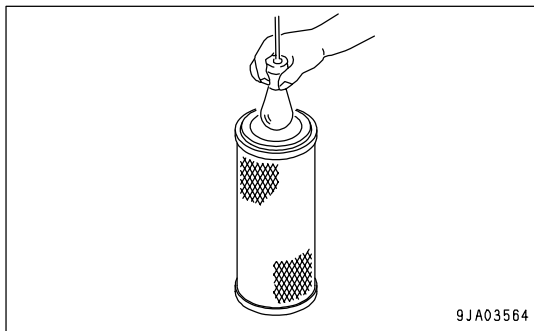

7. Set the cleaned outer element (4) in position.
8. Set the arrow mark on cover (3) at the top, install to the air cleaner body, then secure with clip (2).

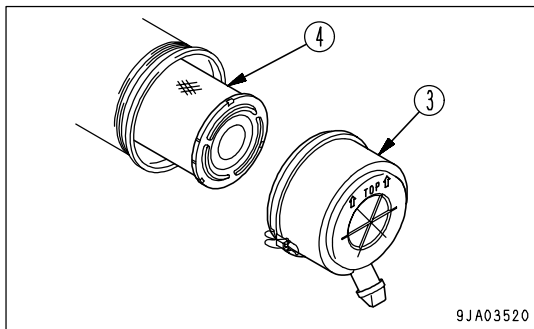

9. Press the button of dust indicator (1) to return the red piston to its original position.

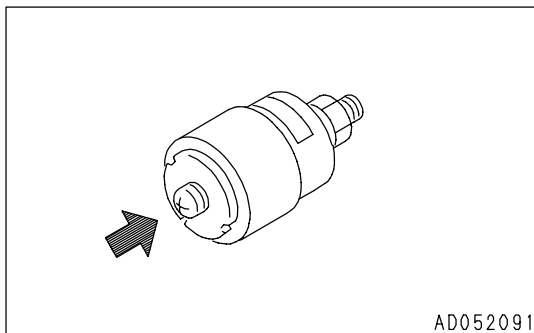

Replacing Element

1. Open the engine rear cover.
2. Remove clips (2), then remove dust cup (3).

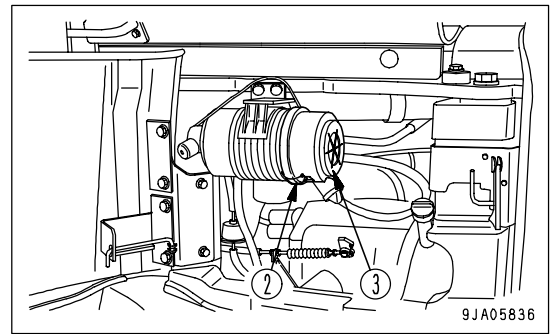

3. Remove outer element (4).
Do not remove inner element (5) at this time, however.
4. Clean dust cup (3) and vacuator valve (6) inside the air cleaner body.
5. Remove inner element (5), then install a new inner element immediately.
6. Set the new outer element (4) in position.
7. Set dust cup (3) with the arrow pointing up, then set it to the air cleaner body and secure it with clip (2).

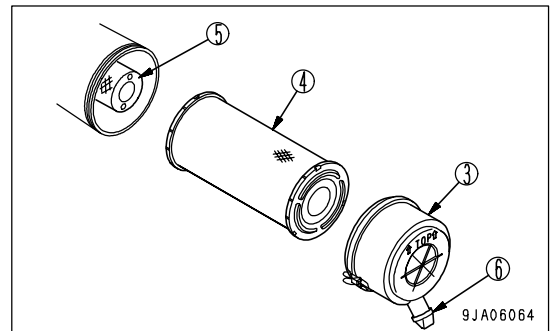

8. Return the red piston in the dust indicator (1) to its original position.

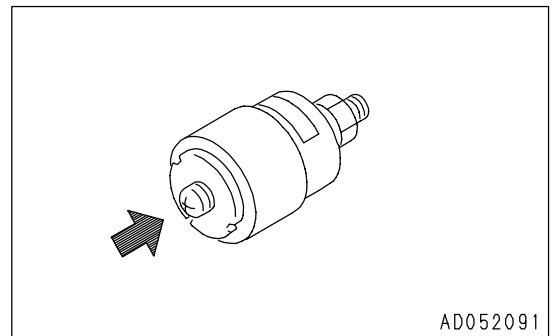

CLEAN INSIDE OF COOLING SYSTEM



WARNING

- Immediately after the engine is stopped, the coolant is at a high temperature and the radiator is under high internal pressure. If the cap is removed to drain the coolant in this condition, there is a hazard of burns. Wait for the temperature to go down, then turn the cap slowly to release the pressure before removing it.
- Cleaning is carried out with the engine running. When standing up or leaving the operator's seat, set the safety lock lever to the LOCK position.
- For details of starting the engine, see "BEFORE STARTING ENGINE (PAGE 3-40)" and "STARTING ENGINE (PAGE 3-54)" in the OPERATION section.
- The engine is operated when washing, so it is dangerous if the machine moves when you are standing behind it. Never stand behind the machine when the engine is running.

Stop the machine on level ground when cleaning or changing the coolant.

Clean the inside of the cooling system, change the coolant and replace the corrosion resistor according to the table below.

Kind of coolant	Cleaning inside of cooling system and changing coolant	Adding corrosion resistor agent KI
Permanent type antifreeze (All season type)	Every year (autumn) or every 2000 hours whichever comes first	Every 1000 hours and when cleaning the inside of the cooling system and when changing coolant.
Non-permanent type antifreeze containing ethylene glycol (winter, one season type)	Every 6 months (spring and autumn) (Drain antifreeze in spring, add antifreeze in autumn)	
When not using antifreeze	Every 6 months or every 1000 hours whichever comes first	

Use a permanent type of antifreeze.

If, for some reason, it is impossible to use permanent type antifreeze, use an antifreeze containing ethylene glycol. The proportion of the mixture differs according to the ambient temperature, but to obtain the corrosion resistance effect, a minimum of 30% by volume is necessary.

In areas where the water is hard, always add Komatsu genuine corrosion resistor agent KI. One packet of corrosion resistor agent contains 100 g (0.22 lb). The standard density of the mixture should be 7 g/liter (0.065 oz/US gal).

When deciding the ratio of antifreeze to water, check the lowest temperature in the past, and decide from the mixing rate table given below.

It is actually better to estimate a temperature about 10°C (18°F) lower when deciding the mixing rate.

Mixing rate of water and antifreeze

Min. atmospheric temperature	°C	Above -10	-15	-20	-25
	°F	Above 14	5	-4	-13
Amount of antifreeze	Liters	2.2	2.6	3.0	3.4
	US gal	0.58	0.69	0.79	0.90
Amount of water	Liters	5.1	4.7	4.3	3.9
	US gal	1.35	1.24	1.14	1.03

! WARNING

Antifreeze is flammable, so keep it away from flame.

Antifreeze is toxic. When removing the drain plug, be careful not to get water containing antifreeze on you. If it gets in your eyes, flush your eyes with large amount of fresh water and see a doctor at once.

Use city water for the coolant.

If river water, well water or other such water supply must be used, contact your Komatsu distributor.

We recommend use of an antifreeze density gauge to control the mixing proportions.

Prepare a container with a capacity of at least 7.3 liters (1.93 US gal) to catch the coolant.

- Prepare a water inlet hose.

1. Open the engine rear cover and cooling cover. For details, see Section "COOLING COVER (PAGE 3-29)".
2. Check that the coolant temperature has gone down enough to make it possible to touch the radiator cap surface by hand, then turn radiator cap (1) slowly until it contacts the stopper to release the pressure.
3. Following this, push radiator cap (1), turn it until it contacts the stopper, then remove it.

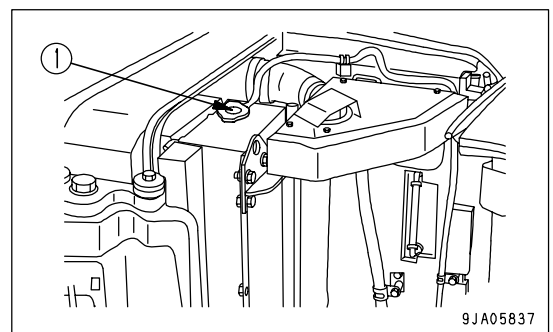

4. Set the container under the drain hose installed to drain valve (2) to catch the coolant.
5. Open drain valve (2) and drain the water.
6. After draining the coolant, close drain valve (2), and fill with city water. When the radiator is full, start the engine and run at low idling to raise the temperature to at least 90°C (194°F), then continue to run for approx. 10 minutes.
7. Stop the engine, open drain valve (2), drain the water, then close drain valve (2).

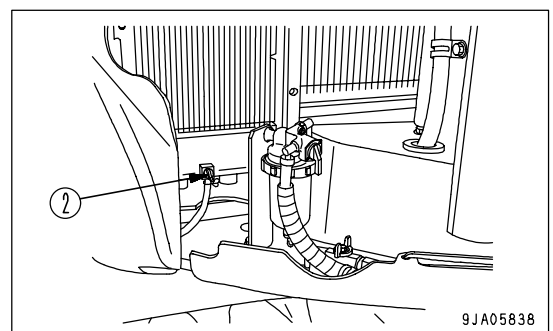

8. Decide the proportions of antifreeze and water according to the table for the mixing rate of water and antifreeze.

9. To remove the air in the coolant, run the engine for 5 minutes at low idling, then for another 5 minutes at high idling. (While doing this, leave the radiator cap removed)
10. After draining off the coolant of sub tank (3) , clean the inside of the sub tank and refill the water between FULL and LOW level.
11. Stop the engine. About 3 minutes later, supply city water up to the water filler, then close radiator cap.

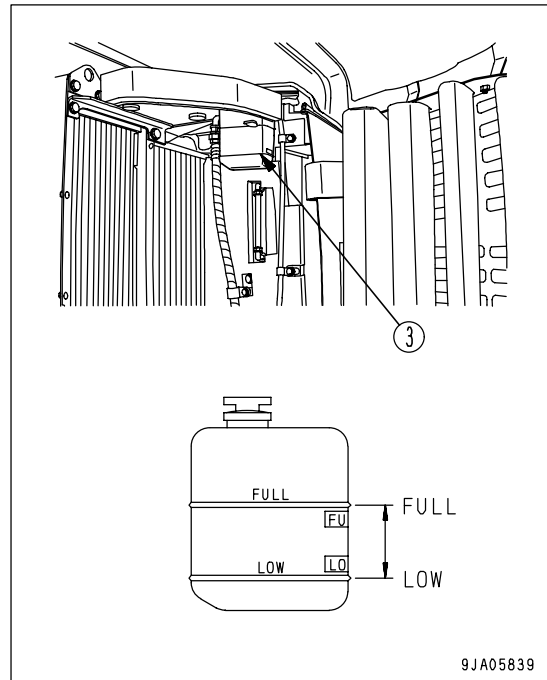

CHECK LEVEL OF BATTERY ELECTROLYTE

Carry out this check before operating the machine.



WARNING

- Do not use the battery if the battery electrolyte level is below the LOWER LEVEL line. This will accelerate deterioration of the inside of the battery and reduce the service life of the battery. In addition, it may also cause an explosion.
- The battery generates flammable gas and there is danger of explosion, so do not bring fire or sparks near the battery.
- Battery electrolyte is dangerous. If it gets in your eyes or on your skin, wash it off with a large amount of water and consult a doctor.
- When adding distilled water to the battery, do not allow the battery electrolyte to go above the UPPER LEVEL line. If the electrolyte level is too high, it may leak and cause damage to the paint surface or corrode other parts.

NOTICE

When adding distilled water in cold weather, add it before starting operations in the morning to prevent the electrolyte from freezing.

Inspect the battery electrolyte level at least once a month and follow the basic safety procedures given below.

When Checking Electrolyte Level from Side of Battery

If it is possible to check the electrolyte level from the side of the battery, check as follows.

1. Open the cover at the right side of the machine.
2. Use a wet cloth to clean the area around the electrolyte level lines and check that the electrolyte level is between the UPPER LEVEL (U.L.) and LOWER LEVEL (L.L.) lines.
If the battery is wiped with a dry cloth, static electricity may cause a fire or explosion.

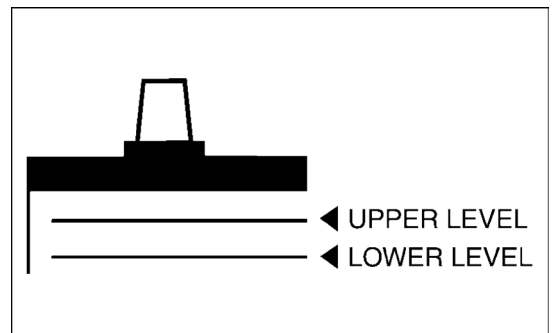

3. If the electrolyte level is below the midway point between the U.L. and L.L. lines, remove cap (1) and add distilled water to the U.L. line.
4. After adding distilled water, tighten cap (1) securely.

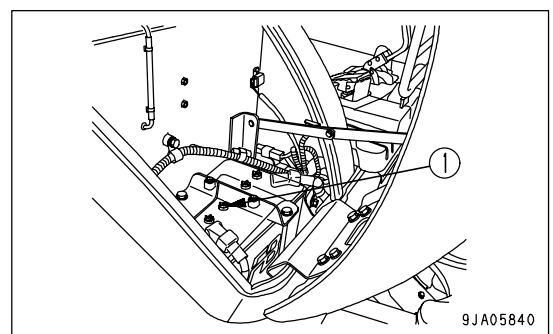

REMARK

If distilled water is added to above the U.L. line, use a syringe to lower the level to the U.L. line. Neutralize the removed fluid with baking soda (sodium bicarbonate), then flush it away with a large amount of water or consult your Komatsu distributor or battery maker.

When It is Impossible to Check Electrolyte Level from Side of Battery

If it is impossible to check the electrolyte level from the side of the battery, or there is no display of the UPPER LEVEL line on the side of the battery, check as follows.

1. Open the cover at the right side of the machine.
2. Remove cap (1) at the top of the battery, look through the water filler port, and check the electrolyte surface. If the electrolyte does not reach the sleeve, add distilled water so that the level reaches the bottom of the sleeve (UPPER LEVEL line) without fail.

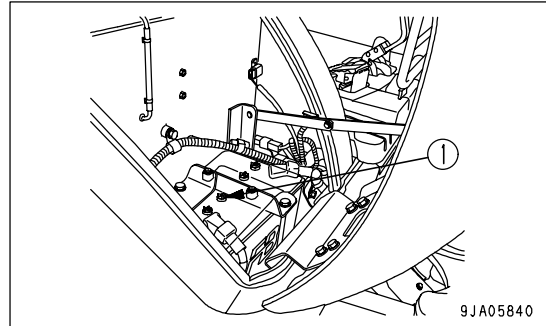

Use the diagram below for reference, and check if the electrolyte reaches the bottom of the sleeve.

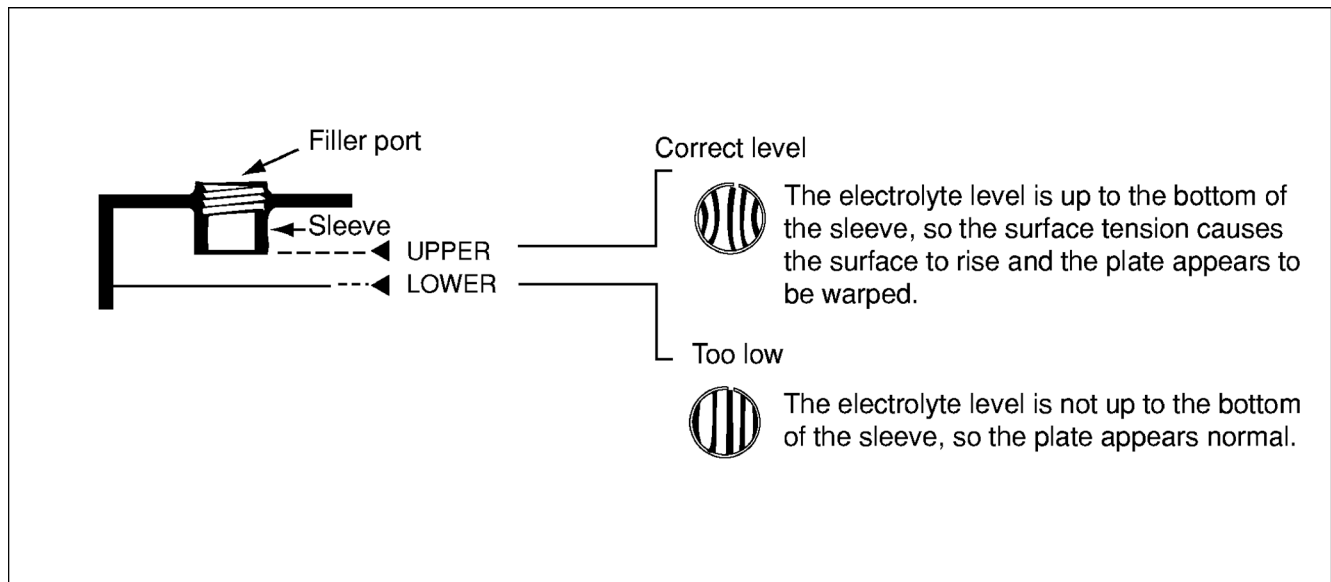

3. After adding distilled water, tighten cap (1) securely.

REMARK

If distilled water is added to above the bottom of the sleeve, use a syringe to lower the level to the bottom of the sleeve. Neutralize the removed fluid with baking soda (sodium bicarbonate), then flush it away with a large amount of water or consult your Komatsu distributor or battery maker.

When It is Possible to Use Indicator to Check Electrolyte Level

If it is possible to use an indicator to check the electrolyte level, follow the instructions given.

CLEAN WATER SEPARATOR ELEMENT



WARNING

Do not bring any fire or flame close.

- Prepare a filter wrench
 - Prepare a container to catch the fuel that is drained.
1. Open the engine rear cover and cooling cover. For details, see Section "COOLING COVER (PAGE 3-29)".
 2. Set handle (1) of the water separator to CLOSED position (A).
 3. Loosen drain plug (2) and drain the accumulated water into a container until red ring (3) reaches the bottom. Then tighten plug (2).
 4. Use a filter wrench to loosen ring (4), take out element cup (5), then remove element (6).
Be careful not to lose red ring (3) inside the cup.
 5. Wash the inside of cup (5) and element (6) with diesel fuel or flushing oil.
 6. After washing, install element (6).
 7. Insert red ring (3) in element cup (5), fill with fuel, then install to the filter holder and tighten ring (4).
Tightening torque: 14.7 to 19.6 N·m (1.5 to 2.0 kgf·m, 10.8 to 14.5 lbft)
 8. Set handle (1) of the water separator to OPEN position (B).
 9. After washing the water separator, bleed the air.
For details of the procedure for bleeding the air, see Section Air Bleeding (PAGE 4-51).

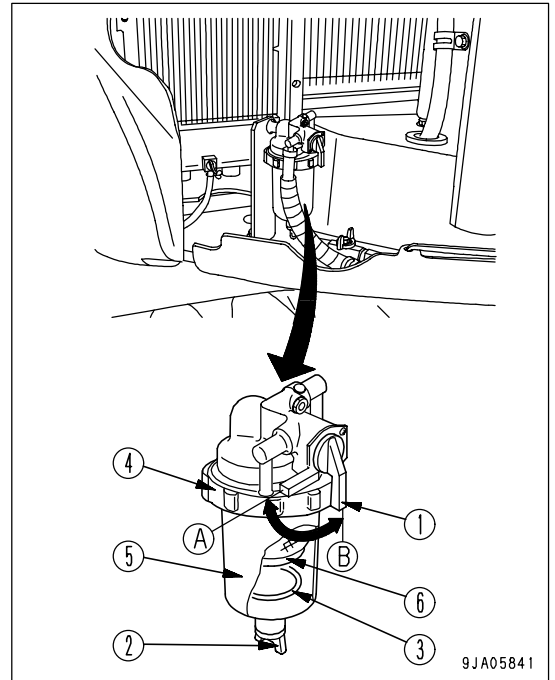

9JA05841

DRAIN WATER AND SEDIMENT FROM FUEL TANK

NOTICE

- Never use trichlene for washing the inside of the tank. Use diesel fuel only.

Carry out this procedure before operating the machine.

- Prepare a container to catch the fuel that is drained.
1. Swing the upper structure so that drain valve (1) is between the tracks.
 2. Open the engine rear cover and cooling cover. For details, see Section "COOLING COVER (PAGE 3-29)".
 3. Open drain valve (1) and drain the sediment and water collected at the bottom together with the fuel.
When doing this, be careful not to get fuel on yourself.
 4. When only clean fuel comes out, tighten drain valve (3).

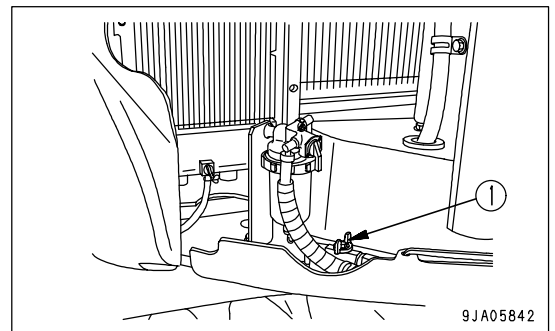

9JA05842

CHECK AND TIGHTEN TRACK SHOE BOLTS

(Machine equipped with road liner, steel shoe)

If the machine is used with track shoe bolts (1) loose, they will break, so tighten any loose bolts immediately.

Road Liner Mounting Bolt - Check/Tighten

After tightening to a tightening torque of $137 \pm 19.6 \text{ N}\cdot\text{m}$ ($14 \pm 2 \text{ kgf}\cdot\text{m}$, $101.3 \pm 14.5 \text{ lbft}$), check that the nut and shoe are in tight contact with the link mating surface.

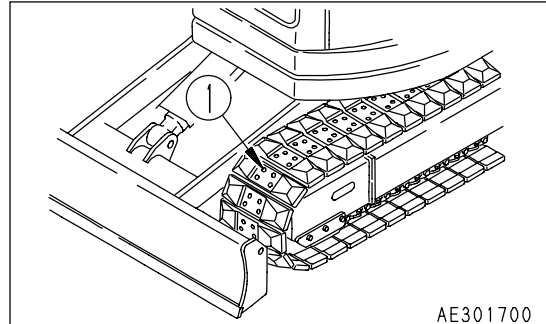

Steel Track Shoe Bolts - Check/Tighten

1. First tighten to a tightening torque of $137 \pm 19.6 \text{ N}\cdot\text{m}$ ($14 \pm 2 \text{ kgf}\cdot\text{m}$, $101.3 \pm 14.5 \text{ lbft}$) then check that the nut and shoe are in close contact with the link contact surface.
2. After checking, tighten a further $90^\circ \pm 10^\circ$.

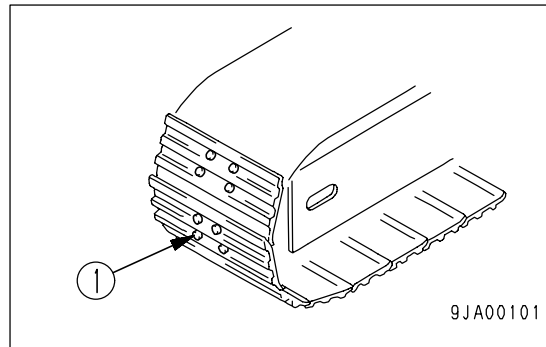

Order for Tightening

Tighten the bolts in the order shown in the diagram on the right. After tightening, check that the nut and shoe are in close contact with the link mating surface.

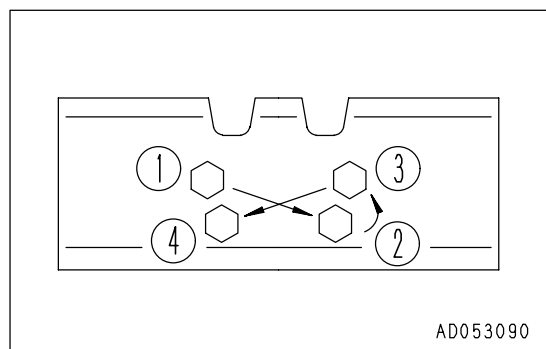
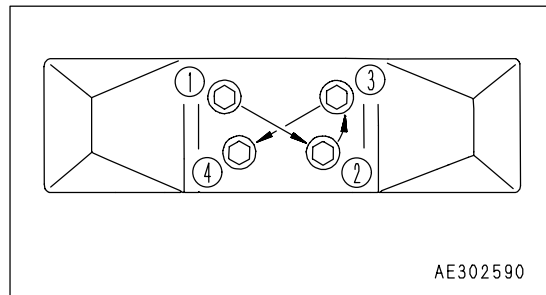

CHECK AND ADJUST TRACK TENSION

(Machine equipped with road liner, steel shoe)

The wear of the pins and bushings on the undercarriage will vary with the working conditions and type of soil, so inspect the track tension frequently in order to maintain the standard tension.

Stop the machine on firm, horizontal ground when carrying out the inspection and maintenance.

Checking

1. Run the engine at low idling, move the machine forward a distance equal to the length of track on ground, then stop the machine.
2. Choose wooden block (3) that will reach from idler (1) to carrier roller (2), then place it on top of the track.
3. Measure the maximum deflection between the top surface of the track and the bottom surface of the wooden block.
 - Standard deflection
Deflection "a" should be 10 to 30 mm (0.4 to 1.2 in).

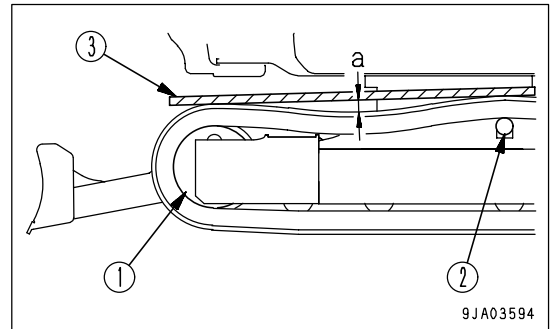

If the track tension is not at the standard value, adjust it in the following manner.

Adjustment



There is danger of plug (1) flying out under the high internal pressure of the grease. Never loosen plug (1) more than 1 turn.

Never loosen any part other than plug (1). Never put your face in the mounting direction of plug (1).

If the track tension cannot be loosened with the procedure given here, please contact your Komatsu distributor.

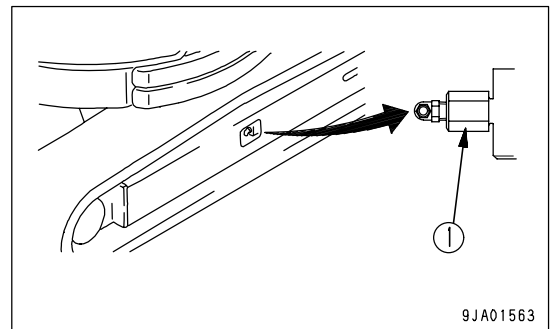

Increasing Track Tension

Prepare a grease gun.

1. Pump in grease through grease fitting (2) with a grease pump.
2. To check if the tension is correct, run the engine at low idling, move the machine slowly forward (by an amount equal to the length of track on ground), then stop the machine.
3. Check the track tension again, and if the tension is not correct, adjust it again.

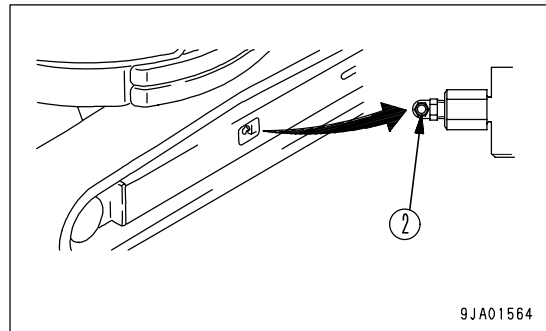

4. Continue to pump in grease until dimension S becomes zero (0). If the tension is still loose, the pin and bushing are excessively worn, so they must be either turned or replaced. Please contact your Komatsu distributor for repairs.

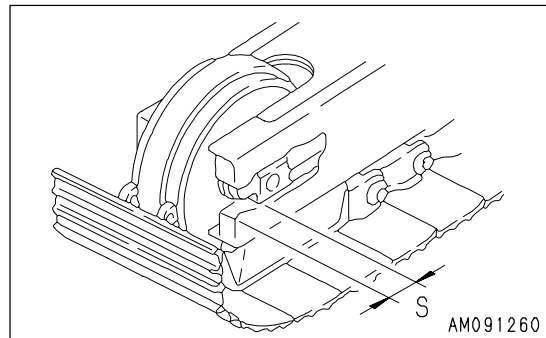

Loosening Track Tension



WARNING

It is extremely dangerous to release the grease by any method except the procedure given below.

If the track tension is not relieved by this procedure, please contact your Komatsu distributor for repairs.

1. Loosen plug (1) gradually to release the grease.
2. When loosening plug (1), turn it a maximum of one turn.
3. If the grease does not come out smoothly, move the machine forwards and backwards a short distance.
4. Tighten plug (1).
5. To check if the tension is correct, run the engine at low idling, move the machine slowly forward (by an amount equal to the length of track on ground), then stop the machine.
6. Check the track tension again, and if the tension is not correct, adjust it again.

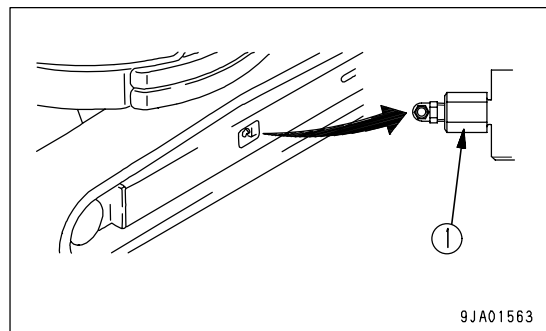

CHECK, RUBBER SHOES OR ROAD LINERS

(Machine equipped with rubber shoes, road liner)

If the rubber shoes or road liner are in the following condition, they must be repaired or replaced, so please contact your Komatsu distributor for repairs or replacement.

Lug Height

- If lug height "a" is reduced by wear, the drawbar pull will drop.
If "a" is less than 5 mm (0.2 in), replace with a new part.

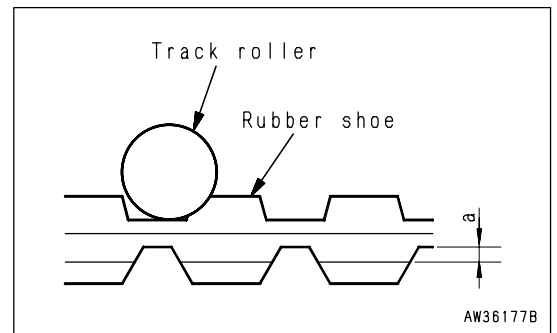
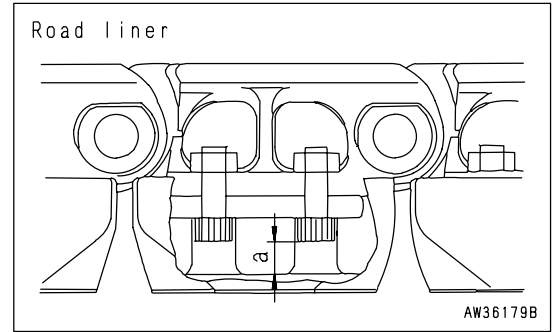

- If the lug wears and the steel cord inside the shoe is exposed for two links or more, replace with a new part.
(Machine equipped with rubber shoes)

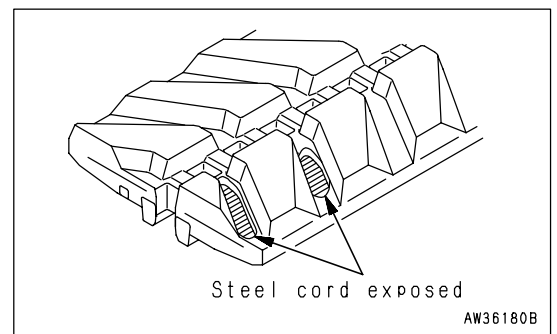

Rubber Shoe Steel Code Cuts

If more than half of the steel cord layer on one side is cut, replace with a new part.

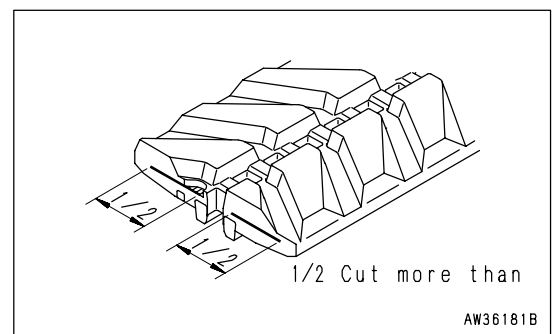

Rubber Shoe Core Separations

If the rubber core has separated at one place or more, replace with a new part.

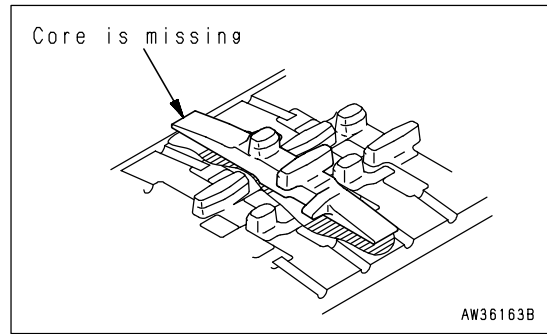

Rubber Shoe Tension

If the rubber shoe is still slack even when grease is pumped in, replace with a new part or replace the seal inside the cylinder.

If the track tension can only be increased to a level where the rubber shoe may come off, there may be not only elongation of the rubber shoe but also damage to the grease cylinder.

Rubber Shoe Cracks

If the cracks between the rubber shoe lugs increase to a size of approx. 60 mm (2.36 in) the rubber shoe must be repaired. Even if the crack is small and short, if the steel cord can be seen inside, carry out repairs immediately.

If the length is less than 30 mm (1.18 in) or the depth of the crack is less than 10 mm (0.39 in), there is no particular need to carry out repairs.

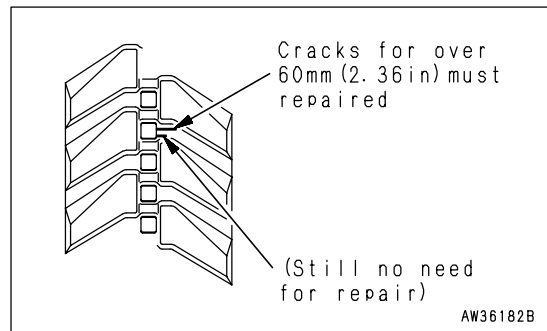

When making judgement whether to replace, repair, or continue using rubber shoe and load liner, please contact your Komatsu distributor.

CHECK AND ADJUST RUBBER SHOE TENSION

(Machine equipped with rubber shoes)

The wear of the rubber shoe will vary with the work conditions and type of soil, so inspect the wear and track tension whenever necessary. Stop the machine on firm, horizontal ground when carrying out the inspection and maintenance.

In particular, on new machines or after new tracks have been installed and the tension has been set to the specified value, the track tension will become loose in the first 5 to 30 hours when the machine has been used for a certain amount of repeated

travel. If the track tension is adjusted frequently until the initial loosening no longer occurs, this will prevent the shoes from coming off due to insufficient track tension.

If operations are carried out when the rubber shoe is loose, the track will come off and it will cause premature wear of the core.

Checking

1. Run the engine at low idling, move the machine forward a distance equal to the length of track on ground, then stop the machine.
2. Choose wooden block (3) that will reach from idler (1) to carrier roller (2), then place it on top of the track.
3. Measure the maximum deflection between the top surface of the rubber shoe and the bottom surface of the wooden block.
 - Standard deflection
Deflection "a" should be 1 to 3 mm (0.039 to 0.118 in).

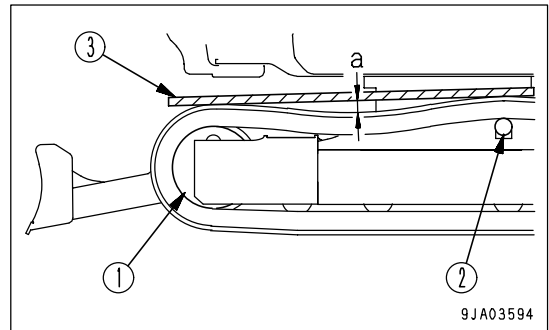

If the track tension is not at the standard value, adjust it in the following manner.

Adjustment

⚠ WARNING

There is danger of the plug flying out under the high internal pressure of the grease. When loosening plug (1), never loosen it more than one turn. Never loosen any part other than plug (1). Never put your face in line with the mount of plug (1).

If the Rubber shoe tension is not relieved by this procedure, please contact your Komatsu distributor.

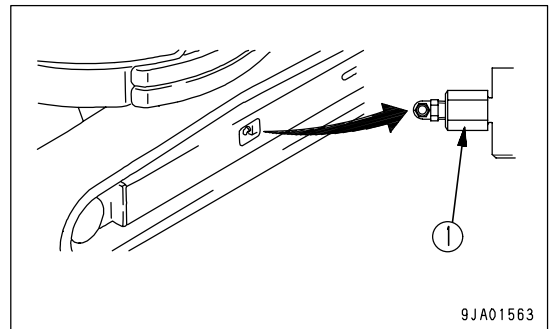

Increasing Track Tension

NOTICE

The standard value is low, so be careful not to tighten the rubber shoe too much.

Prepare a grease gun.

1. Pump in grease through grease fitting (2) with a grease pump.
2. To check if the tension is correct, run the engine at low idling, move the machine slowly forward (by an amount equal to the length of track on ground), then stop the machine.
3. Check the rubber shoe tension again, and if the tension is not correct, adjust it again.
4. If the tension is still low after supplied grease, the rubber shoe needs to be replaced or the seal in the cylinder needs to be replaced. Ask your Komatsu distributor for replacement.

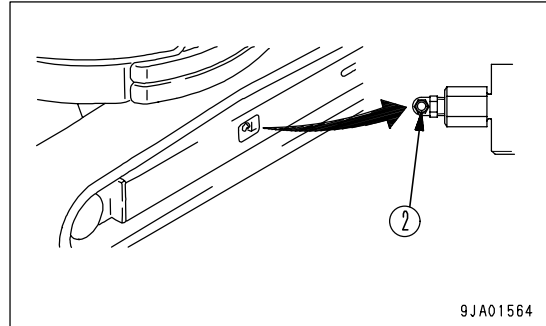

Loosening Track Tension

! WARNING

It is extremely dangerous to release the grease by any method except the procedure given below. If the track tension is not relieved by this procedure, please contact your Komatsu distributor.

1. Loosen plug (1) gradually to release the grease.
2. When loosening plug (1), turn it a maximum of one turn.
3. If the grease does not come out smoothly, move the machine forwards and backwards a short distance.
4. Tighten plug (1).
5. To check if the tension is correct, run the engine at low idling, move the machine slowly forward (by an amount equal to the length of track on ground), then stop the machine.
6. Check the rubber shoe tension again, and if the tension is not correct, adjust it again.
7. Check the track tension again, and if the tension is not correct, adjust it again.

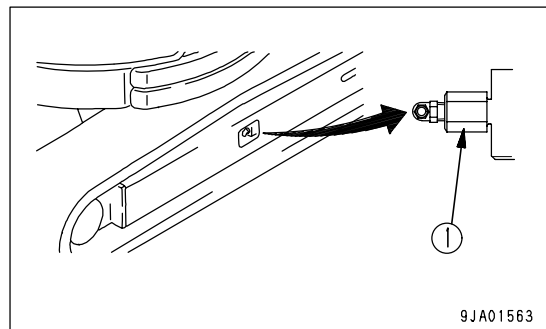

REPLACE RUBBER SHOES

(Machine equipped with rubber shoes)

WARNING

- Carry out this operation with two workers. The operator must move the machine in accordance with the signals from the other worker.
- The rubber shoes are replaced with the machine raised, so it is extremely dangerous if the machine is lowered by mistake during the replacement operation. During the replacement operation, never move the rubber shoe track except the rubber shoe track to be replaced. In addition, never go under or put any part of your body under the rubber shoe or track frame during the replacement operation.
- To check that the track tension is correct, run the engine at low idling, move the machine forward a distance equal to the length of track on ground, then stop the machine.

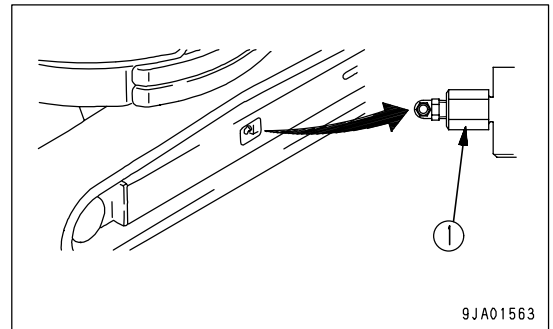

NOTICE

It is possible to change from the rubber shoe to the road liner and steel shoe. However, it is necessary to remove the idler guard and to carry out adjustment, so always contact your Komatsu distributor to have the replacement carried out.

- Prepare a grease gun
- Prepare a steel pipe

Rubber Shoes Removal

WARNING

- It is extremely dangerous to release the grease by any method except the procedure given below. If the rubber shoe tension is not relieved by this procedure, please contact your Komatsu distributor for repairs.
- Check that all the grease has been released before rotating the sprocket to remove the rubber shoe.

1. Raise the chassis with the boom and arm.
When doing this, operate the levers slowly.

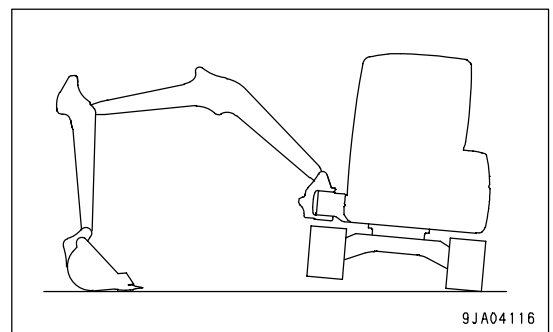

2. Loosen plug (1) gradually to release the grease.
3. When loosening plug (1), turn it a maximum of one turn.

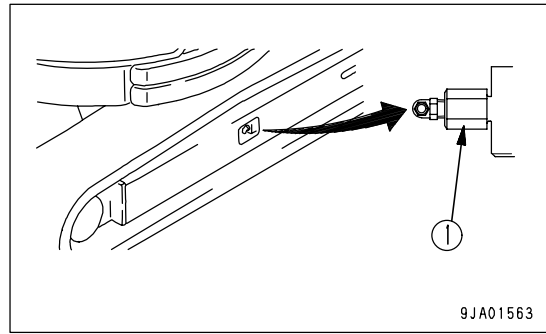

4. Fit the steel pipes inside the rubber shoe, rotate the sprocket in reverse, so that the steel pipes make the rubber shoe come up from the idler, then to the side to remove.

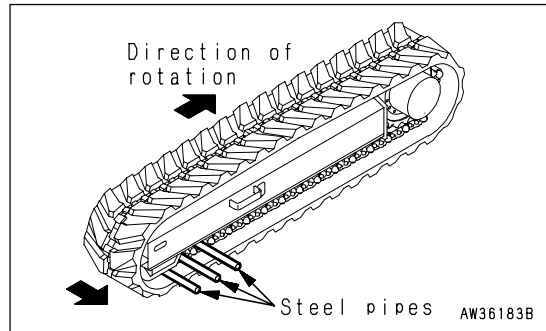

Rubber Shoes Installation

1. Raise the chassis with the boom and arm.
When doing this, operate the levers slowly.

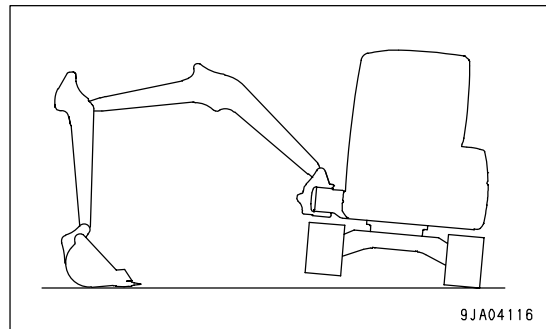

2. Mesh the rubber shoe with the sprocket and fit it over the idler.
3. Rotate the sprocket in reverse, then push in the rubber shoe and stop the rotation.

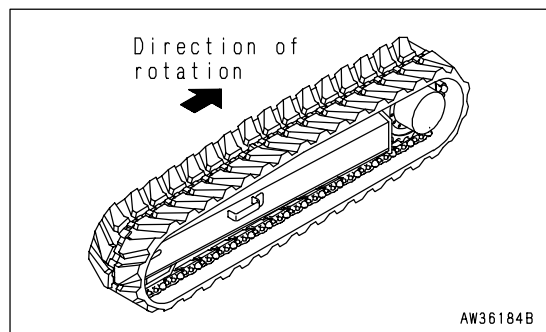

4. Fit a steel pipe in the rubber shoe, then rotate the sprocket again and fit the rubber shoe securely on the idler.

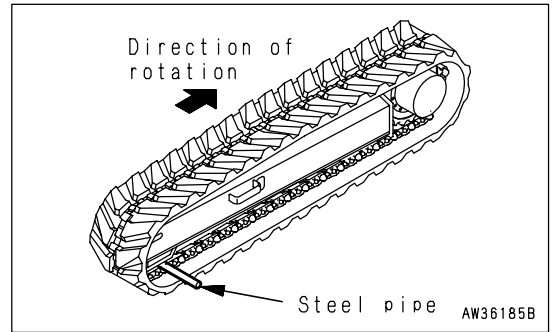

5. Stop the rotation, and check that the rubber shoe is securely fitted to the sprocket and idler.

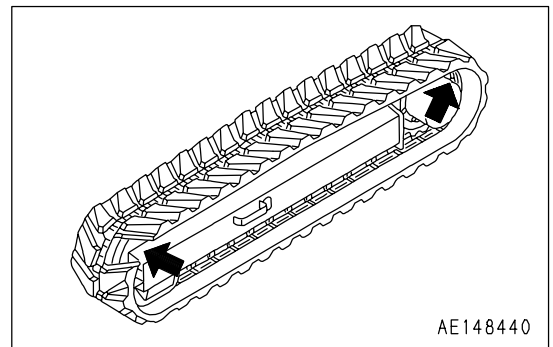

6. Adjust the tension of the rubber shoe.
For details, see "CHECK AND ADJUST RUBBER SHOE TENSION (PAGE 4-33)".
7. Check that the track tension is correct and that the rubber shoe is correctly meshed on the sprocket and idler, then lower the machine to the ground.

REPLACE ROAD LINERS

(Machine equipped with road liner)

- When replacing all the road liner for the machine, please contact your Komatsu distributor to have the replacement carried out.
- When replacing only part of the road liner, use the special road liner removal tool. Please order the tool from your Komatsu distributor.

REPLACE BUCKET TEETH

WARNING

- It is dangerous if the work equipment moves by mistake when the teeth are being replaced.
Set the work equipment in a stable condition, stop the engine, then set the safety lock levers securely to the LOCK position (L).
- The pin is knocked out by force, so there is danger of the pin flying out. Check that nobody is in the surrounding area.
- There is danger of broken pieces flying during the replacement operation, so wear protective glasses, gloves, and other protective equipment.

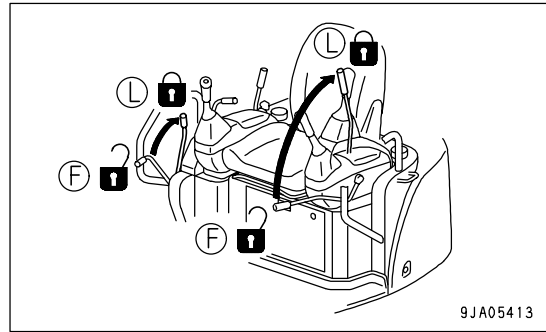

REMARK

For machines equipped with a cab, there is only a safety lock lever on the left.

Replace the bucket teeth before the adapter starts to wear.

1. To make it possible to knock out the pin of tooth (1), set the bottom surface of the bucket on a block, check that the work equipment is in a stable condition, then set the safety lock lever to the LOCK position.
Set so that the bottom face of the bucket is horizontal.

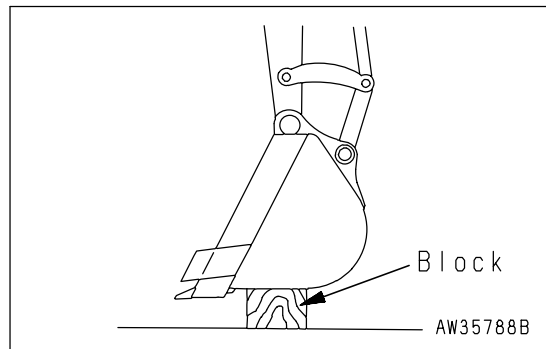

2. Use a hammer and drift to knock out lock pin (2). (If the drift is set against rubber pin lock (3) when it is hit, the rubber pin lock may break. Set it against the back of the pin.)
3. After removing lock pin (2) and rubber pin lock (3), check them.

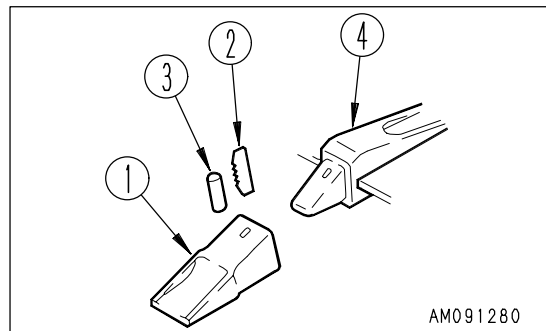

If lock pins and rubber pin locks with the following defects are used, the teeth may come off the bucket. Replace them with new ones.

- The lock pin is too short.

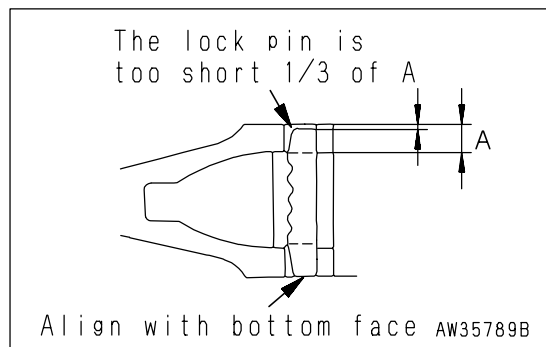

- The rubber of the rubber pin lock is torn, and the steel balls may come out.

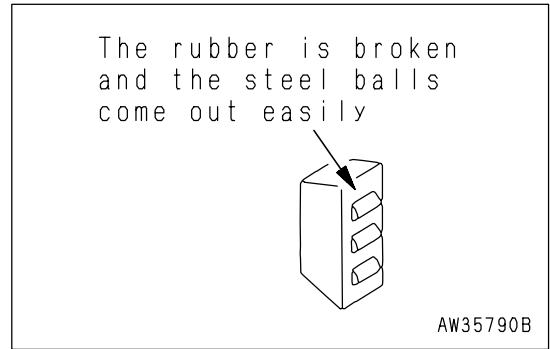

- The steel balls are buried when they are pressed by hand.

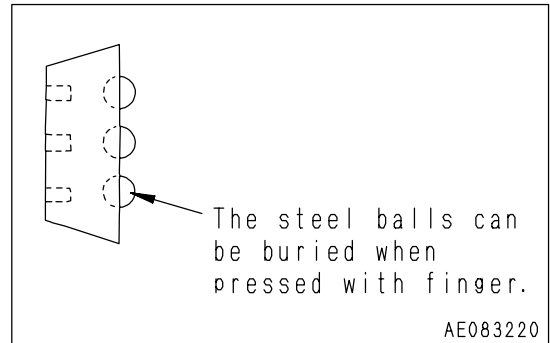

4. Clean the surface of adapter (4) and remove the soil with a knife.

5. Use your hand or a hammer to push rubber pin lock (3) into the hole of the adapter.

When doing this, be careful that the rubber pin lock does not fly out from the adapter surface.

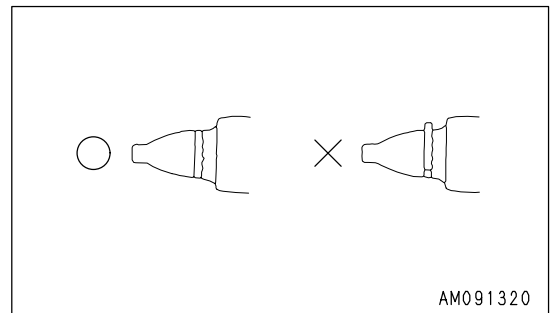

6. Clean the inside of teeth (1), then install it to adapter (4). If there is mud affixed to it or if there are protrusions, the teeth will not enter the adapter properly, and there will not be proper contact at the mating portion.

7. Fit teeth (1) to adapter (4), and confirm that when the pointer is pressed strongly, the rear face of the hole for the pin of the teeth is at the same level as the rear face of the hole for the pin of the adapter.

If the rear face of the hole for the pin of teeth (1) is protruding to the front from the rear face of the pin hole for adapter (4), do not try to knock the pin in.

There is something preventing teeth (1) from entering adapter (4) fully, so remove the obstruction. When teeth (1) enters adapter (4) fully, knock in lock pin (2).

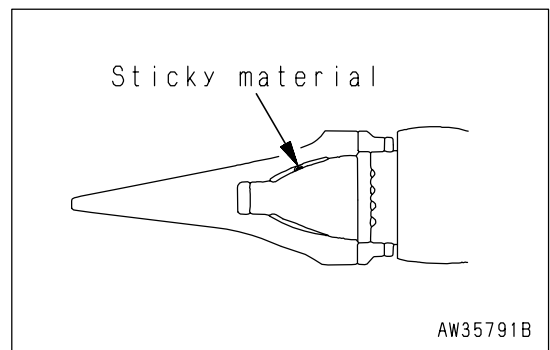

8. Insert lock pin (2) in the hole of the teeth and hit it until its top is the same level as the surface of teeth (1).
9. After replacing a bucket tooth, always check the following.
 - 1) After the lock pin has been knocked in completely, check that it is secured by the point and surface.
 - 2) Lightly hit lock pin (2) in the reverse direction from which it was hit in.
 - 3) Lightly hit the tip of the point from above and below, and hit its sides from right and left.
 - 4) Confirm that rubber pin lock (3) and lock pin (2) are set as shown in the figure.

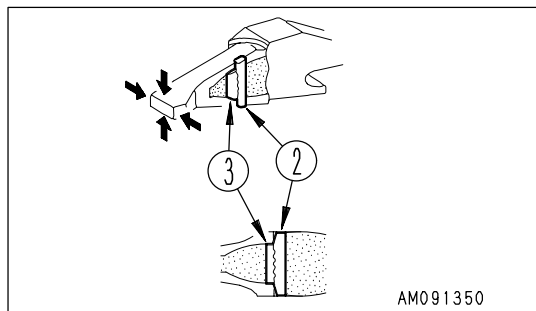
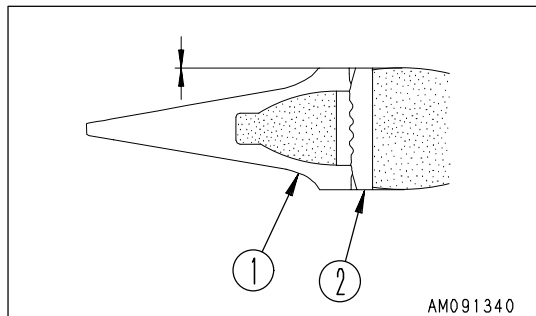

The life of the teeth can be lengthened and the frequency of its replacement can be reduced by turning it upside down so that it will wear evenly.

Replace the rubber pin lock and locking pin at the same time as replacing the teeth. This makes it possible to prevent the teeth from falling out.

CHECK WINDOW WASHER FLUID LEVEL, ADD FLUID

(Machine equipped with cab)

If there is air in the window washer fluid, check the level of the fluid in window washer tank. Add automobile window washer fluid if necessary.

REMARK

Open the engine rear cover and cooling cover. For details, see Section "COOLING COVER (PAGE 3-29)".

When adding fluid, be careful not to let any dust get in.

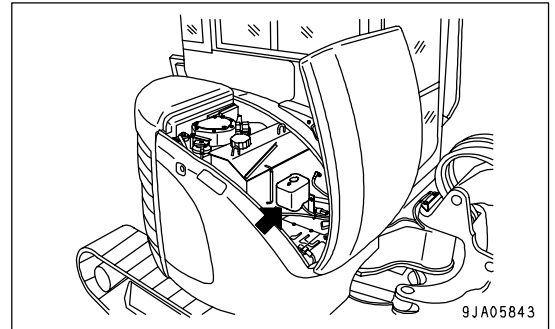

Mixture Ratio of Pure Washer Fluid and Water

The proportion differs according to the ambient temperature, so dilute the washer fluid with water to the following proportions before adding.

Area, season	Proportions	Freezing temperature
Normal	Washer fluid 1/3: water 2/3	-10°C (14°F)
Winter in cold area	Washer fluid 1/2 : water 1/2	-20°C (-4°F)
Winter in extremely cold area	Pure washer fluid	-30°C (-22°F)

There are two types depending on the freezing temperature:

-10°C (14°F) (general use) and -30°C (-22°F) (cold area use), so select according to the area and season.

CHECK, CLEAN AND LUBRICATE CAB SLIDE DOOR RAIL AND ROLLER

(Machine equipped with cab)

Checking

When opening or closing the slide door, if it is clogged with mud and does not move freely, clean and supply grease to roller (2) and rail (1) of the slide door.

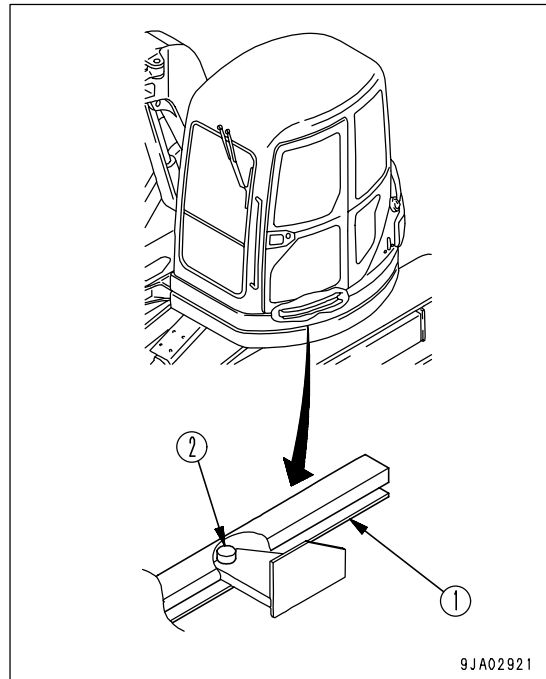

Cleaning

1. Open and close the door, and use a brush to remove any dirt from rail (1).
2. Use a cloth to wipe off any dirt from rail (1).

Greasing

NOTICE

Do not use high-viscosity oil for the lubricant. Use grease only.

1. Spray rail (1) and roller (2) thoroughly with lubricant.
2. After spraying with lubricant, slide the door and check that the door opens and closes smoothly.
If the movement is not smooth, contact your Komatsu distributor for repair.

LUBRICATING

Boom swing cylinder foot pin (1 place)

- Prepare a grease gun

1. Open the engine rear cover and cooling cover. For details, see Section "COOLING COVER (PAGE 3-29)".
2. Remove bolts (1), then remove cover (2).
3. Using a grease gun, supply grease to the grease fitting is marked by arrows.
4. After greasing, wipe off any old grease that was pushed out.

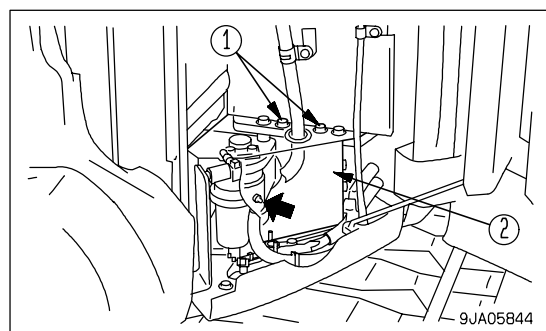

BLEEDING AIR FROM HYDRAULIC SYSTEM

NOTICE

If the pump is operated without filling the pump case with hydraulic oil, there is danger that the pump may be prematurely damaged. Be sure to bleed the air completely.

1. Bleeding air from piston pump

- 1) Remove bolts (1) (M10 x 3), then remove triangular cover (2).
- 2) Remove the oil filler cap from the hydraulic oil tank.

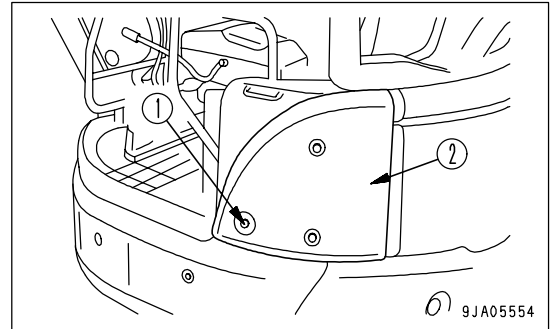

- 3) Loosen air bleed plug (3) and check that oil oozes out from the bleeder plug (completion of air bleeding).
- 4) After completion of the air bleeding operation, tighten the air bleed plug.
- 5) Tighten the oil filler cap of the hydraulic oil tank.
- 6) Install the cover.

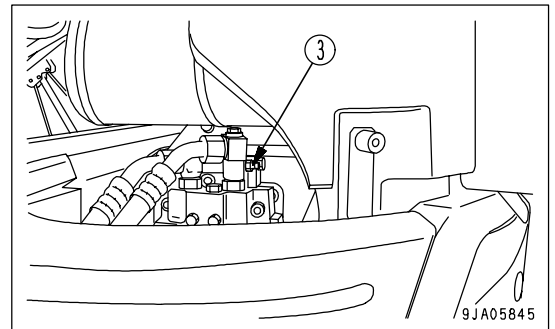

2. Start the engine. For details, see "STARTING ENGINE (PAGE 3-54)".
Run the engine at low idling for 10 minutes, then do as follows.

3. Bleeding air from cylinders

NOTICE

If the engine is run at high speed immediately after startup or a cylinder is pushed up to its stroke end, air taken inside the cylinder may cause damage to the piston packing.

- 1) Run the engine at low idling, and extend and retract each cylinder 4 to 5 times, taking care so that a cylinder may not be brought up to its stroke end. (Stop the cylinder approx. 100 mm (3.9 in) short of its stroke end)
- 2) Next, operate each cylinder 3 to 4 times to the end of its stroke.
- 3) Finally, operate each cylinder 4 to 5 times to the end of its stroke to completely remove the air.

4. Bleeding air from attachment (when installed)

NOTICE

- If the method of bleeding the air from the attachment itself is specified by the manufacturer, bleed the air according to the specified procedure.
- After completing the air bleeding operation, stop the engine, and leave the machine for 5 minutes before starting operations. This will remove the air bubbles in the oil inside the hydraulic cylinders.
- Check that there is no leakage of oil and wipe off any oil that has been spilled.

If a breaker or other attachment has been installed, run the engine at low idling and operate the attachment pedal repeatedly (approx. 10 times) until the air has been bled from the attachment circuit.

CHECK BEFORE STARTING

For details of the following items, see "Checks Before Starting (PAGE 3-42)" in the OPERATION section.

- Check coolant level, add coolant
- Check oil level in engine oil pan, add oil
- Check fuel level, add fuel
- Check oil level in hydraulic tank, add oil
- Check dust indicator
- Check water separator
- Check electric wiring
- Check function of horn

EVERY 500 HOURS MAINTENANCE

LUBRICATING

Lubricating Swing Components



WARNING

When lubricating the swing circle and the swing pinion, do not swing the upper structure while carrying out the lubricating.

- Prepare a grease gun

1. Using a grease pump, pump in grease through the grease fittings shown by arrows.
2. After greasing, wipe off any old grease that was pushed out.

- (1) Swing pinion (1 place)
- (2) Swing circle (1 place)

When lubricating the swing circle and swing pinion, turn the chassis little by little to change the position while carrying out the lubrication.

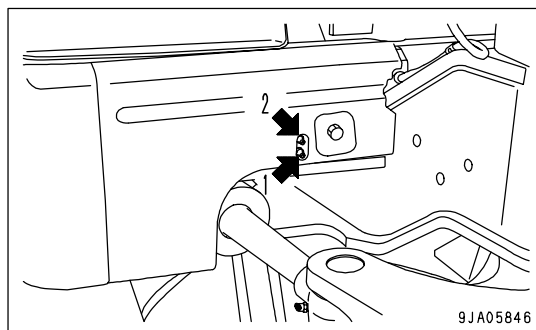

Lubricating Work Equipment

NOTICE

- When breaking in a new machine, carry out lubrication every 10 hours for the first 100 hours of operation.
- If any abnormal sound comes from the greasing point, carry out greasing regardless of the inspection and maintenance interval.
- After carrying out digging work in water, always lubricate the pins that were under water.
- Prepare a grease gun

1. Set the machine to the greasing posture shown on the right diagram, lower the work equipment to the ground, then stop the engine.
2. Using a grease pump, pump in grease through the grease fittings shown by arrows.
3. After greasing, wipe off any old grease that was pushed out.

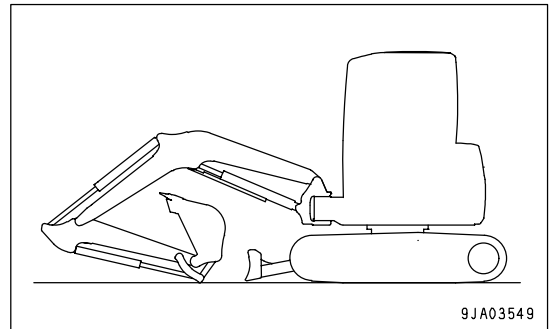

- (1) Bucket - Link connecting pins (1 place)
- (2) Arm - Bucket connection pin (1 place)
- (3) Arm - Link coupling pin (1 place)
- (4) Bucket cylinder rod end (1 place)
- (5) Link coupling pin (1 place)

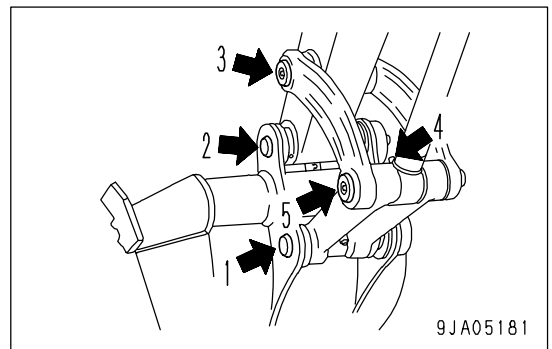

- (6) Blade cylinder foot pin (1 place)
- (7) Blade cylinder rod end (1 place)
- (8) Blade foot pin (2 places)
- (9) Boom cylinder foot pin (1 place)

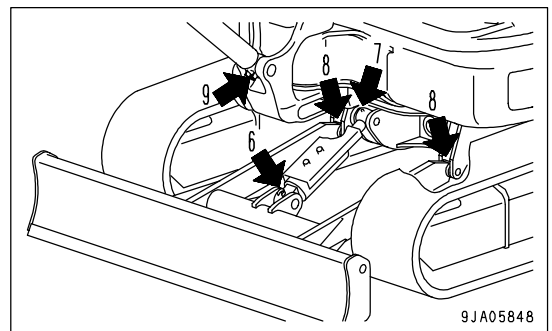

- (10) Boom swing bracket pin (2 places)
- (11) Boom swing cylinder rod end pin (1 place)
- (12) Boom foot pin (2 places)

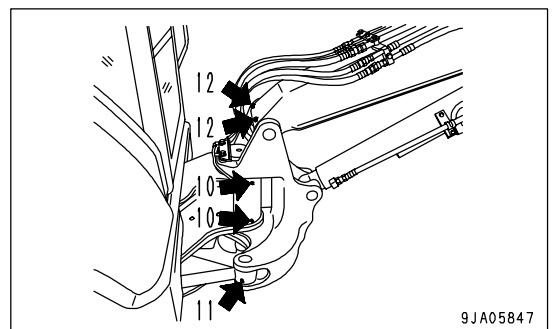

- (13) Boom cylinder rod end (1 place)
- (14) Arm cylinder foot pin (1 place)

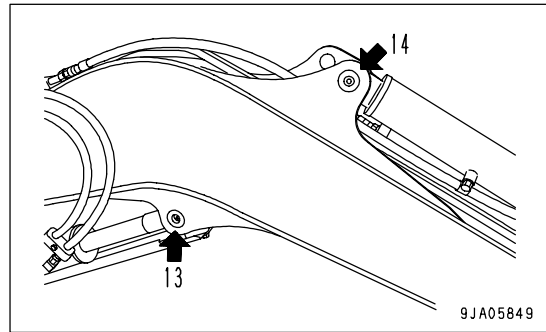

- (15) Arm cylinder rod end (1 place)
- (16) Boom - Arm connecting pins (1 place)
- (17) Bucket cylinder foot pin (1 place)

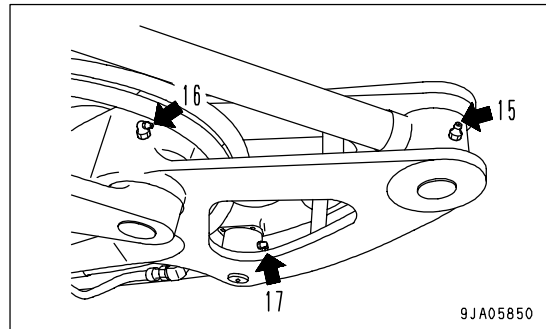

CHANGE OIL IN ENGINE OIL PAN, REPLACE ENGINE OIL FILTER CARTRIDGE

 **WARNING**

Engine parts and oil are at high temperature immediately after the engine is stopped, and will cause serious burns. Wait for the temperature to cool down before starting the operation.

- Refill capacity: 7.4 liters (1.96 US gal)
- Prepare a filter wrench

Change the oil and replace the cartridge once every 6 months, even if the engine has not been operated for 500 hours.

In the same way, change the oil and replace the cartridge once every 500 hours, even if the engine has not been operated for 6 months.

1. Set a container to catch the oil immediately under the drain plug (P) at the bottom of the machine.
2. Remove drain plug (P) slowly to avoid getting oil on yourself, and drain the oil.
3. Check the drained oil, and if there are excessive metal particles or foreign material, please contact your Komatsu distributor.
4. Install drain plug (P).

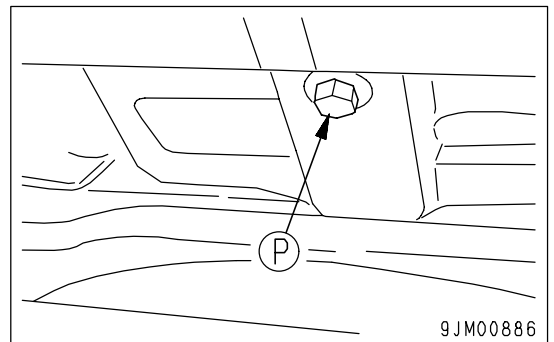

5. Open the engine rear cover.
6. Set a container to catch the oil coming from the drain hose leading from the tray under the filter cartridge.
7. Using a filter wrench, turn filter cartridge (1) counterclockwise to remove it.
8. Clean the filter holder, coat the new filter cartridge packing and threaded portion with clean oil (or coat thinly with grease), then install.

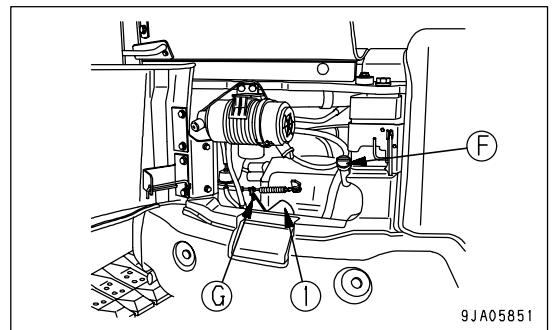

REMARK

Check that there is no old packing affixed to the filter holder. If there is any old packing affixed to the filter, it will cause leakage of oil.

9. When installing; tighten until the packing surface contacts the seal surface of the filter holder, then tighten it up 1/2 to 3/4 of a turn.
10. After replacing the filter cartridge, add oil through oil filler (F) until the oil level is between the H and L marks on the dipstick (G).
11. Run the engine idle for a while, then stop the engine and confirm that the oil level is between the H and L lines according to "Check Oil Level in Engine Oil Pan, Add Oil (PAGE 3-43)".

REPLACE FUEL FILTER CARTRIDGE**WARNING**

- Engine is at high temperature immediately after the machine has been operated. Wait for engine to cool down before replacing the filter.
- Do not bring fire or sparks near the fuel.

- Prepare a filter wrench
- Prepare for cloth.

1. Open the engine rear cover.
2. Spread the cloth beneath the filter cartridge.
3. Using a filter wrench, turn filter cartridge (1) counterclockwise to remove it.

If any fuel spills, wipe it up immediately with a cloth.

4. Clean the filter holder, fill the new filter cartridge with fuel, then coat the packing surface with fuel, and install to the filter holder.
5. When installing, turn to the right to tighten until the packing surface contacts the seal surface of the filter holder, then use a filter wrench to tighten approx. 1 turn.

Tightening torque: 19.6 to 23.5 N·m (2.0 to 2.4 kgf·m, 14.5 to 17.4 lbft)

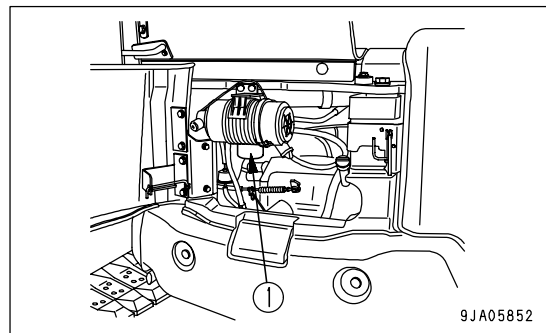

6. After replacing the fuel filter element, bleed air.
For details of the procedure, see "Air Bleeding (PAGE 4-51)".

Air Bleeding

1. Fill the fuel tank with fuel.
2. Open the engine rear cover and cooling cover. For details, see Section "COOLING COVER (PAGE 3-29)".
3. Set handle (1) of the water separator to OPEN position (B).
4. Loosen air bleed bolt (2) of the water separator 2 or 3 turns.
5. When no more bubbles come out with the fuel from air bleed bolt (2), tighten air bleed bolt (2).

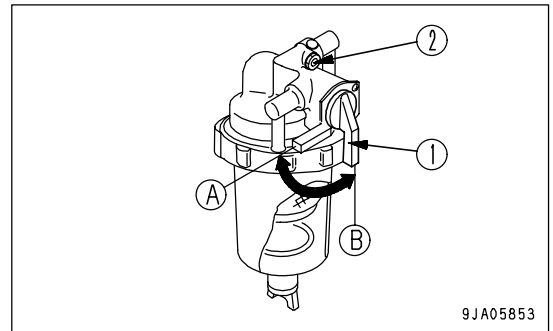

6. Turn the starting switch to the ON position, hold it there for 10 to 15 seconds, then return it to the OFF position.
Air bleeding is carried out automatically by the automatic air bleed device.

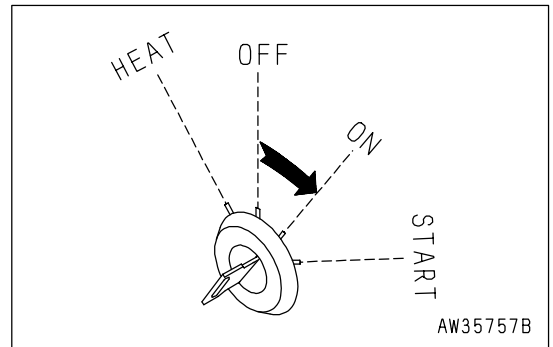

REMARK

When the machine has run out of fuel, carry out the same procedure, to bleed the air.

CHECK OIL LEVEL IN FINAL DRIVE CASE, ADD OIL**WARNING**

- The parts and oil are at high temperature immediately after the engine is stopped, and may cause serious burns. Wait for the temperature to go down before starting the operation.
- If there is still pressure remaining inside the case, the oil or plug may fly out. Loosen the plug slowly to release the pressure.

- Prepare a container to catch drained oil.
- Prepare a hexagon wrench.

1. Set so that plug (G) is at the top, with plug (G) and plug (P) perpendicular to the ground.
2. Set the container to catch oil under plug (P).
3. Remove plug (G) with a hexagonal wrench. Oil level should be near the bottom of the plug hole (G).
4. If the oil level is low, add oil through the hole in plug (G) until the oil overflows.
5. After checking, install plug (G).

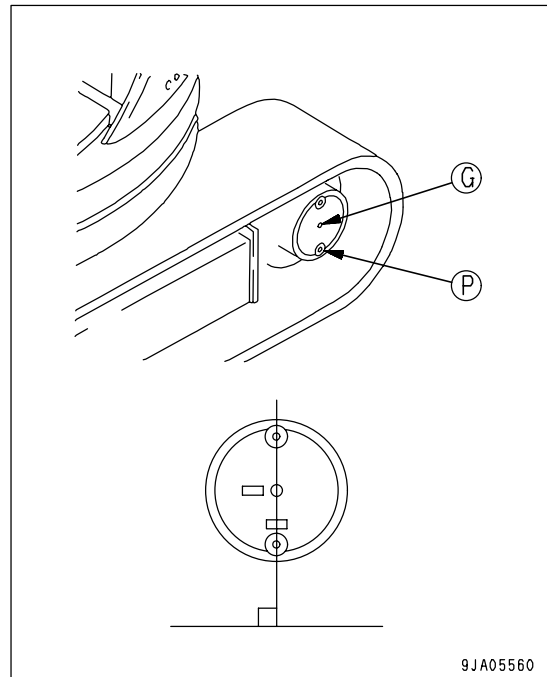

CLEAN AND INSPECT RADIATOR FINS AND OIL COOLER FINS**WARNING**

If compressed air, high-pressure water, or steam hit your body directly, or they cause dirt or dust to be blown up, there is a hazard of serious injury. Always use safety glasses, dust mask, or other protective equipment.

NOTICE

When use the compressed air, keep a distance from air nozzle, to prevents damage to the fins.

To prevent damage to the fins, apply compressed air from and appropriate distance. Damaged fins may cause water leakage or overheating. In a dusty site, check the fins daily, irrespective of the maintenance interval.

1. Open the engine rear cover and cooling cover. For details, see Section "COOLING COVER (PAGE 3-29)".
2. Use compressed air, steam, or water to blow off the mud, dirt, and leaves clogging radiator fins and oil cooler fins (1).

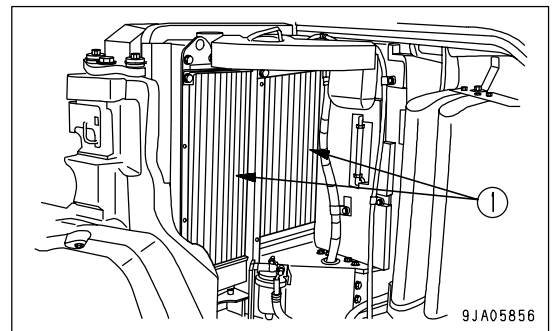

CHECK AND ADJUST COOLING FAN BELT TENSION

Checking

1. The deflection should be approx. 9 to 13 mm (0.355 to 0.5 in) when pressed at a point midway between the crankshaft pulley and the fan pulley with a finger pressure of approx. 98 N (10 kgf).

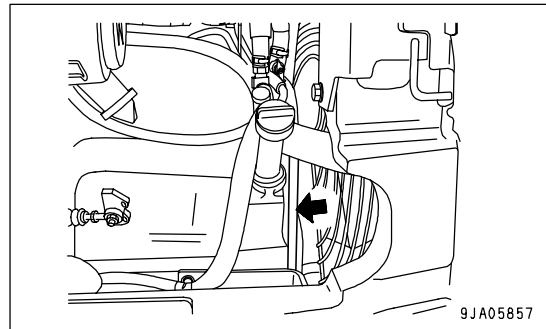

Adjustment

WARNING

- When this maintenance is carried out, it is necessary to open (tilt) the floor.
Before starting the operation to open the floor, read the precautions in Section "CAUTIONS FOR OPENING (TILTING) FLOOR (PAGE 2-34)" in the safety and maintenance sections thoroughly, and refer to the explanation for each part in Section "METHOD OF OPENING (TILTING) FLOOR (PAGE 3-31)" when carrying out the operation. Or ask your Komatsu distributor to carry out the maintenance.
- Immediately after the engine is stopped, the parts and oil are at a high temperature, and will cause burns. Wait for the temperature to go down before starting the operation.

- Prepare a pinch bar.
- Prepare a wooden block.

1. When opening (tilting) the floor, see Section "When Opening (tilt open) (PAGE 3-31)" for details.
2. Insert a bar between alternator (1) and the cylinder block to fix alternator (1) in position. When fixing alternator (1) in position, insert a wooden block between the bar and alternator (1) to prevent any damage to the alternator.
3. Loosen alternator adjustment bolt (2) and mounting bolts (3).
4. Move alternator (1) to adjust so that the belt tension is approx. 7 to 10 mm (0.276 to 0.4 in) when pressed at a point midway between the alternator pulley and the fan pulley with a finger pressure of approx. 98 N (10 kgf).

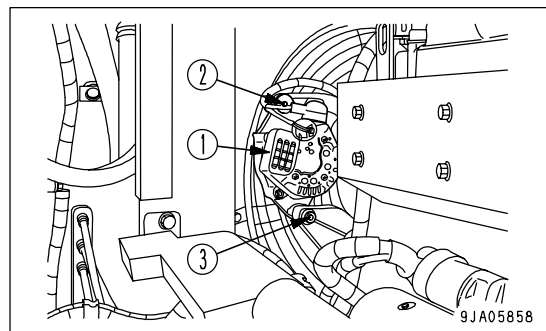

5. Tighten adjustment bolt (2), then tighten mounting bolts (3) to secure alternator (1) in position.
6. Check for damage to the pulleys, and wear of the V-groove and V-belt. Be particularly careful to check that the V-belt is not in contact with the bottom of the V-groove.
7. If the belt is stretched, leaving no allowance for adjustment, or if it is cut or cracked, contact your Komatsu distributor for replacement.
8. After completing the adjustment, close the floor. For details, see Section "When Closing (tilt close) (PAGE 3-34)".

EVERY 1000 HOURS MAINTENANCE

Carry out the maintenance for EVERY 500 HOURS SERVICE at the same time.

REPLACE HYDRAULIC OIL FILTER ELEMENT

⚠ WARNING

- The parts and oil are at high temperature after the engine is stopped, and may cause burns. Wait for the temperature to go down before starting the work.
- When removing the oil filler cap, turn it slowly to release the internal pressure, then remove it.

NOTICE

If the machine is equipped with a hydraulic breaker, the hydraulic oil will deteriorate much faster than during normal bucket operations. For details, see "MAINTENANCE INTERVAL FOR HYDRAULIC BREAKER (PAGE 4-16)" when carrying out maintenance.

1. Open dust cover (1) fully until it is secured in position.
(For details of the method of opening and closing the cover with the lock, see Section "In Case of Engine Rear Cover and Dirt Cover (PAGE 3-28)")

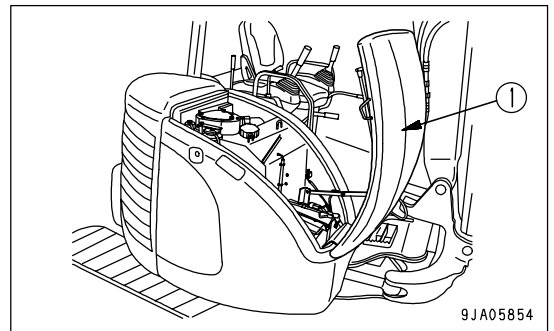

2. Loosen bolts (2), then remove plate (3) to the outside.
3. Remove the cap from oil filler (F), and release the internal pressure.
4. Remove bolts (4), then remove cover (5). When this is done, the cover may fly off under the force of spring (6), so keep the cover pushed down when removing the bolts.
5. After removing spring (6) and valve (7), take out element (8).
6. Clean the rempved parts in diesel oil.

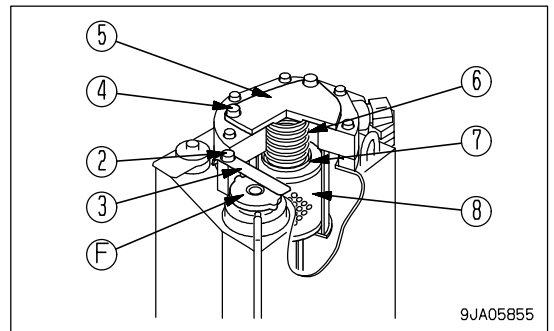

7. Install the new element where old element (8) was installed.
Inspect the O-ring set between the hydraulic tank and cover (5). If there are any scratches, replace the O-ring.
8. Set valve (7) and spring (6) on top of the element.
9. Set cover (5) in position, hold it down by hand, and tighten cover mounting bolts (4) to install cover (5).
10. Extend the boom, arm, and bucket cylinder fully as shown in the diagram on the right, remove the oil filler cap, then install the cap and pressurize the inside of the tank.

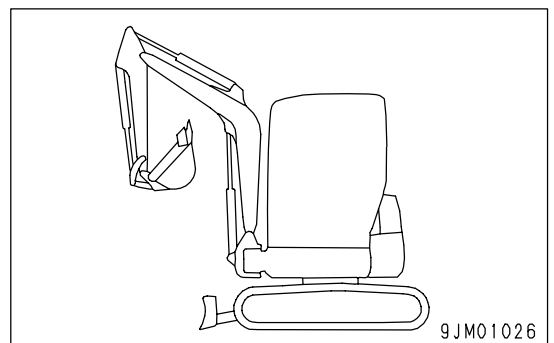

NOTICE

Be sure to pressurize the hydraulic tank. If it is not pressurized, the pump will suck in air, and this will adversely affect the equipment.

11. Close cover (1) at right side of the machine.

CHANGE OIL IN FINAL DRIVE CASE



WARNING

- The parts and oil are at high temperature immediately after the engine is stopped, and may cause serious burns. Wait for the temperature to go down before starting the operation.
- If there is still pressure remaining inside the case, the oil or plug may fly out. Loosen the plug slowly to release the pressure.

- Prepare a container to catch drained oil.
- Prepare a hexagon wrench.

1. Set so that plug (G) is at the top, with plug (G) and plug (P) perpendicular to the ground.
2. Set the container to catch oil under plug (P).
3. Using a hexagon wrench, remove plugs (P) and (G), and drain the oil.
4. Tighten plug (P).
5. Add the replacement amount of oil through the hole of plug (G).
6. When oil comes out from the hole of plug (G), install plug (G).

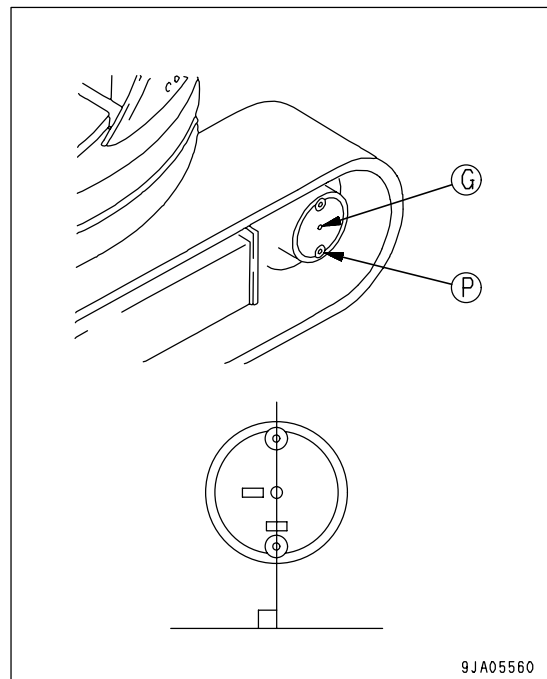

CHECK ENGINE VALVE CLEARANCE, ADJUST

As special tool is required for removing and adjusting the parts, you shall request Komatsu distributor for service.

EVERY 2000 HOURS MAINTENANCE

Carry out the maintenance for EVERY 500 HOURS, and EVERY 1000 HOURS SERVICE at the same time.

CHANGE OIL IN HYDRAULIC TANK, CLEAN STRAINER



WARNING

- The parts and oil are at high temperature after the engine is stopped, and may cause burns. Wait for the temperature to go down before starting the work.
- When removing the oil filler cap, turn it slowly to release the internal pressure, then remove it.

- Container to catch drained oil: Min. 20 liters (5.28 US gal) capacity
- Refill capacity: 20 liters (5.28 US gal)
- Prepare a handle (for the socket wrench).

1. Swing the upper structure so that the drain plug under the hydraulic tank will be between both tracks.

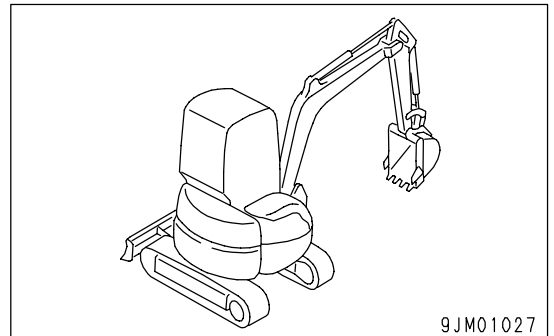

2. Retract the arm and bucket cylinders, then lower the boom and put the teeth in contact with the ground.

3. Lower the blade to the ground.

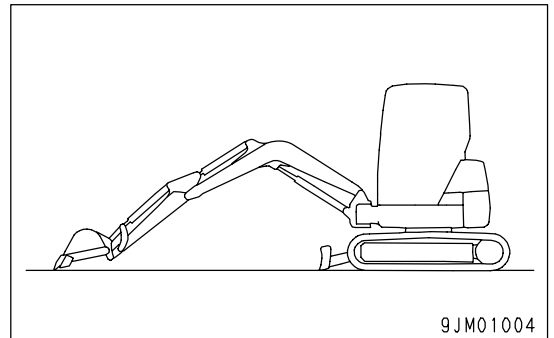

4. Set the safety lock lever to the LOCK position and stop the engine.

REMARK

For machines equipped with a cab, there is only a safety lock lever on the left.

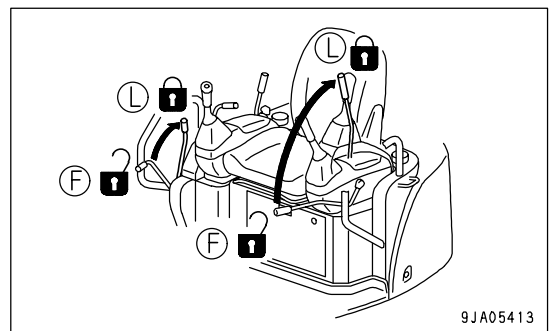

5. Open dust cover (1) fully until it is secured in position.
(For details of the method of opening and closing the cover with the lock, see Section "In Case of Engine Rear Cover and Dirt Cover (PAGE 3-28)")
6. Loosen bolts (2), then remove plate (3) to the outside.
7. Remove the cap from oil filler (F), and release the internal pressure.
8. Set the oil container under the drain plug under the machine. Using the handle, remove drain plug (P) and drain the oil. Check the O-ring installed to plug (P), and if it is damaged, replace the O-ring. After draining the oil, tighten drain plug (P).
Tightening torque: $68.6 \pm 9.81 \text{ N}\cdot\text{m}$ ($7 \pm 1 \text{ kgf}\cdot\text{m}$, $50.6 \pm 7.2 \text{ lbf}\cdot\text{ft}$)

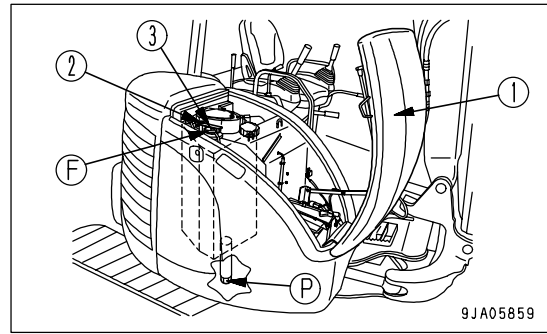

- Take care not to get oil on yourself when you remove drain plug (P).

9. Loosen hose clamp (4), remove hose (5), then remove bolt (6) and take out strainer (7).
10. Remove any dirt stuck to strainer (7), then wash it in clean diesel oil or flushing oil. If strainer (7) is damaged, replace it with a new one.
11. Secure strainer (7) with bolt (6), then install hose (5) and secure it in position with hose clamp (4).
12. Open the engine rear cover and cooling cover. For details, see Section "COOLING COVER (PAGE 3-29)".

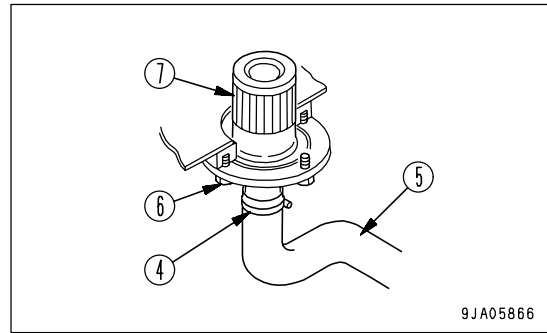

13. Add the replacement amount of oil through oil filler (F). Check that the oil level is between the H and L lines on the sight gauge.

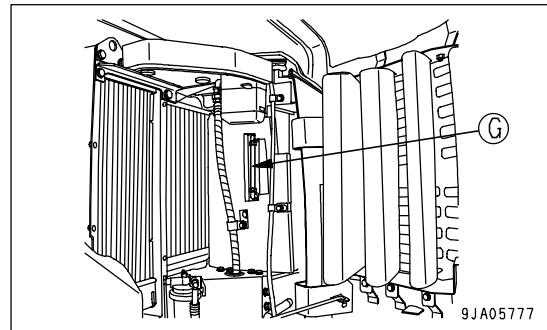

14. Extend the boom, arm, and bucket cylinder fully as shown in the diagram on the right, remove the oil filler cap, then install the cap and pressurize the inside of the tank.

NOTICE

Be sure to pressurize the hydraulic tank. If it is not pressurized, the pump will suck in air, and this will adversely affect the equipment.

15. After replacing the oil, set each control lever to the neutral position and run the engine idle at a low speed for 2 to 3 minutes, then start the normal work.

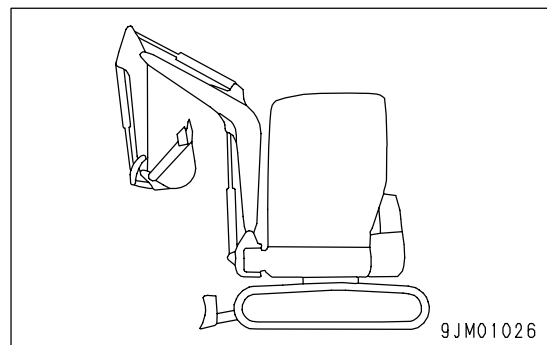

CHECK ALTERNATOR, STARTING MOTOR

The brush may be worn or the bearing may have run out of grease. Contact your Komatsu distributor for inspection or repair.

If the engine is started frequently, carry out inspection every 1000 hours.

SPECIFICATIONS

SPECIFICATIONS

Item		Unit	MX502 (With X weight)
Operating weight	Canopy specified	kg (lb)	5,040 (11,113)
	Cab specified		5,190 (11,444)
Bucket capacity		m ³ (cu.yd)	0.16 (0.21)
Name of engine		-	Komatsu 4D88E-5X diesel engine
Engine horsepower		kW (HP)/rpm	29.4 (39)/2,350
A	Overall length	mm (ft in)	5,550 (18' 3")
B	Overall height	Canopy specified	2,625 (8' 7")
		Cab specified	2,625 (8' 7")
C	Overall width	mm (ft in)	1,960 (6' 5")
D	Track width	mm (ft in)	400 (1' 4")
E	Radius of upper structure	Canopy specified	980 (3' 3")
		Cab specified	980 (3' 3")
F	Length of track	mm (ft in)	2,520 (8' 3")
G	Tumbler center distance	mm (ft in)	2,000 (6' 7")
Min. ground clearance		mm (ft in)	320 (1' 1")
Travel speed (Low/High)		km/h (MPH)	2.8 (1.7)/4.6 (2.9)
Continuous swing speed		rpm	9.0

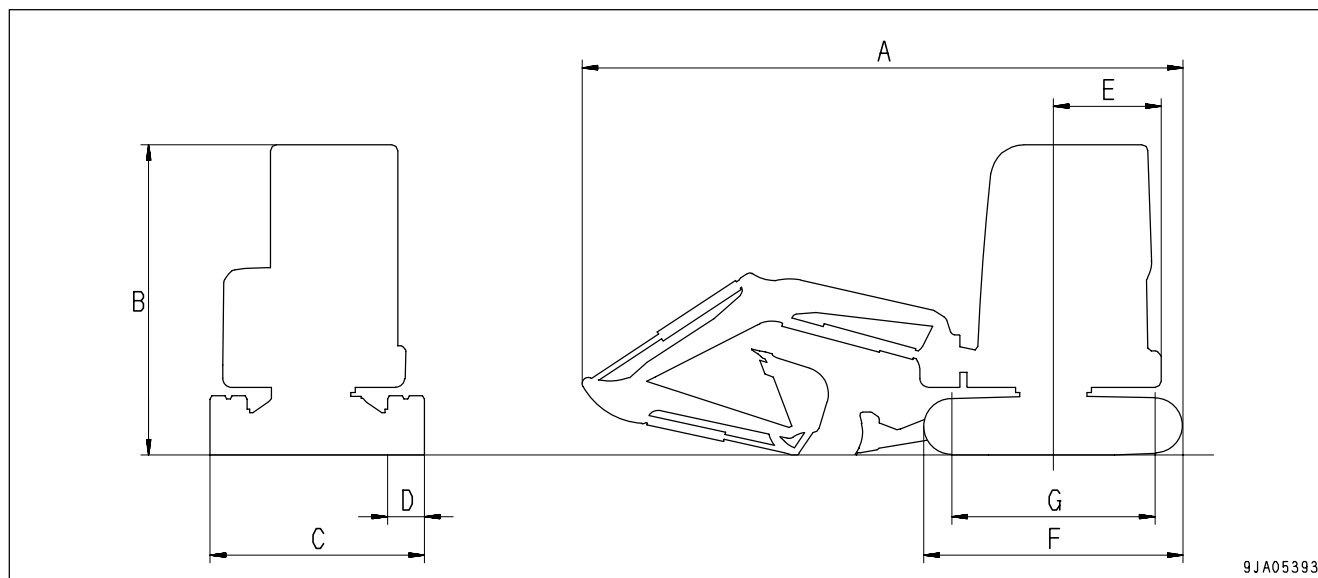

	Working ranges	Unit	MX502
A	Max. digging reach	mm (ft in)	6,220 (20' 5")
B	Max. digging depth	mm (ft in)	3,800 (12' 6")
C	Max. digging height	Canopy specified	5,945 (19' 6")
		Cab specified	5,945 (19' 6")
D	Max. vertical wall depth	mm (ft in)	3,020 (9' 11")
E	Max. dumping height	Canopy specified	4,230 (13' 11")
		Cab specified	4,230 (13' 11")
F	Min. swing radius of work equipment	mm (ft in)	2,270 (7' 5")
	Min. swing radius of work equipment (At boom swing)	mm (ft in)	1,740 (5' 9")
G	Max. reach at ground level	mm (ft in)	6,070 (19' 11")
H	Max. blade lifting height	mm (ft in)	430 (1' 5")
I	Max. blade lowering depth	mm (ft in)	330 (1' 1")

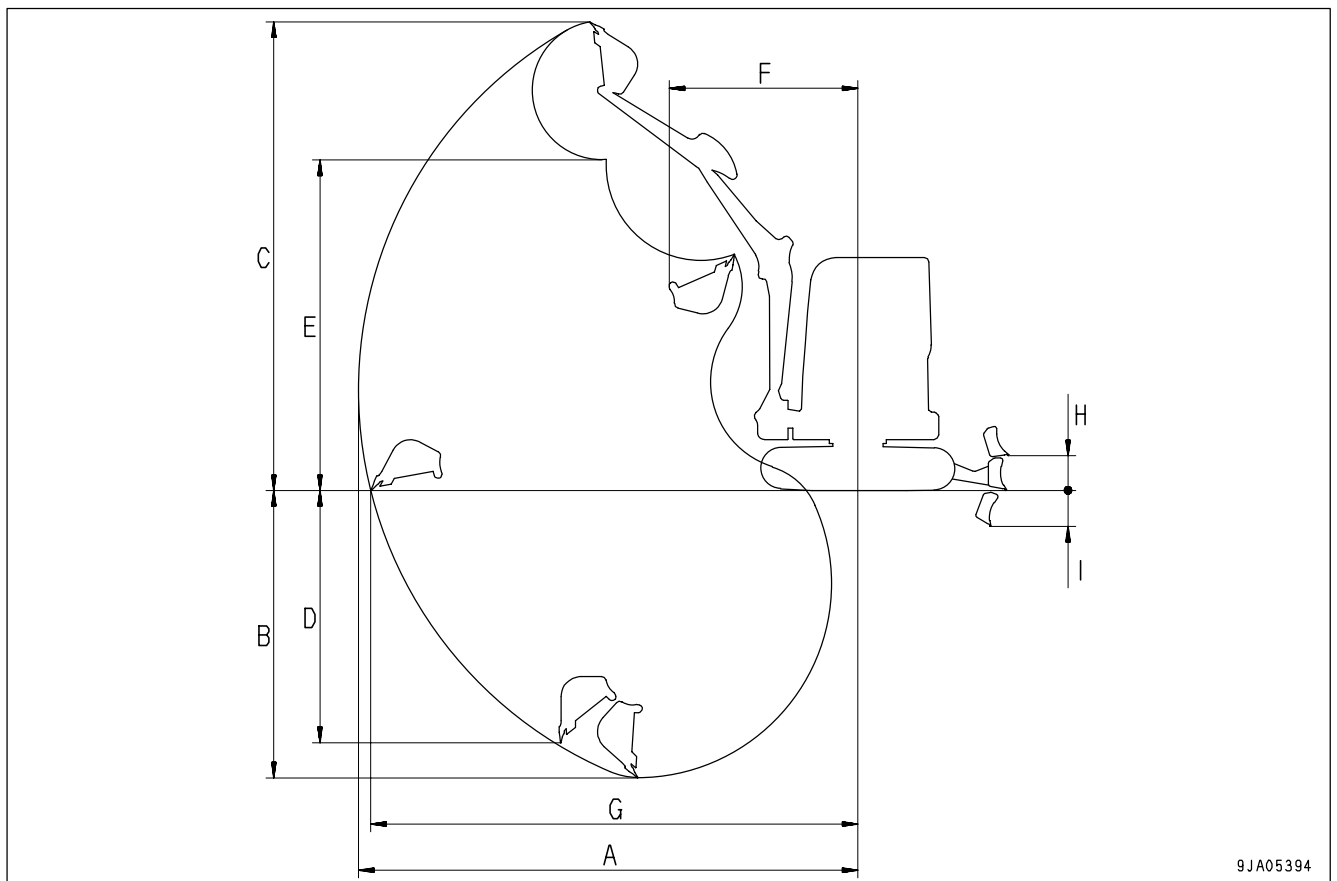

ATTACHMENTS, OPTIONS

 **WARNING**

Please read and make sure that you understand the SAFETY section before reading this section.

ATTACHMENTS AND OPTIONS - GENERAL INFORMATION

SAFETY FIRST

If attachments or options other than those authorized by Komatsu are installed, this will not only affect the life of the machine, but will also cause problems with safety.

When installing attachments not listed in this Operation and Maintenance Manual, contact your Komatsu distributor first.

If you do not contact Komatsu, we cannot accept any responsibility for any accidents or failures.



WARNING

General precautions

- Read the instruction manual for the attachment thoroughly, and do not use this attachment unless you are sure that you have understood the guides completely.
If you lose the instruction manual, always ask the manufacturer or your Komatsu distributors for a new copy.
- Depending on the attachment, install the necessary front guard to the machine.
- Depending on the attachment, the impact noise may make it difficult for fellow workers to transmit instructions for the operation. Before starting operation, decide a leader and determine the signals to be used.
- Do not carry out swinging operations to the side with a heavy load on the attachment. This is particularly dangerous on slopes.
- Comparing with a machine equipped with a bucket, a machine equipped with a breaker has a heavy load at the front of the work equipment and is unstable. To avoid a hazard of tipping over, do not carry out operations with the attachment swung to the side.
- When an attachment is installed, the swing range and center of gravity of the machine are different, and the machine may move in an unexpected way. Be sure that you understand the condition of the machine properly.
- Before starting operations, set up a fence around the machine to prevent people from entering.
Never operate the machine when there are people near the machine.
- To prevent serious accidents caused by misoperation, do not put your foot on the pedal except when operating the pedal.

Precautions for removal and installation operations

When removing or installing the attachments, obey the following precautions and take care to ensure safety during the operation.

- Carry out the removal and installation operation on a flat, firm ground surface.
- When the operation is carried out by two or more workers, determine the signals and follow these during the operation.
- When carrying heavy objects (more than 25 kg or 55 lb), use a crane.
- When removing heavy parts, always support the part before removing it.
When lifting such as heavy parts with a crane, always pay careful attention to the position of the center of gravity.
- It is dangerous to carry out operations with the load kept suspended. Always set the load on a stand, and check that it is safe.
- When removing or installing attachments, make sure that it is in a stable condition and will not fall over.
- Never go under a load suspended from a crane.
Always stand in a position that is safe even if the load should fall.

NOTICE

Qualifications are required to operate a crane. Never allow the crane to be operated by an unqualified person.

For details of removal and installation operations, contact your Komatsu distributor.

ATTACHMENT INSTALLATION

 **WARNING**

Long work equipment or heavy work equipment cause the machine to have poor stability, so there is danger of the machine losing its balance and tipping over when traveling down steep hills or when swinging on slopes. Never do any of the following. They are extremely dangerous.

- Traveling downhill with the work equipment raised
- Traveling across slopes
- Swinging upper structure on slopes
- If heavy-load work equipment is installed, there will be excessive overrun when swinging (the distance from operating to stop the swing to the point where the swing stops completely), so there is danger of mistaking the distance and hitting other objects.

Allow a margin to the stopping point when operating.

In addition, the hydraulic drift (the gradual downward movement caused by the weight of the work equipment when the work equipment is stopped in a raised condition) will also increase.

- If the correct procedure is not used when installing the boom and arm, it may lead to serious damage. Please consult your Komatsu distributor.
- When long work equipment is installed, the working range will suddenly become larger, so there is danger of mistaking the distance and hitting other objects. Allow an ample margin between the work equipment and surrounding obstacles when operating.

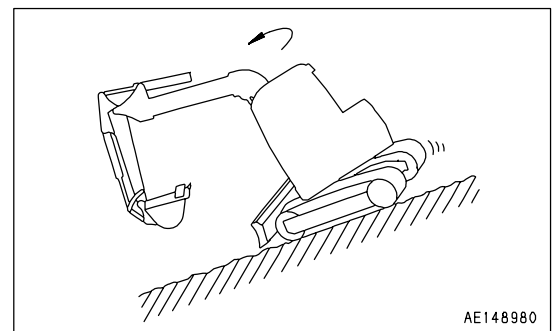
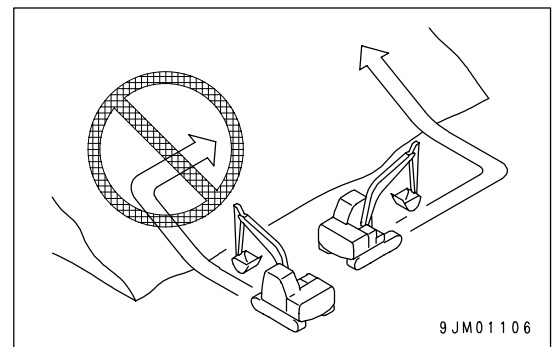
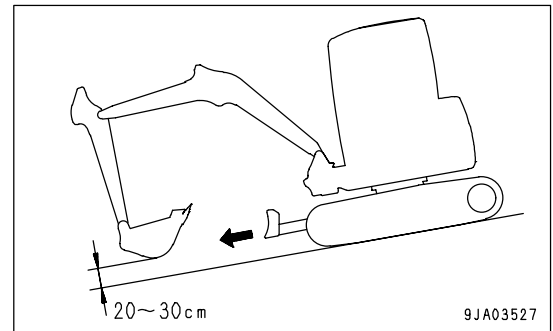

BUCKET WITH HOOK

PROHIBITED OPERATIONS

Operations with Care

- Do not exceed the following loads when carrying out lifting operations.
When standard arm is installed: 215 kg (474 lb)
When long arm is installed: 160 kg (353 lb)
- It is dangerous if the load sways excessively. Lower the engine speed and operate the control levers slowly.
- The swing speed of this machine is 3 to 4 times the speed of a mobile crane. Be particularly careful to check that the surrounding area is safe when operating the swing.
- Check that there is no damage to the hook, stopper, and hook mount. If any abnormality is found, please contact your Komatsu distributor.
- Never travel the machine while lifting a load.
- Depending on the operating posture, there is danger that the wire or pulley may come off from the hook. To avoid these parts from coming off, pay careful attention to the angle of the hook. In addition, do not allow any person to come under or in the area around a raised load.
- If the bucket with hook is turned and used for operations, it will hit the arm during dumping operations, so be careful when using it.
- It is prohibited to swing or offset the boom when carrying out lifting operations.
Set the boom facing the center.
- If a hook is to be installed, please consult your Komatsu distributor.

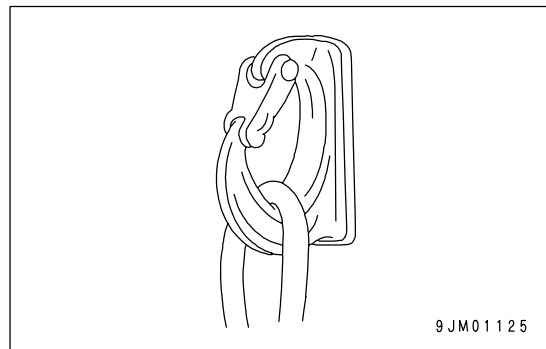
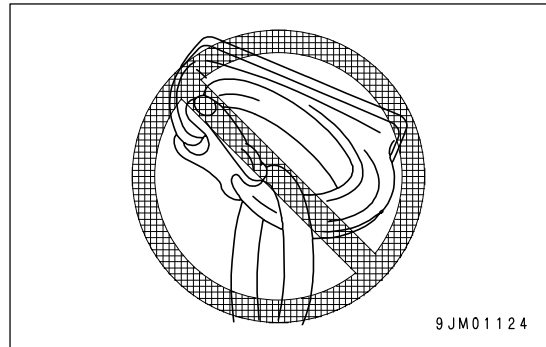

AIR CONDITIONER

CONTROL PANEL AND COMPONENTS

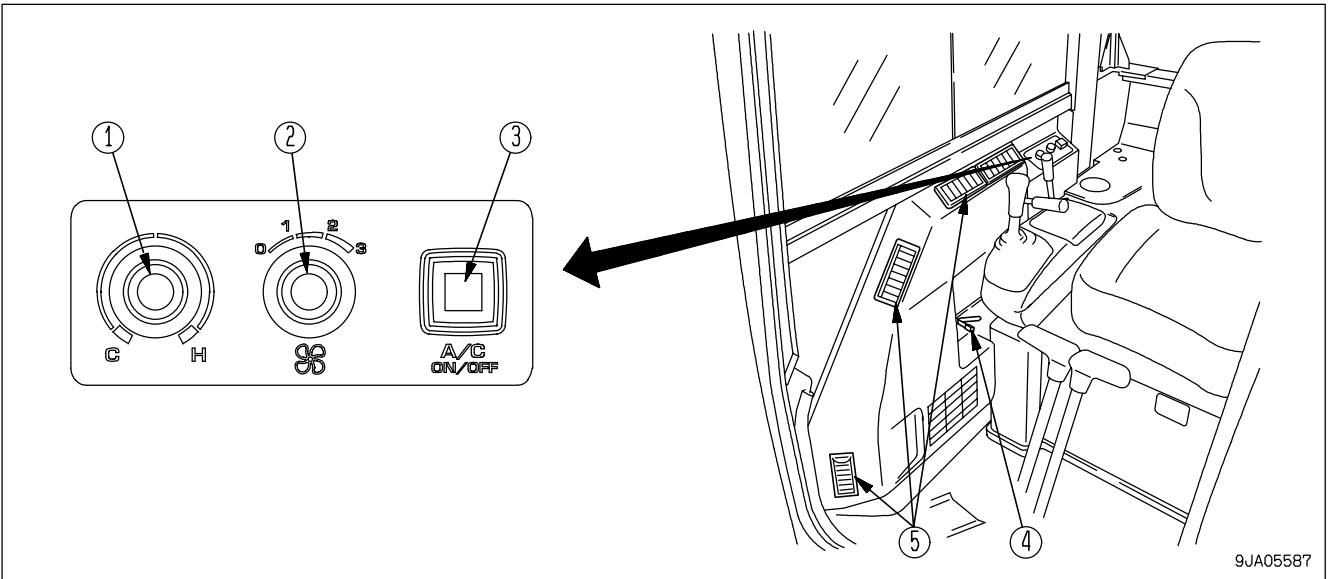

- (1) Temperature control switch
- (2) Air flow selector switch
- (3) Air conditioner switch

- (4) FRESH/RECIRC selector lever
- (5) Vent

Temperature Control Switch

This switch (1) continuously adjusts the temperature between high and low.

The more the switch is turned to the left, the lower the temperature becomes; the more the switch is turned to the right, the higher the temperature becomes.

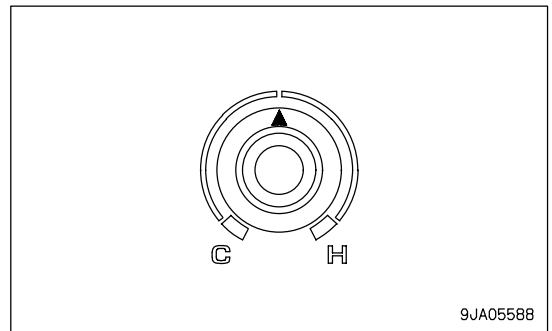

Air Flow Selector Switch

This switch (2) adjusts air flow in three steps.

- Position (3): High
- Position (2): Intermediate
- Position (1): Low
- Position (0): OFF

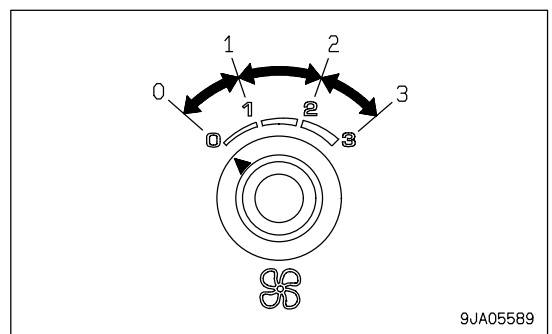

Air Conditioner Switch

This switch (3) is used as the ON/OFF switch for the air conditioner.

Each time this switch is pressed, it switches between ON and OFF. When the switch is ON, the lamp inside the switch lights up.

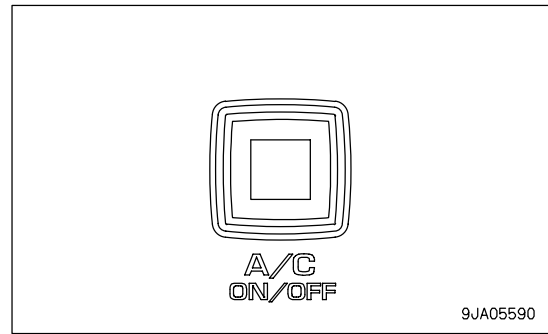
**FRESH/RECIRC Selector Lever**

Use this lever (4) to switch between recirculation of the air inside the cab and intake of fresh air from outside.

Position (A): Fresh air intake

Position (B): Recirculation of air in cab

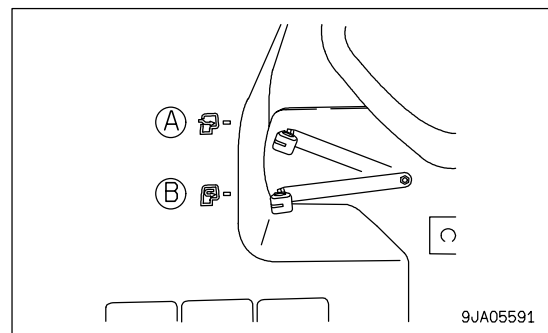
**Vent**

It is possible to change the direction of the airflow by rotating or reversing the louvers of each vent (5).

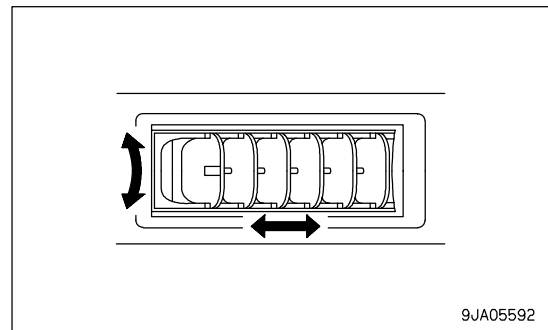
**AIR CONDITIONER CONTROLS****Cooling**

- If you smoke when the cooler is on, the smoke may start to hurt your eyes, so carry out ventilation and cooling for a short time to remove the smoke.
- When running the air conditioner for a long time, carry out ventilation and cooling together once an hour.

Cooling with Care

- When the cooler is on, set the temperature so that it feels slightly cool when entering the cab (5 to 6°C (41 to 42.8 °F) lower than the outside temperature). This temperature difference is considered to be the most suitable for your health, so always be careful to adjust the temperature properly.

AIR CONDITIONER MAINTENANCE

When Required

Check Refrigerant (Gas) Level



WARNING

If the refrigerant used in the cooler gets into your eyes or on your hands, it may cause loss of sight or frostbite. Do not touch the refrigerant. Never loosen any part of the refrigerant circuit.

Do not bring any flame close to any point where the refrigerant gas is leaking.

If there is a lack of refrigerant (gas), the cooling performance will be poor. When operating the cooler at high speed with the engine at full throttle, use the receiver sight glass (inspection window) to check the condition of the refrigerant gas (Freon R134a) flowing in the refrigerant circuit.

- No bubbles in refrigerant flow: Suitable
- Some bubbles in flow (bubbles pass continuously): Lack of refrigerant
- Colorless, transparent: No refrigerant

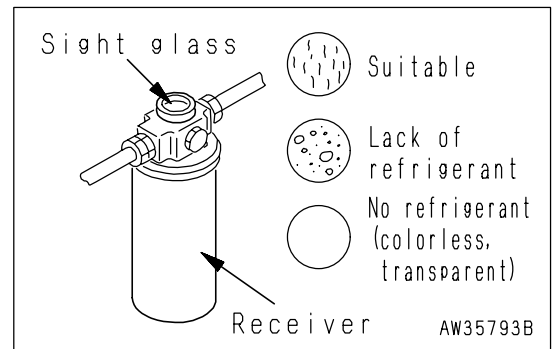

REMARK

When there are bubbles, the refrigerant gas level is low, so contact your refrigerant dealer to have refrigerant added. If the air conditioner is run with the refrigerant gas level low, it will cause damage to the compressor.

Off Season Checks

Even during the off-season, operate the air conditioner for 3 to 5 minutes once a month to maintain the oil film at all parts of the compressor.

Inspection and Maintenance Items

Check,maintenance items	Content of check,maintenance	Guideline for maintenance interval
Refrigerant (gas)	Charge amount	Twice a year (spring,autumn)
Condenser	Clogged fins	Every 500 hours
Compressor	Operating condition	Every 4000 hours
V-belt	Damage,tension	Every 250 hours
Blower motor, fan	Operating condition (does it when required make abnormal noise?)	When required
Control mechanism	Operating condition (does it function normally?)	When required
Piping mounts	Mounting condition,looseness at tightening or connecting portions,leakage of gas,damage	When required

Every 250 Hours Maintenance

CHECK AND ADJUST AIR CONDITIONER COMPRESSOR BELT TENSION

Checking

The belt should deflect 5 to 6 mm (0.197 to 0.236 in) when pressed with a finger force of approx. 58.8 N (6 kgf) at a point midway between the idle pulley and compressor pulley.

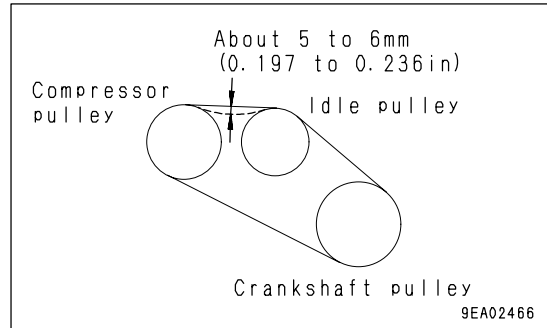

Adjustment

Adjust the belt tension with adjustment nut (2) of idle pulley (1).

1. Open the engine rear cover and loosen locknut (3).
2. Adjust with adjustment nut (2) so that the deflection of the belt is 10 to 15 mm (0.4 to 0.6 in) (approx. 58.8 N (approx. 6 kgf)).
3. Tighten nut (3) to hold idle pulley in position.
4. Check for damage to the pulleys, and wear of the V-groove and V-belt. Be particularly careful to check that the V-belt is not in contact with the bottom of the V-groove.
5. Replace belt if it has stretched, leaving no allowance for adjustment, or if there is a cut or crack on V-belt.
6. When the new V-belt is set, readjust it after operation for an hour.

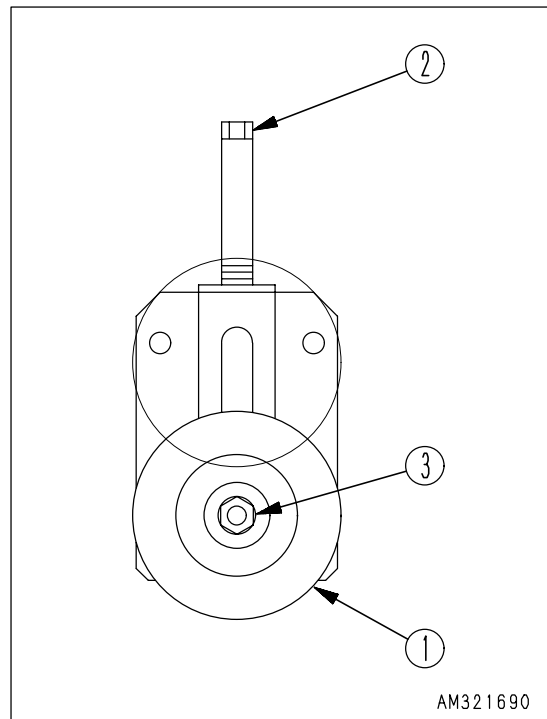

Every 500 Hours Maintenance

Clean Air Conditioner Condenser



WARNING

If compressed air, high-pressure water, or steam hit your body directly, or they cause dirt or dust to be blown up, there is a hazard of serious injury. Always use safety glasses, dust mask, or other protective equipment.

NOTICE

When using compressed air, keep the air nozzle at a distance to prevent damage to the fins. Especially for the aftercooler, blow the air from 300 mm (11.8 in) or more, and at a 45 degree angle.

To prevent damage to the fins, apply compressed air from an appropriate distance. Damaged fins may cause water leakage or overheating. On dusty sites, check the fins daily, regardless of the maintenance interval.

1. Blow off mud, dust or leaves clogging the condenser fins using compressed air.
Steam or wter may be used instead of compressed air.
2. Check the rubber hose. Replace with a new one if the hose is found to have cracks or to be hardened by ageing.
Also, check hose clamps for looseness.

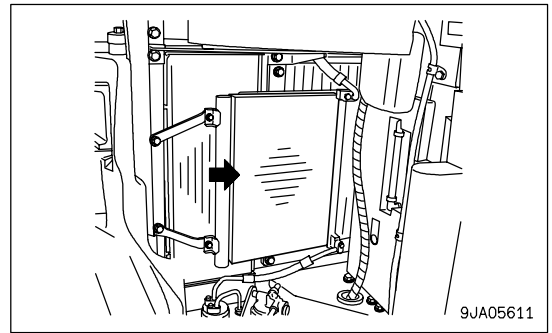

Clean Air Conditioner FRESH Filter

 **WARNING**

If compressed air is used, there is danger that dirt may fly and cause personal injury.
Always wear safety glasses, dust mask, and other protective equipment.

NOTICE

As a guideline, the filters should be cleaned every 500 hours, but on dusty jobsites, clean the filters more frequently.

If the air conditioner has been used, the air filter should be cleaned.
Stop the air conditioner before cleaning the element.

1. Loosen knob (1), then remove filter inspection cover (2).
2. Remove filter (3).
3. Clean the filter (3) with compressed air.

If there is oil on the filter (3) or it is extremely dirty, wash it in water containing a neutral agent.

After washing the filter, dry it thoroughly before using it.

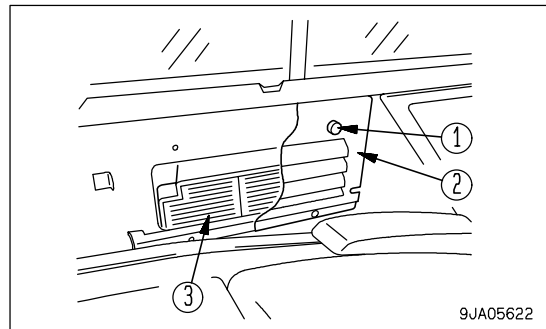
**REMARK**

If the clogging of the filter cannot be removed by blowing it with compressed air or washing in water, replace the filter with a new one.

4. Install cover (2) in position.

Clean Air Conditioner RECIRC Filter

 **WARNING**

If compressed air is used, there is danger that dirt may fly and cause personal injury.
Always wear safety glasses, dust mask, and other protective equipment.

NOTICE

As a guideline, the filters should be cleaned every 500 hours, but on dusty jobsites, clean the filters more frequently.

1. Pull out filter (1) to the front.
2. Clean with compressed air in the same way as for the fresh air filter.
If the filter is extremely dirty, rinse it in water.
After rinsing the filter, dry it completely before installing it again.

REMARK

If the clogging of the filter cannot be removed by blowing it with compressed air or washing in water, replace the filter with a new one.

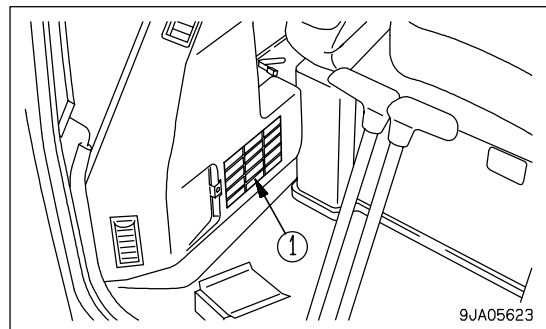

WINDSHIELD WASHER

(Machine equipped with operator's cab)

If the windshield washer is installed, operate it according to the following procedure.

WINDSHIELD WASHER OPERATION

- Wiper and window washer

When the wiper is working and the switch is kept pushed to position (B), washer fluid is sprayed out.

When the switch is released, it returns, and only the wiper operates.

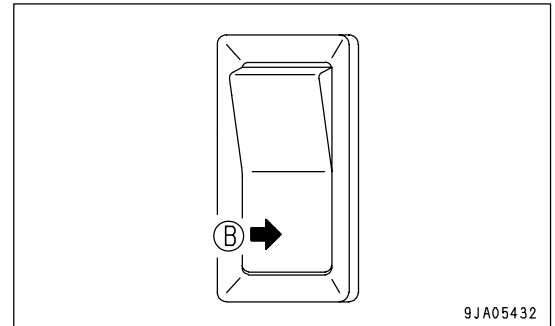

NOTICE

If the windshield washer is operated continuously for more than 10 seconds or operated with the washer fluid tank empty, the motor may be broken.

CHECK WINDOW WASHER FLUID LEVEL, ADD FLUID

If air is mixed in the windshield washer fluid, check the fluid level of washer fluid tank in the engine compartment.

If it is too low, supply the same kind of washer fluid as automobiles use.

At this time, take care that dust does not enter the tank.

Washer Fluid Dilution Ratio

The proportion differs according to the ambient temperature, so dilute the washer fluid with water to the following proportions before adding.

Area,season	Proportions	Freezing temperature
Normal	Washer fluid 1/3: water 2/3	-10°C (14°F)
Winter in cold area	Washer fluid 1/2: water 1/2	-20°C (-4°F)
Winter in extremely cold area	Pure washer fluid	-30°C (-22°F)

There are two types depending on the freezing temperature:

-10°C (14°F) (general use) and -30°C (-22°F) (cold area use), so select according to the area and season.

MACHINE READY FOR ATTACHMENT

There are two types for the hydraulic pressure takeoff: quick coupler and stop valve.

LOCATIONS

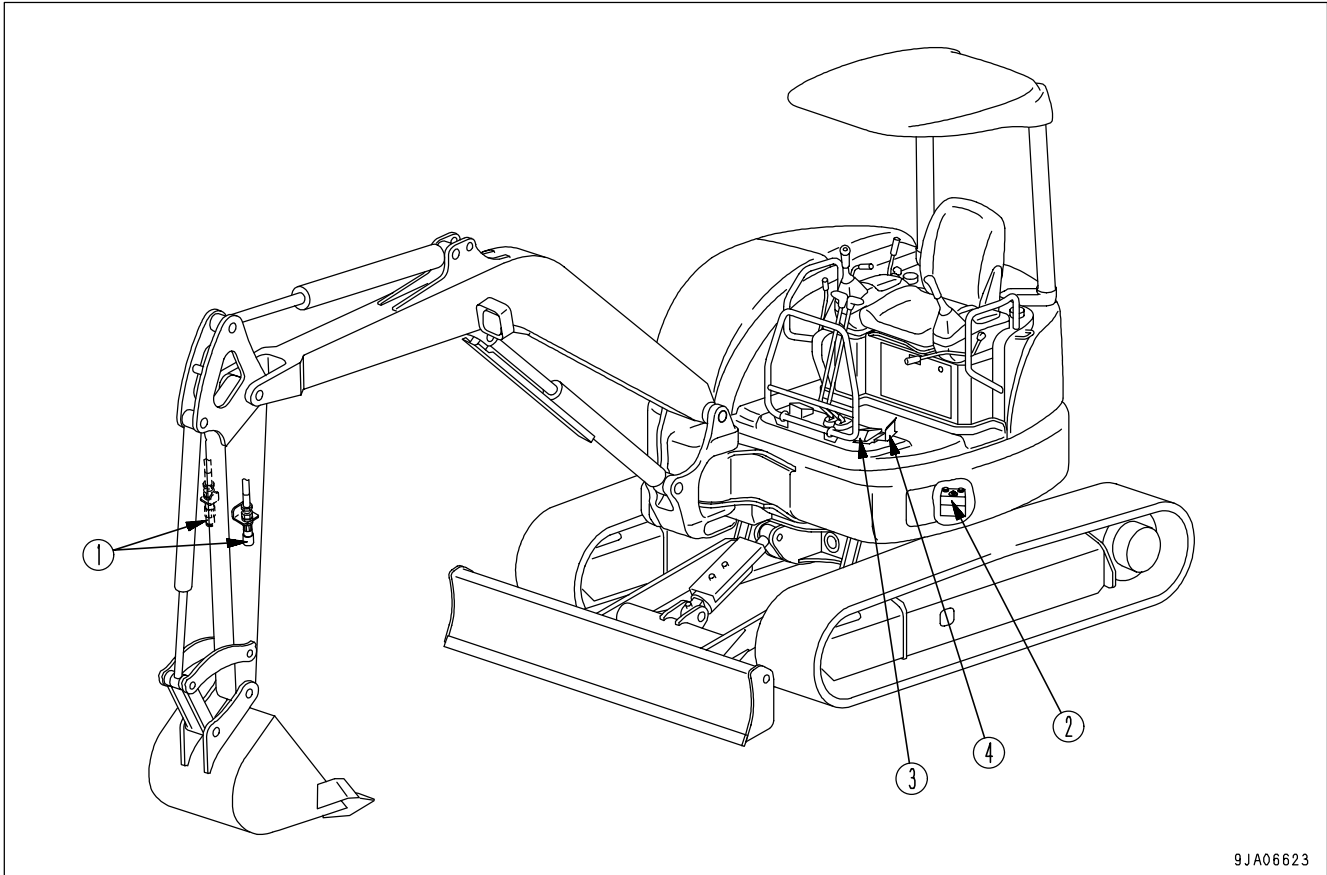

9JA06623

- | | |
|--------------------|---|
| (1) Quick coupler | (3) Attachment control pedal |
| (2) Selector valve | (4) Pedal lock (for attachment control pedal) |

Quick Coupler

This quick coupler (1) is used to connect the piping equipped with quick coupler at the attachment end.

The following products are used for the quick coupler.

Arm left side (hole end): STUCCHI (F FIRG12A BSP)

Arm right side (shaft end): STUCCHI (APM15 3/4 BSP)

When removing the attachment, install this coupler (1) to cap (A).
When installing the attachment, remove cap (A), clean all the dirt from coupler (1), then connect the piping.

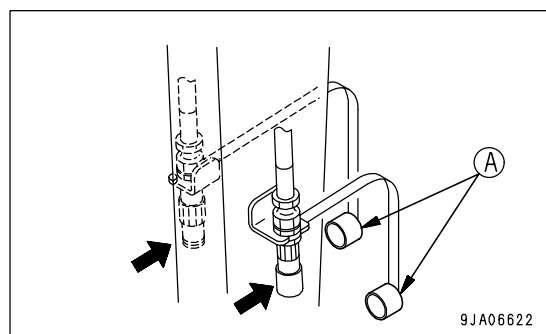

9JA06622

The following products are used for quick coupler cap (A).

Arm left side (hole end): STUCCHI (8151..004)

Arm right side (shaft end): STUCCHI (8151..009)

Selector Valve

This valve (2) switches the flow of hydraulic oil.

Position (a): When using breaker

Turn spool (A) to the left until it is stopped by the stopper.

Position (b): When using general attachment

Turn spool (A) to the right until it is stopped by the stopper.

Width across face of square portion of spool (A): 9 mm (0.355 in)

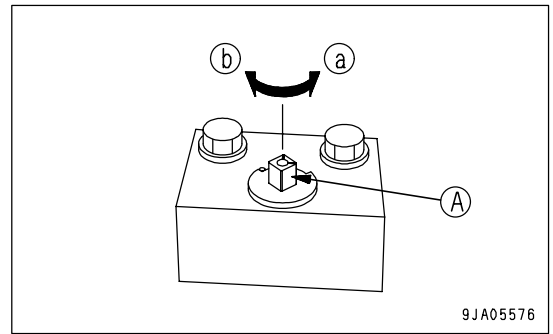

9JA05576

Attachment Control Pedal

This pedal (3) is used to operate the attachment.

Top of pedal depressed: Oil flows to right side of arm (hydraulic tank side).

Bottom of pedal depressed: Oil flows to left side of arm (operator's seat side).

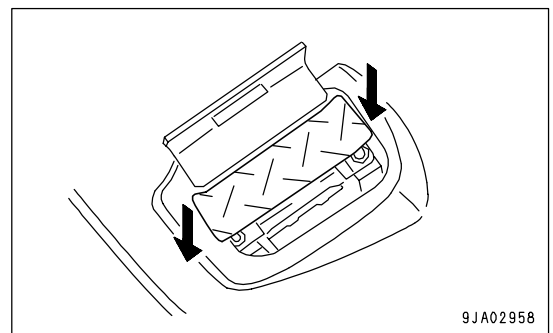

9JA02958

Pedal Lock

(for attachment control pedal)



When attachment operation is not required, lock the attachment control pedal with the pedal lock.

If the attachment control pedal is accidentally pressed while it is not locked, a serious accident may occur.

This plate (4) is a device to lock the attachment control pedal. When the pedal is covered by the plate, it is locked.

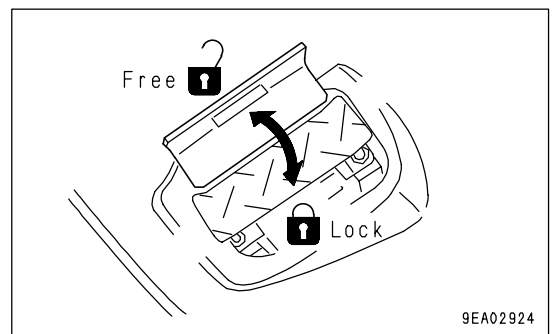

9EA02924

HYDRAULIC CIRCUIT

Hydraulic Circuit Connection

NOTICE

The pressure for the hydraulic equipment for the attachments used on this machine is set at 17.2 MPa (175 Kg/cm²), so check the pressure resistance of the attachment installed.

When connecting the attachment, connect the hydraulic circuit as follows.

1. Lock the attachment control pedal with the pedal lock.
2. Remove the cap of the quick coupler.
Be careful not to damage or lose the parts that are removed.

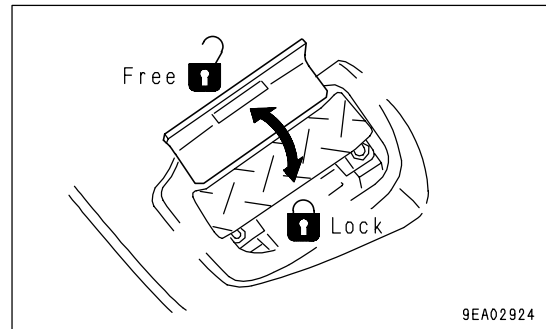

3. Connect the piping (quick coupler) supplied by the attachment manufacturer.

The following products are used for the quick coupler.

Arm left side (hole end): STUCCHI (F FIRG12A BSP)

Arm right side (shaft end): STUCCHI (APM15 3/4 BSP)

The sizes of the quick coupler mount threads on the elbow installed to the block are as follows.

Arm left side (hole end): 1/2" G

Arm right side (shaft end): 3/4" G

REMARK

If the quick coupler size does not match, please contact your Komatsu distributor.

Bleeding Air

After connecting the piping, bleed the air from the circuit.

1. Starting engine

Start the engine according to "STARTING ENGINE (PAGE 3-54)" keep running the engine at low idling for 10 minutes, and carry out the following procedure.

2. Bleeding air from cylinders

Operate each cylinder 3 or 4 times to the end of its stroke.

NOTICE

If, at first, the engine is run at high speed or the cylinder is operated to the end of its stroke, the air inside the cylinder may cause damage to the piston packing or other parts.

3. Bleeding air from attachment (if equipped)

For machine equipped with attachment such as the breaker, actuate the attachment pedal about 10 times to bleed the air completely from the attachment circuit while running the engine at low idling.

NOTICE

If the attachment bleeding procedure is specified by the manufacture, bleed the attachment according to such procedure.

4. Operation

- 1) After completion of bleeding the air, stop the engine, and wait for at least 5 minutes before starting operations. In this way, the air bubbles are removed from the oil inside the hydraulic tank.
- 2) Check for any leakage of oil, and wipe off any oil that has been spilled.

ATTACHMENT OPERATIONS

WARNING

If you leave your foot resting on the pedal during operations and you depress the pedal by mistake, there is danger that the attachment will suddenly move and cause serious personal injury. Always lock the pedal with the lock plate except when operating the pedal.

The operation of the attachment is as follows.

When Using Breaker

Depress the bottom of the pedal to operate the breaker.

REMARK

If it is necessary to adjust the oil flow, please ask your Komatsu distributor to carry out the adjustment.

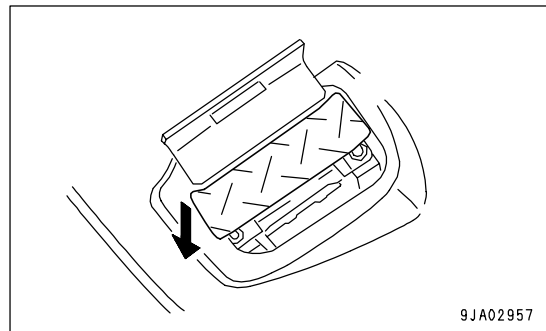

Precautions when Using

- Check that selector valve (1) is at the 1 WAY (breaker) position (a).
- When using the breaker, pull the fuel control lever back fully, then return it slightly and keep it in this position for operations. (The position for 80% of engine output)
If the breaker is operated with the engine at full throttle, it will lead to failure.
- When using the breaker, the hydraulic oil deteriorates more and replace the element at a shorter interval. (For details, see "MAINTENANCE INTERVAL FOR HYDRAULIC BREAKER (PAGE 4-16)".)
- For details of other precautions when handling the breaker, read and use correctly the instruction manual provided by the breaker manufacturer.

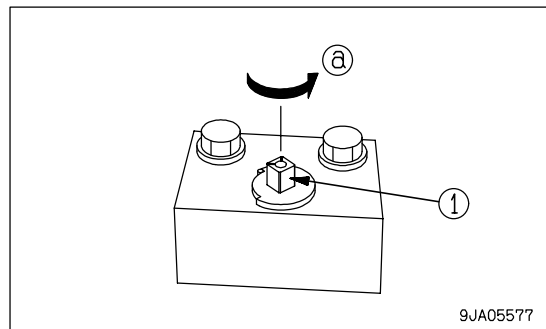

When Using General Attachment Such as Crusher

When the pedal is depressed, the attachment is actuated.

Top of pedal depressed: Oil flows to right side of arm (hydraulic tank side).

Bottom of pedal depressed: Oil flows to left side of arm (operator's seat side).

REMARK

If it is necessary to adjust the oil flow, please ask your Komatsu distributor to carry out the adjustment.

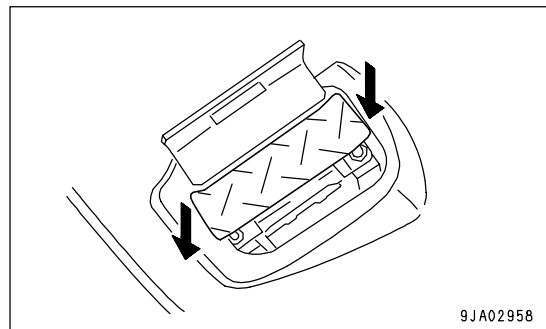

Precautions when Using

- Check that selector valve (1) is at the 2 WAY (crusher or other attachment) position (b).
- For details of other precautions when handling the attachment, read and use correctly the instruction manual provided by the attachment manufacturer.

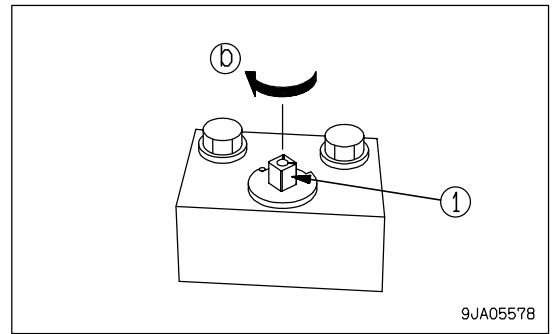

LONG TERM STORAGE

If the machine is not to be used for a long time, do as follows.

- Install the cap to the quick coupler.
- Set the selector valve to the position for general attachments such as the crusher.
- Lock the attachment control pedal with the pedal lock.

If the pedal is operated when a breaker or general attachment is not installed, it will cause overheating or other problems.

SPECIFICATIONS

Hydraulic Specifications

	MX502
Max. flow (engine speed)	70 liter/min (2,350 rpm)
Safety valve setting pressure	17.2 MPa (175 kgf/cm ² , 2,490 PSI)

CHANGING MACHINE CONTROL PATTERN (IF PATTERN CHANGE VALVE EQUIPPED)



WARNING

- When changing the operating pattern of the machine, set the machine in the parking posture, stop the engine, check that the safety lock lever is at the LOCK position, then change the operating pattern.
- To prevent personal injury caused by mistaken operation, test operate the machine and check that the display on the operating pattern card is the same as the movement of the machine.
If it is not the same, replace the operating pattern card immediately with the card that matches the operating pattern.
- When checking the movement of the machine, check carefully that the surrounding area is safe, and operate slowly.

CONTROL PATTERN CHANGE PROCEDURE

1. Open the hatch at the bottom left side of the machine. The pattern selector valve is inside.
2. Follow the steps explained below, when switching the patterns.
 - 1) Loosen hexagon socket head bolt (1).
 - 2) The operating pattern changes when lever (2) is moved up or down.
 - Position (A): ISO pattern
 - Position (B): Backhoe position

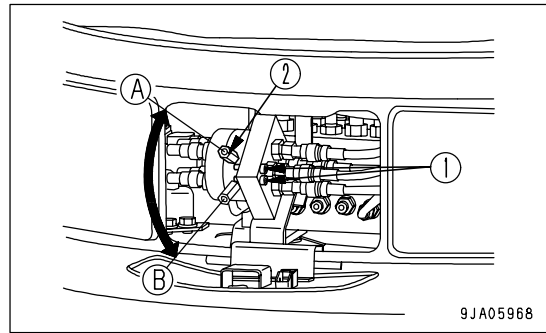

- 3) After switching, tighten hexagon socket head bolt (1).
3. Change to an operating pattern card (insert it in the holder) that matches the selected operating pattern.
4. Start the engine, set the safety lock lever to the FREE position, operate the work equipment levers slowly, and check that the operating pattern has changed.

MACHINE CONTROL PATTERNS



WARNING

After changing the operating pattern, always change the operating pattern card in the operator's compartment.

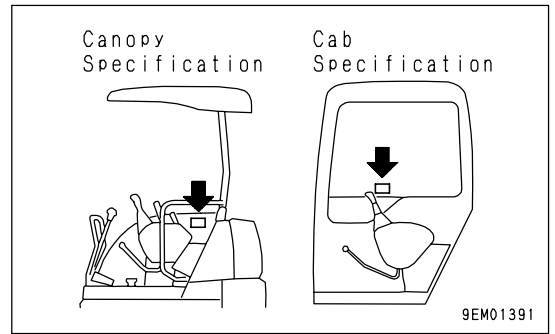

- ISO pattern

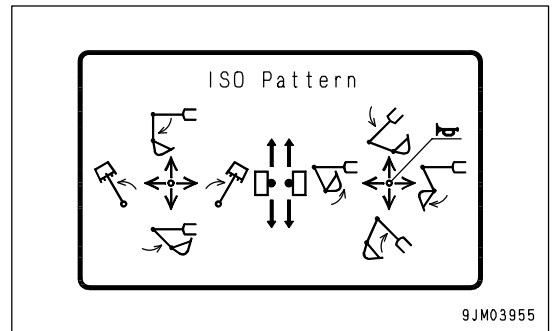

- Backhoe pattern

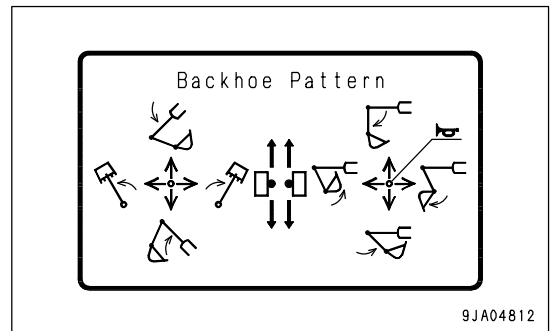

ATTACHMENT GUIDE



WARNING

- Please read the instruction manual for the attachment and the sections of this manual related to attachments and options.
- When installing any attachment or option, there may be problems with safety, so please contact your Komatsu distributor before installing.
- Installing attachments or options without consulting your Komatsu distributor may not only cause problems with safety, but may also have an adverse effect on the operation of the machine and the life of the equipment.
- Any injuries, accidents, or damage resulting from the use of unauthorized attachments or options will not be the responsibility of Komatsu.

ATTACHMENT COMBINATIONS



WARNING

Depending on the type or combination of work equipment, there is danger that the work equipment may hit the cab or machine body.

When using unfamiliar work equipment for the first time, check before starting if there is any danger of interference, and operate with caution.

This is the combination table for buckets to install to the standard arm and long arm.

If a long arm is installed, do not pull the bucket fully in towards the machine. It will hit the machine body. When lowering the boom while digging diagonally, be careful not to let the bucket hit the undercarriage.

Categories

For general digging: digging or loading sand, gravel, clay etc.

For light duty digging: digging or loading dry, uncaked soil and sand, mud etc.

For loading work: loading dry, loose soil and sand

Judgement

○: Can be used

△: Can be used only for light duty work

×: Cannot be used

Name	Capacity m ³ (cu.yd)	Outside width mm (in)	Use	Standard arm	Long arm
Standard bucket	0.16 (0.21)	650 (25.6)	General digging	○	×
Narrow bucket	0.11 (0.14)	500 (19.7)	Narrow digging	○	○

RECOMMENDED ATTACHMENT OPERATIONS

Below described are instructions which must be followed without fail when doing the work using a hydraulic excavator equipped with an attachment.

NOTICE

Select the optimum model of attachment for a hydraulic excavator on which it is to be mounted.

- Depending on machine models of hydraulic excavator, the kind of attachments or the model of specific attachments that can be mounted will vary. Hence, consult your Komatsu distributor for the selection of optimum attachments.

HYDRAULIC BREAKER

Main Applications

- Crushed rock
- Demolition work
- Road construction

This attachment can be used for a wide range of applications including demolition of buildings, breaking up road surfaces or slag, tunnel work, rock crushing and breaking operations in quarries.

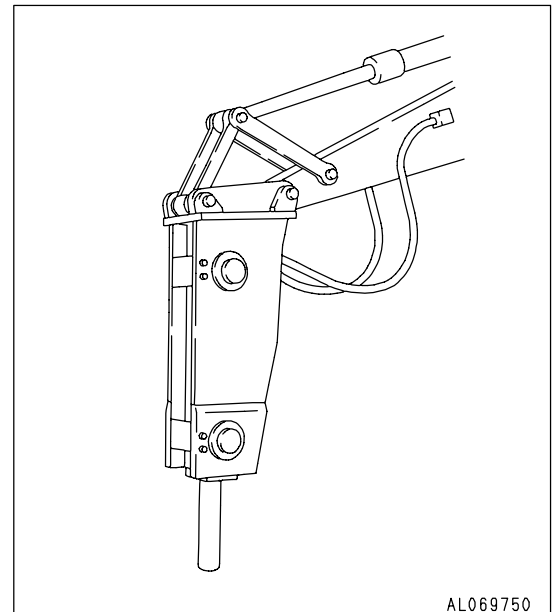

Keep the chisel pushed perpendicularly against the impact surface when carrying out breaking operations.

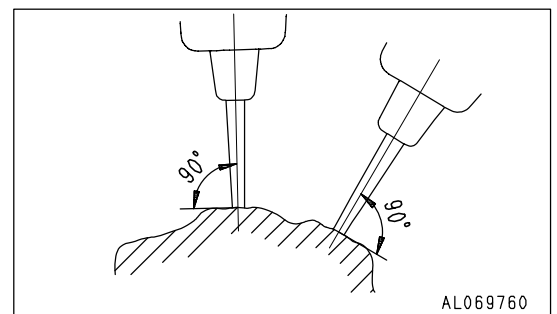

When applying impact, push the chisel against the impact surface and operate so that the chassis rises approx. 5 cm (2 in) off the ground. Do not let the machine come further off the ground than this amount.

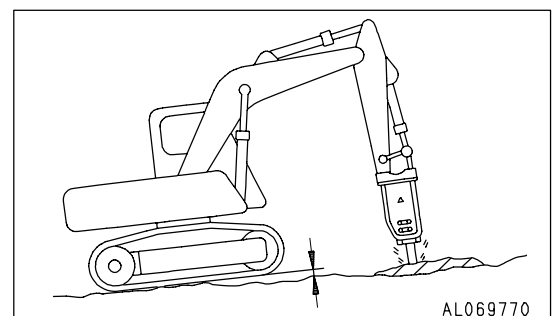

When applying continuous impact to the same impact surface, if the chisel does not penetrate or break the surface within 1 minute, change the point of impact and carry out breaking operations closer to the edge.

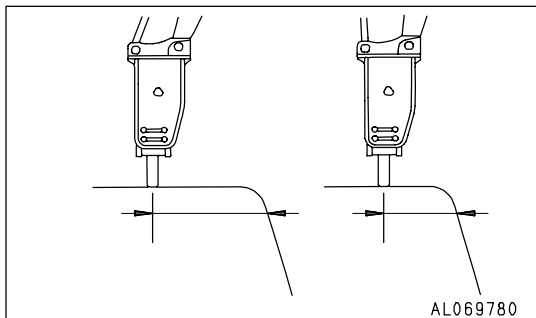

The direction of penetration of the chisel and the direction of the breaker body will gradually move out of line with each other, so always adjust the bucket cylinder to keep them aligned.

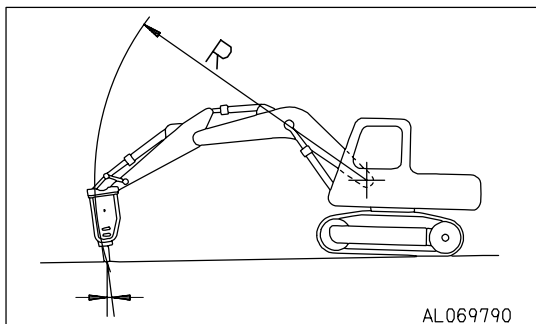

Always keep the chisel pressed against the impact surface properly to prevent using the impact force when there is no resistance.

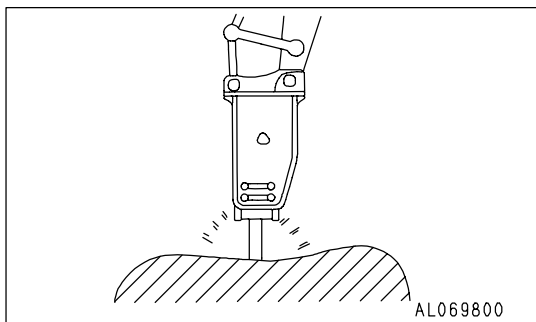

Prohibited Works

To ensure that the machine has a long life, and to ensure that operations are carried out in safety, do not operate the machine in any of the following ways.

- Do not operate all cylinders to the end of their strokes. Always leave approx. 5 cm (2 in) to spare.

Using the mount to gather in pieces of rock

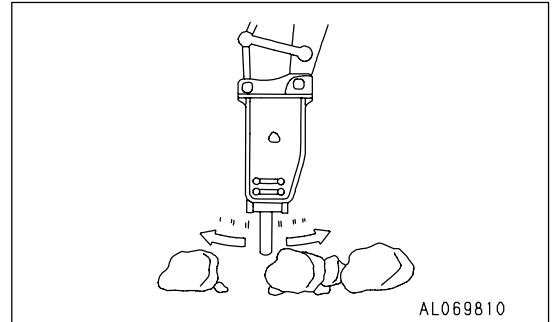

Operations using the swing force

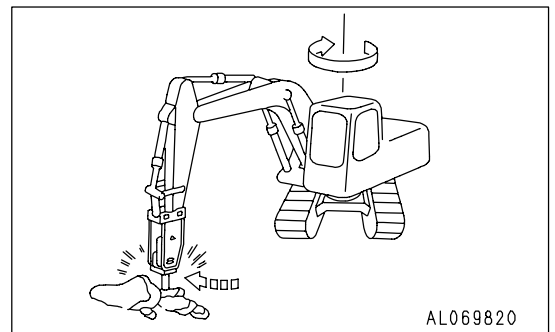

Moving the chisel while carrying out impacting operations

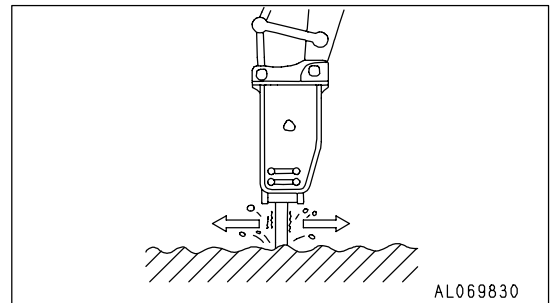

Holding the chisel horizontal or pointed up when carrying out impacting operations

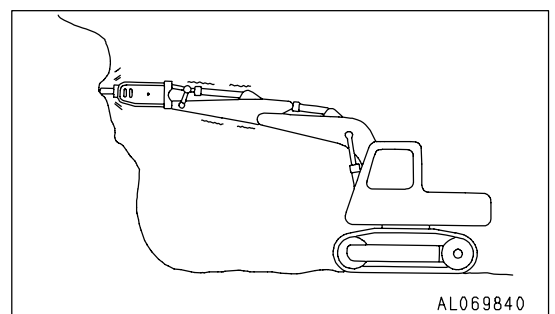

Twisting the chisel when it has penetrated the rock

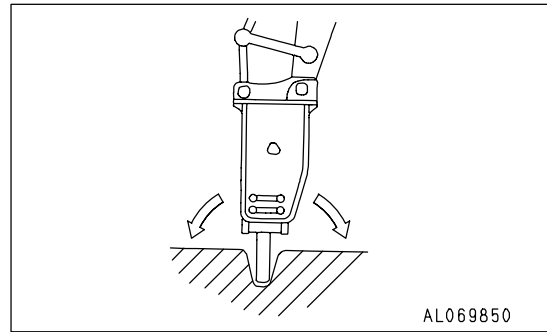

Pecking operations

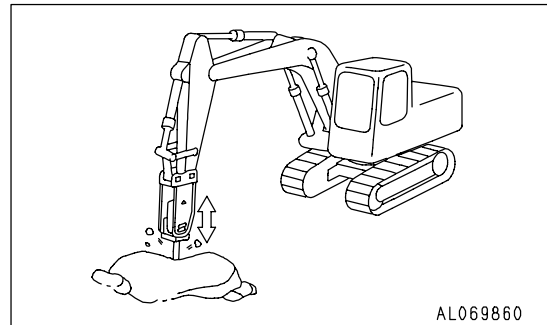

Extending the bucket cylinder fully and thrusting to raise the machine off the ground

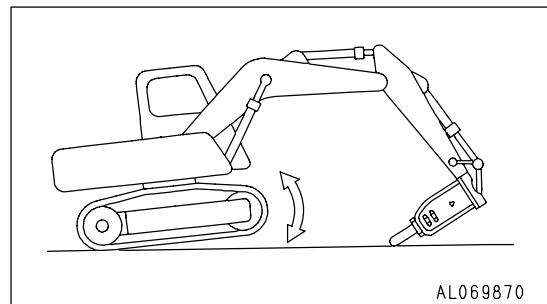

Greasing

Supply grease in the correct position.

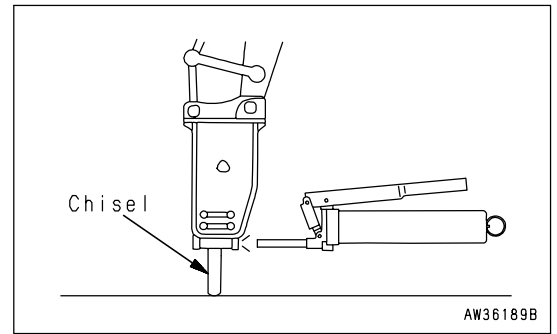

NOTICE

If the breaker is greased in an improper posture, it is filled with more grease than necessary. As a result, soil and sand will enter the hydraulic circuit and can damage the hydraulic components, while the breaker is in use. Therefore, be sure to grease the breaker, holding it in the right posture.

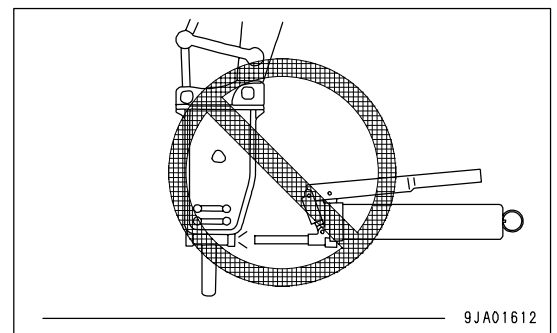
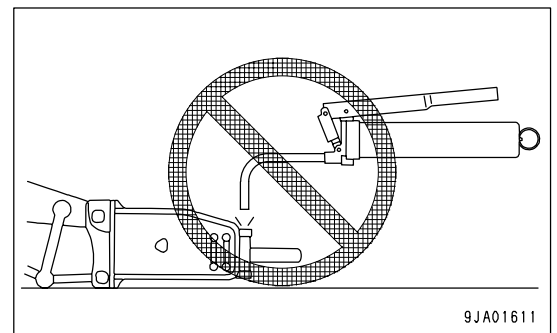

INDEX

<A>			
Air Conditioner -----	6-	5	
Air Conditioner Controls -----	6-	6	
Air Conditioner Maintenance -----	6-	7	
Control Panel and Components -----	6-	5	
Ashtray -----	3-	39	
Attachment Guide -----	6-	20	
Attachment Combinations -----	6-	20	
Attachments and Options - General Information -----	6-	2	
Attachment Installation -----	6-	3	
Safety First -----	6-	2	
Auxiliary Electric Power -----	3-	38	
			
Block Fuse -----	3-	37	
Bucket Replacement -----	3-	80	
Bucket with Hook -----	6-	4	
Prohibited Operations -----	6-	4	
<C>			
Changing Machine Control Pattern (If Pattern Change Valve Equipped) -----	6-	18	
Control Pattern Change Procedure -----	6-	18	
Machine Control Patterns -----	6-	19	
Cold Weather Operation -----	3-	99	
After Cold Weather Season -----	3-	101	
After Daily Work Completion -----	3-	101	
Cab Heater in Cold Weather -----	3-	100	
Cold Weather Operation Information -----	3-	99	
Control Levers and Pedals -----	3-	16	
Controls and Gauges -----	3-	3	
Cover with Lock -----	3-	28	
<D>			
Detailed Controls and Gauges -----	3-	4	
Directions of Machine -----	1-	7	
<E>			
Electric System Maintenance -----	4-	6	
Emergency Escape Hammer -----	3-	27	
Emission Control Information Label and Its Location -----	1-	9	
Engine, After Starting -----	3-	58	
Engine, Before Starting -----	3-	40	
Engine Rear Cover -----	3-	29	
Engine Serial No. Plate And Its Location -----	1-	8	
Engine, Check After Shut Off -----	3-	82	
Engine, Starting -----	3-	54	
Engine, Stopping the -----	3-	61	
Escape from Mud -----	3-	77	
<F>			
Forward -----	1-	2	
Fuse -----	3-	36	
<G>			
General Operation Information -----	3-	74	
Grease Gun Holder -----	3-	39	
<H>			
Handling Hydraulic System -----	4-	7	
Handling Oil, Fuel, Coolant, and Performing Oil Clinic -----	4-	4	
<I>			
Introduction -----	1-	7	
<L>			
Locking -----	3-	83	
Long Term Storage -----	3-	102	
After Storage -----	3-	103	
Before Storage -----	3-	102	
During Storage -----	3-	103	
Lubricants, Coolant and Filters -----	4-	4	
Lubricants, Fuel and Coolant Specifications -----	4-	9	
<M>			
Machine Inspection After Daily Work -----	3-	82	
Machine Operation -----	3-	62	
Machine Operations and Controls -----	3-	40	
Machine Ready for Attachment -----	6-	12	
Attachment Operations -----	6-	16	
Hydraulic Circuit -----	6-	14	
Locations -----	6-	12	
Long term storage -----	6-	17	
Specifications -----	6-	17	
Machine View Illustrations -----	3-	2	
Machine, Steering the -----	3-	67	
Maintenance Information -----	4-	2	
Maintenance Procedure -----	4-	17	
Check Before Starting -----	4-	45	
Every 500 Hours -----	4-	46	

Every 1000 Hours -----	4- 55	<T>	
Every 2000 hours -----	4- 57	Tightening Torque Specifications -----	4- 13
When Required -----	4- 17	Tightening Torque List -----	4- 13
Maintenance Schedule -----	4- 15	Tool Box -----	3- 39
Maintenance Interval for Hydraulic		Transportation -----	3- 89
Breaker -----	4- 16	Lifting Machine -----	3- 96
Maintenance Schedule Chart -----	4- 15	Loading and Unloading with Trailer -----	3- 90
Monitoring System -----	3- 4	Transportation Procedure -----	3- 89
Mud Cover -----	3- 30	Traveling on Slopes -----	3- 75
<O>		Troubles and Actions -----	3-104
Operation Manual Storage -----	3- 39	Battery, Discharged -----	3-106
Overall Machine View -----	3- 2	Other Trouble -----	3-110
<P>		Phenomena That Are Not Failures -----	3-104
Parking Machine -----	3- 81	Running Out of Fuel -----	3-104
Product Identification Number		Severe Job Condition -----	3-105
(PIN)/Machine Serial No. Plate -----	1- 8	Towing the Machine -----	3-105
Product Information -----	1- 8	<W>	
Prohibited Operations -----	3- 72	Wear Parts -----	4- 8
<R>		Wear Parts List -----	4- 8
Recommended Attachment Operations -----	6- 21	Windshield -----	3- 22
Hydraulic Breaker -----	6- 21	Windshield Washer -----	6- 11
Rubber Shoes and Road Liners -----	3- 84	Check Window Washer Fluid level, Add	
<S>		Fluid -----	6- 11
Safety Critical Parts -----	4- 14	Windshield Washer Operation -----	6- 11
Safety Critical Parts List -----	4- 14	Work Equipment Controls and Operations --	3- 70
Safety Information -----	1- 5	Work Possible Using Compact Hydraulic	
Safety Information -----	2- 2	Excavator -----	3- 78
Safety Information -----	2- 10	<Y>	
Safety Labels -----	2- 4	Your Machine Serial Numbers and	
Location of Safety Labels -----	2- 4	Distributor -----	1- 10
Safety Labels -----	2- 5		
Safety Machine Operation -----	2- 19		
Battery -----	2- 28		
Lifting Objects with Bucket -----	2- 31		
Operation -----	2- 21		
Starting Engine -----	2- 19		
Towing -----	2- 30		
Transportation -----	2- 27		
Safety Maintenance Information -----	2- 32		
Service Meter Location -----	1- 9		
Sliding Door -----	3- 26		
Sliding Window -----	3- 26		
Specifications -----	5- 2		
Swinging -----	3- 69		
Switches -----	3- 12		

MX502 HYDRAULIC EXCAVATOR

Form No. SEAM061700T

©2004 KOMATSU

All Rights Reserved

Printed in Japan 03-04
