

Operation & Maintenance Manual

BULLDOZER

D155AX-6

SERIAL NUMBERS 80807 and up

ecot3

⚠ WARNING

Unsafe use of this machine may cause serious injury or death. Operators and maintenance personnel must read this manual before operating or maintaining this machine. This manual should be kept near the machine for reference and periodically reviewed by all personnel who will come into contact with it.

NOTICE

Komatsu has Operation & Maintenance Manuals written in some other languages. If a foreign language manual is necessary, contact your local distributor for availability.

KOMATSU

FOREWORD

CALIFORNIA

Proposition 65 Warning

Diesel engine exhaust and some of its constituents are known to the State of California to cause cancer, birth defects, and other reproductive harm.

CALIFORNIA

Proposition 65 Warning

Battery posts, terminals and related accessories contain lead and lead compounds, chemicals known to the State of California to cause cancer and birth defects or other reproductive harm.

Wash hands after handling.

BEFORE READING THIS MANUAL

This manual gives details of the operation and methods of inspection and maintenance for this machine that must be obeyed in order to use the machine safely. Most accidents are caused by the failure to follow fundamental safety rules for the operation and maintenance of machines.

Read, understand and follow all precautions and warnings in this manual and on the machine before performing operation and maintenance. Failure to do so may result in serious injury or death.

Komatsu cannot predict every circumstance that might involve a potential hazard when the machine is used. Therefore, the safety messages in this manual and on the machine may not include all possible safety precautions. If you carry out any operation, inspection, or maintenance under conditions that are not described in this manual, understand that it is your responsibility to take the necessary precautions to ensure safety. In no event should you or others engage in the prohibited uses or actions described in this manual. Improper operation and maintenance of the machine can be hazardous and could result in serious injury or death.

If you sell the machine, be sure to give this manual to the new owner together with the machine.

Always keep this Operation and Maintenance Manual in the location shown on the right so that all relevant personnel can read it at any time.

Location to Keep Operation & Maintenance Manual
Operation and Maintenance Manual pocket at the rear of the operator's seat

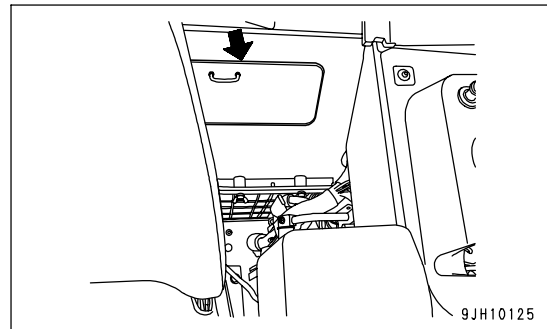

If this manual is lost or damaged, contact your distributor immediately to arrange for its replacement. For details regarding the machine serial No. you will need to provide your Komatsu distributor, see "TABLE TO ENTER SERIAL NO. AND DISTRIBUTOR (PAGE 1-9)".

This manual uses the international units (SI) for units of measurement. For reference, units that have been used in the past are given in ().

The explanations, values, and illustrations in this manual have been prepared based on the latest information available as of the date of its publication. Continuing improvements in the design of this machine may lead to additional changes that are not reflected in this manual. Consult Komatsu or your Komatsu distributor for the latest available information concerning your machine or with questions regarding information contained in this manual.

- The numbers in circles in the illustrations correspond to the numbers in () in the text.

(For example: ① → (1))



Komatsu delivers machines that comply with all applicable regulations and standards of the country to which it has been shipped. If this machine has been purchased in another country, it may lack certain safety devices and specifications that are necessary for use in your country. If there is any question about whether your product complies with the applicable standards and regulations of your country, consult Komatsu or your Komatsu distributor before operating the machine.

SAFETY INFORMATION

To enable you to use the machine safely, and to prevent injury to operators, service personnel or bystanders, the precautions and warnings included in this manual and the safety signs attached to the machine must always be followed.

To identify important safety messages in the manual and on the machine labels, the following signal words are used.

The "Safety Alert Symbol" identifies important safety messages on machines, in manuals, and elsewhere. When you see this symbol, be alert to the risk of personal injury or death. Follow the instructions in the safety message.

- | | |
|--|--|
|  DANGER | This signal word indicates an imminently hazardous situation which, if not avoided, will result in death or serious injury. |
|  WARNING | This signal word indicates a potentially hazardous situation which, if not avoided, could result in death or serious injury. |
|  CAUTION | This signal word indicates a potentially hazardous situation exists which, if not avoided, may result in minor or moderate injury. |

The following signal words are used to alert you to information that must be followed to avoid damage to the machine.

- | | |
|----------------|--|
| NOTICE | This precaution is given where the machine may be damaged or the service life reduced if the precaution is not followed. |
| REMARKS | This word is used for information that is useful to know. |

INTRODUCTION

USE OF MACHINE

This Komatsu machine is designed to be used mainly for the following work:

- Dozing
- Cutting into hard or frozen ground or ditching
- Felling trees, removing stumps
- Pushing
- Ripping

For further details, see "WORK POSSIBLE USING BULLDOZER (PAGE 3-158)" and "RIPPER OPERATION (PAGE 3-149)".

FRONT/REAR, LEFT/RIGHT DIRECTIONS OF MACHINE

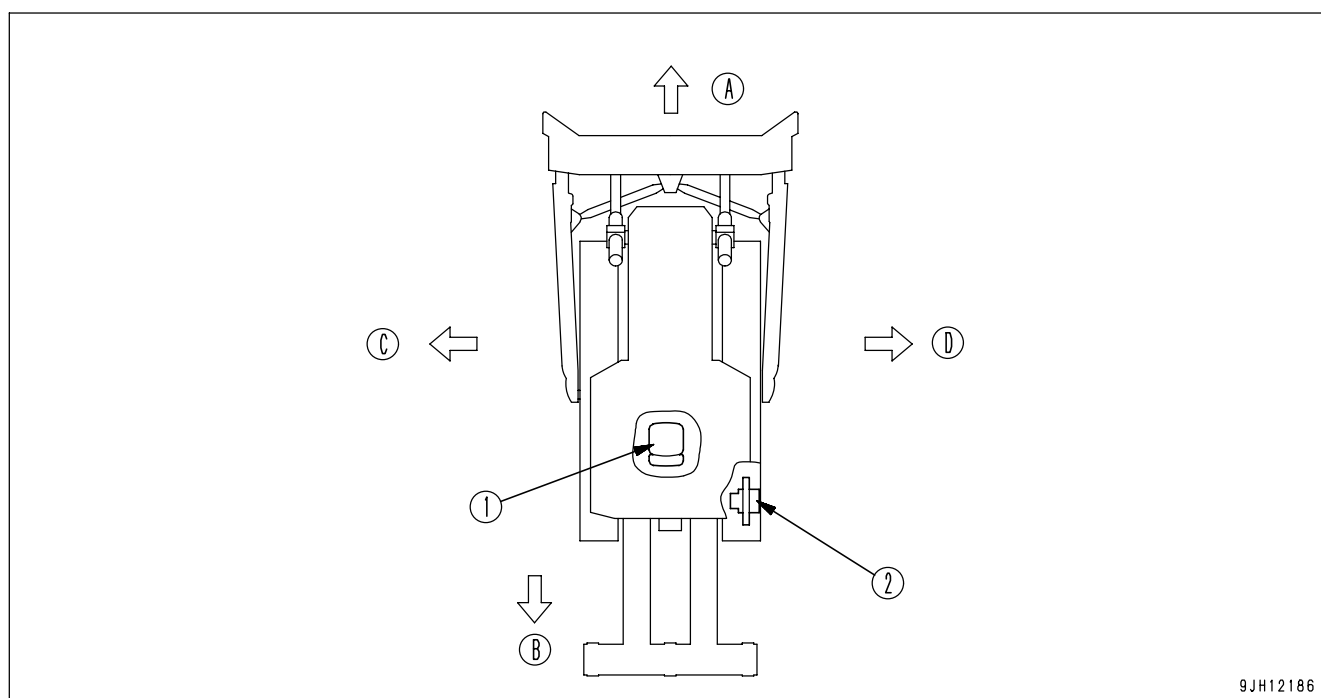

9JH12186

(1) Operator's seat

(A) Front

(C) Left

(2) Sprocket

(B) Rear

(D) Right

In this manual, the terms front, rear, left, and right refer to the travel direction as seen from the operator's seat when the operator's seat is facing the front.

VISIBILITY FROM OPERATOR'S SEAT

The visibility standards (ISO 5006) for this machine require a view shown in the diagram below.

PROXIMITY VISIBILITY

The visibility of this machine in the area 1 m from the outside surface of the machine at a height of 1.5 m is shown in the diagram below. The hatched area (A) shows the area where the view is blocked by part of the machine when mirrors or other aids to visibility are installed as standard. Please be fully aware that there are places that cannot be seen when operating the machine.

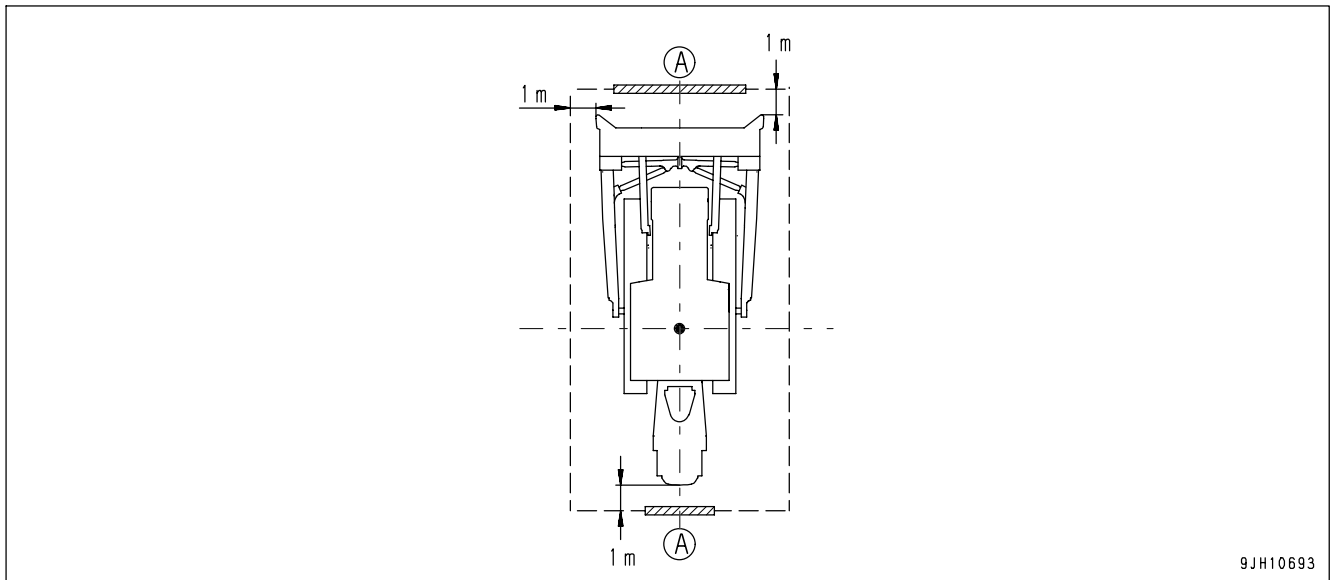

12M CIRCUMFERENCE VISIBILITY

The visibility at a radius of 12 m from the machine is as shown in the diagram below. The hatched areas (B) show the areas where the view is blocked when mirrors or other aids to visibility are installed as standard. Please be fully aware that there are places that cannot be seen when operating the machine.

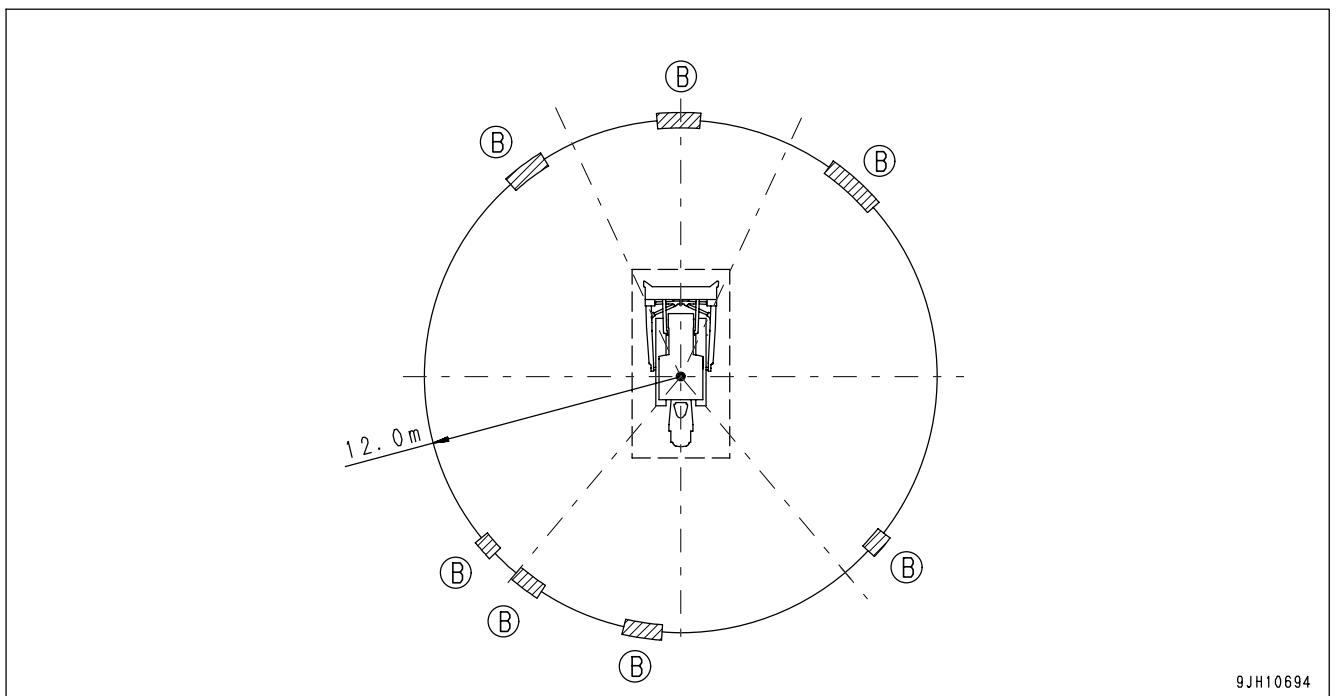

NECESSARY INFORMATION

When requesting service or ordering replacement parts, please inform your Komatsu distributor of the following items.

PRODUCT IDENTIFICATION NUMBER (PIN), MACHINE SERIAL NO. PLATE

Under the front of the console box on the right side of the operator's seat.

The design of the nameplate differs according to the territory.

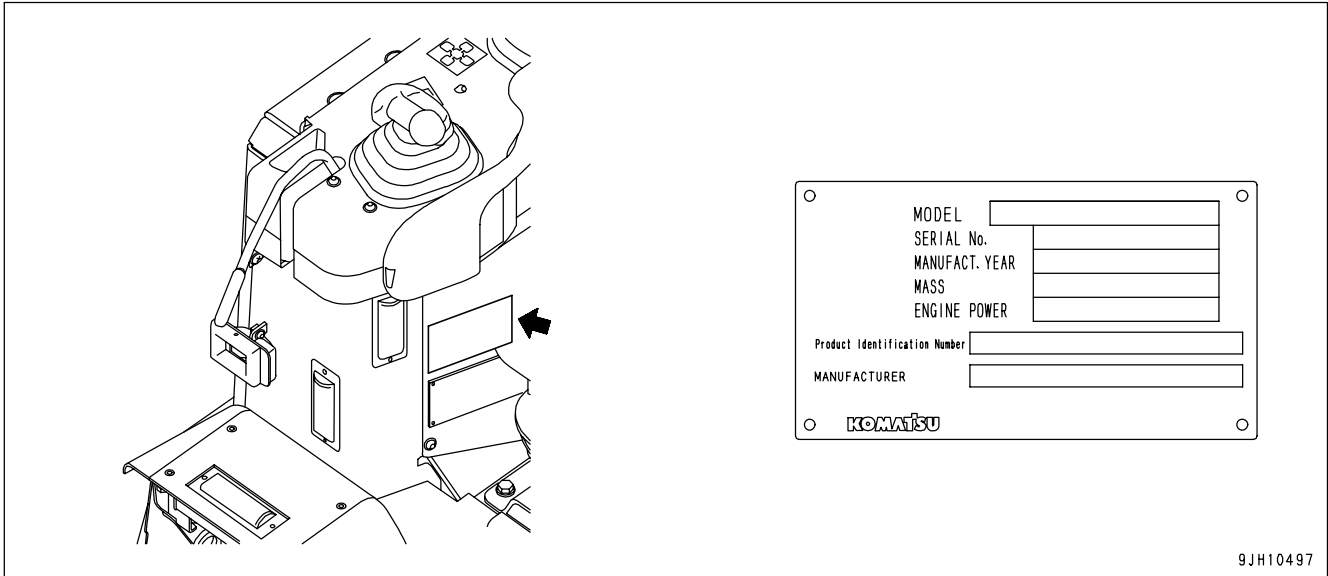

EPA REGULATIONS, ENGINE NUMBER PLATE

- On the upper of the engine starting motor on the right side of the machine.
- This also acts as the EPA plate.

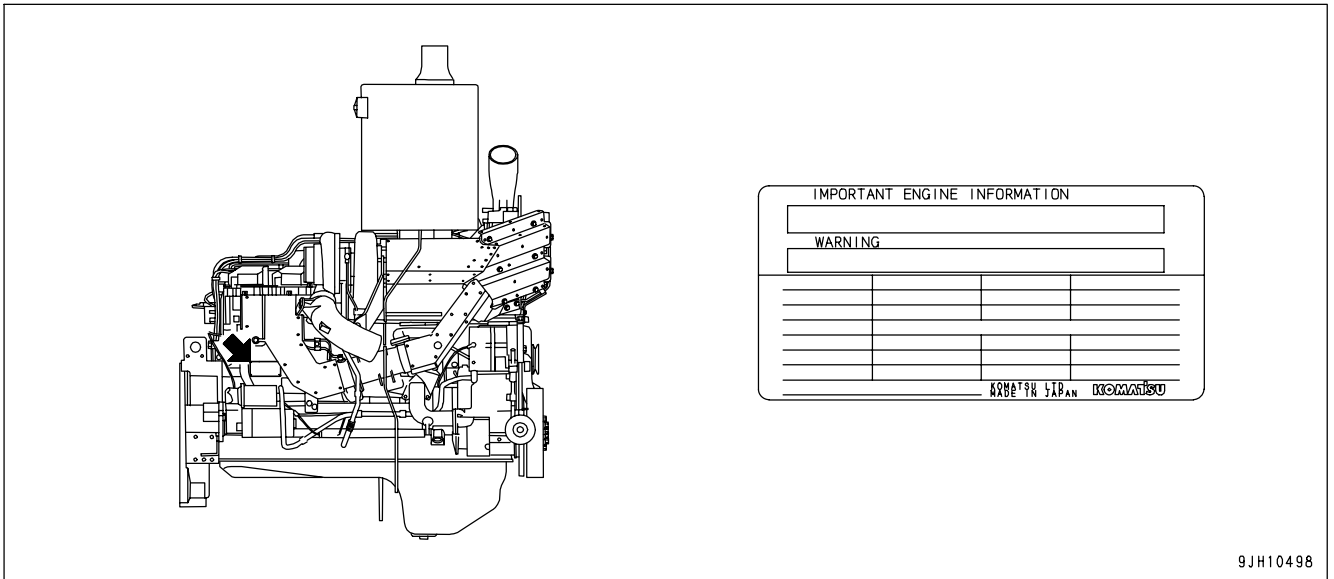

9JH10498

- This is on the top surface of the muffler mounting bracket on the left side of the machine.
- This also acts as the EPA plate.

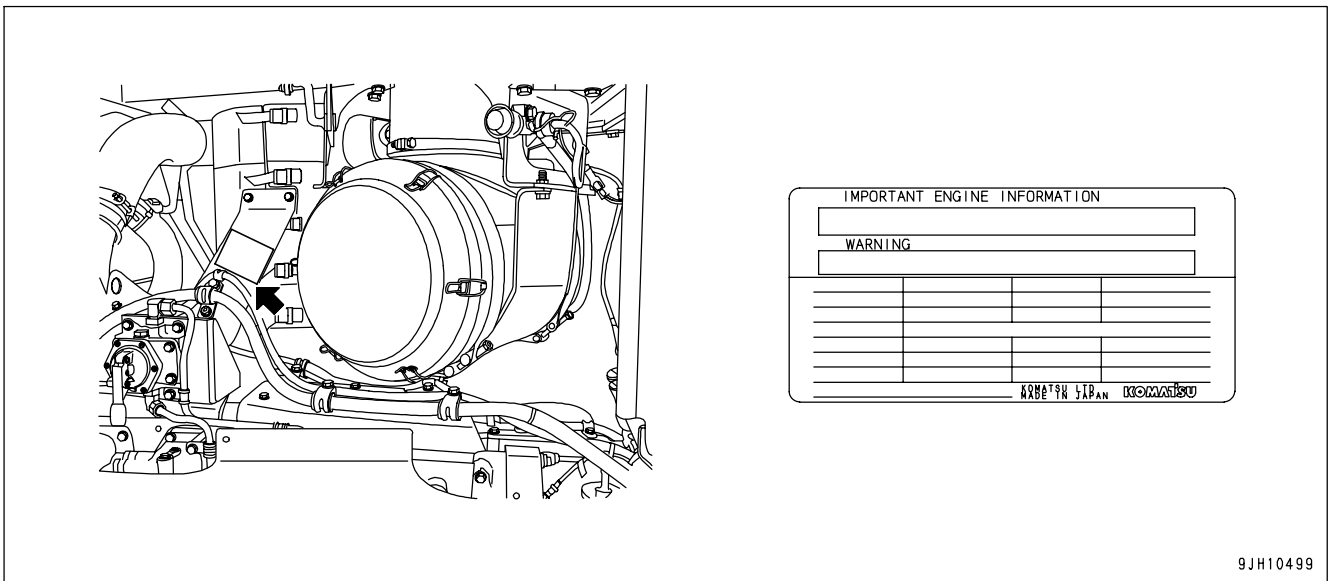

9JH10499

EPA: Environmental Protection Agency, U.S.A.

BLADE SERIAL NO. PLATE POSITION

This is located on the upper right of blade back surface.

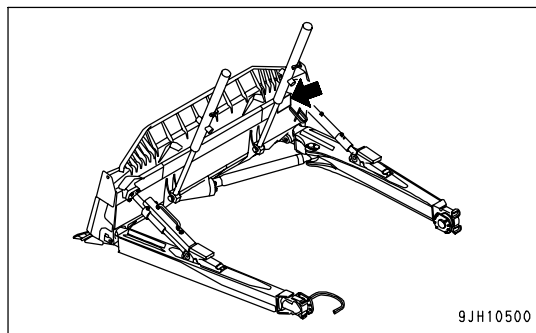

RIPPER SERIAL NO. PLATE POSITION

This is located on the left side surface of ripper beam.

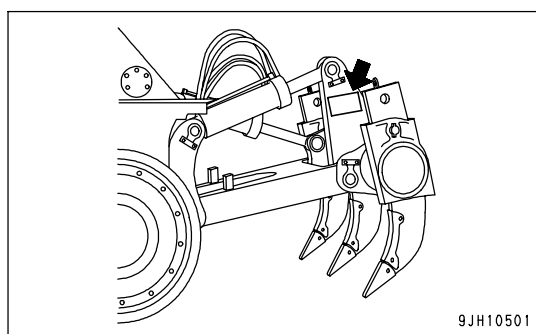

ROPS, FOPS NO. PLATE POSITION

This is at the top rear of the cab.

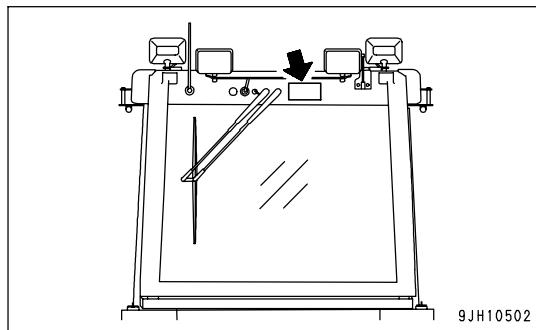

POSITION OF SERVICE METER

On top of the machine monitor

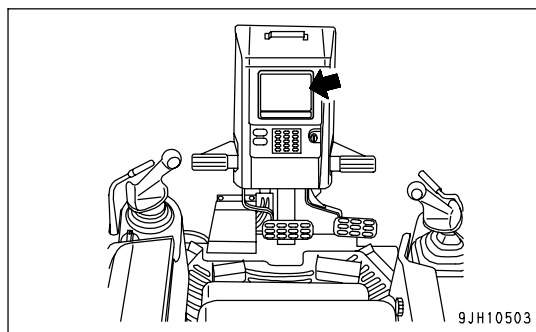

TABLE TO ENTER SERIAL NO. AND DISTRIBUTOR

Machine serial No.	
Engine serial No.	
Product identification number (PIN)	
Distributor name	
Address	-----

Service Personnel	
Phone/Fax	

CONTENTS

FOREWORD	1- 1
BEFORE READING THIS MANUAL	1- 2
SAFETY INFORMATION	1- 3
INTRODUCTION	1- 4
USE OF MACHINE	1- 4
FRONT/REAR, LEFT/RIGHT DIRECTIONS OF MACHINE	1- 4
VISIBILITY FROM OPERATOR'S SEAT	1- 5
NECESSARY INFORMATION	1- 6
PRODUCT IDENTIFICATION NUMBER (PIN), MACHINE SERIAL NO. PLATE	1- 6
EPA REGULATIONS, ENGINE NUMBER PLATE	1- 7
BLADE SERIAL NO. PLATE POSITION	1- 8
RIPPER SERIAL NO. PLATE POSITION	1- 8
ROPS, FOPS NO. PLATE POSITION	1- 8
POSITION OF SERVICE METER	1- 8
TABLE TO ENTER SERIAL NO. AND DISTRIBUTOR	1- 9
SAFETY	2- 1
SAFETY	2- 2
SAFETY LABELS	2- 5
POSITIONS OF SAFETY PICTOGRAMS	2- 6
SAFETY LABELS	2- 7
GENERAL PRECAUTIONS COMMON TO OPERATION AND MAINTENANCE	2- 11
PRECAUTIONS BEFORE STARTING OPERATION	2- 11
PREPARATIONS FOR SAFE OPERATION	2- 11
FIRE PREVENTION	2- 13
PRECAUTIONS WHEN GETTING ON OR OFF MACHINE	2- 14
DO NOT GET CAUGHT IN WORK EQUIPMENT	2- 16
PRECAUTIONS RELATED TO PROTECTIVE STRUCTURES	2- 16
UNAUTHORIZED MODIFICATION	2- 16
PRECAUTIONS RELATED TO ATTACHMENTS AND OPTIONS	2- 16
PRECAUTIONS WHEN RUNNING ENGINE INSIDE BUILDING	2- 17
PRECAUTIONS FOR OPERATION	2- 18
PRECAUTIONS FOR JOBSITE	2- 18
STARTING ENGINE	2- 20
OPERATION	2- 23
TRANSPORTATION	2- 27
TOWING	2- 28
PRECAUTIONS FOR MAINTENANCE	2- 29
PRECAUTIONS BEFORE STARTING INSPECTION AND MAINTENANCE	2- 29
PRECAUTIONS FOR INSPECTION AND MAINTENANCE	2- 33
OPERATION	3- 1
GENERAL VIEW	3- 2
GENERAL VIEW OF MACHINE	3- 2
GENERAL VIEW OF CONTROLS AND GAUGES	3- 3
EXPLANATION OF COMPONENTS	3- 5
MACHINE MONITOR	3- 5
SWITCHES	3- 52
CONTROL LEVERS, PEDALS	3- 56
DUST INDICATOR	3- 64
FUSE BOX	3- 65

CAP WITH LOCK	3- 69
DOOR POCKET	3- 71
ASHTRAY	3- 71
CAR RADIO, HANDLING	3- 72
CAR STEREO, HANDLING	3- 77
HANDLING AIR CONDITIONER	3- 84
OPERATION	3- 98
CHECK BEFORE STARTING ENGINE, ADJUST	3- 98
STARTING ENGINE	3-122
OPERATIONS AND CHECKS AFTER STARTING ENGINE	3-126
STOPPING ENGINE	3-130
MOVING MACHINE	3-131
STOPPING MACHINE	3-133
SHIFTING GEAR	3-134
SHIFTING BETWEEN FORWARD AND REVERSE	3-140
STEERING MACHINE	3-142
PRECAUTIONS FOR OPERATION	3-144
PARKING MACHINE	3-146
CHECK AFTER STOPPING ENGINE	3-147
CHECK AFTER FINISHING WORK	3-148
LOCKING	3-148
RIPPER OPERATION	3-149
OPERATING METHOD FOR RIPPING OPERATIONS	3-152
WORK POSSIBLE USING BULLDOZER	3-158
ADJUSTING POSTURE OF WORK EQUIPMENT	3-160
TIPS FOR LONGER UNDERCARRIAGE LIFE	3-169
TRANSPORTATION	3-173
LOADING, UNLOADING WORK	3-173
METHOD OF LIFTING MACHINE	3-176
PRECAUTIONS FOR TRANSPORTATION	3-178
TRAVELING ON ROADS	3-178
REMOVAL OF CAB	3-179
COLD WEATHER OPERATION	3-181
PRECAUTIONS FOR LOW TEMPERATURE	3-181
AFTER COMPLETION OF WORK	3-183
AFTER COLD WEATHER	3-183
LONG-TERM STORAGE	3-184
BEFORE STORAGE	3-184
DURING STORAGE	3-184
AFTER STORAGE	3-184
STARTING MACHINE AFTER LONG-TERM STORAGE	3-184
TROUBLESHOOTING	3-185
AFTER RUNNING OUT OF FUEL	3-185
METHOD OF TOWING MACHINE	3-187
IF BATTERY IS DISCHARGED	3-188
OTHER TROUBLE	3-191
MAINTENANCE	4- 1
GUIDES TO MAINTENANCE	4- 2
OUTLINES OF SERVICE	4- 5
HANDLING OIL, FUEL, COOLANT, AND PERFORMING OIL CLINIC	4- 5

OUTLINE OF ELECTRIC SYSTEM	4- 8
WEAR PARTS	4- 9
WEAR PARTS LIST	4- 9
RECOMMENDED FUEL, COOLANT, AND LUBRICANT	4- 11
RECOMMENDED BRANDS, RECOMMENDED QUALITY FOR PRODUCTS OTHER THAN KOMATSU GENUINE OIL	4- 13
STANDARD TIGHTENING TORQUES FOR BOLTS AND NUTS	4- 14
TORQUE LIST	4- 14
PERIODIC REPLACEMENT OF SAFETY CRITICAL PARTS	4- 15
SAFETY CRITICAL PARTS	4- 15
MAINTENANCE SCHEDULE CHART	4- 17
MAINTENANCE SCHEDULE CHART	4- 17
SERVICE PROCEDURE	4- 19
INITIAL 250 HOURS SERVICE (ONLY AFTER THE FIRST 250 HOURS) WHEN REQUIRED	4- 19
CHECK BEFORE STARTING	4- 50
EVERY 250 HOURS SERVICE	4- 51
EVERY 500 HOURS SERVICE	4- 60
EVERY 1000 HOURS SERVICE	4- 67
EVERY 2000 HOURS SERVICE	4- 79
EVERY 4000 HOURS SERVICE	4- 88
EVERY 8000 HOURS SERVICE	4- 92
SPECIFICATIONS	5- 1
SPECIFICATIONS	5- 2
ATTACHMENTS, OPTIONS	6- 1
GENERAL PRECAUTIONS	6- 2
PRECAUTIONS RELATED TO SAFETY	6- 2
INTRODUCTION OF ATTACHMENTS AND OPTIONS	6- 3
INTRODUCTION OF ATTACHMENTS AND OPTIONS	6- 3
HEADREST, HANDLING	6- 4
PROCEDURE FOR SELECTING RIPPER POINT	6- 5
PROCEDURE FOR SELECTING RIPPER POINT	6- 5
HANDLING MACHINES EQUIPPED WITH KOMTRAX	6- 6
BASIC PRECAUTIONS	6- 6
INDEX	7- 1

SAFETY

WARNING

Please read and make sure that you fully understand the precautions described in this manual and the safety labels on the machine. When operating or servicing the machine, always follow these precautions strictly.

SAFETY

SAFETY LABEL	2- 5
POSITIONS OF SAFETY PICTOGRAMS	2- 6
SAFETY LABELS	2- 7
GENERAL PRECAUTIONS COMMON TO OPERATION AND MAINTENANCE	2- 11
PRECAUTIONS BEFORE STARTING OPERATION	2- 11
ENSURING SAFE OPERATION	2- 11
UNDERSTANDING THE MACHINE	2- 11
PREPARATIONS FOR SAFE OPERATION	2- 11
PRECAUTIONS REGARDING SAFETY-RELATED EQUIPMENT	2- 11
INSPECTING MACHINE	2- 11
WEAR WELL-FITTING CLOTHES AND PROTECTIVE EQUIPMENT	2- 11
KEEP MACHINE CLEAN	2- 12
PRECAUTIONS INSIDE OPERATOR'S COMPARTMENT	2- 12
PROVIDE FIRE EXTINGUISHER AND FIRST AID KIT	2- 12
IF ANY PROBLEM IS FOUND	2- 12
FIRE PREVENTION	2- 13
ACTION IF FIRE OCCURS	2- 13
PRECAUTIONS TO PREVENT FIRE	2- 13
PRECAUTIONS WHEN GETTING ON OR OFF MACHINE	2- 14
USE HANDRAILS AND STEPS WHEN GETTING ON OR OFF MACHINE	2- 14
NO JUMPING ON OR OFF MACHINE	2- 15
NO PEOPLE ON ATTACHMENTS	2- 15
PRECAUTIONS WHEN STANDING UP FROM OPERATOR'S SEAT	2- 15
PRECAUTIONS WHEN LEAVING MACHINE	2- 15
EMERGENCY EXIT FROM OPERATOR'S CAB	2- 15
DO NOT GET CAUGHT IN WORK EQUIPMENT	2- 16
PRECAUTIONS RELATED TO PROTECTIVE STRUCTURES	2- 16
UNAUTHORIZED MODIFICATION	2- 16
PRECAUTIONS RELATED TO ATTACHMENTS AND OPTIONS	2- 16
PRECAUTIONS WHEN RUNNING ENGINE INSIDE BUILDING	2- 17

PRECAUTIONS FOR OPERATION	2- 18
PRECAUTIONS FOR JOBSITE	2- 18
INVESTIGATE AND CONFIRM JOBSITE CONDITIONS	2- 18
WORKING ON LOOSE GROUND	2- 18
DO NOT GO CLOSE TO HIGH-VOLTAGE CABLES	2- 19
ENSURE GOOD VISIBILITY	2- 19
CHECKING SIGNS AND SIGNALMAN'S SIGNALS	2- 20
BEWARE OF ASBESTOS DUST	2- 20
STARTING ENGINE	2- 20
USE WARNING TAGS	2- 20
INSPECTION AND MAINTENANCE BEFORE STARTING ENGINE	2- 21
PRECAUTIONS WHEN STARTING ENGINE	2- 21
PRECAUTIONS IN COLD AREAS	2- 21
STARTING WITH BOOSTER CABLES	2- 22
OPERATION	2- 23
CHECKS BEFORE OPERATION	2- 23
PRECAUTIONS WHEN TRAVELING IN FORWARD OR REVERSE	2- 23
PRECAUTIONS WHEN TRAVELING	2- 24
TRAVELING ON SLOPES	2- 24
PRECAUTIONS WHEN OPERATING	2- 25
PROHIBITED OPERATIONS	2- 25
METHOD OF USING BRAKES	2- 25
TRAVELING ON SNOW-COVERED OR FROZEN SURFACES	2- 25
PARKING MACHINE	2- 26
TRANSPORTATION	2- 27
LOADING AND UNLOADING	2- 27
TOWING	2- 28
PRECAUTIONS WHEN TOWING	2- 28

PRECAUTIONS FOR MAINTENANCE	2- 29
PRECAUTIONS BEFORE STARTING INSPECTION AND MAINTENANCE	2- 29
DISPLAY WARNING TAG DURING INSPECTION AND MAINTENANCE	2- 29
KEEP WORKPLACE CLEAN AND TIDY	2- 29
SELECT SUITABLE PLACE FOR INSPECTION AND MAINTENANCE	2- 29
ONLY AUTHORIZED PERSONNE	2- 29
APPOINT LEADER WHEN WORKING WITH OTHERS	2- 29
STOP ENGINE BEFORE CARRYING OUT INSPECTION AND MAINTENANCE	2- 30
TWO WORKERS FOR MAINTENANCE WHEN ENGINE IS RUNNING	2- 31
INSTALLING, REMOVING, OR STORING ATTACHMENTS	2- 31
PRECAUTIONS WHEN WORKING AT HIGH PLACES	2- 31
PRECAUTIONS WHEN WORKING ON TOP OF MACHINE	2- 32
PRECAUTIONS WHEN WORKING UNDER MACHINE OR WORK EQUIPMENT	2- 32
PROPER TOOLS	2- 32
PRECAUTIONS FOR INSPECTION AND MAINTENANCE	2- 33
PRECAUTIONS WHEN WELDING	2- 33
HANDLING BATTERY	2- 33
PRECAUTIONS WHEN USING HAMMER	2- 34
PRECAUTIONS WITH HIGH-TEMPERATURE COOLANT	2- 34
PRECAUTIONS WITH HIGH-TEMPERATURE OIL	2- 34
PRECAUTIONS WITH HIGH-PRESSURE OIL	2- 35
PRECAUTIONS WITH HIGH-PRESSURE FUEL	2- 35
HANDLING HIGH-PRESSURE HOSES AND PIPING	2- 35
NOISE	2- 35
PRECAUTIONS WITH HIGH-PRESSURE GREASE WHEN ADJUSTING TRACK TENSION	2- 36
DO NOT DISASSEMBLE RECOIL SPRING	2- 36
HANDLING ACCUMULATOR AND GAS SPRING	2- 37
PRECAUTIONS WITH COMPRESSED AIR	2- 37
MAINTENANCE OF AIR CONDITIONER	2- 37
DISPOSING OF WASTE MATERIALS	2- 37
METHOD OF SELECTING WINDOW WASHER FLUID	2- 37
PERIODIC REPLACEMENT OF SAFETY CRITICAL PARTS	2- 38

SAFETY LABELS

The following warning signs and safety labels are used on this machine.

- Be sure that you fully understand the correct position and content of labels.
- To ensure that the content of labels can be read properly, be sure that they are in the correct place and always keep them clean. When cleaning them, do not use organic solvents or gasoline. These may cause the labels to peel off.
- There are also other labels in addition to the warning signs and safety labels. Handle those labels in the same way.
- If the labels are damaged, lost, or cannot be read properly, replace them with new ones. For details of the part numbers for the labels, see this manual or the actual label, and place an order with Komatsu distributor.

POSITIONS OF SAFETY PICTOGRAMS

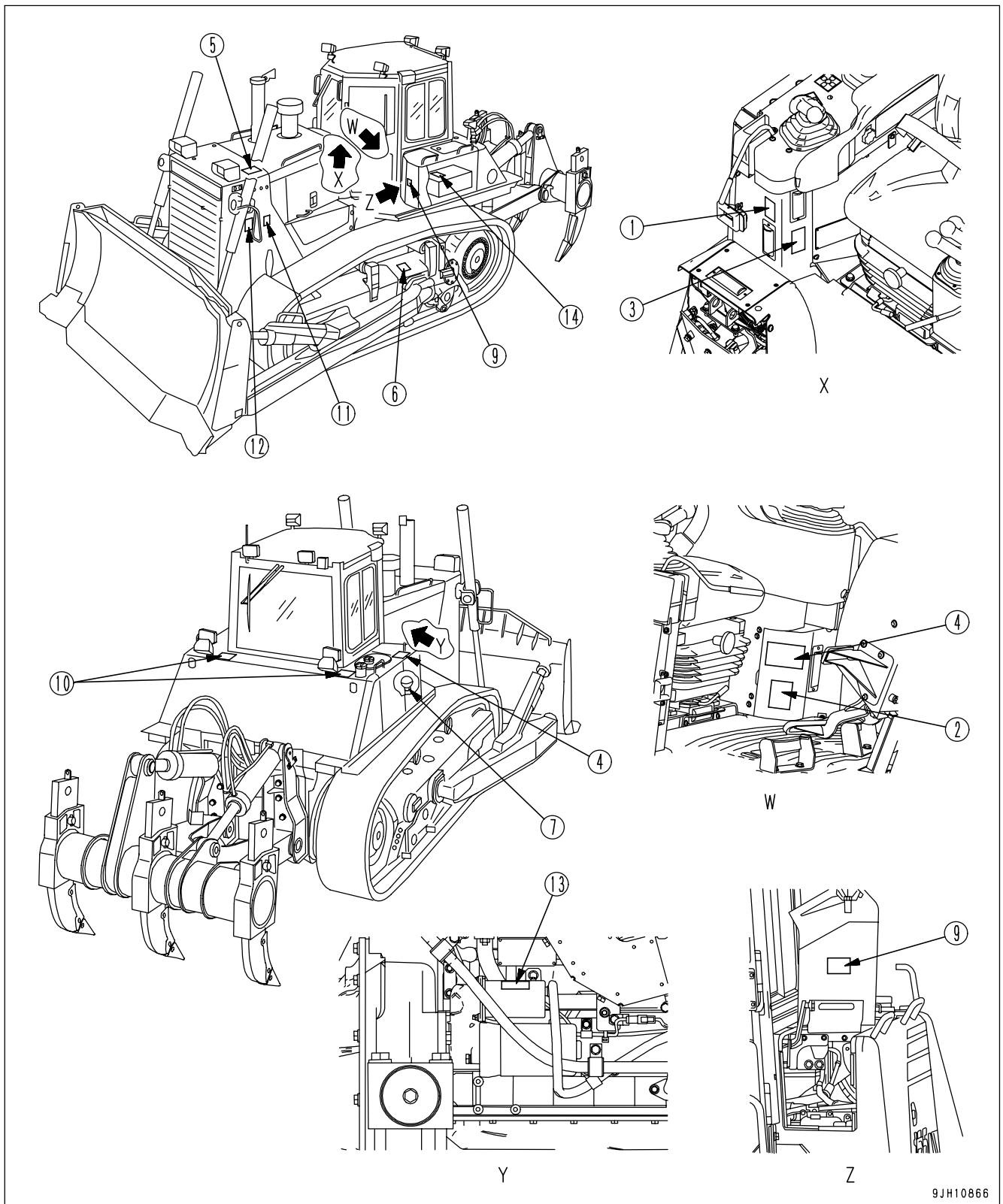

SAFETY LABELS

- (1) Caution before operating or maintaining machine
(09651-03001)

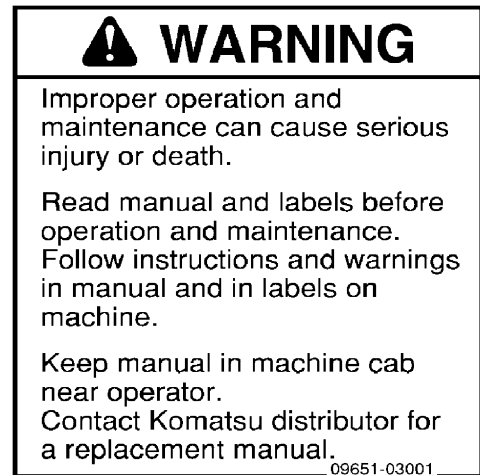

- (2) Caution when traveling in reverse (09802-13000)

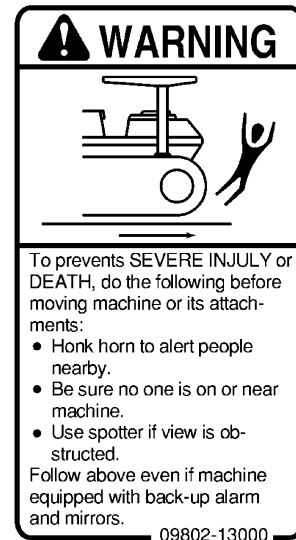

- (3) Caution for leaving the operator's seat (09654-33001)

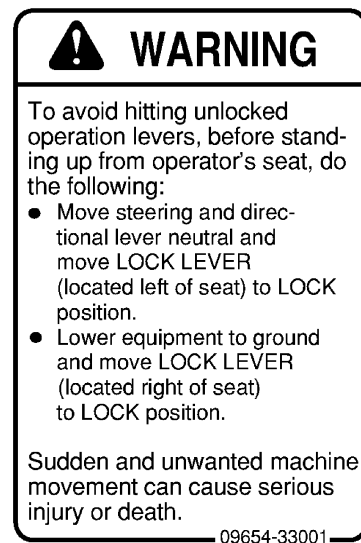

(4) Caution for high-temperature hydraulic oil (09653-03001)



(5) Caution for high-temperature coolant (09668-03001)

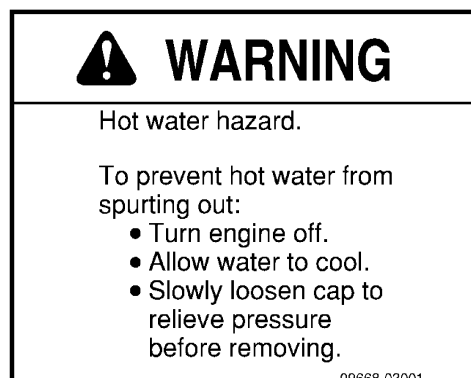

(6) Caution when adjusting track tension (09657-03003)
Safety label is attached to the back side of the inspection cover of the track frame.



(7) Caution for handling accumulator (09659-53000)



(8) Caution for use of seat belt (195-98-12940)

<p>CAUTION</p> <ul style="list-style-type: none"> • ALWAYS USE SEAT BELT WHEN OPERATING MACHINE. • ALWAYS CHECK CONDITION OF THE SEAT BELT, THE CONNECTING BRACKETS AND THE TIGHTENING BOLTS. • ADJUST SEAT TO ALLOW FULL BREAK PEDAL TRAVEL WITH OPERATOR'S BACK AGAINST SEAT BACK. • AFTER ADJUSTING THE HEIGHT, FORE AND AFT POSITION OF THE SEAT, TIGHTEN THE TETHER BELT BEFORE SITTING IN THE SEAT. <p style="text-align: right;">195-98-12940</p>

(9) Caution when handling cable (09808-03000)

<p> WARNING</p>
<p>Improper use of booster cables and battery cables can cause an explosion resulting in serious injury or death.</p> <ul style="list-style-type: none"> • Follow instructions in manual when using booster cable and battery cables. <p style="text-align: right;">09808-03000</p>

(10) Caution about going on top of fuel tank (17A-98-23920)

<p> CAUTION</p>
<p>NEVER be on this fuel tank.</p> <p style="text-align: right;">17A-98-23920</p>

(11) Prohibition of running engine during inspection and maintenance (09667-03001)

<p> CAUTION</p>
<p>While engine is running:</p> <ol style="list-style-type: none"> 1. Do not open cover. 2. Keep away from fan and fan-belt. <p style="text-align: right;">09667-03001</p>

- (12) Caution about going close when machine is moving
(09812-03000)



- (13) Jump start prohibited (09842-A0481)



Start the engine only after sitting down in the operator's seat.

Do not attempt to start the engine by short-circuiting the engine starting circuit. Such an act may cause a serious bodily injury or fire.

- (14) Caution when handling battery

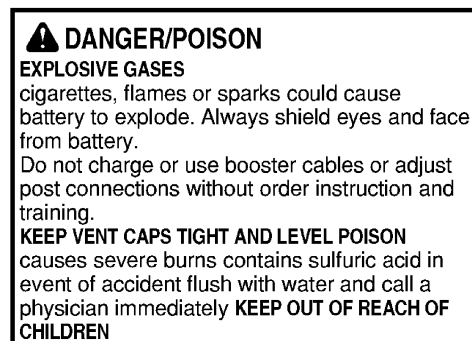

(This plate is stick on the machine by the battery maker.)

GENERAL PRECAUTIONS COMMON TO OPERATION AND MAINTENANCE

Mistakes in operation, inspection, or maintenance may result in serious personal injury or death. Before carrying out operation, inspection, or maintenance, always read this manual and the safety labels on the machine carefully and obey the warnings.

PRECAUTIONS BEFORE STARTING OPERATION

ENSURING SAFE OPERATION

- Only trained and authorized personnel can operate and maintain the machine.
- Follow all safety, precautions, and instructions in this manual when operating or performing inspection or maintenance on the machine.
- If you are not feeling well, or if you are under the influence of alcohol or medication, your ability to safely operate or repair your machine may be severely impaired, putting yourself and everyone else on your job site in danger.
- When working with another operator or with the person on the worksite traffic duty, discuss the content of the operation beforehand and use the determined signals when carrying out the operation.

UNDERSTANDING THE MACHINE

Before operating the machine, read this manual thoroughly. If there are any places in this manual that you do not understand, ask the person in charge of safety to give an explanation.

PREPARATIONS FOR SAFE OPERATION

PRECAUTIONS REGARDING SAFETY-RELATED EQUIPMENT

- Be sure that all guards, covers and mirrors are in their proper position. Have guards and covers repaired immediately if they are damaged.
- Understand the method of use of safety features and use them properly.
- Never remove any safety features. Always keep them in good operating condition.

INSPECTING MACHINE

Check the machine before starting operations. If any abnormality is found, do not operate the machine until repairs of the problem location have been completed.

WEAR WELL-FITTING CLOTHES AND PROTECTIVE EQUIPMENT

- Do not wear loose clothes or any accessories. If these catch on the control levers or protruding parts, there is danger that it may cause the machine to move unexpectedly.
- Always wear a hard hat and safety shoes. If the nature of the work requires it, wear safety glasses, mask, gloves, ear plugs, and safety belt when operating or maintaining the machine.
- If you have long hair and it hangs out from your hard hat, there is a hazard that it may get caught up in the machine, so tie your hair up and be careful not to let it get caught.
- Check that all protective equipment functions properly before using it.

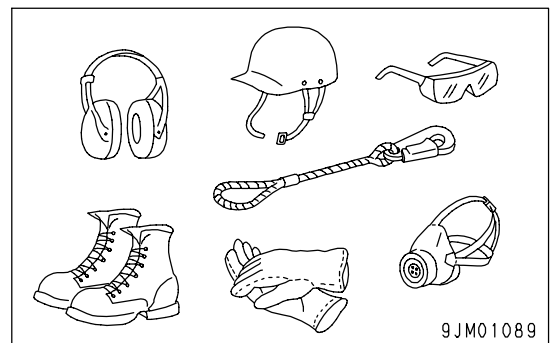

KEEP MACHINE CLEAN

- If you get on or off the machine or carry out inspection and maintenance when the machine is dirty with mud or oil, there is a hazard that you will slip and fall. Wipe off any mud or oil from the machine. Always keep the machine clean.
- If water gets into the electrical system, there is a hazard that it will cause malfunctions or misoperation. If there is any misoperation, there is danger that the machine may move unexpectedly and cause serious personal injury or death. When washing the machine with water or steam, do not allow the water or steam to come into direct contact with electrical components.

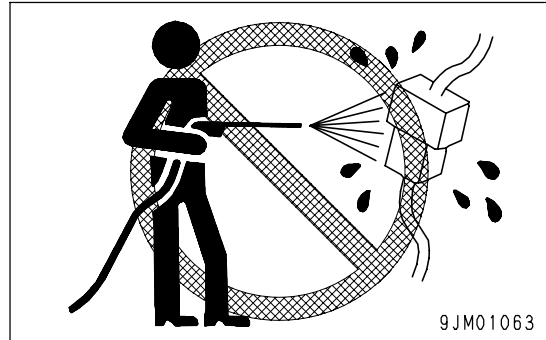
**PRECAUTIONS INSIDE OPERATOR'S COMPARTMENT**

- When entering the operator's compartment, always remove all mud and oil from the soles of your shoes. If you operate the pedal with mud or oil affixed to your shoes, your foot may slip and this may cause a serious accident.
- Do not leave tools or a machine parts lying around inside the operator's compartment. If tools or parts get into the control devices, it may obstruct operation and cause the machine to move unexpectedly, resulting in serious personal injury or death.
- Do not stick suction pads to the window glass. Suction pads act as a lens and may cause fire.
- Do not use a cell phone when driving or operating the machine. This may lead to mistakes in operation, which could cause serious personal injury or death.
- Never bring any dangerous objects such as flammable or explosive items into the operator's compartment.

PROVIDE FIRE EXTINGUISHER AND FIRST AID KIT

Always follow the precautions below to prepare for action if any injury or fire should occur.

- Be sure that fire extinguishers have been provided and read the labels to ensure that you know how to use them in emergencies.
- Carry out periodic inspection and maintenance to ensure that the fire extinguisher can always be used.
- Provide a first aid kit in the storage point. Carry out periodic checks and add to the contents if necessary.

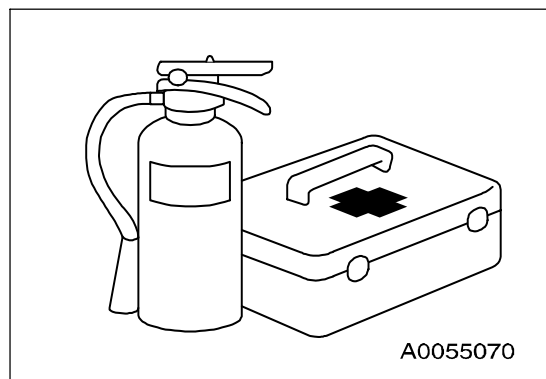
**IF ANY PROBLEM IS FOUND**

If you find any problems in the machine during operation or maintenance (noise, vibration, smell, incorrect gauges, smoke, oil leakage, etc., or any abnormal display on the warning devices or monitor), report to the person in charge and have the necessary action taken. Do not operate the machine until the problem has been corrected.

FIRE PREVENTION

ACTION IF FIRE OCCURS

- Turn the start switch OFF to stop the engine.
- Use the handrails and steps to get off the machine.
- Do not jump off the machine. There is the danger of falling and suffering serious injury.

PRECAUTIONS TO PREVENT FIRE

• Fire caused by fuel, oil, antifreeze, or window washer fluid

Do not bring any flame or fire close to flammable substances such as fuel, oil, antifreeze, or window washer fluid. There is danger that they may catch fire. To prevent fire, always observe the following:

- Do not smoke or use any flame near fuel or other flammable substances.
- Stop the engine before adding fuel.
- Do not leave the machine when adding fuel or oil.
- Tighten all fuel and oil caps securely.
- Be careful not to spill fuel on overheated surfaces or on parts of the electrical system.
- After adding fuel or oil, wipe up any spilled fuel or oil.
- Put greasy rags and other flammable materials into a safe container to maintain safety at the workplace.
- When washing parts with oil, use a non-flammable oil. Do not use diesel oil or gasoline. There is danger that they may catch fire.
- Do not weld or use a cutting torch to cut any pipes or tubes that contain flammable liquids.
- Determine well-ventilated areas for storing oil and fuel. Keep the oil and fuel in the determined place and do not allow unauthorized persons to enter.
- When carrying out grinding or welding work on the machine, move any flammable materials to a safe place before starting.

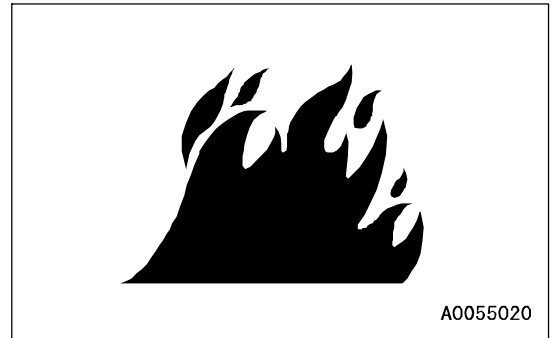

• Fire caused by accumulation of flammable material.

- Remove any dry leaves, chips, pieces of paper, coal dust, or any other flammable materials accumulated or affixed around the engine, exhaust manifold, muffler, or battery, or inside the undercovers.
- To prevent fires spreading from sparks or burning particles from other fires, remove any flammable materials such as dry leaves, chips, pieces of paper, coal dust, or any other flammable materials accumulated around the cooling system (radiator, oil cooler) or inside the undercover.

• Fire coming from electric wiring

Short circuits in the electrical system can cause fire. To prevent fire, always observe the following.

- Keep all electric wiring connections clean and securely tightened.
- Check the wiring every day for looseness or damage. Tighten any loose connectors or wiring clamps. Repair or replace any damaged wiring.

• **Fire coming from piping**

Check that all the hose and tube clamps, guards, and cushions are securely fixed in position.

If they are loose, they may vibrate during operation and rub against other parts. There is danger that this may lead to damage to the hoses and cause high-pressure oil to spurt out, leading to fire, serious personal injury or death.

• **Explosion caused by lighting equipment**

- When checking fuel, oil, battery electrolyte, or coolant, always use lighting with anti-explosion specifications.
- When taking the electrical power for the lighting from the machine itself, follow the instructions in this manual.

PRECAUTIONS WHEN GETTING ON OR OFF MACHINE

USE HANDRAILS AND STEPS WHEN GETTING ON OR OFF MACHINE

To prevent personal injury caused by slipping or falling off the machine, always do as follows.

- Use the parts marked by arrow A in the diagrams when getting on or off the machine.

Never use the parts marked by arrow B when getting on or off the machine. Use them only when moving along the top of the track or when checking or carrying out maintenance inside the side cover, or when filling the tank with oil.

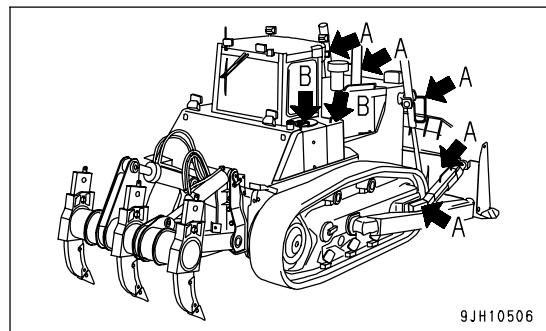
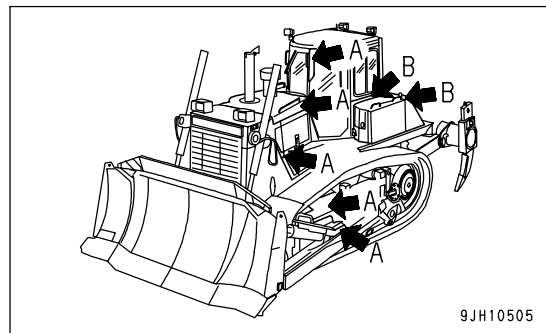

- Always face the machine and maintain at least three-point contact (both feet and one hand, or both hands and one foot) with the handrail and steps to ensure that you support yourself.

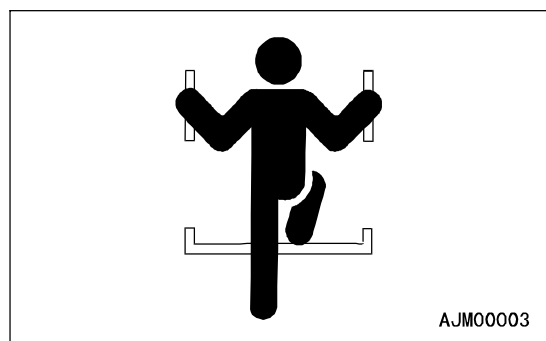

- Before getting on or off the machine, check the handrails and steps, and if there is any oil, grease, or mud on them, wipe it off immediately. In addition, repair any damage and tighten any loose bolts.
- Do not grip the control levers, or work equipment lock lever when getting on or off the machine.
- Never climb on the engine hood or covers where there are no non-slip pads.
- Do not get on or off the machine while holding tools in your hand.

NO JUMPING ON OR OFF MACHINE

- Never jump on or off the machine. Never get on or off a moving machine.
- If the machine starts to move when there is no operator on the machine, do not jump on to the machine and try to stop it.

NO PEOPLE ON ATTACHMENTS

Never let anyone ride on the work equipment or other attachments. There is a hazard of falling and suffering serious personal injury or death.

PRECAUTIONS WHEN STANDING UP FROM OPERATOR'S SEAT

Before standing up from the operator's seat, lower the work equipment completely to the ground, set work equipment lock lever (1) and parking brake lever (2) securely to the LOCK position (L), then stop the engine.

If you accidentally touch the levers when they are not locked, there is a hazard that the machine may suddenly move and cause serious injury or property damage.

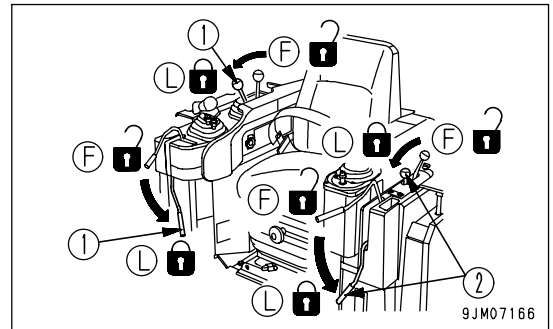
**PRECAUTIONS WHEN LEAVING MACHINE**

If the proper procedures are not taken when parking the machine, the machine may suddenly move off by itself, and this may lead to serious personal injury or death. Always do the following.

- When leaving the machine, always lower the work equipment completely to the ground, set work equipment lock lever (1) and parking brake lever (2) securely to the LOCK position (L), then stop the engine. Use the key to lock all the equipment. Always remove the key, take it with you, and keep it in the specified place.

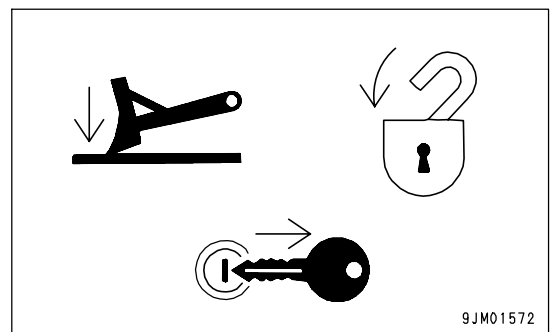
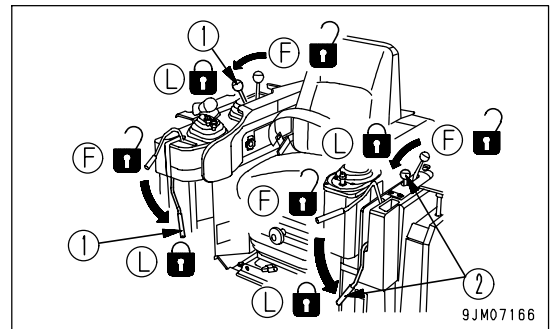
**EMERGENCY EXIT FROM OPERATOR'S CAB**

Machines equipped with a cab have doors on the left and right sides. If the door on the one side does not open, escape from the door on the other side.

DO NOT GET CAUGHT IN WORK EQUIPMENT

The clearance in the area around the work equipment changes according to the movement of the link. If you get caught, you may suffer serious personal injury or death. Do not allow anyone to come close to any rotating or extending/retracting portion.

PRECAUTIONS RELATED TO PROTECTIVE STRUCTURES

The operator's compartment is equipped with a structure (ROPS, FOPS) to protect the operator by absorbing the impact energy. If the machine weight (mass) exceeds the certified value (shown on the ROLL-OVER PROTECTIVE STRUCTURE (ROPS) CERTIFICATION plate), ROPS will not be able to fulfill its function. Do not increase machine weight beyond the certified value by modifying the machine or by installing attachments to the machine. Also, if the function of the protective equipment is impeded, the protective equipment will not be able to protect the operator, and the operator may suffer injury or death. Always observe the following.

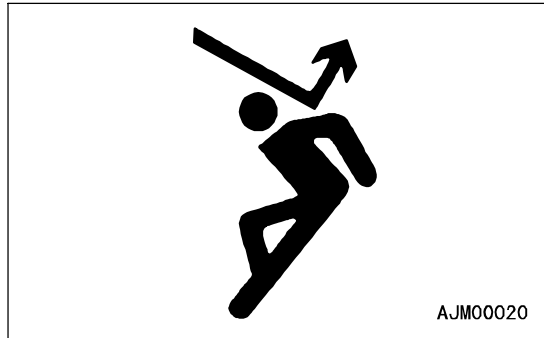

- If the machine is equipped with a protective structure, do not remove the protective structure and carry out operations without it.
- If the protective structure is welded, or holes are drilled in it, or it is modified in any other way, its strength may drop. Consult your Komatsu distributor before carrying out any modifications.
- If the protective structure is damaged or deformed by falling objects or by rolling over, its strength will be reduced and it will not be able to fulfill its function properly. In such cases, always contact your Komatsu distributor for advice on the method of repair.
- Even if the protective structure is installed, always fasten your seat belt properly when operating the machine. If you do not fasten your seatbelt properly, it cannot display its effect.

UNAUTHORIZED MODIFICATION

- Komatsu will not be responsible for any injuries, accidents, product failures or other property damages resulting from modifications made without authorization from Komatsu.
- Any modification made without authorization from Komatsu can create hazards. Before making a modification, consult your Komatsu distributor.

PRECAUTIONS RELATED TO ATTACHMENTS AND OPTIONS

- Any injuries, accidents, product failures or other property damages resulting from the use of unauthorized attachments or parts will not be the responsibility of Komatsu.
- When installing optional parts or attachments, there may be problems with safety or legal restrictions. Therefore contact your Komatsu distributor for advice.
- When installing and using optional attachments, read the instruction manual for the attachment, and the general information related to attachments in this manual.

PRECAUTIONS WHEN RUNNING ENGINE INSIDE BUILDING

The engine exhaust gas contains substances that may damage your health or even cause death. Start or operate the engine in a place where there is good ventilation. If the engine or machine must be operated inside a building or under ground, where the ventilation is poor, take steps to ensure that the engine exhaust gas is removed and that ample fresh air is brought in.

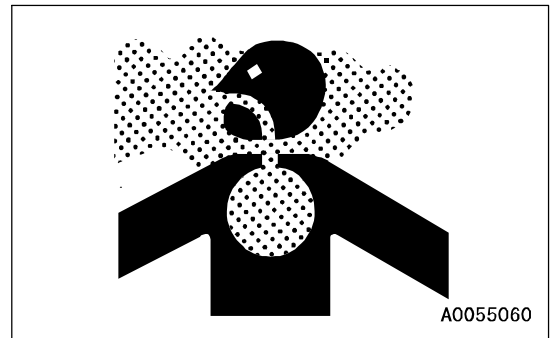

PRECAUTIONS FOR OPERATION

PRECAUTIONS FOR JOBSITE

INVESTIGATE AND CONFIRM JOBSITE CONDITIONS

On the jobsite, there are various hidden dangers that may lead to personal injury or death. Before starting operations, always check the following to confirm that there is no danger on the jobsite.

- When carrying out operations near combustible materials such as thatched roofs, dry leaves or dry grass, there is a hazard of fire, so be careful when operating.
- Check the terrain and condition of the ground at the worksite, and determine the safest method of operation. Do not operate where there is a hazard of landslides or falling rocks.
- If water lines, gas lines, or high-voltage electrical lines may be buried under the worksite, contact each utility and identify their locations. Be careful not to sever or damage any of these lines.
- Take necessary measures to prevent any unauthorized person from entering the operating area.
- In particular, if you need to operate on a road, protect pedestrian and cars by designating a person for worksite traffic duty or by installing fences around the worksite.
- When traveling or operating in water or on soft ground, check the water depth, speed of the current, bedrock, and shape of the ground beforehand and avoid any place that will obstruct travel.

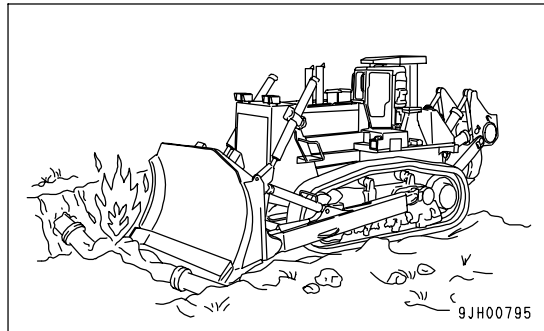

WORKING ON LOOSE GROUND

- Avoid traveling or operating your machine too close to the edge of cliffs, overhangs, and deep ditches. The ground may be weak in such areas. If the ground should collapse under the weight or vibration of the machine, there is a hazard that the machine may fall or tip over. Remember that the soil after heavy rain or blasting or after earthquakes is weak in these areas.
- When working on embankments or near excavated ditches, there is a hazard that the weight and vibration of the machine will cause the soil to collapse. Before starting operations, take steps to ensure that the ground is safe and to prevent the machine from rolling over or falling.

DO NOT GO CLOSE TO HIGH-VOLTAGE CABLES

Do not travel or operate the machine near electric cables. There is a hazard of electric shock, which may cause serious personal injury or death. On jobsites where the machine may go close to electric cables, always do as follows.

- Before starting work near electric cables, inform the local power company of the work to be performed, and ask them to take the necessary action.

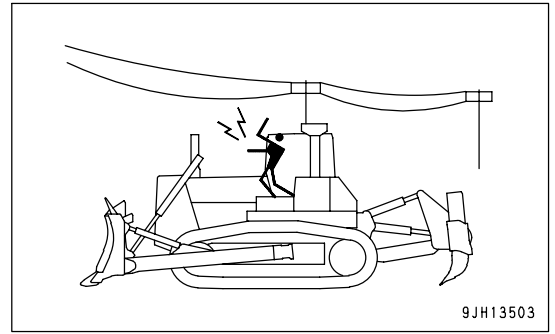

- Even going close to high-voltage cables can cause electric shock, which may cause serious burns or even death. Always maintain a safe distance (see the table on the right) between the machine and the electric cable. Check with the local power company about safe operating procedure before starting operations.
- To prepare for any possible emergencies, wear rubber shoes and gloves. Lay a rubber sheet on top of the seat, and be careful not to touch the chassis with any exposed part of your body.
- Use a signalman to give warning if the machine approaches too close to the electric cables.
- When carrying out operations near high voltage cables, do not let anyone near the machine.
- If the machine should come too close or touch the electric cable, to prevent electric shock, the operator should not leave the operator's compartment until it has been confirmed that the electricity has been shut off. Also, do not let anyone near the machine.

Voltage of Cables	Safety Distance
100V - 200V	Over 2 m (7 ft)
6,600V	Over 2 m (7 ft)
22,000V	Over 3 m (10 ft)
66,000V	Over 4 m (14 ft)
154,000V	Over 5 m (17 ft)
187,000V	Over 6 m (20 ft)
275,000V	Over 7 m (23 ft)
500,000V	Over 11 m (36 ft)

ENSURE GOOD VISIBILITY

This machine is equipped with mirrors to ensure good visibility, but even then there are places that cannot be seen from the operator's seat, so be careful when operating.

When traveling or carrying out operations in places with poor visibility, it is impossible to check for obstacles in the area around the machine and to check the condition of the jobsite. This leads to danger of serious personal injury or death. When traveling or carrying out operations in places with poor visibility, always observe the following.

- Position a signalman if there are areas where the visibility is not good.
- Only one signalman should give signals.
- When working in dark places, turn on the working lamp and front lamps installed to the machine, and set up additional lighting in the work area if necessary.
- Stop operations if the visibility is poor, such as in mist, snow, rain, or dust.
- When checking the mirrors installed to the machine, remove all dirt and adjust the angle of the mirror to ensure good visibility.
- If the machine is equipped with cameras, clean off any dirt from the lens and make sure that the camera gives a clear view.

CHECKING SIGNS AND SIGNALMAN'S SIGNALS

- Set up signs to inform of road shoulders and soft ground. If the visibility is not good, position a signalman if necessary. Operators should pay careful attention to the signs and follow the instructions from the signalman.
- Only one signalman should give signals.
- Make sure that all workers understand the meaning of all signals and signs before starting work.

BEWARE OF ASBESTOS DUST

Asbestos dust in the air can cause lung cancer if it is inhaled. There is danger of inhaling asbestos when working on jobsites handling demolition work or work handling industrial waste. Always observe the following.

- Spray water to keep down the dust.
- Do not use compressed air.
- If there is danger that there may be asbestos dust in the air, always operate the machine from an upwind position, and make sure that all workers operate on the upwind side.
- All workers should use anti-dust masks.
- Do not allow other persons to approach during the operation.
- Always observe the rules and regulations for the work site and environmental standards.

This machine does not use asbestos, but there is a danger that imitation parts may contain asbestos, so always use genuine Komatsu parts.

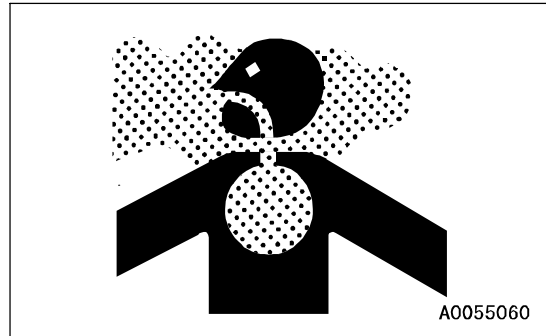

STARTING ENGINE

USE WARNING TAGS

If there is any "DANGER! Do NOT operate!" warning tag displayed, it means that someone is carrying out inspection and maintenance of the machine. If the warning sign is ignored and the machine is operated, there is danger that the person carrying out inspection or maintenance may be caught in the rotating parts or moving parts and suffer serious personal injury or death. Do not start the engine or touch the levers.

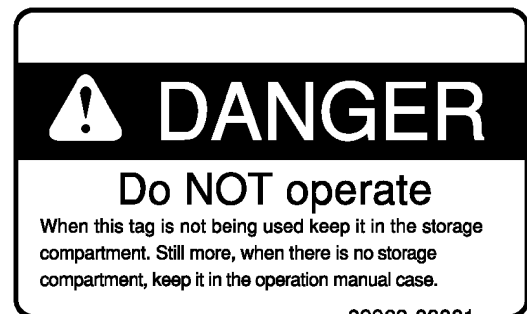
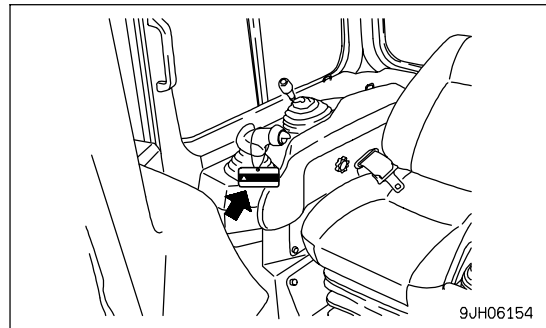

INSPECTION AND MAINTENANCE BEFORE STARTING ENGINE

Carry out the following checks before starting the engine at the beginning of the day's work to ensure that there is no problem with the operation of the machine. If this inspection is not carried out properly problems may occur with the operation of the machine, and there is danger that this may lead to serious personal injury or death.

- Remove all dirt from the surface of the window glass to ensure a good view.
- Carry out the "WALK-AROUND CHECK (PAGE 3-98)".
- Remove all dirt from the surface of the lens of the front lamps and working lamps, and check that they light up correctly.
- Check the coolant level, fuel level, and oil level in engine oil pan, check for clogging of the air cleaner, and check for damage to the electric wiring.
- Check that there is no mud or dust accumulated around the movable parts of any pedals, and check that the pedals work properly.
- Adjust the operator's seat to a position where it is easy to carry out operations, and check that there is no damage or wear to the seat belt or mounting clamps.
- Check that the gauges work properly, check the angle of the mirror, and check that the control levers are all at the Neutral position.
- Before starting the engine, check that work equipment lock lever (1) and parking brake lever (2) are in LOCK position (L).
- Adjust the mirrors so that you can get a good rear-view from the operator's seat.
For the details of adjustment, see "ADJUST MIRROR (PAGE 3-118)".
- If the machine is equipped with cameras, adjust the angle so that the surrounding area can be seen clearly from the operator's seat.
- Check that there are no persons or obstacles above, below, or in the area around the machine.

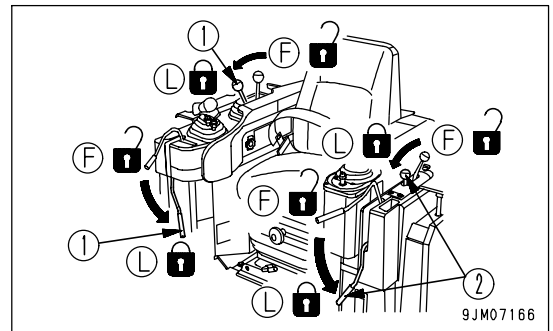

PRECAUTIONS WHEN STARTING ENGINE

- Start and operate the machine only while seated.
- When starting the engine, sound the horn as a warning.
- Do not allow anyone apart from the operator to ride on the machine.
- Do not attempt to start the engine by short-circuiting the engine starting circuit. This may cause fire, serious personal injury or death.

PRECAUTIONS IN COLD AREAS

- Carry out the warming-up operation thoroughly. If the machine is not thoroughly warmed up before the control levers are operated, the reaction of the machine will be slow, and this may lead to unexpected accidents.
- If the battery electrolyte is frozen, do not charge the battery or start the engine with a different power source. There is a hazard that this will ignite the battery and cause the battery to explode.
Before charging or starting the engine with a different power source, melt the battery electrolyte and check that there is no leakage of electrolyte before starting.

STARTING WITH BOOSTER CABLES

If any mistake is made in the method of connecting the booster cables, it may cause the battery to explode, so always do as follows.

- Always wear safety goggles and rubber gloves when starting the engine with booster cable.
- When connecting a normal machine to a problem machine with booster cables, always use a normal machine with the same battery voltage as the problem machine.
- When starting with a booster cable, carry out the starting operation with two workers (one worker sitting in the operator’s seat and the other working with the battery).
- When starting from another machine, do not allow the two machines to touch.
- When connecting the booster cables, turn the starting switch to the OFF position for both the normal machine and problem machine. There is a hazard that the machine will move when the power is connected.
- Be sure to connect the positive (+) cable first when installing the booster cables. Disconnect the negative (-) cable (ground side) first when removing them.
- When removing the booster cables, be careful not to let the booster cable clips touch each other or to let the clips touch the machine.
- For details of the procedure when starting the machine using a booster cable, see "STARTING ENGINE WITH BOOSTER CABLE (PAGE 3-189)".

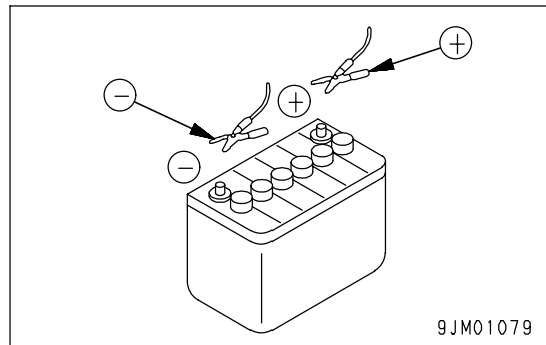
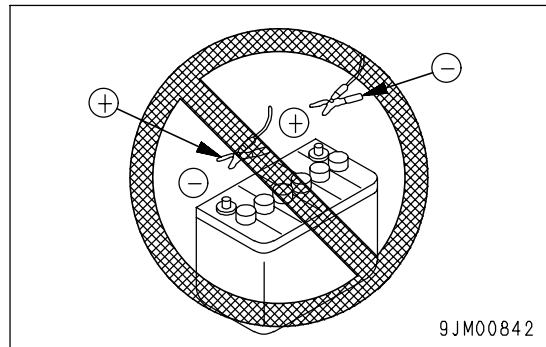

OPERATION

CHECKS BEFORE OPERATION

If the checks before starting are not carried out properly, the machine will be unable to display its full performance, and there is also danger that it may lead to serious personal injury or death.

When carrying out the checks, move the machine to a wide area where there are no obstructions, and pay careful attention to the surrounding area. Do not allow anyone near the machine.

- Always wear the seatbelt. There is danger that you may be thrown out of the operator's seat and suffer serious injury when the brakes are applied suddenly.
- Check the operation of travel, steering and brake systems, and work equipment control system.
- Check for any problem in the sound of the machine, vibration, heat, smell, or gauges; check also that there is no leakage of oil or fuel.
- If any problem is found, carry out repairs immediately.



PRECAUTIONS WHEN TRAVELING IN FORWARD OR REVERSE

- Lock the cab door and windows securely, both when they are open and when they are closed.
- Do not allow anyone apart from the operator to ride on the machine.
- If there are any persons in the area around the machine, there is danger that they may be hit or caught by the machine, and this may lead to serious personal injury or death. Always observe the following before traveling.
 - Always operate the machine only when seated.
 - Before moving off, check again that there is no person or obstruction in the surrounding area.
 - Before moving, sound the horn to warn people in the surrounding area.
 - Check that the backup alarm (alarm buzzer when machine travels in reverse) works properly.
 - If there is an area to the rear of the machine which cannot be seen, position a signalman.

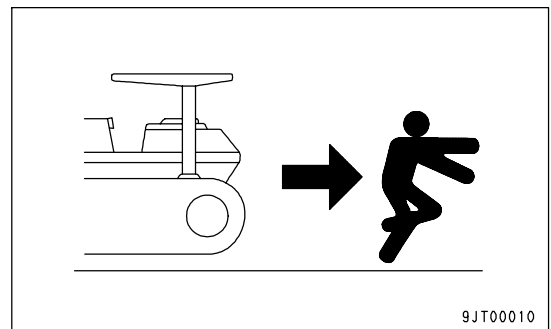

Always be sure to carry out the above precautions even when the machine is equipped with mirrors and cameras.

PRECAUTIONS WHEN TRAVELING

- Never turn the starting switch key to the OFF position when the machine is traveling. If the engine stops when the machine is traveling, it may become impossible to operate the steering, and this may cause serious personal injury or death. If the engine stops, depress the brake pedal immediately to stop the machine.
- When traveling or carrying out operations, always keep a safe distance from people, structures, or other machines to avoid coming into contact with them.
- When traveling on the level ground, keep the work equipment approximately 40 to 50 cm above the ground. Otherwise, the work equipment may contact to the ground and the machine may be turned over.

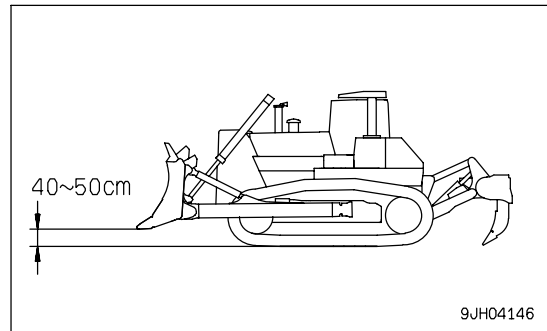

- Avoid traveling over obstacles when possible. If the machine has to travel over an obstacle, keep the work equipment close to the ground and travel at low speed. There is more danger of the machine tipping over to the left or right than tipping over to the front or rear, so do not travel over obstacles which make the machine tilt strongly to the left or right sides.
- When traveling on rough ground, travel at low speed and do not operate the steering suddenly. There is danger that the machine may turn over. The work equipment may hit the ground surface and cause the machine to lose its balance, or may damage the machine or structures in the area.
- When passing over bridges or structures, check first that the structure is strong enough to support the weight of the machine.
- When operating in tunnels, under bridges, under electric wires, or other places where the height is limited, operate slowly and be extremely careful not to let the machine body or work equipment hit anything.

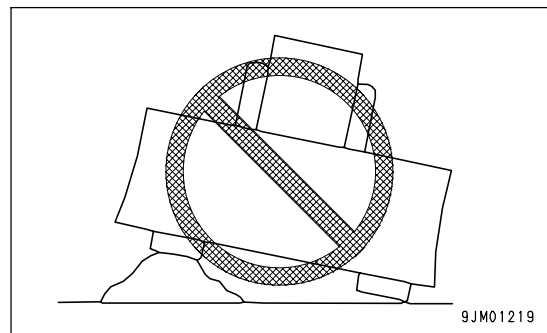

TRAVELING ON SLOPES

To prevent the machine from tipping over or slipping to the side, always do as follows.

- Keep the work equipment approx. 20 to 30 cm (8 to 12 in) above the ground. In case of emergency, lower the work equipment to the ground immediately to help stop the machine.
- Always travel straight up or down a slope. Traveling at an angle or across the slope is extremely dangerous.
- Do not turn on slopes or travel across slopes. Always go down to a flat place to change the position of the machine, then travel on to the slope again.
- Travel on grass, fallen leaves, or wet steel plates with low speed. Even with slight slopes there is a hazard that the machine may slip.
- When traveling downhill, never shift gear or place the transmission at neutral. It is dangerous not to use the braking force of the engine. Always place the transmission in a low gear before starting to travel downhill.
- Apply the brake and use the engine as a brake, if necessary.

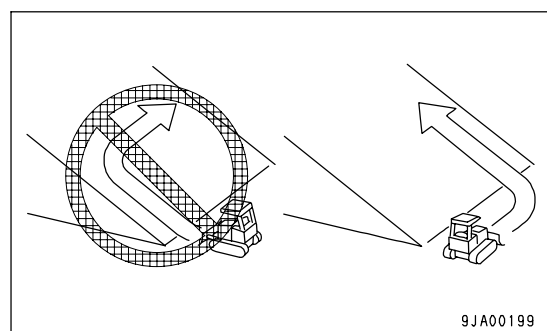

PRECAUTIONS WHEN OPERATING

- Be careful not to approach too close to the edge of cliffs. When making embankments or landfills, or when dropping soil over a cliff, dump one pile, then use the next pile of soil to push the first pile.
- The load suddenly becomes lighter when the soil is pushed over a cliff or when the machine reaches the top of a slope. When this happens, there is danger that the travel speed will suddenly increase, so be sure to reduce the speed.
- If the machine moves with only either side of the blade loaded, its tail may swing. Take care.

PROHIBITED OPERATIONS

- To make it easier to escape if there is any problem, set the tracks at right angles to the road shoulder or cliff with the sprocket at the rear when carrying out operations.
- When using the machine, to prevent personal injury caused by damage to the work equipment or by the machine overturning due to overloading, do not exceed the permitted performance of the machine or the maximum permitted load for the structure of the machine.

METHOD OF USING BRAKES

- When the machine is traveling, do not rest your foot on the brake pedal. If you travel with your foot resting on the pedal, the brake will always be applied, and this will cause the brakes to overheat and fail.
- Do not depress the brake pedal repeatedly if not necessary.
- When traveling downhill, use the braking force of the engine.

TRAVELING ON SNOW-COVERED OR FROZEN SURFACES

- Snow-covered or frozen surfaces are slippery, so be extremely careful when traveling or operating the machine, and do not operate the levers suddenly. Even a slight slope may cause the machine to slip, so be particularly careful when working on slopes.
- With frozen ground surfaces, the ground becomes soft when the temperature rises, and this may cause the machine to tip over or make it impossible for the machine to escape.
- If the machine enters deep snow, there is a hazard that it may tip over or become buried in the snow. Be careful not to leave the road shoulder or to get trapped in a snow drift.
- When clearing snow, the road shoulder and objects placed beside the road are buried in the snow and cannot be seen. There is a hazard of the machine tipping over or hitting covered objects, so always carry out operations carefully.
- When traveling on snow-covered slopes, never apply the foot brake suddenly. Reduce the speed and use the engine as a brake while applying the foot brake intermittently (depress the brake intermittently several times). If necessary, lower the work equipment to the ground to stop the machine.

PARKING MACHINE

- Park the machine on firm, level ground.
- Select a place where there is no hazard of landslides, falling rocks, or flooding.
- Lower the work equipment completely to the ground.
- When leaving the machine, set work equipment lock lever (1) and parking brake lever (2) to the LOCK position (L), and stop the engine.
- Always close the operator's cab door, and use the key to lock all the equipment in order to prevent any unauthorized person from moving the machine. Always remove the key, take it with you, and leave it in the specified place.

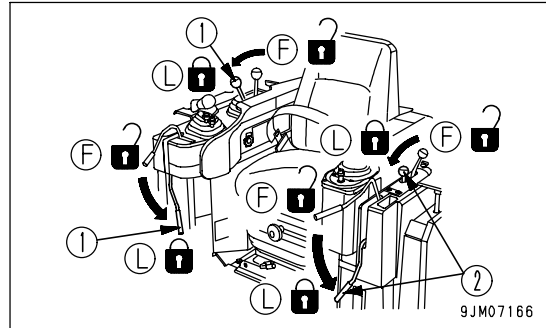

- If it is necessary to park the machine on a slope, always do as follows.
 - Set the work equipment on the downhill side and dig it into the ground.
 - In addition, put blocks under the tracks to prevent the machine from moving.

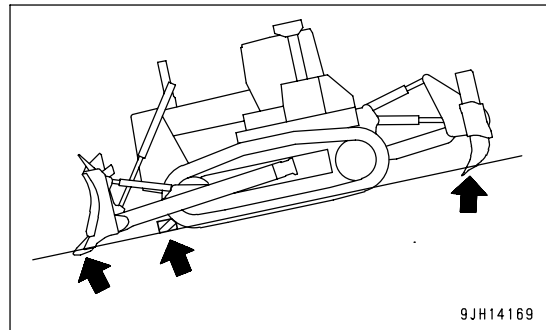

TRANSPORTATION

When the machine is transported on a trailer, there is danger of serious personal injury or death during transportation. Always do as follows.

- Always check the machine dimensions carefully. Depending on the work equipment installed, the machine weight, transportation height, and overall length may differ.
- Check beforehand that all bridges and other structures on the transportation route are strong enough to withstand the combined weight of the transporter and the machine being transported.
- The machine can be divided into parts for transportation, so when transporting the machine, please contact your Komatsu distributor to have the work carried out.

LOADING AND UNLOADING

When loading or unloading the machine, mistaken operation may bring the hazard of the machine tipping over or falling, so particular care is necessary. Always do as follows.

- Perform loading and unloading on firm, level ground only. Maintain a safe distance from the edge of the road or cliff.
 - Always use ramps of adequate strength. Be sure that the ramps are wide, long, and thick enough to provide a safe loading slope. Take suitable steps to prevent the ramps from moving out of position or coming off.
 - Be sure the ramp surface is clean and free of grease, oil, ice and loose materials. Remove dirt from machine-tracks. On a rainy day, in particular, be extremely careful since the ramp surface is slippery.
 - Run the engine at low idling and drive the machine slowly at low speed.
 - When on the ramps, do not operate any lever except for the travel lever.
 - Never correct your steering on the ramps. If necessary, drive off the ramps, correct the direction, then enter the ramps again.
 - The center of gravity of the machine will change suddenly at the joint between the ramps and the track or trailer, and there is danger of the machine losing its balance. Travel slowly over this point.
 - When loading or unloading to an embankment or platform, make sure that it has suitable width, strength, and grade.
 - For machines equipped with a cab, always lock the door after boarding the machine. If this is not done, the door may suddenly open during transportation.
- Refer to "TRANSPORTATION (PAGE 3-173)".

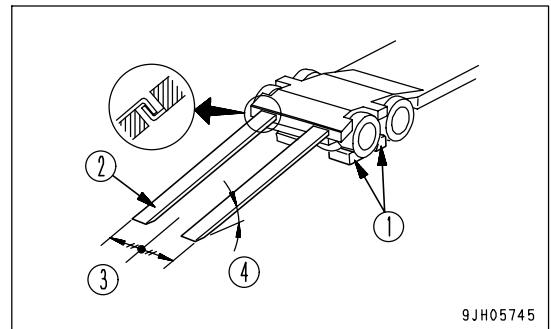

- (1) Blocks
- (2) Ramp
- (3) Centerline of trailer
- (4) Angle of ramps: Max. 15°

TOWING

PRECAUTIONS WHEN TOWING

Always use the correct towing equipment and towing method. Any mistake in the selection of the wire rope or towing bar or in the method of towing a disabled machine may lead to serious personal injury or death.

For towing, see "METHOD OF TOWING MACHINE (PAGE 3-187)".

- Always confirm that the wire rope or drawbar used for towing has ample strength for the weight of the machine being towed.
- Never use a wire rope which has cut strands (A), reduced diameter (B), or kinks (C). There is danger that the rope may break during the towing operation.
- Always wear leather gloves when handling wire rope.
- Never tow a machine on a slope.
- During the towing operation, never stand between the towing machine and the machine being towed.

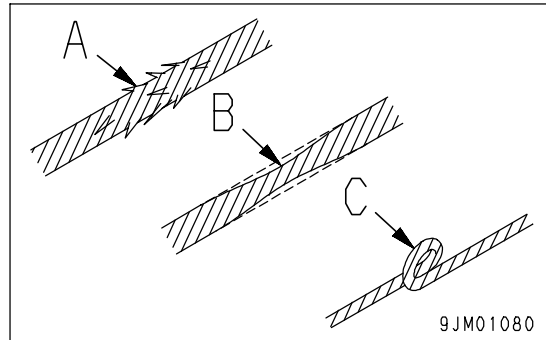

PRECAUTIONS FOR MAINTENANCE

PRECAUTIONS BEFORE STARTING INSPECTION AND MAINTENANCE

DISPLAY WARNING TAG DURING INSPECTION AND MAINTENANCE

When carrying out inspection or maintenance, always attach the "DANGER! Do NOT operate!" warning tag to the work equipment control lever in the operator's cab to alert others that you are working on the machine. If there is any "DANGER! Do NOT operate!" warning tag displayed, it means that someone is carrying out inspection and maintenance of the machine. If the warning sign is ignored and the machine is operated, there is danger that the person carrying out inspection or maintenance may be caught in the rotating parts or moving parts and suffer serious personal injury or death. Do not start the engine or do not touch the levers.

- If necessary, put up signs around the machine also.
Warning tag part number: 09963-03001
When not using this warning tag, keep it in the toolbox.
If there is no toolbox, keep it in the pocket for the Operation and Maintenance Manual

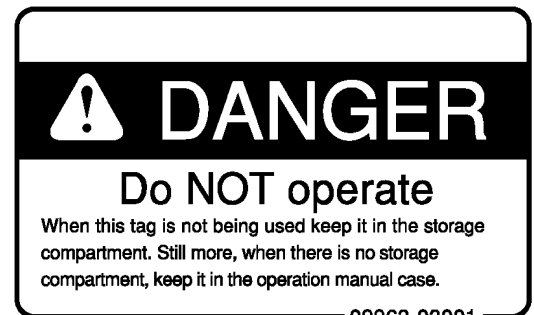
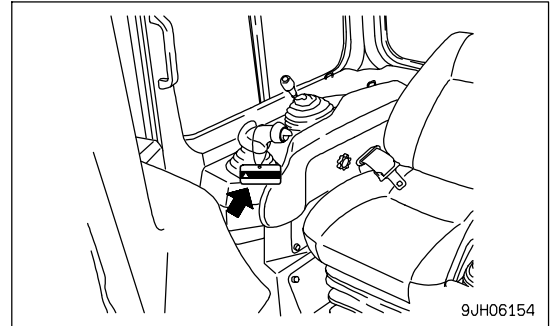

KEEP WORKPLACE CLEAN AND TIDY

Do not leave hammers or other tools lying around in the work place. Wipe up all grease, oil, or other substances that will cause you to slip. Always keep the work place clean and tidy to enable you to carry out operations safely. If the work place is not kept clean and tidy, there is the danger that you will trip, slip, or fall over and injure yourself.

SELECT SUITABLE PLACE FOR INSPECTION AND MAINTENANCE

- Stop the machine on firm, level ground.
- Select a place where there is no hazard of landslides, falling rocks, or flooding.

ONLY AUTHORIZED PERSONNEL

Do not allow any unauthorized personnel into the area when servicing the machine. If necessary, employ a guard.

APPOINT LEADER WHEN WORKING WITH OTHERS

When repairing the machine or when removing and installing the work equipment, appoint a leader and follow his instructions during the operation.

STOP ENGINE BEFORE CARRYING OUT INSPECTION AND MAINTENANCE

- Lower the work equipment completely to the ground and stop the engine before performing any inspection and maintenance.

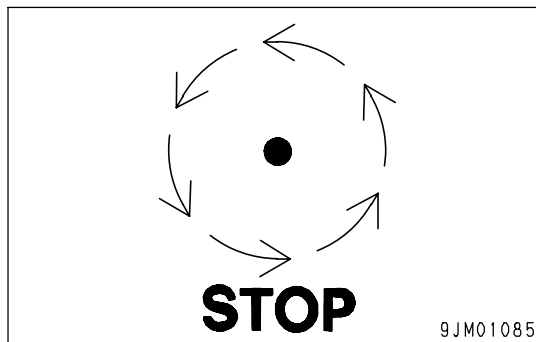

- Turn the starting switch to the ON position, operate the work equipment control lever to the RAISE and LOWER position 2 or 3 times repeatedly to release the remaining pressure in the hydraulic circuit, then set parking brake lever (1) and work equipment lock lever (2) to the LOCK position (L).
- Check that the battery relay is off and main power is not conducted. (Wait for approx. one minute after turning off the engine starting switch key and press the horn switch. If the horn does not sound, it is not activated.)

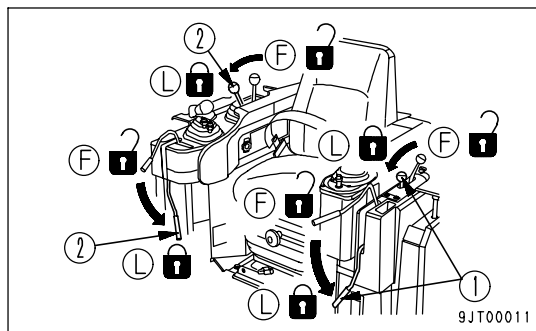

- Put blocks under the track to prevent the machine from moving.

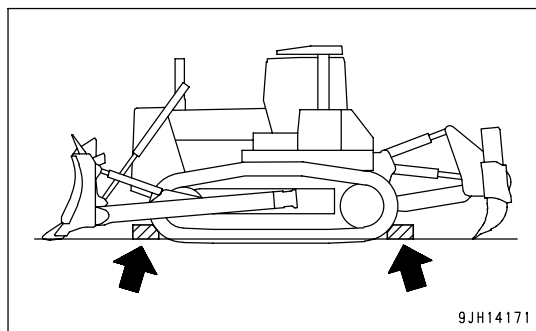

TWO WORKERS FOR MAINTENANCE WHEN ENGINE IS RUNNING

To prevent personal injury, do not carry out maintenance with the engine running. If maintenance must be carried out with the engine running, carry out the operation with at least two workers and do as follows.

- One worker must always sit in the operator's seat and be ready to stop the engine at any time. All workers must maintain contact with the other workers.
- When carrying out operations near the fan, fan belt, or other rotating parts, there is a hazard of being caught in the parts, so be careful not to come close.
- Never drop or insert tools or other objects into the fan, fan belt, or other rotating parts. There is danger that they may contact the rotating parts and break or be sent flying.

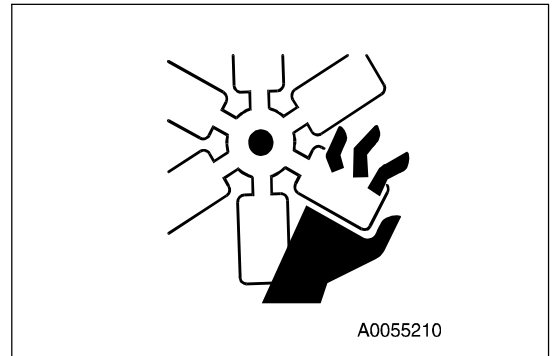

- Set work equipment lock lever (1) and parking brake lever (2) to the LOCK position (L) to prevent the work equipment from moving.
- Do not touch any control levers. If any control lever must be operated, give a signal to the other workers to warn them to move to a safe place.

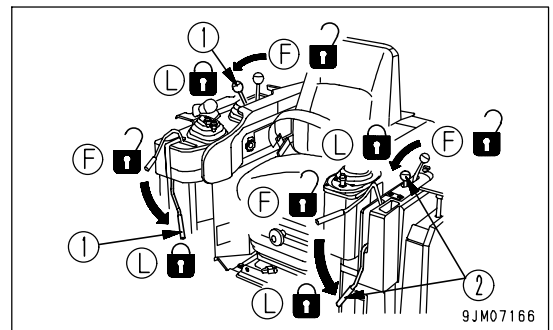
**INSTALLING, REMOVING, OR STORING ATTACHMENTS**

- Appoint a leader before starting removal or installation operations for attachments.
- Place attachments that have been removed from the machine in a stable condition so that they do not fall. And take steps to prevent unauthorized persons from entering the storage area.

**PRECAUTIONS WHEN WORKING AT HIGH PLACES**

When working at high places, use a step ladder or other stand to ensure that the work can be carried out safely.

PRECAUTIONS WHEN WORKING ON TOP OF MACHINE

- Clean up the machine to prevent falling off when performing maintenance, always do as follows.
 - Do not spill oil or grease.
 - Do not scatter the tools.
 - Be careful at the time of the walk on the step.
 - Remove mud and the oils and fats kind of the bottom of shoes.
- Never jump off the machine. When getting on or off the machine, maintain at least three-point contact (both feet and one hand, or both hands and one foot) with the handrail and steps to ensure that you support yourself.
- To prevent personal injury caused by slipping or falling off the machine, never climb on the engine hood or covers except the check passage with non-slip pads.



A0305870

PRECAUTIONS WHEN WORKING UNDER MACHINE OR WORK EQUIPMENT

- Make sure the hoists or jacks you use are in good repair and strong enough to handle the weight of the component. Never use jacks at places where the machine is damaged, bent, or twisted. Never use frayed, twisted or pinched wire rope. Never use bent or distorted hooks.
- It is extremely dangerous to work under the machine if the track shoes are lifted off the ground and the machine is supported only with the work equipment. If any of the control levers is touched by accident, or there is damage occurring to the hydraulic piping, the work equipment or the machine will suddenly drop. This is extremely dangerous. Never work under the work equipment or the machine.
- If it is necessary to raise the work equipment or the machine and then go under it to carry out inspection or maintenance, support the work equipment and machine securely with blocks and stands strong enough to support the weight of the work equipment and machine. If the work equipment and machine are not supported, there is a hazard that they may come down and that this may lead to serious personal injury or death.
- Never use concrete blocks for supports. They can collapse under even light loads.

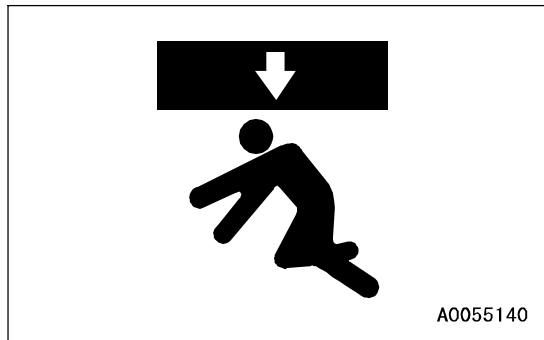

A0055140

PROPER TOOLS

Use only tools suited to the task and be sure to use the tools correctly. Using damaged, deformed, or low quality tools, or making improper use of the tools may cause serious personal injury.

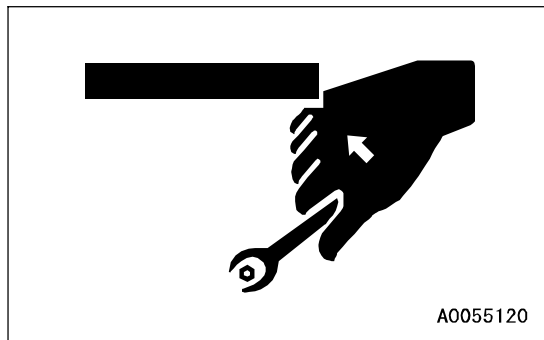

A0055120

PRECAUTIONS FOR INSPECTION AND MAINTENANCE

PRECAUTIONS WHEN WELDING

Welding operations must always be carried out by a qualified welder and in a place equipped with proper equipment. There is a hazard of gas, fire, or electrocution when carrying out welding, so never allow any unqualified personnel to carry out welding.

HANDLING BATTERY

Before inspecting or handling the battery, turn the key in the starting switch to the OFF position.

- **Danger of battery exploding**

When the battery is being charged, flammable hydrogen gas is generated and may explode. In addition, the battery electrolyte includes dilute sulphuric acid. Any mistake in handling may cause serious personal injury, explosion, or fire, so always observe the following.

- Do not use or charge the battery if the battery electrolyte is below the LOWER LEVEL mark. This will cause explosion. Always carry out periodic inspection of the battery electrolyte level, and add distilled water (or commercially available battery filler solution) to the UPPER LEVEL mark.
- Do not smoke or bring any flame close to the battery.
- Hydrogen gas is generated when the battery is being charged, so remove the battery from the machine, take it to a well-ventilated place, remove the battery caps, then carry out the charging.
- After charging, tighten the battery caps securely.

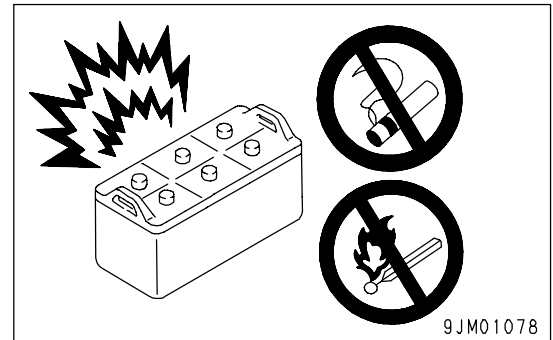

- **Danger from dilute sulphuric acid**

When the battery is being charged, flammable hydrogen gas is generated and may explode. In addition, the battery electrolyte includes dilute sulphuric acid. Any mistake in handling may cause serious personal injury, explosion, or fire, so always observe the following.

- When handling the battery, always wear protective goggles and rubber gloves.
- If battery electrolyte gets into your eyes, immediately wash your eyes with large amounts of fresh water. After that, get medical attention immediately.
- If battery electrolyte gets on your clothes or skin, wash it off immediately with large amounts of water.

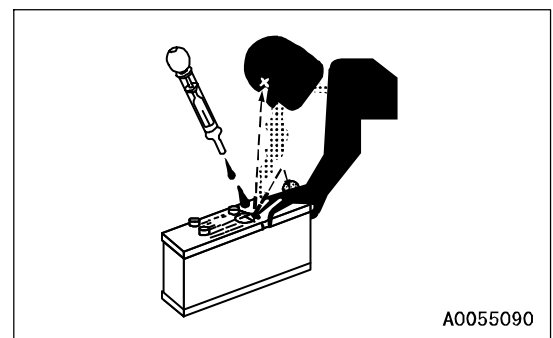

- **Removing battery cables**

Before repairing the electrical system or carrying out electric welding, turn the starting switch OFF. Wait for approx. 1 minute, then remove the negative (-) battery cable to stop the flow of electricity.

• Danger of sparks

There is hazard that sparks will be generated, so always observe the following.

- Do not let tools or other metal objects make any contact between the battery cables. Do not leave tools lying around near the battery.
- When removing the battery cables, remove the ground cable (negative (-) cable) first. When installing, connect the positive (+) cable first, then connect the ground. Tighten the battery cable terminals securely.
- Secure the battery firmly in the specified position.

PRECAUTIONS WHEN USING HAMMER

When using a hammer, pins may fly out or metal particles may be scattered. This may lead to serious personal injury or death. Always do as follows.

- When hitting pins or bucket teeth, there is a hazard that broken pieces might be sent flying and injure people in the surrounding area. Always check that there is no one in the surrounding area.
- If hard metal parts such as pins, bucket teeth, cutting edges, or bearings are hit with a hammer, there is a hazard that pieces might be scattered and cause serious personal injury or death. Always wear safety glasses and gloves.
- If the pin is hit with strong force, there is a hazard that it may fly out and injure people in the surrounding area. Do not allow anyone to enter the surrounding area.

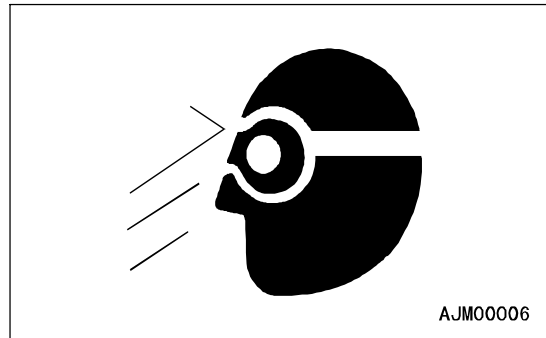

PRECAUTIONS WITH HIGH-TEMPERATURE COOLANT

To prevent burns from boiling water or steam spurting out when checking or draining the coolant, wait for the coolant to cool down to a temperature where the radiator cap can be touched by hand. Then loosen the cap slowly to release the pressure inside the radiator, and remove the cap.

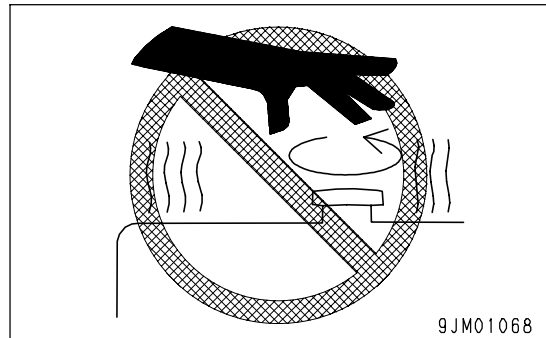

PRECAUTIONS WITH HIGH-TEMPERATURE OIL

To prevent burns from hot oil spurting out or from touching high-temperature parts when checking or draining the oil, wait for the oil to cool down to a temperature where the cap or plug can be touched by hand. Then loosen the cap or plug slowly to release the internal pressure and remove the cap or plug.

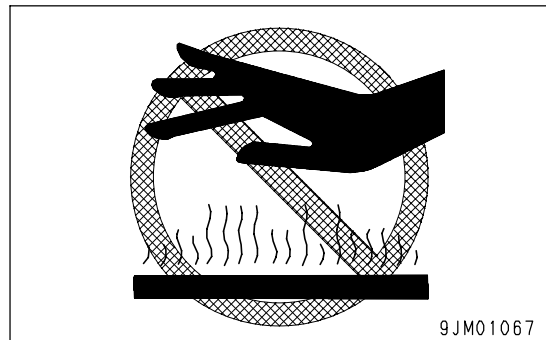

PRECAUTIONS WITH HIGH-PRESSURE OIL

The hydraulic system is always under internal pressure. In addition, the fuel piping is also under internal pressure when the engine is running and immediately after the engine is stopped. When carrying out inspection or replacement of the piping or hoses, check that the internal pressure in the circuit has been released. If this is not done, it may lead to serious personal injury or death. Always do as follows.

- Do not carry out inspection or replacement when the circuit is still under pressure.
Release the pressure in the hydraulic circuit. For details, see "METHOD OF RELEASING PRESSURE IN HYDRAULIC CIRCUIT (PAGE 4-87)".
- If there is any leakage from the piping or hoses, the surrounding area will be wet, so check for cracks in the piping and hoses and for swelling in the hoses.

When carry out inspection, wear safety glasses and leather gloves.

- There is a hazard that high-pressure oil leaking from small holes may penetrate your skin or cause loss of sight if it contacts your skin or eyes directly. If you are hit by a jet of high-pressure oil and suffer injury to your skin or eyes, wash the place with clean water, and consult a doctor immediately for medical attention.

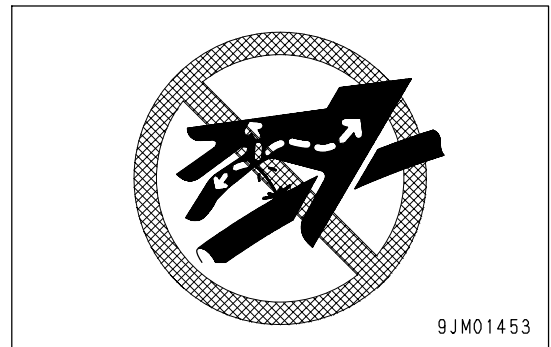

9JM01453

PRECAUTIONS WITH HIGH-PRESSURE FUEL

When the engine is running, high-pressure is generated in the engine fuel piping. When carrying out inspection or maintenance of the fuel piping system, stop the engine and wait for at least 30 seconds to allow the internal pressure to go down before starting the operation.

HANDLING HIGH-PRESSURE HOSES AND PIPING

- If oil or fuel leaks from high-pressure hoses or piping, it may cause fire or misoperation, and lead to serious personal injury, or death. If the hose or piping mounts are loose or oil or fuel is found to be leaking from the mount, stop operations and tighten to the specified torque.

If any damaged or deformed hoses or piping are found, please consult your Komatsu distributor.

Replace the hose if any of the following problems are found.

- Damaged hose or deformed hydraulic fitting.
- Frayed or cut covering or exposed reinforcement wire layer.
- Covering swollen in places.
- Twisted or crushed movable portion.
- Foreign material embedded in covering.

NOISE

When carrying out maintenance of the engine and you are exposed to noise for long periods of time, wear ear covers or ear plugs while working.

If the noise from the machine is too loud, it may cause temporary or permanent hearing problems.

PRECAUTIONS WITH HIGH-PRESSURE GREASE WHEN ADJUSTING TRACK TENSION

- Grease is pumped into the track tension adjustment system under high pressure. If the specified procedure for maintenance is not followed when making adjustment, grease drain valve (1) may fly out and cause serious injury or damage.
- When loosening grease drain valve (1) to loosen track tension, never loosen it more than one turn. In doing so, loosen the valve slowly.
- Never put your face, hands, feet, or any other part of your body directly in front of grease drain valve (1).

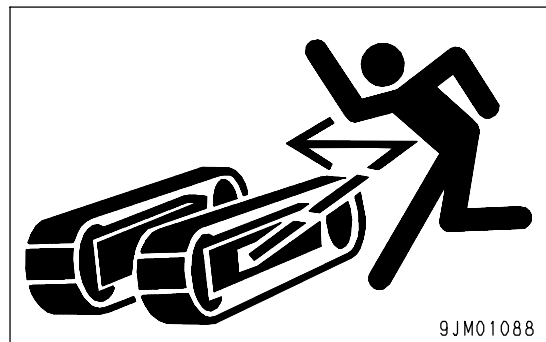
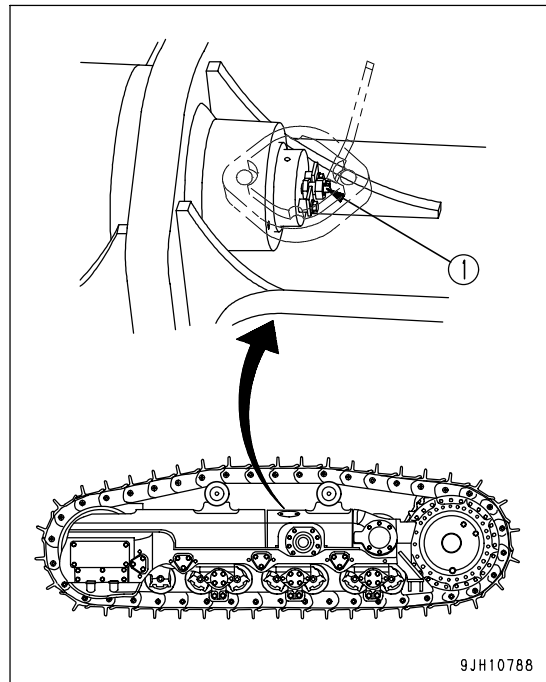

DO NOT DISASSEMBLE RECOIL SPRING

Never disassemble the recoil spring assembly. The recoil spring assembly has a powerful spring that acts to reduce the impact on the idler. If it is disassembled by mistake, the spring may shoot out and cause serious personal injury or death.

It is necessary to disassemble the recoil spring assembly, always ask your Komatsu distributor to carry out the operation.

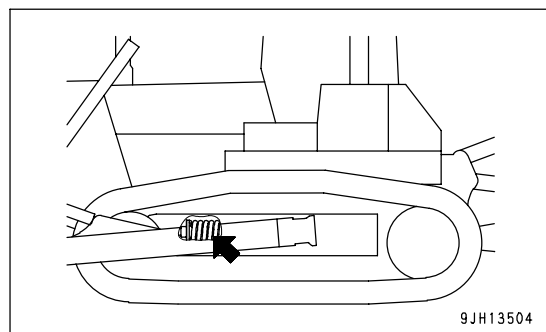

HANDLING ACCUMULATOR AND GAS SPRING

This machine is equipped with an accumulator. Even after the engine stops, if the work equipment control lever is operated soon after stop of the engine in the direction to lower the work equipment, the work equipment goes down under its own weight.

After stopping the engine, set the parking brake lever and the work equipment lock lever to the LOCK position.

The accumulator and gas spring are charged with high-pressure nitrogen gas. If the accumulator is handled mistakenly, it may cause an explosion that could lead to serious personal injury or death. For this reason, always observe the following precautions.

- Do not disassemble the accumulator.
- Do not bring it near flame or dispose of it in fire.
- Do not make holes in it, weld it, or use a cutting torch.
- Do not hit or roll the accumulator, or subject it to any impact.
- When disposing of the accumulator, the gas must be released. Please contact your Komatsu distributor to have this work performed.



PRECAUTIONS WITH COMPRESSED AIR

- When carrying out cleaning with compressed air, there is a hazard of serious personal injury caused by flying dust or particles.
- When using compressed air to clean the filter element or radiator, wear safety glasses, anti-dust mask, gloves, and other protective equipment.

MAINTENANCE OF AIR CONDITIONER

- If air conditioner refrigerant gets into your eyes, it may cause loss of sight; if it contacts your skin, it may cause frostbite. Never loosen any parts of the cooling circuit.

DISPOSING OF WASTE MATERIALS

To prevent pollution, pay careful attention to the method of disposing of waste materials.

- Always put oil drained from your machine in containers. Never drain oil directly onto the ground or dump into the sewage system, rivers, the sea, or lakes.
- Obey appropriate laws and regulations when disposing of harmful objects such as oil, fuel, coolant, solvent, filters, and batteries.

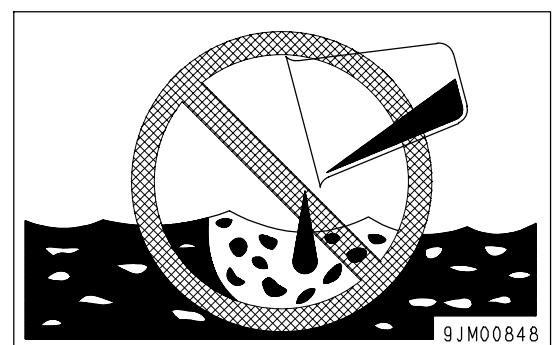

METHOD OF SELECTING WINDOW WASHER FLUID

Use an ethyl alcohol base washer liquid.

Methyl alcohol base washer liquid may irritate your eyes, so do not use it.

PERIODIC REPLACEMENT OF SAFETY CRITICAL PARTS

- To enable this machine to be used safely for a long period, always carry out periodic replacement of safety critical parts that have a particularly close relation to safety, such as hoses and the seatbelt.
For details of the replacement of safety critical parts, see "PERIODIC REPLACEMENT OF SAFETY CRITICAL PARTS (PAGE 4-15)".
- The material of these components naturally changes over time, and repeated use causes deterioration, wear, and fatigue. As a result, there is a hazard that these components may fail and cause serious personal injury or death. It is difficult to judge the remaining life of these components from external inspection or the feeling when operating, so always replace them at the specified interval.
- Replace or repair safety-critical parts if any defect is found, even when they have not reached the specified replacement time.

OPERATION

WARNING

Please read and make sure that you understand the SAFETY section before reading this section.

GENERAL VIEW

GENERAL VIEW OF MACHINE

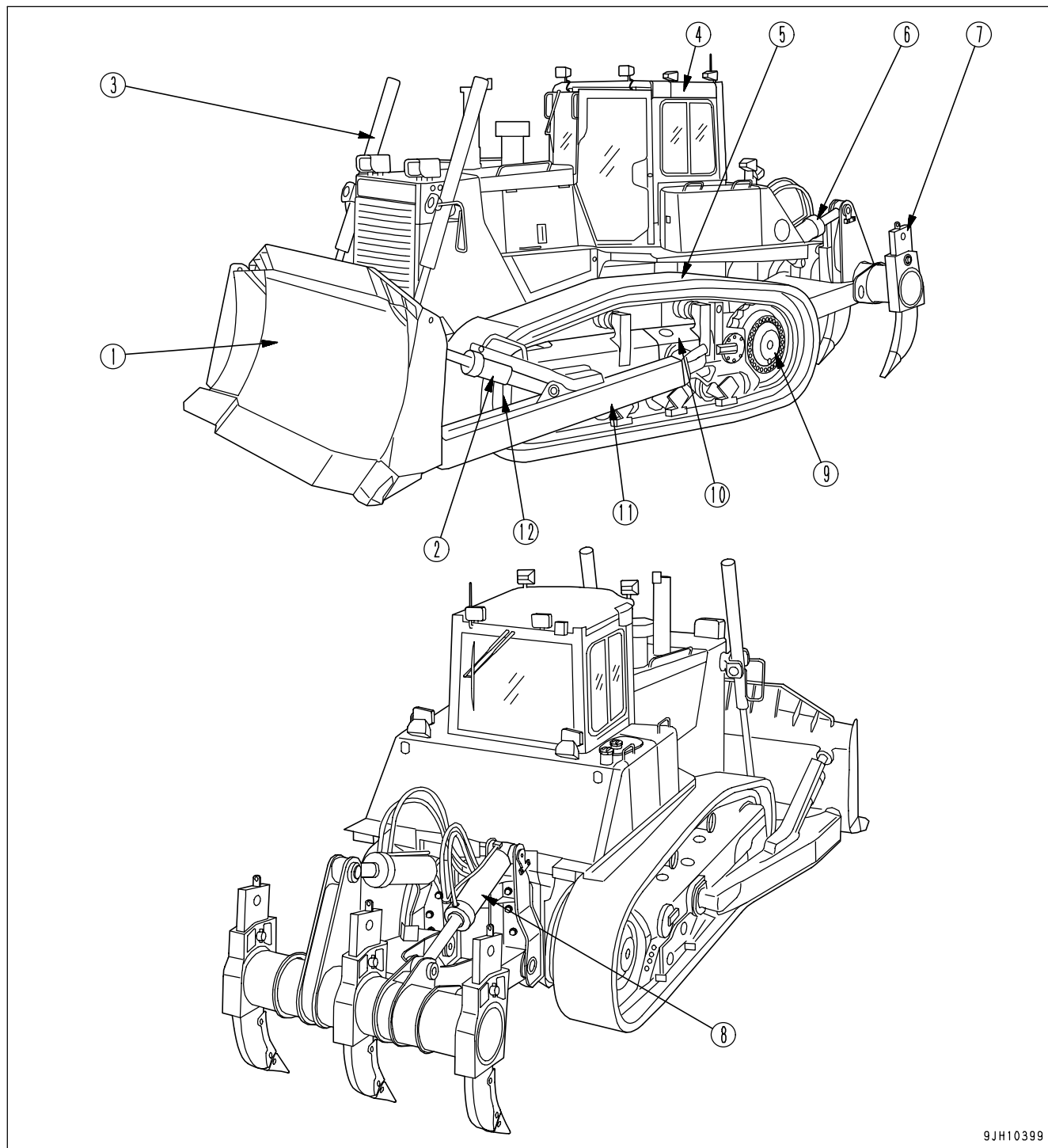

9JH10399

- | | |
|--------------------------|--------------------------|
| (1) Blade | (7) Multi ripper |
| (2) Blade tilt cylinder | (8) Ripper lift cylinder |
| (3) Blade lift cylinder | (9) Sprocket |
| (4) Cab | (10) Track frame |
| (5) Track shoe | (11) Frame |
| (6) Ripper tilt cylinder | (12) Idler |

GENERAL VIEW OF CONTROLS AND GAUGES

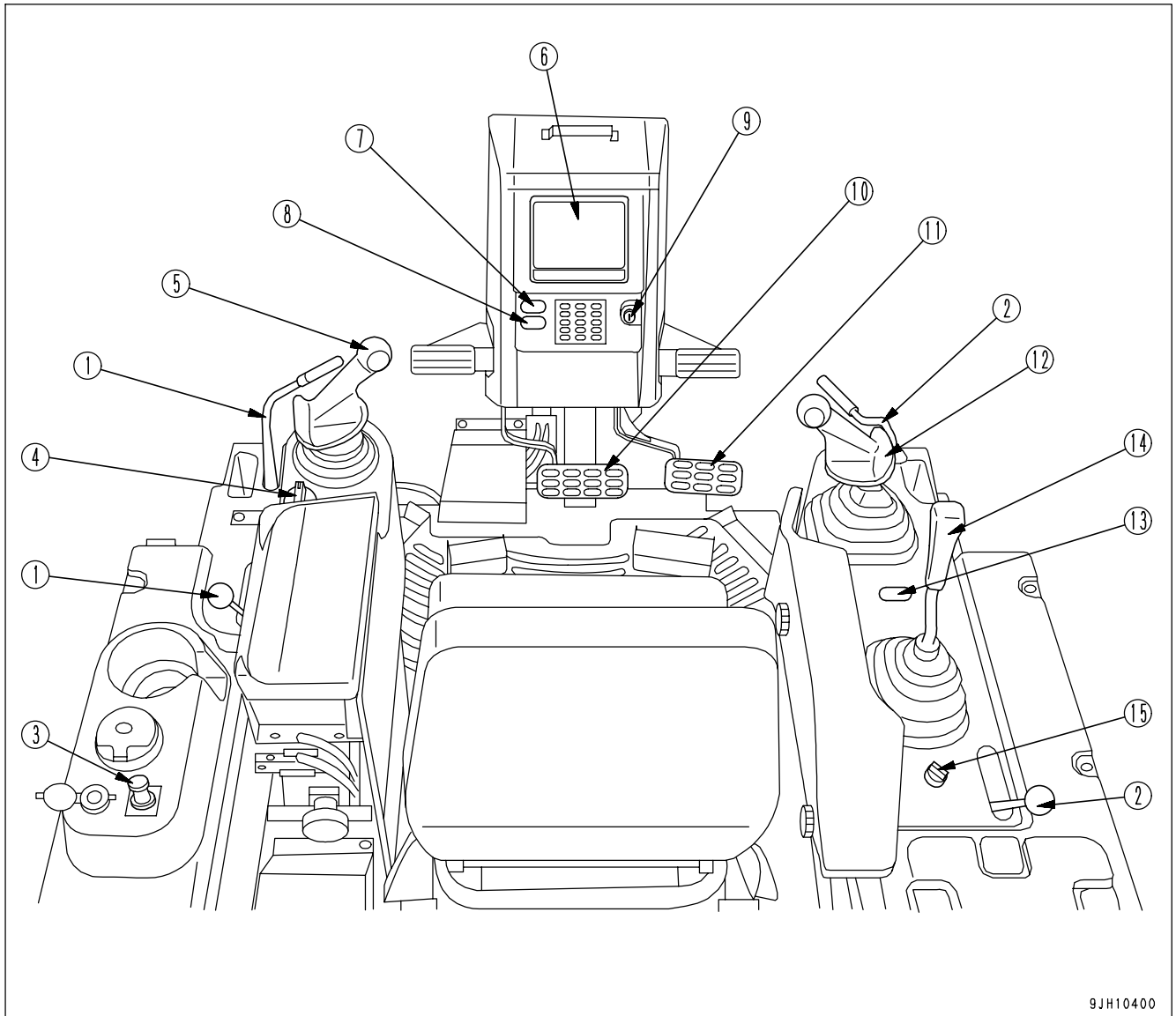

9JH10400

- | | |
|---|--|
| (1) Parking brake lever | (9) Starting switch |
| (2) Work equipment lock lever | (10) Brake pedal |
| (3) Cigarette lighter | (11) Deceleration pedal |
| (4) Fuel control dial | (12) Blade control lever |
| (5) Joystick (steering, directional and gear shift lever) | (13) Horn switch |
| (6) Multi monitor | (14) Ripper control lever |
| (7) Front lamp switch | (15) Pin puller control switch (if equipped) |
| (8) Rear lamp switch | |

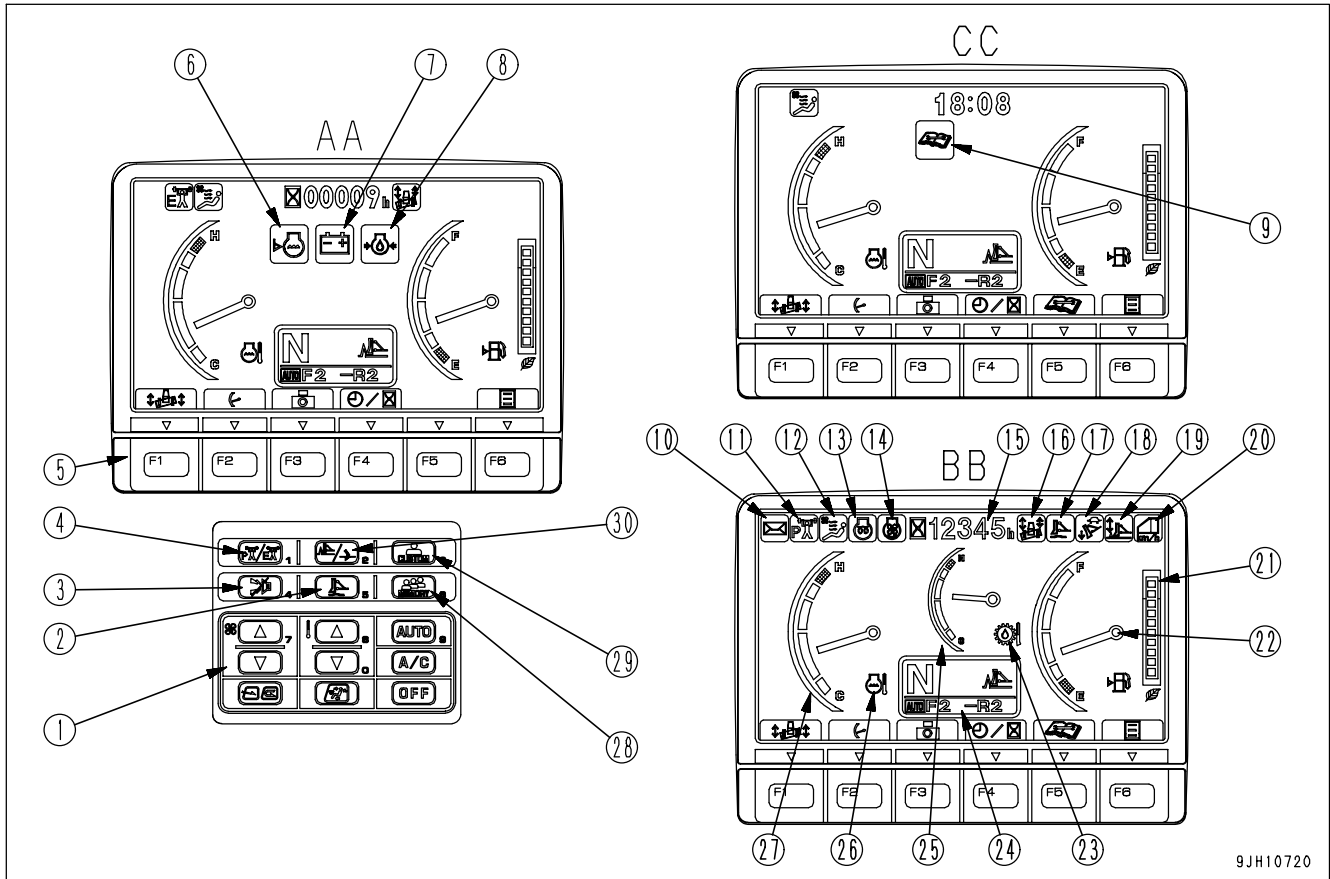

9JH10720

AA: Screen with all lamps lighted up
 BB: Screen for standard
 CC: Maintenance time warning screen

- | | |
|------------------------------------|---|
| (1) Air conditioner switch | (16) Dual tilt mode monitor |
| (2) Float mode switch | (17) Float mode monitor |
| (3) Buzzer cancel switch | (18) Blade slow down monitor |
| (4) Operating mode selector switch | (19) Blade fine control mode monitor |
| (5) Function switch | (20) Reverse slow mode monitor |
| (6) Radiator coolant level monitor | (21) ECO indicator |
| (7) Charge level monitor | (22) Fuel gauge |
| (8) Engine oil pressure monitor | (23) Power train oil temperature, hydraulic oil temperature monitor |
| (9) Maintenance interval monitor | (24) Speed range display |
| (10) Message monitor | (25) Multi-gauge |
| (11) Operation mode monitor | (26) Engine coolant temperature monitor |
| (12) Air conditioner monitor | (27) Engine coolant temperature gauge |
| (13) Engine pre-heating monitor | (28) Customize memory switch |
| (14) Fan reverse monitor | (29) Customize switch |
| (15) Service meter, clock | (30) Gear shift mode selector switch |

EXPLANATION OF COMPONENTS

The following is an explanation of devices needed for operating the machine.

To perform suitable operations correctly and safely, it is important to completely understand methods of operating the equipment, and the meanings of the displays.

MACHINE MONITOR

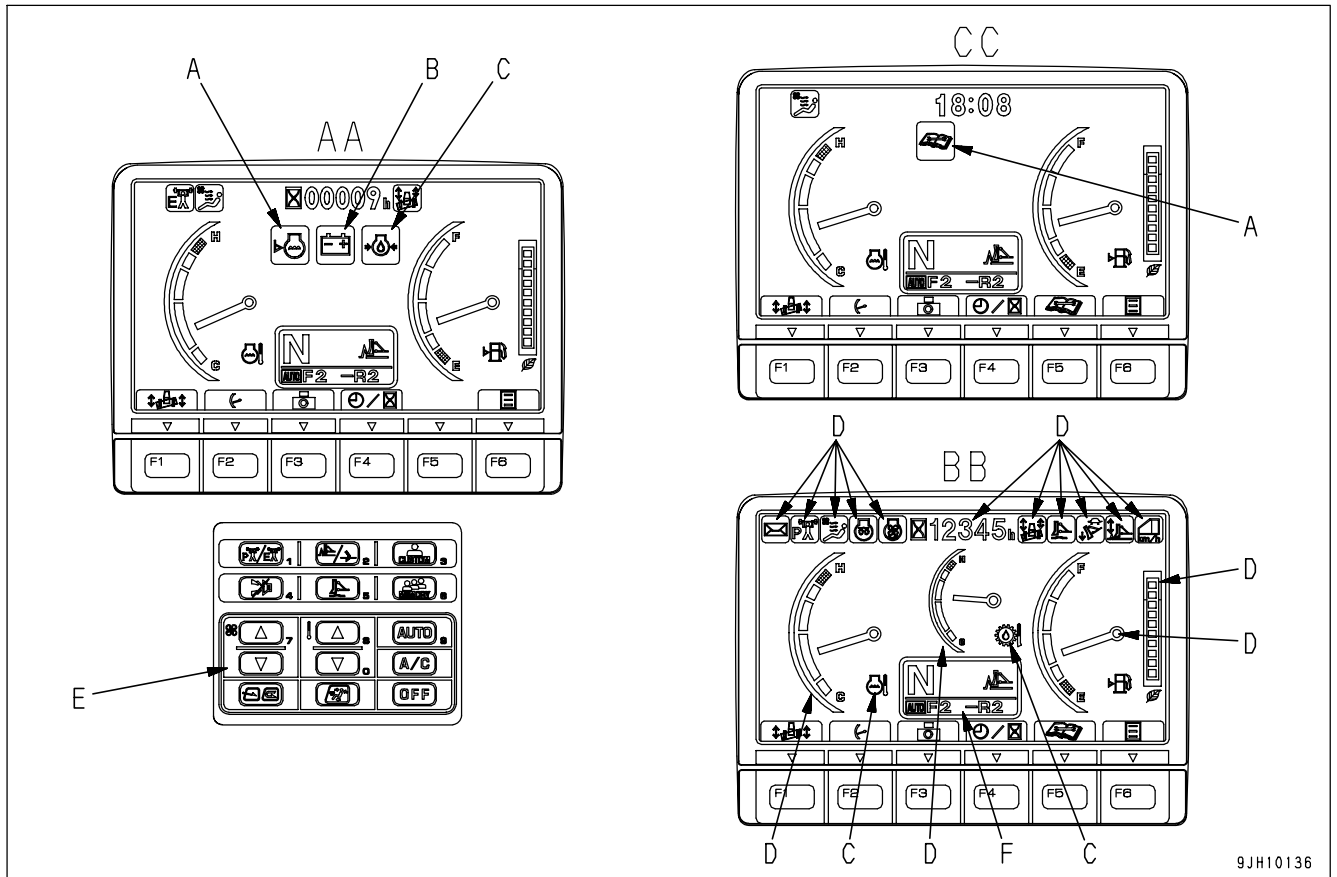

9JH10136

AA: Check before starting screen

BB: Screen for normal

CC: Maintenance time warning screen

A: Emergency monitors

B: Caution monitors

C: Basic check monitors

D: Meter display portion

E: Monitor switches

F: Speed range display

REMARK

One of the features of liquid crystal display panels is that there may be black spots (spots that do not light up) or white spots (spots that stay lighted up) on the screen. If there are fewer than 10 black or white spots, this is not a failure or a defect.

BASIC OPERATION OF MACHINE MONITOR

STARTING ENGINE WHEN SITUATION IS NORMAL

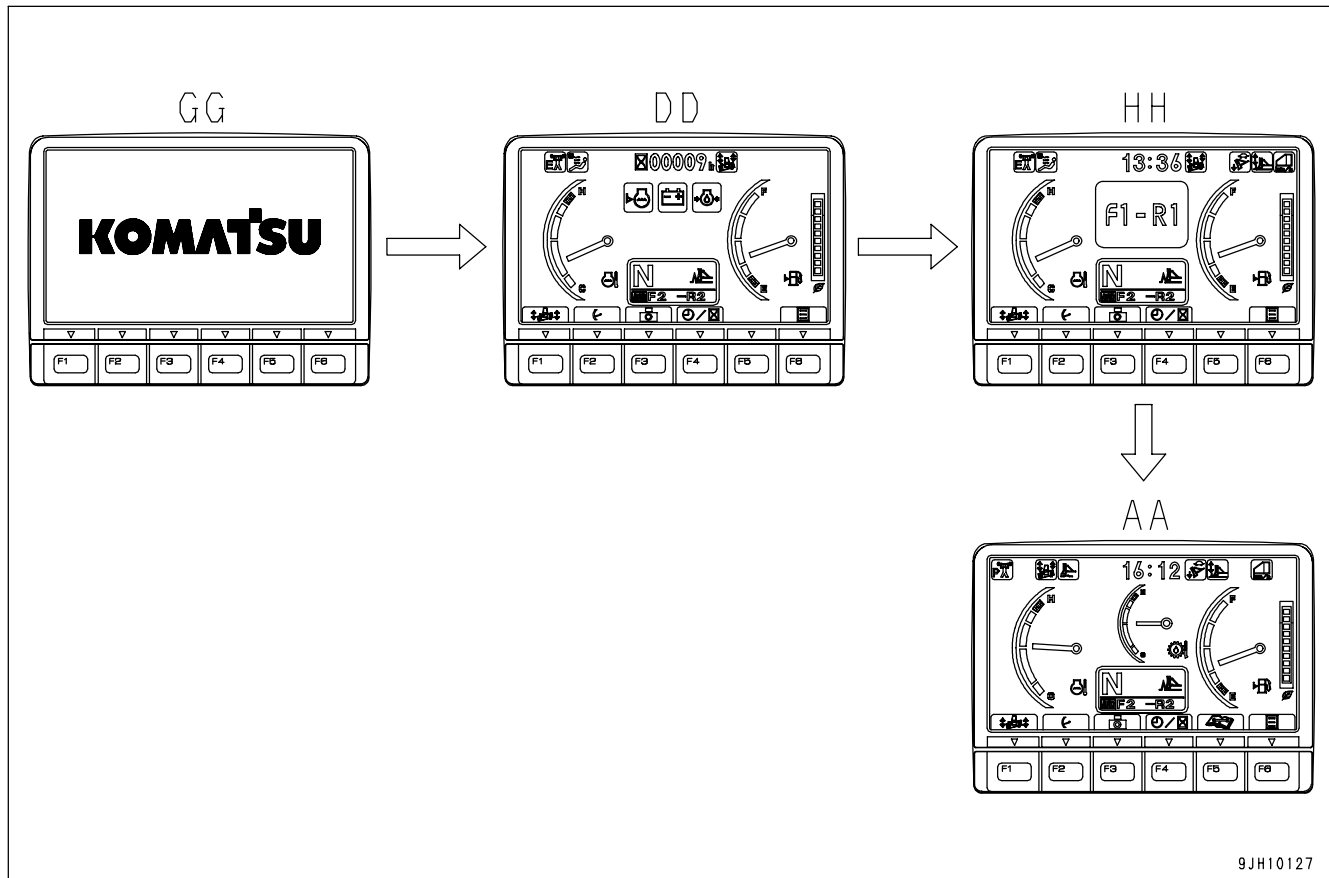

- When the starting switch is turned to the ON position, the opening screen GG is displayed.
- After the opening screen GG is displayed for 2 seconds, the screen switches to the check before starting screen DD.
- After the check before starting screen DD is displayed for 2 seconds, the screen switches to the mode display screen.
- After the mode display screen HH is displayed for 2 seconds, the screen switches to standard display screen AA.

REMARK

When the engine is started, the battery voltage may suddenly drop depending on the temperature and the battery condition. If this happens, the display on the machine monitor may momentarily go out, but this does not indicate any abnormality.

STOPPING ENGINE WHEN SITUATION IS NORMAL

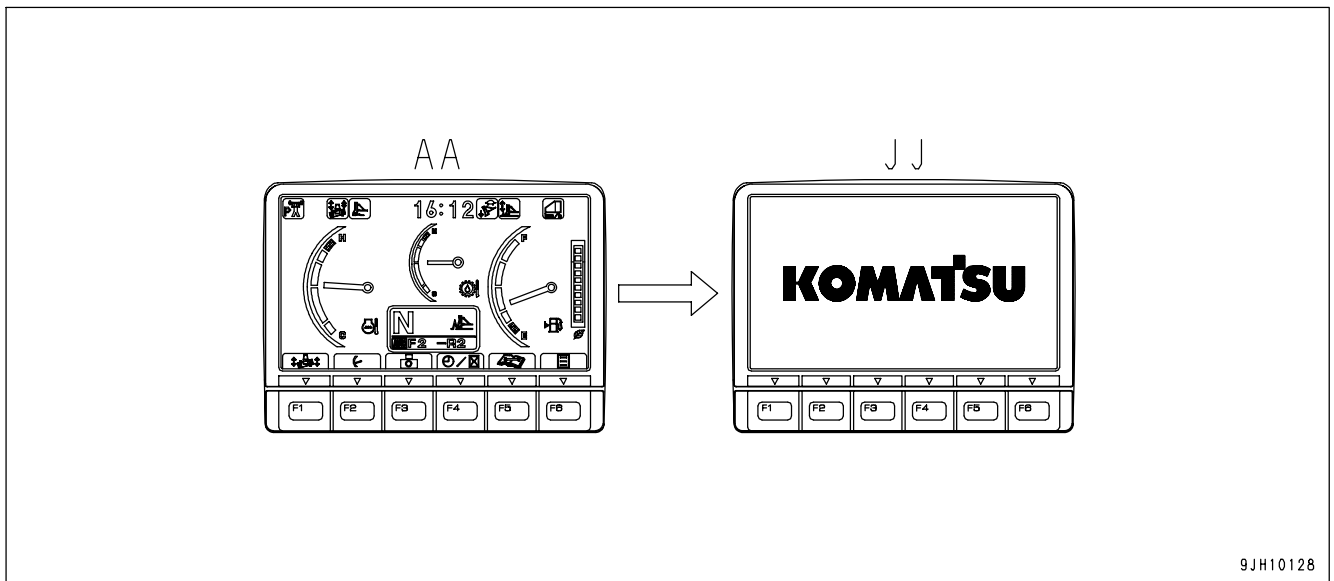

- When the starting switch is turned to the OFF position, ending screen JJ is displayed for 5 seconds, then the display goes out.

IF THERE IS ABNORMALITY WHEN STARTING ENGINE

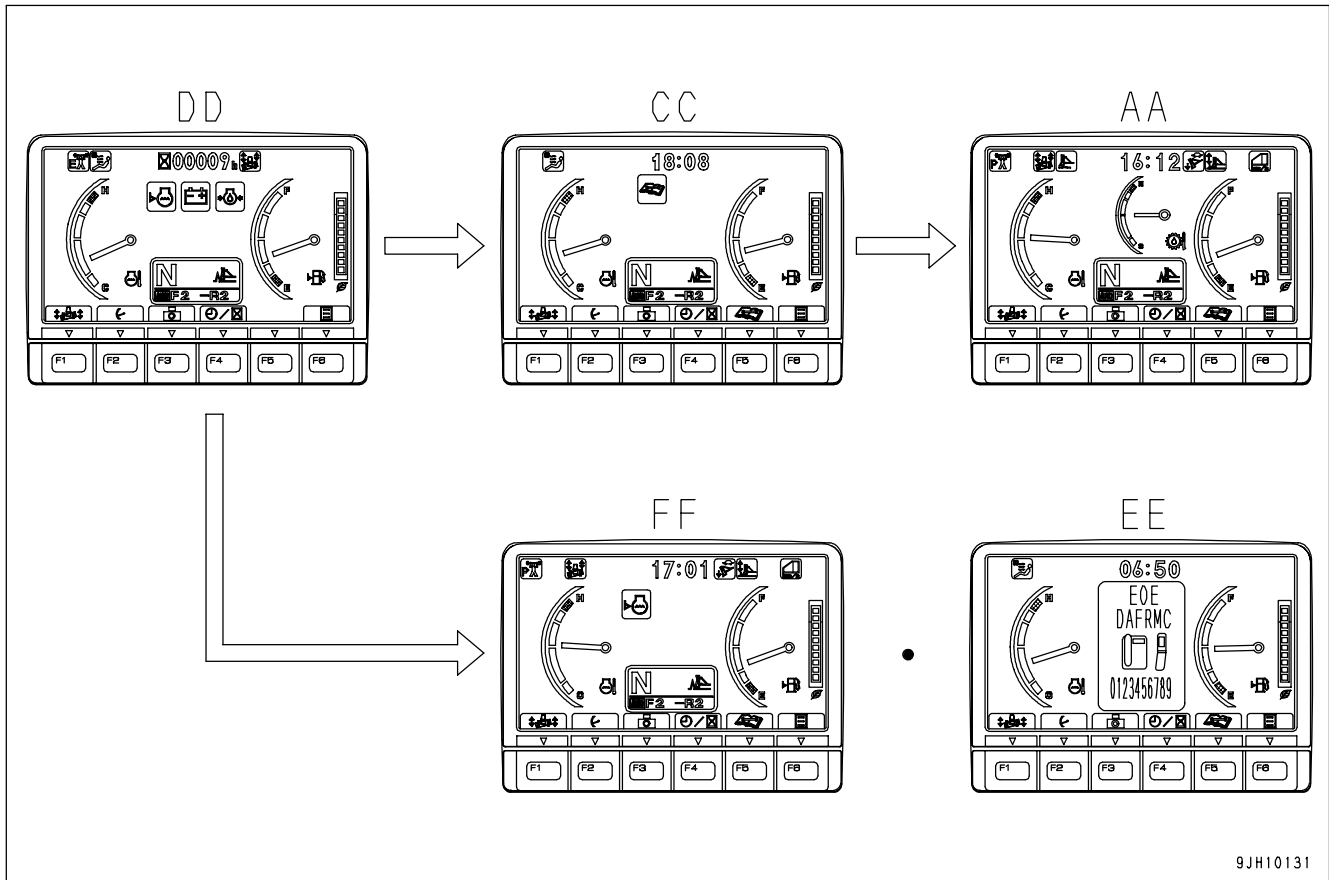

9JH10131

- If there is any abnormality when starting the engine, the check before starting screen DD changes to the maintenance interval warning screen CC, warning screen FF, or error screen EE.
- After displaying the check before starting screen DD for 2 seconds, the screen changes to the maintenance interval warning screen CC.
- After displaying the maintenance interval warning screen CC for 30 seconds, the screen returns to the standard screen BB.
- After displaying the check before starting screen DD for 2 seconds, the screen changes to the warning screen FF or error screen EE.

IF ANY ABNORMALITY OCCURS DURING OPERATION

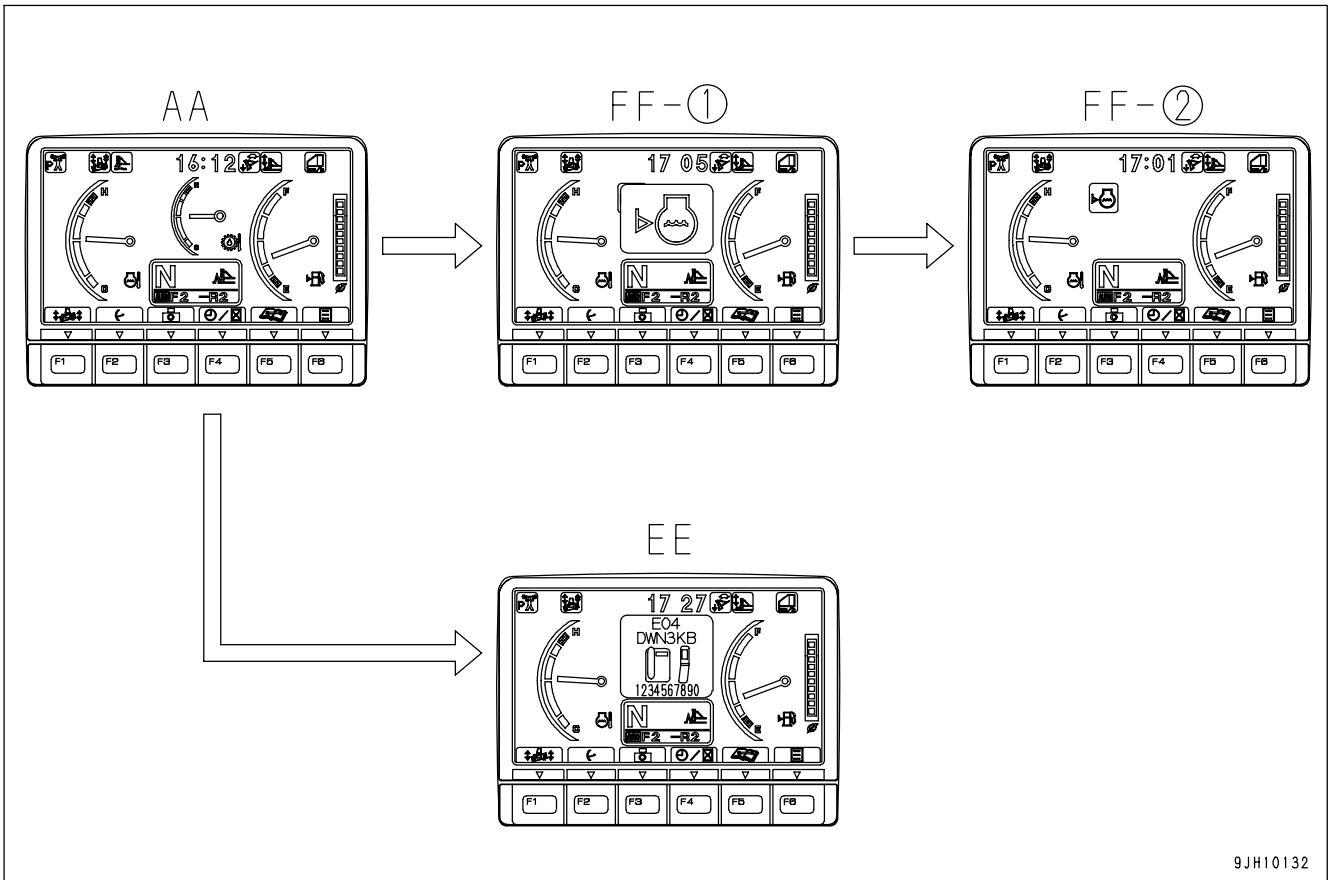

- If any abnormality occurs during operation, the standard screen BB changes to warning screen FF-(1) or the error screen EE.
- After displaying warning screen FF-(1) for 2 seconds, the screen automatically changes to warning screen FF-(2).

EMERGENCY MONITORS

CAUTION

If the monitor lights up red, stop the engine immediately or run at low idle, check applicable location, then perform necessary actions.

These items should be observed while the engine is running. If there is a problem, the monitor for the abnormal location lights up red and buzzer sounds, perform action immediately.

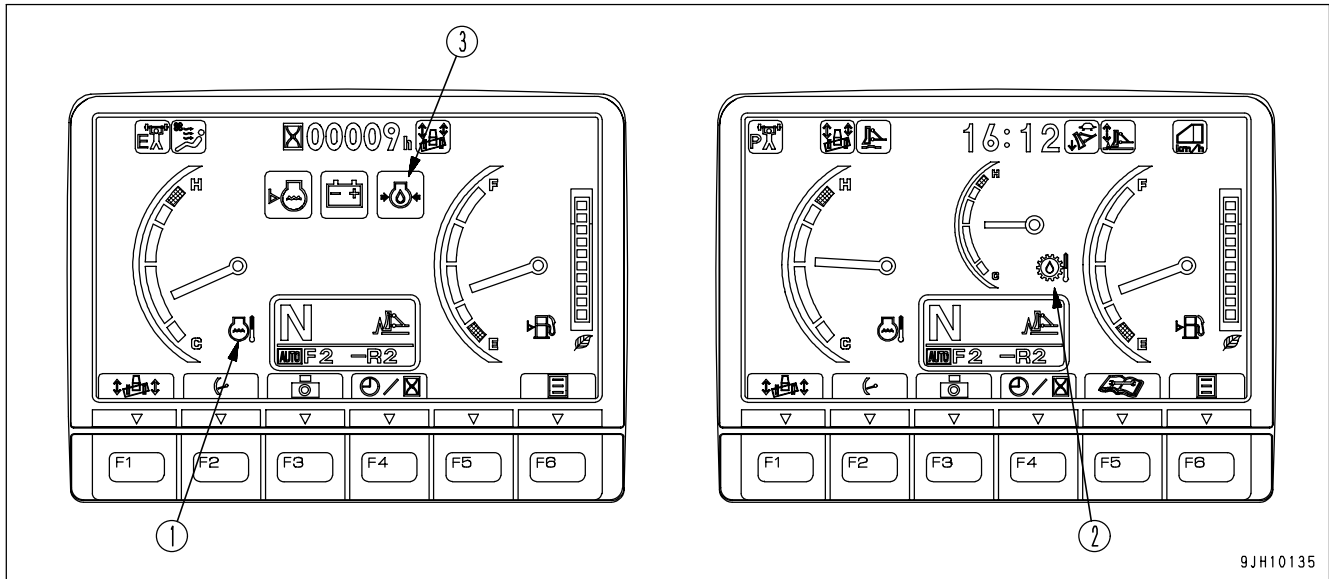

- (1) Engine coolant temperature monitor
- (2) Power train oil temperature monitor
- (3) Engine oil pressure monitor

ENGINE COOLANT TEMPERATURE MONITOR

Monitor (1) warns operator that the engine coolant temperature has risen.

If the engine coolant temperature becomes abnormally high, the monitor shows abnormal display. The overheat prevention system is automatically actuated and the engine speed drops.

Stop operations and run the engine at low idling until monitor (1) shows normal display.

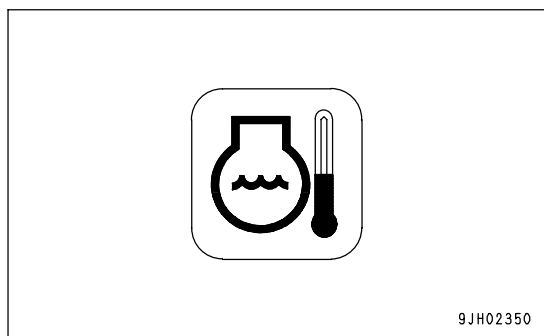

POWER TRAIN OIL TEMPERATURE MONITOR, HYDRAULIC OIL TEMPERATURE MONITOR

This monitor (2) warns of an abnormal rise of power train oil temperature and hydraulic oil temperature. When the temperature becomes abnormally high, an abnormality symbol is displayed. When the symbol appears, stop the work and idle the engine until the monitor returns to the normal symbol, or simply stop the engine.

With this monitor (2), the display can be switched as desired. For details of the method of operation for switching the display, see "MULTI-GAUGE (PAGE 3-36)".
(The display can also be switched by pressing the "F2" key.)

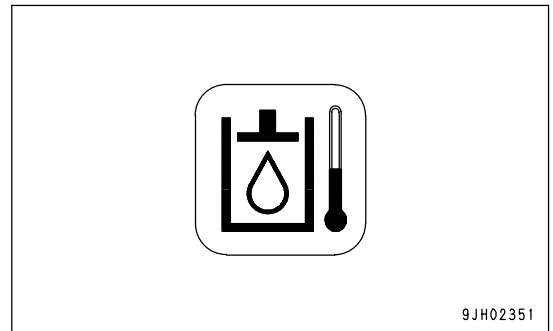
**ENGINE OIL PRESSURE MONITOR**

Monitor (3) lights up red if the engine lubrication oil pressure goes below normal level. If monitor lights up red, stop the engine immediately, check the lubrication system and level of oil in the engine oil pan.

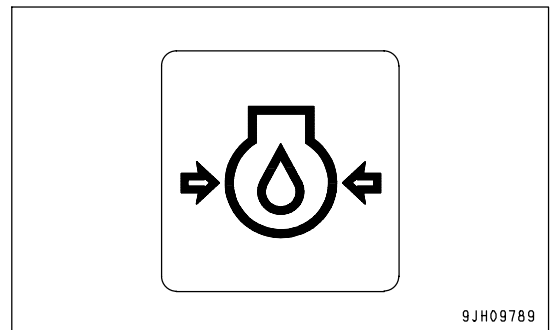

CAUTION MONITORS



If the warning monitor lights up red, stop operations as soon as possible and perform inspection and maintenance of the applicable location. If the warning is ignored, it may lead to failure.

NOTICE

Stop the machine on level ground and check the monitor.

These are items that should be observed while the engine is running. If any abnormality occurs, the screen displays the item that needs immediate action.

If there is an abnormality, the monitor for the abnormal location lights up red.

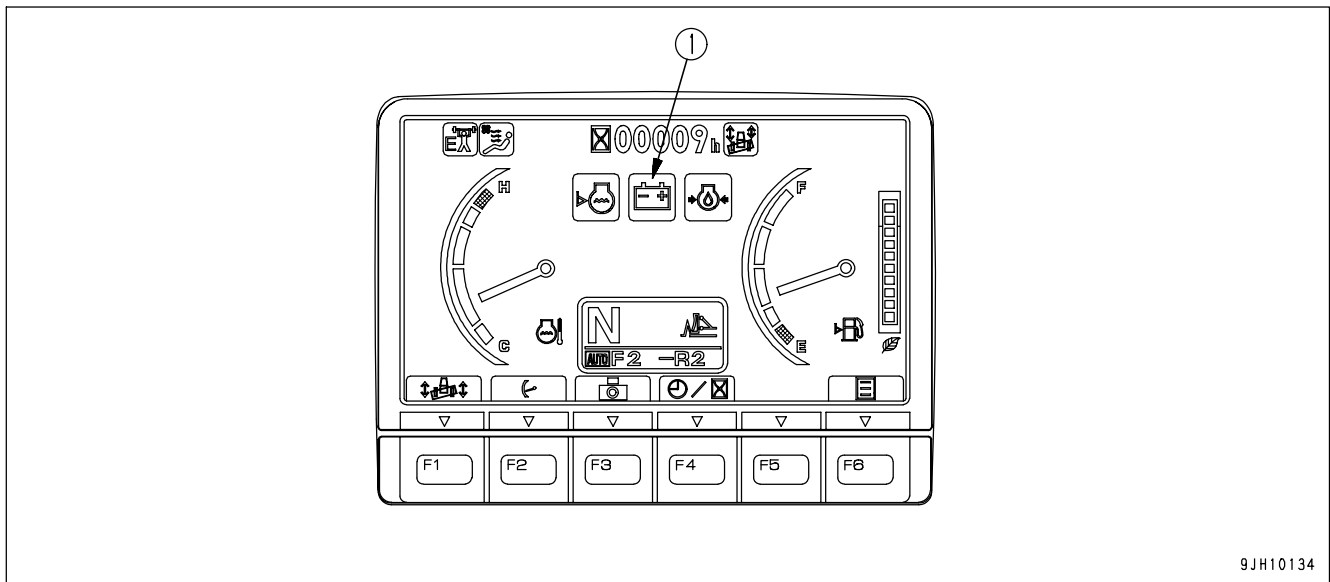

(1) Charge level monitor

CHARGE LEVEL MONITOR

Monitor (1) warns the operator of an abnormality in the charging system while the engine is running.

If the battery is not being charged properly while the engine is running, monitor (1) lights up red.

If the monitor lights up red, check for looseness of the V-belt. If any problem is found, see "OTHER TROUBLE (PAGE 3-191)".

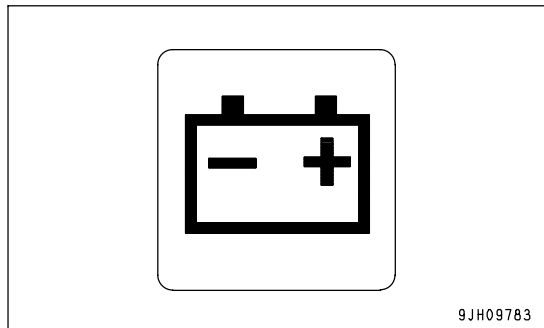

REMARK

- When the starting switch is turned to the ON position, this lamp lights up, and it goes out after the engine starts.

BASIC CHECK MONITORS

! CAUTION

These monitors do not guarantee the condition of the machine.

Do not simply rely on the monitor when carrying out checks before starting (daily inspection). Always get off the machine and check each item directly.

Displays basic items among the check before starting items that must be checked before starting the engine. If there is any abnormality, monitor for the location of abnormality will light up.

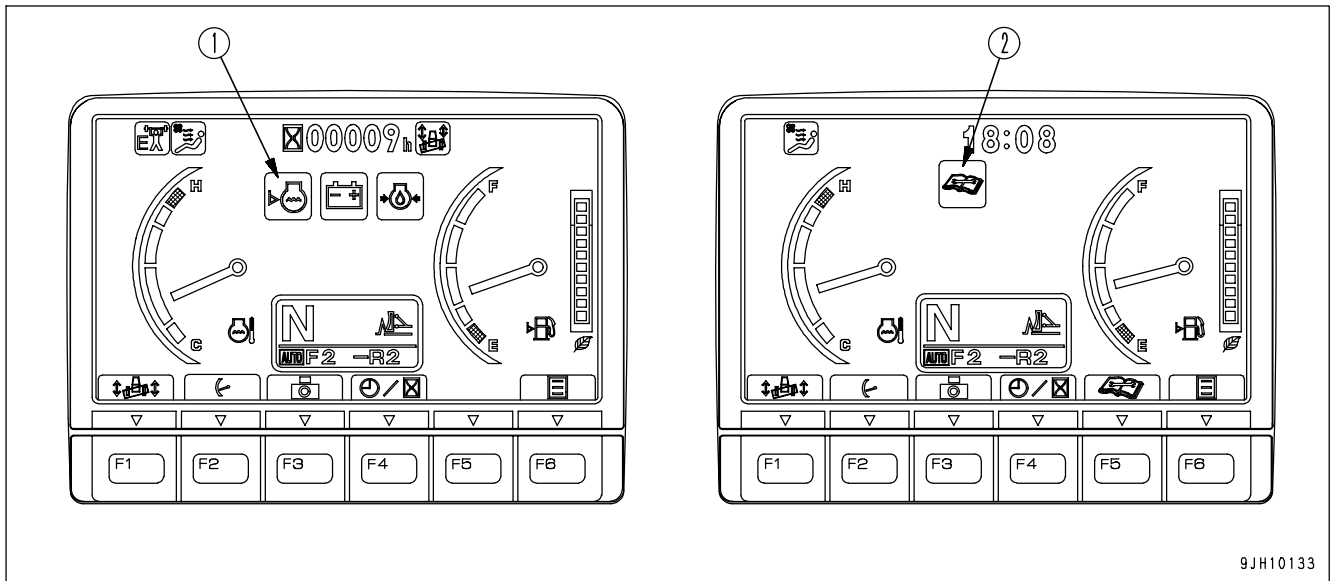

(1) Radiator coolant level monitor

(2) Maintenance interval monitor

RADIATOR COOLANT LEVEL MONITOR

Monitor (1) warns the operator that there has been a drop in the radiator coolant level.

If the radiator coolant is low, the lamp lights up red, so check coolant level in the radiator and subtank, and add coolant.

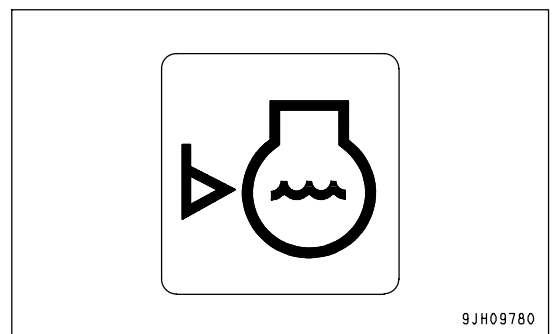

9JH09780

MAINTENANCE INTERVAL MONITOR

This monitor (2) lights up yellow 30 hours before the next periodic maintenance after the previous periodic maintenance work was carried out, and turns red to warn the operator that the set time has passed.

This monitor screen goes out after 30 seconds and the screen returns to the standard working screen.

- For details of the method of checking the maintenance interval, see "MAINTENANCE MODE SELECTOR SWITCH (PAGE 3-29)".

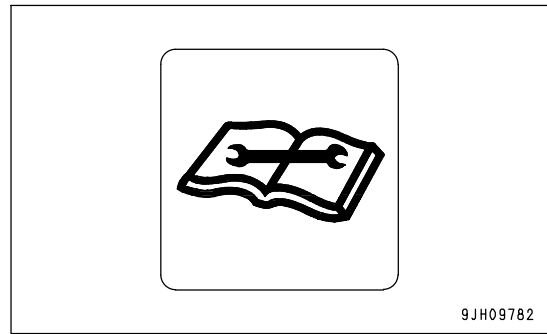

If it is desired to change settings for the maintenance interval, have your Komatsu distributor change the settings.

METER DISPLAY PORTION

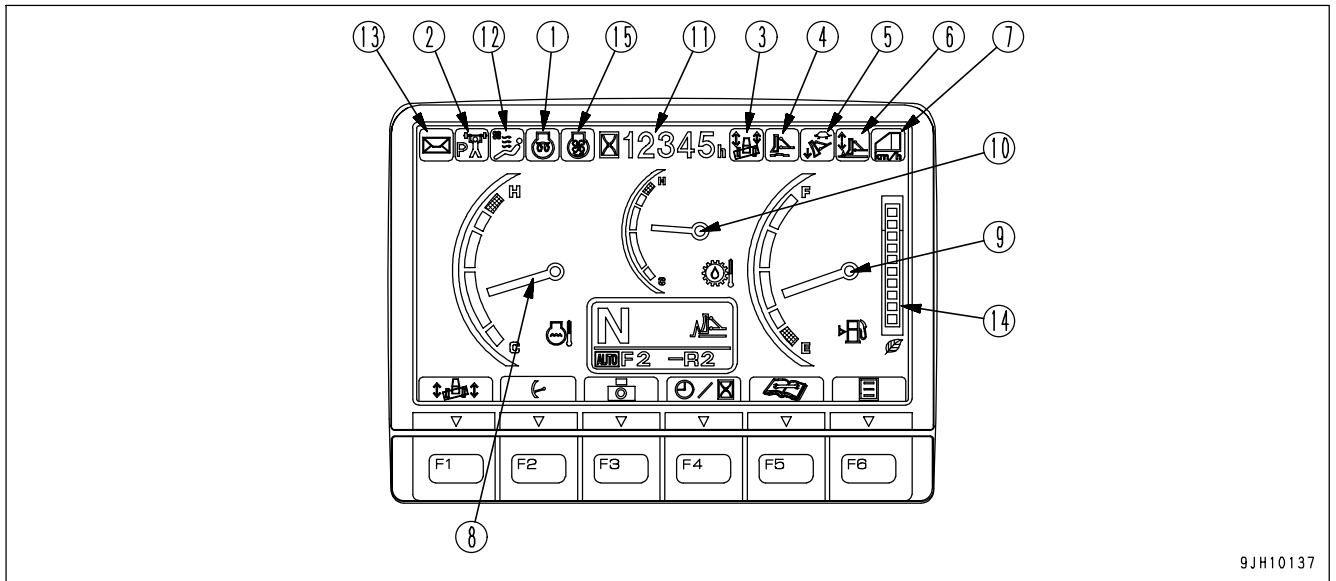

- | | |
|--|--|
| (1) Engine pre-heating monitor | (9) Fuel gauge |
| (2) Operation mode monitor | (10) Multi-gauge |
| (3) Dual tilt mode monitor (if equipped) | (11) Service meter, clock |
| (4) Float mode monitor | (12) Air conditioner monitor |
| (5) Blade slow down monitor | (13) Message monitor (only machines equipped with KOMTRAX) |
| (6) Blade fine control mode monitor | (14) ECO indicator |
| (7) Reverse slow mode monitor | (15) Fan reverse monitor |
| (8) Engine coolant temperature gauge | |

PILOT DISPLAY

- The pilot display at the top of the screen consists of the pilot lamps to confirm the actuation of each function.
- When the starting switch is turned ON, the pilot lamp lights up when the display items are functioning.

ENGINE PRE-HEATING MONITOR

This monitor (1) displays the preheating time needed when starting the engine in temperatures below 0°C (32°F).

When the temperature is low (in cold areas) and the preheating function is automatically actuated, the preheating monitor lights up.

When the preheating is completed, it goes out.

Automatic preheating is for a maximum of approx. 30 seconds.

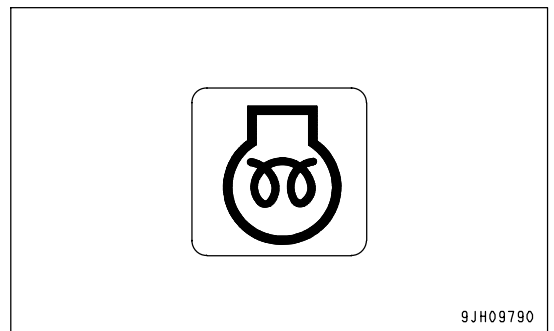

9JH09790

OPERATION MODE MONITOR

This monitor (2) displays the operation mode.

(P): Lights up when mode is set to power mode

(E): Lights up when mode is set to economy mode

The mode switches every time the operation mode selector switch is pressed.

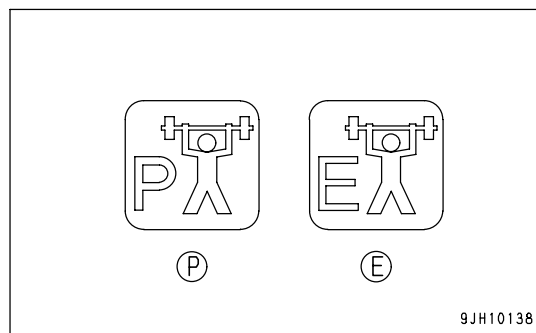
**DUAL TILT MODE MONITOR**

(Only machines equipped with dual tilt)

This monitor (3) lights up when the dual tilt mode is selected.

When this mode is not selected, the system is set to single tilt.

Use the F1 key to select the mode.

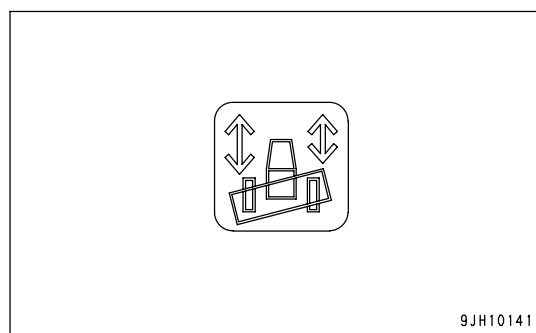
**FLOAT MODE MONITOR**

This monitor (4) lights up when the FLOAT mode is selected.

Each time the FLOAT mode switch is pressed, the FLOAT mode is switched.

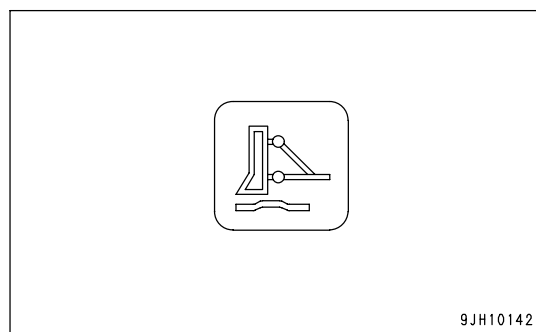

Method of selecting FLOAT mode: 1. Press the FLOAT mode switch to select the FLOAT mode.

2. Keep the button at the top of the work equipment pressed and operate the lever fully to the LOWER position.

Method of canceling FLOAT mode: Press the FLOAT mode switch to cancel the FLOAT mode or operate the blade lever to the RAISE position. Or, move the lever from the NEUTRAL to LOWER position, releasing the button on top of the work equipment knob.

BLADE SLOW DOWN MONITOR

When this monitor (5) is lighted up, the work equipment moves down at a speed proportional to the amount of the lever is operated. When the monitor is out, the lowering speed becomes faster after the lever is operated beyond a certain point.

This mode is selected in the customize mode.

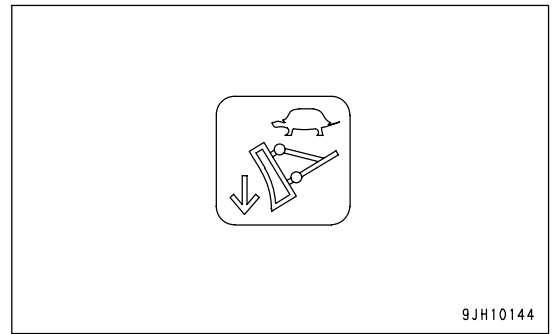
**BLADE FINE CONTROL MODE MONITOR**

When this monitor (6) is lighted up, the movement of the work equipment at the start of the RAISE and LOWER operation is slower.

This mode is selected in the customize mode.

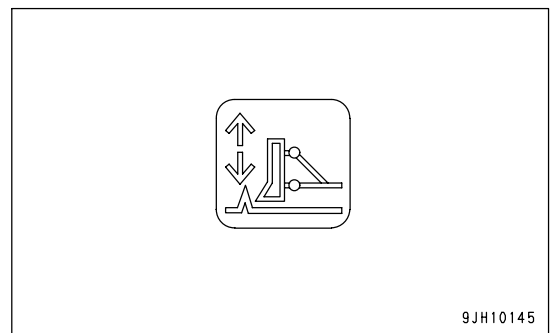
**REVERSE SLOW MODE MONITOR**

When this monitor (7) is lighted up, it is possible to throttle down the engine speed and make the reverse speed slower when traveling in reverse.

This mode is selected in the customize mode.

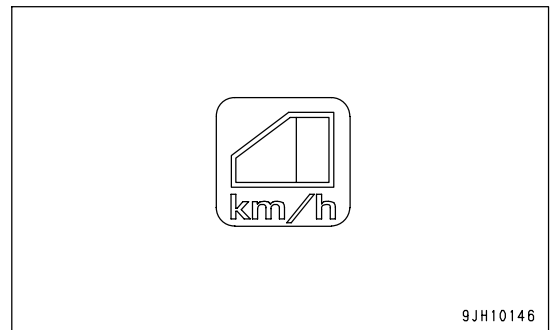

GAUGES AND METER

ENGINE COOLANT TEMPERATURE GAUGE

This meter (8) shows the engine coolant temperature. During normal operations, the indicator should be in the green range. If the indicator enters the red range during operations, the overheat prevention system is actuated.

- (A) - (B): Red range
- (A) - (C): Green range
- (C) - (D): White range

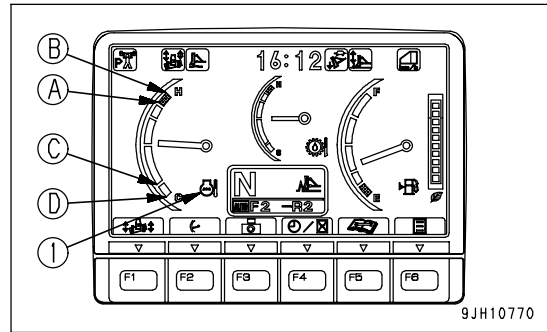

The overheat prevention system is actuated as follows.

Red range (A) position: Engine coolant temperature monitor (1) shows abnormality display

Red range (B) position: Engine speed changes to low idling, engine coolant temperature monitor (1) shows abnormality display, alarm buzzer sounds at same time

The overheat prevention system continues to work until the indicator enters the green range.

FUEL GAUGE

This monitor (9) shows the amount of fuel remaining in the fuel tank. The indicator should be in the green range during operations. If the indicator enters the red range (A) during operation, carry out inspection and add fuel.

- (A) - (B): Indicates red range
- (A) - (C): Indicates green range

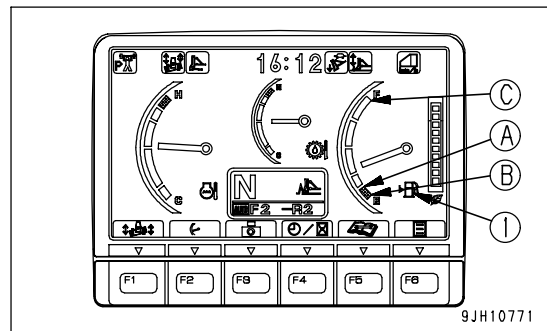

The correct fuel level may not be displayed for a short time when the starting switch is turned ON, but this is not an abnormality.

MULTI-GAUGE

This gauge (10) displays a variety of items, but the following explanation describes the actuation for the power train oil temperature gauge and hydraulic oil temperature gauge.

The indicator should be in the green range during operations.

If the indicator enters the red range (A) during operation, it means that the oil temperature is too high. If this happens, turn the fuel control dial down to approx. 3/4 of the maximum speed, reduce the load, and wait for the oil temperature to go down to the green range.

If the indicator enters the red range during operations and the alarm buzzer sounds, run the engine at low idling and wait for the oil temperature to go down.

- (A) - (B): Red range
- (A) - (C): Green range
- (C) - (D): White range

POWER TRAIN OIL TEMPERATURE GAUGE**NOTICE**

If the power train oil temperature gauge tends to enter red range (A), shift down one speed range to reduce the load on the power train during operations.

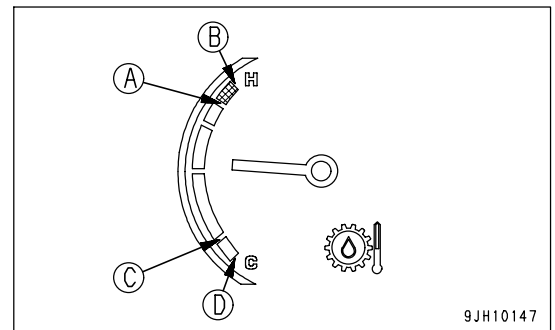
**HYDRAULIC OIL TEMPERATURE GAUGE****NOTICE**

When the indicator comes close to the red range during operation, the hydraulic oil temperature has exceeded 102° C. Then run the engine at low idling or stop it and wait for the oil temperature to go down.

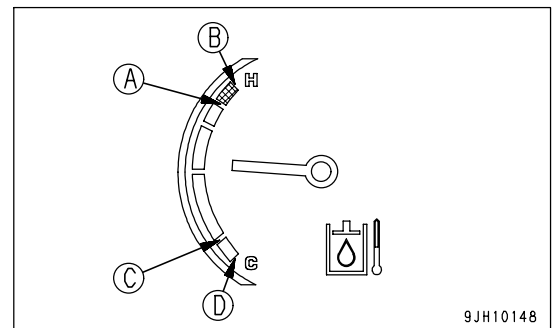

SERVICE METER, CLOCK

This meter (11) shows the total hours of operation of the machine or the present time.

When the engine is running, the service meter advances even if the machine is not moving. The service meter advances 1 for every hour that the machine is working, regardless of the engine speed.

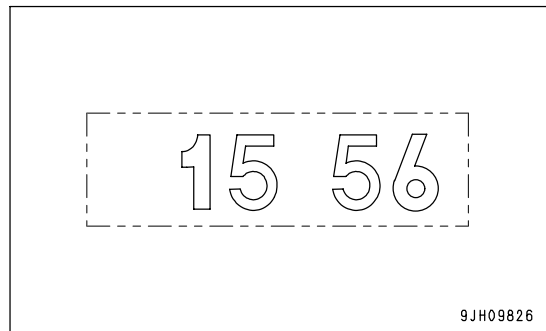
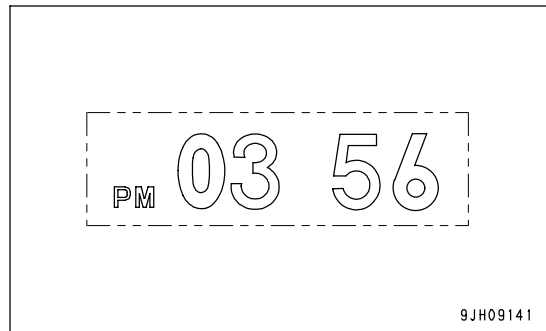
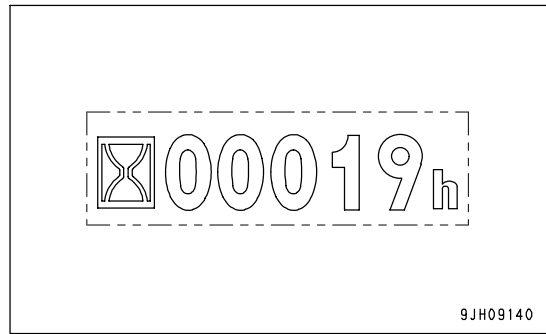

- When the standard screen is being displayed, if function switch F4 is pressed, it is possible to switch between the clock display and the service meter display.
- Clock display (12-hour or 24-hour displays are available)
To set or correct the time, press function switch F6 (user mode switch).

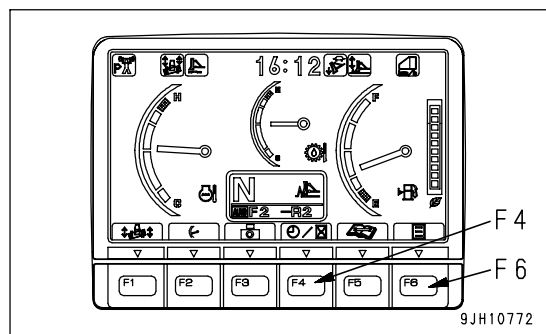

AIR CONDITIONER MONITOR

This monitor (12) displays the working status of the air conditioner.

Monitor lighted up: Air conditioner ON

Monitor off: Air conditioner OFF

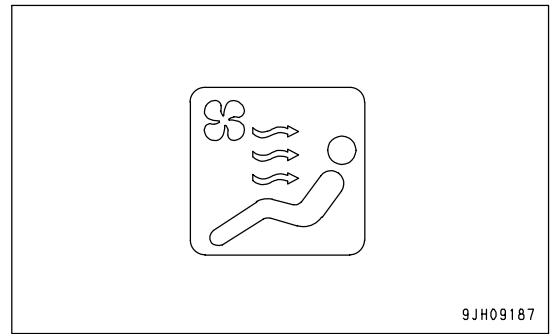

9JH09187

MESSAGE MONITOR (ONLY MACHINES EQUIPPED WITH KOMTRAX)

This monitor (13) lights up when there is a message from Komatsu.

Press function switch F6 on the user menu to display the message.

Lighted up green: There is unread message

Lighted up blue: There is message awaiting reply

OFF: There are no messages

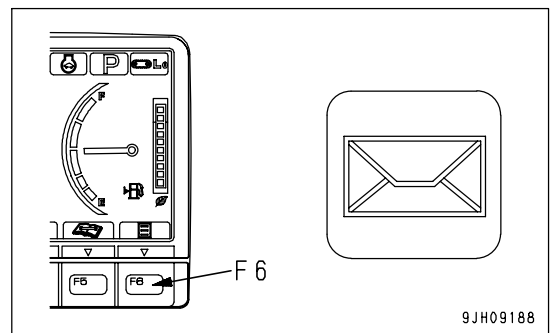

9JH09188

ECO INDICATOR

This gauge (14) shows the working load status.

When the gauge is in green range A, the work load is light to medium. When the gauge is in orange range B, the load is heavy.

- When the gauge enters the orange range, there is no abnormality on the machine, but to protect the environment, reduce the engine output to a point where there is no adverse effect on the operation. Generally, carry out energy-saving operations in the green range. Reducing the frequency of travel also helps to save energy. Consider the best way of saving energy.

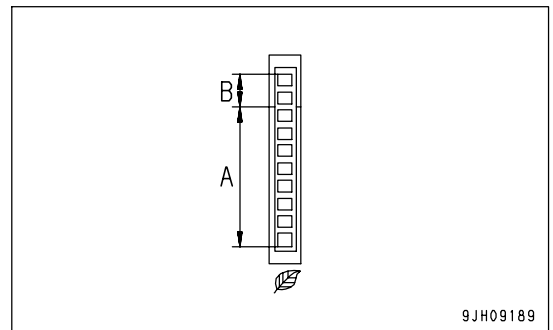

9JH09189

FAN REVERSE MONITOR

This monitor (15) shows that the fan is rotating in reverse.

For details of operating the fan in reverse, see "HYDRAULIC DRIVE FAN REVERSE MODE (PAGE 3-50)".

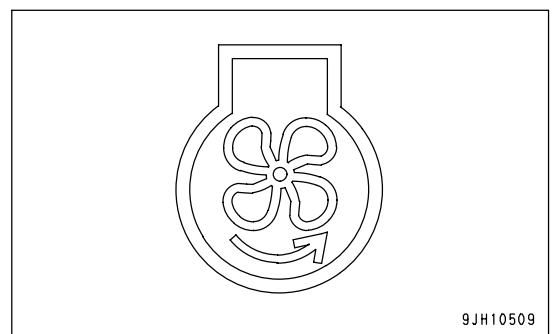

9JH10509

MONITOR SWITCHES PORTION

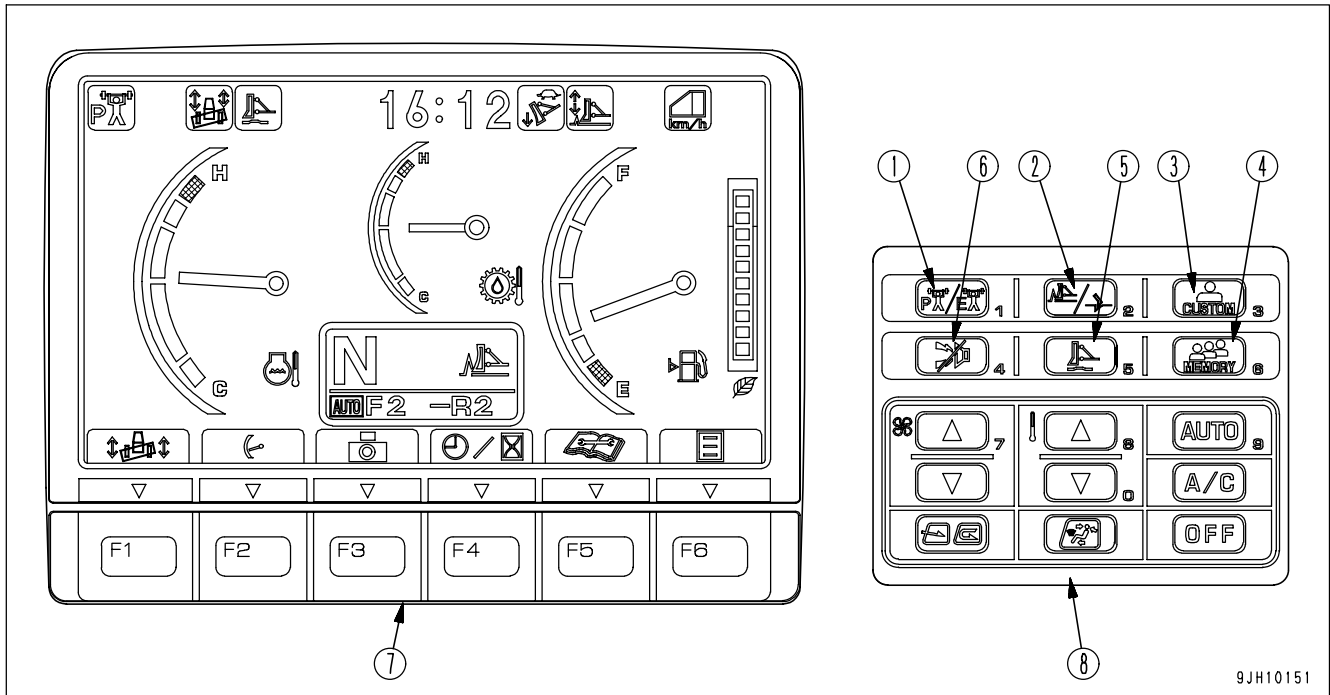

9JH10151

- (1) Operating mode switch
- (2) Gear shift mode selector switch
- (3) Customize switch
- (4) Customize memory switch
- (5) Float mode switch
- (6) Buzzer cancel switch
- (7) Function switches
- (8) Air conditioner switch

OPERATING MODE SELECTOR SWITCH

This switch (1) selects an engine operation mode.

P mode is the normal working mode.

E mode is a less fuel- consuming mode compared with P mode. It is suitable for the work on a rocky terrain where a shoe slip is likely to happen and the work on the soil that causes only light load.

With the engine starting key in the ON position, P mode is automatically selected. Which mode is currently selected is displayed on the upper portion of the screen.

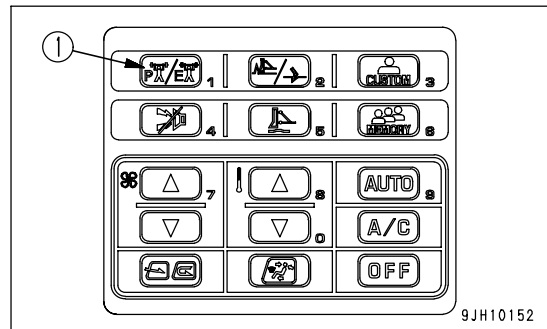

9JH10152

GEAR SHIFT MODE SELECTOR SWITCH

This switch (2) switches the gear shift mode to automatic shift mode and manual shift mode. In the automatic shift mode, the transmission shifts up automatically to the maximum set speed range, and shifts down according to the load.

In the manual shift mode, the transmission shifts down according to the load, but shifting up is carried out manually.

For precautions and details of the gear shift modes, see "SHIFTING GEAR (PAGE 3-134)".

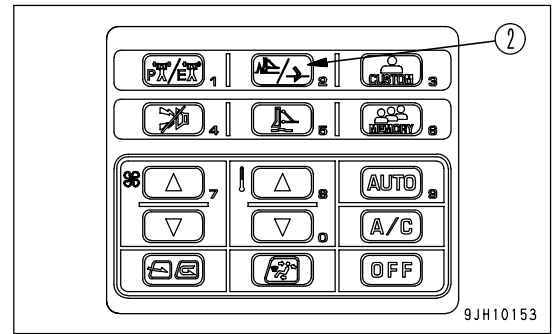

CUSTOMIZE SWITCH

CAUTION

To ensure safety, always stop the machine before changing the mode.

When this switch (3) is pressed, the system switches to the customize mode.

1. Press function key F3 or F4 to set the yellow cursor to the item to be changed.
2. In this condition, use function keys F1 and F2 to switch ON and OFF, use F6 to select, and set each mode to the desired setting.
3. The display returns to a normal screen by pressing the "F6" enter key.
4. If it is desired to reset all items, press function key F2 to turn OFF, then press function key F6.

REMARK

The items set on the screen can be saved for up to 5 people, and it is possible to recall the settings the next time the machine is used. This is called the customize memory function.

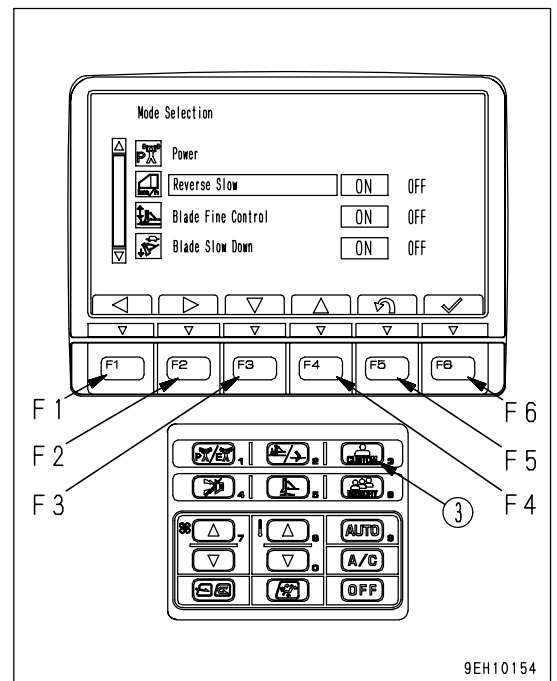

CUSTOMIZE MEMORY SWITCH



To ensure safety, always stop the machine before changing the mode.

With this switch (4) the items set for up to 5 people using the customize function can be saved, and it is possible to recall the settings the next time the machine is used.

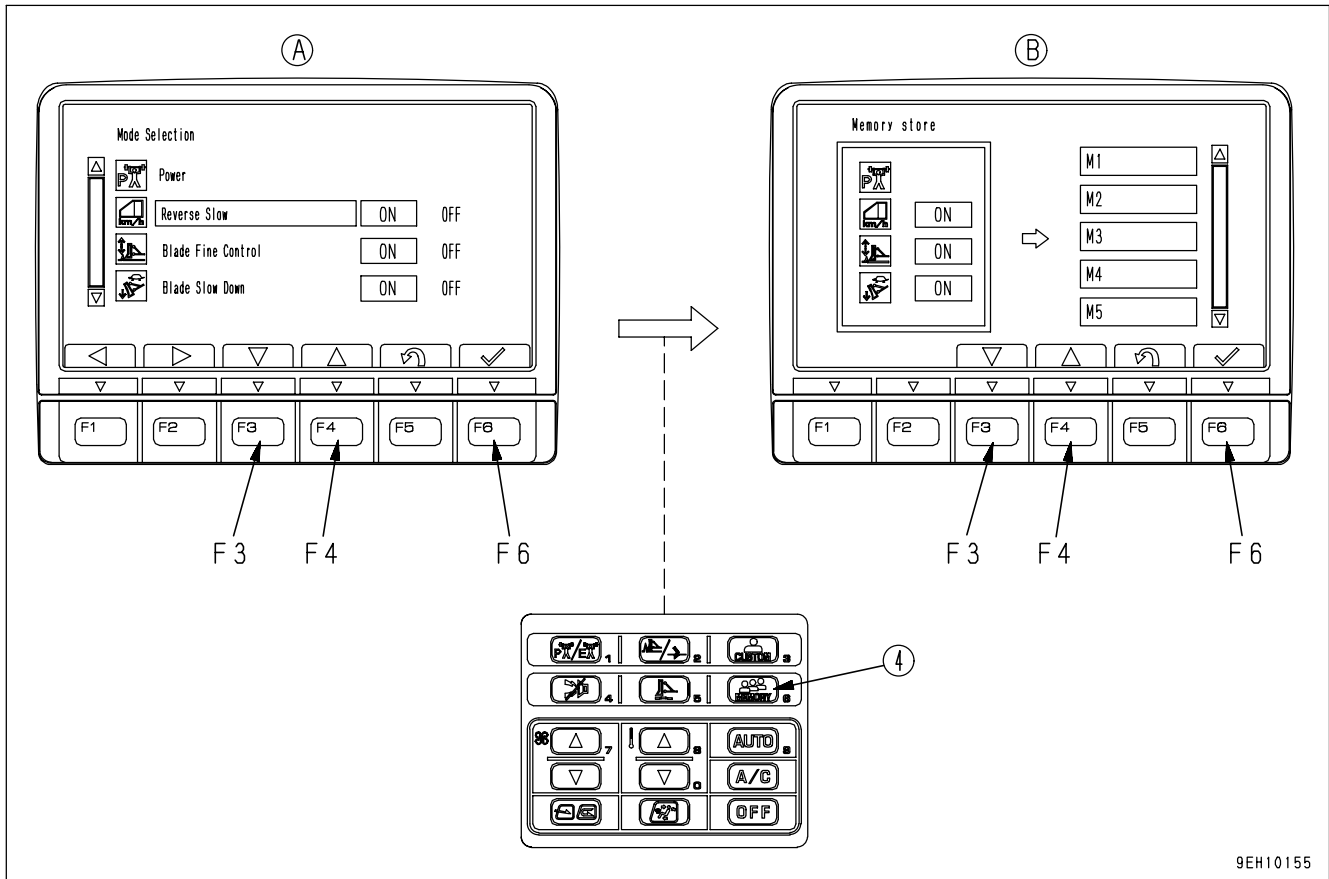

9EH10155

1. Memory store

If customize memory switch (4) is pressed on mode selection screen (A), the screen switches to memory store screen (B). The selected condition can be saved to memory as M1 - M5.

(Use function switches F3 and F4 to select the number for storing the setting, then save it with F6.)

2. To call up items already set in memory, press the customize memory switch on the standard screen. The screen on the right is displayed, so use function switches F3 and F4 to, then confirm the selection with F6.

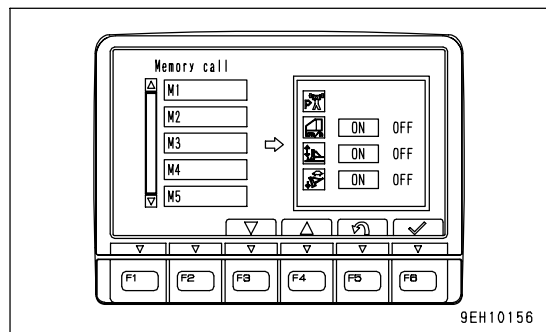

9EH10156

FLOAT MODE SWITCH

This switch (5) is used to select the FLOAT mode for the work equipment.

When this mode is selected, the mark is displayed at the top of the screen.

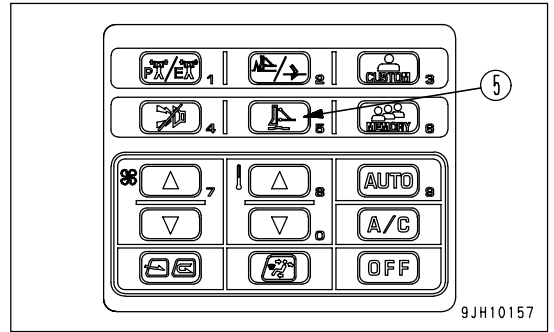

BUZZER CANCEL SWITCH

When this switch (6) is pressed, the warning buzzer for the abnormal warning item stops.

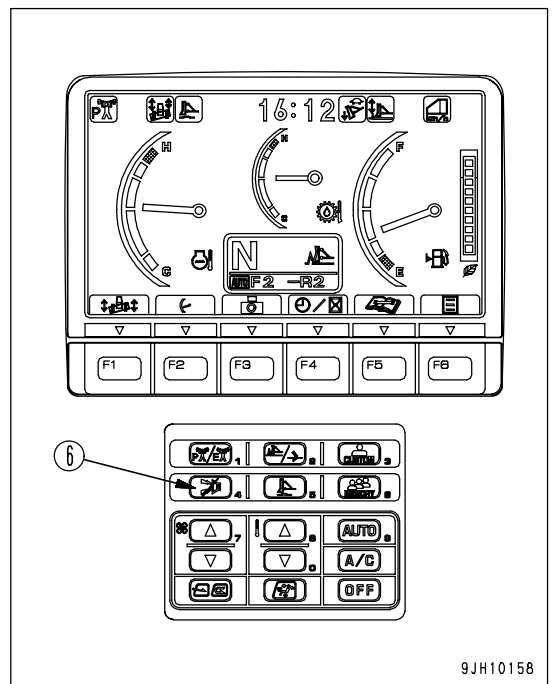

FUNCTION SWITCHES

Function switches (7) consist of 6 switches (F1 to F6). The function of each switch differs according to the content of each screen.

When the monitor display shows the standard screen, the functions are displayed as follows.

- F1: Dual tilt mode switch (if equipped)
 - F2: Multi-gauge display selector switch
 - F4: Service meter/time display selector switch
 - F5: Maintenance mode selector switch
 - F6: User mode selector switch
- Switches F3 are auxiliary switches used when expanding the function.

For explanation of each switch, see "HANDLING FUNCTION SWITCHES (PAGE 3-27)".

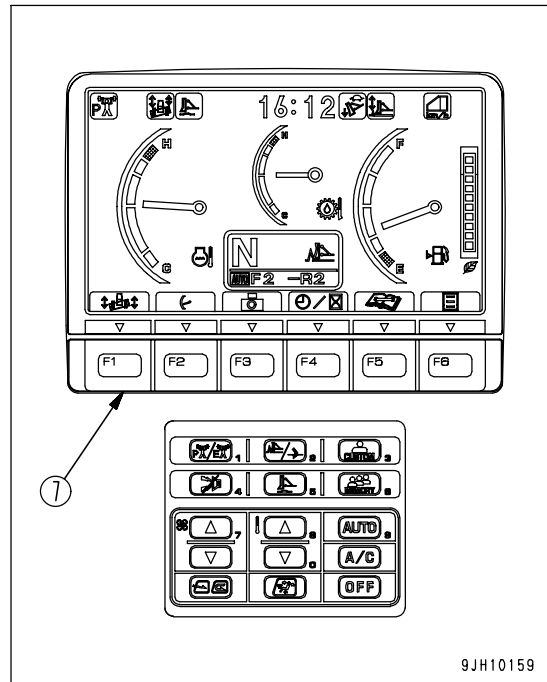

9JH10159

AIR CONDITIONER SWITCH

The air conditioner switches (8) consist of 9 switches.

For explanation of each switch, see "HANDLING AIR CONDITIONER (PAGE 3-84)".

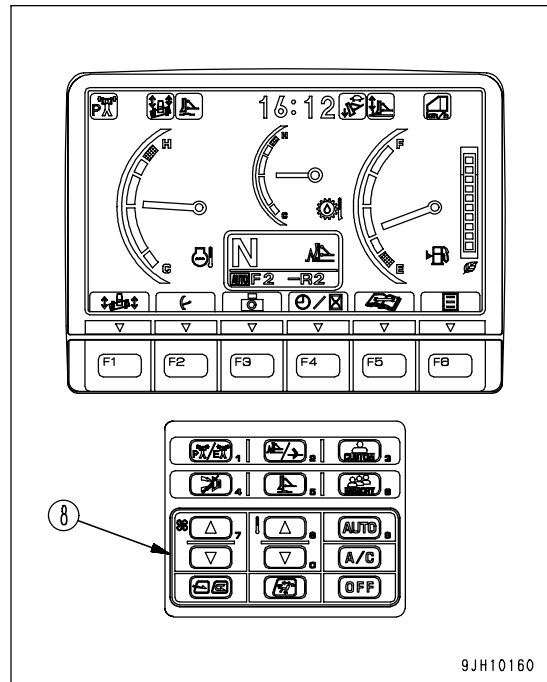

9JH10160

HANDLING FUNCTION SWITCHES

- The function switches (A) at the bottom of the monitor display consist of 6 switches (F1 - F6). The function of each switch differs according to the content of each screen.
- The function of switches (A) on each screen can be confirmed by guidance icons (B) displayed on top of each switch.
- If there is no display in guidance icon (B), even if switch (A) is pressed, it will not function.
- Even if guidance icon (B) is pressed, it will not function. Press switch (A) immediately below the guidance icon display to operate the function.

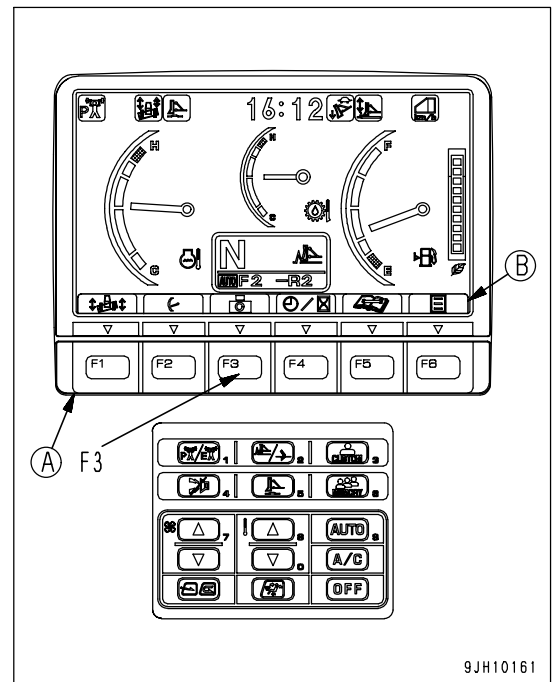

DUAL TILT MODE SWITCH

(Only machines equipped with dual tilt)

Press function switch F1 to switch to dual tilt mode. Press F1 again to return to single tilt.

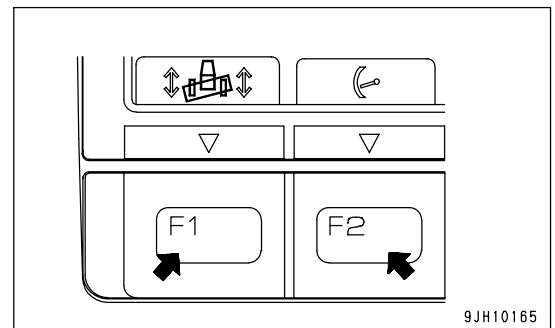

MULTI-GAUGE DISPLAY SELECTOR SWITCH

Multi-gauge display items can be switched by pressing the function switch "F2". For the items, "MULTI-GAUGE (PAGE 3-36)" see.

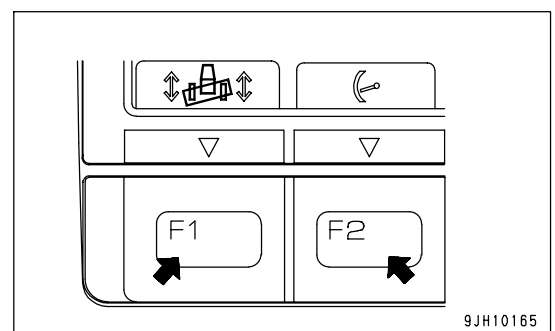

SERVICE METER/CLOCK DISPLAY SELECTOR SWITCH

On the standard screen, it is possible to press switch F4 to switch the service meter and clock display at the top of the monitor display.

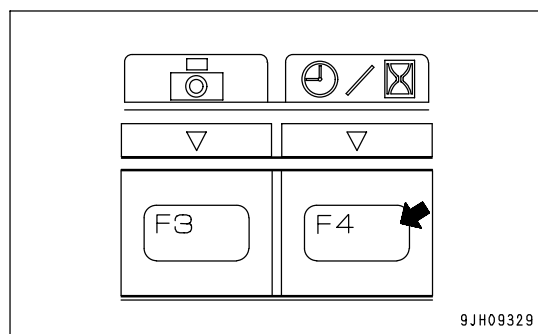
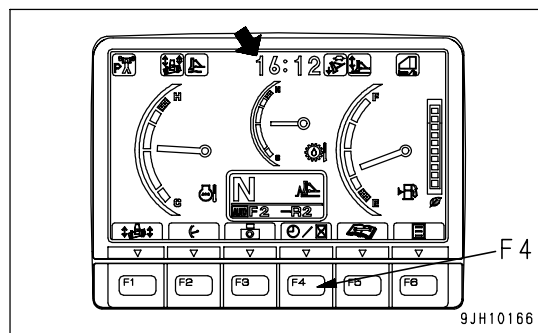

- When the time is being displayed, press switch F4 to switch to the service meter display.
When the service meter is being displayed, press switch F4 to switch to the time display.

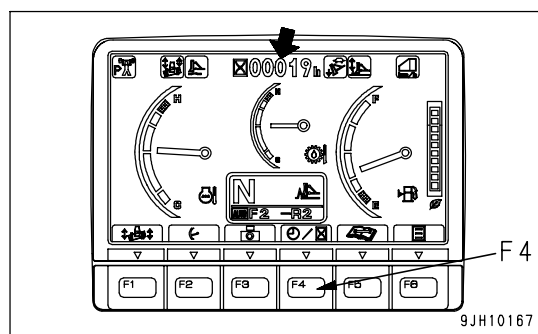

MAINTENANCE MODE SELECTOR SWITCH

When switch F5 is pressed on the standard screen, the monitor display screen switches to the maintenance mode screen.

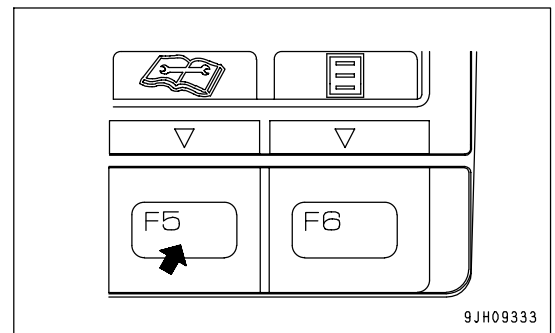
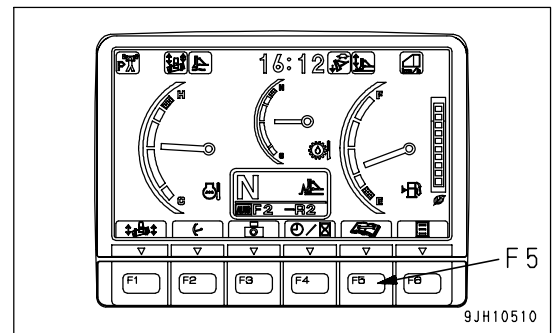

The items on the maintenance display are as follows.

a	b
Change engine oil	500
Replace engine oil filter	500
Replace fuel main filter	1000
Replace fuel pre-filter	500
Replace hydraulic oil filter	2000
Replace corrosion resistor (option)	1000
Check damper case oil level, add oil	2000
Change final drive case oil	1000
Change hydraulic oil	2000
Change P/L oil	1000
Replace P/L oil filter	500

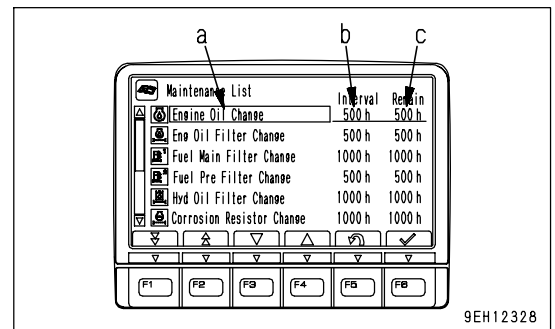

- a: Maintenance items
- b: Default maintenance interval settings (h)
- c: Time remaining until maintenance (h)

OPERATIONS ON MAINTENANCE LIST SCREEN

On the maintenance list screen, it is possible to carry out the following operations with switches F1 to F6.

- F1: Displays next page. When on the last page, it displays the first page.
- F2: Displays previous page. When on the first page, it displays the last page.
- F3: Moves to next item (1 line down). When on the last line, it moves to the first line on the next page.
- F4: Moves to previous item (1 line up). When on the first line, it moves to the last line on the previous page.
- F5: Returns to standard screen.
- F6: Resets remaining time for selected item (item highlighted in yellow) and returns to default setting screen.

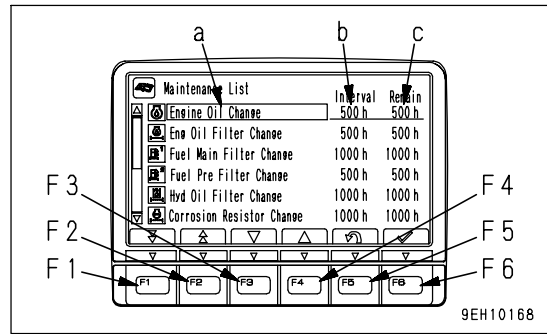

REMARK

When resetting the remaining time, keep switch F6 pressed for at least 1.5 seconds. If switch F6 is not kept pressed for at least 1.5 seconds, the switch operating sound can be heard, but the screen does not switch to the screen for resetting the remaining time.

- If no switch is operated for 30 seconds on the maintenance list screen, the screen automatically returns to the standard screen.

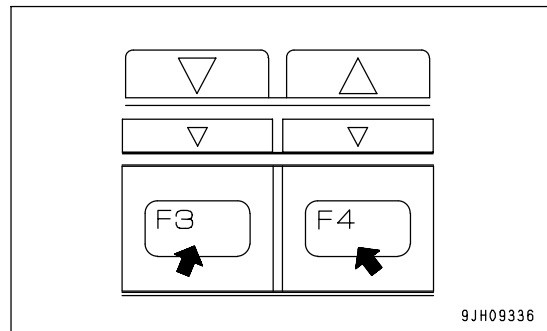
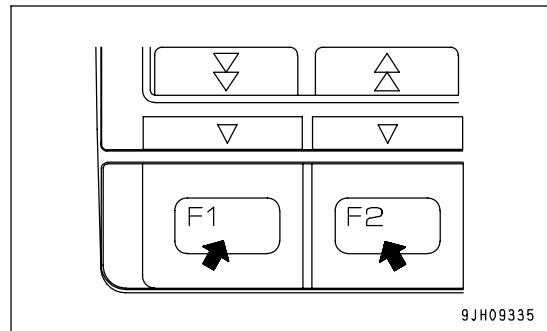

- On the maintenance list screen, if the time remaining until maintenance for any item is less than 30 hours, the remaining time display is highlighted in yellow. If the time remaining until maintenance becomes 0 hours, the remaining time display is highlighted in red.
- If you want to change the setting for the maintenance interval, please consult your Komatsu distributor.

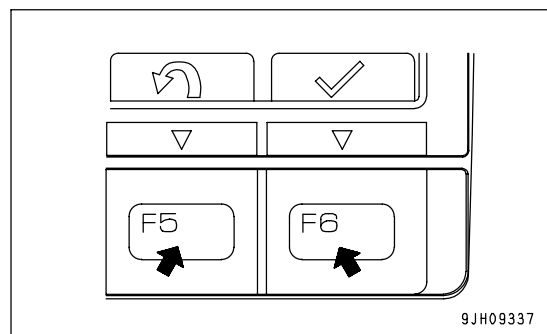

OPERATIONS ON MAINTENANCE INTERVAL RESET SCREEN

On the maintenance interval reset screen, it is possible to carry out the following operations.

F5: Cancels reset, returns to maintenance list screen

F6: Resets remaining time, returns to standard screen

- If no switch is operated for 30 seconds on the maintenance interval reset screen, the screen automatically returns to the standard screen.

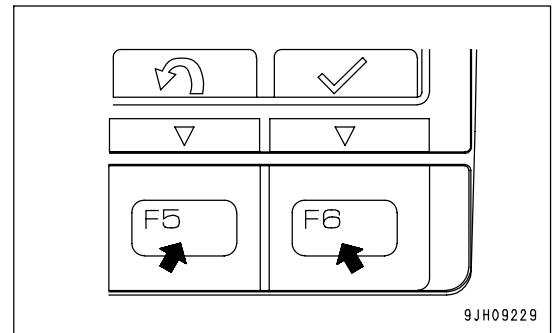
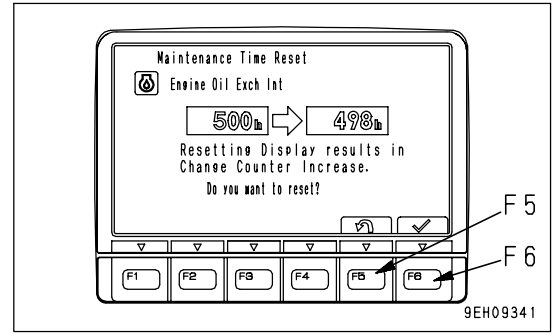

USER MODE SELECTOR SWITCH

When the switch F6 is pressed, the monitor display screen switches to the setting mode screen for the machine.

- On the User Menu screen, it is possible to carry out the following operations with switches F3 to F6.

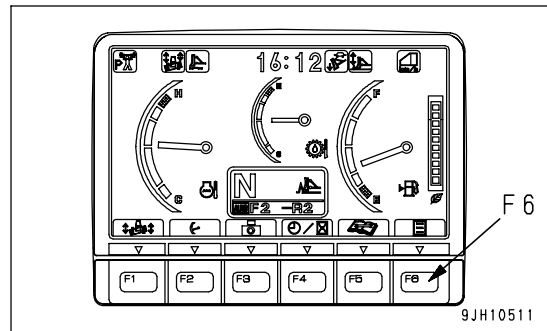
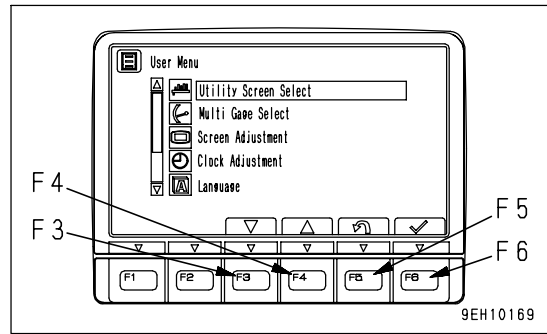

- F3: Moves to next item (1 line down). When on the last line, it moves to the first line on the next page.
- F4: Moves to previous item (1 line up). When on the first line, it moves to the last line on the previous page.

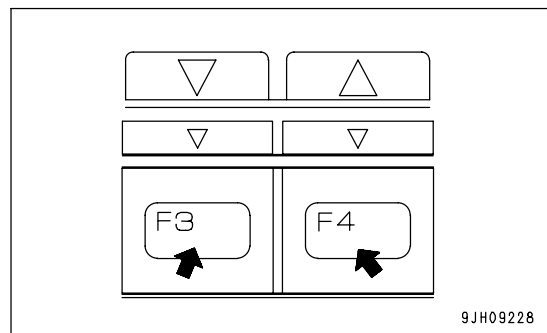

- F5: Returns to standard screen.
- F6: Switches to setting screen for selected item.

- If no switch is operated for 30 seconds on the user menu screen, the screen automatically returns to the previous screen.

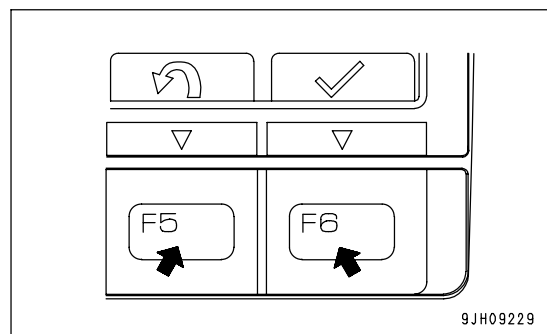

- The following items can be set.

- a: Utility Screen
- b: Multi-gauge
- c: Screen Adjustment
- d: Time Adjustment
- e: Language Setting
- f: Message display
- g: Fan Reverse

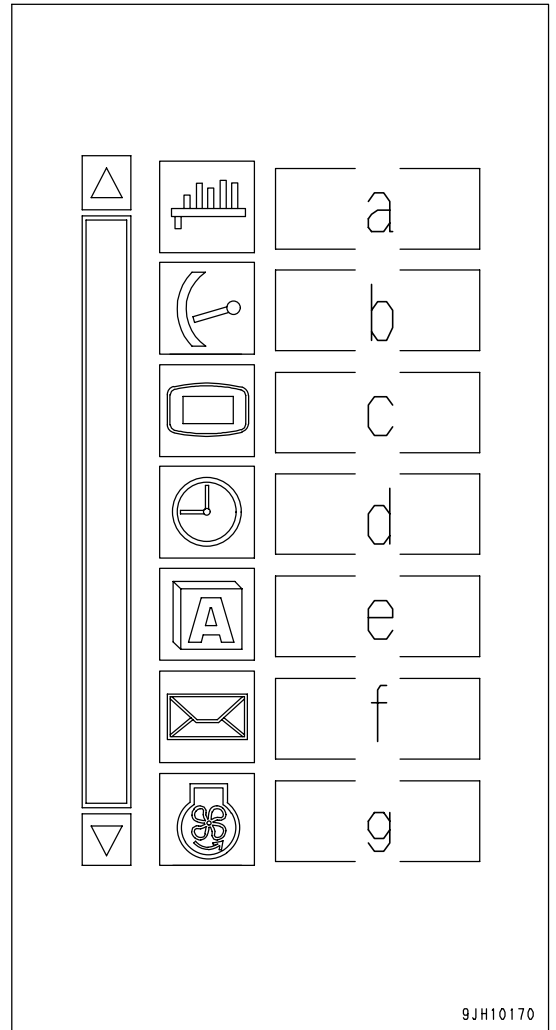

The operation to set a - g is as follows.

UTILITY SCREEN

When the utility graph is selected with switch F6, it becomes possible to select the Standard Display, Load Display, or Body Pitch Display.

Use switches F3 or F4 to select the item, then press switch F6 to confirm.

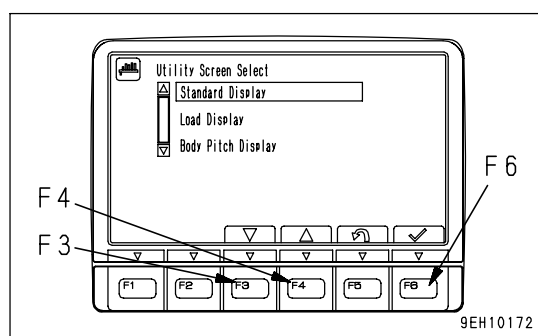
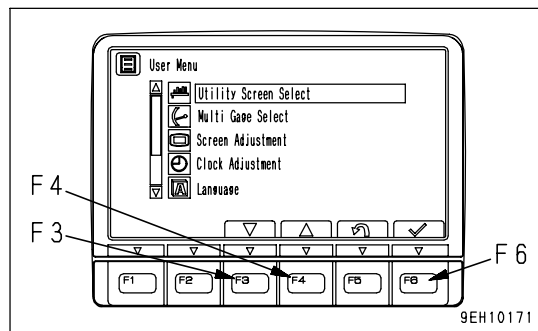

STANDARD DISPLAY

This selects the standard screen.

LOAD DISPLAY

The horizontal axis shows the time and the vertical axis shows the rim pull.

In the same way as with the ECO gauge, we recommend that you use it in the green range.

The graph on the screen is updated every few seconds and scrolls to the left.

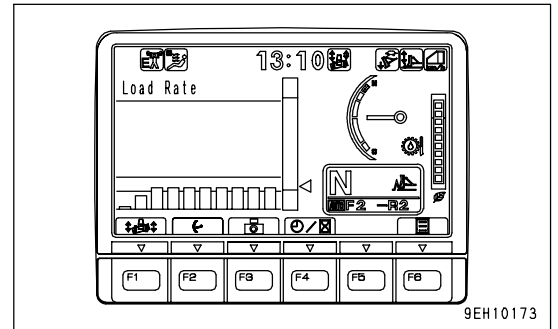

9EH10173

BODY PITCH DISPLAY

The horizontal axis shows the time and the vertical axis shows the pitch angle of the machine.

The graph on the screen is updated every few seconds and scrolls to the left.

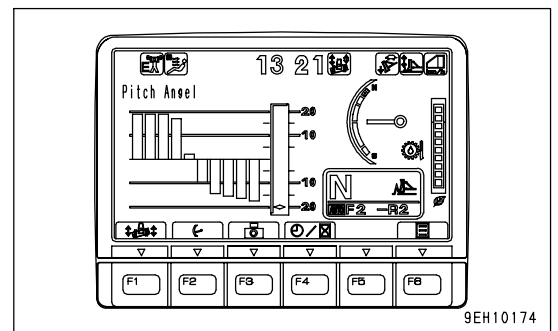

9EH10174

MULTI-GAUGE

With this monitor, it is possible to select the gauge that is displayed in the center.

Use switches F3 or F4 to select the item, then press switch F6 to confirm.

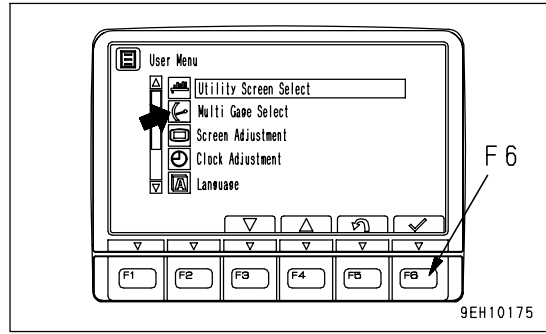

NO.	Multi-gauge selection item	Remarks
1	P/L oil Temperature	There is a caution lamp
2	HYD oil Temperature	There is a caution lamp
3	Vehicle Speed	-
4	HYD Pressure	-
5	ENG Oil Pressure	There is a caution lamp
6	Battery Voltage	-
7	ENG Speed	-
8	Traction	-
9	Time	-
10	ENG Temperature	Utility Screen
11	Fuel	Utility Screen

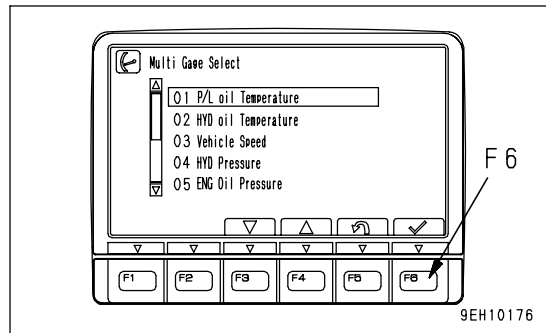

When "**1 Utility Screen" is selected, the engine water temperature gauge and fuel gauge are added on the screen.

An approximate value indicated by the gauge is as follows.

Engine oil pressure

- (1)0.0MPa
- (2)0.2MPa
- (3)0.3MPa
- (4)0.4MPa
- (5)0.5MPa
- (6)0.7MPa

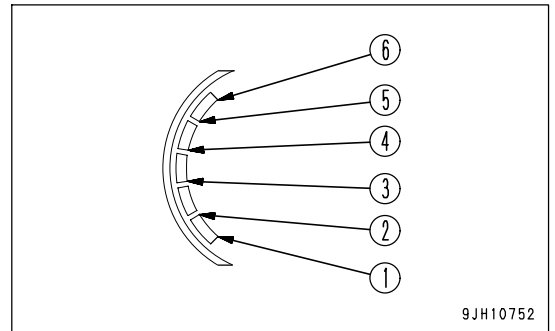

Engine speed

- (1)500rpm
- (2)1,000rpm
- (3)1,500rpm
- (4)2,000rpm
- (5)2,500rpm
- (6)3,000rpm

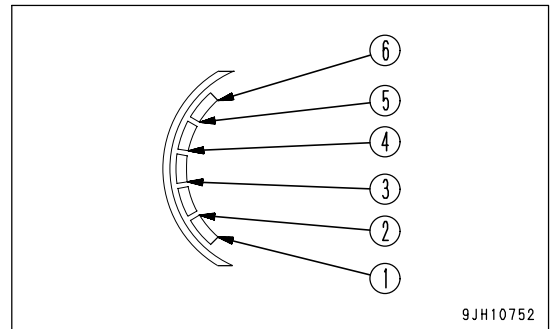

Battery voltage

- (1)0V
- (2)17V
- (3)20V
- (4)25V
- (5)30V
- (6)31V

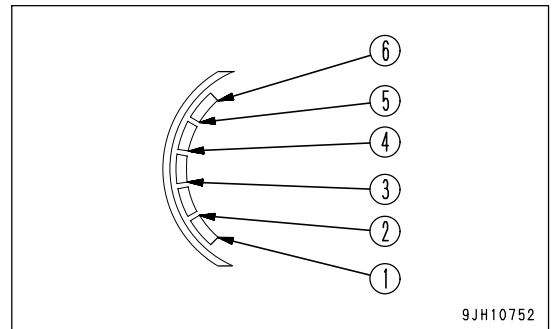

Machine speed

- (1)0km/h
- (2)5km/h
- (3)10km/h
- (4)15km/h

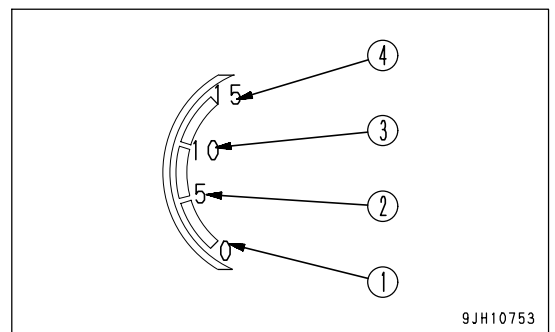

Drawbar pull

- (1)0W
- (2)0.2W
- (3)0.4W
- (4)0.6W
- (5)0.8W
- (6)1.0W

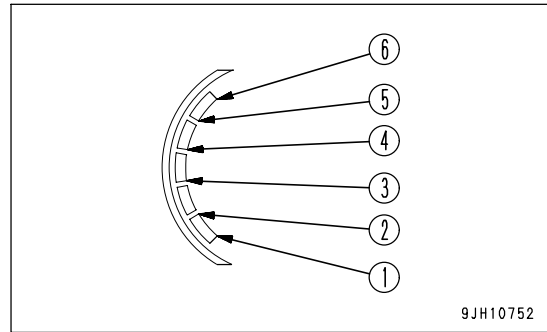

Hydraulic pressure

- (1)0MPa
- (2)10MPa
- (3)20MPa
- (4)30MPa
- (5)40MPa
- (6)50MPa

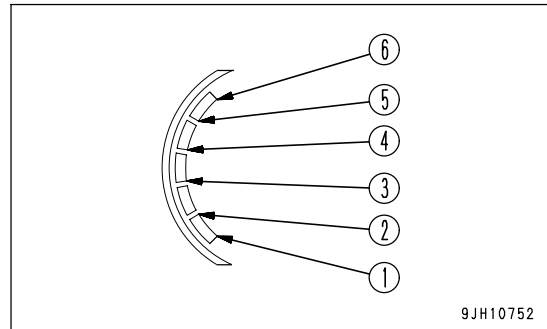

ADJUSTING SCREEN

Use this screen adjustment menu to adjust the brightness, contrast, and back light of the screen.

1. On the standard screen, press switch F6.

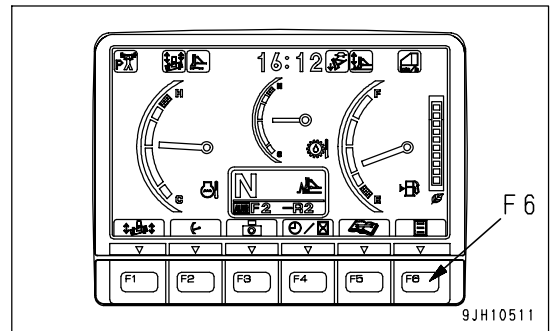
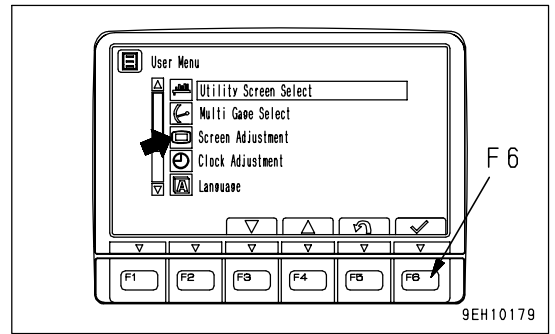

2. Select screen adjustment on the user menu, then press switch F6. The screen switches to the selection menu screen for screen adjustment.

- On machines equipped with cameras, it is possible to adjust the brightness, contrast, and back light of the cameras screen on this menu.

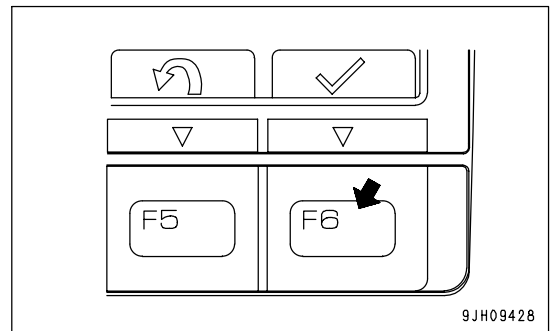

3. Select item to be adjusted (a) or (b) from the selection menu screen for screen adjustment, then press switch F6. The screen switches to the setting screen for the selected item.

(a): Standard screen adjustment

(b): Camera screen adjustment (only machines equipped with camera)

- On the mode selection screen shown on the right, it is possible to carry out the following operations with switches F3 to F6.

- F3: Moves to next item (1 line down).
- F4: Moves to previous item (1 line up).
- F5: Returns to user menu screen.
- F6: Switches to setting screen for selected item.

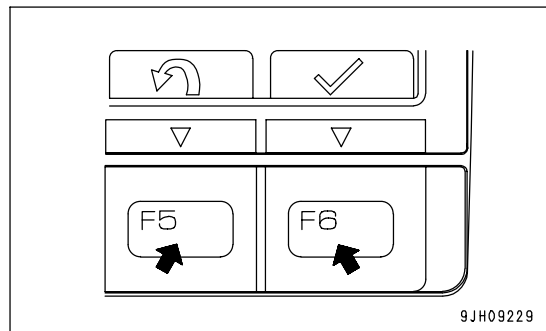
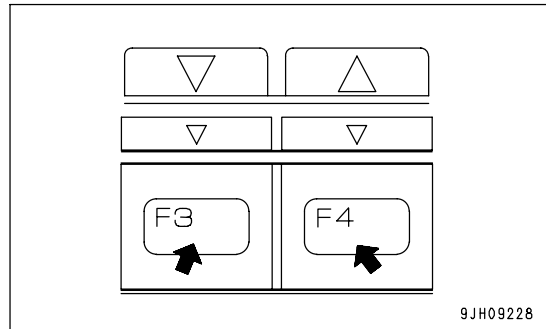
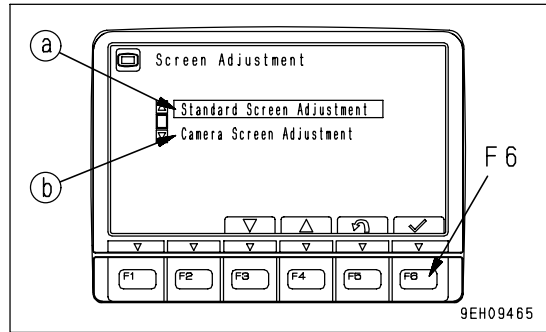

4. Use switches F2 to F6 to adjust the brightness, contrast, and back light of the selected screen.

1) Adjustment screen for standard screen

- If the light switch is at night mode ON, and the standard screen is adjusted, it is possible to adjust the brightness of the monitor screen (night mode).
- If the light switch is at day mode ON or OFF, and the standard screen is adjusted, it is possible to adjust the brightness of the monitor screen (day mode).

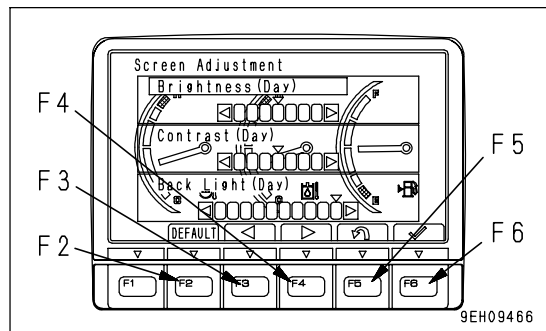

2) Adjusting camera screen

- The background when adjusting the camera image is the image for the No. 1 camera.
- When displaying the camera screen, the screen may become dark if the image is on snow. In such cases, we recommend adjustment of the screen.

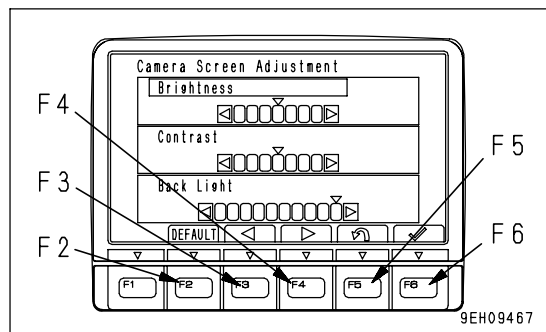

On the screen for Items 1) and 2), it is possible to carry out the following operations with switches F2 to F6.

- F2: Resets all adjusted values to default value
- F3: Indicator of selected item moves 1 segment to left.
- F4: Indicator of selected item moves 1 segment to right.
- F5: Returns to user menu.
- F6: Accepts change and switches to next item setting.

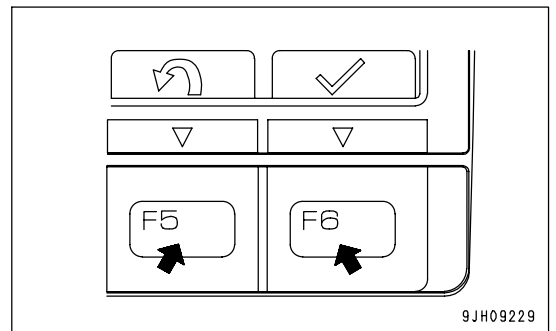
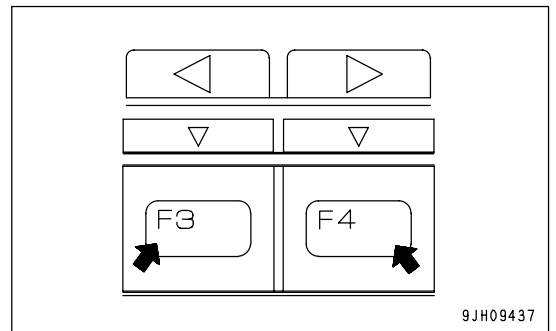
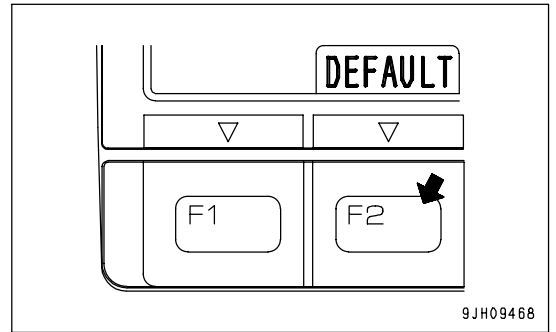

CLOCK ADJUSTMENT

On this clock adjustment menu, it is possible to change the setting of the clock displayed on the pilot monitor of the standard display.

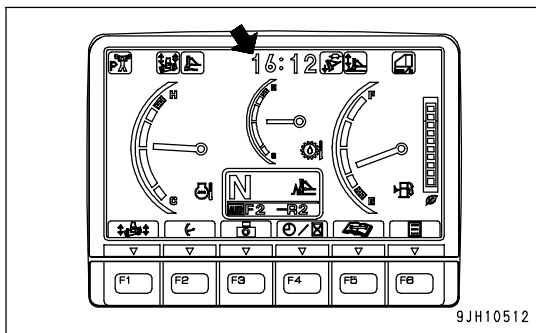

1. On the standard screen, press switch F6.

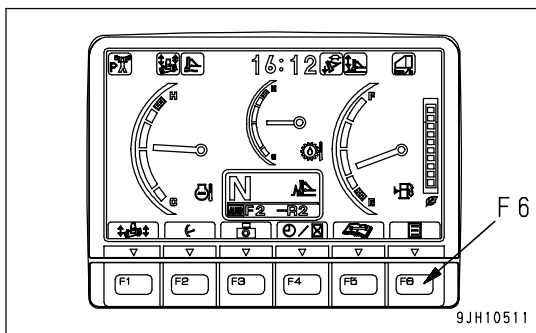

2. Select "Clock Adjustment" on the user menu, then press switch F6. The screen switches to the time adjustment selection menu screen.

- The following three items can be changed.
 - (a) Clock setting
 - (b) 12/24 hour display mode
 - (c) Daylight saving time

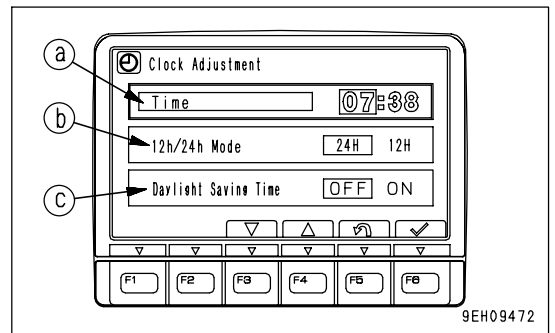
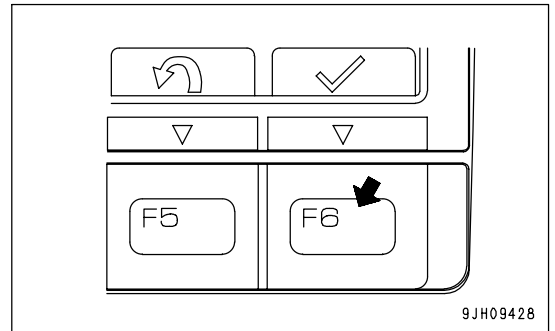
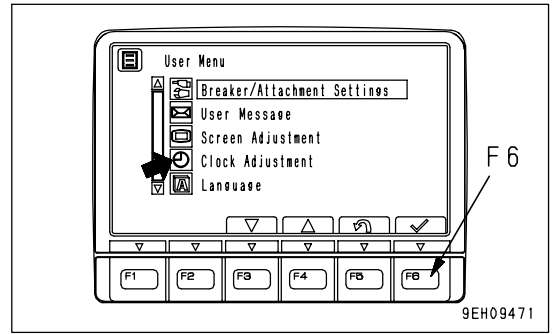

3. On the clock adjustment selection screen, it is possible to carry out the following operations with switches F3 to F6.

• Time

Adjust the hour setting.

1) If "Time" (a) is not highlighted in yellow, press switch F6 to highlight "Time" (a) in yellow. When this is done, hour display (b) changes to orange.

Adjust hour display (b) with the switches as follows. If it is not necessary to change the hour setting, press switch F6.

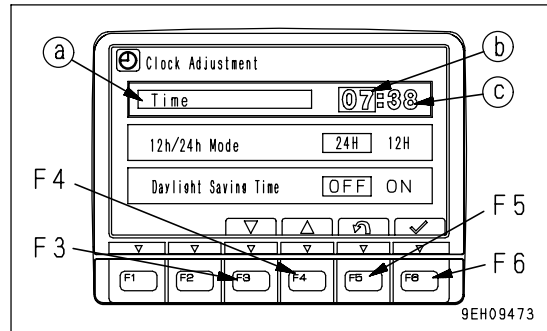

F3: Time advances 1 hour.

F4: Time goes back 1 hour.

F5: Cancels change and returns to user menu.

F6: Accepts change and goes to setting for minutes.

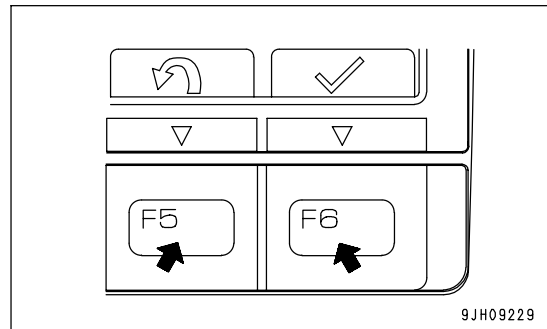
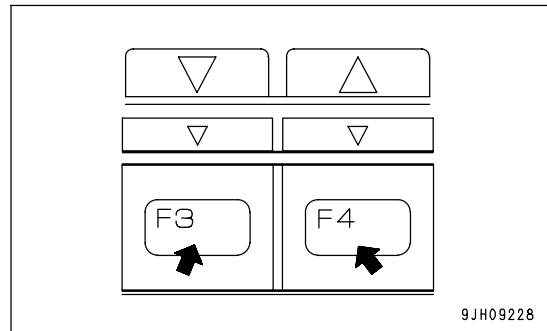

2) When minute display (c) is highlighted in orange, operate the switches as follows to adjust minute display (c).
 If it is not necessary to change the minute setting, press switch F6. If the time has been changed, always press switch F6.

- F3: Time advances 1 minute.
- F4: Time goes back 1 minute.
- F5: Cancels change and returns to user menu.
- F6: Accepts change and goes to setting for 12/24 hour display mode.

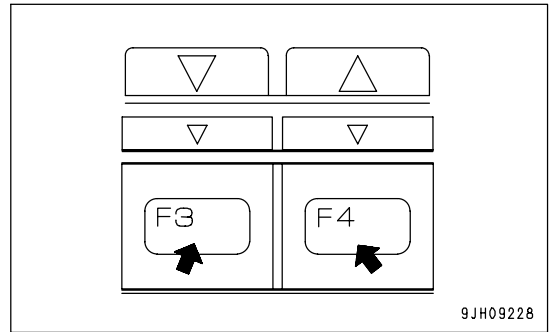

9JH09228

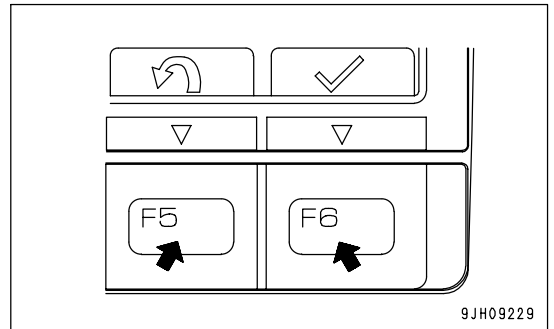

9JH09229

- 12h/24h Mode
 Choose either a 12-hour display (am/pm) or a 24-hour display.

- (b): 24-hour display
- (c): 12-hour display (am/pm)

- 1) If "12h/24h Mode" (a) is not highlighted in yellow, press switch F6 to highlight "12h/24h Mode" (a) in yellow.
- 2) Change the "12h/24h mode" with the switches as follows. The selected display mode (b) or (c) is highlighted in green.

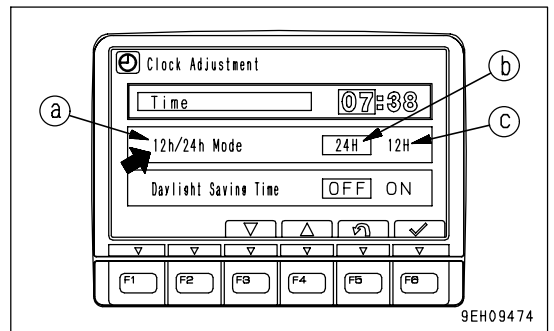

9EH09474

- F3: Moves 1 item to left.
- F4: Moves 1 item to right.
- F5: Cancels change and returns to user menu.
- F6: Accepts change and goes to setting for "Daylight Saving Time".

If the setting has been changed, always press switch F6.

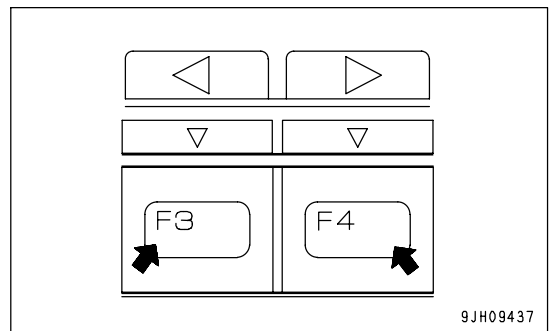

9JH09437

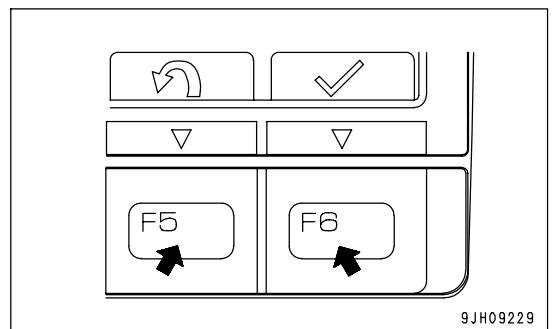

9JH09229

• Daylight Saving Time (Summer time)

1) If daylight saving time is turned ON (a), the clock display becomes 1 hour earlier. If daylight saving time is turned OFF (b), the clock display returns to the set time.

The selected display mode is highlighted in green.

2) Change the daylight saving time with the switches as follows.

F3: Moves 1 item to left.

F4: Moves 1 item to right.

F5: Cancels change and returns to user menu.

F6: Accepts change and goes to setting for "Time".

If the setting has been changed, always press switch F6.

REMARK

Daylight saving time or summer time means moving the clock forward 1 hour to take advantage of the fact that the sun rises early in summer. This system is used in many countries during the summer.

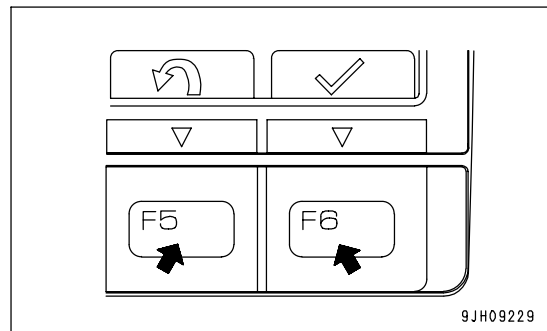
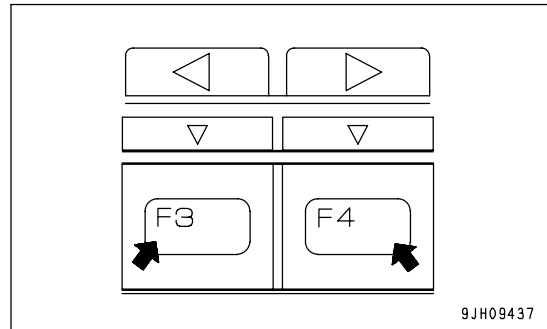
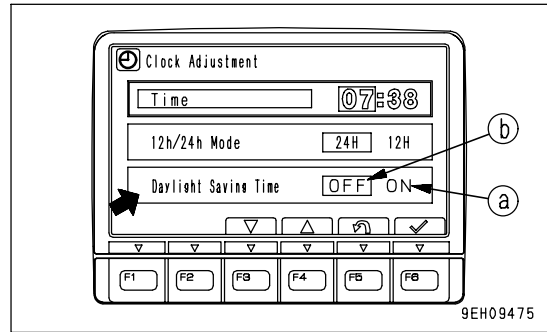

LANGUAGE SELECTION

On this language selection menu, it is possible to select the language used on the monitor display.

- The languages that can be selected are as follows.
Japanese, English, Chinese, French, Spanish, Portuguese, Italian, German, Russian, Turkish

1. On the standard screen, press switch F6.

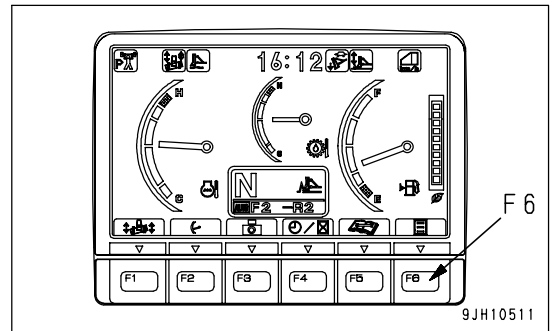

2. Select "Language" on the user menu, then press switch F6.
The screen switches to the language selection menu screen.

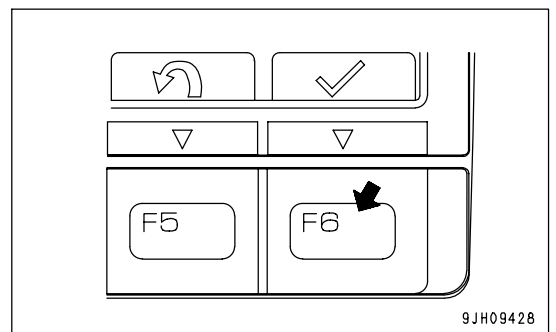
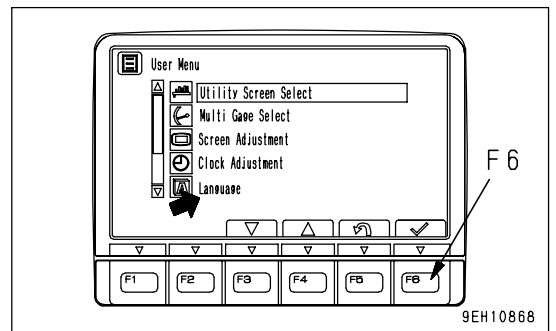

3. Select the language to use for the display, then press switch F6. The screen display changes to the selected language.

- On the language selection screen, it is possible to carry out the following operations with switches F3 to F6.

F3: Moves to item below.

F4: Moves to item above.

F5: Cancels change and returns to user menu screen.

F6: Accepts change and returns to user menu screen.

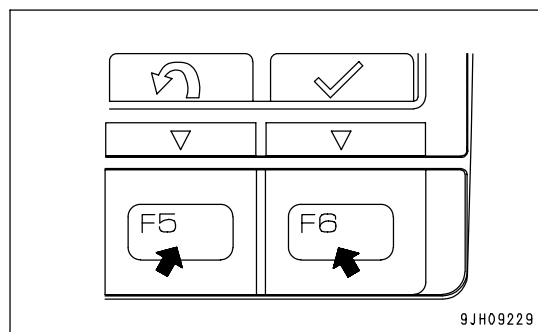
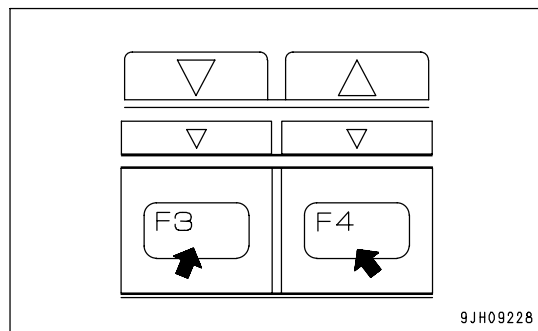
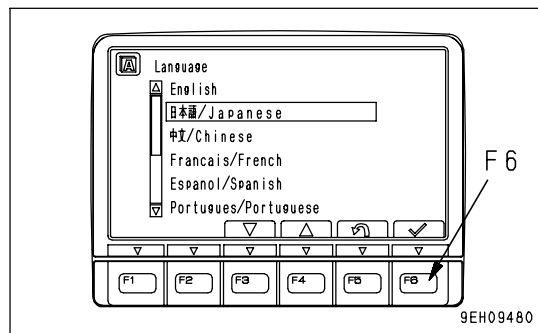

MESSAGE DISPLAY

(Machines equipped with KOMTRAX)

On machines equipped with KOMTRAX, it is possible to see the messages from your Komatsu distributor on this message display menu.

REMARK

At present, there is no territory where it is possible to use the message service.

In territories where it is not possible to use the message service, the message display menu functions as follows.

1. On the standard screen, press switch F6.

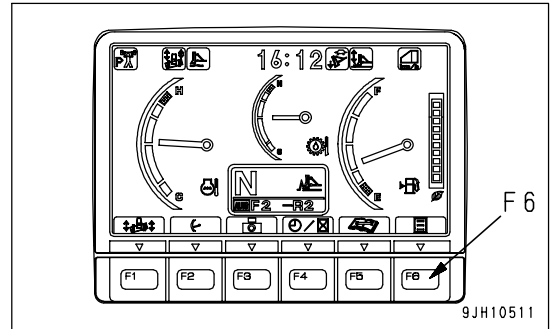

2. Select "User Message" on the User Menu, then press switch F6 to see the messages that have been received.

- If you press switch F5, the screen returns to the user menu screen.

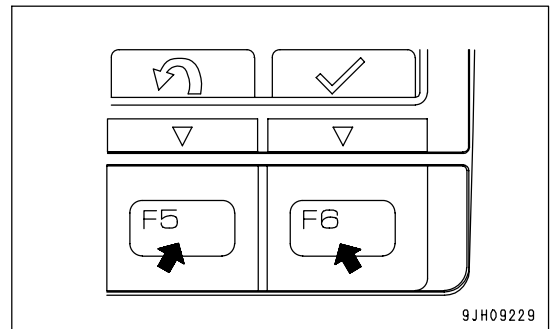
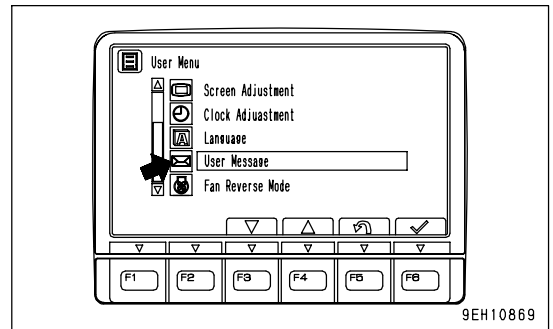

3. "No message" is displayed on the screen.
Press switch F5 to return to the standard screen.

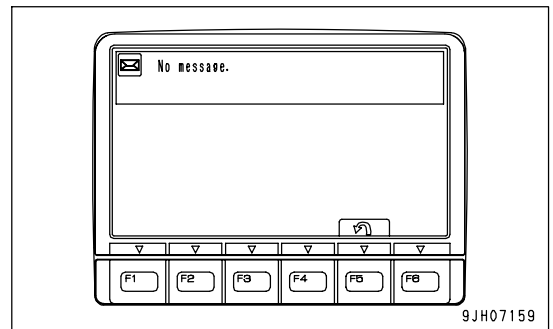

HYDRAULIC DRIVE FAN REVERSE MODE

CAUTION

- In this mode, the fan cannot be rotated in reverse with the engine running.
- Keep parking brake lever and work equipment lock lever in the LOCK position.
- The machine cannot be driven while the fan is rotating in reverse.
- To release the cooling fan from a reverse rotation, turn the fuel control dial to the MIN position, then turn the starting switch to the OFF position and stop the engine.
- When using this mode, carry out the warming-up operation thoroughly. If the warming-up operation is not carried out, the air flow may be small.

NOTICE

When using Fan Reverse for cleaning, use the following procedure.

1. Open both engine side covers.
2. Use the user menu to set the Fan Reverse mode.
3. Start the engine and blow out the dirt.
4. After stopping the engine, check that there is no dirt at any place. Be particularly careful to check that there is no dirt on the exhaust manifold or around the turbocharger.

This mode is for rotating the fan in the reverse direction from normal when cleaning the radiator core. When the starting switch is ON, use switches F3 or F4 to select the item, then press switch F6 to confirm.

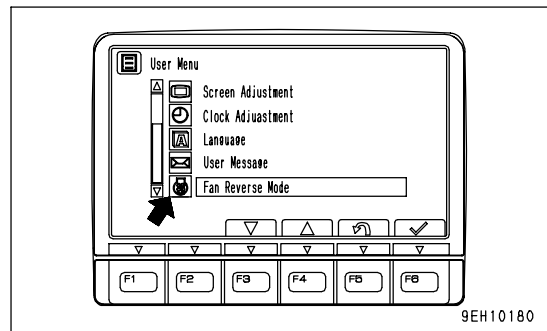

9EH10180

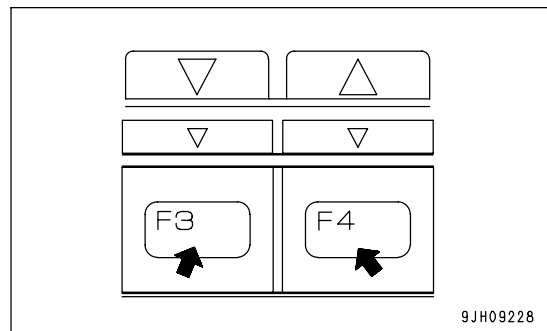

9JH09228

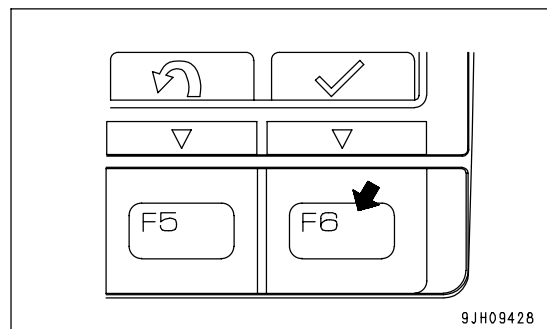

9JH09428

When this mode is selected, the screen in the diagram on the right appears.

When screen (A) is being shown, press switch F6 to complete the preparations for rotating the fan in reverse.

When screen (B) is being shown, the engine can be started.

REMARK

When the icons of the parking brake and work equipment lock lever are not in display, the engine cannot be started.

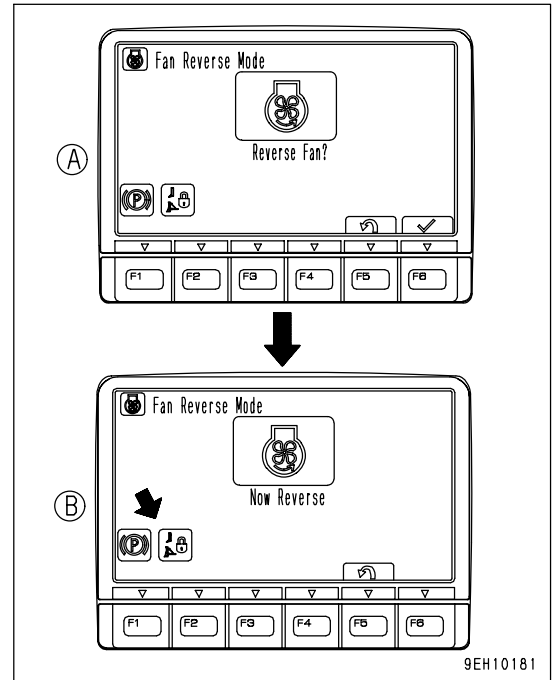

SPEED RANGE DISPLAY

The travel speed range of the machine (F1 for FORWARD 1st, R2 for REVERSE 2nd) is displayed in top left area (a) of the speed range display.

The gear shift mode is displayed in top right area (b).

The preset mode is displayed in bottom area (c).

In addition, when the automatic mode is selected, the AUTO mark is displayed in the bottom left area (d).

For details of the procedure for shifting gear on this machine, see "METHOD OF CHANGING GEAR SHIFT MODE (PAGE 3-135)".

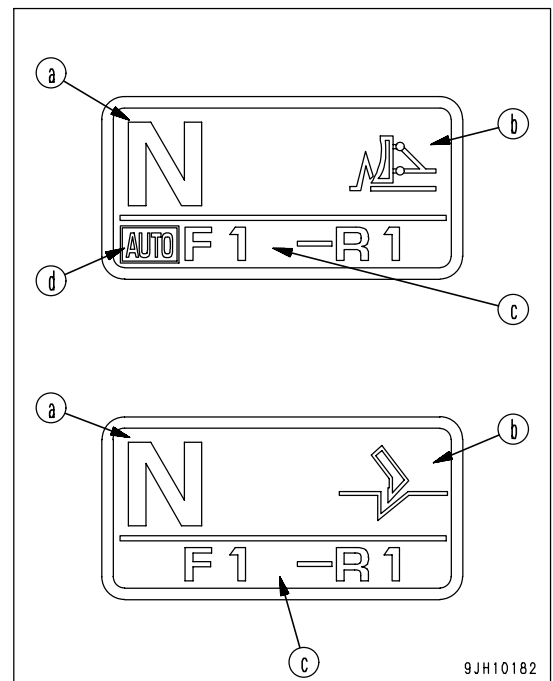

SWITCHES

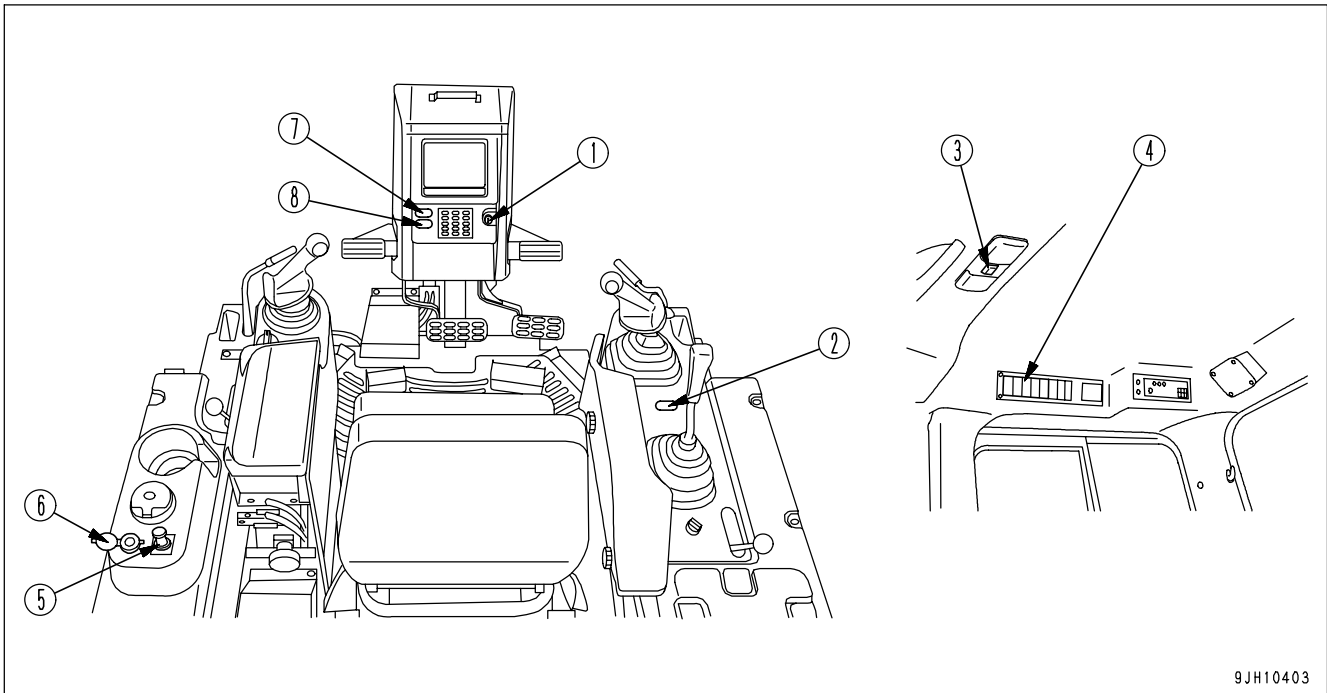

- | | |
|----------------------|-----------------------------|
| (1) Starting switch | (5) Cigarette lighter (24V) |
| (2) Horn switch | (6) Accessory socket (12V) |
| (3) Room lamp switch | (7) Front lamp switch |
| (4) Wiper switch | (8) Rear lamp switch |

STARTING SWITCH

This switch (1) is used to start or stop the engine.

(A): OFF position

At this position, the starting switch key can be inserted and removed. When the switch is turned to this position, all the electric circuits are turned off and the engine stops.

(B): ON position

In this position, electric current flows in the charging and lamp circuits.

Keep the starting switch key at the ON position while the engine is running.

(C): START position

This is the position to start the engine. Hold the key at this position while cranking the engine. Release the key immediately after the engine has been started. The key will return to ON position (B) when released

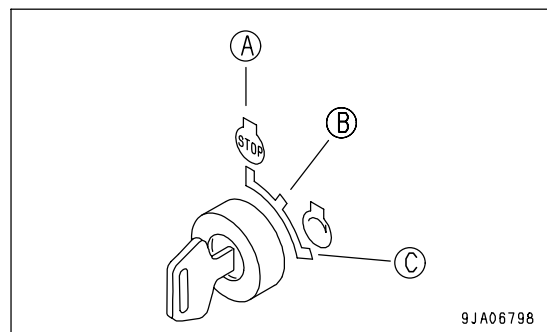

HORN SWITCH

The horn sounds when the button (2) at the rear of the blade control lever at the right side of the operator's seat is pressed.

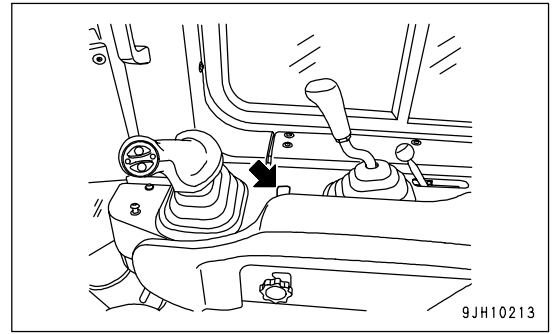

ROOM LAMP SWITCH

This (3) illuminates the room lamp.
 OFF position: Lamp is out
 ON position: Lamp lights up

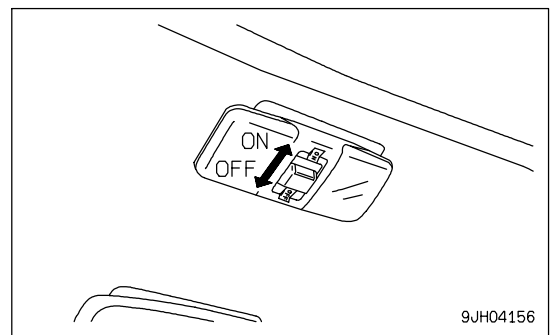

WIPER SWITCH

This (4) activates the wipers.
 The wiper switches are as follows:
 (LH) Left door
 (FF) Front window
 (RH) Right door
 (RR) Rear window
 (INT) Wiper intermittent operation switch
 This is also used as the window washer switch.
 The switch is operated as follows.

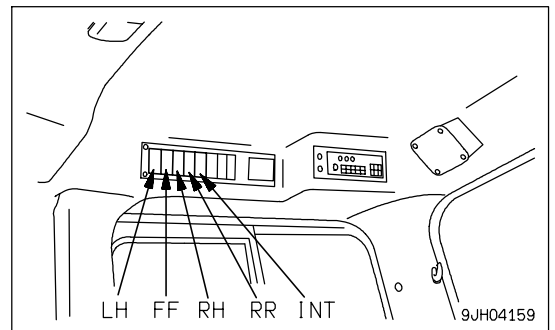

- Wiper only
 If this is switched on, the wiper will start.

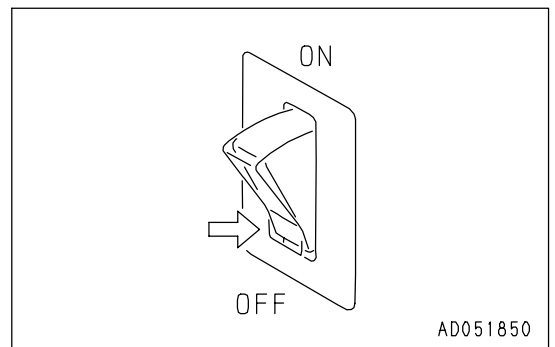

- Wiper and window washer
If this is kept pressed to the ON position while the wiper is working, water will be sprayed out.

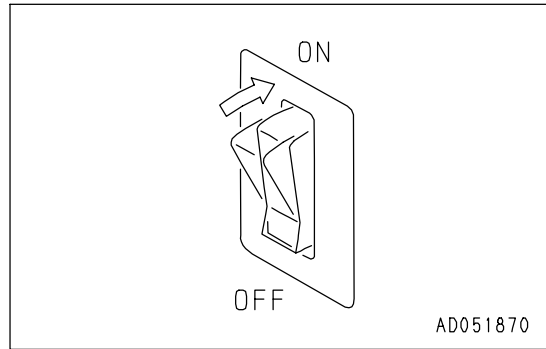

- If the intermittent switch is turned ON, all movement of the wipers will be intermittent.

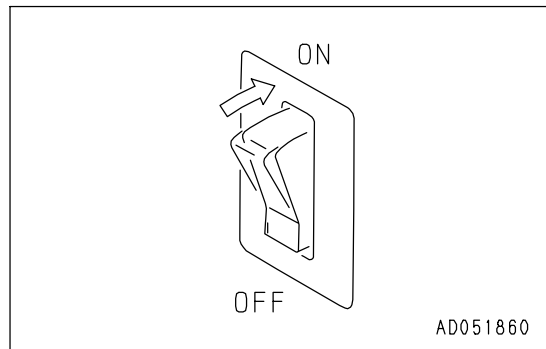

REMARK

- When installing the cab, check the colors and install the washer tank and each window washer hose correctly.
- When installing the cab, carry out the operation in accordance with the cab installation procedure manual held by your Komatsu distributor.

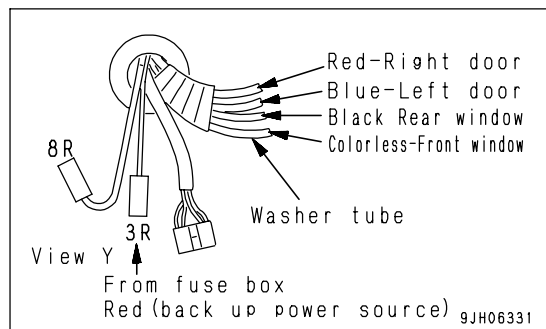
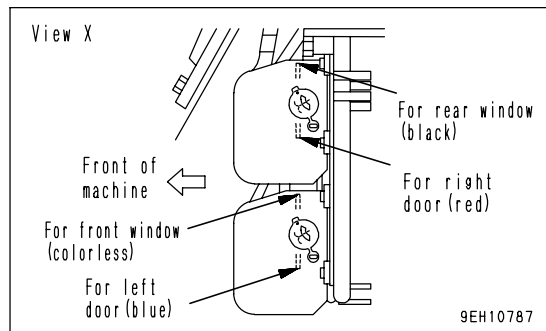
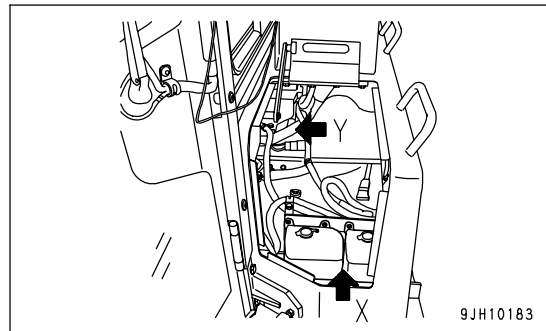

CIGARETTE LIGHTER

This lighter (5) is used to light cigarettes.

When the cigarette lighter is pushed in, it will return to its original position after a few seconds, so take it out to light your cigarette. By removing the cigarette lighter, the socket is available as a power source.

NOTICE

This cigarette lighter is 24V. Do not use it as the power supply for 12V equipment. This will cause failure of the equipment. The capacity of the cigarette lighter is 120W (24V x 5A).

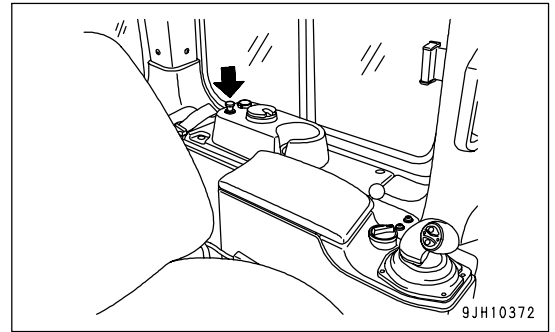

ACCESSORY SOCKET

This (6) is used as the power source for a wireless or other 12V equipment.

Accessory socket capacity: 60W (12V x 5A)

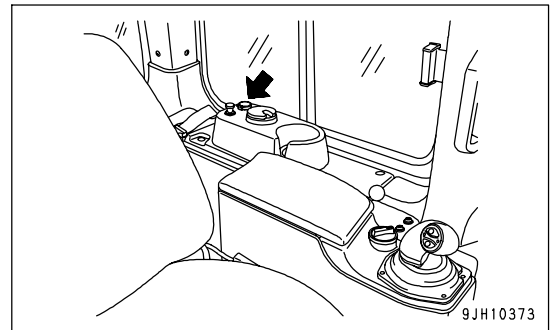

FRONT LAMP SWITCH

Use this switch (7) to light up the front lamps. Positions (a) and (b): Lighted up

REMARK

If the switch is pressed at the moon mark end (a), the monitor panel lighting becomes dimmer.

If the switch is pressed at the sun mark end (b), the monitor panel lighting does not become dimmer.

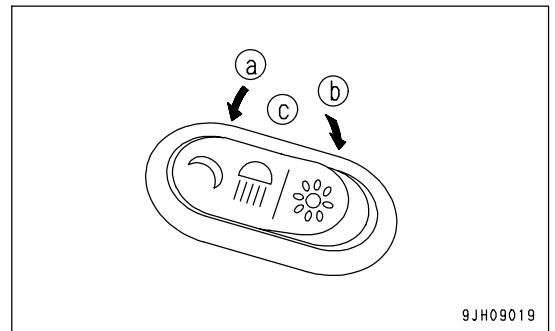

REAR LAMP SWITCH

Use this switch (8) to light up the rear lamp.

ON position (a): Lighted up

OFF position (b): Out

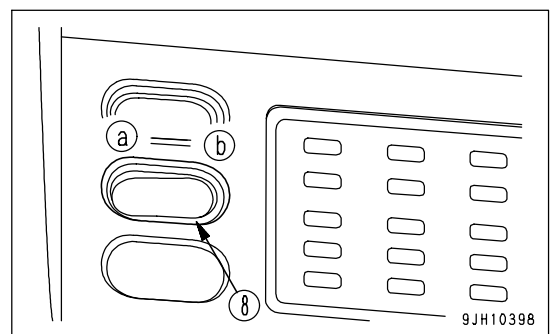

CONTROL LEVERS, PEDALS

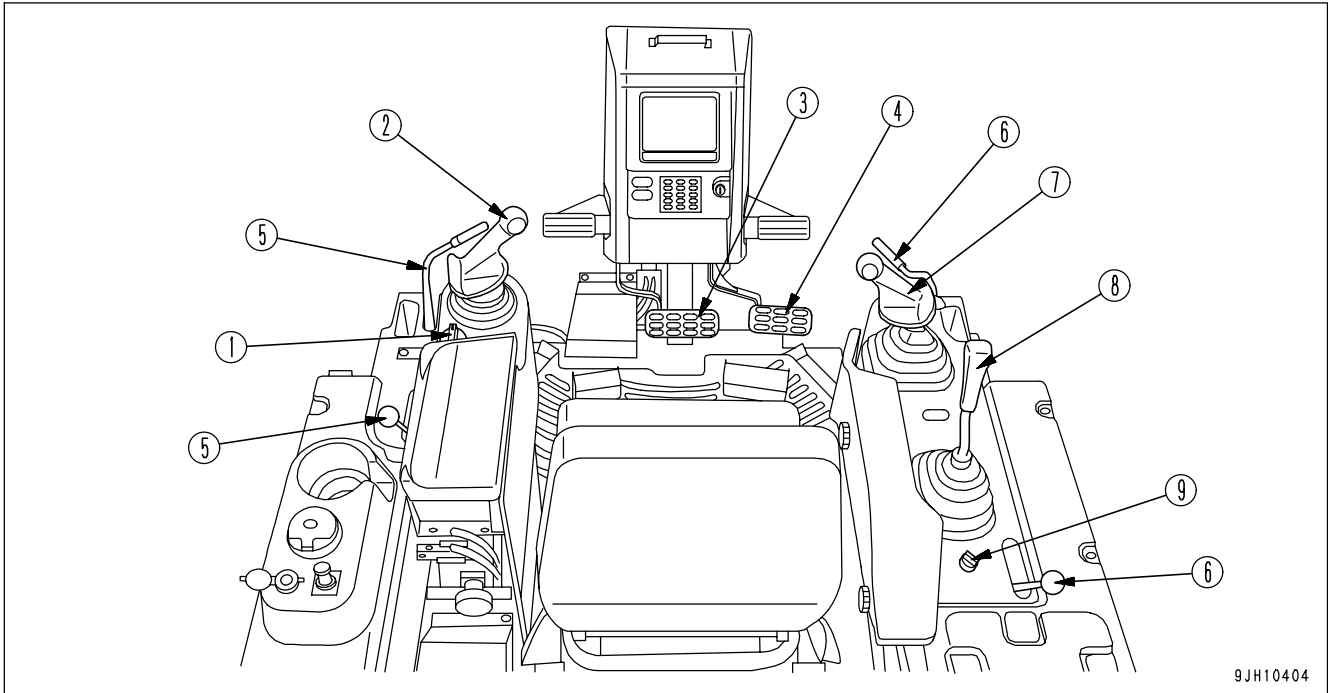

9JH10404

- | | |
|---|---|
| (1) Fuel control dial | (5) Parking brake lever |
| (2) Joystick (steering, directional and gear shift lever) | (6) Work equipment lock lever |
| (3) Brake pedal | (7) Blade control lever |
| (4) Deceleration pedal | (8) Ripper control lever |
| | (9) Pin puller control switch (if equipped) |

FUEL CONTROL DIAL

Dial (1) is used to control the engine speed and output.

- (a) Low idling position: Turn fully to the left
- (b) High idling position: Turn fully to the right

REMARK

When stopping the engine, turn the fuel control dial to the low idling position (MIN) and then switch off the engine.

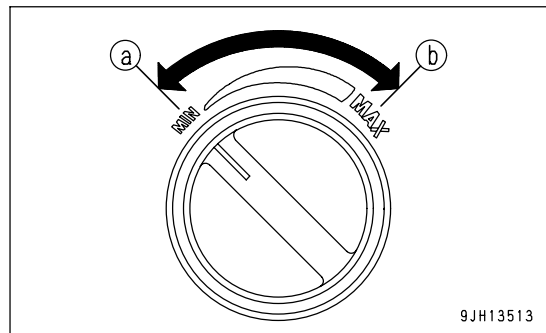

9JH13513

JOYSTICK (STEERING, DIRECTIONAL AND GEAR SHIFT LEVER)

(PCCS lever)

This lever (2) is used to switch between forward and reverse, to steer the machine, or carry out counterrotation turns.

REMARK

PCCS: Palm command control system

- **Forward-reverse shifting**

Position (a): FORWARD

Position (b): REVERSE

Position N: Neutral

Move to the front to drive forward; move to the rear to drive in reverse.

- **Steering**

Position (L): Left turn

Position (R): Right turn

With the lever moved to the front or rear, operate the lever partially to the left or right to turn the machine. The machine will turn gradually in the same direction as the lever is operated.

If the lever is moved fully to the left or right, the machine will turn in a small radius.

REMARK

If the lever is released when steering the machine, the lever will return to the (a) position or the (b) position and the machine will be returned to straight movement.

- **Gear shifting**

When the joystick (steering, direction, and gearshift lever) is in the FORWARD or REVERSE position, press switch (c) or (d) to shift the transmission.

up switch (c): Each time the switch is pressed, the transmission shifts up one speed range.

down switch (d): Each time the switch is pressed, the transmission shifts down one speed range.

For details of the maximum travel speed in each speed range, see "SPECIFICATIONS (PAGE 5-2)".

REMARK

- When the transmission is shifted, the speed range being used is displayed on the display panel on the monitor panel.

Example:

Neutral: N is displayed on the display panel.

FORWARD 2nd: F2 is displayed on the display panel.

REVERSE 3rd: R3 is displayed on the display panel.

When the parking lever is locked, P is displayed.

- For details of the gearshift operation using the shift mode, see "SHIFTING GEAR (PAGE 3-134)". Shift mode selection means the operation to set the selected speed range beforehand in the N position.

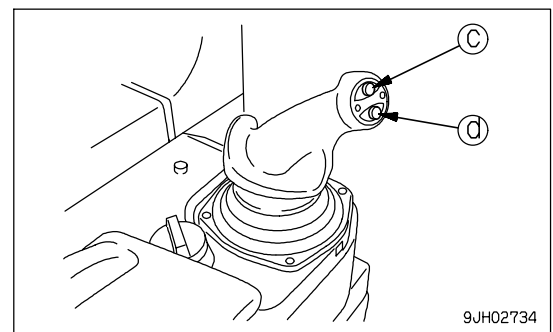
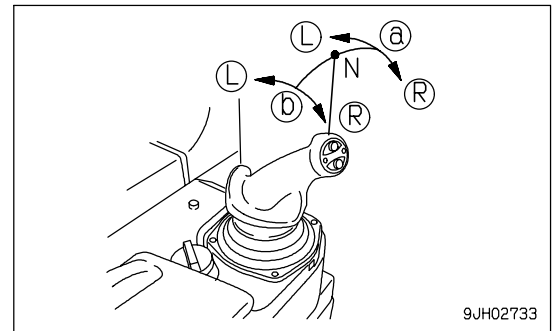

• Operating counter-rotation turn

! WARNING

When operating the counter-rotation turn, if the load on the left and right is not balanced, the machine may make a pivot turn, so check the ground conditions and be careful not to hit any obstacles when carrying out the operation.

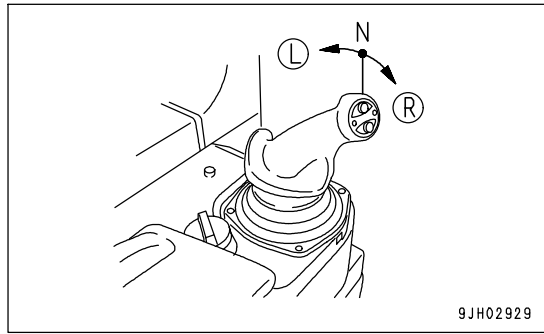

With the lever in the N position, move the lever partially in the direction of turn. The left and right tracks will rotate in opposite directions, and the machine will make a slow counter-rotation turn. If the lever is moved further, the speed of the counter-rotation turn will increase.

(R): Right counter-rotation turn

(L): Left counter-rotation turn

BRAKE PEDAL

! WARNING

Do not place your foot on this pedal unnecessarily.

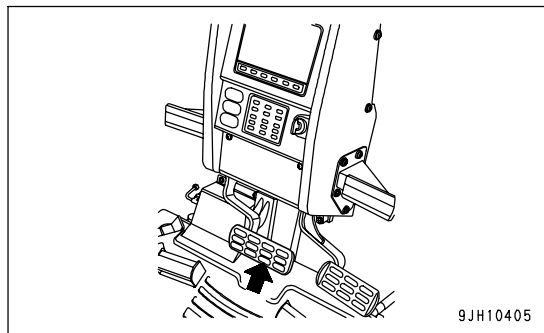

Depress the pedal (3) to apply the right and left brakes.

DECELERATOR PEDAL

! WARNING

- Do not rest your foot on the pedal if you are not using it.
- When passing over the top of a slope or when dumping soil from a cliff, the load on the machine will suddenly be reduced and the travel speed will increase. This situation is dangerous, so use the decelerator pedal to reduce the travel speed of the machine

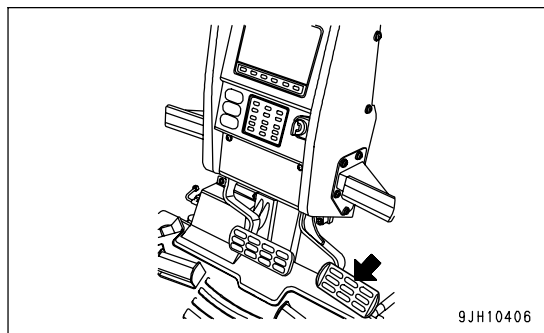

Pedal (4) is used when reducing engine speed or stopping the machine.

When switching between forward and reverse, or when stopping the machine, use this pedal to reduce speed.

PARKING BRAKE LEVER

 **WARNING**

When parking the machine, always set the parking brake lever to the LOCK position.

This lever (5) is used to apply the parking brake.

REMARK

- Before moving the parking brake lever to the LOCK position, return the steering, directional, and gearshift lever to the N position.
- When starting the engine, if the parking brake lever is not in the LOCK position, the limit switch is actuated and it is impossible to start the engine.

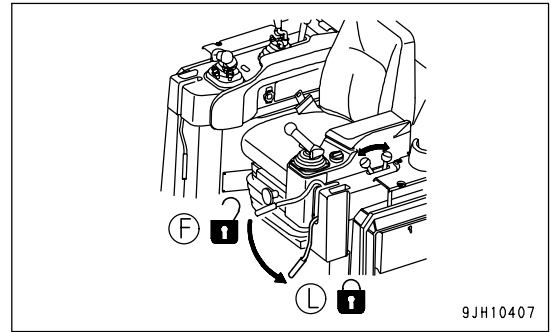

WORK EQUIPMENT LOCK LEVER

 **WARNING**

- When standing up from the operator's seat, always move the work equipment lock lever securely to the LOCK position. If the blade control and ripper control levers are not locked and are touched by accident, it may lead to serious injury or damage.
- If the work equipment lock lever is not completely in the LOCK position, the lock may not be applied. Check that it is in the position shown in the diagram.
- When parking the machine or when performing maintenance, always lower the blade or ripper to the ground, then set the work equipment lock lever to the LOCK position.

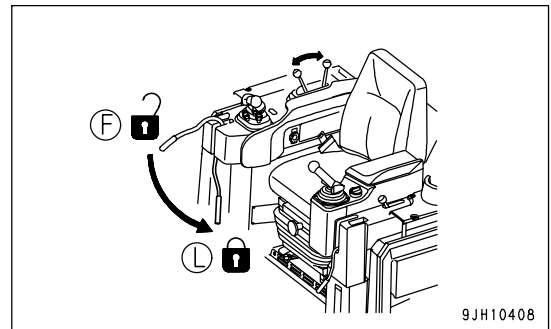

Lever (6) is a device to lock the blade control and ripper control levers.

When it is set to the LOCK position, the TILT, RAISE, LOWER, and FLOAT operations are locked.

REMARK

When starting the engine, to ensure safety, always place the work equipment lock lever at the LOCK position. If the work equipment lock lever is not at the LOCK position, the limit switch is actuated and the engine will not start.

BLADE CONTROL LEVER

Lever (7) is used to operate the blade.

SINGLE TILTDOZER

This lever is used to carry out the blade lift and tilt operations.

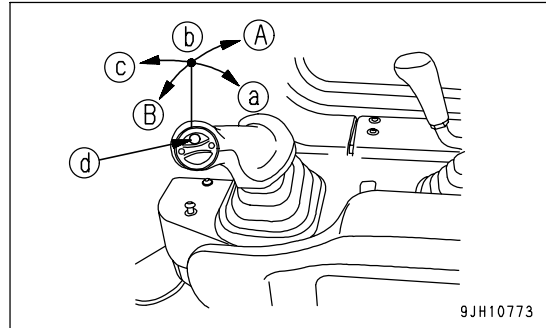

9JH10773

- Lifting control

- (a) RAISE
- (b) HOLD: Blade is stopped and held in position.
- (c) LOWER
- (d) FLOAT button: Blade moves freely under external force.

REMARK

- If the lever is not operated fully in the LOWER direction, it will not enter FLOAT. After operating the FLOAT mode switch on the monitor panel, keep the FLOAT button on the blade control lever pressed and operate the lever fully to the LOWER position. It will enter FLOAT.
- When using the FLOAT mode, the lever is not held in position.

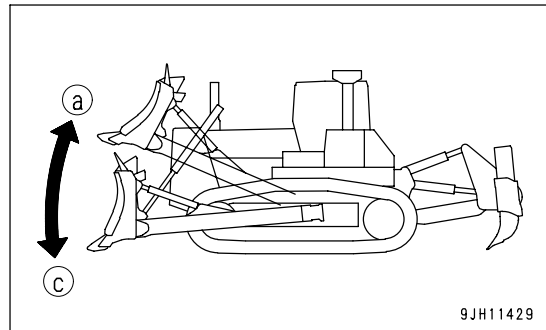

9JH11429

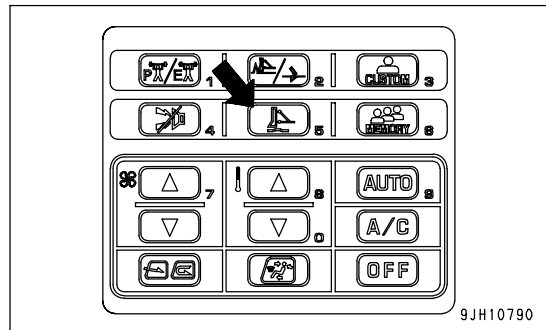

9JH10790

- TILT OPERATION

- (A) RIGHT TILT
- (B) LEFT TILT

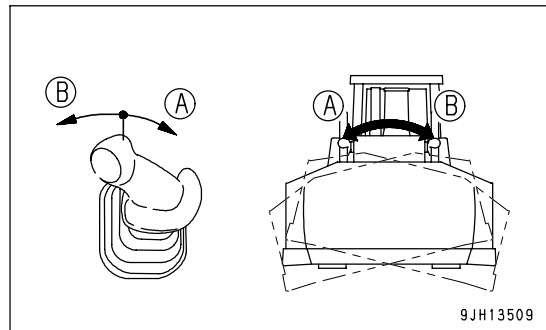

9JH13509

DUAL TILTDOZER

Press function switch F1 to change to the dual tilt mode.

This lever is used to carry out the blade lift, tilt, and pitch operations.

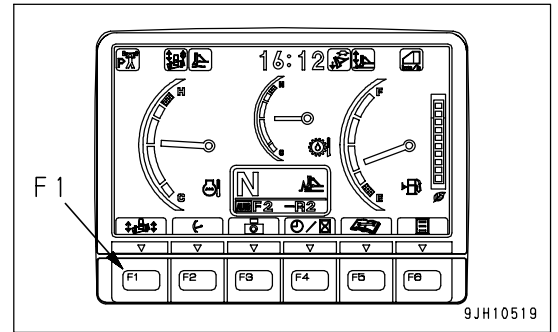

• Lifting control

- (a) RAISE
- (b) HOLD: Blade is stopped and held in position.
- (c) LOWER
- (d) FLOAT button: Blade moves freely under external force.
- (p) PITCH BUTTON

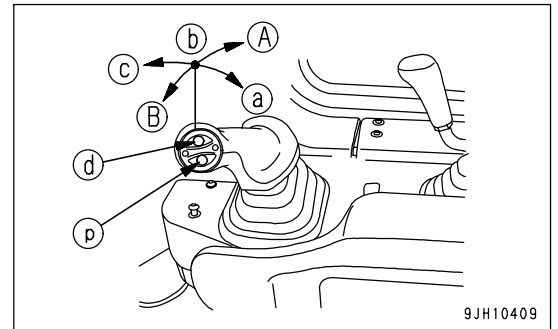

REMARK

- If the lever is not operated fully in the LOWER direction, it will not enter FLOAT. After operating the FLOAT mode switch on the monitor panel, keep the FLOAT button on the blade control lever pressed and operate the lever fully to the LOWER position. It will enter FLOAT.
- When using the FLOAT mode, the lever is not held in position.

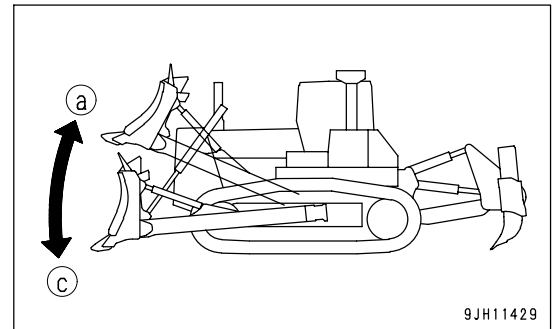

• TILT OPERATION

- (A) RIGHT TILT
- (B) LEFT TILT

REMARK

- With the dual tilt operation, a larger amount of tilt can be obtained than with the single tilt operation.
- With the dual tilt operation, the blade can be operated to RAISE, HOLD, or LOWER.

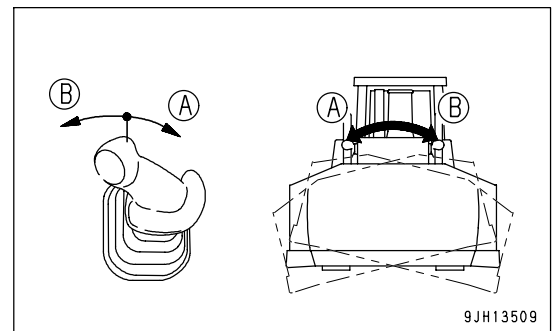

- Single tilt operation

Press function switch F1 to change to single tilt.

- (A) RIGHT TILT
- (B) LEFT TILT

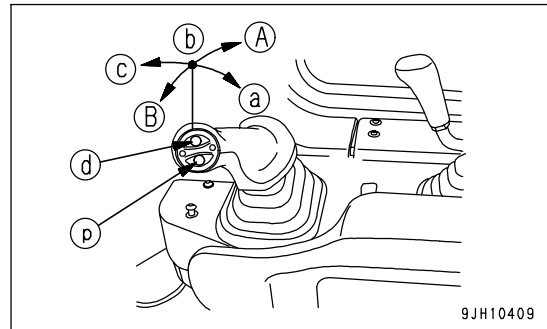
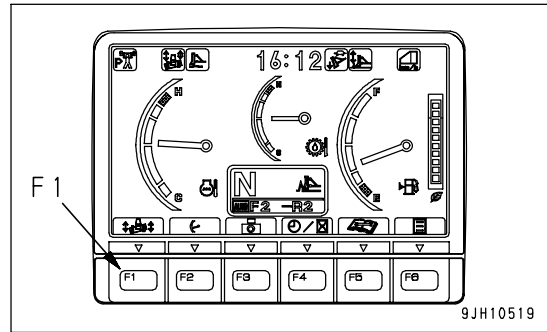

- Pitch control

Rear pitch (R)(cutting angle reduced)

Carry out operation (B) with the pitch button (p) pressed.

Forward pitch (F)(cutting angle increased)

Carry out operation (A) with the pitch button (p) pressed.

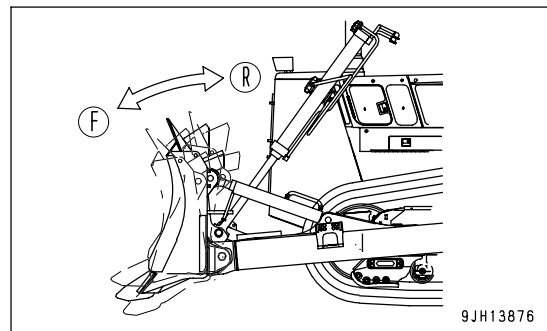

REMARK

- The pitch control can be operated at any of the RAISE, HOLD, or LOWER positions.
- To operate the pitch, keep the pitch button pressed and when the blade control lever is operated to the left or right, the movement begins.
- The pitch circuit is the priority circuit, so during single tilt operations and dual tilt operations, if the pitch button is pressed, the pitch is operated.

OPERATION OF BLADE FOR EACH MODE

Blade Fine Control mode (see "BLADE FINE CONTROL MODE MONITOR (PAGE 3-17)")

ON: Ability for fine control is better than when mode is OFF

OFF: Normal mode

Blade Slow Down mode (see "BLADE SLOW DOWN MONITOR (PAGE 3-17)")

ON: Blade goes down slowly to end of travel

OFF: The front blade begins to rapidly fall at an about 80% point of the control lever stroke.

RIPPER CONTROL LEVER

This lever (8) is used to operate the ripper.

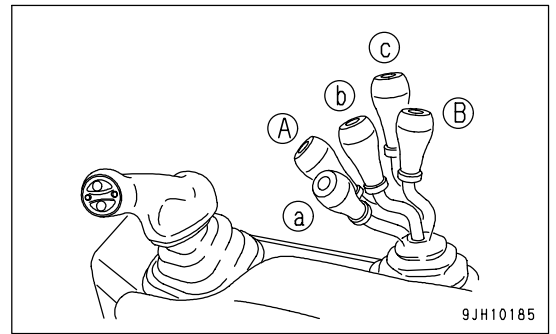

- (a) RAISE
- (b) HOLD: Ripper stops and stays in same position
- (c) LOWER

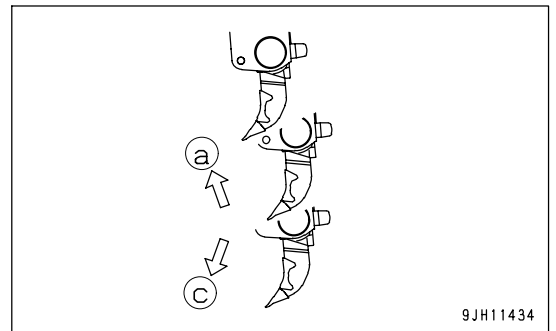

- (A) Digging angle reduced: Cutting angle (α) becomes smaller.
- (B) Digging angle increased: Cutting angle (α) becomes larger.

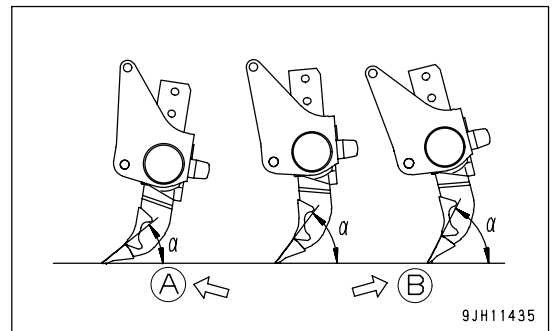

PIN PULLER CONTROL SWITCH

Switch (9) is used to operate the pin puller.

- (a) PULL OUT: Pin is pulled out.
- (b) PUSH IN: Pin is pushed in.

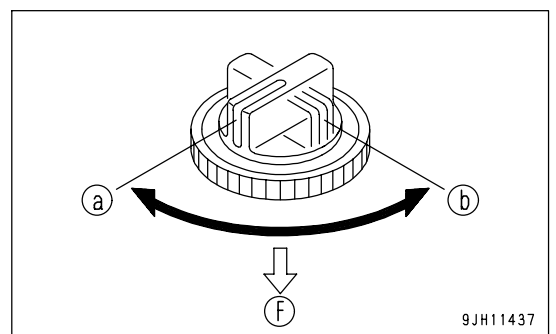

(F)Front of the machine

DUST INDICATOR

This is equipment to warn the operator that the air cleaner element has clogged up.

For an element cleaning method, see "CHECK, CLEAN AND REPLACE AIR CLEANER ELEMENT (PAGE 4-22)".

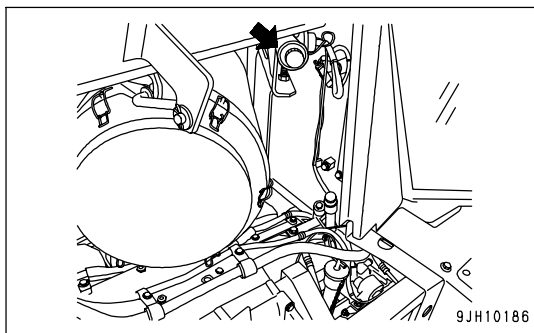

FUSE BOX

NOTICE

Before replacing a fuse, be sure to turn starting switch to the OFF position.

Fuses protect the electrical equipment and wiring from burning out.

If a fuse becomes corroded, or white powder can be seen, or a fuse is loose in the holder, replace the fuse.

Replace a fuse with another of the same capacity.

If the battery cover on the left side of the machine is opened, the fuse box and the circuit breaker can be seen inside.

(1) Fuse box FS2

(2) Fuse box FS1

(3) Circuit breaker

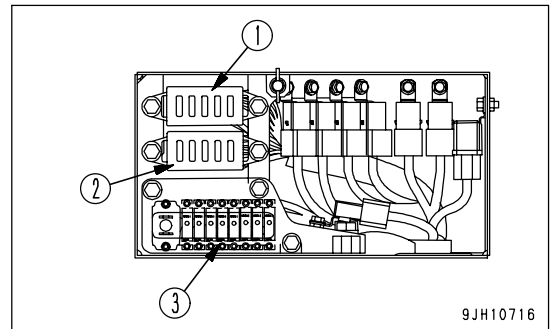

(4) Circuit breaker for main power supply

Open the battery cover inspection window at the rear left of the machine. The circuit breaker for the main power supply is inside

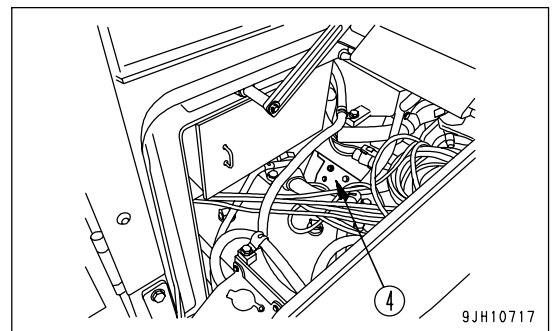

- Cab (machines equipped with cab)

Fuse box is installed at the bottom of the overhead panel.

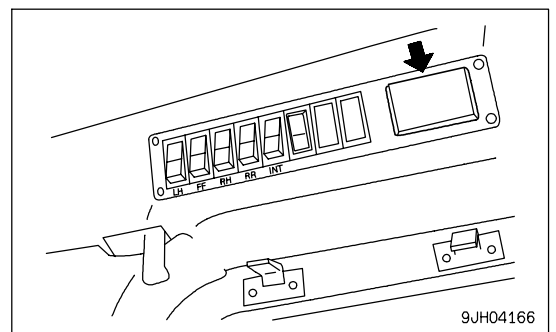

CIRCUIT BREAKER

- If the engine does not start up when the starting switch is turned to the ON position, open up the battery cover and check the battery.
- If excessive current flows through the circuit breaker, it cuts off the electric circuit to prevent damage to the electrical components and wiring.
- To restore the electric circuit after it has been cut off, push in reset button (9). (This springs out when the circuit is cut off.) If the electric circuit is normal, reset button (9) will stay pushed in. If it comes out immediately when it is pushed in, the electric circuit must be checked.

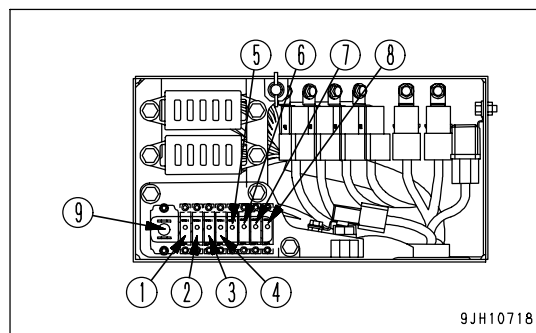

No	Fuse capacity	Circuit
(1)	20A	Permanently ON power source
(2)	20A	Starting switch
(3)	20A	Rear lamp
(4)	20A	Front lamp
(5)	20A	Air conditioner
(6)	20A	Work equipment controller
(7)	20A	Power train controller
(8)	20A	Option

REMARK

The circuit breaker is a device installed in electric circuits where a large current flows. It is installed to protect the electric circuit. It protects the electric components and wiring from damage caused by an abnormal current in the same way as a normal fuse. After repairing and restoring the location of the abnormality, there is no need to replace the breaker. It can be used again.

CIRCUIT BREAKER FOR MAIN POWER SUPPLY

- If the starting motor is not actuated when the starting motor is turned ON, open the battery cover inspection window at the rear left of the machine and inspect circuit breakers (A) and (B). (A) and (B) also act as the reset button.
- If there is a surge of current, the circuit breaker shuts off the circuit to protect the electrical components and wiring from damage.

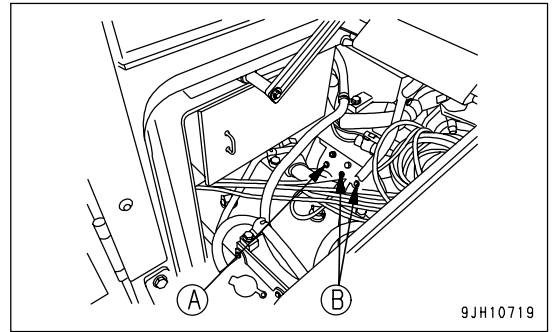

- Turn the starting switch to the OFF position and reset the circuit breaker.
- When resetting the electrical circuit after it has been shut off, press the reset button 5 to 10 minutes after the circuit has been shut off. When the electrical circuit has been shut off, the operation of the reset button is heavier than when the circuit is normal. The height of the reset button is the same, regardless of whether the circuit has been shut off or has been reset, so make note of the effort of the reset button when resetting the circuit.
- Do not keep the circuit breaker reset button longer than necessary.
- If the starting motor does not work even when the circuit breaker has been reset, contact your Komatsu distributor.

REMARK

The capacity of circuit breakers (A) and (B) is as follows.

(A): 30A (for regular cab power supply)

(B): 105A (for general power supply)

FUSE CAPACITY AND NAME OF CIRCUIT

FUSE BOX I

(1) Fuse box fs1

NO.	Fuse capacity	Circuit
1	20A	Permanently ON power source
2	5A	Backup alarm
3	20A	Main power source 1
4	20A	Main power source 2
5	5A	ACC signal (engine)

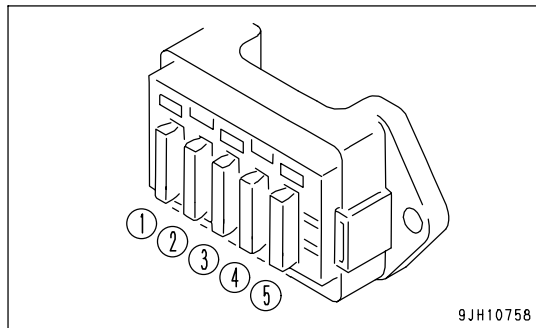

(2) Fuse box fs2

NO.	Fuse capacity	Circuit
1	5A	Pedal brake
2	5A	Parking brake
3	20A	Pin puller, ribbon heater
4	5A	Horn
5	20A	Key ACC

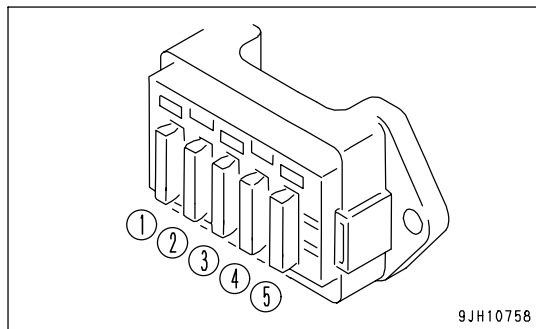

FUSE BOX II

NO.	Fuse capacity	Circuit
(1)	10A	Radio
(2)	20A	Additional work lamp
(3)	20A	12V socket
(4)	20A	Radio, lamp, cigarette lighter
(5)	10A	Front wiper, rear wiper
(6)	10A	Left and right door wiper

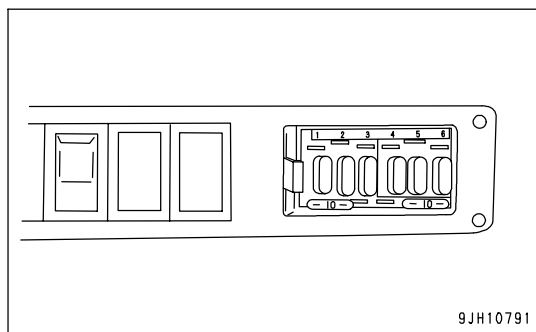

CAP WITH LOCK

Lock-type caps are available for the radiator water filler, power train case oil filler cap, and hydraulic tank oil filler cap. For details of the locations of the caps with locks, see "LOCKING (PAGE 3-148)".

OPENING AND CLOSING CAP WITH LOCK

Use the starting switch key to open and close the locks on the caps except fuel tank cap. The method of opening or closing the locks on the caps are as follows.

OPENING THE COVER

1. Insert the key. Make sure that you have inserted the key fully (1) before turning it. If the key is turned when only partially inserted, it may break.

(L) : Lock position

(F) : Open position

(A) : working angle of key 180°

(B) : 45°

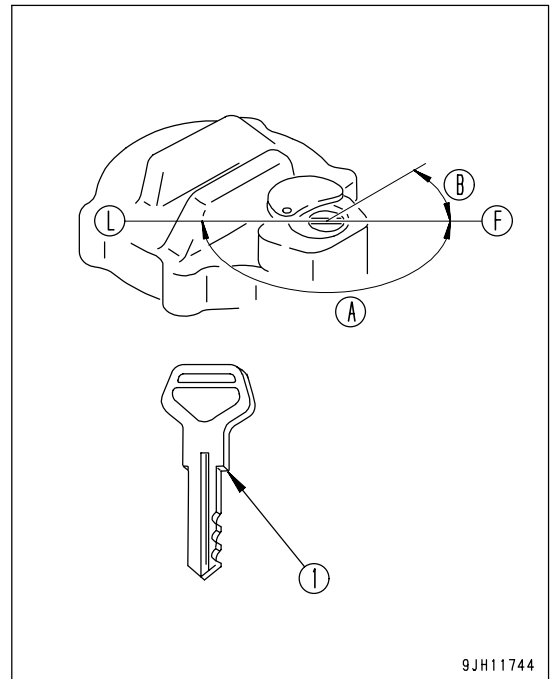

2. Turn the key counterclockwise to align the match mark (2) on the cap with the rotor groove, then turn the cap slowly. When a click is heard, the lock is released, enabling the cap to be opened.

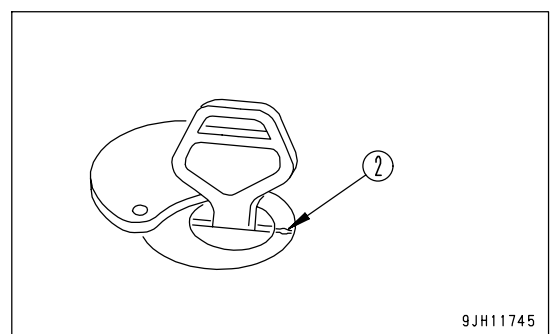

LOCKING THE COVER

1. Turn the cap into place.
2. Turn the key clockwise and take the key out.

METHOD OF OPENING FUEL CAP

The method of opening or closing the fuel tank cap is as follows.

OPENING THE CAP

1. Raise lever (1) in the (a) direction.
2. When lever (1) is turned in the (c) direction (counterclockwise) by approx 35°, it stops at the stopper, and the cap can be opened.

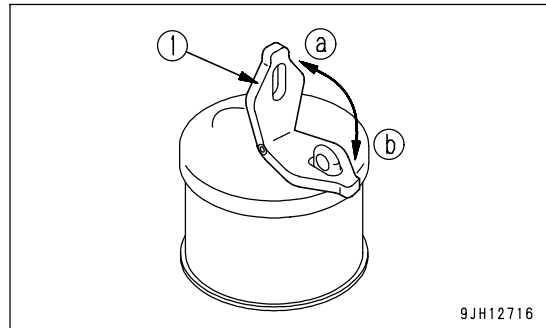
**CLOSING THE CAP**

1. After turning lever (1) in the (c) direction (counterclockwise), keep it in that position and fit the cap.
2. Turn lever (1) in the (d) direction (clockwise) until it stops at the stopper, and then tilt it in the (b) direction.

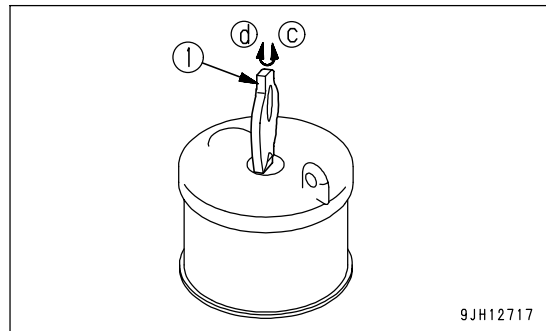

DOOR POCKET

These are inside the left and right doors and can be used for keeping small objects.

Do not put heavy objects such as tools in the pockets.

If the pocket is dirty, turn 2 bolts (1), remove the pocket, and wash it in water.

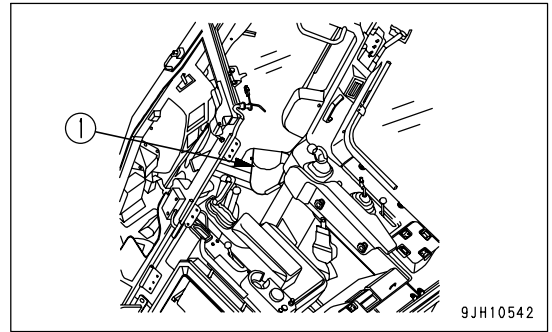

ASHTRAY

This is on the left side of the operator's seat.

Always make sure that you extinguish the cigarette before closing the lid.

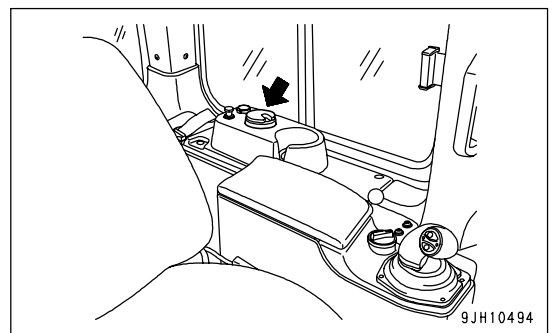

CAR RADIO, HANDLING

EXPLANATION OF COMPONENTS

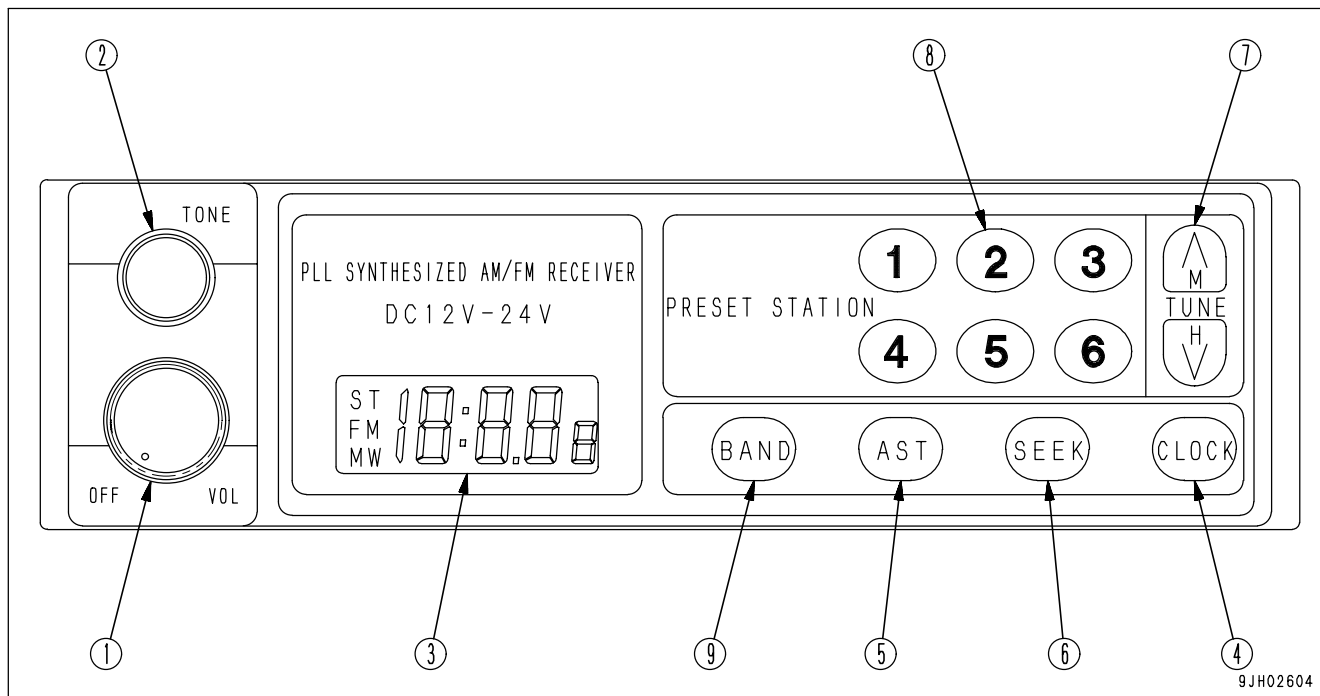

- | | |
|-------------------------------------|----------------------------------|
| (1) Power switch, volume knob | (6) Seek button (SEEK) |
| (2) Tone control knob | (7) Tuning button |
| (3) Display | (8) Preset station buttons |
| (4) Display selector button (CLOCK) | (9) FM/AM selector button (BAND) |
| (5) Station selector button (AST) | |

POWER SWITCH, VOLUME KNOB

When this knob (1) is turned clockwise from the OFF position, a click is heard and the power is turned on. If it is turned further clockwise, the sound from the speakers will gradually increase.

TONE CONTROL KNOB

When this knob (2) is turned clockwise, the high tone is emphasized; when it is turned counterclockwise, the high tone is reduced.

DISPLAY

This display (3) shows the time and the frequency of the signal being received.

DISPLAY SELECTOR BUTTON (CLOCK)

When this button (4) is pressed, the display switches to the clock display. If it is pressed again, the radio frequency is displayed.

STATION SELECTOR BUTTON (AST)

When this button (5) is pressed, the preset stations are called up in turn. When the desired broadcasting station is reached, press the button again to stop it.

If this button is kept pressed for 2 seconds, it switches to auto memory.

SEEK BUTTON (SEEK)

When this button (6) is pressed, it automatically searches for stations that can be received. When it finds a station that can be received, it stops.

TUNING BUTTON

When the ∨ part of this button (7) is pressed, the frequency goes up; when the ∧ part of this button (7) is pressed, the frequency goes down. If the button is kept pressed, the frequency changes continuously.

PRESET BUTTON

When this button (8) is pressed, it is possible to preset one station each for FM and AM.

For details of the method of presetting, see "METHOD OF PRESETTING (PAGE 3-75)".

FM/AM SELECTOR BUTTON (BAND)

When this button (9) is pressed, the band switches between FM and AM. Each time the button is pressed, it switches AM → FM → AM.

METHOD OF USE

METHOD OF LISTENING TO RADIO

1. Turn the starting switch ON, then turn radio power switch (1) ON.
2. Use BAND button (9) to select AM or FM.
3. Select the channel with PRESET STATION button (8) or TUNE button (7).
4. Turn volume knob (1) and TONE control knob (2) to set to the desired volume and tone.
5. To turn the radio OFF, turn the power switch (1) counterclockwise until a click is heard.

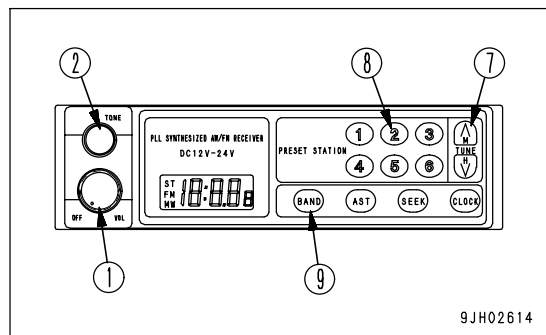
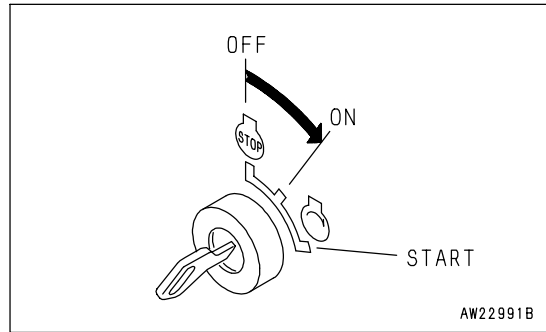

METHOD OF AUTOMATIC TUNING

When SEEK button (6) is pressed, the frequency will move up to a channel that can be received, and then will stop automatically.

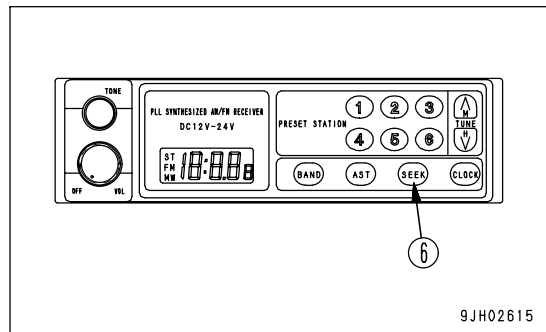

MANUAL STATION SELECTION

If the v part of TUNE button (7) is pressed, the frequency will go up; if the ^ part of the button is pressed, the frequency will go down. If the button is kept pressed, the frequency will move up or down continuously.

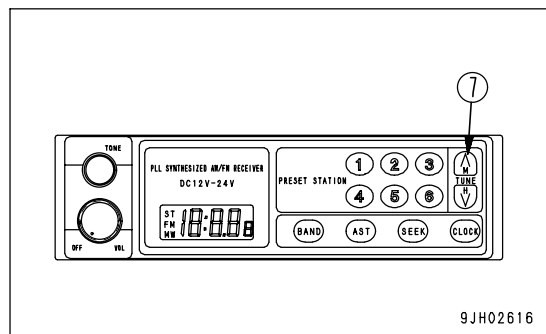

METHOD OF PRESETTING

1. Select the desired preset station.
Use BAND button (9) to select FM or AM, then use TUNE button (7) to select the frequency of the broadcasting station.
2. Decide one of preset buttons (8) to be used for the preset station, and keep it pressed for 2 seconds. The number of the button will be shown on display (3) and the presetting is completed.
3. Repeat Steps 1 - 2 to preset the other broadcasting stations.
 - To change the setting of a preset button to another station, repeat Steps 1 - 2.
 - If the battery is replaced or the power is switched off, all the preset settings are deleted. Carry out the presetting operation again.
 - It is possible to preset 6 FM and 6 AM stations.

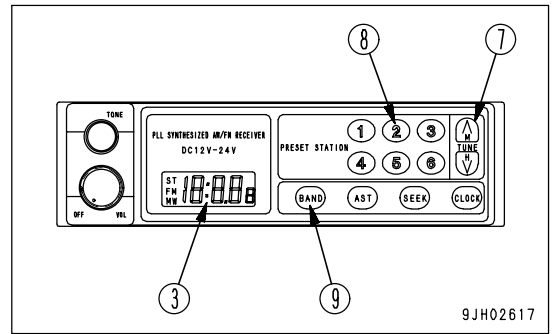

METHOD OF USING AUTO MEMORY

If AST button (5) is kept pressed for 2 seconds, the broadcasting stations that can be received in the area are called up in turn, and the broadcasting stations are automatically saved in the preset memory.

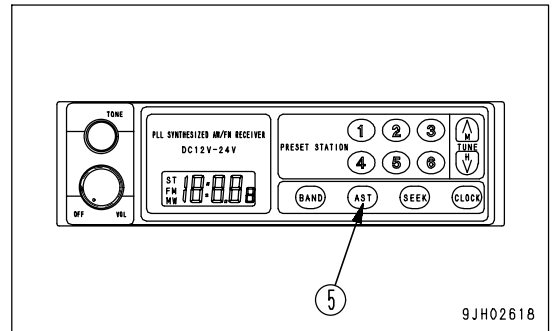

METHOD OF SETTING TIME

1. Turn the starting switch ON, then turn radio power switch (1) ON.
If display (3) is showing the frequency, press display selector button (4) to display the time.
2. To set the time, keep the CLOCK button (4) pressed, and Press the ∨ part of TUNE button (7) to change the minutes Press the ∧ part of TUNE button (7) to change the hours

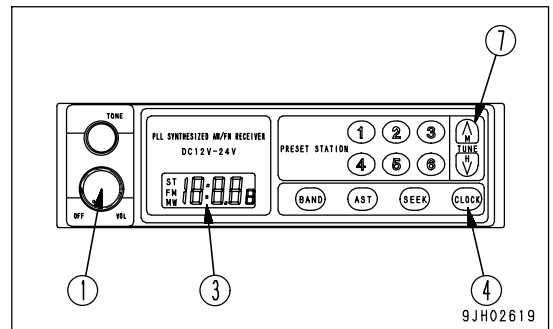
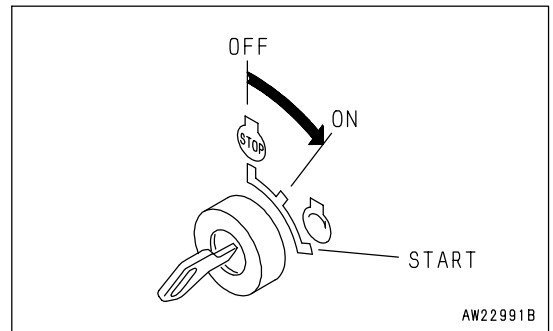

MONAURAL/STEREO AUTOMATIC SELECTION RECEPTION

If the reception of the FM stereo broadcast is weak (when you are far from the broadcasting station or are surrounded by hills), the radio is automatically switched from stereo to monaural to reduce the interference. When the stereo broadcast becomes stronger, it automatically switches back to stereo broadcasting.

ANTENNA**NOTICE**

When transporting the machine or parking it in a garage, always fully retract the antenna to avoid the possibility of breakage.

PRECAUTIONS WHEN USING

- To ensure safety, always keep the sound to a level where it is possible to hear outside sounds during operation.
- If water gets into the speaker case or radio, it may lead to an unexpected failure, so be careful not to get water on the equipment.
- Do not wipe the scales or buttons with solvent such as benzene or thinner. Wipe with a dry soft cloth. If the dirt cannot be removed easily, soak the cloth with alcohol.
- When the battery is replaced, the settings for the preset buttons are all cleared, so set them again.

CAR STEREO, HANDLING

EXPLANATION OF COMPONENTS

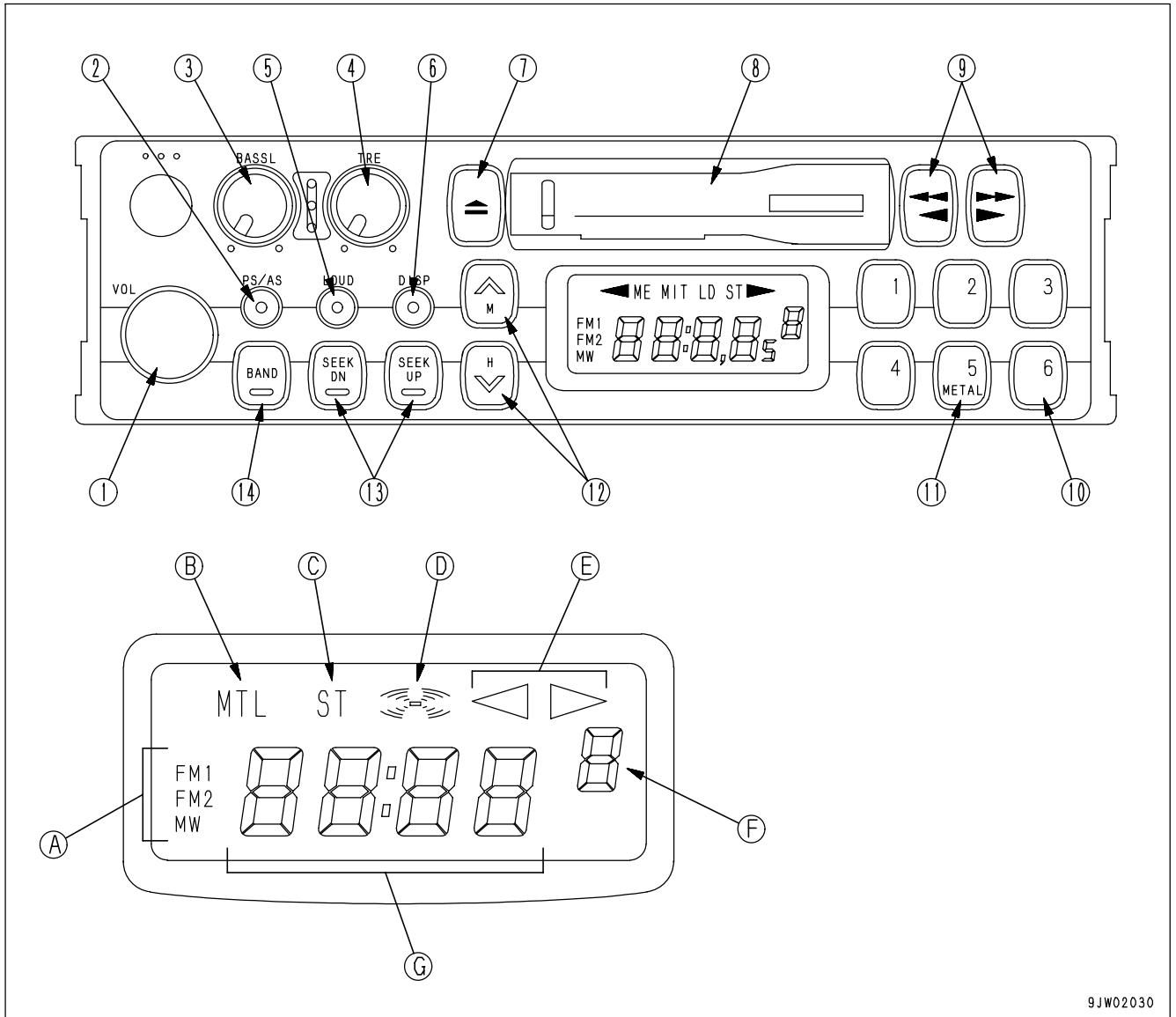

9JW02030

- | | |
|--|----------------------------------|
| (1) Power switch/volume | (8) Cassette door |
| (2) Auto-store/preset scan button | (9) Fast forward, rewind buttons |
| (3) Bass control knob | (10) Preset buttons |
| (4) Treble control knob | (11) Metal tape button |
| (5) Loudness button | (12) Manual tuning buttons |
| (6) Time/radio display selector button | (13) Seek tuning buttons |
| (7) Tape eject button | (14) Band selector button |
-
- | | |
|---------------------------------|----------------------------|
| (A) Band display | (E) Tape direction display |
| (B) Metal tape display | (F) Preset channel display |
| (C) FM stereo reception display | (G) Time/frequency display |
| (D) Loudness display | |

POWER SWITCH/VOLUME

Turn this knob (1) to the right until it clicks to turn the power on.
Turn it further to increase the volume.

AUTO-STORE/PRESET SCAN BUTTON

Use this button (2) to actuate the preset scan and auto-store functions.

- Auto-store

Each time this button is pressed for more than 2 seconds while in radio reception, this auto-store function automatically starts to search for the desired station within a receivable band, and memorize the frequency in the preset memory. During this scanning process, the frequency shown in the right side of display continues to change. This indicates that each frequency is memorized in the auto-store.

REMARK

The auto-store function cannot be used when the channel display is flashing.
When the display is flashing, the preset scan function is being used.

BASS CONTROL KNOB

Turn this knob (3) to the right to emphasize the low tone; turn it to the left to reduce the low tone.
Counterclockwise: Reduce low tone
Clockwise: Emphasize low tone

TREBLE CONTROL KNOB

Turn this knob (4) to the right to emphasize the high tone; turn it to the left to reduce the high tone.
Counterclockwise: Reduce high tone
Clockwise: Emphasize high tone

LOUDNESS BUTTON

This button (5) is used when playing at low volume. It makes it possible to hear more easily by emphasizing the low tone when the low tones are weak.
Push button: Actuated (ON)
Push button again: Canceled (OFF)

TIME/RADIO DISPLAY SELECTOR BUTTON

This button (6) is used to switch between the "Radio/tape display" and the "Time display".

- Correcting time

Press the button to set to the time display.

(A) Correcting hour :

Keep the DISP button pressed and press the bottom tuning button (H) to correct the hour.

(B) Correcting minute :

Keep the DISP button pressed and press the top tuning button (M) to correct the minute.

TAPE EJECT BUTTON

This button (7) is used to stop the tape and to eject the cassette.
When this button is pressed, the tape is ejected and the radio plays.

CASSETTE DOOR

Set the cassette with the exposed portion of the tape on the right side and insert it through the cassette door (8).

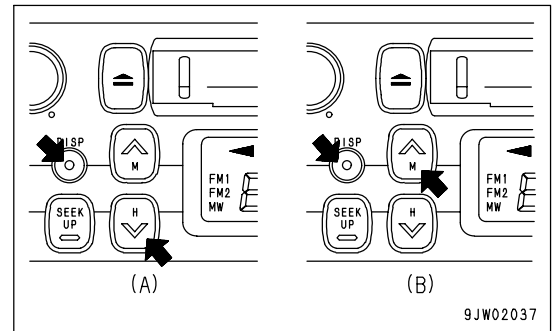

FAST FORWARD, REWIND BUTTONS

These buttons (9) are used to fast-forward or rewind the tape.

- Fast forward/rewind

If you press the button pointing in the same direction as the arrow indicating the direction of play, the tape will be fast forwarded; if you press the button pointing in the opposite direction, the tape will be rewound.

To stop the tape, lightly press the button that is not locked. The fast forward or rewind operation will be canceled.

PRESET BUTTONS

These buttons (10) are used to call up the broadcast station frequencies preset in memory for each of buttons No. 1 to No. 6.

It is possible to preset 18 stations (FM: 12; AM: 6) with these buttons.

METAL TAPE BUTTON

(used also for preset button No. 5)

This button (11) is used when playing a metal or chrome tape. This button is also used for preset button No. 5. When it is pressed, "MTL" appears on the display.

MANUAL TUNING BUTTONS

These buttons (12) are used for manual tuning.

When "TUN ^" button is pressed, the frequency goes up 9 kHz for AM or 0.1 MHz for FM; when "TUN v" button is pressed, the frequency goes down 9 kHz for AM or 0.1 MHz for FM.

If the button is pressed down and held, the frequency will change continuously.

SEEK TUNING BUTTONS

These buttons (13) are used to seek tuning.

When the "SEEK UP" button is pressed, the search automatically goes up; when the "SEEK DN" button is pressed, the search automatically goes down.

When the next station that can be received is found, it automatically stops.

BAND SELECTOR BUTTON

When this button (14) is pressed, the band is switched between FM1, FM2, and MW (AM). The band is shown on the display.

METHOD OF OPERATION

METHOD OF SETTING PRESET BUTTONS

To listen to a preset station, use band selector button (1) to select AM, FM1, or FM2, then press the preset switch number to listen to the desired station.

It is possible to preset six AM stations and 12 FM stations (FM1: 6, FM2: 6).

1. If you are playing a cassette, press the tape eject button to stop the tape.
2. Select the station to be preset.
Use band selector button (1) to select MW (AM), FM1, or FM2, then use the manual tuning button to select the frequency of the broadcasting station.
3. Press manual memory button (2) or seek tuning button (3).
4. Press preset button (4) of the number to be preset for 2 seconds while the frequency display is being shown on the display. (The preset channel and frequency are displayed and the presetting is completed).
5. Repeat Steps 2 to 4 to preset other stations.

REMARK

- Use Steps 2 to 4 also when changing the setting of a preset switch to another station.
- When the power is disconnected, such as when the battery is replaced, all the settings are deleted, so preset the stations again.

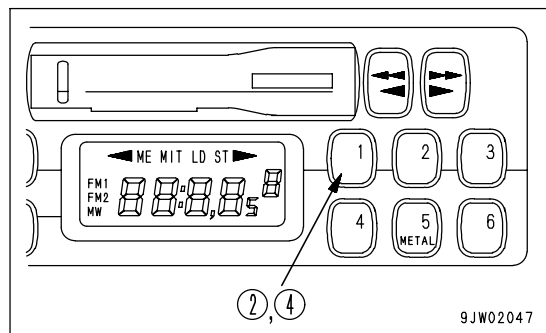
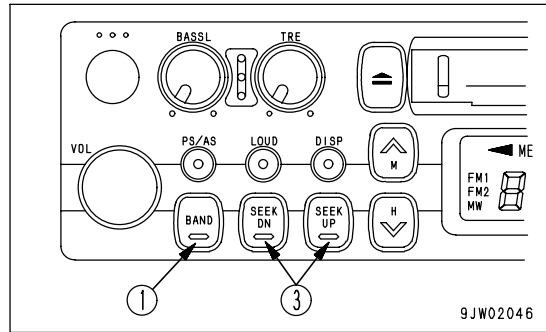

MANUAL MEMORY BUTTON

Select the station to be preset with manual tuning button (1) or seek tuning button (2), then keep button No.1 to button No.6 of button (3) pressed for 2 seconds while the frequency is being displayed to preset the station.

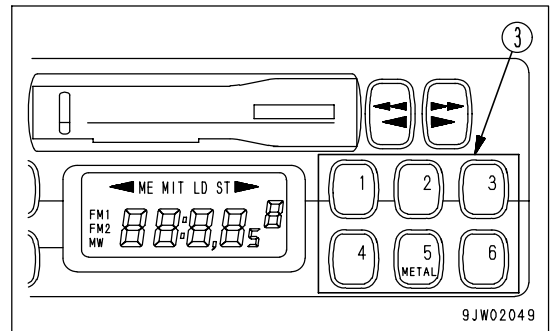
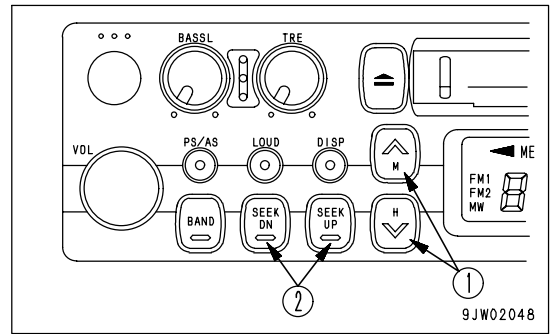

LISTENING TO RADIO

1. Turn the starting switch ON, then turn power switch (1) ON.
2. Set band selector button (2) to AM or FM.
3. Select the station with the preset buttons or manual tuning button (3).
4. Adjust the volume, balance, and tone as desired.
5. When turning the radio OFF, turn power switch (1) to the left until it clicks.

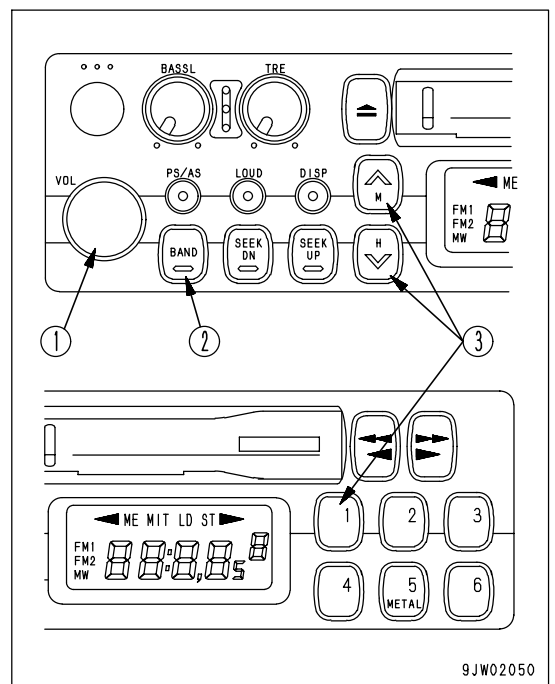

REMARK

- To switch to the radio when listening to a cassette, press the cassette eject button to stop the tape.
- If you insert a cassette when listening to the radio, the tape will start to play.

LISTENING TO CASSETTE TAPE

1. Turn the starting switch ON, then turn power switch (1) ON.
2. Set the cassette with the exposed portion of the tape on the right side and push it past the cassette door. The tape will automatically start playing.
If the arrow indicating the direction of play is pointing to the right, the top side is being played; if the arrow is pointing to the left, the bottom side is being played.
When the tape reaches the end, it is automatically reversed and the other side starts to play.
3. When finished with the tape, press the cassette eject button to eject the tape and automatically switch to the radio.

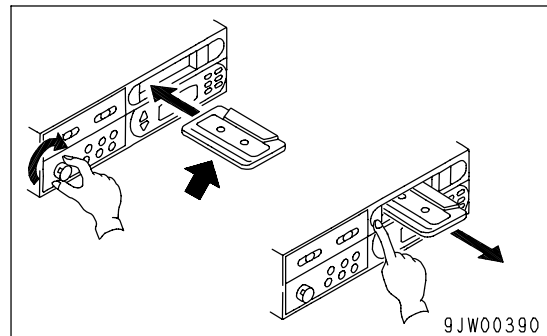
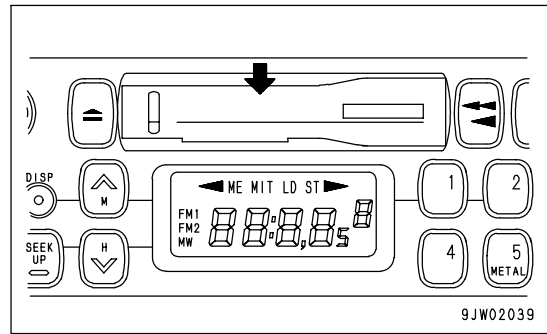

REVERSING TAPE

When listening to the tape, press both FAST FORWARD, REWIND buttons (A) and (B) at the same time lightly. When this is done, the tape direction display will be reversed.

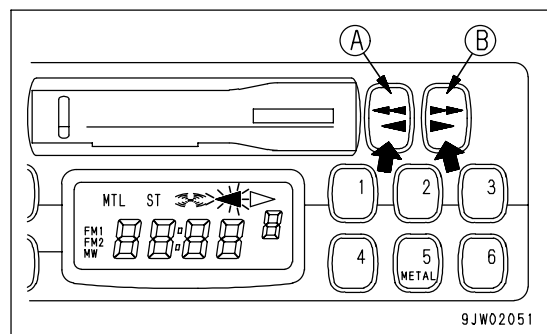

PRECAUTION WHEN USING**WARNING**

- If a voltage greater than the specified voltage is input, it may cause fire, electrocution, or other failure. Never input any voltage other than the specified voltage.
- Places inside the radio are under high voltage. Do not remove the cover.
- Do not carry out any modifications. This may cause fire, electrocution, or other failure.
- If the sound cannot be heard, nothing is displayed, or any other problem occurs, turn off the power switch and ask your Komatsu distributor to make repairs without delay.

- Stow the antenna when traveling in places with low overhead clearance.
- To ensure safety during operations, keep the volume at a level where it is possible to hear other machines.
- If water gets inside the speaker case or radio (auto tuning), it may cause a serious problem, take care not to let water get in these items.
- Do not wipe the scales or buttons with solvent such as benzene or thinner. Wipe with a dry soft cloth. If the dirt cannot be removed easily, soak the cloth with alcohol.

NOTICE**Handling cassette tape**

- Clean the tape head approx. once a month with a commercially available head cleaning tape.
- Do not leave the tape any place where it is exposed to direct sunlight, any place that is excessively dusty, or any place where there is a magnetic field.
- Do not use 120-minute tapes. The tape is thin and it easily gets caught up inside the machine.
- If the tape is slack, it easily gets caught up inside the machine. Use a pencil to wind in the tape to remove any slack.
- Do not use any cassette tape if the label has started to come off. It may cause defective rotation, or it may be impossible to get the tape out of the machine.

HANDLING AIR CONDITIONER

GENERAL LOCATIONS OF CONTROL PANEL

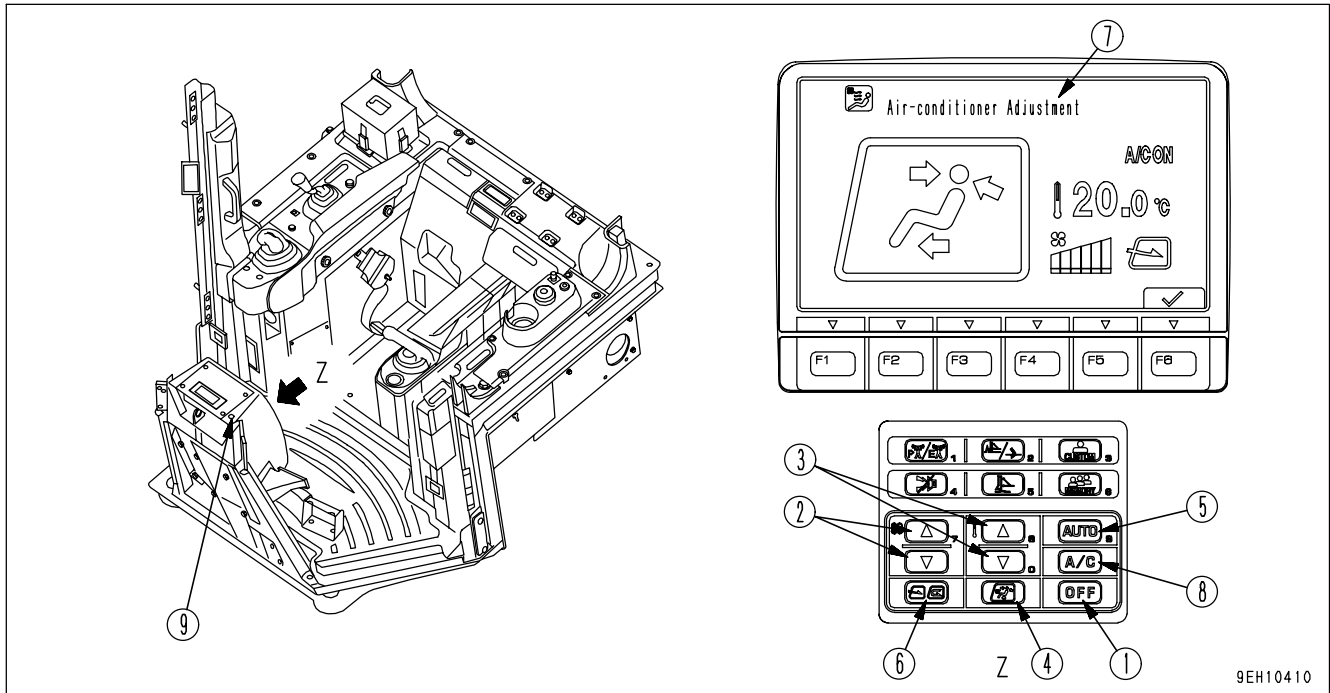

- (1) OFF switch
- (2) Fan switch
- (3) Temperature control switch
- (4) Vent selector switch
- (5) Auto switch
- (6) FRESH/RECIRC selector switch
- (7) Display monitor
- (8) Air conditioner switch
- (9) Sunlight sensor

OFF SWITCH

Switch (1) is used to stop the fan and air conditioner.

REMARK

Even if this switch (1) is pressed, the monitor screen does not switch to the air conditioner adjustment screen.

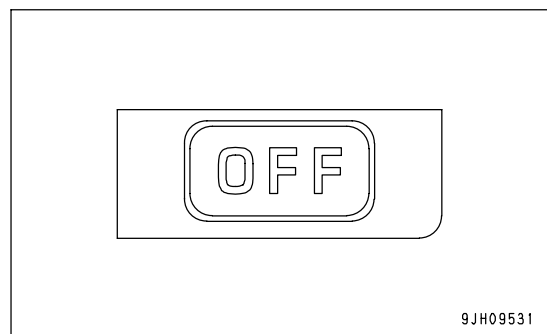

9JH09531

FAN SWITCH

Switch (2) is used to adjust the air flow.

The air flow can be adjusted to six levels.

- Press the \triangle switch to increase the air flow; press the ∇ switch to decrease the air flow.
- During auto operation, the air flow is automatically adjusted.

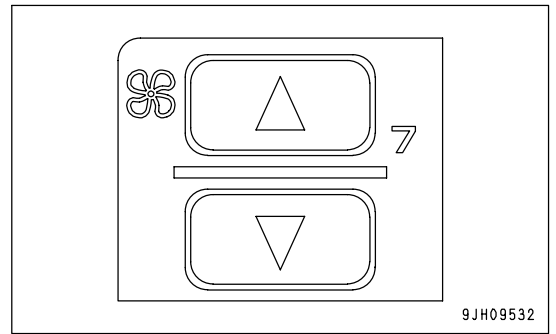

A: Liquid crystal display

B: Air flow

a: Air flow "low"

b: Air flow "medium 1"

c: Air flow "medium 2"

d: Air flow "medium 3"

e: Air flow "medium 4"

f: Air flow "high"

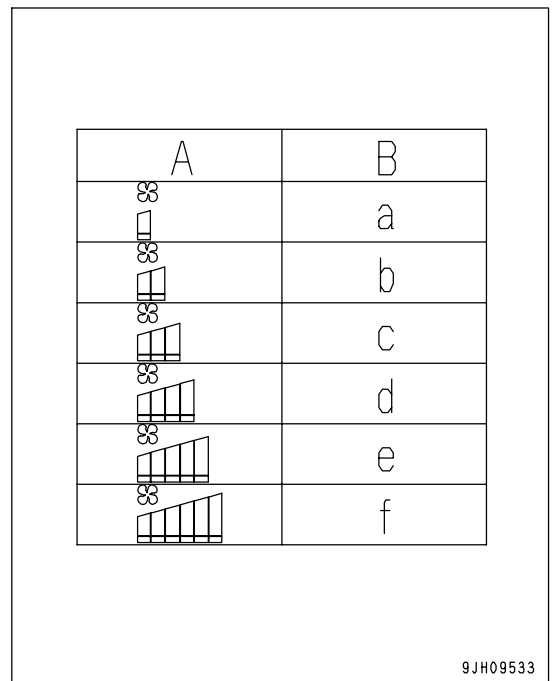

TEMPERATURE CONTROL SWITCH

Switch (3) is used to control temperature inside the cab. The temperature can be set between 18°C (64.4°F) and 32°C (89.6°F).

- Press the \triangle switch to raise the set temperature; press the ∇ switch to lower the set temperature.
- The temperature is generally set at 25°C (77°F).
- The temperature can be set in stages of 0.5°C (0.9°F).

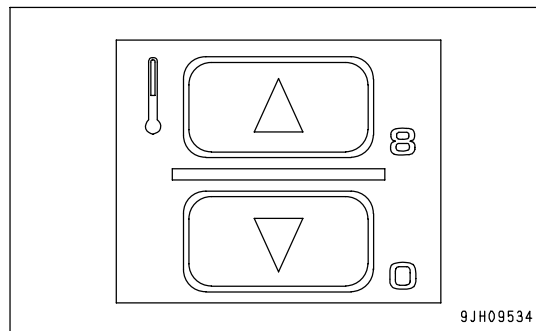

<Monitor display and the function>

Monitor display °C	Set temperature
18.0	Max. cooling
18.5 to 31.5	Adjusts temperature inside cab to set temperature
32.0	Max. heating

REMARK

If the mode is set to auto mode and the temperature setting is set to 18.0 °C (64.4 °F) or 32.0 °C (89.6 °F), the air flow from the fan is always set to HIGH and does not change even when the set temperature is reached.

VENT SELECTOR SWITCH

Switch (4) is used to select the vents.

- When switch (4) is pressed, the display on monitor display (7) switches and air blows out from the vents displayed.
- During automatic operation, the vents are automatically selected.

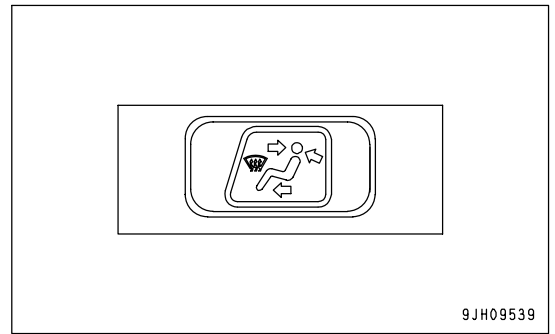

- (A1): Face vent (right and left 1 place)
- (A2): Rear vent (2 places)
- (A3): Front vent (1 place)
- (B): Foot vent (1 place)
- (C1): Door glass vent (right and left 2 places)
- (C2): Front window glass vent (1 place)

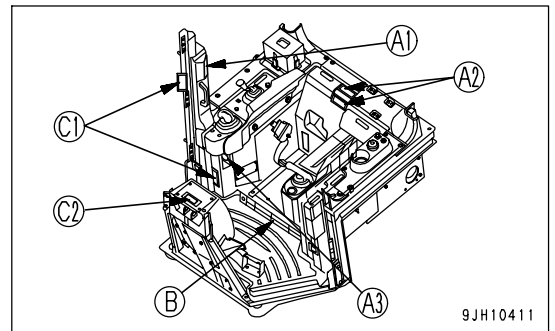

Liquid crystal display	Vent mode	Vent			Remarks
		(A)	(B)	(C)	
	Front and rear vents	○			-
	Front, rear and foot vents	○	○		-
	Foot vent		○		-
	Foot vent Defroster vent		○	○	Cannot be selected for automatic operation
	Defroster vent			○	Cannot be selected for automatic operation

Note 1: Air blows out from vents marked ○

AUTO SWITCH

With switch (5), the air flow, vents, and air source (RECIRC/FRESH) are automatically selected according to the set temperature.

- Press switch (5), then use temperature control switch (3) to set the temperature, and run the air conditioner under automatic control.
- When switching from automatic operation to manual operation, it is possible to use the switches to select the vents and air source (RECIRC/FRESH).

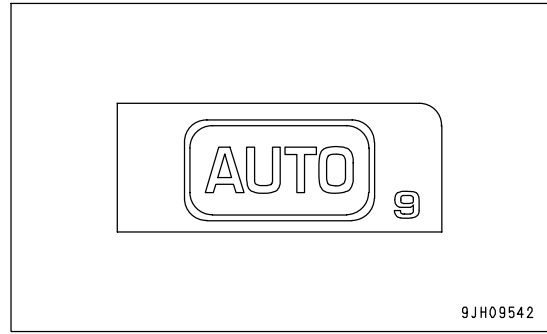

REMARK

When Auto Mode is selected, if the set temperature is set to 18.0 °C (64.4 °F) or 32.0 °C (89.6 °F), the air flow is always set to High, but this is not a problem.

RECIRC/FRESH SELECTOR SWITCH

Switch (6) is used to switch the air source between recirculation of the air inside the cab and intake of fresh air from the outside.

- During automatic operation, the selection of inside air (RECIRC) and outside air (FRESH) is performed automatically.

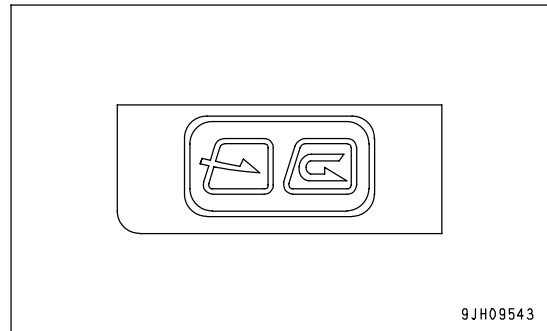

RECIRC	Outside air is shut off and only air inside the cab is circulated. Use this setting to perform rapid cooling of the cab or when outside air is dirty.
FRESH	Outside air is taken into the cab. Use this setting to take in fresh air when performing demisting.

DISPLAY MONITOR

Monitor (7) displays the status of temperature setting (a), air flow (b), and vents (c).

- When OFF switch (1) is pressed, the display of temperature setting (a) and air flow (b) goes out, and operation stops.

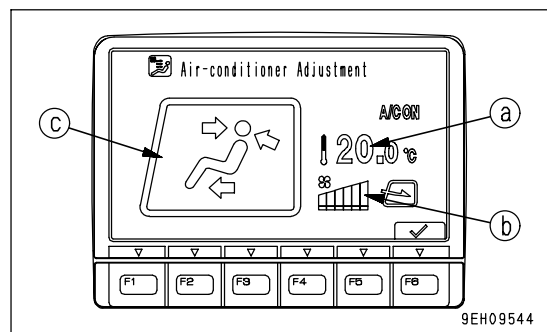

AIR CONDITIONER SWITCH

Switch (8) is used to turn the air conditioner (cooling, dehumidifying, heating) ON or OFF.

- Press air conditioner switch (8) when the fan is operating (when display (b) is shown on the display monitor). The air conditioner is switched ON and starts to work. Press the switch again to stop the air conditioner.
- Air conditioner cannot be operated while the fan is off.

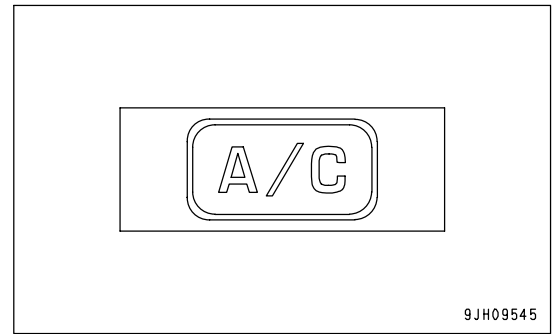
**SUNLIGHT SENSOR**

This sensor (9) automatically adjusts the flow of air from the vents to match the strength of the sun's rays. In addition, it automatically detects changes in the temperature inside the cab caused by changes in the strength of the sun's rays beforehand and automatically adjusts the temperature.

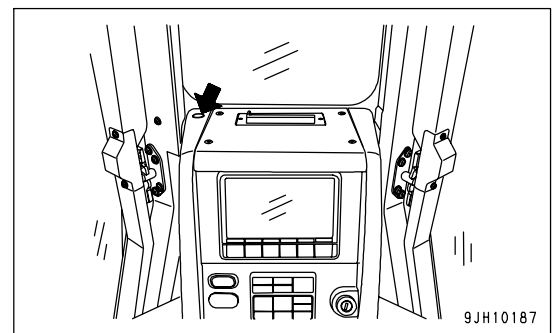

METHOD OF OPERATION

The air conditioner can be operated automatically or manually. Select the method of operation as desired.

AUTOMATIC OPERATION

1. Turn auto switch (5) ON.
 - The monitors for the set temperature (a) and air flow (b) are also displayed.

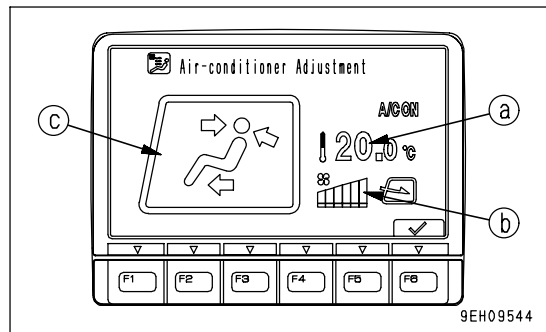
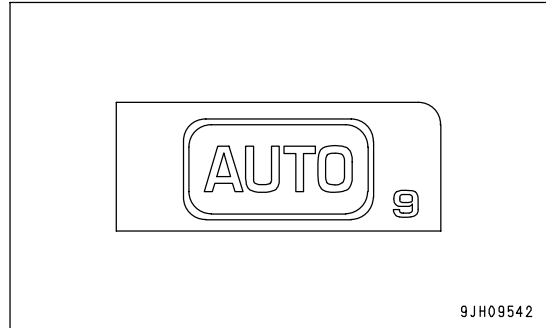

2. Use temperature set switch (3) to set to the desired temperature. The air flow, combination of vents, and selection of fresh or recirculated air is automatically selected according to the set temperature, and the air conditioner is operated automatically to provide the set temperature.

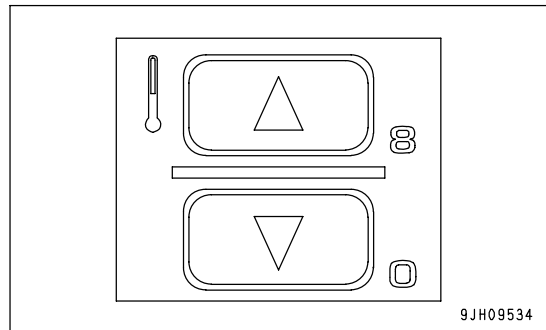

REMARK

When vent display monitor (c) displays (d) or (e), and engine coolant temperature is low, the air flow is automatically limited to prevent cold air from blowing out.

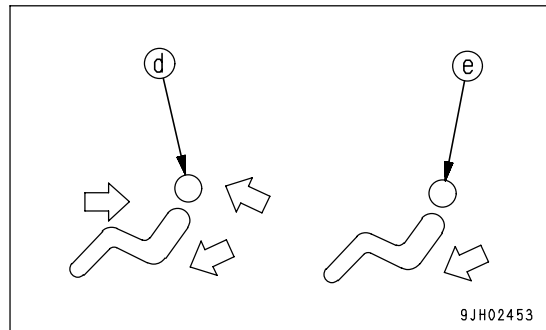

STOPPING AUTOMATIC OPERATION

Press OFF switch (1). Operation stops.

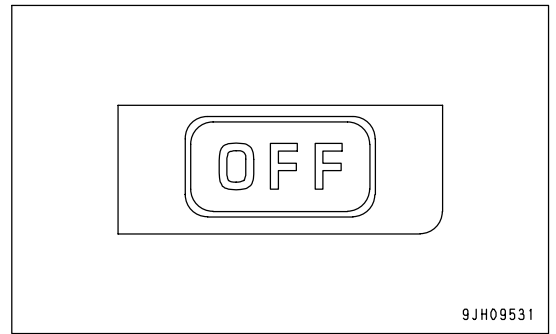

MANUAL OPERATION

1. Press fan switch (2) and adjust the air flow. When doing this, check that temperature setting (a) and air flow (b) are displayed on monitor (7).

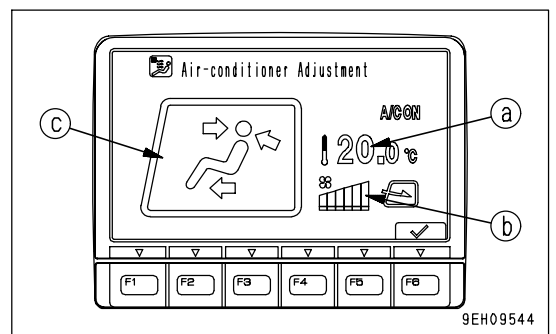
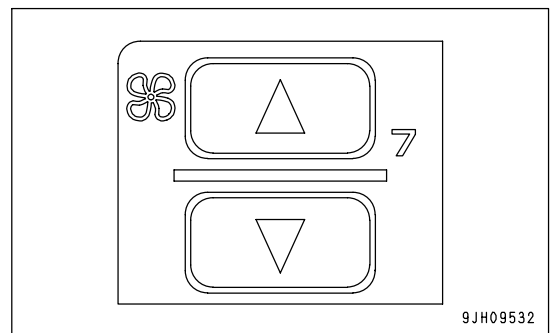

2. Turn air conditioner switch (8) ON.

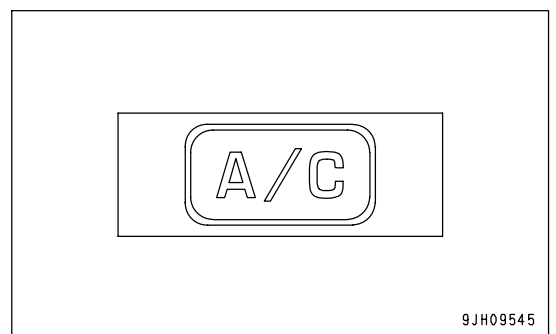

3. Press temperature setting switch (3) and adjust temperature inside the cab.

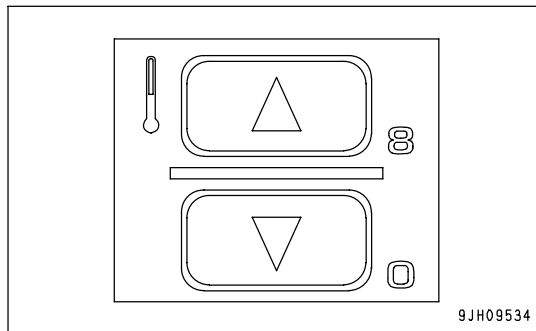

4. Press vent selector switch (4) and select the desired vents. When this is done, the display for vent (c) of the display monitor changes according to the selection.

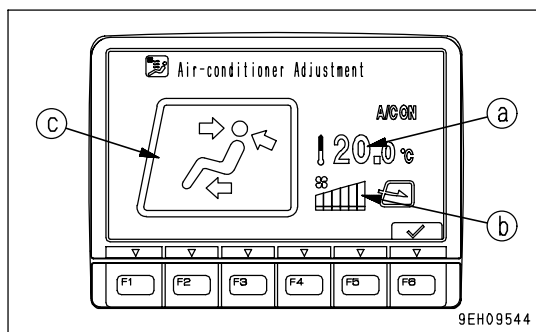
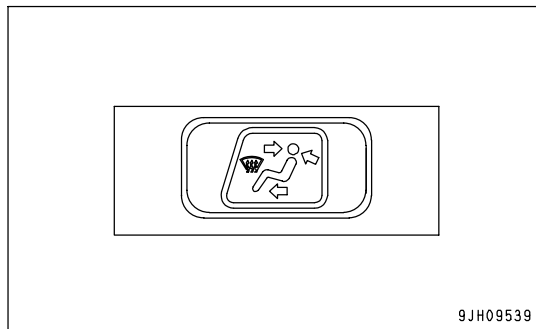

5. Press RECIRC/FRESH selector switch (6) and select recirculation of the air inside the cab (RECIRC) or intake of fresh air from outside (FRESH).

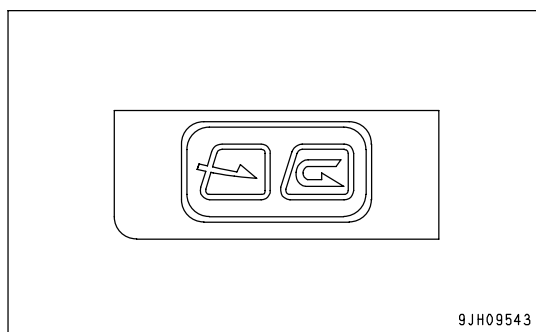

STOPPING MANUAL OPERATION

Press OFF switch (1). Operation stops.

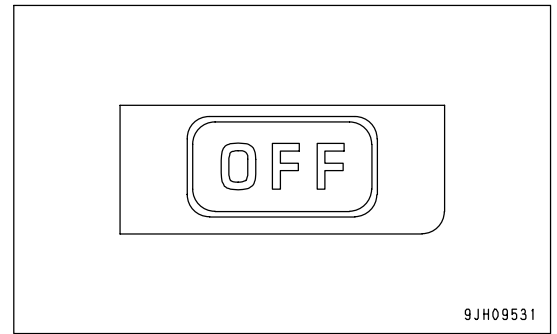

OPERATION WITH COLD AIR TO FACE AND WARM AIR TO FEET

To operate with cold air blowing to the face and warm air blowing to the feet, set as follows.

1. Press fan switch (2) and adjust the air flow. When doing this, check that temperature setting (a) and air flow (b) are displayed on monitor (7).

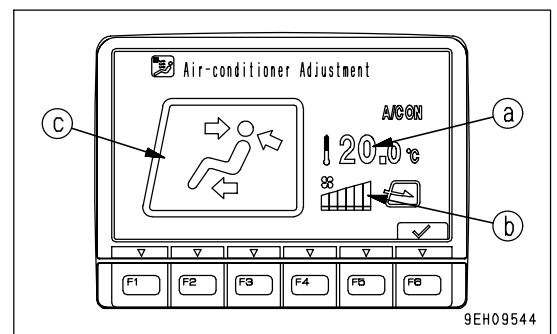
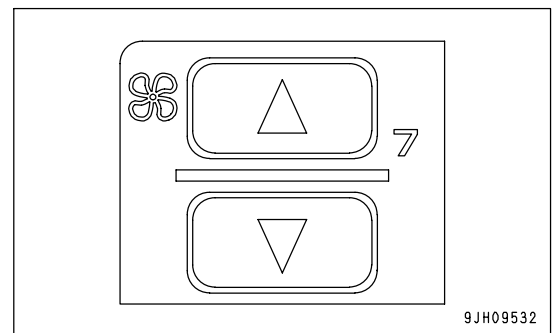

2. Press vent selector switch (4) and set the vent display on the display monitor to the display shown in the diagram on the right.

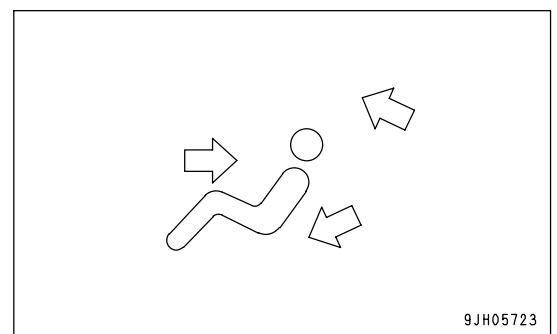

3. Turn air conditioner switch (8) ON.

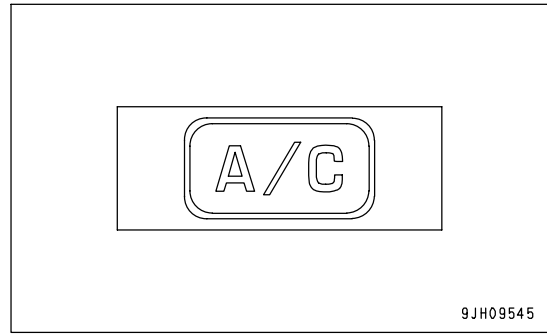

4. Adjust fan switch (2), temperature setting switch (3) and RECIRC/FRESH selector switch (6) to the desired positions.

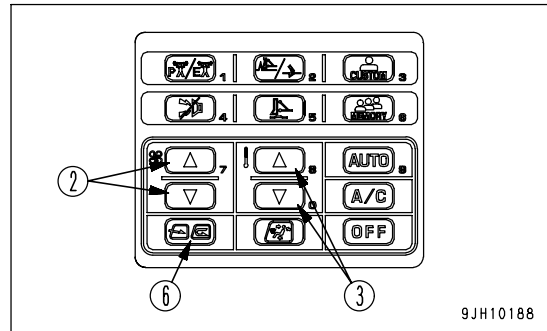

DEFROSTER OPERATION

1. Press fan switch (2) and adjust the air flow. When doing this, check that temperature setting (a) and air flow (b) are displayed on monitor (7).

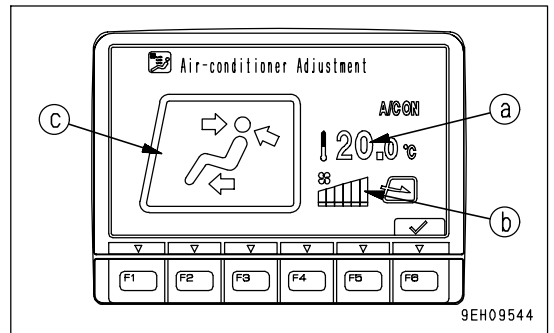
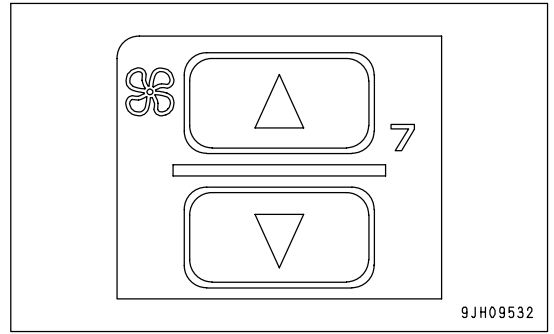

2. Press vent selector switch (4) and set vent display on the display monitor to (f) or (g) as shown in diagram on the right.

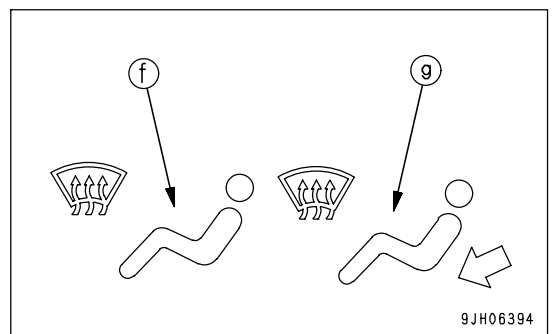
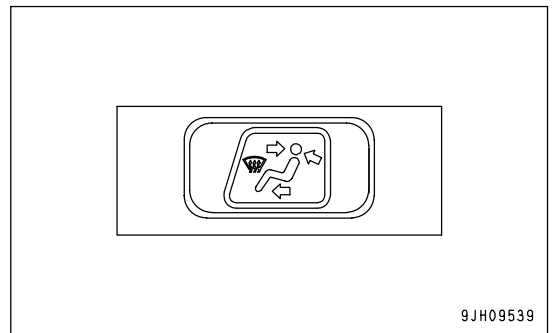

3. Press RECIRC/FRESH selector switch (6) and set it to take in fresh air.

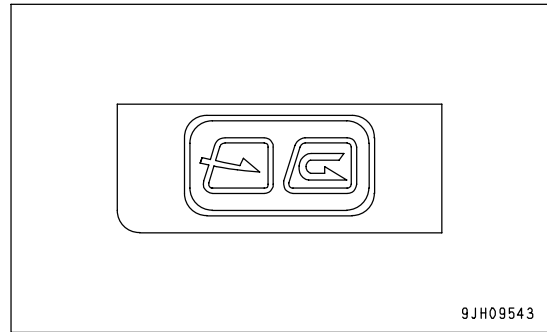

4. Press temperature setting switch (3) and set temperature on the display (7) monitor to maximum heating.

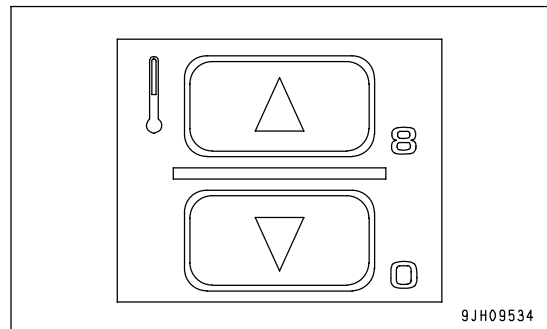

When operating in the rainy season or when it is desired to remove the mist from the window glass or to dehumidify the air, turn air conditioner switch (8) ON.

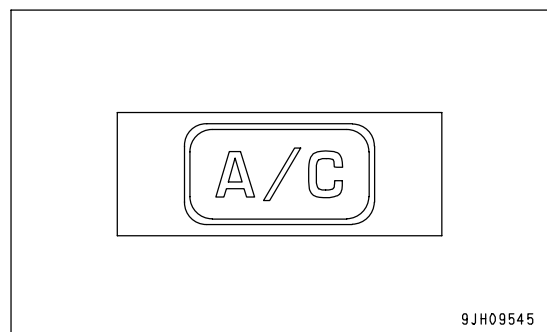

PRECAUTIONS WHEN USING AIR CONDITIONER

NOTICE

- When running the air conditioner, always start with the engine running at low speed. Never start the air conditioner when the engine is running at high speed. It will cause failure of the air conditioner.
- If water gets into the control panel or sunlight sensor, it may lead to unexpected failure, be careful not to let water get on these parts. In addition, never bring any flame near these parts.
- For the auto function of the air conditioner to work properly, always keep the sunlight sensor clean and do not leave anything around the sunlight sensor that may interfere with its sensor function.

WHEN CARRYING OUT COOLING, VENTILATE THE CAB FROM TIME TO TIME

- If you smoke when the air conditioner is on, the smoke may start to hurt your eyes, so open the window and turn the lever to FRESH for a while to remove the smoke while continuing the cooling.
- When running the air conditioner for a long time, turn the lever to the FRESH position once an hour to carry out ventilation and cooling.

BE CAREFUL NOT TO COOL TOO MUCH

When the cooler is on, set the temperature so that it feels slightly cool when entering the cab (5 or 6 °C (9 or 10.8 °F) lower than the outside temperature). This temperature difference is considered to be the most suitable for your health, so always be careful to adjust the temperature properly.

INSPECTION AND MAINTENANCE OF AIR CONDITIONER EQUIPPED MACHINE

- When carrying out an inspection and maintenance of a machine equipped with air conditioner, see "REPLACE AIR CONDITIONER BELT (PAGE 4-40), CLEAN AIR CONDITIONER AIR FILTER (FRESH/RECIRC FILTER) (PAGE 4-42), CHECK AND ADJUST AIR CONDITIONER (PAGE 4-43)" and follow the instruction on the table.
- When the air conditioner is not being used every day, to prevent loss of the film of oil at various parts, run at the engine at low speed from time to time and carry out cooling or dehumidifying heating for several minutes.
- If the temperature inside the cab is low, the air conditioner may not work. In this case, circulate fresh air to warm the inside of the cab. When the air conditioner switch is turned ON, the air conditioner will work.
- If any abnormality is detected in any equipment or sensor used on the air conditioner, "A/C Controller Error" is displayed on the air conditioner monitor screen. If "A/C Controller Error" is displayed, please ask your Komatsu distributor to carry out inspection and repair.

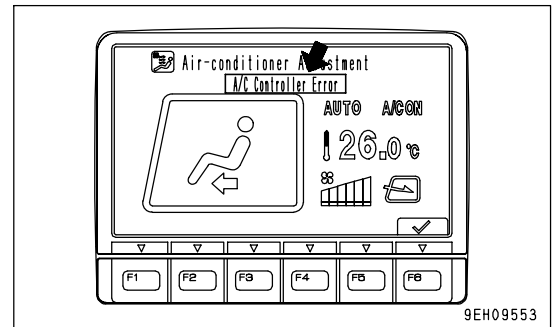

OPERATION

CHECK BEFORE STARTING ENGINE, ADJUST

WALK-AROUND CHECK

Before starting the engine, walk around the machine and look at the underside of chassis for anything unusual like loose bolts and nuts, leakage of fuel, oil and coolant. Also check the condition of the work equipment and the hydraulic system.

Also check for loose wiring, play, and collection of dust at places that reach high temperature.



WARNING

- Leakage of oil or fuel, or accumulation of flammable material around high temperature parts, such as the engine muffler or turbocharger, may cause fire.
Check carefully, and if any abnormality is found, repair it or contact your Komatsu distributor.
- Do not get on or off the machine from the rear. Using this position is dangerous because it is easy to slip and you cannot be seen from the operator's compartment. Always use the handrail and step at the side when getting on or off the machine.

If the machine is at an angle, make it level before checking.

Before starting the engine, look around the machine and under the machine to check for loose nut or bolts, or leakage of oil, fuel, or coolant, and check the condition of the work equipment and hydraulic system. Check also for loose wiring, play, and collection of dust at places which reach high temperatures.

Always carry out the items in this section before starting the engine each day.

1. Check for damage, wear, play in work equipment, cylinders, linkage, hoses
Check that there are no cracks, excessive wear, or play in the work equipment, cylinders, linkage, or hoses. If any abnormality is found, repair it.
2. Remove dirt and dust from around engine, battery radiator.
Check if there is any dirt or dust accumulated around the engine or radiator. Check also if there is any flammable material (dead leaves, twigs, grass, etc.) accumulated around the battery or high temperature engine parts, such as the engine muffler or turbocharger. Remove all such dirt or flammable material.
3. Check for leakage of water or oil around engine
Check that there is no oil leakage from the engine or coolant leakage from the cooling system. If any problem is found, repair it.
4. Check for leakage from fuel line.
Check that there is no leakage of fuel or damage to the hoses and tubes. If any problem is found, carry out repairs.
5. Check for oil leakage from power train case, final drive case, hydraulic tank, hose, joint.
Check that there is no oil leakage. If any problem is found, repair the place where the oil is leaking.
Check for leakage of oil from the undercover. Check the ground for traces of oil leakage.
6. Check of the undercarriage parts
Check track shoe, sprocket, idler, guard for damage, wear, loose bolts, or leakage of oil from rollers, etc.
Repair them if any trouble is found.
If any damage, wear, or oil leakage is found, repair the problem and tighten the bolts.

7. Check for damage to handrail, loose bolts
Repair any damage and tighten any loose bolts.

8. Check for damage to gauges, lamps on the instrument panel and loose bolts.
Check for damage to the panel, gauges and lamps. If any problem is found, replace the parts. Clean off any dirt on the surface. Tighten any loose bolts.

9. Check for damage to the seat belt and mounting clamps.
Check for damage to seat belt and mounting clamps. If damages are found, replace with the new one.

CHECK BEFORE STARTING

Always check the items in this section before starting the engine each day.

CHECK MACHINE MONITOR

1. Turn starting switch (1) to the ON position (B).
2. After the initial KOMATSU screen, check that the basic monitor screen is displayed and that the alarm buzzer sounds for approx. 2 seconds.

REMARK

If the lamps do not light up, there may be a failure or disconnection in the monitor, please contact your Komatsu distributor.

NOTICE

Do not simply use the monitor to carry out the check before starting. Always carry out the check before starting according to the procedure on the following pages.

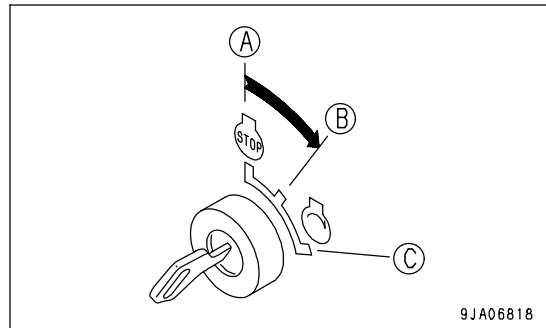
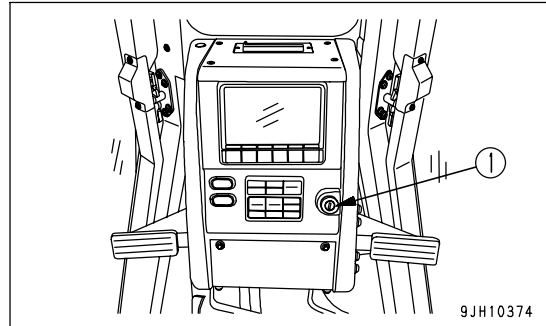

CHECK COOLANT LEVEL, ADD COOLANT

**WARNING**

- Normally, do not open the radiator cap. When checking the coolant level, check the sub-tank when the engine is cold.
- Do not remove the cap when the radiator coolant is hot. Boiling coolant may spurt out. After the coolant temperature goes down, turn the cap slowly to release the pressure, then remove it.

1. Open the engine side cover on the left side of the chassis, and check that the coolant is between the FULL and LOW marks on sub-tank (1). If the coolant level is low, add coolant to the FULL level through the coolant filler port in sub-tank (1).

REMARK

The coolant may overflow from the sub-tank drain hose. This is no problem. It occurs because too much coolant has been added.

2. After adding coolant, tighten the cap securely.
3. If the sub-tank is empty, check for leakage of coolant, then add it to the radiator and sub-tank.
4. After adding coolant, close the engine side cover.

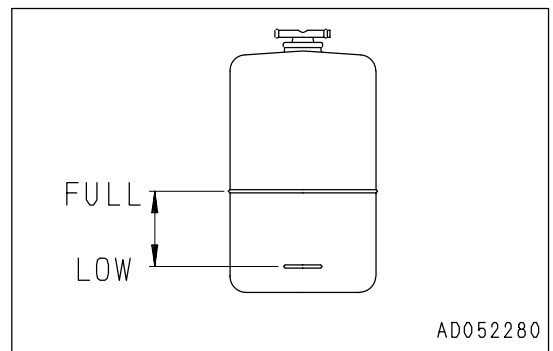
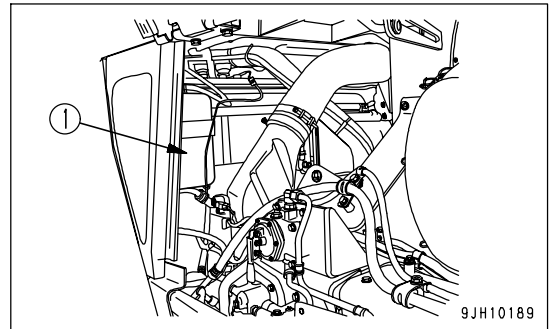

CHECK FUEL LEVEL, ADD FUEL

**WARNING**

When adding fuel, never let the fuel overflow. This may cause a fire. If any fuel is spilled, wipe it up completely. Never bring flames near fuel because it is highly flammable and dangerous.

1. Turn the engine starting switch to the ON position and check the fuel level gauge (G) on the monitor panel for fuel level. After checking, turn the switch back to the OFF position.

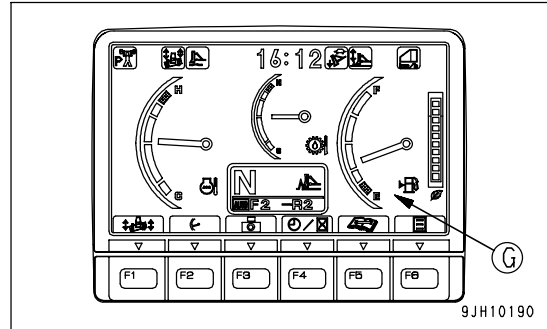

2. After completing work, fill the fuel tank through fuel filler port (F).
3. After adding fuel, tighten the cap securely.
Fuel tank capacity: 625 liters (165 US gal)

REMARK

- When dozing on a grade, make sure there is plenty of fuel in the tank so that the engine fuel line does not become aerated.
- When the filter element of breather (1) gets clogged, pressure inside the tank lowers, hampering the fuel supply. So clean it every now and then.

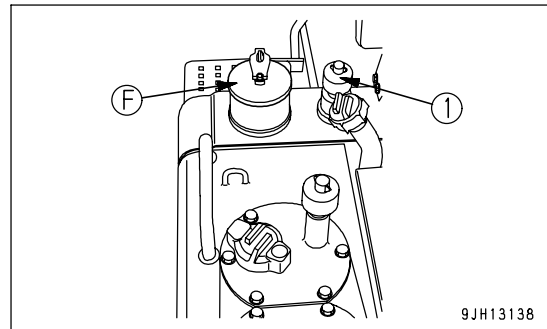

CHECK WATER SEPARATOR, DRAIN WATER AND SEDIMENT

1. Open the side cover on the left side of the machine.

The water separator forms one unit with the fuel filter and is at the bottom.

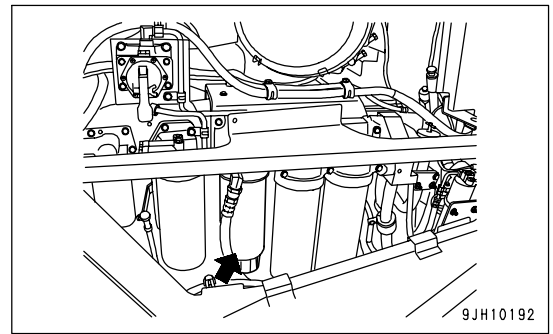

2. It is possible to judge the water level and amount of sediment by looking through transparent cap (2). If there is any water or sediment collected at the bottom, set a container to catch the drain water under drain hose (3).

3. Loosen plug (1) and drain the water.

4. When fuel comes out from drain hose (3), tighten plug (1) immediately.

Tightening torque: 0.2 to 0.45 Nm (0.02 to 0.046 kgm, 0.1 to 0.3 lbft)

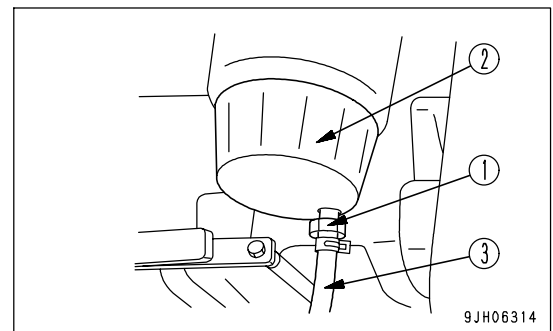
**DRAIN WATER, SEDIMENT FROM FUEL TANK**

Loosen drain valve (1) at the bottom of the fuel tank and drain the sediment and water accumulated at the bottom together with the fuel.

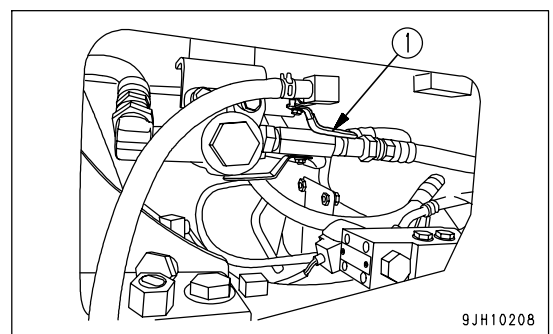
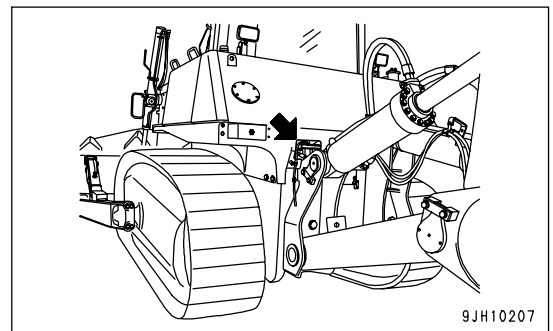

CHECK OIL LEVEL IN ENGINE OIL PAN, ADD OIL

WARNING

Parts and oil are at high temperature immediately after the engine is stopped and may cause serious burns. Wait for the oil temperature to go down before performing this operation.

1. Open the engine side cover on the left side of the chassis.

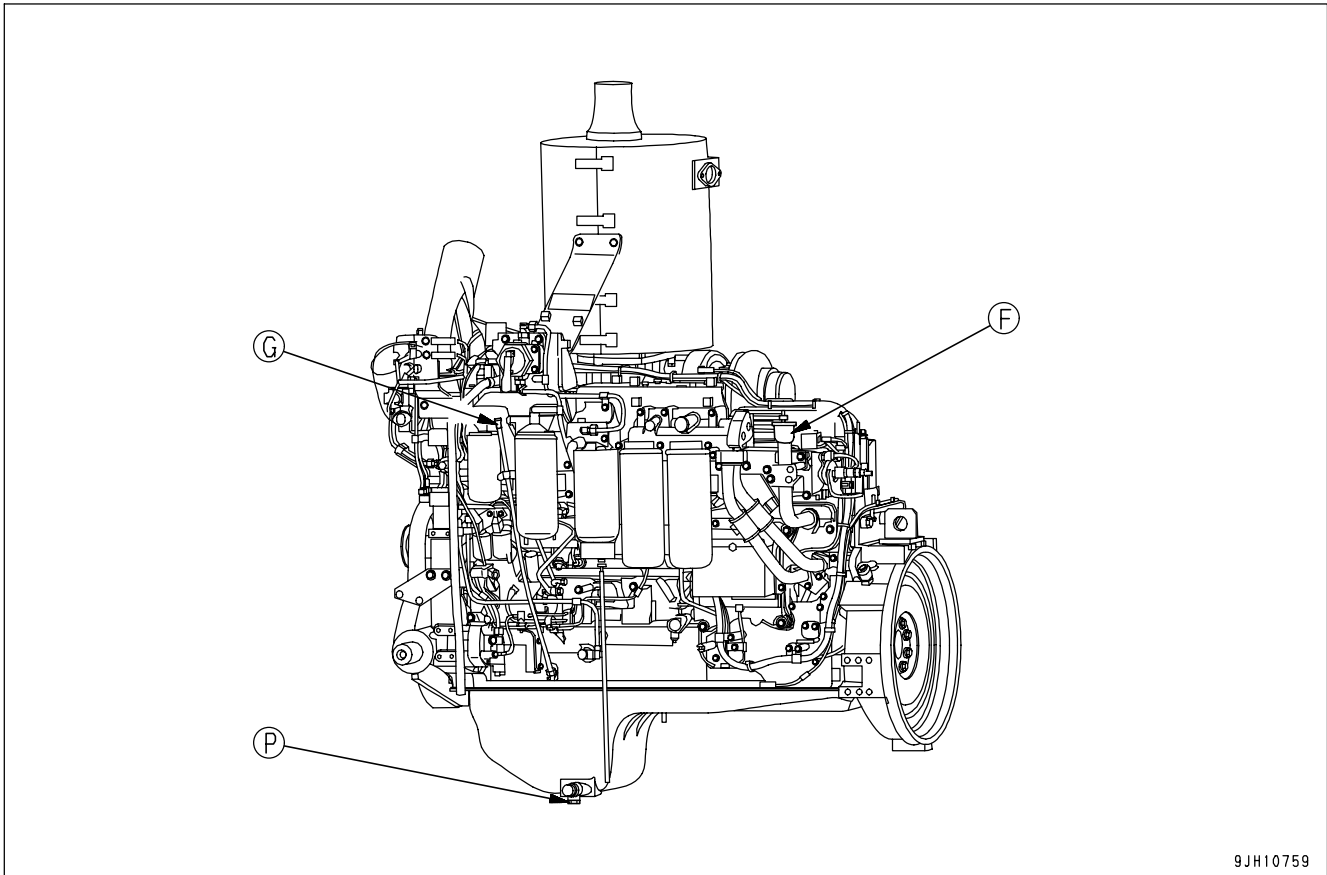

9JH10759

2. Remove dipstick (G), and wipe the oil off with a cloth.
3. Fully insert dipstick (G) into filler pipe, then remove it.
4. The oil level should be between the H and L marks on dipstick (G).
If the oil level is below the L mark, add oil through oil filler port (F).
5. If the oil is above the H mark, drain the excess engine oil from drain plug (P), and check the oil level again.
6. If the oil level is correct, tighten the oil filler cap securely and close the engine side cover.

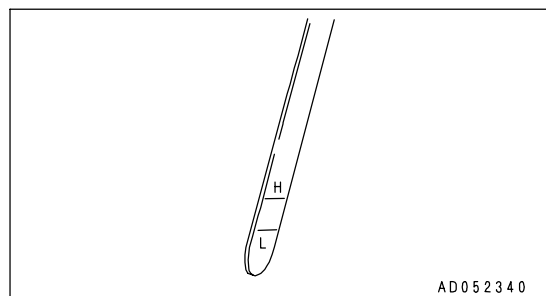

AD052340

REMARK

- Check the oil level with the engine stopped.
- When checking the oil level immediately after stopping the engine, wait for at least 15 minutes after stopping the engine before starting the inspection operation.
- If the machine is at an angle, set it in a level position before starting inspection.
- When adding oil, remove the dipstick from the guide to remove the air inside the crankcase.

CHECK OIL LEVEL IN POWER TRAIN CASE, ADD OIL

1. Remove dipstick (G), and wipe the oil off with a cloth.
2. Fully insert dipstick (G) into filler pipe, then remove it.
3. Check that the oil level is between the H and L marks on dipstick (G).

If the oil level is below the L mark, add oil through oil filler (F).
 The dipstick has two sides for checking the oil level: COLD STOP for use when the engine is stopped and the oil temperature is low; and HOT IDLE for use when the engine is idling and the oil temperature is high.

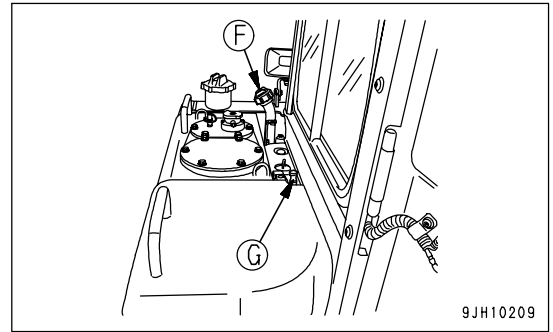

REMARK

When checking the oil level with the engine stopped before starting operations, check the oil level with the side marked COLD STOP. It is also possible to check the oil level even after starting operations when the power train oil temperature is high, but in this case, run the engine at idling and use the side marked HOT IDLE.

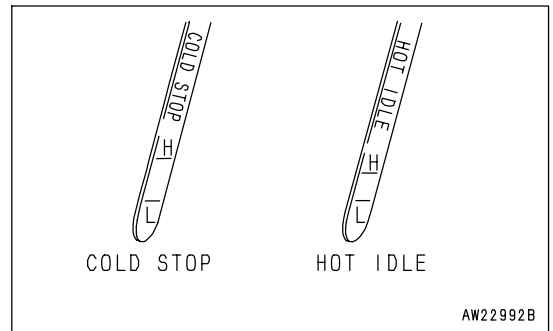

4. When hydraulic oil is above the H level, remove drain cover (1) on the left side of the power train case bottom, take out drain plug (2), drain excess oil by loosening drain plug (3) and then check the oil level again.
5. If the oil level is correct, tighten the oil filter cap securely.

REMARK

When inspecting, if the machine is at an angle, move it to a level place to carry out the check.

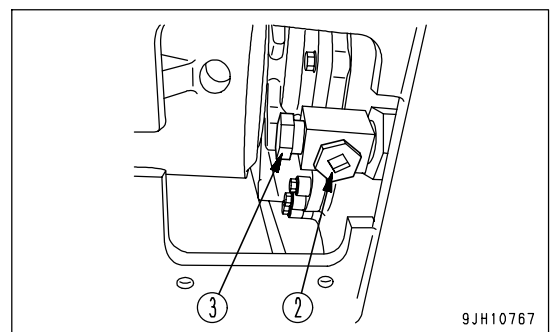
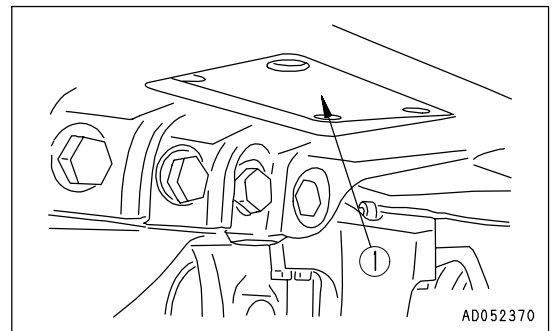

CHECK BRAKE PEDAL TRAVEL

Drive the machine in F2, then depress the brake pedal and check that the machine stops.

CHECK DAMPER CASE OIL LEVEL, ADD OIL

1. Open the engine side cover on the left side of the machine.
2. Remove dipstick (G), and wipe the oil off with a cloth.
3. Fully insert dipstick (G) into filler pipe, then remove it.
4. The oil should be between the H and L marks on dipstick (G).
If the oil is below the L mark, add oil through the dipstick insertion port.

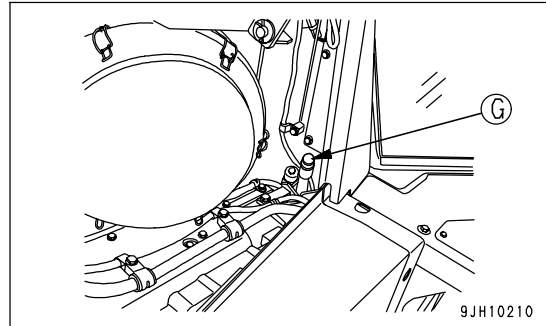

5. If the oil is above the H mark, open inspection cover (2) in the center of the bottom face of the power train case, drain the excess oil from engine damper drain plug (P) (this can be seen towards the front of the machine from the inspection window), then check the oil level again.

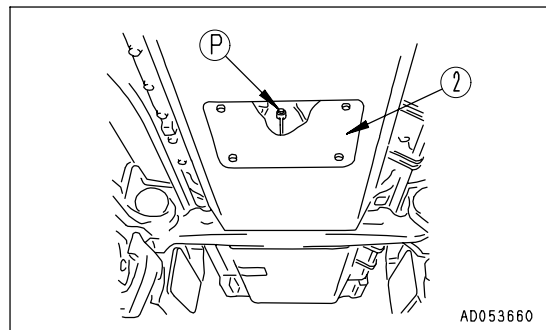
**REMARK**

- Check the oil level while the engine is stopped.
- If the machine is inclined, set it in a level position before checking the oil level.

CHECK OIL LEVEL IN HYDRAULIC TANK, ADD OIL

WARNING

- When removing the oil filler cap, oil may spurt out, so stop the engine and wait for the oil temperature to go down, then turn the cap slowly to release the internal pressure before removing the cap.
- If oil has been added to above the H mark, stop the engine and wait for the hydraulic oil to cool down. Then remove drain plug (P), loosen drain valve (1), and drain the excess oil.

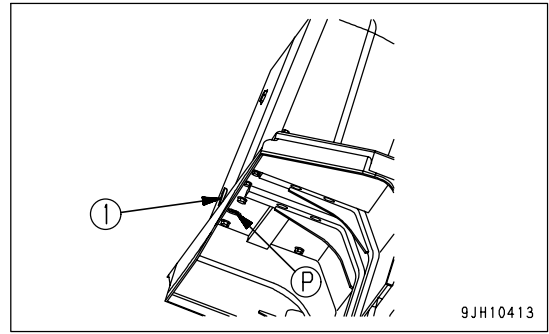

9JH10413

1. Park the machine on the flat ground, hold it in the following posture suitable for an oil check and then stop the engine.

(Sigmadozer)

Lower the blade on the ground so that angle (a) of its backside is 6°.

Lower ripper (b) on the ground vertically so that the pin is at the lowest position.

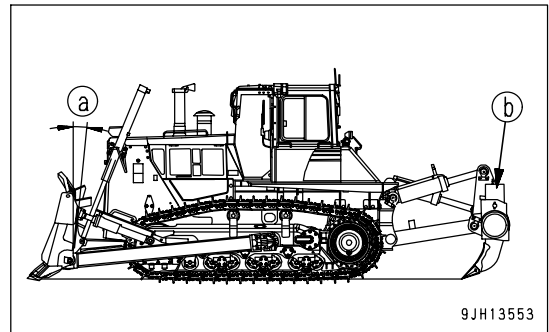

9JH13553

<Reference>

Item		Dimension	Item		Dimension
Blade (DUAL)	Tilt Cylinder length	1,292mm (50.9in)	Blade (SINGLE)	Tilt Cylinder length	1,292mm (50.9in)
				Brace	1,292mm (50.9in)
Ripper (VGR,VMR)	Lift Cylinder length	1,543mm (60.8in)	Ripper (VGR,VMR)	Lift Cylinder length	1,543mm (60.8in)
	Tilt Cylinder length	1,607mm (63.3in)		Tilt Cylinder length	1,607mm (63.3in)

(Semi U-dozer, U-dozer)

Lower the blade on the ground so that backside (a) is upright.
 Lower ripper (b) on the ground vertically so that the pin is at the lowest position.

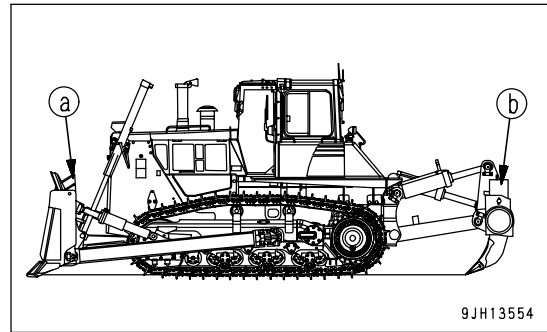

<Reference>

Item		Dimension	Item		Dimension
Blade (DUAL)	Tilt Cylinder length	1,292mm (50.9in)	Blade (SINGLE)	Tilt Cylinder length	1,372mm (54.1in)
				Brace	1,372mm (54.1in)
Ripper (VMR)	Lift Cylinder length	1,543mm (60.8in)	Ripper (VMR)	Lift Cylinder length	1,543mm (60.8in)
	Tilt Cylinder length	1,607mm (63.3in)		Tilt Cylinder length	1,607mm (63.3in)

2. Stop the engine, wait for approx. 5 minutes, then check that the oil level is between the H and L marks on sight gauge (G).

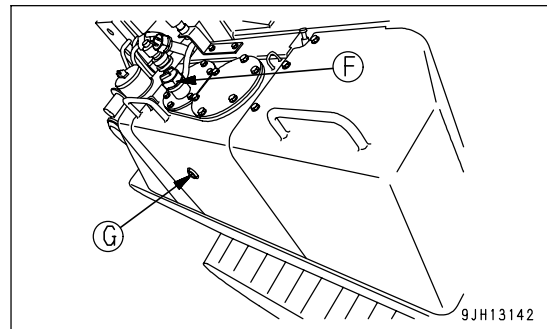

NOTICE

If the oil level is above the H line, do not add oil. Doing so may lead to damage to the oil pressure circuit and spouting out of oil.

3. If the oil level is below the L line, add oil through oil filler (F) at the top of the hydraulic tank.

REMARK

When inspecting, if the machine is at an angle, move it to a level place to carry out the check.

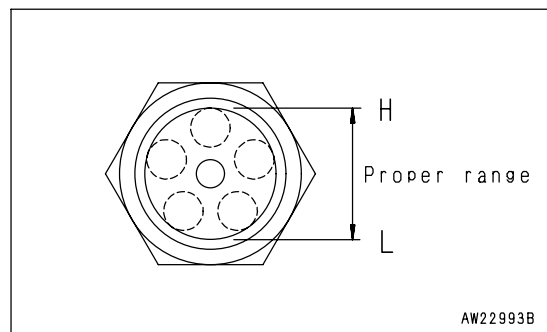

CHECK DUST INDICATOR

1. Check for the yellow piston overlapping the red zone on the dust indicator (1).

2. If the yellow piston is overlapping the red zone, clean or replace the element immediately.

For details of the method of cleaning the element, see "CHECK, CLEAN AND REPLACE AIR CLEANER ELEMENT (PAGE 4-22)".

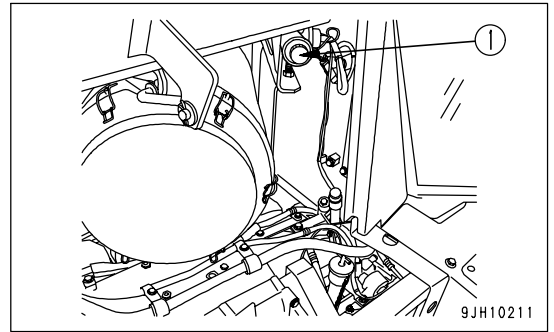

3. After checking, cleaning, and replacing, press the knob of dust indicator (1) to return the yellow piston to its original position.

- In environments where the rubber deteriorates quickly or the surface becomes damaged (in direct sunlight, dusty areas, etc.), replace before it becomes dirty and it becomes difficult to judge the condition.

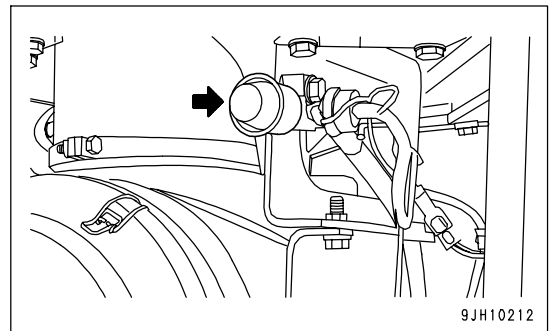

CHECK ELECTRIC WIRING

! WARNING

- If fuses are frequently blown or if there is a short circuit in the electrical wiring, locate the cause and repair or contact your Komatsu distributor.
- Accumulation of flammable material (dead leaves, twigs, grass, etc.) around the battery may cause fire, so always check and remove such material.
- Keep the top surface of the battery clean and check the breather hole in the battery cap. If it is clogged with dirt or dust, wash the battery cap to clear the breather hole.

Check for damage and wrong capacity of the fuse and any sign of disconnection or short circuit in the electric wiring. Check also for loose terminals and tighten any loose parts.

Check the wiring of the "battery", "starting motor" and "alternator" carefully in particular.

Always check if there is any accumulation of flammable material around the battery, and remove such flammable material.

Please contact your Komatsu distributor for investigation and correction of the cause.

CHECK THAT LAMPS LIGHT UP

1. Turn starting switch (1) to the ON position (B).

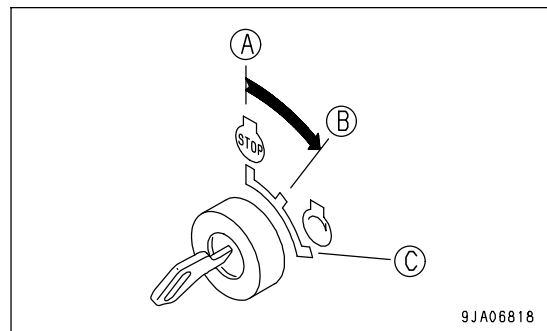

2. Turn the headlamp switch to positions (a) and (b) to check that the headlamps light up.

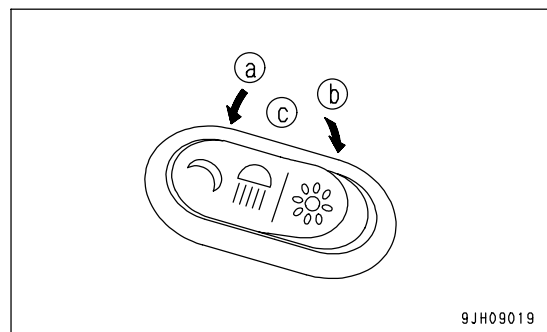

3. Turn the rear lamp switch to position (a) to check that the rear lamps light up.
If the lamps do not light, check for a broken bulb or disconnected wire, contact your Komatsu distributor for repairs.

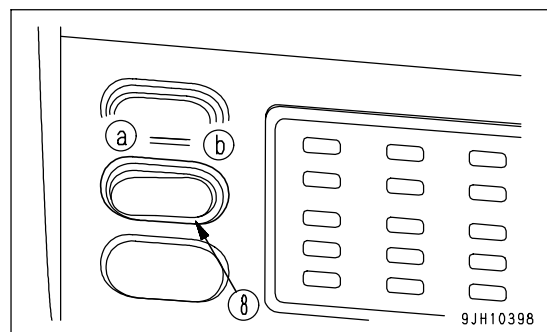

CHECK HORN SOUND

1. Turn starting switch (1) to the ON position (B).

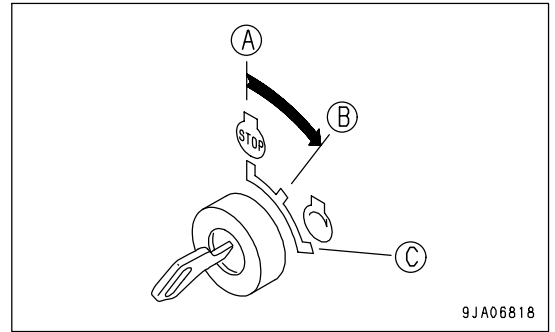

2. Push the horn switch and check that the horn sounds.

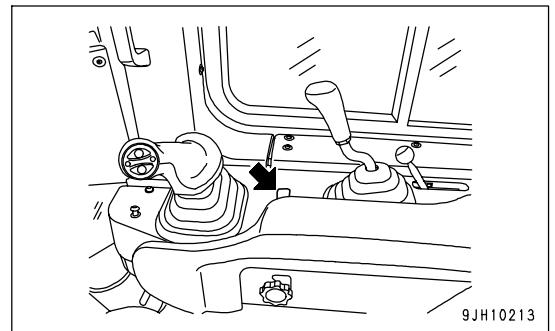

CHECK BACKUP ALARM SOUND

1. Turn starting switch to the ON position (B).

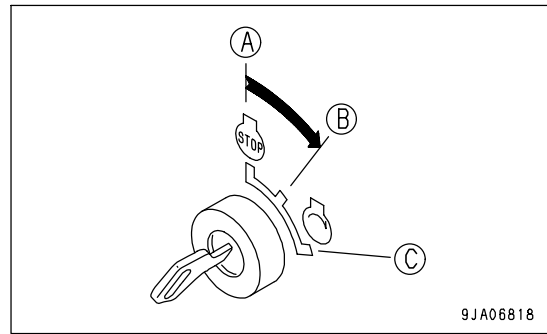

2. Set parking brake lever to the FREE position (F).

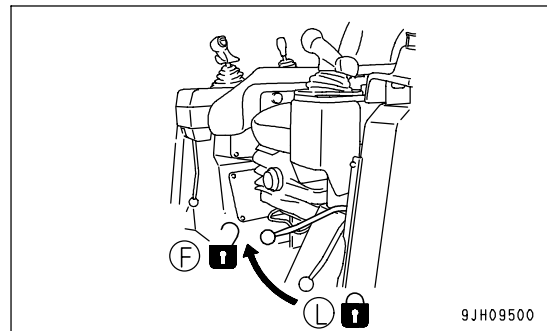

3. While depressing the brake pedal, set joystick to the REVERSE position. The buzzer must sound immediately. Buzzer will continue to sound until the joystick is moved to NEUTRAL or FORWARD position.
4. As soon as it is confirmed that the buzzer is working properly, set the joystick to the NEUTRAL position, put the parking brake lever to the LOCK position, and then release the brake pedal.

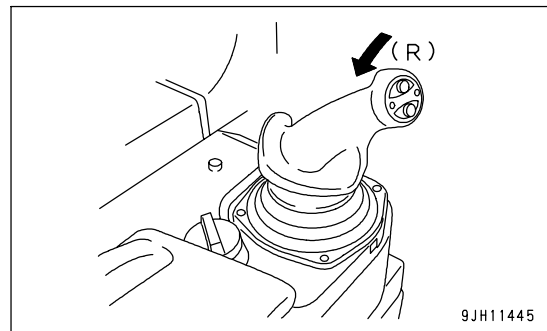

(R): Reverse

ADJUSTMENT

**WARNING**

- Adjust the seat position at the beginning of each shift or when operators change.
- Adjust seat so the brake pedal can be completely depressed with the operator's back against the backrest.

ADJUSTING OPERATOR'S SEAT

**WARNING**

- Park the machine in a safe place and stop the engine when carrying out adjustment of the operator's seat.
- Adjust the seat position at the beginning of each shift or when operators change.
- Adjust the seat so that the brake pedal can be depressed all the way down with the operator's back against the backrest.

Machines equipped with standard seat

(A) Fore-and-aft adjustment

Pull lever (1), set the seat to a position where it is easy to operate, then release the lever.

Fore-aft adjustment: 200 mm (7.9 in) (10 stages)

(B) Weight and height adjustment of seat

- Turn knob (2) under the seat so that weight adjustment indicator (3) displays the green range. The height can be adjusted by turning the knob (2) while the green range is displayed.
- Turn the knob clockwise to raise the seat and turn the knob counterclockwise to lower the seat.

Height adjustment range: stepless, 75 mm (3 in)

Weight adjustment range: 50 to 130 kg (110 to 237 lb)

(C) Adjust reclining angle

REMARK

When the seat is pushed forward, the available reclining angle becomes greater; when the seat is pushed back, the available reclining angle becomes smaller. When moving the backrest, return the backrest to its original position before moving the seat.

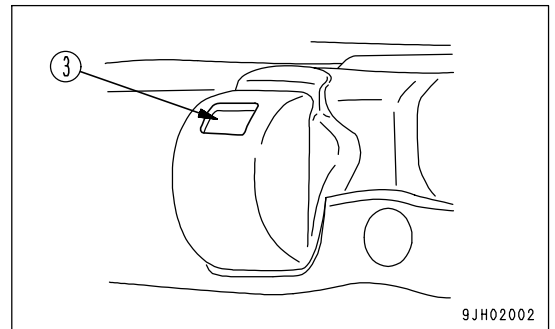
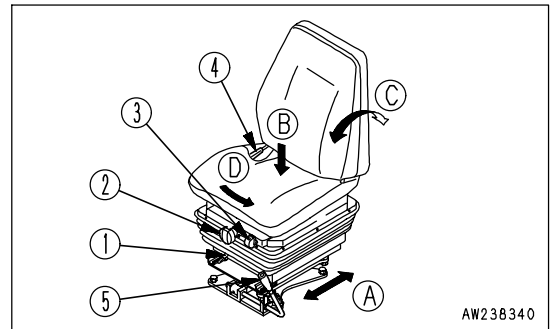

Pull up lever (4), set the seatback to a position where it is easy to operate, then release the lever.

(D) Adjusting direction of seat

Pull lever (5) up to FREE position (F) to release the lock. It is then possible to change the direction of the seat to a position facing 15° to the right.

After changing the direction of the seat, return the lever securely to LOCK position (L).

- Change the direction of the seat to the right for the ease of operation of the ripper.

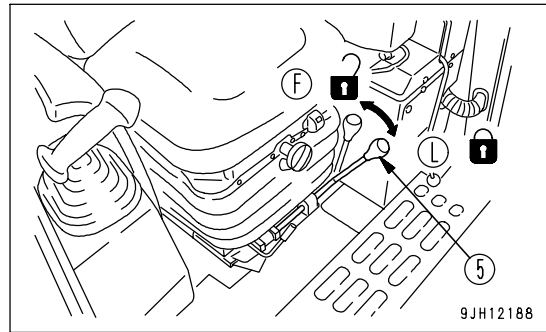
**REMARK**

If the direction of the seat is changed, the steering, directional, and gearshift lever is also interconnected and changes direction.

Machines equipped with air suspension seat

Adjustments (C), (D), and (K) use the air compressor built into the seat, so turn the engine starting switch to the ON position.

NOTICE

There is danger of damage to the air compressor, so do not keep lever (3) operated continuously for more than 1 minute.

(A) Fore-and-aft adjustment

Pull lever (1) up, set the seat to the desired position, then release the lever.

Fore-and-aft adjustment: 190 mm (10 mm x 19 stages)

(B) Adjusting seat angle

Move lever (2) up, move the seat cushion at the front up or down to set to the desired position, then release the lever.

Amount of adjustment

Forward tilt: 3 degrees

Rear tilt: 11 degrees

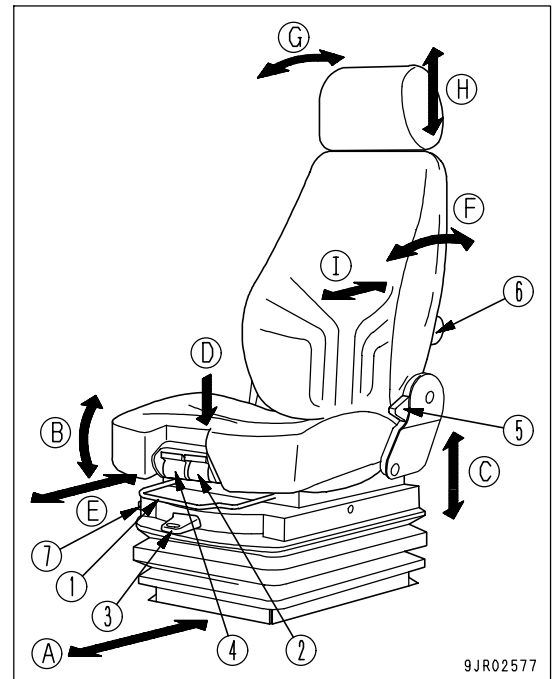

9JR02577

(C) Adjusting seat height

The seat height adjustment uses an air system, and it can be adjusted steplessly.

When adjusting the height, pull lever (3) up fully or push it down fully (when pulling it up, pull it until a click is felt). When the seat is set at the desired height, release the lever. If the lever is kept pulled up, the position where the seat does not rise any further is the maximum height. When the seat reaches the maximum height, the suspension automatically goes down slightly to secure the amount of movement of the lever.

If the operator raises his body from the seat or changes the amount of weight applied to the seat during adjustment, the air in the suspension may be discharged.

Amount of adjustment: 80 mm (3.2 in)

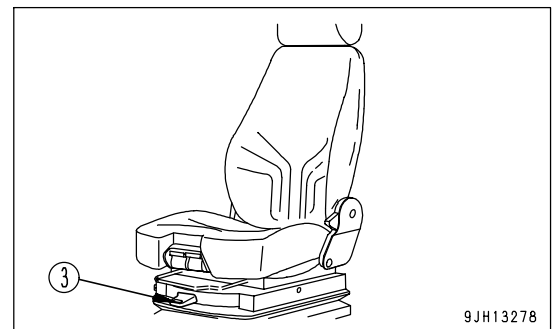

9JH13278

(D) Setting seat for weight

To protect the operator, it is necessary to adjust the suspension to match the operator's weight. When carrying out this adjustment, stop the machine, set the seat to the correct posture, then operate the lever.

Pull up lever (3) lightly a short distance. The weight setting is adjusted automatically. (The air pressure inside the suspension is increased or decreased to match the operator's weight.)

(E) Fore-and-aft adjustment of seat cushion

Operate lever (4) up, set the seat cushion to the desired position, then release the lever.

Fore-and-aft adjustment: 60 mm (2.4 in)

(F) Adjusting reclining angle

Operate lever (5) up and move the back cushion to the front or rear.

But your back firmly against the seat back when carrying out this adjustment. If you move your back away from the seat back, the seat back may suddenly spring forward.

Amount of adjustment

Forward tilt: 20 degrees (over 20 degrees is free)

Rear tilt: 60 degrees

NOTICE

If the seat back is reclined too far, the seat back may hit the rear glass, so use it in a position where it does not contact the glass.

(G) Adjusting headrest angle

Rotate the backrest to the front or rear and set to the desired angle.

Amount of adjustment: 38 degrees

(H) Adjusting headrest height

Move the headrest up or down and set to the desired height.

Amount of adjustment: 100 mm (3.9 in)

(I) Lumbar support

Operate switch (6) to give suitable tension to the lumbar region.

Adjust the curve of the backrest portion as desired.

Push (+): Tension becomes stronger

Push (-): Tension becomes weaker

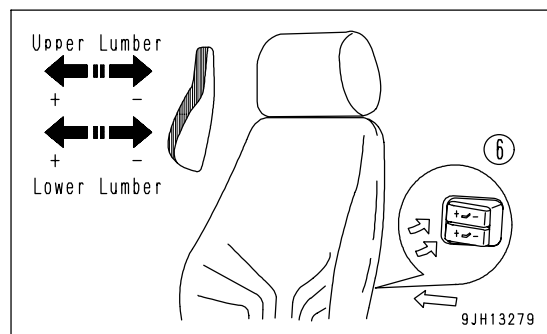

(J) Adjusting hardness of suspension damper

It is possible to adjust the hardness of the suspension damper with knob (7). If knob (7) faces the front of the seat (a), the suspension becomes harder; if it faces the rear of the seat (b), the suspension becomes softer.

Amount of adjustment: 5 stages

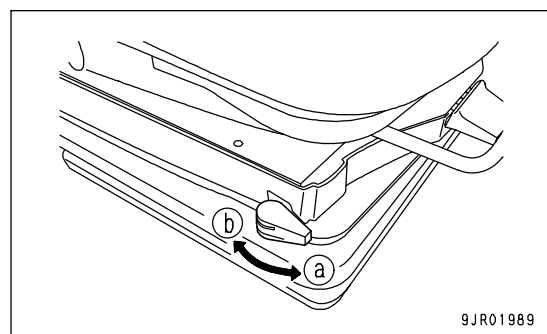

USING SEAT BELT

Always install a seat belt on machines equipped with ROPS.



WARNING

- Before fastening the seat belt, inspect the securing brackets and belt for abnormal conditions. Replace any worn or damaged seat belt or the securing brackets.
- Even no problem can be seen with the belt, always replace the seatbelt once every three years. The date of manufacture is given on the rear side of the belt.
- Adjust and fasten the seat belt before operating the machine.
- Always use the seat belt when operating the machine.
- Fit the seat belt across your lap without twisting.

FASTEN THE BELT AND REMOVE IT

Fasten the belt so that it is tight without being too tight.

1. Sit on the seat, depress the brake pedal fully, and adjust the seat so that your back is pressed against the backrest.
2. Sit on the seat, pull the right belt, then insert tongue (1) securely into buckle (2) until a click is heard. Pull the belt to check that it is firmly locked.
3. When removing the belt, press the red button in buckle (2) to free the belt.
Fit the belt so that it follows your body and is not twisted.

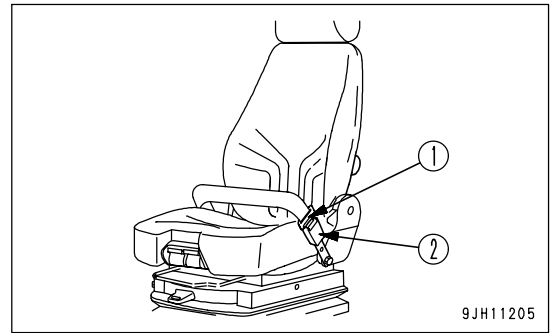

Check that the bolts of the clamp securing the belt to the chassis are not loose. Tighten them if they are loose.

Tightening torque: 24.5 ± 4.9 Nm (2.5 ± 0.5 kgm, 18.1 ± 3.6 lbft)

If the seat belt is scratched or frayed, if any fittings are broken or deformed from long service, replace the seat belt immediately.

ADJUST MIRROR

! WARNING

Be sure to adjust the mirrors before starting work. If they are not adjusted properly, you cannot secure the visibility and may be injured or may injure someone seriously.

Loosen nut (1) of the mirror and adjust the mirror to a position where it gives the best view from the operator's seat. In particular, be sure to adjust the mirror so that people at the rear left or right of the machine can be seen clearly.

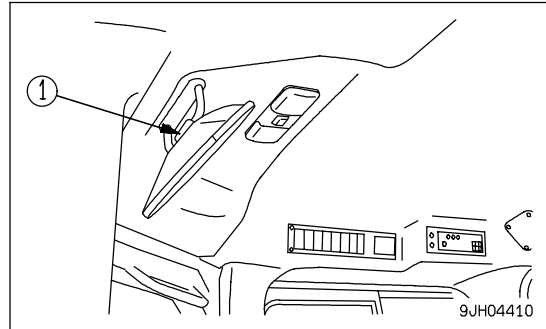

ADJUST JOYSTICK (PCCS LEVER)

! WARNING

After moving case (2) in order to adjust the position of the steering, directional, and gearshift lever, secure lock lever (1) into the notched hole, making sure it is in the LOCK position. If it is not completely locked, the steering, directional, and gearshift lever may unexpectedly move and cause damage, serious injury, or death.

The steering, directional, and speed lever (wrist control type single lever: joystick) can be adjusted by 100 mm (3.9 in) in 5 stages to the front or rear. Adjust to the most suitable position to match the adjustment of the operator's seat.

1. Pull up lock lever (1) to the FREE position (F) at the rear of case (2) on left side of the operator's compartment.
2. With lock lever (1) pulled up, use your other hand to grip the front of case (2), then move it forward with your left and right hands. The joystick moves with case (2).
3. Move case (2) to the desired position until a click is heard. Then pull up lock lever (1) and release it. Lock lever (1) automatically returns to the LOCK position.

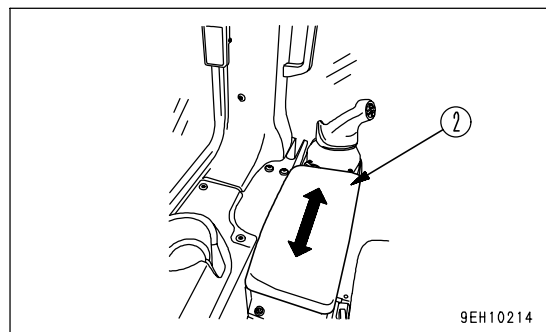
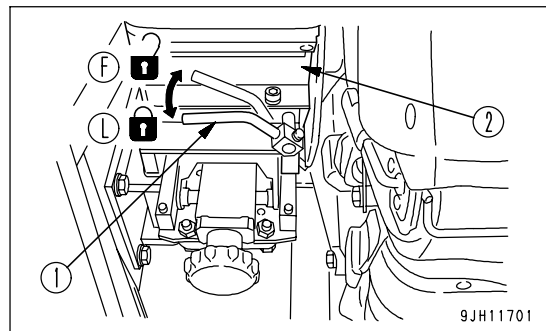

REMARK

PCCS: Palm command control system

ADJUST ARMREST

The height of the armrests on the right and left sides of the operator's seat can be adjusted according to the following procedure. After adjusting the operator's seat, adjust the armrest height properly.

ADJUST ARMREST (RIGHT)

Armrest (1) on the right side of the operator's seat can be adjusted in 3 stages: up 30 mm (1.2 in), standard height (center), or down 25 mm (1.0 in).

1. Loosen knob (2) (2 places).

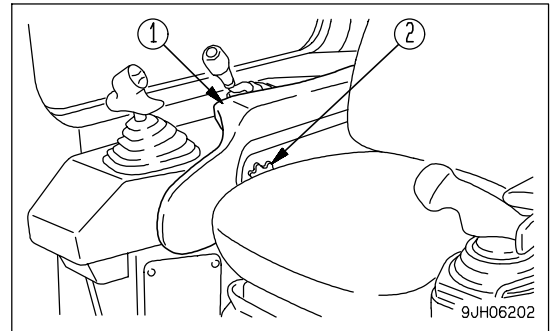

2. Move the armrest on the operator's seat to the front, then align the position of the 3 holes {high (H), middle (M), low (L)}.

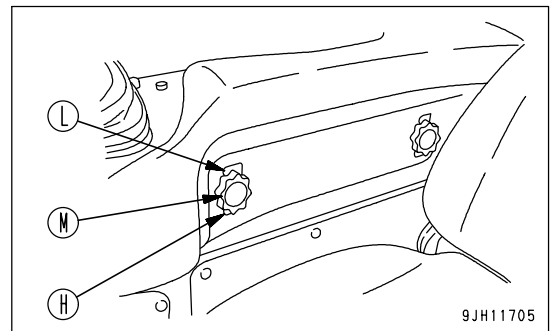

3. Tighten knob (2) securely.

ADJUST ARMREST (LEFT)

The armrest on the left side of the operator's compartment can be adjusted to 2 heights.

It is possible to adjust the standard height up 30 mm (1.2 in) or down 30 mm (1.2 in) gradually.

The joystick moves as a unit.

Turn up/down left adjustment knob (1) to adjust the height. Turn the knob to adjust as follows.

Turn **CLOCKWISE** to move **DOWN**

Turn **COUNTERCLOCKWISE** to move **UP**

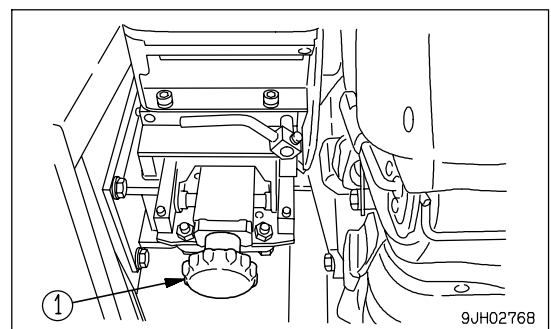

OPERATIONS AND CHECKS BEFORE STARTING ENGINE

! WARNING

- When starting the engine, check and make sure the work equipment lock lever (4) and parking brake lever (1) are secured in the LOCK position.
If the control levers are not locked and they are touched by accident when starting the engine, the work equipment may move unexpectedly, and this may lead to a serious injury or death.
- When standing up from the operator's seat, always set the work equipment lock lever (4) and parking brake lever (1) to the LOCK position, regardless of whether the engine is running or stopped.

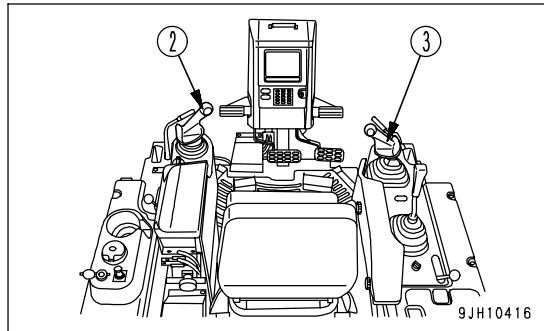
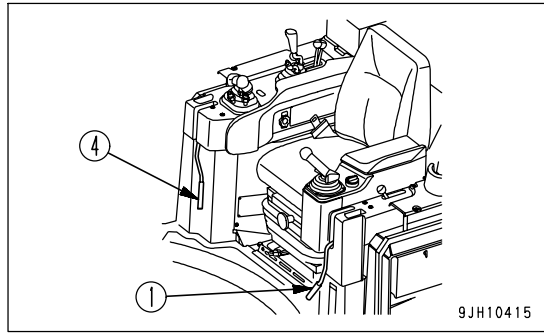

1. Check that parking brake lever (1) is locked.
If this lever is not in the LOCK position (L), the engine will not start.

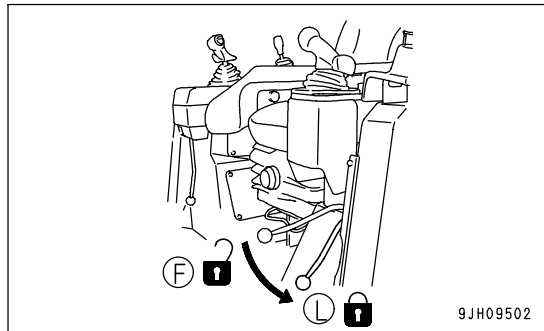

2. Check that joystick (2) is in the N (neutral) position.

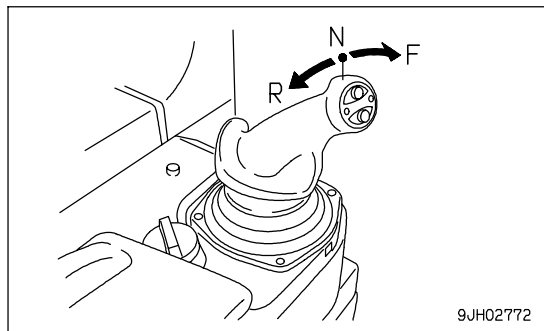

REMARK

The engine cannot be started if joystick (steering, directional, and gearshift lever) (2) is not in the N position.

If joystick (steering, directional, and gearshift lever) (2) is in F or R, the letter P on display panel A will flash.

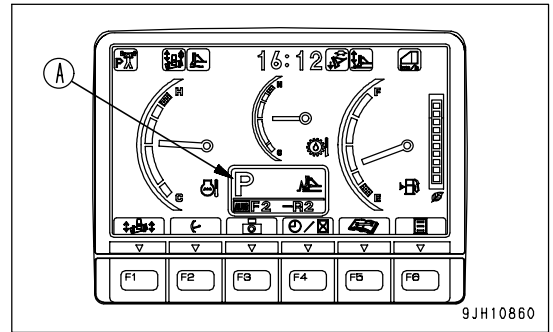

3. Lower the blade to the ground. Check that the blade control lever (3) is HOLD position (b).

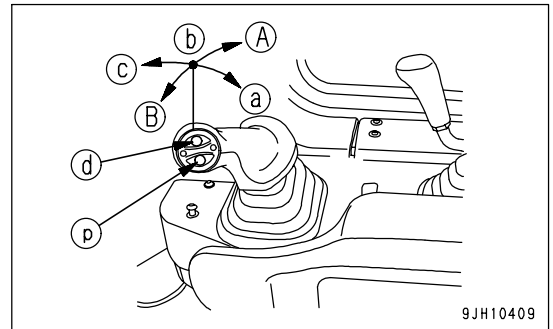

4. Check that the ripper is lowered to the ground.
5. Check that the work equipment lock lever (4) is LOCK position (L).

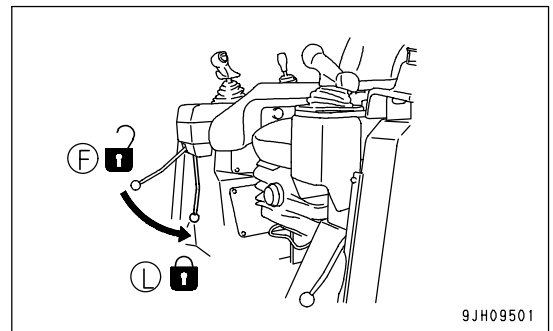

STARTING ENGINE

NORMAL STARTING

WARNING

- Sit down in the operator's seat before starting the engine.
- Do not attempt to start the engine by short-circuiting the engine starting circuit. Such an act may cause serious bodily injury or fire.
- Check that there are no persons or obstacles in the surrounding area, then sound the horn and start the engine.
- Exhaust gas is toxic. When starting the engine in confined spaces, be particularly careful to ensure good ventilation.

NOTICE

- Do not crank the starting motor continuously for more than 20 seconds. If the engine does not start, wait for at least 2 minutes, then repeat the procedure from Step 2.
- Before starting the engine, check that the fuel control dial is in the low idling (MIN) position.
- On this machine, to protect the turbocharger, a turbo protect function is provided. In cold weather, even if fuel control dial (1) is moved immediately after starting the engine, the engine speed may not change for several seconds.
- If the fuel control dial is in the FULL position, the engine will accelerate suddenly and cause damage to the engine parts, so set it to an intermediate or low speed position.

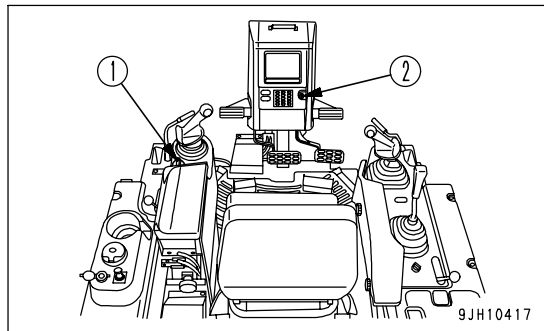

9JH10417

1. Set fuel control dial (1) to the low idling (MIN) position. If the dial is at the high idling (MAX) position, always change it to the low idling (MIN) position.

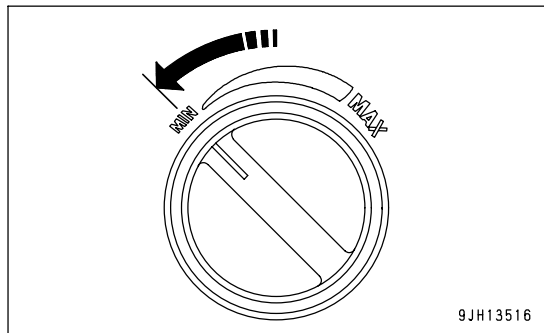

9JH13516

2. Insert the key into starting switch (2) and turn the key to the START position (C). The engine will start.

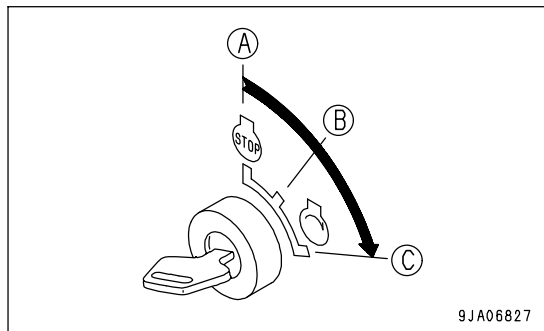

9JA06827

3. When the engine starts, release the key in starting switch (2).
The key will return automatically to the ON position (B).

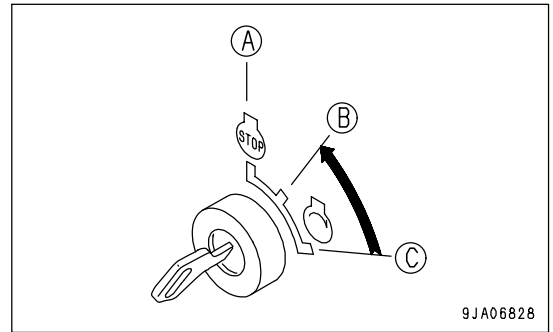

9JA06828

STARTING IN COLD WEATHER

⚠ WARNING

- Start the engine only after sitting down in the operator's seat.
- Do not attempt to start the engine by short-circuiting the engine starting circuit. Such an act may cause a serious bodily injury or fire.
- Check that there are no persons or obstacles in the surrounding area, then sound the horn and start the engine.
- Never use starting aid fluids as they may cause explosions.
- Exhaust gas is toxic. When starting the engine in confined spaces, be particularly careful to ensure good ventilation.

NOTICE

- Do not crank the starting motor continuously for more than 20 seconds. If the engine does not start, wait for at least 2 minutes, then repeat the procedure from Step 2.
- Before starting the engine, check that the fuel control dial is in the low idling (MIN) position.
- On this machine, to protect the turbocharger, a turbo protect function is provided. In cold weather, even if fuel control dial (1) is moved immediately after starting the engine, the engine speed may not change for several seconds.
- If the fuel control dial is in the FULL position, the engine will accelerate suddenly and cause damage to the engine parts, so set it to an intermediate or low speed position.

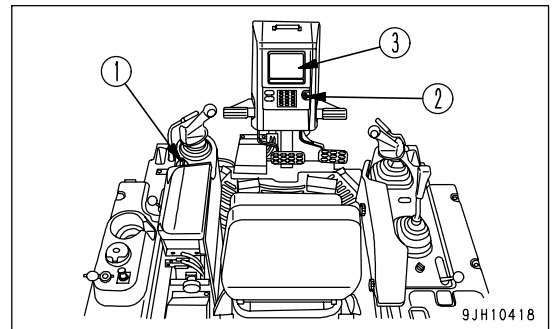

9JH10418

1. Set fuel control dial (1) to the low idling (MIN) position.
If the dial is at the high idling (MAX) position, always change it to the low idling (MIN) position.

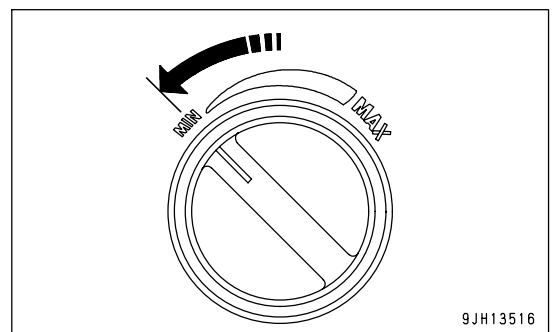

9JH13516

2. Insert the key into starting switch (2) and turn the key to the ON position (B).

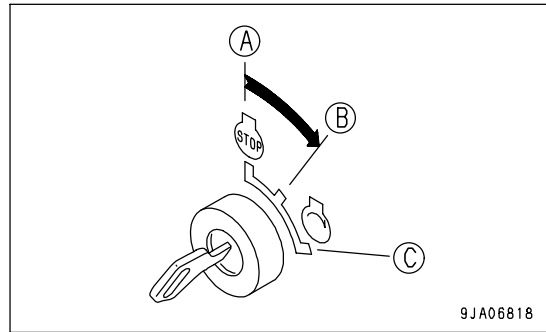

3. Check that engine pre-heating pilot lamp (3) on the monitor panel lights up.

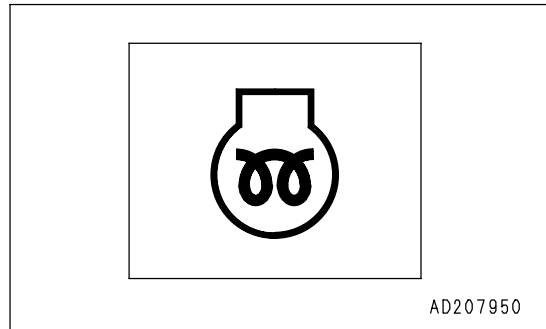

4. Maintain the key in the on position until the pre-heating pilot lamp (3) goes off.

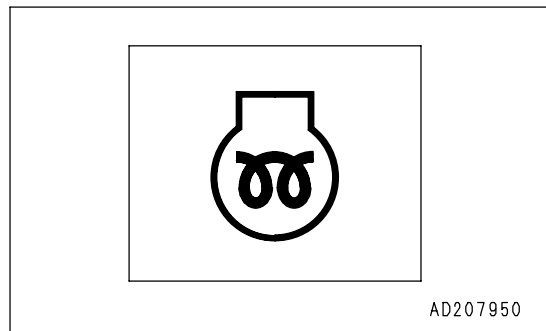

5. When preheating pilot lamp (3) goes off, turn the key of ignition switch (2) to the START position (C) to crank the engine. The time that preheating pilot lamp (3) stays on changes according to the ambient temperature as shown in the table below.

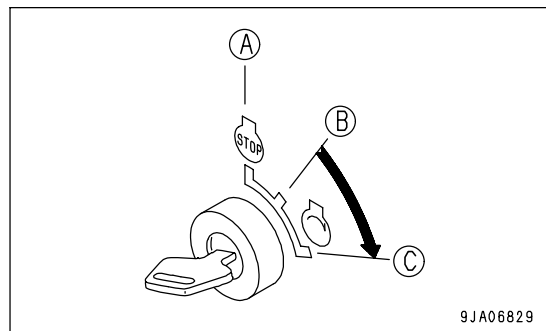

Ambient temperature	Pre-heat time
-5°C to -10°C (23°F to 14°F)	20 to 27 seconds
-10°C to -20°C (14°F to -4°F)	27 to 40 seconds
-20°C to -30°C (-4°F to -22°F)	40 seconds

6. When the engine starts, release the key in starting switch (2).
The key will return automatically to the ON position (B).

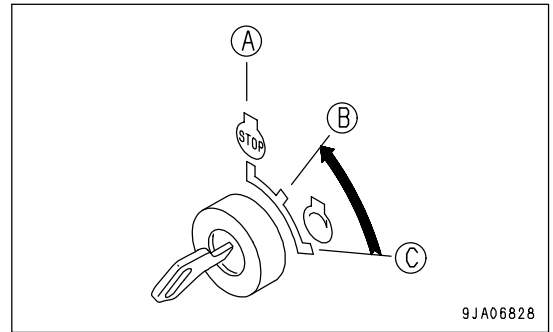

REMARK

Immediately after starting the engine, run at idle. While running the engine, release the decelerator pedal and do not operate the work equipment.

Guideline for idle time

- Cold weather: At least 15 seconds
- 1st start after changing engine oil or engine oil filter: 20 seconds

7. When the engine rotation stabilizes, return to the low idle (MIN) position of fuel control dial (1) and then carry out the warming-up operation.

REMARK

- Regardless of the ambient temperature, if the key in the starting switch (2) is turned from the OFF position to the left, pre-heating pilot lamp (3) will light up and pre-heating will start. (Pre-heating continues while the starting switch is being held to the left.)
For details of the pre-heating time, see the table in Step 5.
- During the pre-heating operation, pre-heating pilot lamp (3) lights up to show that pre-heating is being carried out.
- If the engine does not start with the above operation, wait for at least 2 minutes, and repeat the procedure in Steps 3 and 4.

REMARK

- The turbo protect function is a function to protect the turbocharger. It keeps the engine speed below 1000 rpm for a set time after the engine is started even if the pedal is fully depressed.
- The basic function acts to cancel the actuation of the turbo protect function when the engine oil pressure rises. The settings for the maximum actuation time are as shown below. When the turbo protect function is actuated, the engine speed does not change even when the fuel control dial is moved.

Coolant temperature	Turbo protect time (sec.)
Above 10°C (50°F)	0
10 to -30°C (50 to -22°F)	Change 0 to 20
below -30°C (-22°F)	20

OPERATIONS AND CHECKS AFTER STARTING ENGINE

WARNING

- If there has been any Emergency stop, abnormal actuation or trouble, turn the starting switch key to the OFF position.
- If the work equipment is operated without sufficiently warming the machine up, response of the work equipment to movement of the control lever will be slow, and the work equipment may not respond as the operator desires, so always perform the warming-up operation. Particularly in cold areas, be sure the warming-up operation is completed.

BREAKING IN THE MACHINE

NOTICE

Your Komatsu machine has been thoroughly adjusted and tested before shipment from the factory. However, operating the machine under full load before breaking the machine in can adversely affect the performance and shorten the machine life. Be sure to break in the machine for the initial 100 hours (as indicated on the service meter).

Make sure that you fully understand the content of this manual, and pay careful attention to the following points when breaking in the machine.

- Run the engine at idle for 15 seconds after starting it. During this time, do not operate the control levers or fuel control dial.
- Idle the engine for 5 minutes after starting it up.
- Avoid operation with heavy loads or at high speeds.
- Immediately after starting the engine, avoid sudden starts, sudden acceleration, unnecessary sudden stops, and sudden changes in direction.

WARMING UP OPERATIONS

NOTICE

- Do not carry out operations when the hydraulic oil is still at low temperature, and do not operate the control levers suddenly. Always carry out the warming-up operation until the hydraulic oil temperature monitor shows the green display. Performing the warming-up operation properly will extend the service life of the machine. Do not suddenly accelerate the engine before the warming-up operation is completed.
- Do not run the engine under no load at low idling or high idling continuously for more than 20 minutes. This will have an adverse effect on the environment, and will also have an adverse effect on the internal structure of the turbocharger and engine. If it is necessary to run the engine at idling, apply a load from time to time or run at a mid-range speed.
- If the engine oil pressure caution lamp on machine monitor (2) flashes or the alarm buzzer sounds intermittently, stop the engine and carry out inspection.

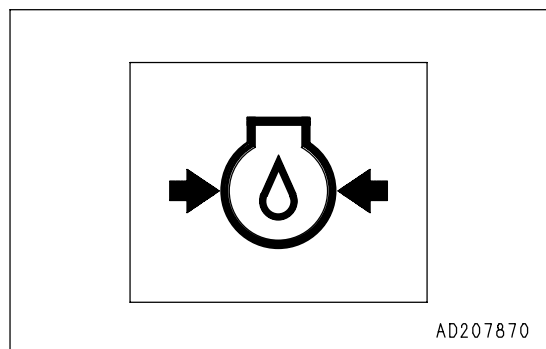
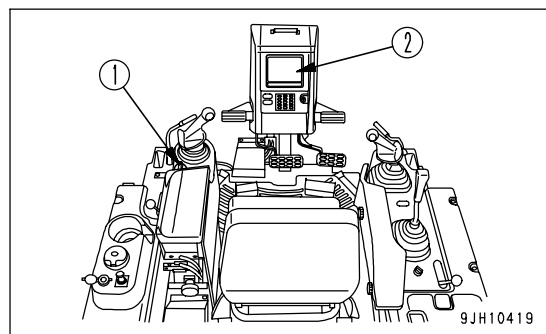

1. Turn fuel control dial (1) to the center position between LOW IDLE (MIN) and HIGH IDLE (MAX) and run the engine at medium speed for about 5 minutes with no load.

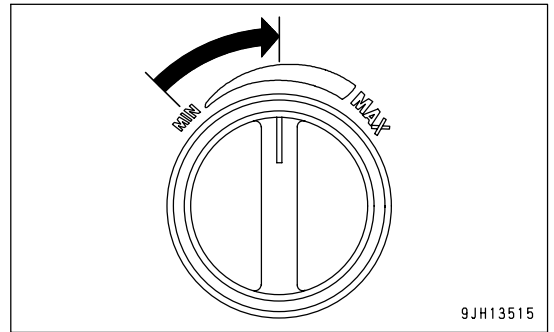

9JH13515

2. After it completing the warming-up operation, check that all gauges and caution lamps work properly. If any problem is found, carry out maintenance or repair. Run the engine under light load until the engine water coolant gauge on machine monitor (2) enters green range (A) - (C).

- (A) - (B): Red range
- (A) - (C): Green range
- (C) - (D): White range

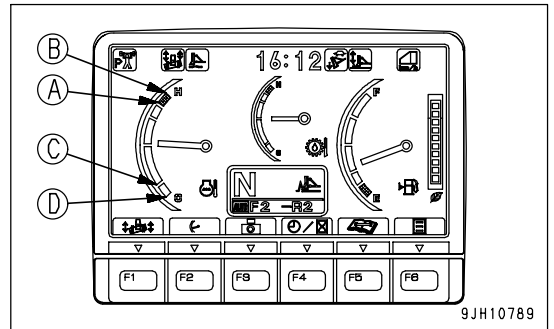

9JH10789

3. Check for abnormal exhaust gas color, noise, or vibration. If any problem is found, contact your Komatsu distributor.

IN COLD AREAS

(AUTOMATIC WARMING-UP OPERATION)

This machine is equipped with an automatic warming-up device.

- When the engine is started, if the engine coolant temperature is low (below 30 °C (86 °F)), the warming-up operation is carried out automatically.
- The automatic warming-up operation is canceled if the engine coolant temperature reaches the specified temperature (30 °C (86 °F)) or if the warming-up operation is continued for 10 minutes. If the engine coolant temperature or hydraulic oil temperature are low after the automatic warming-up operation, warm the engine up further as follows.

1. Turn fuel control dial (1) to the center position between LOW IDLE (MIN) and HIGH IDLE (MAX) and run the engine at medium speed for about 10 minutes with no load.

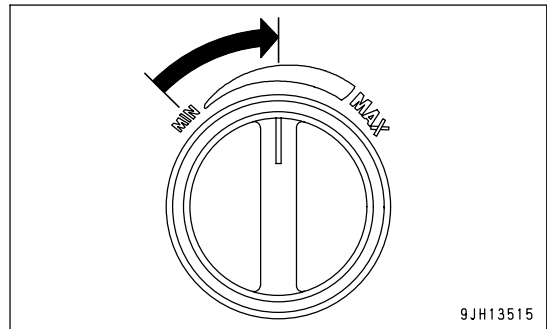
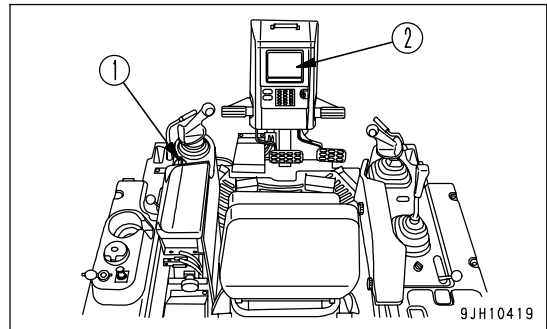

2. Operate blade control lever (4) to the RAISE position, then keep the blade raised to the maximum height and continue to relieve the circuit for 10 minutes.
3. Finally, operate blade control lever (4) and ripper control lever to operate the blade and ripper cylinders several times. If the oil temperature in the work equipment is not properly raised, there will be a time lag in the response of the work equipment and steering.
4. After warm-up is completed, check gauges and caution lamps for proper operation. If any problem is found, repair it. Continue to run the engine under a light load until engine coolant temperature gauge indicator (2) is within the green range (B).
 - (A) - (B): Red range
 - (A) - (C): Green range
 - (C) - (D): White range

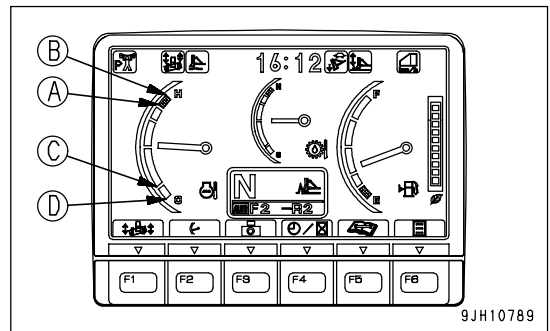
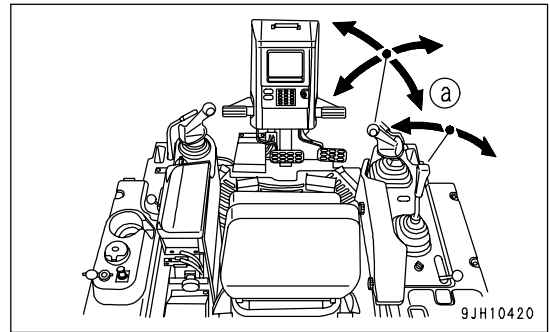

REMARK

If the power train oil temperature is not raised sufficiently, it will take longer to accelerate to the maximum speed.

5. Check for abnormal exhaust gas color, noise, or vibration. If any problem is found, contact your Komatsu distributor.

STOPPING ENGINE

NOTICE

If the engine is stopped without allowing it to cool down, there is danger that the service life of various parts of the engine will be reduced. Except in emergencies, never stop the engine suddenly.

If the engine overheats, do not stop it suddenly. Run it at low speed to allow it to cool down gradually, then stop it.

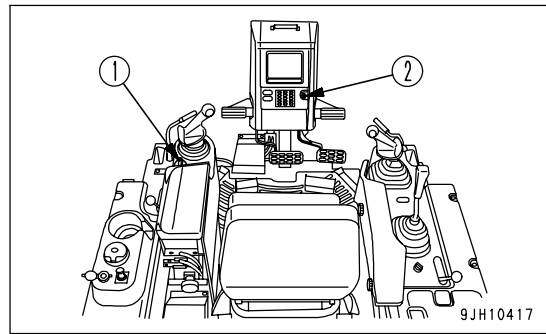

1. Turn fuel control dial (1) in the low idling (MIN) positions and run the engine at low idling speed for 5 minutes to allow the engine to gradually cool down.

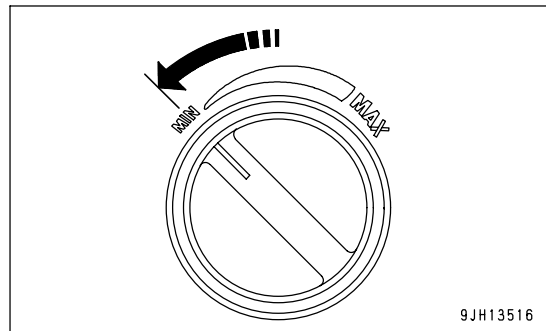

2. Turn the key in starting switch (2) to the OFF position.
The engine will stop.

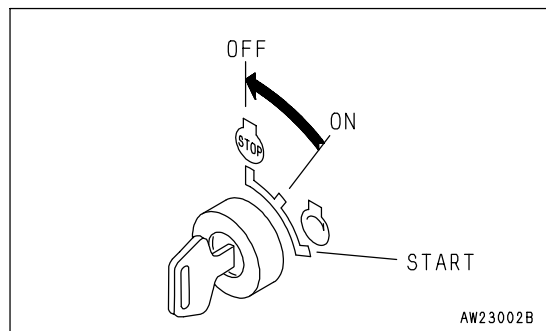

3. Remove the key from starting switch (2).

MOVING MACHINE

WARNING

- Before moving the machine, check that the area around the machine is safe, and always sound the horn before moving.
Do not allow anyone to enter the area around the machine.
The rear of the machine is a blind spot, so be extremely careful when traveling in reverse.
- When moving the machine down a slope, always keep brake pedal (8) depressed, even after releasing parking brake lever (1).
- When moving the machine up a steep slope, turn fuel control dial (5) to high idling (MAX) position and run the engine at full speed, and keep brake pedal (8) and decelerator pedal (6) depressed. Then operate steering, directional, and gearshift lever (4) from the N (neutral) position to the direction of travel and slowly release brake pedal (8). When the travel speed rises, slowly release decelerator pedal (6).

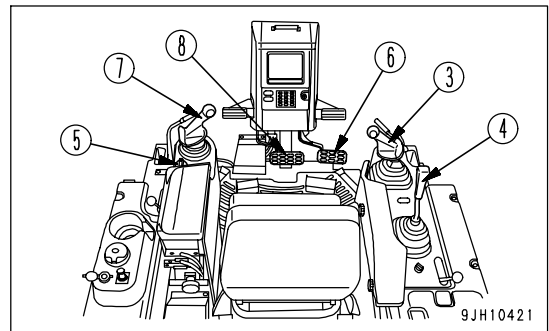
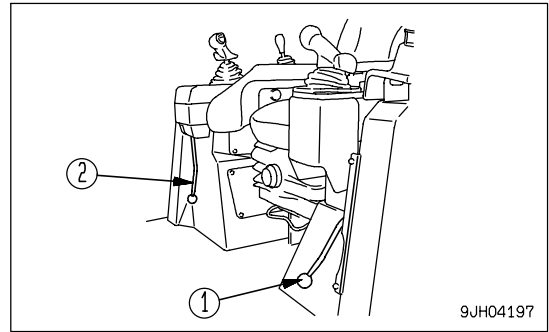

1. Operate parking brake lever (1) to the FREE (F) position.

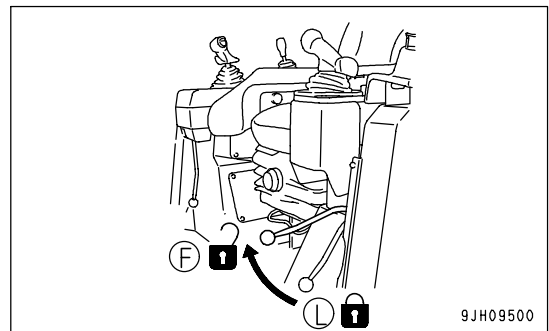

2. Operate work equipment lock lever (2) to the FREE (F) position.

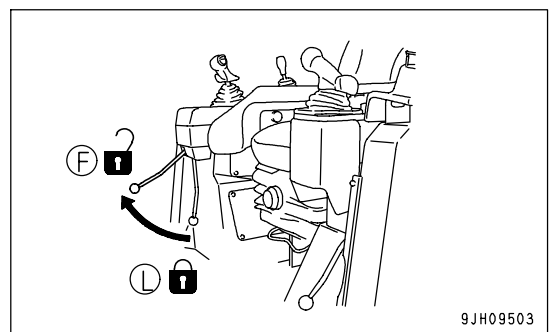

3. Operate blade control lever (3) and ripper control lever (4) to the RAISE position, raise the blade 40 - 50 cm (15.8 - 19.7 in) from the ground, and raise the ripper to the maximum height.

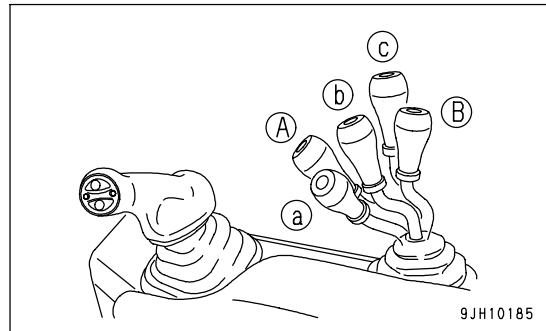
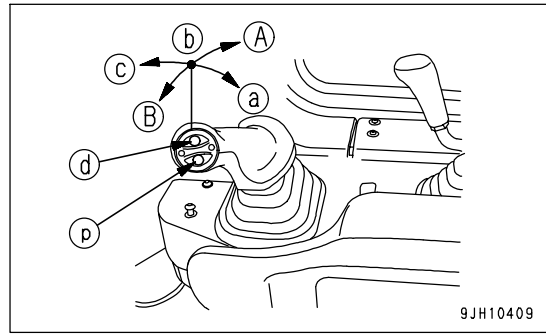

4. Turn fuel control dial (5) to the full speed (MAX) position, raise the engine speed, and fully depress decelerator pedal (6).

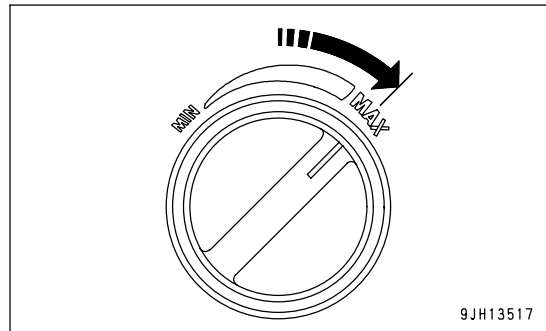

5. Move joystick to the F (FORWARD) or R (REVERSE) position, gradually release decelerator pedal (6) and allow the machine to move.

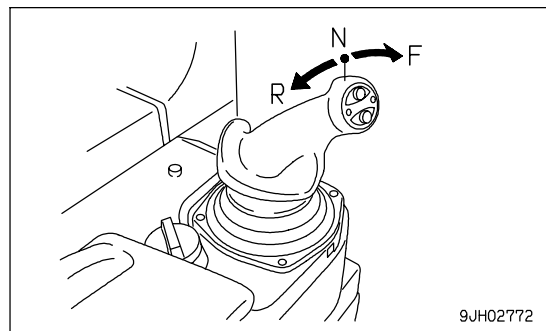

STOPPING MACHINE

⚠ WARNING

- Avoid stopping suddenly. Give yourself ample room when stopping.
- When stopping the machine, select flat hard ground and avoid dangerous places. If it is unavoidably necessary to park the machine on a slope, place the parking brake lever (1) in the LOCK position and insert blocks underneath the track shoes. As an additional safety measure, thrust the blade into the ground.
- If the work equipment control lever is touched by accident, the work equipment may suddenly move, and may cause damage, serious injury, or death. Before leaving the operator's seat, always secure work equipment lock lever (2) in the LOCK position.

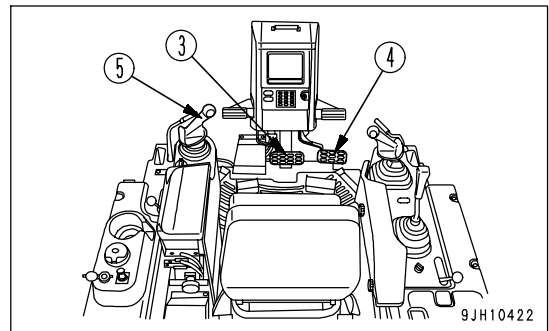
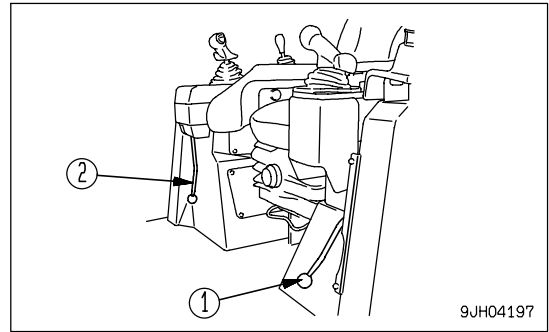

1. Depress brake pedal (3) to apply the brake.

NOTICE

If the brake is depressed when the engine speed or travel speed is high, the brake disc may make a slipping sound. Normally, depress decelerator pedal (4) to reduce the engine speed and travel speed before depressing the brake.

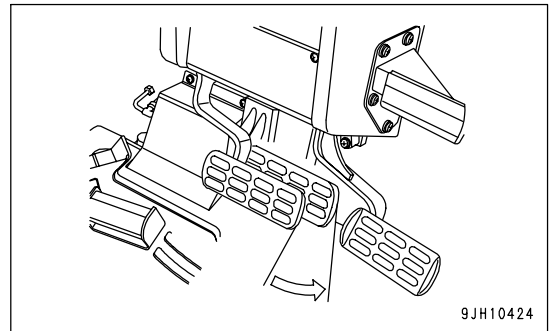

2. Set joystick (5) in the neutral position.

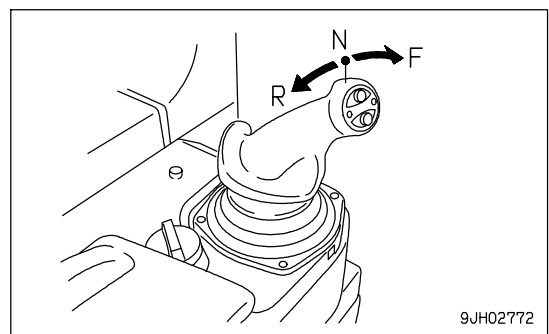

SHIFTING GEAR

The machine does not have to be stopped to shift gears.

1. Move steering, forward-reverse, gear shift lever (1) to the desired gear position to shift gears.

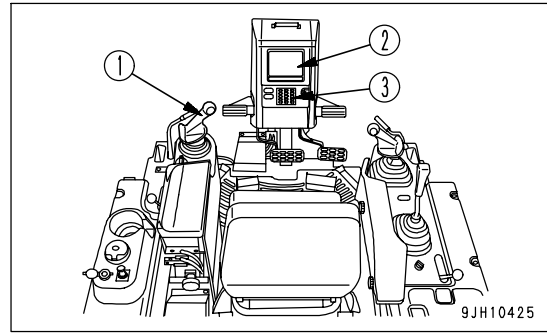

GEAR SHIFTING

- The transmission speed will change when switch (a) or switch (b) is pushed.
- Up switch (a): Each time switch is pressed, transmission speed shifts up one speed
- Down switch (b): Each time switch is pressed, transmission speed shifts down one speed

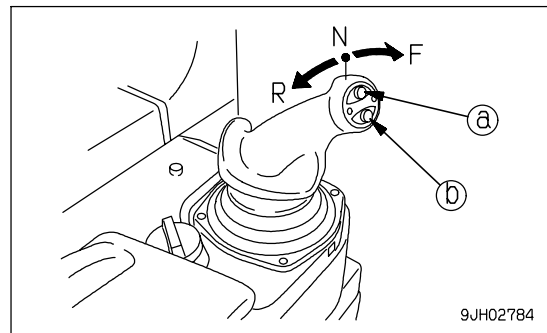

- When the lever is moved to the forward (to set to FORWARD) from the N position, the transmission shifts to F1. If the UP switch is pressed once when the transmission is in F1, the transmission shifts to F2. If the UP switch is pressed once when the transmission is in F2, the transmission shifts to F3. If the DOWN switch is pressed once when the transmission is in F3, the transmission shifts to F2. If the DOWN switch is pressed once when the transmission is in F2, the transmission shifts to F1.
- When the lever is moved to the rear (to set to REVERSE) from the N position, the transmission shifts to R1. If the UP switch is pressed once when the transmission is in R1, the transmission shifts to R2. If the UP switch is pressed once when the transmission is in R2, the transmission shifts to R3. If the DOWN switch is pressed once when the transmission is in R3, the transmission shifts to R2. If the DOWN switch is pressed once when the transmission is in R2, the transmission shifts to R1,

For details of the maximum speed in each speed range, see "SPECIFICATIONS (PAGE 5-2)".

REMARK

The speed range in use is displayed on the panel display according to the gearshift operation.

For example:

- Neutral: N is displayed on the display panel A (2)
- FORWARD 2nd: F2 is displayed on the display panel A (2)
- REVERSE 3rd: R3 is displayed on the display panel A (2)
- When the parking brake lever is locked, P is displayed.

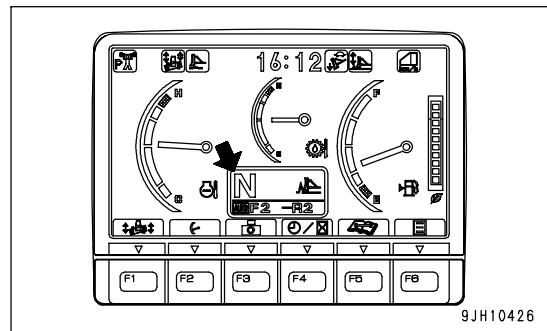

OUTLINE OF GEAR SHIFT MODES

There are two gear shift modes: automatic shift mode and manual shift mode. Select the mode to match the use.

- Automatic shift mode (dozing mode)

This is the mode used for general dozing operations. If a load is applied, the transmission automatically shifts down; when the load is removed, it automatically shifts up to the maximum set speed range. The torque converter lock-up is actuated according to the load and the optimum speed range is automatically selected. As a result, this mode provides excellent fuel consumption and production.
- Manual shift mode (ripping mode)

This is the mode to use for dozing and ripping on rough ground. If a load is applied, the transmission automatically shifts down, but when the load is removed, the transmission does not automatically shift up.

METHOD OF CHANGING GEAR SHIFT MODE

When switching between automatic shift mode and manual shift mode, set the transmission to Neutral and press the gear shift mode selector switch to change the gear shift mode.

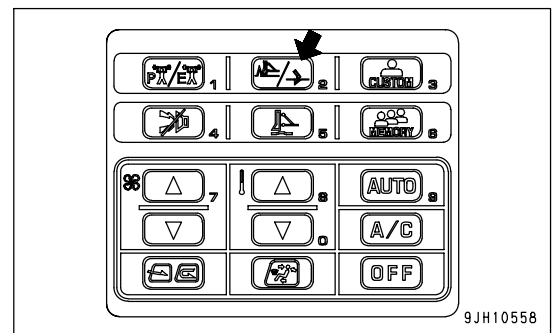

GEAR SHIFT MODE SCREEN DISPLAY

The gear shift mode screen display is shown on the gear shift mode display portion of the monitor panel as follows.

- (A) Automatic shift mode
- (1) Present speed range
 - (2) Preset (speed range when moving machine off) and maximum speed range when traveling
 - (3) (AUTO) mark displaying automatic mode
 - (4) (Dozing) mark displaying automatic mode
- (B) Manual shift mode
- (5) Present speed range
 - (6) Preset (speed range when moving machine off)
 - (7) (Ripping) mark displaying manual mode

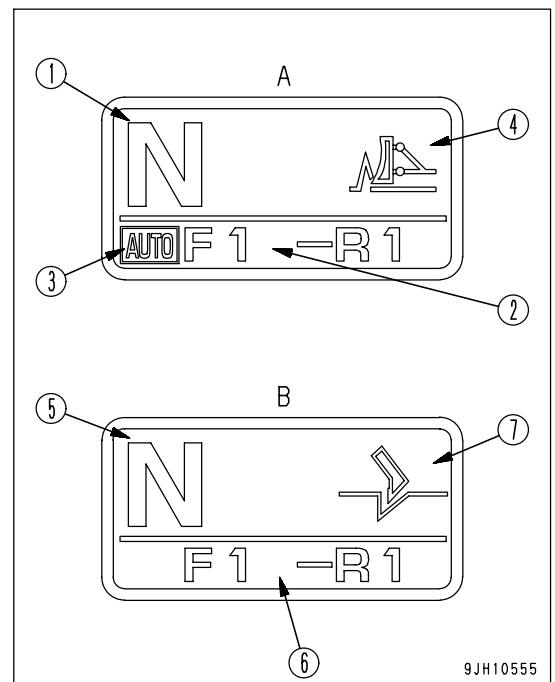

SETTING PRESET WITH SHIFT SWITCH OPERATION AT NEUTRAL

Preset (speed range when moving machine off) and maximum speed range when traveling (automatic mode only) are set by operating the shift switch when the transmission is at neutral.

Automatic mode

Preset (speed range when moving machine off) and maximum speed range when traveling can be set.

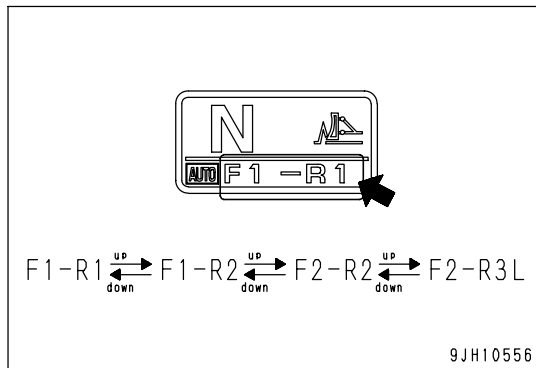

Manual mode

Preset (speed range when moving machine off) can be set.

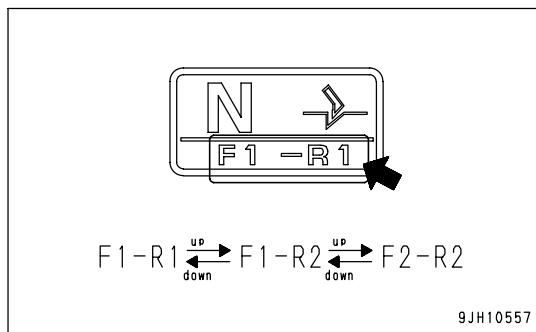

REMARK

When the starting switch is turned ON, the mode is set automatically to automatic mode (set to F1 - R1). When the gear shift mode is switched, F1 - R1 is selected as the default.

GEARSHIFTING OPERATION USING PRESET MODE FUNCTION

- Shift mode selection means that the selected speed range is displayed in the N position before starting.
- When the joystick is in the N position, if UP switch (a) or DOWN switch (b) is pressed, the shift mode selection can be carried out.

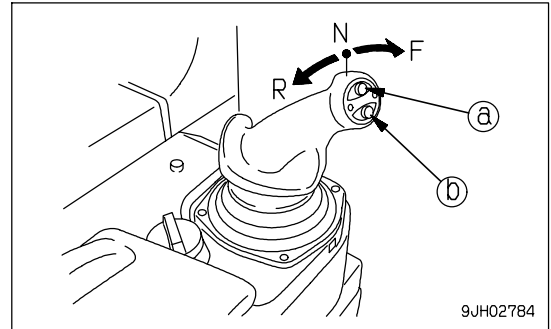

- F1-R1 mode
- F1-R2 mode
- F2-R2 mode

- The selected shift mode is displayed on the speed range display on the machine monitor.

- Shift operation when F1-R1 mode is set

After this mode is set, when the joystick (steering, directional, and gearshift lever) is operated to the front (FORWARD operation), the speed range shifts to F1. When the lever is moved to the rear (REVERSE operation), the speed range shifts to R1.

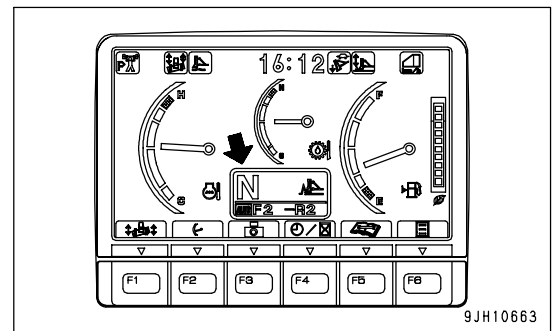

- Shift operation when [F1-R2] mode is set

When the steering, directional, and speed lever is in the N position, if the up switch is pressed once, the mode is set to [F1-R2] mode. After that, if the steering, directional, and speed lever is operated forward (forward travel operation), the transmission is shifted to F1. If it is moved back (reverse travel operation), the transmission is shifted to R2.

- Shift operation when [F2-R2] mode is set

When the steering, directional, and speed lever is in the N position, if the up switch is pressed twice, the mode is set to [F2-R2] mode. After that, if the steering, directional, and speed lever is operated forward (forward travel operation), the transmission is shifted to F2. If it is moved back (reverse travel operation), the transmission is shifted to R2.

SHIFTING SPEED RANGE BY OPERATING SWIFT SWITCH WHEN TRAVELING

It is possible to operate the shift switch when traveling to change the maximum set speed range when traveling (automatic shift mode) or speed range used when traveling (manual shift mode).

Automatic shift mode

- Changing maximum set speed range when traveling
When traveling forward: Possible to change maximum speed range to F1 - F3
When traveling in reverse: Possible to change maximum speed range to R1 - R3

up switch (a): Each time it is pressed, maximum speed range goes up one range

down switch (b): Each time it is pressed, maximum speed range goes down one range

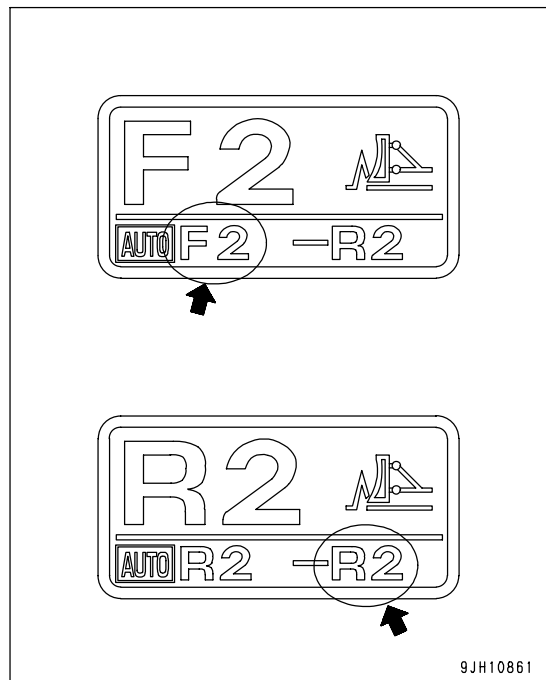
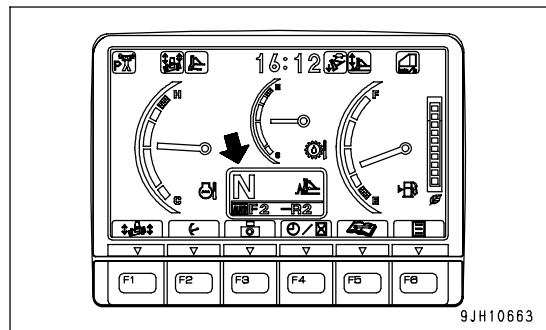
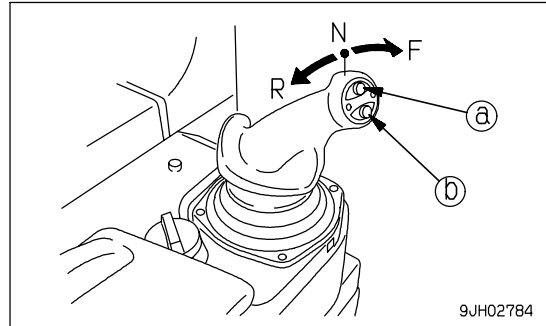

Manual shift mode

- Changing maximum speed range used when traveling
 When traveling forward: Possible to change speed range used to F1 - F3
 When traveling in reverse: Possible to change speed range used to R1 - R3

up switch (a): Each time it is pressed, speed range used goes up one range

down switch (b): Each time it is pressed, speed range used goes down one range

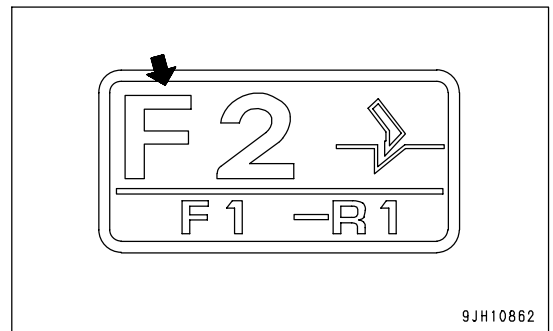
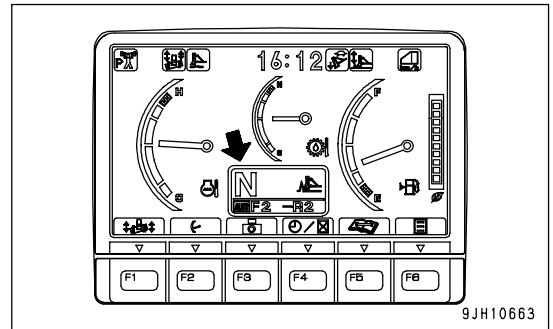
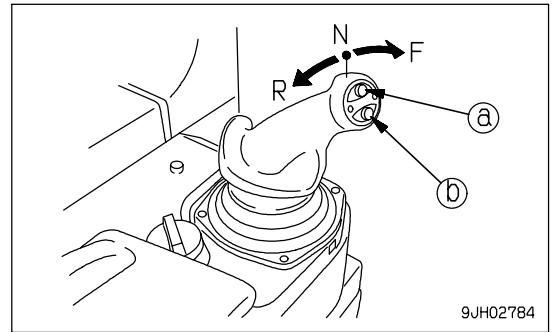

REMARK

F3L and R3L are speed ranges where the engine speed is controlled at 3rd and the speed range is set to a range between 2nd and 3rd.

In automatic shift mode, if the maximum speed range has been changed when traveling, return the steering, directional, and gearshift lever to the Neutral position. The setting is changed to the maximum speed range set before starting to travel (when the transmission was at neutral).

In manual shift mode, the preset (speed range when moving machine off) cannot be changed when the machine is traveling.

NOTICE

- Be careful not to come unnecessarily close to the edge of cliffs. When dropping soil at the edge of a cliff to build an embankment or landfill, always leave one load and use the next load to push the previous load over.
- When reaching the top of a hill, or at the instant when the load is dumped from a cliff, the load will suddenly drop and there is danger that the machine will suddenly increase speed, so depress the decelerator pedal to reduce the speed when dumping the load.
- In automatic shift mode, when a load is applied, the transmission automatically shifts down; when the load is removed, it automatically shifts up to the maximum set speed range. In manual shift mode, if a load is applied, the transmission automatically shifts down, but when the load is removed, the transmission does not automatically shift up.

SHIFTING BETWEEN FORWARD AND REVERSE

WARNING

When switching between FORWARD and REVERSE, first check that the direction of travel is safe.

CAUTION

There is no need to stop the machine even when switching between FORWARD and REVERSE.

To increase safety, operator comfort, and the life of the transmission, leave the engine running at full speed, and always depress the decelerator pedal to lower the engine speed.

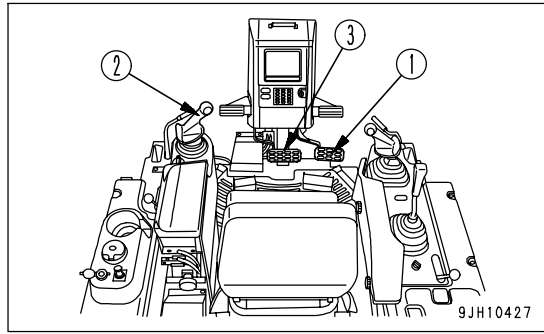

1. Depress decelerator pedal (1) to reduce the engine speed.

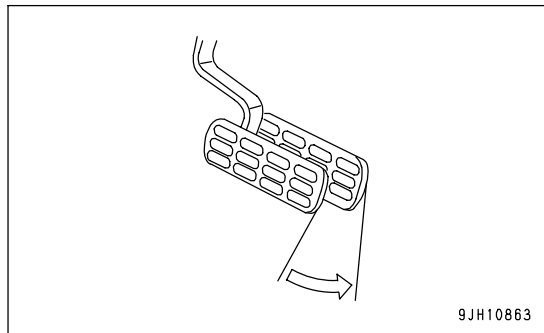

2. Move joystick (2) to the neutral position, reduce the speed, then depress brake pedal (3) and stop the machine.

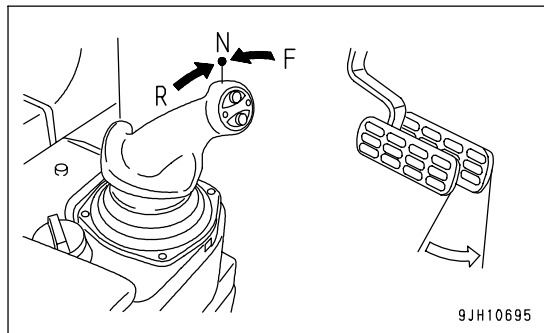

3. After depressing decelerator pedal (1), move steering, forward-reverse, gear shift lever (2) to the desired position.

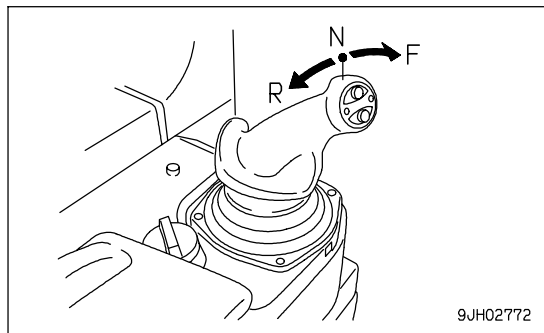

4. Release decelerator pedal (1) and raise the engine speed.

REMARK

When the joystick is placed in REVERSE, the backup alarm will sound.

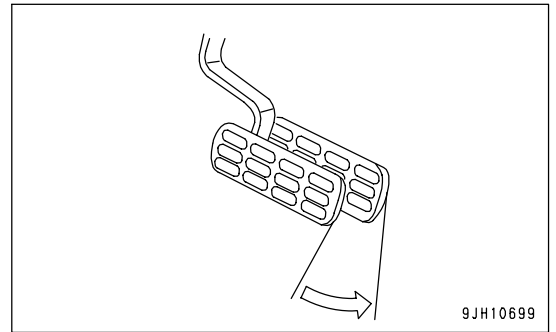

STEERING MACHINE



WARNING

- Avoid as much as possible turning the machine on a slope.
The machine will tend to slip sideways. Particular care should be taken on soft or clay soil.
- Never make a pivot turn at high speed.

NORMAL TURNING

To turn the machine while traveling, incline steering, forward-reverse, gear shift lever (1) in the direction of the turn.

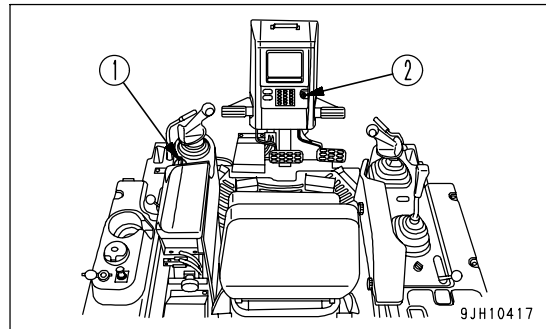

TURNING TO LEFT WHILE TRAVELING FORWARD

If the joystick is pushed forward and moved partially to the left (L), the steering clutch is disengaged and the machine turns gradually to the left.

When turning gradually to the right, push the joystick forward, and move it partially to the right.
Do the same when traveling in reverse.

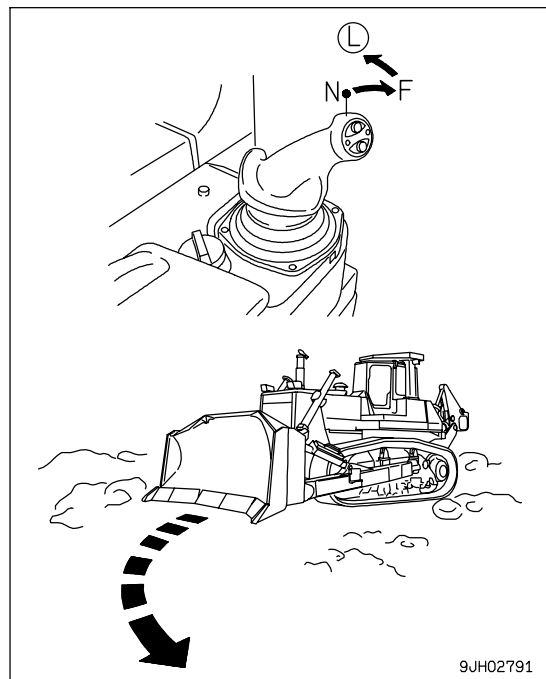

COUNTERROTATION TURNS TO LEFT WHEN TRAVELING FORWARD

NOTICE

When carrying out a counterrotation turn, if the load is not equal on the left and right sides, the machine may carry out a pivot turn, so check the ground conditions and be careful not to hit any obstacles.

With steering, forward-reverse, gear shift lever (1) in the N position, operate the lever partially to the left (L). The left and right tracks will rotate in opposite directions, and the machine will make a slow counterrotation turn. If the lever is moved further, the speed of the counterrotation turn will increase.

REMARK

When making a right counterrotation turn, move the steering, forward-reverse, gear shift lever (1) to the right (R) in the same way.

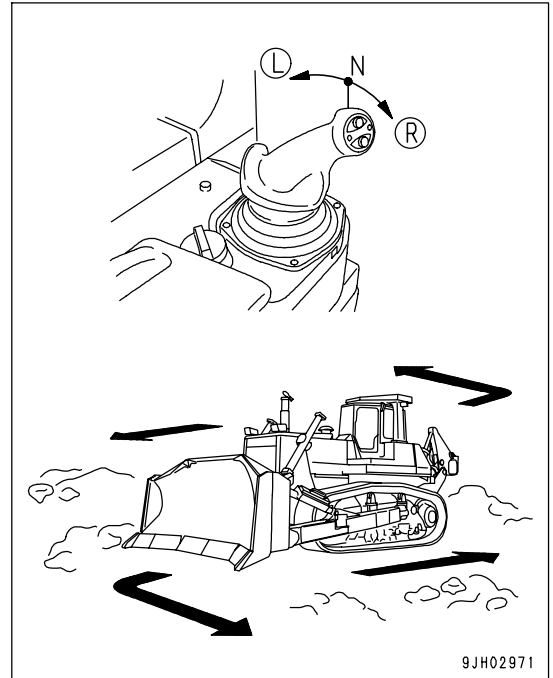

TURNING WHILE DESCENDING A SLOPE

TURNING GRADUALLY TO LEFT WHILE TRAVELING FORWARD

If the joystick (1) is pushed forward and moved partially to the left (L), the machine turns gradually to the left. (Does not become cross steering)

REMARK

When making gradual turns to the right, push the joystick (1) forward, and move it partially to the right. (Does not become reverse steering)

Do the same when traveling in reverse.

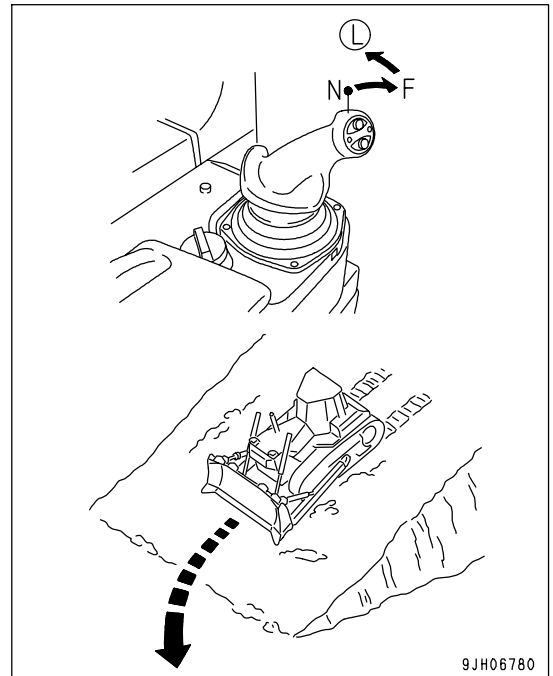

PRECAUTIONS FOR OPERATION

PAY ATTENTION TO GAUGES

If the red range of the power train oil temperature gauge lights up during operation, reduce the load and wait for the temperature to go down.

PERMISSIBLE WATER DEPTH

When operating in water, always keep top surface of the track frame above the surface of the water.

Also, be careful that the engine cooling fan will not come in contact with water. The fan can be damaged.

(A): Permissible water depth line

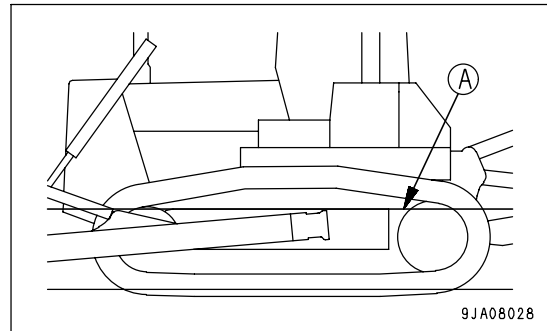

PRECAUTIONS WHEN TRAVELING FOR A LONG TIME

Avoid operating the machine at high speed for a long time, otherwise the temperature of hydraulic oil sharply rises, and that can cause oil leakage from the track rollers or final drive and lower durability.

If there is no way to avoid operating the machine at high speed for a long time, stop the machine every one hour for 30 minutes and let the track rollers and final drive cool off before starting up the machine again.

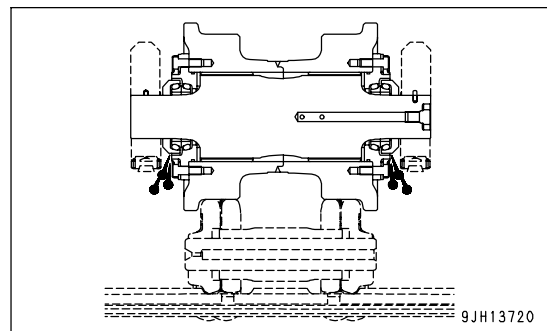

PRECAUTIONS WHEN TRAVELING UP OR DOWN HILLS

METHOD OF USING DECELERATOR PEDAL

When stepping on the decelerator pedal while going uphill, climbing ability will be reduced and the machine will stop. Furthermore, the engine may stall.

USE ENGINE AS BRAKE

When going downhill, move steering, forward-reverse, gear shift lever into low speed to run engine at slow speed and travel down slope using the engine as a brake.

Do not move the steering, forward-reverse, gear shift lever to the NEUTRAL position.

When traveling down hills of more than 15°, shift down to 1st speed (R1 or F1).

BRAKING WHEN TRAVELING DOWNHILL

While descending a slope using the engine as a brake, also apply the brakes.

Failure to brake may result in overrunning, causing engine trouble.

PRECAUTIONS ON SLOPE

BE CAREFUL OF FUEL LEVEL

- If the fuel level in the fuel tank becomes low when the machine is working on slopes, the engine may suck in air because of the angle of the machine or the swaying of the machine. This may make the engine stop, so be careful not to let the fuel level in the fuel tank become too low.
- When working on slopes with an angle of more than 20°, if the fuel level on the fuel gauge enters the red range, add fuel immediately.

(A): Red range

(B): Green range

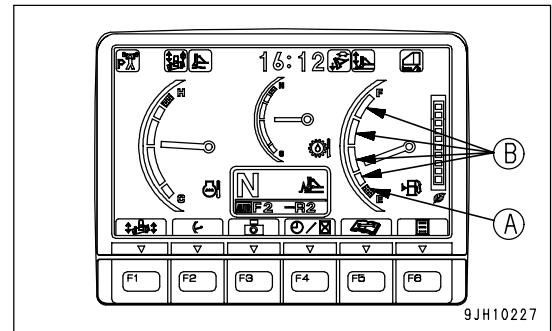

BE CAREFUL OF OIL LEVEL

When operating machine on sloped areas of more than 20°, fill all appropriate components with oil to H level.

PRECAUTIONS WHEN ENGINE STOPS ON SLOPE

If the engine stops while working or traveling on a hill, immediately depress the brake pedal to bring the machine to a complete stop.

METHOD OF USING BRAKES

The following actions cause premature damage to the brakes, so avoid such operations.

- Using emergency brake at full speed
- Using brake with engine running at full speed in first gear (F1, R1) (Machine stall condition)

REMARK

Always depress the decelerator pedal to lower the engine speed before actuating the brakes.

PROHIBITED TO KEEP THE DOOR OPEN DURING OPERATIONS

Always keep the door closed when traveling or carrying out operations.

If the door is open, there is danger of damage from obstacles or strong vibration.

IT IS PROHIBITED TO MODIFY THE CAB GLASS IN ANY WAY THAT WILL OBSTRUCT THE VIEW

- For safety reasons, do not install anything on the cab glass that will obstruct the view.
- Always keep the glass clean to ensure safety during operations.

PRECAUTIONS WHEN OPERATING FLOAT

If the blade is operated to FLOAT when the engine is running at low speed or when it is idling, hunting may occur. Raise the engine speed when carrying out the FLOAT operation.

PARKING MACHINE

**WARNING**

- Avoid stopping suddenly. Give yourself ample room when stopping.
- When stopping the machine, select flat hard ground and avoid dangerous places. If it is unavoidably necessary to park the machine on a slope, place the parking lever (4) in the LOCK position and insert blocks underneath the track shoes. As an additional safety measure, thrust the blade into the ground.
- If the work equipment control lever is touched by accident, the work equipment may suddenly move, and may cause damage, serious injury, or death. Before leaving the operator's seat, always secure work equipment lock lever (7) in the LOCK position.

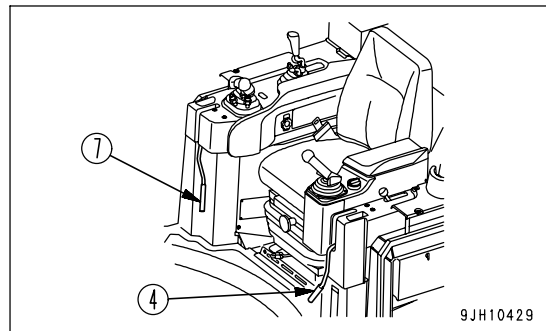
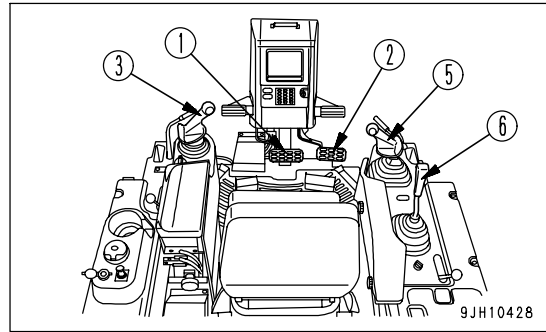

1. Depress brake pedal (1) to stop the machine.

NOTICE

If the brake pedal is depressed when the engine speed or machine travel speed is high, the brake disc may produce a slipping sound. When depressing the brake pedal, usually depress decelerator pedal (2) to reduce the engine speed and machine travel speed.

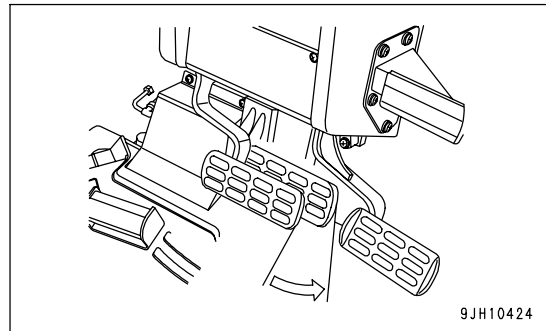

2. Set joystick (steering, directional, and gearshift lever) (3) to the N position.

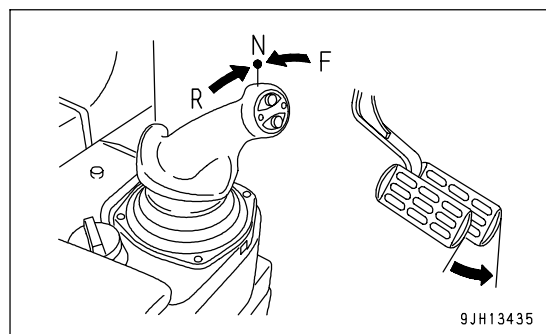

3. Operate parking brake lever (4) to the LOCK (L) position.

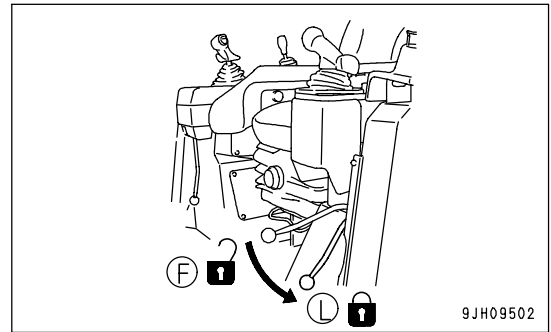

- 4. Operate blade control lever (5) and ripper control lever (6) to LOWER position (c) and lower the blade and ripper to the ground.
- 5. Place blade control lever (5) and ripper control lever (6) at HOLD position (b).

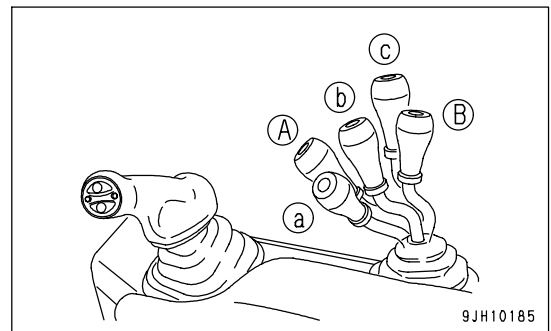
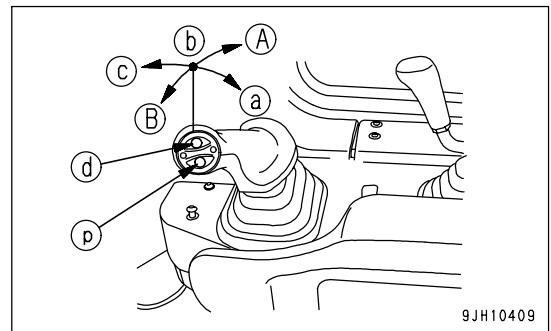

6. Set work equipment lock lever (7) to the LOCK position (L).

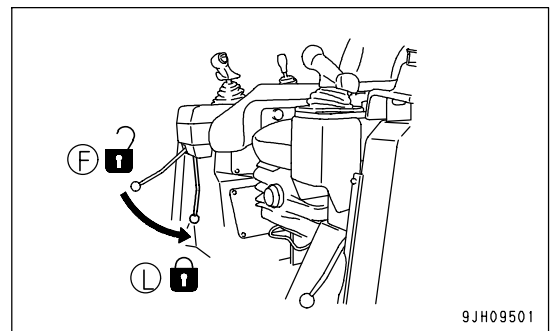

CHECK AFTER STOPPING ENGINE

- 1. Walk around the machine and check the work equipment, machine exterior, and undercarriage, also check for any leakage of oil or coolant. If any problems are found, repair them.
- 2. Fill the fuel tank.
- 3. Check the engine compartment for paper and debris. Clean out any paper and debris to avoid a fire hazard.
- 4. Remove any mud affixed to the undercarriage.

CHECK AFTER FINISHING WORK

Check the engine coolant temperature, engine oil pressure, and fuel level on the machine monitor.

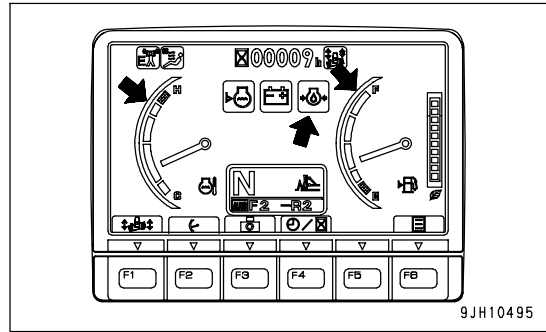

LOCKING

To prevent vandalism, there are locks in the following places.
Places that can be locked with the starting switch key.

- Left and right engine side covers (1) (left side: 1 place; right side: 1 place)
- Battery inspection cover (2)
- Cab door opener (3)
- Cap with lock (4) (if equipped)
 - Radiator cap
 - Fuel tank cap
 - Hydraulic tank cap
 - Hydraulic tank breather
 - Power train oil filler tube cap

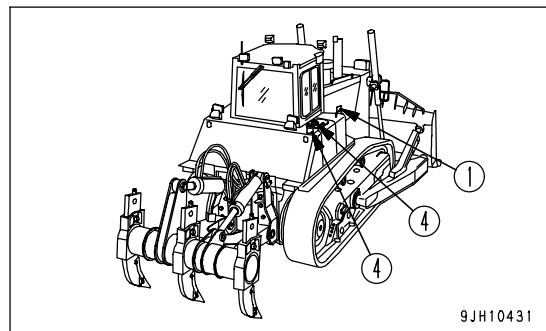
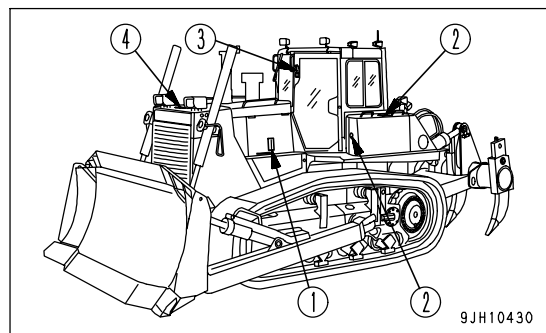

RIPPER OPERATION

EFFECTIVE METHOD OF USE

- The most suitable digging angle for the shank is when the shank is perpendicular to the ground surface (angle at tip: 45° - 50°).
- For comparatively soft rock (seismic velocity: 1200m/s or below), it is also possible to carry out ripping with the shank tilted to the rear (maximum ripping angle).

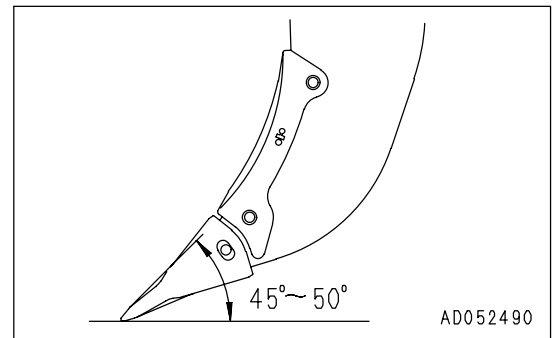

- On comparatively hard bedrock, if ripping is carried out with the shank tilted back, there will be excessive wear of the tip of the point (A), and this will reduce the effectiveness of the self-sharpening ability.
- During ripping operations, if the track starts to slip when ripping boulders or rock that is difficult to rip, use the tilt cylinder.

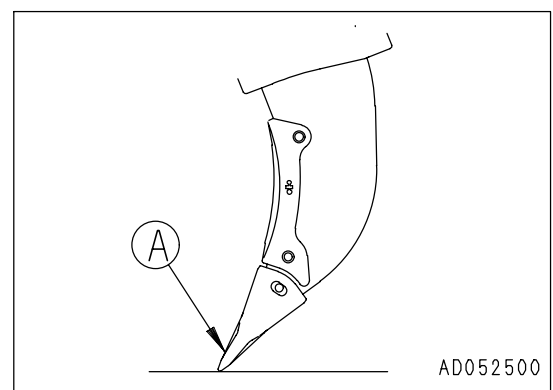

- Selecting a suitable ripper point to match the type of rock is extremely important to obtain effective ripping. A variety of ripper points to match each type of rock is available, so use the information in "PROCEDURE FOR SELECTING RIPPER POINT (PAGE 6-5)" to select the most suitable ripper point.

DIGGING UP BOULDERS OR ROCKBED

When ripping boulders and rockbed that are difficult to rip, if the track slips or the travel speed becomes slower, operate the tilt cylinder to lift up the boulder or rockbed.

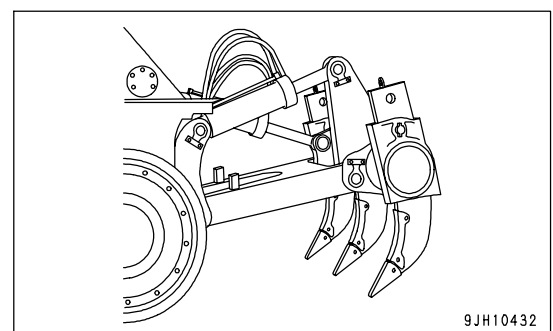

OPERATING ON SLOPES

When using the variable ripper, adjust the length of the tilt cylinder to select dimension L.

Slope face: Sloping face, such as on embankments

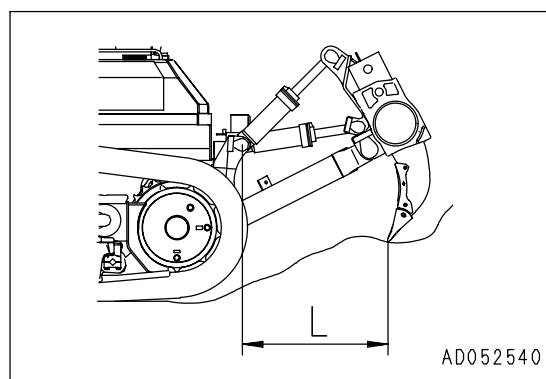
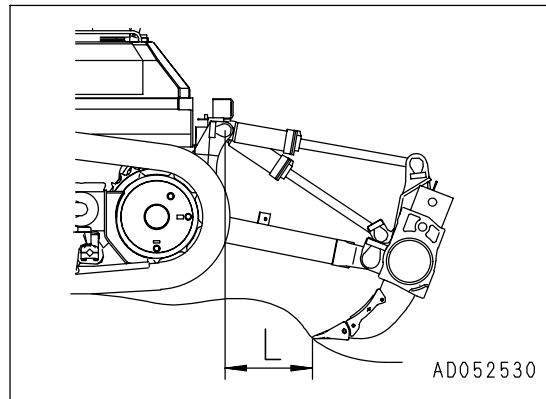

METHOD OF OPERATING PIN PULLER

This operation is used only when a giant ripper is installed.

1. Stop the machine in a safe place and lower the shank to the ground.
2. Operate the pin puller controller switch to the "PULL OUT" position (1) and remove the mounting pin.

REMARK

If the mounting pin cannot be removed by operating the switch, move the ripper slightly up or down and tilt it. This will make it possible to remove the pin.

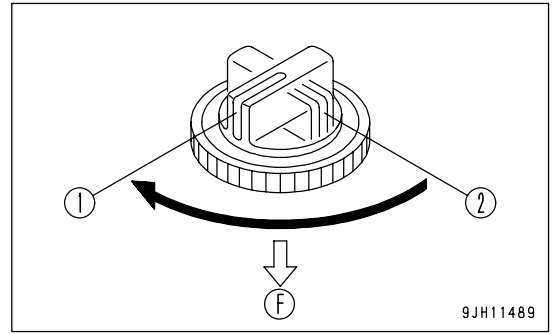

(F)Front of the machine

3. Move the ripper up or down to set to the desired shank position.

REMARK

Align mark of ripper (A) with top surface of holder (B).

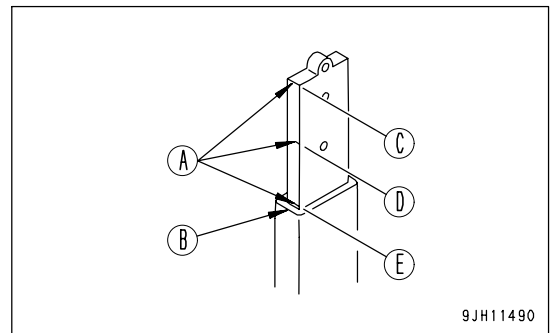

(C)Depth Max.
(D)Depth intermediate
(E)Depth min.

4. Operate the pin puller control switch to insert the mounting pin.
If the pin does not match the position of the hole in the shank, set the pin puller control switch to the "PUSH IN" position (2) and slowly move the ripper up or down.

REMARK

When raising the pin position to increase the digging depth, use a long protector to prevent wear of the shank.

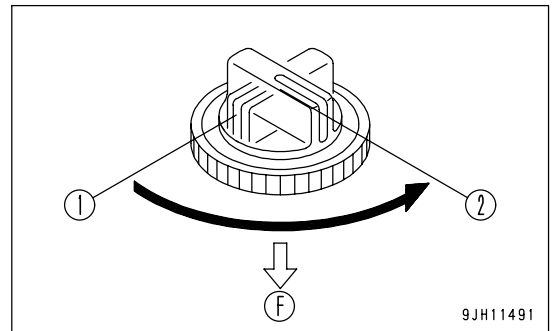

(F)Front of the machine

OPERATING METHOD FOR RIPPING OPERATIONS

BASIC OPERATING METHOD

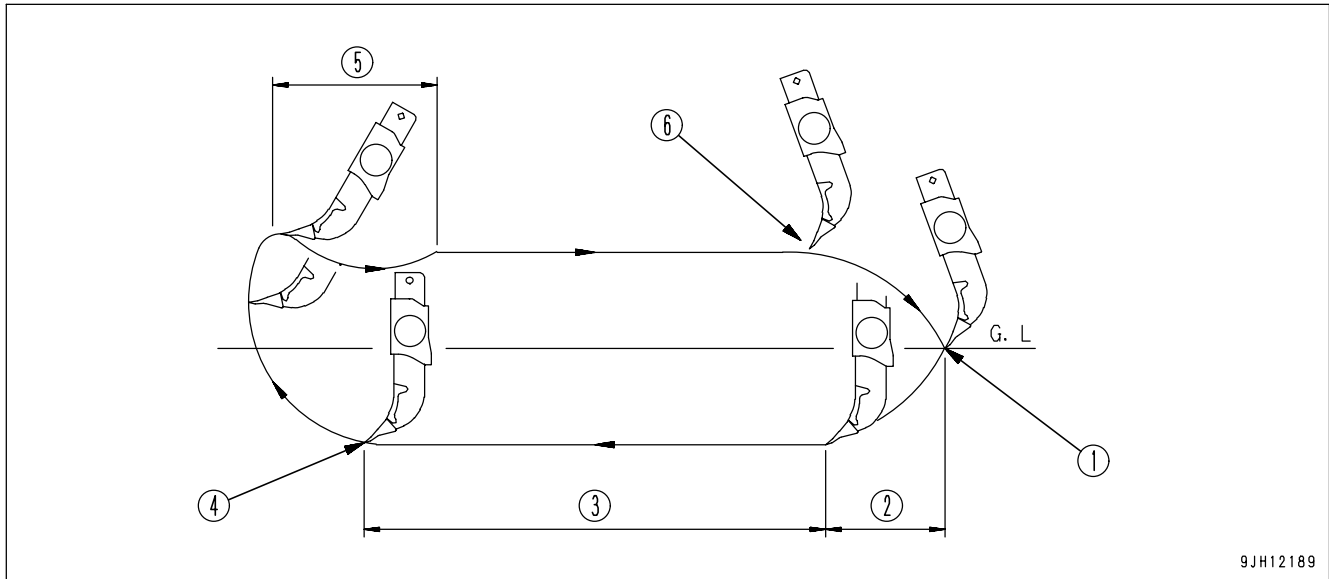

- | | |
|-------------------------------------|---------------------------|
| (1) Point in contact with ground | (4) Start raising ripper |
| (2) Insert point to specified depth | (5) Shank tilted back |
| (3) Ripping | (6) Start lowering ripper |

TRACK OF RIPPER SHANK

Carry out the ripping operation as follows, passing through the points shown in the diagram above.

- (1) Tilt the ripper back, lower the ripper point to the ground that the place to begin ripping, and raise the rear of the machine.
- (2) To press the decelerator pedal and lower the engine speed, set the speed range to F1, and tilt the ripper to insert the point to the specified depth.
- (3) When the ripper point reaches the specified depth, raise the engine speed to full speed and travel forward. Tilt the shank and carry out ripping. If the circuit is relieved even when the shank is tilted, change the shank mounting hole to the hole below and reduce the ripping depth.
- (4) After completing the ripping, travel forward, raise the shank from the bed rock, then travel in reverse.
- (5) While traveling in reverse, tilt the ripper back, and when the starting point for the ripping is reached, lower the ripper.

REMARK

- If the ripper is applied with the rear of the machine raised from the ground, the drawbar pull will be low, so the ripping efficiency will be reduced.
- If the ripping depth is kept constant, there will be no unevenness, and this will increase the efficiency of the dozing operation.

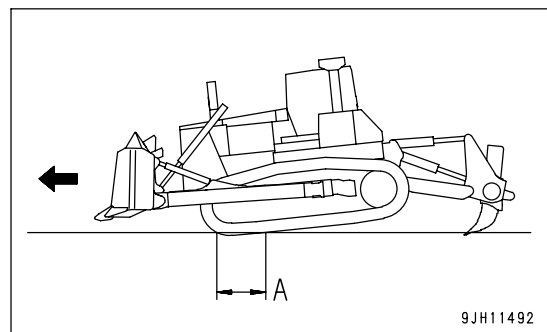

(A)Length of track on ground

RIPPING BY CLIFFS

- When carrying out ripping at the edge of a cliff, tilt the ripper back (B) to make depth (L) longer.

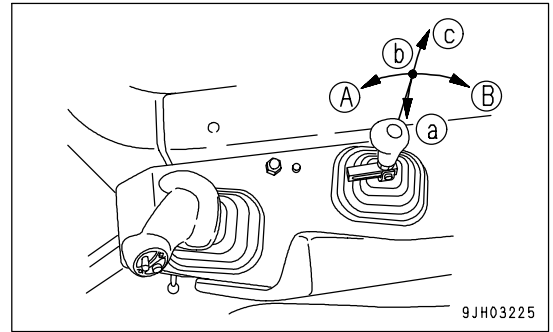

- Depress the decelerator pedal, drive slowly forward, and when the ripper point contacts the cliff, tilt the ripper in (A).

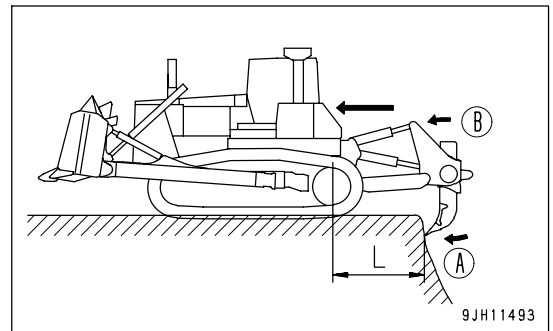

RIPPING BY SLOPE FACES

(Giant ripper)

- When carrying out ripping work at the edge of slope faces, make the ripper tilt back (B) angle small, and if there is an area where the slope face (1) has not been ripped, apply the ripper diagonally.

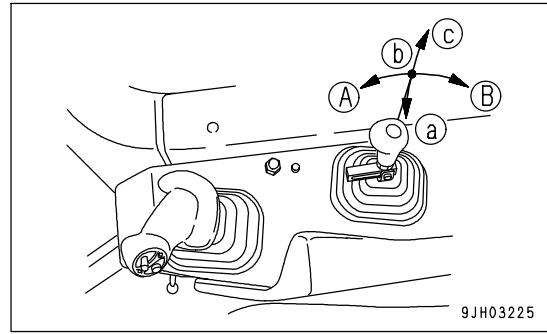

REMARK

In the case of the multi-shank ripper, carry out ripping at right angles to the slope face.

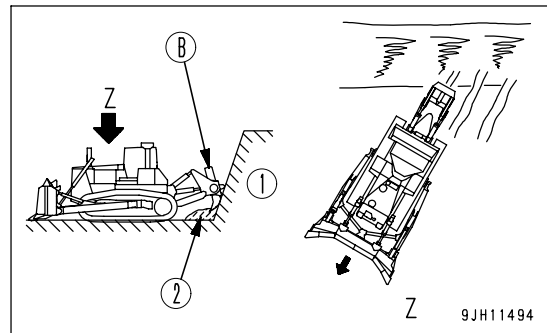

(B)Tilt back (MAX)
 (1)Slope face
 (2)Ripping base

Cross ripping

- On jobsites with hard bedrock, for rocks and boulders which are impossible to break or dig up with one ripping pass, carry out the second ripping pass at right angles to the first ripping direction.
- At the edge of cliffs, where it is impossible to apply the ripper in a cross direction, make the space between the shanks smaller and carry out ripping.

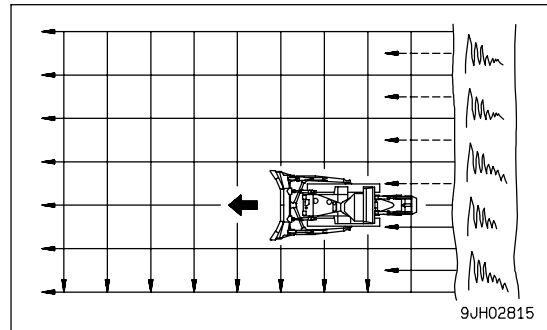

- During the ripping operation, if there is any hard bedrock, carry out ripping in the opposite direction to the direction where the ripper was applied. If it is still impossible to break up the rock, break up the area around the bedrock a little at the time.
- When carrying out concentrated ripping of hard bedrock, the work efficiency is high if the ripper is applied to the whole of the digging face.

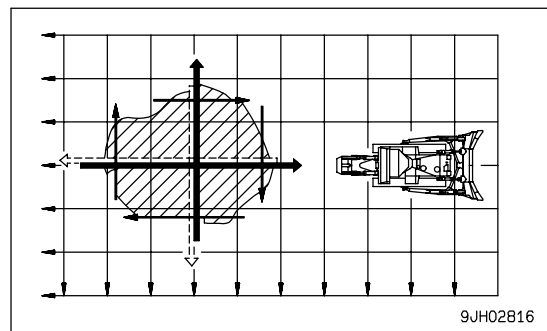

DIGGING UP BOULDERS

During the ripping operation, if boulders are found which are difficult to break and shoe slippage occurs, dig up the boulder as follows.

1. Depress the decelerator pedal and lower the engine speed to a point where there is no shoe slippage.

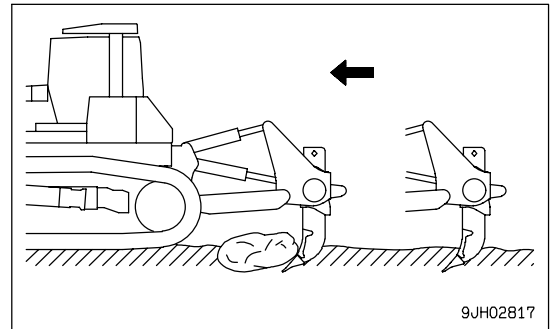

2. Operate the ripper lever to the TILT position and carry out ripping and digging.

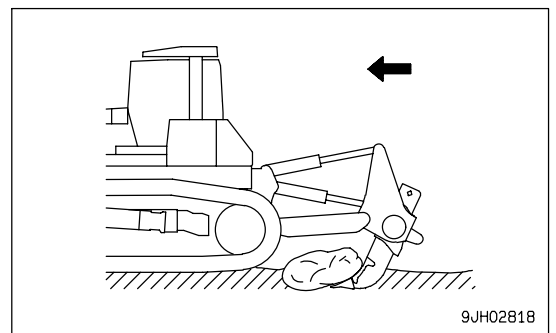

3. If there are boulders which are impossible to break or dig up with the tilt operation, move forward slightly and tilt the shank back, then operate the tilt again and dig up the boulder.

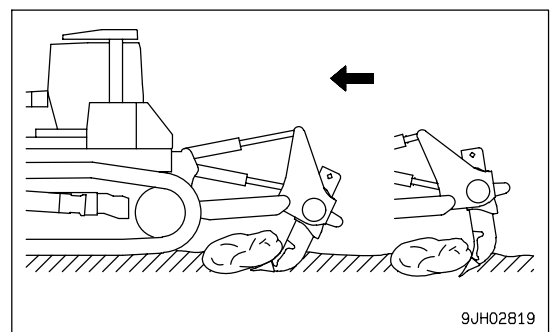

4. Even when the operation in Step 3 is repeated, if it is impossible to break or dig up the boulder, drive back about 10 cm, raise the shank, avoid the rock or boulder that cannot be ripped, then drive forward and start ripping again.

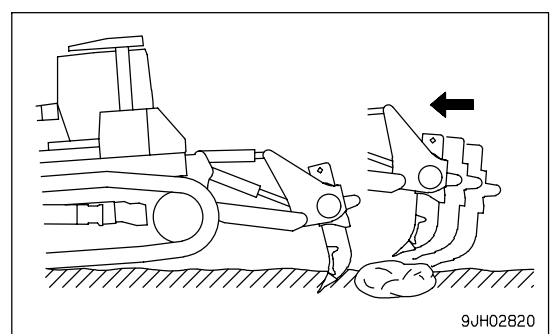

PRECAUTIONS WHEN RIPPING

- For the digging angle when ripping, set so that the top of the shank is perpendicular, then lower the ripper (c).

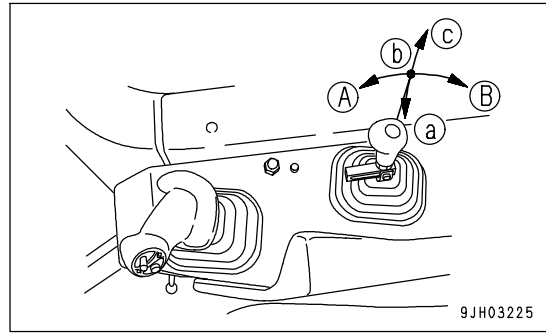

- Do not carry out ripping for long periods with the shank tilted back (B). The tip of the point will wear to a round shape.

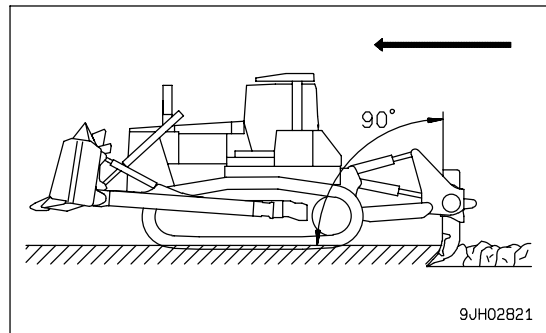

- Do not change the direction of travel during the ripping operation. This will cause breakage of the shank. When changing the direction of travel, remove the shanks from the ground before turning.

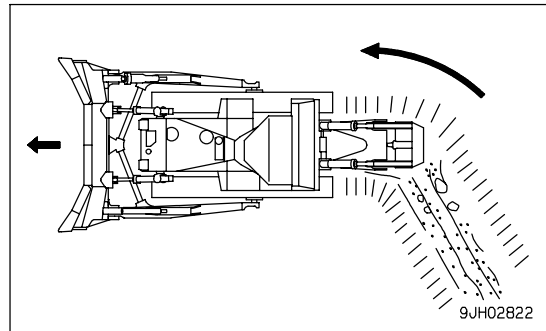

- Never drive in reverse when the ripper point is inserted in the bedrock. The pin installing the point (1) will break and the point will fall off.
Stop the machine, tilt back (B) slightly, then raise the ripper slowly.

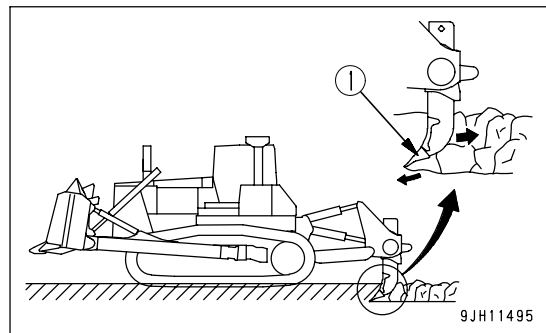

- After ripping, if the broken rock is comparatively large, avoid traveling over the ripping path (2) when traveling in reverse. When traveling in reverse (3), check the rear carefully to avoid hitting any large rocks. As far as possible, choose level ground to travel over.

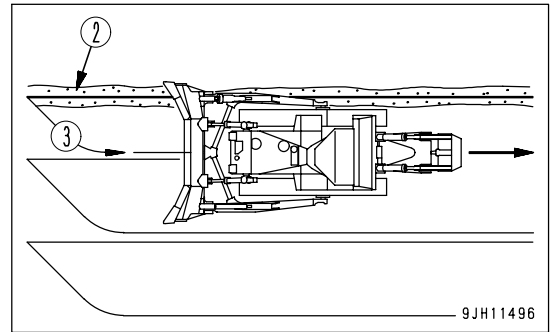

- If ripping operations are carried out with the shank at the maximum length on bedrock, the point will not penetrate the ground properly. This will cause an increase in the load and may lead to breakage of the shank. For this reason, avoid carrying out operations on bedrock with the shank at the maximum length.

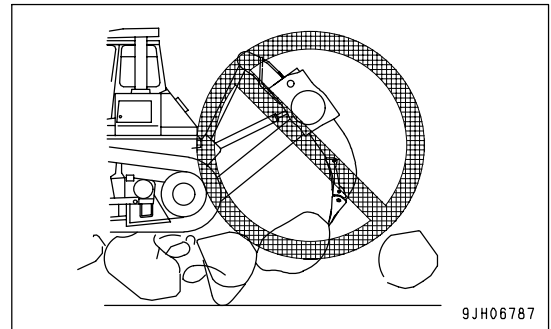

WORK POSSIBLE USING BULLDOZER

If various attachments are used, it is possible to carry out operations in a wider range than listed below.

DOZING

A bulldozer digs and transports dirt in a forward direction. Slope excavation can always be most effectively carried out by proceeding from the top downward.

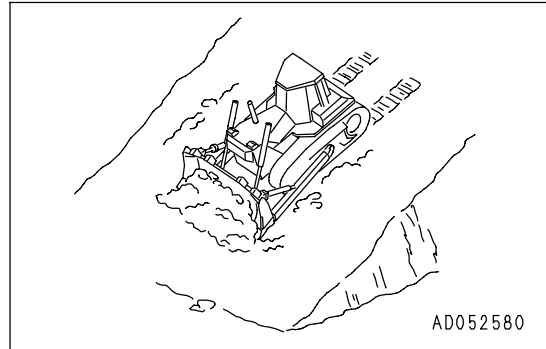

When dozing toward one side only, operate with angled blade (angledozer only).

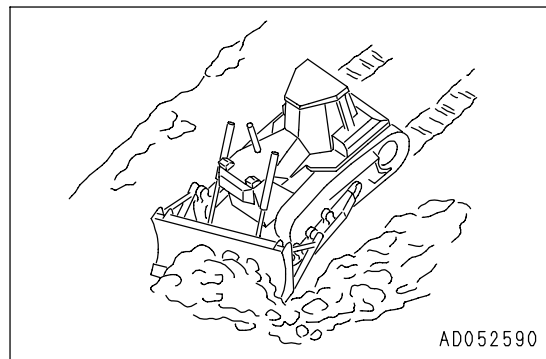

SMOOTHING

NOTICE

Avoid smoothing on rocky or stony ground. It can damage the blade.

When finishing the ground surface to a smooth finish after digging or filling operations, keep a full load of soil in the blade and operate the blade up or down in small movements while traveling forward. When leveling windrows or ruts left by the tracks, set the blade to the FLOAT position, travel at low speed in reverse and drag the blade over the ground surface.

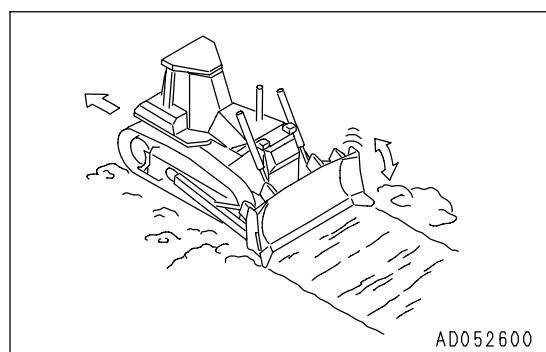

CUTTING INTO HARD OR FROZEN GROUND OR DITCHING

For digging and ditch excavation of hard or frozen ground, tilt the blade. Even hard ground can be dug effectively by a tilted or angled blade.

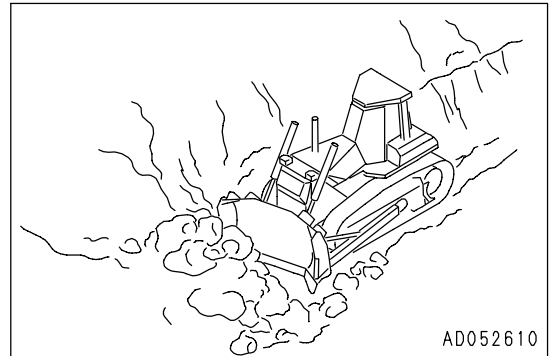

FELLING TREES, REMOVING STUMPS

NOTICE

Do not uproot trees or stumps or fell trees by angling or tilting the blade.

For trees with a diameter of 10 to 30 cm (3.9 to 11.8 in), raise the blade high and push 2 or 3 times to fell the tree.

Next, travel in reverse, and dig the corner of the blade into the ground to cut and dig up the roots.

When doing this, never hit the tree at high speed or apply shock to fell the tree.

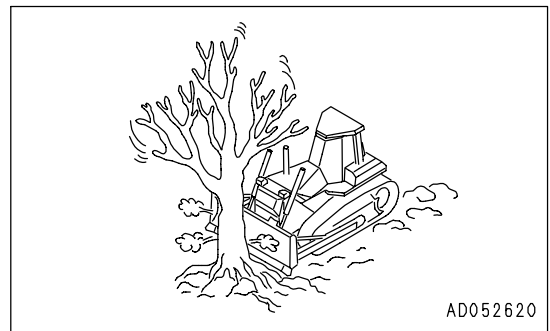

PUSHER OPERATIONS

NOTICE

- Always install a pusher plate when carrying out pusher operations.
- When approaching the other machine, use the decelerator pedal or fuel control dial to reduce the travel speed and approach the other machine slowly. After making contact, raise the travel speed gradually and push at full power.

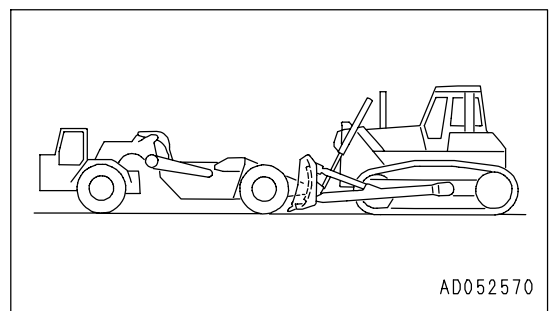

ADJUSTING POSTURE OF WORK EQUIPMENT



WARNING

When adjusting, it is dangerous if the work equipment is moved by mistake. Set the work equipment in a safe condition, then stop the engine and lock the work equipment securely with the work equipment lock lever.

BLADE ADJUSTMENT

TILTING THE TILTDOZER

NOTICE

The maximum tilt is 935 mm (3 ft 1 in).

Adjust the tilt so that it does not exceed the limit of 935 mm (3 ft 1 in).

If the maximum tilt is exceeded, excessive force will be brought to bear on all parts, and this will damage the machine.

When the blade control lever is operated, the following tilt can be obtained.

Right tilt: 460 mm (18.1 in) mm or more

Left tilt: 460 mm (18.1 in) or more

If it is necessary to have a greater tilt, do as follows.

Use bar handle (2) fixed to the right brace to turn brace (1) and change the length (ℓ) of the brace to give a maximum tilt of 1000 mm (3 ft 3 in).

- The standard distance between the joints (ℓ) is as follows.
 - Semi U-dozer: 1372 mm
 - Sigmadozer: 1292 mm

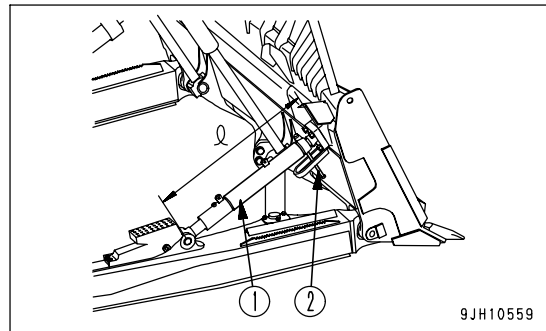

9JH10559

ADJUSTING SHIM IN BLADE CYLINDER CAP

Set the standard shim adjustment in the blade cylinder cap to 4 mm (0.16 in).

Remove shims to balance the wear of the cap and the ball at the end of the piston rod.

The proper clearance to be maintained with the shims is 0.2 to 0.5 mm (0.008 to 0.02 in).

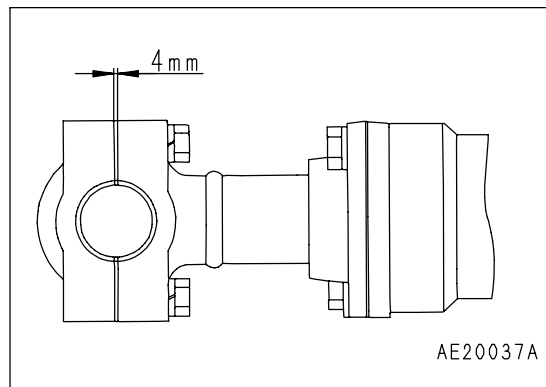

AE20037A

ADJUSTING BRACE



WARNING

If maintenance is carried out with the engine running, always have one worker sitting in the operator's seat while another worker carries out the maintenance. Both workers must mutually confirm the safety during the operation.

Adjustment can be carried out more easily if the engine is started, the inching operation used to carry out tilting to the left and right, and the blade shaken up and down while turning the brace handle (1).

- When extending the brace

It is easy to carry out the adjustment if the blade is set on top of a block and the brace handle is turned.

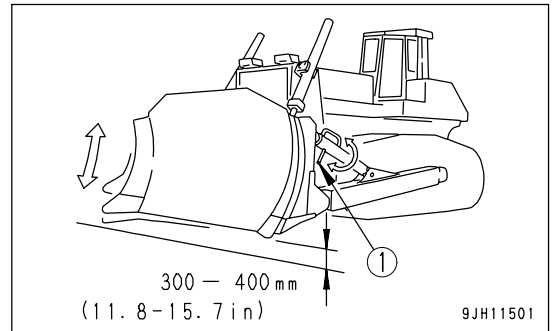

REMARK

When operated in this way, the blade is tilted, so the handle gradually becomes heavier. When this happens, return the blade from the tilt position to the horizontal position and turn the handle again according to the procedure given above.

SHIM ADJUSTMENT

Adjust with shims so that the play in the axial direction (direction of the arrow) at the ball joints (3 places) is within 1 mm (0.039 in).

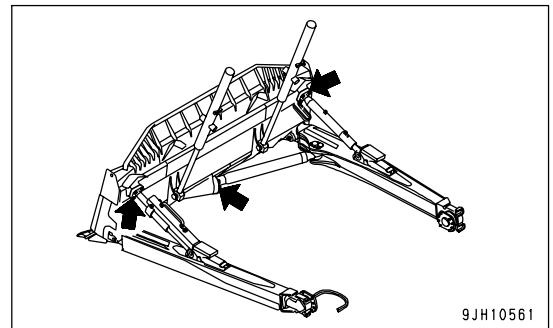

1. Remove shim (1) and tighten bolts (2) to eliminate the ball joint play.
2. Measure clearance "A" and remove bolts (2).
3. Install shim (1) having its thickness of "A" mm to "A + 1" mm ("A" in. to "A + 0.04" in) in place with bolts 2.
4. Confirm that ball joint can move smoothly after tightening bolts.

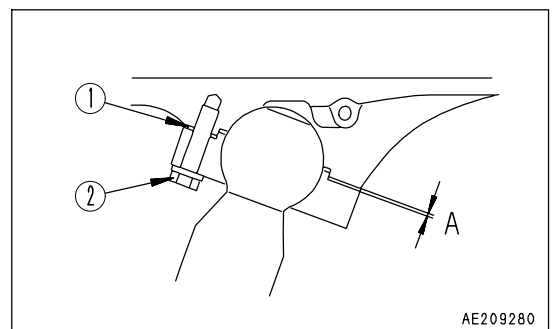

METHOD OF ANGLING BLADE

Angledozer only



WARNING

- When adjusting the amount of angling, it is dangerous if the work equipment is moved by mistake. Set the work equipment in a safe condition, then stop the engine and lock the work equipment securely with the work equipment lock lever.
- Be careful when removing arm (2). After arm (2) is removed, the blade can move freely.

When dozing toward one side only, operate with angled blade.

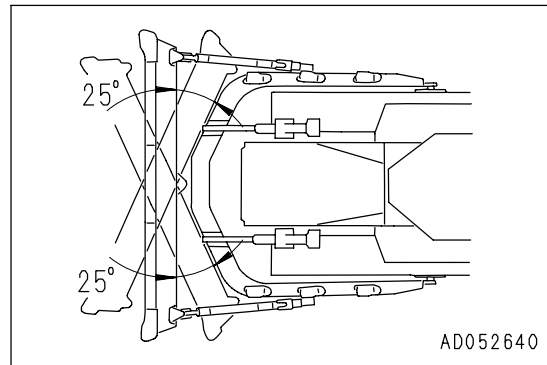

1. Raise the blade 300 - 400 mm above the ground, then put blocks under the frame so that the blade does not come down.

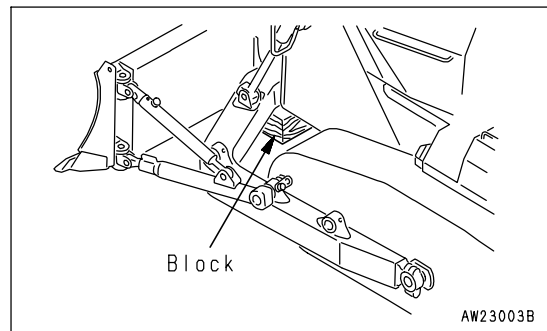

2. Remove pins (1) on the left and right sides, then remove arm (2) from the frame.

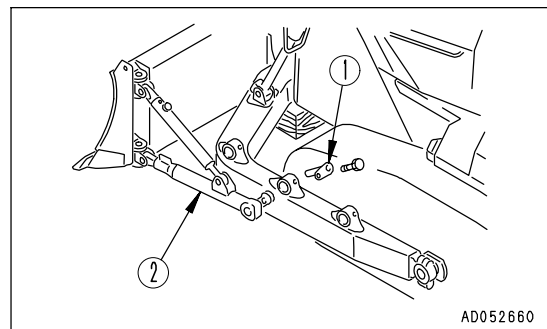

3. Insert arm (2) into the desired position on the bracket on top of the frame (3 places on each side), and insert pins (1).

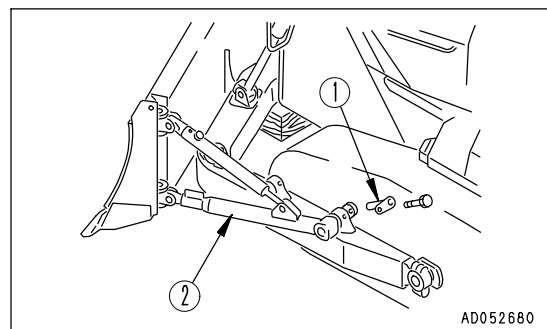

REMARK

When assembling a C-frame to an angledozer, adjust the length of arm (2) and brace (3) so that clearance S of center joint (4) is 20 mm (0.8 in).

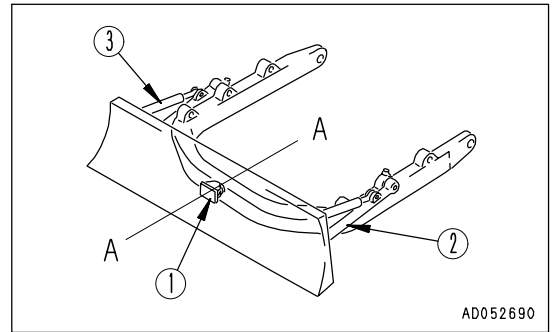

AD052690

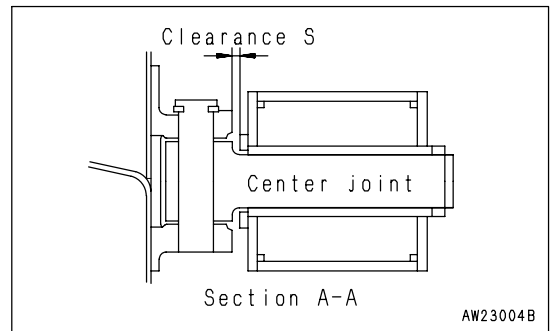

AW23004B

ADJUSTING TILT AMOUNT

(Angledozer, tiltadozer)

WARNING

When adjusting the amount of tilt, it is dangerous if the work equipment is moved by mistake. Set the work equipment in a safe condition, then stop the engine and lock the work equipment securely with the work equipment lock lever.

ANGLEDZOZER

NOTICE

The maximum amount of tilt is 400 mm (15.8 in). Be sure not to exceed 400 mm (15.8 in).

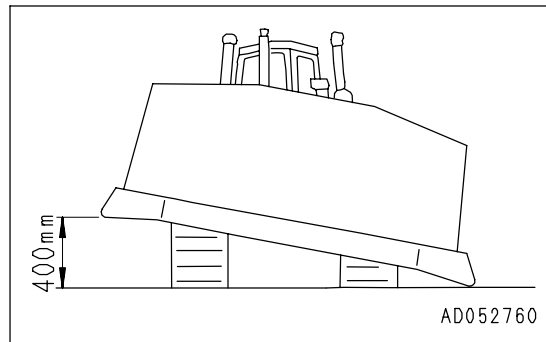

1. Raise the blade 300 - 400 mm above the ground, then put blocks under the frame so that the blade does not come down.

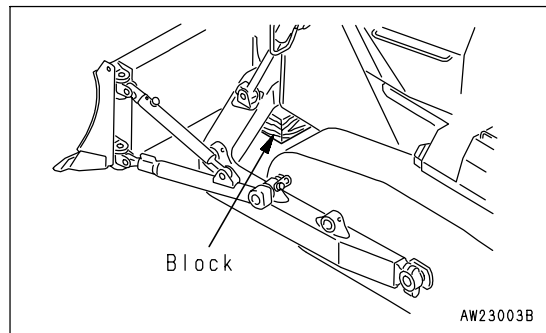

2. Loosen the bolt (1) of the brace, insert a suitable bar into hole (2) of the brace, and turn it.

REMARK

When turning the brace with bar, keep the blade above the ground.

- Right tilt: Make right side shorter, left side longer
- Left tilt: Make left side shorter, right side longer

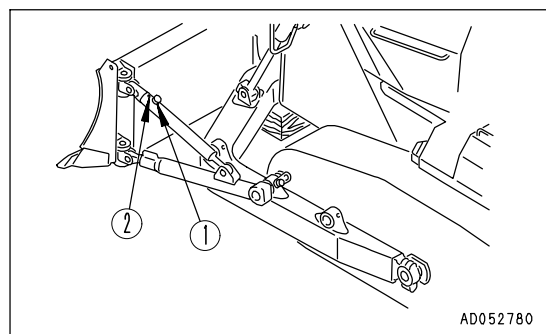

3. Tighten set bolt (1).

NOTICE

The standard distance between the joints of the brace (ℓ) is 1292 mm (4 ft 3 in), but make sure that the maximum tilt does not exceed 400 mm (15.8 in). If the tilt exceeds 400 mm (15.8 in), there will be excessive force brought to bear on the parts, so do not use with a tilt of more than 400 mm (15.8 in).

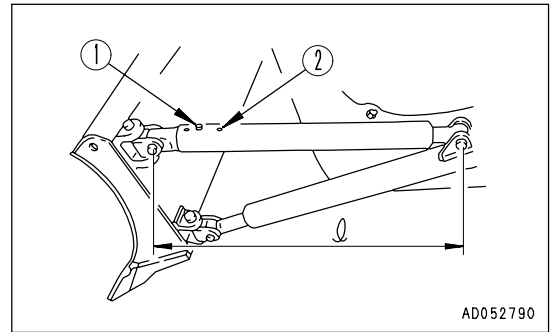

ADJUSTING RIPPER

ADJUSTING DIGGING DEPTH

There are mounting holes in the shank to chose to match the ripping depth. Normally, use the bottom hole, but if particularly deep ripping is needed, use the top hole.

When changing the digging depth, do as follows.

1. Place a pointed object on the tip of pin (1), then hit with a hammer to remove from the opposite side.
2. Remove pin (2) and change the position of the shank hole.
3. Insert pin (1) partially by hand then knock it in with a hammer.
 - The pin is one unit, so when inserting, insert it partially by hand, then knock it in with a hammer.
 - When a giant ripper is installed, use the pin puller.
 For details, see "METHOD OF OPERATING PIN PULLER (PAGE 3-151)".

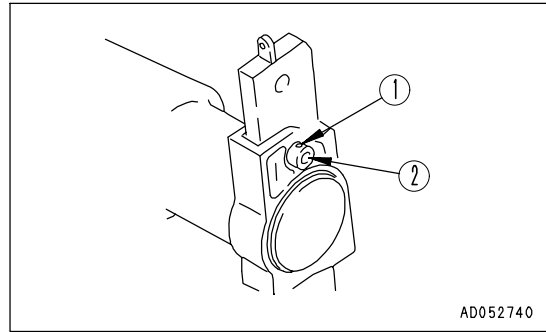

REPLACING POINT AND PROTECTOR

To protect the shank, replace the point and protector installed to the tip of the shank when they are worn.

Put a pin removal bar in contact with the pin marked by the arrow, then hit it with a hammer and remove it from the opposite side.

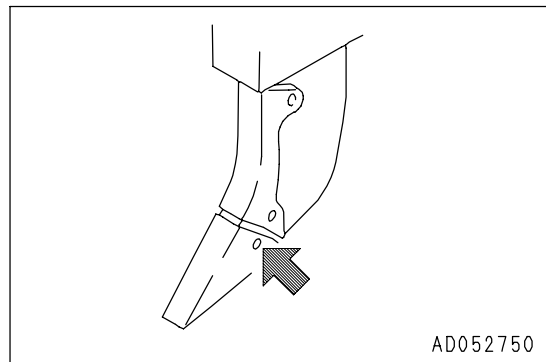

(Unit: mm (in))

NO.	Item	Judgment standard		Action
		Basic dimension	Wear limit	
(1)	Wear of point (a)	335 (13.2)	225 (8.9)	Replace

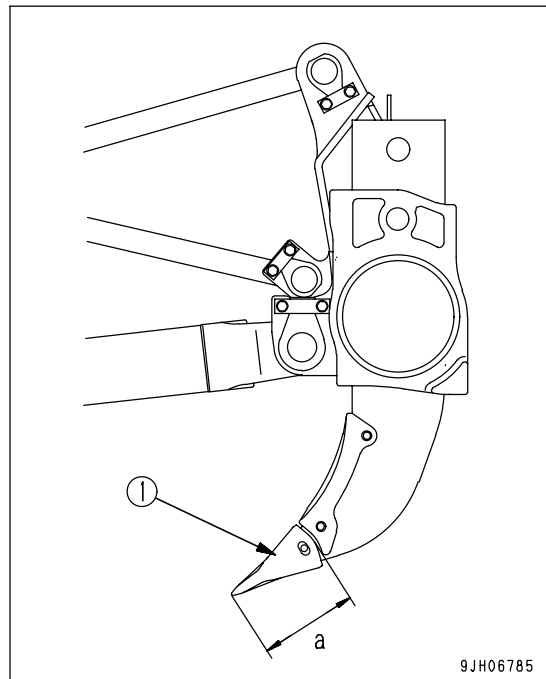

ADJUST ANGLE OF BLADE EDGE

(Angledozer, tiltadozer)



WARNING

It is dangerous if the work equipment moves by mistake when adjusting angle of the blade edge. Set the work equipment in a stable condition, then stop the engine and lock the work equipment securely with the work equipment lock lever.

Adjust the angle (θ) of the blade edge to match the type of soil.

ANGLEDZOZER

To make the length of the left and right braces the same, change distance (ℓ) between the joints and adjust the cutting angle.

Adjust distance (ℓ) between the joints as follows:

To INCREASE distance (ℓ), INCREASE cutting angle (θ).

To DECREASE distance (ℓ), DECREASE cutting angle (θ).

The standard cutting angle (θ) is 54° .

The standard distance (ℓ) between the joints is 1292 mm (4 ft 3 in).

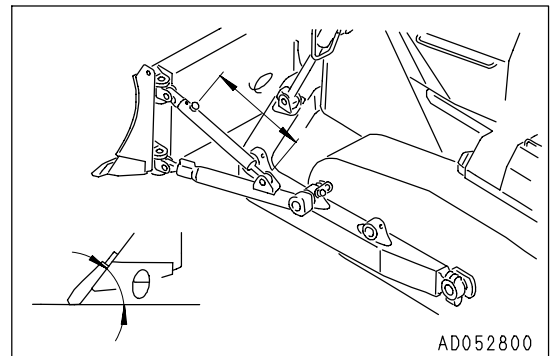

SEMI U-DOZER

Turn the brace with bar handle (1) and the distance (ℓ) between the joints to change the cutting angle (θ) as follows.

INCREASE distance (ℓ) to INCREASE angle (θ)

DECREASE distance (ℓ) to DECREASE angle (θ).

The standard cutting angle (θ) is 52° .

The standard distance (ℓ) between the joints is 1372 mm (4 ft 6 in).

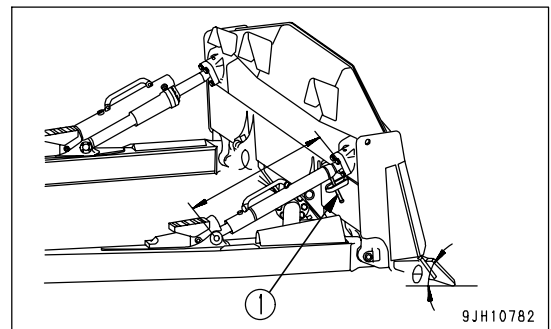

SIGMADOZER

Turn the brace with bar handle (1) and the distance (ℓ) between the joints to change the cutting angle (θ) as follows.

INCREASE distance (ℓ) to INCREASE angle (θ)

DECREASE distance (ℓ) to DECREASE angle (θ).

The standard cutting angle (θ) is 46°.

The standard distance (ℓ) between the joints is 1292 mm (4 ft 3 in).

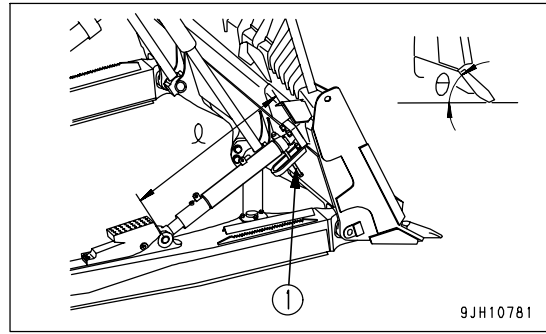

Cutting angle θ	Advantages	Disadvantages
Large	<ul style="list-style-type: none"> • Amount of soil spilled to rear of blade is small • Separation of soil is good and little soil is carried back 	<ul style="list-style-type: none"> • Soil digging resistance and rolling-up resistance are large • Load pushed by blade is small
Small	<ul style="list-style-type: none"> • Soil digging resistance and rolling-up resistance are small • Load pushed by blade is large • Cutting amount on rough surfaces is good 	<ul style="list-style-type: none"> • Amount of soil spilled to rear of blade is large • Separation of soil is poor and a lot of soil is carried back

TIPS FOR LONGER UNDERCARRIAGE LIFE

Undercarriage life greatly varies depending on operation method, inspection and maintenance. For most efficient operation, keep the following points in mind.

OPERATION METHOD

- Select the track shoe that best suits the type of soil to be encountered in service.
Consult your Komatsu distributor when selecting track shoes.
- Do not allow shoe slipping to occur during operation.
If shoe slipping occurs, reduce load on the blade until slipping stops.
- Avoid sudden starts, acceleration or stops, unnecessary high speeds and sharp turns.
- Always operate machine in a straight line whenever possible. When making turns, be careful not to allow the machine to stay to one side, so operation in both turning directions can be done properly. Make turns with the largest possible radius.
- Prior to operation, clear boulders and obstacles to prevent machine from riding over them while operating.
- On a slope, operate the machine parallel to the inclination of the slope. Do not operate across the slope. Also when stopping the machine on a slope, the machine should face the top of the slope.
- When ground inclines to the left or right during digging operations, do not continue to dig with the incline. Move the machine back to level ground and start to dig again.
- If you come across obstacles that are difficult to move during dozing operations or ripper operations, and the idler or sprocket come up from the ground, it means that the operation is excessive for the machine, so avoid such operations.

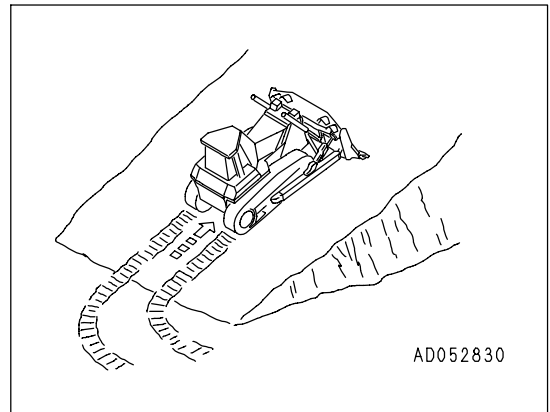

INSPECTION AND ADJUSTING

- Adjust the track shoe to the proper tension.

When adjusting the tension, measure clearance A between the idler and carrier roller in the diagram on the right. The normal clearance is 20 to 30 mm (0.8 to 1.2 in), but on bedrock, set the tension slightly higher, and on viscous ground, set it slightly looser.

(Inspect and adjust the track tension. For details of the method of inspection and maintenance for the track tension, see "WHEN REQUIRED (PAGE 4-20)".

- Check idler rollers for oil leakage as well as for loose bolts and nuts. If any trouble is detected, repair immediately.
- Check clearance B between the idler guide plate and track frame. If clearance B becomes larger, the idler will move to the side and cause the track shoe to come off. For details of the method of inspection and maintenance, see "ADJUST IDLER CLEARANCE (PAGE 4-31)".

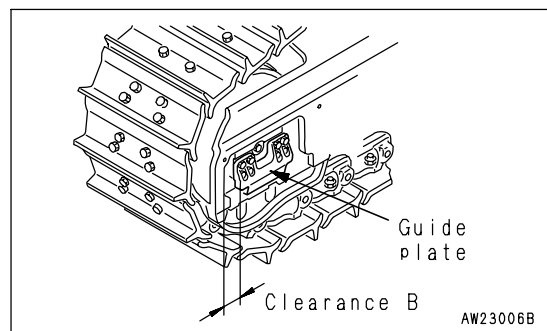
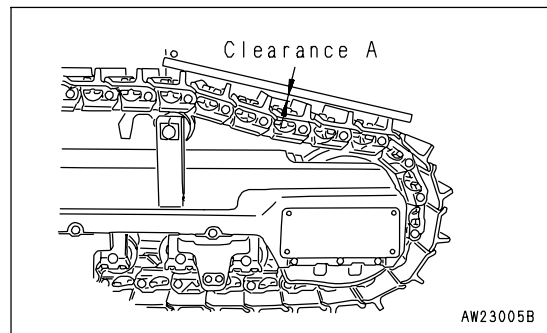

INSPECTION AND REPAIR

Frequent inspection and prompt repair will reduce repair costs.

The following items for inspection will serve as a guide to maintenance service of each undercarriage part. Perform periodical inspection and contact the Komatsu distributor in your area when machine has approached repairable limits and reversing limits.

MEASURING LINK PITCH

1. Insert a wooden block between track shoe and sprocket to take up the slack in track shoes.
2. Measure pitch length of 4 links in stretched portion at least 2 links away for master pin. Of length obtained, 1/4 is the link pitch.

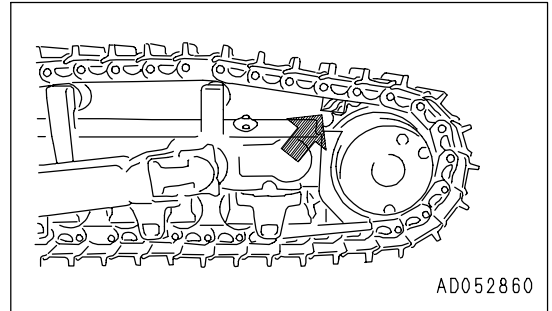

REMARK

Basic link pitch (P): 228.85 mm (9.0 in)

Bushing turning limit link pitch

Heavy-duty: 231.85 mm (9.1 in)

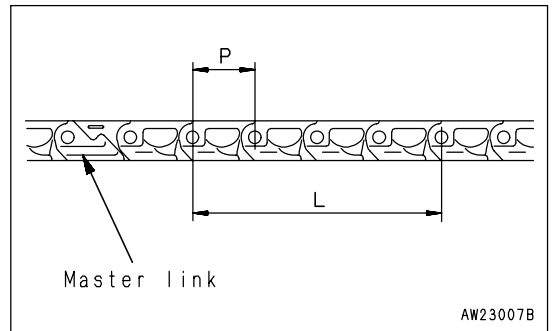

There is no link window on the master link.

MEASURING HEIGHT OF GROUSER

After taking up slack in track shoes, measure height at center of shoe as shown below.

Basic dimension (h): 80 mm (3.2 in)

Repair limit: 30 mm (1.2 in)

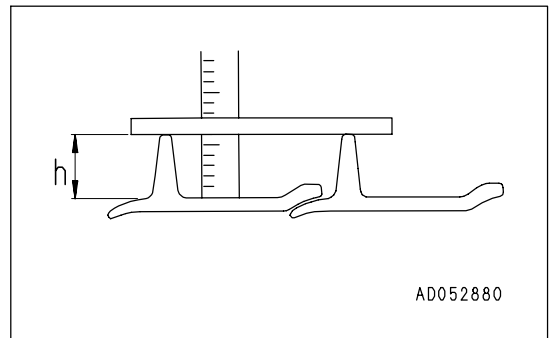

MEASURING OUTSIDE DIAMETER OF TRACK ROLLER

1. Measure the height (dimension C) of the link tread as shown in the diagram.
2. Stop machine at position where link tread, whose size C has been measured completely, contacts roller tread. Then measure size B.
3. Calculate outside diameter of tread (size A):

$$A = (B - C) \times 2$$

Basic dimension (h): 250 mm (9.9 in)

Repair limit: 210 mm (8.3 in)

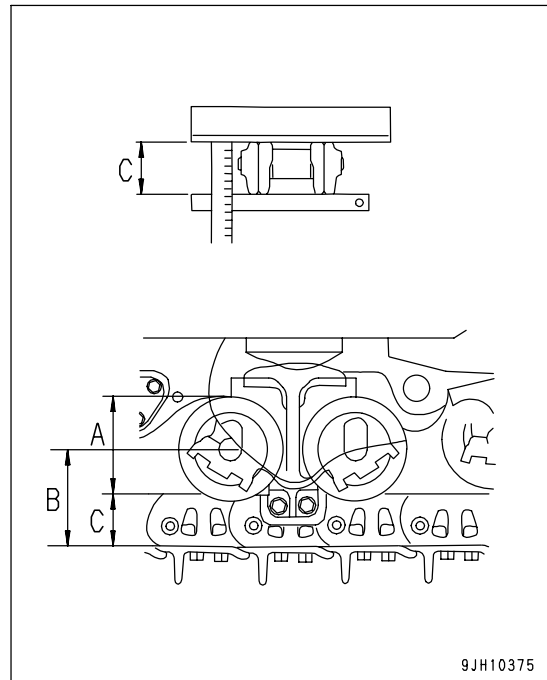

TRANSPORTATION

When transporting the machine, observe all related laws and regulations, and be careful to assure safety.

LOADING, UNLOADING WORK



WARNING

- Make sure the ramp has sufficient width, length and thickness to enable the machine to be safely loaded and unloaded. If the ramp sags appreciably, reinforce it with blocks, etc.
- When loading and unloading the machine, park the trailer on a flat firm roadbed. Keep a fairly long distance between the road shoulder and the machine.
- Remove the mud from the undercarriage to prevent the machine from slipping to the side on slopes. Be sure the ramp surface is clean and free of grease, oil, ice and loose materials.
- Never change the direction of travel when on the ramps. If it is necessary to change direction, drive off the ramps and correct the direction, then drive on to the ramps again.

When loading or unloading, always use ramps or a platform. Proceed as follows.

LOADING

1. Load and unload on firm level ground only.
Maintain a safe distance from the edge of a road.
2. Apply the trailer brakes securely, then put blocks (1) under the tires to prevent the trailer from moving.
 - Set left and right ramps (2) parallel to each other and equally spaced to the left and right of center (3) of the trailer. Make angle of installation (4) a maximum of 15°. If the ramps bend a large amount under the weight of the machine, put blocks under the ramps to prevent them from bending.
3. Set parking brake lever to the FREE position (F).
4. Set the transmission in the 1st gear and run the engine at low idle.
5. Set the travel direction toward the ramps and drive slowly.
6. The center of gravity of the machine shifts suddenly at the border between the ramps and trailer, and the machine is unbalanced and becomes dangerous. Accordingly, pass the border slowly.
7. Stop the machine at the specified position on the trailer.

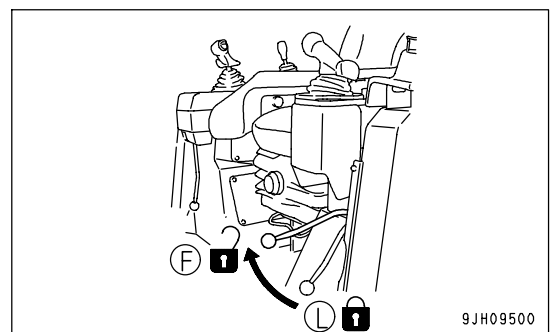
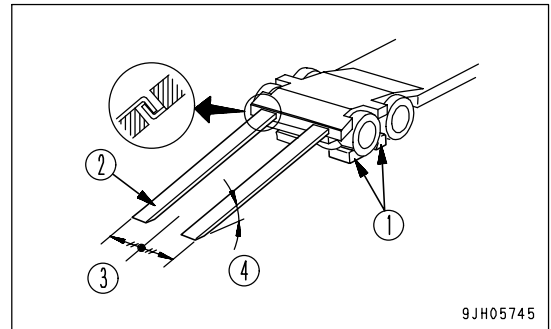

SECURING MACHINE

NOTICE

Stow the antenna away.

Load the machine onto a trailer as follows:

1. Lower the work equipment slowly.
(When transporting with work equipment installed)
2. Set the work equipment lock lever to the LOCK position (L) securely.
(When transporting with work equipment installed)

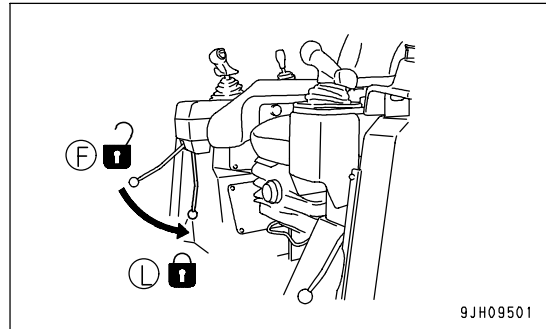

3. Set the parking brake lever to the LOCK position (L) securely.
4. Stop the engine, then remove the key from the starting switch.

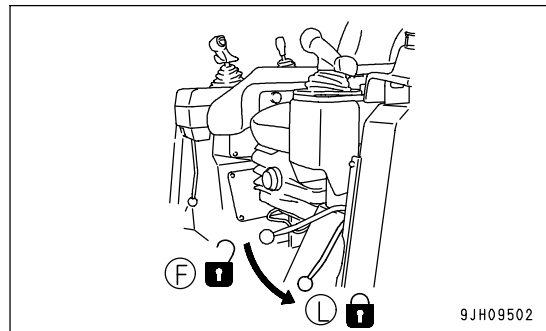

5. Fix the machine as explained below so that it will not move during transportation.

In particular, fix the machine securely to prevent it from slipping sideways.

- 1) Set up chain or wire, following (A) or (B).
 - A: Secure chain or wire around the track shoes.
 - B: Secure chain or wire through the holes of track links.
 - (C): Install a shackle to the undercover hook at the front of the machine as shown in the diagram on the right (a), then secure in position with wire rope.

Fit wire rope to the ripper mount pin at the rear of the machine as shown in the diagram on the right (b) to secure it in position.

- 2) Protect the wire from contacting directly with angular parts of the machine, by inserting pads.

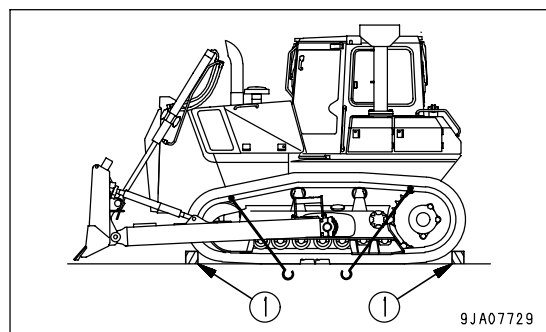
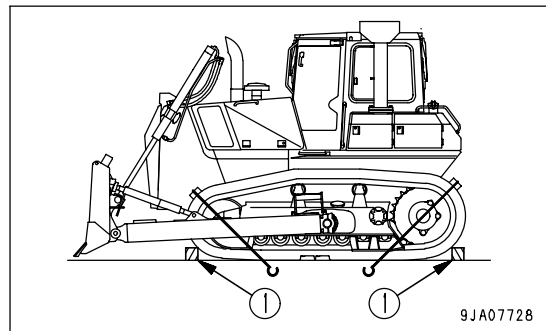

UNLOADING

1. Load and unload on firm level ground only. Maintain a safe distance from the edge of a road.
2. Apply the trailer brakes securely, then put blocks (1) under the tires to prevent the trailer from moving.
 - Set left and right ramps (2) parallel to each other and equally spaced to the left and right of center (3) of the trailer. Make angle of installation (4) a maximum of 15°. If the ramps bend a large amount under the weight of the machine, put blocks under the ramps to prevent them from bending.
3. Remove the chains and wire ropes fastening the machine.
4. Start the engine.
 - Warm the engine up fully.
5. Set main work equipment lock lever to FREE position (F), and raise the work equipment.
 - (When transporting with work equipment installed)

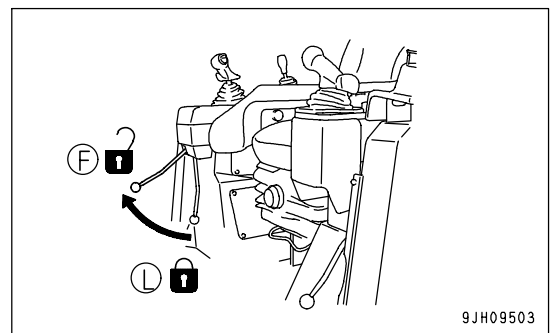
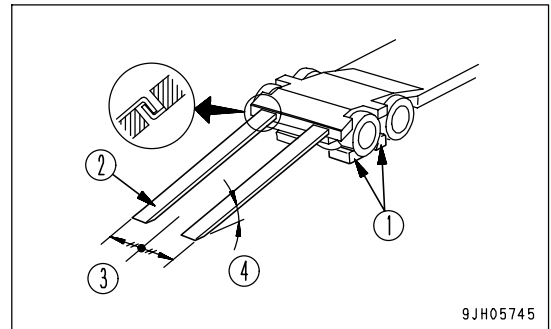

6. Set parking brake lever to the FREE position (F).
7. Set the transmission in the 1st gear and run the engine at low idle.
8. Set the travel direction toward the ramps and drive slowly.
9. The center of gravity of the machine shifts suddenly at the border between the ramps and trailer, and the machine is unbalanced and becomes dangerous. Accordingly, pass the border slowly.
10. Drive down the ramps slowly and carefully until the machine leaves the ramps perfectly.

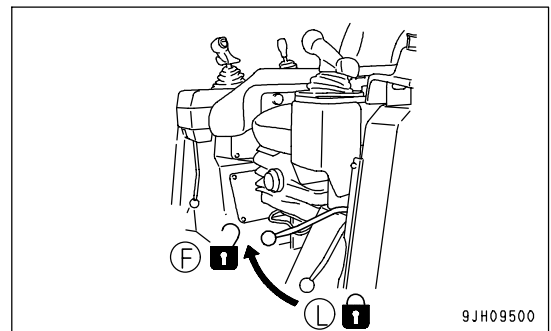

METHOD OF LIFTING MACHINE



WARNING

- The operator carrying out the lifting operation using a crane must be a properly qualified crane operator.
- Never raise the machine with any worker on it.
- Always make sure that the wire rope is of ample strength for the weight of this machine.
- When lifting, keep the machine horizontal.
- When carrying out lifting operations, set the work equipment lock lever and parking brake lever to the LOCK position to prevent the machine from moving unexpectedly.
- Never enter the area under or around a raised machine.

Never try to lift the machine in any posture other than the posture given in the procedure below or using lifting equipment other than in the procedure below.

There is a hazard that the machine may lose its balance.

NOTICE

This method of lifting applies to the standard specification machine.

The method of lifting differs according to the attachments and options installed.

For details of the procedure for machines that are not the standard specification, please consult your Komatsu distributor.

When lifting the machine, stop it on a level place, then observe the following procedure.

1. Set the work equipment lock lever to the LOCK position (L) securely.

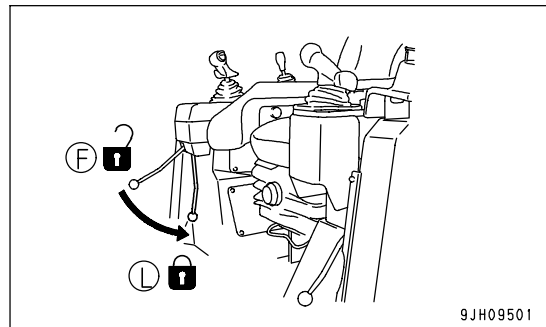

2. Set the parking brake lever to the LOCK position (L) securely.

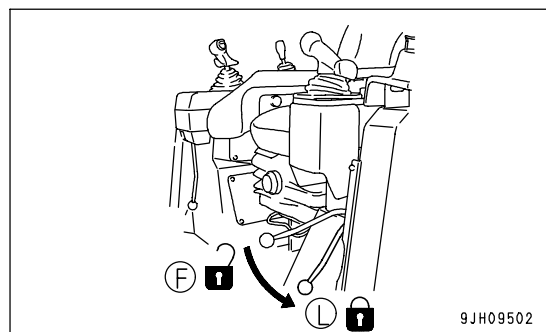

3. Stop the engine.

NOTICE

- Use protectors to prevent the wire rope from being cut on sharp corners and to prevent the wire rope from cutting into the machine bodywork.
 - When using a spreader bar, select an ample width to prevent contact with the machine.
4. Install wire ropes, slings, etc. matched to the weight of the machine to the lifting points as shown in the diagram on the right.
 5. After setting the wire ropes, lift up the machine and stop at 100 to 200 mm (3.9 to 7.9 in) above the ground, and check that the wire ropes are not slack and the machine is level, then lift up slowly.

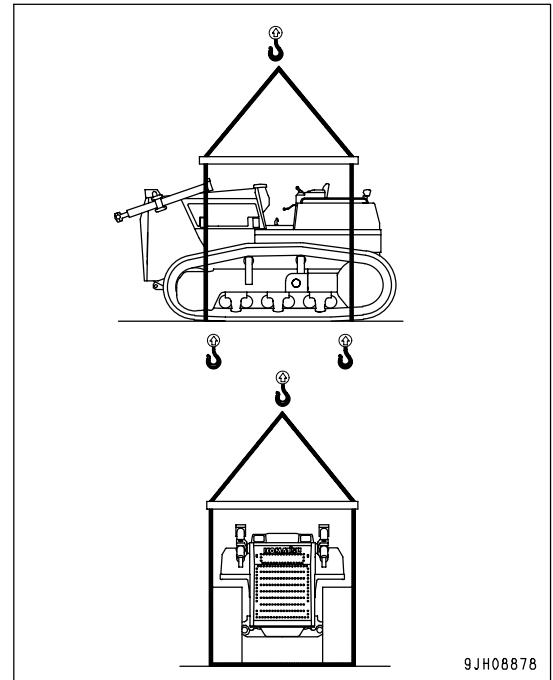

PRECAUTIONS FOR TRANSPORTATION



WARNING

Determine the route for transporting the machine by taking into account the width, height and weight of the machine.

Obey all state and local laws governing the weight, width and length of a load. Observe all regulations governing wide loads.

- Method of transportation

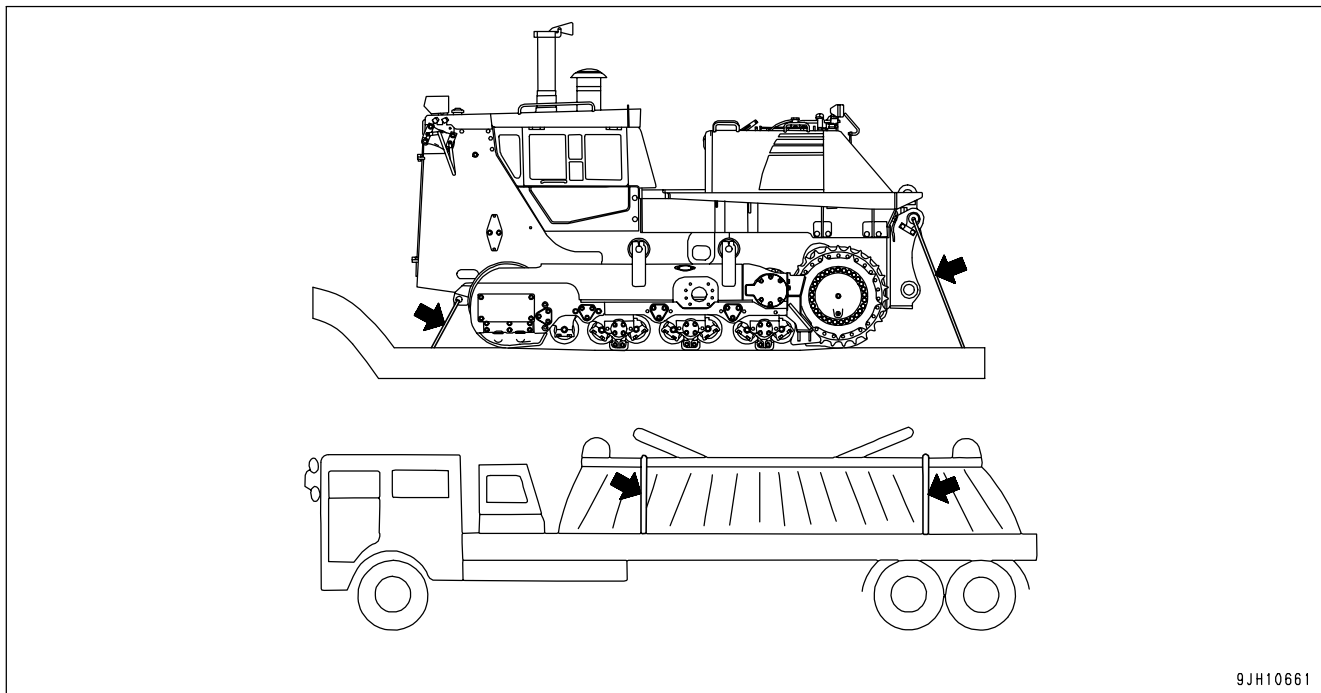

TRAVELING ON ROADS

- When driving on a paved road, use the flat track shoe to protect the pavement.
Even if the travel distance is short, be sure to protect the pavement by placing protective sheets on the road.

REMARK

Note that the asphalt road becomes soft in summer.

REMOVAL OF CAB

If it is necessary to remove the cab for transportation, disconnect the washer hose (1) and the cab power supply wiring (2), washer motor wiring (3), dashboard wiring harnesses (4), GPS wiring (5) (if equipped), Orbcomm wiring (6) (if equipped) from the connector before removing the cab.

1. Remove the floor covers and ducts.
2. Remove the floor cover, then disconnect 4 washer hoses, wiring (4 terminals x 2, dashboard x 1, GPS x 1 (if equipped), Orbcomm x 1 (if equipped)) from the socket.
3. When removing the cab, carry out the operation according to the cab installation manual held by your Komatsu distributor.

REMARK

- After removing, cover with vinyl bag to prevent dirt or dust from entering the washer hose.
- Before removing the cab, check the clearance between the cab and the levers, and use for information as reference for confirming the position when installing the cab.

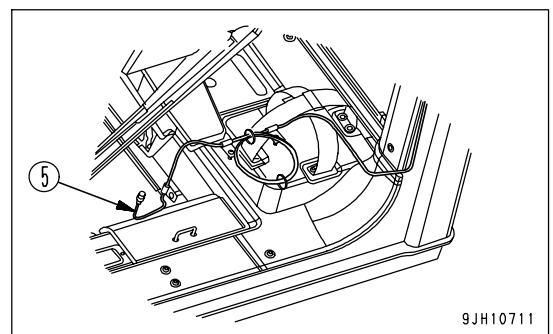
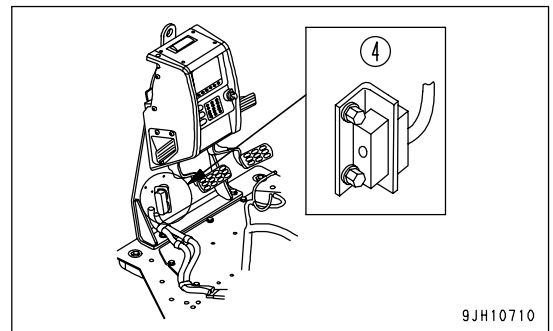
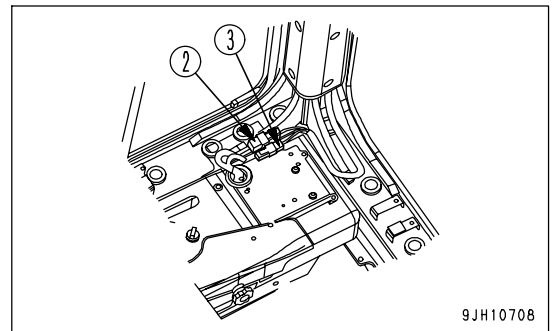
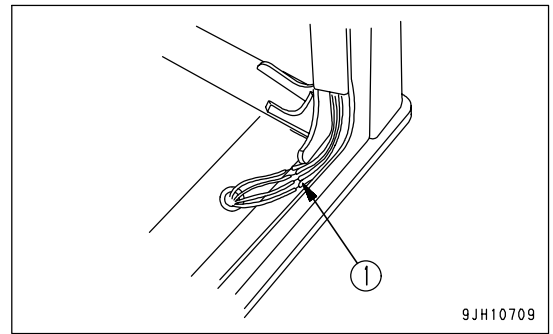

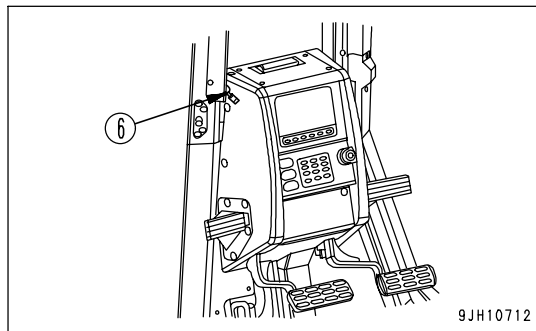

REMARK

- When installing the cab, check the colors and install the washer tank and each window washer hose correctly.
- When installing the cab, carry out the operation in accordance with the cab installation procedure manual held by your Komatsu distributor.

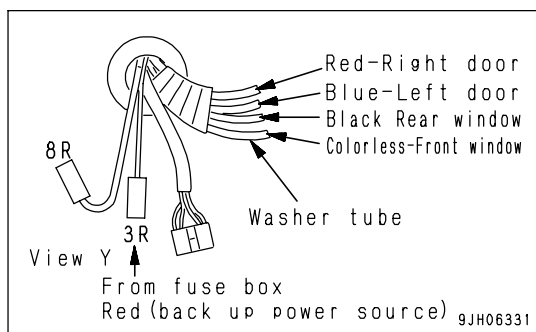
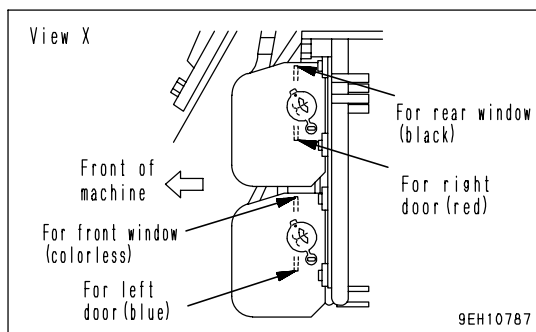
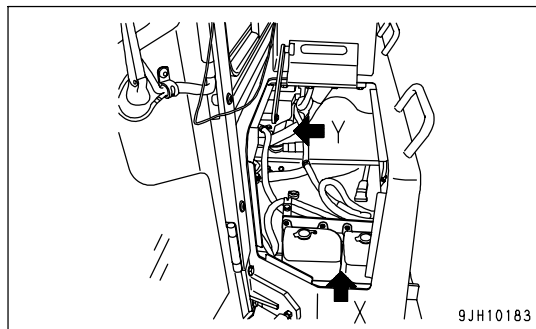

COLD WEATHER OPERATION

PRECAUTIONS FOR LOW TEMPERATURE

If the temperature becomes low, it becomes difficult to start the engine, and the coolant may freeze, so do as follows.

FUEL AND LUBRICANTS

Change to oil with low viscosity for all components. For details of the specified viscosity, see "RECOMMENDED FUEL, COOLANT, AND LUBRICANT (PAGE 4-11)".

COOLANT



WARNING

- Antifreeze is toxic. Be careful not to get it into your eyes or on your skin. If it should get into your eyes or on your skin, wash it off with large amounts of fresh water and see a doctor at once.
- When changing the coolant or when handling coolant containing antifreeze that has been drained when repairing the radiator, please contact your Komatsu distributor or request a specialist company to carry out the operation. Antifreeze is toxic. Do not let it flow into drainage ditches or spray it onto the ground surface.
- Antifreeze is flammable. Do not bring any flame close. Do not smoke when handling antifreeze.

NOTICE

Please use Komatsu genuine supercoolant (AF-NAC) for the coolant. As a basic rule, we do not recommend the use of any coolant other than Komatsu genuine supercoolant.

For details on the amount of antifreeze mixture and on when to change the coolant, see "CLEAN INSIDE OF COOLING SYSTEM (PAGE 4-20)".

BATTERY

 **WARNING**

- The battery generates flammable gas. Do not bring fire or sparks near the battery.
- Battery electrolyte is dangerous. If it gets in your eyes or on your skin, wash it off with a large amount of water and consult a doctor.
- Battery electrolyte dissolves paint. If it gets on the bodywork, wash it off immediately with water.
- If the battery electrolyte is frozen, do not charge the battery or start the engine with a different power source. There is danger that the battery may explode.
- Battery electrolyte is toxic. Do not let it flow into drainage ditches or spray it on to the ground surface.

When the ambient temperature drops, the capacity of the battery will also drop. If the battery charge ratio is low, the battery electrolyte may freeze. Maintain the battery charge as close as possible to 100%. Insulate it against cold temperature to ensure the machine can be started easily the next morning.

REMARK

Measure the specific gravity and calculate the charging rate from the following conversion table.

Charging Rate (%)	Electrolyte Temperature	20°C (68°F)	0°C (32°F)	-10°C (14°F)	-20°C (-4°F)
	100		1.28	1.29	1.30
90		1.26	1.27	1.28	1.29
80		1.24	1.25	1.26	1.27
75		1.23	1.24	1.25	1.26

- As the battery capacity drastically drops in low temperatures, cover or remove the battery from the machine, store the battery in a warm place, and install it again the next morning.
- If the electrolyte level is low, add distilled water in the morning before beginning work. Do not add water after the day's work to prevent diluted electrolyte in the battery from freezing during the night.

AFTER COMPLETION OF WORK



WARNING

Performing idle-running of the tracks is dangerous, stay well away from the tracks.

To prevent mud, water, or the undercarriage from freezing and making it impossible for the machine to move on the following morning, observe the following precautions.

- Remove all the mud and water from the machine body. In particular, wipe the hydraulic cylinder rods clean to prevent damage to the seal caused by mud, dirt, or drops of water on the rod from getting inside the seal.
- Park the machine on hard, dry ground.

If this is impossible, park the machine on boards.

The boards prevent the tracks from freezing to the ground, and allow the machine to be moved the next morning.

- Open the drain valve and drain any water collected in the fuel system to prevent it from freezing.
- Fill the fuel tank to capacity. This minimizes moisture condensation in the tank when the temperature drops.
- After operation in water or mud, remove water from undercarriage as described below to extend undercarriage service life.

AFTER COLD WEATHER

When the season changes and the weather becomes warmer, do as follows.

- Replace the fuel and oil for all parts with oil of the viscosity specified.

For details, see "RECOMMENDED FUEL, COOLANT, AND LUBRICANT (PAGE 4-11)".

LONG-TERM STORAGE

BEFORE STORAGE

When putting the machine in storage for a long time (more than one month), do as follows.

- Clean and wash all parts, then store the machine indoors. If the machine has to be stored outdoors, select level ground and cover the machine with canvas.
- Completely fill the fuel tank. This prevents moisture from collecting.
- Lubricate and change the oil before storage.
- Apply a thin coat of grease to metal surface of the hydraulic piston rods and the idler adjusting rods.
- Disconnect the negative terminals of the battery and cover it, or remove it from the machine and store it separately.
- Place all control levers at the neutral position, set the work equipment lock lever and parking brake lever to the lock position, and set the fuel control dial to the low idling position.
- To prevent rust, fill with Komatsu genuine supercoolant (AF-NAC) to give a density of at least 30% for the engine coolant.

DURING STORAGE



WARNING

If it is necessary to perform the rust-prevention operation while the machine is indoors, open the doors and windows to improve ventilation and prevent gas poisoning.

- During storage, operate and move the machine for a short distance once a month so that a new film of oil will coat moving parts. At the same time, also charge the battery.
- For machines equipped with an air conditioner, run the air conditioner.

AFTER STORAGE

NOTICE

If the machine has been stored without carrying out the monthly rust-prevention operation, consult your Komatsu distributor before using it.

When using the machine after long-term storage, do as follows before using it.

- Wipe off the grease from the hydraulic cylinder rods.
- Add oil and grease at all lubrication points.
- When the machine is stored for a long period, moisture in the air will mix with the oil. Check the oil before and after starting the engine. If there is water in the oil, change all the oil.

STARTING MACHINE AFTER LONG-TERM STORAGE

When starting the engine after the machine has been in storage for a long period, carry out the warming-up operation thoroughly. For details, see the procedure in "WARMING UP OPERATIONS (PAGE 3-126)".

TROUBLESHOOTING

AFTER RUNNING OUT OF FUEL

When starting the engine again after running out of fuel, fill with fuel, then bleed the air from the fuel system before starting the engine.

Always watch the fuel level and be careful not to run out of fuel.

If the engine has stopped because of lack of fuel, it is necessary to use the priming pump to bleed the air completely from the fuel circuit.

PROCEDURE FOR BLEEDING AIR



CAUTION

- This engine consists of higher precision parts than on the conventional fuel injection pump and nozzle, so if dirt gets in, it will cause problems. If there is any dirt stuck to the fuel line, use fuel to wash it off completely.
- Be careful when opening the air bleed plug at the fuel filter head. The system is still under pressure and fuel may spurt out.

1. Loosen air bleed plug (A) at the fuel main filter head (1).

NOTICE

Do not loosen the plug of the fuel pre-filter head. This is at the suction end, so if it is loosened, it will be impossible to bleed the air.

2. Loosen wing nut (4) holding lever (3) of priming pump (2).
3. Push in lever (3) repeatedly.
Check that bubbles come out with the fuel from air bleed plug (A).
4. Coat LT-2A (pressurized material adhesive compound) on air bleeding plug (A) and then tighten it.
Specified tightening torque: 4.9 - 6.9 Nm (0.5 - 0.7 kgm)

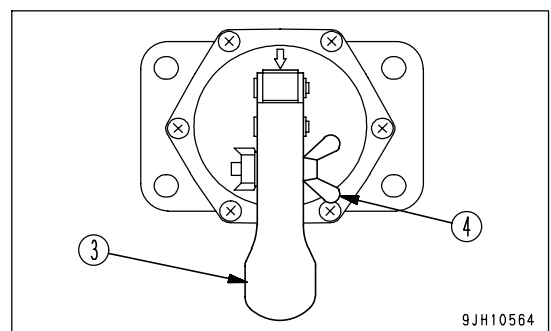
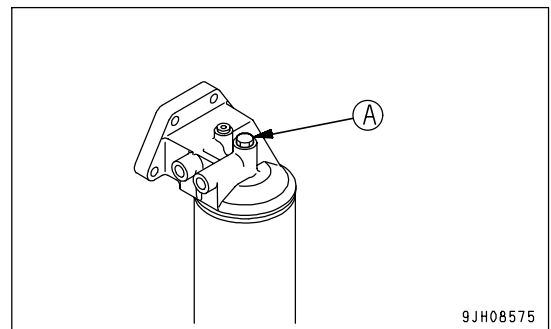
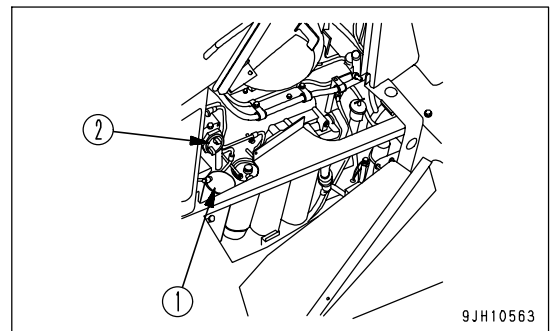

5. Loosen air bleeder (5) of the supply pump.
6. Pump priming pump (approx. 90 to 100 times) until no more bubbles come out with the fuel from air bleeder (5), then tighten air bleeder (5).
Tightening torque: 4.9 to 6.9 Nm (0.5 to 0.7 kgm , 3.6 to 5.1 lbft)

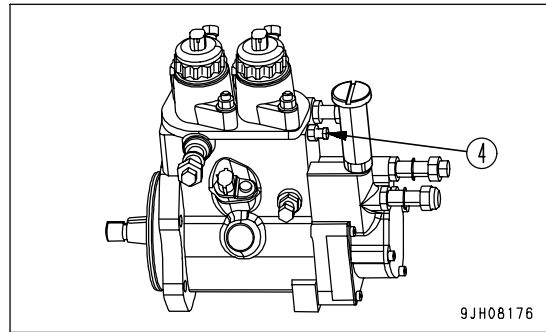

7. Tighten wing nut (4) securely to lock lever (3) in position.
Target tightening torque: 11.8 Nm
(1.2 kgm, 8.7 lbft)
8. Turn the key in the starting switch to the START position and start the engine.
When doing this, do not crank the starting motor continuously for more than 20 seconds. If the engine does not start, wait for at least 2 minutes, then try again. Perform this operation a maximum of 4 times.
9. If the engine does not start, repeat the operation from Step 1.

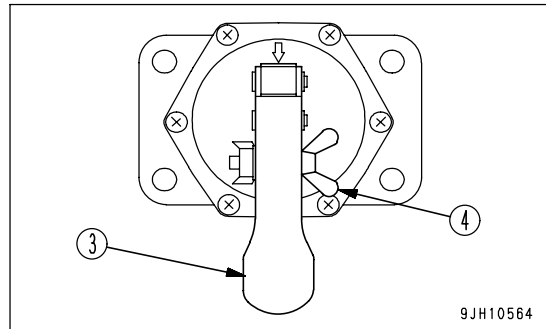

METHOD OF TOWING MACHINE

WARNING

Serious injury or death could result if a disabled machine is towed incorrectly or if there is a mistake in the selection or inspection of the wire rope.

- Always check that the wire rope used for towing has ample strength for the weight of the machine being towed.
- Never use a wire rope which has cut strands (A), reduced diameter (B), or kinks (C). There is danger that the rope may break during the towing operation.
- Always wear leather gloves when handling wire rope.
- Never tow a machine on a slope.
- During the towing operation, never stand between the towing machine and the machine being towed.
- Operate the machine slowly and be careful not to apply any sudden load to the wire rope.

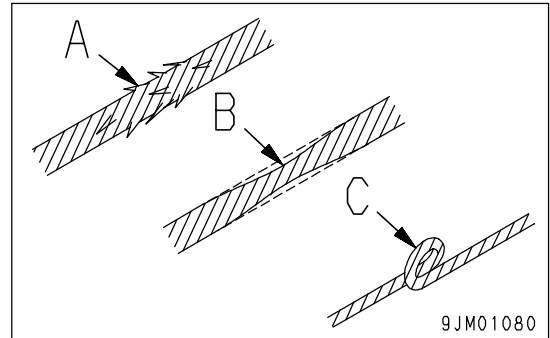
**NOTICE**

The permissible towing force of this machine is 287,330 N (29,300 kg).
Do not use any towing force greater than this.

- If the machine is stuck in mud and cannot escape under its own power, or when towing a heavy object, fit wire to the towing hook as shown in the diagram on the right, or if the machine is equipped with a counterweight, fit the wire to the towing hook on the counterweight and tow the machine.
- When towing a machine, travel at a speed of less than 1 km/h for a distance of only a few meters to a place that is suitable for carrying out repairs.
This is for use only in emergencies.

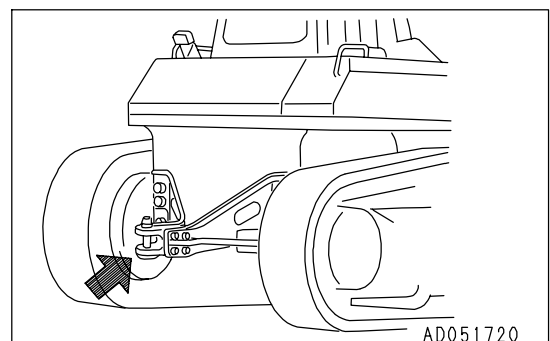
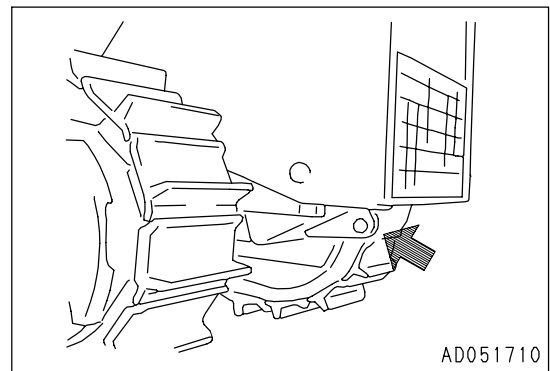

IF BATTERY IS DISCHARGED



WARNING

- It is dangerous to charge a battery when mounted on a machine. Make sure that it is dismantled before charging.
- When checking or handling the battery, stop the engine and turn the starting switch key to the OFF position.
- The battery generates hydrogen gas, so there is a hazard of explosion. Do not bring lighted cigarettes near the battery, or do anything that will cause sparks.
- Battery electrolyte is dilute sulfuric acid, and it will attack your clothes and skin. If it gets on your clothes or on your skin, immediately wash it off with a large amount of water. If it gets in your eyes, wash it out with fresh water and consult a doctor.
- When handling batteries, always wear safety glasses and rubber gloves.
- When removing the battery, first disconnect the cable from the ground (normally the negative (-) terminal). When installing, install the positive (+) terminal first.
If a tool touches the positive terminal and the chassis, there is danger that it will cause a spark, so be extremely careful.
- If the terminals are loose, there is danger that the defective contact may generate sparks that will cause an explosion.
- When removing or installing the terminals, check which is the positive (+) terminal and which is the negative (-) terminal.

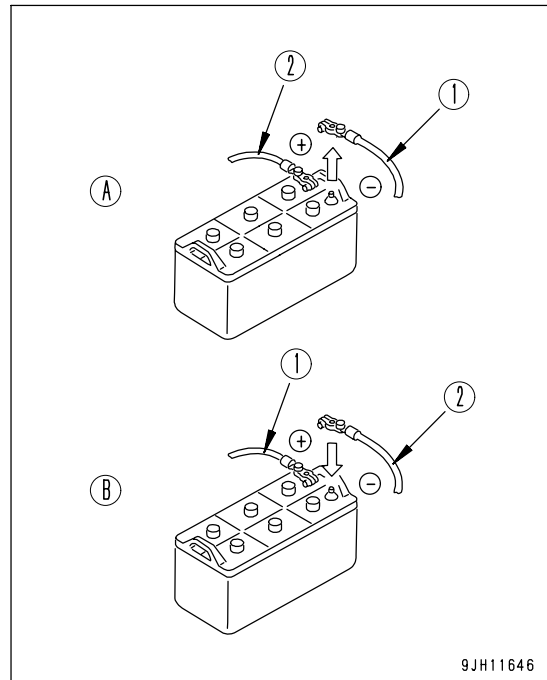

(A) When removing, disconnect the cable from the ground terminal first.

(B) When installing, connect the cable to the positive (+) terminal first.

REMOVAL AND INSTALLATION OF BATTERY

- Before removing the battery, remove the ground cable (normally connected to the negative (-) terminal).
If any tool touches between the positive terminal and the chassis, there is a hazard of sparks being generated.
- When installing the battery, connect the ground cable last.
- When replacing the battery, secure it with battery hold-down.
Tightening torque: Tightening battery terminal: 9.8 to 14.7 Nm (1 to 1.5 kgm, 7.2 to 10.8 lbft)

REMOVAL, INSTALLATION OF BATTERY CABLE

1. Open the battery cover (1).
2. Before removing the battery, remove the ground cable (normally connected to the negative (-) terminal). If any tool touches between the positive terminal and the chassis, there is danger of sparks being generated. Loosen the nut of the terminal and remove the wires from the battery.
3. When installing, connect the ground cable last.
Insert the terminal cable on the battery, then tighten the nut.
Tightening torque: 9.8 to 19.6 Nm (1.0 to 2.0 kgm, 7.2 to 14.5 lbft)
4. Close battery cover (1).

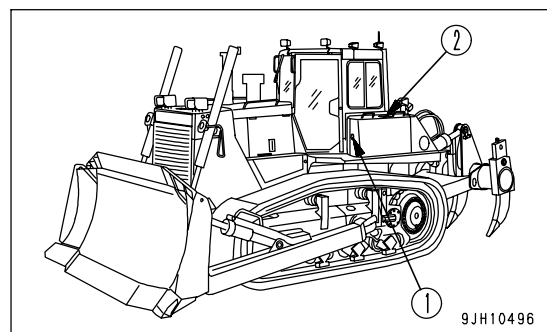

PRECAUTIONS WHEN CHARGING BATTERY

When charging the battery, if the battery is mistakenly handled, there is danger of explosion. Follow the precautions in "IF BATTERY IS DISCHARGED (PAGE 3-188)" and the instructions given in the charger manual, and always do as follows.

- Set the voltage of the charger to match the voltage of the battery to be charged. If the correct voltage is not selected, the charger may overheat and cause an explosion.
- Connect the positive (+) charger clip of the charger to the positive (+) terminal of the battery, then connect the negative (-) charger clip of the charger to the negative (-) terminal of the battery. Be sure to attach the clips securely.
- Set the charging current to 1/10 of the value of the rated battery capacity; when carrying out rapid charging, set it to less than the rated battery capacity.
If the charger current is too high, the electrolyte will leak or dry up, and this may cause the battery to catch fire and explode.
- If the battery electrolyte is frozen, do not charge the battery or start the engine with a different power source. There is a danger that this will ignite the battery electrolyte and cause the battery to explode.

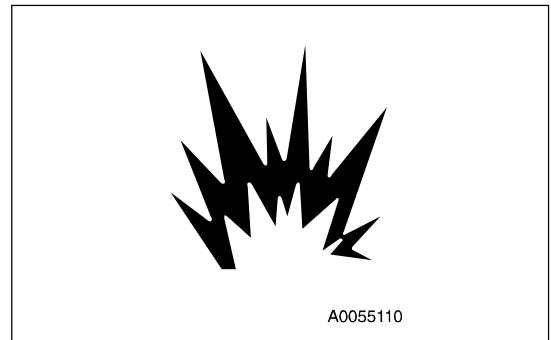

STARTING ENGINE WITH BOOSTER CABLE

When starting the engine with a booster cable, do as follows.

PRECAUTIONS WHEN CONNECTING AND DISCONNECTING BOOSTER CABLE



- When connecting the cables, never contact the positive (+) and negative (-) terminals.
- When starting the engine with a booster cable, wear safety glasses and rubber gloves.
- Be careful not to let the normal machine and problem machine contact each other. This prevents sparks from generating near the battery which could ignite the hydrogen gas given off by the battery.
- Make sure that there is no mistake in the booster cable connections. The final connection is to the engine block of the problem machine, but sparks will be generated when this is done, so connect to a place as far as possible from the battery.
- When disconnecting the booster cable, take care not to bring the clips in contact with each other or with the machine body.

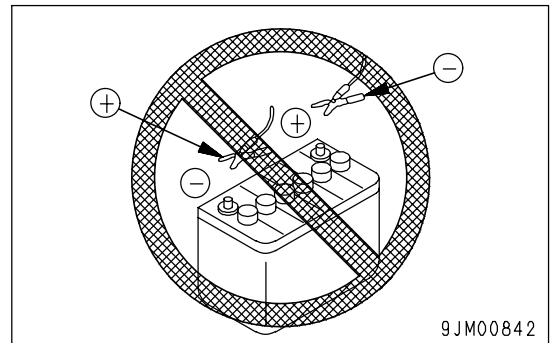

NOTICE

- The size of the booster cable and clip should be suitable for the battery size.
- The battery of the normal machine must be the same capacity as that of the engine to be started.
- Check the cables and clips for damage or corrosion.
- Make sure that the cables and clips are firmly connected.
- Check that the work equipment lock levers and parking brake levers of both machines are in the LOCK position.
- Check that each lever is in the NEUTRAL position.

CONNECTING THE BOOSTER CABLES

Keep the starting switch of the normal machine and problem machine in the OFF position.

Connect the booster cable as follows, in the order of the numbers marked in the diagram.

1. Connect the clip of booster cable (A) to the positive (+) terminal of battery (C) on the problem machine.
2. Connect the clip at the other end of booster cable (A) to the positive (+) terminal of battery (D) on the normal machine.
3. Connect the clip of booster cable (B) to the negative (-) terminal of battery (D) on the normal machine.
4. Connect the clip at the other end of booster cable (B) to engine block (E) on the problem machine.

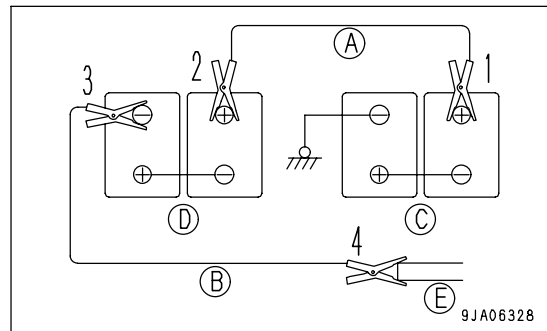

STARTING THE ENGINE



WARNING

Always check that the work equipment lock lever and Parking brake lever is set to the LOCK position, regardless of whether the machine is working normally or has failed. Check also that all the control levers are in the HOLD or NEUTRAL position.

1. Make sure the clips are firmly connected to the battery terminals.
2. Start the engine of the booster machine and keep it running at high idling speed.
3. Turn the starting switch of problem machine to the START position, and start the engine. If the engine doesn't start at first, try it again after 2 minutes.

DISCONNECTING THE BOOSTER CABLES

After the engine has started, disconnect the booster cables in the reverse of the order in which they were connected.

1. Remove the clip of booster cable (B) from engine block (E) on the problem machine.
2. Remove the clip of booster cable (B) from the negative (-) terminal of battery (D) on the normal machine.
3. Remove the clip of booster cable (A) from the positive (+) terminal of battery (D) on the normal machine.
4. Remove the clip of booster cable (A) from the positive (+) terminal of battery (C) on the problem machine.

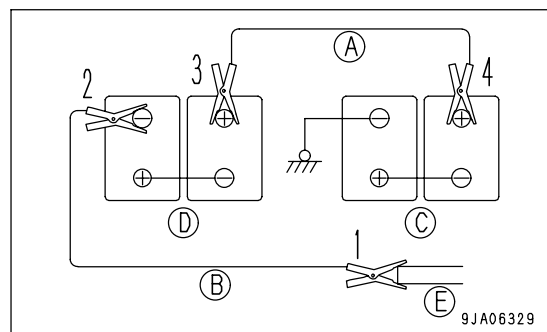

OTHER TROUBLE

ELECTRICAL SYSTEM

- (): Always contact your Komatsu distributor when dealing with these items.
- In cases of problems or causes which are not listed below, contact your Komatsu distributor for repairs.

Problem	Main causes	Remedy
Lamp does not glow brightly even when the engine runs at high speed	• Defective wiring	(• Check, repair loose terminals, disconnections)
Lamp flickers while engine is running	• Defective adjustment of fan belt tension	• Adjust alternator belt tension For details, see EVERY 250 HOURS SERVICE
Charge lamp does not go out even when engine is running	• Defective alternator • Defective wiring	(• Replace) (• Check, repair)
Abnormal noise is generated from alternator	• Defective alternator	(• Replace)
Starting motor does not turn when starting switch is turned to ON	• Defective wiring • Insufficient battery charge • Safety switch out of adjust	(• Check, repair) • Charge (• Adjust safety switch)
Pinion of starting motor keeps going in and out	• Insufficient battery charge	• Charge
Starting motor turns engine sluggishly	• Insufficient battery charge • Defective starting motor	• Charge (• Replace)
Starting motor disengages before engine starts	• Defective wiring • Insufficient battery charge	(• Check, repair) • Charge
Automatic pre-heating is not actuated	• Defective wiring • Defective heater relay • Defective engine controller	(• Check, repair) (• Replace) (• Check, replace)
Outside of electrical heater is not warm when touched by hand	• Defective wiring • Disconnection in electrical intake air heater • Defective operation of heater relay	(• Check, repair) (• Replace) (• Check, repair heater relay)
Air conditioner does not work properly	• Blown fuse • Insufficient battery charge • Defective air conditioner switch • Defective blower switch • Defective compressor	(• Check, repair) • Charge (• Replace air conditioner switch) (• Replace blower switch) (• Replace)

ELECTRONIC CONTROL SYSTEM

When the user code is shown on the display portion of the machine monitor, take the respective measures shown in the self-diagnosis chart below.

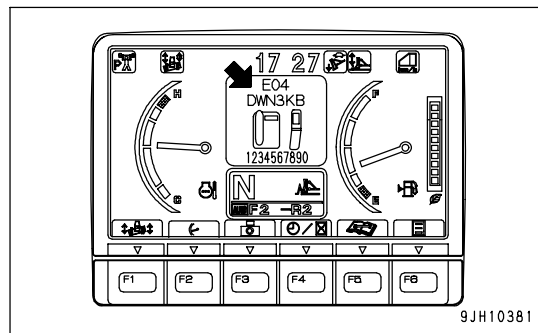

MACHINE MONITORING SYSTEM

Failure code	Buzzer	Caution lamp	Remedy	Problem that appears on machine
E01	-	-	Automatic functions stop, some functions stop, but operation is possible Ask your Komatsu distributor to carry out repairs	Inspect after completing operations
E02	○	○	After user action to stop engine, operations are possible without limit functions when engine is restarted. However, user must be careful when operating. Ask your Komatsu distributor immediately to carry out repairs	Automatic limits stop, but possible to continue operations with care
E03	○	○	Move machine to safe place, then ask your Komatsu distributor immediately to carry out repairs	After steering, directional, and gear shift lever is returned to neutral, engine does not run at full speed. Transmission is fixed in 1st, so move to a safe place and carry out inspection
E04	○	○	Stop machine immediately, then ask your Komatsu distributor immediately to carry out repairs	After steering, directional, and gear shift lever is returned to neutral, engine does not run at full speed and machine cannot travel

CHASSIS

- (): Always contact your Komatsu distributor when dealing with these items.
- In cases of problems or causes which are not listed below, contact your Komatsu distributor for repairs.

Problem	Main causes	Remedy
Machine does not stop even when brake pedal is depressed	<ul style="list-style-type: none"> • Defective brake adjustment, low oil pressure 	<ul style="list-style-type: none"> (• Adjust, check, repair)
Track shoe comes off	<ul style="list-style-type: none"> • Track shoe too loose 	<ul style="list-style-type: none"> • Adjust track tension. See WHEN REQUIRED
Abnormal wear of sprocket	<ul style="list-style-type: none"> • Track shoe too loose or too tight 	
Blade, ripper lifting speed too slow or blade, ripper does not go up	<ul style="list-style-type: none"> • Lack of hydraulic oil • Work equipment lock lever at LOCK position 	<ul style="list-style-type: none"> • Add oil to specified level. See EVERY 250 HOURS SERVICE • Set to FREE position
Swing is operated but upper structure does not swing	<ul style="list-style-type: none"> • Parking brake lever at LOCK position • Defective wiring of lever • Abnormality in HSS pump • Abnormality in HSS motor 	<ul style="list-style-type: none"> • Set to FREE position (• Check, repair) (• Check, replace) (• Check, replace)
Transmission oil pressure does not rise	<ul style="list-style-type: none"> • Gear pump worn or scuffing • Lack of oil in power train case • Clogged oil filter element, strainer in power train case 	<ul style="list-style-type: none"> (• Check, or replace) • Add oil to specified level. See Check before Starting • Clean. See EVERY 1000 HOURS SERVICE
Lack of traction (machine travel speed is low)	<ul style="list-style-type: none"> • Lack of engine power 	<ul style="list-style-type: none"> • See ENGINE
Machine takes time to reach travel speed	<ul style="list-style-type: none"> • Power train oil temperature is low • Lack of engine power 	<ul style="list-style-type: none"> • Carry out warming-up operation • See ENGINE
Even when steering, directional, and gear shift lever is set to travel position, machine does not move off	<ul style="list-style-type: none"> • Lack of oil in power train case • Transmission oil pressure does not rise • Parking brake lever at LOCK position 	<ul style="list-style-type: none"> • Add oil to specified level. See Check before Starting • See "Transmission oil pressure does not rise" above" • Set to FREE position
Machine does not travel in straight line	<ul style="list-style-type: none"> • Defective adjustment of power train controller • Abnormality in HSS pump 	<ul style="list-style-type: none"> (• Adjust) (• Check, replace)
Torque converter overheats (red range at top of power train oil temperature gauge lights up)	<ul style="list-style-type: none"> • Lack of oil in power train case • Transmission oil pressure does not rise • Excessive load during operation 	<ul style="list-style-type: none"> • Add oil to specified level. See Check before Starting • See "Transmission oil pressure does not rise" above • Use transmission speed range one level lower or lighten load and increase speed during operation

ENGINE

- (): Always contact your Komatsu distributor when dealing with these items.
- In cases of problems or causes which are not listed below, contact your Komatsu distributor for repairs.

Problem	Main causes	Remedy
After warming up, engine speed rises but engine oil pressure caution lamp flashes	<ul style="list-style-type: none"> • Lack of oil in oil pan (air being sucked in) • Clogged oil filter cartridge • Defective tightening of oil pipe, pipe joint, oil leakage from damage • Defective caution lamp 	<ul style="list-style-type: none"> • Add oil to specified level. See Check before Starting • Replace. See EVERY 500 HOURS SERVICE (• Check, repair) (• Replace)
Steam spurts out from top of radiator (pressure valve)	<ul style="list-style-type: none"> • Lack of cooling water, water leakage • Dirt or scale accumulated in cooling system 	<ul style="list-style-type: none"> • Check, add cooling water, repair. See Check before Starting • Change coolant, flush inside of cooling system. See WHEN REQUIRED
Red range at top of engine coolant temperature gauge flashes	<ul style="list-style-type: none"> • Clogged or damaged radiator fins • Defective thermostat • Loose radiator filler cap (when operating at high altitudes) • Defective monitor panel 	<ul style="list-style-type: none"> • Clean or repair. See WHEN REQUIRED (• Replace thermostat) • Tighten cap or replace packing (• Replace monitor panel)
White range at bottom of engine coolant temperature gauge flashes	<ul style="list-style-type: none"> • Defective thermostat • Defective monitor panel 	<ul style="list-style-type: none"> (• Replace thermostat) (• Replace monitor panel)
Starting motor turns but engine does not start	<ul style="list-style-type: none"> • Lack of fuel • Air entering fuel line • No fuel inside fuel filter • Cranking of engine by starting motor is slow • Glow signal does not become red • Defective compression <ul style="list-style-type: none"> • Defective valve clearance 	<ul style="list-style-type: none"> • Add fuel. See Check before Starting • Repair places where air enters fuel line (• Fill fuel filter with fuel. See EVERY 500 HOURS SERVICE.) • See ELECTRICAL SYSTEM • See ELECTRICAL SYSTEM (• Adjust clearance)
Exhaust gas is white or bluish	<ul style="list-style-type: none"> • Too much oil in oil pan • Improper fuel 	<ul style="list-style-type: none"> • Drain excess oil. See Check before Starting • Replace with specified fuel
Exhaust gas sometimes becomes black	<ul style="list-style-type: none"> • Clogged air cleaner element • Defective nozzle • Defective compression 	<ul style="list-style-type: none"> • Clean or replace. See WHEN REQUIRED (• Replace nozzle) (• See "Defective compression" above)
Combustion sometimes makes breathing noise	<ul style="list-style-type: none"> • Defective nozzle 	<ul style="list-style-type: none"> (• Replace nozzle)
Abnormal sound is generated (combustion or mechanical)	<ul style="list-style-type: none"> • Low-grade fuel being used • Overheating • Breakage inside muffler • Excessive valve clearance 	<ul style="list-style-type: none"> • Replace with specified fuel • See "Red range at top of engine coolant temperature gauge flashes" above (• Replace muffler) (• Adjust clearance)

Problem	Main causes	Remedy
Error code is displayed on monitor	Contact your Komatsu distributor	
Alarm buzzer sounds		
Engine suddenly lost power (entered delayed mode)		

POINT OF CONTACT TO TELEPHONE WHEN ERROR OCCURS

If an error screen is displayed on the monitor, the telephone number for the point of contact is displayed at the bottom of the error screen.

REMARK

If no point of contact telephone number has been registered, no telephone number is displayed.

It is necessary to register the telephone number, please ask your Komatsu distributor to carry out the registration.

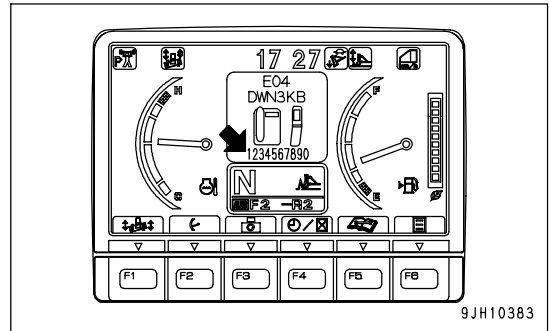

9JH10383

MAINTENANCE

WARNING

Please read and make sure that you understand the SAFETY section before reading this section.

GUIDES TO MAINTENANCE

Do not perform any inspection and maintenance operation that is not found in this manual.
Stop the machine on flat hard ground when performing inspections and maintenance.

CHECK SERVICE METER:

Check the service meter reading every day to see if the time has come for any necessary maintenance to be performed.

KOMATSU GENUINE REPLACEMENT PARTS:

Use Komatsu genuine parts specified in the Parts Book as replacement parts.

KOMATSU GENUINE OILS:

For lubrication of the machine, use the Komatsu genuine lubricants. Moreover use oil of the specified viscosity according to the ambient temperature.

ALWAYS USE CLEAN WASHER FLUID:

Use automobile window washer fluid, and be careful not to let any dirt get into it.

CLEAN OIL AND GREASE:

Use clean oil and grease. Also, keep the containers of the oil and grease clean. Keep foreign materials away from oil and grease.

CHECK FOREIGN MATERIAL IN DRAINED OIL:

After oil is changed or filters are replaced, check the old oil and filters for metal particles and foreign materials. If large quantity of metal particles or foreign materials are found, always report to the person in charge, and carry out suitable action.

FUEL STRAINER:

If your machine is equipped with a fuel strainer, do not remove it while fueling.

WELDING INSTRUCTIONS:

- Turn off the engine starting switch.
- Do not apply more than 200 V continuously.
- Connect grounding cable within 1 m (3.3 ft) of the area to be welded. If grounding cable is connected near instruments, connectors, etc., the instruments may malfunction.
- If a seal or bearing happens to come between the part being welded and grounding point, change the grounding point to avoid such parts.
- Do not use the area around the work equipment pins or the hydraulic cylinders as the grounding point.

OBJECTS IN YOUR POCKETS:

- When opening inspection windows or the oil filler port of the tank to carry out inspection, be careful not to drop nuts, bolts, or tools inside the machine.
If such things are dropped inside the machine, it may cause damage and/or malfunction of the machine, and will lead to failure. If you drop anything inside the machine, always remove it immediately.
- Do not put unnecessary things in your pockets. Carry only things which are necessary for inspection.

DUSTY WORKSITES:

When working at dusty worksites, do as follows:

- Inspect the dust indicator frequently to see if the air cleaner is dirty or clogged.
- Clean the radiator core frequently to avoid clogging.
- Clean and replace the fuel filter frequently.
- Clean electrical components, especially the starting motor and alternator, to avoid accumulation of dust.
- When inspecting or changing the oil, move the machine to a place that is free of dust to prevent dirt from getting into the oil.

AVOID MIXING OILS:

If a different brand or grade of oil has to be added, drain the old oil and replace all the oil with the new brand or grade of oil. Never mix different brand or grade of oil.

LOCKING INSPECTION COVERS:

Lock inspection cover securely into position with the lock bar. If inspection or maintenance is performed with inspection cover not locked in position, there is a danger that it may be suddenly blow shut by the wind and cause injury to the worker.

BLEEDING AIR:

When hydraulic equipment has been repaired or replaced, or the hydraulic piping has been removed and installed again, the air must be bled from the circuit. For details, see "PROCEDURE FOR BLEEDING AIR FROM HYDRAULIC CIRCUIT (PAGE 4-47)".

PRECAUTIONS WHEN INSTALLING HYDRAULIC HOSES:

- When removing parts at locations where there are O-rings or gasket seals, clean the mounting surface, and replace with new parts.
When doing this, be careful not to forget to assemble the O-rings and gaskets.
- When installing the hoses, do not twist them or bend them sharply. If they are installed so, their service life will be shortened extremely and they may be damaged.

CHECKS AFTER INSPECTION AND MAINTENANCE:

If you forget to perform the checks after inspection and maintenance, unexpected problems may occur, and this may lead to serious injury or property damage. Always do the following:

- Checks after operation (with engine stopped)
 - Have any inspection and maintenance points been forgotten?
 - Have all inspection and maintenance items been performed correctly?
 - Have any tools or parts been dropped inside the machine? It is particularly dangerous if parts are dropped inside the machine and get caught in the lever linkage mechanism.
 - Are there any leakage of coolant or oil? Have all nuts and bolts been tightened?
- Checks when engine is running
 - For the checks when the engine is running, see "TWO WORKERS FOR MAINTENANCE WHEN ENGINE IS RUNNING (PAGE 2-31)" in the SAFETY section, and take care of safety sufficiently.
 - Check that the inspected and maintained parts work normally.
 - Raise the engine speed and check for fuel leakage and oil leakage.

PRECAUTIONS WHEN OPENING AND CLOSING ENGINE SIDE COVER:

- When standing on track to open the engine side cover, adopt a standing position, hold the side cover with both thumbs, and open it slowly with your other fingers.
- When the side cover is open, do not open or close the cab.
Before opening or closing the cab, always close the engine side cover first.
Except, however, when the hydraulic driving fan is in the reverse rotation mode.

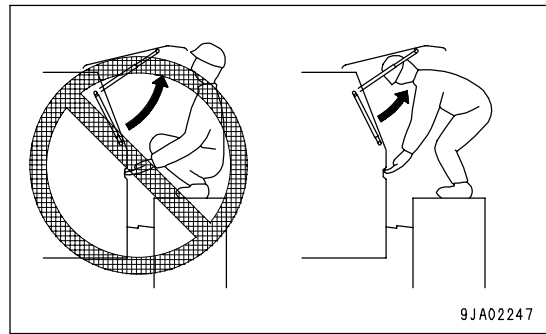

OUTLINES OF SERVICE

- Always use Komatsu genuine parts for replacement parts, grease or oil.
- When changing the oil or adding oil, do not mix different types of oil. When changing the type of oil, drain all the old oil and fill completely with the new oil. Always replace the filter at the same time. (There is no problem if the small amount of oil remaining in the piping mixes with the new oil.)
- Unless there is any specific request, the oil, fuel, and coolant used on the machine when it is shipped from the factory are as shown in the table below.

Item	Type
Engine oil pan	Engine oil 15W40DH (Komatsu genuine parts)
Power train case Final drive case Damper case	Power train oil TO30 (Komatsu genuine parts)
Hydraulic tank	Power train oil T010 (Komatsu genuine parts)
Radiator	Supercoolant AF-NAC (Density: 30% or above) (Komatsu genuine parts)

HANDLING OIL, FUEL, COOLANT, AND PERFORMING OIL CLINIC

OIL

- Oil is used for the engine and hydraulic equipment under extremely severe conditions (high temperature, high-pressure), so the oil deteriorates with use.
Always refer to the Operation and Maintenance Manual and use the recommended oil that matches the grade (class) and maximum and minimum ambient temperatures.
Even if the oil does not appear to be dirty, always change it after the specified interval.
- Oil corresponds to blood in the human body, always be careful when handling it to prevent any impurities (water, metal particles, dirt, etc.) from getting in.
The majority of problems with the machine are caused by the entry of such impurities.
Take particular care not to let any impurities get in when storing or adding oil.
- Never mix oils of different grades or brands.
- Always add the specified amount of oil.
Having too much oil or too little oil are both causes of problems.
- If the oil in the work equipment is not clear, there is probably water or air getting into the circuit. In such cases, please contact your Komatsu distributor.
- When changing the oil, always replace the related filters at the same time.
- We recommend periodic performance of the oil clinic to ensure that you always know the condition of the machine. Please contact your Komatsu distributor for details of the oil clinic.
- When the machine is shipped from the factory, T010 (power train oil) is used for the hydraulic system.
When using H046-HM hydraulic oil, drain all the oil and fill with the specified amount of oil.
Always use oil recommended by Komatsu. If any other oil is used, it will cause clogging of the filter.
There is no problem if the new oil is mixed with the small amount of oil remaining in the piping and cylinders.

FUEL

- To prevent the moisture in the air from condensing and forming water inside the fuel tank, always fill the fuel tank after completing the day's work.
- The fuel pump is a precision instrument, and if fuel containing water or dirt is used, it cannot work properly.
- Be extremely careful not to let impurities get in when storing or adding fuel.
- Always use fuel that matches the temperatures given in the Operation and Maintenance Manual.
 - If the fuel is used in temperatures lower than the specified temperature for use (particularly at temperatures of lower than -15°C), the properties of the fuel will make it congeal.
 - If the fuel is used in temperatures higher than the specified temperature for use, the viscosity will go down, and this may result in a drop in output or other problems.
- Before starting the engine, or when 10 minutes have passed after adding fuel, drain the sediment and water from the fuel tank.
- If the engine runs out of fuel, or if the filters have been replaced, it is necessary to bleed the air from the circuit.

NOTICE

Always use diesel oil for the fuel.

To ensure good fuel consumption characteristics and exhaust gas characteristics, the engine mounted on this machine uses an electronically controlled high-pressure fuel injection device. This device requires high precision parts and lubrication, so if low viscosity fuel with low lubricating ability is used, the durability may drop markedly.

COOLANT AND WATER FOR DILUTION

- The coolant has the important function of preventing corrosion as well as preventing freezing. Even in the areas where freezing is not an issue, the use of antifreeze coolant is essential. Komatsu machines are supplied with Komatsu Supercoolant (AF-NAC). Komatsu Supercoolant (AF-NAC) has excellent anticorrosion, antifreeze and cooling properties and can be used continuously for 2 years or 4000 hours. As a basic rule, we do not recommend the use of any coolant other than Komatsu genuine supercoolant (AF-NAC). If you use another coolant, it may cause serious problems such as corrosion of the engine and parts of the cooling system that use light metals such as aluminum.
- When using Komatsu super coolant (AF-NAC), there is no need to use a corrosion resistor. For details, see "CLEAN INSIDE OF COOLING SYSTEM (PAGE 4-20)".
- When diluting the antifreeze coolant, use distilled water or tap water (soft water). Natural water, such as a river water or well water (hard water), contains large amounts of minerals (calcium, magnesium, etc.), and this makes it easier for scale to form inside the engine or radiator. Once scale is deposited inside the engine or radiator, it is extremely difficult to remove. It also causes overheating due to poor heat exchange, so when you dilute the coolant, we recommend that you use water with an overall hardness of less than 100 PPM.
- When using antifreeze, always observe the precautions given in the Operation and Maintenance Manual.
- The undiluted coolant is flammable, so be particularly careful to keep it away from flame.
- The ratio of Supercoolant (AF-NAC) to water differs according to the ambient temperature. For details of the ratio when mixing, see "CLEAN INSIDE OF COOLING SYSTEM (PAGE 4-20)". Even in areas where it is not necessary to prevent freezing, use Supercoolant (AF-NAC) at a mixing ratio of at least 30% to prevent corrosion of the cooling system. Supercoolant (AF-NAC) may be supplied in premix. In this case, never add diluting water.
- If the engine overheats, wait for the engine to cool before adding coolant.
- If the coolant level is low, it will cause overheating, and will also cause problems with corrosion due to air entering the coolant.

GREASE

- Grease is used to prevent seizure and noises at the joints.
- This construction equipment is used under heavy-duty conditions. Always use the recommended grease and follow the change intervals and recommended ambient temperatures given in this Operation and Maintenance Manual.
- The nipples not included in the MAINTENANCE section are nipples used when overhauling, so they do not need grease.
If any part becomes stiff or generates noise after being used for a long time, grease it.
- Always wipe off all of the old grease that is pushed out when greasing.
Be particularly careful to wipe off the old grease in places where sand or dirt sticking in the grease would cause wear of the rotating parts.

CARRYING OUT KOWA (Komatsu Oil Wear Analysis)

The oil clinic samples the oil periodically and analyzes it. This is a preventive maintenance service, which provides early discovery of abnormal parts and wear of the drive parts of the machine. This then makes it possible to ensure prevention of failures and reduction in downtime.

Komatsu’s long years of experience and rich supply of accumulated data make it possible to accurately determine the condition of your machine. This enables us to locate the problems and to recommend suitable and timely repair methods.

The oil clinic charges the customer only the actual costs, and provides an immediate report of the results of the analysis and recommendations for action to take. This low-cost service can save you high costs and inconvenience in the future, so we strongly recommend you to avail yourself of this service.

KOWA ANALYSIS ITEMS

- Measurement of density of metal wear particles
This uses an ICP (Inductively Coupled Plasma) analyzer to measure the density of iron, copper, and other metal wear particles in the oil.

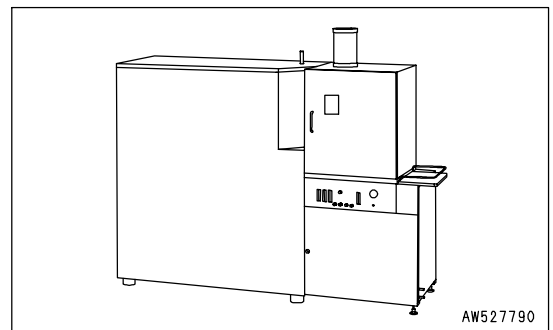

- Measurement of particle quantity
This uses a PQI (Particle Quantifier Index) measurer to measure the quantity of iron particles of 5µm or more, enabling early detection of failures.

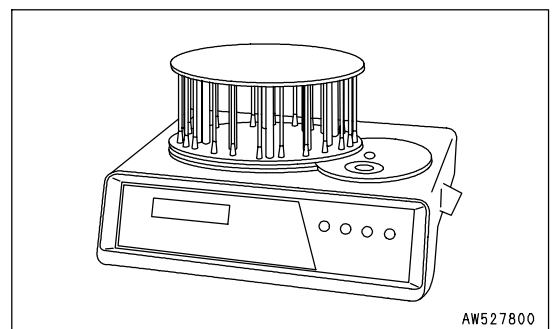

- Others
Measurements are made of items such as the ratio of water or fuel in the oil, and the dynamic viscosity.

OIL SAMPLING

- Sampling interval
250 hours: Engine
500 hours: Other components
- Precautions when sampling
 - Make sure that the oil is well mixed before sampling.
 - Perform sampling at regular fixed intervals.
 - Do not perform sampling on rainy or windy days when water or dust can get into the oil.

For further details of KOWA, please contact your Komatsu distributor.

STORING OIL AND FUEL

- Keep indoors to prevent any water, dirt, or other impurities from getting in.
- When keeping drum cans for a long period, put the drum on its side so that the filler port of the drums is at the side to prevent moisture from being sucked in.
If drums have to be stored outside, cover them with a waterproof sheet or take other measures to protect them.
- To prevent any change in quality during long-term storage, be sure to use in the order of first in - first out (use the oldest oil or fuel first).

FILTERS

- Filters are extremely important safety parts. They prevent impurities in the fuel and air circuits from entering important equipment and causing problems.
Replace all filters periodically. For details, see the Operation and Maintenance Manual.
However, when working in severe conditions, replace the filters at shorter intervals according to the oil and fuel (sulfur content) being used.
- Never try to clean the filters (cartridge type) and use them again. Always replace with new filters.
- When replacing oil filters, check if any metal particles are attached to the old filter. If any metal particles are found, contact your Komatsu distributor.
- Do not open packs of spare filters until just before they are to be used.
- Use of Komatsu genuine filter elements is strongly recommended.

OUTLINE OF ELECTRIC SYSTEM

- It is extremely dangerous if the electrical equipment becomes wet or the covering of the wiring is damaged. This will cause an electrical short circuit and may lead to malfunction of the machine. Do not wash the inside of the operator's cab with water. When washing the machine, be careful not to let water get into the electrical components.
- Service relating to the electric system is checking fan belt tension, checking damage or wear to the fan belt and checking battery fluid level.
- Never install any electric components other than those specified by Komatsu.
- External electro-magnetic interference may cause malfunction of the control system controller, before installing a radio receiver or other wireless equipment, contact your Komatsu distributor.
- When working at the seashore, carefully clean the electric system to prevent corrosion.
- When installing electrical equipment, connect it to the special power source connector.
Do not connect the optional power source to the fuse, starting switch, or battery relay.

WEAR PARTS

Wear parts such as the filter element, air cleaner element etc. are to be replaced at the time of periodic maintenance or before their abrasion limits.

The wear parts should be changed correctly in order to use the machine economically.

When changing parts, use Komatsu genuine parts of excellent quality.

When ordering parts, please check for the part number in the parts book.

WEAR PARTS LIST

The parts in parentheses are to be replaced at the same time.

Item	Part No.	Part Name	Weight (kg(lb))	Q'ty	Replacement frequency	
Engine oil filter	600-211-1340	Cartridge	-	2	Every 500 hour service	
Power train filter	07063-51100 (07000-02130)	Element (O-ring)	-	1 (1)		
Fuel pre-filter	600-319-4500	Cartridge	-	1		
Fuel main filter	600-319-3550	Cartridge	-	1	Every 1000 hour service	
Corrosion resistor	600-411-1161	Cartridge	-	1		
Pilot filter	20Y-62-51691 (706-76-71390)	Element (O-ring)	-	1 (1)		
Power train case breather	07030-00252	breather	-	1		
Fuel tank breather	22U-60-21520	breather	-	1		
Hydraulic tank breather	22U-60-21520	breather	-	1		
Hydraulic oil filter	207-60-71182	Element	-	1	Every 2000 hour service	
Air cleaner	600-185-6100	Element ass'y	-	1	-	
Air conditioner	Fresh filter	14X-911-7750	Filter	-	2	-
	Recirc filter	20Y-979-6261	Filter	-	2	

Item	Part No.	Part Name	Weight (kg(lb))	Q'ty	Replacement frequency	
Blade	Sigmadozer	17A-71-45230	Cutting edge (left)	32.2	1	-
		17A-71-45220	Cutting edge (right)	32.2	1	
		17A-71-45210	Cutting edge	78.5	2	
		17A-71-45712	End bit (left)	51	1	
		17A-71-45722	End bit (right)	51	1	
		17A-71-12451	(Bolt)	-	(34)	
		17M-71-21530	(Nut)	-	(34)	
		01643-22460	(Washer)	-	(34)	
	Sigmadozer (Cemented carbide end bit specification)	17A-71-46680	Cutting edge (left)	32.7	1	-
		17A-71-46670	Cutting edge (right)	32.7	1	
		17A-71-45210	Cutting edge	78.5	2	
		17A-71-46610	End bit (left)	51.6	1	
		17A-71-46620	End bit (right)	51.6	1	
		17A-71-12451	(Bolt)	-	(34)	
		17M-71-21530	(Nut)	-	(34)	
		01643-22460	(Washer)	-	(34)	
	Semi U-dozer	175-70-26310	Cutting edge	48.8	3	-
		175-71-22272	End bit (left)	39	1	
		175-71-22282	End bit (right)	39	1	
		175-71-11463	(Bolt)	-	(14)	
		175-71-11454	(Bolt)	-	(21)	
		175-71-11530	(Nut)	-	(35)	
	U-dozer	175-72-21123	Cutting edge	40.7	4	-
		175-70-21126	End bit (left)	37	1	
175-70-21136		End bit (right)	37	1		
175-71-11454		(Bolt)	-	(24)		
175-71-11463		(Bolt)	-	(14)		
175-71-11530		(Nut)	-	(38)		
Angledozer	175-70-26310	Cutting edge	48.8	1	-	
	175-70-21115	Cutting edge	64.1	2		
	175-71-11454	(Bolt)	-	(25)		
	175-71-11530	(Nut)	-	(25)		
	175-70-21126	End bit (left)	37	1		
	175-70-21136	End bit (right)	37	1		
	175-71-11463	(Bolt)	-	(14)		
	175-71-11530	(Nut)	-	(14)		
Ripper	Multi	175-78-31230	Point	15	3	-
		195-78-21320	Protector	13	3	
		09244-02508	(Pin)	-	(9)	
	Giant	175-78-31230	Point	15	1	
		195-78-21320	Protector	13	1	
		09244-02508	(Pin)	-	3	

NOTICE

When handling parts that weigh more than 25 kg (55 lb), remember that they are heavy objects, and take the necessary care.

RECOMMENDED FUEL, COOLANT, AND LUBRICANT

- Komatsu genuine oils are adjusted to maintain the reliability and durability of Komatsu construction equipment and components.

In order to keep your machine in the best conditioner for long periods of time, it is essential to follow the instructions in this Operation and Maintenance Manual.

- Failure to follow these recommendations may result in shortened life or excess wear of the engine, power train, cooling system, and/or other components.
- Commercially available lubricant additives may be good for the machine, but they may also cause harm. Komatsu does not recommend any commercially available lubricant additive.
- Use the oil recommended according to the ambient temperature in the chart below.
- Specified capacity means the total amount of oil including the oil in the tank and the piping. Refill capacity means the amount of oil needed to refill the system during inspection and maintenance.
- When starting the engine in ambient temperatures below 0°C (50°F), do not use SAE30, even if the daytime temperature rises to 10°C (32°F). Always use multigrade oil such as the recommended SAE10W30 or SAE15W40.
- If the machine is operated at a temperature below -20°C (-4°F), a separate device is needed, so consult your Komatsu distributor.
- When the fuel sulfur content is less than 0.2%, change the engine oil according to the period inspection table given in this Operation and Maintenance Manual.

If the fuel sulfur content is more than 0.2%, change the oil according to the following table.

Sulfur content (%)	Oil change interval
Less than 0.2 %	500 hours
0.2 to 0.5 %	250 hours
0.5 and up	Not recommendable (*)

* If these fuels are used, there is danger that serious trouble may occur because of early deterioration of the engine oil or early wear of the internal parts of the engine. If the local situation makes it necessary to use these fuels, always remember the following.

- 1) Be sure to check Total Basic Number (TBN) of oil frequently by TBN handy checker etc., and change oil based on the result.
- 2) Always be aware that oil change interval is extremely shorter than standard.
- 3) Be sure to carry out periodic engine inspection by distributor's expert since change interval of periodic replacement parts and overhaul interval are also shorter.

Reservoir	Fluid Type	Ambient Temperature, degrees Celsius									Recommended Komatsu Fluids
		-22	-4	14	32	50	68	86	104	122°F	
		-30	-20	-10	0	10	20	30	40	50°C	
Engine oil pan	Engine oil (Note.1)	[Shaded bar from -22 to 68]									Komatsu EOS0W30
		[Shaded bar from -4 to 86]									Komatsu EOS5W40
		[Shaded bar from 14 to 104]									Komatsu EO10W30-DH
		[Shaded bar from 32 to 122]									Komatsu EO15W40-DH
		[Shaded bar from 50 to 86]									Komatsu EO30-DH
Power train oil pan (incl. Transmission,torque converter and bevel gear case)	Powertrain oil (Note.2)	[Shaded bar from -22 to 32]									TO10
		[Shaded bar from 10 to 68]									TO30
Final drive case (each) Damper case	Powertrain oil	[Shaded bar from -22 to 104]									TO30
Hydraulic system	Powertrain oil	[Shaded bar from 14 to 86]									TO10
	Hydraulic oil	[Shaded bar from 14 to 104]									HO46-HM
	Engine oil	[Shaded bar from 14 to 122]									Komatsu EO10W30-DH
		[Shaded bar from 32 to 104]									Komatsu EO15W40-DH
Grease fitting	Hyper grease (Note.3)	[Shaded bar from 14 to 104]									G2-T,G2-TE
	Lithium EP grease	[Shaded bar from 14 to 104]									G2-LI
Cooling system	Supercoolant AF-NAC (Note.4)	[Shaded bar from -22 to 122]									AF-NAC
Fuel tank	Diesel fuel	[Shaded bar from -22 to 68]									ASTM Grade No.1-D S15 ASTM Grade No.1-D S500
		[Shaded bar from 10 to 86]									ASTM Grade No.2-D S15 ASTM Grade No.2-D S500

		Engine oil pan	Damper case	Power train case	Final drive case (each)	Hydraulic system (With blade, without ripper)	Cooling system (including sub-tank)	Fuel tank
Specified capacity	Liters	45	1.5	130	31	240	82	625
	US gal	11.89	0.40	34.35	8.19	63.41	21.66	165
Refill capacity	Liters	37	1.5	90	31	85	-	-
	US gal	9.78	0.40	23.78	8.19	22.46	-	-

NOTICE

Always use diesel oil for the fuel.

To ensure good fuel consumption characteristics and exhaust gas characteristics, the engine mounted on this machine uses an electronically controlled high-pressure fuel injection device. This device requires high precision parts and lubrication, so if low viscosity fuel with low lubricating ability is used, the durability may drop markedly.

Note 1: HTHS (High-Temperature High-Shear Viscosity 150°C), specified by ASTM D4741 must be equal to or higher than 3.5 mPa-S. Komatsu EOS0W30 and EOS5W40 are the most suitable oils.

Note 2: Powertrain oil has different properties from engine oil. Be sure to use the recommended oils.

Note 3: Hyper grease (G2-T, G2-TE) has a high performance.

When it is necessary to improve the lubricating ability of the grease in order to prevent squeaking of pins and bushings, the use of G2-T or G2-TE is recommended.

Note. 4: Supercoolant (AF-NAC)

1) Coolant has the important function of anticorrosion as well as antifreeze.

Even in the areas where freezing is not an issue, the use of antifreeze coolant is essential.

Komatsu machines are supplied with Komatsu Supercoolant AF-NAC. Komatsu Supercoolant AF-NAC has excellent anticorrosion, antifreeze and cooling properties and can be used continuously for 2 years or 4000 hours. Komatsu Supercoolant AF-NAC is strongly recommended wherever available.

2) For details of the ratio when diluting super coolant with water, see "CLEAN INSIDE OF COOLING SYSTEM (PAGE 4-20)".

Supercoolant AF-NAC may be supplied in premix . In this case, always top off with premix solution. (never dilute with water)

3) To maintain the anticorrosion properties of Supercoolant AF-NAC, always keep the density of Supercoolant between 30% and 68%.

RECOMMENDED BRANDS, RECOMMENDED QUALITY FOR PRODUCTS OTHER THAN KOMATSU GENUINE OIL

When using commercially available oils other than Komatsu genuine oil, consult your Komatsu distributor.

STANDARD TIGHTENING TORQUES FOR BOLTS AND NUTS

TORQUE LIST



If nuts, bolts, or other parts are not tightened to the specified torque, it will cause looseness or damage to the tightened parts, and this will cause failure of the machine or problems with operation.

Always pay careful attention when tightening parts.

Unless otherwise specified, tighten the metric nuts and bolts to the torque shown in the table below. If it is necessary to replace any nut or bolt, always use a Komatsu genuine part of the same size as the part that was replaced.

Thread diameter of bolt (a)(mm)	Width across flats (b)(mm)	Tightening torque					
		Target value			Service limit		
		Nm	kgm	lbft	Nm	kgm	lbft
6	10	13.2	1.35	9.8	11.8-14.7	1.2-1.5	8.7-10.8
8	13	31	3.2	23.1	27-34	2.8-3.5	20.3-25.3
10	17	66	6.7	48.5	59-74	6.0-7.5	43.4-54.2
12	19	113	11.5	83.2	98-123	10.0-12.5	72.3-90.4
14	22	177	18	130.2	157-196	16.0-20.0	115.7-144.7
16	24	279	28.5	206.1	245-309	25.0-31.5	180.8-227.8
18	27	382	39	282.1	343-425	35.0-43.5	253.2-314.6
20	30	549	56	405.0	490-608	50.0-62.0	361.7-448.4
22	32	745	76	549.7	662-829	67.5-84.5	488.2-611.2
24	36	927	94.5	683.5	824-1030	84.0-105.0	607.6-759.5
27	41	1320	135.0	976.5	1180-1470	120.0-150.0	868.0-1085.0
30	46	1720	175.0	1265.8	1520-1910	155.0-195.0	1121.1-1410.4
33	50	2210	225.0	1627.4	1960-2450	200.0-250.0	1446.6-1808.3
36	55	2750	280.0	2025.2	2450-3040	250.0-310.0	1808.3-2242.2
39	60	3280	335.0	2423.1	2890-3630	295.0-370.0	2133.7-2676.2

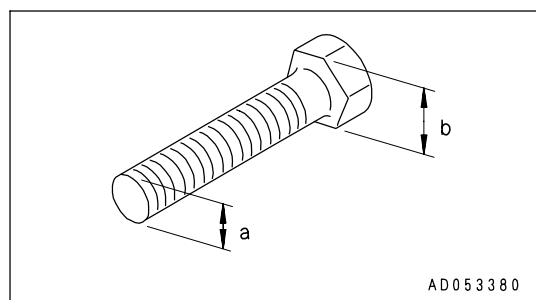

Apply the following table for Hydraulic Hose.

Thread diameter a (mm)	Width across flats b (mm)	Tightening torque					
		Target value			Permissible range		
		Nm	kgm	lbft	Nm	kgm	lbft
10	14	14.7	1.5	10.8	12.7 - 16.7	1.3 - 1.7	9.4 - 12.3
14	19	29.4	3.0	21.7	27.5 - 39.2	2.8 - 4.0	20.3 - 28.9
18	24	78.5	8.0	57.9	58.8 - 98.1	6.0 - 10.0	43.4 - 72.3
22	27	117.7	12.0	86.6	88.3 - 137.3	9.0 - 14.0	65.1 - 101.3
24	32	147.1	15.0	108.5	117.7 - 176.5	12.0 - 18.0	86.8 - 130.2
30	36	215.7	22.0	159.1	176.5 - 245.2	18.0 - 25.0	130.2 - 180.8
33	41	255.0	26.0	188.1	215.7 - 284.4	22.0 - 29.0	159.1 - 209.8

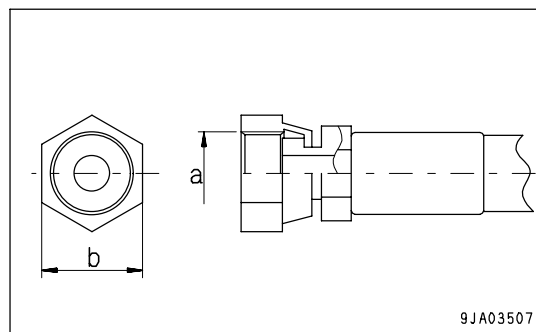

PERIODIC REPLACEMENT OF SAFETY CRITICAL PARTS

For using the machine safely for an extended period of time, you are required to periodically replace the safety (critical and fire prevention) related parts listed in the table of important parts on the following page.

Material quality of these parts can change as time passes and they are likely to wear out or deteriorate. However, it is difficult to determine the extent of wear or deterioration at the time of periodic maintenance. Hence, it is required to replace them with new ones regardless of their condition after a certain period of usage. This is important to ensure that these parts maintain their full performance at all times.

Furthermore, should anything abnormal be found on any of these parts, replace it with a new one even if the periodic replacement time for the part has not yet arrived.

If any of the hose clamps show deterioration like deformation or cracking, replace the clamps at the same time as the hoses.

Also perform the following checks with hydraulic hoses which need to be replaced periodically. Tighten all loose clamps and replace defective hoses, as required.

When replacing hoses, always replace O-rings, gaskets, and other such parts at the same time.

Have your Komatsu distributor replace the critical parts.

SAFETY CRITICAL PARTS

Replace wear parts such as the filter element or air cleaner element at the time of periodic maintenance or before they reach the wear limit. The wear parts should be replaced correctly in order to ensure more economic use of the machine. When replacing parts, always use Komatsu genuine parts.

As a result of our continuous efforts to improve product quality, the part number may change, so inform your Komatsu distributor of the machine serial number and check for the latest part number when ordering parts.

NO.	Safety critical parts for periodic replacement	Q'ty	Replacement interval
1	Fuel hose (fuel strainer - engine entrance)	1	Every 2 years or 4000 hours, whichever comes sooner
2	Fuel hose (engine return spout- fuel tank)	1	
3	Fuel hose (engine supil spout - fuel tank)	1	
4	Fuel hose (fuel tank - fuel strainer)	2	
5	Fuel hose (fuel tank - water drain valve)	1	
6	Hose between torque converter oil cooler and power train assembly	2	
7	Hose between power train pump and power train filter	1	
8	Hose between power train filter and power train assembly	1	
9	Hose between transmission case and steering case	1	
10	Power train pressure detection hose assembly	5	
11	Hose between end face of right pivot shaft and straight frame relay tube	2	
12	Hose between straight frame relay tube and blade tilt cylinder	2	
13	Hose between HSS motor and main control valve	2	
14	Hose between HSS pump and drain relay block	1	
15	Hose between HSS motor and drain relay block	1	
16	Hose between drain relay block (power train) and hydraulic tank	1	
17	Hose between fan pump and drain relay block	1	
18	Hose between fan pump and self pressure reducing valve	2	
19	Hose between self pressure reducing valve and fan motor	3	
20	Hose between accumulator and work equipment lock valve	2	

NO.	Safety critical parts for periodic replacement	Q'ty	Replacement interval	
21	Hose between the oil cooler bypass valve and hydraulic oil cooler	1	Every 2 years or 4000 hours, whichever comes sooner	
22	Hose between self pressure reducing valve and drain relay block	1		
23	Hose between fan motor and hydraulic tank	4		
24	Hose between self pressure reducing valve and work equipment lock valve block	1		
25	Hose between work equipment lock valve block and main control valve	2		
26	Hose between main control valve and hydraulic tank	2		
27	Hose between HSS pump and main control valve	2		
28	Hose between HSS pump and accumulator	1		
29	Hose between HSS pump and HSS pump	1		
30	Hose between main control valve and ripper relay block (fixed multi-shank ripper)	2		
31	Hose between main control valve and ripper relay block (variable multi-shank ripper)	4		
32	Hose between ripper relay block and ripper cylinder (fixed multi-shank ripper)	2		
33	Hose between ripper relay block and ripper cylinder (variable multi-shank ripper)	4		
34	Hose between main control valve and blade tilt relay cover	4		
35	Hose between main control valve and blade relay tube	2		
36	Hose between quick drop valve and hydraulic tank	1		
37	Hose between work equipment lock valve and quick drop valve	1		
38	Hose between radiator guard top and lift cylinder	4		
39	Seat belt	1		Every 3 years
40	High-pressure piping clamps	1S		Every 8000 hours
41	Fuel spray prevention cap	1S		

MAINTENANCE SCHEDULE CHART

MAINTENANCE SCHEDULE CHART

INITIAL 250 HOURS SERVICE (ONLY AFTER THE FIRST 250 HOURS)

REPLACE POWER TRAIN OIL FILTER ELEMENT	4- 63
CHANGE OIL IN POWER TRAIN CASE, WASH STRAINERS (POWER TRAIN PUMP STRAINER, SCAVENGING PUMP STRAINER)	4- 67
CHANGE OIL IN FINAL DRIVE CASE	4- 69
CHANGE OIL IN HYDRAULIC TANK, REPLACE HYDRAULIC OIL FILTER ELEMENT	4- 79

WHEN REQUIRED

CLEAN INSIDE OF COOLING SYSTEM	4- 20
CHECK, CLEAN AND REPLACE AIR CLEANER ELEMENT	4- 22
CHECK AND ADJUST TRACK TENSION	4- 27
CHECK AND TIGHTEN TRACK SHOE BOLTS	4- 30
ADJUST IDLER CLEARANCE	4- 31
REVERSE AND REPLACE THE END BITS AND CUTTING EDGES	4- 32
CLEAN AND CHECK RADIATOR FINS, OIL COOLER FINS, AFTERCOOLER FINS	4- 35
CLEAN, CHECK AIR CONDITIONER CONDENSER FINS	4- 38
CLEAN FUEL TANK STRAINER	4- 38
CLEAN STEERING CLUTCH CASE BREATHER	4- 39
CLEAN HYDRAULIC TANK BREATHER AND FUEL TANK BREATHER	4- 39
REPLACE AIR CONDITIONER BELT	4- 40
CHECK UNDERCARRIAGE OIL	4- 41
CLEAN AIR CONDITIONER AIR FILTER (FRESH/RECIRC FILTER)	4- 42
CHECK AND ADJUST AIR CONDITIONER	4- 43
LUBRICATE DOOR HINGE	4- 44
CHECK DOOR LATCH	4- 44
CHECK DOOR LOCK STRIKER	4- 44
REPLACE DOOR DAMPER	4- 45
CHECK WINDOW WASHER FLUID LEVEL, ADD FLUID	4- 45
REPLACE WIPER BLADE	4- 46
PROCEDURE FOR RELEASING INTERNAL PRESSURE OF HYDRAULIC CIRCUIT	4- 47
LUBRICATING	4- 48
CHECK ELECTRICAL INTAKE AIR HEATER	4- 49

CHECK BEFORE STARTING

EVERY 250 HOURS SERVICE

LUBRICATING	4- 51
CHECK OIL LEVEL IN FINAL DRIVE CASE, ADD OIL	4- 54
CHECK OIL LEVEL IN DAMPER CASE, ADD OIL	4- 54
CHECK LEVEL OF BATTERY ELECTROLYTE	4- 55
CHECK ALTERNATOR DRIVE BELT TENSION, ADJUST	4- 58
CHECK BRAKE PERFORMANCE	4- 59

EVERY 500 HOURS SERVICE

REPLACE FUEL PRE-FILTER CARTRIDGE ----- 4- 60
 CHECK FOR LOOSE ROPSCAB MOUNT BOLTS ----- 4- 62
 REPLACE POWER TRAIN OIL FILTER ELEMENT ----- 4- 63
 CHANGE OIL IN ENGINE OIL PAN, REPLACE ENGINE OIL FILTER CARTRIDGE ----- 4- 64

EVERY 1000 HOURS SERVICE

CHANGE OIL IN POWER TRAIN CASE, WASH STRAINERS (POWER TRAIN PUMP STRAINER,
 SCAVENGING PUMP STRAINER) ----- 4- 67
 CHANGE OIL IN FINAL DRIVE CASE ----- 4- 69
 LUBRICATE UNIVERSAL JOINT ----- 4- 70
 CHECK ALL TIGHTENING POINTS OF ENGIN EXHAUST PIPE CLAMPS ----- 4- 70
 REPLACE POWER TRAIN CASE BREATHER ELEMENT ----- 4- 71
 REPLACE ELEMENTS OF HYDRAULIC TANK BREATHER AND FUEL TANK BREATHER ----- 4- 71
 REPLACE PILOT FILTER ELEMENT ----- 4- 72
 CHECK, CLEAN FUEL STRAINER ----- 4- 74
 REPLACE CORROSION RESISTOR CARTRIDGE ----- 4- 75
 REPLACE FUEL MAIN FILTER CARTRIDGE ----- 4- 76

EVERY 2000 HOURS SERVICE

CHANGE OIL IN HYDRAULIC TANK, REPLACE HYDRAULIC OIL FILTER ELEMENT ----- 4- 79
 CLEAN ENGINE BREATHER ELEMENT ----- 4- 81
 CHECK ALTERNATOR, STARTING MOTOR ----- 4- 81
 CHANGE OIL IN DAMPER CASE, CLEAN DAMPER BREATHER ----- 4- 82
 CHECK PIVOT BEARING OIL LEVEL, ADD OIL ----- 4- 83
 CHECKING CHARGE PRESSURE OF NITROGEN GAS IN ACCUMULATOR (FOR CONTROL
 CIRCUIT) ----- 4- 84

EVERY 4000 HOURS SERVICE

REPLACE ACCUMULATOR (FOR CONTROL CIRCUIT) ----- 4- 88
 CHECK PLAY OF TURBOCHARGER ROTOR ----- 4- 88
 CHECK ENGINE VALVE CLEARANCE, ADJUST ----- 4- 88
 CHECK WATER PUMP ----- 4- 89
 CHECK VIBRATION DAMPER ----- 4- 89
 CHECKING FOR LOOSENESS OF HIGH-PRESSURE CLAMP, HARDENING OF RUBBER ----- 4- 90
 CHECKING FOR MISSING FUEL SPRAY PREVENTION CAP, HARDENING OF RUBBER ----- 4- 91

EVERY 8000 HOURS SERVICE

REPLACE HIGH-PRESSURE PIPING CLAMP ----- 4- 92
 REPLACE FUEL SPLAY PREVENTION CAP ----- 4- 92

SERVICE PROCEDURE

INITIAL 250 HOURS SERVICE (ONLY AFTER THE FIRST 250 HOURS)

Perform the following maintenance only after the first 250 hours.

- Replace power train oil filter element
- Change oil in power train case, wash strainers (power train pump strainer, scavenging pump strainer)
- Change oil in final drive case
- CHANGE OIL IN HYDRAULIC TANK, REPLACE HYDRAULIC OIL FILTER ELEMENT

For details of the method of replacing or maintaining, see EVERY 500 HOURS, EVERY 1000 HOURS and EVERY 2000 HOURS SERVICE.

WHEN REQUIRED

CLEAN INSIDE OF COOLING SYSTEM



- Immediately after the engine is stopped, the coolant is at a high temperature and the radiator is under high internal pressure. If the cap is removed to drain the coolant in this condition, there is a hazard of burns. Wait for the temperature to go down, then turn the cap slowly to release the pressure before removing it.
- Cleaning is carried out with the engine running. When standing up or leaving the operator's seat, set the work equipment lock lever and the parking lever to the LOCK position.
- For details of starting the engine, see "CHECK BEFORE STARTING ENGINE, ADJUST (PAGE 3-98)" and "STARTING ENGINE (PAGE 3-122)" in the OPERATION section.
- Never walk in front of the machine when the engine is running. There is danger of touching the fan.
- It is extremely dangerous to go under the machine to clean it when the engine is running. There is danger that the machine may suddenly move. Never go under the machine when the engine is running.

Stop the machine on level ground when cleaning or changing the coolant.

Clean the inside of the cooling system, change the coolant according to the table below.

Antifreeze coolant	Interval for cleaning inside of cooling system and changing antifreeze coolant	Precautions for use
Komatsu supercoolant (AF-NAC)	Every two years or every 4000 hours whichever comes first	1*

*1: When using Komatsu Supercoolant (AF-NAC), there is no need to use a corrosion resistor.

When no corrosion resistor is used, use the special cover (600-411-9000). Please consult your Komatsu distributor about the method of installing.

When using corrosion resistor, use Komatsu genuine corrosion resistor. If you use another corrosion resistor, it may cause serious problems such as corrosion of the engine and parts of the cooling system that use light metals such as aluminum.

The coolant has the important function of preventing corrosion as well as preventing freezing.

Even in the areas where freezing is not an issue, the use of antifreeze coolant is essential.

Komatsu machines are supplied with Komatsu Supercoolant (AF-NAC). Komatsu Supercoolant (AF-NAC) has excellent anticorrosion, antifreeze and cooling properties and can be used continuously for 2 years or 4000 hours. As a basic rule, we do not recommend the use of any coolant other than Komatsu genuine supercoolant (AF-NAC). If you use another coolant, it may cause serious problems such as corrosion of the engine and parts of the cooling system that use light metals such as aluminum.

To maintain the anticorrosion properties of Supercoolant (AF-NAC), always keep the density of Supercoolant between 30% and 68%.

When deciding the ratio of antifreeze to water, check the lowest temperature in the past, and decide from the mixing table given below.

It is actually better to estimate and temperature about 10°C (18°F) lower when deciding the mixing ratio.

The mixing ratio depends on the ambient temperature, but it should always be a minimum of 30% by volume (antifreeze/total amount of coolant x 100).

Even in areas where it is not necessary to prevent freezing, use Supercoolant (AF-NAC) at a mixing ratio of at least 30% to prevent corrosion of the cooling system.

The freezing temperature of undiluted antifreeze is -15°C (5°F). Do not store undiluted antifreeze at a temperature of below -15°C (5°F).

Mixing rate of water and antifreeze

Min. atmospheric temperature	°C	Above-10	-15	-20	-25	-30	-35	-40
	°F	Above 14	5	-4	-13	-22	-31	-40
Amount of antifreeze	liter	32.1	38.5	42.8	49.2	53.5	57.8	62.1
	US gal	8.48	10.17	11.31	13.00	14.13	15.27	16.41
Amount of water	liter	74.9	68.5	64.2	57.8	53.5	49.2	44.9
	US gal	19.79	18.10	16.96	15.27	14.13	13.00	11.86

WARNING

Super coolant is flammable, so be particularly careful to keep it away from flame.

Super coolant is toxic. When removing the drain plug, be careful not to get coolant on yourself.

If it gets into your eyes, wash your eyes immediately with ample water, then consult a doctor for treatment.

NOTICE

Please use Komatsu genuine supercoolant (AF-NAC) for the coolant. As a basic rule, we do not recommend the use of any coolant other than Komatsu genuine supercoolant.

Always use city water to dilute the coolant. If river water or well water or a simple water supply must be used, please consult your Komatsu distributor.

We recommend the use of a super coolant density meter to control the mixing ratio.

1. Turn cap (3) of the radiator water filler slowly.
2. Set a container to catch the coolant under drain valve (4) at the bottom of the radiator.
3. Open drain valve (4) and drain the water.
4. After draining the coolant, close drain valve (4), and fill with city water. When the radiator is full, start the engine and run at low idling to raise the temperature to at least 90°C (194°F), then continue to run for approx. 10 minutes.
5. Stop the engine, open drain valve (4), and drain the water.
6. After draining the water, clean the radiator with detergent.
When carrying out the flushing operation, follow the instructions given with the flushing agent.
7. Close drain valve (4) and add water to near the mouth of the water filler.
8. To bleed the air mixed in the coolant, run the engine at low idling for 5 minutes, then run for a further 5 minutes at high idling.
(When doing this, leave the water filler cap off.)
9. Drain the coolant inside sub-tank (5), flush the inside of sub-tank (5), then add water to between the FULL and LOW marks.
10. Stop the engine, wait for approx. 3 minutes, then add water to near the mouth of the water filler and tighten cap (3).

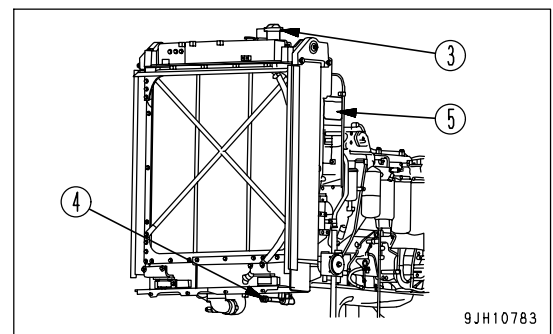

9JH10783

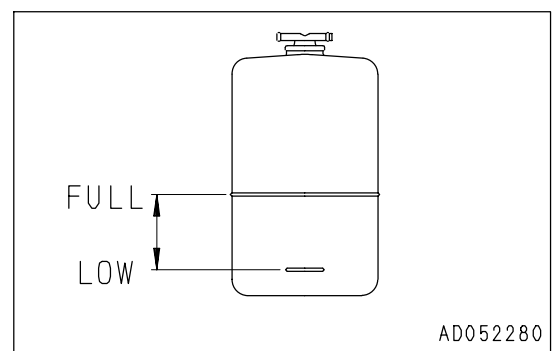

AD052280

CHECK, CLEAN AND REPLACE AIR CLEANER ELEMENT**WARNING**

- Always wear protective glasses, dust mask, or other protective equipment.
- When removing the air cleaner element from the air cleaner body, it is dangerous to pull it out by force.
When working at high places or where the foothold is poor, be careful not to fall because of the reaction when pulling out the outer element.

CHECKING

When the yellow piston inside red zone (A) of the dust indicator (1) overlaps the red zone, clean the air cleaner element. After cleaning, press the reset button.

NOTICE

Always wait for the yellow piston in the dust indicator to overlap the red zone on the outside before cleaning the element.

If the element is cleaned frequently before the yellow piston in the dust indicator overlaps the red zone on the outside, the air cleaner will be unable to display its normal performance and the cleaning effect will become poor.

In addition, the frequency of dust stuck to the element falling inside the inner element during the cleaning operation will increase.

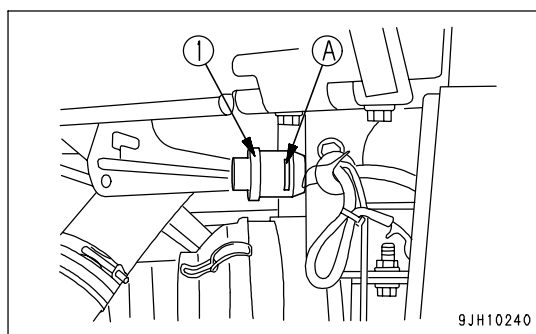

9JH10240

CLEANING OR REPLACING OUTER ELEMENT

NOTICE

Before and after cleaning the element, do not leave or keep it in direct sunlight.

1. Remove 6 holders (2), then remove cover (3) and take out outer element (4).

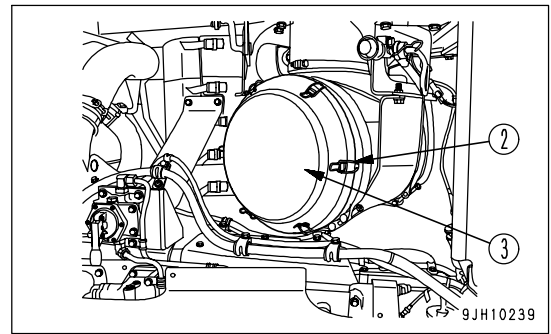

NOTICE

- Never remove the inner element (5). It will allow dirt to enter and cause failure of the engine.
- Do not use a screwdriver or other tool.

2. Hold the outer element (4), move it carefully up and down and to the left and right, and rotate the element to the left and right while pulling it out.
3. After removing the outer element, cover the air connector inside the air cleaner body with a clean cloth or tape to prevent dirt or dust from entering.
4. Use a brush or cloth to remove all the dirt stuck to cover (3) and the inside of air cleaner body (6).

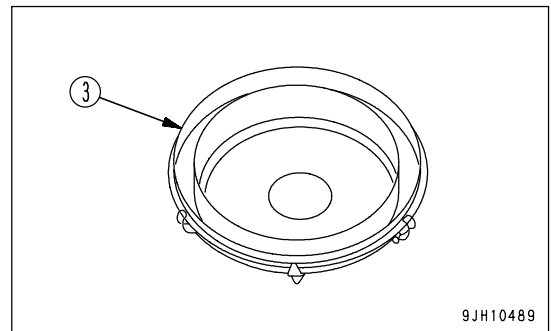
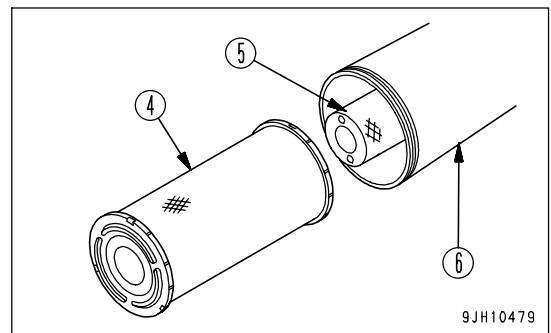

5. Direct dry compressed air (Max. 0.69 MPa (7 kg/cm², 99.4 PSI)) from the inside of the outer element along its folds. Then direct the compressed air from the outside along the folds, and again from the inside.

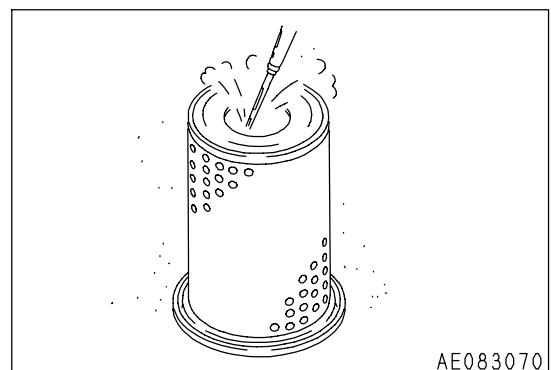

NOTICE

If small holes or thinner parts are found on the element when it is checked with an electric bulb after cleaning and drying, replace the element. When cleaning the element, do not hit it or beat it against something. Do not use an element whose folds or gasket or seal are damaged.

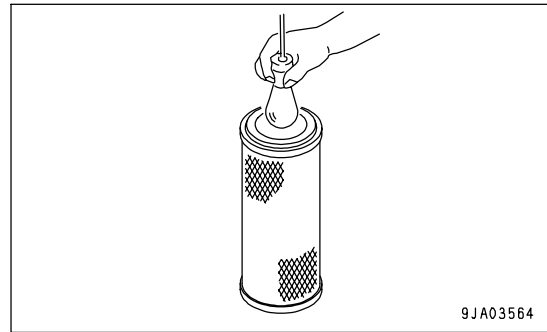

6. Remove the cloth or tape cover installed in Step 3.
7. Check that there is no dirt or oil stuck to the seal portion of the new element or cleaned element. Wipe off any dirt or oil.

NOTICE

- The inner element must not be cleaned and used again. When replacing the outer element, replace the inner element at the same time.
- If the inner element is not installed properly and the outer element and cover are installed, there is danger that the outer element will be damaged.
- The seal portion on imitation parts lacks precision, and allows the entry of dust, which leads to damage of the engine. Do not use such imitation parts.

8. Push the outer element in straight with your hand when installing it to the air cleaner body. If the outer element is held and rocked lightly up and down and to the left and right while pushing it in, the outer element can be inserted easily.

1) Check that the inner element is not loose. If it is loose, insert it securely.

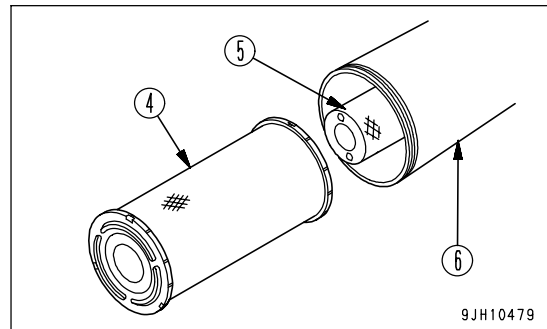

2) If the yellow piston in dust indicator (1) overlaps the red zone (A) on the outer diameter immediately after the outer element is cleaned, replace both the inner and outer elements.

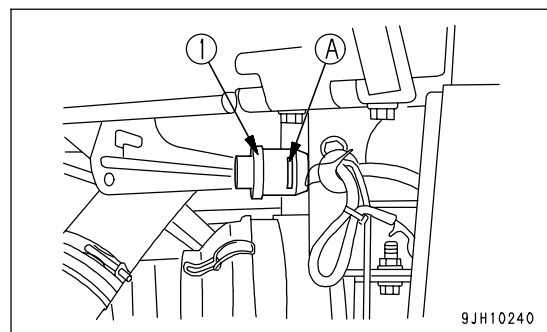

NOTICE

When inserting the element, if the rubber at the tip is swollen or the outer element is not pushed in straight, and cover (3) is assembled by force to hook (2), there is danger that the hook and air cleaner body may be damaged, so be careful when assembling.

9. Install cover (3) as follows.

- 1) Align cover (3) with the element.
- 2) Hook the tip of hook (2) to the protruding part of the air cleaner body and lock it in position.
- 3) When locking hooks (2) in position, apply the hooks in turn on opposite sides (top, bottom, left, right) in the same way as when tightening bolts.
- 4) When cover (3) is installed, check that the clearance between the air cleaner body and cover (3) is not too large. If it is too large, install again.

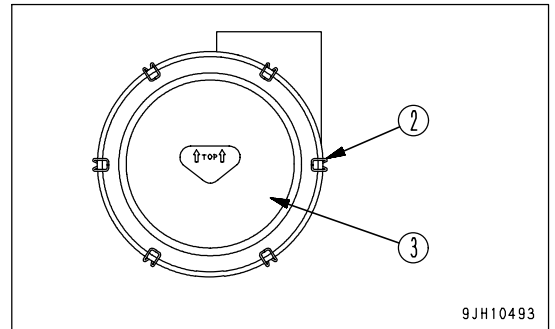
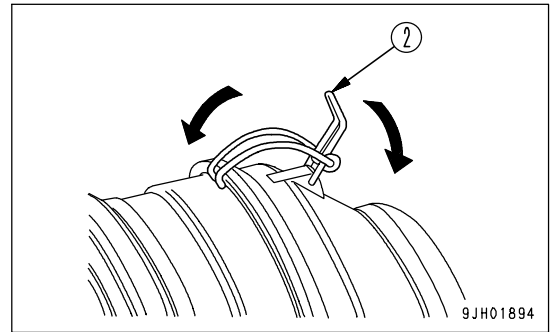

REPLACING ELEMENT

1. Open cover on the right side of the machine.
2. Remove 6 holders (2), then remove cover(3).

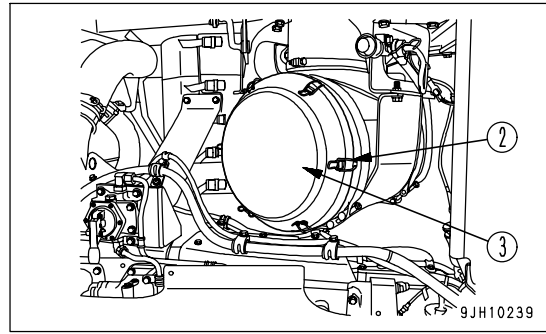

3. Hold the outer element (4), move it carefully up and down and to the left and right, and rotate the element to the left and right while pulling it out.

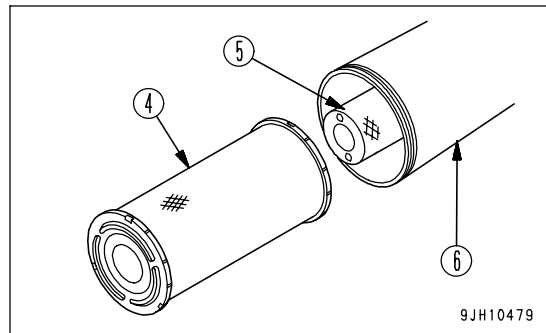

4. Use a brush or cloth to remove all the dirt stuck to cover (3) and the inside of air cleaner body (6).

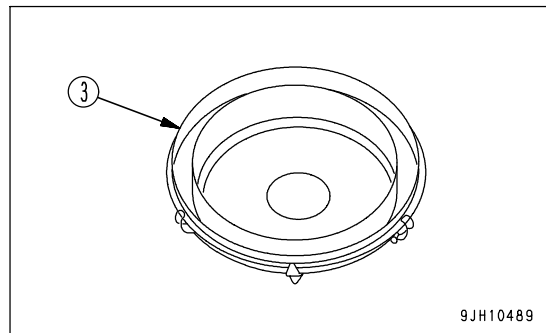

NOTICE

- The inner element must not be cleaned and used again. When replacing the outer element, replace the inner element at the same time.
- If the inner element is not installed properly and the outer element and cover are installed, there is danger that the outer element will be damaged.
- The seal portion on imitation parts lacks precision, and allows the entry of dust, which leads to damage of the engine. Do not use such imitation parts.

5. Remove inner element (5), then quickly install the new inner element.
Push the inner element in properly and check that it is fitted securely.
6. Push new outer element (4) straight into the air cleaner body with your hand.
If you hold the element and move it carefully up and down and to the left and right, it is easier to insert the element.
7. Replace O-ring (7) for cover (3) with new one.

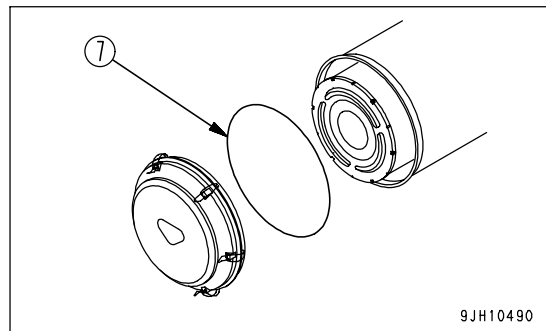

NOTICE

When inserting the element, if the rubber at the tip is swollen or the outer element is not pushed in straight, and cover (3) is assembled by force to hook (2), there is danger that the hook and air cleaner body may be damaged, so be careful when assembling.

8. Install cover (3) as follows.

- 1) Align cover (3) with the element.
- 2) Hook the tip of hook (2) to the protruding part of the air cleaner body and lock it in position.
- 3) When locking hooks (2) in position, apply the hooks in turn on opposite sides (top, bottom, left, right) in the same way as when tightening bolts.
- 4) When cover (3) is installed, check that the clearance between the air cleaner body and cover (3) is not too large. If it is too large, install again.

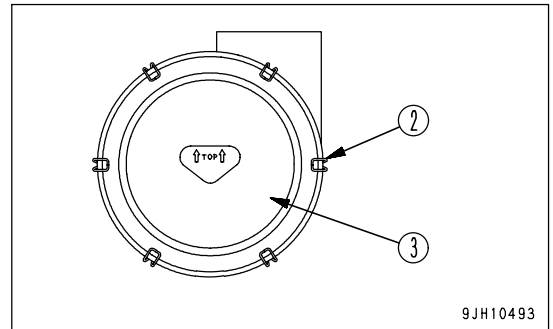
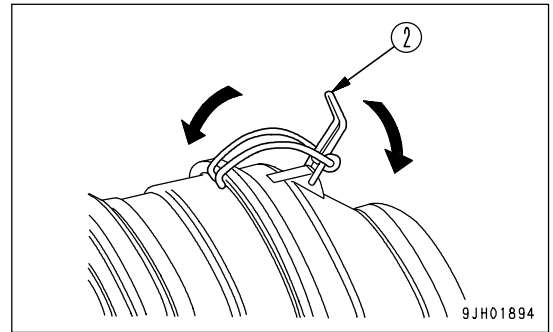

9. After replacing the element, push the dust indicator button to reset it. The yellow piston will return to its original position.

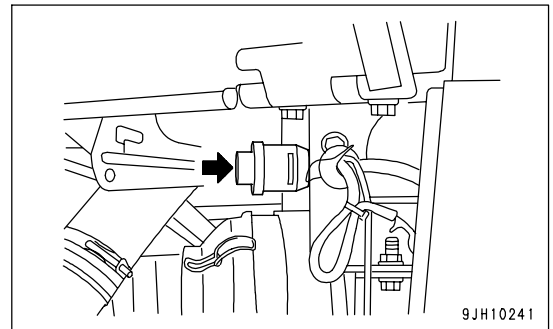

CHECK AND ADJUST TRACK TENSION

The wear of pins and bushings on the undercarriage will vary with the working conditions and types of soil. It is thus necessary to continually inspect the track tension so as to maintain the standard tension.

Carry out the check and adjustment under the same conditions as when operating (on jobsites where the track becomes clogged with mud, measure with the track clogged with mud).

INSPECTION

Stop the machine on level ground (stop with the transmission in FORWARD without applying the brake). Then place a straight bar on the track shoes between the carrier roller and the idler as shown in the figure, and measure the clearance between the bar and the grouser at the midpoint. If the clearance (A) is 20 to 30 mm (0.79 to 1.18 in), the tension is standard.

If the track tension is not at the standard value, adjust it in the following manner.

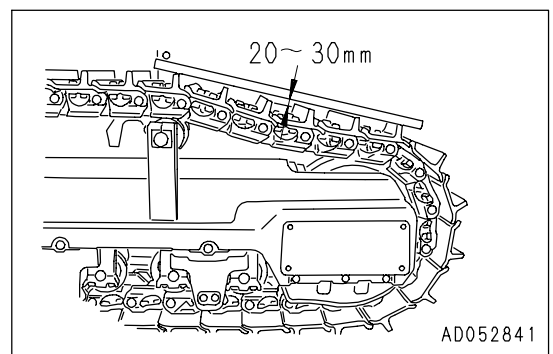

ADJUSTMENT

**WARNING**

There is danger of plug (1) flying out under the high internal pressure of the grease. Never loosen plug (1) more than 1 turn.

Never loosen any part other than plug (1). Never put your face in the mounting direction of plug (1).

If the track tension cannot be loosened with the procedure given here, please contact your Komatsu distributor.

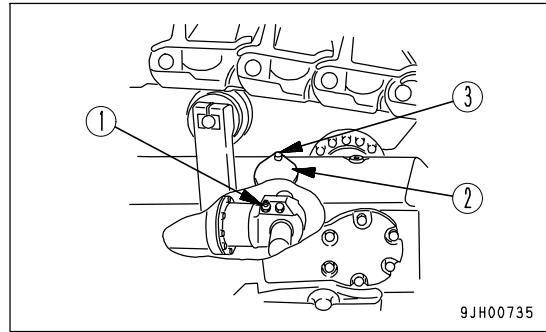

WHEN INCREASING TENSION

1. Remove 2 bolts (3), then remove cover (2).

NOTICE

- The safety label is stuck on the back of cover (2), so be careful not to damage the safety label.
- When removing cover (2), be careful not to let any dirt or soil get in.

2. Pump in grease through the grease fitting with a grease pump.
3. To check that the correct tension has been achieved, move the machine backwards and forwards.
4. Check the track tension again, and if the tension is not correct, adjust it again.
5. Continue to pump in grease until S becomes 0 mm. If the tension is still loose, the pins and bushings are excessively worn, so they must be either turned or replaced. Please contact your Komatsu distributor.

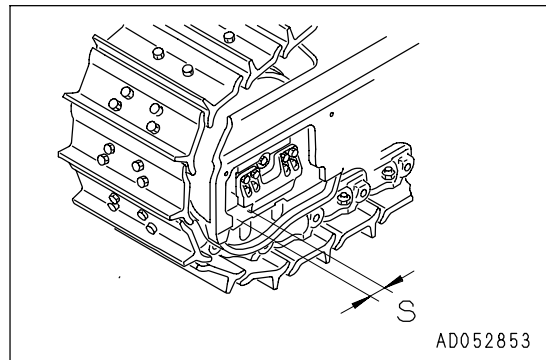

WHEN LOOSENING TENSION

 **WARNING**

It is extremely dangerous to release the grease by any method except the procedure given below. If the track tension is not relieved by this procedure, please contact your Komatsu distributor.

1. Remove 2 bolts (3), then remove cover (2).

NOTICE

- The safety label is stuck on the back of cover (2), so be careful not to damage the safety label.
- When removing cover (2), be careful not to let any dirt or soil get in.

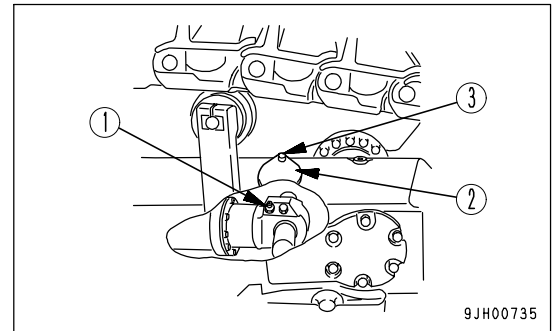

2. Loosen lubricator (1) gradually to release the grease.
3. Turn lubricator(1) a maximum of one turn.
4. If the grease does not come out smoothly, move the machine forwards and backwards a short distance.
5. Tighten lubricator(1).
6. To check that the correct tension has been achieved, move the machine backwards and forwards.
7. Check the track tension again, and if the tension is not correct, adjust it again.

WHEN REMOVING TRACK

**WARNING**

The situation can be extremely dangerous when removing the track.

When following the adjustment procedure above in "WHEN LOOSENING TENSION (PAGE 4-29)", if the track does not become loose, contact your Komatsu distributor for repairs.

CHECK AND TIGHTEN TRACK SHOE BOLTS

Track shoes may be broken, if they are used with loosened shoe bolts (1). Hence whenever a loosened bolt is found, be sure to retighten it.

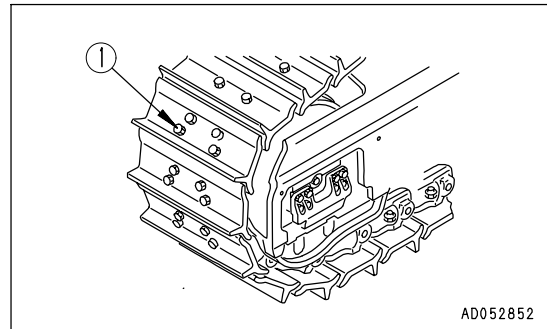

AD052852

METHOD OF TIGHTENING SHOE BOLT

1. First, tighten to a tightening torque of 590 ± 60 Nm (60 ± 6 kgm , 434.0 ± 43.4 lbft), then check that the nut and shoe are in tight contact with the link mounting face.
2. After checking, tighten a further. $120^\circ \pm 10^\circ$.

METHOD OF TIGHTENING MASTER LINK CONNECTING BOLT

1. First, tighten to a tightening torque of 590 ± 60 Nm (60 ± 6 kgm , 434.0 ± 43.4 lbft), then check that the link mounting face is in tight contact.
2. After checking, tighten a further $180^\circ \pm 10^\circ$.

ORDER FOR TIGHTENING

Tighten the bolts in the order shown in the diagram on the right.

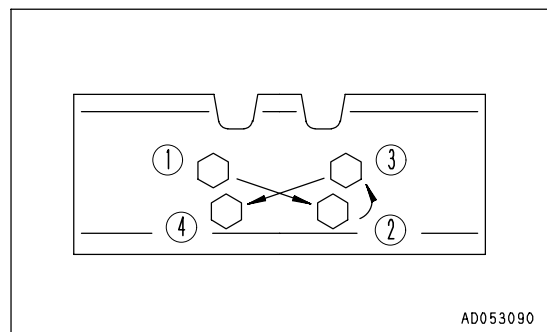

AD053090

ADJUST IDLER CLEARANCE

The idler moves to the front and rear under external force. When this happens, guide plate (2) becomes worn. If guide plate (2) becomes worn, the idler will slip to the side or tilt at an angle. This will lead to the track shoe slipping or cause uneven wear, so adjust as follows.

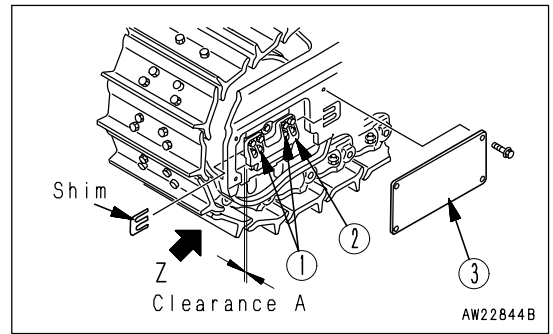

ADJUSTMENT

1. Travel on flat ground for 1 to 2 m (39.4 to 78.8 in), then remove cover (3) (both in and out of) on the side face of the idler.
2. Measure clearance A (4 places: left, right, inside, outside) between the track frame and guide plate.
3. If clearance A is more than 3 mm (0.118 in), loosen bolt (1), and remove the shim to adjust the clearance to a maximum of 0.5 to 1 mm (0.020 to 0.039 in) on each side.

REMARK

The thickness of 1 shim is 1.0 mm (0.039 in).

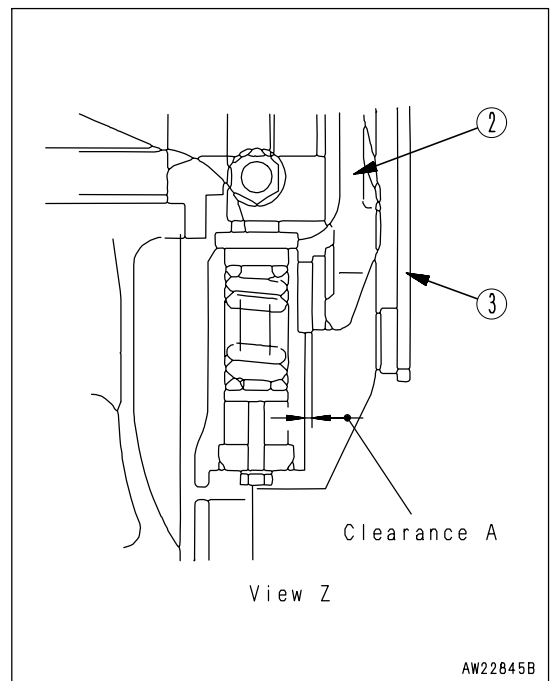

REVERSE AND REPLACE THE END BITS AND CUTTING EDGES



WARNING

It is dangerous if the work equipment moves by mistake when the cutting edges and end bits are being reversed or replaced. Set the work equipment in a stable condition, then stop the engine and lock the blade control lever securely with the work equipment lock lever.

Reverse or replace the end bits and cutting edges before it is worn out to the blade end.

1. Raise the blade to a proper height, position a block under the frame to prevent the blade from falling.
2. Operate the work equipment lock lever to the LOCK position.
3. Measure the wear of the end bit and cutting edge in accordance with the wear standards given below.

Wear standards

(Sigmadozer)

[Unit: mm (in)]

Item		Judgement standard	
No.	Measurement position	Standard dimension	Permissible limit
1	Height of outside of end bit	300 (11.8")	235 (9.25")
2	Width of end bit	640 (25.2")	560 (22.0")
3	Height of inside of end bit	330 (12.9")	235 (9.25")
4	Height of cutting edge	165 (6.5")	105 (4.1")
5	(from center of bolt mounting hole to end face)		115 (4.5")

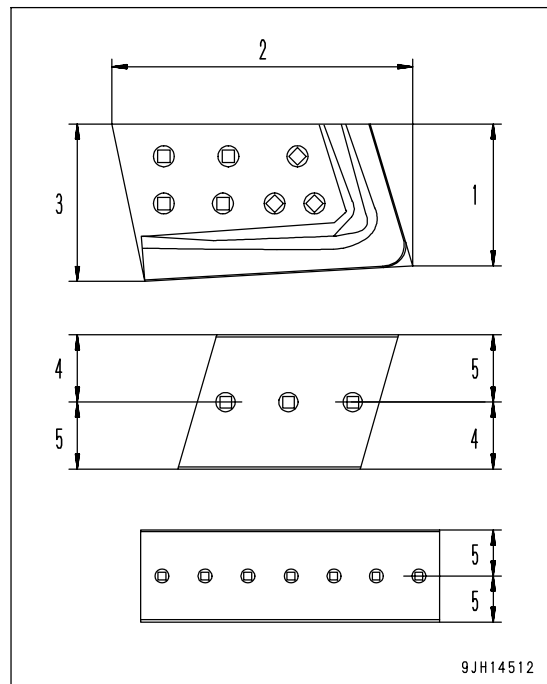

9JH14512

REMARK

The tip (a) of mount plate (b) may wear away when the end bit and cutting edges are replaced and reversed. This wearing shape does not effect the blade life.

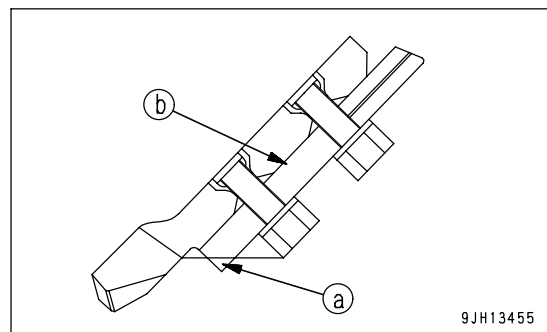

9JH13455

(Semi U-dozer, U-dozer, Angledozer)

The symbols used in the work equipment column are as follows.

A: Semi U-dozer

B: U-dozer, Angledozer

[Unit: mm (in)]

Item			Judgement standard	
No.	Measurement position	Work equipment	Standard dimension	Permissible limit
1	Height of outside of end bit	A	315 (12.4")	235 (9.25")
		B		
2	Width of end bit	A	540 (21.3")	440 (17.3")
		B	492 (19.4")	392 (15.4")
3	Height of inside of end bit	A	254 (10.0")	215 (8.5")
		B		
4	Height of cutting edge (from center of bolt mounting hole to end face)	A	127 (5.0")	102 (4.0")
		B		

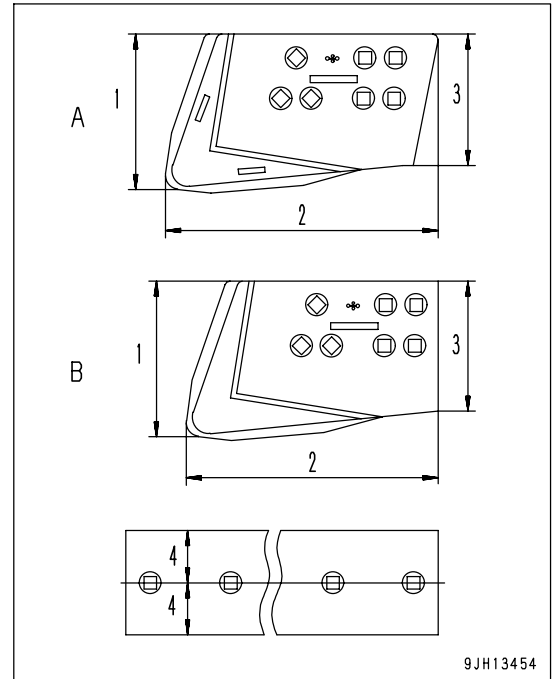

REMARK

- If the cutting edge and the end bit on both sides are worn out, replace with new ones.
 - When wear has developed to the mounting face of mount plate (1), repair the mounting surface and then replace with new cutting edges.
4. Remove the cutting edge and the end bit and clean the mounting surface.
 5. Reverse or replace the cutting edge and the end bit when worn out.

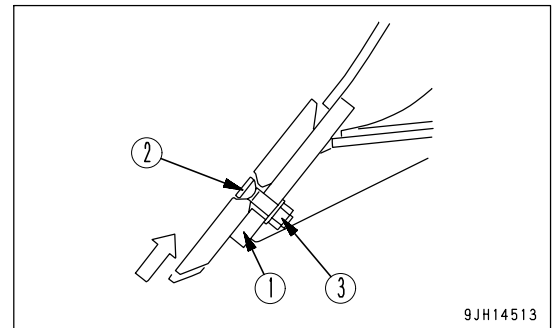

Tightening torque for mounting nut

Sigmdozer: 1330 to 1660 Nm (136 to 169 kgm , 983.7 to 1222.4 lbft)

Angledozer: 738 to 999 Nm (75.3 to 101.9 kgm , 544.6 to 737 lbft)

Semi U-dozer, U-dozer: 735.5 to 1000 Nm (75 to 102 kgm , 542.5 to 737.8 lbft)

If bolt (2) and nut (3) are damaged, replace them with new ones at the same time.

Loosen nut (3) remove bolt (2), then replace or turn.

- 1) Install the cutting edge on the blade and tighten the bolt temporarily. Press the blade against the ground to eliminate the play of bolt (2), then tighten the bolt to the specified torque.

- 2) When installing end bit (4), put top face (5) of the end bit in tight contact with stopper (6), then tighten the bolt.
6. After several hours of running, retourque the nuts.

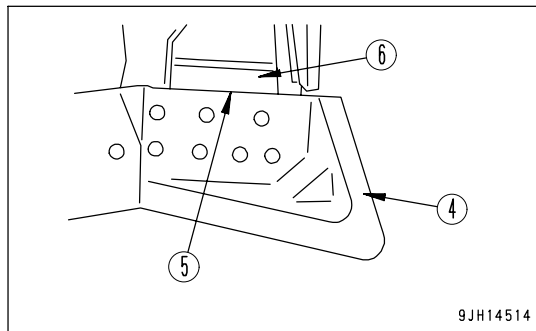

CLEAN AND CHECK RADIATOR FINS, OIL COOLER FINS, AFTERCOOLER FINS

Carry out this procedure if there is any mud or dirt stuck to the radiator or oil cooler.

REMARK

Check the hydraulic cooler hoses. If any hose is cracked or hardened by age, replace with a new hose. Also check and tighten all loose hose clamps.

CLEANING BY ROTATING COOLING FAN IN REVERSE DIRECTION

NOTICE

When rotating the cooling fan in the reverse direction, be extremely careful of flying dust.

When stopping the engine when the cooling fan is rotating in the reverse direction, first run the engine at low idling, then stop it.

The dust and dirt stuck to the radiator and cooler can be blown out by rotating the cooling fan in the reverse direction.

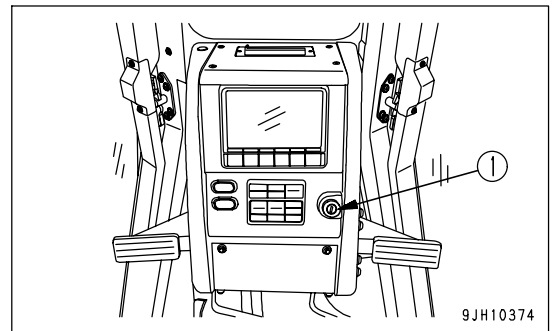

1. Turn starting switch (1) to the "OFF" position and stop the engine.
2. Turn starting switch (1) to the "ON" position.
3. Set the fan reverse mode on the user menu.

For details of the method of setting the fan reverse mode, see "HYDRAULIC DRIVE FAN REVERSE MODE (PAGE 3-50)".

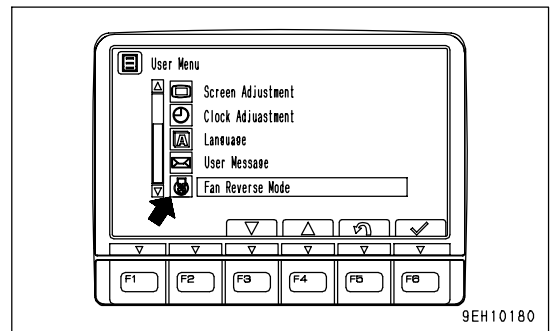

REMARK

When the engine is running, even if the fan rotation selector switch is operated, the direction of rotation of the fan will not change.

The screenshot on the right is displayed to inform the operator that the direction of rotation of the fan has not changed.

Stop the engine once and follow the steps 2 and 3 above.

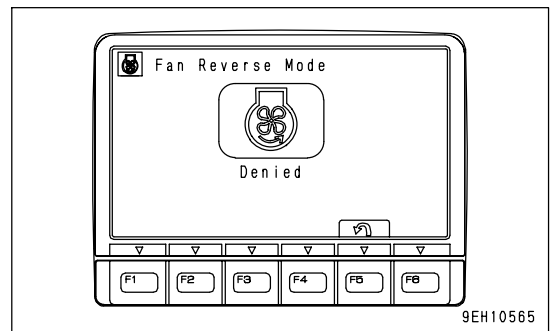

4. Turn starting switch (1) to the START position and start the engine. The cooling fan will rotate in the reverse direction.
5. Run the engine at high idle.
 - Select the time for running the engine at high idle as follows according to the condition of clogging.
 - Normal clogging: 1 to 2 minutes
 - Excessive clogging: 2 to 3 minutes
6. After completing the cleaning, run the engine at low idle for approx. 10 seconds.

7. Turn starting switch (1) to the "OFF" position and stop the engine.
8. Turn starting switch (1) to the "ON" position.
9. Cancel the fan reverse mode on the user menu.

REMARK

If dirt is caught in the radiator fins, blow with compressed air to clean.

CLEANING WITH COMPRESSED AIR**WARNING**

- Directing compressed air, pressurized water, or steam directly at your body, or using these and causing dust to fly may cause personal injury. Always wear protective glasses, anti-dust mask, and other protective equipment.
- When carrying out cleaning, always stop the engine and check that the fan is not rotating. If you touch the fan when it is rotating, it will cause serious personal injury.

NOTICE

When using compressed air for cleaning, blow it keeping some distance to avoid damaging the fins. Damage on the fins can cause water leakage and overheating. In a dusty job site, check the fins every day, regardless of the maintenance interval.

CLEAN RADIATOR FINS

1. Remove bolts (1) at the four corners of the radiator grill, then open radiator grill (2).
2. Clean the radiator fins clogged with mud, dust and leaves with compressed air. Steam or water may be used instead of compressed air.

REMARK

Check the hydraulic cooler hoses. If any hose is cracked or hardened by age, replace with a new hose. Also check and tighten all loose hose clamps.

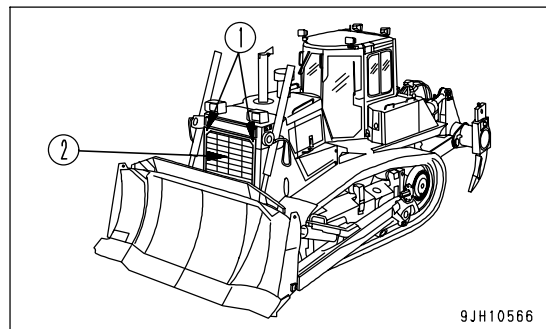

CLEAN OIL COOLER FINS

If the hydraulic cooler fins are clogged or there is dirt caught in the fins, clean and check the fins.

1. Loosen 4 bolts (2) of cover (1) on the right side face of the radiator guard, then remove cover (1).
2. When cover (1) is removed, there is a cleaning hole. Use this hole to check and clean hydraulic cooler fins (3).
3. Use compressed air to blow off the mud, dirt, or leaves clogging the hydraulic cooler fins. It is also possible to use steam or water in place of compressed air.

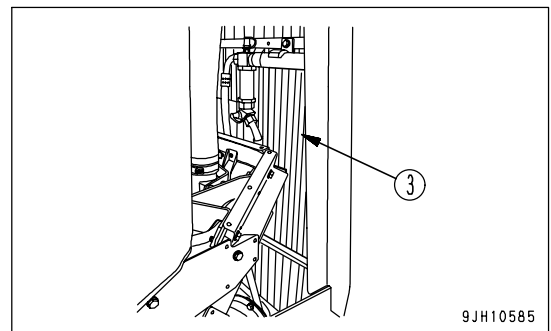
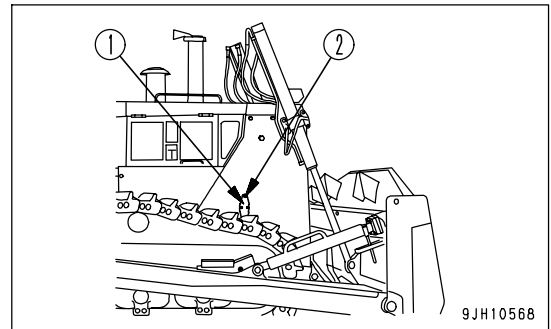

When cleaning the hydraulic cooler, it is possible to rotate the fan in reverse and switch the direction of the air flow. Set the fan reverse mode on the user menu.

The fan reverse rotation speed is 100%, so it can be used to clean the fins.

When the engine is running, the fan rotation selector switch does not work.

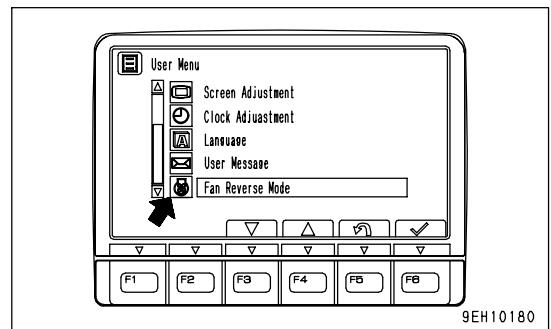

CLEAN AFTERCOOLER FINS

1. Open the engine side cover on the right side of the machine.
2. Blow off dirt, dust and dry leaf shreds that clog the after-cooler fins, with compressed air. Steam or water may well be used for this purpose instead of compressed air.

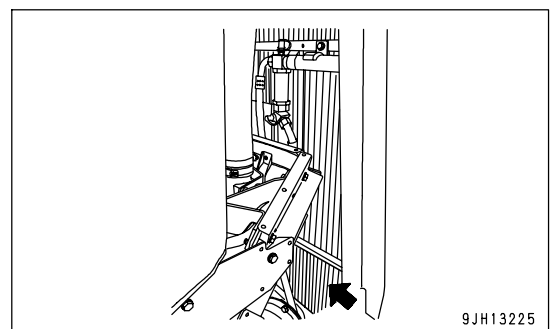

REMARK

Check the hydraulic cooler hoses. If any hose is cracked or hardened by age, replace with a new hose. Also check and tighten all loose hose clamps.

CLEAN, CHECK AIR CONDITIONER CONDENSER FINS

If the air conditioner fins become clogged, clean and inspect.

1. Open the engine side cover on the right side of the machine.
2. Use compressed air to blow off all the mud, dirt, and leaves clogging fins (1).

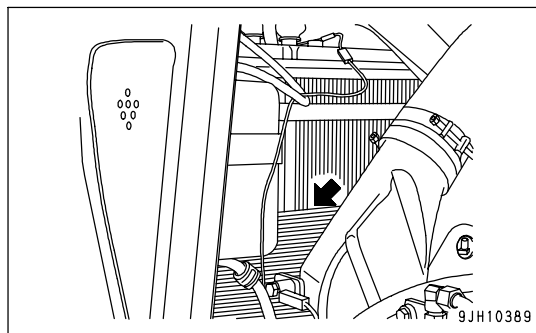
**CLEAN FUEL TANK STRAINER**

Clean the strainer if there is any dirt collected in it.

Remove the filler cap (1) of the fuel tank and take out strainer.

If the strainer is dirty, clean it with diesel fuel.

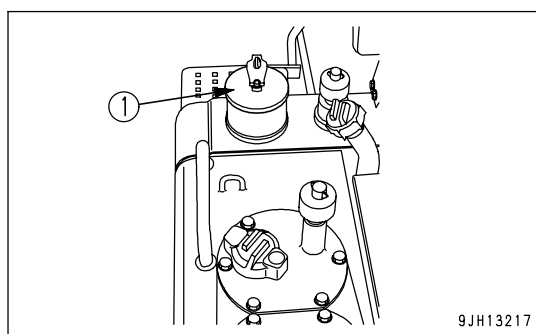

CLEAN STEERING CLUTCH CASE BREATHER

Remove the breather, then wash it in clean diesel oil or flushing oil to rinse the dirt out from inside.

- Power train case breather (1 place)

Remove external cover (2) at the bottom right of the cab. Breather (1) is installed to the right of the window (rear right of the machine).

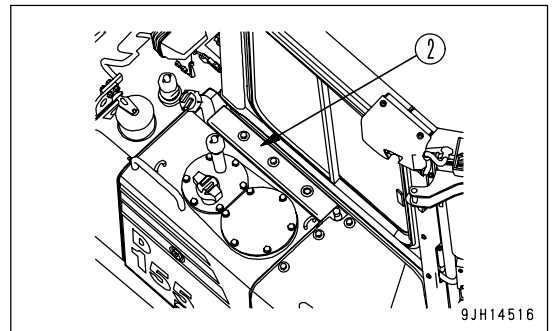
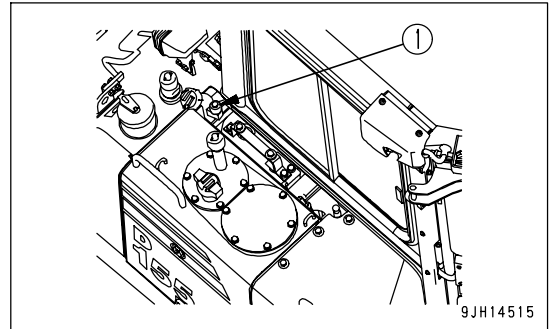

CLEAN HYDRAULIC TANK BREATHER AND FUEL TANK BREATHER

1. Remove nut (2) of breather assembly (1) at the top surface of the hydraulic tank and fuel tank, then remove cover (3).
2. Remove dirt stuck to breather element (4) and wash it with clean light oil or detergent oil.
3. Install cover (3) and nut (2).

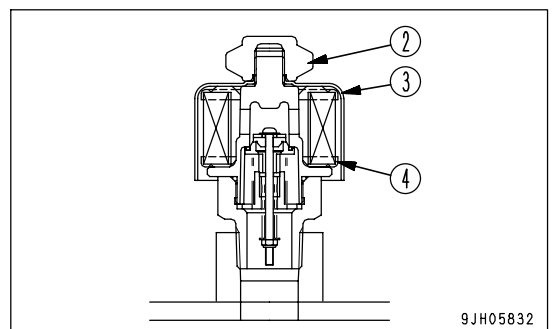
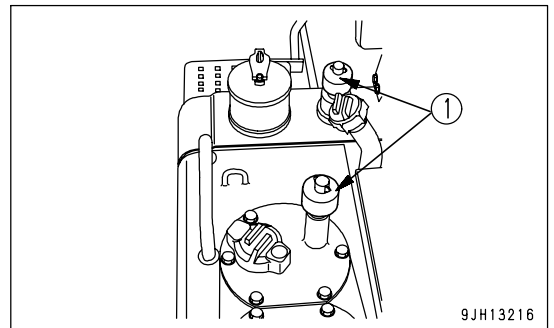

REPLACE AIR CONDITIONER BELT

1. Loosen 4 bolts (1) and jack bolt (2), then move compressor (3) to the side.
2. Replace the V-belt.
 - When adjusting the V-belt, do not push the compressor directly with the bar. Use jack bolt (2).
3. Tighten jack bolt (2) and bolt (1) to apply tension to the V-belt. The deflection of the bolt should be approx. 10 mm (0.4 in) when the belt is pressed at the midpoint between the air compressor pulley and fan pulley with a finger force of approx. 6 kg (58.8 N).

When the belt is a new part, it will stretch at first, so adjust the belt tension again without fail after 2 or 3 days.

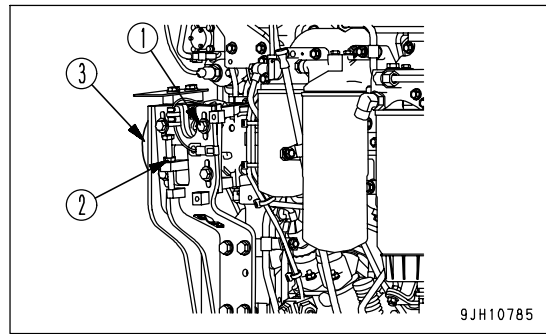

CHECK UNDERCARRIAGE OIL

Stop the machine on level ground, and check for any reduction in the oil in the idler (portion P), track roller (portion Q), bogie shaft (portion S), and carrier roller (portion R).

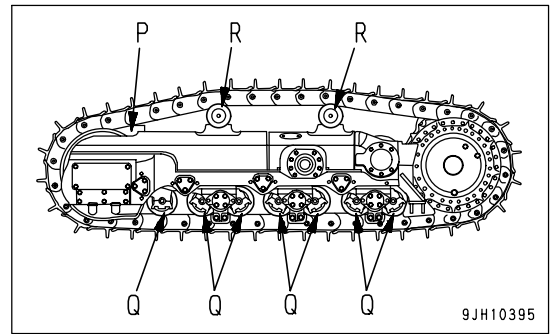

1. Loosen seal bolt (1) slowly and check if oil oozes out from the thread. If oil oozes out, the oil level has not gone down, so tighten the bolt.
2. If no oil comes out even when seal bolt is removed, the oil level is low. Contact your Komatsu distributor for repairs.

REMARK

- If the side cover is not removed, seal bolt (1) at the idler portion cannot be seen.
- There is 1 bogey shaft seal bolt (1) each on the inside and outside.

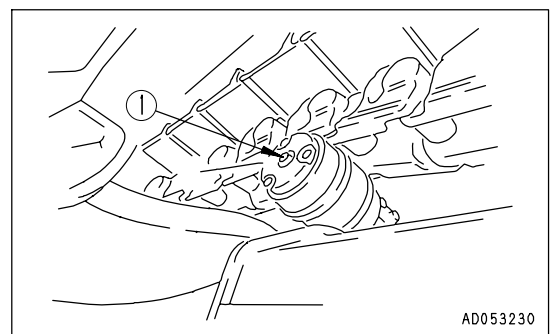
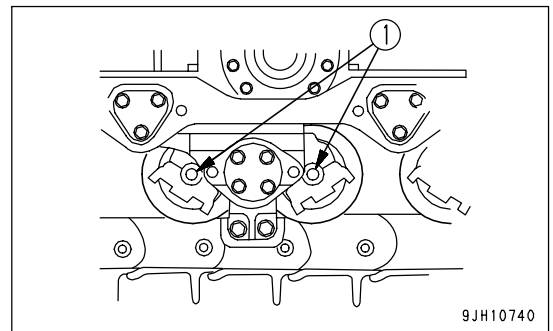
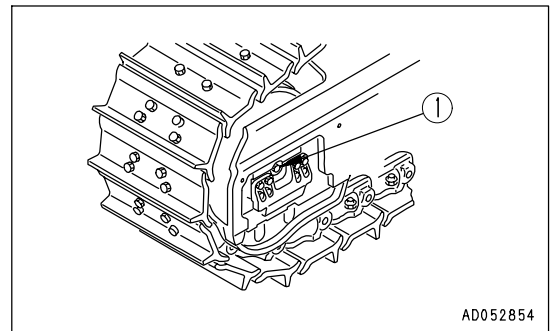

CLEAN AIR CONDITIONER AIR FILTER (FRESH/RECIRC FILTER)

Clean the air conditioner air filter if it becomes clogged or if there is dirt or oil stuck to it.

1. Loosen nut (1) located on the machine's rear left and remove the outer air filter by pulling handle (2).
2. Remove nut (3) located in the rear left inside the operator's cab to remove plate (4). Then remove bracket (5) from portion (a) and detach the inner filter from the bracket.
3. Blow the filter with compressed air for cleaning.

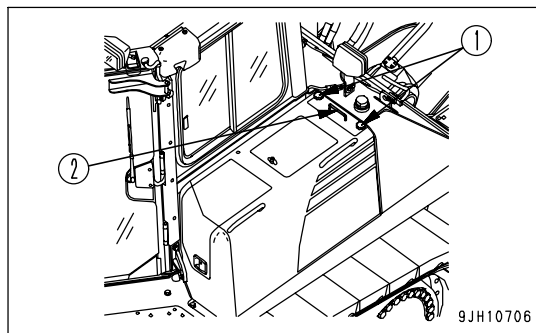
**REMARK**

Filtering capability of the filter can lower due to aging, so be sure to replace it with a new one once a year.

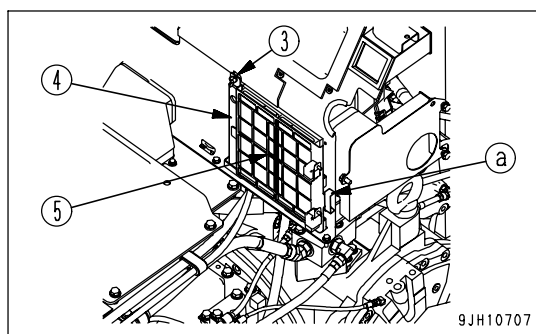

CHECK AND ADJUST AIR CONDITIONER

CHECK TENSION OF COMPRESSOR BELT

If the driving belt slackens, it is likely to slip, lowering the cooling efficiency. Depress the mid point between drive pulley (1) and compressor pulley (2) with a thumb (approx. 58.8 N {6 kg}) every now and then to make sure that deflection amount (A) is approx. 10 mm (0.4 in).

When it is a new belt, elongation is expected in the initial period of use, so be sure to make an adjustment in a few days after the replacement.

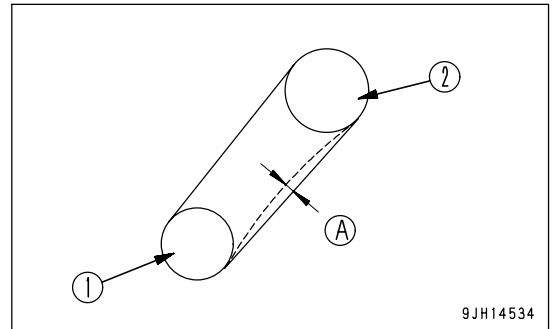

CHECK LEVEL OF REFRIGERANT(GAS)

⚠ WARNING

- When handling refrigerant gas, always follow local laws and regulations.
- The refrigerant used in the cooler is colorless and odorless and does not harm the atmosphere, but if the liquid gets into your eyes or on your hands, it may cause loss of sight or frostbite, so never loosen any part of the refrigerant circuit.

If the level of the refrigerant (gas) is low, the cooling effect will be reduced. Run the engine at high idle, and check the flow of the refrigerant gas (R134a) in the refrigerant circuit through the sight glass (2) (inspection window) of the receiver (1) when the cooler is running at high speed.

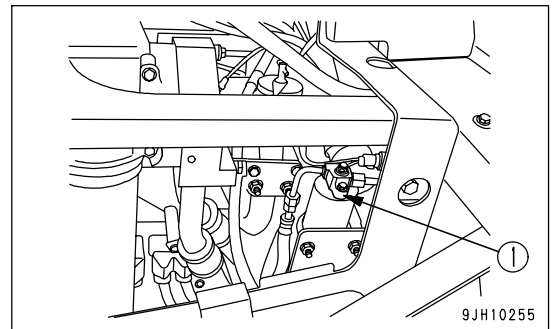

- (A) Correct: No bubbles are included in the flow
- (B) Low: Bubbles are included in the flow (bubbles pass continuously)
- (C) None: Colorless, transparent

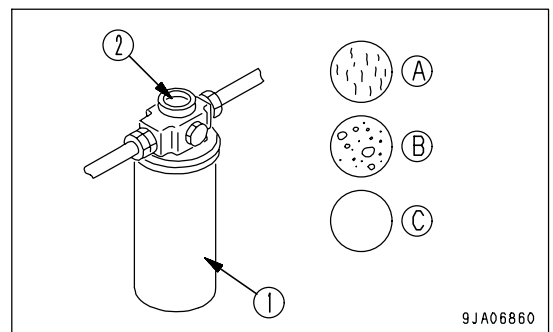

REMARK

- When there are bubbles, the refrigerant gas level is low, so contact your refrigerant dealer to have refrigerant added. If the air conditioner is run with the refrigerant gas level low, it will cause damage to the compressor.
- New R134a is used as the refrigerant.

LUBRICATE DOOR HINGE

If the door makes a squeaking noise when it is opened or closed, spray lubricant in through the split in the hinge bushing. If the bushing is worn, replace the hinge.

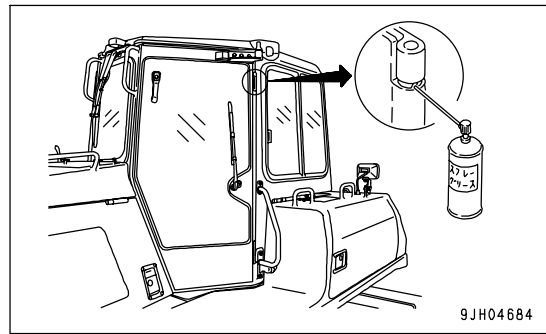

CHECK DOOR LATCH

WARNING

It is quite dangerous if the machine suddenly starts to move during the inspection work. Stop the engine and operate the parking brake lever to the LOCK (L) position without fail.

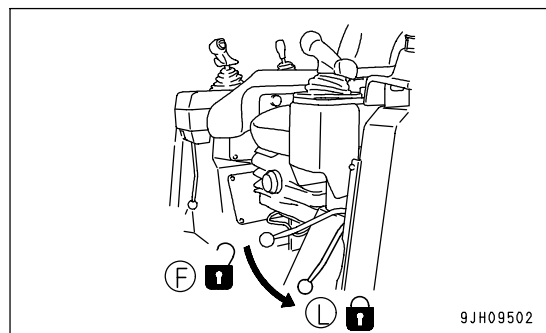

Check

Hold the door open-locked, and check that there is still grease inside the latch. If the amount of grease is low or there is no more grease, coat the inside of the latch with grease from portion (1).

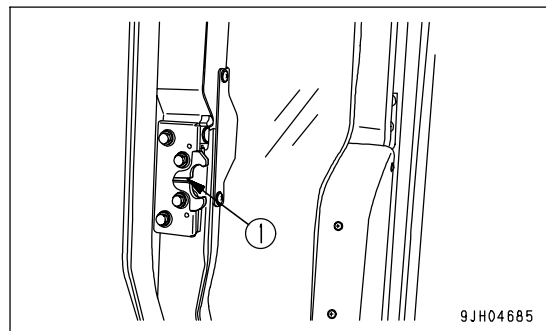

REMARK

If there is no more grease inside the latch, the movement will become poor because of dust inside the latch, and the handle may be stiff when opening the door.

CHECK DOOR LOCK STRIKER

If wear (A) of the door of lock striker exceeds 0.5 mm (0.02 in), replace the striker. If it is used as it is, the play will increase and this may result in breakage of the hinge or door lock.

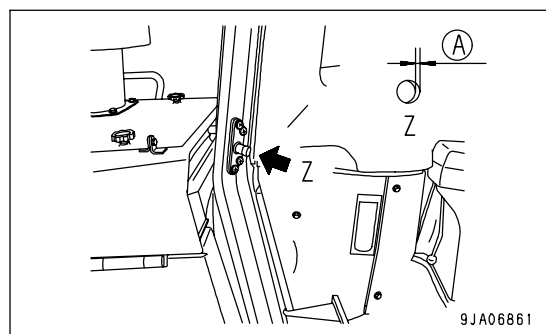

REPLACE DOOR DAMPER

If depth (A) of the groove of door damper rubber (1) is less than 2 mm (0.08 in), replace the damper.

There are 4 dampers: 1 each at the top and bottom on the left and right doors.

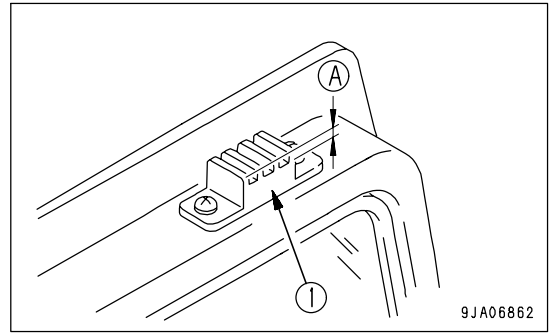

9JA06862

CHECK WINDOW WASHER FLUID LEVEL, ADD FLUID

Carry out this operation when no window washer fluid comes out. Open the battery cover at the rear left of the machine and check the level of the fluid in window washer tank (1). If the level is low, remove cap (2) and add automobile window washer fluid through the filler port.

When adding fluid, be careful not to let any dust get in.

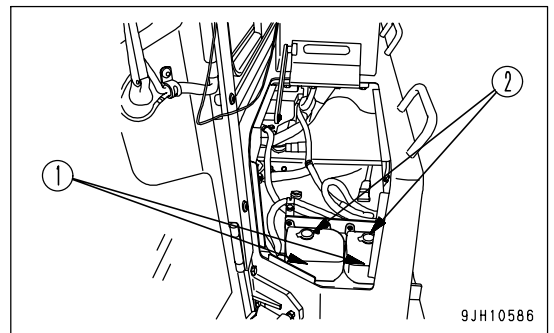

9JH10586

REPLACE WIPER BLADE

If the blade is damaged, it will not wipe the window clean, so replace the blade.

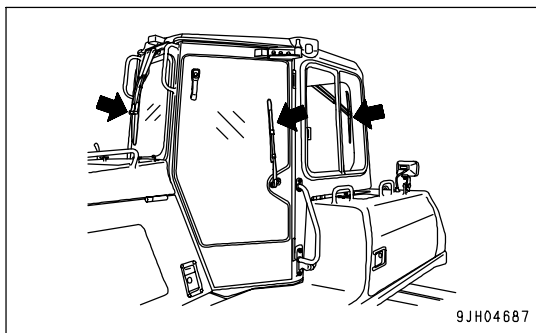

REPLACEMENT

FRONT, REAR WIPER

1. It is hooked at portion (A), so move the blade in the direction of the arrow to remove it.
2. Install the new blade and hook it securely.

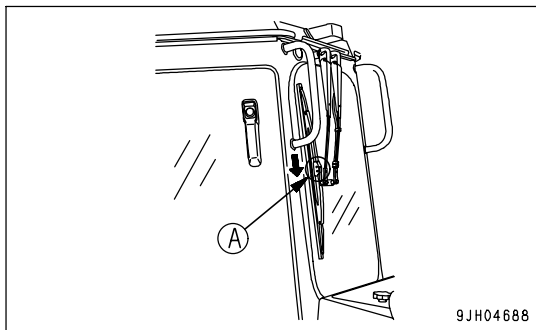

REAR WIPER

1. Remove E-ring (1).
The blade can then be removed.
2. Install a new blade, then install securely with E-ring (1).

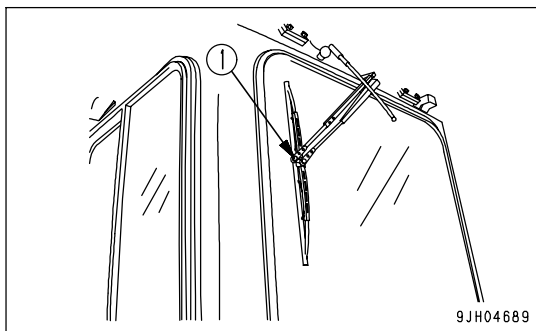

DOOR WIPER

1. It is hooked at portion (A), so move the blade in the direction of the arrow to remove it.
2. Install the new blade and hook it securely.

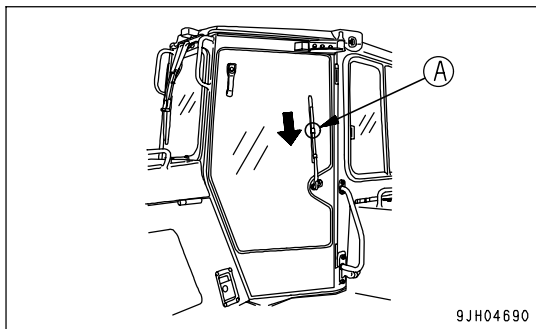

PROCEDURE FOR BLEEDING AIR FROM HYDRAULIC CIRCUIT

See "OPERATIONS AND CHECKS AFTER STARTING ENGINE (PAGE 3-126)".

Since the engine must be started and the blade must be operated, see OPERATION.

NOTICE

If the engine is run at high speed immediately after startup or a cylinder is pushed up to its stroke end, air taken inside the cylinder may cause damage to the piston packing.

1. Bleeding air from cylinders

- 1) Run the engine at low idle, and extend and retract each cylinder 4 to 5 times, taking care that a cylinder is not moved to the end of its stroke. (Stop the cylinder approx. 100 mm (3.9 in) short of its stroke end)
- 2) Next, operate each cylinder 3 to 4 times to the end of its stroke.
- 3) Finally, operate each cylinder 4 to 5 times to the end of its stroke to completely remove the air.

LUBRICATING

1. Lower the work equipment to the ground, then stop the engine.
2. Remove the right and left foot rest.
3. Using a grease pump, pump in grease through the grease fittings shown by arrows.
4. After greasing, wipe off any old grease that was pushed out.

Fuel control (2 places)

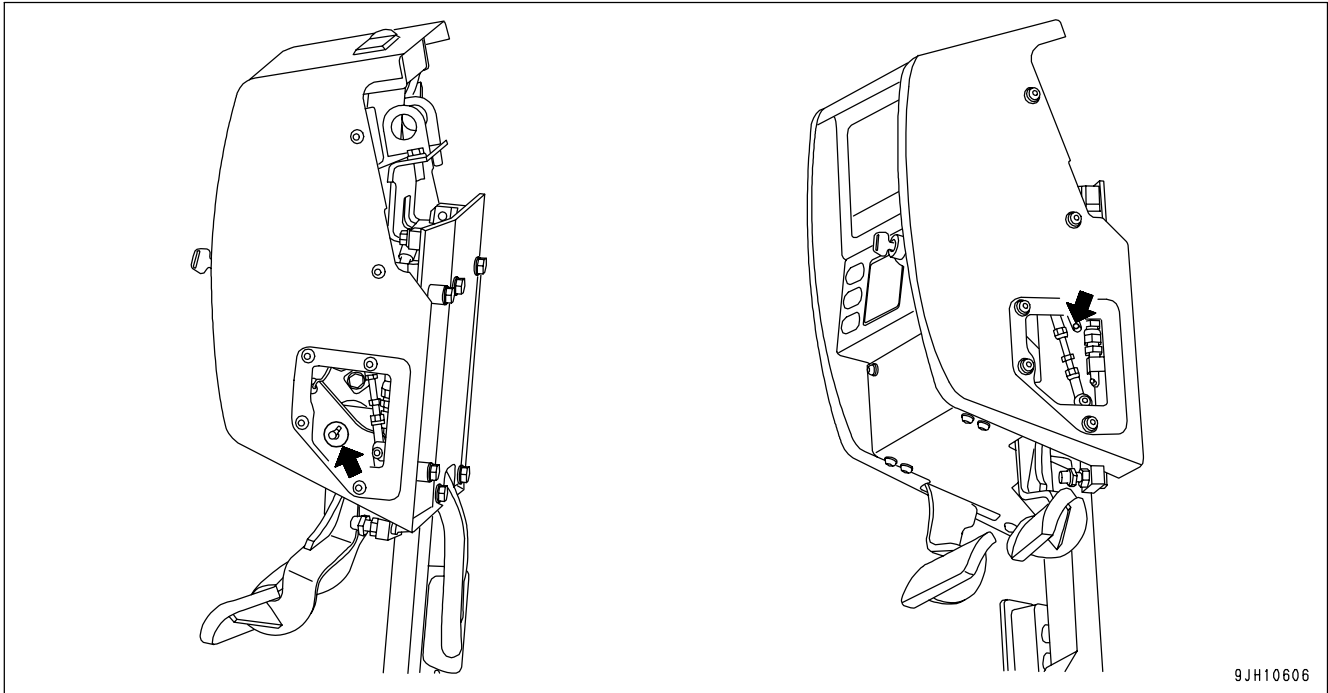

9JH10606

Brake pedal (2 places)

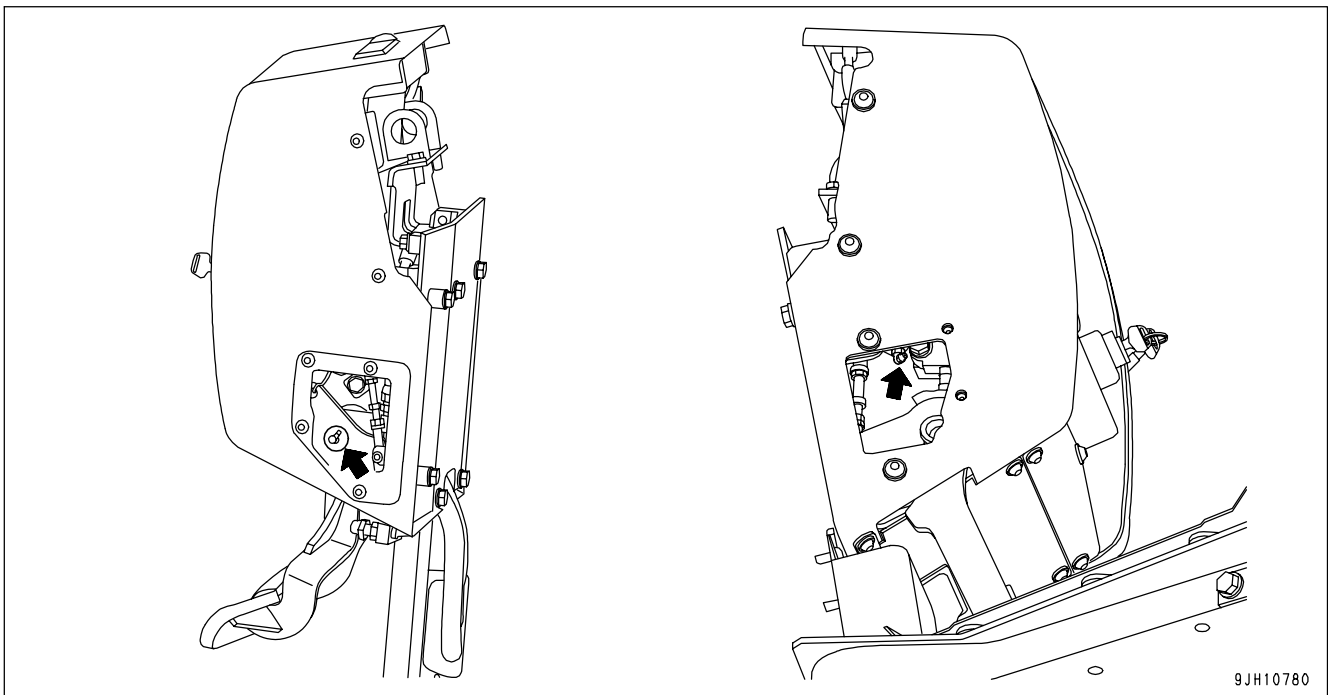

9JH10780

CHECK ELECTRICAL INTAKE AIR HEATER

Check before the cold season starts (once a year).

Remove the electric heater from the engine intake manifold and check for wire disconnections and dirt clinging to it.

When checking and installing the electric heater, replace its gasket with a new one.

CHECK BEFORE STARTING

For details of the following items, see "CHECK BEFORE STARTING (PAGE 3-100)".

- Check machine monitor
- Check coolant level, add coolant
- Check fuel level, add fuel
- Check water separator, drain water and sediment
- Drain water, sediment from fuel tank
- Check oil level in engine oil pan, add oil
- Check oil level in power train case, add oil
- Check brake pedal travel
- Check damper case oil level, add oil
- Check oil level in hydraulic tank, add oil
- Check dust indicator
- Check electric wiring
- Check that lamps light up
- Check horn sound
- Check backup alarm sound

EVERY 250 HOURS SERVICE

LUBRICATING

1. Lower the work equipment to the ground, then stop the engine.
2. Using a grease pump, pump in grease through the grease fittings shown by arrows.
3. After greasing, wipe off any old grease that was pushed out.

- Greasing equalizer bar side pins (2 places)

Left and right sides of machine: 2 places each

- 1) Remove all soil and mud from the top of track frame and cover (1).

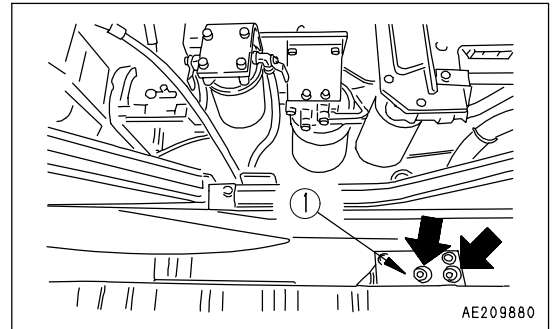

- 2) Climb on top of the straight frame and remove the red plug from (A) between the track frame and track shoe.
- 3) Carry out the greasing from the top of the track shoe.

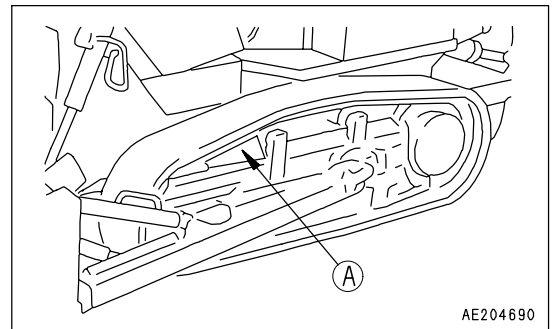

NOTICE

Grease all parts after carrying out operations in water or on swampy ground.

- Grease equalizer bar center pin (1 place)

- 1) Open the engine side cover on the left of the machine.
- 2) Pump in grease through the grease fitting marked by the arrow.

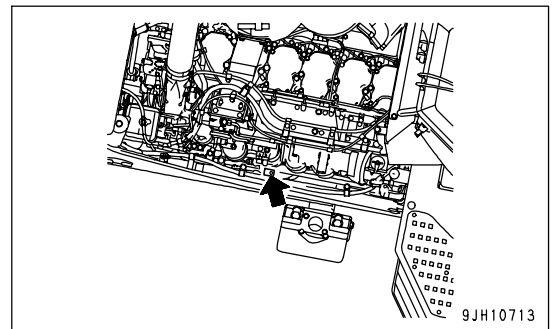

• Sigmadozer

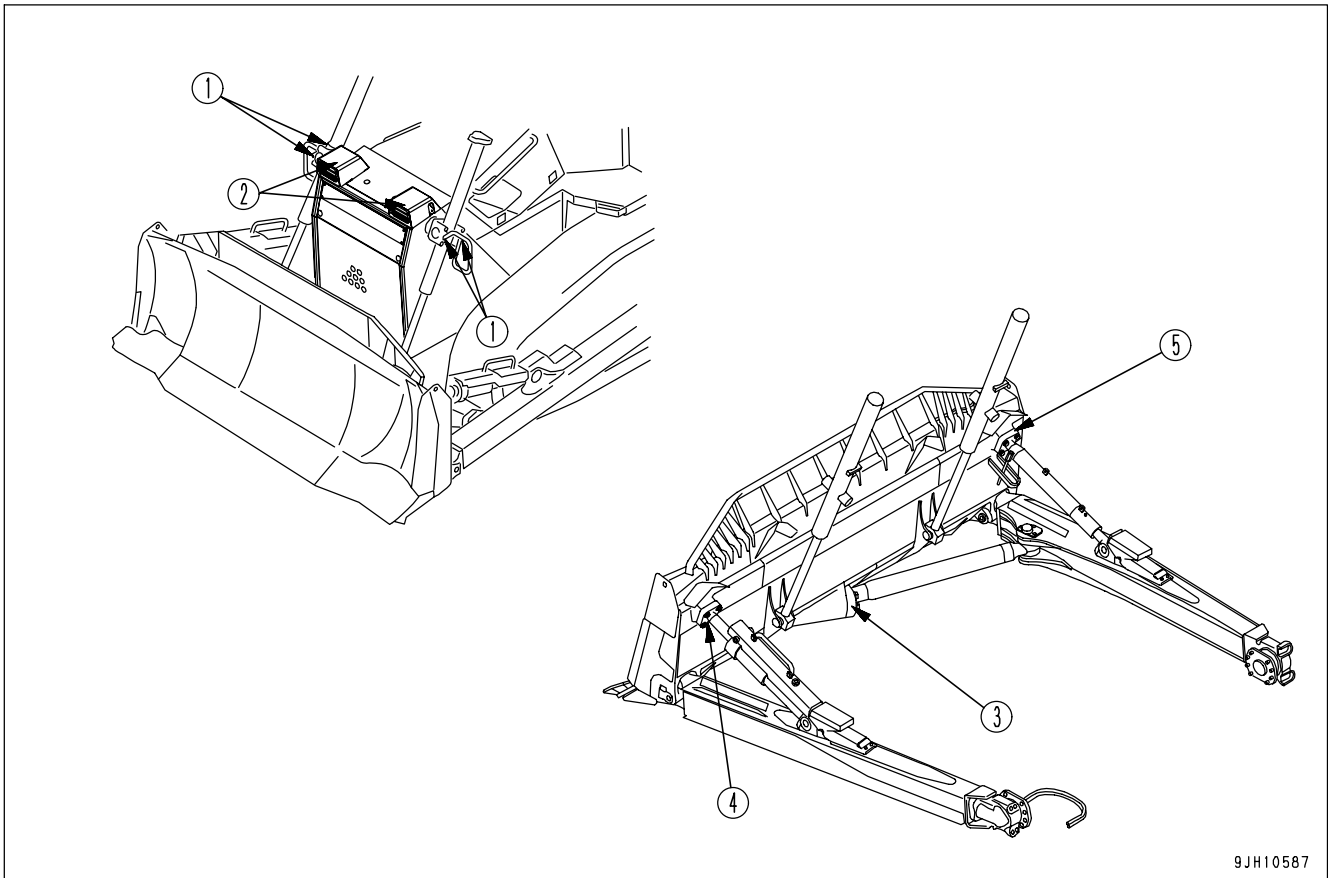

- (1) Lift cylinder support yoke (4 places)
- (2) Lift cylinder support shaft (2 places)
- (3) Blade arm (1 place)

- (4) Tilt cylinder ball joint (1 place)
- (5) Pitch cylinder ball joint (1 place)

• Angledozer

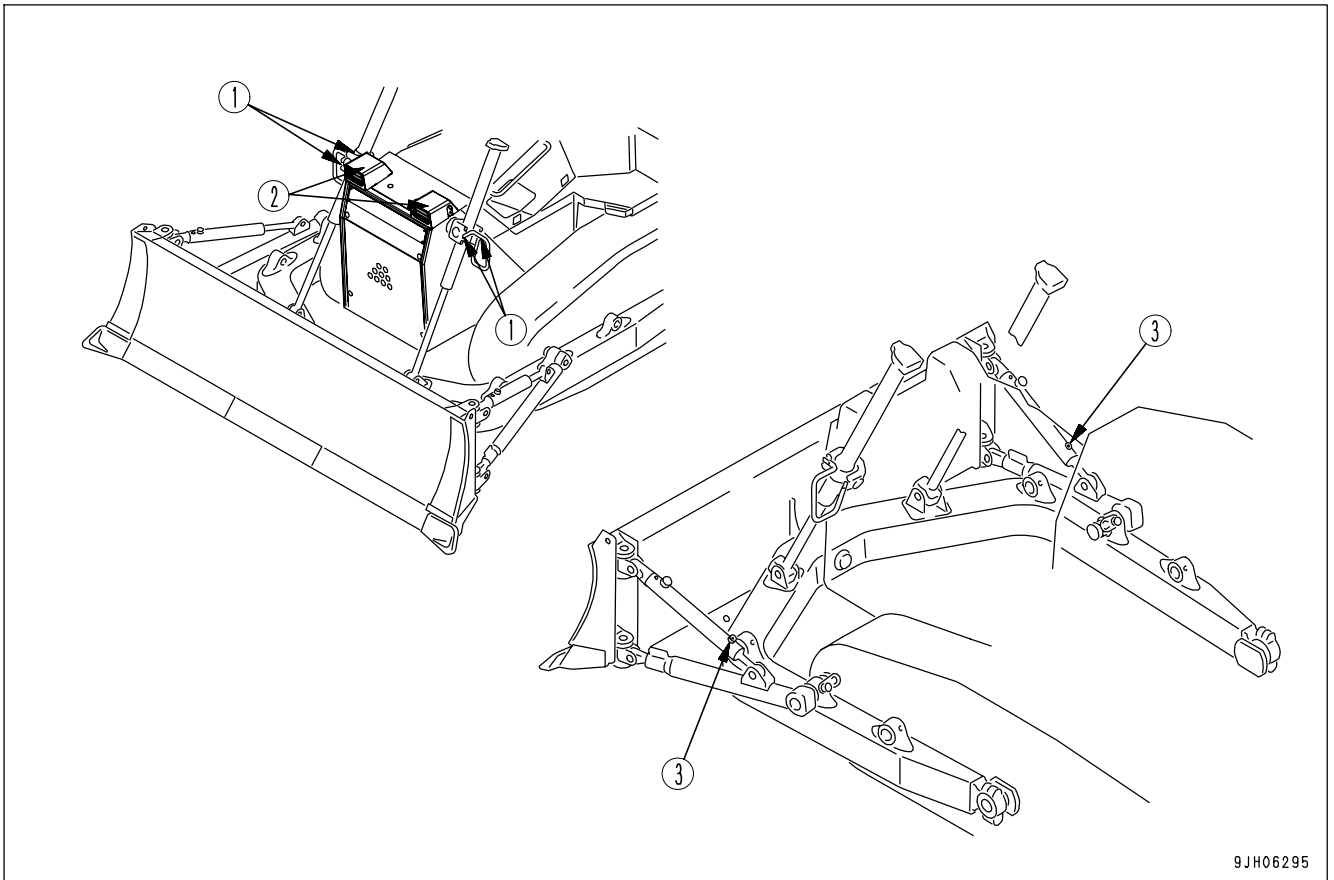

- (1) Lift cylinder support yoke (4 places)
- (2) Lift cylinder support shaft (2 places)

- (3) Tilt brace screw (2 places)

• Ripper

- (1) Tilt cylinder bottom pin (1 place)
- (2) Lift cylinder bottom pin (1 place)
- (3) Tilt cylinder rod end pin (1 place)
- (4) Lift cylinder rod end pin (1 place)
- (5) Arm pin (front) (2 places)
- (6) Arm pin (rear) (2 places)

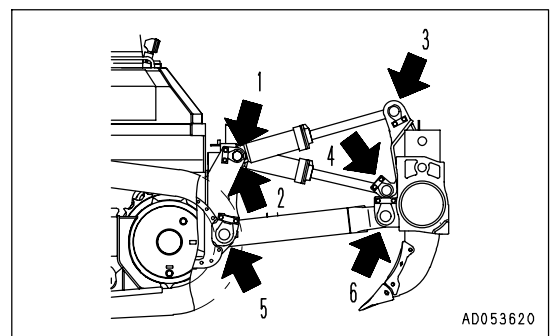

CHECK OIL LEVEL IN FINAL DRIVE CASE, ADD OIL**WARNING**

The oil is at high temperature immediately after the machine has been operated. Wait for the oil to cool down before starting the operation.

1. Stop the machine so that drain plug (1) is at the bottom.
2. Remove oil level plug (2) and check whether the final drive case is filled with oil to lower edge of the plug hole.
3. If the oil level is low, remove plug (3) and add engine oil until it overflows from oil level plug (2).

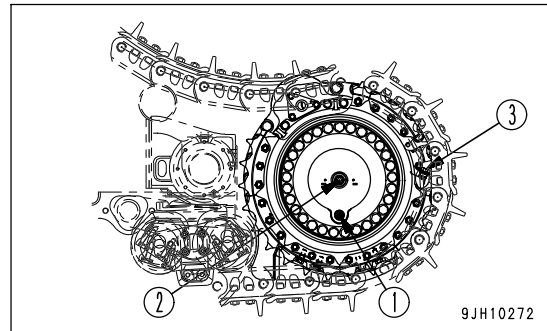
**CHECK OIL LEVEL IN DAMPER CASE, ADD OIL**

1. Open the engine side cover on the left side of the machine.
2. Remove dipstick (G), and wipe the oil off with a cloth.
3. Fully insert dipstick (G) into filler pipe, then remove it.
4. The oil should be between the H and L marks on dipstick (G).
If the oil is below the L mark, add oil through the dipstick insertion port.

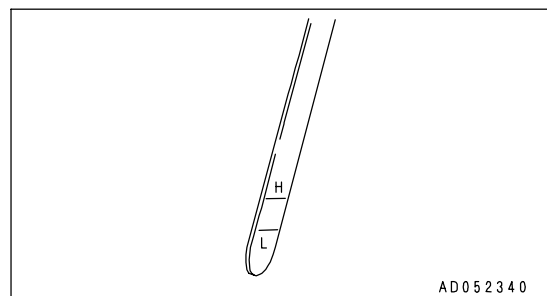
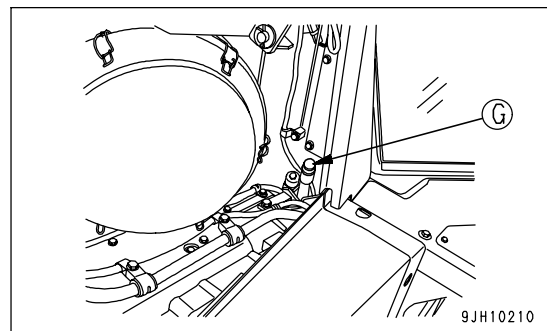

5. If the oil is above the H mark, remove the undercover under the machine, drain the excess oil from drain plug (P), then check the oil level again.

REMARK

- Check the oil level while the engine is stopped.
- If the machine is inclined, set it in a level position before checking the oil level.

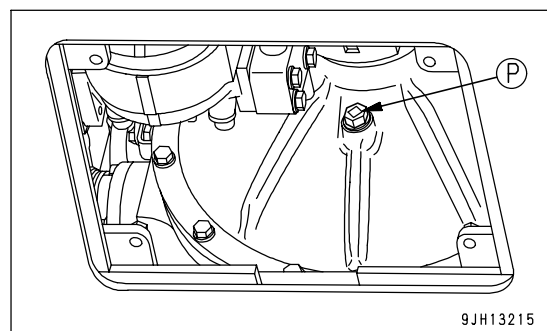

CHECK LEVEL OF BATTERY ELECTROLYTE

Carry out this procedure before operating the machine.

**WARNING**

- Do not use the battery if the battery electrolyte level is below the LOWER LEVEL line. This will accelerate deterioration of the inside of the battery and reduce the service life of the battery. In addition, it may cause an explosion.
- The battery generates flammable gas and there is danger of explosion, do not bring fire or sparks near the battery.
- Battery electrolyte is dangerous. If it gets in your eyes or on your skin, wash it off with a large amount of water and consult a doctor.
- When adding distilled water to the battery, do not allow the battery electrolyte to go above the UPPER LEVEL line. If the electrolyte level is too high, it may leak and cause damage to the paint surface or corrode other parts.

NOTICE

If there is a fear that the battery water may freeze after refilling with purified water (e.g. commercially available replenishment water for a battery), do the replenishment before the day's work on the next day.

Inspect the battery electrolyte level at least once a month and follow the basic safety procedures given below.

REMARK

When replacing the battery, lift the battery cover with a three- point sling, using a small-sized crane.

Open battery cover (1) on the left side of the machine.

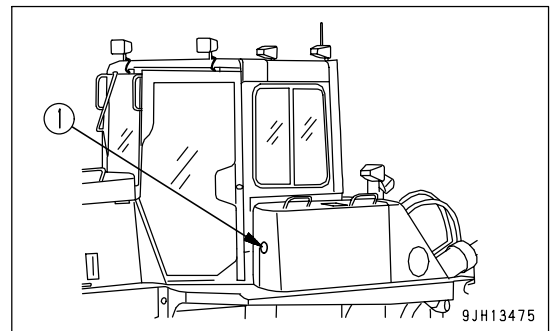

WHEN CHECKING ELECTROLYTE LEVEL FROM SIDE OF BATTERY

If it is possible to check the electrolyte level from the side of the battery, check as follows.

1. Use a wet cloth to clean the area around the electrolyte level lines and check that the electrolyte level is between the UPPER LEVEL (U.L.) and LOWER LEVEL (L.L.) lines.

If the battery is wiped with a dry cloth, static electricity may cause a fire or explosion.

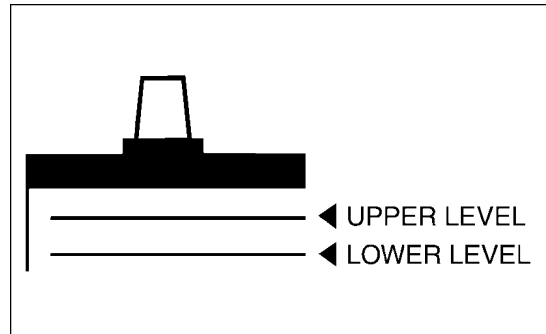

2. If the electrolyte level is below the midway point between the UPPER LEVEL (U.L.) and LOWER LEVEL (L.L.) lines, remove cap (2) and add purified water (e.g. commercially available replenishment water for a battery) to the U.L. line.

3. After adding distilled water, tighten cap (2) securely.

REMARK

If distilled water is added to above the U.L. line, use a syringe to lower the level to the U.L. line. Neutralize the removed fluid with baking soda (sodium bicarbonate), then flush it away with a large amount of water or consult your Komatsu distributor or battery maker.

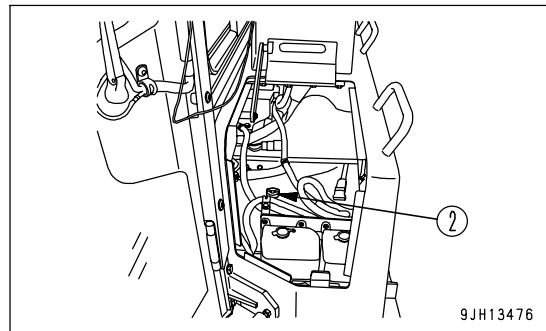

9JH13476

WHEN IT IS IMPOSSIBLE TO CHECK ELECTROLYTE LEVEL FROM SIDE OF BATTERY

If it is impossible to check the electrolyte level from the side of the battery, or there is no display of the UPPER LEVEL line on the side of the battery, check as follows.

1. Remove cap (2) at the top of the battery, look through the water filler port (3), and check the electrolyte surface. If the electrolyte does not reach the sleeve (4), add purified water (e.g. commercially available replenishment water for a battery) so that the level reaches the bottom of the sleeve (UPPER LEVEL line) without fail.

- (A) Suitable level: Electrolyte level is up to bottom of sleeve, so surface tension causes electrolyte surface to bulge and poles appear bent.
- (B) Low: Electrolyte level is not up to bottom of sleeve, so poles appear straight and not bent.

2. After adding distilled water, tighten cap (2) securely.

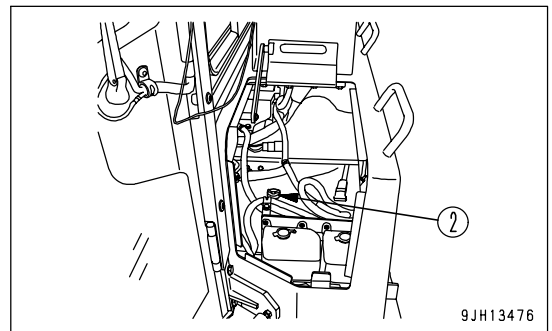

REMARK

If water is added to above the bottom tip of the sleeve, use a pipette to remove electrolyte. Neutralize the removed electrolyte with sodium bicarbonate, then flush it away with a large amount of water. If necessary, contact your Komatsu distributor or your battery maker.

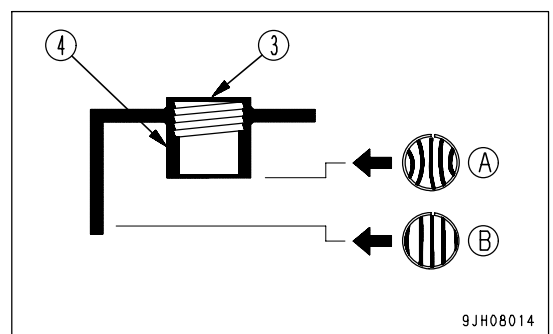

WHEN IT IS POSSIBLE TO USE INDICATOR TO CHECK ELECTROLYTE LEVEL

If it is possible to use an indicator to check the electrolyte level, follow the instructions given.

CHECK ALTERNATOR DRIVE BELT TENSION, ADJUST**CHECKING**

Depress a belt at a mid point between drive pulley (1) and alternator pulley (2) with a thumb to apply 98 N (10 kg) - pressure, and when deflection amount (A) remains between 13 mm and 16 mm (0.51 in and 0.63 in), the deflection is within the standard value.

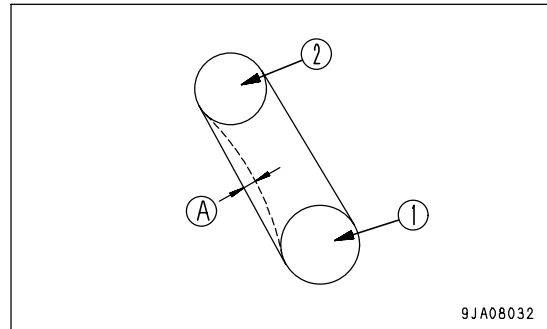
**ADJUSTING**

1. Remove cover mounting bolts (6) (2 places), and remove the cover.
2. Loosen bolts and nuts (1), (2), and (5), then turn nut (4) and adjust the belt tension.
3. After adjusting, tighten bolts and nuts (1), (2), and (5), to secure alternator (3) in position.
4. Reinstall the cover removed in step 1. Confirm that no part of the cover touches any moving part of the alternator.

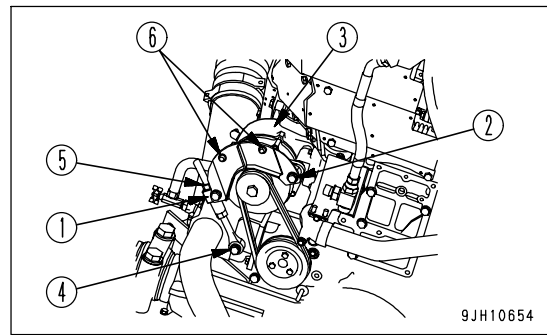
**REMARK**

- Check each pulley for breakage and wear of the V-groove. In particular, check that the V-belt does not touch the bottom of the V-groove.
- If any abnormality is found, ask your Komatsu distributor for replacement of the pulley.
- If the V-belt is so lengthened that it cannot be adjusted any more or if it has any cuts or cracks, replace it.
- When adjusting the V-belt, do not press the alternator directly with a bar, but put a wood piece, etc. in-between them.
- If the V-belt has been replaced with a new part, there will be initial elongation, so inspect and adjust it again after one-hour of operation.

CHECK BRAKE PERFORMANCE



WARNING

If the machine moves during the following operation, please contact your Komatsu distributor for repairs immediately.

NOTICE

Do not place the joystick in the 1st speed position.
 Otherwise, it will cause damage to the machine.

Before starting the engine, check that the area around the machine is safe, then do as follows:

1. Start the engine.
2. After completing the warm-up operation, set fuel control dial (3) to the SLOW position.
3. Set work equipment lock lever (1) to the FREE position then operate blade control lever (6) and ripper control lever (7) to raise the blade and ripper.
 Leave the work equipment lock lever (1) in the FREE position.
4. Set parking lever (2) to the FREE position.
5. Depress brake pedal (5), push the shift-up button to shift to 2nd, then place steering, directional, and gear shift lever (4) in FORWARD.
6. Operate fuel control dial (3) and gradually raise the engine speed to full throttle. (Keep the brake pedal depressed.)
7. Check that the machine does not move. This indicates that brake performance is normal.

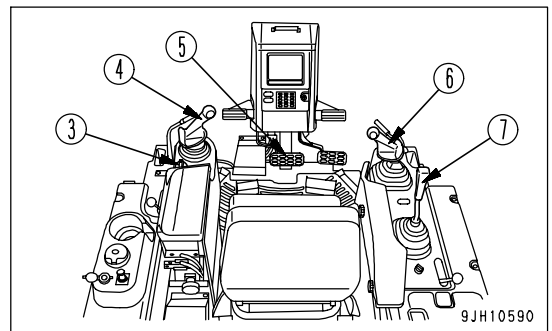
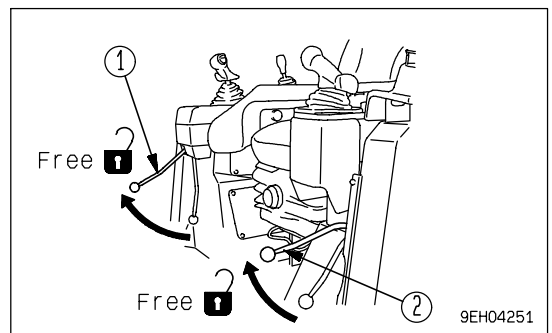

EVERY 500 HOURS SERVICE

Maintenance for every 250 hours should be performed at the same time.

REPLACE FUEL PRE-FILTER CARTRIDGE



WARNING

- After the engine has been operated, all parts are at high temperature, so do not replace the filter immediately. Wait for all parts to cool down before starting the operation.
- High pressure is generated inside the engine fuel piping system when the engine is running. When replacing the filter, wait for at least 30 seconds after stopping the engine to let the internal pressure go down before replacing the filter.
- Do not bring any fire or flame close.

NOTICE

- Genuine Komatsu fuel filter cartridges use a special filter that has highly efficient filtering ability. When replacing the filter cartridge, always use a genuine Komatsu part.
 - The common rail fuel injection system used on this machine consists of more precise parts than the conventional injection pump and nozzle. If any part other than a genuine Komatsu filter cartridge is used, dust or dirt may get in and cause problems with the injection system. Always avoid using substitute parts.
 - When carrying out inspection or maintenance of the fuel system, pay more attention than normal to the entry of dirt. If dirt is stuck to any part, use fuel to wash it off completely.
- Container to catch the oil
 - Prepare a filter wrench

1. Set a container to catch the oil under filter cartridge (1).
2. Using the filter wrench, turn transparent cap (2) to the left. (This cap is used again.)
3. Using the filter wrench, turn filter cartridge (1) to the left to remove it.

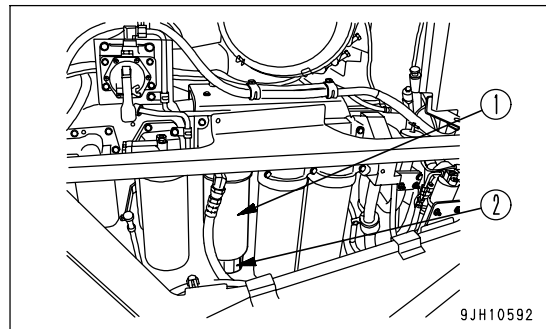

4. Remove seal (4) from transparent cap (3), then clean the cap.
If transparent cap (3) is damaged, replace it with a new part.
5. Coat new seal (4) with clean fuel or oil, then install it to transparent cap (3).
6. Install transparent cap (3) to new filter cartridge (2).
 - Tightening torque for transparent cap:
 - 10.0 Nm (1.0 kgm, 7.2 lbft)
7. Check that the drain plug at the bottom of transparent cap (3) is tightened securely.
Tightening torque: 0.2 - 0.45Nm (0.02 -0.046 kgm, 0.1 - 0.3 lbft)

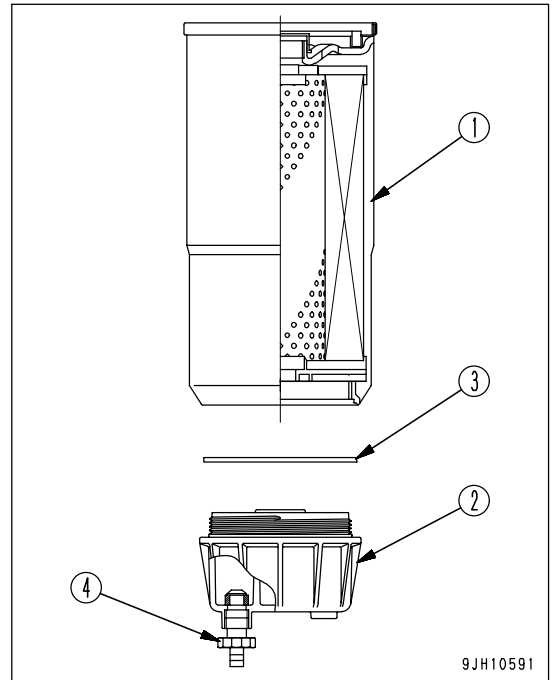

8. Clean the filter holder, fill the new filter cartridge with clean fuel, coat the packing surface thinly with oil, then install to the filter holder.

NOTICE

- When adding fuel, do not remove cap (B). Always add fuel from the 8 small holes (A) on the dirty side.
- After adding fuel, remove cap (B) and install the fuel filter.
- Always fill with clean fuel. Be careful not to let any dirt or dust get into the fuel. In particular, center portion is the clean side, so do not remove cap (B) when adding fuel. Be careful not to let dirt or dust get into center portion on the clean side.

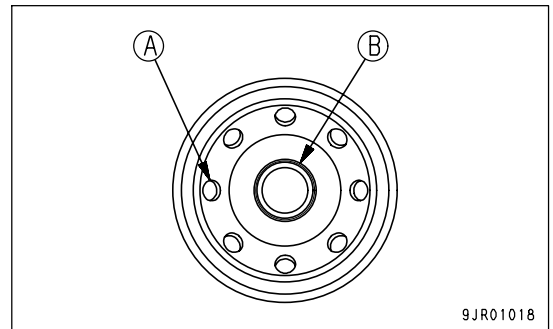

9. When installing, tighten until the packing surface contacts the seal surface of the filter holder, then tighten it 3/4 of a turn.
If the filter cartridge is tightened too far, the packing will be damaged and this will lead to leakage of fuel. If the filter cartridge is too loose, fuel will also leak from the packing, so always tighten the correct amount.
 - When tightening with a filter wrench, be extremely careful not to dent or damage the filter.
10. After replacing the filter cartridge, start the engine and run it at low idling for 10 minutes.
Check for leakage of oil from the filter seal surface. If any oil is leaking, check the tightening of the filter cartridge. If there is still oil leakage, repeat Steps 1 - 5 to remove the filter cartridge, and if any damage or embedded foreign material in the packing surface is found, replace it with a new cartridge and repeat Steps 6 - 13 to install it.

CHECK FOR LOOSE ROPSCAB MOUNT BOLTS

Check that there are no loose or damaged bolts.

METHOD OF TIGHTENING MOUNT BOLT

1. First, tighten bolts (1) - (21) to a tightening torque of 294 ± 29.4 Nm. The order for tightening is as shown in the diagram.
2. Tighten bolts (22) and (23) to a tightening torque of 279 ± 27.9 Nm in the order shown by the direction of the arrow.
3. Use an impact wrench or ordinary wrench to tighten bolts (1) - (21) a further 60° .

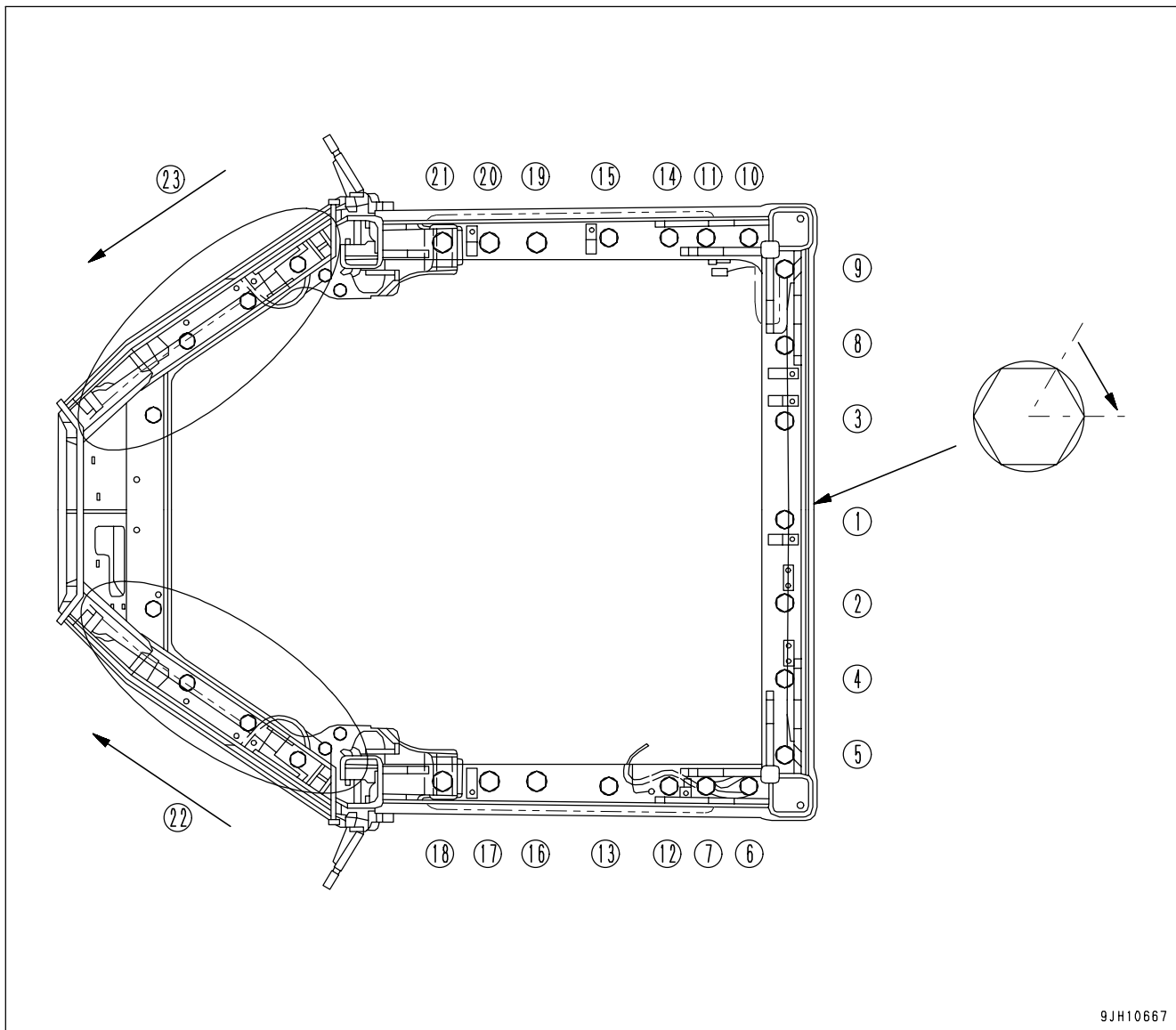

REPLACE POWER TRAIN OIL FILTER ELEMENT

1. Remove bolt (1) to take off cover (2).

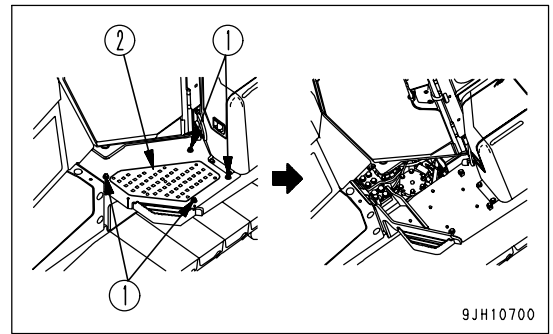

2. Remove mounting bolt (4) of filter (3), then remove cover (5).
3. Take out element.
4. Clean the removed parts and the inside of the case, then install a new element.
Use Komatsu genuine element.
5. Install cover (2) and tighten bolt (1).

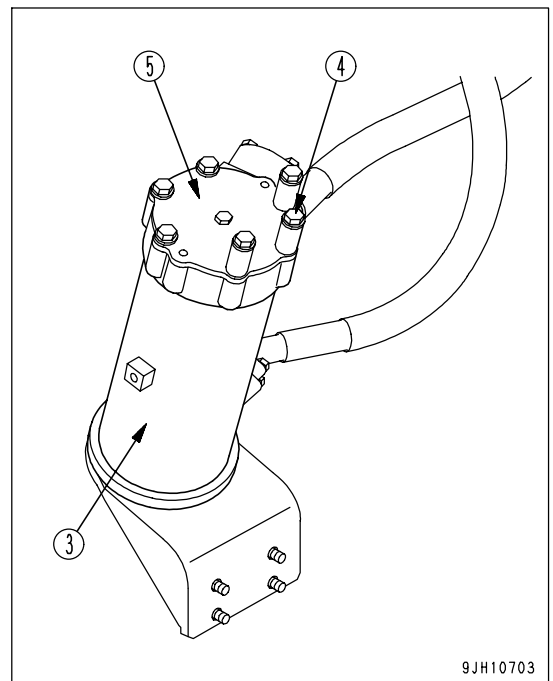

CHANGE OIL IN ENGINE OIL PAN, REPLACE ENGINE OIL FILTER CARTRIDGE

**WARNING**

The oil is at high temperature after the engine has been operated, so never change the oil immediately after finishing operations. Wait for the oil to cool down before changing it.

- Oil replacement amount: 37 liters (9.78 US gal)
- Prepare a socket wrench and filter wrench.

After the machine has been operated for 6 months, even if it has not been operated for 500 hours, change the engine oil and replace the filter cartridge at 6 months.

And after the machine has been operated for 500 hours, even if it has not been operated for 6 months, change the engine oil and replace the filter cartridge at 500 hours.

1. Remove the cover (1) on the bottom of the machine and set a container to catch the drained oil directly under the drain plug.

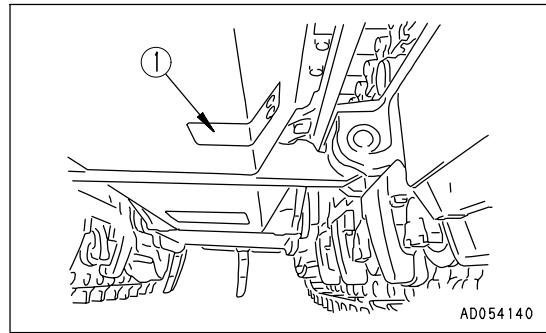

2. Remove cover (A).

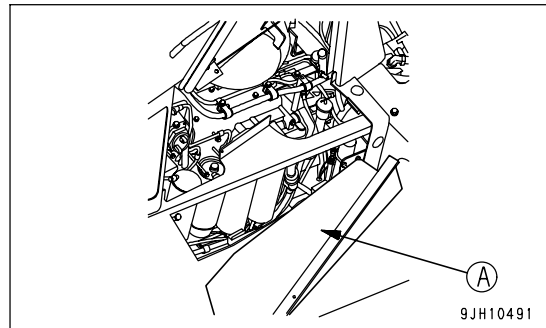

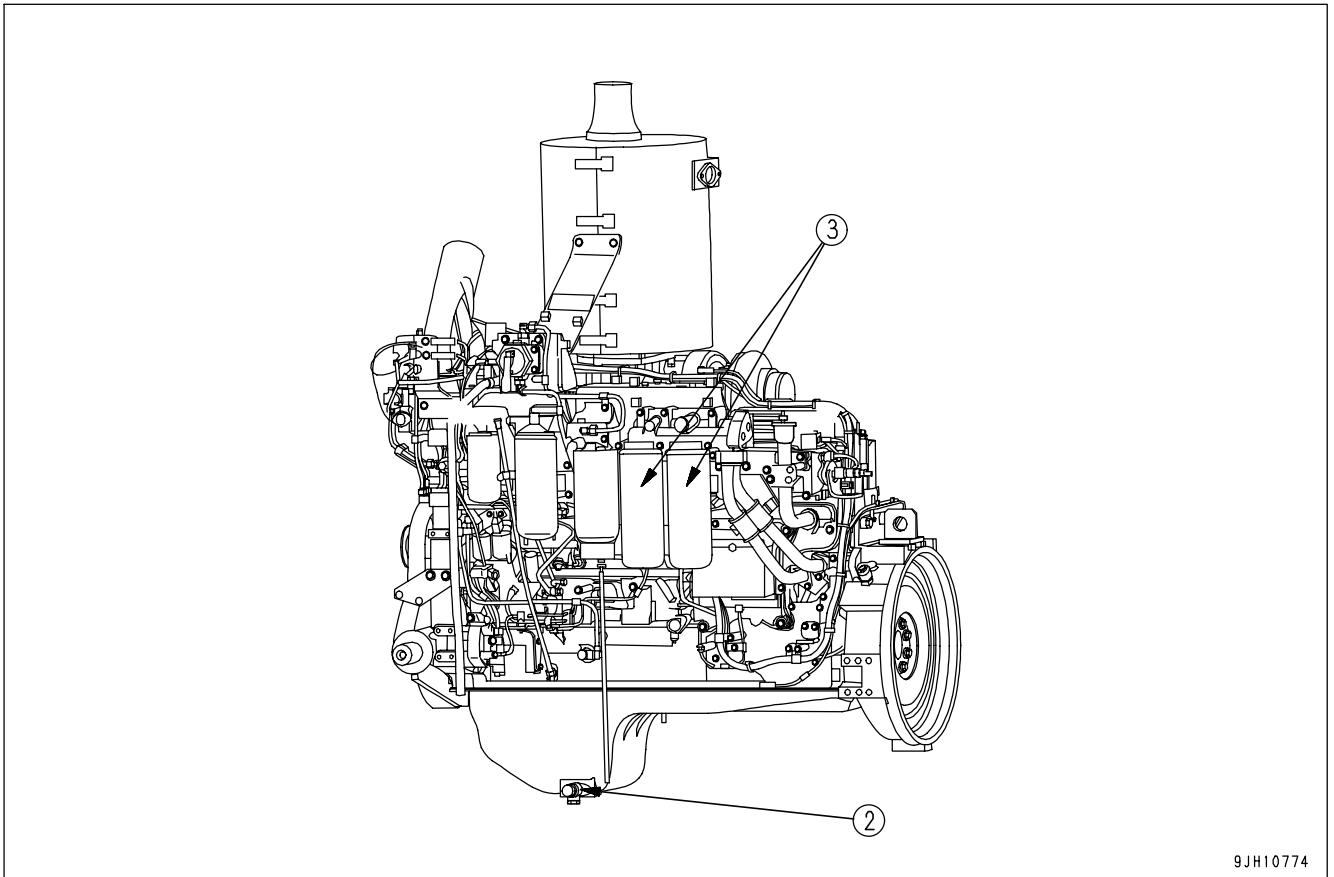

9JH10774

3. Taking care not to get oil over yourself, remove drain plug (P) slowly, then loosen drain valve (2) and drain the oil.

Be careful not to loosen the drain valve too much and deform the stopper pin inside the valve.

4. Check the drained oil, and if there are excessive metal particles or foreign material, please contact your Komatsu distributor.

5. Tighten drain plug (P) and drain valve (2).

Tightening torque for drain plug (P): 68.6 ± 9.81 Nm (7 ± 1 kgm , 50.6 ± 7.2 lbft)

Tightening torque for drain valve (2): 63.7 ± 14.7 Nm (6.5 ± 1.5 kgm , 47 ± 10.8 lbft)

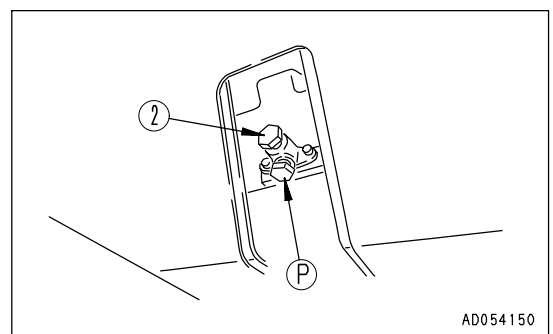

AD054150

6. Using the filter wrench, turn full-flow filter cartridge (3) to the left and remove it.

To prevent getting oil on yourself, do not carry out this operation from immediately under the cartridge.

7. Clean the filter holder, fill the new filter cartridge with engine oil, coat the packing surface and thread with engine oil (or coat it thinly with grease), then install the filter cartridge.

REMARK

Check that there is no old packing stuck to the filter holder. If there is any old packing stuck to the filter, it will cause leakage of oil.

8. When installing, bring the packing face into contact with the filter holder, then tighten a further $3/4 - 1$ turn.
 - When using a filter wrench to tighten, be extremely careful not to damage or dent the filter.
9. After replacing the filter cartridge, add oil through oil filler port (F) so that the oil level is between the H and L marks on dipstick (G).

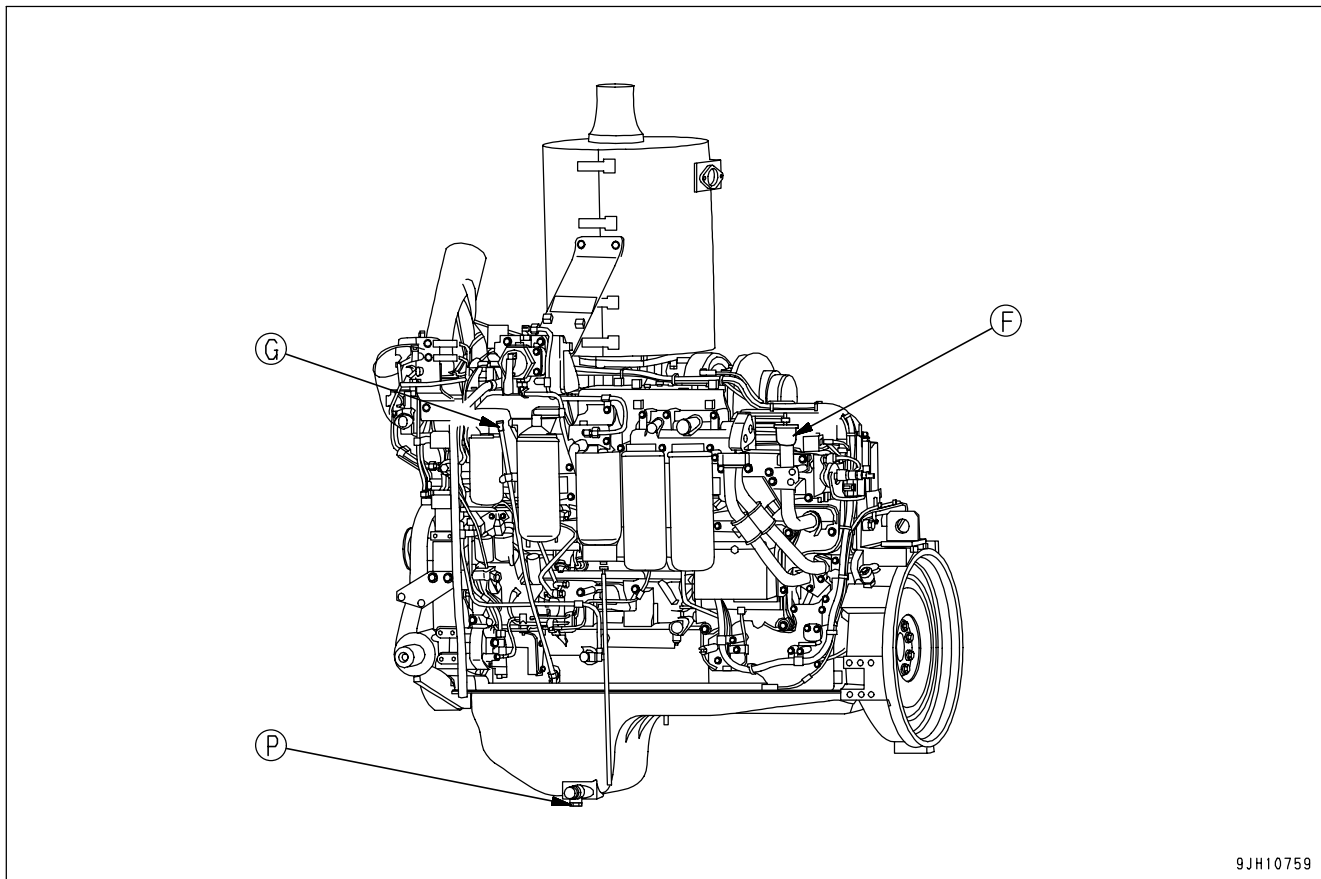

9JH10759

10. Run the engine at idling for a short time, then stop the engine, and check that the oil level is between the H and L marks on the dipstick. For details, see "CHECK OIL LEVEL IN ENGINE OIL PAN, ADD OIL (PAGE 3-104)".

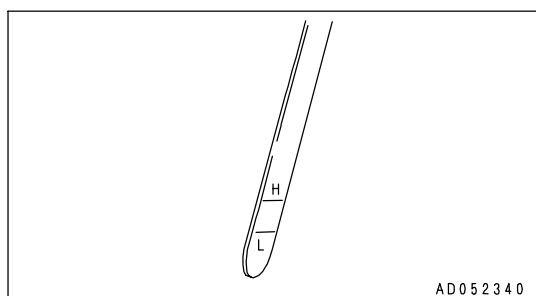

AD052340

EVERY 1000 HOURS SERVICE

Maintenance for every 250 and 500 hours service should be carried out at the same time.

CHANGE OIL IN POWER TRAIN CASE, WASH STRAINERS (POWER TRAIN PUMP STRAINER, SCAVENGING PUMP STRAINER)

! WARNING

- The oil is at high temperature immediately after operations, so wait for the temperature to go down before starting the operation.
- The undercover is heavy. Do not go directly under the cover when opening or closing it. When removing bolts (5), carry out the operation at the rear of the point immediately under the cover so that it is possible to escape at any time.
Prepare the following.

- Oil replacement amount: 90 liters (23.78 US gal)

1. Remove drain cover (1) on the left side of the power train case underside to take off drain plug (2), and then loosen drain plug (P1) to drain oil.
Tighten drain plug (P1) after draining oil.
Do not completely remove drain plug (P1).

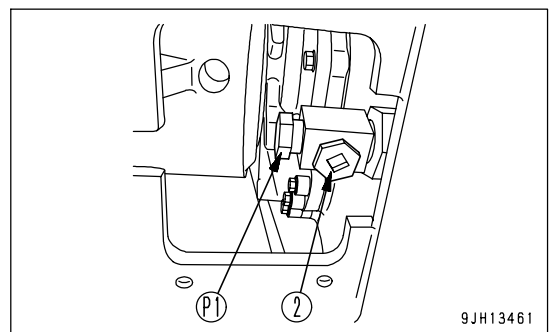
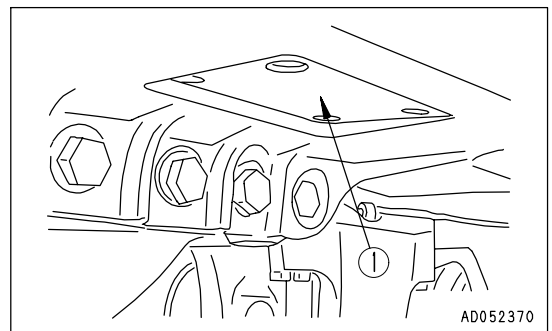

2. Remove inspection cover (3) of the undercover on the bottom rear of the machine as follows.

- 1) Remove 2 bolts (4) on the machine front end.
- 2) Hold down cover (3) and remove 2 bolts (5) on the machine rear end gradually. (Rainwater or other accumulated water may flow out, so be careful.)
- 3) Lower cover (3) gradually and open it. (The front side of the cover is hinged.)

The strainer can be seen at top portion P.

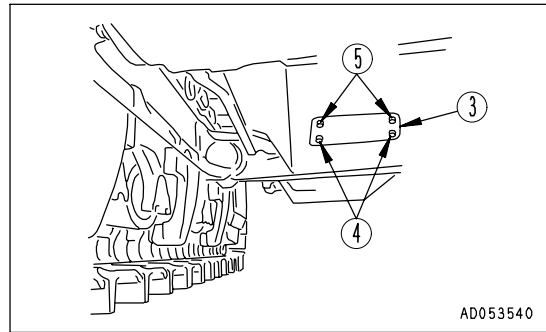

3. Remove drain plug (P2) in the strainer cover, and drain the oil (approx. 4 liters (1.06 US gal)) collected inside the piping.

4. Loosen mounting bolt (6) of the power train strainer, and remove cover (7).
5. Remove spring (8), then remove strainer (9).
6. Remove any dirt stuck to strainer (9), then wash it in clean diesel oil or flushing oil. Wash the removed parts and the inside of the case at the same time.

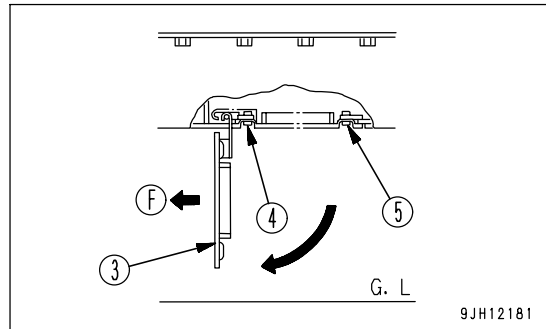

(F)Front of the machine

7. Loosen mounting bolt (10) of the scavenging pump strainer, then remove cover (11).

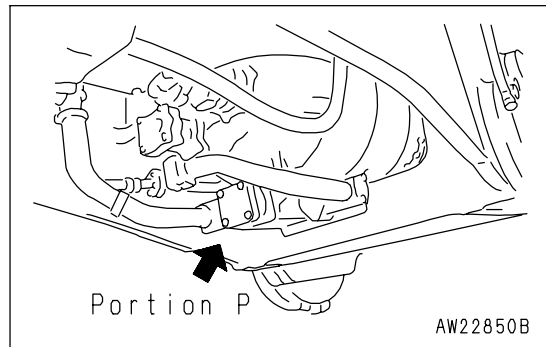

8. Remove strainer (12).
9. Remove any dirt stuck to strainer (12), then wash it in clean diesel oil or flushing oil. Wash the removed parts and the inside of the case at the same time.

10. Install the strainers in their original position.

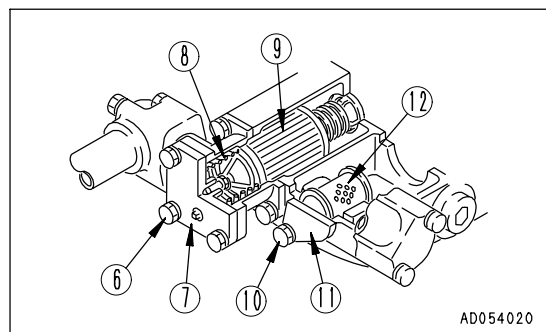

11. Replace the power train oil filter element. For details, see "REPLACE POWER TRAIN OIL FILTER ELEMENT (PAGE 4-63)".
12. Refill the specified quantity of oil through oil filler (F).
13. After filling with oil, check that the oil is at the specified level. For details, see "CHECK OIL LEVEL IN POWER TRAIN CASE, ADD OIL (PAGE 3-105)".
If the spring or strainer are damaged, replace them with a new part.

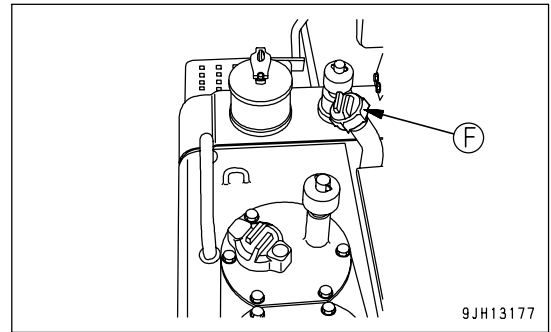

CHANGE OIL IN FINAL DRIVE CASE

⚠ WARNING

The oil is at high temperature immediately after the machine has been operated. Wait for the oil to cool down before starting the operation.

- Oil replacement amount (each): 31 liters (8.19 US gal)

1. Stop the machine so that drain plug (1) is at the bottom.
2. Remove oil level plug (2) and oil filler plug (3), then remove drain plugs (1) and (4) and drain the oil. After draining the oil, tighten the plugs.
3. Add the refill amount of engine oil through the hole of oil filler plug (3).
4. After filling with oil, check that the oil is at the specified level. For details, see "CHECK OIL LEVEL IN FINAL DRIVE CASE, ADD OIL (PAGE 4-54)".

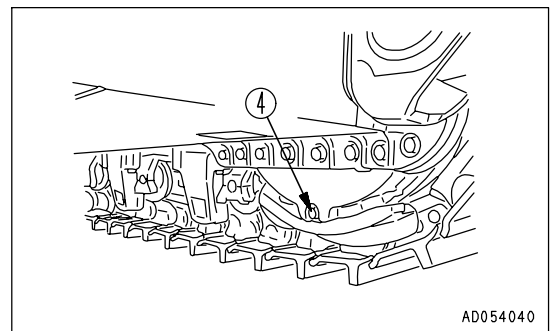
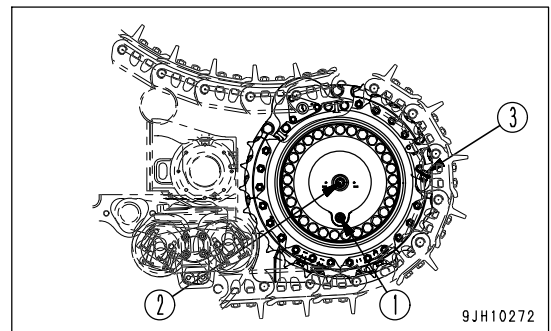

LUBRICATE UNIVERSAL JOINT

! WARNING

The undercover is heavy. Never try to open or close the cover when directly beneath it. When removing bolts(2), carry out the work from the rear of the cover so that you can easily get out of the way.

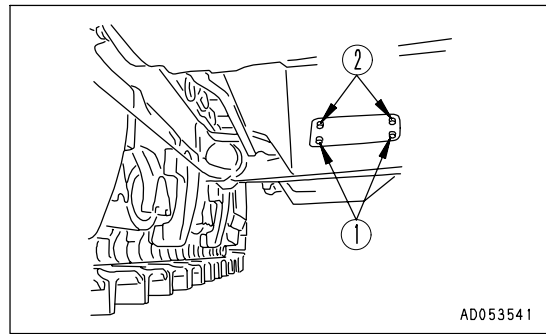

Apply grease to the grease fittings (2 places) shown by arrows.

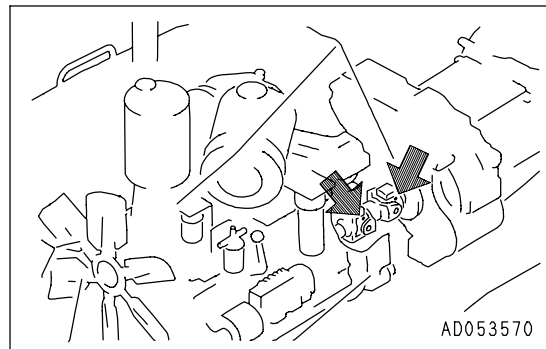

Remove inspection cover (3) of the undercover on the rear bottom of the chassis as follows.

1. Remove 2 bolts (1) toward the front of the machine.
2. Support the cover with your elbow while gradually removing 2 bolts (2) at the rear of the machine.
3. Lower the cover gradually to open it.

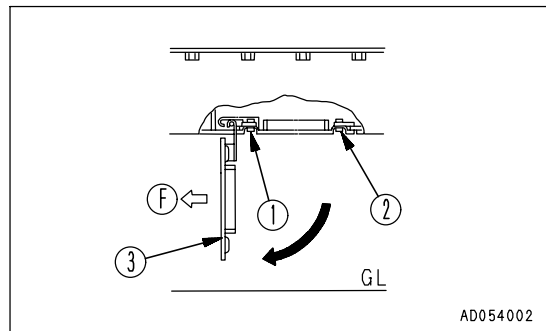

(F)Front of the machine

CHECK ALL TIGHTENING POINTS OF ENGINE EXHAUST PIPE CLAMPS

Please ask your Komatsu distributor to check the tightening of the clamps between the air cleaner - turbocharger - aftercooler - engine.

REPLACE POWER TRAIN CASE BREATHER

Remove the breather, replace it with a new part.

- Power train case breather (1 place)

Remove external cover (2) at the bottom right of the cab. Breather (1) is installed to the right of the window (rear right of the machine).

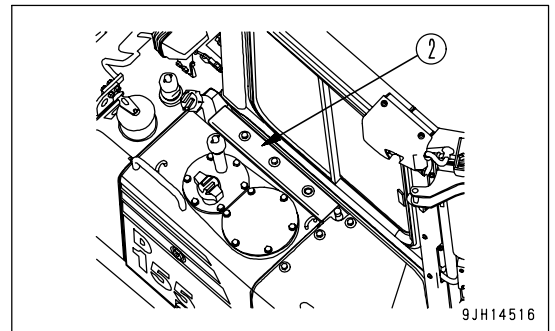
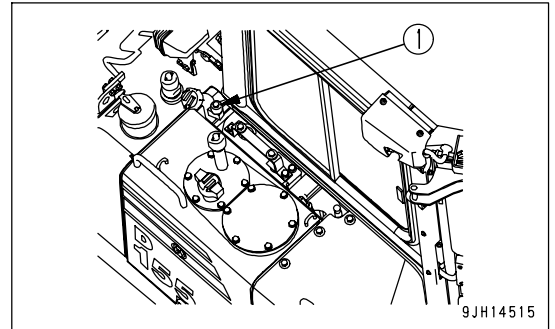

REPLACE ELEMENTS OF HYDRAULIC TANK BREATHER AND FUEL TANK BREATHER

1. Remove nut (2) of breather assembly (1) at the top surface of the hydraulic tank and fuel tank, then remove cover (3).
2. Replace breather element (4) with a new part.
3. Install cover (3) and nut (2).

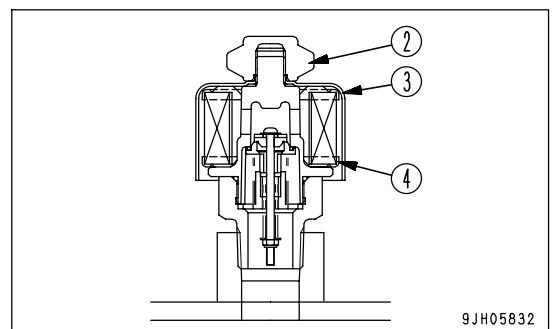
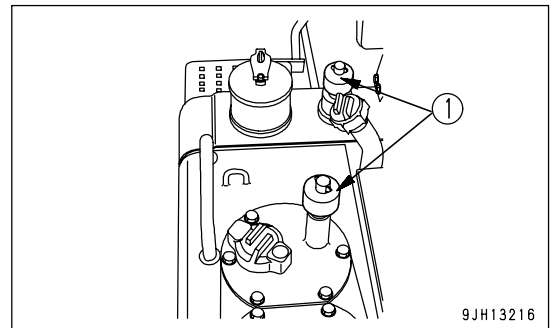

REPLACE PILOT FILTER ELEMENT

1. Loosen slowly oil filler cap (F) on top of the hydraulic tank to eliminate the internal pressure in the hydraulic circuit.

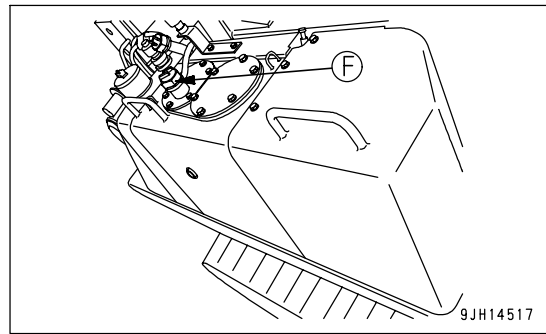

2. Open the left side cover and loosen bolt (1) to take off cover (2).

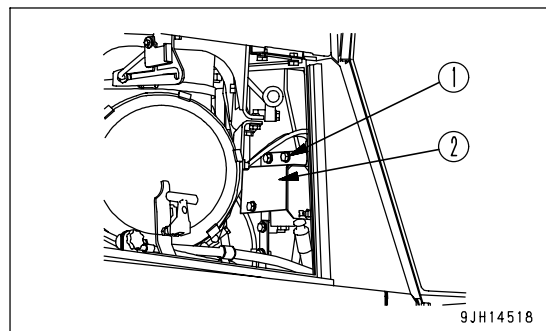

3. Place a container under the filter element to catch the oil.

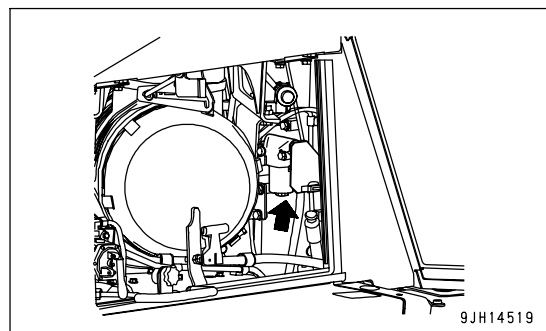

4. After checking that the hydraulic oil temperature has gone down, turn filter case (3) to the left, remove it, then take out element (4).
5. Clean the removed parts, then install new element (4).
 - Element (4) must be installed facing in the correct direction. Set direction Y with the holes in it facing up, and insert the hole in element (4) on the protruding portion inside filter head (6).
6. Install new O-ring (5) to filter case (3), then tighten filter case (3) to a tightening torque of 25 - 35 Nm (2.6 - 3.6 kgm, 18.8 - 26.0 lbf).

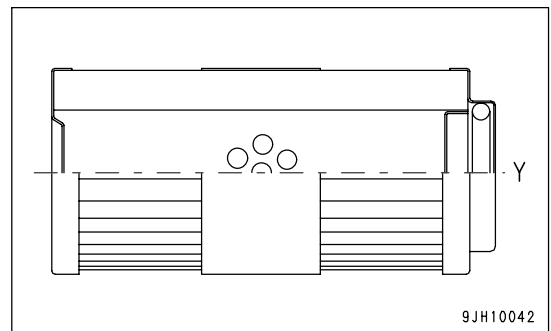
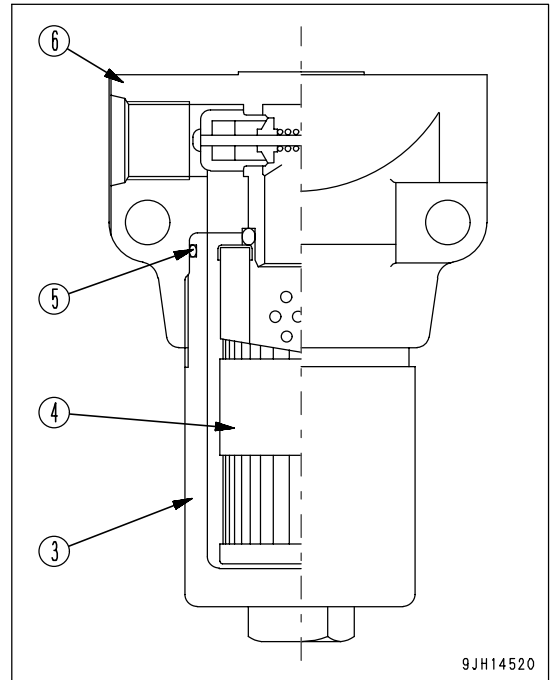

7. Install cover (2) with bolt (1) as before.

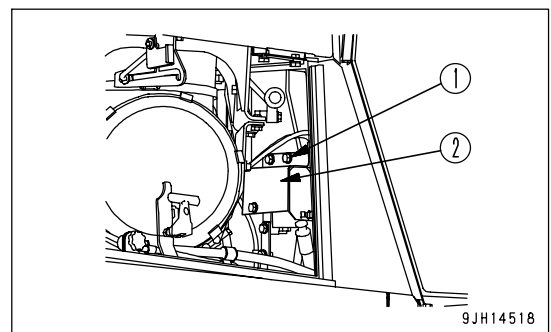

CHECK, CLEAN FUEL STRAINER

1. Tighten fuel supply valve (1) at the bottom of the fuel tank, remove cap (2), then wash the strainer and strainer case. The strainer forms one unit with the cap.
2. After checking and cleaning the strainer, set it in the case, then tighten the cap.
3. After installing, open fuel supply valve (1).

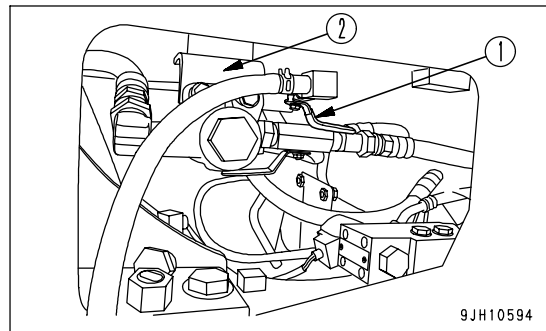
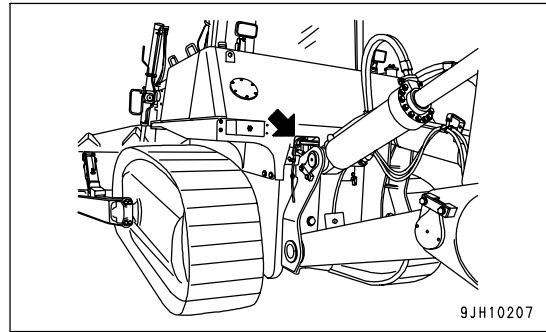

REPLACE CORROSION RESISTOR CARTRIDGE

(If equipped)

**WARNING**

The oil is at high temperature after the engine has been operated, so never replace the cartridge immediately after finishing operations.

Wait for the oil to cool down before replacing cartridge.

- Container to catch coolant
- Prepare a filter wrench

1. Turn valve (1) of corrosion resistor (2) to the CLOSE stopper position.
2. Set a container under the cartridge to catch the coolant.
3. Using a filter wrench, turn cartridge (2) to the left to remove it.
4. Clean the filter holder, coat the seal surface of the new cartridge thinly with oil, then install the cartridge.
 - Always use a genuine Komatsu part for the cartridge.

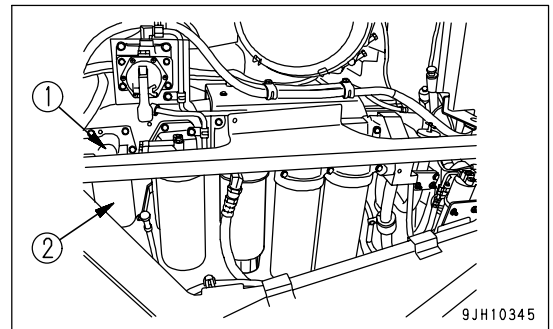

5. When installing the cartridge, bring the packing surface into contact with the seal surface of the filter holder, then tighten a further 2/3 times.

If the filter cartridge is tightened too far, the gasket will be damaged and coolant will leak. If it is too loose, coolant will leak from the gap in the gasket, so always keep the proper tightening angle.
6. Turn valve (1) of corrosion resistor (2) to the OPEN stopper position.
7. After replacing the cartridge, run the engine, and check for any leakage of water from the filter seal surface. If any water leakage is found, check the tightening of the filter cartridge.

REPLACE FUEL MAIN FILTER CARTRIDGE

**WARNING**

- After the engine has been operated, all parts are at high temperature, so do not replace the filter immediately. Wait for all parts to cool down before starting the operation.
- High pressure is generated inside the engine fuel piping system when the engine is running. When replacing the filter, wait for at least 30 seconds after stopping the engine to let the internal pressure go down before replacing the filter.
- Do not bring any fire or flame close.
- Be careful when opening the air bleed plug in the fuel filter head. It is still under pressure, so fuel may spurt out.

NOTICE

- Genuine Komatsu fuel filter cartridges use a special filter that has highly efficient filtering ability. When replacing the filter cartridge, always use a genuine Komatsu part.
 - The common rail fuel injection system used on this machine consists of more precise parts than the conventional injection pump and nozzle. If any part other than a genuine Komatsu filter cartridge is used, dust or dirt may get in and cause problems with the injection system. Always avoid using substitute parts.
 - When carrying out inspection or maintenance of the fuel system, pay more attention than normal to the entry of dirt. If dirt is stuck to any part, use fuel to wash it off completely.
- Container to catch the oil
 - Prepare a filter wrench

1. Set the container to catch the fuel under the filter cartridge.
 - The fuel filter is found by opening the engine side cover on the left of the machine.
2. Remove cover (A).
3. Using a filter wrench, turn filter cartridge (1) counterclockwise on remove it.
4. Clean the filter holder, coat the packing surface of the new filter cartridge thinly with oil, then install the filter cartridge to the filter holder.

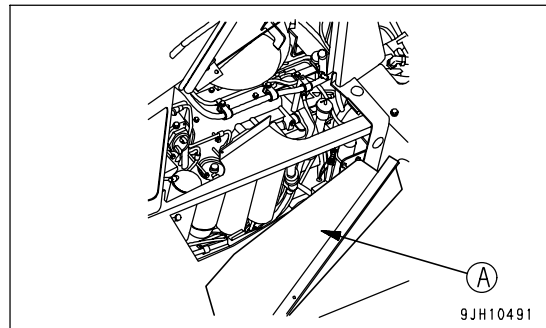
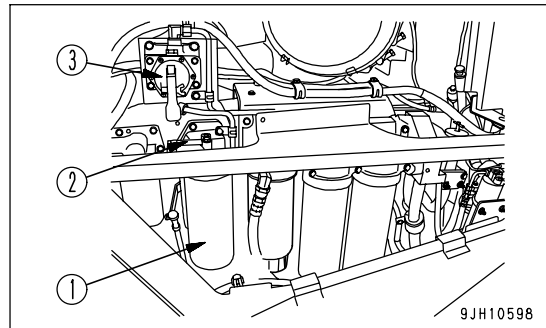

NOTICE

- Do not fill the new filter cartridge with fuel.
- Remove cap (B) and install the filter cartridge.

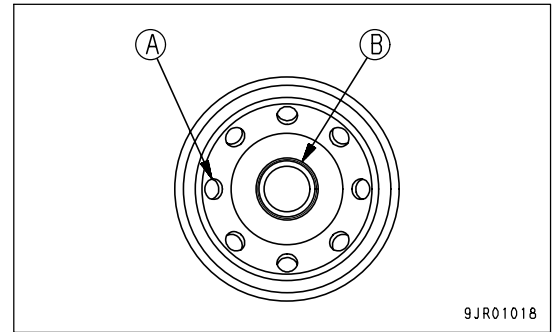

5. When installing, tighten until the packing surface contacts the seal surface of the filter holder, then tighten it 3/4 of a turn.

If the filter cartridge is tightened too far, the packing will be damaged and this will lead to leakage of fuel. If the filter cartridge is too loose, fuel will also leak from the packing, so always tighten the correct amount.

6. After completing the replacement of filter cartridge (2), bleed the air.

Bleed the air as follows:

7. Add fuel to the fuel tank until full (to FULL mark on the fuel gauge).
8. Loosen air bleed plug (C) at the fuel main filter head (3).
9. Loosen wing nut (6) holding lever (5) of priming pump (4).
10. Push in lever (5) repeatedly.
Check that bubbles come out with the fuel from air bleed plug (C).
11. Tighten air bleed plug (C).
Tightening torque: 4.9 to 6.9 Nm (0.5 to 0.7 kgm, 3.6 to 5.1 lbft)
12. Tighten wing nut (6) securely to lock lever (5) in position.
Target tightening torque: 11.8 Nm (1.2 kgm, 8.7 lbft)

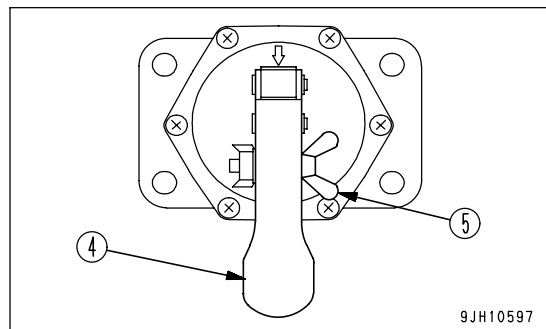
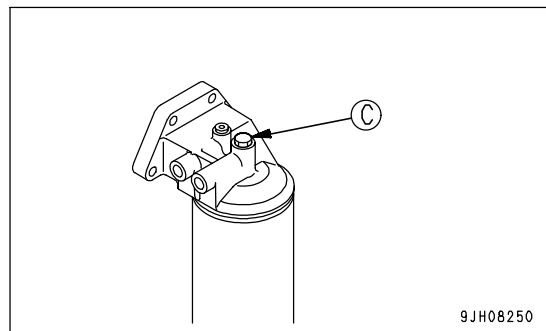
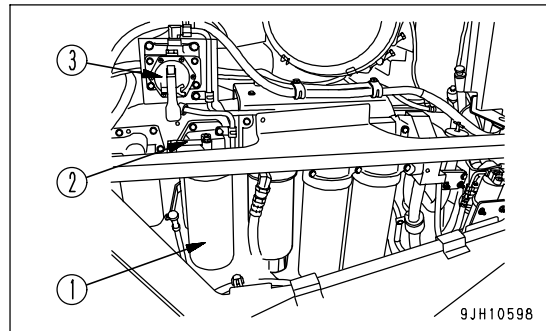

13. After replacing the filter cartridge, start the engine and run it at low idling for 10 minutes.
Check for leakage of fuel from the filter seal surface. If any fuel is leaking, check the tightening of the filter cartridge. If there is still fuel leakage, repeat Steps 1 - 4 to remove the filter cartridge, and if any damage or embedded foreign material in the packing surface is found, replace it with a new cartridge and repeat Steps 5 - 15 to install it.

REMARK

When only the filter cartridge is replaced, it is sufficient that air bleeding is carried out for the filter head alone. But when the fuel piping is removed, air bleeding should also be carried out for the injection pump air-bleeding valve.

EVERY 2000 HOURS SERVICE

Maintenance for every 250, 500 and 1000 hours service should be carried out at the same time.

CHANGE OIL IN HYDRAULIC TANK, REPLACE HYDRAULIC OIL FILTER ELEMENT

 **WARNING**

The oil is at high temperature immediately after the machine has been operated. Wait for the oil to cool down before changing the oil.

When removing the oil filler cap, turn it slowly to release the internal pressure, then remove it carefully.

- Oil replacement amount: 85 liters (22.46 US gal)

1. Park the machine on the flat ground, hold it in the following posture suitable for an oil check and then stop the engine.

(Sigmadozer)

Lower the blade on the ground so that angle (a) of its backside is 6°.

Lower ripper (b) on the ground vertically so that the pin is at the lowest position.

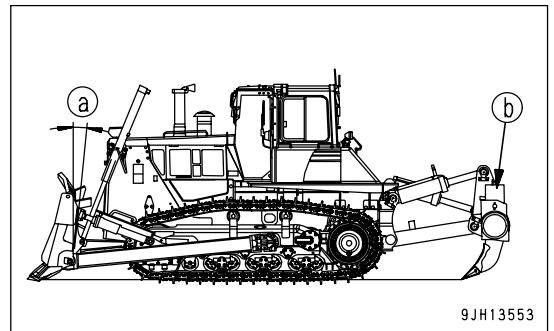

9JH13553

<Reference>

Item		Dimension	Item		Dimension
Blade (DUAL)	Tilt Cylinder length	1,292mm (50.9in)	Blade (SINGLE)	Tilt Cylinder length	1,292mm (50.9in)
				Brace	1,292mm (50.9in)
Ripper (VGR,VMR)	Lift Cylinder length	1,543mm (60.8in)	Ripper (VGR,VMR)	Lift Cylinder length	1,543mm (60.8in)
	Tilt Cylinder length	1,607mm (63.3in)		Tilt Cylinder length	1,607mm (63.3in)

(Semi U-dozer, U-dozer)

Lower the blade on the ground so that backside (a) is upright.
 Lower ripper (b) on the ground vertically so that the pin is at the lowest position.

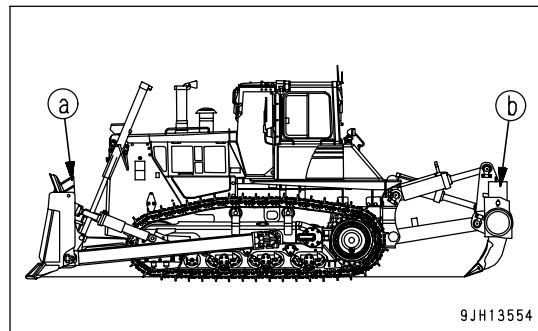

9JH13554

<Reference>

Item		Dimension	Item		Dimension
Blade (DUAL)	Tilt Cylinder length	1,292mm (50.9in)	Blade (SINGLE)	Tilt Cylinder length	1,372mm (54.1in)
				Brace	1,372mm (54.1in)
Ripper (VMR)	Lift Cylinder length	1,543mm (60.8in)	Ripper (VMR)	Lift Cylinder length	1,543mm (60.8in)
	Tilt Cylinder length	1,607mm (63.3in)		Tilt Cylinder length	1,607mm (63.3in)

2. Turn the cap of oil filler port (F) slowly to release the internal pressure, then remove the cap.

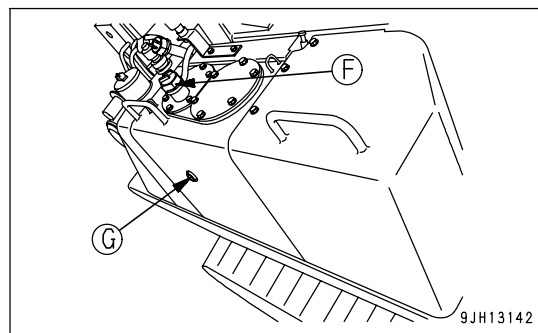

9JH13142

3. Remove plug (1) at the bottom of the hydraulic tank, loosen drain valve (2), and drain the oil. After draining the oil, tighten drain valve (2) and plug (1). When loosening drain valve (2), be careful not to get oil over yourself.

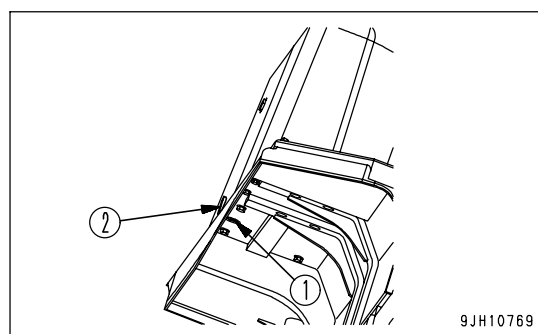

9JH10769

4. Loosen 6 bolts, then remove cover (3). When doing this, the cover may fly out under the force of spring (4), so push the cover down when removing the bolts.
5. After removing spring (4), valve (5) and strainer (6), take out element (7).
 - Inspect the bottom of the filter case for dirt, and remove it, if any. Take good care then not to let fall the dirt into the hydraulic tank.
6. Clean the removed parts in flushing oil.
7. Install the new element in the place where old element (7) was installed.
8. Set valve (5), strainer (6) and spring (4) on top of the element.
9. Set cover (3) in position, push it down by hand, and install the cover with the mousing bolts.
10. Screw in the oil filler cap and install the cover.
11. To bleed the air, start the engine according to "STARTING ENGINE (PAGE 3-122)" and run the engine at low idle for 10 minutes.
12. Stop the engine.
13. After filling with oil, check that the oil is at the specified level. For details, see "CHECK OIL LEVEL IN HYDRAULIC TANK, ADD OIL (PAGE 3-107)".

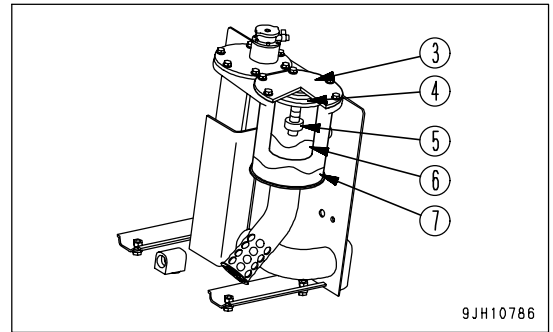

CLEAN ENGINE BREATHER ELEMENT

1. Wipe off all the dirt from around the breather (1).
2. Remove breather (1).
3. Rinse the breather unit in diesel oil or flushing oil, then dry with compressed air.
4. Replace the breather O-ring with a new part, coat with engine oil, then install.

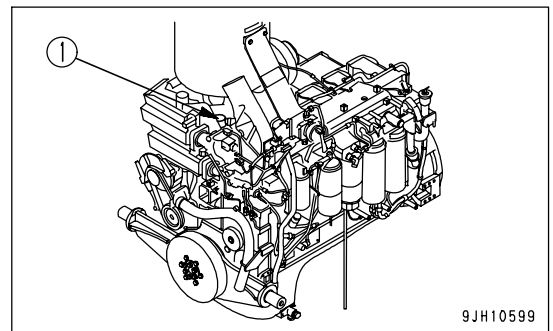

CHECK ALTERNATOR, STARTING MOTOR

The brushes may be worn or the bearing may have run out of grease, contact your Komatsu distributor for inspection and repairs.

If the engine is started frequently, have this inspection carried out every 1000 hours.

CHANGE OIL IN DAMPER CASE, CLEAN DAMPER BREATHER

! WARNING

- The oil is at high temperature immediately after the machine has been operated. Wait for the oil to cool down before carrying out maintenance.
- The undercover is heavy. Do not go directly under the cover when opening or closing it. When removing bolts (4), carry out the operation at the rear of the point immediately under the cover so that it is possible to escape at any time.

- Refill capacity: 1.5 liters (0.40 US gal)

1. Open the engine side cover (1) at the left of the machine; you can see gauge (G).

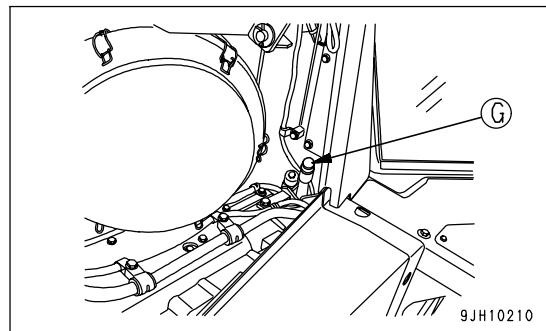
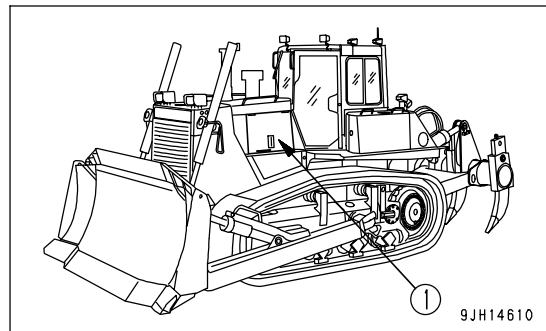

2. Remove the undercover (2) at the bottom rear of the chassis as follows.

- 1) Remove 2 bolts (3) toward the front of the chassis.
- 2) Hold down cover and gradually remove 2 bolts (4) at the machine rear end. (Rainwater or other accumulated water may flow out, so be careful.)

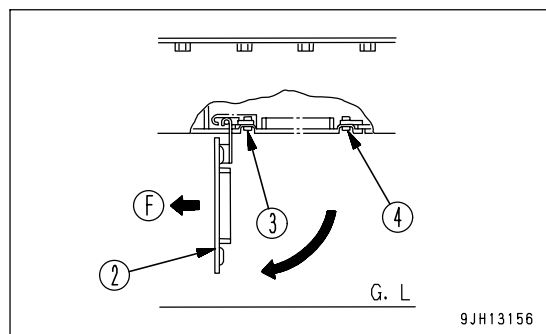

(F)Front of the machine

- 3) Lower cover (2) gradually to open it. Drain plug (P) can be seen at the top.
3. Remove dipstick (G), then remove drain plug (P) and drain the oil.
After draining the oil, tighten drain plug (P).
4. Add oil through the holder of dipstick (G). After adding the oil, insert dipstick (G).
5. Remove any dirt or dust stuck to breather (5), then wash with clean diesel oil or flushing oil. If it cannot be cleaned completely, replace with a new part.
6. Install undercover (2), then close engine side cover (1) on the left side of the machine.

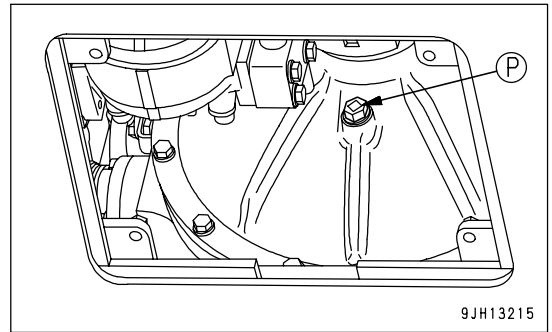

9JH13215

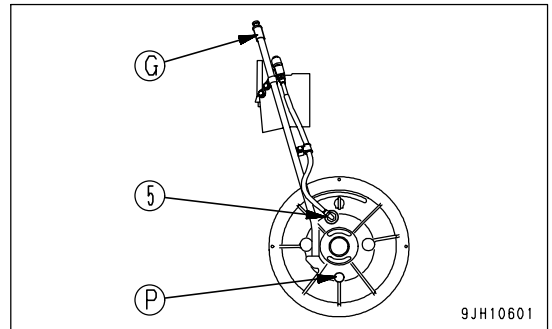

9JH10601

CHECK PIVOT BEARING OIL LEVEL, ADD OIL

1. Remove plug (1).
2. Check that the oil level is up to the oil level (25 mm (1.0 in)) shown in the diagram. If the oil level is low, add engine oil through the hole of plug (1).
3. Install plug (1).

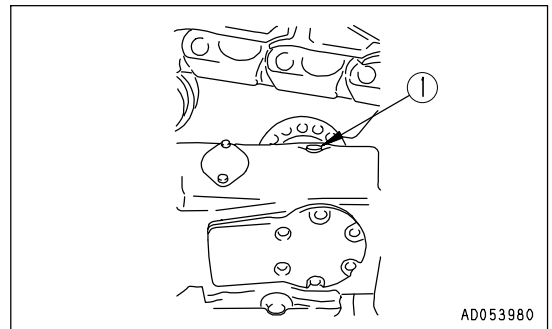

AD053980

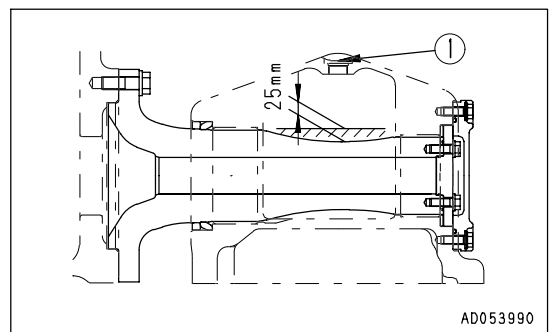

AD053990

CHECKING CHARGE PRESSURE OF NITROGEN GAS IN ACCUMULATOR (FOR CONTROL CIRCUIT) **WARNING**

The accumulator is charged with high-pressure nitrogen gas, so mistaken operation may cause an explosion, which will lead to serious injury or damage. When handling the accumulator, always do as follows.

- The pressure in the hydraulic circuit cannot be completely removed. When removing the hydraulic equipment, do not stand in the direction that the oil spurts out when carrying out the operation. In addition, loosen the bolts slowly when carrying out the operation.
- Do not disassemble the accumulator.
- Do not bring it near flame or dispose of it in fire.
- Do not make holes in it or weld it.
- Do not hit it, roll it, or subject it to any impact.
- When disposing of the accumulator, the gas must be released. Please contact your Komatsu distributor to have this work carried out.

NOTICE

If the nitrogen gas charge pressure in the accumulator is low and operations are continued, it will become impossible to release the remaining pressure inside the hydraulic circuit if a failure occurs on the machine.

FUNCTION OF ACCUMULATOR

The accumulator stores the pressure in the control circuit. Even after the engine is stopped, the control circuit can be operated, so the following actions are possible.

- If the control lever is operated in the direction to lower the work equipment, it is possible for the work equipment to go down under its own weight.
- The pressure in the hydraulic circuit can be released.

The accumulator is installed to the position shown in the diagram on the right.

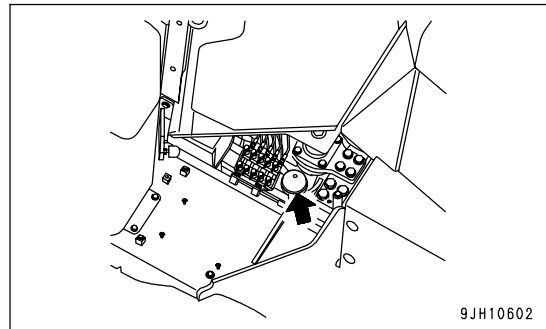

9JH10602

CHECKING FUNCTION OF ACCUMULATOR

 **CAUTION**

When carrying out the inspection, check first that there is no person or obstacle in the surrounding area.

Check the nitrogen gas charge pressure as follows.

1. Stop the machine on firm, level ground.
2. Set the parking brake lever to the LOCK position (L).

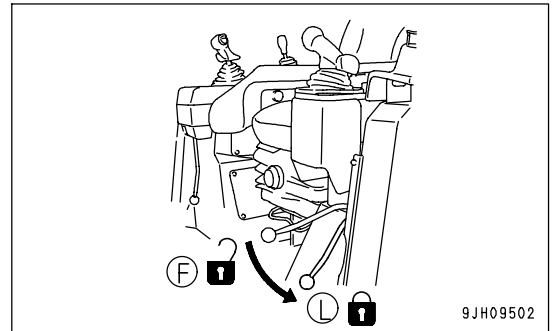

3. Raise the work equipment (blade) to the maximum height.

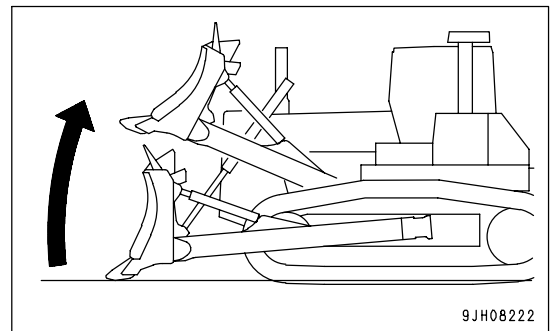

Carry out Steps 4 - 6 within 15 seconds.

When the engine is stopped, the pressure in the accumulator gradually goes down. For this reason, the release can only be carried out immediately after the engine is stopped.

4. Keep the work equipment raised to the maximum height, then turn the starting switch to OFF position (A) to stop the engine.

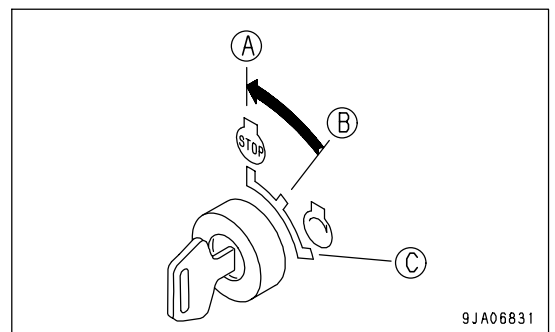

5. Turn the starting switch to the ON position (B).

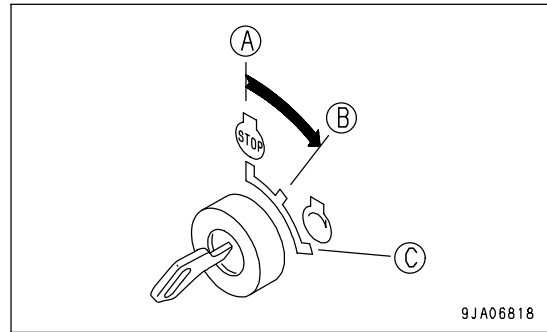

6. Set the work equipment lock lever to the FREE position (F), then operate the blade control lever fully in the LOWER direction and check that the work equipment is completely in contact with the ground.

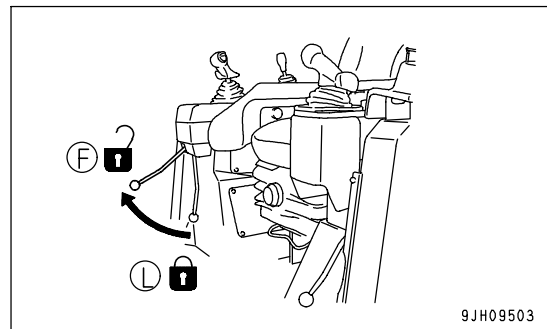

7. If the work equipment goes down under its weight and contacts the ground, the accumulator is normal.
If the work equipment does not go down or stops in midway, the charged pressure of the gas in the accumulator for the hydraulic circuit has probably dropped.
Please contact your Komatsu distributor for inspection.

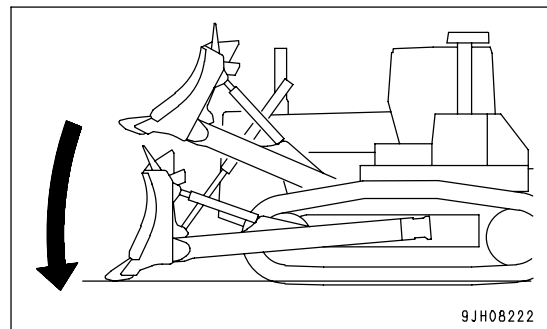

8. This completes the inspection. After completing the inspection, set the work equipment lock lever to the LOCK position and turn the starting switch to the OFF position.

METHOD OF RELEASING PRESSURE IN HYDRAULIC CIRCUIT

1. Lower the work equipment to the ground.
2. Set the parking brake lever and work equipment lock lever to the LOCK position.

Carry out Steps 3 - 5 within 15 seconds.

When the engine is stopped, the pressure in the accumulator gradually goes down. For this reason, the check can only be carried out immediately after the engine is stopped.

3. Stop the engine.
4. Turn the starting switch to the ON position (B).

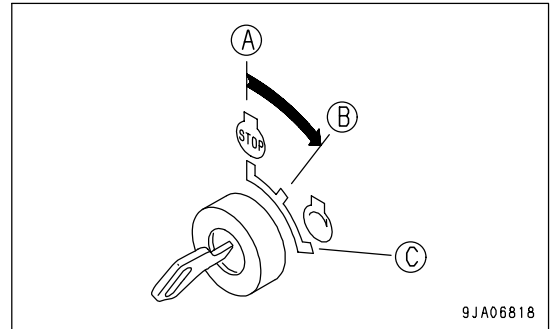

5. Set the work equipment lock lever to the FREE position (F), then operate the blade control lever and ripper control lever fully to the front, rear, left, and right to release the pressure in the hydraulic circuit.

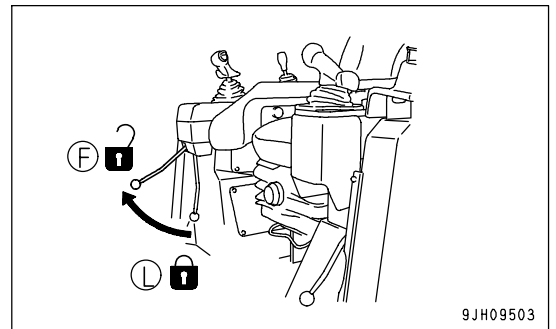

6. Set the work equipment lock lever to the LOCK position and turn the starting switch to the OFF position.

EVERY 4000 HOURS SERVICE

Maintenance for every 250, 500, 1000 and 2000 hours service should be carried out at the same time.

REPLACE ACCUMULATOR (FOR CONTROL CIRCUIT)

Replace the accumulator every 2 years or every 4000 hours, whichever comes sooner.



WARNING

The accumulator is charged with high-pressure nitrogen gas, so mistaken operation may cause an explosion, which will lead to serious injury or damage. When handling the accumulator, always do as follows.

- The pressure in the hydraulic circuit cannot be completely removed. When removing the hydraulic equipment, do not stand in the direction that the oil spurts out when carrying out the operation. In addition, loosen the bolts slowly when carrying out the operation.
- Do not disassemble the accumulator.
- Do not bring it near flame or dispose of it in fire.
- Do not make holes in it or weld it.
- Do not hit it, roll it, or subject it to any impact.
- When disposing of the accumulator, the gas must be released. Please contact your Komatsu distributor to have this work carried out.

If operations are continued after the performance of the accumulator has dropped, it will be impossible to release the remaining pressure in the hydraulic circuit if there should be a failure on the machine. Please ask your Komatsu distributor to replace the accumulator.

The accumulator is installed to the position shown in the diagram on the right.

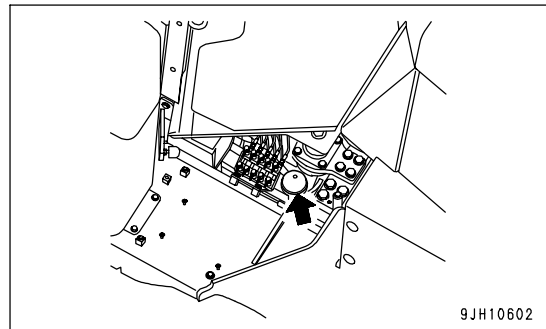

CHECK PLAY OF TURBOCHARGER ROTOR

Contact your Komatsu distributor to have the rotor play checked.

CHECK ENGINE VALVE CLEARANCE, ADJUST

Special tools are needed for inspection and maintenance, so contact your Komatsu distributor.

CHECK WATER PUMP

Check for leakage of oil or water, and check for clogging of breather hole (drain hole) (1). If any abnormality is found, please ask your Komatsu distributor to carry out repairs or replacement.

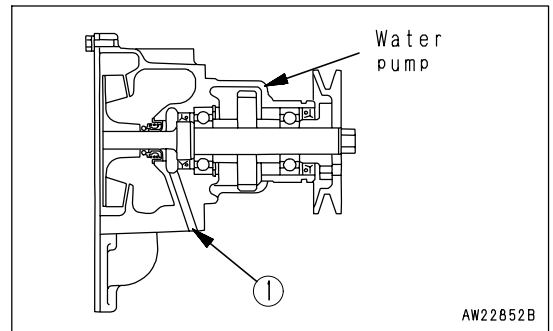
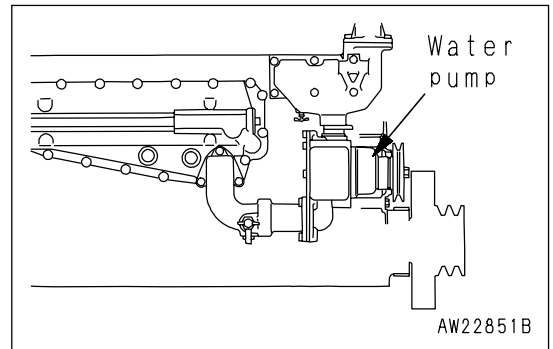

CHECK VIBRATION DAMPER

Check that there is no deformation of the surface of damper (1) and that there are no signs of leakage of damper oil from around the damper.

If any abnormality is found, please ask your Komatsu distributor to carry out replacement.

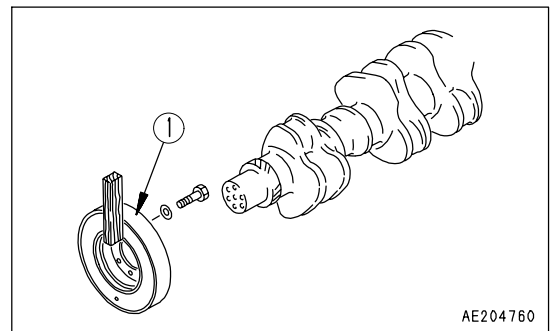

CHECKING FOR LOOSENESS OF HIGH-PRESSURE CLAMP, HARDENING OF RUBBER

Check visually and touch by hand to check that there are no loose mounting bolts for high-pressure piping clamps (1) - (18) in the diagram on the next page and no hardening of any rubber parts. If any problem is found, the part must be replaced. In this case, please ask your Komatsu distributor to carry out the replacement.

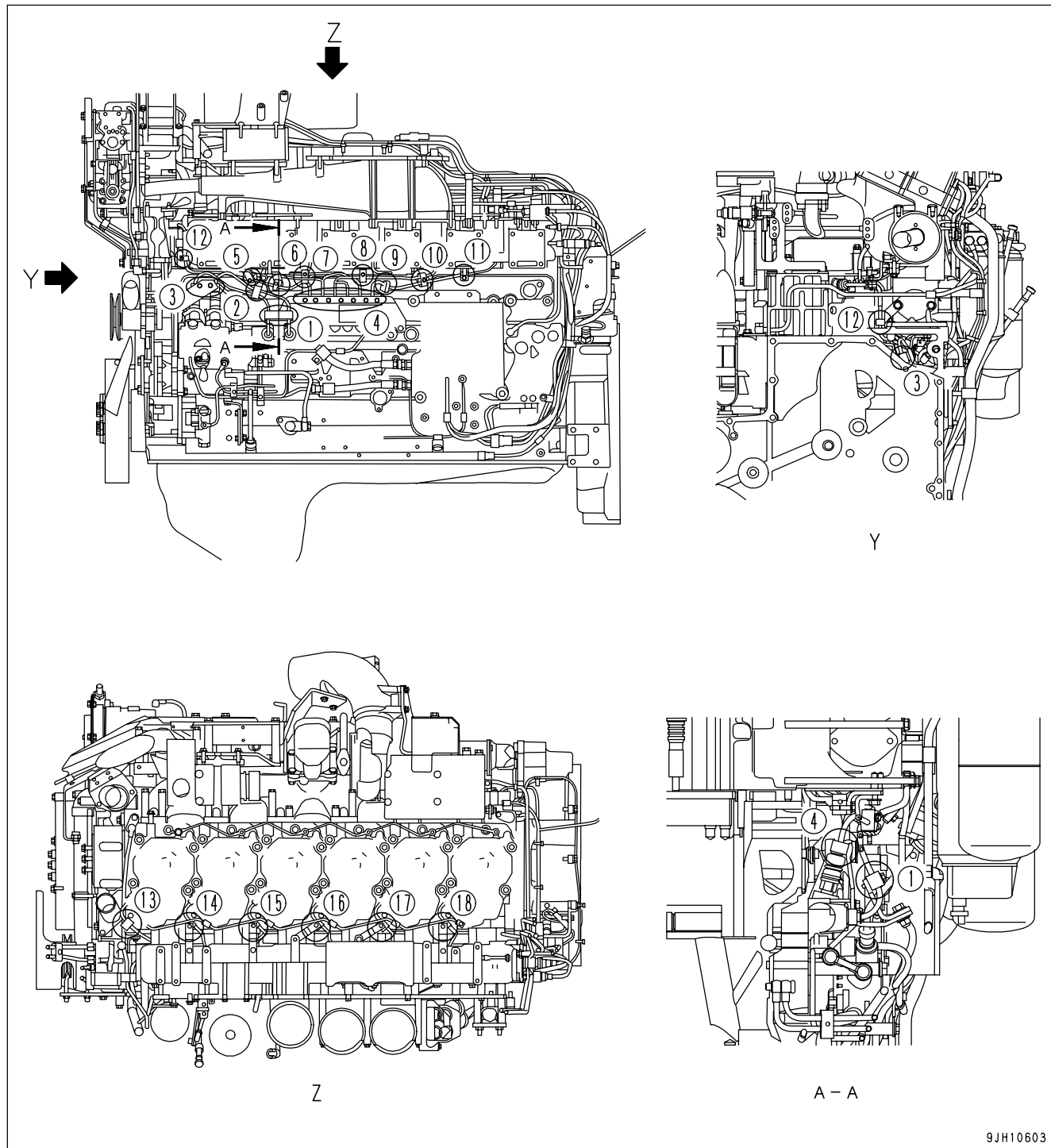

9JH10603

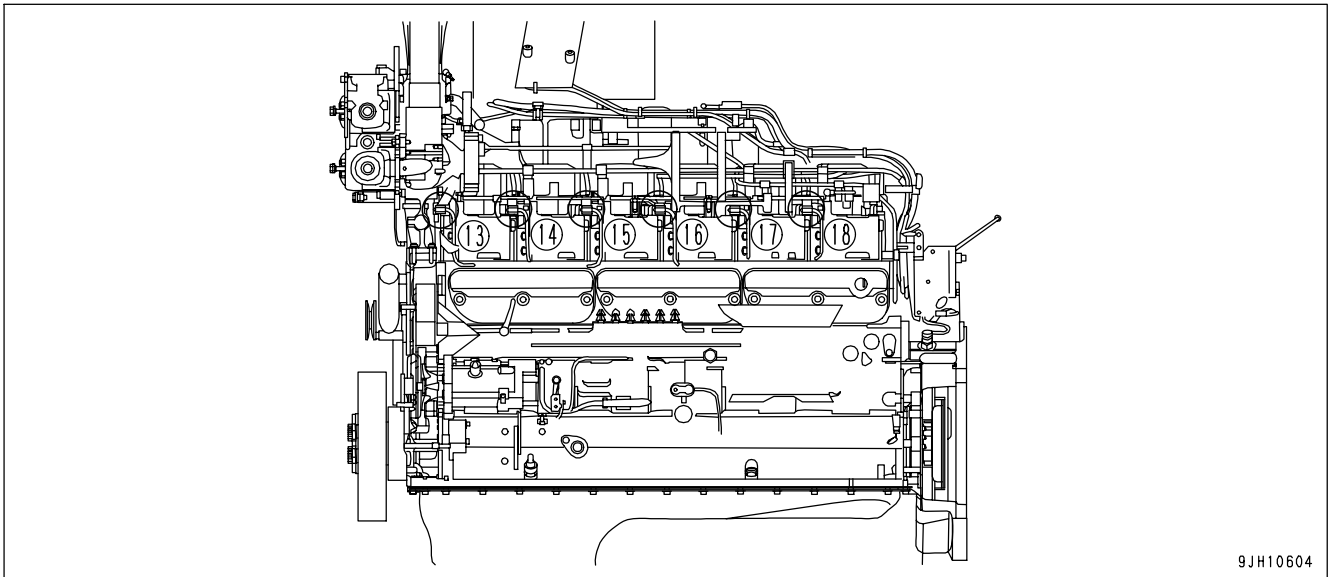

9JH10604

NOTICE

If the engine continues to be used when there are loose bolts, hardened rubber, or missing parts, there is danger of damage or breakage occurring due to vibration and wear at the connections of high-pressure piping. Always check that the proper high-pressure piping clamps are correctly installed.

CHECKING FOR MISSING FUEL SPRAY PREVENTION CAP, HARDENING OF RUBBER

Fuel spray prevention caps (1) - (16) are protection parts installed to prevent fire if any fuel leaks and sprays into contact with high-temperature parts of the engine. Check visually and touch by hand to check that there are no missing caps, no loose mounting bolts, and no hardening of any rubber parts. If any problem is found, the part must be replaced. In this case, please ask your Komatsu distributor to carry out the replacement.

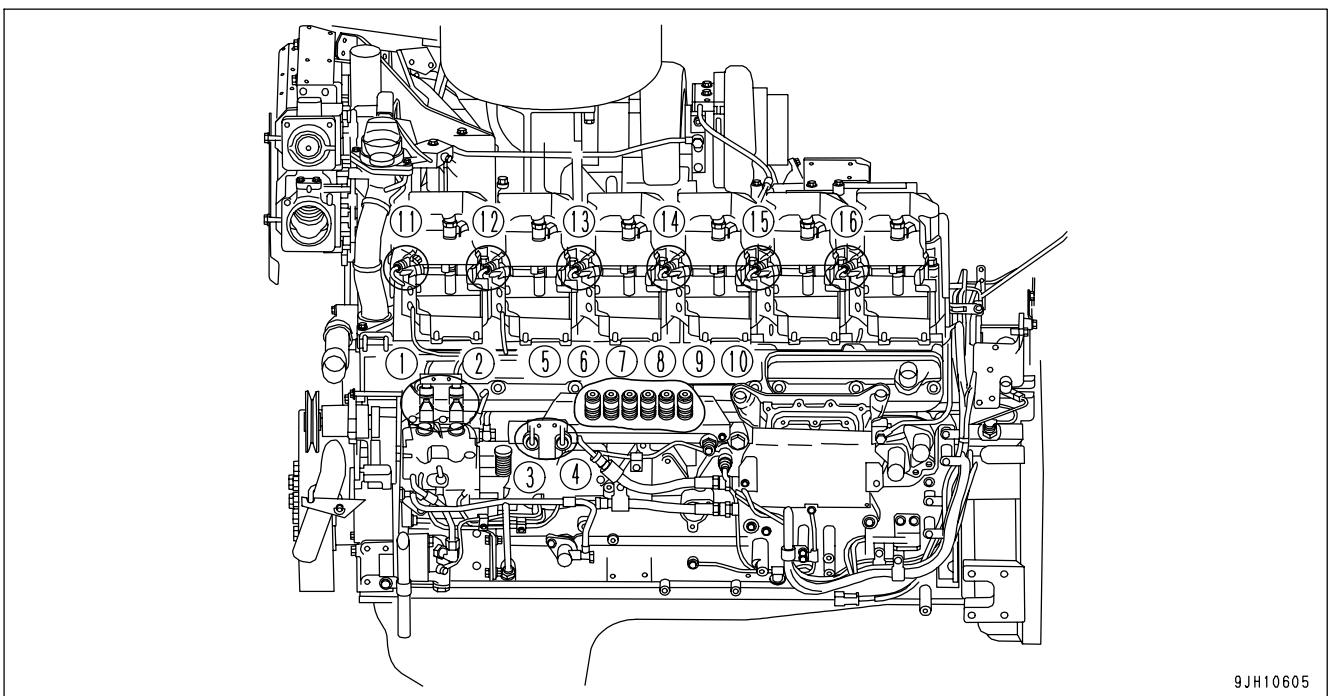

9JH10605

EVERY 8000 HOURS SERVICE

Maintenance for every 250, 500, 1000, 2000, and 4000 hours service should be carried out at the same time.

REPLACE HIGH-PRESSURE PIPING CLAMPS

Contact your Komatsu distributor to have the engine high-pressure clamps replaced.

REPLACE FUEL SPLAY PREVENTION CAPS

Contact your Komatsu distributor to have the fuel spray prevention cap replaced.

SPECIFICATIONS

SPECIFICATIONS

Item		Unit	D155AX-6	
Operating weight (without operator) *1		kg (lb)	39,500 (87,100)	
Blade unit weight (including cylinder)		kg (lb)	5,360 (11,820)	
Ripper unit weight		kg (lb)	2,440 (5,380)	
Name of engine		-	Komatsu SAA6D140E-5 diesel engine	
Engine horsepower		kW (HP) /rpm	239 (320)/1,900	
A	Overall length	mm (ft in)	8,225 (27')	
B	Overall height	mm (ft in)	3,395 (11' 2")	
C	Overall width	mm (ft in)	4,060 (13' 4")	
Travel speed (1st/2nd/3rdLO/3rd)		Forward	km/h (MPH)	3.8/5.6/7.5/11.6 (2.4/3.5/4.7/7.2)
		Reverse	km/h (MPH)	4.6/6.8/9.2/14.0 (2.9/4.2/5.7/8.7)

*1: Hydraulic type tiltdozer (Strengthened SIGMADOZER)
 With hydraulic variable giant ripper, ROPS cab, 560 mm (22.1 in) HD shoe, side cover, air conditioner

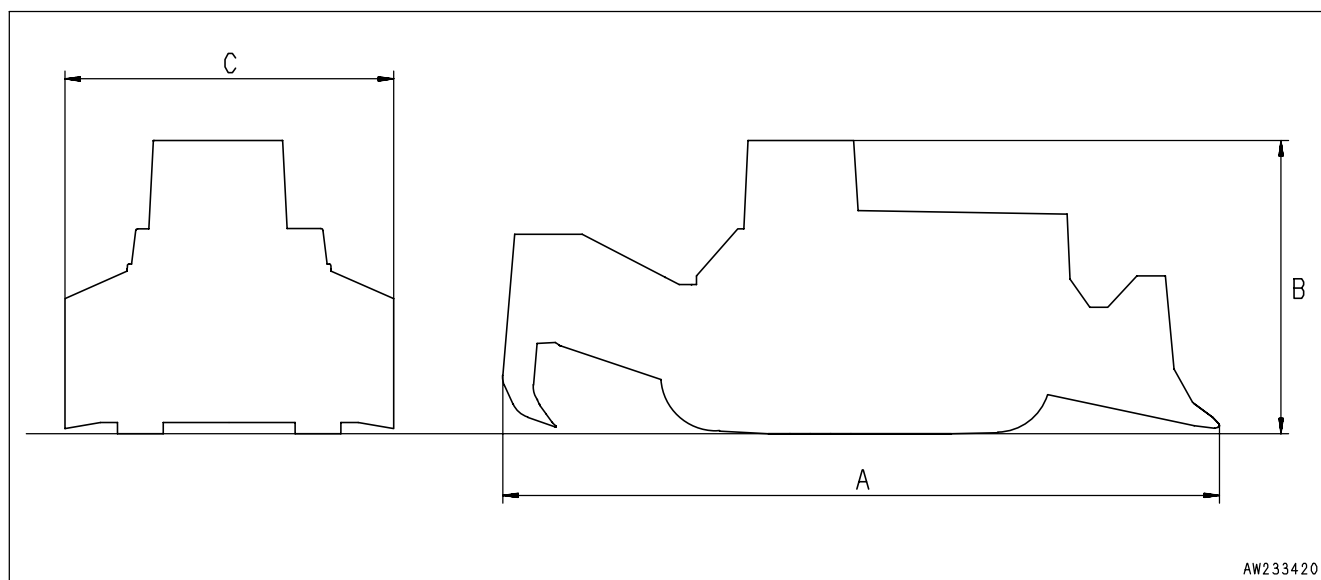

AW233420

ATTACHMENTS, OPTIONS

 **WARNING**

Please read and make sure that you understand the SAFETY section before reading this section.

GENERAL PRECAUTIONS

PRECAUTIONS RELATED TO SAFETY

If attachments or options other than those authorized by Komatsu are installed, this will not only affect the life of the machine, but will also cause problems with safety.

When installing attachments not listed in this Operation and Maintenance Manual, contact your Komatsu distributor first.

If you do not contact Komatsu, we cannot accept any responsibility for any accidents or failures.



WARNING

General precautions

- Read the instruction manual for the attachment thoroughly, and do not use this attachment unless you are sure that you have understood the guides completely.
If you lose the instruction manual, always ask the manufacturer or your Komatsu distributor for a new copy.
- Depending on the attachment, install the necessary front guard on the machine.
- Depending on the attachment, the impact noise may make it difficult for fellow workers to transmit instructions for the operation. Before starting operation, decide a leader and determine the signals to be used.
- Do not carry out swinging operations to the side with a heavy load on the attachment. This is particularly dangerous on slopes.
- Comparing with a machine equipped with a bucket, a machine equipped with a breaker has a heavy load at the front of the work equipment and is unstable. To avoid a hazard of tipping over, do not carry out operations with the attachment swung to the side.
- When an attachment is installed, the swing range and center of gravity of the machine are different, and the machine may move in an unexpected way. Be sure that you understand the condition of the machine properly.
- Before starting operations, set up a fence around the machine to prevent people from entering.
Never operate the machine when there are people near the machine.
- To prevent serious accidents caused by misoperation, do not put your foot on the pedal except when operating the pedal.

Precautions for removal and installation operations

When removing or installing the attachments, obey the following precautions and take care to ensure safety during the operation.

- Carry out the removal and installation operation on a flat, firm ground surface.
- When the operation is carried out by two or more workers, determine the signals and follow these during the operation.
- When carrying heavy objects (more than 25 kg or 55 lb), use a crane.
- When removing heavy parts, always support the part before removing it.
When lifting such as heavy parts with a crane, always pay careful attention to the position of the center of gravity.
- It is dangerous to carry out operations with the load kept suspended. Always set the load on a stand, and check that it is safe.
- When removing or installing attachments, make sure that it is in a stable condition and will not fall over.
- Never go under a load suspended from a crane.
Always stand in a position that is safe even if the load should fall.

NOTICE

Qualifications are required to operate a crane. Never allow the crane to be operated by an unqualified person.

For details of removal and installation operations, contact your Komatsu distributor.

INTRODUCTION OF ATTACHMENTS AND OPTIONS

INTRODUCTION OF ATTACHMENTS AND OPTIONS

Name	Specifications, use
Track shoes	Wide shoe width 610 mm (24 in)
	Wide shoe width 660 mm (26 in)
	Wide shoe width 710 mm (28 in)
	Heavy-duty shoe width 610 mm (24 in)
	Heavy-duty shoe width 660 mm (26 in)
Ripper point	-
Cap with lock	-
Headrest	-

Various other optional parts are available, so please contact your Komatsu distributor.

HEADREST, HANDLING

Use the headrest fully pushed in to the lowest position.

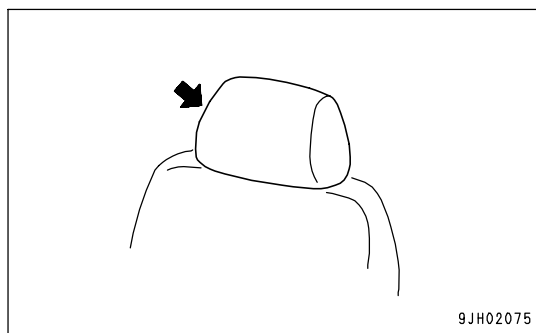

PROCEDURE FOR SELECTING RIPPER POINT

PROCEDURE FOR SELECTING RIPPER POINT

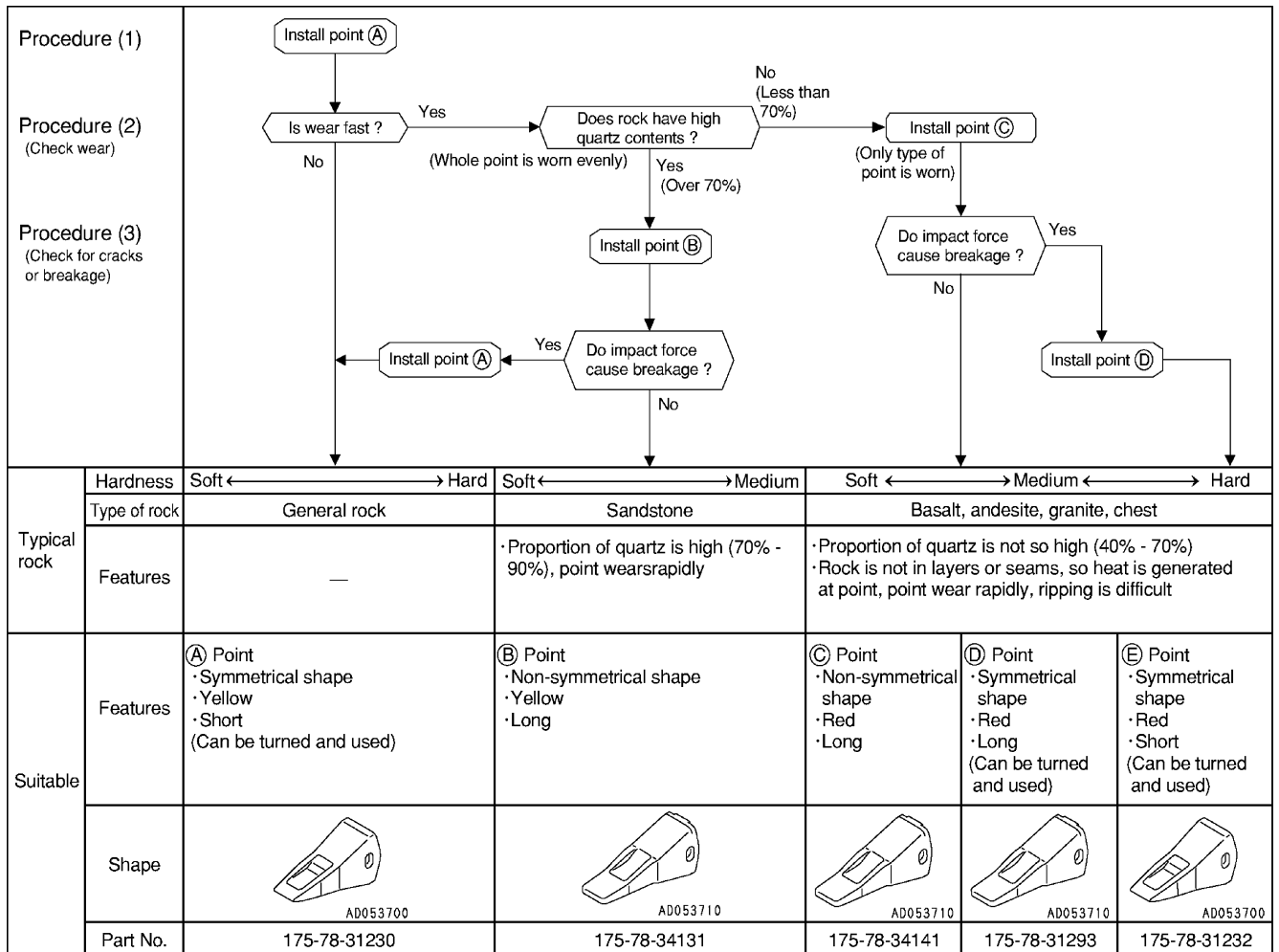

REMARK

- A symmetrical ripper point is suited to a terrain of hard rocks because it recovers penetrability by turning the point after the penetrability drops due to its worn tip.
- Ripper points usually lose their hardness when they undergo intense heat generated by a contact with rocks during the use. In this respect, red ripper points are suited to a terrain of hard rocks where those others are likely to slip during the use, because red ones are made of materials whose hardness less lowers under intense heat, compared with yellow ripper points.

HANDLING MACHINES EQUIPPED WITH KOMTRAX

- KOMTRAX is a machine management system that uses wireless communications.
- A contract with your Komatsu distributor is necessary before the KOMTRAX system can be used. Any customers desiring to use the KOMTRAX system should consult their Komatsu distributor.
- The KOMTRAX equipment is a wireless device using radio waves, so it is necessary to obtain authorization and conform to the laws of the country or territory where the machine equipped with KOMTRAX is being used. Always contact your Komatsu distributor before selling or exporting any machine equipped with KOMTRAX.
- When selling or exporting the machine or at other times when your Komatsu distributor considers it necessary, it may be necessary for your Komatsu distributor to remove the KOMTRAX equipment or to carry out action to stop communications.
- If you do not obey the above precautions, neither Komatsu nor your Komatsu distributor can take any responsibility for any problem that is caused or for any loss that results.

BASIC PRECAUTIONS



WARNING

- Never disassemble, repair, modify, or move the communications terminal, antenna, or cables. This may cause failure or fire on the KOMTRAX equipment or the machine itself. (Your Komatsu distributor will carry out removal and installation of KOMTRAX.)
- Do not allow cables or cords to become caught; do not damage or pull cables or cords by force. Short circuits or disconnected wires may cause failure or fire on the KOMTRAX equipment or the machine itself.
- For anyone wearing a pacemaker, make sure that the communications antenna is at least 22 cm (8.7 in) from the pacemaker. The radio waves may have an adverse effect on the operation of the pacemaker.

NOTICE

- Even when the key in the starting switch of the KOMTRAX system is at the OFF position, a small amount of electric power is consumed. When putting the machine into long-term storage, take the action given in "LONG-TERM STORAGE (PAGE 3-184)".
- Please contact your Komatsu distributor before installing a top guard or other attachment that covers the cab roof.
- Be careful not to get water on the communications terminal or wiring.

REMARK

- The KOMTRAX system uses wireless communications, so it cannot be used inside tunnels, underground, inside buildings, or in mountain areas where radio waves cannot be received. Even when the machine is outside, it cannot be used in areas where the radio signal is weak or in areas outside the wireless communication service area.
- There is absolutely no need to inspect or operate the KOMTRAX communications terminal, but if any abnormality is found, please consult your Komatsu distributor.

INDEX

<A>		PRECAUTIONS BEFORE STARTING	
ADJUSTING POSTURE OF WORK		OPERATION -----	2- 11
EQUIPMENT -----	3-160	PRECAUTIONS RELATED TO	
ASHTRAY -----	3- 71	ATTACHMENTS AND OPTIONS -----	2- 16
		PRECAUTIONS RELATED TO	
BEFORE READING THIS MANUAL -----	1- 2	PROTECTIVE STRUCTURES -----	2- 16
<C>		PRECAUTIONS WHEN GETTING ON	
CAP WITH LOCK -----	3- 69	OR OFF MACHINE -----	2- 14
CAR RADIO, HANDLING -----	3- 72	PRECAUTIONS WHEN RUNNING	
CAR STEREO, HANDLING -----	3- 77	ENGINE INSIDE BUILDING -----	2- 17
CHECK AFTER FINISHING WORK -----	3-148	PREPARATIONS FOR SAFE	
CHECK AFTER STOPPING ENGINE -----	3-147	OPERATION -----	2- 11
CHECK BEFORE STARTING ENGINE,		UNAUTHORIZED MODIFICATION -----	2- 16
ADJUST -----	3- 98	GENERAL VIEW -----	3- 2
COLD WEATHER OPERATION -----	3-181	GENERAL VIEW OF CONTROLS AND	
AFTER COLD WEATHER -----	3-183	GAUGES -----	3- 3
AFTER COMPLETION OF WORK -----	3-183	GENERAL VIEW OF MACHINE -----	3- 2
PRECAUTIONS FOR LOW		GUIDES TO MAINTENANCE -----	4- 2
TEMPERATURE -----	3-181	<H>	
CONTROL LEVERS, PEDALS -----	3- 56	HANDLING AIR CONDITIONER -----	3- 84
<D>		HANDLING MACHINES EQUIPPED	
DOOR POCKET -----	3- 71	WITH KOMTRAX -----	6- 6
DUST INDICATOR -----	3- 64	BASIC PRECAUTIONS -----	6- 6
<E>		HANDLING OIL, FUEL, COOLANT, AND	
EPA REGULATIONS, ENGINE NUMBER		PERFORMING OIL CLINIC -----	4- 5
PLATE -----	1- 7	HEADREST, HANDLING -----	6- 4
EXPLANATION OF COMPONENTS -----	3- 5	<I>	
<F>		INTRODUCTION -----	1- 4
FRONT/REAR, LEFT/RIGHT		INTRODUCTION OF ATTACHMENTS	
DIRECTIONS OF MACHINE -----	1- 4	AND OPTIONS -----	6- 3
FUSE BOX -----	3- 65	INTRODUCTION OF ATTACHMENTS	
<G>		AND OPTIONS -----	6- 3
GENERAL PRECAUTIONS -----	6- 2	<L>	
PRECAUTIONS RELATED TO		LOADING, UNLOADING WORK -----	3-173
SAFETY -----	6- 2	LOCKING -----	3-148
GENERAL PRECAUTIONS COMMON		LONG-TERM STORAGE -----	3-184
TO OPERATION AND MAINTENANCE ----	2- 11	AFTER STORAGE -----	3-184
DO NOT GET CAUGHT IN WORK		BEFORE STORAGE -----	3-184
EQUIPMENT -----	2- 16	DURING STORAGE -----	3-184
FIRE PREVENTION -----	2- 13	STARTING MACHINE AFTER	
		LONG-TERM STORAGE -----	3-184
		<M>	
		MACHINE MONITOR -----	3- 5

MAINTENANCE SCHEDULE CHART -----	4- 17	SAFETY CRITICAL PARTS -----	4- 15
METHOD OF LIFTING MACHINE -----	3-176	SAFETY INFORMATION -----	1- 3
MOVING MACHINE -----	3-131	SAFETY LABELS -----	2- 5
<N>		SERVICE PROCEDURE -----	4- 19
NECESSARY INFORMATION -----	1- 6	CHECK BEFORE STARTING -----	4- 50
<O>		EVERY 1000 HOURS SERVICE -----	4- 67
OPERATING METHOD FOR RIPPING		EVERY 2000 HOURS SERVICE -----	4- 79
OPERATIONS -----	3-152	EVERY 250 HOURS SERVICE -----	4- 51
OPERATION -----	3- 98	EVERY 4000 HOURS SERVICE -----	4- 88
OPERATIONS AND CHECKS AFTER		EVERY 500 HOURS SERVICE -----	4- 60
STARTING ENGINE -----	3-126	EVERY 8000 HOURS SERVICE -----	4- 92
OUTLINE OF ELECTRIC SYSTEM -----	4- 8	INITIAL 250 HOURS SERVICE (ONLY	
OUTLINES OF SERVICE -----	4- 5	AFTER THE FIRST 250 HOURS) -----	4- 19
<P>		WHEN REQUIRED -----	4- 20
PARKING MACHINE -----	3-146	SHIFTING BETWEEN FORWARD AND	
PERIODIC REPLACEMENT OF SAFETY		REVERSE -----	3-140
CRITICAL PARTS -----	4- 15	SHIFTING GEAR -----	3-134
POSITION OF SERVICE METER -----	1- 8	SPECIFICATIONS -----	5- 2
PRECAUTIONS FOR MAINTENANCE -----	2- 29	STANDARD TIGHTENING TORQUES	
PRECAUTIONS BEFORE STARTING		FOR BOLTS AND NUTS -----	4- 14
INSPECTION AND MAINTENANCE -----	2- 29	STARTING ENGINE -----	3-122
PRECAUTIONS FOR INSPECTION		STEERING MACHINE -----	3-142
AND MAINTENANCE -----	2- 33	STOPPING ENGINE -----	3-130
PRECAUTIONS FOR OPERATION -----	2- 18	STOPPING MACHINE -----	3-133
OPERATION -----	2- 23	SWITCHES -----	3- 52
PRECAUTIONS FOR JOBSITE -----	2- 18	<T>	
STARTING ENGINE -----	2- 20	TABLE TO ENTER SERIAL NO. AND	
TOWING -----	2- 28	DISTRIBUTOR -----	1- 9
TRANSPORTATION -----	2- 27	TIPS FOR LONGER UNDERCARRIAGE	
PRECAUTIONS FOR OPERATION -----	3-144	LIFE -----	3-169
PRECAUTIONS FOR		TORQUE LIST -----	4- 14
TRANSPORTATION -----	3-178	TRANSPORTATION -----	3-173
PROCEDURE FOR SELECTING		TRAVELING ON ROADS -----	3-178
RIPPER POINT -----	6- 5	TROUBLESHOOTING -----	3-185
PROCEDURE FOR SELECTING		AFTER RUNNING OUT OF FUEL -----	3-185
RIPPER POINT -----	6- 5	IF BATTERY IS DISCHARGED -----	3-188
PRODUCT IDENTIFICATION NUMBER		METHOD OF TOWING MACHINE -----	3-187
(PIN), MACHINE SERIAL NO. PLATE -----	1- 6	OTHER TROUBLE -----	3-191
<R>		<U>	
RECOMMENDED FUEL, COOLANT,		USE OF MACHINE -----	1- 4
AND LUBRICANT -----	4- 11	<V>	
REMOVAL OF CAB -----	3-179	VISIBILITY FROM OPERATOR'S SEAT ---	1- 5
RIPPER OPERATION -----	3-149	<W>	
<S>		WEAR PARTS -----	4- 9
SAFETY -----	2- 2	WEAR PARTS LIST -----	4- 9
		WORK POSSIBLE USING BULLDOZER ---	3-158

D155AX-6 BULLDOZER

Form No. TEN00310-01
