

Operation & Maintenance Manual

HYDRAULIC
EXCAVATOR

GALEO

PC1250 -8

PC1250SP -8

PC1250LC -8

SERIAL NUMBERS 30001 and up

ecot3

NOTICE

Komatsu has Operation & Maintenance Manuals written in some other languages . If a foreign language manual is necessary , contact your local distributor for availability .

⚠ WARNING

Unsafe use of this machine may cause serious injury or Death. Operators and maintenance personnel must read this manual before operating or maintaining this machine. This manual should be kept near the machine for reference and periodically reviewed by all personnel who will come into contact with it .

KOMATSU

FOREWORD

CALIFORNIA

Proposition 65 Warning

Diesel engine exhaust and some of its constituents are known to the State of California to cause cancer, birth defects, and other reproductive harm.

CALIFORNIA

Proposition 65 Warning

Battery posts, terminals and related accessories contain lead and lead compounds, chemicals known to the State of California to cause cancer and birth defects or other reproductive harm.

Wash hands after handling.

FOREWORD

This manual provides rules and guidelines which will help you use this machine safely and effectively. The precautions in this manual must be followed at all times when performing operation and maintenance. Most accidents are caused by the failure to follow fundamental safety rules for the operation and maintenance of machines. Accidents can be prevented by knowing beforehand conditions that may cause a hazard when performing operation and maintenance.



WARNING

Before beginning operation or maintenance, operators and maintenance personnel must always observe the following points.

- Read this manual thoroughly and understand its contents fully.
- Read the safety messages and safety labels given in this manual carefully so that they should be understood fully.

Keep this manual at the storage location for the Operation and Maintenance Manual given below so that all personnel involved in working on the machine can consult it periodically.

In case this manual should be lost or damaged, immediately contact Komatsu or your Komatsu distributor to obtain a new copy.

When you sell the machine, make sure that this manual should be provided to the new owner together with the machine.

In this manual, measurements are expressed in international standard units (SI). For the reference purpose, weight units used in the past are also displayed in ().

Storage location for the Operation and Maintenance Manual:
magazine box on the left side of the operator's seat.

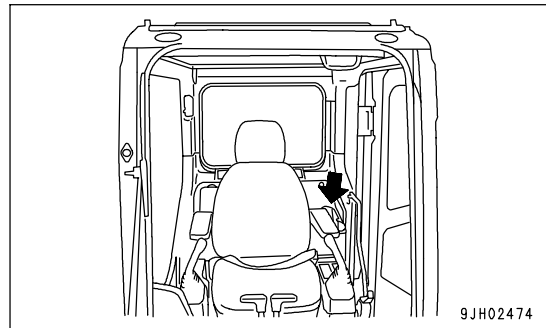

EMISSION CONTROL WARRANTY**EMISSION CONTROL WARRANTY STATEMENT (APPLIES TO CANADA ONLY)****1. Products Warranted**

Komatsu America International Company, Komatsu Mining Systems Inc. and Komatsu Utility Corporation (collectively "Komatsu") produce and/or market products under brand names of Komatsu, Dresser, Dressta, Haulpak and Galion. This emissions warranty applies to new engines bearing the Komatsu name installed in these products and used in Canada in machines designed for industrial off-highway use. This warranty applies only to these engines produced on or after January 1, 2000. This warranty will be administered by Komatsu distribution in Canada.

2. Coverage

Komatsu warrants to the ultimate purchaser and each subsequent purchaser that the engine is designed, built and equipped so as to conform, at the time of sale by Komatsu, with all U.S. Federal emission regulations applicable at the time of manufacture and that it is free from defects in workmanship or material which would cause it not to meet these regulations within five years or 3,000 hours of operation, whichever occurs first, as measured from the date of delivery of the engine to the ultimate purchaser.

3. Limitations

Failures, other than those resulting from defects in materials or workmanship, are not covered by this warranty. Komatsu is not responsible for failures or damage resulting from what Komatsu determines to be abuse or neglect, including, but not limited to: operation without adequate coolant or lubricants; over fueling; over speeding; lack of maintenance of lubricating, cooling or intake systems; improper storage, starting, warm-up, run-in or shutdown practices; unauthorized modifications of the engine. Komatsu is also not responsible for failures caused by incorrect fuel or by water, dirt or other contaminants in the fuel. Komatsu is not responsible for non-engine repairs, "downtime" expense, related damage, fines, all business costs or other losses resulting from a warrantable failure.

KOMATSU IS NOT RESPONSIBLE FOR INCIDENTAL OR CONSEQUENTIAL DAMAGES.

This warranty, together with the express commercial warranties, are the sole warranties of Komatsu. **THERE ARE NO OTHER WARRANTIES, EXPRESS OR IMPLIED, OR OF MERCHANTABILITY OR FITNESS FOR A PARTICULAR PURPOSE.**

GARANTIE SUR LE CONTRÔLE DES ÉMISSIONS**ÉNONCÉ DE GARANTIE SUR LE CONTRÔLE DES ÉMISSIONS (APPLICABLE AU CANADA SEULEMENT):****1. Produits garantis:**

Komatsu America International Company, Komatsu Mining Systems Inc. et Komatsu Utility Corporation (collectivement Komatsu) produisent et/ou font la mise en marché de produits portant les noms de marque Komatsu, Dresser, Dressta, Haulpak et Galion. Cette garantie sur les émissions s'applique à tous les nouveaux moteurs portant le nom Komatsu, installés dans ces produits et utilisés au Canada dans des machines conçues pour utilisation industrielle non-roulière. Cette garantie s'applique seulement sur les moteurs produits à partir du 1er Janvier 2000. Cette garantie sera administrée par la distribution de Komatsu au Canada.

2. Couverture:

Komatsu garantit à l'acheteur ultime et chaque acheteur subséquent que le moteur est conçu, construit et équipé en toute conformité, au moment de la vente par Komatsu, avec toutes les Réglementations fédérales américaines sur les émissions applicables au moment de la fabrication et qu'il est exempt de défauts de construction ou de matériaux qui auraient pour effet de contrevenir à ces réglementations en dedans de 5 ans ou 3000 heures d'opération, mesuré à partir de la date de livraison du moteur au client ultime.

3. Limitations:

Les bris, autres que ceux résultant de défauts de matériaux ou de construction, ne sont pas couverts par cette Garantie. Komatsu n'est pas responsable pour bris ou dommages résultant de ce que Komatsu détermine comme étant de l'abus ou négligence, incluant mais ne se limitant pas à: l'opération sans lubrifiants ou agent refroidissants adéquats; la suralimentation d'essence; la survitesse; le manque d'entretien des systèmes de lubrification, de refroidissement ou d'entrée; de pratiques non-propices d'entreposage, de mise en marche, de réchauffement, de conditionnement ou d'arrêt; les modifications non-autorisées du moteur. De plus, Komatsu n'est pas responsable de bris causés par de l'essence inadéquate ou de l'eau, des saletés ou autres contaminants dans l'essence. Komatsu n'est pas responsable des réparations non-relées au moteur, des dépenses encourues suite aux temps d'arrêts, des dommages relatifs, amendes, et de tout autre coût d'affaires ou autres pertes résultant d'un bris couvert par la garantie.

KOMATSU N'EST PAS RESPONSABLE DES INCIDENTS OU DOMMAGES CONSÉQUENTS.

Cette garantie, ainsi que les garanties expresses commerciales, sont les seules garanties de Komatsu. **IL N'Y A AUCUNE AUTRE GARANTIE, EXPRESSE OU SOUS-ENTENDUE, MARCHANDABLE OU PROPICE A UNE UTILISATION PARTICULIÈRE.**

NOTE IMPORTANTE CONCERNANT LE MOTEUR
 Ce moteur est conforme aux normes XXX US EPA et California Tier 3 relatives aux moteurs à compression destinés aux engins ne devant pas circuler sur route. Ce moteur fonctionne à partir de gazole. **AVERTISSEMENT:** Des blessures peuvent résulter de l'usage de ce modèle dans des conditions d'alimentation, de régime et d'altitude excédant celles publiées par le constructeur; dans ces cas, la garantie peut aussi ne plus jouer.

IMPORTANT ENGINE INFORMATION

This engine conforms to XXXX U.S. EPA and California Tier3 Regulations for large non-road compression ignition engines. This engine is certified to operate on diesel fuel.
WARNING Injury may result and warranty is voided if fuel rate, RPM or altitudes exceed published maximum values for this model and application

Engine Model	ESN	Displacement	Liters
EPA Cert. Family			
European Approval No.			
Gross rated HP/kW	at rpm	Low Idle RPM	RPM
Firing Order		Fuel rate at rated HP/kW	mm3/st
Timing-TDC	deg. BTDC	Valve lash cold (mm)	IN.O. EX.O.
Engine Code		Date of manufacture	

KOMATSU Komatsu Ltd. Made in Japan PT : A3

Komatsu Ltd. Fabriqué au Japon

ENGINE DATEPLATE - ENGLISH / FRENCH



SAFETY INFORMATION

To enable you to use this machine safely, safety precautions and labels are given in this manual and affixed to the machine to give explanations of situations involving potential hazards and of the methods of avoiding such situations.

Signal words

The following signal words are used to inform you that there is a potential hazardous situation that may lead to personal injury or damage.

In this manual and on machine labels, the following signal words are used to express the potential level of hazard.

- | | |
|--|---|
|  DANGER | Indicates an imminently hazardous situation which, if not avoided, will result in death or serious injury. |
|  WARNING | Indicates a potentially hazardous situation which, if not avoided, could result in death or serious injury. |
|  CAUTION | Indicates a potentially hazardous situation which, if not avoided, may result in minor or moderate injury. This word is used also to alert against unsafe practices that may cause property damage. |

Example of safety message using signal word

 WARNING
When standing up from the operator's seat, always place the lock lever in the LOCK position. If you accidentally touch the control levers when they are not locked, this may cause a serious injury or death.

Other signal words

In addition to the above, the following signal words are used to indicate precautions that should be followed to protect the machine or to give information that is useful to know.

NOTICE This word is used for precautions that must be taken to avoid actions which could shorten the life of the machine.

REMARKS This word is used for information that is useful to know.

- Safety labels

Safety labels are affixed to the machine to inform the operator or maintenance worker on the spot when carrying out operation or maintenance of the machine that may involve hazard.

This machine uses "Safety labels using words" and "Safety labels using pictograms" to indicate safety procedures.

Example of safety label using words

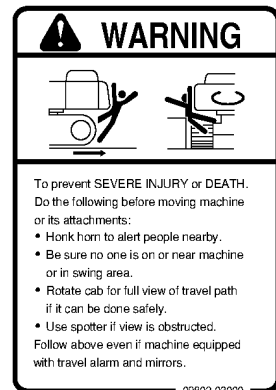

Part No

Safety labels using pictogram

Safety pictograms use a picture to express a level of hazardous condition equivalent to the signal word. These safety pictograms use pictures in order to let the operator or maintenance worker understand the level and type of hazardous condition at all times. Safety pictograms show the type of hazardous condition at the top or left side, and the method of avoiding the hazardous condition at the bottom or right side. In addition, the type of hazardous condition is displayed inside a triangle and the method of avoiding the hazardous condition is shown inside a circle.



Part No

Komatsu cannot predict every circumstance that might involve a potential hazard in operation and maintenance. Therefore, the safety messages in this manual and on the machine may not include all possible safety precautions. If any procedures or actions not specifically recommended or allowed in this manual are used, it is your responsibility to take the necessary steps to ensure safety.

In no event should you engage in prohibited uses or actions described in this manual.

The explanations, values, and illustrations in this manual were prepared based on the latest information available at that time. Continuing improvements in the design of this machine can lead to changes in detail which may not be reflected in this manual. Consult Komatsu or your Komatsu distributor for the latest available information of your machine or for questions regarding information in this manual.

The numbers in circles in the illustrations correspond to the numbers in () in the text. (For example: ① → (1))

INTRODUCTION

This Komatsu machine is designed to be used mainly for the following work:

- Digging work
- Leveling work
- Ditching work
- Loading work

See the section "RECOMMENDED APPLICATIONS (PAGE 3-132)" for further details.

DIRECTIONS OF MACHINE

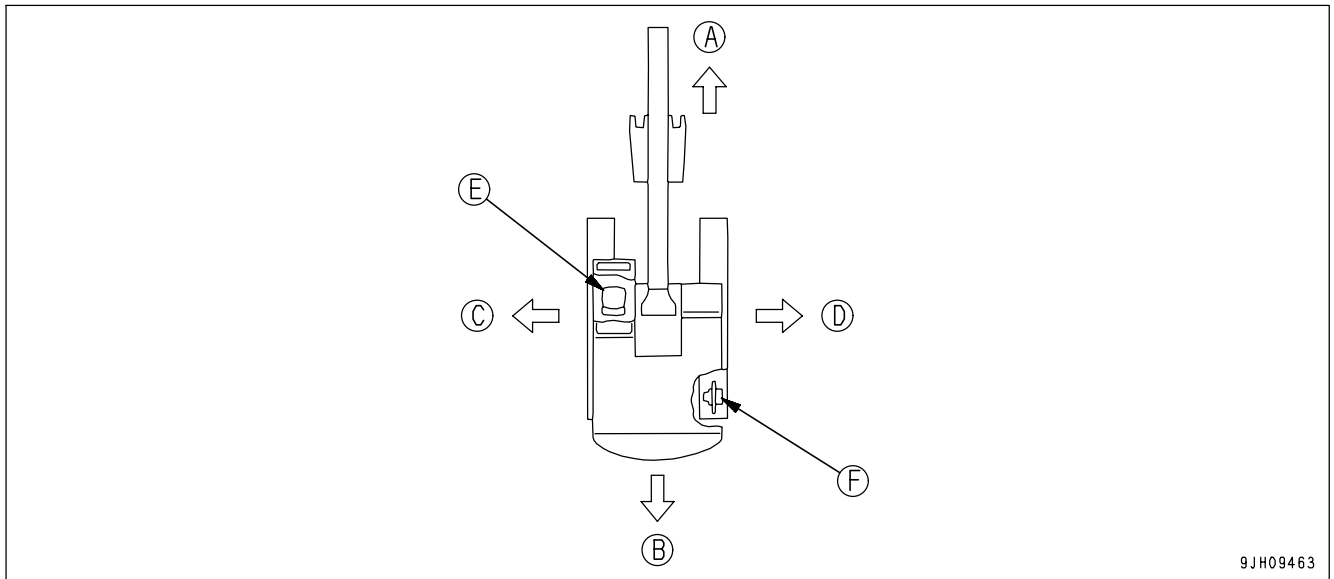

- | | |
|-----------|---------------------|
| (A) Front | (E) Operator's seat |
| (B) Rear | (F) Sprocket |
| (C) Left | |
| (D) Right | |

In this manual, the terms front, rear, left, and right refer to the travel direction as seen from the operator's seat when the operator's seat is facing the front and the sprocket is at the rear of the machine.

VISIBILITY FROM OPERATOR'S SEAT

The visibility standards (ISO 5006) for this machine require a view shown in the diagram below.

PROXIMITY VISIBILITY

The visibility of this machine in the area 1 m from the outside surface of the machine at a height of 1.5 m is shown in the diagram below. The hatched area (A) shows the area where the view is blocked by part of the machine when mirrors or other aids to visibility are installed as standard. Please be fully aware that there are places that cannot be seen when operating the machine.

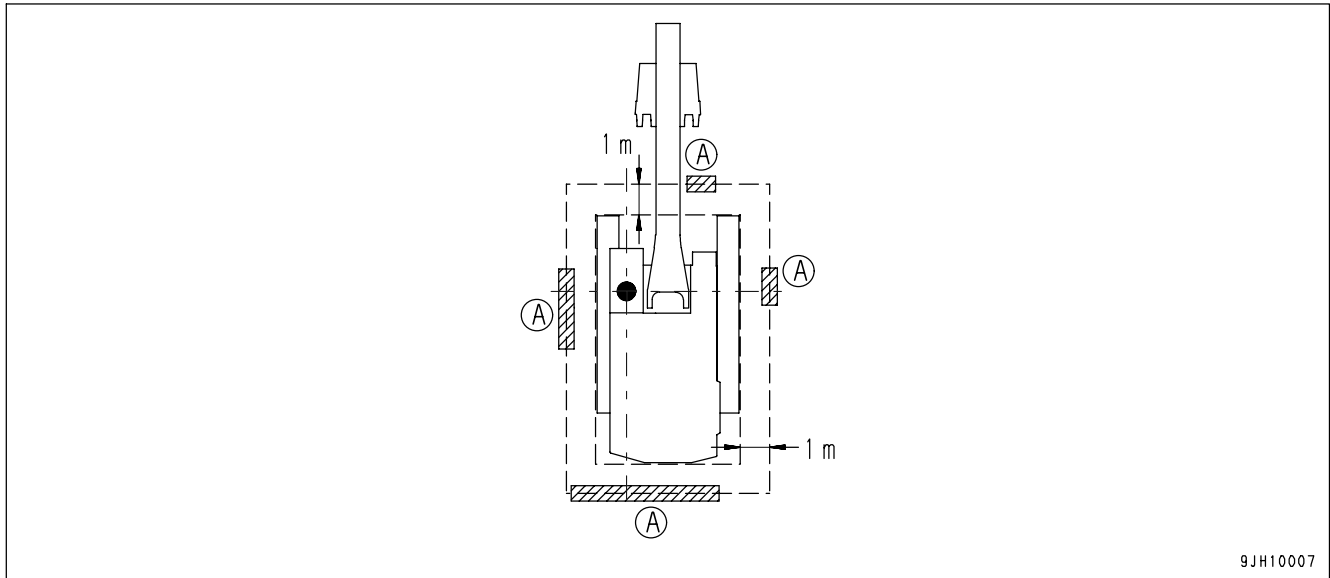

12M CIRCUMFERENCE VISIBILITY

The visibility at a radius of 12 m from the machine is as shown in the diagram below. The hatched areas (B) show the areas where the view is blocked when mirrors or other aids to visibility are installed as standard. Please be fully aware that there are places that cannot be seen when operating the machine.

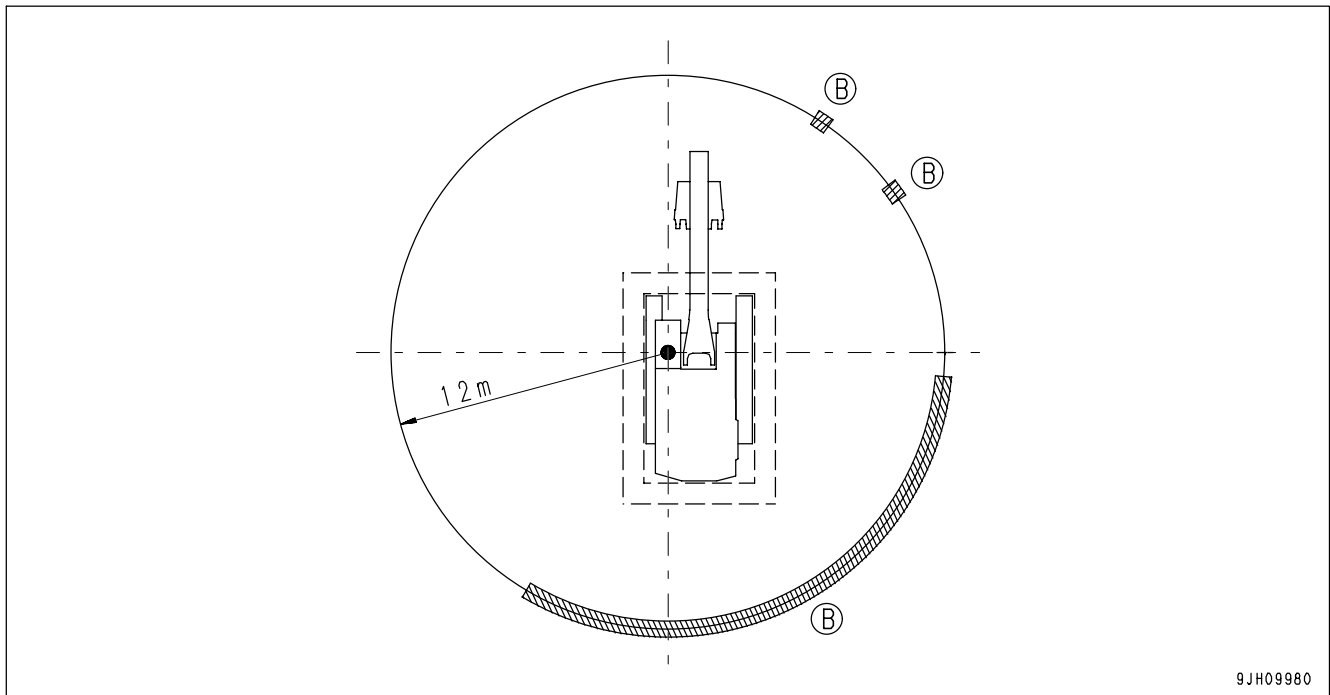

BREAKING-IN THE NEW MACHINE

NOTICE

Your Komatsu machine has been thoroughly adjusted and tested before shipment from the factory. However, operating the machine under full load before breaking the machine in can adversely affect the performance and shorten the machine life.

Be sure to break in the machine for the initial 100 hours (as indicated on the service meter).

Make sure that you fully understand the content of this manual, and pay careful attention to the following points when breaking in the machine.

- Run the engine at idle for 15 seconds after starting it. During this time, do not operate the control levers or fuel control dial.
- Idle the engine for 5 minutes after starting it up.
- Avoid operation with heavy loads or at high speeds.
- Immediately after starting the engine, avoid sudden starts, sudden acceleration, unnecessary sudden stops, and sudden changes in direction.

PRODUCT INFORMATION

When requesting service or ordering replacement parts, please inform your Komatsu distributor of the following items.

PRODUCT IDENTIFICATION NUMBER (PIN)/MACHINE SERIAL NO. PLATE

On the bottom right of the operator's cab

The design of the nameplate differs according to the territory.

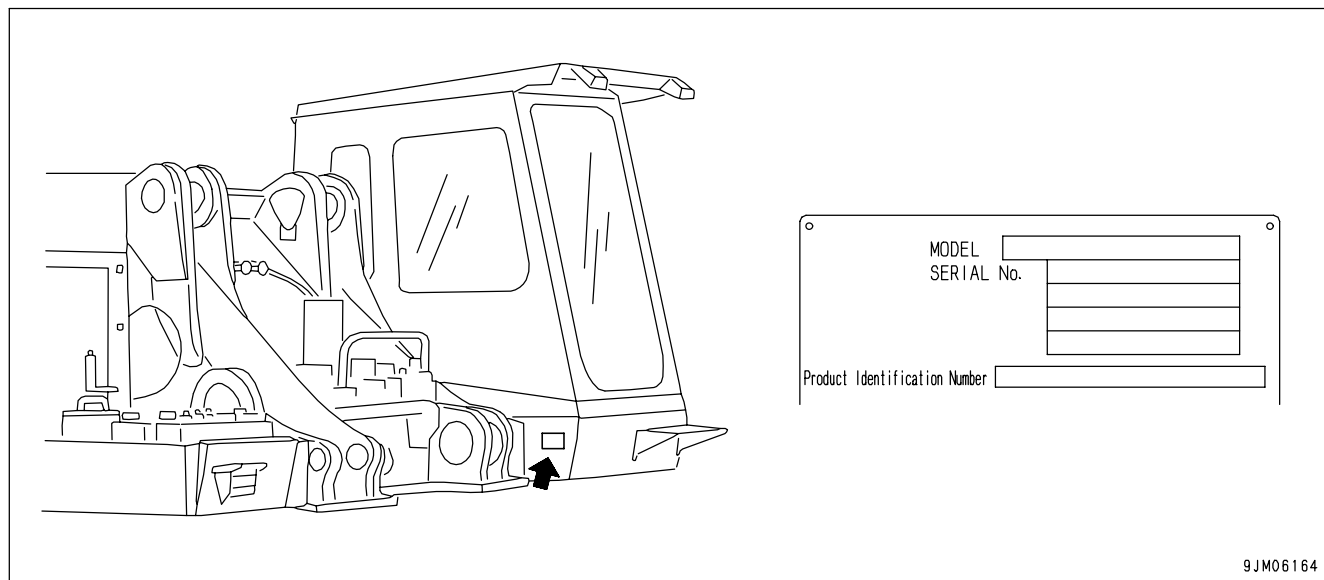

9JM06164

EPA REGULATIONS, ENGINE NUMBER PLATE

Under the air cleaner

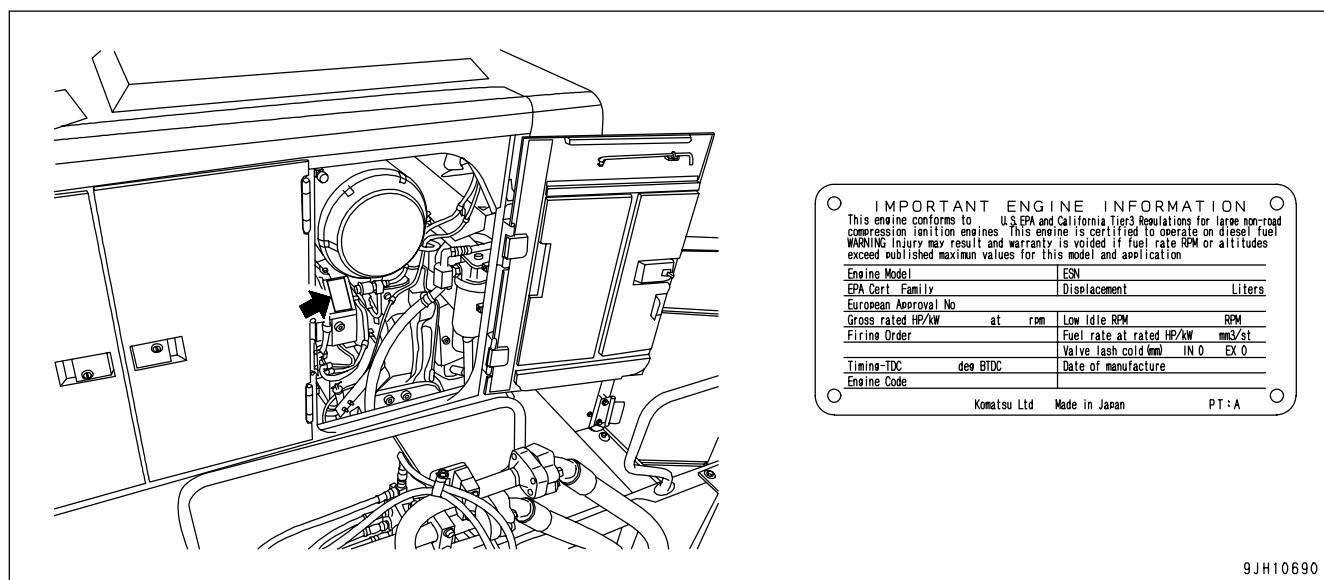

IMPORTANT ENGINE INFORMATION			
This engine conforms to U.S. EPA and California Tier 3 Regulations for large non-road compression ignition engines. This engine is certified to operate on diesel fuel. WARNING: Injury may result and warranty is voided if fuel rate RPM or altitudes exceed published maximum values for this model and application.			
Engine Model	ESN		
EPA Cert. Family	Displacement	Liters	
European Approval No.			
Gross rated HP/kW	at rpm	Low Idle RPM	RPM
Fire Order	Fuel rate at rated HP/kW	mm ³ /st	
Timing-TDC	Valve lash cold (mm)	IN 0	EX 0
Engine Code	Date of manufacture		
Komatsu Ltd. Made in Japan PT:A			

9JH10690

EPA: Environmental Protection Agency, U.S.A.

SERVICE METER LOCATION

On top of the machine monitor

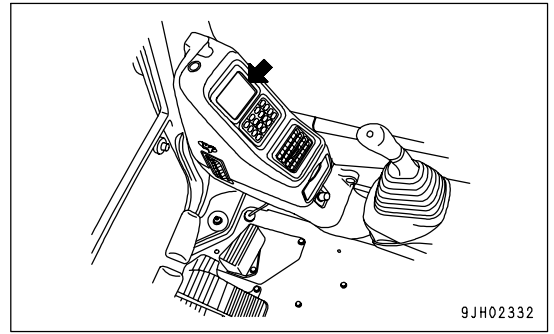

YOUR MACHINE SERIAL NUMBERS AND DISTRIBUTOR

Machine serial No.	
Engine serial No.	
Product identification number (PIN)	
Distributor name	
Address	-----

Service Personnel	-----
Phone/Fax	

CONTENTS

FOREWORD	1- 1
FOREWORD	1- 2
SAFETY INFORMATION	1- 5
INTRODUCTION	1- 7
DIRECTIONS OF MACHINE	1- 7
VISIBILITY FROM OPERATOR'S SEAT	1- 8
BREAKING-IN THE NEW MACHINE	1- 9
PRODUCT INFORMATION	1- 10
PRODUCT IDENTIFICATION NUMBER (PIN)/MACHINE SERIAL NO. PLATE	1- 10
EPA REGULATIONS, ENGINE NUMBER PLATE	1- 10
SERVICE METER LOCATION	1- 11
YOUR MACHINE SERIAL NUMBERS AND DISTRIBUTOR	1- 11
CONTENTS	1- 12
SAFETY	2- 1
SAFETY	2- 2
SAFETY LABELS	2- 4
LOCATION OF SAFETY LABELS	2- 5
SAFETY LABELS	2- 6
GENERAL PRECAUTIONS	2- 12
SAFETY MACHINE OPERATION	2- 21
STARTING ENGINE	2- 21
OPERATION	2- 23
TRANSPORTATION	2- 29
BATTERY	2- 30
TOWING	2- 32
LIFTING OBJECTS WITH BUCKET	2- 33
SAFETY MAINTENANCE INFORMATION	2- 34
OPERATION	3- 1
MACHINE VIEW ILLUSTRATIONS	3- 2
OVERALL MACHINE VIEW	3- 2
CONTROLS AND GAUGES	3- 3
DETAILED CONTROLS AND GAUGES	3- 5
MONITORING SYSTEM	3- 5
SWITCHES	3- 34
CONTROL LEVERS AND PEDALS	3- 40
EMERGENCY EXIT FROM OPERATOR'S CAB	3- 43
DOOR LOCK	3- 43
CAP WITH LOCK	3- 44
HOT AND COOL BOX	3- 46
MAGAZINE BOX	3- 46
ASHTRAY	3- 46
FIRE EXTINGUISHER	3- 46
AIR CONDITIONER CONTROLS	3- 47
RADIO	3- 61
AUXILIARY ELECTRIC POWER	3- 66
FUSE	3- 67
CIRCUIT BREAKER	3- 68
CONTROLLER	3- 70
TOOL BOX	3- 70

GREASE PUMP	3- 71
MACHINE OPERATIONS AND CONTROLS	3- 75
BEFORE STARTING ENGINE	3- 75
STARTING ENGINE	3- 98
AFTER STARTING ENGINE	3-101
STOPPING THE ENGINE	3-111
MACHINE OPERATION	3-112
STEERING THE MACHINE	3-116
SWINGING	3-118
WORK EQUIPMENT CONTROLS AND OPERATIONS	3-119
WORKING MODE	3-121
PROHIBITED OPERATIONS	3-122
GENERAL OPERATION INFORMATION	3-127
TRAVELING ON SLOPES	3-129
ESCAPE FROM MUD	3-131
RECOMMENDED APPLICATIONS	3-132
BUCKET REPLACEMENT	3-133
PARKING MACHINE	3-135
MACHINE INSPECTION AFTER DAILY WORK	3-136
LOCKING	3-137
TRANSPORTATION	3-138
TRANSPORTATION PROCEDURE	3-138
PRECAUTIONS FOR TRANSPORTATION	3-138
LIFTING MACHINE	3-138
SHIPPING MACHINE INFORMATION	3-140
TRANSPORTATION POSTURE	3-141
COLD WEATHER OPERATION	3-149
COLD WEATHER OPERATION INFORMATION	3-149
AFTER DAILY WORK COMPLETION	3-152
AFTER COLD WEATHER SEASON	3-152
LONG TERM STORAGE	3-153
BEFORE STORAGE	3-153
DURING STORAGE	3-153
AFTER STORAGE	3-153
STARTING MACHINE AFTER LONG-TERM STORAGE	3-154
TROUBLES AND ACTIONS	3-155
RUNNING OUT OF FUEL	3-155
PHENOMENA THAT ARE NOT FAILURES	3-155
TOWING THE MACHINE	3-156
SEVERE JOB CONDITION	3-156
DISCHARGED BATTERY	3-157
OTHER TROUBLE	3-161
MAINTENANCE	4- 1
MAINTENANCE INFORMATION	4- 2
OUTLINE OF SERVICE	4- 4
HANDLING OIL, FUEL, COOLANT, AND PERFORMING OIL CLINIC	4- 4
ELECTRIC SYSTEM MAINTENANCE	4- 7
WEAR PARTS	4- 8
WEAR PARTS LIST	4- 8
RECOMMENDED FUEL, COOLANT, AND LUBRICANT	4- 9

RECOMMENDED BRANDS, RECOMMENDED QUALITY FOR PRODUCTS OTHER THAN KOMATSU GENUINE OIL	4- 11
TIGHTENING TORQUE SPECIFICATIONS	4- 12
TIGHTENING TORQUE LIST	4- 12
SAFETY CRITICAL PARTS	4- 13
SAFETY CRITICAL PARTS LIST	4- 13
MAINTENANCE SCHEDULE	4- 14
MAINTENANCE SCHEDULE CHART	4- 14
MAINTENANCE PROCEDURE	4- 16
INITIAL 100 HOURS MAINTENANCE (ONLY AFTER THE FIRST 100 HOURS)	4- 16
INITIAL 500 HOURS MAINTENANCE (ONLY AFTER THE FIRST 500 HOURS)	4- 16
WHEN REQUIRED	4- 17
CHECK BEFORE STARTING	4- 43
EVERY 10 HOURS MAINTENANCE	4- 44
EVERY 100 HOURS MAINTENANCE	4- 46
EVERY 250 HOURS MAINTENANCE	4- 47
EVERY 500 HOURS MAINTENANCE	4- 51
EVERY 1000 HOURS MAINTENANCE	4- 63
EVERY 2000 HOURS MAINTENANCE	4- 74
EVERY 4000 HOURS MAINTENANCE	4- 80
EVERY 5000 HOURS MAINTENANCE	4- 83
EVERY 8000 HOURS MAINTENANCE	4- 85
SPECIFICATIONS	5- 1
SPECIFICATIONS	5- 2
ATTACHMENTS AND OPTIONS	6- 1
GENERAL PRECAUTIONS FOR SAFETY	6- 2
PRECAUTIONS WHEN SELECTING	6- 2
READ THE INSTRUCTION MANUAL THOROUGHLY	6- 2
PRECAUTIONS WHEN REMOVING OR INSTALLING	6- 2
PRECAUTIONS WHEN USING	6- 2
ATTACHMENT GUIDE	6- 3
COMBINATIONS OF WORK EQUIPMENT	6- 3
SELECTION OF TRACK SHOES	6- 7
AUTO-GREASING SYSTEM	6- 8
EXPLANATION OF COMPONENTS	6- 8
OPERATION	6- 13
TROUBLESHOOTING	6- 17
MAINTENANCE	6- 18
HANDLING MACHINES EQUIPPED WITH VHMS	6- 24
VHMS INSTALLED, COMMUNICATIONS TERMINAL NOT INSTALLED	6- 24
VHMS AND COMMUNICATIONS TERMINAL INSTALLED	6- 25
LOADING SHOVEL	7- 1
EXPLANATION OF COMPONENTS	7- 2
SWITCHES	7- 2
FUSE	7- 5
OPERATIONS	7- 6
OPERATION OF WORK EQUIPMENT	7- 6
PRECAUTIONS DURING OPERATION	7- 8
EXCAVATOR WORK	7- 12
PRECAUTIONS WHEN DISASSEMBLING MACHINE	7- 13

RELEASING PRESSURE	7- 13
TRANSPORTATION	7- 14
MACHINE CONFIGURATION FOR TRANSPORT	7- 14
WEAR PARTS	7- 21
WEAR PARTS LIST	7- 21
MAINTENANCE	7- 22
CHECK BEFORE STARTING	7- 22
EVERY 10 HOURS MAINTENANCE	7- 24
EVERY 5000 HOURS MAINTENANCE	7- 25
SPECIFICATION	7- 27
COMBINATION OF WORK EQUIPMENT	7- 28
COMBINATION OF WORK EQUIPMENT	7- 28
INDEX	8- 1

SAFETY

WARNING

Please read and make sure that you fully understand the precautions described in this manual and the safety labels on the machine. When operating or servicing the machine, always follow these precautions strictly.

SAFETY

SAFETY LABELS	2- 4
LOCATION OF SAFETY LABELS	2- 5
SAFETY LABELS	2- 6
SAFETY INFORMATION	
Safety rules	2- 12
If problems are found	2- 12
Working wear and personal protective items	2- 12
Fire extinguisher and first aid kit	2- 12
Safety equipment	2- 12
Keep machine clean	2- 13
Keep operator's compartment clean	2- 13
Leaving operator's seat with lock	2- 13
Handrails and steps	2- 14
Precautions when working in high place	2- 14
Mounting and dismounting	2- 14
No persons on attachments	2- 14
Do not get caught in articulated portion	2- 15
Burn prevention	2- 15
Fire prevention and explosion prevention	2- 16
Action if fire occurs	2- 17
Windshield washer fluid	2- 17
Falling objects, flying objects and intruding objects prevention	2- 17
Attachment installation	2- 17
Attachment combinations	2- 17
Cab window glasses	2- 17
Unauthorized modifications	2- 18
Safety at jobsite	2- 18
Working on loose ground	2- 18
Distance to high voltage cables	2- 19
Ensure good visibility	2- 19
Ventilation for enclosed area	2- 20
Signalman's signal and signs	2- 20
Emergency exit from operator's cab	2- 20
Asbestos dust hazard prevention	2- 20

SAFETY MACHINE OPERATION	2- 21
STARTING ENGINE	2- 21
Checks before starting engine	2- 21
Safety rules for starting engine	2- 21
Starting engine in cold weather	2- 22
OPERATION	2- 23
Checks before operation	2- 23
Safety rules for changing machine directions	2- 23
Safety rules for traveling	2- 24
Traveling on slopes	2- 24
Operations on slopes	2- 25
Prohibited operations	2- 26
Operations on snow	2- 27
Parking machine	2- 28
TRANSPORTATION	2- 29
Loading and unloading	2- 29
Shipping the machine	2- 29
BATTERY	2- 30
Battery hazard prevention	2- 30
Starting engine with booster cables	2- 31
TOWING	2- 32
Safety rules for towing	2- 32
LIFTING OBJECTS WITH BUCKET	2- 33
Safety rules for lifting objects	2- 33
SAFETY MAINTENANCE INFORMATION	2- 34
Warning Tag	2- 34
Keep Work Place Clean and Tidy	2- 34
Appoint Leader when Working with Others	2- 34
Stop Engine Before Carrying Out Maintenance	2- 35
Two Workers for Maintenance when Engine is Running	2- 36
Proper Tools	2- 36
Accumulator, Gas spring	2- 37
Personnel	2- 37
Attachments	2- 37
Work Under the Machine	2- 37
Noise	2- 37
When Using Hammer	2- 38
Welding Works	2- 38
Removing Battery Terminals	2- 38
Safety First when Using High-pressure Grease to Adjust Track Tension	2- 38
Do Not Disassemble Recoil Springs	2- 39
Safety Rules for High-pressure Oil	2- 39
Precaution for High Fuel Pressure	2- 39
Safety Handling High-pressure Hoses	2- 39
Precaution for High Voltage	2- 40
Waste Materials	2- 40
Air Conditioner Maintenance	2- 40
Compressed Air	2- 40
Periodic Replacement of Safety Critical Parts	2- 40

SAFETY LABELS

The following warning signs and safety labels are used on this machine.

- Be sure that you fully understand the correct position and content of labels.
- To ensure that the content of labels can be read properly, be sure that they are in the correct place and always keep them clean. When cleaning them, do not use organic solvents or gasoline. These may cause the labels to peel off.
- There are also other labels in addition to the warning signs and safety labels. Handle those labels in the same way.
- If the labels are damaged, lost, or cannot be read properly, replace them with new ones. For details of the part numbers for the labels, see this manual or the actual label, and place an order with Komatsu distributor.

LOCATION OF SAFETY LABELS

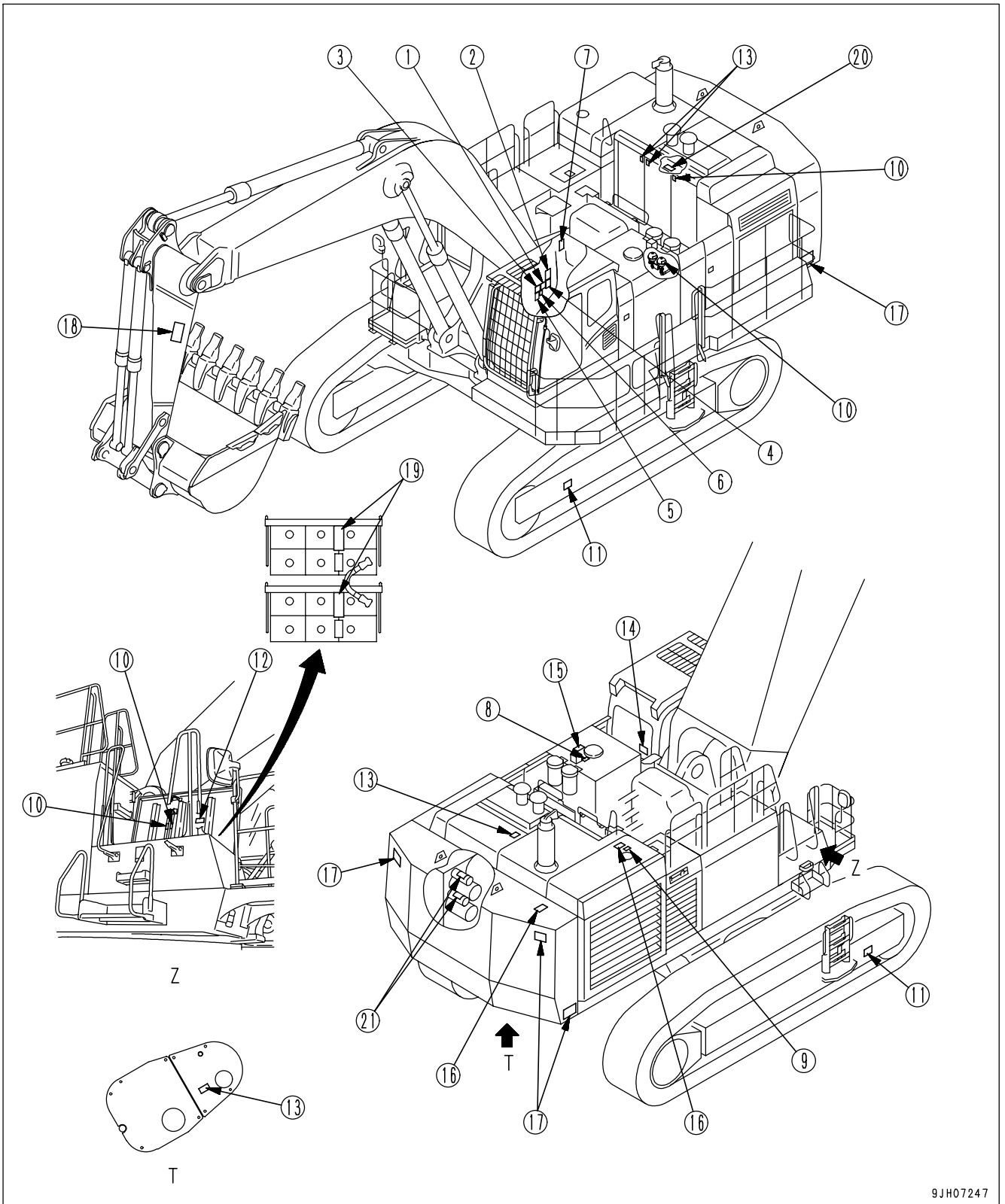

9JH07247

SAFETY LABELS

- (1) Caution before operating or maintaining machine
(09651-03001)

 WARNING
<p>Improper operation and maintenance can cause serious injury or death.</p> <p>Read manual and labels before operation and maintenance. Follow instructions and warnings in manual and in labels on machine.</p> <p>Keep manual in machine cab near operator. Contact Komatsu distributor for a replacement manual.</p>
09651-03001

- (2) Caution before operating (09802-03000)

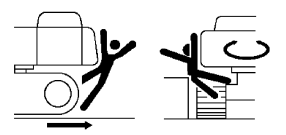
 WARNING

<p>To prevent SEVERE INJURY or DEATH, do the following before moving machine or its attachments:</p> <ul style="list-style-type: none"> • Honk horn to alert people nearby. • Be sure no one is on or near machine or in swing area. • Rotate cab for full view of travel path if it can be done safely. • Use spotter if view is obstructed. <p>Follow above even if machine is equipped with travel alarm and mirrors.</p>
09802-03000

- (3) Caution for leaving operator's seat (09654-03001)

 WARNING
<p>To avoid hitting unlocked operation levers, lower equipment to ground and move LOCK LEVER (located near seat) to LOCK position before standing up from operator's seat.</p> <p>Sudden and unwanted machine movement can cause serious injury or death.</p>
09654-03001

(4) Caution for going close to electric cables (09801-03001)

DANGER

Hazardous voltage hazard.
Serious injury or death can occur if machine or attachments are not kept safe distance away from electric lines.

VOLTAGE		SAFE DISTANCE
LOW VOLTAGE	100V 200V	2m
	6.600V	2m
	22.000V	3m
SPECIAL HIGH VOLTAGE	66.000V	4m
	154.000V	5m
	187.000V	6m
	275.000V	7m
	500.000V	11m

09801-03001

(5) Caution for operating pattern (09822-03000)

WARNING

In order to prevent an accident resulting in injury or death caused by error-operation, confirm the machine motion and indicated operating pattern, when operating machines. Pay attention to the circumference and operate slowly when confirming the machine motion.

ISO pattern

09822-03000

- (6) Caution when opening or closing front window
(09839-03000)

 WARNING
<p>To open or close the front or ceiling window, never stand up from the operator's seat before throwing the lock lever to the LOCK position.</p> <p>Inadvertently touching any of the working equipment control levers might cause the machine to start moving all of a sudden, probably resulting in a serious injury.</p> <p style="text-align: right;">09839-03000</p>

- (7) Caution when stowing front window (09803-03000)

 WARNING
<p>When raising window, lock it in place with lock pins on both sides.</p> <p>Falling window can cause injury.</p> <p style="text-align: right;">09803-03000</p>

- (8) Caution for high-temperature hydraulic oil (09653-03001)

 WARNING
<p>Hot oil hazard.</p> <p>To prevent hot oil from spurting out:</p> <ul style="list-style-type: none"> • Turn engine off. • Allow oil to cool. • Slowly loosen cap to relieve pressure before removing. <p style="text-align: right;">09653-03001</p>

- (9) Caution with high-temperature coolant (09668-03001)

 WARNING
<p>Hot water hazard.</p> <p>To prevent hot water from spurting out:</p> <ul style="list-style-type: none"> • Turn engine off. • Allow water to cool. • Slowly loosen cap to relieve pressure before removing. <p style="text-align: right;">09668-03001</p>

(10) Caution for handling accumulator and gas spring
(09659-53000)

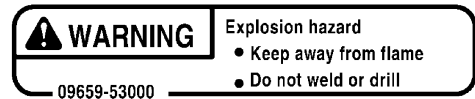

(11) Caution for adjusting track tension (09657-03003)



(12) Caution for handling cable (09808-03000)

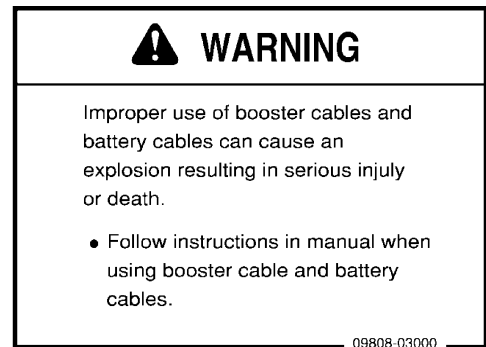

(13) Stopping rotation for inspection and maintenance
(09667-03001)

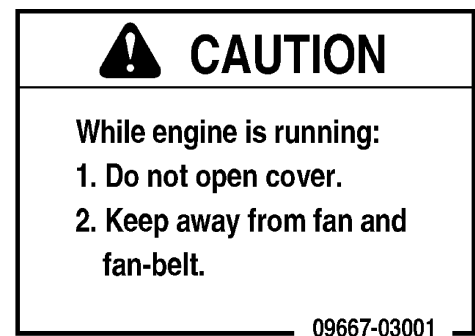

- (14) Explanation of methods for emergency escape
(20Y-00-31170)

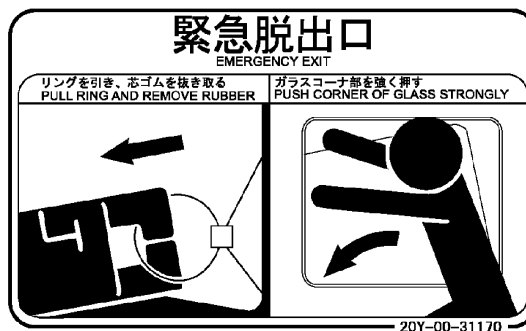

- (15) Caution against falling (09805-23000)



- (16) Caution against falling (09805-13000)



- (17) Prohibited to enter within swing range (09133-23000)



(18) Beware of work equipment (09134-A1681)



Sign indicates a hazard of being hit by the working device of the machine.

Keep away from machine during operation.

(19) Caution when handling battery (14X-98-11370)

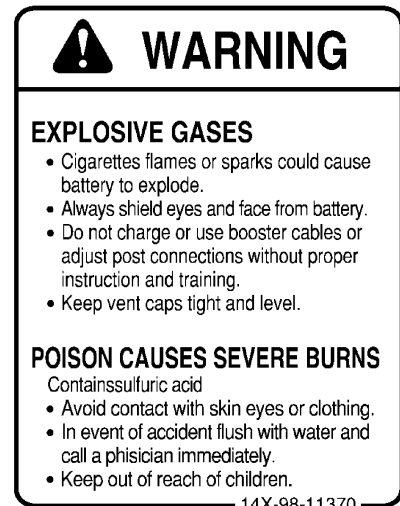

EXPLOSIVE GASES

- Cigarettes flames or sparks could cause battery to explode.
- Always shield eyes and face from battery.
- Do not charge or use booster cables or adjust post connections without proper instruction and training.
- Keep vent caps tight and level.

POISON CAUSES SEVERE BURNS

Contains sulfuric acid

- Avoid contact with skin eyes or clothing.
- In event of accident flush with water and call a physician immediately.
- Keep out of reach of children.

14X-98-11370

(20) Caution for high-pressure fuel (6217-71-9331)

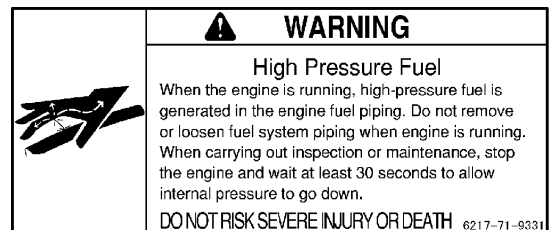

WARNING

High Pressure Fuel

When the engine is running, high-pressure fuel is generated in the engine fuel piping. Do not remove or loosen fuel system piping when engine is running. When carrying out inspection or maintenance, stop the engine and wait at least 30 seconds to allow internal pressure to go down.

DO NOT RISK SEVERE INJURY OR DEATH 6217-71-9331

(21) Prohibition of jump start (09842-A0481)



Start the engine only after sitting down in the operator's seat.

Do not attempt to start the engine by short-circuiting the engine starting circuit. Such an act may cause a serious bodily injury or fire.

GENERAL PRECAUTIONS

SAFETY RULES

- Only trained and authorized personnel can operate and maintain the machine.
- Follow all safety rules, precautions and instructions in this manual when operating or performing maintenance on the machine.
- If you are not feeling well, or if you are under the influence of alcohol or medication, your ability to safely operate or repair your machine may be severely impaired, putting yourself and everyone else on your job site in danger.
- When working with another operator or with the person on the worksite traffic duty, discuss the content of the operation beforehand and use the determined signals when carrying out the operation.

IF PROBLEMS ARE FOUND

If you find any problems in the machine during operation or maintenance (noise, vibration, smell, incorrect gauges, smoke, oil leakage, etc., or any abnormal display on the warning devices or monitor), report to the person in charge and have the necessary action taken. Do not operate the machine until the problem has been corrected.

WORKING WEAR AND PERSONAL PROTECTIVE ITEMS

- Do not wear loose clothing and accessories. There is a hazard that they may catch on control levers or other protruding parts.
- If you have long hair and it hangs out from your hard hat, there is a hazard that it may get caught up in the machine, so tie your hair up and be careful not to let it get caught.
- Always wear a hard hat and safety shoes. If the nature of the work requires it, wear safety glasses, mask, gloves, ear plugs, and safety belt when operating or maintaining the machine.
- Check that all protective equipment functions properly before using it.

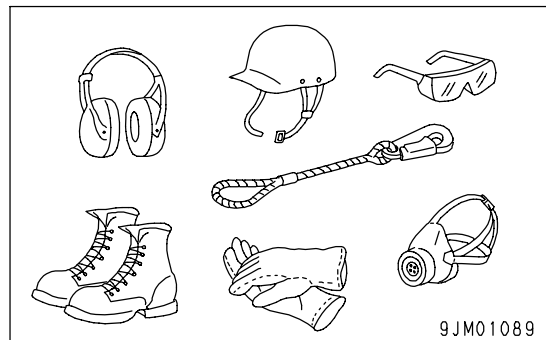

FIRE EXTINGUISHER AND FIRST AID KIT

Always follow the precautions below to prepare for action if any injury or fire should occur.

- Be sure that fire extinguishers have been provided and read the labels to ensure that you know how to use them in emergencies.
- Carry out periodic inspection and maintenance to ensure that the fire extinguisher can always be used.
- Provide a first aid kit in the storage point. Carry out periodic checks and add to the contents if necessary.

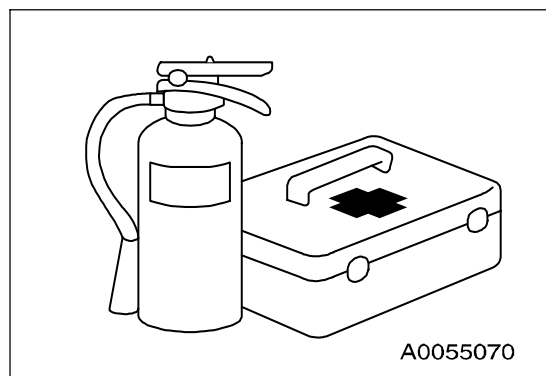

SAFETY EQUIPMENT

- Be sure that all guards, covers and mirrors are in their proper position. Have guards and covers repaired immediately if they are damaged.
- Understand the method of use of safety features and use them properly.

- Never remove any safety features. Always keep them in good operating condition.

KEEP MACHINE CLEAN

- If water gets into the electrical system, there is a hazard that it will cause malfunctions or misoperation. Do not use water or steam to wash the electrical system (sensors, connectors).
- If inspection and maintenance is carried out when the machine is still dirty with mud or oil, there is a hazard that you will slip and fall, or that dirt or mud will get into your eyes. Always keep the machine clean.

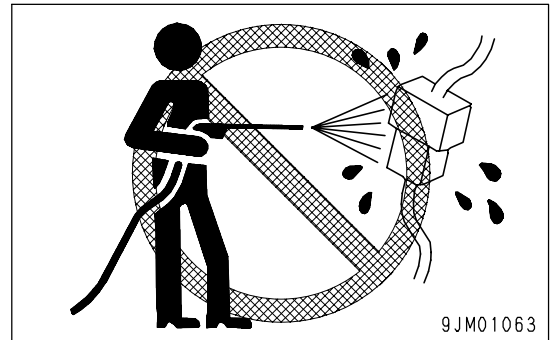

KEEP OPERATOR'S COMPARTMENT CLEAN

- When entering the operator's compartment, always remove all mud and oil from the soles of your shoes. If you operate the pedal with mud or oil affixed to your shoes, your foot may slip and this may cause a serious accident.
- Do not leave parts or tools lying around the operator's compartment.
- Do not stick suction pads to the window glass. Suction pads act as a lens and may cause fire.
- Do not use cellular telephones inside the operator's compartment when driving or operating the machine.
- Never bring any dangerous objects such as flammable or explosive items into the operator's compartment.

LEAVING OPERATOR'S SEAT WITH LOCK

- Before standing up from the operator's seat (such as when opening or closing the front window or roof window, or when removing or installing the bottom window, or when adjusting the operator's seat), always lower the work equipment completely to the ground, set lock lever (1) securely to the LOCK position (L), then stop the engine. If you accidentally touch the control levers or control pedals when they are not locked, there is a hazard that the machine may suddenly move and cause serious injury or property damage.

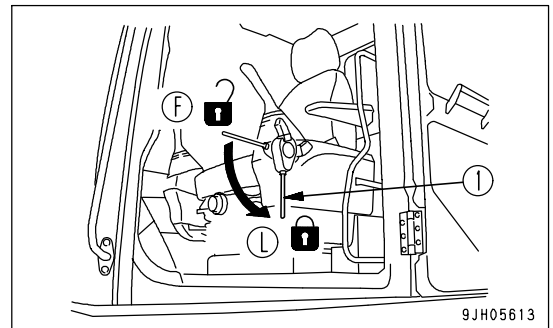

- When leaving the machine, always lower the work equipment completely to the ground, set lock lever (1) securely to the LOCK position (L), then stop the engine. Use the key to lock all the equipment. Always remove the key, take it with you, and keep it in the specified place.

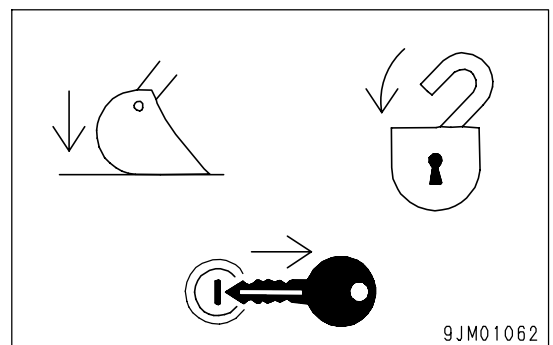

HANDRAILS AND STEPS

To prevent personal injury caused by slipping or falling off the machine, always do as follows.

- Use the handrails and steps marked by arrows in the diagram on the right when getting on or off the machine.

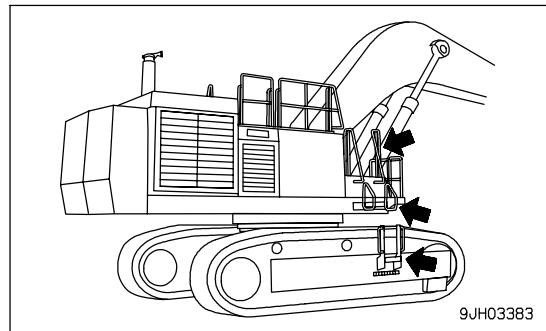
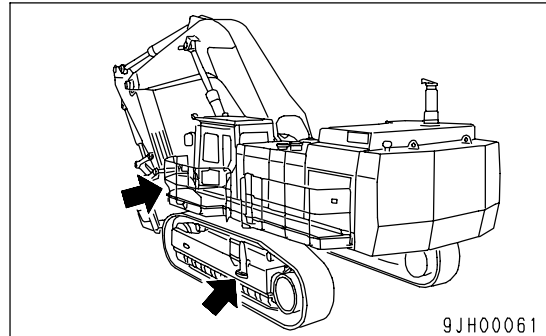

- To ensure safety, always face the machine and maintain three-point contact (both feet and one hand, or both hands and one foot) with the handrails and steps (including the track shoe) to ensure that you support yourself.
- Do not grip the control levers or lock lever when getting on or off the machine.
- Never climb on the engine hood or covers where there are no non-slip pads.
- Before getting on or off the machine, check the handrails and steps (including the track shoe). If there is any oil, grease, or mud on the handrails or steps (including the track shoe), wipe it off immediately. Always keep these parts clean. Repair any damage and tighten any loose bolts.
- Do not get on or off the machine while holding tools in your hand.

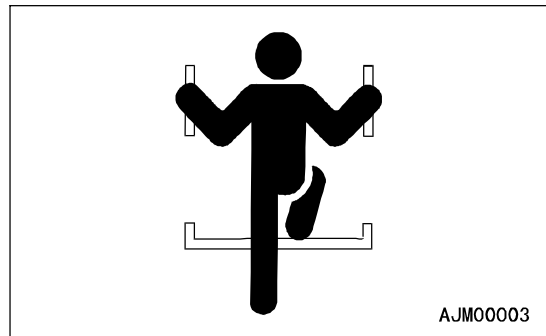
**PRECAUTIONS WHEN WORKING IN HIGH PLACES**

When working at high places, use a step ladder or other stand to ensure that the work can be carried out safely.

MOUNTING AND DISMOUNTING

- Never jump on or off the machine. Never get on or off a moving machine.
- If the machine starts to move when there is no operator on the machine, do not jump on to the machine and try to stop it.

NO PERSONS ON ATTACHMENTS

Never let anyone ride on the work equipment, or other attachments. There is a hazard of falling and suffering serious injury.

DO NOT GET CAUGHT IN ARTICULATED PORTION

The clearance around the work equipment will change according to the movement of the link. If you get caught, this may lead to serious personal injury. Do not allow anyone to approach any rotating or telescoping part.

BURN PREVENTION**Hot coolant**

- To prevent burns from hot water or steam spurting out when checking or draining the coolant, wait for the water to cool to a temperature where it is possible to touch the radiator cap by hand before starting the operation. Even when the coolant has cooled down, loosen the cap slowly to relieve the pressure inside the radiator before removing the cap.

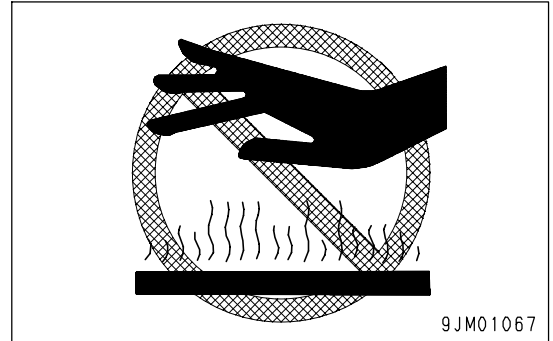
**Hot oil**

- To prevent burns from hot oil spurting out when checking or draining the oil, wait for the oil to cool to a temperature where it is possible to touch the cap or plug by hand before starting the operation. Even when the oil has cooled down, loosen the cap or plug slowly to relieve the internal pressure before removing the cap or plug.

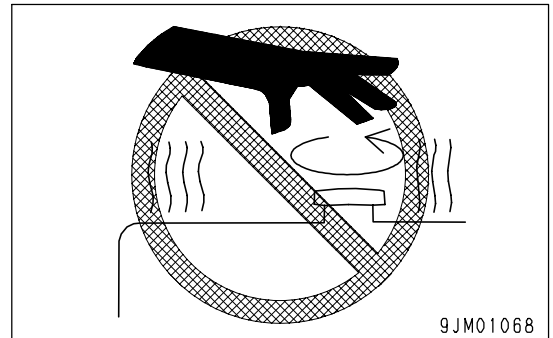

FIRE PREVENTION AND EXPLOSION PREVENTION**• Fire caused by fuel or oil**

Fuel, oil, antifreeze, and window washer liquid are particularly flammable and can be hazardous. To prevent fire, always observe the following:

- Do not smoke or use any flame near fuel or oil.
- Stop the engine before refueling.
- Do not leave the machine while adding fuel or oil.
- Tighten all fuel and oil caps securely.
- Do not spill fuel on overheated surfaces or on parts of the electrical system.
- Use well-ventilated areas for adding or storing oil and fuel.
- Keep oil and fuel in the determined place and do not allow unauthorized persons to enter.
- After adding fuel or oil, wipe up any spilled fuel or oil.
- When carrying out grinding or welding work on the chassis, move any flammable materials to a safe place before starting.
- When washing parts with oil, use a non-flammable oil. Diesel oil and gasoline may catch fire, so do not use them.
- Put greasy rags and other flammable materials into a safe container to maintain safety at the work place.
- Do not weld or use a cutting torch to cut any pipes or tubes that contain flammable liquids.

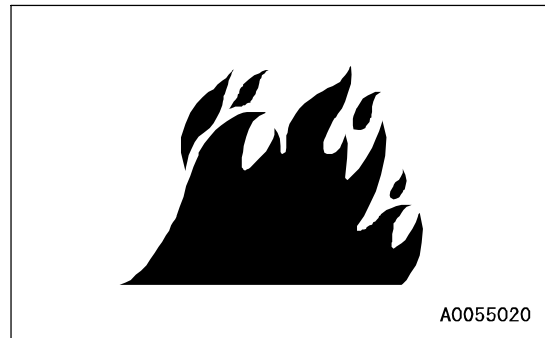
**• Fire caused by accumulation of flammable material.**

Remove any dry leaves, chips, pieces of paper, dust, or any other flammable materials accumulated or affixed around the engine, exhaust manifold, muffler, or battery, or inside the undercovers.

• Fire coming from electric wiring

Short circuits in the electrical system can cause fire.

- Always keep electric wiring connections clean and securely tightened.
- Check the wiring every day for looseness or damage. Tighten any loose connectors or wiring clamps. Repair or replace any damaged wiring.

• Fire coming from hydraulic line

Check that all the hose and tube clamps, guards, and cushions are securely fixed in position.

If they are loose, they may vibrate during operation and rub against other parts. This may lead to damage to the hoses, and cause high-pressure oil to spurt out, leading to fire damage or serious injury.

• Explosion caused by lighting equipment

When checking fuel, oil, battery electrolyte, window washer fluid, or coolant, always use lighting with antiexplosion specifications. If such lighting equipment is not used, there is danger of explosion that may cause serious injury.

When taking the electrical power for the lighting from the machine itself, follow the instructions in of "AUXILIARY ELECTRIC POWER (PAGE 3-66)".

ACTION IF FIRE OCCURS

If a fire occurs, escape from the machine as follows.

- Turn the start switch OFF to stop the engine.
- Use the handrails and steps to get off the machine.

WINDSHIELD WASHER FLUID

Use an ethyl alcohol base washer liquid.

Methyl alcohol base washer liquid may irritate your eyes, so do not use it.

FALLING OBJECTS, FLYING OBJECTS AND INTRUDING OBJECTS PREVENTION

On jobsites where there is a hazard that falling objects, flying objects, or intruding objects may hit or enter the operator's cab, consider the operating conditions and install the necessary guards to protect the operator.

- When carrying out demolition or breaker operations, install a front guard and use a laminated coating sheet on the front glass.
- When working in mines or quarries where there is a hazard of falling rock, install FOPS (Falling Objects Protective Structure) and a front guard, and use a laminated coating sheet on the front glass.
- When carrying out the above operations, always close the front window. In addition, always ensure that bystanders are a safe distance away and are not in hazard from falling or flying objects.
- The above recommendations assume that the conditions are for standard operations, but it may be necessary to add additional guards according to the operating conditions on the jobsite. Always contact your Komatsu distributor for advice.

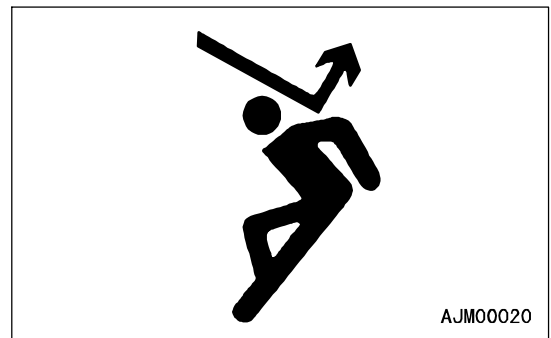
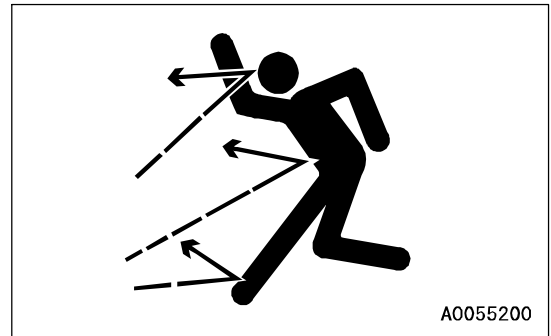
**ATTACHMENT INSTALLATION**

- When installing optional parts or attachments, there may be problems with safety or legal restrictions. Therefore contact your Komatsu distributor for advice.
- Any injuries, accidents, product failures or other property damages resulting from the use of unauthorized attachments or parts will not be the responsibility of Komatsu.
- When installing and using optional attachments, read the instruction manual for the attachment, and the general information related to attachments in this manual.

ATTACHMENT COMBINATIONS

Depending on the type or combination of work equipment, there is a hazard that the work equipment may hit the cab or other parts of the machine. Before using unfamiliar work equipment, check if there is any hazard of interference, and operate with caution.

CAB WINDOW GLASSES

- If a pane of the cab window on the work equipment side is broken, the work equipment may directly hit the operator. In that case, stop the machine immediately and replace the broken pane with new one.
- The ceiling window is made of organic glass (polycarbonate), and as such it is apt to break easily when receiving damage on the surface, thereby deteriorating its protective characteristic. If there is a crack or damage caused by a fallen rock, or when any sign of them is noticed, replace it with a new window.

UNAUTHORIZED MODIFICATIONS

If this machine is modified without permission from Komatsu, there is danger that problems may occur with safety and that this may lead to serious personal injury. Modifications may have an adverse effect on items such as machine strength and visibility. Before making any modifications, please consult your Komatsu distributor. Komatsu cannot take any responsibility for accidents, failures, or damage caused by modifications not authorized by Komatsu.

SAFETY AT JOBSITE

Before starting operations, thoroughly check the area for any unusual conditions that could be dangerous.

- When carrying out operations near combustible materials such as thatched roofs, dry leaves or dry grass, there is a hazard of fire, so be careful when operating.
- Check the terrain and condition of the ground at the worksite, and determine the safest method of operation. Do not operate where there is a hazard of landslides or falling rocks.
- If water lines, gas lines, or high-voltage electrical lines may be buried under the worksite, contact each utility and identify their locations. Be careful not to sever or damage any of these lines.
- Take necessary measures to prevent any unauthorized person from entering the operating area.
- When traveling or operating in shallow water or on soft ground, check the shape and condition of the bedrock, and the depth and speed of flow of the water before starting operations.

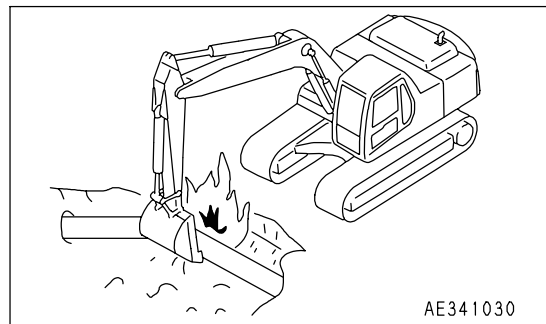
**WORKING ON LOOSE GROUND**

- Avoid traveling or operating your machine too close to the edge of cliffs, overhangs, and deep ditches. The ground may be weak in such areas. If the ground should collapse under the weight or vibration of the machine, there is a hazard that the machine may fall or tip over. Remember that the soil after heavy rain or blasting or after earthquakes is weak in these areas.
- When working on embankments or near excavated ditches, there is a hazard that the weight and vibration of the machine will cause the soil to collapse. Before starting operations, take steps to ensure that the ground is safe and to prevent the machine from rolling over or falling.

DISTANCE TO HIGH VOLTAGE CABLES

Do not travel or operate the machine near electric cables. There is a hazard of electric shock, which may cause serious personal injury or death. On jobsites where the machine may go close to electric cables, always do as follows.

- Before starting work near electric cables, inform the local power company of the work to be performed, and ask them to take the necessary action.

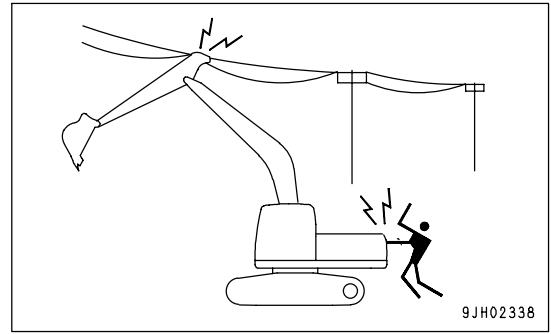

- Even going close to high-voltage cables can cause electric shock, which may cause serious burns or even death. Always maintain a safe distance (see the table on the right) between the machine and the electric cable. Check with the local power company about safe operating procedure before starting operations.
- To prepare for any possible emergencies, wear rubber shoes and gloves. Lay a rubber sheet on top of the seat, and be careful not to touch the chassis with any exposed part of your body.
- Use a signalman to give warning if the machine approaches too close to the electric cables.
- When carrying out operations near high voltage cables, do not let anyone near the machine.
- If the machine should come too close or touch the electric cable, to prevent electric shock, the operator should not leave the operator's compartment until it has been confirmed that the electricity has been shut off.
Also, do not let anyone near the machine.

Voltage of Cables	Safety Distance
100 V - 200 V	Over 2 m (7 ft)
6,600 V	Over 2 m (7 ft)
22,000 V	Over 3 m (10 ft)
66,000 V	Over 4 m (14 ft)
154,000 V	Over 5 m (17 ft)
187,000 V	Over 6 m (20 ft)
275,000 V	Over 7 m (23 ft)
500,000 V	Over 11 m (36 ft)

ENSURE GOOD VISIBILITY

This machine is equipped with mirrors to improve the visibility, but even with mirrors, there are places, which cannot be seen from the operator's seat, so always be careful when operating.

When operating or traveling in places with poor visibility, if it is impossible to confirm the condition of the job side or obstacle is in the area around the machine, there is danger that the machine may suffer damage or the operator may suffer serious personal injury. When operating or traveling in places with poor visibility, always observe the following items strictly.

- If the visibility cannot be sufficiently assured, position a flagman if necessary. The operator should pay careful attention to the signs and follow the instructions of the flagman.
- The signals should be given only by one flagman.
- When working in dark places, turn on the working lamps and front lamps of the machine, and if necessary, set up additional lighting in the area.
- Stop operations if there is poor visibility, such as in fog, snow, rain, or sand storms.
- Check the mirrors on the machine before starting operations every day. Clean off any dirt and adjust the view to ensure good visibility.

VENTILATION FOR ENCLOSED AREA

Exhaust fumes from the engine can kill.

- If it is necessary to start the engine within an enclosed area, or when handling fuel, flushing oil, or paint, open the doors and windows to ensure that adequate ventilation is provided to prevent gas poisoning.

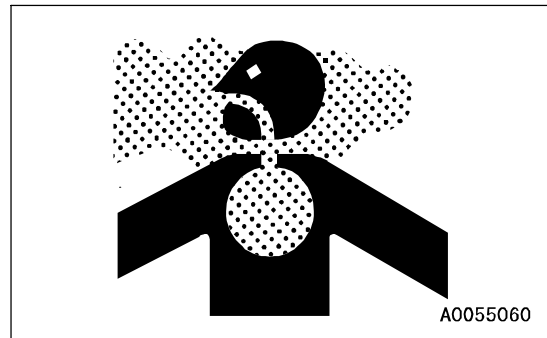
**SIGNALMAN'S SIGNAL AND SIGNS**

- Set up signs to inform of road shoulders and soft ground. If the visibility is not good, position a signalman if necessary. Operators should pay careful attention to the signs and follow the instructions from the signalman.
- Only one signalman should give signals.
- Make sure that all workers understand the meaning of all signals and signs before starting work.

EMERGENCY EXIT FROM OPERATOR'S CAB

If for some reason, the cab door does not open, use the rear window as an emergency escape. For details, see "EMERGENCY EXIT FROM OPERATOR'S CAB (PAGE 3-43)" in this manual.

ASBESTOS DUST HAZARD PREVENTION

Asbestos dust in the air can cause lung cancer if it is inhaled. There is danger of inhaling asbestos when working on jobsites handling demolition work or work handling industrial waste. Always observe the following.

- Spray water to keep down the dust when cleaning. Do not use compressed air for cleaning.
- If there is danger that there may be asbestos dust in the air, always operate the machine from an upwind position. All workers should use an approved respirator.
- Do not allow other persons to approach during the operation.
- Always observe the rules and regulations for the work site and environmental standards.



This machine does not use asbestos, but there is a danger that imitation parts may contain asbestos, so always use genuine Komatsu parts.

SAFETY MACHINE OPERATION

STARTING ENGINE

If there is a warning tag hanging from the work equipment control lever, do not start the engine or touch the levers.

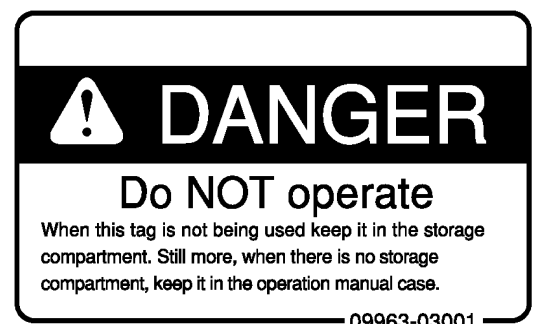
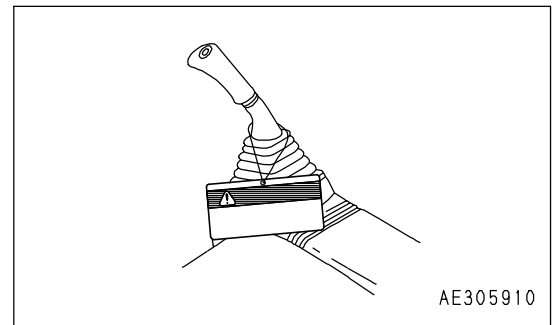

CHECKS BEFORE STARTING ENGINE

Carry out the following checks before starting the engine at the beginning of the day's work.

- Remove all dirt from the surface of the window glass to ensure a good view.
- Remove all dirt from the surface of the lens of the working lamps, and check that they light up correctly.
- Check the coolant level, fuel level, and oil level in engine oil pan, check for clogging of the air cleaner, and check for damage to the electric wiring.
- Adjust the operator's seat to a position where it is easy to carry out operations, and check that there is no damage or wear to the seat belt or mounting clamps.
- Check the operation of the instruments and gauges, check the angle of the mirror, and check that the control levers are all at the Neutral position.
- Before starting the engine, check that lock lever (1) is in LOCK position (L).
- Adjust the mirrors so that the rear of the machine can be seen clearly from the operator's seat.
When adjusting, see "Rearview Mirrors (PAGE 3-91)".
- Check that there are no persons or obstacles above, below, or in the area around the machine.

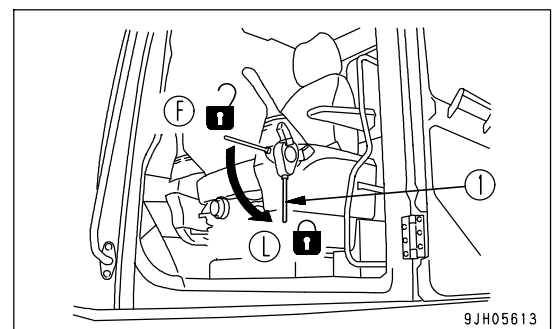

SAFETY RULES FOR STARTING ENGINE

- Start and operate the machine only while seated.
- Do not attempt to start the engine by short-circuiting the engine starting circuit. Such an act may cause a serious bodily injury or fire.
- When starting the engine, sound the horn as a warning.

- Do not allow anyone apart from the operator to ride on the machine.

STARTING ENGINE IN COLD WEATHER

- Carry out the warming-up operation thoroughly. If the machine is not thoroughly warmed up before the control levers or control pedals are operated, the reaction of the machine will be slow or the machine may move in a way not expected by the operator. Particularly in cold weather, be sure to carry out the warming-up operation thoroughly.
- If the battery electrolyte is frozen, do not charge the battery or start the engine with a different power source. There is a hazard that this will ignite the battery and cause the battery to explode. Before charging or starting the engine with a different power source, melt the battery electrolyte and check that there is no leakage of electrolyte before starting.

OPERATION

CHECKS BEFORE OPERATION

When carrying out the checks, move the machine to a wide area where there are no obstructions, and operate slowly. Do not allow anyone near the machine.

- Always fasten your seat belt.
- Check that the movement of the machine matches the display on the control pattern card. If it does not match, replace it immediately with the correct control pattern card.
- Check the operation of the work equipment, travel system and swing system.
- Check for any problem in the sound of the machine, vibration, heat, smell, or gauges; check also that there is no leakage of oil or fuel.
- If any problem is found, carry out repairs immediately.

SAFETY RULES FOR CHANGING MACHINE DIRECTIONS

- Always operate the machine only when seated.
- Do not allow anyone apart from the operator to ride on the machine.
- Check that the travel alarm works properly.
- Always lock the door and windows of the operator's compartment in position (open or closed).
On jobsites where there is a hazard of flying objects or of objects entering the operator's compartment, check that the door and windows are securely closed.
- If there is an area to the rear of the machine which cannot be seen, position a signal person. Take special care not to hit other machines or people when turning or swinging the machine.
- Before travelling, sound the horn to warn people in the area.
- Before travelling, check again that there is no one in the surrounding area, and that there are no obstacles.

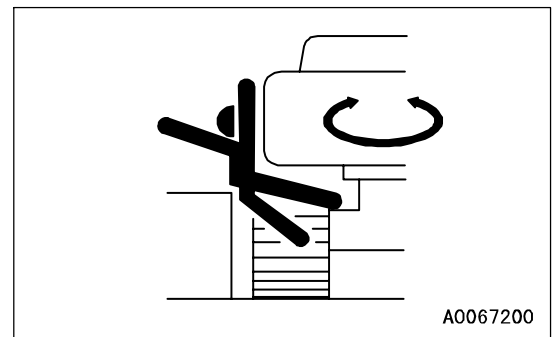
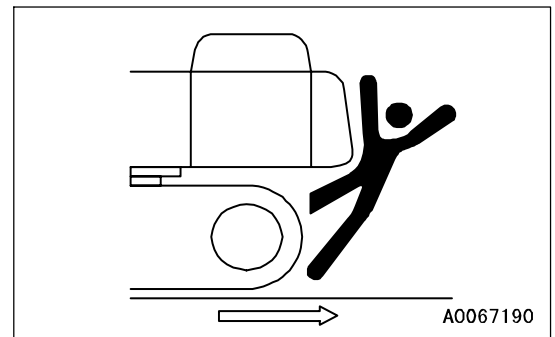

- Before traveling, set the machine so that sprocket (1) is behind the operator's seat.

If sprocket (1) is in front of the operator's cab, the machine moves in the opposite direction from the operation of the lever (front and rear travel is reversed, left and right steering is reversed). Be extremely careful when operating the machine in this situation.

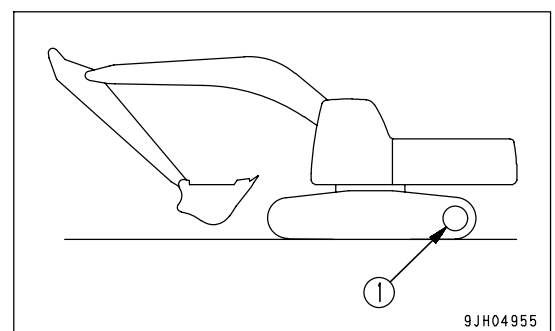

SAFETY RULES FOR TRAVELING

- When traveling on level ground, keep the work equipment at a height of 40 to 50 cm (16 to 20 in) from the ground.
- If the work equipment blocks the view and it is difficult to travel in safety, raise the work equipment to a greater height.
- When traveling on rough ground, travel at low speed and do not operate the steering suddenly. There is danger that the machine may turn over. The work equipment may hit the ground surface and cause the machine to lose its balance, or may damage the machine or structures in the area.
- When traveling on rough ground or steep slopes, if the machine is equipped with auto-deceleration, always turn the auto-deceleration switch OFF (cancel).
- Avoid traveling over obstacles when possible. If the machine has to travel over an obstacle, keep the work equipment close to the ground and travel at low speed. Never travel over obstacles which make the machine tilt strongly to one side.
- When traveling or carrying out operations, always keep a safe distance from people, structures, or other machines to avoid coming into contact with them.
- When passing over bridges or structures, check first that the structure is strong enough to support the weight of the machine.
- When operating in tunnels, under bridges, under electric wires, or other places where the height is limited, operate slowly and be extremely careful not to let the machine body or work equipment hit anything.

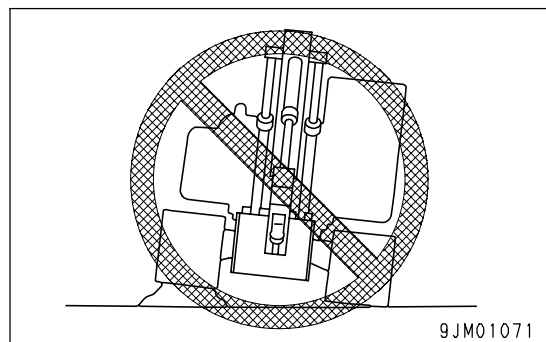
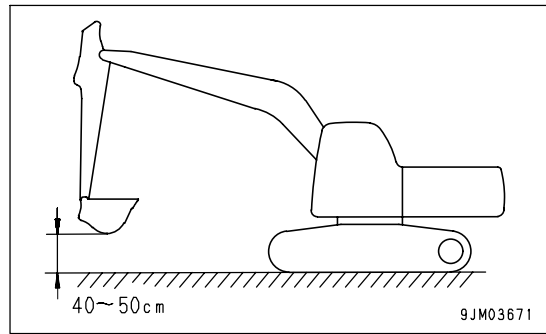
**TRAVELING ON SLOPES**

To prevent the machine from tipping over or slipping to the side, always do as follows.

- Keep the work equipment approx. 20 to 30 cm (8 to 12 in) above the ground. In case of emergency, lower the work equipment to the ground immediately to help stop the machine.
- When traveling uphill, set the machine with the operator's seat on the uphill side; when traveling downhill, set the operator's seat on the downhill side. Check that the ground under the machine is safe when traveling.

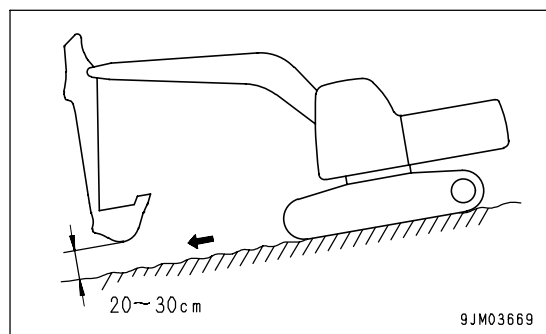
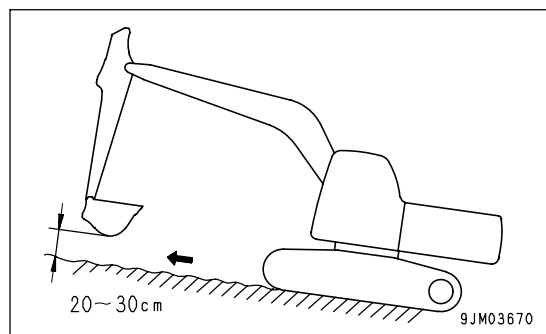

- When traveling up a steep slope, extend the work equipment to the front to improve the balance, keep the work equipment approximately 20 to 30 cm (8 to 12 in) above the ground, and travel at low speed.
- When traveling downhill, lower the engine speed, keep the travel lever close to the neutral position, and travel at low speed.

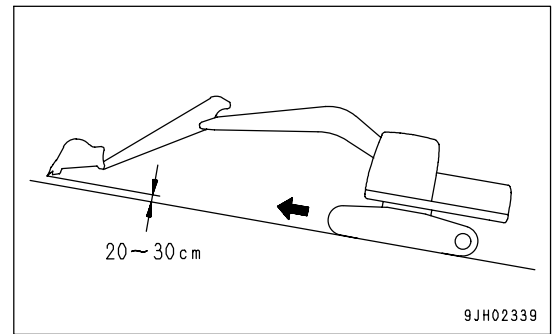

- Always travel straight up or down a slope. Traveling at an angle or across the slope is extremely dangerous.
- Do not turn on slopes or travel across slopes. Always go down to a flat place to change the position of the machine, then travel on to the slope again.
- Travel on grass, fallen leaves, or wet steel plates with low speed. Even with slight slopes there is a hazard that the machine may slip.

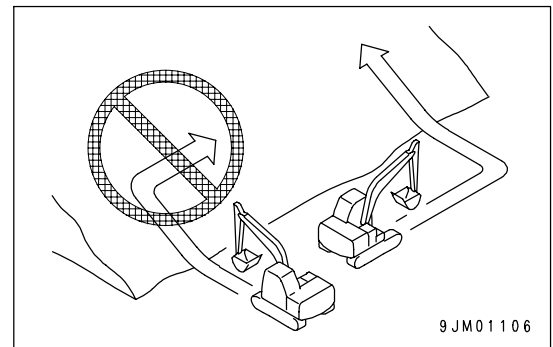

OPERATIONS ON SLOPES

- When working on slopes, there is a hazard that the machine may lose its balance and turn over when the swing or work equipment are operated. This may lead to serious injury or property damage, so always provide a stable place when carrying out these operations, and operate carefully.
- Do not swing the work equipment from the uphill side to the downhill side when the bucket is loaded. This operation is dangerous, and may cause the machine to tip over.
- If the machine has to be used on a slope, pile the soil to make a platform (A) that will keep the machine as horizontal as possible.

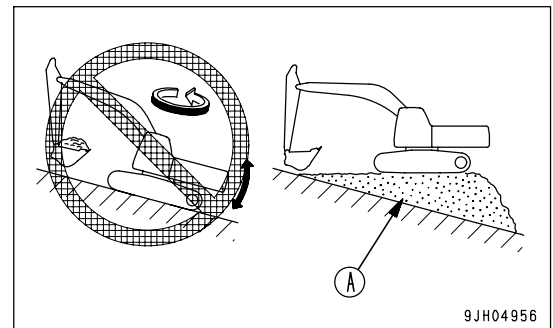

PROHIBITED OPERATIONS

- Never dig the work face under an overhang. There is a hazard that rocks may fall or that the overhang may collapse and fall on top of the machine.

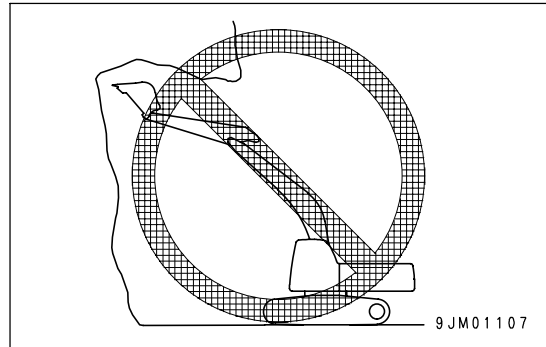

- Do not excavate too deeply under the front of the machine. The ground under the machine may collapse and cause the machine to fall.

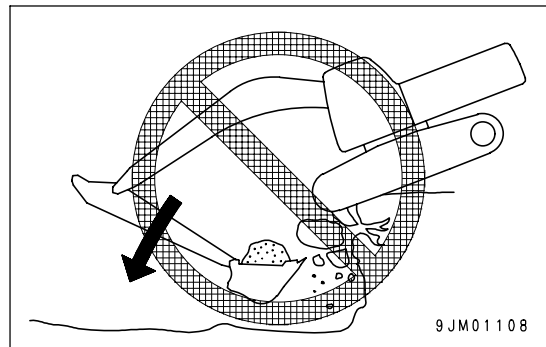

- To make it easier to escape if there is any problem, set the tracks at right angles to the road shoulder or cliff with the sprocket at the rear when carrying out operations.

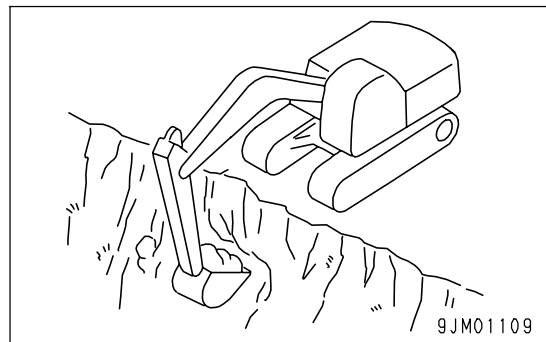

- Do not carry out demolition work under the machine. There is a hazard that the machine may become unstable and tip over.
- When working on or from the top of buildings or other structures, check the strength and the structure before starting operations. There is a hazard of the building collapsing and causing serious injury or damage.

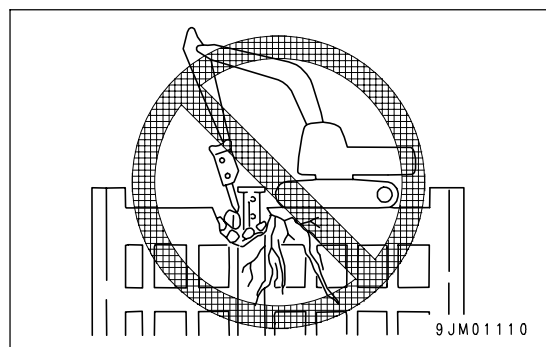

- When carrying out demolition work, do not carry out demolition above your head. There is a hazard of broken parts falling or of the building collapsing and causing serious injury or property damage.

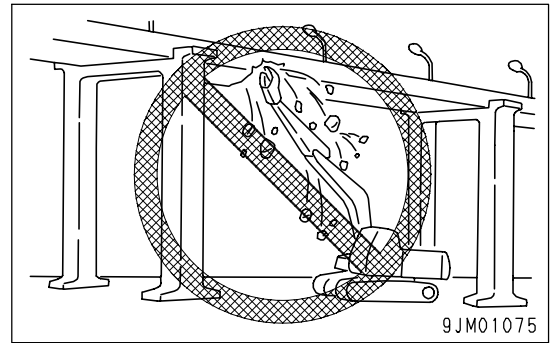

- Do not use the impact force of the work equipment for breaking work. There is a hazard of damage to the work equipment, or a hazard of serious personal injury being caused by flying pieces of broken materials, or of the machine tipping over due to reaction from the impact.
- Generally speaking, the machine is more liable to overturn when the work equipment is at the side than when it is at the front or rear.

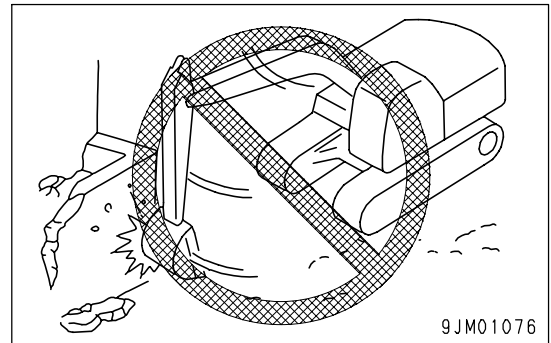

- When using a breaker or other heavy work equipment, there is a hazard of the machine losing its balance and tipping over. When operating on flat ground as well as on slopes.
 - Do not suddenly lower, swing, or stop the work equipment.
 - Do not suddenly extend or retract the boom cylinder. There is a hazard that impact will cause the machine to tip over.
- Do not pass the bucket over the head of other workers or over the operator's seat of dump trucks or other hauling equipment. The load may spill or the bucket may hit the dump truck and cause serious personal injury or death.

OPERATIONS ON SNOW

- Snow-covered or frozen surfaces are slippery, so be extremely careful when traveling or operating the machine, and do not operate the levers suddenly. Even a slight slope may cause the machine to slip, so be particularly careful when working on slopes.
- With frozen ground surfaces, the ground becomes soft when the temperature rises, and this may cause the machine to tip over or make it impossible for the machine to escape.
- If the machine enters deep snow, there is a hazard that it may tip over or become buried in the snow. Be careful not to leave the road shoulder or to get trapped in a snow drift.
- When clearing snow, the road shoulder and objects placed beside the road are buried in the snow and cannot be seen. There is a hazard of the machine tipping over or hitting covered objects, so always carry out operations carefully.

PARKING MACHINE

- Park the machine on firm, level ground.
- Select a place where there is no hazard of landslides, falling rocks, or flooding.
- Lower the work equipment completely to the ground.

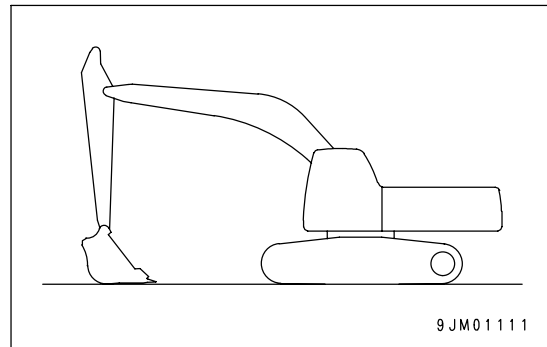

- When leaving the machine, set lock lever (1) to the LOCK position (L), then stop the engine.
- Always close the operator's cab door, and use the key to lock all the equipment in order to prevent any unauthorized person from moving the machine. Always remove the key, take it with you, and leave it in the specified place.
- If it is necessary to park the machine on a slope, always do as follows.
 - Set the bucket on the downhill side, then dig it into the ground.
 - Put blocks under the tracks to prevent the machine from moving.

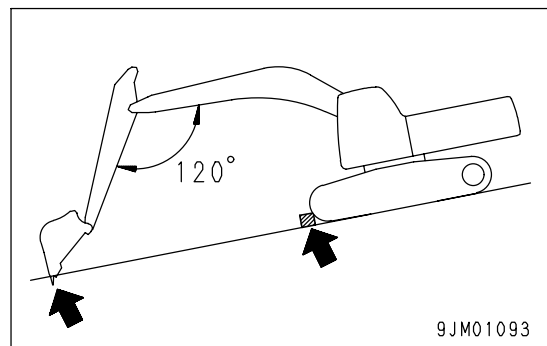
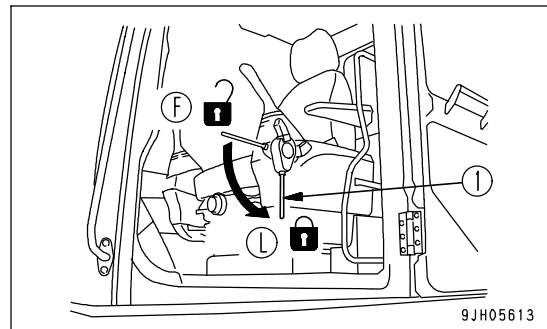

TRANSPORTATION

This machine must be disassembled for transportation. When transporting the machine, please consult your Komatsu distributor.

LOADING AND UNLOADING

When loading or unloading the machine, mistaken operation may bring the hazard of the machine tipping over or falling, so particular care is necessary. Always do as follows.

- Perform loading and unloading on firm, level ground only. Maintain a safe distance from the edge of the road or cliff.
 - Never use the work equipment to load or unload the machine. There is danger that the machine may fall or tip over.
 - Always use ramps of adequate strength. Be sure that the ramps are wide, long, and thick enough to provide a safe loading slope. Take suitable steps to prevent the ramps from moving out of position or coming off.
 - Be sure the ramp surface is clean and free of grease, oil, ice and loose materials. Remove dirt from machine-tracks. On a rainy day, in particular, be extremely careful since the ramp surface is slippery.
 - Turn the auto-decelerator switch OFF (auto-deceleration function released).
 - Run the engine at low speed and travel slowly.
 - When on the ramps, do not operate any lever except for the travel lever.
 - Never correct your steering on the ramps. If necessary, drive off the ramps, correct the direction, then enter the ramps again.
 - The center of gravity of the machine will change suddenly at the joint between the ramps and the track or trailer, and there is danger of the machine losing its balance. Travel slowly over this point.
 - When loading or unloading to an embankment or platform, make sure that it has suitable width, strength, and grade.
 - When swinging the upper structure on the trailer, the trailer is unstable, so pull in the work equipment and swing slowly.
 - For machines equipped with a cab, always lock the door after boarding the machine. If this is not done, the door may suddenly open during transportation.
- Refer to "TRANSPORTATION (PAGE 3-138)".

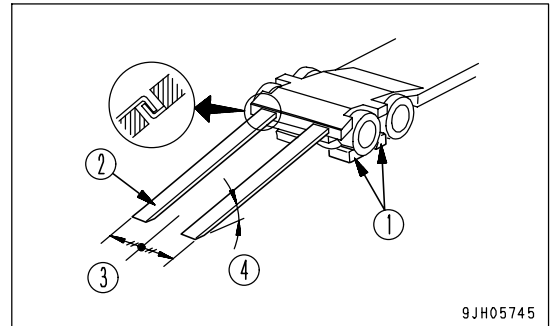

- (1) Blocks
- (2) Ramp
- (3) Centerline of trailer
- (4) Angle of ramps: Max. 15°

SHIPPING THE MACHINE

When shipping the machine on a trailer, do as follows.

- The weight, transportation height, and overall length of the machine differ according to the work equipment, so be sure to confirm the dimensions.
- When passing over bridges or structures on private land, check first that the structure is strong enough to support the weight of the machine. When traveling on public roads, check first with the relevant authorities and follow their instructions.
- For details of the shipping procedure, see "TRANSPORTATION (PAGE 3-138)" in the OPERATION section.

BATTERY

BATTERY HAZARD PREVENTION

Battery electrolyte contains sulphuric acid, and batteries generate flammable hydrogen gas, which may explode. Mistaken handling can lead to serious injury or fire. For this reason, always observe the following precautions.

- Do not use or charge the battery if the battery electrolyte level is below the LOWER LEVEL line. This may cause an explosion. Check the battery electrolyte level periodically and add distilled water to bring the electrolyte level to the UPPER LEVEL line.
- When working with batteries, always wear safety glasses and rubber gloves.
- Never smoke or use any flame near the battery.

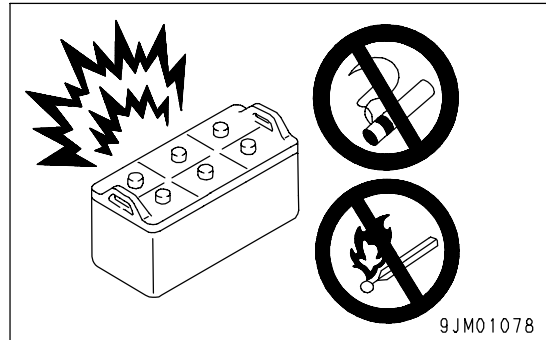

- If you spill acid on your clothes or skin, immediately flush the area with large amount of water.
- If acid gets into your eyes, flush them immediately with large amount of water and seek medical attention.

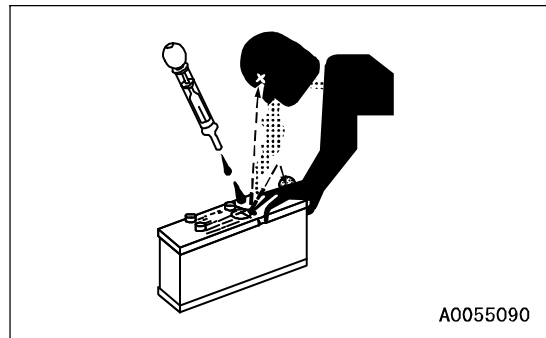

- Before working with batteries, turn the starting switch to the OFF position.

As there is a hazard that sparks will be generated, always do as follows.

- Do not let tools or other metal objects make any contact between the battery terminals. Do not leave tools or other metal objects lying around near the battery.
- When disconnecting the battery terminals, wait for approx. one minute after turning off the engine starting switch key, and be sure to disconnect the grounding terminal (negative (-) terminal) first. Conversely, when connecting them, begin with the positive (+) terminal and then the grounding (-) terminal. Make sure that all the terminals are connected securely.
- Flammable hydrogen gas is generated when the battery is charged, so remove the battery from the chassis, take it to a well-ventilated place, and remove the battery caps before charging it.
- Tighten the battery caps securely.
- Install the battery securely to the determined place.

STARTING ENGINE WITH BOOSTER CABLES

If any mistake is made in the method of connecting the booster cables, it may cause the battery to explode, so always do as follows.

- When starting with a booster cable, carry out the starting operation with two workers (one worker sitting in the operator's seat and the other working with the battery).
- When starting from another machine, do not allow the two machines to touch.
- When connecting the booster cables, turn the starting switch OFF position for both the normal machine and problem machine. There is a hazard that the machine will move when the power is connected.
- Be sure to connect the positive (+) cable first when installing the booster cables. Disconnect the negative (-) cable (ground side) first when removing them.
- When removing the booster cables, be careful not to let the booster cable clips touch each other or to let the clips touch the machine.
- Always wear safety glasses and rubber gloves when starting the engine with booster cables.
- When connecting a normal machine to a problem machine with booster cables, always use a normal machine with the same battery voltage as the problem machine.
- For details of the starting procedure when using booster cables, see "Starting Engine with Booster Cables (PAGE 3-159)" in the OPERATION section.

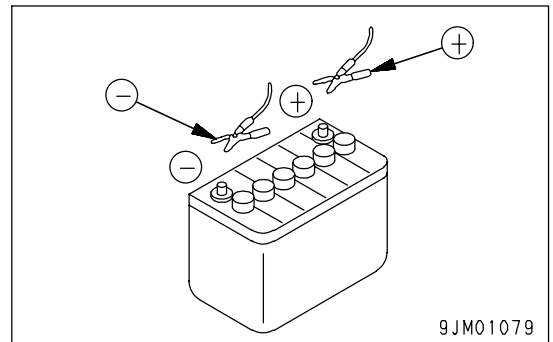
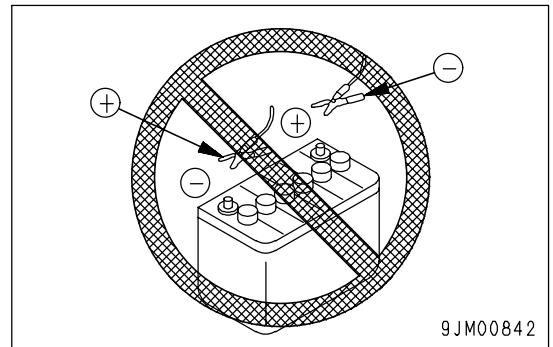

TOWING

SAFETY RULES FOR TOWING

Serious injury or death could result if a disabled machine is towed incorrectly or if there is a mistake in the selection or inspection of the wire rope.

For towing, see "TOWING THE MACHINE (PAGE 3-156)".

- Always check that the wire rope used for towing has ample strength for the weight of the machine being towed.
- Never use a wire rope which has cut strands (A), reduced diameter (B), or kinks (C). There is danger that the rope may break during the towing operation.

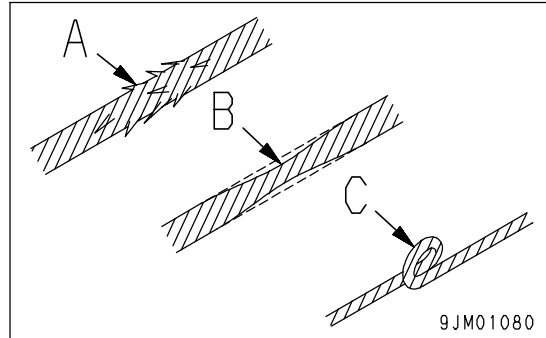

- Always wear leather gloves when handling wire rope.
- Never tow a machine on a slope.
- During the towing operation, never stand between the towing machine and the machine being towed.
- Operate the machine slowly and be careful not to apply any sudden load to the wire rope.

LIFTING OBJECTS WITH BUCKET

SAFETY RULES FOR LIFTING OBJECTS

- Determine the signals to be used and place a signalman in position.
- To prevent the machine from tipping over or falling, carry out the operation on flat ground.
- To prevent the danger of contact with a raised load or the danger from a falling load, do not allow any worker inside the area.
- It is dangerous if the raised load hits any person or structure. When swinging or operating the work equipment, check carefully that the surrounding area is safe.
- Do not swing or operate the work equipment suddenly. There is danger that this may cause the load to sway and the machine to tip over.
- Do not leave the operator's seat when there is a raised load.
- Do not use the work equipment or swing to pull the load in any direction. There is danger that the hook may break and the load come off, causing the work equipment to move suddenly and cause personal injury.

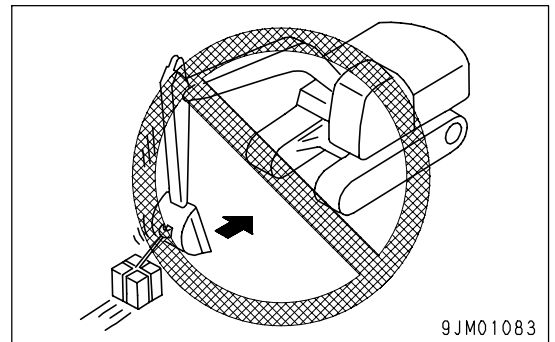
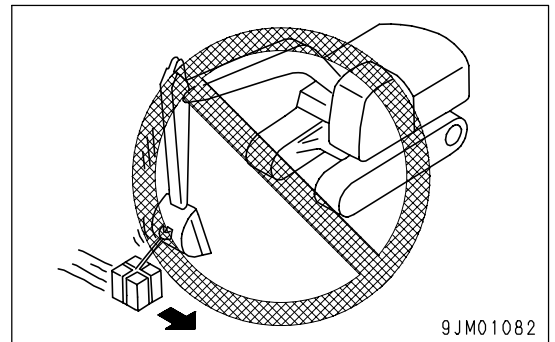

SAFETY MAINTENANCE INFORMATION

WARNING TAG

- Always attach the "DO NOT OPERATE" warning tag to the work equipment control lever in the operator's cab to alert others that you are performing service or maintenance on the machine. Attach additional warning tags around the machine if necessary. Warning tag Part No. 09963-03001
Keep this warning tag in the tool box while it is not used. If there is no toolbox, keep the tag in the operation manual pocket.
- If any other person starts the engine, or touches or operates the control levers or control pedals while you are performing service or maintenance, you may suffer serious injury.

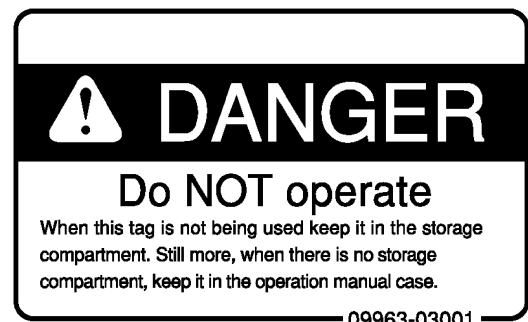
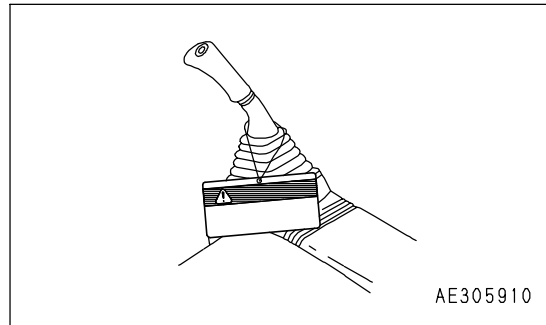

KEEP WORK PLACE CLEAN AND TIDY

- Do not leave hammers or other tools lying around in the work place. Wipe up all grease, oil, or other substances that will cause you to slip. Always keep the work place clean and tidy to enable you to carry out operations safely. If the work place is not kept clean and tidy, there is the danger that you will trip, slip, or fall over and injure yourself.
- When cleaning the ceiling window which is made of organic glass (polycarbonate), use tap water and avoid use of organic solvents for cleaning. An organic solvent like benzene, toluene or methanol can invite a chemical reaction like dissolution and decomposition on the window glass, deteriorating polycarbonate in use.

APPOINT LEADER WHEN WORKING WITH OTHERS

When repairing the machine or when removing and installing the work equipment, appoint a leader and follow his instructions during the operation.

STOP ENGINE BEFORE CARRYING OUT MAINTENANCE

- Stop the machine on firm, level ground.
- Select a place where there is no hazard of landslides, falling rocks, or flooding.
- Lower the work equipment completely to the ground and stop the engine.
- Turn the starting switch to the ON position. Operate the work equipment control lever back and forth, left and right at the full stroke 2 to 3 times to eliminate the remaining internal pressure in the hydraulic circuit, and then push up lock lever (1) to the LOCK position (L).
- Check that the battery relay is off and main power is not conducted. (Wait for approx. one minute after turning off the engine starting switch key and press the horn switch. If the horn does not sound, it is not activated.)

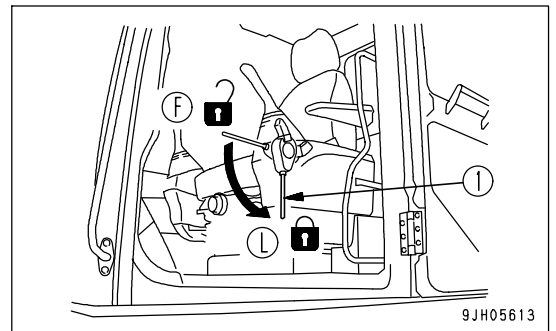
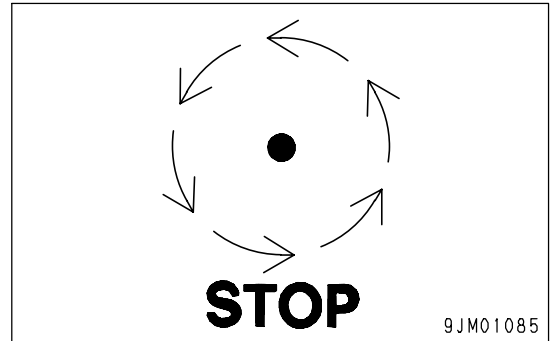

- Put blocks under the track to prevent the machine from moving.

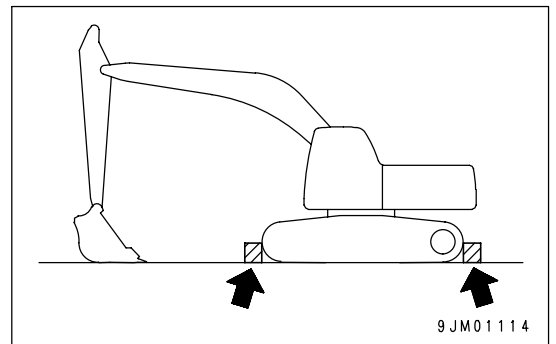

TWO WORKERS FOR MAINTENANCE WHEN ENGINE IS RUNNING

To prevent personal injury, do not carry out maintenance with the engine running. If maintenance must be carried out with the engine running, carry out the operation with at least two workers and do as follows.

- One worker must always sit in the operator's seat and be ready to stop the engine at any time. All workers must maintain contact with the other workers.
- When carrying out operations near the fan, fan belt, or other rotating parts, there is a hazard of being caught in the parts, so be careful not to come close.
- Never drop or insert tools or other objects into the fan or fan belt. Parts may break or be sent flying.

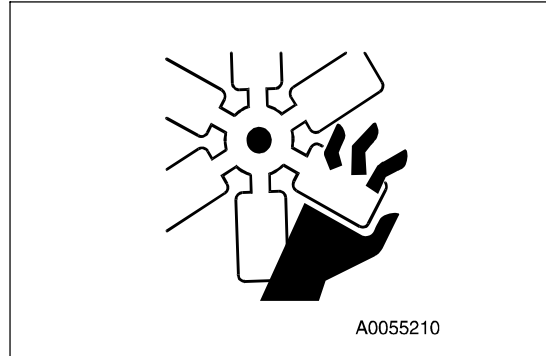

- Set lock lever (1) to the LOCK position (L) to prevent the work equipment from moving.
- Do not touch any control levers or control pedals. If any control levers or control pedals must be operated, always give a signal to the other workers to warn them to move to a safe place.

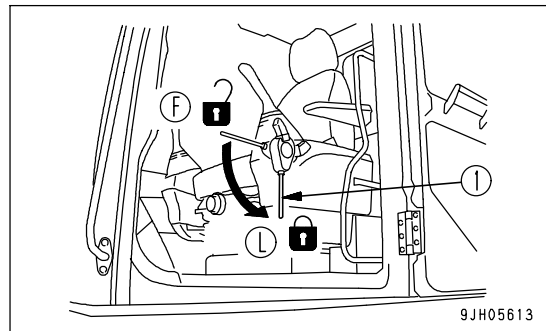
**PROPER TOOLS**

Use only tools suited to the task and be sure to use the tools correctly. Using damaged, low quality, faulty, makeshift tools or improper use of the tools could cause serious personal injury.

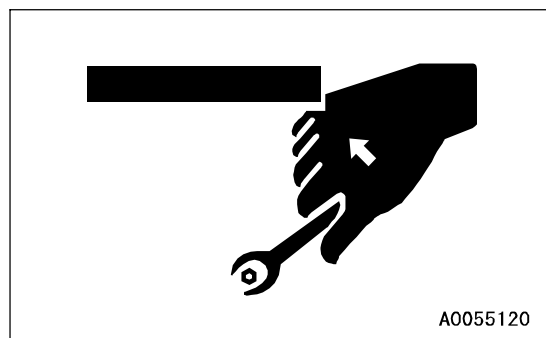

ACCUMULATOR, GAS SPRING

The accumulator and gas springs is charged with high-pressure nitrogen gas. When handling the accumulator, careless procedure may cause an explosion which could lead to serious injury or property damage. For this reason, always observe the following precautions.

- Do not disassemble the accumulator.
- Do not bring it near flame or dispose of it in fire.
- Do not make holes in it, weld it, or use a cutting torch.
- Do not hit or roll the accumulator, or subject it to any impact.
- When disposing of the accumulator, the gas must be released.

Please contact your Komatsu distributor to have this work performed.

**PERSONNEL**

Do not allow any unauthorized personnel into the area when servicing the machine. If necessary, employ a guard.

ATTACHMENTS

- Appoint a leader before starting removal or installation operations for attachments.
- Place attachments that have been removed from the machine in a stable condition so that they do not fall. And take steps to prevent unauthorized persons from entering the storage area.

**WORK UNDER THE MACHINE**

- If it is necessary to go under the work equipment or the machine to carry out service and maintenance, support the work equipment and machine securely with blocks and stands strong enough to support the weight of the work equipment and machine.
- It is extremely dangerous to work under the machine if the track shoes are lifted off the ground and the machine is supported only with the work equipment. If any of the control levers is touched by accident, or there is damage occurring to the hydraulic piping, the work equipment or the machine will suddenly drop. This is extremely dangerous. Never work under the work equipment or the machine.

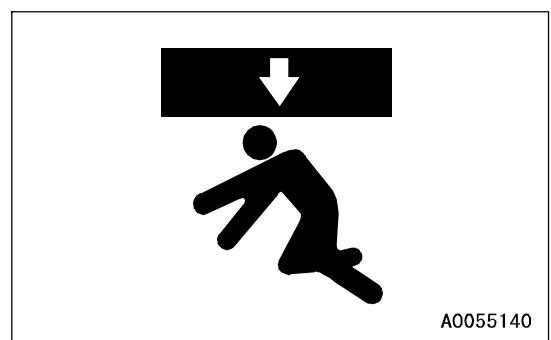
**NOISE**

When carrying out maintenance of the engine and you are exposed to noise for long periods of time, wear ear covers or ear plugs while working.

If the noise from the machine is too loud, it may cause temporary or permanent hearing problems.

WHEN USING HAMMER

When using a hammer, pins may fly out or metal particles may be scattered. This may lead to serious injury. Always do as follows.

- If hard metal parts such as pins, bucket teeth, cutting edges, or bearings are hit with a hammer, there is a hazard that pieces might be scattered and cause serious personal injury. Always wear safety glasses and gloves.
- When hitting pins or bucket teeth, there is a hazard that broken pieces might be sent flying and injure people in the surrounding area. Always check that there is no one in the surrounding area.
- There is a hazard that the pin hit with strong force may fly out and injure people in the surrounding area.

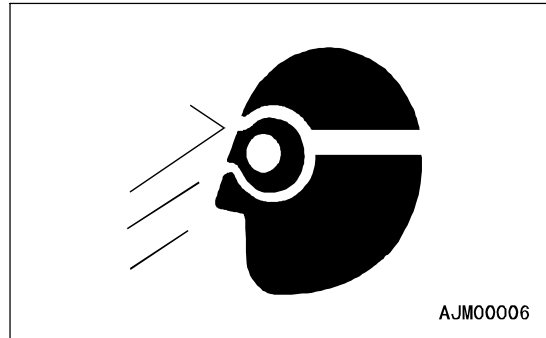

AJM00006

WELDING WORKS

Welding operations must always be carried out by a qualified welder and in a place equipped with proper equipment. There is a hazard of gas, fire, or electrocution when carrying out welding, so never allow any unqualified personnel to carry out welding.

REMOVING BATTERY TERMINALS

When repairing or welding the electrical system, wait for approx. one minute after turning off the engine starting switch key, and then disconnect the negative (-) terminal of the battery to stop the flow of electricity.

SAFETY FIRST WHEN USING HIGH-PRESSURE GREASE TO ADJUST TRACK TENSION

- Grease is pumped into the track tension adjustment system under high pressure.

If the specified procedure for maintenance is not followed when making adjustment, grease drain plug (1) may fly out and cause serious injury or property damage.

- When loosening grease drain plug (1) to loosen the track tension, never loosen it more than one turn. Loosen the grease drain plug slowly.
- Never put your face, hands, feet, or any other part of your body close to grease drain plug (1).

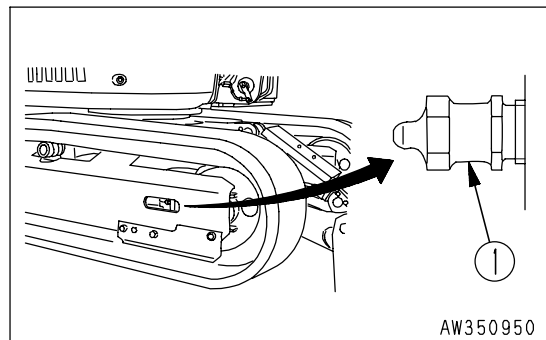

AW350950

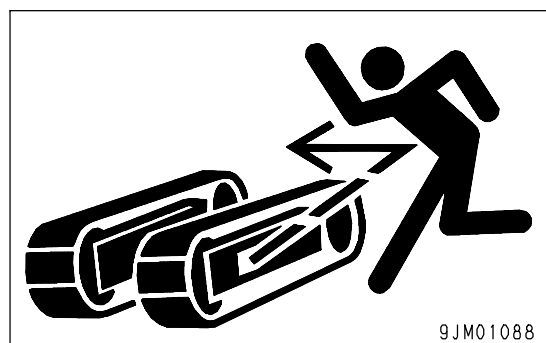

9JM01088

DO NOT DISASSEMBLE RECOIL SPRINGS

Never attempt to disassemble the recoils spring assembly. It contains a spring under high pressure which serves as a shock absorber for the idler. If it is disassembled by mistake, the spring will fly out and cause serious injury. When it becomes necessary to disassemble it, ask your Komatsu distributor to do the work.

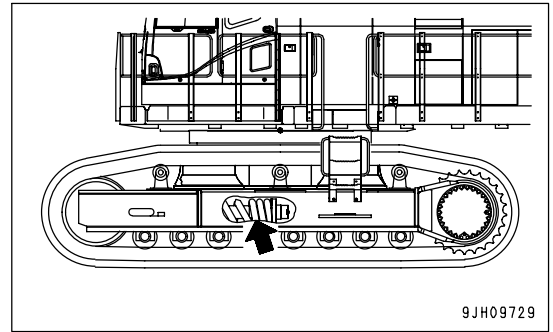
**SAFETY RULES FOR HIGH-PRESSURE OIL**

The hydraulic system is always under internal pressure. When inspecting or replacing piping or hoses, always check that the pressure in the hydraulic circuit has been released. If the circuit is still under pressure, it will lead to serious personal injury, so always do as follows.

- Release the pressure in the hydraulic circuit. For details, see "METHOD OF RELEASING PRESSURE IN HYDRAULIC CIRCUIT (PAGE 4-79)". Do not carry out any inspection or replacement work when the hydraulic system is under pressure.
- If there is any leakage from the piping or hoses, the surrounding area will be wet, so check for cracks in the piping and hoses and for swelling in the hoses.

When carry out inspection, wear safety glasses and leather gloves.

- There is a hazard that high-pressure oil leaking from small holes may penetrate your skin or cause blindness if it contacts your eyes directly. If you are hit by a jet of high-pressure oil and suffer injury to your skin or eyes, wash the place with clean water, and consult a doctor immediately for medical attention.

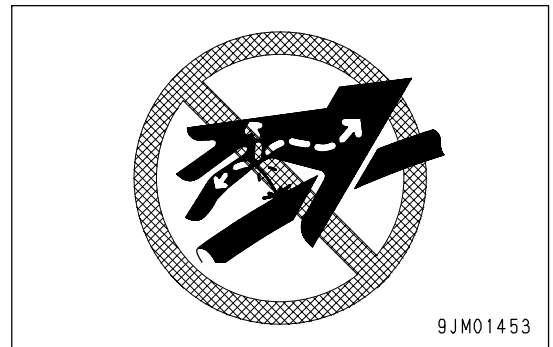
**PRECAUTION FOR HIGH FUEL PRESSURE**

High pressure is generated inside the engine fuel piping when the engine is running. When carrying out inspection or maintenance of the fuel piping system, wait for at least 30 seconds after stopping the engine to let the internal pressure go down before starting inspection or maintenance.

SAFETY HANDLING HIGH-PRESSURE HOSES

- If oil or fuel leaks from high-pressure hoses, it may cause fire or defective operation, which may lead to serious injury. If any loose bolts are found, stop work and tighten to the specified torque. If any damaged hoses are found, stop operations immediately and contact your Komatsu distributor.

Replace the hose if any of the following problems are found.

- Damaged or leaking hydraulic fitting.
- Frayed or cut covering or exposed reinforcement wire layer.
- Covering swollen in places.
- Twisted or crushed movable portion.
- Foreign material embedded in covering.

PRECAUTION FOR HIGH VOLTAGE

When the engine is running or immediately after it has stopped, high voltage is generated at the injector terminal and inside the engine controller, so there is danger of electrocution. Never touch the injector terminal or the inside of the engine controller.

If it is necessary to touch the injector terminal or the inside of the engine controller, please contact your Komatsu distributor.

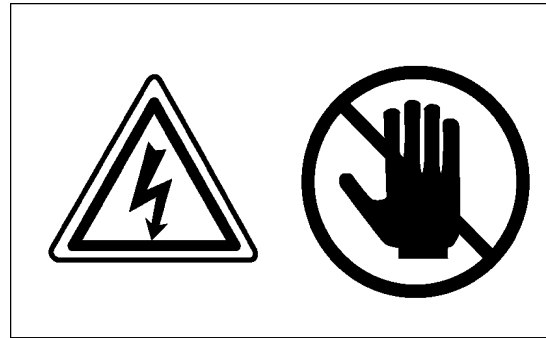
**WASTE MATERIALS**

To prevent pollution, pay careful attention to the method of disposing of waste materials.

- Always put oil drained from your machine in containers. Never drain oil directly onto the ground or dump into the sewage system, rivers, the sea, or lakes.
- Obey appropriate laws and regulations when disposing of harmful objects such as oil, fuel, coolant, solvent, filters, and batteries.

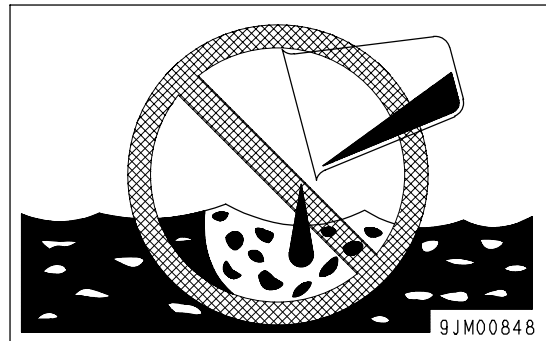
**AIR CONDITIONER MAINTENANCE**

If air conditioner refrigerant gets into your eyes, it may cause blindness; if it touches your skin, it may cause frostbite. Never touch refrigerant.

COMPRESSED AIR

- When carrying out cleaning with compressed air, there is a hazard of serious injury caused by flying particles.
- When using compressed air to clean elements or the radiator, always wear safety glasses, dust mask, gloves, and other protective equipment.

PERIODIC REPLACEMENT OF SAFETY CRITICAL PARTS

- For using the machine safely for an extended period of time, replace safety-critical parts like hoses and seat belts periodically.

Replacement of safety-critical parts: See "SAFETY CRITICAL PARTS (PAGE 4-13)".

- The material of these components naturally changes over time, and repeated use causes deterioration, wear, and fatigue. As a result, there is a hazard that these components may fail and cause serious injury or death. It is difficult to judge the remaining life of these components from external inspection or the feeling when operating, so always replace them at the specified interval.
- Replace or repair safety-critical parts if any defect is found, even when they have not reached the specified replacement time.

OPERATION

WARNING

Please read and make sure that you understand the SAFETY section before reading this section.

MACHINE VIEW ILLUSTRATIONS

OVERALL MACHINE VIEW

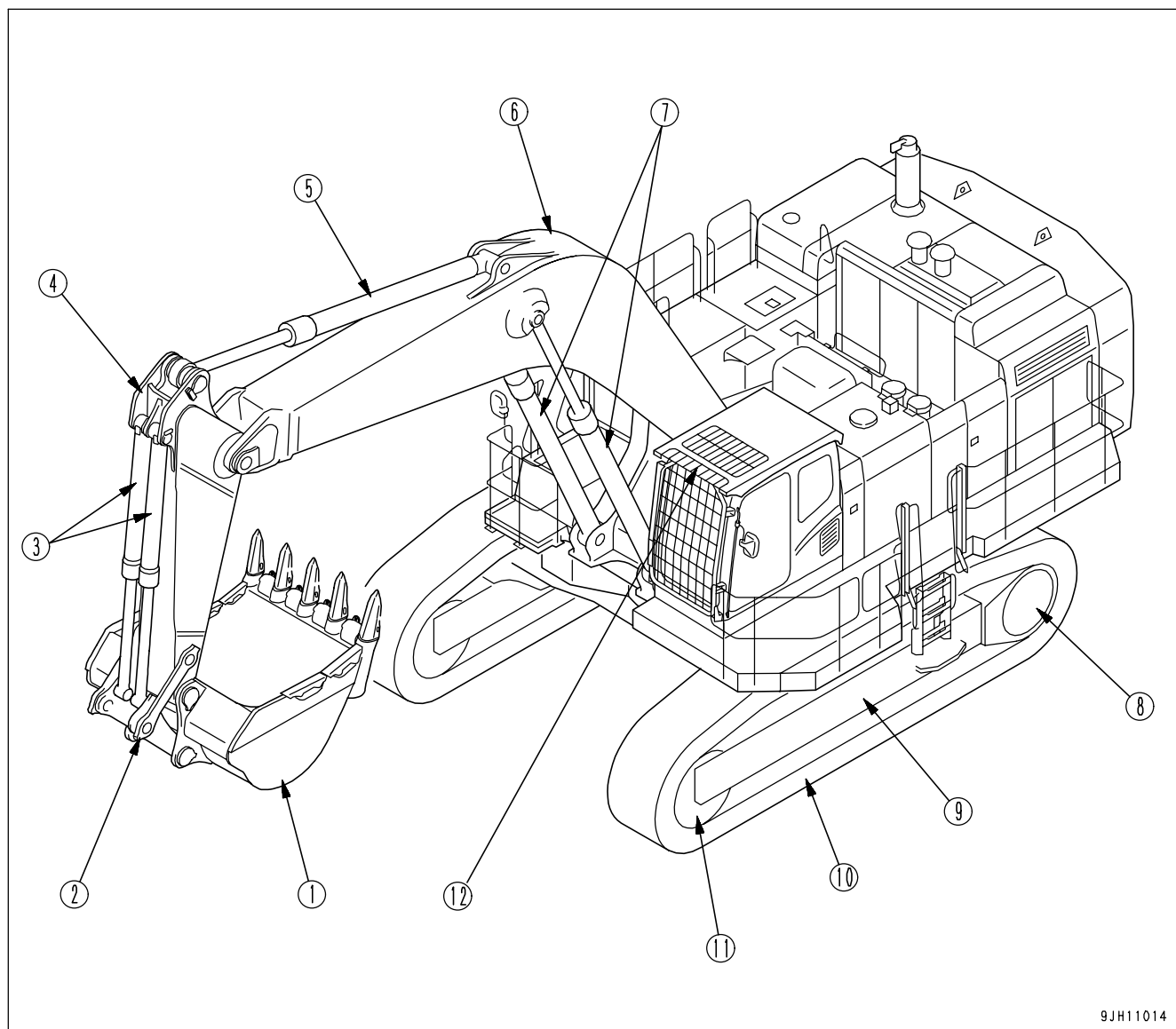

9JH11014

- | | |
|---------------------|---------------------|
| (1) Bucket | (7) Boom cylinder |
| (2) Bucket link | (8) Sprocket |
| (3) Bucket cylinder | (9) Track frame |
| (4) Arm | (10) Track shoe |
| (5) Arm cylinder | (11) Idler |
| (6) Boom | (12) Overhead guard |

CONTROLS AND GAUGES

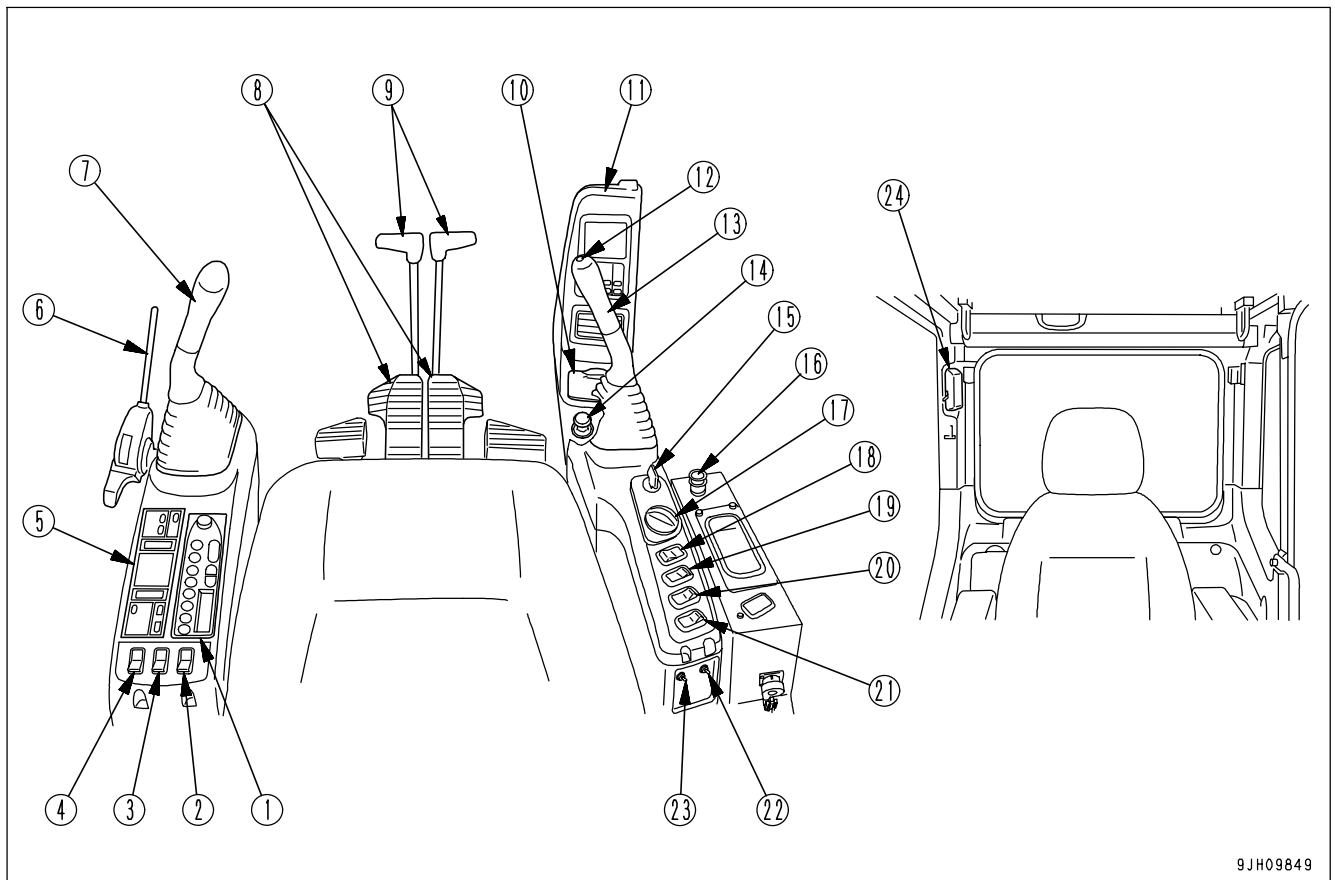

9JH09849

- | | |
|--|---|
| (1) Radio | (12) Horn switch |
| (2) Large capacity airflow air conditioner blower switch (if equipped) | (13) R.H. work equipment control lever |
| (3) Revolving warning lamp switch (if equipped) | (14) Cigarette lighter |
| (4) Lower wiper switch (machines equipped with fixed front window cab) | (15) Starting switch |
| (5) Air conditioner control panel | (16) Step light switch |
| (6) Lock lever | (17) Fuel control dial |
| (7) L.H. work equipment control lever | (18) Lamp switch |
| (8) Travel pedals | (19) Swing lock switch |
| (9) Travel levers | (20) Machine push-up switch |
| (10) Ashtray | (21) Boom shockless control switch |
| (11) Machine monitor | (22) Swing parking brake release switch |
| | (23) Emergency pump drive switch |
| | (24) Room lamp switch |

Machine monitor

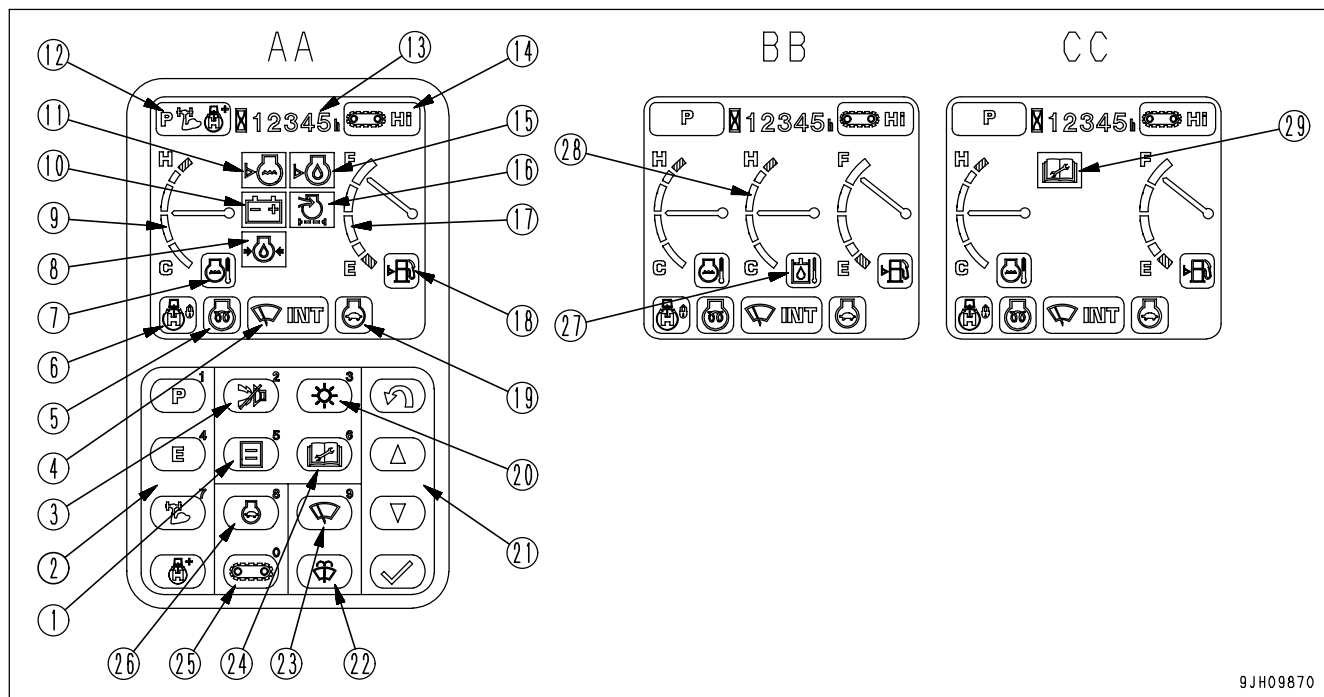

9JH09870

- AA: Screen with all lamps lighted up
- BB: Screen for standard
- CC: Maintenance time warning screen

- | | |
|---|--|
| (1) User mode adjustment switch | (16) Air cleaner clogging monitor |
| (2) Working mode selector switch (basic switch) | (17) Fuel gauge |
| (3) Alarm buzzer stop switch | (18) Fuel level monitor |
| (4) Wiper monitor | (19) Auto-deceleration monitor |
| (5) Engine pre-heating monitor | (20) Liquid crystal monitor adjustment switch |
| (6) Swing lock monitor | (21) Input confirmation switch |
| (7) Engine coolant temperature monitor | (22) Window washer switch |
| (8) Engine oil pressure monitor | (23) Wiper switch |
| (9) Engine coolant temperature gauge | (24) Maintenance switch |
| (10) Charge level monitor | (25) Travel speed selector switch (selection switch) |
| (11) Radiator coolant level monitor | (26) Auto-deceleration switch (selection switch) |
| (12) Working mode monitor | (27) Hydraulic oil temperature monitor |
| (13) Service meter | (28) Hydraulic oil temperature gauge |
| (14) Travel speed monitor | (29) Maintenance interval monitor |
| (15) Engine oil level monitor | |

DETAILED CONTROLS AND GAUGES

The following is an explanation of devices needed for operating the machine.

To perform suitable operations correctly and safely, it is important to completely understand methods of operating the equipment, and the meanings of the displays.

MONITORING SYSTEM

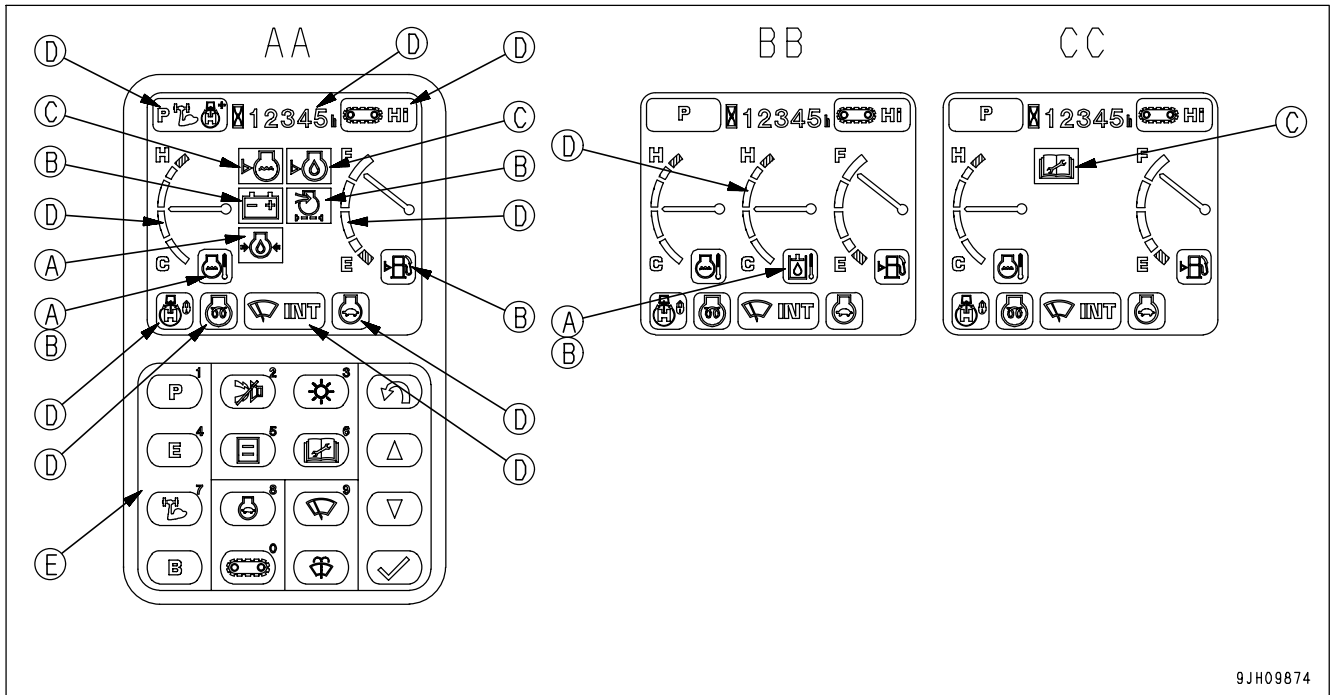

9JH09874

- AA: Screen with all lamps lighted up
- BB: Screen for standard
- CC: Maintenance time warning screen

- (A) Emergency monitors
- (B) Caution monitors
- (C) Basic check monitors
- (D) Meter display portion
- (E) Monitor switches portion

Basic Operation of Machine Monitor

Starting Engine When Situation is Normal

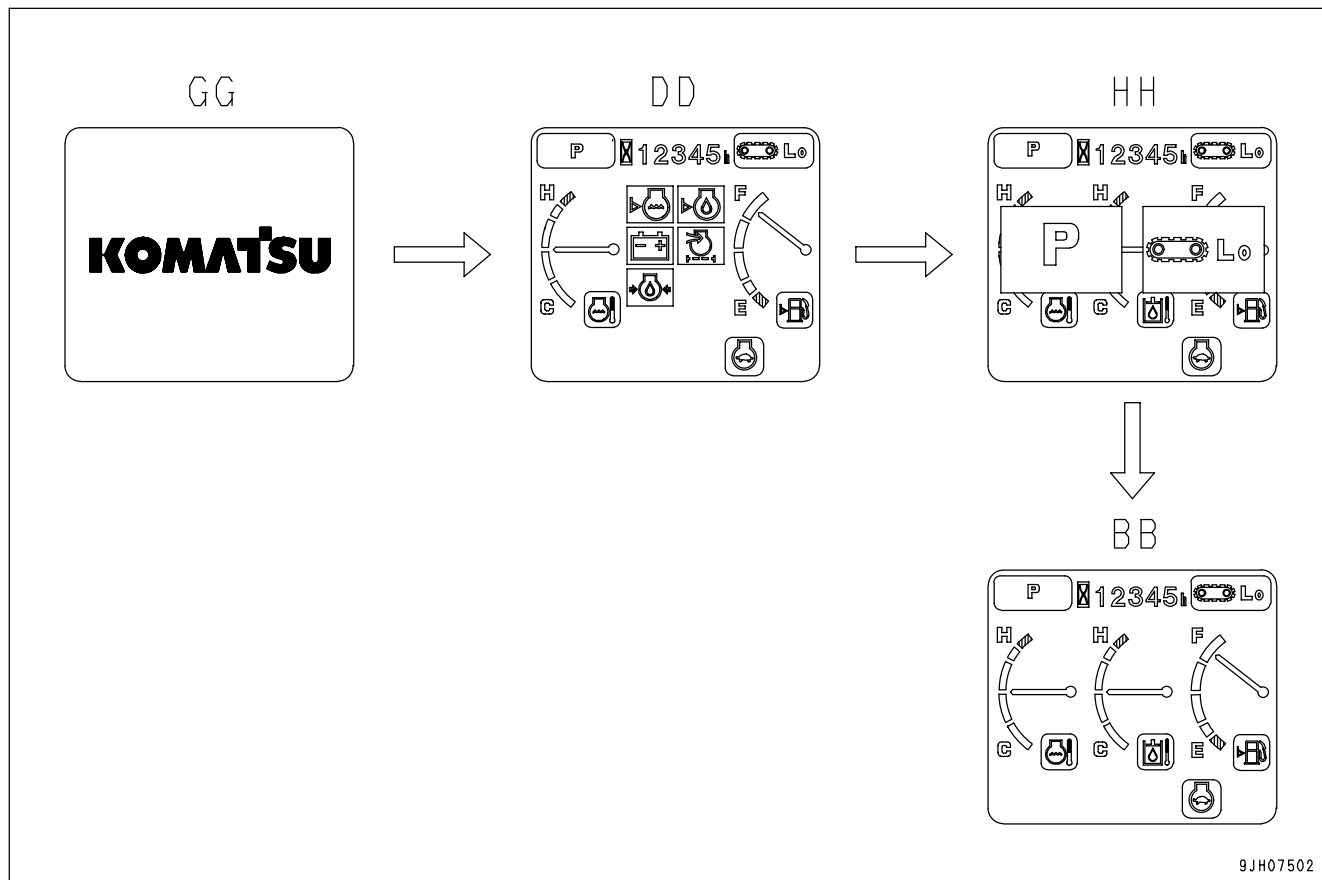

9JH07502

- When the starting switch is turned to the ON position, the opening screen GG is displayed.
- After the opening screen GG is displayed for 2 seconds, the screen switches to the check before starting screen DD.
- After the check before starting screen DD is displayed for 2 seconds, the screen switches to the working mode/travel mode display screen HH.
- After the working mode/travel mode display screen HH is displayed for 2 seconds, the screen switches to standard screen BB.

REMARK

When the engine is started, the battery voltage may suddenly drop depending on the temperature and the battery condition. If this happens, the display on the machine monitor may momentarily go out, but this does not indicate any abnormality.

If There Is Abnormality When Starting Engine

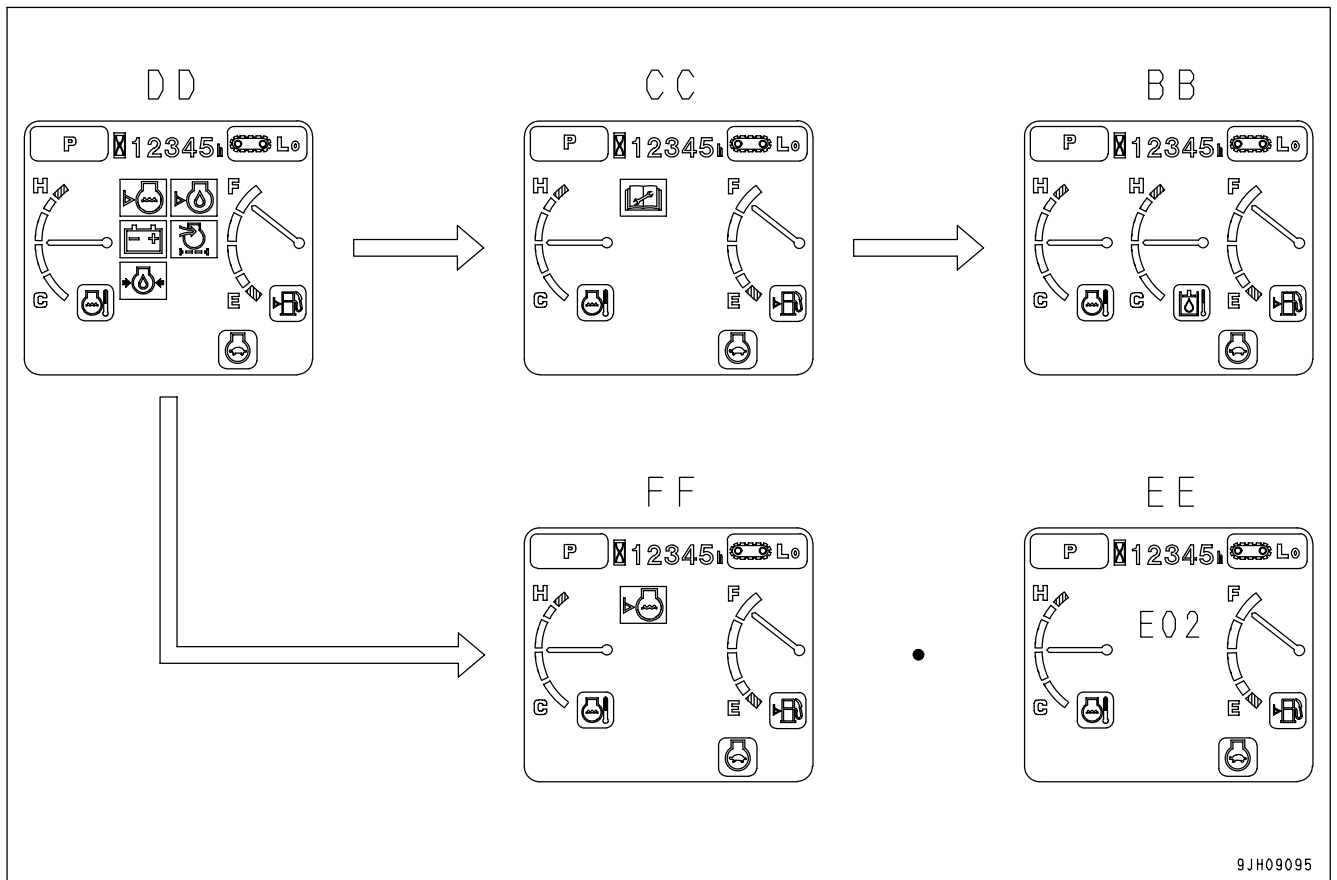

9JH09095

- If there is any abnormality when starting the engine, the check before starting screen DD changes to the maintenance interval warning screen CC, warning screen FF, or error screen EE.
- After displaying the check before starting screen DD for 2 seconds, the screen changes to the maintenance interval warning screen CC.
- After displaying the maintenance interval warning screen CC for 30 seconds, the screen returns to the standard screen BB.
- After displaying the check before starting screen DD for 2 seconds, the screen changes to the warning screen FF or error screen EE.

If Any Abnormality Occurs During Operation

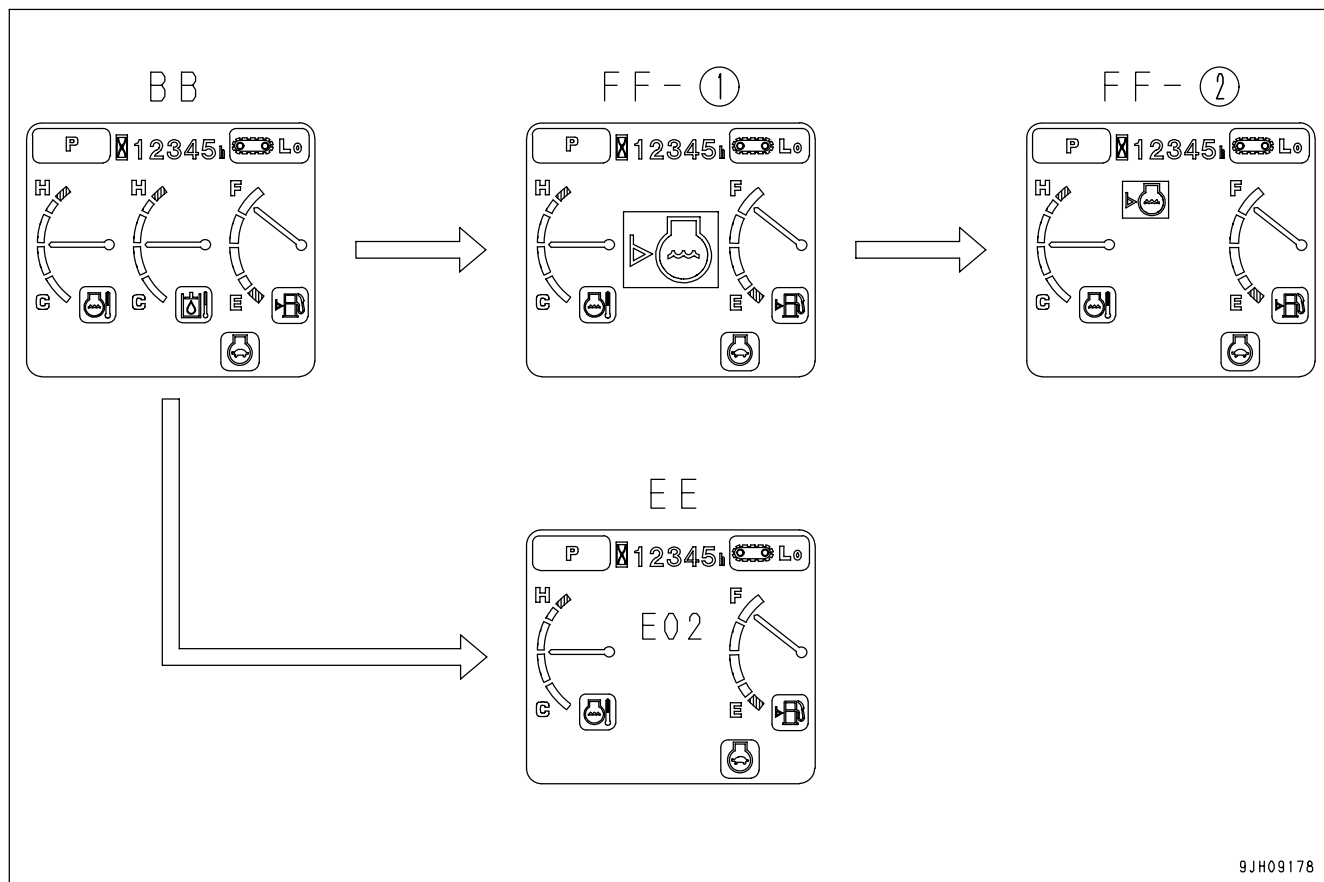

9JH09178

- If any abnormality occurs during operation, the standard screen BB changes to warning screen FF-(1) or the error screen EE.
- After displaying warning screen FF-(1) for 2 seconds, the screen automatically changes to warning screen FF-(2).

REMARK

The colors lighting up the monitors related to the emergency stop items, caution items, and basic check items are as follows.

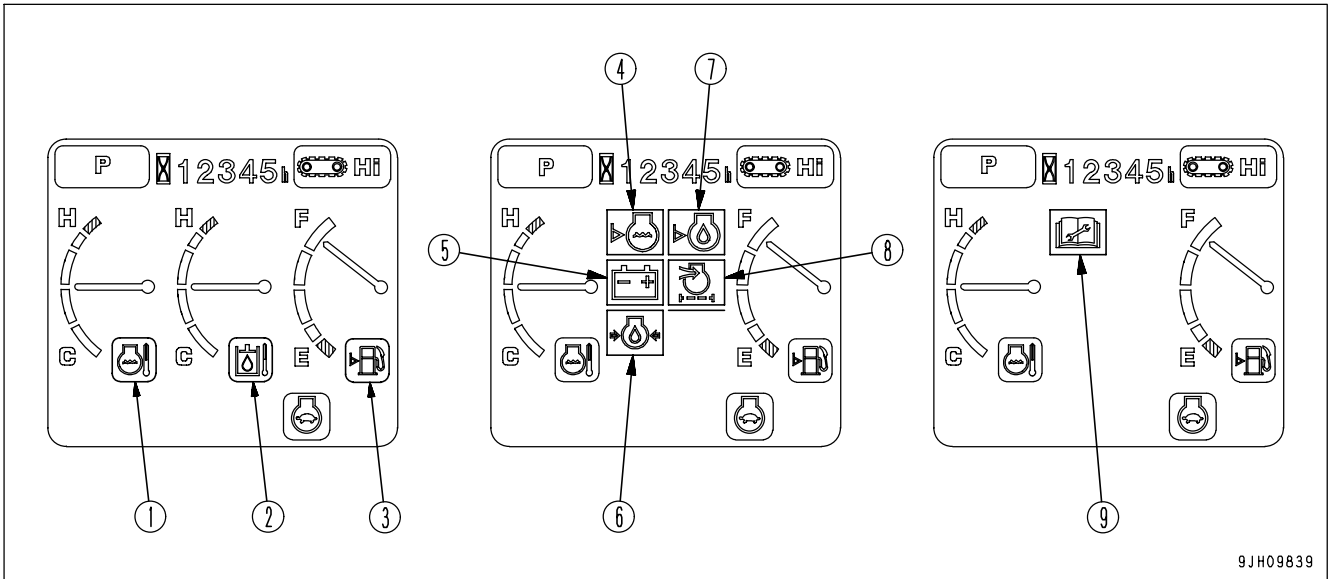

9JH09839

	Type of monitor	Color when monitor lights up		
		When normal	When abnormal	At low temperature
(1)	Engine coolant temperature monitor	Green	Red	White
(2)	Hydraulic oil temperature monitor	Green	Red	White
(3)	Fuel level monitor	Green	Red	-
(4)	Radiator coolant level monitor	OFF	Red	-
(5)	Charge monitor	OFF	Red	-
(6)	Engine oil pressure monitor	OFF	Red	-
(7)	Engine oil level monitor	OFF	Red	-
(8)	Air cleaner clogging monitor	OFF	Red	-
(9)	Maintenance interval monitor	OFF	Red	-

Emergency Monitors



If the monitor lights up red, stop the engine immediately or run at low idle, check applicable location, then perform necessary actions.

These items should be observed while the engine is running. If there is a problem, the monitor for the abnormal location lights up red and buzzer sounds, perform action immediately.

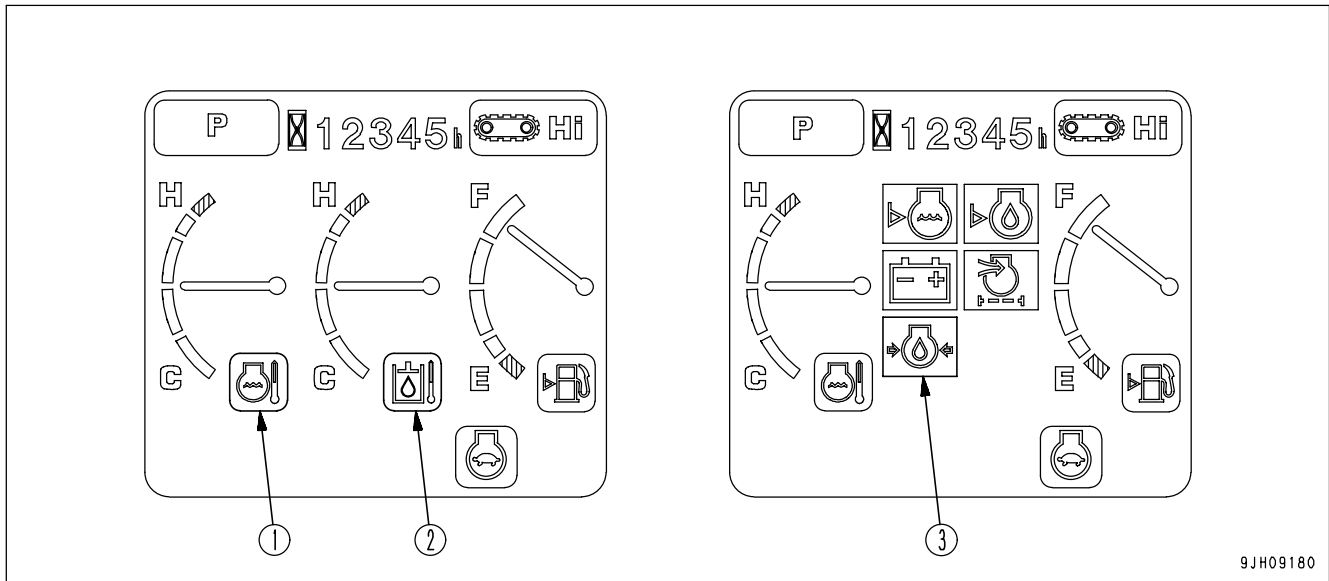

- (1) Engine coolant temperature monitor
- (2) Hydraulic oil temperature monitor

- (3) Engine oil pressure monitor

Engine Coolant Temperature Monitor

Monitor (1) warns operator that the engine coolant temperature has risen.

If engine coolant temperature becomes abnormally high, monitor lights up red, overheat prevention system is automatically actuated, and the engine speed goes down.

Stop operations and run engine at low idle until monitor (1) changes to green.

Check for clogging of the radiator grill or any other problem that will cause overheating.

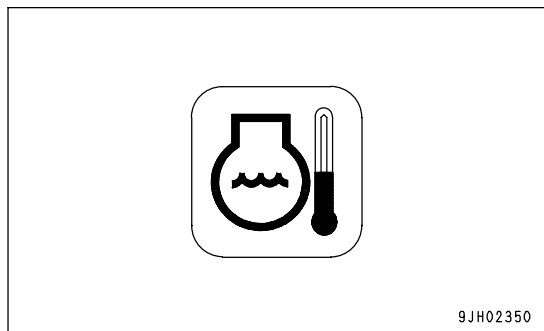

Hydraulic Oil Temperature Monitor

Monitor (2) warns operator that the hydraulic oil temperature has risen.

If monitor lights up red during operations, run engine at low idle or stop the engine and wait until the oil temperature goes down and monitor (2) changes to green.

Check for clogging of the radiator grill or any other problem that will cause overheating.

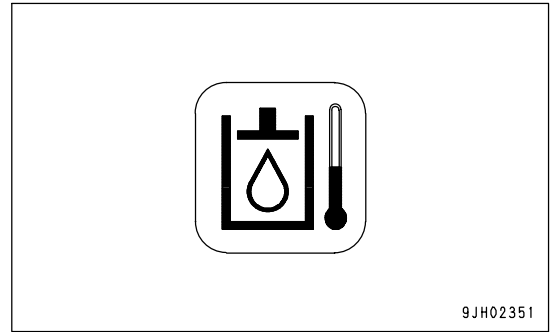
**Engine Oil Pressure Monitor**

Monitor (3) lights up red if the engine lubrication oil pressure goes below normal level. If monitor lights up red, stop the engine immediately, check the lubrication system and level of oil in the engine oil pan.

REMARK

When the engine is started or stopped, the lamp may light up momentarily and the buzzer sound, but this does not indicate an abnormality.

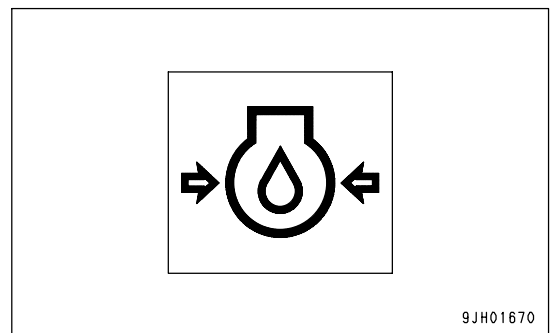

Caution Monitors



If the warning monitor lights up red, stop operations as soon as possible and perform inspection and maintenance of the applicable location. If the warning is ignored, it may lead to failure.

These are items that should be observed while the engine is running. If any abnormality occurs, the screen displays the item that needs immediate action.

If there is an abnormality, the monitor for the abnormal location lights up red.

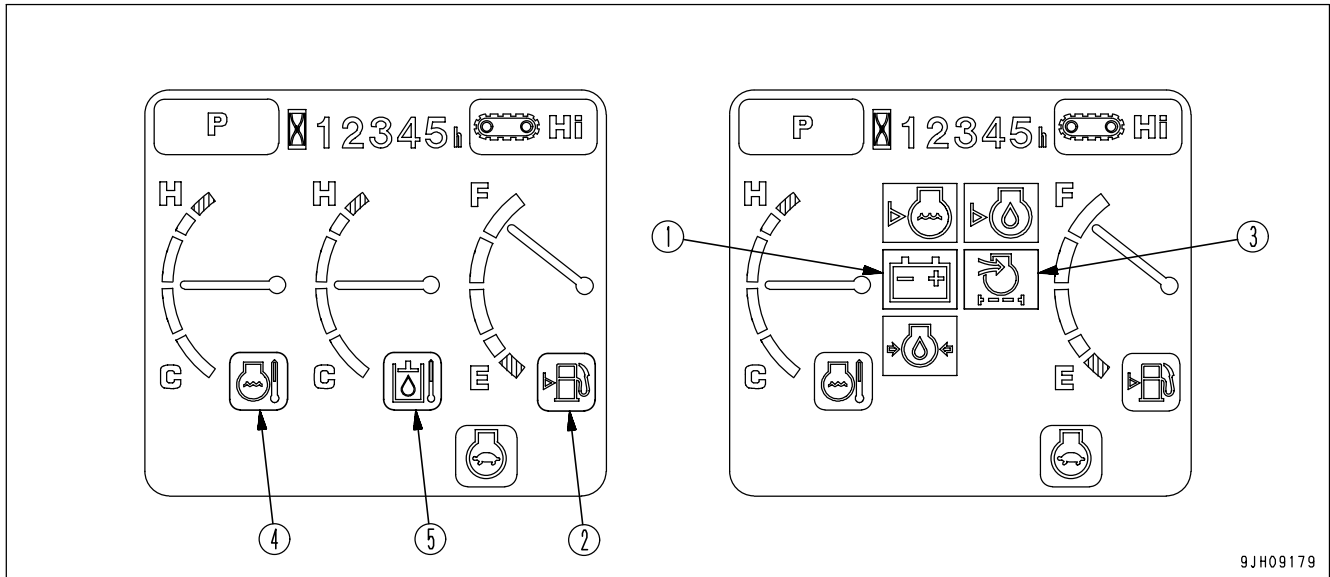

- (1) Charge level monitor
- (2) Fuel level monitor
- (3) Air cleaner clogging monitor
- (4) Engine water temperature monitor
- (5) Hydraulic oil temperature monitor

Charge Level Monitor

Monitor (1) warns the operator of an abnormality in the charging system while the engine is running.

If the battery is not being charged properly while the engine is running, monitor (1) lights up red.

If monitor lights up red, check the V-belt for looseness. If any abnormality is found, perform the necessary actions. For details, see "OTHER TROUBLE (PAGE 3-161)".

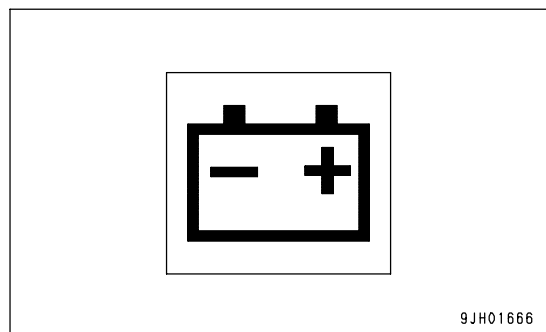

REMARK

When the engine is started or stopped, the lamp may light up momentarily and the buzzer sound, but this does not indicate an abnormality.

Fuel Level Monitor

Monitor (2) lights up to warn the operator the fuel level in the tank is low.

If the remaining amount of fuel goes down to 210 liters (55.48 US gal), the light changes from green to red, so add fuel as soon as possible.

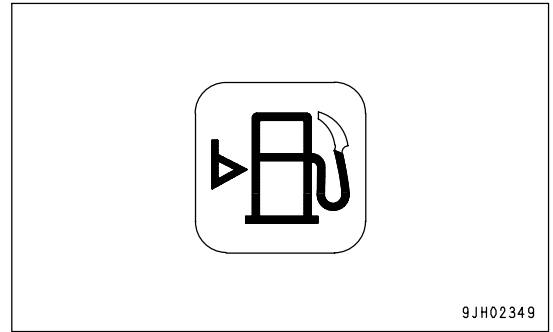
**Air Cleaner Clogging Monitor**

Monitor (3) warns the operator of a clogged air cleaner.

If the monitor lights up red, stop the engine, inspect and clean the air cleaner. For details, see "CHECK, CLEAN AND REPLACE AIR CLEANER ELEMENT (PAGE 4-17)".

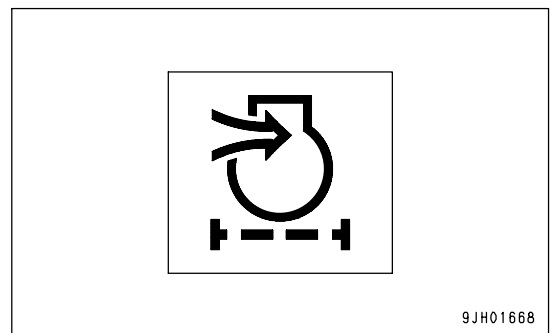
**Engine Coolant Temperature Monitor**

If monitor (4) lights up white in low temperatures, perform warming-up operation. For details, see "Engine Warm Up (PAGE 3-101)". Continue warming-up operation until monitor (4) changes to green.

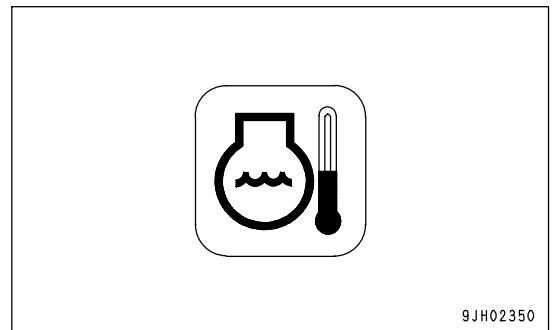
**Hydraulic Oil Temperature Monitor**

If monitor (5) lights up white in low temperatures, perform warming-up operation. For details, see "Hydraulic Equipment Warm Up (PAGE 3-104)". Continue warming-up operation until monitor (5) changes to green.

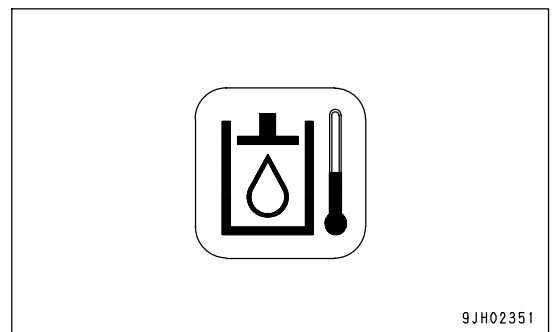

Basic Check Monitors



These monitors do not guarantee the condition of the machine.

Do not simply rely on the monitor when carrying out checks before starting (daily inspection). Always get off the machine and check each item directly.

Displays basic items among the check before starting items that must be checked before starting the engine. If there is any abnormality, monitor for the location of abnormality will light up.

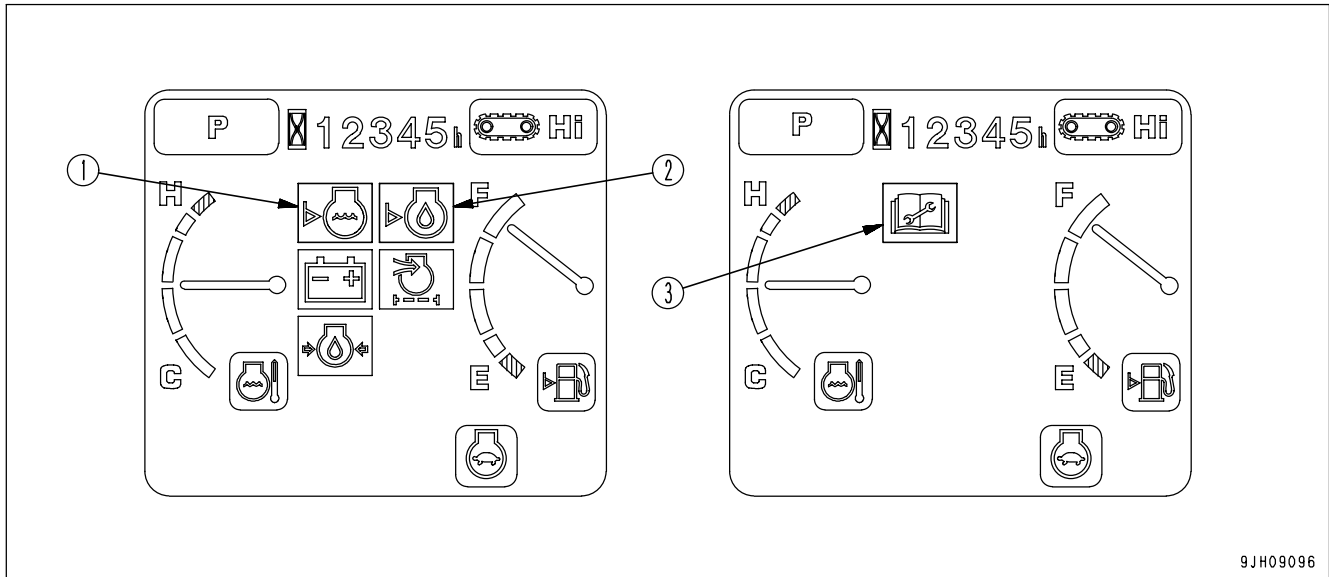

- (1) Radiator coolant level monitor
- (2) Engine oil level monitor

- (3) Maintenance interval monitor

Radiator Coolant Level Monitor

Monitor (1) warns the operator that there has been a drop in the radiator coolant level.

If the radiator coolant is low, the lamp lights up red, so check coolant level in the radiator and subtank, and add coolant.

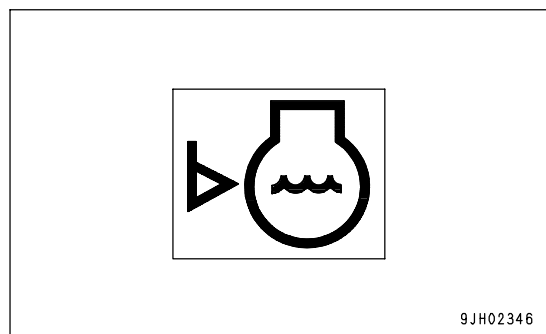

Engine Oil Level Monitor

Monitor (2) warns the operator that the oil level in the engine oil pan has dropped.

If oil level in the engine oil pan is low, the lamp lights up red, so check the oil level, and add oil.

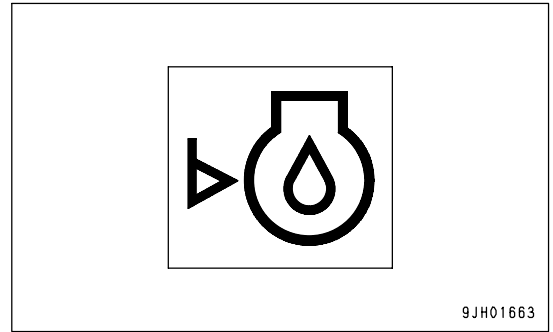
**Maintenance Interval Monitor**

This monitor (3) lights up when the maintenance time gets close and remains lighted after the maintenance time has already passed.

- Lighted yellow: The maintenance time is due within 30 hours.
- Lighted red: The maintenance time has already passed.

This monitor lights up when the starting switch is turned to the ON position. It goes off after 30 seconds and the display changes to the normal screen.

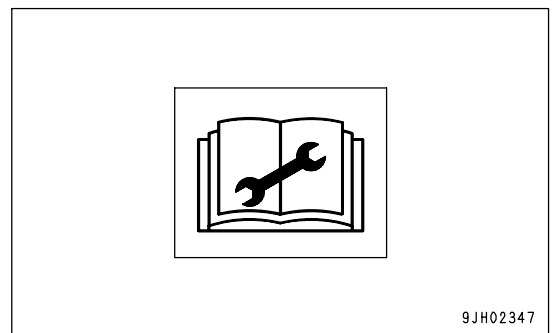
**REMARK**

- For details of the method of confirming the maintenance interval, see "Maintenance Switch (PAGE 3-25)".
- If it is desired to change settings for the maintenance interval, have your Komatsu distributor change the settings.

Meter Display Portion

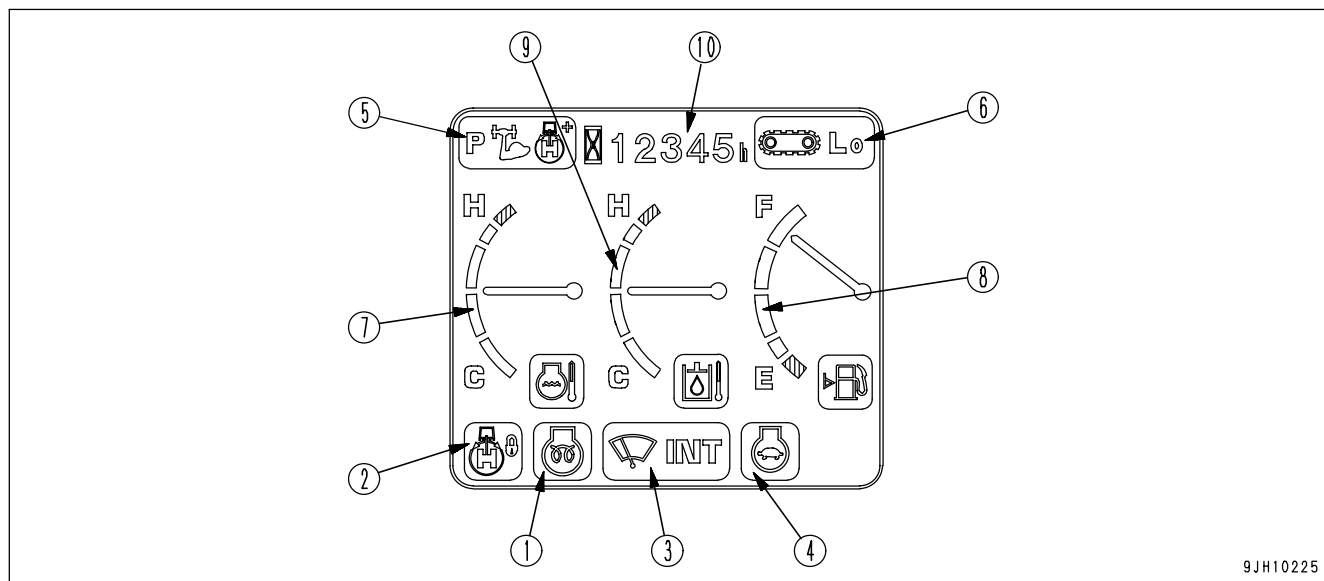

Pilot display

- (1) Engine pre-heating monitor
- (2) Swing lock monitor
- (3) Wiper monitor
- (4) Auto-deceleration monitor
- (5) Working mode monitor
- (6) Travel speed monitor

Gauges and Meter

- (7) Engine coolant temperature gauge
- (8) Fuel gauge
- (9) Hydraulic oil temperature gauge
- (10) Service meter

Pilot Display

When the starting switch is ON, the pilot display lights up when the display items are functioning.

Engine Pre-heating Monitor

This monitor (1) lights up when the engine preheating electric heater is actuated. When the ambient temperature is low and the starting switch is set to the ON position, the lamp lights up, and when the preheating is completed, it goes out.

The preheating time differs according to the ambient temperature.

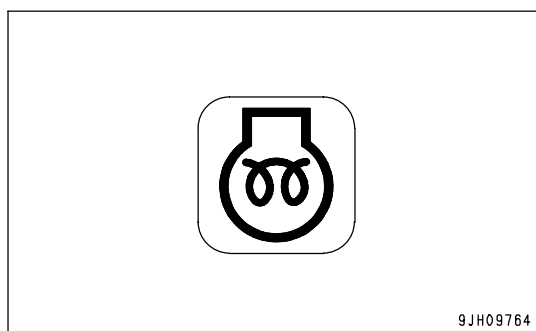

Swing Lock Monitor

This monitor (2) informs the operator that the swing lock is being actuated.

Actuated: Lights up

When the swing lock switch is turned ON (ACTUATED), the monitor lamp lights up.

This lamp lights up when the swing parking brake release switch is set to the FREE position.

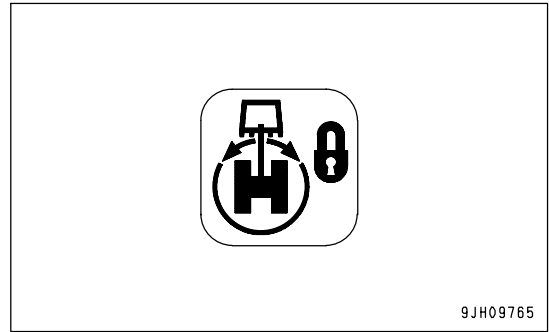

REMARK

The swing motor is equipped with a disc brake that mechanically stops the rotation. When the swing lock monitor is lighted up, the brake remains applied.

Wiper Monitor

Monitor (3) indicates operating status of the wiper.

The monitor display when wiper switch is operated, as follows.

When ON lights up: Wiper moves continuously

When INT lights up: Wiper moves intermittently

OFF: Wiper stops

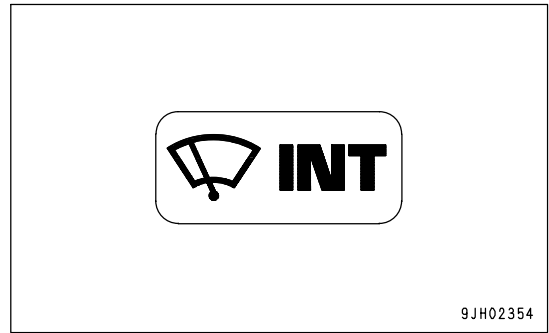

Auto-deceleration Monitor

Monitor (4) shows if the auto-deceleration is being actuated.

The monitor display when auto-deceleration switch is operated, as follows.

Auto-deceleration monitor ON: Auto-deceleration actuated

Auto-deceleration monitor OFF: Auto-deceleration canceled

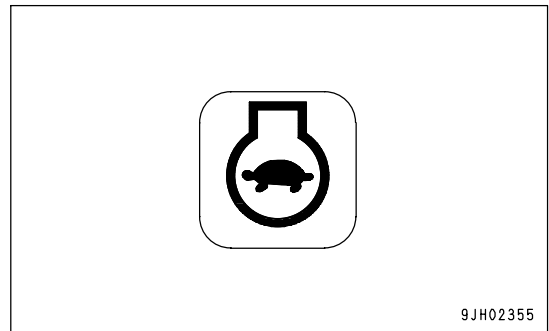

Working Mode Monitor

Monitor (5) displays the set working mode.

The monitor display when working mode switch is operated, as follows.

P: P mode (for heavy-load operations)

E: E mode (for operations with emphasis on fuel economy)

(X): Heavy-duty lift (boom lifting power increased when raising boom independently)

(Y): Swing priority mode (priority given to swing when operating boom and swing simultaneously)

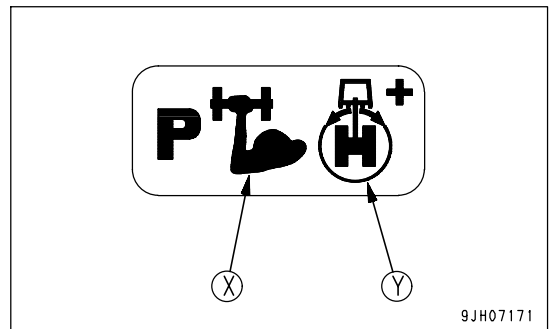

Travel Speed Monitor

Monitor (6) displays set mode for the travel speed.

The monitor display when the travel speed selector switch is operated, as follows.

Lo : Low speed

Hi : High speed

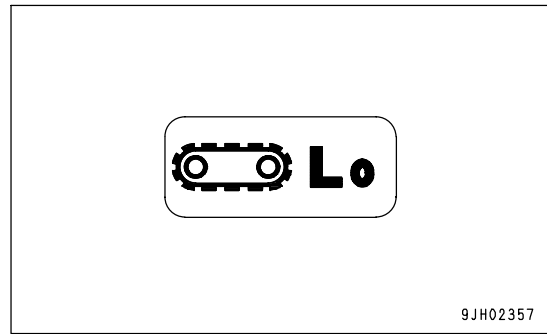

9JH02357

Gauges and Meter

Engine Coolant Temperature Gauge

This meter (7) indicates the engine cooling water temperature.

During normal operations, the indicator should be in the black range. If the indicator enters the red range during operations, the overheat prevention system is actuated.

(A) - (B): Red range

(A) - (C): Black range

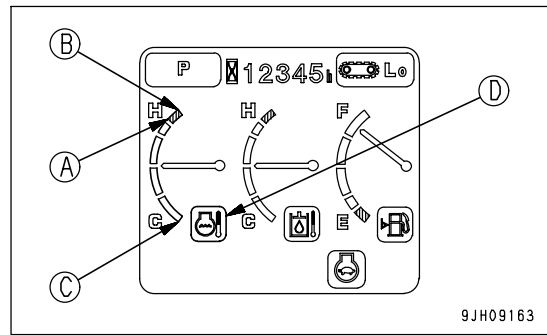

9JH09163

The overheat prevention system acts as follows.

Red range position (A) : Engine water temperature monitor (D) lights up red.

Red range position (B) : Engine speed is reduced to low idling, engine water temperature monitor (D) lights up red, and the alarm buzzer sounds at same time.

The overheat prevention system remains actuated until the indicator returns to the black range.

When the engine is started, if the indicator is at position (C), engine water temperature monitor (D) lights up white.

In this case, carry out the warming-up operation. For details, see "Engine Warm Up (PAGE 3-101)".

Fuel Gauge

This meter (8) displays the level of the fuel in the fuel tank.

During operations, the indicator should be in the black range.

If the indicator enters red range (A) during operations, there is less than 300 liters (79.26 US gal) of fuel remaining in the tank, so check and add fuel.

(A) - (B): Red range

(A) - (C): Black range

REMARK

If the indicator enters red range (B), there is less than 210 liters (55.48 US gal) of fuel remaining.

When the indicator is in the red range (B), fuel level monitor (D) lights up red.

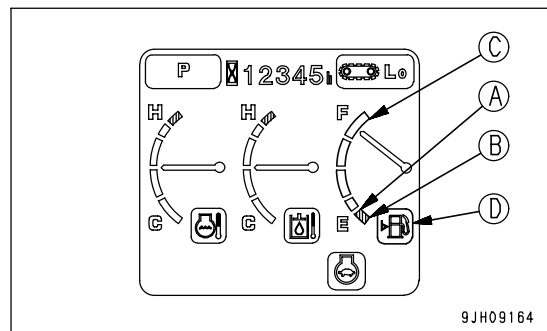

9JH09164

If the indicator enters the red range (A) to (B), do not carry out operations on steep slopes. There is danger of the engine stalling.
 The correct fuel level may not be displayed for a short time when the starting switch is turned ON, but this is not an abnormality.

Hydraulic Oil Temperature Gauge

Meter (9) displays the hydraulic oil temperature.
 During operations, the indicator should be in the black range (A) to (C).
 If the indicator enters red range (A) during operations, the hydraulic oil temperature has gone above 102°C (215.6°F).
 Stop the engine or run it at low idle and wait for the hydraulic oil temperature to go down.

REMARK

When the indicator is in the red range (A) to (B), the hydraulic oil temperature is as follows.
 Red range position (A) : More than 102°C (215.6°F)
 Red range position (B) : More than 105°C (221°F)
 When the indicator is in the red range (A) to (B), fuel level monitor (D) lights up red.
 If the indicator is at position (C) when the engine is started, the hydraulic oil temperature is 20°C (68°F) or lower, and hydraulic oil temperature monitor (D) lights up white. In this case, carry out the warming-up operation. For details, see "Hydraulic Equipment Warm Up (PAGE 3-104)".

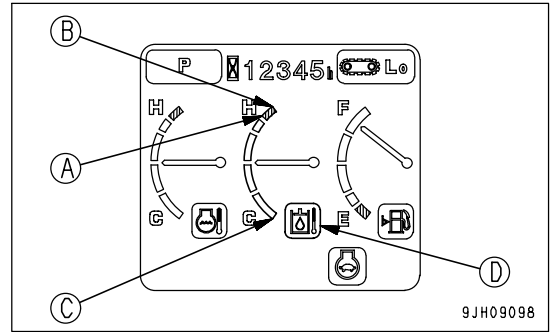

Service Meter

This monitor (10) displays the total time that the machine has been operated.
 Use the time display to set the maintenance interval. When the starting switch is ON, the service meter advances even if the machine is not moving.
 The service meter advances by 1 for every hour of operation, regardless of the engine speed.



Monitor Switches Portion

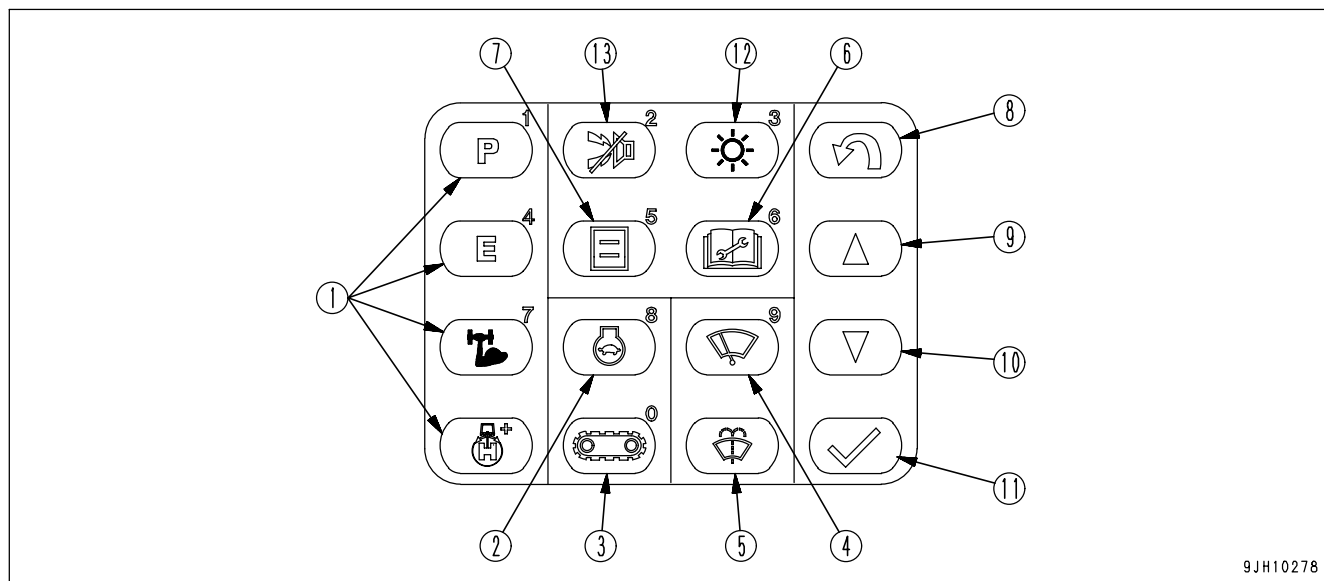

9JH10278

- (1) Working mode selector switch (basic switch)
- (2) Auto-deceleration switch (selection switch)
- (3) Travel speed selector switch (selection switch)
- (4) Wiper switch
- (5) Window washer switch
- (6) Maintenance switch
- (7) User mode adjustment switch
- (8) Back switch
- (9) Up switch
- (10) Down switch
- (11) Input confirmation switch
- (12) Adjusting brightness and contrast
- (13) Alarm buzzer stop switch

Working Mode Selector Switch (Basic Switch)

Switch (1) is used to set the power and movement of the work equipment.

Operations can easily be performed by selecting the mode to match the type of operation.

P mode : For heavy-load operations

E mode : For operations with emphasis on fuel economy

Heavy-duty lift mode : Boom lifting power increased when raising boom independently

Swing priority mode : Priority given to swing when operating boom and swing simultaneously

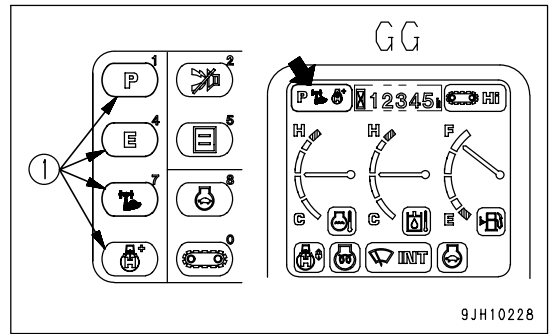

- When the engine is started, the working mode is set automatically to P mode. When the switch is pressed, it is possible to select the other modes. The monitor display GG on the monitor display portion changes for each mode.
- If it is desired to have the working mode set to start automatically in E, L, or B mode (default option setting), have your Komatsu distributor change the setting.

REMARK

When the mode selector switch is pressed, the mode is displayed in the center of monitor display portion (GG), and the screen returns to standard screen (BB) after 2 seconds. (Diagram on the right is an example of display for the E mode.)

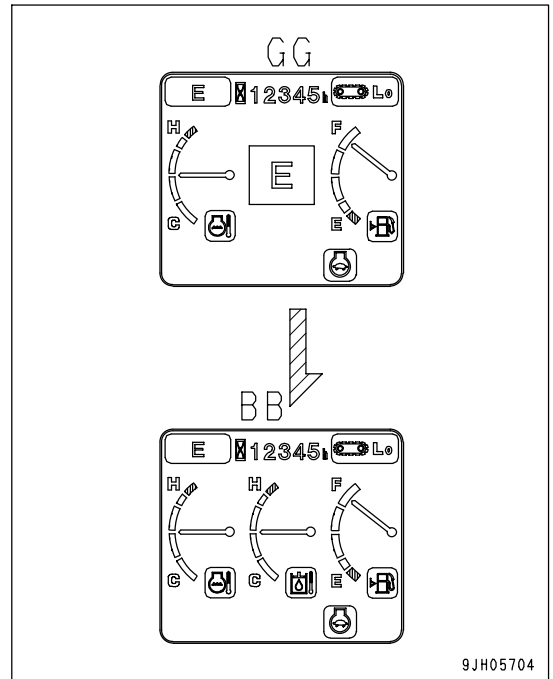

Auto-deceleration Switch (Selection Switch)

When switch (2) is pressed, the auto-deceleration is actuated, if the control levers are in neutral position, the engine speed is automatically lowered to reduce fuel consumption.

Monitor display portion GG ON : Auto-deceleration actuated

Monitor display portion GG OFF : Auto-deceleration canceled

Each time the switch is pressed, auto-deceleration switches between actuated and canceled.

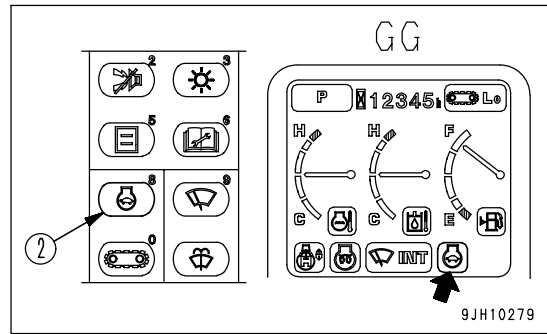

• Auto-deceleration function

When the auto-deceleration function is ON, if the work equipment and travel levers are returned to the N position, the engine speed will drop after 4 seconds from the operating speed to idling speed.

This makes it possible to reduce fuel consumption.

If any lever is operated when the machine is in this condition, engine speed will return to the previous operating speed to make it possible to perform operations.

REMARK

When the auto-deceleration switch is pressed and the auto-deceleration is actuated, the mode is displayed in the center of display portion (GG), and the screen returns to standard screen (BB) after 2 seconds.

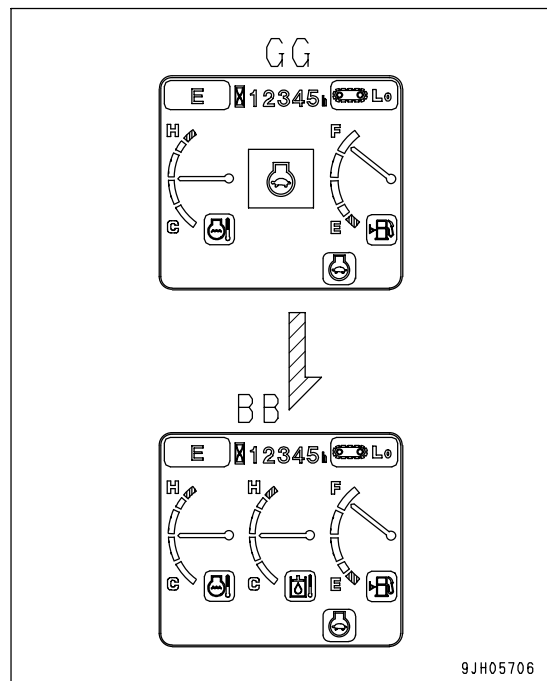

Travel Speed Selector Switch (Selection Switch)

WARNING

- When loading or unloading from a trailer, always travel at low speed (with travel speed selector switch (3) at the Lo position). Never operate travel speed selector switch (3) while loading or unloading.
- If the travel speed is switched between Hi and Lo when the machine is traveling, the machine may deviate to one side, even when traveling in a straight line.
Stop the machine before switching the travel speed.

This switch (3) is used to set the travel speed to 2 stages.

Lo lights up : Low-speed travel

Hi lights up : Hi-speed travel

When the engine is started, the speed is automatically set to Lo.

Each time that the switch is pressed, the display changes Lo →

Hi → Lo in turn.

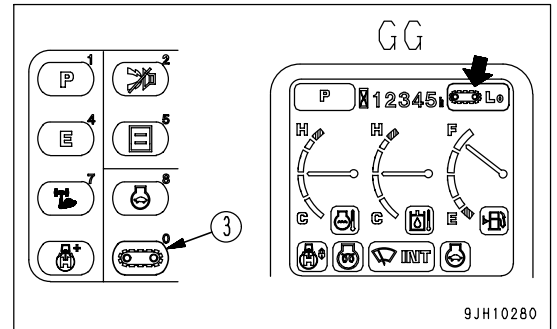

When traveling in high speed (Hi), if travel power is needed, such as when traveling on soft ground or on slopes, the speed automatically switches to low speed (Lo), so there is no need to operate the switch. The monitor display stays at Hi.

REMARK

Each time that the travel speed selector switch is operated, the mode is displayed in the center of display portion (GG), and the screen returns to standard screen (BB) after 2 seconds.

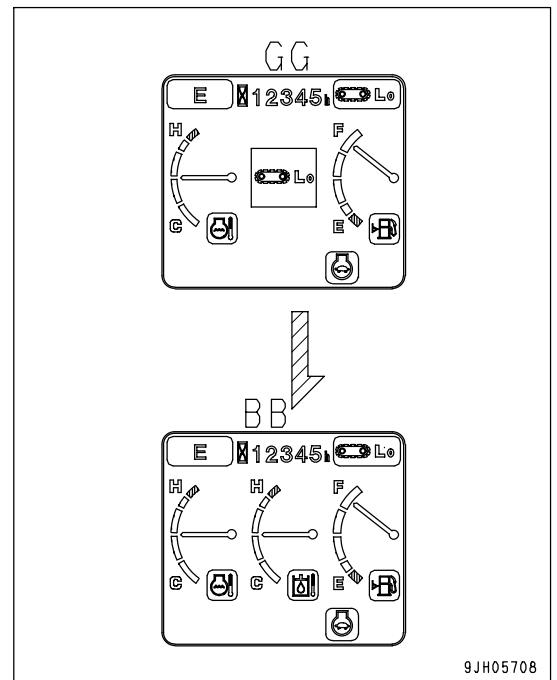

Wiper Switch

This switch (4) actuates the front window wiper.
 Each time the switch is pressed, it changes ON → INT → stop (OFF).

Monitor display portion GG INT lighted up: Wiper moves intermittently

Monitor display portion GG ON lighted up: Wiper moves continuously

Monitor display portion GG OFF: Wiper stops

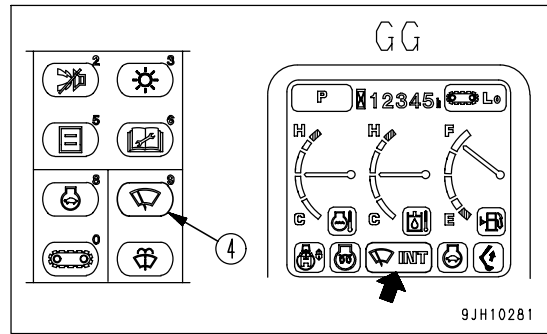

REMARK

Each time that the wiper switch is operated, the mode is displayed in the center of display portion (GG). The screen returns to standard screen (BB) after 2 seconds.

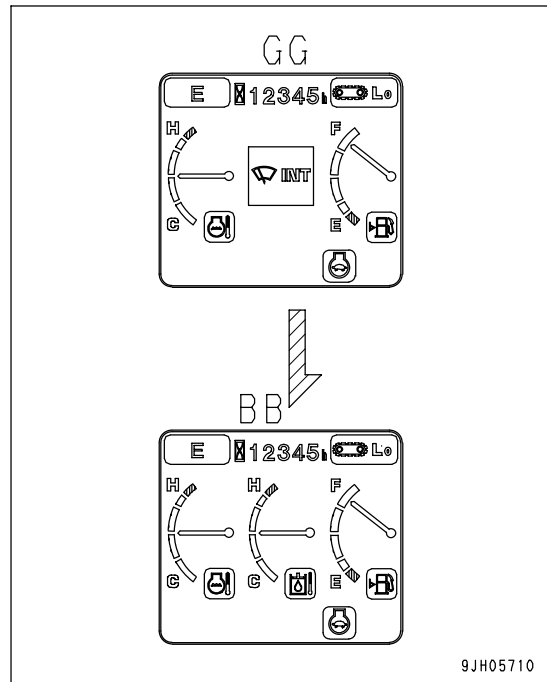

Window Washer Switch

This switch (5) is kept continuously pressed, window washer fluid is sprayed out on the front glass. When the switch is released, the spray stops.

- If switch (5) is kept pressed when the wiper is stopped, the window washer fluid will spray out, and at the same time, the wiper will be actuated continuously. When switch (5) is released, the wiper will continue to operate for 2 cycles, then stop.
- If the wiper is moving intermittently and switch (5) is kept pressed continuously, window washer fluid will spray out, and at the same time, the wiper will be actuated continuously. When switch (5) is released, the wiper will continue to operate for 2 cycles, then return to intermittent operation.

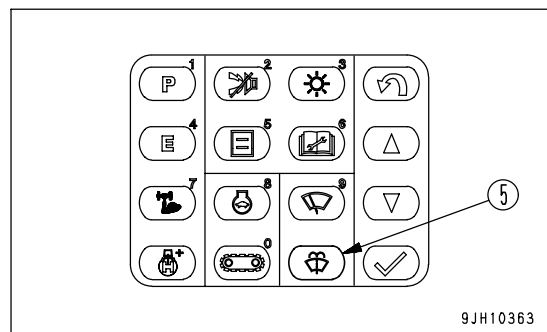

Maintenance Switch

- Switch (6) is used to check the time remaining until maintenance.

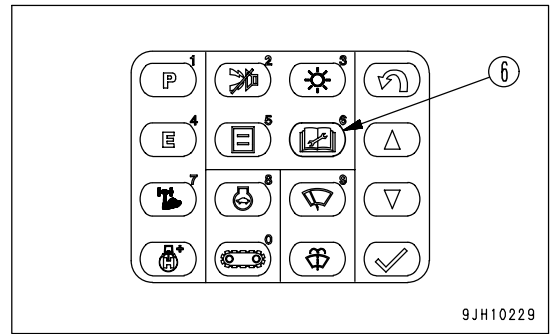

- When switch (6) is pressed, screen on the monitor display changes to the maintenance screen, as shown in diagram on the right.

The time remaining until maintenance is indicated by the color of each monitor display. After confirming the maintenance time, perform the maintenance.

- White display: More than 30 hours remaining until maintenance
- Yellow display: Less than 30 hours remaining until maintenance
- Red display : Maintenance time has already passed

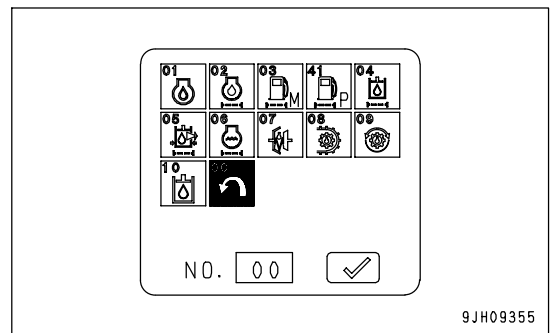

NOTICE

1. If monitor display portion GG changes to the maintenance timing warning screen when the engine is started or when the machine is being operated, stop operations immediately.
2. Press switch (6) to display the maintenance screen.
Perform maintenance for any location indicated by the monitor that has lighted red.

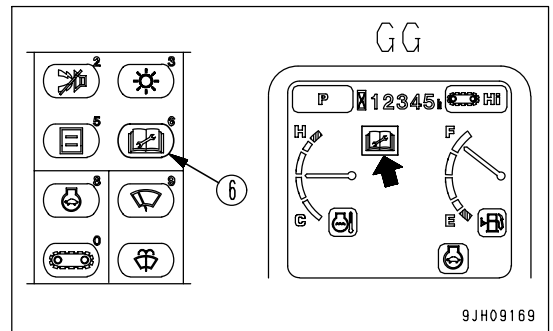

- Maintenance display items are as follows:

Monitor No.	Maintenance item	Default set screen (H)
01	Change engine oil	500
02	Replace engine oil filter	500
03	Replace fuel main filter	500
41	Replace fuel pre-filter	500
04	Replace hydraulic oil filter	1000
05	Replace hydraulic tank breather	1000
06	Replace corrosion resistor (Machines equipped with corrosion resistor)	1000
07	Change PTO case oil	1000
08	Change final drive case oil	2000
09	Change swing machinery case oil	1000
10	Change hydraulic oil	5000

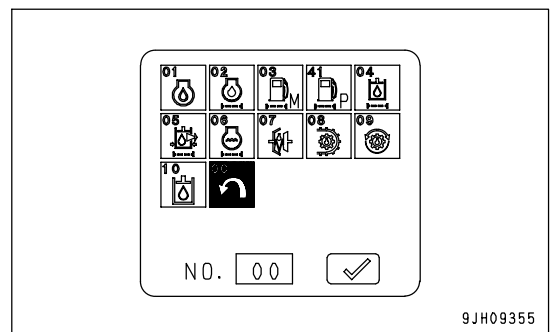

If it is desired to change settings for the maintenance interval, have your Komatsu distributor change the settings.

- How to check a remaining time up to the next maintenance and reset after the maintenance is carried out is as explained below.

1. Look at the maintenance screen, press up switch (9) or down switch (10) on the monitor switch portion, and select the item. (Color of the monitor for selected item is inverted to black.)

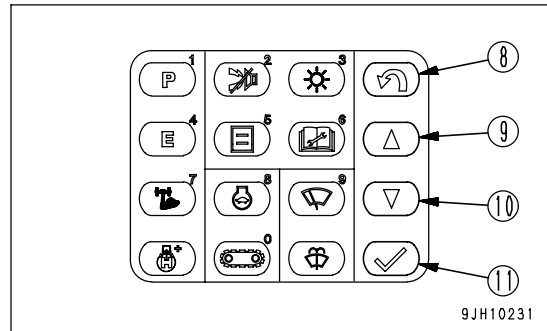

2. After selecting the monitor item, press input confirmation switch (11). Display screen will switch to the time remaining until maintenance. (Press back switch (8) to return to the previous screen.)

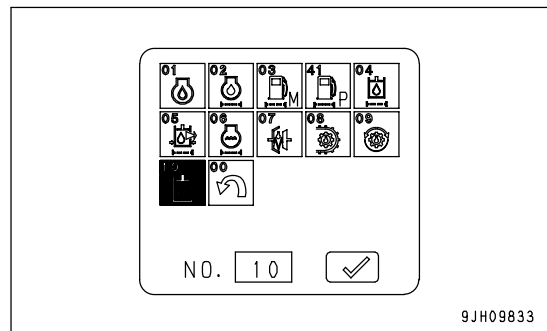

3. Check the time remaining until maintenance.
 (a): Time remaining until maintenance
 (b): Default setting for maintenance interval

When only checking the time remaining until maintenance, press back switch (8) twice.

The screen will return to the normal operation monitor screen. When canceling time remaining until maintenance and returning to the default time setting, press input confirmation switch (11). The screen will switch to the default setting screen.

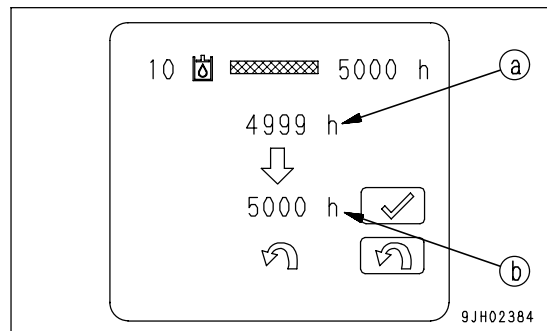

4. After checking the time on the default setting screen, press input confirmation switch (11). The screen will return to the maintenance screen. (Press back switch (8) to return to the previous screen.)

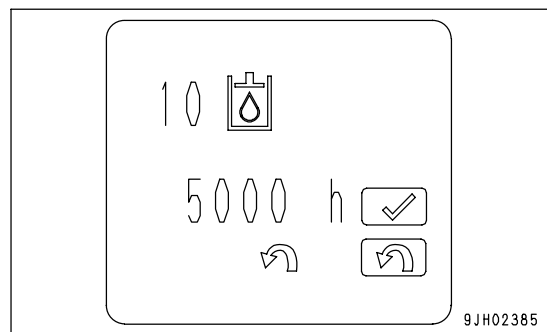

User Mode Adjustment Switch

Press this switch (7) to set to fan reverse rotation and to adjust the set value for the economy mode.

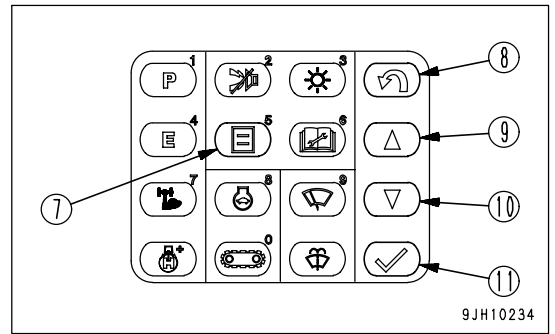

Fan Reverse Rotation

1. Press switch (7) and the monitor display screen changes to the fan reverse rotation and economy mode adjustment screen show on the right.

01: Fan reverse rotation menu
02: Economy mode adjustment menu

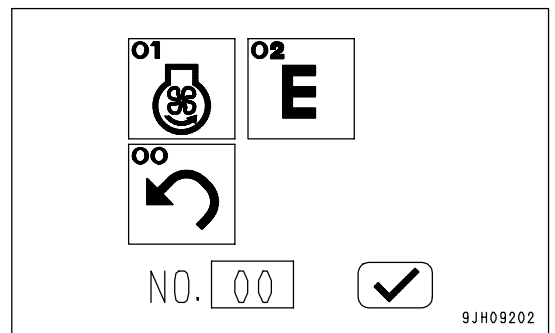

2. Fan reverse rotation means that the air from the fan blows to the outside of the machine. This can be used when cleaning to remove insects or dirt stuck to the net.

Check first that there is no flammable or burning material in the surrounding area that will be sucked in, then operate the switch to rotate the fan in reverse.

3. Set the lock lever securely to the LOCK position (L).

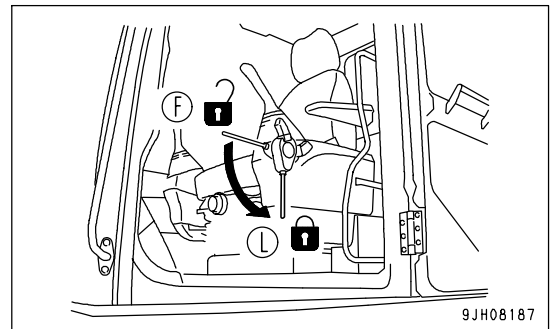

4. Use UP switch (9) or DOWN switch (10) to select "01: Fan reverse rotation", then press input confirmation switch (11) to accept the input. The screen changes to the screen on the right (green display).

To switch the fan to reverse rotation, press input confirmation switch (11).

(Press Back switch (8) to return to the previous screen.)

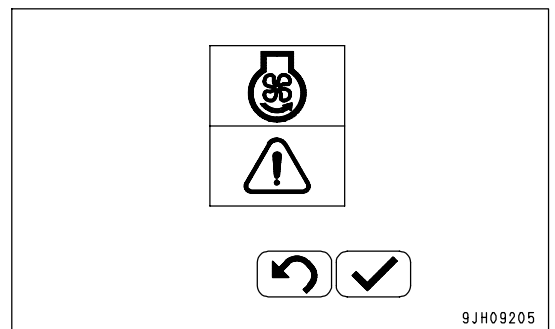

5. When the fan rotation is being changed, the screen changes to the waiting screen. The engine is automatically set to low idling, and after approx. 15 seconds, the fan rotates in reverse. After another approx. 4 seconds, the engine speed returns to normal.

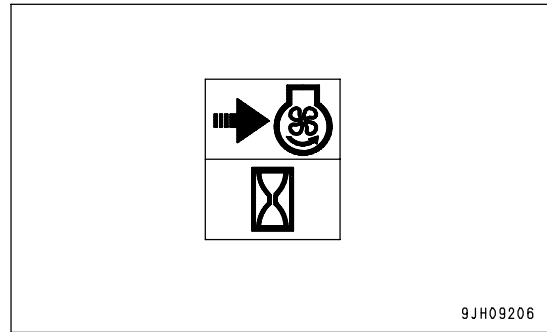

NOTICE

- The fan rotation speed is proportional to the engine speed. When the engine is running at low idling, the fan also rotates at minimum speed. If it is desired to raise the fan rotating speed, use the fuel control dial to raise the engine speed.
- When rotating the fan in reverse with the engine stopped, change to this screen, then turn the starting switch to the START position. This screen does not change until the engine starts, so if it is desired to cancel, turn the starting switch to the OFF position.

6. When the fan rotates in reverse, the screen switches automatically to the screen shown on the right (yellow display). While the fan is rotating in reverse, the screen maintains this display.

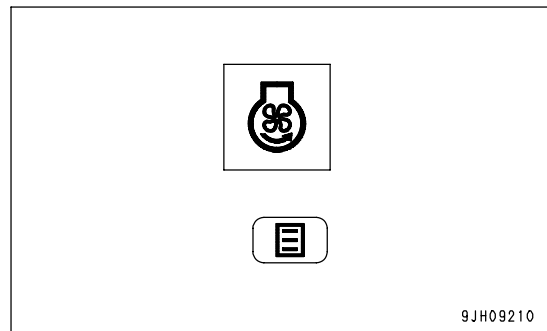

7. If any abnormality occurs when the fan is rotating in reverse, a warning monitor is displayed as shown in the diagram on the right. If the warning monitor is displayed, see "MONITORING SYSTEM (PAGE 3-5)" and follow the instructions.

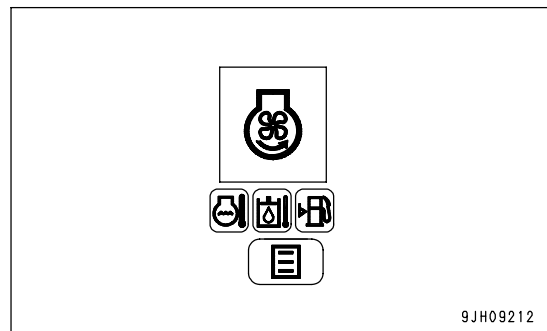

8. When changing the fan rotation direction from reverse direction to the normal direction, press User mode adjustment switch (7).

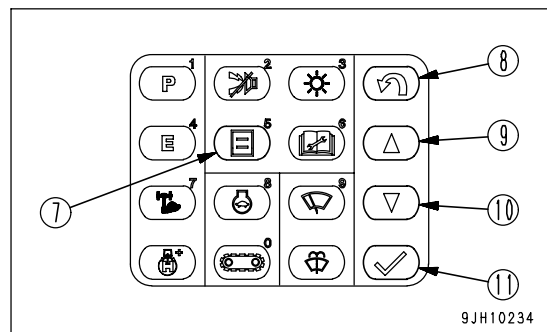

9. When changing the fan rotation direction from reverse direction to the normal direction, press input confirmation switch (11).
(Press Back switch (8) to return to the previous screen.)

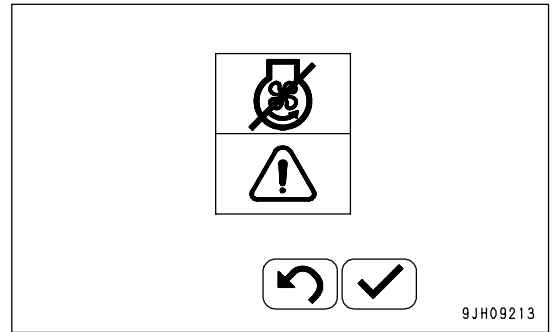

10. When the fan rotation is being changed, the screen changes to the waiting screen. The engine is automatically set to low idling, and after approx. 15 seconds, the fan rotates in the normal direction. After another approx. 4 seconds, the engine speed returns to normal.

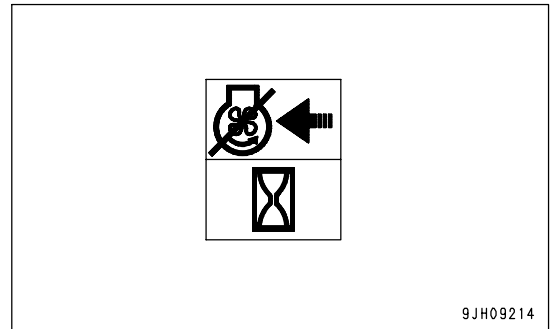

11. When the fan returns to rotating in the normal direction, the display switches automatically to the initial screen.

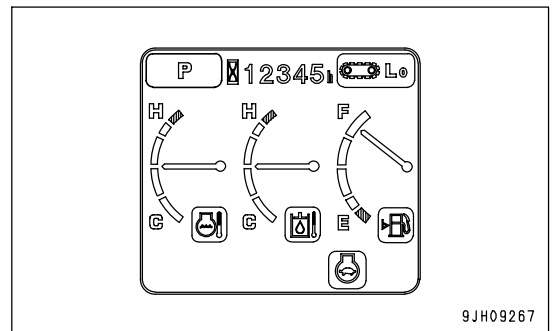

REMARK

- In some cases, the screen in Step 1 may switch to the screen on the right (red display) without switching to the screen in Step 4, and the fan may not rotate in reverse. This is designed to protect the equipment and to prevent the fan from rotating in reverse depending on the water temperature and hydraulic oil temperature.
- If it is desired to rotate the fan in reverse, press Back switch (8), switch to the initial screen, run the engine at low idling or stop it, then carry out the warming-up or cooling-down operation.
- If the water temperature and hydraulic temperature on the initial screen indicates ranges (A) - (B) shown in the diagram on the right, the fan can be rotated in reverse. Carry out the procedure in order from Step 1.
- The system is controlled so that when the fan is rotating in reverse, the work equipment makes almost no movement even when the levers are operated. Rotating the fan in reverse is intended for use in cleaning the radiator, so when carrying out operations and moving the work equipment, switch the fan to the normal direction of rotation before starting operations.

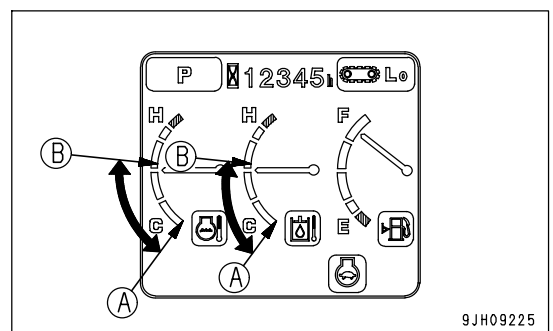
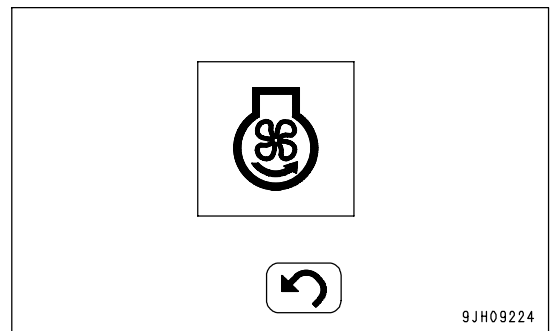

Adjusting Set Value of Economy Mode

1. Press switch (7) and the monitor display screen changes to the fan reverse rotation and economy mode adjustment screen show on the right.

01: Fan reverse rotation menu

02: Economy mode adjustment menu

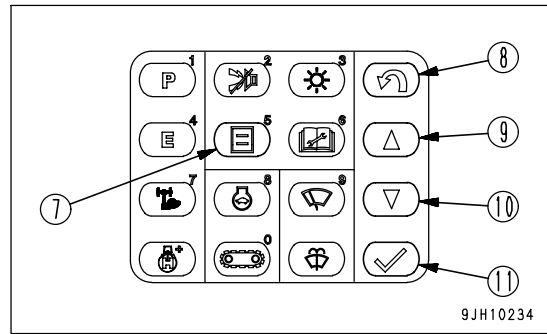

2. When adjusting the set value of the economy mode, adjusting the engine output can provide an improvement in fuel consumption in E mode.

Use UP switch (9) or DOWN switch (10) to select "02: Fan reverse rotation", then press enter switch (11) to accept the input. The screen changes to the screen on the right.

There are four levels that can be set: E0, E1, E2, and E3, as shown in the diagram on the right.

(It is set to E0 when the machine is shipped from the factory.)

3. Use UP switch (9) or DOWN switch (10) to select E0 - E3.

4. Press input confirmation switch (11).

The relationship between fuel consumption and production is as follows.

E0: Default set value (maximum emphasis on production, not on fuel consumption)

E1: Economy adjustment 1 (emphasis on production)

E2: Economy adjustment 2 (emphasis on fuel consumption)

E3: Economy adjustment 3 (maximum emphasis on fuel consumption, not on production)

For details of productivity in each mode, see "Setting Economy Mode (PAGE 3-121)".

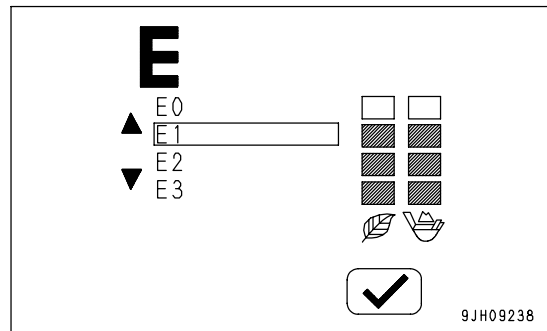
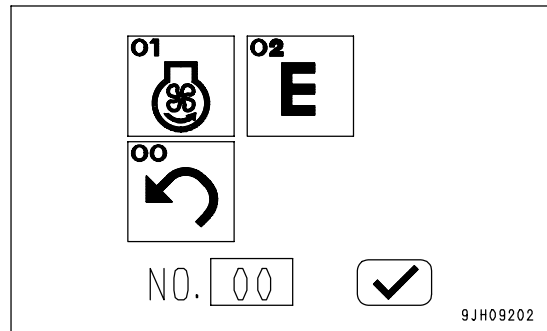

REMARK

The closer the selection is made to E3, the better the fuel consumption becomes, but the production is reduced accordingly.

Back Switch

Press switch (8) when in the maintenance mode, brightness/contrast adjustment mode, or select mode. The screen will return to the previous screen on the monitor display.

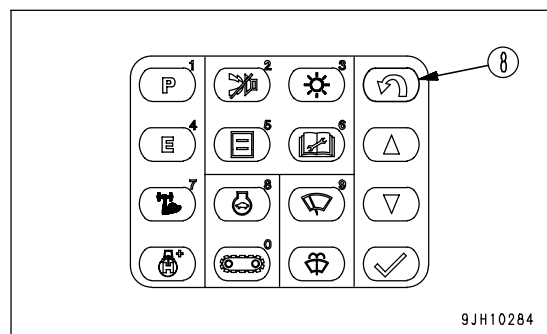

Up Switch, Down Switch

Press up switch (9) or down switch (10) when in the maintenance mode, brightness/contrast adjustment mode, or select mode to move the cursor on the monitor display (colors of selected monitor are inverted) up, down, left, or right.

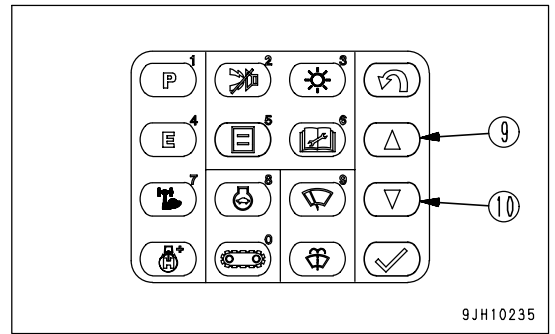

Input Confirmation Switch

Press switch (11) to confirm selected mode when in the maintenance mode, brightness/contrast adjustment mode, or select mode.

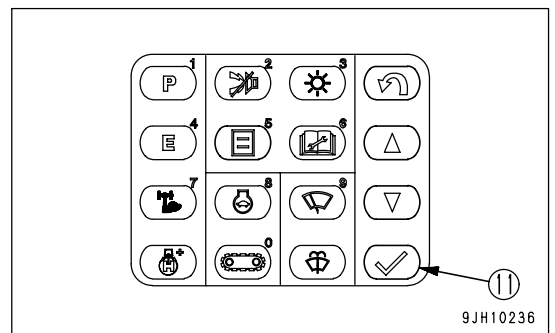

Liquid Crystal Monitor Adjustment Switch

Press switch (12) to adjust the brightness or contrast of the display monitor.

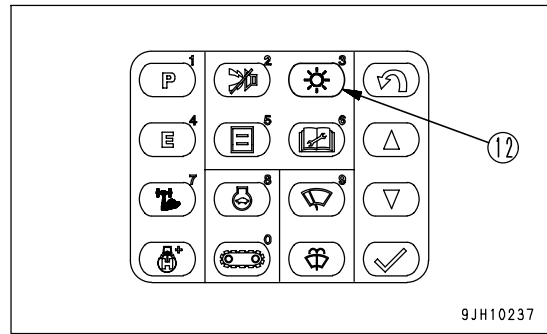

Adjusting Brightness

1. When monitor adjustment switch (12) is pressed, the monitor display screen changes to the brightness/contrast screen shown in the diagram on the right.

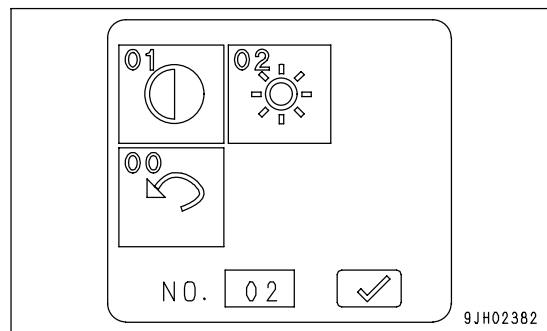

2. Use the brightness/contrast screen and press up switch (9) or down switch (10) to select brightness of the monitor. (The selected monitor is inverted to black.)

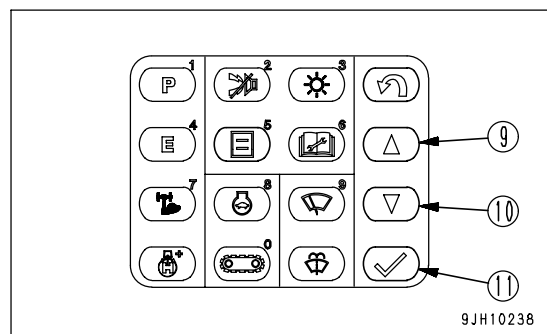

3. When the screen changes to the brightness adjustment screen, press up switch (9) or down switch (10) to adjust the brightness.
 4. After completing adjustment of the brightness, press input confirmation switch (11).

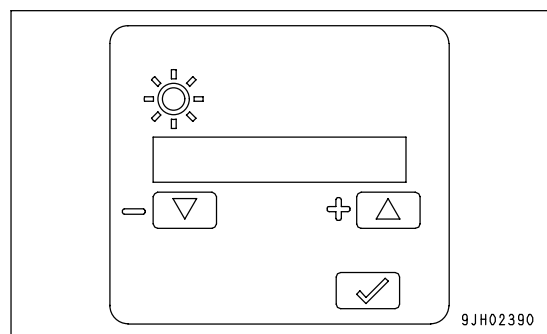

Adjusting Contrast

1. When monitor adjustment switch (12) is pressed, the monitor display screen changes to the brightness/contrast screen shown in the diagram on the right.

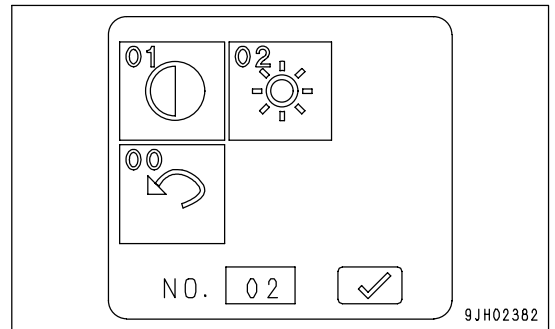

2. Use the brightness/contrast screen and press up switch (9) or down switch (10) to select the contrast monitor. (The selected monitor is inverted to black.)

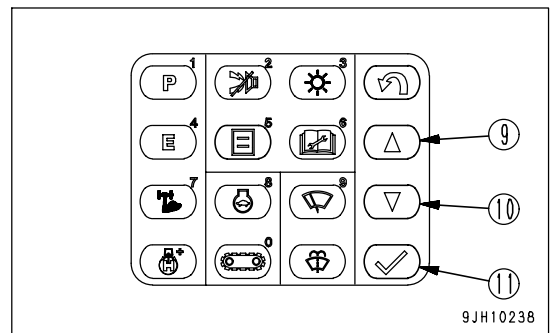

3. When the screen changes to the contrast adjustment screen, press up switch (9) or down switch (10) to adjust the contrast.
 4. After completing adjustment of the contrast, press input confirmation switch (11).

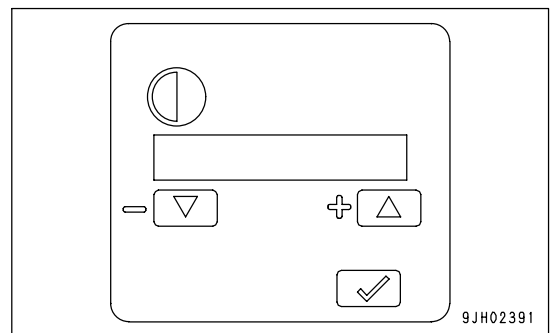

REMARK

When the machine is shipped from the factory, the backlighting is set to the maximum plus (+). The contrast is set to the middle value. After adjusting, even if the starting switch is turned OFF, the adjusted value is retained.

Alarm Buzzer Stop Switch

Use this switch (13) to stop the alarm buzzer when it is sounding during operation to indicate an abnormality in the warning item.

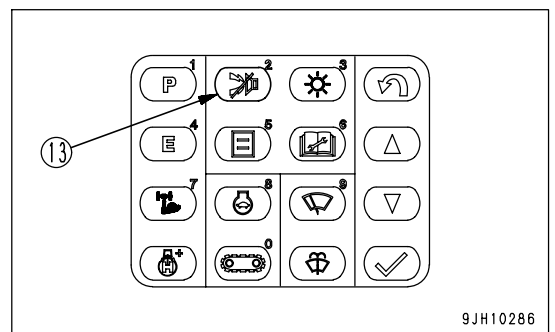

SWITCHES

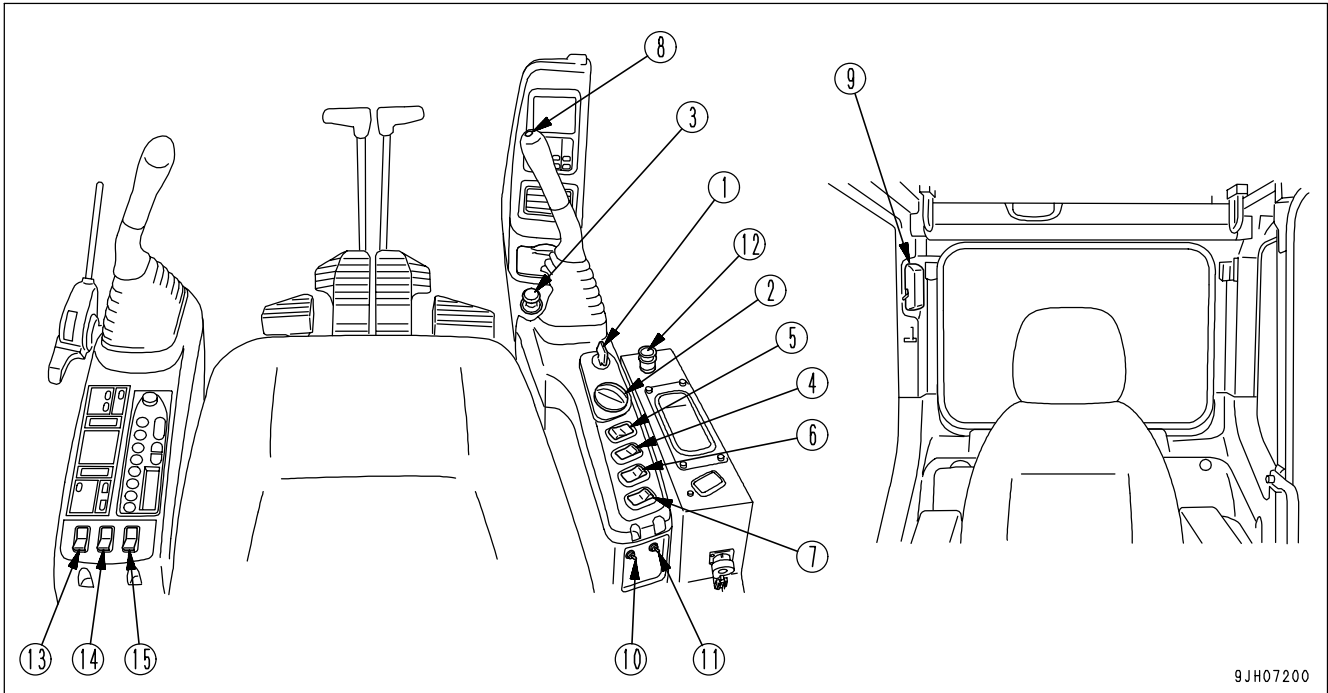

9JH07200

- (1) Starting switch
- (2) Fuel control dial
- (3) Cigarette lighter
- (4) Swing lock switch
- (5) Lamp switch
- (6) Machine push-up switch
- (7) Boom shockless control switch
- (8) Horn switch
- (9) Room lamp switch
- (10) Emergency pump drive switch
- (11) Swing parking brake release switch
- (12) Step light switch
- (13) Lower wiper switch (machines equipped with fixed front window cab)
- (14) Revolving warning lamp switch (if equipped)
- (15) Large capacity airflow air conditioner blower switch (if equipped)

Starting Switch

Starting switch (1) is used to start or stop the engine.

(A): OFF position

The key can be inserted or withdrawn. Switches for the electrical system (except room lamp), are all turned off and the engine is stopped.

(B): ON position

Electric current flows through the charging and lamp circuits. Keep starting switch key in the ON position while the engine is running.

(C): START position

This is the engine-start position. Keep the key at this position during cranking. Immediately after starting the engine, release the key. It will automatically return to the ON position (B).

(D): HEAT position

Regardless of the ambient temperature, the preheating monitor lights up when the key is set to the HEAT position. It then flashes after approx. 30 seconds to inform the operator that the preheating has been completed.

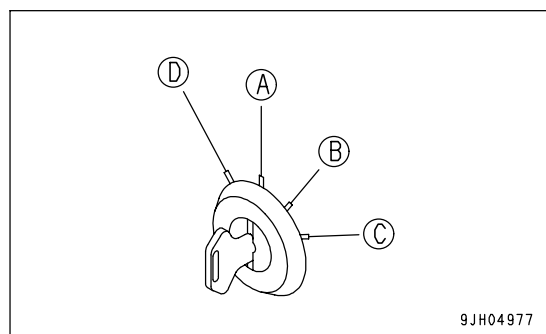

9JH04977

Fuel Control Dial

Dial (2) adjusts the engine speed and output.

- (a) Low idling (MIN): Turned fully to the left
 (b) Full speed (MAX): Turned fully to the right

REMARK

When the fuel control dial is turned, the engine speed does not change for the first few notches from MIN and the last few notches before MAX, but this does not indicate any abnormality.

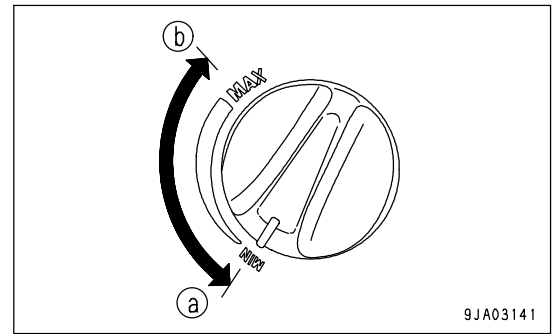
**Cigarette Lighter**

Lighter (3) is used to light cigarettes.

To use, push the lighter in. After a few seconds it will spring back.

Pull out the lighter and light your cigarette.

By removing the cigarette lighter, the socket is available as a power source for the yellow flashing lamp.

Max. current is 85 W (24V x 3.5 A).

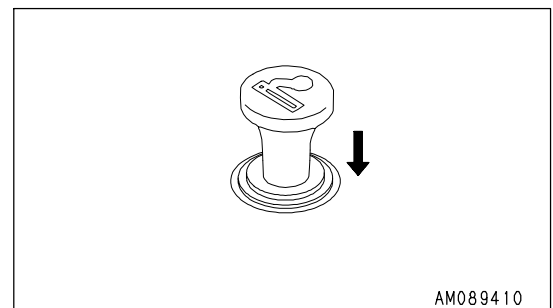
**Swing Lock Switch**

 **WARNING**

- When not using the swing operation, e.g. when traveling, put the swing lock switch to the OFF position.
- On slopes, even when the swing lock switch is at the ON position, the weight of the work equipment may cause the upper structure to swing if the swing control lever is operated in the downhill direction.

Switch (4) is used to lock the upper structure so it cannot swing.

(a) ON position (actuated) : The swing lock is always applied, and the upper structure will not swing even if the swing is operated. In this condition, the swing lock lamp lights up.

(b) OFF position (canceled) : The swing lock is applied only when all the work equipment control levers are in neutral; when any work equipment control lever is operated, the swing lock is canceled.

The swing lock is actuated approx. 5 seconds after all the control levers are placed in the neutral position.

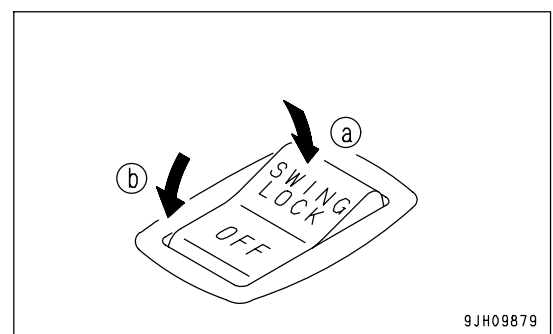

Lamp Switch

Switch (5) is used to turn on the front lamps, working lamps, additional lamps at top front of the cab, and monitor lighting.

- (a) ON: Lamps light up
- (b) OFF: Lamps go off

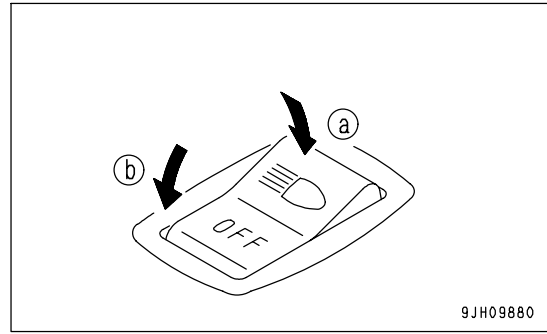

Machine Push-up Switch



When using the boom thrust force to push up the chassis when moving down from a bench, there is danger that the machine may suddenly go down and turn over, so set to the high-pressure setting.

This switch (6) is used to switch the safety valve set pressure at the head end of the boom cylinder to two levels.

- (a) Low pressure setting:
 The boom thrust force is weak, so swaying of the chassis is small during digging operations, and digging can be performed smoothly.
 This is used for general digging operations on normal ground, soft rock, or blasted rock.
- (b) High pressure setting:
 The boom thrust force becomes more powerful, so it is easy to twist and swing or escape from soft ground. It is effective in performing digging operations using the bucket and weight of the machine in confined areas.

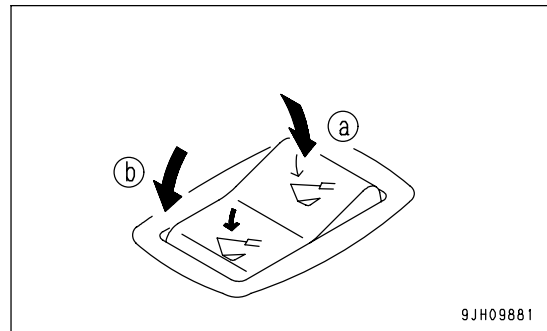

Boom Shockless Control Switch

Switch (7) controls the shaking of work equipment when the boom is stopped.

Effect

- The shaking and spillage of load from the bucket is reduced.
- Operator fatigue is reduced when operating for long periods, so operations can be performed safely.

REMARK

- When the switch is at the ON position (a) and the boom is stopped, the movement of the boom until it stops will increase slightly.
Be careful when using this operation until you become accustomed to it.
- The boom drifts down and it is difficult to position it, so set this switch to the OFF position (b) when carrying out operations with a raised load.

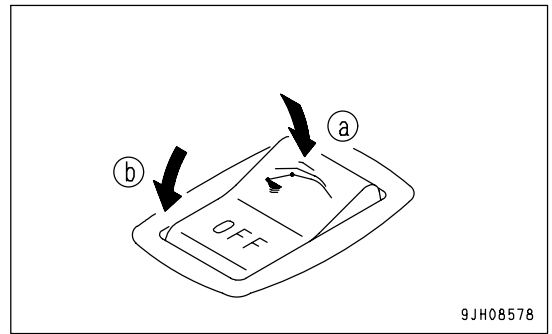

Horn Switch

When the switch (8) at the tip of the right work equipment control lever is pressed, the horn will sound.

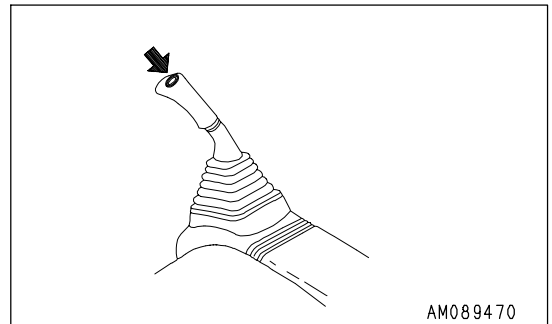

Room Lamp Switch

NOTICE

It is possible to turn on the interior cab room lamp even when starting switch is in the OFF position, do not forget to turn it off.

Use this switch (9) to light up the room lamp.

Position (a) ON: Lights up

Position (b) OFF: Goes out

The room lamp lights up even when the starting switch is in the OFF position.

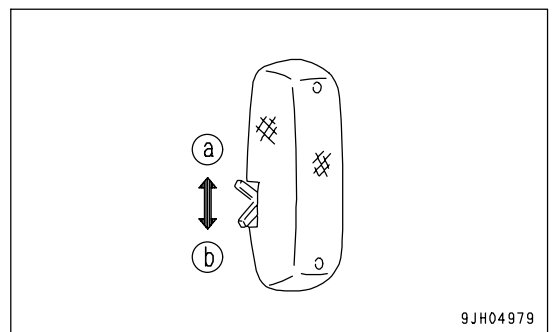

Emergency Pump Drive Switch

NOTICE

Emergency pump drive switch is provided to make it possible to perform work for a short time when there is a failure in the pump control system. It is necessary to repair the abnormal location as soon as possible.

This switch (10) is used to make it possible to carry out operations temporarily if any problem should occur in the pump control system (when the display shows "E02").

- (a) EMERGENCY: When abnormal (move switch up)
- (b) NORMAL: When normal (move switch down)

If the display shows "E02", move the switch up to make it possible to carry out work.

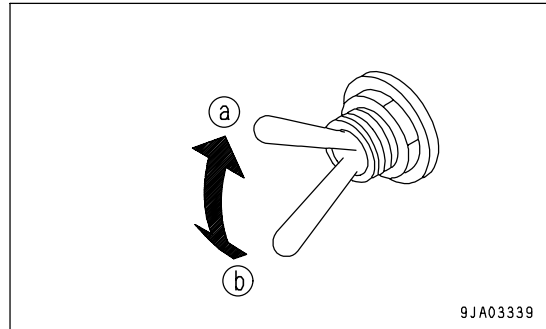

Swing Parking Brake Release Switch

NOTICE

This switch makes it possible to perform swing operations for a short even when there is a problem in the swing parking brake electric system. **DO NOT** use this switch except in emergencies. Repair the problem as soon as possible.

Switch (11) makes it possible to temporarily perform operations should any abnormality occur in the swing brake system (when monitor display shows E03).

- (a) Release: Position for abnormality (switch moved up)
- (b) Normal: Normal position (switch moved down)
 - When the monitor display is "E03", move this switch up to make it possible to perform operations.
 - When this switch is set to release position (a), the swing lock monitor flashes.

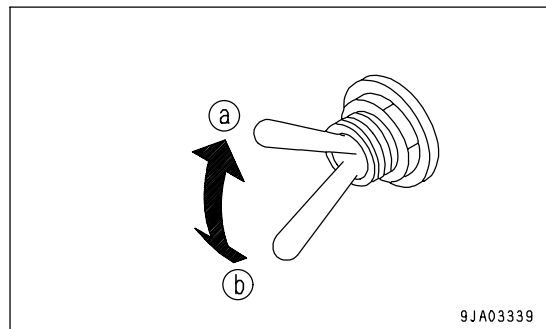

Step Light Switch

Use switch (12) when dismantling the machine at night.

- When the switch is pressed, the step light will light up for approx. 60 seconds.
- Even if the starting switch key is at the OFF position, the step light will light up for approx. 60 seconds when the switch is pressed.

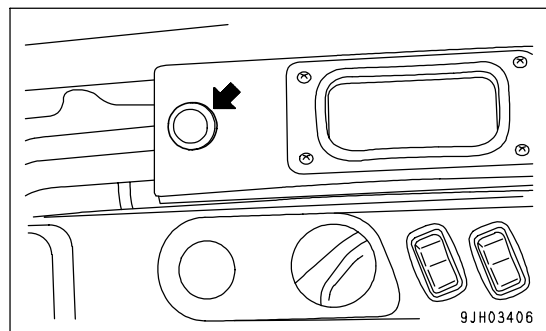

Lower Wiper Switch

(machines equipped with fixed front window cab)

This switch (13) operates the lower wiper (A).

(a) ON position: Lower wiper (A) is actuated

(b) OFF position: Lower wiper (A) stops

If this switch is turned to the ON position at the same time as the wiper switch, the wiper and lower wiper (A) will be actuated in turn.

REMARK

- If the wiper and lower wiper are being actuated at the same time, lower wiper will not stop even when the wiper switch (monitor) is turned OFF. To stop the lower wiper, turn switch (13) OFF.
- When the wiper is under continuous operation at the ON position, if the lower wiper switch is turned ON, the wiper and lower wiper will be actuated in turn.
- If the lower wiper switch is at the ON position and is operating continuously, and the wiper is actuated with the machine monitor, the lower wiper (both INT and ON) and wiper will be actuated in turn.

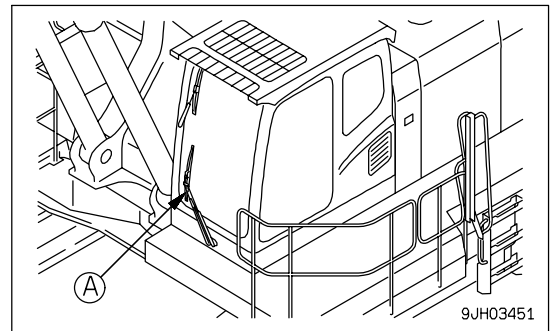
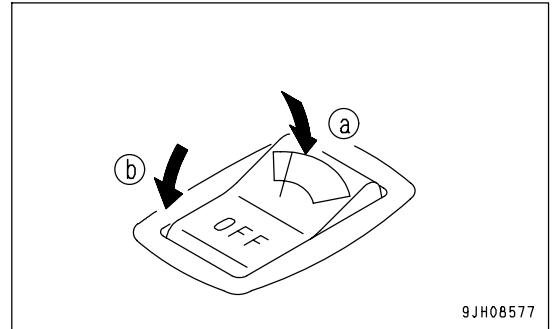

Revolving Warning Lamp Switch

(If equipped)

This switch (14) turns on and rotates the yellow rotating lamp located on top of the cab.

(a) ON: Lamps light up

(b) OFF: Lamps go off

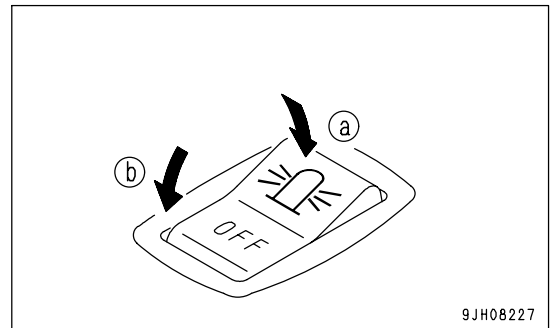

Large Capacity Airflow Air Conditioner Blower Switch

(If equipped)

This switch (13) operates the large-capacity airflow air conditioner blower.

(a) ON: Large-capacity air conditioner blower is actuated

(b) OFF: Large-capacity air conditioner blower is stopped

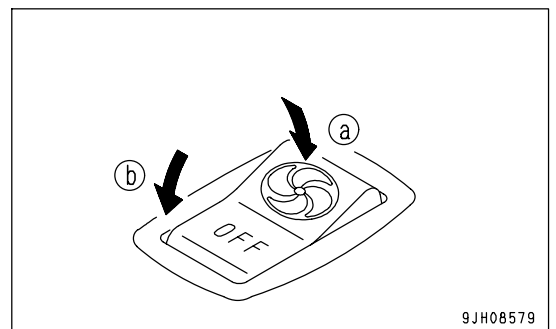

CONTROL LEVERS AND PEDALS

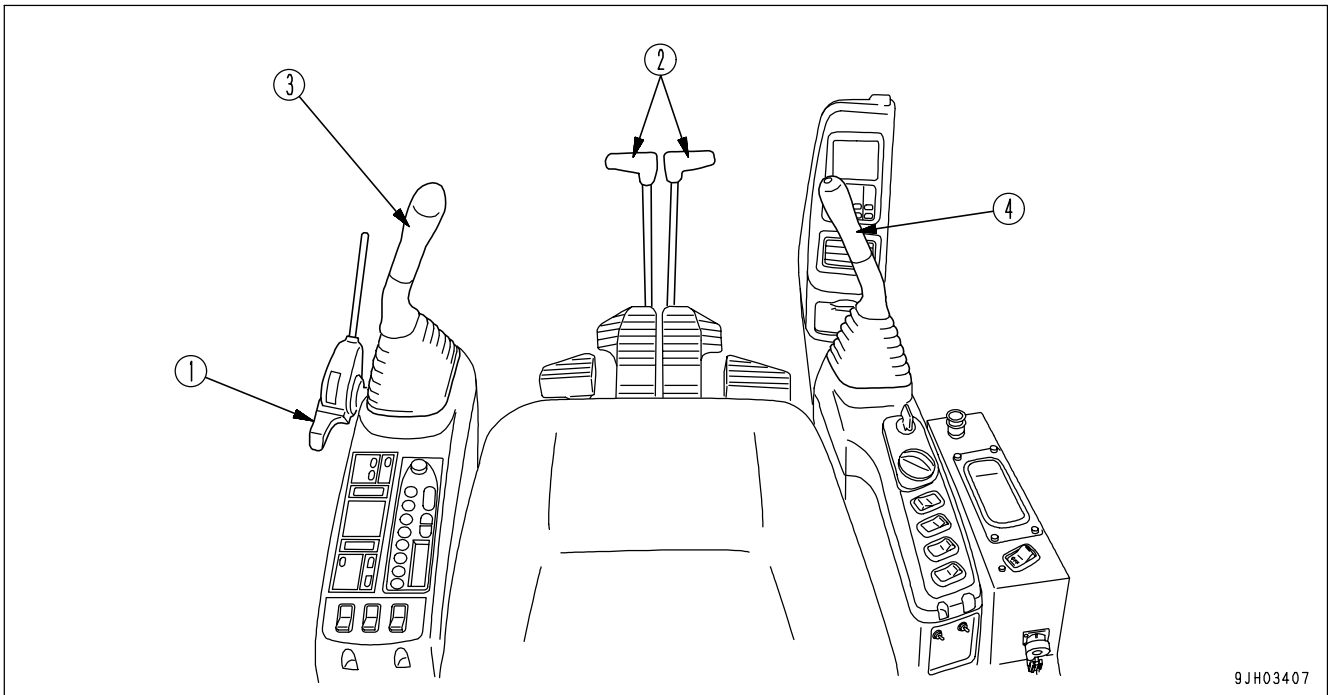

9JH03407

- | | |
|--|---|
| (1) Lock lever | (3) Left work equipment control lever
(with auto-deceleration system) |
| (2) Travel levers
(with pedal and auto-deceleration system) | (4) Right work equipment control lever
(with auto-deceleration system) |

Lock Lever

! WARNING

- When standing up from the operator's seat, push lock lever (1) down securely to set it to LOCK position (L). If lock lever (1) is not in LOCK position (L) and the control levers are touched by mistake, it may lead to serious personal injury.
- Check lock lever (1) is placed securely at LOCK position (L).
- Be careful not to touch the work equipment control levers when pulling lock lever (1) up or pushing it down.

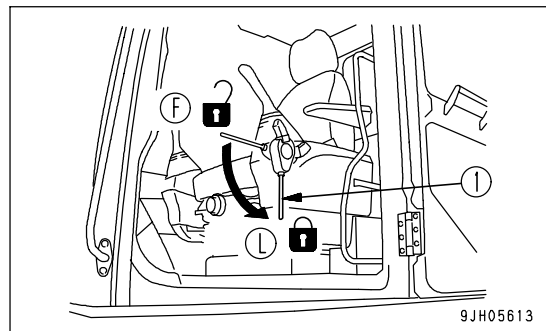

9JH05613

This lever (1) is a device to lock the work equipment, swing, travel, and attachment (if equipped) control levers. Push the lever (1) down to apply the lock.

This lock lever (1) is a hydraulic lock, even if it is in the lock position (L), the work equipment control lever and travel lever will move, but the work equipment, travel motor, and swing motor will not work.

Travel Levers

**WARNING**

- Do not rest your foot on the pedal during operations. If the pedal is depressed by mistake, the machine may suddenly move and cause a serious accident. Be extremely careful when operating the pedal for travel or steering operations. When you are not using the pedal, do not rest your foot on it.
- If the track frame is facing the rear, the direction of travel operations will be reversed when the travel lever is operated. (The machine will travel forward when operated in reverse, and in reverse when operated forward; the left and right directions will also be reversed.)
- When operating the travel levers, check if the track frame is facing the front or the rear. (If the sprocket is at the rear, the track frame is facing the front.)

This lever (2) is used to change the direction of travel between forward and reverse. () shows the pedal operation.

(a) FORWARD: The lever is pushed forward
(The pedal is angled forward)

(b) REVERSE: The lever is pulled back
(The pedal is angled back)

N (Neutral): The machine stops

REMARK

If the lever is shifted to the FORWARD or REVERSE position from the Neutral position, the alarm sounds to warn that the machine is starting to move.

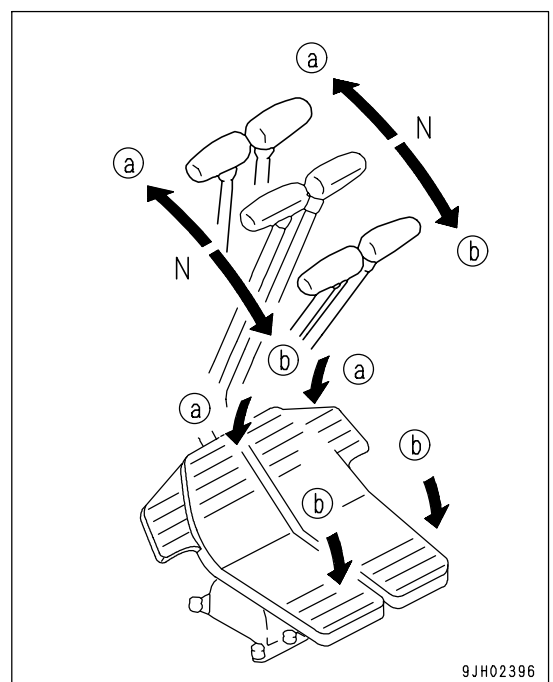

9JH02396

Work Equipment Control Lever

Left work equipment control lever (3) is used to operate the arm and upper structure.

Arm operation

- (a) Arm OUT
- (b) Arm IN

Swing operation

- (c) Swing to right
- (d) Swing to left

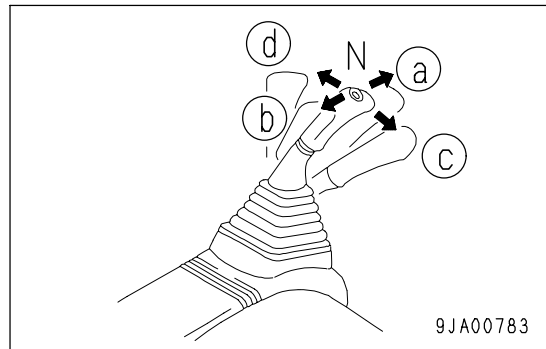

N (Neutral) : The upper structure and arm are held in position and do not move.

Right work equipment control lever (4) is used to operate the boom and bucket.

Boom operation

- (a) RAISE
- (b) LOWER

Bucket operation

- (c) DUMP
- (d) CURL

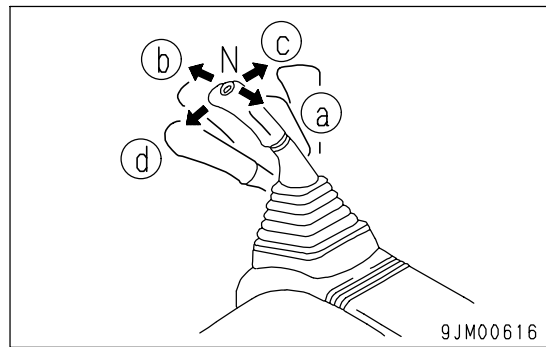

N (Neutral) : The boom and bucket are held in position and do not move.

REMARK

The engine speed for all control levers (travel, work equipment, attachment) is changed as follows by the auto-deceleration mechanism.

- When the travel lever and work equipment control levers are at the neutral position, even if the fuel control dial is above midrange speed, the engine speed will go down to a midrange speed. If one of these levers is operated, the engine speed will rise to the speed set by the fuel control dial.
- If all the control levers are at the neutral position, the engine speed goes down approx. 100 rpm, then after approx. 4 seconds, the engine speed goes down to the deceleration speed (approx. 1300 rpm).

EMERGENCY EXIT FROM OPERATOR'S CAB

If it should become impossible to open the cab door, open the rear window and use it as an emergency escape.

Remove the rear window as follows.

1. Pull ring (1) and completely remove seal (2) from the rubber core.
2. With pressure push on corner of the window, the glass will fall outside.

NOTICE

Remove the rear window only when using it as an escape route during emergencies. Do not remove it at any other time.

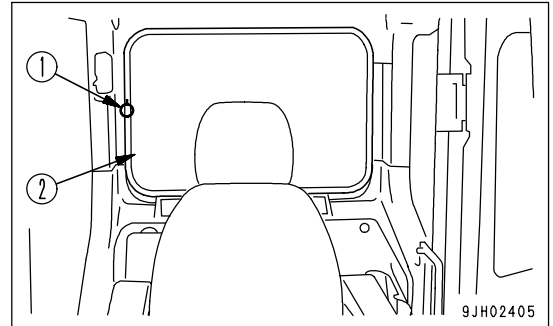

DOOR LOCK



WARNING

- Before releasing the door lock, always stop the machine on flat ground.
- Never release the door lock on a slope. The door may suddenly close and cause injury.
- When releasing the door lock, do not extend your body or hands outside the machine and do not put your hands on the door frame. The door may suddenly close and cause injury.

Use the door lock to fix the door in position after opening it.

1. Push the door against catch (1) to lock it in position.
2. When closing the door, push down the lever (2) on the left of the operator's seat to release the catch.
3. When attaching the door in position, lock it firmly to the catch.

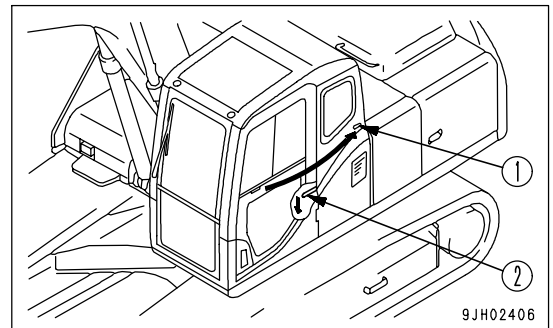

CAP WITH LOCK

Use the starting switch key to open and close the locks on the caps and covers.

For details of the locations of the caps and covers with locks, see "LOCKING (PAGE 3-137)".

Insert the key as far as it will go to the shoulder (A). If the key is turned before it is inserted all the way, it may break.

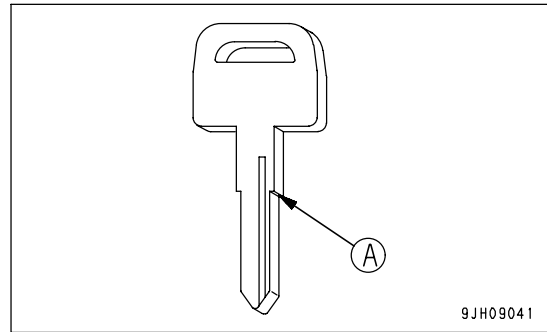

Opening and Closing Caps with Lock

Opening the Cap

1. Insert the key into the key slot.
2. Turn the starting switch key counterclockwise, align the key slot with the match mark (3) on the cap, then open the cap.
 - (1): Open
 - (2): Lock

REMARK

- A type is used for the fuel tank cap. B type is used for the hydraulic tank.
- With this type, if the cap rotates freely, it is locked. In this condition, the cap cannot be removed from the tank. Turn the starting switch key counterclockwise, align counter mark (3) on the cap with the groove of the rotor, then turn the cap slowly until a click is heard. This releases the lock and the cap can be opened.

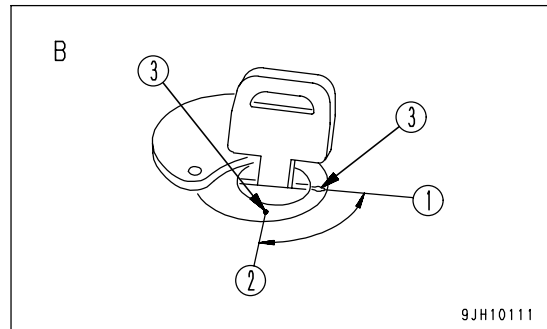
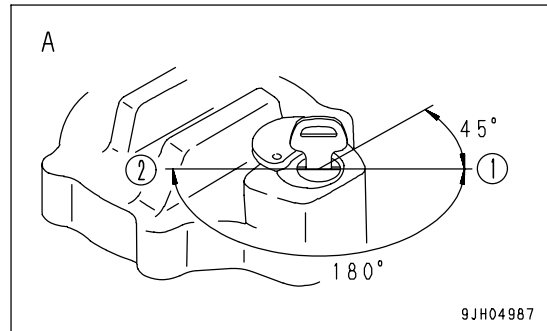

Locking the Cap

1. Turn the cap until tight, then insert the key into the key slot.
2. Turn the starting switch key to LOCK position (2), then remove the key.

Opening and Closing Cover with Lock

Opening the Cover (Locked Cover)

1. Insert the key into the key slot.
2. Turn the key counterclockwise and open the cover by pulling the cover grip.
(A): Open
(B): Lock

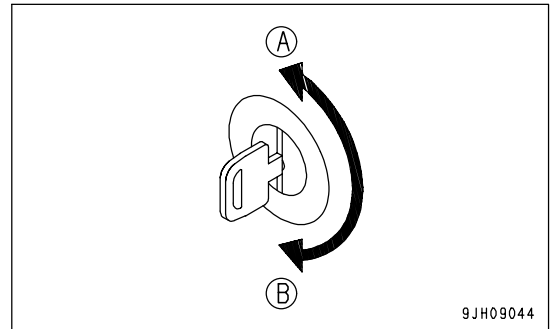

Locking the Cover

1. Close the cover and insert the key into the key slot.
2. Turn the key clockwise and take the key out.

HOT AND COOL BOX

Located on the right side at rear of the operator's seat. It is interconnected with the air conditioner. Box stays warm when the heater is used, and box stays cool when the air conditioning is used.

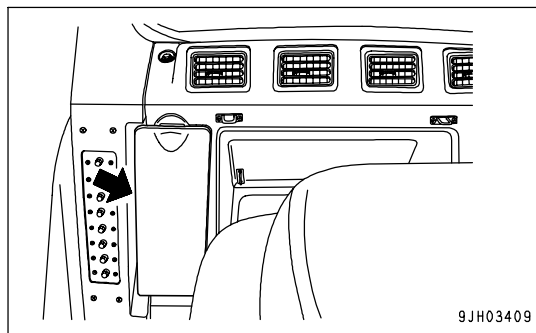

MAGAZINE BOX

(with cup holder)

Located on left side of the operator's seat. Keep the Operation and Maintenance Manual in this box so that it can be taken out and read whenever necessary.

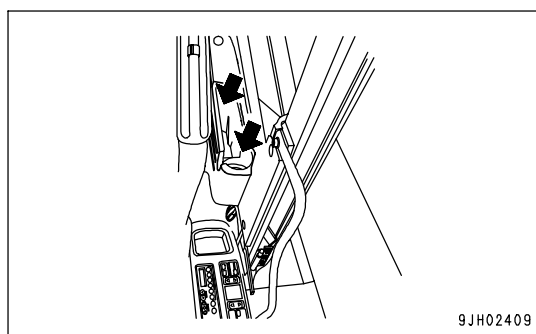

ASHTRAY

This is under the machine monitor at the front right of the operator's compartment.

Always make sure that you extinguish your cigarette, then put it in the ashtray and close the lid.

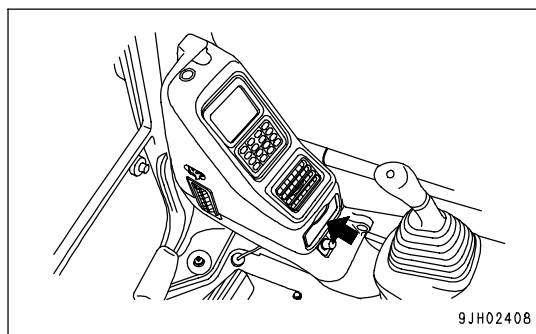

FIRE EXTINGUISHER

(If equipped)

The fire extinguisher can be set at the rear left of the cab. When installing, please consult your Komatsu distributor.

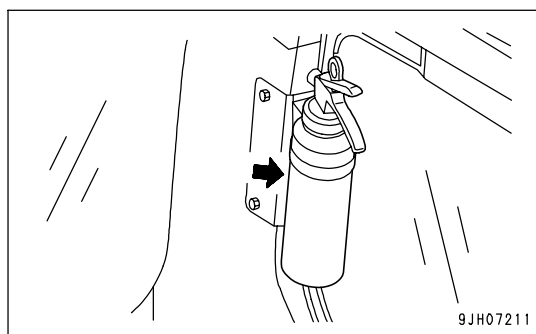

AIR CONDITIONER CONTROLS

Air Conditioner Control Panel

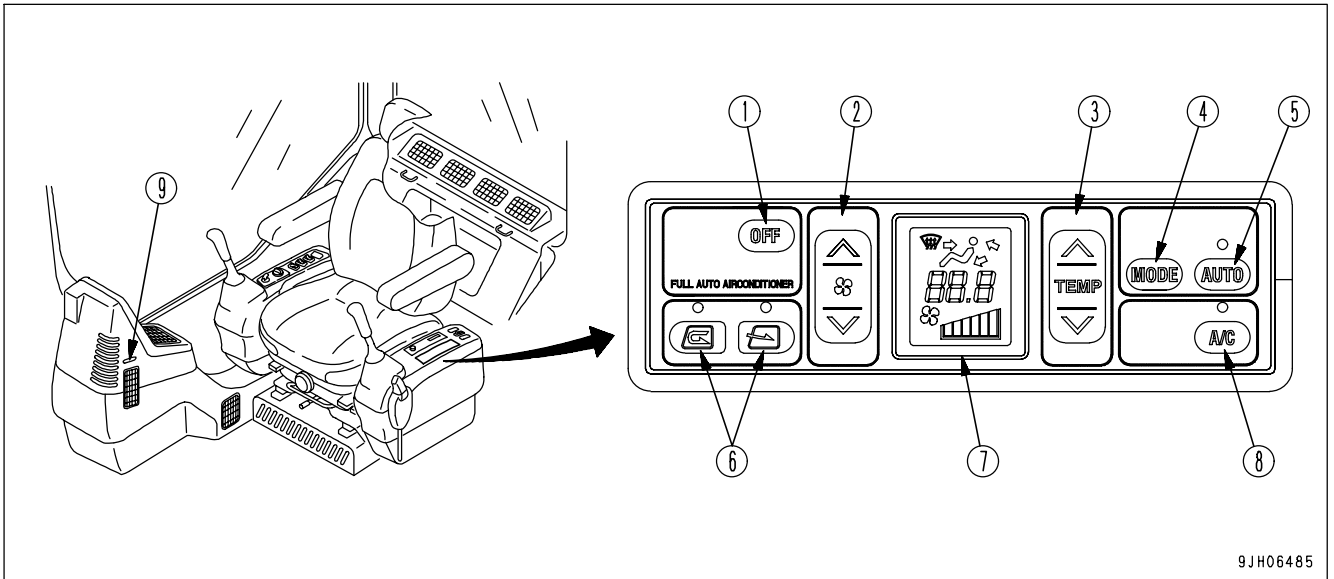

- | | |
|--------------------------------|----------------------------------|
| (1) OFF switch | (6) FRESH/RECIRC selector switch |
| (2) Fan switch | (7) Display monitor |
| (3) Temperature control switch | (8) Air conditioner switch |
| (4) Vent selector switch | (9) Defroster selector lever |
| (5) Auto switch | |

OFF Switch

Switch (1) is used to stop the fan and air conditioner.

- When OFF switch (1) is pressed, the set temperature and air flow display on display monitor (7), the lamps above auto switch (5), and air conditioner (8) go out, and operation stops.

REMARK

When switch (1) is turned to the OFF position, the lamp above FRESH/RECIRC selector switch (6) does not go out, but this is not a problem.



Fan Switch

Switch (2) is used to adjust the air flow.

The air flow can be adjusted to six levels.

- Press the ^ switch to increase the air flow; press the v switch to reduce the air flow.
- During auto operation, the air flow is automatically adjusted.

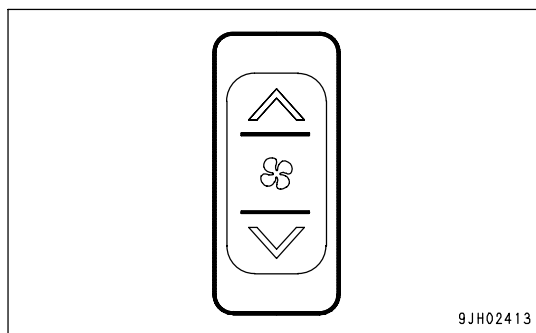

Monitor display and air flow

A: Liquid crystal display

B: Air flow

a: Air flow "low"

b: Air flow "medium 1"

c: Air flow "medium 2"

d: Air flow "medium 3"

e: Air flow "medium 4"

f: Air flow "high"

A	B
	a
	b
	c
	d
	e
	f

Temperature Control Switch

Switch (3) is used to control temperature inside the cab. The temperature can be set between 18°C (64.4°F) and 32°C (89.6°F).

- Press the ^ switch to raise the set temperature; press the v switch to lower the set temperature.
- The temperature is generally set at 25°C (77°F).
- The temperature can be set in stages of 0.5°C (0.9°F).

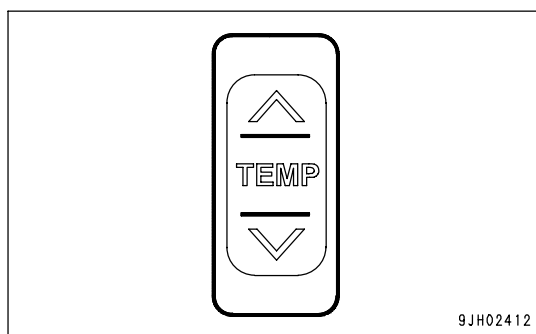

<Monitor display and the function>

Monitor display °C	Set temperature
18.0	Max. cooling
18.5 to 31.5	Adjusts temperature inside cab to set temperature
32.0	Max. heating

REMARK

If the mode is set to auto mode and the temperature setting is set to 18.0 °C (64.4 °F) or 32.0 °C (89.6 °F), the air flow from the fan is always set to HIGH and does not change even when the set temperature is reached.

Vent Selector Switch

Switch (4) is used to select the vents.

- When switch (4) is pressed, the display on monitor display (7) switches and air blows out from the vents displayed.
- During automatic operation, the vents are automatically selected.

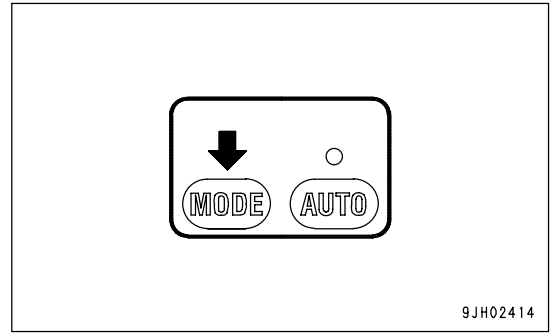

- (A): Rear vents (4 places)
- (B): Face vent (1 place)
- (C): Foot vent (1 place)
- (D1): Front window vent (1 place)
- (D2): Front window vent (1 place)

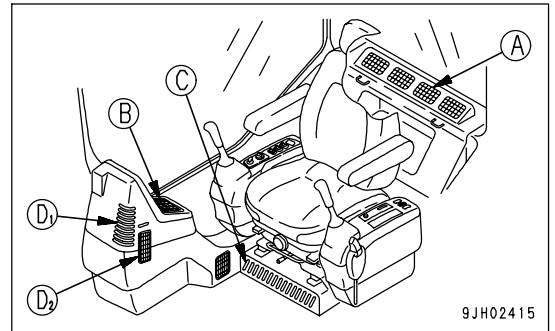

- Front window vent (D2) can be opened or closed by hand.

Liquid crystal display	Vent mode	Vent				Remarks
		(A)	(B)	(C)	(D)	
	Front and rear vents (including defroster vent)	○	○		(○)	—
	Front, rear, and foot vents (including defroster vent)	○	○	○	(○)	—
	Foot vent			○		—
	Front, foot vents (including defroster vent)		○	○	(○)	Cannot be selected for automatic operation
	Front vents (including defroster vent)		○		(○)	Cannot be selected for automatic operation

Note 1: Air blows out from vents marked ○

Note 2: The defroster vents can be opened or closed manually with the vent lever.

Auto Switch

With switch (5), the air flow, vents, and air source (RECIRC/FRESH) are automatically selected according to the set temperature.

- When auto switch (5) is pressed, the lamp above the auto switch lights up.
- Press switch (5), then use temperature control switch (3) to set the temperature, and run the air conditioner under automatic control.
- When the control is switched from automatic operation to manual operation, it is possible to operate the to change air flow, vents, and air source (RECIRC/FRESH). When manual control is used, lamp above the auto switch goes out.

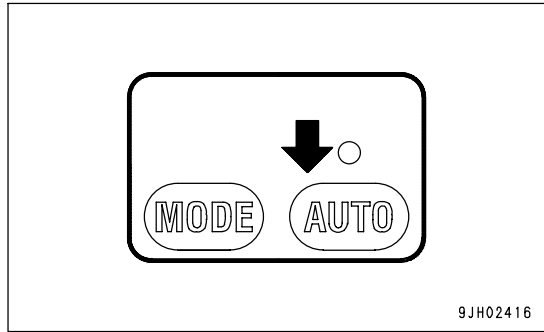

9JH02416

REMARK

When Auto Mode is selected, if the set temperature is set to 18.0 °C (64.4 °F) or 32.0 °C (89.6 °F), the air flow is always set to High, but this is not a problem.

FRESH/RECIRC Selector Switch

Switch (6) is used to switch the air source between recirculation of the air inside the cab and intake of fresh air from the outside.

- When RECIRC button (A) or FRESH button (B) is pressed, lamp (C) above the switch lights up to indicate the source of the air flow.
- During automatic operation, the selection of inside air (RECIRC) and outside air (FRESH) is performed automatically.

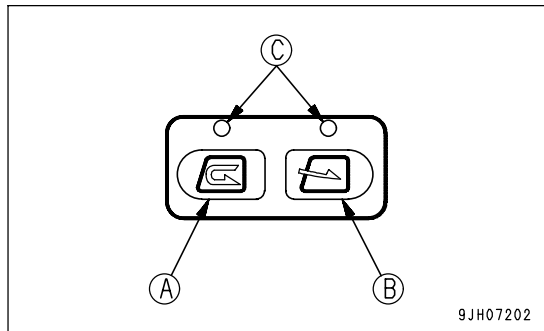

9JH07202

RECIRC	Outside air is shut off and only air inside the cab is circulated. Use this setting to perform rapid cooling of the cab or when outside air is dirty.
FRESH	Outside air is taken into the cab. Use this setting to take in fresh air when performing demisting.

Display Monitor

Monitor (7) displays the status of temperature setting (a), air flow (b), and vents (c).

- When OFF switch (1) is pressed, the display of temperature setting (a) and air flow (b) goes out, and operation stops.

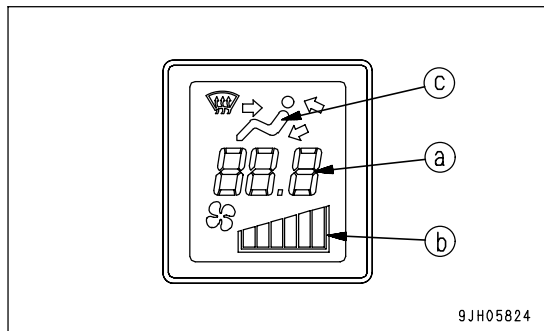

9JH05824

Air Conditioner Switch

Switch (8) is used to turn the air conditioner (cooling, dehumidifying, heating) ON or OFF.

- When the fan is actuated (display (b) is shown) and air conditioner switch (8) is pressed, the air conditioner is switched ON, lamp above the air conditioner switch lights up, and the air conditioner starts.

When switch (8) is pressed again, the air conditioner is switched OFF, lamp above the air conditioner switch goes out, and the air conditioner stops.

- Air conditioner cannot be operated while the fan is off.

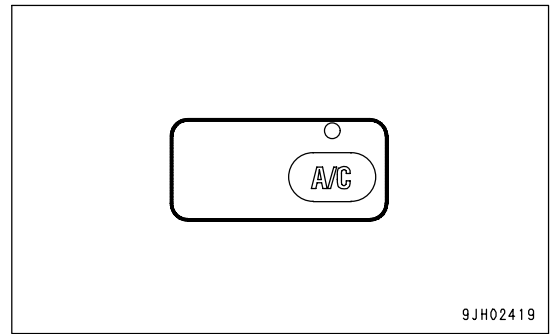
**Defroster Selector Lever**

Lever (9) is used in cold or rainy weather to remove mist that forms on the front glass.

(A) Selector lever forward: To defroster (open)

(B) Selector lever back: Closed

The defroster can be used when the vent selector switch is set to face or face and foot.

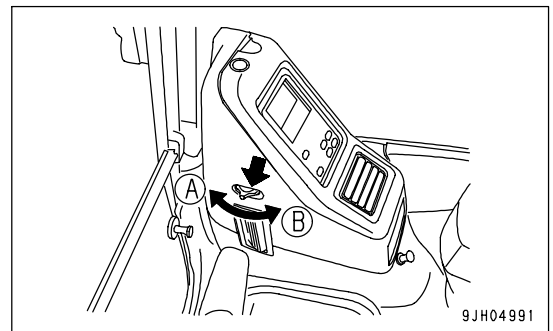

Method of Operation

The air conditioner can be operated automatically or manually. Select the method of operation as desired.

Automatic Operation

1. Turn auto switch (5) ON.
 - The lamp above switch (5) lights up.
 - The set temperature (a) and air flow (b) are displayed on the monitor.

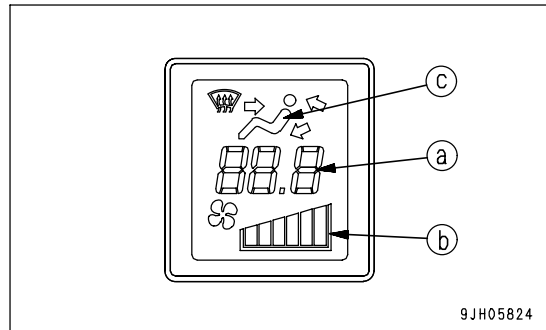
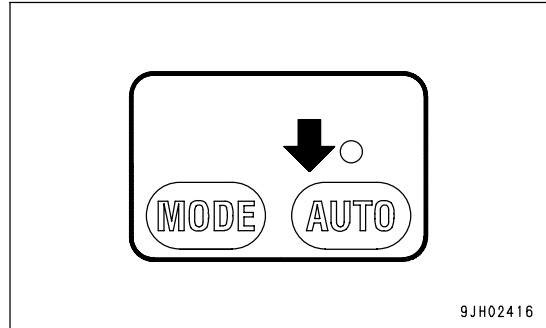

2. Use temperature set switch (3) to set to the desired temperature. The air flow, combination of vents, and selection of fresh or recirculated air is automatically selected according to the set temperature, and the air conditioner is operated automatically to provide the set temperature.

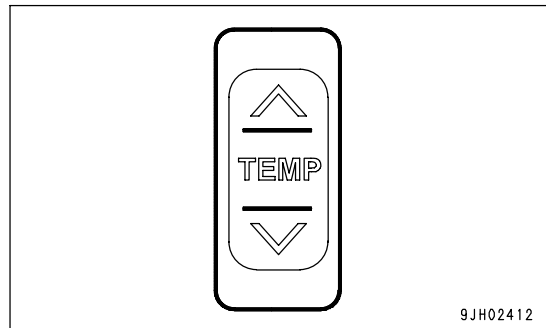

REMARK

When vent display monitor (c) displays (d) or (e), and engine coolant temperature is low, the air flow is automatically limited to prevent cold air from blowing out.

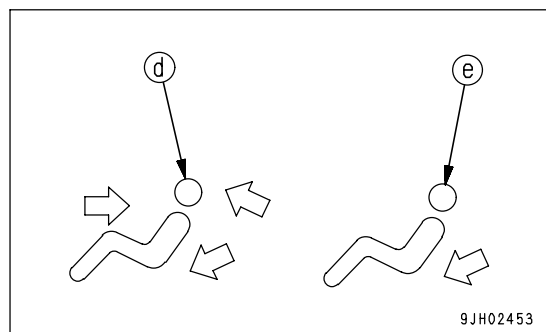

Stopping Automatic Operation

Press OFF switch (1). The displays for temperature setting (a) and air flow (b) on monitor (7), and lamps above auto switch (5) and air conditioner switch (8) go out, the operation stops.



Manual Operation

1. Press fan switch (2) and adjust the air flow. When doing this, check that temperature setting (a) and air flow (b) are displayed on monitor (7).

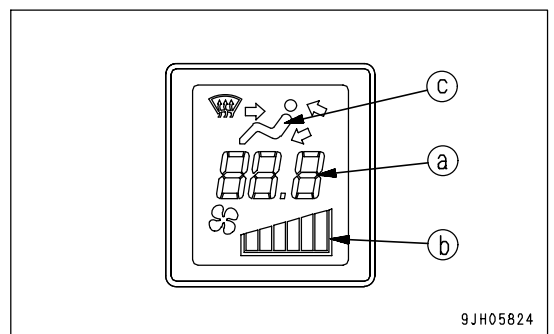
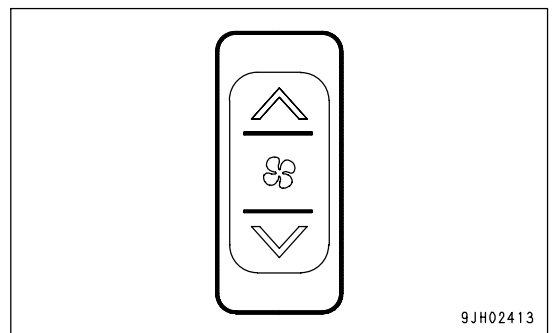

2. Turn air conditioner switch (8) ON. Check that the lamp above air conditioner switch lights up.

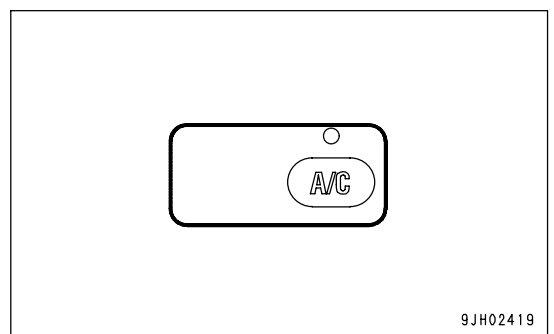

3. Press temperature setting switch (3) and adjust temperature inside the cab.

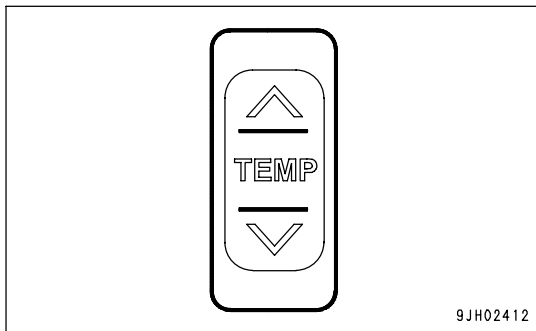

4. Press vent selector switch (4) and select the desired vents. When this is done, the display for vent (c) of the display monitor changes according to the selection.

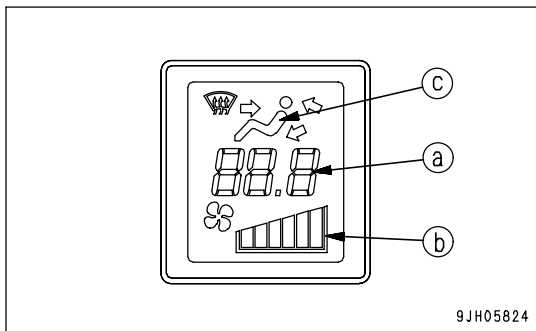
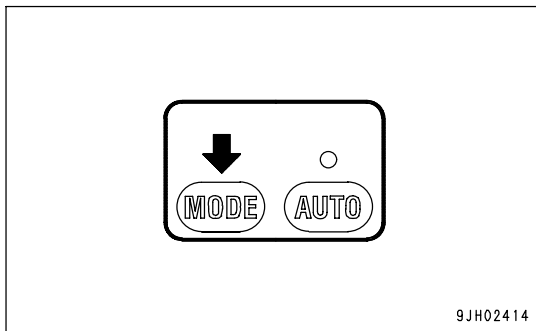

5. Press either RECIRC button (A) or FRESH button (B) of RECIRC/FRESH selector switch (6).

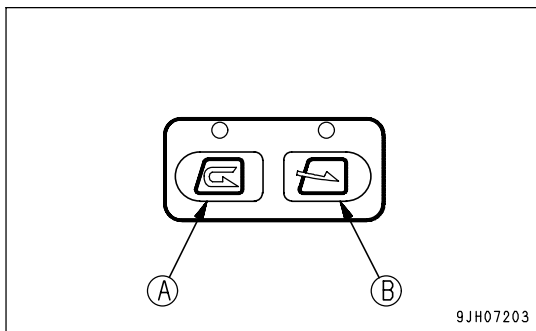

Stopping Manual Operation

Press OFF switch (1). The displays for temperature setting (a) and air flow (b) on monitor (7), and lamps above auto switch (5) and air conditioner switch (8) go out, the operation stops.



Operation with Cold Air to Face and Warm Air to Feet

To operate with cold air blowing to the face and warm air blowing to the feet, set as follows.

1. Press fan switch (2) and adjust the air flow. When doing this, check that temperature setting (a) and air flow (b) are displayed on monitor (7).

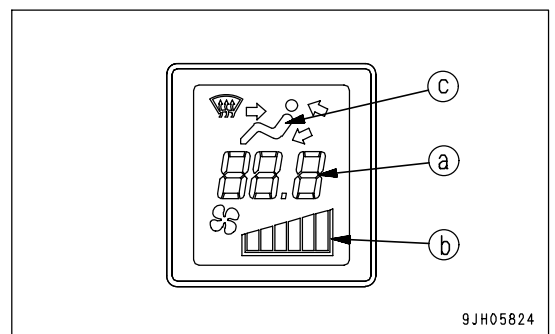
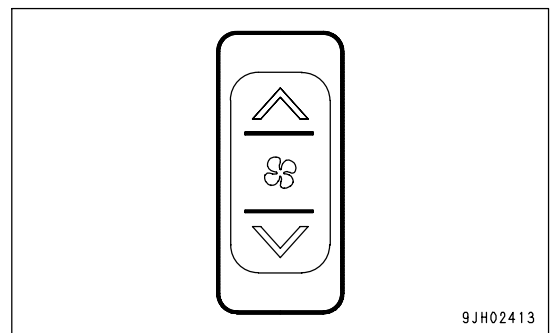

2. Press vent selector switch (4) and set the vent display on the display monitor to the display shown in the diagram on the right.

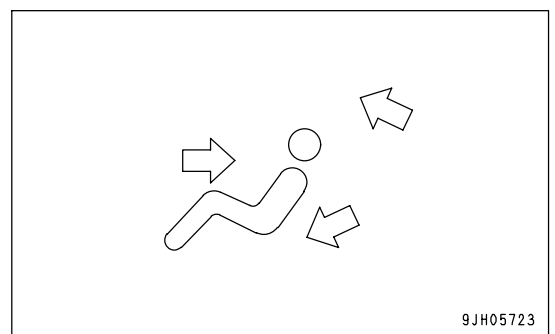

- 3. Turn air conditioner switch (8) ON. Check that the lamp above air conditioner switch lights up.

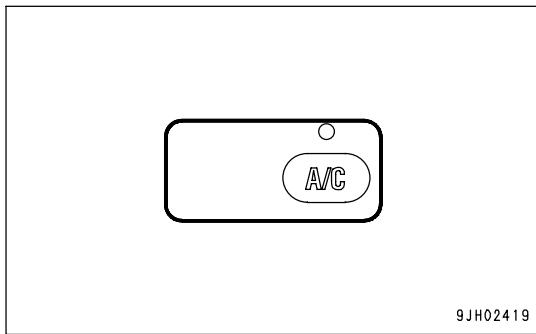

- 4. Adjust fan switch (2), temperature setting switch (3) and RECIRC/FRESH selector switch (6) to the desired positions.

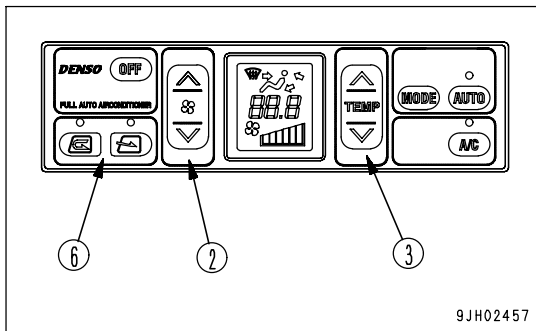

Defroster Operation

- 1. Press fan switch (2) and adjust the air flow. When doing this, check that temperature setting (a) and air flow (b) are displayed on monitor (7).

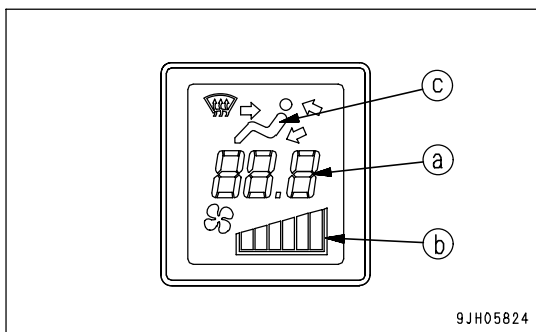
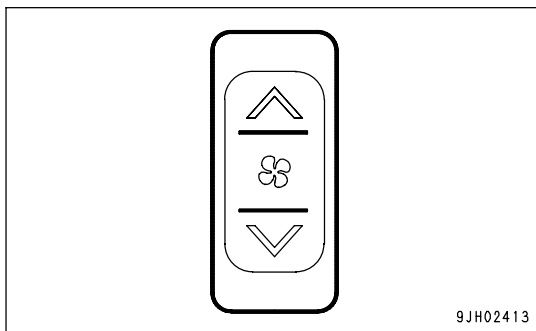

2. Press vent selector switch (4) and set vent display on the display monitor to (f) or (g) as shown in diagram on the right.

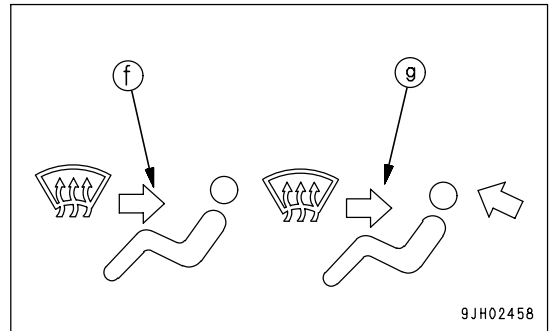
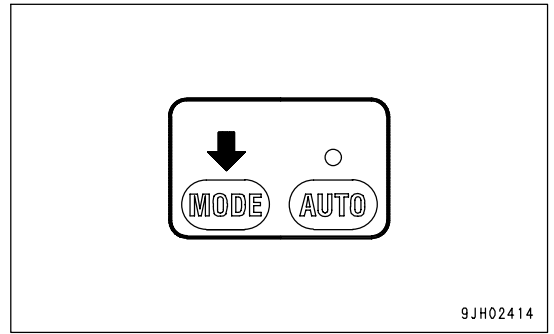

3. Press RECIRC/FRESH selector switch (6) and set it to take in fresh air.

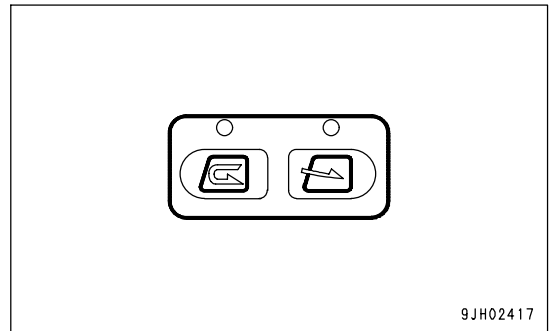

4. Press temperature setting switch (3) and set temperature on the display (7) monitor to maximum heating.

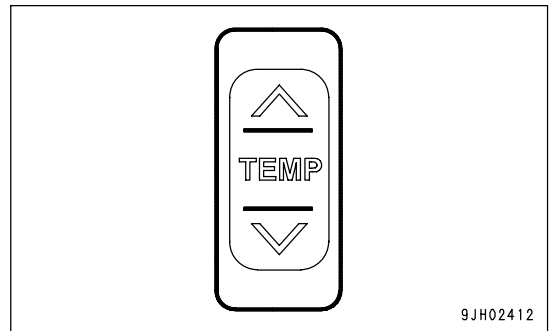

5. Adjust vents (A), (B), and (D2) so air blows onto the window glass.
(Vents (C) and (D1) are fixed and cannot be adjusted.)

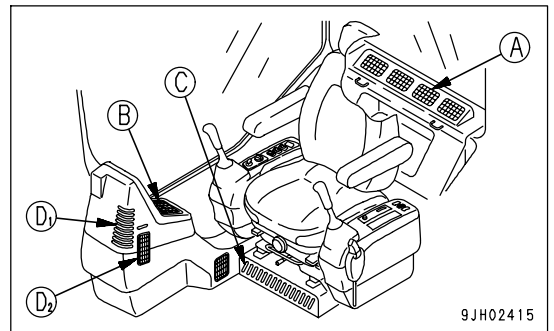

When operating in the rainy season or when it is desired to remove the mist from the window glass or to dehumidify the air, turn air conditioner switch (8) ON.

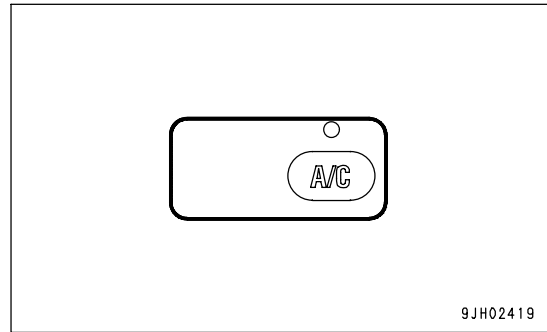

Use Air Conditioner with Care

NOTICE

- When running the air conditioner, always start with the engine running at low speed. Never start the air conditioner when the engine is running at high speed. It will cause failure of the air conditioner.
- If water gets into the control panel or sunlight sensor, it may lead to unexpected failure, be careful not to let water get on these parts. In addition, never bring any flame near these parts.
- For the auto function of the air conditioner to work properly, always keep the sunlight sensor clean and do not leave anything around the sunlight sensor that may interfere with its sensor function.

Ventilation

- When running the air conditioner for a long time, turn the lever to the FRESH position once an hour to carry out ventilation and cooling.
- If you smoke when the air conditioner is on, the smoke may start to hurt your eyes, so open the window and turn the lever to FRESH for a while to remove the smoke while continuing the cooling.

Temperature Control

When the cooler is on, set the temperature so that it feels slightly cool when entering the cab (5 or 6 °C (9 or 10.8 °F) lower than the outside temperature). This temperature difference is considered to be the most suitable for your health, so always be careful to adjust the temperature properly.

Inspection and maintenance of Air Conditioner Equipped Machine

When carrying out an inspection and maintenance of a machine equipped with air conditioner, see "CHECK AND MAINTENANCE AIR CONDITIONER (PAGE 4-34),CLEAN AIR CONDITIONER FRESH/RECIRC FILTERS (PAGE 4-57),CHECK, REPLACE ALTERNATOR, AIR CONDITIONER COMPRESSOR DRIVE BELTS (PAGE 4-59)" and follow the instruction on the table.

Other Functions

Self-diagnostic Function

It is possible to perform troubleshooting of various sensors and equipment used on the air conditioner.

1. Turn the starting switch key to the ON (B) position.

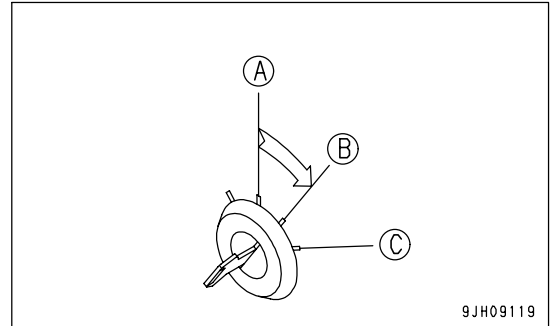

2. Press OFF switch (1). The temperature setting and air flow display on the liquid crystal display portion go out and operation stops.



3. If the "∨" and "∧" parts of temperature setting switch (3) are kept pressed at the same time for at least 3 seconds, the troubleshooting mode is displayed on the liquid crystal display portion.

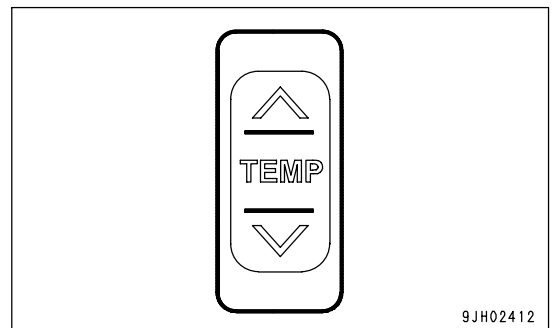

<Monitor display and failure mode>

Display	Failure mode
E--	No failure
E11	Disconnection in recirculated air sensor
E12	Short circuit in recirculated air sensor
E13	Disconnection in fresh air sensor
E14	Short circuit in fresh air sensor
E15	Disconnection in coolant temperature sensor
E16	Short circuit in coolant temperature sensor
E18	Short circuit in sunlight sensor
E21	Disconnection in vent sensor
E22	Short circuit in vent sensor
E43	Problem in vent damper
E44	Problem in air mix damper
E45	Problem in RECIRC/FRESH air damper
E51	Problem in refrigerant pressure

- When more than one failure is detected, press the "v" or "^" portion of temperature setting switch (3) to display the failures in turn.
- After completing the troubleshooting, press OFF switch (1) again to return to the normal display.

If any problem is detected by the self-diagnostic function, contact your Komatsu distributor perform inspection and repair.

Function to Switch Set Temperature Display Between Fahrenheit and Celsius

It is possible to switch the set temperature display between °F and °C.

If the "v" and "^" portions of temperature setting switch (3) are pressed at the same time for more than 5 seconds while the fan is running, the temperature display will switch between °F and °C. (Note that the unit is not displayed.)

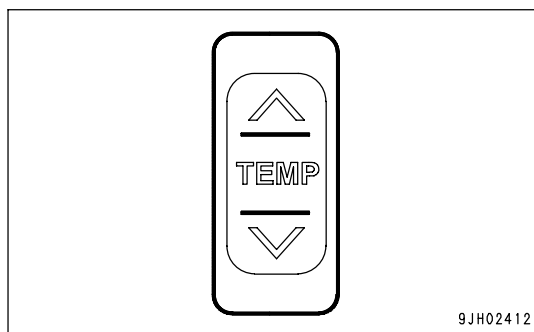

	Liquid crystal display range
°C	18.0 to 32.0
°F	63 to 91

RADIO

Control Panel

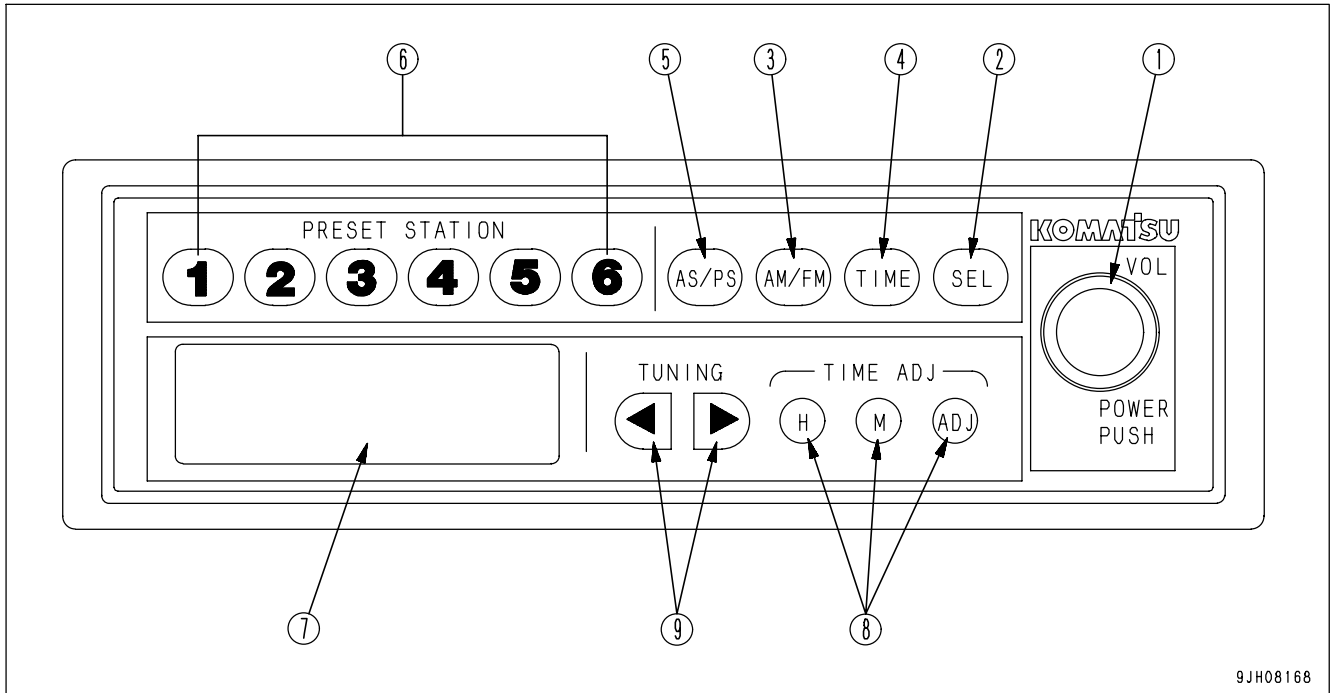

9JH08168

- | | |
|---|--|
| (1) Power switch, Volume control knob, Balance control knob | (5) AS/PS button |
| (2) SEL button | (6) Preset station buttons (1,2,3,4,5,6) |
| (3) FM/AM selection button | (7) Display |
| (4) Display selection button | (8) Time reset button |
| | (9) Tuning button |

Power switch, Volume control knob, Balance control knob

Press this knob (1) to turn the power for the radio on. The frequency is displayed on display (7). Press the knob again to turn the power off.

Turn the knob clockwise to increase the volume; press counterclockwise to reduce the volume. The range for the volume is VOL 0 - VOL 40.

SEL button

Each time this button (2) is pressed, the mode changes as follows: VOL (volume) → BAS (bass) → TRE (treble) → BAL (balance). The mode is displayed on display (7). For details of each mode, see "Method of Operating Mode (PAGE 3-64)".

FM/AM Selection Button (AM/FM)

Press this button (3) to select the desired band.

Each time the button is pressed, the band changes FM → AM → FM . . .

Display Selection Button (TIME)

On this machine, priority is given to the frequency display. When the frequency is being displayed, press button (4) and the display will show the present time for 5 seconds. After 5 seconds pass, the display returns automatically to the frequency display. If any button other than TIME ADJ (H, M, ADJ) is pressed within 5 seconds, the display returns to the frequency display. For details of the method of adjusting the time, see "Setting Correct Time (PAGE 3-64)".

AS/PS button

This button (5) actuates the auto store and preset scan functions.

- Auto store

If this button is kept pressed for at least 2 seconds during radio reception, it will automatically search for six available AM and FM stations each, starting with the lowest frequency and going up to the highest frequency. These frequencies can then be saved in the preset memory.

- Preset scan

If this button is pressed within 2 seconds, it is possible to select one of the already preset stations. Wait for 6 sec. after pressing the button and then press the button again to select the next preset station. If it is impossible to receive the preset frequency, the selection advances after 1 second to the next preset station.

Preset Station Buttons (1, 2, 3, 4, 5, 6)

If this button (6) has been used to decide which stations to preset, it is possible to select the desired station at a touch. It is possible to preset 6 stations each for both AM and FM.

For details of the method of presetting the stations, see "Method of Setting with Preset Button (PAGE 3-63)".

REMARK

The preset button can be used to save the frequency manually. To save the frequency automatically, use the Auto store button.

Display

This display (7) shows the reception band, frequency, preset No., and time.

Time Reset Button

Use this button (8) when adjusting the time. For details of the method of adjusting the time, see "Setting Correct Time (PAGE 3-64)".

H: Hour

M: Minute

ADJ: Sets to 00 minutes

Tuning Button (TUNING)

Use this button (9) to change the frequency.

For further details, see "Method of Tuning (PAGE 3-63)"

Controls of Radio

Method of Setting with Preset Button

1. Press power switch (1) and display the frequency on display (7).
2. Use tuning button (9) to set to the desired frequency. There are two methods for tuning: auto tuning and manual tuning.
3. With the display (7) showing the desired frequency, keep the desired Preset button No pressed for at least 1.5 seconds. The reception sound will disappear, but when the presetting operation (saving to memory) is completed, the sound will appear again and the Preset No and frequency will be shown on the display to show that the presetting operation has been completed.

After completing the presetting, press Preset button (6) and release it within approx. 1.5 seconds. This will make it possible to receive the channel preset to that button. One channel each for AM and FM can be preset to each Preset button.

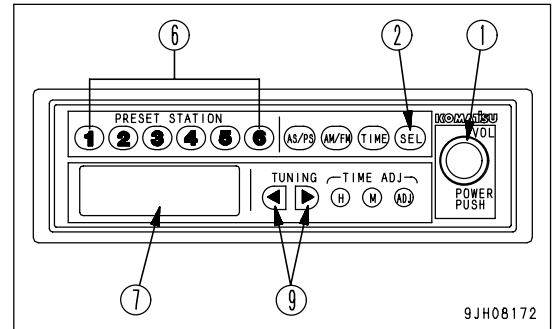

REMARK

It is also possible to save to the Preset button by using the auto store button.

Method of Tuning

1. Press power switch (1) and display the frequency on display (7).
2. Use tuning button (9) to set to the desired frequency. There are two methods for tuning: auto tuning and manual tuning.

- Manual tuning

Press tuning button (9) until the frequency is displayed on display (7).

< button: Frequency moves down

> button: Frequency moves up

When the frequency reaches the top or bottom frequency, it automatically continues as follows: Top → Bottom, or Bottom → Top.

- Auto tuning

Press tuning button (9) for at least 3 seconds. When a station is picked up, the tuning automatically stops. To search for the next station, press the tuning button again for at least 3 seconds.

< button: Frequency moves down

> button: Frequency moves up

If this button is pressed during auto tuning, the auto tuning will be cancelled and the setting will return to the frequency in use before the button was pressed.

Method of Operating Mode

- (BAS) Bass adjustment: When button (2) is pressed, BAS is displayed on display (7). If knob (1) is turned clockwise within 5 seconds, the bass sound is emphasized. If the knob is turned counterclockwise, the bass sound is reduced.
- (TRE) Treble adjustment: When button (2) pressed, TRE is displayed on display (7). If knob (1) is turned clockwise within 5 seconds, the treble sound is emphasized. If the knob is turned counterclockwise, the treble sound is reduced.
- (BAL) Balance adjustment: When button (2) is pressed, BAL is displayed on display (7). If knob (1) is turned clockwise within 5 seconds, the sound from the right speaker is increased. If the knob is turned counterclockwise, the sound from the left speaker is increased. When it is set to BAL 0, the sound from the left and right speakers is balanced.

REMARK

With each mode, the display is returned automatically to its original setting after 5 seconds.

Setting Correct Time

1. Press display selector button (4) to display the time.
After 5 seconds, the display will return to the frequency display and the time cannot be corrected. If this happens, press display selector button (4) again.
2. Press time adjustment button (8) to select Hour or Minute.
 - H button: Adjusts the hour (each time the button is pressed, the time advances by one hour)
 - M button: Adjusts the minute (each time the button is pressed, the time advances by one minute)
 - If the H or M button is kept pressed, the time will advance continuously until the button is released.
 - ADJ button: When the ADJ button is pressed, the time is reset as follows.
 - When display is 00 - 05 minutes, time is returned to 00 min. 00 sec. (No change in hour)
(10:05 → 10:00)
 - When display is 55 - 59 minutes, time is advanced to 00 min. 00 sec. (Hour advances)
(10:59 → 11:00)
 - When display is 06 - 54 minutes, time cannot be reset. (Time stays same)
(10:26 → 10:26)

Use the H, M, and ADJ buttons to set to the correct time.

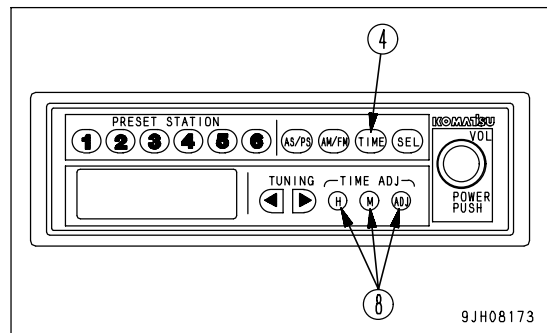

Antenna

When transporting the machine or parking the machine inside the garage, stow away the antenna to prevent it from causing any obstruction. The procedure for stowing the antenna away is as follows.

1. Loosen antenna mounting bolt (1) and store the antenna at position (A).
2. Tighten bolt(1).

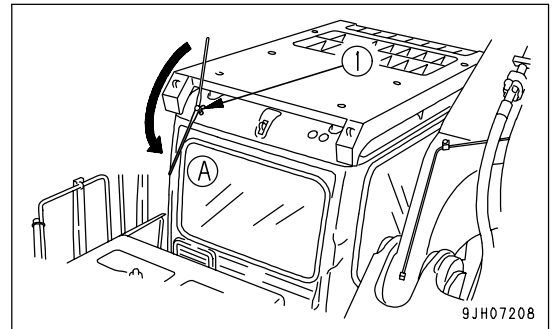

Use Radio with Care

- To ensure safety, always keep the sound to a level where it is possible to hear outside sounds during operation.
- If water gets into the speaker case or radio, it may lead to an unexpected failure, so be careful not to get water on the equipment.
- Do not wipe the scales or buttons with solvent such as benzene or thinner. Wipe with a dry soft cloth. If the dirt cannot be removed easily, soak the cloth with alcohol.
- When the battery is disconnected or replaced, settings for the preset buttons and clock are cleared, so all settings must be reprogrammed.

AUXILIARY ELECTRIC POWER

24V Power Source

NOTICE

Do not use this as the power supply for 12V equipment.
It will cause failure of the equipment.

Pull out the connector plug for taking out electric power from the rear side of the panel.

Maximum usable electric power is 85 W (24 V x 3.5 A).

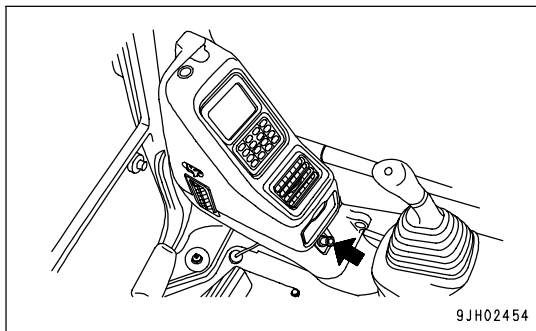

12V Power Source

(If equipped)

This power source can be used up to a capacity of 60W (12V x 5A).

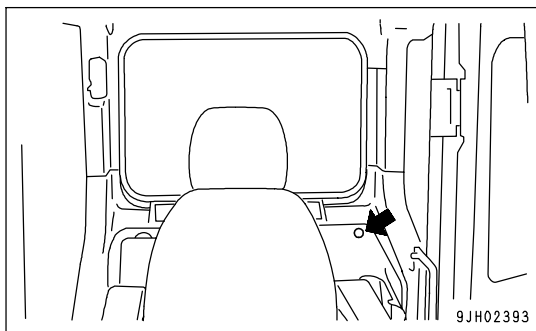

FUSE

NOTICE

Before replacing a fuse, be sure to turn off the starting switch.

The fuses protect the electrical equipment and wiring from burning out.

If the fuse becomes corroded, or white powder can be seen, or the fuse is loose in the fuse holder, replace the fuse.

Replace the fuse with another of the same capacity.

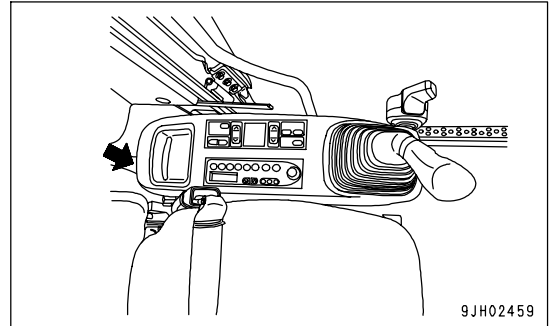

Fuse Capacities and Circuit Names

No.	Fuse capacity	Name of circuit
(1)	10A	Redundancy
(2)	10A	Solenoid valve
(3)	10A	PPC lock solenoid
(4)	20A	Window washer, cigar lighter
(5)	10A	Horn, flash lamp light (if equipped)
(6)	10A	Auto greasing system (if equipped)
(7)	10A	Rotating lamp (if equipped)
(8)	10A	Spare
(9)	10A	Radio
(10)	10A	Ribbon heater relay
(11)	25A	Air conditioner unit
(12)	20A	VHMS (if equipped)
(13)	10A	Optional power source (2), Travel alarm 12V power supply (if equipped)
(14)	10A	Optional power source (1)
(15)	5A	Key switch (acc., engine controller)
(16)	10A	Radio backup
(17)	10A	Network pass (regular power)
(18)	20A	VHMS (regular power) (if equipped)
(19)	10A	Room lamp
(20)	10A	Step ligh

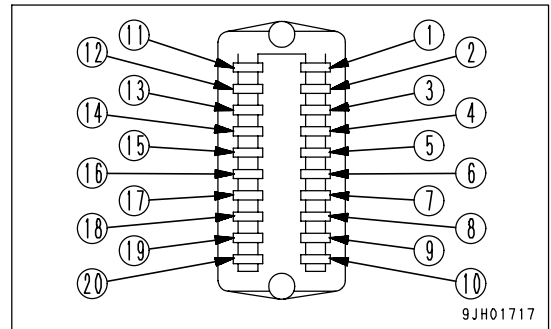

CIRCUIT BREAKER

NOTICE

When resetting the circuit breaker, always turn the starting switch OFF first.

- If the starting switch does not work even when the starting switch is turned ON, open the circuit breaker box inside the grease pump box at the front right of the machine and carry out inspection.
- If an excess current is generated, the circuit breaker cuts off electrical current to protect electrical components and wiring from damage. To return the circuit electrical current to normal after it has been cut off, push in the reset button.
If the electric circuit is working normally, the reset button remains in. If the reset button pops out again immediately after it is pushed in, it is necessary to check the electric circuit.

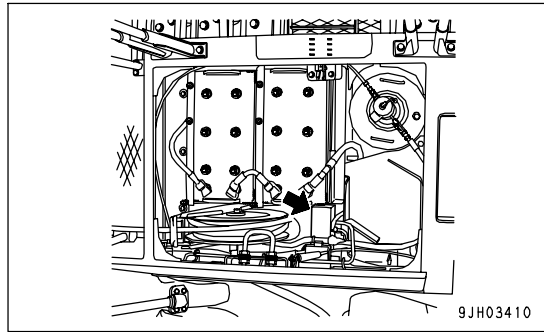

REMARK

- The circuit breaker is a circuit protection device installed to circuits where large current flows. It protects the electrical components and wiring from damage caused by an abnormal current in the same way as a normal fuse. After repairing and restoring the location of the abnormality, there is no need to replace the breaker. It can be used again.
- If the starting motor does not work even when the starting switch is turned to the ON position, breaker (8), (9) has probably cut off the circuit, so check and restore circuit breaker (8), (9).
- If the electrical equipment does not work even when the fuse is replaced, breaker (1) or (11) has probably cut off the circuit, so check and restore circuit breaker (1) or (11).

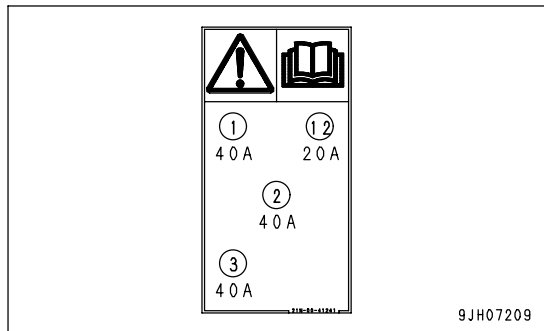

No.	Fuse capacity	Name of circuit
(1)	40A	Fuse box
(2)	40A	Circuit breaker No. 4 - 7
(3)	40A	Circuit breaker No. 8 - 11
(12)	20A	Electric priming pump switch timer

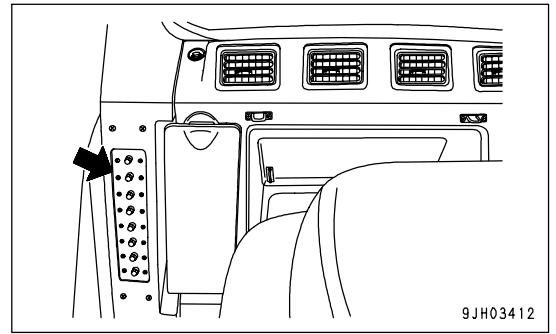

No.	Fuse capacity	Name of circuit
(4)	20A	Monitor
(5)	20A	Working lamp, right front light of machine
(6)	20A	Pump controller
(7)	20A	Cab upper head lamp
(8)	20A	Starting switch
(9)	20A	Engine controller (direct from battery)
(10)	20A	Monitor (direct from battery)
(11)	20A	Fuse box (direct from battery)

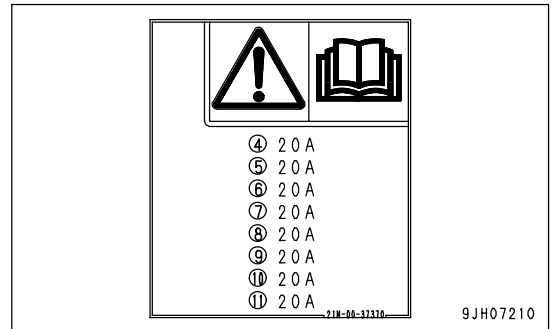

CONTROLLER

Controller installed.

NOTICE

- Be careful not to get water, mud, or juice on the controller. This will cause failure.
 - The engine controller has been given moisture prevention treatment, so there is no problem if rain gets on it, but do not spray it with water when washing the machine.
 - If any abnormality occurs in the controller, do not disassemble it yourself. Contact your Komatsu distributor for repairs.
- Engine controller
This is under the fuel pre-filter inside the engine room.

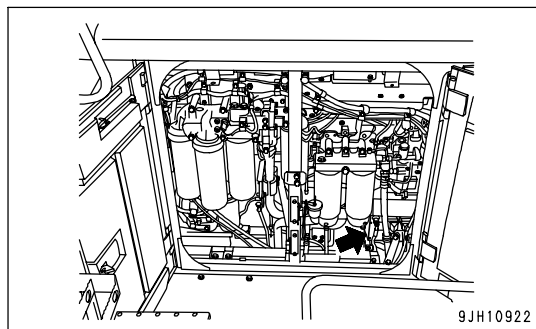

- Pump controller
This is on the rear of the operator's seat.

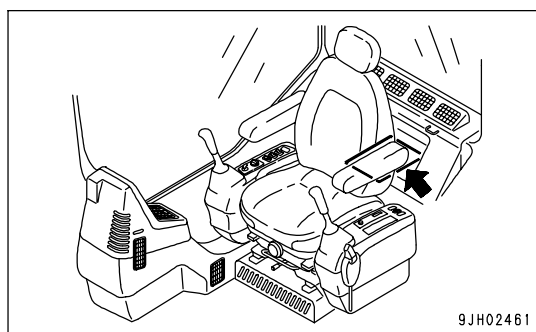

TOOL BOX

(Cloth bag)

Open the door of the tool box at the rear of the cab. The cloth bag is stored inside the box.

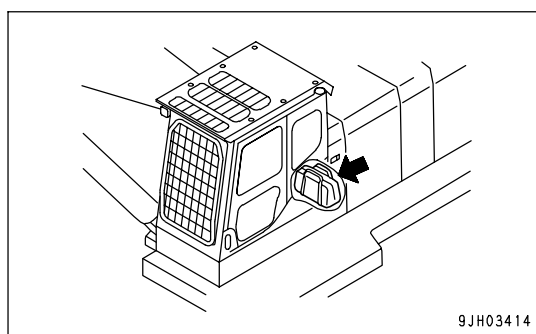

GREASE PUMP

This is stored inside the grease pump box on the right side of the chassis.

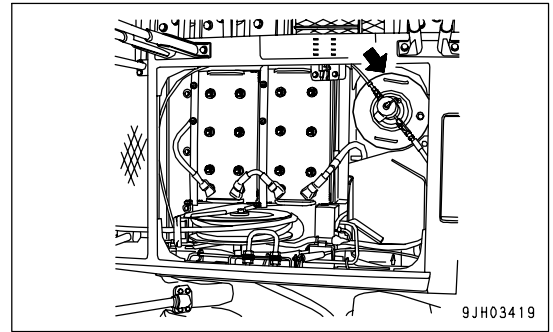

Method of Use

1. Open cover (1).
2. Rotate the lever of valve (2) upward 90° to set it to the (A) position.
3. When the lever of grease gun (3) is pulled, grease is discharged and the pump also starts automatically.
4. When the lever of grease gun (3) is released, the supply of grease stops.
5. After using, rotate the lever of valve (2) downward 90° to set it to the (B) position.

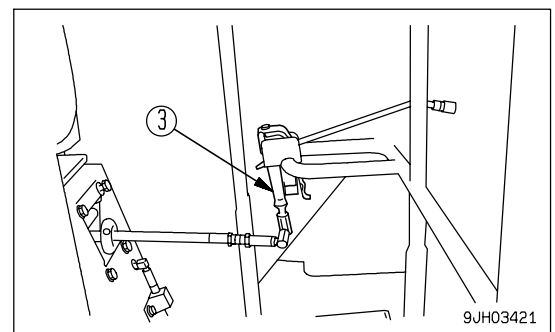
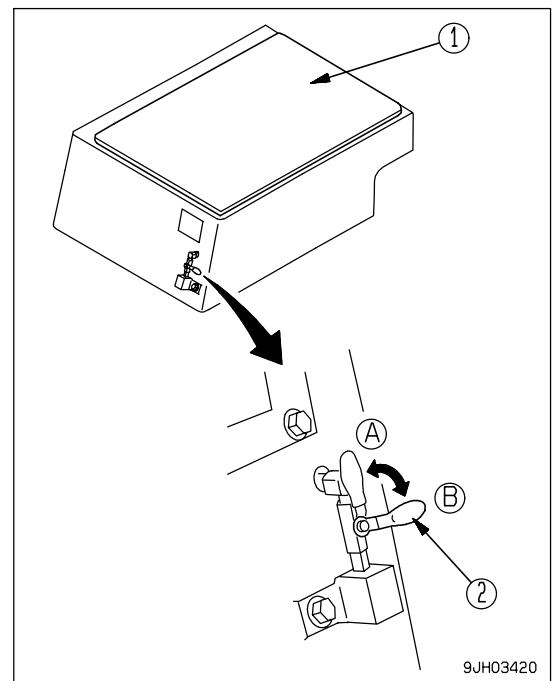

Precautions when Using

NOTICE

When not using the grease pump, always rotate the lever of valve (2) down 90° to set it to the (B) position to prevent internal pressure from forming inside grease gun (3).

- Set so that the grease fitting and the nozzle at the tip of the grease gun are perpendicular.

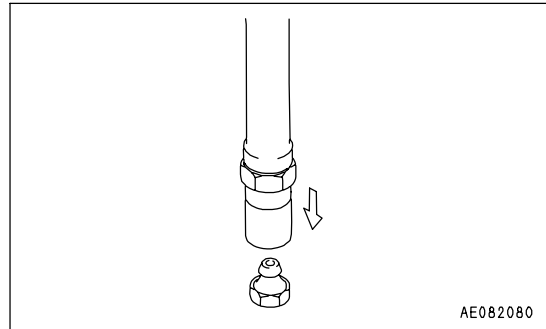

- When removing the nozzle at the tip of the grease gun from the nipple, carefully angle the tip of the nozzle slightly and remove it.
- When there is only a small amount of grease left in the grease can, the pump will not pump out grease, so move the grease to the center or fill the can with new grease.

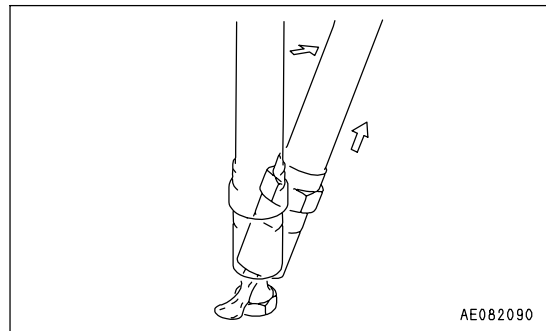

Supplying Grease

1. Remove 3 wing bolts (2) from grease can (1), then remove cover (3) from the pump.
2. Remove follow plate (4) inside the grease can.

REMARK

If the hollow in the center of the follow plate is not fully filled with grease, air will be sucked in and it may not be possible to use all the grease.

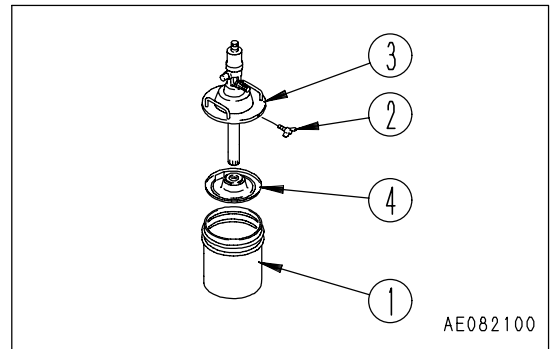

3. Fill grease can (1) with fresh grease, set follow plate (4) on top of the grease so that it is horizontal, then push down by hand until grease comes out from the packing in the center of follow plate (4).

- When setting the follow plate on top of the grease, fill the inside of the raised part in the center of the follow plate with grease. This will make the operation go more smoothly.

4. Insert the pump into the packing at the center of follow plate (4), set cover (3) on grease can (1), then tighten 3 wing bolts (2) uniformly to hold in position.

- The pump will operate for a short time and then stop, but the first grease includes air inside the pump, so it is cloudy white and not suitable for use.

5. Loosen check valve (5), and pump out all the grease which has air in it from hole (6) at the bottom of check valve (5).

6. After bleeding the air, close check valve (5) securely.

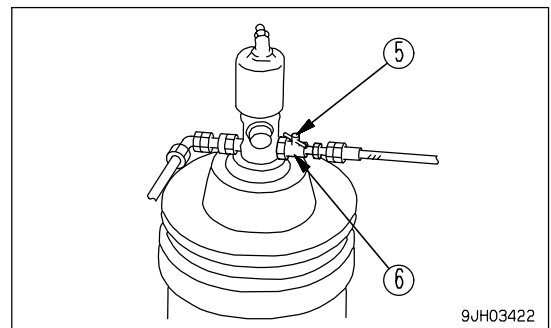
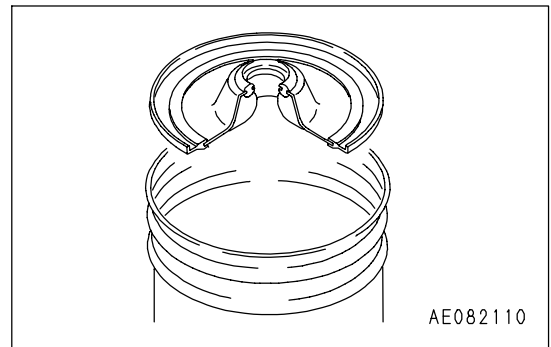

7. After bleeding the air inside the pump, pull the lever of the grease gun to completely discharge the grease mixed with air inside the hose and grease gun.

- When filling with grease, be extremely careful not to let sand or dirt stick to the follow plate or pump suction portion.
- If there is ample grease, but the pump does not pump out any grease, the follow plate may not be correctly set in position, so set it in position again correctly.
- The standard grease can contains 16 liters (4.23 US gal). If an 18 liters (4.76 US gal) can is used, there will be more grease left.

REMARK

Put the spare grease can beside the grease pump in the grease pump box at the right side of the machine.

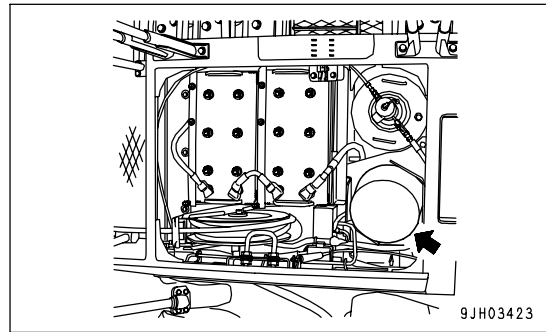

MACHINE OPERATIONS AND CONTROLS

BEFORE STARTING ENGINE

Walk-around Checks

Before starting the engine, walk around the machine and look at the underside of chassis for anything unusual like loose bolts and nuts, leakage of fuel, oil and coolant. Also check the condition of the work equipment and the hydraulic system.

Also check for loose wiring, play, and collection of dust at places that reach high temperature.



WARNING

Remove any flammable materials from around the battery, engine, muffler, turbocharger, or other high temperature engine parts. Leakage of fuel or oil will cause the machine to catch fire. Check carefully, be sure to repair any problem, or contact your Komatsu distributor.

Perform the following inspections and cleaning every day before starting engine for the day's work.

1. Check for damage, wear, play in work equipment, cylinders, linkage, hoses
Check for cracks, excessive wear, play in work equipment, cylinders, linkage, and hoses. If any problem is found, repair it.
2. Remove dirt and debris from around the engine, battery, and radiator.
Check for dirt accumulated around the engine and radiator. Also check for flammable material (dry leaves, twigs, etc.) around the battery, engine muffler, turbocharger, or other high temperature engine parts. If any dirt or flammable materials are found, remove them.
For the method of removing dirt from the radiator, see "CLEAN,CHECK RADIATOR FINS,OIL COOLER FINS,FUEL COOLER FINS,AFTERCOOLER FINS,CONDENSER FINS (machines equipped with air conditioner),PTO OIL COOLER (PAGE 4-56)".
3. Check for coolant and oil leakage around the engine
Check for oil leakage from the engine and coolant leaks from the cooling system. If any problem is found, repair it.
4. Check for leakage from fuel line.
Check that there is no leakage of fuel or damage to the hoses and tubes. If any problem is found, carry out repairs.
5. Check for oil leakage from hydraulic equipment, hydraulic tank, hoses, and joints
Check for oil leakage. If any problem is found, repair the area where oil is leaking.
6. Check the undercarriage (track, sprocket, idler, guard) for damage, wear, loose bolts, or leakage of oil from rollers.
If any problem is found, repair it.
7. Check for problems in handrails, steps, loose bolts.
If any problem is found, repair it. Tighten any loose bolts.

8. Check for problem in gauges, monitor.

Check for problem in the gauges and monitor in the operator's cab. If any problem is found, replace the parts. Clean off any dirt from the surface.

9. Clean, check rear view mirror

Check that there is no damage to the rear view mirror. If it is damaged repair. Clean the surface of the mirror and adjust the angle so that the area at the rear can be seen from the operator's seat.

10. Seat belt and mounting clamps

Check for damage or wear to the seat belt and mounting clamps. If there is any damage, replace with new parts.

11. Check stopper plate

Check that there is no abnormality in the stopper plate. If any abnormality is found, clean it or replace it with a new part.

Checks Before Starting

Always check the items in this section before starting the engine each day.

Check Coolant Level, Add Coolant



WARNING

- Do not open the radiator cap unless necessary. When checking the coolant, always wait for the engine to cool down and check the sub tank.
- Immediately after the engine is stopped, the coolant is at a high temperature and the radiator is under high internal pressure. If the cap is removed to check the coolant level in this condition, there is a hazard of burns. Wait for the temperature to go down, then turn the cap slowly to release the pressure and remove it carefully.

1. Open cover (1) of the sub tank inspection window at the front of the radiator side (right side of machine) of the engine hood, and check that the coolant level is between the FULL and LOW lines on the two sub tanks (2). If the coolant level is low, add water through the water filler to sub tanks (2) to the FULL level.
2. After adding coolant, tighten the cap securely.
3. If the sub-tank is empty, check for water leakage, and check the water level in the radiator. If the cooling water is insufficient, supply water to the radiator and then to the sub-tank.

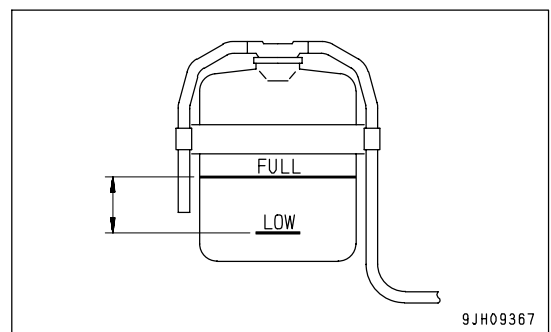
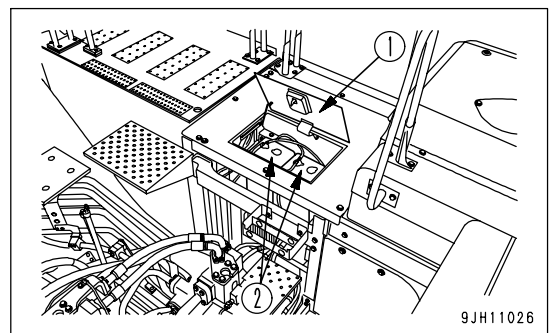

REMARK

- When adding water to the radiator, remove cover (3), then loosen radiator cap (4) slowly. After checking that the pressure has been released, push in the cap, keep it pushed in, then loosen it further and remove it.
- Check that the level of the coolant is above the hatched portion in the diagram on the right. If the water level is low, add water through the water filler port.
- After adding water, install radiator cap (4).
When operating in cold areas, see "COLD WEATHER OPERATION (PAGE 3-149)"

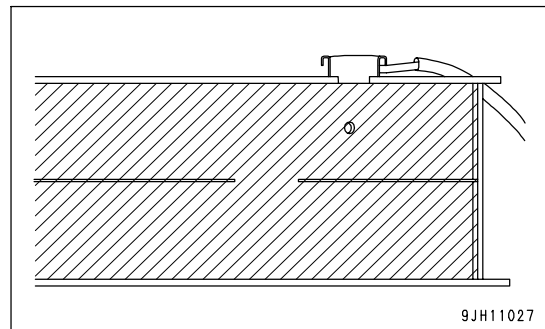
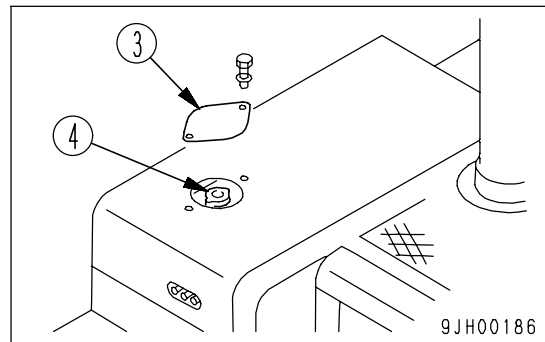

Check Oil Level in Engine Oil Pan, Add Oil

**WARNING**

Parts and oil are at high temperature immediately after the engine is stopped and may cause serious burns. Wait for the oil temperature to go down before performing this operation.

1. Open the engine room door.
2. Remove dipstick (G), and wipe the oil off with a cloth.
3. Fully insert dipstick (G) into filler pipe (F), then remove it.

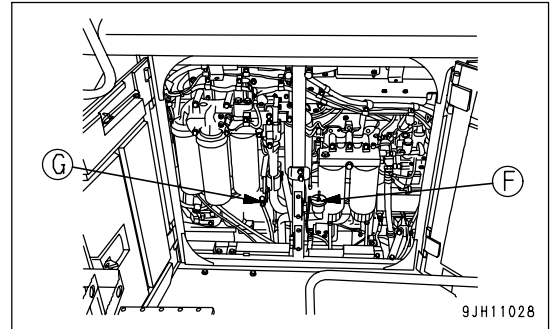

4. The oil level should be between the H and L marks on the ENGINE STOPPED side of dipstick (G).
If the oil level is below the L mark, add oil through oil filler (F).

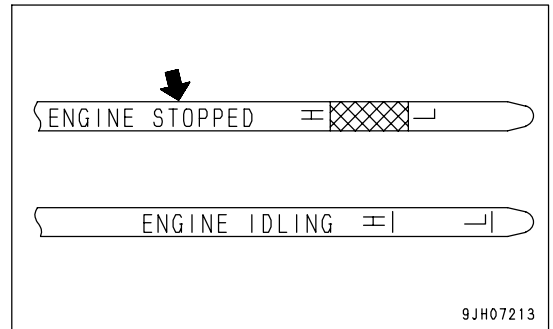

5. If the oil level is above the H mark on the gauge, drain the excess oil from drain valve (P) at the bottom of the engine oil pan, then check the oil level again.
6. If the oil level is correct, tighten the oil filter cap securely.

REMARK

When checking the oil level after the engine has been operated, wait for at least 15 minutes after stopping the engine before checking.

If the machine is at an angle, make it horizontal before checking.

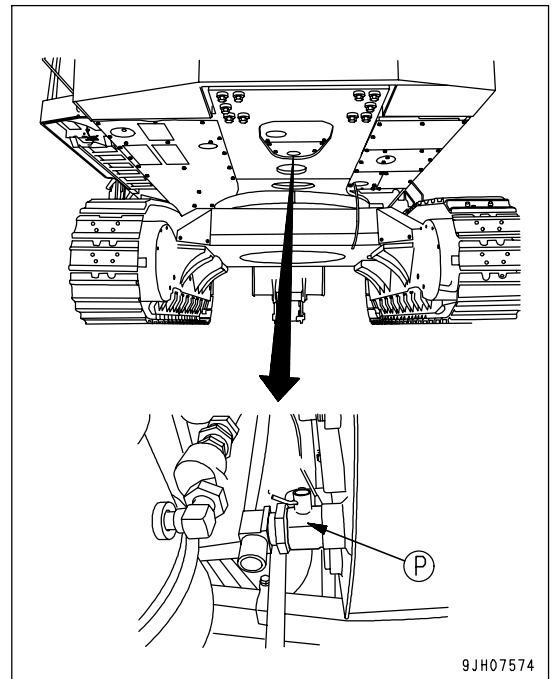

Check Fuel Level, Add Fuel



When adding fuel, never let the fuel overflow. This may cause a fire. If any fuel is spilled, wipe it up completely. Never bring flames near fuel because it is highly flammable and dangerous.

1. Open fuel filler cap (F) of the fuel tank.
2. When fuel filler cap (F) is opened, float gauge (G) comes up in proportion to the remaining fuel level in the tank. Check that the fuel tank is full. Inspect the fuel level both visually and with float gauge (G).
3. If the fuel tank is not full, add fuel through the fuel filler until float gauge (G) rises to the maximum position. Fuel tank capacity: 1360 liters (359.31 US gal) Position of tip (a) of float gauge (G) when fuel tank is full: Approx 50 mm (2 in)

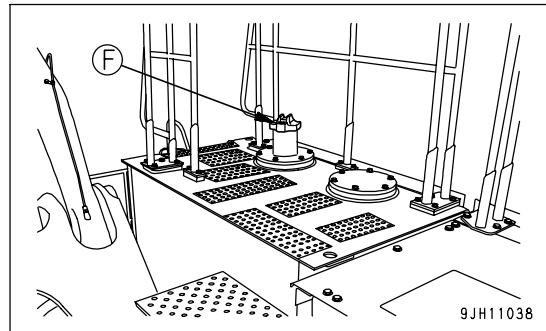

4. After refilling with fuel, push float gauge (G) straight down with fuel filler cap (F) and then tighten the cap securely.

REMARK

If breather hole (1) in the cap is clogged, the pressure in the tank will drop and fuel will not flow. Clean the hole from time to time.

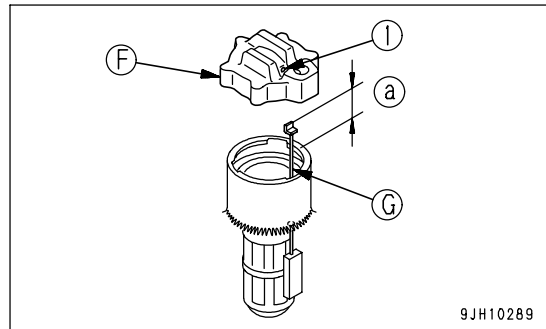

Check for Water and Sediment in Water Separator, Drain Water

1. Open the engine room door.
2. The water separator forms one unit with fuel pre-filter (1).

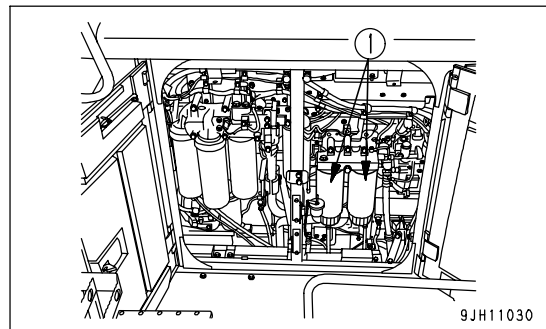

3. It is possible to judge the water level and amount of sediment by looking through transparent cap (2). If there is any water or sediment collected at the bottom, set a container to catch the drain water under drain hose (3).
4. Loosen drain valve (4) and drain the water.
5. When fuel starts to drain from drain hose (3), tighten drain valve (4) immediately. Tightening torque: 0.2 to 0.45 Nm (0.02 to 0.046 kgm, 0.1 to 0.3 lbft)

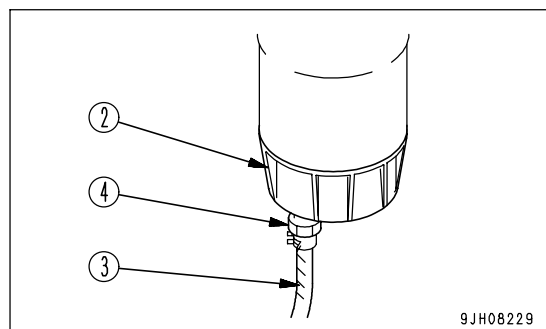

Check Oil Level in Hydraulic Tank, Add Oil

**WARNING**

- The parts and oil are at high temperature immediately after the engine is stopped, and may cause burns. Wait for the temperature to go down before starting the work.
- When removing the oil filler cap, turn it slowly to release the internal pressure, then remove it.

1. Set the work equipment in the posture shown in the diagram on the right, then check the oil level and add oil if necessary.
2. If the work equipment is not in the condition shown in the diagram on the right, start the engine, run the engine at low speed, retract the arm and bucket cylinder rods fully, then lower the boom, set the bucket teeth in contact with the ground, and stop the engine.
3. Within 15 seconds after stopping the engine, move each control lever (for work equipment and travel) to the full stroke in all directions to release the internal pressure.
4. Check oil level gauge (G) at the rear of the hydraulic tank. The oil level should be within the specified range for that oil temperature. If the oil level is low, add oil.

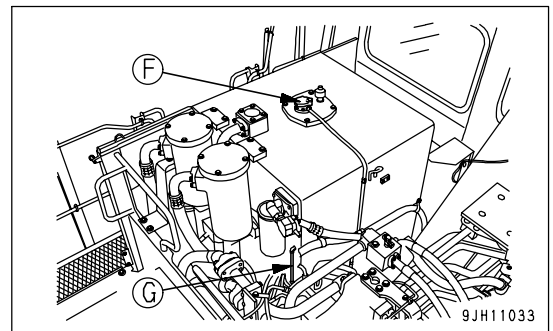
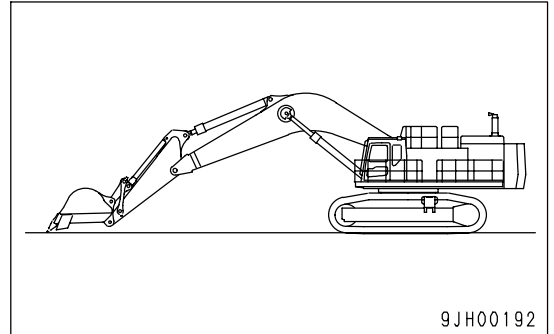

The proper way to check the hydraulic oil level is as follows.

- When the hydraulic oil is at normal temperature (15°C to 30°C), the oil level should be within the blue range of gauge label (a) in the diagram on the right.
 - When the hydraulic oil is at high temperature (50°C to 80°C), the oil level should be within the red range of gauge label (b) in the diagram on the right.
5. If the level is below the correct line, add oil through filler port (F) at the top of the hydraulic tank.

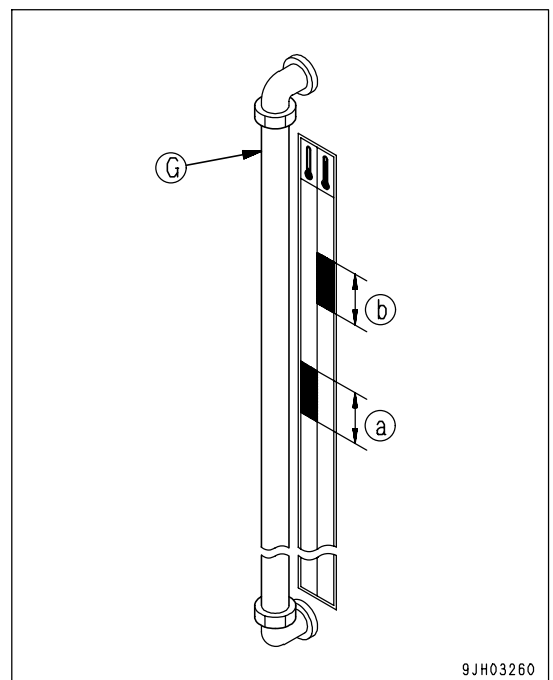

NOTICE

Do not add oil above the correct level. This will damage the hydraulic circuit and cause oil to spurt out.

If oil is added above the correct level, remove plug (1) under the chassis, then loosen drain valve (P) and drain the excess oil.

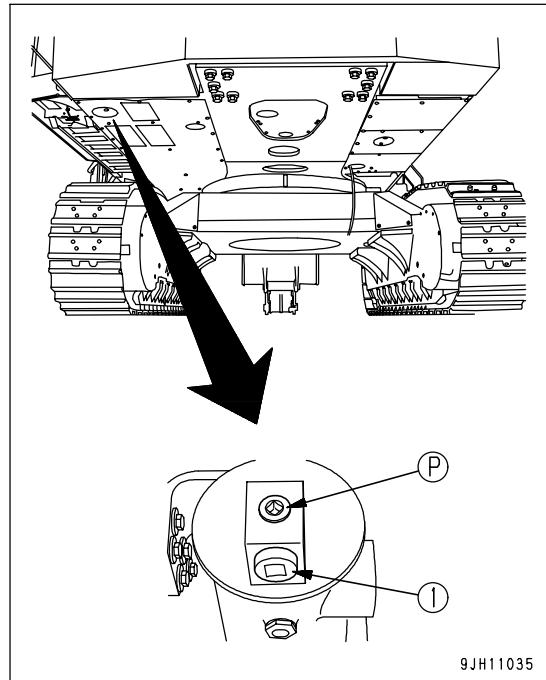

Check Oil Level in Swing Machinery Case, Add Oil

**WARNING**

Parts and oil are at high temperature immediately after the engine is stopped and may cause serious burns. Wait for the oil temperature to go down before performing this operation.

There are 2 swing machinery cases: one at the front of the swing circle and the other at the rear.

Swing machinery at front of machine

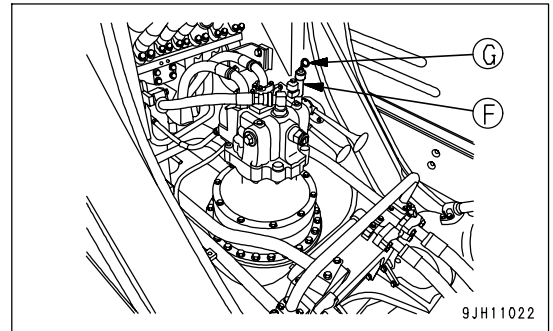

Swing machinery at rear of machine

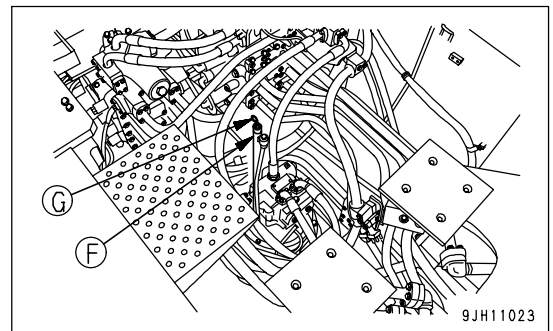

1. Remove dipstick (G) and wipe the oil from the dipstick with a cloth.
2. Fully insert dipstick (G) into the filler pipe.
3. Pull out dipstick (G) and check that the oil level is between the (H) and (L) marks on the dipstick.
4. If the oil does not reach the (L) mark on dipstick (G), add oil through dipstick insertion hole (F).

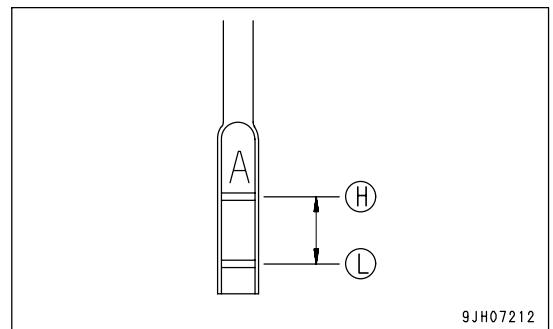

5. If the oil level is above the (H) mark on dipstick (G), loosen drain valve (P) and drain the excess oil.
- When draining the oil, first pull hose (1) out from inspection hole (2), then loosen the drain valve (P).

Swing machinery at front of machine

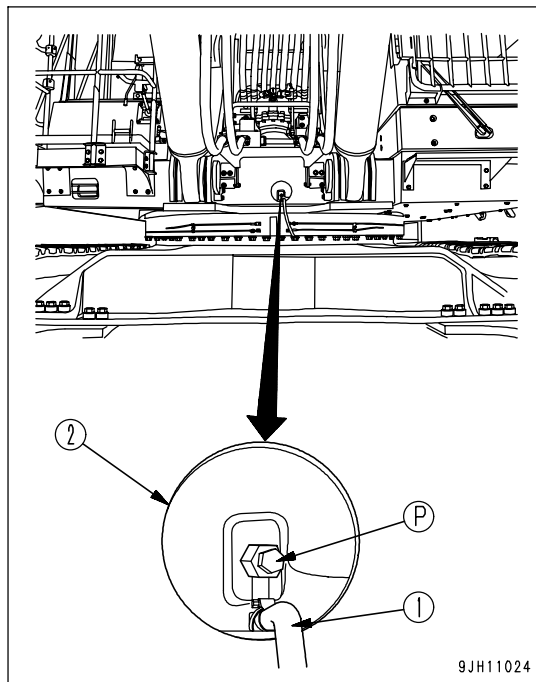

Swing machinery at rear of machine

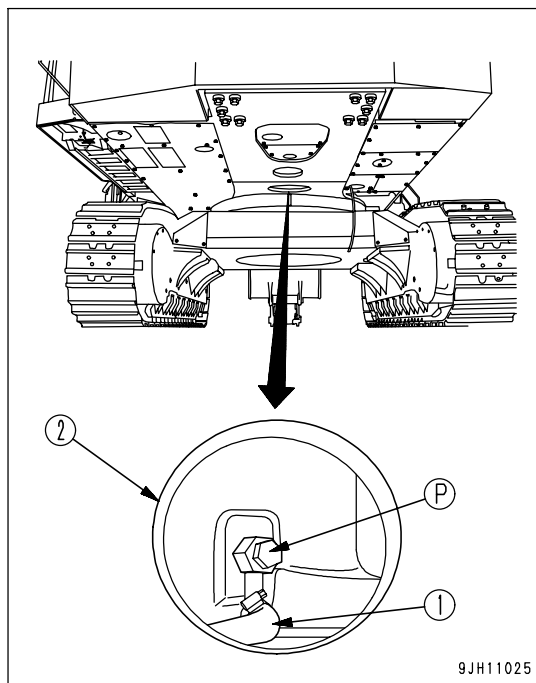

6. After checking oil level or adding oil, fully insert dipstick (G) into the filler pipe.

Check Oil Level in PTO Case, Add Oil

**WARNING**

Parts and oil are at high temperature immediately after the engine is stopped and may cause serious burns. Wait for the oil temperature to go down before performing this operation.

NOTICE

Park the machine on flat ground and stop the engine. After waiting for more than 30 minutes after stopping the engine, check the oil level.

1. Open the door of the air cleaner room.
2. Remove dipstick (G), and wipe the oil off with a cloth.
3. Fully insert dipstick (G) into filler pipe (F), then remove it.

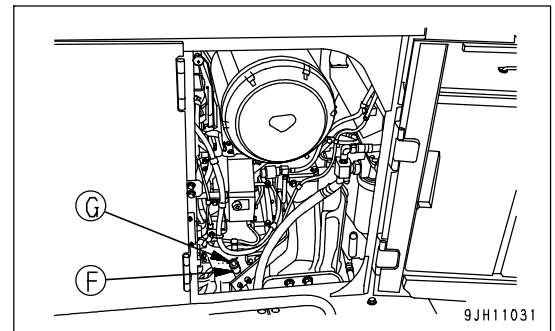

4. The oil level should be between the H and L marks on the ENGINE STOPPED side of dipstick (G).
If the oil level is below the L mark, add oil through oil filler (F).
5. If the oil level is above the H mark on the gauge, drain the excess oil. For details, see Steps 1 - 2 of "CHANGE OIL IN PTO CASE (PAGE 4-68)".

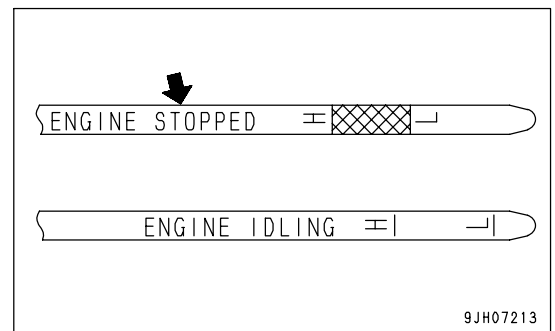
**NOTICE**

If the oil level is too high, always drain the excess oil to bring the oil to the correct level. Failure to do this will cause overheating.

Check Air Cleaner For Clogging

1. Confirm that the air cleaner clogging monitor does not light up.
2. If it lights up, immediately clean or replace the element.

For details of method of cleaning the element, see "CHECK, CLEAN AND REPLACE AIR CLEANER ELEMENT (PAGE 4-17)".

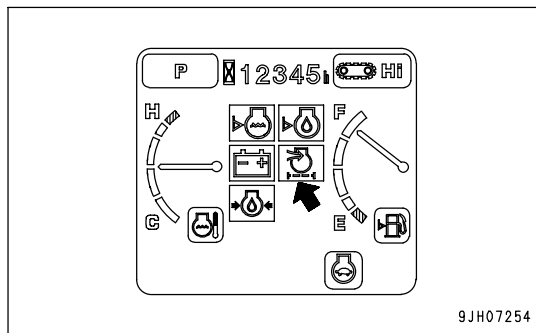

9JH07254

REMARK

Dust indicator (1) gives a guideline for the cleaning interval for the air cleaner element. If the yellow piston on the inside overlaps the red zone on the outside circumference of dust indicator (1), it is time to clean the element.

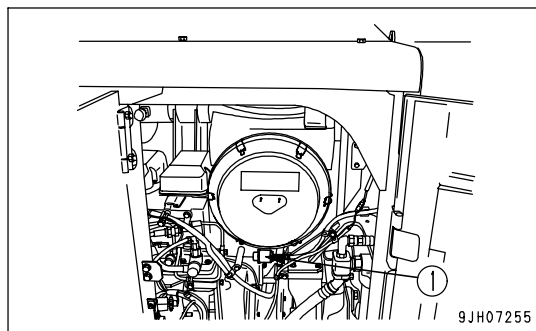

9JH07255

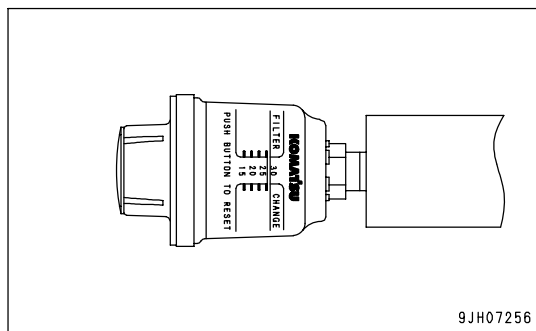

9JH07256

Check Working Lamp Switch

Check that the working lamps and lamps inside the instruments light up properly. Check also that there is no dirt or damage.

If any lamp does not light up, the bulb is probably blown up or there is a disconnection, so ask your Komatsu distributor to carry out repairs.

1. Turn the starting switch to the ON position.
2. Set the lamp switch to ON position (a) and check that the working lamp lights up.

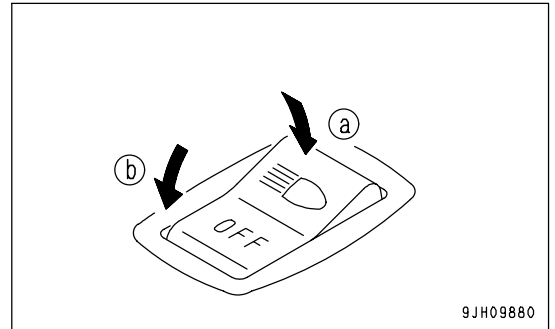

Check Electric Wiring



CAUTION

- If fuses are frequently blown or if there are traces of short-circuiting on the electrical wiring, promptly ask your Komatsu distributor to locate the cause and make the repair.
- Keep the top surface of the battery clean and check the breather hole in the battery cap. If it is clogged with dirt or dust, wash the battery cap to clear the breather hole.

Check that there is no damage to the fuses; that fuses of the specified capacity are used; that there is no disconnection or trace of short-circuiting in the electric wiring and no damage to the covering. Check also that there is no loosened terminals. If any, tighten them.

Moreover, pay particular attention to the electric wiring when checking the battery, engine starting motor and alternator.

Be sure to check that there is no inflammable material accumulated around the battery. If any is found, remove immediately.

Check Function of Horn

1. Turn the starting switch to the ON position.
2. Press the horn switch and check that the horn sounds immediately.

Note that if the air tank is empty or the water drain valve in the air tank is at the OPEN position, the horn will not sound. Check that the water drain Valve is at the CLOSE position, start the engine and wait for 1 or 2 minutes, then press the horn switch again to check if it sounds.

If the horn still does not sound, please contact your Komatsu distributor for repairs.

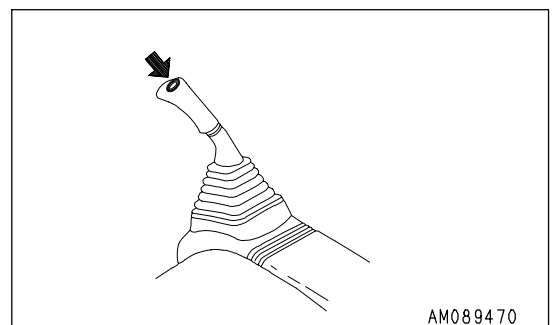

Drain Water And Sediment from Fuel Tank

1. Set a container under the drain hose to catch the drained fuel.
2. Pull out drain hose (1) from hole (2) in the cover.
3. Turn drain valve (3) to the OPEN position (O) and drain all the sediment and water accumulated at the bottom together with the fuel.
4. When clean fuel comes out, turn drain valve (3) to the CLOSE position (S).

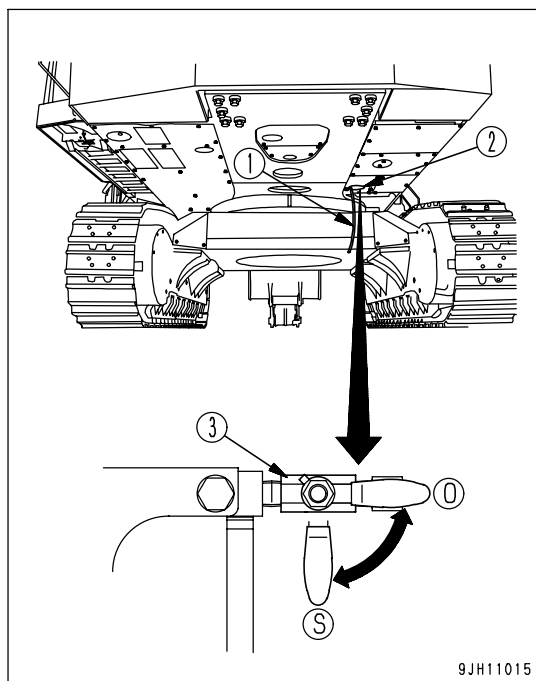
**Drain Water from Air Tank**

1. Set air tank drain valve (1) under the chassis to the OPEN position (O) and drain in the water accumulated inside the air tank.
2. When no more water comes out, set drain valve (1) to the CLOSE position (S).

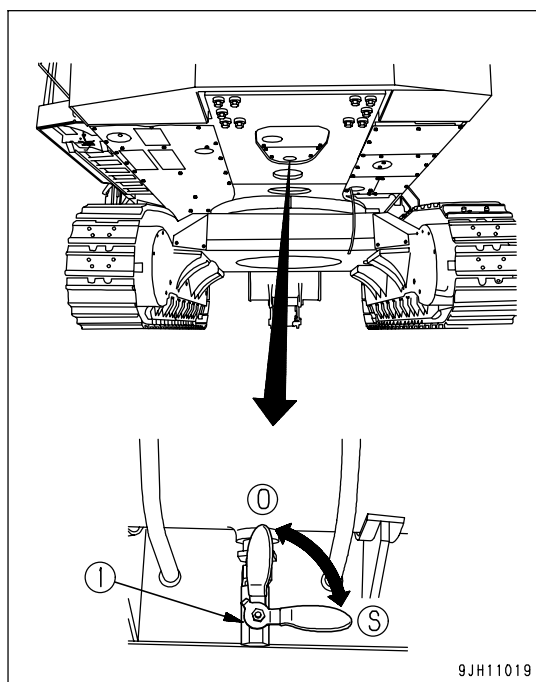

Adjustment

Seat Adjustment



WARNING

When adjusting the position of the operator's seat, always set the lock lever to the LOCK position to prevent any accidental contact with the control levers.

- Always adjust the operator's seat before starting each operation or when the operators change shift.
- Adjust the operator's seat so control levers and switches can be operated freely and easily with the operator's back against the backrest.

(A) Fore-and-aft adjustment

Pull lever (1) up, set the seat to the desired position, then release the lever.

Fore-and-aft adjustment: 160 mm (6.3 in) (16 stages)

(B) Adjusting reclining

REMARK

The seat can be reclined more when the seat is pushed to the front. The amount of reclining decreases as the seat is pushed back, so when moving the seat back, return the seatback to the upright position.

Pull up lever (2) and set the backrest to a position that is comfortable for operation, then release the lever.

Sit with your back against the seat backrest when adjusting. If your back is not against the backrest, the backrest may suddenly move forward.

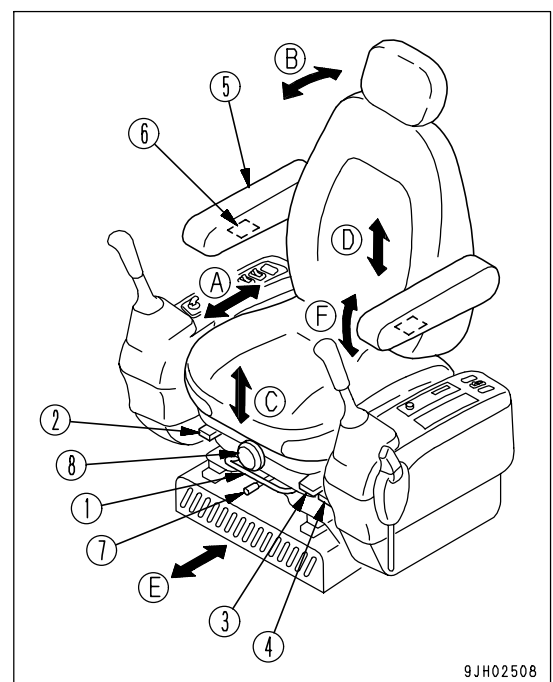

9JH02508

(C) Adjusting seat tilt

- Forward tilt

Push lever (3) down to adjust angle of the front of seat. (4 stages)

- To raise the angle at front of the seat, keep the lever pushed down and apply your weight to the rear of seat.
- To lower the angle at front of the seat, keep the lever pushed down and apply your weight to the front of seat.

- Rear tilt

Pull lever (4) up to adjust angle of the rear of seat. (4 stages)

- To raise the angle at rear of the seat, keep lever (3) pulled up, and stand up slightly to remove your weight from the seat.
- To lower the angle at rear of the seat, keep lever (3) pulled up, and apply your weight to the seat.

Amount of tilt: Up 13°, down 13°

- Adjusting seat height

It is possible to move the seat up or down by combining adjustments forward tilt and rear tilt.

After setting the forward tilt or rear tilt to the desired height, operate the opposite part to set the seat horizontal then secure in position.

Height adjustment: 60 mm (2.4 in)

(D) Adjusting armrest angle

Armrest (5) can be made to spring up by hand approx. 90°.

In addition, by turning the bottom (6) of the armrest by hand it is possible to make fine vertical adjustments of the armrest angle.

Armrest adjustment angle: 25°.

REMARK

- If the seat back is tipped to the front without raising the armrest(5), armrest will rise automatically.
- If the cable at the rear of armrest (5) is tense (when the seat back is tipped to the front), armrest (5) cannot be adjusted by turning dial (6). When adjusting the angle of armrest (5), set the seat back to a position where it is easy to carry out operations, then adjust the armrest.

(E) Overall fore-and-aft adjustment of seat

Move lever (7) to right, set to the desired position, then release the lever. In this case, the operator's seat, left and right control levers, and lock lever all slide together.

Fore-and-aft adjustment:180 mm (7.1 in) (9 stages)

(F) Adjusting suspension

Turn knob (8) to the right to make the suspension harder, or to the left to make the suspension softer. Adjust the reading of the dial to match the operator's weight and select the optimum suspension.

REMARK

To obtain the optimum adjustment, turn the knob (8) so that the indicator of the weight display (kg) in the transparent portion of knob (8) is the same as the operator's weight.

Rearview Mirrors

 **WARNING**

Be sure to adjust the mirrors before starting work. If they are not adjusted properly, you cannot secure the visibility and may be injured or may injure someone seriously.

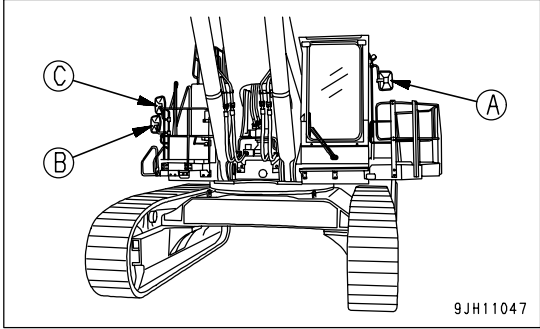

Mirror (A)

Adjust the mirror mount so that it is possible to see people at the rear left of the machine.

- Install the side view mirror in the location indicated in the figure at right.
- (L): 100 mm (3.9 in)
- Fix mirror securing stay (1) the way the side view mirror stretches outward to the maximum.
- If the side view mirror does not move smoothly when adjusting its angle, loosen mirror securing screw (2) and mirror securing stay bolt (3).

Tightening torque of screw (2): 1.5 - 2.0 Nm
(0.15 - 0.20 kgm, 1.1 - 1.4 lbft)

- When adjusting the side view mirror angle, make an adjustment so that the side of the machine comes into view on the mirror as shown in the figure at right.

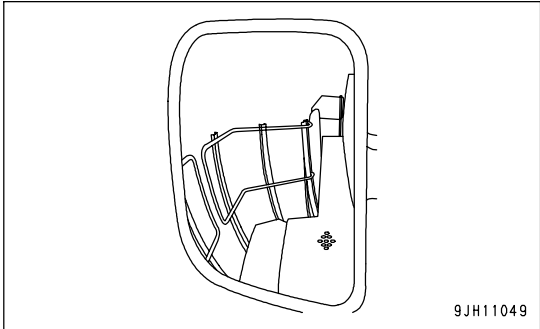
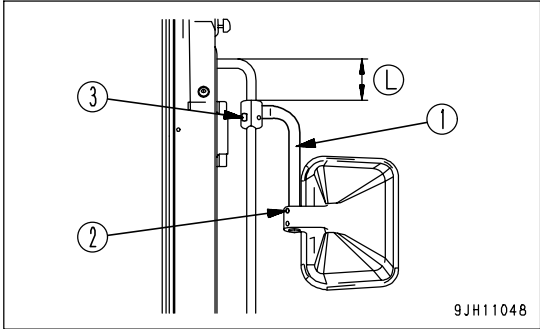

Mirror (B)

Adjust the mirror mount so that it is possible to see people at the rear right of the machine.

- Install the side view mirror in the location indicated in the figure at right.

(L): 30 mm (1.2 in)

(Q): 90°

(R): 75°

- If the side view mirror does not move smoothly when adjusting its angle, loosen mirror securing screw (4) and mirror securing stay bolt (5).

Tightening torque of screw (4): 1.5 - 2.0 Nm

(0.15 - 0.20 kgm, 1.1 - 1.4 lbft)

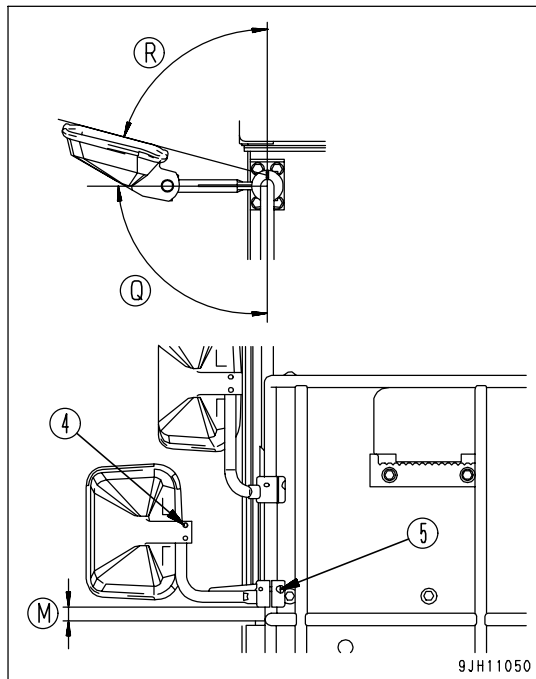

- When adjusting the side view mirror angle, make an adjustment so that the side of the machine comes into view on the mirror as shown in the figure at right.

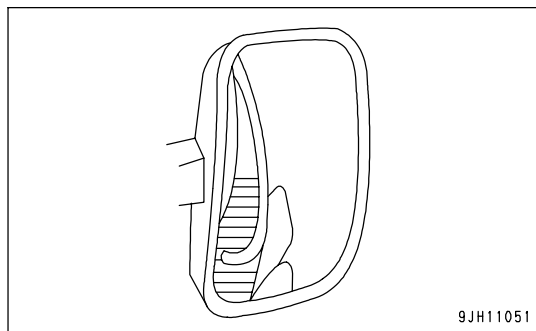

Mirror (C)

Adjust the mirror mount so that it is possible to see people at the rear right of the machine.

- Install the side view mirror in the location indicated in the figure at right.
 (L): 240 mm (9.5 in)
 (Q): 60°
 (R): 55°
- If the side view mirror does not move smoothly when adjusting its angle, loosen mirror securing screw (6) and mirror securing stay bolt (7).
 Tightening torque of screw (6): 1.5 - 2.0 Nm
 (0.15 - 0.20 kgm, 1.1 - 1.4 lbft)

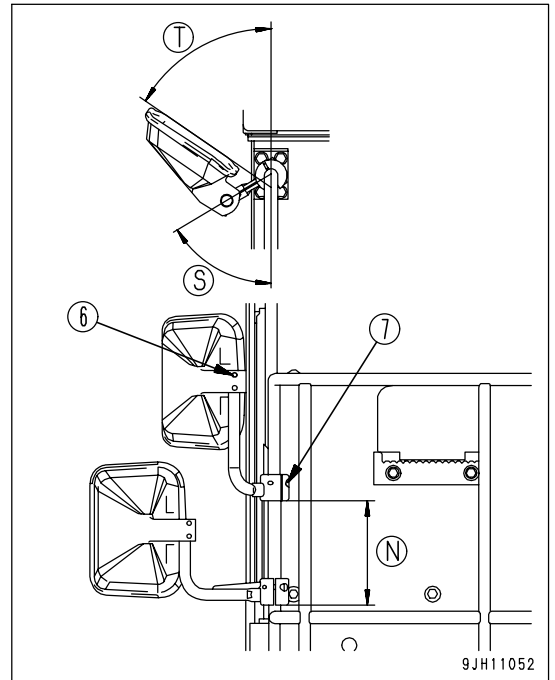

- When adjusting the side view mirror angle, make an adjustment so that the side of the machine comes into view on the mirror as shown in the figure at right.

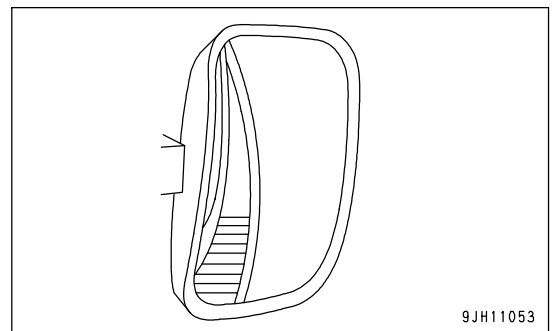

Seat Belt



WARNING

- Before fitting the seat belt, check that there is no problem in the belt mount bracket or mounting belt. If it is worn or damaged, replace the seat belt.
- Even if no problem can be seen in the belt, replace the seat belt every 3 years. The date of manufacture of the belt is shown on the back of the belt.
- Always wear the seat belt during operations.
- Fit the seat belt so that it is not twisted.

Fastening and Removing

This seat belt has a wind-in device, so it is not necessary to adjust the length.

Fastening Seat Belt

Hold grip (2) and pull the belt out from wind-in device (1), check that the belt is not twisted, then insert tongue (3) into buckle (4) securely.

When doing this, pull the belt lightly to check that it is properly locked.

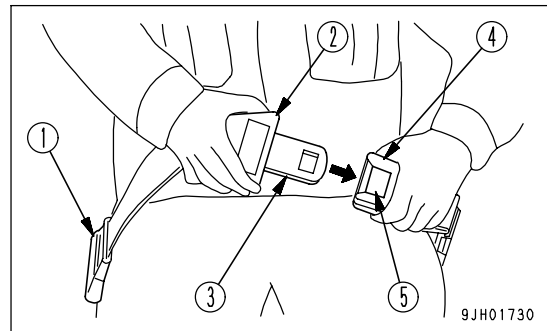

Removing Belt

Press button (5) in buckle (4), and remove tongue (3) from buckle (4).

The belt is automatically wound in, hold grip (2) and return the belt slowly to wind-in device (1).

Operations Before Starting Engine

**WARNING**

When starting the engine, check that the lock lever is securely at the LOCK position.

If the lock lever is not locked securely and the control levers or control pedal are touched when the engine is started, the machine may move unexpectedly, and this may lead to serious personal injury.

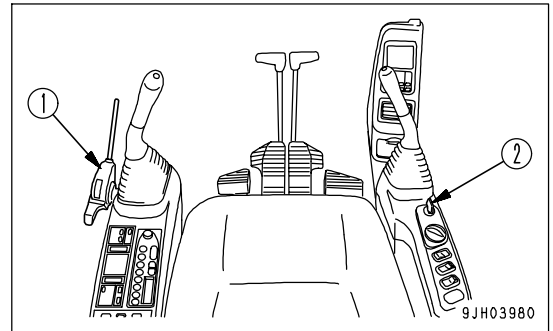

1. Check that lock lever (1) is at the LOCK position (L).
2. Check that each control lever and control pedal is at the Neutral position.

If the control levers and control pedal are not being touched, they will be at the Neutral position.

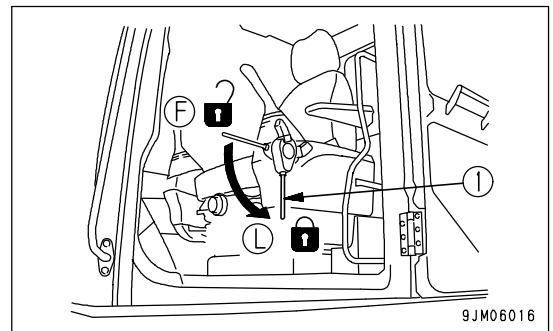

3. Insert key into starting switch (2), turn the key to ON position (B), then perform the following checks.

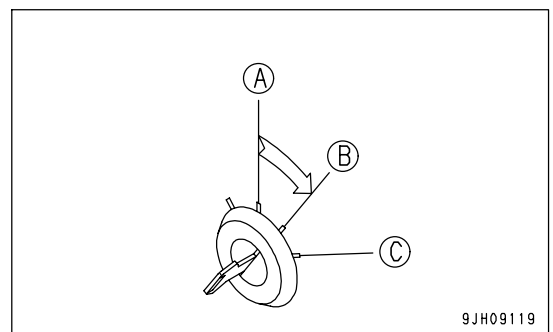

- If a password has been set, the input display screen is shown on the monitor screen.
After inputting the password, press input confirmation switch (3).

REMARK

For details of the method of setting, changing, or canceling the password, see separate "PROCEDURE FOR SETTING, CHANGING, OR CANCELING PASSWORD".

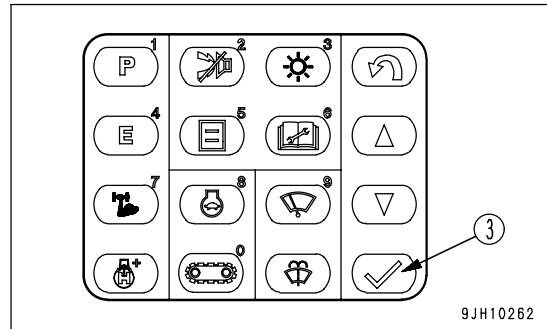
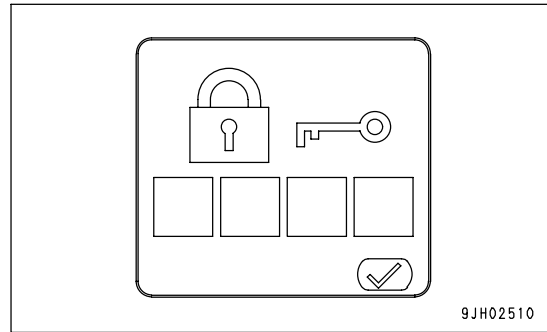

1) The buzzer sounds for approx. 1 second, and the following monitors and meters light up for approx. 3 seconds.

- Radiator coolant level monitor (4)
- Engine oil level monitor (5)
- Charge level monitor (6)
- Fuel level monitor (7)
- Engine coolant temperature monitor (8)
- Engine oil pressure monitor (9)
- Engine coolant temperature gauge (10)
- Fuel gauge (11)
- Air cleaner clogging monitor (12)

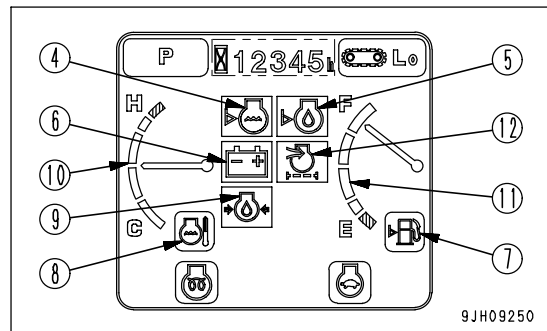

If the monitors do not light up or the buzzer does not sound, there is probably a failure in the monitor, so contact your Komatsu distributor for repairs.

2) After approx. 3 seconds, the screen switches to the working mode/travel speed display monitor. Then it switches to the normal screen.

- Fuel level monitor (7)
- Engine coolant temperature monitor (8)
- Engine coolant temperature gauge (10)
- Fuel gauge (11)
- Hydraulic oil temperature gauge (13)
- Hydraulic oil temperature monitor (14)

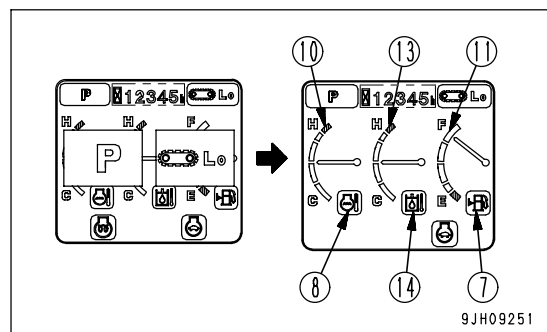

- 3) If the hydraulic oil temperature gauge goes out and caution lamp (15) stays lighted up red, perform inspection immediately for the item which is lighted up red.

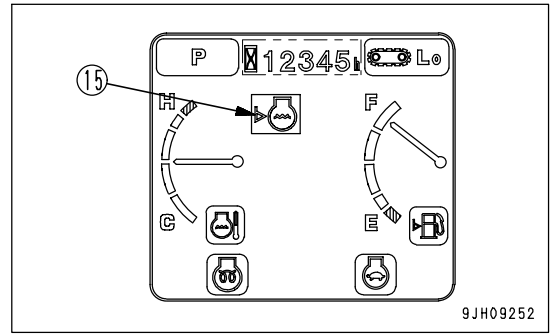

- 4) If there are any items where the maintenance time has passed, maintenance interval monitor (16) lights up for 30 seconds. Press maintenance switch (17), check the item, then perform maintenance immediately.

For details of the method of checking the maintenance interval, see "Maintenance Switch (PAGE 3-25)" in the Detailed controls and gauges.

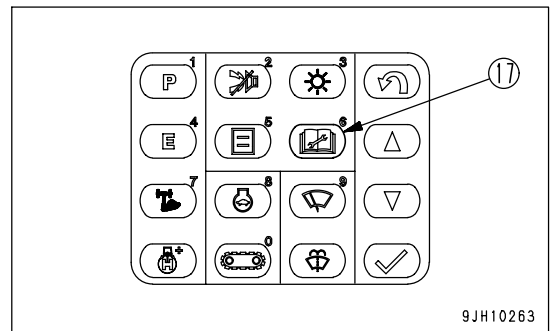
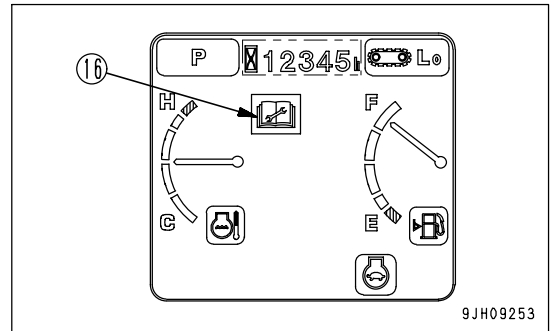

STARTING ENGINE

WARNING

- Start the engine only after sitting down in the operator's seat.
- Do not attempt to start the engine by short-circuiting the engine starting circuit. Such an act may cause a serious bodily injury or fire.
- Check that there are no persons or obstacles in the surrounding area, then sound the horn and start the engine.
- Never use starting aid fluids as they may cause explosions.
- Exhaust gas is toxic. When starting the engine in confined spaces, be particularly careful to ensure good ventilation.

NOTICE

- Before starting the engine, check that fuel control dial (2) is at the low idling (MIN) position. If the fuel control dial is at the full speed (MAX) position, the engine will accelerate suddenly and cause damage to the engine parts.
- Do not keep the key in starting switch (3) at the START position continuously for more than 20 seconds.
If the engine does not start, wait for at least 2 minutes, then start again from the beginning.
- After the engine starts, wait for the engine oil pressure monitor to go out. Do not touch the control levers or control pedal while the engine oil pressure monitor is lighted up.

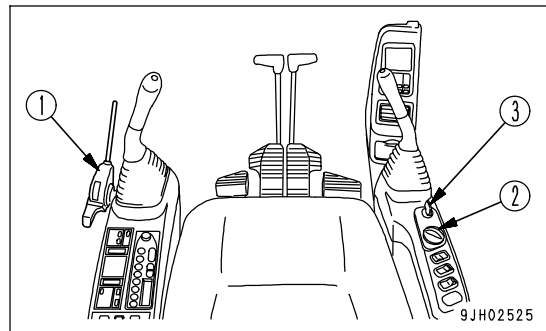

This machine is equipped with an engine automatic preheating device that functions to start the engine preheating automatically.

If the ambient temperature is low, the preheating monitor will light up when the key in starting switch (3) is turned to the ON position to inform the operator that preheating has been started automatically.

1. Check the lock lever (1) is in the LOCK position (L). If the lock lever is in the FREE position (F), the engine does not start.

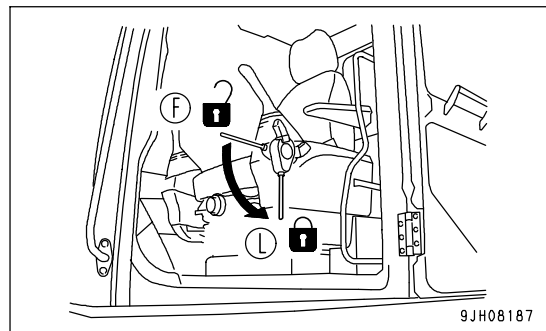

2. Set fuel control dial (2) to the low idling (MIN) position.

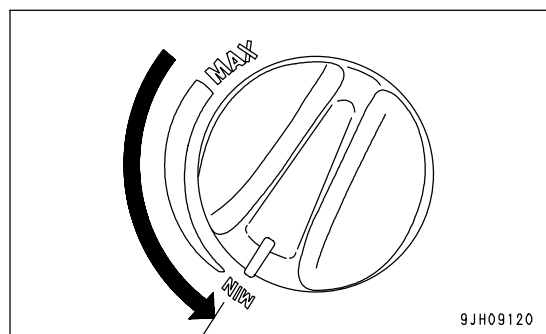

3. Turn the key in starting switch (3) to ON position (B).

If the ambient temperature is low, the preheating monitor lights up and automatic preheating is carried out. Keep the key in starting switch (3) at the ON position until the preheating monitor goes out.

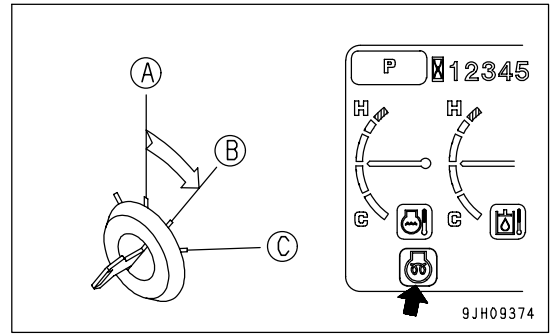

The time that the preheating monitor stays lighted up depends on the ambient temperature as shown in the table on the right.

Ambient temperature	Lighting time
Above 0 °C	0 seconds
-20 °C to 0 °C	20 seconds to 45 seconds
below -20 °C	45 seconds

4. If the preheating monitor does not light up, or it lights up and then goes out to inform that the engine preheating has been completed, turn the key in starting switch (3) to the START position (C) and start the engine.

REMARK

If the ambient temperature is low, the engine may not start even when the key in the starting switch (3) is kept at the START position for 20 seconds. If this happens, wait for at least 2 minutes, then start again from the beginning.

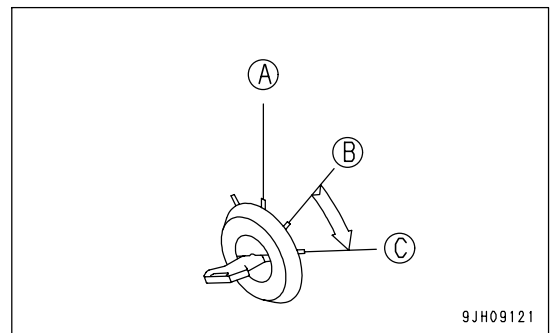

5. After the engine starts, release the key in starting switch (3). The key will automatically return to the ON position (B).

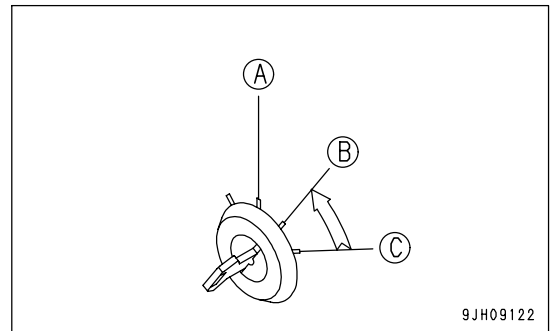

6. Even if the engine starts, wait for the engine oil pressure monitor to go out. Do not touch the control levers or control pedal while the engine oil pressure monitor is lighted up.

NOTICE

If the engine oil pressure monitor does not go out even after 4 to 5 seconds have passed, stop the engine immediately. Check the oil level, check for leakage of oil, and take the necessary action.

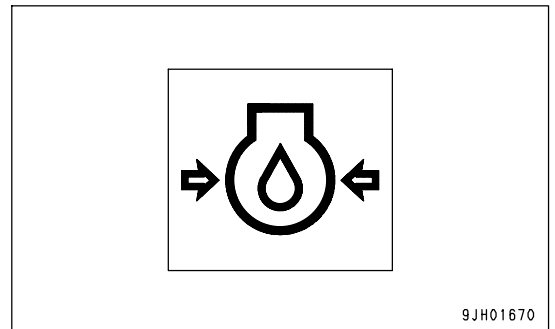

REMARK

Regardless of the ambient temperature, it is possible to start the engine preheating manually.

1. Turn the key in starting switch (3) to the left from OFF position (A). The preheating monitor lights up and engine preheating starts.

(Preheating continues while the key in starting switch (3) is held at the left position.)

- During the preheating operation, the preheating monitor lights up to show that preheating is taking place.
2. The preheating monitor starts lighting about 30 seconds after preheating starts and then goes off in about 10 seconds.
 3. After the preheating monitor goes off, turn the key in starting switch (3) to START position (C). The engine will start.

If the engine cannot be started with the above procedure, wait for at least two minutes, then start again from Step 1.

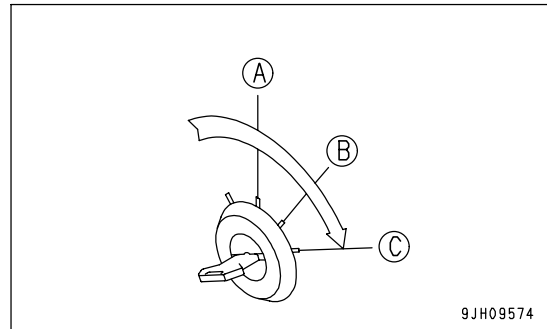
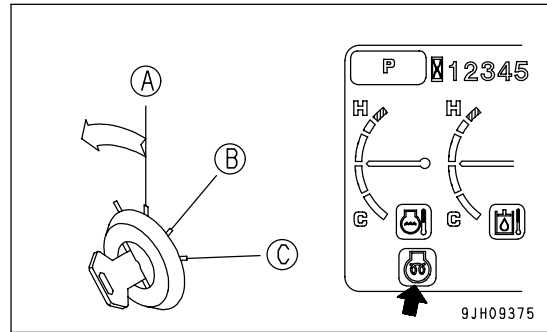
**REMARK**

Immediately after the engine is started, the engine lubricating oil pressure has not risen sufficiently, so the turbo protection function acts to prevent the engine speed from going above 1000 rpm for a maximum of 20 seconds even if the fuel control dial is operated.

AFTER STARTING ENGINE



WARNING

- **Emergency stop**
If there has been any abnormal actuation or trouble, turn the starting switch key to the OFF position.
- **Do not carry out operations or operate the levers or pedals suddenly while the hydraulic oil is at low temperature. Always carry out the warm-up operation for the hydraulic equipment until the hydraulic oil temperature monitor is displayed green.**
- **If the warm-up operation for the hydraulic equipment is not carried out thoroughly, and the machine is moved, the reaction of the control levers and pedals will be slow and the movement may not be what the operator intended. Always warm up the hydraulic equipment. In particular, in cold areas, always warm up the hydraulic equipment thoroughly.**

There are two types of warm-up operation: warm up the engine and warm up the hydraulic equipment. In addition, depending on the environment, the method of carrying out the warm-up operation may differ, so carry out the warm-up operation according to the items given in the appropriate section.

(When only the engine is warmed up, the hydraulic equipment is not warmed up, so always carry out the warm-up operation for the hydraulic equipment separately from the warm-up operation for the engine. Warm up the hydraulic equipment thoroughly ensures that the hydraulic oil is warmed up and that warm hydraulic oil circulates in all the control circuits.)

Checking of Engine Startability and Noise

When starting the engine, check that the engine causes no abnormal noise and that it starts up easily and smoothly. Check also that there is no abnormal noise when the engine is idling or when the revolution rises slightly.

- When there is an abnormal noise at the engine startup and if that condition continues, the engine may be damaged. In that case, ask your Komatsu distributor to check the engine as soon as possible.

Checking of Engine Acceleration and Deceleration

When stopping the machine during the operation, check that there is no irregular engine revolution or that the engine does not stop suddenly.

Check also that the engine speed rises smoothly when the fuel control dial is turned to the full (Max).

- Carry out these checks in a safe place, watching out for danger in the surroundings.
- When the engine performs very badly at low idling and in the acceleration and if that condition continues, the engine may be damaged or confuse the operator's sense of driving or lower the braking efficiency, and as a result lead to an unexpected accident. In that case, ask your Komatsu distributor to check the engine as soon as possible.

Engine Warm Up

NOTICE

- **Do not accelerate the engine suddenly until the warm-up operation has been completed.**
- **Do not run the engine at low idling or high idling under no load for more than 20 minutes. This will have an adverse effect on the environment, and will also have an adverse effect on the internal structure of the engine. If it is necessary to run the engine at idling for more than 20 minutes, apply a load from time to time or run at a mid-range speed.**

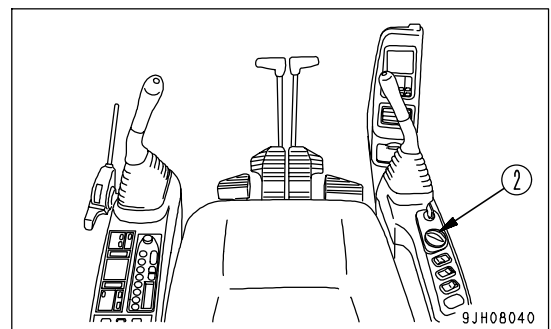

After the engine starts, do not start operating the machine immediately. First, carry out the following operations and checks.

1. This machine is equipped with an automatic engine warm-up system, so if the engine water temperature is below 30 °C after the engine is started, the engine warm-up operation starts automatically. When the engine automatic warm-up operation starts, the engine speed is maintained at a speed higher than the normal low idling speed.

If the engine water temperature goes above 30 °C or if the warm-up operation has been continued for more than 10 minutes, the automatic warm-up operation is cancelled and the engine speed drops to the normal low idling speed.

2. Check that engine water temperature monitor (1) displays green.

If it displays white, use the procedure in Step 3 to carry out additional warm up of the engine until the monitor displays green.

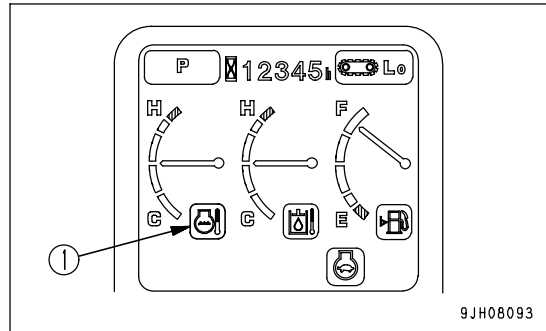

3. Turn fuel control dial (2) to a point midway between low idling (MIN) and full speed (MAX), run the engine at a mid-range speed, and run under no load until engine water temperature monitor (1) displays green.

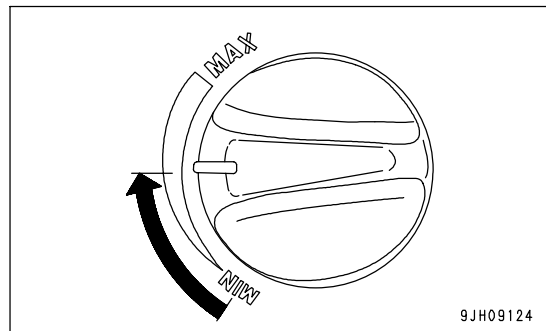

If the engine water temperature monitor displays green, the engine warm-up operation is completed. After checking that the engine water temperature monitor displays green, carry out the warming-up operation for the hydraulic equipment.

NOTICE

Canceling automatic warm-up operation

If it becomes necessary in an emergency to cancel the automatic warm-up operation or to lower the engine speed to low idle, do as follows.

1] Turn fuel control dial (2) to the full speed (MAX) position and hold it for 3 seconds.

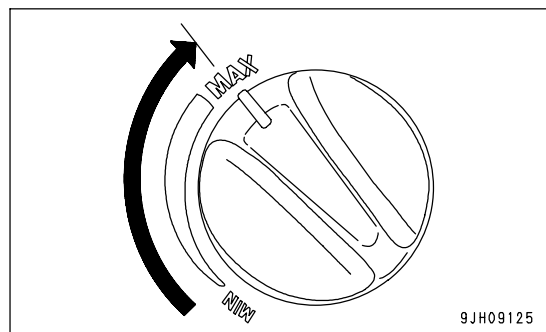

2] When fuel control dial (2) is returned to the low idle (MIN) position, the engine speed will drop.

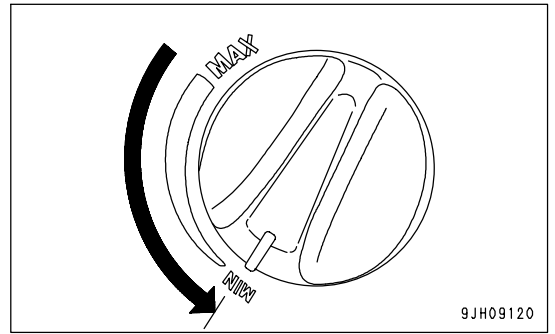

9JH09120

Hydraulic Equipment Warm Up

! WARNING

- Before carrying out the warm-up operation for the hydraulic equipment, turn the swing lock switch ON, check on the monitor that the swing lock is actuated, then start the warm-up operation.
- When warming up the hydraulic equipment, check that there is no person or obstacle in the surrounding area, then sound the horn and start the operation.
- Carry out the warm-up operation for the hydraulic equipment until the hydraulic oil temperature monitor displays green.
- The warm-up operation for the hydraulic equipment is necessary not only for the circuit between the pump and cylinders and between the pump and motor, but also for all the control circuits. Do not carry out the operation just for one cylinder or motor, or the operation just in one direction. Carry out the operation in both directions for the work equipment (boom, arm, bucket), swing, travel, and attachment (if equipped).

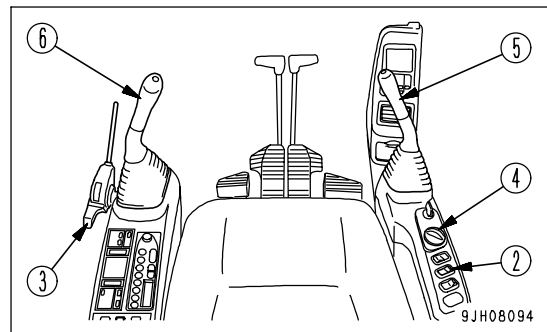

1. Check that engine water temperature monitor (1) displays green.
If it displays white, carry out additional warm up of the engine until engine water temperature monitor (1) displays green.
For details of the procedure, see "Engine Warm Up (PAGE 3-101)".

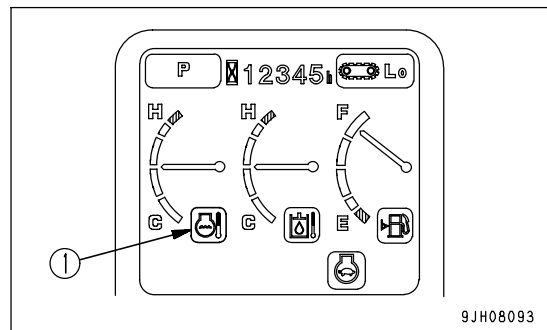

2. Turn swing lock switch (2) ON and check that the swing lock monitor lights up.

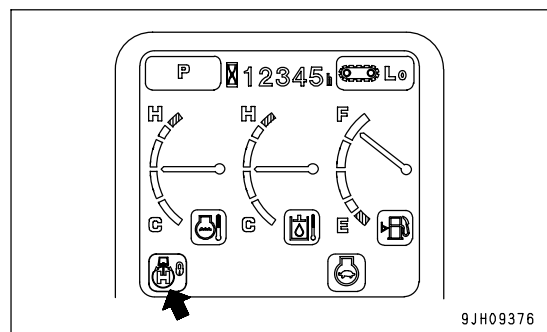

- To complete the warm-up operation of the hydraulic equipment more quickly, set the working mode to P mode (heavy-duty mode).

For details of the procedure for setting the working mode, see "Working Mode Selector Switch (Basic Switch) (PAGE 3-21)".

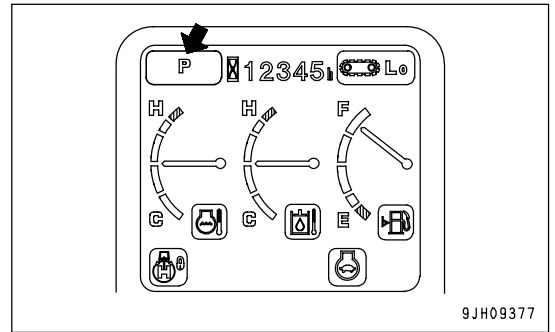

- Move lock lever (3) slowly to the FREE position (F), then raise the bucket from the ground.

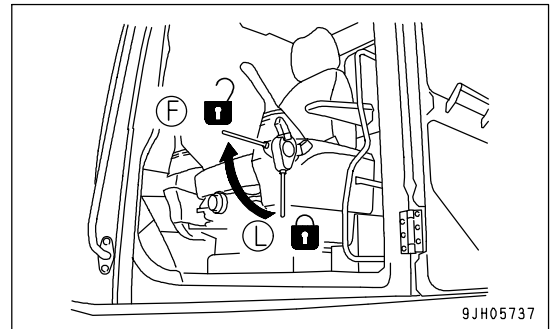

- Turn fuel control dial (4) to a point midway between low idling (MIN) and full speed (MAX).

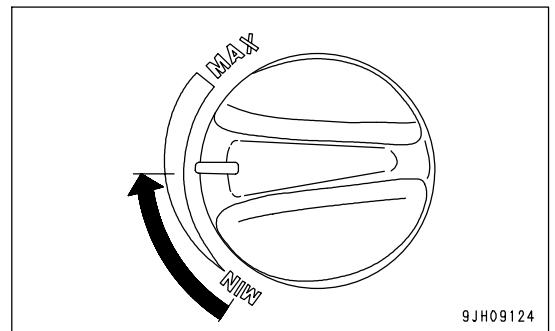

NOTICE

When the work equipment is retracted, take care that it does not interfere with the machine body or ground.

- Move right work equipment control lever (5) slowly in the direction to pull in the bucket (D). Operate the lever to the end of its travel and hold it in position for 30 seconds.
- Move right work equipment control lever (5) slowly in the direction to push out the bucket (C). Operate the lever to the end of its travel and hold it in position for 30 seconds.
- Next, move left work equipment control lever (6) slowly in the direction to pull in the arm (B). Operate the lever to the end of its travel and hold it in position for 30 seconds.
- Move left work equipment control lever (6) slowly in the direction to push out the arm (A). Operate the lever to the end of its travel and hold it in position for 30 seconds.
- Repeat the operation in Steps 6 to 9 for 5 minutes.

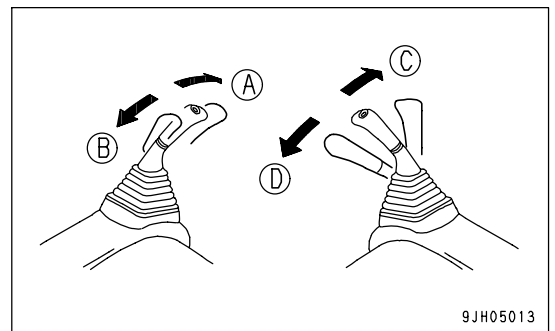

11. Check that hydraulic oil temperature monitor (7) is displaying green.
 If the hydraulic oil temperature monitor is not displaying green (it is displaying white), repeat Steps 6 to 10 until the display is green.

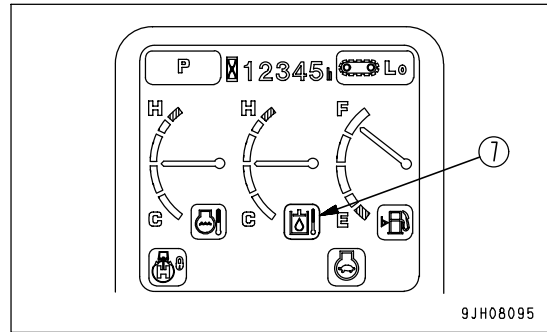

12. Check that engine water temperature monitor (1) displays green.
 If it displays white, carry out additional warm up of the engine until engine water temperature monitor (1) displays green.
 For details of the procedure, see "Engine Warm Up (PAGE 3-101)".

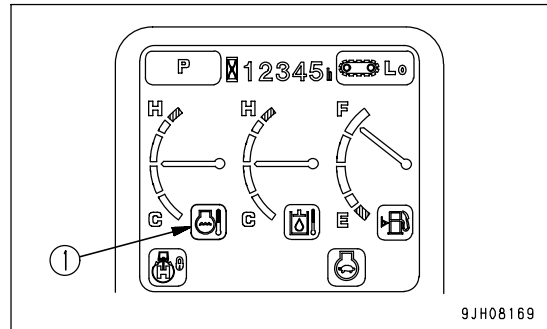

13. Check that the hydraulic oil temperature monitor and engine water temperature monitor are displaying green, then check that all the gauges and caution monitors on the machine monitor our in the following status.

- Radiator coolant level monitor (8): OFF
- Charge level monitor (9): OFF
- Engine oil pressure monitor (10): ON
- Engine oil level monitor (11): OFF
- Air cleaner clogging monitor (12): OFF
- Engine preheating lamp (13): OFF
- Engine water temperature gauge (14): Indicator in green range
- Engine water temperature monitor (1): Green display
- Hydraulic oil temperature gauge (15): Indicator in black range
- Hydraulic oil temperature monitor (7): Green display
- Fuel gauge (16): Indicator in black range
- Fuel level monitor (17): Green display

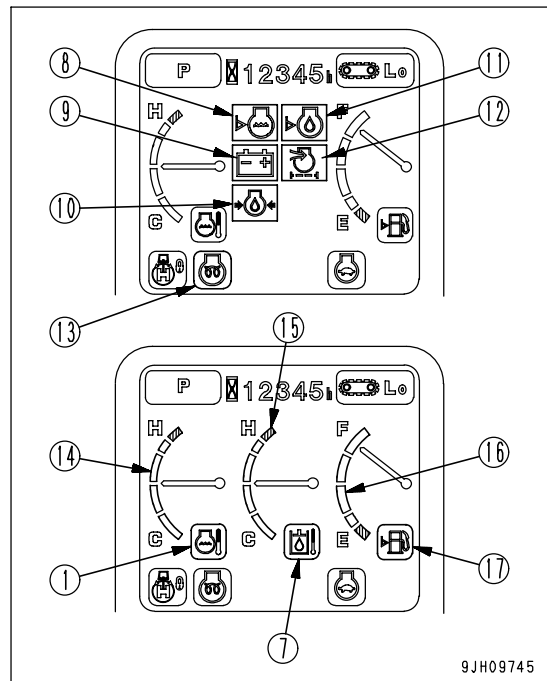

14. Check for abnormal exhaust gas color, noise, or vibration. If any problem is found, contact your Komatsu distributor.

In cold temperatures (ambient temperature below 0°C), even when the hydraulic oil temperature monitor displays green, carry out additional Step 15 to warm up all the hydraulic equipment.

15. Turn fuel control dial (4) to the full speed (MAX) position, repeat Steps 6 to 9 for 3 to 5 minutes, then check again that the hydraulic oil temperature monitor is displaying green. If it is not displaying green, repeat Steps 6 to 9 for 3 to 5 minutes until hydraulic oil temperature monitor (7) displays green.

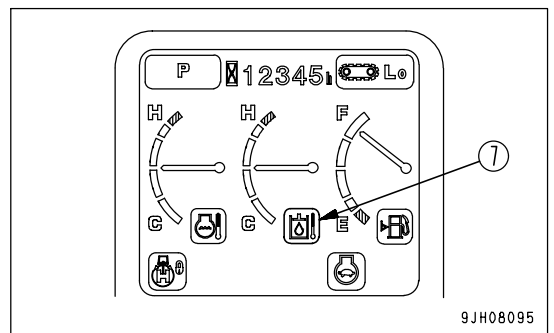
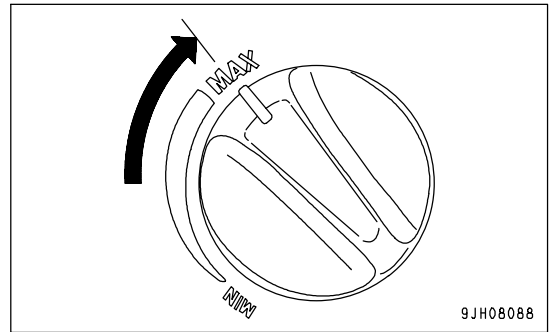

For both normal temperatures and cold temperatures, carry out the following operation.

16. Check that fuel control dial (4) is at a point midway between low idling (MIN) and full speed (MAX). If it is not at the midway position, set it to the midway position and run the engine at a mid-range speed before operating.

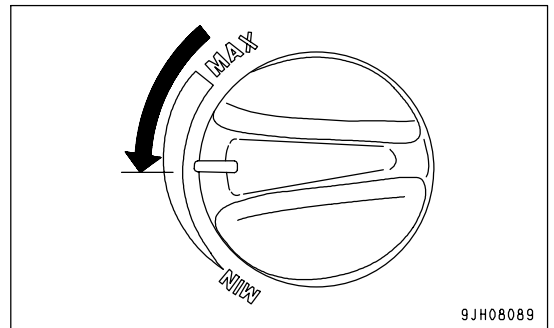

17. Before starting operations, repeat the following operations slowly 3 to 5 times to circulate warm oil through the control circuits.

- Boom operation RAISE (E) ↔ LOWER (F)
- Arm operation IN (B) ↔ OUT (A)
- Bucket operation CURL (D) ↔ DUMP (C)

When carrying out swing operations, release swing lock switch (2), check that swing lock monitor (18) goes out, then operate the swing.

- Swing operation Left (G) ↔ Right (H)

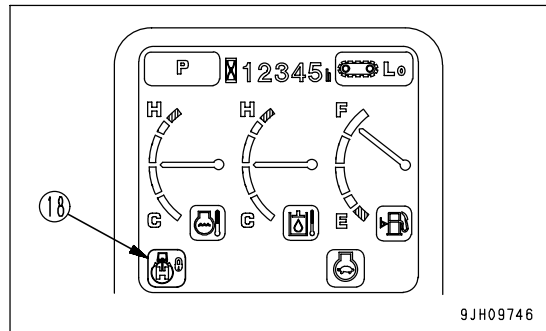
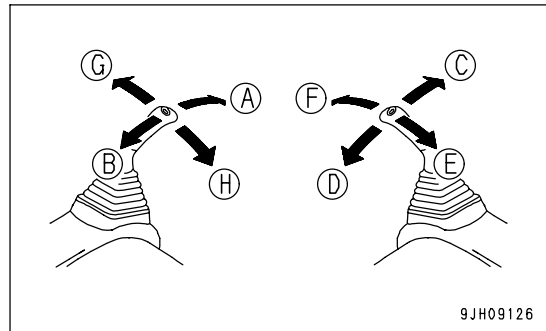

- Travel (Lo) operation FORWARD (A) ↔ REVERSE (B)

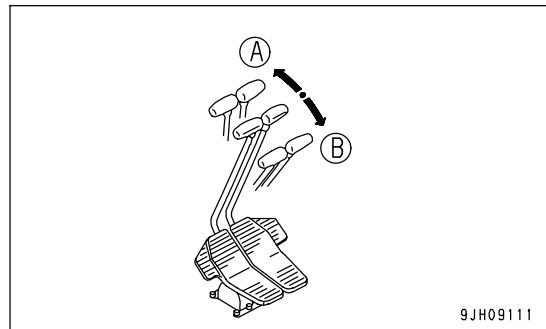

18. Check that hydraulic oil temperature monitor (7) is displaying green.

If the hydraulic oil temperature monitor is not displaying green (it is displaying white), repeat Steps 6 to 10 until the display is green.

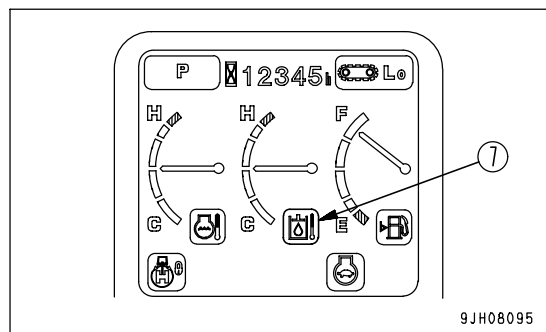

If the hydraulic oil temperature monitor displays green, the hydraulic equipment warm-up operation is completed. After confirming that the hydraulic oil temperature monitor displays green, carry out the following procedure.

Operation After Completion Of Warm-Up Operation

1. Check that hydraulic oil temperature monitor (7) displays green.

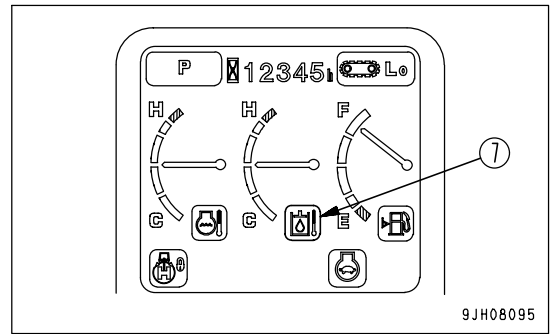

2. Push working mode selector switch (19) of the machine monitor to select the working mode to be used.

For details of the procedure for selecting the working mode, see "Working Mode Selector Switch (Basic Switch) (PAGE 3-21)".

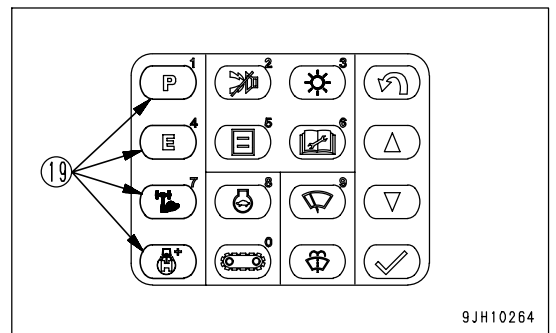

• Working mode monitor display

- 1) P mode

For heavy-duty operations

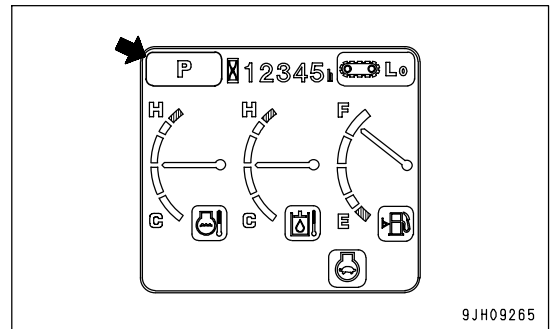

- 2) E mode

For operations with emphasis on fuel economy

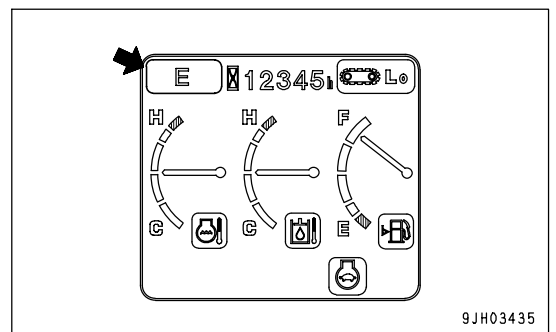

3) Heavy-duty lift

Boom lifting power increased when raising boom independently

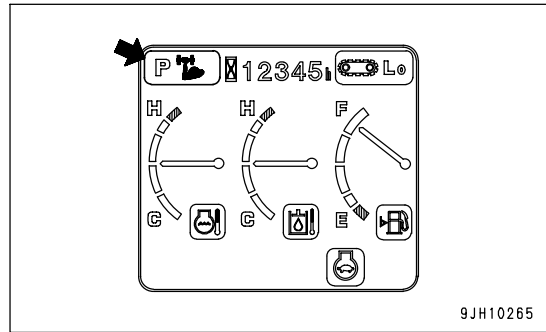

4) Swing priority mode

Priority given to swing when operating boom and swing simultaneously

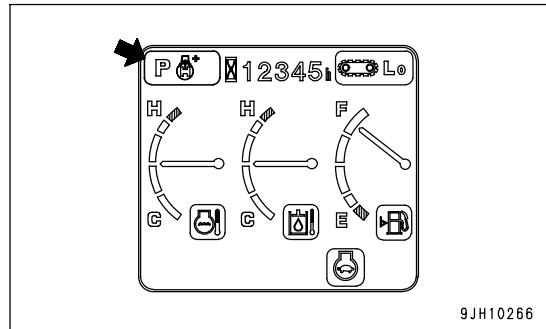

STOPPING THE ENGINE

NOTICE

If the engine is stopped abruptly, service life of component parts of the engine may be considerably reduced. Do not stop the engine abruptly except in an emergency. If the engine has overheated, do not try to stop it abruptly but run it at medium speed to allow it to cool down gradually, and then stop it.

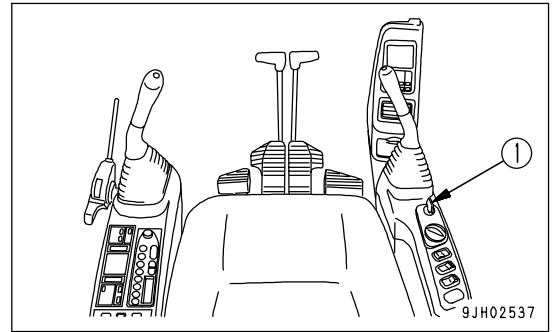

1. Run the engine at low idle for about 5 minutes to cool down gradually.
2. Turn the key in starting switch (1) to the OFF position (A) and stop the engine.
3. Remove the key from starting switch (1).

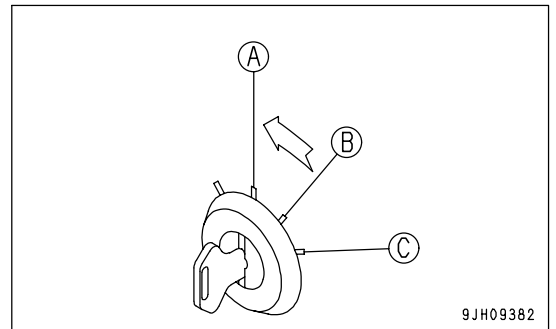

MACHINE OPERATION

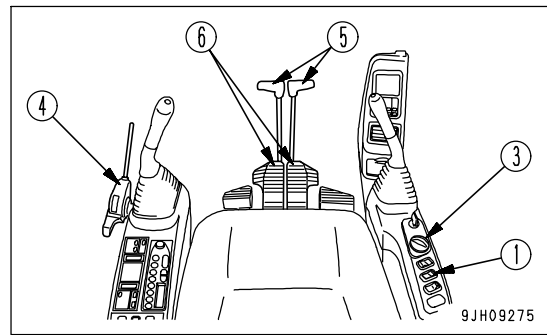

WARNING

- Before operating the control lever, check the direction of the track frame. If the track frame is facing the rear (if the sprocket is at the front), the machine moves in the opposite direction from the operation of the travel lever (front and rear travel is reversed, left and right steering is reversed).
- Before starting the machine off, check that the area around the machine is safe, and sound the horn.
- Do not allow anyone to enter the area around the machine.
- Clear any obstacles from the travel path.
- There is a blind spot at the rear of the machine, so be particularly careful when traveling in reverse.
- If the control lever is operated when the auto deceleration is being actuated, the engine speed will suddenly rise, so be careful when operating.
- Before starting the machine off, check that the travel alarm sounds normally.

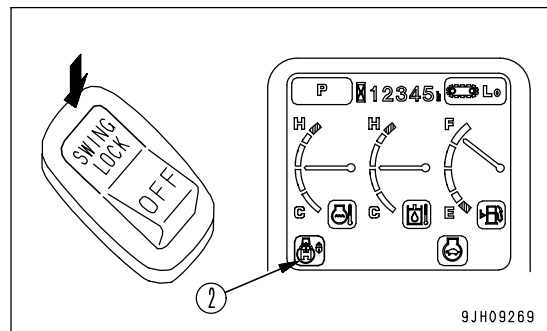

Preparations for Moving the Machine

1. Set swing lock switch (1) to the ON (actuated) position and confirm that swing lock monitor lamp (2) lights up.



2. Turn fuel control dial (3) towards the full speed (MAX) position to increase the engine speed.

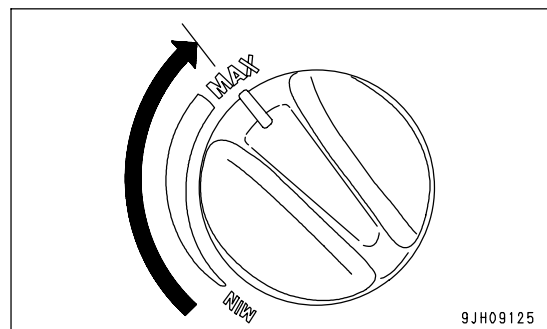

Moving Machine Forward

1. Set lock lever (4) in the FREE position (F), fold the work equipment, and raise it 40 to 50 cm (16 to 20 in) from the ground.
 - If the work equipment blocks the view and it is difficult to travel in safety, raise the work equipment to a greater height.

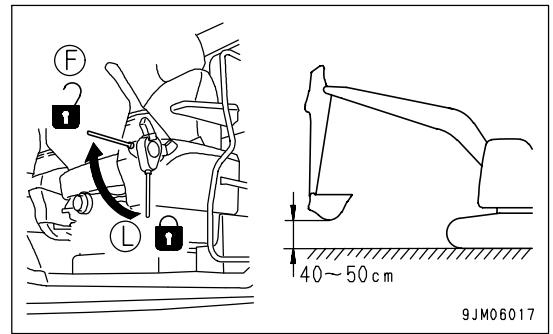

2. Operate the right and left travel levers (5), or the right or left travel pedals (6) as follows:

- When sprocket (A) is at the rear of the machine:
Slowly push the levers (5) forward, or slowly depress the front part of the pedals (6) to move the machine forward.

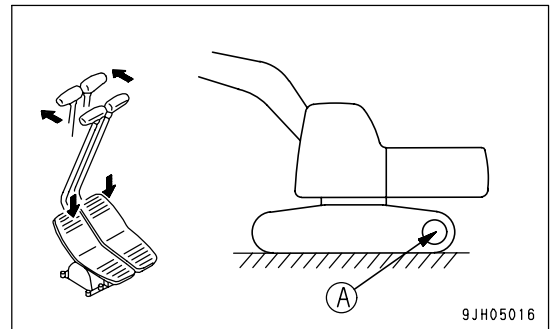

- When sprocket (A) is at the front of the machine:
Slowly pull the levers (5) backward, or slowly depress the rear part of the pedals (6) to move the machine forward.

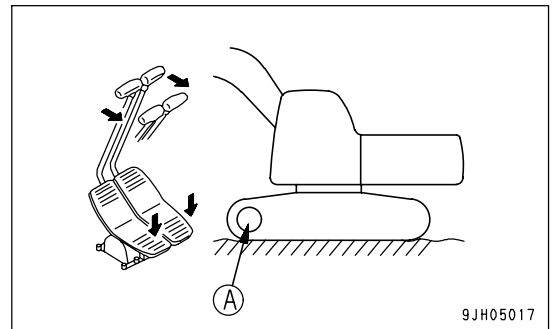

3. Check that the travel alarm sounds properly. If the travel alarm does not sound, please contact your Komatsu distributor for repair.

REMARK

In cold temperatures, if the machine travel speed is not normal, thoroughly perform the warming-up operation. In addition, if the undercarriage is clogged with mud and the machine travel speed is not normal, remove the soil and mud from the undercarriage.

Moving Machine Backward

1. Set lock lever (4) in the FREE position (F), fold the work equipment, and raise it 40 to 50 cm (16 to 20 in) from the ground.

- If the work equipment blocks the view and it is difficult to travel in safety, raise the work equipment to a greater height.

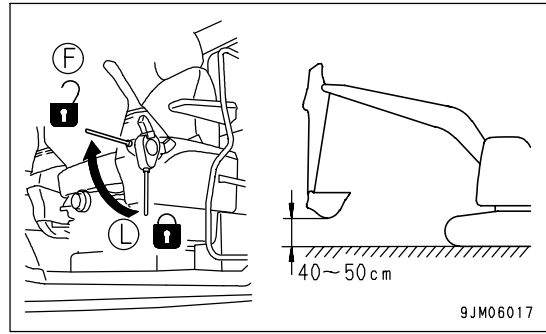

2. Operate the right and left travel levers (5), or the right or left travel pedals (6) as follows:

- When sprocket (A) is at the rear of the machine:
Slowly pull the levers (5) backward, or slowly depress the rear part of the pedals (6) to move the machine backward.

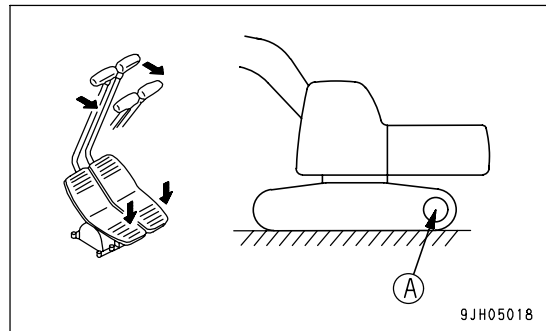

- When sprocket (A) is at the front of the machine:
Slowly push the levers (5) forward, or slowly depress the front part of the pedals (6) to move the machine backward.

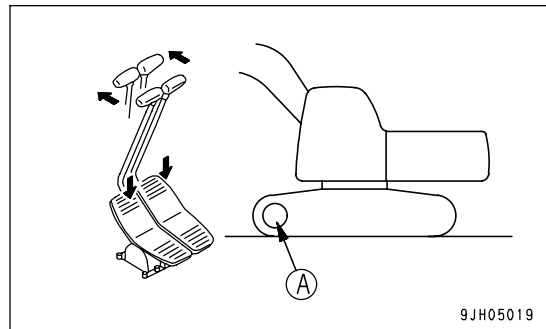

3. Check that the travel alarm sounds properly. If the travel alarm does not sound, please contact your Komatsu distributor for repair.

Stopping Machine

Avoid stopping suddenly. Give yourself ample room when stopping.

1. Put the left and right travel levers (1) in the neutral position, then stop the machine.

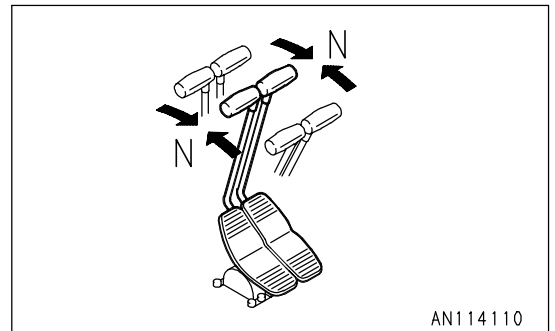
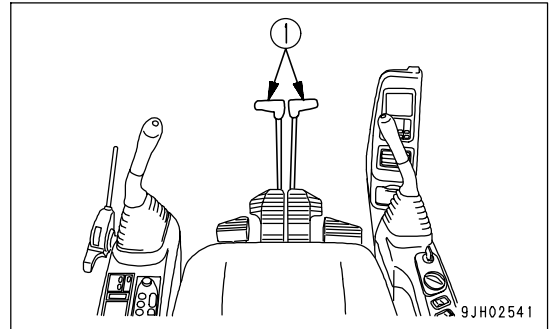

STEERING THE MACHINE

Steering



WARNING

Before operating the travel levers, check the direction of the track frame (the position of the sprocket). If the sprocket is at the rear, the machine moves in the reverse direction to the operation of the travel levers.

Use the travel levers to change direction.

Avoid sudden changes of direction as much as possible. Especially when performing counter-rotation (spin turn), stop the machine before turning.

Operate two travel levers (1) as follows.

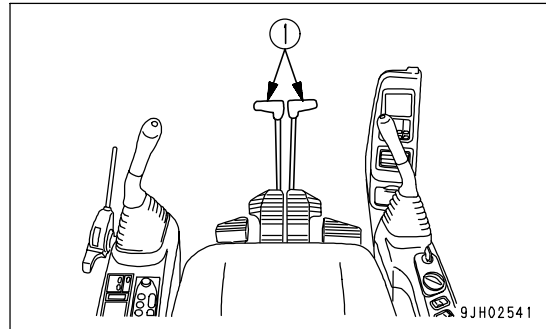

Steering the Machine when Stopped

When turning to the left:

Push the right travel lever forward to turn to the left when traveling forward; and pull it back to turn left when traveling in reverse.

(A): Forward left turn

(B): Reverse left turn

REMARK

When turning to the right, operate the left travel lever in the same way.

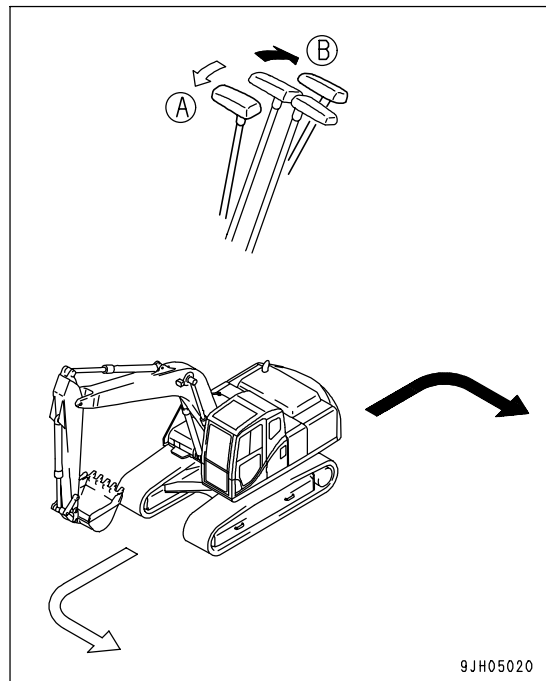

Changing Direction of the Machine

When turning to the left:

If the left travel lever is returned to the neutral position, the machine will turn to the left.

(A): Forward left turn

(B): Reverse left turn

REMARK

When turning to the right, operate the right travel lever in the same way.

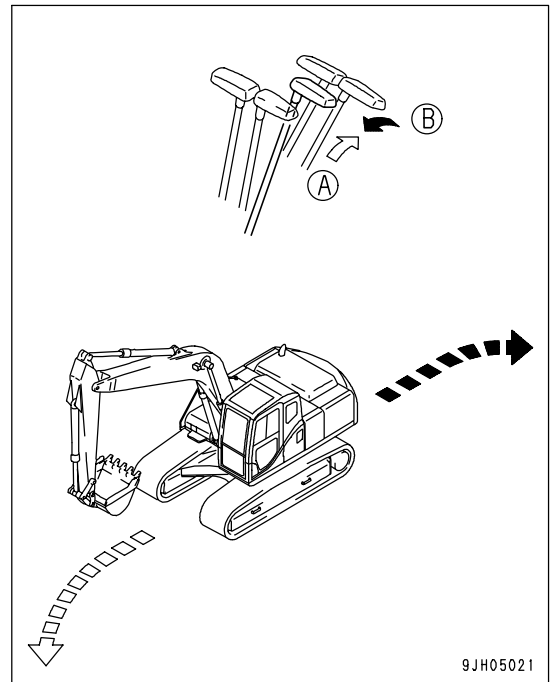

Counter-rotation Turn (Spin Turn)

When using counter-rotation (spin turn) to turn left, pull the left travel lever back and push the right travel lever forward.

REMARK

When using counter-rotation to turn right, pull the right travel lever back and push the left travel lever forward.

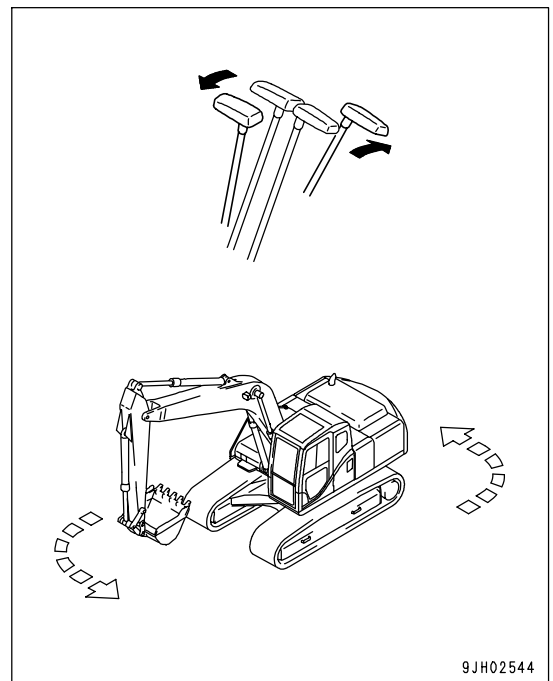

SWINGING

! WARNING

The tail of the machine extends outside the tracks. Before operating the swing, check that the area around the machine is safe.

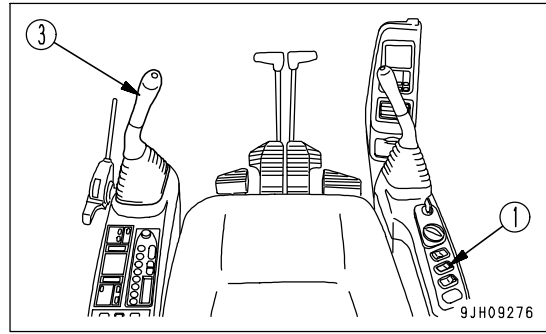

1. Before starting the swing operation, turn swing lock switch (1) OFF and check that swing lock monitor (2) has gone out.

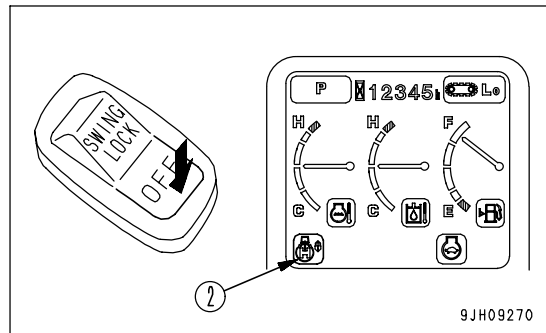

2. Operate left work equipment control lever (3) to swing the upper structure.
 - (A): Left swing
 - (B): Right swing

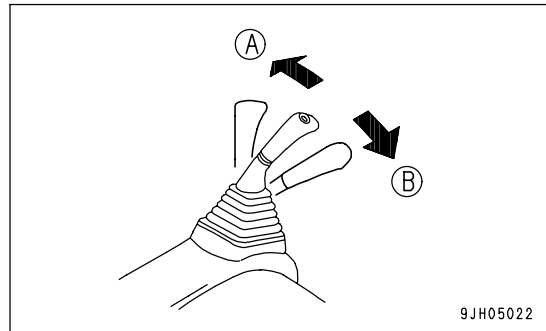

3. When not using the swing, turn swing lock switch (1) ON. Check that swing lock monitor (2) lights up.

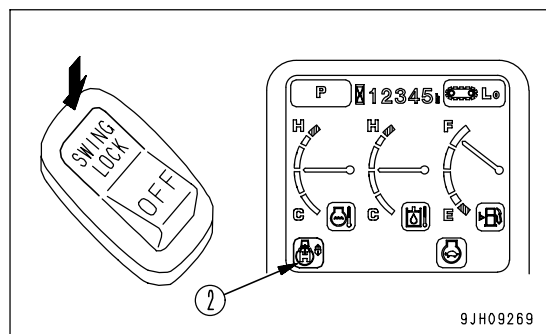

WORK EQUIPMENT CONTROLS AND OPERATIONS



WARNING

- If the lever is operated when the engine speed has been lowered by the auto-deceleration function, the engine speed will suddenly rise, so operate the levers carefully.

Use the control levers to operate the work equipment.

Note that when the levers are released, they return to the HOLD position and the work equipment is held in that position.

- If the work equipment control levers are returned to the neutral position when the machine is stopped, even if the fuel control dial is set to FULL, the auto-deceleration mechanism will act to reduce the engine speed to a mid-range speed.

REMARK

With this machine, an accumulator is installed in the operating circuit, if less than 15 seconds has passed since the engine was stopped, when the starting switch is turned to the ON position even with the engine stopped, it is possible to operate the levers to lower work equipment to the ground.

In addition, this operation can also be used to release the remaining pressure in the hydraulic cylinder circuit or to lower the boom after the machine has been loaded onto a trailer.

- Arm control

Move the left work equipment control lever to the front or rear to operate the arm.

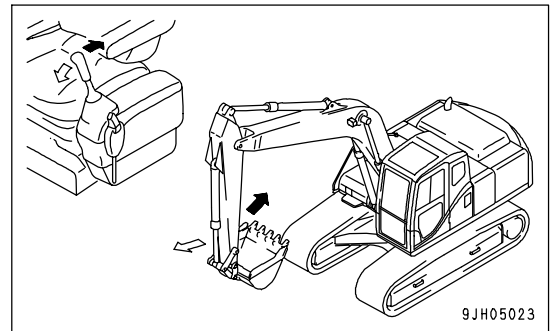

- Swing control

Move the left work equipment control lever to the left or right to swing the upper structure.

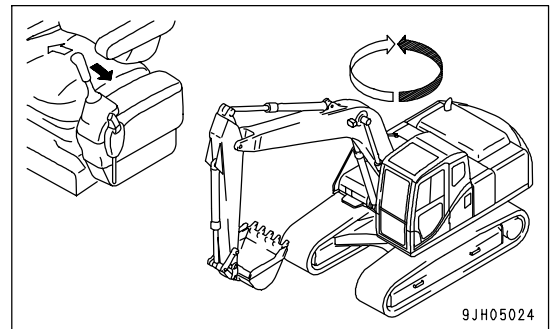

- Boom control

Move the right work equipment control lever to the front or rear to operate the boom.

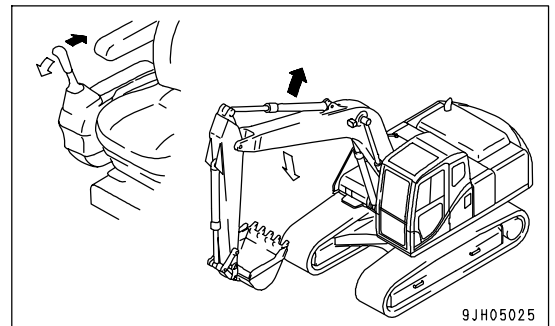

- Bucket control

Move the right work equipment control lever to the left or right to operate the bucket.

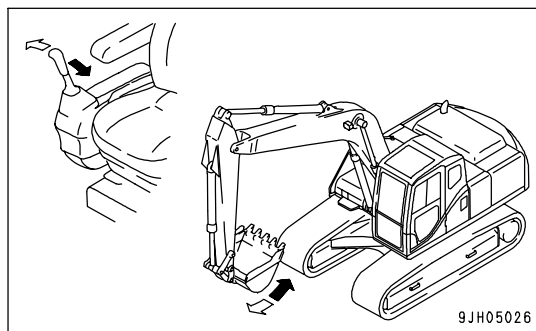

WORKING MODE

Working Mode

The mode selector switch can be used to switch the mode to match operating conditions and purpose, thereby enabling work to be performed efficiently.

Make effective use of each mode as follows.

When the starting switch is turned to the ON position, the working mode is set to P mode (digging).

Use the working mode switch to set the mode to the most efficient mode to match the type of work.

Working mode	Applicable operations
P mode	Normal digging, loading operations (Operations with emphasis on productivity)
E mode	Normal digging, loading operations (operation with emphasis on fuel economy)
Heavy-duty lift mode	Normal digging, loading operations (boom lifting power increased when raising boom independently)
Swing priority mode	Normal digging, loading operations (priority given to swing when operating boom and swing simultaneously)

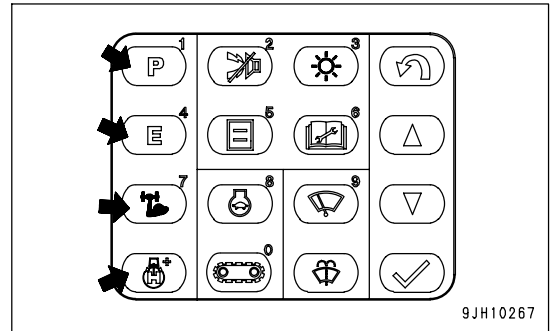

9JH10267

Setting Economy Mode

We recommend adjusting the economy mode settings to give the fuel consumption and production in the table below.

REMARK

The closer the selection is made to E3, the better the fuel consumption becomes, but the production is reduced accordingly.

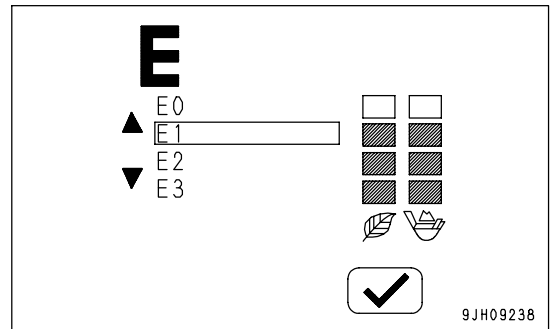

9JH09238

Mode	Dumping and loading		Handling overburden		Excavated and blasted rock	Pit excavation	Handling remaining walls	Trenching		Lifting work
	Blasted rock	Loosened sandy soil	Soft rock	Sandy bedrock				Soft rock	Sandy bedrock	
E0	◎	◎	○	◎	○	○	○	○	○	◎
E1	○	○	△	△	△	△	△	△	△	◎
E2	△	△	△	△	×	×	×	×	△	○
E3	×	△	×	×	×	×	×	×	×	○

◎ : Work possible without problem (can carry out that operation without problem)

○ : Work possible (can carry out operation with some minor problems)

△ : Work possible (can carry out operation but there are many problems)

× : Work impossible (too many problems, cannot carry out operation)

PROHIBITED OPERATIONS



WARNING

- If it is necessary to operate the work equipment control lever when the machine is traveling, stop the machine, then operate the control lever.
- If any lever is operated when the auto-deceleration is being actuated, the engine speed will suddenly increase, so be careful when operating.

Operations Using Swing Force

Do not use the swing force to compact soil or break objects. This is not only dangerous, but will also drastically reduce the life of the machine.

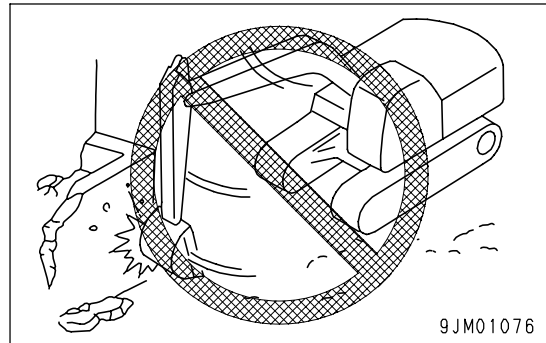

Operations Using Travel Force

Do not dig the bucket into the ground and use the travel force to carry out excavation. This will damage the machine or work equipment.

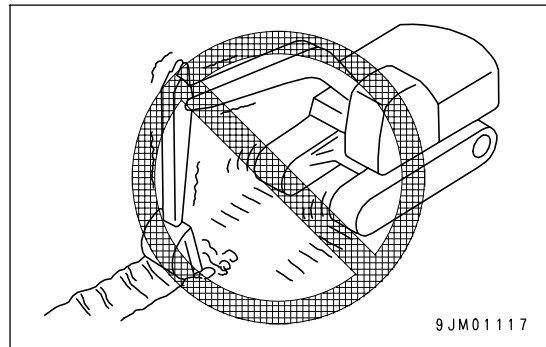

Prohibited to Extend Hydraulic Cylinder to End of Stroke

If the work equipment is used with the cylinder rod operated to its stroke end, and given impact by some external force, the hydraulic cylinders will be damaged, causing personal injury. Avoid operations with the hydraulic cylinder fully retracted or fully extended.

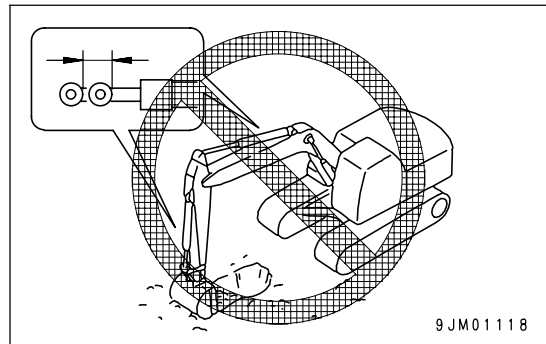

Operations Using Bucket Dropping Force

Do not use the dropping force of the machine for digging, or use the dropping force of the bucket as a pickaxe, breaker, or pile driver. This will drastically reduce the life of the machine.

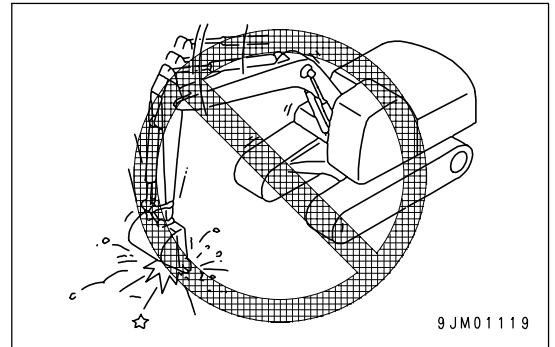

Operations Using Bucket as Lever

Do not use the bucket to lever rocks out. If the back of the bucket contacts the rock behind, the principle of the lever will bring excessive force to bear on the machine or work equipment, and there is danger that this may lead to breakage or damage of the machine.

In such situations, use only the force of the arm and bucket to carry out the digging operation. If any excessive force is brought to bear, the safety valve in the hydraulic system automatically controls the force within the specified range, and this prevents damage to the machine.

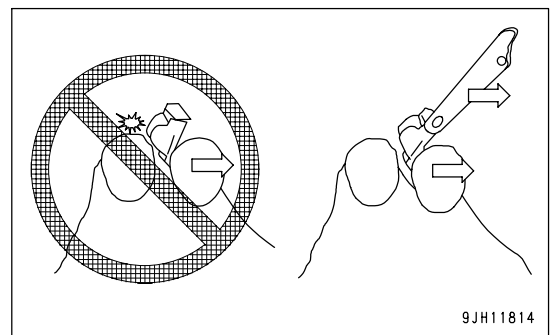

Operations Using Machine Dropping Force

Do not use the dropping force of the machine for digging.

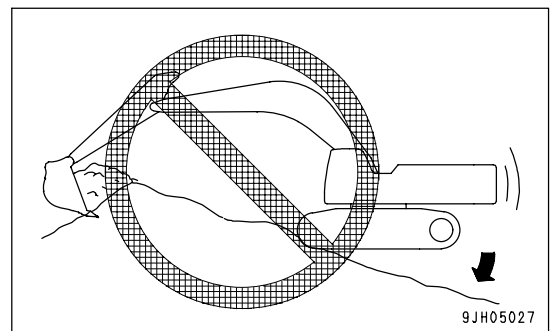
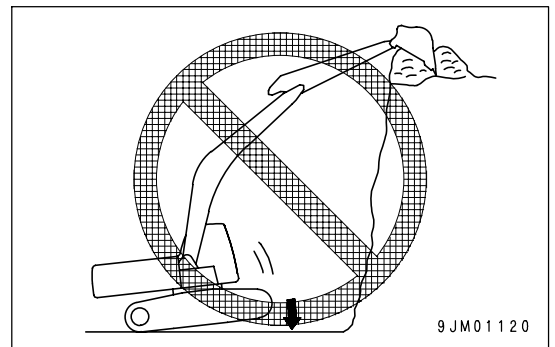

Operations Digging at an Angle without Engaging Teeth

Do not swing the upper structure when digging hard rock at a position higher than the machine if the bucket teeth will not penetrate the rock. The teeth will slip on the rock surface and generate excessive vibration of the machine, and this will lead to cracking of the work equipment or frame.

In addition, if the bucket teeth slip and hit the rock, there will be excessive impact load on the work equipment and frame, and this will reduce the service life of the machine.

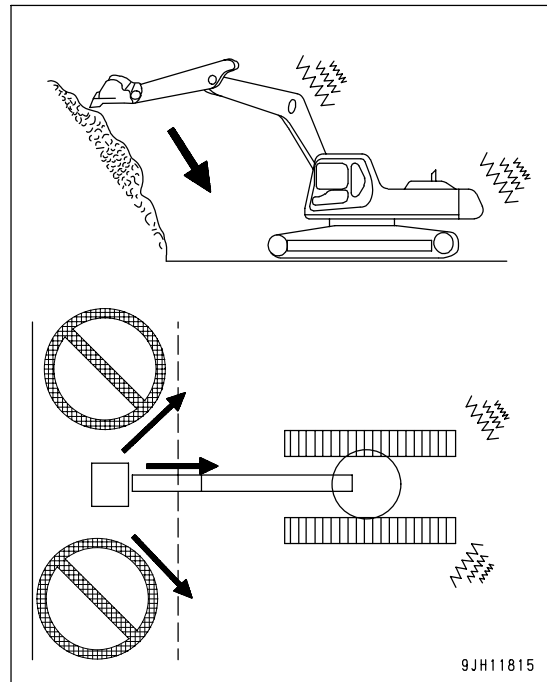

Digging Hard Rocky Ground

Do not attempt to directly excavate hard rocky ground with the work equipment. It is better to excavate it after breaking up by some other means. This will not only save the machine from damage but will make for better economy.

Operations When Machine is Not Stable

Do not carry out operations when the machine is not in a stable position. This will generate a twisting load on the frame and other parts and will reduce the service life of the machine.

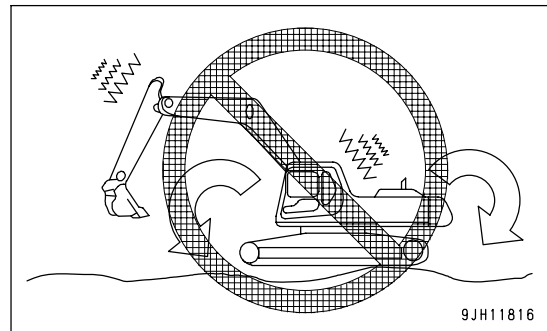

When carrying out operations in such a place, pile soil under the front of the track or take other measures to stabilize the machine before starting the operation.

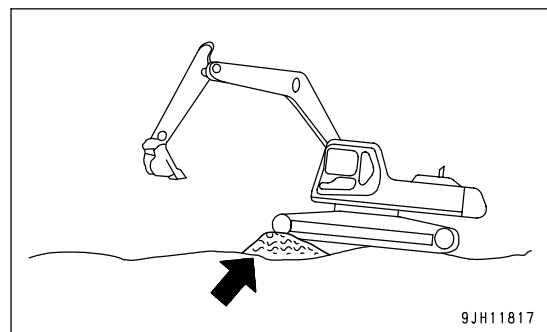

Swinging or Traveling When Rock Is on Top of Track Assembly

Do not swing the upper structure or travel if there is a rock on top of the track assembly. It will contact the undercover or frame and cause damage. In the worst case, it may cause damage to the hydraulic equipment and result in a serious breakdown.

During operations, always check that there is no rock, pieces of rock, or mud on top of the track assembly.

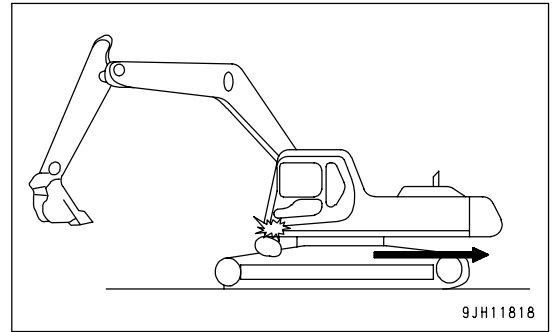
**Sudden Lever or Pedal Shifting High Speed Travel**

- (1) Do not operate the levers and pedals suddenly or take any other action to move the machine quickly.
- (2) Do not operate the levers or pedals suddenly from FORWARD (A) to REVERSE (B) (or from REVERSE (B) to FORWARD (A)).
- (3) Do not operate the levers or pedals suddenly (do not release them suddenly) to stop the machine when traveling at high speed.

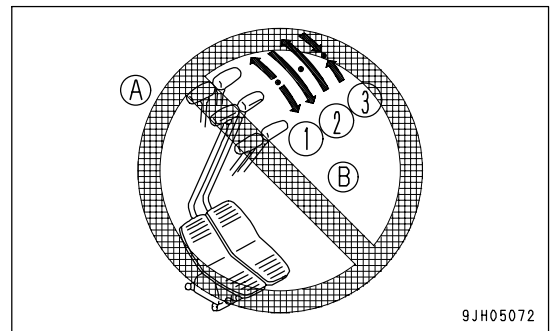

High-Speed Travel Operations on Rough Ground

Do not travel at high speed on rough ground or rocks. Each time the machine travels over rough parts of the ground surface, the thrusting load on the machine will increase and reduce the service life of the machine.

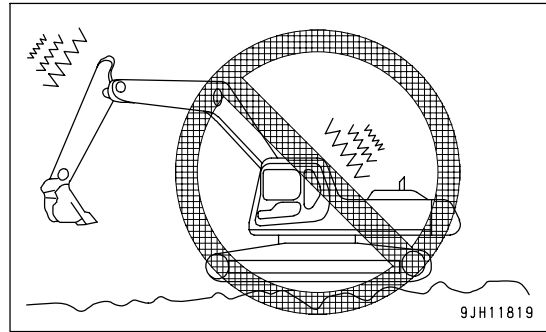

To protect the machine when traveling on rough ground or on rocks, there is a cushion structure in the idler (1), so set the idler facing in the direction of travel and travel at low speed.

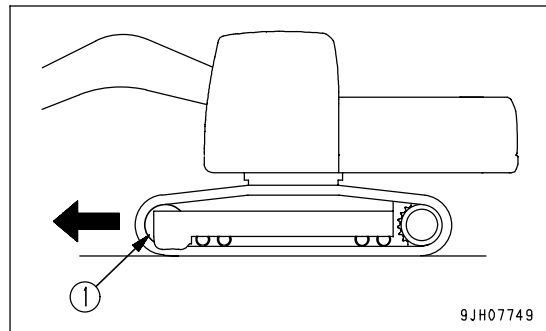
**Long-Time Continuous Travel Operations**

Do not travel continuously at high speed for two hours or more. The lubricating oil inside the track rollers will rise to a high temperature, and there is danger that this will cause damage to the oil seal or leakage of oil.

When traveling continuously for a long time, stop the machine for 15 minutes every 2 hours to allow the lubricating oil inside the track rollers to cool down.

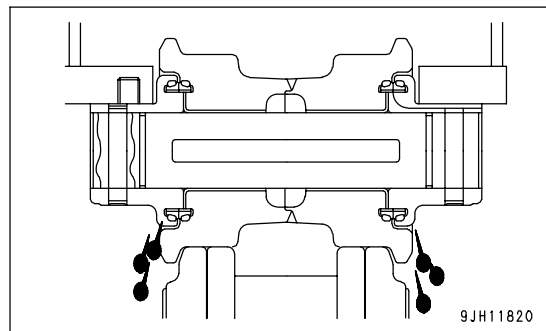

GENERAL OPERATION INFORMATION

Traveling

Traveling over boulders, tree stumps, or other obstacles will cause a big shock to the chassis (and in particular to the tracks), and this will cause damage to the machine. For this reason, always remove any obstacles or travel around them, or take other steps to avoid traveling over such obstacles as far as possible.

If there is no way to avoid traveling over an obstacle, reduce the travel speed, keep the work equipment close to the ground, and try to travel so that the center of the track passes over the obstacle.

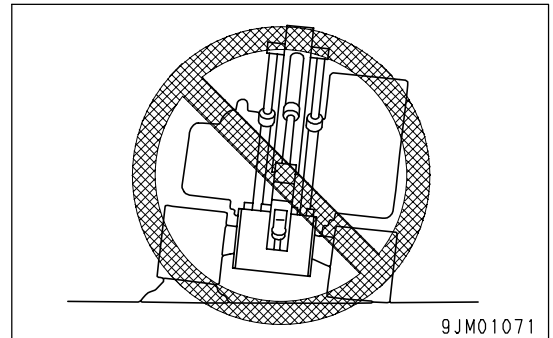

High Speed Travel

On uneven roadbeds such as rock beds or uneven roads with large rocks, travel at Lo speed. When traveling at high speed, set the idler in the forward direction.

- To switch the travel speed, press travel speed selector switch (1). The travel speed is displayed as Lo, Mi, or Hi on the monitor display.

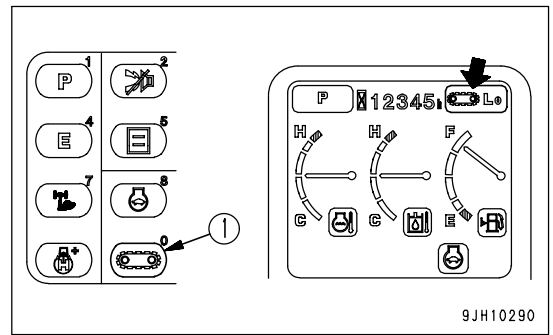

Precautions when Carrying Out Operations Continually with the Work Equipment in the Same Posture

Precautions when carrying out operations continually with the work equipment in the same posture.

When operations are carried out continuously with the cylinder operated slightly, operate the cylinder occasionally by a large amount to ensure greasing of the work equipment pins. This will prevent loss of grease at the pins.

Permissible Water Depth

NOTICE

When driving the machine out of water, if the angle of the machine exceeds 15°, the rear of the upper structure will go under water, and water will be thrown up by the cooling fan. This may cause the fan to break. Be extremely careful when driving the machine out of water.

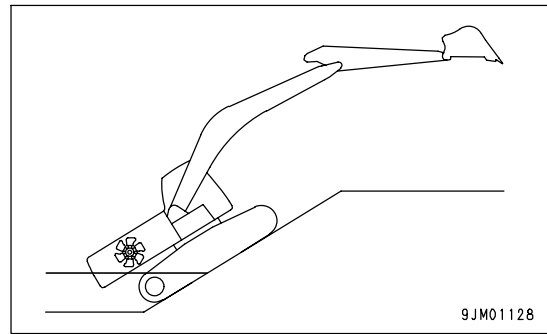

Do not drive the machine in water deeper than the center of carrier roller (1).

Supply grease to the parts which have been under water for a long time until the used grease is projected out of the bearings (around the bucket pin, in particular).

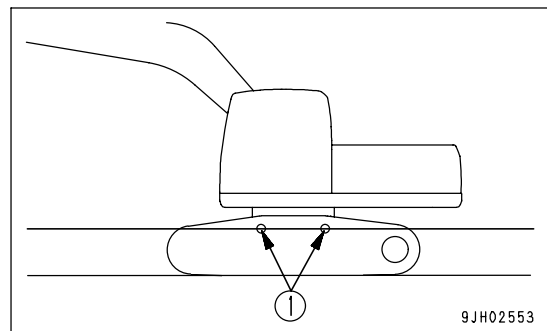

TRAVELING ON SLOPES

! WARNING

- Turning or operating the work equipment when working on slopes may cause the machine to lose its balance and turn over, so avoid such operations.
It is particularly dangerous to swing downhill when the bucket is loaded. If such operations have to be performed, pile soil to make a platform (A) on the slope so the machine is kept horizontal during operation.
- Do not travel up or down steep slopes. There is danger that the machine may turn over.
- When traveling, raise the bucket approx. 20 to 30cm (8 to 12 in) from the ground.
Do not travel downhill in reverse.
- Never turn on slopes or travel across slopes.
Always go down to a flat place to perform these operations. It may be longer, but it will ensure safety.
- Always operate or travel in such a way that it is possible to stop safely at any time if the machine slips or becomes unstable.

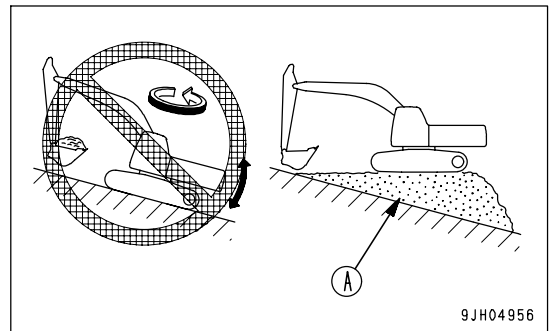
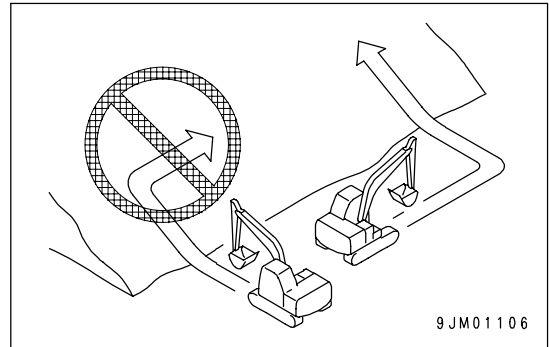

1. When traveling down steep hills, use the travel lever and fuel control lever to keep the travel speed low.
When traveling down slopes of more than 15°, set the work equipment in the posture shown in the figure on the right, and lower the engine speed.

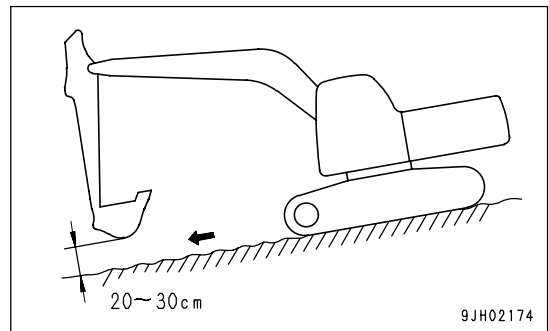

2. When traveling up a steep hill of more than 15°, set the work equipment to the posture shown in the diagram on the right.

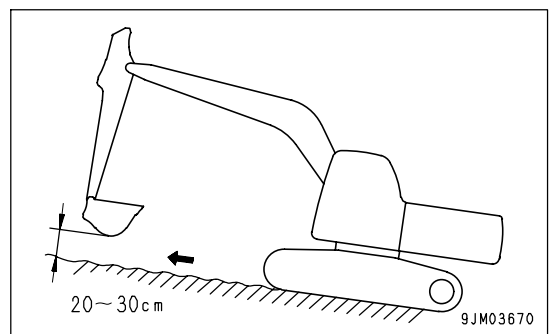

- When traveling up a steep slope, extend the work equipment to the front to improve the balance, keep the work equipment approximately 20 to 30 cm (8 to 12 in) above the ground, and travel at low speed.

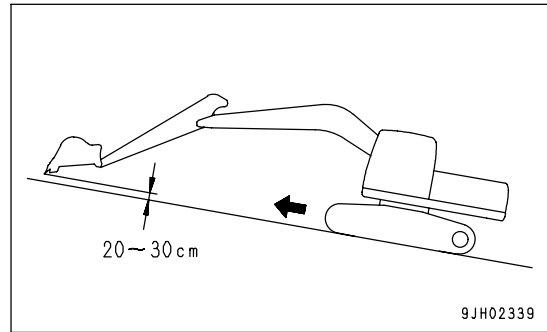

Traveling Downhill

Put the travel lever in the neutral position. This will cause the brake to be automatically applied.

Engine Stopped on Slope

If the engine stops when traveling uphill, move the travel levers to the neutral position, lower the bucket to the ground, stop the machine, then start the engine again.

Cab Doors on Slope



WARNING

Do not open or close the door when the machine is on a slope. The operating effort may suddenly change. Always keep the door locked in position when it is open and when it is closed.

- If the engine stops when the machine is on a slope, never use the left work equipment control lever to carry out swing operations. The upper structure will swing under its own weight.

ESCAPE FROM MUD

Always operate carefully to avoid getting stuck in mud. If the machine does get stuck in mud, do as follows to get the machine out.

- Place the machine push-up switch at high-pressure set position (b). This will increase the pushing power of the boom and make it easier to escape.

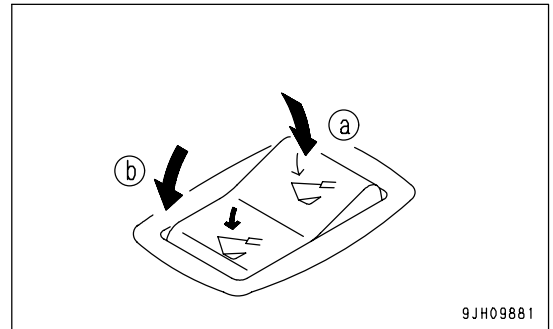

Track on One Side Stuck

NOTICE

When using the boom or arm to raise the machine, always have the bottom of the bucket in contact with the ground. The angle between the boom and arm should be 90° to 110°.

The same applies when using the bucket installed in the reverse direction.

When only one side is stuck in mud, use the bucket to raise the track, then lay boards or logs and drive the machine out.

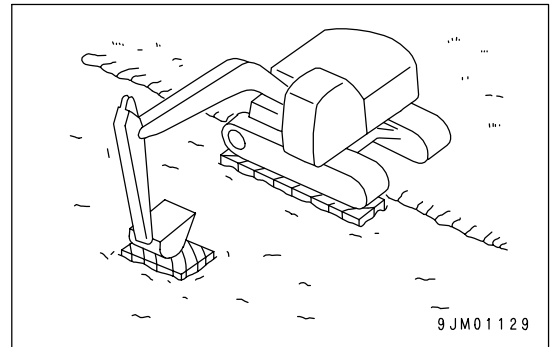

Tracks on Both Sides Stuck

When the tracks on both sides are stuck in mud and they slip, making it impossible for the machine to move, lay boards or logs as explained above, and dig the bucket into the ground in front. Then pull in the arm as in normal digging operations and put the travel levers in the FORWARD position to pull the machine out.

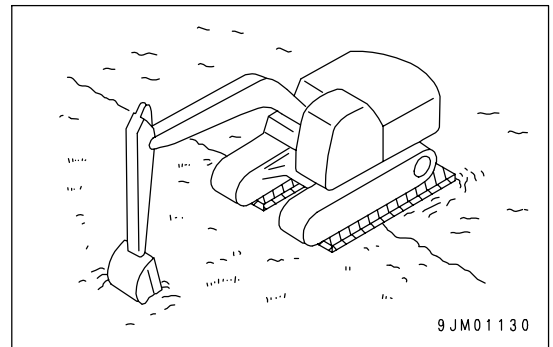

RECOMMENDED APPLICATIONS

In addition to the following, it is possible to further increase the range of applications by using various attachments.

Backhoe Work

A backhoe is suitable for excavating areas that are lower than the machine.

When the condition of the machine is as shown in the diagram on the right (angle between [bucket cylinder and link] and [arm cylinder and arm] is 90°), the maximum excavation force is obtained from the pushing force of each cylinder.

When excavating, use this angle effectively to optimize your working efficiency.

The range for excavating with the arm is from a 45° angle away from the machine to a 30° angle towards the machine.

There may be some differences depending on the excavation depth, but try to stay within the above range rather than operating the cylinder to the end of its stroke.

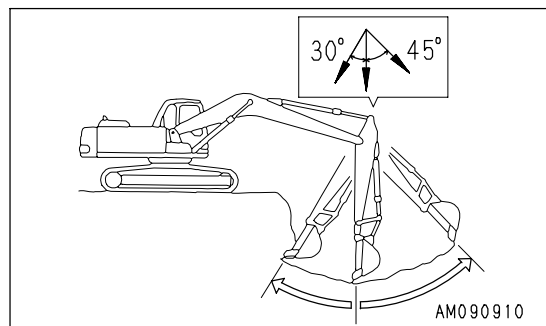
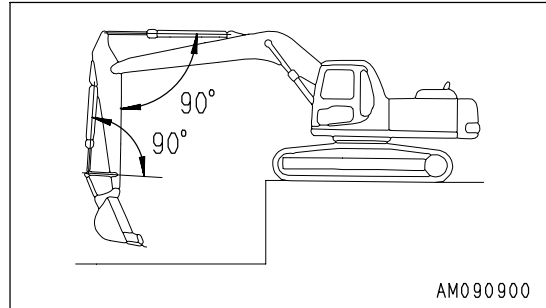

Ditching Work

Ditching work can be performed efficiently by attaching a bucket which matches the digging operation and then setting the tracks parallel to the line of the ditch to be excavated.

To excavate a wide ditch, first dig both sides and then finally remove the center portion.

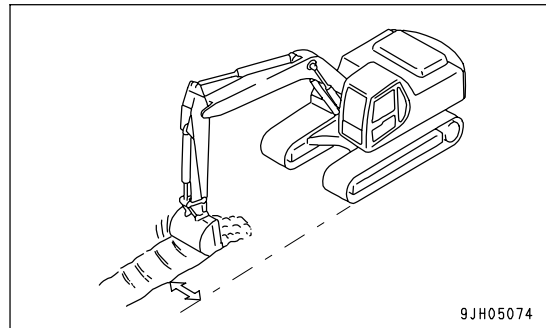

Loading Work

In places where the swing angle is narrow, work efficiency can be enhanced by locating the dump truck in a place easily visible to the operator.

Loading is easier and capacity greater if you begin from the front of the dump truck body than if loading is done from the side.

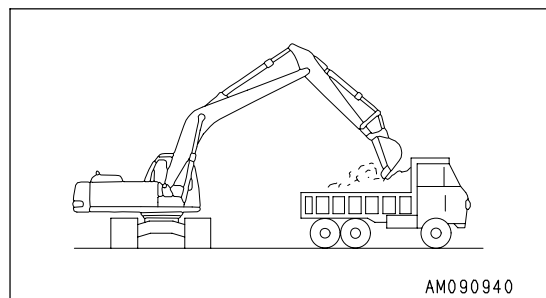

BUCKET REPLACEMENT



WARNING

- When pins are knocked in with a hammer, pieces of metal may fly and cause serious injury.
When carrying out this operation, always wear goggles, hard hat, gloves, and other protective equipment.
- When the bucket is removed, place it in a stable condition.
- If pins are hit with a strong force, there is a hazard that the pin may fly out and injure people in the surrounding area. Make sure that there is no one in the surrounding area before starting the operation.
- When removing the pins, do not stand behind the bucket. In addition, be extremely careful not to put your foot under the bucket while standing at the side for the work.
- When removing or inserting pins, be extremely careful not to get your fingers caught.
- Never insert your fingers into the pin holes when aligning the holes.

Stop the machine on a firm and flat surface and do the work. When performing joint work, appoint a lead and follow that person's instructions and signals.

Replacement

1. Place the bucket in contact with a flat surface.

NOTICE

When removing the bucket, set the bucket cylinder (5) facing down as shown in the diagram in the right to prevent the front link (4) from jumping up under the weight of the bucket cylinder (5).

REMARK

When removing the pins, place the bucket so that it is in light contact with the ground.

If the bucket is lowered strongly to the ground, the resistance will be increased and it will be difficult to remove the pins.

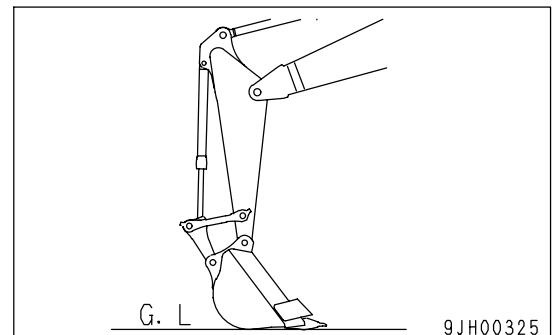

- Remove the stopper at the end of the pin, then pull out pins (A) and (B) and remove the bucket.

NOTICE

After removing the pins, make sure that mud or sand does not get on them. Dust seals are fitted at both ends of the bushings, be careful not to damage them.

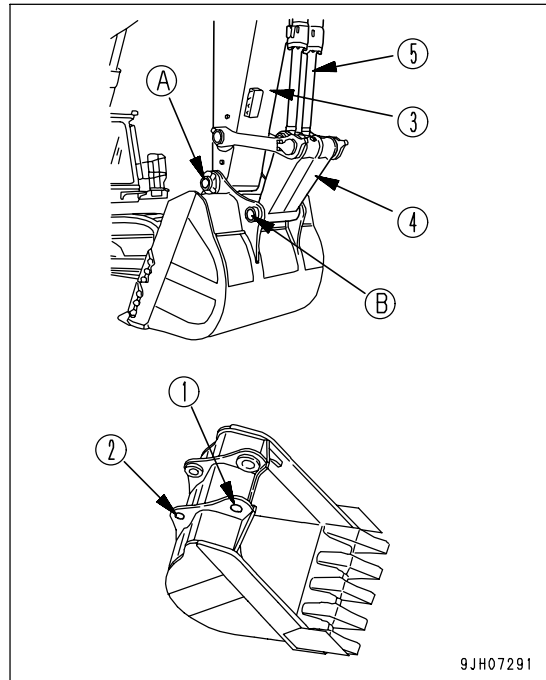

9JH07291

- Align the arm (3) with holes (1) of the replacement bucket and the link (4) with holes (2), then insert grease-coated pins (A) and (B) into hole (1) and hole (2) respectively.

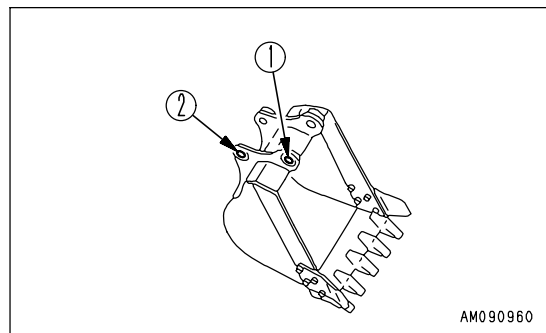

AM090960

REMARK

- Carry out installation in the reverse order to removal.
- When installing bucket (6), it is easy to damage the O-ring (7), so fit O-ring (7) to bucket (6) in the position shown in diagram on the right. After inserting pin, fit the O-ring correctly in the groove.
- Install the stopper bolts and nuts for each pin, then grease the pin.
- Add fresh grease sufficiently until it is pushed out of the edge.
- If the dust seal is damaged when replacing the bucket, replace it with a new one. If the defective dust seal is not replaced, dirt and sand enter the pin portion and cause abnormal wear to the pin.

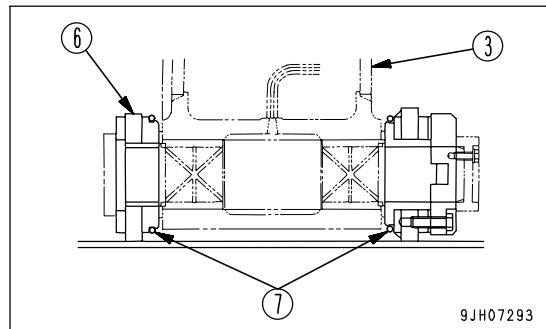

9JH07293

PARKING MACHINE

⚠ WARNING

- Avoid stopping suddenly. Give yourself ample room when stopping.
- When stopping the machine, select flat hard ground and avoid dangerous places.
If it is unavoidably necessary to park the machine on a slope, insert blocks underneath the track shoes. As an additional safety measure, thrust the bucket into the ground.
- If the control lever is touched by accident, the machine may move suddenly, and this may lead to a serious accident.
Before leaving the operator's compartment, always set the lock lever securely to LOCK position.

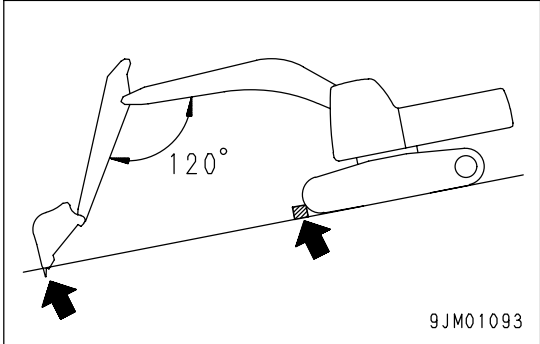

1. Put left and right travel levers (1) in the neutral position.
The machine stops.

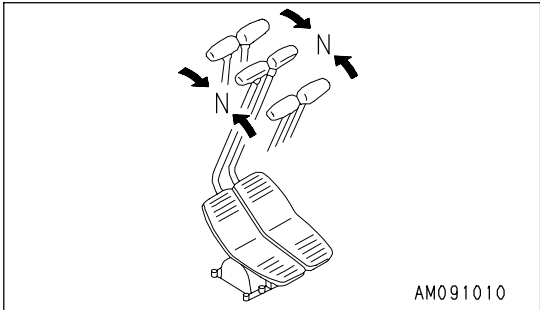
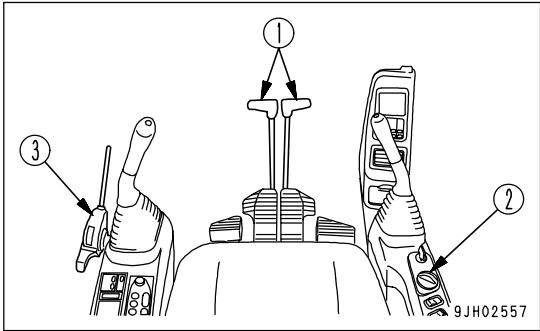

2. Turn fuel control dial (2) to lower the engine speed to low idle.

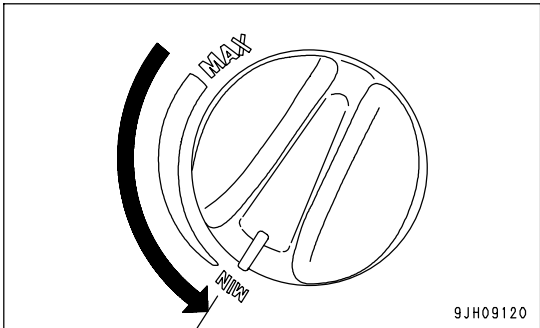

- Lower the bucket horizontally until the bottom touches the ground.

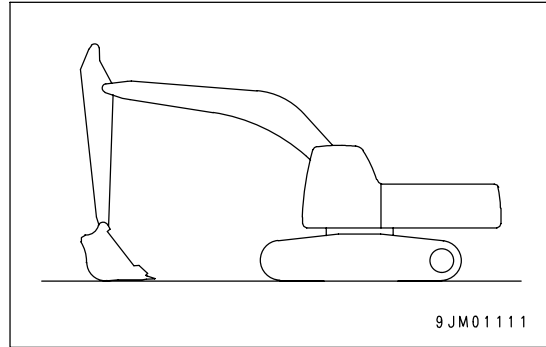

- Set lock lever (3) in the LOCK position (L).

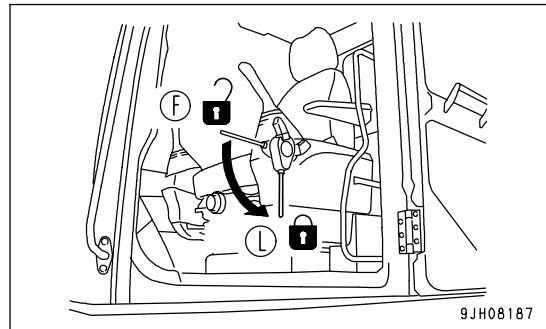

- Check the engine cooling water temperature and engine oil pressure with the machine monitor.

- If the coolant temperature gauge is in the red range, allow it to cool until the indicator enters the black range, then stop the engine. For details of the inspection and action to take, see "TROUBLES AND ACTIONS (PAGE 3-155)".
- If the engine oil pressure monitor lights up, stop the engine immediately. For details of the inspection and action to take, see "TROUBLES AND ACTIONS (PAGE 3-155)".

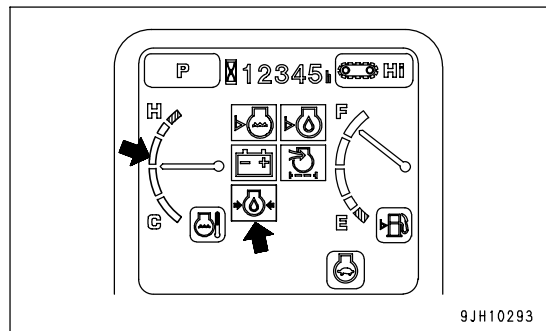

- Stop the engine. For details on the procedure for stopping the engine, see "STOPPING THE ENGINE (PAGE 3-111)".

MACHINE INSPECTION AFTER DAILY WORK

- Walk around the machine and check the work equipment, machine exterior, and undercarriage, also check for any leakage of oil or coolant. If any problems are found, repair them.
- Fill the fuel tank.
- Check the engine compartment for paper and debris. Clean out any paper and debris to avoid a fire hazard.
- Remove any mud affixed to the undercarriage.

LOCKING

Always lock the following places.

- (1) Operator's cab door
Always close the window.
- (2) Fuel tank filler port cap
- (3) Hydraulic tank filler port cap
- (4) Battery box cover
- (5) Engine room door (2 place)
- (6) Air cleaner room door
- (7) Right side door of the machine
- (8) Tool box door
- (9) Sub-tank inspection cover
- (10) Maintenance floor entrance door

REMARK

Use the starting switch key to lock and unlock all these places.

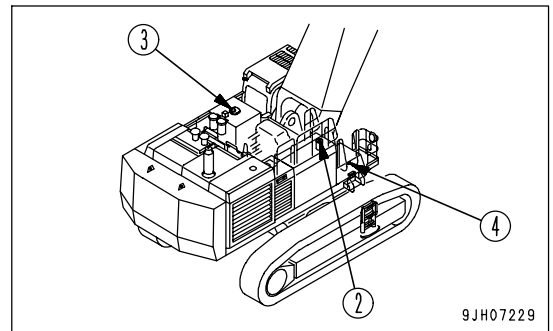
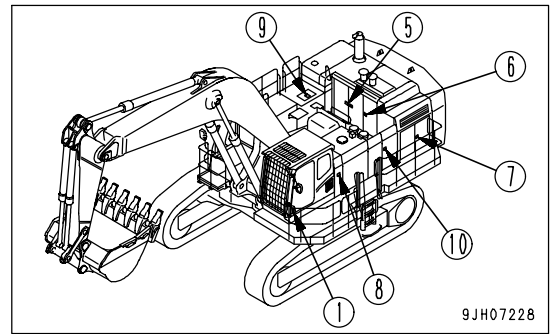

TRANSPORTATION

When transporting the machine, observe all related laws and regulations, and be careful to assure safety.

TRANSPORTATION PROCEDURE

Select the method of transportation to match the weight and dimensions given in "SPECIFICATIONS (PAGE 5-2)". Note that the weight and dimensions given in SPECIFICATIONS may differ according to the type of shoe or arm, or other attachments.

PRECAUTIONS FOR TRANSPORTATION



WARNING

This machine must be disassembled for transportation. When transporting the machine, please consult your Komatsu distributor.

LIFTING MACHINE



WARNING

- The operator carrying out the lifting operation using a crane must be a properly qualified crane operator.
- Never raise the machine with any worker on it.
- Always make sure that the wire rope is of ample strength for the weight of this machine.
- When lifting, keep the machine horizontal.
- When carrying out lifting operations, set the lock lever to the LOCK position to prevent the machine from moving unexpectedly.
- Never enter the area under or around a raised machine.

Never try to lift the machine in any posture other than the posture given in the procedure below or using lifting equipment other than in the procedure below.

There is a hazard that the machine may lose its balance.

NOTICE

This method of lifting applies to the standard specification machine.

The method of lifting differs according to the attachments and options installed.

For details of the procedure for machines that are not the standard specification, please consult your Komatsu distributor.

For weight, see "SPECIFICATIONS (PAGE 5-2)".

When lifting the machine, carry out the operation on flat ground as follows.

1. Lifting machine

(lifting upper structure)

Fit wires to boom foot pins (1) and lifting bracket (2) , and lift the machine.

- Lifting load is 26.7 tons (58,874 lb) (fuel: empty, hydraulic oil: M level).
- Diameter of boom foot pin (1): 160 mm (6.3 in)
- Diameter of hole at lifting position of lifting bracket (2): 70 mm (2.8 in)
- (G): center of gravity
- (L): 3,375 mm (11 ft 1 in)

2. The mark for the center of gravity installed to the machine shows the position of the center of gravity in the condition shown in the diagram on the right.

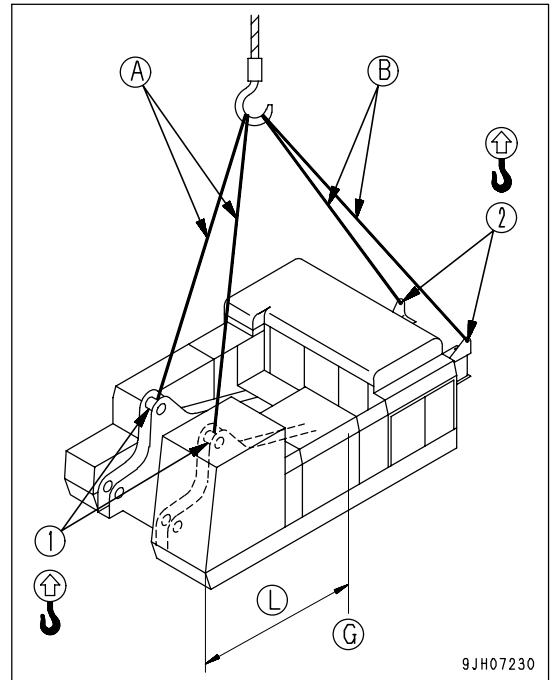

(M): Distance between centers (horizontal) measurement
5,100mm (16 ft 9 in)

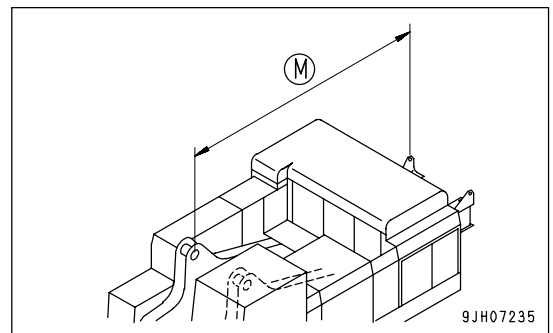

3. Combination of wire length

The length of the wire is the length from the pin and center of the hole.

- When using the following wire, use wire of more than the length given below.
- In addition, select a wire length that will bring the lifting position directly above the center of gravity of the machine.

	Unit	Combination
(A)	mm (ft in)	70,00 (22' 12")
(B)	mm (ft in)	80,00 (26' 3")

4. After the machine comes off the ground, check the hook condition and the lifting posture, and then lift slowly.

SHIPPING MACHINE INFORMATION

**WARNING**

Load the machine on a level and hard place. Secure a sufficient distance between the road shoulder and the machine.

NOTICE

Stow the antenna away.

After placing the machine on the specified position of the trailer, secure it according to the following procedure.

1. Close all doors, windows, and covers.
 - Lock the covers, caps, and doors fitted with locks.
2. Set the lock lever securely to the LOCK position (L).

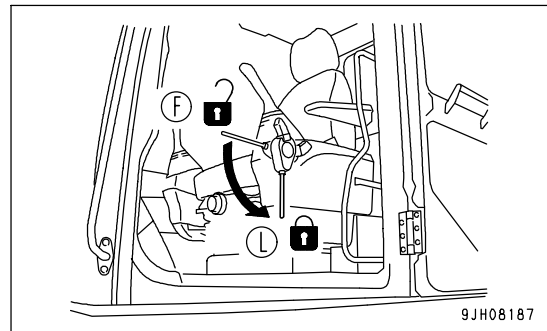

3. Place blocks under both ends of the tracks to prevent the undercarriage assembly from moving during transportation, and secure the undercarriage with chains or wires of suitable strength.

Be particularly careful to secure the undercarriage in position so that it does not slip to the side.

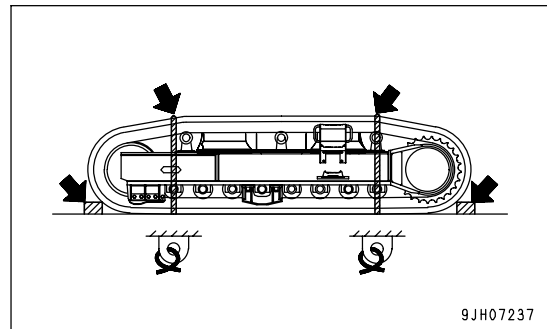

4. To prevent the machine assembly from moving during transportation, secure the machine with chains or wire rope of suitable strength.

Be particularly careful to secure the machine assembly in position so it does not slip to the side.

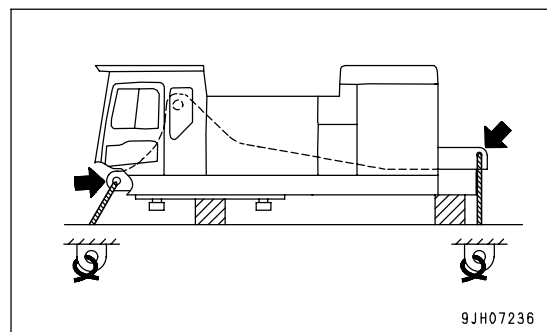

TRANSPORTATION POSTURE

This machine can be divided into seven units for transportation. When transporting, contact your Komatsu distributor.

Seven Units for Transportation

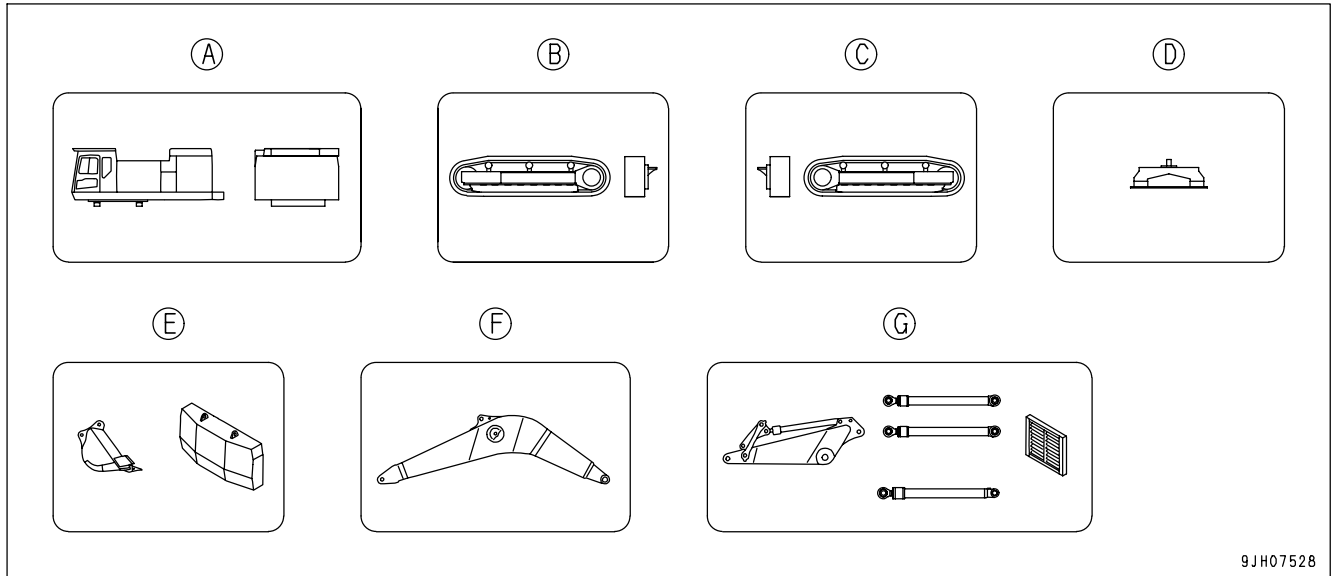

- (A) Upper Structure
- (B) Undercarriage (right)
- (C) Undercarriage (left)
- (D) Center frame

- (E) Counterweight and bucket
- (F) Boom
- (G) Arm and Boom cylinder and Arm cylinder and Outer cover

Posture for Each Unit

(dimensions in diagram are in mm.)

Upper Structure

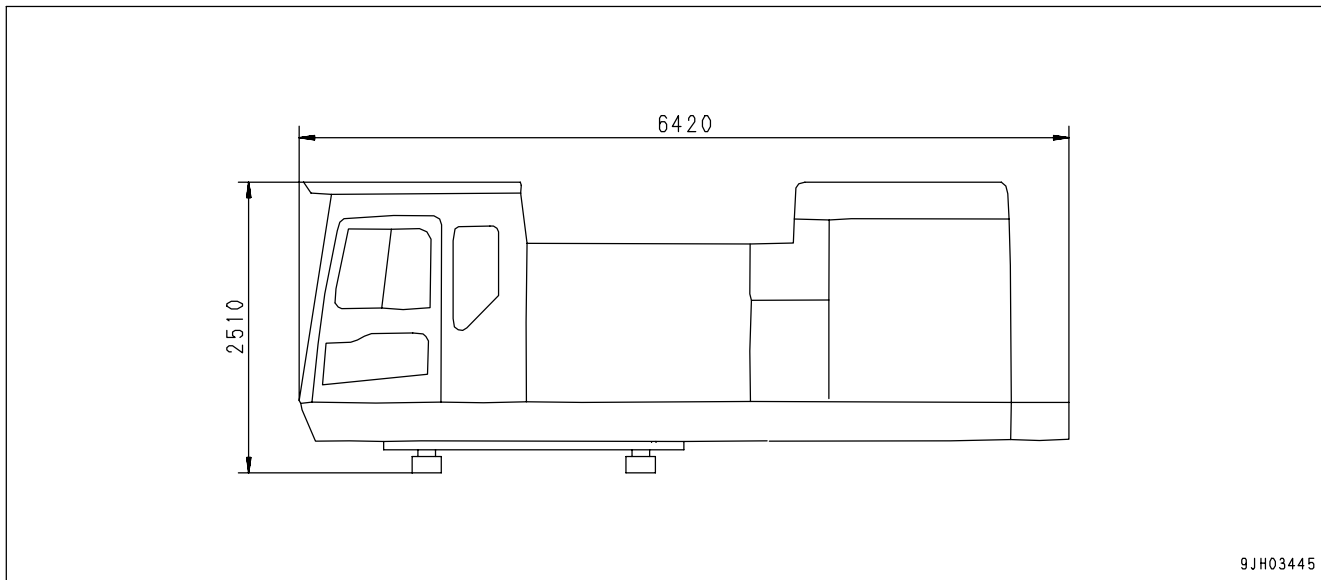

Unit		PC1250-8, PC1250SP-8, PC1250LC-8
Overall width	mm (ft in)	3,490 (11' 5")
Weight	kg (lb)	26,700 (58,874) (fuel: empty, Hydraulic oil: M level)

Secure the upper structure to the platform with a chain and block.

Undercarriage

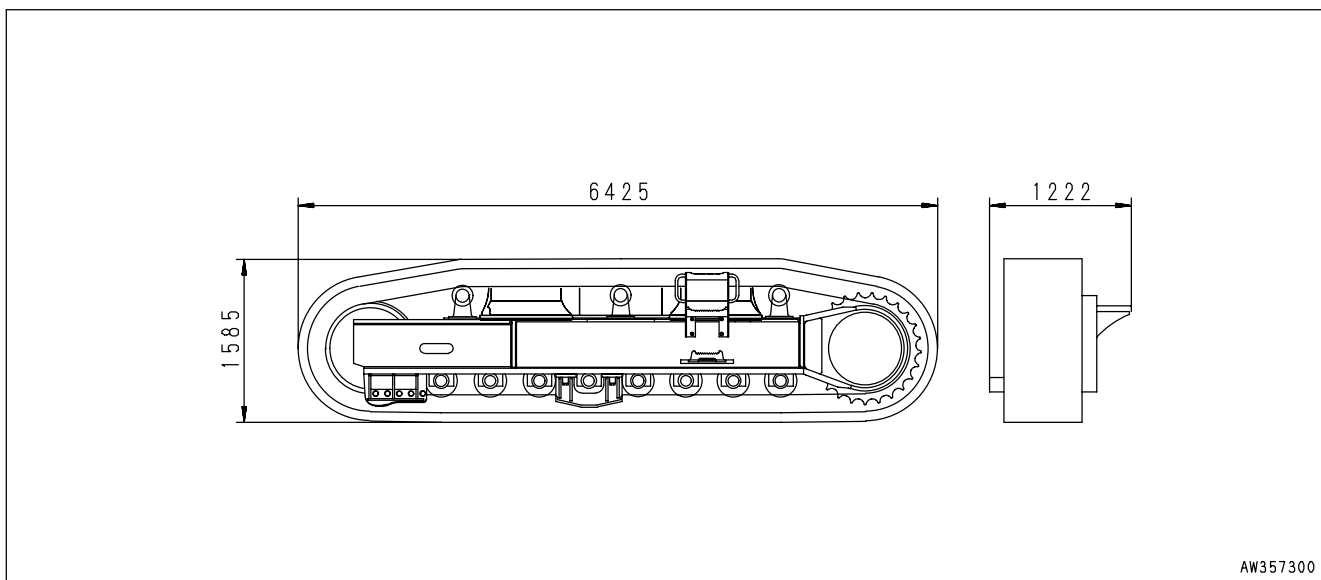

Unit		PC1250-8, PC1250SP-8, PC1250LC-8	
Amount		1 (left)	1 (Right)
Weight	kg (lb)	15,250 (33,626)	15,250 (33,626)

If there is a warning tag hanging on the work equipment control lever, do not start the engine.

Center Frame

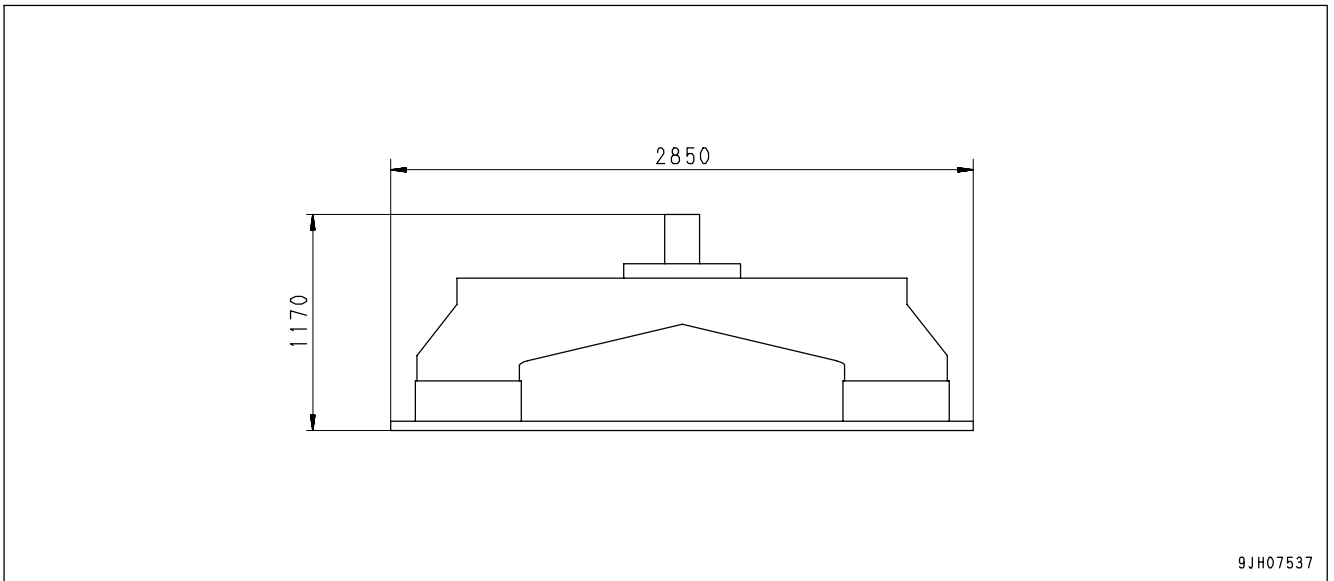

Unit		PC1250-8, PC1250SP-8, PC1250LC-8
Weight	kg (lb)	9,700 (21,389)

Counterweight

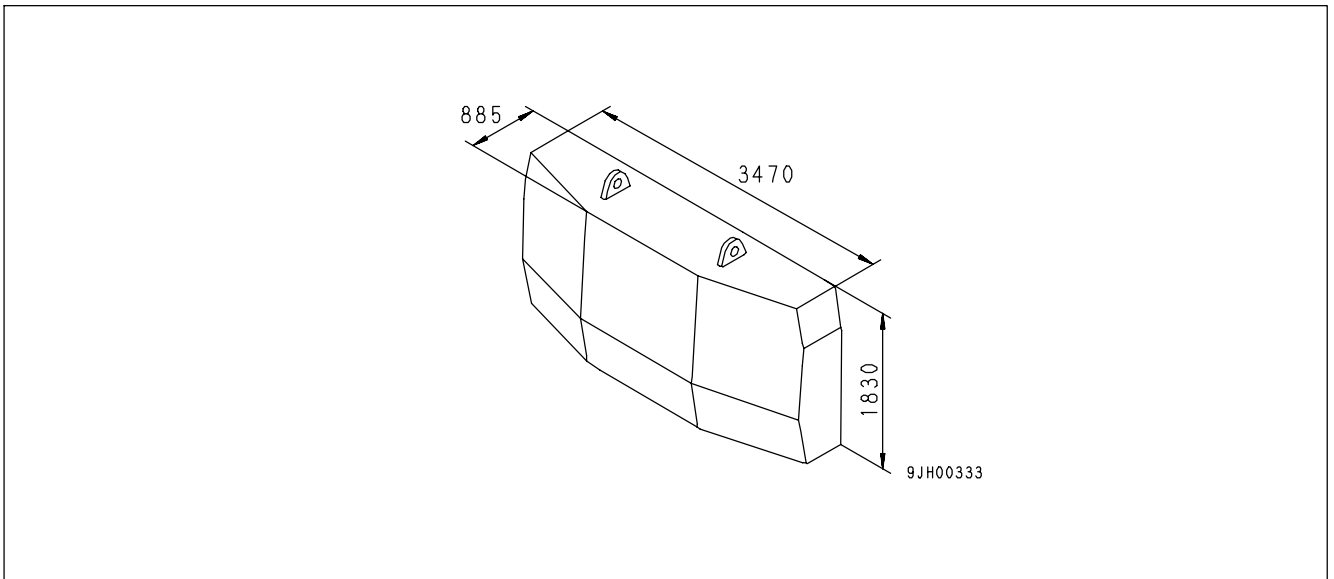

Unit		PC1250-8, PC1250SP-8, PC1250LC-8
Weight	kg (lb)	18,000 (39,690)

Boom

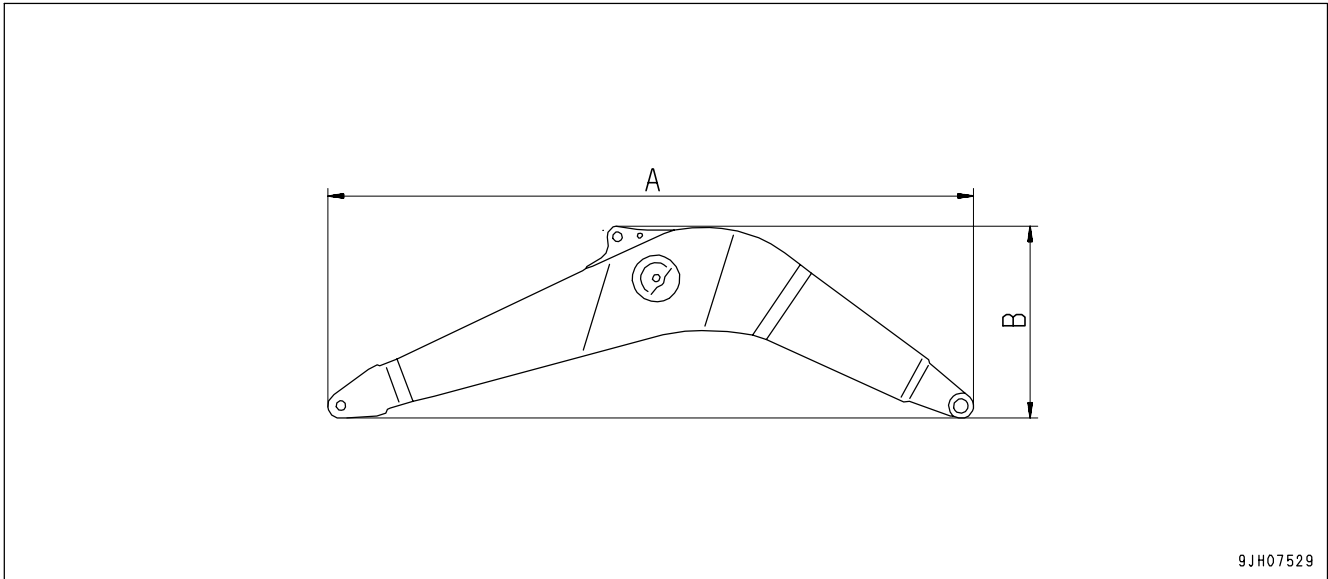

9JH07529

Unit		PC1250-8 PC1250LC-8	PC1250SP-8
A	mm (ft in)	9,475 (31' 1")	8,170 (26' 10")
B	mm (ft in)	2,894 (9' 6")	3,095 (10' 2")
Overall width	mm (ft in)	1,474 (4' 10")	1,474 (4' 10")
Weight	kg (lb)	11,200 (24,696)	11,100 (24,476)

Arm

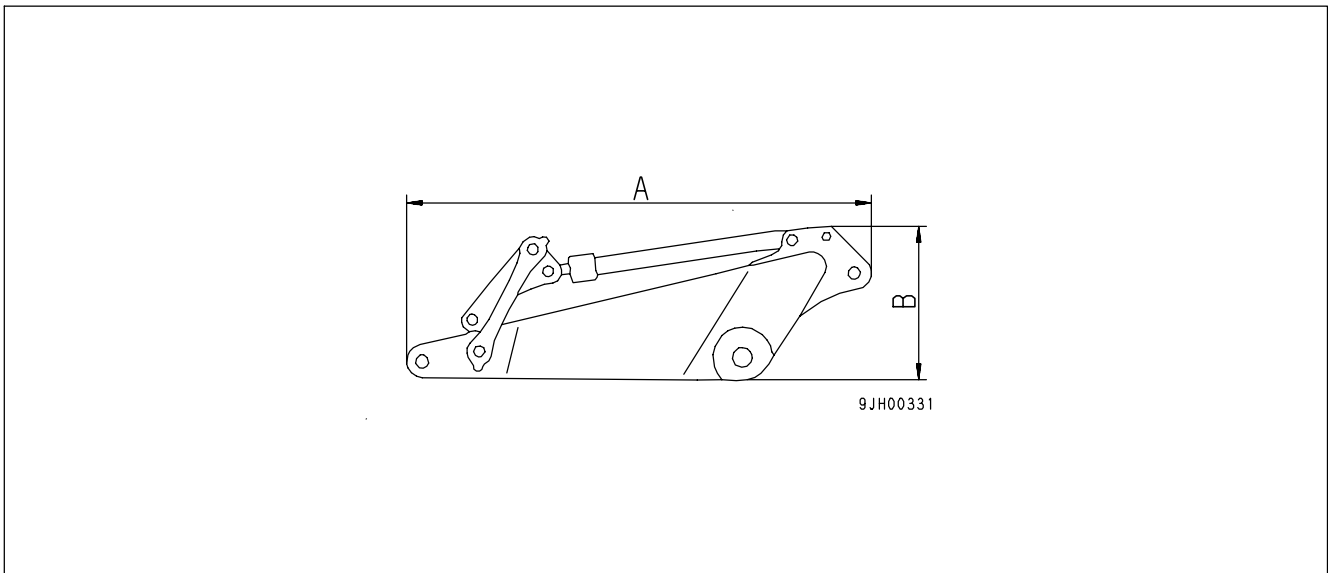

9JH00331

Unit		PC1250-8 PC1250LC-8	PC1250SP-8
A	mm (ft in)	4,895 (16' 1")	4,914 (16' 1")
B	mm (ft in)	1,626 (5' 4")	1,683 (5' 6")
Overall width	mm (ft in)	890 (2'11")	890 (2'11")
Weight	kg (lb)	6,200 (13,671)	6,400 (14,112)

Bucket

(except side cutter, shroud)

Unit		PC1250-8 PC1250LC-8	PC1250SP-8
A	mm (ft in)	2,580 (8' 6")	2,527 (8' 3")
B	mm (ft in)	2,276 (7' 6")	2,420 (7' 11")
Overall width	mm (ft in)	2,250 (7' 5")	2,520 (8' 3")
Weight	kg (lb)	5,500 (12,128)	6,300 (18,892)

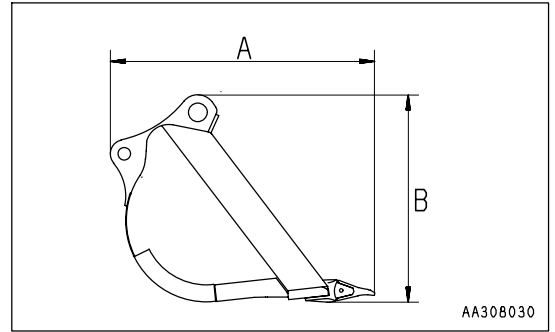

Boom Cylinder

Unit		same for all models
Weight	kg (lb)	2,400 (5,292) [1,200 (2,646) × 2]

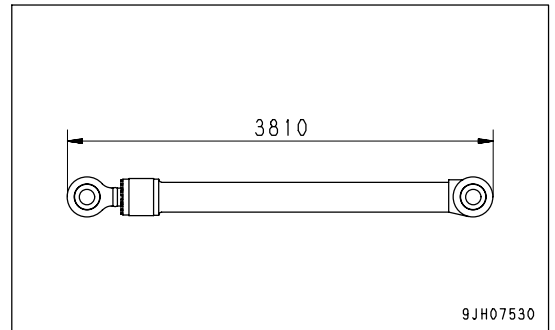

Arm Cylinder

Unit		same for all models
Weight	kg (lb)	1,500 (3,308)

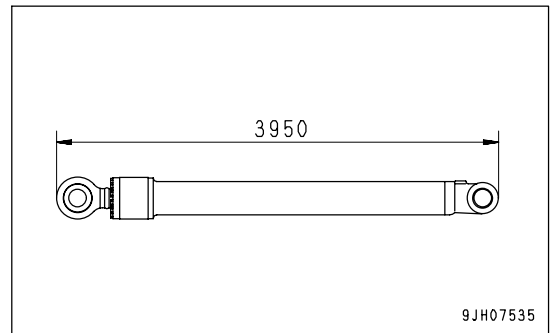

Outer Cover

- Radiator duct (same for all models)

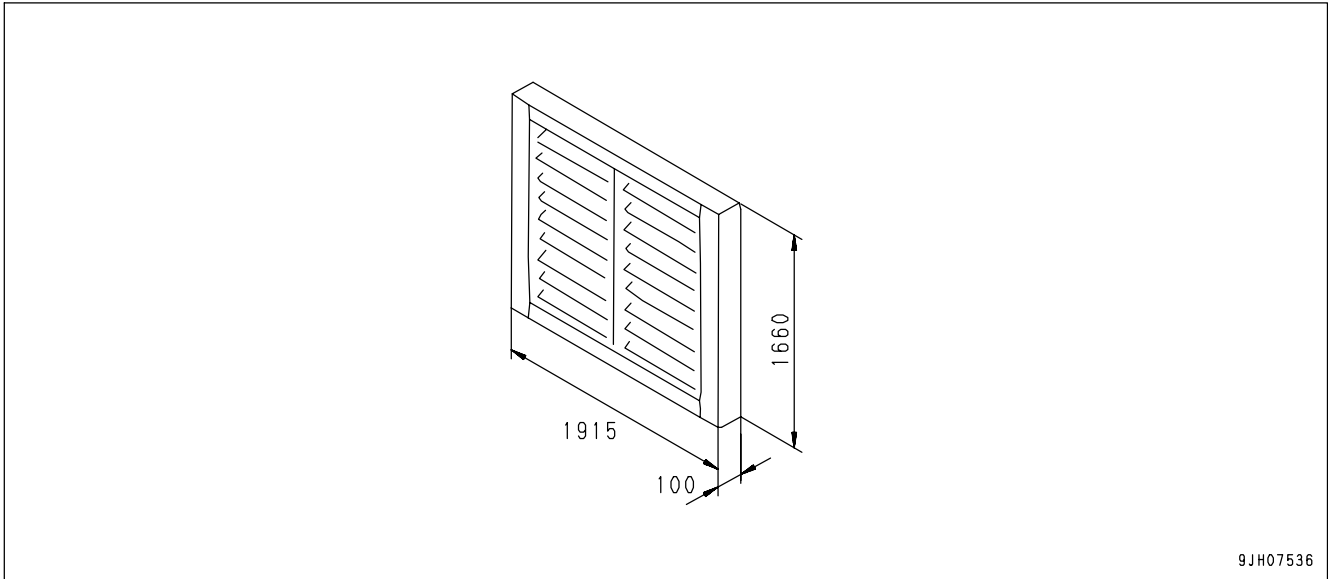

Unit		PC1250-8, PC1250SP-8, PC1250LC-8
Weight	kg (lb)	100 (221)

- Radiator duct upper cover (same for all models)

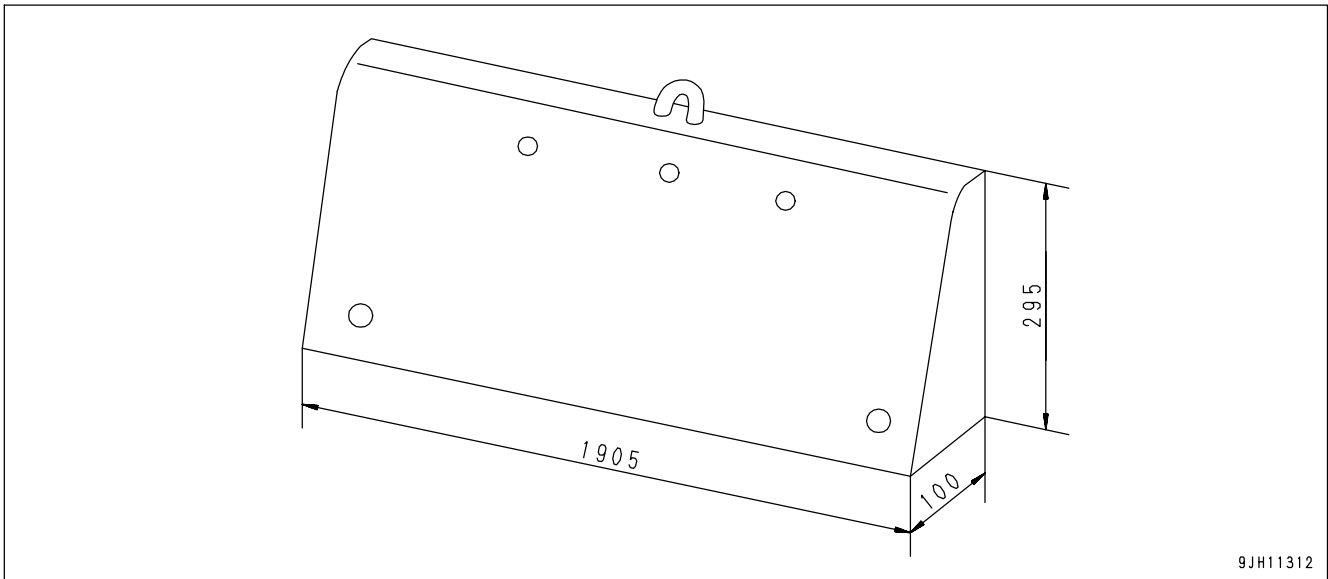

Unit		PC1250-8, PC1250SP-8, PC1250LC-8
Weight	kg (lb)	17 (37)

- Catwalk (right) : (same for all models)

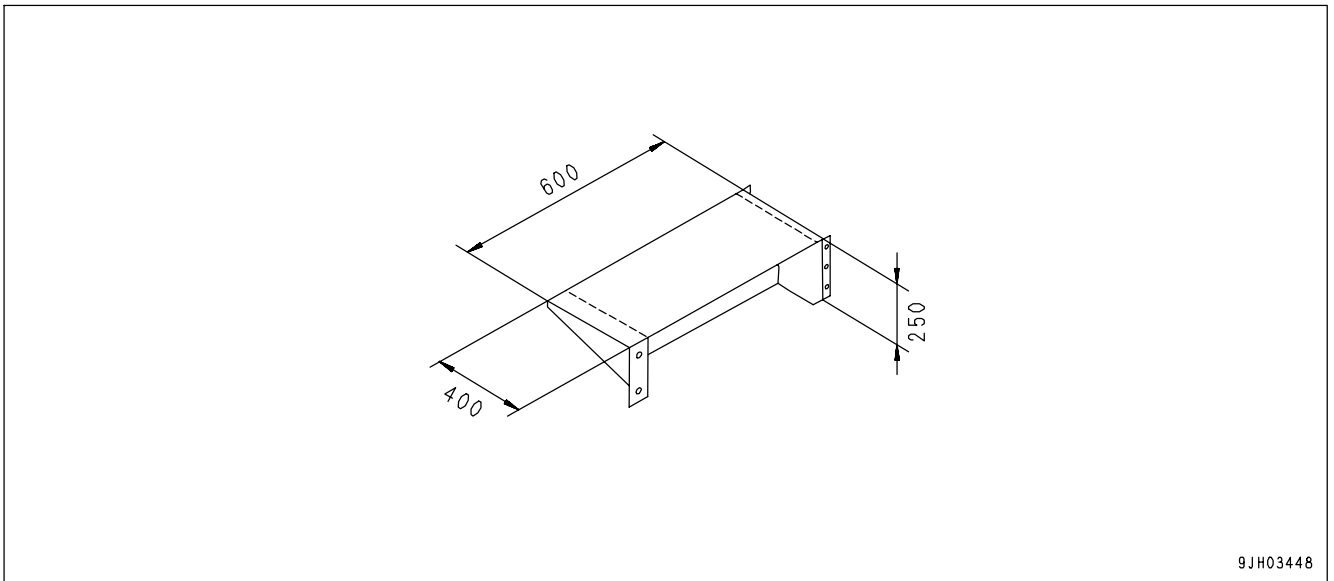

9JH03448

Unit		PC1250-8, PC1250SP-8, PC1250LC-8
Weight	kg (lb)	17 (37)

- Catwalk (left, front) : (same for all models)

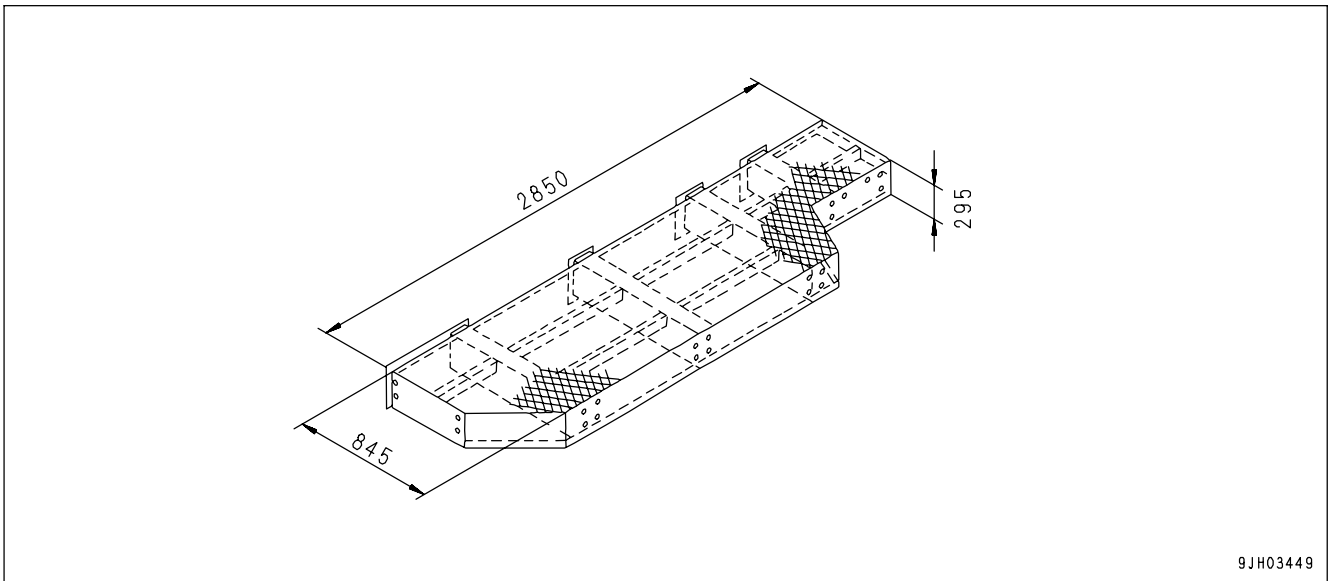

9JH03449

Unit		PC1250-8, PC1250SP-8, PC1250LC-8
Weight	kg (lb)	150 (331)

- Catwalk (left, rear) : (same for all models)

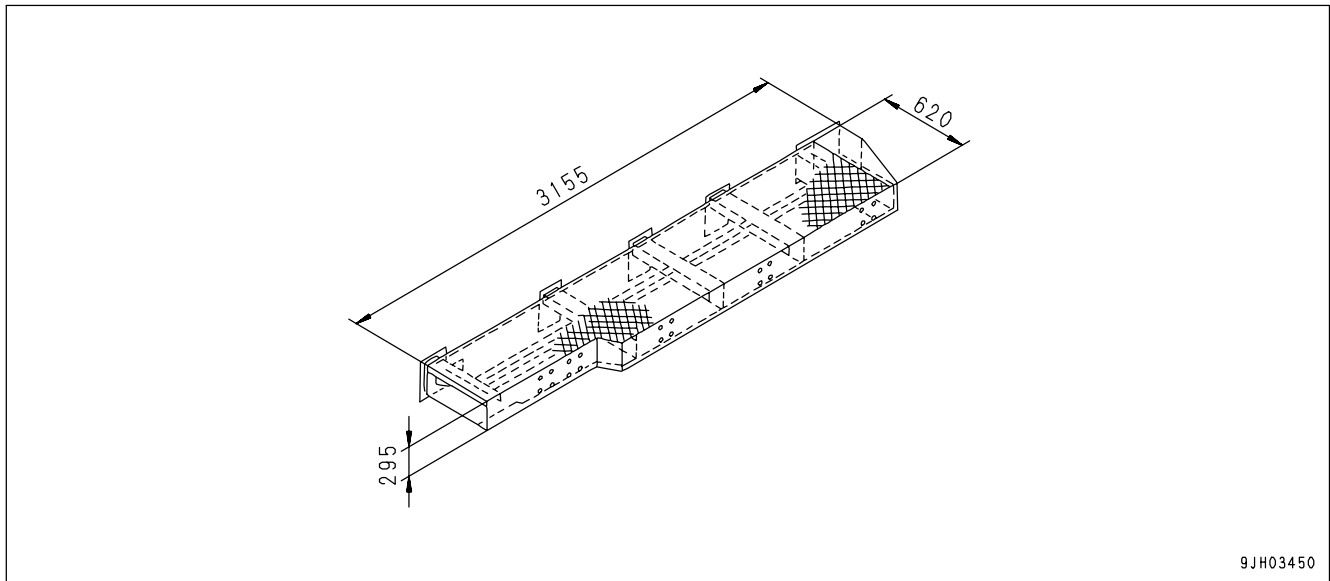

9JH03450

Unit		PC1250-8, PC1250SP-8, PC1250LC-8
Weight	kg (lb)	160 (353)

COLD WEATHER OPERATION

COLD WEATHER OPERATION INFORMATION

If the temperature becomes low, it becomes difficult to start the engine, and the coolant may freeze, so do as follows.

Fuel and Lubricants

Change to fuel and oil with low viscosity for all components. For details of the specified viscosity, see "RECOMMENDED FUEL, COOLANT, AND LUBRICANT (PAGE 4-9)".

Cooling System Coolant



WARNING

- Antifreeze is toxic. Be careful not to get it into your eyes or on your skin. If it should get into your eyes or on your skin, wash it off with large amounts of fresh water and see a doctor at once.
- When changing the coolant or when handling coolant containing antifreeze that has been drained when repairing the radiator, please contact your Komatsu distributor or request a specialist company to carry out the operation. Antifreeze is toxic. Do not let it flow into drainage ditches or spray it onto the ground surface.
- Antifreeze is flammable. Do not bring any flame close. Do not smoke when handling antifreeze.

NOTICE

Please use Komatsu genuine supercoolant (AF-NAC) for the coolant. As a basic rule, we do not recommend the use of any coolant other than Komatsu genuine supercoolant.

For details of the antifreeze mixture when changing the coolant, see "CLEAN INSIDE OF COOLING SYSTEM (PAGE 4-20)".

Battery

 **WARNING**

- The battery generates flammable gas. Do not bring fire or sparks near the battery.
- Battery electrolyte is dangerous. If it gets in your eyes or on your skin, wash it off with a large amount of water and consult a doctor.
- Battery electrolyte dissolves paint. If it gets on the bodywork, wash it off immediately with water.
- If the battery electrolyte is frozen, do not charge the battery or start the engine with a different power source. There is danger that the battery may explode.
- Battery electrolyte is toxic. Do not let it flow into drainage ditches or spray it on to the ground surface.

When the ambient temperature drops, the capacity of the battery will also drop. If the battery charge ratio is low, the battery electrolyte may freeze. Maintain the battery charge as close as possible to 100%. Insulate it against cold temperature to ensure the machine can be started easily the next morning.

REMARK

Measure the specific gravity and calculate the charging rate from the following conversion table.

Charging Rate (%)	Electrolyte Temperature	20°C (68°F)	0°C (32°F)	-10°C (14°F)	-20°C (-4°F)
	100		1.28	1.29	1.30
90		1.26	1.27	1.28	1.29
80		1.24	1.25	1.26	1.27
75		1.23	1.24	1.25	1.26

- As the battery capacity drastically drops in low temperatures, cover or remove the battery from the machine, store the battery in a warm place, and install it again the next morning.
- If the electrolyte level is low, add distilled water in the morning before beginning work. Do not add water after the day's work to prevent diluted electrolyte in the battery from freezing during the night.

Monitor

A feature of the liquid crystal monitor is that the screen becomes dark and is difficult to read in cold weather (particularly with the starting switch ON).

In this case, adjust the brightness and contrast of the screen.

For details, see "Liquid Crystal Monitor Adjustment Switch (PAGE 3-32)".

If the screen is dark, increase the brightness and contrast (extend the scale in the + Δ direction) to make the screen brighter and easier to read.

Brightness

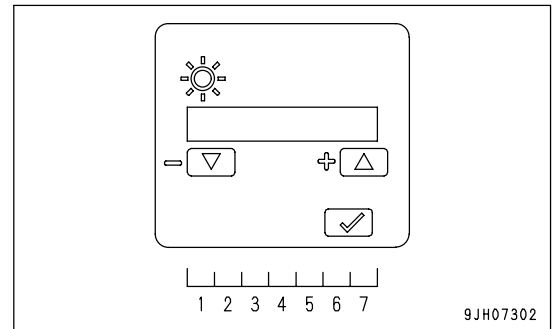

Contrast

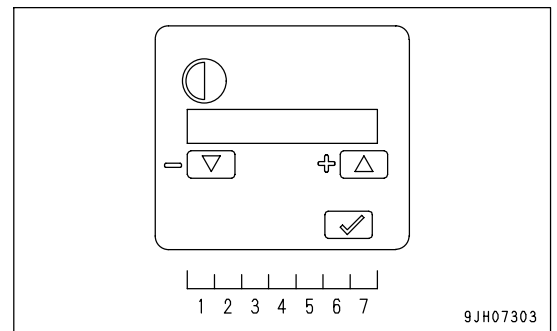

Guideline for bar display for brightness and contrast in cold weather

Ambient temperature	Brightness	Contrast
-10°C (14°F)	7 (max)	5 - 4
-20°C (-4°F)	7	7 - 6

AFTER DAILY WORK COMPLETION



WARNING

Performing idle-running of the tracks is dangerous, stay well away from the tracks.

To prevent mud, water, or the undercarriage from freezing and making it impossible for the machine to move on the following morning, observe the following precautions.

- Remove all the mud and water from the machine body. In particular, wipe the hydraulic cylinder rods clean to prevent damage to the seal caused by mud, dirt, or drops of water on the rod from getting inside the seal.
- Park the machine on hard, dry ground.

If this is impossible, park the machine on boards.

The boards prevent the tracks from freezing to the ground, and allow the machine to be moved the next morning.

- Open the drain valve and drain any water collected in the fuel system to prevent it from freezing.
 - Fill the fuel tank to capacity. This minimizes moisture condensation in the tank when the temperature drops.
 - After operation in water or mud, remove water from undercarriage as described below to extend undercarriage service life.
1. Swing 90° with engine at low idle and bring the work equipment to the side of the track.
 2. Jack up the machine until the track is raised slightly from the ground. Rotate the track under no load. Repeat this procedure on both the left and right sides.

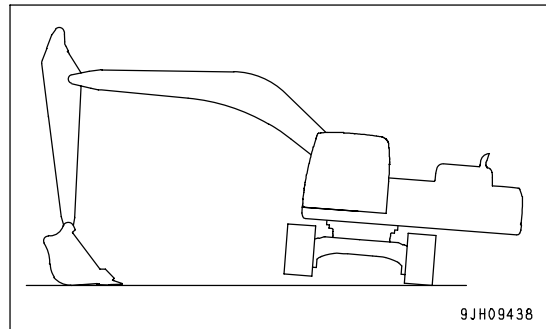

AFTER COLD WEATHER SEASON

When the season changes and the weather becomes warmer, do as follows.

- Replace the fuel and oil for all parts with oil of the viscosity specified.
For details, see "RECOMMENDED FUEL, COOLANT, AND LUBRICANT (PAGE 4-9)".

LONG TERM STORAGE

BEFORE STORAGE

NOTICE

To protect the hydraulic cylinder piston rod while in storage, keep the work equipment in the posture shown at right.

(This prevents rust from developing on the piston rod)

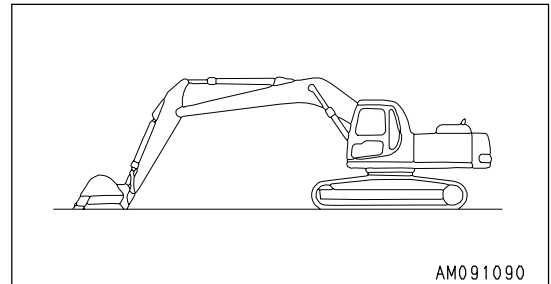

When putting the machine in storage for a long time (more than one month), do as follows.

- Clean and wash all parts, then store the machine indoors. If the machine has to be stored outdoors, select level ground and cover the machine with canvas.
- Completely fill the fuel tank. This prevents moisture from collecting.
- Lubricate and change the oil before storage.
- Coat the exposed portion of the hydraulic cylinder piston rod with grease.
- Disconnect the negative terminals of the battery and cover it or remove it from the machine and store it separately.
- Lock each control lever and pedal with the lock lever and pedal lock.
- To prevent rust, fill with Komatsu genuine supercoolant (AF-NAC) to give a density of at least 30% for the engine coolant.

DURING STORAGE



WARNING

If it is necessary to perform the rust-prevention operation while the machine is indoors, open the doors and windows to improve ventilation and prevent gas poisoning.

- During storage, operate and move the machine for a short distance once a month so that a new film of oil will coat moving parts. At the same time, also charge the battery.
- When operating the work equipment, wipe off all the grease from the hydraulic cylinder rods.
- If the machine is equipped with an air conditioner, operate the air conditioner for 3 to 5 minutes once a month to lubricate all parts of the air conditioner compressor. Always run the engine at low idle when doing this. In addition, check the refrigerant level twice a year.

AFTER STORAGE

NOTICE

If the machine has been stored without carrying out the monthly rust-prevention operation, consult your Komatsu distributor before using it.

When using the machine after long-term storage, do as follows before using it.

- Wipe off the grease from the hydraulic cylinder rods.
- Add oil and grease at all lubrication points.
- When the machine is stored for a long period, moisture in the air will mix with the oil. Check the oil before and after starting the engine. If there is water in the oil, change all the oil.

STARTING MACHINE AFTER LONG-TERM STORAGE

When starting the engine after long-term storage, carry out the warming-up operation thoroughly. For details, see "Engine Warm Up (PAGE 3-101)".

TROUBLES AND ACTIONS

RUNNING OUT OF FUEL

When starting the engine again after running out of fuel, fill with fuel, then bleed the air from the fuel system before starting the engine.

For details of the method of bleeding the air, see "BLEEDING AIR FROM FUEL CIRCUIT (PAGE 4-40)".

PHENOMENA THAT ARE NOT FAILURES

Note that the following phenomena are not failures:

- When the arm control lever is operated to the IN position and the work equipment is lowered under no load from a high position, the arm speed will drop momentarily when the arm is more or less at the vertical position.

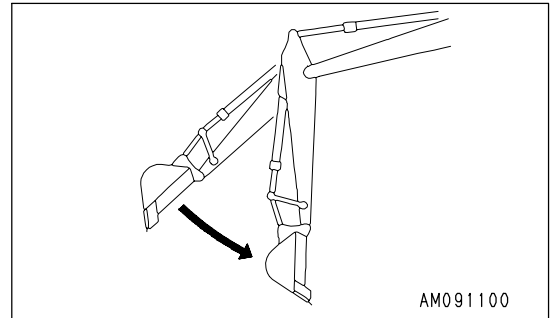

- When the bucket control lever is operated to the CURL position and the work equipment is lowered under no load from a high position, the bucket speed will drop momentarily when the bucket teeth are more or less at the horizontal position.
- The bucket or arm will fluctuate by itself during heavy-duty digging operations.

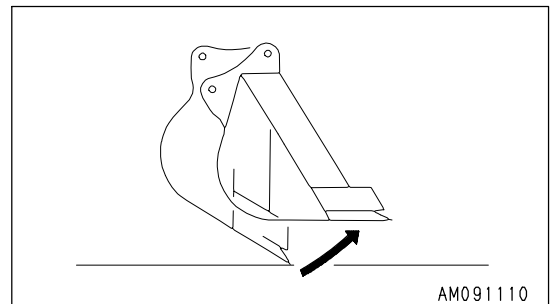

- When starting or stopping the swing, noise will be emitted from the brake valve.
- When going down a steep slope at low speed, a noise will be emitted from the travel motor brake valve.

TOWING THE MACHINE



WARNING

Serious injury or death could result if a disabled machine is towed incorrectly or if there is a mistake in the selection or inspection of the wire rope.

- Always check that the wire rope used for towing has ample strength for the weight of the machine being towed.
- Never use a wire rope which has cut strands (A), reduced diameter (B), or kinks (C). There is danger that the rope may break during the towing operation.
- Always wear leather gloves when handling wire rope.
- Never tow a machine on a slope.
- During the towing operation, never stand between the towing machine and the machine being towed.
- Operate the machine slowly and be careful not to apply any sudden load to the wire rope.

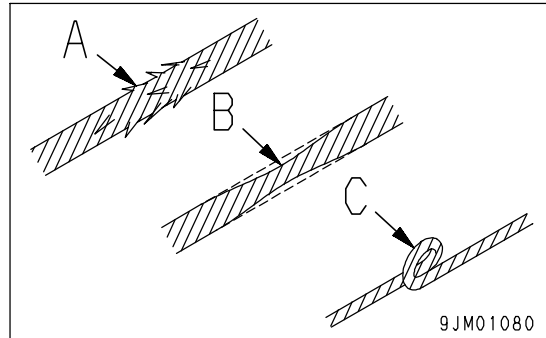

NOTICE

The maximum towing capacity for this machine is 686,000N (70,000 kg). Always carry out towing operations within the maximum towing capacity.

- If the machine sinks in mud and cannot get out under its own power, or if the drawbar pull of the excavator is being used to tow a heavy object, use a wire rope as shown in the diagram on the right.
- Place pieces of wood between wire ropes and body to prevent damage to ropes and body.
- Hold the wire rope level and direct it straight to the track frame.
- When towing a machine, travel at a speed of less than 1 km/h for a distance of only a few meters to a place that is suitable for carrying out repairs.

This is for use only in emergencies.

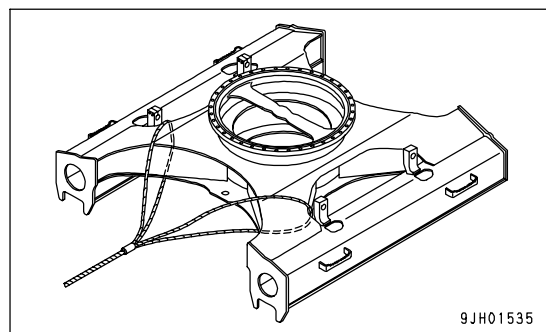
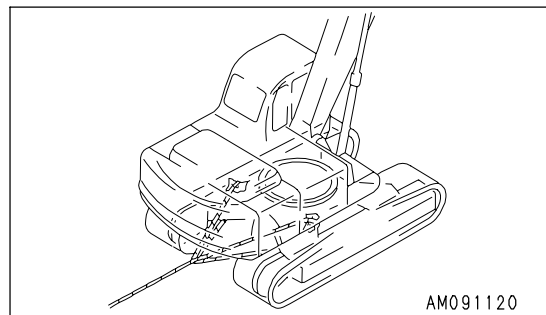

SEVERE JOB CONDITION

- When carrying out digging operations in water, if the work equipment mounting pin goes into the water, carry out greasing every time the operation is carried out.
 - For heavy-duty operations and deep digging, carry out greasing of the work equipment mounting pins every time before operation.
- After greasing, operate the boom, arm and bucket several times, then grease again.

DISCHARGED BATTERY

 **WARNING**

- It is dangerous to charge a battery when mounted on a machine. Make sure that it is dismantled before charging.
- When checking or handling the battery, stop the engine and turn the starting switch key to the OFF position.
- The battery generates hydrogen gas, so there is a hazard of explosion. Do not bring lighted cigarettes near the battery, or do anything that will cause sparks.
- Battery electrolyte is dilute sulfuric acid, and it will attack your clothes and skin. If it gets on your clothes or on your skin, immediately wash it off with a large amount of water. If it gets in your eyes, wash it out with fresh water and consult a doctor.
- When handling batteries, always wear safety glasses and rubber gloves.
- When removing the battery, first disconnect the cable from the ground (normally the negative (-) terminal). When installing, install the positive (+) terminal first.
If a tool touches the positive terminal and the chassis, there is danger that it will cause a spark, so be extremely careful.
- If the terminals are loose, there is danger that the defective contact may generate sparks that will cause an explosion.
- When removing or installing the terminals, check which is the positive (+) terminal and which is the negative (-) terminal.

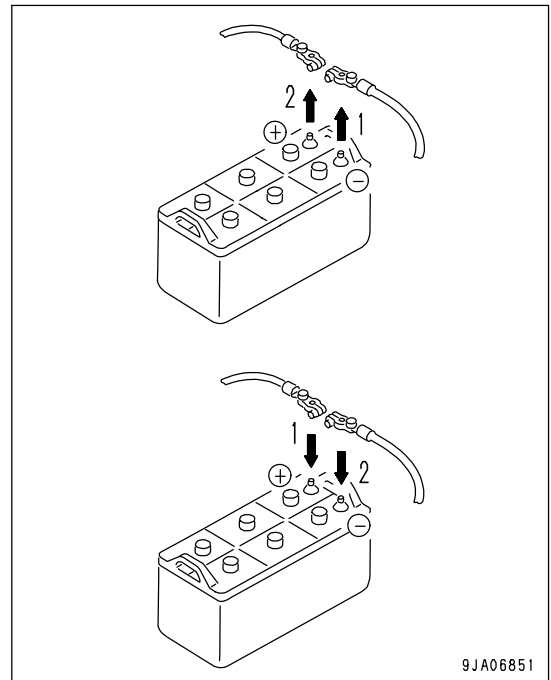

9JA06851

Battery Removal and Installation

- Before removing the battery, remove the ground cable (normally connected to the negative (-) terminal).
If any tool touches between the positive terminal and the chassis, there is a hazard of sparks being generated.
- When installing the battery, connect the ground cable last.
- When replacing the battery, fix the battery securely in position with the battery mounting clamp.
Tightening torque of mounting bolt: 9.8 to 19.6 Nm (1.0 to 2.0 kgm, 7.2 to 14.5 lbft)

Battery Charges

When charging the battery, if the battery is not handled correctly, there is a hazard that the battery may explode. Always follow the instructions of "DISCHARGED BATTERY (PAGE 3-157)" and the instruction manual accompanying the charger, and do as follows.

- Set the voltage of the charger to match the voltage of the battery to be charged. If the correct voltage is not selected, the charger may overheat and cause an explosion.
- Connect the positive (+) charger clip of the charger to the positive (+) terminal of the battery, then connect the negative (-) charger clip of the charger to the negative (-) terminal of the battery. Be sure to attach the clips securely.
- Set the charging current to 1/10 of the value of the rated battery capacity; when carrying out rapid charging, set it to less than the rated battery capacity.
If the charger current is too high, the electrolyte will leak or dry up, and this may cause the battery to catch fire and explode.
- If the battery electrolyte is frozen, do not charge the battery or start the engine with a different power source. There is a danger that this will ignite the battery electrolyte and cause the battery to explode.
- Do not use or charge the battery if the battery electrolyte level is below the LOWER LEVEL line. This may cause an explosion. Check the battery electrolyte level periodically and add distilled water to bring the electrolyte level to the UPPER LEVEL line.

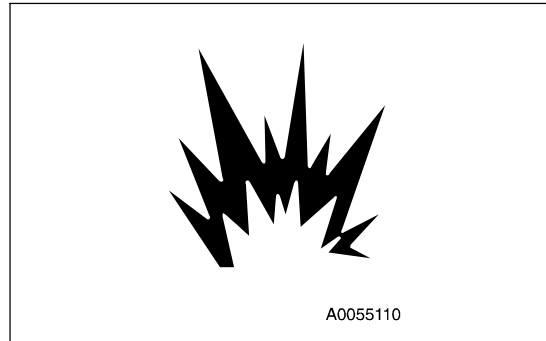

Starting Engine with Booster Cables

When starting the engine with a booster cable, do as follows.

Connecting and Disconnecting Booster Cables



WARNING

- When connecting the cables, never contact the positive (+) and negative (-) terminals.
- When starting the engine with a booster cable, always wear safety glasses.
- Be careful not to let the normal machine and problem machine contact each other. This prevents sparks from generating near the battery which could ignite the hydrogen gas given off by the battery. If hydrogen gas explodes, it could cause serious injury.
- Be careful not to make a mistake when connecting a booster cable. In the last connection (to the upper structure frame), a spark will be caused, connect the cable to a spot as far away from the battery as possible. (Avoid the work equipment, however, because it is not a good conductor)
- When removing the booster cable, exercise good care so that the booster cable clips may not contact each other, or they contact the chassis.

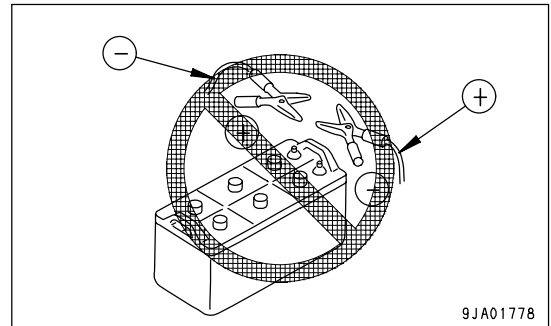

NOTICE

- The starting system for this machine uses 24V. For the normal machine, also use a 24V battery.
- The size of the booster cable and clip should be suitable for the battery size.
- The battery of the normal machine must be the same capacity as that of the engine to be started.
- Check the cables and clips for damage or corrosion.
- Make sure that the cables and clips are firmly connected.
- Check that the lock levers and parking brake levers of both machine are in the LOCK position.
- Check that each lever is in the NEUTRAL position.

Booster Cable Connection

Keep the starting switch of the normal machine and problem machine in the OFF position.

Connect the booster cable as follows, in the order of the numbers marked in the diagram.

1. Connect the clip of booster cable (A) to the positive (+) terminal of battery (C) on the problem machine.
2. Connect the clip at the other end of booster cable (A) to the positive (+) terminal of battery (D) on the normal machine.
3. Connect the clip of booster cable (B) to the negative (-) terminal of battery (D) on the normal machine.
4. Connect the other clip of booster cable (B) to the revolving frame (E) of the problem machine.

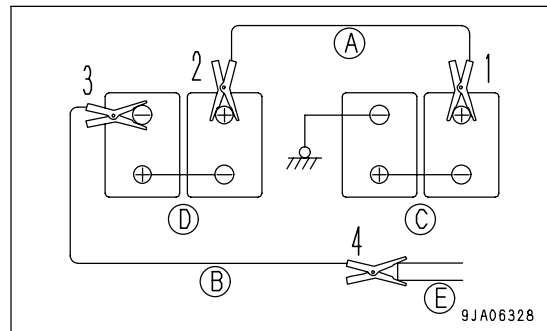

Starting the Engine



WARNING

Always check that the lock lever is set to the LOCK position, regardless of whether the machine is working normally or has failed. Check also that all the control levers are in the neutral position.

1. Make sure the clips are firmly connected to the battery terminals.
2. Start engine of the normal machine and run it at high idle speed.
3. Turn the starting switch of the problem machine to the START position and start the engine.
If the engine doesn't start at first, try again after 2 minutes or so.

Booster Cable Disconnection

After the engine has started, disconnect the booster cables in the reverse of the order in which they were connected.

1. Remove one clip of booster cable (B) from the revolving frame (E) of the problem machine.
2. Remove the clip of booster cable (B) from the negative (-) terminal of battery (D) on the normal machine.
3. Remove the clip of booster cable (A) from the positive (+) terminal of battery (D) on the normal machine.
4. Remove the clip of booster cable (A) from the positive (+) terminal of battery (C) on the problem machine.

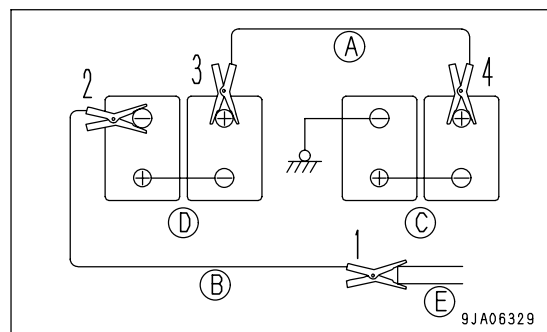

OTHER TROUBLE

Electrical System

- (): Always contact your Komatsu distributor when dealing with these items.
- In cases of problems or causes which are not listed below, contact your Komatsu distributor for repairs.

Problem	Main causes	Remedy
Lamp does not glow brightly even when the engine runs at high speed	<ul style="list-style-type: none"> • Defective wiring, deterioration of battery • Loose alternator drive belt 	<ul style="list-style-type: none"> (• Check, repair loose terminals, disconnections, replace battery) • Replace alternator drive belt, Check tension pulley
Lamp flickers while engine is running		
Charge level monitor does not go out even when engine is running	<ul style="list-style-type: none"> • Defective alternator • Defective wiring 	<ul style="list-style-type: none"> (• Replace) (• Check, repair)
Abnormal noise is generated from alternator	<ul style="list-style-type: none"> • Defective alternator 	<ul style="list-style-type: none"> (• Replace)
Starting motor does not turn when starting switch is turned to ON	<ul style="list-style-type: none"> • Defective wiring • Defective starting motor • Insufficient battery charge 	<ul style="list-style-type: none"> (• Check, repair) (• Replace) • Charge
Pinion of starting motor keeps going and out	<ul style="list-style-type: none"> • Insufficient battery charge • Defective safety relay 	<ul style="list-style-type: none"> • Charge (• Replace)
Starting motor turns engine sluggishly	<ul style="list-style-type: none"> • Insufficient battery charge • Defective starting motor 	<ul style="list-style-type: none"> • Charge (• Replace)
Starting motor disengages before engine starts	<ul style="list-style-type: none"> • Defective wiring, defective ring gear pinion • Insufficient battery charge 	<ul style="list-style-type: none"> (• Check, repair) • Charge
Engine pre-heating monitor does not light	<ul style="list-style-type: none"> • Defective wiring • Defective heater relay • Defective monitor 	<ul style="list-style-type: none"> (• Check, repair) (• Replace) (• Replace)
Oil pressure monitor does not light up when engine is stopped (starting switch at ON position)	<ul style="list-style-type: none"> • Defective monitor • Defective caution lamp switch 	<ul style="list-style-type: none"> (• Replace) (• Replace)
Outside of electrical heater is not warm when touched by hand	<ul style="list-style-type: none"> • Defective wiring • Disconnection in electric heater • Defective operation of heater relay switch 	<ul style="list-style-type: none"> (• Check, repair) (• Replace) (• Replace)

Chassis

- (): Always contact your Komatsu distributor when dealing with these items.
- In cases of problems or causes which are not listed below, contact your Komatsu distributor for repairs.

Problem	Main causes	Remedy
Speed of travel, swing, boom, arm, bucket is slow	• Lack of hydraulic oil	• Add oil to specified level, see CHECK BEFORE STARTING
Pump generates abnormal noise (sucking in air)	• Clogged element in hydraulic tank strainer, lack of oil	• Clean, see EVERY 2000 HOURS SERVICE
Excessive rise in hydraulic oil temperature	• Dirty oil cooler • Lack of hydraulic oil	• Clean, see EVERY 500 HOURS SERVICE • Add oil to specified level, see CHECK BEFORE STARTING
Track comes off	• Track too loose	• Adjust track tension, see WHEN REQUIRED
Abnormal wear of sprocket		
Boom rises slowly, does not rise	• Lack of hydraulic oil	• Add oil to specified level, CHECK BEFORE STARTING
Does not swing	• Swing lock switch still applied	• Turn swing lock switch OFF

Engine

- (): Always contact your Komatsu distributor when dealing with these items.
- In cases of problems or causes which are not listed below, contact your Komatsu distributor for repairs.

Problem	Main causes	Remedy
Engine oil pressure monitor lights up	<ul style="list-style-type: none"> • Engine oil pan oil level is low (sucking in air) • Clogged oil filter cartridge • Defective tightening of oil pipe, pipe joint, oil leakage from damaged point • Defective engine oil pressure sensor • Defective monitor 	<ul style="list-style-type: none"> • Add oil to specified level, see CHECK BEFORE STARTING • Replace cartridge, see EVERY 500 HOURS SERVICE (• Check, repair) (• Replace sensor) (• Replace monitor)
Steam spurts out from top of radiator (pressure valve)	<ul style="list-style-type: none"> • Coolant level low, leakage of water • Dirt or scale accumulated in cooling system • Clogged radiator fins or damaged fins 	<ul style="list-style-type: none"> • Check, add coolant, repair, see CHECK BEFORE STARTING • Change coolant, flush inside of cooling system, see WHEN REQUIRED • Clean or repair, see EVERY 500 HOURS SERVICE
Radiator coolant level monitor lights up	<ul style="list-style-type: none"> • Defective thermostat • Loose radiator filler cap (high-altitude operations) • Defective water level sensor • Defective monitor 	<ul style="list-style-type: none"> (• Replace thermostat) • Tighten cap or replace packing (• Replace sensor) (• Replace monitor)
Engine does not start when starting motor is turned	<ul style="list-style-type: none"> • Lack of fuel • Air in fuel system • Defective fuel injection pump or defective nozzle • Starting motor cranks engine sluggishly • Engine pre-heating monitor does not light up • Defective compression (defective valve clearance) 	<ul style="list-style-type: none"> • Add fuel, see CHECK BEFORE STARTING • Repair place where air is sucked in, see EVERY 500 HOURS SERVICE (• Replace pump or nozzle) • See ELECTRICAL SYSTEM • See ELECTRICAL SYSTEM (• Adjust valve clearance)
Exhaust gas is white or blue	<ul style="list-style-type: none"> • Too much oil in oil pan • Improper fuel 	<ul style="list-style-type: none"> • Set oil to specified level, see CHECK BEFORE STARTING • Change to specified fuel
Exhaust gas occasionally turns black	<ul style="list-style-type: none"> • Clogged air cleaner element • Defective nozzle • Defective compression • Defective turbocharger 	<ul style="list-style-type: none"> • Clean or replace, see WHEN REQUIRED (• Replace nozzle) (• See defective compression above) (• Clean or replace turbocharger)
Combustion noise occasionally make breathing sound	<ul style="list-style-type: none"> • Defective nozzle 	<ul style="list-style-type: none"> (• Replace nozzle)
Abnormal noise generated (combustion or mechanical)	<ul style="list-style-type: none"> • Low-grade fuel being used • Overheating • Damage inside muffler • Excessive valve clearance 	<ul style="list-style-type: none"> • Change to specified fuel • Refer to "Radiator coolant level monitor lights up" as above (• Replace muffler) (• Adjust valve clearance)

Electronic Control System

If an error code appears on the machine monitor display (normally displays TIME), follow the countermeasure table as shown below in the self-diagnosis.

Machine Monitoring System

Monitor display	Error mode	Remedy
E02	Error in pump control system	When emergency pump drive switch is up, normal operations become normal, but carry out inspection immediately. (*)
E03	Error in swing brake system	Turn the swing holding brake release switch is up to release the brake. When applying the swing brake, operate it manually with the swing lock switch. Depending on the cause of the problem, it may not be possible to release it. In any case, have it inspected immediately. (*)
E10	Error in fuel line and swing sensor system (engine stop)	Have inspection carried out immediately.
E11	Error in engine controller system (engine protection, output down)	Move machine to a safe posture, and carry out inspection immediately.
E14	Error in throttle system	Move machine to a safe posture, and carry out inspection immediately.
E15	Error in sensor and engine controller power source	It is possible to carry out normal driving operations, but have inspection carried out immediately.
E0E	Network error	Move machine to a safe posture, and carry out inspection immediately.
In the case where the monitor will not display error codes and work equipment operation and swing operation cannot be carried out.		Have inspection carried out immediately.

(*): For details of handling the emergency pump drive switch and swing brake cancel switch, see "Emergency Pump Drive Switch (PAGE 3-38)" and "Swing Parking Brake Release Switch (PAGE 3-38)".

Point of Contact to Telephone when Error Occurs

If an error screen is displayed on the monitor, the screen changes as follows each time input confirmation switch (1) is pressed.

Error screen -> screen A -> screen B -> screen C -> error screen
Check the point of contact telephone number on screen B.

REMARK

If the point of contact telephone number has not been registered, screen B is not displayed.

If it is necessary to register the point of contact telephone number, ask your Komatsu distributor to register it.

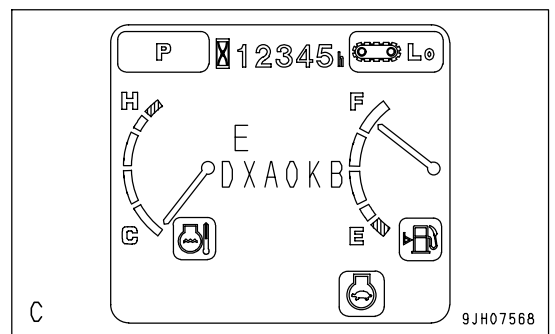
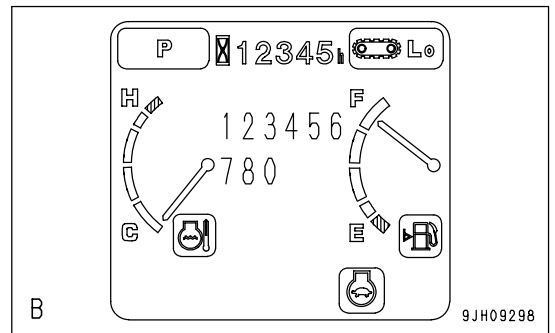
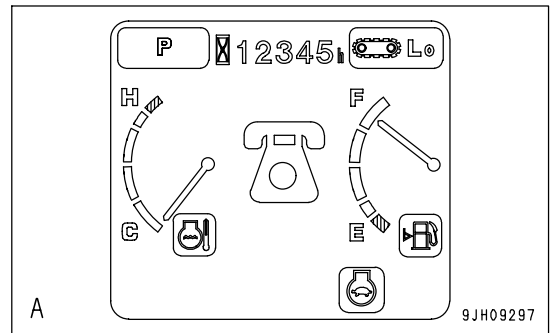
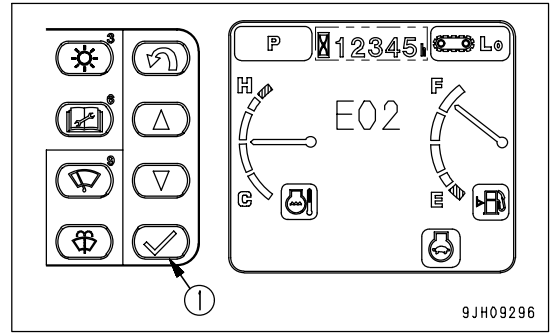

MAINTENANCE

WARNING

Please read and make sure that you understand the SAFETY section before reading this section.

MAINTENANCE INFORMATION

Do not perform any inspection and maintenance operation that is not found in this manual.

Service Meter Reading

Check the service meter reading every day to see if the time has come for any necessary maintenance to be performed.

Komatsu Genuine Replacement Parts

Use Komatsu genuine parts specified in the Parts Book as replacement parts.

Komatsu Genuine Lubricants

For lubrication of the machine, use the Komatsu genuine lubricants. Moreover use oil of the specified viscosity according to the ambient temperature.

Windshield Washer Fluid

Use automobile window washer fluid, and be careful not to let any dirt get into it.

Fresh and Clean Lubricants

Use clean oil and grease. Also, keep the containers of the oil and grease clean. Keep foreign materials away from oil and grease.

Check Drained Oil and Used Filter

After oil is changed or filters are replaced, check the old oil and filters for metal particles and foreign materials. If large quantity of metal particles or foreign materials are found, always report to the person in charge, and carry out suitable action.

Fuel Strainer

If your machine is equipped with a fuel strainer, do not remove it while fueling.

Welding Instructions

- Cut off power. Wait for approx. one minute after turning off the engine starting switch key, and then disconnect the negative (-) terminal of the battery.
- Do not apply more than 200 V continuously.
- Connect grounding cable within 1 m (3.3 ft) of the area to be welded. If grounding cable is connected near instruments, connectors, etc., the instruments may malfunction.
- If a seal or bearing happens to come between the part being welded and grounding point, change the grounding point to avoid such parts.
- Do not use the area around the work equipment pins or the hydraulic cylinders as the grounding point.

Do not Drop Things Inside Machine

- When opening inspection windows or the oil filler port of the tank to carry out inspection, be careful not to drop nuts, bolts, or tools inside the machine.
If such things are dropped inside the machine, it may cause damage and/or malfunction of the machine, and will lead to failure. If you drop anything inside the machine, always remove it immediately.
- Do not put unnecessary things in your pockets. Carry only things which are necessary for inspection.

Dusty Jobsite

When working at dusty worksites, do as follows:

- Clean the radiator fins and other parts of the heat exchange equipment more frequently, and take care not to let the fins become clogged.
- Replace the fuel filter more frequently.
- Clean electrical components, especially the starting motor and alternator, to avoid accumulation of dust.
- When checking and replacing the oil or filters, move the machine to a place where there is no dust and take care to prevent dust from entering the system.

Avoid Mixing Lubricants

If a different brand or grade of oil has to be added, drain the old oil and replace all the oil with the new brand or grade of oil. Never mix different brand or grade of oil.

Locking the Inspection Covers

Lock inspection cover securely into position with the lock bar. If inspection or maintenance is performed with inspection cover not locked in position, there is a danger that it may be suddenly blow shut by the wind and cause injury to the worker.

Hydraulic System - Air Bleeding

When hydraulic equipment has been repaired or replaced, or the hydraulic piping has been removed and installed again, the air must be bled from the circuit. For details, see "BLEEDING AIR FROM HYDRAULIC SYSTEM (PAGE 4-37)".

Hydraulic Hose Installation

- When removing parts at locations where there are O-rings or gasket seals, clean the mounting surface, and replace with new parts.
When doing this, be careful not to forget to assemble the O-rings and gaskets.
- When installing the hoses, do not twist them or bend them sharply. If they are installed so, their service life will be shortened extremely and they may be damaged.

Checks After Inspection and Maintenance Works

If you forget to perform the checks after inspection and maintenance, unexpected problems may occur, and this may lead to serious injury or property damage. Always do the following:

- Checks after operation (with engine stopped)
 - Have any inspection and maintenance points been forgotten?
 - Have all inspection and maintenance items been performed correctly?
 - Have any tools or parts been dropped inside the machine? It is particularly dangerous if parts are dropped inside the machine and get caught in the lever linkage mechanism.
 - Are there any leakage of coolant or oil? Have all nuts and bolts been tightened?
- Checks when operating engine
 - For details of the checks when operating the engine, see "TWO WORKERS FOR MAINTENANCE WHEN ENGINE IS RUNNING (PAGE 2-36)" and pay careful attention to safety.
 - Are the inspection and maintenance items working properly?
 - Is there any leakage of fuel or oil when the engine speed is raised?

OUTLINE OF SERVICE

- Always use Komatsu genuine parts for replacement parts, grease or oil.
- When changing the oil or adding oil, do not mix different types of oil. When changing the type of oil, drain all the old oil and fill completely with the new oil. Always replace the filter at the same time. (There is no problem if the small amount of oil remaining in the piping mixes with the new oil.)
- Unless otherwise specified, when the machine is shipped from the factory, it is filled with the oil and coolant listed in the table below.

Item	Type
Engine oil pan	Engine oil EO15W40DH (Komatsu genuine parts)
PTO case	Powertrain oil TO30 (Komatsu genuine parts)
Swing machinery case	
Final drive case	
Hydraulic oil system	Powertrain oil TO10 (Komatsu genuine parts)
Radiator	Supercoolant AF-NAC (density: 30% or above) (Komatsu genuine parts)

HANDLING OIL, FUEL, COOLANT, AND PERFORMING OIL CLINIC

OIL

- Oil is used in the engine and hydraulic equipment under extremely severe conditions (high temperature, high pressure), and deteriorates with use.
Always use oil that matches the grade and maximum and minimum ambient temperatures recommended in the Operation and Maintenance Manual. Even if the oil is not dirty, always change the oil at the specified interval.
- Oil corresponds to blood in the human body, always be careful when handling it to prevent any impurities (water, metal particles, dirt, etc.) from getting in.
The majority of problems with the machine are caused by the entry of such impurities.
Take particular care not to let any impurities get in when storing or adding oil.
- Never mix oils of different grades or brands.
- Always add the specified amount of oil.
Having too much oil or too little oil are both causes of problems.
- If the oil in the work equipment is not clear, there is probably water or air getting into the circuit. In such cases, please contact your Komatsu distributor.
- When changing the oil, always replace the related filters at the same time.
- We recommend you have an analysis made of the oil periodically to check the condition of the machine. For those who wish to use this service, please contact your Komatsu distributor.
- When using commercially available oil, it may be necessary to reduce the oil change interval.
We recommend that you use the Komatsu oil clinic to carry out a detailed checks of the characteristics of the oil.

FUEL

- To prevent the moisture in the air from condensing and forming water inside the fuel tank, always fill the fuel tank after completing the day's work.
- The fuel pump is a precision instrument, and if fuel containing water or dirt is used, it cannot work properly.
- Be extremely careful not to let impurities get in when storing or adding fuel.
- Always use the fuel specified for the temperature in the Operation and Maintenance Manual.
 - If the fuel is used at temperatures lower than the specified temperature (particularly at temperatures below -15 °C (5°F), the fuel will solidify.
 - If the fuel is used at temperatures higher than the specified temperature, the viscosity will drop, and this may result in problems such as a drop in output.
- Before starting the engine, or when 10 minutes have passed after adding fuel, drain the sediment and water from the fuel tank.
- If the engine runs out of fuel, or if the filters have been replaced, it is necessary to bleed the air from the circuit.
- If there is any foreign material in the fuel tank, wash the tank and fuel system.

NOTICE

Always use diesel oil for the fuel.

To ensure good fuel consumption characteristics and exhaust gas characteristics, the engine mounted on this machine uses an electronically controlled high-pressure fuel injection device. This device requires high precision parts and lubrication, so if low viscosity fuel with low lubricating ability is used, the durability may drop markedly.

COOLANT AND WATER FOR DILUTION

- The coolant has the important function of preventing corrosion as well as preventing freezing. Even in the areas where freezing is not an issue, the use of antifreeze coolant is essential. Komatsu machines are supplied with Komatsu Supercoolant (AF-NAC). Komatsu Supercoolant (AF-NAC) has excellent anticorrosion, antifreeze and cooling properties and can be used continuously for 2 years or 4000 hours. As a basic rule, we do not recommend the use of any coolant other than Komatsu genuine supercoolant (AF-NAC). If you use another coolant, it may cause serious problems such as corrosion of the engine and parts of the cooling system that use light metals such as aluminum.
- When using Komatsu Supercoolant (AF-NAC), there is no need to use a corrosion resistor. For details, see "CLEAN INSIDE OF COOLING SYSTEM (PAGE 4-20)".
- When diluting the antifreeze coolant, use distilled water or tap water (soft water). Natural water, such as a river water or well water (hard water), contains large amounts of minerals (calcium, magnesium, etc.), and this makes it easier for scale to form inside the engine or radiator. Once scale is deposited inside the engine or radiator, it is extremely difficult to remove. It also causes overheating due to poor heat exchange, so when you dilute the coolant, we recommend that you use water with an overall hardness of less than 100 PPM.
- When using antifreeze, always observe the precautions given in the Operation and Maintenance Manual.
- Antifreeze coolant is flammable, so be sure to keep it away from flame.
- The ratio of Supercoolant (AF-NAC) to water differs according to the ambient temperature. For details of the ratio when mixing, see "CLEAN INSIDE OF COOLING SYSTEM (PAGE 4-20)". Even in areas where it is not necessary to prevent freezing, use Supercoolant (AF-NAC) at a mixing ratio of at least 30% to prevent corrosion of the cooling system. Supercoolant (AF-NAC) may be supplied in premix. In this case, never add diluting water.
- If the engine overheats, wait for the engine to cool before adding coolant.
- If the coolant level is low, it will cause overheating, and will also cause problems with corrosion due to air entering the coolant.

GREASE

- Grease is used to prevent seizure and noises at the joints.
- This construction equipment is used under heavy-duty conditions. Always use the recommended grease and follow the change intervals and recommended ambient temperatures given in this Operation and Maintenance Manual.
- Grease fittings not included in the maintenance section are grease fittings for overhaul, so they do not need grease.
If any part becomes stiff after being used for long time, add grease.
- Always wipe off all of the old grease that is pushed out when greasing.
Be particularly careful to wipe off the old grease in places where sand or dirt sticking in the grease would cause wear of the rotating parts.

CARRYING OUT KOWA (Komatsu Oil Wear Analysis)

KOWA is a maintenance service that makes it possible to prevent machine failures and downtime. With KOWA, the oil is periodically sampled and analyzed. This enables early detection of wear of the machine drive parts and other problems.

We strongly recommend you to use this service. The oil analysis is carried out at actual cost, so the cost is low, and the results of the analysis are reported together with recommendations which will reduce repair costs and machine downtime.

KOWA ANALYSIS ITEMS

- Measurement of density of metal wear particles
This uses an ICP (Inductively Coupled Plasma) analyzer to measure the density of iron, copper, and other metal wear particles in the oil.

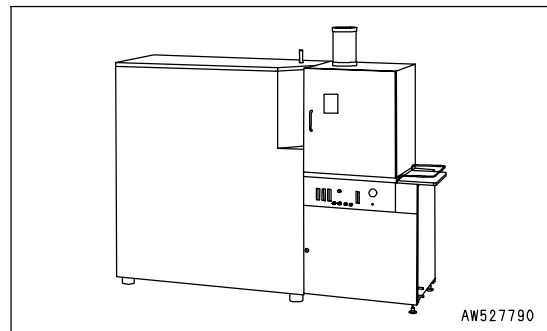

- Measurement of quantity of particles
This uses a PQI (Particle Quantifier Index) measurer to measure the quantity of iron particles of 5µm or more, enabling early detection of failures.

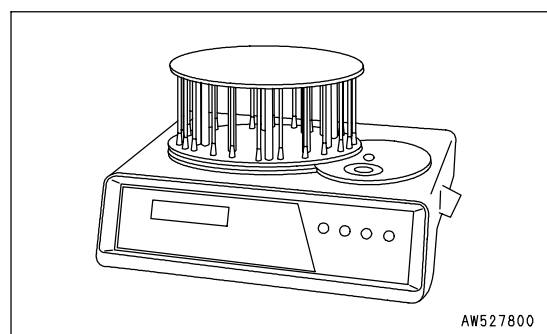

- Others
Measurements are made of items such as the ratio of water in the oil, density of the antifreeze coolant, ratio of fuel in the oil, and dynamic viscosity, enabling a highly precise diagnosis of the machine's health.

OIL SAMPLING

- Sampling interval
 - 250 hours: Engine
 - 500 hours: Other components
- Precautions when sampling
 - Make sure that the oil is well mixed before sampling.
 - Perform sampling at regular fixed intervals.
 - Do not perform sampling on rainy or windy days when water or dust can get into the oil.

For further details of KOWA, please contact your Komatsu distributor.

STORING OIL AND FUEL

- Keep indoors to prevent any water, dirt, or other impurities from getting in.
- When keeping drum cans for a long period, put the drum on its side so that the filler port of the drums is at the side to prevent moisture from being sucked in.
If drums have to be stored outside, cover them with a waterproof sheet or take other measures to protect them.
- To prevent any change in quality during long-term storage, be sure to use in the order of first in - first out (use the oldest oil or fuel first).

FILTERS

- Filters are extremely important safety parts. They prevent impurities in the fuel and air circuits from entering important equipment and causing problems.
Replace all filters periodically. For details, see the Operation and Maintenance Manual.
However, when working in severe conditions, replace the filters at shorter intervals according to the oil and fuel (sulfur content) being used.
- Never try to clean the filters (cartridge type) and use them again. Always replace with new filters.
- When replacing oil filters, check if any metal particles are attached to the old filter. If any metal particles are found, contact your Komatsu distributor.
- Do not open packs of spare filters until just before they are to be used.
- Always use Komatsu genuine filters.

ELECTRIC SYSTEM MAINTENANCE

- It is extremely dangerous if the electrical equipment becomes wet or the covering of the wiring is damaged. This will cause an electrical short circuit and may lead to malfunction of the machine. Do not wash the inside of the operator's cab with water. When washing the machine, be careful not to let water get into the electrical components.
- Service relating to the electric system is checking fan belt tension, checking damage or wear to the fan belt and checking battery fluid level.
- Never install any electric components other than those specified by Komatsu.
- External electro-magnetic interference may cause malfunction of the control system controller, before installing a radio receiver or other wireless equipment, contact your Komatsu distributor.
- When working at the seashore, carefully clean the electric system to prevent corrosion.
- When installing electrical equipment, connect it to the special power source connector.
Do not connect the optional power source to the fuse, starting switch, or battery relay.

WEAR PARTS

Replace wear parts such as the filter element or air cleaner element at the time of periodic maintenance or before they reach the wear limit. The wear parts should be replaced correctly in order to ensure more economic use of the machine. When replacing parts, always use Komatsu genuine parts.

As a result of our continuous efforts to improve product quality, the part number may change, so inform your Komatsu distributor of the machine serial number and check for the latest part number when ordering parts.

WEAR PARTS LIST

The parts in parentheses are to be replaced at the same time.

Item	Part No.	Part Name	Q'ty	Change interval
Fuel pre-filter	600-319-3440	Cartridge	2	Every 500 hours
Fuel main filter	600-319-3520	Cartridge	1	Every 500 hours
Pilot filter	424-16-11140	Element	1	Every 500 hours
Drain filter	21N-60-12210	Cartridge	1	Every 500 hours
Engine oil filter	600-211-1340	Cartridge	3	Every 500 hours
Hydraulic oil filter	209-60-77531 (07000-15180)	Element (O-ring)	2 (2)	Every 1000 hours
Hydraulic tank breather	421-60-35170 20Y-60-21470	Element Element	1 1	Every 1000 hours
Corrosion resistor (if equipped)	600-411-1171	Cartridge	1	Every 1000 hours
Air cleaner	600-185-6100	Element assembly	1	-
Line filter	21N-62-31221 (07000-12055)	Element (O-ring)	3 (3)	-
	(07000-12070)	(O-ring)	(3)	
	(07001-02070)	(Backup ring)	(3)	
Bucket	21N-70-37721 (21N-70-37731)	Tooth (XS type) (Pin)	5 (5)	-
	427-70-13611	Side shroud	4	
	21N-939-3330	Pin	8	
	(209-939-7110)	(Shim)	(16)	
	(209-939-7120)	(Shim)	(8)	
	21N-70-14180	Side cutter (left)	1	
	21N-70-14190	Side cutter (right)	1	
21N-09-11121	(Bolt)	(12)		
21N-09-11131	(Nut)	(12)		

RECOMMENDED FUEL, COOLANT, AND LUBRICANT

- Komatsu genuine oils are adjusted to maintain the reliability and durability of Komatsu construction equipment and components.

In order to keep your machine in the best conditioner for long periods of time, it is essential to follow the instructions in this Operation and Maintenance Manual.

- Failure to follow these recommendations may result in shortened life or excess wear of the engine, power train, cooling system, and/or other components.
- Commercially available lubricant additives may be good for the machine, but they may also cause harm. Komatsu does not recommend any commercially available lubricant additive.
- Use the oil recommended according to the ambient temperature in the chart below.
- Specified capacity means the total amount of oil including the oil in the tank and the piping. Refill capacity means the amount of oil needed to refill the system during inspection and maintenance.
- When starting the engine in temperatures below 0°C (32°F), be sure to use the recommended multi-grade oil, even if the ambient temperature may become higher during the course of the day.
- If the machine is operated at a temperature below -20°C (-4°F), a separate device is needed, so consult your Komatsu distributor.
- When the fuel sulfur content is less than 0.2%, change the engine oil according to the period inspection table given in this Operation and Maintenance Manual.

If the fuel sulfur content is more than 0.2%, change the oil according to the following table.

Sulfur content (%)	Oil change interval
Less than 0.2 %	500 hours
0.2 to 0.5 %	250 hours
0.5 and up	Not recommendable (*)

* If these fuels are used, there is danger that serious trouble may occur because of early deterioration of the engine oil or early wear of the internal parts of the engine. If the local situation makes it necessary to use these fuels, always remember the following.

- 1) Be sure to check Total Basic Number (TBN) of oil frequently by TBN handy checker etc., and change oil based on the result.
- 2) Always be aware that oil change interval is extremely shorter than standard.
- 3) Be sure to carry out periodic engine inspection by distributor's expert since change interval of periodic replacement parts and overhaul interval are also shorter.

Reservoir	Fluid Type	Ambient Temperature, degrees Celsius									Recommended Komatsu Fluids
		-22	-4	14	32	50	68	86	104	122 °F	
		-30	-20	-10	0	10	20	30	40	50 °C	
Engine oil pan	Engine oil	(Note.1)									Komatsu EOS0W30
		(Note.1)									Komatsu EOS5W40
		(Note.1)									Komatsu EO10W30-DH
		(Note.1)									Komatsu EO15W40-DH
		(Note.1)									Komatsu EO30-DH
PTO case	Powertrain oil (Note.2)	(Note.1)									TO10
		(Note.1)									TO30
Swing machinery case Final drive case	Powertrain oil	(Note.1)									TO30
Hydraulic system	Powertrain oil	(Note.1)									TO10
	Hydraulic oil	(Note.1)									HO46-HM
Grease fitting (Note.3)	Hyper grease (Note.4)	(Note.1)									G2-T, G2-TE
	Lithium EP grease	(Note.1)									G2-LI
Cooling system	Supercoolant AF-NAC (Note.5)	(Note.1)									AF-NAC
Fuel tank	Diesel fuel	(Note.1)									ASTM Grade No.1-D S15 ASTM Grade No.1-D S500
		(Note.1)									ASTM Grade No.2-D S15 ASTM Grade No.2-D S500

• ASTM: American Society of Testing and Material

		Engine Oil pan	PTO case	Swing machinery case (Each)	Final drive case (Each)	Hydraulic oil system	Cooling system	Fuel tank
Specified capacity	Liter	97	13.5	24.3	22	1180	142	1360
	US gal	25.63	3.57	6.42	5.81	311.76	37.52	359.31
Refill capacity	Liter	86	13.5	24.3	21	670	142	-
	US gal	22.72	3.57	6.42	5.55	177.01	37.52	-

NOTICE

Always use diesel oil for the fuel.

To ensure good fuel consumption characteristics and exhaust gas characteristics, the engine mounted on this machine uses an electronically controlled high-pressure fuel injection device. This device requires high precision parts and lubrication, so if low viscosity fuel with low lubricating ability is used, the durability may drop markedly.

Note 1: HTHS (High-Temperature High-Shear Viscosity 150°C), specified by ASTM D4741 must be equal to or higher than 3.5 mPa-S. Komatsu EOS0W30 and EOS5W40 are the most suitable oils.

Note 2: Powertrain oil has different properties from engine oil. Be sure to use the recommended oils.

Note 3: If the machine is equipped with an auto-greasing system, see "AUTO-GREASING SYSTEM (PAGE 6-8)".

Note 4: Hyper grease (G2-T, G2-TE) has a high performance.

When it is necessary to improve the lubricating ability of the grease in order to prevent squeaking of pins and bushings, the use of G2-T or G2-TE is recommended.

Note. 5: Supercoolant (AF-NAC)

1) Coolant has the important function of anticorrosion as well as antifreeze.

Even in the areas where freezing is not an issue, the use of antifreeze coolant is essential.

Komatsu machines are supplied with Komatsu Supercoolant AF-NAC. Komatsu Supercoolant AF-NAC has excellent anticorrosion, antifreeze and cooling properties and can be used continuously for 2 years or 4000 hours.

Komatsu Supercoolant AF-NAC is strongly recommended wherever available.

2) For details of the ratio when diluting super coolant with water, see "CLEAN INSIDE OF COOLING SYSTEM (PAGE 4-20)".

Supercoolant AF-NAC may be supplied in premix . In this case, always top off with premix solution. (never dilute with water)

3) To maintain the anticorrosion properties of Supercoolant AF-NAC, always keep the density of Supercoolant between 30% and 68%.

RECOMMENDED BRANDS, RECOMMENDED QUALITY FOR PRODUCTS OTHER THAN KOMATSU GENUINE OIL

When using commercially available oils other than Komatsu genuine oil, consult your Komatsu distributor.

TIGHTENING TORQUE SPECIFICATIONS

TIGHTENING TORQUE LIST



If nuts, bolts, or other parts are not tightened to the specified torque, it will cause looseness or damage to the tightened parts, and this will cause failure of the machine or problems with operation.

Always pay careful attention when tightening parts.

Unless otherwise specified, tighten the metric nuts and bolts to the torque shown in the table below. If it is necessary to replace any nut or bolt, always use a Komatsu genuine part of the same size as the part that was replaced.

Thread diameter of bolt (a)(mm)	Width across flats (b)(mm)	Tightening torque					
		Target value			Service limit		
		Nm	kgm	lbft	Nm	kgm	lbft
6	10	13.2	1.35	9.8	11.8-14.7	1.2-1.5	8.7-10.8
8	13	31	3.2	23.1	27-34	2.8-3.5	20.3-25.3
10	17	66	6.7	48.5	59-74	6.0-7.5	43.4-54.2
12	19	113	11.5	83.2	98-123	10.0-12.5	72.3-90.4
14	22	172	17.5	126.6	153-190	15.5-19.5	112.1-141
16	24	260	26.5	191.7	235-285	23.5-29.5	170.0-213.4
18	27	360	37	267.6	320-400	33.0-41.0	238.7-296.6
20	30	510	52.3	378.3	455-565	46.5-58.0	336.3-419.5
22	32	688	70.3	508.5	610-765	62.5-78.0	452.1-564.2
24	36	883	90	651	785-980	80.0-100.0	578.6-723.3
27	41	1295	132.5	958.4	1150-1440	118.0-147.0	853.5-1063.3
30	46	1720	175.0	1265.8	1520-1910	155.0-195.0	1121.1-1410.4
33	50	2210	225.0	1627.4	1960-2450	200.0-250.0	1446.6-1808.3
36	55	2750	280.0	2025.2	2450-3040	250.0-310.0	1808.3-2242.2
39	60	3280	335.0	2423.1	2890-3630	295.0-370.0	2133.7-2676.2

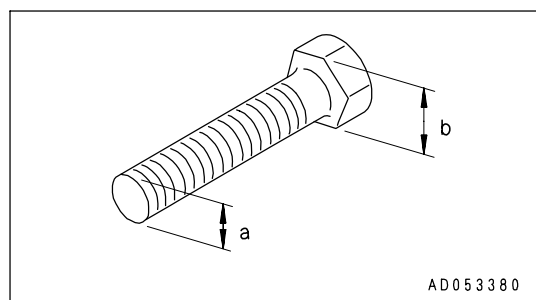

Apply the following table for Hydraulic Hose.

Hose nominal number	Width across flat a (mm)	Tightening torque					
		Target valve			Service limit		
		Nm	kgm	lbft	Nm	kgm	lbft
02	19	44	4.5	32.5	35-54	3.5-5.5	25.3-47.0
03	22	74	7.5	54.2	54-93	5.5-9.5	39.8-68.7
	24	78	8.0	57.9	59-98	6.0-10.0	43.4-72.3
04	27	103	10.5	75.9	84-132	8.5-13.5	61.5-97.6
05	32	157	16.0	115.7	128-186	13.0-19.0	94.0-137.4
06	36	216	22.0	159.1	177-245	18.0-25.0	130.2-180.8

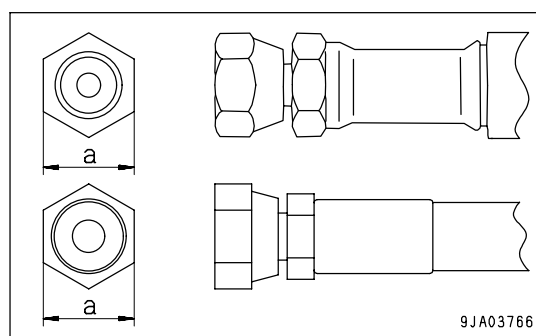

SAFETY CRITICAL PARTS

For using the machine safely for an extended period of time, you must periodically replace the safety critical and fire prevention-related parts listed in the table of important parts.

Material quality of these parts can change as time passes and they are likely to wear out or deteriorate. However, it is difficult to determine the extent of wear or deterioration at the time of periodic maintenance. Hence, it is required to replace them with new ones regardless of their condition after a certain period of usage. This is important to ensure that these parts maintain their full performance at all times.

Furthermore, should anything abnormal be found on any of these parts, replace it with a new one even if the periodic replacement time for the part has not yet arrived.

If any of the hose clamps show deterioration like deformation or cracking, replace the clamps at the same time as the hoses.

Also perform the following checks with hydraulic hoses which need to be replaced periodically. Tighten all loose clamps and replace defective hoses, as required.

When replacing hoses, always replace O-rings, gaskets, and other such parts at the same time.

Have your Komatsu distributor replace the critical parts.

SAFETY CRITICAL PARTS LIST

No.	Safety critical parts for periodic replacement	Q'ty	Replacement interval
1	Fuel hose (fuel tank - fuel pre-filter)	1	Every 2 years or 4000 hours, whichever comes sooner
2	Fuel return hose (engine - fuel cooler)	1	
3	Fuel return hose (fuel cooler - fuel tank)	1	
4	Fuel spill hose (engine - fuel tank)	1	
5	No.1 pump outlet hose	2	
6	No.2 pump outlet hose	2	
7	No.3 pump outlet hose	2	
8	No. 3 pump relay hose	1	
9	Left 5-spool inlet branch hose	1	
10	Right 4-spool inlet branch hose	1	
11	No.1 and No.2 pump relay hose	2	
12	Heater hose (engine - heater)	2	
13	Hydraulic pump suction hose	4	
14	Swing line hose	4	
15	Boom cylinder line hose (B/H)	4	
16	Arm cylinder line hose (B/H)	7	
17	Bucket cylinder line hose (B/H)	7	
18	Fuel hose (fuel pre-filter - feed pump)	1	
19	Fuel hose (feed pump - cooling plate)	1	
20	Fuel hose (cooling plate - fuel block)	1	
21	Fuel hose (supply pump overflow)	1	
22	EGR valve oil supply hose	1	
23	Bypass valve oil supply hose	1	
24	Seat belt	1	Every 3 years
25	High-pressure piping clamp	20	Every 8000 hours
26	Missing fuel spray prevention cap	10	

MAINTENANCE SCHEDULE

MAINTENANCE SCHEDULE CHART

INITIAL 100 HOURS MAINTENANCE (ONLY AFTER THE FIRST 100 HOURS)	
CLEAN STRAINER OF PTO LUBRICATING OIL FILTER	4- 59
INITIAL 500 HOURS MAINTENANCE (ONLY AFTER THE FIRST 500 HOURS)	
CHANGE OIL IN SWING MACHINERY CASE	4- 66
CHANGE OIL IN PTO CASE	4- 68
CHANGE OIL IN FINAL DRIVE CASE	4- 74
WHEN REQUIRED	
CHECK, CLEAN AND REPLACE AIR CLEANER ELEMENT	4- 17
CLEAN INSIDE OF COOLING SYSTEM	4- 20
CHECK AND TIGHTEN TRACK SHOE BOLTS	4- 24
CHECK AND ADJUST TRACK TENSION	4- 25
REPLACE BUCKET TEETH (XS)	4- 28
ADJUST BUCKET CLEARANCE	4- 32
CHECK WINDOW WASHER FLUID LEVEL, ADD FLUID	4- 33
CHECK AND MAINTENANCE AIR CONDITIONER	4- 34
CLEAN LINE FILTER, REMOVE DIRT	4- 35
CHECK GAS SPRING	4- 36
BLEEDING AIR FROM HYDRAULIC SYSTEM	4- 37
BLEEDING AIR FROM FULE CIRCUIT	4- 40
CHECKS BEFORE STARTING	
EVERY 10 HOURS MAINTENANCE	
LUBRICATING	4- 44
EVERY 100 HOURS MAINTENANCE	
LUBRICATING SWING CIRCLE	4- 46
EVERY 250 HOURS MAINTENANCE	
CHECK OIL LEVEL IN FINAL DRIVE CASE, ADD OIL	4- 47
CHECK LEVEL OF BATTERY ELECTROLYTE	4- 48
CHECK AND TIGHTEN TRACK FRAME AND AXLE CONNECTING BOLTS	4- 50

EVERY 500 HOURS MAINTENANCE

REPLACE FUEL PRE-FILTER CARTRIDGE ----- 4- 51

REPLACE FULE MAIN FILTER CARTRIDGE ----- 4- 53

CHECK SWING PINION GREASE LEVEL, ADD GREASE ----- 4- 55

CLEAN, CHECK RADIATOR FINS, OIL COOLER FINS,FUEL COOLER FINS,
AFTERCOOLER FINS, CONDENSER FINS (machines equipped with air conditioner),
PTO OIL COOLER ----- 4- 56

CLEAN INTERNAL AND EXTERNAL AIR FILTERS OF AIR CONDITIONER ----- 4- 57

REPLACE PILOT FILTER ELEMENT ----- 4- 58

CLEAN STRAINER OF PTO LUBRICATING OIL FILTER----- 4- 59

CHECK, REPLACE ALTERNATOR, AIR CONDITIONER COMPRESSOR DRIVE BELTS ----- 4- 59

REPLACE DRAIN FILTER CARTRIDGE ----- 4- 60

CHANGE OIL IN ENGINE OIL PAN, REPLACE ENGINE OIL FILTER CARTRIDGE ----- 4- 61

EVERY 1000 HOURS MAINTENANCE

REPLACE HYDRAULIC OIL FILTER ELEMENT ----- 4- 63

REPLACE BREATHER ELEMENT IN HYDRAULIC TANK ----- 4- 64

CLEAN HYDRAULIC TANK RETURN STRAINER ----- 4- 65

CHANGE OIL IN SWING MACHINERY CASE ----- 4- 66

CHANGE OIL IN PTO CASE ----- 4- 68

REPLACE CORROSION RESISTOR CARTRIDGE ----- 4- 69

GREASE, CHECK TENSION PULLEY ASSEMBLY OF ALTERNATOR, AIR CONDITIONER
COMPRESSOR DRIVE BELT ----- 4- 70

CHECK WELDED STRUCTURE ----- 4- 71

EVERY 2000 HOURS MAINTENANCE

CHANGE OIL IN FINAL DRIVE CASE ----- 4- 74

CHECK BOOST PIPING HOSE CLAMPS ----- 4- 74

CHECK ALTERNATOR ----- 4- 74

CHECK ENGINE VALVE CLEARANCE, ADJUST ----- 4- 74

CLEAN HYDRAULIC TANK STRAINER ----- 4- 75

CHECKING CHARGE PRESSURE OF NITROGEN GAS IN ACCUMULATOR (FOR CONTROL
CIRCUIT) ----- 4- 76

EVERY 4000 HOURS MAINTENANCE

CHECK WATER PUMP ----- 4- 80

CHECK STARTING MOTOR ----- 4- 80

CHECK AIR COMPRESSOR, ADJUST ----- 4- 80

REPLACE ACCUMULATOR (FOR CONTROL CIRCUIT) ----- 4- 80

CHECK FOR LOOSENESS OF HIGH-PRESSURE PIPING CLAMP, HARDENING OF RUBBER ----- 4- 81

CHECK FOR MISSING FUEL SPRAY PREVENTION CAP, HARDENING OF RUBBER ----- 4- 82

EVERY 5000 HOURS MAINTENANCE

CHANGE OIL IN HYDRAULIC TANK, CLEAN STRAINER ----- 4- 83

EVERY 8000 HOURS MAINTENANCE

REPLACE HIGH-PRESSURE PIPING CLAMP ----- 4- 85

REPLACE FUEL SPRAY PREVENTION CAP ----- 4- 85

OVERHAUL STARTING MOTOR AND ALTERNATOR ----- 4- 85

MAINTENANCE PROCEDURE

INITIAL 100 HOURS MAINTENANCE (ONLY AFTER THE FIRST 100 HOURS)

Perform the following maintenance only after the first 100 hours.

- Clean strainer of PTO lubricating oil filter

For details of the method of maintaining, see EVERY 500 HOURS MAINTENANCE.

INITIAL 500 HOURS MAINTENANCE (ONLY AFTER THE FIRST 500 HOURS)

Carry out the following maintenance only after the first 500 hours of operation on new machines.

- Change oil in swing machinery case
- Change oil in PTO case
- Change oil in final drive case

Special tools are needed for inspection and maintenance, so contact your Komatsu distributor.

For details of the method of replacing or maintaining, see EVERY 1000 HOURS and EVERY 2000 HOURS SERVICE.

WHEN REQUIRED

CHECK, CLEAN AND REPLACE AIR CLEANER ELEMENT

⚠ WARNING

- When using compressed air, there is danger of dirt flying and causing personal injury. Always wear protective glasses, dust mask, or other protective equipment.
- When removing the outer element from the air cleaner body, it is dangerous to pull it out by force. When working in high places or where the foothold is poor, be careful not to fall because of the reaction when pulling out the outer element.

Checking

If air cleaner clogging monitor (1) of the monitor panel flashes, clean the air cleaner element.

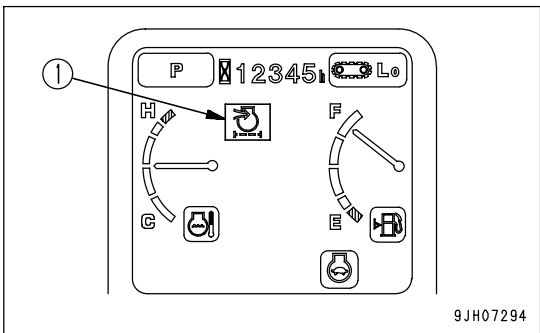

Replacing

- Replacing element, O-ring
 - If one year has passed since installing the element or if air cleaner clogging monitor (1) on the monitor panel flashes immediately after the element is cleaned, replace the outer element, inner element, and O-ring.

REMARK

Dust indicator (4) gives a guideline for the cleaning interval for the air cleaner element. If the yellow piston on the inside overlaps the red zone on the outside circumference of dust indicator (4), it is time to clean the element.

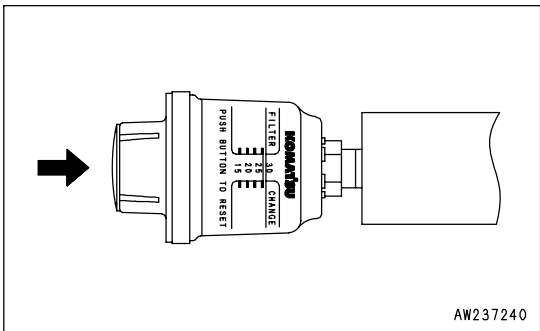
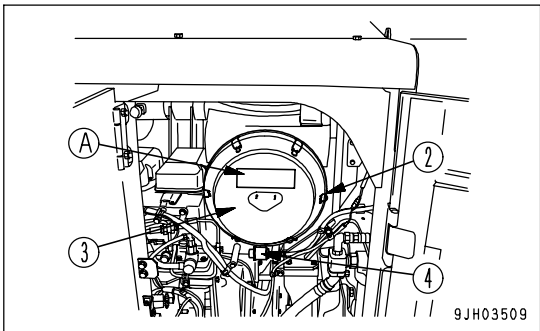

NOTICE

- Do not clean the air cleaner element until the air cleaner clogging monitor on the monitor panel light up. If the element is cleaned frequently before the air cleaner clogging monitor light up, the air cleaner will not be able to display its performance fully, and the cleaning efficiency will also go down. In addition, during the cleaning operation, more dirt stuck to the element will fall inside the inner element.
- If inspection, cleaning, or maintenance is carried out with the engine running, dirt will enter the engine and cause damage to the engine. Always stop the engine before carrying out these operations.

Cleaning Outer Element

1. Open the right door of the machine, remove 6 hooks (2), then remove cover (3).

NOTICE

Before and after cleaning the element, do not leave or keep it in direct sunlight.

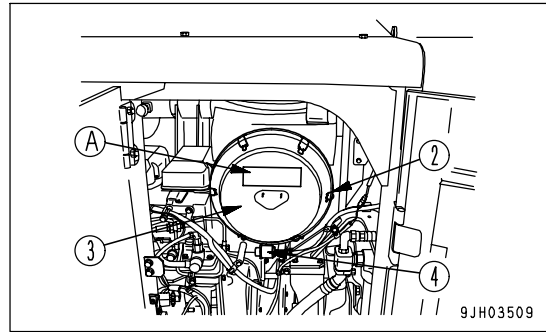

2. Hold the outer element (5), rock it lightly up and down and to the left and right, and rotate the element to the left and right to pull it out.

NOTICE

- Never remove the inner element (6). It will allow dirt to enter and cause failure of the engine.
- Do not use a screwdriver or other tool.

3. After removing the outer element (5), cover the inner element (6) with a clean cloth or tape to prevent dirt or dust from entering.

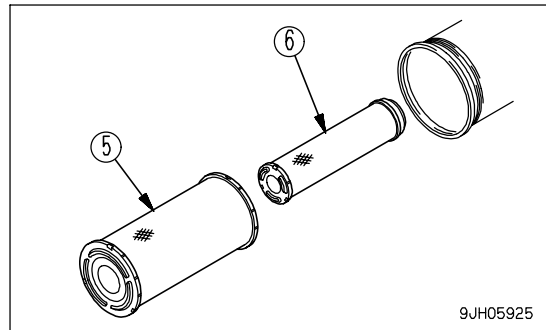

4. Wipe off or brush off the dirt stuck to cover (3) and the inside of the air cleaner body (7).

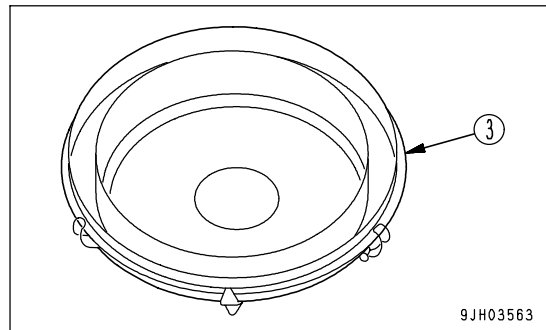
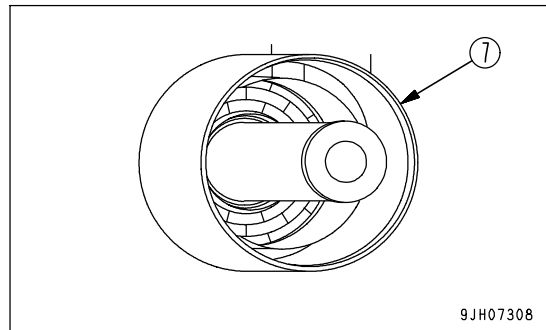

5. Direct dry compressed air (less than 0.69 MPa (7 kg/cm², 99.4 PSI)) to the outer element from inside along its folds, then direct it from outside along its folds and again from inside.

- 1) Replace the outer element once a year or when monitor (1) flashes. Replace the inner element at the same time.
- 2) Check that there is no play in the inner element. If any play is found, push it in properly.
- 3) Replace both inner and outer elements when the air cleaner clogging monitor (1) lights up soon after installing the cleaned outer element even though it has not been cleaned 6 times.

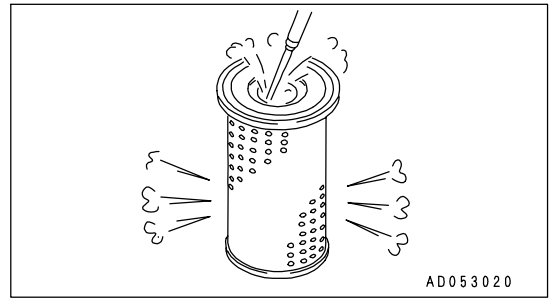

6. Remove the cloth or tape cover installed in Step 3.
7. If small holes or thinner parts are found on the element when it is checked by shining a light through it after cleaning, replace the element.

NOTICE

- When cleaning the element, do not hit or beat it against anything.
- Do not use an element whose folds or gasket or seal are damaged.

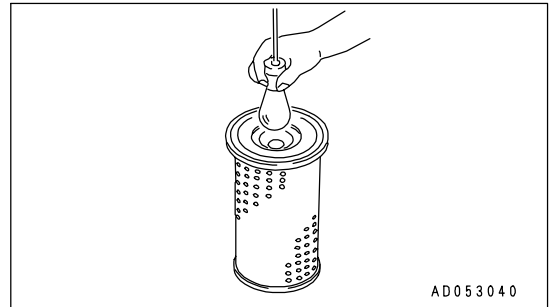

Replacing Inner Element

1. First remove the outer element, and then remove the inner element.
2. Cover the air connector side (outlet side) with a clean cloth or tape.
3. Clean the air cleaner body interior, then remove the cover installed in Step 2.
4. Fit a new inner element to the connector.
Do not clean and reinstall an inner element.
5. Install the outer element and the cover.
6. After replacing the element, push the dust indicator button to reset it. The yellow piston will return to its original position.

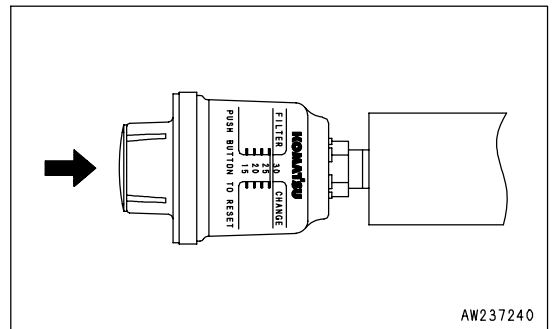

CLEAN INSIDE OF COOLING SYSTEM

 **WARNING**

- Immediately after the engine is stopped, the coolant is at a high temperature and the radiator is under high internal pressure. If the cap is removed to drain the coolant in this condition, there is a hazard of burns. Wait for the temperature to go down, then turn the cap slowly to release the pressure before removing it.
- When starting the engine while cleaning the machine, set the lock lever in the lock position to prevent the machine from moving.
- For details of starting the engine, see "BEFORE STARTING ENGINE (PAGE 3-75)" and "STARTING ENGINE (PAGE 3-98)" in the OPERATION section.
- There is danger of touching the fan if the undercover is left removed.
Never enter behind the machine when the engine is running.

Stop the machine on level ground when cleaning or changing the coolant.

Clean the inside of the cooling system, change the coolant according to the table below.

Antifreeze coolant	Interval for cleaning inside of cooling system and changing antifreeze coolant	Precautions for use
Komatsu supercoolant (AF-NAC)	Every two years or every 4000 hours whichever comes first	1*

*1: When using Komatsu Supercoolant (AF-NAC), there is no need to use a corrosion resistor. When no corrosion resistor is used, use the special cover (600-411-9000). Please consult your Komatsu distributor about the method of installing.
When using corrosion resistor, use Komatsu genuine corrosion resistor. If you use another corrosion resistor, it may cause serious problems such as corrosion of the engine and parts of the cooling system that use light metals such as aluminum.

The coolant has the important function of preventing corrosion as well as preventing freezing. Even in the areas where freezing is not an issue, the use of antifreeze coolant is essential. Komatsu machines are supplied with Komatsu Supercoolant (AF-NAC). Komatsu Supercoolant (AF-NAC) has excellent anticorrosion, antifreeze and cooling properties and can be used continuously for 2 years or 4000 hours. Komatsu Supercoolant (AF-NAC) is strongly recommended wherever available.

To maintain the anticorrosion properties of Supercoolant (AF-NAC), always keep the density of Supercoolant between 30% and 68%.

When deciding the ratio of antifreeze to water, check the lowest temperature in the past, and decide from the mixing table given below.

It is actually better to estimate and temperature about 10°C (18°F) lower when deciding the mixing ratio.

The mixing ratio depends on the ambient temperature, but it should always be a minimum of 30% by volume (antifreeze/total amount of coolant x 100).

Even in areas where it is not necessary to prevent freezing, use Supercoolant (AF-NAC) at a mixing ratio of at least 30% to prevent corrosion of the cooling system.

The freezing temperature of undiluted antifreeze is -15°C (5°F). Do not store undiluted antifreeze at a temperature of below -15°C (5°F).

Mixing rate of water and antifreeze

Min. atmospheric temperature	°C	Above-10	-15	-20	-25	-30	-35	-40
	°F	Above14	5	-4	-13	-22	-31	-40
Amount of antifreeze	liter	42.7	51.2	58.2	65.5	71.2	76.8	82.5
	US gal	11.28	13.53	15.38	17.31	18.81	20.29	21.80
Amount of water	liter	99.6	91.1	84.0	76.8	71.2	65.5	59.8
	US gal	26.31	24.07	22.19	20.29	18.81	17.31	15.80
Volume ratio (%)		30	36	41	46	50	54	58

! WARNING

- Antifreeze is flammable, so keep it away from flame.
Antifreeze is toxic. When open the drain valve, be careful not to get water containing antifreeze on you. If it gets in your eyes, flush your eyes with large amount of fresh water and see a doctor at once.
- When changing the coolant or draining the coolant from the radiator before carrying out repairs, ask a specialist company to handle any coolant containing antifreeze, or contact your Komatsu distributor. Antifreeze is toxic, so never pour it into drainage water ditches or drain it onto the ground surface.

Use antifreeze and appropriate water for diluting. (for details, see "COOLANT AND WATER FOR DILUTION (PAGE 4-5)")

We recommend use of an antifreeze density gauge to control the mixing proportions.

Prepare a container whose capacity is larger than the specified coolant volume to catch drained coolant.

Prepare a hose to supply antifreeze coolant and water.

1. Stop the machine on level ground, then stop the engine.
2. Open the engine room door and turn valve (1) of the corrosion resistor to the CLOSED position.

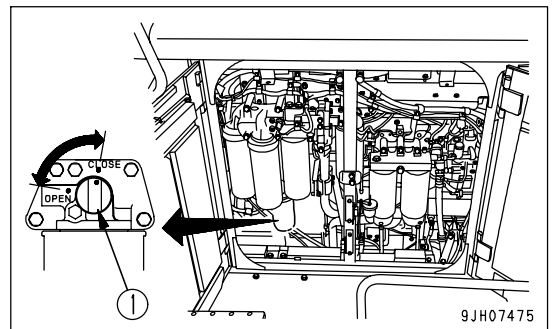

3. Remove cover (2).
4. Check that the cooling water temperature has gone down enough to make it possible to touch the radiator cap surface by hand, then turn radiator cap (3) slowly until it contacts the stopper to release the pressure.
5. Following this, push radiator cap (3), turn it until it contacts the stopper, then remove it.

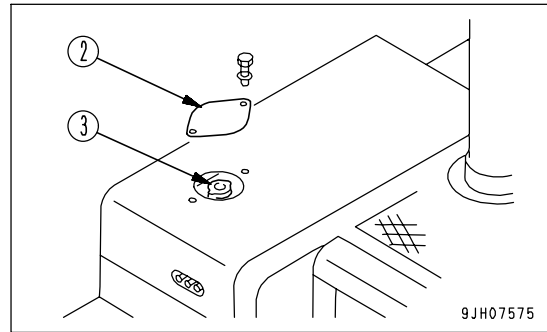

6. Remove drain valve cover (4) on the radiator side and drain valve cover (5) on the engine side.

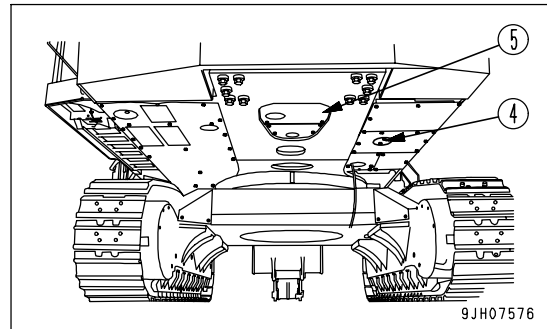

7. Set containers to catch the drained coolant under drain valve (6) on the radiator side and drain valve (7) on the engine site. Open drain valves (6) and (7), and drain the coolant.
8. After draining the antifreeze solution, close drain valve (6), (7), then fill with clean water. After the radiator is filled with water, start and run the engine at low idling speed. After the water temperature rises above 90°C (194°F), run the engine for about 10 minutes.
9. Stop the engine and open drain valves (6), (7) to drain the water.
10. After draining the water, clean the radiator with detergent. For the cleaning method, follow the instruction of detergent.
11. Close drain valves (6), (7).

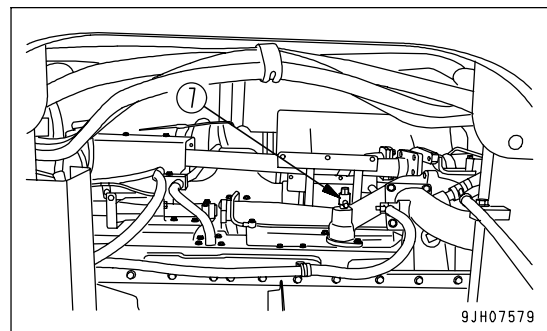
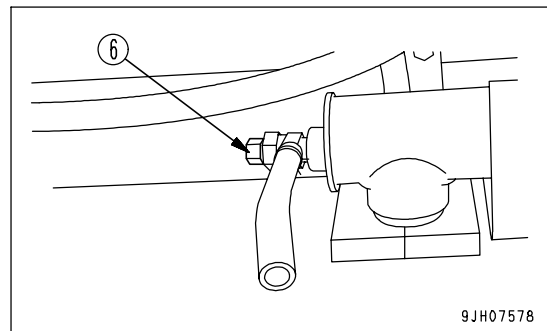

12. Install the covers (4) and (5).
13. Replace the corrosion resistor, then turn valve (1) to the OPEN position. (Only on machines equipped with corrosion resistor)
For details of the method of replacing the corrosion resistor, see "REPLACE CORROSION RESISTOR CARTRIDGE (PAGE 4-69)".
14. Add coolant mixed with antifreeze until it overflows from the water filler.
Decide the proportions of antifreeze and water according to the table for the mixing rate of water and antifreeze.
15. Run the engine at low idling for 5 minutes to remove the air from the water, then run at high idling for 5 minutes. (Leave radiator cap (3) removed when doing this.)

16. Open sub-tank inspection cover (8), drain the coolant from sub-tank (9), wash the inside of the sub-tank, then add water to between the FULL and LOW marks.
 - If the sub-tank is extremely dirty and it is difficult to clean, replace it with a new part.
17. Stop the engine, wait for approx. 3 minutes, add city water up to near the mouth of the filler port, then tighten radiator cap (3).
18. Install cover (2).

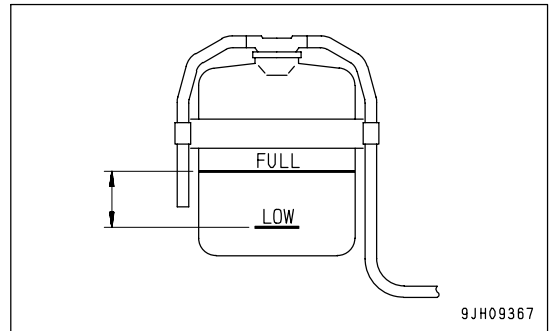
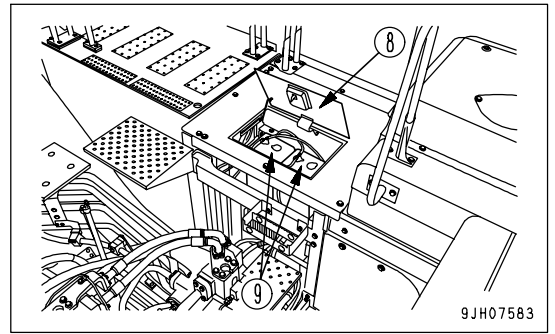

CHECK AND TIGHTEN TRACK SHOE BOLTS

If the machine is used with track shoe bolts (1) loose, they will break, so tighten any loose bolts immediately.

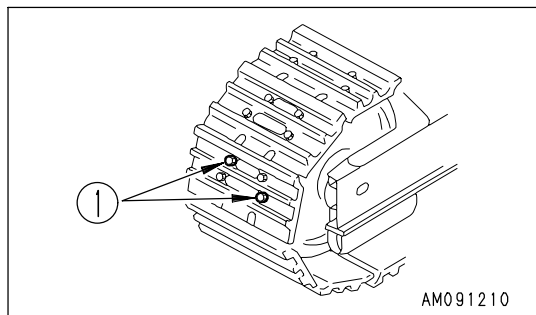

AM091210

Tightening

1. First, tighten to a tightening torque of 1372 ± 137.2 Nm (140 ± 14 kgm, $1,012.6 \pm 101.3$ lbft), then check that the nut and shoe are in tight contact with the link mating surface.
2. After checking, further tighten to the tightening torque of $150^\circ \pm 10^\circ$.

Order for Tightening

Tighten the bolts in the order shown in the diagram on the right. After tightening, check that the nut and shoe are in close contact with the link mating surface.

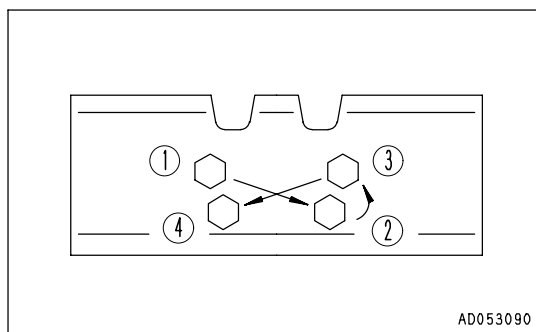

AD053090

CHECK AND ADJUST TRACK TENSION

! WARNING

- For details of starting the engine and operating the work equipment, see "BEFORE STARTING ENGINE (PAGE 3-75)", "STARTING ENGINE (PAGE 3-98)", "AFTER STARTING ENGINE (PAGE 3-101)", and "WORK EQUIPMENT CONTROLS AND OPERATIONS (PAGE 3-119)" in the OPERATION section.

Wear on pins and bushings of the undercarriage will vary with working conditions and type of soil, so inspect the track tension every now and then in order to maintain the standard tension.

For carrying out inspection and adjustment of track shoes, park the machine on the flat and solid ground.

Checking

1. Run the engine at low idle, then move the machine forward for a distance equal to the track length on ground, and slowly stop the machine.
2. Place wooden bar (3) on top of the track from No. 2 roller (1) to No. 3 roller (2).
3. Measure the maximum deflection between bottom surface of the wooden bar and top surface of the track shoe. Deflection "a" should be 10 - 30 mm (0.4 - 1.2 in).

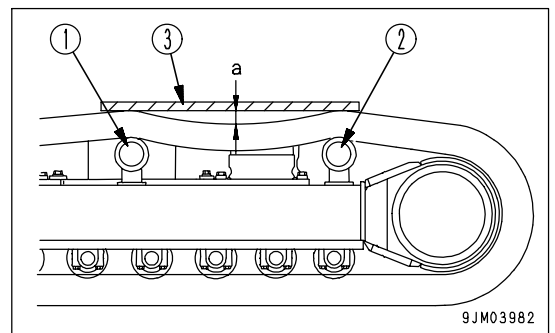

If the track tension is not at the standard value, adjust it in the following manner.

Adjustment

! WARNING

There is danger of plug (1) flying out under the high internal pressure of the grease. Never loosen plug (1) more than 1 turn. Never loosen any part other than plug (1). Never put your face in the mounting direction of plug (1).

If the track tension cannot be loosened with the procedure given here, please contact your Komatsu distributor.

Increasing Track Tension

Prepare a grease pump.

1. Pump in grease through valve (1) using a grease gun.
2. To check that the tension is correct, move the machine slowly forward and in reverse.
3. Check the track tension again, and if the tension is not correct, adjust it again.

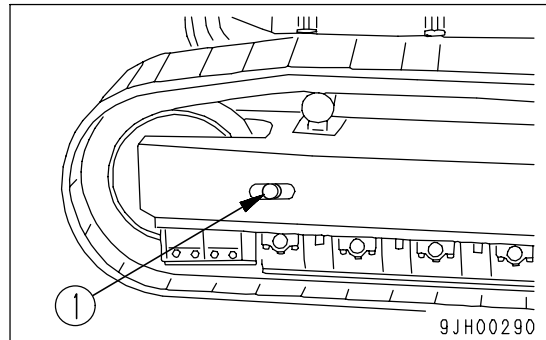

4. Continue to pump in grease until (A) becomes 200 mm (7.9 in). If the tension is still loose, the pin and bushing are excessively worn, so they must be either turned or replaced. Please contact your Komatsu distributor.

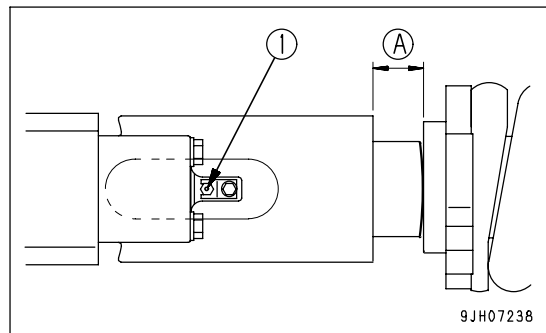

Loosening Track Tension

**WARNING**

There is danger of valve (1) flying out under the high internal pressure of the grease. Never loosen valve (1) more than 1 turn. Never loosen any part other than valve (1). Never put your face in the mounting direction of valve (1).

If the track tension cannot be loosened with the procedure given here, please contact your Komatsu distributor.

1. Loosen plug (1) gradually to release the grease.
2. Turn plug (1) a maximum of one turn.
3. If the grease does not come out smoothly, move the machine forwards and backwards a short distance.
4. Tighten plug (1).
5. To check that the correct tension has been achieved, move the machine backwards and forwards.
6. Check the track tension again, and if the tension is not correct, adjust it again.

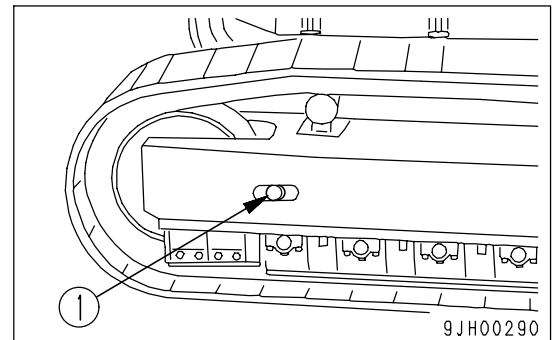

REPLACE BUCKET TEETH (XS)

Replace teeth

Replace the bucket teeth before the adapter starts to wear.

WARNING

- It is dangerous if the work equipment moves by mistake when the teeth are being replaced.
Set the work equipment in a stable condition, then stop the engine and set the lock lever securely to the LOCK position.
- There is a hazard that fragments will fly during the replacement work, so always wear protective equipment like safety glasses and gloves.
- If the tooth pins cannot be removed in this procedure, for safety's sake, be sure to ask your Komatsu distributor for the replacement.

Prepare for a socket wrench for 16 mm- width across flats.

1. Set the bucket with the bottom of the bucket on block (3) so that pin (1) can be removed, then stop the engine.

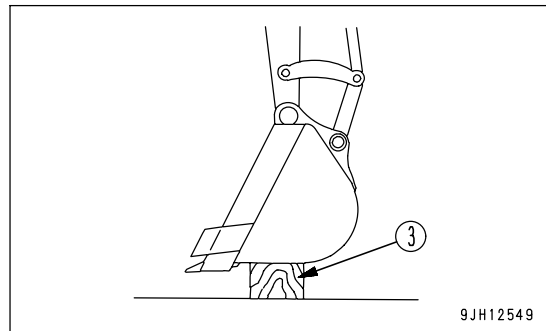

2. Within 15 seconds after stopping the engine, move each control lever (for work equipment and travel) to the full stroke in all directions to release the internal pressure.
3. Check that the work equipment is in a stable condition, then set the lock lever to the LOCK position (L).

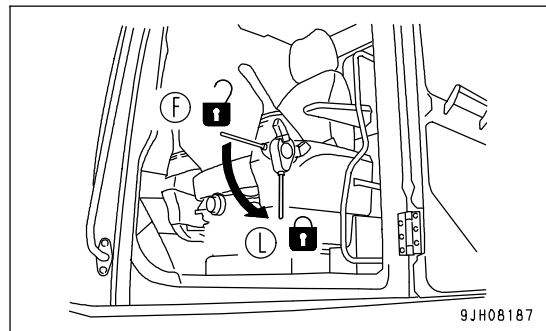

4. Fit a socket wrench to the head of pin (1), then turn it counterclockwise 90° to release the lock of the pin.

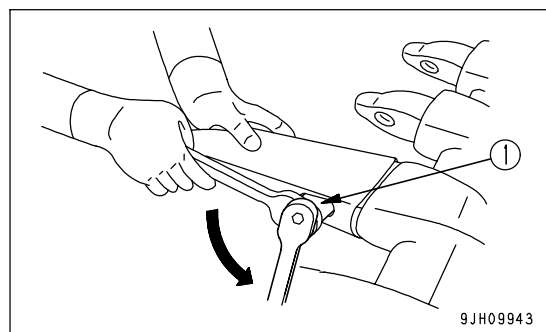

5. Push pin (1) out by hand or with a hammer in the direction of the arrow to remove the teeth (2).

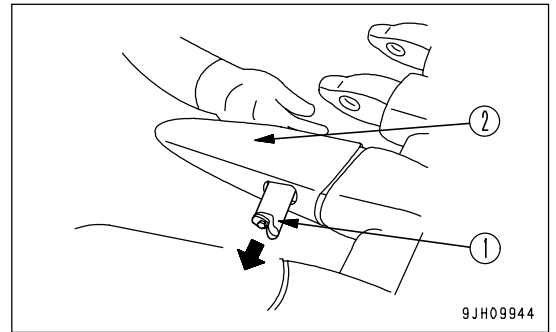

6. Clean the mounting surface, fit new tooth (2) to the adapter, insert new pin (1), then tighten 90° clockwise with the socket wrench to lock the pin and complete the installation.

REMARK

Turn the tooth upside down and rotate the installation positions. Such practice allows wear on the teeth to develop evenly, the lifetime to be extended, and the replacement frequency to be reduced.

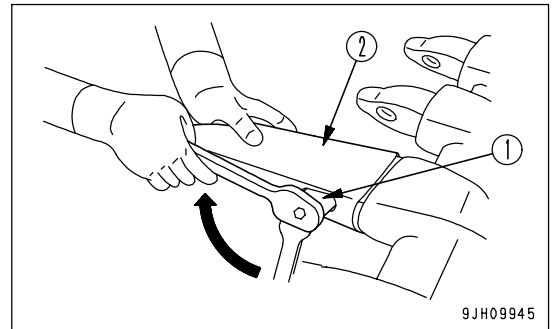

NOTICE

- To prevent a tooth from slipping off, also replace the pins with a new one when the teeth are replaced.
- To prevent tooth (4) and (5) at the either end from slipping off, insert the pins from within (i.e. in the direction shown with an arrow).

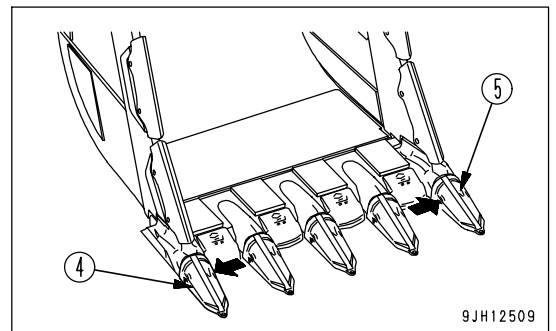

How to Remove Slings Loop

! WARNING

- In case a slinging loop is fitted to the bucket tooth, remove it. If digging work is started without the slinging loop being removed, there is the danger that the slinging loop is broken and broken pieces are sent flying around.
- It is quite dangerous if the work equipment begins to move by mistake while the slinging loop is being removed.
Hold the work equipment in a steady and safe posture; stop the engine; and put the lock lever in the "LOCK" position.
- While the slinging loop is being removed, there is the danger that broken slinging loop pieces are sent flying around, so wear protective tools such as safety glasses.
- Never hit the tooth against a boulder for the purpose of removing the slinging loop.
There is the danger that the broken slinging loop will be sent flying around in pieces, causing a personal injury.

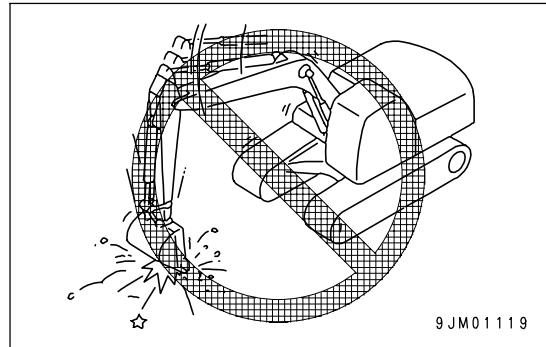

NOTICE

If the machine is operated without the sling being removed, the following problems may possibly arise.

- When the work equipment is pulled back, the slinging loop at the tip of the tooth interferes with the boom.
- A crack occurring at the time of sling breakage progresses to the tooth, resulting in the breakage of the machine itself.
- The sling is broken in the digging operation, broken pieces are mixed in the sand and earth to be loaded.

Be sure to remove the slinging loop in the following steps.

1. Put block (3) under the bottom of the bucket and stop the engine.

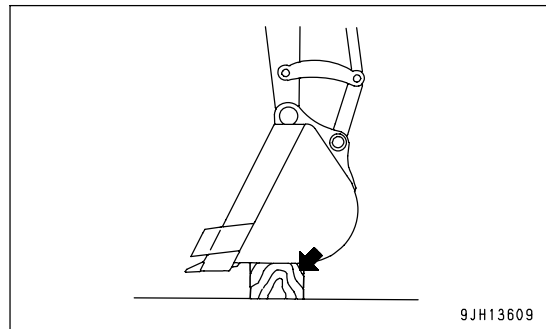

2. Within 15 seconds after stopping the engine, move each control lever (for work equipment and travel) to the full stroke in all directions to release the internal pressure.
3. Check that the work equipment is in a stable condition, then set the lock lever to the LOCK position (L).

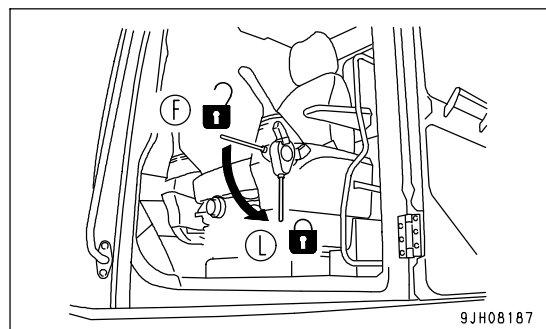

4. Preheat the slinging loop to be cut to 100-150 oC and use a gas cutter to cut the slinging.
 - Tip of tooth (1)
 - Top of tooth (2)

NOTICE

When cutting the slinging loop at each part of the bucket, cut at the following cutting positions (A) - (A) or (B) - (B), according to the shape of the loop.

In addition, when doing this, be careful that the cutting surface does not cut into the main body of the bucket parts.

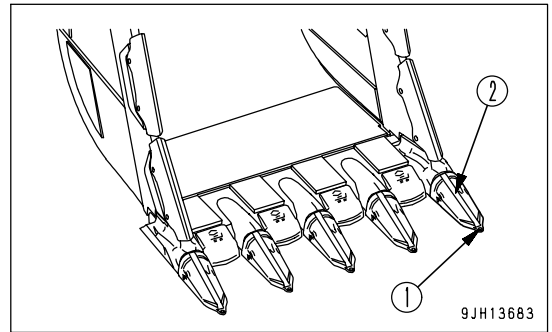

- Cutting position (A) - (A)
This applies to tip of tooth (1).
Cut at the bottom of the hole in the lifting loop.

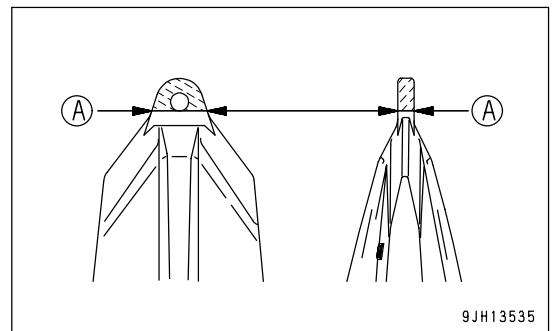

- Cutting position (B) - (B)
This applies to top of tooth (2).
Cut at a position 10-20 mm (0.4 - 0.8 in) from the main body of the bucket part.

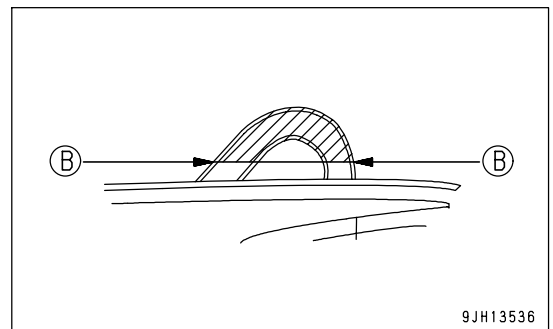

5. Finish the cutting surface smoothly, using a grinding machine.
6. Check that there is no crack on the cutting surface.

ADJUST BUCKET CLEARANCE

! WARNING

It is dangerous if the work equipment is mistakenly moved when adjusting the bucket clearance.

Set the work equipment in a stable condition, stop the engine, then set lock lever (1) securely to the LOCK position (L).

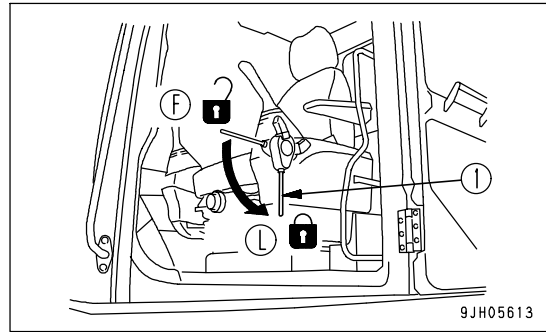

If there is excessive free play on the coupling section of the bucket and arm, adjust the bucket clearance in the following manner.

1. Set the work equipment to the position shown in the diagram on the right, then stop the engine and set the lock lever (1) to the LOCK position (L).
2. Loosen 3 bolts (3), 6 bolts (4), plate (2) and plate (6).
3. Take out shims (5) equivalent in size to free play (a).
Thickness of shim (5) is 0.5 mm or 1.0 mm (0.02 or 0.04 in).
When free play (a) is less than a thickness of shim, do not compress the shims by tightening bolt (2).
4. Tighten 3 bolts (3) and 6 bolts (4).

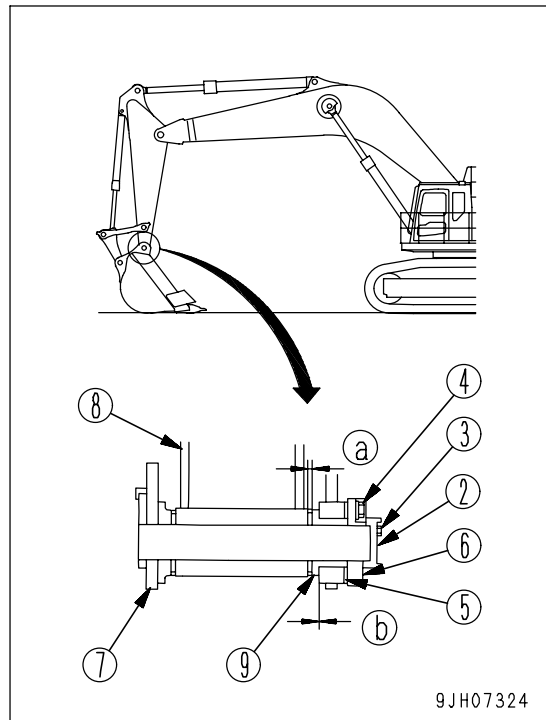

- (7): Bucket
- (8): Arm
- (9): Bush

With this adjustment, clearance (b) becomes larger, but play (a) is removed.

CHECK WINDOW WASHER FLUID LEVEL, ADD FLUID

If there is air in the window washer fluid, check the level of the fluid in window washer tank (1). Add automobile window washer fluid if necessary.

When adding fluid, be careful not to let any dust get in.

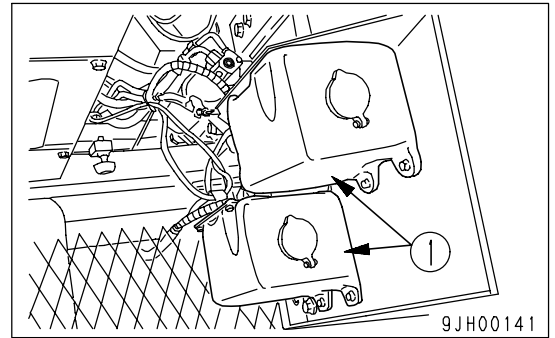

Mixture Ratio of Pure Washer Fluid and Water

The proportion differs according to the ambient temperature, so dilute the washer fluid with water to the following proportions before adding.

Operation area and season	Mixture ratio	Freezing temperature
Normal	Pure washer fluid 1/3: water 2/3	- 10°C (14°F)
Winter in cold region	Pure washer fluid 1/2: water 1/2	- 20°C (- 4°F)
Winter in extremely cold region	Pure washer fluid	- 30°C (- 22°F)

There are two types depending on the freezing temperature:

-10°C (14°F) (general use) and -30°C (-22°F) (cold area use), select according to the area and season.

CHECK AND MAINTENANCE AIR CONDITIONER

(Machine equipped with air conditioner)

Check Level of Refrigerant (gas)



WARNING

If the refrigerant used in the air conditioner gets into your eyes or on your hands, it may cause loss of sight or frostbite. Do not touch the refrigerant. Never loosen any part of the refrigerant circuit.

Do not bring any flame close to any point where the refrigerant gas is leaking.

If the level of the refrigerant (gas) is low, the cooling effect will be reduced. Run the engine at high idle, and check the flow of the refrigerant gas (R134a) in the refrigerant circuit through the sight glass (2) (inspection window) of the receiver (1) when the cooler is running at high speed.

Open the tool box door at the rear of the cab. Receiver (1) is inside.

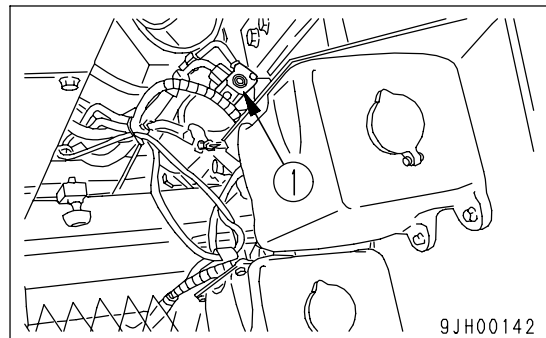

- (A) No bubbles in refrigerant flow: Suitable
- (B) Some bubbles in flow (bubbles pass continuously): Lack of refrigerant
- (C) Colorless, transparent: No refrigerant

REMARK

When there are bubbles, the refrigerant gas level is low, so contact your Komatsu distributors to have refrigerant added. If the air conditioner is run with the refrigerant gas level low, it will cause damage to the compressor.

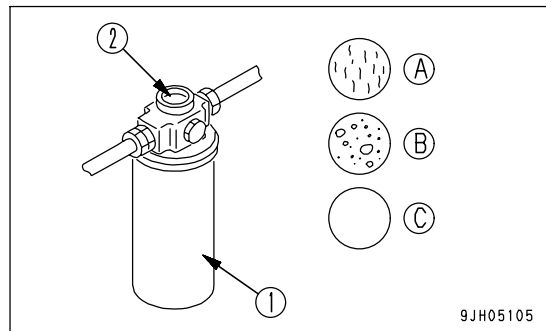

Inspection During Off Season

Even during the off-season, operate the air conditioner for 3 to 5 minutes once a month to maintain the oil film at all parts of the compressor.

Inspection and Maintenance Items

Check, maintenance items	Content of check, maintenance	Guideline for maintenance interval
Refrigerant (gas)	Charge amount	Twice a year (spring, autumn)
Condenser	Clogged fins	Every 500 hours
Compressor	Operating condition	Every 4000 hours
Belt	Damage	Every 500 hours
Blower motor, fan	Operating condition (does it make abnormal noise?)	When required
Control mechanism	Operating condition (does it function normally?)	When required
Piping mounts	Mounting condition, looseness at tightening or connecting portions, leakage of gas, damage	When required

CLEAN LINE FILTER, REMOVE DIRT

If there is any abnormality in the pump or other hydraulic equipment, remove the dirt from inside the line filter as follows.

- Before removing the dirt from inside the line filter, release the internal pressure in the hydraulic circuit. For details, see "METHOD OF RELEASING PRESSURE IN HYDRAULIC CIRCUIT (PAGE 4-79)".

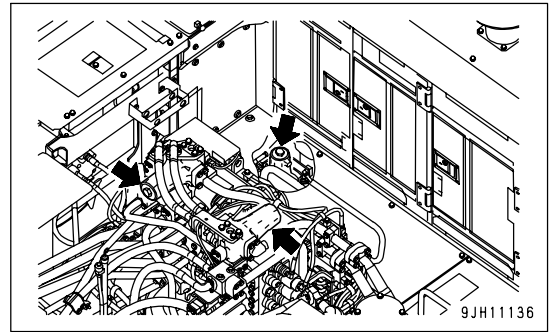

1. Remove cover (1).
2. Install a bolt (10 mm, 0.4 in) in bolt hole (A) of element (2), then hold the bolt and pull out element (2).
3. Clean element (2).
 - When cleaning the element, clean the dirt and dust stuck to side surface (B) of the filter case.
4. Replace O-ring (3) of element (2) with a new part, then insert element (2) into the filter case.
5. Replace backup ring (4) and O-ring (5) of cover (1) with new parts, then install cover (1) to the filter case.

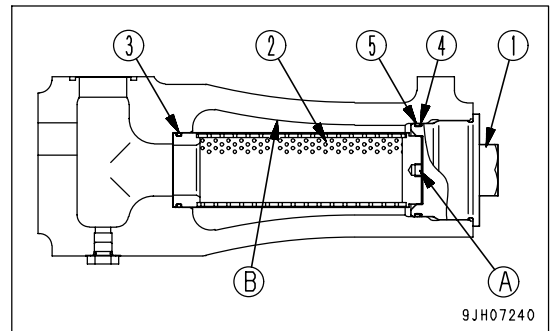

Tightening torque of cover (1): 181 Nm (18.5 kgm, 133.8 lbf)

After assembling the line filter again, bleed the air. For details, see "BLEEDING AIR FROM HYDRAULIC SYSTEM (PAGE 4-37)".

CHECK GAS SPRING



WARNING

The gas spring is charged with high-pressure nitrogen gas, so mistaken operation may cause an explosion, which will lead to serious injury or damage. When handling the gas spring, always do as follows.

- Do not disassemble the accumulator.
- Do not bring it near flame or dispose of it in fire.
- Do not make holes in it or weld it.
- Do not hit it, roll it, or subject it to any impact.
- When disposing of the accumulator, the gas must be released. Please contact your Komatsu distributor to have this work carried out.

The gas spring is fitted to the battery box cover.

In the following cases, please ask your Komatsu distributor to carry out inspection, repair, and replacement.

- When the cover cannot be opened with light effort.
- When the cover do not stay open.
- When oil or gas is found to be leaking from the gas spring.

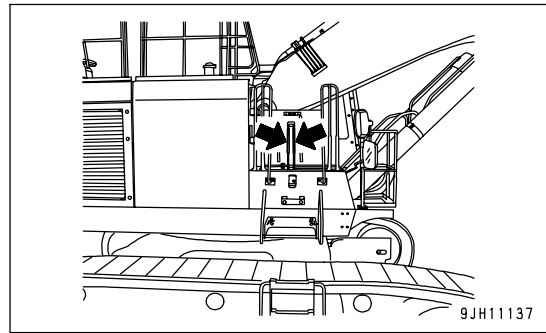

BLEEDING AIR FROM HYDRAULIC SYSTEM

For details of the procedure when starting the engine, see "STARTING ENGINE (PAGE 3-98)". If necessary, refer to the OPERATION volume for the sections for starting the engine, moving the machine off, steering, and stopping.

CAUTION

When starting the engine to bleed the air, cancel the automatic warming-up operation before starting.

- Method of canceling automatic warming-up operation
 1. Turn the starting switch ON.
 2. Hold the fuel control dial at the MAX position for 3 seconds.
 3. Turn the fuel control dial to the MIN position.
 4. Start the engine.

NOTICE

- Bleed the air as follows.
 1. Pump (work equipment, swing) (Bleed the air without starting the engine)
 2. Work equipment circuit
- Bleed the air from the pump with the engine stopped.
- Run the engine at the speed of 1000 rpm or below and operate the cylinders slowly.
- Do not carry out the operation suddenly, or raise the cylinder pressure, or operate the cylinder to the end of its stroke.
- When operating the cylinder for the first stroke (extending and retracting), operate particularly slowly.
- When operating the cylinder for the first stroke, there is a large amount of air inside the circuit, so the work equipment will not move for at least 10 seconds. Be careful not to operate the lever to the end of the stroke.
- Use clean oil of NAS7 class or above when filling the pump. Be sure to use a clean oil can.

Bleed the air from the various components in the order below (1.-6.).

1. Bleeding air from pump (Do this before starting the engine)
 - 1) Loosen air bleed plug (1) and check that oil (4) oozes out from the air bleeder (3).

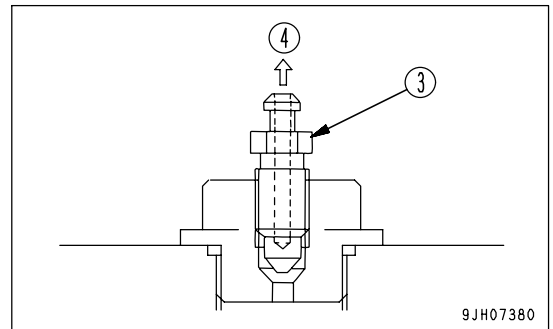

- 2) If no oil oozes out, remove the drain hose from the pump case, and add hydraulic oil through drain port (2) to fill the pump case.
Oil will come out when the drain hose is removed, so secure the hose mouthpiece at a position higher than the level of the oil in the hydraulic tank.
- 3) After completing the air bleed operation, tighten air bleeder (1) and install the drain hose.

NOTICE

If the drain hose is installed first, oil will spurt out from air bleed (1) hole. If the pump is operated without filling the pump case with hydraulic oil, abnormal heat will be generated and this may cause premature damage to the pump.

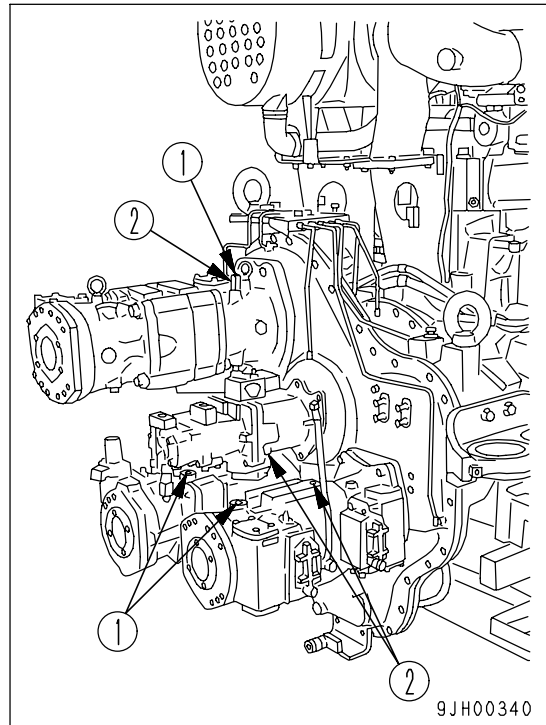

2. Starting engine

Cancel the automatic warming-up operation, start the engine, and run it at low idling for 10 minutes after starting. After that, do as follows.

3. Bleeding air from cylinders

- 1) Run the engine at low idle, and extend and retract each cylinder 4 to 5 times, taking care that a cylinder is not moved to the end of its stroke. (Stop the cylinder approx. 100 mm (3.9 in) short of its stroke end)
- 2) Next, operate each cylinder 3 to 4 times to the end of its stroke.
- 3) Finally, operate each cylinder 4 to 5 times to the end of its stroke to completely remove the air.

NOTICE

If the engine is run at high speed immediately after startup or a cylinder is pushed up to its stroke end, air taken inside the cylinder may cause damage to the piston packing.

4. Bleeding air from swing motor (bleed the air only when the oil inside the swing motor case has been drained)

- 1) Run the engine at low idling, remove hose (1) at port S, and check that oil oozes out from port S hose (1).

NOTICE

Do not operate the swing under any circumstances.

- 2) If oil does not ooze out, stop the engine, remove port S hose (1), and fill the inside of the motor case with hydraulic oil.

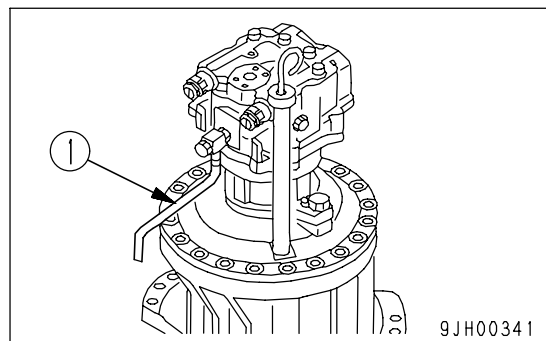

- 3) After completely bleeding the air, tighten port S hose (1).
- 4) Run the engine at low idle, and slowly swing the upper structure at least 2 times uniformly to the left and right.

NOTICE

If the air is not bled from the swing motor, the motor bearings may be damaged.

5. Bleeding air from attachment (when installed)

If an attachment has been installed, run the engine at low idling and operate the attachment pedal repeatedly (approx. 10 times) until the air has been bled from the attachment and circuit.

NOTICE

- If the method of bleeding the air from the attachment itself is specified by the manufacturer, bleed the air according to the specified procedure.
- After completing the air bleeding operation, stop the engine, and leave the machine for 5 minutes before starting operations. This will remove the air bubbles in the oil inside the hydraulic cylinders.
- Check that there is no leakage of oil and wipe off any oil that has been spilled.

6. Bleeding air from travel motor circuit

If the piping has been removed from the travel motor circuit, bleed the air after reassembling. To bleed the air, run the engine at low idling and do as follows.

- 1) Start the engine and run at low idling.
- 2) Remove travel motor cover (1), then loosen air bleed plug (2) one turn.

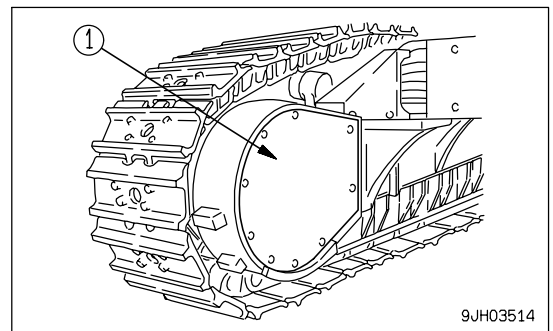

9JH03514

NOTICE

Do not loosen plug (2) more than one turn.

- 3) Carry out fine operation of the travel lever and set to FORWARD and REVERSE 4 - 5 times.
- 4) When no more cloudy white oil comes out from air bleed plug (2), tighten air bleed plug (2).
- 5) Install the travel motor cover.

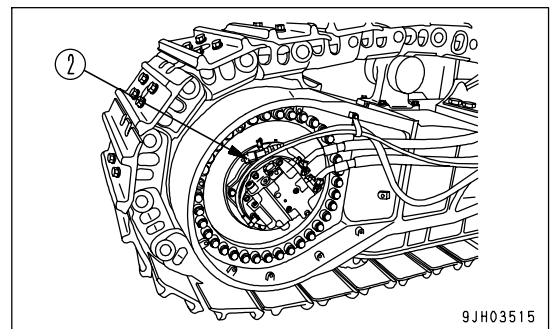

9JH03515

BLEEDING AIR FROM FUEL CIRCUIT

This machine is equipped with an electric priming pump to bleed the air from the fuel circuit. In the following cases, use the procedure below to bleed the air.

- When fuel filter has been replaced
- When engine has run out of fuel
- When starting the engine for the first time after replacing the supply pump or modifying the piping or any other parts

WARNING

When using the electric priming pump, do not loosen the air bleed plug for the fuel circuit. When the electric priming pump is operated, pressure is applied to the fuel circuit, so if the air bleed plug is loosened, fuel will spurt out and create a dangerous situation.

1. Turn the key in starting switch (1) to the OFF position (A).

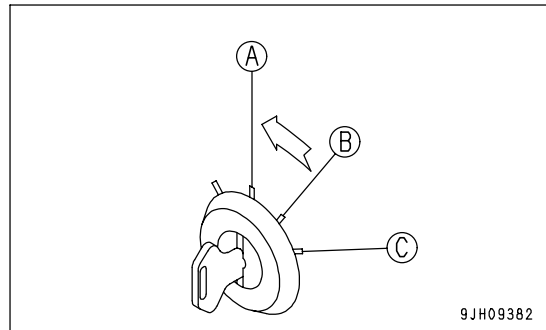

2. Turn the valve (1) at the bottom of the fuel tank to the OPEN position (O).

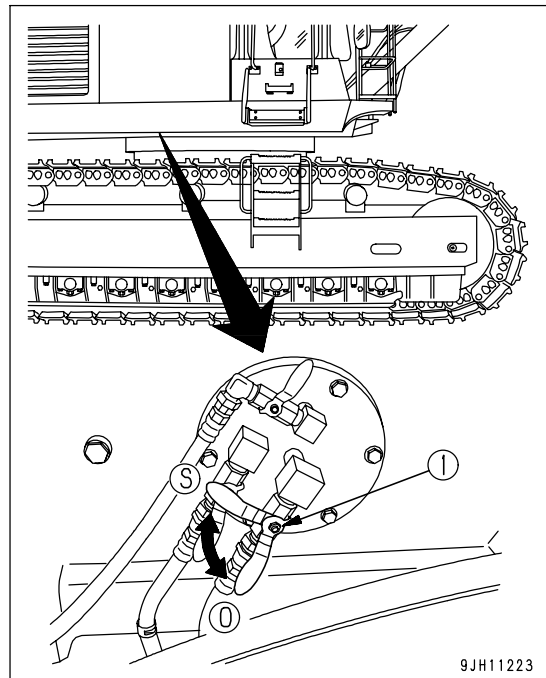

3. Open the engine room door.

4. Turn the air bleed valve (2) to the open position (O).

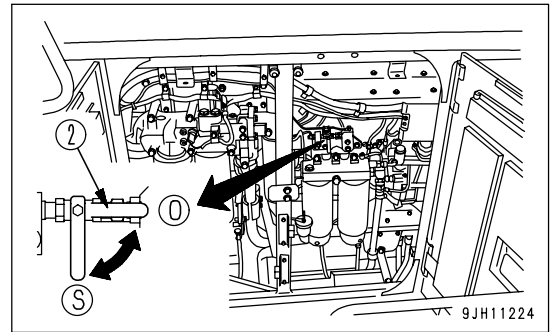

5. Turn electric priming pump switch (3) to the ON position (A). Lamp (4) flashes and the electric priming pump starts. Release electric priming pump switch (3). Switch (3) will return automatically to the original position (N).

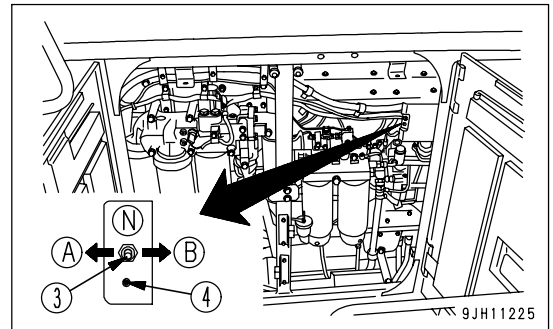

REMARK

- While lamp (4) is flashing, the electric priming pump is actuated for 30 seconds and then stops for 10 seconds. This action is repeated until lamp (4) goes out.
- If this switch is turned to the OFF position (B) when the lamp is flashing, the lamp will go out and the electric priming pump will stop.
- When the lamp is flashing, the electric priming pump will stop, but this does not indicate any abnormality.

6. When the specified time (approx. 7 minutes) has passed, lamp (4) automatically goes out and the electric priming pump stops.
7. The electric priming pump automatically stops working (the monitor lamp goes off), when the fuel circuit is emptied of fuel as in the instance that the engine stops due to fuel exhaustion, or in the instance that the fuel hose, tube or priming pump has been maintained or replaced. In that case, tilt the electric priming pump switch back to the ON position (A) so as to allow the pump to work again.
8. When the lamp goes out, the air bleed operation is completed.
9. Turn air bleed valve (2) to the closed position (S).

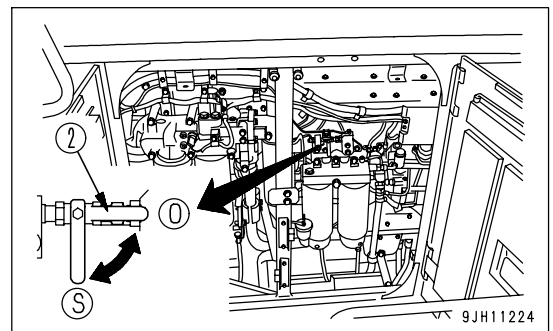

10. Start the engine.

If the engine does not start, the probable reason is that the air has not been completely bled.

Do as follows, then start the engine again.

- 1) Check that the air bleed valve is closed.
- 2) Turn electric priming pump switch (3) ON position (A).
- 3) Try to start the engine while the electric priming pump is in operation. If the engine still does not start, wait for approx. 2 minutes, and then repeat steps 2) and 3).
- 4) After the engine has started, run the engine for approx. 5 minutes to bleed air from the fuel system completely.

NOTICE

Do not keep the starting motor rotating continuously for more than 20 seconds.

If the engine will not start, wait for at least 2 minutes before trying to start the engine again.

CHECK BEFORE STARTING

For details of the following items, see "Checks Before Starting (PAGE 3-77)" in the OPERATION section.

- Check coolant level, add coolant
- Check oil level in engine oil pan, add oil
- Check fuel level, add fuel
- Check for water and sediment in water separator, drain water
- Check oil level in hydraulic tank, add oil
- Check oil level in swing machinery case, add oil
- Check oil level in PTO case, add oil
- Check air cleaner for clogging
- Check working lamp switch
- Check electric wiring
- Check function of horn
- Drain water and sediment from fuel tank
- Drain water from air tank

EVERY 10 HOURS MAINTENANCE

LUBRICATING

1. Set to the greasing posture below, lower the work equipment to the ground, then stop the engine.
2. Using a grease pump, pump in grease through the grease fittings shown by arrows.
3. After greasing, wipe off any old grease that was pushed out.

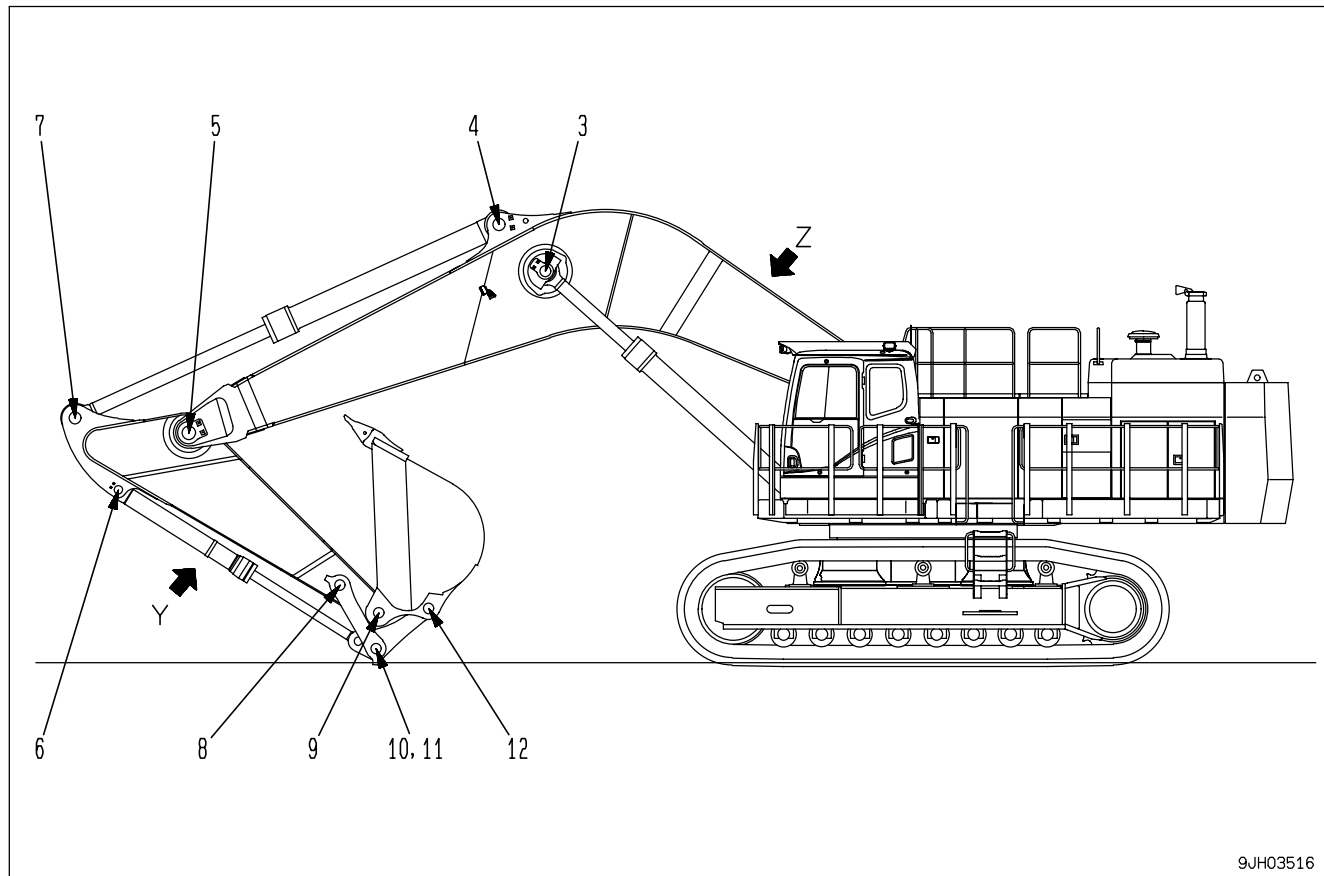

9JH03516

(1) Boom cylinder foot pin (2 places)

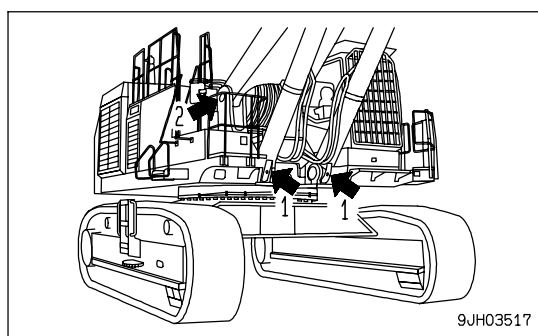

9JH03517

- (2) Boom foot pin (2 places)
- (3) Boom cylinder rod end pin (2 places)
- (4) Arm cylinder foot pin (1 place)

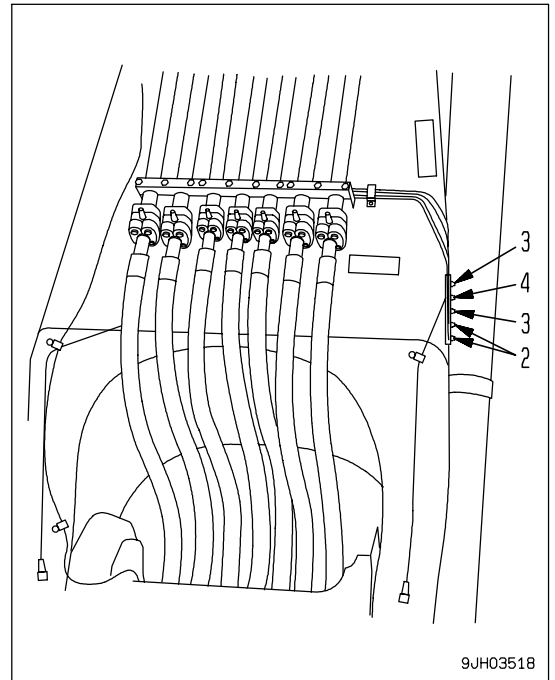

- (5) Boom - Arm coupling pin (1 place)
- (6) Bucket cylinder foot pin (2 point)
- (7) Arm cylinder rod pin (1 place)
- (8) Arm - Link coupling pin (1 place)
- (9) Arm-Bucket coupling pin (2 point)
- (10) Link coupling pin (2 places)
- (11) Bucket cylinder rod end pin (2 point)
- (12) Bucket-Link coupling pin (1 place)

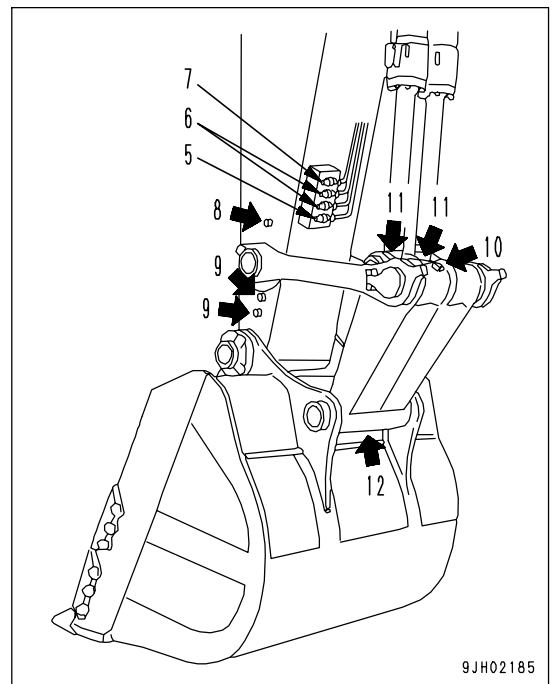

EVERY 100 HOURS MAINTENANCE

Maintenance for every 10 hours service should be carried out at the same time.

LUBRICATING SWING CIRCLE

(4 points)

1. Lower the work equipment to the ground.
2. Using a grease pump, pump in grease through the grease fittings shown by arrows.
3. After greasing, wipe off any old grease that was pushed out.

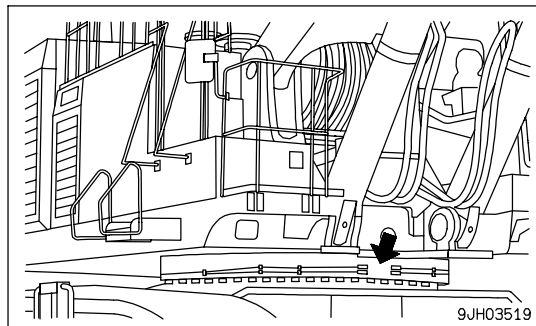

EVERY 250 HOURS MAINTENANCE

Maintenance for every 10 hours service should be carried out at the same time.

CHECK OIL LEVEL IN FINAL DRIVE CASE, ADD OIL

⚠ WARNING

- The parts and oil are at high temperature immediately after the engine is stopped, and may cause serious burns. Wait for the temperature to go down before starting the operation.
- If there is still pressure remaining inside the case, the oil or plug may fly out. Loosen the plug slowly to release the pressure.

- Prepare a handle.
 1. Set the TOP mark at the top, with the UP mark and plug (P) perpendicular to the ground surface.
 2. Remove plug (F) using the handle. When the oil level reaches a point 10 mm (0.4 in) below the bottom of the plug hole, the correct amount of oil has been added.
 3. If the oil level is too low, install plug (F), operate the travel levers, and drive forward or in reverse to rotate the sprocket one turn. Then repeat Step 2 to check again.
 4. If the oil level is low, add oil through the hole of plug (F). Add oil until oil overflows from the hole of plug (F).
 5. After checking, install plug (F).

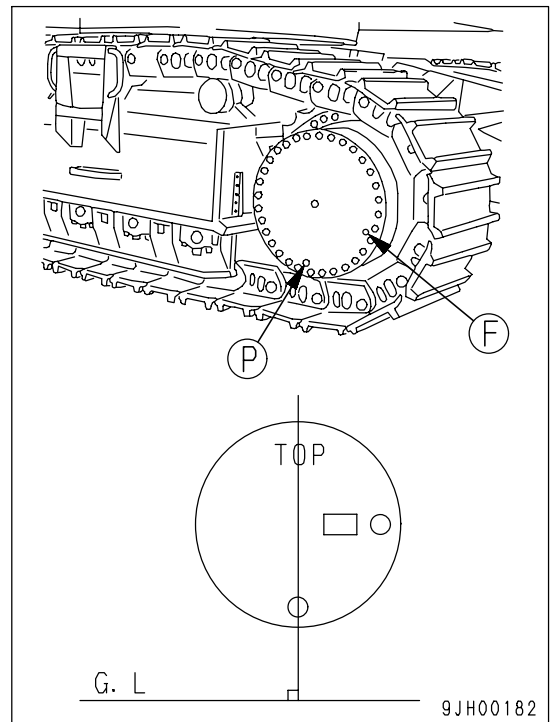

CHECK LEVEL OF BATTERY ELECTROLYTE

Carry out this procedure before operating the machine.

! WARNING

- Do not use the battery if the battery electrolyte level is below the LOWER LEVEL line. This will accelerate deterioration of the inside of the battery and reduce the service life of the battery. In addition, it may cause an explosion.
- The battery generates flammable gas and there is danger of explosion, do not bring fire or sparks near the battery.
- Battery electrolyte is dangerous. If it gets in your eyes or on your skin, wash it off with a large amount of water and consult a doctor.

NOTICE

- When adding distilled water to the battery, do not allow the battery electrolyte to go above the UPPER LEVEL line. If the electrolyte level is too high, it may leak and cause damage to the paint surface or corrode other parts.
- When adding distilled water in cold weather, add it before starting operations in the morning to prevent the electrolyte from freezing.

Inspect the battery electrolyte level at least once a month and follow the basic safety procedures given below. Open cover (1) at the rear left side of the machine. The batteries are installed at (A) part.

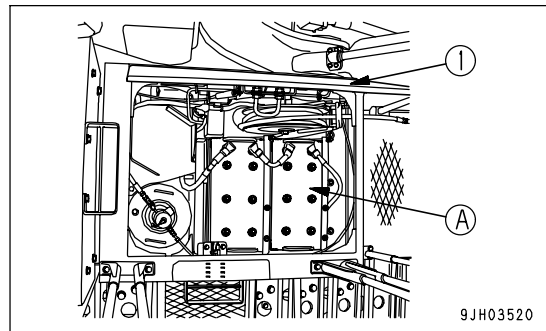

When Checking Electrolyte Level from Side of Battery

If it is possible to check the electrolyte level from the side of the battery, check as follows.

1. Use a wet cloth to clean the area around the electrolyte level lines and check that the electrolyte level is between the UPPER LEVEL (U.L.) and LOWER LEVEL (L.L.) lines. If the battery is wiped with a dry cloth, static electricity may cause a fire or explosion.

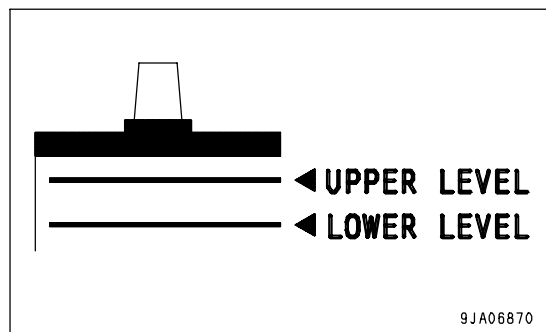

2. If the electrolyte level is below the midway point between the UPPER LEVEL (U.L.) and LOWER LEVEL (L.L.) lines, remove cap (2) and add distilled water to the U.L. line.
3. After adding distilled water, tighten cap (2) securely.

REMARK

If distilled water is added to above the UPPER LEVEL (U.L.) line, use a syringe to lower the level to the UPPER LEVEL (U.L.) line. Neutralize the removed fluid with baking soda (sodium bicarbonate), then flush it away with a large amount of water or consult your Komatsu distributor or battery maker.

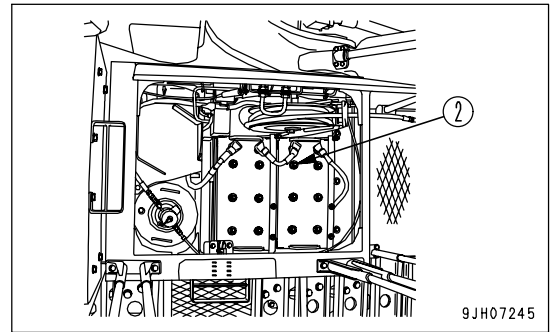

When it is Impossible to Check Electrolyte Level from Side of Battery

If it is impossible to check the electrolyte level from the side of the battery, or there is no display of the UPPER LEVEL line on the side of the battery, check as follows.

1. Remove cap (2) at the top of the battery, look through the water filler port (3), and check the electrolyte surface. If the electrolyte does not reach the sleeve (4), add distilled water so that the level reaches the bottom of the sleeve (UPPER LEVEL line) without fail.
 - (A) Suitable level: Electrolyte level is up to bottom of sleeve, so surface tension causes electrolyte surface to bulge and poles appear bent.
 - (B) Low: Electrolyte level is not up to bottom of sleeve, so poles appear straight and not bent.
2. After adding distilled water, tighten cap (2) securely.

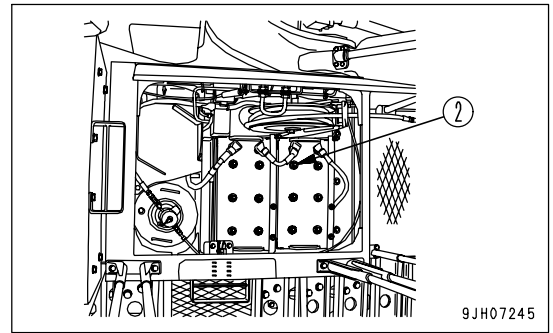

REMARK

If water is added to above the bottom tip of the sleeve, use a pipette to remove electrolyte. Neutralize the removed electrolyte with sodium bicarbonate, then flush it away with a large amount of water. If necessary, contact your Komatsu distributor or your battery maker.

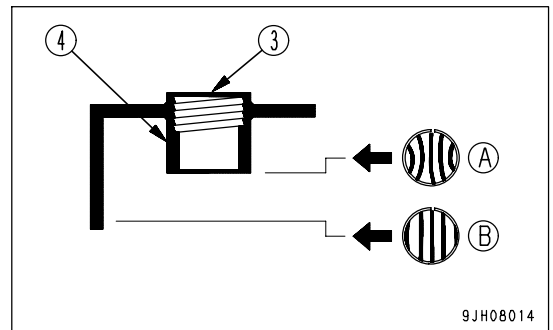

When it is Possible to Use Indicator to Check Electrolyte Level

If it is possible to use an indicator to check the electrolyte level, follow the instructions given.

CHECK AND TIGHTEN TRACK FRAME AND AXLE CONNECTING BOLTS

Bolts (1) connecting the track frame and axle will break if they remain loose, so loose bolts must always be retightened.

- Tightening torque: 3260 ± 370 Nm (333 ± 38 kgm, 2410 ± 275 lbft)

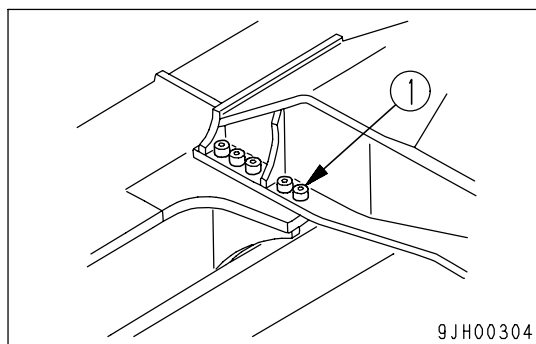

EVERY 500 HOURS MAINTENANCE

Maintenance for every 10, 100, and 250 hours of service should be performed at the same time.

REPLACE FUEL PRE-FILTER CARTRIDGE



WARNING

- After the engine has been operated, all parts are at high temperature, so do not replace the filter immediately. Wait for all parts to cool down before starting the operation.
- High pressure is generated inside the engine fuel piping system when the engine is running. When replacing the filter, wait for at least 30 seconds after stopping the engine to let the internal pressure go down before replacing the filter.
- Do not bring any fire or flame close.

NOTICE

- Genuine Komatsu fuel filter cartridges use a special filter that has highly efficient filtering ability. When replacing the filter cartridge, always use a genuine Komatsu part.
- The common rail fuel injection system used on this machine consists of more precise parts than the conventional injection pump and nozzle. If any part other than a genuine Komatsu filter cartridge is used, dust or dirt may get in and cause problems with the injection system. Always avoid using substitute parts.
- When carrying out inspection or maintenance of the fuel system, pay more attention than normal to the entry of dirt. If dirt is stuck to any part, use fuel to wash it off completely.

- Prepare a container to catch drain fuel.
- Prepare a filter wrench

1. Turn the valve (5) at the bottom of the fuel tank to the CLOSE position (S).

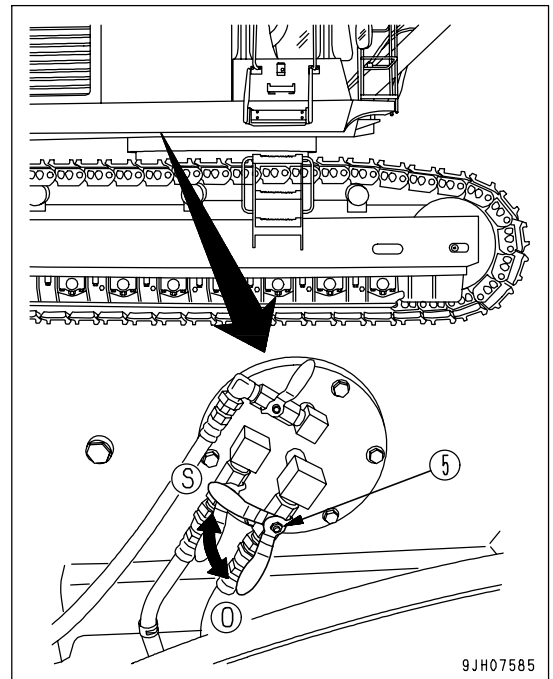

2. Set the container to catch the fuel under the filter cartridge (1).
3. Remove transparent cup (2) from the filter and inspect it. If it is broken or damaged, replace it with a new part.
4. Using a filter wrench, turn filter cartridge (1) counterclockwise on remove it.

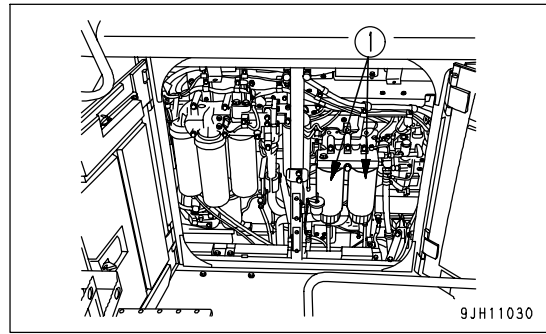

5. Clean transparent cup (2) and remove seal (3). Coat the new seal with clean fuel or oil.
6. Install transparent cup (2) to the new filter cartridge. Tightening torque for cup: 10 Nm (1.0 kgm, 7.2 lbft)

NOTICE

It is not necessary to fill the filter cartridge with oil.

Cap (A) is installed to prevent dirt from entering the inside of the filter cartridge.

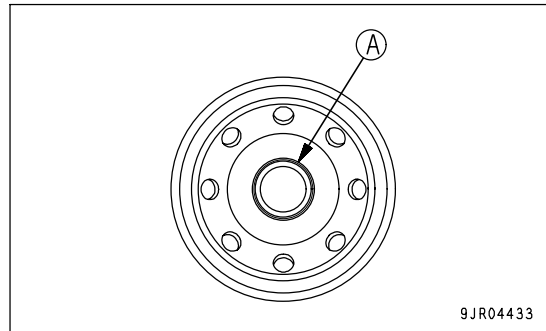

When replacing the filter cartridge, check that drain plug (4) at the bottom of transparent cup (2) is securely tightened.
(Tightening torque: 0.2-0.4 Nm (0.02 - 0.046 kgm, 0.1 - 0.3 lbft))

7. Clean the filter cartridge mount on the filter holder and check that there is no dirt or damage. In particular, if there is dirt or damage to seal surfaces (B) or (C), air will be sucked in or fuel will leak, and it will lead to the entry of dirt.
8. Coat the packing surface of the filter cartridge with oil.
9. Remove filter cartridge cap (A), check that there is no dirt or damage to the filter holder and filter cartridge, then install the filter cartridge to the filter holder.
10. When installing, tighten until the packing surface contacts the seal surface of the filter holder, then tighten it 3/4 of a turn. If the filter cartridge is tightened too far, the packing will be damaged and this will lead to leakage of fuel. If the filter cartridge is too loose, fuel will also leak from the packing, so always tighten the correct amount.

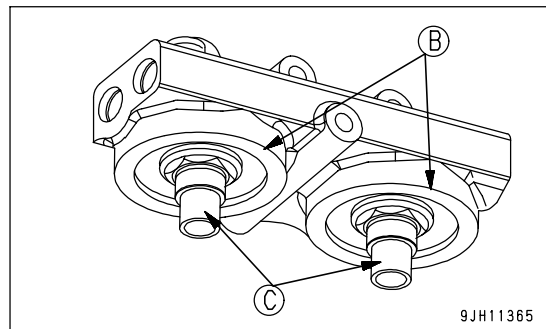
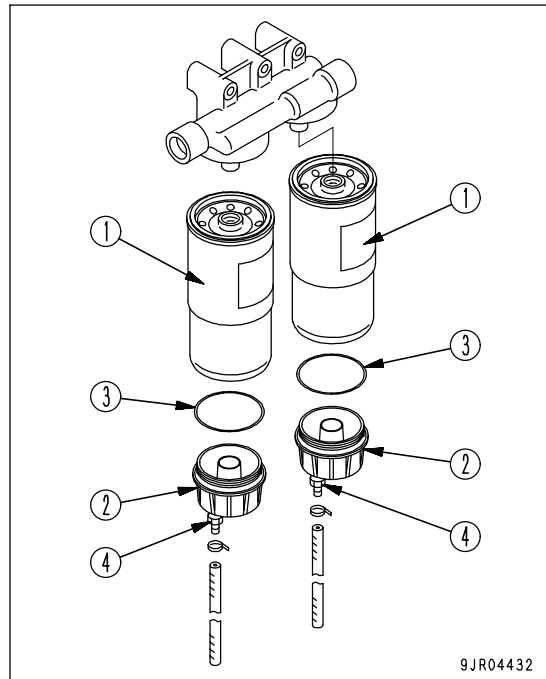

REPLACE FUEL MAIN FILTER CARTRIDGE

⚠ WARNING

- After the engine has been operated, all parts are at high temperature, so do not replace the filter immediately. Wait for all parts to cool down before starting the operation.
- High pressure is generated inside the engine fuel piping system when the engine is running. When replacing the filter, wait for at least 30 seconds after stopping the engine to let the internal pressure go down before replacing the filter.
- Do not bring any fire or flame close.

NOTICE

- Genuine Komatsu fuel filter cartridges use a special filter that has highly efficient filtering ability. When replacing the filter cartridge, always use a genuine Komatsu part.
 - The common rail fuel injection system used on this machine consists of more precise parts than the conventional injection pump and nozzle. If any part other than a genuine Komatsu filter cartridge is used, dust or dirt may get in and cause problems with the injection system. Always avoid using substitute parts.
 - When carrying out inspection or maintenance of the fuel system, pay more attention than normal to the entry of dirt. If dirt is stuck to any part, use fuel to wash it off completely.
- Prepare a container to catch drain fuel.
 - Prepare a filter wrench

1. Set the container to catch the fuel under the filter cartridge (1).
2. Using a filter wrench, turn filter cartridge (1) counterclockwise on remove it.

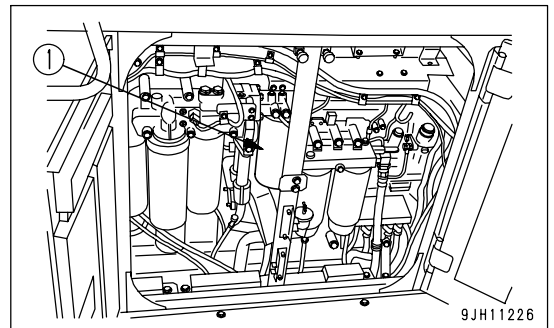

3. Clean the filter cartridge mount on the filter holder and check that there is no dirt or damage. In particular, if there is dirt or damage to seal surfaces (B) or (C), air will be sucked in or fuel will leak, and it will lead to the entry of dirt.
4. Coat the packing surface of the filter cartridge with oil.

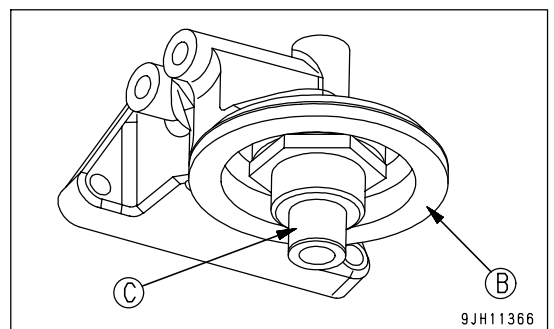

5. Remove filter cartridge cap (A), check that there is no dirt or damage to the filter holder and filter cartridge, then install the filter cartridge to the filter holder.

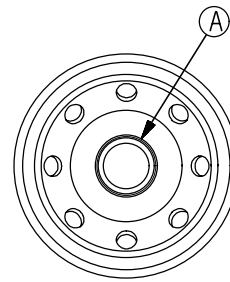

9JR04433

NOTICE

Do not fill the filter cartridge with fuel.

Cap (A) is installed to prevent dirt from entering the inside of the filter cartridge.

6. When installing, tighten until the packing surface contacts the seal surface of the filter holder, then tighten it 3/4 of a turn.
If the filter cartridge is tightened too far, the packing will be damaged and this will lead to leakage of fuel. If the filter cartridge is too loose, fuel will also leak from the packing, so always tighten the correct amount.
7. After completing replacement of fuel filter cartridge (1), open the fuel valve under the fuel tank and bleed the air. For details, see "BLEEDING AIR FROM FUEL CIRCUIT (PAGE 4-40)".
8. After completely bleeding the air, start the engine and check that there is no leakage of fuel from the filter seal surface. If any leakage of fuel is found, check that the filter cartridge is tightened properly. If the fuel still leaks, repeat Steps 1 and 2 to remove the filter cartridge, then check the packing surface for damage or embedded dirt. If any problem is found, replace the cartridge with a new part, then repeat Steps 3 - 8 to install the new cartridge.

CHECK SWING PINION GREASE LEVEL, ADD GREASE

- Prepare a scale.
- 1. Before starting the inspection, swing 2 times to the right or left, then lower the work equipment to the ground and stop the engine.
- 2. Open the grease pump box on the right side of the machine, remove 3 bolts (1), then remove plate (2) at the spare grease can location point.
- 3. Remove bolts (3) (4 bolts) on the top of the revolving frame and remove cover (4).

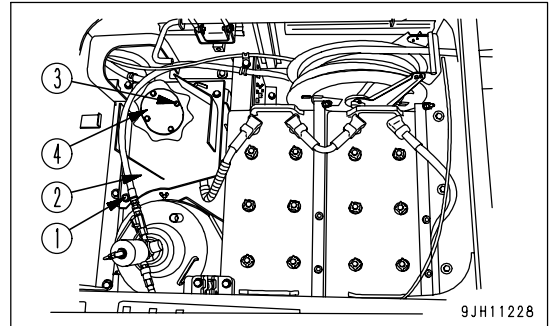

- 4. Insert a scale into the grease and check that the depth of the grease is approx. 36 mm (1.4 in). Add grease if necessary. Insert the scale (A) in the position shown in the diagram on the right when measuring.

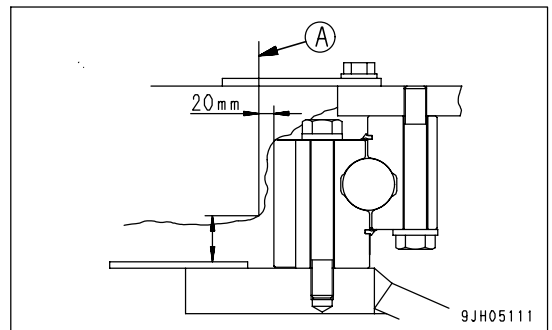

If the grease is particularly milky due to ingress of water, etc., then remove bolts (5) and cover (6) from the bottom of the track frame and remove the grease. Replace all of the grease with new grease.

The total amount of grease is 55 liters (49.5 kg) (14.5 US gal) (109 lb)).

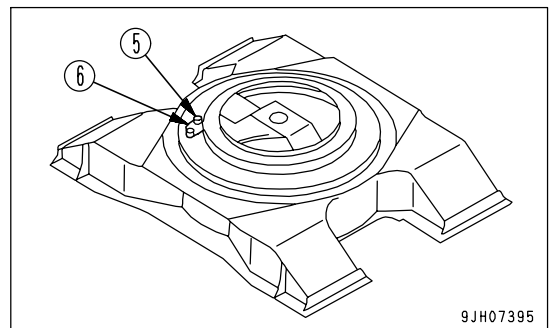

- 5. Install cover (4) with bolts (3) .
- 6. Install plate (2) with bolts (1).

CLEAN,CHECK RADIATOR FINS,OIL COOLER FINS,FUEL COOLER FINS,AFTERCOOLER FINS,CONDENSER FINS (machines equipped with air conditioner),PTO OIL COOLER

! WARNING

If compressed air, high-pressure water, or steam hits your body directly or dirt is sent flying by the compressed air, high-pressure water, or steam, there is danger of personal injury. Always wear protective glasses, dust mask, and other protective equipment.

NOTICE

When using compressed air, use from a distance to prevent damage to the fins.

In particular, with the fuel cooler and aftercooler, blow with compressed air at an angle of 45° with the nozzle at a distance of at least 300 mm (11.8 in).

Never blow the compressed air at right angles to the core. If the fins are damaged, it may cause coolant leakage or overheating.

On dusty jobsites, check the fins daily, irrespective of the maintenance interval.

1. Open rear ducts (1) and (2) at the right side of the machine.
For duct (1), remove 4 bolts (3); for duct (2), remove 8 bolts (4).
Then open the ducts.
2. Blow off mud, dust or leaves clogging the radiator fins (E), oil cooler fins (D), fuel cooler fins (B), after cooler fins (C) and PTO cooler (F) using compressed air. At the same time, clean the net in front of the oil cooler. Clean the condenser fins (A) on machines equipped with air conditioner.
Steam or water may be used instead of compressed air, but maintain the proper distance from the fins.
Cleaning can also be carried out by rotating the fan in reverse.
The aftercooler fan is not equipped with a fan reverse rotation function.
For details of rotating the fan in reverse, see "Fan Reverse Rotation (PAGE 3-27)".
3. Check the rubber hose. Replace with a new one if the hose is found to have cracks or to be hardened by aging.
Also, check hose clamps for looseness.

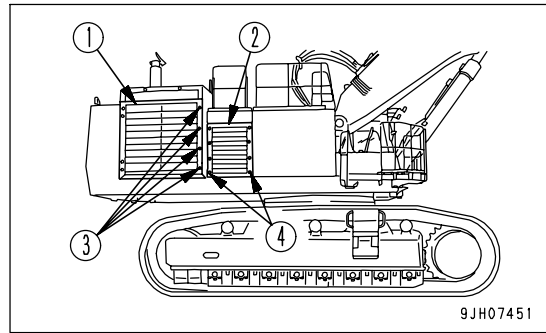

9JH07451

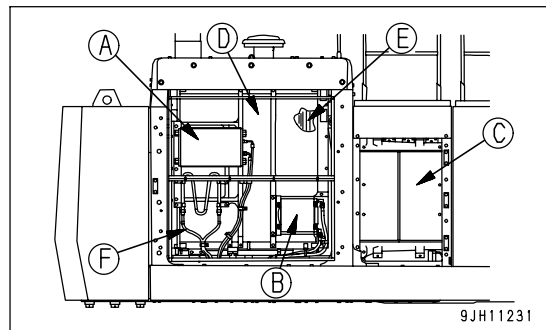

9JH11231

CLEAN AIR CONDITIONER FRESH/RECIRC FILTERS

! WARNING

If compressed air scattered around dust and debris, there is danger of injury. Always wear protective equipment such as protective glasses and mask.

NOTICE

As a guideline, the filters should be cleaned every 500 hours, but on dusty jobsites, clean the filters more frequently.

REMARK

If the filter becomes clogged, the air flow will be reduced, and there will be an abnormal noise from the air conditioner unit.

Cleaning Recirculated Air Filter

1. Remove wing bolts (1) from the inspection window at the bottom rear left on the inside of the operator's cab, then take out the recirculated air filter.
2. Clean the filter with compressed air. If there is oil on the filter, or if the filter is extremely dirty, wash it in a neutral agent. After rinsing it in water, dry it thoroughly before using it again. If the clogging of the filter cannot be removed by blowing with air or washing in water, replace the filter with a new part.

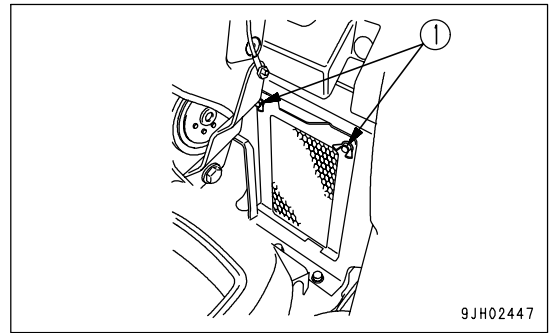

Cleaning Fresh Air Filter

1. Pull up the lock release lever (1) under the door release lever to release the lock.

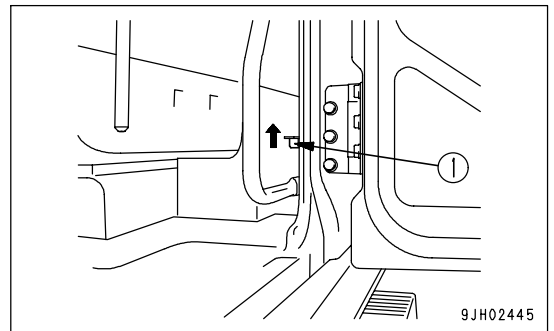

2. Open cover (2) at the bottom left of the operator's cab by hand, pull out filter case (3) from the inside, then remove the filter.

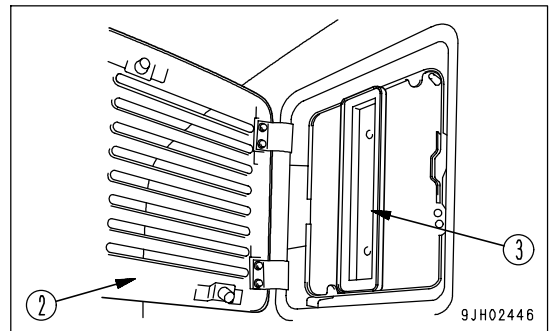

3. Clean the filter with compressed air. If there is oil on the filter, or if the filter is extremely dirty, wash it in a neutral agent. After rinsing it in water, dry it thoroughly before using it again.
If the clogging of the filter cannot be removed by blowing with air or washing in water, replace the filter with a new part.
4. After cleaning, insert the filter in filter case (3) again, open the cover at the bottom left of the operator's cab by hand, return the filter case to its original position, then close the cover. When doing this, check that the lock is applied.

REPLACE PILOT FILTER ELEMENT



WARNING

After the engine is stopped, the parts and oil are at high temperature, so there is danger of burns. Wait for the temperature to go down before starting the operation.

1. Set a container under drain plug (1) to catch the oil.
 2. Loosen bolt (2), then remove filter case (3).
 3. Remove element (4).
 4. Tighten drain plug (1).
 5. Insert a new element, then install filter case (3) and tighten bolt (2).
 6. Tighten bolt (2).
- Tightening torque: 65 to 88 Nm (6.6 to 9.0 kgm, 48 to 65 lbft)

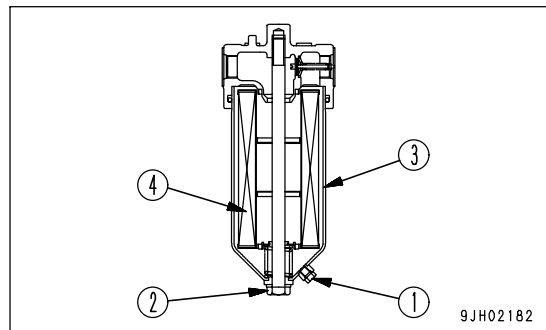
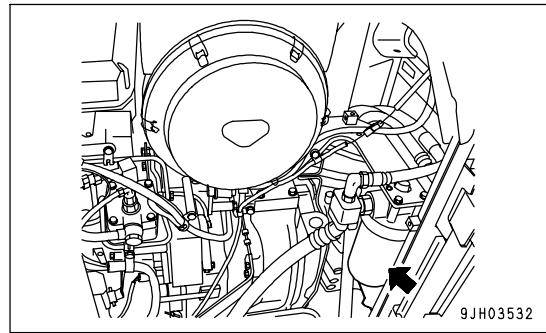

CLEAN STRAINER OF PTO LUBRICATING OIL FILTER

! WARNING

- The parts and oil are at high temperature after the engine is stopped, and may cause serious burns. Wait for the temperature to go down before cleaning the engine breather.
- When using compressed air, there is a hazard that dirt may be blown up and cause serious injury. Always use safety glasses, dust mask, or other protective equipment.

1. Open the cover at the rear left of the machine, then remove filter case (1).
2. Take out the strainer, remove any dirt stuck to the strainer, then wash it in flushing oil.
If the strainer is damaged, replace it with a new part.
3. Install the strainer and filter case (1).

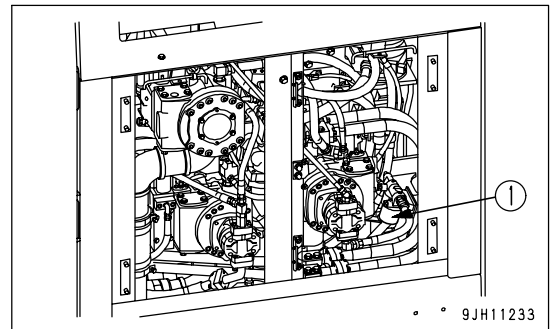

9JH11233

CHECK, REPLACE ALTERNATOR, AIR CONDITIONER COMPRESSOR DRIVE BELTS

Checking

Check the belt and when the following conditions exist, replace the belt

- When cracking and peeling of the belt occurs.
- When belt is worn and there are vertical cracks.

Replacement

1. Loosen locknut (2) of push bolt (1), then screw in push bolt fully and loosening tension pulley.
2. Replace the belt.
3. Loosen push bolt (1) until approx. 90 mm (3.5 in) of the thread can be seen, then tighten locknut (2).

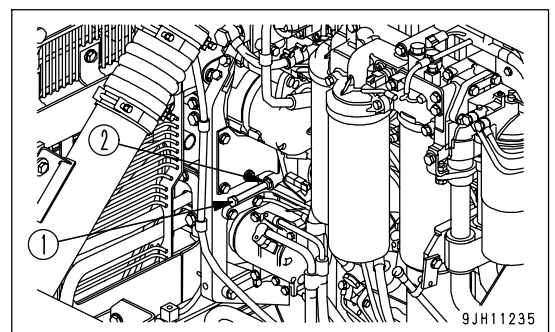

9JH11235

REPLACE DRAIN FILTER CARTRIDGE

1. Using a filter wrench, turn the filter cartridge (1) to the left to remove it.

2. Fill the new filter cartridge with hydraulic oil, coat the packing surface with oil, then install it.

When installing it, bring the packing surface into contact with the seal surface of the filter holder, then tighten a further 1/2 - 3/4 turns.

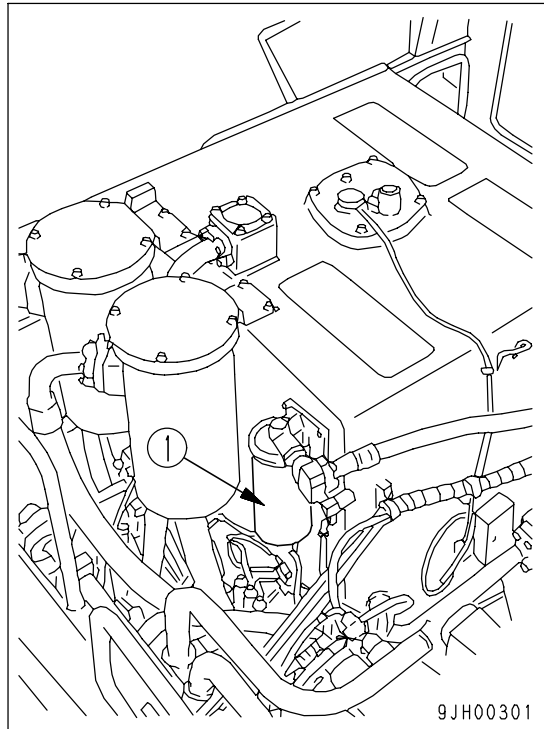

CHANGE OIL IN ENGINE OIL PAN, REPLACE ENGINE OIL FILTER CARTRIDGE

! WARNING

Parts and oil are at high temperature immediately after the engine is stopped and may cause serious burns. Wait for the oil temperature to go down before performing this operation.

- Refill capacity: 86 liters (22.7 US gal) (When filter is replaced)
- Prepare a filter wrench

1. Remove cover (1) under the chassis.
2. Set a container directly under drain valve (P) under the engine to catch the drained oil.
3. Take the drain hose from the tool box and install it to drain valve (P).
4. To prevent it getting oil on yourself, turn lever (3) of drain valve (P) slowly to the open position (O).

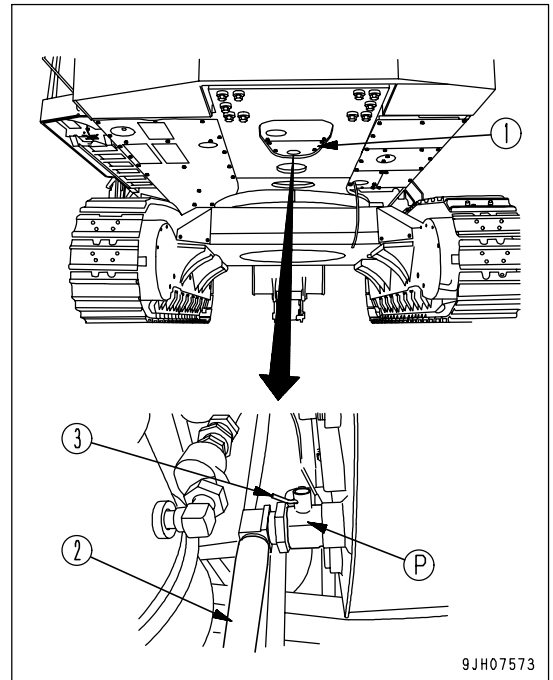

REMARK

Do as follows to set lever (3) to the open position (O).

A: Pull lever (3) slightly forward.

B: Turn lever (3) from position (S) to position (O).

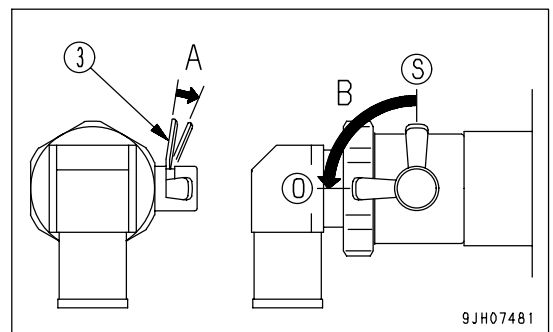

5. After draining the oil, turn the drain valve to the closed position (S).
6. Install cover (1).

7. Open the engine room door.
8. Use a filter wrench to turn 3 filter cartridge (4) to the left to remove it.
9. Clean the filter holder, fill the new filter cartridge with clean oil, coat the thread and packing surface of the new filter cartridge with clean oil (or coat it thinly with grease), then install it to the filter holder.

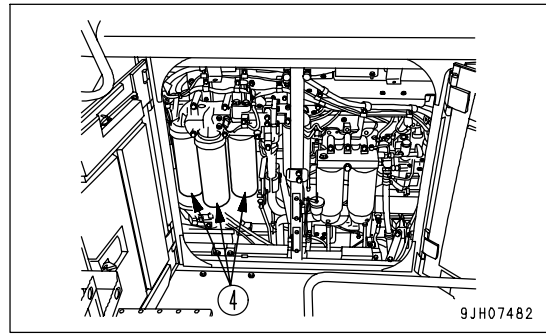

REMARK

Check that there is no old packing stuck to the filter holder. If there is any old packing stuck to the filter, it will cause leakage of oil.

10. When installing, tighten until the packing surface contacts the seal surface of the filter holder, then tighten it a further 3/4 to 1 turn.

11. After replacing the filter cartridge, add oil through oil filler (F). Add oil until the oil level is between the H and L marks on the ENGINE STOPPED side of dipstick (G).

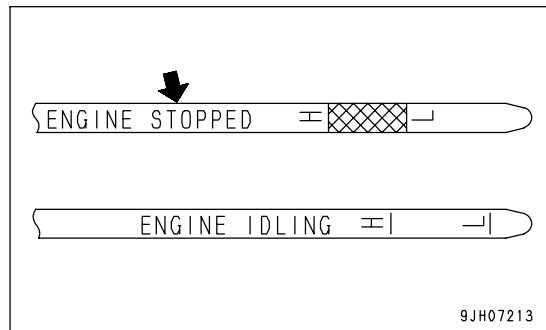
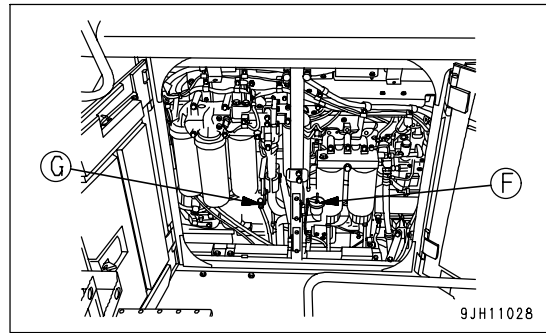

12. Run the engine for a short time at low idling, then stop the engine. Check that the oil level gauge is between the H and L marks. For details, see "Check Oil Level in Engine Oil Pan, Add Oil (PAGE 3-79)".

EVERY 1000 HOURS MAINTENANCE

Maintenance for every 10, 100, 250, and 500 hours of service should be performed at the same time.

REPLACE HYDRAULIC OIL FILTER ELEMENT

! WARNING

- The parts and oil are at high temperature immediately after the engine is stopped, and may cause burns. Wait for the temperature to go down before starting the work.
- When removing the oil filler cap, turn it slowly to release the internal pressure, then remove it.

1. Remove the cap from oil filler (F) on top of the hydraulic tank, and release the internal pressure.
2. Loosen 4 bolts, then remove cover (1).
When doing this, the cover may fly out under the force of spring (2), hold the cover down when removing the bolts.
3. After removing spring (2), valve (3) and strainer (5), take out element (4).

 - If there are metal particles or foreign material inside strainer (5), contact your Komatsu distributor.

4. Clean the removed parts in flushing oil.
5. Install the new element in the place where old element (4) was installed.

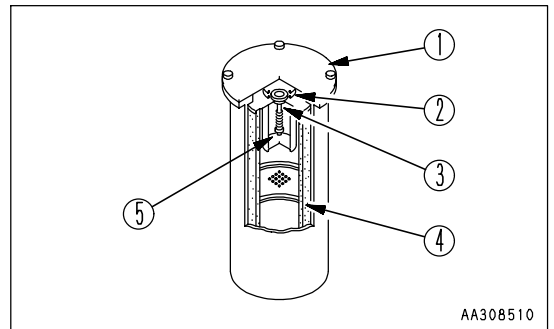
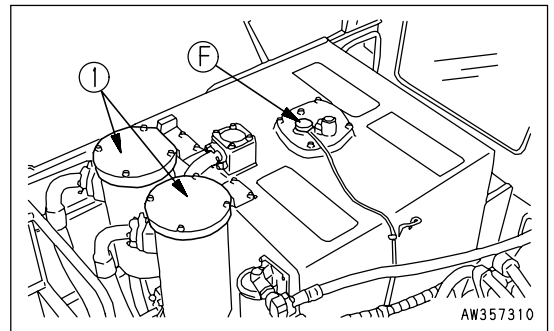

REMARK

When doing this, check that the seat surfaces (both ends) of spring (2) are horizontal. Check that the seat surface of the spring is not raised as shown in diagram (A) on the right.

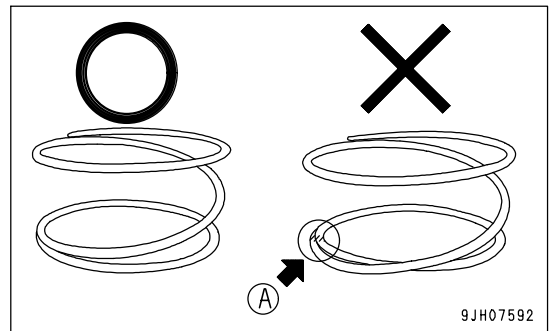

6. Set valve (3), strainer (5) and spring (2) on top of the element.
7. Set cover (1) in position, push it down by hand, and install the cover with the mounting bolts.
8. Install the cap of oil filler port (F).
9. To bleed the air, start the engine according to "STARTING ENGINE (PAGE 3-98)" and run the engine at low idle for 10 minutes.
10. Stop the engine.

REMARK

Operate the machine after halting for more than 5 minutes to eliminate bubbles in the oil inside the tank.

11. Check for oil leakage and wipe off any spilled oil.

REPLACE BREATHER ELEMENT IN HYDRAULIC TANK

! WARNING

- The parts and oil are at high temperature immediately after the engine is stopped, and may cause burns. Wait for the temperature to go down before starting the work.
- When removing the oil filler cap, turn it slowly to release the internal pressure, then remove it.

1. Set the work equipment to the hydraulic oil level inspection posture.

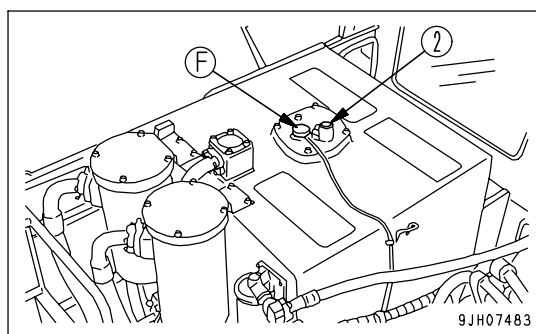

2. Remove the cap of oil filler (F) at the top of the hydraulic tank.
 3. Replace element (1) inside the cap.

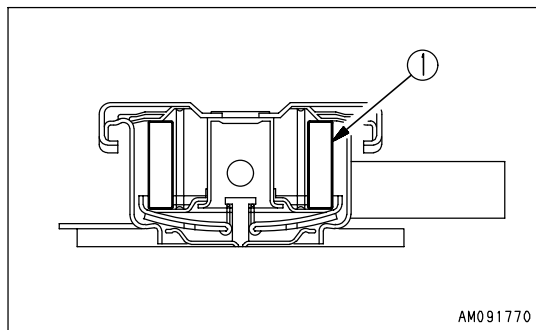

4. Remove nut (3) of breather assembly (2) at the top of the hydraulic tank, then remove cover (4).
 5. Replace filter element (5) with a new element.
 6. Install cover (4) and nut (3).

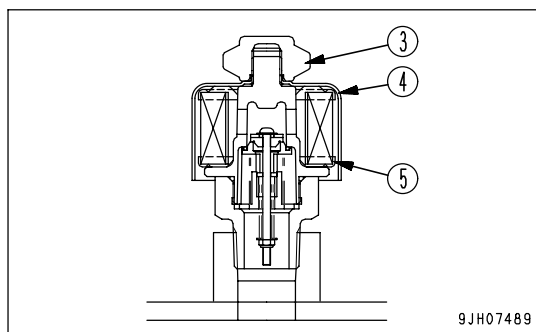

CLEAN HYDRAULIC TANK RETURN STRAINER

! WARNING

- The parts and oil are at high temperature immediately after the engine is stopped, and may cause burns. Wait for the temperature to go down before starting the work.
- When removing the oil filler cap, turn it slowly to release the internal pressure, then remove it.

1. Remove cap (F) from the oil filler port at the top of the hydraulic tank.

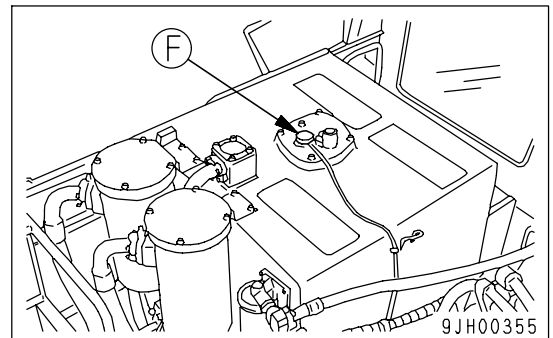

2. Remove (4) mounting bolts (1) of the return strainer holder cover at the top of the hydraulic tank, then remove return filter holder cover (2).
3. Remove strainer (3).
4. Remove any dirt stuck to strainer (3), then wash it with flushing oil. If the strainer is damaged, replace it with a new part.
5. Insert strainer (3), hold it down with return strainer holder cover (2), set it in position, then tighten bolts (1).

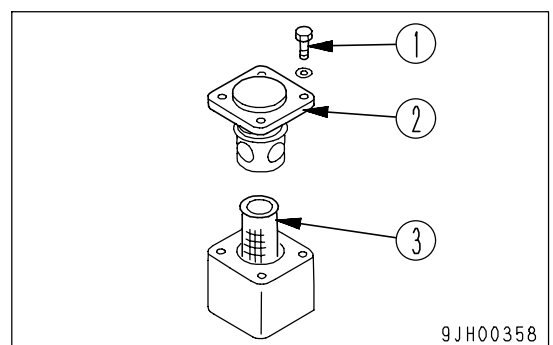
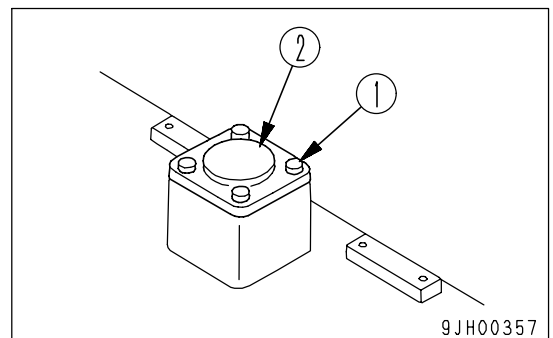

CHANGE OIL IN SWING MACHINERY CASE

! WARNING

Parts and oil are at high temperature immediately after the engine is stopped and may cause serious burns. Wait for the oil temperature to go down before performing this operation.

• Refill capacity: 48.6 liters (12.84 US gal) (24.3 liters X 2 (6.42 US gal X 2))

1. Pull out drain hose (1) under the chassis from inspection window (2).
2. Set a container under the drain hose to catch the drained oil.
3. Loosen drain valve (P) under the body, drain the oil, then tighten the drain valve again.

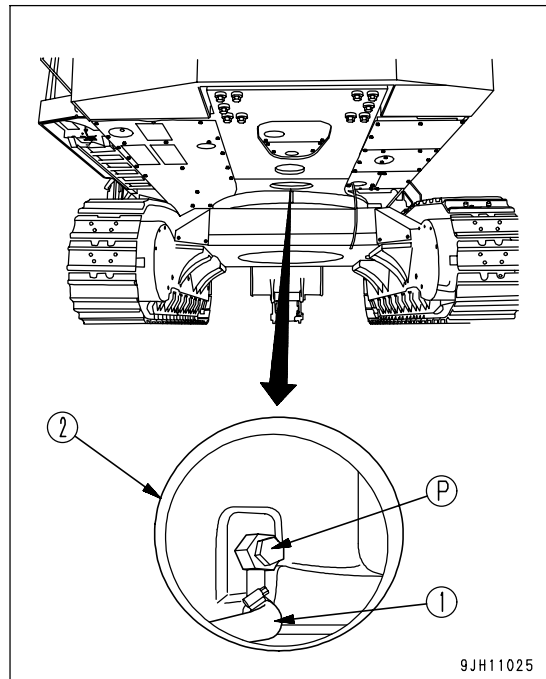
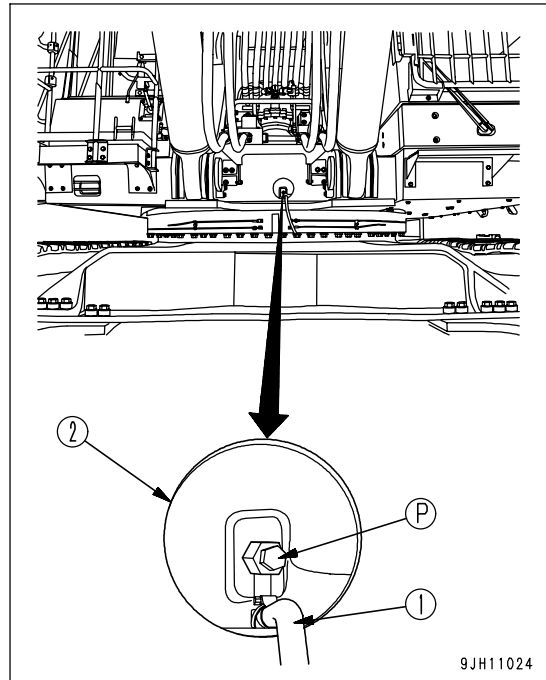

4. Replace breather (3).
5. Remove dipstick (G) and air bleed plug (4) (remove air bleed plug (4) only when supplying oil to the front machinery), then add the specified amount of oil through dipstick guide (F).
6. After filling with oil, install air bleed plug (4) of the front machinery.
7. Check the oil level. For details, see "Check Oil Level in Swing Machinery Case, Add Oil (PAGE 3-83)".
8. Immediately after changing the oil, oil level is variable. So operate for one hour, then check the oil level again.

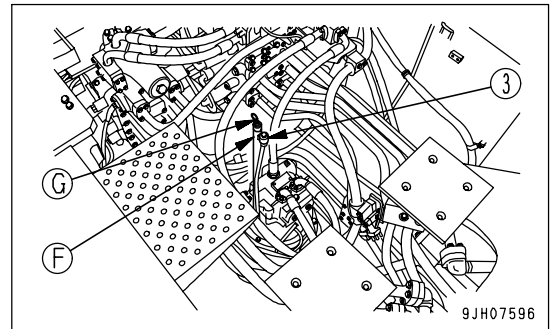
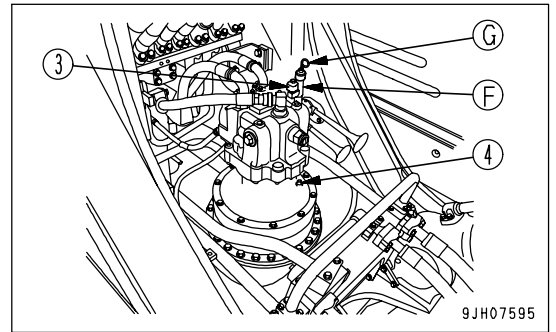

CHANGE OIL IN PTO CASE

! WARNING

Parts and oil are at high temperature immediately after the engine is stopped and may cause serious burns. Wait for the oil temperature to go down before performing this operation.

NOTICE

Park the machine on flat ground and stop the engine. After waiting for more than 30 minutes after stopping the engine, check the oil level.

- Refill capacity: 13.5 liters (3.57 US gal)
- 1. Remove plug (1) under the chassis, loosen drain valve (2), and drain the oil.
Be careful not to loosen the drain valve too far and deform the stopper pin inside the valve.
- 2. After draining the oil, tighten drain valve (2), then install plug (1).
Tightening torque of drain valve (2): 49.0 - 78.5 Nm (5 - 8 kgm, 36.2 - 57.9 lbft)
Tightening torque of plug (1): 58.8 - 78.5 Nm (6 - 8 kgm, 43.4 - 57.9 lbft)

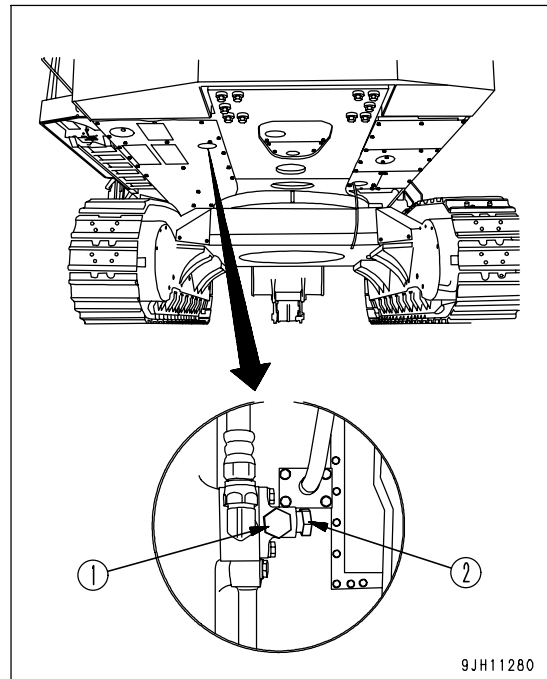

- 3. Refill the specified quantity of oil through oil filler (F).
- 4. Check the oil level. For details, see "Check Oil Level in PTO Case, Add Oil (PAGE 3-85)".

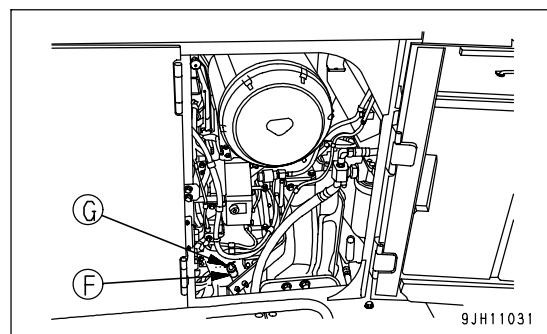

REPLACE CORROSION RESISTOR CARTRIDGE

(If equipped)



WARNING

The oil is at high temperature after the engine has been operated, so never replace the cartridge immediately after finishing operations.

Wait for the oil to cool down before replacing cartridge.

- Container to catch drained coolant
- Prepare a filter wrench for fuel filter element.

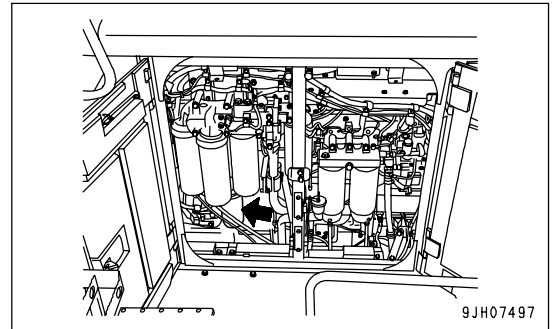

1. Turn valve (1) to the CLOSE position.
2. Set a container to catch the coolant under the cartridge.
3. Using a filter wrench, remove cartridge (2).
4. Clean the filter holder, coat the packing surface and thread of the new cartridge with oil, then install it to the filter holder.
5. When installing, tighten until the packing surface contacts the seal surface of the filter holder, then tighten it up 2/3 of a turn. If the filter cartridge is tightened too far, the packing will be damaged and this will lead to leakage of coolant. If the filter cartridge is too loose, coolant will also leak from the packing, so always tighten to the correct amount.
6. Turn valve (1) to the OPEN position.
7. After replacing the cartridge, start the engine and check for any coolant leakage from the filter seal surface. If there is any leakage, check if the cartridge is tightened properly.

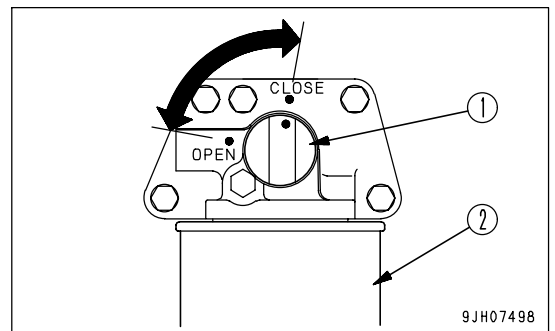

GREASE, CHECK TENSION PULLEY ASSEMBLY OF ALTERNATOR, AIR CONDITIONER COMPRESSOR DRIVE BELT

Using a grease gun, lubricate the grease fitting marked by the arrow.

(1) Tension pulley assembly (1 place)

- Check the pulley for play or leakage of grease. If any problem is found, please ask your Komatsu distributor to carry out disassembly and repair or replacement.

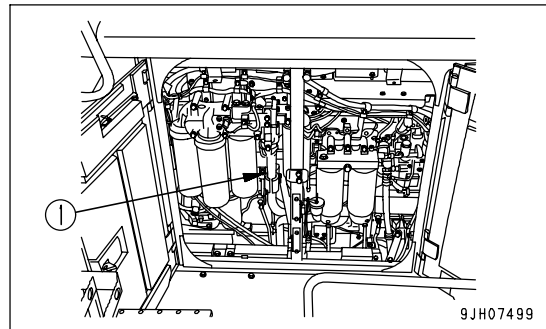

CHECK WELDED STRUCTURE

(Color check)

Cracks in welded structures can be seen easily with a color check. Check the revolving frame, center frame, boom, and arm every 1000 hours.

In particular, carry out a color check on the important check points (marked with a circle).

The procedure for the color check is as follows.

1. Prepare the materials needed for the color check. (Detergent, penetrating agent, developing solution)
 2. Spray with detergent and wash to remove all the dirt and oil from the place to be checked.
 3. After washing, dry the area, then spray with penetrating agent and leave for 5 - 20 minutes.
 4. Spray with detergent, then clean the surface with a cloth.
 5. Clean the surface again, then spray with developing solution.
 6. Leave for 15 - 20 minutes, then check visually for cracks.
 7. If there are any cracks, carry out the repair procedure to repair.
- If there are any cracks, color can be seen.

- Revolving frame

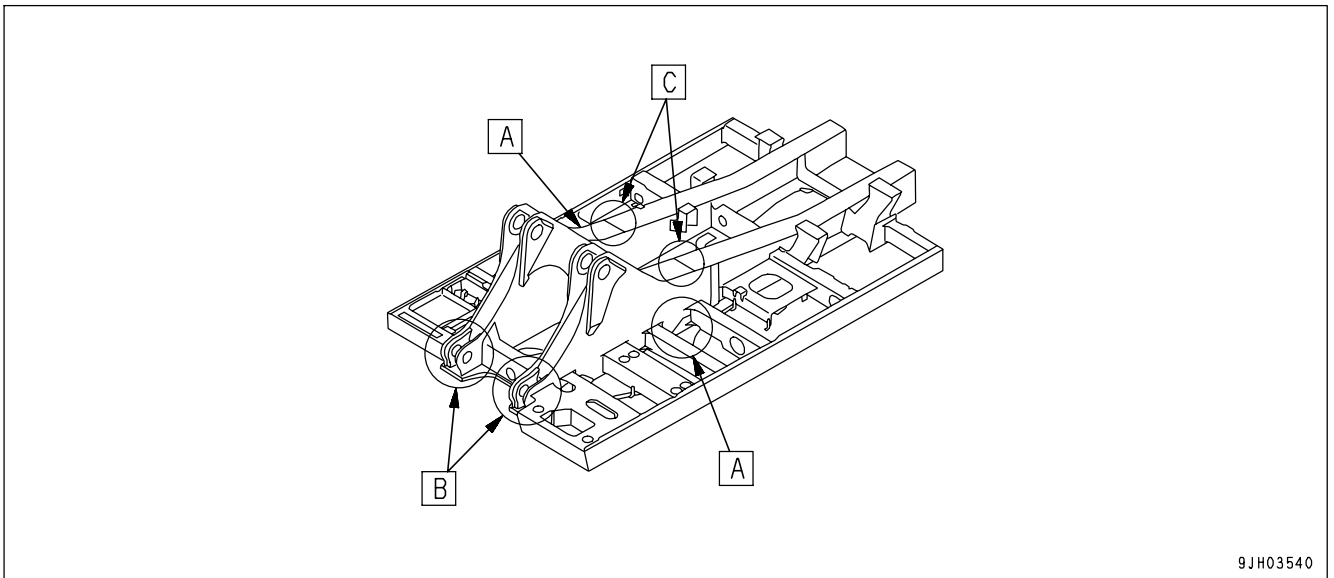

9JH03540

- Center frame

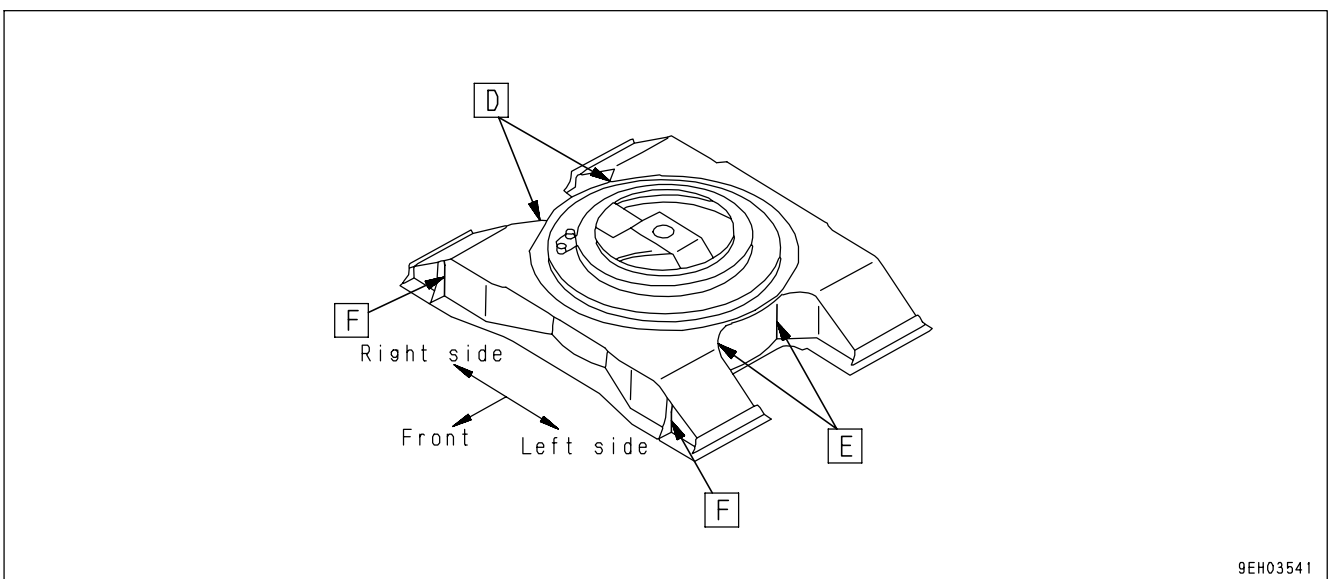

9EH03541

• Boom

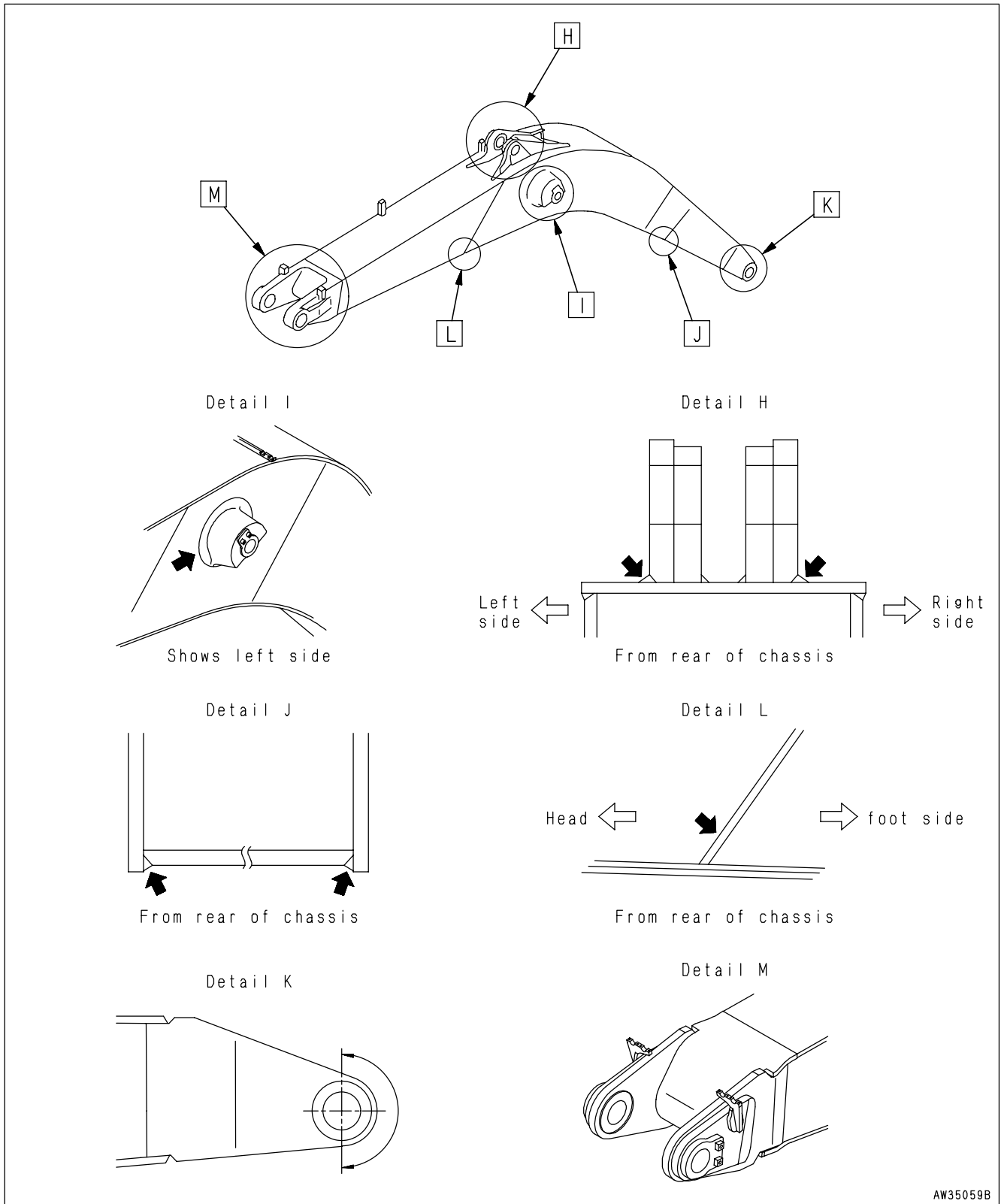

AW35059B

• Arm

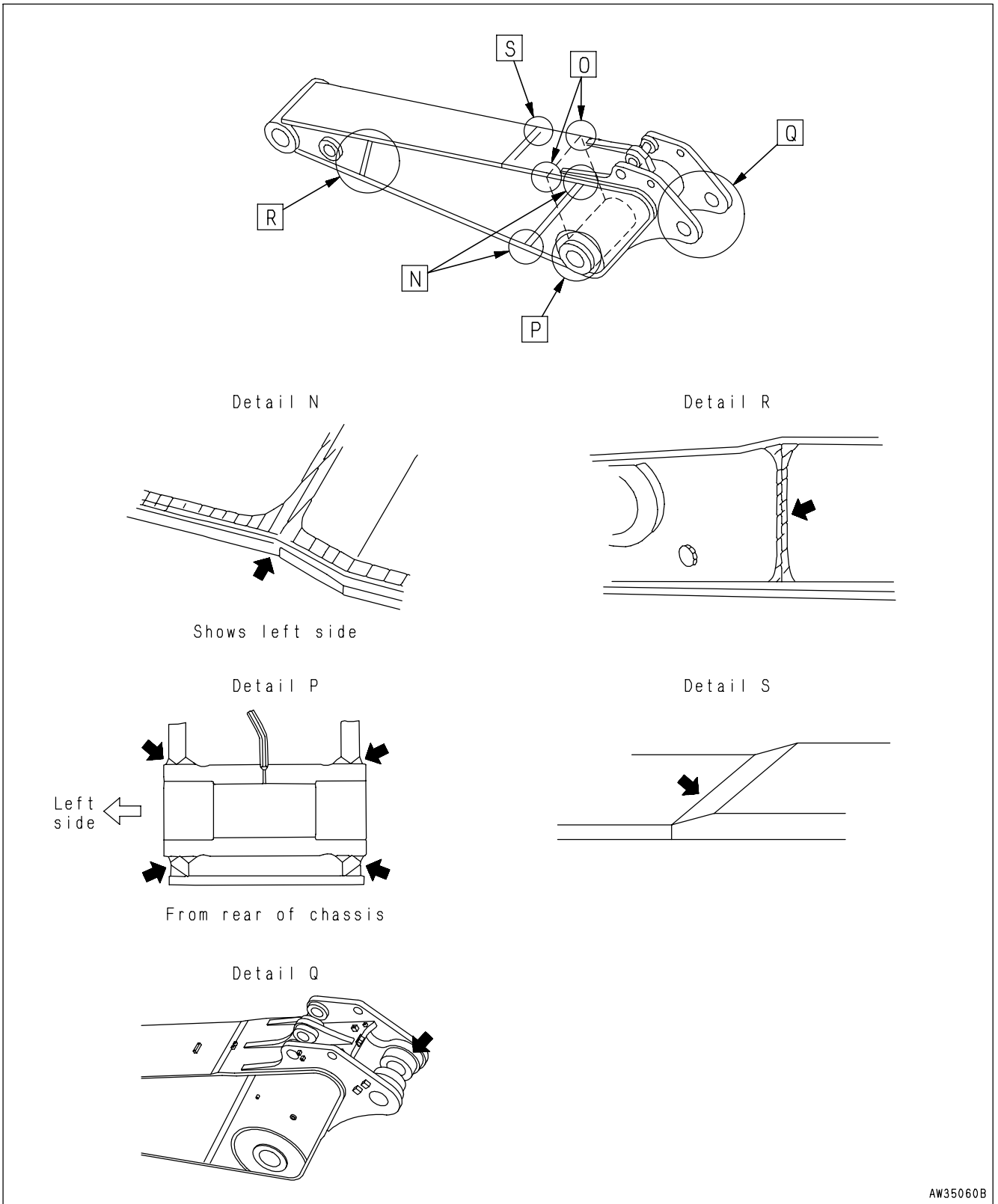

EVERY 2000 HOURS MAINTENANCE

Maintenance for every 10, 100, 250, 500, and 1000 hours of service should be performed at the same time.

CHANGE OIL IN FINAL DRIVE CASE

WARNING

- The parts and oil are at high temperature immediately after the engine is stopped, and may cause serious burns. Wait for the temperature to go down before starting the operation.
- If there is still pressure remaining inside the case, the oil or plug may fly out. Loosen the plug slowly to release the pressure.

- Refill capacity: each 22 liters (5.8 US gal)
- Refill capacity: Left, right 21 liters (5.6 US gal) each
- Prepare a handle.
 1. Set the TOP mark at the top, with the TOP mark and plug (P) perpendicular to the ground surface.
 2. Set a container under plug (P) to catch the oil.
 3. Remove plugs (P) and (F) with the handle and drain the oil.

REMARK

Check the O-rings in the plugs for damage. If necessary, replace with new ones.

4. Tighten plug (P).
5. Add oil through the hole of plug (F).
6. When the oil overflows from the hole of plug (F), install plug (F).
Tightening torque of plugs (P) and (F) :
93.1 - 122.5 Nm (9.5 - 12.5 kgm, 68.7 - 90.4 lbft)

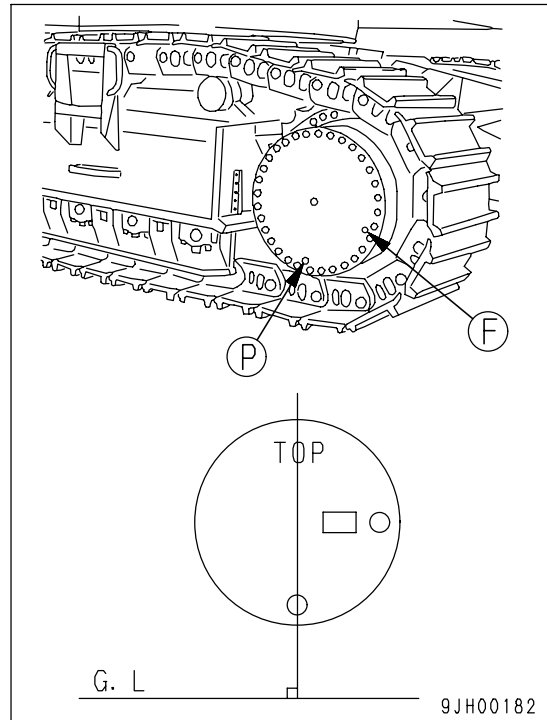

CHECK BOOST PIPING HOSE CLAMPS

Ask your Komatsu distributor to carry out the inspection.

CHECK ALTERNATOR

There is a possibility that the bearing is short of grease. Call your Komatsu distributor for inspection and repair.

CHECK ENGINE VALVE CLEARANCE, ADJUST

Special tools are needed for inspection and maintenance, so contact your Komatsu distributor.

CLEAN HYDRAULIC TANK STRAINER

! WARNING

- After the engine is stopped, the parts and oil are at high temperature, so there is danger of burns. Wait for the temperature to go down before starting the operation.
- When the cap of the oil filler port is removed, oil may spurt out, so turn it slowly to release the internal pressure, then remove it carefully.
- When removing cover (1), the cover may fly off under the force of spring (2), so loosen the 4 bolts slowly.

1. Remove cap (F) from the oil filler port at the top of the hydraulic tank.
2. Remove cover (1) and lift up the top of rod (3) from above to take out spring (2) and strainer (4).
3. Remove any dirt stuck to strainer (4), then wash it in flushing oil. If strainer (4) is damaged, replace it with a new part.
4. When installing, check that the O-ring at the bottom of strainer (4) is not out of place or twisted, then coat the surface of the O-ring with grease, insert it on to tank protrusion (5), and install.
5. Install cover (1) with bolts.

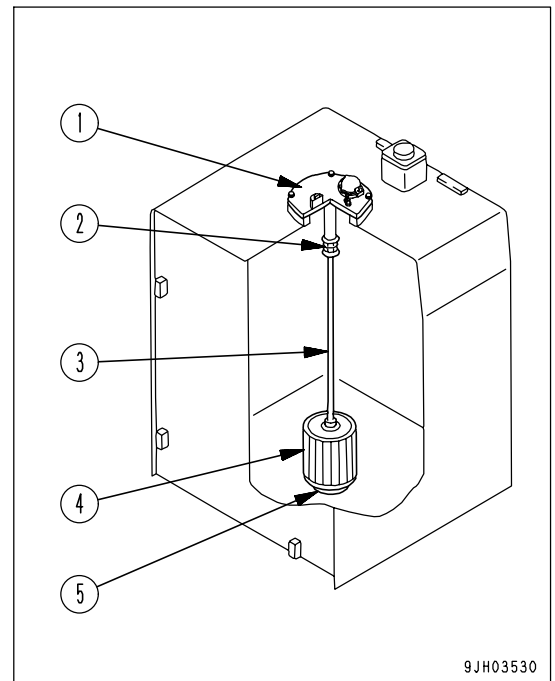
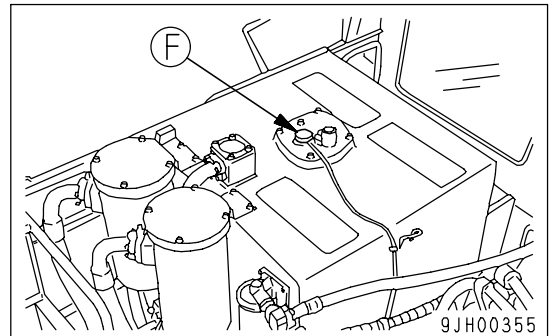

CHECKING CHARGE PRESSURE OF NITROGEN GAS IN ACCUMULATOR (FOR CONTROL CIRCUIT)

WARNING

The accumulator is charged with high-pressure nitrogen gas, so mistaken operation may cause an explosion, which will lead to serious injury or damage. When handling the accumulator, always do as follows.

- The pressure in the hydraulic circuit cannot be completely removed. When removing the hydraulic equipment, do not stand in the direction that the oil spurts out when carrying out the operation. In addition, loosen the bolts slowly when carrying out the operation.
- Do not disassemble the accumulator.
- Do not bring it near flame or dispose of it in fire.
- Do not make holes in it or weld it.
- Do not hit it, roll it, or subject it to any impact.
- When disposing of the accumulator, the gas must be released. Please contact your Komatsu distributor to have this work carried out.

NOTICE

If the nitrogen gas charge pressure in the accumulator is low and operations are continued, it will become impossible to release the remaining pressure inside the hydraulic circuit if a failure occurs on the machine.

FUNCTION OF ACCUMULATOR

The accumulator stores the pressure in the control circuit. Even after the engine is stopped, the control circuit can be operated, so the following actions are possible.

- If the control lever is operated in the direction to lower the work equipment, it is possible for the work equipment to go down under its own weight.
- The pressure in the hydraulic circuit can be released.

The accumulator is installed to the position shown in the diagram on the right.

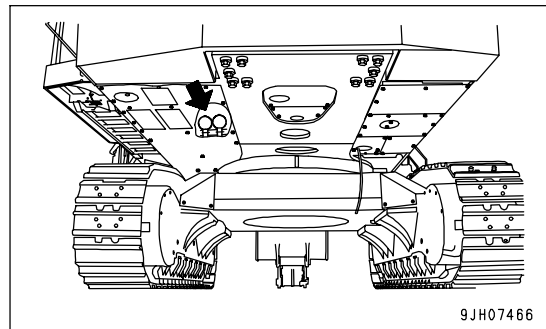

CHECKING FUNCTION OF ACCUMULATOR

 **CAUTION**

When carrying out the inspection, check first that there is no person or obstacle in the surrounding area.

Check the nitrogen gas charge pressure as follows.

1. Stop the machine on firm, level ground.
2. Hold the work equipment in the maximum reach posture (arm fully out, bucket fully dumped) at a height (A) 1.5 m (4 ft 11 in) from the ground.

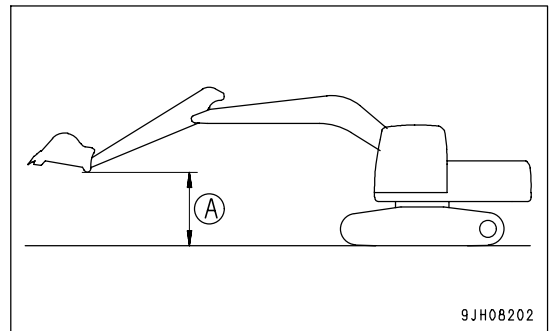

Carry out Steps 3 - 5 within 15 seconds.

When the engine is stopped, the pressure in the accumulator gradually goes down. For this reason, the check can only be carried out immediately after the engine is stopped.

3. Keep the work equipment at the maximum reach, turn the starting switch to the OFF position (A), and stop the engine.

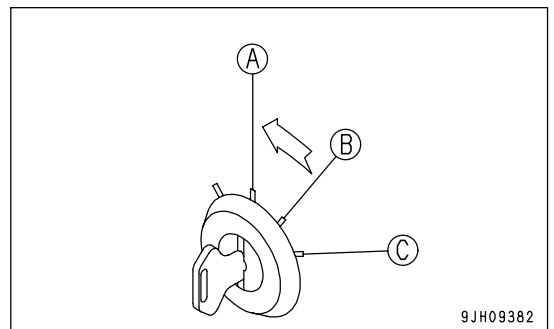

4. Turn the starting switch to the ON position (B).

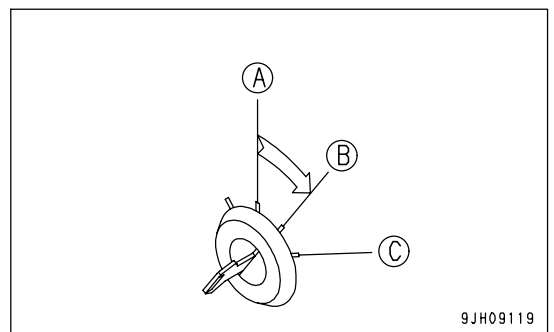

5. With the lock lever at the FREE position (F), operate the work equipment control levers fully in the LOWER direction and check that the work equipment is lowered to the ground.

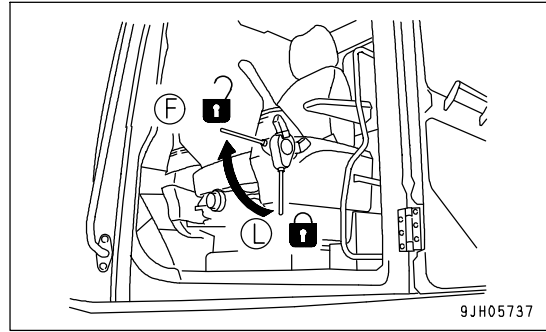

6. If the work equipment goes down under its weight and contacts the ground, the accumulator is normal.
 If the work equipment does not go down or stops in midway, the charged pressure of the gas in the accumulator for the hydraulic circuit has probably dropped.
 Please contact your Komatsu distributor for inspection.

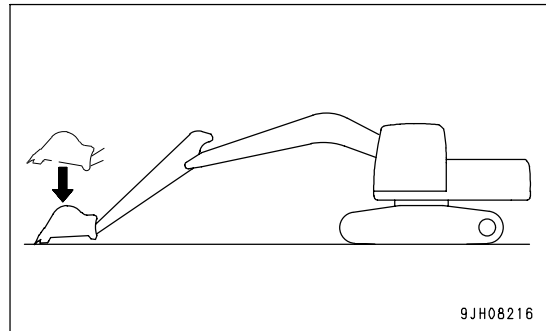

7. This completes the inspection. After completion of the inspection, set the lock lever to the LOCK position and turn the starting switch to the OFF position.

METHOD OF RELEASING PRESSURE IN HYDRAULIC CIRCUIT

! WARNING

- The hydraulic system is always under internal pressure, so when inspecting or replacing the piping or hoses, always release the pressure in the circuit before starting. If the pressure is not released, high pressure oil may spurt out and cause serious personal injury.
- The parts and oil are at high temperature after the engine is stopped, and may cause serious burns. Wait for the temperature to go down before starting the operation.
- When the oil filler cap is removed, oil may spurt out, so turn the cap slowly to release the pressure before removing the cap.

1. Stop the machine on firm horizontal ground, lower the work equipment to the ground as shown in the diagram on the right, then stop the engine.

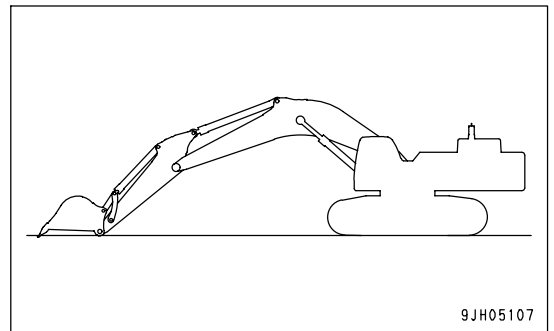

- Set the lock lever at the FREE position (F).

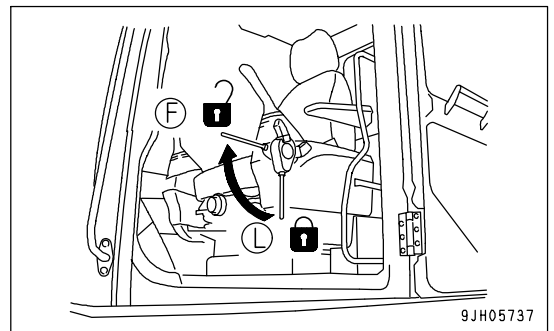

2. Turn the starting switch to the ON position.
3. Operate each work equipment control lever to the full stroke within 5 - 6 seconds after stopping the engine.
4. Remove the cap of the hydraulic tank.
5. Start the engine, run for approx. 10 seconds, then stop the engine again.
 - Do not run the engine at more than 1000 rpm.
 - Set the work equipment control levers to the HOLD position.
6. Turn the starting switch to the ON position.
7. Operate each work equipment control lever to the full stroke within 5 - 6 seconds after stopping the engine.
 - Repeat Steps 5 - 7 three times.

EVERY 4000 HOURS MAINTENANCE

Maintenance for every 10, 100, 250, 500, 1000, and 2000 hours of service should be performed at the same time.

CHECK WATER PUMP

Check that there is no oil leakage, water leakage. If any abnormality is found, contact your Komatsu distributor for disassembly and repair or replacement.

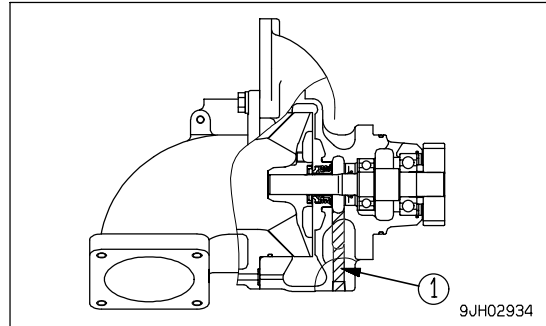

CHECK STARTING MOTOR

Wear on the brush and the bearings short of grease are suspected, so ask the Komatsu distributor in your territory for the repairs.

CHECK AIR COMPRESSOR, ADJUST

As special tool is required for checking and adjusting the parts, request Komatsu distributor for service.

REPLACE ACCUMULATOR (FOR CONTROL CIRCUIT)

Replace the accumulator every 2 years or every 4000 hours, whichever comes sooner.

! WARNING

The accumulator is charged with high-pressure nitrogen gas, so mistaken operation may cause an explosion, which will lead to serious injury or damage. When handling the accumulator, always do as follows.

- The pressure in the hydraulic circuit cannot be completely removed. When removing the hydraulic equipment, do not stand in the direction that the oil spurts out when carrying out the operation. In addition, loosen the bolts slowly when carrying out the operation.
- Do not disassemble the accumulator.
- Do not bring it near flame or dispose of it in fire.
- Do not make holes in it or weld it.
- Do not hit it, roll it, or subject it to any impact.
- When disposing of the accumulator, the gas must be released. Please contact your Komatsu distributor to have this work carried out.

If operations are continued after the performance of the accumulator has dropped, it will be impossible to release the remaining pressure in the hydraulic circuit if there should be a failure on the machine. Please ask your Komatsu distributor to replace the accumulator.

The accumulator is installed to the position shown in the diagram on the right.

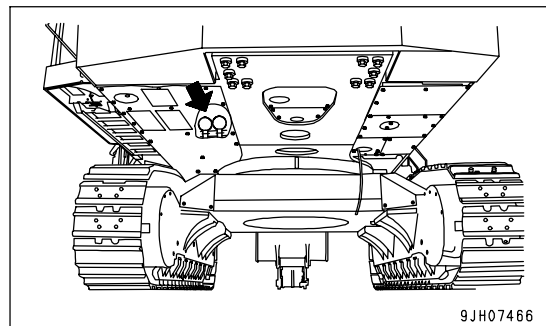

CHECK FOR LOOSENESS OF HIGH-PRESSURE PIPING CLAMP, HARDENING OF RUBBER

Check visually and touch by hand to check that there are no loose mounting bolts for high-pressure piping clamps (1) - (20) in the diagram and no hardening of any rubber parts. If any problem is found, the part must be replaced. In this case, please ask your Komatsu distributor to carry out the replacement.

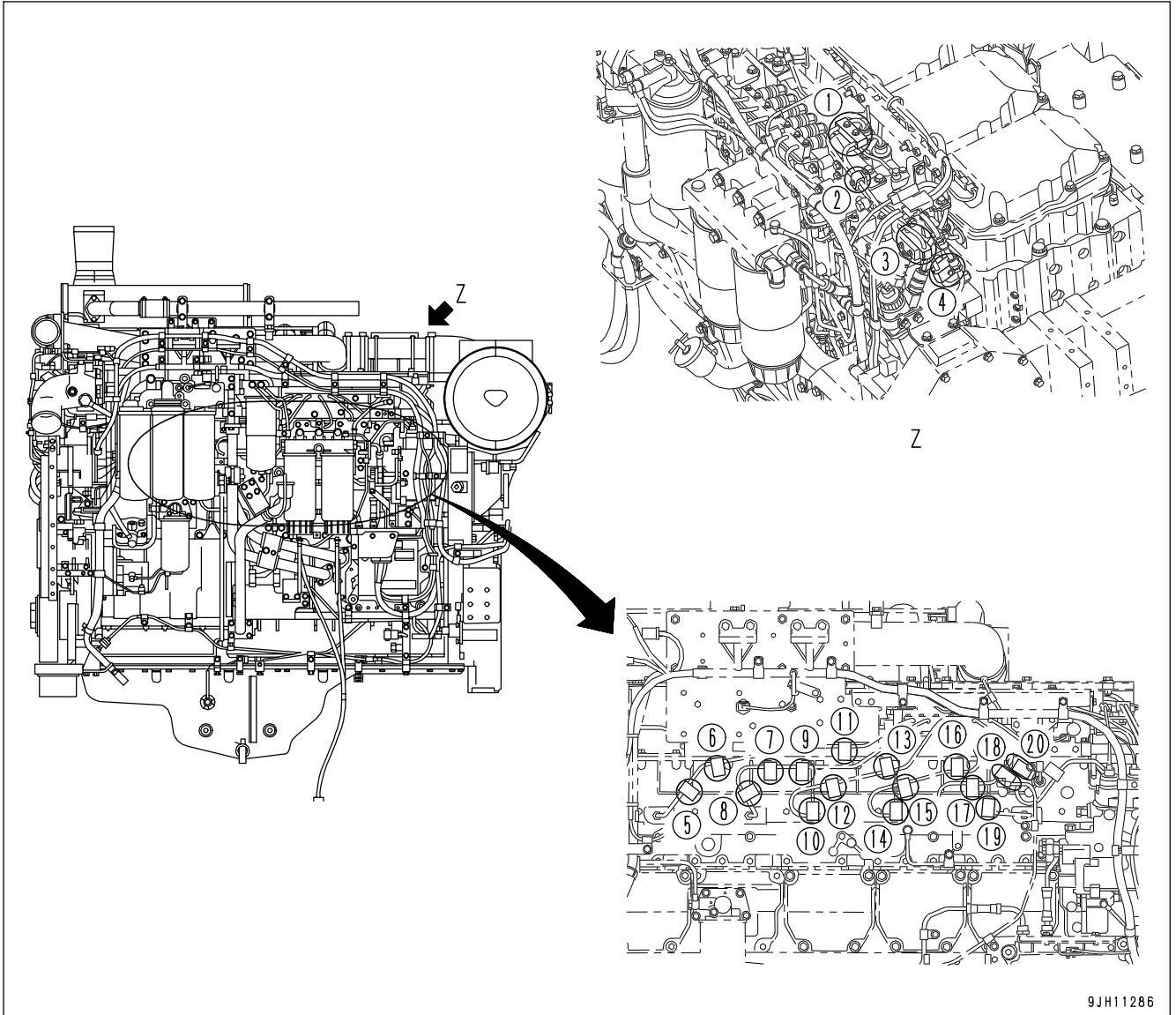

9JH11286

NOTICE

If the engine continues to be used when there are loose bolts, hardened rubber, or missing parts, there is danger of damage or breakage occurring due to vibration and wear at the connections of high-pressure piping. Always check that the proper high-pressure piping clamps are correctly installed.

CHECK FOR MISSING FUEL SPRAY PREVENTION CAP, HARDENING OF RUBBER

Fuel spray prevention caps (1) - (16) and fuel spray prevention cover (17) are protective parts installed to prevent fire caused by fuel leaking and spraying out on to high temperature parts of the engine. Check visually that there are no missing caps or loose bolts, and feel with your finger to check that the rubber has not hardened. If there is any problem, the problem part must be replaced. Contact your Komatsu distributor for part replacement.

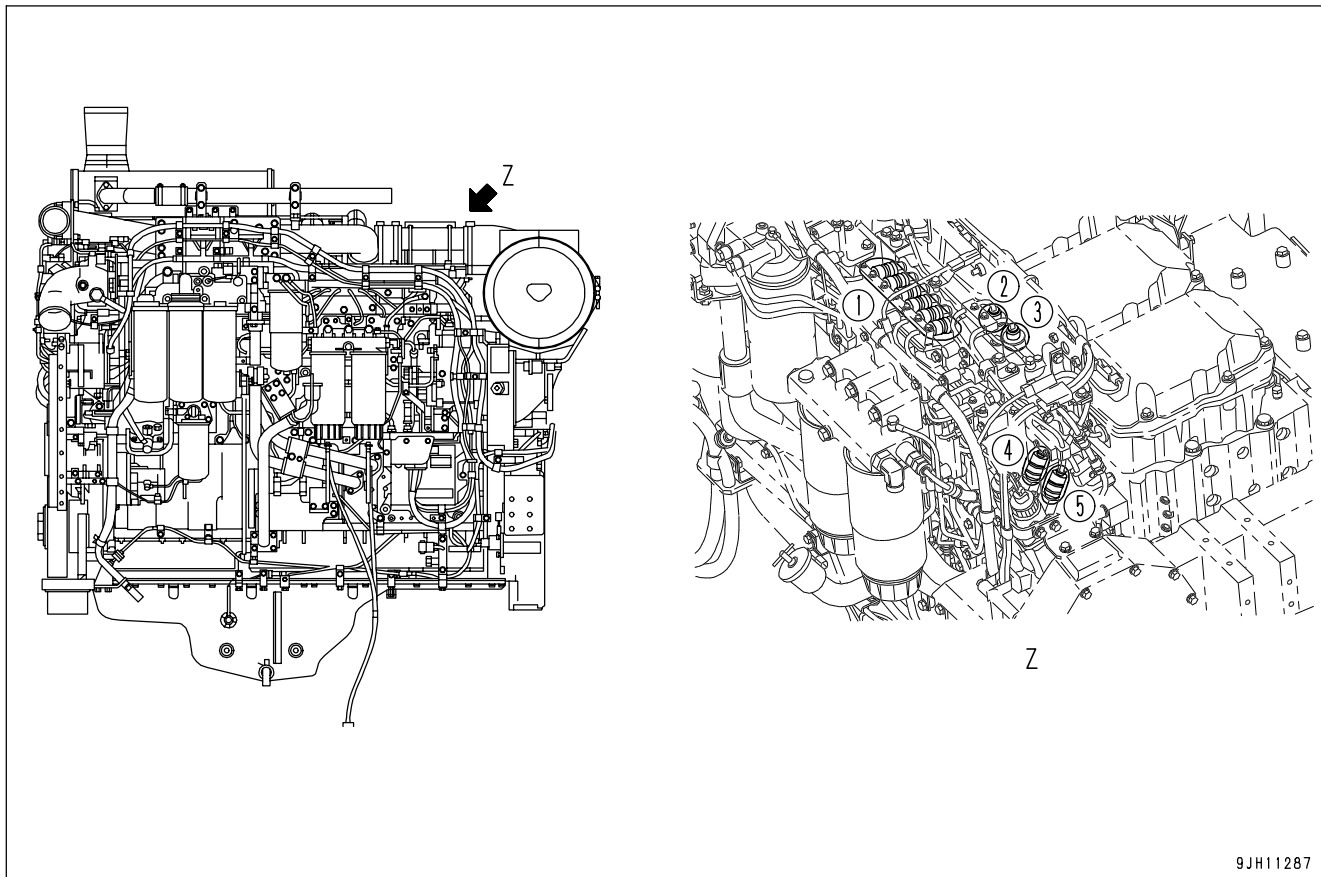

9JH11287

EVERY 5000 HOURS MAINTENANCE

Maintenance for every 10, 100, 250, 500, 1000, and 2000 hours of service should be performed at the same time.

CHANGE OIL IN HYDRAULIC TANK, CLEAN STRAINER



WARNING

- The parts and oil are at high temperature immediately after the engine is stopped, and may cause burns. Wait for the temperature to go down before starting the work.
- When removing the oil filler cap, turn it slowly to release the internal pressure, then remove it.

- Refill capacity: 670 liters (177.01 US gal)
 - Prepare a handle for socket wrench set
1. Swing the upper structure so that the drain plug under the hydraulic tank will be between both tracks.
 2. Retract the arm and bucket cylinders, then lower the boom and put the teeth in contact with the ground.
 3. Set the lock lever to the LOCK position and stop the engine.

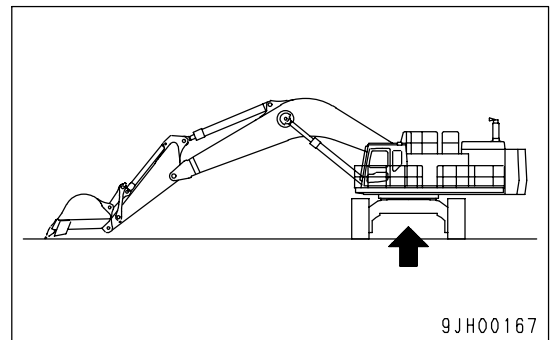

4. Remove the cap of oil filler (F) at the top of the hydraulic tank.

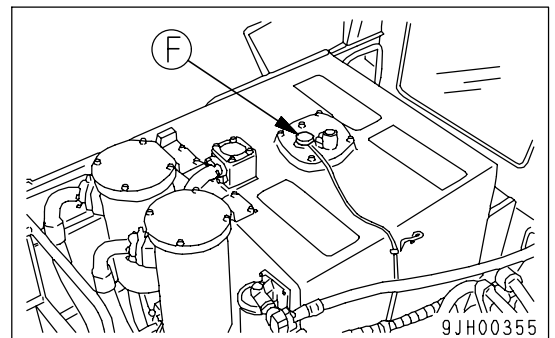

- Set the container to catch the oil under the drain plug at the bottom of the chassis. Remove plug (1), then loosen drain valve (P) and drain the oil. After draining the oil, tighten drain valve (P) and plug (1).

Tightening torque: $68.6 \pm 9.8 \text{ Nm}$ ($7 \pm 1 \text{ kgm}$, $50 \pm 7 \text{ lbft}$)

When removing drain valve (P), take care not to pour oil over yourself.

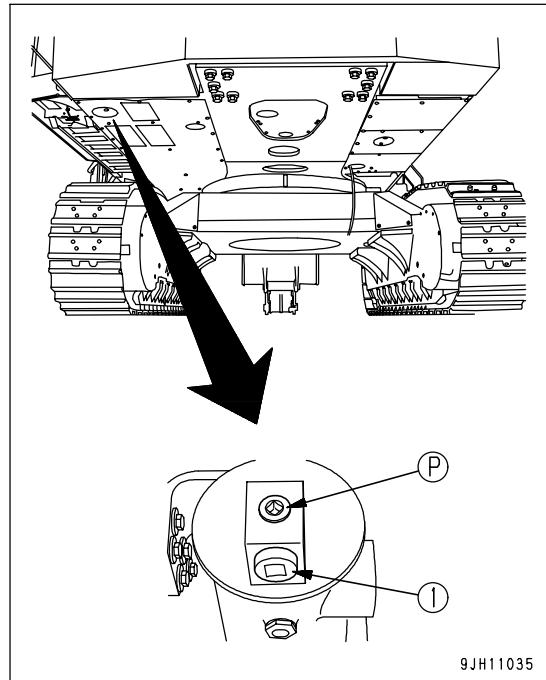

- Remove 4 bolts, then remove cover (4). When doing this, cover (4) may fly off because of the force of spring (5), so keep the cover pushed down when removing the bolts.

- Hold the top of rod (6) and pull up to remove spring (5) and strainer (7).

- Remove any dirt stuck to strainer (7), then wash in clean diesel oil or flushing oil. If strainer (7) is broken, replace it with a new part.

- When installing, insert strainer (7) into protruding part (8) of the tank, and assemble.

- Fill with the specified amount of oil through oil filler port (F). Check that the oil level is within the correct range on the sight gauge.

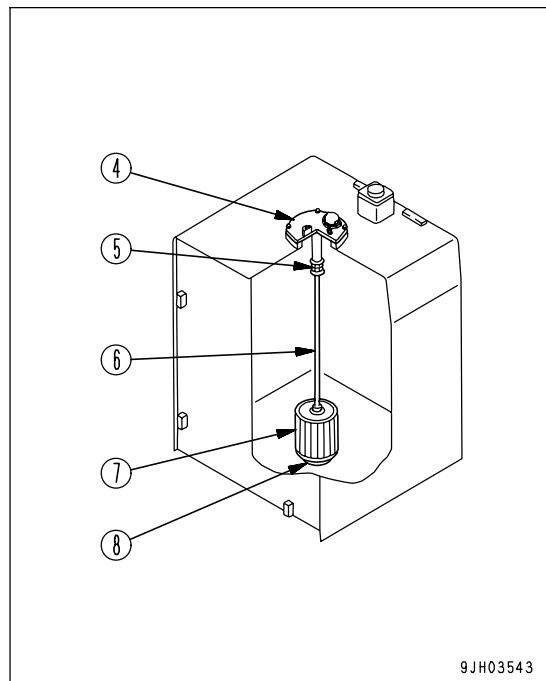

- Bleed the air from the circuit after cleaning or replacing the filter element or strainer, or after changing the oil.

EVERY 8000 HOURS MAINTENANCE

Maintenance for every 10, 100, 250, 500, 1000, 2000, and 4000 hours of service should be performed at the same time.

REPLACE HIGH-PRESSURE PIPING CLAMP

Contact your Komatsu distributor to have the engine high-pressure clamps replaced.

REPLACE FUEL SPRAY PREVENTION CAP

Contact your Komatsu distributor to have the fuel spray prevention cap replaced.

OVERHAUL STARTING MOTOR AND ALTERNATOR

Ask your Komatsu distributor to carry out this work.

SPECIFICATIONS

SPECIFICATIONS

Item	Unit	PC1250-8	PC1250SP-8	PC1250LC-8
Operating weight	kg (lb)	109,900 (242,330)	111,700 (246,299)	113,500 (250,268)
Bucket capacity	m ³ (cu.yd)	5.2 (6.8)	6.7 (8.8)	5.2 (6.8)
Name of engine	-	KOMATSU SAA6D170E-5 diesel engine		
Engine horsepower	kW (HP) /rpm	502 (672)/1,800		
A Overall length	mm (ft in)	16,020 (52' 7")	14,790 (48' 6")	16,020 (52' 7")
B Overall height	mm (ft in)	6,040 (19' 10")	6,265 (20' 7")	6,040 (19' 10")
C Overall width	mm (ft in)	5,355 (17' 7")	5,355 (17' 7")	5,355 (17' 7")
D Track width	mm (ft in)	700 (2' 4")	700 (2' 4")	700 (2' 4")
E Height of cab	mm (ft in)	4,120 (13' 6")	4,120 (13' 6")	4,120 (13' 6")
F Radius of upper structure	mm (ft in)	4,870 (15' 12")	4,870 (15' 12")	4,870 (15' 12")
G Length of track	mm (ft in)	6,425 (21' 1")	6,425 (21' 1")	7,400 (24' 3")
H Tumbler center distance	mm (ft in)	4,995 (16' 5")	4,995 (16' 5")	5,970 (19' 7")
I Min. ground clearance	mm (ft in)	990 (3' 3")	990 (3' 3")	990 (3' 3")
Travel speed (Lo/Mi/Hi)	km/h (MPH)	2.1/3.2 (1.3/2.0)		
Swing speed	rpm	5.5		

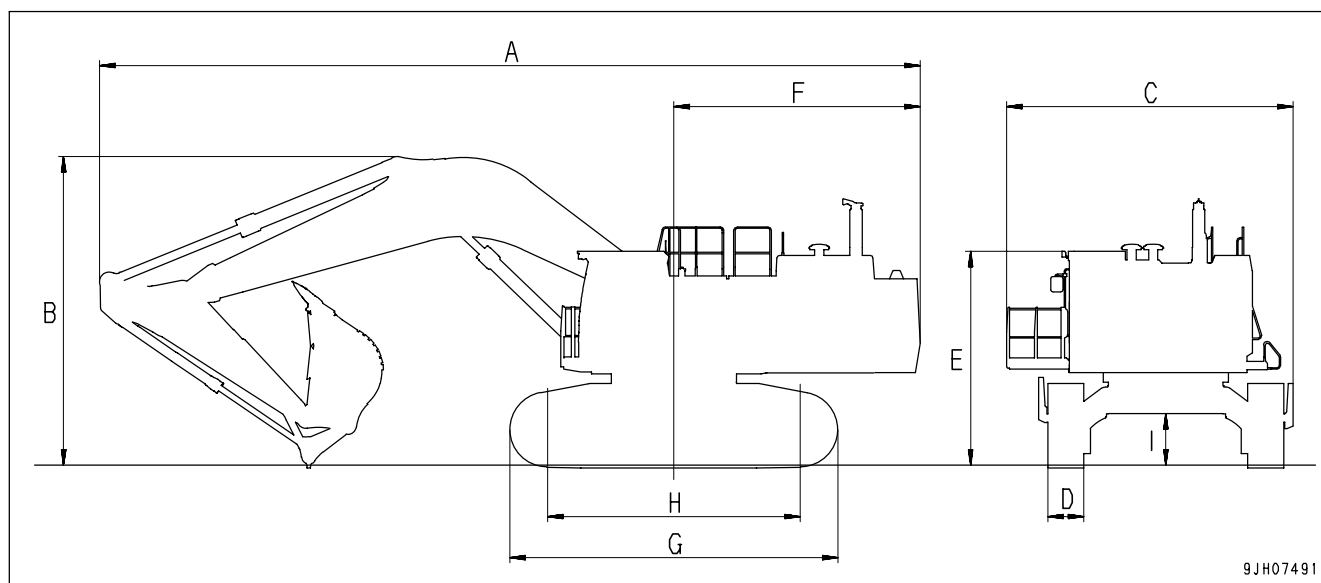

	Working ranges	Unit	PC1250-8	PC1250SP-8	PC1250LC-8
A	Max. digging reach	mm (ft in)	15,350 (50' 4")	14,070 (46' 2")	15,350 (50' 4")
B	Max. digging depth	mm (ft in)	9,350 (30' 8")	7,900 (25' 11")	9,350 (30' 8")
C	Max. digging height	mm (ft in)	13,400 (43' 12")	13,000 (42' 8")	13,400 (43' 12")
D	Max. vertical wall depth	mm (ft in)	7,610 (24' 12")	5,025 (16' 6")	7,610 (24' 12")
E	Max. dumping height	mm (ft in)	8,680 (28' 6")	8,450 (27' 9")	8,680 (28' 6")
F	Max. reach at ground level	mm (ft in)	15,000 (49' 3")	13,670 (44' 10")	15,000 (49' 3")

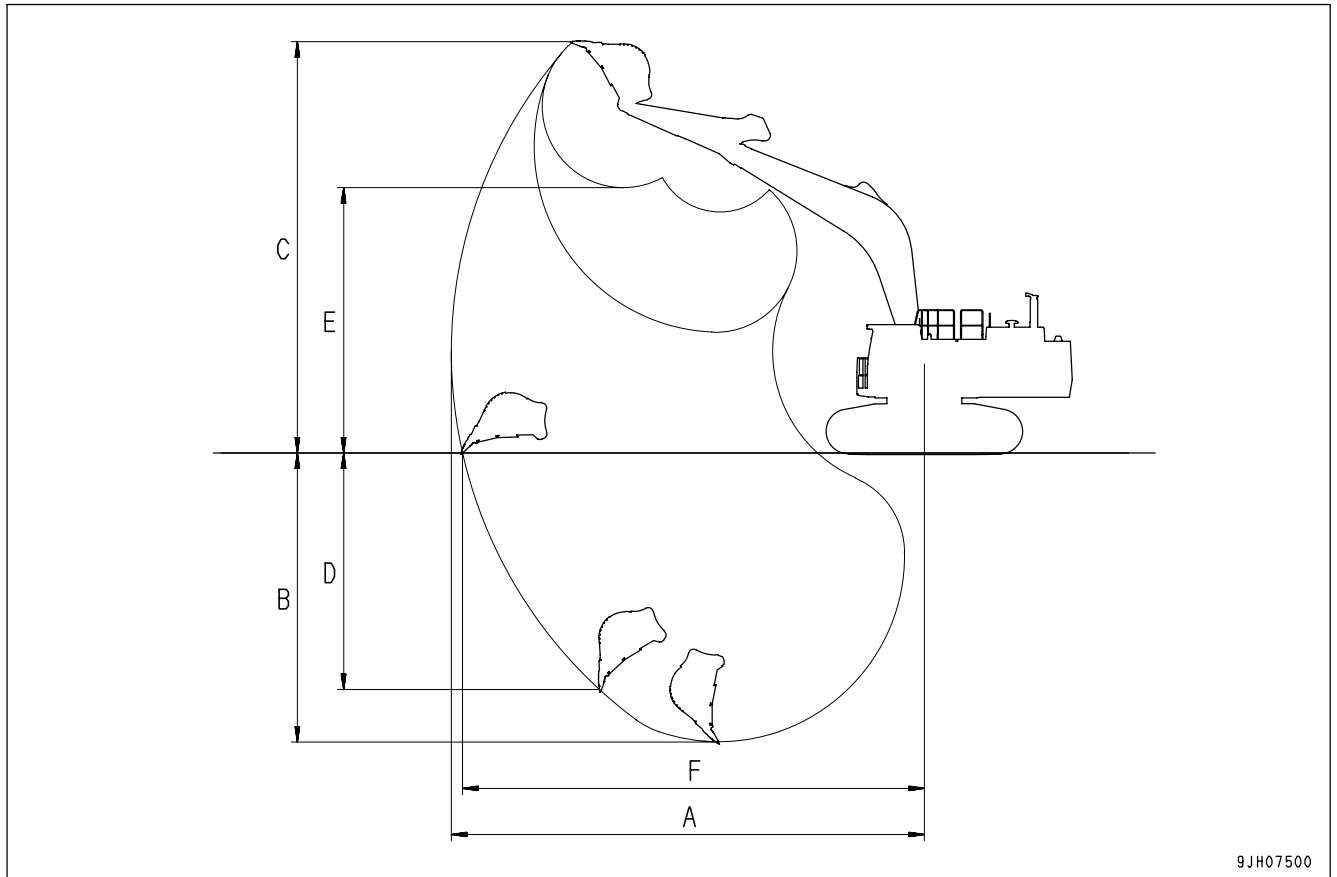

ATTACHMENTS, OPTIONS

 **WARNING**

Please read and make sure that you understand the SAFETY section before reading this section.

GENERAL PRECAUTIONS FOR SAFETY

When installing attachments or options to the machine, it is necessary to pay attention to safety. Please obey the following precautions strictly when selecting, installing, or using attachments or options.

PRECAUTIONS WHEN SELECTING

- Please consult your Komatsu distributor before installing attachments or options to the machine. Depending on the type of attachment or option, it may be necessary to install a front guard, overhead guard, or other safety structure to the machine. There may also be problems of the attachment or option hitting the operator's cab.
- Install only attachments or options authorized by Komatsu. Komatsu cannot accept any responsibility for any accident, damage, or failure caused by the use of attachments or options not authorized by Komatsu.

READ THE INSTRUCTION MANUAL THOROUGHLY

- Before installing or using any attachment or option, make sure that you thoroughly read and understand the instruction manuals for the machine and the attachment or option.
- If you lose the instruction manual or it is damaged, always obtain a new copy from the attachment manufacturer or your Komatsu distributor.

PRECAUTIONS WHEN REMOVING OR INSTALLING

When removing or installing the attachment or option, obey the following precautions, and take care to ensure safety during the operation.

- Carry out the removal and installation operation on a flat, firm ground surface.
- When the operation is carried out by two or more workers, choose the leader and follow his instructions.
- Use a crane when handling heavy objects (more than 25 kg (55 lb)). (The crane must be operated by a qualified operator.)
- Never go under a load raised by the crane.
- Do not carry out operations with the load kept raised by the crane. Always use a stand to prevent the load from falling.
- When removing a heavy part, consider the balance after it is removed. To prevent the machine from tipping over, set a support in position if necessary before removing the part.
- Before installing or after removing the attachment or option, set it in a stable condition to prevent it from falling over.
- For details of the removal or installation operation, please consult your Komatsu distributor.

PRECAUTIONS WHEN USING

When long or heavy work equipment is installed, remember the following precautions. Before starting operations, move the machine to a safe place and carry out a test operation to make sure that you fully understand the movement, center of gravity, and working range of the machine.

- Do not swing the work equipment if the machine is at an angle. If the work equipment is swung with the machine at an angle, there is danger that the machine will tip over.
- Always maintain a safe distance from obstacles in the surrounding area when operating. If long work equipment is installed, the working range becomes larger.
- If heavy work equipment is installed, pay careful attention to the following precautions.
 - The swing overrun (the distance the work equipment moves before completely stopping after the swing brake is applied) will be greater. There is danger of hitting objects if the swing overrun is miscalculated, so allow extra space to the swing position when swinging.
 - The hydraulic drift of the work equipment (the amount of the work equipment moves down under its own weight when it is stopped in a raised position) also becomes greater. Do not stop the work equipment in a raised position; always lower it to the ground.
 - Do not swing, lower, or stop the work equipment suddenly. There is danger that the machine may tip over.
 - Do not suddenly extend or retract the boom cylinder. The shock may cause the machine to tip over.

ATTACHMENT GUIDE



WARNING

- Please read the instruction manual for the attachment and the sections of this manual related to attachments and options.
- When installing any attachment or option, there may be problems with safety, so please contact your Komatsu distributor before installing.
- Installing attachments or options without consulting your Komatsu distributor may not only cause problems with safety, but may also have an adverse effect on the operation of the machine and the life of the equipment.
- Any injuries, accidents, or damage resulting from the use of unauthorized attachments or options will not be the responsibility of Komatsu.

COMBINATIONS OF WORK EQUIPMENT



WARNING

Depending on the type or combination of work equipment, there is danger that the work equipment may hit the cab or machine body.

When using unfamiliar work equipment for the first time, check before starting if there is any danger of interference, and operate with caution.

Select the combination of boom, arm, and bucket from the combinations shown in the table below.

Model		PC1250					PC1250SP	Bucket width [mm (in)]		
Boom		Standard boom 9.1 m					SP boom 7.8 m			
Arm		Standard arm	Strong arm	Semilong arm	Strong Semilong arm	Long arm	SP arm	Excluding side cutter side shroud	Including side cutter side shroud	
Work equipment	Bucket m ³ <cb.yd>	3.4 <4.4>	-	-	B	-	A	-	1,500 (59.1 in)	1,670 (65.8 in)
		4.0 <5.2>	B	-	A	-	C	-	1,710 (67.4 in)	1,880 (74.1 in)
		5.0 <6.5>	A	-	C	-	-	-	2,050 (80.8 in)	2,220 (87.5 in)
		5.2 <6.8>	-	A	-	C	-	-	2,050 (80.8 in)	2,110 (83.1 in)
	Bucket m ³ <cb.yd>	5.2 <6.8> standard strong	-	B	-	C	-	-	2,050 (80.8 in)	2,110 (83.1 in)
		6.7 <8.8>	-	-	-	-	-	A	2,280 (89.8 in)	2,340 (92.2 in)
		6.7 <8.8> wide strong	-	-	-	-	-	B	2,280 (89.8 in)	2,340 (92.2 in)

A: For standard operations (density up to 1.8 t/m³ 3,000 lb/yb³)

B: Possible to use only for heavy work (density up to 2.1 t/m³ 3,500 lb/yb³)

C: Possible to use only for light work (density up to 1.5 t/m³ 2,500 lb/yb³)

-: Impossible to use

Model		PC1250LC				Bucket width [mm (in)]	
Boom		Standard boom 9.1 m					
Arm		Standard arm	Semilong arm	Strong Semilong arm	Long arm	Excluding side cutter side shroud	Including side cutter side shroud
Work equipment	3.4 <4.4>	-	B	-	A	1,500 (59.1 in)	1,670 (65.8 in)
	4.0 <5.2>	B	A	-	C	1,710 (67.4 in)	1,880 (74.1 in)
	5.0 <6.5>	A	C	-	-	2,050 (80.8 in)	2,220 (87.5 in)
	5.2 <6.8>	-	-	C	-	2,050 (80.8 in)	2,110 (83.1 in)
	5.2 <6.8> standard strong	-	-	C	-	2,050 (80.8 in)	2,110 (83.1 in)
	6.7 <8.8>	-	-	-	-	2,280 (89.8 in)	2,340 (92.2 in)
	6.7 <8.8> wide strong	-	-	-	-	2,280 (89.8 in)	2,340 (92.2 in)

A: For standard operations (density up to 1.8 t/m³ 3,000 lb/yb³)

B: Possible to use only for heavy work (density up to 2.1 t/m³ 3,500 lb/yb³)

C: Possible to use only for light work (density up to 1.5 t/m³ 2,500 lb/yb³)

-: Impossible to use

Working Range Diagram

	Working ranges	Unit	PC1250-8 Standard arm	PC1250-8 Strong arm	PC1250-8 Semilong arm	PC1250-8 Strong Semilong arm	PC1250-8 Long arm	PC1250SP -8 SE arm
A	Max. digging reach	mm (ft in)	15,350 (50'4")	15,350 (50'4")	16,340 (53'7")	16,340 (53'7")	17,450 (57'3")	14,070 (46'2")
B	Max. digging depth	mm (ft in)	9,350 (30'8")	9,350 (30'8")	10,440 (34'3")	10,440 (34'3")	11,590 (38')	7,900 (25'11")
C	Max. digging height	mm (ft in)	13,400 (43'12")	13,400 (43'12")	13,490 (44'3")	13,490 (44'3")	13,910 (45'8")	13,000 (42'8")
D	Max. vertical wall depth	mm (ft in)	7,610 (24'12")	7,610 (24'12")	8,490 (27'10")	8,490 (27'10")	9,480 (31'1")	5,025 (16'6")
E	Max. dumping height	mm (ft in)	8,680 (28'6")	8,680 (28'6")	9,000 (29'6")	9,000 (29'6")	9,440 (30'12")	8,450 (27'9")
F	Max. reach at ground level	mm (ft in)	15,000 (49'3")	15,000 (49'3")	16,000 (52'6")	16,000 (52'6")	17,130 (56'2")	13,670 (44'10")

	Working ranges	Unit	PC1250LC-8 Standard arm	PC1250LC-8 Semilong arm	PC1250LC-8 Strong Semilong arm	PC1250LC-8 Long arm
A	Max. digging reach	mm (ft in)	15,350 (50'4")	16,340 (53'7")	16,340 (53'7")	17,450 (57'3")
B	Max. digging depth	mm (ft in)	9,350 (30'8")	10,440 (34'3")	10,440 (34'3")	11,590 (38')
C	Max. digging height	mm (ft in)	13,400 (43'12")	13,490 (44'3")	13,490 (44'3")	13,910 (48'8")
D	Max. vertical wall depth	mm (ft in)	7,610 (24'12")	8,490 (29'6")	8,490 (29'6")	9,480 (31'1")
E	Max. dumping height	mm (ft in)	8,680 (28'6")	9,000 (29'6")	9,000 (29'6")	9,440 (30'12")
F	Max. reach at ground level	mm (ft in)	15,000 (49'3")	16,000 (55'6")	16,000 (55'6")	17,130 (56'2")

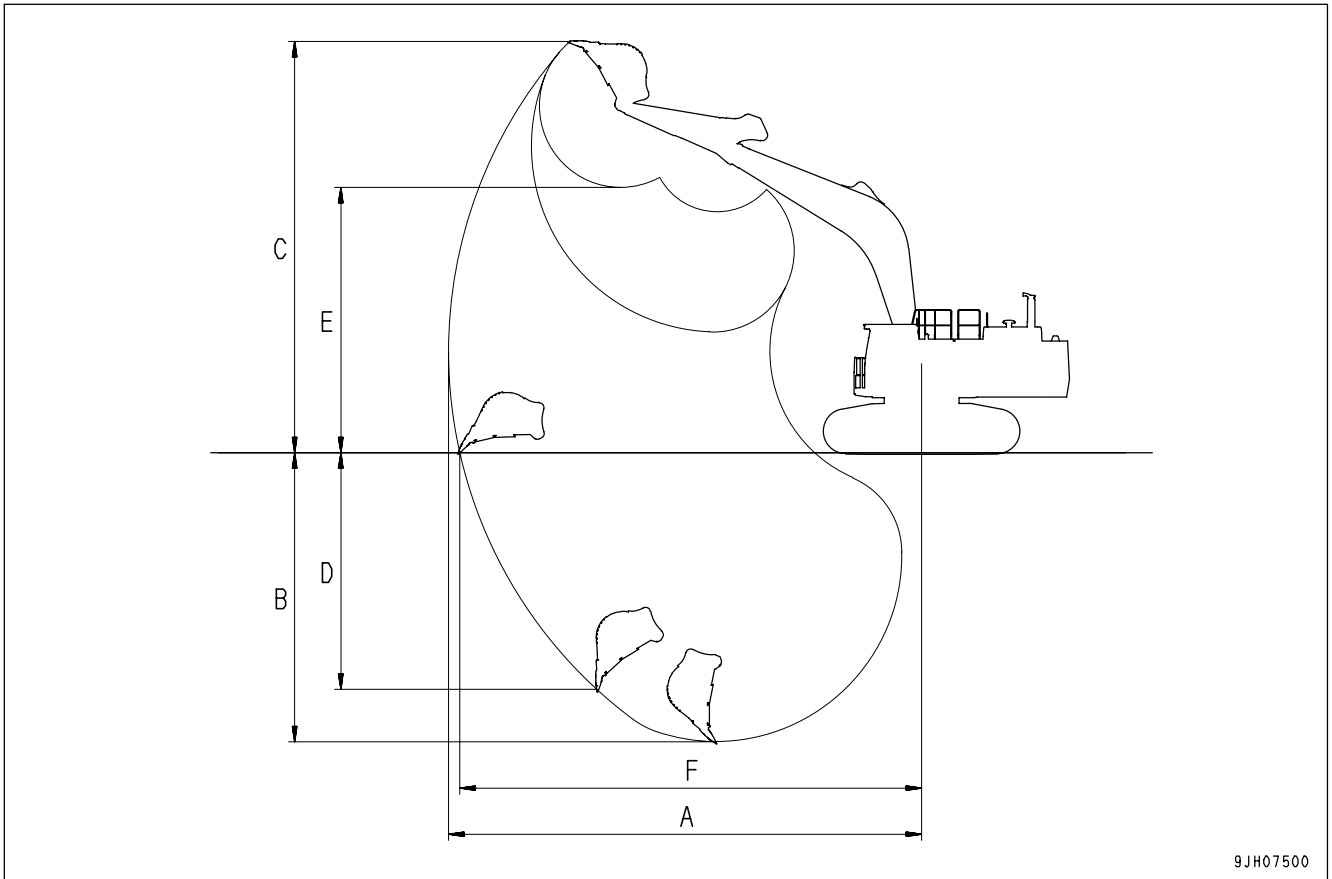

SELECTION OF TRACK SHOES

Select the most suitable track shoe to match the operating conditions. Check the use in the table below, and select the shoe from the table on the next page.

Category	Use	Precautions when using	Remarks
A	Cocky ground, river bed, normal soil	Travel in Lo speed when traveling on rough ground with obstacles such as large boulders and fallen trees.	Categories "B" are wide shoes, so there are restrictions on their use. Therefore, before using, check the restrictions and consider carefully the conditions of use before recommending a suitable shoe width. If necessary, give the customer guidance in their use. When selecting the shoe width, select the narrowest shoe possible within the range that will give no problem with flotation and ground pressure. If a wider shoe than necessary is used, there will be a large load on the shoe, and this may lead to bending of the shoe, cracking of the links, breakage of the pins, loosening of the shoe bolts, or other problems.
B	Normal soil, soft land	<ul style="list-style-type: none"> • Use only for ground where "B" sink and are impossible to use. • Cannot be used on rough ground where there are large obstacles such as boulders and fallen trees. • Travel in Hi speed only on flat ground; when it is impossible to avoid traveling over obstacles, lower the travel speed to approx. half of Lo speed. 	

Shoe		Double grouser shoe				
Model		PC1250		PC1250SP	PC1250LC	
Shoe width	mm (in)	700 (27.6 in)	1000 (39.4 in)	700 (27.6 in)	1000 (39.4 in)	1200 (47.3 in)
Overall width of crawler	mm (in)	4600 (15'1")	4900 (16'1")	4600 (15'1")	4900 (16'1")	5100 (16'9")
Ground pressure	MPa (kg/cm ²)	0.13 (1.35)	0.09 (0.96)	0.13 (1.36)	0.09 (0.88)	0.07 (0.74)
category of use		A	B	A	B	B

AUTO-GREASING SYSTEM

EXPLANATION OF COMPONENTS

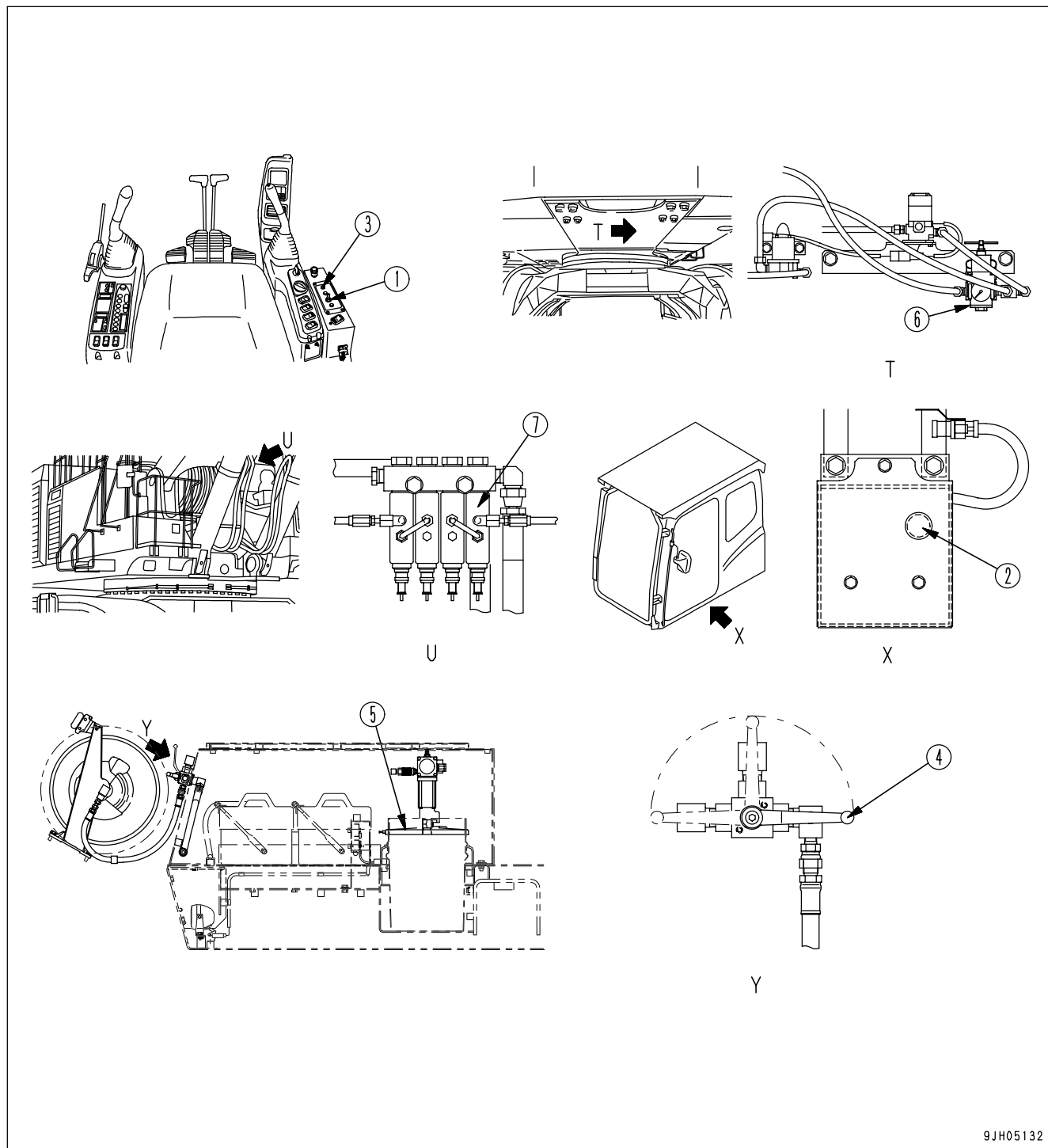

- (1) Auto-greasing switch
- (2) Interval adjustment dial
- (3) Warning lamp (red)
- (4) Auto-greasing/grease gun selector valve lever
- (5) Grease pump
- (6) Regulator
- (7) Injector

Auto-greasing Switch

This switch (1) actuates the greasing system.

- When this switch is set to the AUTO position, the lamp (green) lights up and the auto-greasing system starts to operate.
If the auto-greasing switch is at AUTO when the machine starting switch is turned ON, the greasing system is actuated immediately.
- When the auto-greasing switch is set to the MANUAL position, the lamp (green) lights up and the auto-greasing system starts to operate regardless of the timer.
- When using the grease gun, set the auto-greasing switch to the MANUAL position. This position is also used when checking operation of the grease pump and when bleeding the air from the grease line.

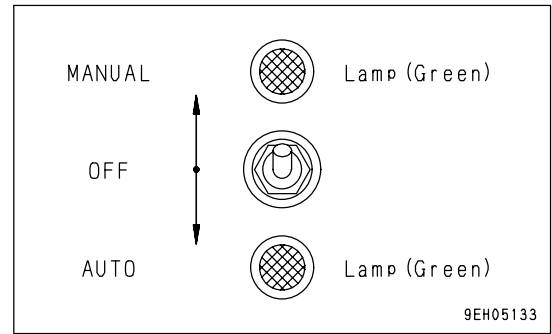

Interval Adjustment Dial

This dial (2) is used to adjust the greasing interval for auto-greasing. Remove the rubber cap; the adjustment dial is inside.

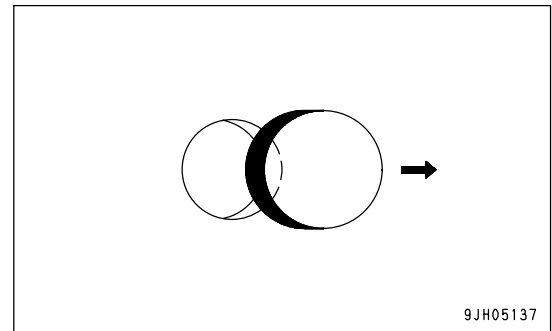

Warning Lamp (red)

This lamp (3) lights up when there is an abnormality in the auto-greasing system. The buzzer also sounds at the same time.

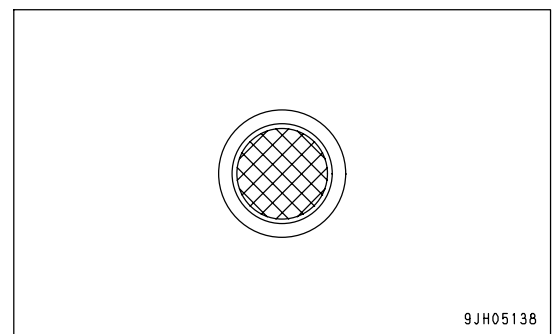

Auto-greasing/Grease Gun Selector Valve Lever

- This lever (4) is used to switch the flow of grease to the grease gun. When using the auto-greasing system, set it to the AUTO position (A); when using the grease gun, set it to the GREASE GUN position (B).
- After using the grease gun, always return the lever to the auto-greasing position.

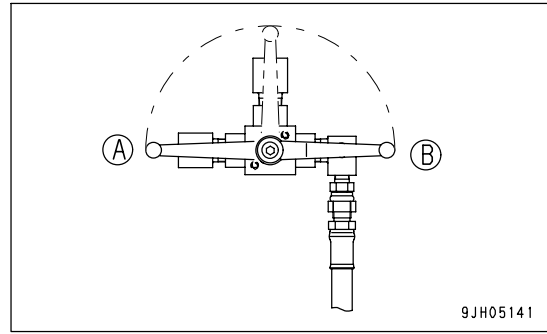

Grease Pump

- This pump (5) supplies the grease.
- For details of the method of handling the grease pump, see "GREASE PUMP (PAGE 3-71)".

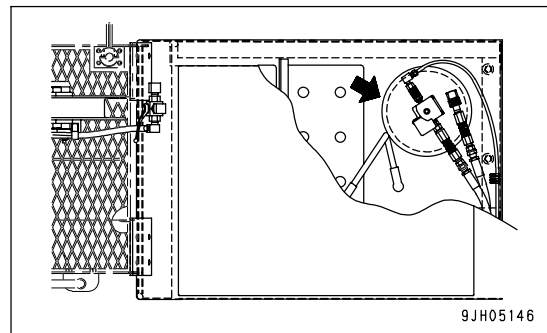

Regulator



WARNING

Do not raise the pressure in the regulator above a maximum of 0.49 MPa (5 kg/cm²). The pump pressure ratio is 50:1, so the grease pressure rises to 24.5 MPa (250 kg/cm²). If the system is used at above the specified pressure, there is danger that it may lead to a serious accident.

- This regulator (6) adjusts and stabilizes the compressed air sent from the compressor to a suitable pressure.
- The regulator pressure is set to 0.44 MPa (4.5 kg/cm²) when the machine is shipped from the factory.

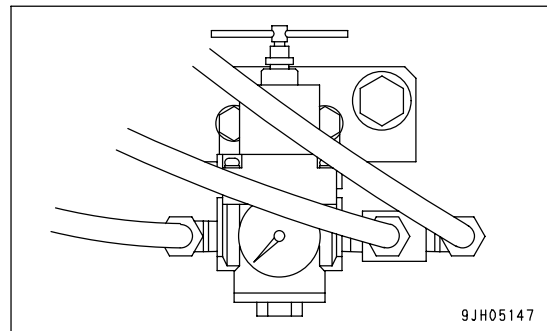

Injector

This injector (7) supplies the grease sent from grease pump (5) to the greasing points.

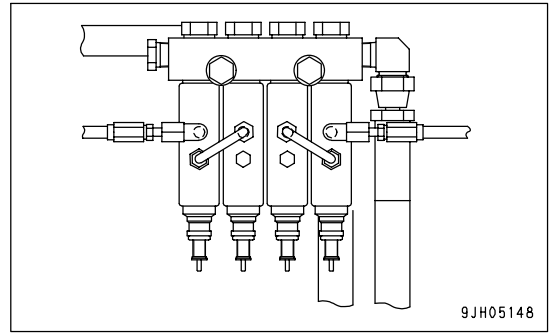

Greasing Points for Auto-greasing System

! CAUTION

- If there is an abnormality and the auto-greasing system does not function, supply the grease manually to greasing points (1) - (8). For details, see the INSPECTION AND MAINTENANCE section.
- Greasing points (9) - (13) are not included in the auto-greasing system, so supply the grease manually to these greasing points. For details, see the INSPECTION AND MAINTENANCE section.

The greasing points for the auto-greasing system are as follows.

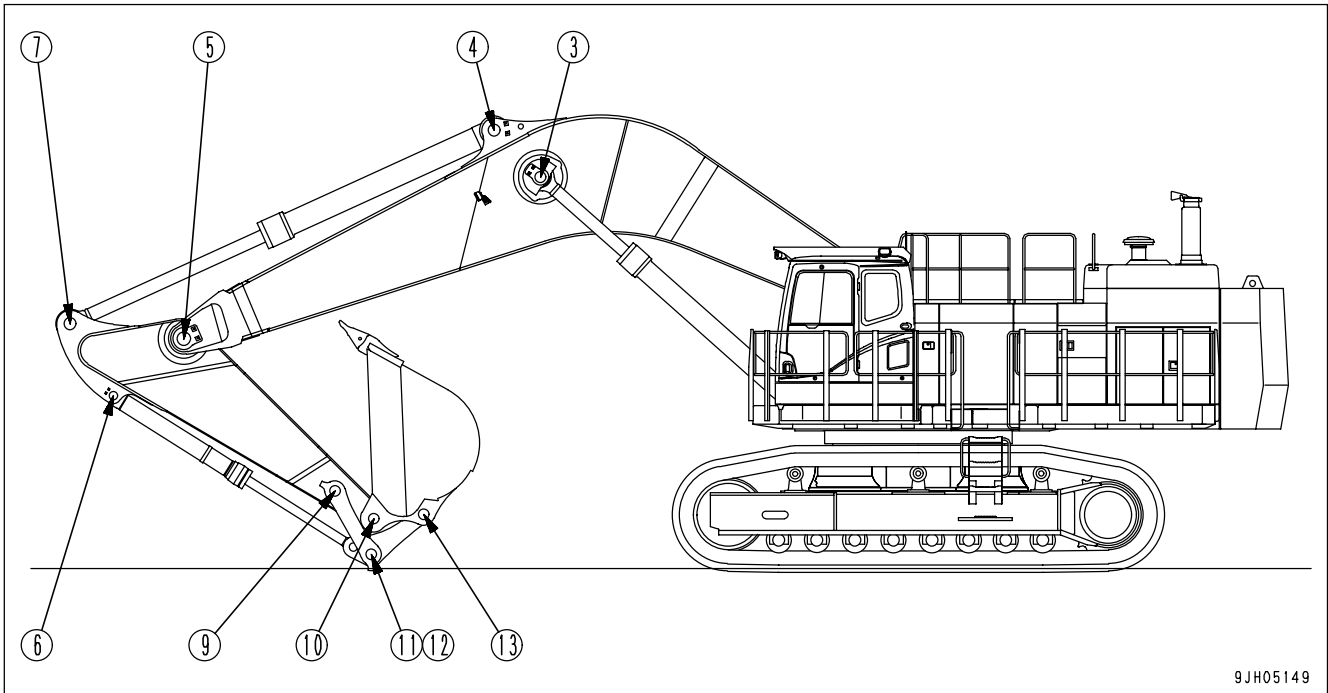

9JH05149

- (1) Boom cylinder foot pin (2 places)
- (2) Boom foot pin (2 places)
- (3) Boom cylinder rod pin (2 places)
- (4) Arm cylinder foot pin (1 place)
- (5) Boom-Arm coupling pin (1 place)
- (6) Bucket cylinder foot pin (2 places)
- (7) Arm cylinder rod pin (1 place)
- (8) Swing circle (4 places)

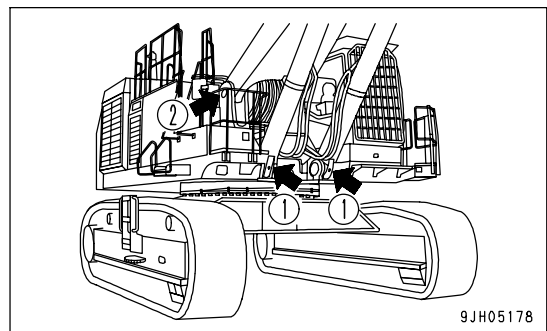

9JH05178

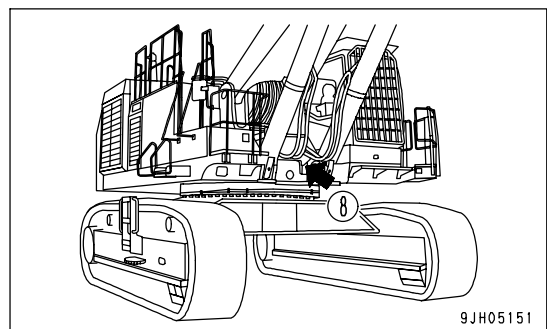

9JH05151

OPERATION

CHECK BEFORE STARTING OPERATIONS

- Check that there is ample grease in the grease pail in the grease pump inside the battery case. If the pump has run out of grease, replace the grease pail.
- Check that the grease pail is not dented or deformed.
- Check that the auto-greasing/grease gun selector valve lever inside the battery case is at the auto-greasing position (A).

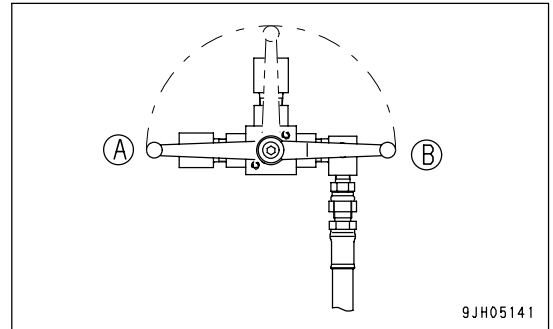

OPERATING PROCEDURE FOR AUTO-GREASING SWITCH

- To operate the auto-greasing system, turn the machine starting switch ON, then operate the auto-greasing switch on the box on the side of the console on the right side of the operator's seat.

Operating With Auto-greasing Switch at Auto Position

- When the auto-greasing switch is set to the AUTO position, the lamp (green) lights up and the auto-greasing system starts to operate.
- When the machine starting switch is turned ON, if the auto-greasing switch is already at the AUTO position, the greasing operation will start immediately.

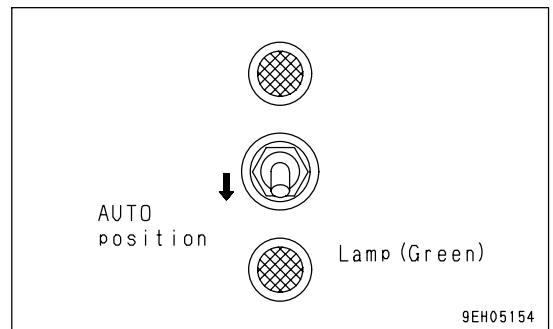

Operating With Auto-greasing Switch at Manual Position

- When the auto-greasing switch is set to the MANUAL position, the lamp (green) lights up and the auto-greasing system starts to operate regardless of the timer.
- When using the grease gun, set the auto-greasing switch to the MANUAL position. This position is also used when checking operation of the grease pump and when bleeding the air from the grease line.
- During manual operations, the auto-greasing system does not operate. After using the grease gun, always return the auto-greasing switch to the AUTO position.

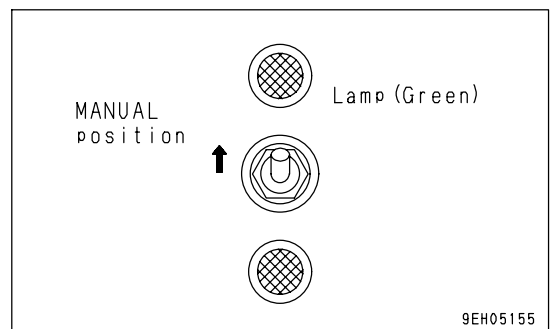

- Set the auto-greasing switch to the OFF position when it is necessary to stop the auto-greasing system, such as when the grease piping is broken or damaged.

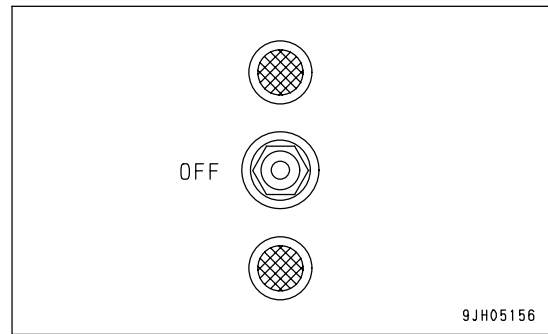

9JH05156

METHOD OF ADJUSTING INTERVAL TIMER

CAUTION

The setting of the interval timer differs according to the type of machine and the type of work. For this reason, it is necessary for the customer himself to set the interval timing to match the working condition of the machine.

- The interval timer is installed to control the greasing interval of the auto-greasing system.
- The greasing interval can be changed freely with the adjustment dial of the interval timer. The set interval has an error of about $\pm 15\%$, however (for both stopping and starting).

Examine: when timer is set to 20 minutes

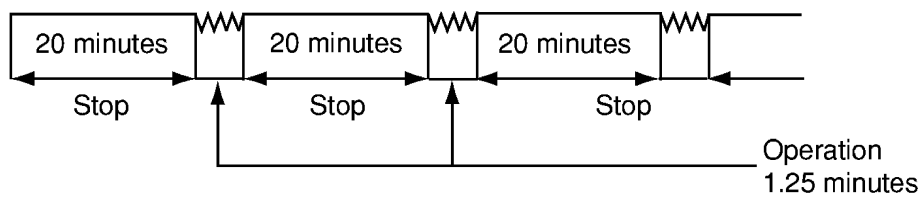

The greasing interval is set to 20 minutes when the machine is shipped from the factory.

Adjustment procedure

1. Remove rubber cap (1) on the front face of the timer box.
The adjustment dial can be seen inside.

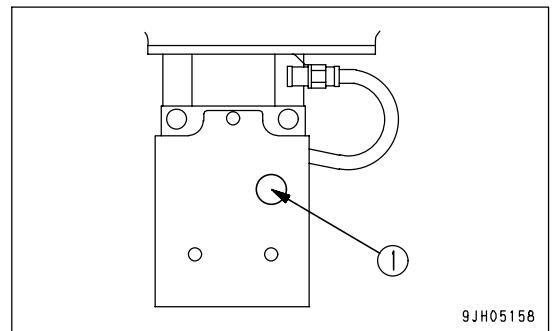

2. Using long-nosed pliers, turn the adjustment dial to set to the desired interval timing.
3. After adjusting, install cap (1).

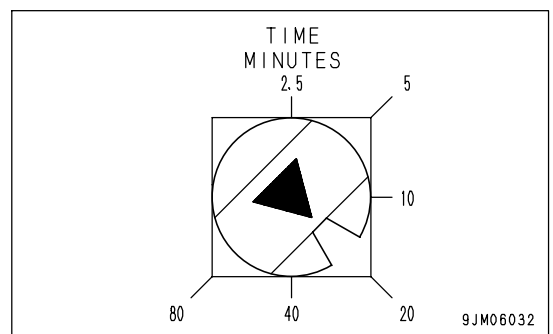

METHOD OF ADJUSTING INJECTOR DISCHARGE AMOUNT

CAUTION

The setting of the injector discharge amount differs according to the type of machine and the type of work. For this reason, it is necessary for the customer himself to set the injector discharge amount to match the working condition of the machine.

- The injector is operated by the pressure from the pump, and it feeds grease of the specified quantity to the bearing.
- To see if the injector works normally, check the operation of indicator pin (1) in its hard. If the injector is normal, the pin is retracted first. If the pump stops and the pressure is lost, the pin returns and it is reset for the next greasing.
- Although the injector can be overhauled and repaired, replace it with a spare one, if possible, when it has any trouble.

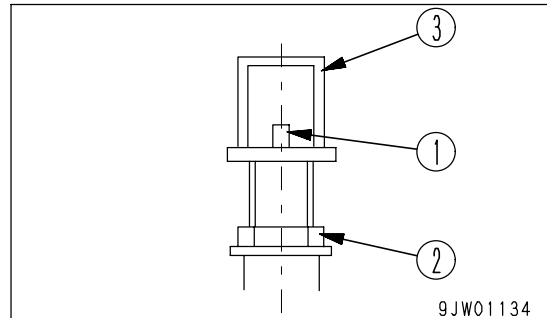

The injector discharge amount is set to the center position (0.7 cc/ST) when the machine is shipped from the factory.

Adjustment procedure

Adjust the discharge from the injector with adjustment screw (3) on its hard.

1. To reduce the discharge, loosen lock nut (2) and turn adjustment screw (3) clockwise. If the adjustment screw stops (at the stopper), the discharge is minimized.
2. If the adjustment screw is returned by 10 turns from the fully tightened position (minimum discharge) in 1] above, the discharge is maximized (1.3 cc/ST).
3. After adjusting the discharge from the injector, be sure to tighten lock nut (2).

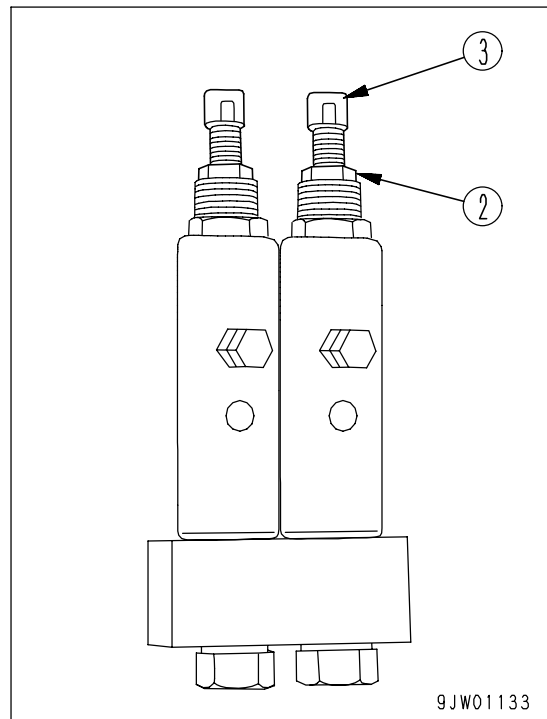

- Tightening torque for locknut (2): 19.6 to 24.5 Nm (2.0 to 2.5 kgm, 14.5 to 18.1 lbft)

	Discharge/time
Turn clockwise to stopper	0.13 cc (Min)
Turn counterclockwise by 10 turns from above position	1.30 cc (Max)

TROUBLESHOOTING

There is an auto-greasing warning lamp and injector actuation indicator at the position to inform of abnormalities in the auto-greasing system.

AUTO-GREASING WARNING LAMP (RED)

If there is any abnormality in the pressurization of the grease line, the buzzer sounds and the warning lamp (red) lights up.

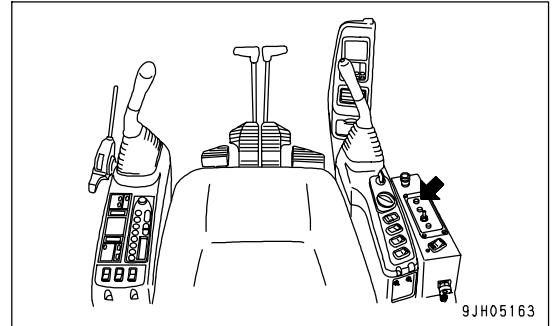

INJECTOR ACTION INDICATOR

The indicator pin moves up and down according to the increase or decrease in pressure in the grease line to inform the operator that grease is being supplied to the greasing points. If the grease is not being supplied normally, the indicator pin does not move even when the pressure increases or decreases, so it is possible to detect the abnormality.

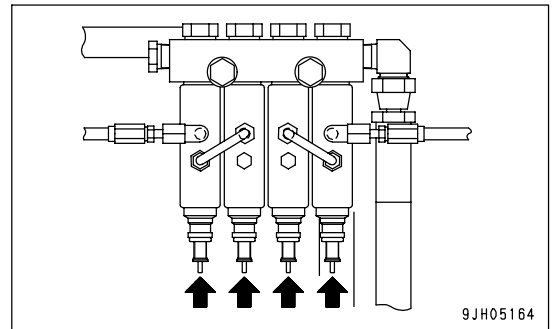

Condition	Main cause	Action
Auto-greasing warning lamp lights up (buzzer sounds)	<ul style="list-style-type: none"> • Greasing system is being run with empty grease pail • Grease pail is deformed, so air is being sucked in without follower plate going down • Grease is leaking from grease piping (piping from pump to injector) • Grease is leaking from injector • Defective pressurization of pump 	<ul style="list-style-type: none"> • Replace grease pail • Check, repair • Replace • Replace
Injector actuation indicator does not work	<ul style="list-style-type: none"> • Defective injector • NLGI No. 2 or equivalent grease is being used in cold area 	<ul style="list-style-type: none"> • Replace • Change to grease for cold weather (NLGI No. 0 or equivalent)

If any problem occurs where the cause is not listed in the above table, please contact your Komatsu distributor for repairs.

MAINTENANCE

REPLACE GREASE PAIL



- Do not use a grease pail if it is dented or deformed.
Follower plate (2) will not come down, or air pockets will form, so the grease will not be sucked in.
- After using the pail, remove all grease that leaked or sprayed out.

If pail (1) runs out of grease, replace pail (1).

- Check that grease dose not leak from the piping between the pail (1) and follower plate (2).

NOTICE

Do not remove follower plate (2). If follower plate (2) is not used, pump (3) will be unable to suck up the grease even if there is still a large quantity of grease in the can.

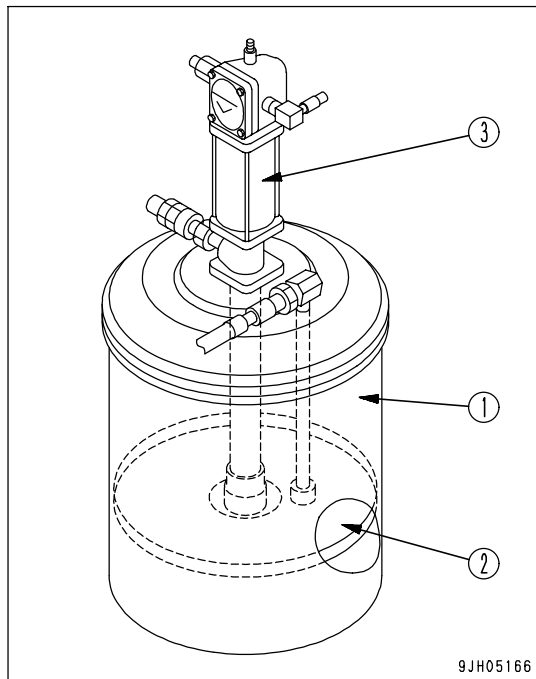

Select the grease to use from the following table to match the ambient temperature.

KIND OF FLUID	AMBIENT TEMPERATURE							
	-22	-4	14	32	50	68	86	104°F
	-30	-20	-10	0	10	20	30	40°C
Grease					NLGI No. 2			
	NLGI No. 0				(*1)			

*1: If cold-weather grease (NLGI No. 0) is used in warm areas, some grease will drip from the tip of the work equipment pins, but there is no problem with the lubrication.

PROCEDURE FOR BLEEDING AIR FROM GREASE LINE



WARNING

There is no check device to prevent reverse flow in the service grease nipple installed to the injector. If you forget to tighten the cap, there is danger that high-pressure grease may spurt out when the grease pump is actuated.

Be sure not to forget to tighten the cap.

If the grease pump has been run empty or the grease piping has been disassembled and assembled again, and large amounts of air have got into the grease line, bleed the air from the grease line.

NOTICE

If air is left in the circuit, the grease pressure will not rise to the specified level or will take a long time to rise to the specified level, and the injector will not work normally.

Items to check

- Loosen the plug installed to each injector to bleed air from the main piping. This work shall be carry out by two persons.
- Start bleeding at the injector nearest the grease pump, then bleed at the other injectors in order.
(Swing circle -> Boom cylinder bottom -> Boom -> Arm)
- Check that the auto-greasing/grease gun selector valve lever inside the battery case is at the auto-greasing position.

Method of bleeding air

1. Remove plug (2) from injector (1).

- This plug (2) is installed to the manifold end of each end injector. If air must be bled from the main piping, remove this plug.

2. The other person should set the auto-greasing switch on the box on the side of the console on the right side of the operator's seat to the MANUAL position and operate the grease pump.

For details of the method of operating the grease pump, see "OPERATION (PAGE 6-13)".

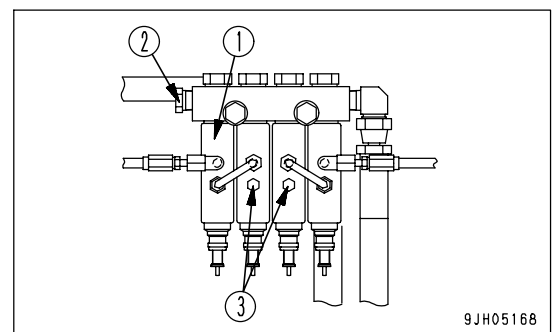

3. Discharge the air with the grease from the injector plug hole. (Often the grease becomes cloudy white because of the air.)

4. When normal grease comes out, set the auto-greasing switch to the OFF position and stop the grease pump.

5. Tighten plug (2) of the injector to prevent the grease from leaking.
 - Tightening torque of plug (2): 19.6 - 24.9 Nm (2.0 - 3.0 kgm, 14.5 - 21.7 lbf)

Carry out Steps 1 to 5 for every injector.

6. Remove cap (4) from service grease nipple (3) of the injector.
7. Operate the grease gun manually to fully charge all the branch lines with grease.

For details of the location of the injectors, see "Greasing Points for Auto-greasing System (PAGE 6-12)".

REMARK

If the auto-greasing system does not work properly and grease is not supplied, use the grease gun and carry out greasing manually from service grease nipple (3) installed to each injector.

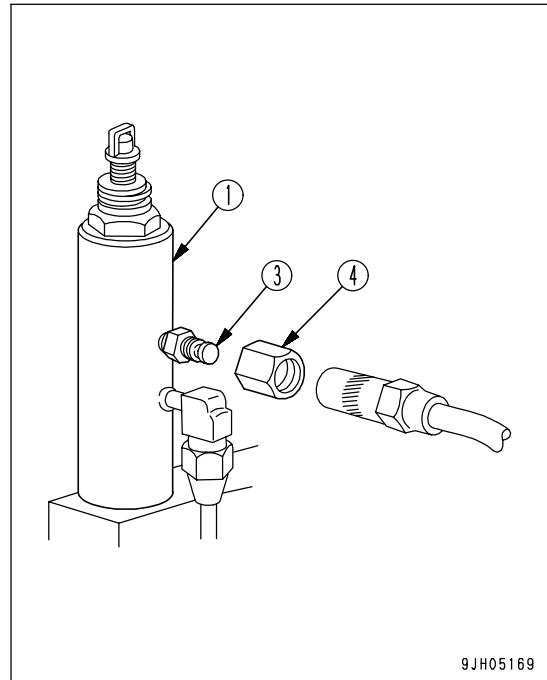

8. Tighten cap (4) of service grease nipple (3) of the injector.
 - Tightening torque of cap (4): 3.92 to 5.88 Nm (0.4 to 0.6 kgm, 2.9 to 4.3lbf)
 - There is no check device to prevent reverse flow in service grease nipple (3). If you forget to tighten cap (4), there is danger that high-pressure grease may spurt out when the grease pump is actuated. Be sure not to forget to tighten the cap.
9. After completing the operation in the Steps 1 to 8, set the auto-greasing switch on the box on the side of the console on the right side of the operator's seat to the AUTO position.

10. Turn the machine starting switch ON and check that indicator pin (5) of each injector is working properly. If the condition is normal, indicator pin (5) moves up and down in a piston movement.

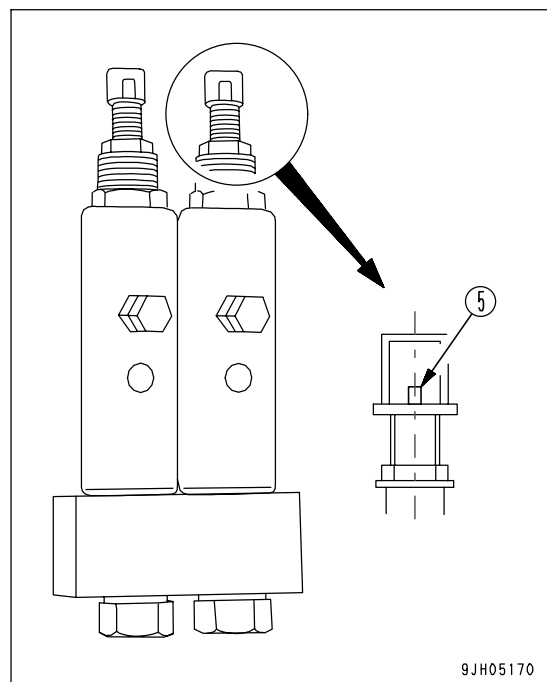

INJECTOR POSITION IN AUTO-GREASING SYSTEM AND MANUAL GREASING

**WARNING**

There is no check device to prevent reverse flow in the service grease nipple installed to the injector. If you forget to tighten the cap, there is danger that high-pressure grease may spurt out when the grease pump is actuated.

Be sure not to forget to tighten the cap.

Injector (a) acts to send the grease supplied from the grease pump to each greasing point. If the auto-greasing system does not work properly and grease is not supplied, use the grease gun and carry out greasing manually from service grease nipple (b) installed to each injector.

- There is no check device to prevent reverse flow in service grease nipple (b). If you forget to tighten cap (c), there is danger that high-pressure grease may spurt out when the grease pump is actuated. Be sure not to forget to tighten the cap.

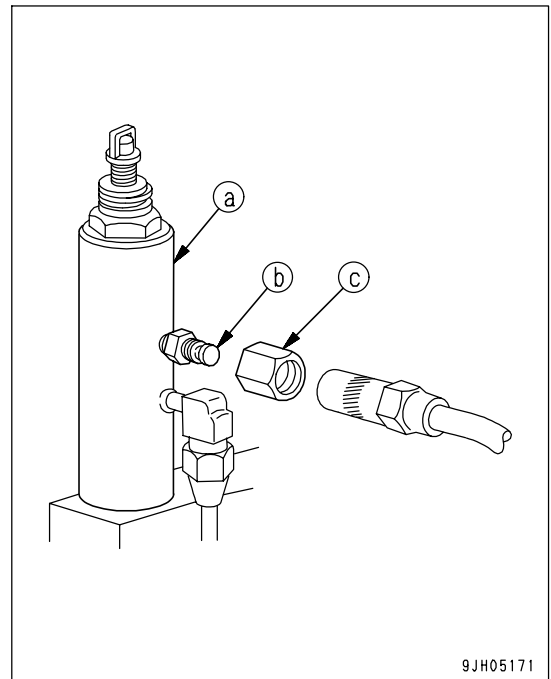

The locations of the service grease nipples for each injector are as follows.

- (1) Boom cylinder foot pin (right) (2 places)
- (2) Boom cylinder foot pin (left) (2 places)
- (3) Boom foot pin (right) (2 places)
- (4) Boom foot pin (left) (2 places)
- (5) Boom cylinder rod pin (right) (1 place)
- (6) Boom cylinder rod pin (left) (1 place)
- (7) Arm cylinder foot pin (right) (1 place)
- (8) Boom-arm connecting pin (2 places)
- (9) Bucket cylinder foot pin (right) (1 place)
- (10) Bucket cylinder foot pin (left) (1 place)
- (11) Arm cylinder rod pin (1 place)
- (12) Swing circle (4 places)

- When greasing places on top of the arm: boom-arm connecting pin (8), bucket cylinder foot pins (9) and (10), and arm cylinder rod pin (11), the greasing can be carried out manually from the central block.

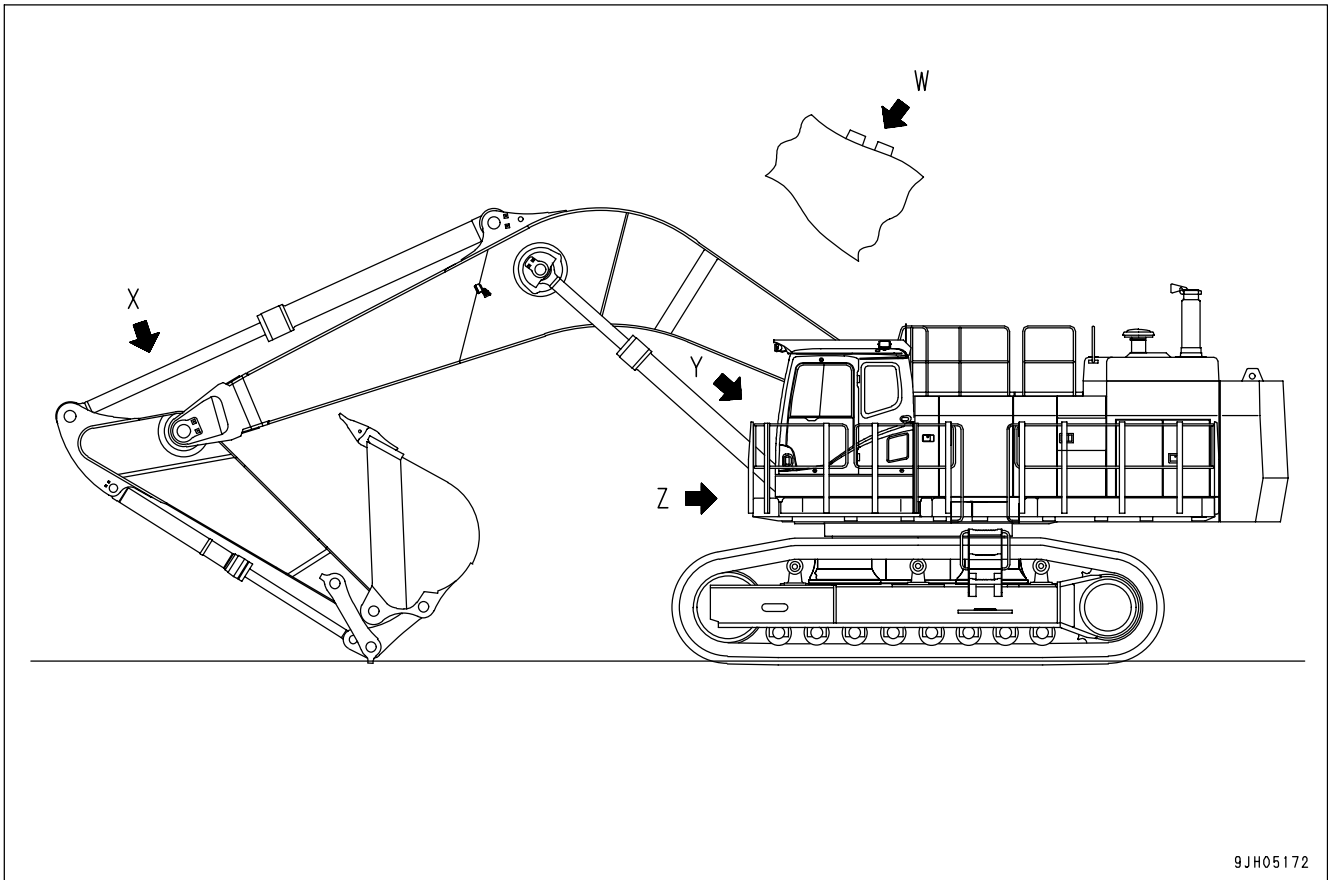

9JH05172

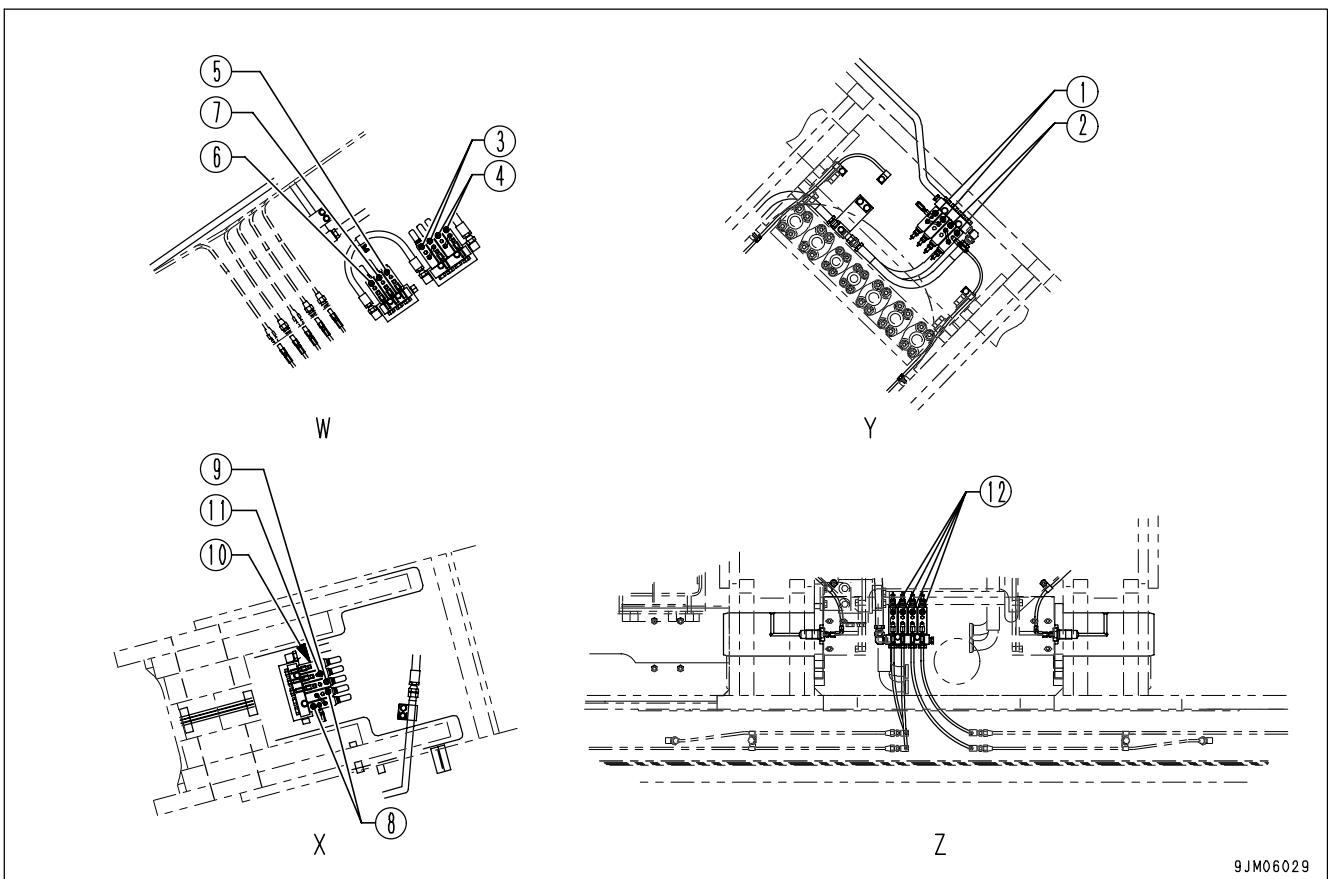

9JM06029

EVERY 10 HOURS MAINTENANCE

Greasing Points not Including in Auto-greasing System

1. Set to the greasing posture below, lower the work equipment to the ground, then stop the engine.
2. Using a grease gun, supply grease to the grease fitting is marked by arrows.
3. After greasing, wipe off any old grease that was pushed out.

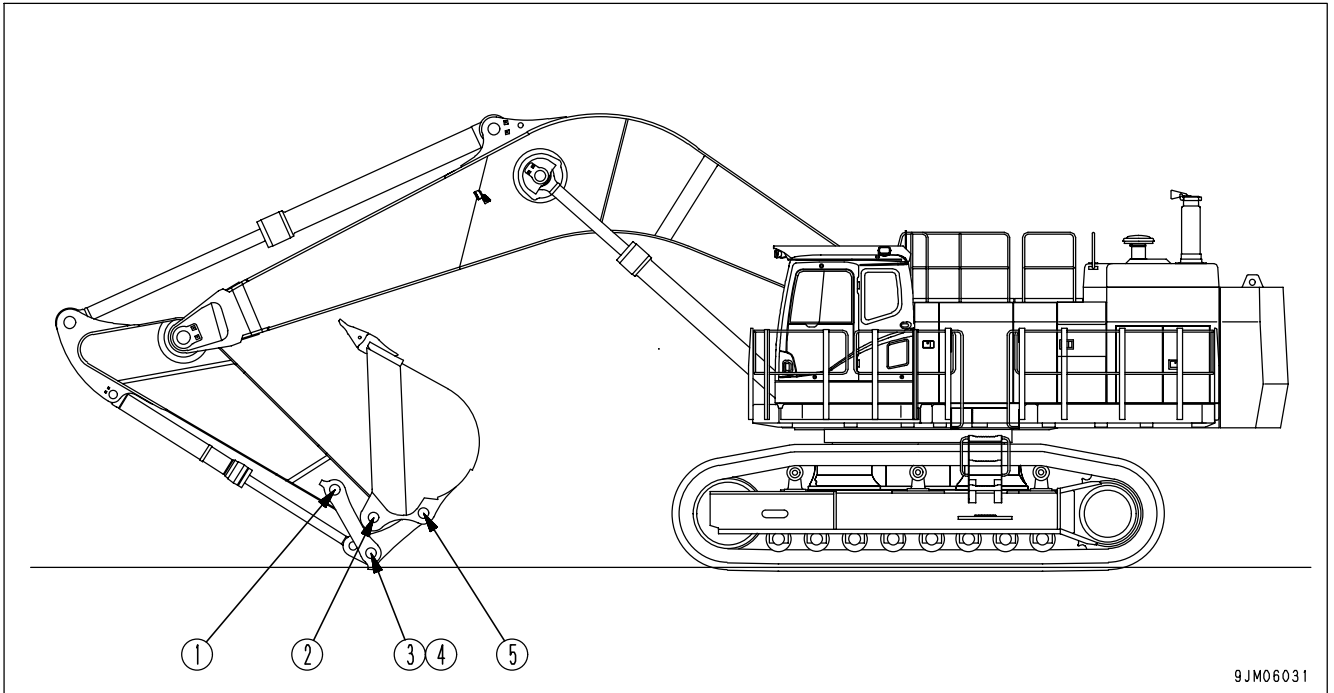

9JM06031

- (1) Arm-Link coupling pin (1 place)
- (2) Arm-Bucket coupling pin (2 places)
- (3) Link coupling pin (1 place)
- (4) Buket cylinder rod end pin (2 places)
- (5) Bucket-Link coupling pin (1 place)

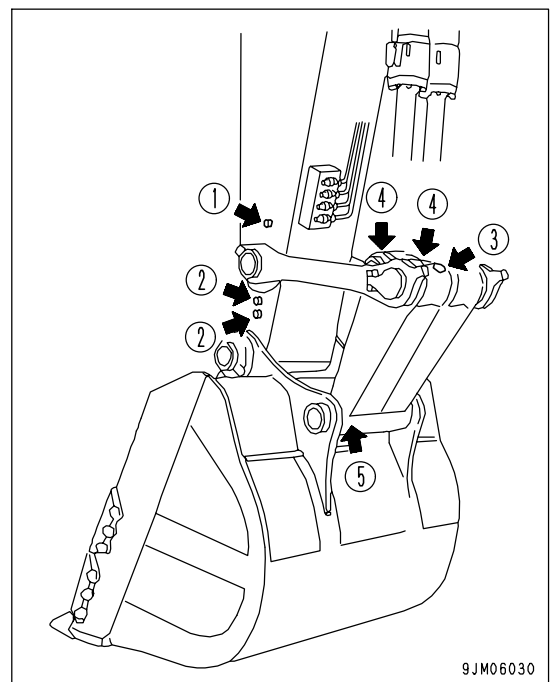

9JM06030

HANDLING MACHINES EQUIPPED WITH VHMS

- VHMS is a machine management system. When a communications terminal is installed, it is possible to transmit data.
- A contract is necessary before the VHMS communications terminal can be used. Any customers desiring to use the VHMS system should consult their Komatsu distributor.

VHMS INSTALLED, COMMUNICATIONS TERMINAL NOT INSTALLED

BASIC PRECAUTIONS



WARNING

- Never disassemble, repair, modify, or move the VHMS, antenna, or cables. This may cause failure or fire on the VHMS equipment or the machine itself. (Your Komatsu distributor will carry out removal and installation of VHMS.)
- Do not allow cables or cords to become caught; do not damage or pull cables or cords by force. Short circuits or disconnected wires may cause failure or fire on the VHMS equipment or the machine itself.

REMARK

There is absolutely no need to inspect or operate the VHMS, but if any abnormality is found, please contact your Komatsu distributor.

VHMS AND COMMUNICATIONS TERMINAL INSTALLED

- The VHMS equipment is a wireless device using radio waves, so it is necessary to obtain authorization and conform to the laws of the country or territory where the machine equipped with VHMS is being used. Always contact your Komatsu distributor before selling or exporting any machine equipped with VHMS.
- When selling or exporting the machine or at other times when your Komatsu distributor considers it necessary, it may be necessary for your Komatsu distributor to remove the VHMS equipment or to carry out action to stop communications.
- If you do not obey the above precautions, neither Komatsu nor your Komatsu distributor can take any responsibility for any problem that is caused or for any loss that results.

BASIC PRECAUTIONS



WARNING

- Never disassemble, repair, modify, or move the VHMS, terminal, antenna, or cables. This may cause failure or fire on the VHMS equipment or the machine itself. (Your Komatsu distributor will carry out removal and installation of the VHMS and terminal.)
- Do not allow cables or cords to become caught; do not damage or pull cables or cords by force. Short circuits or disconnected wires may cause failure or fire on the VHMS equipment or the machine itself.
- For anyone wearing a pacemaker, make sure that the communications antenna is at least 22 cm from the pacemaker. The radio waves may have an adverse effect on the operation of the pacemaker.

NOTICE

- Please contact your Komatsu distributor before installing a top guard or other attachment that covers the antenna.
- Be careful not to get water on the communications terminal or wiring.

REMARK

- The communications terminal uses wireless communications, so it cannot be used inside tunnels, underground, inside buildings, or in mountain areas where radio waves cannot be received. Even when the machine is outside, it cannot be used in areas where the radio signal is weak or in areas outside the wireless communication service area.
- There is absolutely no need to inspect or operate the VHMS or communications terminal, but if any abnormality is found, please contact your Komatsu distributor.

LOADING SHOVEL

WARNING

When using a loading shovel specification machine, the method for operation is different in some way from the standard machine. This section gives the explanation for the parts that are different.

EXPLANATION OF COMPONENTS

SWITCHES

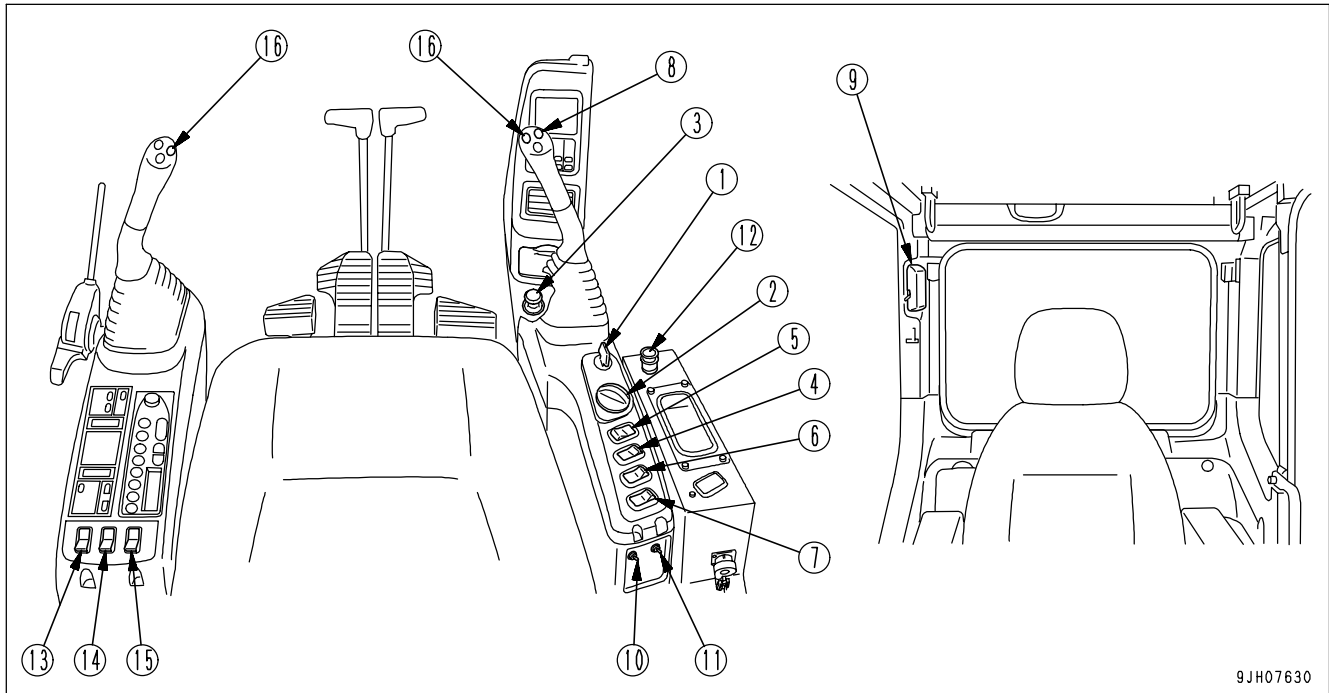

9JH07630

- | | |
|-----------------------------------|---|
| (1) Starting switch | (10) Emergency pump drive switch |
| (2) Fuel control dial | (11) Swing parking brake release switch |
| (3) Cigarette lighter | (12) Step light switch |
| (4) Swing lock switch | (13) Lower wiper switch (machines equipped with fixed front window cab) |
| (5) Lamp switch | (14) Revolving warning lamp switch (if equipped) |
| (6) Machine push-up switch | (15) Large capacity airflow air conditioner blower switch (if equipped) |
| (7) Boom shockless control switch | (16) Bottom dump switch |
| (8) Horn switch | |
| (9) Room lamp switch | |

For the loading specification machine, explanation is given only of the different switches.

Starting Switch

Fuel Control Dial

(with Auto-deceleration System)

Cigarette Lighter

Swing Lock Switch

Lamp Switch

Machine Push-up Switch**Shackles Boom Control Switch****Horn Switch**

When the switch (8) at the tip of the right work equipment control lever is pressed, the horn will sound.

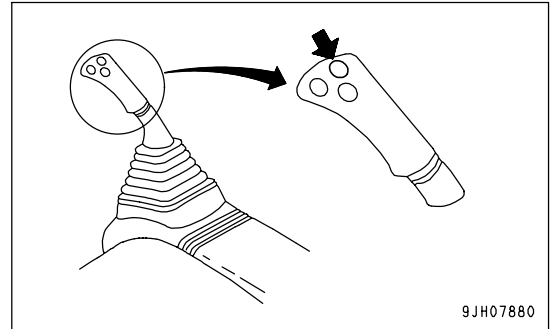
**Room Lamp Switch****Emergency Pump Drive Switch****Swing Parking Brake Release Switch****Step Light Switch****Lower Wiper Switch****Rotating Lamp Switch**

(If equipped)

Large Capacity Airflow Air Conditioner Blower Switch

(If equipped)

Bottom Dump Switch

Use this switch (16) to open and close the front bucket.

If the button at the tip of the left work equipment control lever is depressed, the bucket will close.

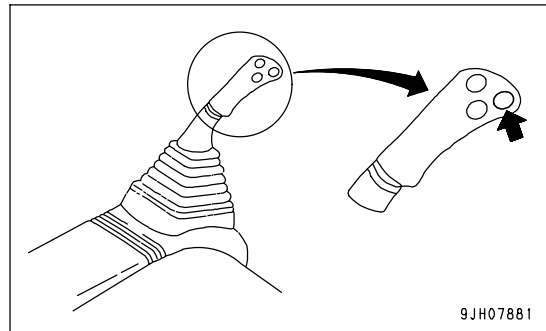

If the button at the tip of the right work equipment control lever is depressed, the front bucket will open.

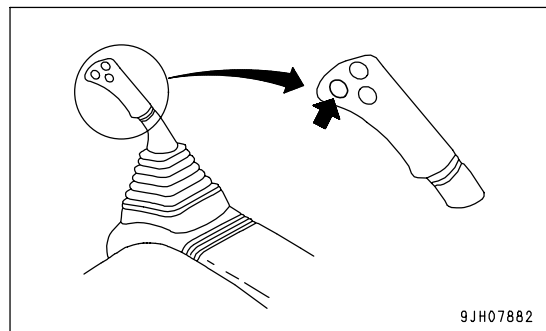

For explanation of switches (1) to (7) and (9) to (15), see "SWITCHES (PAGE 3-34)".

FUSE

NOTICE

Before replacing a fuse, be sure to turn off the starting switch.

Fuse Capacities and Circuit Name

No.	Fuse capacity	Name of circuit
(1)	10A	Redundancy
(2)	10A	Solenoid valve
(3)	10A	PPC lock solenoid
(4)	20A	Window washer, cigar lighter
(5)	10A	Horn, flash lamp light (if equipped), L/S (if equipped)
(6)	10A	Auto greasing system (if equipped)
(7)	10A	Rotating lamp (if equipped)
(8)	10A	L/S (if equipped)
(9)	10A	Radio
(10)	10A	Ribbon heater relay
(11)	25A	Air conditioner unit
(12)	20A	VHMS (if equipped)
(13)	10A	Optional power source (2), Travel alarm 12V power supply (if equipped)
(14)	10A	Optional power source (1)
(15)	5A	Key switch (acc., engine controller)
(16)	10A	Radio backup
(17)	10A	Network pass (regular power)
(18)	20A	VHMS (regular power) (if equipped)
(19)	10A	Room lamp
(20)	10A	Step light

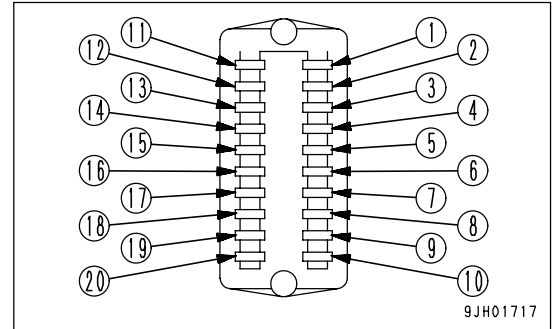

OPERATIONS

OPERATION OF WORK EQUIPMENT

WARNING

- If the lever is operated in the deceleration range, the engine speed will suddenly rise. Operate the levers carefully.
- If the work equipment control levers are operated quickly, the engine speed will suddenly rise. Operate the levers carefully.

The work equipment is operated with the left work equipment control lever and right work equipment control lever. The left work equipment control lever operates the arm, swing, and bottom dump (CLOSE); the right work equipment control lever operates the boom, bucket, and bottom dump (OPEN).

The relationship between the operation of the lever and the movement of the work equipment is as shown in the diagram on the right.

When the lever is released, it returns to the HOLD position and the work equipment is held in position.

- If the work equipment control levers are returned to the neutral position when the machine is stopped, even if the fuel control dial is set to FULL, the auto-deceleration mechanism will act to reduce the engine speed to a mid-range speed.

REMARK

If the key in the starting switch is turned ON within 15 seconds after stopping the engine, it is possible to lower the work equipment to the ground by operating the levers.

In addition, the levers can also be operated to release any remaining pressure inside the hydraulic cylinder circuit and to lower the boom after loading the machine on a trailer.

Arm operation

- (A): Arm OUT
- (B): Arm IN

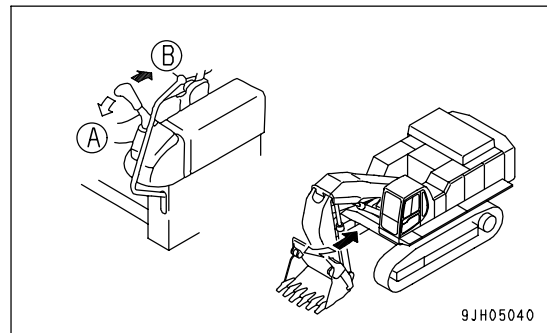

Swing operation

- (A): Left swing
- (B): Right swing

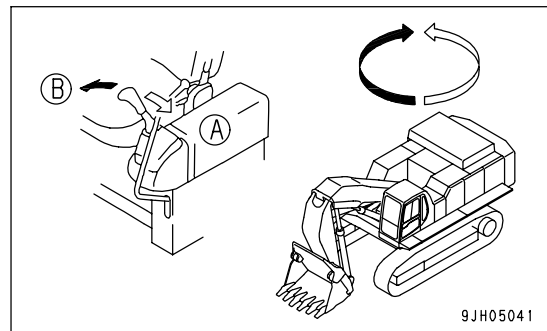

Boom operation

- (A): Boom RIASE
- (B): Boom LOWER

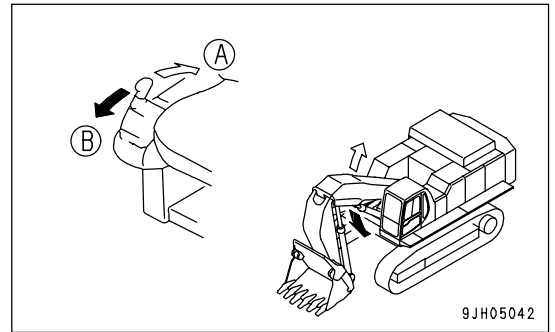

Bucket operation

- (A): Bucket DUMP
- (B): Bucket CURL

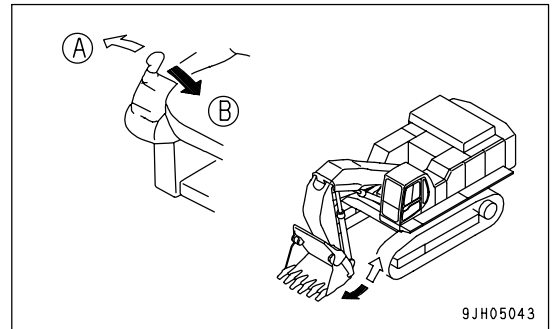

Bottom dump operation

- (A): OPEN
- (B): CLOSE

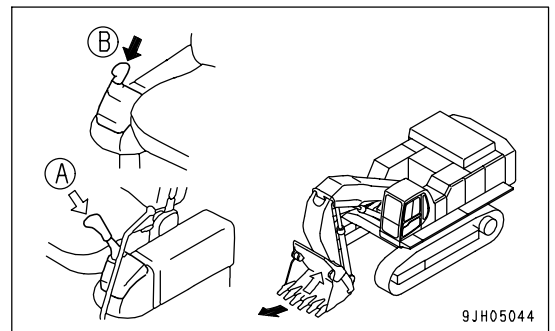

PRECAUTIONS DURING OPERATION

! WARNING

- When the arm is pushed out to the front, the speed momentarily becomes slow around the vertical position of the arm.
- Turning or operating the work equipment when working on slopes may cause the machine to lose its balance and turn over, so avoid such operations.
It is particularly dangerous to swing downhill when the bucket is loaded. If such operations have to be performed, pile soil to make a platform (A) on the slope so the machine is kept horizontal during operation.
- Do not travel up or down steep slopes. There is danger that the machine may turn over.

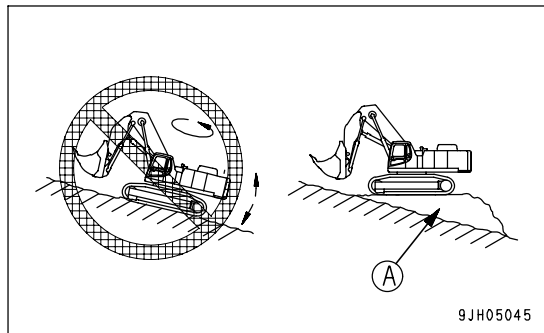
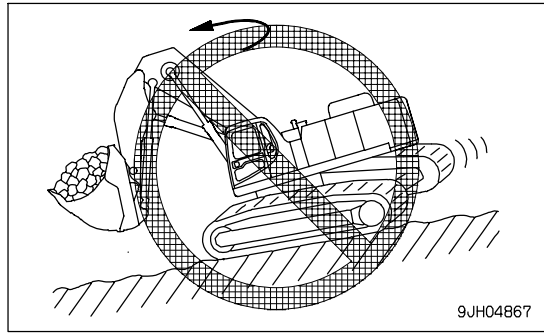

It is Prohibited to Use the Swing Force for Operations.

Do not use bucket swing force to compact soil or break an earth wall, or do not dig the bucket teeth into the ground while swinging the bucket. Such a way of using the bucket can cause damage to the work equipment.

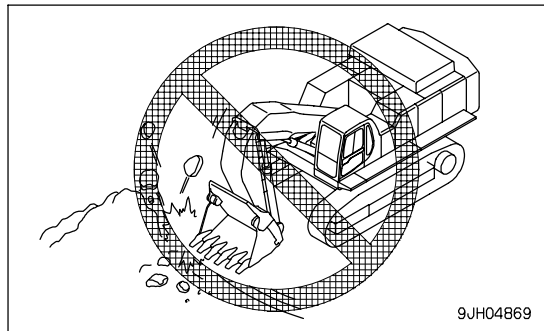

It is Prohibited to Use the Travel Force for Operations.

Do not move off and excavate with the bucket left dug into the ground.

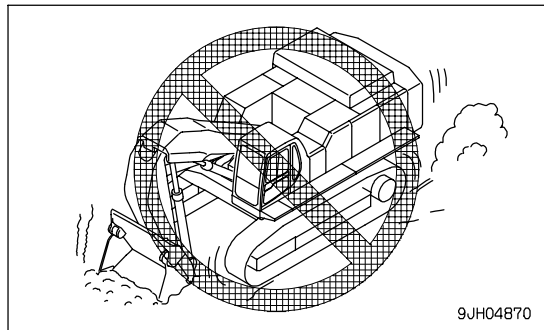

Do not Carry Out Operations with the Hydraulic Cylinder at the End of its Stroke.

If the cylinder is operated to the end of its stroke during operations, a large force will be brought to bear on the stopper inside the cylinder, and this will reduce the service life of the machine, so leave room (distance a) at the end of the stroke as far as possible.

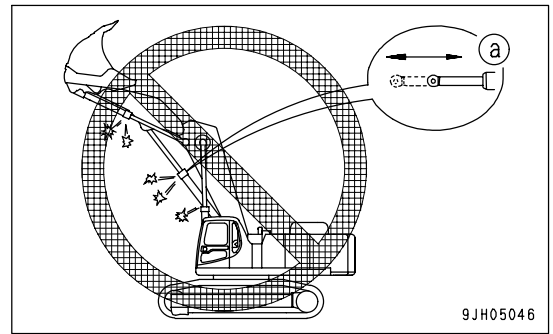
**It is Prohibited to Use the Dropping Force of the Bucket for Operations.**

Do not use the dropping force of the bucket as a pickaxe, breaker, or pile driver. This will bring excessive force to bear on the rear of the machine, and will not only damage the machine, but is also dangerous.

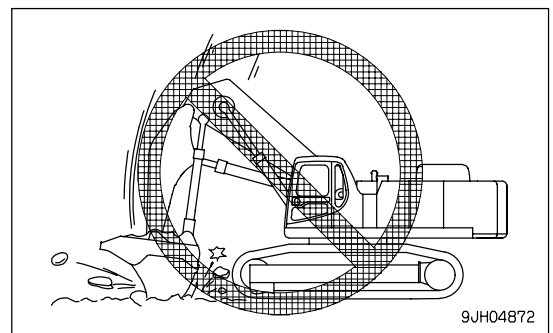
**Be Careful of Stability when Swinging.**

During swing operations, the stability of the machine differs to the front, rear, left and right, and there is danger that it may tip over.

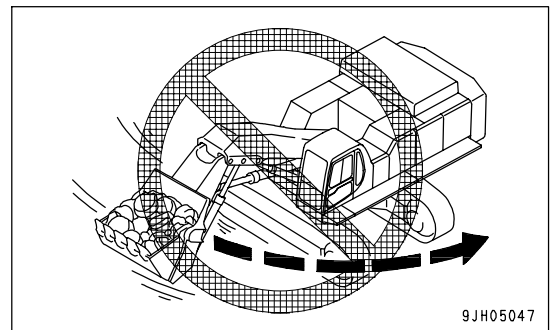
**It is Prohibited to Use the Tilt Operation for Digging.**

Do not set the teeth vertically when the bucket is pulled in, and then use the tilt operation to carry out digging.

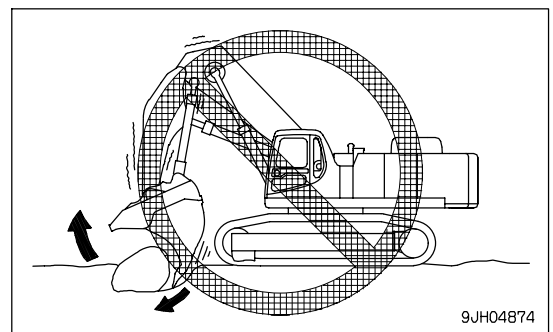

It is Prohibited to Grip Rocks.

Do not use the bottom dump bucket to grip rocks.

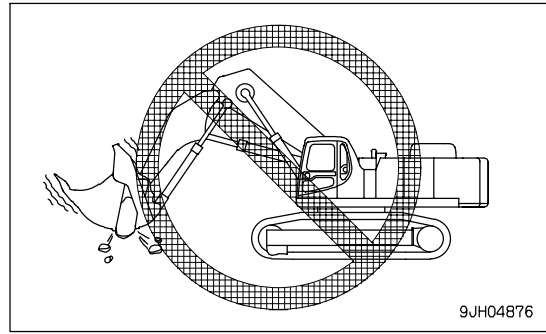

It is Prohibited to Use the Bucket for Leaving Operations.

Using the rear bucket to carry out leveling operations will bring an excessive force to bear on the work equipment, so do not use the rear bucket in this way.

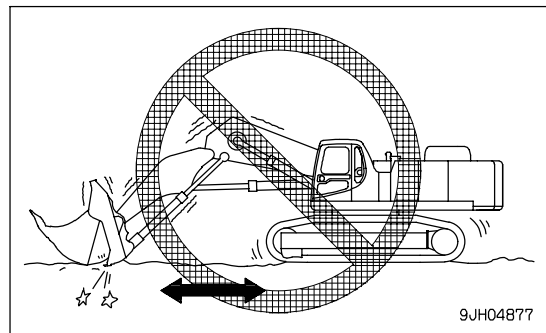

Be Careful not to Spill the Load.

When the bucket is fully loaded, do not raise the boom fully. If the boom is raised fully, the load will spill to the rear and cause danger to the operator.

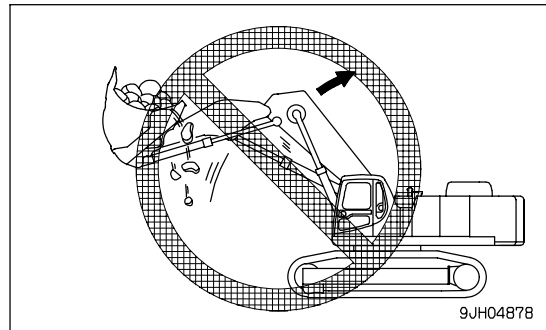

Be Careful not to Hit the Undercarriage.

If the upper structure is set diagonally to the track frame when carrying out digging operations, the work equipment will hit the track links.

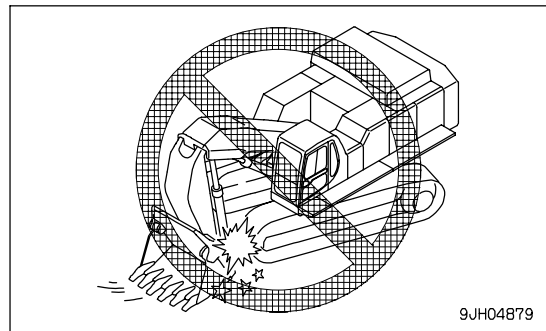

Scraping-down Operations are Prohibited.

Never use the front bucket of a bottom-dump bucket to scrap down rocks or soil.

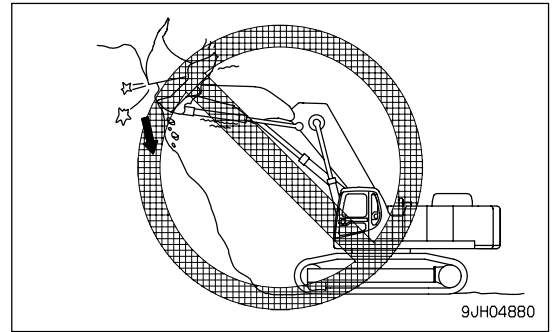
**Digging Rocky Ground**

Do not attempt to directly excavate hard rocky ground with the work equipment. It is better to excavate it after breaking up by some other means. This will not only save the machine from damage but will make for better economy.

Phenomena that do not Indicate Failure

Note that the following phenomena are not failures:

- When starting or stopping the swing, noise will be emitted from the brake valve.
- When going down a steep slope at low speed, a noise will be emitted from the travel motor.
- The arm may sometimes stop when the bucket teeth become more or less horizontal.

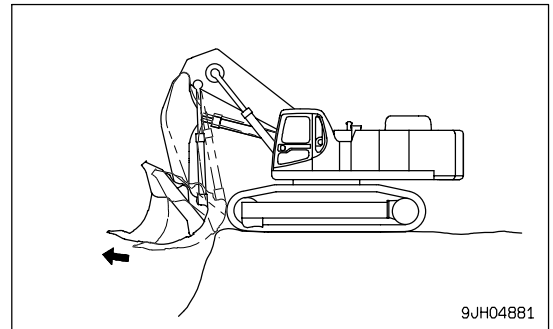

- The bottom dump of the bucket may sometimes stop at the bottom horizontal position when the bottom dump control lever changes from open to close.

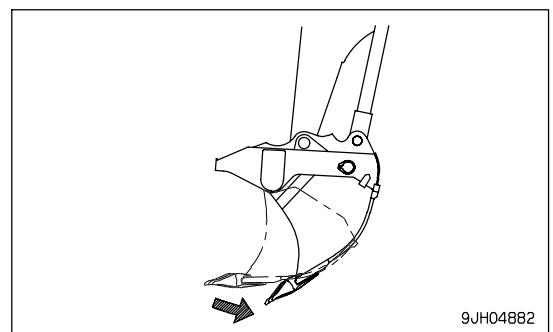

EXCAVATOR WORK

In addition to the following, it is possible to further increase the range of applications by using various attachments.

Shovel Work

This is suitable for digging a place which is higher than the machine's position. It is most efficient if the arm's digging angle is from vertical to 60° forward, and the arm cylinder is used effectively.

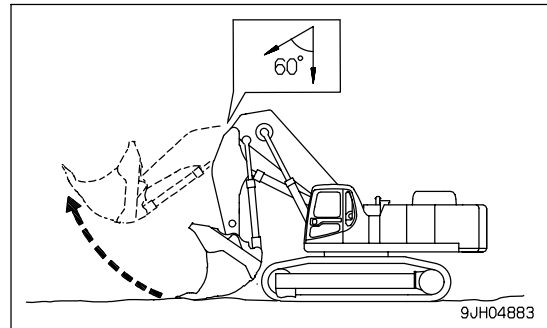

A simple method of seeing the angle of the bucket teeth to the ground surface is to use the teeth and the part of the rear bucket shown in the diagram on the right. Check that the part of the rear bucket is more or less parallel to the teeth.

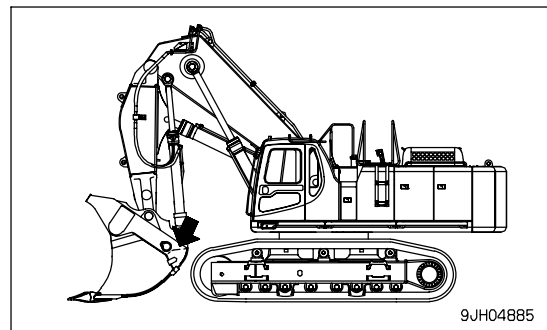

Loading Work

In places where the swing angle is small, work efficiency can be enhanced by locating the dump truck in a place easily visible to the operator.

Loading is easier if the excavator is placed beside the dump truck for loading. This way means more earth can be loaded more effectively than by a loader working behind the truck.

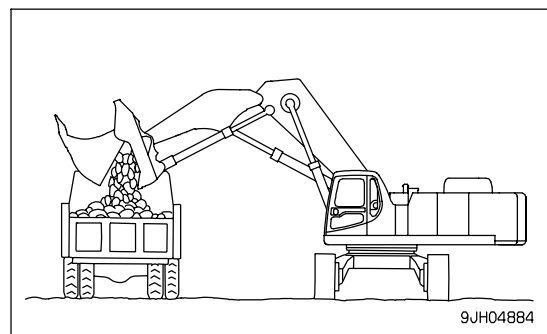

PRECAUTIONS WHEN DISASSEMBLING MACHINE

RELEASING PRESSURE

When disassembling the machine or removing the piping during inspection or maintenance, always release the pressure as follows.

Releasing Pressure from Work Equipment Circuit, Swing Circuit, Travel Circuit



WARNING

- The hydraulic system is always under internal pressure, so when inspecting or replacing the piping or hoses, always release the pressure in the circuit before starting. If the pressure is not released, high pressure oil may spurt out and cause serious personal injury.
- The parts and oil are at high temperature after the engine is stopped, and may cause serious burns. Wait for the temperature to go down before starting the operation.
- When the oil filler cap is removed, oil may spurt out, so turn the cap slowly to release the pressure before removing the cap.

1. Stop the machine on firm horizontal ground, lower the work equipment to the ground as shown in the diagram on the right, then stop the engine.

- Set the lock lever to FREE position.

2. Operate each work equipment control lever to the full stroke within 5 - 6 seconds after stopping the engine.

- Leave the starting switch at the ON position.

3. Remove the cap of the hydraulic tank.

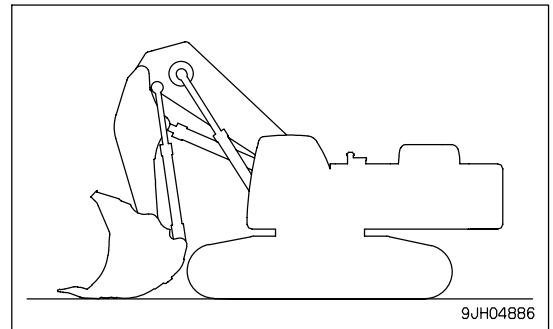

4. Start the engine, run for approx. 10 seconds, then stop the engine again.

- Do not run the engine at more than 1000 rpm.
- Set the work equipment control levers to the HOLD position.

5. Operate each work equipment control lever to the full stroke within 5 - 6 seconds after stopping the engine.

- Repeat Steps 4 - 5 three times.

Releasing Pressure in Accumulator Circuit

After stopping the engine, set lock lever to the FREE position, then operate each work equipment control lever 3 - 4 times to the end of the stroke. After 1 minute, the internal pressure will be relieved.

- Do not loosen any piping until at least 1 minute has passed after relieving the internal pressure.

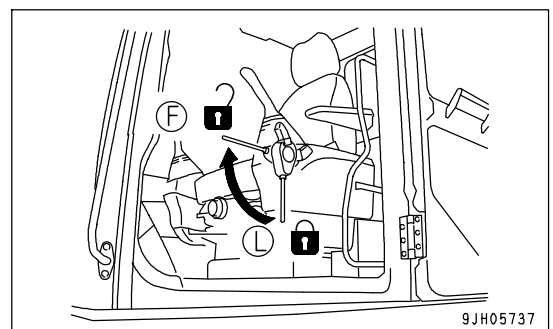

TRANSPORTATION

MACHINE CONFIGURATION FOR TRANSPORT

This machine can be divided into eight units for transportation. When transporting, contact your Komatsu distributor.

Eight Units for Transportation

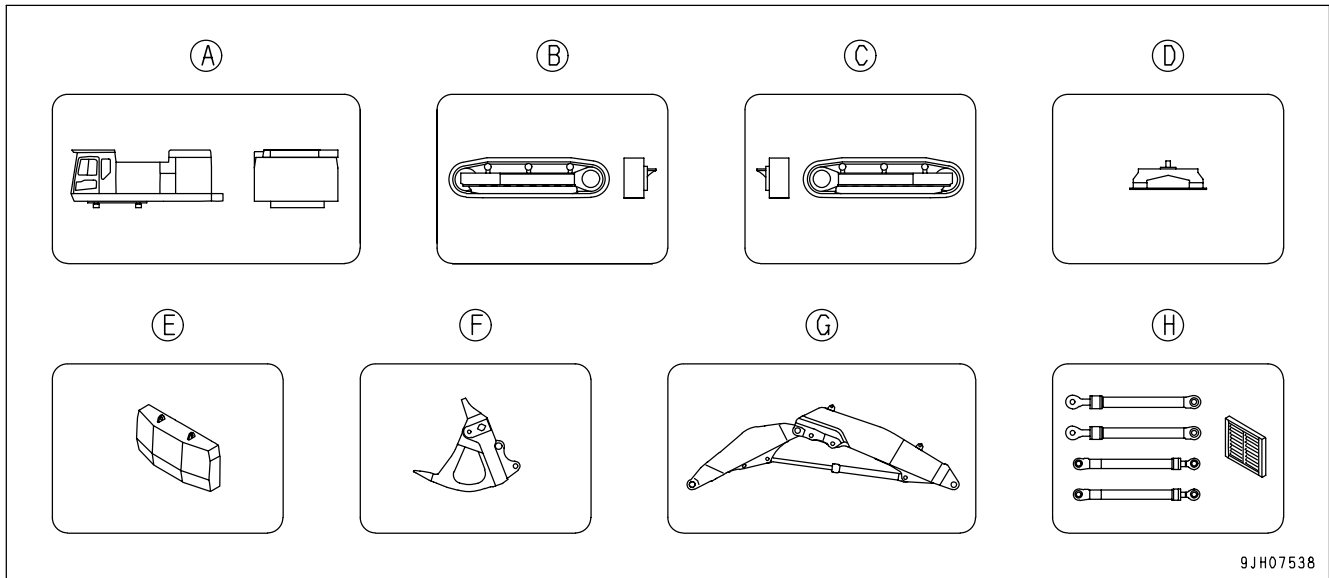

- (A) Upper Structure
- (B) Undercarriage (right)
- (C) Undercarriage (left)
- (D) Center frame

- (E) Counterweight
- (F) Bucket
- (G) Work equipment
- (H) boom cylinder and Bucket cylinder and Outer cover

Posture for Each unit

(dimensions in diagram are in mm.)

Upper Structure

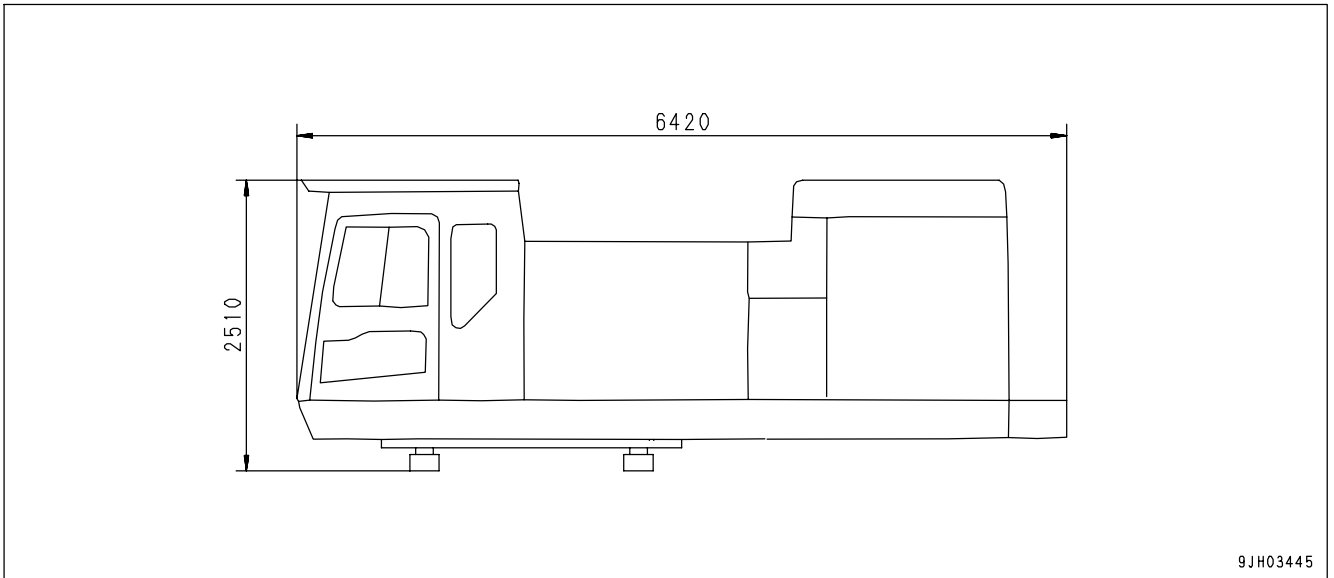

Unit		PC1250-8
Overall width	mm (ft in)	3,490 (11' 5")
Weight	kg (lb)	26,700 (58,874) (fuel: empty, Hydraulic oil: M level)

Secure the upper structure to the platform with a chain and block.

Undercarriage

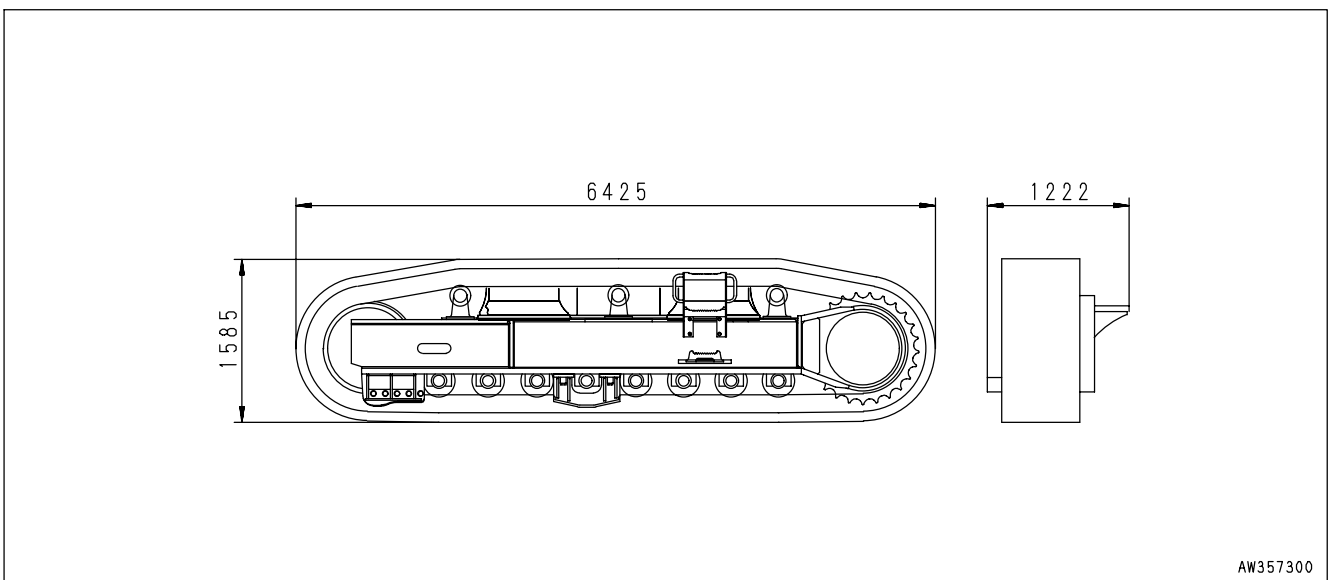

Unit		PC1250-8	
Amount		1 (left)	1 (Right)
Weight	kg (lb)	15,250 (33,626)	15,250 (33,626)

If there is a warning tag hanging on the work equipment control lever, do not start the engine.

Center Frame

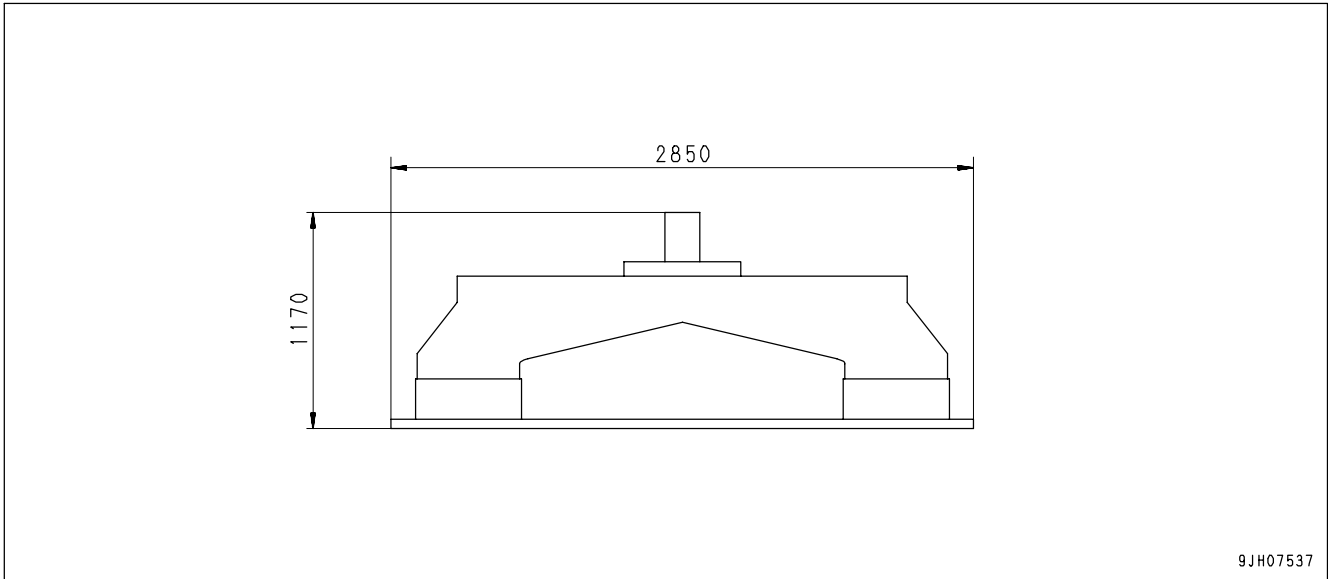

9JH07537

Unit		PC1250-8
Weight	kg (lb)	9,700 (21,389)

Counterweight

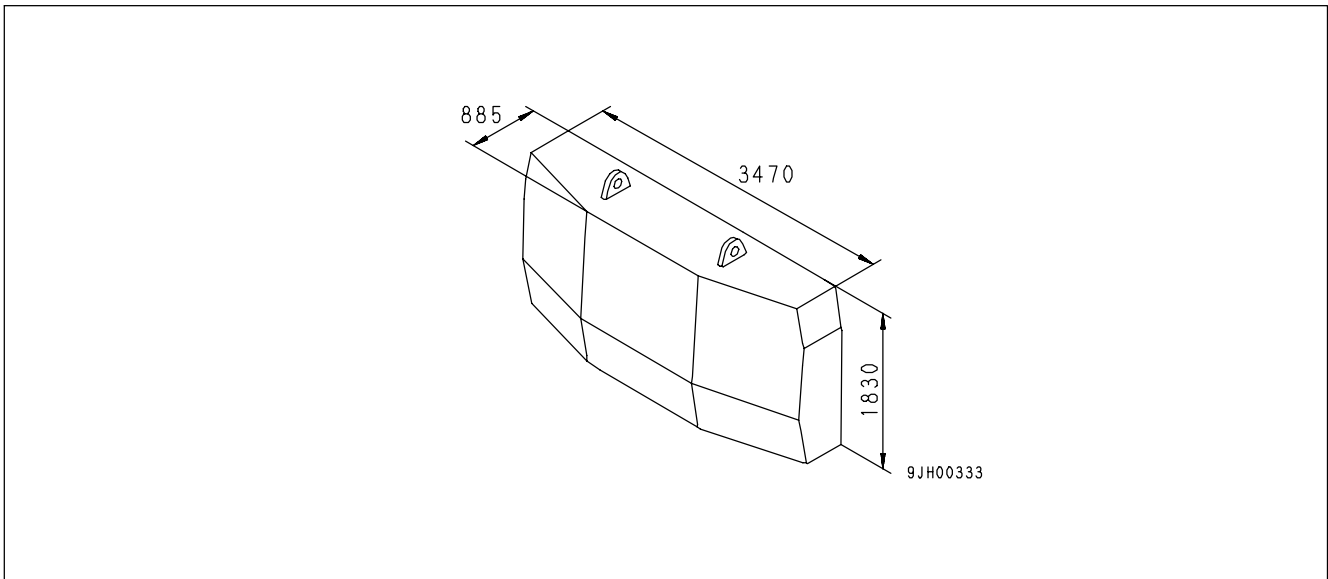

9JH00333

Unit		PC1250-8
Weight	kg (lb)	18,000 (39,690)

Bucket

Unit		PC1250-8
A	mm (ft in)	3,000 (9' 10")
B	mm (ft in)	2,700 (8' 10")
Overall width	mm (ft in)	2,700 (8' 10")
Weight	kg (lb)	9,300 (20,507)

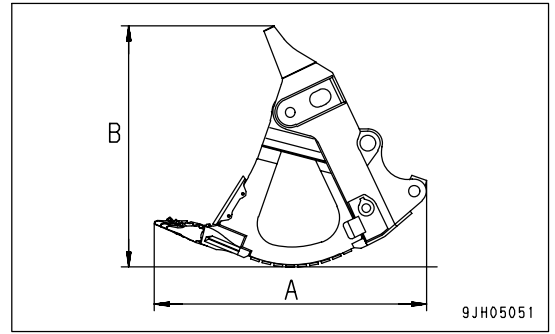

Work Equipment

Unit		PC1250-8
A	mm (ft in)	8,730 (28' 8")
B	mm (ft in)	2,750 (9')
Overall width	mm (ft in)	2,000 (6' 7")
Weight	kg (lb)	16,000 (35,280)

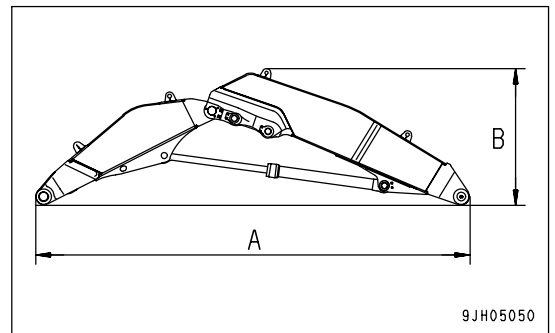

Boom Cylinder

Unit		PC1250-8
A	mm (ft in)	3,520 (11' 7")
Weight	kg (lb)	2,160 (4,763) [1,080 (2,381) × 2]

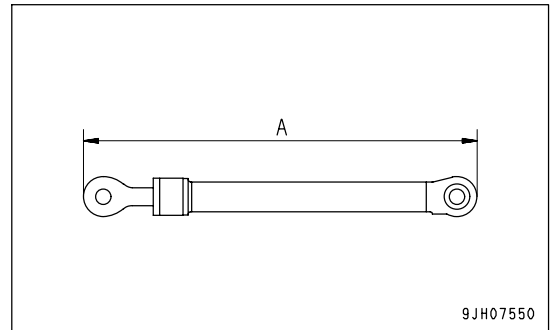

Bucket Cylinder

Unit		PC1250-8
A	mm (ft in)	3,300 (10' 10")
Weight	kg (lb)	1,700 (3,749) [850 (1,874) × 2]

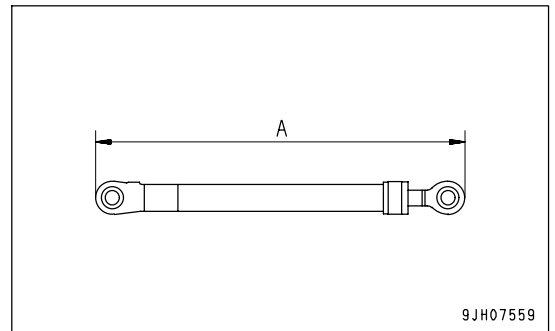

Outer Cover

- Radiator duct (same for all models)

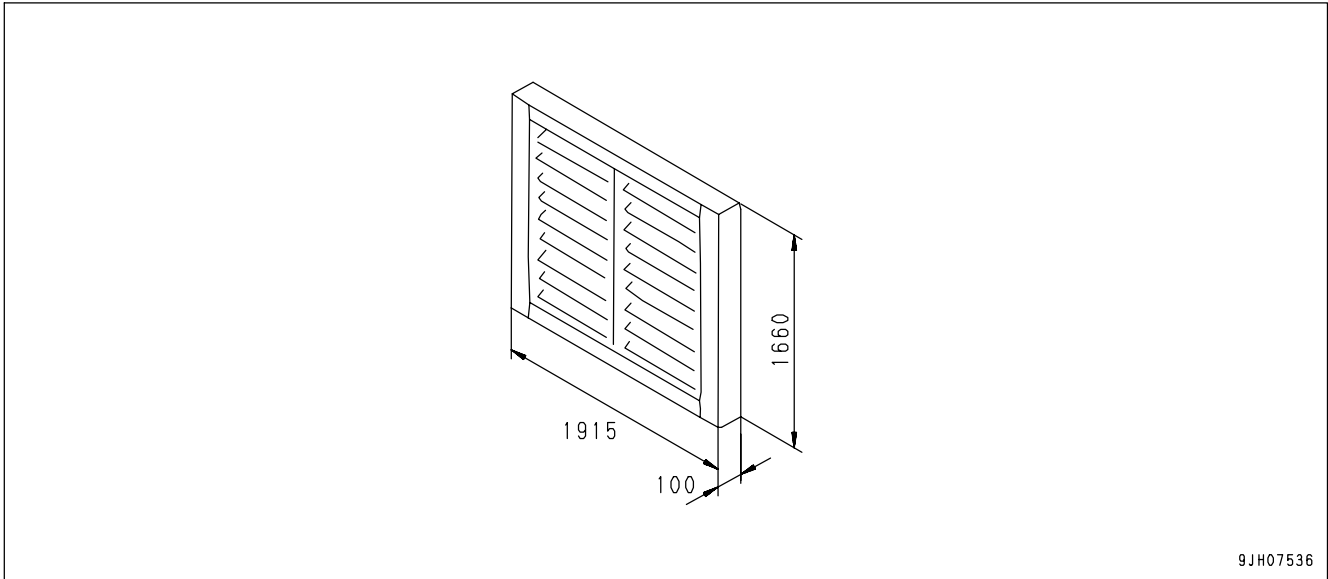

Unit		PC1250-8
Weight	kg (lb)	100 (221)

- Radiator duct upper cover (same for all models)

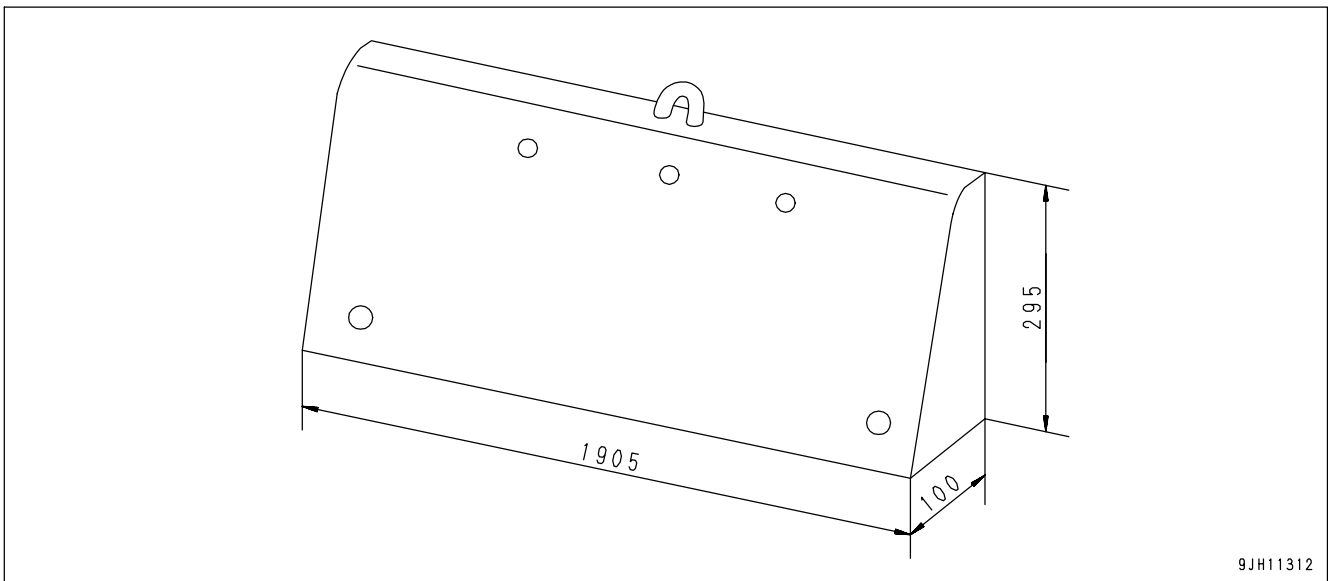

Unit		PC1250-8
Weight	kg (lb)	17 (37)

- Catwalk (right) : (same for all models)

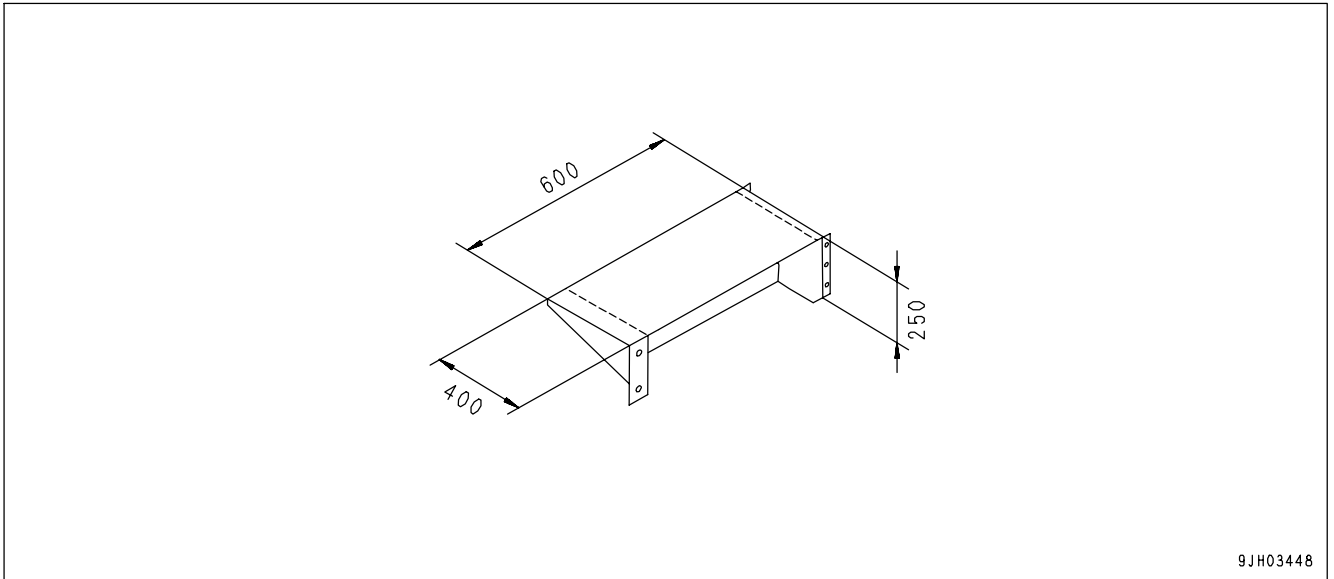

9JH03448

Unit		PC1250-8
Weight	kg (lb)	17 (37)

- Catwalk (left, front) : (same for all models)

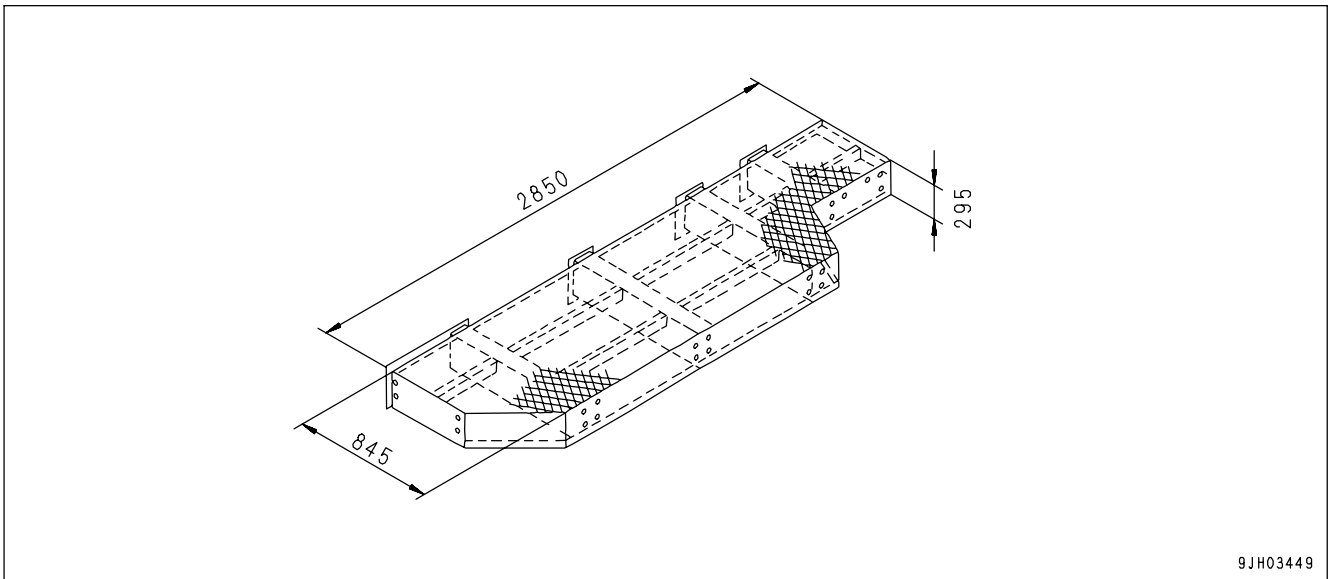

9JH03449

Unit		PC1250-8
Weight	kg (lb)	150

- Catwalk (left, rear) : (same for all models)

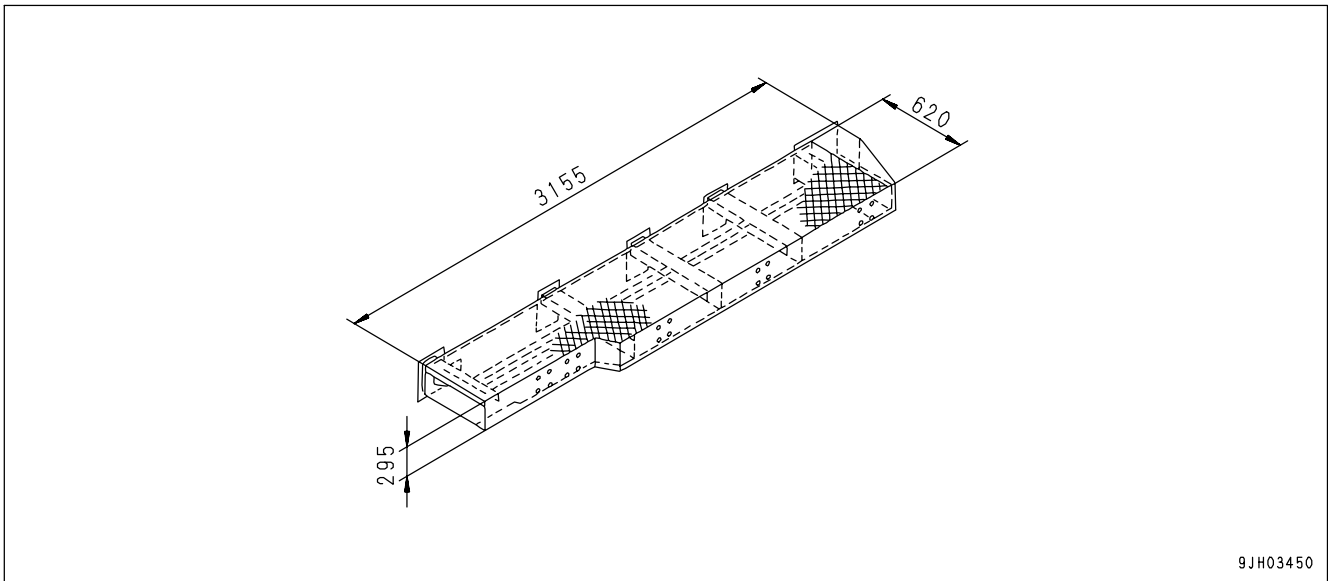

9JH03450

Unit	PC1250-8
Weight	kg (lb)
	150 (331)

WEAR PARTS

Replace wear parts such as the filter element or air cleaner element at the time of periodic maintenance or before they reach the wear limit. The wear parts should be replaced correctly in order to ensure more economic use of the machine. When replacing parts, always use Komatsu genuine parts.

As a result of our continuous efforts to improve product quality, the part number may change, so inform your Komatsu distributor of the machine serial number and check for the latest part number when ordering parts.

WEAR PARTS LIST

The parts in parentheses are to be replaced at the same time.

Item	Part No.	Part Name	Q'ty	Change interval
Fuel pre-filter	600-319-3440	Cartridge	2	Every 500 hours
Fuel main filter	600-319-3520	Cartridge	1	Every 500 hours
Pilot filter	424-16-11140	Element	1	Every 500 hours
Drain filter	21N-60-12210	Cartridge	1	Every 500 hours
Engine oil filter	600-211-1340	Cartridge	3	Every 500 hours
Hydraulic oil filter	209-60-77531 (07000-15180)	Element	2 (2)	Every 1000 hours
Hydraulic tank breather	421-60-35170 20Y-60-21470	Element (O-ring)	1 1	Every 1000 hours
Corrosion resistor (if equipped)	600-411-1171	Cartridge	1	Every 1000 hours
Air cleaner	600-185-6100	Element assembly	1	-
Line filter	21N-62-31221 (07000-12055)	Element (O-ring)	3 (3)	-
	(07000-12070)	(O-ring)	(3)	
	(07001-02070)	(Backup ring)	(3)	
Bucket	21N-70-37721 (21N-70-37731)	Tooth (XS type) (Pin)	6 (6)	-
	427-70-13611	Side shroud	2	
	21N-939-3330	Pin	4	
	(209-939-7110)	(Shim)	(8)	
	(209-939-7120)	(Shim)	(4)	

MAINTENANCE

CHECK BEFORE STARTING

Check Oil Level in Hydraulic Tank, Add Oil



WARNING

- The parts and oil are at high temperature immediately after the engine is stopped, and may cause burns. Wait for the temperature to go down before starting the work.
- When removing the oil filler cap, turn it slowly to release the internal pressure, then remove it.

1. Set the work equipment in the posture shown in the diagram on the right, then check the oil level and add oil if necessary.
2. If the work equipment is not in the condition shown in the diagram on the right, start the engine, run the engine at low speed, retract the arm and bucket cylinder rods fully, then lower the boom, set the bucket teeth in contact with the ground, and stop the engine.
3. Within 15 seconds after stopping the engine, move each control lever (for work equipment and travel) to the full stroke in all directions to release the internal pressure.
4. Check oil level gauge (G) at the rear of the hydraulic tank. The oil level should be within the specified range for that oil temperature. If the oil level is low, add oil.

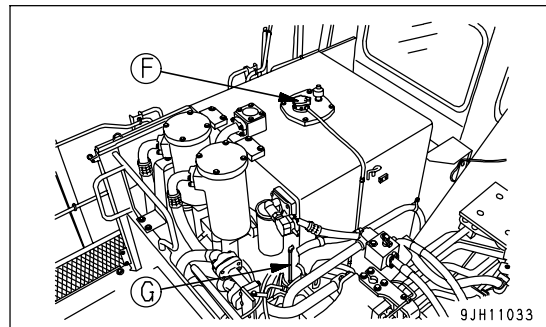
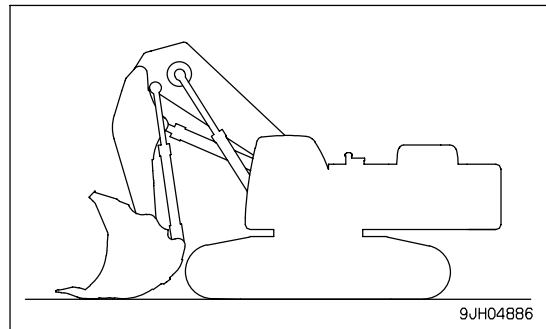

The proper way to check the hydraulic oil level is as follows.

- When the hydraulic oil is at normal temperature (15°C to 30°C), the oil level should be within the blue range of gauge label (a) in the diagram on the right.
- When the hydraulic oil is at high temperature (50°C to 80°C), the oil level should be within the red range of gauge label (b) in the diagram on the right.

5. If the level is below the correct line, add oil through filler port (F) at the top of the hydraulic tank.

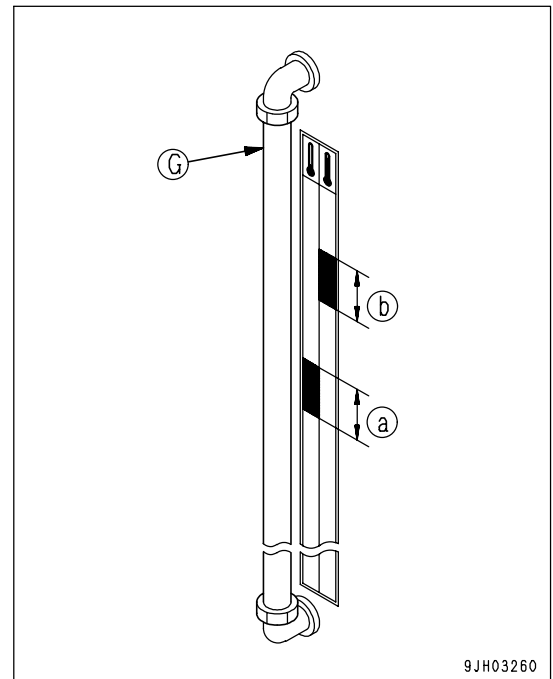

NOTICE

Do not add oil above the correct level. This will damage the hydraulic circuit and cause oil to spurt out.

If oil is added above the correct level, remove plug (1) under the chassis, then loosen drain valve (P) and drain the excess oil.

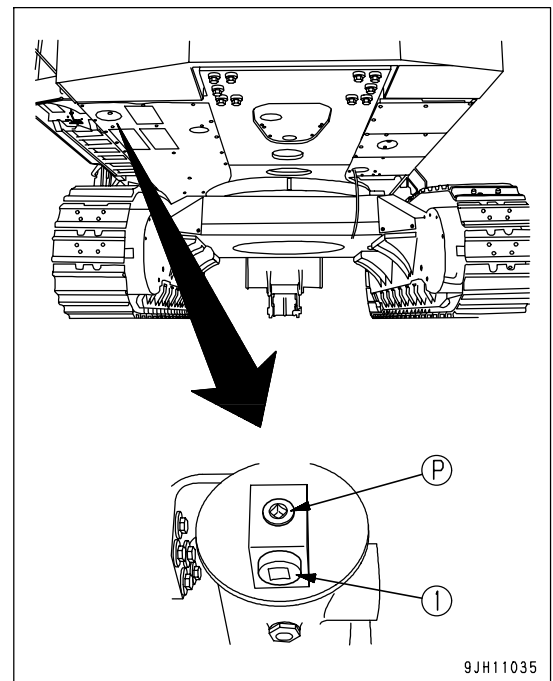

EVERY 10 HOURS MAINTENANCE

LUBRICATING

1. Set to the greasing posture below, lower the work equipment to the ground, then stop the engine.
2. Using a grease pump, pump in grease through the grease fittings shown by arrows.
3. After greasing, wipe off any old grease that was pushed out.

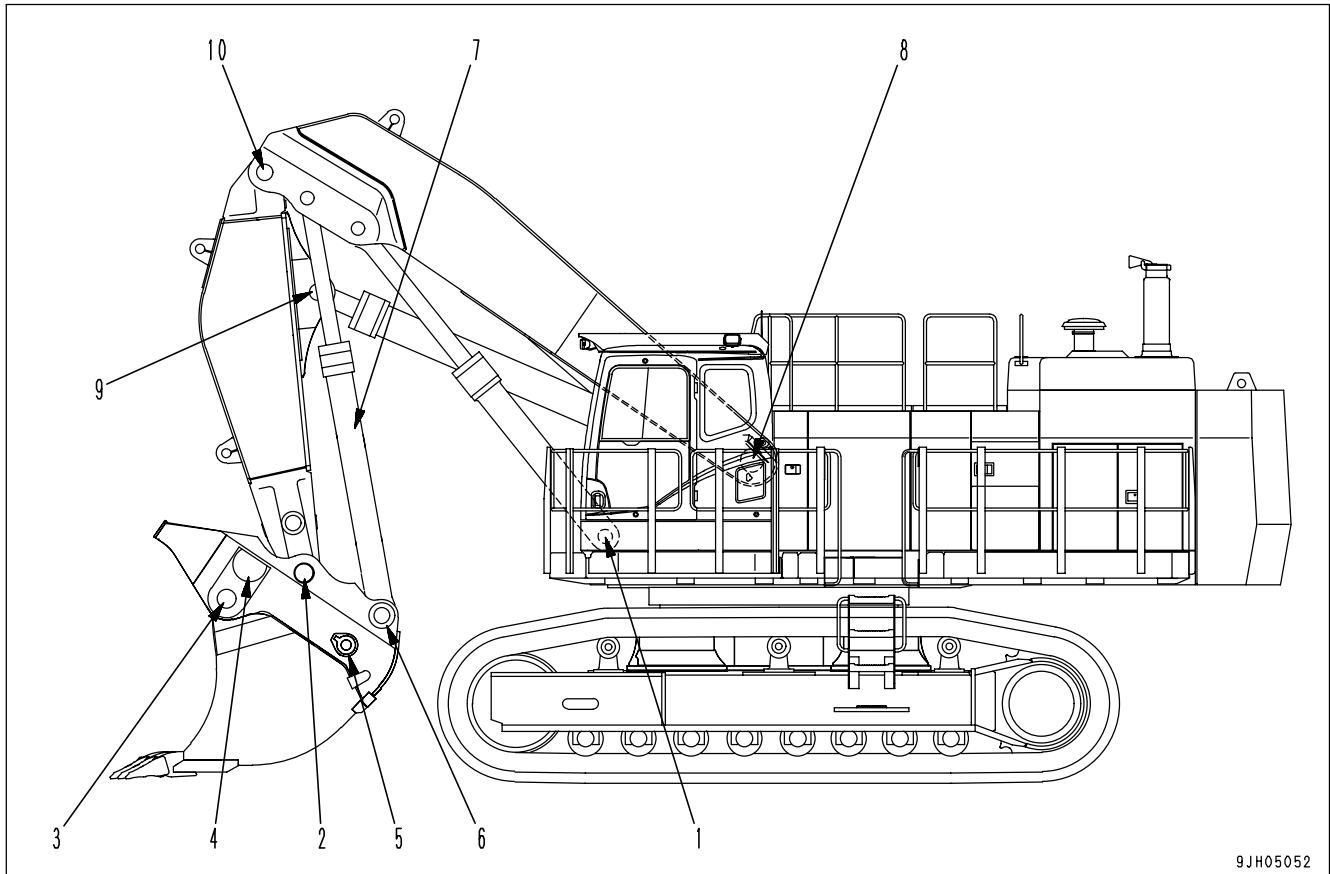

9JH05052

- (1) Boom cylinder foot pin (2 places)
- (2) Arm - Bucket coupling pin (2 place)
- (3) Bucket hinge pin (2 places)
- (4) Bottom dump cylinder rod end pin (2 places)
- (5) Bottom dump cylinder foot pin (2 places)
- (6) Bucket cylinder foot pin
- (7) Bucket cylinder rod end - Link coupling pin (4 places)
- (8) Boom centralized lubricating block (10 places)
 - Boom foot pin
 - Arm cylinder foot pin
 - Boom cylinder rod end pin
 - Bucket cylinder rod end pin
 - Boom - Arm coupling pin (Boom side)
- (9) Arm cylinder rod end pin (1 place)
- (10) Boom - Arm coupling pin (Arm side) (2 places)

EVERY 5000 HOURS MAINTENANCE

Maintenance for every 10 hours service should be carried out at the same time.

CHANGE OIL IN HYDRAULIC TANK, CLEAN STRAINER**WARNING**

- The parts and oil are at high temperature immediately after the engine is stopped, and may cause burns. Wait for the temperature to go down before starting the work.
- When removing the oil filler cap, turn it slowly to release the internal pressure, then remove it.

- Refill capacity: 670 liters (177.01 US gal)
 - Prepare a handle for socket wrench set
1. Swing the upper structure so that the drain plug under the hydraulic tank will be between both tracks.
 2. Retract the arm and bucket cylinders, then lower the boom and put the teeth in contact with the ground.
 3. Set the lock lever to the LOCK position and stop the engine.

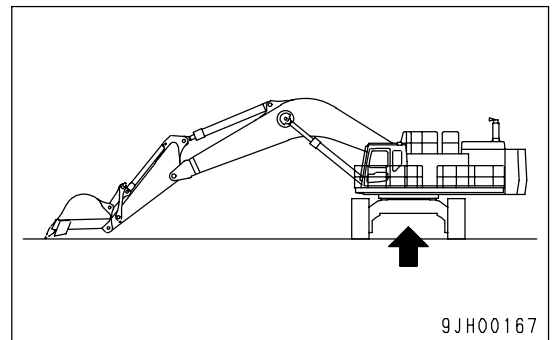

4. Remove the cap of oil filler (F) at the top of the hydraulic tank.

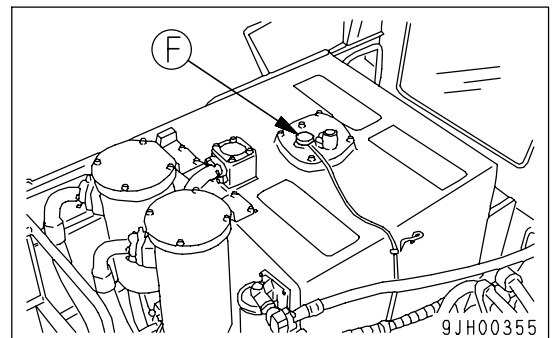

5. Set the container to catch the oil under the drain plug at the bottom of the chassis. Remove plug (1), then loosen drain valve (P) and drain the oil. After draining the oil, tighten drain valve (P) and plug (1).

Tightening torque: $68.6 \pm 9.8 \text{ Nm}$ ($7 \pm 1 \text{ kgm}$, $50 \pm 7 \text{ lbft}$)

When removing drain valve (P), take care not to pour oil over yourself.

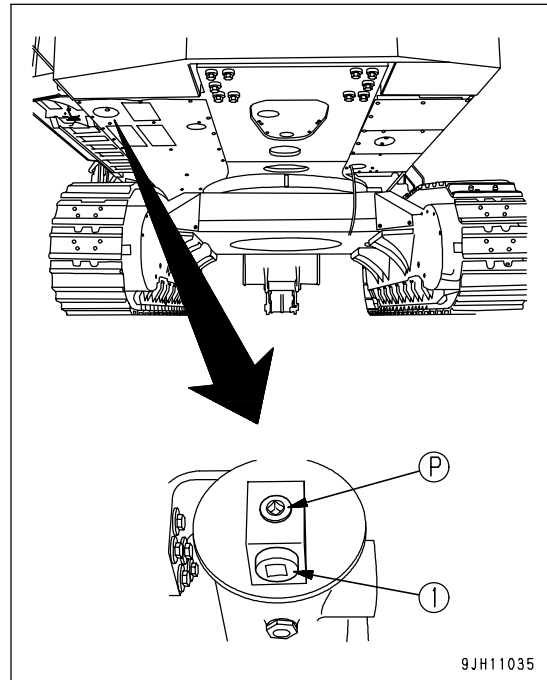

9JH11035

6. Remove 4 bolts, then remove cover (4). When doing this, cover (4) may fly off because of the force of spring (5), so keep the cover pushed down when removing the bolts.

7. Hold the top of rod (6) and pull up to remove spring (5) and strainer (7).

8. Remove any dirt stuck to strainer (7), then wash in clean diesel oil or flushing oil. If strainer (7) is broken, replace it with a new part.

9. When installing, insert strainer (7) into protruding part (8) of the tank, and assemble.

10. Fill with the specified amount of oil through oil filler port (F). Check that the oil level is within the correct range on the sight gauge.

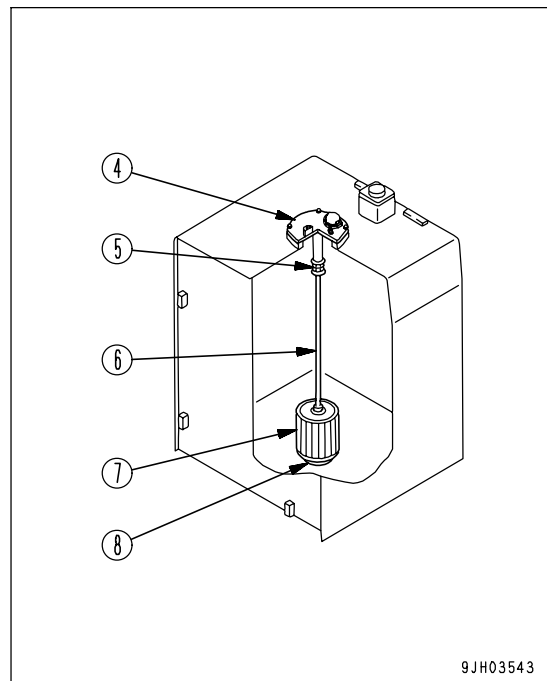

9JH03543

11. Bleed the air from the circuit after cleaning or replacing the filter element or strainer, or after changing the oil.

SPECIFICATION

Item	Unit	PC1250-8
Operating weight	kg (lb)	110,900 (244,535)
Bucket capacity	m ³ (cu.yd)	6.5 (8.5)
Name of engine	-	KOMATSU SAA6D170E-5 diesel engine
Engine horsepower	kW(HP)/rpm	502(672)/1,800
A Overall length	mm (ft in)	10,940 (35' 11")
B Overall height	mm (ft in)	6,200 (20' 4")
C Overall width	mm (ft in)	5,600 (18' 4")
D Track width	mm (ft in)	700 (2' 4")
E Height of cab	mm (ft in)	4,120 (13' 6")
F Radius of upper structure	mm (ft in)	4,870 (15' 12")
G Length of track	mm (ft in)	6,425 (21' 1")
H Tumbler center distance	mm (ft in)	4,995 (16' 5")
I Min. ground clearance	mm (ft in)	990 (3' 3")
Travel speed (Lo/Hi)	km/h (MPH)	2.1/3.2 (1.3/2.0)
Swing speed	rpm	5.5

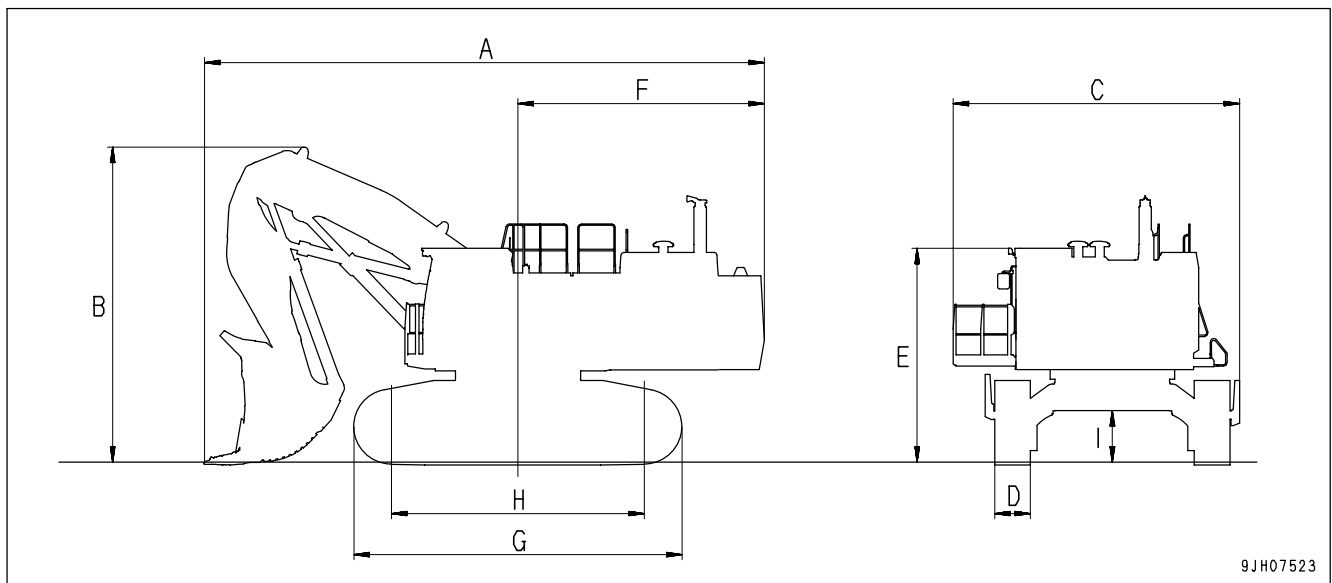

9JH07523

COMBINATION OF WORK EQUIPMENT



WARNING

Depending on the type or combination of work equipment, there is danger that the work equipment may hit the cab or machine body.

When using unfamiliar work equipment for the first time, check before starting if there is any danger of interference, and operate with caution.

COMBINATION OF WORK EQUIPMENT

Select the combination of boom, arm, and bucket from the combinations shown in the table below.

- For the dimensions of A to F, see the specifications shown in the working range diagram

Work equipment	Boom		5.3 m (17'5")
	Arm		3.8 m (12'6")
	Bucket capacity		6.5 m ³ (8.5 cu.yd)
	Bucket width		2680 mm (8'10")
	Loosen specific gravity of soil to be handled	2.1	×
		1.8	○
1.5		○	

Working Range Diagram

Working ranges		PC1250-8 Loading shovel
		Without bucket link
A	Max. digging reach	11,400 (37' 5")
B	Max. digging depth	10,900 (35' 9")
C	Max. digging height	12,330 (40' 5")
D	Max. vertical wall depth	3,650 (11' 12")
E	Max. dumping height	6,130 (20' 1")
F	Max. reach at ground level	6,760 (22' 2")

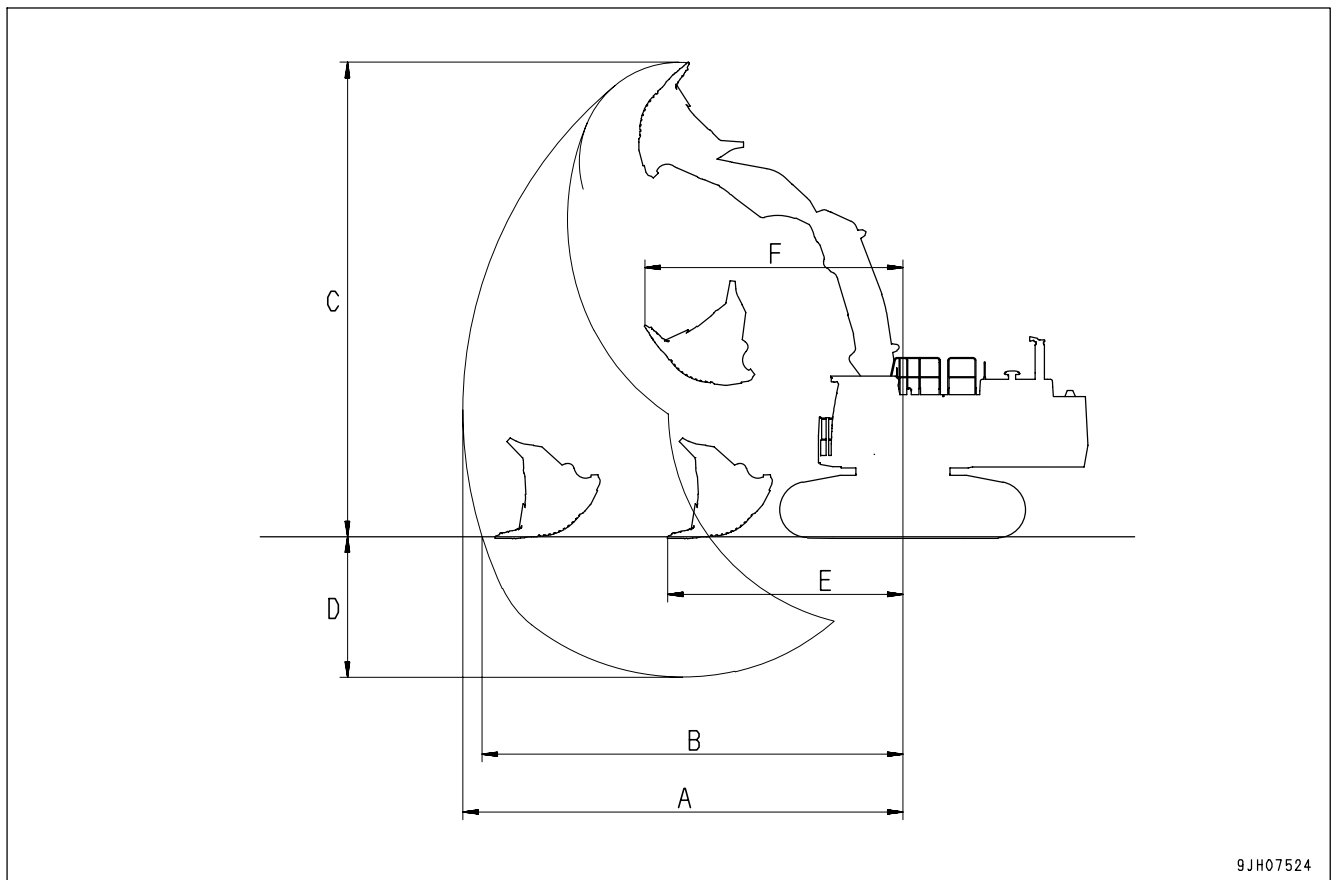

INDEX

<A>			
AFTER STARTING ENGINE	-----	3-101	
AIR CONDITIONER CONTROLS	-----	3- 47	
ASHTRAY	-----	3- 46	
ATTACHMENT GUIDE	-----	6- 3	
COMBINATIONS OF WORK			
EQUIPMENT	-----	6- 3	
AUTO-GREASING SYSTEM	-----	6- 8	
AUXILIARY ELECTRIC POWER	-----	3- 66	
			
BEFORE STARTING ENGINE	-----	3- 75	
BREAKING-IN THE NEW MACHINE	-----	1- 9	
BUCKET REPLACEMENT	-----	3-133	
<C>			
CAP WITH LOCK	-----	3- 44	
CIRCUIT BREAKER	-----	3- 68	
COLD WEATHER OPERATION	-----	3-149	
AFTER COLD WEATHER SEASON	-----	3-152	
AFTER DAILY WORK COMPLETION	-----	3-152	
COLD WEATHER OPERATION			
INFORMATION	-----	3-149	
COMBINATION OF WORK EQUIPMENT	--	7- 28	
COMBINATION OF WORK			
EQUIPMENT	-----	7- 28	
CONTROL LEVERS AND PEDALS	-----	3- 40	
CONTROLLER	-----	3- 70	
CONTROLS AND GAUGES	-----	3- 3	
<D>			
DETAILED CONTROLS AND GAUGES	----	3- 5	
DIRECTIONS OF MACHINE	-----	1- 7	
DOOR LOCK	-----	3- 43	
<E>			
ELECTRIC SYSTEM MAINTENANCE	-----	4- 7	
EMERGENCY EXIT FROM			
OPERATOR'S CAB	-----	3- 43	
EPA REGULATIONS, ENGINE NUMBER			
PLATE	-----	1- 10	
ESCAPE FROM MUD	-----	3-131	
EXCAVATOR WORK	-----	7- 12	
EXPLANATION OF COMPONENTS	-----	7- 2	
<F>			
FIRE EXTINGUISHER	-----	3- 46	
FOREWORD	-----	1- 2	
FUSE	-----	3- 67	
FUSE	-----	7- 5	
<G>			
GENERAL OPERATION INFORMATION	---	3-127	
GENERAL PRECAUTIONS	-----	2- 12	
GENERAL PRECAUTIONS FOR			
SAFETY	-----	6- 2	
PRECAUTIONS WHEN REMOVING			
OR INSTALLING	-----	6- 2	
PRECAUTIONS WHEN SELECTING	----	6- 2	
PRECAUTIONS WHEN USING	-----	6- 2	
READ THE INSTRUCTION MANUAL			
THOROUGHLY	-----	6- 2	
GREASE PUMP	-----	3- 71	
<H>			
HANDLING MACHINES EQUIPPED			
WITH VHMS	-----	6- 24	
VHMS AND COMMUNICATIONS			
TERMINAL INSTALLED	-----	6- 25	
VHMS INSTALLED,			
COMMUNICATIONS TERMINAL NOT			
INSTALLED	-----	6- 24	
HANDLING OIL, FUEL, COOLANT, AND			
PERFORMING OIL CLINIC	-----	4- 4	
HOT AND COOL BOX	-----	3- 46	
<I>			
INTRODUCTION	-----	1- 7	
<L>			
LIFTING MACHINE	-----	3-138	
LOCKING	-----	3-137	
LONG TERM STORAGE	-----	3-153	
AFTER STORAGE	-----	3-153	
BEFORE STORAGE	-----	3-153	
DURING STORAGE	-----	3-153	
STARTING MACHINE AFTER			
LONG-TERM STORAGE	-----	3-154	
<M>			
MACHINE INSPECTION AFTER DAILY			
WORK	-----	3-136	
MACHINE OPERATION	-----	3-112	

MACHINE OPERATIONS AND CONTROLS -----	3- 75	<R>	
MACHINE VIEW ILLUSTRATIONS -----	3- 2	RADIO -----	3- 61
OVERALL MACHINE VIEW -----	3- 2	RECOMMENDED APPLICATIONS -----	3-132
MAGAZINE BOX -----	3- 46	RECOMMENDED FUEL, COOLANT, AND LUBRICANT -----	4- 9
MAINTENANCE -----	7- 22	RECOMMENDED BRANDS, RECOMMENDED QUALITY FOR PRODUCTS OTHER THAN KOMATSU GENUINE OIL -----	4- 11
CHECK BEFORE STARTING -----	7- 22		
EVERY 10 HOURS MAINTENANCE -----	7- 24	<S>	
EVERY 5000 HOURS MAINTENANCE -----	7- 25	SAFETY -----	2- 2
MAINTENANCE INFORMATION -----	4- 2	SAFETY CRITICAL PARTS -----	4- 13
MAINTENANCE PROCEDURE -----	4- 16	SAFETY CRITICAL PARTS LIST -----	4- 13
CHECK BEFORE STARTING -----	4- 43	SAFETY INFORMATION -----	1- 5
EVERY 10 HOURS MAINTENANCE -----	4- 44	SAFETY LABELS -----	2- 4
EVERY 100 HOURS MAINTENANCE -----	4- 46	SAFETY MACHINE OPERATION -----	2- 21
EVERY 1000 HOURS MAINTENANCE -----	4- 63	BATTERY -----	2- 30
EVERY 2000 HOURS MAINTENANCE -----	4- 74	LIFTING OBJECTS WITH BUCKET -----	2- 33
EVERY 250 HOURS MAINTENANCE -----	4- 47	OPERATION -----	2- 23
EVERY 4000 HOURS MAINTENANCE -----	4- 80	TOWING -----	2- 32
EVERY 500 HOURS MAINTENANCE -----	4- 51	TRANSPORTATION -----	2- 29
EVERY 5000 HOURS MAINTENANCE -----	4- 83	SAFETY MAINTENANCE	
EVERY 8000 HOURS MAINTENANCE -----	4- 85	INFORMATION -----	2- 34
INITIAL 100 HOURS MAINTENANCE (ONLY AFTER THE FIRST 100 HOURS) -----	4- 16	SELECTION OF TRACK SHOES -----	6- 7
INITIAL 500 HOURS MAINTENANCE (ONLY AFTER THE FIRST 500 HOURS) -----	4- 16	SERVICE METER LOCATION -----	1- 11
WHEN REQUIRED -----	4- 17	SHIPPING MACHINE INFORMATION -----	3-140
MAINTENANCE SCHEDULE -----	4- 14	SPECIFICATION -----	7- 27
MAINTENANCE SCHEDULE CHART -----	4- 14	SPECIFICATIONS -----	5- 2
MONITORING SYSTEM -----	3- 5	STARTING ENGINE -----	3- 98
		STEERING THE MACHINE -----	3-116
<O>		STOPPING THE ENGINE -----	3-111
OPERATION OF WORK EQUIPMENT -----	7- 6	SWINGING -----	3-118
OPERATIONS -----	7- 6	SWITCHES -----	3- 34
OUTLINE OF SERVICE -----	4- 4	SWITCHES -----	7- 2
<P>		<T>	
PARKING MACHINE -----	3-135	TIGHTENING TORQUE LIST -----	4- 12
PRECAUTIONS DURING OPERATION -----	7- 8	TIGHTENING TORQUE	
PRECAUTIONS FOR		SPECIFICATIONS -----	4- 12
TRANSPORTATION -----	3-138	TOOL BOX -----	3- 70
PRECAUTIONS WHEN		TRANSPORTATION -----	3-138
DISASSEMBLING MACHINE -----	7- 13	TRANSPORTATION -----	7- 14
RELEASING PRESSURE -----	7- 13	MACHINE CONFIGURATION FOR TRANSPORT -----	7- 14
PRODUCT IDENTIFICATION NUMBER (PIN)/MACHINE SERIAL NO. PLATE -----	1- 10	TRANSPORTATION POSTURE -----	3-141
PRODUCT INFORMATION -----	1- 10	TRANSPORTATION PROCEDURE -----	3-138
PROHIBITED OPERATIONS -----	3-122	TRAVELING ON SLOPES -----	3-129
		TROUBLES AND ACTIONS -----	3-155
		DISCHARGED BATTERY -----	3-157

INDEX

OTHER TROUBLE	3-161
PHENOMENA THAT ARE NOT FAILURES	3-155
RUNNING OUT OF FUEL	3-155
SEVERE JOB CONDITION	3-156
TOWING THE MACHINE	3-156
 <V>	
VISIBILITY FROM OPERATOR'S SEAT ---	1- 8
 <W>	
WEAR PARTS	4- 8
WEAR PARTS	7- 21
WEAR PARTS LIST	4- 8
WEAR PARTS LIST	7- 21
WORK EQUIPMENT CONTROLS AND OPERATIONS	3-119
WORKING MODE	3-121
 <Y>	
YOUR MACHINE SERIAL NUMBERS AND DISTRIBUTOR	1- 11

PC1250-8, PC1250SP-8, PC1250LC-8 GALEO HYDRAULIC EXCAVATOR

Form No. TEN00146-02

©2007 KOMATSU
All Rights Reserved
Printed in Japan 10-07
