

Operation & Maintenance Manual

ARTICULATED
DUMP TRUCK

HM300-2

SERIAL NUMBERS 2785 and up

ecot3

WARNING

Unsafe use of this machine may cause serious injury or death. Operators and maintenance personnel must read this manual before operating or maintaining this machine. This manual should be kept near the machine for reference and periodically reviewed by all personnel who will come into contact with it.

NOTICE

Komatsu has Operation & Maintenance Manuals written in some other languages. If a foreign language manual is necessary, contact your local distributor for availability.

KOMATSU

FOREWORD

CALIFORNIA

Proposition 65 Warning

Diesel engine exhaust and some of its constituents are known to the State of California to cause cancer, birth defects, and other reproductive harm.

CALIFORNIA

Proposition 65 Warning

Battery posts, terminals and related accessories contain lead and lead compounds, chemicals known to the State of California to cause cancer and birth defects or other reproductive harm.

Wash hands after handling.

BEFORE READING THIS MANUAL

This manual gives details of the operation and methods of inspection and maintenance for this machine that must be obeyed in order to use the machine safely. Most accidents are caused by the failure to follow fundamental safety rules for the operation and maintenance of machines.

Read, understand and follow all precautions and warnings in this manual and on the machine before performing operation and maintenance. Failure to do so may result in serious injury or death.

Komatsu cannot predict every circumstance that might involve a potential hazard when the machine is used. Therefore, the safety messages in this manual and on the machine may not include all possible safety precautions. If you carry out any operation, inspection, or maintenance under conditions that are not described in this manual, understand that it is your responsibility to take the necessary precautions to ensure safety. In no event should you or others engage in the prohibited uses or actions described in this manual. Improper operation and maintenance of the machine can be hazardous and could result in serious injury or death.

If you sell the machine, be sure to give this manual to the new owner together with the machine.

Always keep this Operation and Maintenance Manual in the location shown on the right so that all relevant personnel can read it at any time.

Storage location for the Operation and Maintenance Manual:
On inside of left door

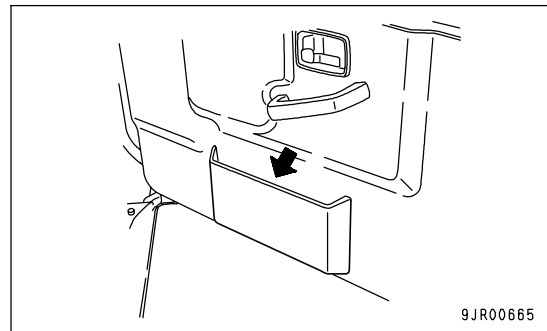

If this manual is lost or damaged, contact your distributor immediately to arrange for its replacement. For details regarding the machine serial No. you will need to provide your Komatsu distributor, see "TABLE TO ENTER SERIAL NO. AND DISTRIBUTOR (PAGE 1-6)".

This manual uses the international units (SI) for units of measurement. For reference, units that have been used in the past are given in ().

The explanations, values, and illustrations in this manual have been prepared based on the latest information available as of the date of its publication. Continuing improvements in the design of this machine may lead to additional changes that are not reflected in this manual. Consult Komatsu or your Komatsu distributor for the latest available information concerning your machine or with questions regarding information contained in this manual.

- The numbers in circles in the illustrations correspond to the numbers in () in the text.

(For example: ① → (1))



Komatsu delivers machines that comply with all applicable regulations and standards of the country to which it has been shipped. If this machine has been purchased in another country, it may lack certain safety devices and specifications that are necessary for use in your country. If there is any question about whether your product complies with the applicable standards and regulations of your country, consult Komatsu or your Komatsu distributor before operating the machine.

SAFETY INFORMATION

To enable you to use the machine safely, and to prevent injury to operators, service personnel or bystanders, the precautions and warnings included in this manual and the safety signs attached to the machine must always be followed.

To identify important safety messages in the manual and on the machine labels, the following signal words are used.

The "Safety Alert Symbol" identifies important safety messages on machines, in manuals, and elsewhere. When you see this symbol, be alert to the risk of personal injury or death. Follow the instructions in the safety message.

- | | |
|--|--|
|  DANGER | This signal word indicates an imminently hazardous situation which, if not avoided, will result in death or serious injury. |
|  WARNING | This signal word indicates a potentially hazardous situation which, if not avoided, could result in death or serious injury. |
|  CAUTION | This signal word indicates a potentially hazardous situation exists which, if not avoided, may result in minor or moderate injury. |

The following signal words are used to alert you to information that must be followed to avoid damage to the machine.

- | | |
|----------------|--|
| NOTICE | This precaution is given where the machine may be damaged or the service life reduced if the precaution is not followed. |
| REMARKS | This word is used for information that is useful to know. |

INTENDED USE

USE OF MACHINE

This Komatsu machine is designed to be used mainly for the following work:

- Traveling with a load

DIRECTIONS OF MACHINE

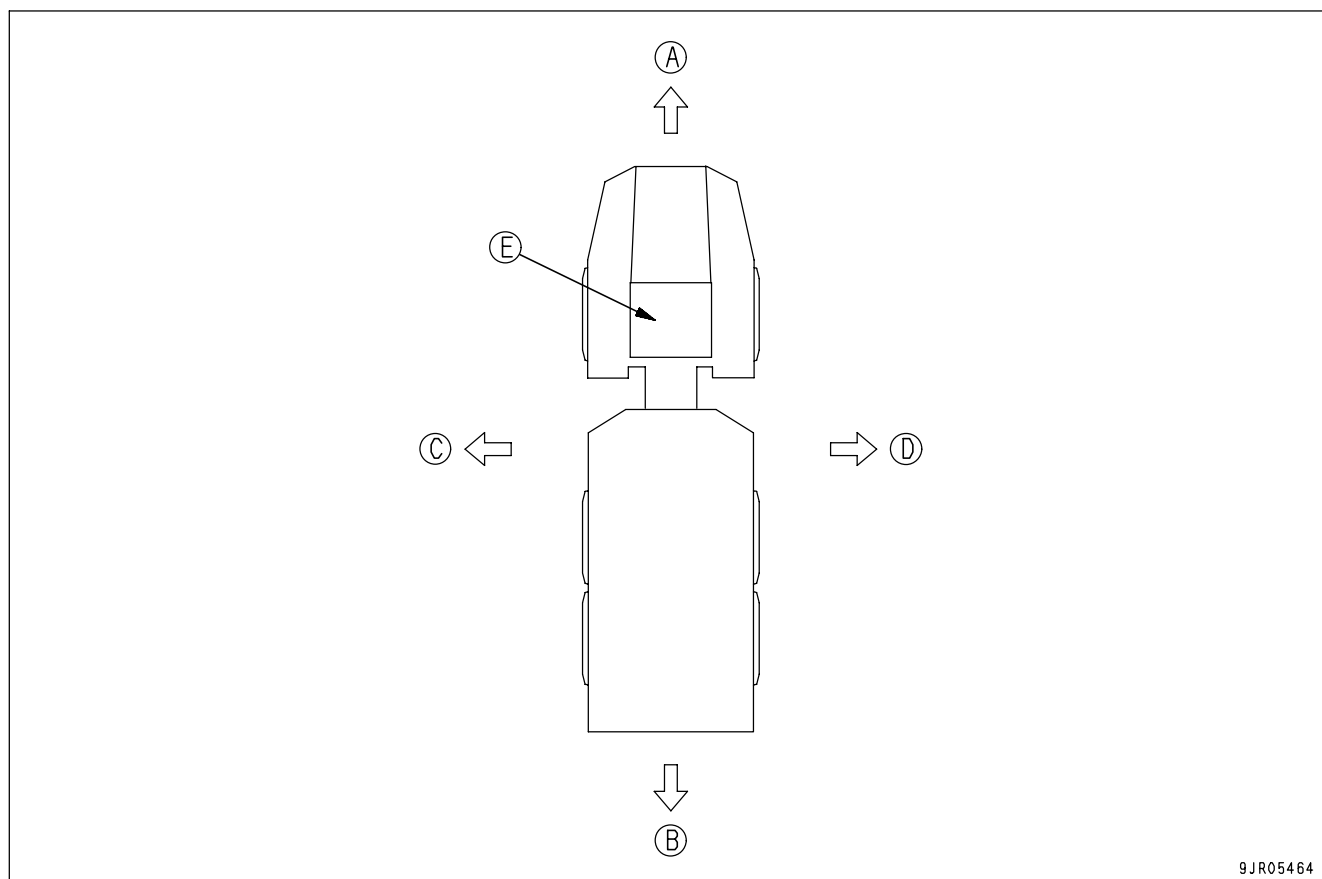

9JR05464

In this manual, the directions of the machine (front, rear, left, right) are determined according to the view from the operator's seat in the direction of travel (front) of the machine.

- (A) FRONT
- (B) REAR
- (C) LEFT

- (D) RIGHT
- (E) OPERATOR'S SEAT

VISIBILITY FROM OPERATOR'S SEAT

This machine complies with the visibility standard (ISO 5006).

This machine maintains a close visibility of a height of 1.5 m at a point 1 m away from the outside surface of the machine, and a visibility for a circumference of 12 m.

LOCATION OF PLATES, TABLE TO ENTER SERIAL NO. AND DISTRIBUTOR

When requesting service or ordering replacement parts, please inform your Komatsu distributor of the following items.

PRODUCT IDENTIFICATION NUMBER (PIN)/MACHINE SERIAL NO. PLATE

This is at the rear right of the cab.

The design of the nameplate differs according to the territory.

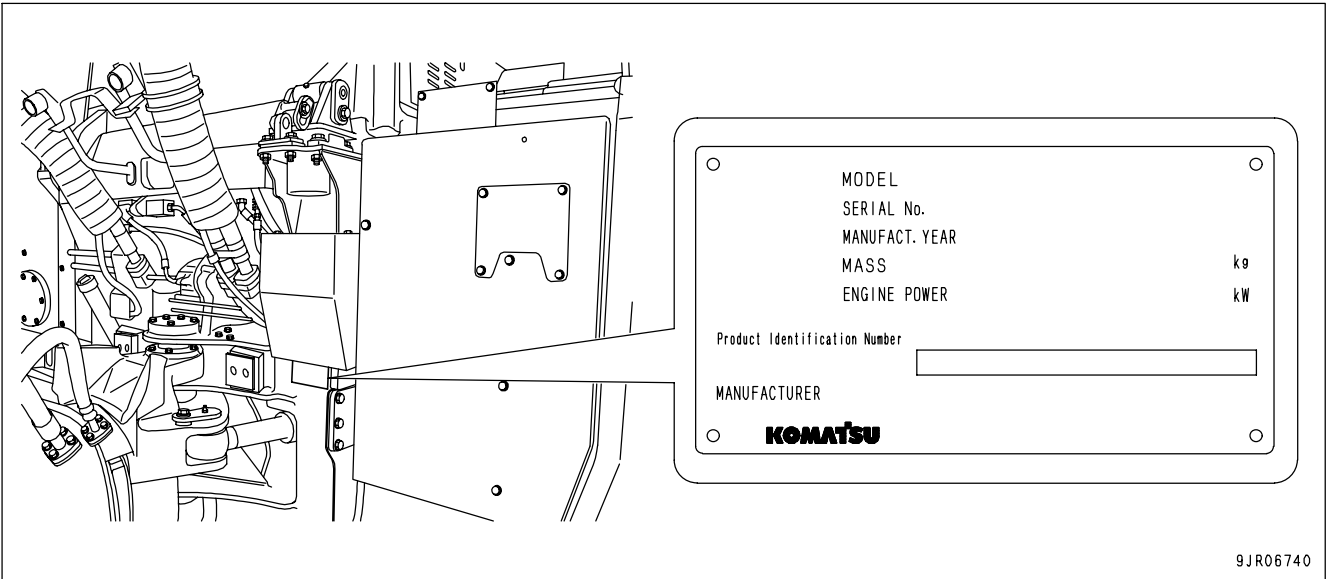

EPA REGULATIONS, ENGINE NUMBER PLATE

It is located on the upper left side of the engine cylinder block if you look from the fan side.

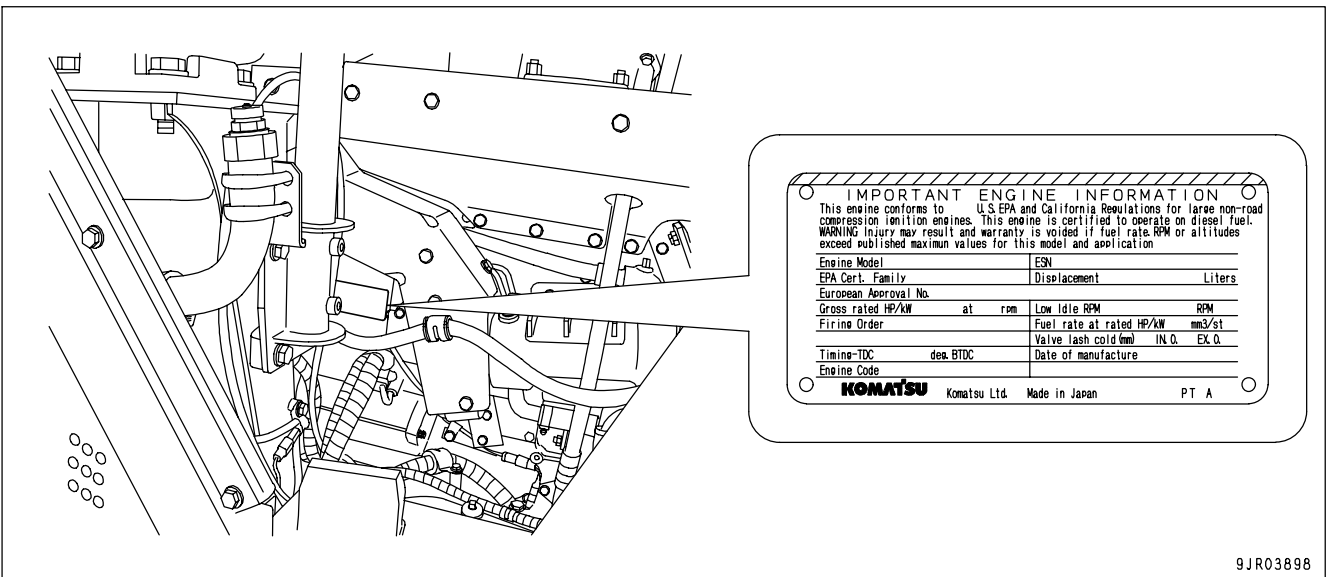

EPA: Environmental Protection Agency, U.S.A.

SERVICE METER POSITION

It is at the center bottom of the machine monitor.

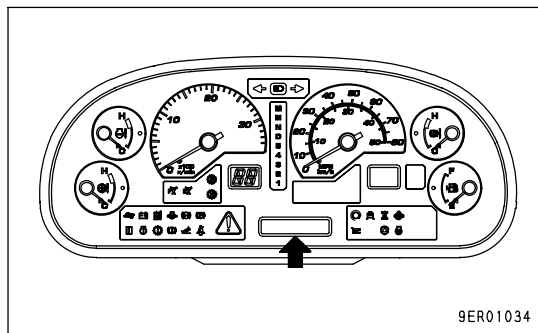

9ER01034

TABLE TO ENTER SERIAL NO. AND DISTRIBUTOR

Machine serial No.	
Engine serial No.	
Product identification number (PIN)	
Distributor name	
Address	-----

Service Personnel	
Phone/Fax	-----

CONTENTS

FOREWORD	1- 1
BEFORE READING THIS MANUAL	1- 2
SAFETY INFORMATION	1- 3
INTENDED USE	1- 4
USE OF MACHINE	1- 4
DIRECTIONS OF MACHINE	1- 4
VISIBILITY FROM OPERATOR'S SEAT	1- 4
LOCATION OF PLATES, TABLE TO ENTER SERIAL NO. AND DISTRIBUTOR	1- 5
PRODUCT IDENTIFICATION NUMBER (PIN)/MACHINE SERIAL NO. PLATE	1- 5
EPA REGULATIONS, ENGINE NUMBER PLATE	1- 5
SERVICE METER POSITION	1- 6
TABLE TO ENTER SERIAL NO. AND DISTRIBUTOR	1- 6
SAFETY	2- 1
SAFETY	2- 2
SAFETY LABELS	2- 5
POSITION FOR ATTACHING SAFETY LABELS	2- 6
SAFETY LABELS	2- 7
GENERAL PRECAUTIONS COMMON TO OPERATION AND MAINTENANCE	2- 13
PRECAUTIONS BEFORE STARTING OPERATION	2- 13
PREPARATIONS FOR SAFE OPERATION	2- 13
FIRE PREVENTION	2- 15
PRECAUTIONS WHEN GETTING ON OR OFF MACHINE	2- 16
DO NOT GET CAUGHT IN ARTICULATING PORTION AND DUMP BODY	2- 18
PRECAUTIONS RELATED TO PROTECTIVE STRUCTURES	2- 18
UNAUTHORIZED MODIFICATION	2- 18
PRECAUTIONS RELATED TO ATTACHMENTS AND OPTIONS	2- 19
PRECAUTIONS WHEN RUNNING ENGINE INSIDE BUILDING	2- 19
PRECAUTIONS FOR OPERATION	2- 20
PRECAUTIONS FOR JOBSITE	2- 20
STARTING ENGINE	2- 22
OPERATION	2- 25
TRANSPORTATION	2- 29
TOWING	2- 30
PRECAUTIONS FOR MAINTENANCE	2- 31
PRECAUTIONS BEFORE STARTING INSPECTION AND MAINTENANCE	2- 31
PRECAUTIONS FOR INSPECTION AND MAINTENANCE	2- 36
TIRES	2- 41
OPERATION	3- 1
GENERAL VIEW	3- 2
GENERAL VIEW OF MACHINE	3- 2
GENERAL VIEW OF CONTROLS AND GAUGES	3- 3
EXPLANATION OF COMPONENTS	3- 5
MACHINE MONITOR	3- 5
OTHER FUNCTIONS OF MACHINE MONITOR	3- 26
SWITCHES	3- 30
CONTROL LEVERS AND PEDALS	3- 40
BODY PIVOT PIN	3- 45
ARTICULATE LOCK	3- 45
LOCATION OF FIRE EXTINGUISHER	3- 46

DUST INDICATOR	3- 46
CIRCUIT BREAKER	3- 46
FUSES	3- 47
CAR RADIO	3- 50
CAR STEREO	3- 56
AIR CONDITIONER	3- 64
OPERATION	3- 69
CHECK BEFORE STARTING ENGINE	3- 69
STARTING ENGINE	3- 84
OPERATIONS, CHECKS AFTER STARTING ENGINE	3- 86
STOPPING ENGINE	3- 87
CHECKS AFTER STOPPING ENGINE	3- 87
MOVING MACHINE OFF (FORWARD, REVERSE), STOPPING	3- 88
SHIFTING GEAR	3- 93
TRAVELING DOWNHILL	3- 95
STEERING THE MACHINE	3-101
OPERATION USING DIFFERENTIAL LOCK	3-102
LOADING OPERATIONS	3-103
DUMP OPERATIONS	3-105
CAB TILT OPERATION	3-107
PRECAUTIONS FOR OPERATION	3-110
PARKING MACHINE	3-111
CHECKS AFTER COMPLETION OF WORK	3-112
LOCKING	3-112
HANDLING TIRES	3-113
DETERMINING AND MAINTAINING TRAVEL ROAD	3-114
DETERMINING TRAVEL ROAD	3-114
MAINTAINING TRAVEL ROAD	3-114
TRANSPORTATION	3-115
PRECAUTIONS WHEN TRANSPORTING	3-115
STEPS FOR TRANSPORTATION	3-115
METHOD OF SECURING MACHINE	3-116
METHOD OF LIFTING MACHINE	3-117
COLD WEATHER OPERATION	3-121
PRECAUTIONS FOR LOW TEMPERATURE	3-121
PRECAUTIONS AFTER COMPLETION OF WORK	3-122
AFTER COLD WEATHER	3-123
LONG-TERM STORAGE	3-124
BEFORE STORAGE	3-124
DURING STORAGE	3-124
AFTER STORAGE	3-124
PRECAUTIONS BEFORE TRAVELING AFTER LONG-TERM STORAGE	3-124
TROUBLESHOOTING	3-125
AFTER RUNNING OUT OF FUEL	3-125
IF TRANSMISSION HAS TROUBLE	3-126
METHOD OF LOWERING DUMP BODY IN EMERGENCY	3-126
METHOD OF TOWING MACHINE	3-127
IF BATTERY IS DISCHARGED	3-131
OTHER TROUBLE	3-135
MAINTENANCE	4- 1

GUIDES TO MAINTENANCE	4- 2
OUTLINE OF SERVICE	4- 4
HANDLING OIL, FUEL, COOLANT, AND PERFORMING OIL CLINIC	4- 4
OUTLINE OF ELECTRIC SYSTEM	4- 8
WEAR PARTS	4- 9
WEAR PARTS LIST	4- 9
RECOMMENDED FUEL, COOLANT, AND LUBRICANT	4- 10
USE OF FUEL, COOLANT AND LUBRICANTS ACCORDING TO AMBIENT TEMPERATURE ----	4- 11
RECOMMENDED BRANDS, RECOMMENDED QUALITY FOR PRODUCTS OTHER THAN KOMATSU GENUINE OIL	4- 12
STANDARD TIGHTENING TORQUES FOR BOLTS AND NUTS	4- 13
TORQUE LIST	4- 13
PERIODIC REPLACEMENT OF SAFETY CRITICAL PARTS	4- 15
SAFETY CRITICAL PARTS	4- 16
MAINTENANCE SCHEDULE CHART	4- 17
MAINTENANCE SCHEDULE CHART	4- 17
SERVICE PROCEDURE	4- 19
INITIAL 250 HOURS SERVICE (ONLY AFTER THE FIRST 250 HOURS)	4- 19
WHEN REQUIRED	4- 20
CHECK BEFORE STARTING	4- 39
EVERY 50 HOURS SERVICE	4- 40
EVERY 250 HOURS SERVICE	4- 41
EVERY 500 HOURS SERVICE	4- 52
EVERY 1000 HOURS SERVICE	4- 59
EVERY 2000 HOURS SERVICE	4- 69
EVERY 4000 HOURS SERVICE	4- 76
EVERY 6000 HOURS SERVICE	4- 79
EVERY 8000 HOURS SERVICE	4- 80
SPECIFICATIONS	5- 1
SPECIFICATIONS	5- 2
ATTACHMENTS, OPTIONS	6- 1
HANDLING AUTOMATIC RETARDER, ACCELERATOR CONTROL(ARAC)	6- 2
EXPLANATION OF COMPONENTS	6- 2
METHOD OF OPERATION	6- 3
HANDLING PAYLOAD METER HM	6- 4
FEATURES OF PAYLOAD METER HM	6- 4
METHOD OF USING ACCURATELY	6- 5
GENERAL LOCATIONS	6- 7
CONTENT OF DISPLAY (CONTROLLER, EXTERNAL DISPLAY LAMPS)	6- 10
EXTERNAL DISPLAY LAMPS	6- 12
DETAILS OF DATA STORED IN MEMORY OF PAYLOAD METER	6- 14
OPERATION OF SWITCHES	6- 17
ABNORMALITY AND WARNING DISPLAY (ERROR CODE)	6- 30
WHEN ERROR CODE F-09 IS DISPLAYED	6- 31
PROCEDURE WHEN DOWNLOADING	6- 32
OTHERS	6- 35
USE OF REAR VIEW MONITOR	6- 36
NAME AND FUNCTON OF EACH PART OF REAR VIEW MONITOR	6- 36
SETTING OF REAR VIEW MONITOR	6- 39
CAUTIONS WHEN USING REAR VIEW MONITOR	6- 39

HANDLING DUMPING COUNTER-----	6- 40
HANDLING BATTERY DISCONNECTOR SWITCH -----	6- 41
HANDLING MACHINES EQUIPPED WITH KOMTRAX -----	6- 43
BASIC PRECAUTIONS -----	6- 43
INDEX -----	7- 1

SAFETY

WARNING

Please read and make sure that you fully understand the precautions described in this manual and the safety labels on the machine. When operating or servicing the machine, always follow these precautions strictly.

SAFETY

SAFETY LABELS	2- 5
POSITION FOR ATTACHING SAFETY LABELS	2- 6
SAFETY LABELS	2- 7
GENERAL PRECAUTIONS COMMON TO OPERATION AND MAINTENANCE	2- 13
PRECAUTIONS BEFORE STARTING OPERATION	2- 13
ENSURING SAFE OPERATION	2- 13
UNDERSTANDING THE MACHINE	2- 13
PREPARATIONS FOR SAFE OPERATION	2- 13
PRECAUTIONS REGARDING SAFETY-RELATED EQUIPMENT	2- 13
INSPECTING MACHINE	2- 13
WEAR WELL-FITTING CLOTHES AND PROTECTIVE EQUIPMENT	2- 13
KEEP MACHINE CLEAN	2- 14
PRECAUTIONS INSIDE OPERATOR'S COMPARTMENT	2- 14
PROVIDE FIRE EXTINGUISHER AND FIRST AID KIT	2- 14
IF ANY PROBLEM IS FOUND	2- 14
FIRE PREVENTION	2- 15
ACTION IF FIRE OCCURS	2- 15
PRECAUTIONS TO PREVENT FIRE	2- 15
PRECAUTIONS WHEN GETTING ON OR OFF MACHINE	2- 16
USE HANDRAILS AND STEPS WHEN GETTING ON OR OFF MACHINE	2- 16
NO JUMPING ON OR OFF MACHINE	2- 16
NO PEOPLE ON DUMP BODY	2- 17
PRECAUTIONS WHEN STANDING UP FROM OPERATOR'S SEAT	2- 17
PRECAUTIONS WHEN LEAVING MACHINE	2- 17
EMERGENCY EXIT FROM OPERATOR'S CAB	2- 18
DO NOT GET CAUGHT IN ARTICULATING PORTION AND DUMP BODY	2- 18
PRECAUTIONS RELATED TO PROTECTIVE STRUCTURES	2- 18
UNAUTHORIZED MODIFICATION	2- 18
PRECAUTIONS RELATED TO ATTACHMENTS AND OPTIONS	2- 19
PRECAUTIONS WHEN RUNNING ENGINE INSIDE BUILDING	2- 19

PRECAUTIONS FOR OPERATION	2- 20
PRECAUTIONS FOR JOBSITE	2- 20
INVESTIGATE AND CONFIRM JOBSITE CONDITIONS	2- 20
WORKING ON LOOSE GROUND	2- 20
DO NOT GO CLOSE TO HIGH-VOLTAGE CABLES	2- 20
ENSURE GOOD VISIBILITY	2- 21
CHECKING SIGNS AND SIGNALMAN'S SIGNALS	2- 21
BEWARE OF ASBESTOS DUST	2- 21
STARTING ENGINE	2- 22
USE WARNING TAGS	2- 22
CHECKS BEFORE STARTING ENGINE	2- 23
PRECAUTIONS WHEN STARTING ENGINE	2- 23
PRECAUTIONS IN COLD AREAS	2- 23
STARTING WITH BOOSTER CABLES	2- 24
OPERATION	2- 25
CHECKS BEFORE OPERATION	2- 25
PRECAUTIONS WHEN TRAVELING IN FORWARD OR REVERSE	2- 25
PRECAUTIONS WHEN TRAVELING	2- 26
TRAVELING ON SLOPES	2- 26
PRECAUTIONS WHEN OPERATING	2- 26
PRECAUTIONS WHEN LOADING DUMP BODY	2- 27
PRECAUTIONS WHEN OPERATING DUMP BODY	2- 27
TRAVELING ON SNOW-COVERED OR FROZEN SURFACES	2- 27
PARKING MACHINE	2- 28
TRANSPORTATION	2- 29
LOADING AND UNLOADING	2- 29
TOWING	2- 30
WHEN TOWING	2- 30

PRECAUTIONS FOR MAINTENANCE	2- 31
PRECAUTIONS BEFORE STARTING INSPECTION AND MAINTENANCE	2- 31
DISPLAY WARNING TAG DURING INSPECTION AND MAINTENANCE	2- 31
KEEP WORKPLACE CLEAN AND TIDY	2- 31
SELECT SUITABLE PLACE FOR INSPECTION AND MAINTENANCE	2- 31
ONLY AUTHORIZED PERSONNEL	2- 31
APPOINT LEADER WHEN WORKING WITH OTHERS	2- 31
STOP ENGINE BEFORE CARRYING OUT INSPECTION AND MAINTENANCE	2- 32
TWO WORKERS FOR MAINTENANCE WHEN ENGINE IS RUNNING	2- 34
INSTALLING, REMOVING, OR STORING ATTACHMENTS	2- 35
PRECAUTIONS WHEN WORKING AT HIGH PLACES	2- 35
PRECAUTIONS WHEN WORKING UNDER MACHINE	2- 35
PROPER TOOLS	2- 35
PRECAUTIONS FOR INSPECTION AND MAINTENANCE	2- 36
PRECAUTIONS WHEN WELDING	2- 36
HANDLING BATTERY	2- 36
PRECAUTIONS WHEN USING HAMMER	2- 37
PRECAUTIONS WITH HIGH-TEMPERATURE COOLANT	2- 37
PRECAUTIONS WITH HIGH-TEMPERATURE OIL	2- 37
PRECAUTIONS WITH HIGH-PRESSURE OIL	2- 38
PRECAUTIONS WITH HIGH-PRESSURE FUEL	2- 38
HANDLING HIGH-PRESSURE HOSES AND PIPING	2- 38
NOISE	2- 38
HANDLING SUSPENSION CYLINDER, ACCUMULATOR, GAS SPRING	2- 39
PRECAUTIONS WITH COMPRESSED AIR	2- 39
MAINTENANCE OF AIR CONDITIONER	2- 39
DISPOSING OF WASTE MATERIALS	2- 39
METHOD OF SELECTING WINDOW WASHER FLUID	2- 39
PERIODIC REPLACEMENT OF SAFETY CRITICAL PARTS	2- 40
TIRES	2- 41
HANDLING TIRES	2- 41
PRECAUTIONS WHEN STORING TIRES	2- 42

SAFETY LABELS

The following warning signs and safety labels are used on this machine.

- Be sure that you fully understand the correct position and content of labels.
- To ensure that the content of labels can be read properly, be sure that they are in the correct place and always keep them clean. When cleaning them, do not use organic solvents or gasoline. These may cause the labels to peel off.
- There are also other labels in addition to the warning signs and safety labels. Handle those labels in the same way.
- If the labels are damaged, lost, or cannot be read properly, replace them with new ones. For details of the part numbers for the labels, see this manual or the actual label, and place an order with Komatsu distributor.

POSITION FOR ATTACHING SAFETY LABELS

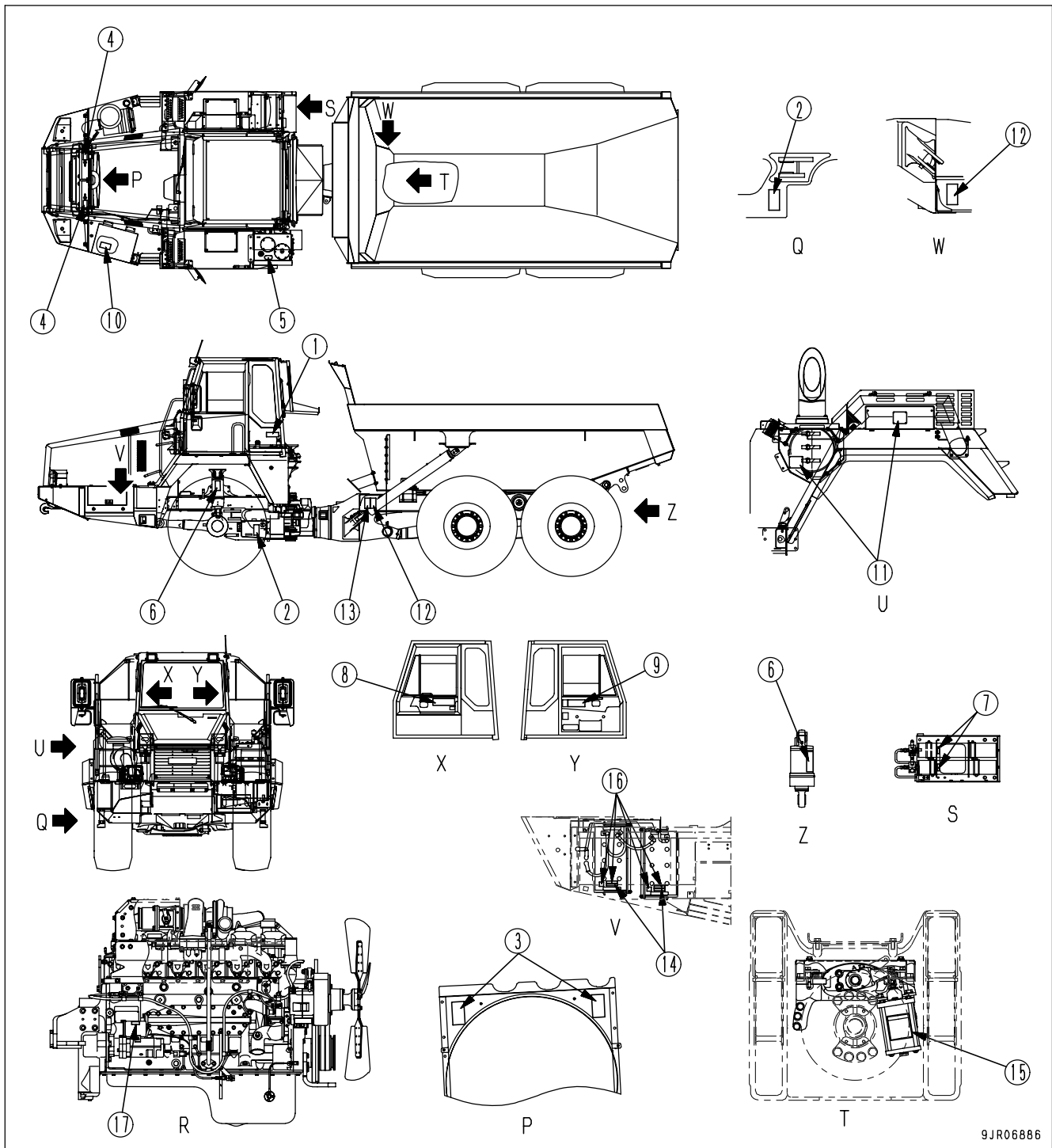

9JR06886

SAFETY LABELS

(1) Caution for modification of ROPS/FOPS (09620-A2000)

ROPS/FOPS CERTIFICATION			
This product's structure complies with the standard provided that it is properly equipped on the machine which mass is less than the specified maximum mass.			
KOMATSU	ROPS : ISO 3471:1994, SAE J1501, SAE J1503	MACHINE MODEL	FOPS : ISO 3449:1992
MODEL	ROPS : ISO 3471:1994, SAE J1501, SAE J1503	MACHINE MODEL	FOPS LEVEL No. <input type="text"/>
SERIAL No.	MAX. MASS		kg (lb)
WARNING	<ul style="list-style-type: none"> • If any modification is applied to the ROPS or FOPS, it may affect the strength and may not comply with the standard. Consult Komatsu Distributor before attaching. • ROPS or FOPS may provide less protection if it has been structurally damaged or involved roll-over. Consult Komatsu Distributor in that case. • Always wear seat belt when moving. 		
Komatsu Ltd. 2-3-6 Akasaka, Minato-ku, Tokyo, Japan 09620-A2000			

(2) Caution for rotating parts (09667-53000)



(3) Caution for checking engine room (09667-23001)

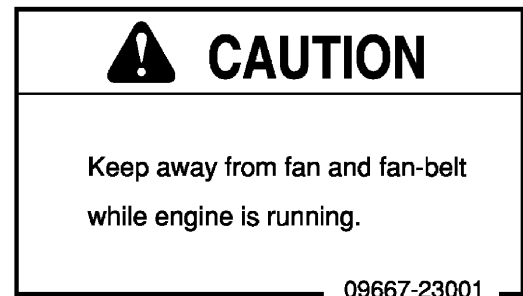

(4) Precaution when releasing radiator cap (09668-03001)



(5) Caution for opening hydraulic tank cap (09653-03001)



(6) Warning for handling suspension (09659-33000)

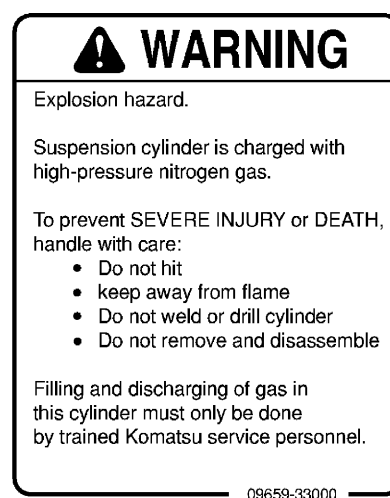

(7) Precautions for handling accumulator (09659-53000)

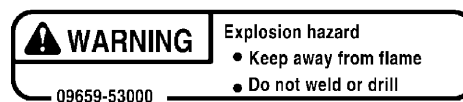

- (8) Warning for electric wire
- Warning for crush hazard when inspection and maintenance
- Warning for inspection of emergency steering system, brake system
- Warning for leaving operator's seat, stopping engine
- Warning for retarder oil temperature
- (56B-93-12181)

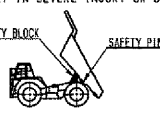
<p>⚠ DANGER</p>  <p>HAZARDOUS VOLTAGE HAZARD. SERIOUS INJURY OR DEATH CAN OCCUR IF MACHINE OR ATTACHMENTS ARE NOT KEPT SAFE DISTANCE AWAY FROM ELECTRIC LINES.</p> <table border="1" style="width: 100%; border-collapse: collapse;"> <thead> <tr> <th>VOLTAGE</th> <th>SAFE DISTANCE</th> </tr> </thead> <tbody> <tr> <td>LOW VOLTAGE</td> <td></td> </tr> <tr> <td>100 V 200 V</td> <td>2 m</td> </tr> <tr> <td>6,600 V</td> <td>3 m</td> </tr> <tr> <td>22,000 V</td> <td>3 m</td> </tr> <tr> <td>66,000 V</td> <td>4 m</td> </tr> <tr> <td>SPECIAL HIGH VOLTAGE</td> <td></td> </tr> <tr> <td>164,000 V</td> <td>5 m</td> </tr> <tr> <td>197,000 V</td> <td>6 m</td> </tr> <tr> <td>276,000 V</td> <td>7 m</td> </tr> <tr> <td>500,000 V</td> <td>11 m</td> </tr> </tbody> </table>	VOLTAGE	SAFE DISTANCE	LOW VOLTAGE		100 V 200 V	2 m	6,600 V	3 m	22,000 V	3 m	66,000 V	4 m	SPECIAL HIGH VOLTAGE		164,000 V	5 m	197,000 V	6 m	276,000 V	7 m	500,000 V	11 m	<p>⚠ DANGER</p> <p>CRUSH HAZARD TO HOLD THE DUMP BODY IN A SAFE RAISED POSITION, ALWAYS DO THE FOLLOWING:</p> <ul style="list-style-type: none"> · MOVE HOIST CONTROL LEVER TO 'HOLD' AND SAFETY 'LOCK' TO LOCK. · LOCK DUMP BODY WITH SAFETY PIN. · PLACE BLOCK BETWEEN FRAME AND BODY. <p>SEE MANUAL FOR MORE COMPLETE INSTRUCTIONS. FAILURE TO FOLLOW THESE INSTRUCTIONS COULD RESULT IN SEVERE INJURY OR DEATH.</p> 	<p>NOTICE</p> <p>1 EMERGENCY STEERING SYSTEM (DAILY CHECK) CHECK THE FUNCTION WITH THE ENGINE STOP ON FLAT GROUND.</p> <ol style="list-style-type: none"> 1. TURN THE STARTING SWITCH TO THE 'ON' POSITION. 2. APPLY THE EMERGENCY STEERING SWITCH TO THE 'ON' POSITION AND CHECK THE STEERING WHEEL CAN BE OPERATED. 3. TURN THE EMERGENCY STEERING SWITCH TO 'OFF' POSITION. 4. RELEASE THE PARKING BRAKE. THE SYSTEM WILL ACTIVATE WITHIN 1 SECOND. 5. APPLY THE PARKING BRAKE. <p>2 BRAKE SYSTEM (DAILY CHECK) CHECK THE FUNCTION ON FLAT GROUND. REFER TO 'OPERATION & MAINTENANCE MANUAL' FOR PROPER DIRECTIONS.</p> <p>DO NOT USE RETARDER BRAKE FOR PARKING.</p>	<p>NOTICE</p> <p>WHEN LEAVING OPERATOR SEAT</p> <ol style="list-style-type: none"> 1. LOWER DUMP BODY. 2. PARK THE MACHINE ON LEVEL GROUND. 3. STOP ENGINE AND APPLY PARKING BRAKE COMPLETELY. <p>BLOCK WHEELS SECURELY BEFORE LEAVING MACHINE. IDLE ENGINE FOR 5 MINUTES BEFORE SHUTTING IT DOWN.</p> <hr/> <p>⚠ WARNING</p> <p>IF THE RETARDER OIL TEMPERATURE CAUTION LAMP LIGHTS UP, STOP MACHINE IMMEDIATELY. OR THE BRAKES WILL FAIL. SET THE SHIFT LEVER TO THE N POSITION, RUN THE ENGINE UNDER NO LOAD AT A MID-RANGE SPEED, AND WAIT FOR THE LAMP TO GO OUT.</p> <p style="text-align: right; font-size: small;">56B-93-12181</p>
VOLTAGE	SAFE DISTANCE																								
LOW VOLTAGE																									
100 V 200 V	2 m																								
6,600 V	3 m																								
22,000 V	3 m																								
66,000 V	4 m																								
SPECIAL HIGH VOLTAGE																									
164,000 V	5 m																								
197,000 V	6 m																								
276,000 V	7 m																								
500,000 V	11 m																								

- If the machine comes too close to electric cables, there is danger of electrocution. Always keep a safe distance from electric cables.
- There is danger that the dump body may come down. Before carrying out inspection or maintenance with the dump body raised, always read the Operation and Maintenance Manual and take the correct action.

- (9) Caution before starting
- Caution when traveling in reverse
- Caution for operating hoist control lever
- (569-93-81730)

<p>⚠ WARNING</p> <p>IMPROPER OPERATION AND MAINTENANCE CAN CAUSE SERIOUS INJURY OR DEATH.</p> <p>READ MANUAL AND LABELS BEFORE OPERATION AND MAINTENANCE. FOLLOW INSTRUCTIONS AND WARNINGS IN MANUAL AND IN LABELS ON MACHINE.</p> <p>KEEP MANUAL IN MACHINE CAB NEAR OPERATOR. CONTACT KOMATSU DISTRIBUTOR FOR A REPLACEMENT MANUAL.</p>	<p>⚠ WARNING</p>  <p>TO PREVENT SEVERE INJURY OR DEATH, DO THE FOLLOWING BEFORE MOVING MACHINE OR ITS DUMP BODY.</p> <ul style="list-style-type: none"> · HONK HORN TO ALERT PEOPLE NEARBY. · BE SURE NO ONE IS ON OR NEAR MACHINE. · USE SPOTTER IF VIEW IS OBSTRUCTED. <p>FOLLOW ABOVE EVEN IF MACHINE IS EQUIPPED WITH BACK-UP ALARM AND MIRRORS.</p>	<p>NOTICE</p> <p>BE SURE TO LOWER DUMP BODY AND KEEP HOIST CONTROL LEVER AT THE FLOAT POSITION DURING TRAVEL.</p>  <p style="text-align: right; font-size: small;">569-93-81730</p>
--	---	---

(10) Caution when handling battery cable (09808-03000)

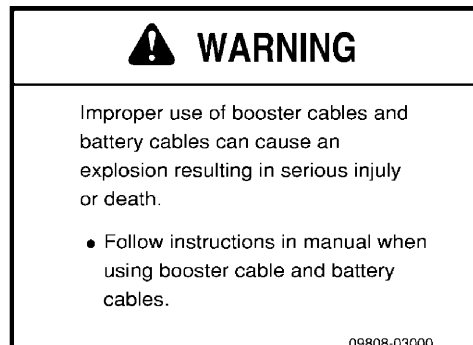

(11) Exhaust pipe is hot! (09817-A1103)



Sign indicates a burn hazard from touching heated parts, such as engine, motor, or muffler during or right after operation. Never touch when hot.

(12) Prohibited to enter (09162-23000)

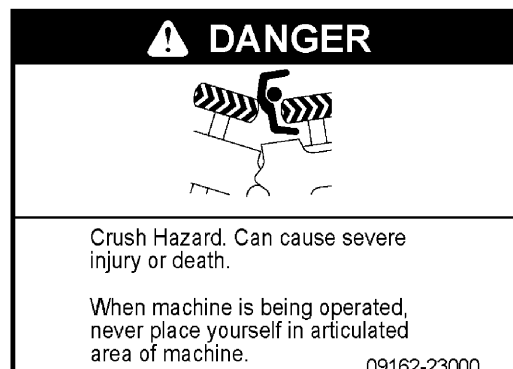

(13) Cation for articulate lock (09161-23000)

⚠ WARNING

If safety bar is unlocked, machine can jackknife unexpectedly when it is being transported or hoisted.

Jackknifing can cause serious injury or death to bystanders.

- Always lock safety bar when machine is being transported or hoisted.
- If necessary, lock safety bar during servicing or maintenance.

09161-23000

(14) Precaution when handling battery
(This plate is fixed in position by the battery maker)

	
火気厳禁 メガネ着用 こども禁止 強酸注意 説明書熟読 爆発注意 ●水蒸気発生、取扱いを誤ると引火爆発の恐れあり ●工具等でショートやスパークをさせない。充電は風通しのよい所で行う ●ブラスターケーブルの使用は取扱説明書に従う ●バッテリー液(硫酸)で失明ややけどの恐れあり ●液がついたらすぐに多量の水で洗い、目の場合は医師の治療を受ける ●爆発の恐れあり、液面はLOWER以下で使用しない ●液漏れの恐れあり、UPPER以上に補水しない	公称電圧 12V
DANGER KEEP SPARKS, FLAME, CIGARETTES AWAY. ÉLOIGENEZ LES ÉTINCELLES, FLAMME, CIGARETTES.	

(15) Caution for parking brake
(This plate is fixed in position by the chamber maker)

⚠ 警告 WARNING

チャンバ内のスプリングを取り外さないでください。チャンバ内の部品は、補給対象外です。チャンパの切断、溶断または改造を行わないでください。重大なけがや死亡事故の原因となります。

DO NOT ATTEMPT TO REMOVE SPRING(S).
THEY ARE NOT SERVICEABLE.
DO NOT CUT, SAW, TORCH OR MODIFY THIS CHAMBER, SERIOUS INJURY OR DEATH MAY RESULT.

- (16) Caution when handling battery (09664-30011)
(For USA, Puerto Rico)

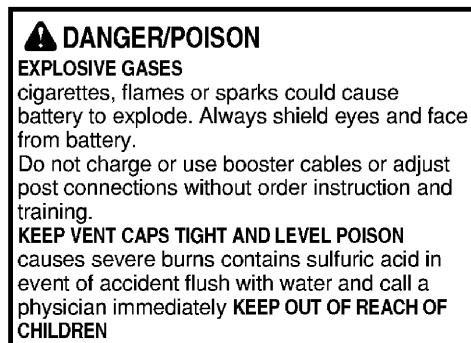

Distr. By
 KOMATSU AMERICA CORP.
 :Rolling Meadows IL60008, USA
 KOMATSU LATIN AMERICA CORP.
 :Miami, FL 33126, USA

- (17) Prohibited to jump start (09842-A0481)
(This plate is fixed to the starting motor)



Start the engine only after sitting down in the operator's seat.

Do not attempt to start the engine by short-circuiting the engine starting circuit. Such an act may cause a serious bodily injury or fire.

GENERAL PRECAUTIONS COMMON TO OPERATION AND MAINTENANCE

Mistakes in operation, inspection, or maintenance may result in serious personal injury or death. Before carrying out operation, inspection, or maintenance, always read this manual and the safety labels on the machine carefully and obey the warnings.

PRECAUTIONS BEFORE STARTING OPERATION

ENSURING SAFE OPERATION

- Only trained and authorized personnel can operate and maintain the machine.
- Follow all safety, precautions, and instructions in this manual when operating or performing inspection or maintenance on the machine.
- If you are not feeling well, or if you are under the influence of alcohol or medication, your ability to safely operate or repair your machine may be severely impaired, putting yourself and everyone else on your job site in danger.
- When working with another operator or with the person on the worksite traffic duty, discuss the content of the operation beforehand and use the determined signals when carrying out the operation.

UNDERSTANDING THE MACHINE

Before operating the machine, read this manual thoroughly. If there are any places in this manual that you do not understand, ask the person in charge of safety to give an explanation.

PREPARATIONS FOR SAFE OPERATION

PRECAUTIONS REGARDING SAFETY-RELATED EQUIPMENT

- Be sure that all guards, covers and mirrors are in their proper position. Have guards and covers repaired immediately if they are damaged.
- Understand the method of use of safety features and use them properly.
- Never remove any safety features. Always keep them in good operating condition.

INSPECTING MACHINE

Check the machine before starting operations. If any abnormality is found, do not operate the machine until repairs of the problem location have been completed.

WEAR WELL-FITTING CLOTHES AND PROTECTIVE EQUIPMENT

- Do not wear loose clothes or any accessories. If these catch on the control levers or protruding parts, there is danger that it may cause the machine to move unexpectedly.
- Always wear a hard hat and safety shoes. If the nature of the work requires it, wear safety glasses, mask, gloves, ear plugs, and safety belt when operating or maintaining the machine.
- If you have long hair and it hangs out from your hard hat, there is a hazard that it may get caught up in the machine, so tie your hair up and be careful not to let it get caught.
- Check that all protective equipment functions properly before using it.

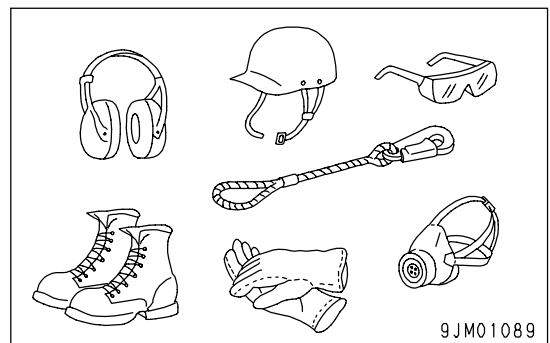

KEEP MACHINE CLEAN

- If you get on or off the machine or carry out inspection and maintenance when the machine is dirty with mud or oil, there is a hazard that you will slip and fall. Wipe off any mud or oil from the machine. Always keep the machine clean.
- If water gets into the electrical system, there is a hazard that it will cause malfunctions or misoperation. If there is any misoperation, there is danger that the machine may move unexpectedly and cause serious personal injury or death. When washing the machine with water or steam, do not allow the water or steam to come into direct contact with electrical components.

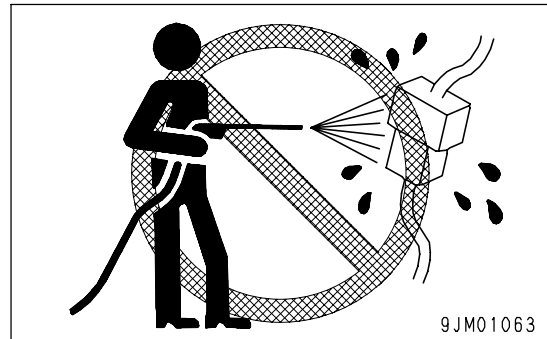
**PRECAUTIONS INSIDE OPERATOR'S COMPARTMENT**

- When entering the operator's compartment, always remove all mud and oil from the soles of your shoes. If you operate the pedal with mud or oil affixed to your shoes, your foot may slip and this may cause a serious accident.
- Do not leave tools or a machine parts lying around inside the operator's compartment. If tools or parts get into the control devices, it may obstruct operation and cause the machine to move unexpectedly, resulting in serious personal injury or death.
- Do not stick suction pads to the window glass. Suction pads act as a lens and may cause fire.
- Do not use a cell phone when driving or operating the machine. This may lead to mistakes in operation, which could cause serious personal injury or death.
- Never bring any dangerous objects such as flammable or explosive items into the operator's compartment.

PROVIDE FIRE EXTINGUISHER AND FIRST AID KIT

Always follow the precautions below to prepare for action if any injury or fire should occur.

- Be sure that fire extinguishers have been provided and read the labels to ensure that you know how to use them in emergencies.
- Carry out periodic inspection and maintenance to ensure that the fire extinguisher can always be used.
- Provide a first aid kit in the storage point. Carry out periodic checks and add to the contents if necessary.

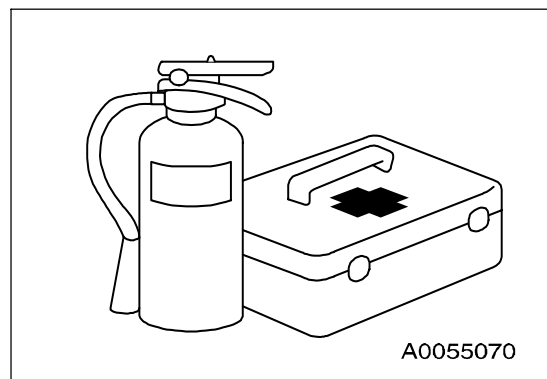
**IF ANY PROBLEM IS FOUND**

If you find any problems in the machine during operation or maintenance (noise, vibration, smell, incorrect gauges, smoke, oil leakage, etc., or any abnormal display on the warning devices or monitor), report to the person in charge and have the necessary action taken. Do not operate the machine until the problem has been corrected.

FIRE PREVENTION

ACTION IF FIRE OCCURS

- Turn the start switch OFF to stop the engine.
- Use the handrails and steps to get off the machine.
- Do not jump off the machine. There is the danger of falling and suffering serious injury.

PRECAUTIONS TO PREVENT FIRE

- **Fire caused by fuel, oil, antifreeze, or window washer fluid**

Do not bring any flame or fire close to flammable substances such as fuel, oil, antifreeze, or window washer fluid. There is danger that they may catch fire. To prevent fire, always observe the following:

- Do not smoke or use any flame near fuel or other flammable substances.
- Stop the engine before adding fuel.
- Do not leave the machine when adding fuel or oil.
- Tighten all fuel and oil caps securely.
- Be careful not to spill fuel on overheated surfaces or on parts of the electrical system.
- After adding fuel or oil, wipe up any spilled fuel or oil.
- Put greasy rags and other flammable materials into a safe container to maintain safety at the workplace.
- When washing parts with oil, use a non-flammable oil. Do not use diesel oil or gasoline. There is danger that they may catch fire.
- Do not weld or use a cutting torch to cut any pipes or tubes that contain flammable liquids.
- Determine well-ventilated areas for storing oil and fuel. Keep the oil and fuel in the determined place and do not allow unauthorized persons to enter.
- When carrying out grinding or welding work on the machine, move any flammable materials to a safe place before starting.

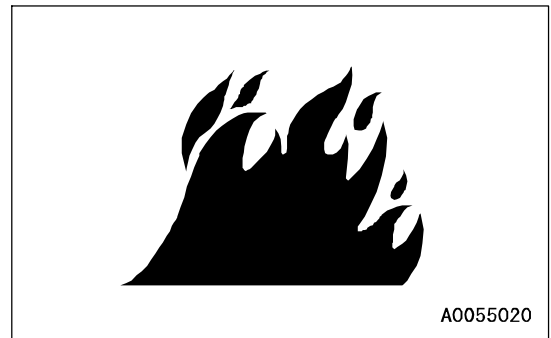

- **Fire caused by accumulation of flammable material.**

Remove any dry leaves, chips, pieces of paper, coal dust, or any other flammable materials accumulated or affixed around the engine, exhaust manifold, muffler, or battery, or inside the undercovers.

- **Fire coming from electric wiring**

Short circuits in the electrical system can cause fire. To prevent fire, always observe the following.

- Keep all electric wiring connections clean and securely tightened.
- Check the wiring every day for looseness or damage. Tighten any loose connectors or wiring clamps. Repair or replace any damaged wiring.

- **Fire coming from piping**

Check that all the hose and tube clamps, guards, and cushions are securely fixed in position.

If they are loose, they may vibrate during operation and rub against other parts. There is danger that this may lead to damage to the hoses and cause high-pressure oil to spurt out, leading to fire, serious personal injury or death.

- **Explosion caused by lighting equipment**

- When checking fuel, oil, battery electrolyte, or coolant, always use lighting with anti-explosion specifications.

PRECAUTIONS WHEN GETTING ON OR OFF MACHINE

USE HANDRAILS AND STEPS WHEN GETTING ON OR OFF MACHINE

To prevent personal injury caused by slipping or falling off the machine, always do as follows.

- Use the handrails and steps marked by arrows (A) in the diagram on the right when getting on or off the machine.

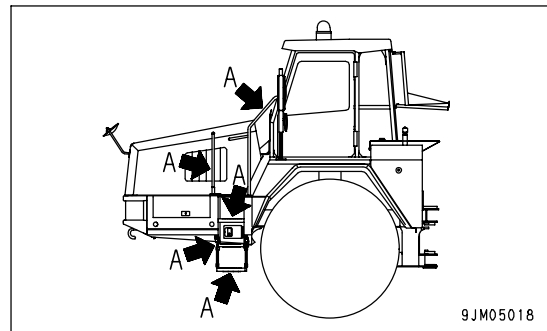

- The handrails and steps marked by arrows (B) are for escaping in emergencies.

Use these when escaping from the machine in a fire or other emergencies. Do not use them in normal situations.

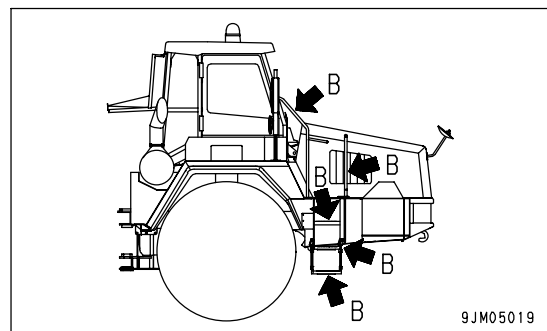

- Always face the machine and maintain at least three-point contact (both feet and one hand, or both hands and one foot) with the handrail and steps to ensure that you support yourself.

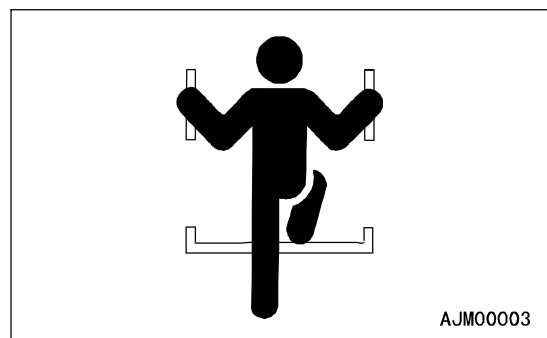

- Before getting on or off the machine, check the handrails and steps, and if there is any oil, grease, or mud on them, wipe it off immediately. In addition, repair any damage and tighten any loose bolts.
- Do not grip the control levers when getting on or off the machine.
- Never climb on the engine hood or covers where there are no non-slip pads.
- Do not get on or off the machine while holding tools in your hand.

NO JUMPING ON OR OFF MACHINE

- Never jump on or off the machine. Never get on or off a moving machine.
- If the machine starts to move when there is no operator on the machine, do not jump on to the machine and try to stop it.

NO PEOPLE ON DUMP BODY

Never let anyone ride in the dump body. There is danger of falling and suffering serious personal injury.

PRECAUTIONS WHEN STANDING UP FROM OPERATOR'S SEAT

Before standing up from the operator's seat to adjust the operator's seat, always lower the dump body completely, lock with dump lever lock knob (1), set gear shift lever (2) to the N position, set parking brake switch (3) to the PARKING position, then stop the engine.

If this is not done and the control levers are touched by mistake, there is danger that the machine may suddenly move and cause serious personal injury or death.

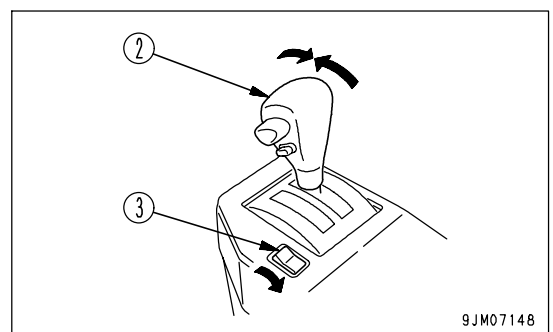
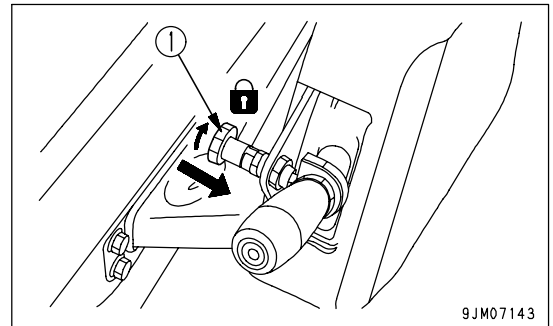
**PRECAUTIONS WHEN LEAVING MACHINE**

If the proper procedures are not taken when parking the machine, the machine may suddenly move off by itself, and this may lead to serious personal injury or death. Always do the following.

- When leaving the machine, always lower the dump body completely, lock with dump lever lock knob (1), set gear shift lever (2) to the N position, set parking brake switch (3) to the PARKING position, then stop the engine.

Lock all places and always take the key with you and leave it in the specified location.

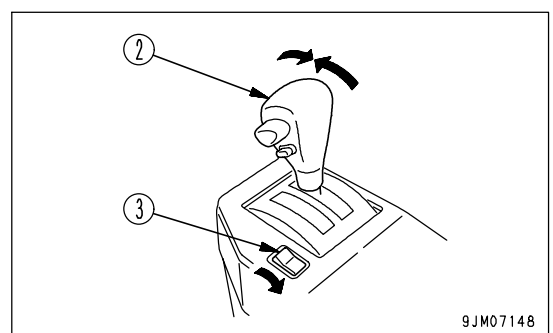
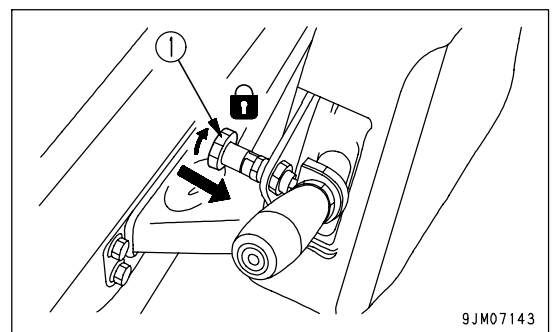

EMERGENCY EXIT FROM OPERATOR'S CAB

Machines equipped with a cab have doors on the left and right sides. If the door on the one side does not open, escape from the door on the other side.

DO NOT GET CAUGHT IN ARTICULATING PORTION AND DUMP BODY

- If the clearance at the articulating portion changes and you get caught in it, you will suffer serious personal injury or death. Do not allow anyone to come inside the articulation range.
- The clearance in the area around the dump body changes according to the movement of the dump body. If you are caught, there is danger that you will suffer serious injury or death. Do not allow anyone near any of the rotating or telescopic parts.

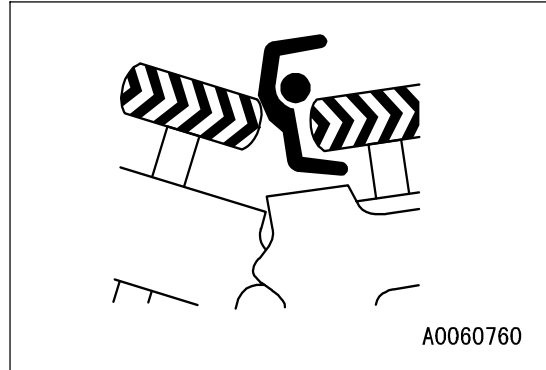
**PRECAUTIONS RELATED TO PROTECTIVE STRUCTURES**

The operator's compartment is equipped with a structure (such as ROPS, FOPS) to protect the operator by absorbing the impact energy. As for the machine equipped with ROPS, if the machine weight (mass) exceeds the certified value (shown on the ROLL-OVER PROTECTIVE STRUCTURE (ROPS) CERTIFICATION plate), ROPS will not be able to fulfill its function. Do not increase machine weight beyond the certified value by modifying the machine or by installing attachments to the machine. Also, if the function of the protective equipment is impeded, the protective equipment will not be able to protect the operator, and the operator may suffer injury or death. Always observe the following.

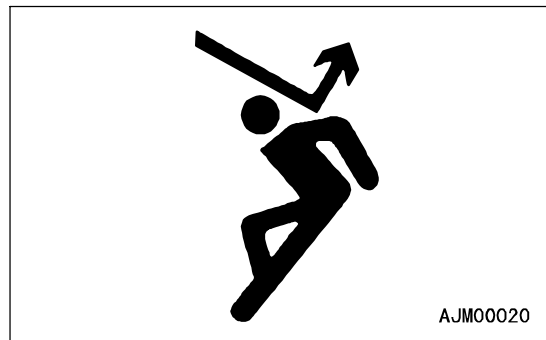

- If the machine is equipped with a protective structure, do not remove the protective structure and carry out operations without it.
- If the protective structure is welded, or holes are drilled in it, or it is modified in any other way, its strength may drop. Consult your Komatsu distributor before carrying out any modifications.
- If the protective structure is damaged or deformed by falling objects or by rolling over, its strength will be reduced and it will not be able to fulfill its function properly. In such cases, always contact your Komatsu distributor for advice on the method of repair.
- Even if the protective structure is installed, always fasten your seat belt properly when operating the machine. If you do not fasten your seatbelt properly, it cannot display its effect.

UNAUTHORIZED MODIFICATION

- Komatsu will not be responsible for any injuries, accidents, product failures or other property damages resulting from modifications made without authorization from Komatsu.
- Any modification made without authorization from Komatsu can create hazards. Before making a modification, consult your Komatsu distributor.
- Do not try to increase the capacity of the dump body or make any other modifications. Such modifications will cause a drop in the braking efficiency, the balance of the machine will become poor, and this may lead to an unexpected accident.

PRECAUTIONS RELATED TO ATTACHMENTS AND OPTIONS

- Any injuries, accidents, product failures or other property damages resulting from the use of unauthorized attachments or parts will not be the responsibility of Komatsu.
- When installing optional parts or attachments, there may be problems with safety or legal restrictions. Therefore contact your Komatsu distributor for advice.
- When installing and using optional attachments, read the instruction manual for the attachment, and the general information related to attachments in this manual.

PRECAUTIONS WHEN RUNNING ENGINE INSIDE BUILDING

The engine exhaust gas contains substances that may damage your health or even cause death. Start or operate the engine in a place where there is good ventilation. If the engine or machine must be operated inside a building or under ground, where the ventilation is poor, take steps to ensure that the engine exhaust gas is removed and that ample fresh air is brought in.

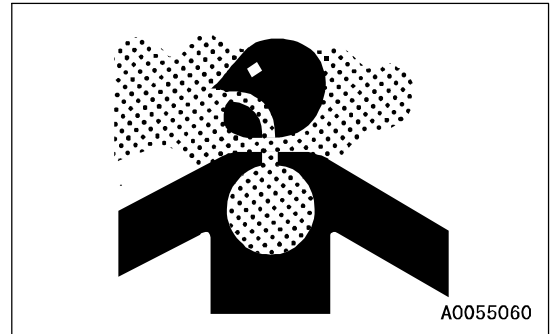

PRECAUTIONS FOR OPERATION

PRECAUTIONS FOR JOBSITE

INVESTIGATE AND CONFIRM JOBSITE CONDITIONS

On the jobsite, there are various hidden dangers that may lead to personal injury or death. Before starting operations, always check the following to confirm that there is no danger on the jobsite.

- Check the terrain and condition of the ground at the worksite, and determine the safest method of operation. Do not operate where there is a hazard of landslides or falling rocks.
- Take necessary measures to prevent any unauthorized person from entering the operating area.
- When traveling or operating in water or on soft ground, check the water depth, speed of the current, bedrock, and shape of the ground beforehand and avoid any place that will obstruct travel.
- Maintain the travel path on the jobsite so that there is no obstruction to travel operations.

WORKING ON LOOSE GROUND

- Avoid traveling or operating your machine too close to the edge of cliffs, overhangs, and deep ditches. The ground may be weak in such areas. If the ground should collapse under the weight or vibration of the machine, there is a hazard that the machine may fall or tip over. Remember that the soil after heavy rain or blasting or after earthquakes is weak in these areas.
- When working on embankments or near excavated ditches, there is a hazard that the weight and vibration of the machine will cause the soil to collapse. Before starting operations, take steps to ensure that the ground is safe and to prevent the machine from rolling over or falling.

DO NOT GO CLOSE TO HIGH-VOLTAGE CABLES

Do not travel or operate the machine near electric cables. There is a hazard of electric shock, which may cause serious personal injury or death. On jobsites where the machine may go close to electric cables, always do as follows.

- Before starting work near electric cables, inform the local power company of the work to be performed, and ask them to take the necessary action.

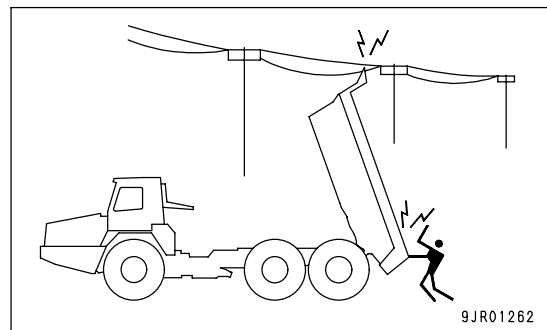

- Even going close to high-voltage cables can cause electric shock, which may cause serious burns or even death. Always maintain a safe distance (see the table on the right) between the machine and the electric cable. Check with the local power company about safe operating procedure before starting operations.
- To prepare for any possible emergencies, wear rubber shoes and gloves. Lay a rubber sheet on top of the seat, and be careful not to touch the chassis with any exposed part of your body.
- Use a signalman to give warning if the machine approaches too close to the electric cables.

Voltage of Cables	Safety Distance
100V - 200V	Over 2 m (7 ft)
6,600V	Over 2 m (7 ft)
22,000V	Over 3 m (10 ft)
66,000V	Over 4 m (14 ft)
154,000V	Over 5 m (17 ft)
187,000V	Over 6 m (20 ft)
275,000V	Over 7 m (23 ft)
500,000V	Over 11 m (36 ft)

- When carrying out operations near high voltage cables, do not let anyone near the machine.
- If the machine should come too close or touch the electric cable, to prevent electric shock, the operator should not leave the operator's compartment until it has been confirmed that the electricity has been shut off. Also, do not let anyone near the machine.

ENSURE GOOD VISIBILITY

This machine is equipped with mirrors to ensure good visibility, but even then there are places that cannot be seen from the operator's seat, so be careful when operating.

When traveling or carrying out operations in places with poor visibility, it is impossible to check for obstacles in the area around the machine and to check the condition of the jobsite. This leads to danger of serious personal injury or death. When traveling or carrying out operations in places with poor visibility, always observe the following.

- Position a signalman if there are areas where the visibility is not good.
- Only one signalman should give signals.
- When working in dark places, turn on the working lamp and front lamps installed to the machine, and set up additional lighting in the work area if necessary.
- Stop operations if the visibility is poor, such as in mist, snow, rain, or dust.
- When checking the mirrors installed to the machine, remove all dirt and adjust the angle of the mirror to ensure good visibility.
- If the machine is equipped with cameras, clean off any dirt from the lens and make sure that the camera gives a clear view.

CHECKING SIGNS AND SIGNALMAN'S SIGNALS

- Set up signs to inform of road shoulders and soft ground. If the visibility is not good, position a signalman if necessary. Operators should pay careful attention to the signs and follow the instructions from the signalman.
- Only one signalman should give signals.
- Make sure that all workers understand the meaning of all signals and signs before starting work.

BEWARE OF ASBESTOS DUST

Asbestos dust in the air can cause lung cancer if it is inhaled. There is danger of inhaling asbestos when working on jobsites handling demolition work or work handling industrial waste. Always observe the following.

- Spray water to keep down the dust.
- Do not use compressed air.
- If there is danger that there may be asbestos dust in the air, always operate the machine from an upwind position, and make sure that all workers operate on the upwind side.
- All workers should use anti-dust masks.
- Do not allow other persons to approach during the operation.
- Always observe the rules and regulations for the work site and environmental standards.

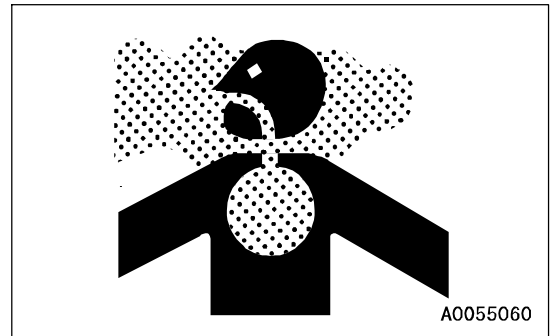

This machine does not use asbestos, but there is a danger that imitation parts may contain asbestos, so always use genuine Komatsu parts.

STARTING ENGINE

USE WARNING TAGS

If there is any "DANGER! Do NOT operate!" warning tag displayed, it means that someone is carrying out inspection and maintenance of the machine. If the warning sign is ignored and the machine is operated, there is danger that the person carrying out inspection or maintenance may be caught in the rotating parts or moving parts and suffer serious personal injury or death. Do not start the engine or touch the levers.

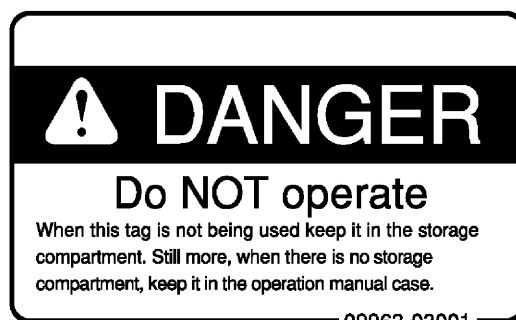
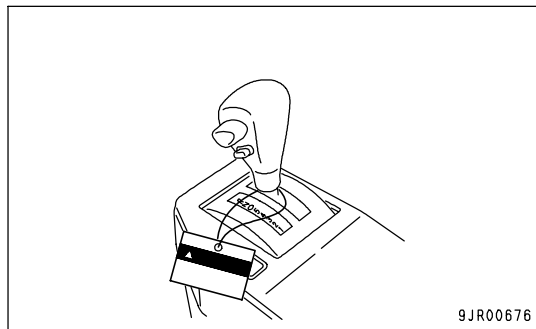

09963-03001

CHECKS BEFORE STARTING ENGINE

Carry out the following checks before starting the engine at the beginning of the day's work to ensure that there is no problem with the operation of the machine. If this inspection is not carried out properly problems may occur with the operation of the machine, and there is danger that this may lead to serious personal injury or death.

- Remove all dirt from the surface of the window glass to ensure a good view.
- Carry out the "WALK-AROUND CHECK (PAGE 3-69)".
- Remove all dirt from the surface of the lens of the front lamps, working lamps, and rear combination lamp, and check that they light up correctly.
- Check the coolant level, fuel level, and oil level in engine oil pan, check for clogging of the air cleaner, and check for damage to the electric wiring.
- Check that there is no mud or dust accumulated around the movable parts of the accelerator pedal or brake pedal, and check that the pedals work properly.
- Adjust the operator's seat to a position where it is easy to carry out operations, and check that there is no damage or wear to the seat belt or mounting clamps.
- Check that the gauges work properly, check the angle of the mirrors, and check that the gear shift lever is at the N position and that the dump control lever is at the HOLD position.
- Before starting the engine, check that the lock knob of the dump control lever is at the LOCK position.
- Adjust the mirrors so that the rear of the machine can be seen easily from the operator's seat. For details of the method of adjusting, see "ADJUSTING MIRROR (PAGE 3-82)".
- Check that there are no persons or obstacles above, below, or in the area around the machine.
- Check that the parking brake switch is at the PARKING position.
- Check that the articulation lock is fixed securely at the FREE position.

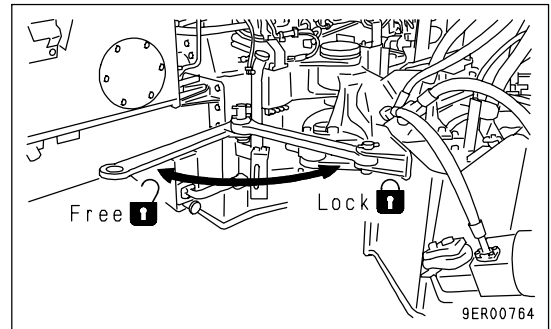
**PRECAUTIONS WHEN STARTING ENGINE**

- Start and operate the machine only while seated.
- When starting the engine, sound the horn as a warning.
- If another person is allowed on the machine, that person may sit only in the assistant's seat.
- Do not attempt to start the engine by short-circuiting the engine starting circuit. This may cause fire, serious personal injury or death.
- Check that the backup alarm (alarm buzzer when machine travels in reverse) works properly.

PRECAUTIONS IN COLD AREAS

- Carry out the warming-up operation thoroughly. If the machine is not thoroughly warmed up before the control levers are operated, the reaction of the machine will be slow, and this may lead to unexpected accidents.
- If the battery electrolyte is frozen, do not charge the battery or start the engine with a different power source. There is a hazard that this will ignite the battery and cause the battery to explode.
Before charging or starting the engine with a different power source, melt the battery electrolyte and check that there is no leakage of electrolyte before starting.

STARTING WITH BOOSTER CABLES

If any mistake is made in the method of connecting the booster cables, it may cause the battery to explode, so always do as follows.

- Always wear safety goggles and rubber gloves when starting the engine with booster cable.
- When connecting a normal machine to a problem machine with booster cables, always use a normal machine with the same battery voltage as the problem machine.
- When starting with a booster cable, carry out the starting operation with two workers (one worker sitting in the operator's seat and the other working with the battery).
- When starting from another machine, do not allow the two machines to touch.
- When connecting the booster cables, turn the starting switch to the OFF position for both the normal machine and problem machine. There is a hazard that the machine will move when the power is connected.
- Be sure to connect the positive (+) cable first when installing the booster cables. Disconnect the negative (-) cable (ground side) first when removing them.
- When removing the booster cables, be careful not to let the booster cable clips touch each other or to let the clips touch the machine.
- For details of the starting procedure when using booster cables, see "STARTING ENGINE WITH BOOSTER CABLE (PAGE 3-133)" in the OPERATION section.

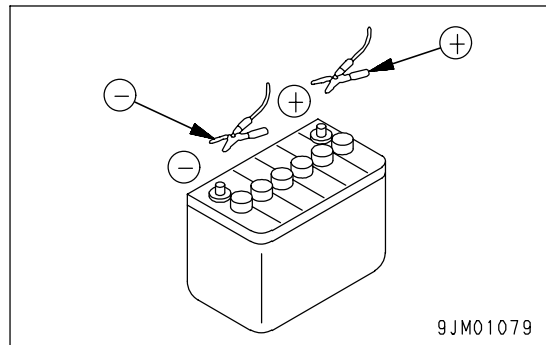
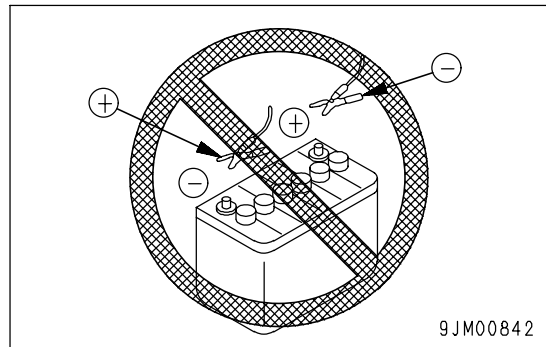

OPERATION

CHECKS BEFORE OPERATION

If the checks before starting are not carried out properly, the machine will be unable to display its full performance, and there is also danger that it may lead to serious personal injury or death.

When carrying out the checks, move the machine to a wide area where there are no obstructions, and pay careful attention to the surrounding area. Do not allow anyone near the machine.

- Always wear the seatbelt. There is danger that you may be thrown out of the operator's seat and suffer serious injury when the brakes are applied suddenly.
 - Check the operation of travel, steering and brake systems, and dump body control system.
 - Check for any problem in the sound of the machine, vibration, heat, smell, or gauges; check also that there is no leakage of oil or fuel.
 - If any problem is found, carry out repairs immediately.
- Before starting to travel or carry out operations, check that articulation lock (1) is fixed securely at the FREE position.

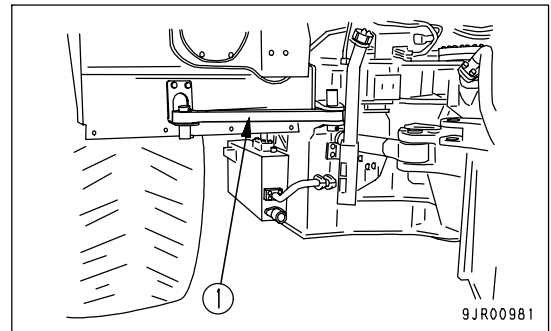
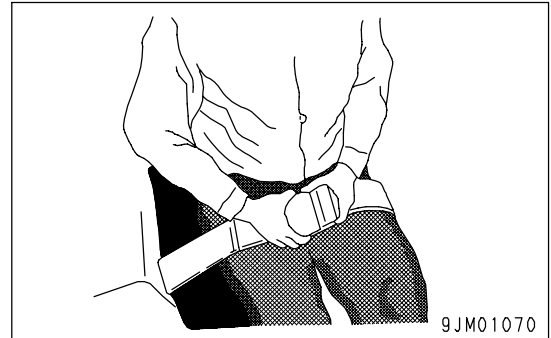

PRECAUTIONS WHEN TRAVELING IN FORWARD OR REVERSE

- Lock the cab door and windows securely, both when they are open and when they are closed.
- If another person is allowed on the machine, that person may sit only in the assistant's seat.
- If there are any persons in the area around the machine, there is danger that they may be hit or caught by the machine, and this may lead to serious personal injury or death. Always observe the following before traveling.
 - Always operate the machine only when seated.
 - Before moving off, check again that there is no person or obstruction in the surrounding area.
 - Before moving, sound the horn to warn people in the surrounding area.
 - Check that the backup alarm (alarm buzzer when machine travels in reverse) works properly.
 - If there is an area to the rear of the machine which cannot be seen, position a signalman.

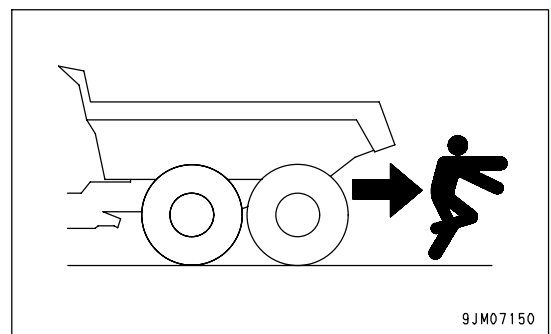

Always be sure to carry out the above precautions even when the machine is equipped with mirrors and cameras.

PRECAUTIONS WHEN TRAVELING

- Never turn the key in the starting switch to the OFF position. It is dangerous if the engine stops when the machine is traveling, because the steering becomes heavy. There is danger that this will cause misoperation of the steering wheel and may lead to serious personal injury or death. If the engine stops, depress the brake pedal immediately to stop the machine.
- When traveling or carrying out operations, always keep a safe distance from people, structures, or other machines to avoid coming into contact with them.
- Try to avoid having the machine climb over obstacles. If that is unavoidable, let the machine do that at a low speed. Nonetheless avoid a big obstacle that greatly tilts the machine to the right or left, because in such a case the machine can easily overturn sideways.
- When traveling on rough ground, travel at low speed and avoid sudden changes in direction to prevent the machine from turning over.
- Do not load the dump body above the maximum payload. The brakes will lose their effect.
- Lower the dump body, setting the dump lever at FLOAT position, then travel.
- When passing over bridges or structures, check first that the structure is strong enough to support the weight of the machine.
- When operating in tunnels, under bridges, under electric wires, or other places where the height is limited, operate slowly and be extremely careful not to let the machine body or work equipment hit anything.
- If you drive the machine at high speed continuously for a long time, the tires will overheat and the internal pressure will become abnormally high. This may cause the tires to burst. If a tire bursts, it produces a large destructive force, and this may cause serious injury or death.

If you are going to travel continuously, please consult your Komatsu distributor.

- When travelling, and particularly when travelling downhill, never set the gear shift lever to the Neutral position. Always keep it in a speed range when travelling.
 - If the gear shift lever is at Neutral, it will be impossible to use the braking force of the engine and the steering will become heavier. In addition, there will be insufficient cooling oil for the retarder, so there is danger that this will result in overheating, which will lead to defective operation of the brakes.
 - The transmission and other parts of the power train may be damaged, and there is danger that this will lead to serious injury or death.

TRAVELING ON SLOPES

To prevent the machine from tipping over or slipping to the side, always do as follows.

- When traveling downhill, use the retarder brake to reduce speed. Do not turn the steering wheel suddenly.
- Travel on grass, fallen leaves, or wet steel plates with low speed. Even with slight slopes there is a hazard that the machine may slip.
- If the engine should stop on a slope, apply the brakes fully and apply the parking brake also to stop the machine.
- Do not shift gear while traveling downhill or travel downhill with the transmission in neutral.
It is dangerous if the engine has no braking effect. Always set the transmission to a lower gear before starting to travel downhill.

PRECAUTIONS WHEN OPERATING

- When using the machine, to prevent personal injury caused by damage to the work equipment or by the machine overturning due to overloading, do not exceed the permitted performance of the machine or the maximum permitted load for the structure of the machine.
- When operating in tunnels, or under bridges or electric wires, or in other places where the height is limited, operate slowly and be extremely careful not to let the dump body contact anything.
- To prevent accidents caused by hitting other objects, always operate the machine at a speed which is safe for operation, particular in confined spaces, indoors, and in places where there are other machines.

PRECAUTIONS WHEN LOADING DUMP BODY

- Do not load the dump body so that the load is on one side. Always carry out loading that the load is spread uniformly.
- Do not leave or return to the operator's seat while the dump body is being loaded.

PRECAUTIONS WHEN OPERATING DUMP BODY

- Before starting the dumping operation, check to be sure there is no person or object behind the machine.
- Stop the machine in the correct position, and check again that there is no person or object behind the machine. Give the determined signal, then slowly operate the dump body. If necessary, use blocks for the wheels or position a flagman.
- Not carry out dumping operations on slopes. The machine stability will become poor and there is danger that it may tip over.
- Do not travel with the body raised.
- When carrying out dumping operations, set the machine in a straight line. If dumping operations are carried out with the machine articulated, the machine stability will become poor there is danger that it may tip over.
- Be careful when raising the dump body. When the dump body is raised, the center of gravity of the machine changes continuously. If the ground is soft, this will affect the stability of the machine.
- Take care particularly when dumping sticky material (wet clay, frozen material, etc.) on a soft ground. The stability of the machine is reduced and there is danger that it may tip over.

TRAVELING ON SNOW-COVERED OR FROZEN SURFACES

- Snow-covered or frozen surfaces are slippery, so be extremely careful when traveling or operating the machine, and do not operate the levers suddenly. Even a slight slope may cause the machine to slip, so be particularly careful when working on slopes.
- With frozen ground surfaces, the ground becomes soft when the temperature rises, and this may cause the machine to tip over or make it impossible for the machine to escape.
- When traveling on snow-covered roads, always fit tire chains.
- If the machine enters deep snow, there is a hazard that it may tip over or become buried in the snow. Be careful not to leave the road shoulder or to get trapped in a snow drift.
- Do not apply the brakes suddenly on snow-covered slopes. Reduce speed, use the braking force of the engine, and pump the brakes (depress the brake pedal several times) to stop the machine.
- Do not try to carry out dumping operations when the load inside the dump body is frozen. There is danger that this may cause the machine to tip over.

PARKING MACHINE

- Park the machine on firm, level ground.
- Select a place where there is no hazard of landslides, falling rocks, or flooding.
- When leaving the machine, always lower the dump body completely, lock with dump lever lock knob (1), set gear shift lever (2) to the N position, set parking brake switch (3) to the PARKING position, then stop the engine.
- Always close the operator's cab door, and use the key to lock all the equipment in order to prevent any unauthorized person from moving the machine. Always remove the key, take it with you, and leave it in the specified place.

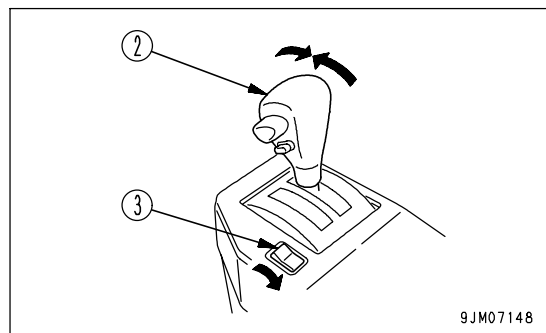
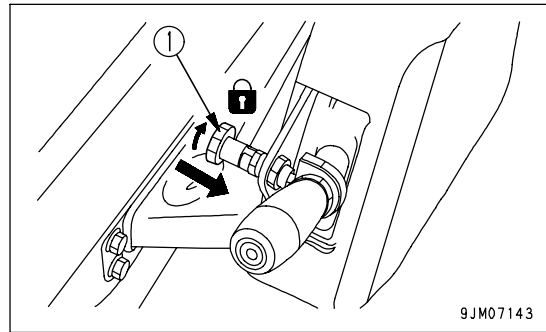

- If it is necessary to park the machine on a slope, set blocks under the wheels to prevent the machine from moving.

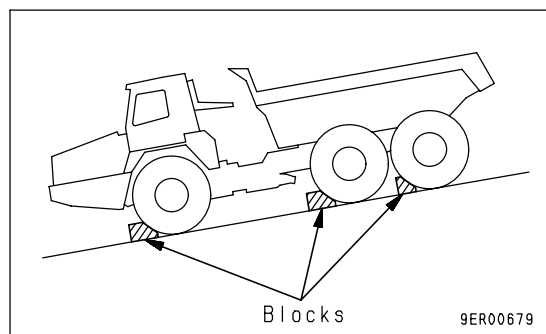

TRANSPORTATION

When the machine is transported on a trailer, there is danger of serious personal injury or death during transportation. Always do as follows.

- Always check the machine dimensions carefully. Depending on the attachments installed, the machine weight, transportation height, and overall length may differ.
- Check beforehand that all bridges and other structures on the transportation route are strong enough to withstand the combined weight of the transporter and the machine being transported.
- The machine can be divided into parts for transportation, so when transporting the machine, please contact your Komatsu distributor to have the work carried out.
- Lock the articulation lock to prevent the machine from articulating.
- For the procedure when transporting, see "TRANSPORTATION (PAGE 3-115)".

LOADING AND UNLOADING

When loading or unloading the machine, mistaken operation may bring the hazard of the machine tipping over or falling, so particular care is necessary. Always do as follows.

- Perform loading and unloading on firm, level ground only. Maintain a safe distance from the edge of the road or cliff.
 - Always use ramps of adequate strength. Be sure that the ramps are wide, long, and thick enough to provide a safe loading slope. Take suitable steps to prevent the ramps from moving out of position or coming off.
 - Be sure the ramp surface is clean and free of grease, oil, ice and loose materials. Remove dirt from the tire of the machine. On a rainy day, in particular, be extremely careful since the ramp surface is slippery.
 - Run the engine at low idling and drive the machine slowly at low speed.
 - Never correct your steering on the ramps. If necessary, drive off the ramps, correct the direction, then enter the ramps again.
 - When loading or unloading to an embankment or platform, make sure that it has suitable width, strength, and grade.
 - For machines equipped with a cab, always lock the door after loading the machine. If this is not done, the door may open during transportation.
- For details, see "TRANSPORTATION (PAGE 3-115)".

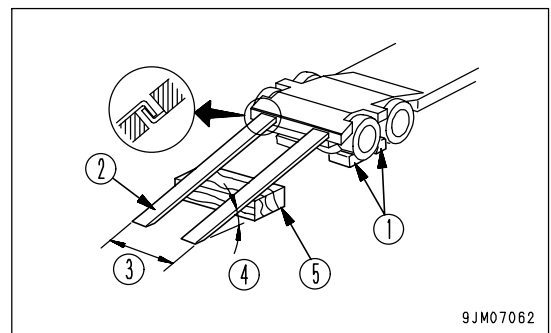

- (1) Blocks
- (2) Ramp
- (3) Width of ramps: Same width as tiers
- (4) Angle of ramps: Max. 15°
- (5) Block

TOWING

WHEN TOWING

Always use the correct towing equipment and towing method. Any mistake in the selection of the wire rope or towing bar or in the method of towing a disabled machine may lead to serious personal injury or death.

For details of the procedure for towing, see the "METHOD OF TOWING MACHINE (PAGE 3-127)"

- Always confirm that the wire rope or drawbar used for towing has ample strength for the weight of the machine being towed.
- Never use a wire rope which has cut strands (A), reduced diameter (B), or kinks (C). There is danger that the rope may break during the towing operation.
- Always wear leather gloves when handling wire rope.
- Never tow a machine on a slope.
- During the towing operation, never stand between the towing machine and the machine being towed.

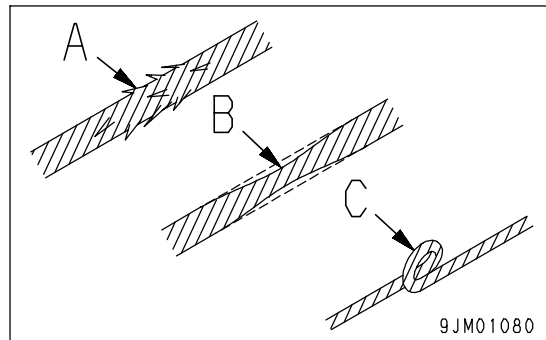

PRECAUTIONS FOR MAINTENANCE

PRECAUTIONS BEFORE STARTING INSPECTION AND MAINTENANCE

DISPLAY WARNING TAG DURING INSPECTION AND MAINTENANCE

If there is any "DANGER! Do NOT operate!" warning tag displayed, it means that someone is carrying out inspection and maintenance of the machine. If the warning sign is ignored and the machine is operated, there is danger that the person carrying out inspection or maintenance may be caught in the rotating parts or moving parts and suffer serious personal injury or death. Do not start the engine or touch the levers.

- If necessary, put up signs around the machine also.
Warning tag part number: 09963-03001
When not using this warning tag, keep it in the toolbox.
If there is no toolbox, keep it in the pocket for the Operation and Maintenance Manual

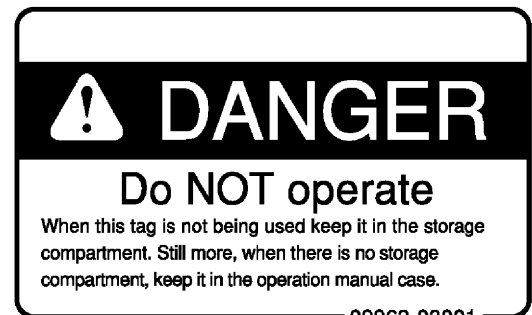
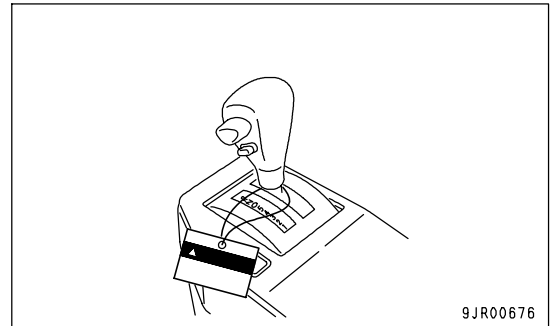

KEEP WORKPLACE CLEAN AND TIDY

Do not leave hammers or other tools lying around in the work place. Wipe up all grease, oil, or other substances that will cause you to slip. Always keep the work place clean and tidy to enable you to carry out operations safely. If the work place is not kept clean and tidy, there is the danger that you will trip, slip, or fall over and injure yourself.

SELECT SUITABLE PLACE FOR INSPECTION AND MAINTENANCE

- Stop the machine on firm, level ground.
- Select a place where there is no hazard of landslides, falling rocks, or flooding.

ONLY AUTHORIZED PERSONNEL

Do not allow any unauthorized personnel into the area when servicing the machine. If necessary, employ a guard.

APPOINT LEADER WHEN WORKING WITH OTHERS

When repairing the machine or when removing and installing the work equipment, appoint a leader and follow his instructions during the operation.

STOP ENGINE BEFORE CARRYING OUT INSPECTION AND MAINTENANCE

- Always stop the machine before performing any inspection and maintenance.

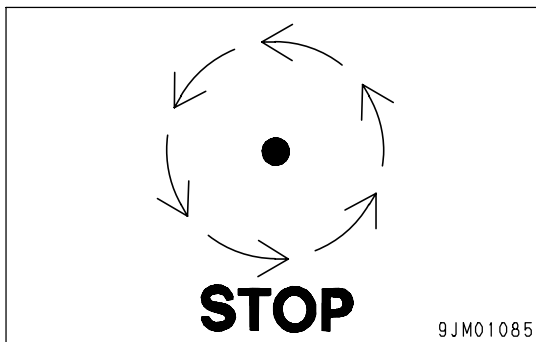

- Lower the dump body completely, set dump lever (1) to the HOLD position, lock with dump lever lock knob (2), then stop the engine.

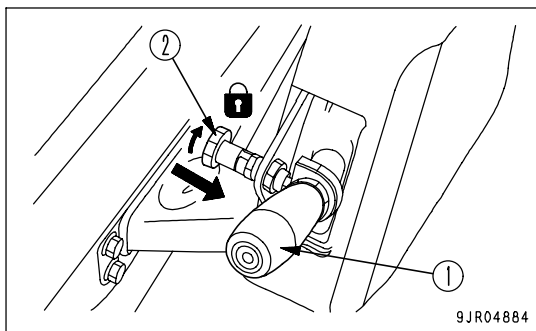

- Set parking brake switch (3) to the PARKING position to apply the parking brake, then put blocks in front of and behind the tires to prevent the machine from moving.

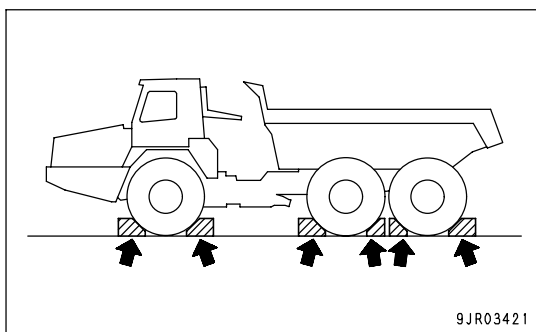
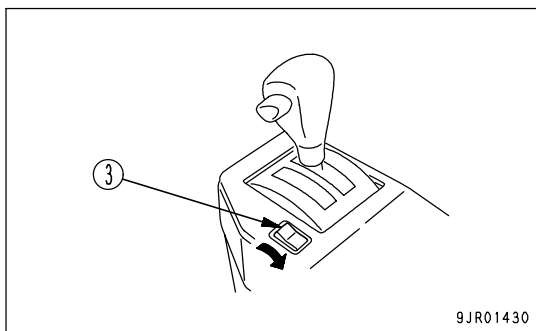

- Lock the front and rear frames with articulation lock (4).

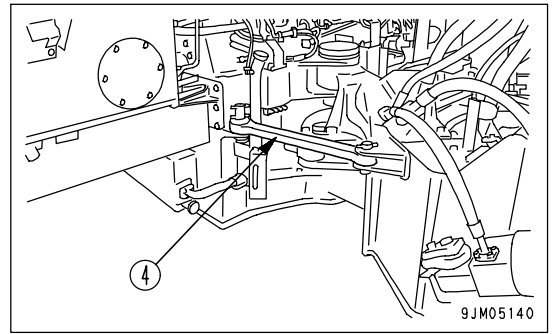

TWO WORKERS FOR MAINTENANCE WHEN ENGINE IS RUNNING

To prevent personal injury, do not carry out maintenance with the engine running. If maintenance must be carried out with the engine running, carry out the operation with at least two workers and do as follows.

- One worker must always sit in the operator's seat and be ready to stop the engine at any time. All workers must maintain contact with the other workers.
- When carrying out operations near the fan, fan belt, or other rotating parts, there is a hazard of being caught in the parts, so be careful not to come close.
- Never drop or insert tools or other objects into the fan, fan belt, or other rotating parts. There is danger that they may contact the rotating parts and break or be sent flying.

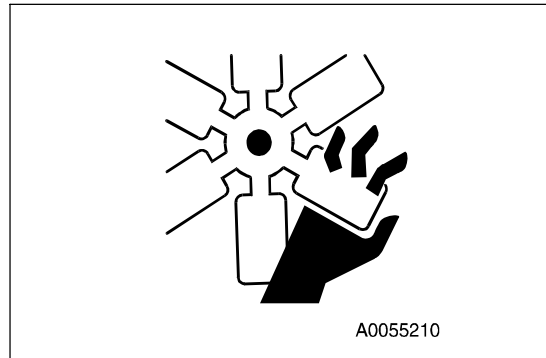

- Lower the dump body completely, set dump lever (1) to the HOLD position, lock with dump lever lock knob (2), and take steps to prevent the dump body from moving.

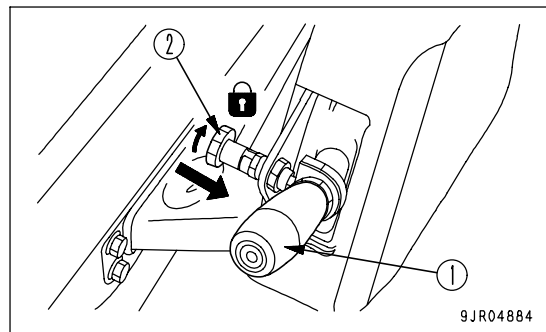

- Set parking brake switch (3) to the PARKING position to apply the parking brake, then put blocks in front of and behind the tires to prevent the machine from moving.
- Do not touch any control levers. If any control lever must be operated, give a signal to the other workers to warn them to move to a safe place.

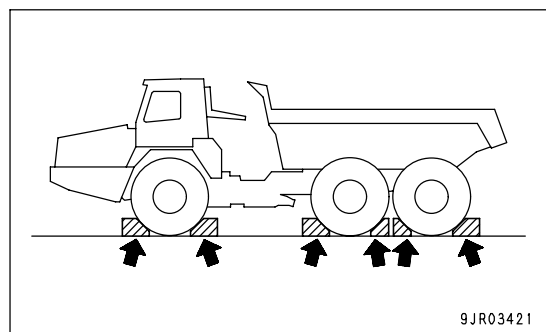
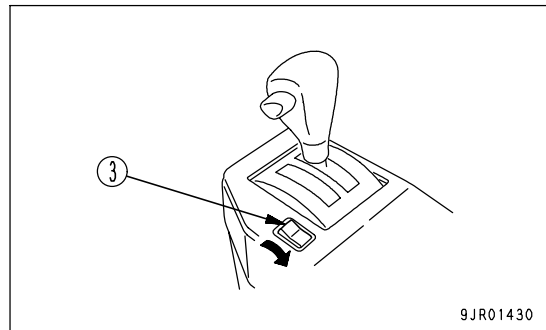

INSTALLING, REMOVING, OR STORING ATTACHMENTS

- Appoint a leader before starting removal or installation operations for attachments.
- Place attachments that have been removed from the machine in a stable condition so that they do not fall. And take steps to prevent unauthorized persons from entering the storage area.

**PRECAUTIONS WHEN WORKING AT HIGH PLACES**

When working at high places, use a step ladder or other stand to ensure that the work can be carried out safely.

PRECAUTIONS WHEN WORKING UNDER MACHINE

- When carrying out inspection with the dump body raised, always set the dump control lever to the HOLD position, set the lock knob to the LOCK position, then insert the body pivot pin. If the body pivot pin is not inserted, the dump body may go down when the dump control lever is operated, and catch or cause serious injury or even death to the person carrying out the inspection.
- Always carry out the operation to remove or insert the body pivot pin with at least two workers. This operation is carried out with the dump body raised, so if the dump body comes down during the operation, it may lead to serious injury or even death.

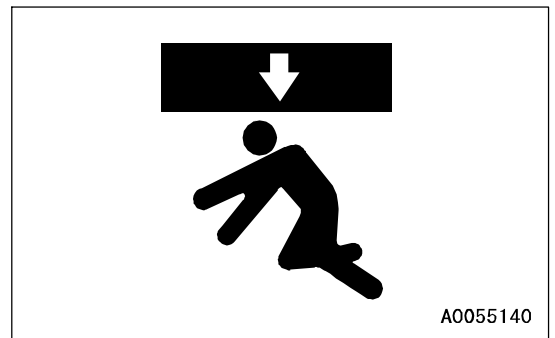

A0055140

For details, see "BODY PIVOT PIN (PAGE 3-45)".

- Make sure the hoists or jacks you use are in good repair and strong enough to handle the weight of the component. Never use jacks at places where the machine is damaged, bent, or twisted. Never use frayed, twisted or pinched wire rope. Never use bent or distorted hooks.
- Never use concrete blocks for supports. They can collapse under even light loads.

PROPER TOOLS

Use only tools suited to the task and be sure to use the tools correctly. Using damaged, deformed, or low quality tools, or making improper use of the tools may cause serious personal injury.

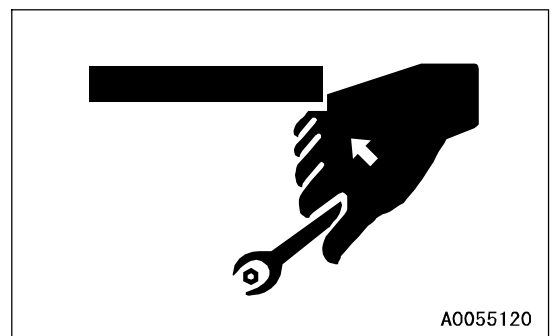

A0055120

PRECAUTIONS FOR INSPECTION AND MAINTENANCE

PRECAUTIONS WHEN WELDING

Welding operations must always be carried out by a qualified welder and in a place equipped with proper equipment. There is a hazard of gas, fire, or electrocution when carrying out welding, so never allow any unqualified personnel to carry out welding.

HANDLING BATTERY

Before inspecting or handling the battery, turn the key in the starting switch to the OFF position.

- When installing the optional battery disconnecter switch, turn the battery disconnecter switch to the OFF position. For details, see "HANDLING BATTERY DISCONNECTOR SWITCH (PAGE 6-41)".

- **Danger of battery exploding**

When the battery is being charged, flammable hydrogen gas is generated and may explode. In addition, the battery electrolyte includes dilute sulphuric acid. Any mistake in handling may cause serious personal injury, explosion, or fire, so always observe the following.

- Do not use or charge the battery if the battery electrolyte is below the LOWER LEVEL mark. This will cause explosion. Always carry out periodic inspection of the battery electrolyte level, and add distilled water (or commercially available battery filler solution) to the UPPER LEVEL mark.
- Do not smoke or bring any flame close to the battery.
- Hydrogen gas is generated when the battery is being charged, so remove the battery from the machine, take it to a well-ventilated place, remove the battery caps, then carry out the charging.
- After charging, tighten the battery caps securely.

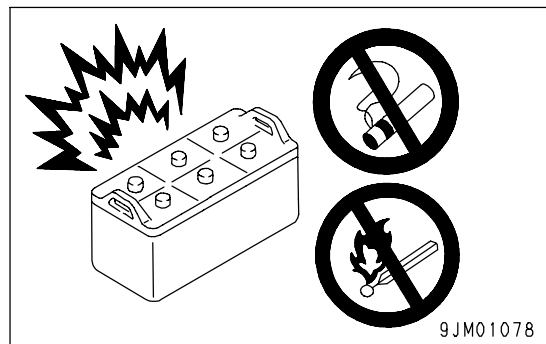

- **Danger from dilute sulphuric acid**

When the battery is being charged, flammable hydrogen gas is generated and may explode. In addition, the battery electrolyte includes dilute sulphuric acid. Any mistake in handling may cause serious personal injury, explosion, or fire, so always observe the following.

- When handling the battery, always wear protective goggles and rubber gloves.
- If battery electrolyte gets into your eyes, immediately wash your eyes with large amounts of fresh water. After that, get medical attention immediately.
- If battery electrolyte gets on your clothes or skin, wash it off immediately with large amounts of water.

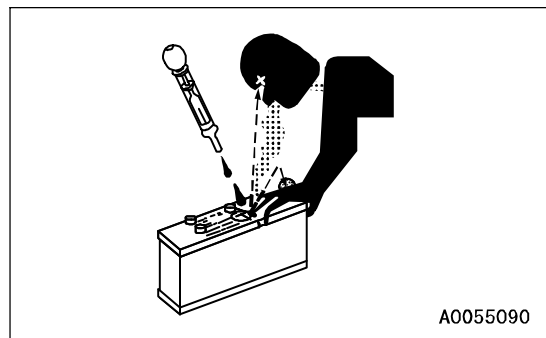

- **Removing battery cables**

Before repairing the electrical system or carrying out electrical welding, turn the starting switch OFF. Wait for approx. 1 minute, then remove the negative (-) battery cable to stop the flow of electricity.

- For machines equipped with a battery disconnecter switch, set the battery disconnecter switch to the OFF position.

For details, see "HANDLING BATTERY DISCONNECTOR SWITCH (PAGE 6-41)".

- **Danger of sparks**

There is hazard that sparks will be generated, so always observe the following.

- Do not let tools or other metal objects make any contact between the battery cables. Do not leave tools lying around near the battery.
- When removing the battery cables, remove the ground cable (negative (-) cable) first. When installing, connect the positive (+) cable first, then connect the ground. Tighten the battery cable terminals securely.
- Secure the battery firmly in the specified position.

PRECAUTIONS WHEN USING HAMMER

When using a hammer, pins may fly out or metal particles may be scattered. This may lead to serious personal injury or death. Always do as follows.

- If pins are hit with a hammer, there is a hazard that the metal particles may fly out and injure people in the surrounding area. Always make sure that no-one is in the surrounding area before using the hammer.
- If hard metal parts such as pins, or bearings are hit with a hammer, there is a hazard that pieces might be scattered and cause serious personal injury or death. Always wear safety glasses and gloves.
- If the pin is hit with strong force, there is a hazard that it may fly out and injure people in the surrounding area. Do not allow anyone to enter the surrounding area.

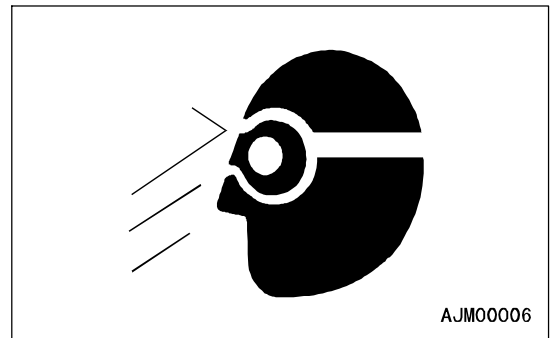

PRECAUTIONS WITH HIGH-TEMPERATURE COOLANT

To prevent burns from boiling water or steam spurting out when checking or draining the coolant, wait for the coolant to cool down to a temperature where the radiator cap can be touched by hand. Then loosen the cap slowly to release the pressure inside the radiator, and remove the cap.

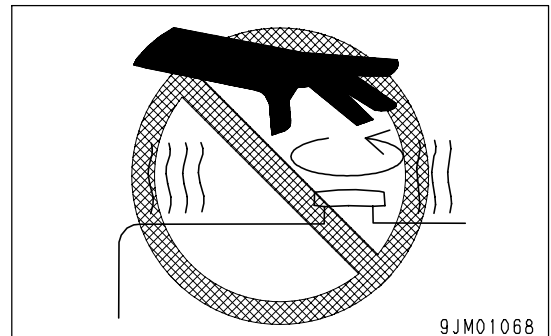

PRECAUTIONS WITH HIGH-TEMPERATURE OIL

To prevent burns from hot oil spurting out or from touching high-temperature parts when checking or draining the oil, wait for the oil to cool down to a temperature where the cap or plug can be touched by hand. Then loosen the cap or plug slowly to release the internal pressure and remove the cap or plug.

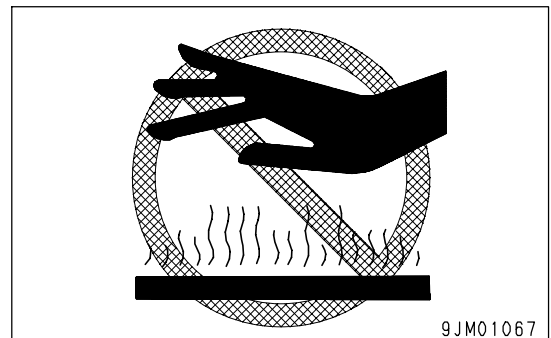

PRECAUTIONS WITH HIGH-PRESSURE OIL

The hydraulic system is always under internal pressure. In addition, the fuel piping is also under internal pressure when the engine is running and immediately after the engine is stopped. When carrying out inspection or replacement of the piping or hoses, check that the internal pressure in the circuit has been released. If this is not done, it may lead to serious personal injury or death. Always do as follows.

- Do not carry out inspection or replacement work with the circuit under pressure.
- If there is any leakage from the piping or hoses, the surrounding area will be wet, so check for cracks in the piping and hoses and for swelling in the hoses.

When carry out inspection, wear safety glasses and leather gloves.

- There is a hazard that high-pressure oil leaking from small holes may penetrate your skin or cause loss of sight if it contacts your skin or eyes directly. If you are hit by a jet of high-pressure oil and suffer injury to your skin or eyes, wash the place with clean water, and consult a doctor immediately for medical attention.

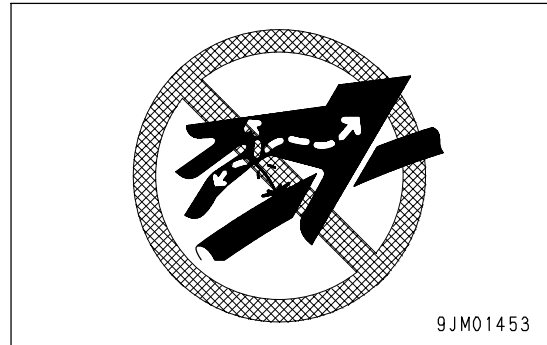
**PRECAUTIONS WITH HIGH-PRESSURE FUEL**

When the engine is running, high-pressure is generated in the engine fuel piping. When carrying out inspection or maintenance of the fuel piping system, stop the engine and wait for at least 30 seconds to allow the internal pressure to go down before starting the operation.

HANDLING HIGH-PRESSURE HOSES AND PIPING

- If oil or fuel leaks from high-pressure hoses or piping, it may cause fire or misoperation, and lead to serious personal injury, or death. If the hose or piping mounts are loose or oil or fuel is found to be leaking from the mount, stop operations and tighten to the specified torque.

If any damaged or deformed hoses or piping are found, please consult your Komatsu distributor.

Replace the hose if any of the following problems are found.

- Damaged hose or deformed hydraulic fitting.
- Frayed or cut covering or exposed reinforcement wire layer.
- Covering swollen in places.
- Twisted or crushed movable portion.
- Foreign material embedded in covering.

NOISE

When carrying out maintenance of the engine and you are exposed to noise for long periods of time, wear ear covers or ear plugs while working.

If the noise from the machine is too loud, it may cause temporary or permanent hearing problems.

HANDLING SUSPENSION CYLINDER, ACCUMULATOR, GAS SPRING

The suspension cylinders, accumulator, and gas springs are charged with high-pressure nitrogen gas. If any mistake is made in handling, there is danger that it may cause an explosion or serious personal injury. To prevent accidents, always do as follows.

- Do not remove or disassemble unless necessary.
- Do not bring it near flame or dispose of it in fire.
- Do not make holes in it, weld it, or use a cutting torch.
- Do not hit or roll the accumulator, or subject it to any impact.
- Ask your Komatsu distributor when sealing gas into the cylinder or replacing gas from it.
- When disposing of the accumulator, the gas must be released. Please contact your Komatsu distributor to have this work performed.

**PRECAUTIONS WITH COMPRESSED AIR**

- When carrying out cleaning with compressed air, there is a hazard of serious personal injury caused by flying dust or particles.
- When using compressed air to clean the filter element or radiator, wear safety glasses, anti-dust mask, gloves, and other protective equipment.

MAINTENANCE OF AIR CONDITIONER

If air conditioner refrigerant gets into your eyes, it may cause loss of sight; if it contacts your skin, it may cause frostbite. Never loosen any parts of the cooling circuit.

DISPOSING OF WASTE MATERIALS

To prevent pollution, pay careful attention to the method of disposing of waste materials.

- Always put oil drained from your machine in containers. Never drain oil directly onto the ground or dump into the sewage system, rivers, the sea, or lakes.
- Obey appropriate laws and regulations when disposing of harmful objects such as oil, fuel, coolant, solvent, filters, and batteries.

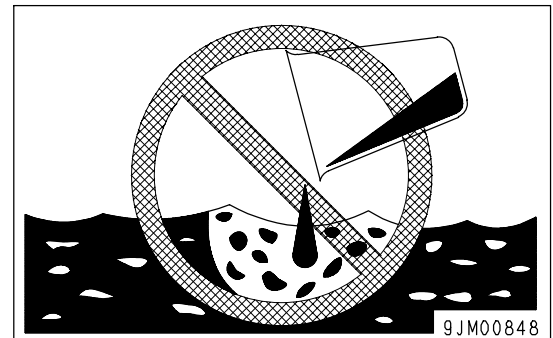
**METHOD OF SELECTING WINDOW WASHER FLUID**

Use an ethyl alcohol base washer liquid.

Methyl alcohol base washer liquid may irritate your eyes, so do not use it.

PERIODIC REPLACEMENT OF SAFETY CRITICAL PARTS

- For using the machine safely for an extended period of time, replace safety-critical parts like hoses and seat belts periodically.

Replacement of safety-critical parts: See "PERIODIC REPLACEMENT OF SAFETY CRITICAL PARTS (PAGE 4-15)".

- The material of these components naturally changes over time, and repeated use causes deterioration, wear, and fatigue. As a result, there is a hazard that these components may fail and cause serious personal injury or death. It is difficult to judge the remaining life of these components from external inspection or the feeling when operating, so always replace them at the specified interval.
- Replace or repair safety-critical parts if any defect is found, even when they have not reached the specified replacement time.

TIRES

HANDLING TIRES

If tires or rims are handled mistakenly, there is danger that the tire may explode or be damaged, or that the rim may fly off and cause serious personal injury or death.

To maintain safety, always do as follows.

- Maintenance, disassembly, repair, and assembly of the tires and rims requires special equipment and special technology, so always ask your Komatsu distributor to carry out these operations.
- Use only specified tires and inflate them to the specified pressure.

Suitable inflation pressure : see HANDLING TIRES (PAGE 3-113).

- When pumping up the tires, check that no other person is standing near the tire, and install an air chuck with a clip that can be secured to the air valve.

To prevent the tire inflation pressure from becoming too high, measure the pressure from time to time with an air gauge while pumping up the tire.

- If the tire pressure goes down abnormally or the rim parts do not fit the tire, there is a problem with the tire or rim parts. Always contact your Komatsu distributor for repairs.
- If the rim parts are not fitted properly when the tire is being pumped up, there is danger that the rim parts may fly off, so set up a protective fence around the tire, and do not stand directly in front of the rim. Stand beside the tread when pumping up the tire.
- Do not adjust the tire inflation pressure immediately after traveling at high speed or carrying out operations under heavy load.
- Never carry out welding or light a fire near the tire.
- Always release all pressure from a single tire or from both tires of a dual assembly prior to removing any rim components.
- Before removing the tire from the machine for repairs, remove the valve partially to release the air from the tire, then remove the tire.

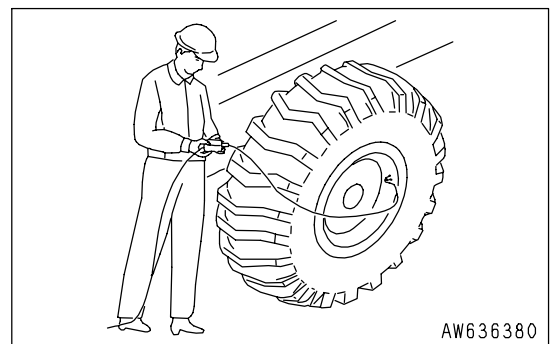
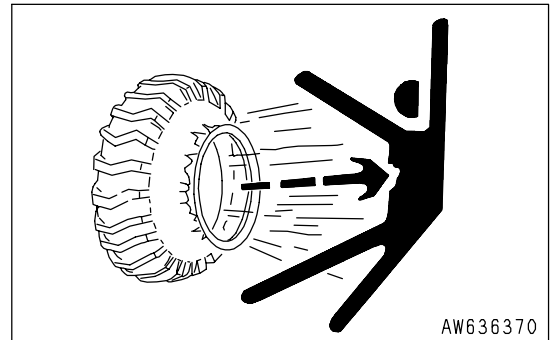

PRECAUTIONS WHEN STORING TIRES

Tires for construction equipment are extremely heavy, it may lead to serious personal injury or death. To maintain safety, always do as follows.

- As a basic rule, store the tires in a warehouse which unauthorized persons cannot enter.
If the tires must be stored outside, always erect a fence and put up "No Entry" signs.
- Stand the tire on level ground, and block it securely so that it cannot roll or fall over if any person should touch it.
Do not lay the tire on its side. This will deform the tire and cause it to deteriorate.
- If the tire should fall over, do not attempt to stop it. Get out of the way quickly.

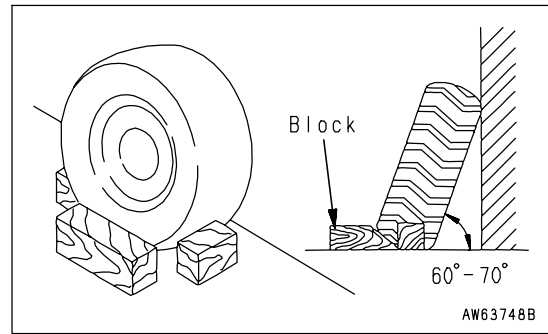

OPERATION

WARNING

Please read and make sure that you understand the SAFETY section before reading this section.

GENERAL VIEW

GENERAL VIEW OF MACHINE

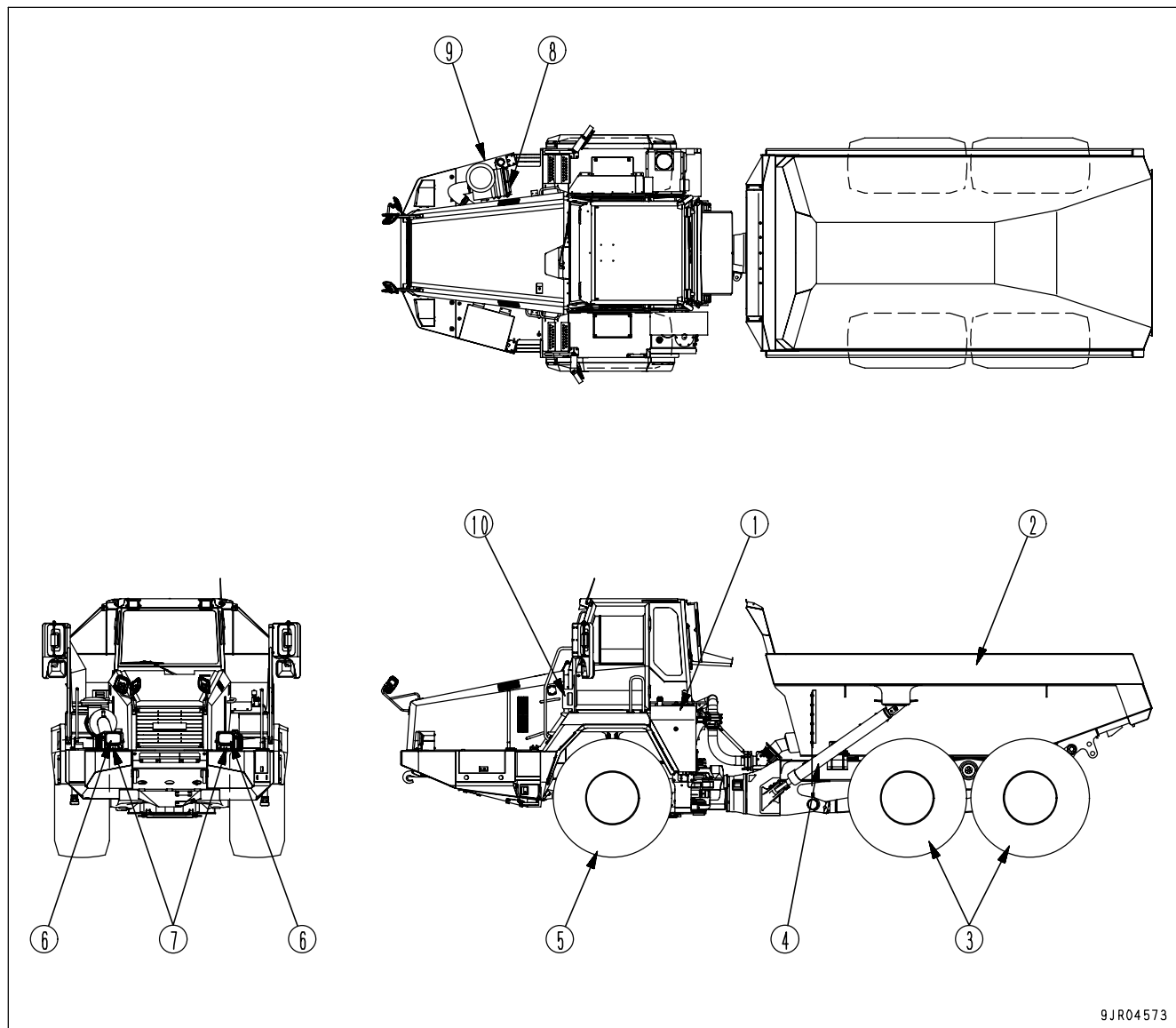

9JR04573

- | | |
|--------------------|--------------------------------------|
| (1) Hydraulic tank | (6) Turn signal lamp |
| (2) Dump body | (7) Head lamp |
| (3) Rear wheel | (8) Air cleaner |
| (4) Hoist cylinder | (9) Fuel tank |
| (5) Front wheel | (10) Fire extinguisher (if equipped) |

GENERAL VIEW OF CONTROLS AND GAUGES

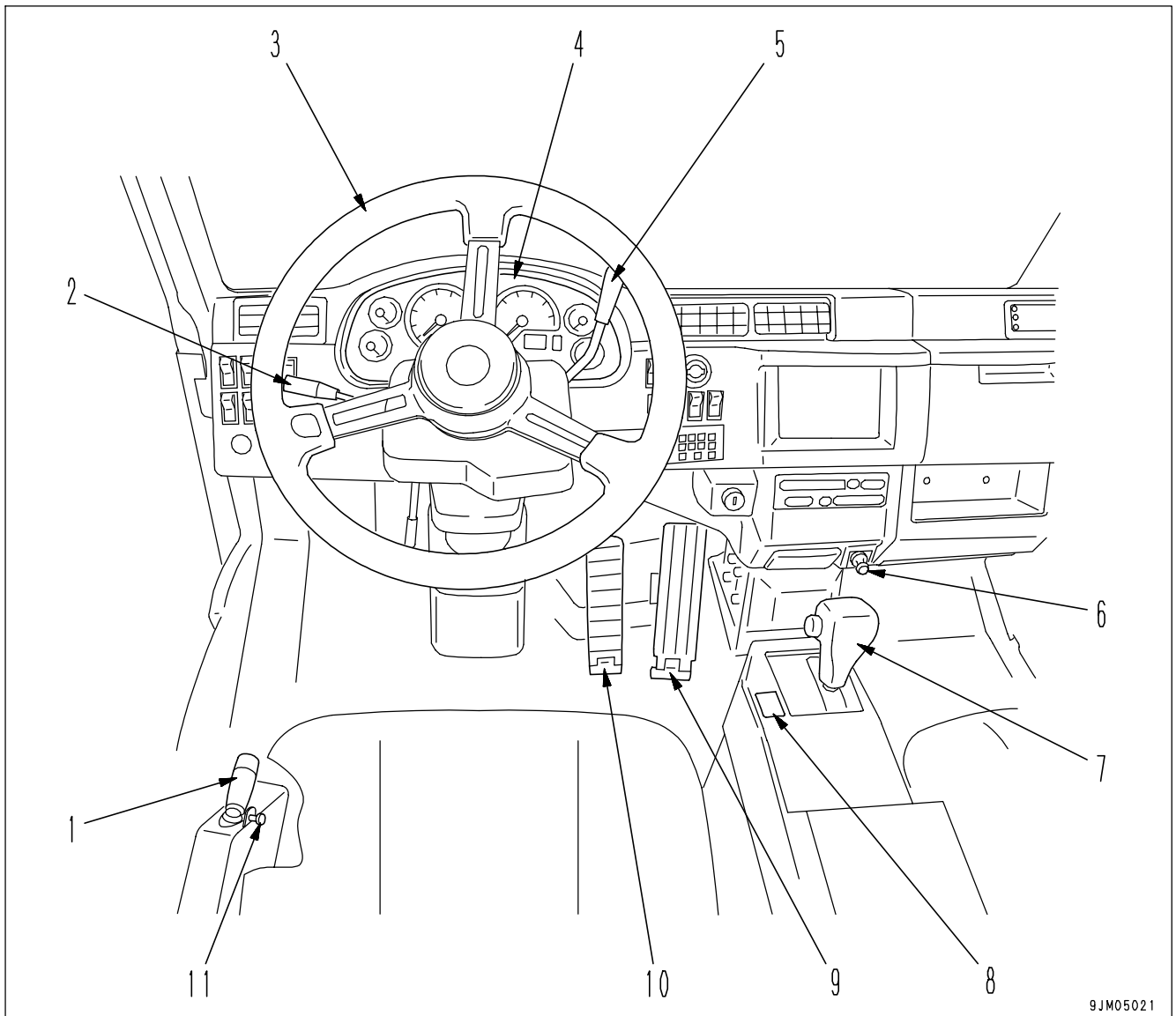

9JM05021

- | | |
|---|---------------------------|
| (1) Dump lever | (7) Gear shift lever |
| (2) Lamp switch, Turn signal lever, Dimmer switch | (8) Parking brake switch |
| (3) Steering wheel | (9) Accelerator pedal |
| (4) Machine monitor | (10) Brake pedal |
| (5) Retarder control lever | (11) Dump lever lock knob |
| (6) Cigarette lighter | |

- Enlargement of machine monitor

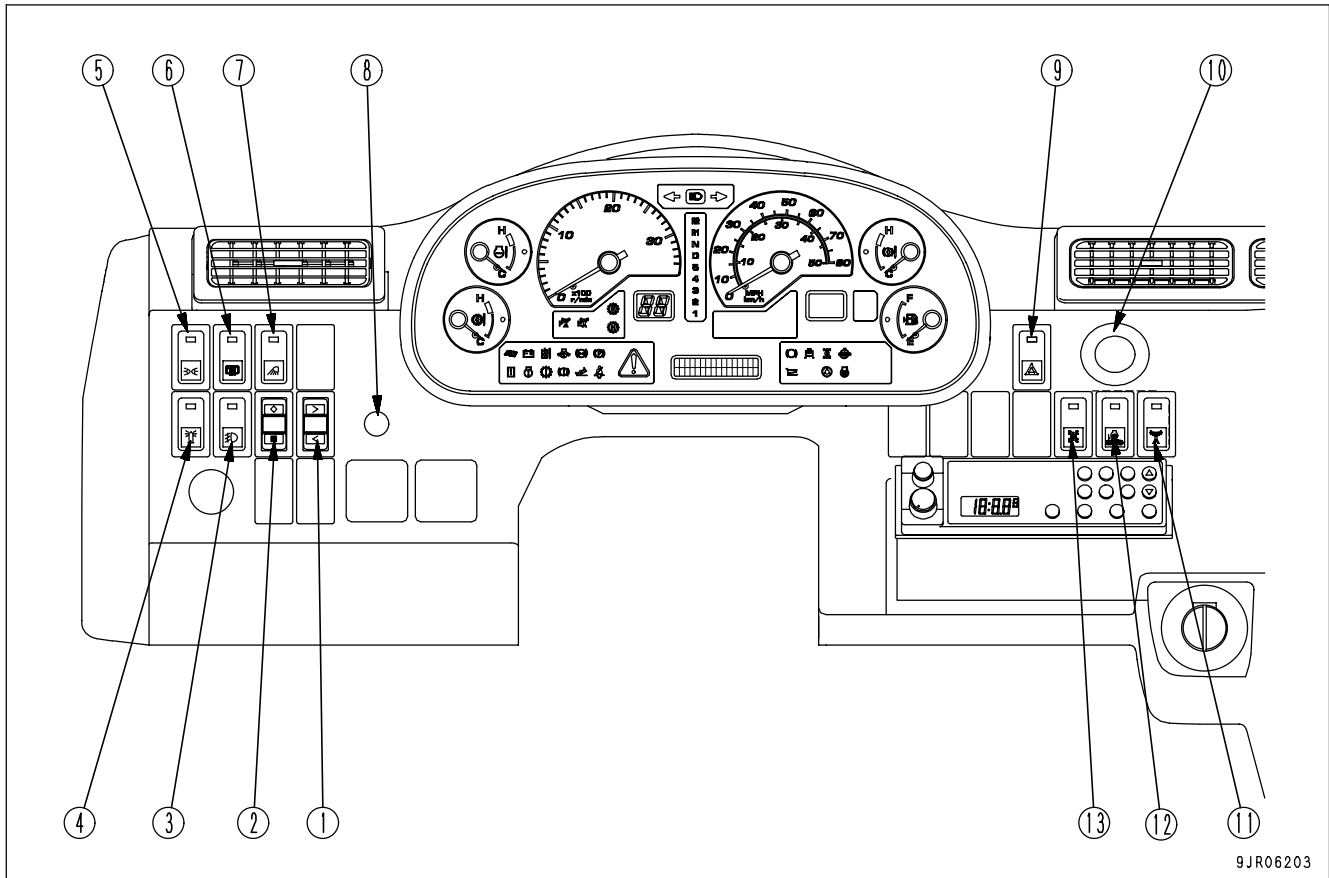

9JR06203

- | | |
|---|--|
| (1) Machine monitor mode selector switch 2 | (8) Night lighting dimmer switch |
| (2) Machine monitor mode selector switch 1 | (9) Hazard lamp switch |
| (3) Fog lamp switch (if equipped) | (10) Emergency steering switch |
| (4) Yellow rotating lamp switch (if equipped) | (11) Power mode selector switch |
| (5) Side lamp switch (if equipped) | (12) AISS LOW switch |
| (6) Switch for rear window glass with heated wire | (13) Inter-axle differential lock switch |
| (7) Working lamp (front) switch | |

EXPLANATION OF COMPONENTS

The following is an explanation of devices needed for operating the machine.

To perform suitable operations correctly and safely, it is important to completely understand methods of operating the equipment, and the meanings of the displays.

MACHINE MONITOR

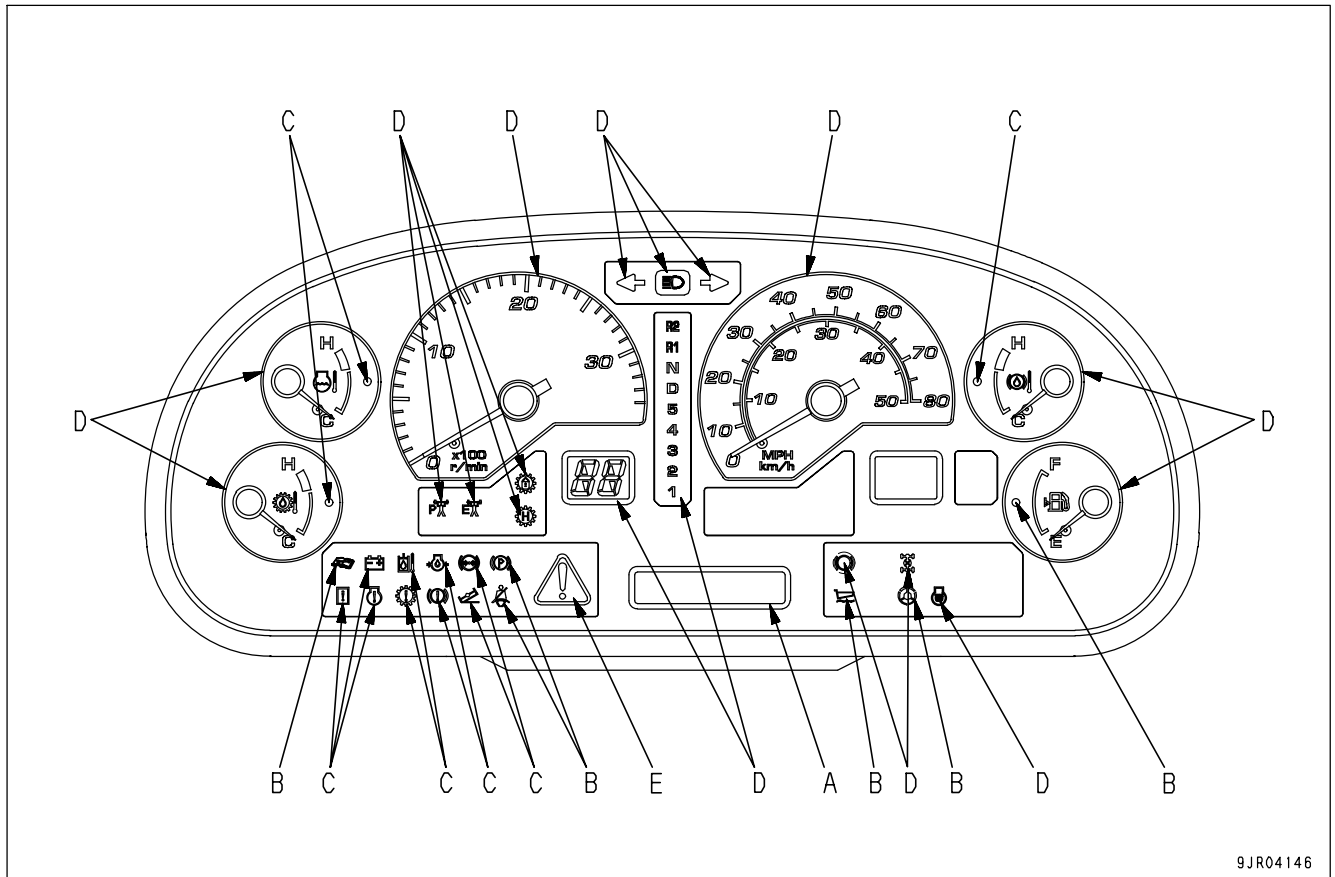

9JR04146

- A: Character display
 B: Caution items
 C: Emergency stop item

- D: Meter display portion
 E: Central warning lamp

NOTICE

When the engine starting switch is turned to the ON position before starting the engine, a system check is carried out for 3 seconds.

- The central warning lamp lights up for 2 seconds, and then goes out.
- The alarm buzzer sounds for 2 seconds, and then stops.
- The machine monitor lamp lights up for 2 seconds and then goes out for 1 second. If there is any abnormality or if anything is operated, the respective display lamp lights up.
- The shift indicator displays "88" for 2 seconds and then goes out for 1 second. After this, the speed range is displayed.
- After a 3-second system check, the meter starts to function.
- The character display shows "KOMATSU" for 3 seconds.
- If the lamps or any other parts do not work, it there is a probability that there is a failure in the machine monitor or disconnection of the electric wiring, so please ask your Komatsu distributor to carry out inspection.
- If the gear shift lever is not at the Neutral position when the starting switch is turned to the ON position, when the system check is completed, the shift lever position pilot lamp will flash, the central warning lamp will light up, and the alarm buzzer will continue to sound intermittently. If this happens, move the gear shift lever to the Neutral position. The shift lever position pilot lamp will display N, the central warning lamp will go out, and the buzzer will stop.

Check central warning lamp, alarm buzzer, monitor lamps, and meters.

Before starting the engine, turn the starting switch to the ON position and check that the machine monitor does as follows.

If the machine monitor does not work, there is probably a failure in the machine monitor system, so please ask your Komatsu distributor to carry out inspection.

- The central warning lamp lights up for 2 seconds, then goes out.
- The alarm buzzer sounds for 2 seconds, then stops.
- The machine monitor lamp lights up for 2 seconds and then goes out for 1 second.
- The shift indicator displays "88" for 2 seconds, then goes out for 1 second.
- The meters start the operations after the system is checked for 3 seconds.
- The character display displays "KOMATSU" for 3 seconds.

CHARACTER DISPLAY

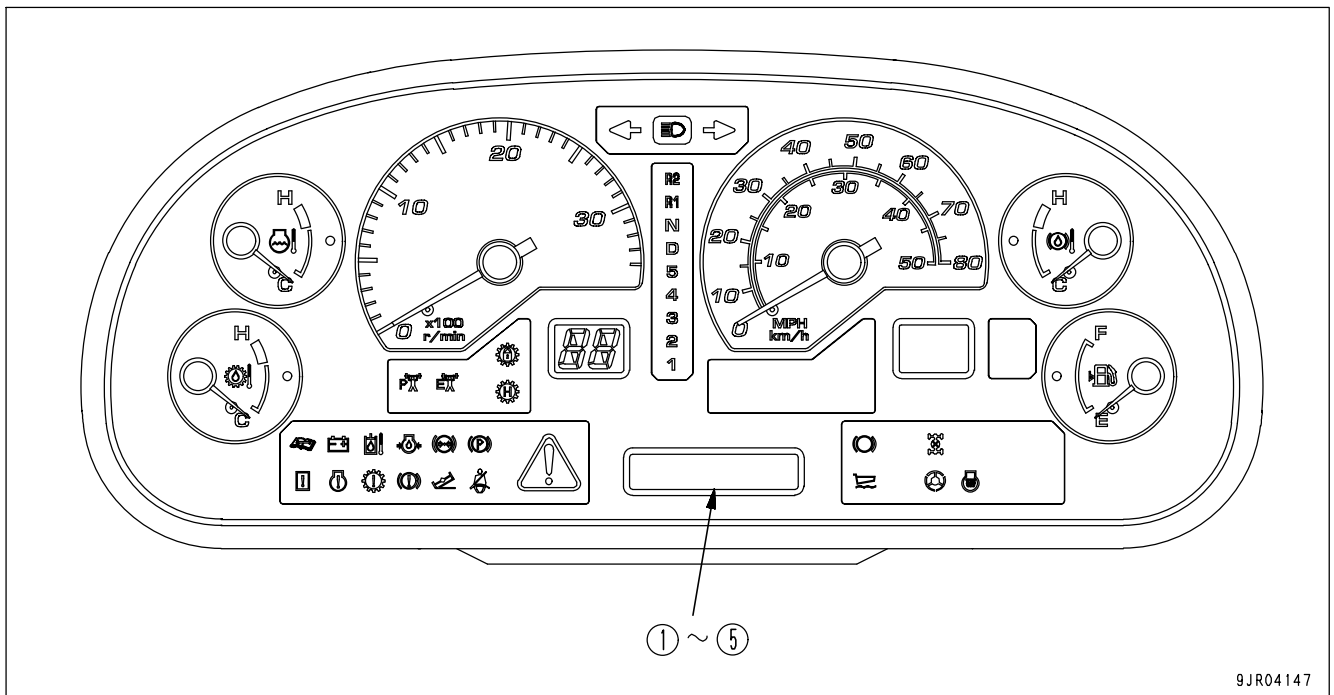

9JR04147

The character display can display the following items.

- | | |
|-----------------------------|--|
| (1) Service meter | (4) Action code display |
| (2) Odometer | (5) Filter, oil replacement time display |
| (3) Reverse travel odometer | |

Normally, the service meter/odometer is displayed on the character display.

If the machine has failed, or if there has been excessive load on the machine, or if it is necessary to carry out inspection and maintenance, an action code is displayed to recommend suitable action.

When the replacement time approaches or has passed, the system will indicate the filter to be replaced or oil to be changed. This indication is given after the starting switch is turned to the ON position and the system check is completed. The maintenance caution lamp will flash or light up, and at the same time, the character display will indicate the filter or oil needing replacement.

NOTICE

The character display indicates machine failure and other information related to maintenance. When turning the starting switch to the ON position, always check the display to confirm that there is no abnormality on the machine before starting to operate or drive the machine.

SERVICE METER

This meter (1) shows the total time that the machine has been operating.

The service meter advances when the engine is running, even if the machine is not being operated.

The service meter advances by 1 for every hour that the engine is running, regardless of the engine speed.

Even when the starting switch is at the OFF position, the total hours of operation is displayed while the top portion (◇) of machine monitor mode selector switch 1 is being pressed.

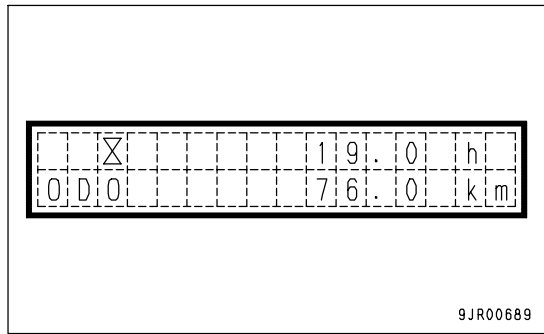

9JR00689

NOTICE

When the starting switch is at the OFF position, if the total operating time is displayed even though the top portion (◇) of machine monitor mode selector switch 1 is not being pressed, there is probably a failure in the equipment, so please ask your Komatsu distributor to carry out inspection.

ODOMETER

This meter (2) indicates the total distance traveled in kilometers.

Even when the starting switch is at the OFF position, the total travel distance is displayed while the top portion (◇) of machine monitor mode selector switch 1 is being pressed.

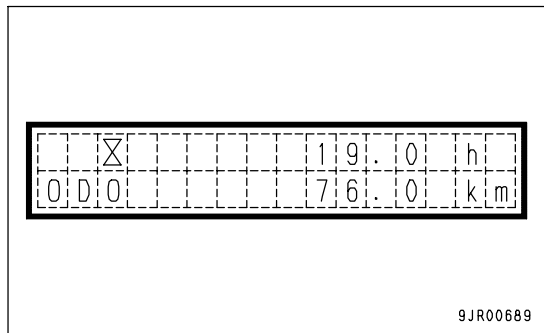

9JR00689

NOTICE

When the starting switch is at the OFF position, if the total travel distance is displayed even though the top portion (◇) of machine monitor mode selector switch 1 is not being pressed, there is probably a failure in the equipment, so please ask your Komatsu distributor to carry out inspection.

REVERSE TRAVEL ODOMETER

This meter (3) indicates the total distance traveled in reverse in kilometers.

For details of the method of displaying the total distance traveled in reverse, see "OTHER FUNCTIONS OF MACHINE MONITOR (PAGE 3-26)".

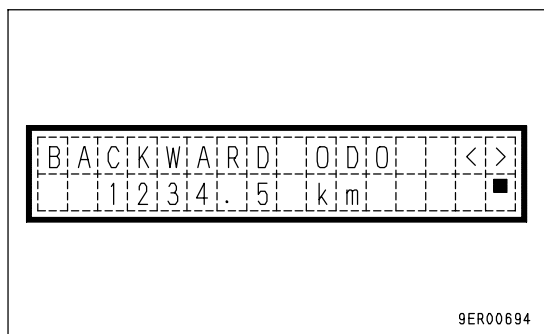

9ER00694

ACTION CODE DISPLAY



When action code E03 is displayed on the character display, stop the machine immediately. Then check "ACTION CODE (PAGE 3-140)" and ask your Komatsu distributor to carry out repairs.

If the machine has failed, or if there has been excessive load on the machine, or if it is necessary to carry out inspection and maintenance, an action code is displayed on this panel (4) to recommend suitable action.

If more than one failure occurs at the same time, the most important action code is displayed. The order of importance, starting from the highest, is E03, E02, and E01. If failures of equal importance occur at the same time, the latest one is displayed.

When action codes E02 or E03 occur, the alarm buzzer sounds intermittently and the central warning lamp lights up.

E03: When this code is displayed, stop the machine immediately, check the failure code, and contact your Komatsu distributor for repairs.

REMARK

- The top line of the character display displays "E03" and the bottom line displays "CHECK RIGHT NOW" and "CALL" in turn for 3 seconds each.
- On the right side of the "CALL" display, a telephone number is displayed. If no telephone number has been set, this space is blank. For details of the method of setting the telephone number, see "INPUT METHOD FOR TELEPHONE NUMBER (PAGE 3-28)".

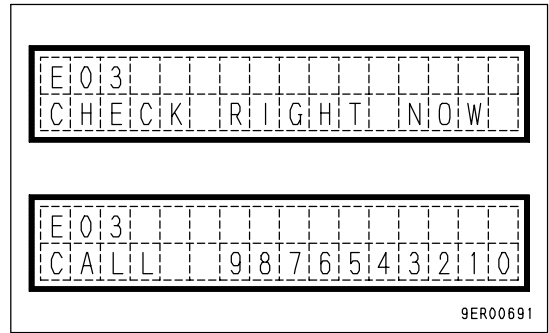

E02: If an overrun related display is given, reduce the engine speed and machine speed while continuing operations.
 If an overheat related display is given, stop the machine and run at the engine under no load at a mid-range speed.
 If the same action code is displayed even when the above action is taken, check the failure code and ask your Komatsu distributor to carry out repairs.

REMARK

The top line of the character display displays "E02" and the bottom line displays the condition of the machine related to overrun or overheat.

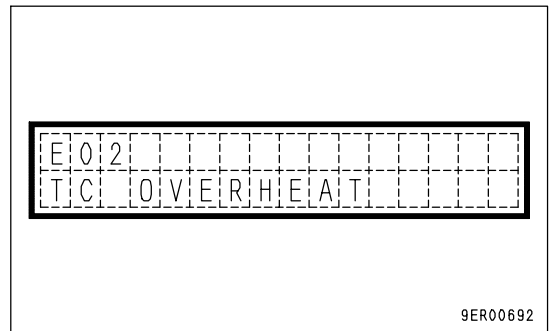

E01: When a maintenance location is displayed and the maintenance caution lamp lights up, carry out inspection and maintenance of the indicated location after completing the day's operations or when the operators change shifts.

If E01 is displayed together with MAINTENANCE, check the failure code and have repairs carried out.

REMARK

"E01" is displayed on the top line of the character display and "MAINTENANCE" or the part of the machine requiring inspection, filling of fluid, or replacement is displayed on the bottom line.

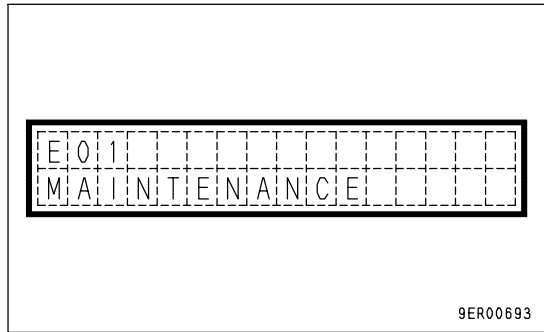

9ER00693

FILTER, OIL REPLACEMENT TIME DISPLAY

After completion of the system check, if any replacement interval is approaching or has passed, the filter or oil name is displayed on this display portion (5) for 30 seconds. At the same time, the maintenance caution lamp also flashes or lights up.

After replacing the filter or changing the oil, reset the replacement time. For details, see "RESET METHOD FOR FILTER, OIL REPLACEMENT TIME (PAGE 3-27)".

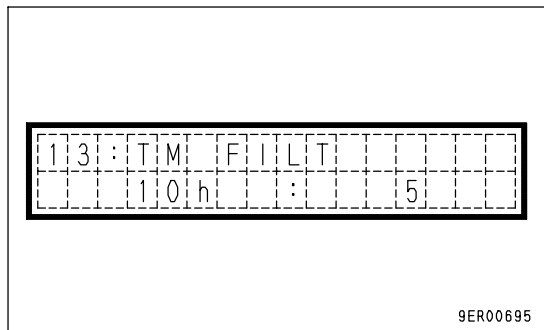

9ER00695

REMARK

- The top line of the character display shows the ID number and name of the item needing replacement. The bottom line shows the time remaining to replacement and the total number of times the item has been replaced.
- After giving the display for 30 seconds, the display does not appear again until the starting switch is turned again to the ON position.
- If an action code is displayed, the message in the diagram above is not displayed on the character display.
- If there are more than 2 items to be displayed, they are displayed for 3 seconds in turn.
- If there are more than 10 items to be displayed, all the items are displayed once each.
- The filter or oil replacement time is displayed when there are 30 hours remaining to replacement.
- When the replacement interval approaches, the maintenance caution lamp flashes, and if the replacement interval has passed, the lamp lights up.

Items for display of filter, oil replacement time

Item	Replacement interval	Character display	ID number
Fuel prefilter	500	FUEL P FILT	41
Engine oil filter	500	ENG FILT	02
Engine oil	500	ENG OIL	01
Transmission oil	1000	TM OIL	12
Transmission oil filter	1000	TM FILT	13
Fuel main filter	1000	FUEL FILT	03
Corrosion resistor(*)	1000	CORR RES	06
Brake oil filter	1000	BK OIL FILT	14
Brake cooling oil filter	1000	BK C FILT	16
Hydraulic filter	2000	HYD FILT	04
Differential case oil	2000	DIFF OIL	11
Final drive oil	2000	FNL OIL	08
Hydraulic oil	4000	HYD OIL	10

*This machine is not equipped with a corrosion resistor. If a display is given, reset the change interval. For details, see "RESET METHOD FOR FILTER, OIL REPLACEMENT TIME (PAGE 3-27)".

REMARK

See the section below for details of the procedure for replacing the filter and oil.

- Fuel prefilter
"REPLACE FUEL PREFILTER CARTRIDGE (PAGE 4-53)"
- Engine oil filter
"CHANGE OIL IN ENGINE OIL PAN, REPLACE ENGINE OIL FILTER CARTRIDGE (PAGE 4-52)"
- Engine oil
"CHANGE OIL IN ENGINE OIL PAN, REPLACE ENGINE OIL FILTER CARTRIDGE (PAGE 4-52)"
- Transmission oil
"CHANGE OIL IN TRANSMISSION CASE (PAGE 4-62)"
- Transmission oil filter
"REPLACE TRANSMISSION OIL FILTER ELEMENT - VALVE SIDE (PAGE 4-61)"
- Fuel main filter
"REPLACE FUEL MAIN FILTER CARTRIDGE (PAGE 4-59)"
- Brake oil filter
"CHANGE OIL IN BRAKE OIL TANK, REPLACE BRAKE OIL FILTER ELEMENT (PAGE 4-62)"
- Brake cooling oil filter
"REPLACE TRANSMISSION OIL FILTER ELEMENT - BRAKE COOLING SIDE (PAGE 4-61)"
- Hydraulic filter
"REPLACE HYDRAULIC FILTER ELEMENT (PAGE 4-71)"
- Differential case oil
"CHANGE OIL IN DIFFERENTIAL CASE (PAGE 4-70)"
- Final drive oil
"CHANGE OIL IN FINAL DRIVE CASE (PAGE 4-69)"
- Hydraulic oil
"CHANGE OIL IN HYDRAULIC TANK (PAGE 4-76)"

CAUTION ITEMS

! CAUTION

If the lamp lights up during travel, inspect the location of the problem quickly and take the necessary action.

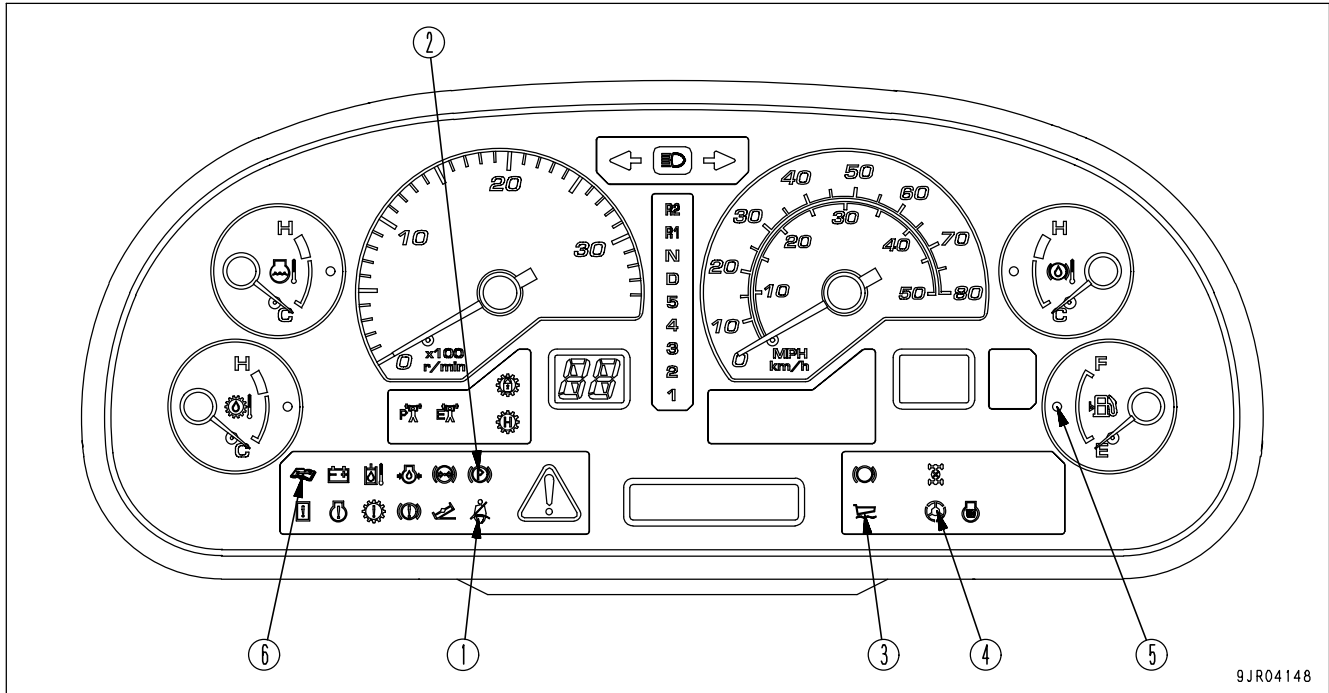

9JR04148

- (1) Seat belt caution lamp
- (2) Parking brake pilot lamp
- (3) Dump body pilot lamp
- (4) Emergency steering pilot lamp
- (5) Fuel level caution lamp
- (6) Maintenance caution lamp

SEAT BELT CAUTION LAMP

This lamp (1) lights up if the seat belt is not fastened. There is danger when traveling, so always fasten your seat belt.

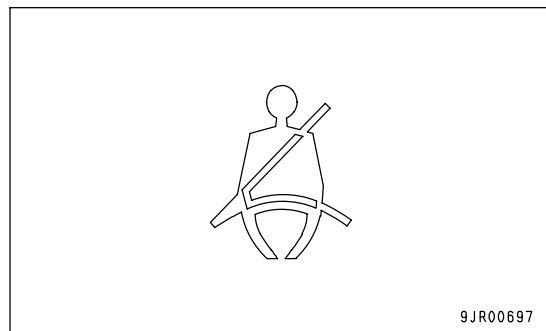

9JR00697

PARKING BRAKE PILOT LAMP

This lamp (2) lights up when the parking brake is applied.

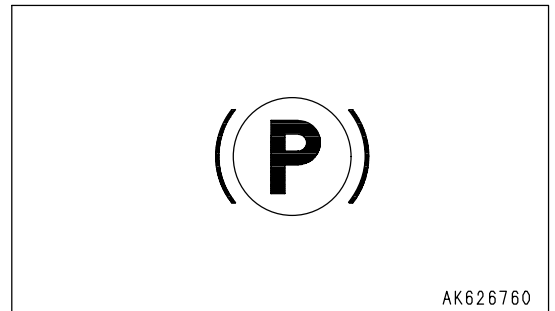

DUMP BODY PILOT LAMP

This lamp (3) lights up when the dump lever is not at FLOAT or when the dump body is raised.

When the engine is stopped, the dump body is held in the HOLD condition, regardless of the position of the dump lever, so when the starting switch is turned to the ON position, this lamp lights up. Cancel the HOLD condition of the dump body to turn the lamp off. For details, see "CANCELING DUMP BODY HOLD CONDITION (PAGE 3-87)".



EMERGENCY STEERING PILOT LAMP

This lamp (4) lights up when the emergency steering is actuated. If any abnormality should occur in the steering oil pressure circuit when the machine is traveling, the auto emergency steering is actuated and the related lamp lights up.

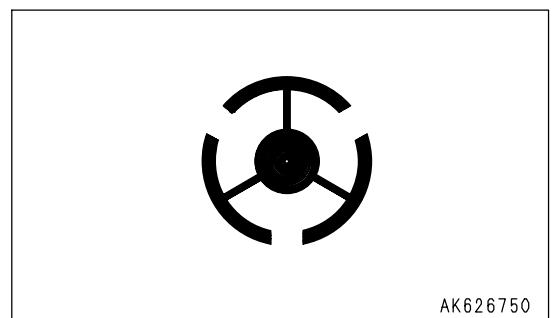

FUEL LEVEL CAUTION LAMP

This lamp (5) lights up when the level of the fuel remaining in the fuel tank goes below 57 liters (15.06 US gal). If it lights up, check the fuel level and add fuel.

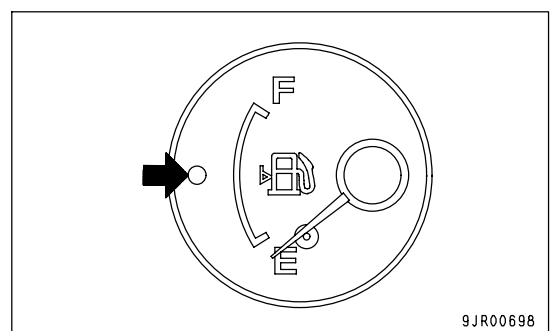

MAINTENANCE CAUTION LAMP

This lamp (6) lights up if any of the the following are applicable. When it lights up, action code "E01" and the location needing maintenance are displayed on the character display at the same time, so carry out inspection, filling, or replacement.

- Drop in engine oil level
- Clogged air cleaner
- Clogged transmission oil filter
- Drop in engine cooling coolant level

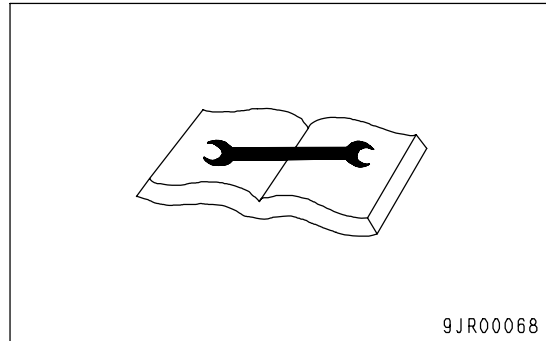

The following sensors and switches are available as options. For this reason, these monitor display functions are also optional.

- Clogged engine oil filter
- Drop in hydraulic oil level
- Clogged hydraulic filter
- Clogged brake cooling oil filter

REMARK

In addition to the above, this lamp also flashes or lights up when the filter or oil replacement time is being displayed.

EMERGENCY STOP ITEM

! CAUTION

If the lamp lights up, stop operations immediately, then check the corresponding area and carry out the action.

If any problem is found in the emergency stop items, the alarm buzzer will sound intermittently, and the lamp for the location of the problem and the central warning lamp will light up.

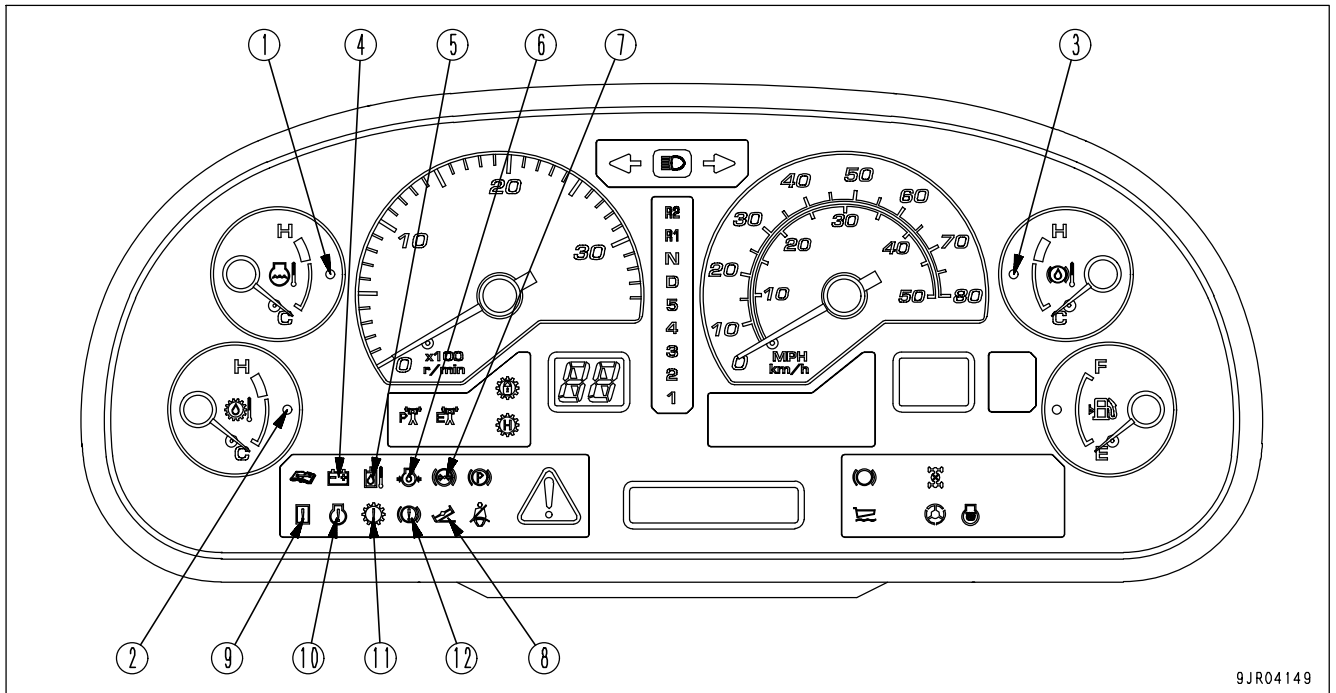

9JR04149

- | | |
|---|---|
| (1) Engine water temperature caution lamp | (7) Brake oil pressure caution lamp |
| (2) Torque converter oil temperature caution lamp | (8) Tilt caution lamp |
| (3) Retarder oil temperature caution lamp | (9) Machine monitor, option system caution lamp |
| (4) Battery charge circuit caution lamp | (10) Engine system caution lamp |
| (5) Steering oil temperature caution lamp | (11) Transmission system caution lamp |
| (6) Engine oil pressure caution lamp | (12) Retarder system caution lamp |

ENGINE WATER TEMPERATURE CAUTION LAMP

This lamp (1) warns the operator that the engine coolant temperature has risen.

When it lights up, "E02 ENGINE OVERHEAT" is displayed on the character display and the engine output is automatically restricted. Run the engine under no load at a mid-range speed until the lamp goes out.

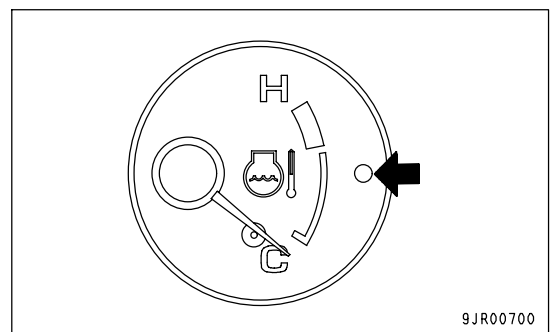

9JR00700

TORQUE CONVERTER OIL TEMPERATURE CAUTION LAMP

This lamp (2) warns the operator that the torque converter oil temperature has risen.

When it lights up, "E02 TC OVERHEAT" is displayed on the character display at the same time, so stop the machine in a safe place, set the shift lever to the N position, and run the engine under no load at a mid-range speed until the lamp goes out.

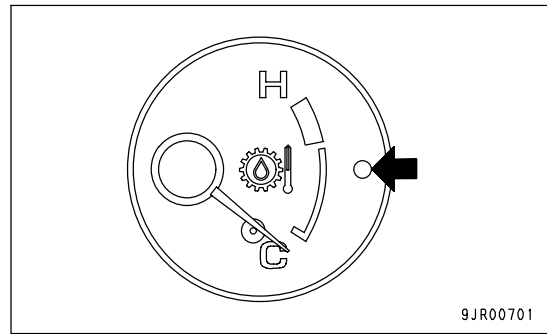
**RETARDER OIL TEMPERATURE CAUTION LAMP**

This lamp (3) warns the operator that the brake oil temperature has risen.

When it lights up, "E02 BRAKE OVERHEAT" is displayed on the character display at the same time, so stop the machine in a safe place, set the shift lever to the N position, and run the engine under no load at a mid-range speed until the lamp goes out.

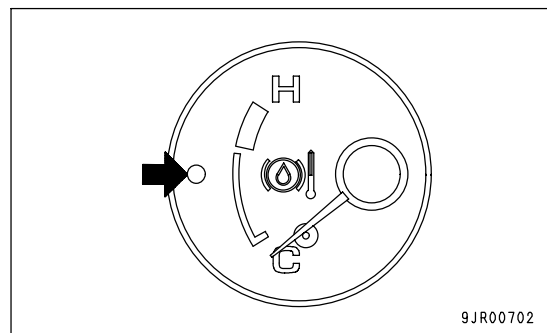
**BATTERY CHARGE CIRCUIT CAUTION LAMP**

This lamp (4) lights up when the engine is running to warn the operator that there is an abnormality in the charging system.

When it lights up, "E03 CHECK RIGHT NOW" is displayed on the character display, so move the machine immediately to a safe place, stop the engine, then check the charging circuit.

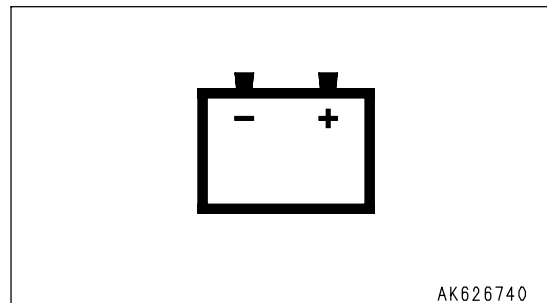
**STEERING OIL TEMPERATURE CAUTION LAMP**

This lamp (5) lights up to warn the operator that the steering oil temperature has risen.

When it lights up, "E02 STRG OVERHEAT" is displayed on the character display at the same time, so stop the machine in a safe place, set the shift lever to the N position, and run the engine under no load at a mid-range speed until the lamp goes out.

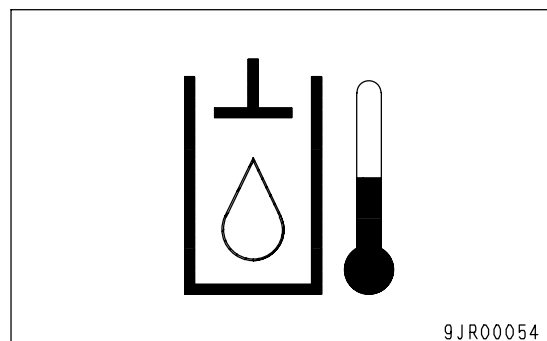

ENGINE OIL PRESSURE CAUTION LAMP

This lamp (6) lights up to warn the operator that the engine lubricating oil pressure has dropped.

When it lights up, "E03 CHECK RIGHT NOW" is displayed on the character display and the engine output is automatically restricted. Move the machine immediately to a safe place, stop the engine, then carry out inspection.

This lamp lights up if the oil pressure goes below the specified pressure when the engine is running. This lamp does not light up if the engine is not running.

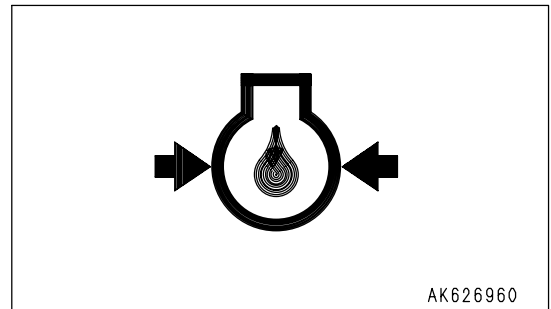
**BRAKE OIL PRESSURE CAUTION LAMP**

This lamp (7) lights up if the brake oil pressure goes below the specified pressure.

When the engine is stopped, the central warning lamp and alarm buzzer do not function.

If the brake oil pressure remains below the specified pressure when 30 seconds has passed since the engine was started, "E03 CHECK RIGHT NOW" is displayed on the character display, so move the machine immediately to a safe place, stop the engine, then carry out inspection.

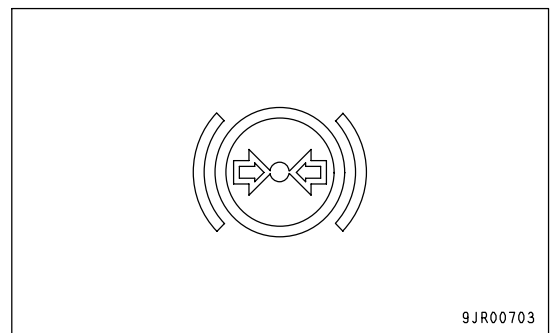
**TILT CAUTION LAMP**

This lamp (8) lights up when the dump lever is at the RAISE position and the rear of the machine is tilted beyond the stability limit on the left or right side. Lower the dump body and move the machine to a safe horizontal place.

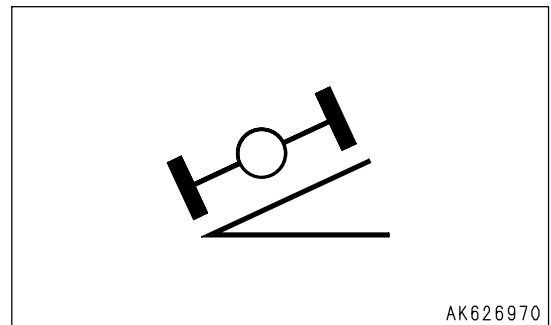
**MACHINE MONITOR, OPTION SYSTEM CAUTION LAMP**

This lamp (9) lights up when a problem has been detected in the machine monitor or in the system for an installed option.

"E03 CHECK RIGHT NOW" is displayed on the character display, so move the machine immediately to a safe place, stop the engine, then carry out inspection.

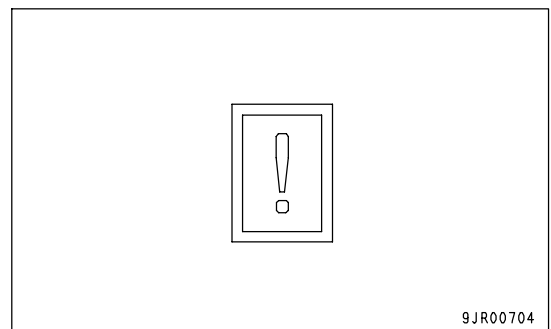

ENGINE SYSTEM CAUTION LAMP

This lamp (10) lights up when a problem has been detected in the system controlled by the engine controller.

"E03 CHECK RIGHT NOW" is displayed on the character display, so move the machine immediately to a safe place, stop the engine, then carry out inspection.

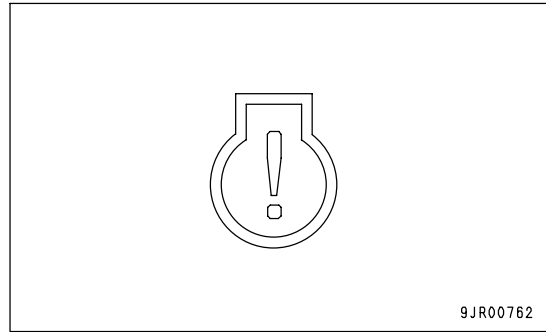
**TRANSMISSION SYSTEM CAUTION LAMP**

This lamp (11) lights up when a problem has been detected in the system controlled by the transmission controller.

"E03 CHECK RIGHT NOW" is displayed on the character display, so move the machine immediately to a safe place, stop the engine, then carry out inspection.

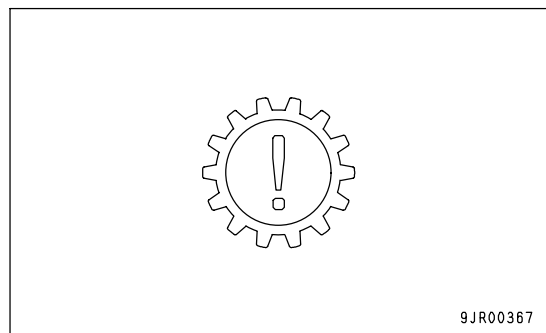
**RETARDER SYSTEM CAUTION LAMP**

This lamp (12) lights up when a problem has been detected in the system controlled by the retarder controller.

"E03 CHECK RIGHT NOW" is displayed on the character display, so move the machine immediately to a safe place, stop the engine, then carry out inspection.

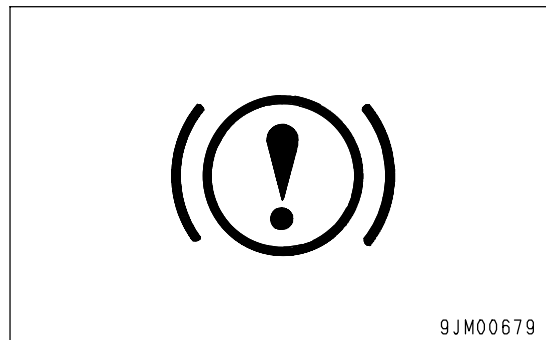

METER DISPLAY PORTION

PILOT DISPLAY PORTION

When the starting switch is ON, the pilot display lights up when the display items are functioning.

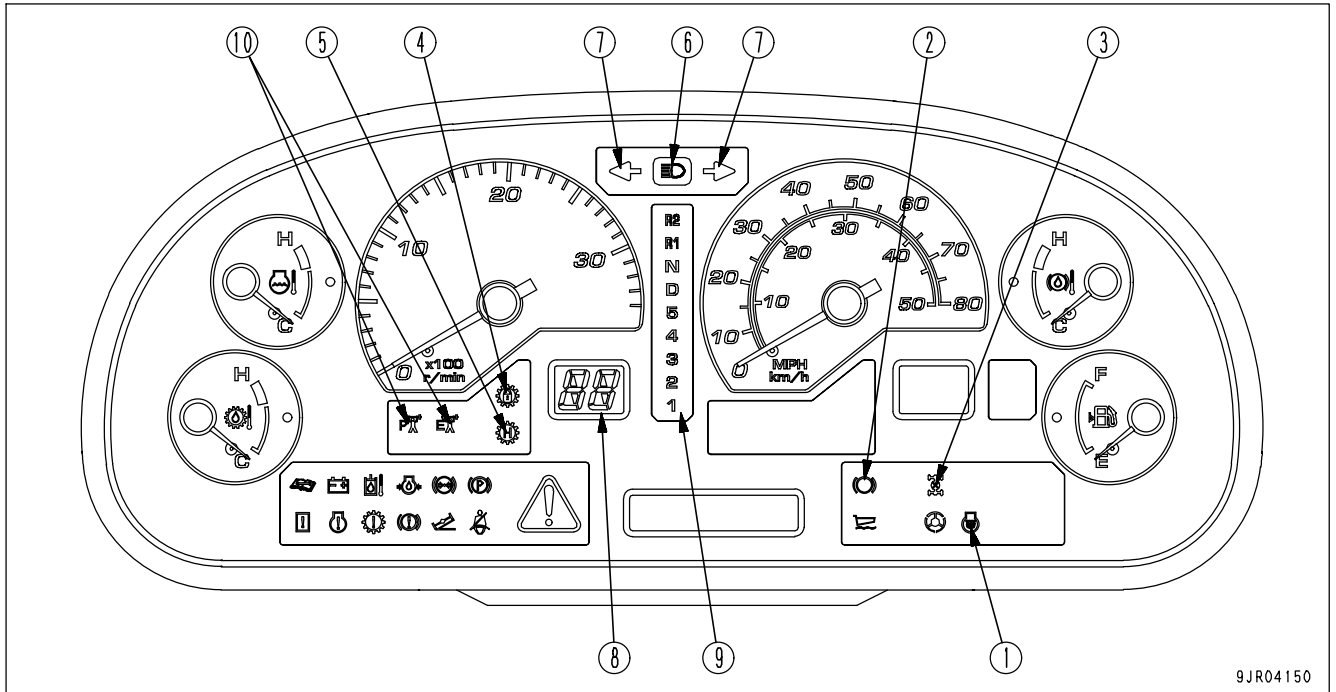

9JR04150

- | | |
|---|-------------------------------------|
| (1) Engine pre-heating pilot lamp | (6) Head lamp high beam pilot lamp |
| (2) Retarder pilot lamp | (7) Turn signal pilot lamp |
| (3) Inter-axle differential lock pilot lamp | (8) Shift indicator |
| (4) Lock-up pilot lamp | (9) Shift lever position pilot lamp |
| (5) Shift hold pilot lamp | (10) Power mode pilot lamp |

ENGINE PRE-HEATING PILOT LAMP

This lamp (1) lights up when the electrical heater for pre-heating the engine is being actuated. When the starting switch is turned to the ON position in cold weather, the lamp lights up. It goes out after 20 to 30 seconds to indicate that the pre-heating has been completed.

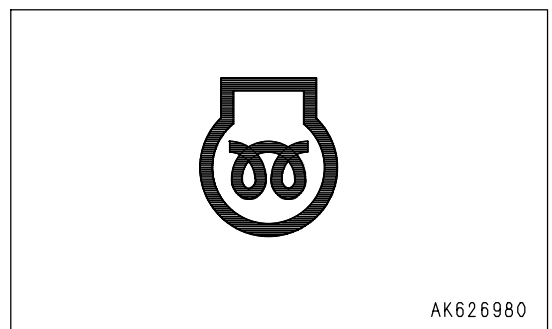

AK626980

RETARDER PILOT LAMP

This lamp (2) lights up when the retarder control lever is pulled and the retarder is actuated.

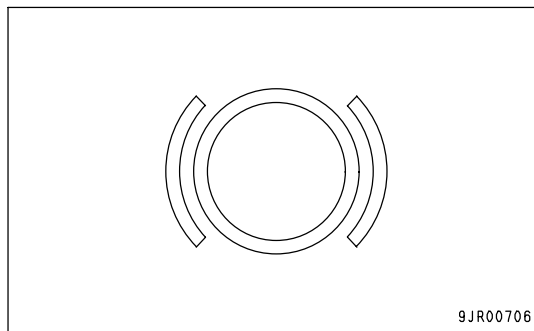
**INTER-AXLE DIFFERENTIAL LOCK PILOT LAMP**

This lamp (3) lights up when the inter-axle differential lock is actuated.

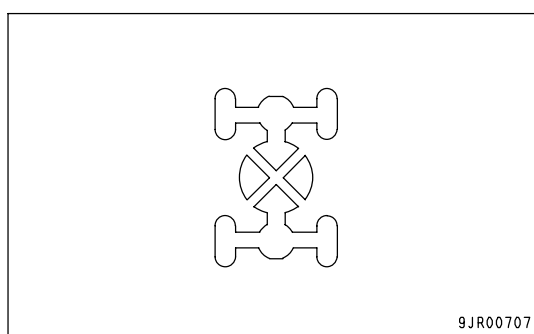
**LOCKUP PILOT LAMP**

This lamp (4) lights up when the torque converter lockup is engaged and the transmission is shifted to direct drive.

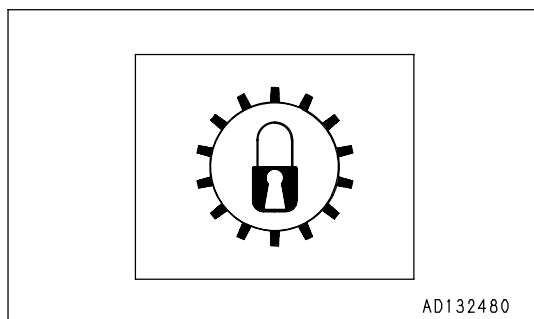
**SHIFT HOLD PILOT LAMP**

This lamp (5) lights up when the shift hold function is actuated.

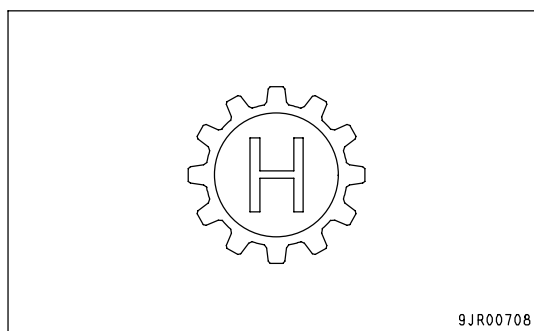

HEAD LAMP HIGH BEAM PILOT LAMP

This lamp (6) lights up when the head lamps are set to high beam.

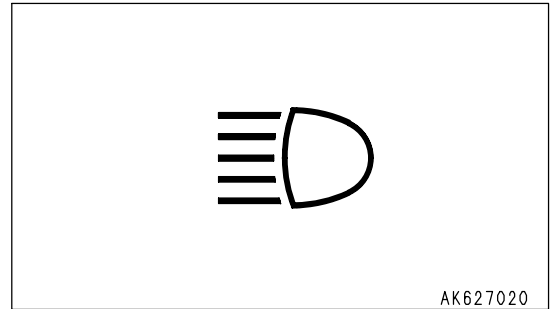

TURN SIGNAL PILOT LAMP

This lamp (7) flashes at the same time as the turn signal lamp flashes.

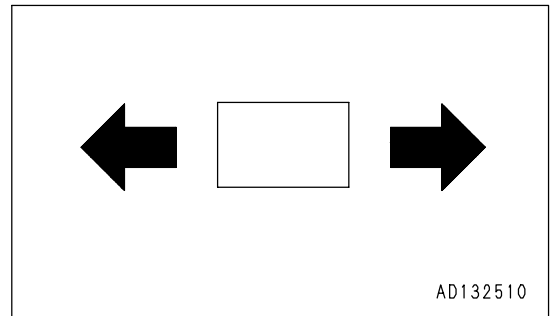

SHIFT INDICATOR

This indicator (8) shows the transmission shift range (speed range).

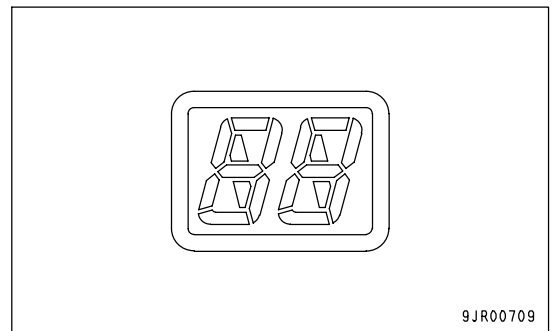

SHIFT LEVER POSITION PILOT LAMP

This lamp (9) displays the position of the shift lever.
The character for the selected gear shift lever position lights up.

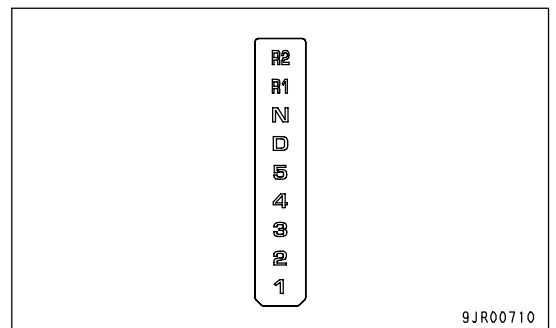

POWER MODE PILOT LAMP

This lamp (10) displays the power mode.

When the mode is selected with the power mode selector switch, either High Power (P) or Economy (E) lights up.

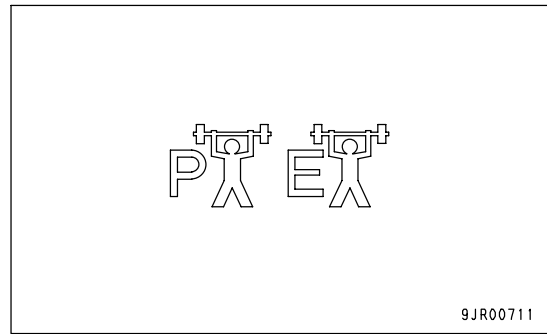

METERS

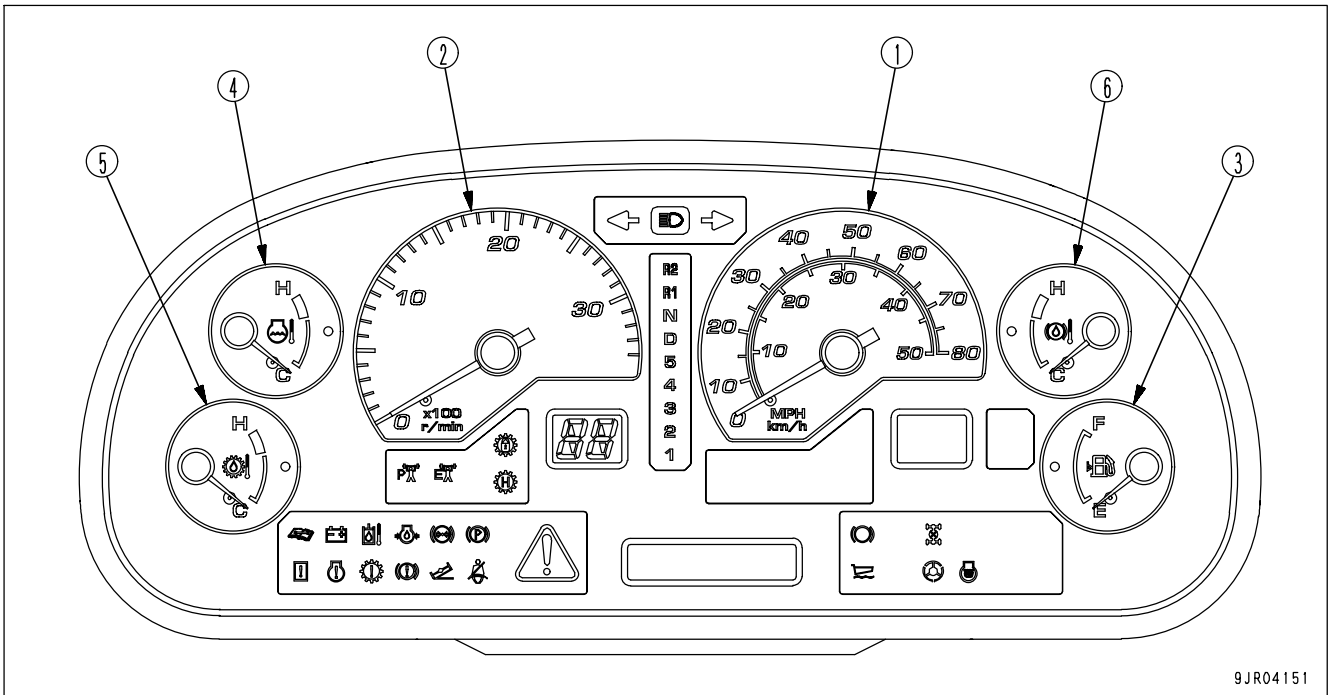

9JR04151

- (1) Speedometer
- (2) Engine tachometer
- (3) Fuel gauge
- (4) Engine water temperature gauge
- (5) Torque converter oil temperature gauge
- (6) Retarder oil temperature gauge

SPEEDOMETER

This meter (1) indicates the travel speed of the machine.

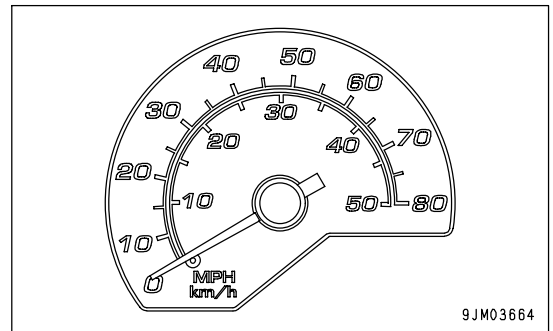

9JM03664

ENGINE TACHOMETER

This meter (2) shows the engine speed.

If the indicator enters the red range when the engine is running, the alarm buzzer sounds and the central warning lamp lights up, so reduce the engine speed and machine travel speed while continuing operations.

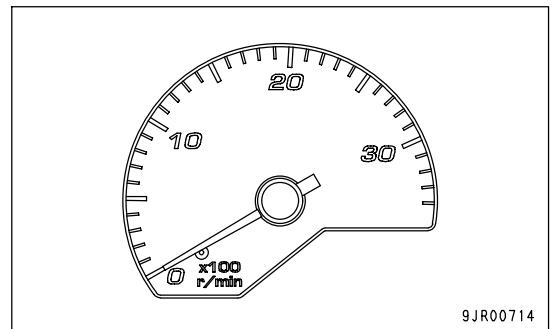

9JR00714

FUEL GAUGE

This meter (3) shows the amount of fuel remaining in the fuel tank. When the fuel level caution lamp lights up, it indicates that there is less than 57 liters (15.06 US gal) of fuel remaining in the tank, so check and add fuel.

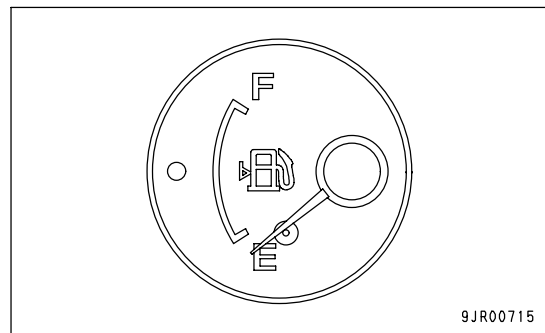
**ENGINE WATER TEMPERATURE GAUGE**

This meter (4) indicates the engine coolant temperature. The indicator should be in the white range during normal operations. If the indicator enters the red range when the engine is running, the alarm buzzer sounds, the central warning lamp lights up, and "E02 ENGINE OVERHEAT" is displayed on the character display, so run the engine under no load at a mid-range speed and wait until the indicator returns to the white range. If the indicator enters the red range, the engine output is automatically restricted.

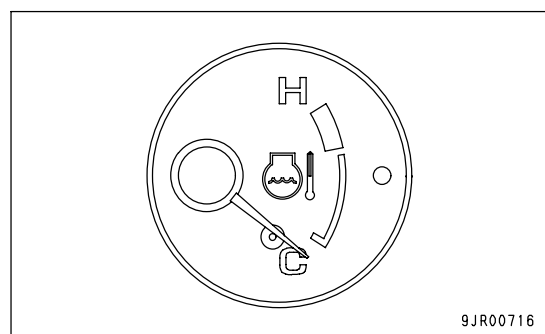
**TORQUE CONVERTER OIL TEMPERATURE GAUGE**

This meter (5) indicates the torque converter oil temperature. The indicator should be in the white range during normal operations. If the indicator enters the red range when the engine is running, the alarm buzzer sounds, the central warning lamp lights up, and "E02 TC OVERHEAT" is displayed on the character display, so stop the machine in a safe place, return the gear shift lever to the N position, run the engine under no load at a mid-range speed and wait until the torque converter oil temperature caution lamp goes out.

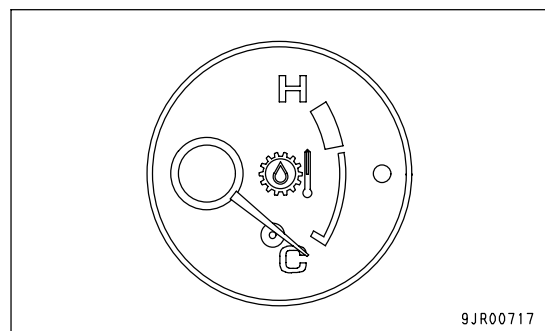
**RETARDER OIL TEMPERATURE GAUGE**

This meter (6) indicates the retarder oil temperature. The indicator should be in the white range during normal operations. If the indicator enters the red range when the engine is running, the alarm buzzer sounds, the central warning lamp lights up, and "E02 BRAKE OVERHEAT" is displayed on the character display, so stop the machine in a safe place, return the gear shift lever to the N position, run the engine under no load at a mid-range speed and wait until the retarder oil temperature caution lamp goes out.

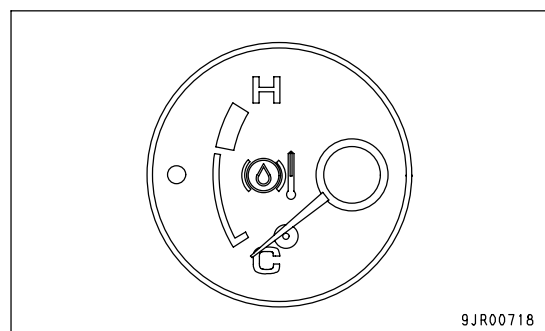

CENTRAL WARNING LAMP

The central warning lamp lights up if the machine is in any of the following conditions. The alarm buzzer sounds intermittently at the same time.

- When a problem has occurred in any of "EMERGENCY STOP ITEM (PAGE 3-15)".
- When action code "E02" or "E03" is displayed on the character display.
- If the parking brake is applied, but the gear shift lever is not at the N position.
- When the dump lever is not at the FLOAT position or the dump body is raised and the gear shift lever is not at the N position.
- When the engine tachometer indicator is in the red range.

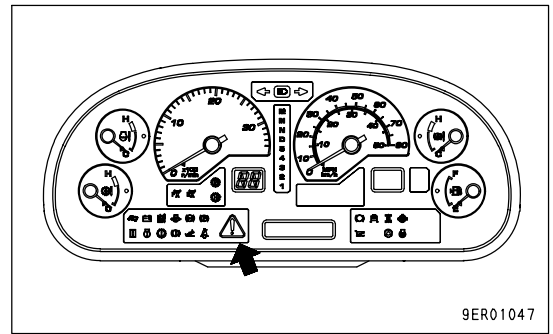

OTHER FUNCTIONS OF MACHINE MONITOR

DISPLAY METHOD FOR REVERSE TRAVEL ODOMETER

Use this when checking the overall distance that the machine has traveled in reverse.

1. Check that the character display is displaying the service meter/odometer reading, or is displaying an action code. If anything other than this is being displayed, turn the starting switch OFF, then turn the starting switch again to the ON position and wait until the above display is given.
2. Press the (◇) of machine monitor mode selector switch 1. The reverse travel odometer reading is displayed.
3. When completing the operation, press (■) of machine monitor mode selector switch 1 or turn the starting switch OFF.

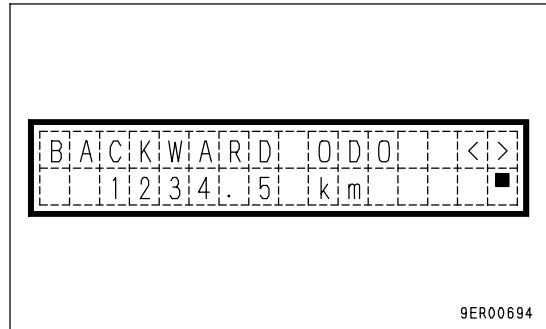

RESET METHOD FOR FILTER, OIL REPLACEMENT TIME

The filter and oil replacement time is displayed on the character display, so if the filter and oil have been replaced, reset the filter and oil change time.

1. Press the (◇) of machine monitor mode selector switch 1, and display the reverse travel in odometer.
2. Press (>) or (<) of machine monitor mode selector switch 2 and display "MAINTENANCE MONITOR".

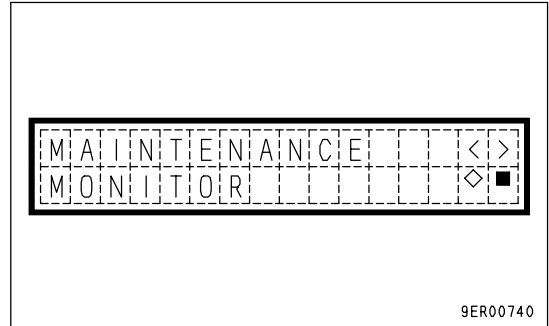

3. Press the (◇) of machine monitor mode selector switch 1. It will change to the display in the diagram on the right. The bottom line shows two items: the replacement time on the left and the total number of times the item has been replaced on the right.

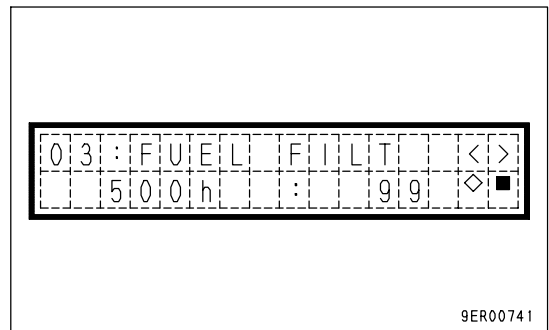

4. Press the (>) or (<) portion of machine monitor mode selector switch 2 to display the item to be reset.

5. When the item to be reset is displayed, press the (◇) portion of machine monitor mode selector switch 1 to give the display shown in the diagram on the right.

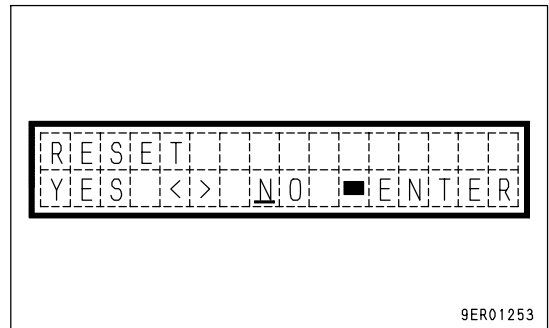

The top line displays "RESET" and the "item to be reset" in turn.

6. When resetting the replacement time, press (>) or (<) of machine monitor mode selector switch 2, align the cursor with "YES", then press (■) of machine monitor mode selector switch 1. It will reset and returned to the previous screen. To abandon, align the cursor with "NO", then press (■) of machine monitor mode selector switch 1.

7. When resetting the replacement time for another item, carry out the procedure from Step 4. After completing, press (■) of machine monitor mode selector switch 1 twice or turn the starting switch OFF.

INPUT METHOD FOR TELEPHONE NUMBER

When an error for action code "E03" occurs, it is possible to display the telephone number.

- 1. Press the (◇) of machine monitor mode selector switch 1 and display the reverse travel odometer.
- 2. Press (>) or (<) of machine monitor mode selector switch 2 and display "TEL".

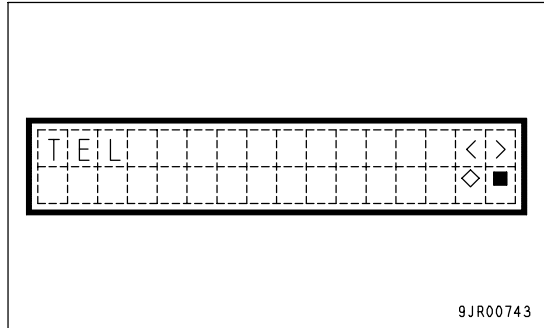

- 3. Press (◇) of machine monitor mode selector switch 1. It will change to the display in the diagram on the right.
When the telephone number has been input, the telephone number is displayed when action code "E03" is next displayed.

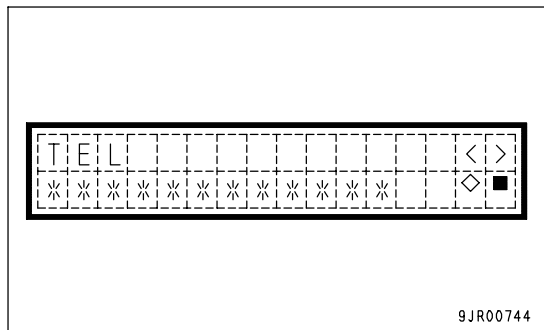

- 4. Up to 12 digits can be displayed for the telephone number. Input from the first digits.
The cursor is displayed at the input position. Press the (>) or (<) portion of machine monitor mode selector switch 2 to select 0 - 9 (to input a space, select "").
When the number to be input is displayed, press the (◇) portion of machine monitor mode selector switch 1 to select the number. The cursor will go to the position to input the next digit.

- 5. Repeat the procedure in Step 4 until the last digit. At the last digit, press (◇) of machine monitor mode selector switch 1 to return to the previous screen.
If there is a mistake in the input or the input is to be stopped, press (■) of machine monitor mode selector switch 1 to return to the previous screen.
- 6. When completing the operation, press (■) of machine monitor mode selector switch 1 twice or turn the starting switch OFF.

METHOD FOR SELECTING LANGUAGE

Use this when switching the language displayed on the character display.

1. Press the (◇) of machine monitor mode selector switch 1 and display the reverse travel odometer.
2. Press (>) or (<) of machine monitor mode selector switch 2 and display "LANGUAGE".

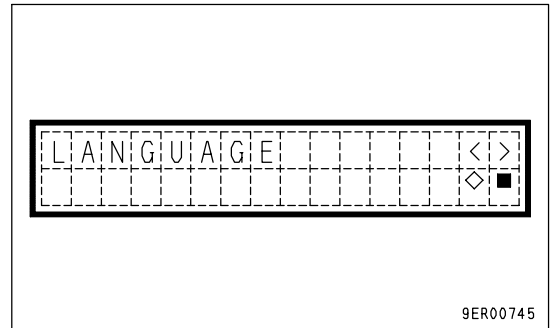

3. Press the (◇) of machine monitor mode selector switch 1. The present language selection is displayed.
4. Press the (>) or (<) portion of machine monitor mode selector switch 2 to select the desired language.

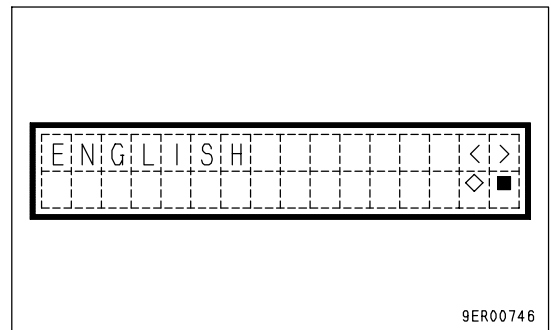

The available languages are English, Japanese, German, French, Italian, Spanish, and Swedish.

Language	Display
English	ENGLISH
Japanese	日本語
German	DEUTSCH
French	FRANCAIS
Italian	ITALIANO
Spanish	Español
Swedish	SVENSKA

5. When the (◇) portion of machine monitor mode selector switch 1 is pressed, the selected language is set and the screen returns to the previous screen.
6. When completing the operation, press (■) of machine monitor mode selector switch 1 twice or turn the starting switch OFF.

SWITCHES

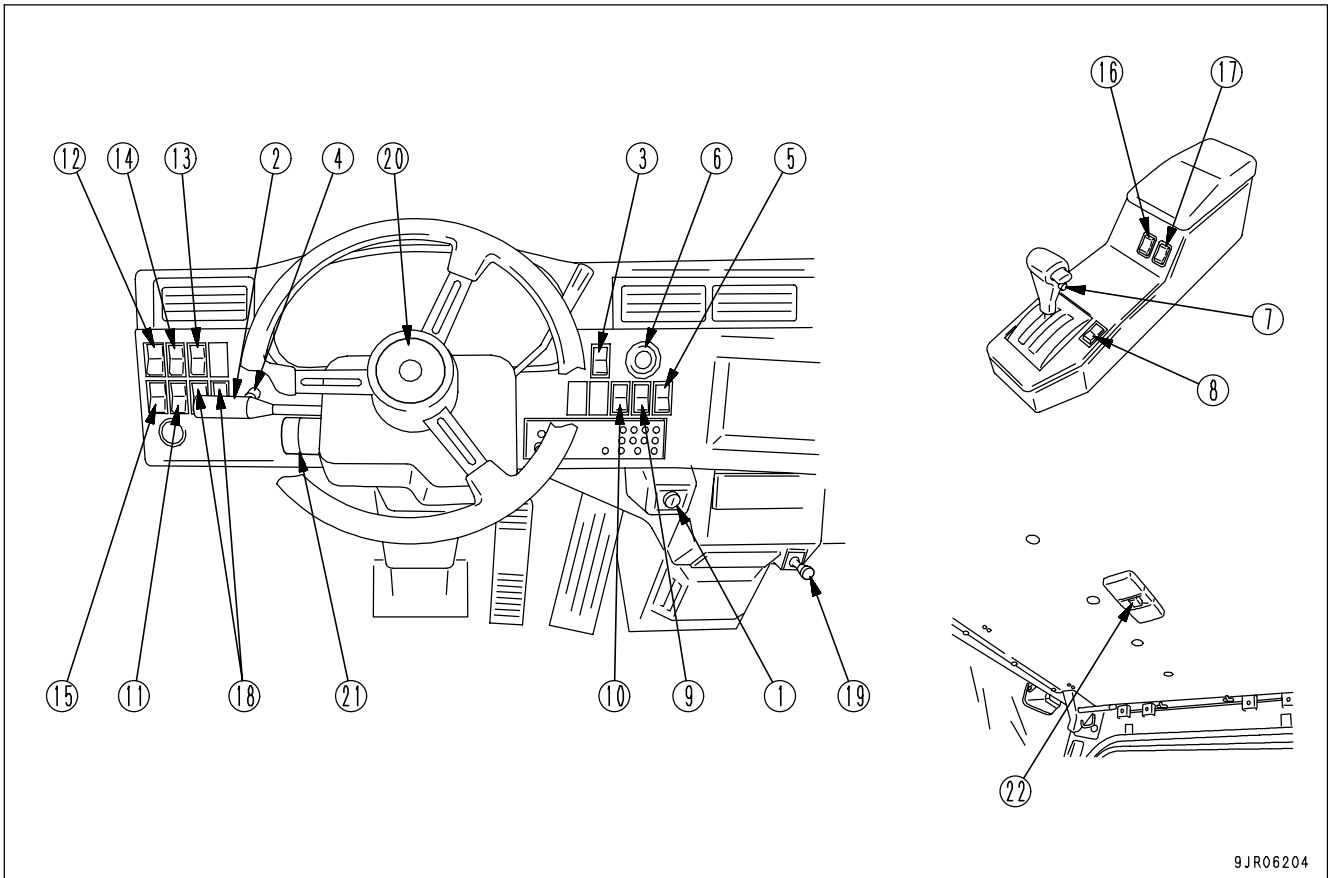

9JR06204

- | | |
|--|--|
| (1) Starting switch | (11) Fog lamp switch (if equipped) |
| (2) Lamp switch | (12) Side lamp switch (if equipped) |
| Turn signal lever | (13) Working lamp (front) switch |
| Dimmer switch | (14) Switch for rear window glass with heated wire |
| (3) Hazard lamp switch | (15) Yellow rotating lamp switch (if equipped) |
| (4) Night lighting dimmer switch | (16) Power window switch (right) (if equipped) |
| (5) Power mode selector switch | (17) Power window switch (left) |
| (6) Emergency steering switch | (18) Machine monitor mode selector switch 1, 2 |
| (7) Shift hold switch | (19) Cigarette lighter |
| (8) Parking brake switch | (20) Horn button |
| (9) AISS LOW switch | (21) Wiper, window washer switch |
| (10) Inter-axle differential lock switch | (22) Room lamp switch |

STARTING SWITCH

This switch (1) is used to start or stop the engine.

OFF position :

The key can be removed from the starting switch, the flow of electricity to the electrical system is cut, and the engine stops.

ON position :

In this position, electric current flows in the charging and lamp circuits.

Keep the starting switch key at the ON position while the engine is running.

When turning the starting switch ON or OFF, if the starting switch is held at a position between ON and OFF, the controller may detect this as a problem. If this happens, return the starting switch to the OFF position, then operate it as usual to the ON position.

In cold weather, if the key is turned ON, engine preheating starts automatically and the preheating pilot lamp lights up. When preheating is completed, the preheating pilot lamp goes out.

START position :

This is the position to start the engine. Hold the key at this position while cranking. Release the key immediately after the engine has been started. The key will return to the ON position when released.

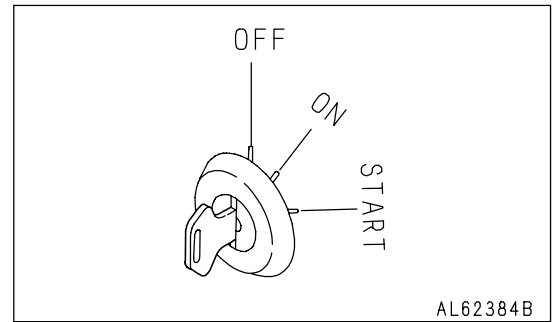

LAMP SWITCH

This switch (2) lights up the head lamps, side clearance lamps, tail lamps, machine monitor lighting, and rear lamps.

Position (a): OFF

Position (b): Side clearance lamps, tail lamps, rear lamps, and machine monitor lighting light up.

Position (c): The head lamps light up in addition to the side clearance lamps, tail lamps, rear lamps, and machine monitor lighting.

The lamp switch can be turned to switch the lighting regardless of the position of the turn signal lever.

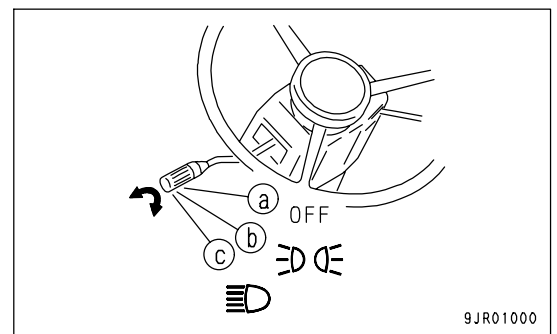

TURN SIGNAL LEVER

This lever (2) operates the turn signal lamp.

(a) Right turn: Push the lever forward

(b) Left turn: Push the lever back

When the lever is operated, the turn signal pilot lamp also flashes. The lever is automatically returned when the steering wheel is turned back. If the lever does not return, move it by hand.

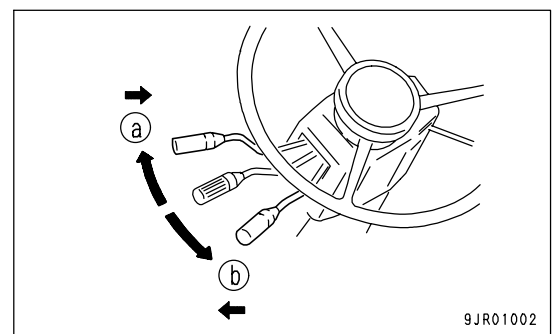

DIMMER SWITCH

Use this switch (2) to switch the head lamps to high beam or low beam.

Each time switch (2) is moved up in direction (a), the head lamp beam changes between high beam and low beam. When the switch is released, it automatically returns to original position (b). When the lamp switch is OFF, if the switch is operated in direction (a), the head lamps light up at the high beam position.

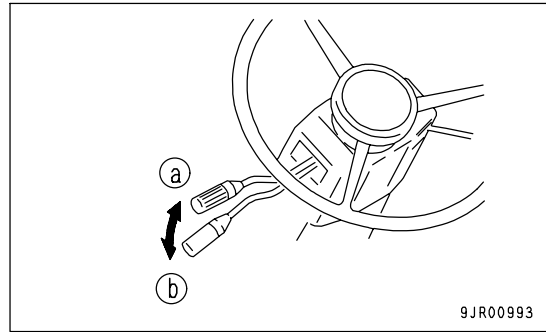
**HAZARD LAMP SWITCH**

This switch (3) is used to make the left and right turn signal indicators flash.

(a): OFF

(b): Turn signal lamp and turn signal pilot lamp flash

When the lamp switch is turned ON, the icon inside the switch lights up, regardless of the position of the switch.

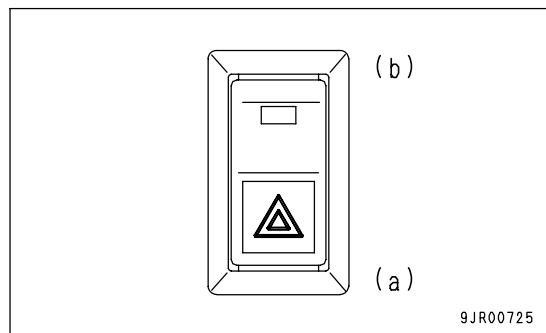
**NIGHT LIGHTING DIMMER SWITCH**

Use this switch (4) to adjust the brightness of the internal lighting of the machine monitor and the pilot lamp when they are lighted up. Turn the knob to the right to make the lighting brighter; turn it to the left to make the lighting dimmer.

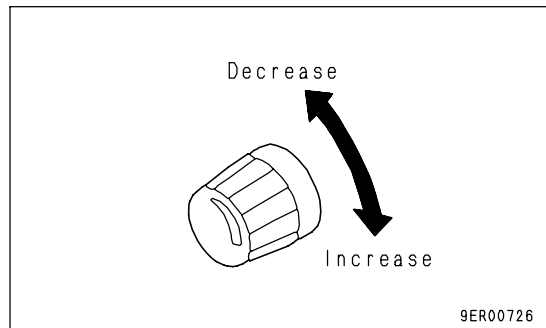

POWER MODE SELECTOR SWITCH

This switch (5) is used to switch the power mode. This makes it possible to travel economically in a way suited to the operating conditions.

If portion (a) of the switch is pressed, high-power mode pilot lamp (P) lights up and the system is switched to the high-power mode. If portion (b) of the switch is pressed, economy mode pilot lamp (E) lights up and the system is switched to the economy mode.

(a): High power mode (general operations)

Normal standard operating conditions

(b): Economy mode (operations on flat ground)

Work with emphasis on fuel consumption, such as work on flat ground where the maximum power is not needed

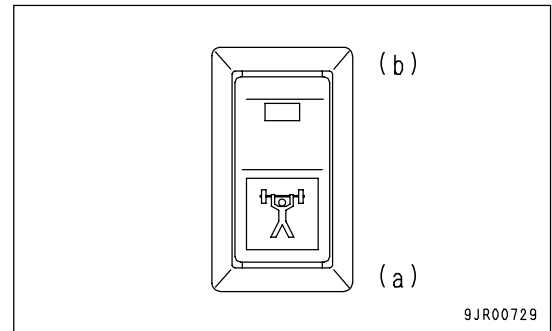

When the lamp switch is turned ON, the icon inside the switch lights up, regardless of the position of the switch.

EMERGENCY STEERING SWITCH**WARNING**

Do not continue to use the emergency steering pump for more than 90 seconds. If the emergency steering is used continuously for more than 90 seconds, there is danger that the pump may burn out or be damaged, or that it may cause a fire.

This switch (6) is used to actuate the emergency steering pump.

When the switch is pressed, the emergency pump is actuated to make it possible to operate the steering.

When the switch is ON, the pilot lamp (red) inside the switch and the pilot lamp on the machine monitor light up.

When the emergency steering is being used, keep the travel speed to a maximum of 5 km/h (3.1 MPH).

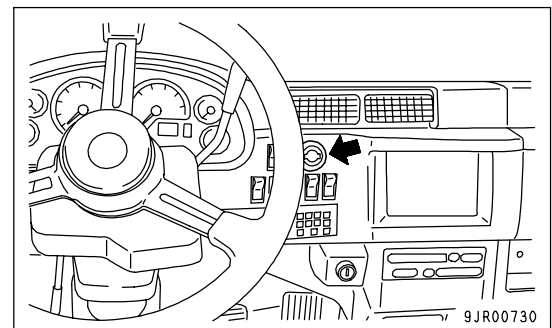

The emergency steering is actuated automatically in the following cases.

- When the steering hydraulic pump fails
- When the engine has stopped during operation

When the emergency steering is actuated, stop the machine promptly and perform inspection.

If the starting switch is at the ON position and the parking brake switch is at the TRAVEL position when the engine is stopped, the automatic emergency steering is actuated after 1 second, so set the parking brake switch to the PARKING position.

SHIFT HOLD SWITCH

Use this switch (7) to actuate the shift hold function.

When this switch is pressed once, the shift hold pilot lamp lights up and the shift hold function is actuated.

When the shift hold function is actuated, the transmission is not shifted up from the present transmission speed.

If the travel speed drops excessively when the shift hold function is being actuated, the transmission shifts down, but when the travel speed increases, the transmission is held at the original speed range

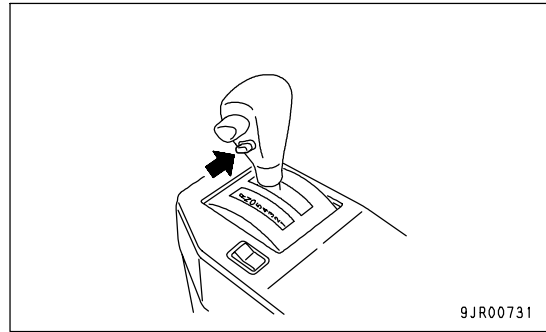

The shift hold function can be canceled by carrying out the following operations.

- 1) When the gear shift lever is operated to another position.
- 2) When the shift hold switch is pressed again.

There may be hunting of the transmission (repeatedly shifting up or down for a short time) depending on the travel road surface, uphill grade, or payload condition of the machine. If this happens, to improve the riding comfort and to protect the transmission, travel with the transmission fixed in a low speed range.

PARKING BRAKE SWITCH

**WARNING**

When parking or leaving the machine, always apply the parking brake.

This switch (8) is used to actuate and release the parking brake valve.

(a): Parking

The parking brake is applied.

(b): Travel

The parking brake is released.

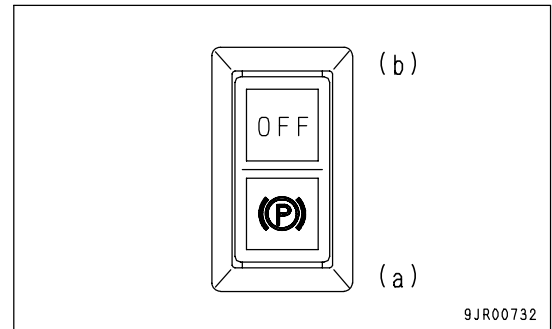

When the switch is set to the PARKING position, the parking brake pilot lamp lights up.

When the switch is set to the PARKING position, if the gear shift lever is at any position other than N, the central warning lamp will flash and the alarm buzzer will sound.

If the pressure in the brake circuit drops (below 5.4 MPa {55 kg/cm², 781 PSI}), the parking brake is automatically applied. For details of the method of canceling the parking brake, see "WHEN PARKING BRAKE HAS BEEN ACTUATED IN EMERGENCY (PAGE 3-130)".

When the lamp switch is turned ON, the icon inside the switch lights up, regardless of the position of the switch.

REMARK

If the engine is stopped with the parking brake switch at TRAVEL, the parking brake will be applied automatically even though the parking brake switch is at TRAVEL. When starting the engine again, operate the parking brake switch to PARKING, and then move it back to TRAVEL to release the parking brake.

NOTICE

During loading operations, do not apply the parking brake. Apply the retarder brake.

AISS LOW SWITCH

Using this switch (9), it is possible to switch the AISS freely between AUTO and LOW. Use each position as follows.

(a): AUTO position

For normal operations

(b): LOW position

When fine control of the machine is needed, such as when putting it into a garage.

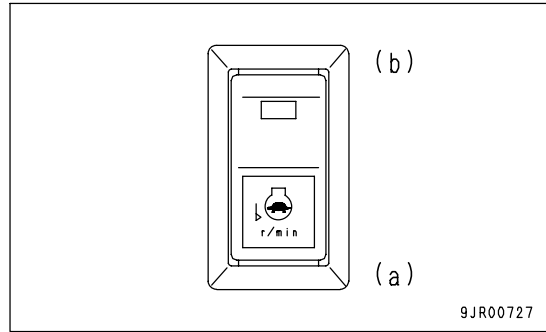

If the switch is at AUTO position:

- When the machine is stopped, if the parking brake or retarder brake are actuated, the idling speed is automatically adjusted to low speed. When the parking brake is released and the machine is moved off, the speed is automatically adjusted to high speed.
- The water temperature is detected, and when it is at low temperature, the idle is automatically adjusted to high speed to reduce the warming-up time.

When the lamp switch is turned ON, the icon inside the switch lights up, regardless of the position of the switch.

INTER-AXLE DIFFERENTIAL LOCK SWITCH

This switch (10) can be used to switch the actuating conditions for the inter-axle differential lock.

When this switch is pressed, the system is switched to MANUAL.

When the switch is not pressed or is pressed to return it, the system is switched to AUTO.

AUTO: The slippage of the front axle is detected and the inter-axle differential lock is automatically actuated.

MANUAL: When the gear shift lever is at the F3, F2, F1, N, R1, or R2 position, the inter-axle differential lock is actuated.

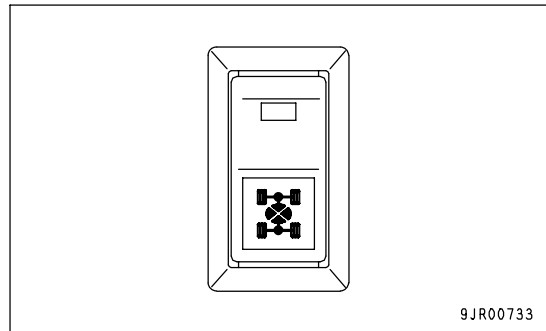

Regardless of the position of the switch, when the differential lock is actuated, the inter-axle differential lock pilot lamp lights up.

When the lamp switch is turned ON, the icon inside the switch lights up, regardless of the position of the switch.

For details when using the differential lock, see "OPERATION USING DIFFERENTIAL LOCK (PAGE 3-102)".

FOG LAMP SWITCH

(If equipped)

This switch (11) is used to switch on the fog lamp.

(a): Fog lamp goes out

(b): Fog lamp lights up

When the lamp switch is turned ON, the icon inside the switch lights up, regardless of the position of the switch.

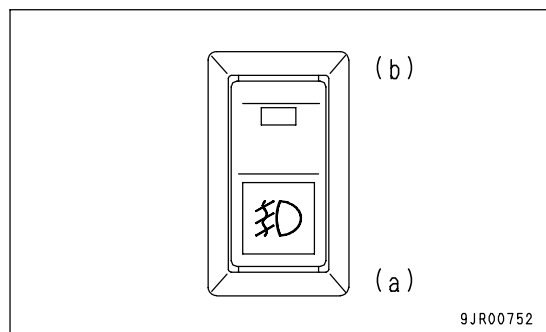

SIDE LAMP SWITCH

(If equipped)

This switch (12) is used to switch on the side lamp.

- (a): Side lamp goes out
- (b): Side lamp lights up

When the lamp switch is turned ON, the icon inside the switch lights up, regardless of the position of the switch.

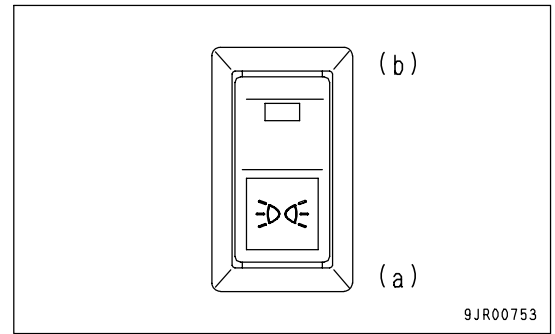

WORKING LAMP (FRONT) SWITCH

This switch (13) is used to switch on the working lamp (front).

- (a): Working lamp goes out
- (b): Working lamp lights up

When the lamp switch is turned ON, the icon inside the switch lights up, regardless of the position of the switch.

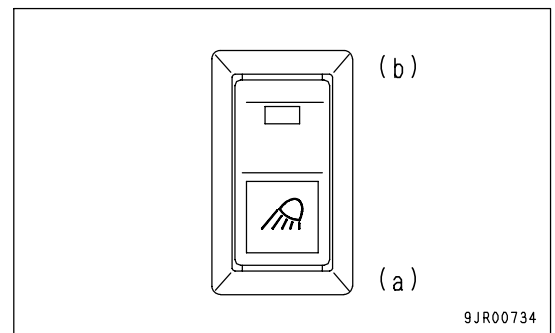

SWITCH FOR REAR WINDOW GLASS WITH HEATED WIRE

Use this switch (14) to turn the heater for the rear glass ON/OFF.

- (a): Wire heater OFF
- (b): Wire heater ON

When the lamp switch is turned ON, the icon inside the switch lights up, regardless of the position of the switch.

REMARK

The wire heater does not automatically turn OFF when it becomes hot, so when it is not needed, turn the switch manually to the OFF position.

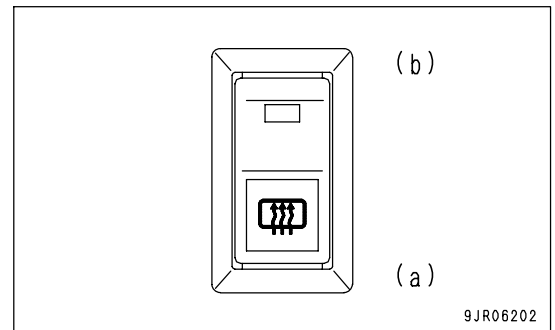

YELLOW ROTATING LAMP SWITCH

(If equipped)

This switch (15) is used to switch the yellow rotating lamp on and off. When the lamp is switched on, it lights up and rotates.

- (a): Yellow rotating lamp goes out
- (b): Yellow rotating lamp lights up

When the lamp switch is turned ON, the icon inside the switch lights up, regardless of the position of the switch.

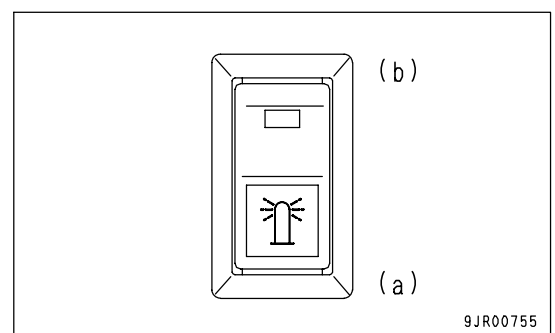

POWER WINDOW SWITCH (RIGHT) (LEFT)
(The right power window is optional.)

 **WARNING**

When closing the window glass, be careful not to get anyone's hands or head caught.
There is danger of serious injury if anyone is caught in the window glass.

 **CAUTION**

After fully opening or fully closing the window glass, release the switch immediately. If the switch is kept operated, it may cause failure of the power window.

Switches (16) and (17) are used to open and close the window glass. The switches can only be used when the starting switch is at the ON position.

- (A): Glass goes down
- (B): Glass goes up

When the glass reaches the top or bottom and stops, release the switch.

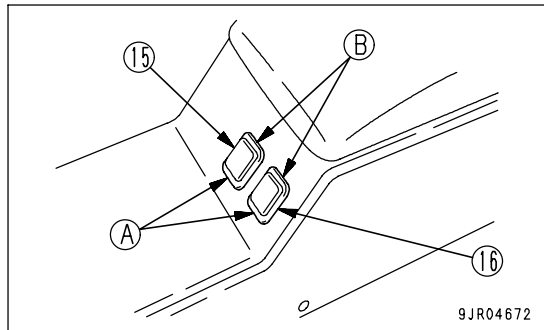

MACHINE MONITOR MODE SELECTOR SWITCH 1, 2

This switch (18) is used to operate the character display.

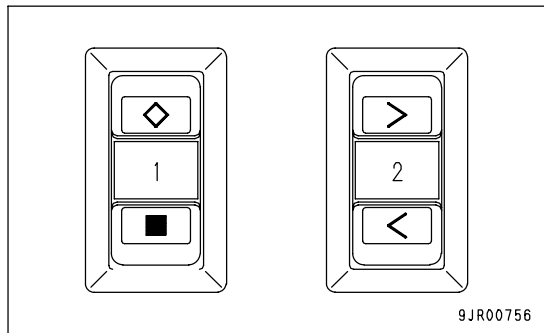

CIGARETTE LIGHTER

This switch (19) is used to light cigarettes.

When the cigarette lighter is pushed in, it will return to its original position after several seconds, then pull it out and use it to light your cigarette.

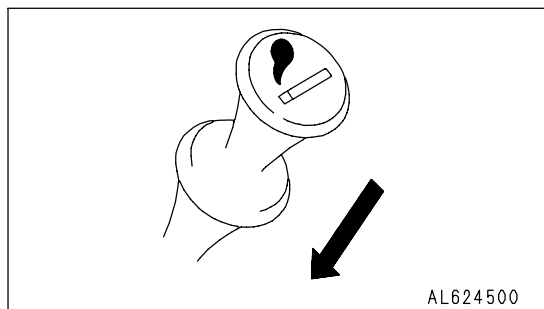

HORN BUTTON

When the horn button (20) in the center of the steering wheel is pressed, the horn will sound.

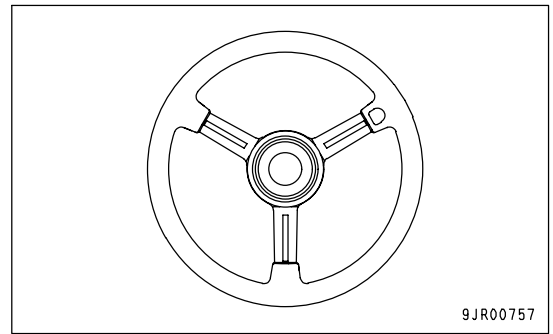

WIPER, WINDOW WASHER SWITCH

This switch (21) is used to operate the wiper for the front glass and rear glass.

Using the wiper when the glass is dry will scratch the glass. Spray with window washer fluid before actuating the wiper.

Front wiper

Position (a) (OFF): Stopped

Position (b) (INT): Wiper moves once every 4 to 7 seconds

Position (c) (LOW): Wiper moves at low speed

Position (d) (Hi): Wiper moves at high speed

When the button at the tip of the switch is pressed, washer fluid is sprayed out.

Do not keep the button pressed for more than 10 seconds.

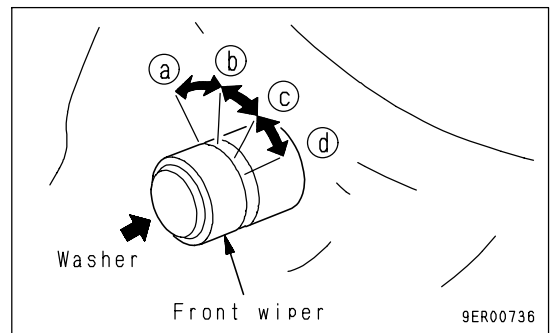

Rear wiper

Position (a): Washer fluid is sprayed out

Position (b) (OFF): Stopped

Position (c): Wiper is actuated

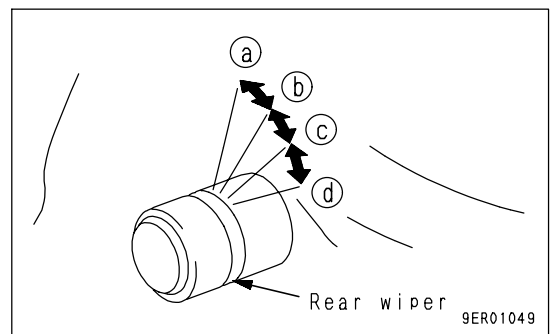

ROOM LAMP SWITCH

The switch (22) is used to turn the room lamp ON and OFF.

Position (a): OFF

Position (b): Lights up when the door opens

Position (c): Lights up

REMARK

- The room lamp lights up even when the starting switch is at the OFF position, so when leaving the operator's compartment, set the switch to position (a) or (b).
- When carrying out operations with the door fully opened, set the switch to position (a) (OFF).

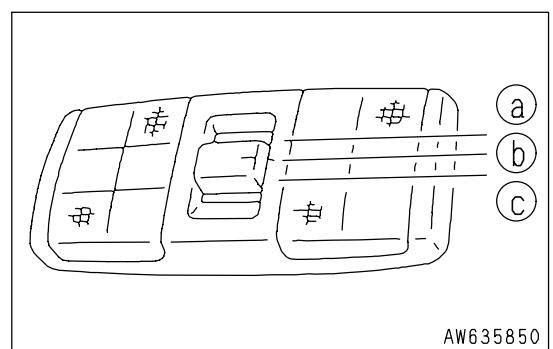

CONTROL LEVERS AND PEDALS

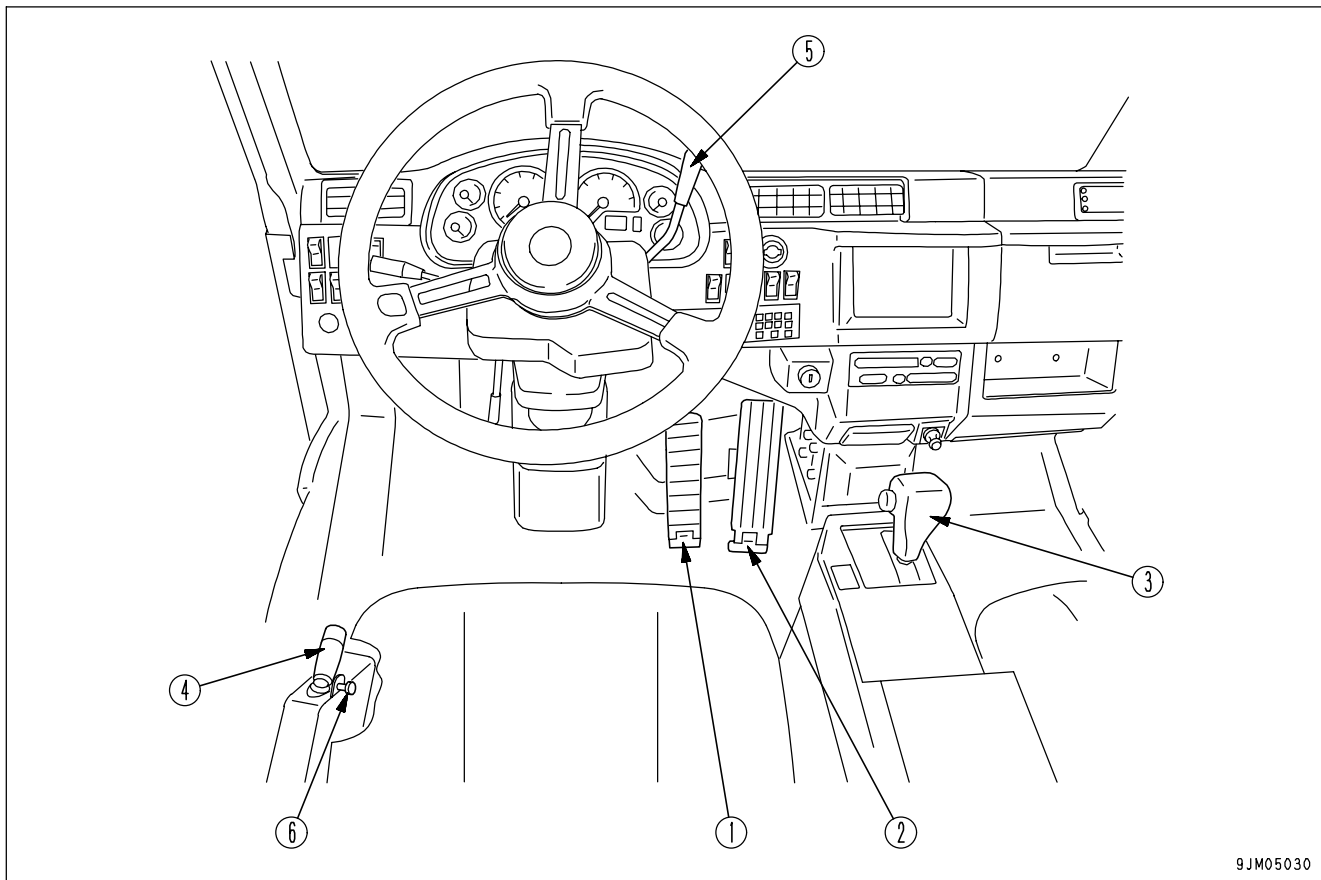

9JM05030

- (1) Brake pedal
- (2) Accelerator pedal
- (3) Gear shift lever
- (4) Dump lever
- (5) Retarder control lever
- (6) Dump lever lock knob

BRAKE PEDAL

This pedal (1) is used to apply the wheel brakes.

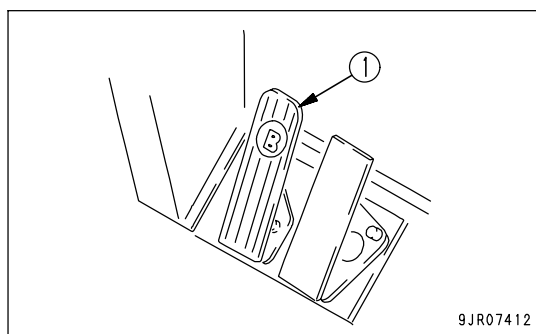

9JR07412

ACCELERATOR PEDAL

Use this pedal (2) to control the engine speed.
It can be operated freely from low idling to full throttle.

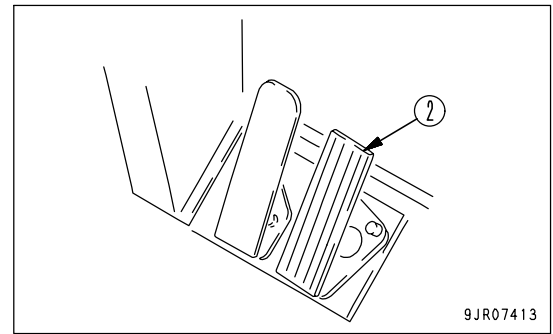
**GEAR SHIFT LEVER**

The gear range can be selected with this lever (3) to match the travel conditions.

Position D:

This is used when traveling normally. When this position is used, the transmission is set automatically between the 2nd torque converter drive and 6th gear according to the travel speed. While the dump body is raised, however, the transmission is fixed to the 2nd gear and is not changed. Keep the dump body lowered during travel. The maximum travel speed in this position is 58.6 km/h (36.4 MPH).

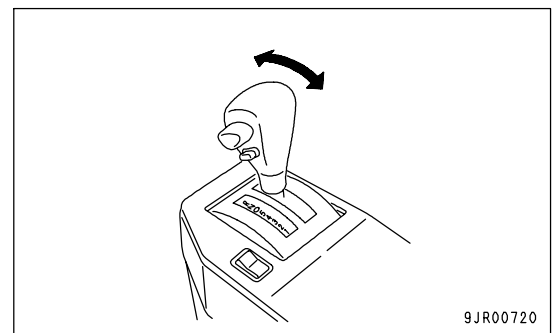
**REMARK**

If the machine is driven when the dump body is not completely lowered, if the gear shift lever is at position D, the speed range is fixed at 2nd and the transmission cannot be shifted. (This conforms to EU safety standard (EN474-6 5.1.3).)

Position R1:

This is used when traveling in reverse. When this position is used, the transmission is fixed in R1 and the travel is carried out in torque converter drive or direct drive according to the travel speed. The maximum travel speed in this position is 7.6 km/h (4.7 MPH).

Position R2:

This is used when traveling in reverse. When this position is used, the transmission is fixed in R2 and the travel is carried out in torque converter drive or direct drive according to the travel speed. The maximum travel speed in this position is 18.1 km/h (11.2 MPH).

The machine cannot be driven in reverse if the dump body is raised. Lower the dump body, set the dump lever to FLOAT, then operate the gear shift lever to R1 or R2.

Positions 5 - 1:

Use these positions when traveling on soft ground or places where it is difficult to travel at high speed, when starting uphill with the machine loaded, or when traveling downhill when it is necessary to use the braking force of the engine. While the dump body is raised, the transmission is fixed to the 1st gear and is not changed. Keep the dump body lowered during travel.

REMARK

If the machine is driven when the dump body is not completely lowered, if the gear shift lever is at a position between 5 and 1, the speed range is fixed at 1st and the transmission cannot be shifted. (This conforms to EU safety standard (EN474-6 5.1.3).)

- The automatic gear shifting range for each position is as shown below.

Position	Speed range	Max. speed [km/h (MPH)]
R2	R2nd torque converter - direct	18.1 (11.2)
R1	R1st torque converter - direct	7.6 (4.7)
D	2nd torque converter - 6th direct	58.6 (36.4)
5	1st torque converter - 5th direct	38.4 (23.9)
4	1st torque converter - 4th direct	25.5 (15.8)
3	1st torque converter - 3rd direct	16.2 (10.1)
2	1st torque converter - 2nd direct	10.7 (6.6)
1	1st torque converter - 1st direct	6.8 (4.2)

Always place the gear shift lever securely in position when operating it.

If the gear shift lever is not placed securely in position, the shift lever position pilot lamp display on the machine monitor may go out and the transmission system caution lamp may light up.

Before shifting between forward and reverse, stop the machine completely and then run the engine at low idle.

When starting the engine, if the gear shift lever is not at the N (neutral) position, the engine will not start.

When the starting switch is turned from the OFF position to the ON position, if the gear shift lever is not at the N (neutral) position, the shift lever position pilot lamp flashes, the central warning lamp lights up, and the alarm buzzer sounds. When this happens, if the gear shift lever is returned to the N (neutral) position, the lamps will go out and the buzzer will stop.

When the parking brake is applied, if the gear shift lever is not at the N (Neutral) position, the central warning lamp will light up and the alarm buzzer will sound.

If the gear shift lever is set to any position other than N (neutral) when the dump lever is at a position other than FLOAT or the dump body is still raised, the central warning lamp will light up and the alarm buzzer will sound.

The gear shift lever must not be returned to the N (neutral) position while traveling.

Release the accelerator pedal and run the engine at low idle when moving the shift lever from the N position to the forward or reverse position.

When moving the shift lever from the N (neutral) position to the R1 (reverse) position or from the N position to the D position, press the lock button on the shift lever before operating it.

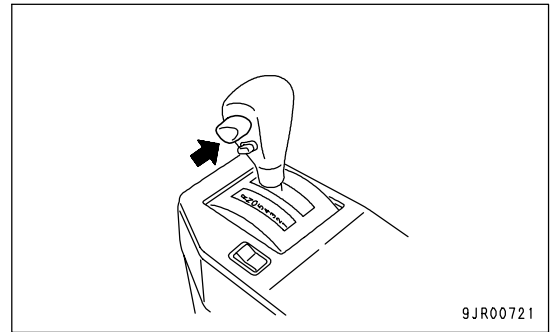

9JR00721

When the shift hold switch is pressed, the shift hold function is actuated and the shift hold pilot lamp lights up. When the shift hold function is actuated, the transmission is not shifted up from the present transmission speed.

The shift hold function can be canceled by carrying out the following operations.

- 1) When the gear shift lever is operated to another position.
- 2) When the shift hold switch is pressed again.

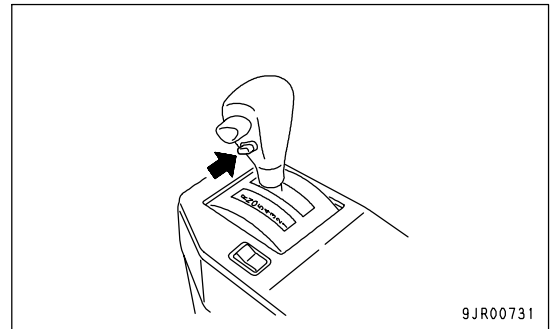

9JR00731

DUMP LEVER



To prevent damage to the dump body caused by vibration from the road, always lower the dump body when traveling and set the dump lever to the FLOAT position.

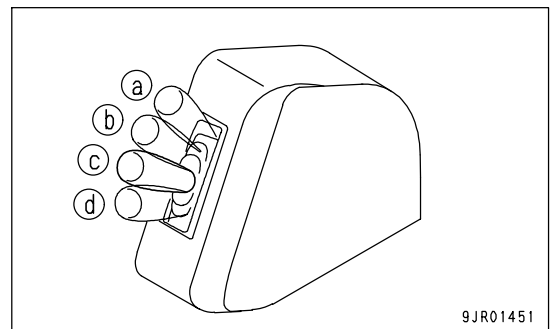

9JR01451

This lever (4) is used to operate the dump body.

- (a) RAISE
- (b) HOLD: The dump body stops and is held in position.
- (c) FLOAT: The dump body moves freely under external force.
- (d) LOWER

Always set to the FLOAT position when traveling.

It is impossible to travel in reverse if the dump body is raised.

If the engine stops, the dump body is held in the HOLD condition, regardless of the position of the dump lever. When the engine is started again, the dump body is held in the HOLD condition and the body pilot lamp lights up. For details of the method of canceling the HOLD condition, see "CANCELING DUMP BODY HOLD CONDITION (PAGE 3-87)".

RETARDER CONTROL LEVER

CAUTION

The retarder must not be used as a parking brake.

Use this lever (5) to operate the retarder when traveling downhill. The more the lever is pulled, the greater the braking force becomes.

When the retarder is operated, the retarder pilot lamp lights up.

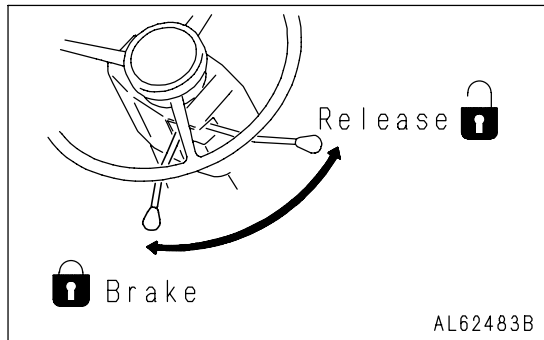

When leaving the operator's seat, always apply the parking brake.

DUMP LEVER LOCK KNOB

WARNING

When carrying out inspection with the dump body raised, always set the dump lever to the HOLD position, lock it with the dump lever lock knob, and use the body pivot pin.

This device (6) is used to lock the dump lever.

To set it to the FREE position, pull the lock knob out fully, then turn it to hold it in position.

To set it to the LOCK position, pull the lock knob out and turn it to remove it from the fixed position. The knob is pushed into the lock hole in the dump lever by the force of the spring, and the dump lever is locked. Check that the dump lever is securely locked.

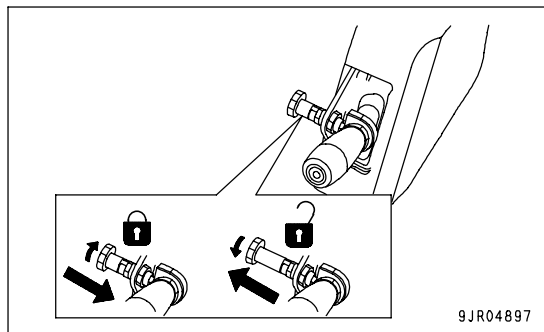

BODY PIVOT PIN



WARNING

When carrying out inspection of the machine with the dump body raised, always set the dump lever to the HOLD position, lock with the dump lever lock knob, then use the body pivot pin.

This is a safety device for the dump body. Use it when carrying out inspection and maintenance with the dump body raised.

Raise the dump body fully, insert body pivot pins (1).

Always insert the body pivot pin on both sides.

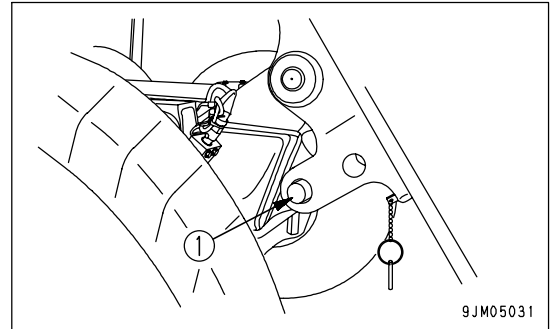

STOWING BODY PIVOT PIN

Store the body pivot pin under the rear of the dump body.

Insert body pivot pin (1), then insert lock pin (2) to stow the body pivot pin.

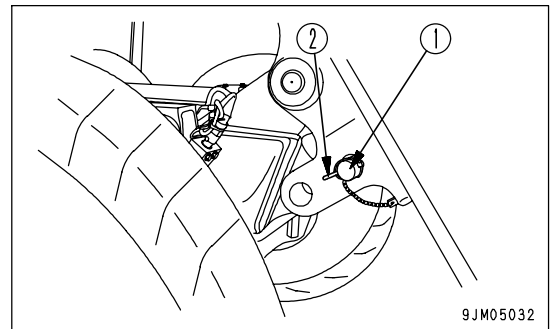

ARTICULATE LOCK



WARNING

If the machine is transported or raised without applying the articulation lock, the machine may suddenly articulate. This may cause serious injury to persons in the surrounding area.

- When transporting or raising the machine, always apply the articulation lock.
- Apply the articulation lock if necessary when carrying out maintenance.

The articulation lock is a device to lock the front frame and rear frame to prevent the machine from articulating.

LOCK position: Always set to this position when transporting or raising the machine.

Set to the **LOCK** position if necessary when carrying out maintenance.

FREE position: Always set to this position when traveling

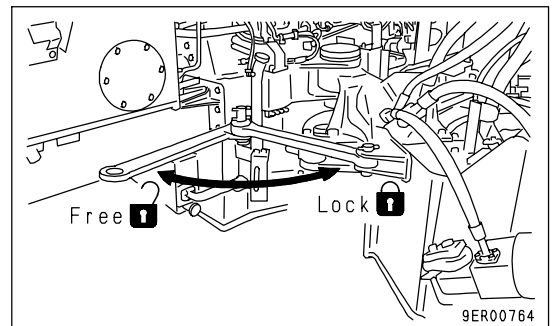

LOCATION OF FIRE EXTINGUISHER

Fire extinguisher (1) is installed to the left front of the machine.

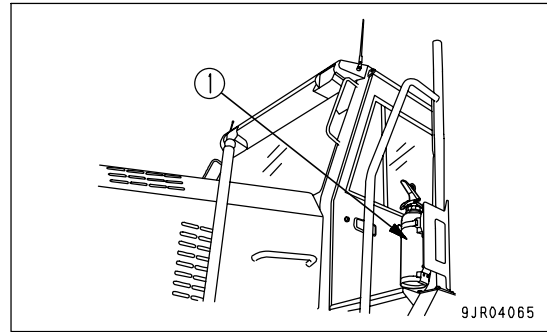

DUST INDICATOR

This device indicates clogging of the air cleaner.

Depending on the degree of clogging of the element, red line (1) appears in the transparent portion. If red line (1) indicates 7.5 kPa (30 INCHES H₂O) (0.076 kg/cm², 1.1 PSI), clean the element immediately.

After cleaning, press top portion (2) of the indicator to return red line (1) to its original position.

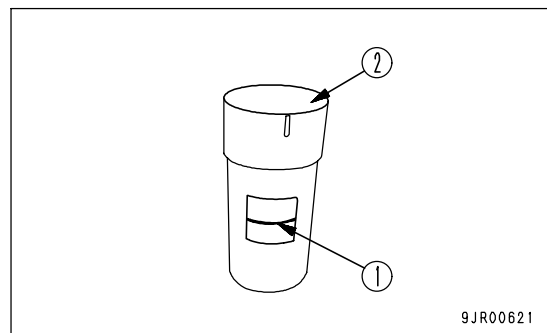

CIRCUIT BREAKER

After the circuit breaker operates, it can be reset by pushing in the reset button. If the reset button comes out soon after it is pushed in, there may be a short circuit in the electric circuit. In this case, ask your Komatsu distributor for repair.

- (1) For primary power supply (30 A)
- (2) For primary power supply (Direct) and engine controller (30 A)
- (3) For secondary power supply (Accessory power) (80 A)

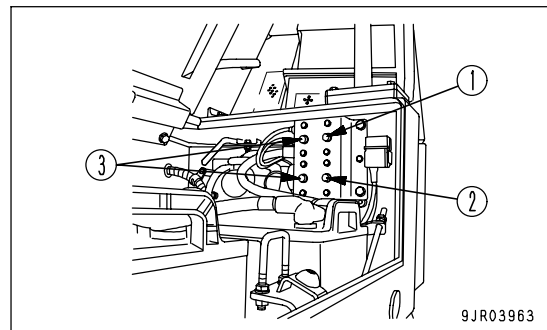

FUSES

The fuses protect the electrical equipment and wiring from burning out.

If the fuse becomes corroded, or white powder can be seen, or the fuse is loose in the fuse holder, replace the fuse.

NOTICE

- When replacing any fuse, always turn the power off (turn the starting switch to OFF).
- When replacing the fuse, always use a fuse of the same capacity and type.

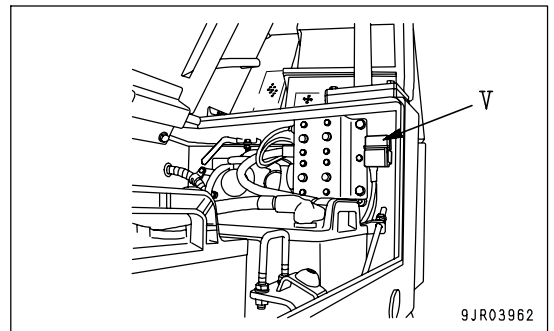
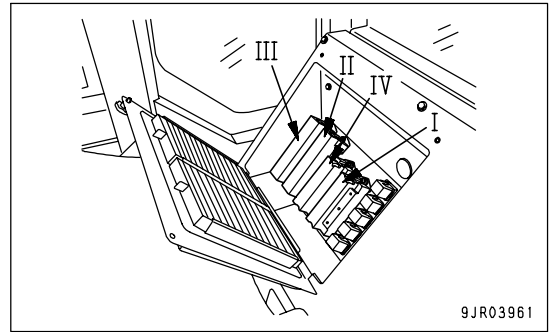

FUSE CAPACITY AND CIRCUIT NAME

Fuse BOX I (BT1)

No.	Capacity	Name of circuit
(1)	20A	Main lamp
(2)	10A	Turn signal lamp
(3)	20A	Head lamp (right)
(4)	20A	Head lamp (left)
(5)	10A	Side lamp (right)
(6)	10A	Side lamp (left)
(7)	10A	Stop lamp
(8)	20A	Backup lamp, backup buzzer
(9)	20A	Working lamp (front)
(10)	20A	-

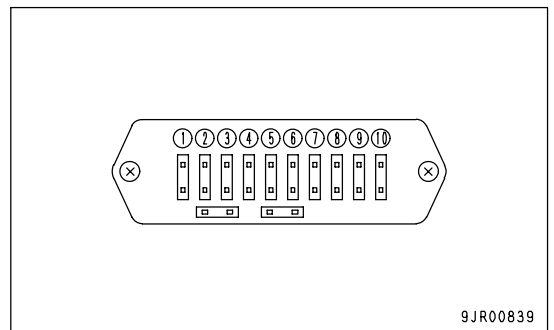

Fuse box II (BT2)

No.	Capacity	Name of circuit
(11)	5A	Engine controller
(12)	10A	KOMTRAX
(13)	10A	Machine monitor
(14)	10A	Parking brake
(15)	10A	Rear view monitor
(16)	20A	Front wiper
(17)	20A	Rear wiper
(18)	10A	Machine monitor, KOMTRAX
(19)	10A	Retarder controller
(20)	20A	Terminal a
(21)	10A	Transmission controller
(22)	20A	Hazard lamp
(23)	10A	Emergency steering
(24)	10A	Room lamp
(25)	20A	Direct from battery (spare)

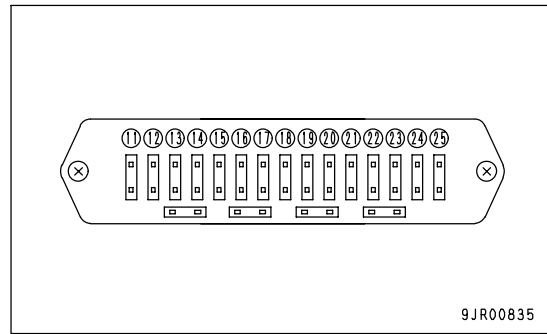

Fuse box III (BT3)

No.	Capacity	Name of circuit
(26)	20A	Fog lamp (if equipped)
(27)	20A	Air conditioner controller (if equipped)
(28)	10A	Heater
(29)	10A	Heater
(30)	10A	Machine monitor
(31)	10A	Retarder controller
(32)	10A	Transmission controller
(33)	10A	Emergency steering, Parking brake relay
(34)	20A	Power window (right)
(35)	20A	Power window (left)
(36)	20A	
(37)	20A	
(38)	20A	
(39)	30A	Rear heater
(40)	30A	Engine controller

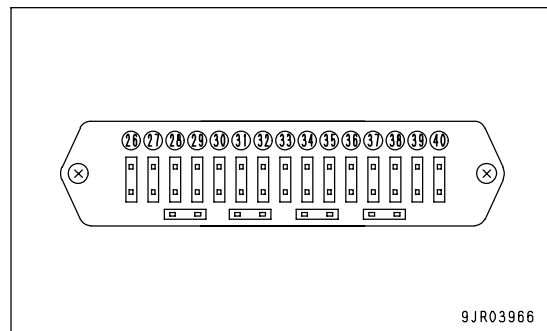

Fuse box IV (BT4)

No.	Capacity	Name of circuit
(41)	10A	Spot Light (if equipped), Room lamp 2
(42)	10A	Radio
(43)	10A	Yellow rotating lamp (if equipped) Step lamp (if equipped)
(44)	20A	Side lamp (if equipped)
(45)	10A	Auto-preheater
(46)	10A	Horn
(47)	10A	Tachograph (if equipped)
(48)	10A	Cigarette lighter
(49)	10A	Air suspension seat
(50)	10A	Air conditioner

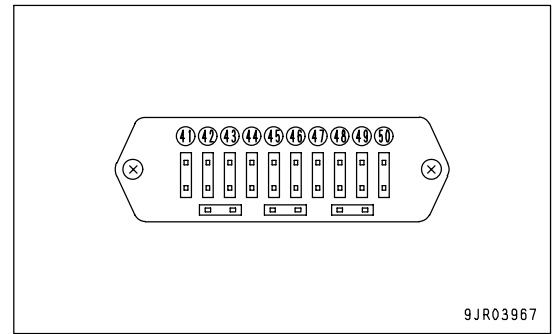

Fuse box V

No.	Capacity	Name of circuit
(51)	120A	Power supply for electrical intake air heater

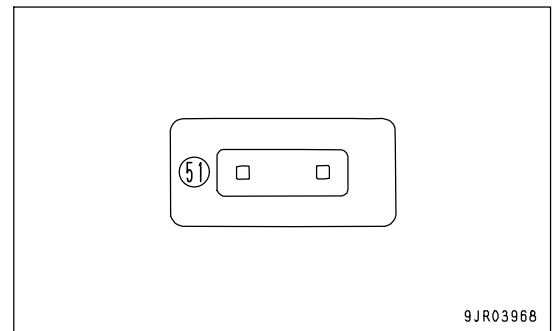

Precautions when adding electrical equipment

⚠ CAUTION

If the electrical equipment system is changed, problems may occur in the machine control. Do not make any changes to the electrical system.

If you want to make any change to the electrical system, please contact your Komatsu distributor.

CAR RADIO

(If equipped)

EXPLANATION OF COMPONENTS

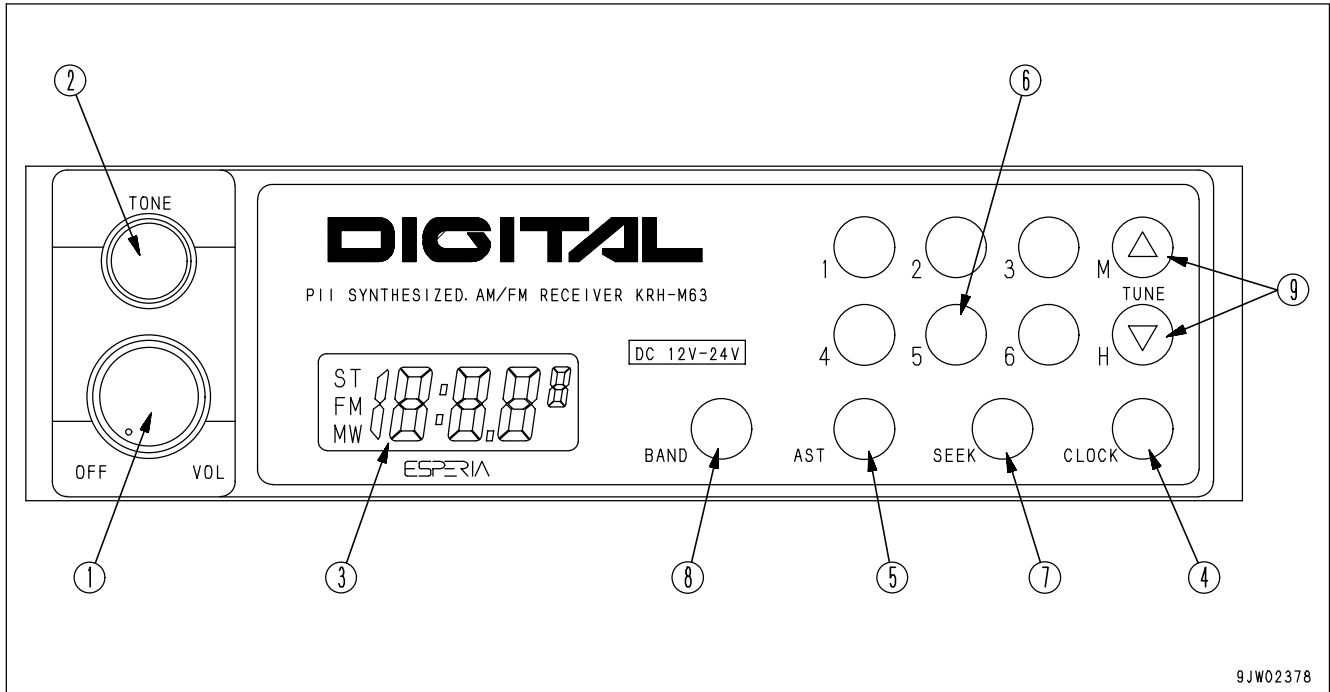

- (1) Power switch/Volume
- (2) Tone control knob
- (3) Display
- (4) Clock button/Displaying frequency
- (5) AST
- (6) Preset switch
- (7) Seek
- (8) Band selector switch
- (9) Tuning switch

POWER SWITCH/VOLUME

When this switch (1) is turned to the right, it clicks and the power is turned on. If it is turned further, the speaker volume is adjusted.

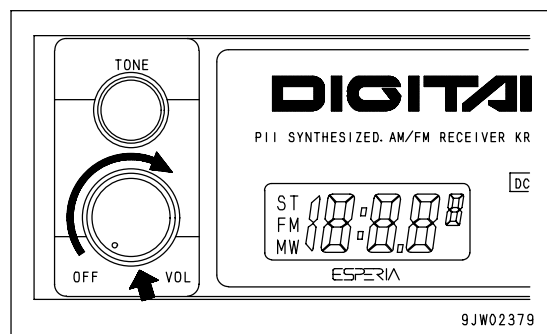

TONE CONTROL KNOB

If this knob (2) is turned to the right, the high tone is emphasized;
if it is turned to the left, the high tone is reduced.

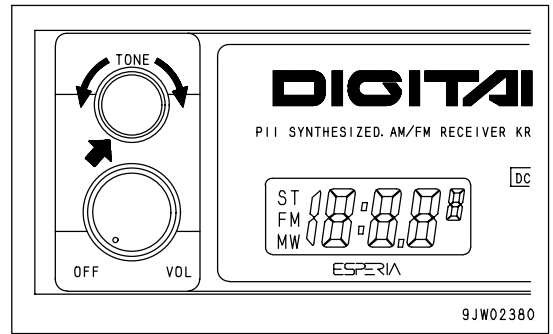

DISPLAY

This display (3) shows the radio reception frequency and the operating mode.

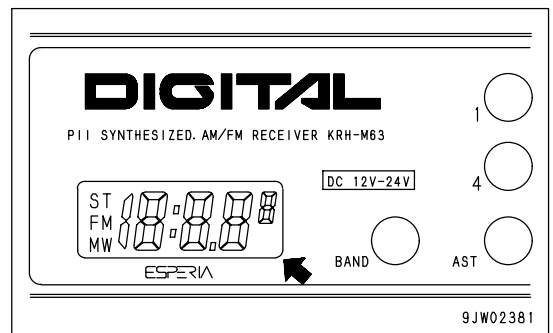

CLOCK BUTTON/DISPLAYING FREQUENCY

When this button (4) is pressed, the display changes to the time.
If it is pressed again, it displays the frequency.

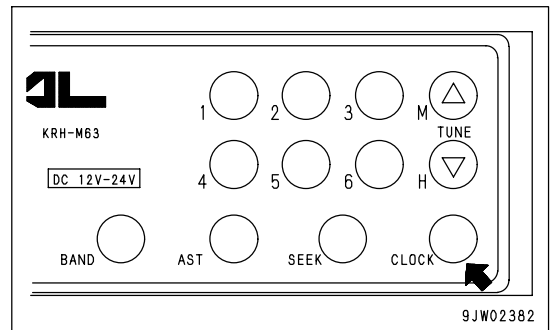

AST

When this button (5) is pressed, the preset stations are called up in turn.

When the desired broadcasting station is reached, press the button again to stop it.

If the button is kept pressed continuously for 2 seconds, it is set to auto memory.

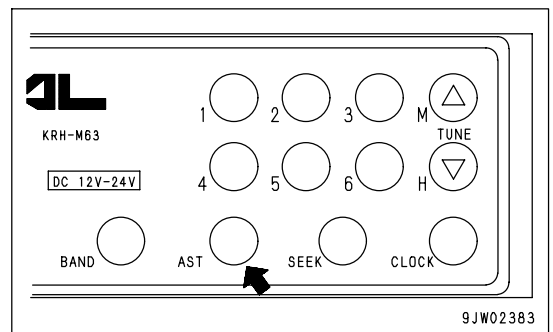

PRESET SWITCH

With this switch (6), each button can be set to one station each for FM and MW (AM). (For details of the method of resetting, see "METHOD OF PRESET (PAGE 3-54)".)

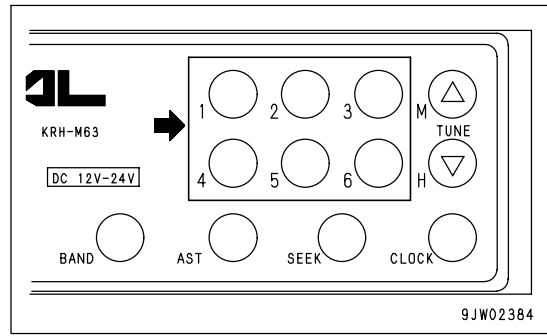

SEEK

When this switch (7) ("SEEK") is pressed, it automatically searches for stations that can be received, and when it receives a station, it stops.

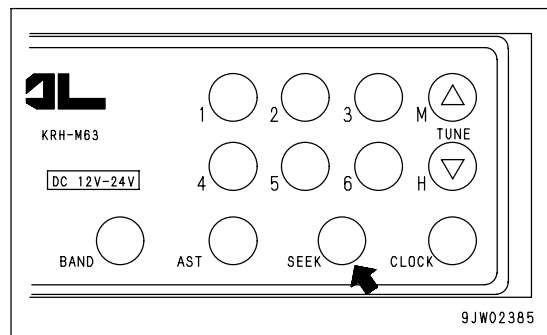

BAND SELECTOR SWITCH

When this switch (8) ("BAND") is pressed, the band is switched between FM and MW (AM).

The reception band and frequency are displayed on the display.

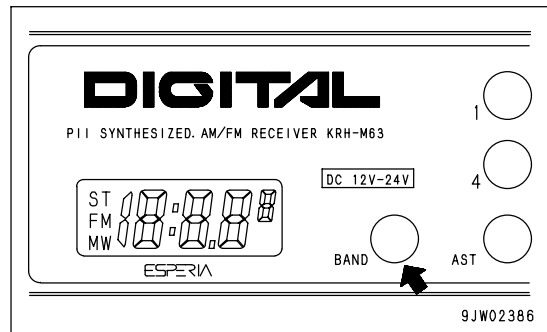

TUNING SWITCH

When the "TUNE" button Δ of switch (9) is pressed, the frequency goes up; when the ∇ button is pressed, the frequency goes down. If it is kept pressed, the frequency changes continuously.

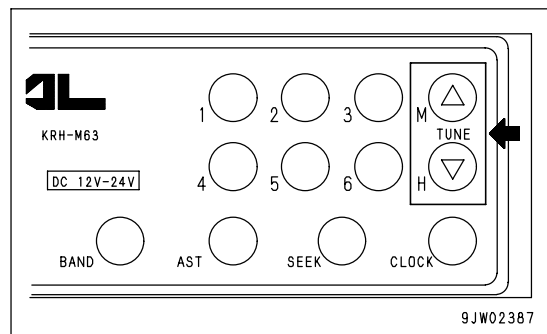

METHOD OF OPERATION

LISTENING TO RADIO

1. This switches on power (1) for the radio.
2. "BAND" switch (2) is used to select MW (AM) or FM.
3. Use the preset switch or tuning switch (3) to select the station.
4. Adjust the volume and tone as desired.
5. To turn the radio OFF, turn VOL knob (1) to the left until a click is heard.

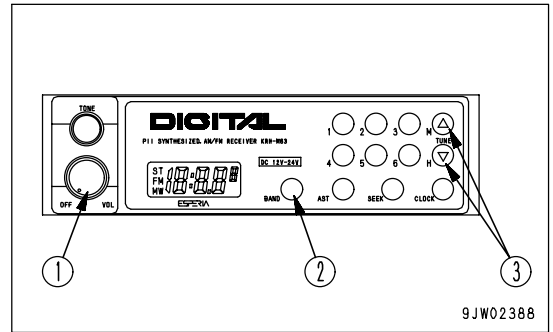

METHOD OF AUTOMATIC TUNING

When the "SEEK" switch is pressed, it moves up to higher frequencies and when it finds a station that can be received, it stops automatically.

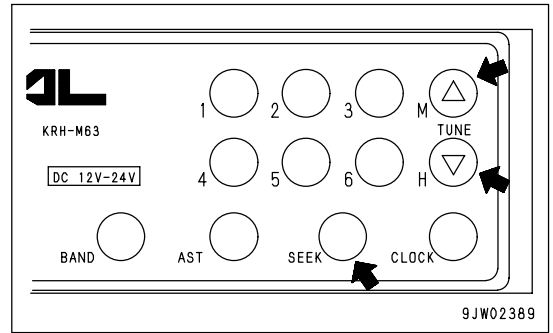

METHOD OF MANUAL TUNING

When the TUNE button Δ is pressed, the frequency goes up; when the ∇ button is pressed, the frequency goes down. If it is kept pressed, the frequency changes continuously.

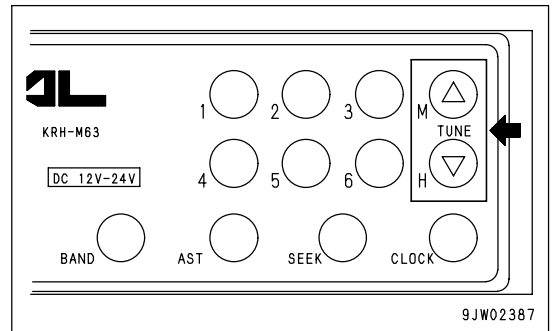

METHOD OF PRESET

1. Select the desired preset station.

Use the "BAND" button to select MW (AM) or FM, and use the "TUNE" button to select the frequency of the broadcasting station.

2. Decide the number of the button to be preset, and keep it pressed for 2 seconds. The number of the button will be displayed and the presetting is completed.

3. Repeat Steps 1 to 2 to preset other broadcasting stations.

- To change the setting of a preset switch to another station, repeat Steps 1 to 2.
- If the battery is replaced or the power is switched off, all the preset settings are deleted. Carry out the presetting operation again.
- It is possible to preset 6 AM (MW) stations and 6 FM stations.

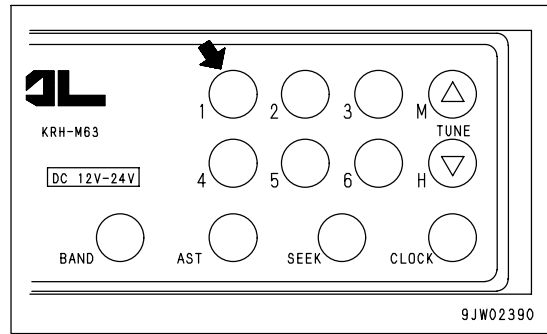

METHOD OF AUTOMATIC MEMORY

If the "AST" button is pressed for 2 seconds, the broadcasting stations that can be received in the area are called up in turn, and the broadcasting stations are automatically saved in the preset memory.

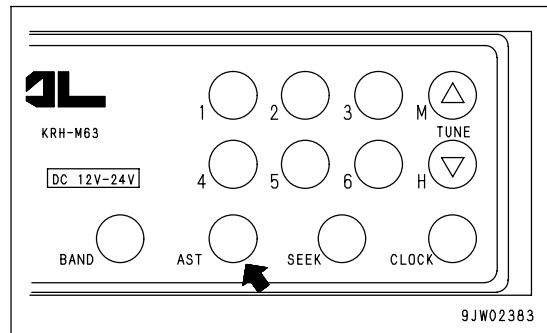

AUTOMATIC SWITCHING RECEPTION OF MONAURAL/STEREO

If the reception of the FM stereo broadcast being received is weak (when you are far from the broadcasting station or are surrounded by hills), the radio is automatically switched from stereo to monaural to reduce the interference. When the stereo broadcast becomes stronger, it automatically switches back to stereo broadcasting.

ADJUSTING TIME

1. Turn the radio power ON. If the display shows the frequency, set the CLOCK button to the time display.
2. To set the time, keep the CLOCK button pressed and Press the Δ button to change the minutes
Press the ∇ button to change the hours

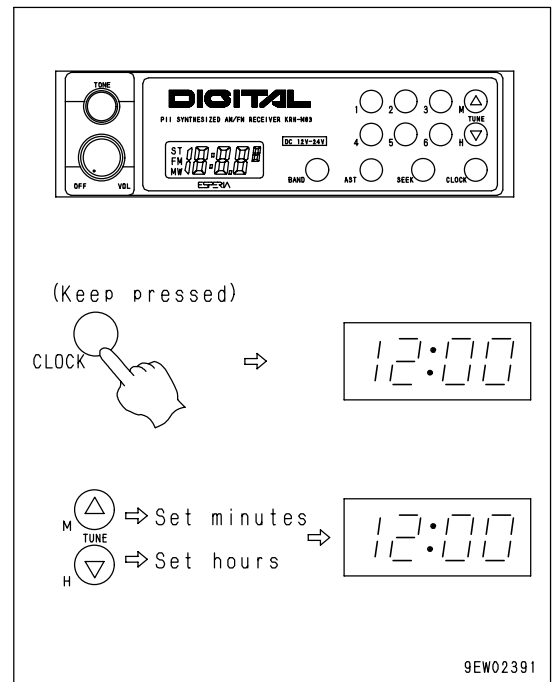

PRECAUTIONS FOR USE

- Stow the antenna when traveling in places with low overhead clearance.
- To ensure safety, always keep the sound to a level where it is possible to hear outside sounds during operation.
- If water gets into the speaker case or radio, it may lead to an unexpected failure, so be careful not to get water on the equipment.
- Do not wipe the scales or buttons with solvent such as benzene or thinner. Wipe with a dry soft cloth. If the dirt cannot be removed easily, soak the cloth with alcohol.

CAR STEREO

(If equipped)

EXPLANATION OF COMPONENTS

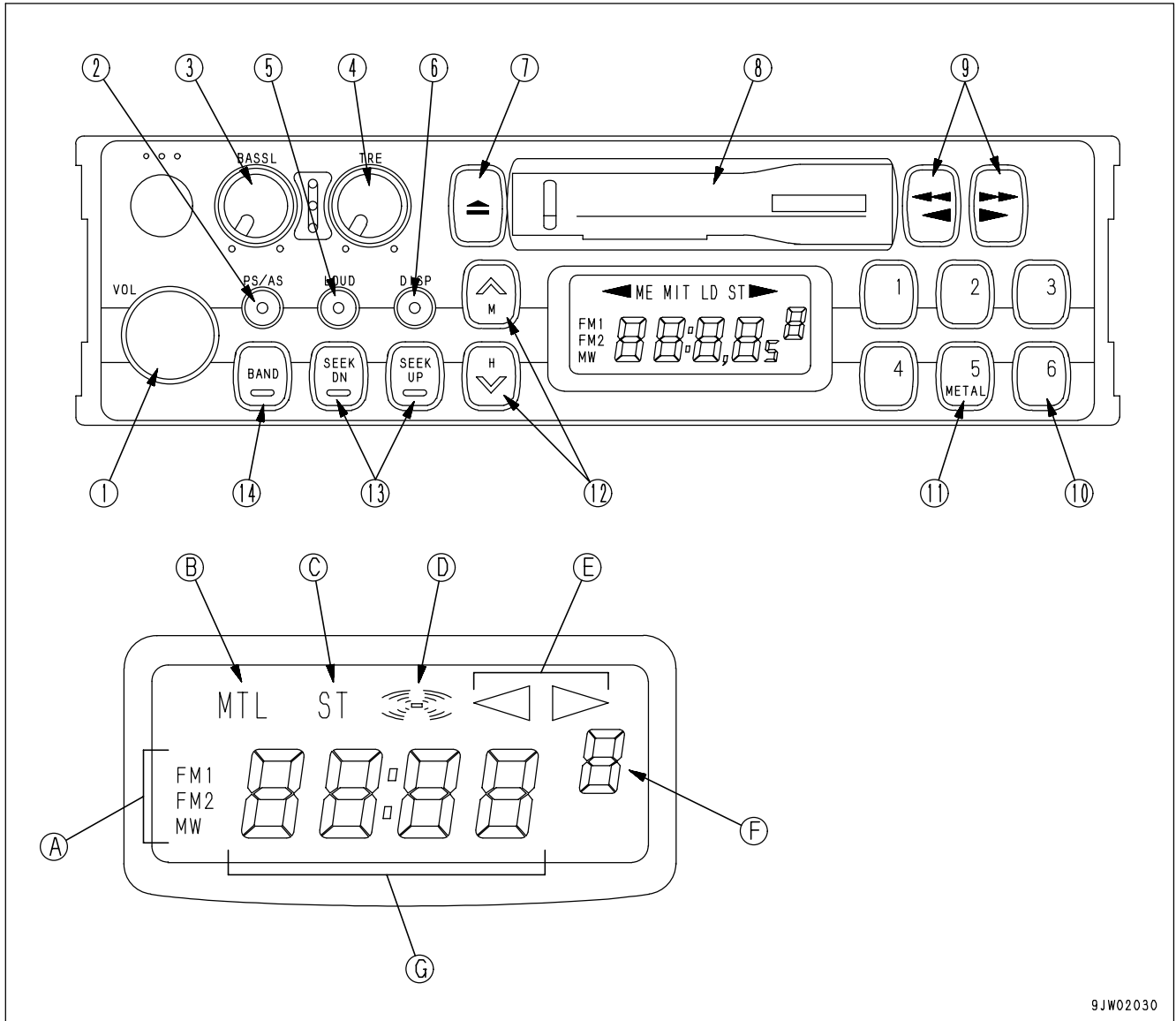

9JW02030

- (1) Power switch/Volume
- (2) Auto-store/Prescan button
- (3) Bass control knob
- (4) Treble control knob
- (5) Loudness button
- (6) Time/Radio display selector button
- (7) Tape eject button
- (8) Cassette door
- (9) Fast forward, rewind buttons
- (10) Preset buttons
- (11) Metal tape button
- (12) Manual tuning buttons
- (13) Seek tuning buttons
- (14) Band selector button
- (A) Band display
- (B) Metal tape display
- (C) FM stereo reception display
- (D) Loudness display
- (E) Tape direction display
- (F) Preset channel display
- (G) Time/Frequency display

POWER SWITCH/VOLUME

Turn this knob (1) to the right until it clicks to turn the power on.
Turn it further to increase the volume.

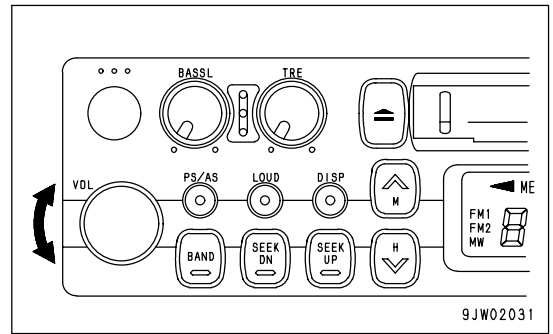

AUTO-STORE/PRESET SCAN BUTTON

Use this button (2) to actuate the preset scan and auto-store functions.

- Auto-store

Each time this button is pressed for more than 2 seconds while in radio reception, this auto-store function automatically starts to search for the desired station within a receivable band, and memorize the frequency in the preset memory. During this scanning process, the frequency shown in the right side of display continues to change. This indicates that each frequency is memorized in the auto-store.

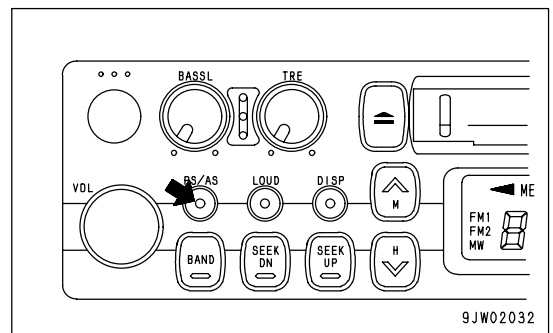

REMARK

The auto-store function cannot be used when the channel display is flashing.
When the display is flashing, the preset scan function is being used.

- Preset scan

If this button is pressed for less than 0.5 second while in radio reception, programs from the six preset stations in the same band will be broadcast one after another for 5 seconds each, starting from No. 1 through No. 6 stations consecutively.

When the desired station is found, press the button again. This stops the preset scan tuning process and switches to ordinary broadcasting. The same process will be repeated continuously until the button is pressed again.

BASS CONTROL KNOB

Turn this knob (3) to the left to reduce the low tones; turn it to the right to emphasize the low tones.

- Direction (a): Low tone reduced
- Direction (b): Low tone emphasized

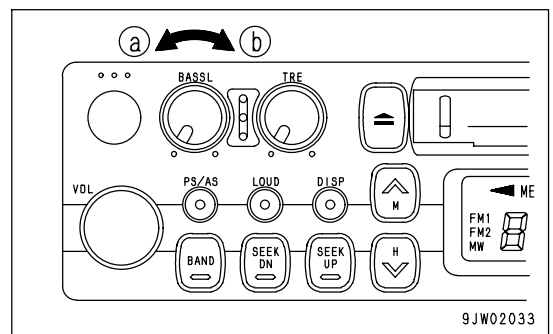

TREBLE CONTROL KNOB

Turn this button (4) to the left to reduce the low tones; turn it to the right to emphasize the high tones.

Direction (a): High tone reduced

Direction (b): High tone emphasized

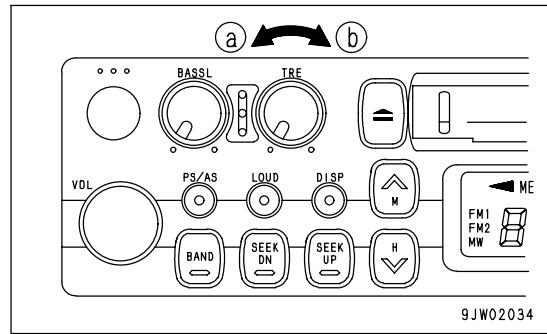

LOUDNESS BUTTON

This button (5) is used when playing at low volume. It makes it possible to hear more easily by emphasizing the low tone when the low tones are weak.

Push button: Actuated (ON)

Push button again: Canceled (OFF)

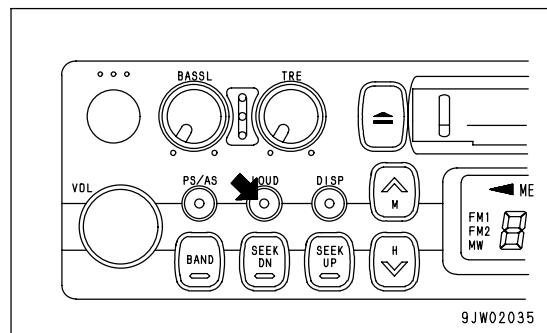

TIME/RADIO DISPLAY SELECTOR BUTTON

This button (6) is used to switch between the "Radio/tape display" and the "Time display".

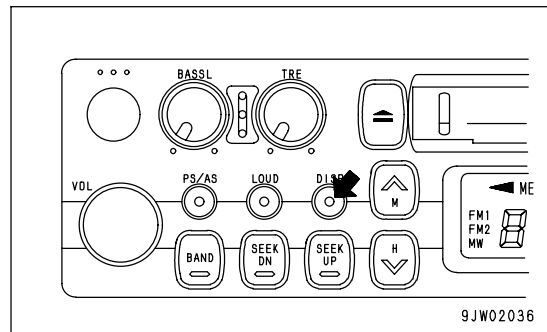

• Correcting the time

Press the button to set the time display.

(A) Correcting hour:

Keep the DISP button pressed and press the bottom (H) of the TUNING button to correct the hour.

(B) Correcting minute:

Keep the DISP button pressed and press the top (M) of the TUNING button to correct the minute.

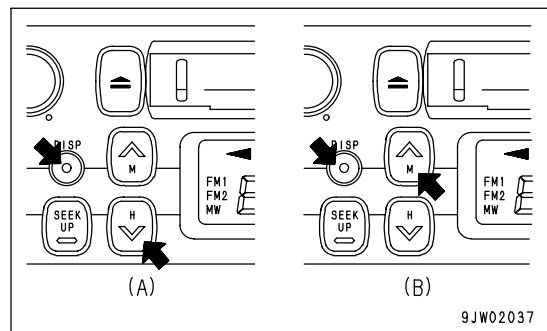

TAPE EJECT BUTTON

This button (7) is used to stop the tape and to eject the cassette. When this button is pressed, the tape is ejected and the radio plays.

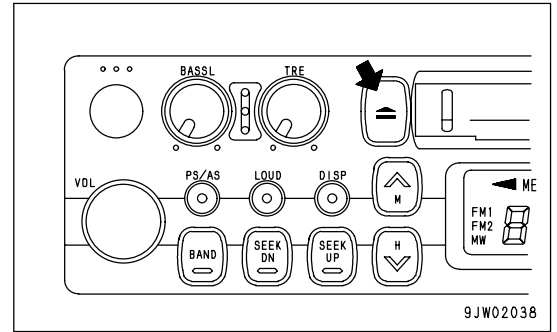

CASSETTE DOOR

Set the cassette with the exposed portion of the tape on the right side and insert it through the cassette door (8).

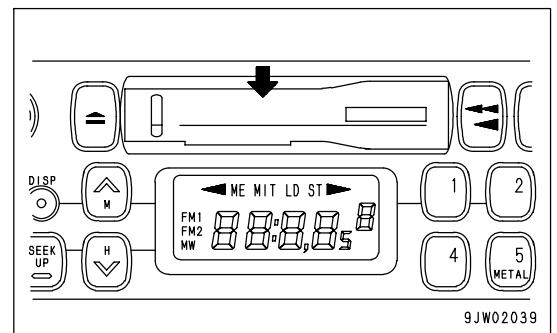

FAST FORWARD, REWIND BUTTONS

These buttons (9) are used to fast-forward or rewind the tape.

- Fast-forward/rewind

If you press the button pointing in the same direction as the lighted arrow indicating the direction of play, the tape will be fast-forwarded; if you press the button pointing in the opposite direction, the tape will rewind.

To stop the tape, lightly press the button that is not locked. The fast-forward or rewind operation will be canceled.

If the fast-forward and rewind buttons are pressed at the same time, the tape will change sides.

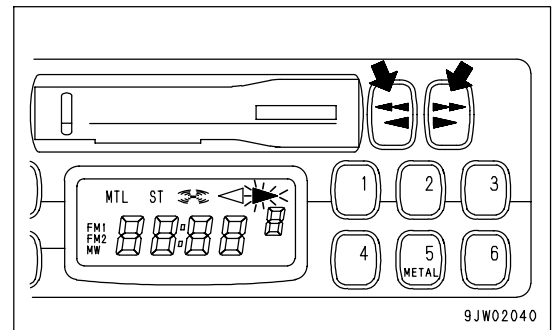

PRESET BUTTONS

These buttons (10) are used to call up the broadcast station frequencies preset in memory for each of buttons No. 1 to No. 6. It is possible to preset 18 stations (FM: 12; AM: 6) with these buttons.

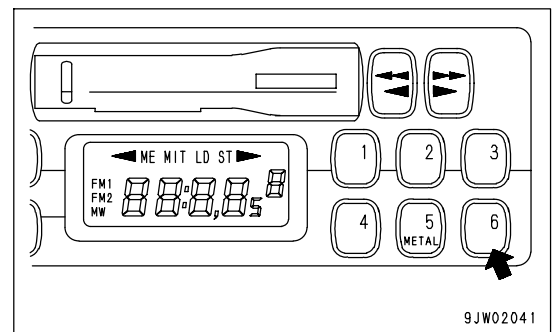

METAL TAPE BUTTON

(used also for preset button No. 5)

This button (11) is used when playing a metal or chrome tape. This button is also used for preset button No. 5. When it is pressed, "MTL" appears on the display.

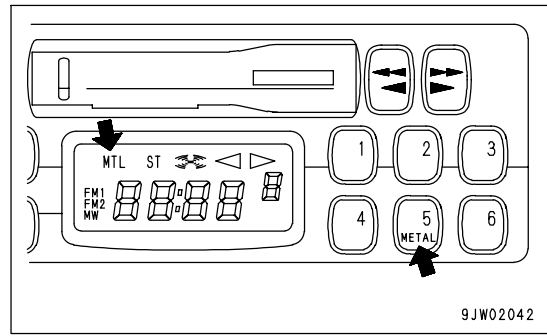

9JW02042

MANUAL TUNING BUTTONS

These buttons (12) are used for manual tuning.

When "TUN ^" button is pressed, the frequency goes up 9 kHz for AM or 0.1 MHz for FM; when "TUN v" button is pressed, the frequency goes down 9 kHz for AM or 0.1 MHz for FM.

If the button is pressed down and held, the frequency will change continuously.

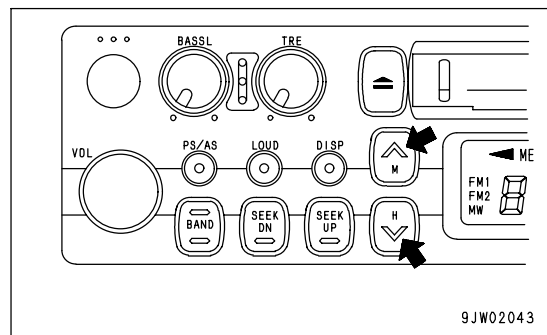

9JW02043

SEEK TUNING BUTTONS

These buttons (13) are used to seek tuning.

When the "SEEK UP" button is pressed, the search automatically goes up; when the "SEEK DN" button is pressed, the search automatically goes down.

When the next station that can be received is found, it automatically stops.

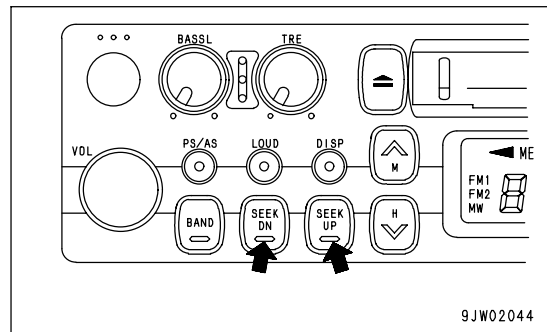

9JW02044

BAND SELECTOR BUTTON

When this button (14) is pressed, the band is switched between FM1, FM2, and MW (AM). The band is shown on the display.

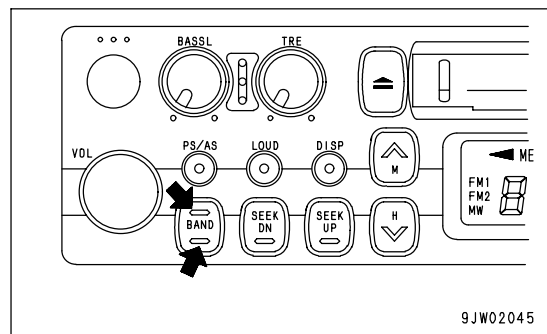

9JW02045

METHOD OF OPERATION

METHOD OF SETTING PRESET BUTTONS

To listen to a preset station, use band selector button (1) to select AM, FM1, or FM2, then press the preset switch number to listen to the desired station.

It is possible to preset six AM stations and 12 FM stations (FM1: 6, FM2: 6).

1. If you are playing a cassette, press the tape eject button to stop the tape.
2. Select the station to be preset.
Use band selector button (1) to select MW (AM), FM1, or FM2, then use the manual tuning button to select the frequency of the broadcasting station.
3. Press manual memory button (2) or seek tuning button (3).
4. Press preset button (4) of the number to be preset for 2 seconds while the frequency display is being shown on the display. (The preset channel and frequency are displayed and the presetting is completed).
5. Repeat Steps 2 to 4 to preset other stations.

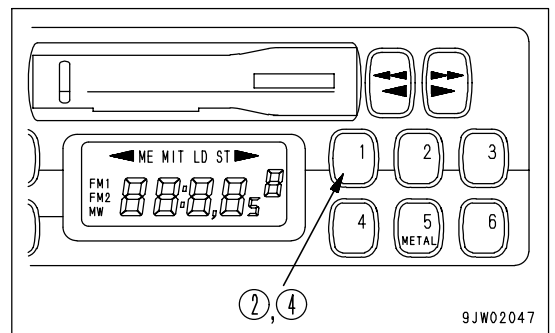
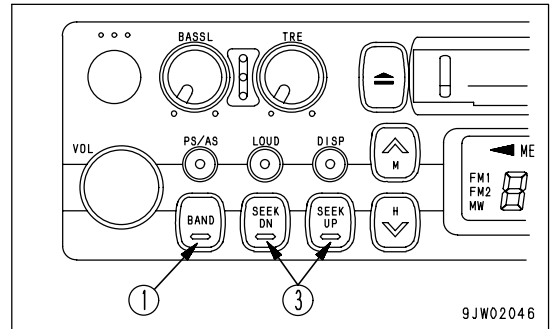

REMARK

- Use Steps 2 to 4 also when changing the setting of a preset switch to another station.
- When the power is disconnected, such as when the battery is replaced, all the settings are deleted, so preset the stations again.

MANUAL MEMORY BUTTON

Select the station to be preset with manual tuning button (1) or seek tuning button (2), then keep button No.1 to button No.6 of button (3) pressed for 2 seconds while the frequency is being displayed to preset the station.

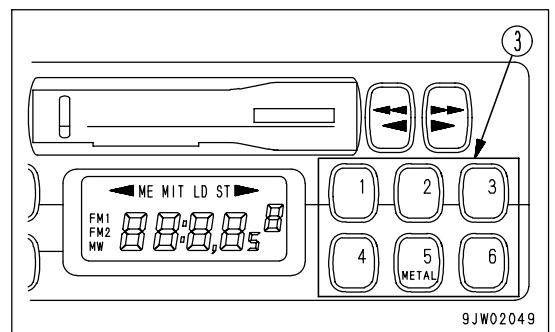
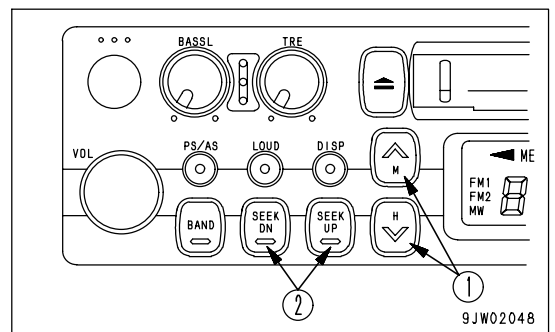

LISTENING TO RADIO

1. Turn the starting switch ON, then turn power switch (1) ON.
2. Set band selector button (2) to AM or FM.
3. Select the station with the preset buttons or manual tuning button (3).
4. Adjust the volume, balance, and tone as desired.
5. When turning the radio OFF, turn power switch (1) to the left until it clicks.

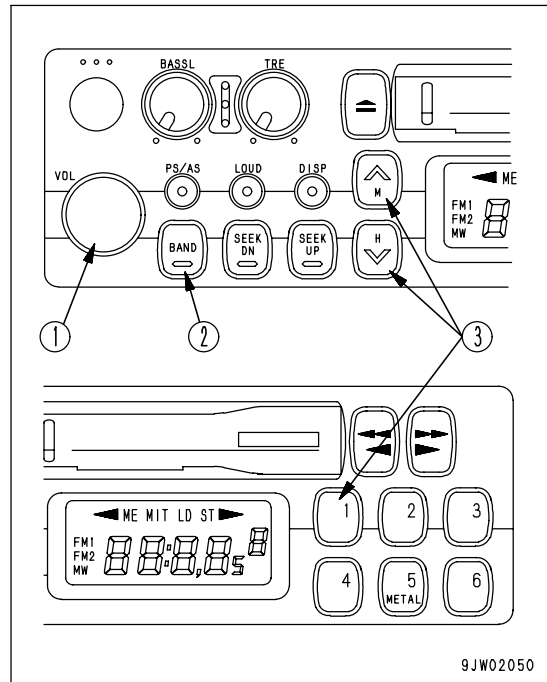

REMARK

- To switch to the radio when listening to a cassette, press the cassette eject button to stop the tape.
- If you insert a cassette when listening to the radio, the tape will start to play.

LISTENING TO CASSETTE TAPE

1. Turn the starting switch ON, then turn power switch (1) ON.
2. Set the cassette with the exposed portion of the tape on the right side and push it past the cassette door. The tape will automatically start playing.
If the arrow indicating the direction of play is pointing to the right, the top side is being played; if the arrow is pointing to the left, the bottom side is being played.
When the tape reaches the end, it is automatically reversed and the other side starts to play.
3. When finished with the tape, press the cassette eject button to eject the tape and automatically switch to the radio.

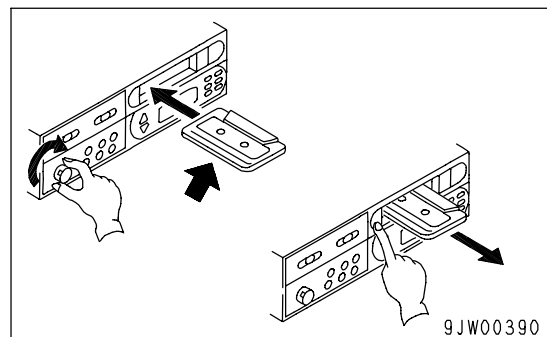
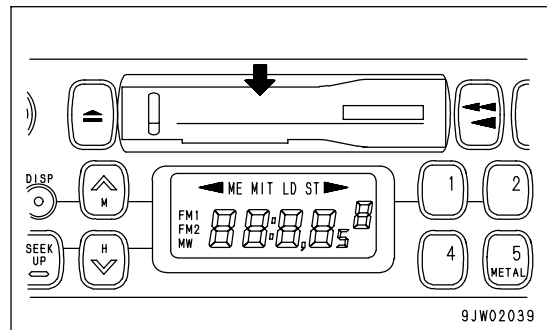

REVERSING TAPE

When listening to the tape, press both FAST FORWARD, REWIND buttons (A) and (B) at the same time lightly.

When this is done, the tape direction display will be reversed.

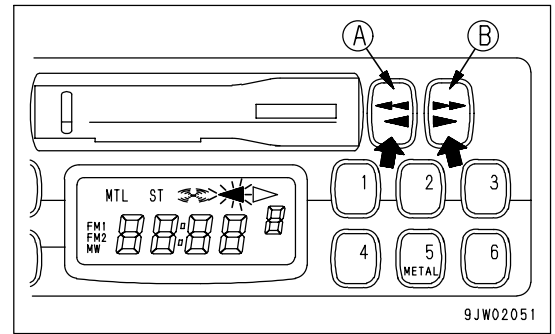
**PRECAUTIONS FOR USE**

- Stow the antenna when traveling in places with low overhead clearance.
- To ensure safety during operations, keep the volume at a level where it is possible to hear other machines.
- If water gets inside the speaker case or radio (auto tuning), it may cause a serious problem, take care not to let water get in these items.
- Do not wipe the scales or buttons with solvent such as benzene or thinner. Wipe with a dry soft cloth. If the dirt cannot be removed easily, soak the cloth with alcohol.

NOTICE**Handling cassette tape**

- Clean the tape head approx. once a month with a commercially available head cleaning tape.
- Do not leave the tape any place where it is exposed to direct sunlight, any place that is excessively dusty, or any place where there is a magnetic field.
- Do not use 120-minute tapes. The tape is thin and it easily gets caught up inside the machine.
- If the tape is slack, it easily gets caught up inside the machine. Use a pencil to wind in the tape to remove any slack.
- Do not use any cassette tape if the label has started to come off. It may cause defective rotation, or it may be impossible to get the tape out of the machine.

AIR CONDITIONER

By taking fresh air into the cab through a filter, it is possible to raise the pressure inside the cab. This makes it possible to provide a pleasant working environment even on dusty jobsites.

GENERAL LOCATIONS ON CONTROL PANEL

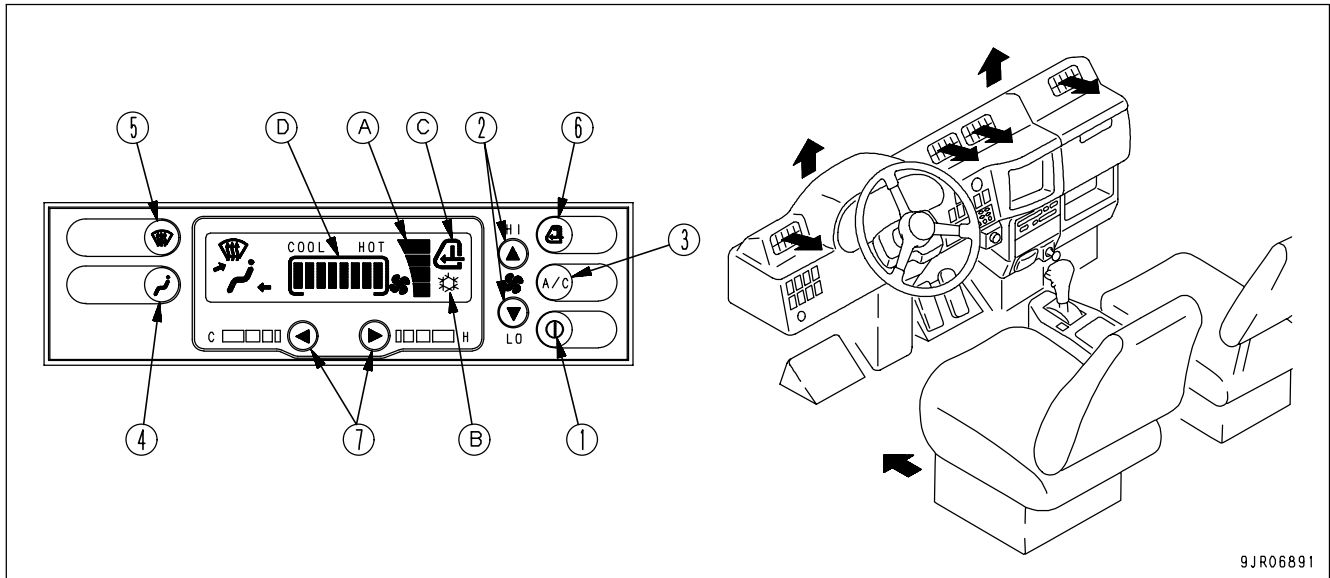

- (1) ON/OFF switch
- (2) Fan switch
- (3) Air conditioner switch
- (4) Mode selector switch
- (5) DEF switch
- (6) RECIRC/FRESH selector switch
- (7) Temperature control switch

Air conditioner monitor

- (A) Air flow bar
- (B) Air conditioner operation symbol
- (C) RECIRC/FRESH selector symbol
- (D) Temperature bar

ON/OFF SWITCH

Use this switch (1) to turn the air conditioner ON/OFF.

When the switch is turned ON, the air conditioner monitor displays the setting being used when the switch was previously turned OFF.

FAN SWITCH

With this switch (2) it is possible to adjust the air flow from the fan to 4 levels.

Press the ^ switch to increase the air flow; press the v switch to reduce the air flow.

The air flow is shown in air flow bar (A) on the air conditioner monitor.

AIR CONDITIONER SWITCH

Use this switch (3) to actuate the cooling, heating, or dehumidifying functions, or to stop the air conditioner.

When the switch is pressed, air conditioner operation symbol (B) is displayed on the air conditioner monitor. When the switch is pressed again, the air conditioner is switched OFF and the operation symbol goes out.

MODE SELECTOR SWITCH



Use this switch (4) to select the vents.

There are three combinations of vents: FACE, FACE/FOOT, and FOOT.

Each time the switch is pressed, the vent display on the air conditioner monitor changes in the order FACE, FACE/FOOT, FOOT, FACE.

REMARK

Air also blows out from the defroster vent in FOOT mode.

Air conditioner monitor display	Condition of vents
	FACE
	FACE/FOOT
	FOOT

DEF SWITCH

Use this switch (5) to change the vents to the DEF mode.

When the switch is pressed, the vent display on the air conditioner monitor changes as shown in the diagram on the right.

When the DEF switch is pressed in any of the FACE, FACE/FOOT, or FOOT modes, the system changes to the DEF mode. In addition, when the DEF mode is being used, if the mode selector switch is pressed, it will return to the mode being used before switching to the DEF mode.

REMARK

Air also blows out from the foot vent in DEF mode.

Air conditioner monitor display	Condition of vents
	DEF



RECIRC/FRESH SELECTOR SWITCH

Use this switch (6) to switch between recirculation of the internal air (RECIRC) or intake of external air (FRESH). When the switch is pressed, the display of RECIRC/FRESH selector symbol (C) on the air conditioner monitor changes.

(It changes in the order RECIRC, FRESH, RECIRC.)

RECIRC: Only the air inside the cab is circulated. Use this position when it is needed to carry out quick heating or cooling of the cab, or when the outside air is dirty (smells or is dusty).

FRESH: Fresh air is taken in from the outside for normal heating or cooling of the cab. Use this position to make the air inside the cab fresh or to remove the mist from the cab windows. When the air conditioner takes in fresh air from the outside, the pressure inside the cab rises and this prevents the entry of dirt. The higher the position of the fan switch, the more efficient this becomes.

Air conditioner monitor display	Condition of vents
	RECIRC
	FRESH

TEMPERATURE CONTROL SWITCH

Use this switch (7) to adjust the temperature of the air blowing out from the vents. The adjustment can be made to 8 levels from low temperature to high temperature.

The temperature of the air blowing out from the vents is displayed on temperature bar (D) on the monitor. The lower the number of segments lighted up on the bar, the lower the temperature is.

Press the > switch to raise the temperature; press the < switch to lower the temperature.

Even when the starting switch is turned OFF, the settings of each mode are retained in memory. However, in the following cases, the settings must be made again.

- When there has been abnormal interference from outside

METHOD OF OPERATION

With the FACE vents, it is possible to adjust the direction of the air flow and to turn it on or off. However, do not set to the FACE mode with the vents closed.

COOLING

1. Press ON/OFF switch (1) to turn on the air conditioner power.
2. Press fan switch (2) to set the air flow to the maximum.
3. Press temperature control switch (3) to lower the temperature.
4. Press air conditioner switch (4) to set to COOLING.
5. Press RECIRC/FRESH selector switch (5) to set to RECIRC.
6. Press mode selector switch (6) to set the vents to FACE.
7. When the temperature inside the cab goes down, set to the desired temperature and air flow.

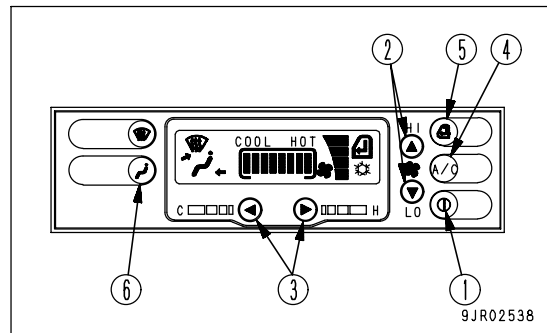

NOTICE

If operations are continued for a long time with the air conditioner set to the lowest temperature and minimum air flow, there is danger that the receiver drier may freeze.

If it freezes and no cold air comes out, stop using the cooling, and set to a higher temperature and the maximum air flow. Run for a short time under these conditions, then return to the cooling operation.

HEATING

1. Press ON/OFF switch (1) to turn on the air conditioner power.
2. Press fan switch (2) to set the air flow to the maximum.
3. Press temperature control switch (3) to raise the temperature.
4. Press RECIRC/FRESH selector switch (4) to set to FRESH.
5. Press mode selector switch (5) to set the vents to FOOT.
6. When the temperature inside the cab goes up, set to the desired temperature and air flow.

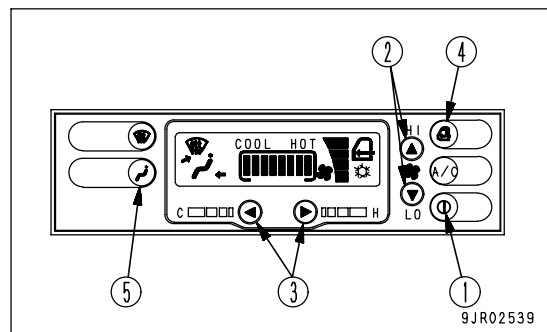

REMARK

The heating uses the heat from the engine cooling water, so it is effective only when the cooling water is hot.

DEHUMIDIFYING, DEFROSTING

1. Press ON/OFF switch (1) to turn on the air conditioner power.
2. Press fan switch (2) to set to the desired air flow.
3. Press temperature control switch (3) to set to the desired temperature.
4. Press RECIRC/FRESH selector switch (4) to set to FRESH.
5. Press mode selector switch (5) or DEF switch (6) to set the vents to the desired position.
6. Press air conditioner switch (7) to operate the cooling.

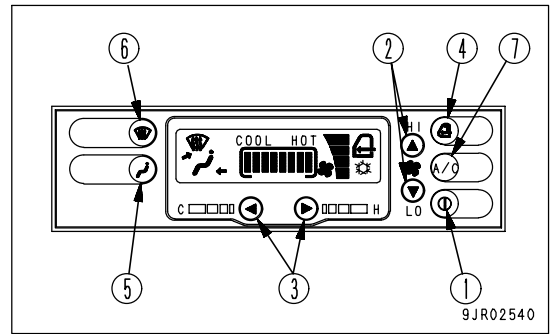
**REMARK**

- If the ambient temperature is below 0°C (32°F), the air conditioner cooling may not work. In this case, set to RECIRC and warm up the inside of the cab, then turn the air conditioner switch ON to operate the cooling.
- When defrosting, if the temperature control switch is pressed to set the temperature bar to the maximum (all 8 segments on the bar light up), this will improve the efficiency of removing the frost and preventing mist.

PRECAUTIONS WHEN USING AIR CONDITIONER

To prevent putting any excessive load on the engine or compressor, turn the air conditioner ON only when the engine is running.

Carry out ventilation from time to time when using the cooling.

- When turning the cooling on, if the temperature inside the cab is high, open the doors and windows to bring in fresh air before starting the air conditioner.
- If you smoke when using the cooling, your eyes may sting. If this happens, switch temporarily to cooling and ventilation to remove the smoke.
- When using the air conditioner for a long time, carry out ventilation and cooling once every hour.

Be careful not to cool the cab too much.

For reasons of health, the optimum setting for cooling is considered to be when it feels slightly cool (5 or 6°C (9 or 10.8°F) lower than the ambient temperature) when you enter the cab. Do not make the temperature inside the cab too low or direct the air flow directly onto your skin.

Be extremely careful to select the appropriate temperature.

When cooling is not being used (off-season)

To prevent leakage of the refrigerant from the air conditioner cooling circuit, operate the air conditioner for several minutes 2 or 3 times a month during the off-season. If the air conditioner is left for a long time when the refrigerant is leaking, it may cause internal rust.

INSPECTION AND MAINTENANCE

Even when not using the air conditioner, run the compressor at low speed for several minutes once a week to prevent the loss of the oil film at various parts of the compressor. (When the engine is running at low speed, set the temperature of the air coming from the vents to the medium position (the condition where the temperature bar shows 4).)

Clean the air filter and check the refrigerant. For details, see "CLEAN AIR CONDITIONER AIR FILTER (PAGE 4-29)" and "CHECK REFRIGERANT (GAS) LEVEL (PAGE 4-30)".

To enable the air conditioner to perform to the full and to maintain a pleasant working environment, always contact your Komatsu distributor to have the air conditioner refilled with refrigerant and to carry out other checks.

OPERATION

CHECK BEFORE STARTING ENGINE

WALK-AROUND CHECK

Before starting the engine, look around the machine and under the machine to check for loose nuts or bolts, or leakage of oil, fuel, or coolant, and check the condition of the hydraulic system.

Check also for loose wiring, play, and accumulation of dust in places that get very hot and are exposed to extremely high temperatures.



WARNING

- Always hang the warning tag from the gear shift lever.
- Leakage of oil or fuel, or accumulation of flammable material around the battery or high temperature parts of the engine, such as the engine muffler or turbocharger, may cause fire. Check carefully, and if any problem is found, repair it or contact your Komatsu distributor.

Perform the following inspections and cleaning every day before starting engine for the day's work.

1. Check the dump body, frame, tires, cylinders, linkage, and hoses for cracks or excessive wear or play.
Check the dump body, frame, tires, cylinders, linkage, and hoses for cracks or excessive wear or play, and carry out repairs if any problem is found.
2. Remove dirt from around engine, battery, radiator, and aftercooler.
Check that there is no dirt or dust accumulated around the engine, radiator or aftercooler. Check also that there is no flammable material (dry leaves, twigs, etc.) accumulated around the battery, or engine, muffler, turbocharger, or other high temperature parts of the engine. Remove any dirt or flammable materials that are found.
3. Check for leakage of water or oil around engine
Check that there is no oil leakage from the engine or coolant leakage from the cooling system. If any problem is found, repair it.
4. Check for leakage from fuel line.
Check that there is no leakage of fuel or damage to the hoses and tubes. If any problem is found, carry out repairs.
5. Check for oil leakage from transmission case, differential case, final drive case, hydraulic tank, brake control oil tank, hoses, and joints
Check that there is no oil leakage. If any problem is found, repair the place where the oil is leaking.
Check for leakage of oil from the undercover. Check the ground for traces of oil leakage.
6. Check for damaged or worn tires, wheels, and wheel hub bolts and nuts, check for loose wheel hub bolts and nuts.
Check for cracks or peeling of the tires and for cracks or wear to the wheels (side rim, rim base, lock ring). Tighten any loose wheel hub bolts or nuts. If any abnormality is found, repair or replace the part.
If any valve caps are missing, install new caps.
7. Check for loose air cleaner mounting bolts.
Check for the loose bolts. If loose, tighten them.

8. Check dump body mount rubber

Check for any cracks, embedded foreign objects, or loose bolts.

9. Check for damage to handrail, loose bolts

Repair any damage and tighten any loose bolts.

10. Check for damage to gauges, lamps on the instrument panel and loose bolts.

Check for damage to the panel, gauges and lamps. If any problem is found, replace the parts. Clean off any dirt on the surface. Tighten any loose bolts.

11. Check rear view mirror, under view mirror

Check that the mirrors are not damaged. Replace them if they are damaged. Clean the surface of the mirrors and adjust the angle so that the operator can see the area to the rear and under the machine from the operator's seat.

12. Check for damage to the seat belt and mounting clamps.

Check for damage to seat belt and mounting clamps. If damages are found, replace with the new one.

- Check for any loose bolts of the clamps mounting the equipment to the machine. Tighten any loose bolts.
- If the seat belt is scratched or frayed, if any fittings are broken or deformed from long service, replace the seat belt immediately.

13. Inspect tires.

**WARNING**

If worn or damaged tires are used, they may burst and cause serious injury or death.

To ensure safety, do not use the following tires.

Wear:

- Tires with a tread grooves of less than 15% of that of a new tire
- Tires with extreme uneven wear or with stepped-type wear

Damage:

- Tires with damage that has reached the cords, or with cracks in the rubber
- Tires with cut or pulled cords
- Tires with peeled (separated) surface
- Tires with damaged bead
- Leaking or improperly repaired tubeless tires
- Deteriorated, deformed or abnormally damaged tires, which do not seem usable

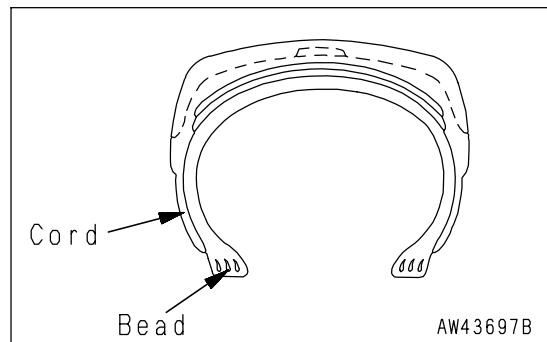

14. Inspect rims.

**WARNING**

Check the rims (wheels) and rings for deformation, corrosion and cracks.

In particular, check the side rings, lock rings and rim flanges thoroughly.

CHECK BEFORE STARTING

Perform the contents of this section before starting the work of each day.

CHECK COOLANT LEVEL, ADD COOLANT



WARNING

- In normal situations, do not open the radiator cap. When checking the coolant level, wait for the engine to cool down and check using the reserve tank.
- Immediately after the engine is stopped, the coolant is at high temperature and the radiator is under high internal pressure. If you open the cap in this condition, you will suffer burns. Always wait for the temperature to go down, turn the cap slowly to release the pressure, then remove the cap carefully.

1. Open the engine hood and check that the coolant in reservoir tank (1) is between the FULL and LOW marks.
2. If the level is LOW, remove cap (2) and add the engine coolant up to the FULL mark.

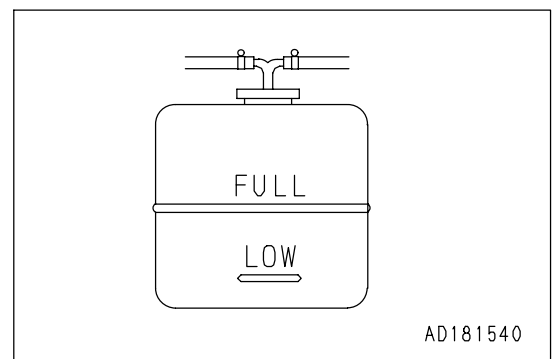
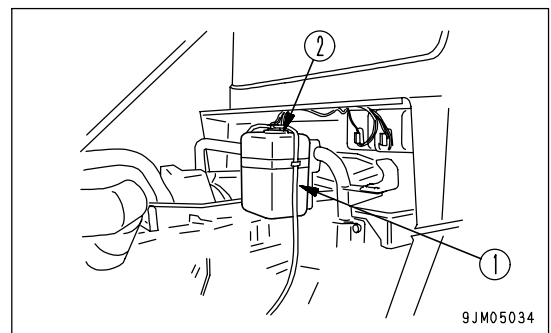

3. If there is no coolant in the reservoir tank, add Supercoolant (AF-NAC) of the same density as the Supercoolant in the radiator. Add the Supercoolant through water filler (3) at the top of the radiator, then add Supercoolant to the reservoir tank.
4. Check that there is no oil in the engine coolant or any other problem.
5. After adding coolant, tighten the cap securely.
6. If more coolant is added than normal, then check for water leakage.

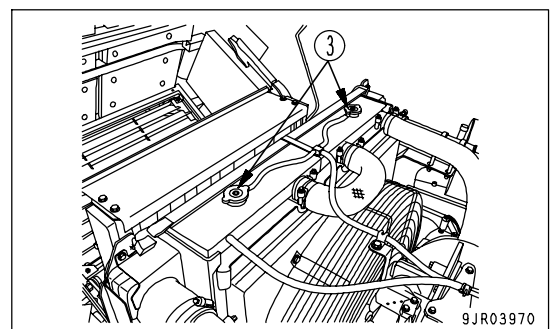

CHECK DUST INDICATOR

1. Check that the red line in the transparent portion of dust indicator (1) does not indicate 7.5 kPa (30 INCHES H₂O) (0.076 kg/cm², 1.1 PSI).
2. If the red line indicates 7.5 kPa (30 INCHES H₂O) (0.076 kg/cm², 1.1 PSI), clean or replace the air cleaner element immediately.
For details of the method of cleaning the element, see "CHECK, CLEAN OR REPLACE AIR CLEANER (PAGE 4-20)".
3. After cleaning or replacing, press the top of dust indicator (1) to return the red line to its original position.

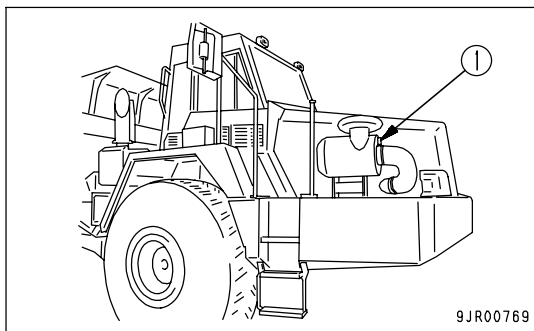

CHECK OIL LEVEL IN ENGINE OIL PAN, ADD OIL

**WARNING**

Parts and oil are at high temperature immediately after the engine is stopped and may cause serious burns. Wait for the oil temperature to go down before performing this operation.

1. Open the engine hood cover and check the oil level with the dipstick (G).
2. Take out the dipstick (G) and wipe off the oil with cloth.
3. Fully insert dipstick (G) into filler pipe, then remove it.
4. The oil level should be between the H and L marks on dipstick (G).
If the oil level is below the L mark, add oil through oil filler port (F).

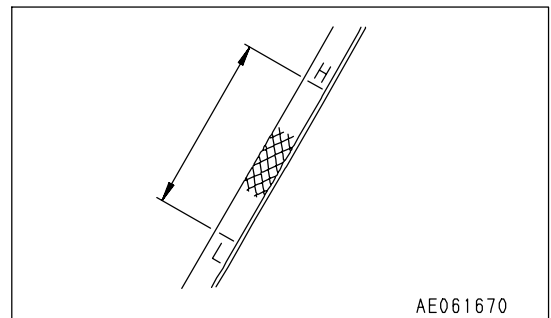
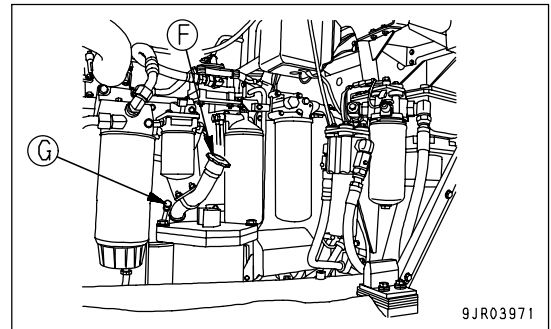

5. If the oil level is above the H mark, open the underguard of the engine, remove drain plug (1), and loosen drain valve (2) to drain the excessive oil, and then check the oil level again.
6. If the oil level is correct, tighten the handle of the oil filler cap securely.

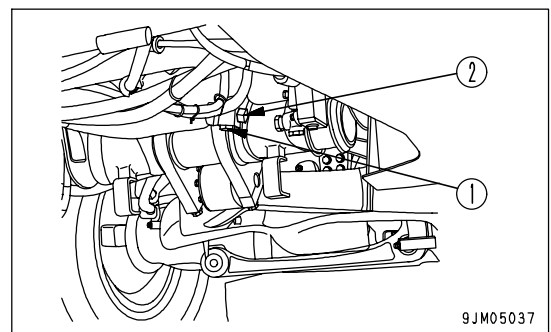
**REMARK**

- When checking the oil level after the engine has been operated, wait for at least 15 minutes after the engine is stopped before checking the oil level.
- If the machine is at an angle, set the machine horizontal before checking the oil level.

CHECK OIL LEVEL IN TRANSMISSION CASE, ADD OIL

1. After starting the engine, run it at low idling and check the oil level using the "LOW TEMPERATURE" scale on sight gauge (G).
2. If the oil level is low, add oil through oil filler port (F).

NOTICE

- The oil level changes according to the oil temperature, so check the oil level after completing the warming-up operation.
- During operations or when idling the engine after operations, check the oil level using the "HIGH TEMPERATURE" scale.

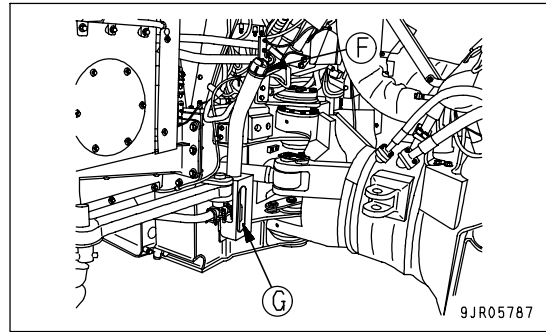
**CHECK OIL LEVEL IN HYDRAULIC TANK, ADD OIL**

WARNING

If the oil filler cap is removed without releasing the internal pressure, oil will spurt out, so turn the oil filler cap slowly to release the internal pressure, then remove it carefully.

1. Check with sight gauge (G1).
 2. If the oil level does not reach the window of gauge (G1), add oil through oil filler (F).
 3. When checking the oil level after adding oil, check with dipstick (G2).
- The oil should be between the H and L marks on dipstick (G2).
If the oil level is below the L mark, add oil through oil filler port (F).

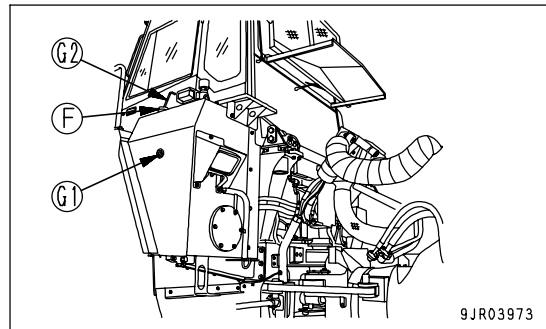
**DRAIN WATER, SEDIMENT FROM FUEL TANK**

Loosen valve (1) at the bottom of the fuel tank, and drain the water and sediment collected at the bottom of the tank together with the fuel.

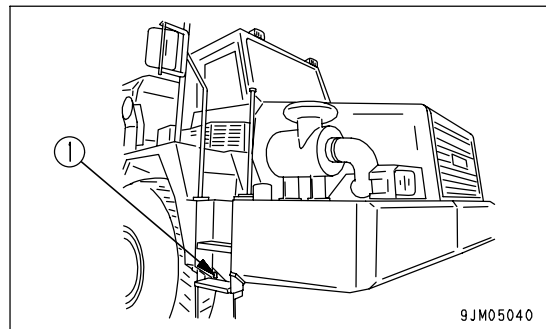

CHECK FUEL LEVEL, ADD FUEL**WARNING**

- When adding fuel, be careful not to let the fuel overflow. The fuel may cause fire. Always wipe up all the spilled fuel.
- If fuel spills onto dirt and sand sticking to the machine, remove it and dirt and sand together.
- Since fuel is flammable and dangerous, do not bring fire near it.

1. Check with fuel gauge (1) on the machine monitor.
2. After completing operations, add fuel through fuel filler (F) to fill the tank.
Fuel tank capacity: 384 liters (101.45 US gal)
3. After adding fuel, tighten the cap securely.

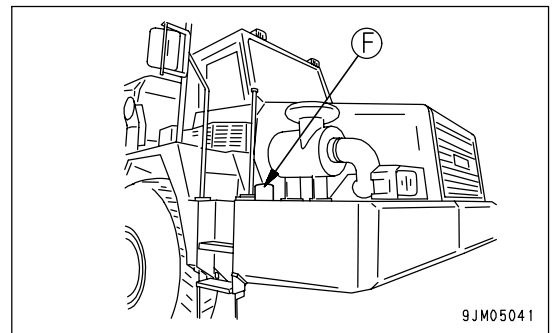
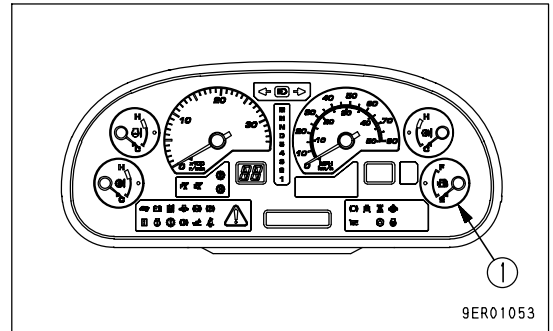
**REMARK**

- If the breather hole in the cap is clogged, the pressure inside the tank will go down and this may cause the fuel to stop flowing. To prevent this, clean the breather hole from time to time.
- To prevent air from being sucked into the engine, always pay careful attention to the fuel level in the tank.

CHECK WHEEL HUB BOLTS, TIGHTEN

Check for loose wheel hub bolts (1). If any are found, tighten them.

Tightening torque: 824 to 1030 Nm

(84 to 105 kgm, 607.6 to 759.5 lbft)

Insert a socket wrench in a pipe, then apply a force of 932N {95 kg} at a point 1 meter from the fulcrum. This will give a tightening torque of 932Nm {95 kgm, 687.1 lbft}.

When tightening the hub bolts after replacing the tires, travel for 5 to 6 km, then check the tightening torque to ensure that there are no loose bolts.

If any wheel hub bolt is broken, replace all the wheel hub bolts for that wheel.

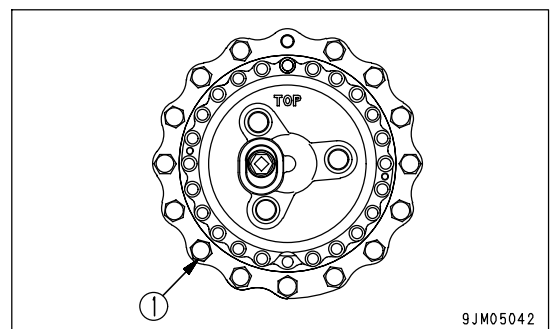

CHECK CENTRAL WARNING LAMP, ALARM BUZZER, MONITOR LAMPS AND METERS

Before starting the engine, turn the starting switch to the ON position and check that the machine monitor does as follows.

If the machine monitor does not work, there is probably a failure in the machine monitor system, so please ask your Komatsu distributor to carry out inspection.

- The central warning lamp lights up for 2 seconds, then goes out.
- The alarm buzzer sounds for 2 seconds, then stops.
- The machine monitor lamp lights up for 2 seconds and then goes out for 1 second.
- The shift indicator displays "88" for 2 seconds, then goes out for 1 second.
- The meters start the operations after the system is checked for 3 seconds.
- The character display displays "KOMATSU" for 3 seconds.

CHECK BRAKING EFFECT

Check if the braking capacity of the parking brake, foot brake, and retarder brake.

If any abnormality is found, ask Komatsu distributor to repair.

CHECK EMERGENCY STEERING



WARNING

Do not continue to use the emergency steering pump for more than 90 seconds. If the emergency steering is used continuously for more than 90 seconds, there is danger that the pump may burn out or be damaged, or that it may cause a fire.

Check manual emergency steering

1. Turn starting switch key to the ON position.
2. Turn emergency steering switch (1) ON, turn the steering wheel, and check that the steering can be operated.

If the steering is not operated when the steering wheel is turned, please ask your Komatsu distributor to carry out inspection.

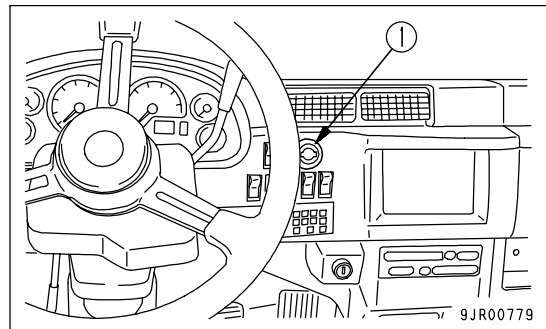

Check auto-emergency steering

1. Turn the starting switch key to the START position and start the engine.
2. Check that the brake oil pressure caution lamp is OFF, then pull retarder control lever (2) fully and stop the engine.
3. Turn starting switch key to the ON position.
4. Set parking brake switch (3) to "TRAVEL", and check that the emergency steering motor is actuated after 1 second, and that the steering is operated when the steering wheel is turned.

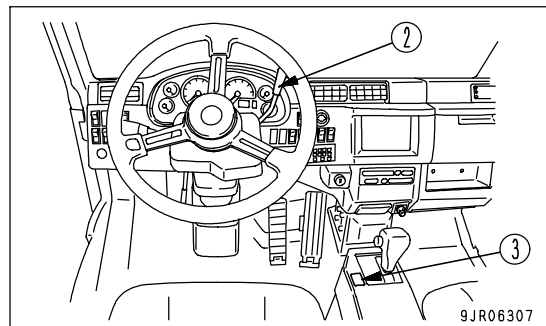

CHECK BACKUP ALARM

1. Turn the engine starting switch to the ON position.
2. Place the gear shift lever in the R position and check that the backup alarm is working.

CHECK ELECTRIC WIRING



WARNING

- If the fuse blows frequently or there are signs of short circuits in the electrical wiring, investigate the cause immediately and carry out repairs or contact your Komatsu distributor.
- Keep the top surface of the battery clean and check the breather hole in the battery cap. If it is clogged with dirt or dust, wash the battery cap to clean the breather hole.

Check for damage and wrong capacity of the fuse and any sign of disconnection or short circuit in the electrical wiring. Check also for loose terminals and tighten any loose parts.

Check the wiring of the "battery", "starting motor" and "alternator" carefully, in particular.

Always check if there is any accumulation of flammable material around the battery, and remove such flammable material.

Please contact your Komatsu distributor for investigation and correction of any problems found.

CHECK INFLATION PRESSURE OF TIRES

Use a tire pressure gauge to measure the tire inflation pressure before starting operations when the tires are cool.

Check for damage or wear to the tires and the rims.

Check for loose wheel hub bolts.

The proper inflation pressure is shown below.

Tire size	Inflation pressure [MPa (kg/cm ² , PSI)]		
	Front tire	Center tire	Rear tire
23.5-R25 (standard)	0.44 (4.5, 63.9)	0.44 (4.5, 63.9)	0.44 (4.5, 63.9)
750/65 R25 (30/65 R25) (if equipped)	0.34 (3.5, 49.7)	0.40 (4.1, 58.2)	0.40 (4.1, 58.2)

NOTICE

If the tires are used when the inflation pressure is less than the value given in the table above, the rim may be damaged.

Always keep the tire inflation pressure within +0 to +0.03 MPa (0.3 kg/cm², 4.3 PSI) of the value in the table above.

CHECK WATER SEPARATOR

The water separator and fuel prefilter (1) are made one and composed of (2) to (4) in the lower section.

1. It is possible to judge the amount of water or sediment through transparent cap (2). If water or sediment has accumulated, put a container under drain hose (4) to catch the drained water.
2. Loosen drain valve (3) to drain the water.
3. If fuel starts flowing out through drain hose (4), close valve (3) immediately.

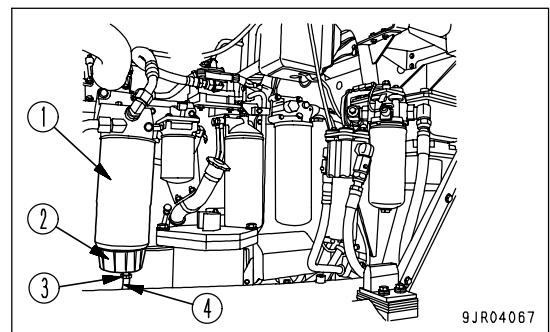

9JR04067

CHECK ACTUATION OF BODY POSITIONER

1. Turn the starting switch key to the START position and start the engine.
2. Operate the dump control lever to the RAISE position, then release it.
Check that the dump body stops before the end of the stroke.

REMARK

If the hoist cylinder is extended fully, there will be impact shock. If the body positioner is functioning, the cylinder will stop before the end of its stroke and there will be no impact shock when it stops.

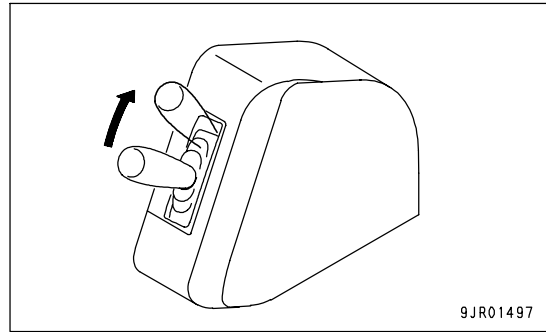

9JR01497

CHECK CAB MOUNT BOLTS, PINS

Check that there are no loose cab mounting bolts (1) (left, right: 4 each). Tighten any loose bolts.

Tightening torque: 245 to 309 Nm {25 to 31.5 kgm, 180 to 227 lbf}

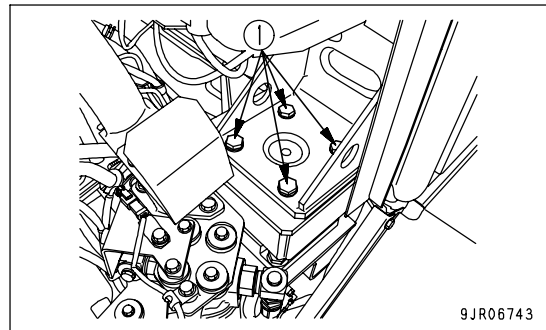

9JR06743

Check that there are no loose or broken cab mount pins (2) (left, right: 1 each).

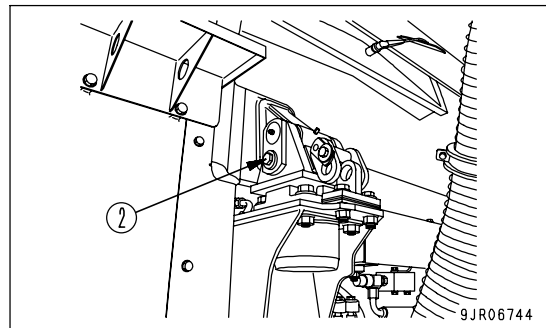

9JR06744

ADJUSTMENT BEFORE OPERATION

ADJUSTING OPERATOR'S SEAT

⚠ WARNING

- Park the machine in a safe place and stop the engine when carrying out adjustment of the operator's seat.
- Adjust the seat before starting operations or when changing operators.
- Adjust the position of the operator's seat so that you can depress the brake pedal fully with your back against the seat backrest.

(A) Fore-and-aft adjustment

Move lever (1) up, move the seat to the desired position, then release the lever.

Fore-and-aft adjustment: 180 mm (7.1 in)
[10 mm (0.4 in) x 18 stages]

(B) Adjusting seat angle

Pull rear lever (2) up to increase the load on the rear of the seat. The seat will tilt to the rear.

Push front lever (2) down to increase the load on the front of the seat. The seat will tilt to the front.

Adjustment range: 13 degrees (Front tilt, rear tilt: 4 stages each)

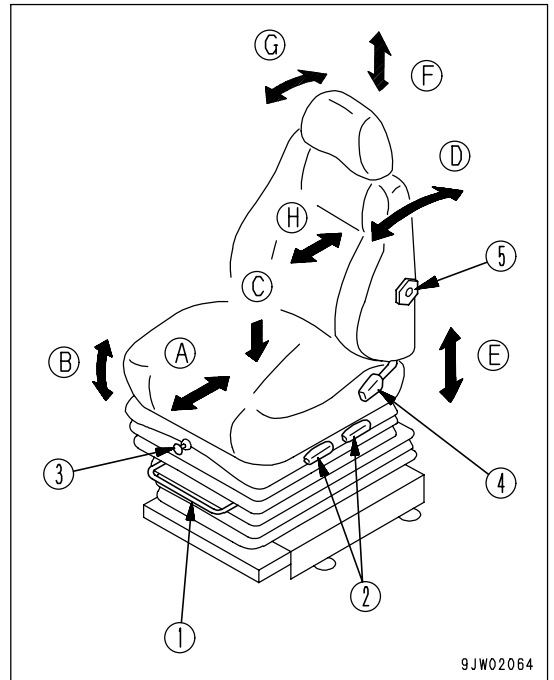

(C) Setting seat for operator's weight

Sit on the seat and adjust the strength of the suspension with valve (3).

Adjustment range (Target): 50 kg (110 lb) to 120 kg (265 lb)

Push: Suspension is strengthened.

Pull: Suspension is weakened.

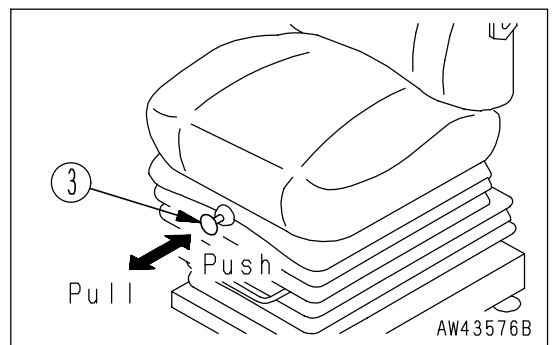

(D) Adjusting backrest angle

Move lever (4) up and move the backrest to the front or rear.

When doing this, keep your back pressed against the seat back.

If your back is not against the seat back, the seat back may spring back suddenly.

Adjustment range: 66° to the front (3° x 22 stages)

72° to rear (3° x 24 stages)

NOTICE

If the seat back is reclined too far, the headrest may hit the rear glass, so move it to a position where it does not contact the glass.

(E) Seat height adjustment

Operate lever (2) up or down to raise or lower the seat. This also acts to adjust the seat angle, so adjust the seat angle while setting the seat to the desired position.

Adjustment range: 60 mm (2.4 in)

(F) Adjusting headrest height

Move the headrest up or down to the desired height.

Adjustment range: 50 mm (2.0 in)

(G) Adjusting headrest angle

Rotate the headrest to the front or rear.

(H) Lumbar support

Turn grip (5) to adjust the tension applied to the lower back.

ADJUST SEAT BELT

**WARNING**

- Before fitting the seat belt, check the belt mounting bracket and seat belt to check that there is no abnormality. If it is worn or damaged, replace the seat belt.
- Even if there appears to be no problem in the seat belt, replace the seat belt once every 3 years. The date of manufacture is woven on the reverse side of the belt.
- Adjust and fasten the seat belt before starting to travel.
- Always use the seat belt when traveling.
- Do not use the seat belt with either half of the belt twisted.

Fastening and removing belt

Fit the seat belt so that it fits tightly, without being too tight.

1. Sit on the seat, depress the brake pedal fully, and adjust the seat so that your back is pressed against the backrest.
2. Sit in the seat, pull the right side of the belt, then insert tongue (1) into buckle (2) until a click is heard.
Fit the belt so that it follows your body and is not twisted.
3. When removing the belt, press the red button in buckle (2) to free the belt.

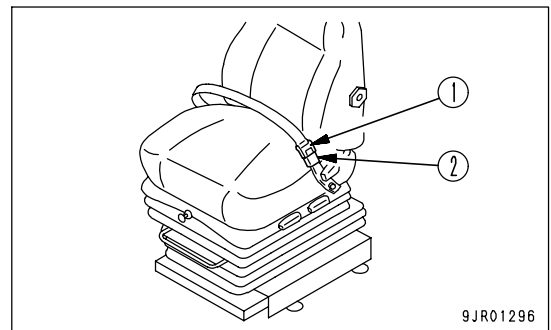

ADJUST STEERING WHEEL TILT

**WARNING**

Always stop the machine before adjusting the tilt of the steering wheel.

It is possible to tilt the steering wheel to the front or rear and to adjust the height. Pull the lever up and set the steering wheel to the desired position, then push the lever down to fix the steering wheel securely in position.

Amount of adjustment: Front/rear: 80 mm/80 mm (3.2 in/3.2 in)
(from center of steering wheel)
Up: 33 mm (1.3 in)
Down: 17 mm (0.7 in)

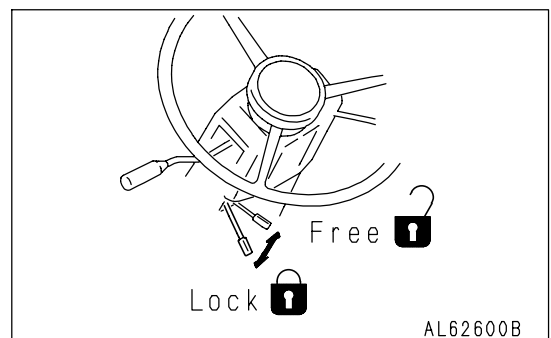

ADJUSTING MIRROR

! WARNING

Be sure to adjust the mirrors before starting work. If they are not adjusted properly, you cannot secure the visibility and may be injured or may injure someone seriously.

Loosen mirror securing bolt (1), screw (2) and nut (3) and adjust the mirror position the way it assures the best view from the operator's seat.

- Adjust the position and angle of each mirror so that it reflects a sight 200 mm above the ground and up to 1500 mm. In the adjustment, make sure that part of the dump truck's image also comes into view.
- View Range
 - Mirror A: Shaded area (A) should be in view.
 - Mirror B: Shaded area (B) should be in view.
 - Mirror C: Shaded area (C) should be in view.
 - Mirror D: Shaded area (D) should be in view.
 - Mirror E: Shaded area (E), tire's ground contact point (G') and ground (G'') should be in view.
 - Mirror F: Shaded area (F) should be in view.
 - Mirror G: Shaded area (G), tire's ground contact point (G') and ground (G'') should be in view.

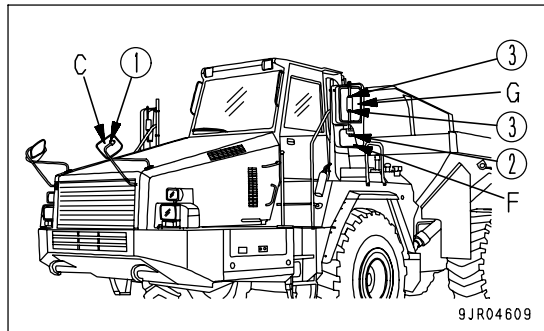
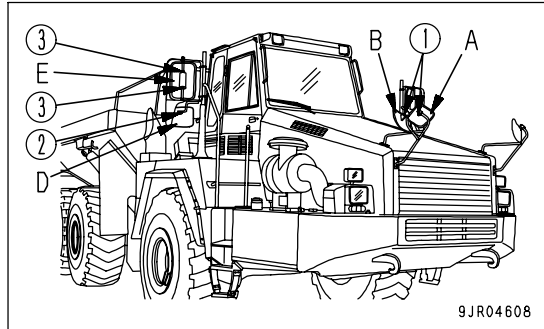

Rear Monitor (optional): Shaded area (H) should be in view.

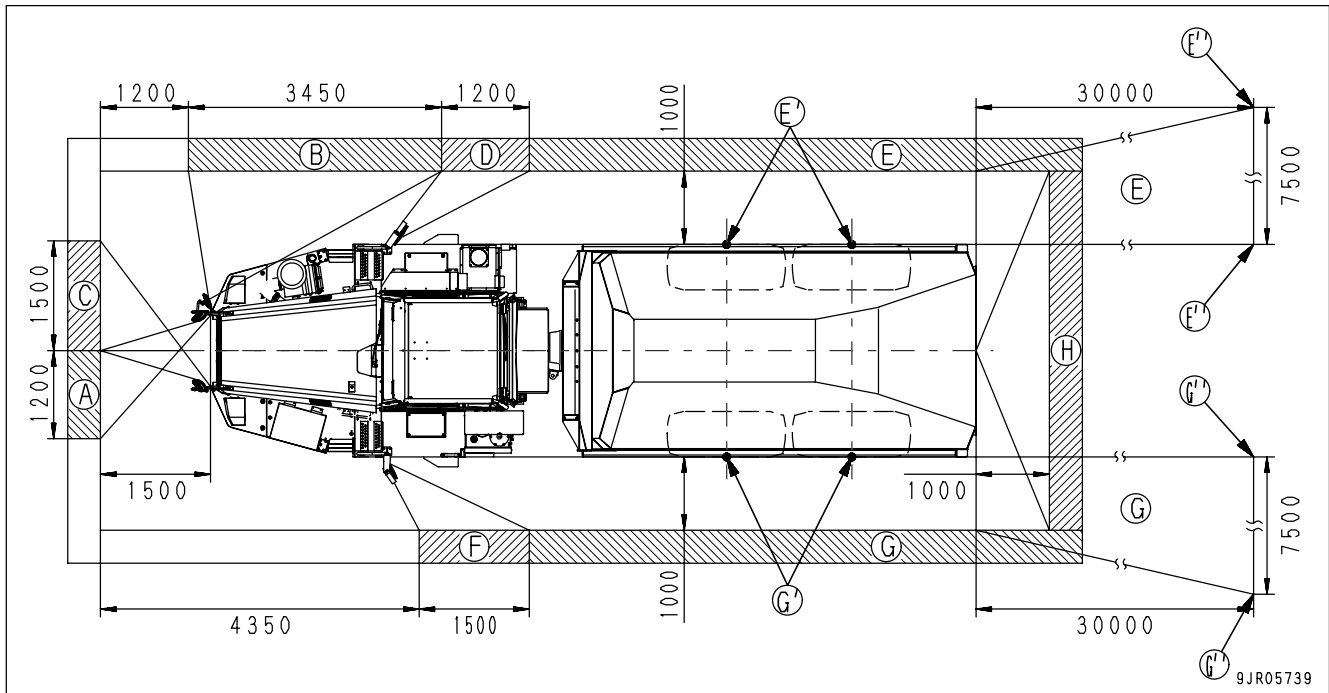

OPERATIONS, CHECKS BEFORE STARTING

WARNING

- When starting the engine, check that the shift lever is set in the N (neutral) position and that the parking brake switch is at PARKING position.
- Before standing up from the operator's seat, place the shift lever at N (neutral) position, and set the parking brake switch to the PARKING position.

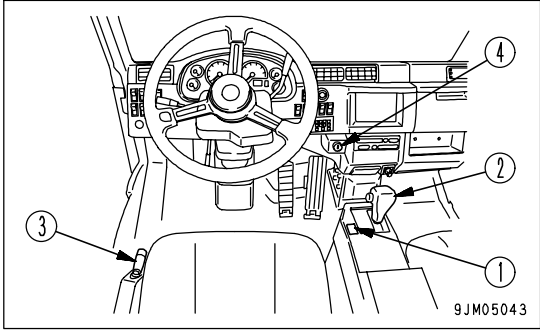

1. Check that parking brake switch (1) is in the PARKING position.

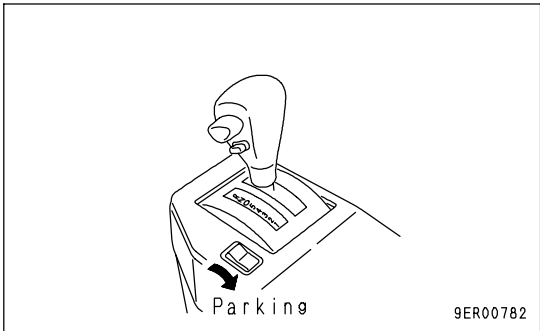

2. Check that gear shift lever (2) is at the N position.

REMARK

If the starting switch is turned to the ON position when the gear shift lever is not at the N position, the gear shift lever position pilot lamp and central warning lamp will flash, and the alarm buzzer will sound.

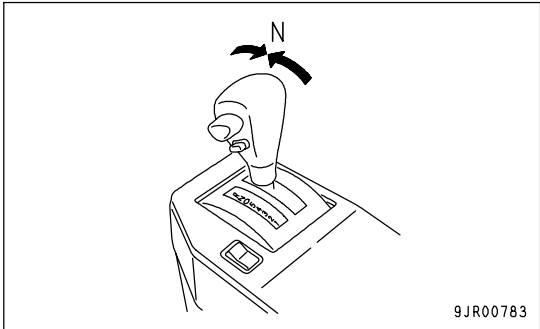

3. Check that dump lever (3) is at the HOLD position.

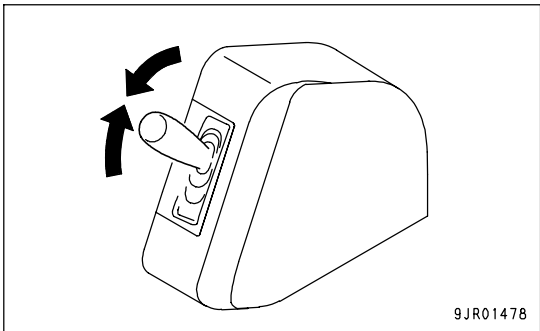

4. Turn the key in starting switch (4) to the ON position and check that there is no abnormality display on the machine monitor.

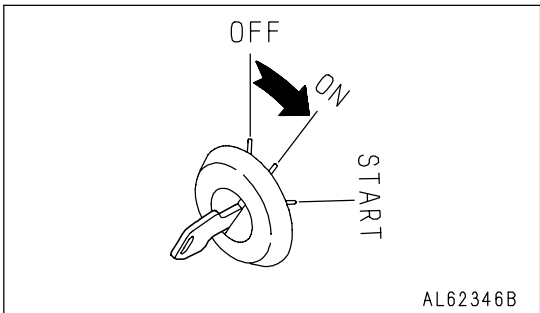

STARTING ENGINE

WARNING

- Start the engine only after sitting down in the operator's seat.
- Do not attempt to start the engine by short-circuiting the engine starting circuit. Such an act may cause a serious bodily injury or fire.
- Check that there are no persons or obstacles in the surrounding area, then sound the horn and start the engine.
- Never use starting aid fluids as they may cause explosions.
- Exhaust gas is toxic. When starting the engine in confined spaces, be particularly careful to ensure good ventilation.

NOTICE

- Do not accelerate the engine sharply until it is warmed up.
- Do not operate the starting motor continuously for more than 20 seconds.
- If the engine fails to start, wait for 2 minutes or so, and then try to start again.
- When starting the engine, do not depress the accelerator pedal. Even if the accelerator pedal is depressed just after the engine is started, the engine speed is limited by the turbo protect function. After the turbo protect time, however, the engine speed rises sharply and the turbocharger may be damaged.

1. Turn the key of starting switch (1) to the ON position.

The engine preheating pilot lamp lights up according to the engine coolant temperature, and preheating of the engine starts. When the preheating is completed, the engine preheating pilot lamp goes out.

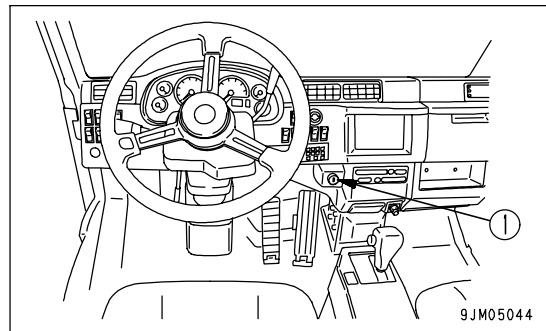

The pre-heating times are as shown below.

Engine water temperature	Preheating time
above - 5°C (23°F)	-
- 5°C to - 20°C (23°F to - 4°F)	20 to 40 sec
below - 20°C (- 4°F)	40 sec

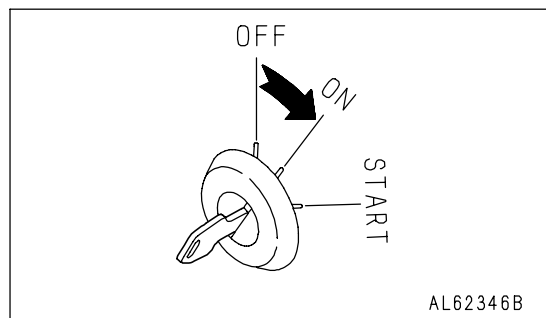

REMARK

When the starting switch is turned to the ON position, if the engine coolant temperature is above -5°C (23°F), though preheating of the engine is carried out. In this case, it is possible to start the engine immediately.

2. After the preheater pilot lamp goes off, turn the key of the starting switch to the START position, and the engine will start.

REMARK

When starting the engine, the monitor may flash while the starting motor is turning, but if the monitor lamp goes out after the engine is started, there is no problem.

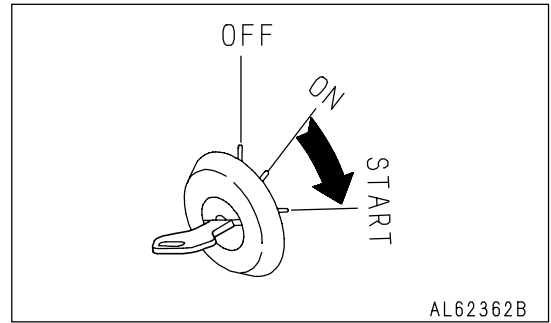

3. After the engine starts, release the key of the starting switch.

REMARK

If the engine fails to start, return the key of the starting switch to the OFF position, and then start the operation again from step 1. If the starting switch is not returned to the OFF position, the automatic preheater does not operate.

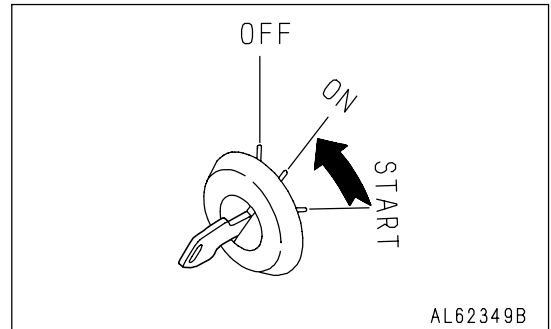

4. Do not operate the accelerator pedal immediately after starting the engine. Run the engine for at least 15 seconds at low idling.

When the engine is started for the first time after the engine oil or engine oil filter is replaced, continue the low idle run for at least 20 seconds to circulate the engine oil in the engine.

REMARK

- Since the turbocharger rotates at very high speed, it is seized if not lubricated well. To prevent this, the turbo protect mechanism works for a certain time just after the engine starts, depending on the engine coolant temperature.

Engine water temperature	Turbo protect time
above 10°C (50°F)	0 sec
-10°C to 10°C (14°F to 50°F)	0 to 5 sec
below -10°C (14°F)	5 sec

- Just after the engine starts, the injection characteristics are changed for a certain time to keep the low idle speed a little high, depending on the engine coolant temperature. The engine acceleration characteristics are also changed so that the engine will be accelerated moderately.

Engine water temperature	Injection characteristics change time
above 20°C (68°F)	0 sec
0°C to 20°C (32°F to 68°F)	0 to 6 sec
-20°C to 0°C (-4°F to 32°F)	6 to 12 sec
-30°C to -20°C (-22°F to -4°F)	12 to 15 sec

OPERATIONS, CHECKS AFTER STARTING ENGINE

BREAKING-IN THE MACHINE



CAUTION

Your Komatsu machine has been thoroughly adjusted and tested before shipment. However, operating the machine under severe conditions at the beginning can adversely affect the performance and shorten the machine life.

Be sure to break-in the machine for the initial 100 hours (as indicated by the service meter).

During break-in operations, follow the precautions described in this manual.

- Idle the engine for 5 minutes after starting it up.
- Avoid operation with heavy loads or at high speeds.
- Immediately after starting the engine, avoid sudden starts, sudden acceleration, unnecessary sudden stops, and sudden changes in direction.

WARMING-UP OPERATION

NOTICE

- Do not accelerate the engine sharply during the warming-up operation. Sharp acceleration can shorten the service life of the engine parts.
- Do not continue the low idle or high idle operation for more than 20 minutes. It can cause oil leakage from the turbocharger.

1. After the engine starts, run it for 5 minutes in the range between low idling and medium speed to warm it up.
2. Check if the indicator of the engine coolant temperature gauge is in the white range (above (A)).

If the indicator is in the white range (above (A)), the warming-up operation is completed.

If the indicator has not reached the white range (above (A)), continue the warming-up operation.

After finishing the warming-up operation, check that the machine monitor is normal.

If the machine monitor is abnormal, ask your Komatsu distributor for inspection/repair.

If the machine monitor is abnormal, ask your Komatsu distributor for inspection/repair.

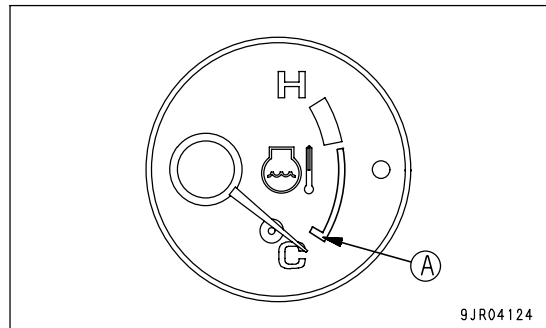

9JR04124

REMARK

While the AISS LOW switch is in the AUTO position and the engine water temperature is low, the low idle speed is set a little high automatically.

3. Check that the steering operation is normal, the lamps light up and go off normally, the horn sounds, and the exhaust gas color, sound, and vibration are normal. If any of them is abnormal, ask your Komatsu distributor for inspection/repair.

CANCELING DUMP BODY HOLD CONDITION

WARNING

If the HOLD is canceled when the dump body is raised, the body will go down under its own weight. This is very dangerous. Always lower the dump body before stopping the engine.

If the engine is stopped, the body will stay in the HOLD condition, regardless of the position of the dump lever.

If the engine is started in this condition, the dump body pilot lamp will light up.

Return the dump control lever to the HOLD position, then move it to the FLOAT position to cancel the dump body HOLD condition.

When the dump body is set to the FLOAT condition, the body pilot lamp will go out.

STOPPING ENGINE

NOTICE

- If the engine is suddenly stopped without allowing it to cool down, there is danger that the life of the engine parts will be shortened, so never stop the engine suddenly except in emergency. Allow the engine to cool down gradually before stopping it.
- Set the dump lever to the FLOAT position, lower the dump body, then stop the engine.

1. Set the gear shift lever to the N position, then set the parking brake switch to the PARKING position.
2. Lower the dump body and set the dump lever to the HOLD position.
3. Run the engine at low idle for about 5 minutes to cool down gradually.
4. Turn the key of starting switch (1) to the OFF position to stop the engine.
5. Remove the key from starting switch (1).

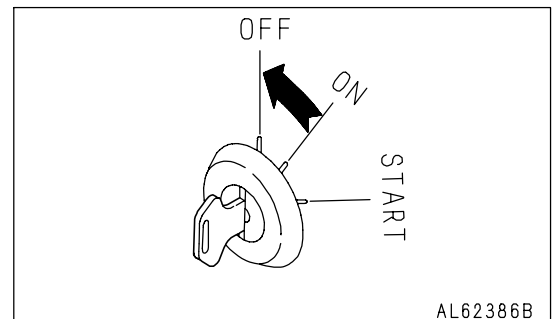
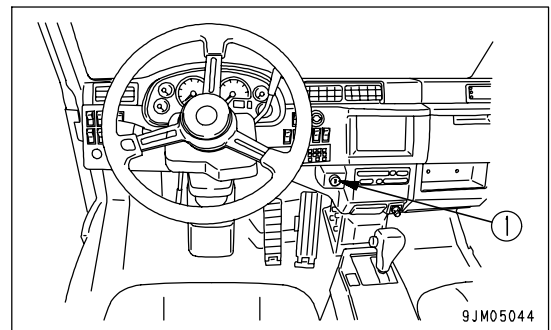

CHECKS AFTER STOPPING ENGINE

1. Walk around the machine and check the work equipment, bodywork, and undercarriage, and check also for oil and water leakage.
2. Fill the fuel tank.
3. Check the engine compartment for paper and debris. Clean out any paper and debris to avoid a fire hazard.
4. Remove any mud affixed to the undercarriage.

MOVING MACHINE OFF (FORWARD, REVERSE), STOPPING

MOVING MACHINE FORWARD

WARNING

- When moving the machine off, check that the area around the machine is safe, then sound the horn before starting.
- Do not allow people to get near the machine.
- Clear the machine's travel path of any obstacle.
- Pay a particular attention to the blind spot at the rear of the machine, when traveling the machine in reverse.

1. Check that there is no warning display on the machine monitor.
2. Fasten the seat belt.

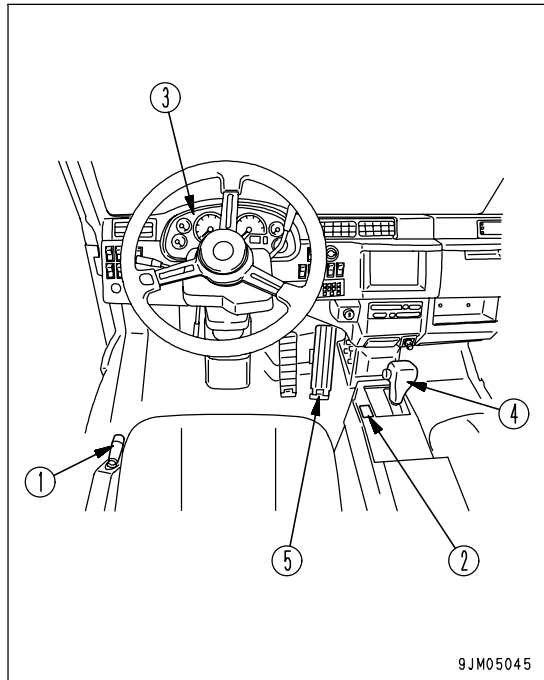

3. Set dump lever (1) to the FLOAT position and check that the body pilot lamp goes out.
If the dump body pilot lamp is lighted up, operate the dump lever to the HOLD position, then operate it to the FLOAT position to cancel the dump body HOLD condition.

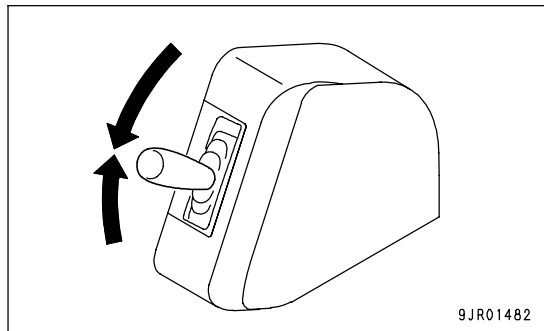

4. Depressed the brake pedal fully. Then set parking brake switch (2) to the TRAVEL position to release the parking brake.

REMARK

If the engine is stopped with the parking brake switch at TRAVEL, the parking brake will be applied even though the switch is at TRAVEL. In this case, operate the switch to PARKING, and then move it back to TRAVEL to release the parking brake.

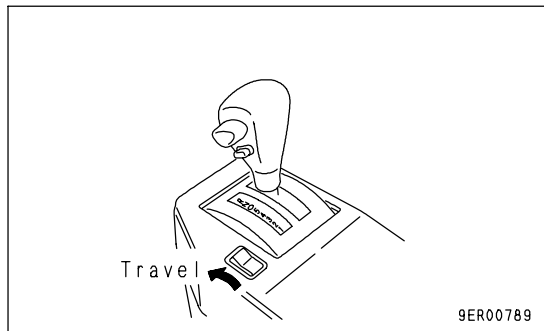

5. Check that retarder pilot lamp (3) is not lighted up, then set gear shift lever (4) to the desired position.

NOTICE

- Always place the gear shift lever securely in position when operating it. If the gear shift lever is not placed securely in position, the shift lever position pilot lamp display on the machine monitor may go out and the transmission system caution lamp may light up.
- Always release the accelerator pedal when moving the gear shift lever from N (Neutral) to R (Reverse) or F (Forward).

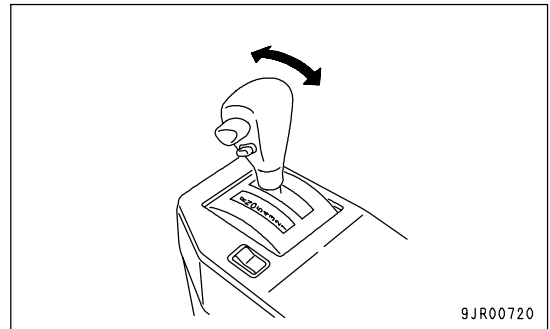
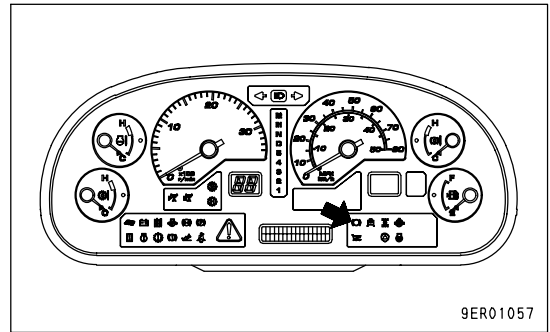

6. Depress accelerator pedal (5) to move the machine off.

NOTICE

- If the gear shift lever is shifted to a position other than N when the parking brake has not been released, the central warning lamp will flash and the alarm buzzer will sound.
- If the gear shift lever is shifted to a position other than N when the dump lever is at a position other than FLOAT or the body is raised, the central warning lamp will flash and the alarm buzzer will sound.
- Do not operate the gear shift lever with the accelerator pedal depressed. This will cause a big shock and will also reduce the service life of the machine.

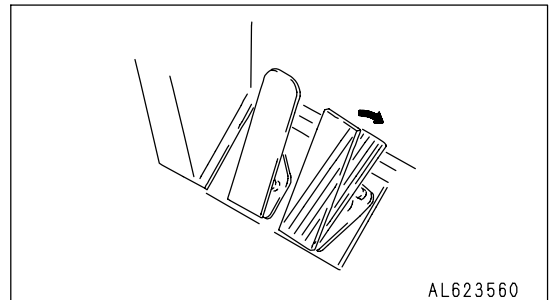

MOVING MACHINE IN REVERSE

! WARNING

- When switching between FORWARD and REVERSE, check that the new direction of travel is safe.
There is a blind spot behind the machine, so use extreme caution when reversing the machine.
- Always stop the machine completely before shifting between FORWARD and REVERSE.

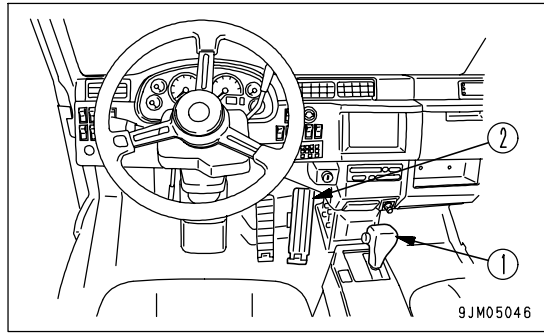

Operate gear shift lever (1) to the R1 or R2 position, then gradually depress accelerator panel (2) to move the machine off.

NOTICE

- The machine cannot be driven in reverse if the dump body is raised. Lower the dump body, set the dump lever to FLOAT, then operate the gear shift lever to R1 or R2.
- When switching between Forward and Reverse, stop the machine completely and run the engine at low idling when shifting the direction of travel.
After moving the gear shift lever, do not accelerate until it is detected that the transmission clutch is engaged.
- Do not operate the gear shift lever with the accelerator pedal depressed. This will cause a big shock and will also reduce the service life of the machine.

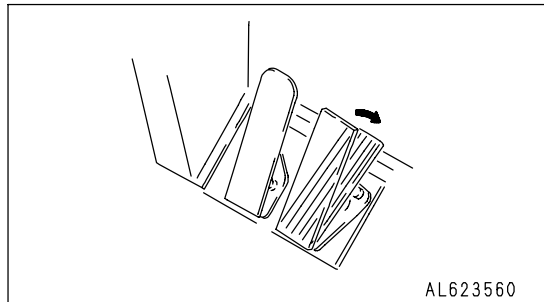
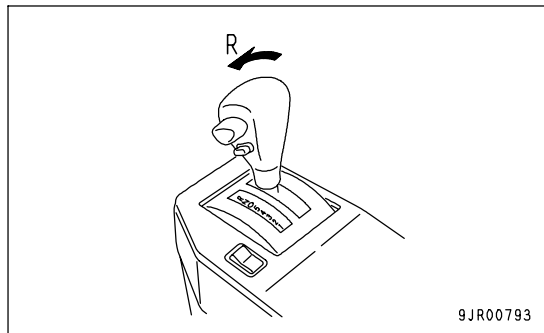

STOPPING MACHINE**WARNING**

- Avoid sudden stopping. As far as possible, leave a margin when stopping the machine.
- If the foot brake is used repeatedly or is kept depressed for a long time, the brake may overheat and its life will be shortened.
- If the parking brake is used to stop the machine, the parking brake will be damaged. Do not use the parking brake except when stopping in emergencies or when parking the machine after stopping it.

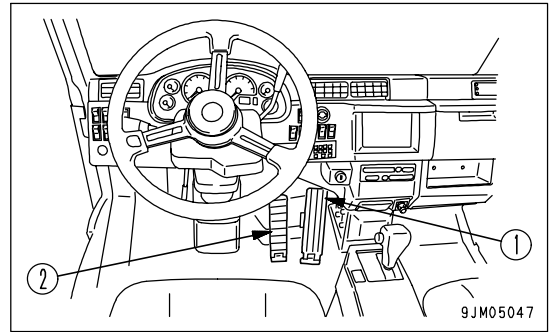
**NORMAL STOPPING**

Release accelerator pedal (1), and depress brake pedal (2) to stop the machine.

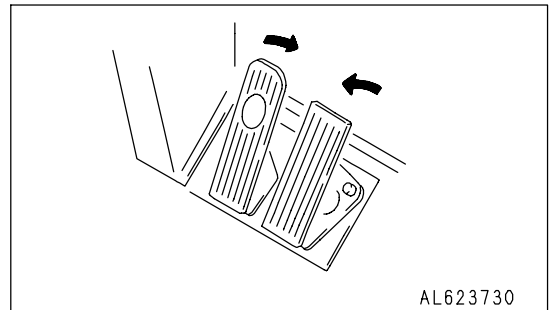

STOPPING IN EMERGENCY

If there should be a failure in the foot brake, stop the machine as follows.

**WARNING**

- When the machine stops, put blocks under the tires immediately.
- If the parking brake is used to make an emergency stop, the performance of the parking brake may drop below the standard value, so it is necessary to repair and adjust the parking brake. Please ask your Komatsu distributor to carry out the repair and adjustment.

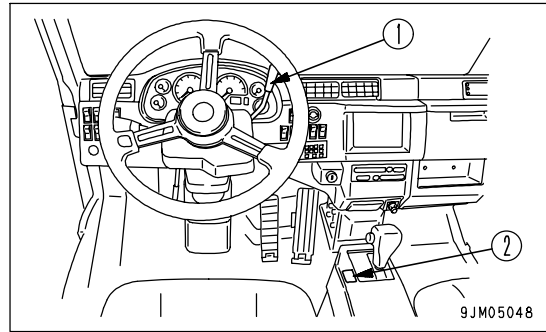

1. Pull retarder control lever (1) fully to apply the retarder.

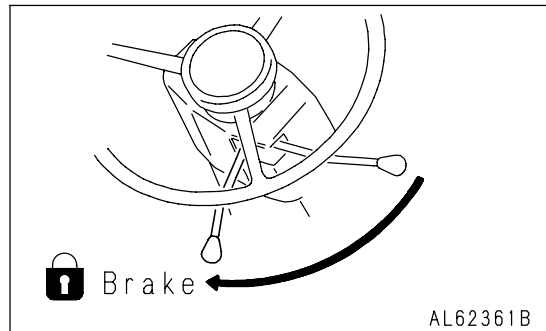

2. If operating retarder control lever (1) does not give enough braking force, set parking brake switch (2) to PARKING to apply the parking brake.

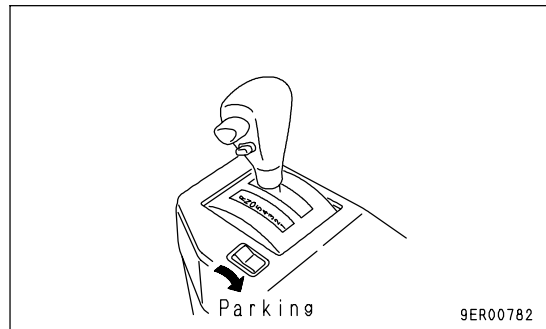

3. If an emergency stop has been made, put blocks under the tires immediately, then try to find the cause, and repair it on site.

SHIFTING GEAR



WARNING

Do not operate the gear shift lever to the N (Neutral) position when traveling or when going downhill. Always travel with the gear shift lever in a speed range position.

- It is dangerous to drive the machine with the gear shift lever at N. The braking force of the engine cannot be used and the steering will become heavy. In addition, there will be insufficient cooling oil for the retarder, and this will lead to overheating or defective operation of the brakes.
- There may also be damage to the transmission or other parts of the power train, and there is danger of unexpected accidents.

When shifting gear, do as follows.

This machine is equipped with automatic transmission, so if gear shift lever (1) is set at the desired position, the transmission will shift automatically to match the travel speed.

When the dump body is raised, if the gear shift lever is at the D position, the transmission is fixed in 2nd, and if it is at positions 1 - 5, the transmission is fixed in 1st. Keep the dump body lowered when traveling.

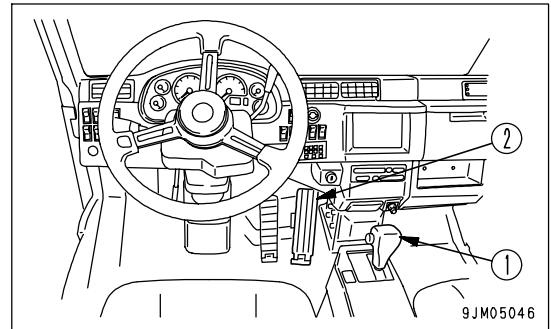

NOTICE

- When switching between Forward and Reverse, stop the machine completely and run the engine at low idling when shifting the direction of travel.
After moving the gear shift lever, do not accelerate until it is detected that the transmission clutch is engaged.
- Do not operate the gear shift lever with the accelerator pedal depressed. This will cause a big shock, and will also reduce the service life of the machine.

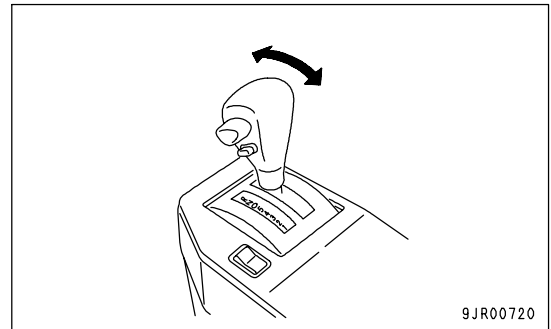

SHIFTING UP

1. When accelerator pedal (2) is depressed to accelerate the machine, the lockup clutch is engaged to shift the transmission to direct drive.
2. If the machine is accelerated further, the transmission will automatically shift up.

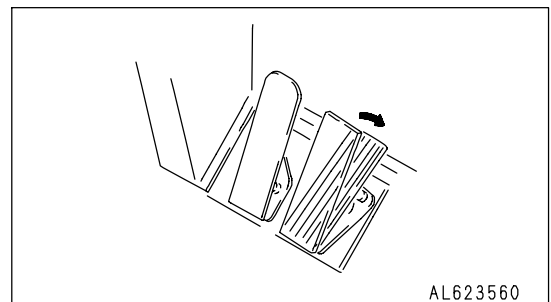

SHIFTING DOWN

If accelerator pedal (2) is released, the machine speed will be reduced, and the transmission will automatically shift down.

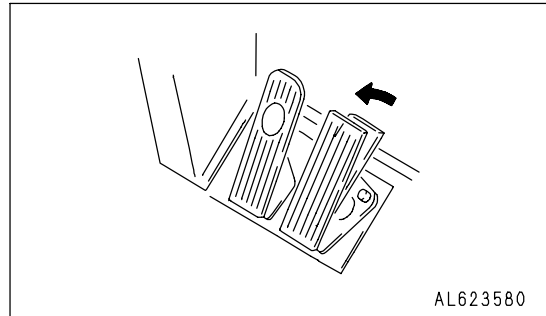

AL623580

DOWN SHIFT INHIBIT

If the gear shift lever is operated when the machine is traveling, the travel speed may be faster than the maximum speed allowed for the new speed range. In this case, do not shift gear immediately. Reduce the travel speed and then shift down. This will prevent the engine from overrunning.

SHIFTING DOWN WHEN USING FOOTBRAKE

When using the foot brake to reduce speed, 3rd speed is held for longer than normal to reduce the shock when shifting gear.

OVERRUN PROTECTION DEVICE

If the engine speed reaches the red range of the tachometer when the machine is traveling, the central warning lamp will light up and the alarm buzzer will sound. If the travel speed and engine speed continue to rise, the brake is automatically applied to reduce the travel speed of the machine in order to prevent the engine speed from rising too far.

TRAVELING DOWNHILL

When traveling downhill, travel at a safe speed which matches the width of the road, the condition of the road surface, and other conditions of the jobsite.



WARNING

- When the machine stops, put blocks under the tires immediately.
- For the maximum permissible speed when traveling downhill using the retarder, see the brake performance curve for the downhill distance and grade. Traveling continuously downhill at a speed greater than the maximum permitted speed on the brake performance curve is dangerous as the retarder brake may be damaged.
- If the retarder oil temperature caution lamp on the machine monitor lights up when the retarder is being used, shift down to travel downhill. (When this happens, the central warning lamp lights up and the alarm buzzer sounds.)
If the caution lamp does not go out even when the transmission is shifted down, stop the machine immediately, set the gear shift lever to the N position, run the engine at 1800 rpm, and wait for the caution lamp to go out.
- If the retarder loses its effect when it is used for traveling downhill, do as follows.
 1. Release the retarder control lever completely, then operate the retarder control lever again.
 2. If the retarder still has no effect even when the retarder control lever is operated again, return the retarder control lever completely to the released position, then depress the brake pedal to stop the machine, and contact your Komatsu distributor for repairs.
- Operate the retarder control lever gradually. If the braking force is applied suddenly, there is danger that the tires may slip.
- Do not operate the gear shift lever to the N (Neutral) position when traveling or when going downhill. Always travel with the gear shift lever in a speed range position.
 - It is dangerous to drive the machine with the gear shift lever at N. The braking force of the engine cannot be used and the steering will become heavy. In addition, there will be insufficient cooling oil for the retarder, and this will lead to overheating or defective operation of the brakes.
 - There may also be damage to the transmission or other parts of the power train, and there is danger of unexpected accidents.

NOTICE

- If the retarder control lever is operated when traveling downhill, the transmission can be shifted down sooner than with normal deceleration. It is also possible to travel without shifting up.
- Do not accelerate or shift up when using the retarder. The engine speed will rise and this may cause the alarm buzzer to sound and the central warning lamp to flash.

- 1. Let accelerator pedal (1) back before starting to travel downhill and operate retarder control lever (2) to reduce speed.

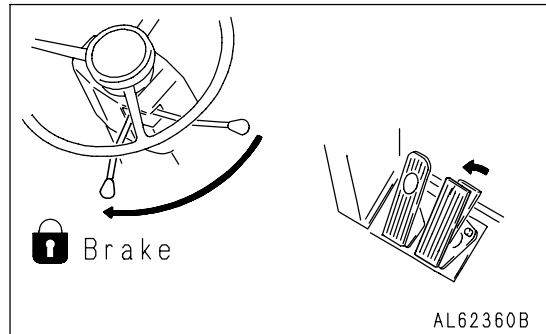
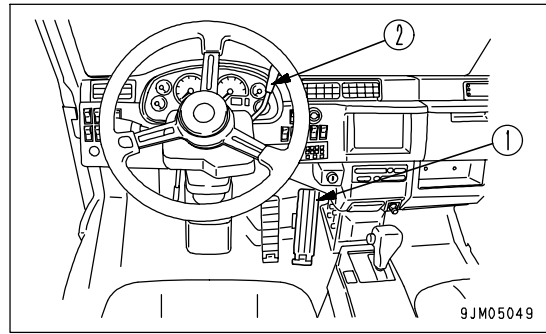

- 2. Move the gear shift lever to the position (5, 4, 3, 2) that matches the maximum permitted speed on the brake performance curve.

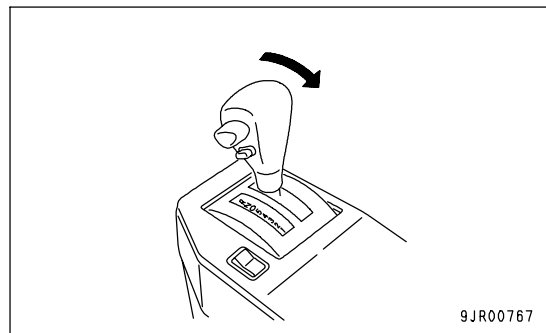

- 3. When traveling downhill, operate retarder control lever (2), set the engine speed to above 1800 rpm, and travel so that the indicator of the retarder oil temperature gauge is within the white range.

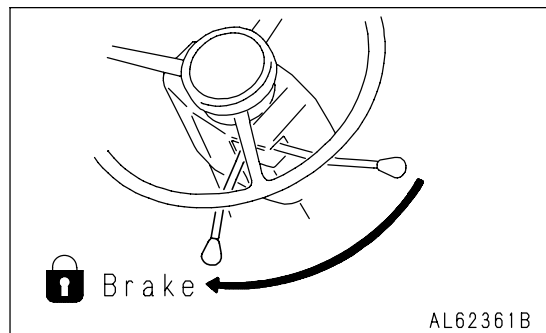

BRAKE PERFORMANCE CURVE

- Method of using graph

Example: Downhill distance: 1500 m (4921 ft)

Travel resistance: -11% [grade resistance: -13%, rolling resistance: 2%]

Load: 27 tons

Obtain the maximum permissible speed and the transmission speed range from the graph when traveling downhill under the above conditions.

1. Use the brake performance curve for downhill distance of 1,500 m (4,921 ft).
2. Starting from point (A) which corresponds to the overall weight of the machine, draw a perpendicular line down.
3. Take the point where it crosses the line for travel resistance -11% as (B) and draw a horizontal line.
4. Take the point where it crosses the performance curve as (C), and draw a perpendicular line down. Take the point where this line crosses the travel speed scale as (D).
5. The following information can be obtained from this procedure.

From point (D): Maximum permissible speed = 24 km/h (14.9 MPH)

From point (C): Speed range = F4

This maximum permissible speed is one guideline determined from the retarder brake performance, so on an actual jobsite, determine a safe travel speed below the maximum permissible speed to match the conditions of the jobsite so that the retarder brake oil temperature gauge is always in the white range when traveling.

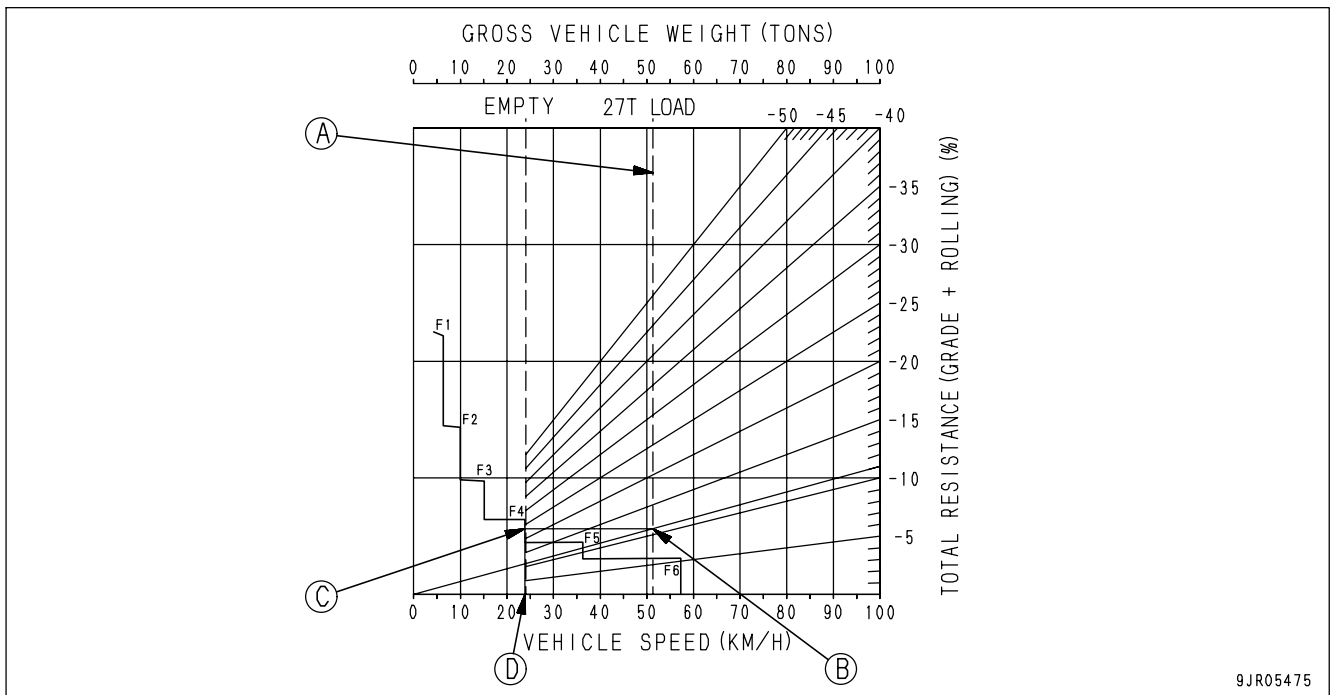

9JR05475

- Brake performance
[Downhill distance: 450 m (1476 ft)]

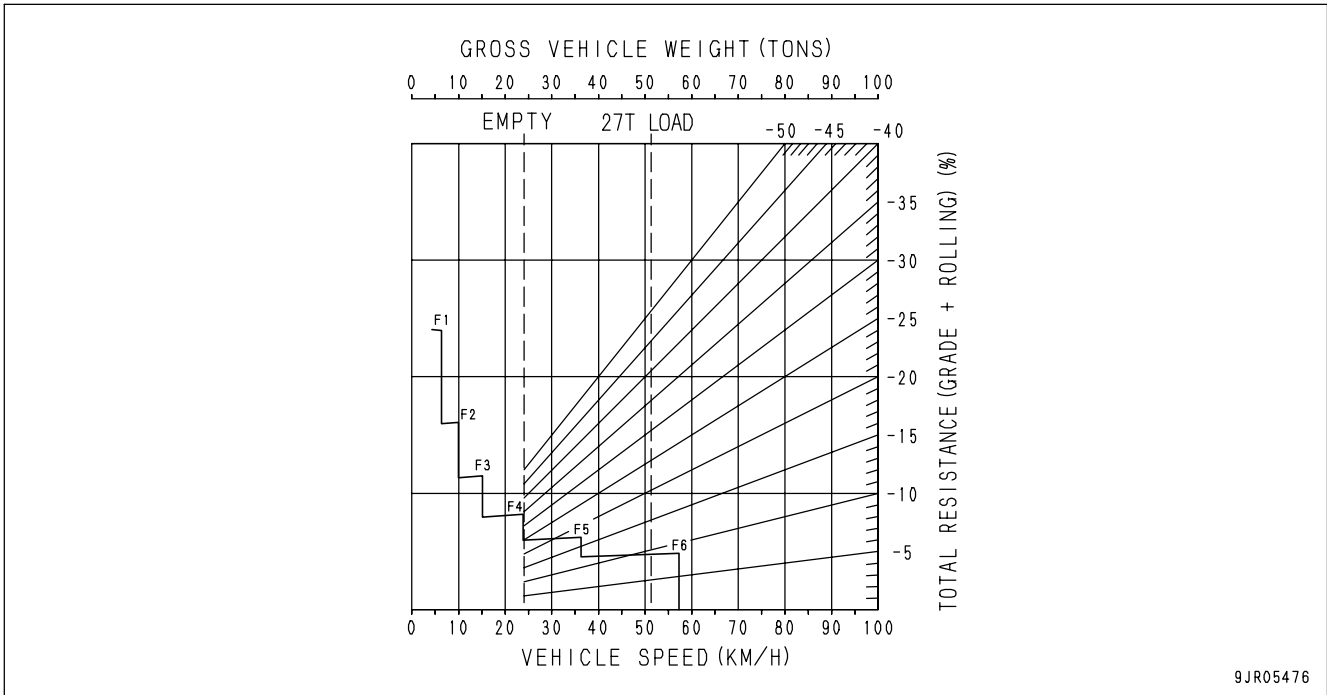

- Brake performance
[Downhill distance: 600 m (1968 ft)]

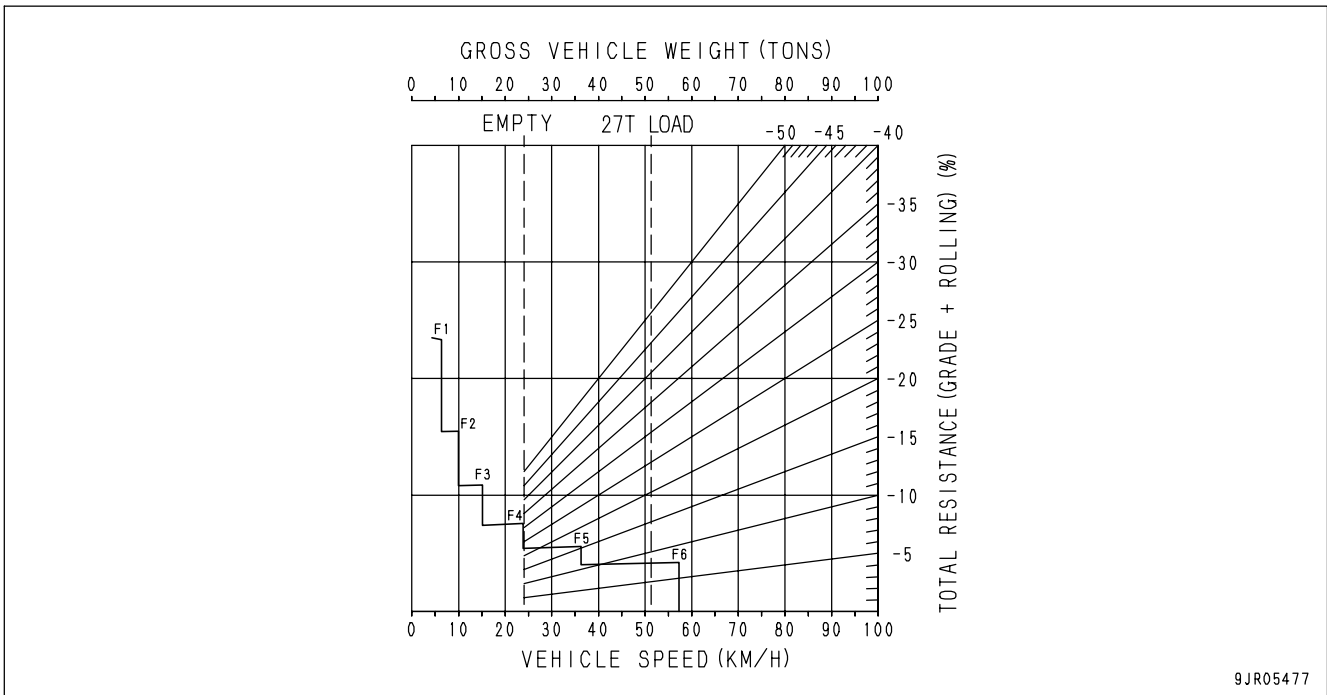

- Brake performance
[Downhill distance: 900 m (2952 ft)]

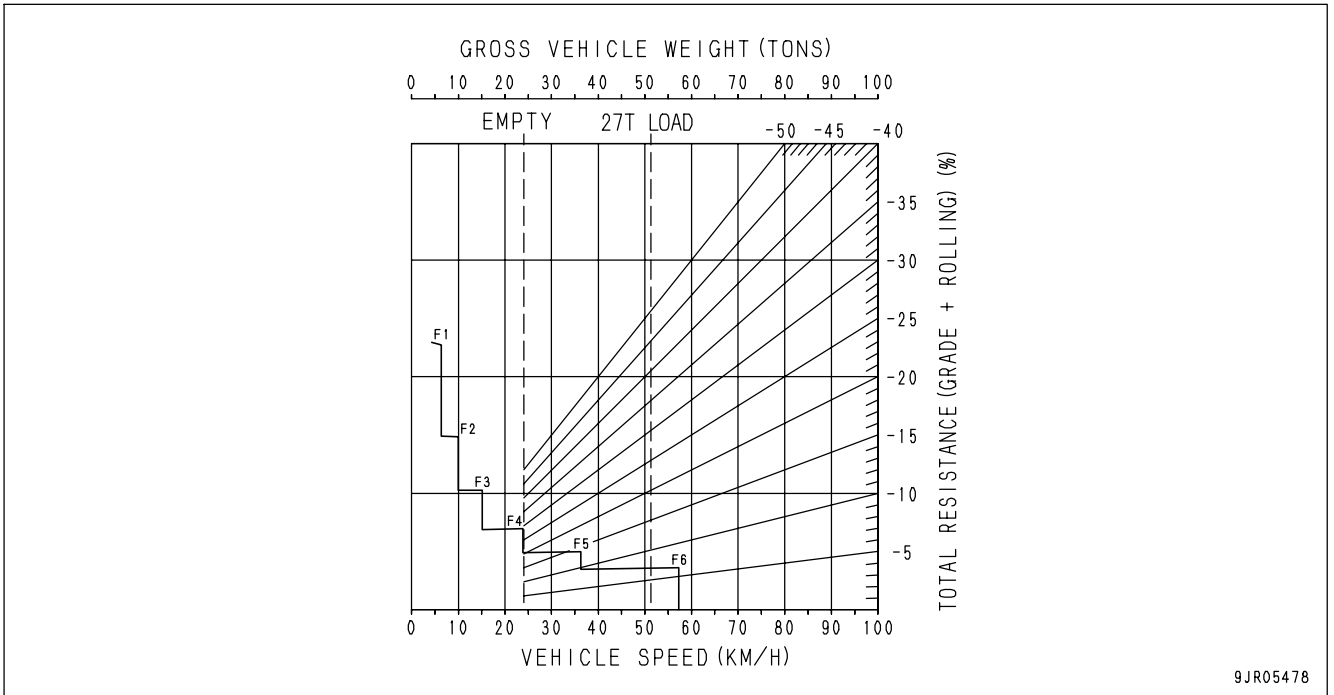

9JR05478

- Brake performance
[Downhill distance: 1500 m (4921 ft)]

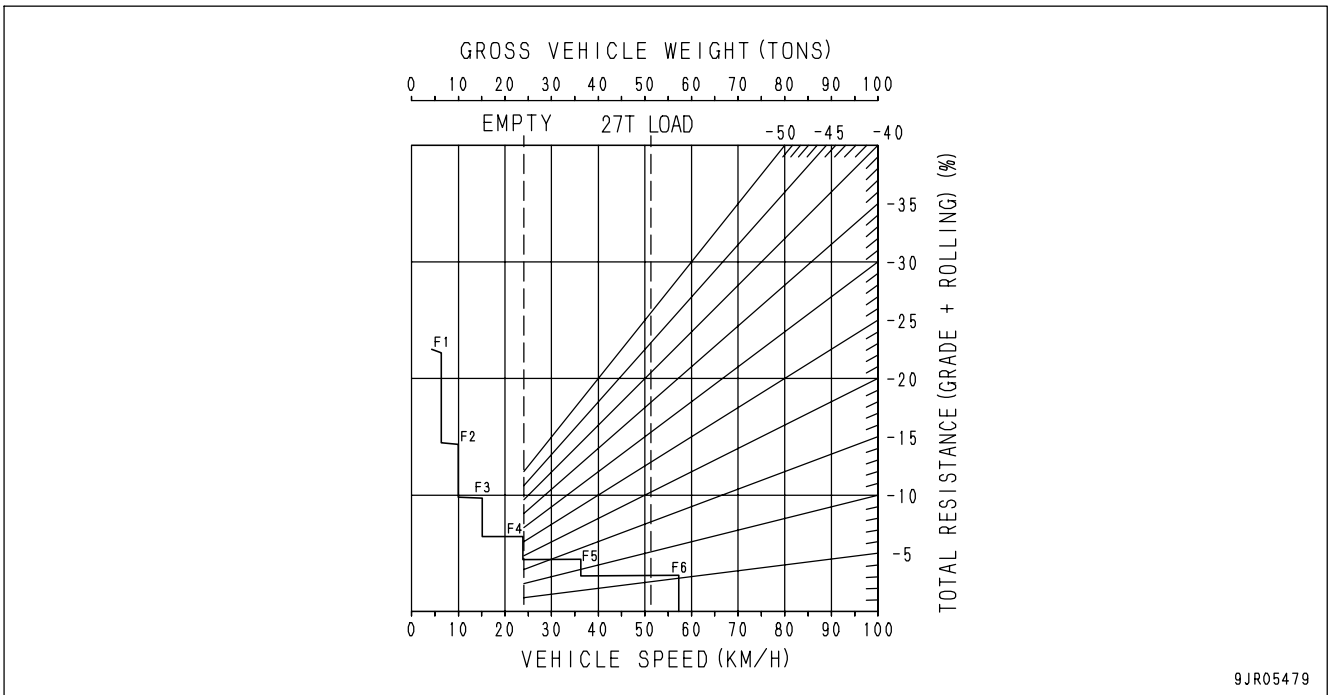

9JR05479

- Brake performance
[Downhill distance: Continuous]

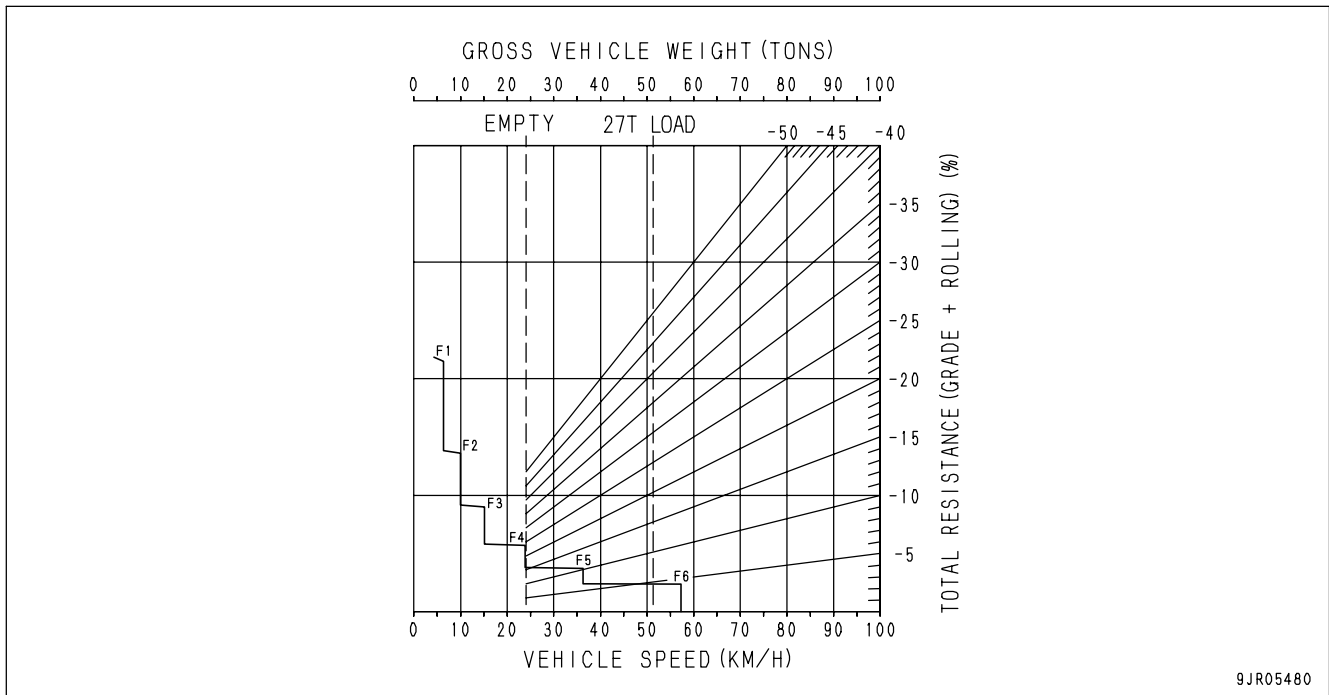

9JR05480

STEERING THE MACHINE



WARNING

If the machine is turned at high speed or on a steep slope, there is danger that it will turn over, so do not operate the steering in such conditions.



CAUTION

- If the steering wheel has been turned fully to the left or right, do not continue to apply force to turn it further. The oil temperature inside the steering hydraulic circuit will rise and cause overheating.
- When the steering nears the end of the turn on the left or right, turn the steering wheel more slowly. Turning the steering wheel suddenly to the end of the turn will cause damage to the machine.

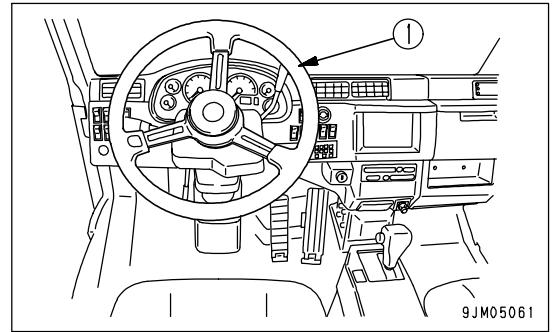

To turn the machine when traveling, turn steering wheel (1) in the direction of the turn.

On roads where there are curves, let the accelerator pedal back before coming to the curve, shift down to the lowest speed range possible then depress the accelerator pedal again to continue driving. Do not enter the curve at high speed.

REMARK

- The angle of the steering wheel may change (the position of the spoke may change slightly) when the machine is traveling, but this is not a failure.
- If force is applied to the steering wheel when the tires have been turned fully to the left or right, the steering wheel will turn a little at a time, but this is not a failure.

OPERATION USING DIFFERENTIAL LOCK

When traveling on roads where the tires are likely to slip, avoid sudden changes in speed, and use the differential lock (inter-axle differential lock) when traveling.

Operate the inter-axle differential lock switch to actuate the differential lock 5 to 10 m (16 ft 5 in to 32 ft 10 in) before entering a road surface where the tires are likely to slip.

To make full use of the performance of the differential lock and to reduce tire wear, it is important to use the differential lock before the tires slip.

NOTICE

As far as possible, do not use the differential lock (inter-axle differential lock) when turning.

If the differential lock is used when turning:

- It will be more difficult to operate the steering wheel.
- It will become more difficult to turn than when the differential lock is not used, and in some cases, it may not be possible to steer around curves which were previously possible.
- If the machine is turned when the differential lock is actuated, the inside wheels and outside wheels will attempt to rotate at the same speed. This will result in slipping and premature wear of the tires, and may also damage the road surface.

METHOD OF USING INTER-AXLE DIFFERENTIAL LOCK

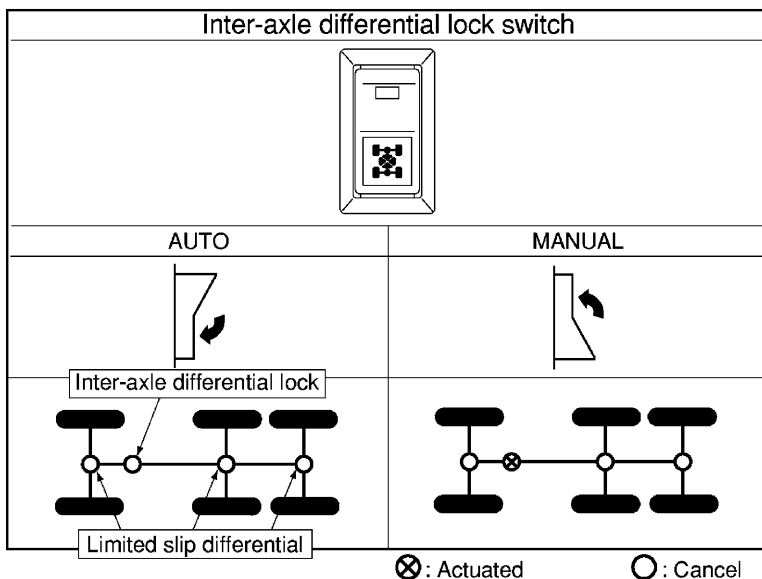

Set the inter-axle differential lock switch to MANUAL before entering soft ground or a road surface where the tires are likely to slip, and actuate the inter-axle differential lock. When traveling again on hard ground, cancel the switch.

REMARK

When the inter-axle differential lock is at AUTO, if the tires slip and there is a difference in rotation between the front and rear tires, the inter-axle differential lock is automatically actuated.

WHEN TIRES ARE STUCK IN GROUND

If the wheels get stuck, to stop the wheels from spinning, do as follows.

If it is impossible to get the machine out even when repeating the procedure below, use a bulldozer to tow the machine out.

1. Release the accelerator pedal to stop the wheels from spinning.
2. Actuate the inter-axle differential lock.
3. Set the gear shift lever to position "5" and raise the engine speed.
4. Release the accelerator pedal and brake pedal.
5. Set the shift lever to position R1 and raise the engine speed.
6. Repeat Steps 1 - 5 to move the machine backwards and forwards until it can escape.

LOADING OPERATIONS



WARNING

Do not load the dump body when the dump body is raised.

When loading large rocks or when using a large-sized loader, if the load is dumped directly into the dump body, it may result in deformation of parts of the dump body. To prevent this, when loading large rocks, first load with soil to act as a cushion, then load the large rocks on top of the cushion. This will reduce the impact shock on the dump body.

In addition, when loading rocks that exceed the following conditions, install the optional body reinforcement plate.

- Rocks with one side over 0.3 m (11.8 in)
- Rocks of hardness more than 4.5 (Mohs scale)
- Rocks with a weight of more than 150 kg (331 lb)
- When transporting steel ingots

NOTICE

- When traveling, always set the dump lever to the FLOAT position, regardless of whether the machine is loaded or not loaded.
- If the dump lever is not at the FLOAT position and the gear shift lever is not at the N position, the central warning lamp will flash and the alarm buzzer will sound.

HANDLING TAILGATE

(If equipped)



WARNING

When hauling rocks or materials with high viscosity, always remove the tailgate.

When removing or installing the tailgate, please consult your Komatsu distributor.

NOTICE

- Install a tailgate when hauling fluid materials such as finely crushed soil.
- Do not use a tailgate if the dump body is loaded with rocks, gravel, or materials of high viscosity. There is danger that the tailgate may be damaged, the loaded material may get caught in the tailgate during dumping operations, or that the operator's cab may come off the ground.

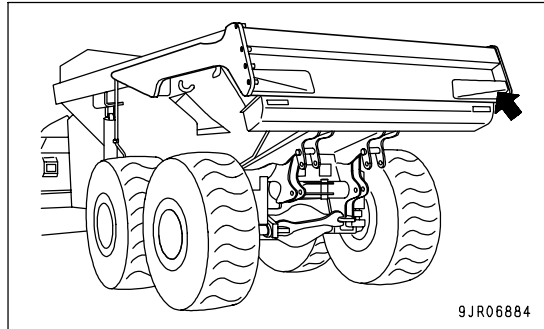

DUMP OPERATIONS

! WARNING

- Always follow the instructions of the signalman when carrying out dumping operations.
 - When dumping large rocks, operate the dump body slowly.
 - When carrying out inspection or maintenance with the dump body raised, always use the body pivot pin and lock the dump lever at the HOLD position.
- For details, see "BODY PIVOT PIN (PAGE 3-45)".

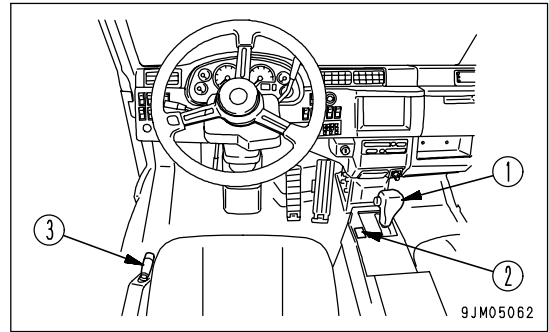

Operate the dump body as follows.

1. Place gear shift lever (1) at the N position, and set parking brake switch (2) to the PARKING position.

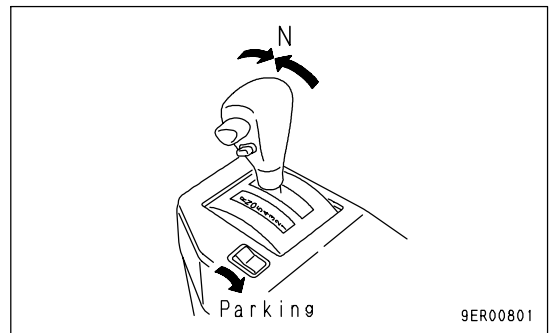

2. Move dump lever (3) to the RAISE position, then depress the accelerator pedal to raise the dump body.
If the dump lever is released when it is at the RAISE position, it is held at the RAISE position and the dump body will continue to rise.
The dumping speed increases in proportion to the engine speed.

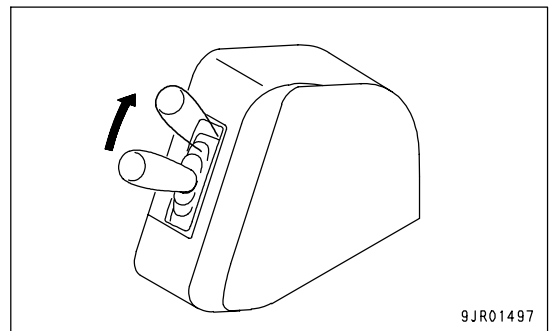

3. When the dump body rises to the previously set position, dump lever (3) returns to the HOLD position. The dump body is then held at that position.
If it is necessary to raise the dump body further, operate dump lever (3) to the RAISE position and the dump body will rise. If dump lever (3) is released, dump lever (3) will return to the HOLD position and the dump body will stop at that position.

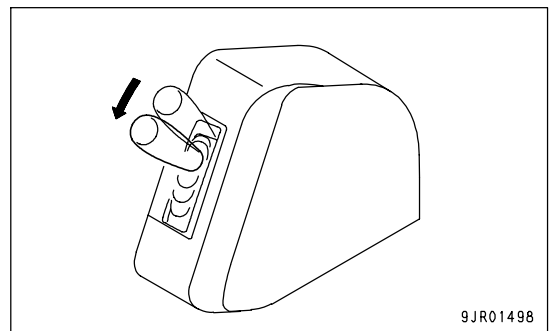

When raising the dump body, to prevent any impact load on the hydraulic circuit or hoist cylinder, let the accelerator pedal back when the dump body approaches the maximum tilt angle.

4. When dump lever (3) is moved to the LOWER position, the dump body will start to move down.

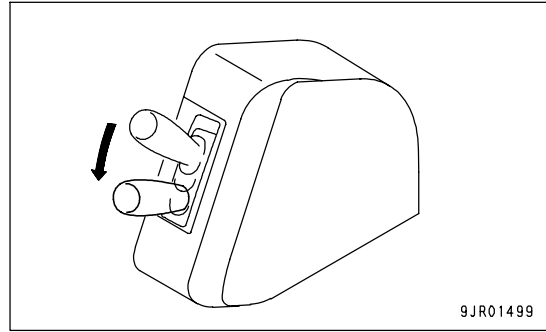

5. When the dump body has moved down a certain distance, move dump lever (3) to the FLOAT position. (When the lever is released, it will return to the FLOAT position.) The dump body will then move down under its own weight.

REMARK

If the machine is driven when the dump body is not completely lowered, if the gear shift lever is at position D, the speed range is fixed at 2nd; if it is at a position between 5 and 1, the speed range is fixed at 1st. Lower the dump body before traveling.

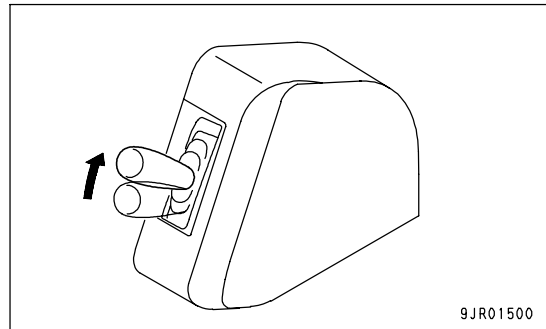

CAB TILT OPERATION



WARNING

To prevent serious injury or death if the cab comes down, always observe the following strictly when tilting the cab.

Precautions before performing cab tilt operation

- Perform the cab tilt operation on a flat place.
- When operating the cab tilt, to prevent contact between the cab and body (machine), set the machine facing directly to the front and secure the front and rear frames with the articulation lock.
- Set the parking brake switch to the "PARKING" position to apply the parking brake.
- Lock the dump control lever with the dump lever lock knob.
- Put blocks under the tires to prevent the machine from moving.
- Do not perform the cab tilt operation in the strong wind.

Precautions when performing cab tilt operation

- Do not operate the cab tilt when the machine is loaded.
- Do not stand under the cab during the cab tilt operation.
- When the cab is tilted up, lock it securely in position with the lock bar.
- While the cab is tilted up, do not ride on or get off it.
- While the cab is tilted up, do not operate the gear shift lever or dump lever.
- Do not start the engine while the cab is tilted up. If it is necessary to start the engine when carrying out inspection, check first that there is no one under the cab.
- Do not subject to the machine to any large impact force while the cab is tilted up.
- When using the tilt cylinder to lower the cab, do not reduce the hydraulic pressure suddenly. Adjust the lowering speed and lower the cab slowly.
- The lock bar is set on the left inside of the engine hood. After using it, be sure to return it.

WHEN USING CRANE

1. Remove lock bolt (2) from guard (1) at the rear of the cab, then lock guard (1) in position with rod (3).

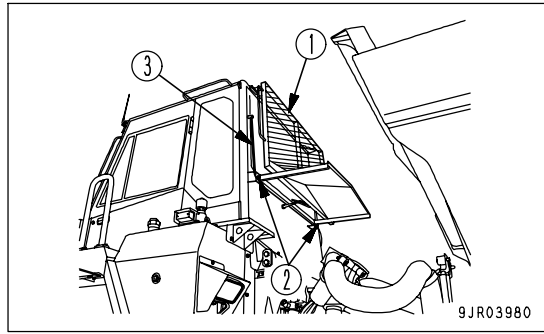

2. Remove pin (4) in the mount at the rear of the cab, and insert it in hole (6).

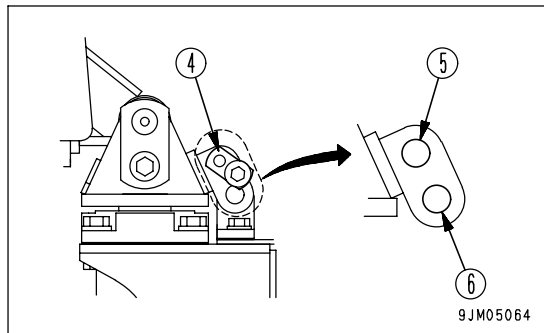

3. Remove cab mounting bolts (7) (8 pieces).
4. Install the sling to hooks (8) installed to the front of the cab (on both right and left sides) and lift up the cab.
5. After tilting up the cab, fix it with lock bar (9).
6. Make sure that lock bar (9) is installed in the correct direction and lock it securely with lock (10).
7. After returning the cab to its original position, insert pin (4) in hole (5).

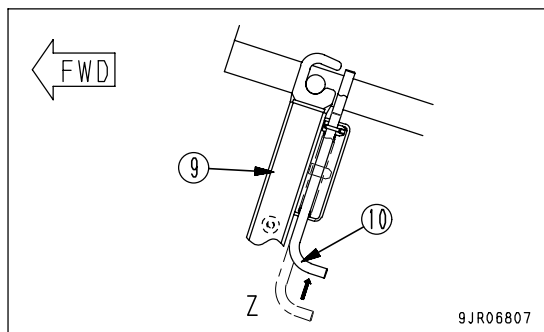
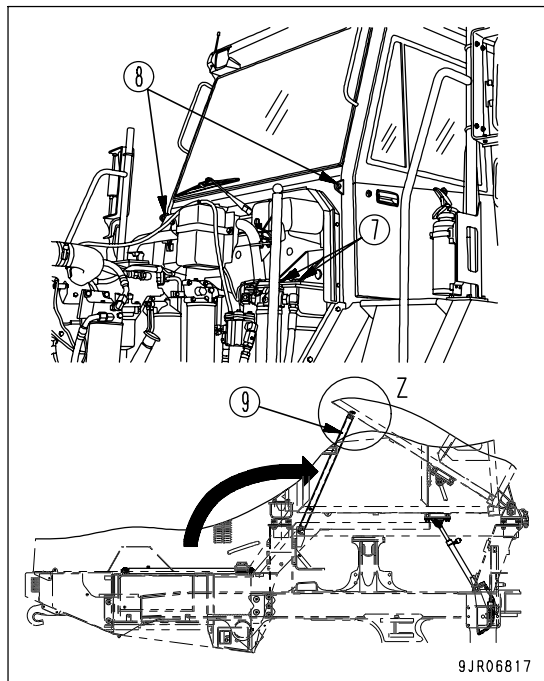

WHEN USING TILT CYLINDER

(If equipped)

1. Remove lock bolt (2) from guard (1) at the rear of the cab, then lock guard (1) in position with rod (3).

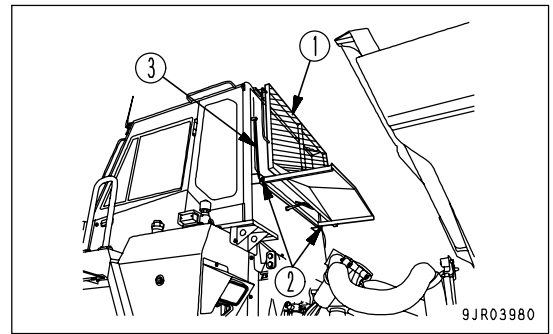

2. Remove pin (4) in the mount at the rear of the cab, and insert it in hole (6).

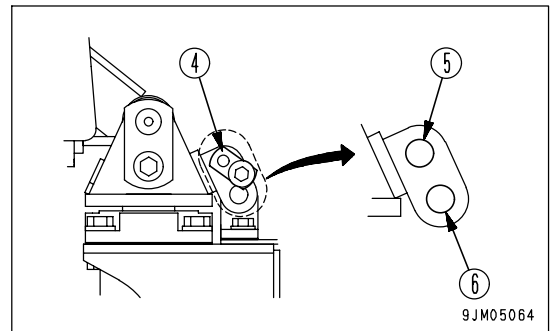

3. Remove the cab mounting bolts (8 pieces).
4. Apply hydraulic pressure (20.6 to 34.3 MPa (210 to 350 kg/cm², 2980 to 4970 PSI) to hose (7) behind the front right wheel and raise the cab.
5. After tilting up, fixed the cab in position with lock bar (8).
6. Make sure that lock bar (8) is installed in the correct direction and lock it securely with lock (9).
7. After returning the cab to its original position, insert pin (4) in hole (5).

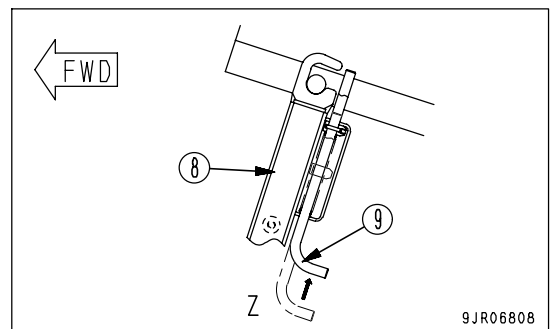
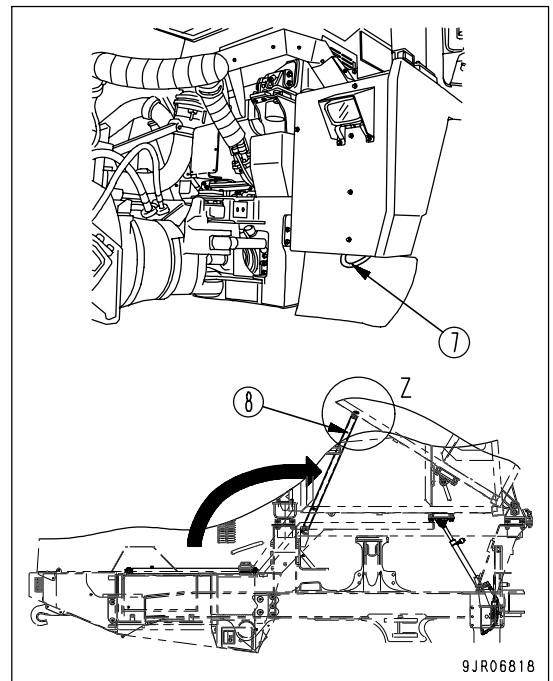

PRECAUTIONS FOR OPERATION

- When traveling on roads in rain or snow, or when traveling on muddy or soft ground, consider the loaded condition of the machine and be extremely careful not to let the tires slip or the machine spin and sink into the ground.
- If the engine should stop when the machine is traveling, stop the machine immediately, then move the gear shift lever to the N position, and start the engine again.
- If the central warning lamp and pilot lamp for any EMERGENCY item on the machine monitor should flash and the buzzer sounds during operation, stop the machine immediately and investigate the cause.
For details, see "TROUBLESHOOTING (PAGE 3-125)".
- When loading, be careful to load the dump body uniformly, and be particularly careful to avoid loading too much at the front.
- When traveling on slippery road surfaces, operate the retarder control lever slowly and shift the transmission down to prevent the wheels from locking.

PERMISSIBLE WATER DEPTH

Do not go into water or swampy ground where the water is deeper than the permissible water depth (up to the bottom surface of differential case (1)).

After completing operations, wash the machine and lubricate the parts where water has entered.

If the machine travels in water or swampy ground, water may enter the drain tank. Referring to "RECOVER OIL LEAKING FROM FLOATING SEAL (PAGE 4-57)", draw up the water with the attached hand pump.

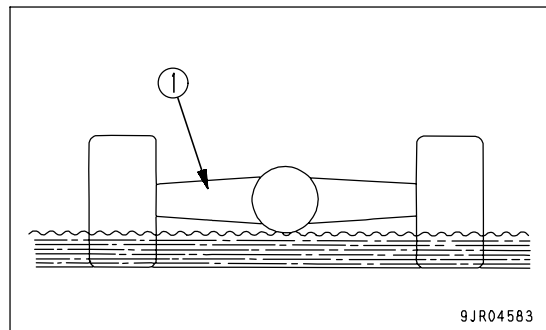

PARKING MACHINE

! WARNING

- Avoid sudden stopping. As far as possible, leave a margin when stopping the machine.
- Park the machine on firm, horizontal ground.
Do not park the machine on a slope.
If it is unavoidably necessary to park the machine on a slope, put blocks under the tires to prevent the machine from moving.
- If the gear shift lever is touched by mistake, the machine may move suddenly, and this may lead to a serious injury or death. Before standing up from the operator's seat, always set the parking brake switch securely to the PARKING position.
- The retarder must not be used as a parking brake.

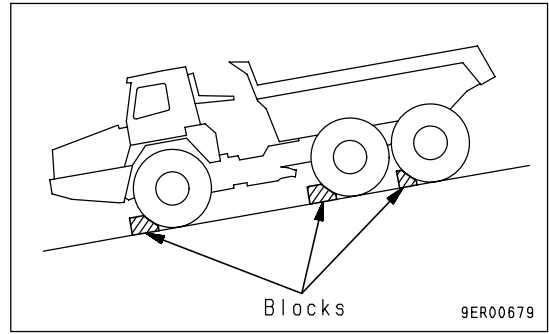

! CAUTION

To prevent damage to the parking brake, apply the parking brake only when parking the machine or carrying out dumping operations.

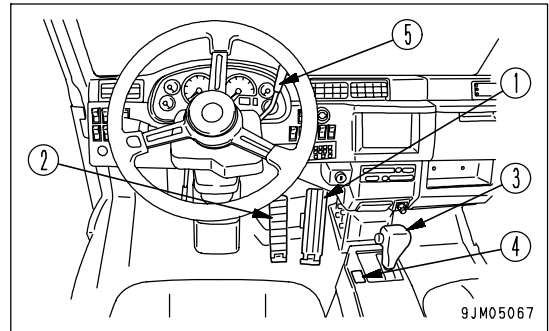

1. Release accelerator pedal (1), then depress brake pedal (2) to stop the machine.

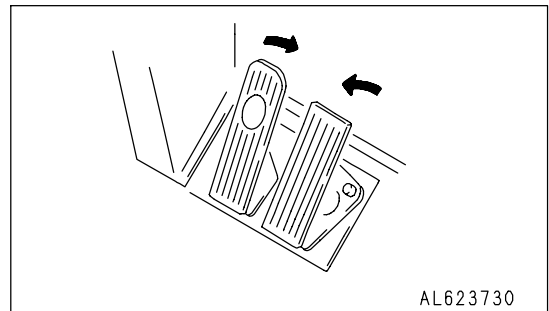

2. Move gear shift lever (3) to the N position, then set parking brake switch (4) to the PARKING position to apply the parking brake.

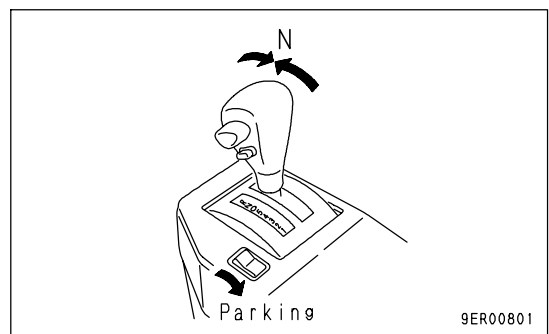

3. When in the operator's compartment, pull retarder control lever (5) fully to apply the retarder.

NOTICE

The retarder must not be used as a parking brake.

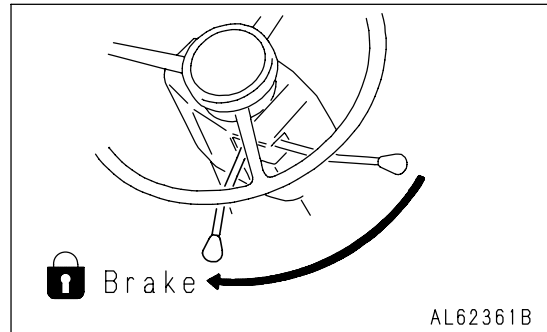
**CHECKS AFTER COMPLETION OF WORK**

Use the machine monitor to check the engine coolant temperature, engine oil pressure, and fuel level. If the engine has overheated, do not stop the engine suddenly. Run it at a mid-range speed to cool it gradually before stopping.

LOCKING

Always lock the following places.

- (1) Fuel filler cap of fuel tank
- (2) Cab door (left, right)
- (3) Engine hood
- (4) Tool box
- (5) Battery box

REMARK

The starting switch key is used for locking places (1), (2), (3), (4) and (5).

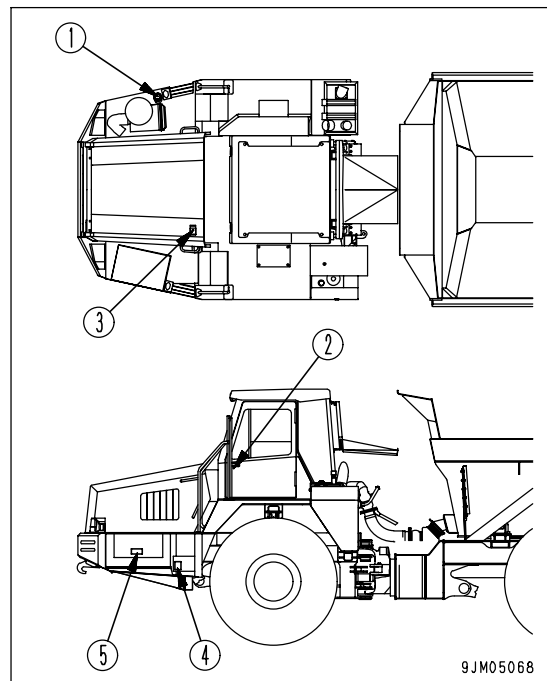

HANDLING TIRES

PRECAUTIONS WHEN HANDLING TIRES

WARNING

To ensure safety, the defective tires given below must be replaced with new tires.

- Tires where the bead wire has been cut, broken, or greatly deformed
- Excessively worn tires where more than 1/4 of the circumference of the carcass ply (excluding the breaker) is exposed
- Tires where damage to the carcass exceeds 1/3 of the tire width
- Tires where ply separation has occurred
- Tires where radial cracks extend to the carcass
- Tires where there is abnormal deterioration, deformation, and damage, and the tire cannot withstand use.

Please contact your Komatsu distributor when replacing the tires. It is dangerous to jack up the machine without taking due care.

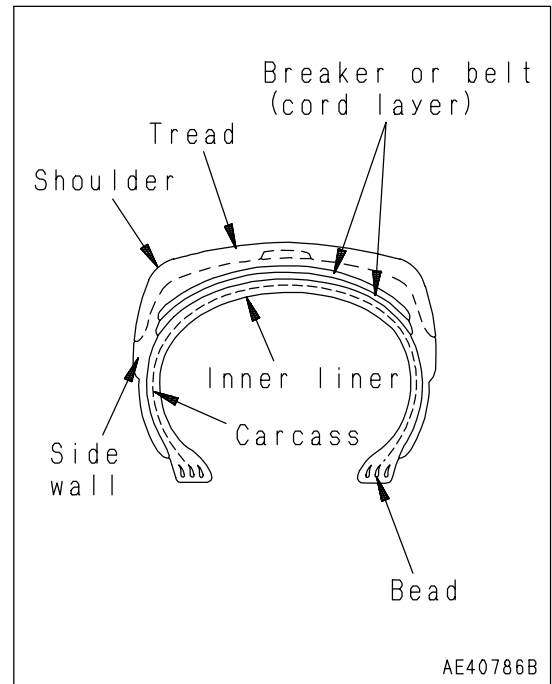

PRECAUTIONS FOR LONG DISTANCE TRAVEL

If the machine travels continuously at high speed for a long distance, there will be a marked increase in the generation of heat in the tire. This may cause premature damage to the tire, so be careful of the following points.

- Travel only when empty.
- Check the tire inflation pressure before starting for the day when the tires are cold, and adjust to the following inflation pressure.
- Do not reduce the tire inflation pressure when traveling.

Tire size	Inflation pressure [MPa (kg/cm ² , PSI)]		
	Front tire	Center tire	Rear tire
23.5-R25 (standard)	0.44 (4.5, 63.9)	0.44 (4.5, 63.9)	0.44 (4.5, 63.9)
750/65 R25 (30/65 R25) (if equipped)	0.34 (3.5, 49.7)	0.40 (4.1, 58.2)	0.40 (4.1, 58.2)

NOTICE

If the tires are used when the inflation pressure is less than the value given in the table above, the rim may be damaged. Always keep the tire inflation pressure within +0 to +0.03 MPa (0.3 kg/cm², 4.3 PSI) of the value in the table above.

- The maximum travel speed must be kept to less than 40 km/h (24.9 MPH). Stop for at least one hour for every one hour of travel to allow the tires and other components to cool down.
- Never travel with water or dry ballast in the tires.

DETERMINING AND MAINTAINING TRAVEL ROAD

Determining and traveling the road in the jobsite is an extremely important factor both for reasons of safety and for reducing the cycle time. To ensure safety in operations, do as follows.

DETERMINING TRAVEL ROAD

- As far as possible, restrict the travel road to one-way travel.
- If it is impossible to keep to one-way traffic, make the road with ample width to enable trucks traveling in opposite directions to pass each other. If it is impossible to provide a sufficient road width, provide passing places at various points along the road.
- Always design the road so that the loaded truck passes on the side closest to the hill face.
- If there are curves with poor visibility along the road, set up mirrors.
- In places where the road should be weak or likely to collapse, set up a sign at a point at least 1.5 m (4 ft 11 in) from the road shoulder to warn of the danger.
- It is important to set up lighting or reflectors to enable the road to be traveled at night.
- The grade of slope should be kept within 10% (approx. 6°) as far as possible, and emergency escape points should be set up on downhill slopes in case of any brake failure.
- Increase the number of places where the road continues in a straight line. If there are curves in high-speed travel areas, make the radius of the curve as large as possible.
- Small S curves are particularly dangerous, so avoid such curves. The radius of the curve must be a minimum of 12 to 15 m (39 ft 4 in to 49 ft 3 in).
- Make the radius of curves as large as possible.
- Make the road wider at curves than it is in straight areas.
- Make the surface of the road slightly higher on the outside of curves.
- Be particularly careful to strengthen the road shoulder on the outside of curves.
- Design the travel road as far as possible so that it does not cross any other travel road. In particular, when roads cross at an angle on slopes, there is danger that a difference in height will be created in the road, and this will make the machine sway strongly when traveling at high speed.
- Cut the slope face to provide a special road for the trucks.

MAINTAINING TRAVEL ROAD

Carry out the necessary action according to the conditions to insure that the road can always be traveled in safety.

- Remove any unevenness in the travel surface, sloping to the left or right, or drooping of the road shoulder. Make the road of ample strength and remove such obstacles as rocks and tree stumps.
- Maintain the road from time to time with a bulldozer or motor grader.
- Spray the road with water at suitable intervals to prevent dust from rising and reducing the visibility.

TRANSPORTATION

PRECAUTIONS WHEN TRANSPORTING

Always obey the traffic regulations when transporting the machine by road.



WARNING

This machine must be disassembled for transportation. When transporting the machine, please consult your Komatsu distributor.

STEPS FOR TRANSPORTATION

As a basic rule, always transport the machine on a trailer.

When selecting the trailer, see the weights and dimensions given in "SPECIFICATIONS (PAGE 5-2)".

Note that the specifications for the weights and dimensions for transportation differ according to the type of tires and type of dump body.

METHOD OF SECURING MACHINE

After loading the machine in the specified position, secure it in place as follows.

1. Set the parking brake switch to the PARKING position to apply the parking brake.
2. Turn the key in the starting switch to the OFF position to stop the engine.
3. Remove the key from the starting switch.

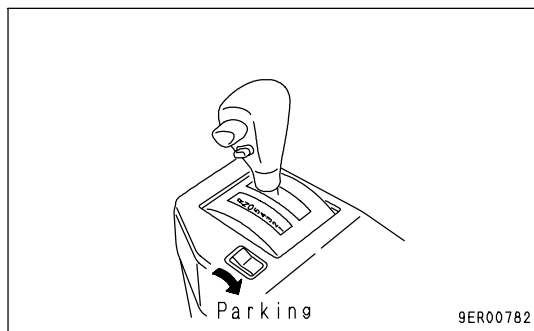

4. Lock the front frame and rear frame with the articulation lock.

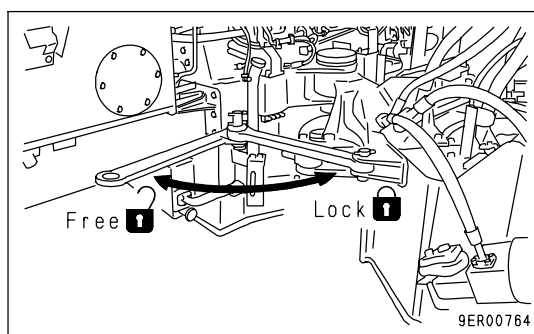

5. Put blocks in front of and behind the wheels and secure the machine with chains or wire rope of a suitable strength to prevent the machine from moving during transportation.

NOTICE

Always retract the antenna and reassemble the mirrors so that they are within the width of the machine.

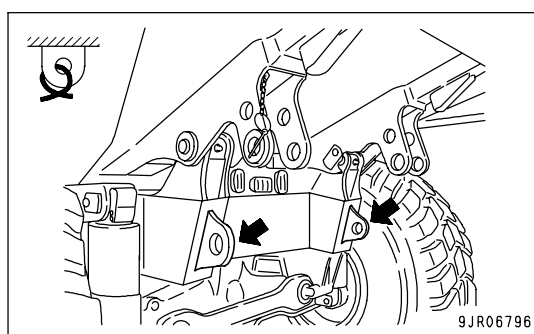
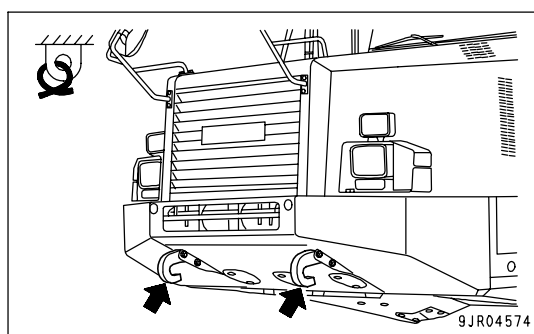

METHOD OF LIFTING MACHINE

When lifting the machine at a port or any other place, always use the following procedure to lift it.



WARNING

- The operator carrying out the lifting operation using a crane must be a properly qualified crane operator.
- Never raise the machine with any worker on it.
- Always make sure that the wire rope is of ample strength for the weight of this machine.
- When lifting, keep the machine horizontal.
- Before starting the lifting operation, always stop the engine, apply the parking brake, and use the articulation lock to prevent the front frame from articulating.
- Never enter the area around or under the machine when it is raised.

Never try to lift the machine in any posture other than the posture given in the procedure below or using lifting equipment other than in the procedure below.

There is a hazard that the machine may lose its balance.

NOTICE

This method of lifting applies to the standard specification machine.

The method of lifting differs according to the attachments and options installed.

For details of the procedure for machines that are not the standard specification, please consult your Komatsu distributor.

For the weight of the standard specification machine, see "WEIGHT TABLE (PAGE 3-118)".

NOTICE

- Use protectors to prevent the wire rope from being cut on sharp corners and to prevent the wire rope from cutting into the machine bodywork.
- When using a spreader bar, select an ample width to prevent contact with the machine.

Please consult your Komatsu distributor before carrying out lifting work.

LOCATION OF LIFTING POSITION MARK

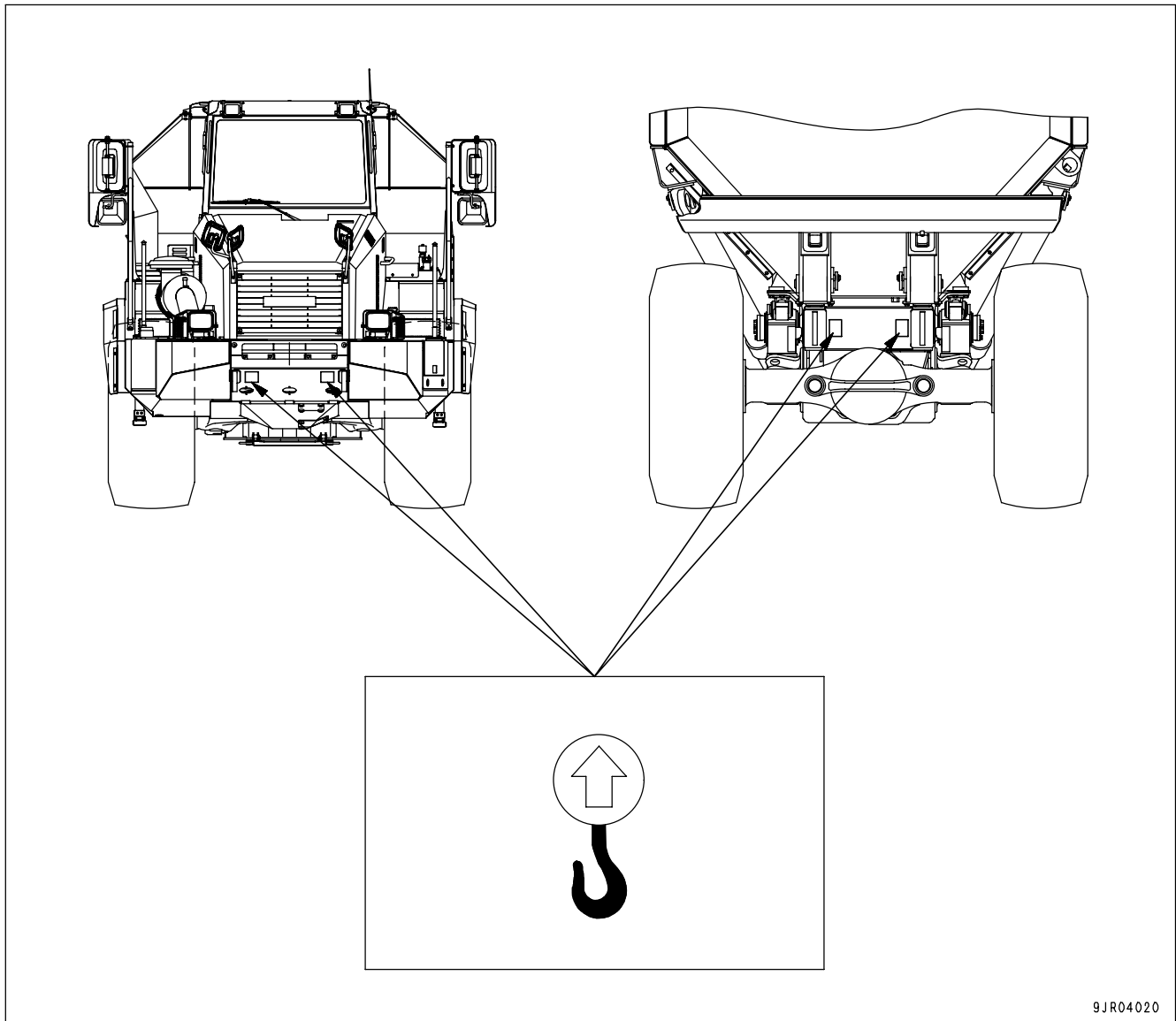

9JR04020

WEIGHT TABLE

	Machine weight	Front wheel load	Center wheel load	Rear wheel load	Center of gravity (from front axle)
HM300-2	24040 kg (53008 lb)	13410 kg (29569 lb)	5670 kg (12502 lb)	4960 kg (10937 lb)	2165 mm (7 ft 1 in)

LIFTING PROCEDURE

Lifting work can be carried out only with machines displaying a lifting mark.

When carrying out the lifting operation, stop the machine on firm level ground, and do as follows.

1. Start the engine, set the machine facing directly to the front, place the dump lever at the FLOAT position, and check that the dump body pilot lamp goes out.

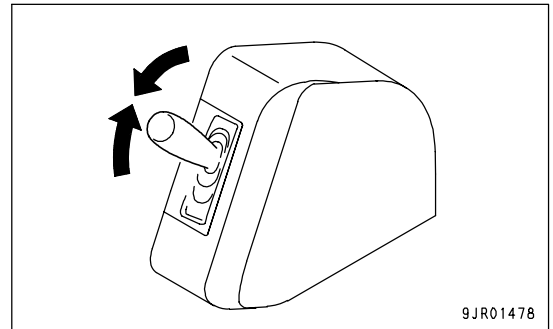

2. Stop the engine, apply the brake, check that the area around the operator's compartment is safe, then lock with the articulation lock to prevent the front frame and rear frame from articulating.

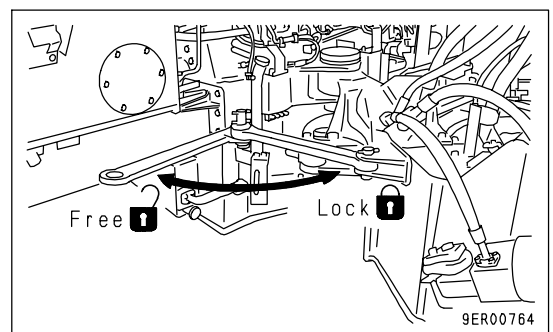

3. To prevent damage to front grill (1) during lifting operations, remove front grill (1) before starting.

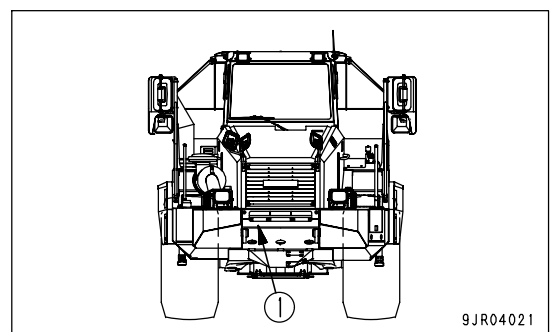

4. Select wire ropes, slings, spreader bars and other lifting equipment to match the weight of the machine, and fit the wire ropes to the lifting hooks at the front of the front frame and the rear of the rear frame (lifting hook marks).
5. Fit protector blocks at contact points (2) between the lifting equipment and the body to prevent damage to the lifting equipment.
6. When the machine comes off the ground (raised 10 to 20 cm(3.9 to 7.9 in)), stop the lifting operation, check carefully that the machine is balanced and that the wire ropes are not loose, then continue the lifting operation slowly.

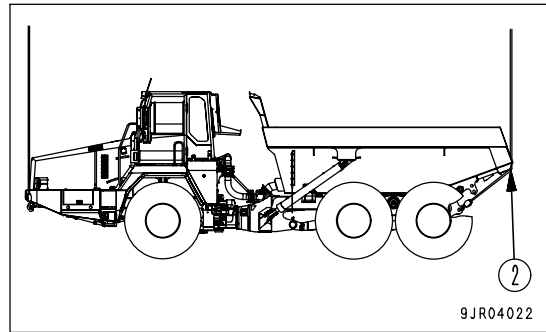

COLD WEATHER OPERATION

PRECAUTIONS FOR LOW TEMPERATURE

If the temperature becomes low, it becomes difficult to start the engine, and the coolant may freeze, so do as follows.

FUEL AND LUBRICANTS

Change to fuel and oil with low viscosity for all components. For details of the specified viscosity, see "RECOMMENDED FUEL, COOLANT, AND LUBRICANT (PAGE 4-10)".

COOLANT



WARNING

- Antifreeze is toxic. Be careful not to get it into your eyes or on your skin. If it should get into your eyes or on your skin, wash it off with large amounts of fresh water and see a doctor at once.
- When changing the coolant or when handling coolant containing antifreeze that has been drained when repairing the radiator, please contact your Komatsu distributor or request a specialist company to carry out the operation. Antifreeze is toxic. Do not let it flow into drainage ditches or spray it onto the ground surface.

NOTICE

Please use Komatsu genuine supercoolant (AF-NAC) for the coolant. As a basic rule, we do not recommend the use of any coolant other than Komatsu genuine supercoolant.

The Supercoolant is already diluted with distilled water, so it is not flammable.

For details of the Supercoolant (AF-NAC) density and on when to change the coolant, see "CLEAN INSIDE OF COOLING SYSTEM (PAGE 4-26)".

BATTERY

 **WARNING**

- The battery generates flammable gas. Do not bring fire or sparks near the battery.
- Battery electrolyte is dangerous. If it gets in your eyes or on your skin, wash it off with a large amount of water and consult a doctor.
- Battery electrolyte dissolves paint. If it gets on the bodywork, wash it off immediately with water.
- If the battery electrolyte is frozen, do not charge the battery or start the engine with a different power source. There is danger that the battery may explode.
- Battery electrolyte is toxic. Do not let it flow into drainage ditches or spray it on to the ground surface.

When the ambient temperature drops, the capacity of the battery will also drop. If the battery charge ratio is low, the battery electrolyte may freeze. Maintain the battery charge as close as possible to 100%. Insulate it against cold temperature to ensure the machine can be started easily the next morning.

Measure the specific gravity and calculate the rate of charge from the following conversion table.

Charging Rate (%)	Electrolyte Temperature	20°C (68°F)	0°C (32°F)	-10°C (14°F)	-20°C (-4°F)
	100		1.28	1.29	1.30
90		1.26	1.27	1.28	1.29
80		1.24	1.25	1.26	1.27
75		1.23	1.24	1.25	1.26

When adding distilled water in cold weather, add it before starting operations in the morning to prevent the electrolyte from freezing.

INSTALLATION OF RADIATOR CURTAIN

(If equipped)

If the indicator of the engine coolant temperature gauge does not enter the white range, install a radiator curtain. The amount of opening of the radiator curtain can be adjusted to "fully closed", "one window open", or "both windows open", so adjust the amount of opening according to the ambient temperature to ensure that the indicator of the engine coolant temperature gauge enters the white range.

PRECAUTIONS AFTER COMPLETION OF WORK

To prevent mud, water, or the undercarriage from freezing and making it impossible for the machine to move on the following morning, observe the following precautions.

- Mud and water on the machine body should be completely removed. This is to prevent damage to the seal caused by water in mud or dirt getting inside the seal and freezing.
- Park the machine on a firm, dry surface.
If such a place is not available, put steel sheets of the ground and park the machine on top of the steel sheets. This prevents the undercarriage from freezing to the ground surface, and allows the machine to be started easily the next morning.
- Open the drain valve at the bottom of the fuel tank to drain the water accumulated in the fuel system and prevent it from freezing.
- The performance of the battery drops in low temperatures, so cover it or remove it from the machine and keep it in a warm place, and then install it again the next morning.
- If the electrolyte level is low, add distilled water in the morning before beginning work. Do not add water after the day's work to prevent diluted electrolyte in the battery from freezing during the night.

AFTER COLD WEATHER

When the season changes and the weather becomes warmer, do as follows.

- Replace the fuel and oil for all parts with oil of the viscosity specified.

For details, see "RECOMMENDED FUEL, COOLANT, AND LUBRICANT (PAGE 4-10)".

LONG-TERM STORAGE

BEFORE STORAGE

When keeping in long-term storage (more than one month), store as follows.

- Wash and clean all parts and house the machine in a dry building. Never leave it outdoors.
If the machine must be stored outdoors, select a flat area and cover the machine with a waterproof sheet.
- Completely fill the fuel tank. This prevents moisture from collecting.
- Lubricate and change the oil before storage.
- Coat the exposed portion of the hydraulic cylinder piston rod with grease.
- Disconnect the negative terminals of the battery and cover it or remove it from the machine and store it separately.
- Apply the parking brake.
- Set the tire inflation pressure for each tire to within the range of the specified inflation pressure for the type of tire.
- Push the retarder control lever forward to the OFF position.
- Place the gear shift lever at the N position and turn the starting switch OFF.
- To prevent rust, fill with Komatsu genuine supercoolant (AF-NAC) to give a density of at least 30% for the engine coolant.

DURING STORAGE



WARNING

If it is necessary to perform the rust-prevention operation while the machine is indoors, open the doors and windows to improve ventilation and prevent gas poisoning.

During the storage period, operate the machine once a month to prevent loss of the oil film at the lubricated parts. At the same time, charge the battery.

Before operating the work equipment, wipe off all the grease from hydraulic piston rods.

AFTER STORAGE

NOTICE

If the machine has been stored without carrying out the monthly rust-prevention operation, consult your Komatsu distributor before using it.

When using the machine after long-term storage, do as follows before using it.

- Wipe off the grease from the hydraulic cylinder rods.
- Add oil and grease at all lubrication points.
- When the machine is stored for a long period, moisture in the air will mix with the oil. Check the oil before and after starting the engine. If there is water in the oil, change all the oil.

PRECAUTIONS BEFORE TRAVELING AFTER LONG-TERM STORAGE

1. Check all the oil and water levels before traveling.
2. When traveling after long-term storage, travel forward at a speed of 10 to 15 km/h (6.2 to 9.3 MPH) for 5 minutes or 1 km to run the machine in, then change to normal travel.

TROUBLESHOOTING

AFTER RUNNING OUT OF FUEL

If the engine runs out of fuel, add fuel to the fuel tank, then bleed the air from the fuel system before starting the engine.

PROCEDURE FOR BLEEDING AIR

CAUTION

- The fuel injection pump and nozzle of this engine consist of more precise parts than the conventional ones. If foreign matter enters them, it can cause a trouble. Accordingly, if dust sticks to the fuel system, wash it off with clean fuel.
- Be careful when opening the air bleed plug in the fuel filter head. The internal pressure may cause the fuel to spurt out.

1. Fill the fuel tank with fuel.
2. Loosen air bleeding plug (1) at the fuel main filter head.
Do not loosen the plug at the filter head of the fuel prefilter. If it is loosened, air is not bled.
3. Loosen wing nut (3) holding lever (4) of priming pump (2).
Pump lever (4) up and down to carry out priming. Continue until bubbles stop coming out with the fuel from the hole for air bleed plug (1).
4. Tighten air bleeding plug (1) and then tighten wing bolt (3) of priming pump (2) securely to lock lever (4).
 - Tightening torque for air bleeding plug
7.8 to 9.8Nm{0.8 to 1kgm}
 - Tightening torque for wing screw
6.9 to 12.7Nm{0.7 to 1.3kgm}
5. Turn the key in the starting switch to the START position and start the engine.
When doing this, do not keep the starting motor rotating continuously for more than 20 seconds.
If the engine does not start, wait for at least 2 minutes before trying again. Carry out this operation a maximum of 4 times.
6. If the engine does not start, repeat the procedure from Step 2.

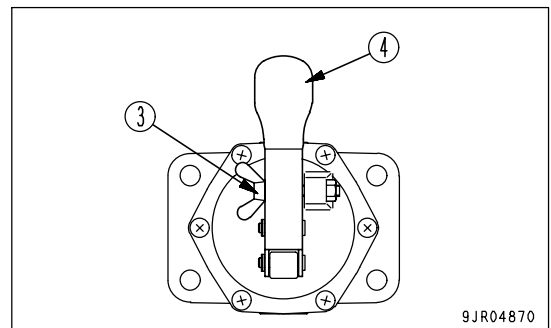
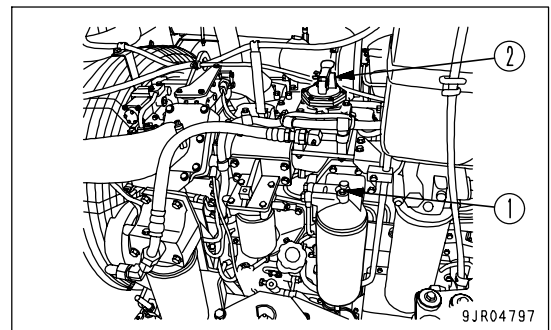

IF TRANSMISSION HAS TROUBLE

If the transmission has any trouble, operate the machine according to the following procedure.

1. Use the foot brake to reduce the speed and stop the machine at a safe place.
2. Set the gear shift lever to the N position, then set the parking brake switch to the PARKING position.
3. In some trouble modes, the gear is not shifted even if the shift lever is operated.

In this case, perform the following procedure.

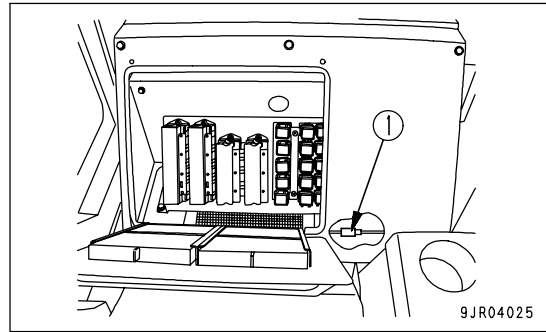

- 1) When the starting switch is at the ON position or the engine is started, disconnect (pull out) emergency connector (1) (No. A1 (female), A1 (male), white 1-pin connector), then connect (insert) again.
- 2) Set the parking brake switch to the TRAVEL position.
- 3) Operate the gear shift lever to move the machine to a safe place without depressing the accelerator pedal.

If the gear shift lever is operated with the accelerator pedal depressed, the emergency escape function will not work. In addition, the emergency escape function may not work for some failure codes.

While the emergency escape function is actuated, the machine monitor shift indicator displays "E" and the transmission shift range in turn.

METHOD OF LOWERING DUMP BODY IN EMERGENCY

When the dump body needs to be lowered to the seat while the engine cannot be started for some trouble, perform the following procedure.

1. Remove cover (2) from the rear of hydraulic tank (1).
2. Loosen locknut (4) of manual lower valve (3).
3. Turn grip (5) of valve (3) counterclockwise.
The oil in the hoist cylinder is drained into the hydraulic tank and the dump body lowers.
4. Tighten grip (5) and locknut (4) and install cover (2).

If the dump body does not go down even when the above method is used, please consult your Komatsu distributor.

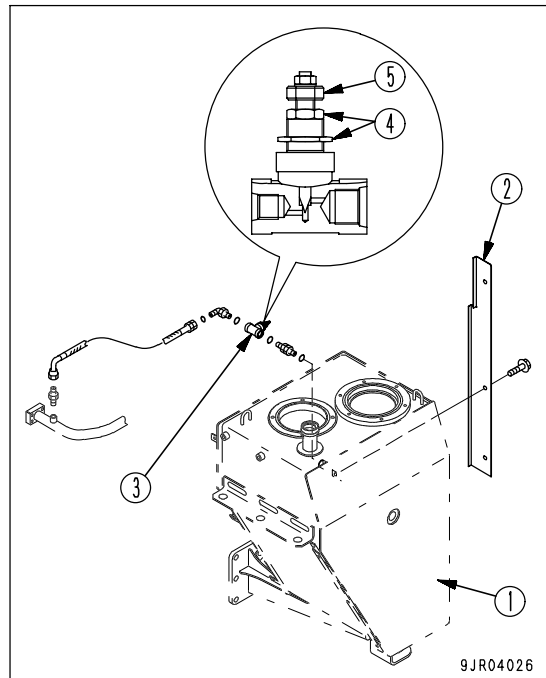

METHOD OF TOWING MACHINE



WARNING

Injury or death could result if a disabled machine is towed incorrectly or if there is a mistake in the selection of the wire rope or drawbar.

- Always confirm that the wire rope or drawbar used for towing has ample strength for the weight of the machine being towed.
- Never use a wire rope which has cut strands (A), reduced diameter (B), or kinks (C). There is danger that the rope may break during the towing operation.
- Always wear leather gloves when handling wire rope.
- Never tow a machine on a slope.
- Never go between the towing machine and the towed machine during the towing operation.
- If the machine moves suddenly, a load is applied suddenly to the towing wire or drawbar, and the towing wire or drawbar may break. Move the machine gradually to a constant speed.
- Be extremely careful if there is a failure in the engine or brake system: the brakes will not work.
- If the steering and the brakes on the disabled machine cannot be operated, do not let anyone ride on the disabled machine.

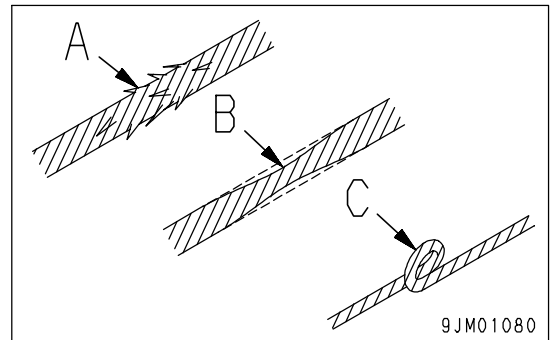

NOTICE

- The permissible towing capacity for this machine is 176800N (18030 kg). Do not tow any load greater than this.
- Towing is only permitted in order to move a disabled machine to a place where it is possible to carry out inspection and maintenance. It must not be towed for long distances.
- Please consult your Komatsu distributor for information about towing a disabled machine.

This machine must not be towed except in emergencies. When towing the machine, take the following precautions.

- When towing a machine, tow it at a low speed of less than 2 km/h (1.2 MPH), and for a distance of a few meters to a place where repairs can be carried out. The machine should be towed only in emergencies. If the machine must be moved long distances, use a transporter.
- Use a towing machine of the same class as the machine being towed. Check that the towing machine has ample braking power, weight, and rimpull to allow it to control both machines on slopes or on the tow road.
- When towing, set the articulate lock of the towed machine to the LOCK position. However, when towing in places where it is needed to steer, set the articulate lock to the FREE position. Use two towing machines of the same class or larger than the machine being towed: connect one machine each to the front and rear of the machine being towed.
- Use the specified hook for both the towing machine and the machine being towed.
- To protect the operator if the towing wire or towing bar breaks, install protective plates on both the towing machine and the machine being towed.
- There are towing hooks under the front frame and at the rear of the rear frame. Use only these hooks when towing. Do not use any other place for towing.
- When fitting the towing wire, check the condition of the hook to make sure that there is no problem.
- Keep the angle of the towing wire as small as possible. Keep the angle between the center lines of the two machines to within 30 degrees.
- Towing may be carried out under various differing conditions, so it is impossible to determine beforehand the requirements for towing.

Towing on flat horizontal roads will require the minimum rimpull, while towing on slopes or on uneven road surfaces will require the maximum rimpull.

- If the pressure in a hydraulic circuit has dropped because of leakage of oil, the parking brake will be applied, so release the parking brake before towing.

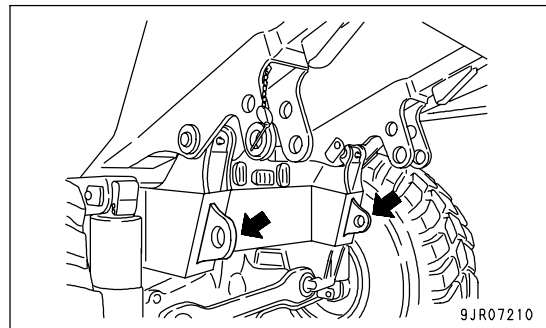
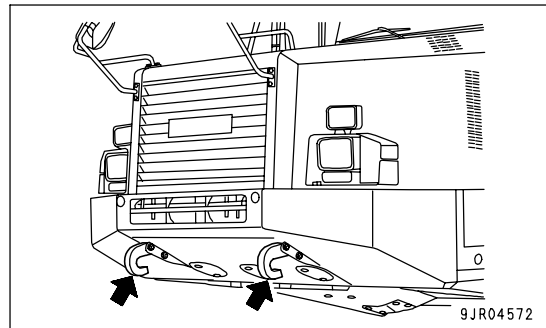

- Before releasing the parking brake, always put blocks under all six wheels. If the wheels are not blocked, there is danger that the machine may move.

Connect with the towing wire or drawbar, and remove the blocks from the wheels when the disabled machine is in a condition where it cannot run away.

- When carrying out the operation to release the parking brake, check that the surrounding area is safe.
- If the parking brake is released, the brakes will not work, so pay careful attention to safety.
- When towing down a slope, use two towing machines. One machine should be uphill from the disabled machine and should be connected with towing wire or a drawbar to pull the disabled machine back and keep it stable. The other machine should tow the disabled machine downhill.

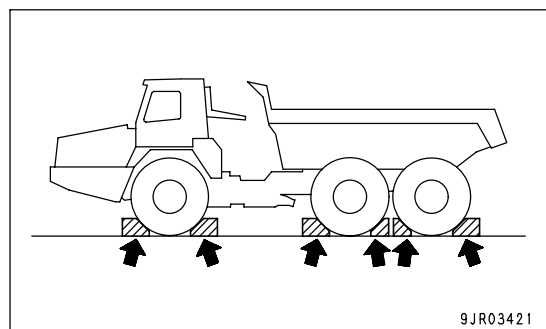

WHEN ENGINE RUNS

- If the transmission and steering wheel can be operated, and the engine is running, it is possible to tow the machine out of mud or to move it for a short distance to the edge of the road.
- Check the effect of the brakes, and if the brakes do not work properly, take the action given in "When engine does not run".
- Check if it is possible to steer the machine. If the machine cannot be steered, follow the procedure given in "WHEN ENGINE DOES NOT RUN".
- The operator should sit on the machine being towed and operate the steering in the direction that the machine is towed.
- Always run the engine to allow the steering and brakes to be used.

WHEN ENGINE DOES NOT RUN

- The brakes will not work, so be extremely careful.
- Connect the towing machine securely to the towed machine. Use two towing machines of the same class or larger than the machine being towed: connect one machine each to the front and rear of the machine being towed.
- If it is necessary to change the direction of the machine being towed, it is possible to use the emergency steering, but it can be used for a maximum of only 90 seconds.
- If the emergency steering cannot be used, disconnect two hydraulic hoses each on the left and right from the steering cylinders, then carry out the towing operation. When removing the hoses, block the hoses with plugs and fit oil containers to the mouthpiece of the cylinder to prevent oil from draining to the ground.

WHEN PARKING BRAKE HAS BEEN ACTUATED IN EMERGENCY

If the pressure in the hydraulic circuit goes down abnormally because of oil leakage or some other cause, the parking brake is automatically applied.

It is necessary to tow or move the machine, the parking brake must be released. Release the parking brake as follows.

METHOD OF RELEASING PARKING BRAKE

Please ask your Komatsu distributor to release the parking brake.



WARNING

- If any problem occurs in the brake hydraulic system, there is a high probability that the wheel brakes will not work properly, so when towing, always travel at low speed.
- When releasing the parking brake, check that the surrounding area is safe and always put blocks under the wheels before starting. If the wheels are not blocked, there is danger that the machine may move suddenly.
- Always stop the engine before starting the operation to release the parking brake.

1. Stop the engine.

2. Put blocks under the wheels.

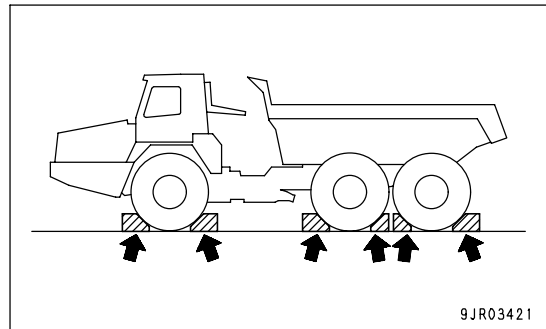

3. Push down the lock portion of parking brake adjustment screw (1), then turn adjustment screw (1) clockwise.

4. Check that there is a clearance between the parking brake pad and disc brake.

5. When the parking brake is released, tow the machine immediately to a safe position.

For details of the method of towing, see "METHOD OF TOWING MACHINE (PAGE 3-127)".

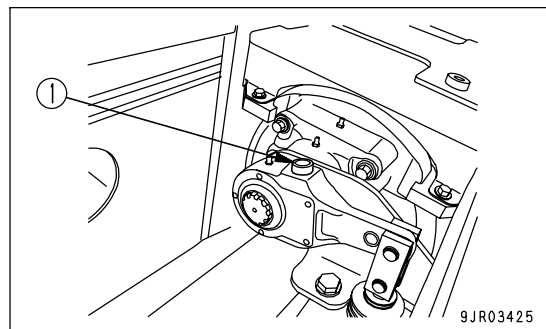

IF BATTERY IS DISCHARGED

WARNING

- It is dangerous to charge a battery when installed on a machine. Make sure that it is removed before charging.
- When checking or handling the battery, stop the engine and turn the starting switch key to the OFF position.
- The battery generates hydrogen gas, so there is a hazard of explosion. Do not bring lighted cigarettes near the battery, or do anything that will cause sparks.
- Battery electrolyte is dilute sulfuric acid, and it will attack your clothes and skin. If it gets on your clothes or on your skin, immediately wash it off with a large amount of water. If it gets in your eyes, wash it out with fresh water and consult a doctor.
- When handling batteries, always wear safety glasses and rubber gloves.
- When removing the battery, first disconnect the cable from the ground (normally the negative (-) terminal). When installing, install the positive (+) terminal first.
If a tool touches the positive terminal and the chassis, there is danger that it will cause a spark, so be extremely careful.
- If the terminals are loose, there is danger that the defective contact may generate sparks that will cause an explosion.
- When removing or installing the terminals, check which is the positive (+) terminal and which is the negative (-) terminal.

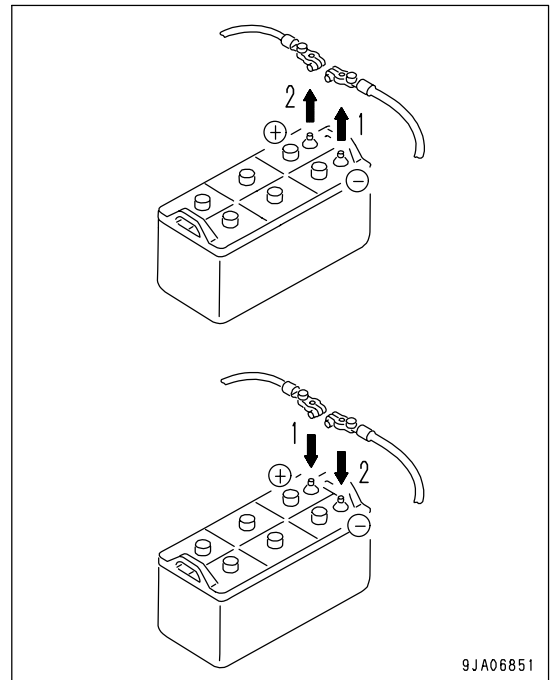

REMOVAL AND INSTALLATION OF BATTERY

- Before removing the battery, remove the ground cable (normally connected to the negative (-) terminal).
If any tool touches between the positive terminal and the chassis, there is a hazard of sparks being generated.
- When installing the battery, connect the ground cable last.

PRECAUTIONS FOR CHARGING BATTERY

CHARGING BATTERY WHEN MOUNTED ON MACHINE

When charging the battery, if the battery is mistakenly handled, there is danger of explosion. Follow the precautions in "IF BATTERY IS DISCHARGED (PAGE 3-131)" and the instructions given in the charger manual, and always do as follows.

- Set the voltage of the charger to match the voltage of the battery to be charged. If the correct voltage is not selected, the charger may overheat and cause an explosion.
- Connect the positive (+) charger clip of the charger to the positive (+) terminal of the battery, then connect the negative (-) charger clip of the charger to the negative (-) terminal of the battery. Be sure to attach the clips securely.
- Set the charging current to 1/10 of the value of the rated battery capacity; when carrying out rapid charging, set it to less than the rated battery capacity.
If the charger current is too high, the electrolyte will leak or dry up, and this may cause the battery to catch fire and explode.
- If the battery electrolyte is frozen, do not charge the battery or start the engine with a different power source. There is a danger that this will ignite the battery electrolyte and cause the battery to explode.
- Do not use or charge the battery if the battery electrolyte level is below the LOWER LEVEL line. This may cause an explosion. Check the battery electrolyte level periodically and add distilled water to bring the electrolyte level to the UPPER LEVEL line.

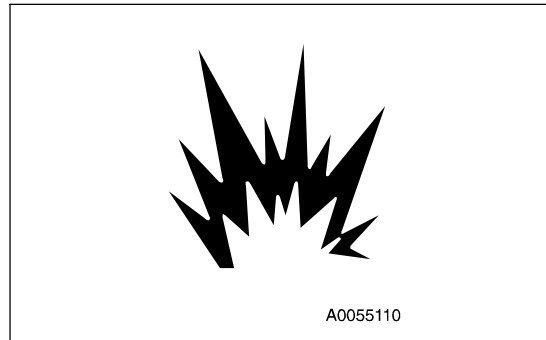

STARTING ENGINE WITH BOOSTER CABLE

When starting the engine with a booster cable, do as follows.

PRECAUTIONS WHEN CONNECTING AND DISCONNECTING BOOSTER CABLE

WARNING

- When connecting the cables, never contact the positive (+) and negative (-) terminals.
- When starting the engine with a booster cable, wear safety glasses and rubber gloves.
- Be careful not to let the normal machine and problem machine contact each other. This prevents sparks from generating near the battery which could ignite the hydrogen gas given off by the battery.
- Make sure that there is no mistake in the booster cable connections. The final connection is to the engine block of the problem machine, but sparks will be generated when this is done, so connect to a place as far as possible from the battery.
- When disconnecting the booster cable, take care not to bring the clips in contact with each other or with the machine body.

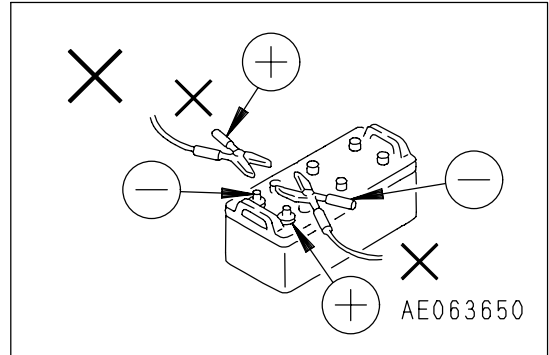

NOTICE

- The size of the booster cable and clip should be suitable for the battery size.
- The battery of the normal machine must be the same capacity as that of the problem machine.
- Check the cables and clips for damage or corrosion.
- Make sure that the cables and clips are firmly connected.

CONNECTING THE BOOSTER CABLES

Keep the starting switch of the normal machine and problem machine in the OFF position.

Connect the booster cable as follows, in the order of the numbers marked in the diagram.

1. Connect one clip of booster cable (A) to the positive (+) terminal of the problem machine.
2. Connect the other clip of booster cable (A) to the positive (+) terminal of the normal machine.
3. Connect one clip of booster cable (B) to the negative (-) terminal of the normal machine.
4. Connect the other clip of booster cable (B) to the engine block of the problem machine.

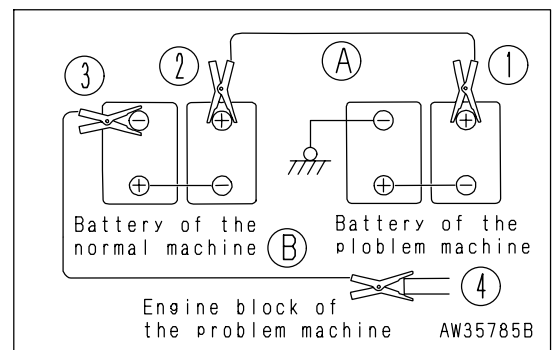

STARTING THE ENGINE



Make sure that the parking brake switch is at PARKING position and the gear shift lever is at N (neutral) position for both normal machine and the problem machine.

1. Make sure the clips are firmly connected to the battery terminals.
2. Start engine of the normal machine and run it at high idle speed.
3. Turn the starting switch of the problem machine to the START position and start the engine.
If the engine doesn't start at first, try again after 2 minutes or so.

DISCONNECTING THE BOOSTER CABLES

After the engine has started, disconnect the booster cables in the reverse of the order in which they were connected.

1. Remove one clip of booster cable (B) from the engine block of the problem machine.
2. Remove the other clip of booster cable (B) from the negative (-) terminal of the normal machine.
3. Remove one clip of booster cable (A) from the positive (+) terminal of the normal machine.
4. Remove the other clip of booster cable (A) from the positive (+) terminal of the problem machine.

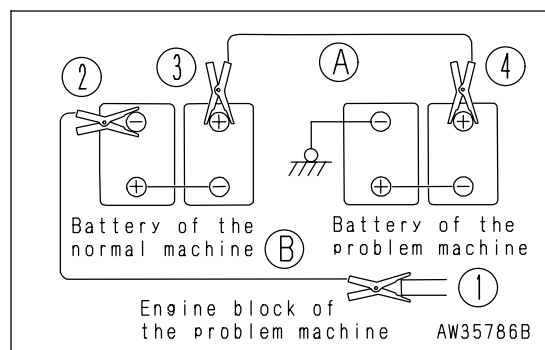

OTHER TROUBLE

ELECTRICAL SYSTEM

- (): Always contact your Komatsu distributor when dealing with these items.
- In cases of problems or causes which are not listed below, contact your Komatsu distributor for repairs.

Problem	Main causes	Remedy
Lamp does not glow brightly even when engine runs at high speed	<ul style="list-style-type: none"> • Defective wiring • Insufficient battery charge • Defective adjustment of belt tension 	(<ul style="list-style-type: none"> • Check, repair loose terminals, disconnections • Charge, Add distilled water • Adjust alternator belt tension See EVERY 250 HOURS SERVICE
Lamp flickers while engine is running		
Battery charge caution pilot lamp lights up while engine is running	<ul style="list-style-type: none"> • Defective alternator • Defective wiring 	(<ul style="list-style-type: none"> • Replace • Check, repair
Abnormal noise is generated from alternator	<ul style="list-style-type: none"> • Defective alternator 	(<ul style="list-style-type: none"> • Replace
Starting motor does not rotate even when starting switch is turned ON	<ul style="list-style-type: none"> • Defective wiring • Defective starting switch • Insufficient battery charge • Defective battery relay 	(<ul style="list-style-type: none"> • Check, repair • Replace switch • Charge • Replace relay
Starting motor turns engine sluggishly	<ul style="list-style-type: none"> • Defective wiring • Insufficient battery charge 	(<ul style="list-style-type: none"> • Check, repair • Charge
Starting motor disengages before engine starts	<ul style="list-style-type: none"> • Defective wiring • Insufficient battery charge 	(<ul style="list-style-type: none"> • Check, repair • Charge

CHASSIS

- (): Always contact your Komatsu distributor when dealing with these items.
- In cases of problems or causes which are not listed below, contact your Komatsu distributor for repairs.

Problem	Main causes	Remedy
Torque converter oil temperature caution lamp flashes	<ul style="list-style-type: none"> • Leakage of oil or entry of air due to damage or defective tightening of oil pipe, pipe joint • Wear, scuffing of gear pump • Insufficient oil in transmission case • Loose fan belt • Clogged oil cooler • Long distance traveled in torque converter range • Disconnected, broken wiring to sensor 	<ul style="list-style-type: none"> (• Check, repair) (• Check, repair) • Add oil to specified level. See CHECK BEFORE STARTING • Replace belt. See EVERY 250 HOURS SERVICE (• Clean or replace) • Drive in direct range (• Repair, connect wiring)
Steering wheel is heavy	<ul style="list-style-type: none"> • Lack of grease at link • Internal leakage inside steering cylinder 	<ul style="list-style-type: none"> • Add grease (• Replace cylinder seal)
Steering wheel pulls	<ul style="list-style-type: none"> • Tire inflation pressure not uniform on left and right • Dragging, pulling of front brake 	<ul style="list-style-type: none"> • Make tire inflation pressure uniform. See CHECK BEFORE STARTING • Check wear of brake disc For details, see EVERY 1000 HOURS SERVICE
Braking effect is poor when brake pedal is depressed	<ul style="list-style-type: none"> • Disc has reached wear limit • Front, center disc has reached wear limit • Insufficient oil pressure • Insufficient brake oil 	<ul style="list-style-type: none"> (• Replace disc) (• Replace disc) • Charge to specified pressure • Add oil to the transmission case See CHECK BEFORE STARTING • Bleed air See WHEN REQUIRED
Brake pulls to one side	<ul style="list-style-type: none"> • Air in brake circuit 	<ul style="list-style-type: none"> • Bleed air See WHEN REQUIRED
Dump body speed is slow	<ul style="list-style-type: none"> • Defective gear pump • Insufficient oil 	<ul style="list-style-type: none"> (• Replace gear pump) • Add oil to specified level. See CHECK BEFORE STARTING
Suspension is hard	<ul style="list-style-type: none"> • Soil or sand entering through damaged dust seal has damaged U-packing, causing leakage of gas • Gas leaking from valve core 	<ul style="list-style-type: none"> (• Replace U-packing) (• Replace valve core)

Problem	Main causes	Remedy
Wheel on one side tends to slip	<ul style="list-style-type: none"> • Air in brake circuit (between slack adjuster and brake) • Excessive difference in wear between left and right tires • Excessive difference in division of load between left and right wheels (unbalanced load) • Excessive deformation of disc 	<ul style="list-style-type: none"> • Bleed air from brakes (left, right). See WHEN REQUIRED. (• Replace tires) • Make load uniform (• Disassemble and adjust brake)

IF ACCELERATOR PEDAL HAS FAILED

The accelerator pedal is equipped with a potentiometer that detects the amount that the accelerator pedal is depressed. In addition, there is a switch that judges if the accelerator pedal is being depressed or if it has been released.

If it is impossible to detect correctly the amount that the accelerator pedal is depressed because of breakage of the accelerator pedal or defective wiring, the engine controller controls the engine in accordance with the signal from this judgment switch. When the accelerator pedal is being depressed, the engine speed is set to 1500 rpm; when the accelerator pedal is released, the engine speed is set to low idling. The speed differs according to the load.

Operate the accelerator pedal to move the machine to a safe place, then check the failure code and contact your Komatsu distributor.

When operating the accelerator pedal, release the pedal to turn it to the OFF position (low idling) or depress it fully to set to 1500 rpm.

If the accelerator pedal is depressed half way, it may be impossible to judge if the accelerator pedal is being operated.

REMARK

If the engine controller cannot correctly receive the signal for the amount that the accelerator pedal is depressed, the central warning lamp will flash, the alarm buzzer will sound, and action code "E03" will be displayed.

ENGINE

- (): Always contact your Komatsu distributor when dealing with these items.
- In cases of problems or causes which are not listed below, contact your Komatsu distributor for repairs.

Problem	Main causes	Remedy
Engine oil pressure caution lamp lights up	<ul style="list-style-type: none"> • Insufficient oil in oil pan • Clogged oil filter cartridge • Oil leakage due to damage caused by defective tightening of oil pan, pipe joint • Disconnection, broken wiring to sensor 	<ul style="list-style-type: none"> • Add oil to specified level. See CHECK BEFORE STARTING • Replace cartridge, see EVERY 500 HOURS SERVICE (• Check, repair) (• Repair, connect wiring)
Steam spurts out from top of radiator (pressure valve)	<ul style="list-style-type: none"> • Insufficient coolant, water leakage • Loose fan belt 	<ul style="list-style-type: none"> • Check, add cooling water. See CHECK BEFORE STARTING • Replace belt. See EVERY 250 HOURS SERVICE
Maintenance caution lamp lights up, and character display shows "E01" and drop in coolant level.	<ul style="list-style-type: none"> • Dirt or scale accumulated in cooling system • Radiator fins clogged or damaged 	<ul style="list-style-type: none"> • Change coolant, clean inside of cooling system. See WHEN REQUIRED • Clean or repair. See EVERY 500 HOURS SERVICE
Indicator of engine coolant temperature gauge is in red range	<ul style="list-style-type: none"> • Defective coolant temperature gauge • Defective thermostat 	<ul style="list-style-type: none"> (• Replace water temperature gauge) (• Replace thermostat)
Engine coolant temperature caution lamp lights up	<ul style="list-style-type: none"> • Defective thermostat seal • Loose radiator filler cap • Disconnection, broken wiring to sensor 	<ul style="list-style-type: none"> (• Replace thermostat seal) • Tighten or replace cap (• Repair, connect wiring)
Indicator of engine coolant temperature gauge stays at lowest position and does not rise	<ul style="list-style-type: none"> • Defective engine coolant temperature gauge • Defective thermostat • In cold weather, cold wind is blowing strongly against engine 	<ul style="list-style-type: none"> (• Replace engine coolant temperature gauge monitor) (• Replace thermostat) (• Install radiator curtain)
Engine does not start even when starting motor is turned	<ul style="list-style-type: none"> • Insufficient fuel • Air in fuel system • No fuel in fuel filter • Starting motor cranks engine too slowly • Starting motor does not turn • Defective valve clearance (defective compression) • Gear shift lever is not at N (neutral) position 	<ul style="list-style-type: none"> • Add fuel. See CHECK BEFORE STARTING (• Repair place where air is leaking in) • Fill filter with fuel. See EVERY 500 HOURS SERVICE • See electrical components • See electrical components (• Adjust valve clearance) • Set gear shift lever to N (neutral) position
Fuel supply occasionally stops	<ul style="list-style-type: none"> • Clogged fuel tank breather tube 	<ul style="list-style-type: none"> (• Replace breather tube)

Problem	Main causes	Remedy
Excessive oil consumption	<ul style="list-style-type: none"> • Oil leakage • Excessive oil in oil pan 	<ul style="list-style-type: none"> (• Check, repair) • Add oil to specified level. See CHECK BEFORE STARTING
Exhaust gas is white or bluish	<ul style="list-style-type: none"> • Worn piston, ring, cylinder liner • Poor quality fuel being used • Defective turbocharger 	<ul style="list-style-type: none"> (• Replace) • Replace with specified fuel (• Check, replace)
Exhaust gas is black	<ul style="list-style-type: none"> • Clogged air cleaner element • Worn piston, ring, cylinder liner • Defective compression • Defective turbocharger • Defective exhaust brake • Defective injector 	<ul style="list-style-type: none"> • Clean or replace. See WHEN REQUIRED (• Check, repair) • See adjustment of clearance above (• Check, replace) (• Check, replace, repair) (• Check, adjust, repair)
Engine hunts	<ul style="list-style-type: none"> • Air entering suction side of fuel line 	<ul style="list-style-type: none"> (• Repair place where air is leaking in)
Combustion noise occasionally makes breathing sound	<ul style="list-style-type: none"> • Defective nozzle 	<ul style="list-style-type: none"> (• Replace nozzle)
There is knocking (combustion or mechanical)	<ul style="list-style-type: none"> • Poor quality fuel being used • Overheating 	<ul style="list-style-type: none"> • Replace with specified fuel • See "Indicator of engine coolant temperature gauge is in red range" above

ACTION CODE

If any problem occurs, stop the machine, apply the parking brake and check the service code, then contact your Komatsu distributor for repairs.

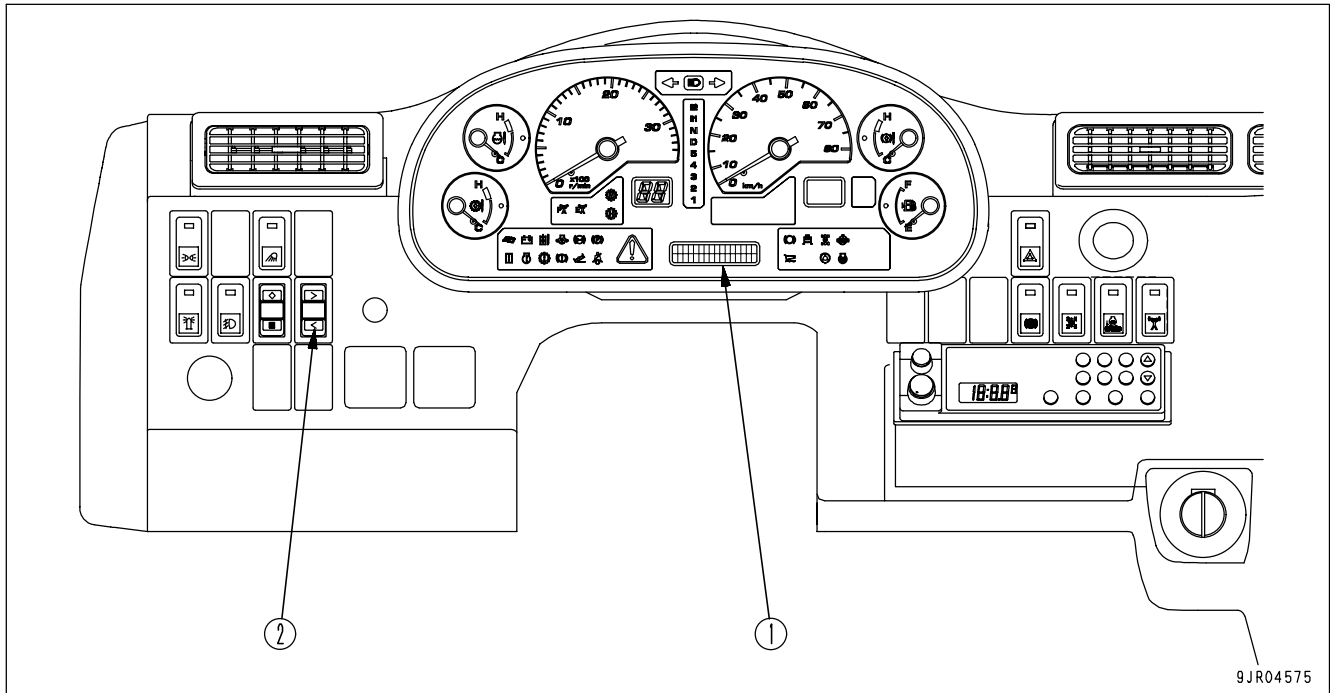

If action code "E03" is displayed on the character display (1), or if an action code is displayed after taking the remedy when action code "E02" was displayed, or if "MAINTENANCE" is displayed together with action code "E01", do as follows to check the failure code.

1. If an action code is displayed, pressed the top (>) portion of machine monitor mode selector switch (2) and check the failure code. The failure code is displayed on character display (1).
2. Press the top (>) portion of machine monitor mode selector switch (2) again. The service meter and odometer will be displayed for several seconds, and the screen will then return to the action code screen. If more than one failure has occurred, the next failure code is displayed.
3. Check the failure code, then contact your Komatsu distributor for repairs.

REMARK

- The 6-digit code displayed on the left of the line at the top of the character display is the failure code.
- The code displayed at the right side of the failure code shows the controller that detected the failure code.
MON: Machine monitor
TM: Transmission controller
ENG: Engine controller
BK: Retarder controller
- The line at the bottom of the character display shows the system where the failure was generated.

MAINTENANCE

WARNING

Please read and make sure that you understand the SAFETY section before reading this section.

GUIDES TO MAINTENANCE

Do not perform any inspection and maintenance operation that is not found in this manual.

CHECK SERVICE METER:

Check the service meter reading every day to see if the time has come for any necessary maintenance to be performed.

KOMATSU GENUINE REPLACEMENT PARTS:

Use Komatsu genuine parts specified in the Parts Book as replacement parts.

KOMATSU GENUINE OILS:

For lubrication of the machine, use the Komatsu genuine lubricants. Moreover use oil of the specified viscosity according to the ambient temperature.

ALWAYS USE CLEAN WASHER FLUID:

Use automobile window washer fluid, and be careful not to let any dirt get into it.

ALWAYS USE CLEAN OIL AND GREASE:

Use clean oil and grease. Also, keep the containers of the oil and grease clean. Keep foreign materials away from oil and grease.

CHECKING FOREIGN MATERIALS IN DRAINED OIL AND ON FILTERS:

After changing the oil or replacing the filter, check the drained oil and filter for metal particles and foreign materials. If large quantities of metal particles or foreign materials are found, always report to the person in charge and carry out suitable action. In addition, when replacing the engine oil filter, fill the new filter with the specified clean oil, then install it.

OIL CHANGE:

If your machine is equipped with a fuel strainer, do not remove it while fueling.

WELDING INSTRUCTIONS:

- Turn off the engine starting switch.
- Do not apply more than 200 V continuously.
- Connect grounding the cable within 1 m (3.28 ft) from the area to be welded. Connecting grounding cable near meters and connectors will lead to the failure of meters.
- If a seal or bearing happens to come between the part being welded and grounding point, change the grounding point to avoid such parts.
- Do not use the area around the pins or the hydraulic cylinders as the grounding point.
Sparks will cause damage to the plated portion.

DO NOT DROP THINGS INSIDE MACHINE:

- When opening inspection windows or the oil filler port of the tank to carry out inspection, be careful not to drop nuts, bolts, or tools inside the machine.
If such things are dropped inside the machine, it may cause damage and/or malfunction of the machine, and will lead to failure. If you drop anything inside the machine, always remove it immediately.
- Do not put unnecessary things in your pockets. Carry only things which are necessary for inspection.

DUSTY WORKSITES:

When working at dusty worksites, do as follows:

- Inspect the dust indicator frequently to see if the air cleaner is clogged.
Clean the air cleaner element at a shorter interval than specified.
- Clean the radiator core frequently to avoid clogging.
- Clean and replace the fuel filter frequently.
- Clean electrical components, especially the starting motor and alternator, to avoid accumulation of dust.
- When inspecting or changing the oil, move the machine to a place that is free of dust to prevent dirt from getting into the oil.

AVOID MIXING OILS:

If a different brand or grade of oil has to be added, drain the old oil and replace all the oil with the new brand or grade of oil. Never mix different brand or grade of oil.

LOCKING INSPECTION COVERS:

Lock inspection cover securely into position with the lock bar. If inspection or maintenance is performed with inspection cover not locked in position, there is a danger that it may be suddenly blow shut by the wind and cause injury to the worker.

BLEEDING AIR FROM HYDRAULIC CIRCUIT:

If the hydraulic components have been repaired or replaced and if the hydraulic hoses, pipes, etc. have been disconnected, it is necessary to bleed air in the circuit. See "WHEN REQUIRED (PAGE 4-20)".

PRECAUTIONS WHEN INSTALLING HYDRAULIC HOSES:

- When removing parts at locations where there are O-rings or gasket seals, clean the mounting surface, and replace with new parts.
When doing this, be careful not to forget to assemble the O-rings and gaskets.
- When installing the hoses, do not twist them or bend them sharply. If they are installed so, their service life will be shortened extremely and they may be damaged.

CHECKS AFTER INSPECTION AND MAINTENANCE:

If you forget to perform the checks after inspection and maintenance, unexpected problems may occur, and this may lead to serious injury or property damage. Always do the following:

- Checks after operation (with engine stopped)
 - Have any inspection and maintenance points been forgotten?
 - Have all inspection and maintenance items been performed correctly?
 - Have any tools or parts been dropped inside the machine? It is particularly dangerous if parts are dropped inside the machine and get caught in the lever linkage mechanism.
 - Are there any leakage of coolant or oil? Have all nuts and bolts been tightened?
- Check when the engine is running
 - See "TWO WORKERS FOR MAINTENANCE WHEN ENGINE IS RUNNING (PAGE 2-34)" in the section on safety for checking when the engine is running. Pay enough attention for safety.
 - Check if the inspected and serviced area is normally operated.
 - Increase the engine speed to check for the leak of fuel and oil.

OUTLINE OF SERVICE

- Always use Komatsu genuine parts for replacement parts, grease or oil.
- When changing the oil or adding oil, do not mix different types of oil. When changing the type of oil, drain all the old oil and fill completely with the new oil. Always replace the filter at the same time. (There is no problem if the small amount of oil remaining in the piping mixes with the new oil.)
- Unless otherwise specified, when the machine is shipped from the factory, it is filled with the oil and coolant listed in the table below.

Item	Type
Engine oil pan	Engine oil EO15W40DH (Komatsu genuine parts)
Transmission case (incl. brake oil tank)	Power train oil TO10 (Komatsu genuine parts)
Hydraulic oil tank	Power train oil TO10 (Komatsu genuine parts)
Front suspension Rear suspension	Hydraulic oil HO-MVK (Komatsu genuine parts)
Front differential case Center differential case Rear differential case Front final drive case Center final drive case Rear final drive case	Axle oil AXO80 (Komatsu genuine parts)
Radiator	Supercoolant AF-NAC (Density:30% or above)(Komatsu genuine parts)

HANDLING OIL, FUEL, COOLANT, AND PERFORMING OIL CLINIC

OIL

- Oil is used in the engine and hydraulic equipment under extremely severe conditions (high temperature, high pressure), and deteriorates with use.
Always use oil that matches the grade and maximum and minimum ambient temperatures recommended in the Operation and Maintenance Manual. Even if the oil is not dirty, always change the oil at the specified interval.
- Oil corresponds to blood in the human body, always be careful when handling it to prevent any impurities (water, metal particles, dirt, etc.) from getting in.
The majority of problems with the machine are caused by the entry of such impurities.
Take particular care not to let any impurities get in when storing or adding oil.
- Never mix oils of different grades or brands.
- Always add the specified amount of oil.
Having too much oil or too little oil are both causes of problems.
- If the oil in the work equipment is not clear, there is probably water or air getting into the circuit. In such cases, please contact your Komatsu distributor.
- When changing the oil, always replace the related filters at the same time.
- We recommend you have an analysis made of the oil periodically to check the condition of the machine. For those who wish to use this service, please contact your Komatsu distributor.
- When using commercially available oil, it may be necessary to reduce the oil change interval.
We recommend that you use the Komatsu oil clinic to carry out a detailed checks of the characteristics of the oil.

FUEL

- To prevent the moisture in the air from condensing and forming water inside the fuel tank, always fill the fuel tank after completing the day's work.
- The fuel pump is a precision instrument, and if fuel containing water or dirt is used, it cannot work properly.
- Be extremely careful not to let impurities get in when storing or adding fuel.
- Always use the fuel specified for the temperature in the Operation and Maintenance Manual.
 - If the fuel is used at temperatures lower than the specified temperature (particularly at temperatures below -15 °C (5°F), the fuel will solidify.
 - If the fuel is used at temperatures higher than the specified temperature, the viscosity will drop, and this may result in problems such as a drop in output.
- Before starting the engine, or when 10 minutes have passed after adding fuel, drain the sediment and water from the fuel tank.
- If the engine runs out of fuel, or if the filters have been replaced, it is necessary to bleed the air from the circuit.
- If there is any foreign material in the fuel tank, wash the tank and fuel system.

NOTICE

Always use diesel fuel. Never use any other fuel.

The engine on this machine uses electronic control and high-pressure fuel injection equipment to enable it to provide good fuel consumption and good exhaust gas characteristics. For this reason, high-precision parts and lubricating ability are demanded. Using low-viscosity fuel with poor lubricating ability will cause a marked reduction in the durability of the engine.

COOLANT AND WATER FOR DILUTION

- The coolant has the important function of preventing corrosion as well as preventing freezing. Even in the areas where freezing is not an issue, the use of antifreeze coolant is essential. Komatsu machines are supplied with Komatsu Supercoolant (AF-NAC). Komatsu Supercoolant (AF-NAC) has excellent anticorrosion, antifreeze and cooling properties and can be used continuously for 2 years or 4000 hours. As a basic rule, we do not recommend the use of any coolant other than Komatsu genuine supercoolant (AF-NAC). If you use another coolant, it may cause serious problems, such as corrosion of the engine and aluminum parts of the cooling system.
- When using antifreeze, always observe the precautions given in the Operation and Maintenance Manual.
- The Supercoolant is already diluted with distilled water, so it is not flammable.
- With the Supercoolant (AF-NAC), the density used for the coolant differs according to the ambient temperature. For details of the coolant density, see "CLEAN INSIDE OF COOLING SYSTEM (PAGE 4-26)". Even in areas where it is not considered necessary to prevent freezing, always use Supercoolant (AF-NAC) with a density of over 30% in order to prevent corrosion of the cooling system. Supercoolant (AF-NAC) is diluted with distilled water that does not contain any ions or water-hardening substances. Never dilute the Supercoolant with ordinary water.
- If the engine overheats, wait for the engine to cool before adding coolant.
- If the coolant level is low, it will cause overheating, and will also cause problems with corrosion due to air entering the coolant.

GREASE

- Grease is used to prevent seizure and noises at the joints.
- This construction equipment is used under heavy-duty conditions. Always use the recommended grease and follow the change intervals and recommended ambient temperatures given in this Operation and Maintenance Manual.
- Grease fittings not included in the maintenance section are grease fittings for overhaul, so they do not need grease.
If any part becomes stiff after being used for long time, add grease.
- Always wipe off all of the old grease that is pushed out when greasing.
Be particularly careful to wipe off the old grease in places where sand or dirt sticking in the grease would cause wear of the rotating parts.

CARRYING OUT KOWA (Komatsu Oil Wear Analysis)

KOWA is a maintenance service that makes it possible to prevent machine failures and downtime. With KOWA, the oil is periodically sampled and analyzed. This enables early detection of wear of the machine drive parts and other problems.

We strongly recommend you to use this service. The oil analysis is carried out at actual cost, so the cost is low, and the results of the analysis are reported together with recommendations which will reduce repair costs and machine downtime.

KOWA ANALYSIS ITEMS

- Measurement of density of metal wear particles
This uses an ICP (Inductively Coupled Plasma) analyzer to measure the density of iron, copper, and other metal wear particles in the oil.

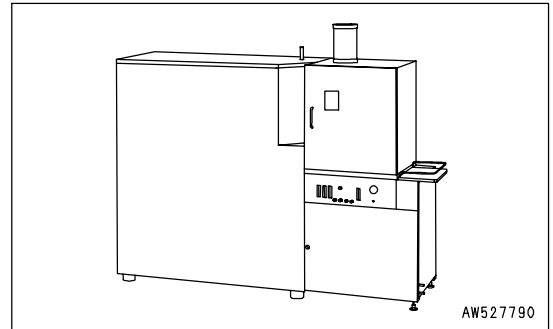

- Measurement of quantity of particles
This uses a PQI (Particle Quantifier Index) measurer to measure the quantity of iron particles of 5µm or more, enabling early detection of failures.

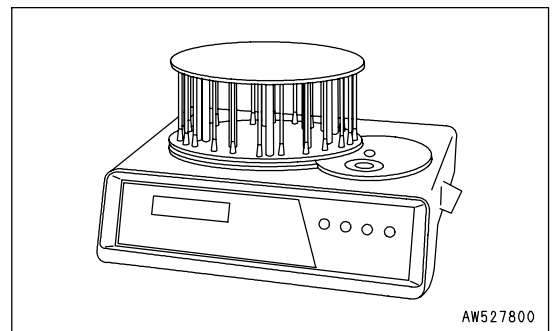

- Others
Measurements are made of items such as the ratio of water in the oil, density of the antifreeze coolant, ratio of fuel in the oil, and dynamic viscosity, enabling a highly precise diagnosis of the machine's health.

OIL SAMPLING

- Sampling interval
250 hours: Engine
500 hours: Other components
- Precautions when sampling
 - Make sure that the oil is well mixed before sampling.
 - Perform sampling at regular fixed intervals.
 - Do not perform sampling on rainy or windy days when water or dust can get into the oil.

For further details of KOWA, please contact your Komatsu distributor.

STORING OIL AND FUEL

- Keep indoors to prevent any water, dirt, or other impurities from getting in.
- When keeping drum cans for a long period, put the drum on its side so that the filler port of the drums is at the side to prevent moisture from being sucked in.
If drums have to be stored outside, cover them with a waterproof sheet or take other measures to protect them.
- To prevent any change in quality during long-term storage, be sure to use in the order of first in - first out (use the oldest oil or fuel first).

FILTERS

- Filters are extremely important safety parts. They prevent impurities in the fuel and air circuits from entering important equipment and causing problems.
Replace all filters periodically. For details, see the Operation and Maintenance Manual.
However, when working in severe conditions, replace the filters at shorter intervals according to the oil and fuel (sulfur content) being used.
- Never try to clean the filters (cartridge type) and use them again. Always replace with new filters.
- When replacing oil filters, check if any metal particles are attached to the old filter. If any metal particles are found, contact your Komatsu distributor.
- When replacing the engine oil filter, fill the new filter with the specified clean oil, then install it.
- Do not open packs of spare filters until just before they are to be used.
- Always use Komatsu genuine filters.

OUTLINE OF ELECTRIC SYSTEM

- It is extremely dangerous if the electrical equipment becomes wet or the covering of the wiring is damaged. This will cause an electrical short circuit and may lead to malfunction of the machine. Do not wash the inside of the operator's cab with water. When washing the machine, be careful not to let water get into the electrical components.
- Service relating to the electric system is checking fan belt tension, checking damage or wear to the fan belt and checking battery fluid level.
- Never install any electric components other than those specified by Komatsu.
- External electro-magnetic interference may cause malfunction of the control system controller, before installing a radio receiver or other wireless equipment, contact your Komatsu distributor.
- When working at the seashore, carefully clean the electric system to prevent corrosion.
- When installing an operator's cab cooler or any other electrical equipment, connect it to an independent power source connector. The cables to supply power to the optional equipment must never be connected to the fuse, starting switch, or battery relay.

WEAR PARTS

Wear parts such as the filter element, air cleaner element, etc. are to be replaced at the time of periodic maintenance or before their abrasion limits.

The wear parts should be changed correctly in order to use the machine economically.

For part change, Komatsu genuine parts of excellent quality should be used.

When ordering parts, please check the part number in the parts book.

WEAR PARTS LIST

The parts in parentheses are to be replaced at the same time.

Item	Part No.	Part Name	Q'ty	Replacement frequency
Engine oil filter	600-211-1340	Cartridge	1	EVERY 500 HOURS
Fuel pre-filter(*)	600-319-4540	Cartridge	1	
Fuel main filter(*)	600-319-3550	Cartridge	1	
Transmission oil filter (Valve side)	714-07-28712	Cartridge	1	EVERY 1000 HOURS
Transmission oil filter (Brake cooling side)	07063-51210 (07000-F5180)	Element (O-ring)	1 (1)	
Brake oil filter	569-43-83920 (07000-12065) (07001-02065)	Element (O-ring) (Back-up ring)	1 (1) (1)	
Fuel tank breather	421-60-35170	Element	1	
Hydraulic filter	07063-51142 (07000-F5180)	Element (O-ring)	1 (1)	EVERY 2000 HOURS
Air cleaner	600-185-6100	Element Ass'y	1	-
	600-185-6110	Outer element	1	-

*: If the fuel filter gets clogged before its periodic replacement time is arrived at, replace both the fuel pre-filter and fuel main filter together.

RECOMMENDED FUEL, COOLANT, AND LUBRICANT

- Komatsu genuine oils are adjusted to maintain the reliability and durability of Komatsu construction equipment and components.

In order to keep your machine in the best conditioner for long periods of time, it is essential to follow the instructions in this Operation and Maintenance Manual.

- Failure to follow these recommendations may result in shortened life or excess wear of the engine, power train, cooling system, and/or other components.
- Commercially available lubricant additives may be good for the machine, but they may also cause harm. Komatsu does not recommend any commercially available lubricant additive.
- Use the oil recommended according to the ambient temperature in the chart below.
- Specified capacity means the total amount of oil including the oil in the tank and the piping. Refill capacity means the amount of oil needed to refill the system during inspection and maintenance.
- When starting the engine in temperatures below 0°C (32°F), be sure to use the recommended multi-grade oil, even if the ambient temperature may become higher during the course of the day.
- If the machine is operated at a temperature below -20°C (-4°F), a separate device is needed, so consult your Komatsu distributor.
- When the fuel sulfur content is less than 0.2%, change the engine oil according to the period inspection table given in this Operation and Maintenance Manual.

If the fuel sulfur content is more than 0.2%, change the oil according to the following table.

Sulfur content (%)	Oil change interval
Less than 0.2%	500 hours
0.2 to 0.5%	250 hours
0.5% and up	Not recommendable (*)

* If these fuels are used, there is danger that serious trouble may occur because of early deterioration of the engine oil or early wear of the internal parts of the engine. If the local situation makes it necessary to use these fuels, always remember the following.

- 1) Be sure to check Total Basic Number (TBN) of oil frequently by TBN handy checker etc., and change oil based on the result.
- 2) Always be aware that oil change interval is extremely shorter than standard.
- 3) Be sure to carry out periodic engine inspection by distributor's expert since change interval of periodic replacement parts and overhaul interval are also shorter.

USE OF FUEL, COOLANT AND LUBRICANTS ACCORDING TO AMBIENT TEMPERATURE

Reservoir	Fluid Type	Ambient Temperature, degrees Celsius										Recommended Komatsu Fluids	
		-22	-4	14	32	50	68	86	104	122 °F			
		-30	-20	-10	0	10	20	30	40	50 °C			
Engine oil pan	Engine oil	(Note.1)										Komatsu EOS0W30	
		(Note.1)										Komatsu EOS5W40	
		(Note.1)										Komatsu EO10W30DH	
		(Note.1)										Komatsu EO15W40DH	
		(Note.1)										Komatsu EO30DH	
Transmission Case (incl. brake oil tank)	Power train oil (Note.2)	(Note.1)										TO10	
Hydraulic oil tank	Power train oil	(Note.1)										TO10	
	Hydraulic oil	(Note.1)										HO46-HM HO-MVK	
Front suspension Rear suspension	Hydraulic oil	(Note.1)										HO-MVK	
Front differential case Center differential case Rear differential case Front final drive case Center final drive case Rear final drive case	Axle oil	(Note.1)										AXO80	
Grease fitting	Hyper grease (Note.3)	(Note.1)										G2-T, G2-TE	
	Lithium EP grease	(Note.1)										G2-LI	
	Lithium grease	(Note.1)										G2-LI-S	
	Lithium grease	(Note.1)										GLT2-LI	
Cooling system	Supercoolant AF-NAC (Note.4)	(Note.1)										AF-NAC	
Fuel tank	Diesel fuel	(Note.1)										ASTM Grade No.1-D S15 ASTM Grade No.1-D S500	
		(Note.1)										ASTM Grade No.2-D S15 ASTM Grade No.2-D S500	

• ASTM: American Society of Testing and Material

Reservoir		Engine oil pan	Transmission case (Incl. brake oil tank)	Hydraulic tank	Front suspension (each)	Rear suspension (each)	Front differential
		Capacity					
Specified	Liters	44	165	171	3	2.2	14
	US gal	11.62	43.59	45.18	0.79	0.58	3.70
Refill	Liters	37	77.5	120	3	2.2	14
	US gal	9.78	20.48	31.70	0.79	0.58	3.70

Reservoir		Front final drive case (each)	Center differential case	Center final drive case (each)	Rear differential case	Rear final drive case (each)	Fuel tank	Cooling system
		Capacity						
Specified	Liters	4.5	25	4.0	25	5.0	384	65
	US gal	1.19	6.61	1.06	6.61	1.32	101.45	17.17
Refill	Liters	4.0	24.5	3.5	25	4.5	–	59
	US gal	1.06	6.47	0.92	6.61	1.19	–	15.59

NOTICE

Always use diesel oil for the fuel.

To ensure good fuel consumption characteristics and exhaust gas characteristics, the engine mounted on this machine uses an electronically controlled high-pressure fuel injection device. This device requires high precision parts and lubrication, so if low viscosity fuel with low lubricating ability is used, the durability may drop markedly.

Note 1: HTHS (High-Temperature High-Shear Viscosity 150°C), specified by ASTM D4741 must be equal to or higher than 3.5 mPa·S. Komatsu EOS0W30 and EOS5W40 are the most suitable oils.

Note 2: Powertrain oil has different properties from engine oil. Be sure to use the recommended oils.

Note 3: Hyper grease (G2-T, G2-TE) has a high performance.

When it is necessary to improve the lubricating ability of the grease in order to prevent squeaking of pins and bushings, the use of G2-T or G2-TE is recommended.

Note 4: Supercoolant (AF-NAC)

1) Coolant has the important function of anticorrosion as well as antifreeze.

Even in the areas where freezing is not an issue, the use of antifreeze coolant is essential.

Komatsu machines are supplied with Komatsu Supercoolant AF-NAC. Komatsu Supercoolant AF-NAC has excellent anticorrosion, antifreeze and cooling properties and can be used continuously for 2 years or 4000 hours. Komatsu Supercoolant AF-NAC is strongly recommended wherever available.

2) For details of the Supercoolant AF-NAC density, see "CLEAN INSIDE OF COOLING SYSTEM (PAGE 4-26)". Supercoolant AF-NAC is supplied already diluted. In this case, add the pre-diluted fluid to keep the tank full. (Never dilute the Supercoolant with ordinary water.)

3) To maintain the anticorrosion properties of Supercoolant AF-NAC, always keep the density of Supercoolant between 30% and 68%.

RECOMMENDED BRANDS, RECOMMENDED QUALITY FOR PRODUCTS OTHER THAN KOMATSU GENUINE OIL

When using commercially available oils other than Komatsu genuine oil, consult your Komatsu distributor.

STANDARD TIGHTENING TORQUES FOR BOLTS AND NUTS

TORQUE LIST

Unless otherwise specified, tighten the metric nuts and bolts to the torque shown in the table below.

The tightening torque is determined by the width across the flats (b) of the nut and bolt.

If it is necessary to replace any nut or bolt, always use a Komatsu genuine part of the same size as the part that was replaced.

Thread diameter of bolt (a)(mm)	Width across flats (b)(mm)	Tightening torque					
		Target value			Service limit		
		Nm	kgm	lbft	Nm	kgm	lbft
6	10	13.2	1.35	9.8	11.8-14.7	1.2-1.5	8.7-10.8
8	13	31	3.2	23.1	27-34	2.8-3.5	20.3-25.3
10	17	66	6.7	48.5	59-74	6.0-7.5	43.4-54.2
12	19	113	11.5	83.2	98-123	10.0-12.5	72.3-90.4
14	22	177	18	130.2	157-196	16.0-20.0	115.7-144.7
16	24	279	28.5	206.1	245-309	25.0-31.5	180.8-227.8
18	27	382	39	282.1	343-425	35.0-43.5	253.2-314.6
20	30	549	56	405.0	490-608	50.0-62.0	361.7-448.4
22	32	745	76	549.7	662-829	67.5-84.5	488.2-611.2
24	36	927	94.5	683.5	824-1030	84.0-105.0	607.6-759.5
27	41	1320	135.0	976.5	1180-1470	120.0-150.0	868.0-1085.0
30	46	1720	175.0	1265.8	1520-1910	155.0-195.0	1121.1-1410.4
33	50	2210	225.0	1627.4	1960-2450	200.0-250.0	1446.6-1808.3
36	55	2750	280.0	2025.2	2450-3040	250.0-310.0	1808.3-2242.2
39	60	3280	335.0	2423.1	2890-3630	295.0-370.0	2133.7-2676.2

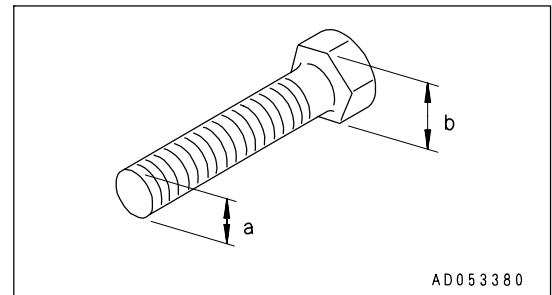

NOTICE

When tightening panels or other parts having tightening fixtures made of plastic, be careful not to use excessive torque: doing so will damage the plastic parts. Pay enough attention when you tighten up.

Apply the following table for Hydraulic Hose.

- Taper seal

Thread diameter of bolt (a)(mm)	Width across flats (b)(mm)	Tightening torque					
		Target value			Service limit		
		Nm	kgm	lbft	Nm	kgm	lbft
10	14	14.7	1.5	10.8	12.7-16.7	1.3-1.7	9.4-12.3
14	19	29.4	3.0	21.7	27.5-39.2	2.8-4.0	20.3-28.9
18	24	78.5	8.0	57.3	58.8-98.1	6.0-10.0	43.4-72.3
22	27	117.7	12.0	86.8	88.3-137.3	9.0-14.0	65.1-101.3
24	32	147.1	15.0	108.5	117.7-176.5	12.0-18.0	86.8-130.2
30	36	215.7	22.0	159.1	176.5-245.2	18.0-25.0	130.2-180.8
33	41	255.0	26.0	188.1	215.7-284.4	22.0-29.0	159.1-209.8

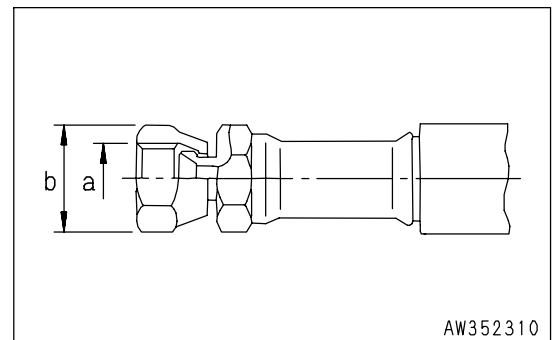

• Face seal

Nominal - No. of threads (a)	Width across flats (b) (mm)	Tightening torque					
		Target value			Permissible range		
		Nm	kgm	lbft	Nm	kgm	lbft
9/16 -18UNF	19	44	4.5	32.5	35 - 63	3.5 - 6.5	25.3 - 47.0
11/16 -16UN	22	74	7.5	54.2	54 - 93	5.5 - 9.5	39.8 - 68.7
13/16 -16UN	27	103	10.5	75.9	84 - 132	8.5 - 13.5	61.5 - 97.6
1 -14UNS	32	157	16.0	115.7	128 - 186	13.0 - 19.0	94.0 - 137.4
13/16 -12UN	36	216	22.0	159.1	177 - 245	18.0 - 25.0	130.2 - 180.8

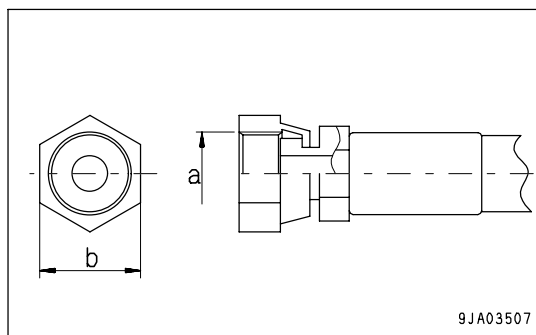

PERIODIC REPLACEMENT OF SAFETY CRITICAL PARTS

To ensure safety at all times when operating or driving the machine, the user of the machine must always carry out periodic maintenance. In addition, to further improve safety, the parts in the safety-critical parts list on the next page must also be replaced at the specified interval. These parts are particularly closely connected to safety and fire prevention, so please contact your Komatsu distributor to have them replaced.

Material quality of these parts can change as time passes and they are likely to wear out or deteriorate. However, it is difficult to determine the extent of wear or deterioration at the time of periodic maintenance. Hence, it is required to replace them with new ones regardless of their condition after a certain period of usage. This is important to ensure that these parts maintain their full performance at all times.

Furthermore, should anything abnormal be found on any of these parts, replace it with a new one even if the periodic replacement time for the part has not yet arrived.

If any of the hose clamps show deterioration like deformation or cracking, replace the clamps at the same time as the hoses.

Also perform the following checks with hydraulic hoses which need to be replaced periodically. Tighten all loose clamps and replace defective hoses, as required.

When replacing hoses, always replace O-rings, gaskets, and other such parts at the same time.

SAFETY CRITICAL PARTS

No.	Safety critical parts for periodic replacement	Replacement interval	Remarks
1	Fuel hose (fuel tank - fuel supply pump)	Every 4000 hours or 2 years, whichever comes sooner	
2	Fuel hose (fuel supply pump - fuel tank)		
3	Spill hose (engine outlet connector - fuel tank)		
4	Water separator (case, O-ring, plug)		
5	Rubber hose for brake piping		
6	High-pressure hose in steering circuit (pump ↔ demand valve ↔ steering valve ↔ steering cylinder)		
7	High-pressure hose in hoist circuit (pump ↔ demand valve ↔ hoist valve ↔ hoist cylinder)		
8	Hose at discharge side of retarder cooling pump		
9	Hose at discharge side of transmission pump		
10	High-pressure hose in brake control circuit (pump ↔ accumulator charge valve ↔ accumulator)	Every 2000 hours or 1 year, whichever comes sooner	
11	Brake valve parts		
12	Parking brake valve parts		
13	Accumulator charge valve parts		
14	Retarder control valve parts		
15	Parking brake chamber parts		
16	Slack adjuster parts		
17	Seat belt	Every 3 years	Replace

MAINTENANCE SCHEDULE CHART

MAINTENANCE SCHEDULE CHART

INITIAL 250 HOURS SERVICE (ONLY AFTER THE FIRST 250 HOURS)

Change oil in engine oil pan, replace engine oil filter cartridge	4- 52
Replace fuel prefilter cartridge	4- 53
Replace fuel main filter cartridge	4- 59
Replace transmission filter element (valve side, brake cooling side)	4- 61
Change oil in transmission case	4- 62
Change oil in brake oil tank, replace brake oil filter element	4- 62
Change oil in final drive case	4- 69
Change oil in differential case	4- 70
Replace hydraulic filter element	4- 71
Change oil in hydraulic tank	4- 76

WHEN REQUIRED

Check, clean or replace air cleaner	4- 20
Clean inside of cooling system	4- 26
Check level of window washer fluid, add fluid	4- 29
Clean air conditioner air filter	4- 29
Check refrigerant (gas) level	4- 30
Check dump body	4- 30
Check length of suspension cylinder	4- 31
Bleed air from front brake	4- 32
Bleed air from center brake	4- 33
Check play of output coupling of output shaft	4- 34
Selection and inspection of tires	4- 35
Adjust parking brake	4- 37
Cleaning hydraulic tank strainer	4- 38

CHECK BEFORE STARTING

EVERY 50 HOURS SERVICE

Lubrication	4- 40
-------------------	-------

EVERY 250 HOURS SERVICE

Lubrication	4- 41
Check drive shaft	4- 42
Clean overflow hose	4- 43
Check level of battery electrolyte	4- 44
Check fan belt and alternator belt tension, adjust	4- 46
Check air conditioner compressor belt tension, adjust	4- 47
Check frame, A-arm	4- 48
Check braking capacity of foot brake	4- 49
Check braking capacity of retarder brake	4- 49
Check braking capacity of parking brake	4- 50
Check wear of parking brake pads	4- 50
Check of accumulator gas pressure	4- 51

EVERY 500 HOURS SERVICE

Change oil in engine oil pan, replace engine oil filter cartridge -----	4- 52
Replace fuel prefilter cartridge -----	4- 53
Lubricate cab mount pin (left and right: 1 place each) -----	4- 54
Check oil level in final drive case, add oil -----	4- 54
Check oil level in differential case, add oil -----	4- 55
Clean, check radiator fins and after cooler fins -----	4- 56
Recover oil leaking from floating seal -----	4- 57

EVERY 1000 HOURS SERVICE

Replace fuel main filter cartridge -----	4- 59
Replace fuel tank breather element -----	4- 60
Replace transmission filter element -----	4- 61
Change oil in transmission case -----	4- 62
Change oil in brake oil tank, replace brake oil filter element -----	4- 62
Lubrication -----	4- 65
Lubricating parking brake -----	4- 66
Check wear of brake disc -----	4- 67
Check of engine air intake piping clamps for looseness -----	4- 68

EVERY 2000 HOURS SERVICE

Change oil in final drive case -----	4- 69
Change oil in differential case -----	4- 70
Replace hydraulic filter element -----	4- 71
Clean transmission case strainer -----	4- 72
Clean breather -----	4- 73
Check accumulator gas pressure -----	4- 75
Check alternator -----	4- 75
Check, adjust engine valve clearance -----	4- 75
Check vibration damper -----	4- 75

EVERY 4000 HOURS SERVICE

Change oil in hydraulic tank -----	4- 76
Check starting motor -----	4- 76
Check water pump -----	4- 76
Check air compressor -----	4- 76
Check fan pulley and tension pulley -----	4- 76
Check for loose engine high-pressure piping clamps, hardening of rubber -----	4- 77
Checking for missing fuel spray prevention cap, hardening of rubber -----	4- 77
Check exhaust pipe fire prevention cover -----	4- 78

EVERY 6000 HOURS SERVICE

Lubricate drive shaft -----	4- 79
-----------------------------	-------

EVERY 8000 HOURS SERVICE

Replace engine high-pressure piping clamps -----	4- 80
Replace fuel spray prevention cap -----	4- 80
Overhaul starting motor and alternator -----	4- 80

SERVICE PROCEDURE

INITIAL 250 HOURS SERVICE (ONLY AFTER THE FIRST 250 HOURS)

Perform the following maintenance only after the first 250 hours.

- Change oil in engine oil pan, replace engine oil filter cartridge
- Replace fuel prefilter cartridge
- Replace fuel main filter cartridge
- Replace transmission filter element (valve side, brake cooling side)
- Change oil in transmission case
- Change oil in brake oil tank, replace brake oil filter element
- Change oil in final drive case
- Change oil in differential case
- Replace hydraulic filter element
- Change oil in hydraulic tank

For details of the method of replacing or maintaining, see EVERY 500 HOURS, EVERY 1000 HOURS, EVERY 2000 HOURS SERVICE and EVERY 4000 HOURS SERVICE.

WHEN REQUIRED

CHECK, CLEAN OR REPLACE AIR CLEANER

After the outer element has been cleaned 6 times, or if the air cleaner element has been used for one year, replace the outer element, inner element, and O-ring. For details of the procedure for replacement, see "REPLACE ELEMENT (PAGE 4-24)".

If the maintenance caution lamp lights up and the character display displays action code "E01" and "AIR FILTER" during operation immediately after the outer element is cleaned, replace the element even if the outer element has not been cleaned 6 times or the air cleaner element has not been used more than 1 year.

CHECKING

NOTICE

Do not clean the outer element until the red line of the dust indicator is at 7.5 kPa. If the element is cleaned frequently, the filtering efficiency of the air cleaner will drop and this will reduce the service life of the engine.

1. Check if the red line of dust indicator (1) is at 7.5 kPa. If it is at 7.5 kPa, clean the outer element.

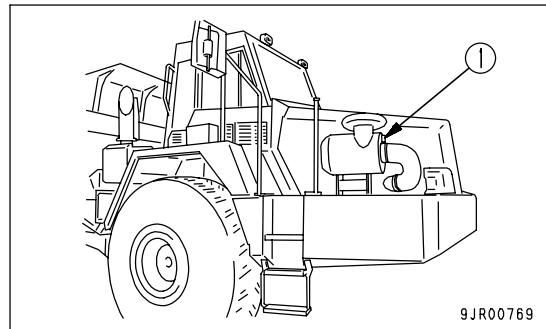

REMARK

There is maintenance caution lamp (2) on the machine monitor. If the maintenance caution lamp lights up and the character display (3) displays "E01" and "AIR FILTER" during operation, the air cleaner is clogged. Clean the outer element in this case, too.

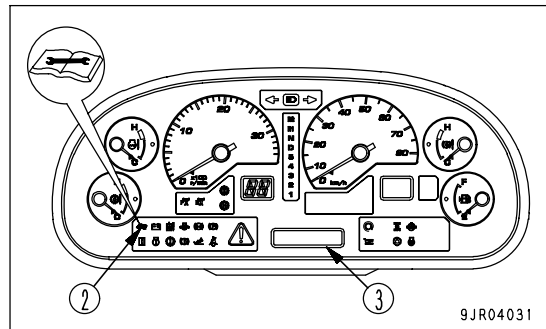

CLEAN OUTER ELEMENT

! WARNING

- Dirt will fly if compressed air is used for cleaning. If dirt gets into your eyes it may cause blindness, and if you breathe in the dust it may damage your lungs. To prevent these problems, always wear safety glasses, dust mask, and other protective equipment.
- When pulling out the air cleaner element, make sure that you are standing on a firm place. If your footing is not secure when you carry out the operation, there is danger of falling and suffering injury.

NOTICE

Clean only the outer element. Do not remove the inner element. If the inner element is removed while the outer element is being cleaned, dirt may enter the engine and cause damage to the engine.

1. Stop the engine.
2. Remove 6 hooks (5) from dust cap (4), then remove the dust cap.

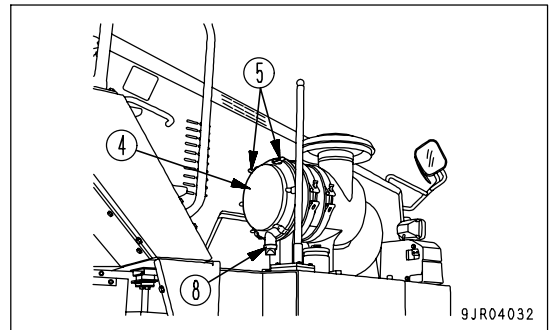

3. Hold outer element (6) with both hands, and move it up and down and to the left and right while pulling it out.
4. Hold inner element (7) so that it does not come out, and clean the inside of the air cleaner body with a dry cloth.
5. Use a dry cloth or compressed air to clean off the dirt stuck to dust cup (4) and vacuator valve (8).
6. Check that there are no cracks in the lip of the vacuator valve (8). If any cracks are found, replace with a new part.

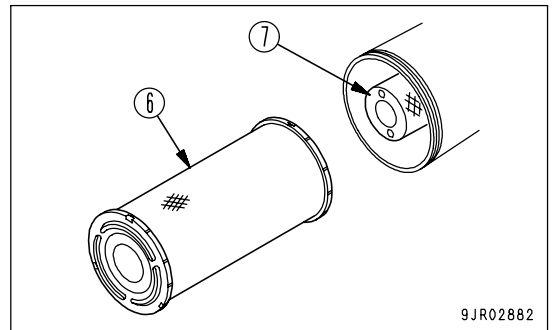

NOTICE

- If a damaged element is used, air will pass the air cleaner filter and will be sucked into the engine. Never use any cleaning method that will damage the element. If the element is damaged, replace it with a new element.
- Never tap or hit the element against any other object when cleaning it.
- Do not use an element with damaged folds or a damaged gasket or seal.

7. Blow dry compressed air (0.69 MPa {7 kg/cm²}) from the inside of outer element (6) along the folds. Next, blow along the folds from the outside, then blow again from the inside.

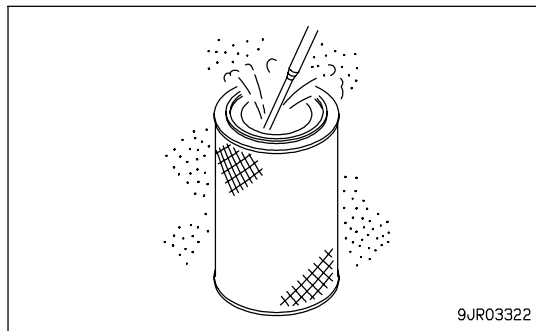

8. After cleaning, shine a light bulb from inside outer element (6) to check. If any holes or thin places are found, replace the outer element.

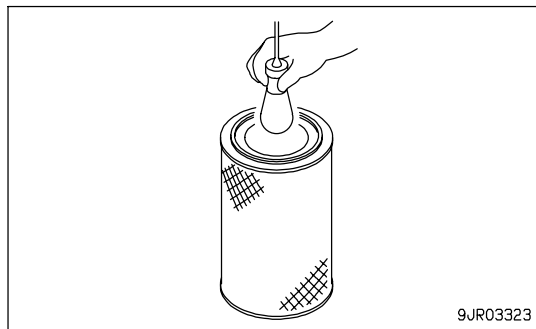

9. Install outer element (6) in the air cleaner body.

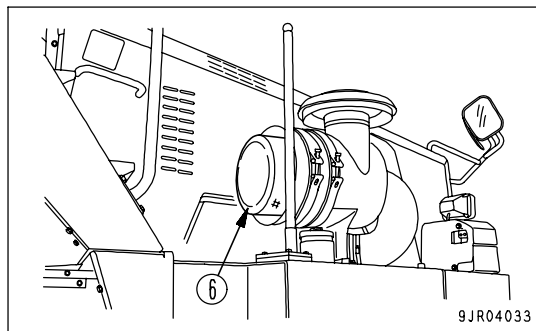

10. Check that O-ring (9) is fitted to dust cup (4). Next, set so that vacuator valve (8) of dust cup (4) is at the bottom, and insert it into the air cleaner body.

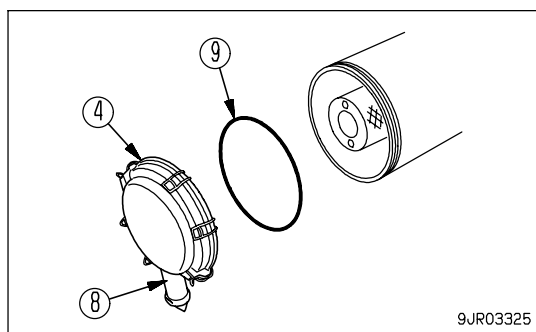

11. Fit 6 hooks (5) of dust cap (4) to the protruding parts of the air cleaner body to lock in position.

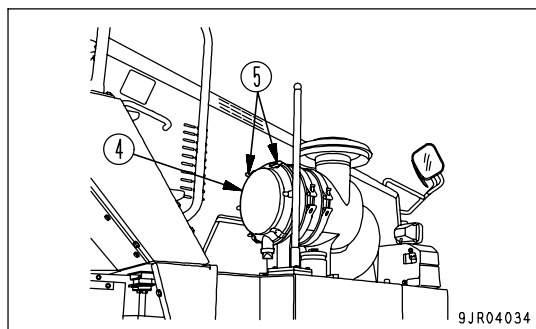

12. Push the head of dust indicator (1) to return the red line to its original position.

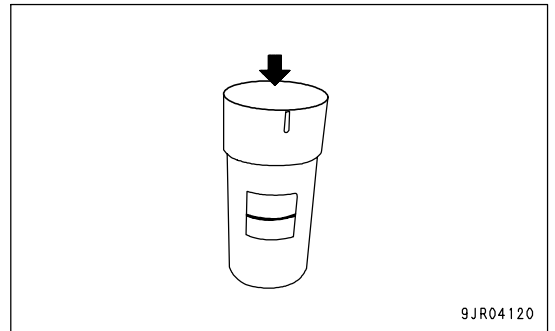
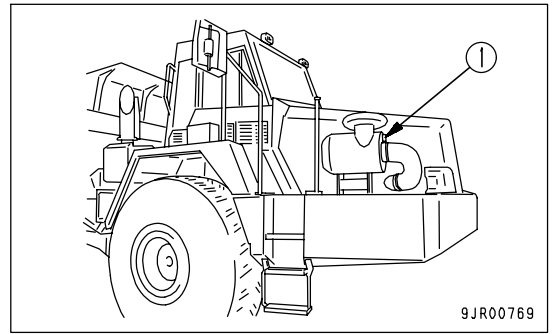

REPLACE ELEMENT

**WARNING**

When pulling out the air cleaner element, make sure that you are standing on a firm place. If your footing is not secure when you carry out the operation, there is danger of falling and suffering injury.

1. Stop the engine.
2. Remove 6 hooks (5) from dust cap (4), then remove the dust cap.

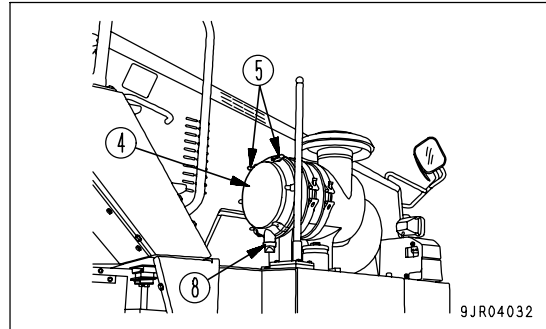

3. Hold outer element (6) with both hands, and move it up and down and to the left and right while pulling it out.
4. Hold inner element (7) so that it does not come out, and clean the inside of the air cleaner body with a dry cloth.
5. Use a dry cloth or compressed air to clean off the dirt stuck to dust cup (4) and vacuator valve (8).
6. Check that there are no cracks in the lip of the vacuator valve (8). If any cracks are found, replace with a new part.

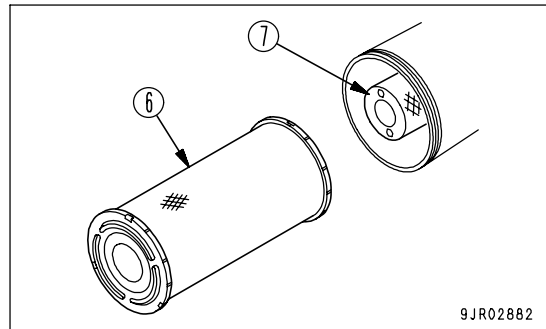

7. Pull out inner element (7) and install a new inner element.
8. Install outer element (6) in the air cleaner body.

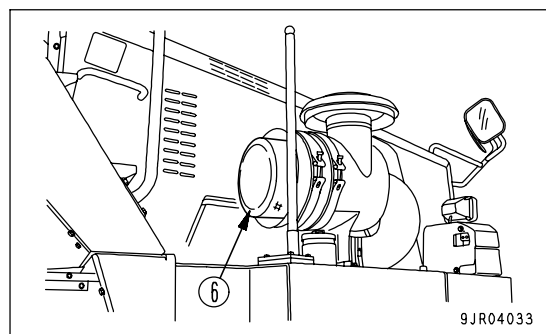

- 9. Replace O-ring (9) with a new part.
Next, set so that vacuator valve (8) of dust cup (4) is at the bottom, and insert it into the air cleaner body.

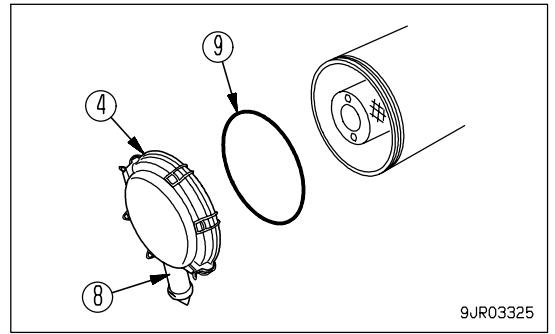

- 10. Fit 6 hooks (5) of dust cap (4) to the protruding parts of the air cleaner body to lock in position.

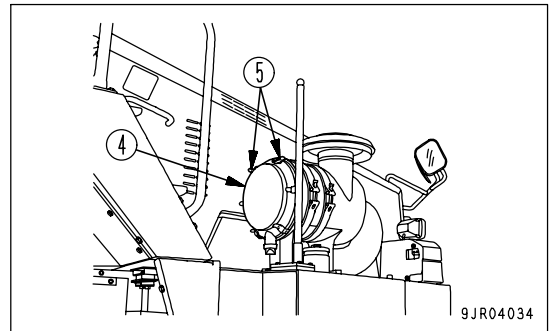

- 11. Push the head of dust indicator (1) to return the red line to its original position.

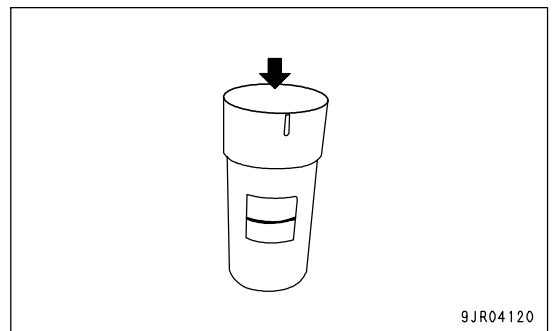
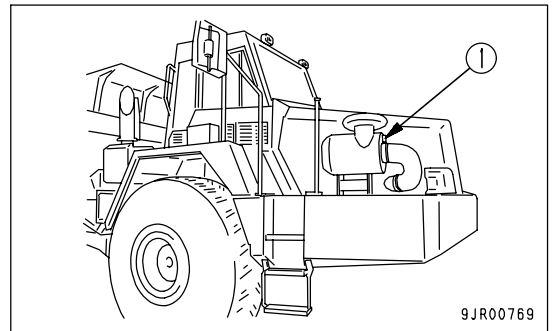

CLEAN INSIDE OF COOLING SYSTEM



- Immediately after the engine is stopped, the coolant is at high temperature and the radiator is under high internal pressure. If the radiator cap is removed in this condition and the water is drained, it may cause burns. To prevent this, wait for the temperature to go down, then turn the cap slowly to release the internal pressure.
- Start the engine and flush the system. When standing up or leaving the operator's seat, set the gear shift lever to the N position and set the parking brake switch to the PARKING position.
- For details of starting the engine, see "OPERATIONS, CHECKS BEFORE STARTING (PAGE 3-83)" and "STARTING ENGINE (PAGE 3-84)" in the OPERATION section of the Operation and Maintenance Manual.
- When the undercover is removed, there is danger of touching the fan.
Never go to the front of the machine when the engine is running.

Stop the machine on level ground when cleaning or changing the coolant.

Clean the inside of the cooling system, change the coolant according to the table below.

Antifreeze coolant	Interval for cleaning inside of cooling system and changing antifreeze coolant
Komatsu supercoolant (AF-NAC)	Every two years or every 4000 hours whichever comes first

The coolant has the important function of preventing corrosion as well as preventing freezing.

Even in the areas where freezing is not an issue, the use of antifreeze coolant is essential.

Komatsu machines are supplied with Komatsu Supercoolant (AF-NAC). Komatsu Supercoolant (AF-NAC) has excellent anticorrosion, antifreeze and cooling properties and can be used continuously for 2 years or 4000 hours. As a basic rule, we do not recommend the use of any coolant other than Komatsu genuine supercoolant (AF-NAC). If you use another coolant, it may cause serious problems, such as corrosion of the engine and aluminum parts of the cooling system.

To maintain the anticorrosion properties of Supercoolant (AF-NAC), always keep the density of Supercoolant between 30% and 68%.

Supercoolant (AF-NAC) is already diluted with distilled water. When using coolant, investigate the lowest temperatures in the past and decide the density for the coolant from the coolant density table below.

When actually deciding the density for the coolant, set it for a temperature 10°C (18°F) below the actual temperature.

The coolant density varies according to the ambient temperature, but it must always be a minimum of 30%.

Coolant density table

Minimum Temp	°C	Above -10	-15	-20	-25	-30	-35	-40	-45	-50
	°F	Above 14	5	-4	-13	-22	-31	-40	-49	-58
Concentration (%)		30	36	41	46	50	54	58	61	64

WARNING

- Antifreeze is toxic. When open the drain valve, be careful not to get water containing antifreeze on you. If it gets in your eyes, flush your eyes with large amount of fresh water and see a doctor at once.
- When changing the coolant or draining the coolant from the radiator before carrying out repairs, ask a specialist company to handle any coolant containing antifreeze, or contact your Komatsu distributor. Antifreeze is toxic, so never pour it into drainage water ditches or drain it onto the ground surface.

The Supercoolant is already diluted with distilled water, so it is not flammable. (For details of the distilled water, see "COOLANT AND WATER FOR DILUTION (PAGE 4-5)". Check the density with a coolant tester.

Prepare a container that is a larger than the specified amount of coolant, then drain the coolant into it.

Prepare a hose to use when filling with coolant.

1. Stop the engine.
2. Open the underguard (1) of the engine and take out coolant drain hoses (3 pieces).

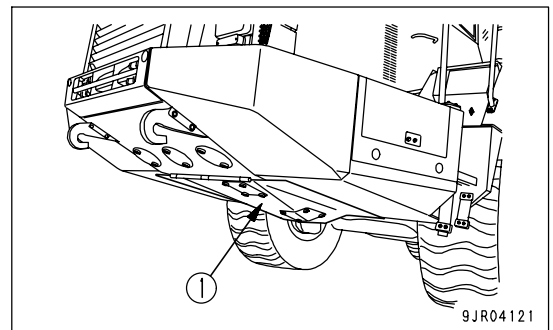

3. Turn radiator cap (2) slowly to release the pressure, then remove it.

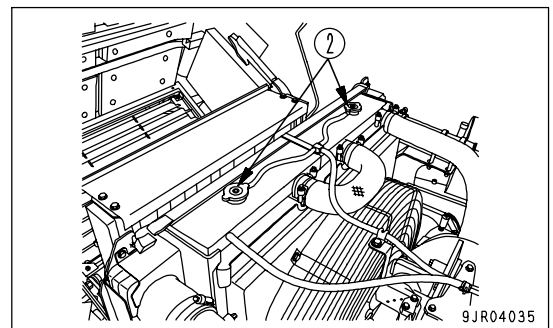

4. Open drain valve (3) at the bottom of the radiator and drain valve (4) of the oil cooler and drain the water.

5. After draining the water, close drain valves (3) and (4), and fill with city water.

6. When the radiator is full of water, start the engine and run at low idling.

After that, raise the coolant temperature to at least 90°C (194° F) (guideline: the indicator of the engine coolant temperature gauge is horizontal), then run for 10 minutes.

7. Stop the engine, open drain valves (3) and (4), and drain the water. After draining the water, close them.

8. Add Supercoolant through the water filler up to the bottom of the filler port.

For details of the Supercoolant density, see the COOLANT DENSITY TABLE.

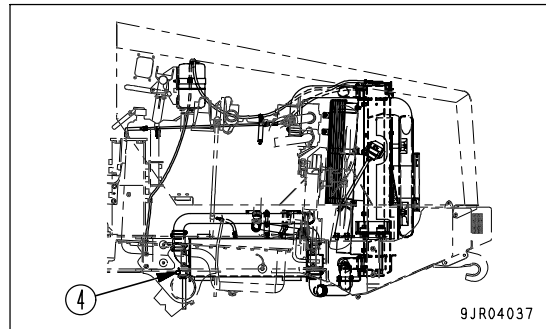
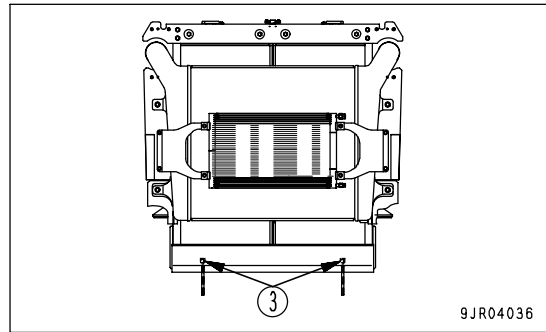

9. To remove the air contained in the coolant, run the engine at low idling for 5 minutes, then at high idling for a further 5 minutes. (When doing this, leave the coolant filler cap OFF.)

10. Stop the engine. About 3 minutes later, supply the coolant up to the coolant filler, then close radiator cap.

11. Drain the coolant from inside of reservoir tank (5), flush the inside of the reservoir tank, then fill with the coolant to a point between the FULL and LOW marks.

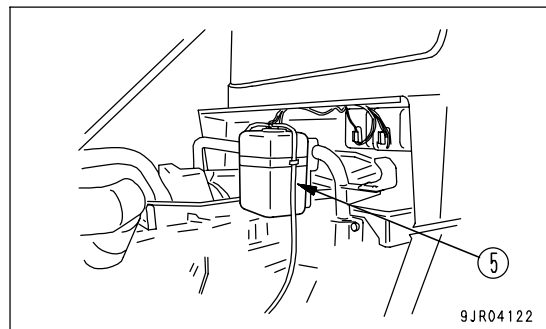

CHECK LEVEL OF WINDOW WASHER FLUID, ADD FLUID

Carry out this check if there is air in the window washer fluid.

Check the level of the fluid in window washer tank (1), and if it is low, fill with automobile window washer fluid.

Be careful not to let dirt or dust get in when adding fluid.

When operating at below freezing point, use fluid with antifreeze.

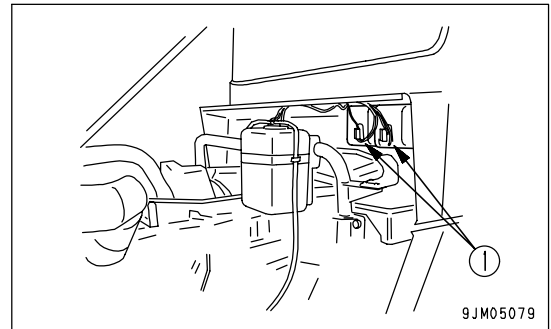

CLEAN AIR CONDITIONER AIR FILTER

If the air filter at the suction port of the air conditioner unit or the air filter at the fresh air intake port become clogged, the cooling or heating capacity will drop, so clean the filters once a week.

1. Open cover (1) on the side of the cab.
2. Pull out the air filter (FRESH filter) and clean it with compressed air.

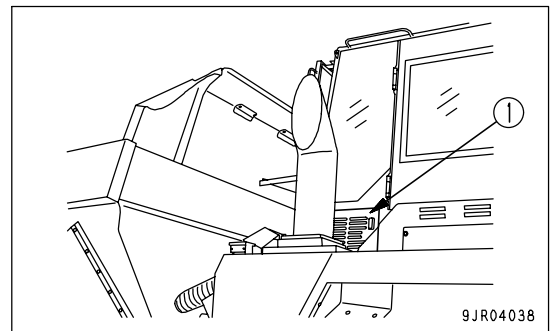

3. Open cover (2) at the right side at the rear of the operator's seat.
4. Pull out the air filter (RECIRC filter), then use a weak jet of compressed air to blow off the dust or clean with a soft brush.

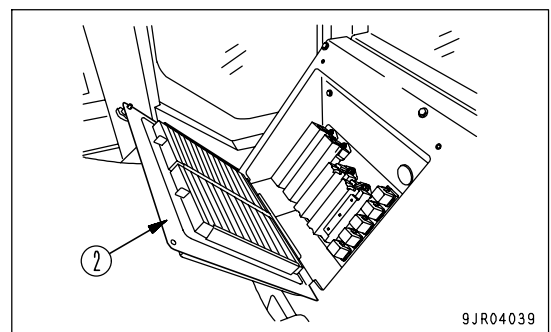

CHECK REFRIGERANT (GAS) LEVEL

WARNING

If the refrigerant used in the air conditioner gets into your eyes or on your hands, it may cause loss of sight or frostbite. Do not touch the refrigerant. Never loosen any part of the refrigerant circuit.

Do not bring any flame close to any point where the refrigerant gas is leaking.

If the cooling effect is poor, there is probably lack of refrigerant (gas).

In this case, check sight glass (2) of receiver drier (1) near the left side of the radiator guard.

Before carrying out inspection, set to the following conditions.

- Start the engine and run it at approx. 1,500 rpm.
- Turn the air conditioner ON/OFF switch to the ON position.
- Set the air flow to the maximum position.
- Set the temperature to the lowest position.
- Open the doors and windows fully.
- Turn the air conditioner switch ON.

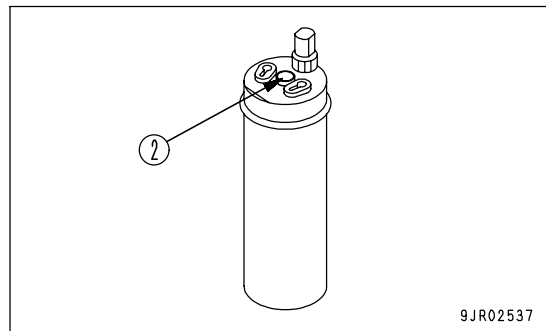
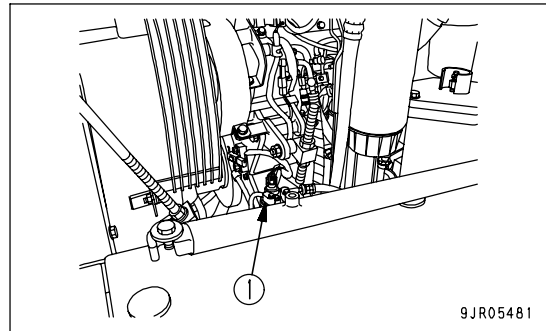

If the condition of sight glass (2) is "correct" as shown in the diagram on the right, the condition is normal. (After the air conditioner switch is turned ON, a small number of bubbles will be seen, but after that, the fluid becomes a transparent, milky white color.)

If the condition of sight glass (2) is "insufficient" as shown in the diagram on the right, there is lack of refrigerant, so ask your Komatsu distributor to charge with refrigerant. (After the air conditioner switch is turned ON, bubbles can be seen continuously.)

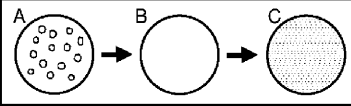
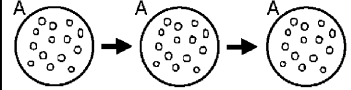
Refrigerant	Condition in sight glass
Correct	
Insufficient	

- A: Bubbles mixed with liquid refrigerant
- B: All refrigerant is clear liquid
- C: Oil and refrigerant are separated; liquid is thin milky white

CHECK DUMP BODY

Check that there are no cracks in the dump body.

1. Clean the dump body to make it easier to check.
2. Check all parts of the dump body for damage.

If any cracks or abnormal wear are found, carry out repairs.

Contact your Komatsu distributor for details of the repair procedure.

CHECK LENGTH OF SUSPENSION CYLINDER

If the machine reacts to the rough ground conditions when traveling, such as making high bounds or the cylinder retracting and hitting the stopper, check the following.

CHECK LENGTH OF CYLINDER

Check front suspension (1) and the rear suspension (2) with the machine unloaded.

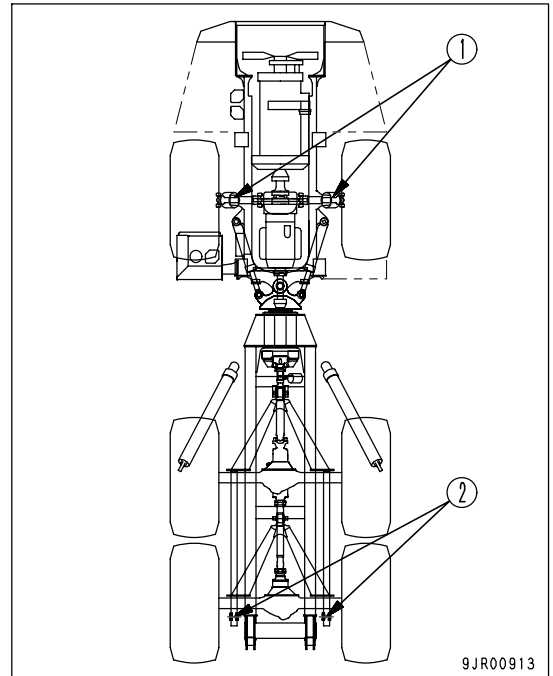

1. Remove cover (3).
2. Measure distance (A) from the shoulder at the head end of the suspension cylinder rod to the top surface of the flange.

Front suspension dimension (A): 153 to 173 mm (6.0 to 6.8 in)

Rear suspension dimension (A): 96 to 106 mm (3.8 to 4.2 in)

3. If any abnormality is found when checking the front and rear suspension, please contact your Komatsu distributor for inspection.

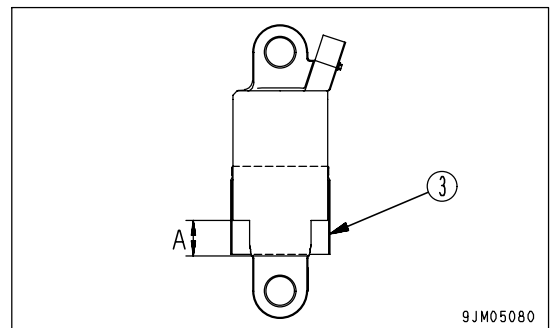

BLEED AIR FROM FRONT BRAKE**WARNING**

Stop the machine on level ground and put blocks under the wheels before bleeding the air.

To make it easier to bleed the air, warm the oil up to a temperature of at least 40°C (104°F) before bleeding the air. Bleed the air from the front brakes in the same way on both the left and right sides.

1. Start the engine, check that the oil in the transmission case is the specified level, and check if the retarder oil pressure caution lamp is out.
2. Remove the cap installed to bleeder screw (1) of the slack adjuster, then insert a vinyl hose.
Prepare a container with oil in it and insert the other end of the hose approx. 50 mm (2.0 in) below the surface of the oil.
(Use any commercially available vinyl hose.)
3. Depress the brake pedal and loosen bleeder screw (1) approx. 3/4 turns. Keep the pedal depressed until no more bubbles come out from the vinyl hose.
4. Pull the retarder control lever and loosen bleeder screw (1) approx. 3/4 turns. Keep the retarder control lever depressed until no more bubbles come out from the vinyl hose.
5. After bleeding the air, tighten bleeder screw (1) securely and fit the cap.
6. The procedure for bleeder screw (2) of the front brake is the same as for the slack adjuster (with Step 4 excluded).

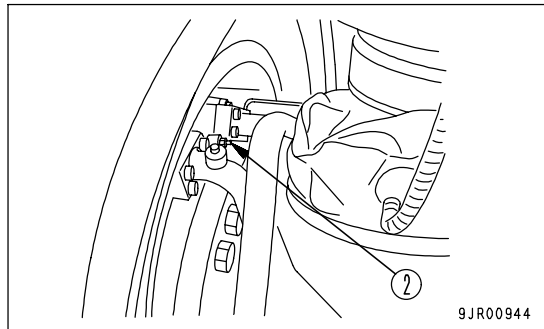
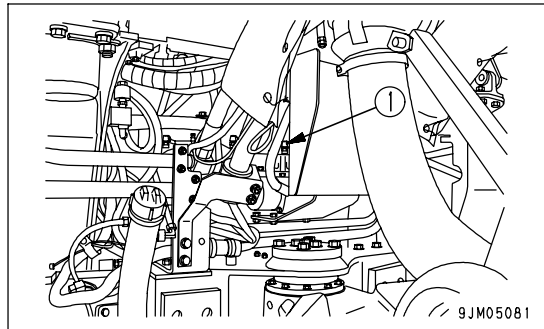
**NOTICE**

The brake oil pressure caution lamp may light up during the air bleed operation. If this happens, tighten the bleeder screw and depress the brake pedal 8 - 10 times to charge the accumulator with oil pressure.

Use sight gauge (H) to check if there is oil remaining in the brake oil tank. If there is no oil, stop the engine. (When the engine is stopped, the oil level will rise and oil will be automatically supplied to the brake oil tank.)

7. After finishing air bleeding, stop the engine (for 2 to 3 minutes), and adjust the oil level so that it reaches the specified level. For details, see "CHECK OIL LEVEL IN TRANSMISSION CASE, ADD OIL (PAGE 3-74)".

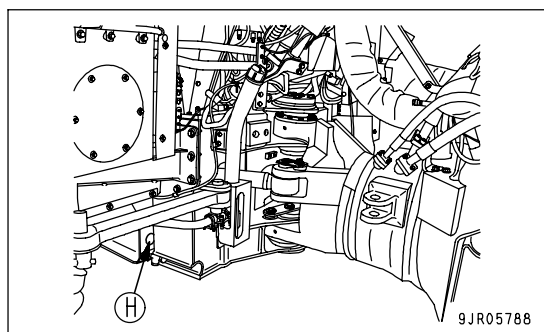

BLEED AIR FROM CENTER BRAKE

 **WARNING**

Stop the machine on level ground and put blocks under the wheels before bleeding the air.

To make it easier to bleed the air, warm the oil up to a temperature of at least 40°C (104°F) before bleeding the air. Bleed the air from the center brakes in the same way on both the left and right sides.

1. Start the engine, check that the oil in the transmission case is the specified level, and check if the retarder oil pressure caution lamp is out.
2. Remove the cap installed to bleeder screw (1) of the slack adjuster, then insert a vinyl hose.
Prepare a container with oil in it and insert the other end of the hose approx. 50 mm (2.0 in) below the surface of the oil.
(Use any commercially available vinyl hose.)
3. Depress the brake pedal and loosen bleeder screw (1) approx. 3/4 turns. Keep the pedal depressed until no more bubbles come out from the vinyl hose.
4. Pull the retarder control lever and loosen bleeder screw (1) approx. 3/4 turns. Keep the retarder control lever depressed until no more bubbles come out from the vinyl hose.
5. After bleeding the air, tighten bleeder screw (1) securely and fit the cap.
6. The procedure for bleeder screw (2) of the center brake is the same as for the slack adjuster (with Step 4 excluded).

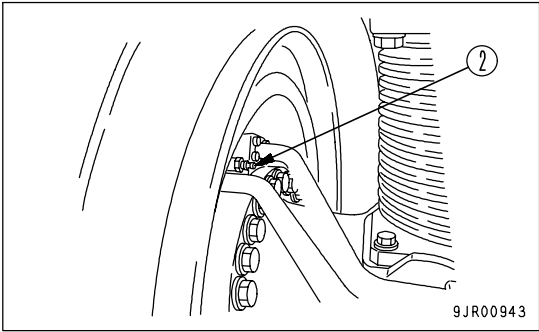
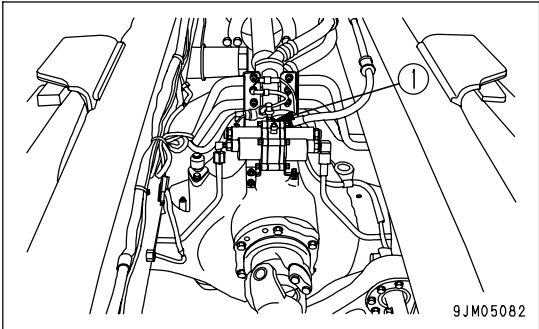

NOTICE

The brake oil pressure caution lamp may light up during the air bleed operation. If this happens, tighten the bleeder screw and use sight gauge (H) to check if there is oil remaining in the brake oil tank. If there is no oil, stop the engine. (When the engine is stopped, the oil level will rise and oil will be automatically supplied to the brake oil tank.)

7. After finishing air bleeding, stop the engine (for 2 to 3 minutes), and adjust the oil level so that it reaches the specified level. For details, see "CHECK OIL LEVEL IN TRANSMISSION CASE, ADD OIL (PAGE 3-74)".

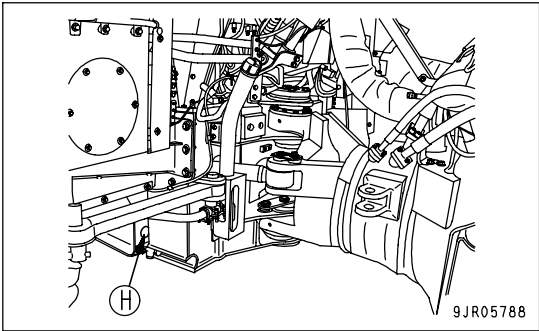

CHECK PLAY OF OUTPUT COUPLING OF OUTPUT SHAFT

**WARNING**

To prevent the machine from moving, set the parking brake switch to PARKING, stop the engine, then put blocks under the wheels.

If any abnormal noise occurs around the output shaft (1) or front drive shaft (2), the rubber inside the output shaft may be deteriorated or damaged, so check the play of the coupling (3) as follows.

1. Set wire (4) as shown in the diagram.
Using the tip of the wire as a benchmark, measure the amount of movement (L) of the coupling.
2. Using bar (5), rotate the coupling at a force of approx. 49 N {5 kg} in the direction around the circumference.
When doing this, mark the position of the wire.
3. Check that the engine fan is not rotating.

REMARK

If excessive force is used in rotating the coupling, the engine rotates freely and it becomes impossible to judge accurately.

4. Rotate the coupling in the reverse direction from Step 2.
When doing this, mark the position of the wire in the same way as in Step 2.

5. Measure the amount of movement (L) of the coupling using the marks made in Steps 2 and 4.

If amount of movement (L) is more than 12 mm (0.5 in), the rubber inside the output shaft may be deteriorated or damaged, so contact your Komatsu distributor and ask for disassembly and inspection of the internal parts of the output shaft.

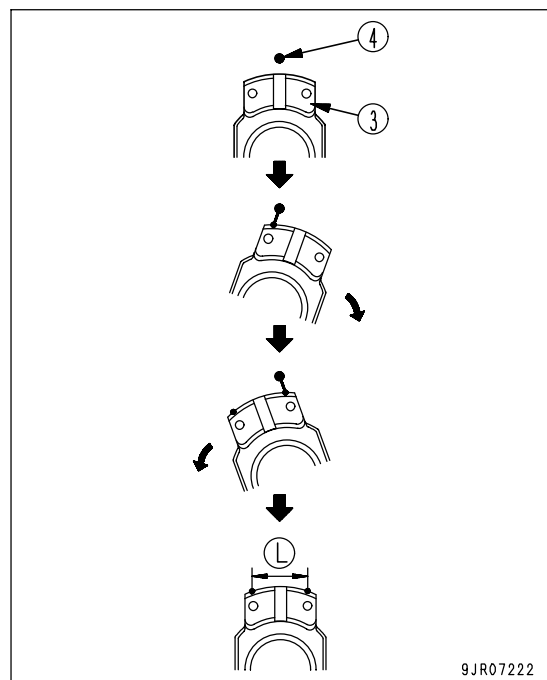
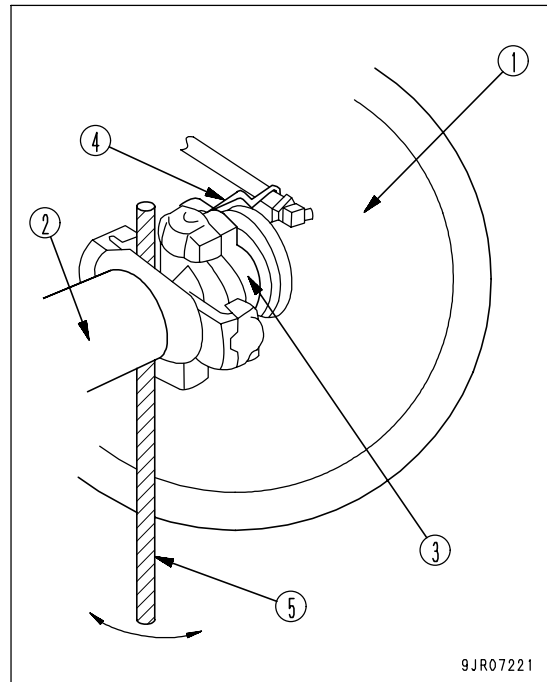

SELECTION AND INSPECTION OF TIRES

! WARNING

If a tire or a rim is handled improperly, the tire may burst or may be damaged and the rim may be broken and scattered, and that can cause serious injury or death.

- Since maintenance, disassembly, repair and assembly of the tires and rims require special equipment and skill, be sure to ask a tire repair shop to do the work.
- Never carry out welding or light a fire near the tire.

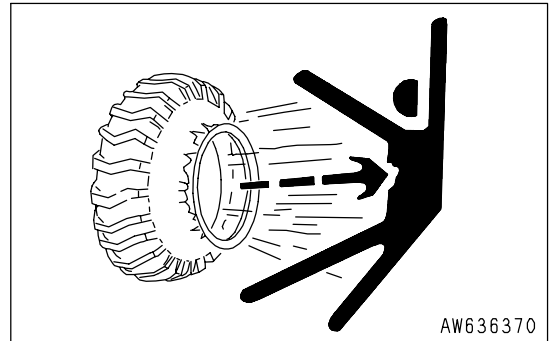

SELECTION OF TIRES

! WARNING

Select the tires according to the conditions of use and the weight of the attachments on the machine. Use only specified tires and inflate them to the specified pressure.

Select the tires according to the conditions of use and the weight of the attachments of the machine. Use the following table.

Since the travel speed indicated on the speedometer varies with the tire size, consult your Komatsu distributor when using optional tires.

	Maximum load [kg (lb)]	Tire size	Remarks
Front tire	8250 (18191)	23.5-R25	Type 1 for construction equipment
Center tire	8250 (18191)	23.5-R25	
Raer tire	8250 (18191)	23.5-R25	

CHECK OF INFLATION PRESSURE OF TIRES AND INFLATION OF THEM

! WARNING

- When inflating the tire, check that no one can enter the area around the tire, and always use an air chuck with a clip that can be fixed to the air valve.
- While inflating the tire, check the inflation pressure occasionally so that it will not rise too high.
- If the rim is not fitted normally, it may be broken and scattered while the tire is inflated. Accordingly, place a guard around the tire and do not work in front of the rim but work on the tread side of the tire.
- Abnormal drop of inflation pressure and abnormal fitting of the rim indicate a trouble in the tire or rim. In this case, be sure to ask a tire repair shop for repair.
- Be sure to observe the specified inflation pressure.
- Do not adjust the inflation pressure of the tires just after high-speed travel or heavy-load work.

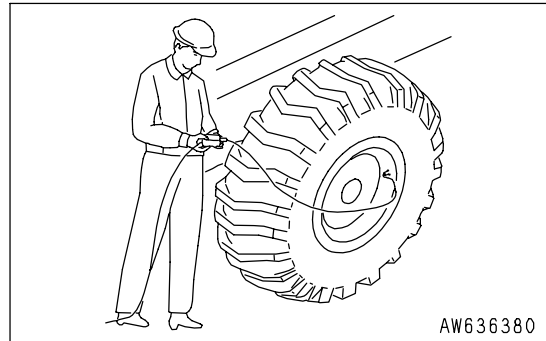

Check

Use a tire pressure gauge to measure the tire inflation pressure before starting operations when the tires are cool.

Inflation of tires

Adjust the inflation pressure properly.

When inflating a tire, use an air chuck which can be fixed to the air valve of the tire as shown in the figure. Do not work in front of the rim but work on the tread side of the tire.

The proper inflation pressure is shown below.

Tire size	Inflation pressure [MPa (kg/cm ² , PSI)]		
	Front tire	Center tire	Rear tire
23.5-R25 (standard)	0.44 (4.5, 63.9)	0.44 (4.5, 63.9)	0.44 (4.5, 63.9)
750/65 R25 (30/65 R25) (if equipped)	0.34 (3.5, 49.7)	0.40 (4.1, 58.2)	0.40 (4.1, 58.2)

NOTICE

If the tires are used when the inflation pressure is less than the value given in the table above, the rim may be damaged. Always keep the tire inflation pressure within +0 to +0.03 MPa (0.3 kg/cm², 4.3 PSI) of the value in the table above.

PRECAUTIONS WHEN REPLACING TIRE

After tightening hub bolts (1) when replacing the tire, travel for 5 to 6 km, tighten the bolts again to settle all the contacting parts.

In particular, there are more contacting parts on the rear wheels than on the front wheels, so it will take time for the parts to settle. For this reason, repeat the tightening process during the first 50 hours after installation.

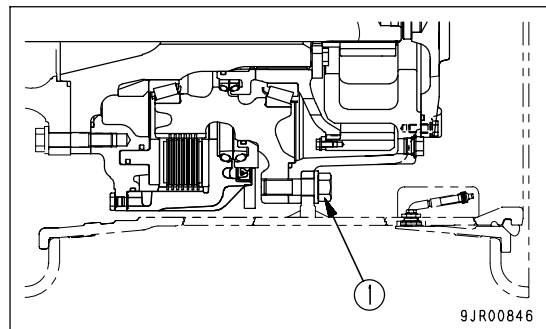

ADJUST PARKING BRAKE

! WARNING

- To prevent the parking brake from being automatically applied during the adjustment operation, raise the brake oil pressure to a sufficiently high level and hang a warning notice that can be seen clearly to prevent any other person from operating the parking brake switch.
- Never put any oil or grease on the surface of the pad or disc.

If the parking brake effect is poor, adjust as follows.

1. Check that the brake oil pressure caution lamp is turned OFF (the brake accumulator pressure is sufficiently high), and then release the parking brake.
2. Push down the lock portion of parking brake adjustment screw (1) and turn it counterclockwise to bring the pad into tight contact with the disc.
3. Push down the lock portion of parking brake adjustment screw (1) and turn it back clockwise $240 \pm 15^\circ$ (2/3 turns).

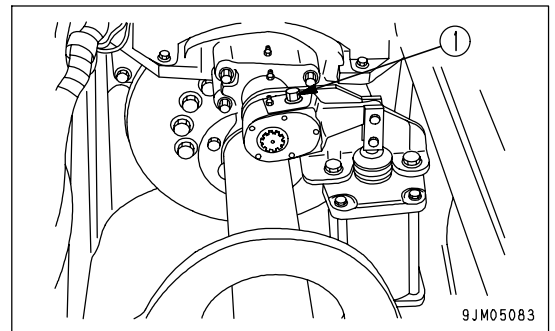

Measure the thickness of the pad, and if it is less than 1.5 mm (0.06 in), contact your Komatsu distributor to have it replaced.

When carrying out the first adjustment after replacing the pad, push down the lock portion of adjustment screw (1) and turn it back clockwise $360 \pm 15^\circ$ (1 turn).

After adjusting, check the braking capacity of the parking brake. See "CHECK BRAKING CAPACITY OF PARKING BRAKE (PAGE 4-50)". If the machine moves, contact your Komatsu distributor for inspection.

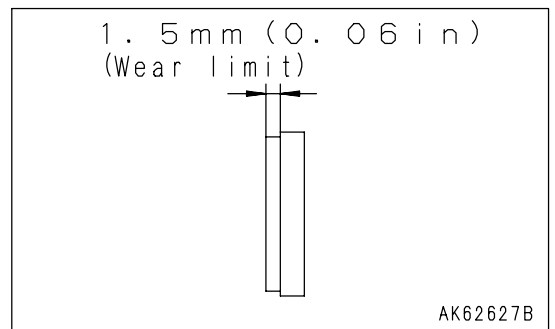

CLEAN HYDRAULIC TANK STRAINER



WARNING

- The parts and oil are at high temperature immediately after the engine is stopped, and may cause burns. Wait for the temperature to go down before starting the work.
- When removing the oil filler cap, turn it slowly to release the internal pressure, then remove it.

1. Raise the front side of the cab. For details, see "CAB TILT OPERATION (PAGE 3-107)".
2. Turn the cap of oil filler (F) to release the internal pressure before removing the cap.

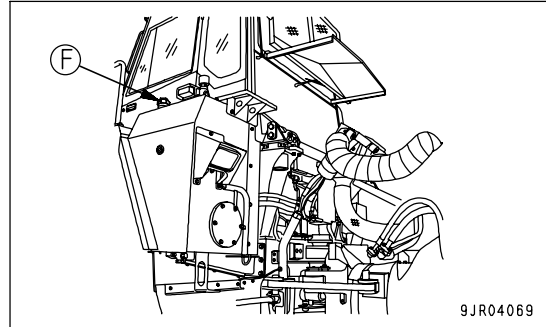

3. Remove hydraulic oil strainer cap (1), then remove the strainer from the strainer case.
4. Wash the strainer and strainer case.
5. After carrying out inspection and cleaning, set the strainer in the strainer case and tighten cap (1).
When doing this, replace the O-ring.
6. Install the cap of oil filler (F).

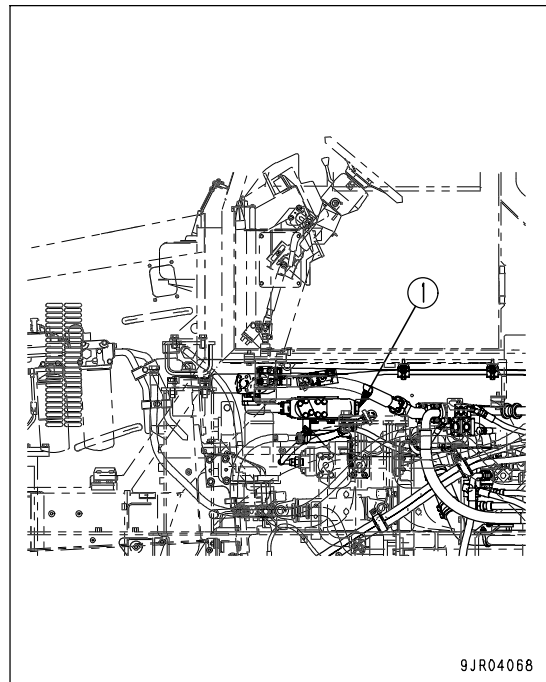

CHECK BEFORE STARTING

For details of the following items, see "CHECK BEFORE STARTING (PAGE 3-71)".

- Check coolant level, add coolant
- Check dust indicator
- Check oil level in engine oil pan, add oil
- Check oil level in transmission case, add oil
- Check oil level in hydraulic tank, add oil
- Drain water, sediment from fuel tank
- Check fuel level, add fuel
- Check wheel hub bolts, tighten
- Check central warning lamp, alarm buzzer, monitor lamps and meters
- Check braking effect
- Check manual emergency steering
- Check auto-emergency steering
- Check backup alarm
- Check electric wiring
- Check inflation pressure of tires
- Check water separator
- Check actuation of body positioner
- Check cab mount bolts, pins

EVERY 50 HOURS SERVICE

LUBRICATION

1. Stop the engine.
2. Use the grease pump to pump in grease through the grease fitting marked by the arrow.
3. Check visually that the greasing has been carried out properly.
4. After greasing, wipe off any old grease that was pushed out.

Carry out the greasing operation every day when operating in places where the grease flows out easily, such as when traveling through mud or water.

(1) Front suspension (left) (2 places)

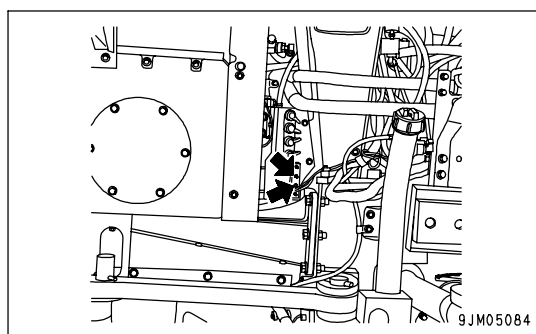

(2) Front suspension (right) (2 places)

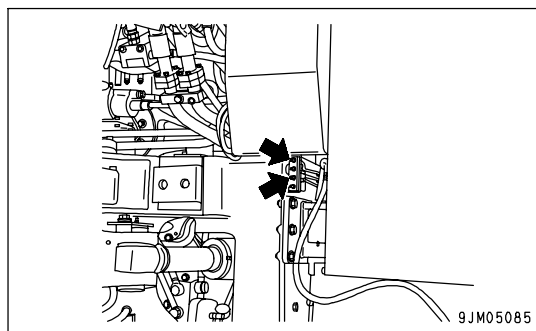

(3) Rear suspension (left and right: 2 places each)

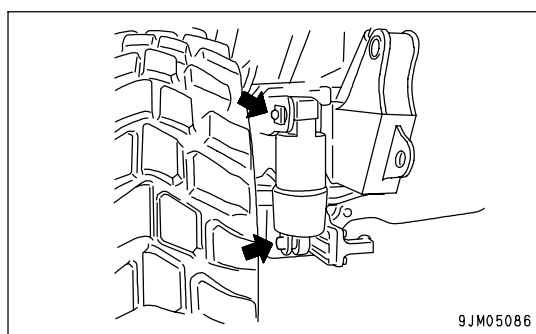

EVERY 250 HOURS SERVICE

Maintenance for every 50 hours service should be carried out at the same time.

LUBRICATION

1. Stop the engine.
2. Using a grease pump, pump in grease through the grease fittings shown by arrows.
3. Check visually that the greasing has been carried out properly.
4. After greasing, wipe off any old grease that was pushed out.

Carry out the greasing operation every day when operating in places where the grease flows out easily, such as when traveling through mud or water.

(1) Steering cylinder (left) (2 places)

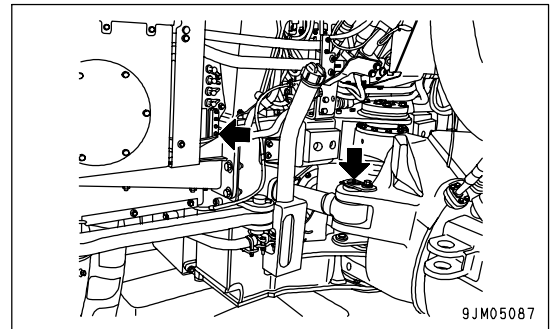

(2) Steering cylinder (right) (2 places)

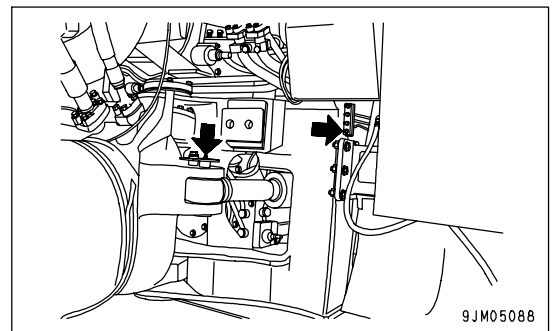

(3) Hoist cylinder (left and right: 2 places each)

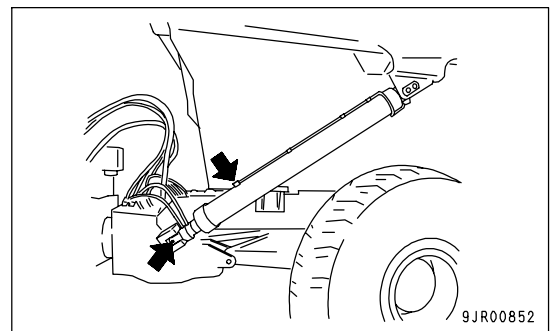

(4) Body hinge pin (2 places)

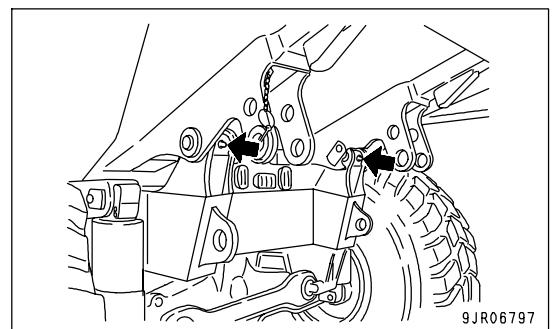

(5) Hitch bearing (2 place)

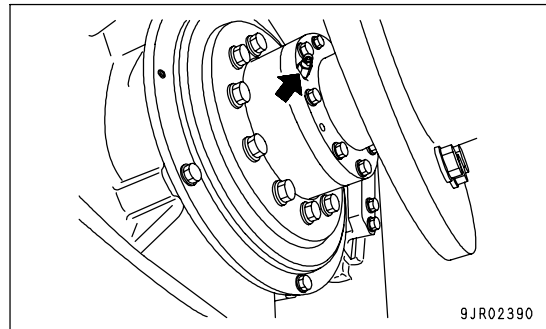
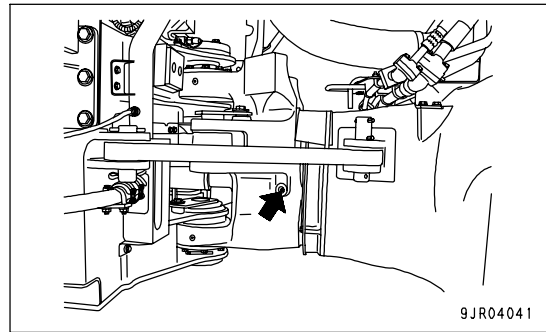

CHECK DRIVE SHAFT

If there is any problem, such as looseness of the drive shaft connection, play in the spline or bearing portion, or runout of the shaft, please contact your Komatsu distributor for repair.

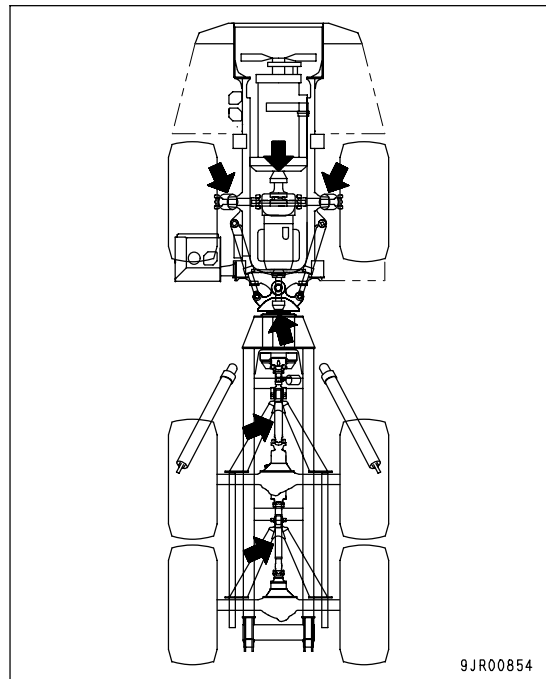

CLEAN OVERFLOW HOSE**WARNING**

If compressed air scattered around dust and debris, there is danger of injury. Always wear protective equipment such as protective glasses and mask.

The overflow hoses are installed to the front and center wheels. Remove and clean all of the 4 hoses.

1. Remove overflow hose (1).
2. After removing the hose, use compressed air to blow out the soil and dirt from the tube.
3. Install overflow hose (1).

Front

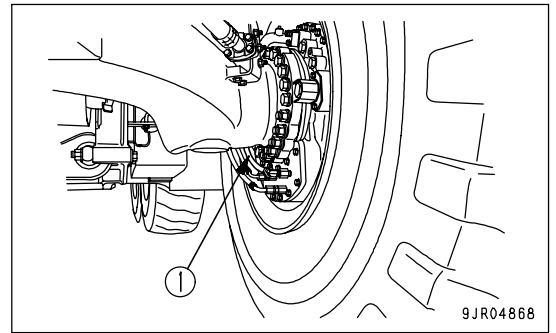

Center

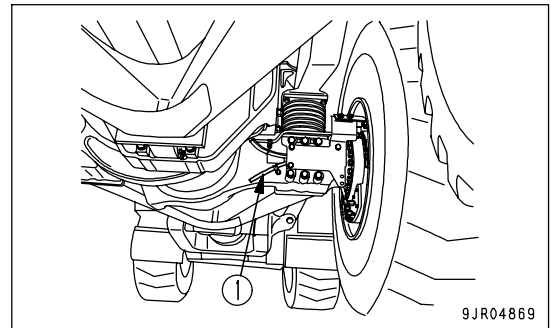

CHECK LEVEL OF BATTERY ELECTROLYTE

Carry out this procedure before operating the machine.



WARNING

- Do not use the battery if the battery electrolyte level is below the LOWER LEVEL line. This will accelerate deterioration of the inside of the battery and reduce the service life of the battery. In addition, it may cause an explosion.
- The battery generates flammable gas and there is danger of explosion, do not bring fire or sparks near the battery.
- Battery electrolyte is dangerous. If it gets in your eyes or on your skin, wash it off with a large amount of water and consult a doctor.
- When adding distilled water to the battery, do not allow the battery electrolyte to go above the UPPER LEVEL line. If the electrolyte level is too high, it may leak and cause damage to the paint surface or corrode other parts.

NOTICE

If there is a fear that the battery water may freeze after refilling with purified water (e.g. commercially available replenishment water for a battery), do the replenishment before the day's work on the next day.

Inspect the battery electrolyte level at least once a month and follow the basic safety procedures given below.

WHEN CHECKING ELECTROLYTE LEVEL FROM SIDE OF BATTERY

If it is possible to check the electrolyte level from the side of the battery, check as follows.

1. Use a wet cloth to clean the area around the electrolyte level lines and check that the electrolyte level is between the UPPER LEVEL (U.L.) and LOWER LEVEL (L.L.) lines. If the battery is wiped with a dry cloth, static electricity may cause a fire or explosion.

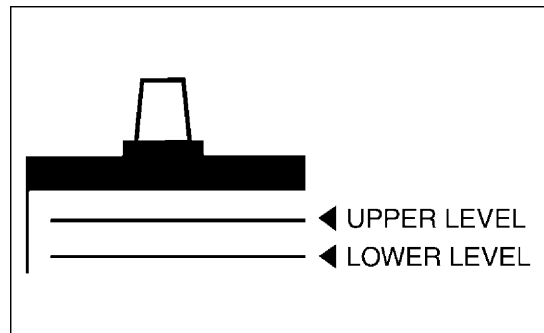

2. If the electrolyte level is below the midway point between the U.L and L.L lines, remove cap (1) and add distilled water to the U.L line.
3. After adding distilled water, tighten cap (1) securely.

REMARK

If distilled water is added to above the U.L. line, use a syringe to lower the level to the U.L. line. Neutralize the removed fluid with baking soda (sodium bicarbonate), then flush it away with a large amount of water or consult your Komatsu distributor or battery maker.

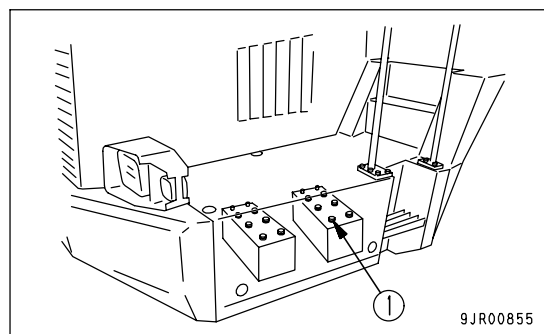

9JR00855

WHEN IT IS IMPOSSIBLE TO CHECK ELECTROLYTE LEVEL FROM SIDE OF BATTERY

If it is impossible to check the electrolyte level from the side of the battery, or there is no display of the UPPER LEVEL line on the side of the battery, check as follows.

1. Remove cap (1) at the top of the battery, look through the water filler port, and check the electrolyte surface. If the electrolyte does not reach the sleeve, add distilled water so that the level reaches the bottom of the sleeve (UPPER LEVEL line) without fail.

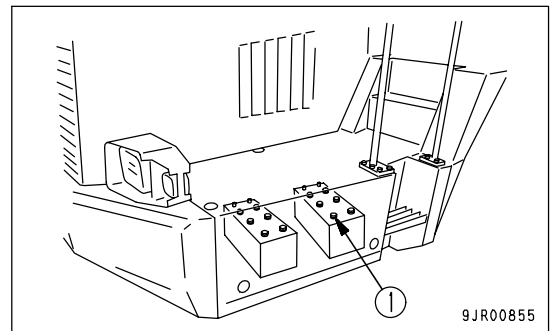

Use the diagram below for reference, and check if the electrolyte reaches the bottom of the sleeve.

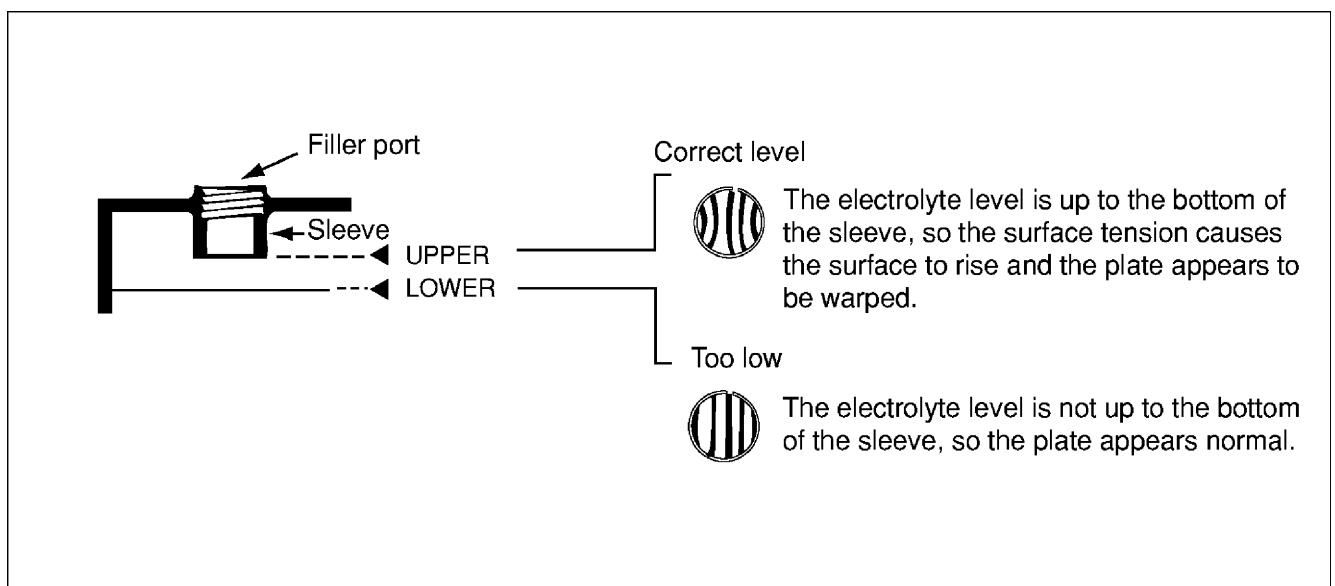

2. After adding distilled water, tighten cap (1) securely.

REMARK

If water is added to above the bottom tip of the sleeve, use a pipette to remove electrolyte. Neutralize the removed electrolyte with sodium bicarbonate, then flush it away with a large amount of water. If necessary, contact your Komatsu distributor or your battery maker.

WHEN IT IS POSSIBLE TO USE INDICATOR TO CHECK ELECTROLYTE LEVEL

If it is possible to use an indicator to check the electrolyte level, follow the instructions given.

CHECK FAN BELT AND ALTERNATOR BELT TENSION, ADJUST

CHECKING

Press the belt at a point midway between the fan pulley and alternator pulley with a finger pressure of approx. 58.8 N {6 kg}. If the deflection is approx. 13 - 16 mm (0.51 - 0.63 in), the belt tension is normal.

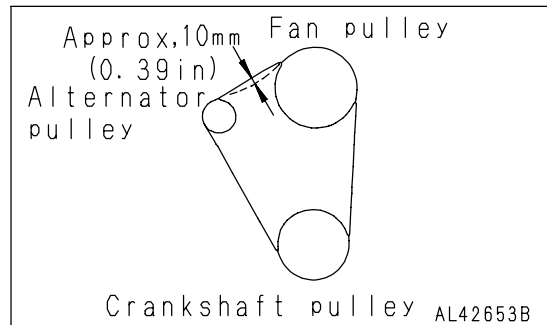

ADJUSTING

1. Loosen bolts (1), (2) and nut (3), then turn nut (4) to adjust the tension of the belt.
2. After adjusting, tighten bolts (1), (2) and nut (3) to secure alternator (5).

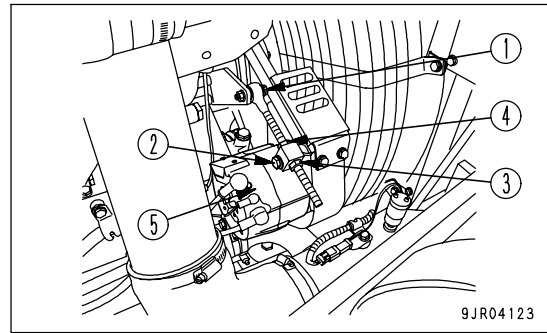

REMARK

- Check each pulley for breakage and wear of the V-groove. In particular, check that the V-belt does not touch the bottom of the V-groove.
- If any abnormality is found, ask your Komatsu distributor for replacement of the pulley.
- If the V-belt is so lengthened that it cannot be adjusted any more or if it has any cuts or cracks, replace it.
- If the V-belt has been replaced with a new part, there will be initial elongation, so inspect and adjust it again after one-hour of operation.
- Be careful not to tighten the belt too much.

CHECK AIR CONDITIONER COMPRESSOR BELT TENSION, ADJUST

CHECKING

Press the belt at a point midway between air conditioner compressor pulley (1) and drive pulley (2) with a finger pressure of approx. 58.8 N {6 kg}.

If deflection (A) is 10 mm (0.4 in), the belt tension is normal.

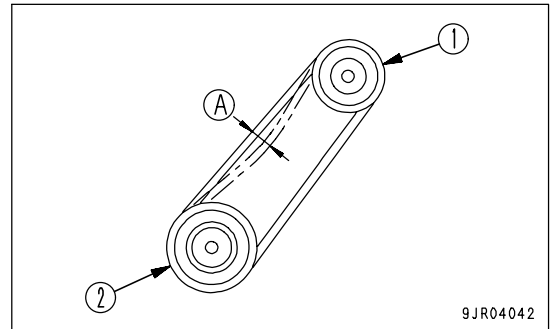

ADJUSTING

1. Loosen bolt (1).
2. Press the belt at a point midway between the air conditioner compressor pulley and drive pulley with a finger pressure of approx. 58.8 N {6 kg} and turn nut (2) to adjust so that the deflection is approx. 10 mm (0.4 in).
3. Tighten bolt (1) and nut (2) to secure the compressor in position.
4. Check each pulley for damage, wear of the V-groove, and wear of the V-belt. In particular, be sure to check that the V-belt is not touching the bottom of the V-groove.
5. If the V-belt is so lengthened that it cannot be adjusted any more or if it has any cuts or cracks, replace it.
6. If the V-belt has been replaced with a new part, there will be initial elongation, so adjust the belt again after operating for 2 to 3 days.

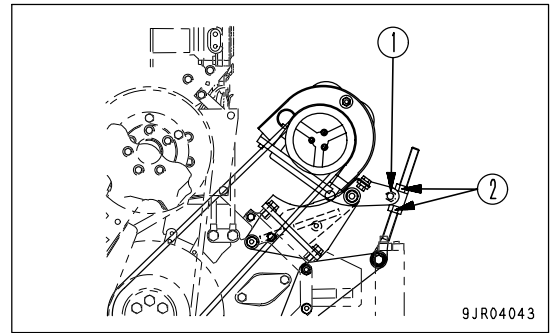

CHECK FRAME, A-ARM**WARNING**

When carrying out inspection with the dump body raised, always set the dump lever to the HOLD position, lock it with the dump lever lock knob, and use the body pivot pin.

1. Wash the frame and A-frame to make it easier to check.
2. Check that there is no damage to the frame or A-frame.
In particular, check the hatched area in the diagram. If any cracks or other damage are found, carry out repairs.
Please contact your Komatsu distributor for details of the repair procedure.

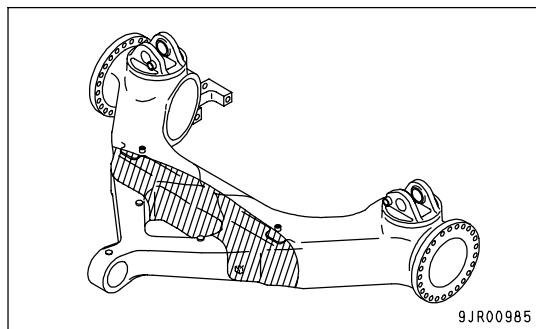
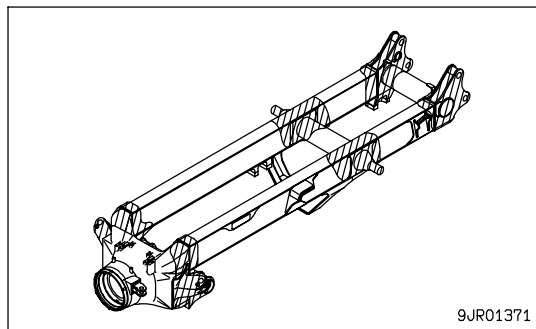
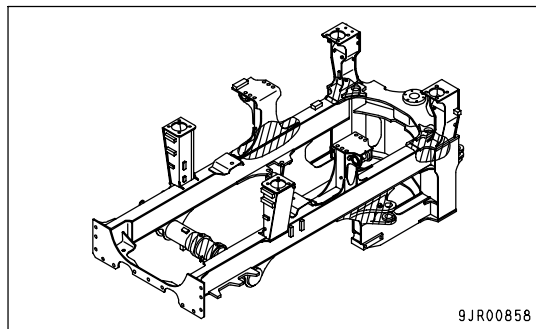

CHECK BRAKING CAPACITY OF FOOT BRAKE

! WARNING

If the machine moves when the braking capacity is being checked, it may lead to serious personal injury. If the machine moves, lower the engine speed immediately, return the gear shift lever to the N (Neutral) position and set the parking brake switch to the PARKING position.

Check the braking capacity of the foot brake as follows.

1. Stop the machine on flat ground and depress service brake (1).
 2. Set gear shift lever (2) to the D position, gradually raise the engine speed. If the machine does not move even when the engine speed reaches 1440 rpm, it is normal.
 3. Lower the engine speed, set shifting lever at N position, and then set parking brake at PARKING position.
- If any abnormality is found, ask your Komatsu distributor for repair.

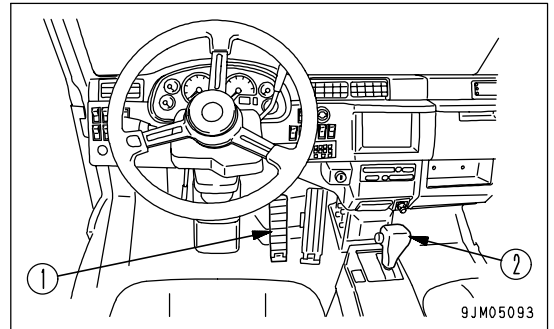

NOTICE

There is danger of damage inside the transmission, so always do this with the gear shift lever at the "D" position. Do not use any other position.

CHECK BRAKING CAPACITY OF RETARDER BRAKE

! WARNING

If the machine moves when the braking capacity is being checked, it may lead to serious personal injury. If the machine moves, lower the engine speed immediately, return the gear shift lever to the N (Neutral) position and depress the foot brake.

Check the braking capacity of the retarder brake as follows.

1. Stop the machine on flat ground and pull retarder control lever (1) fully.
2. Set gear shift lever (2) to the D position, gradually raise the engine speed. If the machine does not move even when the engine speed reaches 1440 rpm, it is normal.
3. Lower the engine speed, set gear shift lever at N position. If any problem is found, ask your Komatsu distributor for repair.

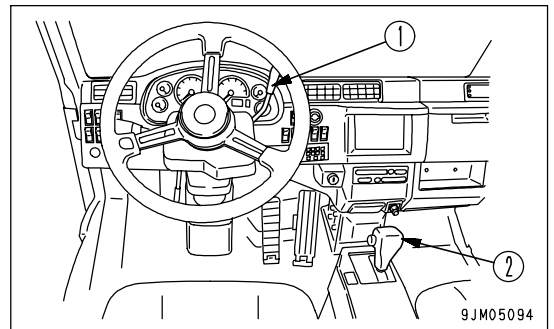

NOTICE

There is danger of damage inside the transmission, so always do this with the gear shift lever at the "D" position. Do not use any other position.

CHECK BRAKING CAPACITY OF PARKING BRAKE

WARNING

If the machine moves when the braking capacity is being checked, it may lead to serious personal injury. If the machine moves, lower the engine speed immediately, return the gear shift lever to the N (Neutral) position and depress the foot brake.

Check the braking capacity of the parking brake as follows.

1. Stop the machine on flat ground and set parking brake switch (1) to PARKING.
2. Set gear shift lever (2) to the D position, gradually raise the engine speed. If the machine does not move even when the engine speed reaches 1490 rpm, it is normal.
3. Lower the engine speed, set gear shift lever at N position. If any problem is found, ask your Komatsu distributor for repair.

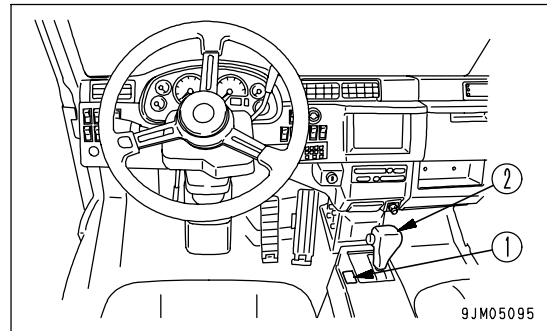

NOTICE

There is danger of damage inside the transmission, so always do this with the gear shift lever at the "D" position. Do not use any other position.

CHECK WEAR OF PARKING BRAKE PADS

WARNING

Never put any oil or grease on the surface of the pad or disc.

Measure the thickness of the pad, and if it is less than 1.5 mm (0.06 in), contact your Komatsu distributor.

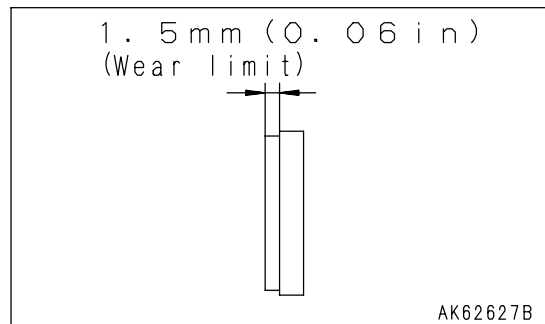

CHECK OF ACCUMULATOR GAS PRESSURE

For handling of the accumulator, see "HANDLING SUSPENSION CYLINDER, ACCUMULATOR, GAS SPRING (PAGE 2-39)".

If the engine stops during travel, the brake can be operated with the oil pressure in the accumulator temporarily.

CHECK OF FUNCTION

1. Stop the machine on a flat place and set the parking brake switch to the PARKING position.
2. Start the engine and run it at medium speed for 1 minute, and then stop it.
3. Turn the starting switch to the ON position and depress the brake pedal several times. After the brake pedal is depressed some times, the brake oil pressure caution lamp lights up.
 - If the brake oil pressure caution lamp lights up when the brake pedal is depressed 4 times or less, the gas pressure in the accumulator may be low. Ask your Komatsu distributor for inspection.
 - If the brake oil pressure caution lamp does not light up when the brake pedal is depressed 5 times, the gas pressure in the accumulator is normal.

REMARK

Check the function within 5 minutes after stopping the engine. If the engine is kept stopped, the gas pressure in the accumulator lowers and cannot be checked.

EVERY 500 HOURS SERVICE

Maintenance for every 50 and 250 hours service should be carried out at the same time.

CHANGE OIL IN ENGINE OIL PAN, REPLACE ENGINE OIL FILTER CARTRIDGE**WARNING**

Immediately after the engine is stopped, the oil and parts are at high temperature, and this will cause burns. Wait for the temperature to go down before starting the operation.

- Refill capacity: 37 liters (9.78 US gal)
- Prepare a filter wrench and a container to catch the oil.

1. Remove the bolts and cover (1).
2. Set the oil container immediately under the drain valve.

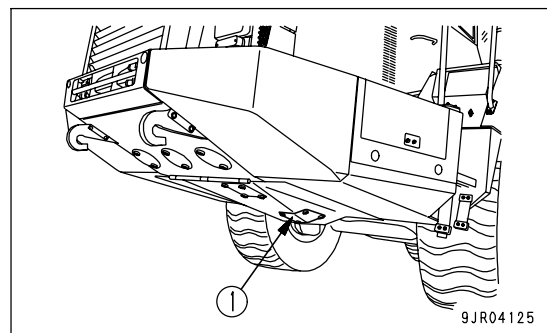

3. Remove drain plug (2), then loosen drain valve (3) slowly to avoid getting oil on yourself, and drain the oil. Be careful not to loosen the drain valve too far and deform the stopper pin inside the valve.
4. Check the drained oil, and if there are excessive metal particles or foreign material, please contact your Komatsu distributor.
5. Tighten drain valve (3) and drain plug (2).
Tighten both of drain plug (2) and drain valve (3) to $68.6 \pm 9.8 \text{ Nm}$ { $7 \pm 1 \text{ kgm}$, $50.6 \pm 7.2 \text{ lbft}$ }.

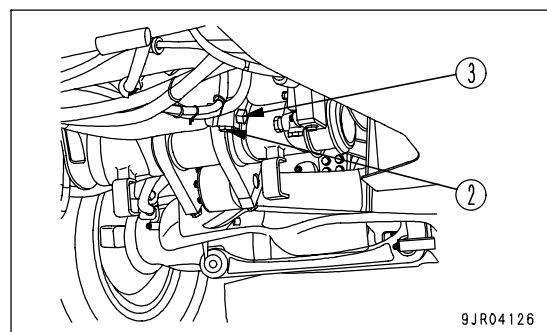

6. Using the filter wrench, turn filter cartridge (4) to the left to remove it.

When doing this, to prevent getting oil on yourself, do not carry out this operation from immediately under the cartridge.

In particular, if this operation is carried out immediately after stopping the engine, a large amount of oil will come out, so wait for 10 minutes before starting the operation.

7. Clean the filter head, fill the new filter cartridge with oil, coat the packing face and thread with oil (or coat thinly with grease), then install the filter cartridge.

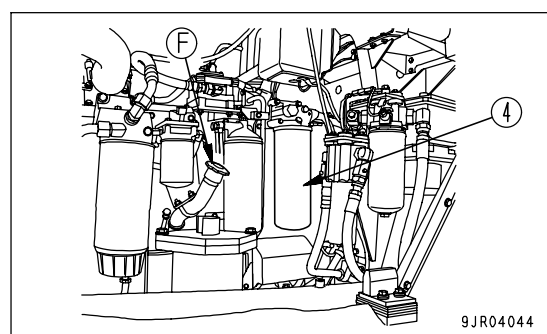

8. Install the filter cartridge. When doing this, be careful not to damage the outside cylinder of the cartridge.

When installing the filter cartridge, tighten until the packing face is in contact with the filter head, then tighten a further 3/4 to 1 turn.

9. Pour in the specified amount of engine oil from oil filler (F).

10. Run the engine for a short time at idle, then check the oil if it is filled up to a specified level. For details, see "CHECK OIL LEVEL IN ENGINE OIL PAN, ADD OIL (PAGE 3-73)".

REPLACE FUEL PREFILTER CARTRIDGE

! WARNING

- Immediately after the engine is stopped, the parts are at high temperature. Do not replace the filter immediately. Wait for the temperature of all parts to go down.
- High pressure is generated inside the engine fuel piping system when the engine is running. When replacing the filter, wait for at least 30 seconds after stopping the engine to let the internal pressure go down before replacing the filter.
- Do not bring any fire or flame close.

NOTICE

- Genuine Komatsu fuel filter cartridges use a special filter that has highly efficient filtering ability. When replacing the filter cartridge, always use a genuine Komatsu part.
- The common rail fuel injection system used on this machine consists of more precise parts than the conventional injection pump and nozzle. If any part other than a genuine Komatsu filter cartridge is used, dust or dirt may get in and cause problems with the injection system. Always avoid using substitute parts.
- When carrying out inspection or maintenance of the fuel system, pay more attention than normal to the entry of dirt. If dirt is stuck to any part, use fuel to wash it off completely.
- Prepare a filter wrench and a container to catch the fuel.

When replacing the fuel main filter cartridge (1000 hours), replace the fuel prefilter cartridge first.

1. Place a container under the fuel prefilter cartridge to catch the fuel.
2. Turn water separator cup (2) installed to the bottom of filter cartridge (1) to the left and remove it. (Use this cup again.)
3. Using a filter wrench, turn filter cartridge (1) counterclockwise to remove it.
4. Install cup (2) removed before to the underside of the new fuel prefilter cartridge. (At this time, be sure to replace the O-ring with new one.)
 - Tightening torque of cup: 10 Nm {1.0 kgm, 7.2 lbft}
5. Clean the filter head.

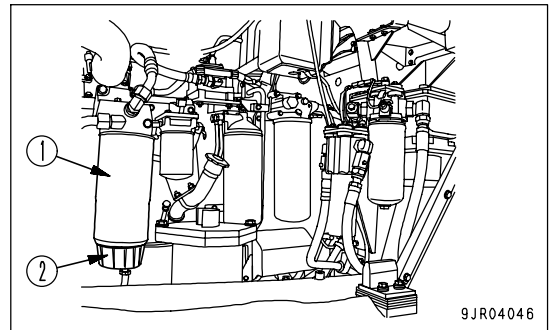

NOTICE

When filling the filter cartridge with fuel, carry out the filling operation with cap (A) fitted.

Cap (A) acts to prevent the entry of dirt or dust into the filter cartridge.

6. Fill the filter cartridge with clean fuel through the 8 small holes (B) in the new filter cartridge.
7. Coat the packing surface of the filter cartridge with oil.

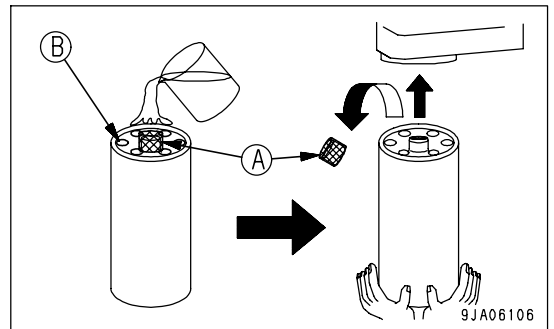

8. Remove cap (A) from the filter cartridge, then install the filter cartridge to the filter head.

9. When installing, tighten until the packing surface contacts the seal surface of the filter head, then tighten it 3/4 of a turn.

If the filter cartridge is tightened too far, the packing will be damaged and this will lead to leakage of fuel. If the filter cartridge is too loose, fuel will also leak from the packing, so always tighten the correct amount.

- When tightening with a filter wrench, be extremely careful not to dent or damage the filter.

10. Check that the drain plug at the bottom of the water separator cup is tightened securely.

Tightening torque: 0.2 to 0.45 Nm (0.02 to 0.046 kgm, 0.1 to 0.3 lbf)

11. Start the engine, check that there is no leakage of fuel from the filter seal surface or water separator mounting surface, then run for approx. 10 minutes at low idling.

LUBRICATE CAB MOUNT PIN (LEFT AND RIGHT: 1 PLACE EACH)

1. Stop the engine.
2. Using a grease pump, pump in grease through the grease fittings shown by arrows.
3. After greasing, wipe off any old grease that was pushed out.

Carry out the greasing operation every day when operating in places where the grease flows out easily, such as when traveling through mud or water.

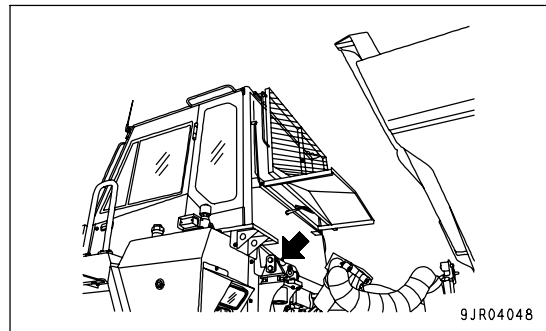

CHECK OIL LEVEL IN FINAL DRIVE CASE, ADD OIL

WARNING

- Immediately after the engine is stopped, the oil and parts are at high temperature, and this will cause burns. Wait for the temperature to go down before starting the operation.
- If there is still pressure remaining inside the case, the oil or plug may fly out. Turn the plug slowly to release the pressure, then remove it carefully.

1. Stop the machine so that the TOP casting mark is at the top and drain plug (P) is at the bottom.
2. Remove plug (G) and check that the oil is near the bottom edge of the plug hole.
3. If the oil level is too low, add oil through the plug hole until the oil overflows.
4. Repeat the procedure in Steps 1 - 3 and check the oil level and add oil to all the final drive cases (front, center, rear).

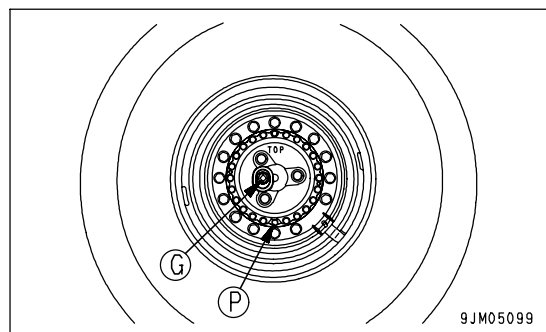

CHECK OIL LEVEL IN DIFFERENTIAL CASE, ADD OIL

! WARNING

- Immediately after the engine is stopped, the oil and parts are at high temperature, and this will cause burns. Wait for the temperature to go down before starting the operation.
- If the plug is removed, oil may spurt out, so turn it slowly to release the internal pressure, then remove it carefully.

1. Remove plug (G) and check that the oil is near the bottom edge of the plug hole.
2. If the oil level in the front differential case is low, add oil through oil filler port (F) until oil overflows from the plug hole.
3. If the oil level in the center or rear differential case is low, add oil through the plug hole until oil overflows from the plug hole.

Front

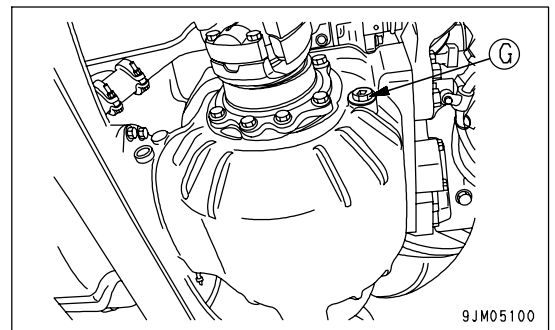

9JM05100

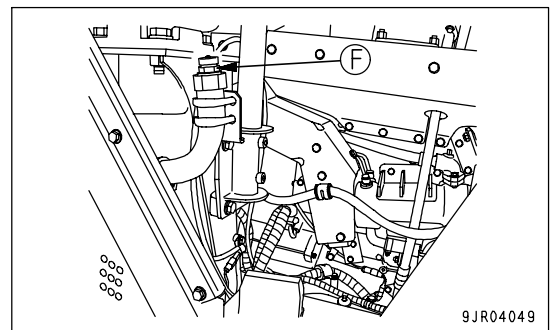

9JR04049

Center

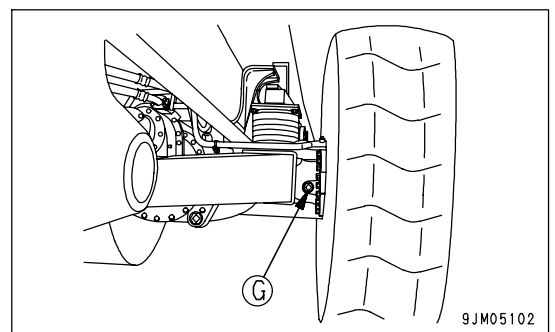

9JM05102

Rear

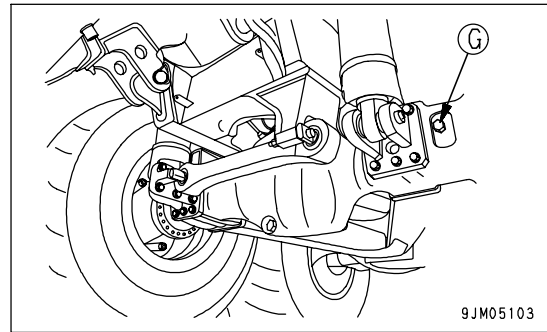

9JM05103

CLEAN, CHECK RADIATOR FINS AND AFTER COOLER FINS

! WARNING

If compressed air scattered around dust and debris, there is danger of injury. Always wear protective equipment such as protective glasses and mask.

If the radiator fins or aftercooler fins become clogged or bent, this will cause overheating of the engine.

Inspect the fins. If any fins are clogged, clean the fins.

If any pin is bent, please ask your Komatsu distributor to carry out repairs.

- Cleaning can be carried out by using jets of air, steam, or water, but be careful not to let the nozzle contact the fin.
- When using compressed air or steam, keep the nozzle at a right angle to the radiator and after cooler.
- Examine the rubber hose, and if any cracks or brittle places are found, replace the hose. In addition, check also for loose hose clamps.

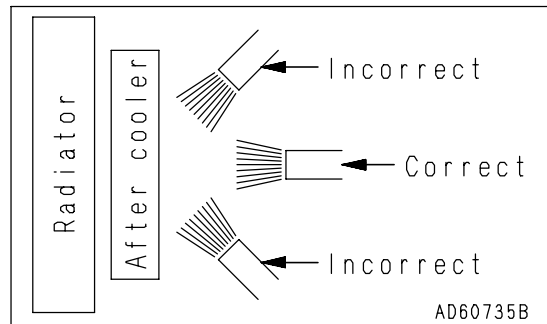

AD60735B

NOTICE

If steam jet nozzle (1) is brought too close to fins (2), the fins can be damaged, so keep a good distance in between when cleaning.

Use the following values as a benchmark.

- Jet pressure: Lower than 9.8 MPa (100 kg/cm²)
- Nozzle diameter: Less than 2 mm (0.08 in)
- Distance between nozzle and fin (A): More than 100 mm (4 in)

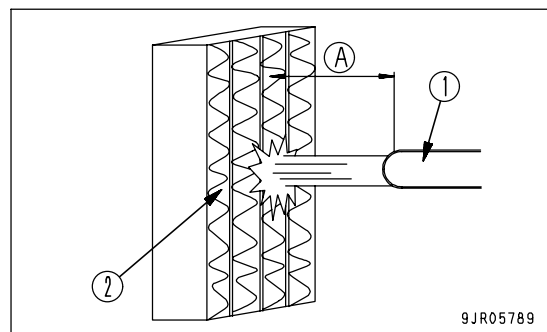

9JR05789

RECOVER OIL LEAKING FROM FLOATING SEAL

There are 4 oil suction openings. Use the hand pump supplied with the machine to collect the oil from all the suction openings.

REMARK

If oil is flowing out of the overflow hose, collect the oil, even if before 500 hours.

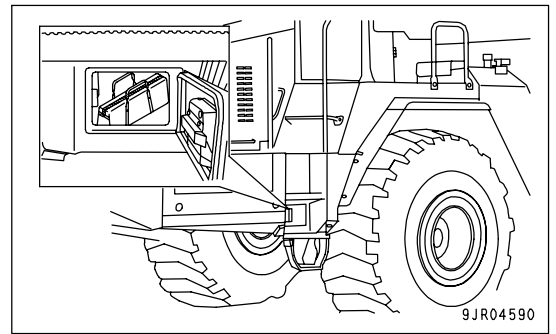

1. Remove the cap of an oil suction opening.
2. Connect the coupler (female) of the attached hand pump to the coupler (male) of the suction opening.
3. Put the oil outlet hose of the hand pump in the oil receiving container.
4. Operate the hand pump at least 10 times to pump up the oil.

Front axle (left)

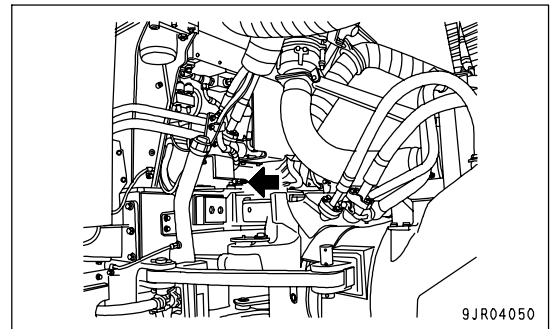

Front axle (right)

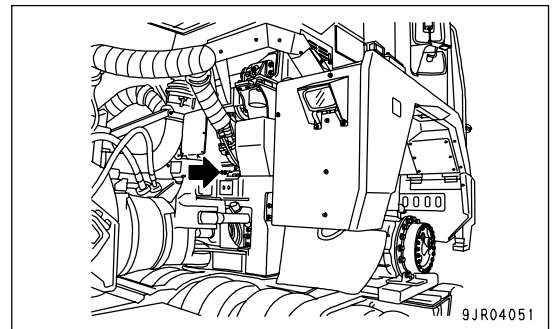

Center axle (left, right)

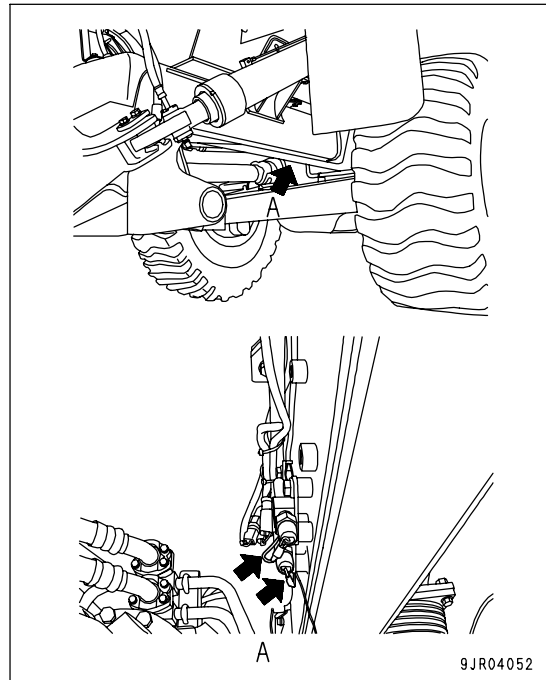

EVERY 1000 HOURS SERVICE

Maintenance for every 50, 250 and 500 hours should be carried out at the same time.

REPLACE FUEL MAIN FILTER CARTRIDGE



WARNING

- Immediately after the engine is stopped, the parts are at high temperature. Do not replace the filter immediately. Wait for the temperature of all parts to go down.
- High pressure is generated inside the engine fuel piping system when the engine is running. When replacing the filter, wait for at least 30 seconds after stopping the engine to let the internal pressure go down before replacing the filter.
- Do not bring any fire or flame close.

NOTICE

- Genuine Komatsu fuel filter cartridges use a special filter that has highly efficient filtering ability. When replacing the filter cartridge, always use a genuine Komatsu part.
- The common rail fuel injection system used on this machine consists of more precise parts than the conventional injection pump and nozzle. If any part other than a genuine Komatsu filter cartridge is used, dust or dirt may get in and cause problems with the injection system. Always avoid using substitute parts.
- When carrying out inspection or maintenance of the fuel system, pay more attention than normal to the entry of dirt. If dirt is stuck to any part, use fuel to wash it off completely.
- Prepare a filter wrench and a container to catch the fuel.

After replacing the fuel pre-filter cartridge, replace the fuel main filter cartridge.

1. Place a container under the filter cartridge to catch the fuel.
2. Using a filter wrench, turn filter cartridge (1) counterclockwise to remove it.
3. Clean the filter head, coat the packing surface of the new filter cartridge thinly with oil, then install the filter cartridge to the filter head.

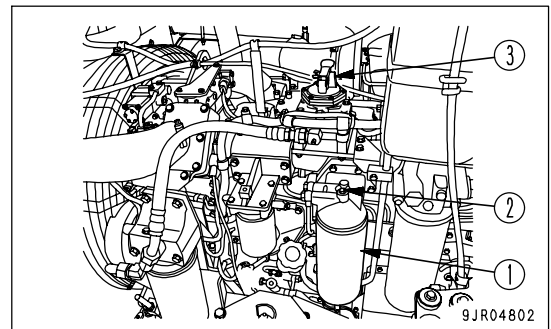

NOTICE

Do not add fuel to the fuel main filter cartridge.

4. When installing, tighten until the packing surface contacts the seal surface of the filter head, then tighten it 3/4 of a turn. If the filter cartridge is tightened too far, the packing will be damaged and this will lead to leakage of fuel. If the filter cartridge is too loose, fuel will also leak from the packing, so always tighten the correct amount.
 - When tightening with a filter wrench, be extremely careful not to dent or damage the filter.
5. After replacing filter cartridge (1), loosen air bleed plug (2). Do not loosen the plug in the filter head of the fuel prefilter. It will become impossible to bleed the air.
6. Fill the fuel tank with fuel.

7. Loosen wing nut (4) holding lever (5) of priming pump (3). Pump lever (5) up and down to carry out priming. Continue until bubbles stop coming out with the fuel from the hole for air bleed plug (2).
8. Tighten air bleeding plug (2) and then tighten wing bolt (4) of priming pump (3) securely to lock lever (5).
 - Tightening torque for air bleeding plug
7.8 to 9.8Nm{0.8 to 1kgm}
 - Tightening torque for wing screw
6.9 to 12.7Nm{0.7 to 1.3kgm}
9. After replacing the filter cartridge, start the engine and check that there is no leakage of fuel from the filter seal surface. If there is any leakage of fuel, check the tightening of the filter cartridge. If there is still leakage of fuel, follow Step 1 and 2 to remove the filter cartridge, then check the packing surface for damage or foreign material. If any damage or foreign material is found in the packing, replace the cartridge with a new part, then repeat Steps 3 - 9 to install the filter cartridge.

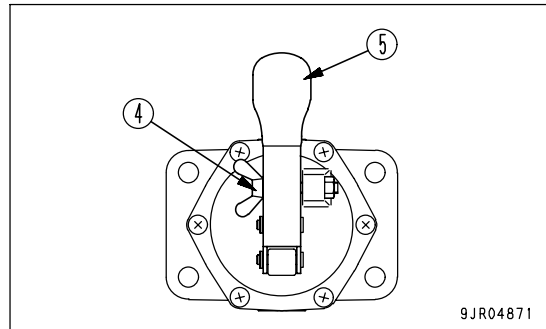
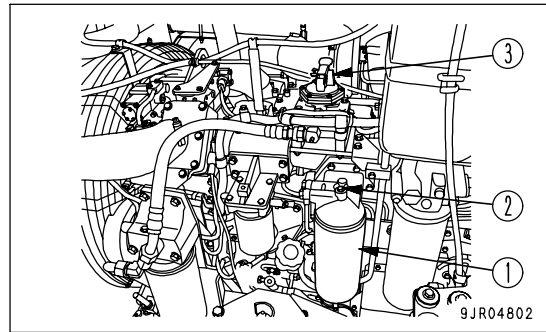

REPLACE FUEL TANK BREATHER ELEMENT



WARNING

Immediately after the engine is stopped, the oil and parts are at high temperature, and this will cause burns. Wait for the temperature to go down before starting the operation.

1. Remove nut (2) of breather assembly (1) at the top surface of the fuel tank, then remove cover (3).
2. Replace breather element (4) with a new part.
3. Install cover (3) and nut (2).

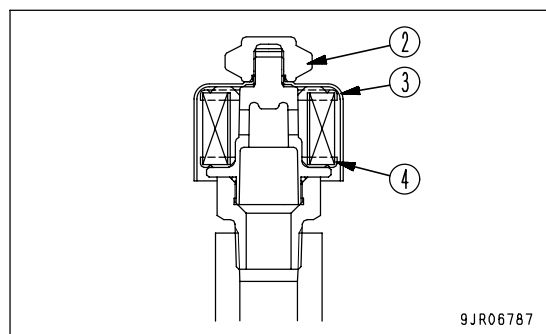
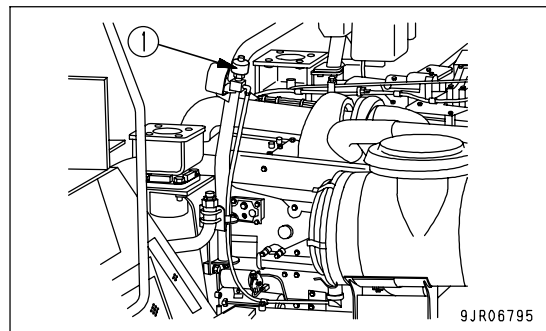

REPLACE TRANSMISSION FILTER ELEMENT

! WARNING

- The parts and oil are at high temperature immediately after the engine is stopped, and may cause burns. Wait for the temperature to go down before starting the work.
- When removing the oil filler cap, turn it slowly to release the internal pressure, then remove it.

VALVE SIDE

- Prepare a filter wrench and a container to catch the oil.
1. Place a container under the filter case to catch the oil.
 2. Remove drain plug (1) at the filter head, drain the oil, then tighten the plug again.
 3. Using a filter wrench, turn filter cartridge (2) to the left to remove it.
 4. Clean the filter head, coat the seal surface of the new filter cartridge thinly with clean oil, then install it.
Tightening torque: 49 to 59 Nm (5 to 6 kgm, 36.2 to 43.4 lbf)
 5. Add oil. For details, see "CHECK OIL LEVEL IN TRANSMISSION CASE, ADD OIL (PAGE 3-74)".

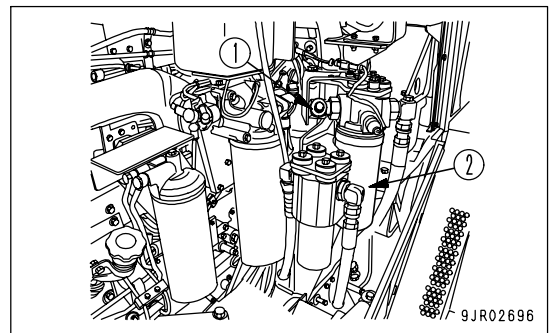

BRAKE COOLING SIDE

1. Remove bolt (1), then remove cover (2).
2. Place a container immediately under the drain plug to catch the oil.
Remove drain plug (P), drain the oil, then tighten the plug again.
3. Remove the element, then wash the inside of the filter case, the strainer at the bottom of the filter case, and the parts that were removed.
4. Install the new element, then install cover (2) with bolt (1).
5. Add oil. For details, see "CHECK OIL LEVEL IN TRANSMISSION CASE, ADD OIL (PAGE 3-74)".
6. Remove the cap installed to bleeder screw (3), then insert a vinyl hose. Prepare a container with oil in it and insert the other end of the hose approx. 50 mm (2.0 in) below the surface of the oil. (Use any commercially available vinyl hose.)
7. Start the engine, loosen bleeder screw (3) approx. 3/4 turns, and keep the engine running at idling until fewer bubbles come out from the vinyl hose.
8. Tighten bleeder screw (3) properly, then install the cap.
9. Check that the oil level in the transmission case is up to the specified level.
10. If the oil level is low, add oil.

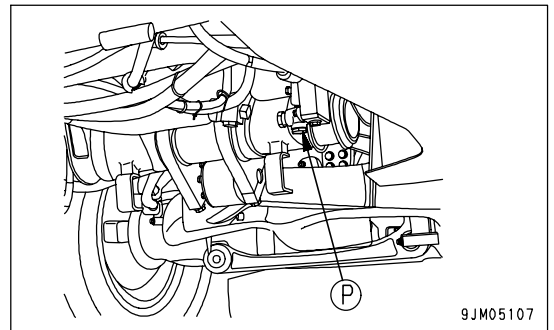
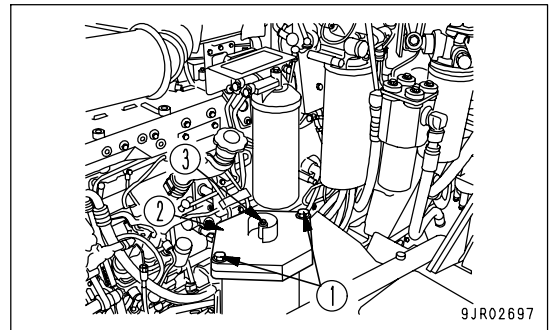

REMARK

When the air is bled from inside the case, the transmission oil level becomes stable.

CHANGE OIL IN TRANSMISSION CASE

CHANGE OIL IN BRAKE OIL TANK, REPLACE BRAKE OIL FILTER ELEMENT

WARNING

- The parts and oil are at high temperature immediately after the engine is stopped, and may cause burns. Wait for the temperature to go down before starting the work.
- When removing the oil filler cap, turn it slowly to release the internal pressure, then remove it.

- Refill capacity: 77.5 liters (20.48 US gal) (Including transmission case, brake oil tank, and filter cases.)

Carry out the following items at the same time in order to drain oil completely.

- REPLACE TRANSMISSION FILTER ELEMENT (PAGE 4-61)
- CHANGE OIL IN TRANSMISSION CASE (PAGE 4-62)
- CHANGE OIL IN BRAKE OIL TANK, REPLACE BRAKE OIL FILTER ELEMENT (PAGE 4-62)

- Prepare a filter wrench and a container to catch the oil.

1. Depress the brake pedal at least 20 times to reduce the pressure inside the brake control accumulator to 0.
2. Place a container immediately under drain plug (P) to catch the oil.
3. Remove drain plug (P), drain the oil, then tighten the plug again.

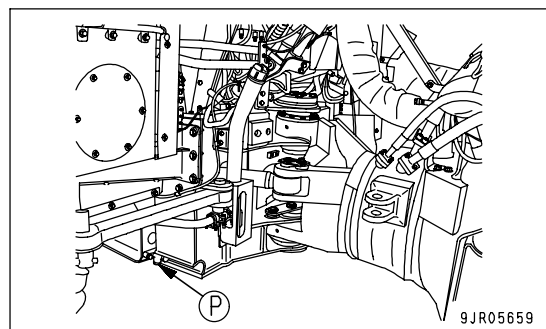
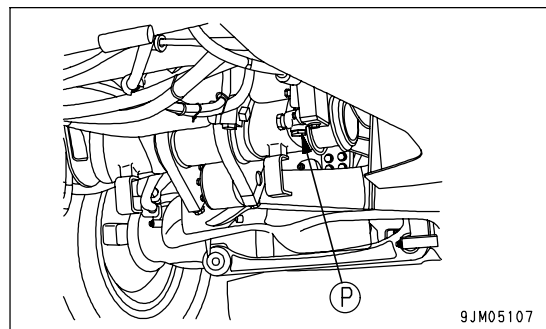
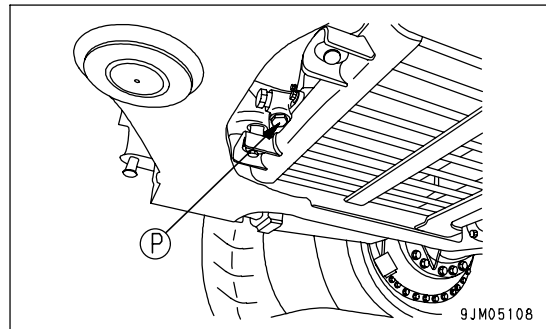

4. Place a container immediately under filter case (1), then remove filter case (1).

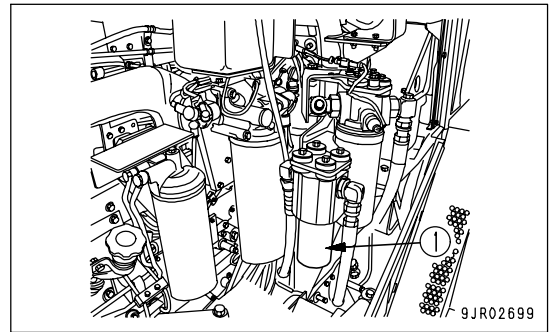

5. Take out the element and wash the inside of the filter case.
 Replace O-ring (2) and backup ring (3) on the filter case with new parts, coat thinly with clean oil, then install.
6. Assemble a new element in the filter case, coat the O-ring of the element thinly with clean oil, then install.
 Tightening torque: 78.4 to 98 Nm
 {8 to 10 kgm, 57.9 to 72.3 lbft}

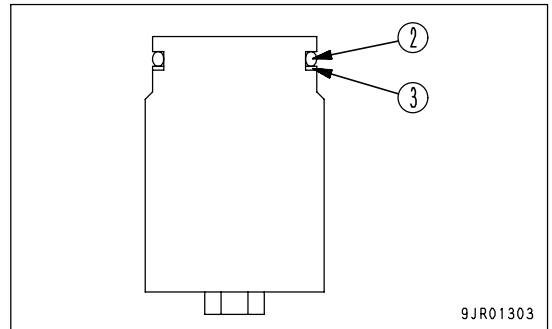

7. Before starting the engine, add 80 liters (21.14 US gal) of oil through oil filler port (F).
 When oil is added, the level will temporarily go above the oil level on sight gauge (G), but this does not indicate any abnormality.
8. Start the engine and run at low idling.

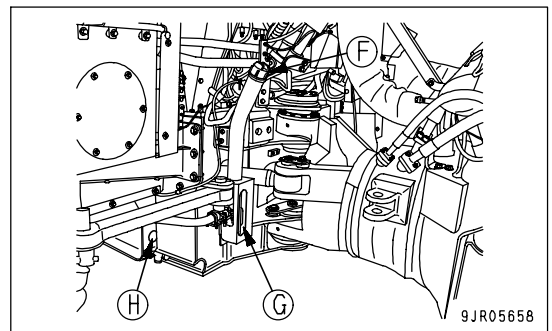

NOTICE

Do not start the engine before filling with oil. If the engine is started when there is no oil in the system, it will cause damage to the transmission and hydraulic pump.

9. Add oil through oil filler port (F) until the oil level is between the H and L marks on sight gauge (G). When running the engine at low idling, be careful not to let the oil level in the brake oil tank go below sight gauge (H). If the oil level goes below sight gauge (H), stop the engine to raise the oil level in the brake oil tank.

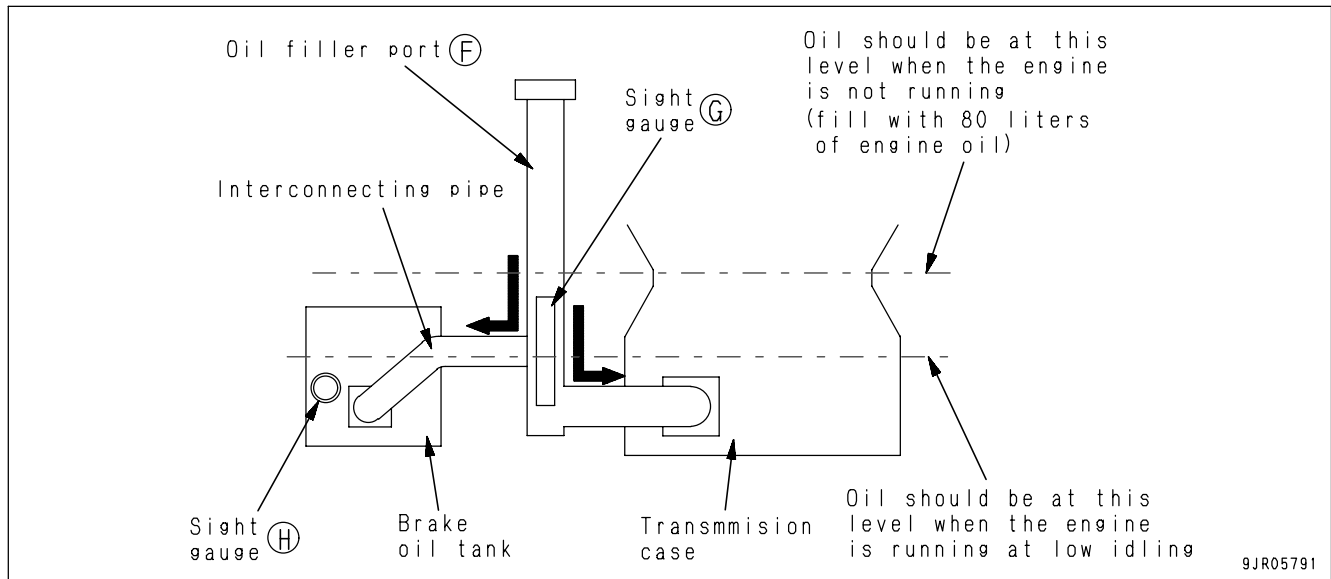

10. Remove the cap from bleeder screw (1) and insert a vinyl hose. (Use a commercially available vinyl hose.)
11. Put the other end of the vinyl hose approx. 50 mm into a container of oil.
12. Loosen bleeder screw (1) approx. 3/4 turns and run the engine at low idling until no more bubbles come out from the vinyl hose.
13. When no more bubbles come out, tighten bleeder screw (1) securely, remove the vinyl hose, then install the cap.

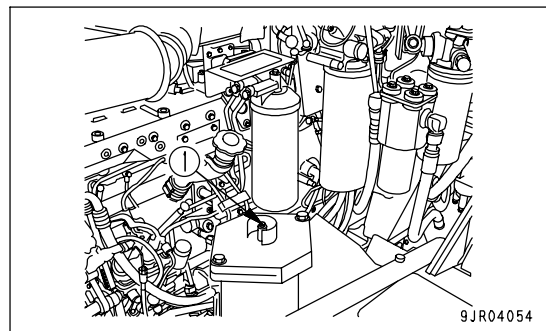

14. Carry out the warming-up operation of the engine until the torque converter oil temperature gauge goes above 40°.
15. When the torque converter oil temperature gauge rises to 40°, bleed the air from the brakes.
 Front brake: See "BLEED AIR FROM FRONT BRAKE (PAGE 4-32)".
 Center brake: See "BLEED AIR FROM CENTER BRAKE (PAGE 4-33)".

NOTICE

- Do not re-use the oil drained when bleeding the air. It will cause damage to the equipment.
- Be careful not to let the oil level in the brake oil tank go below sight gauge (H) during the air bleed operation. This will cause damage to the pump.

16. After completely bleeding the air from the brakes, stop the engine for approx. 2 - 3 minutes. After that, check the oil level in the transmission case and add oil to bring it to the specified level. For details, see "CHECK OIL LEVEL IN TRANSMISSION CASE, ADD OIL (PAGE 3-74)".

LUBRICATION

1. Using a grease pump, pump in grease through grease fittings marked by arrows.
2. After greasing, wipe off any old grease that was pushed out.

Carry out the greasing operation every day when operating in places where the grease flows out easily, such as when traveling through mud or water.

(1) Transmission front mount (1 place)

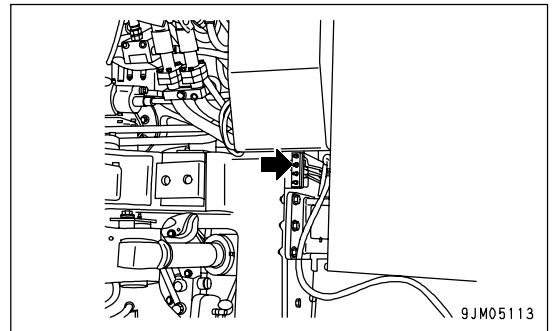

(2) Transmission rear mount (1 place)

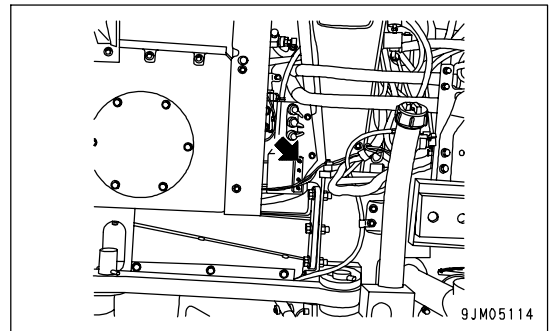

(3) Center hinge pin (2 places)

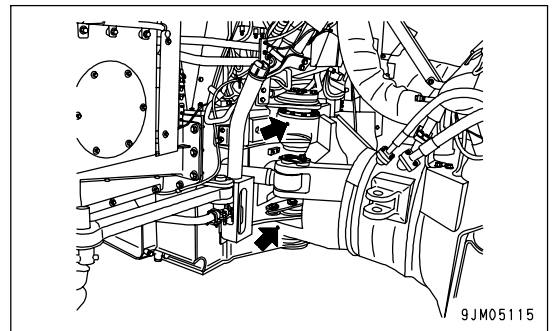

LUBRICATING PARKING BRAKE

**WARNING**

- When carrying out maintenance, raise the brake oil pressure sufficiently to prevent the parking brake from being automatically applied. In addition, hang a warning tag that can be seen clearly to prevent any other person from operating the parking brake switch.
- Do not get any oil or grease on the brake disc or pad surface.

1. Stop the machine in a flat place and put the blocks under the tires to prevent the machine from moving.
2. Raise the dump body and secure it in position with the body pivot pin.
3. Before starting operations, raise the brake oil pressure sufficiently to prevent the parking brake from being automatically applied, and check that the brake pressure caution lamp is not lighted up.
4. Release the parking brake and stop the engine.
5. Using a grease pump, pump in grease through fittings (1) and (2) (2 places) in the parking brake body and fitting (3) (1 place) in the slack adjuster.

NOTICE

Do not use air pressure or oil pressure to carry out high-pressure greasing.

6. After completing the greasing operation, remove fitting (1).
If grease comes out, wipe off all the grease that comes out.

REMARK

Removing fitting (1) makes it possible to release the abnormal internal pressure created by excessive greasing.

7. If no grease comes out, install fitting (1).

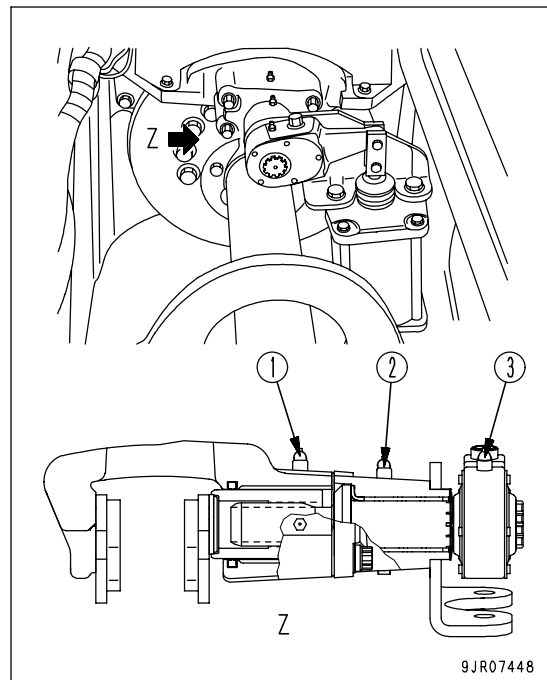

9JR07448

8. Check the braking capacity. For details, see "CHECK BRAKING CAPACITY OF PARKING BRAKE (PAGE 4-50)".
9. If the machine moves when the braking capacity is checked, adjust the parking brake. For details, see "ADJUST PARKING BRAKE (PAGE 4-37)".

CHECK WEAR OF BRAKE DISC

! WARNING

- Carry out this check when the brake oil temperature is below 60°C (140°F).
- If the disc wear approaches the wear limit, check the condition frequently, regardless of the maintenance interval. In addition, check the retarder capacity carefully.

1. Stop the machine on level ground, set the parking brake switch to the PARKING position, then check that the other brakes are not applied before starting inspection.
2. Turn the starting switch ON and check that the retarder oil pressure caution lamp is out.
If the retarder oil pressure caution lamp is lighted up, start the engine, run the engine at 2000 rpm, and if the lamp goes out, turn the starting switch OFF.
3. Remove cap nut (1).

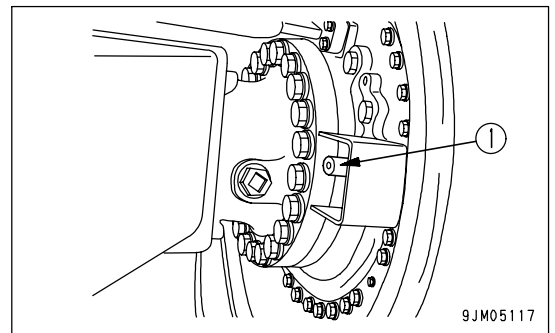

4. Depress the brake pedal, keep it depressed, and push in rod (2) of the gauge until it contacts the piston.
5. If mark (3) at position "A" of rod (2) enters beyond guide end face (4), it means that the disc has reached the wear limit.
For the front brake, use the mark at position "A", and for the center brake, use the mark at position "B".
If the disc has reached the wear limit, please contact your Komatsu distributor for inspection and maintenance.
6. Tighten cap nut (1) removed in Step 3.
Tightening torque: 14.7 to 19.6 Nm
(1.5 to 2.0 kgm, 10.8 to 14.5 lbft)

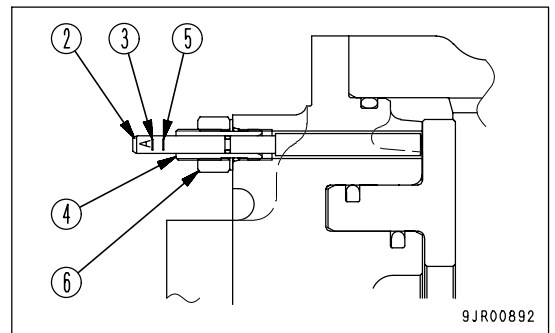

REMARK

- With new machines, the position of the guide is adjusted so that mark (5) comes to end face (4) of the guide, so do not loosen locknut (6) except when replacing the disc.
- Carry out the operation with two workers. One worker depresses the brake pedal and the other pushes in the rod.
- If the rod is pushed in when the engine is running, the rod will be pushed back by the brake cooling oil pressure, so always carry out this operation with the engine stopped.
- There are marks on the rod at three places (A, B, C), but for the front brake, use the mark at position "A", and for the center brake, use the mark at position "B".

CHECK OF ENGINE AIR INTAKE PIPING CLAMPS FOR LOOSENESS

Check for looseness in the intake piping clamps between the air cleaner, turbocharger, aftercooler, and engine. Tighten any loose clamps.

Tightening torque of clamp (1): 8.8 ± 0.5 Nm { 0.9 ± 0.05 kgm, 6.5 ± 0.4 lbft}

Tightening torque of clamp (2): 9.8 ± 0.5 Nm { 1.0 ± 0.05 kgm, 7.2 ± 0.4 lbft}

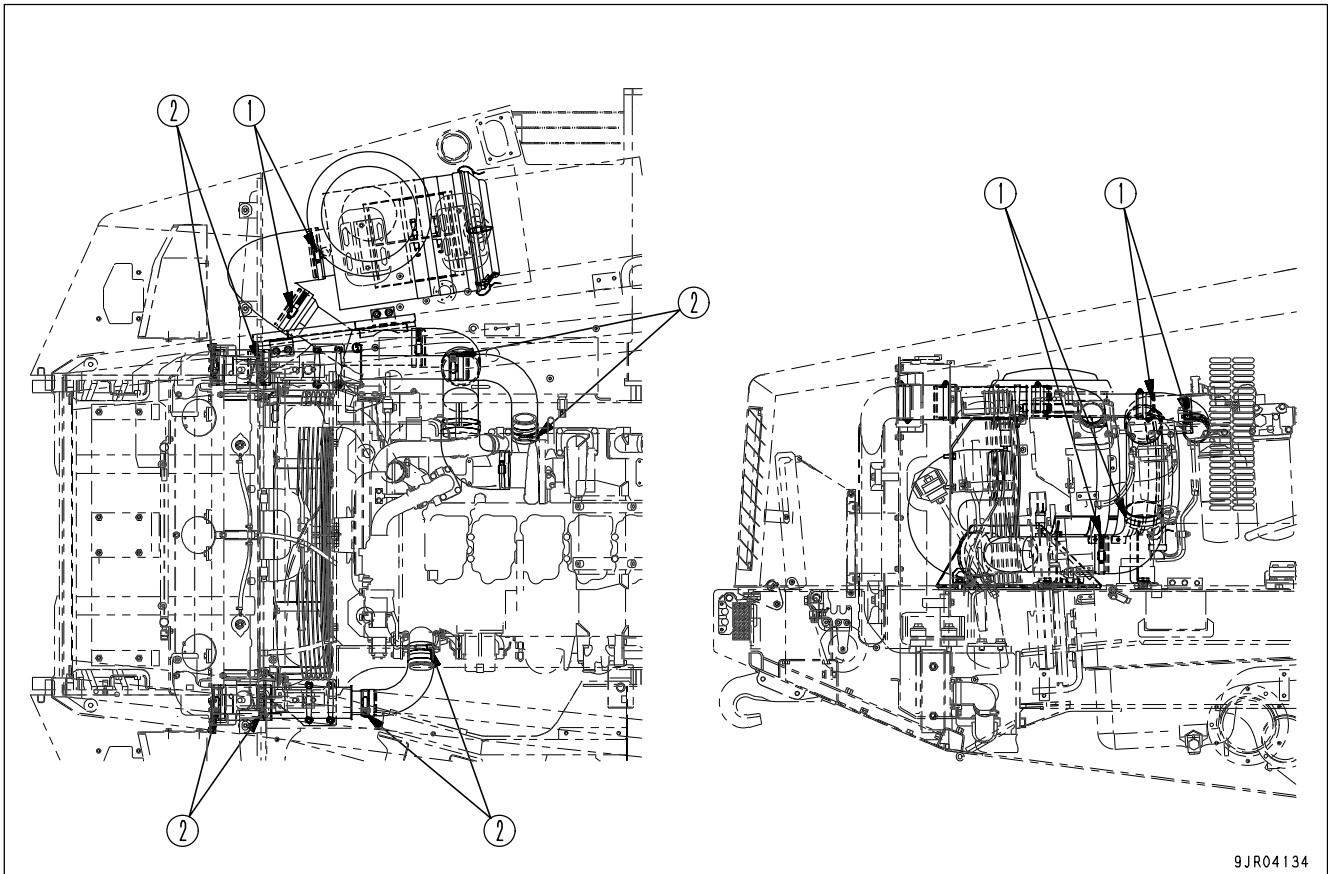

EVERY 2000 HOURS SERVICE

Maintenance for every 50, 250, 500 and 1000 hours service should be carried out at the same time.

CHANGE OIL IN FINAL DRIVE CASE



WARNING

- Immediately after the engine is stopped, the oil and parts are at high temperature, and this will cause burns. Wait for the temperature to go down before starting the operation.
- If there is still pressure remaining inside the case, the oil or plug may fly out. Turn the plug slowly to release the pressure, then remove it carefully.

- Refill capacity: Front left, right 4.0 liters (1.06 US gal) each
 Center left, right 3.5 liters (0.92 US gal) each
 Rear left, right 4.5 liters (1.19 US gal) each

1. Stop the machine so that the TOP casting mark is at the top and drain plug (P) is at the bottom.
2. Remove drain plug (P), drain the oil, then tighten the plug again.
3. Add oil through the hole for plug (G) to the specified level.
4. After adding oil, check that the oil is at the specified level. See "CHECK OIL LEVEL IN FINAL DRIVE CASE, ADD OIL (PAGE 4-54)".
5. Repeat the procedure in Steps 1 - 4 and change the oil to all the final drive cases (front, center, rear).

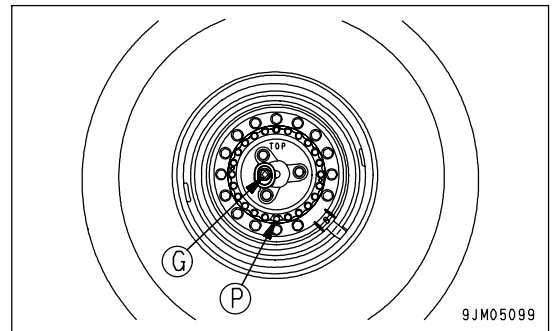

CHANGE OIL IN DIFFERENTIAL CASE

**WARNING**

- Immediately after the engine is stopped, the oil and parts are at high temperature, and this will cause burns. Wait for the temperature to go down before starting the operation.
- If there is still pressure remaining inside the case, the oil or plug may fly out. Turn the plug slowly to release the pressure, then remove it carefully.

- Refill capacity: Front 14.0 liters (3.70 US gal)
Center 24.5 liters (6.47 US gal)
Rear 25.0 liters (6.61 US gal)

1. Remove drain plug (P), drain the oil, then tighten the plug again.
2. Add oil to the specified level through the hole for plug (G) or oil filler port (F).
3. After adding oil, check that the oil is at the specified level. See "CHECK OIL LEVEL IN DIFFERENTIAL CASE, ADD OIL (PAGE 4-55)".
4. Repeat the procedure in Steps 1 - 3 and change the oil to all the differential cases (front, center, rear).

Front

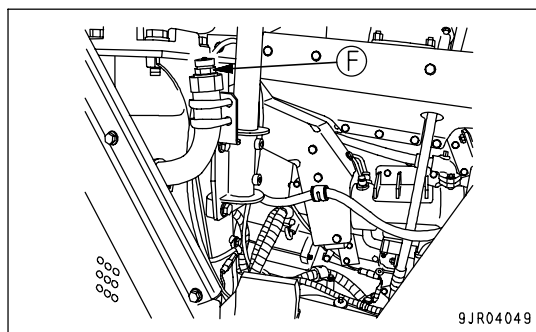
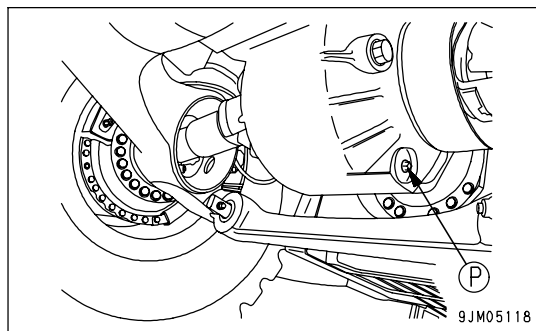

Center

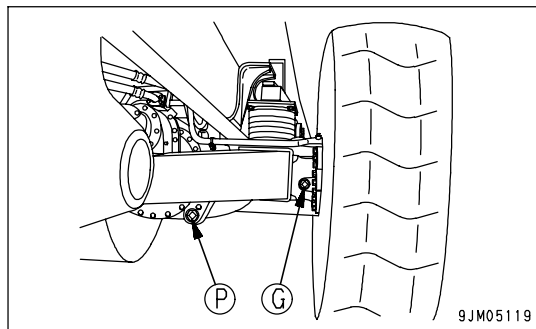

Rear

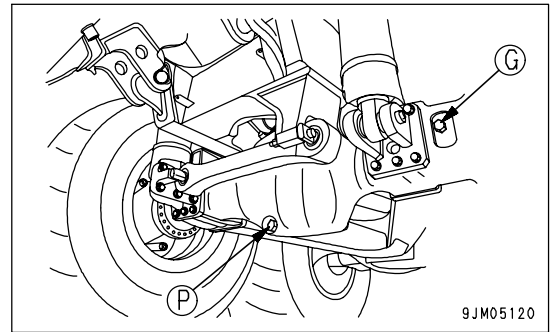

REPLACE HYDRAULIC FILTER ELEMENT

! WARNING

- The parts and oil are at high temperature immediately after the engine is stopped, and may cause burns. Wait for the temperature to go down before starting the work.
- When removing the oil filler cap, turn it slowly to release the internal pressure, then remove it.

1. Remove bolt (1), then remove cover (2).
2. Turn the cap of oil filler (F) slowly to release the internal pressure, then remove the cap.
3. Remove bolts (3), then remove cover (4).
4. Take out the element, then wash the inside of the case and the removed parts.
5. Install the new element, then install cover (4) with bolts (3).
6. Install cover (2) with bolts (1).

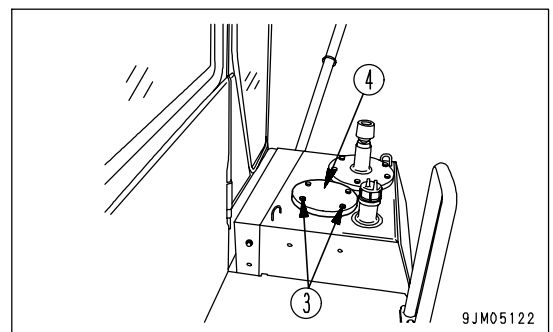
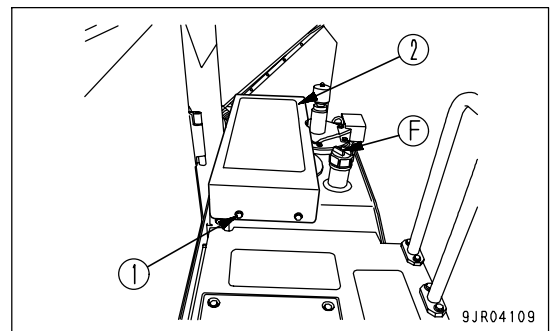

CLEAN TRANSMISSION CASE STRAINER**WARNING**

- The parts and oil are at high temperature immediately after the engine is stopped, and may cause burns. Wait for the temperature to go down before starting the work.
- When removing the oil filler cap, turn it slowly to release the internal pressure, then remove it.

Drain the oil from the transmission case before starting the operation. For details, see Section "CHANGE OIL IN TRANSMISSION CASE (PAGE 4-62)".

1. Remove bolt (1), then remove cover (2) and take out the strainer.
2. Remove any dirt stuck to the strainer, then wash it in clean diesel oil or flushing oil. If the strainer is damaged, replace it.
3. Install the strainers in their original position.

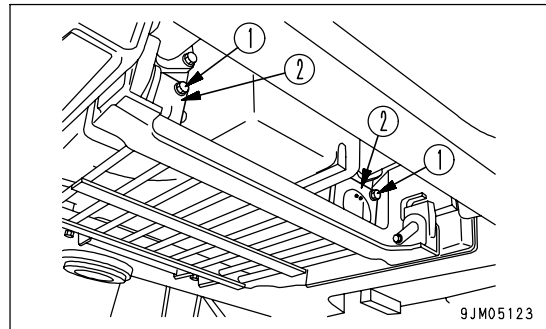

CLEAN BREATHER

 **WARNING**

- The parts and oil are at high temperature after the engine is stopped, and may cause serious burns. Wait for the temperature to go down before cleaning the engine breather.
- When using compressed air, there is a hazard that dirt may be blown up and cause serious injury. Always use safety glasses, dust mask, or other protective equipment.

Remove any mud or dirt from around the breather, then remove the breather and use clean diesel fuel or flushing oil to flush out the dirt inside.

- Transmission

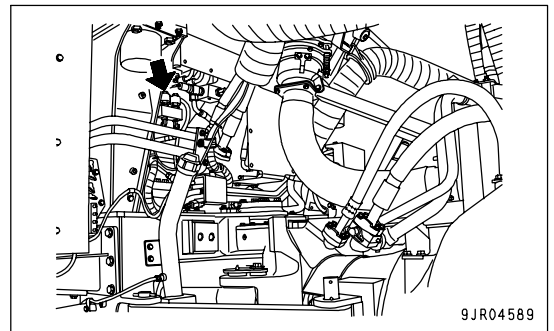

- Hydraulic tank

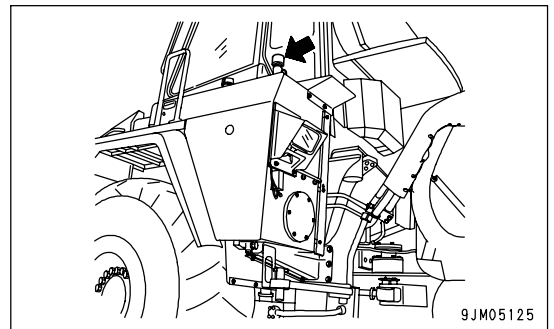

- Differential case (front)

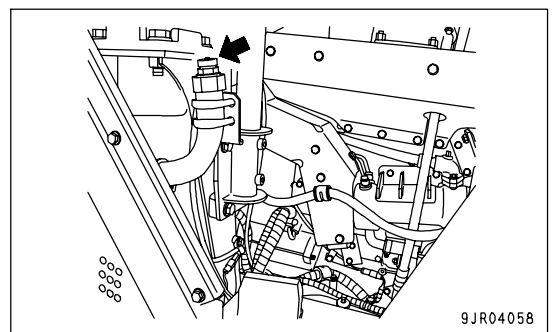

- Differential case (center)

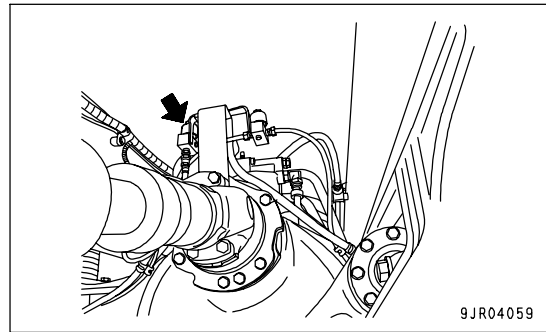

- Differential case (rear)

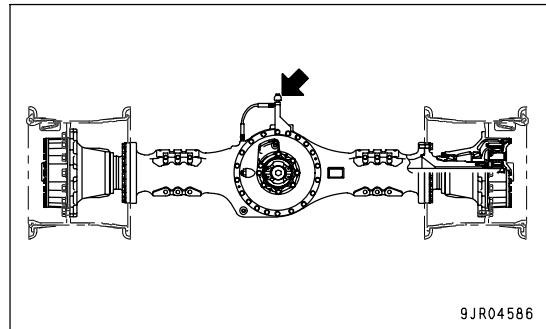

- Final drive case (front, left)

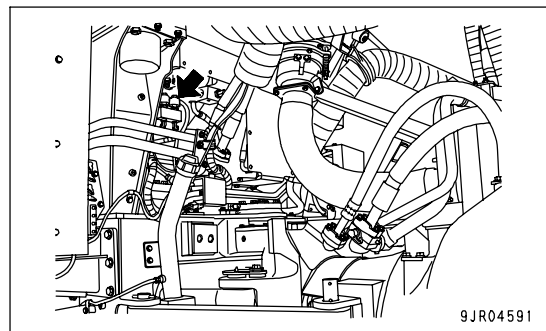

- Final drive case (front, right)

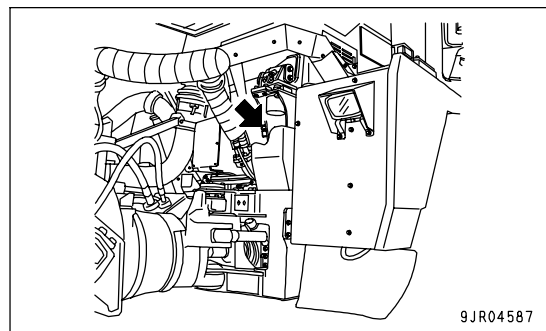

- Final drive case (center)

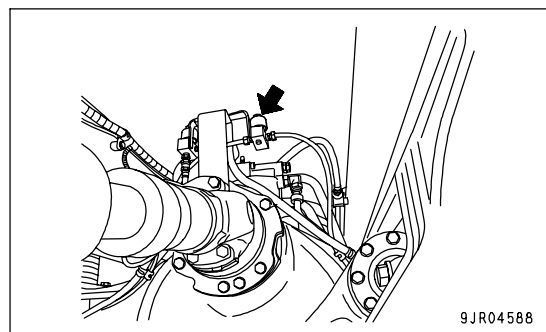

CHECK ACCUMULATOR GAS PRESSURE

Please contact your Komatsu distributor to have the gas pressure checked when making periodically replacement of safety parts or carrying out the legally required 2000 hour or every year service.

CHECK ALTERNATOR

There is the possibility that the brush has worn out, or the bearing has run short of grease, so call on your Komatsu distributor for an inspection or repairs.

CHECK, ADJUST ENGINE VALVE CLEARANCE

Special tools are needed for inspection and maintenance, so contact your Komatsu distributor.

CHECK VIBRATION DAMPER

Check that there are no cracks or peeling in the outside surface of the rubber.

If any cracks or peeling are found, contact your Komatsu distributor to have the parts replaced.

EVERY 4000 HOURS SERVICE

Maintenance for every 50, 250, 500, 1000 and 2000 hours service should be carried out at the same time.

CHANGE OIL IN HYDRAULIC TANK



WARNING

- The parts and oil are at high temperature immediately after the engine is stopped, and may cause burns. Wait for the temperature to go down before starting the work.
- When removing the oil filler cap, turn it slowly to release the internal pressure, then remove it.

- Refill capacity: 120 liters (31.70 US gal)

1. Lower the dump body and stop the engine.
2. Turn the cap of oil filler (F) to release the internal pressure before removing the cap.
3. Taking care not to get any oil on you, remove drain plug (P), drain the oil, then tighten the plug again.
4. Pour in the specified amount of engine oil from oil filler (F).
5. After adding oil, check that the oil is at the specified level. For details of the oil to use, see "CHECK OIL LEVEL IN HYDRAULIC TANK, ADD OIL (PAGE 3-74)".

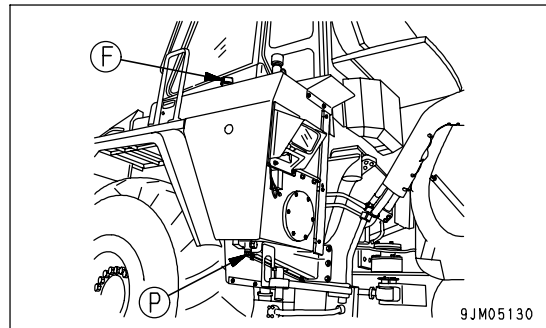

CHECK STARTING MOTOR

The brushes may be worn or the bearing may have run out of grease, contact your Komatsu distributor for inspection and repairs.

If the engine is started frequently, have this inspection carried out every 1000 hours.

CHECK WATER PUMP

Check around the water pump for water leakage. If any part is leaking, ask your Komatsu distributor for inspection/repair.

CHECK AIR COMPRESSOR

Ask your Komatsu distributor to carry out this work.

CHECK FAN PULLEY AND TENSION PULLEY

Check for play of the pulley and leakage of grease. If any problem is found, please contact your Komatsu distributor.

CHECK FOR LOOSE ENGINE HIGH-PRESSURE PIPING CLAMPS, HARDENING OF RUBBER

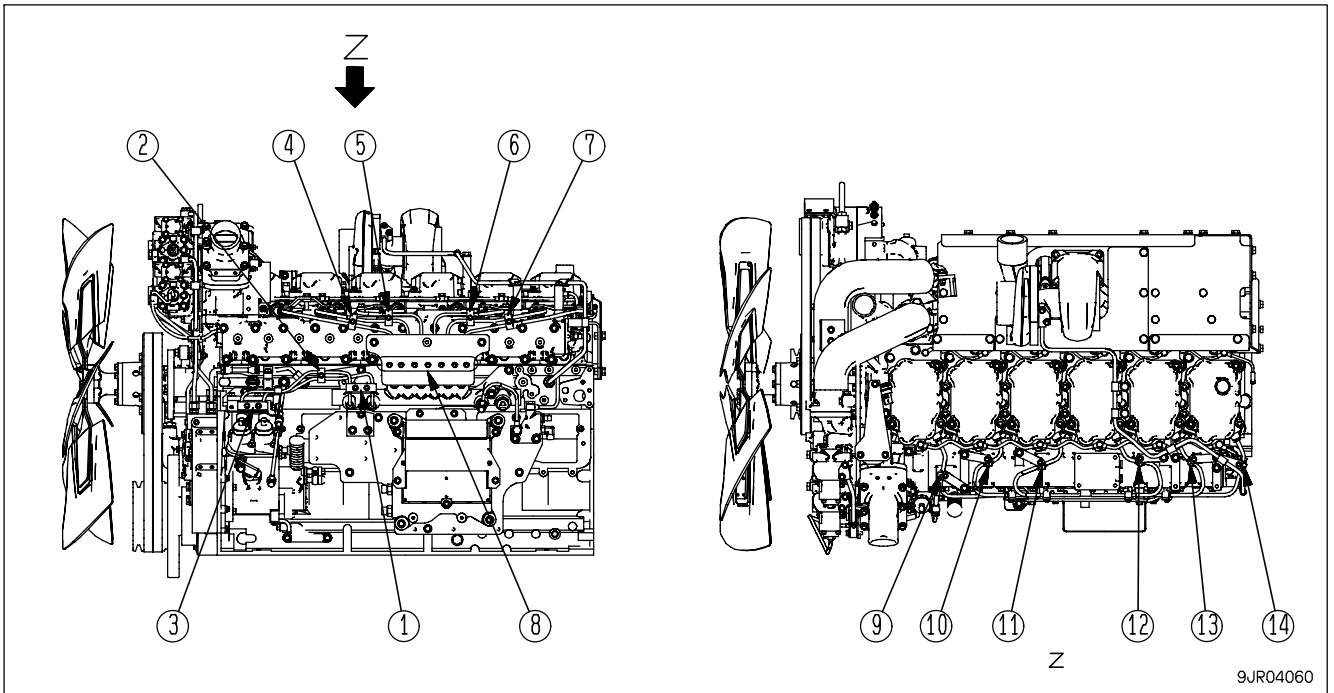

Check visually and touch with your fingers to check that there are no loose bolts or hardening of rubber parts at clamps (1) to (14). If there is any looseness or hardened rubber, contact your Komatsu distributor for replacement.

CHECKING FOR MISSING FUEL SPRAY PREVENTION CAP, HARDENING OF RUBBER

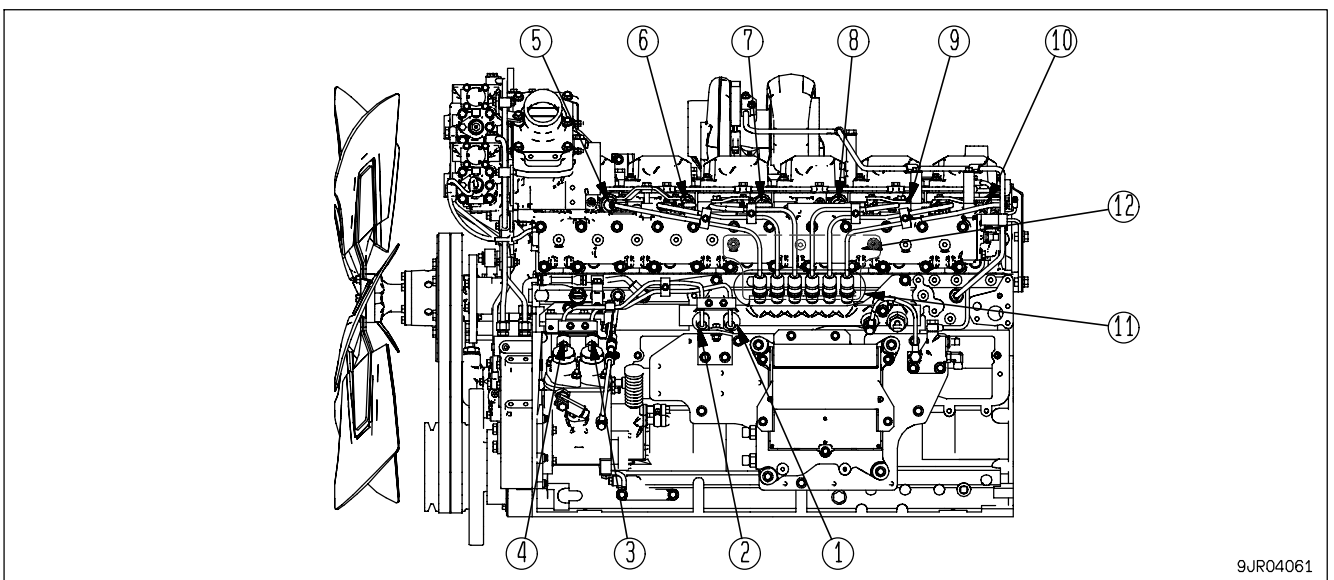

Check for any missing fuel spray prevention caps (1) to (11) or fuel spray prevention cover (12), and check also for any hardened rubber portions. If there are any missing caps or cover or the rubber is hardened, please contact your Komatsu distributor for repairs.

CHECK EXHAUST PIPE FIRE PREVENTION COVER**WARNING**

All the parts are at high temperature immediately after the engine is stopped, and may cause burns. Wait for the temperature to go down before starting the work.

Exhaust pipe fire prevention cover (1) may suffer material deterioration or damage depending on the conditions of use and the operating environment of the machine.

Open the engine hood and check exhaust pipe fire prevention cover (1). If any deterioration or damage to the material is found, please ask your Komatsu distributor to replace it.

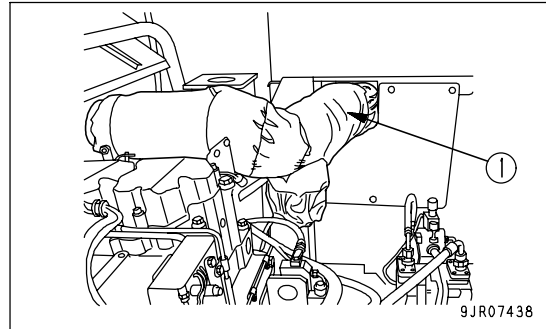

9JR07438

EVERY 6000 HOURS SERVICE

Maintenance for every 50, 250, 500, 1000, 2000 and 4000 hours service should be carried out at the same time.

LUBRICATE DRIVE SHAFT

When greasing, use lithium grease (G2-LI), and carry out the greasing every 6000 hours or every 2 years.

1. Using a grease pump, pump in grease through the grease fittings marked by the arrows.
2. Grease the spider portion until grease comes out from the cap seal.
3. After greasing, wipe off any old grease that was pushed out.

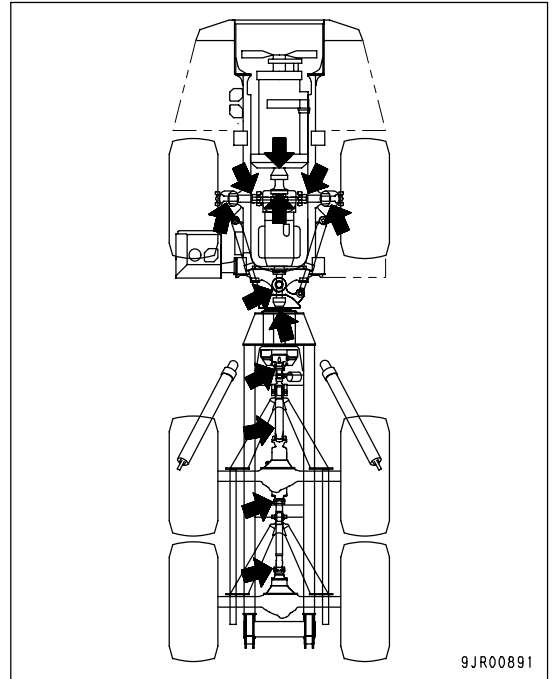

GREASING PROCEDURE FOR FRONT DRIVE SHAFT

 **WARNING**

When checking the positions of the grease holes and grease fittings, ensure that the machine is stopped. It is very dangerous to check the positions of the grease holes and grease fittings while the machine is running.

Check that grease hole (1) of the A-frame (at the rear of the machine) is matched with grease fitting (2) of the spider.

If grease hole (1) is not matched with grease fitting (2) of the spider, match them according to the following procedure.

1. Move the machine forward or reverse.
Do not go under the machine at this time.
2. Stop the engine and secure the machine by putting chocks under the tires.
3. Check that grease hole (1) is matched with grease fitting (2).
4. If grease hole (1) is not matched with grease fitting (2), match them by repeating steps 1 and 2.

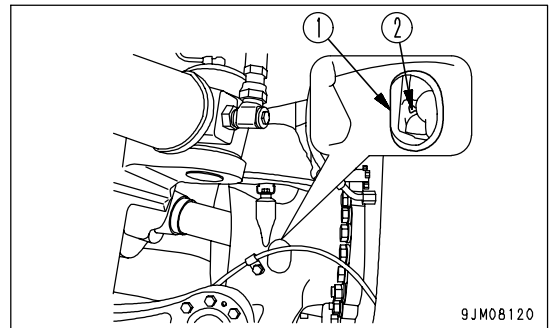

EVERY 8000 HOURS SERVICE

Maintenance for every 50, 250, 500, 1000, 2000, 4000 and 6000 hours service should be carried out at the same time.

REPLACE ENGINE HIGH-PRESSURE PIPING CLAMPS

Ask your Komatsu distributor to carry out this work.

REPLACE FUEL SPRAY PREVENTION CAP

Ask your Komatsu distributor to carry out this work.

OVERHAUL STARTING MOTOR AND ALTERNATOR

Ask your Komatsu distributor to carry out this work.

SPECIFICATIONS

SPECIFICATIONS

Item		Unit	HM300-2	
Overall weight (unladen weight + max. payload + 1 operator (75kg (165 lb)))		kg (lb)	51415 (113370)	
Unladen weight		kg (lb)	24040 (53008)	
Max. payload		kg (lb)	27300 (60197)	
Dump body capacity	Struck	m ³ (cu.yd)	12.9 (16.9)	
	Heaped (2 : 1)	m ³ (cu.yd)	16.6 (21.7)	
Dumping speed (at 2000 rpm) (raised)		sec	12	
Name of engine		-	Komatsu SAA6D125E-5 diesel engine	
Flywheel horsepower		kW (HP)/rpm	254 (340)/2000	
Max. torque		Nm (kgm, lbft)/rpm	1706 (174, 1258)/1400	
A	Overall length	mm (ft in)	10440 (34' 3")	
B	Overall height	mm (ft in)	3520 (11' 7")	
C	Overall height when dumping	mm (ft in)	6430 (21' 1")	
D	Overall width	mm (ft in)	2900 (9' 6")	
E	Min. ground clearance (bottom of rear axle)	mm (ft in)	510 (1' 8")	
Min. turning radius		mm (ft in)	7960 (26' 1")	
Travel speed	Forward	1st	km/h (MPH)	6.8 (4.2)
		2nd	km/h (MPH)	10.7 (6.6)
		3rd	km/h (MPH)	16.2 (10.1)
		4th	km/h (MPH)	25.5 (15.8)
		5th	km/h (MPH)	38.4 (23.9)
		6th	km/h (MPH)	58.6 (36.4)
	Reverse	1st	km/h (MPH)	7.6 (4.7)
		2nd	km/h (MPH)	18.1 (11.2)
Temperature range when using		°C (°F)	-20 to 40°C (-4 to 104°F)	

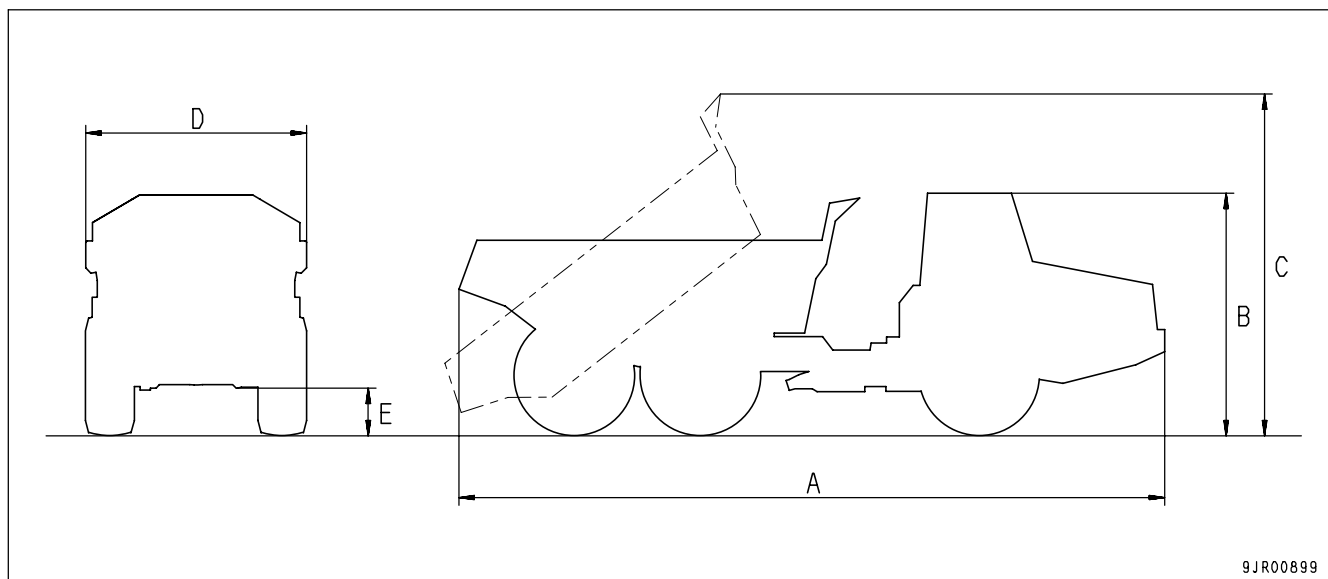

ATTACHMENTS, OPTIONS

 **WARNING**

Please read and make sure that you understand the SAFETY section before reading this section.

HANDLING AUTOMATIC RETARDER, ACCELERATOR CONTROL(ARAC)

This is a system to automatically activate the retarder when an operator wants to use it on a downslope or slow down on a flat hauling road. It enables the retarder to automatically function according to the present selected gear speed and engine revolution, thus making it easier for an operator to use the retarder.



WARNING

- The ARAC system begins to function when the automatic retarder, accelerator control switch is in the ON position. Check that this switch is turned on before running down on a slope.
- The ARAC system may not assure thorough braking force to slow down, depending on a slope inclination, load weight and selected gear speed. In that case, use the retarder control lever and brake pedal to slow down to a safety speed.
- The tires may be locked when the dump truck is running on a slippery hauling road and the ARAC system is in service. If that happens, stop using the ARAC system.
- Should some anomaly happen on the ARAC system and disable an operator from secure control of the dump truck, the system is put in the OFF condition and released, while the alarm buzzer sounds. In that case, keep control of the dump truck, using the retarder control lever and brake pedal, bring the truck to a halt in a safe place and turn off the automatic retarder, accelerator control switch.

EXPLANATION OF COMPONENTS

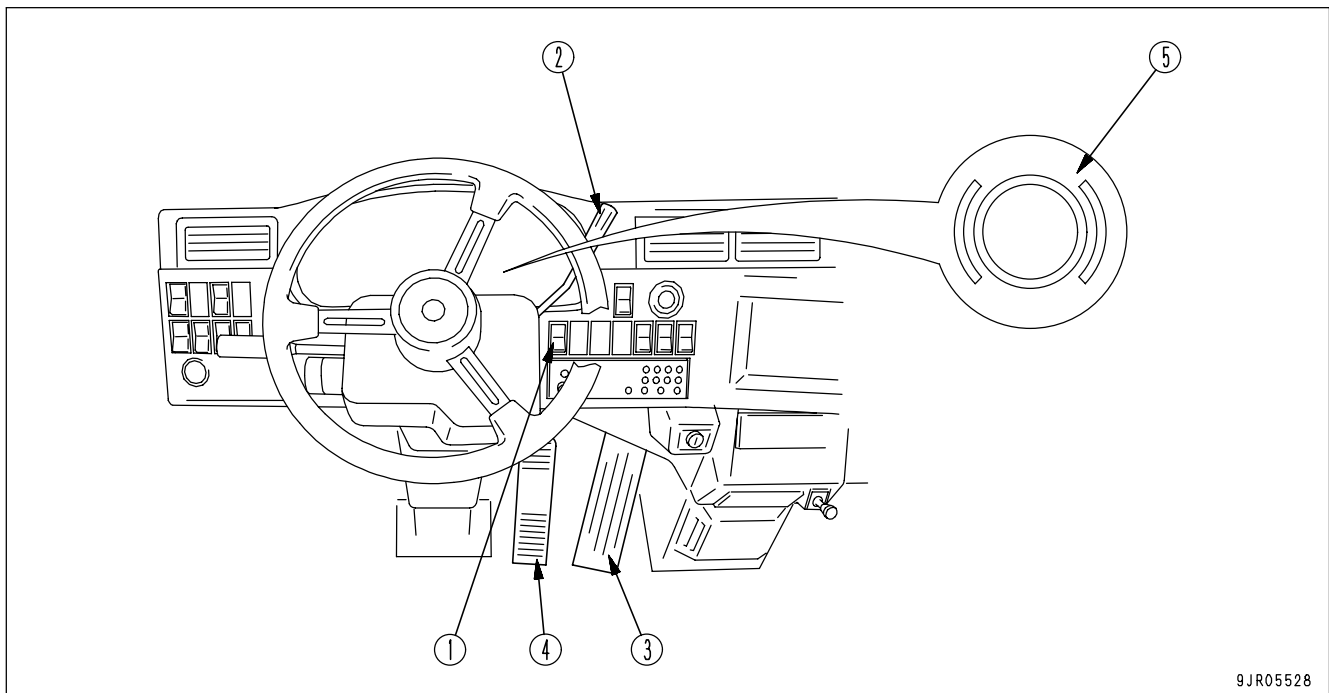

9JR05528

- | | |
|--|-------------------------|
| (1) Automatic retarder, accelerator control switch | (4) Brake pedal |
| (2) Retarder control lever | (5) Retarder pilot lamp |
| (3) Accelerator pedal | |

AUTOMATIC RETARDER, ACCELERATOR CONTROL SWITCH

This switch (1) is used to turn on and off the ARAC system.

(A): If the accelerator pedal is released when the machine is traveling at a speed of more than 7 km/h (4.3 MPH), the ARAC system is actuated and the retarder pilot lamp lights up. (If the engine speed is low, even when the ARAC system is actuated, the retarder pilot lamp may not light up.)

(B): The ARAC system does not function.

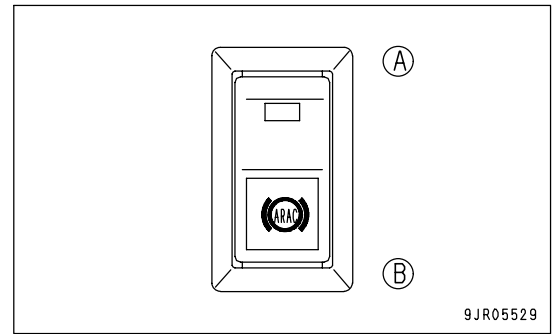
**RETARDER CONTROL LEVER**

This lever (2) activates the retarder even while the ARAC system is in service.

REMARK

When the ARAC system is in service, the retarder control lever has some play. It does not mean that the retarder does not work, but that the ARAC system is in service.

ACCELERATOR PEDAL

The ARAC system functions only while accelerator pedal (3) is released.

BRAKE PEDAL

This pedal (4) can activate the wheel brakes even while the ARAC system is in service.

RETARDER PILOT LAMP

This lamp (5) lights on when the ARAC system begins to function and when the retarder is operated with the retarder control lever.

METHOD OF OPERATION**ACTUATION OF ARAC SYSTEM**

The ARAC system is actuated when the auto retarder, accelerator control switch is turned ON.

When the auto retarder, accelerator control switch is turned ON, the retarder is automatically actuated according to the travel speed and engine speed at that point.

If the accelerator pedal is depressed when the ARAC system is being actuated, actuation of the ARAC stops and the machine speed increases.

If the brake pedal or retarder control lever are actuated while the ARAC is being actuated, the machine can be slowed down or stopped in the same way as for normal brake operations.

HANDLING PAYLOAD METER HM

FEATURES OF PAYLOAD METER HM

1. MEASURING LOADING

The payload meter-HM inputs the signals from the pressure sensors, clinometer, body float detection, and neutral detection, and uses the built-in microcomputer to calculate the amount loaded.

2. THREE MEASUREMENT METHODS

Payload meter HM has three measurement modes.

- Loading mode
- Travel mode
- Dumping mode

These three measurement modes are used in each cycle. It is possible to select the results of one of the three measurement mode to record as cycle data. The method of recording data can be selected by operating the switch (service check mode). Please select the appropriate method of measurement to suit your needs. Normally, measurement in the travel mode is most accurate. For details, please consult your Komatsu distributor.

3. PANEL DISPLAY

The calculations for the payload are displayed on the payload meter display. It is possible to use the switch to display the aggregate payload for the total cycle during a certain period.

4. EXTERNAL DISPLAY LAMP

There are three lamps on the external display: green, yellow, red. The payload is displayed by the external display lamps. The total payload if one more load is added is estimated, and the appropriate lamp flashes.

5. WRITING OPERATION DATA

The payload meter automatically records dump truck operation data, such as time, for each cycle, together with the time and date of starting or stopping the engine, time and date of the occurrence and remedy for abnormalities or warnings, from any given time.

Recorded data are retained when the power is turned off, so it is possible to send (download) the data to a personal computer from the payload meter through a cable connected to the port (ANSI/EIA RS-232C) inside the cab. In addition, based on these data, the truck operation data can be displayed on a personal computer screen, printed out, or converted to LOTUS 1-2-3 or EXCEL data.

METHOD OF USING ACCURATELY

1. LENGTH OF SUSPENSION CYLINDER

The payload meter uses the signal from the suspension pressure sensor to measure the load. Adjust the length of the suspension cylinder periodically to the proper range. For details, please consult your Komatsu distributor.

2. CARRYING OUT CALIBRATION

Carry out calibration travel in the following cases.

- When the machine has been brought into the jobsite
- When the machine has been modified (when the machine weight has changed)
- When the suspension cylinder gas has been adjusted
- When the fixed periodic interval has passed

Carry out the calibration travel on a flat, straight road of approx. 120 m (393 ft 8 in) with no uneven places.

If the measurement is carried out on a road that is not flat or not straight, it will be impossible to achieve accurate measurement.

3. METHOD USING TRAVEL MODE

When method using travel mode is selected

- The accuracy varies according to the condition of the road. Carry out the calibration on a road that is as flat as possible. This will make it possible to carry out accurate measurement. To make highly precise measurements, carry out maintenance of the road surface first.
- The accuracy varies according to the distance travelled. The longer the distance travelled, the more accurate the measurement becomes. Carry out the measurement only when traveling at a speed of at least 8 km/h (5.0 MPH) and on a grade of less than 5°. Even on roads fulfilling the above conditions, the minimum distance is 100 m (328 ft 1 in).

4. METHOD USING DUMPING MODE

When method using dumping mode is selected

- Carry out where working range is flat area
- Carry out the work in a place where the grade is within $\pm 5^\circ$. If the grade is more than $\pm 5^\circ$, the accuracy will be poor.
- Do not put the blocks in strong contact with the tires. If there is strong contact, the payload measurement value will be higher than the actual value.
- When dumping, use the parking brake. Release the foot brake or retarder brake.
- Stop with the brake and wait for the pitching of the machine to stop before raising the dump body. To obtain an accurate value, apply the parking brake and release the foot brake or retarder brake. Then wait for 3 to 5 seconds before dumping.

5. METHOD USING LOADING MODE

To obtain an accurate value using the loading mode (including external display lamp)

- The better the loading place is maintained, the more accurate a measurement can be obtained.
- Carry out the work in a place where the grade is within $\pm 5^\circ$. If the grade is more than $\pm 5^\circ$, the accuracy will be poor.
- When loading, use the parking brake. Release the foot brake or retarder brake.
- Do not start loading until the machine is completely stopped.
- When the equalizer bar is in contact with stopper

1) If the equalizer bar is in contact with the stopper, an accurate measurement cannot be obtained.

2) If the machine is stopped empty at the loading point, the payload meter-HM detects contact between the equalizer bar and stopper.

If the equalizer bar contacts the stopper, error code "F-FL" is shown on the display and all the external display lamps flash.

3) If all the external display lamps flash, do not carry out loading.

4) If error code "F-FL" is displayed, drive the machine forward until "F-FL" goes out, then stop the machine.

5) When moving the machine, set the gear shift lever to D. When stopping the machine, wait for the machine to stop completely, then shift the gear shift lever to N.

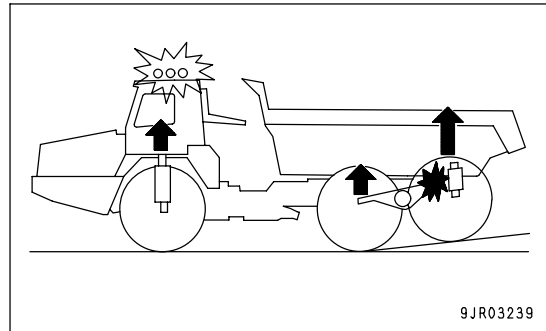

6. DOWNLOADING

The payload meter can store 2900 cycles in memory. (Normally, enough for more than 1 month's work)

If the data in memory exceed 2900 cycles, the newest data are written over the oldest data and are saved in memory. Before operating and saving, download the data to a PC, then clear the data.

GENERAL LOCATIONS

CONTROLLER SCREEN

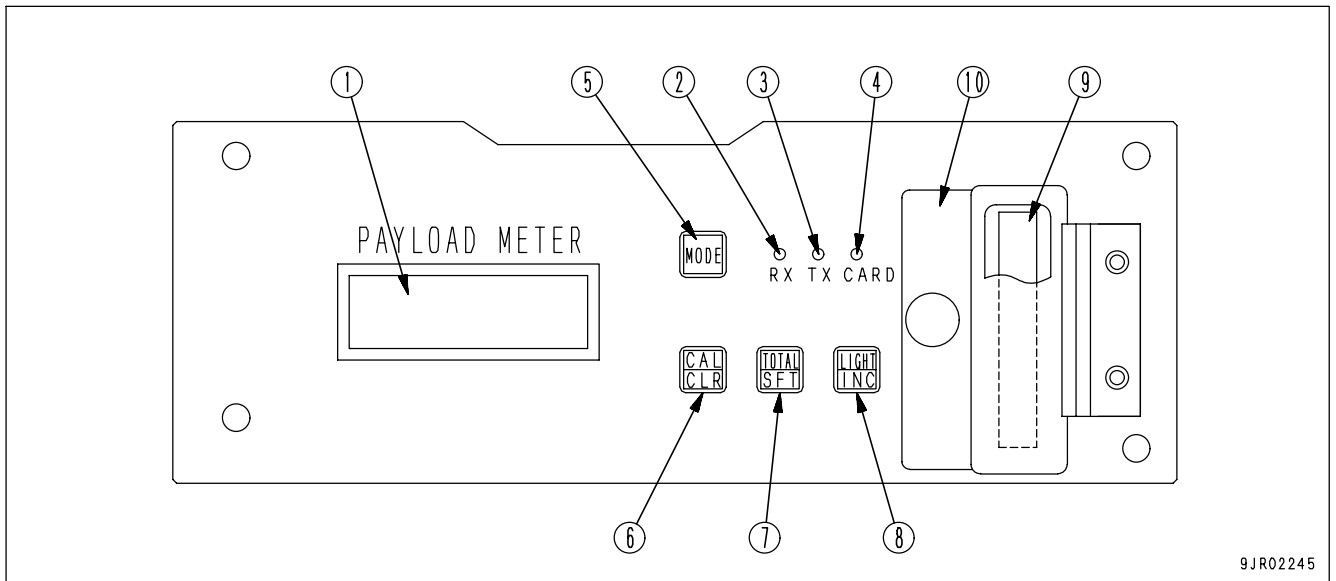

- (1) Display panel
- (2) Reception pilot lamp (Rx busy)
- (3) Transmission pilot lamp (Tx busy)
- (4) Memory card access lamp (CARD busy)
- (5) MODE switch

- (6) CAL/CLR switch
- (7) TOTAL/SFT switch
- (8) LIGHT/INC switch
- (9) Memory card
- (10) Cover

LEFT FACE OF CONTROLLER

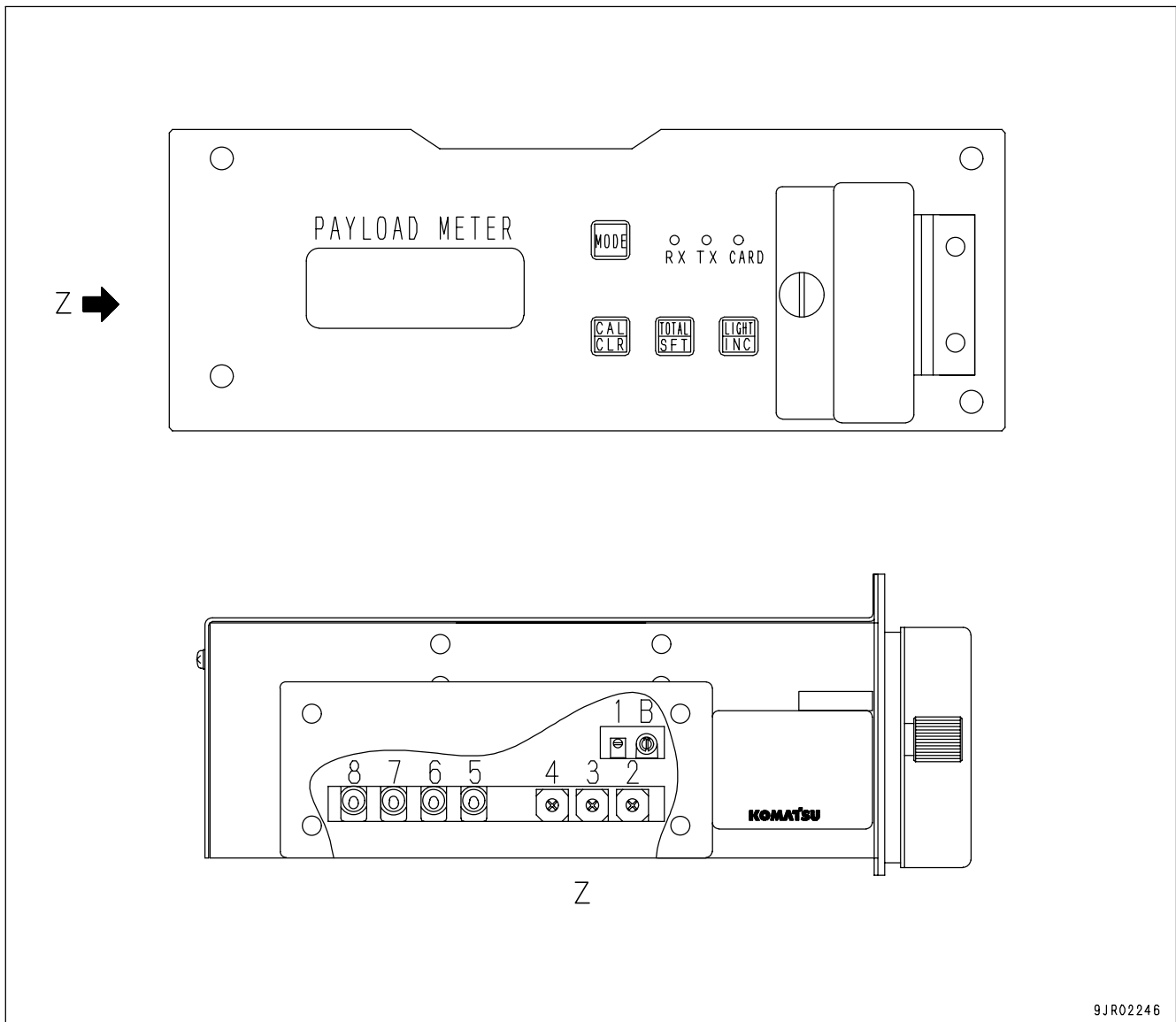

NOTICE

The switches on the left side are set when the machine is shipped from the factory.
Do not touch switch.

EXTERNAL DISPLAY LAMPS

The external display lamps are on top of the cab. To make them visible for the digging operator or wheel loader, there are two sets of external display lamps: each set consists of three lamps (green, yellow, red).

- (1) Green lamp
- (2) Yellow lamp
- (3) Red lamp

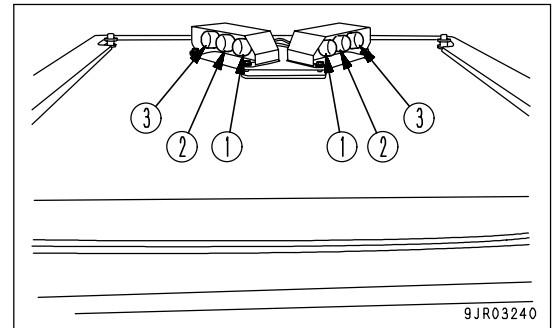

COMMUNICATIONS CABLE CONNECTION PORT FOR PERSONAL COMPUTER

The port for connecting the communication cable is on the left side of the starting switch.

When not using the communication cable connection port, fit the connector cap.

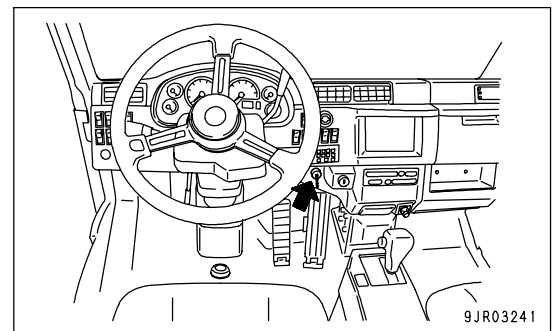

CONTENT OF DISPLAY (CONTROLLER, EXTERNAL DISPLAY LAMPS)

WHEN THE POWER IS ON

When the power is turned ON, the displays on the controller display and external display lamps are as follows.

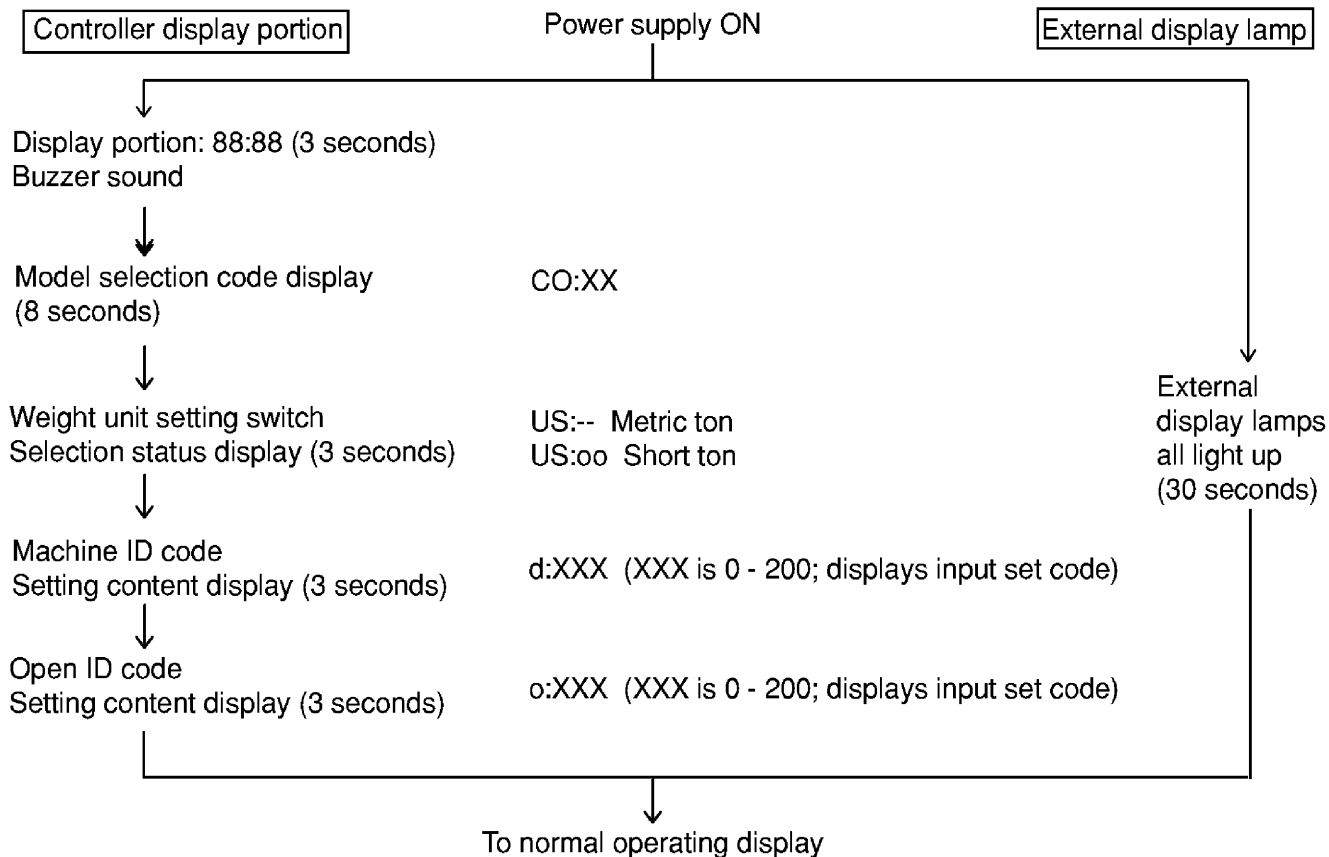

DISPLAY DURING NORMAL OPERATIONS

Condition of machine		Gear shift lever position	Dump body position	Display panel	External display lamps
When empty	Stopped	N	seated	Time display	OFF
	Traveling	Except N	seated	Time display	OFF
During loading	Stopped	N	seated	Payload display	Payload display and display of estimate
	Traveling (*1)	Except N	seated	Travel distance display	OFF
When loaded	Stopped	N	seated	Payload display	Payload display
	Traveling	Except N	seated	Time display	OFF
When dumping (*2)		N	seated → unseated	Total payload display (*3) [100 tons]	OFF
When abnormality or warning is generated		-	-	See "ABNORMALITY AND WARNING DISPLAY (ERROR CODE)"	

*1: If the machine is stopped again before traveling 5 m (16 ft 5 in), the machine display portion/external display lamps will both return to the loading stopped display. After traveling more than 5 m (16 ft 5 in), the machine will recognize the payload.

*2: When the dump body is raised, the payload for that cycle is confirmed. If the dump body is lowered fully again and more than 50% of the specified standard payload is remaining, it will be taken as mistaken operation. It will not be recognized as the completion of dumping.

*3: The display for the total payload is given in units of 100 t (rounded to the nearest 100).

For the method of clearing the total payload (resetting of the measurement to 0), see "FORCED DISPLAY OF TOTAL PAYLOAD AND OVERALL NUMBER OF CYCLES (PAGE 6-20)".

Even if the power for the payload meter is turned off when the machine is traveling empty, the condition of the machine during loading or when traveling loaded is retained, so when operations are started again, the payload meter starts from the same condition of the machine.

Do not turn off the power during dumping. The correct data will not be written.

NOTICE

- There are cases where there is a difference between the condition of the machine recognized by the payload meter and the actual condition of the dump truck, an accurate measurement cannot be made. In the following cases (1) - (3), please consult your Komatsu distributor.
 - (1) When a new controller has been installed
 - (2) When the controller has been replaced
 - (3) When the internal battery has been replaced
- If the above "Normal operation display" is not given, stop the machine unloaded, and raise and lower the dump body.
- Do not turn the power off during dumping. If the power is turned off when the dump body is raised, it may be impossible to record the cycle data accurately.

EXTERNAL DISPLAY LAMPS

DISPLAY LEVEL FOR LAMPS



WARNING

If the red lamp lights up, the machine is overloaded. Do not haul a load under this condition. To prevent overloading, we recommend loading only up to a range where the yellow lamp lights up.

- The external lamps display the payload as follows.

	Color of lamp	HM300-2
1	Green	13.7 tons and up
2	Yellow	24.6 tons and up
3	Red	28.7 tons and up

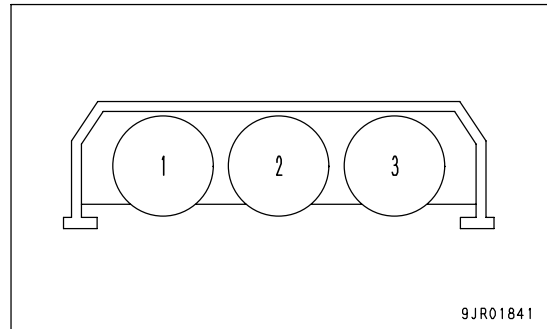

ESTIMATE DISPLAY

- When the load changes in steps for each bucket loaded, the system estimates the total payload if one more bucket is loaded, and flashes the appropriate lamp to prevent overloading.
- The predicted load display and actual payload display are shown at the same time.

[Example: expected number of bucket loads: 5]

- 1st bucket 5 tons
- 2nd bucket 5 tons (total: 10 tons)
- 3rd bucket 5 tons (total: 15 tons)
- 4th bucket 5 tons (total: 20 tons)
- 5th bucket 5 tons (total: 25 tons)

When the machine is loaded in this way, the external display lamps light up as shown in the chart below.

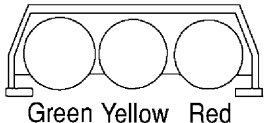
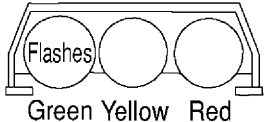
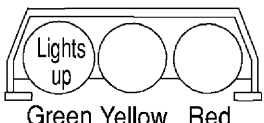
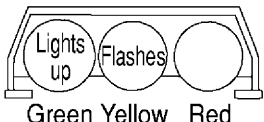
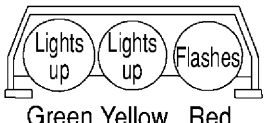
No. of loads	External display lamp	Remarks
1st bucket	 <p>Green Yellow Red</p>	<ul style="list-style-type: none"> • The weight actually loaded is 5 tons, so no lamp lights up. • The predicted load is 10 tons, so no lamp flashes.
2nd bucket	 <p>Green Yellow Red</p>	<ul style="list-style-type: none"> • The weight actually loaded is 10 tons, so no lamp lights up. • The predicted load is 15 tons, so the green lamp flashes.
3rd bucket	 <p>Green Yellow Red</p>	<ul style="list-style-type: none"> • The weight actually loaded is 15 tons, so the green lamp lights up. • The predicted load is 20 tons, so no lamp flashes.
4th bucket	 <p>Green Yellow Red</p>	<ul style="list-style-type: none"> • The weight actually loaded is 20 tons, so the green lamp lights up. • The predicted load is 25 tons, so the yellow lamp flashes.
5th bucket	 <p>Green Yellow Red</p>	<ul style="list-style-type: none"> • The weight actually loaded is 25 tons, so the green and yellow lamps light up. • The predicted load is 30 tons, so the red lamp flashes.

NOTICE

- If the red lamp flashes, and the same load as in the last bucket is loaded, the total load will exceed 105%.
- If the red lamp flashes and the yellow lamp also lights up, do not load anything.
- If the red lamp flashes and the yellow lamp also flashes, load half a bucket.

REMARK

It is possible to change the lighting-up conditions of the lamp by operating the switch of the payload meter controller. Please consult your Komatsu distributor before making any changes.

DETAILS OF DATA STORED IN MEMORY OF PAYLOAD METER

The payload meter stores the data in this section in non-volatile RAM.

This data are retained even when the power is switched OFF, so they can be used later as follows.

It is possible to transmit data to a personal computer by using a communication cable (RS-232C). (The data can be downloaded.)

The data saved in the personal computer can be converted to data that can be processed by LOTUS 1-2-3 or EXCEL, so it is possible to use these data to carry out data processing as desired.

REMARK

For details, see the software manual.

CYCLE DATA

The cycle data are saved in RAM every time the load is dumped.

The maximum limit for saving cycle data is 2900 cycles. If the data in memory exceed 2900 cycles, the newest data are written over the oldest data and are saved in memory.

If more than 2600 cycles are saved in memory (space for 300 cycles remaining), error code "L:FUL" is displayed. If error code "L:FUL" is displayed, download the data to a PC, then clear the data.

Item	Unit	Range	
Engine operation No.	Integer	1 - 65535	See engine ON/OFF data When dumping
Month	Month	1 - 12	
Day	Day	1 - 31	
Time Hour	Hour	0 - 23	
Time Min	Minute	0 - 59	
Machine ID	Integer	0 - 200	
Open ID	Integer	0 - 200	
Payload	MT or ST	0 - 6553.5	
Warning items for each cycle	-	-	See (*1)

(MT: Metric Ton; ST: Short Ton)

*1: Abnormalities and warnings that occur during the cycle are displayed.

For details, see the output examples in the software manual.

ENGINE ON/OFF DATA

The data are saved to RAM both when the engine is started and when it is stopped.

The maximum limit for saving engine ON/OFF data is 115 ON/OFF sets. If the data in memory exceed 115 sets, the newest data are written over the oldest data.

If more than 105 sets are saved in memory (space for 10 sets remaining), error code "E:FUL" is displayed. If error code "E:FUL" is displayed, download the data to a PC, then clear the data.

Item	Unit	Range	
Engine operation No.	Integer	1 - 65535	Consecutive numbers for engine operation (*1)
Year (last 2 digits)	Year	0 - 99	Shows when engine was switched ON
Month	Month	1 - 12	
Day	Day	1 - 31	
Time Hour	Hour	0 - 23	
Time Min	Minute	0 - 59	

Year (last 2 digits)	Year	0 - 99	Shows when engine was switched OFF
Month	Month	1 - 12	
Day	Day	1 - 31	
Time Hour	Hour	0 - 23	
Time Min	Minute	0 - 59	

Total payload	MT or ST	0 - 9999000	Total payload from time engine was switched ON to time engine was switched OFF
Overall number of cycles	Times	0 - 9999	

(MT: Metric Ton; ST: Short Ton)

*1: Every time the engine is switched ON, the engine operation No. advances by one, and is recorded. The engine operation No. in the cycle data and the engine operation No. in the problem/warning data, which are recorded from the time the engine is switched ON to the time it is switched OFF, are all recorded as an equal value. As a result, when using a personal computer later to compile the data, it is possible to determine what time during the engine operation the cycle data or system problem refers to.

ABNORMALITY, WARNING DATA

When a problem or warning occurs or is restored in the payload meter system, these data are recorded in RAM. The maximum limit for problem/warning data is 230 sets of occur/restore.

Item	Unit	Range	
Error code	-		See section on abnormality/warning display (*1) Shows when abnormality restored
Engine operation No. when occurred	Integer	0 - 65535	
Number of times of occurrence since engine was switched ON	Times	1 - 255	
Year (last 2 digits)	Year	0 - 99	
Month	Month	1 - 12	
Day	Day	1 - 31	
Time Hour	Hour	0 - 23	
Time Min	Minute	0 - 59	
<hr/>			
Engine operation No. when restored	Integer	0 - 65535	Shows when abnormality restored
Year (last 2 digits)	Year	0 - 99	
Month	Month	1 - 12	
Day	Day	1 - 31	
Time Hour	Hour	0 - 23	
Time Min	Minute	0 - 59	

*1: Every time the engine is switched ON, the engine operation No. advances by one, and is recorded. The engine operation No. in the cycle data and the engine operation No. in the abnormality/warning data, which are recorded from the time the engine is switched ON to the time it is switched OFF, are all recorded as an equal value. As a result, when using our personal computer later to compile the data, it is possible to determine what time during the engine operation the cycle data or system abnormality refers to.

OPERATION OF SWITCHES

By operating the switches on the payload meter, it is possible to force the following operations.

- "CARRYING OUT CALIBRATION (PAGE 6-18)"
- "FORCED DISPLAY OF TOTAL PAYLOAD AND OVERALL NUMBER OF CYCLES (PAGE 6-20)"
- "OPERATOR CHECK MODE (PAGE 6-21)"
 - (a) Memory card dump operation (PAGE 6-23)
 - (b) Open ID setting (PAGE 6-24)
 - (c) Machine ID setting (PAGE 6-25)
 - (d) Adjusting time, date (PAGE 6-26)
 - (e) Data all clear operation (PAGE 6-28)
- "DIMMING LIGHTS ON MONITOR DISPLAY (PAGE 6-29)"
- "SERVICE CHECK MODE (PAGE 6-29)"

CARRYING OUT CALIBRATION

WHEN CARRYING OUT CALIBRATION

NOTICE

Carry out calibration in the following cases.

- When the machine is delivered, and at each change of season
- When the suspension cylinder gas pressure and oil has been adjusted (When the suspension has been adjusted.)
- When the machine has been modified and the unloaded weight of the machine has changed more than 100 kg (221 lb)
- When the suspension pressure sensor has been replaced
- When any other change has been made around the suspension
- When there is a difference between the condition of the machine recognized by the payload meter and the actual condition of the dump truck. For details, see Section "DISPLAY DURING NORMAL OPERATIONS (PAGE 6-11)".

PREPARATIONS BEFORE CARRYING OUT CALIBRATION

- Check that the length of the suspension is within the proper range. For details, see Section "CHECK LENGTH OF SUSPENSION CYLINDER (PAGE 4-31)".
- When carrying out calibration, use a flat, straight road with no uneven places. (Distance: approx. 120 m (393 ft 8 in))
- Carry out the checks with the machine unloaded. Be sure to completely remove all the soil remaining inside the dump body.

METHOD OF CARRYING OUT CALIBRATION (METHOD OF OPERATION)

1. Move the gearshift lever to the N position and keep CAL/CLR switch (1) pressed for at least 2 seconds. (The letters CAL flash)
2. Press CAL/CLR switch (1) again. (Letters CAL light up.)
3. Shift the gear shift lever to 2, depress the accelerator pedal fully, and travel in a straight line. When the travel speed goes above 9 km/h (5.6 MPH), the elapsed time is displayed.

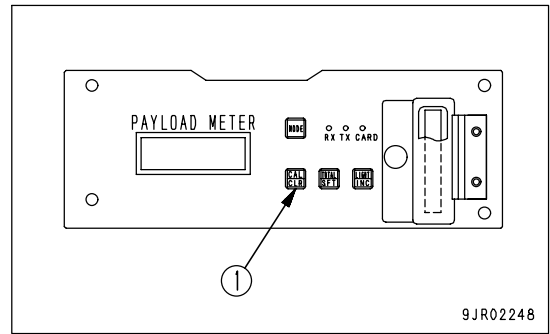

4. The present payload measurement value is displayed 30 seconds after carrying out calibration travel.
5. Stop the machine slowly. After stopping the machine completely, return the gearshift lever to N . Use the parking brake. Release the foot brake or retarder brake.
6. If the dump body is empty, the measurement value for the payload is measured as approx. 0.0 tons. If more than ± 1 tons is displayed for the payload, carry out calibration travel again.
7. Press the MODE switch. The display changes to the normal operation display.

NOTICE

- Carry out the calibration on a flat road surface with no uneven places. The flatter the road surface is, the more accurate the measurement becomes.
- Travel in a straight line. (Distance: Approx. 120 m (393 ft 8 in))
- Be careful to carry out the calibration accurately. If calibration is not carried out accurately, there will be an error in the measurement of the payload, so the measurement will not be correct.
- Shift the gear shift lever to 2 and depress the accelerator pedal fully. Do not let the accelerator pedal back.
- The calibration data are saved to the internal RAM. After calibration is being carried out, even if the power is turned off, the data are retained.
- If it is desired to stop the calibration during the calibration operation, press the MODE switch while the letters CAL are flashing in Step 1. The display will change from CAL to the normal display.
- If an error occurs on the machine, depending on the error, it may be impossible to carry out calibration. For details, see Section "ABNORMALITY AND WARNING DISPLAY (ERROR CODE) (PAGE 6-30)"

FORCED DISPLAY OF TOTAL PAYLOAD AND OVERALL NUMBER OF CYCLES

- The payload meter displays the total payload when the load is dumped, but it is also possible to use the following operation to display the total payload and overall number of cycles.
- For the total payload and overall number of cycles, each time the load is dumped, its weight is added. Furthermore, it is possible to clear this figure and return the total to 0 at any time. However, when this operation is carried out, if any abnormality or warning has occurred, the error code for that abnormality or warning is displayed in turn.

Method for forced display operation

1. Press TOTAL/SFT switch (1).
The total payload is displayed (100 tons units, rounded to the nearest 10 tons) (lights up).
2. Press TOTAL/SFT switch (1) again.
The overall number of cycles is displayed. (Unit: times) (lights up)
3. Press TOTAL/SFT switch (1) again.
":" is displayed (lights up) for 2 seconds, then the display returns to the display for normal operation.

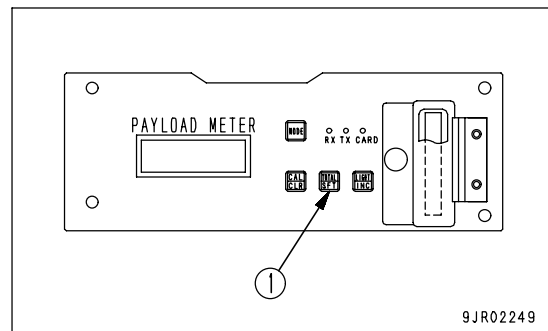

It is possible to clear all the data for total payload and overall number of cycles whenever desired. After the values are cleared, the total payload and overall number of cycles are calculated again from 0.

Method of clearing total payload and overall number of cycles

1. Press TOTAL/SFT switch (1) to display the total payload and overall number of cycles.
2. Keep CAL/CLR switch (2) pressed for at least 2 seconds.
The total payload or overall number of cycles display will flash.
3. Keep CAL/CLR switch (2) pressed again for at least 2 seconds.
After ":" is displayed for 2 seconds, if the display returns to the normal operation display, the zero clear operation is completed.

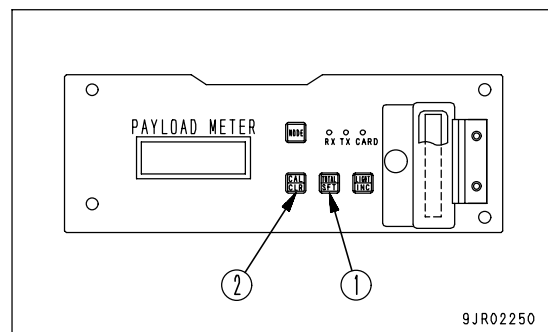

REMARK

- Zero clear is carried out at the same time for both the total payload and total number of cycles. It is impossible to clear only one of the above types of data.
- The maximum limit for total payload/total number of cycles is as follows.
Total payload: 999900.0 tons
Total number of cycles: 9999
- Before exceeding the maximum limit, carry out the zero clear procedure for total payload/total number of cycles.

OPERATOR CHECK MODE

By using the operator check mode, it is possible to forcibly display, set, or correct the following.

(a) Memory card dump

This takes the data stored inside the payload and saves it to the memory card inserted in the payload meter.

(b) Open ID setting

This is used when inputting, correcting, or setting the desired ID.

Available range for setting: 0 - 200

There is no particular effect on the function of the payload meter if this is not set.

[Example of use of open ID]

Number to indicate location of work face

Operator ID number

(c) Machine ID setting

This is used when inputting, correcting, or setting the dump truck ID.

Available range for setting: 0 - 200

(d) Adjusting time, date

Use this to set the time and date on the payload meter.

(e) Data all clear

This forcibly erases all the cycle data, engine ON/OFF data, and abnormality and warning data.

The data for total payload and overall number of cycles are not cleared. For details, see "Method of clearing total payload and overall number of cycles (PAGE 6-20)".

METHOD OF OPERATION

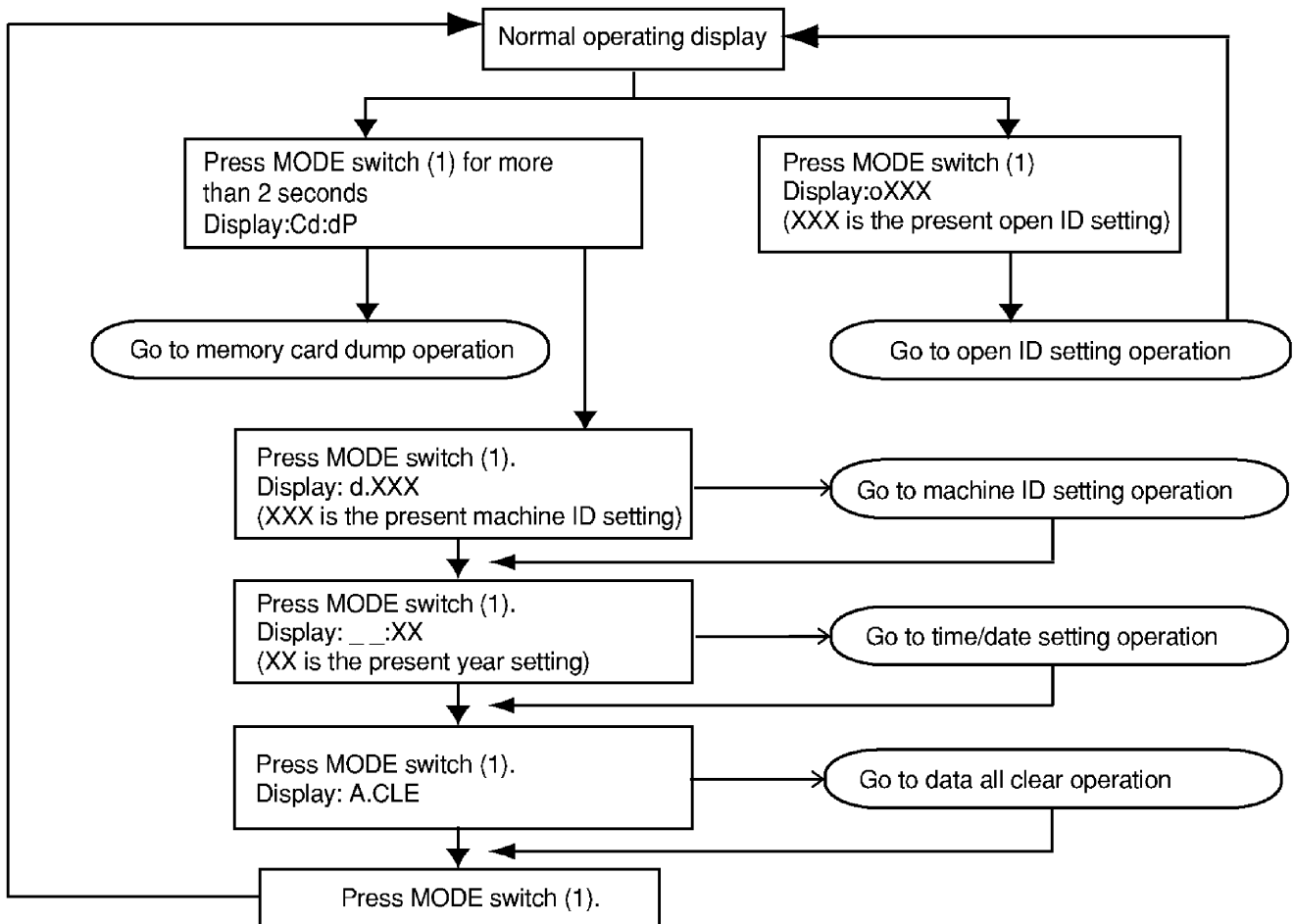
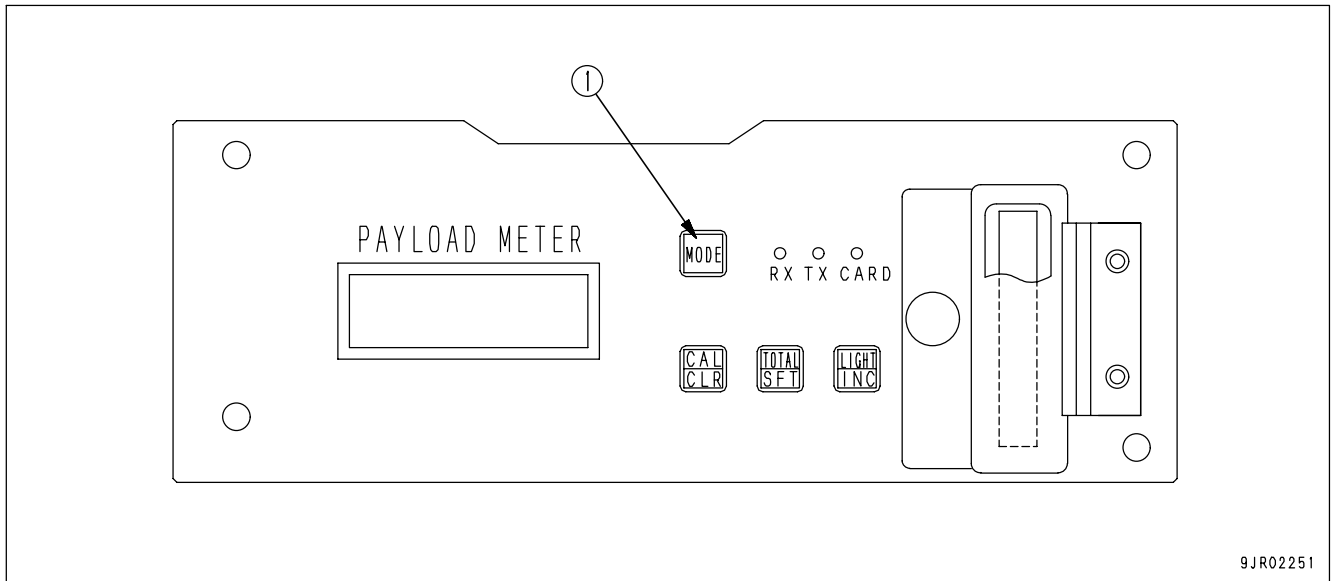

(a) Memory card dump operation

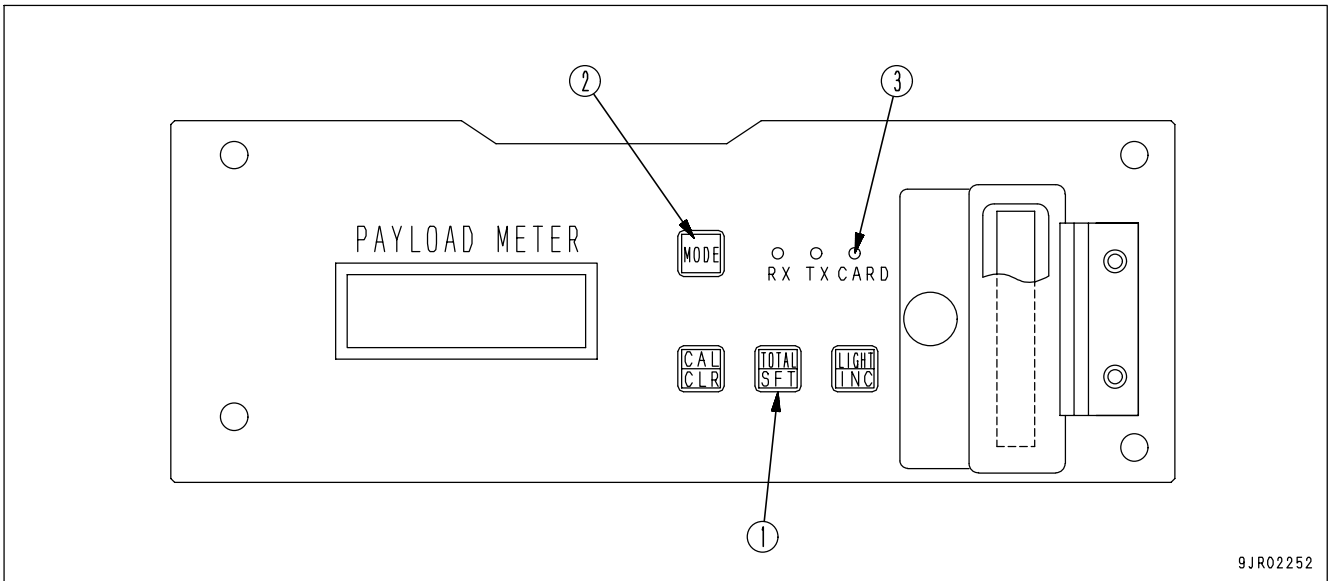

1. When the display is Cd:dP (Cd lights up, dP flashes), press TOTAL/SFT switch (1). The lighted up Cd display will change and start flashing.

REMARK

If you wish to stop the memory card dump operation when the display is Cd:dP (both Cd and dP are flashing), press MODE switch (2). The memory card dump operation is not carried out, and the display returns to the normal operation display.

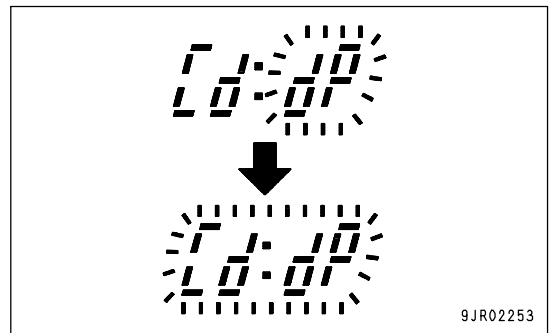

2. Press TOTAL/SFT switch (1) again.
 The panel display goes out and memory card access lamp (3) lights up.
 When the memory card dump operation is completed, it automatically returns to the normal operation display.

(b) Open ID setting

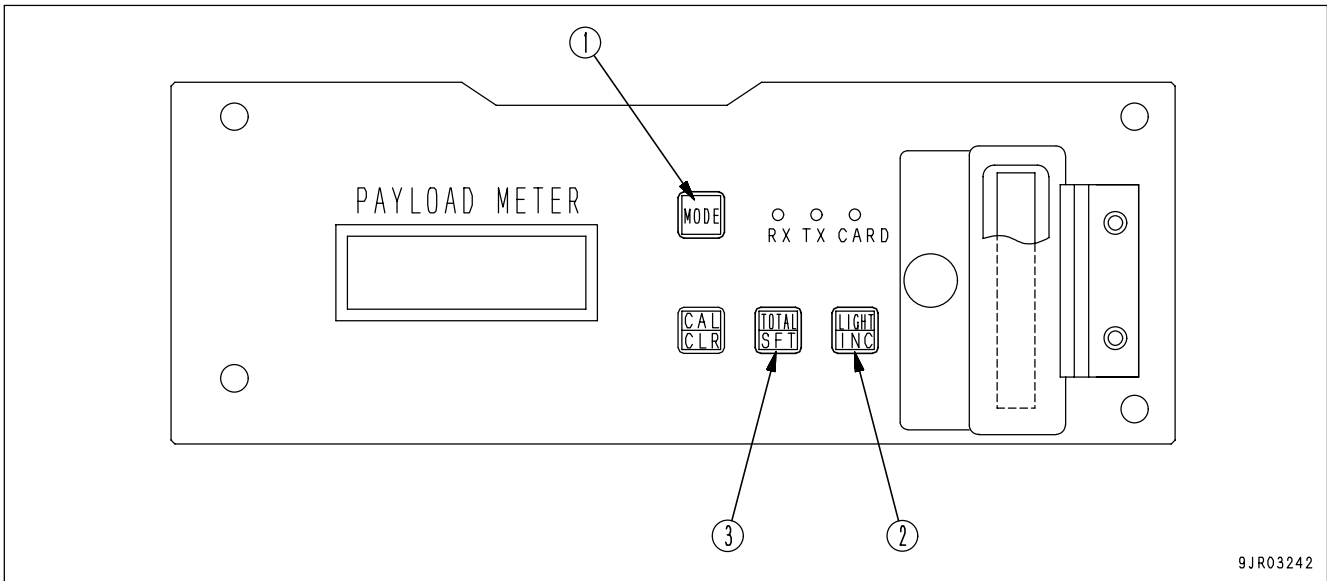

9JR03242

1. Press MODE switch (1).

The display changes from the normal operation display to "o.XXX" (o.XX lights up and the last X flashes).
Possible range for setting XXX: 0 - 200

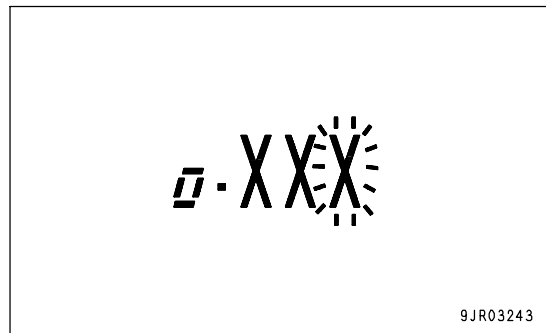

9JR03243

2. If it is necessary to correct the digit for the units, press LIGHT/INC switch (2) and correct the number.

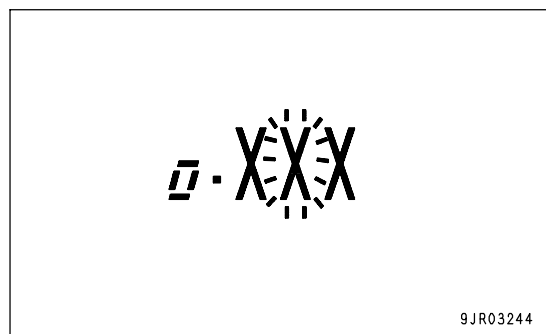

9JR03244

3. Press TOTAL/SFT switch (3).

The flashing digit in o.XXX moves one place to the left and it is possible to correct the digit for the tens.
If it is necessary to correct the digit for the tens, press LIGHT/INC switch (2) and correct the number.

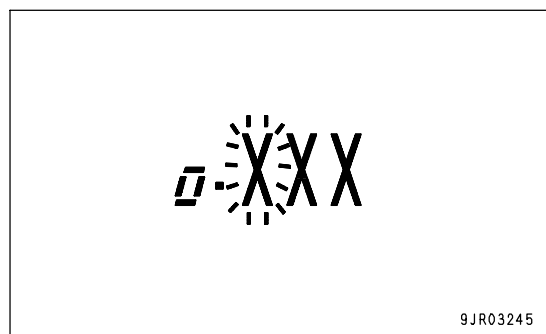

9JR03245

4. Press TOTAL/SFT switch (3).

The flashing digit in o.XXX moves one place to the left and it is possible to correct the digit for the hundreds.
If it is necessary to correct the digit for the hundreds, press LIGHT/INC switch (2) and correct the number.

After completing the correction of the Open ID, press MODE switch (1). The display will return to the normal operation display.

(c) Machine ID setting

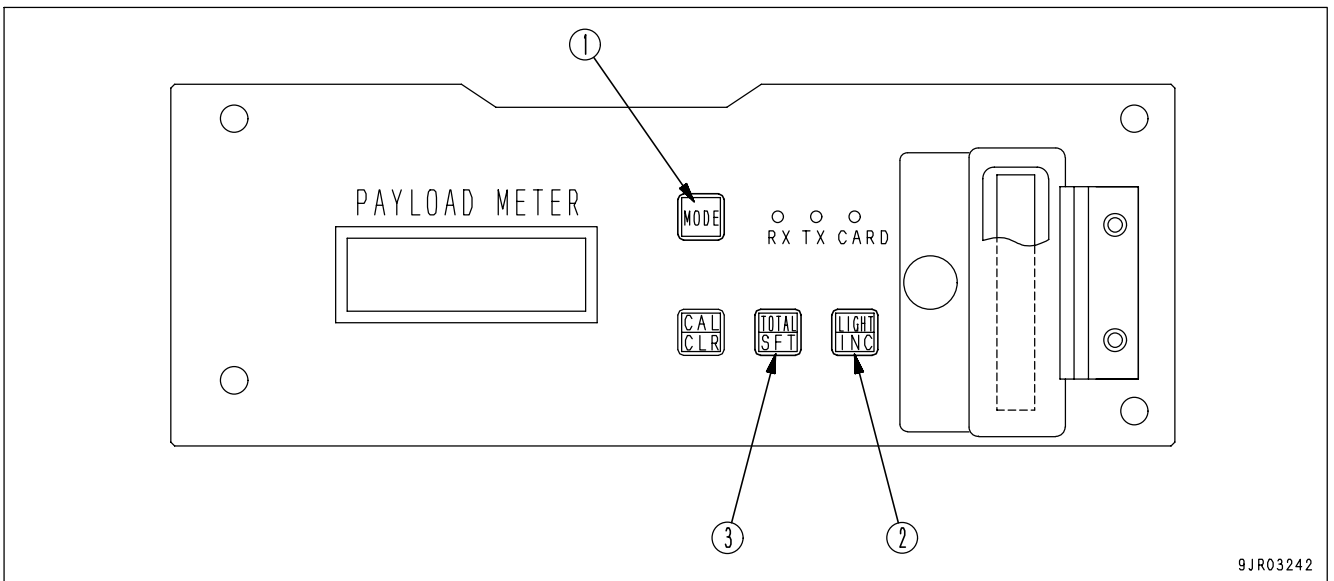

1. Keep MODE switch (1) pressed for at least 2 seconds.
 The display changes from the normal operation display to "d.XXX" (d.XX lights up and the last X flashes).
 Possible range for setting XXX: 0 - 200

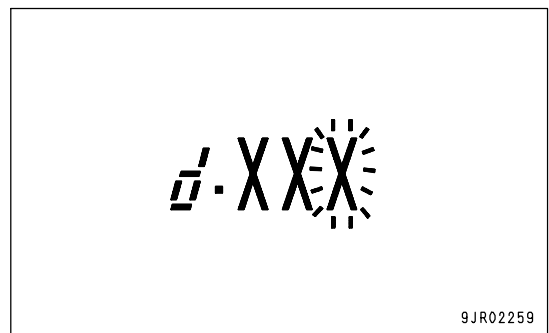

2. If it is necessary to correct the digit for the units, press LIGHT/INC switch (2) and correct the number.

3. Press TOTAL/SFT switch (3).
 The flashing digit in d.XXX moves one place to the left and it is possible to correct the digit for the tens.
 If it is necessary to correct the digit for the tens, press LIGHT/INC switch (2) and correct the number.

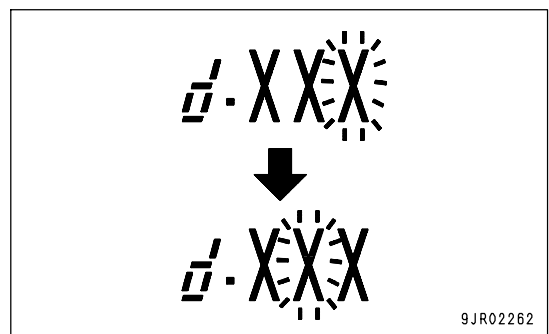

4. Press TOTAL/SFT switch (3).
 The flashing digit in d.XXX moves one place to the left and it is possible to correct the digit for the hundreds.
 If it is necessary to correct the digit for the hundreds, press LIGHT/INC switch (2) and correct the number.

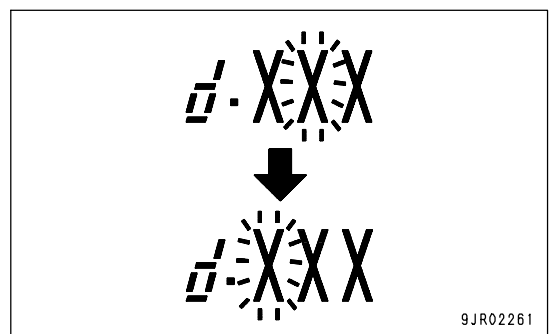

When the correcting of the machine ID is completed, press MODE switch (1). The display will change to the time and date display.

(d) Adjusting time, date

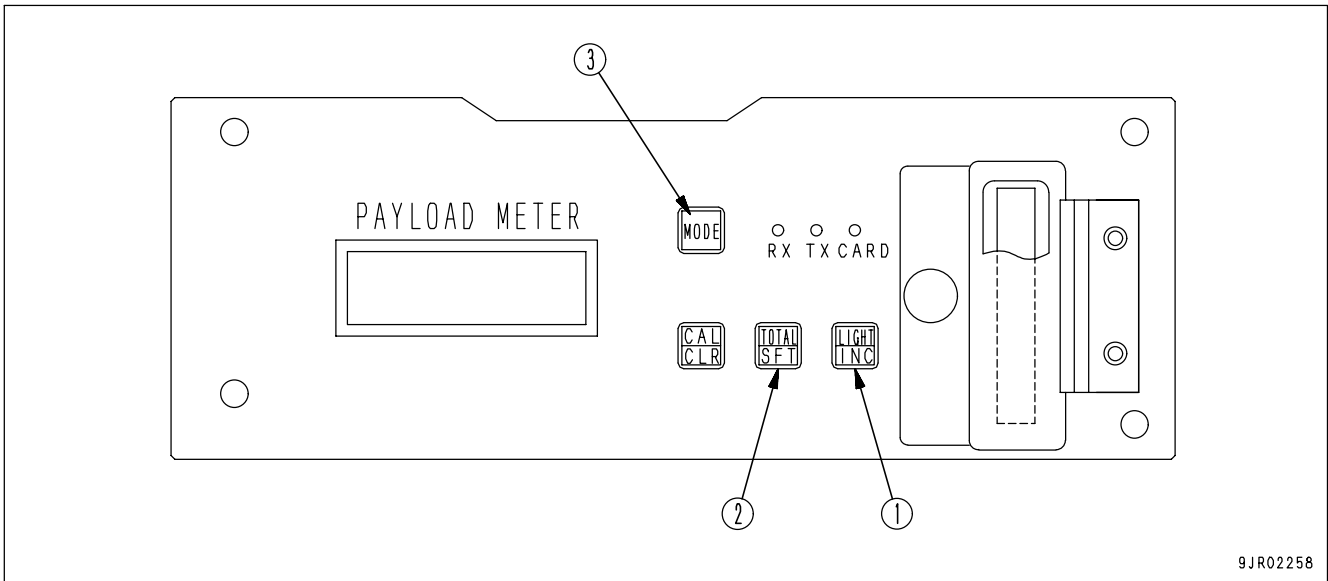

1. When "__.XX is displayed (XX indicates the final two digits of the year. The units digit flashes), if it is necessary to correct the units, press LIGHT/INC switch (1) and carry out the correction. Possible range for setting XX: 0 - 99

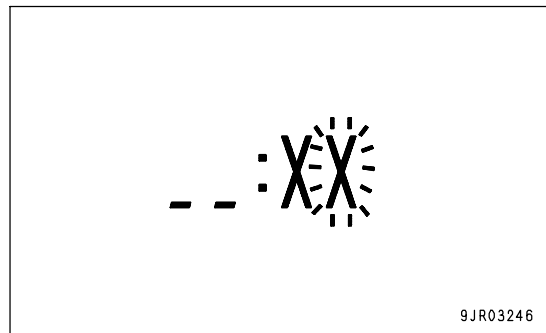

2. Press TOTAL/SFT switch (2). The flashing digit will change from the units to the digit for the tens. If it is necessary to correct the tens, press LIGHT/INC switch (1) and carry out the correction.

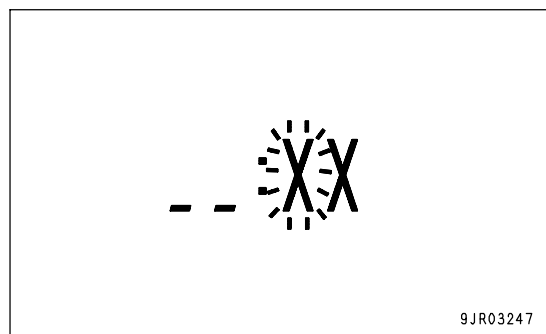

3. Press TOTAL/SFT switch (2). The display will change to the "MM:dd" display (MM flashes). (MM: month;dd: day) If it is necessary to correct the month display, press LIGHT/INC switch (1) and carry out the correction. Possible range for setting MM: 1 - 12

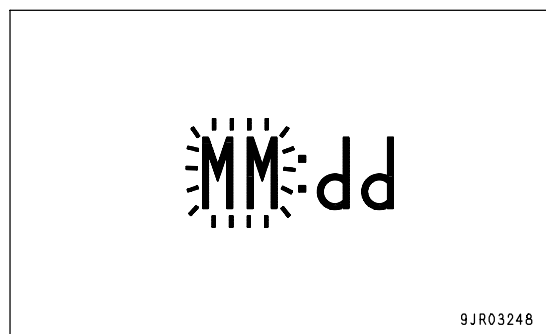

4. Press TOTAL/SFT switch (2). The flashing will change from "MM" to "dd".

If it is necessary to correct the day display, press LIGHT/INC switch (1) and carry out the correction.

Possible range for setting dd: 1 - 31

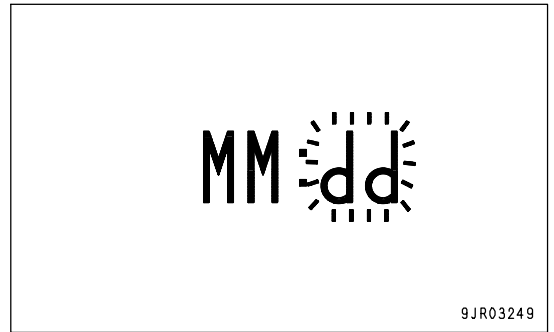

5. Press TOTAL/SFT switch (2). The display will change to the "HH:mm" display (HH flashes). (HH: hour; mm: minute)

If it is necessary to correct the hour display, press LIGHT/INC switch (1) and carry out the correction. Set the time display to a 24 hour display.

Possible range for setting HH: 1 - 23

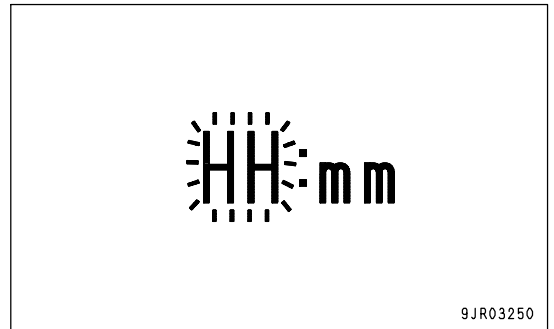

6. Press TOTAL/SFT switch (2). The flashing will change from "HH" to "mm".

If it is necessary to correct the minute display, press LIGHT/INC switch (1) and carry out the correction.

Possible range for setting mm: 0 - 59

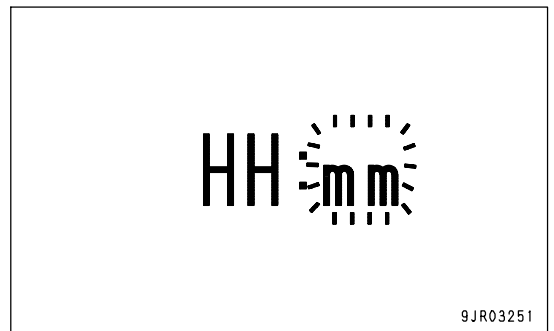

7. If TOTAL/SFT switch (2) is pressed again when the minute display is flashing, the screen returns to the display for correcting the year, and correction can be made again.

8. When correction is completed for the time and date, press MODE switch (3). The screen changes to the data all clear operation display.

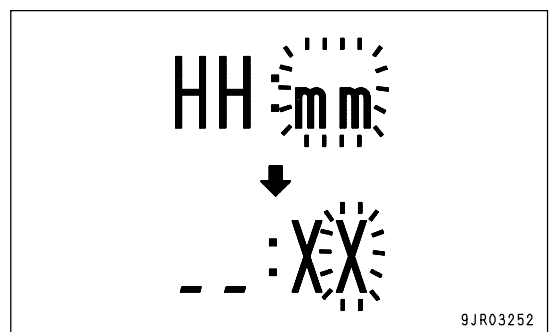

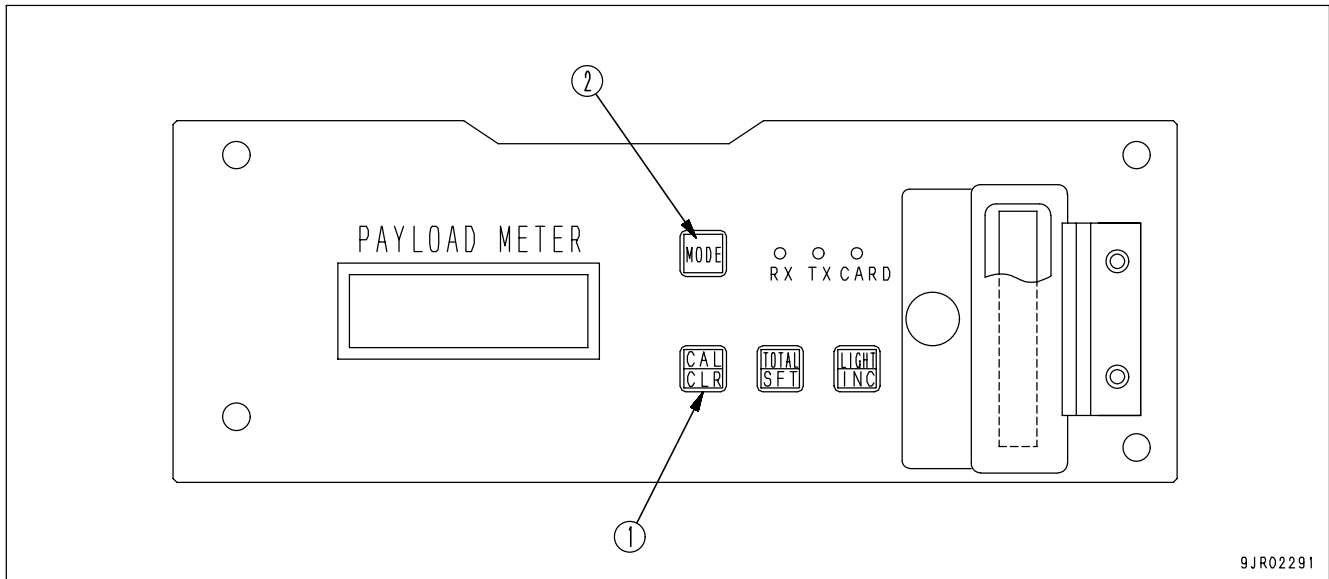
(e) Data all clear operation

9JR02291

The cycle data, engine ON/OFF data, and abnormality/warning data are all forcibly deleted. It is not possible to clear the total payload or total number of cycles with this operation. To clear the total payload or total number of cycles, see Section "Method of clearing total payload and overall number of cycles (PAGE 6-20)".

1. When the display is A.CLE (A lights up, CLE flashes), keep CAL/CLR switch (1) pressed for at least 2 seconds. The lighted up A display will change and start flashing.

REMARK

If you wish to stop the data all clear operation when the display is A.CLE (both A and CLE are flashing), press MODE switch (2). The data all clear operation is not carried out, and the display returns to the normal operation display.

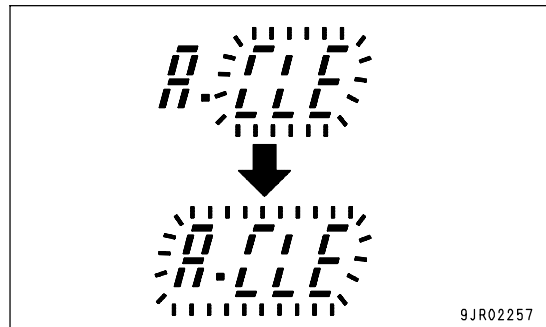

9JR02257

2. Keep CAL/CLR switch (1) pressed again for at least 2 seconds.
A.CLE lights up, and when the data clear operation is completed, the display automatically returns to the normal operation display.
3. Turn the switch OFF.

REMARK

Before clearing the data, always download the data to a PC.

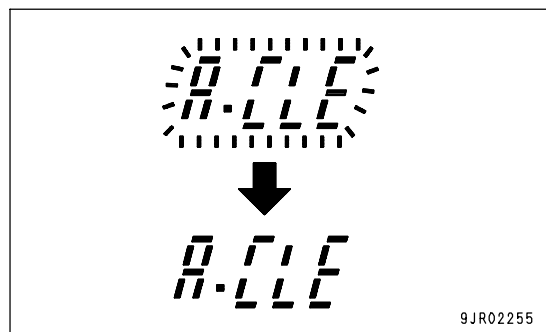

9JR02255

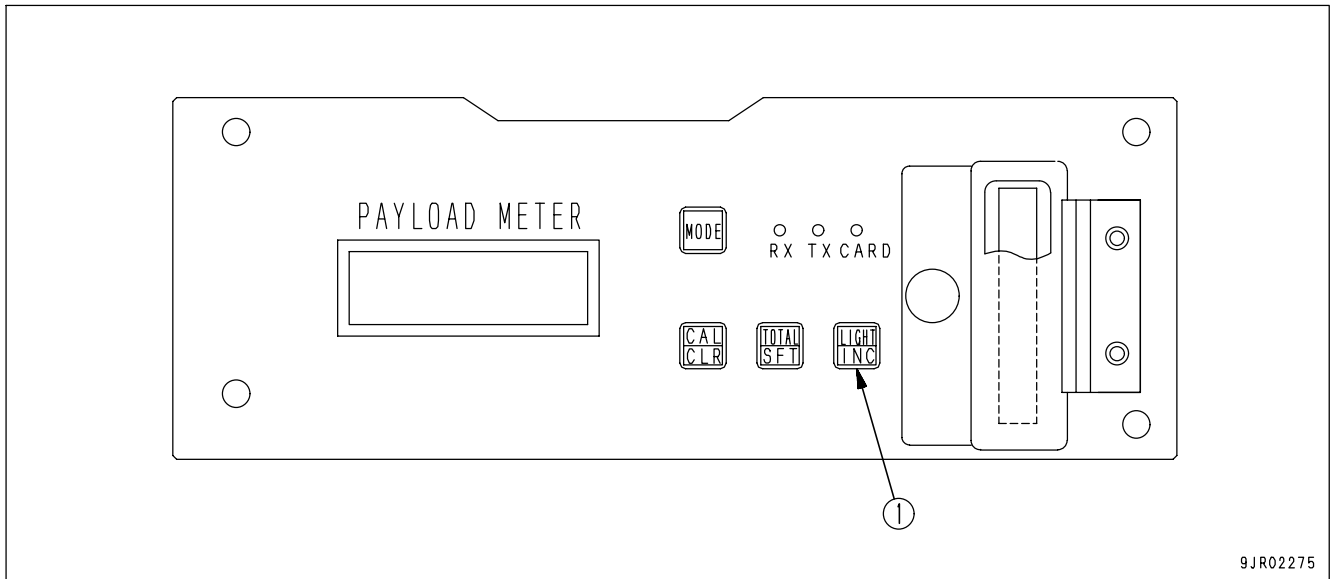
DIMMING LIGHTS ON MONITOR DISPLAY

If you want to change the brightness of the monitor display, do as follows.

Press LIGHT/INC switch (1). Each time the switches pressed, the lighting will become one level darker; and if the switches pressed when that the lighting is darkest, it will return to the brightest level.

The brightness can be changed in ten stages.

SERVICE CHECK MODE

By operating the service check mode, it is possible to carry out display, setting, and correction of the following items. If it is designed to correct the method of operation and setting, please ask your Komatsu distributor.

- (a) Detailed display of calibration data
- (b) Data all clear (service area)
- (c) Input signal status display
- (d) Formatting
- (e) Setting parameters

ABNORMALITY AND WARNING DISPLAY (ERROR CODE)

The payload meter always carries out self-diagnosis of the system, and if any problem or warning occurs, it is displayed by the monitor panel and the external display lamps.

If more than one abnormality occurs at the same time, the error codes are displayed in turn.

No.	Content	Content of error code display		Saving error codes	Remarks
		Machine display panel	External display lamp		
1	Drop in backup battery voltage	F-09 flashing	-	000-009	*1
2	Disconnection in R terminal	F-18 flashing	-	000-018	*1
3	Abnormality in sensor power source (18V)	F-20 flashing	All flashing	000-020	*1,*2
4	Short circuit with ground, disconnection in front left suspension pressure sensor system	F-21 flashing	All flashing	000-021	*1,*2
5	Short circuit with ground, disconnection in front right suspension pressure sensor system	F-22 flashing	All flashing	000-022	*1,*2
6	Short circuit with ground, disconnection in rear left suspension pressure sensor system	F-23 flashing	All flashing	000-023	*1,*2
7	Short circuit with ground, disconnection in rear right suspension pressure sensor system	F-24 flashing	All flashing	000-024	*1,*2
8	Short circuit with power source in front left suspension pressure sensor system	F-25 flashing	All flashing	000-025	*1,*2
9	Short circuit with power source in front right and suspension pressure sensor system	F-26 flashing	All flashing	000-026	*1,*2
10	Short circuit with power source in rear left suspension pressure sensor system	F-27 flashing	All flashing	000-027	*1,*2
11	Short circuit with power source in rear right suspension pressure sensor system	F-28 flashing	All flashing	000-028	*1,*2
12	Short circuit with ground, disconnection in clinometer system	F-31 flashing	All flashing	000-031	*1,*2
13	Short circuit in relay for external display lamp (green)	F-41 flashing	All flashing	000-041	*1
14	Short circuit in relay for external display lamp (yellow)	F-42 flashing	All flashing	000-042	*1
15	Short circuit in relay for external display lamp (red)	F-43 flashing	All flashing	000-043	*1
16	Cycle data memory FULL	L:FUL flashing	-	000-011	*3
17	Engine ON/OFF data memory FULL	E:FUL flashing	-	000-012	*4
18	Calibration not performed	F.CAL flashing	All flashing	-	*1
19	Calibration of clinometer not performed	F.ICL flashing	All flashing	-	*1
20	Equalizer bar contacting stopper	F-FL flashing	All flashing	-	*5
21	Articulation angle too large when dumping	F-AC flashing	All flashing	-	*6

*1: Please consult your Komatsu distributor.

*2: If this problem occurs, it is impossible to carry out calibration travel.

*3: Cycle data FULL

- (1) If more than 2600 cycles are saved in memory (space for 300 cycles remaining), "L:FUL" flashes.
- (2) If more cycles are recorded and the total exceeds 2900 cycles, numbers 2901, 2902, etc. are saved in memory, but the oldest cycle data are deleted in turn.
- (3) If this error code flashes, download to the PC, then delete all data. For details, see Section "(e) Data all clear operation (PAGE 6-28)".

*4: Engine ON/OFF data FULL

- (1) If more than 105 times are saved in memory (space for 10 times remaining), "E:FUL" flashes.
- (2) If more times of engine ON/OFF are recorded and the total exceeds 115 times, numbers 116, 117, etc. are saved in memory, but the oldest engine ON/OFF data are deleted in turn.
- (3) If this error code flashes, download to the PC, then delete all data. For details, see Section "(e) Data all clear operation (PAGE 6-28)".

*5: When equalizer bar contacts stopper

- (1) If the equalizer bar is in contact with the stopper, an accurate measurement cannot be obtained. If the machine is stopped empty at the loading point, contact between the equalizer bar and stopper is detected.
- (2) Drive the machine forward a little at a time until error code "F-FL" disappears from the display. Set the gearshift lever at D. After stopping the machine, return the gearshift lever to N.

*6: Articulation angle too large

If the dumping mode is selected when measuring, the measured value is saved immediately before the dump body is raised. If the articulation angle is too large when the measurement is made, the accuracy will be poor.

"F-AC" is displayed when the dumping mode has been selected and the articulation has been turned more than half (approx. 22.5°) when the machine is stopped while loaded.

If "F-AC" is displayed when dumping, set the machine facing straight so that the error code is not displayed.

WHEN ERROR CODE F-09 IS DISPLAYED

The payload meter has an internal battery to prevent the recorded data from being deleted when the key in the starting switch is turned to the OFF position.

If the battery voltage drops, error message [F-09] is displayed. If [F-09] is displayed, it is necessary to replace the internal battery. Please consult your Komatsu distributor.

PROCEDURE WHEN DOWNLOADING



CAUTION

- When handling the cables, be careful not to damage them or pull them by force.
- Do not leave the connectors disconnected.
- Take steps to prevent dirt from entering the connector portion.
- Do not let any metal objects touch the connector portion.

Download the recorded data to a personal computer which has the separately sold special software installed.

DOWNLOADING FROM DOWNLOAD CONNECTOR INSIDE CAB

1. Connect the download cable supplied with the special software. Connect the other end of the cable to the RS232C port of the personal computer.
2. Turn the starting switch to the ON position.
3. Start up the personal computer and use the special software to download the data.
4. After completing the download, remove the download cable and fit the connector cap.

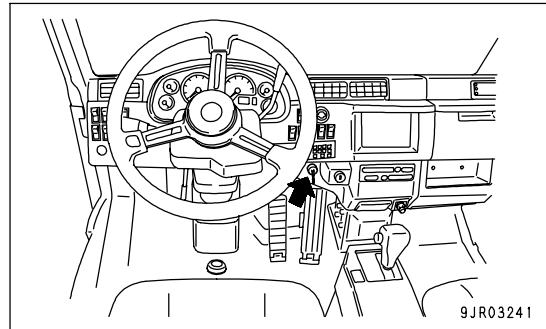

DOWNLOAD SOFTWARE

For details of installing the software, see the instruction manual provided with the download software.

1. When the installation is completed, the icon shown in the diagram on the right is created.



2. Double click the icon. The download software is started and the screen shown in the diagram on the right is displayed. After that, screen [G1000] is displayed, so click [PLM]. [CARD] and [PMC] are not used, so do not click them.

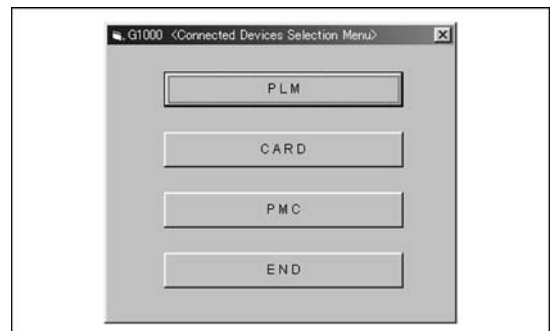

3. Click [Parameter Setting] on screen [G2000]. [PLM Remote Control] is not used, so do not click it.

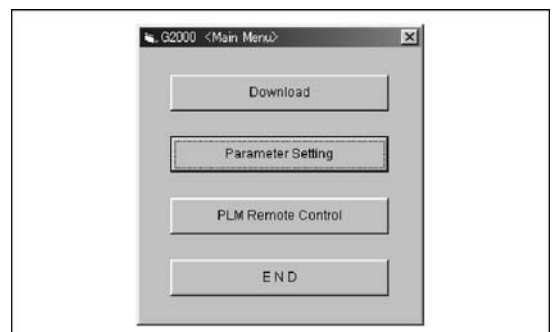

4. Click [Unit Setting] on screen [G2200]. Screen [G2210] is displayed.

[User's Comment] is not used, so do not click it.



5. With screen [G2210], it is possible to select the communications port (com1, com2), specify the destination for saving the download data, specify the file name, and select the unit to use for the data. Even if all the files are not needed, always select all the files.

Once a setting has been made, there is no need to set it again when carrying out the next download.

Click [ENTER] to return to screen [G2200].

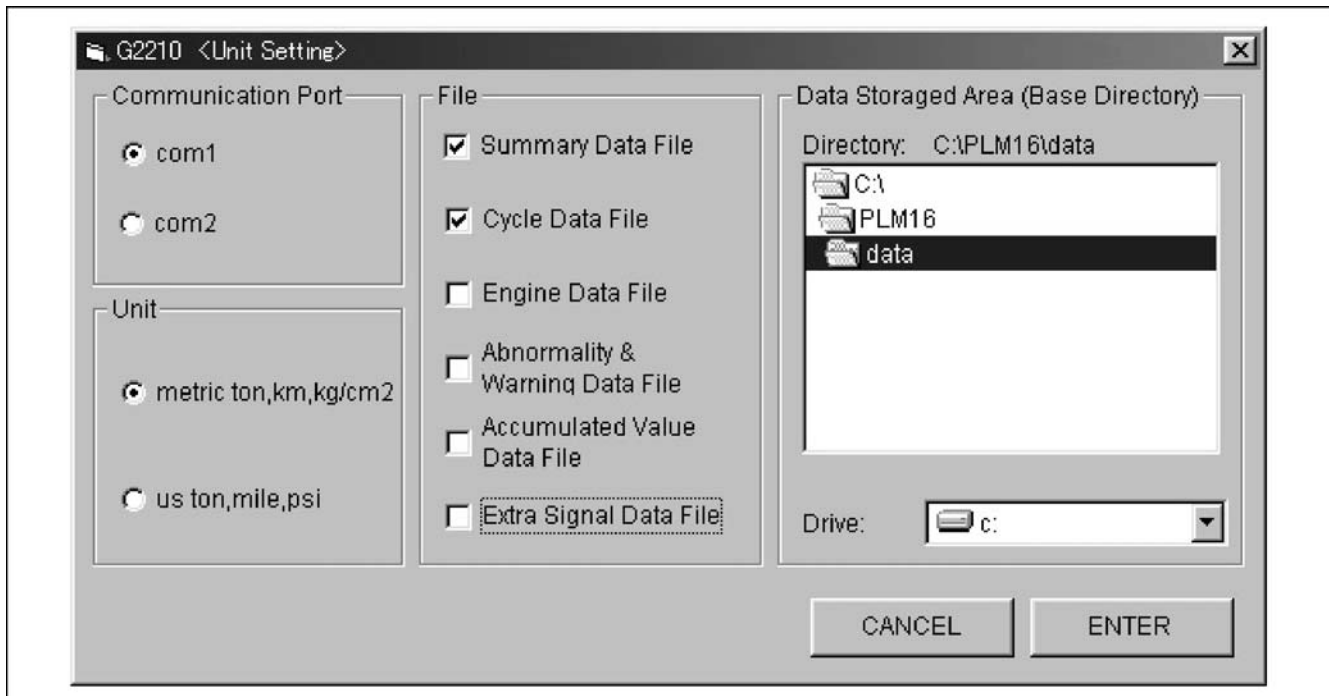

6. On screen [G2200], click [BACK] to return to screen [G2000].

7. Click [Download] on screen [G2000]. Screen [G2100] is displayed, so click [START] to download.

After completing the download operation, click the [X] at the top right of the screen to close the screen.

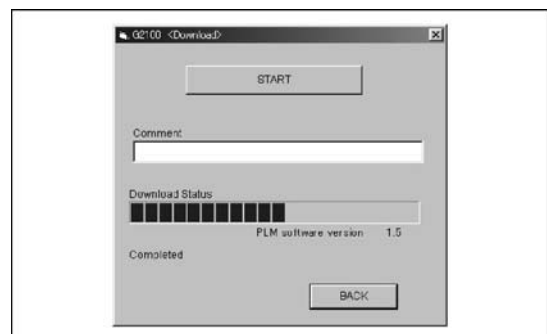

REMARK

- Depending on the version of the software, screen [G2101 <Download - File ID>] is displayed. Input the file ID, then click [OK] to start the download operation.
- After completing the download, the following file data are displayed.

- (1) INDEX.csv (file index)
- (2) CYC.csv (cycle data)
- (3) ENG.csv (engine on/off data)
- (4) FAU.csv (fault data)
- (5) TOT.csv (total data)
- (6) SM1.csv (summary1 data)
- (7) SM2.csv (summary2 data)
- (8) EXT.csv (external signal data)

On the HM300-2 payload meter, only files (2) - (4) are active.

OTHERS

- If the payload and external display lamp display is different, or there is some error in the directory where the data is downloaded by the special software, there may be a mistake in the setting for the machine.
In such a case, please consult your Komatsu distributor.
- For computers without an RS232C port, it may be possible to use a third party USB-RS232C conversion adapter.
However, this does not guarantee the operation.
- The download software supports COM1 and COM2, so check which port it can be connected to.

USE OF REAR VIEW MONITOR

! WARNING

- Never operate any of the switches while in running. If you do so, there is the fear that you may make an error in the truck operation, or neglect to watch the hauling road ahead for safety, and as a result cause a serious personal injury.
- The rear view monitor is an aid for checking obstacles in the rear. An image appearing on the monitor is limited. So when backing up the dump truck, be sure to make a visual check, not relying solely on the monitor.
- An image on the rear view monitor does not show an actual distance, so drive the dump truck slowly, when backing it up.

When the dump truck is backed up and the rear view monitor is set in operation, a monitor display enables the driver to check the rear for safety.

NAME AND FUNCTION OF EACH PART OF REAR VIEW MONITOR

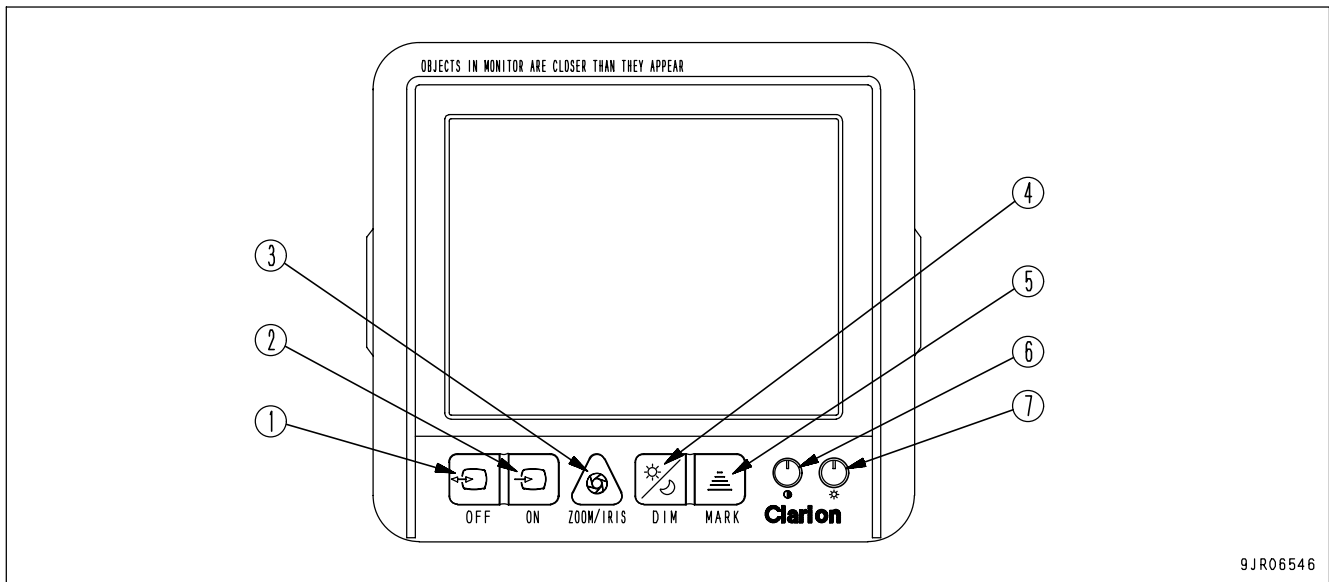

- | | |
|---|---|
| <p>(1) Auto Switch</p> <p>(2) Manual Switch</p> <p>(3) Zoom / Iris Switch (Reverse Light Compensation Switch)</p> | <p>(4) Bright / Dim Light Selector Switch</p> <p>(5) Mark Switch (not operable with this machine)</p> <p>(6) Contrast Adjustment Knob</p> <p>(7) Brightness Adjustment Knob</p> |
|---|---|

AUTO SWITCH

When an image of a camera is shown on the monitor display and this switch (1) is pressed, the camera image disappears and the display turns into a waiting condition.

When the gearshift lever is put into the "R" position while the display is in the waiting condition, an image of the rear view automatically appears.

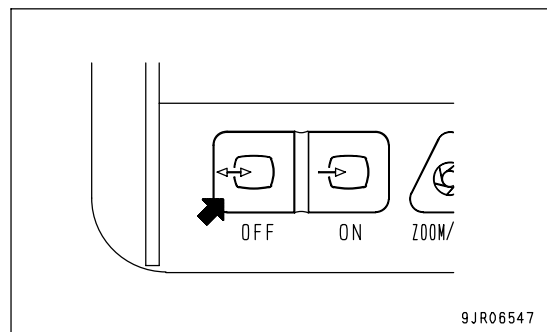

MANUAL SWITCH

When this switch (2) is pressed, an image of a camera appears on the monitor display.

At that time, a mark "CAM1" appears on the upper left side of the display and a figure "5" on the upper right side of the display.

REMARK

- When the manual switch is pressed to call an image and the operation is suspended thereafter, the image disappears in approx. 5 minutes, turning the display into a waiting condition. This is a function in case the operator forgets to switch off the display (timer function).
- The time until the monitor display is automatically switched off is shown on the upper right side of the display. It changes by minute and in the descending order as 5→4 →3 → 2 → 1. Moreover, when the remaining time comes down to just 10 seconds before the monitor display goes off, the last figure "1" on the upper right side begins to flash.
- When the manual switch is pressed to call an image and it is pressed again while the image is shown on the monitor display, it remains on the display for approx. 5 more minutes from the moment the switch is pressed.
- When the gearshift lever is in the "R" position, the timer function does not work.

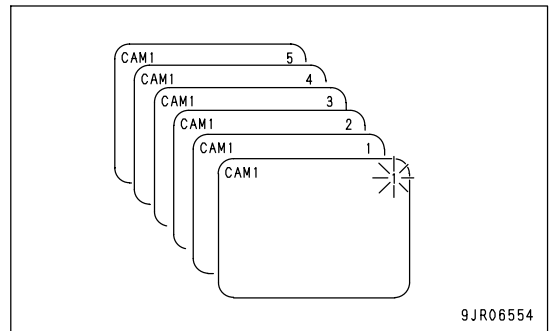
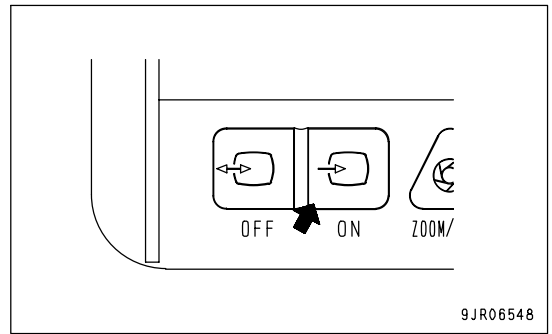

ZOOM/IRIS SWITCH (REVERSE LIGHT COMPENSATION SWITCH)

Zoom Function (press the switch)

By pressing this switch (3), an image on the monitor display can be enlarged by 1.4 times.

At that time, a mark of "ZOOM" is shown on the upper right side of the display.

When the switch is pressed again, "ZOOM" disappears and the display returns to the original image.

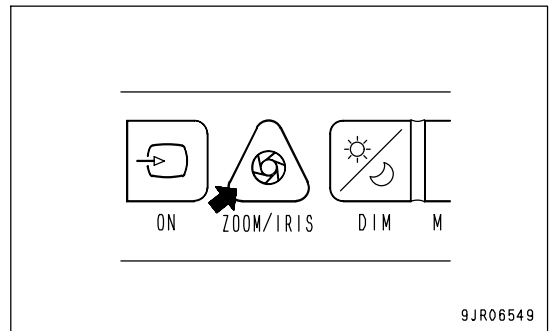

Iris Function (Reverse Light Compensation Function) (Keep the switch pressed for more than 1 second.)

! WARNING

When the iris function is activated (turned "ON"), the whole monitor display becomes brighter. As a result, some portion on the display becomes difficult to read or discern, while it is easy to do so with the iris function turned "OFF". Therefore do not use this function except when it is necessary to read or see a dim portion.

When it is difficult to see a monitor display due to a reverse light, keep this switch (3) for more than 1 second, and then the iris function (reverse light compensation function) is turned "ON", turning the display brighter and making it easier to see.

At that time, a mark of "IRIS" appears on the upper left side of the display.

If the switch is further kept pressed for more than 1 second, the iris function (reverse light compensation function) is turned "OFF" and "IRIS" mark goes off.

BRIGHT/DIM LIGHT SELECTOR SWITCH

When this switch is pressed, the brightness of the monitor display lowers.

A mark of "DIM" appears on the upper left side of the display then. When the switch is pressed again, the brightness returns to the original level, and "DIM" mark goes off.

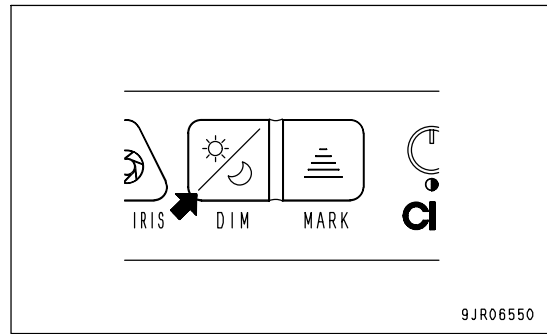

MARK SWITCH

This switch is used to change the display position of the mark, but it does not apply to this machine, so this function cannot be used.

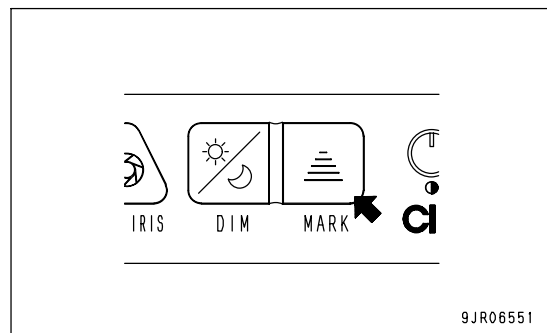

CONTRAST ADJUSTMENT KNOB

With this knob (6), contrast on the monitor display can be adjusted to be either stronger or weaker.

To side (A): Contrast becomes stronger.

To side (B): Contrast becomes weaker.

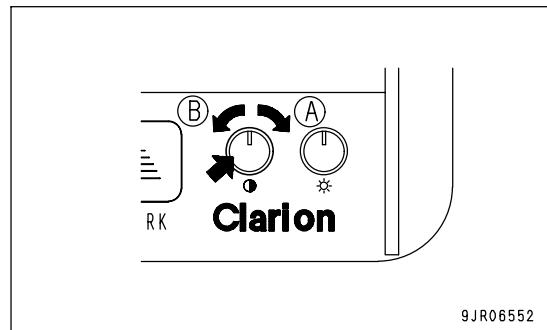

BRIGHTNESS ADJUSTMENT KNOB

With this knob (7), brightness (luminance) on the monitor display can be adjusted.

To side (A): Brightness increases.

To side (B): Brightness decreases.

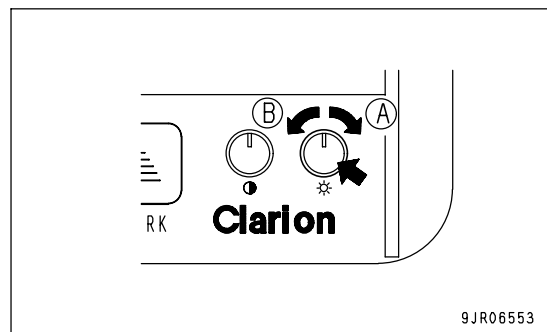

SETTING OF REAR VIEW MONITOR

HOW TO SET DISPLAY MODE

A mark of "CAM1", "DIM", "IRIS" and "ZOOM" appears on the upper left side of the monitor display, depending on the sort of ongoing operation.

Every mark is set to go off in approx. 2 seconds after it lights up (2- second display mode).

It is possible use the following operation to switch the display to the normal display. (Continuous display mode)

1. Press mark switch (2) while pressing manual switch (1) at the same time.

A "Cam1" mark lights up on the upper left side of the monitor display, and the display mode changes to the continuous display mode.

2. When it is required to return to the 2- second display mode, press mark switch (2), while pressing manual switch (1) at the same time, the same way as in step 1 above.

After a "Cam1" mark remains lighted for approx. 2 seconds on the upper left side of the monitor display, only the mark disappears, and the display mode changes to the 2- second display mode.

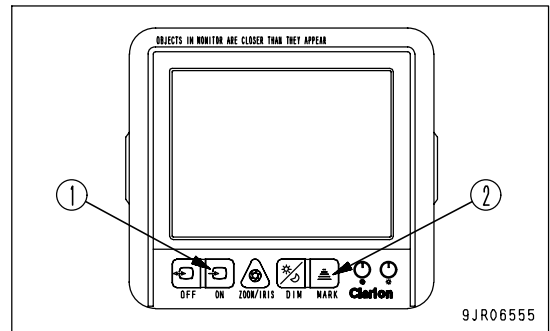

REMARK

In both the 2-second display mode and continuous display mode, the time remaining until the mark and monitor screen disappear is always displayed.

CAUTIONS WHEN USING REAR VIEW MONITOR

WARNING

- Do not attempt to disassemble or modify the monitor. There is a danger of electric shock or fire.
- Do not attempt to open the monitor backside cover. There is a danger of electric shock, as high voltage power is conducted internally.
- Do not use the monitor if it is suspected of defect. There is a fear of electric shock or fire, should it be used in spite of a defect. In that case, ask your Komatsu distributor for repair or replacement.
- In case a foreign material has got into the monitor or it gets wet, or if a smoke comes out of the monitor or it gives a bad smell, stop the use immediately. It poses a big danger to use the monitor when any such abnormality exists. In that case, consult your Komatsu distributor.
- When replacing a fuse, be sure to use one with the specified capacity of 3A. Should a fuse with a higher- than- specified capacity be used, it can cause fire.

- As a general rule, this product should be replaced after a total usage time of approximately 3000 hours (or approximately 3 years), though this may differ according to usage conditions.
- When cleaning the monitor, use dry soft cloth or wet cloth after having well wrung the water out. If it is very dirty, use neutral detergent. Do not use thinner or alcohol.
- Sometimes an image on the monitor display is blurred due to the camera lens being smeared. In that case, clean the camera lens with dry soft cloth or wet cloth after having well wrung the water out.

HANDLING DUMPING COUNTER

The dumping counter is an automatic counting function to count the number of loads that have been dumped.

The number of loads dumped is displayed on the character display.

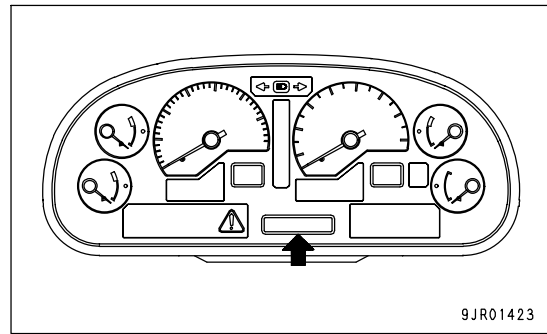

METHOD OF DISPLAYING, RESETTING DUMPING COUNTER

1. Check that the character display is displaying the service meter/odometer reading, or is displaying an action code. If anything other than this is being displayed, turn the starting switch OFF, then turn the starting switch again to the ON position and wait until the above display is given.
2. Press (◇) of machine monitor mode selector switch 1. The character display shows the dumping counter.

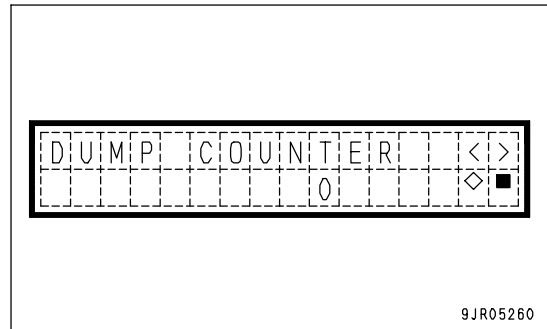

3. When resetting the number of loads dumped, press (◇) of machine monitor mode selector switch 1. The display shows the screen on the right.
4. Press (◇) of machine monitor mode selector switch 1. The number of loads dumped is reset and the display returns to the previous screen.
To abandon the resetting operation, press (■) of machine monitor mode selector switch 1 to return to the previous screen.
5. When completing the operation, press (■) of machine monitor mode selector switch 1 or turn the starting switch OFF.

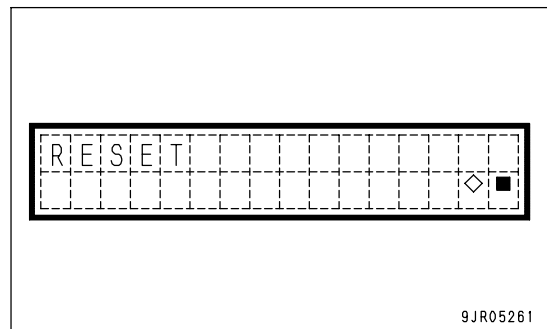

HANDLING BATTERY DISCONNECTOR SWITCH

CAUTION

- When the engine is running, do not operate the battery disconnecter switch to shut off the electrical circuit. When the circuit is shut off, electric noise is generated, and this may damage the electric circuit or the controllers.
- Keep this switch at the ON (connected) position except when putting the machine into long-term storage or when carrying out maintenance of the electrical system.
- Before turning the battery disconnecter switch to the OFF (disconnected) position, always turn the starting switch OFF, and wait for at least 1 minute after the engine stops. If the battery disconnecter switch is turned OFF (disconnected) when the starting switch is ON or when the engine is running, there is danger of failure or abnormality occurring in the electrical system.
- When the switch is turned to the OFF (disconnected) position, all electrical systems are shut off, and the data for the clock and radio station selection are lost.

The battery isolator prevents consumption of the battery power caused by short circuits or electrical leakage from the equipment during long-term storage.

When repairing any electrical circuit or carrying out welding operations, cut the battery disconnecter switch (at the position marked by the arrow in the diagram below) to prevent damage to the electrical circuit.

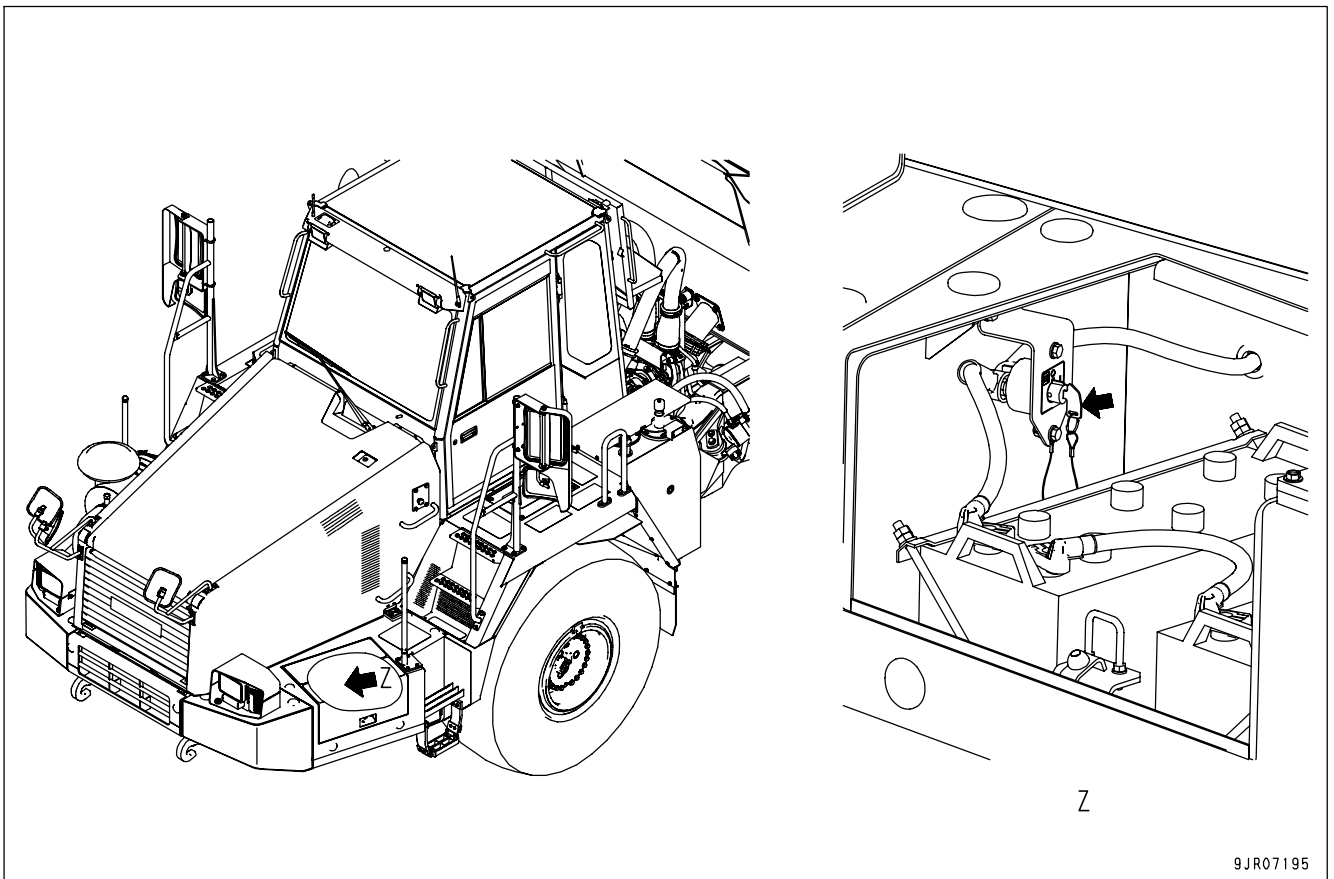

Position (A) (disconnected): The battery circuit is shut off and no electricity flows in the circuit.

The switch key can be removed in this position.

Position (B) (connected): The battery circuit is connected and electricity flows in the circuit.

The switch key is held in position.

Always set to this position before starting the engine.

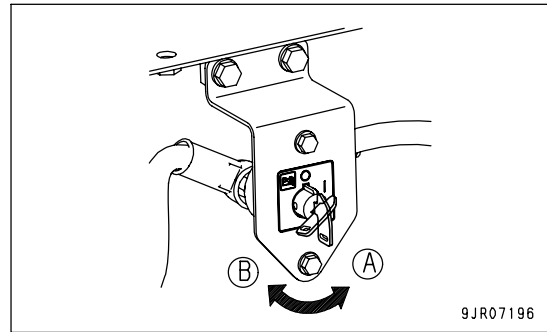

HANDLING MACHINES EQUIPPED WITH KOMTRAX

- KOMTRAX is a machine management system that uses wireless communications.
- A contract with your Komatsu distributor is necessary before the KOMTRAX system can be used. Any customers desiring to use the KOMTRAX system should consult their Komatsu distributor.
- The KOMTRAX equipment is a wireless device using radio waves, so it is necessary to obtain authorization and conform to the laws of the country or territory where the machine equipped with KOMTRAX is being used. Always contact your Komatsu distributor before selling or exporting any machine equipped with KOMTRAX.
- When selling or exporting the machine or at other times when your Komatsu distributor considers it necessary, it may be necessary for your Komatsu distributor to remove the KOMTRAX equipment or to carry out action to stop communications.
- If you do not obey the above precautions, neither Komatsu nor your Komatsu distributor can take any responsibility for any problem that is caused or for any loss that results.

BASIC PRECAUTIONS



WARNING

- Never disassemble, repair, modify, or move the communications terminal, antenna, or cables. This may cause failure or fire on the KOMTRAX equipment or the machine itself. (Your Komatsu distributor will carry out removal and installation of KOMTRAX.)
- Do not allow cables or cords to become caught; do not damage or pull cables or cords by force. Short circuits or disconnected wires may cause failure or fire on the KOMTRAX equipment or the machine itself.
- For anyone wearing a pacemaker, make sure that the communications antenna is at least 22 cm (8.7 in) from the pacemaker. The radio waves may have an adverse effect on the operation of the pacemaker.

NOTICE

- Even when the key in the starting switch of the KOMTRAX system is at the OFF position, a small amount of electric power is consumed. When putting the machine into long-term storage, take the action given in "LONG-TERM STORAGE (PAGE 3-124)".
- Please contact your Komatsu distributor before installing a top guard or other attachment that covers the cab roof.
- Be careful not to get water on the communications terminal or wiring.

REMARK

- The KOMTRAX system uses wireless communications, so it cannot be used inside tunnels, underground, inside buildings, or in mountain areas where radio waves cannot be received. Even when the machine is outside, it cannot be used in areas where the radio signal is weak or in areas outside the wireless communication service area.
- There is absolutely no need to inspect or operate the KOMTRAX communications terminal, but if any abnormality is found, please consult your Komatsu distributor.

INDEX

<A>		PRECAUTIONS BEFORE STARTING	
AIR CONDITIONER	3- 64	OPERATION	2- 13
ARTICULATE LOCK	3- 45	PRECAUTIONS RELATED TO	
		ATTACHMENTS AND OPTIONS	2- 19
BEFORE READING THIS MANUAL	1- 2	PRECAUTIONS RELATED TO	
BODY PIVOT PIN	3- 45	PROTECTIVE STRUCTURES	2- 18
<C>		PRECAUTIONS WHEN GETTING ON	
CAB TILT OPERATION	3-107	OR OFF MACHINE	2- 16
CAR RADIO	3- 50	PRECAUTIONS WHEN RUNNING	
CAR STEREO	3- 56	ENGINE INSIDE BUILDING	2- 19
CHECK BEFORE STARTING ENGINE	3- 69	PREPARATIONS FOR SAFE	
CHECKS AFTER COMPLETION OF		OPERATION	2- 13
WORK	3-112	UNAUTHORIZED MODIFICATION	2- 18
CHECKS AFTER STOPPING ENGINE	3- 87	GENERAL VIEW	3- 2
CIRCUIT BREAKER	3- 46	GENERAL VIEW OF CONTROLS AND	
COLD WEATHER OPERATION	3-121	GAUGES	3- 3
AFTER COLD WEATHER	3-123	GENERAL VIEW OF MACHINE	3- 2
PRECAUTIONS AFTER		GUIDES TO MAINTENANCE	4- 2
COMPLETION OF WORK	3-122	<H>	
PRECAUTIONS FOR LOW		HANDLING AUTOMATIC RETARDER,	
TEMPERATURE	3-121	ACCELERATOR CONTROL(ARAC)	6- 2
CONTROL LEVERS AND PEDALS	3- 40	EXPLANATION OF COMPONENTS	6- 2
<D>		METHOD OF OPERATION	6- 3
DETERMINING AND MAINTAINING		HANDLING BATTERY DISCONNECTOR	
TRAVEL ROAD	3-114	SWITCH	6- 41
DETERMINING TRAVEL ROAD	3-114	HANDLING DUMPING COUNTER	6- 40
MAINTAINING TRAVEL ROAD	3-114	HANDLING MACHINES EQUIPPED	
DUMP OPERATIONS	3-105	WITH KOMTRAX	6- 43
DUST INDICATOR	3- 46	BASIC PRECAUTIONS	6- 43
<E>		HANDLING OIL, FUEL, COOLANT, AND	
EXPLANATION OF COMPONENTS	3- 5	PERFORMING OIL CLINIC	4- 4
<F>		HANDLING PAYLOAD METER HM	6- 4
FUSES	3- 47	ABNORMALITY AND WARNING	
<G>		DISPLAY (ERROR CODE)	6- 30
GENERAL PRECAUTIONS COMMON		CONTENT OF DISPLAY	
TO OPERATION AND MAINTENANCE	2- 13	(CONTROLLER, EXTERNAL	
DO NOT GET CAUGHT IN		DISPLAY LAMPS)	6- 10
ARTICULATING PORTION AND		DETAILS OF DATA STORED IN	
DUMP BODY	2- 18	MEMORY OF PAYLOAD METER	6- 14
FIRE PREVENTION	2- 15	EXTERNAL DISPLAY LAMPS	6- 12
		FEATURES OF PAYLOAD METER	
		HM	6- 4
		GENERAL LOCATIONS	6- 7
		METHOD OF USING ACCURATELY	6- 5
		OPERATION OF SWITCHES	6- 17
		OTHERS	6- 35

PROCEDURE WHEN DOWNLOADING -----	6- 32	OPERATIONS, CHECKS AFTER STARTING ENGINE -----	3- 86
WHEN ERROR CODE F-09 IS DISPLAYED -----	6- 31	OTHER FUNCTIONS OF MACHINE MONITOR -----	3- 26
HANDLING TIRES -----	3-113	OUTLINE OF ELECTRIC SYSTEM -----	4- 8
		OUTLINE OF SERVICE -----	4- 4
<I>		<P>	
IF TRANSMISSION HAS TROUBLE -----	3-126	PARKING MACHINE -----	3-111
INTENDED USE -----	1- 4	PERIODIC REPLACEMENT OF SAFETY CRITICAL PARTS -----	4- 15
DIRECTIONS OF MACHINE -----	1- 4	PRECAUTIONS FOR MAINTENANCE -----	2- 31
USE OF MACHINE -----	1- 4	PRECAUTIONS BEFORE STARTING INSPECTION AND MAINTENANCE -----	2- 31
VISIBILITY FROM OPERATOR'S SEAT -----	1- 4	PRECAUTIONS FOR INSPECTION AND MAINTENANCE -----	2- 36
		TIRES -----	2- 41
<L>		PRECAUTIONS FOR OPERATION -----	2- 20
LOADING OPERATIONS -----	3-103	OPERATION -----	2- 25
LOCATION OF FIRE EXTINGUISHER -----	3- 46	PRECAUTIONS FOR JOBSITE -----	2- 20
LOCATION OF PLATES, TABLE TO ENTER SERIAL NO. AND DISTRIBUTOR -----	1- 5	STARTING ENGINE -----	2- 22
PRODUCT IDENTIFICATION NUMBER (PIN)/MACHINE SERIAL NO. PLATE -----	1- 5	TOWING -----	2- 30
SERVICE METER POSITION -----	1- 6	TRANSPORTATION -----	2- 29
TABLE TO ENTER SERIAL NO. AND DISTRIBUTOR -----	1- 6	PRECAUTIONS FOR OPERATION -----	3-110
LOCKING -----	3-112	PRECAUTIONS WHEN TRANSPORTING -----	3-115
LONG-TERM STORAGE -----	3-124		
AFTER STORAGE -----	3-124	<R>	
BEFORE STORAGE -----	3-124	RECOMMENDED FUEL, COOLANT, AND LUBRICANT -----	4- 10
DURING STORAGE -----	3-124	RECOMMENDED BRANDS, RECOMMENDED QUALITY FOR PRODUCTS OTHER THAN KOMATSU GENUINE OIL -----	4- 12
PRECAUTIONS BEFORE TRAVELING AFTER LONG-TERM STORAGE -----	3-124	USE OF FUEL, COOLANT AND LUBRICANTS ACCORDING TO AMBIENT TEMPERATURE -----	4- 11
<M>		<S>	
MACHINE MONITOR -----	3- 5	SAFETY -----	2- 2
MAINTENANCE SCHEDULE CHART -----	4- 17	SAFETY CRITICAL PARTS -----	4- 16
METHOD OF LIFTING MACHINE -----	3-117	SAFETY INFORMATION -----	1- 3
METHOD OF LOWERING DUMP BODY IN EMERGENCY -----	3-126	SAFETY LABELS -----	2- 5
METHOD OF SECURING MACHINE -----	3-116	SERVICE PROCEDURE -----	4- 19
MOVING MACHINE OFF (FORWARD, REVERSE), STOPPING -----	3- 88	CHECK BEFORE STARTING -----	4- 39
		EVERY 1000 HOURS SERVICE -----	4- 59
<O>		EVERY 2000 HOURS SERVICE -----	4- 69
OPERATION -----	3- 69	EVERY 250 HOURS SERVICE -----	4- 41
OPERATION USING DIFFERENTIAL LOCK -----	3-102	EVERY 4000 HOURS SERVICE -----	4- 76
		EVERY 50 HOURS SERVICE -----	4- 40

INDEX

EVERY 500 HOURS SERVICE -----	4- 52
EVERY 6000 HOURS SERVICE -----	4- 79
EVERY 8000 HOURS SERVICE -----	4- 80
INITIAL 250 HOURS SERVICE (ONLY AFTER THE FIRST 250 HOURS) -----	4- 19
WHEN REQUIRED -----	4- 20
SHIFTING GEAR -----	3- 93
SPECIFICATIONS -----	5- 2
STANDARD TIGHTENING TORQUES FOR BOLTS AND NUTS -----	4- 13
STARTING ENGINE -----	3- 84
STEERING THE MACHINE -----	3-101
STEPS FOR TRANSPORTATION -----	3-115
STOPPING ENGINE -----	3- 87
SWITCHES -----	3- 30
 <T>	
TORQUE LIST -----	4- 13
TRANSPORTATION -----	3-115
TRAVELING DOWNHILL -----	3- 95
TROUBLESHOOTING -----	3-125
AFTER RUNNING OUT OF FUEL -----	3-125
IF BATTERY IS DISCHARGED -----	3-131
METHOD OF TOWING MACHINE -----	3-127
OTHER TROUBLE -----	3-135
 <U>	
USE OF REAR VIEW MONITOR -----	6- 36
CAUTIONS WHEN USING REAR VIEW MONITOR -----	6- 39
NAME AND FUNCTION OF EACH PART OF REAR VIEW MONITOR -----	6- 36
SETTING OF REAR VIEW MONITOR ---	6- 39
 <W>	
WEAR PARTS -----	4- 9
WEAR PARTS LIST -----	4- 9

HM300-2 ARTICULATED DUMP TRUCK

Form No. TEN00344-01

©2010 KOMATSU
All Rights Reserved
Printed in Japan 02-10
