

Operation & Maintenance Manual

DUMP TRUCK

HD465-7E0
HD605-7E0

SERIAL NUMBERS

HD465- 10001-10037
HD465- 10101 and up
HD605- 8001 - 8032
HD605- 10101 and up

ecot3

⚠ WARNING

Unsafe use of this machine may cause serious injury or death. Operators and maintenance personnel must read this manual before operating or maintaining this machine. This manual should be kept near the machine for reference and periodically reviewed by all personnel who will come into contact with it.

NOTICE

Komatsu has Operation & Maintenance Manuals written in some other languages. If a foreign language manual is necessary, contact your local distributor for availability.

KOMATSU

FOREWORD

CALIFORNIA

Proposition 65 Warning

Diesel engine exhaust and some of its constituents are known to the State of California to cause cancer, birth defects, and other reproductive harm.

CALIFORNIA

Proposition 65 Warning

Battery posts, terminals and related accessories contain lead and lead compounds, chemicals known to the State of California to cause cancer and birth defects or other reproductive harm.

Wash hands after handling.

BEFORE READING THIS MANUAL

This manual gives details of the operation and methods of inspection and maintenance for this machine that must be obeyed in order to use the machine safely. Most accidents are caused by the failure to follow fundamental safety rules for the operation and maintenance of machines.

Read, understand and follow all precautions and warnings in this manual and on the machine before performing operation and maintenance. Failure to do so may result in serious injury or death.

Komatsu cannot predict every circumstance that might involve a potential hazard when the machine is used. Therefore, the safety messages in this manual and on the machine may not include all possible safety precautions. If you carry out any operation, inspection, or maintenance under conditions that are not described in this manual, understand that it is your responsibility to take the necessary precautions to ensure safety. In no event should you or others engage in the prohibited uses or actions described in this manual. Improper operation and maintenance of the machine can be hazardous and could result in serious injury or death.

If you sell the machine, be sure to give this manual to the new owner together with the machine.

Always keep this Operation and Maintenance Manual in the location shown on the right so that all relevant personnel can read it at any time.

Storage location for the Operation and Maintenance Manual:
On inside of left door

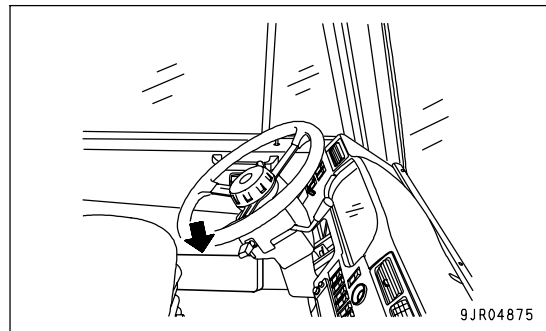

If this manual is lost or damaged, contact your distributor immediately to arrange for its replacement. For details regarding the machine serial No. you will need to provide your Komatsu distributor, see "TABLE TO ENTER SERIAL NO. AND DISTRIBUTOR (PAGE 1-8)".

This manual uses the international units (SI) for units of measurement. For reference, units that have been used in the past are given in ().

The explanations, values, and illustrations in this manual have been prepared based on the latest information available as of the date of its publication. Continuing improvements in the design of this machine may lead to additional changes that are not reflected in this manual. Consult Komatsu or your Komatsu distributor for the latest available information concerning your machine or with questions regarding information contained in this manual.

- The numbers in circles in the illustrations correspond to the numbers in () in the text.

(For example: ① → (1))

Komatsu delivers machines that comply with all applicable regulations and standards of the country to which it has been shipped. If this machine has been purchased in another country, it may lack certain safety devices and specifications that are necessary for use in your country. If there is any question about whether your product complies with the applicable standards and regulations of your country, consult Komatsu or your Komatsu distributor before operating the machine.

EMISSION CONTROL WARRANTY**EMISSION CONTROL WARRANTY STATEMENT (APPLIES TO CANADA ONLY)****1. Products Warranted**

Komatsu America International Company, Komatsu Mining Systems Inc. and Komatsu Utility Corporation (collectively "Komatsu") produce and/or market products under brand names of Komatsu, Dresser, Dressta, Haulpak and Galion. This emissions warranty applies to new engines bearing the Komatsu name installed in these products and used in Canada in machines designed for industrial off-highway use. This warranty applies only to these engines produced on or after January 1, 2000. This warranty will be administered by Komatsu distribution in Canada.

2. Coverage

Komatsu warrants to the ultimate purchaser and each subsequent purchaser that the engine is designed, built and equipped so as to conform, at the time of sale by Komatsu, with all U.S. Federal emission regulations applicable at the time of manufacture and that it is free from defects in workmanship or material which would cause it not to meet these regulations within five years or 3,000 hours of operation, whichever occurs first, as measured from the date of delivery of the engine to the ultimate purchaser.

3. Limitations

Failures, other than those resulting from defects in materials or workmanship, are not covered by this warranty. Komatsu is not responsible for failures or damage resulting from what Komatsu determines to be abuse or neglect, including, but not limited to: operation without adequate coolant or lubricants; over fueling; over speeding; lack of maintenance of lubricating, cooling or intake systems; improper storage, starting, warm-up, run-in or shutdown practices; unauthorized modifications of the engine. Komatsu is also not responsible for failures caused by incorrect fuel or by water, dirt or other contaminants in the fuel. Komatsu is not responsible for non-engine repairs, "downtime" expense, related damage, fines, all business costs or other losses resulting from a warrantable failure.

KOMATSU IS NOT RESPONSIBLE FOR INCIDENTAL OR CONSEQUENTIAL DAMAGES.

This warranty, together with the express commercial warranties, are the sole warranties of Komatsu. **THERE ARE NO OTHER WARRANTIES, EXPRESS OR IMPLIED, OR OF MERCHANTABILITY OR FITNESS FOR A PARTICULAR PURPOSE.**

GARANTIE SUR LE CONTRÔLE DES ÉMISSIONS**ÉNONCÉ DE GARANTIE SUR LE CONTRÔLE DES ÉMISSIONS (APPLICABLE AU CANADA SEULEMENT):****1. Produits garantis:**

Komatsu America International Company, Komatsu Mining Systems Inc. et Komatsu Utility Corporation (collectivement Komatsu) produisent et/ou font la mise en marché de produits portant les noms de marque Komatsu, Dresser, Dressta, Haulpak et Galion. Cette garantie sur les émissions s'applique à tous les nouveaux moteurs portant le nom Komatsu, installés dans ces produits et utilisés au Canada dans des machines conçues pour utilisation industrielle non-roulière. Cette garantie s'applique seulement sur les moteurs produits à partir du 1er Janvier 2000. Cette garantie sera administrée par la distribution de Komatsu au Canada.

2. Couverture:

Komatsu garantit à l'acheteur ultime et chaque acheteur subséquent que le moteur est conçu, construit et équipé en toute conformité, au moment de la vente par Komatsu, avec toutes les Réglementations fédérales américaines sur les émissions applicables au moment de la fabrication et qu'il est exempt de défauts de construction ou de matériaux qui auraient pour effet de contrevenir à ces réglementations en dedans de 5 ans ou 3000 heures d'opération, mesuré à partir de la date de livraison du moteur au client ultime.

3. Limitations:

Les bris, autres que ceux résultant de défauts de matériaux ou de construction, ne sont pas couverts par cette Garantie. Komatsu n'est pas responsable pour bris ou dommages résultant de ce que Komatsu détermine comme étant de l'abus ou négligence, incluant mais ne se limitant pas à: l'opération sans lubrifiants ou agent refroidissants adéquats; la suralimentation d'essence; la survitesse; le manque d'entretien des systèmes de lubrification, de refroidissement ou d'entrée; de pratiques non-propices d'entreposage, de mise en marche, de réchauffement, de conditionnement ou d'arrêt; les modifications non-autorisées du moteur. De plus, Komatsu n'est pas responsable de bris causés par de l'essence inadéquate ou de l'eau, des saletés ou autres contaminants dans l'essence. Komatsu n'est pas responsable des réparations non-relées au moteur, des dépenses encourues suite aux temps d'arrêts, des dommages relatifs, amendes, et de tout autre coût d'affaires ou autres pertes résultant d'un bris couvert par la garantie.

KOMATSU N'EST PAS RESPONSABLE DES INCIDENTS OU DOMMAGES CONSÉQUENTS.

Cette garantie, ainsi que les garanties expresses commerciales, sont les seules garanties de Komatsu. **IL N'Y A AUCUNE AUTRE GARANTIE, EXPRESSE OU SOUS-ENTENDUE, MARCHANDABLE OU PROPICE A UNE UTILISATION PARTICULIÈRE.**

NOTE IMPORTANTE CONCERNANT LE MOTEUR
 Ce moteur est conforme aux normes XXX US EPA et California Tier 3 relatives aux moteurs à compression destinés aux engins ne devant pas circuler sur route. Ce moteur fonctionne à partir de gazole. **AVERTISSEMENT:** Des blessures peuvent résulter de l'usage de ce modèle dans des conditions d'alimentation, de régime et d'altitude excédant celles publiées par le constructeur; dans ces cas, la garantie peut aussi ne plus jouer.

IMPORTANT ENGINE INFORMATION

This engine conforms to XXXX U.S. EPA and California Tier3 Regulations for large non-road compression ignition engines. This engine is certified to operate on diesel fuel.
WARNING Injury may result and warranty is voided if fuel rate, RPM or altitudes exceed published maximum values for this model and application

Engine Model	ESN	Displacement	Liters
EPA Cert. Family			
European Approval No.			
Gross rated HP/kW	at rpm	Low Idle RPM	RPM
Firing Order		Fuel rate at rated HP/kW	mm ³ /st
Timing-TDC	deg. BTDC	Valve lash cold (mm)	IN.O. EX.O.
Engine Code		Date of manufacture	

KOMATSU Komatsu Ltd. Made in Japan PT : A3

Komatsu Ltd. Fabriqué au Japon

The diagram includes the following callouts:

- Modèle du moteur** (Engine Model)
- Famille d'agrément EPA** (EPA Cert. Family)
- Numéro d'agrément européen** (European Approval No.)
- Puissance brute HP/kW à tr/mn** (Gross rated HP/kW at rpm)
- Ordre d'allumage** (Firing Order)
- PMH (degré)** (Timing-TDC deg. BTDC)
- Code moteur** (Engine Code)
- Numéro de série du moteur** (ESN)
- Cylindrée litres** (Displacement Liters)
- Ralenti à tr/mn** (Low Idle RPM)
- Consommation à la puissance nominale HP/kW mm³/st** (Fuel rate at rated HP/kW)
- Jeu des soupapes à froid (mm) IN.O. EX.O.** (Valve lash cold (mm) IN.O. EX.O.)
- Date de fabrication** (Date of manufacture)



ENGINE DATEPLATE - ENGLISH / FRENCH

SAFETY INFORMATION

To enable you to use the machine safely, and to prevent injury to operators, service personnel or bystanders, the precautions and warnings included in this manual and the safety signs attached to the machine must always be followed.

To identify important safety messages in the manual and on the machine labels, the following signal words are used.

The "Safety Alert Symbol" identifies important safety messages on machines, in manuals, and elsewhere. When you see this symbol, be alert to the risk of personal injury or death. Follow the instructions in the safety message.

- | | |
|--|--|
|  DANGER | This signal word indicates an imminently hazardous situation which, if not avoided, will result in death or serious injury. |
|  WARNING | This signal word indicates a potentially hazardous situation which, if not avoided, could result in death or serious injury. |
|  CAUTION | This signal word indicates a potentially hazardous situation exists which, if not avoided, may result in minor or moderate injury. |

The following signal words are used to alert you to information that must be followed to avoid damage to the machine.

- | | |
|----------------|--|
| NOTICE | This precaution is given where the machine may be damaged or the service life reduced if the precaution is not followed. |
| REMARKS | This word is used for information that is useful to know. |

INTENDED USE

USE OF MACHINE

This Komatsu machine is designed to be used mainly for the following work:

- Traveling with a load

GENERAL VIEW AND DIRECTIONS OF MACHINE

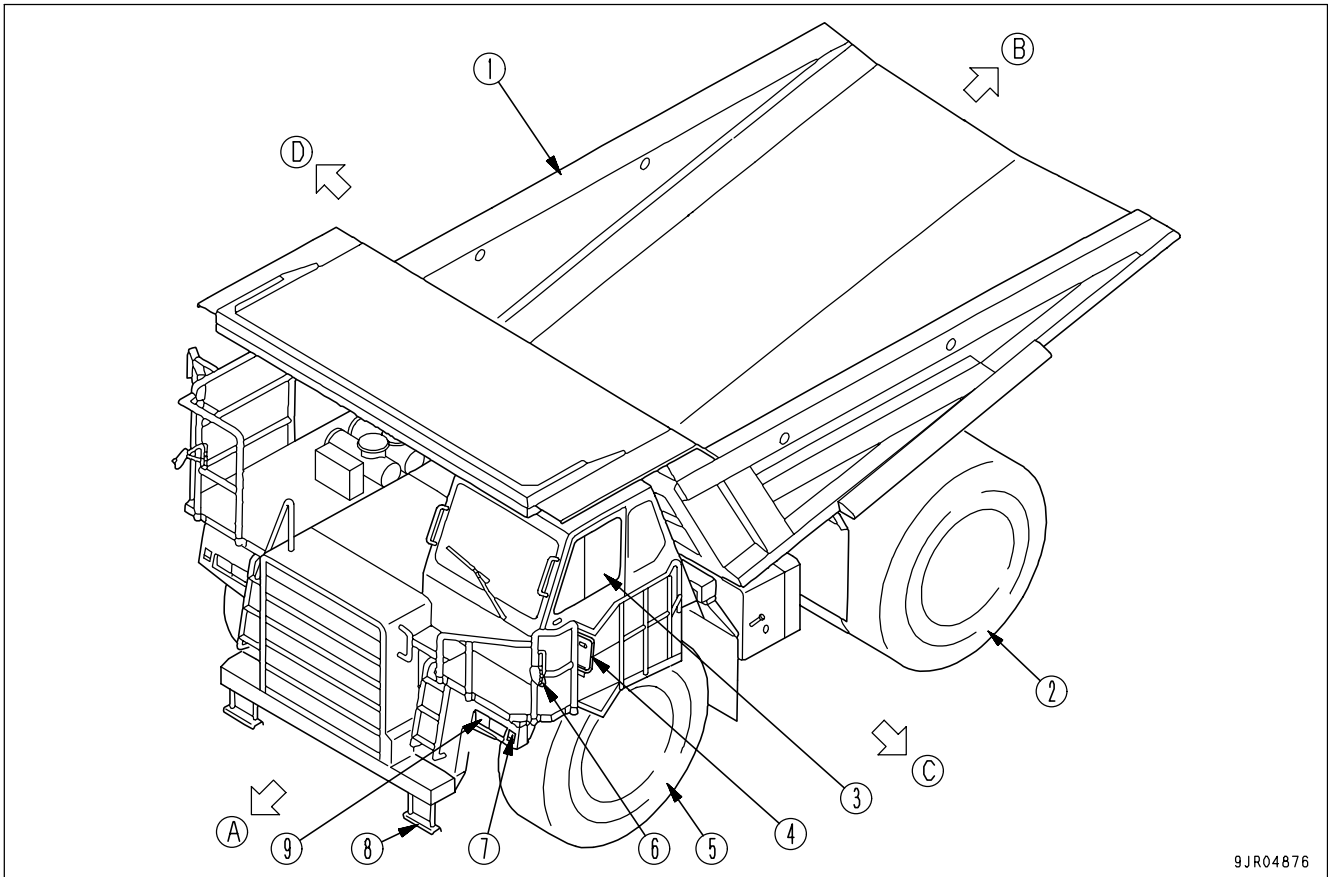

In this manual, the directions of the machine (front, rear, left, right) are determined according to the view from the operator's seat in the direction of travel (front) of the machine.

- | | |
|----------------------|-----------------------|
| (1) Dump body | (6) Under mirror |
| (2) Rear wheel | (7) Turn signal light |
| (3) Operator's cab | (8) Step |
| (4) Rear view mirror | (9) Head lamp |
| (5) Front wheel | |
| (A) Front | (C) Left |
| (B) Rear | (D) Right |

VISIBILITY FROM OPERATOR'S SEAT

This machine complies with the visibility standard (ISO 5006).

This machine maintains a close visibility of a height of 1.5 m at a point 1 m away from the outside surface of the machine, and a visibility for a circumference of 12 m.

LOCATION OF PLATES, TABLE TO ENTER SERIAL NO. AND DISTRIBUTOR

When requesting service or ordering replacement parts, please inform your Komatsu distributor of the following items.

PRODUCT IDENTIFICATION NUMBER (PIN)/MACHINE SERIAL NO. PLATE

It is located on the left front end of the frame.
The design of the nameplate differs according to the territory.

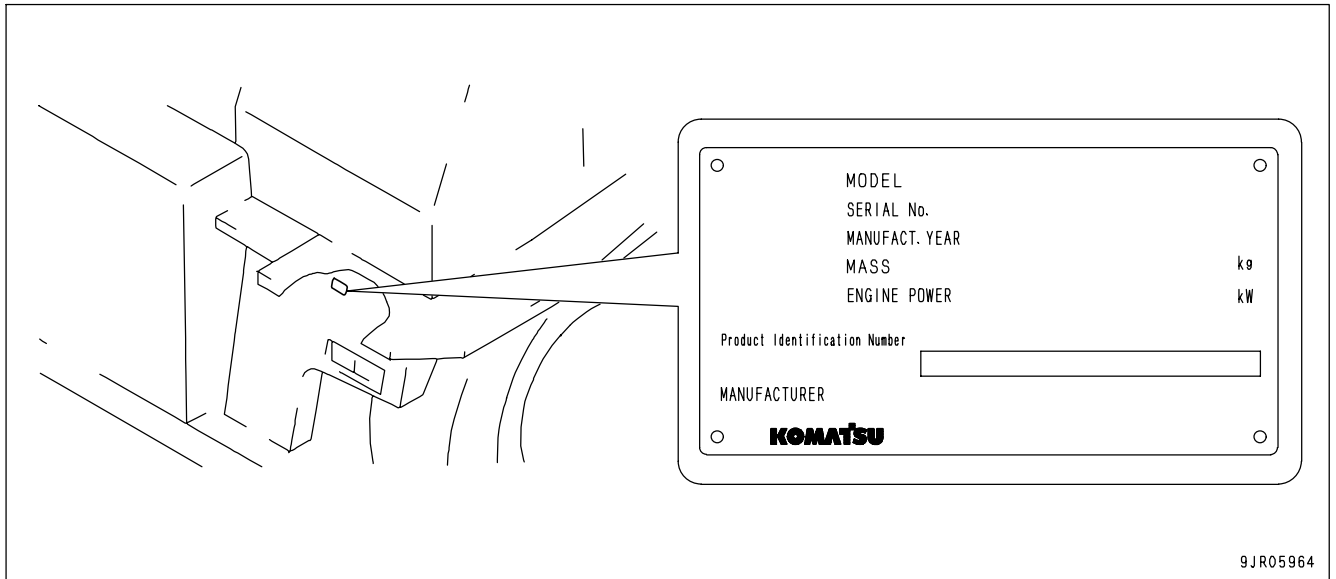

EPA REGULATIONS, ENGINE NUMBER PLATE

It is located on the upper left side of the engine cylinder block if you look from the fan side.

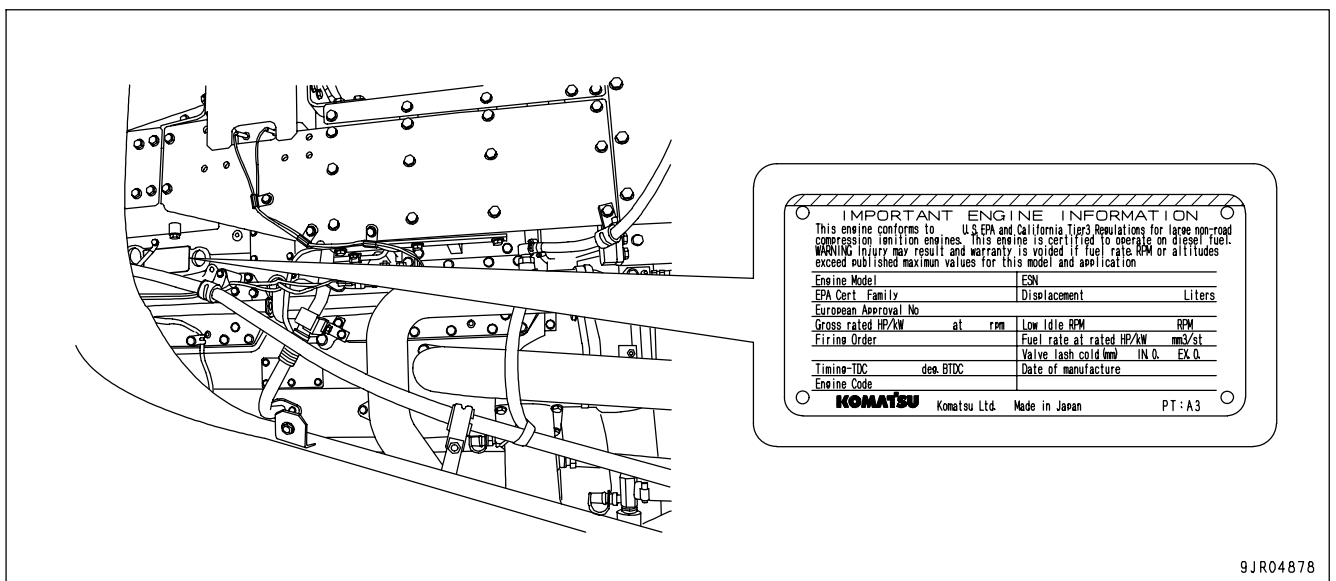

EPA: Environmental Protection Agency, U.S.A.

SERVICE METER POSITION

It is displayed at the center bottom of the machine monitor.

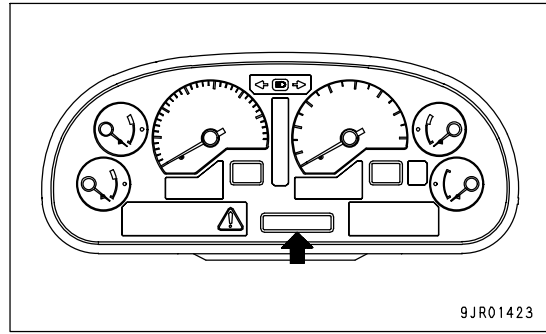

TABLE TO ENTER SERIAL NO. AND DISTRIBUTOR

Machine serial No.	
Engine serial No.	
Product identification number (PIN)	
Distributor name	
Address	-----

Service Personnel	
Phone/Fax	-----

CONTENTS

FOREWORD ----- 1- 1

 BEFORE READING THIS MANUAL ----- 1- 2

 SAFETY INFORMATION ----- 1- 5

 INTENDED USE ----- 1- 6

 USE OF MACHINE ----- 1- 6

 GENERAL VIEW AND DIRECTIONS OF MACHINE ----- 1- 6

 VISIBILITY FROM OPERATOR'S SEAT ----- 1- 6

 LOCATION OF PLATES, TABLE TO ENTER SERIAL NO. AND DISTRIBUTOR ----- 1- 7

 PRODUCT IDENTIFICATION NUMBER (PIN)/MACHINE SERIAL NO. PLATE ----- 1- 7

 EPA REGULATIONS, ENGINE NUMBER PLATE ----- 1- 7

 SERVICE METER POSITION ----- 1- 8

 TABLE TO ENTER SERIAL NO. AND DISTRIBUTOR ----- 1- 8

SAFETY ----- 2- 1

 IMPORTANT SAFETY INFORMATION ----- 2- 2

 SAFETY LABELS ----- 2- 5

 POSITION FOR ATTACHING SAFETY LABELS ----- 2- 6

 SAFETY LABELS ----- 2- 7

 GENERAL PRECAUTIONS COMMON TO OPERATION AND MAINTENANCE ----- 2- 12

 PRECAUTIONS BEFORE STARTING OPERATION ----- 2- 12

 PREPARATIONS FOR SAFE OPERATION ----- 2- 12

 FIRE PREVENTION ----- 2- 14

 PRECAUTIONS WHEN GETTING ON OR OFF MACHINE ----- 2- 15

 DO NOT GET CAUGHT IN DUMP BODY ----- 2- 17

 PRECAUTIONS RELATED TO PROTECTIVE STRUCTURES ----- 2- 17

 UNAUTHORIZED MODIFICATION ----- 2- 17

 PRECAUTIONS RELATED TO ATTACHMENTS AND OPTIONS ----- 2- 18

 PRECAUTIONS WHEN RUNNING ENGINE INSIDE BUILDING ----- 2- 18

 PRECAUTIONS FOR OPERATION ----- 2- 19

 PRECAUTIONS FOR JOBSITE ----- 2- 19

 STARTING ENGINE ----- 2- 21

 OPERATION ----- 2- 23

 TRANSPORTATION ----- 2- 27

 TOWING ----- 2- 28

 PRECAUTIONS FOR MAINTENANCE ----- 2- 29

 PRECAUTIONS BEFORE STARTING INSPECTION AND MAINTENANCE ----- 2- 29

 PRECAUTIONS FOR INSPECTION AND MAINTENANCE ----- 2- 33

 TIRES ----- 2- 38

OPERATION ----- 3- 1

 GENERAL VIEW ----- 3- 2

 GENERAL VIEW OF MACHINE ----- 3- 2

 GENERAL VIEW OF CONTROLS AND GAUGES ----- 3- 3

 DASHBOARD ----- 3- 4

 EXPLANATION OF COMPONENTS ----- 3- 5

 GENERAL VIEW OF MACHINE ----- 3- 5

 OPERATOR'S CAB ----- 3- 8

 CONTROL LEVERS AND PEDALS ----- 3- 10

 MACHINE MONITOR ----- 3- 15

 DISPLAY OF CHARACTER DISPLAY ----- 3- 28

 OTHER FUNCTIONS OF CHARACTER DISPLAY ----- 3- 32

SWITCHES	3- 36
BODY PIVOT PIN	3- 46
LOCATION OF FIRE EXTINGUISHER	3- 47
DUST INDICATOR	3- 47
FUSES	3- 48
CAR RADIO	3- 51
CAR STEREO	3- 53
AIR CONDITIONER	3- 58
OPERATION	3- 63
CHECK BEFORE STARTING ENGINE	3- 63
STARTING ENGINE	3- 88
OPERATIONS, CHECKS AFTER STARTING ENGINE	3- 91
STOPPING ENGINE	3- 91
MOVING MACHINE OFF (FORWARD, REVERSE), STOPPING	3- 92
SHIFTING GEAR	3- 98
TRAVELING DOWNHILL	3-100
STEERING THE MACHINE	3-113
LOADING OPERATIONS	3-113
DUMP OPERATIONS	3-114
PRECAUTIONS FOR OPERATION	3-116
PARKING MACHINE	3-117
CHECKS AFTER COMPLETION OF WORK	3-117
CHECKS AFTER STOPPING ENGINE	3-118
LOCKING	3-118
HANDLING TIRES	3-119
DETERMINING AND MAINTAINING TRAVEL ROAD	3-123
DETERMINING TRAVEL ROAD	3-123
MAINTAINING TRAVEL ROAD	3-123
WORKSITE	3-124
EXAMINATION AND CONFIRMATION OF WORKSITE	3-124
WORKING ON LOOSE GROUND	3-124
DO NOT GO CLOSE TO HIGH-VOLTAGE CABLE	3-125
ENSURE GOOD VISIBILITY	3-125
CONFIRMATION OF MARK	3-125
TRANSPORTATION	3-126
PRECAUTIONS WHEN TRANSPORTING	3-126
STEPS FOR TRANSPORTATION	3-126
METHOD OF SECURING MACHINE	3-127
METHOD OF LIFTING MACHINE	3-128
COLD WEATHER OPERATION	3-131
PRECAUTIONS FOR LOW TEMPERATURE	3-131
PRECAUTIONS AFTER COMPLETION OF WORK	3-133
AFTER COLD WEATHER	3-133
LONG-TERM STORAGE	3-134
BEFORE STORAGE	3-134
DURING STORAGE	3-134
AFTER STORAGE	3-134
PRECAUTIONS BEFORE TRAVELING AFTER LONG-TERM STORAGE	3-134
TROUBLESHOOTING	3-135
AFTER RUNNING OUT OF FUEL	3-135

IF TRANSMISSION HAS TROUBLE -----	3-135
METHOD OF LOWERING DUMP BODY IN EMERGENCY -----	3-136
METHOD OF TOWING MACHINE -----	3-138
IF BATTERY IS DISCHARGED -----	3-142
ACTION IF FIRE OCCURS -----	3-146
OTHER TROUBLE -----	3-147
MAINTENANCE -----	4- 1
GUIDES TO MAINTENANCE -----	4- 2
SECONDARY MATERIALS FOR OPERATION -----	4- 9
HANDLING OIL, FUEL, COOLANT, AND PERFORMING OIL CLINIC -----	4- 9
OUTLINE OF ELECTRIC SYSTEM -----	4- 13
WEAR PARTS -----	4- 14
WEAR PARTS LIST -----	4- 14
RECOMMENDED FUEL, COOLANT, AND LUBRICANT -----	4- 15
USE OF FUEL, COOLANT AND LUBRICANTS ACCORDING TO AMBIENT TEMPERATURE -----	4- 16
RECOMMENDED BRANDS, RECOMMENDED QUALITY FOR PRODUCTS OTHER THAN KOMATSU GENUINE OIL -----	4- 17
STANDARD TIGHTENING TORQUES FOR BOLTS AND NUTS -----	4- 18
TORQUE LIST -----	4- 18
PERIODIC REPLACEMENT OF SAFETY CRITICAL PARTS -----	4- 19
SAFETY CRITICAL PARTS -----	4- 19
MAINTENANCE SCHEDULE CHART -----	4- 20
MAINTENANCE SCHEDULE CHART -----	4- 20
SERVICE PROCEDURE -----	4- 22
INITIAL 250 HOURS SERVICE (ONLY AFTER THE FIRST 250 HOURS) -----	4- 22
WHEN REQUIRED -----	4- 23
CHECK BEFORE STARTING -----	4- 48
EVERY 250 HOURS SERVICE -----	4- 49
EVERY 500 HOURS SERVICE -----	4- 63
EVERY 1000 HOURS SERVICE -----	4- 73
EVERY 2000 HOURS SERVICE -----	4- 83
EVERY 4000 HOURS SERVICE -----	4- 86
EVERY 8000 HOURS SERVICE -----	4- 90
EVERY 15000 HOURS SERVICE -----	4- 91
SPECIFICATIONS -----	5- 1
SPECIFICATIONS -----	5- 2
ATTACHMENTS, OPTIONS -----	6- 1
SELECTING DUMP BODY -----	6- 2
HANDLING TACHOGRAPH (TCO20-90W) -----	6- 3
EXPLANATION OF COMPONENTS -----	6- 3
METHOD OF USE -----	6- 6
HANDLING AIR SUSPENSION SEAT -----	6- 10
OPERATOR'S SEAT ADJUSTMENT -----	6- 10
REMOVAL AND INSTALLATION OF HEADREST -----	6- 14
HANDLING AUTOMATIC SPIN REGULATOR (ASR) -----	6- 15
EXPLANATION OF COMPONENTS -----	6- 15
ACTUATION OF ASR SYSTEM -----	6- 16
PRECAUTION WHEN USING ASR SYSTEM -----	6- 16
TROUBLESHOOTING -----	6- 17
BLEEDING AIR FROM ASR CIRCUIT -----	6- 18

HANDLING ANTI SKID BRAKE SYSTEM (ABS)-----	6- 19
EXPLANATION OF COMPONENTS -----	6- 19
ABS SYSTEM CHECK AFTER STARTING ENGINE -----	6- 20
OPERATION OF ABS -----	6- 21
PRECAUTION WHEN USING ABS SYSTEM -----	6- 21
TROUBLESHOOTING -----	6- 22
HANDLING PAYLOAD METER (VHMS BUILT-IN TYPE) -----	6- 23
OUTLINE OF SYSTEM -----	6- 23
NORMAL OPERATION DISPLAY -----	6- 24
EXTERNAL DISPLAY LAMPS -----	6- 26
PERFORMING CALIBRATION -----	6- 27
DATA STORED IN PAYLOAD METER -----	6- 29
PROCEDURE WHEN DOWNLOADING -----	6- 30
MACHINE ID, OPEN ID -----	6- 34
PAYLOAD (CYCLE DATA ITEM) -----	6- 36
SERVICE FUNCTIONS -----	6- 36
OTHERS -----	6- 36
HANDLING PAYLOAD METER II (CARD TYPE) -----	6- 37
METHOD OF USING ACCURATELY -----	6- 38
GENERAL LOCATIONS -----	6- 39
CONTENT OF DISPLAY (CONTROLLER, EXTERNAL DISPLAY LAMPS) -----	6- 44
EXTERNAL DISPLAY LAMPS -----	6- 48
DETAILS OF DATA STORED IN MEMORY OF PAYLOAD METER -----	6- 50
OPERATION OF SWITCHES -----	6- 55
PROBLEM AND WARNING DISPLAY (ERROR CODE) -----	6- 77
WHEN ERROR CODE F-09 IS DISPLAYED (PROCEDURE FOR REPLACING BATTERY) -----	6- 84
OPERATION WHEN ERROR CODE F.CAL IS DISPLAYED OR CONTROLLER HAS BEEN REPLACED -----	6- 87
USE OF REAR VIEW MONITOR -----	6- 90
NAME AND FUNCTION OF EACH PART OF REAR VIEW MONITOR -----	6- 90
SETTING OF REAR VIEW MONITOR -----	6- 93
CAUTIONS WHEN USING REAR VIEW MONITOR -----	6- 93
HANDLING DUMPING COUNTER -----	6- 94
HANDLING BATTERY ISOLATOR -----	6- 95
HANDLING MACHINES EQUIPPED WITH VHMS -----	6- 97
VHMS INSTALLED, COMMUNICATIONS TERMINAL NOT INSTALLED -----	6- 97
VHMS AND COMMUNICATIONS TERMINAL INSTALLED -----	6- 97
PROCEDURE WHEN DOWNLOADING -----	6- 98
CHECK BEFORE STARTING -----	6- 98
INDEX -----	7- 1

SAFETY

Please read and make sure that you fully understand the precautions described in this manual and the safety labels on the machine. When operating or servicing the machine, always follow these precautions strictly.

IMPORTANT SAFETY INFORMATION

SAFETY LABELS	2- 5
POSITION FOR ATTACHING SAFETY LABELS	2- 6
SAFETY LABELS	2- 7
GENERAL PRECAUTIONS COMMON TO OPERATION AND MAINTENANCE	2- 12
PRECAUTIONS BEFORE STARTING OPERATION	2- 12
ENSURING SAFE OPERATION	2- 12
UNDERSTANDING THE MACHINE	2- 12
PREPARATIONS FOR SAFE OPERATION	2- 12
PRECAUTIONS REGARDING SAFETY-RELATED EQUIPMENT	2- 12
INSPECTING MACHINE	2- 12
WEAR WELL-FITTING CLOTHES AND PROTECTIVE EQUIPMENT	2- 12
KEEP MACHINE CLEAN	2- 13
PRECAUTIONS INSIDE OPERATOR'S COMPARTMENT	2- 13
PROVIDE FIRE EXTINGUISHER AND FIRST AID KIT	2- 13
IF ANY PROBLEM IS FOUND	2- 13
FIRE PREVENTION	2- 14
ACTION IF FIRE OCCURS	2- 14
PRECAUTIONS TO PREVENT FIRE	2- 14
PRECAUTIONS WHEN GETTING ON OR OFF MACHINE	2- 15
USE HANDRAILS AND STEPS WHEN GETTING ON OR OFF MACHINE	2- 15
NO JUMPING ON OR OFF MACHINE	2- 15
NO PEOPLE ON DUMP BODY	2- 15
PRECAUTIONS WHEN STANDING UP FROM OPERATOR'S SEAT	2- 16
PRECAUTIONS WHEN LEAVING MACHINE	2- 16
EMERGENCY EXIT FROM OPERATOR'S CAB	2- 16
DO NOT GET CAUGHT IN DUMP BODY	2- 17
PRECAUTIONS RELATED TO PROTECTIVE STRUCTURES	2- 17
UNAUTHORIZED MODIFICATION	2- 17
PRECAUTIONS RELATED TO ATTACHMENTS AND OPTIONS	2- 18
PRECAUTIONS WHEN RUNNING ENGINE INSIDE BUILDING	2- 18

PRECAUTIONS FOR OPERATION	2- 19
PRECAUTIONS FOR JOBSITE	2- 19
INVESTIGATE AND CONFIRM JOBSITE CONDITIONS	2- 19
WORKING ON LOOSE GROUND	2- 19
DO NOT GO CLOSE TO HIGH-VOLTAGE CABLES	2- 19
ENSURE GOOD VISIBILITY	2- 20
CHECKING SIGNS AND SIGNALMAN'S SIGNALS	2- 20
BEWARE OF ASBESTOS DUST	2- 20
STARTING ENGINE	2- 21
USE WARNING TAGS	2- 21
CHECKS BEFORE STARTING ENGINE	2- 21
PRECAUTIONS WHEN STARTING ENGINE	2- 22
PRECAUTIONS IN COLD AREAS	2- 22
STARTING WITH BOOSTER CABLES	2- 22
OPERATION	2- 23
CHECKS BEFORE OPERATION	2- 23
PRECAUTIONS WHEN TRAVELING IN FORWARD OR REVERSE	2- 23
PRECAUTIONS WHEN TRAVELING	2- 24
TRAVELING ON SLOPES	2- 24
PRECAUTIONS WHEN OPERATING	2- 24
PRECAUTIONS WHEN LOADING DUMP BODY	2- 25
PRECAUTIONS WHEN OPERATING DUMP BODY	2- 25
TRAVELING ON SNOW-COVERED OR FROZEN SURFACES	2- 25
PARKING MACHINE	2- 26
TRANSPORTATION	2- 27
LOADING AND UNLOADING	2- 27
TOWING	2- 28
WHEN TOWING	2- 28

PRECAUTIONS FOR MAINTENANCE ----- 2- 29

 PRECAUTIONS BEFORE STARTING INSPECTION AND MAINTENANCE ----- 2- 29

 DISPLAY WARNING TAG DURING INSPECTION AND MAINTENANCE ----- 2- 29

 KEEP WORKPLACE CLEAN AND TIDY ----- 2- 29

 SELECT SUITABLE PLACE FOR INSPECTION AND MAINTENANCE ----- 2- 29

 ONLY AUTHORIZED PERSONNEL ----- 2- 29

 APPOINT LEADER WHEN WORKING WITH OTHERS ----- 2- 29

 STOP ENGINE BEFORE CARRYING OUT INSPECTION AND MAINTENANCE ----- 2- 30

 TWO WORKERS FOR MAINTENANCE WHEN ENGINE IS RUNNING ----- 2- 31

 INSTALLING, REMOVING, OR STORING ATTACHMENTS ----- 2- 32

 PRECAUTIONS WHEN WORKING AT HIGH PLACES ----- 2- 32

 PRECAUTIONS WHEN WORKING UNDER MACHINE ----- 2- 32

 PROPER TOOLS ----- 2- 32

PRECAUTIONS FOR INSPECTION AND MAINTENANCE ----- 2- 33

 PRECAUTIONS WHEN WELDING ----- 2- 33

 HANDLING BATTERY ----- 2- 33

 PRECAUTIONS WHEN USING HAMMER ----- 2- 34

 PRECAUTIONS WITH HIGH-TEMPERATURE COOLANT ----- 2- 34

 PRECAUTIONS WITH HIGH-TEMPERATURE OIL ----- 2- 34

 PRECAUTIONS WITH HIGH-PRESSURE OIL ----- 2- 35

 PRECAUTIONS WITH HIGH-PRESSURE FUEL ----- 2- 35

 HANDLING HIGH-PRESSURE HOSES AND PIPING ----- 2- 35

 NOISE ----- 2- 35

 HANDLING SUSPENSION CYLINDER, ACCUMULATOR, GAS SPRING ----- 2- 36

 PRECAUTIONS WITH COMPRESSED AIR ----- 2- 36

 MAINTENANCE OF AIR CONDITIONER ----- 2- 36

 DISPOSING OF WASTE MATERIALS ----- 2- 36

 METHOD OF SELECTING WINDOW WASHER FLUID ----- 2- 36

 PERIODIC REPLACEMENT OF SAFETY CRITICAL PARTS ----- 2- 37

TIRES ----- 2- 38

 HANDLING TIRES ----- 2- 38

 PRECAUTIONS WHEN STORING TIRES ----- 2- 39

SAFETY LABELS

The following warning signs and safety labels are used on this machine.

- Be sure that you fully understand the correct position and content of labels.
- To ensure that the content of labels can be read properly, be sure that they are in the correct place and always keep them clean. When cleaning them, do not use organic solvents or gasoline. These may cause the labels to peel off.
- There are also other labels in addition to the warning signs and safety labels. Handle those labels in the same way.
- If the labels are damaged, lost, or cannot be read properly, replace them with new ones. For details of the part numbers for the labels, see this manual or the actual label, and place an order with Komatsu distributor.

POSITION FOR ATTACHING SAFETY LABELS

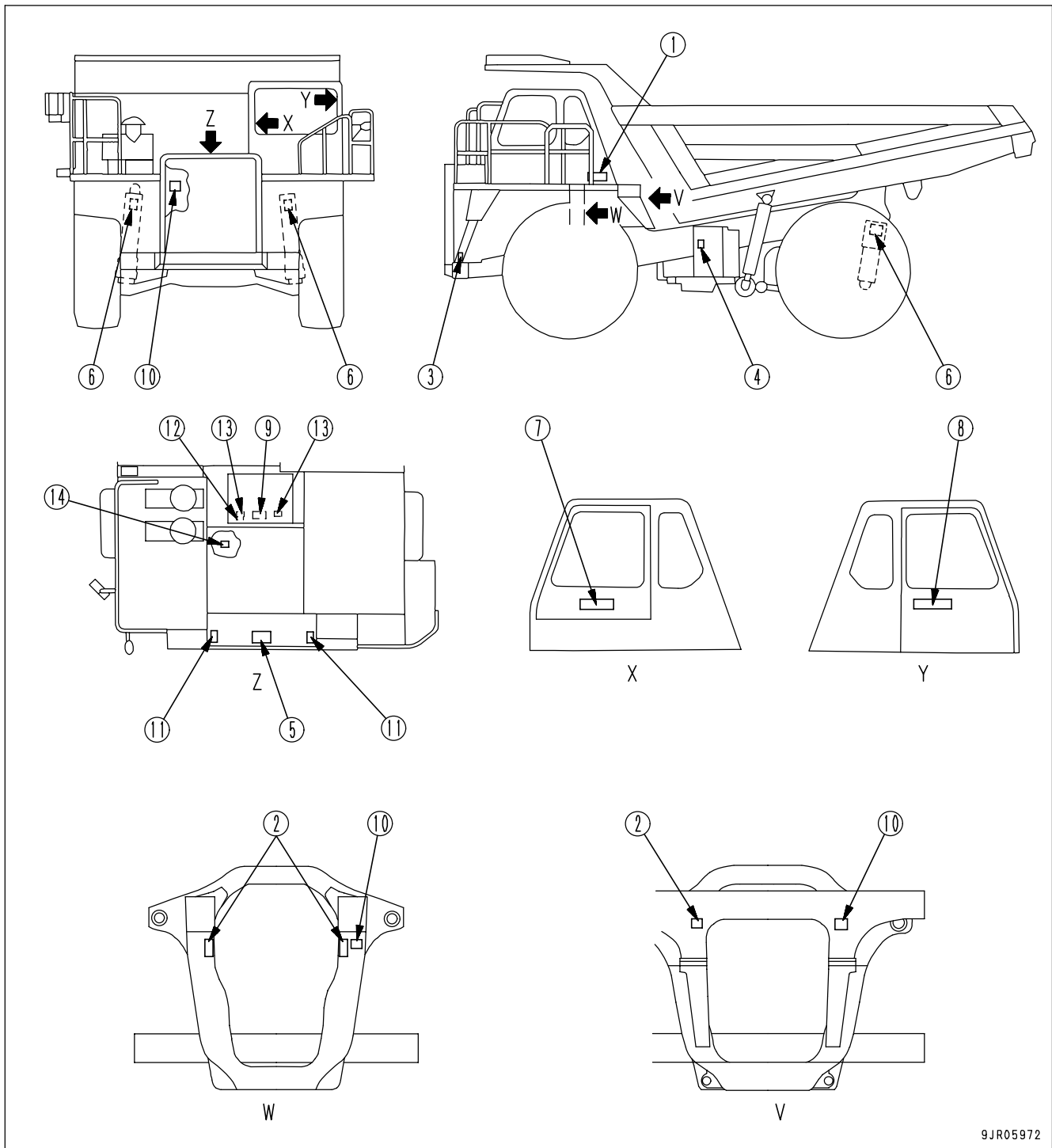

9JR05972

SAFETY LABELS

(1) Caution for modification of ROPS/FOPS (09620-A2000)

KOMATSU ROPS/FOPS CERTIFICATION			
This protective structure complies with the standard provided that it is properly equipped on the machine which mass is less than the specified maximum mass.			
ROPS : ISO 5471-1994, SAE J1063/MA194		FOPS : ISO 5449-1992	
MODEL	MACHINE MODEL	FOPS LEVEL No. <input type="checkbox"/>	
SERIAL No.	MAX MASS	kg (LBS)	
<p>WARNING</p> <ul style="list-style-type: none"> • If some modification is applied to the ROPS or FOPS, it might not enough strength and might not be complied with the standard. Consult Komatsu Distributor before altering. • ROPS or FOPS may provide less protection if it has been structurally damaged or involved roll-over. Consult Komatsu Distributor in that case. • Always wear seat belt when moving. 			
Komatsu Ltd. 2-3-6 Akaseka, Minato-ku, Tokyo, Japan 09620-A2000			

(2) Caution for rotation of front drive shaft (09667-53000)



(3) Caution for rotation of engine fan, fan belt (without side cover for engine) (09667-23001)

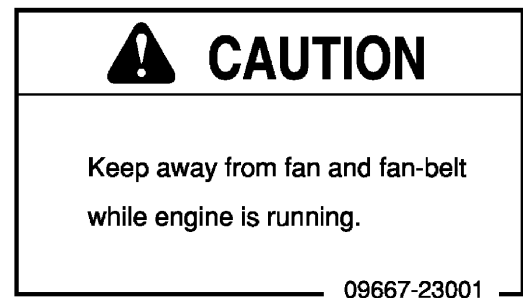

(3) Caution for rotation of engine fan, fan belt (with side cover for engine) (09667-03001)

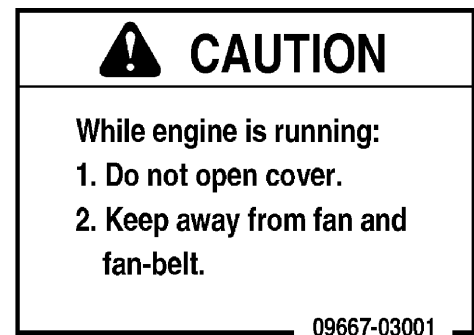

(4) Caution for opening hydraulic tank cap (09653-03001)



(5) Caution for opening radiator cap (09668-03001)



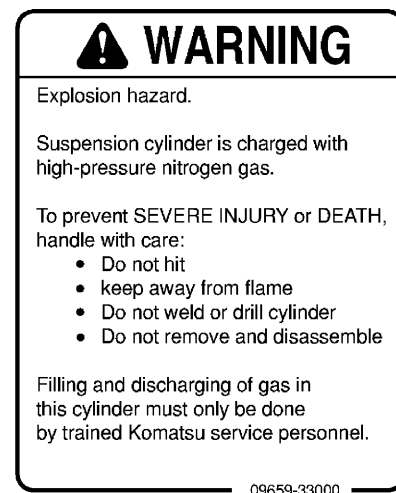

(6) Warning for handling suspension (09659-33000)



(7) Warnings for electric wire

Warnings for crush hazard when inspection and maintenance
(56B-93-12180)

<p>⚠ DANGER</p>  <p>HAZARDOUS VOLTAGE HAZARD. SERIOUS INJURY OR DEATH CAN OCCUR IF MACHINE OR ATTACHMENTS ARE NOT KEPT SAFE DISTANCE AWAY FROM ELECTRIC LINES.</p> <table border="1"> <thead> <tr> <th>VOLTAGE</th> <th>SAFE DISTANCE</th> </tr> </thead> <tbody> <tr> <td>LOW VOLTAGE</td> <td></td> </tr> <tr> <td>100 V 200 V</td> <td>2 m</td> </tr> <tr> <td>6,000 V</td> <td>2 m</td> </tr> <tr> <td>22,000 V</td> <td>3 m</td> </tr> <tr> <td>68,000 V</td> <td>4 m</td> </tr> <tr> <td>154,000 V</td> <td>5 m</td> </tr> <tr> <td>192,000 V</td> <td>6 m</td> </tr> <tr> <td>278,000 V</td> <td>7 m</td> </tr> <tr> <td>SPECIAL HIGH VOLTAGE</td> <td></td> </tr> <tr> <td>500,000 V</td> <td>11 m</td> </tr> </tbody> </table>	VOLTAGE	SAFE DISTANCE	LOW VOLTAGE		100 V 200 V	2 m	6,000 V	2 m	22,000 V	3 m	68,000 V	4 m	154,000 V	5 m	192,000 V	6 m	278,000 V	7 m	SPECIAL HIGH VOLTAGE		500,000 V	11 m	<p>⚠ DANGER</p> <p>CRUSH HAZARD TO HOLD THE DUMP BODY IN A SAFE RAISED POSITION, ALWAYS DO THE FOLLOWING: - MOVE HOIST CONTROL LEVER TO "HOLD" AND SAFETY "LOCK" TO LOCK. - LOCK DUMP BODY WITH SAFETY PIN. - PLACE BLOCK BETWEEN FRAME AND BODY. SEE MANUAL FOR MORE COMPLETE INSTRUCTIONS. FAILURE TO FOLLOW THESE INSTRUCTIONS COULD RESULT IN SEVERE INJURY OR DEATH.</p> 	<p>NOTICE</p> <p>EMERGENCY STEERING SYSTEM (DAILY CHECK) CHECK THE FUNCTION WITH THE ENGINE STOP ON FLAT GROUND. 1. TURN THE STARTING SWITCH TO THE "ON" POSITION. 2. APPLY THE EMERGENCY STEERING SWITCH TO THE "ON" POSITION AND CHECK THE STEERING WHEEL CAN BE OPERATED. 3. TURN THE EMERGENCY STEERING SWITCH TO "OFF" POSITION. 4. RELEASE THE PARKING BRAKE. THE SYSTEM WILL ACTIVATE WITHIN 1 SECOND. 5. APPLY THE PARKING BRAKE. BRAKE SYSTEM (DAILY CHECK) CHECK THE FUNCTION ON FLAT GROUND. REFER TO "OPERATION & MAINTENANCE MANUAL" FOR PROPER DIRECTIONS. DO NOT USE RETARDER BRAKE FOR PARKING.</p>	<p>NOTICE</p> <p>WHEN LEAVING OPERATOR SEAT 1. LOWER DUMP BODY. 2. PARK THE MACHINE ON LEVEL GROUND. 3. STOP ENGINE AND APPLY PARKING BRAKE COMPLETELY. BLOCK WHEELS SECURELY BEFORE LEAVING MACHINE. IDLE ENGINE FOR 5 MINUTES BEFORE SHUTTING IT DOWN.</p> <p>⚠ WARNING</p> <p>IF THE RETARDER OIL TEMPERATURE CAUTION LAMP LIGHTS UP, STOP MACHINE IMMEDIATELY. OR THE BRAKES WILL FAIL. SET THE SHIFT LEVER TO THE "N" POSITION, RUN THE ENGINE UNDER NO LOAD AT A MID-RANGE SPEED, AND WAIT FOR THE LAMP TO GO OUT.</p> <p>56B-93-12180</p>
VOLTAGE	SAFE DISTANCE																								
LOW VOLTAGE																									
100 V 200 V	2 m																								
6,000 V	2 m																								
22,000 V	3 m																								
68,000 V	4 m																								
154,000 V	5 m																								
192,000 V	6 m																								
278,000 V	7 m																								
SPECIAL HIGH VOLTAGE																									
500,000 V	11 m																								

- If the machine comes too close to electric cables, there is danger of electrocution. Always keep a safe distance from electric cables.
- There is danger that the dump body may come down. Before carrying out inspection or maintenance with the dump body raised, always read the Operation and Maintenance Manual and take the correct action.

(8) Caution before starting

Caution when traveling in reverse
(569-93-81730)

<p>⚠ WARNING</p> <p>IMPROPER OPERATION AND MAINTENANCE CAN CAUSE SERIOUS INJURY OR DEATH.</p> <p>READ MANUAL AND LABELS BEFORE OPERATION AND MAINTENANCE. FOLLOW INSTRUCTIONS AND WARNINGS IN MANUAL AND IN LABELS ON MACHINE.</p> <p>KEEP MANUAL IN MACHINE CAB NEAR OPERATOR. CONTACT KOMATSU DISTRIBUTOR FOR A REPLACEMENT MANUAL.</p>	<p>⚠ WARNING</p>  <p>TO PREVENT SEVERE INJURY OR DEATH, DO THE FOLLOWING BEFORE MOVING MACHINE OR ITS DUMP BODY. - HONK HORN TO ALERT PEOPLE NEARBY. - BE SURE NO ONE IS ON OR NEAR MACHINE. - USE SPOTTER IF VIEW IS OBSTRUCTED. FOLLOW ABOVE EVEN IF MACHINE IS EQUIPPED WITH BACK-UP ALARM AND MIRRORS.</p>	<p>NOTICE</p> <p>BE SURE TO LOWER DUMP BODY AND KEEP HOIST CONTROL LEVER AT THE FLOAT POSITION DURING TRAVEL.</p>  <p>569-93-81730</p>
--	--	--

(9) Caution when handling battery cable (09808-03000)

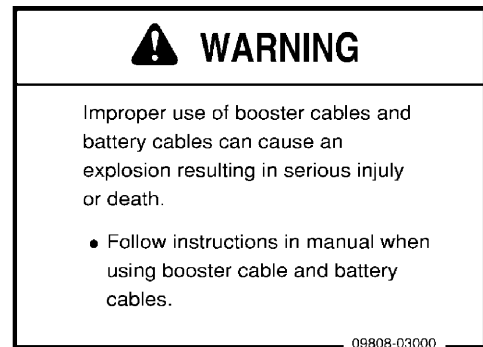

(10) Exhaust pipe is hot! (09817-K088B)



Sign indicates a burn hazard from touching hot heated parts, such as engine, motor, or muffler during or right after operation.

(11) Caution for avoiding falling down (09805-13000)



(12) Caution when handling battery (09664-30011)
(For North America only)

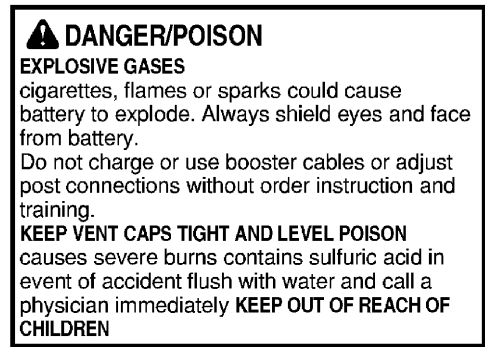

Distr. By
KOMATSU AMERICA CORP.
:Rolling Meadows IL60008, USA
KOMATSU LATIN AMERICA CORP.
:Miami, FL 33126, USA

(13)Precautions when handling battery
(The battery manufacturer sticks this caution plate on the battery.)



(14)Jump start prohibited (09842-A0481)
(This plate is stuck on the starting motor.)



Start the engine only after sitting down in the operator's seat.

Do not attempt to start the engine by short-circuiting the engine starting circuit. Such an act may cause a serious bodily injury or fire.

GENERAL PRECAUTIONS COMMON TO OPERATION AND MAINTENANCE

Mistakes in operation, inspection, or maintenance may result in serious personal injury or death. Before carrying out operation, inspection, or maintenance, always read this manual and the safety labels on the machine carefully and obey the warnings.

PRECAUTIONS BEFORE STARTING OPERATION

ENSURING SAFE OPERATION

- Only trained and authorized personnel can operate and maintain the machine.
- Follow all safety, precautions, and instructions in this manual when operating or performing inspection or maintenance on the machine.
- If you are not feeling well, or if you are under the influence of alcohol or medication, your ability to safely operate or repair your machine may be severely impaired, putting yourself and everyone else on your job site in danger.
- When working with another operator or with the person on the worksite traffic duty, discuss the content of the operation beforehand and use the determined signals when carrying out the operation.

UNDERSTANDING THE MACHINE

Before operating the machine, read this manual thoroughly. If there are any places in this manual that you do not understand, ask the person in charge of safety to give an explanation.

PREPARATIONS FOR SAFE OPERATION

PRECAUTIONS REGARDING SAFETY-RELATED EQUIPMENT

- Be sure that all guards, covers and mirrors are in their proper position. Have guards and covers repaired immediately if they are damaged.
- Understand the method of use of safety features and use them properly.
- Never remove any safety features. Always keep them in good operating condition.

INSPECTING MACHINE

Check the machine before starting operations. If any abnormality is found, do not operate the machine until repairs of the problem location have been completed.

WEAR WELL-FITTING CLOTHES AND PROTECTIVE EQUIPMENT

- Do not wear loose clothes or any accessories. If these catch on the control levers or protruding parts, there is danger that it may cause the machine to move unexpectedly.
- Always wear a hard hat and safety shoes. If the nature of the work requires it, wear safety glasses, mask, gloves, ear plugs, and safety belt when operating or maintaining the machine.
- If you have long hair and it hangs out from your hard hat, there is a hazard that it may get caught up in the machine, so tie your hair up and be careful not to let it get caught.
- Check that all protective equipment functions properly before using it.

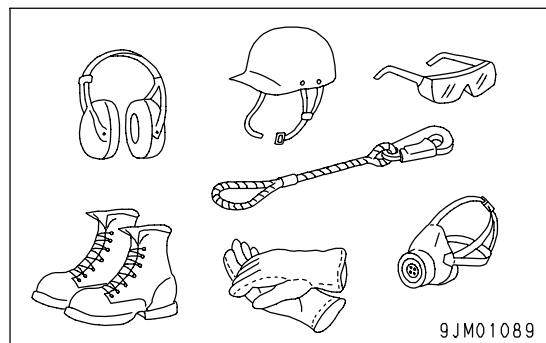

9JM01089

KEEP MACHINE CLEAN

- If you get on or off the machine or carry out inspection and maintenance when the machine is dirty with mud or oil, there is a hazard that you will slip and fall. Wipe off any mud or oil from the machine. Always keep the machine clean.
- If water gets into the electrical system, there is a hazard that it will cause malfunctions or misoperation. If there is any misoperation, there is danger that the machine may move unexpectedly and cause serious personal injury or death. When washing the machine with water or steam, do not allow the water or steam to come into direct contact with electrical components.

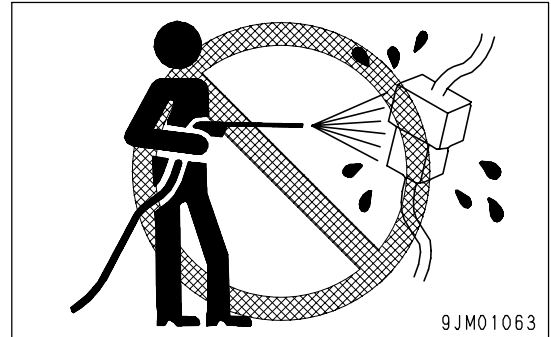
**PRECAUTIONS INSIDE OPERATOR'S COMPARTMENT**

- When entering the operator's compartment, always remove all mud and oil from the soles of your shoes. If you operate the pedal with mud or oil affixed to your shoes, your foot may slip and this may cause a serious accident.
- Do not leave tools or a machine parts lying around inside the operator's compartment. If tools or parts get into the control devices, it may obstruct operation and cause the machine to move unexpectedly, resulting in serious personal injury or death.
- Do not stick suction pads to the window glass. Suction pads act as a lens and may cause fire.
- Do not use a cell phone when driving or operating the machine. This may lead to mistakes in operation, which could cause serious personal injury or death.
- Never bring any dangerous objects such as flammable or explosive items into the operator's compartment.

PROVIDE FIRE EXTINGUISHER AND FIRST AID KIT

Always follow the precautions below to prepare for action if any injury or fire should occur.

- Be sure that fire extinguishers have been provided and read the labels to ensure that you know how to use them in emergencies.
- Carry out periodic inspection and maintenance to ensure that the fire extinguisher can always be used.
- Provide a first aid kit in the storage point. Carry out periodic checks and add to the contents if necessary.

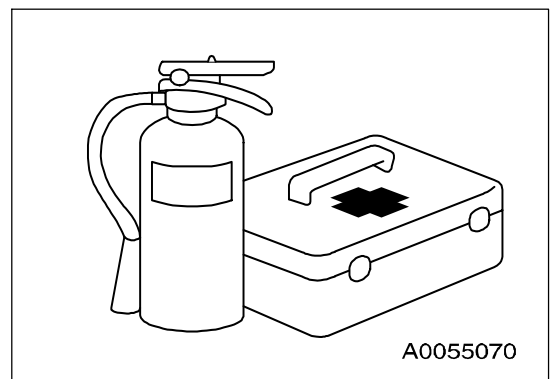
**IF ANY PROBLEM IS FOUND**

If you find any problems in the machine during operation or maintenance (noise, vibration, smell, incorrect gauges, smoke, oil leakage, etc., or any abnormal display on the warning devices or monitor), report to the person in charge and have the necessary action taken. Do not operate the machine until the problem has been corrected.

FIRE PREVENTION

ACTION IF FIRE OCCURS

- Turn the start switch OFF to stop the engine.
- Use the handrails and steps to get off the machine.
- Do not jump off the machine. There is the danger of falling and suffering serious injury.

PRECAUTIONS TO PREVENT FIRE

• Fire caused by fuel, oil, antifreeze, or window washer fluid

Do not bring any flame or fire close to flammable substances such as fuel, oil, antifreeze, or window washer fluid. There is danger that they may catch fire. To prevent fire, always observe the following:

- Do not smoke or use any flame near fuel or other flammable substances.
- Stop the engine before adding fuel.
- Do not leave the machine when adding fuel or oil.
- Tighten all fuel and oil caps securely.
- Be careful not to spill fuel on overheated surfaces or on parts of the electrical system.
- After adding fuel or oil, wipe up any spilled fuel or oil.
- Put greasy rags and other flammable materials into a safe container to maintain safety at the workplace.
- When washing parts with oil, use a non-flammable oil. Do not use diesel oil or gasoline. There is danger that they may catch fire.
- Do not weld or use a cutting torch to cut any pipes or tubes that contain flammable liquids.
- Determine well-ventilated areas for storing oil and fuel. Keep the oil and fuel in the determined place and do not allow unauthorized persons to enter.
- When carrying out grinding or welding work on the machine, move any flammable materials to a safe place before starting.

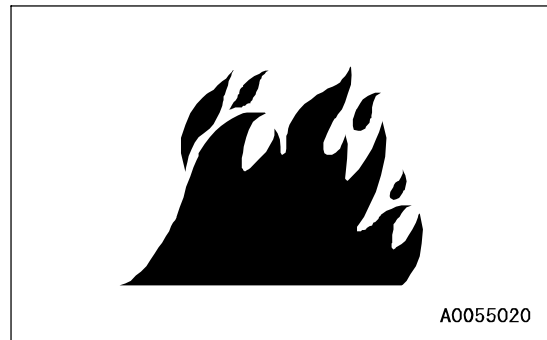

• Fire caused by accumulation of flammable material.

Remove any dry leaves, chips, pieces of paper, coal dust, or any other flammable materials accumulated or affixed around the engine, exhaust manifold, muffler, or battery, or inside the undercovers.

• Fire coming from electric wiring

Short circuits in the electrical system can cause fire. To prevent fire, always observe the following.

- Keep all electric wiring connections clean and securely tightened.
- Check the wiring every day for looseness or damage. Tighten any loose connectors or wiring clamps. Repair or replace any damaged wiring.

• Fire coming from piping

Check that all the hose and tube clamps, guards, and cushions are securely fixed in position.

If they are loose, they may vibrate during operation and rub against other parts. There is danger that this may lead to damage to the hoses and cause high-pressure oil to spurt out, leading to fire, serious personal injury or death.

- **Explosion caused by lighting equipment**
 - When checking fuel, oil, battery electrolyte, or coolant, always use lighting with anti-explosion specifications.

PRECAUTIONS WHEN GETTING ON OR OFF MACHINE

USE HANDRAILS AND STEPS WHEN GETTING ON OR OFF MACHINE

To prevent personal injury caused by slipping or falling off the machine, always do as follows.

- Use the handrails and steps marked by arrows in the diagram on the right when getting on or off the machine.

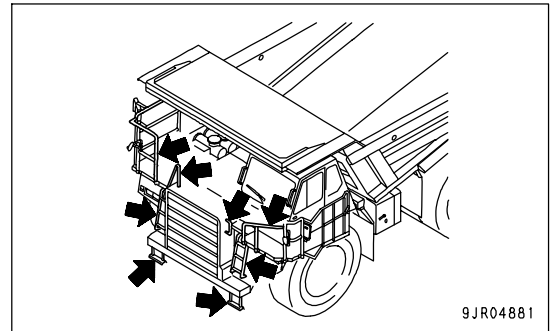

- Always face the machine and maintain at least three-point contact (both feet and one hand, or both hands and one foot) with the handrail and steps to ensure that you support yourself.

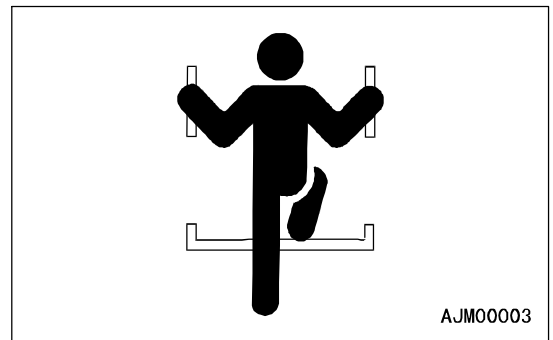

- Before getting on or off the machine, check the handrails and steps, and if there is any oil, grease, or mud on them, wipe it off immediately. In addition, repair any damage and tighten any loose bolts.
- Do not grip the control levers when getting on or off the machine.
- Never climb on the engine hood or covers where there are no non-slip pads.
- Do not get on or off the machine while holding tools in your hand.

NO JUMPING ON OR OFF MACHINE

- Never jump on or off the machine. Never get on or off a moving machine.
- If the machine starts to move when there is no operator on the machine, do not jump on to the machine and try to stop it.

NO PEOPLE ON DUMP BODY

Never let anyone ride in the dump body. There is danger of falling and suffering serious personal injury.

PRECAUTIONS WHEN STANDING UP FROM OPERATOR'S SEAT

Before standing up from the operator's seat to adjust the operator's seat, always lower the dump body completely, lock with dump lever lock knob (1), set gear shift lever (2) to the N position, set parking brake switch (3) to the PARKING position, then stop the engine.

If this is not done and the control levers are touched by mistake, there is danger that the machine may suddenly move and cause serious personal injury or death.

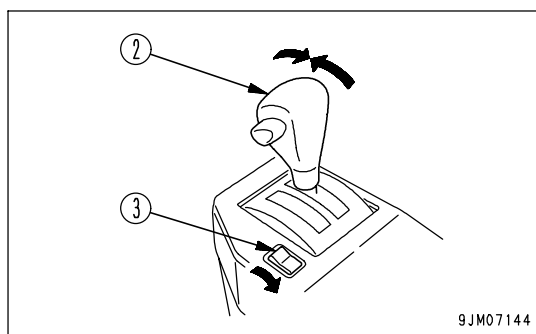
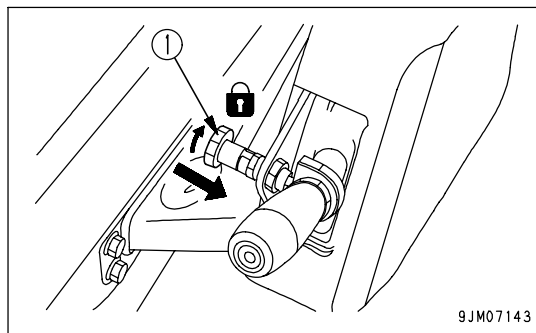

PRECAUTIONS WHEN LEAVING MACHINE

If the proper procedures are not taken when parking the machine, the machine may suddenly move off by itself, and this may lead to serious personal injury or death. Always do the following.

- When leaving the machine, always lower the dump body completely, lock with dump lever lock knob (1), set gear shift lever (2) to the N position, set parking brake switch (3) to the PARKING position, then stop the engine.

Lock all places and always take the key with you and leave it in the specified location.

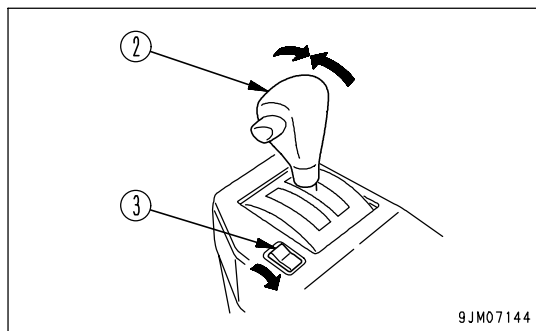
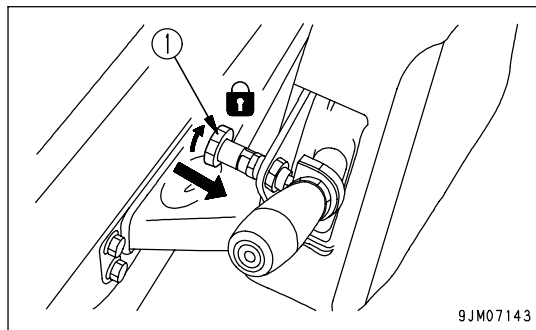

EMERGENCY EXIT FROM OPERATOR'S CAB

Machines equipped with a cab have doors on the left and right sides. If the door on the one side does not open, escape from the door on the other side.

DO NOT GET CAUGHT IN DUMP BODY

The clearance in the area around the dump body changes according to the movement of the dump body. If you are caught, there is danger that you will suffer serious injury or death.

Do not allow anyone near any of the rotating or telescopic parts.

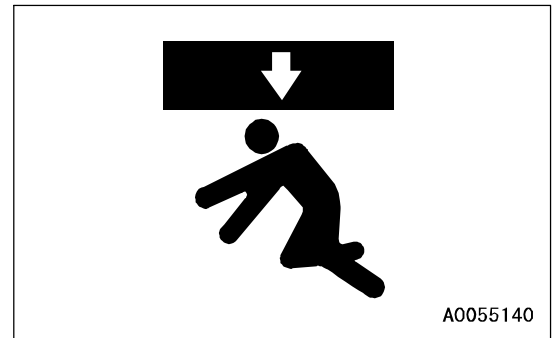

PRECAUTIONS RELATED TO PROTECTIVE STRUCTURES

The operator's compartment is equipped with a structure (ROPS, FOPS) to protect the operator by absorbing the impact energy. If the machine weight (mass) exceeds the certified value (shown on the ROLL-OVER PROTECTIVE STRUCTURE (ROPS) CERTIFICATION plate), ROPS will not be able to fulfill its function. Do not increase machine weight beyond the certified value by modifying the machine or by installing attachments to the machine. Also, if the function of the protective equipment is impeded, the protective equipment will not be able to protect the operator, and the operator may suffer injury or death. Always observe the following.

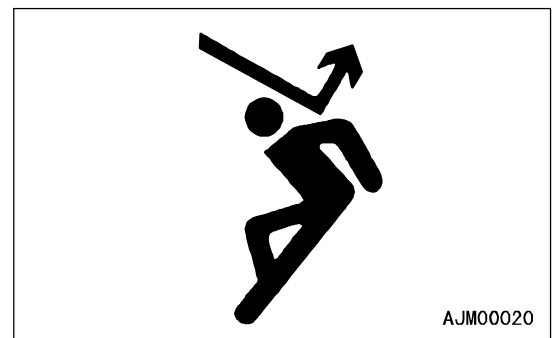

- If the machine is equipped with a protective structure, do not remove the protective structure and carry out operations without it.
- If the protective structure is welded, or holes are drilled in it, or it is modified in any other way, its strength may drop. Consult your Komatsu distributor before carrying out any modifications.
- If the protective structure is damaged or deformed by falling objects or by rolling over, its strength will be reduced and it will not be able to fulfill its function properly. In such cases, always contact your Komatsu distributor for advice on the method of repair.
- Even if the protective structure is installed, always fasten your seat belt properly when operating the machine. If you do not fasten your seatbelt properly, it cannot display its effect.

UNAUTHORIZED MODIFICATION

- Komatsu will not be responsible for any injuries, accidents, product failures or other property damages resulting from modifications made without authorization from Komatsu.
- Any modification made without authorization from Komatsu can create hazards. Before making a modification, consult your Komatsu distributor.
- Do not try to increase the capacity of the dump body or make any other modifications. Such modifications will cause a drop in the braking efficiency, the balance of the machine will become poor, and this may lead to an unexpected accident.

PRECAUTIONS RELATED TO ATTACHMENTS AND OPTIONS

- Any injuries, accidents, product failures or other property damages resulting from the use of unauthorized attachments or parts will not be the responsibility of Komatsu.
- When installing optional parts or attachments, there may be problems with safety or legal restrictions. Therefore contact your Komatsu distributor for advice.
- When installing and using optional attachments, read the instruction manual for the attachment, and the general information related to attachments in this manual.

PRECAUTIONS WHEN RUNNING ENGINE INSIDE BUILDING

The engine exhaust gas contains substances that may damage your health or even cause death. Start or operate the engine in a place where there is good ventilation. If the engine or machine must be operated inside a building or under ground, where the ventilation is poor, take steps to ensure that the engine exhaust gas is removed and that ample fresh air is brought in.

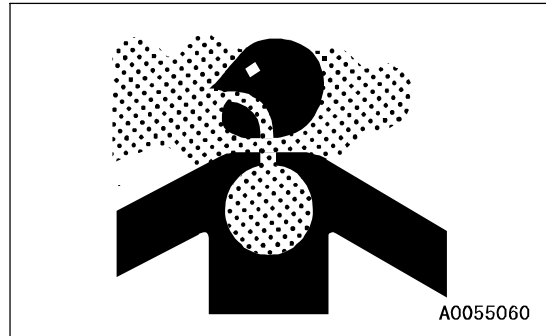

PRECAUTIONS FOR OPERATION

PRECAUTIONS FOR JOBSITE

INVESTIGATE AND CONFIRM JOBSITE CONDITIONS

On the jobsite, there are various hidden dangers that may lead to personal injury or death. Before starting operations, always check the following to confirm that there is no danger on the jobsite.

- Check the terrain and condition of the ground at the worksite, and determine the safest method of operation. Do not operate where there is a hazard of landslides or falling rocks.
- Take necessary measures to prevent any unauthorized person from entering the operating area.
- When traveling or operating in water or on soft ground, check the water depth, speed of the current, bedrock, and shape of the ground beforehand and avoid any place that will obstruct travel.
- Maintain the travel path on the jobsite so that there is no obstruction to travel operations.

WORKING ON LOOSE GROUND

- Avoid traveling or operating your machine too close to the edge of cliffs, overhangs, and deep ditches. The ground may be weak in such areas. If the ground should collapse under the weight or vibration of the machine, there is a hazard that the machine may fall or tip over. Remember that the soil after heavy rain or blasting or after earthquakes is weak in these areas.
- When working on embankments or near excavated ditches, there is a hazard that the weight and vibration of the machine will cause the soil to collapse. Before starting operations, take steps to ensure that the ground is safe and to prevent the machine from rolling over or falling.

DO NOT GO CLOSE TO HIGH-VOLTAGE CABLES

Do not travel or operate the machine near electric cables. There is a hazard of electric shock, which may cause serious personal injury or death. On jobsites where the machine may go close to electric cables, always do as follows.

- Before starting work near electric cables, inform the local power company of the work to be performed, and ask them to take the necessary action.

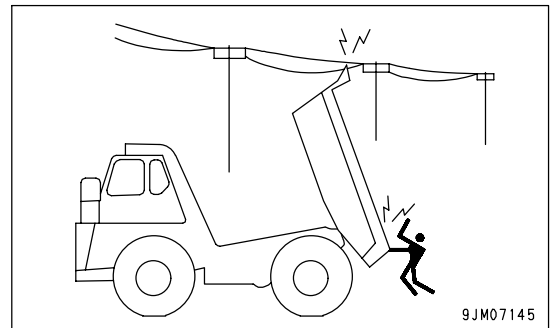

- Even going close to high-voltage cables can cause electric shock, which may cause serious burns or even death. Always maintain a safe distance (see the table on the right) between the machine and the electric cable. Check with the local power company about safe operating procedure before starting operations.
- To prepare for any possible emergencies, wear rubber shoes and gloves. Lay a rubber sheet on top of the seat, and be careful not to touch the chassis with any exposed part of your body.
- Use a signalman to give warning if the machine approaches too close to the electric cables.
- When carrying out operations near high voltage cables, do not let anyone near the machine.
- If the machine should come too close or touch the electric cable, to prevent electric shock, the operator should not leave the operator's compartment until it has been confirmed that the electricity has been shut off. Also, do not let anyone near the machine.

Voltage of Cables	Safety Distance
100V - 200V	Over 2 m (7 ft)
6,600V	Over 2 m (7 ft)
22,000V	Over 3 m (10 ft)
66,000V	Over 4 m (14 ft)
154,000V	Over 5 m (17 ft)
187,000V	Over 6 m (20 ft)
275,000V	Over 7 m (23 ft)
500,000V	Over 11 m (36 ft)

ENSURE GOOD VISIBILITY

This machine is equipped with mirrors to ensure good visibility, but even then there are places that cannot be seen from the operator's seat, so be careful when operating.

When traveling or carrying out operations in places with poor visibility, it is impossible to check for obstacles in the area around the machine and to check the condition of the jobsite. This leads to danger of serious personal injury or death. When traveling or carrying out operations in places with poor visibility, always observe the following.

- Position a signalman if there are areas where the visibility is not good.
- Only one signalman should give signals.
- When working in dark places, turn on the working lamp and front lamps installed to the machine, and set up additional lighting in the work area if necessary.
- Stop operations if the visibility is poor, such as in mist, snow, rain, or dust.
- When checking the mirrors installed to the machine, remove all dirt and adjust the angle of the mirror to ensure good visibility.
- If the machine is equipped with cameras, clean off any dirt from the lens and make sure that the camera gives a clear view.

CHECKING SIGNS AND SIGNALMAN'S SIGNALS

- Set up signs to inform of road shoulders and soft ground. If the visibility is not good, position a signalman if necessary. Operators should pay careful attention to the signs and follow the instructions from the signalman.
- Only one signalman should give signals.
- Make sure that all workers understand the meaning of all signals and signs before starting work.

BEWARE OF ASBESTOS DUST

Asbestos dust in the air can cause lung cancer if it is inhaled. There is danger of inhaling asbestos when working on jobsites handling demolition work or work handling industrial waste. Always observe the following.

- Spray water to keep down the dust.
- Do not use compressed air.
- If there is danger that there may be asbestos dust in the air, always operate the machine from an upwind position, and make sure that all workers operate on the upwind side.
- All workers should use anti-dust masks.
- Do not allow other persons to approach during the operation.
- Always observe the rules and regulations for the work site and environmental standards.

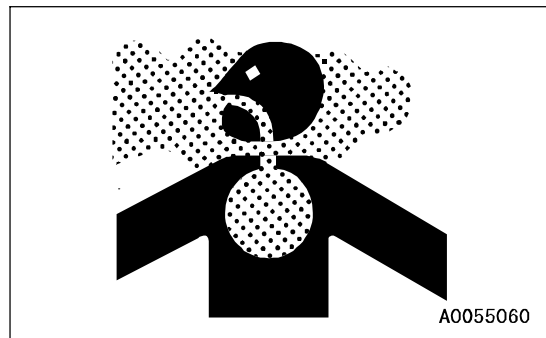

This machine does not use asbestos, but there is a danger that imitation parts may contain asbestos, so always use genuine Komatsu parts.

STARTING ENGINE

USE WARNING TAGS

If there is any "DANGER! Do NOT operate!" warning tag displayed, it means that someone is carrying out inspection and maintenance of the machine. If the warning sign is ignored and the machine is operated, there is danger that the person carrying out inspection or maintenance may be caught in the rotating parts or moving parts and suffer serious personal injury or death. Do not start the engine or touch the levers.

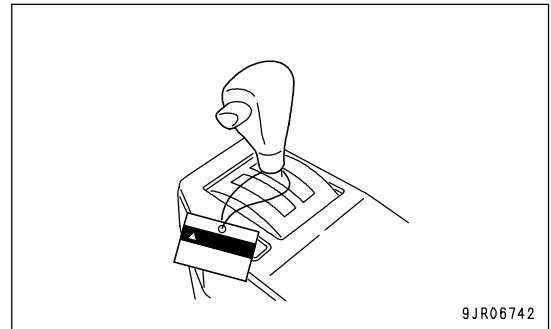

9JR06742

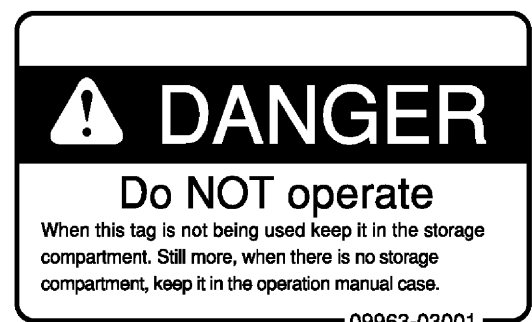

CHECKS BEFORE STARTING ENGINE

Carry out the following checks before starting the engine at the beginning of the day's work to ensure that there is no problem with the operation of the machine. If this inspection is not carried out properly problems may occur with the operation of the machine, and there is danger that this may lead to serious personal injury or death.

- Remove all dirt from the surface of the window glass to ensure a good view.
- Carry out the "WALK-AROUND CHECK (PAGE 3-63)".
- Remove all dirt from the surface of the lens of the front lamps, working lamps, and rear combination lamp, and check that they light up correctly.
- Check the coolant level, fuel level, and oil level in engine oil pan, check for clogging of the air cleaner, and check for damage to the electric wiring.
- Check that there is no mud or dust accumulated around the movable parts of the accelerator pedal or brake pedal, and check that the pedals work properly.
- Adjust the operator's seat to a position where it is easy to carry out operations, and check that there is no damage or wear to the seat belt or mounting clamps.
- Check that the gauges work properly, check the angle of the mirrors, and check that the gear shift lever is at the N position and that the dump control lever is at the HOLD position.
- Before starting the engine, check that the lock knob of the dump control lever is at the LOCK position.
- Adjust the mirrors so that the rear of the machine can be seen easily from the operator's seat. For details of the method of adjusting, see "ADJUSTING MIRROR (PAGE 3-84)".
- Check that there are no persons or obstacles above, below, or in the area around the machine.
- Check that the parking brake switch is at the PARKING position.

PRECAUTIONS WHEN STARTING ENGINE

- Start and operate the machine only while seated.
- When starting the engine, sound the horn as a warning.
- If another person is allowed on the machine, that person may sit only in the assistant's seat.
- Do not attempt to start the engine by short-circuiting the engine starting circuit. This may cause fire, serious personal injury or death.
- Check that the backup alarm (alarm buzzer when machine travels in reverse) works properly.

PRECAUTIONS IN COLD AREAS

- Carry out the warming-up operation thoroughly. If the machine is not thoroughly warmed up before the control levers are operated, the reaction of the machine will be slow, and this may lead to unexpected accidents.
- If the battery electrolyte is frozen, do not charge the battery or start the engine with a different power source. There is a hazard that this will ignite the battery and cause the battery to explode. Before charging or starting the engine with a different power source, melt the battery electrolyte and check that there is no leakage of electrolyte before starting.

STARTING WITH BOOSTER CABLES

If any mistake is made in the method of connecting the booster cables, it may cause the battery to explode, so always do as follows.

- Always wear safety goggles and rubber gloves when starting the engine with booster cable.
- When connecting a normal machine to a problem machine with booster cables, always use a normal machine with the same battery voltage as the problem machine.
- When starting with a booster cable, carry out the starting operation with two workers (one worker sitting in the operator's seat and the other working with the battery).
- When starting from another machine, do not allow the two machines to touch.
- When connecting the booster cables, turn the starting switch to the OFF position for both the normal machine and problem machine. There is a hazard that the machine will move when the power is connected.
- Be sure to connect the positive (+) cable first when installing the booster cables. Disconnect the negative (-) cable (ground side) first when removing them.
- When removing the booster cables, be careful not to let the booster cable clips touch each other or to let the clips touch the machine.
- For details of the starting procedure when using booster cables, see "STARTING ENGINE WITH BOOSTER CABLE (PAGE 3-144)" in the OPERATION section.

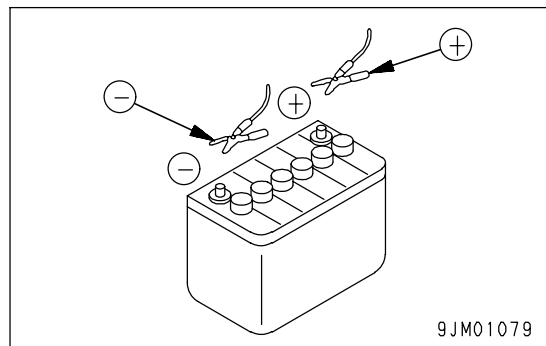
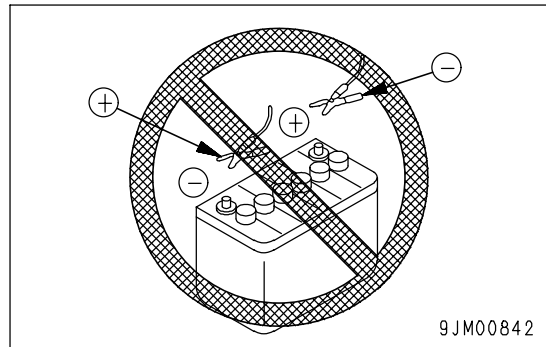

OPERATION

CHECKS BEFORE OPERATION

If the checks before starting are not carried out properly, the machine will be unable to display its full performance, and there is also danger that it may lead to serious personal injury or death.

When carrying out the checks, move the machine to a wide area where there are no obstructions, and pay careful attention to the surrounding area. Do not allow anyone near the machine.

- Always wear the seatbelt. There is danger that you may be thrown out of the operator's seat and suffer serious injury when the brakes are applied suddenly.
- Check the operation of travel, steering and brake systems, and dump body control system.
- Check for any problem in the sound of the machine, vibration, heat, smell, or gauges; check also that there is no leakage of oil or fuel.
- If any problem is found, carry out repairs immediately.

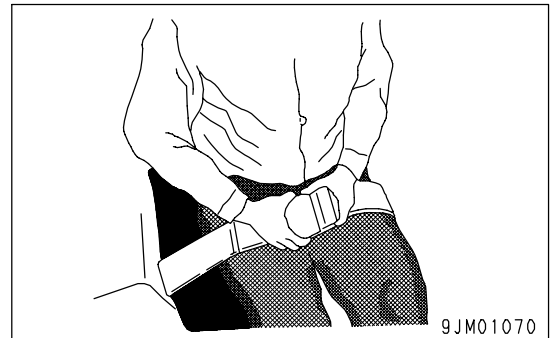

PRECAUTIONS WHEN TRAVELING IN FORWARD OR REVERSE

- Lock the cab door and windows securely, both when they are open and when they are closed.
- If another person is allowed on the machine, that person may sit only in the assistant's seat.
- If there are any persons in the area around the machine, there is danger that they may be hit or caught by the machine, and this may lead to serious personal injury or death. Always observe the following before traveling.
 - Always operate the machine only when seated.
 - Before moving off, check again that there is no person or obstruction in the surrounding area.
 - Before moving, sound the horn to warn people in the surrounding area.
 - Check that the backup alarm (alarm buzzer when machine travels in reverse) works properly.
 - If there is an area to the rear of the machine which cannot be seen, position a signalman.

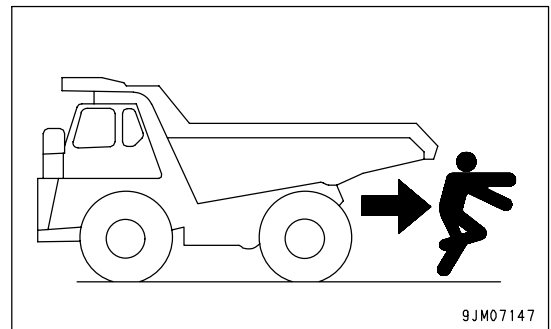

Always be sure to carry out the above precautions even when the machine is equipped with mirrors and cameras.

PRECAUTIONS WHEN TRAVELING

- Never turn the key in the starting switch to the OFF position. It is dangerous if the engine stops when the machine is traveling, because the steering becomes heavy. There is danger that this will cause misoperation of the steering wheel and may lead to serious personal injury or death. If the engine stops, depress the brake pedal immediately to stop the machine.
- When traveling or carrying out operations, always keep a safe distance from people, structures, or other machines to avoid coming into contact with them.
- Try to avoid having the machine climb over obstacles. If that is unavoidable, let the machine do that at a low speed. Nonetheless avoid a big obstacle that greatly tilts the machine to the right or left, because in such a case the machine can easily overturn sideways.
- When traveling on rough ground, travel at low speed and avoid sudden changes in direction to prevent the machine from turning over.
- Do not load the dump body above the maximum payload. The brakes will lose their effect.
- Lower the dump body, setting the dump lever at FLOAT position, then travel.
- When passing over bridges or structures, check first that the structure is strong enough to support the weight of the machine.
- When operating in tunnels, under bridges, under electric wires, or other places where the height is limited, operate slowly and be extremely careful not to let the machine body or work equipment hit anything.
- If you drive the machine at high speed continuously for a long time, the tires will overheat and the internal pressure will become abnormally high. This may cause the tires to burst. If a tire bursts, it produces a large destructive force, and this may cause serious injury or death.

If you are going to travel continuously, please consult your Komatsu distributor.

- When travelling, and particularly when travelling downhill, never set the gear shift lever to the Neutral position. Always keep it in a speed range when travelling.
 - If the gear shift lever is at Neutral, it will be impossible to use the braking force of the engine and the steering will become heavier. In addition, there will be insufficient cooling oil for the retarder, so there is danger that this will result in overheating, which will lead to defective operation of the brakes.
 - The transmission and other parts of the power train may be damaged, and there is danger that this will lead to serious injury or death.

TRAVELING ON SLOPES

To prevent the machine from tipping over or slipping to the side, always do as follows.

- When traveling downhill, use the retarder brake to reduce speed. Do not turn the steering wheel suddenly.
- Travel on grass, fallen leaves, or wet steel plates with low speed. Even with slight slopes there is a hazard that the machine may slip.
- If the engine should stop on a slope, apply the brakes fully and apply the parking brake also to stop the machine.
- Do not shift gear while traveling downhill or travel downhill with the transmission in neutral.
It is dangerous if the engine has no braking effect. Always set the transmission to a lower gear before starting to travel downhill.

PRECAUTIONS WHEN OPERATING

- When using the machine, to prevent personal injury caused by damage to the work equipment or by the machine overturning due to overloading, do not exceed the permitted performance of the machine or the maximum permitted load for the structure of the machine.
- When operating in tunnels, or under bridges or electric wires, or in other places where the height is limited, operate slowly and be extremely careful not to let the dump body contact anything.
- To prevent accidents caused by hitting other objects, always operate the machine at a speed which is safe for operation, particular in confined spaces, indoors, and in places where there are other machines.

PRECAUTIONS WHEN LOADING DUMP BODY

- Do not load the dump body so that the load is on one side. Always carry out loading that the load is spread uniformly.
- Do not leave or return to the operator's seat while the dump body is being loaded.

PRECAUTIONS WHEN OPERATING DUMP BODY

- Before starting the dumping operation, check to be sure there is no person or object behind the machine.
- Stop the machine in the correct position, and check again that there is no person or object behind the machine. Give the determined signal, then slowly operate the dump body. If necessary, use blocks for the wheels or position a flagman.
- Not carry out dumping operations on slopes. The machine stability will become poor and there is danger that it may tip over.
- Do not travel with the body raised.
- Be careful when raising the dump body. When the dump body is raised, the center of gravity of the machine changes continuously. If the ground is soft, this will affect the stability of the machine.
- Take care particularly when dumping sticky material (wet clay, frozen material, etc.) on a soft ground. The stability of the machine is reduced and there is danger that it may tip over.

TRAVELING ON SNOW-COVERED OR FROZEN SURFACES

- Snow-covered or frozen surfaces are slippery, so be extremely careful when traveling or operating the machine, and do not operate the levers suddenly. Even a slight slope may cause the machine to slip, so be particularly careful when working on slopes.
- With frozen ground surfaces, the ground becomes soft when the temperature rises, and this may cause the machine to tip over or make it impossible for the machine to escape.
- When traveling on snow-covered roads, always fit tire chains.
- If the machine enters deep snow, there is a hazard that it may tip over or become buried in the snow. Be careful not to leave the road shoulder or to get trapped in a snow drift.
- Do not apply the brakes suddenly on snow-covered slopes. Reduce speed, use the braking force of the engine, and pump the brakes (depress the brake pedal several times) to stop the machine.
- Do not try to carry out dumping operations when the load inside the dump body is frozen. There is danger that this may cause the machine to tip over.

PARKING MACHINE

- Park the machine on firm, level ground.
- Select a place where there is no hazard of landslides, falling rocks, or flooding.
- When leaving the machine, always lower the dump body completely, lock with dump lever lock knob (1), set gear shift lever (2) to the N position, set parking brake switch (3) to the PARKING position, then stop the engine.
- Always close the operator's cab door, and use the key to lock all the equipment in order to prevent any unauthorized person from moving the machine. Always remove the key, take it with you, and leave it in the specified place.

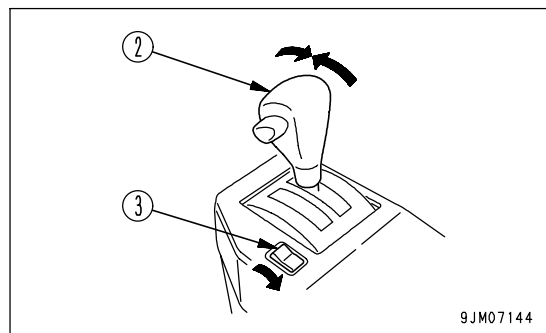
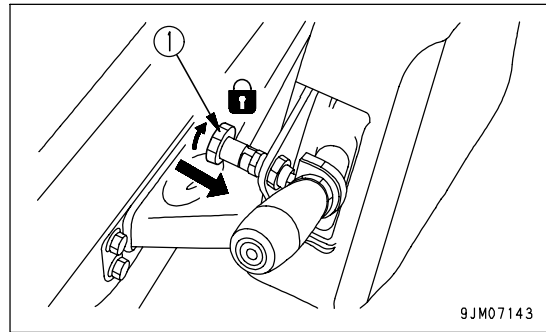

- If it is necessary to park the machine on a slope, set blocks under the wheels to prevent the machine from moving.

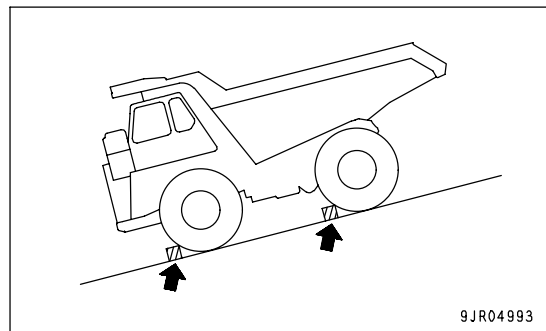

TRANSPORTATION

When the machine is transported on a trailer, there is danger of serious personal injury or death during transportation. Always do as follows.

- Always check the machine dimensions carefully. Depending on the attachments installed, the machine weight, transportation height, and overall length may differ.
- Check beforehand that all bridges and other structures on the transportation route are strong enough to withstand the combined weight of the transporter and the machine being transported.
- The machine can be divided into parts for transportation, so when transporting the machine, please contact your Komatsu distributor to have the work carried out.
- For the procedure when transporting, see "TRANSPORTATION (PAGE 3-126)".

LOADING AND UNLOADING

When loading or unloading the machine, mistaken operation may bring the hazard of the machine tipping over or falling, so particular care is necessary. Always do as follows.

- Perform loading and unloading on firm, level ground only. Maintain a safe distance from the edge of the road or cliff.
- Always use ramps of adequate strength. Be sure that the ramps are wide, long, and thick enough to provide a safe loading slope. Take suitable steps to prevent the ramps from moving out of position or coming off.
- Be sure the ramp surface is clean and free of grease, oil, ice and loose materials. Remove dirt from the tire of the machine. On a rainy day, in particular, be extremely careful since the ramp surface is slippery.
- Run the engine at low idling and drive the machine slowly at low speed.
- Never correct your steering on the ramps. If necessary, drive off the ramps, correct the direction, then enter the ramps again.
- When loading or unloading to an embankment or platform, make sure that it has suitable width, strength, and grade.
- For machines equipped with a cab, always lock the door after loading the machine. If this is not done, the door may open during transportation.

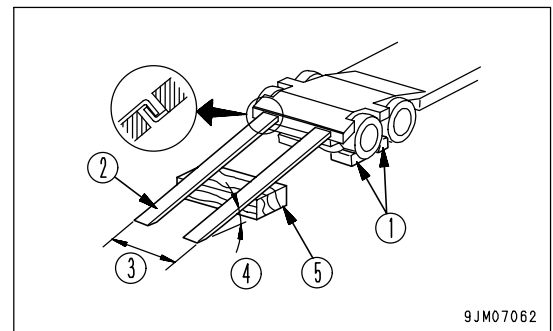

- (1) Blocks
- (2) Ramp
- (3) Width of ramps: Same width as tiers
- (4) Angle of ramps: Max. 15°
- (5) Block

For details, see "TRANSPORTATION (PAGE 3-126)".

TOWING

WHEN TOWING

Always use the correct towing equipment and towing method. Any mistake in the selection of the wire rope or towing bar or in the method of towing a disabled machine may lead to serious personal injury or death.

For details of the procedure for towing, see the "METHOD OF TOWING MACHINE (PAGE 3-138)"

- Always confirm that the wire rope or drawbar used for towing has ample strength for the weight of the machine being towed.
- Never use a wire rope which has cut strands (A), reduced diameter (B), or kinks (C). There is danger that the rope may break during the towing operation.
- Always wear leather gloves when handling wire rope.
- Never tow a machine on a slope.
- During the towing operation, never stand between the towing machine and the machine being towed.

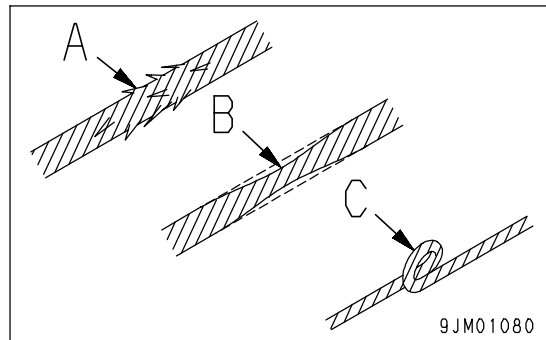

PRECAUTIONS FOR MAINTENANCE

PRECAUTIONS BEFORE STARTING INSPECTION AND MAINTENANCE

DISPLAY WARNING TAG DURING INSPECTION AND MAINTENANCE

If there is any "DANGER! Do NOT operate!" warning tag displayed, it means that someone is carrying out inspection and maintenance of the machine. If the warning sign is ignored and the machine is operated, there is danger that the person carrying out inspection or maintenance may be caught in the rotating parts or moving parts and suffer serious personal injury or death. Do not start the engine or touch the levers.

- If necessary, put up signs around the machine also.
Warning tag part number: 09963-03001
When not using this warning tag, keep it in the toolbox.
If there is no toolbox, keep it in the pocket for the Operation and Maintenance Manual

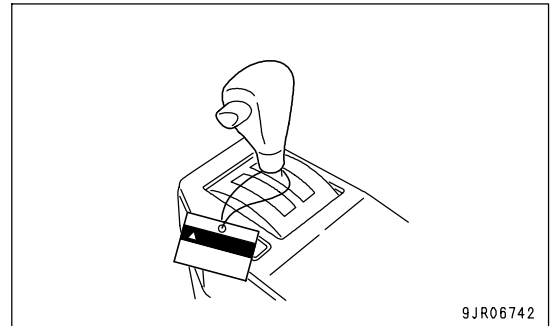

9JR06742

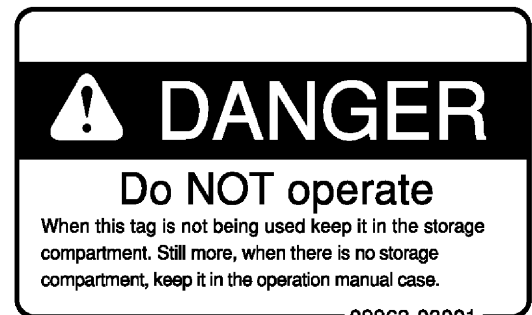

KEEP WORKPLACE CLEAN AND TIDY

Do not leave hammers or other tools lying around in the work place. Wipe up all grease, oil, or other substances that will cause you to slip. Always keep the work place clean and tidy to enable you to carry out operations safely. If the work place is not kept clean and tidy, there is the danger that you will trip, slip, or fall over and injure yourself.

SELECT SUITABLE PLACE FOR INSPECTION AND MAINTENANCE

- Stop the machine on firm, level ground.
- Select a place where there is no hazard of landslides, falling rocks, or flooding.

ONLY AUTHORIZED PERSONNEL

Do not allow any unauthorized personnel into the area when servicing the machine. If necessary, employ a guard.

APPOINT LEADER WHEN WORKING WITH OTHERS

When repairing the machine or when removing and installing the work equipment, appoint a leader and follow his instructions during the operation.

STOP ENGINE BEFORE CARRYING OUT INSPECTION AND MAINTENANCE

- Always stop the machine before performing any inspection and maintenance.

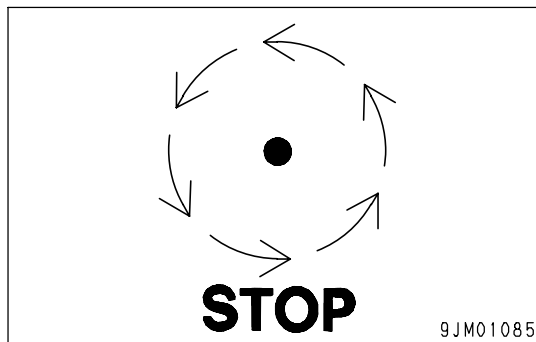

- Lower the dump body completely, set dump lever (1) to the HOLD position, lock with dump lever lock knob (2), then stop the engine.

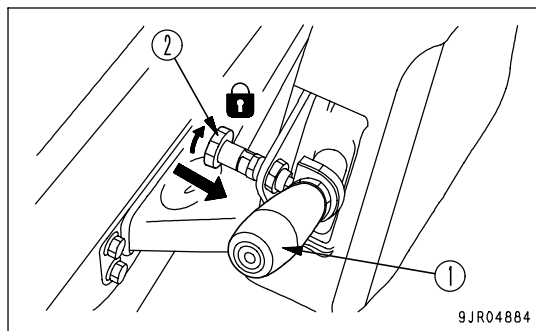

- Set parking brake switch (3) to the PARKING position to apply the parking brake, then put blocks in front of and behind the tires to prevent the machine from moving.

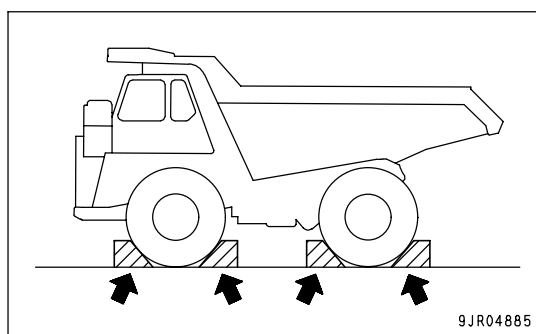
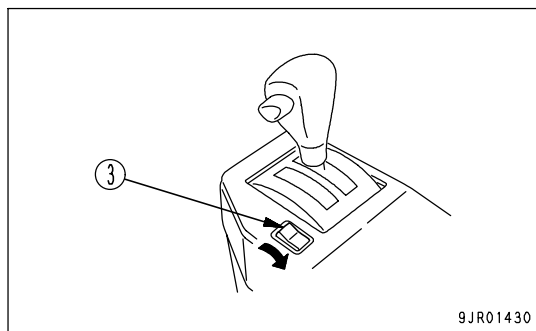

TWO WORKERS FOR MAINTENANCE WHEN ENGINE IS RUNNING

To prevent personal injury, do not carry out maintenance with the engine running. If maintenance must be carried out with the engine running, carry out the operation with at least two workers and do as follows.

- One worker must always sit in the operator's seat and be ready to stop the engine at any time. All workers must maintain contact with the other workers.
- When carrying out operations near the fan, fan belt, or other rotating parts, there is a hazard of being caught in the parts, so be careful not to come close.
- Never drop or insert tools or other objects into the fan, fan belt, or other rotating parts. There is danger that they may contact the rotating parts and break or be sent flying.

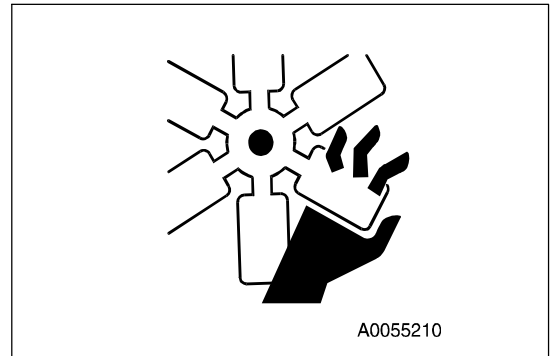

- Lower the dump body completely, set dump lever (1) to the HOLD position, lock with dump lever lock knob (2), and take steps to prevent the dump body from moving.

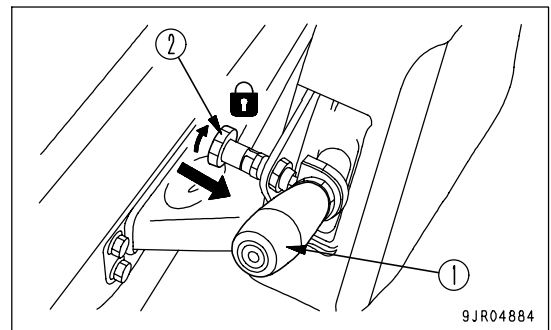

- Set parking brake switch (3) to the PARKING position to apply the parking brake, then put blocks in front of and behind the tires to prevent the machine from moving.
- Do not touch any control levers. If any control lever must be operated, give a signal to the other workers to warn them to move to a safe place.

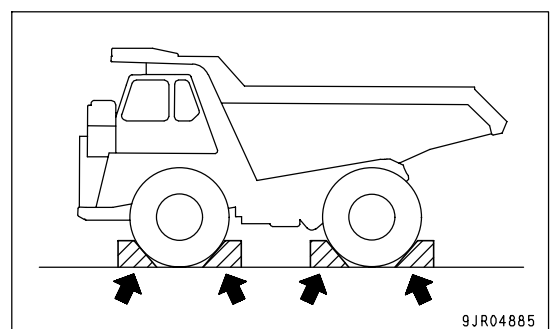
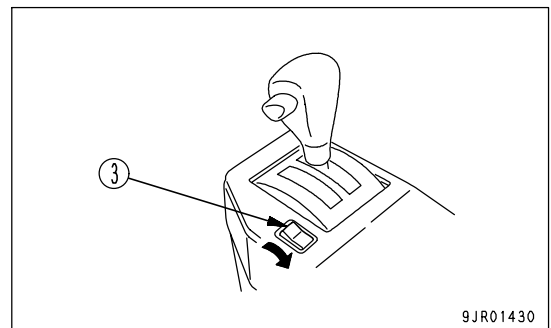

INSTALLING, REMOVING, OR STORING ATTACHMENTS

- Appoint a leader before starting removal or installation operations for attachments.
- Place attachments that have been removed from the machine in a stable condition so that they do not fall. And take steps to prevent unauthorized persons from entering the storage area.



PRECAUTIONS WHEN WORKING AT HIGH PLACES

When working at high places, use a step ladder or other stand to ensure that the work can be carried out safely.

PRECAUTIONS WHEN WORKING UNDER MACHINE

- When carrying out inspection with the dump body raised, always set the dump control lever to the HOLD position, set the lock knob to the LOCK position, then insert the body pivot pin. If the body pivot pin is not inserted, the dump body may go down when the dump control lever is operated, and catch or cause serious injury or even death to the person carrying out the inspection.
- Always carry out the operation to remove or insert the body pivot pin with at least two workers. This operation is carried out with the dump body raised, so if the dump body comes down during the operation, it may lead to serious injury or even death.

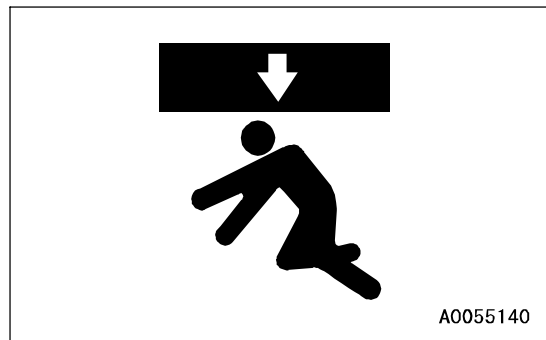

For details, see "BODY PIVOT PIN (PAGE 3-46)".

- Make sure the hoists or jacks you use are in good repair and strong enough to handle the weight of the component. Never use jacks at places where the machine is damaged, bent, or twisted. Never use frayed, twisted or pinched wire rope. Never use bent or distorted hooks.
- Never use concrete blocks for supports. They can collapse under even light loads.

PROPER TOOLS

Use only tools suited to the task and be sure to use the tools correctly. Using damaged, deformed, or low quality tools, or making improper use of the tools may cause serious personal injury.

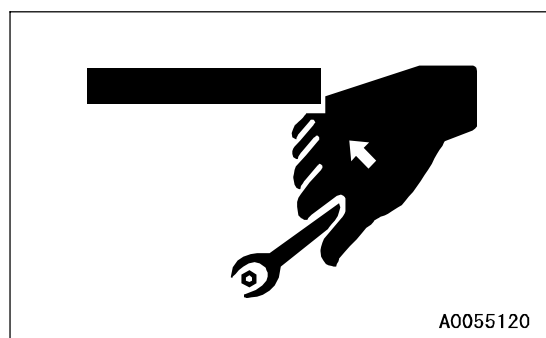

PRECAUTIONS FOR INSPECTION AND MAINTENANCE

PRECAUTIONS WHEN WELDING

Welding operations must always be carried out by a qualified welder and in a place equipped with proper equipment. There is a hazard of gas, fire, or electrocution when carrying out welding, so never allow any unqualified personnel to carry out welding.

HANDLING BATTERY

Before inspecting or handling the battery, turn the key in the starting switch to the OFF position.

- **Danger of battery exploding**

When the battery is being charged, flammable hydrogen gas is generated and may explode. In addition, the battery electrolyte includes dilute sulphuric acid. Any mistake in handling may cause serious personal injury, explosion, or fire, so always observe the following.

- Do not use or charge the battery if the battery electrolyte is below the LOWER LEVEL mark. This will cause explosion. Always carry out periodic inspection of the battery electrolyte level, and add distilled water (or commercially available battery filler solution) to the UPPER LEVEL mark.
- Do not smoke or bring any flame close to the battery.
- Hydrogen gas is generated when the battery is being charged, so remove the battery from the machine, take it to a well-ventilated place, remove the battery caps, then carry out the charging.
- After charging, tighten the battery caps securely.

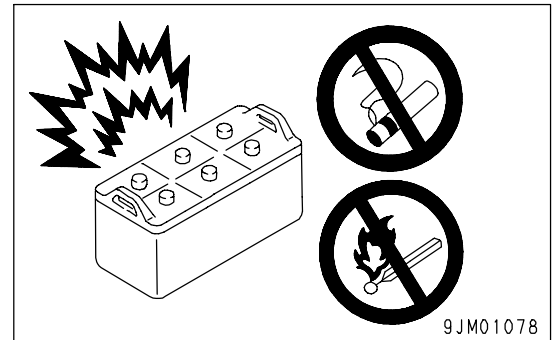

- **Danger from dilute sulphuric acid**

When the battery is being charged, flammable hydrogen gas is generated and may explode. In addition, the battery electrolyte includes dilute sulphuric acid. Any mistake in handling may cause serious personal injury, explosion, or fire, so always observe the following.

- When handling the battery, always wear protective goggles and rubber gloves.
- If battery electrolyte gets into your eyes, immediately wash your eyes with large amounts of fresh water. After that, get medical attention immediately.
- If battery electrolyte gets on your clothes or skin, wash it off immediately with large amounts of water.

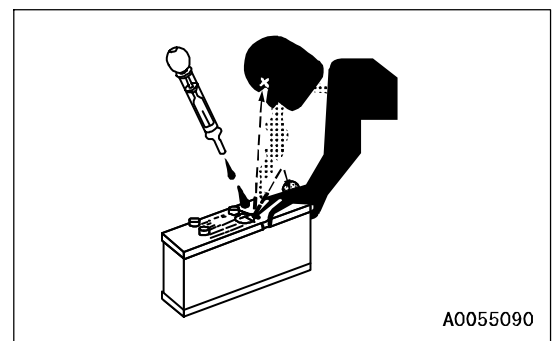

- **Removing battery cables**

Before repairing the electrical system or carrying out electric welding, turn the starting switch OFF. Wait for approx. 1 minute, then remove the negative (-) battery cable to stop the flow of electricity.

• Danger of sparks

There is hazard that sparks will be generated, so always observe the following.

- Do not let tools or other metal objects make any contact between the battery cables. Do not leave tools lying around near the battery.
- When removing the battery cables, remove the ground cable (negative (-) cable) first. When installing, connect the positive (+) cable first, then connect the ground. Tighten the battery cable terminals securely.
- Secure the battery firmly in the specified position.

PRECAUTIONS WHEN USING HAMMER

When using a hammer, pins may fly out or metal particles may be scattered. This may lead to serious personal injury or death. Always do as follows.

- If pins are hit with a hammer, there is a hazard that the metal particles may fly out and injure people in the surrounding area. Always make sure that no-one is in the surrounding area before using the hammer.
- If hard metal parts such as pins, or bearings are hit with a hammer, there is a hazard that pieces might be scattered and cause serious personal injury or death. Always wear safety glasses and gloves.
- If the pin is hit with strong force, there is a hazard that it may fly out and injure people in the surrounding area. Do not allow anyone to enter the surrounding area.

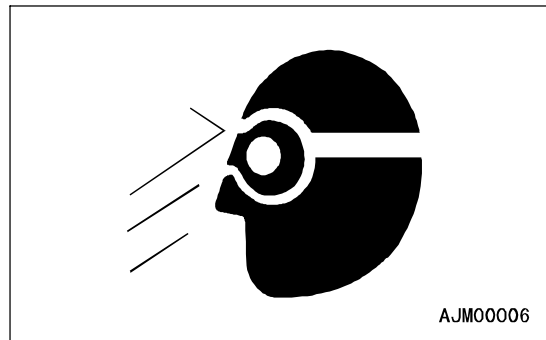

PRECAUTIONS WITH HIGH-TEMPERATURE COOLANT

To prevent burns from boiling water or steam spurting out when checking or draining the coolant, wait for the coolant to cool down to a temperature where the radiator cap can be touched by hand. Then loosen the cap slowly to release the pressure inside the radiator, and remove the cap.

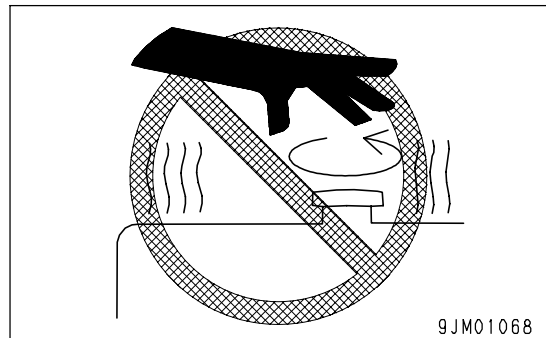

PRECAUTIONS WITH HIGH-TEMPERATURE OIL

To prevent burns from hot oil spurting out or from touching high-temperature parts when checking or draining the oil, wait for the oil to cool down to a temperature where the cap or plug can be touched by hand. Then loosen the cap or plug slowly to release the internal pressure and remove the cap or plug.

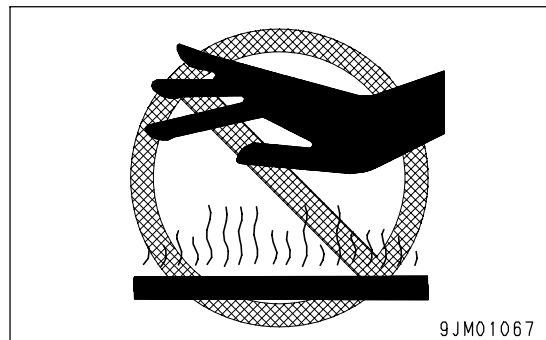

PRECAUTIONS WITH HIGH-PRESSURE OIL

The hydraulic system is always under internal pressure. In addition, the fuel piping is also under internal pressure when the engine is running and immediately after the engine is stopped. When carrying out inspection or replacement of the piping or hoses, check that the internal pressure in the circuit has been released. If this is not done, it may lead to serious personal injury or death. Always do as follows.

- Do not carry out inspection or replacement work with the circuit under pressure.
- If there is any leakage from the piping or hoses, the surrounding area will be wet, so check for cracks in the piping and hoses and for swelling in the hoses.

When carry out inspection, wear safety glasses and leather gloves.

- There is a hazard that high-pressure oil leaking from small holes may penetrate your skin or cause loss of sight if it contacts your skin or eyes directly. If you are hit by a jet of high-pressure oil and suffer injury to your skin or eyes, wash the place with clean water, and consult a doctor immediately for medical attention.

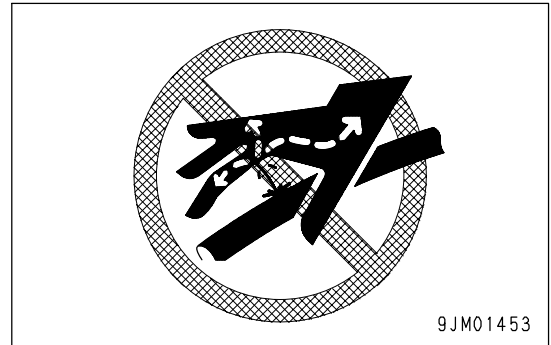
**PRECAUTIONS WITH HIGH-PRESSURE FUEL**

When the engine is running, high-pressure is generated in the engine fuel piping. When carrying out inspection or maintenance of the fuel piping system, stop the engine and wait for at least 30 seconds to allow the internal pressure to go down before starting the operation.

HANDLING HIGH-PRESSURE HOSES AND PIPING

- If oil or fuel leaks from high-pressure hoses or piping, it may cause fire or misoperation, and lead to serious personal injury, or death. If the hose or piping mounts are loose or oil or fuel is found to be leaking from the mount, stop operations and tighten to the specified torque.

If any damaged or deformed hoses or piping are found, please consult your Komatsu distributor.

Replace the hose if any of the following problems are found.

- Damaged hose or deformed hydraulic fitting.
- Frayed or cut covering or exposed reinforcement wire layer.
- Covering swollen in places.
- Twisted or crushed movable portion.
- Foreign material embedded in covering.

NOISE

When carrying out maintenance of the engine and you are exposed to noise for long periods of time, wear ear covers or ear plugs while working.

If the noise from the machine is too loud, it may cause temporary or permanent hearing problems.

HANDLING SUSPENSION CYLINDER, ACCUMULATOR, GAS SPRING

The suspension cylinders, accumulator, and gas springs are charged with high-pressure nitrogen gas. If any mistake is made in handling, there is danger that it may cause an explosion or serious personal injury. To prevent accidents, always do as follows.

- Do not remove or disassemble unless necessary.
- Do not bring it near flame or dispose of it in fire.
- Do not make holes in it, weld it, or use a cutting torch.
- Do not hit or roll the accumulator, or subject it to any impact.
- Ask your Komatsu distributor when sealing gas into the cylinder or replacing gas from it.
- When disposing of the accumulator, the gas must be released. Please contact your Komatsu distributor to have this work performed.



PRECAUTIONS WITH COMPRESSED AIR

- When carrying out cleaning with compressed air, there is a hazard of serious personal injury caused by flying dust or particles.
- When using compressed air to clean the filter element or radiator, wear safety glasses, anti-dust mask, gloves, and other protective equipment.

MAINTENANCE OF AIR CONDITIONER

If air conditioner refrigerant gets into your eyes, it may cause loss of sight; if it contacts your skin, it may cause frostbite. Never loosen any parts of the cooling circuit.

DISPOSING OF WASTE MATERIALS

To prevent pollution, pay careful attention to the method of disposing of waste materials.

- Always put oil drained from your machine in containers. Never drain oil directly onto the ground or dump into the sewage system, rivers, the sea, or lakes.
- Obey appropriate laws and regulations when disposing of harmful objects such as oil, fuel, coolant, solvent, filters, and batteries.

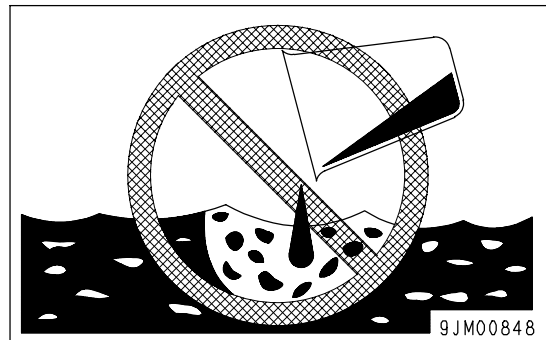

METHOD OF SELECTING WINDOW WASHER FLUID

Use an ethyl alcohol base washer liquid.

Methyl alcohol base washer liquid may irritate your eyes, so do not use it.

PERIODIC REPLACEMENT OF SAFETY CRITICAL PARTS

- For using the machine safely for an extended period of time, replace safety-critical parts like hoses and seat belts periodically.
Replacement of safety-critical parts: See "PERIODIC REPLACEMENT OF SAFETY CRITICAL PARTS (PAGE 4-19)".
- The material of these components naturally changes over time, and repeated use causes deterioration, wear, and fatigue. As a result, there is a hazard that these components may fail and cause serious personal injury or death. It is difficult to judge the remaining life of these components from external inspection or the feeling when operating, so always replace them at the specified interval.
- Replace or repair safety-critical parts if any defect is found, even when they have not reached the specified replacement time.

TIRES

HANDLING TIRES

If tires or rims are handled mistakenly, there is danger that the tire may explode or be damaged, or that the rim may fly off and cause serious personal injury or death.

To maintain safety, always do as follows.

- Maintenance, disassembly, repair, and assembly of the tires and rims requires special equipment and special technology, so always ask your Komatsu distributor to carry out these operations.
- Use only specified tires and inflate them to the specified pressure.

Suitable inflation pressure : see HANDLING TIRES (PAGE 3-119).

- When pumping up the tires, check that no other person is standing near the tire, and install an air chuck with a clip that can be secured to the air valve.

To prevent the tire inflation pressure from becoming too high, measure the pressure from time to time with an air gauge while pumping up the tire.

- If the tire pressure goes down abnormally or the rim parts do not fit the tire, there is a problem with the tire or rim parts. Always contact your Komatsu distributor for repairs.
- If the rim parts are not fitted properly when the tire is being pumped up, there is danger that the rim parts may fly off, so set up a protective fence around the tire, and do not stand directly in front of the rim. Stand beside the tread when pumping up the tire.
- Do not adjust the tire inflation pressure immediately after traveling at high speed or carrying out operations under heavy load.
- Never carry out welding or light a fire near the tire.
- Always release all pressure from a single tire or from both tires of a dual assembly prior to removing any rim components.
- Before removing the tire from the machine for repairs, remove the valve partially to release the air from the tire, then remove the tire.

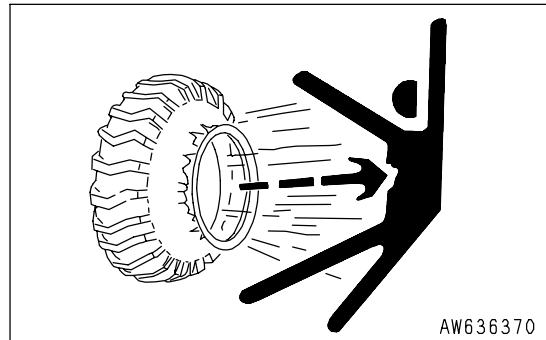

AW636370

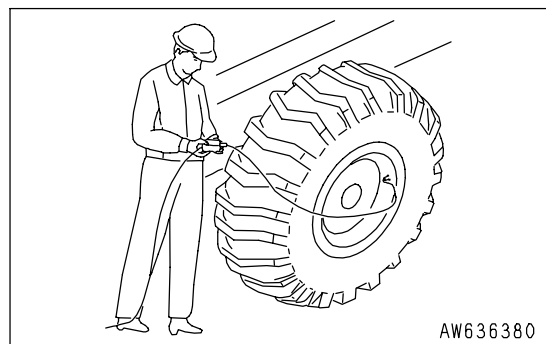

AW636380

PRECAUTIONS WHEN STORING TIRES

Tires for construction equipment are extremely heavy, it may lead to serious personal injury or death. To maintain safety, always do as follows.

- As a basic rule, store the tires in a warehouse which unauthorized persons cannot enter.
If the tires must be stored outside, always erect a fence and put up "No Entry" signs.
- Stand the tire on level ground, and block it securely so that it cannot roll or fall over if any person should touch it.
Do not lay the tire on its side. This will deform the tire and cause it to deteriorate.
- If the tire should fall over, do not attempt to stop it. Get out of the way quickly.

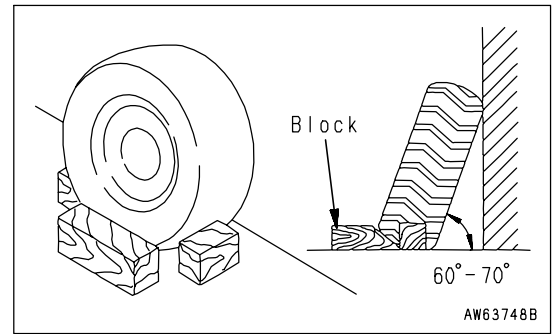

OPERATION

Please read and make sure that you understand the SAFETY section before reading this section.

GENERAL VIEW

GENERAL VIEW OF MACHINE

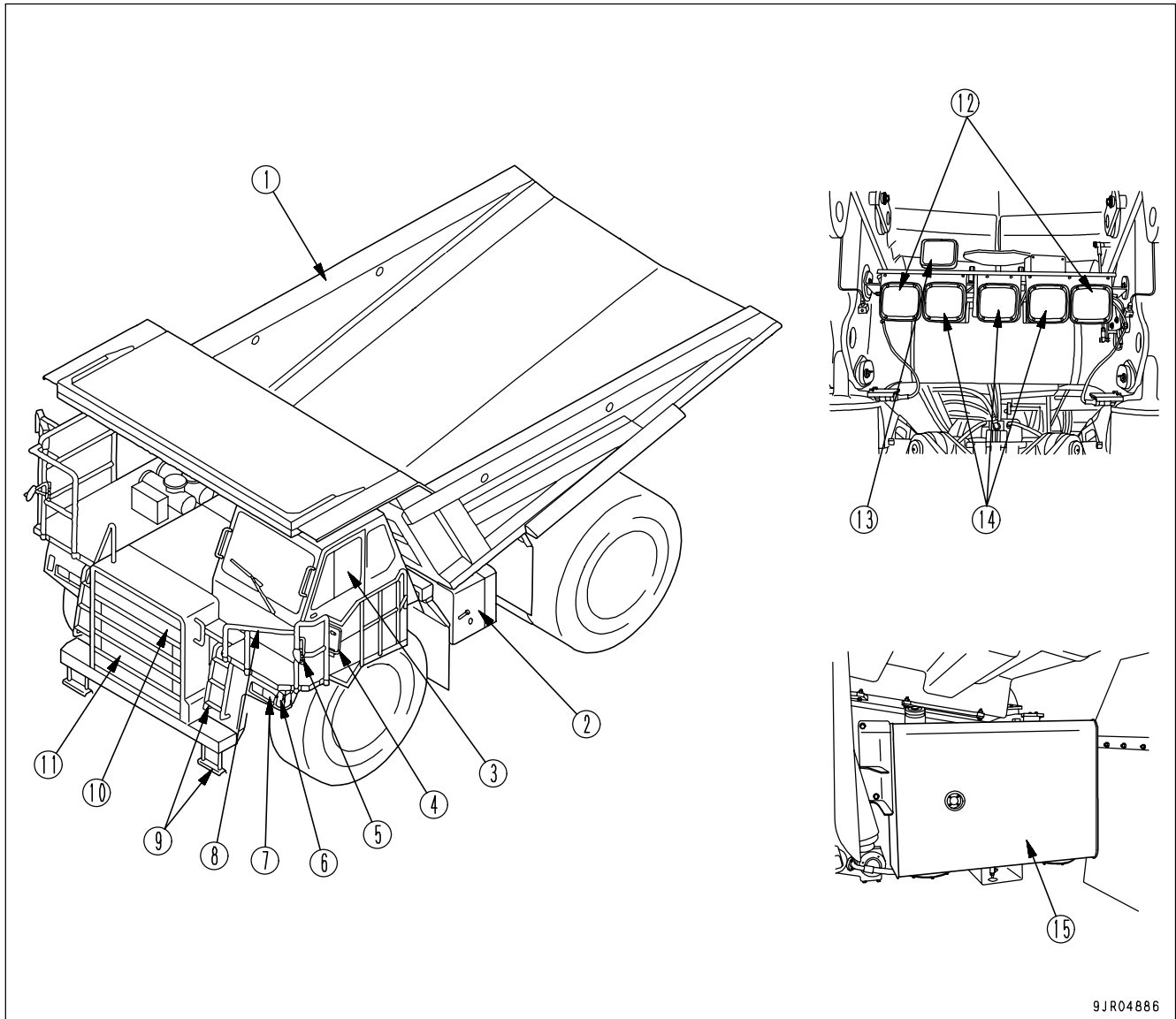

9JR04886

This illustration shows the HD465-7.

- | | |
|---------------------------------|----------------------------|
| (1) Dump body | (9) Step |
| (2) Steering and Hoist oil tank | (10) Radiator |
| (3) Operator's cab | (11) Aftercooler |
| (4) Rear view mirror | (12) Rear combination lamp |
| (5) Under mirror | (13) Back-up lamp |
| (6) Combination lamp | (14) Tail lamp |
| (7) Head lamp | (15) Fuel tank |
| (8) Handrail | |

GENERAL VIEW OF CONTROLS AND GAUGES

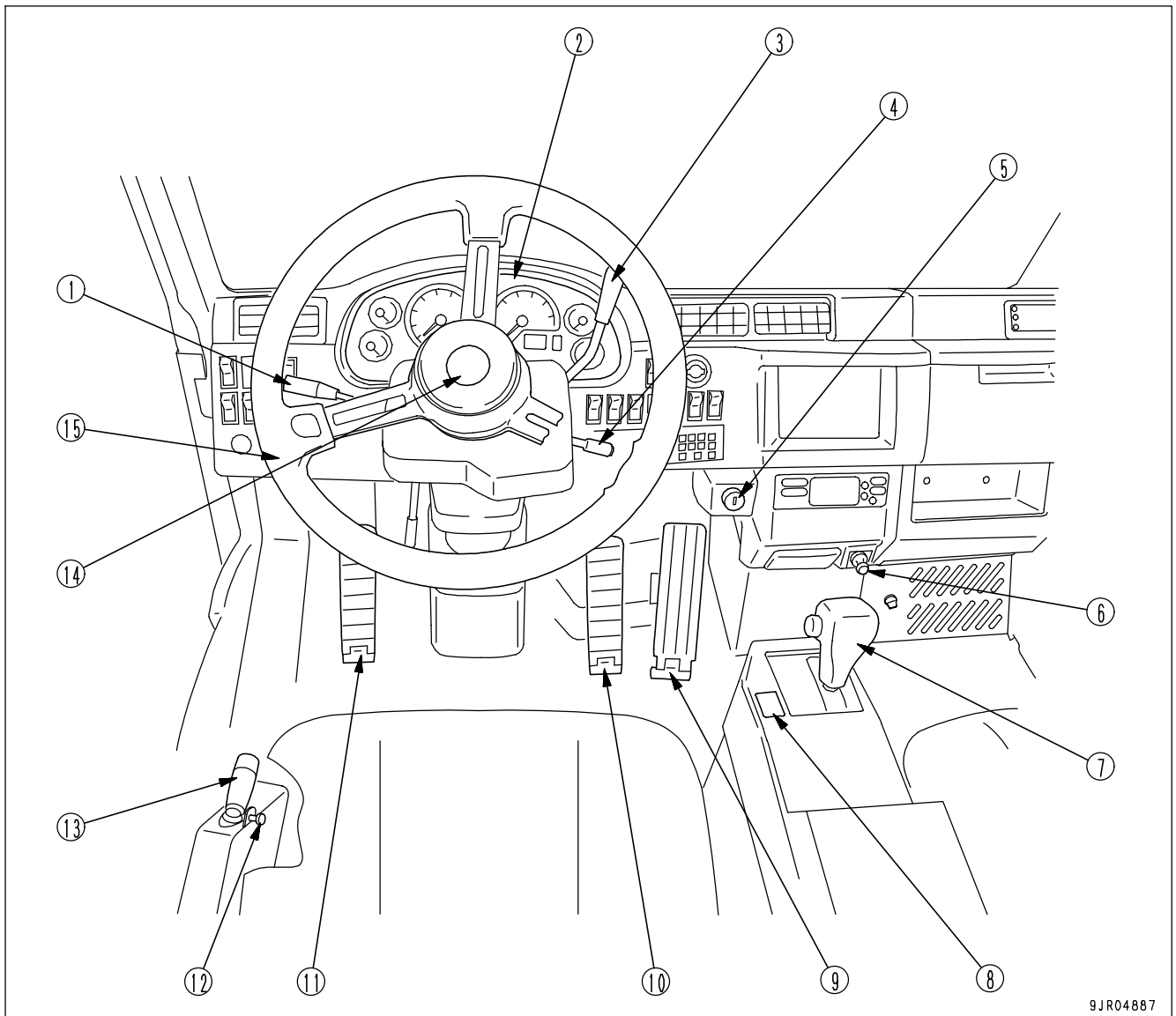

9JR04887

- | | |
|--|----------------------------|
| (1) Lamp switch, Turn signal switch, Dimmer switch | (9) Accelerator pedal |
| (2) Machine monitor | (10) Brake pedal |
| (3) Retarder control lever | (11) Secondary brake pedal |
| (4) Auto retarder (ARSC) set lever | (12) Dump lever lock knob |
| (5) Starting switch | (13) Dump lever |
| (6) Cigarette lighter | (14) Horn button |
| (7) Shift lever | (15) Steering wheel |
| (8) Parking brake switch | |

DASHBOARD

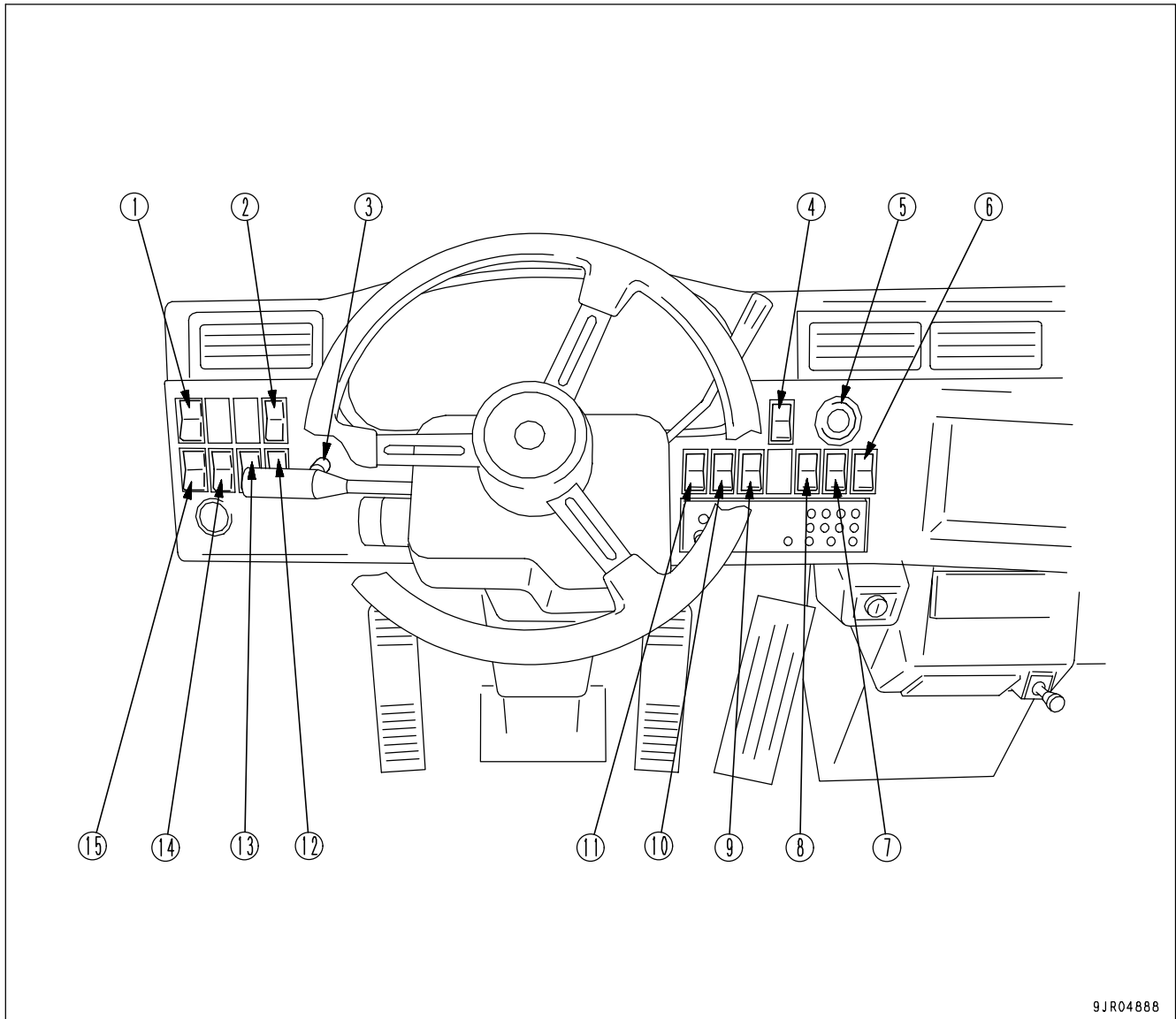

9JR04888

- | | |
|---|--|
| (1) Side lamp switch (if equipped) | (8) Front brake cut-off switch (if equipped) |
| (2) Machine monitor bulb check switch | (9) Auto retarder (ARSC) switch |
| (3) Monitor lighting dimmer switch | (10) ASR switch (if equipped) |
| (4) Hazard lamp switch | (11) ABS switch (if equipped) |
| (5) Emergency steering switch | (12) Machine monitor mode selector switch 2 |
| (6) Power mode selector switch | (13) Machine monitor mode selector switch 1 |
| (7) Automatic idling setting system (AISS LOW) switch | (14) Fog lamp switch (if equipped) |
| | (15) Yellow rotating lamp switch (if equipped) |

EXPLANATION OF COMPONENTS

This section explains about the components needed for operation.

In order to carry out work correctly, safely and comfortably, it is important to correctly understand the method of operating the components and the contents of the displays.

GENERAL VIEW OF MACHINE

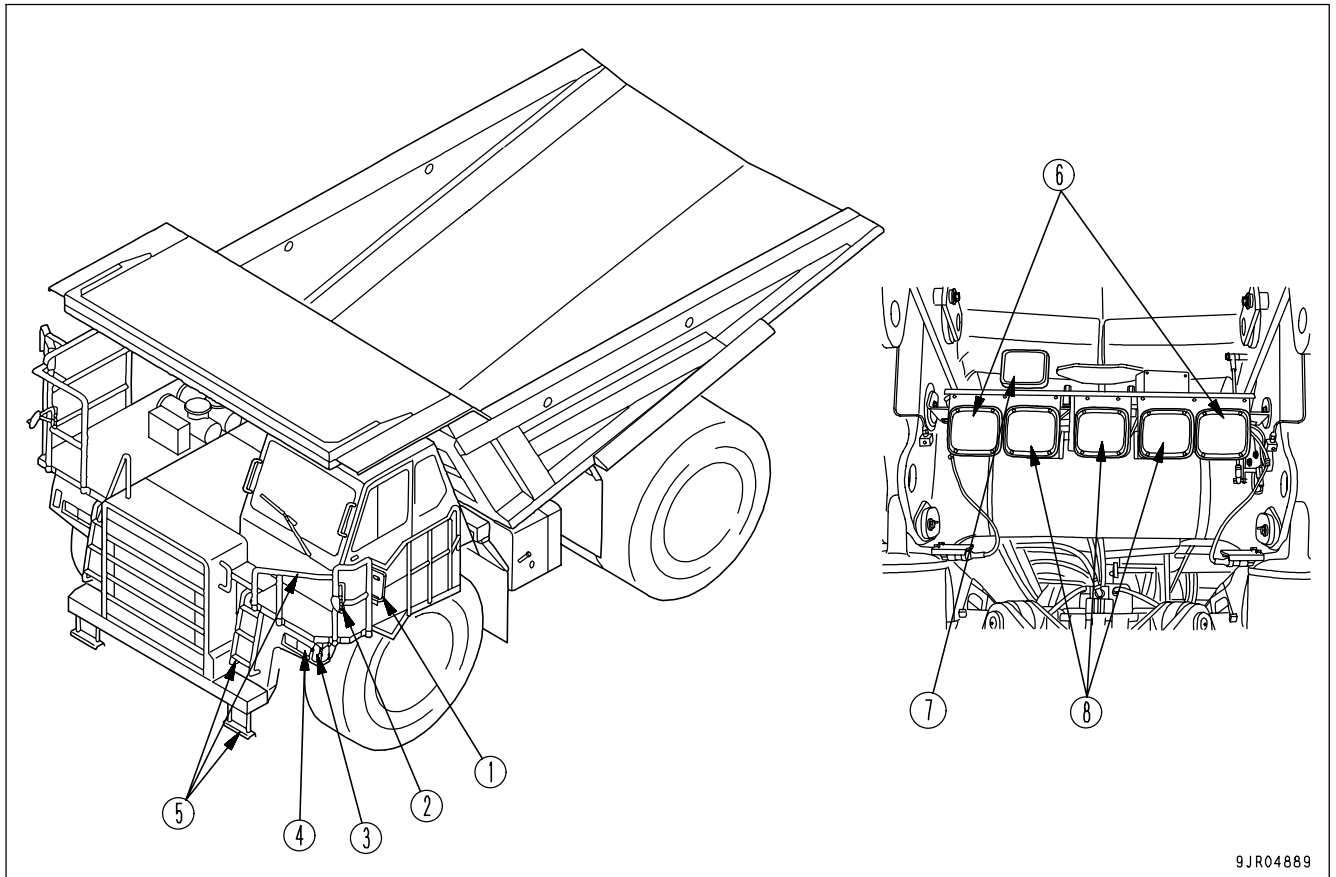

9JR04889

- | | |
|----------------------|---------------------------|
| (1) Rear view mirror | (5) Handrail and step |
| (2) Under mirror | (6) Rear combination lamp |
| (3) Combination lamp | (7) Back-up lamp |
| (4) Head lamp | (8) Tail lamp |

REAR VIEW MIRROR

Use this rear view mirror (1) to check the area at the rear of the machine from the operator's seat.

Before starting operations, adjust the angle of the mirror to ensure a good view to the rear.

To ensure that the angle of the mirror does not change during operation, check that there is no looseness of the mount.

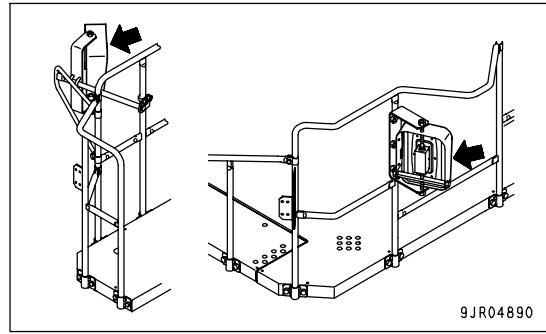

UNDER MIRROR

Use this mirror (2) to check the area under the machine from the operator's seat.

Before starting operations, adjust the angle of the mirror to ensure a good view under the machine.

To ensure that the angle of the mirror does not change during operation, check that there is no looseness of the mount.

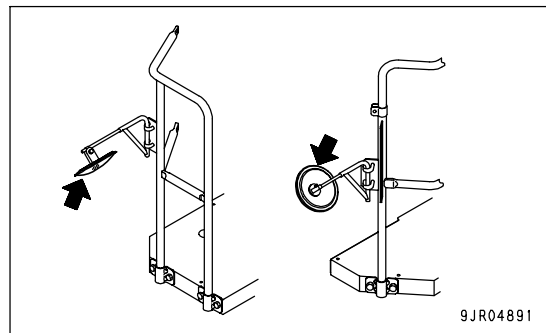

COMBINATION LAMP

The turn signal lamp and clearance lamp are built into this combination lamp (3).

Turn signal lamp: Turn signal lamp in direction of turning flashes when turn signal lever is operated. If the hazard lamp switch is turned ON, both the left and right turn signal lamps flash at the same time.

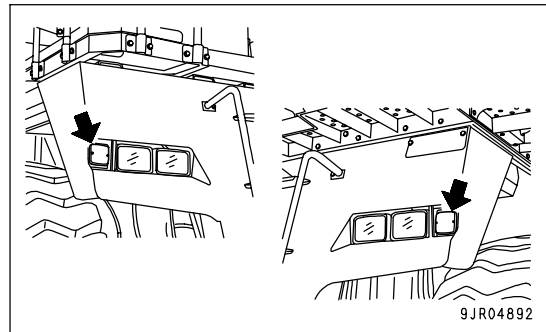

Clearance lamp: Clearance lamps light up when lamp switch is turned ON.

These show the maximum extension of the machine to the left and right at night.

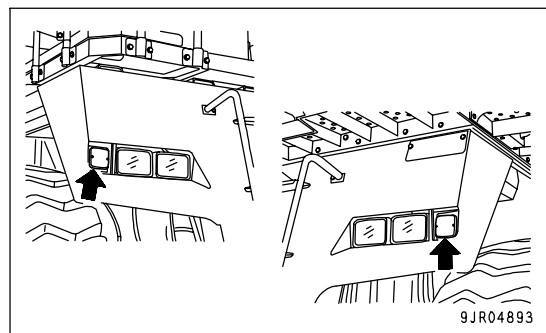

HEAD LAMP

This head lamp (4) lights up the road and the area ahead when the machine is traveling at night.

Turn the lamp on and off with this lamp switch.

Use the dimmer switch to switch between high beam and low beam.

HANDRAIL AND STEP**WARNING**

To prevent yourself from slipping and falling when getting on or off the machine, always observe the following precautions. If you fall, there is danger of injury.

- When getting on or off the machine, always face the machine and maintain at least three-point contact (both feet and one hand, or both hands and one foot) with the handrail and steps to ensure that you support yourself.
- Before getting on or off the machine, check the handrails and steps. If there is any oil, grease, or mud on them, wipe it off immediately. In addition, repair any damage and tighten any loose bolts.
- Do not get on or off the machine while holding tools.
- Never climb onto the engine hood, covers, or other places where there are no anti-slip pads.

Use the handrail and steps (5) when getting on or off the machine to carry out inspection or operation. These are at two places on the left and right at the front of the machine.

REAR COMBINATION LAMP

On rear combination lamp (6), the turn signal lamp in the direction of turning flashes when the turn signal lever is operated.

If the hazard lamp switch is turned ON, both the left and right turn signal lamps flash at the same time.

BACK-UP LAMP

This back-up lamp (7) lights up when the machine travels in reverse.

When the gear shift lever is set to "R", it lights up to ensure that the machine is traveling in reverse.

TAIL LAMP

The stop lamp and tail lamp are built into this tail lamp (8).

Stop lamp: Lights up to inform following vehicles that brake has been depressed and machine will stop.

Tail lamp: Tail lamp lights up when lamp switch is turned ON.

These display the position of the rear of the machine at night.

OPERATOR'S CAB

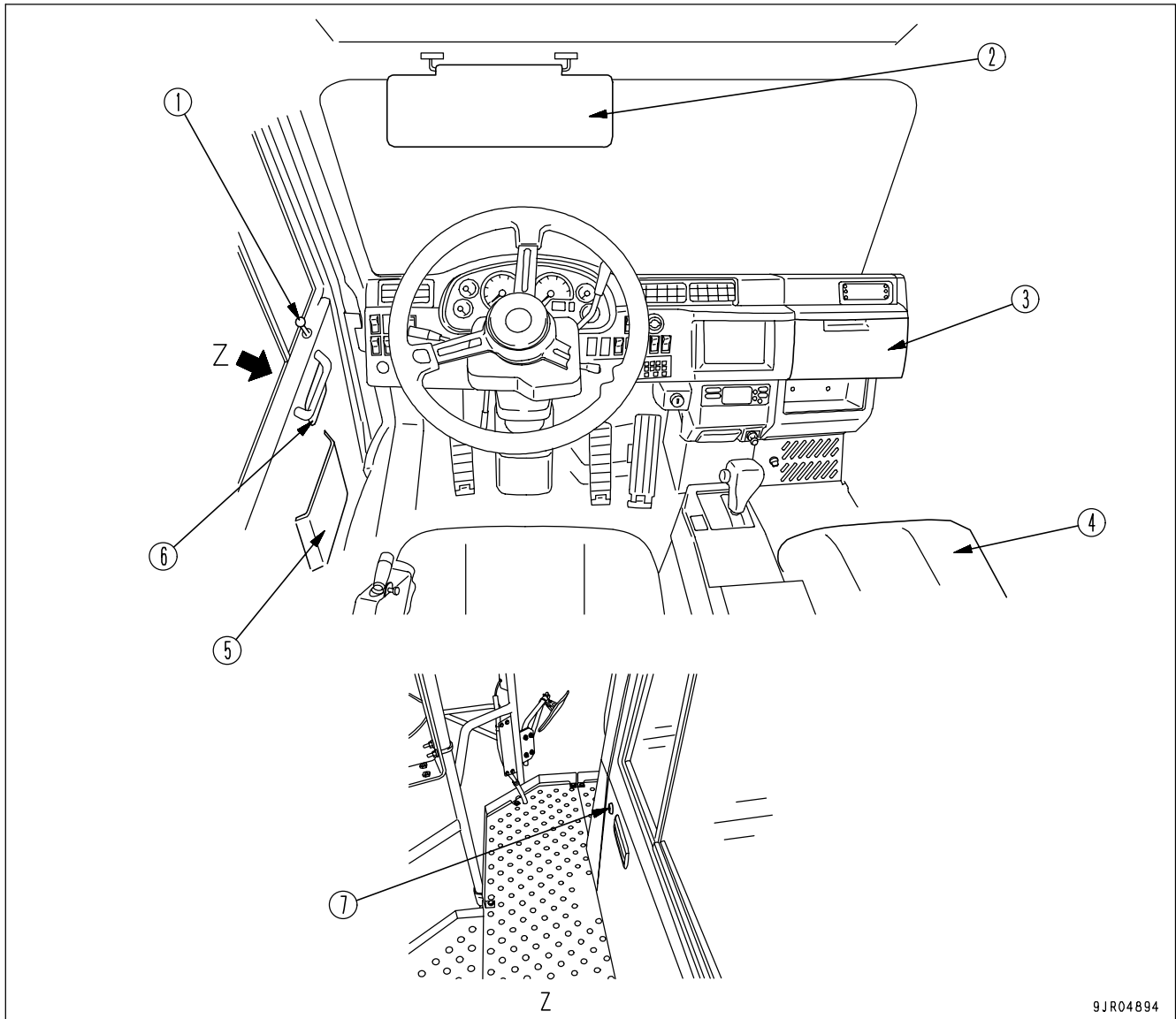

9JR04894

- | | |
|-------------------------------|-----------------|
| (1) Door lock knob | (5) Door pocket |
| (2) Sun visor | (6) Door handle |
| (3) Dashboard pocket | (7) Door lock |
| (4) First aid kit storage box | |

DOOR LOCK KNOB

Use this door lock knob (1) to lock the door from inside the operator's compartment.

Raise knob:It be able to open door

Lower knob:It be able to lock door

There are doors on the left and right.

SUN VISOR

The angle of this sun visor (2) can be adjusted to prevent the sun from shining in your eyes from the front of the machine when traveling. When not using it, push it up towards the ceiling.

DASHBOARD POCKET

This dashboard pocket (3) is on the right side of the dashboard and is used for holding small objects. Hold the grip and pull it to open.

FIRST AID KIT STORAGE BOX**WARNING**

Make sure that a first aid kit is provided in case of injury. If immediate action is taken in case of injury, the extent of the injury can be reduced. Keep the first aid kit in the specified place, check the contents periodically, and replace any items that have been used or are missing.

Keep the first aid kit in this first aid kit storage box (4).

Spring the assistant's seat up and put the first aid box in the storage box.

DOOR POCKET

This door pocket (5) is in the door at the side of the operator's seat. Keep this manual in the door pocket.

DOOR HANDLE

Use this door handle (6) to open and close the door.

There are door handles for the doors on both the left and right. Raise the handle by hand to open the door.

DOOR LOCK

When completing operations and leaving the machine, lock this door lock (7) to lock the operator's cab.

The key is also used in the starting switch.

The lock is under the door handle on the left and right doors.

CONTROL LEVERS AND PEDALS

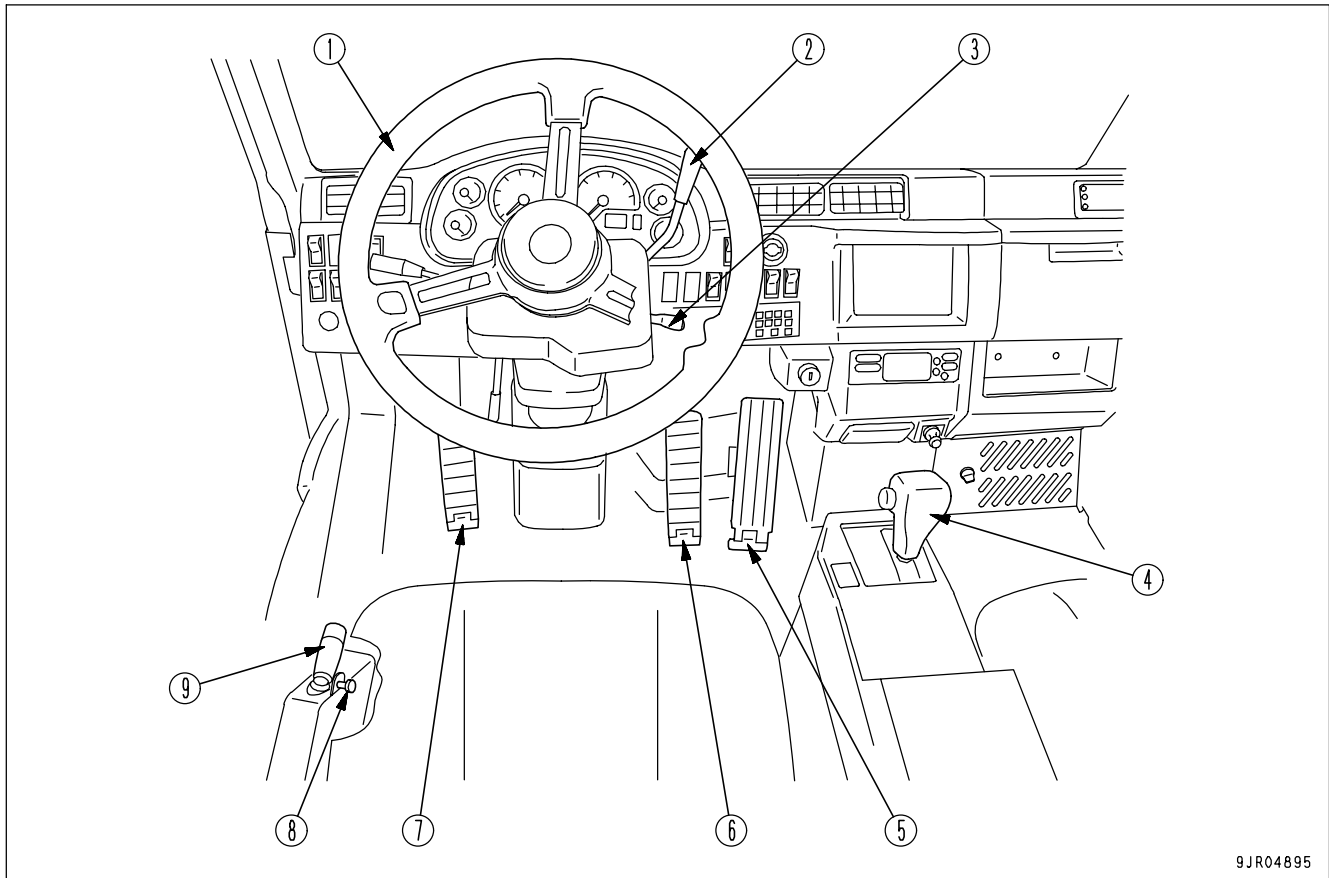

9JR04895

- | | |
|------------------------------------|---------------------------|
| (1) Steering wheel | (6) Brake pedal |
| (2) Retarder control lever | (7) Secondary brake pedal |
| (3) Auto retarder (ARSC) set lever | (8) Dump lever lock knob |
| (4) Gear shift lever | (9) Dump lever |
| (5) Accelerator pedal | |

STEERING WHEEL

NOTICE

When the steering wheel is turned fully to the right or left, do not apply force to try to turn it further. The temperature of the steering hydraulic circuit will rise and cause overheating, and this will lead to damage of steering related components.

Use this steering wheel (1) to steer the machine when traveling. When it is turned to the right, the machine turns to the right; when it is turned to the left, the machine turns to the left.

REMARK

The steering for this machine is operated by hydraulic cylinders. When the steering wheel is turned, pressurized oil proportional to the amount of the steering wheel is turned flows from the hydraulic equipment on the steering shaft to the steering hydraulic cylinder, and moves the steering.

RETARDER CONTROL LEVER

**WARNING**

Do not use the retarder control lever instead of the parking brake. If the retarder is used as a parking brake when the starting switch is ON, the braking force will gradually become weaker. If the machine is parked on a slope, the machine may move off without the operator and cause serious personal injury.

Use this retarder control lever (2) to adjust the travel speed when traveling downhill.

When the retarder control lever is pulled back (a), the retarder is applied. The braking force can be adjusted by the amount that the lever is pulled.

When the retarder is actuated, the retarder pilot lamp on the machine monitor lights up.

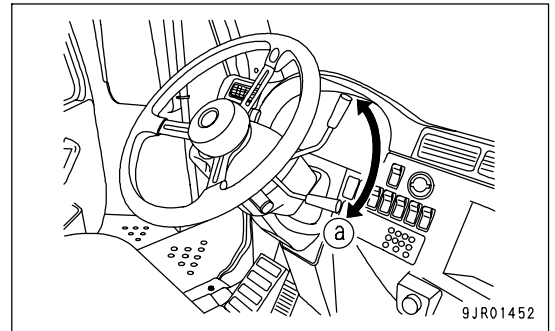
**AUTO RETARDER (ARSC) SET LEVER**

Use this auto retarder (ARSC) set lever (3) to set the travel speed for the auto retarder (ARSC), to adjust the travel speed, or to cancel the setting.

- (A): Set travel speed
- (B): Reduce travel speed setting (tap down)
- (C): Cancel setting
- (D): Increase travel speed setting (tap up)

For details of handling the Auto retarder (ARSC), see "ARSC(AUTOMATIC RETARDER SPEED CONTROL) (PAGE 3-102)".

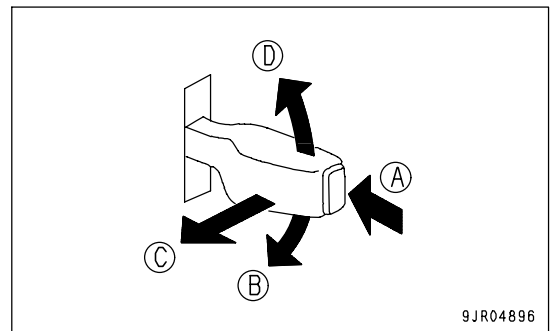

GEAR SHIFT LEVER

Use this gear shift lever (4) to select the speed range for the transmission to match the travel conditions.

The relationship between the range of the transmission for each position of the gear shift lever and the direction of travel and a maximum travel speed is as follows.

Position	Speed range	Max.speed [km/h(MPH)]	
		HD465	HD605
D	2nd torque converter - 7th direct	70.0 (43.5)	70.0 (43.5)
6	1st torque converter - 6th direct	52.5 (32.6)	52.5 (32.6)
5	1st torque converter - 5th direct	39.0 (24.2)	39.0 (24.2)
4	1st torque converter - 4th direct	29.5(18.3)	29.0 (18.0)
3	1st torque converter - 3rd direct	21.5 (13.4)	21.0 (13.0)
2	1st torque converter - 2rd direct	16.0 (9.9)	15.5 (9.6)
L	1st torque converter - 1st direct	11.5 (7.1)	11.0 (6.8)
R	REVERSE torque converter	12.0 (7.5)	11.5 (7.1)

When moving the gear shift lever from the N position to any other position, press the lock button on the lever and move it to the desired position. The selected position is displayed on the shift indicator at the side of the gear shift lever.

The selected shift position is also displayed on the shift indicator on the machine monitor. When operating the gear shift lever, check the shift indicator display to confirm that the desired position has been selected.

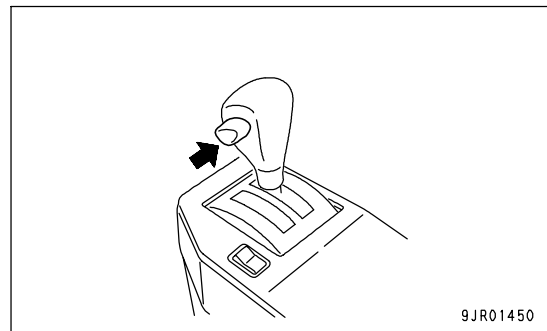

Set the gear shift lever securely in the desired position. If it is not set properly in position, the machine cannot travel, and the transmission system caution lamp on the machine monitor will light up.

Position R:

This is the position for traveling in reverse.

If the dump body is still raised, position R cannot be selected. Lower the dump body, set the dump control lever to FLOAT, then press the lock button on the lever and move the lever to position R.

Position N:

The transmission is in Neutral. In this position, the engine can be started.

When parking the machine, always set the gear shift lever to position N. When starting the engine, always check that the gear shift lever is at position N. If the gear shift lever is not at position N, and it is attempted to start the engine, the central warning lamp lights up and the alarm buzzer sounds.

Position D :

This is the position for normal travel.

If the dump body is still raised, the transmission is fixed in 1st speed and will not shift to any other speed range. When traveling, lower the dump body, set the dump control lever to FLOAT, then press the lock button on the lever and move the lever to position D.

REMARK

To comply with the EU safety standards (EN 474-6 5.1.3), if the machine travels with the dump body not completely lowered, the transmission is fixed in 1st and the gear cannot be shifted.

Positions 6 - L:

Select the desired position in places where it is difficult to travel at high speed, when traveling on soft ground, when starting off up a slope when the machine is loaded, or when using the engine as a brake when traveling downhill.

When switching between FORWARD and REVERSE, release the accelerator pedal, depress the brake pedal to stop the machine completely, then run the engine at low idle and change the direction. Press the lock button on the gear shift lever and move the lever from position N to position R or to any position from D to 6.

If the dump control lever is not at the FLOAT position or the dump body is still raised, and the gear shift lever is moved from position N to any other position, the central warning lamp lights up and the alarm buzzer sounds.

Do not place the gear shift lever in position N when the machine is traveling. It will be impossible for the transmission to control the travel speed.

ACCELERATOR PEDAL

Use this accelerator pedal (5) to adjust the engine speed.

The engine speed can be adjusted freely between low idle and full throttle by the amount that the pedal is depressed.

BRAKE PEDAL

Use this brake pedal (6) to apply the front brakes and rear brakes to adjust the travel speed of the machine.

The braking force of the front brakes and rear brakes can be adjusted by the amount that the pedal is depressed.

SECONDARY BRAKE PEDAL

Use secondary brake pedal (7) to apply the front brake and parking brake to stop the machine.

Use this brake when the brake suddenly does not work due to damage to the brake pedal.

REMARK

If the pressure of accumulated in the brake hydraulic circuit accumulator goes down, the secondary brake will be actuated automatically. To move the machine, it is necessary to cancel the secondary brake. For details of the method of canceling the secondary brake, see "WHEN PARKING BRAKE HAS BEEN ACTUATED IN EMERGENCY (PAGE 3-141)".

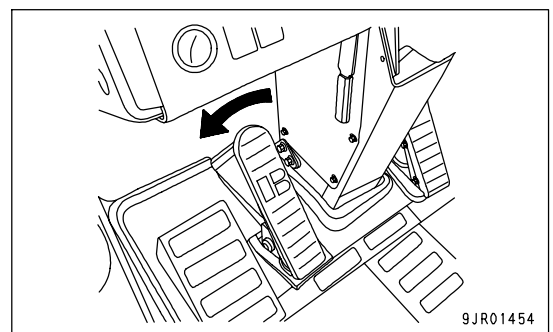

DUMP LEVER LOCK KNOB



When carrying out inspection with the dump body raised, always set the dump control lever to the HOLD position, set the dump control lever lock knob to the LOCK position, then insert the body pivot pin. If the body pivot pin is not inserted, the dump body may go down when the dump control lever is operated, and catch or cause serious injury or even death to the person carrying out the inspection.

This dump control lever lock knob (8) is a device to prevent the dump control lever to move from the HOLD position to another position.

Locking dump control lever

Set the dump control lever to the FLOAT position, then turn the head of the dump control lever lock knob. The dump control lever lock knob will move in towards the dump control lever, and when it cannot be turned any more, the dump control lever is locked.

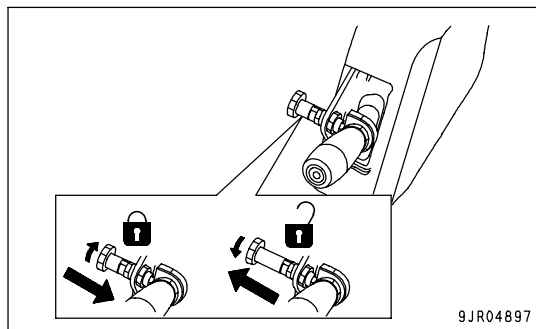

Releasing dump control lever lock

Pull out the head of the dump control lever lock knob and turn it. When the dump control lever lock knob does not go back to the lock position, the lock is released.

DUMP LEVER

NOTICE

When the machine is traveling, the dump body may sway. If this happens, and the dump body cannot move under external force, the hoist cylinder or dump body will be damaged. To prevent damage, always set the dump control lever to the FLOAT position when traveling.

Use this dump control lever (9) to operate the dump body. The position of the dump control lever and the movement of the dump body are as follows.

- (A) RAISE: Dump body goes up
- (B) HOLD: Dump body stops and is held in position
- (C) FLOAT: No force is applied by hoist cylinder to raise or lower dump body. Dump body moves freely under external force.
- (D) LOWER: Dump body goes down

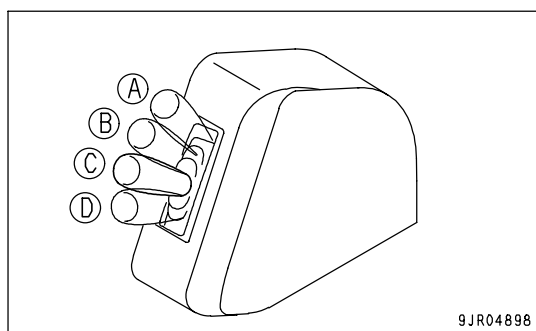

MACHINE MONITOR

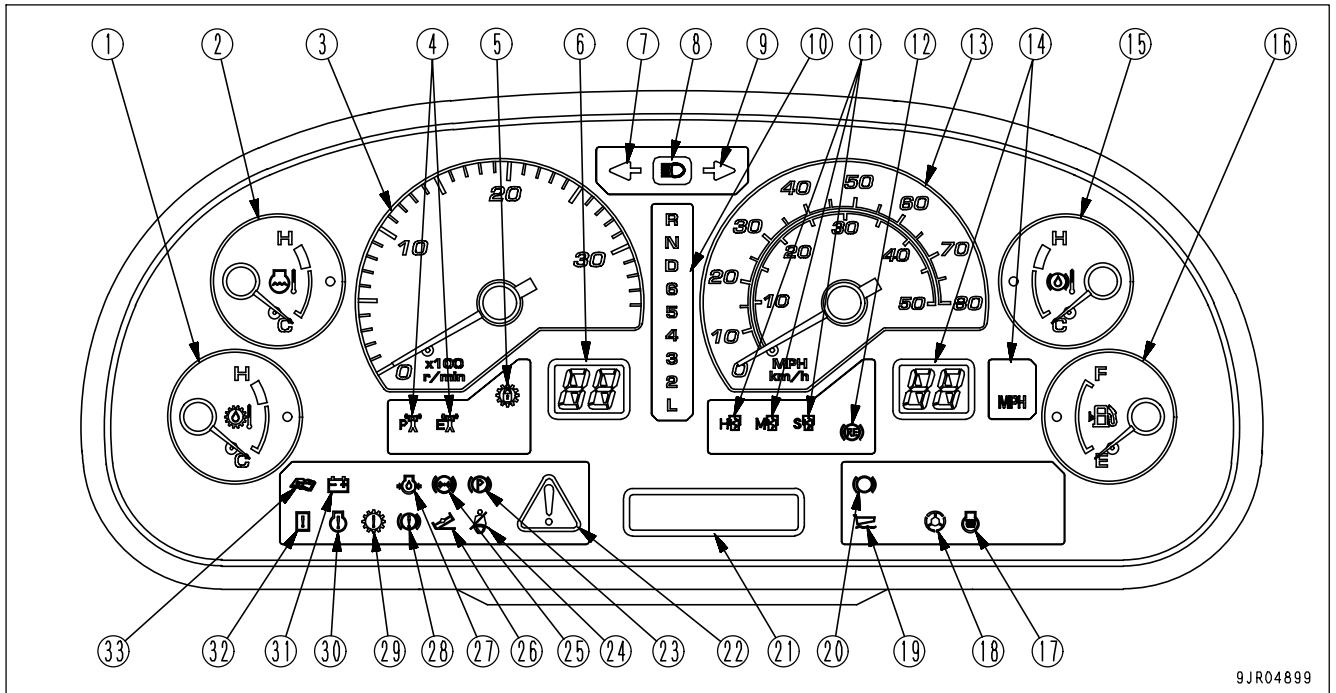

9JR04899

- | | |
|--|--|
| <ul style="list-style-type: none"> (1) Torque converter oil temperature (2) Engine water temperature (3) Engine tachometer (4) Power mode pilot lamp (5) Lockup pilot lamp (6) Shift indicator (7) Turn signal pilot lamp (left) (8) Head lamp high beam pilot lamp (9) Turn signal pilot lamp (right) (10) Shift lever position pilot lamp (11) Auto suspension mode pilot lamp (if equipped) (12) Auto retarder ready pilot lamp (13) Speedometer (14) Auto retarder set speed indicator (15) Retarder oil temperature (16) Fuel gauge (17) Preheating pilot lamp | <ul style="list-style-type: none"> (18) Emergency steering pilot lamp (19) Dump body pilot lamp (20) Retarder pilot lamp (21) Character display (22) Central warning lamp (23) Parking brake pilot lamp (24) Seat belt caution lamp (25) Brake oil pressure caution lamp (accumulator oil pressure) (26) Tilt caution lamp (if equipped) (27) Engine oil pressure caution lamp (28) Retarder system caution lamp (29) Transmission system caution lamp (30) Engine system caution lamp (31) Battery charge circuit caution lamp (32) Machine monitor, option system caution lamp (33) Maintenance caution lamp |
|--|--|

TORQUE CONVERTER OIL TEMPERATURE

This torque converter oil temperature gauge (1) shows the torque converter oil temperature.

Range (A) (white range): Indicator should be in this range during normal operations

Range (B) (red range): If indicator enters red range during operations, oil is overheating

If this happens, caution lamp (C) inside the torque converter oil temperature gauge lights up, the alarm buzzer sounds intermittently, the central warning lamp lights up, and "E02 TC OVERHEAT" is displayed on the character display.

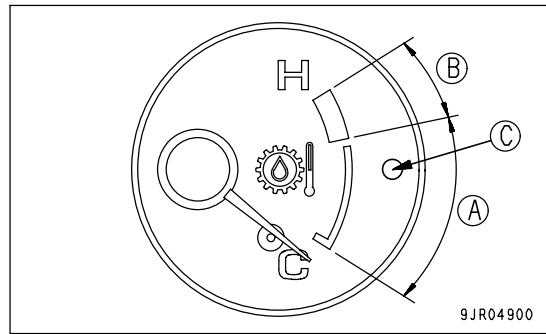

If the torque converter oil temperature gauge displays overheating, move the machine to a safe place, and stop the machine. Then set the gear shift lever to position N, run the engine under no load at a mid-range speed and wait until caution lamp (C) inside the torque converter oil temperature gauge goes out.

ENGINE WATER TEMPERATURE

This engine water temperature gauge (2) shows the engine water temperature.

Range (A) (white range): Indicator should be in this range during normal operations

Range (B) (red range): If indicator enters red range during operations, coolant is overheating

If this happens, caution lamp (C) inside the engine water temperature gauge lights up, the alarm buzzer sounds intermittently, the central warning lamp lights up, and "E02 ENGINE OVERHEAT" is displayed on the character display.

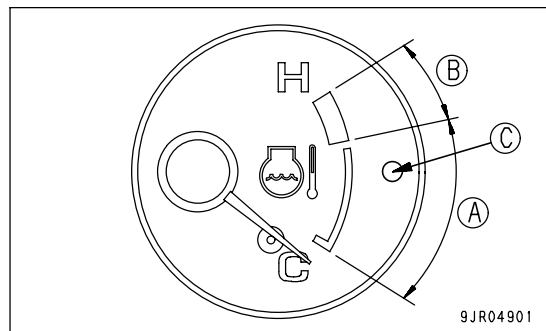

If the engine water temperature gauge displays overheating, move the machine to a safe place, and stop the machine. Then set the gear shift lever to position N, run the engine under no load at a mid-range speed and wait until caution lamp (C) inside the engine water temperature gauge goes out. In addition, if the indicator enters red range (A), the engine output is automatically restricted.

ENGINE TACHOMETER

NOTICE

If the engine overruns, it may cause serious damage to the engine, and the engine will need an overhaul. If the engine speed enters range (B), release the accelerator pedal, depress the brake pedal, and reduce the machine speed.

This engine tachometer (3) shows the engine speed.

Range (A): Indicator should be in this range during normal operations.

Range (B): If indicator enters this range during operations, engine is overrunning.

If the indicator enters this range, the alarm buzzer sounds and the central warning lamp lights up. Release the accelerator, depress the brake pedal, and reduce the machine travel speed.

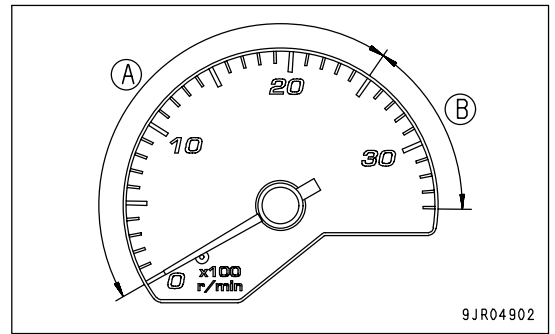

9JR04902

POWER MODE PILOT LAMP

This power mode pilot lamp (4) shows the power mode setting. The mode selected by the power mode selector switch lights up to indicate the mode that is being used.

P: High power mode (normal operations)

E: Economy mode (operations on flat ground)

For details of the method of using the power mode, see "POWER MODE SELECTOR SWITCH (PAGE 3-40)".

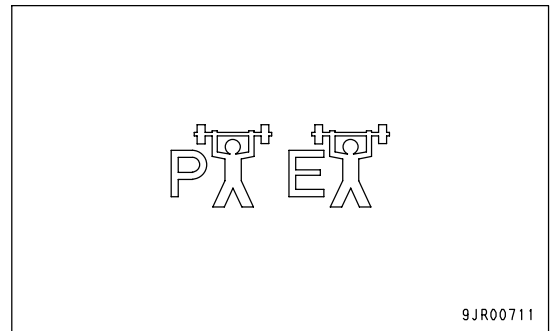

9JR00711

LOCKUP PILOT LAMP

This lockup pilot lamp (5) shows if the torque converter is being used. When the lockup is engaged and the torque converter enters direct drive, this lamp lights up. When the lockup is cancelled, it goes out.

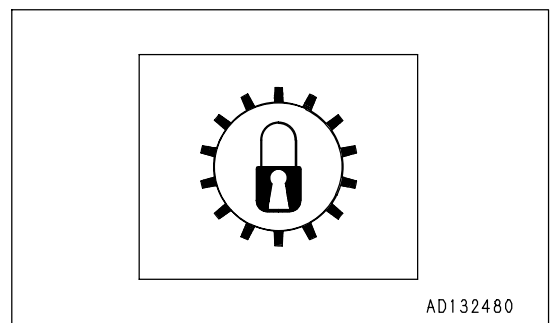

AD132480

SHIFT INDICATOR

This shift indicator (6) shows the transmission shift position (speed range) selected by the gear shift lever. The letter or numeral showing the shift position (speed range) selected by the gear shift lever lights up.

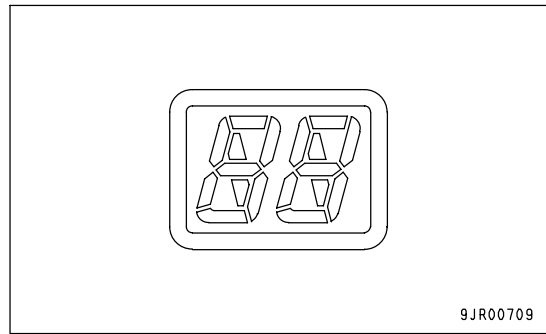
**TURN SIGNAL PILOT LAMP(LEFT)**

This turn signal pilot lamp (left) (7) shows the turn signal lamp is flashing, at the left side of machine.

When the turn signal lever is operated to the left, the turn signal lamp flashes. When the turn signal lever is returned to the center position, the lamp goes out.

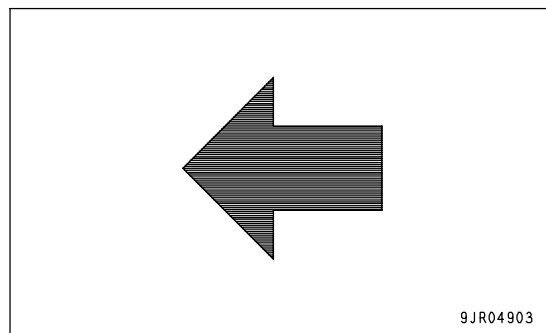
**HEAD LAMP HIGH BEAM PILOT LAMP**

This head lamp high beam pilot lamp (8) shows the beam position for the head lamp.

When the head lamp lights up and the dimmer switch is set to high beam (A) position, the high beam pilot lamp lights up. When the dimmer switch is set to low beam (B) position, the high beam pilot lamp goes out.

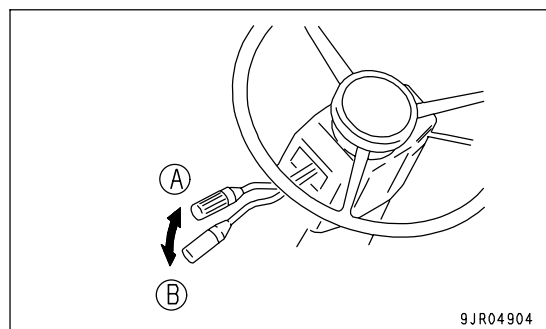
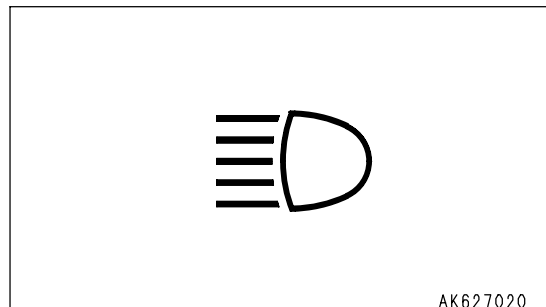

TURN SIGNAL PILOT LAMP(RIGHT)

This turn signal pilot lamp (right) (9) shows the turn signal lamp is flashing, at the right side of machine.

When the turn signal lever is operated to the right, the turn signal lamp flashes, and when the turn signal lever is returned to the center position, the lamp goes out.

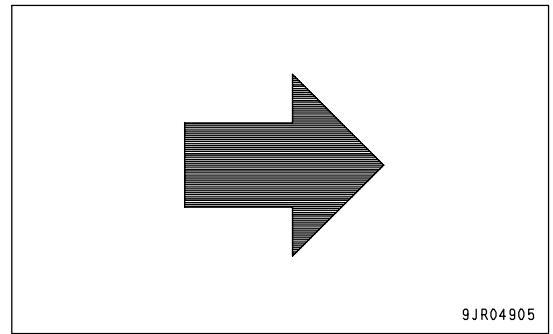
**SHIFT LEVER POSITION PILOT LAMP**

This shift lever position pilot lamp (10) shows the position of the gear shift lever. The letter or numeral showing the position of the gear shift lever lights up.

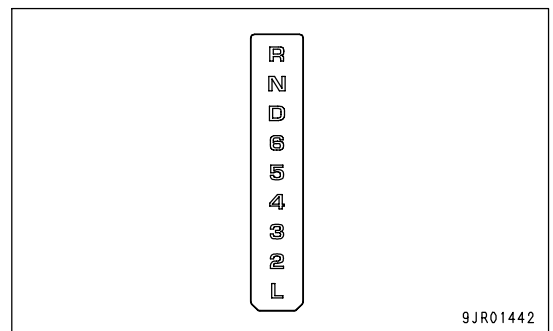

AUTO SUSPENSION MODE PILOT LAMP

(If equipped)

This auto suspension pilot lamp (11) shows the suspension mode being used.

With this machine, an automatic suspension system is available as an option. This system automatically selects the hardness of the suspension according to the condition of the machine load and the operating condition of the brakes, steering, and dump control.

H (hard mode): When the machine is loaded, if the machine is used under hard conditions, the suspension becomes harder.

M (medium mode): For normal operations when the machine is loaded, this mode is used and the suspension is set to medium strength.

S (soft mode): When the machine is not loaded, the suspension become softer.

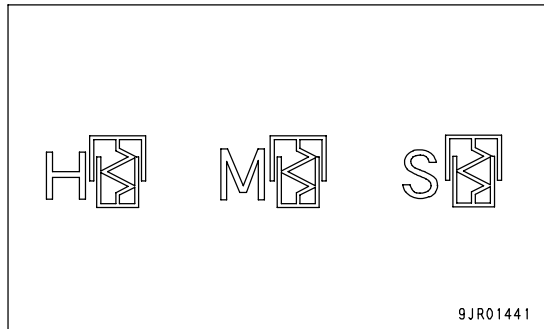

AUTO RETARDER READY PILOT LAMP

This auto retarder ready pilot lamp (12) shows the auto retarder setting. If the auto retarder (ARSC) is being actuated, the lamp lights up to show that the auto retarder speed control is being actuated. When the auto retarder speed control setting is cancelled, the lamp goes out.

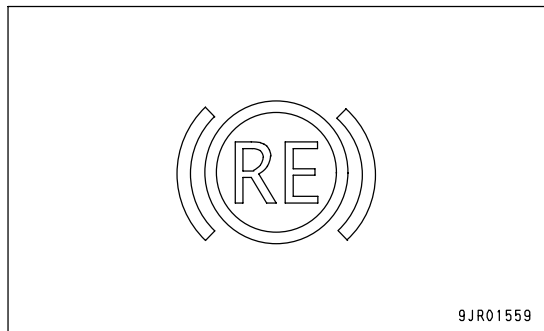

SPEEDOMETER

This speedometer (13) shows the travel speed of the machine.

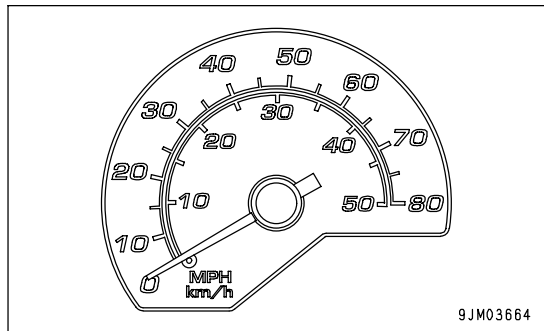

AUTO RETARDER SET SPEED INDICATOR

This auto retarder set speed indicator (14) shows the travel speed set by the auto retarder (ARSC) set lever. When the set speed has been cancelled, "0" is displayed.

When the switch of the auto retarder (ARSC) set lever is turned OFF, the indicator goes out.

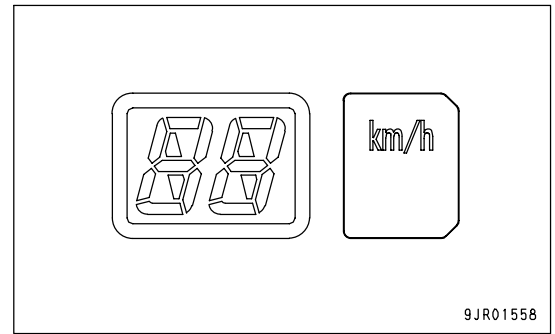

RETARDER OIL TEMPERATURE

This retarder oil temperature gauge (15) shows the retarder oil temperature.

Range (A) (white range): Indicator should be in this range during normal operations.

Range (B) (red range): If indicator enters red range during operations, oil is overheating

If this happens, caution lamp (C) inside the retarder oil temperature gauge lights up, the alarm buzzer sounds intermittently, the central warning lamp lights up, and "E02 BRAKE OVERHEAT" is displayed on the character display.

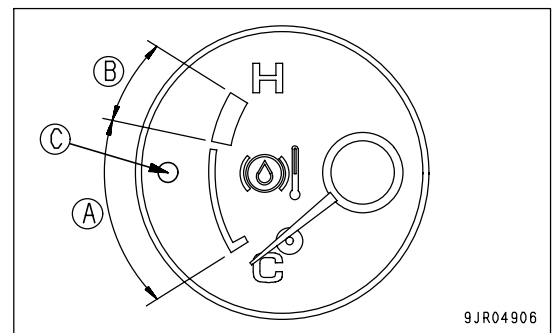

If the retarder oil temperature gauge displays overheating, move the machine to a safe place, and stop the machine. Then set the gear shift lever to position N, run the engine under no load at a mid-range speed and wait until caution lamp (C) inside the retarder oil temperature gauge goes out.

FUEL GAUGE

This fuel gauge (16) shows the amount of fuel remaining in the fuel tank.

If the indicator comes close to the "E" position, add fuel.

In addition, caution lamp (C) inside the fuel gauge lights up when the fuel level comes close to the "E" position. If caution lamp (C) lights up, add fuel immediately.

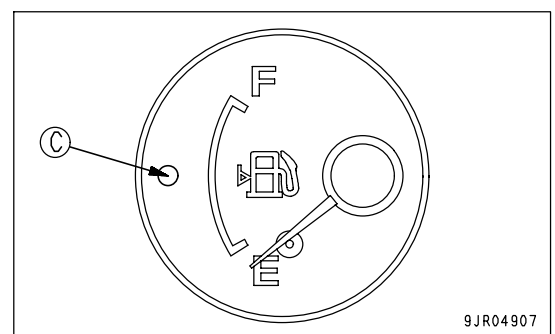

PREHEATING PILOT LAMP

This preheating pilot lamp (17) shows if the engine preheating electrical heater is actuated.

When the starting switch is turned ON, if the engine water temperature is low, the preheating electrical heater is actuated and the pilot lamp lights up. After 20 - 30 seconds, it goes out to inform the operator that preheating has been completed. When the preheating is completed, start the engine.

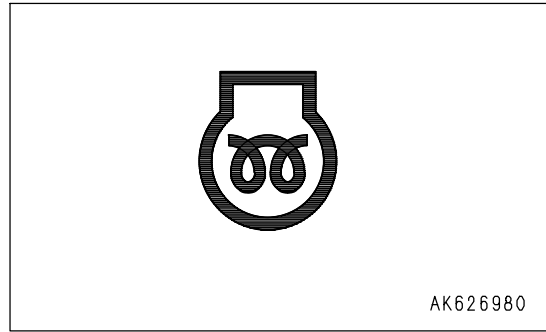
**EMERGENCY STEERING PILOT LAMP**

This emergency steering pilot lamp (18) displays an operation condition of the emergency steering. The lamp lights up when the emergency steering is activated.

When the dump truck is equipped with an auto emergency steering, and if some abnormality occurs in the steering hydraulic circuit while the dump truck is running, the lamp lights up and the auto emergency steering is activated.

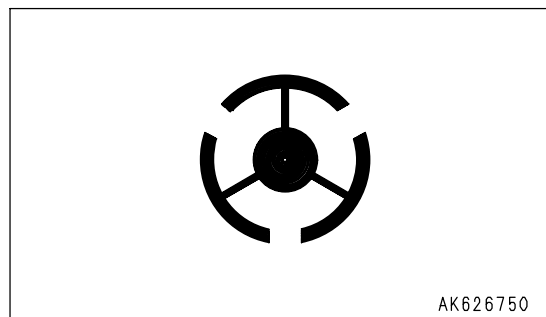
**DUMP BODY PILOT LAMP**

This dump body pilot lamp (19) lights up when the dump control lever is not at the FLOAT position or the dump body is not completely lowered and seated on the frame.

**RETARDER PILOT LAMP**

This retarder pilot lamp (20) shows if the retarder is actuated.

When the retarder control lever is pulled and the retarder is actuated, the lamp lights up. When the retarder control lever is returned and the retarder is cancelled, the lamp goes out.

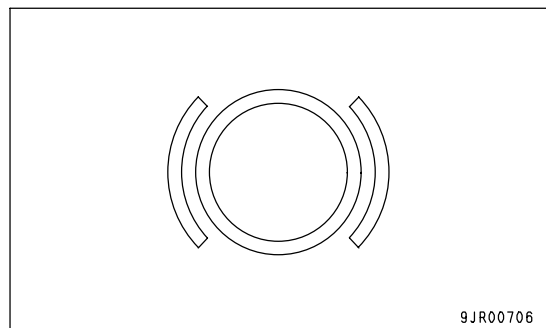

CHARACTER DISPLAY

This character display (21) shows the following items.

- Service meter
- Odometer
- Reverse travel odometer
- Action code display
- Filter, oil replacement time display
- Payload display (if equipped)

For details of the display, see "DISPLAY OF CHARACTER DISPLAY (PAGE 3-28)".

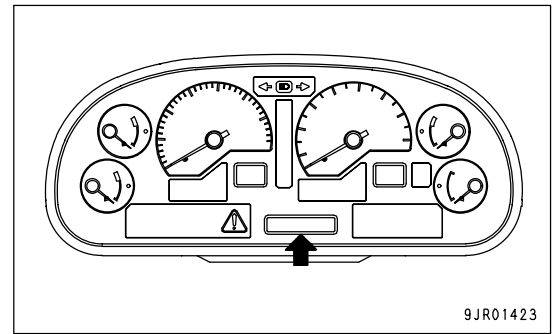
**CENTRAL WARNING LAMP**

This central warning lamp (22) lights up when the machine is in the following condition.

When the central warning lamp lights up, the alarm buzzer sounds intermittently.

- When caution lamps related to emergency stop light up.
 - Torque converter oil temperature caution lamp
 - Engine water temperature caution lamp
 - Retarder oil temperature caution lamp
 - Brake oil pressure caution lamp (accumulator oil pressure)
 - Tilt caution lamp (if equipped)
 - Engine oil pressure caution lamp
 - Retarder system caution lamp
 - Transmission system caution lamp
 - Steering oil temperature caution lamp (if equipped)
 - Engine system caution lamp
 - Battery charge circuit caution lamp
 - Machine monitor, option system caution lamp
- When character display shows action code "E02 " or "E03 ".
- When secondary brake is actuated and gear shift lever is not at position N.
- When dump control lever is not at FLOAT position, dump body is raised, and gear shift lever is not at position N.
- When the engine tachometer indicates the red range.

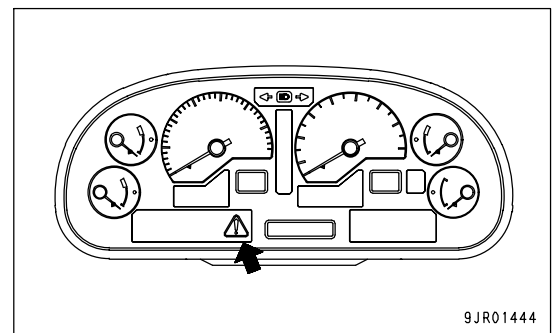
**PARKING BRAKE PILOT LAMP**

This parking brake pilot lamp (23) shows if the parking brake is applied. When the parking brake switch is operated, the emergency brake is applied and the pilot lamp lights up.

If the machine is to travel, release the parking brake and check that the parking brake pilot lamp goes out.

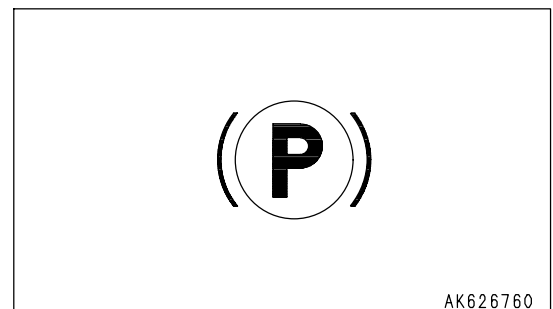

SEAT BELT CAUTION LAMP

This seatbelt monitor lamp (24) shows if the operator is wearing the seatbelt. If the operator is not wearing the seatbelt, the lamp lights up. When operating the machine, always wear the seatbelt and check that the seatbelt caution lamp goes out.

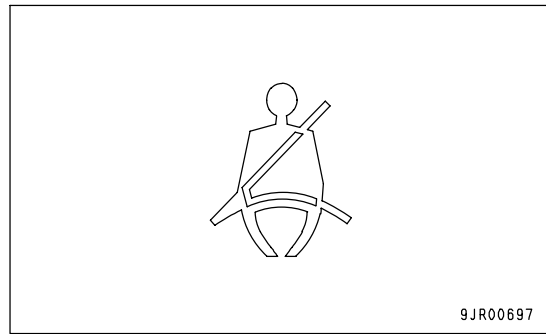
**BRAKE OIL PRESSURE CAUTION LAMP(ACCUMULATOR OIL PRESSURE)**

This brake oil pressure caution lamp (25) shows that the brake oil pressure has dropped. If the oil pressure in the brake accumulator goes below the specified value when the engine is being operated, the caution lamp lights up, the alarm buzzer sounds intermittently, the central warning lamp lights up, and "E02 CHECK RIGHT NOW" is displayed on the character display.

After the engine is started, if the accumulator oil pressure is still below the specified pressure even after 30 seconds, the brake oil pressure caution lamp lights up.

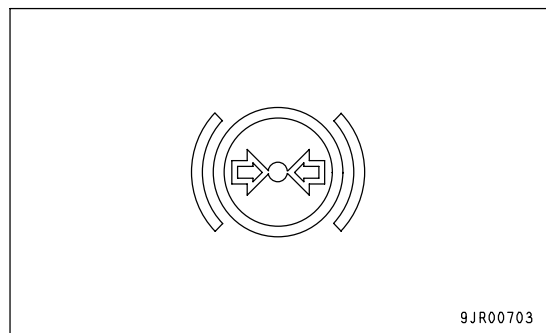

If the brake oil pressure caution lamp lights up, move the machine to a safe place, and stop the machine. Then set the gear shift lever to position N and take the necessary action. For details, see "ACTION CODE (PAGE 3-152)".

TILT CAUTION LAMP

(If equipped)

If the dump body is not completely seated on the frame and the machine tilts to the left or right more than the permitted tilt angle, tilt caution lamp (26) lights up, the alarm buzzer sounds intermittently, and the central warning lamp lights up.

If this tilt caution lamp lights up, move the machine to a safe place, stop the machine, and lower the dump body. Then move to a horizontal place.

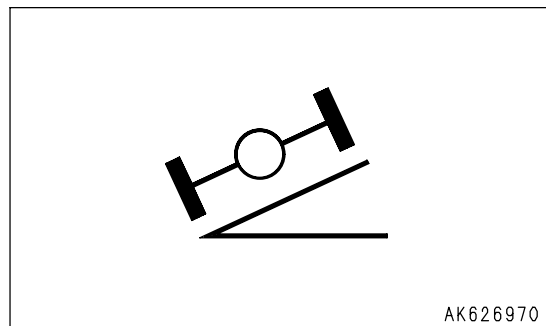

ENGINE OIL PRESSURE CAUTION LAMP

This engine oil pressure caution lamp (27) shows that there is a problem in the engine oil pressure. If any problem occurs in the pressure of the engine lubricating oil when the engine is running, the caution lamp lights up, the alarm buzzer sounds intermittently, the central warning lamp lights up, "E02 CHECK RIGHT NOW " is displayed on the character display, and the engine output is restricted.

If the engine oil pressure caution lamp lights up, move the machine to a safe place, and stop the machine. Then set the gear shift lever to position N and take the necessary action. For details, see "ACTION CODE (PAGE 3-152)".

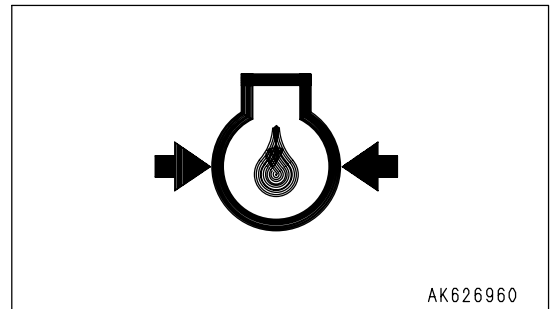
**RETARDER SYSTEM CAUTION LAMP**

This retarder system caution lamp (28) shows that there is a problem in the retarder system. If any problem is detected in the control system of the retarder controller, the caution lamp lights up, the alarm buzzer sounds intermittently, the central warning lamp lights up, and "E03 CHECK RIGHT NOW " is displayed on the character display.

If the retarder system caution lamp lights up, move the machine to a safe place, and stop the machine. Then set the gear shift lever to position N and take the necessary action. For details, see "ACTION CODE (PAGE 3-152)".

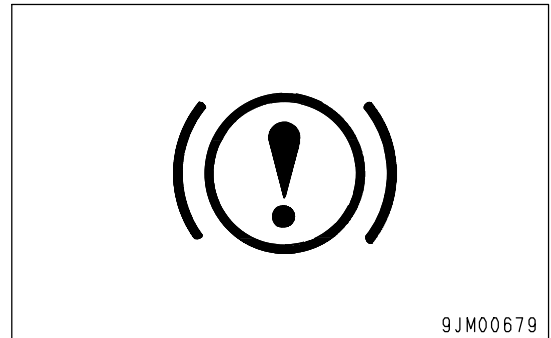
**TRANSMISSION SYSTEM CAUTION LAMP**

This transmission system caution lamp (29) shows that there is a problem in the transmission controller. If any problem is detected in the control system of the transmission controller, the caution lamp lights up, the alarm buzzer sounds intermittently, the central warning lamp lights up, and "E03 CHECK RIGHT NOW " is displayed on the character display.

If the transmission system caution lamp lights up, move the machine to a safe place, and stop the machine. Then set the gear shift lever to position N and take the necessary action. For details, see "ACTION CODE (PAGE 3-152)".

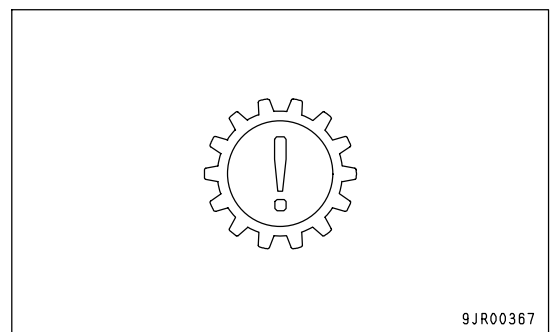

ENGINE SYSTEM CAUTION LAMP

This engine system caution lamp (30) shows that there is a problem in the engine system controller. If any problem is detected in the control system of the engine controller, the caution lamp lights up, the alarm buzzer sounds intermittently, the central warning lamp lights up, and "E03 CHECK RIGHT NOW " is displayed on the character display.

If the engine system caution lamp lights up, move the machine to a safe place, and stop the machine. Then set the gear shift lever to position N and take the necessary action. For details, see "ACTION CODE (PAGE 3-152)".

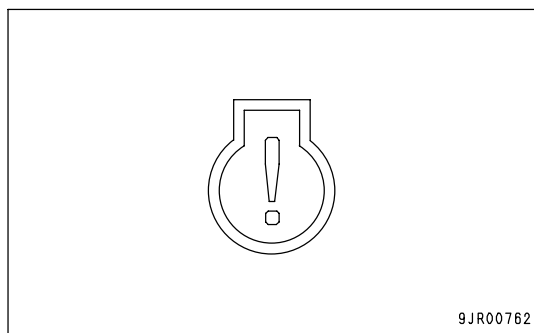
**BATTERY CHARGE CIRCUIT CAUTION LAMP**

This battery charge circuit caution lamp (31) shows that there is a problem in the battery charge circuit. If any problem is detected in the charging system while the engine is running, the caution lamp lights up, the alarm buzzer sounds intermittently, the central warning lamp lights up, and "E03 CHECK RIGHT NOW " is displayed on the character display.

If the battery charge circuit caution lamp lights up, move the machine to a safe place, and stop the machine. Then stop the engine and check for any disconnections or broken wiring in the engine charging system.

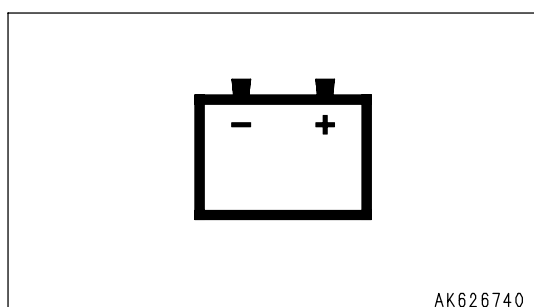
**MACHINE MONITOR,OPTION SYSTEM CAUTION LAMP**

This machine monitor/option system caution lamp (32) shows that there is a problem in the machine monitor/option system. If any problem is detected in the machine monitor or system installed with the option, the caution lamp lights up, the alarm buzzer sounds intermittently, the central warning lamp lights up, and "E03 CHECK RIGHT NOW" is displayed on the character display.

If the machine monitor/option system caution lamp lights up, move the machine to a safe place, and stop the machine. Then set the gear shift lever to position N and take the necessary action. For details, see "ACTION CODE (PAGE 3-152)".

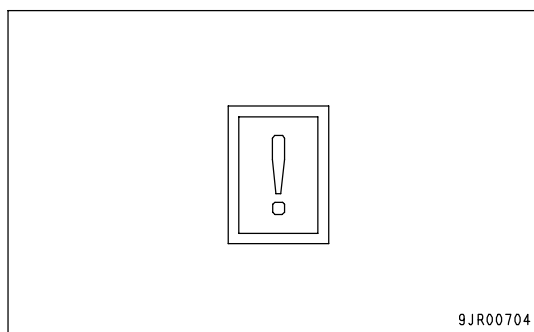

MAINTENANCE MONITOR CAUTION LAMP

This maintenance monitor caution lamp (34) lights up if maintenance is necessary, and "E01" and the location of the place requiring maintenance are displayed on the character display.

Carry out inspection or replacement, or add fluid at the indicated location. For details, see the applicable item in the MAINTENANCE Section.

- Clogged air cleaner
- Clogged transmission oil filter
- Drop in engine cooling water level

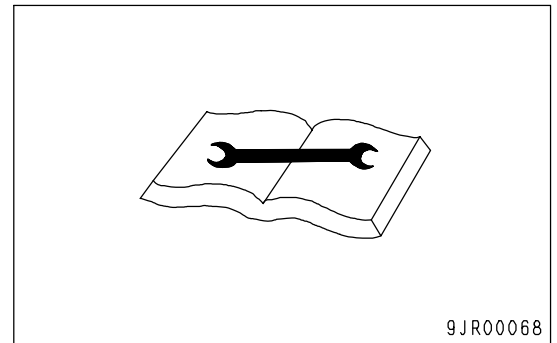

If equipped

- Drop in engine oil level
- Clogged engine oil filter
- Drop in oil level in steering, hoist oil tank
- Clogged steering, hoist oil filter
- Clogged brake cooling oil filter
- Worn brake disc (rear)
- Drop in battery electrolyte level
- Drop in transmission oil level

REMARK

In addition to the above items, if the character display shows the replacement time for filters or oil, the maintenance caution lamp flashes or lights up.

DISPLAY OF CHARACTER DISPLAY

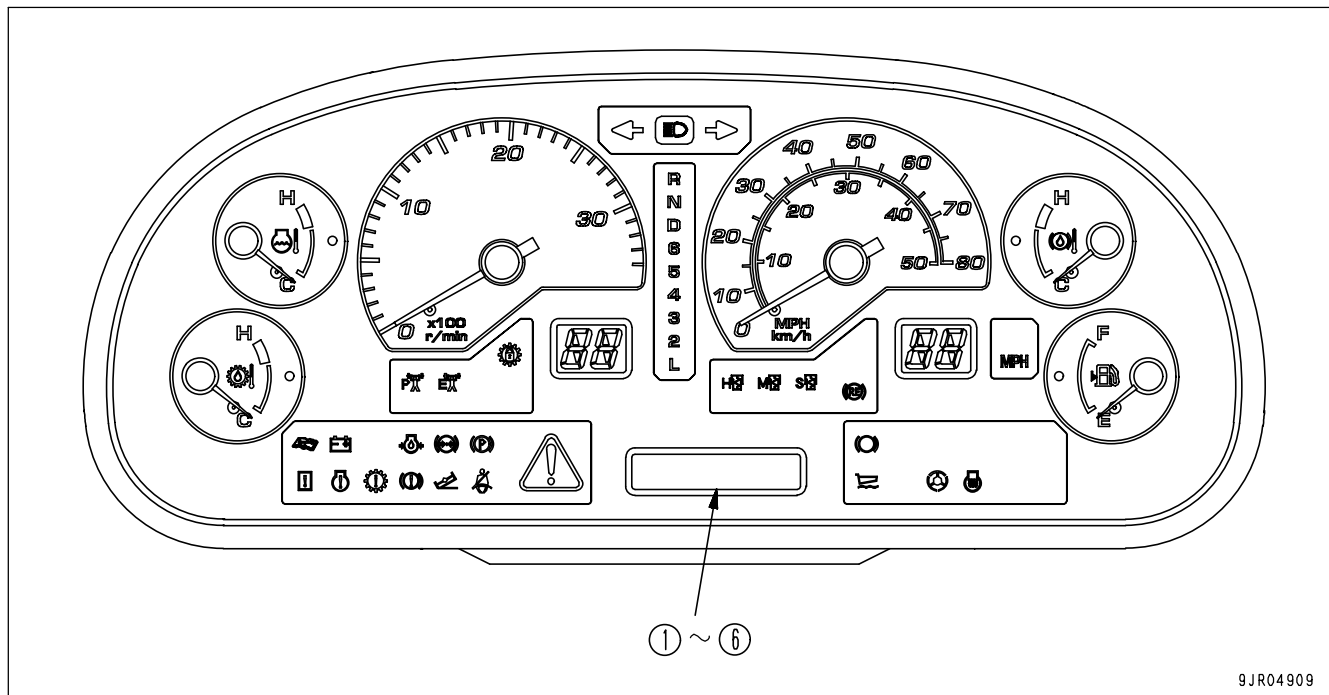

The following items can be displayed on the character display.

- | | |
|-----------------------------|--|
| (1) Service meter | (4) Action code display |
| (2) Odometer | (5) Filter, oil replacement time display |
| (3) Reverse travel odometer | (6) Payload display (if equipped) |

- Normally, service meter (1) is displayed on the top line and odometer (2) is displayed on the bottom line.
- Reverse travel odometer (3) and payload display (6) can be displayed by switching the display.
- If any failure occurs on the machine, action code (4) is automatically displayed.
- When the time is reached for replacing the filters or changing the oil, after the system check is completed when the starting switch is turned ON, the maintenance monitor caution lamp flashes or lights up and the filter, oil replacement time (5) is displayed for the items that need replacing.

SERVICE METER

The total hours of operation is displayed on the top line of the character display.

If the engine is running, the service meter advances even if the machine is not moving.

The meter advances by 1 for every one hour that passes, regardless of the engine speed.

ODOMETER

The total distance travelled is displayed in units of km on the bottom line of the character display.

REVERSE TRAVEL ODOMETER

The total distance travelled in reverse is displayed in units of km.

For details of the reverse travel odometer display, see "OTHER FUNCTIONS OF CHARACTER DISPLAY (PAGE 3-32)".

ACTION CODE DISPLAY

If "MAINTENANCE" is displayed for action codes E03, E02, or E01, stop the machine immediately, check the failure code for details, see "ACTION CODE (PAGE 3-152)", and ask your Komatsu distributor to carry out repairs.

If a failure occurs on the machine, or there is an excessive load on the machine, or it is necessary to carry out inspection or maintenance, the action code recommending suitable action is displayed on the top line of this display, and details of the action to take are displayed on the bottom line.

If more than one failure occurs at the same time, the action code for the most serious failure is displayed. The codes in order of seriousness are: E03, E02, and E01. If more than one failure with the same level of seriousness occurs at the same time, the most recently occurring failure is displayed.

In addition, the alarm buzzer sounds intermittently and the central warning lamp lights up for action codes E02 and E03 only.

Action code E03: (High level of seriousness)

If this code is displayed, stop the machine immediately, check the failure code, then have repairs carried out.

REMARK

- The top line of the character display displays "E03" and the bottom line displays "CHECK RIGHT NOW" and "CALL" in turn for 3 sec each.
- It is possible to set so that a telephone number is displayed on the right side of the "CALL" display. For details of setting the telephone number, see "INPUT METHOD FOR TELEPHONE NUMBER (PAGE 3-34)".

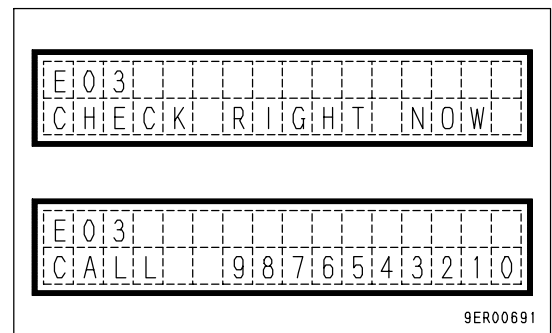
**Action code E02: (Medium level of seriousness)**

If an overrun related display is given, reduce the engine speed and machine speed while continuing operations. If an overheat related display is given, stop the machine and run at the engine at a mid-range speed under no load. After taking the above action, if an action code is displayed, check the failure code and ask your Komatsu distributor to carry out repairs.

REMARK

The top line of the character display displays "E02" and the bottom line displays the condition of the machine related to overrun or overheat.

Action code E01: (Low level of seriousness)

If the location needing maintenance is displayed and the maintenance caution lamp lights up, carry out the appropriate inspection and maintenance after completing work or when the operators change shifts.

If "MAINTENANCE" is displayed together with "E01", check the failure code and have repairs carried out.

REMARK

"E01" is displayed on the top line of the character display and "MAINTENANCE" or the part of the machine requiring inspection, filling of fluid, or replacement is displayed on the bottom line.

FILTER,OIL REPLACEMENT TIME DISPLAY

This display appears after completion of the system check. The top line shows the ID number and the filter or oil that is approaching time for replacement. The bottom line shows the remaining time. The display is given for 30 seconds. At the same time, the maintenance caution lamp flashes or lights up.

After replacing the filter or changing the oil, reset the replacement interval. For details, see "RESET METHOD FOR FILTER,OIL REPLACEMENT TIME (PAGE 3-33)".

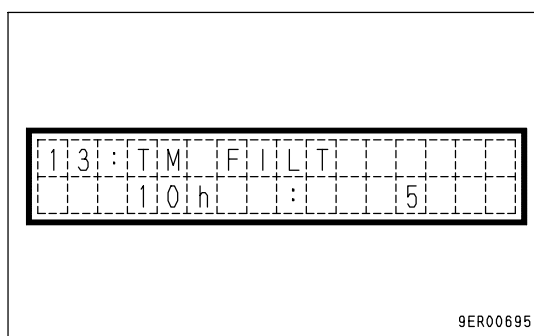

9ER00695

Items for display of filter, oil replacement time

Item	Replacement interval	Character display	ID number
Fuel prefilter	500	FUEL P FILT	41
Fuel main filter	500	FUEL FILT	03
Engine oil filter	500	ENG FILT	02
Engine oil	500	ENG OIL	01
Transmission oil filter	500	TM FILT	13
Corrosion resistor	1000	CORR RES	06
Torque converter, transmission and rear brake cooling oil	1000	TC/TM/BKOIL	24
Brake oil filter	1000	BK OIL FILT	14
Brake cooling oil filter	1000	BK C FILT	16
Steering, hoist oil filter	2000	HYD FILT	04
Differential case oil	2000	DIFF OIL	11
Final drive oil	2000	FNL OIL	08
Steering, hoist oil	4000	HYD OIL	10

REMARK

1) Displays related to filter and oil replacement time

- The top line shows the ID number and name of the item to be replaced; the bottom line displays in turn the time remaining before replacement and the total number of times that replacement has been carried out.
- The display is given for 30 seconds. When the starting switch is turned again to the ON position, the display does not appear.
- If an action code is being displayed, the message in the illustration above does not appear on the character display.
- If two or more items are displayed, each one is displayed for 3 seconds in turn.
- If there are more than 10 items, all the items are displayed once each.
- The display appears 30 hours before the filter or oil replacement time.
- When the replacement time approaches, the maintenance caution lamp flashes; when the replacement time is exceeded, it lights up.

2) Explanation of filter, oil replacement procedure

For details of the replacement procedure for filters and oil, see the appropriate item listed below.

- Fuel pre-filter
"REPLACE FUEL PREFILTER CARTRIDGE (PAGE 4-64)"
- Fuel main filter
"REPLACE FUEL MAIN FILTER CARTRIDGE (PAGE 4-66)"
- Engine oil filter
"CHANGE OIL IN ENGINE OIL PAN, REPLACE ENGINE OIL FILTER CARTRIDGE (PAGE 4-63)"
- Engine oil
"CHANGE OIL IN ENGINE OIL PAN, REPLACE ENGINE OIL FILTER CARTRIDGE (PAGE 4-63)"
- Transmission oil filter
"REPLACE TRANSMISSION VALVE OIL FILTER ELEMENT (PAGE 4-68)"
- Corrosion resistor
"REPLACE CORROSION RESISTOR CARTRIDGE (PAGE 4-73)"
- Torque converter, transmission and rear brake cooling oil
"CHANGE OIL IN TRANSMISSION CASE, BRAKE SUB TANK, WASH STRAINER (PAGE 4-74)"
- Brake oil filter
"REPLACE BRAKE OIL FILTER ELEMENT (PAGE 4-78)"
- Brake cooling oil filter
"REPLACE TRANSMISSION AND REAR BRAKE COOLING OIL FILTER ELEMENT (PAGE 4-77)"
- Steering, hoist oil filter
"REPLACE STEERING, HOIST OIL TANK FILTER ELEMENT (PAGE 4-83)"
- Differential case oil
"CHANGE OIL IN DIFFERENTIAL CASE (PAGE 4-85)"
- Final drive oil
"CHANGE OIL IN FINAL DRIVE CASE (PAGE 4-84)"
- Steering, hoist oil
"CHANGE OIL IN STEERING, HOIST OIL TANK (PAGE 4-86)"

PAYLOAD DISPLAY

(If equipped)

The signals from the pressure sensors, monitor, body float detection, and travel speed detection are detected and the microcomputer built into the controller calculates the payload. The payload display (payload meter VHMS built-in type) is then displayed on the character display. For details, see "HANDLING PAYLOAD METER (VHMS BUILT-IN TYPE) (PAGE 6-23)" in the ATTACHMENT section.

OTHER FUNCTIONS OF CHARACTER DISPLAY

DISPLAY MEYHOD FOR REVERSE TRAVEL ODOMETER

Use this when checking the total travel distance in reverse.

1. Check that the character display is showing the service meter/odometer, or the action code. If it is giving any other display, turn the starting switch OFF, then turn the starting switch to the ON position and wait for the above display to be given.
2. Press the (◇) of machine monitor mode selector switch 1. It display the overall traveled reverse.
3. When completing the operation, press (■) of machine monitor mode selector 1. Also it enable to completing the operation, turn the starting switch OFF.

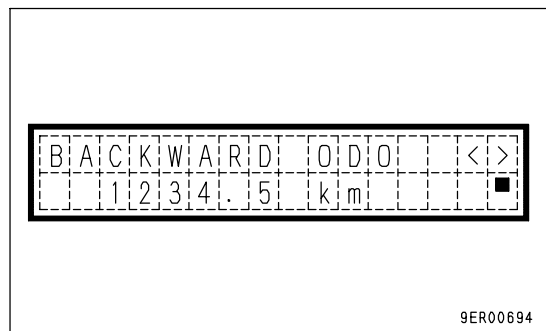
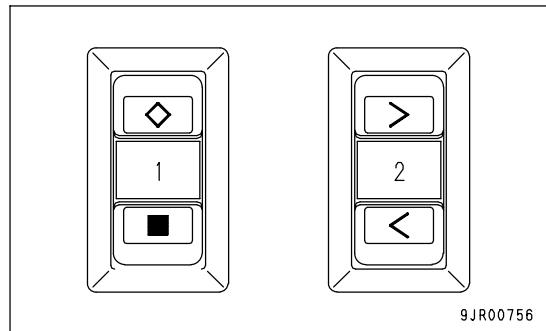

RESET METHOD FOR FILTER,OIL REPLACEMENT TIME

The filter and oil replacement time is displayed on the character display, so if the filter and oil have been replaced, reset the filter and oil change time.

1. Press the (◇) of machine monitor mode selector switch 1, and display the reverse travel in odometer.
2. Press (>) or (<) of machine monitor mode selector switch 2 and display "MAINTENANCE MONITOR".

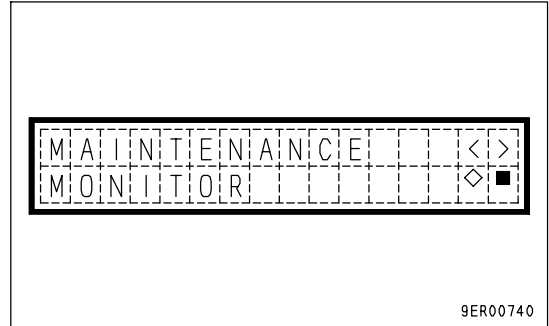

3. Press the (◇) of machine monitor mode selector switch 1. It will change to the display in the diagram on the right. The bottom line shows two items: the replacement time on the left and the total number of times the item has been replaced on the right.
4. Press (>) or (<) of machine monitor mode selector switch 2 and display the item to be reset.

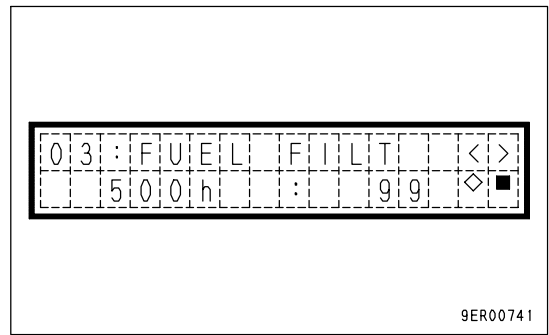

5. Press the (◇) of machine monitor mode selector switch 1. It will change to the display in the diagram on the right. The top line shows [Reset] and [Item to be reset] in turn.
6. When resetting the replacement time, press (>) or (<) of machine monitor mode selector switch 2, align the cursor with "YES", then press (■) of machine monitor mode selector switch 1. It will reset and returned to the previous screen. To abandon, align the cursor with "NO", then press (■) of machine monitor mode selector switch 1.

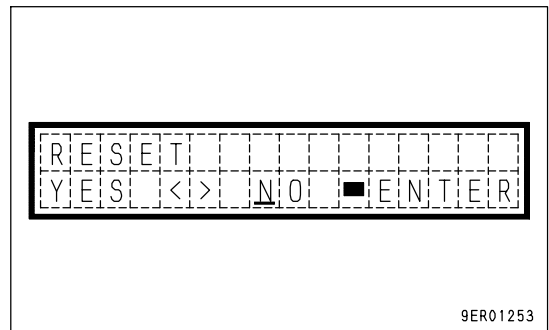

7. When resetting the replacement time for another item, carry out the procedure from Step 4. When completing the operation, press (■) of machine monitor selector switch 1. Also it enable to completing the operation, turn the starting switch OFF.

INPUT METHOD FOR TELEPHONE NUMBER

When an error for action code "E03" occurs, it is possible to display the telephone number.

1. Press the (◇) of machine monitor mode selector switch 1 and display the reverse travel odometer.
2. Press (>) or (<) of machine monitor mode selector switch 2 and display "TEL".

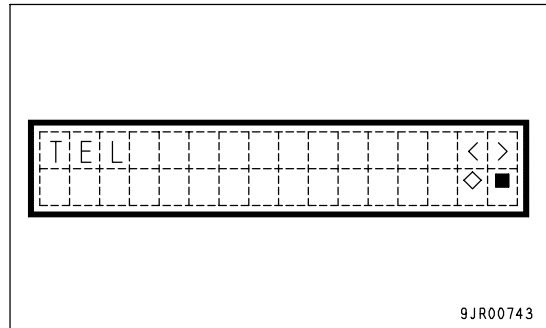

3. Press (◇) of machine monitor mode selector switch 1. It will change to the display in the diagram on the right.

Once the telephone number is input, the input number will be displayed next time.

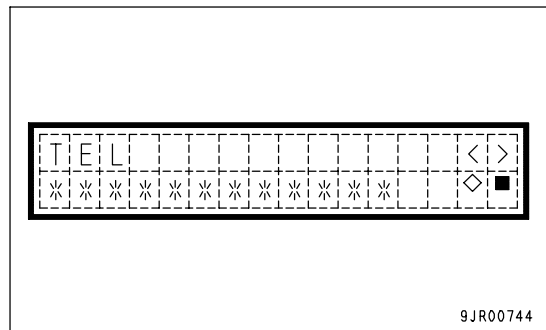

4. Up to 12 digits can be displayed for the telephone number. Input from the first digits.

The cursor is displayed at the input position. Press (>) or (<) of machine monitor mode selector switch 2 and display "0 - 9". To leave a blank, select "**".

When the input value is decided, press (◇) of machine monitor mode selector switch 1. The cursor will move to the next position.

5. Repeat the procedure in Step 4 until the last digit. At the last digit, press (◇) of machine monitor mode selector switch 1 to return to the previous screen. If there is a mistake in the input or the input is to be stopped, press (■) of machine monitor mode selector switch 1 to return to the previous screen.
6. When completing the operation, press (■) of machine monitor selector switch 1. Also it enable to completing the operation, turn the starting switch OFF.

METHOD FOR SELECTING LANGUAGE

Use this when switching the language displayed on the character display.

1. Press the (◇) of machine monitor mode selector switch 1 and display the reverse travel odometer.
2. Press (>) or (<) of machine monitor mode selector switch 2 and display "LANGUAGE".

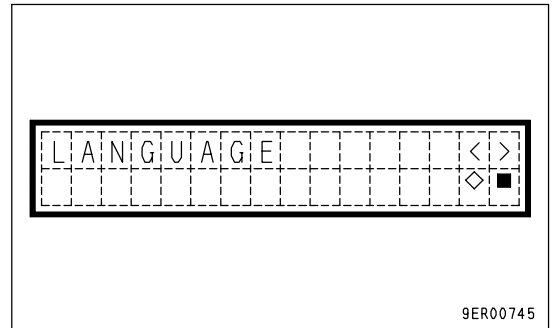

3. Press the (◇) of machine monitor mode selector switch 1. The presently selected language is displayed.
4. Press (>) or (<) of machine monitor mode selector switch 2 and select the language.

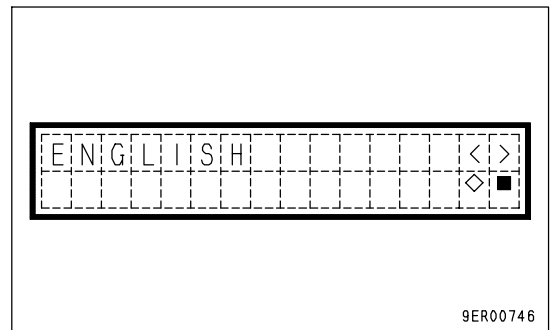

The available languages are English, Japanese, German, French, Italian, Spanish, and Swedish.

Language	Display
English	ENGLISH
Japanese	日本語
German	DEUTSCH
Franch	FRANCAIS
Italian	ITALIANO
Spanish	Español
Swedish	SVENSKA

5. When the (◇) of machine monitor mode selector switch 1 is pressed, the language is set and the screen returns to the previous screen.
6. When completing the operation, press (■) of machine monitor selector switch 1. Also it enable to completing the operation, turn the starting switch OFF.

SWITCHES

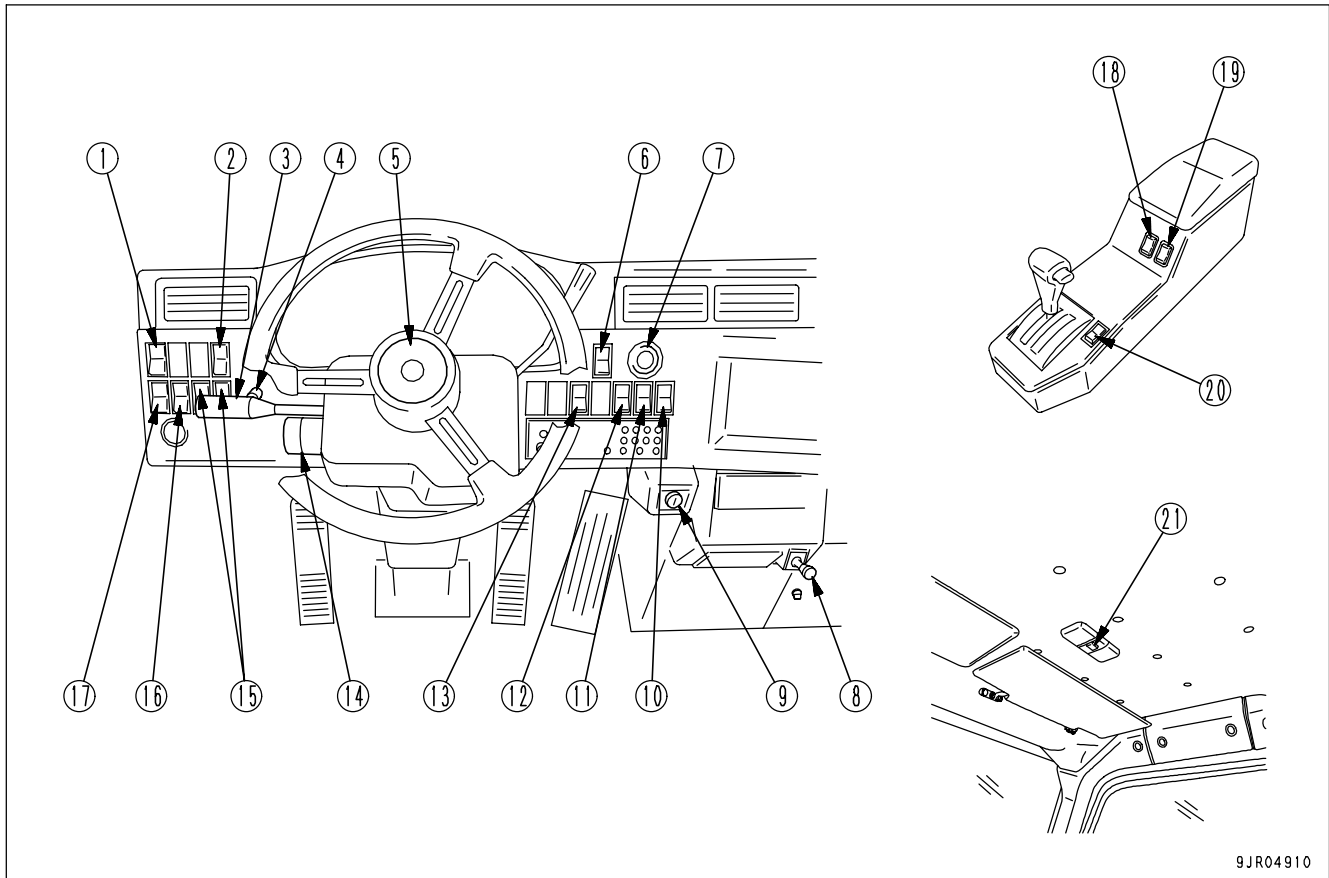

9JR04910

- | | |
|---|--|
| (1) Side lamp switch (if equipped) | (11) Automatic idling setting system (AISS LOW) switch |
| (2) Machine monitor bulb check switch | (12) Front brake cut-off switch |
| (3) Lamp switch
Turn signal lever
Dimmer switch | (13) Auto retarder (ARSC) switch |
| (4) Monitor lighting dimmer switch | (14) Wiper, window washer switch |
| (5) Horn button | (15) Machine monitor mode selector switch 1, 2 |
| (6) Hazard lamp switch | (16) Fog lamp switch (if equipped) |
| (7) Emergency steering switch | (17) Yellow rotating lamp switch (if equipped) |
| (8) Cigarette lighter | (18) Power window switch (right) (if equipped) |
| (9) Starting switch | (19) Power window switch (left) |
| (10) Power mode selector switch | (20) Parking brake switch |
| | (21) Room lamp switch |

SIDE LAMP SWITCH

(If equipped)

Use this side lamp switch (1) to turn the side lamps on or off.

When portion (A) of the switch is pressed, the side lamp lights up and the monitor lamp inside portion (A) of the switch also lights up.

When portion (B) of the switch is pressed, the side lamp goes out and the monitor lamp inside portion (A) of the switch also goes out.

When the machine head lamps are turned on, the icon inside portion (B) of the side lamp switch lights up.

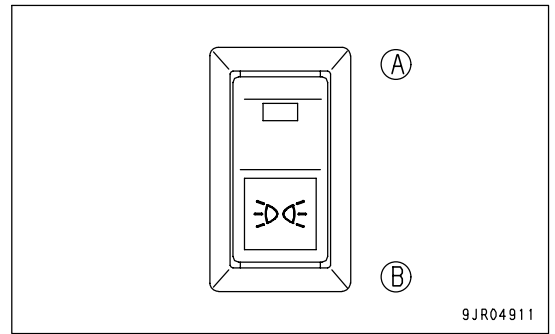

MACHINE MONITOR BULB CHECK SWITCH

Use this machine monitor bulb check switch (2) to check the machine monitor bulb is blow out or not.

Before starting the engine, turn the starting switch to the ON position and press this machine monitor bulb check switch (2) to check that the machine monitor lamps light up properly.

When the machine monitor bulb check switch is pressed, all the machine monitor lamps should light up. If any machine monitor lamp does not light up, repair or replace the bulb.

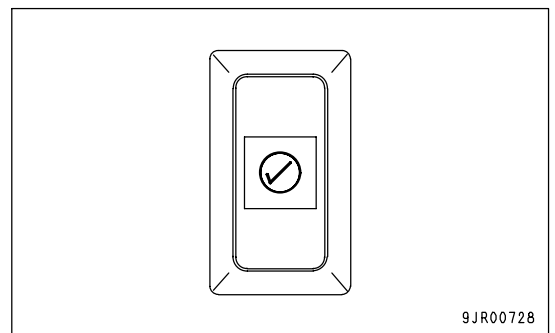

LAMP SWITCH

Use this lamp switch (3) to turn the head lamps, clearance lamps, tail lamps, internal illumination of machine monitor, and rear lamps on and off.

The tip of the lever can be rotated to the following positions.

Position (A): OFF

Position (B): Clearance lamps, tail lamps, rear lamps, and internal illumination of machine monitor light up

Position (C): Head lamps light up in addition to lamps at position (B) (clearance lamps, tail lamps, rear lamps, and internal illumination of machine monitor)

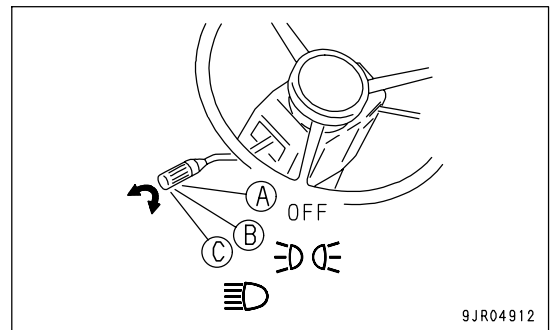

TURN SIGNAL LEVER

Use this turn signal lever (3) to make the turn signal flash in the direction of turning.

Position (A) (right turn): Turn signal on right side of machine flashes, turn signal indicator lamp on machine monitor also flashes.

Position (B) (center): Lamps are not actuated.

Position (C) (left turn): Turn signal on left side of machine flashes, turn signal indicator lamp on machine monitor also flashes.

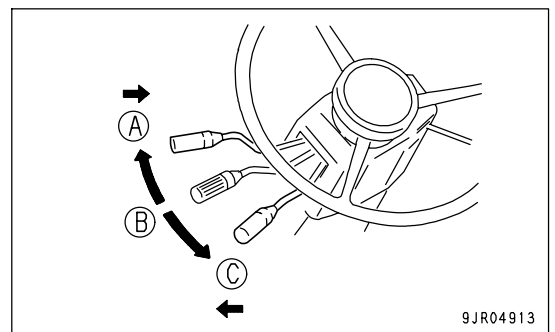

Operate the lever in the direction of turning, then turn the machine with the steering wheel. When the steering wheel is returned, the turn signal lever also returns automatically to the center position. If the turn signal lever does not return automatically, return it to the center position by hand.

DIMMER SWITCH

Use this dimmer switch (3) to switch the head lamp between high beam and low beam.

When the turn signal lever is moved up in direction (A), the head lamps switch to high beam and the head lamp high beam pilot lamp on the machine monitor lights up. When the lever is released, it returns to position (B). If the turn signal lever is moved up in direction (A) again, the head lamps switch to low beam and the head lamp high beam pilot lamp on the machine monitor goes out. When the lever is released, it returns to position (B).

If the lamp switch is OFF, and the turn signal lever is moved up and held at position (A), the head lamp lights up on high beam.

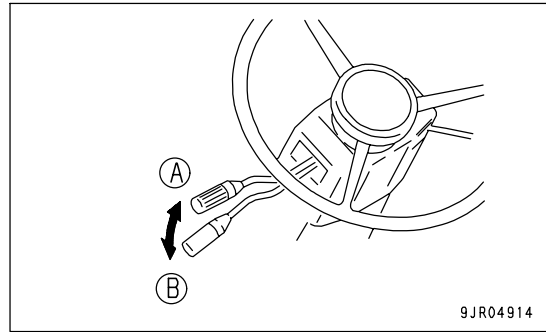
**MONITOR LIGHTING DIMMER SWITCH**

Use this monitor lighting dimmer switch (4) to adjust the brightness of the internal illumination of the machine monitor, the pilot lamps, and the caution lamps.

If the monitor light dimmer switch is turned to the right, the lamps become brighter. If it is turned to the left, the lamps become dimmer. Adjust to the desired brightness.

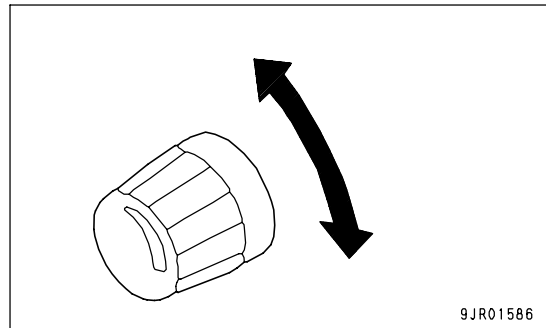
**HORN BUTTON**

When the horn button (5) in the center of the steering wheel is pressed, the horn will sound.

Use this button when starting the machine off or when warning of people in the surrounding area of danger.

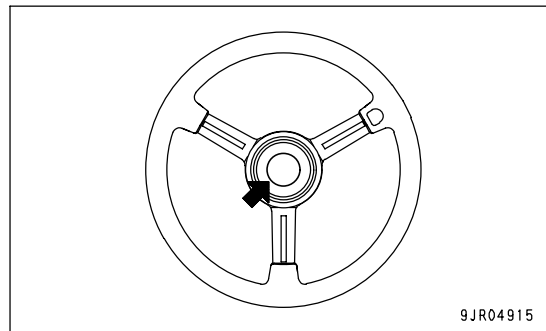

HAZARD LAMP SWITCH

When this hazard lamp switch (6) is operated, the left and right turn signals flash at the same time.

Use this when the machine is stopped.

When portion (A) of the switch is pressed, the left and right turn signal lamps flash at the same time and the monitor lamp inside portion (A) of the switch also lights up.

When portion (B) of the switch is pressed, the left and right turn signal lamps go out and the monitor lamp inside portion (A) of the switch also goes out.

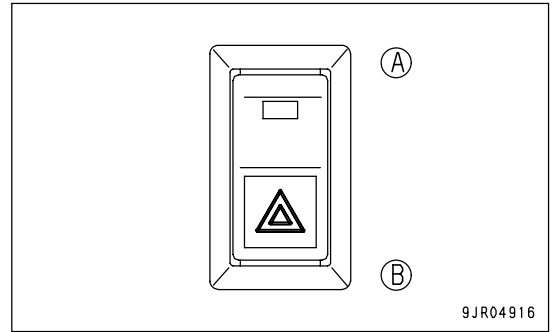

If the machine head lamps are lighted up, the icon inside portion (B) of the hazard lamp switch lights up.

EMERGENCY STEERING SWITCH

Use this emergency steering switch (7) to actuate the emergency steering pump.

When this switch is pressed, the emergency steering pump is actuated, the red monitor lamp inside the switch lights up, the pilot lamp on the machine monitor lights up, and it becomes possible to operate the steering.

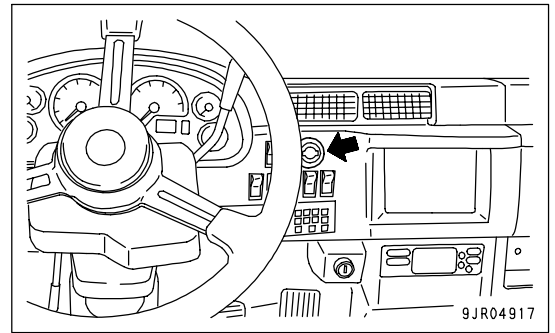

CIGARETTE LIGHTER

Use this cigarette lighter (8) to light cigarettes.

CAUTION

- Do not touch the glowing red portion of the cigarette lighter. It will burn you.
- After using the cigarette lighter, replace it the cigarette lighter socket. Do not leave the cigarette lighter lying around when it is red hot. It will cause fire if it comes into contact with flammable substances in the operator's compartment or operator's seat.

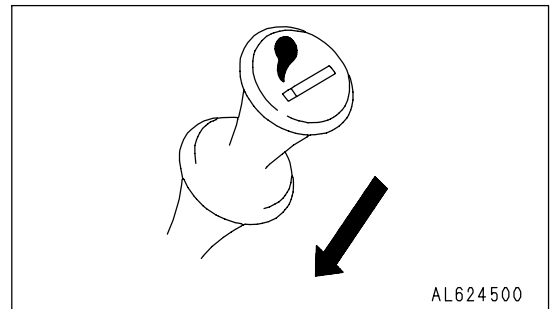

1. Push the cigarette lighter in once. After several seconds, the cigarette lighter will glow red and will return to its original position
2. Pull the cigarette lighter out and use it to light your cigarette.

The cigarette lighter can also be used as a DC 24 V power source.
Capacity: DC 24V 10A

STARTING SWITCH

Use this starting switch (9) to start or stop the engine.

When the key is inserted in the starting switch, it can be turned to the following positions.

OFF position:

In this position, the key can be inserted or removed. When it is turned to the OFF position, all the electrical systems on the machine are turned off and the engine stops.

ON position:

When the key is at the ON position, electricity flows in the charging circuit and lamp circuits. Keep the key at the ON position when the engine is running.

When turning the starting switch key to the ON and OFF positions, if the key is held between the ON and OFF positions, the controller may detect a problem. If this happens, turn the switch to the OFF position, then turn it again to the ON position in the same way as for normal operations.

In cold weather, if the key is turned to the ON position, depending on the engine water temperature, the engine preheater may be actuated and the machine monitor preheating pilot lamp may light up. After completion of preheating, the preheating pilot lamp will go out. When it goes out, turn the key to the START position to start the engine.

START position:

Turn the key to this position to start the engine. When the key is turned to the START position, the starting motor is actuated and starts cranking. When the engine starts, release the key. The key will return automatically to the ON position.

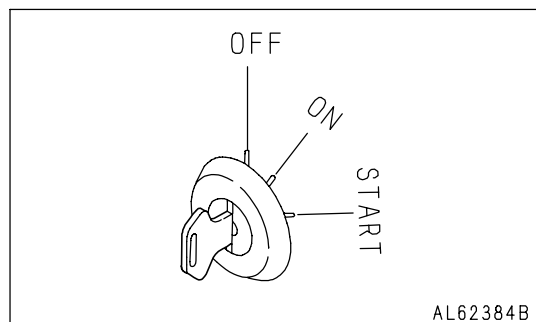
**POWER MODE SELECTOR SWITCH**

Use this power mode selector switch (10) to set the travel system to the most economical travel setting to match the operating conditions.

There are two power modes.

(A): Economy mode (operations on level ground)

Use this position when operating on level ground where high output power is not needed and when the emphasis is on reducing fuel consumption.

(B): High power mode (general operations)

Use this position for normal operating conditions.

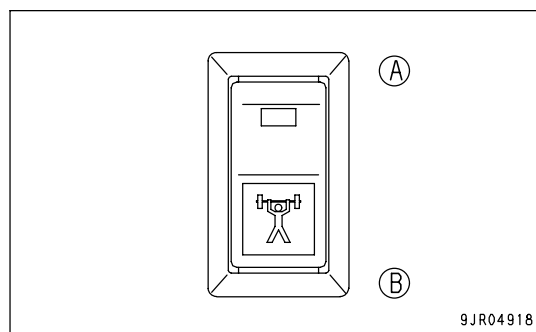

When portion (A) of the switch is pressed, the mode switches to the economy mode, the economy mode pilot lamp on the machine monitor lights up, and the monitor lamp inside the switch also lights up.

When portion (B) of the switch is pressed, the mode switches to the high power mode, the power mode pilot lamp on the machine monitor lights up, and the monitor lamp inside the switch goes out.

When the head lamps are turned on, the icon inside portion (B) of the power mode selector switch lights up.

AUTOMATIC IDLING SETTING SYSTEM (AISS LOW) SWITCH

Use this switch (11) to switch between automatic and low speed for the AISS system. Use each position as follows.

(A): Low speed (LOW) position

Use this position when fine control of the travel speed is needed, such as when parking the machine.

(B): Automatic (AUTO) position

Use this position when carrying out normal operations.

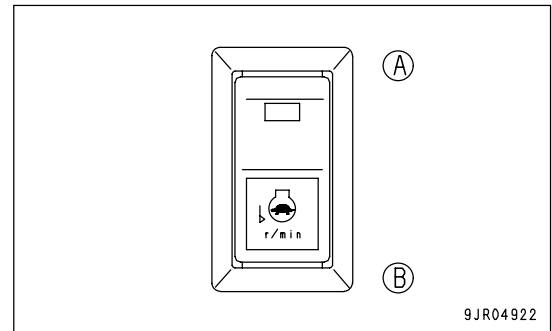

When portion (B) of the switch is pressed, the automatic idling setting system function is actuated and the monitor lamp inside the switch at portion (A) lights up.

If the switch is at AUTO position:

- If the parking brake or retarder brake are operated, the idle is automatically adjusted to low speed. When the parking brake and retarder brake are released, the idle is automatically adjusted to high speed.
- The water temperature is detected, and when it is at low temperature, the idle is automatically adjusted to high speed to reduce the warming-up time.

When the head lamps are turned on, the icon inside position (B) of automatic idling system (ALSS LOW) switch lights up.

FRONT BRAKE CUT-OFF SWITCH

Use this front brake cut-off switch (12) to select a method of braking to match the road surface conditions.

When portion (A) of the switch is pressed, the front brake cut-off function is actuated, so braking force is applied only to the rear brakes, and the monitor lamp inside portion (A) of the switch lights up.

When portion (B) of the switch is pressed, braking force is applied to both the front and rear brakes, and the monitor lamp inside portion (A) of the switch goes out.

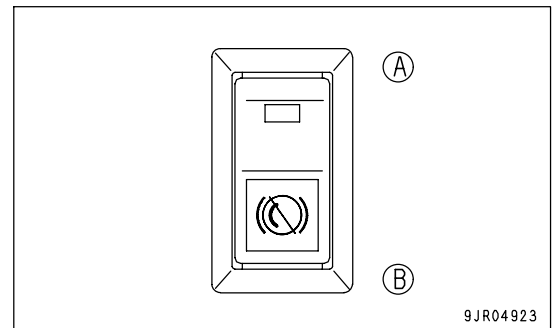

When traveling on a soft road surface, if the front brakes are actuated, the machine may tip over when the brakes are applied, so travel with the front brakes off.

When the head lamps are turned on, the icon inside portion (B) of the front brake cut-off switch lights up.

REMARK

When the secondary brake is applied, the front brake cut-off switch is ignored and both the front brakes and parking brakes are applied.

AUTO RETARDER (ARSC) SWITCH

Use this auto retarder (ARSC) switch (13) to turn the auto retarder (ARSC) system on or off.

When portion (A) of the switch is pressed, the auto retarder (ARSC) is turned ON and the monitor lamp inside portion (A) of the switch lights up.

When portion (B) of the switch is pressed, the auto retarder (ARSC) is turned OFF and the monitor lamp inside portion (B) of the switch goes out.

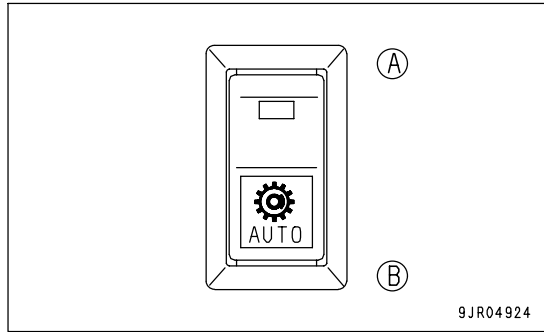

When the head lamps are turned on, the icon inside portion (B) of the auto retarder (ARSC) switch lights up.

WIPER, WINDOW WASHER SWITCH

Use this wiper/window washer switch (14) to operate the front glass wiper and to spray out window washer fluid.

Front wiper

Position (A) (OFF): Wiper stopped

Position (B) (INT): Wiper moves once every 4 - 7 second

Position (C) (LOW): Wiper moves at low speed

Position (D) (HI): Wiper moves at high speed

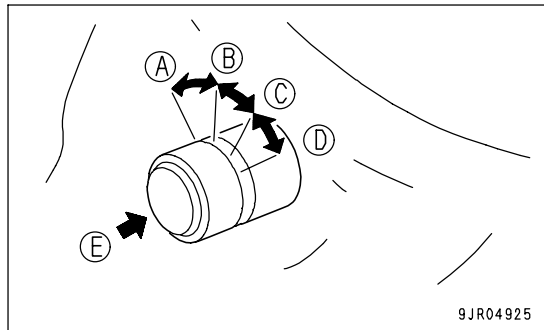

Spraying out window washer fluid

Press button (E) at the tip of the wiper/window washer switch to spray out window washer fluid.

Do not continue to spray out washer fluid continuously for more than 10 seconds. If fluid is sprayed out for more than 10 seconds, the drive motor may be damaged.

MACHINE MONITOR MODE SELECTOR SWITCH 1, 2

Use these switches (15) to select the content of the display on the character display.

For details of using these switches, see "OTHER FUNCTIONS OF CHARACTER DISPLAY (PAGE 3-32)".

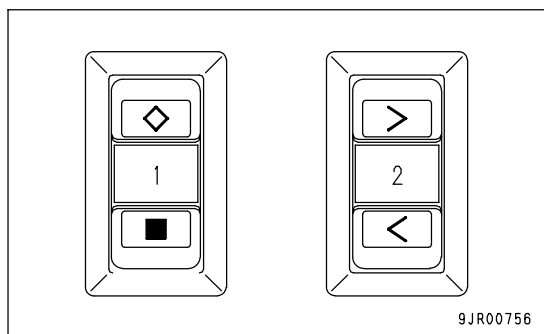

FOG LAMP SWITCH

(If equipped)

Use this fog lamp switch (16) to switch the fog lamp on and off.

When portion (A) of the switch is pressed, the fog lamp lights up and the monitor lamp inside portion (A) of the switch also lights up.

When portion (B) of the switch is pressed, the fog lamp goes out and the monitor lamp inside portion (A) of the switch also goes out.

When the head lamps are turned on, the icon inside portion (B) of the fog lamp switch lights up.

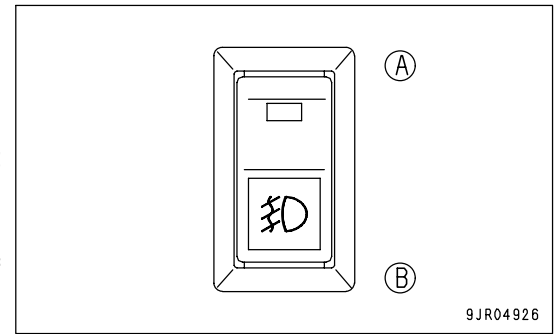
**YELLOW ROTATING LAMP SWITCH**

(If equipped)

Use this yellow rotating lamp switch (17) to turn the yellow rotating lamp on and off.

When portion (A) of the switch is pressed, the yellow rotating lamp lights up and the monitor lamp inside portion (A) of the switch also lights up.

When portion (B) of the switch is pressed, the yellow rotating lamp goes out and the monitor lamp inside portion (A) of the switch also goes out.

When the front lamps on the machine light up, the icon inside portion (B) of the yellow rotating lamp switch lights up.

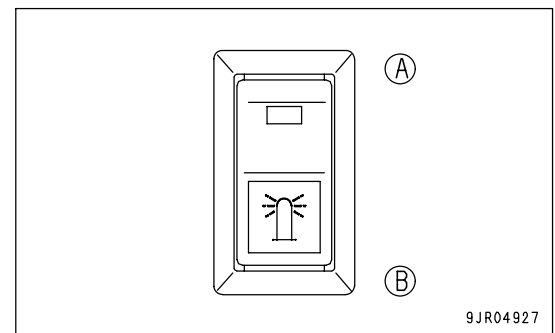

POWER WINDOW SWITCH (RIGHT) (LEFT)
(The right power window is optional.)**WARNING**

Before closing the window glass, make sure that no one has put his head or hand through the window. If the hands or head are caught between the frame and the window glass, there is danger of serious injury if someone's hand is caught, and there is danger of death if someone's head is caught.

**CAUTION**

Do not keep the switch pressed in the same direction after the window glass is fully opened or fully closed. This will cause overheating and damage of the power window motor.

When the starting switch is ON, use these power window switches (18) and (19) to open and close the left and the right window glass. When portion (A) of the switch is pressed, the window glass will go up. When portion (B) of the switch is pressed, the window glass will go down.

When the window glass is fully open or fully closed and the glass stops moving, release the switch immediately.

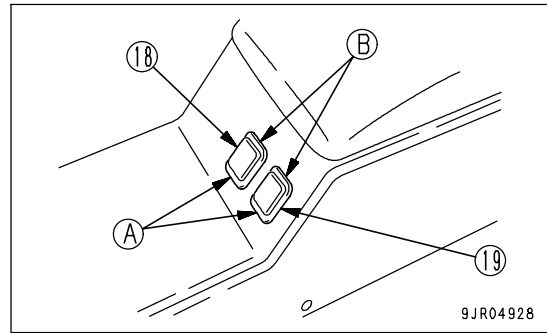

PARKING BRAKE SWITCH

 **CAUTION**

When stopping or parking the machine, always apply the parking brake. On slopes, there is danger that the machine may move off without any operator on board, leading to serious personal injury involving people in the area around the machine.

Use this parking brake switch (20) to apply and release the parking brake.

When portion (A) of the switch is pressed, the parking brake is released and the parking brake pilot lamp on the machine monitor goes out.

When portion (B) of the switch is pressed, the parking brake is applied and the parking brake pilot lamp on the machine monitor lights up.

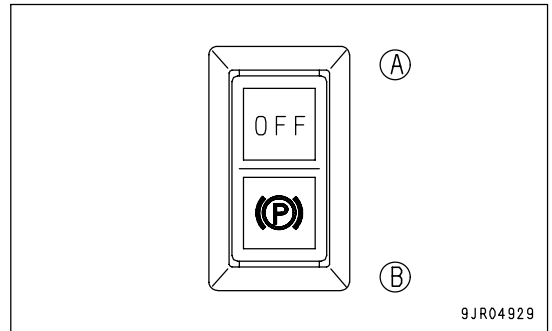

If the parking brake is set to PARKING position when the gear shift lever is at any position other than N, the central warning lamp will light up and the alarm buzzer will sound. Always set the gear shift lever to N before applying the parking brake.

When the head lamps are turned on, the icon inside portion (B) of the parking brake switch lights up.

REMARK

If the engine is stopped without applying the parking brake, or the parking brake switch is set to the "RELEASE" position when the engine is stopped, the parking brake will be applied when the engine is started. If this happens, turn the parking brake switch to the PARKING position, then release the parking brake.

ROOM LAMP SWITCH

Use this room lamp switch (21) to turn the lighting inside the cab on and off.

The positions of the switch are as follows.

Position (A): OFF

Position (B): Lights up when door of operator's compartment is opened

Position (C): Always lights up

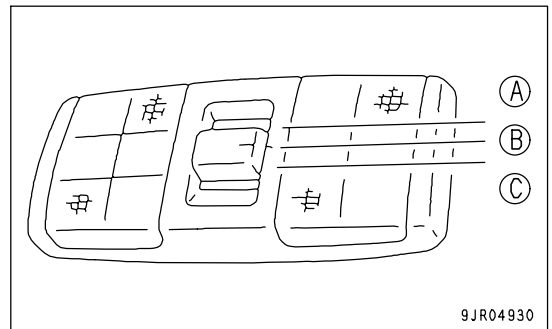

REMARK

- The room lamp can be turned on or off without using the starting switch. When leaving the operator's compartment, make sure that the room lamp switch is set to position (A) or (B).
- If the door of the operator's compartment is to be left open, set the room lamp switch to position (A) (OFF).

BODY PIVOT PIN



- Always carry out the operation to remove or insert the body pivot pin with at least two workers. This operation is carried out with the dump body raised, so if the dump body goes down during the operation, it will lead to serious injury or even death.
- When carrying out inspection with the dump body raised, always set the dump control lever to the HOLD position, set the dump control lever lock knob to the LOCK position, then insert the body pivot pin. If the body pivot pin is not inserted, the dump body may go down when the dump control lever is operated, and catch or cause serious injury or even death to the person carrying out the inspection.

The body pivot pin is a device to prevent the dump body from coming down. It is used when carrying out inspection and maintenance with the dump body raised. There are body pivot pins on the left and right sides, so always use the body pivot pins on both the left and right sides.

The method of using the body pivot pin is as follows.

PREVENTION OF BODY LOWER

1. Remove stopper pin (2) inserted in body pivot pin (1), then pull out body pivot pin (1).
2. Set dump control lever (3) to the RAISE position, raise the dump body to the maximum height, then set the lever to the HOLD position.
3. Insert body pivot pin (1) into the dump body and frame.
4. Set the dump control lever to the FLOAT position, then set the lock knob to the LOCK position.
5. Stop the engine.

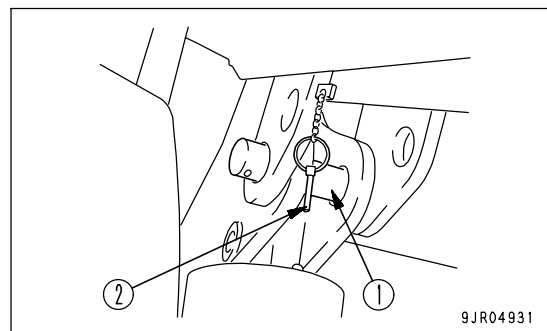

Carry out inspection and maintenance with the dump body in this condition.

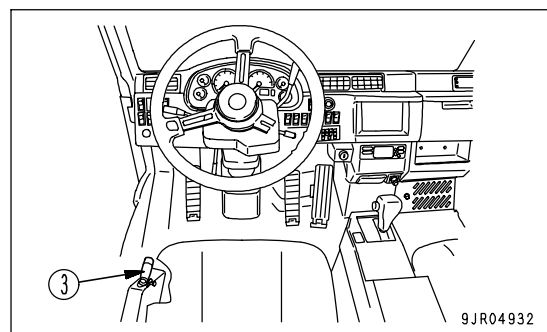

STOWING BODY PIVOT PIN

Store the body pivot pin under the rear of the dump body.

Insert body pivot pin (1), then insert lock pin (2) to stow the body pivot pin.

1. Start the engine.
2. Set dump control lever (3) to the FLOAT position.
3. Remove body pivot pin (1) from the dump body and frame.
4. Set the dump control lever to the LOWER position and lower the dump body.
5. When the dump body is completely seated, insert body pivot pin (1) into the body.
6. To prevent the body pivot pin from coming out, insert lock pin (2) into body pivot pin (1).

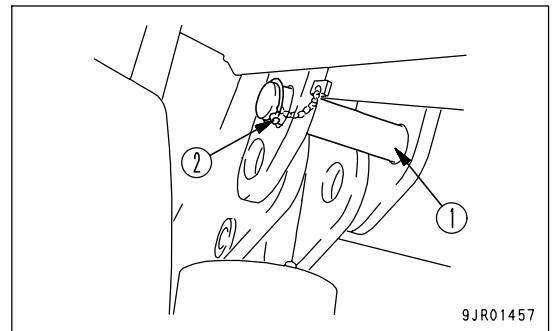
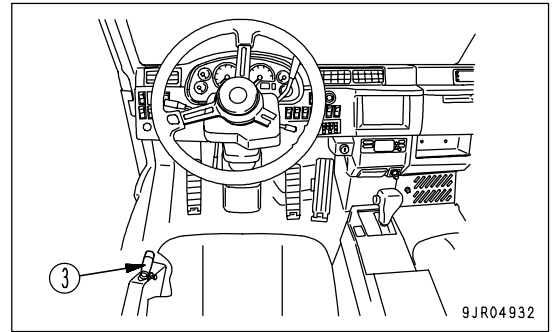
**LOCATION OF FIRE EXTINGUISHER**

(If equipped)

Fire extinguisher (1) is installed to the left front of the machine.

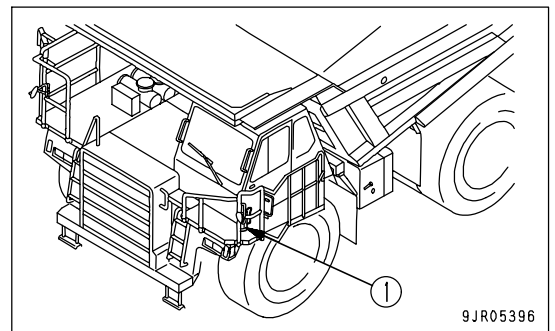
**DUST INDICATOR**

This displays the amount that the air cleaner is clogged.

Yellow display (1) appears in the transparent portion according to the amount that the air cleaner element is clogged. When yellow display (1) reaches the 7.5 kPa {0.076 kg/cm²} position, clean or replace the element. For details of the procedure for cleaning or replacing, see "CHECK, CLEAN OR REPLACE AIR CLEANER (PAGE 4-23)". After cleaning or replacing, press top portion (2) of the dust indicator to reset yellow display (1) to its original position.

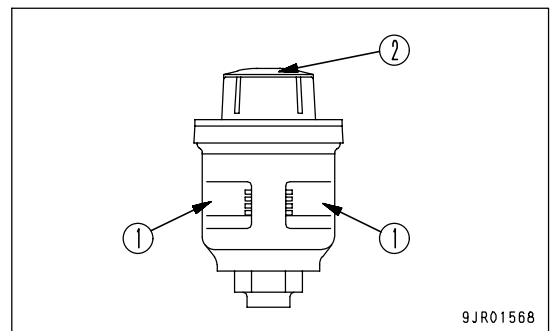
**REMARK**

Yellow display (1) in the transparent portion of the dust indicator is locked in steps by the resistance of the intake air when the engine is running, so even when the engine is stopped, it is possible to know the amount that the air cleaner is clogged. When the top portion (2) of the dust indicator is pressed, the lock is released.

FUSES

NOTICE

- When replacing any fuse, always replace it with a fuse of the same capacity and same type. If the capacity of the fuse is too low, the fuse will blow when the power is turned on; if it is too high, excessive current will flow in the circuit and this may damage the electrical equipment.
- When replacing the fuse, always turn the power off (turn the starting switch to the OFF position) before starting. If the new fuse is installed while the power is on, excessive current may flow and cause the fuse to blow again immediately.

Fuses "BT1", "BT2", "BT3", AND "BT4" are inside the cover at the rear of the operator's seat; fuses "V" are inside the battery box. If any problem occurs in the electrical system and excessive current flows, the fuse will blow to protect the electrical components and wiring. If the fuse blows, check the electrical components and wiring, repair the cause of the fuse blowing, then replace the fuse.

If any fuse is corroded or is covered in white powder, or there is looseness between the fuse and fuse holder, replace the fuse.

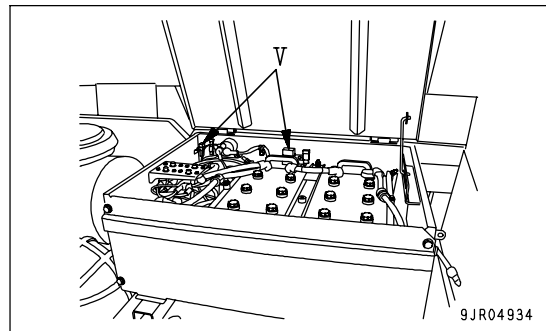
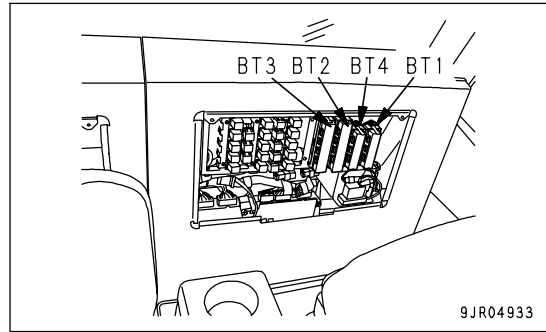

FUSE CAPACITY AND CIRCUIT NAME

The fuse capacity and name of circuit for the fuses in each fuse box are as follows.

Fuse box BT1

No.	Capacity	Name of circuit
(1)	10A	Main lamp, Small lamp
(2)	10A	Turn signal lamp
(3)	20A	Head lamp (low beam)
(4)	20A	Head lamp (high beam)
(5)	20A	Head lamp (low beam)
(6)	20A	Head lamp (high beam)
(7)	10A	Stop lamp
(8)	20A	Backup lamp
(9)	10A	Small lamp
(10)	20A	VHMS controller

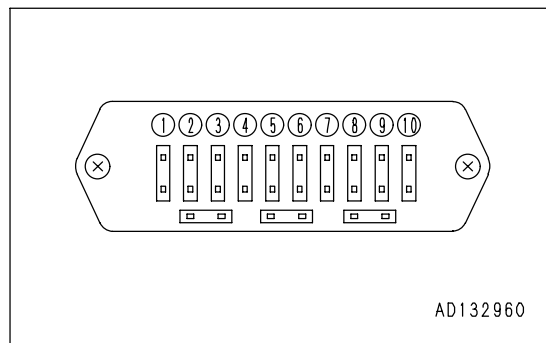

Fuse box BT2

No.	Capacity	Name of circuit
(11)	10A	Machine monitor, payload meter 2 controller
(12)	10A	Back camera (if equipped), VHMS down load
(13)	10A	Parking brake electric circuit
(14)	20A	Power window (left)
(15)	20A	Power window (right)
(16)	10A	Payload meter 2 controller
(17)	10A	Horn
(18)	10A	Machine monitor
(19)	10A	Transmission controller
(20)	20A	Terminal B
(21)	10A	Retarder controller, ABS controller
(22)	20A	Hazard lamp
(23)	10A	Emergency steering
(24)	10A	Room lamp, radio
(25)	10A	Machine monitor, VHMS controller

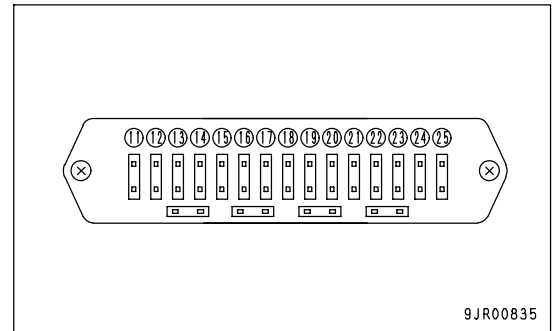

Fuse box BT3

No.	Capacity	Name of circuit
(26)	20A	Fog lamp (if equipped)
(27)	20A	Air conditioner controller (if equipped)
(28)	20A	Heater (if equipped)
(29)	20A	Heater (if equipped)
(30)	20A	ABS controller
(31)	20A	Retarder controller
(32)	10A	Transmission controller, Shift lever power
(33)	10A	Emergency steering, parking brake relay
(34)	10A	Radio
(35)	5A	Engine controller
(36)	30A	Engine controller
(37)		
(38)	30A	Engine controller
(39)		
(40)	20A	Spare

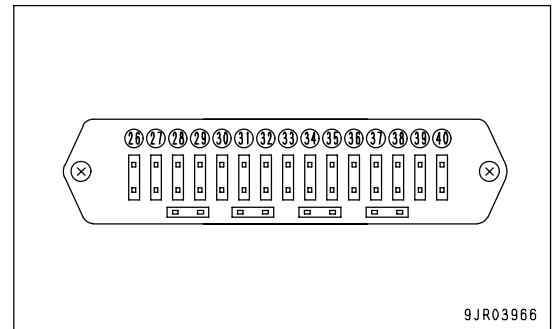

Fuse box BT4

No.	Capacity	Name of circuit
(41)	10A	Room lamp
(42)	10A	Engine preheat power
(43)	20A	Yellow rotating lamp (if equipped)
(44)	20A	Side lamp (if equipped)
(45)	20A	Electric operator's seat heater (if equipped), Air suspension seat (if equipped)
(46)	10A	Payload external display lamp (if equipped)
(47)	10A	Tachograph (if equipped), cigarette lighter
(48)	20A	Air conditioner
(49)	20A	Spare
(50)	20A	Front wiper

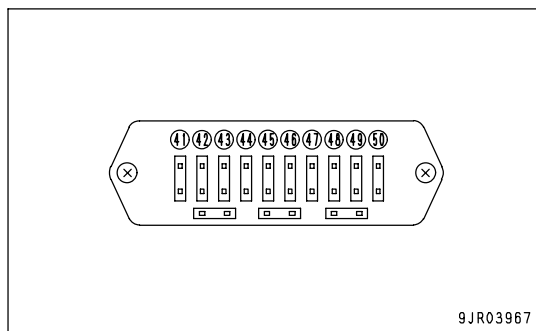

Fuse box V (Inside battery box)

No.	Capacity	Name of circuit
(51)	10A	Power source for emergency system
(52)	120A	Power source for engine heater

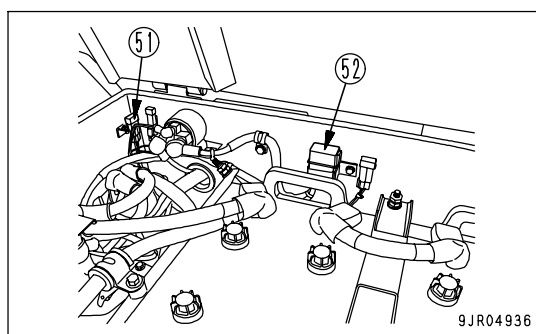

CAR RADIO

EXPLANATION OF COMPONENTS

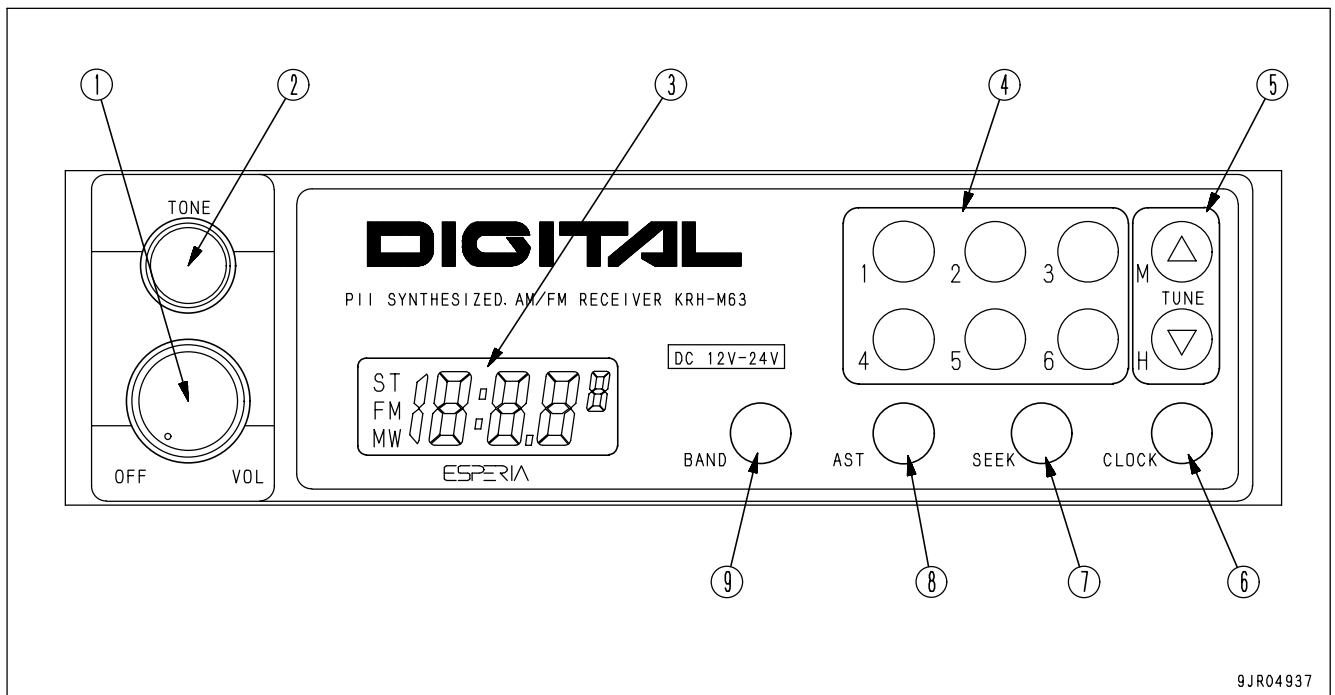

- | | |
|------------------------------|---------------------------------------|
| (1) Power switch/Volume knob | (6) Clock button/Displaying frequency |
| (2) Tone control knob | (7) Seek button |
| (3) Display | (8) AST button |
| (4) Preset button | (9) Band selector button |
| (5) Tuning button | |

POWER SWITCH/VOLUME KNOB

When Power switch/Volume knob (1) is turned to the right, it clicks and the power is turned on. If it is turned further, the speaker volume is adjusted.

TONE CONTROL KNOB

If the tone control knob (2) is turned to right, the high tone is emphasized: if it is turned to the left, the high tone is reduced.

DISPLAY

This display (3) shows the clock, the radio frequency and the operation mode.

PRESET BOTTON

With Preset button (4), each button can be set to one station each for FM and MW (AM).

TUNE BUTTON

When the "△" of Tuning button (5) is pressed, the frequency goes up; when the "▽" of Tuning button (5) is pressed, the frequency goes down.

If it is kept pressed, the frequency changes continuously.

If it is used while pressing the CLOCK button, the time can be set.

CLOCK BUTTON

When Clock button (6) is pressed, the display changes to the time.
If it is pressed again, it displays the frequency.

REMARK

Adjusting time

1. Turn the radio power on. If the display is showing the frequency, press the CLOCK button to display the time.
2. With the CLOCK button pressed
Press the Δ button. The minutes can be set.
Press the ∇ button. The hour can be set.

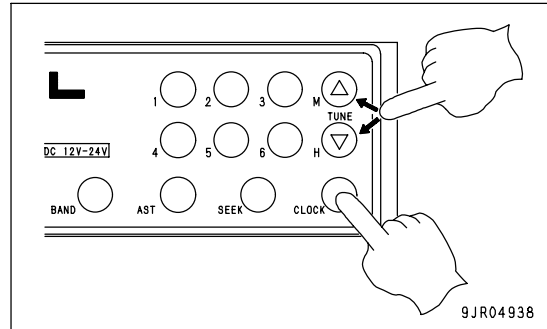
**SEEK BUTTON**

When Seek button (7) is pressed, it automatically searches for stations that can be received, and when it receives a station, it stops.

BAND BUTTON

When Band button (8) is pressed, the band is switched between FM and MW (AM).
The reception band and frequency are displayed on the display.

AST BUTTON

When AST button (9) is pressed, the preset stations are called up in turn.
When the desired broadcasting station is reached, press the button again to stop it.
If the button is kept pressed continuously for 2 seconds, it is set to auto memory.

REMARK

The auto memory automatically saves the broadcasting stations that are in the preset memory.

PRECAUTIONS FOR USE

- To ensure safety, always keep the sound to a level where it is possible to hear outside sounds during operation.
- If water gets into the speaker case or radio, it may lead to an unexpected failure, so be careful not to get water on the equipment.
- Do not wipe the scales or buttons with solvent such as benzene or thinner. Wipe with a dry soft cloth. If the dirt cannot be removed easily, soak the cloth with alcohol.

CAR STEREO

(If equipped)

EXPLANATION OF COMPONENTS

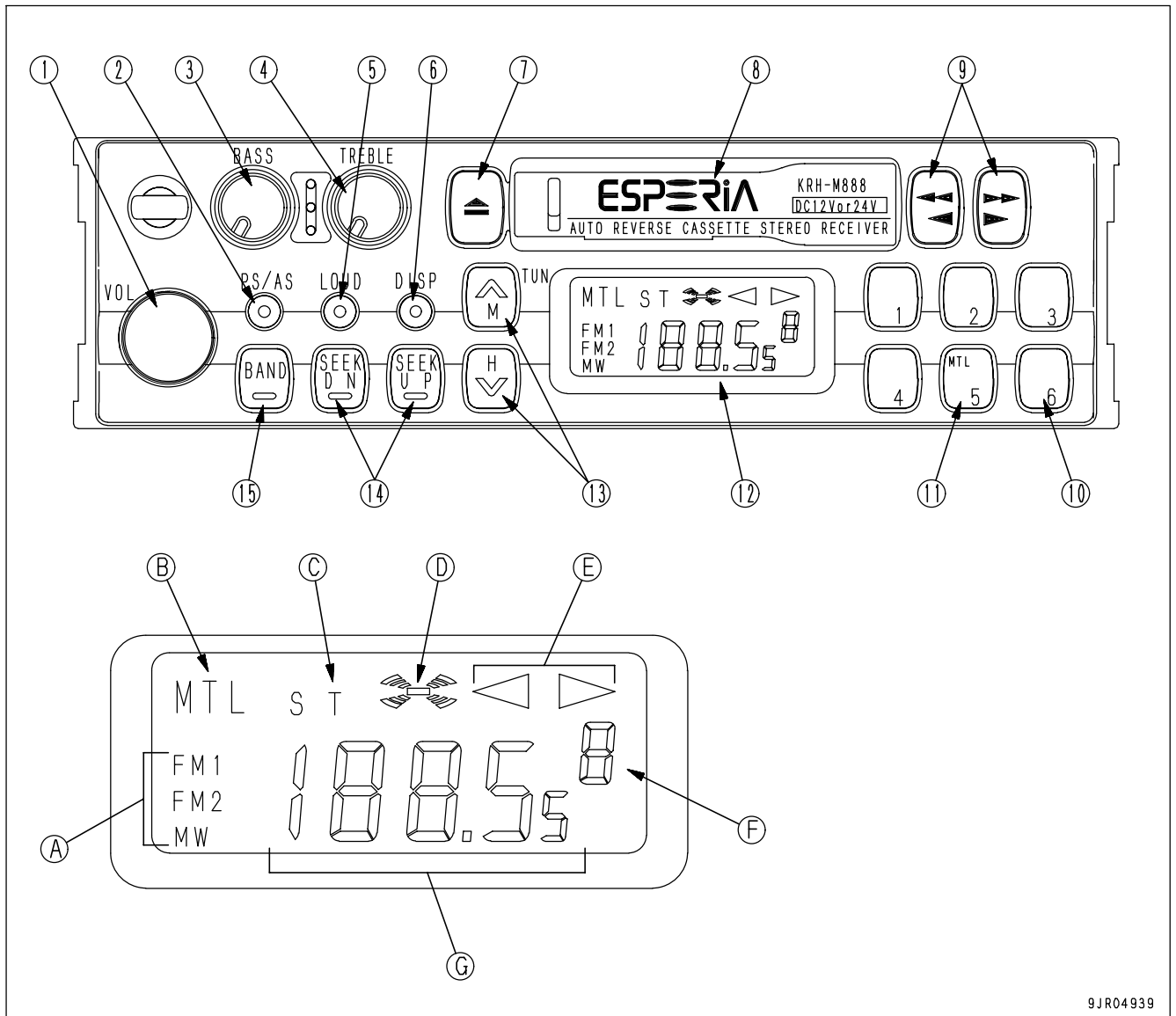

9JR04939

Details of display

- | | |
|---------------------------------|----------------------------|
| (A) Band display | (E) Tape direction display |
| (B) Metal tape display | (F) Preset channel display |
| (C) FM stereo reception display | (G) Time/Radio display |
| (D) Loudness display | |

- | | |
|--|----------------------------------|
| (1) Power switch/Volume knob | (9) Fast forward, rewind buttons |
| (2) Auto-store/Preset scan button | (10) Preset buttons |
| (3) Bass control knob | (11) Metal tape button |
| (4) Treble control knob | (12) Display |
| (5) Loudness button | (13) Manual tuning buttons |
| (6) Time/Radio display selector button | (14) Seek tuning buttons |
| (7) Tape eject button | (15) Band selector button |
| (8) Cassette door | |

POWER SWITCH/VOLUME KNOB

When Power switch/Volume knob (1) is turned to the right, it clicks and the power is turned on. If it is turned further, the speaker volume is adjusted.

AUTO-STORE/PRESET SCAN BUTTON

Use Auto-store/Preset scan button (2) to actuate the preset scan and auto-store functions.

- Auto-store

Each time this button is pressed for more than 2 seconds while in radio reception, this auto-store function automatically starts to search for the desired station within a receivable band, and memorize the frequency in the preset memory. During this scanning process, the frequency shown in the right side of display continues to change. This indicates that each frequency is memorized in the auto-store.

REMARK

The auto-store function cannot be used when the channel display is flashing.

When the display is flashing, the preset scan function is being used.

- Preset scan

If this button is pressed for less than 0.5 second while in radio reception, programs from the six preset stations in the same band will be broadcast one after another for 5 seconds each, starting from No. 1 through No. 6 stations consecutively.

When the desired station is found, press the button again. This stops the preset scan tuning process and switches to ordinary broadcasting. The same process will be repeated continuously until the button is pressed again.

BASS CONTROL KNOB

Turn Bass control knob (3) to the left to reduce the low tones; turn it to the right to emphasize the low tones.

TREBLE CONTROL KNOB

Turn Treble control knob (4) to the left to reduce the low tones; turn it to the right to emphasize the high tones.

LOUDNESS BUTTON

Loudness button (5) is used when playing at low volume. It makes it possible to hear more easily by emphasizing the low tone when the low tones are weak.

When the loudness is operated, the loudness display mark is shown on the display.

Push button: Actuated (ON)

Push button again: Canceled (OFF)

TIME/RADIO DISPLAY SELECTOR BUTTON

Time/Radio selector button (6) is used to switch between the "Time display" and the "Radio/tape display"

Correcting the time

Press the button to set the time display.

Correcting hour: Keep the DISP button pressed and press the "v" of Manual tuning button to correct the hour.

Correcting minute: Keep the DISP button pressed and press the "^" of Manual tuning button to correct the minute.

TAPE EJECT BUTTON

Tape eject button (7) is used to stop the tape and to eject the cassette. When this button is pressed, the tape is ejected and the radio plays.

CASSETTE DOOR

Set the cassette with the exposed portion of the tape on the right side and insert it through the cassette door (8).

FAST FORWARD, REWIND BUTTONS

Fast forward, rewind button (9) are used to fast-forward or rewind the tape.

If you press the button pointing in the same direction as the lighted arrow indicating the direction of play, the tape will be fast-forward; if you press the button pointing in the opposite direction, the tape will rewind.

To stop the tape, lightly press the button that is not locked. The fast-forward or rewind operation will be canceled.

If the fast forward and rewind buttons are pressed at the same time, the tape will change sides.

PRESET BUTTONS

Preset button (10) are used to call up the broadcast station frequencies preset in memory for each of buttons No. 1 to No. 6.

It is possible to preset 18 stations (FM: 12; AM: 6) with these buttons.

METAL TAPE BUTTON

(used also for preset button No. 5)

Metal tape button (11) is used when playing a metal or chrome tape. This button is also used for preset button No. 5. When it is pressed, "MTL" appears on the display.

DISPLAY

Display (12) shows the following.

(A) Band display

This shows the band selected by the band selector button.

(B) Metal tape display

When metal tape is used and the metal tape button is pressed, "MTL" is displayed to show that the setting is for metal tape.

(C) FM stereo reception display

When the FM reception is in stereo, "ST" is displayed to show that the broadcast is in stereo.

(D) Loudness display

When the loudness function is being actuated with the loudness button, the loudness mark is displayed to show that the loudness function is being used.

(E) Tape direction display

This displays the tape direction when the tape is being played.

(F) Preset channel display

This displays the number of the channel set with the preset button.

(G) Time/Radio display

This displays the present time or radio frequency according to the setting of the time/radio display selector button.

MANUAL TUNING BUTTONS

Manual tuning buttons (13) are used for manual tuning.

When " \wedge " button is pressed, the frequency goes up 9 kHz for AM or 0.1 MHz for FM; when " \vee " button is pressed, the frequency goes down 9 kHz for AM or 0.1 MHz for FM. If the button is pressed down and held, the frequency will change continuously.

SEEK TUNING BUTTONS

Seek tuning buttons (14) are used to seek tuning.

When the "SEEK UP" button is pressed, the search automatically goes up; when the "SEEK DOWN" button is pressed, the search automatically goes down.

When the next station that can be received is found, it automatically stops.

BAND SELECTOR BUTTON

When Band selector button (15) is pressed, the band is switched between FM1, FM2, and MW (AM). The band is shown on the display. If the FM reception is in stereo, "ST" is displayed on the display.

PRECAUTIONS FOR USE

- To ensure safety during operations, keep the volume at a level where it is possible to hear other machines.
- If water gets inside the speaker case or stereo (auto tuning), it may cause a serious problem, take care not to let water get in these items.
- Do not wipe the scales or buttons with solvent such as benzene or thinner. Wipe with a dry soft cloth. If the dirt cannot be removed easily, soak the cloth with alcohol.

Handling cassette tape

- Clean the tape head approx. Once a month with a commercially available head cleaning tape.
- Do not leave the tape any place where it is exposed to direct sunlight, any place that is excessively dusty, or any place where there is a magnetic field.
- Do not use 120-minute tapes. The tape is thin and it easily gets caught up inside the machine.
- If the tape is slack, it easily gets caught up inside the machine. Use pencil to wind in the tape to remove any slack.
- Do not use any cassette tape if the label has started to come off. It may cause defective rotation, or it may be impossible to get the tape out of the machine.

AIR CONDITIONER

(If equipped)

By taking fresh air into the cab through a filter, it is possible to raise the pressure inside the cab. This makes it possible to provide a pleasant working environment even on dusty jobsites.

GENERAL LOCATIONS ON CONTROL PANEL

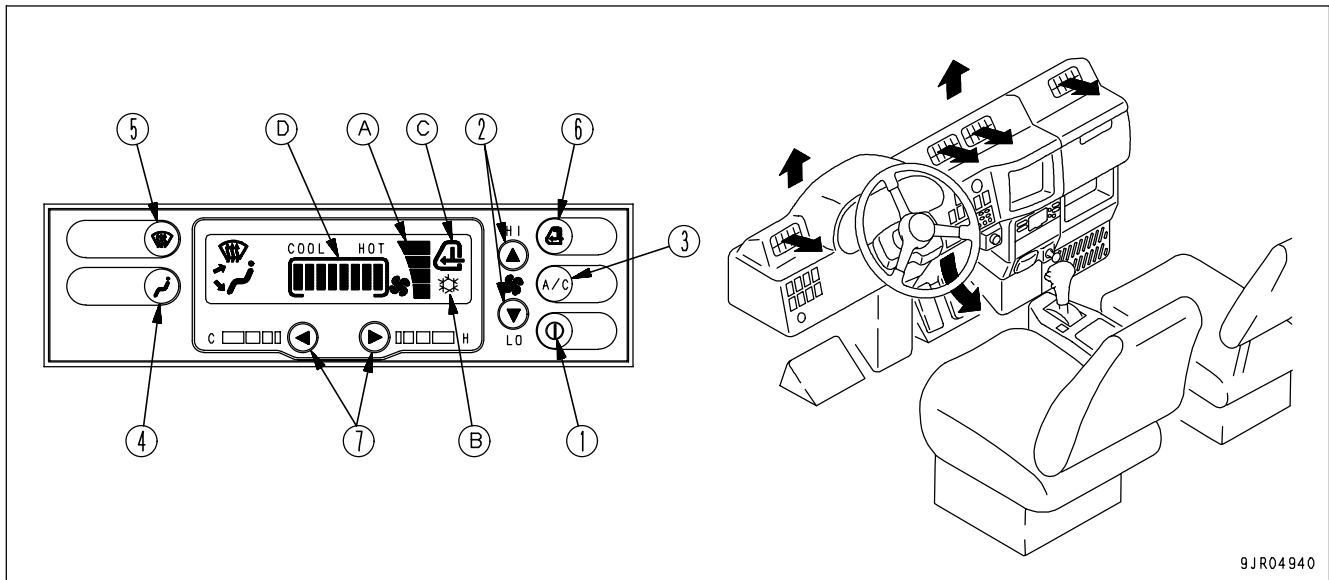

- (1) ON/OFF switch
- (2) Fan switch
- (3) Air conditioner switch
- (4) Mode selector switch
- (5) DEF switch
- (6) RECIRC/FRESH selector switch
- (7) Temperature control switch

Air conditioner monitor

- (A) Air flow bar
- (B) Air conditioner operation symbol
- (C) RECIRC/FRESH selector symbol
- (D) Temperature bar

ON/OFF SWITCH

Use this switch (1) to turn the air conditioner ON/OFF.

When the switch is turned ON, the air conditioner monitor displays the setting being used when the switch was previously turned OFF.

FAN SWITCH

With this switch (2) it is possible to adjust the air flow from the fan to 4 levels.

Press the ^ switch to increase the air flow; press the v switch to reduce the air flow.

The air flow is shown in air flow bar (A) on the air conditioner monitor.

AIR CONDITIONER SWITCH

Use this switch (3) to actuate the cooling, heating, or dehumidifying functions, or to stop the air conditioner.

When the switch is pressed, air conditioner operation symbol (B) is displayed on the air conditioner monitor. When the switch is pressed again, the air conditioner is switched OFF and the operation symbol goes out.

MODE SELECTOR SWITCH



Use this switch (4) to select the vents.

There are three combinations of vents: FACE, FACE/FOOT, and FOOT.

Each time the switch is pressed, the vent display on the air conditioner monitor changes in the order FACE, FACE/FOOT, FOOT, FACE.

REMARK

Air also blows out from the defroster vent in FOOT mode.

Air conditioner monitor display	Condition of vents
	FACE
	FACE/FOOT
	FOOT

DEF SWITCH

Use this switch (5) to change the vents to the DEF mode.

When the switch is pressed, the vent display on the air conditioner monitor changes as shown in the diagram on the right.

When the DEF switch is pressed in any of the FACE, FACE/FOOT, or FOOT modes, the system changes to the DEF mode. In addition, when the DEF mode is being used, if the mode selector switch is pressed, it will return to the mode being used before switching to the DEF mode.

REMARK

Air also blows out from the foot vent in DEF mode.

Air conditioner monitor display	Condition of vents
	DEF



RECIRC/FRESH SELECTOR SWITCH

Use this switch (6) to switch between recirculation of the internal air (RECIRC) or intake of external air (FRESH). When the switch is pressed, the display of RECIRC/FRESH selector symbol (C) on the air conditioner monitor changes.

(It changes in the order RECIRC, FRESH, RECIRC.)

RECIRC: Only the air inside the cab is circulated. Use this position when it is needed to carry out quick heating or cooling of the cab, or when the outside air is dirty (smells or is dusty).

FRESH: Fresh air is taken in from the outside for normal heating or cooling of the cab. Use this position to make the air inside the cab fresh or to remove the mist from the cab windows. When the air conditioner takes in fresh air from the outside, the pressure inside the cab rises and this prevents the entry of dirt. The higher the position of the fan switch, the more efficient this becomes.

Air conditioner monitor display	Condition of vents
	RECIRC
	FRESH

TEMPERATURE CONTROL SWITCH

Use this switch (7) to adjust the temperature of the air blowing out from the vents. The adjustment can be made to 8 levels from low temperature to high temperature.

The temperature of the air blowing out from the vents is displayed on temperature bar (D) on the monitor. The lower the number of segments lighted up on the bar, the lower the temperature is.

Press the > switch to raise the temperature; press the < switch to lower the temperature.

Even when the starting switch is turned OFF, the settings of each mode are retained in memory. However, in the following cases, the settings must be made again.

- When there has been abnormal interference from outside

METHOD OF OPERATION

With the FACE vents, it is possible to adjust the direction of the air flow and to turn it on or off.

However, do not set to the FACE mode with the vents closed.

COOLING

1. Press ON/OFF switch (1) to turn on the air conditioner power.
2. Press fan switch (2) to set the air flow to the maximum.
3. Press temperature control switch (3) to lower the temperature.
4. Press air conditioner switch (4) to set to COOLING.
5. Press RECIRC/FRESH selector switch (5) to set to RECIRC.
6. Press mode selector switch (6) to set the vents to FACE.
7. When the temperature inside the cab goes down, set to the desired temperature and air flow.

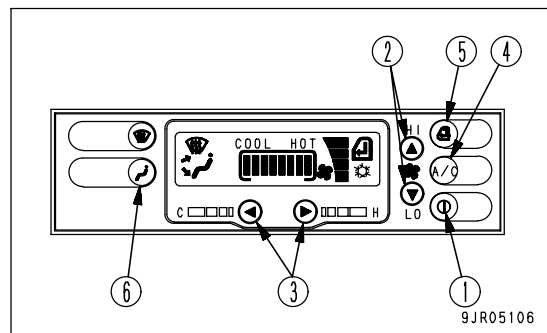

NOTICE

If operations are continued for a long time with the air conditioner set to the lowest temperature and minimum air flow, there is danger that the receiver drier may freeze.

If it freezes and no cold air comes out, stop using the cooling, and set to a higher temperature and the maximum air flow. Run for a short time under these conditions, then return to the cooling operation.

HEATING

1. Press ON/OFF switch (1) to turn on the air conditioner power.
2. Press fan switch (2) to set the air flow to the maximum.
3. Press temperature control switch (3) to raise the temperature.
4. Press RECIRC/FRESH selector switch (4) to set to FRESH.
5. Press mode selector switch (5) to set the vents to FOOT.
6. When the temperature inside the cab goes up, set to the desired temperature and air flow.

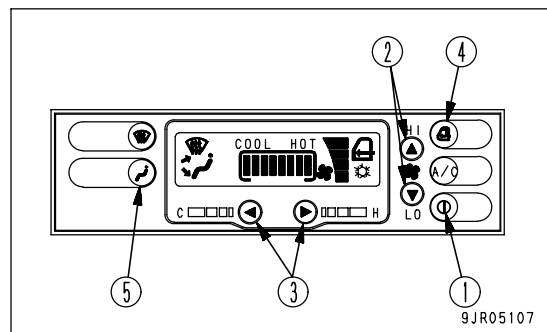

REMARK

The heating uses the heat from the engine cooling water, so it is effective only when the cooling water is hot.

DEHUMIDIFYING, DEFROSTING

1. Press ON/OFF switch (1) to turn on the air conditioner power.
2. Press fan switch (2) to set to the desired air flow.
3. Press temperature control switch (3) to set to the desired temperature.
4. Press RECIRC/FRESH selector switch (4) to set to FRESH.
5. Press mode selector switch (5) or DEF switch (6) to set the vents to the desired position.
6. Press air conditioner switch (7) to operate the cooling.

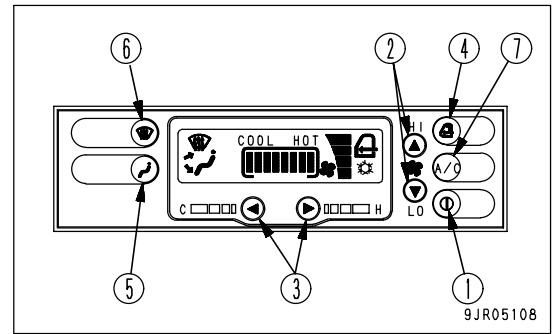
**REMARK**

- If the ambient temperature is below 0°C (32°F), the air conditioner cooling may not work. In this case, set to RECIRC and warm up the inside of the cab, then turn the air conditioner switch ON to operate the cooling.
- When defrosting, if the temperature control switch is pressed to set the temperature bar to the maximum (all 8 segments on the bar light up), this will improve the efficiency of removing the frost and preventing mist.

PRECAUTIONS WHEN USING AIR CONDITIONER

To prevent putting any excessive load on the engine or compressor, turn the air conditioner ON only when the engine is running.

Carry out ventilation from time to time when using the cooling.

- When turning the cooling on, if the temperature inside the cab is high, open the doors and windows to bring in fresh air before starting the air conditioner.
- If you smoke when using the cooling, your eyes may sting. If this happens, switch temporarily to cooling and ventilation to remove the smoke.
- When using the air conditioner for a long time, carry out ventilation and cooling once every hour.

Be careful not to cool the cab too much.

For reasons of health, the optimum setting for cooling is considered to be when it feels slightly cool (5 or 6°C (9 or 10.8°F) lower than the ambient temperature) when you enter the cab. Do not make the temperature inside the cab too low or direct the air flow directly onto your skin.

Be extremely careful to select the appropriate temperature.

When cooling is not being used (off-season)

To prevent leakage of the refrigerant from the air conditioner cooling circuit, operate the air conditioner for several minutes 2 or 3 times a month during the off-season. If the air conditioner is left for a long time when the refrigerant is leaking, it may cause internal rust.

INSPECTION AND MAINTENANCE

Even when not using the air conditioner, run the compressor at low speed for several minutes once a week to prevent the loss of the oil film at various parts of the compressor. (Run the engine at low speed and set the temperature control lever to the central position.)

When cleaning the air conditioner air filter or checking the refrigerant level, see "CLEAN AIR CONDITIONER AIR FILTER (PAGE 4-32)" and "CHECK REFRIGERANT (GAS) LEVEL (PAGE 4-33)" for details.

To enable the air conditioner to perform to the full and to maintain a pleasant working environment, always contact your Komatsu distributor to have the air conditioner refilled with refrigerant and to carry out other checks.

OPERATION



WARNING

- Only trained and qualified personnel may operate this machine. If untrained or unqualified personnel operate the machine, they may make a mistake in the operation, and this may lead to serious personal injury.
- Do not operate the machine or carry out inspection or maintenance if you are not feeling well, or if you are taking medicine which will make you sleepy, if you have been drinking, or you are in a mentally unstable condition. If you operate the machine or carry out inspection or maintenance in such a condition, it may lead to serious personal injury.
- Do not wear jewelry or other accessories. These may catch on the dump control lever or other protruding parts and cause you to fall or suffer injury.
- Do not wear loose clothing. There is danger that loose clothing may catch on the dump control lever or gear shift lever and cause the machine to move unexpectedly during operation, leading to serious personal injury.

CHECK BEFORE STARTING ENGINE

WALK-AROUND CHECK

Before starting the engine, look around the machine and under the machine to check for loose nuts or bolts, or leakage of oil, fuel, or coolant, and check the condition of the hydraulic system.

Check that there is no loose wiring and no accumulation of dust or flammable material around high-temperature parts.



WARNING

- If there is a DO NOT OPERATE warning sign on gear shift lever (1), it means that someone is carrying out inspection and maintenance of the machine. If the warning sign is ignored and the machine is operated, the service man may be caught in moving or rotating parts of the machine, and suffer serious personal injury. Always follow the warning sign and do not start the engine or touch any levers.
- When carrying out the checks, check that there is no leakage of oil or fuel and no accumulation of flammable material around the battery or around turbocharger (1), exhaust manifold (2), muffler and other high-temperature parts. Remove any flammable material and repair fuel and oil leaks. If this action is not taken, it may lead to fire. If it is impossible to repair, please ask your Komatsu distributor to carry out repairs.

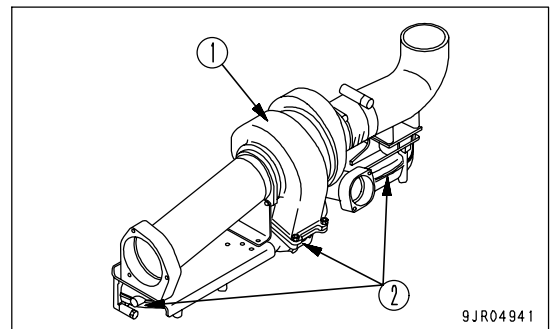

The content of these items shows the items that must be checked at the beginning of each day. Carry out these checks in combination with CHECK BEFORE STARTING (PAGE 3-68).

Before starting the operation, display a DO NOT OPERATE warning sign.

(Even on machines carrying out night operations, carry out these checks at the beginning of the day's operation.)

1. Check the dump body, frame, cylinders, linkage, and hoses for cracks or excessive wear or play.

Check the dump body, frame, cylinders, linkage, and hoses for cracks or excessive wear or play, and carry out repairs if any problem is found.

2. Remove dirt from around engine, battery, radiator, and aftercooler.



WARNING

Check that there is no accumulation of dry leaves, chips, pieces of paper, coal dust, or other flammable materials around the engine exhaust manifold, muffler, battery, or inside the underguard. If any flammable materials are found, remove them. There is danger that failure to remove them may cause fire.

Check that there is no dirt or dust accumulated around the engine, radiator or aftercooler. Check also that there is no flammable material (dry leaves, twigs, etc.) accumulated around the battery, or engine, muffler, turbocharger, or other high temperature parts of the engine. Remove any dirt or flammable materials that are found.

3. Check for leakage of water or oil around engine.

Check that there is no oil leakage from the engine or coolant leakage from the cooling system. If any problem is found, repair it.

4. Check for leakage from fuel line.

Check that there is no leakage of fuel or damage to the hoses and tubes. If any problem is found, carry out repairs.

5. Check for oil leakage from transmission case, differential case, final drive case, steering/hoist oil tank, hoses, and joint.

Check that there is no oil leakage. If any problem is found, repair the place where the oil is leaking. Check for leakage of oil from the undercover. Check the ground for traces of oil leakage.

6. Check for damaged or worn tires, wheels, and wheel hub bolts and nuts, check for loose wheel hub bolts and nuts.

Check for cracks or peeling of the tires and for cracks or wear to the wheels (side rim, rim base, lock ring). Tighten any loose wheel hub bolts or nuts. If any abnormality is found, repair or replace the part. If any valve caps are missing, install new caps.

7. Check for loose air cleaner mounting bolts.

Check for the loose bolts. If loose, tighten them.

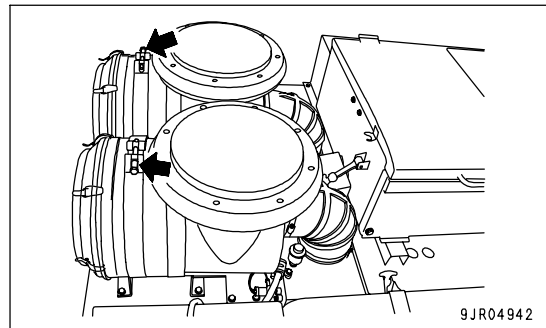

8. Check dump body mount rubber.

Check that there are no cracks, embedded foreign materials, or loose bolts in bottom mount portion (1) and front mount portion (2).

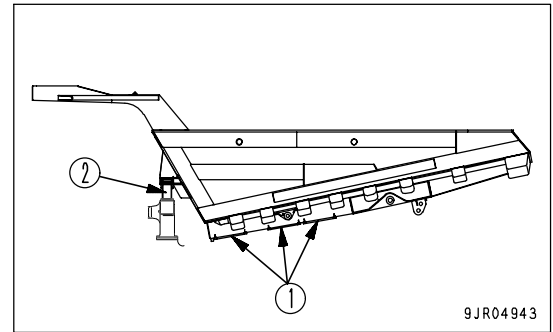
**9. Check for damage to handrail, loose bolts.**

Repair any damage and tighten any loose bolts.

10. Check for damage to gauges, lamp on the instrument panel.

Check for damage to the panel, gauges and lamps. If any problem is found, replace the parts. Clean off any dirt on the surface. Tighten any loose bolts.

11. Check rear view mirror, under view mirror.

Check that the mirrors are not damaged. Replace them if they are damaged. Clean the surface of the mirrors and adjust the angle so that the operator can see the area to the rear and under the machine from the operator's seat.

12. Check for damage to the seat belt and mounting clamps.

Check for damage to seat belt and mounting clamps. If damages are found, replace with the new one.

- Check that there are no loose bolts in the mounting clamps mounting the seat belts to the machine. If any loose bolts are found, contact your Komatsu distributor and have them tightened to the specified tightening torque.
- When the belt has been used for a long time, if any external damage or fraying of the belt can be seen, or if the clamps are broken or deformed, replace the seat belt Ass'y.

13. Inspect tires.

**WARNING**

If any worn or damaged tire is used, there is danger that the tire may suddenly explode or be damaged, and this may lead to serious personal injury. If any defective tires are found during inspection, replace them with new tires or tires with no problems.

Check the following items, and replace any worn or damaged tires with new tires or tires with no problems.

Wear:

- Tires with a tread grooves of less than 15% of that of a new tire
- Tires with extreme uneven wear or with stepped-type wear

Damage:

- Tires with damage that has reached the cords, or with cracks in the rubber
- Tires with cut or pulled cords
- Tires with peeled (separated) surface
- Tires with damaged bead
- Leaking or improperly repaired tubeless tires
- Deteriorated, deformed or abnormally damaged tires, which do not seem usable

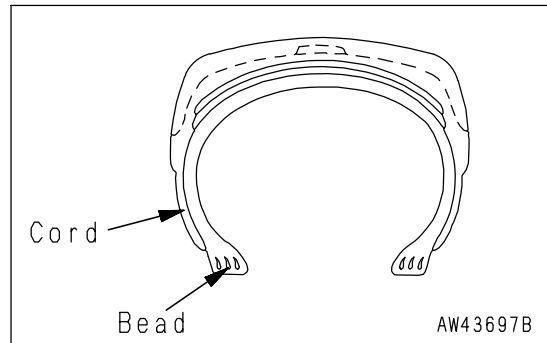

14. Inspect rims.

**WARNING**

If rims or rings are used when they are deformed, corroded, damaged, or cracked, the ring may fly off when the tires are inflated and cause damage or serious personal injury. If any problem is found when inspecting the rims or rings, replace with a new rim or ring or with a rim or ring that has no problem.

Check the following places visually, and if any problem is found with the rim or ring, replace with a new rim or ring or with a rim or ring that has no problem.

- Check that there is no deformation, damage, corrosion, or cracks in rim (1) (particularly the flange portion).
- Check that there is no deformation, corrosion, damage, or cracks in side ring (2).
- Check that there is no deformation, corrosion, damage, or cracks in lock ring (3).

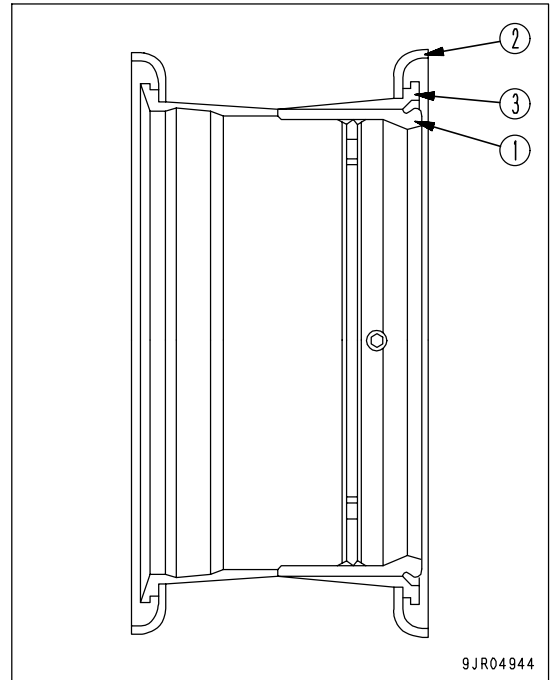

CHECK BEFORE STARTING

WARNING

During operation, or during inspection and maintenance, if any problem is noticed on the machine (noise, vibration, smell, wrong display by gauges, smoke, oil leakage, or problem displays on the warning devices or monitors), stop the machine on flat ground where it does not obstruct any other machines, then report immediately to the jobsite supervisor and carry out the necessary repairs. If the machine continues to be operated without repairing the problems, it may lead to serious personal injury.

The content of these items shows the items that must be checked at the beginning of each day. Carry out these checks in combination with WALK-AROUND CHECK (PAGE 3-63).
(Even on machines carrying out night operations, carry out these checks at the beginning of the day's operation.)

CHECK COOLANT LEVEL, ADD COOLANT

WARNING

Immediately after the machine is stopped, the pressure inside the radiator is high, so if the radiator cap is opened, hot water will spurt out and may cause burns.

- Inspect the sub tank when checking the coolant level. Do not open the radiator cap.
- If there is no cooling water in the sub tank, and water is added, wait for the temperature of the radiator cap to go down, then turn it slowly to release the internal pressure before opening it completely.

1. Before starting the engine, check that the cooling water in sub tank (1) is between the FULL and LOW marks.
2. If the level is LOW, remove the cap (2) of sub tank and add the engine coolant up to the FULL mark.

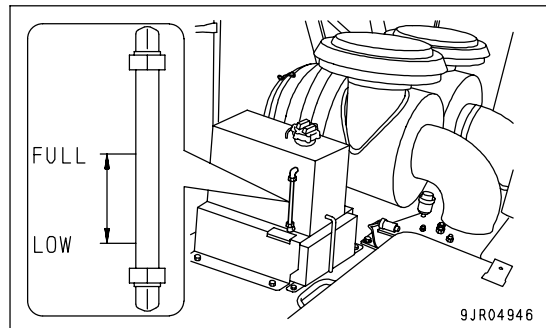
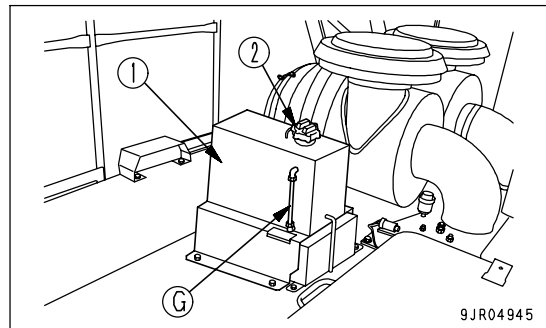

3. If there is no coolant in the subtank, add water to the radiator through water filler (3) at the top of the radiator, then add water to the subtank.
4. Check that there is no oil in the cooling water. If there is oil in the cooling water, there is probably some problem with the engine. Please contact your Komatsu distributor to have the engine inspected.
5. After adding water, tighten the cap securely.

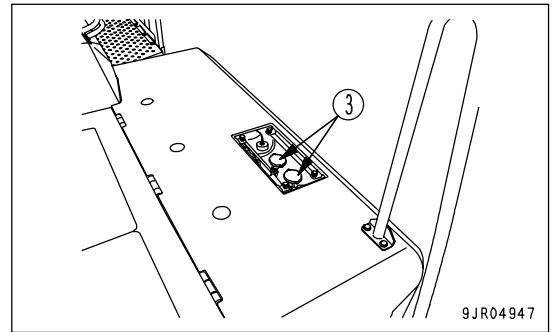

CHECK DUST INDICATOR

1. Check that the yellow display in the transparent portion of dust indicator (1) does not indicate 7.5 kPa (0.076 kg/cm², 1.1 PSI).
2. If the red line indicates 7.5 kPa (0.076 kg/cm², 1.1 PSI), clean or replace the air cleaner element immediately.
For details of the method of cleaning the element, see "CHECK, CLEAN OR REPLACE AIR CLEANER (PAGE 4-23)".
3. After checking, cleaning, or replacing, press the top of dust indicator (1) to return the yellow display to its original position.

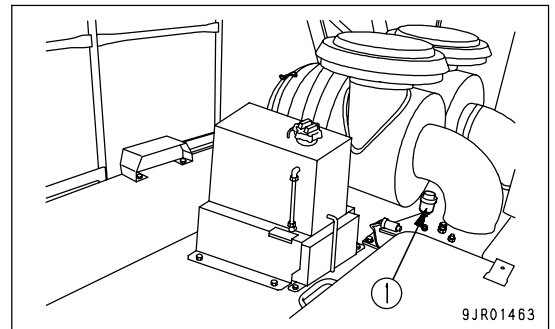

CHECK OIL LEVEL IN ENGINE OIL PAN, ADD OIL



WARNING

Immediately after the engine is stopped, the oil and parts are at high temperature, so there is danger of suffering burns during the operation. Wait for the temperature to go down before starting the operation.

Before starting the engine, check the level of the oil in the engine oil pan with dipstick (G).

1. Take out the dipstick (G) and wipe off the oil with cloth.
2. Insert dipstick (G) fully into the dipstick guide, then pull it out again.

When inserting the dipstick, insert it so that the "ENGINE STOPPED" mark on the dipstick is facing the engine.

3. The oil level should be between the H and L marks on the ENGINE STOPPED side of dipstick (G).

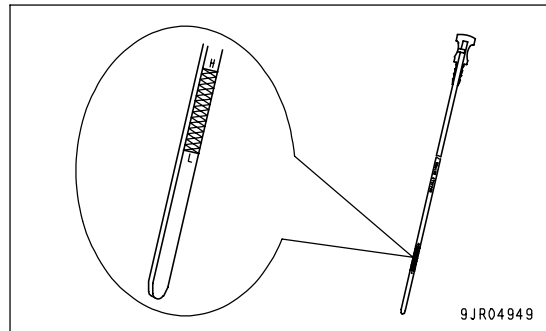
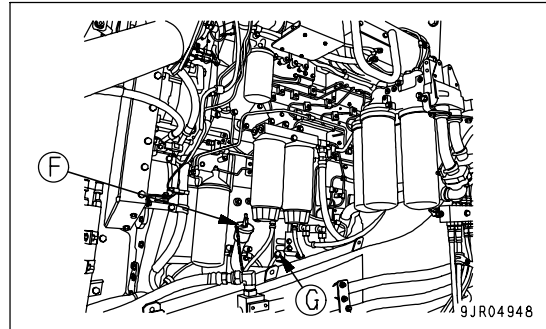

4. If the oil is below the "L" mark, add oil through oil filler port (F). If the oil is above the "H" mark, set a container in position to catch the oil, remove drain plug (1), then loosen drain valve (2) to drain the excess oil into the container. After draining the excess oil, check the oil level in the engine oil pan again.

REMARK

- If the oil level in the engine oil pan is checked immediately after the engine is stopped, the oil in the oil line has probably not returned to the oil pan, so wait for at least 15 minutes before checking the oil level.
- The dipstick is marked on one side with "ENGINE STOPPED" for checking the oil level when the engine is stopped and on the other side with "ENGINE IDLING" for checking the oil level when the engine is idling. However, for this check, stop the engine and use the side with the "ENGINE STOPPED" mark.
- It is also possible to carry out the check with the engine idling, but in that case, always do as follows.
 - Check that the engine water temperature is in the white range.
 - Use the ENGINE IDLING side of the dipstick.
 - Remove the oil filler cap before carrying out the inspection.

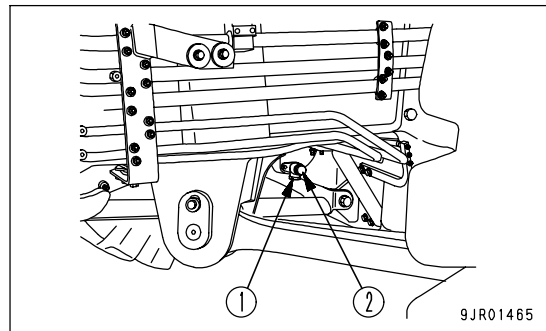

5. If the oil level in the engine oil pan is correct, tighten the handle on the oil filler cap securely.

CHECK OIL LEVEL IN TRANSMISSION CASE, ADD OIL

NOTICE

- The oil level changes according to the oil temperature, so check the oil level after carrying out the warming-up operation. If the machine is used when check is carried out with the oil at low temperature, the oil level may not be correct and this may damage the equipment.
- As a guideline when checking the oil level with the engine stopped, always make the final check with the engine running at low idle after the engine has been warmed up.

1. Start the engine.
2. Run the engine at low idle and check with sight gauge (G2).
The oil level should be between the H and L marks.
3. If the oil is below the L mark, add oil through oil filler port (F).

REMARK

Sight gauge (G1) is provided as a guideline for checking the oil level with the engine stopped.

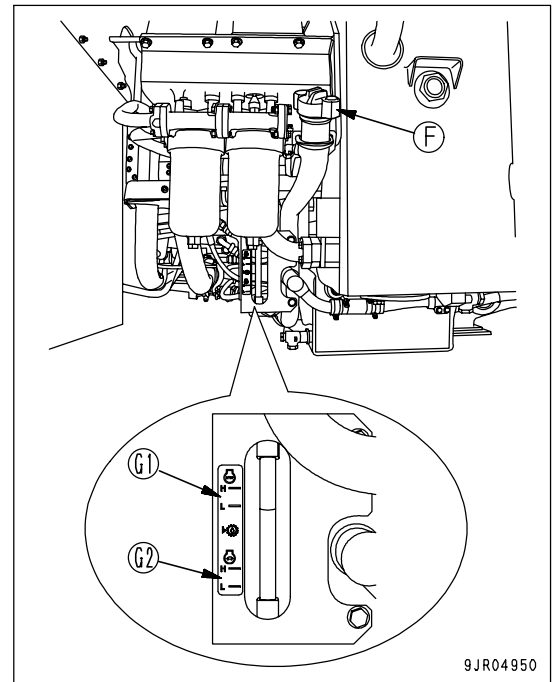

CHECK OIL LEVEL IN STEERING AND HOIST OIL TANK, ADD OIL

**WARNING**

Immediately after the machine is stopped, the pressure inside the tank is high, so if the cap is opened, hot oil will spurt out and may cause burns. Turn the cap slowly to release the pressure inside the tank before opening the oil filler cap.

1. Check with sight gauge (G). If the oil level is up to the window of sight gauge (G), it is suitable.
2. If the oil level is not up to the window of sight gauge (G), add oil through oil filler (F).

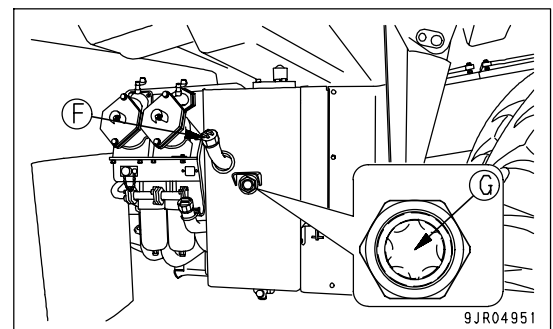

CHECK OIL LEVEL IN BRAKE SUB-TANK, ADD OIL

! WARNING

Immediately after the machine is stopped, the pressure inside the tank is high, so if the cap is opened, hot oil will spurt out and may cause burns. Turn the cap slowly to release the pressure inside the tank before opening the oil filler cap.

1. Check with sight gauge (H). If the oil level is up to the window of sight gauge (H), it is suitable.

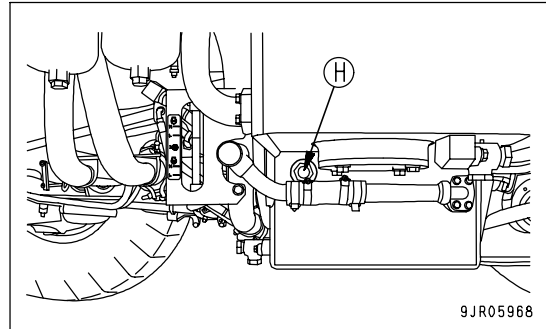

2. If the oil level is not up to the window of sight gauge (H), add oil through oil filler (F).

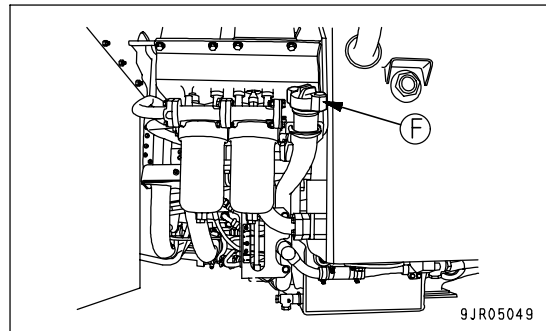

CHECK FOR LEAKAGE OF OIL FROM REAR BRAKE OIL RECOVERY TANK BREATHER

1. Check that no oil is leaking to the ground from the breather. Check also that no oil is leaking from overflow tube (1) of the rear brake oil recovery tank.
2. If any oil is leaking, recover the oil. For details, see "RECOVER OIL LEAKING FROM FLOATING SEAL (PAGE 4-81)".

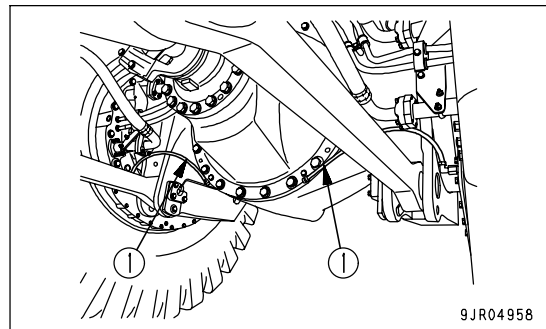

DRAIN WATER, SEDIMENT FROM FUEL TANK

If the sediment or water inside the fuel tank flows to the engine, it will cause engine trouble. Drain the sediment and water collected at the bottom of the fuel tank.

1. Set a container under the fuel tank to catch the fuel.
2. Loosen valve (1) and drain of the sediment and water collected at the bottom of the fuel tank together with the fuel.
3. When the fuel being drained out becomes clean, tighten valve (1).

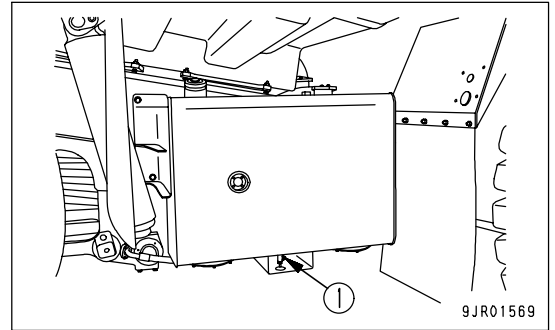
**CHECK LEVEL OF FUEL IN FUEL TANK, ADD FUEL****WARNING**

Fuel is a dangerous substance and catches fire easily, so it may cause fire.

- Never bring fuel close to any flame.
- When adding fuel, check the fuel level and be careful not to let the fuel overflow from the tank filler port.
- If fuel is spilled or overflows from the fuel tank, wipe up the area completely.

1. Check the fuel level with fuel gauge (G), which is installed in the side of the fuel tank.

"F" means FULL, and "E" means EMPTY.

2. If the fuel gauge (G) show "E", add fuel through fuel filler (F) to fill the fuel tank.
3. After completing operations, add fuel through fuel filler (F) to fill the fuel tank.

Fuel tank capacity: 780 liters (206.1 US gal)

When adding fuel, stop the engine and set the parking switch to "PARKING" position.

4. After adding fuel, tighten the cap securely.

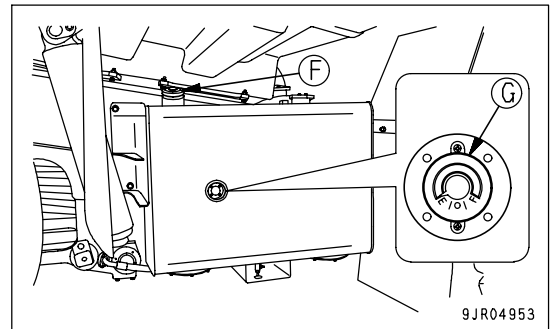
**REMARK**

- If the breather hole (1) in the cap becomes clogged, the pressure inside the tank will go down and the fuel may not flow, therefore clean the breather hole from to from using diesel fuel.
- If the engine runs out of fuel, the engine will stop and will suck in air. After adding fuel, it is necessary to bleed the air from the system. To avoid the need to carry out the air bleed operation, always be sure to fill the tank before it becomes empty.
- Excess fuel in the tank may spill out due to thermal expansion when the fuel temperature rises. Be careful not to fill with too much fuel.

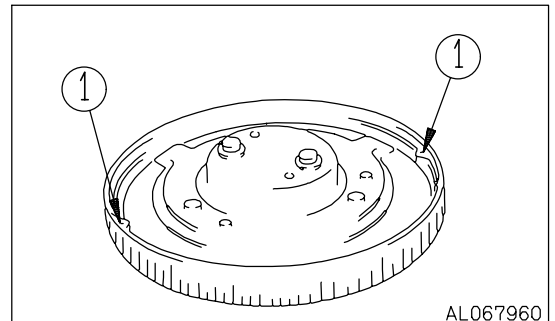

CHECK WHEEL HUB NUTS, TIGHTEN

Check for loose wheel hub nuts (1). If any are found, tighten them.

Tightening torque: 1519 to 1617 Nm

(155 to 165 kgm, 1121 to 1193 lbft)

REMARK

Insert a socket wrench in a pipe, and apply the force of 1568 N (160 kg, 353 lb) at a point 1 m from the fulcrum to give a tightening torque of 1568 Nm (160kgm, 1570 lbft). When apply the force of 884 N (80 kg, 176 lb) at a point 2 m from the fulcrum to give a tightening torque of 1568 Nm (160kgm, 1570 lbft).

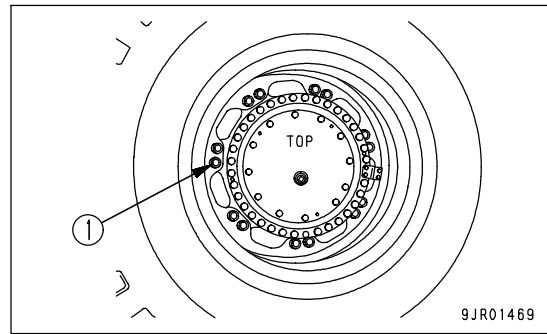

When tightening the hub nuts after replacing the tires, travel for 5 to 6 km, then check the tightening torque to ensure that there are no loose bolts.

If any stud bolt used to install the rim is broken, replace all the stud bolts for that wheel.

CHECK CENTRAL WARNING LAMP, ALARM BUZZER, MONITOR LAMPS AND METERS

Before starting the engine, turn the starting switch to the ON position, press machine monitor check switch (1), and check that the monitor lamps light up, that the meters and gauges perform one cycle, and that the machine model name, monitor software version, etc. appear on the character display.

If any instrument does not work or give the display, there is probably a failure, so ask your Komatsu distributor to carry out inspection.

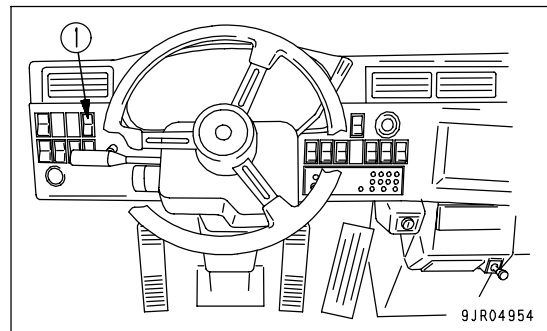
**CHECK BRAKING EFFECT**

Check that the parking brake, foot brake, and retarder brake work properly.

If there is any problem, please contact your Komatsu distributor for repair.

CHECK BRAKING CAPACITY OF SECONDARY BRAKE

 **WARNING**

When checking the capacity of the secondary brake, there is danger that the machine may suddenly move and be damaged or cause serious personal injury. Always do the following.

- Select a wide, flat area with sufficient distance to make it possible to stop the machine if it suddenly moves.
- If the machine suddenly moves when the capacity of the secondary brake is being checked, reduce the engine speed immediately, move the gear shift lever to the N position, and set the parking brake to the PARKING position to stop the machine.
- If inspection is carried out when the dump body pilot lamp is lighted up and the shift indicator is at F1, there is danger of damage to the internal parts of the transmission.

When carrying out inspection, seat the dump body securely and check that the body pilot lamp has gone out. In addition, set the gear shift lever to the "D" position and check that the shift indicator shows F2.

Check the braking capacity of the secondary brake as follows.

1. Select a wide flat area.
2. Raise the engine speed, reduce the pressure in the front brake accumulator and parking brake accumulator, and check that the caution lamp does not light up.
3. Set the parking brake to the TRAVEL position and depress secondary brake pedal (1).

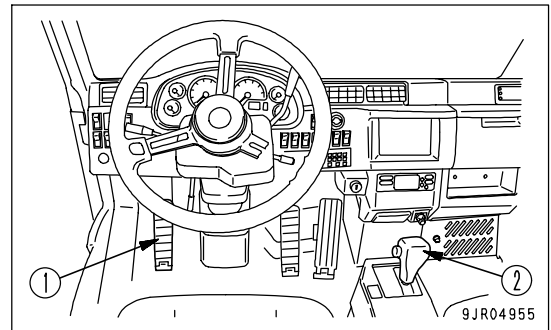

4. Set gear shift lever (2) to the "D" position, gradually raise the engine speed until it reaches full speed. The machine should not move when this happens. If the machine moves, there is a problem in the brake.
5. Lower the engine speed and set the shift lever to "N" position and set the parking brake switch to the "PARKING" position.
6. If there is a problem in the brake, ask your Komatsu distributor to carry out repairs.

REMARK

"Secondary brake" means that the front brake and parking brake are applied at the same time.

CHECK EMERGENCY STEERING

Check manual emergency steering

1. Turn starting switch to the ON position.
2. Turn emergency steering switch (1) ON, and check that the steering wheel can be operated.

If the steering wheel cannot be operated, please contact your Komatsu distributor.

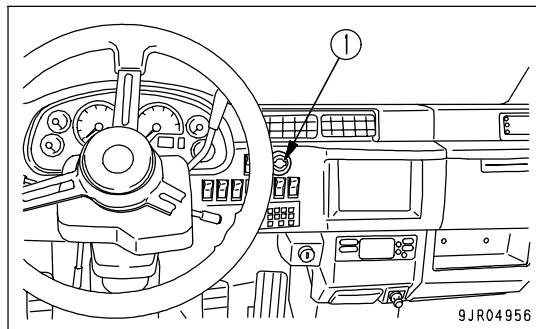

REMARK

- The emergency steering pump can be used for a maximum of 90 seconds.
- When using the emergency steering pump, travel at a maximum speed of 5 km/h.
- When the machine is stopped, if the starting switch is turned to the ON position with the parking brake switch at the TRAVEL position, the auto-emergency steering is actuated automatically after 1 second, so always set the parking brake switch to the PARKING position before turning the starting switch ON.

Check auto-emergency steering

(Machines equipped with auto emergency steering)

1. Start the engine.
2. Check that the brake oil pressure caution lamp is off.
3. Pull retarder control lever (2) fully and stop the engine.
4. Turn starting switch key to the ON position.
5. Check that the emergency steering motor is actuated 1 second after the parking brake switch (3) is set to the TRAVEL position and that the steering wheel can be operated.

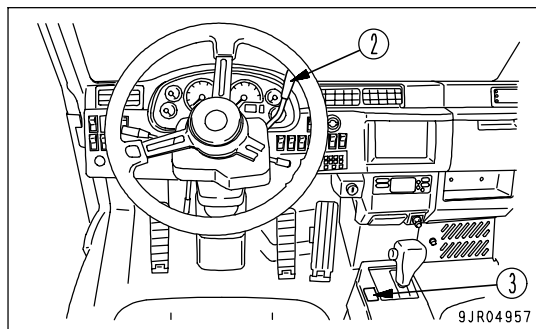

REMARK

On machines equipped with auto-emergency steering, the emergency steering is actuated automatically in the following cases.

- When the steering hydraulic pump fails.
- When the engine stops during travel, dumping, or other operations.

If the emergency steering is actuated, stop the machine immediately and carry out inspection.

When the machine is stopped, if the starting switch is turned to the ON position with the parking brake switch at the TRAVEL position, the auto-emergency steering is actuated automatically after 1 second, so always set the parking brake switch to the PARKING position before turning the starting switch ON.

CHECK BACKUP ALARM

1. Turn starting switch to the ON position.
2. Place the gear shift lever in the R position.
3. Check that the backup alarm is working.

CHECK ELECTRIC WIRING**WARNING**

- There is danger of short circuits in the electric wiring or connectors causing fire. Always do as follows.
 - o Clean all the electric wiring connectors and tighten the connections securely.
 - o During the daily checks before starting, check that there are no loose or damaged electric wires. Tighten any loose connectors or wiring clamps. Repair or replace any damaged wiring.
 - Wipe all the dirt off the top surface of the battery with a damp cloth. If a dry cloth is used, it will generate static electricity. This will ignite the flammable gas generated when the battery is charged and cause an explosion.
-

**CAUTION**

- If the fuse blows, it is a warning that some problem is starting to occur in the equipment. A short circuit in the electrical wiring shows that there is a problem in the covering of the wiring. If a fuse blows or there are traces of a short circuit in the electric wiring, check for the cause immediately and ask your Komatsu distributor to carry out repairs. If short circuits in the electric wiring are left as they are and not repaired, there is danger that the electrical equipment will be damaged and it may become impossible to operate the machine.
 - If the battery breather hole becomes clogged, the pressure inside the battery case will increase because of the hydrogen gas and oxygen gas generated during the charging operation. This will break the battery case or lid, and the battery electrolyte will leak. There is danger that this battery electrolyte will damage other equipment and that the machine will be unable to move. Wash with water to remove the dirt clogging the battery breather hole.
-

1. Check if any fuse is blown. Check also if any fuse other than a fuse of the specified capacity is being used. If the fuse is blown, replace it with a new fuse. If the fuse is of the wrong capacity, replace it with a fuse of the specified capacity.
2. Check that there is no disconnection in the electric wiring, no signs of short circuits, and no damage to the installation of the wiring. If any problem is found, ask your Komatsu distributor to carry out repairs.
3. Check that there are no loose terminals on the battery, starting motor, or alternator. Tighten any loose terminals.
4. Check that there is no flammable material around the battery. If any flammable material is found, remove it.
5. Check the breather hole in the battery cap. If it is clogged with mud or any other material, wash the battery cap with water to clean out the material clogging it.
6. Wipe the top surface of the battery with a damp cloth. Do not use a dry cloth.

CHECK INFLATION PRESSURE OF TIRES

Measure the inflation pressure with a tire pressure gauge, while the tires are cool, before starting work.

Check for damage or wear to the tires and the rims.

Check for loose wheel hub bolts.

The proper inflation pressure is shown below.

- HD465-7

Tire size	Inflation pressure [MPa (kg/cm ² , PSI)]
24.00-35-36PR (standard)	0.47 to 0.50 (4.75 to 5.05, 67.4 to 71.7)
24.00R35 ★ ★ (if equipped)	0.69 to 0.72 (7.0 to 7.3, 99.4 to 104)

- HD605-7

Tire size	Inflation pressure [MPa (kg/cm ² , PSI)]
24.00R35 ★ ★ (standard)	0.69 to 0.72 (7.0 to 7.3, 99.4 to 104)
24.00-35-48PR (if equipped)	0.64 to 0.67 (6.5 to 6.8, 92.3 to 96.6)

If the tires are used when the inflation pressure is less than the value given in the table above, the rim may be damaged, Always keep the inflation pressure the value given in the table above.

CHECK WATER SEPARATOR

The water separator and fuel prefilter (1) are made one and composed of (2) to (4) in the lower section.

1. Close supply valve of the fuel tank.
2. Water and sediment on the bottom can be checked through transparent cap (2). If there is water or sediment, prepare a container to receive it under drain hose (4).
3. Loosen drain valve (3) to drain the water.
4. If fuel starts flowing out through drain hose (4), close valve (3) immediately.

Tightening torque: 0.2 to 0.45 Nm
(0.02 to 0.046 kgm, 0.1 to 0.3 lbft)

5. Open fuel valve on the fuel tank.

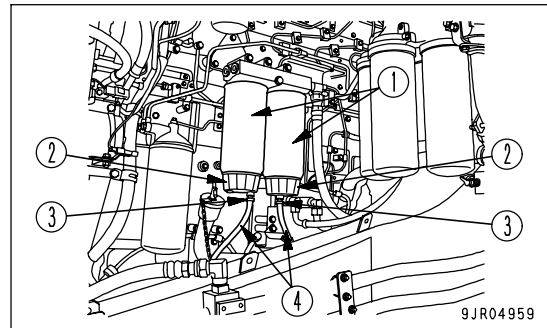

DOES BODY POSITIONER OPERATE NORMALLY?

ADJUSTMENT BEFORE OPERATION

GETTING INTO OPERATOR'S COMPARTMENT



WARNING

- Never jump on the machine. There is danger that your feet will slip, and you will fall and be injured.
- Never jump off the machine. There is danger that you will break a bone or suffer other injury when landing.
- When entering the operator's compartment, wipe off all mud and oil from the soles of your shoes. If you try to operate the pedals with mud or oil on the soles of your shoes, your foot may slip and the machine may move unexpectedly, causing serious personal injury.
- Do not leave tools or machine parts lying around inside the operator's compartment. If tools or parts get into the equipment being operated, it will obstruct the operation and the machine may move unexpectedly, causing serious personal injury.
- Do not fix suction pads to the window glass. The suction pad will act as a lens and may cause a fire.
- Do not use a cell phone when driving or operating the machine. This may lead to mistakes in operation, which will cause serious personal injury.
- Do not bring any dangerous items, such as explosives or items that may ignite, into the operator's compartment. These may cause fire.

-
- When getting on the machine, use the handrails and steps. Do not jump on the machine.
 - When entering the operator's compartment, wipe off all mud and oil from the soles of your shoes.
 - Do not leave tools or machine parts lying around inside the operator's compartment.
 - Do not use a cell phone when driving or operating the machine.
 - Do not bring any dangerous items, such as explosives or items that may ignite, into the operator's compartment.

ADJUSTING OPERATOR'S SEAT



WARNING

- If you try to adjust the operator's seat during operations, the seat will move during the adjustment operation, and there is danger that this will cause mistaken operation which may lead to serious personal injury. Always stop the machine on level ground in a safe place before adjusting the operator's seat. Adjust the seat before starting to travel or when the operators change shifts.
- If the operator's seat is not in the proper position, it may be impossible to operate the brakes during an emergency, which may lead to serious personal injury. Always adjust the operator's seat so that it is possible to depress the brake pedal fully when sitting with your back against the backrest.
- If the operator's seat is not fixed in position, it may move if there is impact during operation. This may cause mistaken operation, which will lead to serious personal injury. After adjusting the operator's seat, move it lightly to check that it is securely held in position.

-
- Adjust the position of the operator's seat so that you can depress the brake pedal fully with your back against the seat backrest.
 - To ensure that the seatbelt can display its effect fully, do not put any cushion between your back and the seatback.
 - Do not put any objects under or in front of the operator's seat that may make it impossible to secure the seat properly in position.

! WARNING

When standing up from the operator's seat, place the gear shift lever in N position and set the parking brake switch to PARKING position. Place the dump control lever at HOLD and lock with the lock knob, then stop the engine. If you touch the gear shift lever or dump control lever, the machine may suddenly move and cause serious personal injury.

FORE-AND-AFT ADJUSTMENT OF OPERATOR'S SEAT

1. Pull up lever (1) and slide the operator's seat to the front or rear.
2. Set the seat to the desired position, then release lever (1).
Fore-and-aft adjustment: 180 mm (10 mm x 18 stages)

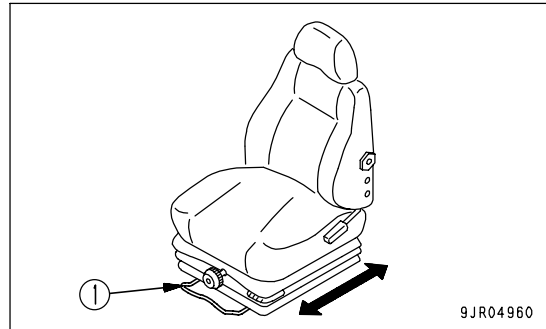

ADJUSTING OPERATOR'S SEAT ANGLE

BACKWARD

1. Pull up lever (2) and apply your weight to the rear of the seat cushion. The seat cushion will tilt to the rear.
2. Set the seat cushion to the desired angle, then release lever (2).

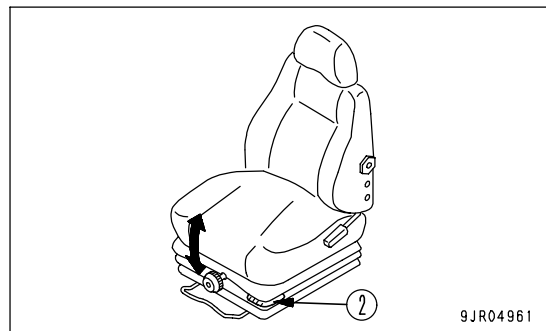

FORWARD

1. Push down lever (2) and apply your weight to the front of the seat cushion. The seat cushion will tilt to the front.
2. Set the seat cushion to the desired angle, then release lever (2).
Amount of adjustment: 13 degrees

HEIGHT ADJUSTMENT OF OPERATOR'S SEAT

1. Operate lever (2) up or down to adjust the height of the seat cushion.
2. Set the seat cushion to the desired height, then release lever (2).

This adjustment procedure is also used for adjusting the seat angle, so adjust the seat angle as desired.

Height adjustment: 60 mm

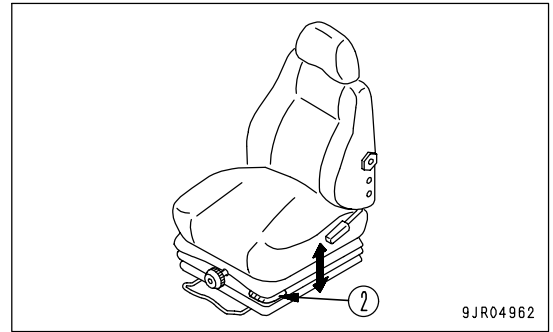
**SETTING OPERATOR'S SEAT FOR OPERATOR'S WEIGHT**

Turn knob (3) to adjust the strength of the suspension.

Guideline for weight adjustment: 50 kg - 120 kg

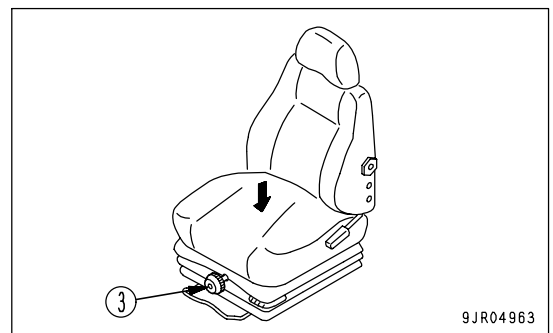
**ADJUSTING RECLINING**

1. Sit with your back pressed against the seatback, then pull up lever (4).
2. Push with your back to adjust the seatback to the desired angle, then release lever (4).

Adjustment amount: Forward tilt 66° (3° x 22 stages)

Rear tilt 30° (3° x 10 stages)

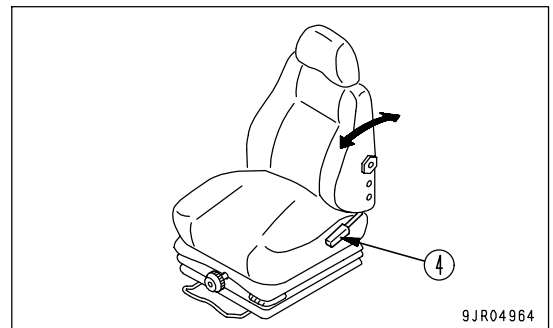

 **WARNING**

If the height of the headrest is not properly adjusted, the headrest cannot protect your head from being thrown back if the machine is hit from behind, and this may lead to serious injury. Before starting to travel, adjust the height of the headrest so that the center of the headrest is at the back of your head. Never remove the headrest.

ADJUSTING HEADREST HEIGHT

Move the headrest up or down to adjust to the desired height.

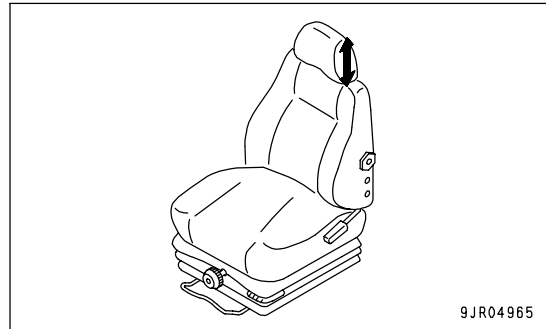
**ADJUSTING HEADREST ANGLE**

Tilt the headrest to the front or rear to set it to the desired angle.

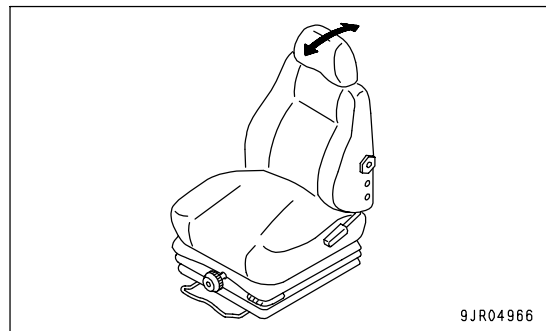
**ADJUSTING LUMBAR SUPPORT TENSION**

Turn knob (5) to adjust the tension to give the desired support to your lumbar region.

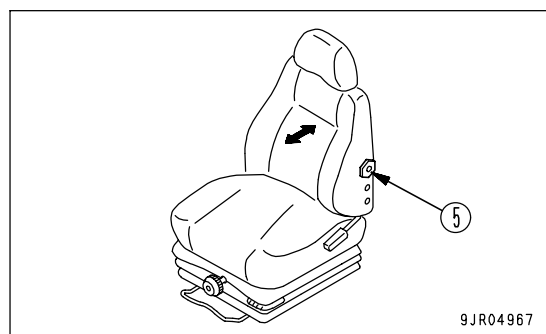

ADJUST SEAT BELT

**WARNING**

The seatbelt is a protective device that is designed to prevent you from hitting your head on the dashboard or front glass if the machine suffers impact from the front during operations. If it is not used correctly, the seatbelt will not be able to perform its protective function and you may suffer serious injury. Always do as follows.

- Always replace the seatbelt if the belt mounts are damaged or there are cuts in the belt.
- Before starting to travel, sit in the proper operating posture and adjust the seatbelt.
- Make sure that the seatbelt is not twisted.
- Even if no abnormality can be seen in the seatbelt, replace the belt every three years. The date of manufacture is shown on the reverse side of the belt.

Fastening and removing belt

Fasten the belt so that it is tight without being too tight.

1. Sit in the operator's seat, depress the brake pedal fully and adjust the seat so that your back is pressed against the seatback.
2. Sit in the operator's seat, then pull the belt on the right and insert tongue (1) into buckle (2) securely until it makes a clicking sound.
3. To release the seatbelt, press the red button on the buckle (2). The belt will be released.
Fit the belt so that it follows your body and is not twisted.

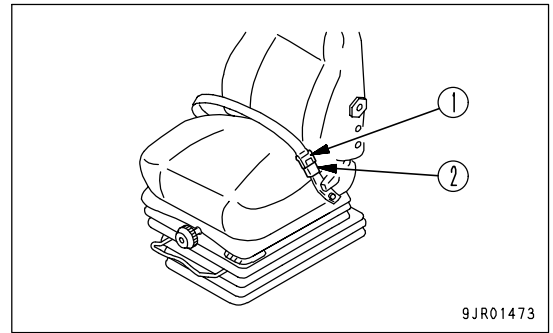

ADJUST STEERING WHEEL TILT

**WARNING**

- Always stop the machine before adjusting the steering wheel tilt. If the steering wheel tilt is adjusted when the machine is traveling, it may lead to mistakes in operation, which will cause serious personal injury.
- Always fix the steering wheel securely in position after adjusting the tilt. If the steering wheel is not fixed securely in position, the steering wheel position may suddenly change during operation, and this may lead to mistakes in operation, which will cause serious personal injury.

The tilt of steering wheel can be adjusted to the front and rear, and up and down.

1. Pull the lever up. Steering wheel column become free.
2. Set the steering wheel column to the desired position.
3. Push down the lever. The steering wheel column become lock position.

Amount of adjustment: Front/rear: 80 mm/80 mm (3.2 in/3.2 in)
(from center of steering wheel)
Up: 33 mm (1.3 in)
Down: 17 mm (0.7 in)

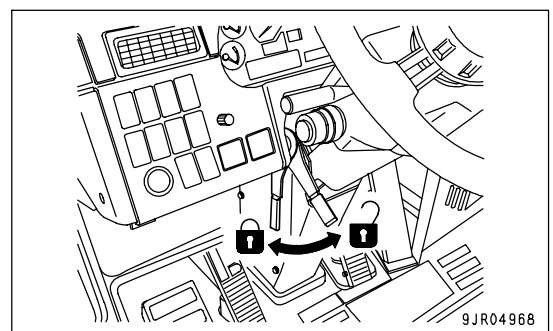

ADJUSTING MIRROR

! WARNING

Be sure to adjust the mirrors before starting work. If they are not adjusted properly, you cannot secure the visibility and may be injured or may injure someone seriously.

Loosen the bolt and nut installing the mirror, then adjust the mirror to a position which gives the best view from the operator's seat.

- Adjust the position and angle of each mirror so that it reflects a sight 200 mm above the ground and up to 1500 mm. In the adjustment, make sure that part of the dump truck's image also comes into view.

• Range of visibility

Mirror A: Must be possible to see hatched portion (A), area around point (A') where the tire contacts the ground, ground surface (A'') and the top edge of the dump body

Mirror B: Must be possible to see hatched portion (B)

Mirror C: Must be possible to see hatched portion (C) and part of the machine

Mirror D: Must be possible to see hatched portion (D), area around point (D') where the tire contacts the ground, ground surface (D'') and the top edge of the dump body

Mirror E: Must be possible to see hatched portion (E), hatched portion (D), area around point (D') where the tire contacts the ground, ground surface (D'') and the top edge of the dump body

Mirror F: Must be possible to see hatched portion (F) and part of the machine

Mirror G: Must be possible to see hatched portion (G) and part of the machine

Rear monitor (if equipped): Must be possible to see hatched portion (H)

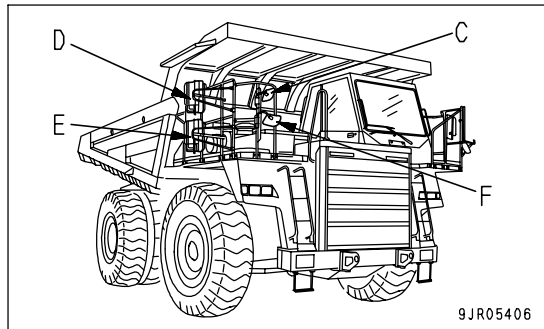
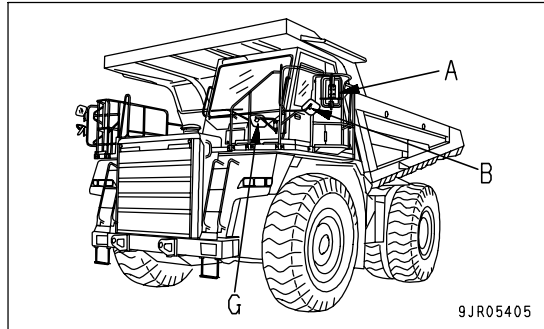

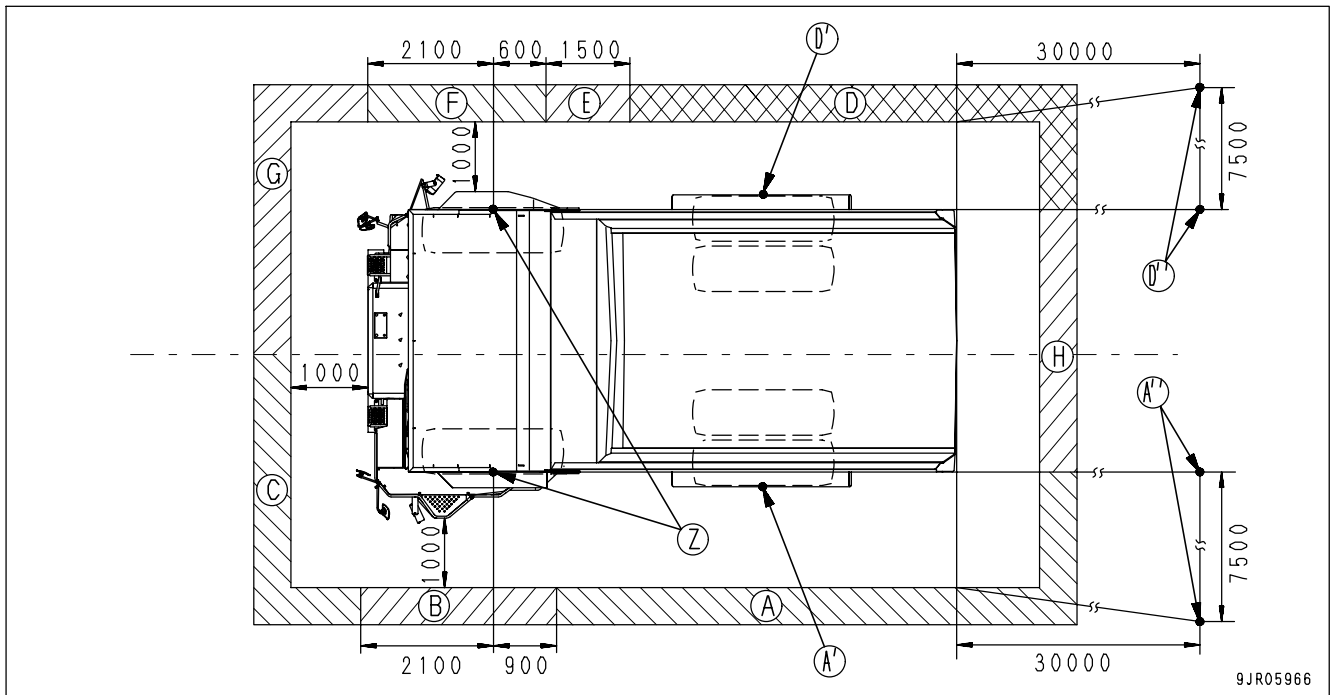

(Z): Ground contact point of tire used as base

OPERATIONS, CHECKS BEFORE STARTING

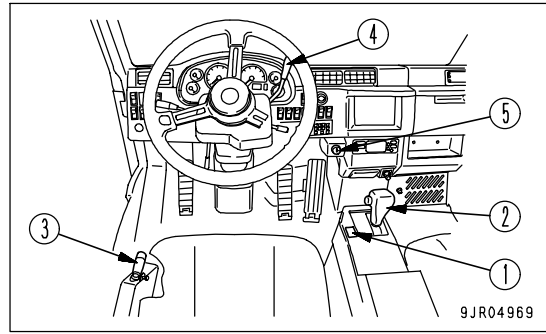

1. Set the parking brake switch (1) to the PARKING position.

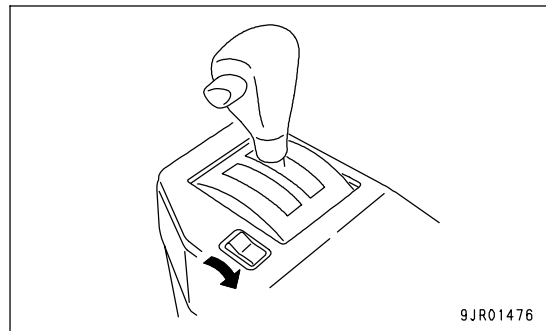

2. Set the shift lever (2) to N position.

REMARK

If the gear shift lever is not at the N position and the starting switch is turned to the ON position, the gear shift lever position pilot lamp and the central warning lamp will flash, and the alarm buzzer will sound.

If this happens, return the gear shift lever to the N position. The pilot lamp and central warning lamp will go out and the alarm buzzer will stop.

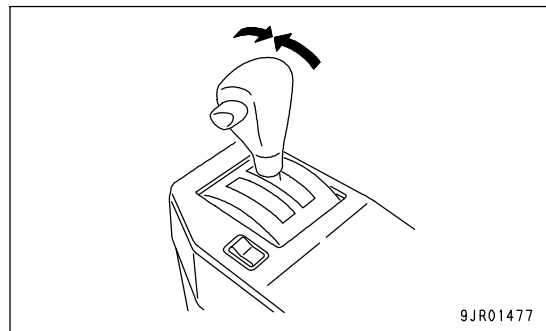

3. Set dump lever (3) to the HOLD position.

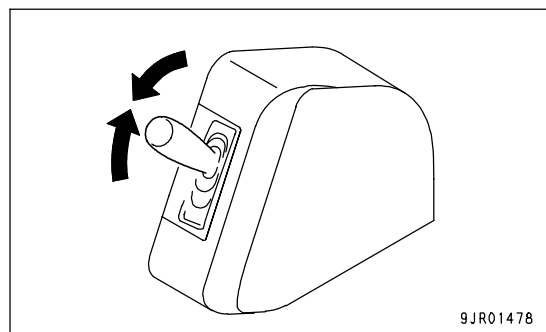

4. Set retarder control lever (4) to the RELEASE position.

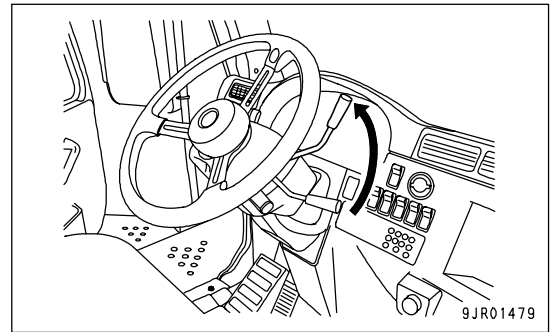

5. Insert the key in the starting switch (5) and turn it to the ON position. After doing this, check that there is no problem on the machine monitor (no lighting up of monitor lamps for travel speed, engine speed, oil temperature, or water temperature, fuel level, cautions, positions).

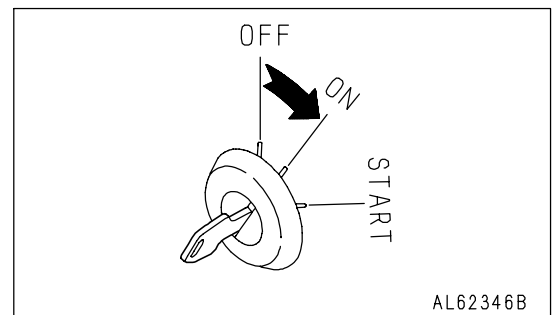

Before starting the engine, turn the starting switch to the ON position and carry out the 3-second system check. The displays for the system check are as follows.

- The meters go through the 3-second system check, then normal operation starts.
- The central warning lamp lights up for 2 seconds and then goes out.
- The alarm buzzer sounds for 2 seconds and stops.
- The monitor lamps light up for 2 seconds and then go out for one second.
- The gear shift indicator displays "88" for 2 seconds and then goes out for one second.

If the gear shift lever is not at the N position when the starting switch is turned ON, after completion of the system check, the gear shift lever position pilot lamp flashes, the central warning lamp lights up, and the alarm buzzer sounds intermittently. If this happens, return the gear shift lever to the N position. The central warning lamp will go out and the buzzer will stop.

"KOMATSU SYSTEM CHECK" is displayed on the character display for 3 seconds.

If no display appears, there is probably a failure or disconnection in the wiring, so ask your Komatsu distributor to carry out repairs.

STARTING ENGINE

NORMAL STARTING

WARNING

- When starting the engine, sit in the operator's seat, sound the horn to warn people in the surrounding area that the machine is about to move, then start the engine. If the machine is started off without giving a warning, there is danger that the people in the area around the machine may suffer serious personal injury.
- Do not short circuit the starting motor circuit to start the engine. If the starting motor circuit is short circuited, sparks are generated and this may cause fire or other damage.
- The engine exhaust gas is dangerous to the health and includes components that may cause death. When the machine is inside a building, open the windows and doors, and remove any objects that may obstruct the flow of air. After starting the engine, move the machine outside the building immediately and carry out the warming-up operation. Do not carry out the warming-up operation inside the building.

NOTICE

- Avoid suddenly accelerating the engine before the warming-up operation is completed. If the oil in the engine and hydraulic components is at low temperature, and the engine is suddenly accelerated, the lubricating oil film in the engine and hydraulic components will be lost, and this will cause wear and other problems.
- Do not keep the starting motor running continuously for more than 20 seconds. If the starting motor is run for more than 20 seconds, the voltage in the battery will drop, the starting motor speed will go down, and it will be unable to start the engine. Wait for at least two minutes to allow the battery voltage to recover before trying to start the engine again.

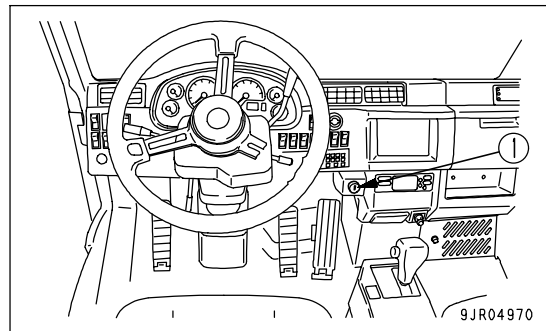

1. Turn the key of starting switch (1) to the START position.
The engine will start.

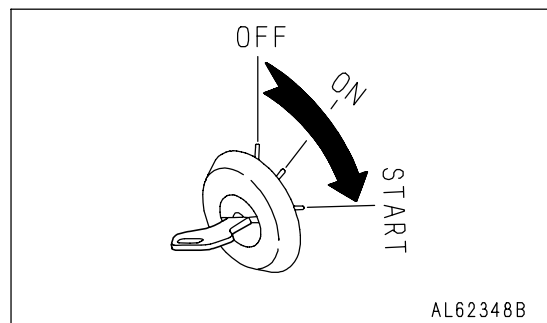

2. When the engine starts, release the key in starting switch (1).
The key will return automatically to the ON position.

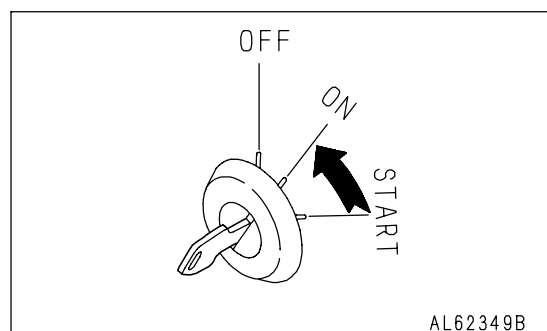

STARTING IN COLD WEATHER

! WARNING

- When starting the engine, sit in the operator's seat, sound the horn to warn people in the surrounding area that the machine is about to move, then start the engine. If the machine is started off without giving a warning, there is danger that the people in the area around the machine may suffer serious personal injury.
- Do not short circuit the starting motor circuit to start the engine. If the starting motor circuit is short circuited, sparks are generated and this may cause fire or other damage. The engine exhaust gas is dangerous to the health and includes components that may cause death.
- When the machine is inside a building, open the windows and doors, and remove any objects that may obstruct the flow of air. After starting the engine, move the machine outside the building immediately and carry out the warming-up operation. Do not carry out the warming-up operation inside the building.
- Do not use any starting aid fluid when starting in cold weather. Starting aid fluid ignites easily, so there is a danger of explosion.

NOTICE

- Avoid suddenly accelerating the engine before the warming-up operation is completed. If the oil in the engine and hydraulic components is at low temperature, and the engine is suddenly accelerated, the lubricating oil film in the engine and hydraulic components will be lost, and this will cause wear and other problems.
- Do not keep the starting motor running continuously for more than 20 seconds. If the starting motor is run for more than 20 seconds, the voltage in the battery will drop, the starting motor speed will go down, and it will be unable to start the engine. Wait for at least two minutes to allow the battery voltage to recover before trying to start the engine again.

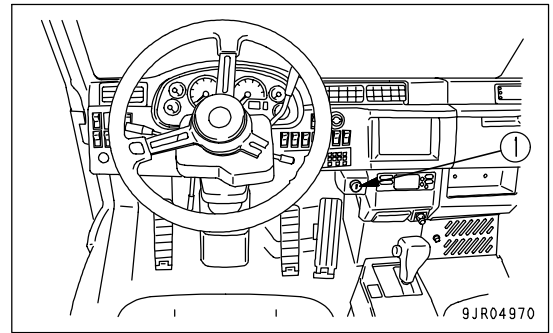

1. Turn the key of starting switch (1) to the ON position.
The pre-heating will start automatically according to the engine water temperature and the pre-heating pilot lamp will light up.

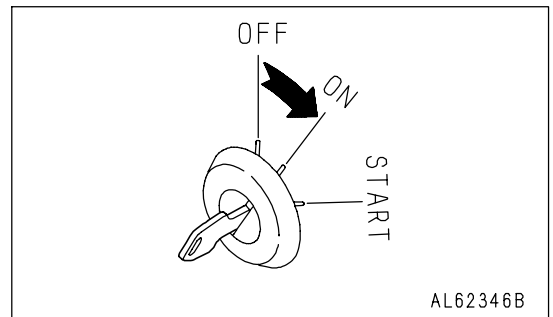

The pre-heating times are as shown follows

Engine water temperature	Pre-heating time
below 0°C (32°F)	30 sec

When the pre-heating is completed, the pre-heating pilot lamp will go out.

2. Turn the key of starting switch (1) to the START position.
The engine will start.

REMARK

When the engine is started, the machine monitor may flash while the starting motor is rotating, but if it goes out after the engine starts, there is no problem.

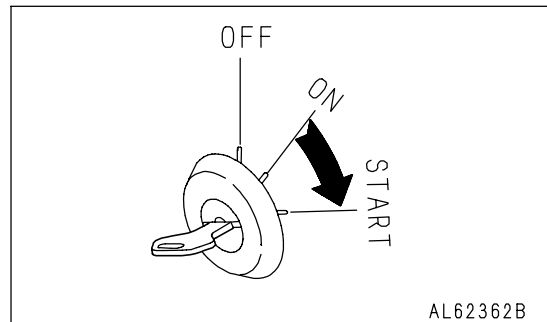

3. When the engine starts, release the key in starting switch (1).
The key will return automatically to the ON position.

REMARK

- If the engine does not start, turn the key in starting switch (1) to the OFF position, then turn it back to the ON position. The preheating will automatically start again according to the engine water temperature.
- Immediately after the engine is started, the turbo protect function is actuated to prevent the engine speed from rising above 1000 rpm even when the accelerator pedal is depressed.

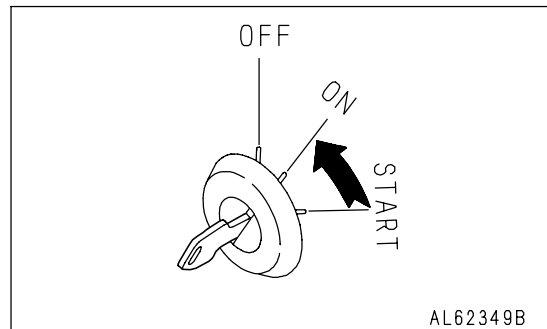
**AUTOMATIC WARMING-UP OPERATION**

After the engine starts, if the engine water temperature is low (below 50°C (122°F)), the warming-up operation (engine speed: 945 rpm) is automatically carried out. When the water temperature goes above 50°C (122°F), the warming-up operation is canceled.

OPERATIONS, CHECKS AFTER STARTING ENGINE

WARMING-UP OPERATION

NOTICE

- Avoid accelerating the engine suddenly before the warming-up operation is completed.
Do not run the engine for more than 20 minutes at low idling or high idling.
If it is necessary to idle the engine, apply a load from time to time or run at a mid-range speed.
- On machines equipped with auto emergency steering, if the machine is not fully warmed up, the emergency steering may be actuated momentarily when the parking brake switch is set to TRAVEL or the dump control lever is operated.

After the engine starts, do not start operating the machine immediately. First, carry out the following operations and checks.

1. After starting the engine, run the engine at low idle for 5 minutes for warming up operation.
2. After the warming-up operation, check that the machine monitor is normal.
If there is any problem, carry out maintenance or repair.
When the AISS LOW switch is at the AUTO position and the engine water temperature is still low, high idle revolution is automatically maintained.
3. Check if there is no problem in the steering operation, flashing of lights, sound of horn, exhaust gas color, noise, or vibration. If any problem is found, repair it.
Immediately after the engine is started, if the steering oil temperature is low, the steering will be slightly heavy, so avoid traveling at high speed.
If there are any problems, please ask your Komatsu distributor to carry out adjustment and repairs.

STOPPING ENGINE

NOTICE

Except when stopping in emergencies, run the engine at low idle to cool it down gradually after operations. If the engine is stopped without allowing it to cool down, the turbocharger is still rotating under inertia, so there will be lack of lubricating oil and this will reduce the service life of the machine.

REMARK

If the engine overheats, "E02 ENGINE OVERHEAT" is displayed on the character display and the engine output is automatically limited. Run the engine under no load at a mid-range speed until the lamp goes out.

1. Set the shift lever to the N position, then set the parking brake switch to the PARKING position.
2. Lower the dump body and set the dump lever to the HOLD position.
3. Run the engine at low idle for about 5 minutes to cool down gradually.
4. Turn the key of starting switch (1) to the OFF position to stop the engine.
5. Remove the key from starting switch (1).

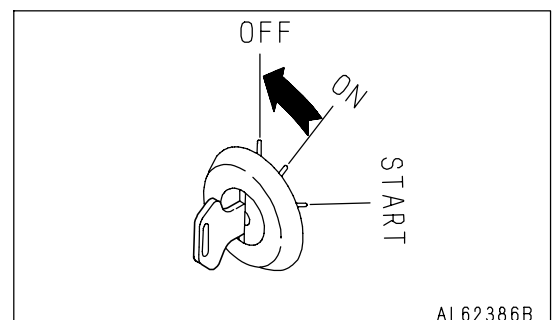
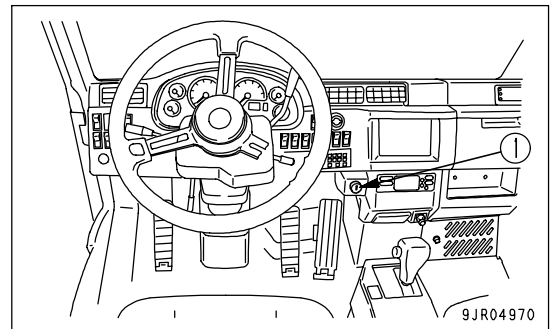

MOVING MACHINE OFF (FORWARD, REVERSE), STOPPING

MOVING MACHINE FORWARD

WARNING

- When operating the machine, always sit in the operator's seat. If you do not sit in the operator's seat, it will be impossible to stop operations if an problem occurs and there is danger that this may lead to serious personal injury.
- Do not allow any other person on the machine unless they are sitting in the assistant's seat. If they are not sitting in the assistant's seat, there is danger that they may fall when the machine is traveling and suffer serious personal injury.
- Always wear the seatbelt. There is danger that you may be thrown out of the operator's seat when the brakes are applied suddenly and suffer serious injury.
- If there is any person in the area around the machine when it is traveling, there is danger that person may be hit or caught up by the machine and suffer serious personal injury. Before starting to travel, always do as follows.
 - o Before moving the machine off, check again that there is no person or obstacle in the surrounding area.
 - o Before starting to move the machine, sound the horn to warn the people in the surrounding area.
- When traveling on snow-covered or icy roads, there is danger that the machine may slip when traveling and tip over or fall off the road. This may lead to serious personal injury and damage. Always do as follows.
 - o Fit tire chains.
 - o Do not apply the brake suddenly on slopes. Reduce the speed and use the braking force of the engine together with the foot brake (depress the foot brake repeatedly; do not keep it depressed) to stop the machine.
 - o Do not enter areas where the snow is deep. There is danger of driving off the road.

1. Check that there is no warning display on the machine monitor.
2. Fasten the seat belt.

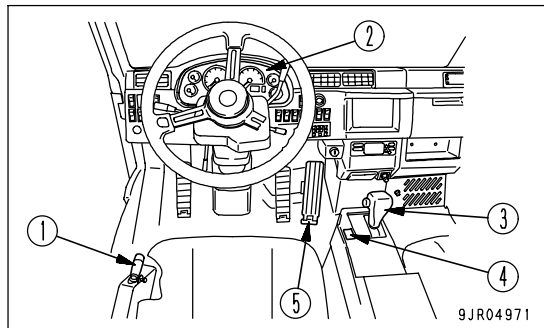

3. Check that dump lever (1) is at the FLOAT position and that the dump body pilot lamp is out.
If the dump body pilot lamp is lighted up, operate the dump lever to the HOLD position, then operate it to the FLOAT position to cancel the dump body HOLD condition.

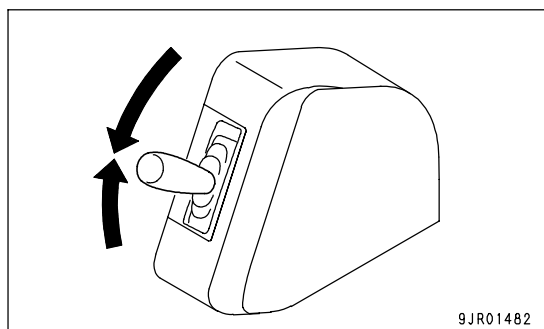

REMARK

When the engine is started, even if the dump control lever is at the FLOAT position, electrically, the dump body is at the HOLD position.

4. Depressed the brake pedal fully.
5. Set the parking brake switch (4) to the TRAVEL position to release the parking brake.

REMARK

If the engine is stopped with the parking brake switch at TRAVEL, the parking brake will be applied automatically even though the parking brake switch is at TRAVEL. When starting the engine again, operate the parking brake switch to PARKING, and then move it back to TRAVEL to cancel the parking brake.

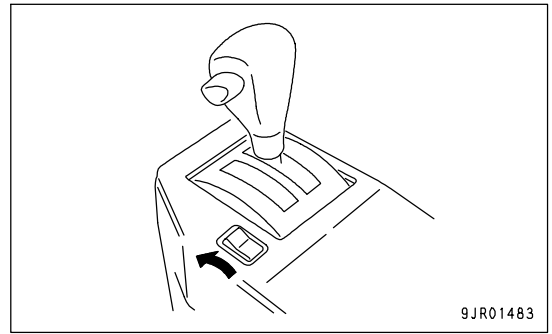

9JR01483

6. Check that retarder pilot lamp (2) is not lighted up, then set gear shift lever (3) to the desired position.

REMARK

When the gear shift lever is operated, if it is not placed securely in position, the shift position display on the panel may go out and the transmission system caution lamp may light up.

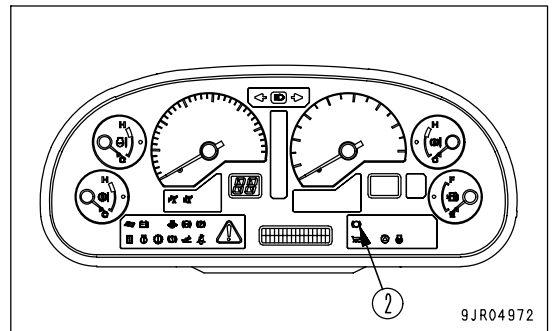

9JR04972

NOTICE

When shifting gear, if a sudden load is applied to the transmission, the service life of the machine will be reduced. Do not operate the gear shift lever with the accelerator pedal depressed.

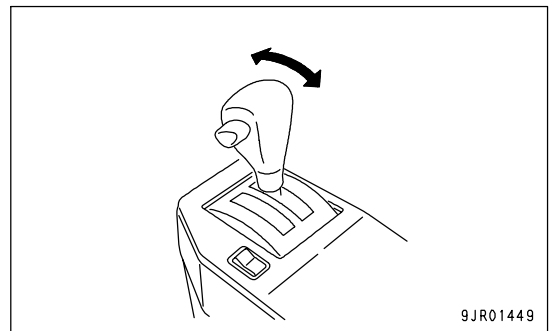

9JR01449

WARNING

- Never turn the starting switch key to the OFF position when the machine is traveling. If the engine stops when the machine is traveling, the steering will become heavy, so there is danger that this may cause mistaken operation of the steering, which may lead to serious personal injury. If the engine stops, depress the brake pedal immediately and stop the machine.
- When traveling, always maintain a suitable distance to avoid hitting people, structures, or other machines.

7. Depress accelerator pedal (5) to move the machine off.

REMARK

- If the shift lever is shifted to a position other than N when the parking brake has not been released, the central warning lamp will flash and the alarm buzzer will sound.
- If the gear shift lever is shifted to a position other than N when the dump lever is at a position other than FLOAT or the body is raised, the central warning lamp will flash and the alarm buzzer will sound.

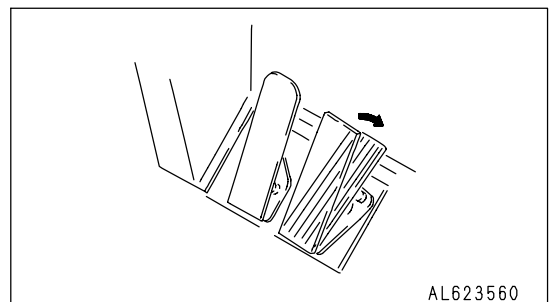

AL623560

MOVING MACHINE IN REVERSE

WARNING

- When operating the machine, always sit in the operator's seat. If you do not sit in the operator's seat, it will be impossible to stop operations if a problem occurs and there is danger that this may lead to serious personal injury.
- Do not allow any other person on the machine unless they are sitting in the assistant's seat. If they are not sitting in the assistant's seat, there is danger that they may fall when the machine is traveling and suffer serious personal injury.
- Always wear the seatbelt. There is danger that you may be thrown out of the operator's seat when the brakes are applied suddenly and suffer serious injury.
- If there is any person in the area around the machine when it is traveling, there is danger that person may be hit or caught up by the machine and suffer serious personal injury. Before starting to travel, always do as follows.
 - o Before traveling in reverse, check again that there is no person or obstacle in the surrounding area.
 - o Before starting to move the machine, sound the horn to warn the people in the surrounding area.
 - o When traveling in reverse, check first that the backup alarm sounds properly.
 - o If there is a blind spot behind the machine which cannot be seen, position a signalman.
- When traveling on snow-covered or icy roads, there is danger that the machine may slip when traveling and tip over or fall off the road. This may lead to serious personal injury and damage. Always do as follows.
 - o Fit tire chains.
 - o Do not apply the brake suddenly on slopes. Reduce the speed and use the braking force of the engine together with the foot brake (depress the foot brake repeatedly; do not keep it depressed) to stop the machine.
 - o Do not enter areas where the snow is deep. There is danger of driving off the road.

1. Stop the machine and run the engine at low idle.
2. Look in the side view mirror and rear view mirror to confirm that there is no person or obstacle behind the machine.
3. If the rear monitor is installed, use the rear monitor to confirm that there is no person or obstacle behind the machine.

NOTICE

When shifting gear, if a sudden load is applied to the transmission, the service life of the machine will be reduced. Do not operate the gear shift lever with the accelerator pedal depressed.

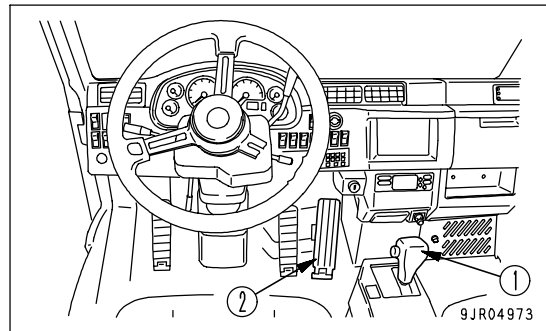

4. Place gear shift lever (1) in the R position and depress accelerator pedal (2) gradually. The machine will move in reverse.

REMARK

- The machine cannot travel in reverse when the dump body is raised. Lower the dump body, set the dump lever to the FLOAT position, then set the shift lever to the R position.
- If the shift lever is moved to "Position R" while the machine is running forward (at a speed above 4 km/h), it is kept in the neutral position until the travel speed goes down; the brakes are automatically applied; and the engine is throttled down.

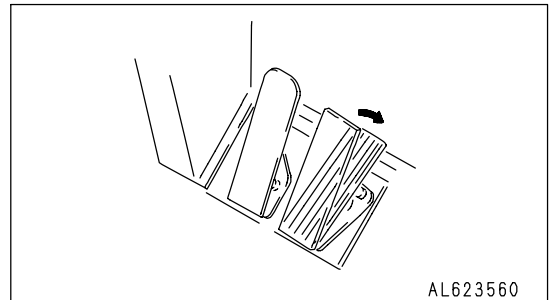
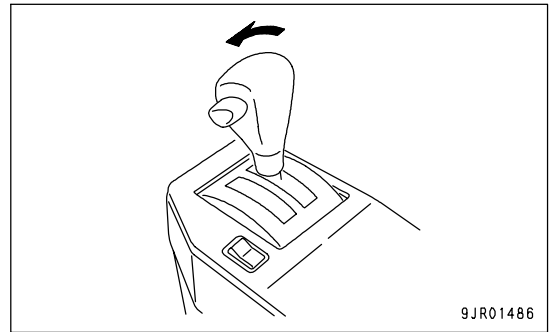

STOPPING MACHINE



WARNING

- When stopping the machine, reduce speed gradually. Do not stop the machine suddenly. If the machine is stopped suddenly, there is danger that the machine will turn to one side. This may lead to serious personal injury.
- Do not depress the brake pedal repeatedly or keep it depressed for long periods. If the brakes are used repeatedly, there is danger that the brakes may overheat and fail to have any effect even when the brake pedal is depressed. This may lead to serious personal injury.
- If the parking brake is used repeatedly to stop the machine, the parking brake will be damaged and it will be unable to maintain the proper braking capacity. This may lead to serious personal injury. Use the parking brake only when parking the machine or when stopping the machine in emergencies.

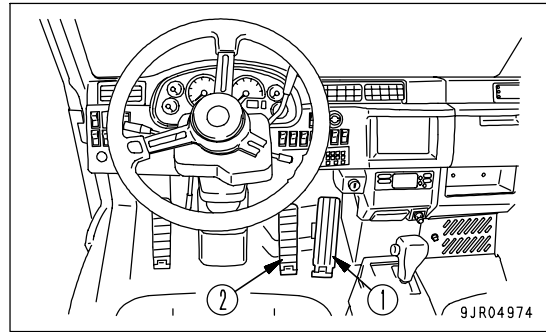

NORMAL STOPPING

Release accelerator pedal (1), and depress brake pedal (2). The machine will stop.

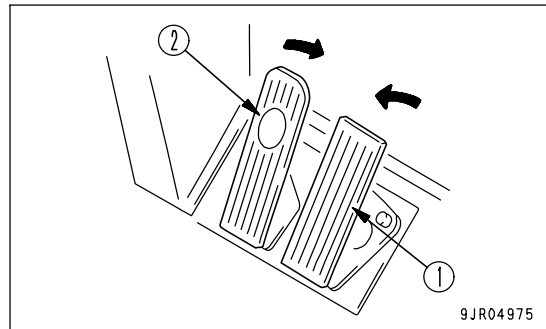

STOPPING IN EMERGENCY

If it is impossible to stop the machine using only the foot brake, stop the machine as follows.

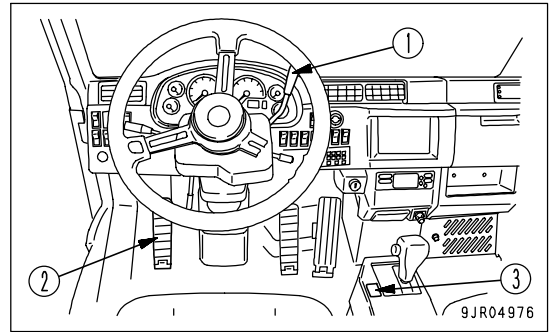

WARNING

If the foot brake has failed and the emergency brake has been used, stop the machine on flat ground, and put blocks under the tires. If the machine moves, there is danger that people in the surrounding area may suffer serious personal injury.

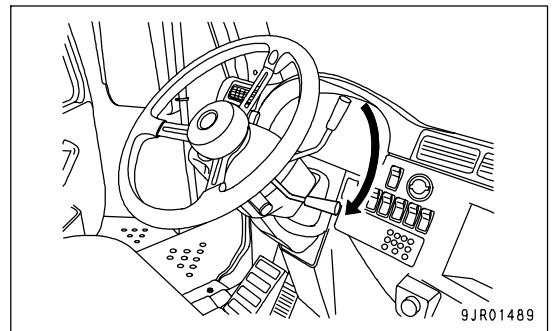

1. Pull retarder control lever (1) fully to apply the retarder.
The machine will stop.

If operating retarder control lever (1) does not provide sufficient braking force, stop the machine as follows.



2. Depress secondary brake pedal (2) to stop the machine.
The secondary brake actuates both the front brake and the parking brake.

REMARK

If the machine is stopped with the secondary brake, the central warning lamp will flash and the alarm buzzer will sound. If this happens, return the shift lever to the N position to cancel the warning lamp and alarm buzzer.

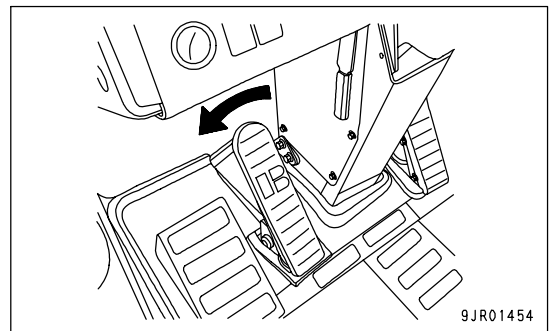

3. When the machine stops, set parking brake switch (3) to the PARKING position.
4. After making an emergency stop, put blocks under the tires immediately.

Investigate the failure of the front brakes and ask your Komatsu distributor to carry out repairs.

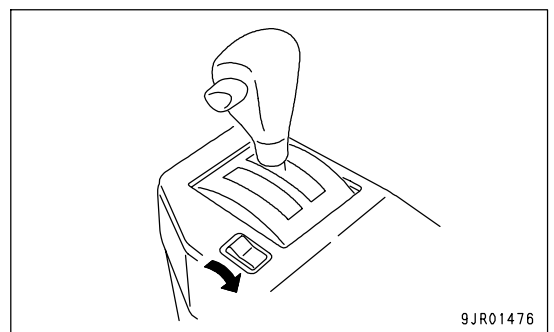

SHIFTING GEAR

WARNING

Do not move the gear shift lever to the N position when the machine is traveling or when it is traveling down a slope. Always place the transmission in gear before traveling.

- If the transmission is in Neutral, the engine cannot provide any braking effect and the steering wheel will become heavier. In addition, there will be lack of cooling oil for the retarder, so there is danger that it will overheat or that the actuation of the brake will be poor.
- There may also be damage to the transmission or other parts of the power train, and there is danger of unexpected accidents.

NOTICE

When shifting gear, if a sudden load is applied to the transmission, the service life of the machine will be reduced. Do not operate the gear shift lever with the accelerator pedal depressed.

Use the gear shift lever to shift gear and provide the desired machine travel speed.

The gear shifting system on this machine is automatic, so if gear shift lever (1) is set to the desired position, the machine travel speed is automatically controlled by operating accelerator pedal (2).

Regardless of the position of the gear shift lever, if the dump body is raised, the speed range is set to 1st. Always lower the dump body when traveling.

When changing the direction of travel between forward and reverse, stop the machine completely, run the engine at low idle, then shift direction. When shifting the gear shift lever from N to R, and when shifting from D to 6, press lock button (3) on the gear shift lever before operating the lever.

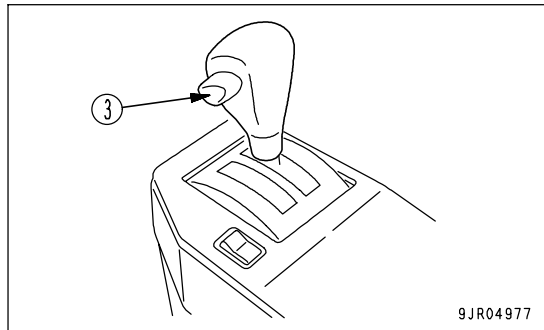
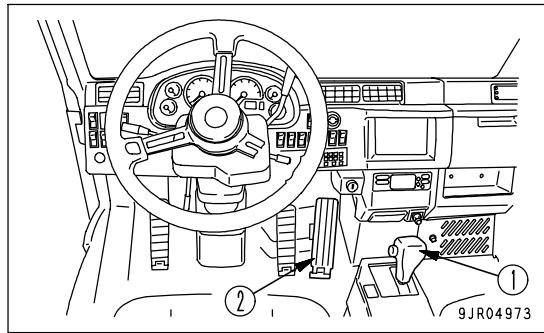

SHIFTING UP

1. Depress accelerator pedal (2). The machine accelerates and the lock-up clutch is engaged to set to direct drive.
2. Depress accelerator pedal (2) further to accelerate. The transmission is automatically shifted up.

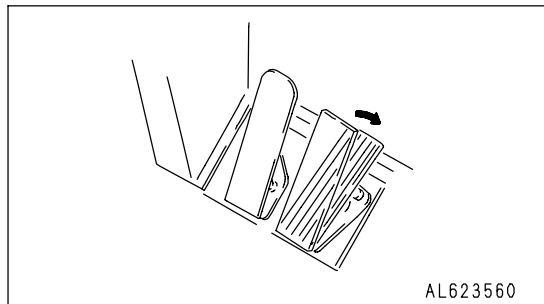

SHIFTING DOWN

Release accelerator pedal (2).

The machine decelerates and the transmission is automatically shifted down.

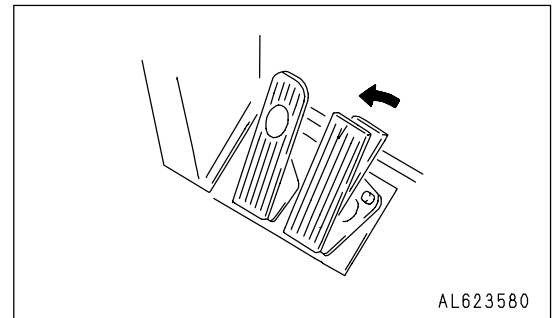
**DOWN SHIFT INHIBIT**

If the gear shift lever is operated when the machine is traveling, and the travel speed is faster than the maximum speed for each gear position, the transmission is not shifted immediately but is shifted down when the travel speed drops. This prevents overrunning of the engine.

SHIFTING DOWN WHEN USING FOOTBRAKE

When the foot brake is used to reduce the travel speed, if the machine is traveling with the transmission in the range from 2nd to 4th, the transmission will not shift down to a lower range until the travel speed goes down to the 2nd range or the brake is released. Maintaining the speed range reduces the speed when shifting, and this reduces the shock.

SKIP SHIFT

For normal shifting, the transmission shifts one gear range at a time.

When traveling uphill and the travel speed drops suddenly, the transmission jumps one gear range when shifting down to reduce the transmission shock.

OVERRUN PREVENTION DEVICE

If the engine tachometer enters the red range during operations, the alarm buzzer will sound and the central warning lamp will light up at the same time, so lower the engine speed and the travel speed. If the machine is accelerated to a speed higher than the maximum speed set for each range of the gear shift lever, the overrun prevention device is actuated to apply the retarder and reduce the travel speed.

TRAVELING DOWNHILL



WARNING

- Always keep to the permitted speed when going downhill using the retarder. If the permitted speed is exceeded, the brakes will overheat and will make it impossible to provide the braking force. This may lead to serious personal injury. For details of the maximum permitted speed, see the brake performance graph for the downhill distance and grade.
- Operate the retarder control lever slowly. If it is operated suddenly, a sudden braking force will be generated. As a result the tires may slip and the machine may turn in one direction or tip over, and this may lead to serious personal injury.
- Do not move the gear shift lever to the N position when the machine is traveling or when it is traveling down a slope. Always place the transmission in gear before traveling.
 - If the transmission is in Neutral, the engine cannot provide any braking effect and the steering wheel will become easier. In addition, there will be lack of cooling oil for the retarder, so there is danger that it will overheat or that the actuation of the brake will be poor.
 - There may also be damage to the transmission or other parts of the power train, and there is danger of unexpected accidents.

- For the maximum permissible speed when traveling downhill using the retarder, see the brake performance graph for the downhill distance and graph. If the machine continues to travel downhill at a speed greater than the maximum permissible speed on the brake performance graph, there is danger that the retarder will overheat, or even fail.
- If the retarder oil temperature caution lamp on the machine monitor lights up when the retarder is being used, shift down to travel downhill. (When this happens, the central warning lamp lights up and the alarm buzzer sounds.) If the retarder system caution lamp does not go out even when the transmission is shifted down, stop the machine immediately, set the shift lever to the N position, run the engine at 2000 rpm, and wait for the retarder system caution lamp to go out.
- If the retarder loses its effect when it is used for traveling downhill, do as follows.
 1. Release the retarder control lever completely, then operate the retarder control lever again.
 2. If the retarder has no braking effect even when the retarder control lever is operated again, release the retarder control lever completely, depress the brake pedal, stop the machine on flat ground, put blocks under the tires, then ask your Komatsu distributor to carry out repairs.
- If the retarder control lever is operated when traveling downhill, the transmission can be shifted down sooner than with normal deceleration. It is also possible to travel without shifting up.
- When traveling downhill, do not use the foot brake except in an emergency. Using the foot brake will cause overheating of the front brake and reduce the life.

REMARK

Do not accelerate or shift up when using the retarder. The engine speed will rise and this may cause the alarm buzzer to sound and the central warning lamp to flash.

1. Before starting to travel downhill, release accelerator pedal (1).
2. Operate retarder control lever (2) to reduce the travel speed to the set speed limit.

REMARK

For details of setting the speed limit, see "BRAKE PERFORMANCE CURVE (PAGE 3-105)".

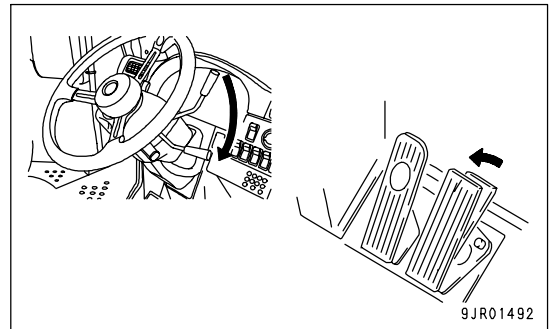
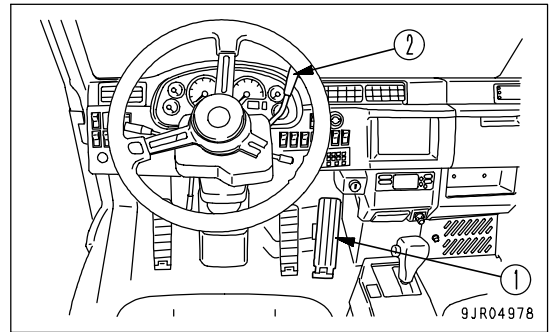

3. Leave the gear shift lever in position D.
When the machine reduces speed, the transmission will automatically shift down to the appropriate gear range.

If the condition of the road makes it necessary to travel downhill in 1st, set the gear shift lever to any position except D (6, 5, 4, 3, 2, L).

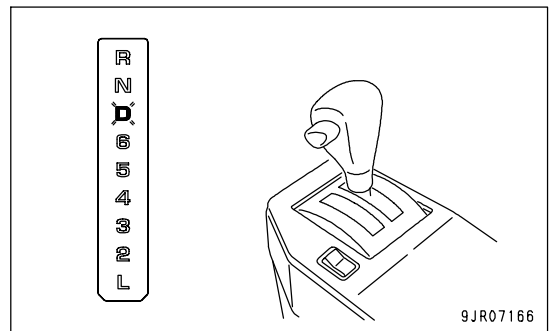

4. When traveling downhill, operate retarder control lever (2), run the engine at a speed of 1800 to 2200 rpm, and travel so that the retarder brake oil temperature gauge is in the white range.

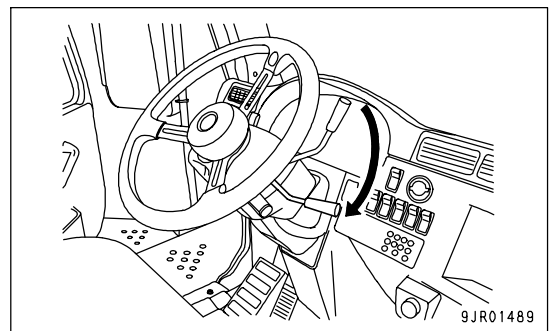

ARSC(AUTOMATIC RETARDER SPEED CONTROL)

When traveling downhill, if the switch is pressed at the speed that is to be maintained, the retarder is automatically actuated to prevent the travel speed from exceeding the set speed, so this makes retarder operations easy.

WARNING

- If the travel speed is set at a speed that exceeds the maximum permissible speed obtained from the brake performance graph, the brakes will overheat and make it impossible to provide the braking force. This may lead to serious personal injury. Set the travel speed within a range that does not exceed the permitted speed.
- When traveling on slippery road surfaces, when the automatic retarder speed control (ARSC) is actuated, the tires may lock and it may become impossible to operate the steering. There is danger that this will cause serious personal injury to people in the area around the machine. When traveling on slippery road surfaces, do not use the automatic retarder speed control (ARSC).
- When traveling with the auto retarder, if the alarm buzzer sounds, depress the brake pedal or retarder control lever of the machine, stop the machine or on level ground, then turn the auto retarder (ARSC) switch OFF. If any abnormality occurs in the automatic retarder system control, it will be impossible to control the travel speed, so this may lead to serious personal injury.

METHOD OF OPERATION

ACTION OF ARSC SYSTEM

1. Turn ARSC system switch (1) ON.

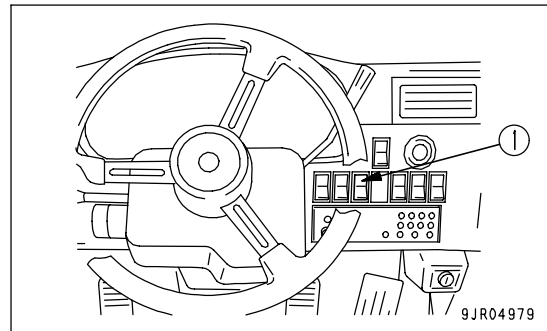

2. Travel at the speed desired to set the ARSC, then push set switch (2) of the ARSC set lever. The travel speed at that point is set as the downhill speed. The set travel speed is displayed on ARSC set speed indicator (3).

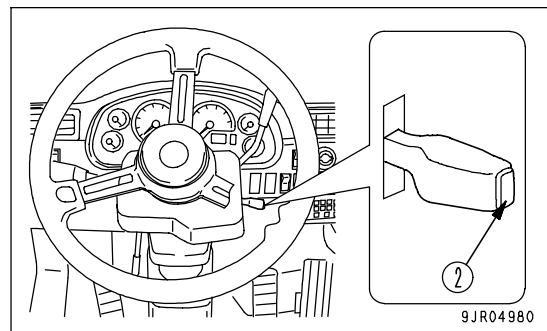

3. Before starting to travel downhill, reduce the travel speed to below the ARSC set travel speed.
4. When reaching the point to travel downhill, release the accelerator pedal and check that ARSC ready pilot lamp (4) lights up.

5. When traveling downhill, if the machine starts to exceed the set travel speed, the retarder is actuated automatically. While it is being actuated, retarder pilot lamp (5) lights up.

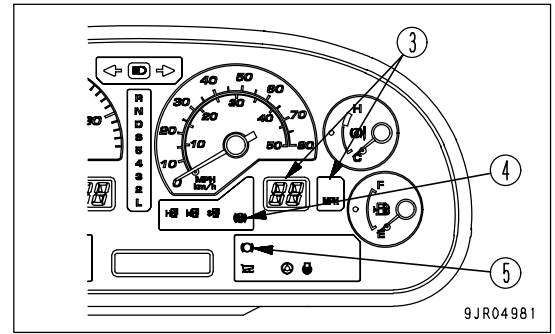

REMARK

- The set travel speed is saved to memory and displayed on the ARSC set speed indicator on the machine.
- If the accelerator pedal is depressed while the ARSC is being actuated, the actuation of the ARSC is canceled and the machine accelerates.
- If the brake pedal or retarder control lever is actuated while the ARSC is being actuated, it is possible to reduce speed or stop the machine in the same way as for the normal brake operation.
- When the set travel speed is close to the point for shifting gear or to the point where the grade of the slope changes, even when the ARSC is being actuated, the transmission may shift up or down.
- The time when the set travel speed converges is different depending on the grade of the slope.
- The speed displayed on the speedometer and the set travel speed may be slightly different.

METHOD OF SPEED SETTING



CAUTION

Set the travel speed so that it does not exceed the maximum permissible travel speed obtained from the brake performance graph. If the travel speed is set higher than the maximum permissible travel speed, the retarder brake may overheat and be damaged.

- If the actual machine speed during the setting operation is less than 10 km/h (6.2 MPH), the speed is set to 10 km/h (6.2 MPH). If it is higher than 55 km/h (34.2 MPH), it is set to 55 km/h (34.2 MPH). In all other cases, it is set to the actual travel speed.
- The travel speeds that can be set depend on the selection of the gear shift lever as follows.
When the gear shift lever is at the D, 6, 5, 4, 3, 2, or L positions, the range for the set speed is 10 to 55 km/h (6.2 to 34.2 MPH).
It is impossible to set the speed when the gear shift lever is at the N or R positions.

METHOD OF CARRYING OUT FINE ADJUSTMENT OF SET TRAVEL SPEED

If you want to raise the set speed by 1 km/h (tap up), push the auto retarder (ARSC) set lever up once.

If you want to lower the set speed by 1 km/h (tap down), pull the auto retarder (ARSC) set lever down once.

REMARK

Release the auto retarder (ARSC) set lever after changing the set travel speed.

If the set switch and cancel are operated at the same time, the cancel operation is given priority.

If the set switch and tap up are operated at the same time, the tap up operation is given priority.

If the set switch and tap down are operated at the same time, the tap down operation is given priority.

The tap up and tap down operations are used for making fine adjustment of the set travel speed.

It is possible to adjust the set travel speed up to ± 5 km/h (3.1 MPH) when traveling in ARSC (when the accelerator pedal released). When the accelerator pedal is being depressed, it is possible to operate freely in a range from 10 to 55 km/h (from 6.2 to 34.2 MPH).

METHOD OF INCREASING SET TRAVEL SPEED

If it is desired to increase the set speed, depress the accelerator pedal to increase speed, and when the desired set travel speed is reached, press the set switch on the auto retarder (ARSC) set lever. The set travel speed will be changed to the new speed.

METHOD OF DECREASING SET TRAVEL SPEED

If it is desired to decrease the set speed, operate the retarder control lever to reduce speed, and when the desired set travel speed is reached, press the set switch on the auto retarder (ARSC) set lever. The set travel speed will be changed to the new speed.

REMARK

After using the retarder control lever to reduce the speed, return it to its original position.

If the lever is operated suddenly, the brakes will be applied suddenly.

TRAVELING AGAIN AT SET TRAVEL SPEED

If you travel repeatedly on the same slope, set the travel speed. It is then possible to use that set travel speed by actuating the ARSC without having to reset.

Before entering a downhill slope, if the travel speed has been adjusted to a speed lower than the set speed displayed on the auto retarder set speed indicator, the auto retarder READY pilot lamp lights and the ARSC is actuated when the accelerator pedal is released.

REMARK

When traveling at a speed greater than the set speed displayed on the auto retarder set speed indicator, the ARSC is not actuated even when the accelerator pedal is released. When this happens, the auto retarder READY pilot lamp also does not light up. Always adjust the travel speed to a speed lower than the set speed displayed on the auto retarder set speed indicator, and check that the auto retarder READY pilot lamp lights up.

Before starting to travel down a slope, check again that a suitable set speed is displayed on the auto-retarder set speed indicator and that the auto-retarder ready pilot lamp is lighted up.

METHOD OF CANCELING SET TRAVEL SPEED

There are two methods of canceling the set travel speed.

Method 1: Keep the auto retarder (ARSC) set lever pulled up for at least 1 second to cancel the setting. When this happens, the auto retarder set speed indicator shows 0.

Method 2: If the auto retarder (ARSC) switch is turned OFF, the control is canceled. When this happens, the auto retarder set speed indicator goes out.

REMARK

With method 1, to prevent the setting from being cancelled if the switch is touched by mistake, the switch must be pulled up and kept for at least 1 sec. at that position to cancel the setting.

RECOMMENDED SET TRAVEL SPEED

Set the travel speed so that the engine speed is between 1800 rpm and 2200 rpm or more and travel at a speed that keeps the retarder oil pressure gauge inside the white range.

If there is danger that the retarder oil may overheat, the set travel speed is automatically reduced 1 km/h (0.6 MPH) every 3 seconds. The set travel speed indicator display also goes down automatically.

The lower value for the set travel speed when the speed is automatically reduced is 10 km/h (6.2 MPH).

BRAKE PERFORMANCE CURVE

HD465-7

- Method of using graph

Example: Downhill distance: 1500 m (4921 ft)

Travel resistance: -11% [grade resistance: -13%, rolling resistance: 2%]

Load: 55 tons

Obtain the maximum permissible speed and the transmission speed range from the graph when traveling downhill under the above conditions.

1. Use the brake performance graph for the downhill distance of 1,500 m (4,921 ft).
2. Starting from point (A) which corresponds to the overall weight of the machine, draw a perpendicular line down.
3. Take the point where it crosses the line for travel resistance -11% as (B) and draw a horizontal line.
4. Take the point where it crosses the performance curve as (C), and draw a perpendicular line down. Take the point where this line crosses the travel speed scale as (D).
5. As a result of the above, the following items change.
 The maximum permitted speed changes from point (D) to 29.5 km/h (18.3 MPH)
 The speed range changes from point (C) to F4

This maximum permissible speed is one guideline determined from the retarder brake performance, so on an actual jobsite, determine a safe travel speed below the maximum permissible speed to match the conditions of the jobsite so that the retarder brake oil temperature gauge is always in the white range when traveling.

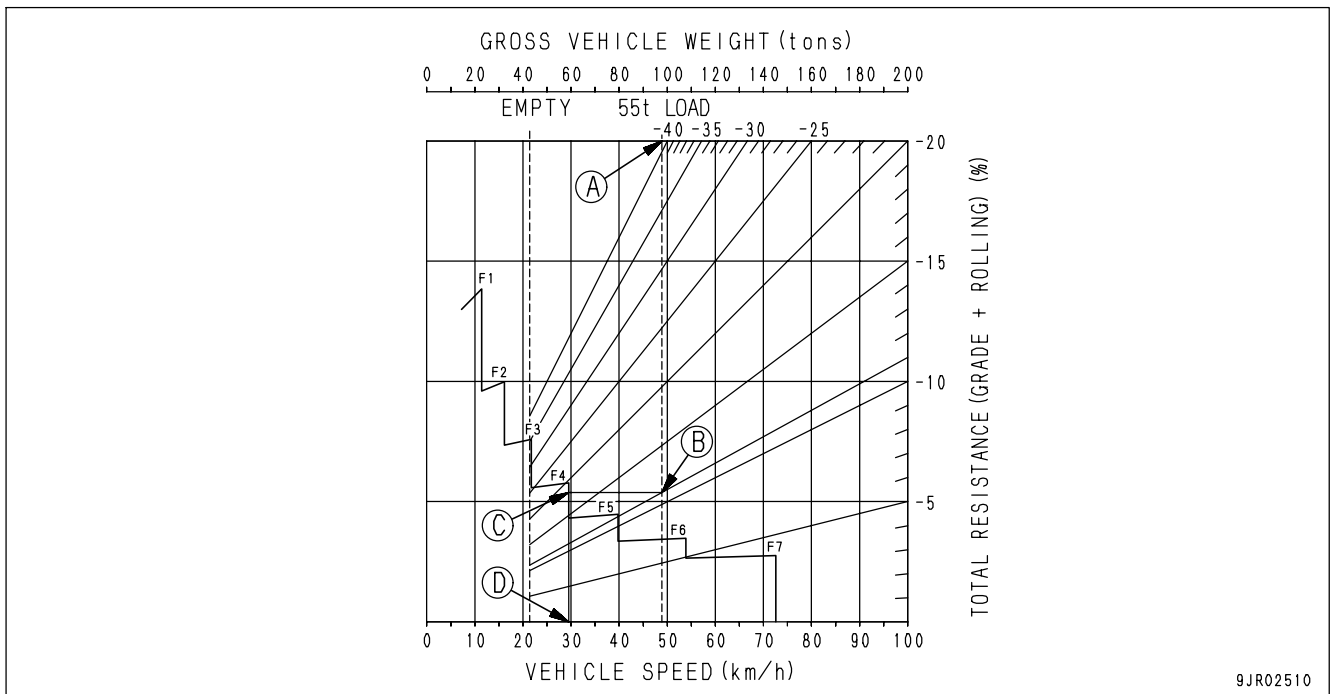

9JR02510

- Brake performance

[Downhill distance: 450 m (1,476 ft)]

(Tire size: 24.00-35-36PR)

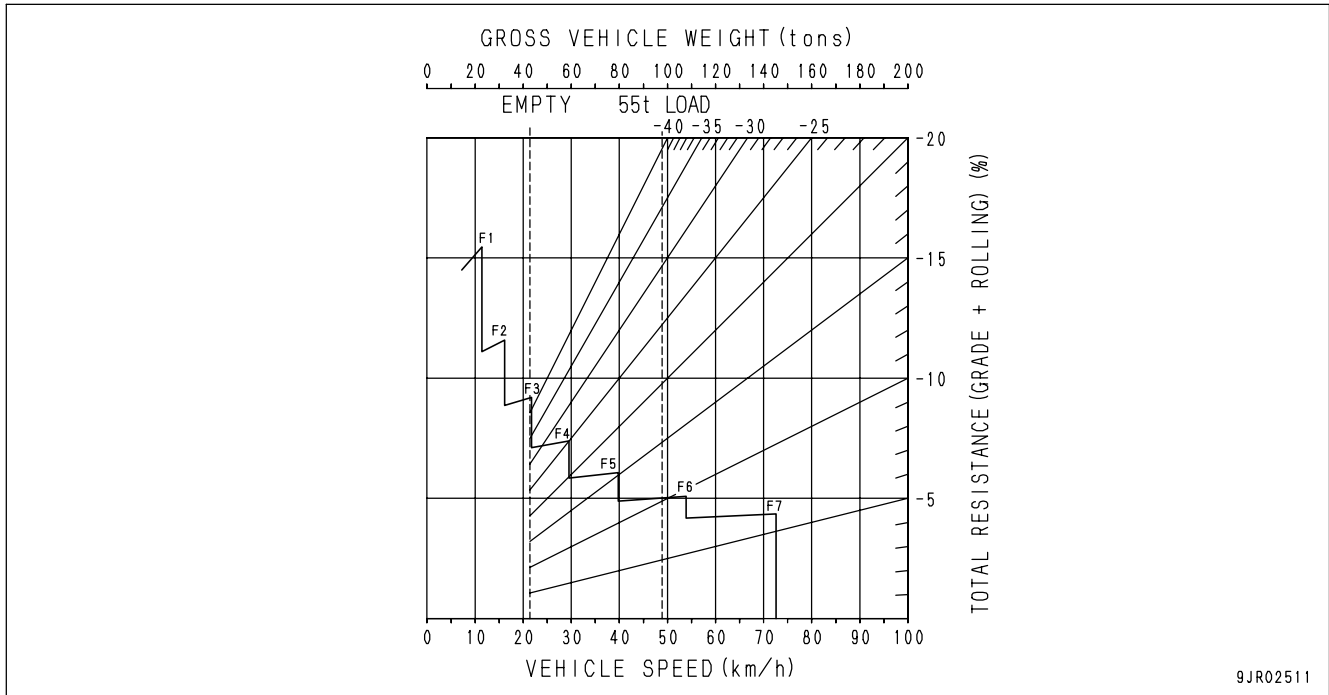

9JR02511

- Brake performance

[Downhill distance: 600 m (1,968 ft)]

(Tire size: 24.00-35-36PR)

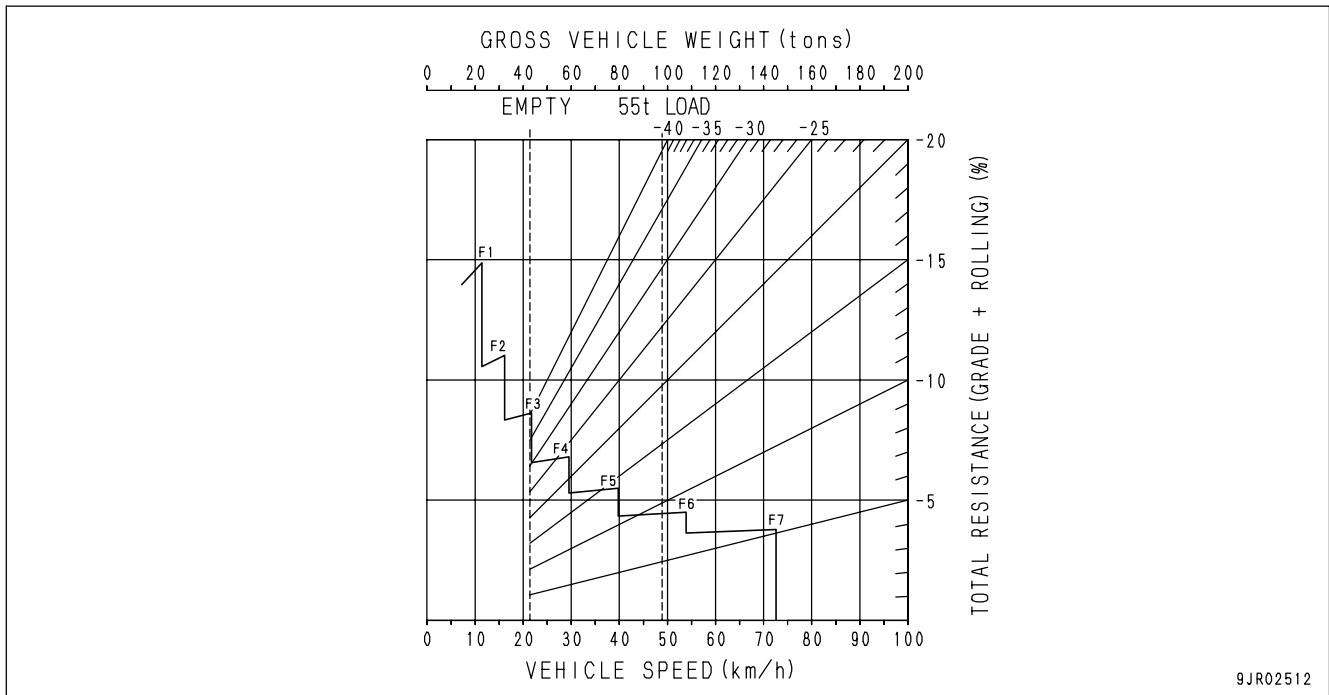

9JR02512

- Brake performance
 [Downhill distance: 900 m (2,952 ft)]
 (Tire size: 24.00-35-36PR)

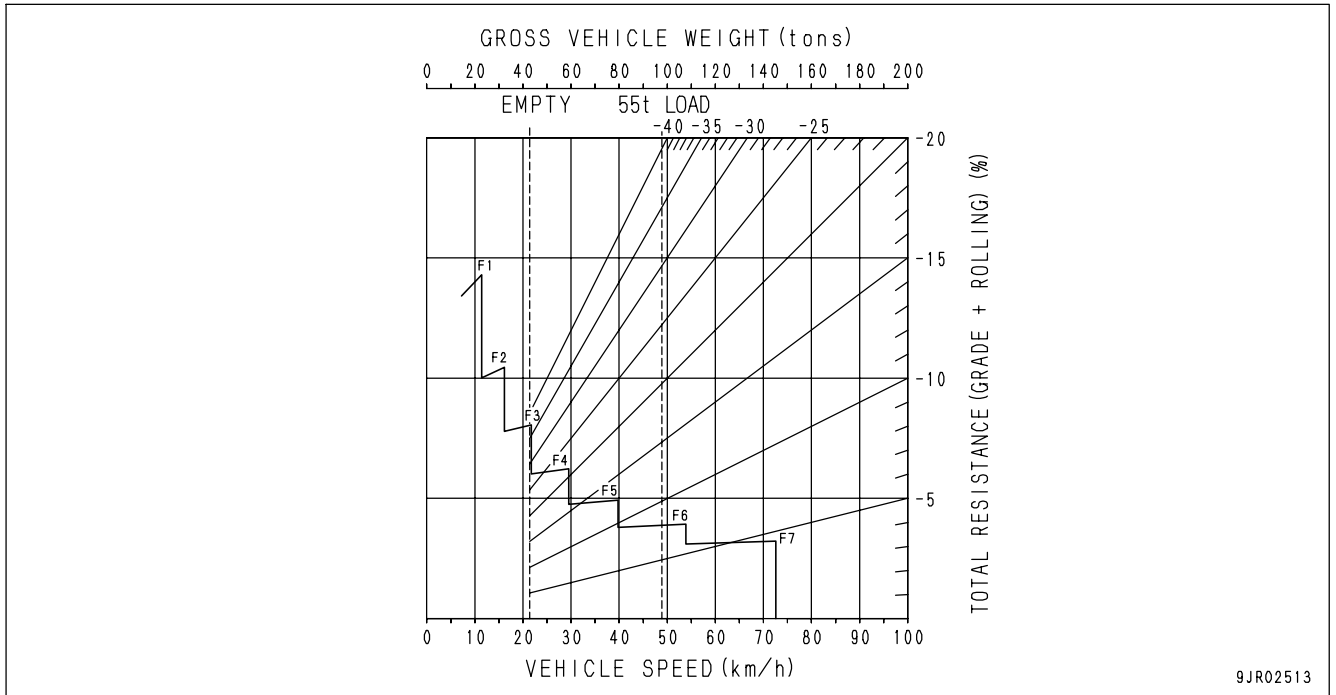

9JR02513

- Brake performance
 [Downhill distance: 1,500 m (4,921 ft)]
 (Tire size: 24.00-35-36PR)

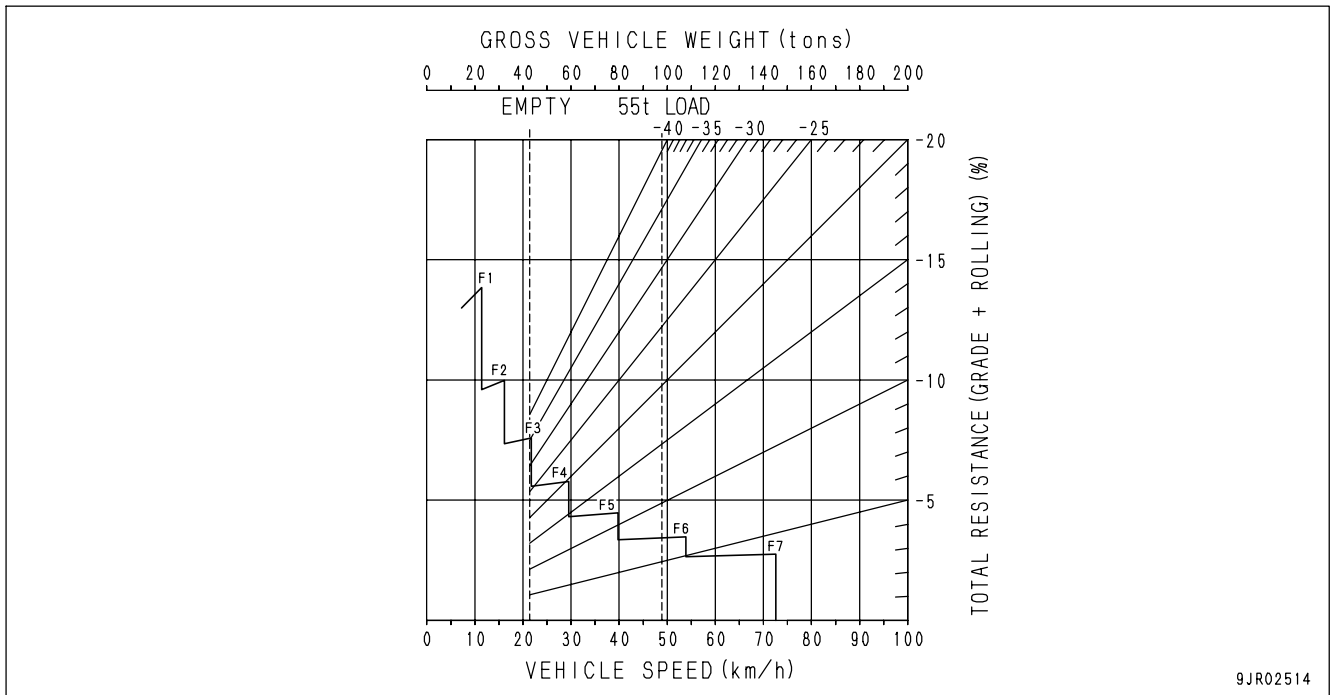

9JR02514

- Brake performance
[Downhill distance: Continuous]
(Tire size: 24.00-35-36PR)

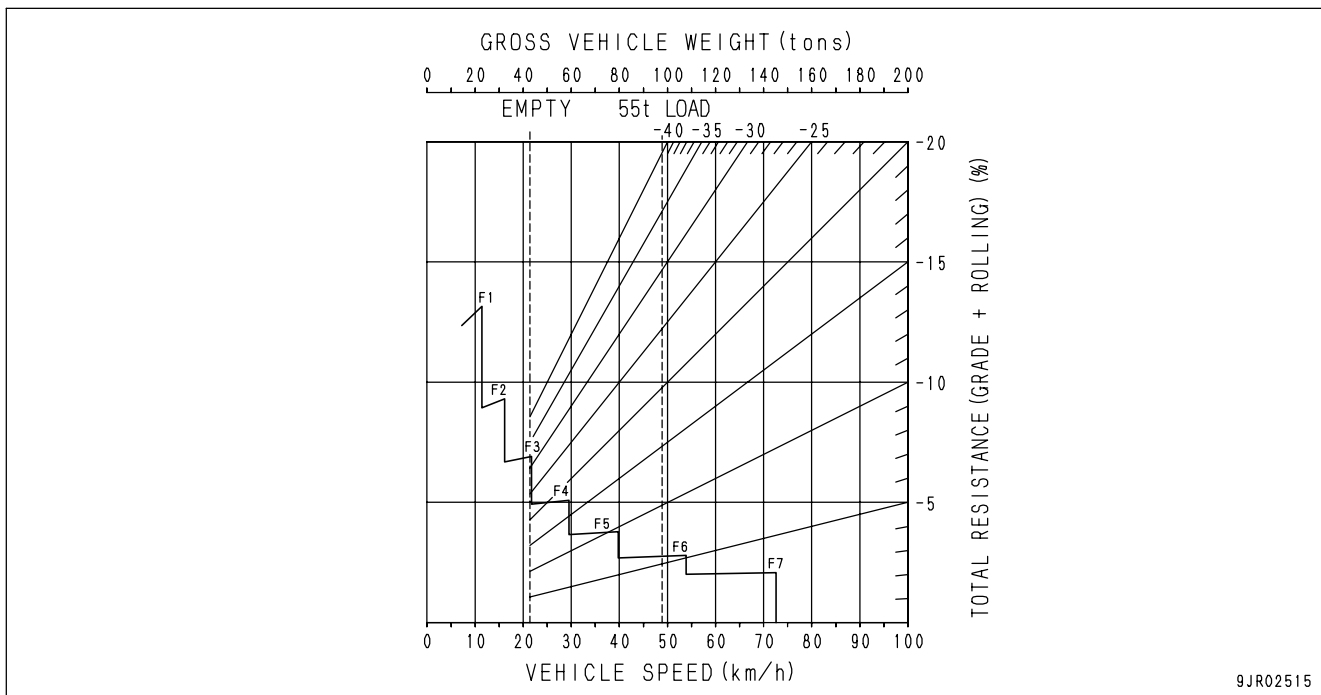

9JR02515

HD605-7

- Method of using graph

Example: Downhill distance: 1500 m (4921 ft)

Travel resistance: -11% [grade resistance: -13%, rolling resistance: 2%]

Load: 63 tons

Obtain the maximum permissible speed and the transmission speed range from the graph when traveling downhill under the above conditions.

1. Use the brake performance graph for the downhill distance of 1500 m (4921 ft).
2. Starting from point (A) which corresponds to the overall weight of the machine, draw a perpendicular line down.
3. Take the point where it crosses the line for travel resistance -11% as (B) and draw a horizontal line.
4. Take the point where it crosses the performance curve as (C), and draw a perpendicular line down. Take the point where this line crosses the travel speed scale as (D).
5. As a result of the above, the following items change.

The maximum permitted speed changes from point (D) to 22.0 km/h (13.7 MPH)

The speed range changes from point (C) to F3

This maximum permissible speed is one guideline determined from the retarder brake performance, so on an actual jobsite, determine a safe travel speed below the maximum permissible speed to match the conditions of the jobsite so that the retarder brake oil temperature gauge is always in the white range when traveling.

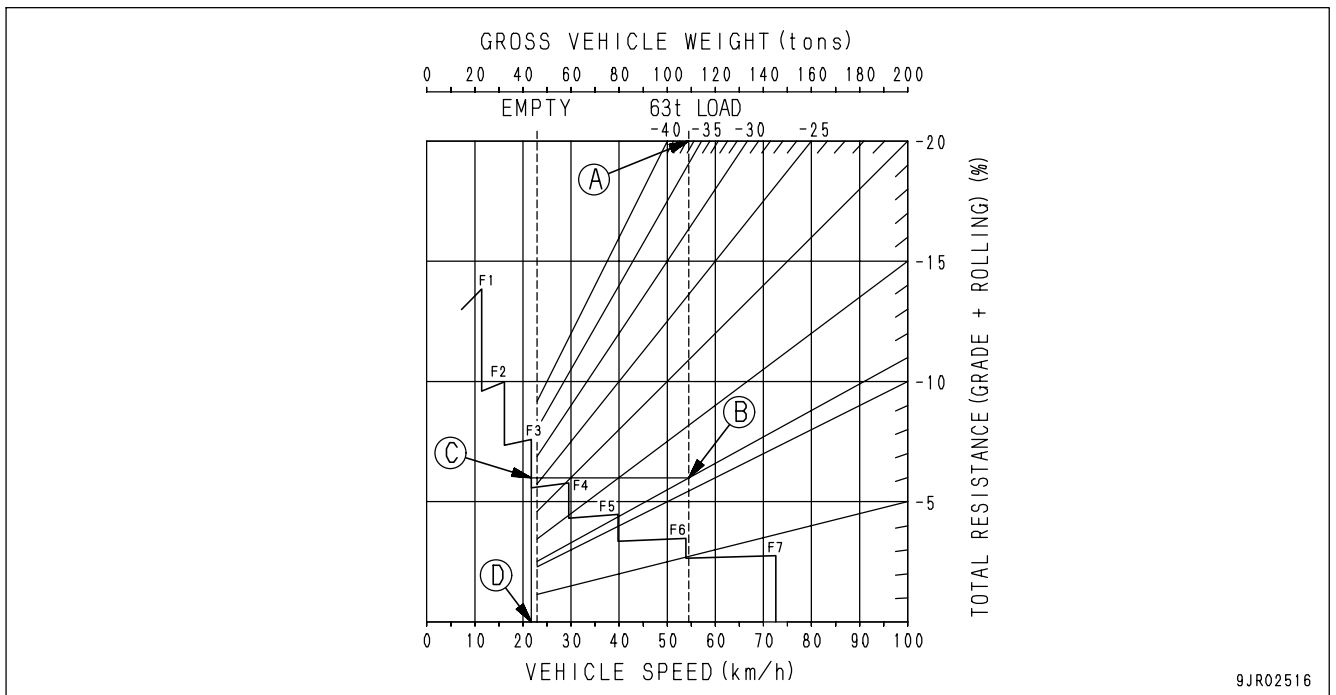

- Brake performance

[Downhill distance: 450 m (1,476 ft)]

(Tire size: 24.00R35★★)

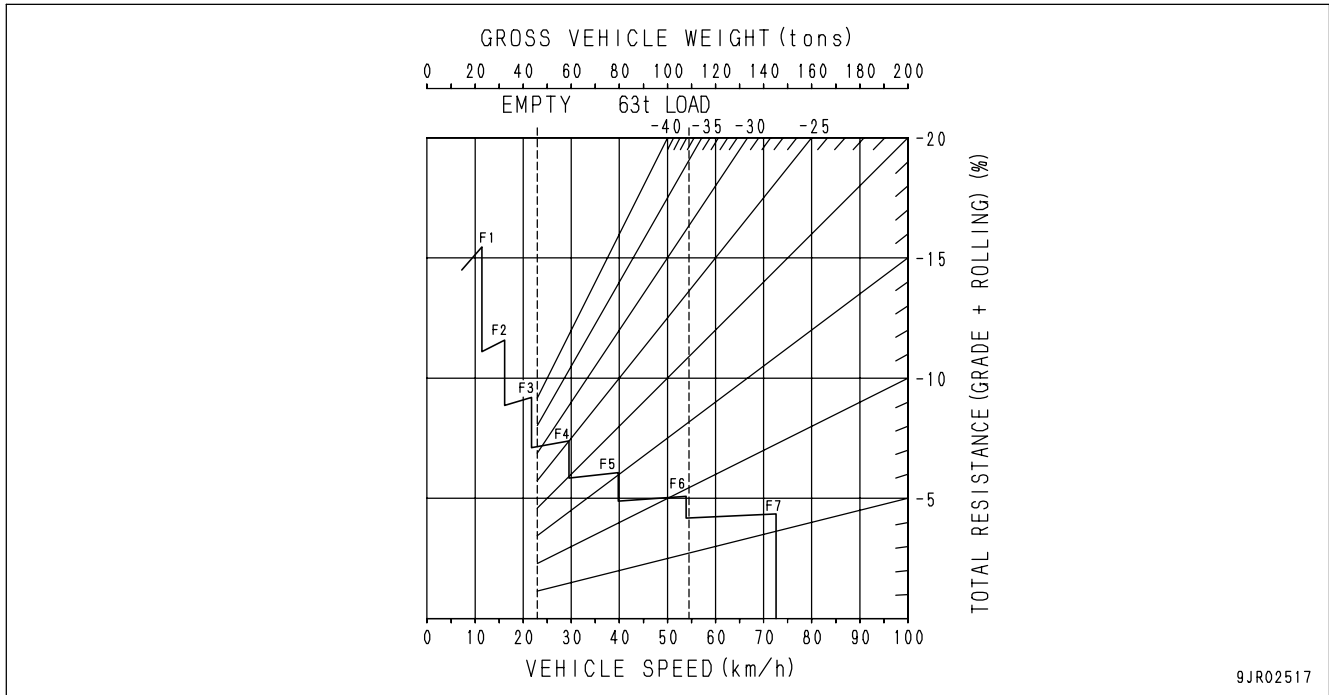

9JR02517

- Brake performance

[Downhill distance: 600 m (1,968 ft)]

(Tire size: 24.00R35★★)

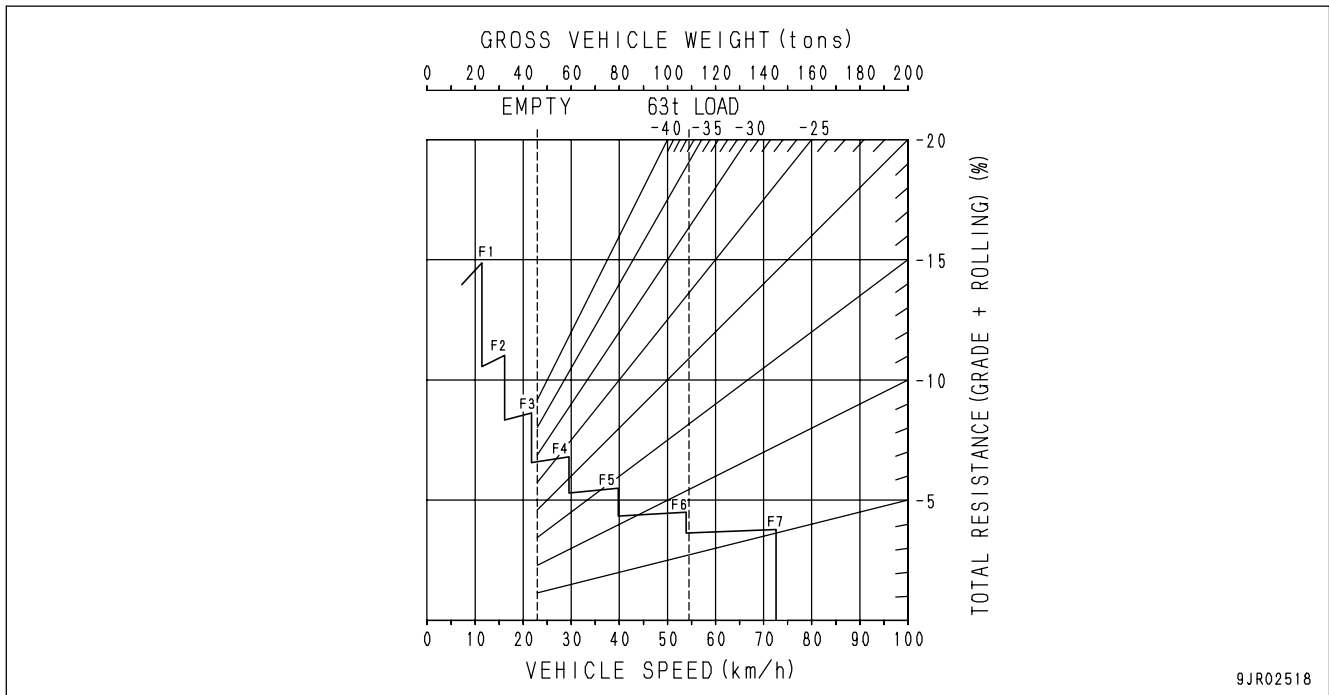

9JR02518

- Brake performance
 [Downhill distance: 900 m (2,952 ft)]
 (Tire size: 24.00R35 ★ ★)

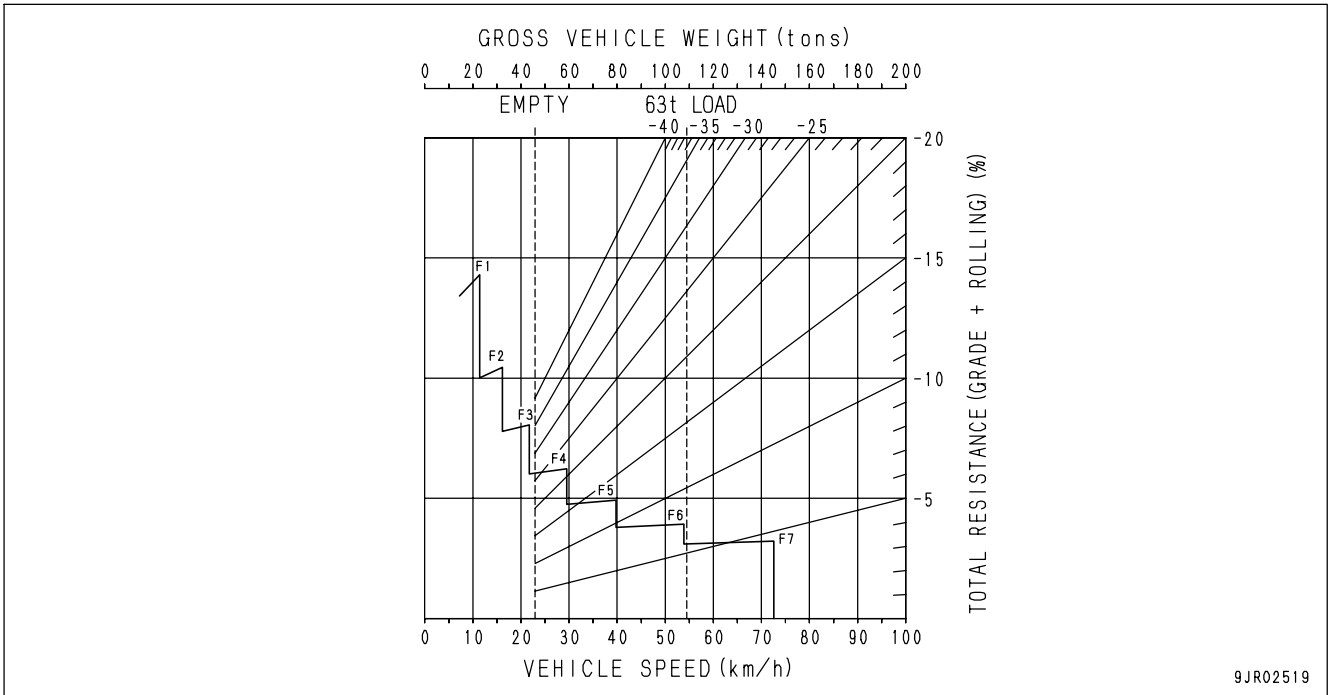

9JR02519

- Brake performance
 [Downhill distance: 1,500 m (4,921 ft)]
 (Tire size: 24.00R35 ★ ★)

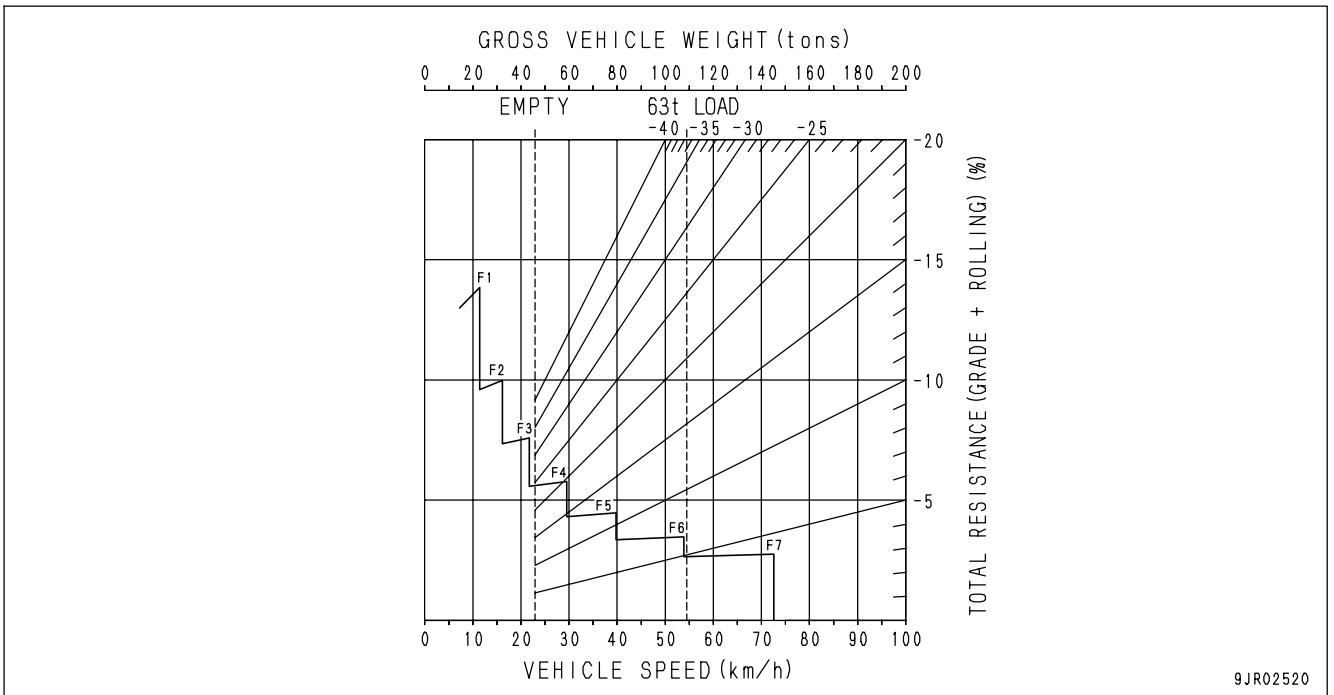

9JR02520

- Brake performance
 [Downhill distance: Continuous]
 (Tire size: 24.00R35 ★ ★)

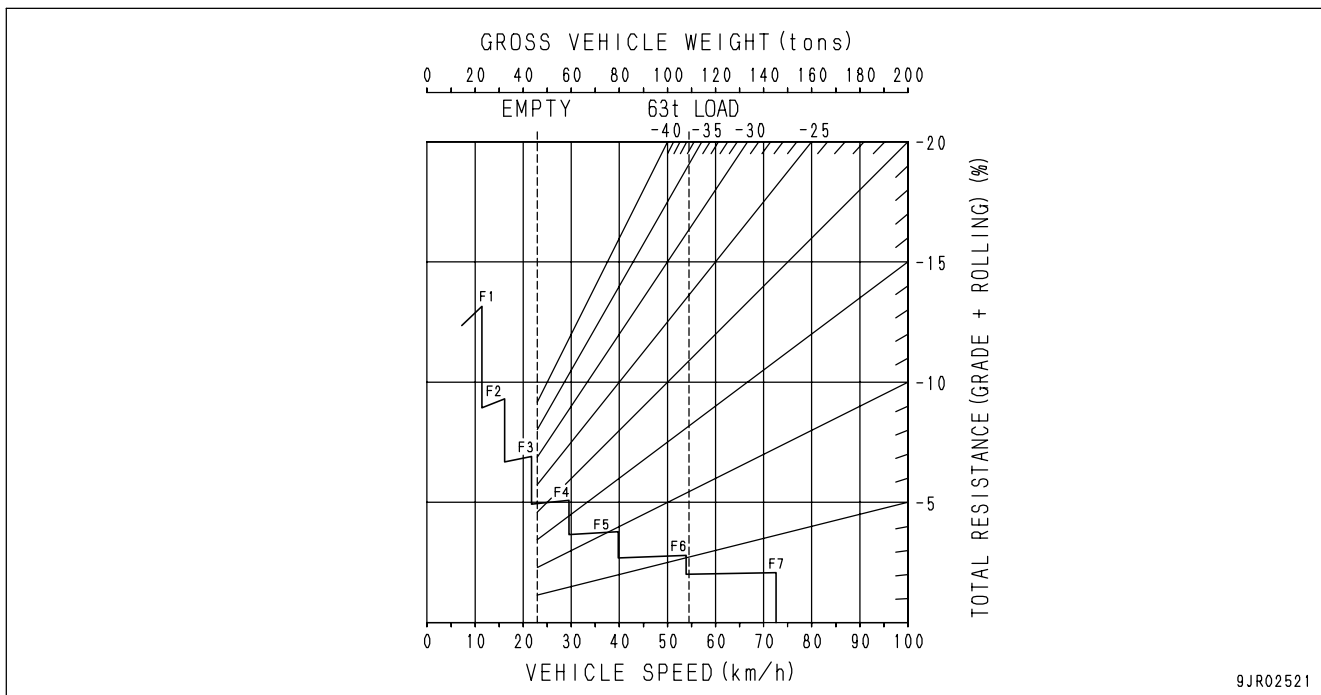

9JR02521

STEERING THE MACHINE

WARNING

Do not operate the steering when traveling at high speed or on steep slopes. There is danger that the machine may tip over and cause serious damage or serious personal injury to people in the area around the machine.

CAUTION

Do not continue to apply force after the steering wheel has been turned fully to the right or left. The oil temperature inside the circuit will rise and cause overheating, and this may damage the equipment.

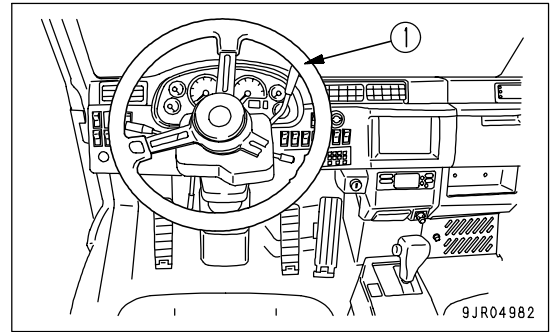

To turn the machine when traveling, turn steering wheel (1). The machine will turn.

When traveling around a curve, release the accelerator pedal before entering the curve, shift down to a lower speed range, then depress the accelerator pedal to travel around the curve.

REMARK

- Because of the characteristics of hydraulic systems, the angle of the steering wheel may change while the machine is traveling (the position of the spokes on the steering wheel may vary slightly), but this is not a failure.
- If force is applied to the steering wheel when the tires have been turned fully to the left or right, the steering wheel will turn a little at a time, but this is not a failure.

LOADING OPERATIONS

When using a large wheel loader to load large rocks, if the rocks are loaded directly into the dump body, parts of the dump body may be deformed. To prevent this, when loading large rocks, first load sand or soil to act as a cushion, then load the rocks on top of this to reduce the impact on the dump body.

In addition, when loading rocks that exceed the following conditions, install the optional dump body reinforcement plate.

- Rocks with one side over 0.5 m (1 ft 8 in)
- Rocks of hardness more than 4.5 (Mohs scale)
- Rocks with a weight of more than 300 kg (662 lb)
- When transporting steel ingots

For the types and the selection of the dump body, see "SELECTING DUMP BODY (PAGE 6-2)". (HD465-7 only)

DUMP OPERATIONS

WARNING

- It is difficult to confirm the situation in the area around the dumping point from the operator's seat, so there is danger of serious personal injury if anyone is in the surrounding area.
When dumping the load from the dump body, follow the signals from a signalman.
- When dumping large rocks, reduce the dumping speed. If the dumping speed is fast, there will be a sudden change in the center of gravity of the machine, and there is danger that this may cause the machine to tip over or suffer damage, leading to serious personal injury.

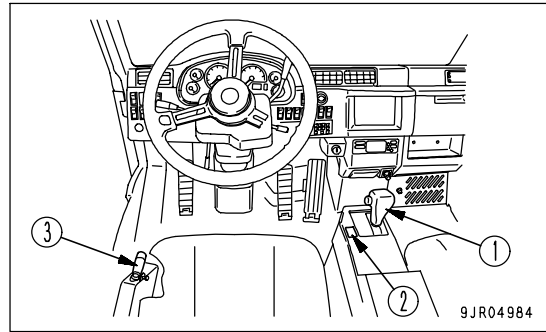

NOTICE

On machines equipped with auto emergency steering, if the machine is not fully warmed up, the emergency steering may be actuated momentarily when the parking brake switch is set to TRAVEL or the dump control lever is operated.

REMARK

When the dump control lever is not at the "FLOAT" position and the dump body is not seated, if the gear shift lever is operated from N to another position, the central warning lamp lights up and the alarm buzzer sounds.

Operate the dump body as follows.

1. Place gear shift lever (1) at the N position, and set parking brake switch (2) to the PARKING position.

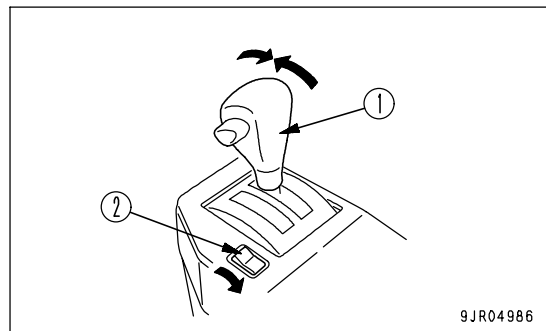

2. Move dump lever (3) to the RAISE position, then depress the accelerator pedal. The dump body will raise.

If the dump lever is released when it is at the RAISE position, it is held at the RAISE position and the dump body will continue to rise.

The dumping speed increases in proportion to the engine speed.

When the dump body rises to the previously set position, dump lever (3) returns to the HOLD position. The dump body is held at that position.

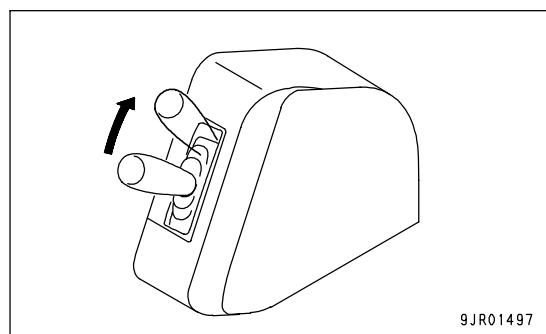

NOTICE

- When raising the dump body, reduce the pressure on the accelerator pedal when the dump body comes close to the maximum angle. If the dump body is raised to the maximum height at a high lifting speed, the hoist cylinders will suffer impact load and may be damaged.
- Regardless of the position of the gear shift lever, if the parking brake switch is at the "TRAVEL" position and the dump body is raised, the speed range is fixed at 1st. Lower the dump body before traveling.

3. If it is necessary to raise the dump body further, operate dump lever (3) to the RAISE position and raise the dump body further. If dump lever (3) is released, dump lever (3) will return to the HOLD position and the dump body will stop at that position.

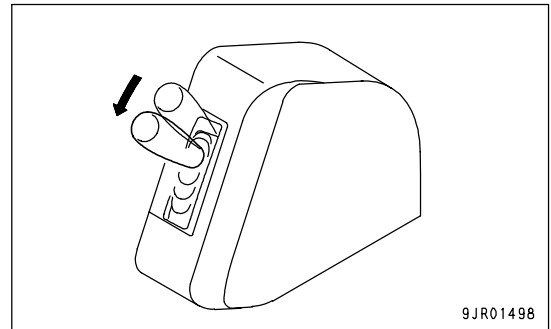

4. When dump lever (3) is moved to the LOWER position. The dump body will start to move down.

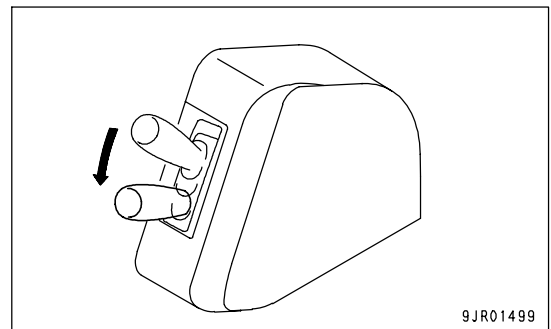

5. When the dump body has moved down a certain distance, move dump lever (3) to the FLOAT position. (When the lever is released, it will return to the FLOAT position.) The dump body will then move down under its own weight.

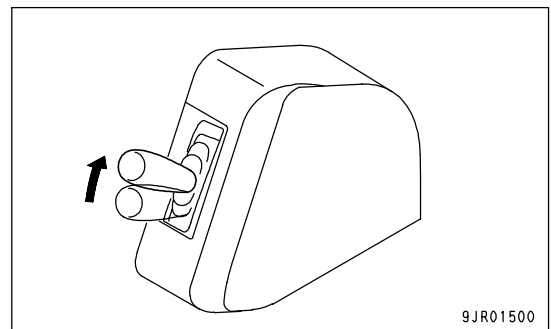

The dump control is carried out electrically. If there is any problem in the sensors or valves, a failure code is displayed and the dump body is held in position. If it is desired to move the dump body forcibly for inspection or repair, please ask your Komatsu distributor to carry out the operation.

PRECAUTIONS FOR OPERATION

- When traveling on roads in rain or snow, or when traveling on muddy or soft ground, consider the loaded condition of the machine and be extremely careful not to let the tires slip or the machine spin and sink into the ground.
- If the engine should stop when the machine is traveling, stop the machine immediately, then move the gear shift lever to the N position, and start the engine again.
- If the central warning lamp and the machine monitor caution lamp flash and the alarm buzzer sounds during operations, stop the machine immediately and check for the cause.
(For details, see "TROUBLESHOOTING (PAGE 3-135)".)
- When loading, be careful to load the dump body uniformly, and be particularly careful to avoid loading too much at the front.
- On slippery road surfaces, apply the retarder control lever slowly and shift the transmission down to prevent the rear wheels from locking.
- When traveling through pools of water, water may inside the front brakes and cause a big drop in the braking force, so drive carefully in such areas. If water should get into the brakes, depress the brake pedal several times while traveling to produce friction heat between the pad and disc to remove the water.

PERMISSIBLE WATER DEPTH

If there is no way to avoid running the dump truck in the water during the operation, make sure that it does not go deeper than the allowable depth (i.e. up to the inner surface of rim (1)).

Moreover, flush the dump truck with fresh water after the work and apply grease to the portions soaked in water.

While the dump truck was running in the water, water may have seeped into the drain tank. In that case, drain the water accumulated in the tank in reference to "RECOVER OIL LEAKING FROM FLOATING SEAL (PAGE 4-81)".

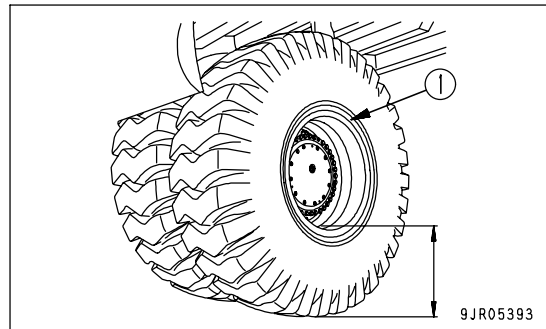

PARKING MACHINE



WARNING

- Park the machine on firm, horizontal ground. If the machine is parked on a slope, it may suddenly move and cause serious personal injury. If the machine has to be parked on a slope, always put blocks under the tires.
- When leaving the operator's compartment, set the parking brake switch to the PARK position, set the gear shift lever to the N position and the dump control lever to the HOLD position, then turn the starting switch OFF. If the proper procedure is not carried out to prevent the machine from moving, the machine may suddenly move if the levers are touched, and this may lead to serious personal injury.

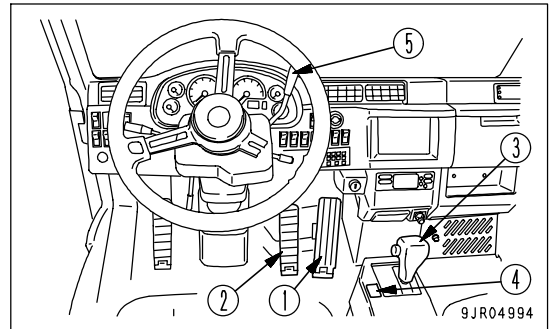
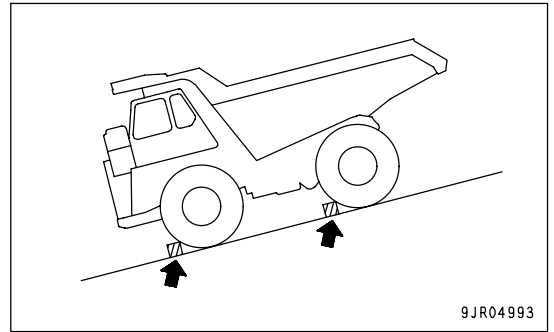

1. Release accelerator pedal (1), then depress brake pedal (2).
The machine will stop.

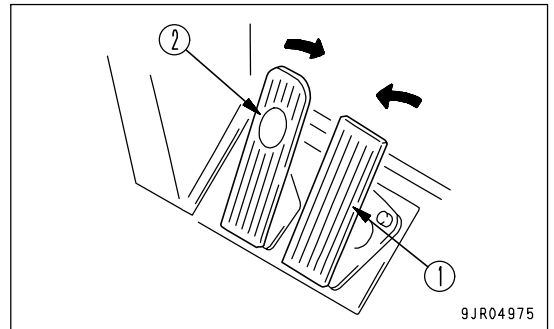

2. Move shift lever (3) to the N position, then set parking brake switch (4) to the PARKING position.
The parking brake will be apply.

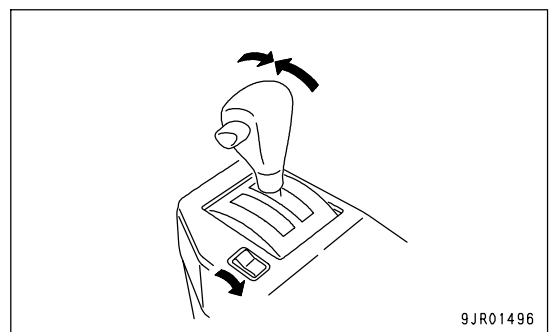

CHECKS AFTER COMPLETION OF WORK

1. Use the machine monitor to check the engine water temperature, engine oil pressure, and fuel level.
2. If the engine has overheated, do not stop the engine suddenly. Run it at a mid-range speed to cool it gradually before stopping.
3. Remove the key.

CHECKS AFTER STOPPING ENGINE

1. Check the engine compartment for paper and debris. Clean out any paper and debris to avoid a fire hazard.
2. Fill the fuel tank.
3. Remove any mud affixed to the undercarriage.
4. Walk around the machine and check the dump body, body work, and undercarriage, and check also for leakage of oil and water.

LOCKING

Always lock the following places.

- (1) Fuel filler cap of fuel tank
- (2) Operator's cab door (left, right)

REMARK

The starting switch key is used for locking places (1) and (2).

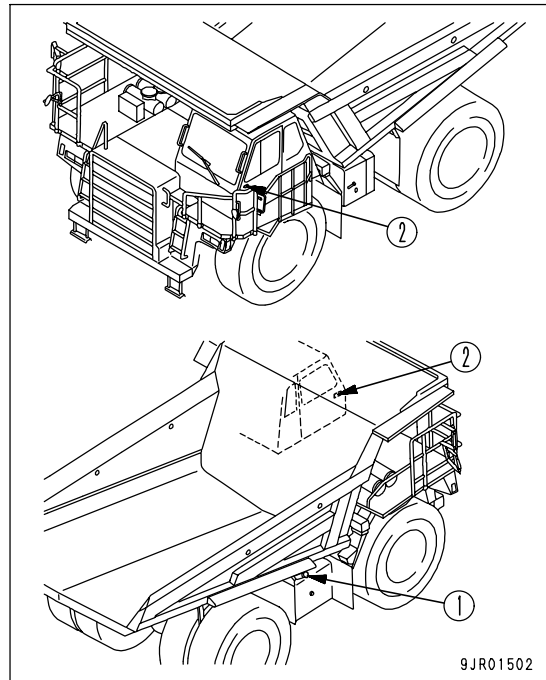

HANDLING TIRES

PRECAUTIONS WHEN HANDLING TIRES

WARNING

If tires in the following condition are used, there is danger that the tire may burst when the machine is traveling, causing the machine to tip over or parts to fly off. This may result in damage or serious personal injury. Always replace damaged tires with new tires.

- Tires where the bead wire has been cut, broken, or greatly deformed
- Excessively worn tires where more than 1/4 of the circumference of the carcass ply (excluding the breaker) is exposed
- Tires where damage to the carcass exceeds 1/3 of the tire width
- Tires where ply separation has occurred
- Tires where radial cracks extend to the carcass
- Tires where there is abnormal deterioration, deformation, and damage, and the tire cannot withstand use.

Please contact your Komatsu distributor when replacing the tires. Always be careful when jacking up the machine. If the machine is not jacked up properly, the machine may lose its balance, come down, and cause a serious accident.

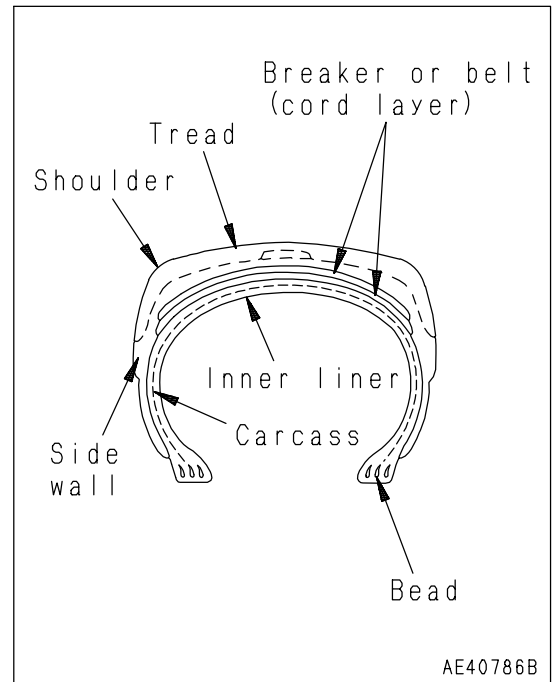

T.Km.P.H (Ton-Km-Per-Hour Rating)

Tires for construction equipment are used under severe conditions that bear no comparison with the tires used on cars, buses, or ordinary trucks, so they are specially designed to withstand these conditions.

Compared with ordinary tires, far greater heat is produced in the rubber internal parts of off-road tires when the machine is traveling. If they are used continuously under conditions which exceed the permitted load and travel speed of the tire, the internal temperature will exceed the limit, and the rubber may become soft and heat separation occur.

The T.Km.P.H rating is provided as a standard to allow the machine to travel without causing the above problems. If tires are used for work that exceeds the tires' T.Km.P.H rating (the T.Km.P.H rating for the work is greater than the T.Km.P.H rating for the tires), tire trouble will become more frequent because of the generation of heat. In such cases, do as follows.

- Make the operating conditions easier so that the operation T.Km.P.H. of the work is lowered.
- Increase the size of the tires to a tire with a high T.Km.P.H.

TIRE T.Km.P.H.AND MAXIMUM SPEED FOR CONTINUOUS TRAVEL (REFERENCE)

- HD465-7

	Tire T.Km.P.H.for ambient temperature				Max.speed for continuous travel for ambient temperature (km/h)				
	16°C	27°C	38°C	49°C		16°C	27°C	38°C	49°C
Size 24.00-35-36PR (standard) structure CR Code No. E3 (TRA)	335	313	292	270	When empty (front wheel standard)	37	35	33	30
					When loaded (rear wheel standard)	23	22	20	19
Size 24.00R35 ★ ★ (if equipped) structure CR Code No. E4 (VRLSA)	396	355	314	293	When empty (front wheel standard)	35.1	31.4	27.8	25.9
					When loaded (rear wheel standard)	21.5	19.3	17.0	15.9

- HD605-7

	Tire T.Km.P.H.for ambient temperature				Max.speed for continuous travel for ambient temperature (km/h)				
	16°C	27°C	38°C	49°C		16°C	27°C	38°C	49°C
Size 24.00R35 ★ ★ (standard) structure CR Code No. E4 (VRLSA)	396	355	314	293	When empty (front wheel standard)	35.1	31.4	27.8	25.9
					When loaded (rear wheel standard)	21.5	19.3	17.0	15.9
Size 24.00-35-48PR (if equipped) structure CR Code No. E3 (TRA)	335	313	292	270	When empty (front wheel standard)	37	35	33	30
					When loaded (rear wheel standard)	23	22	20	19

METHOD OF CALCULATING WORK T.Km.P.H.

Work T.Km.P.H. = average load per tire x average travel speed for one day

Average travel speed = round trip distance x number of round trips per day/total operating hours per day

Average load = (load when empty + load when loaded) /2

The total operating hours per day includes the stopping time and rest periods.

* The T.Km.P.H. in the table may differ slightly according to the tire maker, so concerning operations which require travel near the travel speed given in the table, consult your Komatsu distributor.

PRECAUTIONS FOR LONG DISTANCE TRAVEL**WARNING**

Always maintain the tire inflation pressure at the specified value. If the tire is not at the proper inflation pressure, the rim will be damaged. If the rim is damaged, there is danger that the ring may fly off when the tire is inflated and cause serious personal injury.

If the machine travels continuously at high speed for a long distance, there will be a marked increase in the generation of heat in the tire. This may cause premature damage to the tire, so be careful of the following points.

- Travel only when empty.
- Check the tire inflation pressure before starting for the day when the tires are cold, and adjust to the following inflation pressure.
- Do not reduce the tire inflation pressure when traveling.

- HD465-7

Tire size	Inflation pressure [MPa (kg/cm ² , PSI)]
24.00-35-36PR (standard)	0.47 to 0.50 (4.75 to 5.05, 67.4 to 71.7)
24.00R35 ★ ★ (if equipped)	0.69 to 0.72 (7.0 to 7.3, 99.4 to 104)

- HD605-7

Tire size	Inflation pressure [MPa (kg/cm ² , PSI)]
24.00R35 ★ ★ (standard)	0.69 to 0.72 (7.0 to 7.3, 99.4 to 104)
24.00-35-48PR (if equipped)	0.64 to 0.67 (6.5 to 6.8, 92.3 to 96.6)

- Travel at a maximum speed of 40 km/h. If the machine travels at a speed up to the T.Km.P.H rating of the tire, the T.Km.P.H rating of the tire will be exceeded, so it is necessary to stop for at least one hour after traveling for one hour in order to cool the tires and other components.
- If the machine travels continuously at a speed lower than the T.Km.P.H rating of the tire, it is possible to travel for longer periods.
- Never travel with water or dry ballast in the tires.

STORING TIRE



WARNING

Tires for construction equipment are extremely heavy, so if mistakes are made in handling them, it may cause serious personal injury. Always do as follows.

- As a basic rule, store the tires in a warehouse where unauthorized people cannot enter. If the tires must be stored outside, always put up a fence and "NO ENTRY" signs.
- Stand the tire upright on horizontal ground, and block it securely so that it will not fall over if touched by an unauthorized person. If a tire is laid on its side, the tire will be crushed and deteriorate. If a tire starts to fall over, do not attempt to stop it. Escape immediately to a safe place.

- Store the tires in a warehouse where unauthorized people cannot enter.
If the tires must be stored outside, always put up a fence around the tire.
- Stand the tire upright on horizontal ground and block it securely.

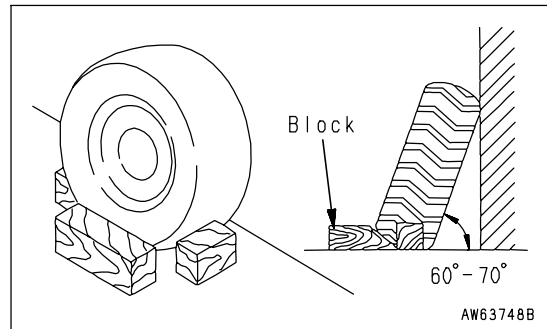

DETERMINING AND MAINTAINING TRAVEL ROAD

Determining and traveling the road in the jobsite is an extremely important factor for reasons of safety.

To ensure safety in operations, do as follows.

DETERMINING TRAVEL ROAD

- To prevent contact with machines traveling in the opposite direction, restrict the travel road to one-way traffic as far as possible.
- If it is impossible to keep to one-way traffic, make the road with ample width to enable trucks traveling in opposite directions to pass each other. If it is impossible to provide a sufficient road width, provide passing places at various points along the road.
- To avoid the danger of the road shoulder collapsing, set up the passing places so that the loaded machine is always on the inside (next to the slope face).
- If there are curves with poor visibility along the road, set up mirrors.
- If the road shoulder is soft or liable to collapse, put up signs at least 1.5 m from the road shoulder to warn of the danger.
- Set up lighting or reflectors if the road is to be travelled at night.
- The grade of slope should be kept within 10% (approx. 6°) as far as possible, and emergency escape points should be set up on downhill slopes in case of any brake failure.
- Make as many straight stretches on the travel road as possible. In particular, make the radius of curves as large as possible at the midway point, where the machine is traveling at high speed.
- Avoid small S-curves. They are particularly dangerous. The minimum radius of curves should be 12 - 15 m.
- Make the radius of curves as large as possible.
- Make the road wider at curves than it is in straight areas.
- Make the outside of the curve slightly higher.
- Be particularly careful to strengthen the road shoulder on the outside of curves.
- As far as possible, avoid having other roads cross the travel road. In particular, on slopes, where the crossing road is higher on one side, a ramp is formed on the travel road, and machines traveling at high speed will sway strongly to the side. This will not only cause spillage of the load but will also hinder travel operations.
- Cut the slope face to provide a special road for the trucks.

MAINTAINING TRAVEL ROAD

Carry out the necessary action according to the conditions to insure that the road can always be traveled in safety.

- Remove any uneven places on the road surface, places where the road is angled to the left or right, and places where the road shoulder sags. To ensure that the road has ample strength, remove rocks, tree stumps, or other obstructions.
- Maintain the road from time to time with a bulldozer or motor grader.
- Spray the road with water at suitable intervals to prevent dust from rising and reducing the visibility.

WORKSITE



WARNING

- Before starting operations, check that there is no danger on the worksite. If you do not understand the dangers of the worksite before starting operations, there is danger that the machine may fall, or that the ground will collapse, or there will be a rock fall, leading to injury or damage.
- Do not travel or carry out operations on unstable ground (edge of cliffs, road shoulder, near deep ditches, on embankments, or near excavated ditches). There is danger that the weight and vibration of the machine may cause the ground to collapse or the machine to tip over and fall, leading to injury or damage.
- Do not travel or carry out operations near electric cables. There is danger of suffering electric shock.
- If the machine travels or carries out operations in places where the visibility is poor, it will be impossible to see obstacles around the machine or to confirm the condition of the worksite. There is danger that this will lead to damage or serious personal injury. Always take action to ensure good visibility.
- On soft road shoulders or ground surfaces, set up signs to make the condition of the ground clear. If you do not know the condition of the worksite, the machine may tip over and fall, leading to injury or damage. In addition, make sure that all operators fully understand the meaning of all the signs.

EXAMINATION AN CONFIRMATION OF WORKSITE

Before starting operations, thoroughly check the area for any unusual conditions that could be dangerous. Always do as follows.

- Check the terrain and condition of the ground at the worksite, and determine the safest method of operation. Do not operate where there is a hazard of landslides or falling rocks.
- Take necessary measures to prevent any unauthorized person from entering the operating area.
- Before operating in shallow water or on soft ground, check the depth of the water, speed of the current, and the firmness and shape of the ground. Avoid any area where there is any obstruction to travel operations.
- Maintain the travel path on the jobsite so that there is no obstruction to travel operations.

WORKING ON LOOSE GROUND

- Avoid traveling or operating your machine too close to the edge of cliffs, overhangs, and deep ditches. The ground may be weak in such areas. Remember that the soil after heavy rain or blasting or after earthquakes is weak in these areas.
- When the working on embankments or near excavated ditches, take steps before starting operations to ensure that the ground is safe.

DO NOT GO CLOSE TO HIGH-VOLTAGE CABLE

Do not travel or carry out operations near electric cables. There is danger of suffering electric shock. Always do as follows on worksites where there is danger of the machine coming into contact with electric cables.

- Before starting work near electric cables, inform the local power company of the work to be performed, and ask them to take the necessary action.
 - In areas where there are high-voltage cables, even going close to the cables can cause electric shock, so always maintain a safe distance from the cables.
 - To prepare for any possible emergencies, wear rubber shoes and gloves. Lay a rubber sheet on top of the seat, and be careful not to touch the chassis with any exposed part of your body.
 - Use a signalman to give warning if the machine approaches too close to the electric cables.
 - When carrying out operations near high voltage cables, do not let anyone near the machine.
 - If the machine should come too close or touch the electric cable, to prevent electric shock, the operator should not leave the operator's compartment until it has been confirmed that the electricity has been shut off.
- Also, do not let anyone come close to the machine.

Voltage of Cables	Safety Distance
100V - 200V	Over 2 m (7 ft)
6600V	Over 2 m (7 ft)
22000V	Over 3 m (10 ft)
66000V	Over 4 m (14 ft)
154000V	Over 5 m (17 ft)
187000V	Over 6 m (20 ft)
275000V	Over 7 m (23 ft)
500000V	Over 11 m (36 ft)

ENSURE GOOD VISIBILITY

If the machine travels or carries out operations in places where the visibility is poor, always do as follows.

- If it is impossible to ensure good visibility, position a signalman where necessary. The operator should pay careful attention to signs and follow the instructions of the signalman.
- Only one signalman should give signals.
- When working in dark places, turn on the working lamp and front lamps installed to the machine, and set up additional lighting in the work area if necessary.
- Stop operation if the visibility is poor, such as in mist, snow, rain, or dust.

CONFIRMATION OF MARK

On soft road shoulders or ground surfaces, set up signs to make the condition of the ground clear. In addition, make sure that all operators fully understand the meaning of all the signs.

TRANSPORTATION

PRECAUTIONS WHEN TRANSPORTING

Always obey the traffic regulations when transporting the machine by road.



WARNING

- This machine must be disassembled for transportation. When transporting the machine, please consult your Komatsu distributor.
- When transporting the machine, there is danger of damage or serious personal injury from accidents. Always do as follows.
 - o The weight of the machine, transportation height, and overall length of the machine differ according to the attachment installed. Always check the specifications of the machine to be transported.
 - o Select a suitable transportation route, and when traveling over bridges or other structures, make sure beforehand that the structure is able to withstand the combined weight of the transporter and the machine being transported.

STEPS FOR TRANSPORTATION

As a basic rule, always transport the machine on a trailer.

When selecting the trailer, see the weights and dimensions given in "SPECIFICATIONS (PAGE 5-2)".

Note that the specifications for the weights and dimensions for transportation differ according to the type of tires and type of dump body.

METHOD OF SECURING MACHINE

After loading the machine in the specified position, secure it in place as follows.

1. Set the parking brake switch to the PARKING position to apply the parking brake.

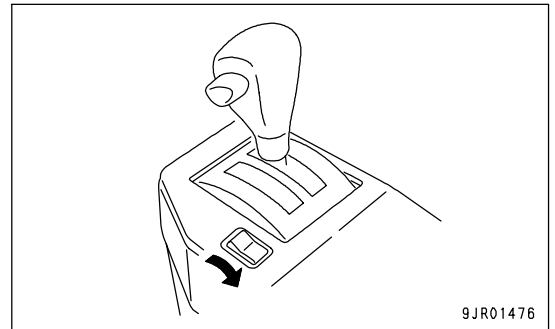

2. Turn the key in the starting switch to the OFF position to stop the engine.

3. Remove the key from the starting switch.

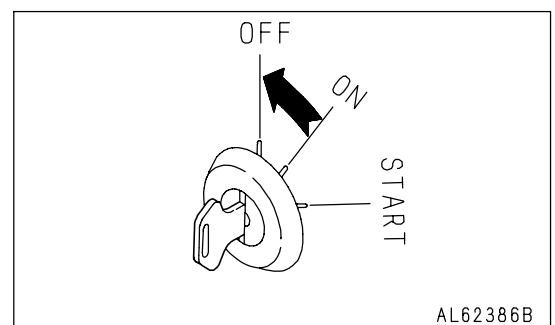

4. To prevent the machine from moving during transportation, insert blocks under the front and rear of each tire and secure the machine firmly in position with chains or wire rope. Be particularly careful to secure the machine firmly so that it does not slide to the side.

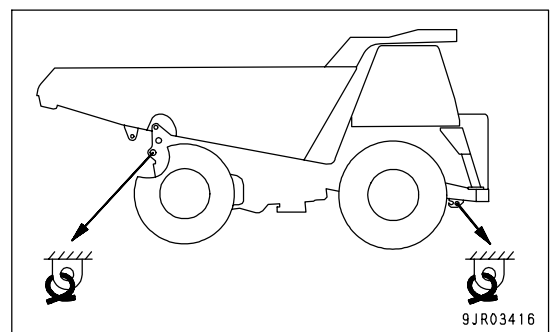

NOTICE

Always retract the antenna and reassemble the mirrors so that they are within the width of the machine.

METHOD OF LIFTING MACHINE

When lifting the machine at a port or any other place, always use the following procedure to lift it.



WARNING

When carrying out lifting operations, if mistakes are made in the operation, there is danger that the machine will fall and cause serious personal injury. Always do as follows.

- Always make sure that the wire rope is of ample strength for the weight of this machine.
- In order to prevent the wire rope from being cut, use protective material at places where the wire rope may catch on sharp corners.
- When raising the machine, keep it horizontal.
- Do not go under a raised machine or let any other person enter the area around the machine.
- Do not lift the machine when there is anyone on the machine.
- Stop the engine, then set the parking brake switch to the **PARKING** position to apply the parking brake.

Never try to lift the machine in any posture other than the posture given in the procedure below or using lifting equipment other than in the procedure below.

There is a hazard that the machine may lose its balance.

This method of lifting applies to the standard specification machine.

The method of lifting differs according to the attachments and options installed.

For details of the procedure for machines that are not the standard specification, please consult your Komatsu distributor.

For the weight of the standard specification machine, see "SPECIFICATIONS (PAGE 5-2)"

When using a spreader bar, use a size that will not come into contact with the machine.

Please consult your Komatsu distributor before carrying out lifting work.

LOCATION OF LIFTING POSITION MARK

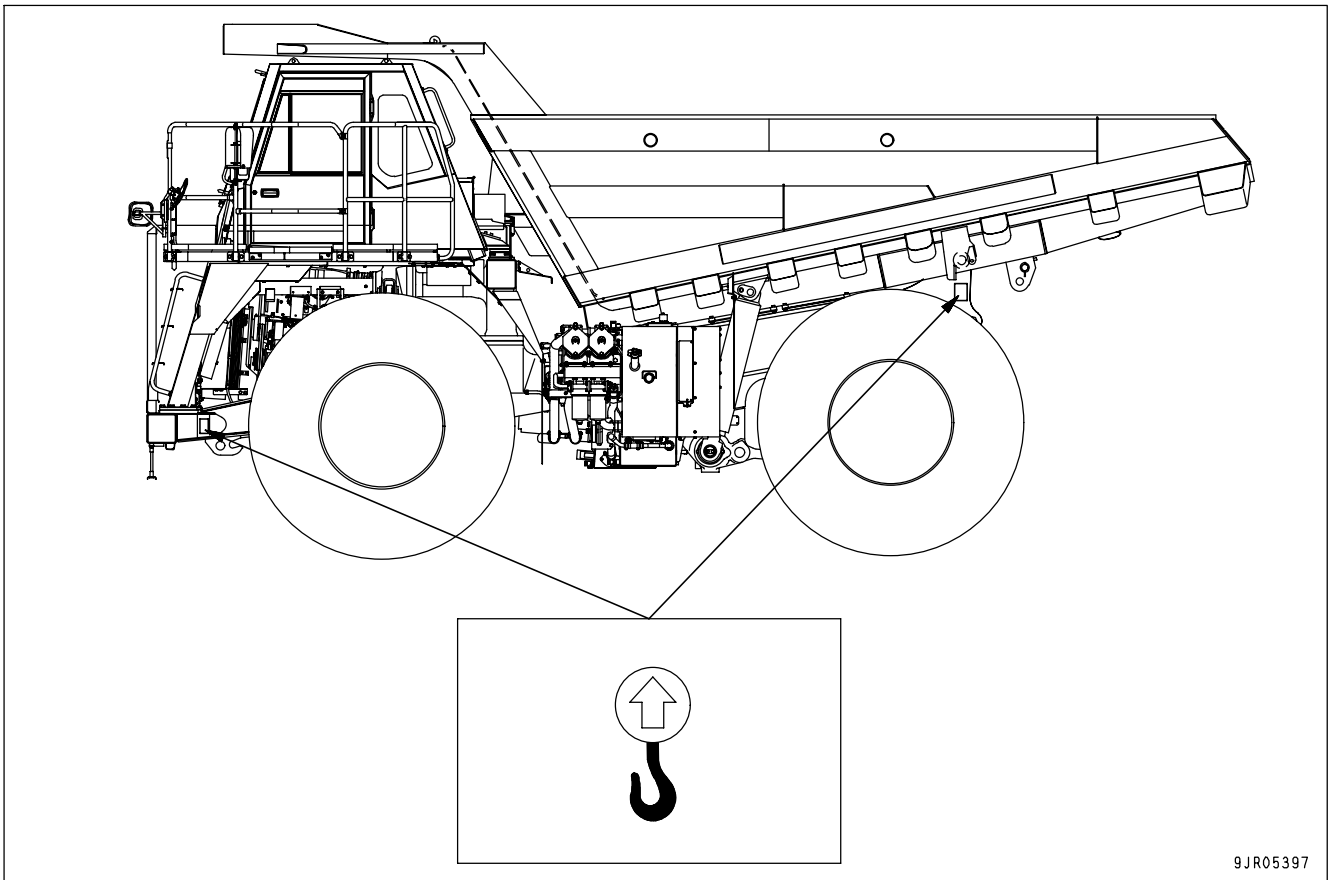

9JR05397

WEIGHT TABLE

	Machine weight	Front wheel load	Rear wheel load	Center of gravity (from front axle)
HD465-7	43100kg (95063 lb)	20257kg (44667 lb)	22843kg (50369 lb)	2280mm (7 ft 6 in)
HD605-7	46200kg (101871 lb)	21714kg (47879 lb)	24486kg (53992 lb)	2280mm (7 ft 6 in)

LIFTING PROCEDURE

Lifting work can be carried out only with machines displaying a lifting mark.

When carrying out the lifting operation, stop the machine on firm level ground, and do as follows.

1. Start the engine, set the dump lever to the FLOAT position, and check that the body pilot lamp goes out.
2. Stop the engine.

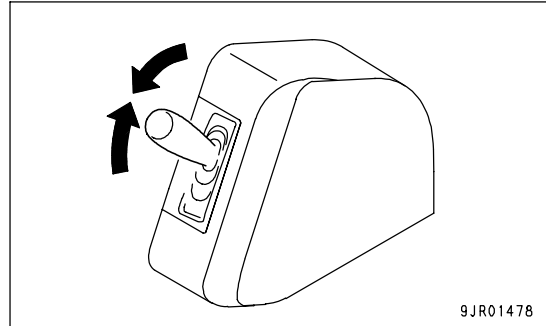

3. Set the parking brake switch to the PARKING position to apply the parking brake, and check that the area around the operator's compartment is safe.

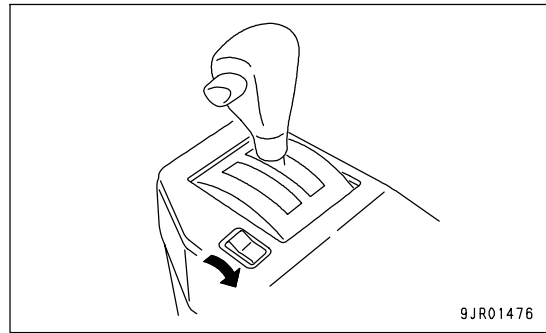

CAUTION

Always wear leather gloves when handling lifting equipment. You will suffer injury to your hands if you carry out the operation with bare hands.

4. Use wire rope, slings, and spreader bars to match the weight of the machine, and fit the wire rope to the lifting points.

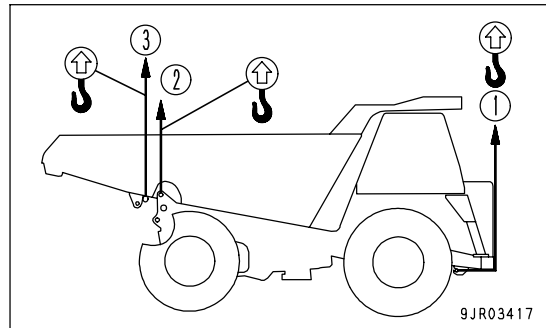

REMARK

The lifting positions for the machine differs according to the conditions.

Machine with body: Positions (1) and (3)

Total: 4 places (2 at front, 2 at rear)

Machine without body: Positions (1) and (2)

Total: 4 places (2 at front, 2 at rear)

5. Fit protector blocks at the contact points between the lifting equipment and the body to prevent damage to the King equipment.
6. When the machine comes off the ground (raised 10 - 20 cm), stop and check carefully that the machine is balanced and that the wire rope is not loose.
7. Raise the machine slowly, then lower it to the target point.

COLD WEATHER OPERATION

PRECAUTIONS FOR LOW TEMPERATURE

If the temperature becomes low, it becomes difficult to start the engine, and the coolant may freeze, so do as follows.

FUEL AND LUBRICANTS

Change to fuel and oil with low viscosity for all components. For details of the specified viscosity, see "RECOMMENDED FUEL, COOLANT, AND LUBRICANT (PAGE 4-15)".

COOLANT



WARNING

- Supercoolant contains substances that are toxic to humans. When handling Supercoolant, always use rubber gloves and protective glasses. If Supercoolant gets into your eyes, immediately wash your eyes and the back of your eyelids for at least 15 minutes with large amounts of fresh water. If there is any pain, swelling, or irritation, see a doctor for medical attention. In addition, if Supercoolant gets on your skin, wash it off thoroughly with large amounts of water and soap. If any external change is seen or you feel pain, see a doctor for medical attention.
- Supercoolant also contains substances that are toxic to the environment. When changing the cooling water or when repairing the radiator, do not drain the coolant into drainage ditches or spread it on the ground surface if Supercoolant has been added to the cooling water. After recovering cooling water which has had Supercoolant added, contact a specialist disposal company or your Komatsu distributor.
- Concentrated Supercoolant fluid may ignite. If you bring it close to a flame, it may cause fire. Do not use any flame close to concentrated Supercoolant.

NOTICE

Please use Komatsu genuine supercoolant (AF-NAC) for the coolant. As a basic rule, we do not recommend the use of any coolant other than Komatsu genuine supercoolant.

For details on the amount of antifreeze mixture and when to change the coolant, see "CLEAN INSIDE OF COOLING SYSTEM (PAGE 4-29)".

BATTERY

 **WARNING**

- Do not bring any flame close to the battery. During the charging operation, hydrogen and oxygen gas are generated, so there is danger of explosion.
- If battery electrolyte (dilute sulphuric acid) gets into your eyes, there is danger of losing your sight. When handling the battery, always wear protective glasses and rubber gloves. If battery electrolyte gets in your eyes, immediately wash your eyes and the backs of your eyelids for at least 15 minutes with large amounts of fresh water, then see a doctor immediately for medical attention.
- If battery electrolyte gets on your skin, it will cause chemical burns. If battery electrolyte gets on your skin, wash it off immediately with large amounts of water. When doing this, do not use any alkaline fluid as a neutralizer. If it gets on your clothes, wash it off in large amounts of water. Then take your clothes off and wash them further in large amounts of water. If you suffer any chemical burn, get medical attention immediately.
- The battery electrolyte contains dilute sulphuric acid. This is a dangerous substance, and it will damage the environment if it is drained into drainage ditches. If the battery electrolyte leaks, do not drain it into a drainage ditch. Use an adsorbent mat or soil to collect it. Then use sodium bicarbonate or slaked lime to neutralize it, and wash it away with large amounts of water.
- Wipe all the dirt off the top surface of the battery with a damp cloth. If a dry cloth is used, it will generate static electricity. This will ignite the oxygen and hydrogen gas generated when charging the battery and cause an explosion.

NOTICE

If there is battery electrolyte on the machine, wash it off with water. The battery electrolyte is acid, so it will attack the paintwork and cause corrosion where it is in contact with the machine.

When the ambient temperature goes down, the battery capacity drops. In addition, if the charging rate drops, there is danger that the battery electrolyte may freeze, so maintain the charging rate as close to 100% as possible, and be careful to maintain the battery temperature to prepare for starting next morning.

Use a hydrometer (specific gravity meter) to measure the specific gravity of the battery electrolyte, then use the following table to convert the charging rate.

Charging Rate (%)	Electrolyte Temperature	20°C (68°F)	0°C (32°F)	-10°C (14°F)	-20°C (-4°F)
	100		1.28	1.29	1.30
90		1.26	1.27	1.28	1.29
80		1.24	1.25	1.26	1.27
75		1.23	1.24	1.25	1.26

When adding distilled water in cold weather, add it before starting operations in the morning to prevent the electrolyte from freezing.

INSTALLATION OF RADIATOR CURTAIN

(If equipped)

If the ambient temperature is low and it is difficult for the engine water temperature gauge display to enter the white range, install a radiator curtain. It is possible to adjust the amount that the radiator curtain is opened or closed (fully closed, window on one side open, window on both sides open). Select the amount of opening according to the ambient temperature so that the engine water temperature gauge display enters the white range.

PRECAUTIONS AFTER COMPLETION OF WORK

To prevent mud, water, or the undercarriage from freezing and making it impossible for the machine to move on the following morning, observe the following precautions.

- Mud and water on the machine body should be completely removed. This is to prevent damage to the seal caused by water in mud or dirt getting inside the seal and freezing.
- Park the machine on a firm, dry, horizontal ground surface.

If this is impossible, park the machine on wooden boards.

The boards help protect the tracks from being frozen in soil and the machine can start next morning.

- Open the drain valve and drain any water collected in the fuel system to prevent it from freezing.
- The battery capacity drops markedly in low temperatures, so take steps to maintain the battery temperature. Cover it or remove it from the machine and keep it in a warm place, then install it again next morning.
- If the electrolyte level is low, add distilled water in the morning before beginning work. Do not add water after the day's work to prevent diluted electrolyte in the battery from freezing during the night.

REMARK

If distilled water is added to the battery, the specific gravity of the battery electrolyte will go down, and this will make it freeze in cold temperatures. When adding distilled water, add it before the start of the day's operation.

AFTER COLD WEATHER

After the cold season ends and the temperature goes up, do as follows.

- Replace the fuel and oil for all parts with oil of the viscosity specified.
For details, see "RECOMMENDED FUEL, COOLANT, AND LUBRICANT (PAGE 4-15)".

LONG-TERM STORAGE

BEFORE STORAGE

When keeping in long-term storage (more than one month), store as follows.

- After every part is washed and dried, house the machine in a dry building. Never leave it outdoors.
In case it is indispensable to leave it outdoors, park the machine on the flat ground and cover it with canvas etc.
- Completely fill the fuel tank. This prevents moisture from collecting.
- Lubricate and change the oil before storage.
- Coat the exposed portion of the hydraulic cylinder piston rod with grease. This will prevent the formation of rust.
- Disconnect the negative (-) terminal of the battery, remove the battery from the machine, and put it in storage.
- Apply the parking brake.
- Adjust the inflation pressure of each tire so that it is within the specified inflation pressure range.
- Push the retarder control lever forward to the OFF position.
- Place the shift lever at the N position and turn the starting switch OFF.
- To prevent rust, fill with Komatsu genuine supercoolant (AF-NAC) to give a density of at least 30% for the engine coolant.

DURING STORAGE



The engine exhaust gas is dangerous to the health and includes components that may cause death. Do not carry out the rust-prevention operation inside a building. If the engine is run inside a building, exhaust gas will fill the room. This will damage your health and may even cause death.

During long-term storage, carry out the rust-prevention operation once a month. When doing this, install the battery on the machine, then start the engine to prevent the loss of the film of lubricating oil. Charge the battery at the same time.

If the machine is to be kept in storage, carry out all the items in the procedure for BEFORE STORAGE. Before operating the work equipment, wipe off all the grease from hydraulic piston rods.

AFTER STORAGE

NOTICE

If the once-a-month rust-prevention operation is not carried out, there is danger that the oil film will be lost at the lubricated parts. For this reason, it is necessary to carry out forced lubrication before operating the machine. If the machine is operated with no oil film, there will be gouging at the lubricated parts and this will cause damage to the machine.

When using the machine after long-term storage, do as follows before using it.

- Install the battery again. When doing this, connect the ground side last. Charge the battery at the same time.
- Wipe off the grease from the hydraulic cylinder rods.
- Add oil and grease at all lubrication points.
- When the machine is stored for a long period, moisture in the air will mix with the oil. Check the oil before and after starting the engine. If there is water in the oil, change all the oil.

PRECAUTIONS BEFORE TRAVELING AFTER LONG-TERM STORAGE

1. Check all the oil and water levels before traveling.
2. When traveling after long-term storage, travel forward at speed of 10 to 15 km/h (6.2 to 9.3 MPH) for 5 minutes or 1 km to run the machine in, then change to normal travel.

TROUBLESHOOTING

AFTER RUNNING OUT OF FUEL

When the dump truck has run out of fuel, fill the fuel tank with fuel, bleed air from the fuel system and start up the engine again.

For an air bleeding method, see "BLEED AIR FROM FUEL CIRCUIT (PAGE 4-37)".

IF TRANSMISSION HAS TROUBLE

If the transmission has any trouble, operate the machine according to the following procedure.

1. Decelerate the machine with the brake and stop it on a safe place.
2. Set the gear shift lever to the N position, then set the parking brake switch to the PARKING position.
3. In some trouble modes, the gear is not shifted even if the gear shift lever is operated.

In this case, perform the following procedure.

- 1) When the starting switch is at the ON position or the engine is started, disconnect (pull out) emergency connector (1) (No. A1 (female), A1 (male), white 1-pin connector), then connect (insert) again.
- 2) Set the parking brake switch to the TRAVEL position.
- 3) Operate the gear shift lever to move the machine to a safe place without depressing the accelerator pedal.

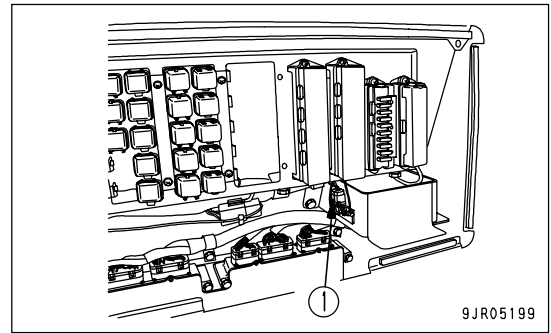

If the gear shift lever is operated with the accelerator pedal depressed, the emergency escape function will not work. In addition, the emergency escape function may not work for some failure codes.

While the emergency escape function is working, the shift indicator of the machine monitor displays "E" and the shift range (gear speed) of the transmission alternately.

METHOD OF LOWERING DUMP BODY IN EMERGENCY



WARNING

There is danger of being trapped by the dump body, so when lowering the dump body in an emergency, always carry out the operation from the ground and do not go under the dump body.

When the dump body needs to be lowered to the seat while the engine cannot be started for some trouble, perform the following procedure.

The following tool is needed to lower the dump body.

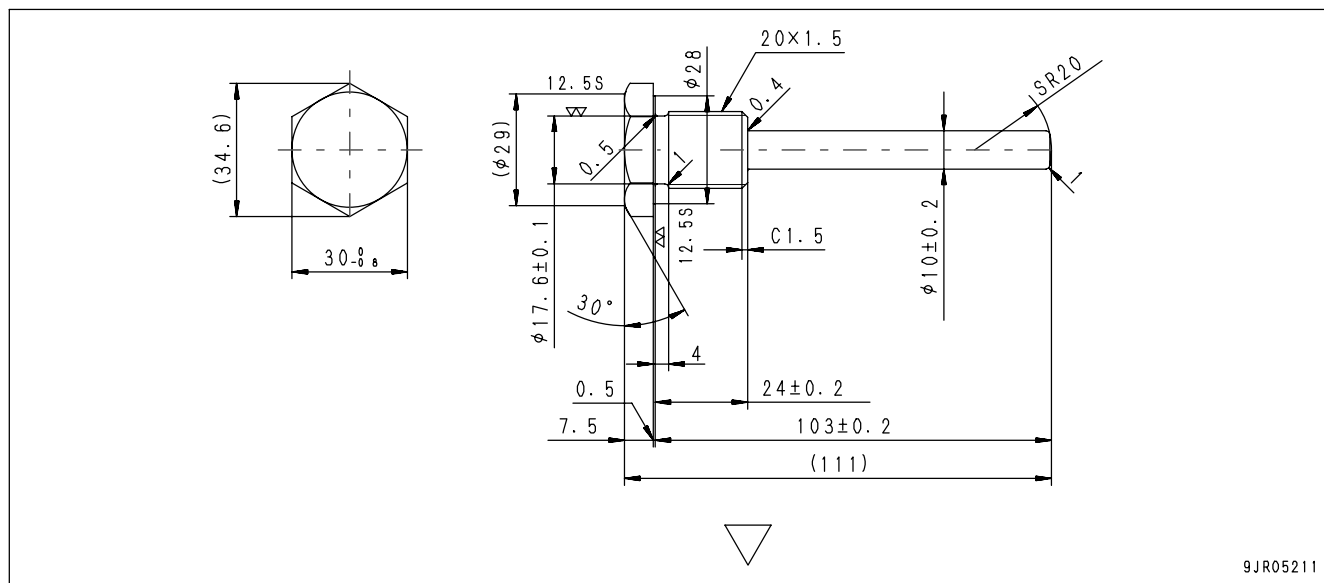

1. Remove hydraulic tank cap (F) and release the remaining pressure in the hoist circuit.

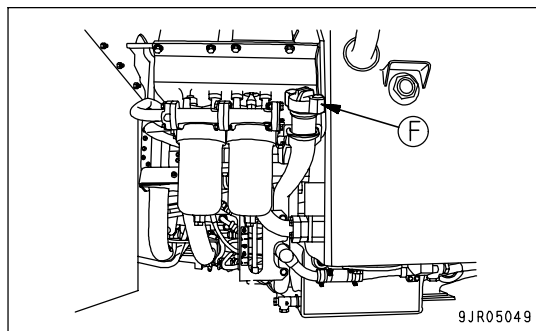

2. Remove plug (1) of hoist valve located at the back of the hydraulic tank.
3. Fit an extension to the tool and slowly screw it in the hole of plug (1).
When screwing the tool in, start on the front tire house side.
The dump body will go down under its own weight, so adjust the amount that the tool is screwed in to let the dump body down slowly.
4. Remove the tool and install plug (1).

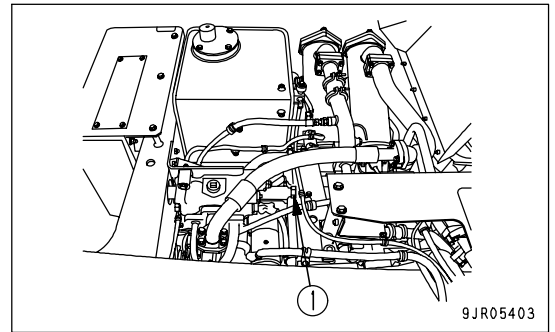

If the dump body does not go down even when the above method is used, please consult your Komatsu distributor.

METHOD OF TOWING MACHINE



WARNING

- Do not tow a machine if the engine or brakes on the machine to be towed have failed. If the machine being towed cannot be braked, the tension of the wire rope during the towing operation will be unstable and the machine being towed may hit the machine towing it and cause a serious accident.
- When towing, use the towing hooks. Always confirm that the wire rope used for towing has ample strength for the weight of the machine being towed. If the wire rope is not fitted properly or does not have sufficient strength, the wire rope may come off or break during the towing operation and cause a serious accident.
- Do not apply a sudden load to the wire rope. If a load is suddenly applied, the wire rope may break or the hook may break and cause a serious accident.
- Serious personal injury could result if a disabled machine is towed incorrectly or if there is a mistake in the selection of the wire rope. Always do as follows.
 - o To prevent injury, always wear leather gloves when handling wire rope.
 - o Never go between the towing machine and the towed machine during the towing operation.
 - o Never tow a machine on a slope. There is danger that the machine may tip over.
 - o Never use a wire rope that has cut strands (A), reduced diameter (B), or kinks (C). There is danger that the rope may break during the towing operation.

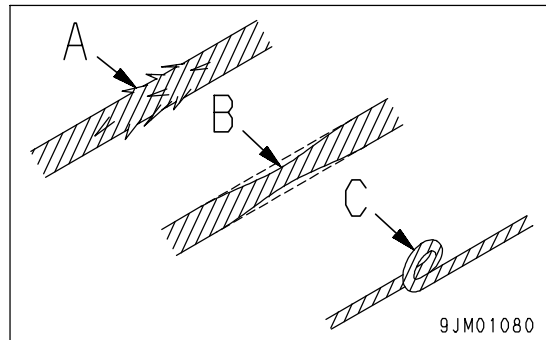

NOTICE

- The max. traction force of this dump truck is as indicated below. If you attempt to tow a load with higher traction force, the dump truck will suffer damage on the frame.
 - HD465: 316785 N (32325 kg)
 - HD605: 339570 N (34650 kg)
- When towing the dump truck for a transportation purpose, limit towing only to a nearby inspection and maintenance station and avoid a long haul.
 - A long haul can cause damage to the power train of the dump truck.

Please consult your Komatsu distributor for information about towing a disabled machine.

This machine must not be towed except in emergencies. When towing the machine, take the following precautions.

- When towing a machine, tow it at a low speed of less than 2 km/h (1.2 MPH), and for a distance of a few meters to a place where repairs can be carried out. the machine should be towed only in emergencies. If the machine must be moved long distance, transport the machine using the Trailer truck.
- Use a towing machine of the same class as the machine being towed.
Check that the towing machine has ample braking power, weight, and rimpull to allow it to control both machines on slopes or on the tow road.
- Use the specified hook for both the towing machine and the machine being towed.
- To protect the operator if the towing wire or towing bar breaks, install protective plates on both the towing machine and the machine being towed.
- There are towing hooks under the front frame and under the rear axle. Do not use any other part for the towing hook.

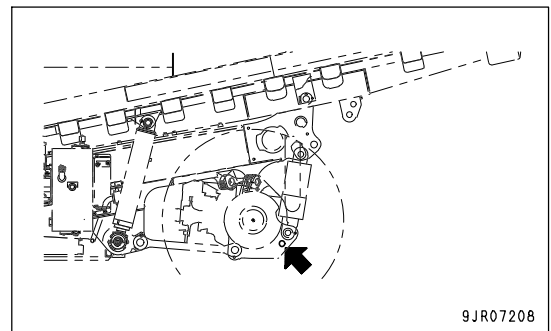
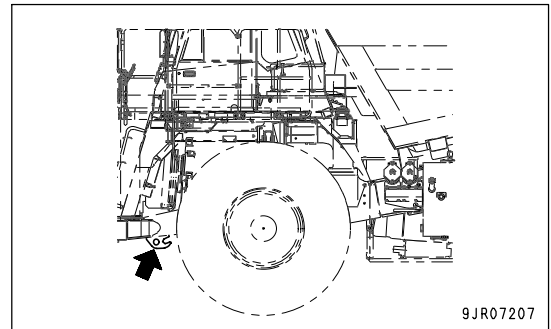

- When fitting the towing wire, check the condition of the hook to make sure that there is no problem.
- Keep the angle of the towing wire as small as possible.
Keep the angle between the center lines of the two machines to within 30 degrees.
- Towing may be carried out under various differing conditions, so it is impossible to determine beforehand the requirements for towing.
Towing on flat horizontal roads will require the minimum rimpull, while towing on slopes or on uneven road surfaces will require the maximum rimpull.
- If the pressure in a hydraulic circuit has dropped because of leakage of oil, the parking brake will be applied, so release the parking brake before towing.
- Before releasing the parking brake, always put blocks under all four wheels. If the wheels are not blocked, there is danger that the machine may move.
Connect with the towing wire or drawbar, and remove the blocks from the wheels when the disabled machine is in a condition where it cannot run away.
- When releasing the parking brake, check first that the surrounding area is safe.
- When the parking brake is released, the brakes cannot be used, so check carefully that the situation is safe.
- When towing down a slope, use two towing machines. One machine should be uphill from the disabled machine and should be connected with towing wire or a drawbar to pull the disabled machine back and keep it stable. The other machine should tow the disabled machine downhill.

WHEN ENGINE RUNS

NOTICE

When starting to move, the operator of the towing machine should give a signal to the operator of the machine being towed. If the towing machine moves off while the brakes are still applied on the machine being towed, a force greater than the permissible load will be applied to the towing portion and the machine will be damaged.

If the tires are stuck in mud and the machine cannot escape under its own power, if there is no problem in the travel system and the steering wheel can be operated, tow the machine as follows.

1. One operator sits in the operator's compartment of the towing machine.
2. Fit wire rope to the towing pin of the towing machine and to the towing pin of the machine to be towed.
When doing this, always check that the wire rope is of ample strength to take the weight of the machine being towed.
3. Start the engine of the towing machine.
4. Operate the towing machine to tow the problem machine slowly.
The towing speed should be a maximum of 2 km/h.
5. The operator of the problem machine should operate the steering to follow the direction of the towing machine.
6. Move the problem machine to a position where it can travel under its own power, then stop the towing operation.
7. Set the parking brake on the machine being towed to PARKING.
8. Remove the wire rope from the towing pins.

WHEN ENGINE DOES NOT RUN

1. Put blocks under the wheels.
2. If the emergency steering cannot be used, remove the hydraulic hoses to the steering cylinders (left and right: 2 each).
After removing the hoses, fit blind plugs.
Fit a container to the steering cylinder to catch the oil.
3. Prepare 2 towing machines.
For the towing machines, use machines that are equal in size or larger than the machine to be towed.
4. Position towing machines in front of and behind the machine to be towed, and fit wire rope to the front or rear of the towing machines.
When doing this, always check that the wire rope is of ample strength to take the weight of the machine being towed.
5. Release the parking brake on the machine to be towed.
For details of the method of releasing the parking brake, see "WHEN PARKING BRAKE HAS BEEN ACTUATED IN EMERGENCY (PAGE 3-141)".
6. Remove the blocks from the machine to be towed.
7. Tow the machine slowly.
The towing speed should be a maximum of 2 km/h.
If the emergency steering can be used, it is possible to steer the machine with the emergency steering. The maximum length of use should be less than 90 seconds.

WHEN PARKING BRAKE HAS BEEN ACTUATED IN EMERGENCY

If the pressure in the hydraulic circuit goes down abnormally because of oil leakage or some other problem, the parking brake is automatically applied.

If it is necessary to use the towing machine to move the failed machine, and the parking brake must be released, use the following method to release the brake.

After moving the machine, please ask your Komatsu distributor to carry out repairs.

METHOD OF RELEASING PARKING BRAKE IN EMERGENCY



WARNING

Before releasing the parking brake, always put blocks under the tires. If the tires are not blocked, the machine may suddenly move and cause serious personal injury.

1. When releasing the parking brake manually, prepare 20 M12 bolts (distance under head: 65 to 80 mm (2.6 to 3.2 in); thread pitch: 1.75 mm (0.069 in)(coarse thread)) and 20 M12 washers.
2. Prepare a container to catch the oil.
3. Stop the engine.
4. Put blocks under the wheels.
5. Set the container to catch the oil under the brake portion.
6. Remove plug (1) from the rear axle brake portion.

REMARK

There are 10 plugs on the right side and 10 plugs on the left side.

7. Pass the brake release bolt through the washer and insert it into the plug hole.

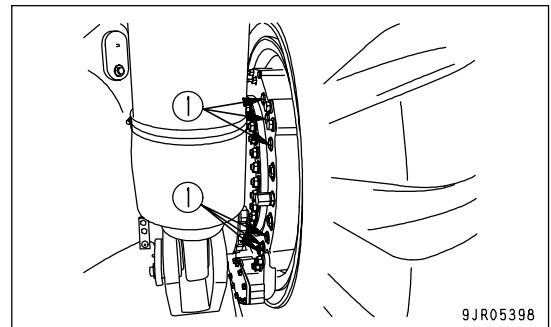

9JR05398

NOTICE

If the bolts are not tightened uniformly, the internal piston will be distorted or damaged. Tighten the bolts in turn on diagonally opposite sides.

8. Tighten the brake release bolts uniformly. (Both left and right sides)

IF BATTERY IS DISCHARGED



WARNING

- Do not charge the battery when it is mounted on the machine. Always remove it before charging it. If it is charged while still mounted on the machine, if the cable comes off during the charging operation, the clip and parts of the machine will come in contact. This will cause a spark, ignite the flammable gas generated inside the battery, and cause an explosion.
- Do not bring any flame close to the battery. During the charging operation, flammable gas is generated inside the battery, so there is danger of explosion.
- If battery electrolyte (dilute sulphuric acid) gets in your eyes, you may lose your eyesight. Always wear protective glasses and rubber gloves when handling the battery. If battery electrolyte gets into your eyes, immediately wash your eyes with large amounts of fresh water for at least 15 minutes, and be sure to wash behind your eyelids. After that, get medical attention immediately.
- If battery electrolyte gets on your skin, it will cause chemical burns. If battery electrolyte gets on your skin, wash it off immediately with large amounts of water. When doing this, do not use any alkaline fluid as a neutralizer. If battery electrolyte gets on your clothes, wash it off with large amounts of water. Then take your clothes off and wash them further in large amounts of water. If you suffer any chemical burn, get medical attention immediately.
- If the terminals are loose, improper contact will cause sparks, and there is danger that the flammable gas generated inside the battery will ignite and cause an explosion. Always install the terminals securely.

REMOVAL AND INSTALLATION OF BATTERY

1. When removing the battery, disconnect ground terminal (negative (-) terminal) (1) first.

REMARK

The negative (-) terminal of the battery is connected to the machine. For this reason, if any tool contacts between the machine and the positive (+) terminal of the battery, the battery will be short-circuited and this will cause sparks.

2. Remove connection cable (2) between the 2 batteries.
3. Finally, disconnect positive (+) terminal (3).
4. Remove battery clamps (4).

This makes it possible to remove the batteries from the machine.

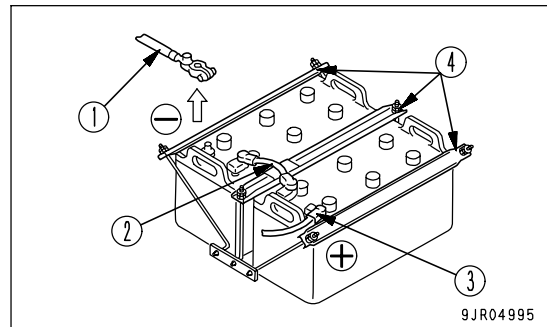

5. When installing the battery, connect positive (+) terminal (3) from the battery relay first.
6. Install connection cable (2) between the 2 batteries.
7. Connect ground terminal (negative (-) terminal) (1) to the battery.

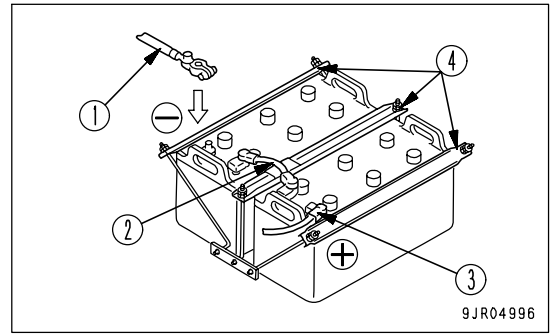
**NOTICE**

If the battery is not secured in position, the battery will move during operation. This will lead to leakage of the battery electrolyte or damage to the battery case, and will damage the machine. Always secure the battery with the clamps.

8. Secure the battery in position with the battery clamps.
Tightening torque for tightening nut: 9.8 - 14.0 Nm {1.0 - 1.5 kgm}

PRECAUTIONS FOR CHARGING BATTERY

When the charging the battery, if the battery is mistakenly handled, there is danger of explosion. Follow the precautions in "IF BATTERY IS DISCHARGED (PAGE 3-142)" and the instructions given in the charger manual, and always do as follows.

- Set the voltage of the charger to match the voltage of the battery to be charged. If the correct voltage is not selected, the charger may overheat and cause an explosion.
- Connect the positive (+) charger clip of the charger to the positive (+) terminal of the battery, then connect the negative (-) charger clip of the charger to the negative (-) terminal of the battery. Be sure to attach the clips securely.
- Set the charging current to 1/10 of the value of the rated battery capacity; when carrying out rapid charging, set it to less than the rated battery capacity.
If the charger current is too high, the electrolyte will leak or dry up, and this may cause the battery to catch fire and explode.
- If the battery electrolyte is frozen, do not charge the battery or start the engine with a different power source. There is a danger that this will ignite the battery electrolyte and cause the battery to explode.
- Do not use or charge the battery if the battery electrolyte level is below the LOWER LEVEL line. This may cause an explosion. Check the battery electrolyte level periodically and add distilled water to bring the electrolyte level to the UPPER LEVEL line.

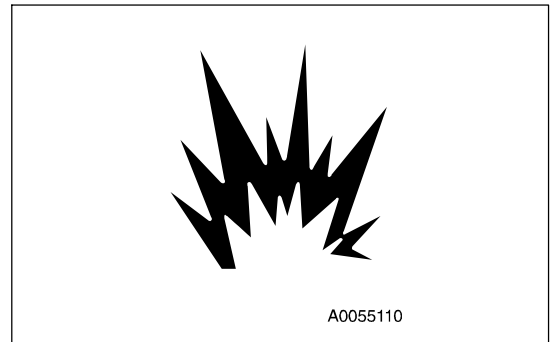

STARTING ENGINE WITH BOOSTER CABLE

When starting the engine with a booster cable, do as follows.

PRECAUTIONS WHEN CONNECTING AND DISCONNECTING BOOSTER CABLE



WARNING

If any mistake is made in the method of connecting the booster cables, the battery may explode. Always do as follows.

- When starting the engine using a booster cable, always wear protective glasses and rubber gloves.
- When connecting booster cables, always connect to a machine that has the same battery voltage as the problem machine.
- When starting the engine using a booster cable, always use two workers for the starting operation: one sits in the operator's seat, the other carries out the work with the battery.
- When using a normal machine to start a problem machine, be careful not to let the normal machine and problem machine touch each other.
- When connecting the booster cables, turn the starting switches OFF on both the normal machine and the problem machine. There is danger that the machine may move when the electric power is connected.
- Be sure to connect the positive (+) cable first when installing the booster cables. Disconnect the ground (negative (-)) cable first when removing them.
- When removing the booster cable, be careful not to let the booster cable clips contact each other or the machine.

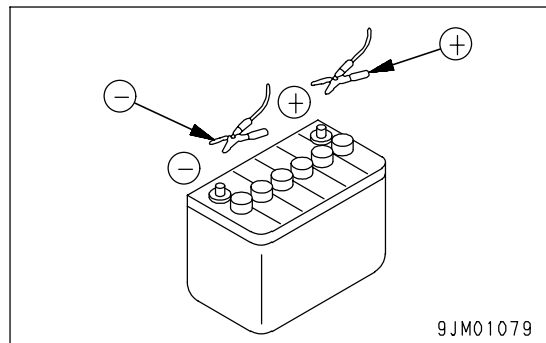
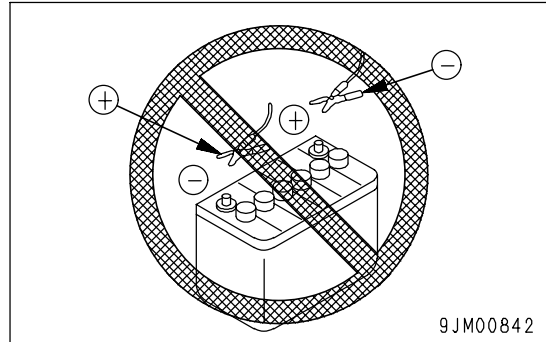

- The size of the booster cable and clip should be suitable for the battery size.
- The battery of the normal machine must be the same capacity as that of the problem machine.
- Check the cables and clips for damage or corrosion.
- Connect the clips securely so that they do not come off.

CONNECTING THE BOOSTER CABLES

Keep the starting switch of the normal machine and problem machine in the OFF position.

Connect the booster cable as follows, in the order of the numbers marked in the diagram.

1. Connect one clip of booster cable (A) to the positive (+) terminal of the problem machine.
2. Connect the other clip of booster cable (A) to the positive (+) terminal of the normal machine.
3. Connect one clip of booster cable (B) to the negative (-) terminal of the normal machine.
4. Connect the other clip of booster cable (B) to the engine block of the problem machine.

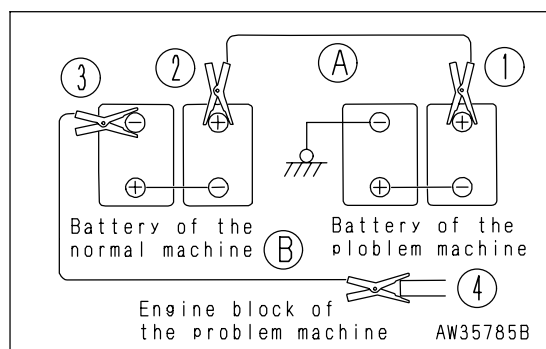

STARTING THE ENGINE

**WARNING**

Apply the parking brakes, set the gear shift lever to the N position on both the normal machine and the problem machine to prevent the machine from moving during the starting operation. If the machine moves, it may lead to serious personal injury.

1. Make sure the clips are firmly connected to the battery terminals.
2. Start engine of the normal machine and run it at high idle speed.
3. Turn the starting switch of the problem machine to the START position and start the engine.
If the engine doesn't start at first, try again after 2 minutes or so.

DISCONNECTING THE BOOSTER CABLES

After the engine has started, disconnect the booster cables in the reverse of the order in which they were connected.

1. Remove one clip of booster cable (B) from the engine block of the problem machine.
2. Remove the other clip of booster cable (B) from the negative (-) terminal of the normal machine.
3. Remove one clip of booster cable (A) from the positive (+) terminal of the normal machine.
4. Remove the other clip of booster cable (A) from the positive (+) terminal of the problem machine.

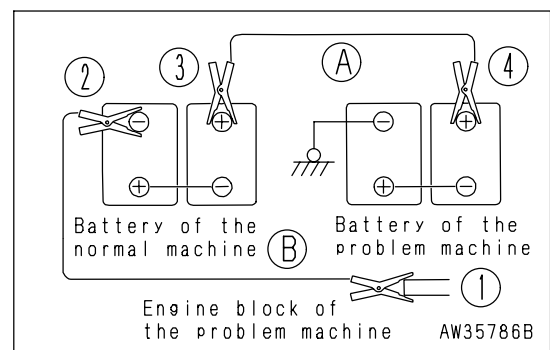

ACTION IF FIRE OCCURS



WARNING

- Always provide a fire extinguisher for use if a fire occurs. It is possible to prevent damage to the machine if a fire is extinguished immediately. Check the fire extinguisher periodically and make sure that you know the way of using it.
- If a fire occurs on the machine, escape from the machine as follows to ensure your own safety.
 - 1) Turn the starting switch OFF, stop the engine, and remove the key.
 - 2) Leave the operator's compartment through the door in the direction of safety, and use the handrails and steps when escaping from the machine. Do not jump off the machine. There is danger that you will fall and suffer injury.

Always provide a fire extinguisher for use if a fire occurs.

If a fire occurs,

1. Turn the starting switch OFF, stop the engine, and remove the key.
2. Using the handrails and the steps, escape from the machine.
3. Use the fire extinguisher immediately to put out the fire.

OTHER TROUBLE

ELECTRICAL SYSTEM

- (): Always contact your Komatsu distributor when dealing with these items.
- In cases of problems or causes which are not listed below, contact your Komatsu distributor for repairs.

Problem	Main causes	Remedy
Lamp does not glow brightly even when engine runs at high speed	• Defective wiring	(• Check, repair loose terminals, disconnections)
	• Insufficient battery charge	• Charge, Add distilled water
Lamp flickers while engine is running	• Defective belt	• Check, replace belt. See EVERY 500 HOURS SERVICE.
Battery charge system caution pilot lamp lights up while engine is running	• Defective alternator	(• Replace)
	• Defective wiring	(• Check, repair)
Abnormal noise is generated from alternator	• Defective alternator	(• Replace)
Starting motor does not turn when starting switch is turned to START	• Defective wiring	(• Check, repair)
	• Defective starting switch	(• Replace switch)
	• Insufficient battery charge	• Charge
	• Defective battery switch	(• Replace switch)
	• Loose ground cable terminals between engine and chassis	• Check, repair
Starting motor turns engine sluggishly	• Defective wiring	(• Check, repair)
	• Insufficient battery charge	• Charge
Starting motor disengages before engine starts	• Defective wiring	(• Check, repair)
	• Insufficient battery charge	• Charge

CHASSIS

- (): Always contact your Komatsu distributor when dealing with these items.
- In cases of problems or causes which are not listed below, contact your Komatsu distributor for repairs.

Problem	Main causes	Remedy
Torque converter oil temperature caution lamp flashes	• Leakage of oil or entry of air due to damage or defective tightening of oil pipe, pipe joint	(• Check, repair)
	• Wear, scuffing of gear pump	(• Check, repair)
	• Insufficient oil in transmission case	• Add oil to specified level. See CHECK BEFORE STARTING.
	• Loose fan belt	• Replace belt. See EVERY 500 HOURS SERVICE.
	• Clogged oil cooler	(• Clean or replace)
	• Long distance traveled in torque converter range	• Drive in direct range
	• Disconnected, broken wiring to sensor	(• Repair, connect wiring)
Steering wheel is heavy	• Lack of grease at link	• Add grease
	• Internal leakage inside steering cylinder	(• Replace cylinder seal)
Steering wheel pulls	• Tire inflation pressure not uniform on left and right	• Make tire inflation pressure uniform. See CHECK BEFORE STARTING.
	• Dragging, pulling of front brake	• Check wear of front brake pad. For details, see EVERY 500 HOURS SERVICE.
Braking effect is poor when brake pedal is depressed Brake pulls to one side	• Pad has reached wear limit	(• Replace pad)
	• Rear disc has reached wear limit	(• Replace disc)
	• Insufficient oil pressure	• Charge to specified pressure
	• Insufficient brake oil	• Add oil to the transmission case. See CHECK BEFORE STARTING.
	• Air in brake circuit	• Bleed air. See WHEN REQUIRED.
Dump body speed is slow	• Defective gear pump	(• Replace gear pump)
	• Insufficient oil	• Add oil to specified level. See CHECK BEFORE STARTING.
Suspension is hard	• Entry of soil or sand due to breakage of dust seal, gas leakage due to breakage of U-packing	(• Replace U-packing)
	• Gas leaking from valve core	(• Replace valve core)

Problem	Main causes	Remedy
Wheel on one side tends to slip	• Air in rear brake circuit (between slack adjuster and rear brake)	• Bleed air from rear brakes (left, right). See WHEN REQUIRED.
	• Excessive difference in wear between left and right tires	(• Replace tires)
	• Excessive difference in division of load between left and right wheels (unbalanced load)	• Make load uniform
	• Excessive deformation of disc	(• Disassemble and adjust brake)

IF ACCELERATOR PEDAL HAS FAILED

In addition to the detector that detects the amount the accelerator the pedal is depressed, there is also a discrimination switch installed to distinguish if the accelerator pedal is being depressed or has been released.

If there is defective wiring or a failure in the accelerator pedal, and the supplied detector cannot correctly detect the amount that the accelerator pedal is depressed, the engine controller will control the engine according to the signal from the discrimination switch. When the accelerator pedal is being depressed, the engine speed is set to 1500 rpm; when the accelerator pedal is released, the engine speed is set to low idle. The engine speed may differ according to the load.

Use the accelerator pedal to move the machine to a safe place, then check the failure code and contact your Komatsu distributor.

When operating the accelerator pedal, use one of the two following positions: release the pedal completely to set it to the OFF position (low idle); or depress it fully (1500 rpm).

If the accelerator pedal is partially depressed, the controller may be unable to distinguish if it is being depressed or not.

REMARK

If the engine controller does not correctly receive the signal for the amount the accelerator pedal is depressed, the central warning lamp will flash, the alarm buzzer will sound, and user code 02 will be displayed on the character display.

ENGINE

- (): Always contact your Komatsu distributor when dealing with these items.
- In cases of problems or causes which are not listed below, contact your Komatsu distributor for repairs.

Problem	Main causes	Remedy
Engine oil pressure caution lamp lights up	• Insufficient oil in oil pan	• Add oil to specified level. See CHECK BEFORE STARTING.
	• Clogged oil filter cartridge	• Replace cartridge, see EVERY 500 HOURS SERVICE.
	• Oil leakage due to damage caused by defective tightening of oil pan, pipe joint	(• Check, repair)
	• Disconnection, broken wiring to sensor	(• Repair, connect wiring)
Steam spurts out from top of radiator (pressure valve) Drop in engine water level is displayed on the character display and the maintenance caution lamp lights up Coolant temperature gauge is in red range Engine coolant temperature caution lamp flashes	• Insufficient coolant, coolant leakage	• Check, add coolant. See CHECK BEFORE STARTING.
	• Loose fan belt	• Replace belt. See EVERY 500 HOURS SERVICE.
	• Dirt or scale accumulated in cooling system	• Change coolant, clean inside of cooling system. See WHEN REQUIRED.
	• Radiator fins clogged or damaged	• Clean or repair. See WHEN REQUIRED.
	• Defective coolant temperature gauge	(• Replace coolant temperature gauge)
	• Defective thermostat	(• Replace thermostat)
	• Defective thermostat seal	(• Replace thermostat seal)
	• Loose radiator filler cap	• Tighten or replace cap.
Coolant temperature gauge display stays at lowest level and does not rise	• Disconnection, broken wiring to sensor	(• Repair, connect wiring)
	• Defective coolant temperature gauge	(• Replace coolant temperature gauge)
	• Defective thermostat	(• Replace thermostat)
Engine does not start even when starting motor is turned	• In cold weather, cold wind is blowing strongly against engine	(• Install radiator curtain)
	• Insufficient fuel	• Add fuel. See CHECK BEFORE STARTING.
	• Air in fuel system	(• Repair place where air is leaking in)
	• Starting motor cranks engine too slowly	• See electrical components
	• Starting motor does not turn	• See electrical components
Fuel stops from time to time	• Defective valve clearance (defective compression)	(• Adjust valve clearance)
	• Crushed fuel tank breather tube	(• Replace breather tube)

Problem	Main causes	Remedy
Excessive oil consumption	• Oil leakage	(• Check, repair)
	• Excessive oil in oil pan	• Add oil to specified level. See CHECK BEFORE STARTING.
Exhaust gas is white or bluish	• Worn piston, ring, cylinder liner	(• Replace)
	• Improper fuel	• Replace with specified fuel
	• Defective turbocharger	(• Check, replace)
Exhaust gas is black	• Clogged air cleaner element	• Clean or replace. See WHEN REQUIRED.
	• Compression insufficient • Valve clearance not adequate • Piston, piston ring or cylinder liner worn out	• See "Valve Clearance Adjustment" above. (• Check, repair)
	• Nozzle defective	(• Nozzle replacement)
	• Defective turbochaeger	(• Check, replace)
Engine hunts	• Air entering suction side of fuel line	(• Repair place where air is leaking in)
Combustion noise ocaasionally makes breathing sound	• Defecyive nozzle	(• Replace nozzle)
There is strange noise (combustion or mechanical)	• Poor quality fuel being used	• Replace with specified fuel
	• Overheating	• See "Water temperature gauge is in red range" above.
	• Valve clearance in excess	(• Valve clearance adjustment)

ACTION CODE

If any problem occurs, stop the machine, apply the parking brake and check the service code, then contact your Komatsu distributor for repairs.

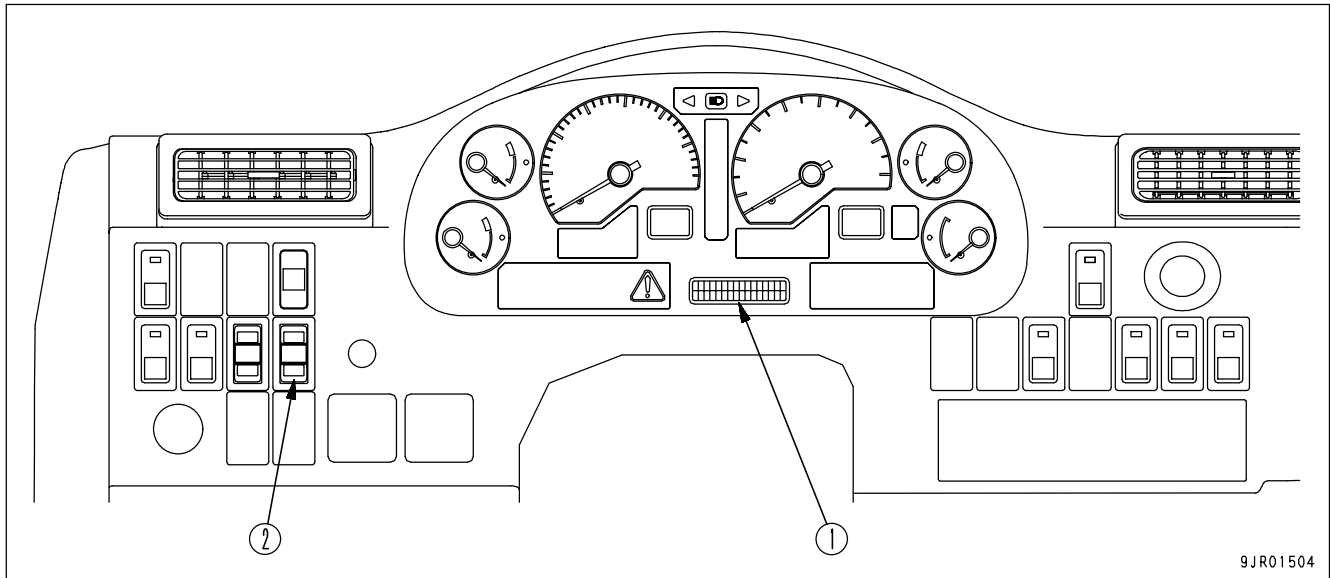

If action code "E03" is displayed on the character display (1), or if an action code is displayed after taking the remedy when action code "E02" was displayed, or if "MAINTENANCE" is displayed together with action code "E01", do as follows to check the failure code.

1. If an action code is displayed, pressed the top (>) portion of machine monitor mode selector switch (2) and check the failure code.
The failure code is displayed on character display (1).
2. Press the top (>) portion of machine monitor mode selector switch (2) again.
The service meter and odometer will be displayed for several seconds, and the screen will then return to the action code screen.
If more than one failure has occurred, the next failure code is display.
3. Check the failure code, then contact your Komatsu distributor and report the failure code for repairs.

REMARK

- The 6-digit code displayed on the left of the line at the top of the character display is the failure code.
- The code displayed at the right side of the failure code shows the controller that detected the failure code.
MON: Machine monitor
TM: Transmission controller
ENG: Engine controller
BK: Retarder controller
- The line at the bottom of the character display shows the system where the failure was generated.

MAINTENANCE

Please read and make sure that you understand the SAFETY section before reading this section.

GUIDES TO MAINTENANCE



WARNING

- During inspection and maintenance of the machine, if anyone starts the engine or operates the machine, and there is a serviceman carrying out inspection, he may suffer serious personal injury. Always do as follows.
 - o When carrying out inspection and maintenance, always hang a "DO NOT OPERATE" warning sign on the gear shift lever (1) to make it clear that the machine is being inspected. If necessary, put signs up around the machine also.
 - o If there is a "DO NOT OPERATE" sign on the machine, it means that the machine is undergoing inspection and maintenance. Do not start the engine or operate the machine.
 - o When not using the warning sign, keep it in the toolbox. If there is no toolbox, keep it on the machine together with the Operation and Maintenance Manual.
- If the machine moves unexpectedly during maintenance, it may lead to serious personal injury. During the maintenance operation, allow only the necessary workers to approach the machine. If necessary, position a worker to observe the area around the machine.
- When working together with others, there is danger that communication problems between the workers may lead to unexpected accidents. When repairing the machine, decide on one person to give instructions for the operation, and always follow that person's instructions.
- When selecting the place to carry out inspection and maintenance, choose flat firm ground that is safe for the operation, with no danger of landslide, falling rocks, or flooding. If the place is not suitable for inspection and maintenance, there is danger of serious personal injury or damage.
- When carrying out inspection and maintenance with the engine running, always carry out the work with at least two workers and obey the following precautions strictly. During inspection and maintenance operations, there is danger that the machine may suddenly move or that the maintenance worker may be caught up in rotating parts and suffer serious personal injury.
 - o Set the parking brake switch to the PARKING position to apply the brake, then put blocks under the tires to prevent the machine from moving.
 - o One person should sit in the operator's seat so that the engine can be stopped at any time. All workers should be in communication all the time.
 - o Lower the dump body, set the dump control lever to the HOLD position, lock the dump control lever with the lock knob, then stop the engine.
 - o When carrying out operations close to the fan, fan belt, or other rotating parts, be careful not to let any part of your body come close or to let your clothing get caught up in the rotating parts.
 - o During inspection and maintenance, do not touch the steering wheel, gear shift lever, or dump control lever unless necessary. If it is necessary to touch these parts during inspection and maintenance, always give a signal to the other workers and have them move back to a safe place.
 - o If tools or parts are dropped or inserted into the fan or fan belt, they may fly off and cause injury. Do not drop or insert any parts or tools.

Do not perform any inspection and maintenance operation that is not found in this manual.



CAUTION

- If the place of operation for carrying out inspection and maintenance is not kept tidy, there is danger of people tripping up, slipping, or falling over and being injured. Always put away hammers and other tools that are lying around in the work area, and wipe up all oil, grease, or other slippery substances. Always keep the workplace clean and tidy to enable operations to be carried out in safety.
 - Always use the proper tools and handle them correctly. Do not use damaged or deformed tools or tools intended for another purpose. Using such tools may cause injury.
-

CHECK SERVICE METER:

Check the service meter reading every day to see if the time has come for any necessary maintenance to be performed.

KOMATSU GENUINE REPLACEMENT PARTS:

Use Komatsu genuine parts specified in the Parts Book as replacement parts. Please consult Komatsu distributor for replacement parts.

KOMATSU GENUINE OILS:

For lubrication of the machine, use the Komatsu genuine lubricants. Moreover use oil of the specified viscosity according to the ambient temperature.

ALWAYS USE CLEAN WINDOW WASHER FLUID:

Use automobile window washer fluid, and be careful not to let any dirt get into it.

ALWAYS USE CLEAN OIL AND GREASE:

Use clean oil and grease. Also, keep the containers of the oil and grease clean. Keep foreign materials away from oil and grease.

CHECKING FOREIGN MATERIALS IN DRAINED OIL AND ON FILTERS:

After oil is changed or filters are replaced, check the oil and changed filters for metal particles and foreign material. If large quantity of metal particles or foreign materials are found, always report to the person in charge, and carry out suitable action.

OIL CHANGE:

If your machine is equipped with a fuel strainer, do not remove it while fueling.

PERSONAL PROTECTIVE ITEMS:

! WARNING

- Always wear a hardhat and safety boots. Depending on the nature of the work, also wear protective glasses, mask, earplugs, safety belt, or other protective equipment. If you do not use suitable protective equipment, you may suffer injury.
- If your hair extends outside your hardhat, it may be caught in rotating parts of the machine and you may suffer injury. If your hair is long, tie it up and make sure that it does not extend outside your hardhat.

Always wear suitable clothes for the job. Wear a hardhat to protect your head and safety boots to protect your feet. Depending on the nature of the work, also wear protective glasses, earplugs, safety belt, or other protective equipment.

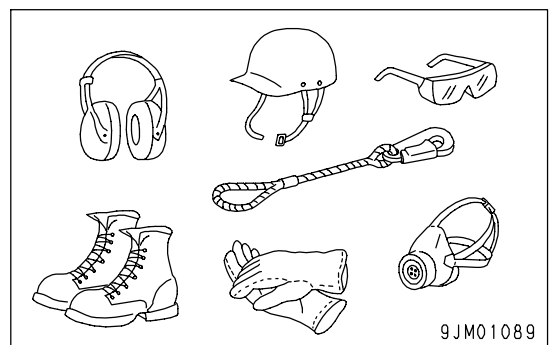

KEEP MACHINE CLEAN:**WARNING**

- If there is mud or oil on the machine, your feet may slip when you get on the machine or when you carry out inspection and maintenance. This may cause you to fall and suffer injury. Always wipe off any mud or oil stuck to the machine, and keep the machine clean.
- If water gets into the electrical system, the electrical equipment may not work properly or may be actuated by mistake. If it is actuated by mistake, there is danger that the machine may move unexpectedly and cause serious personal injury. When cleaning the machine, do not wash the electrical system (sensors, connectors) with water or steam.

Always keep the machine clean.

Wipe off any mud or grease stuck to the machine.

Do not spray water on electrical equipment or clean it with steam.

PRECAUTION FOR LIGHTING EQUIPMENT:**WARNING**

When inspecting the fuel, oil, battery electrolyte, window washer fluid, or coolant, always use explosion-proof lighting equipment. If explosion-proof lighting equipment is not used, the fuel, oil, battery electrolyte, window washer fluid, or coolant may ignite and cause an explosion, leading to serious personal injury.

The fuel, oil, battery electrolyte, window washer fluid, and coolant used on this machine are flammable. There is danger that they may be ignited by sparks from the lighting equipment. Always use explosion-proof lighting equipment.

The cigarette lighter can be used as the power source on the machine. Always use equipment with a capacity equal to or less than the cigarette lighter. For details, see "CIGARETTE LIGHTER (PAGE 3-39)".

HANDLING SUSPENSION CYLINDER, ACCUMULATOR:**WARNING**

The suspension cylinder and accumulator are charged with high-pressure nitrogen gas. If any mistake is made in handling them, there is danger of causing an explosion, which may lead to serious personal injury. To prevent accidents, always do as follows.

- Do not remove or disassemble this equipment unless necessary.
- Do not bring it near flame or dispose of it in fire.
- Do not make holes in it, weld it, or use a cutting torch.
- Do not bear any shock by hammering, rolling, etc..

The suspension cylinder and accumulator are charged with high-pressure nitrogen gas. It is dangerous if any mistake is made in handling them.

When charging with nitrogen gas or when releasing the gas, ask your Komatsu distributor to carry out the operation.

PRECAUTION FOR FIRE:

**WARNING**

Do not bring any flame close to fuel, oil, antifreeze, or window washer fluid. There is danger that they may ignite and cause a fire. Do not bring them close to any flame. If any of these fluids is spilled, wipe it up immediately.

- Do not smoke or use any flame close to fuel, oil, antifreeze, or window washer fluid.
- Do not start the engine when adding fuel or oil.
- Do not leave the machine when adding fuel, oil, antifreeze, or window washer fluid. Always check that no fluid has spilled during the filling operation.
- After adding fuel or oil, tighten all the caps securely to prevent any fuel or oil from spilling.
- Be extremely careful not to spill fuel on hot surfaces or on parts of the electrical system.
- After adding fuel or oil, wipe up all the spilled fuel and oil with a cloth.
- After wiping up fuel or oil with a cloth, put the cloth and other flammable substances in the specified container, and store the container in a place where there is no danger of the contents catching fire.
- Use a non-flammable oil as the fluid for washing parts. Do not use fuel, gasoline, or any other fluid that may catch fire.
- Do not weld or use a gas cutter on pipes or tubes that carry flammable fluids.
- Fuel and oil evaporate, so keep them in a place where there is good ventilation.
- Always store the fuel and oil in the specified place and within the maximum specified amount. Do not allow any unauthorized person to enter the area.
- When carrying out grinding operations or welding operations on the machine, move the machine to a place where there is no danger of any substance catching fire.

UNAUTHORIZED MODIFICATION:

**WARNING**

Do not to carry out any unauthorized modification of the machine. If the machine is modified, problems may occur with safety, and this may lead to serious personal injury. Before making any modification, always consult your Komatsu distributor.

Consult your Komatsu distributor regarding modifications. If you carry out modifications without consulting anyone, the machine may not function properly and problems may occur with safety.

WELDING INSTRUCTIONS:

**WARNING**

All welding operations should be carried out by a qualified welder with the proper equipment. During welding operations, gas is generated, and there is danger of fire and electrocution. Never allow any unqualified person to carry out welding operations.

- Turn off the engine starting switch.
- Do not apply more than 200 V continuously.
- Connect grounding cable within 1 m (3.3 ft) of the area to be welded. If grounding cable is connected near instruments, connectors, etc., the instruments may malfunction.
- If a seal or bearing happens to come between the part being welded and grounding point, change the grounding point to avoid such parts.
- Do not use the area around the pins or the hydraulic cylinders as the grounding point. Sparks will cause damage to the plated portion.

DO NOT DROP THINGS INSIDE MACHINE:

- When opening inspection windows or the oil filler port of the tank to carry out inspection, be careful not to drop nuts, bolts, or tools inside the machine.
If such things are dropped inside the machine, it may cause damage and/or malfunction of the machine, and will lead to failure. If you drop anything inside the machine, always remove it immediately.
- Do not put unnecessary things in your pockets. Carry only things which are necessary for inspection.

AVOID MIXING OILS:

If a different brand or grade of oil has to be added, drain the old oil and replace all the oil with the new brand or grade of oil. Never mix different brand or grade of oil.

LOCKING INSPECTION COVERS:**WARNING**

After opening the inspection cover, secure it in position with the lock bar. If it is not locked and a gust of wind blows during the inspection operation, the inspection cover may shut suddenly and cause injury.

Lock inspection cover securely into position with the lock bar at inspection or maintenance.

HANDLING HIGH-PRESSURE HOSES, PIPING:**WARNING**

- Fix the hoses, tubes, guards, and piping cushions securely in position. If they are loose, they will vibrate during operation and rub against other parts. There is danger that will cause wear or make holes in the hoses or tubes, allowing high-pressure oil to spurt out and cause a fire.
- If the oil or fuel leaks from the high-pressure hoses or piping, there is danger of fire or serious personal injury caused by defective operation. If any loose hose or piping mounts are found, or there is oil or fuel leaking from the mounts, stop operations and tighten to the specified tightening torque. If any damage or deformation of the hoses or piping is found, consult your Komatsu distributor. If the following conditions are found, replace the hose.
 - Damaged or leaking hydraulic fitting.
 - Frayed or cut covering or exposed reinforcement wire layer.
 - Covering swollen in places.
 - Twisted or crushed movable portion.
 - Foreign material embedded in covering.

If there is any leakage of oil or fuel from the hoses or piping, tighten to the specified tightening torque. For details of the specified tightening torque, see "STANDARD TIGHTENING TORQUES FOR BOLTS AND NUTS (PAGE 4-18)".

If the hoses or piping are damaged, replace them.

PRECAUTION WHEN REMOVING HYDRAULIC PIPING:**WARNING**

The hydraulic circuit is always under internal pressure. When inspecting or replacing the hoses or piping, check that the pressure in the circuit has been released. Failure to do this may cause serious personal injury. Always do as follows.

- Never carry out inspection or replacement when the piping is under pressure.
- If there is any leakage of oil from the hoses or piping, or the hoses or piping or the surrounding area are wet, check the piping for cracks and the hoses for cracks and swelling.
- Always wear protective glasses, gloves, or other protective equipment when carrying out inspection.
If high-pressure oil leaks from a small hole and hits your skin or and eyes directly, there is danger that it may make holes in your skin or cause you to lose your eyesight. If you are hit on the skin or in the eyes by high-pressure oil and suffer serious injury, wash the oil off with clean water, then get immediate medical attention.

The hydraulic circuit is always under pressure. Always release the pressure in the circuit before removing the hoses or piping. With the brake circuit, depress the brake pedal at least 20 times before starting the operation to reduce the pressure in the accumulator to 0.

BLEEDING AIR FROM HYDRAULIC CIRCUIT:

If the hydraulic components have been repaired or replaced and if the hydraulic hoses, pipes, etc. have been disconnected, it is necessary to bleed air in the circuit. See "WHEN REQUIRED (PAGE 4-23)".

PRECAUTIONS WHEN INSTALLING HYDRAULIC HOSES:

- When removing parts at locations where there are O-rings or gasket seals, clean the mounting surface, and replace with new parts.
When doing this, be careful not to forget to install the O-rings and gaskets.
- When installing the hoses, do not twist them or bend them sharply. If they are installed so, their service life will be shortened extremely and they may be damaged.

CHECKS AFTER INSPECTION AND MAINTENANCE:

If you forget to perform the checks after inspection and maintenance, unexpected problems may occur, and this may lead to serious injury or property damage. Always do the following:

- Checks after operation (with engine stopped)
 - Have any inspection and maintenance points been forgotten?
 - Have all inspection and maintenance items been performed correctly?
 - Have any tools or parts been dropped inside the machine? It is particularly dangerous if parts are dropped inside the machine and get caught in the lever linkage mechanism.
 - Are there any leakage of coolant or oil? Have all nuts and bolts been tightened?
- Check when the engine is running
 - See "TWO WORKERS FOR MAINTENANCE WHEN ENGINE IS RUNNING (PAGE 2-31)" in the section on safety for checking when the engine is running. Pay enough attention for safety.
 - Check if the inspected and serviced area is normally operated.
 - Increase the engine speed to check for the leak of fuel and oil.

WASTE MATERIALS:

**WARNING**

To prevent pollution of the environment, always pay careful attention to proper disposal of waste materials.

- Always dispose of waste fluids in cans or in a tank. Never allow the waste fluid to drain into the ground; never pour it into rivers, sewerage systems, sea, or lakes.
- When dealing with toxic wastes, such as oil, fuel, coolant, solvent, filters, or batteries, dispose of them according to the applicable laws and regulations.

When changing the oil or coolant, or replacing filters, put all waste coming from the machine in a container. Considering the effect of these waste materials on the environment, ask a specialist disposal company or your Komatsu distributor to dispose of waste materials.

SECONDARY MATERIALS FOR OPERATION

- Always use Komatsu genuine parts replacement parts, grease or oil.
- When changing the oil or adding oil, do not mix different types of oil. When changing the type of oil, drain all the old oil and fill completely with the new oil. Always replace the filter at the same time. (There is no problem if the small amount of oil remaining in the piping mixes with the new oil.)
- Unless otherwise specified, when the machine is shipped from the factory, it is filled with the oil and coolant listed in the table below.

Item	Type
Engine oil pan	Engine oil EO15W40-DH (Komatsu genuine parts)
Transmission case	Power train oil TO30 (Komatsu genuine parts)
Steering hoist oil tank	Power train oil TO10 (Komatsu genuine parts)
Front suspension Rear suspension	Hydraulic oil HO-MVK (Komatsu genuine parts)
Differential case Final drive case	Power train oil TO30 (Komatsu genuine parts)
Radiator	Supercoolant AF-NAC (Density:30% or above) (Komatsu genuine parts)

HANDLING OIL, FUEL, COOLANT, AND PERFORMING OIL CLINIC

OIL

- Oil is used in the engine and hydraulic equipment under extremely severe conditions (high temperature, high pressure), so it deteriorates with time.
Always use the recommended lubricant and the recommended grade to match the maximum and minimum temperatures. For details, see "RECOMMENDED FUEL, COOLANT, AND LUBRICANT (PAGE 4-15)".
Even if the oil does not appear to be dirty, always change it at the specified interval.
- Oil corresponds to blood in the human body, so always be careful when handling it to prevent any impurities (water, metal particles, dirt, etc.) from getting in.
The majority of problems with the machine are caused by the entry of such impurities.
Take particular care not to let any impurities get in when storing or adding oil.
- Never mix oils of different grades or brands.
- Always add the specified amount of oil.
Having too much oil or too little oil are both causes of problems.
- If the oil in the work equipment is not clear, there is probably water or air getting into the circuit. In such cases, please contact your Komatsu distributor.
- When changing the oil, always replace the related filters at the same time.
- We recommend you have an analysis made of the oil periodically to check the condition of the machine. For those who wish to use this service, please contact your Komatsu distributor.
- When using commercially available oil, it may be necessary to reduce the replacement interval for the oil.
In this case, we also recommend that you use the Komatsu oil clinic.
For details of the oil clinic, see "CARRYING OUT KOWA(Komatsu Oil Wear Analysis) (PAGE 4-10)".

CARRYING OUT KOWA(Komatsu Oil Wear Analysis)

The oil clinic samples the oil periodically and analyzes it. This is a preventive maintenance service, which provides early discovery of abnormal parts and wear of the drive parts of the machine. This then makes it possible to ensure prevention of failures and reduction in downtime.

Komatsu's long years of experience and rich supply of accumulated data make it possible to accurately determine the condition of your machine. This enables us to locate the problems and to recommend suitable and timely repair methods.

The oil clinic charges the customer only the actual costs, and provides an immediate report of the results of the analysis and recommendations for action to take. This low-cost service can save you high costs and inconvenience in the future, so we strongly recommend you to avail yourself of this service.

KOWA ANALYSIS ITEMS

- Measurement of density of metal wear particles

This uses an ICP (Inductively Coupled Plasma) analyzer to measure the density of iron, copper, and other metal wear particles in the oil.

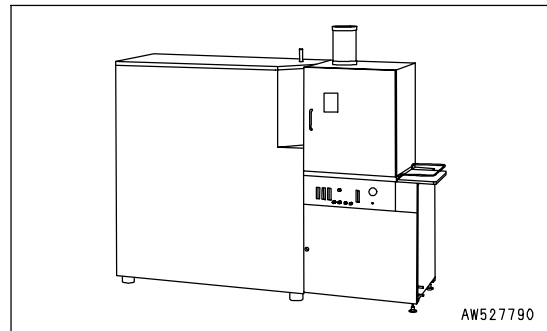

- Measurement of quantity of particles

This uses a PQI (Particle Quantifier Index) measurer to measure the quantity of iron particles of 5 μ m or more, enabling early detection of failures.

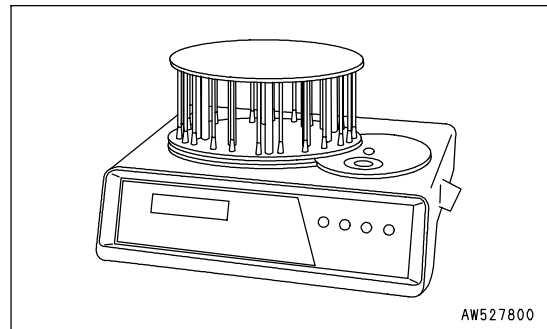

- Others

Measurements are made of items such as the ratio of water in the oil, density of the antifreeze coolant, ratio of fuel in the oil, and dynamic viscosity, enabling a highly precise diagnosis of the machine's health.

OIL SAMPLING

- Sampling interval

250 hours: Engine

500 hours: Other components

- Precautions when sampling

- Oil sampling should be done after completing of work.
- Perform sampling at regular fixed intervals.
- Do not perform sampling on rainy or windy days when water or dust can get into the oil.

For further details of KOWA, please contact your Komatsu distributor.

FUEL

- After completing the day's operations, fill the fuel tank to force out any air containing moisture. This will prevent the moisture from condensing and mixing with the fuel.
- The fuel pump is a precision instrument, and if fuel containing water or dirt is used, it cannot work properly.
- Be extremely careful not to let impurities get in when storing or adding fuel.
- Always use the fuel specified for the temperature in the Operation and Maintenance Manual.
 - If the fuel is used at temperatures lower than the specified temperature (particularly at temperatures below -15 °C (5°F), the fuel will solidify.
 - If the fuel is used at temperatures higher than the specified temperature, the viscosity will drop, and this may result in problems such as a drop in output.
- Before starting the engine, or when 10 minutes have passed after adding fuel, drain the sediment and water from the fuel tank.
- If the engine runs out of fuel, or if the filters have been replaced, it is necessary to bleed the air from the circuit.
- If there is any foreign material in the fuel tank, wash the tank and fuel system.
- Excess fuel in the tank may spill out due to thermal expansion when the fuel temperature rises. Be careful not to fill with too much fuel.

NOTICE

Use only diesel fuel.

The engine mounted on this machine employs electronic control and a high-pressure fuel injection device to obtain good fuel consumption and good exhaust gas characteristics. For this reason, it requires high precision for the parts and good lubrication. If kerosene or other fuel with low lubricating ability is used, there will be a big drop in durability.

COOLANT AND WATER FOR DILUTION

- The coolant has the important function of preventing corrosion as well as preventing freezing. Even in the areas where freezing is not an issue, the use of antifreeze coolant is essential. Komatsu machines are supplied with Komatsu Supercoolant (AF-NAC). Komatsu Supercoolant (AF-NAC) has excellent anticorrosion, antifreeze and cooling properties and can be used continuously for 2 years or 4000 hours. As a basic rule, we do not recommend the use of any coolant other than Komatsu genuine supercoolant (AF-NAC). If you use another coolant, it may cause serious problems such as corrosion of the engine and parts of the cooling system that use light metals such as aluminum.
- When using Komatsu Supercoolant (AF-NAC), there is no need to use a corrosion resistor. For details, see "CLEAN INSIDE OF COOLING SYSTEM (PAGE 4-29)".
- When diluting the antifreeze coolant, use distilled water or tap water (soft water). Natural water, such as a river water or well water (hard water), contains large amounts of minerals (calcium, magnesium, etc.), and this makes it easier for scale to form inside the engine or radiator. Once scale is deposited inside the engine or radiator, it is extremely difficult to remove. It also causes overheating due to poor heat exchange, so when you dilute the coolant, we recommend that you use water with an overall hardness of less than 100 PPM.
- When using antifreeze, always observe the precautions given in the Operation and Maintenance Manual.
- Antifreeze coolant is flammable, so be sure to keep it away from flame.
- The ratio of Supercoolant (AF-NAC) to water differs according to the ambient temperature. For details of the ratio when mixing, see "CLEAN INSIDE OF COOLING SYSTEM (PAGE 4-29)". Even in areas where it is not necessary to prevent freezing, use Supercoolant (AF-NAC) at a mixing ratio of at least 30% to prevent corrosion of the cooling system. Supercoolant (AF-NAC) may be supplied in premix. In this case, never add diluting water.
- If the engine overheats, wait for the engine to cool before adding coolant.
- If the coolant level is low, it will cause overheating, and will also cause problems with corrosion due to air entering the coolant.

GREASE

- Grease is used to prevent seizure and noises at the joints.
- Construction equipment is used under heavy-duty conditions. Always use the recommended grease to match the ambient temperature, and change the grease at the specified interval given in the Operation and Maintenance Manual. For details of the grease to use, see "RECOMMENDED FUEL, COOLANT, AND LUBRICANT (PAGE 4-15)".
- Grease fittings not listed in the inspection and maintenance section are grease fittings that are used at the time of overhaul, so there is no need to grease these points.
When using the machine after it has been in storage for a long time, carry out greasing if there is any stiffness or screeching.
- Always wipe off all of the old grease that is pushed out when greasing.
Be particularly careful to wipe off the old grease in places where sand or dirt sticking in the grease would cause wear of the rotating parts.

STORING OIL AND FUEL

- Keep indoors to prevent any water, dirt, or other impurities from getting in.
- When keeping drum cans for a long period, put the drum on its side so that the filler port of the drums is at the side to prevent moisture from being sucked in.
If drums have to be stored outside, cover them with a waterproof sheet or take other measures to protect them.
- To prevent any change in quality during long-term storage, be sure to use in the order of first in - first out (use the oldest oil or fuel first).

FILTERS

- Filters are extremely important safety parts. They prevent impurities in the fuel and air circuits from entering important equipment and causing problems.
Replace all filters periodically. For details, see the Operation and Maintenance Manual.
However, when working in severe conditions, replace the filters at shorter intervals according to the oil and fuel (sulfur content) being used.
- Never try to clean the filters (cartridge type) and use them again. Always replace with new filters.
- When replacing oil filters, check if any metal particles are attached to the old filter. If any metal particles are found, contact your Komatsu distributor.
- Do not open packs of spare filters until just before they are to be used.
- Use of Komatsu genuine filter elements is strongly recommended.

OUTLINE OF ELECTRIC SYSTEM

- It is extremely dangerous if the electrical equipment becomes wet or the covering of the wiring is damaged. This will cause an electrical short circuit and may lead to malfunction of the machine. Do not wash the inside of the operator's cab with water. When washing the machine, be careful not to let water get into the electrical components.
- Service relating to the electric system is checking fan belt tension, checking damage or wear to the fan belt and checking battery fluid level.
- Never install any electric components other than those specified by Komatsu.
- External electro-magnetic interference may cause malfunction of the control system controller, before installing a radio receiver or other wireless equipment, contact your Komatsu distributor.
- When working at the seashore, carefully clean the electric system to prevent corrosion.

WEAR PARTS

Wear parts such as the filter element, air cleaner element, etc. are to be replaced at the time of periodic maintenance or before their abrasion limits.

The wear parts should be changed correctly in order to use the machine economically.

For part change, Komatsu genuine parts of excellent quality should be used.

When ordering parts, please check the part number in the parts book.

WEAR PARTS LIST

The parts in parentheses are to be replaced at the same time.

Item	Part No.	Part name	Q'ty	Replacement frequency
Engine oil filter	600-211-1340	Cartridge	3	EVERY 500 HOURS
Fuel pre-filter(*)	600-319-4540	Cartridge	2	
Fuel main filter(*)	600-319-3550	Cartridge	1	
Transmission oil filter	569-16-81160 (07000-02125)	Element (O-ring)	2 (2)	
Corrosion resistor	600-411-1171	Cartridge	1	EVERY 1000 HOURS
Brake oil filter	569-43-83920 (07000-12065) (07001-02065)	Element (O-ring) (Back-up ring)	1 (1) (1)	
Transmission, rear brake cooling oil filter	07063-51210 (07000-F5180)	Element (O-ring)	1 (1)	
Steering, hoist oil filter	07063-51210 (07000-F5180)	Element (O-ring)	1 (1)	EVERY 2000 HOURS
Air cleaner	600-185-6100	Element Ass'y	2	WHEN REQUIRED
	600-185-6110	Outer element	2	
Payload meter (if equipped) inner battery	581-86-55710	Battery	1	

*: If the fuel filter gets clogged before its periodic replacement time is arrived at, replace both the fuel pre-filter and fuel main filter together.

RECOMMENDED FUEL, COOLANT, AND LUBRICANT

- Komatsu genuine oils are adjusted to maintain the reliability and durability of Komatsu construction equipment and components.

In order to keep your machine in the best conditioner for long periods of time, it is essential to follow the instructions in this Operation and Maintenance Manual.

- Failure to follow these recommendations may result in shortened life or excess wear of the engine, power train, cooling system, and/or other components.
- Commercially available lubricant additives may be good for the machine, but they may also cause harm. Komatsu does not recommend any commercially available lubricant additive.
- Use the oil recommended according to the ambient temperature in the chart below.
- Specified capacity means the total amount of oil including the oil in the tank and the piping. Refill capacity means the amount of oil needed to refill the system during inspection and maintenance.
- When starting the engine in temperatures below 0°C (32°F), be sure to use the recommended multi-grade oil, even if the ambient temperature may become higher during the course of the day.
- If the machine is operated at a temperature below -20°C (-4°F), a separate device is needed, so consult your Komatsu distributor.
- When the fuel sulfur content is less than 0.2%, change the engine oil according to the period inspection table given in this Operation and Maintenance Manual.

If the fuel sulfur content is more than 0.2%, change the oil according to the following table.

Sulfur content (%)	Oil change interval
Less than 0.2%	500 hours
0.2 to 0.5%	250 hours
0.5% and up	Not recommendable (*)

* If these fuels are used, there is danger that serious trouble may occur because of early deterioration of the engine oil or early wear of the internal parts of the engine. If the local situation makes it necessary to use these fuels, always remember the following.

- 1) Be sure to check Total Basic Number (TBN) of oil frequently by TBN handy checker etc., and change oil based on the result.
- 2) Always be aware that oil change interval is extremely shorter than standard.
- 3) Be sure to carry out periodic engine inspection by distributor's expert since change interval of periodic replacement parts and overhaul interval are also shorter.

USE OF FUEL, COOLANT AND LUBRICANTS ACCORDING TO AMBIENT TEMPERATURE

Reservoir	Fluid Type	Ambient Temperature, degrees Celsius										Recommended Komatsu Fluids	
		-22	-4	14	32	50	68	86	104	122 °F			
		-30	-20	-10	0	10	20	30	40	50°C			
Engine oil pan	Engine oil	(Note.1)										Komatsu EOS0W30	
		(Note.1)										Komatsu EOS5W40	
		(Note.1)										Komatsu EO10W30DH	
		(Note.1)										Komatsu EO15W40DH	
		(Note.1)										Komatsu EO30DH	
Transmission Case	Power train oil (Note.2)	(Note.1)										TO10	
		(Note.1)										TO30	
Steering, hoist oil tank	Power train oil	(Note.1)										TO10	
	Hydraulic oil	(Note.1)										HO46-HM	
		(Note.1)										HO-MVK	
Front suspension Rear suspension	Hydraulic oil	(Note.1)										HO-MVK	
Differential case Final drive case	Power train oil	(Note.1)										TO30	
		(Note.1)										TO50	
Grease fitting	Hyper grease (Note.3)	(Note.1)										G2-T, G2-TE	
	Lithium EP grease	(Note.1)										G2-LI	
Cooling system	Supercoolant AF-NAC (Note.4)	(Note.1)										AF-NAC	
Fuel tank	Diesel fuel	(Note.1)										ASTM Grade No.1-D S15 ASTM Grade No.1-D S500	
		(Note.1)										ASTM Grade No.2-D S15 ASTM Grade No.2-D S500	

• ASTM: American Society of Testing and Material

Capacity \ Reservoir		Engine oil pan	Transmission case	Steering, hoist oil tank	Front suspension (each)	Rear suspension (each)	Differential case
		Specified	Liters	86	318	180	16.5
US gal	22.7		84.0	47.6	4.4	3.0	25.1
Refill	Liters	80	215	122	-	-	95
	US gal	21.1	56.8	32.2	-	-	25.1

Capacity \ Reservoir		Final drive case (each)	Fuel tank	Cooling system
		Specified	Liters	32
US gal	8.5		206.1	41.5
Refill	Liters	21	-	-
	US gal	5.6	-	-

NOTICE

Use only diesel fuel.

The engine mounted on this machine employs electronic control and a high-pressure fuel injection device to obtain good fuel consumption and good exhaust gas characteristics. For this reason, it requires high precision for the parts and good lubrication. If kerosene or other fuel with low lubricating ability is used, there will be a big drop in durability.

Note 1: HTHS (High-Temperature High-Shear Viscosity 150°C), specified by ASTM D4741 must be equal to or higher than 3.5 mPa·S. Komatsu EOS0W30 and EOS5W40 are the most suitable oils.

Note 2: Powertrain oil has different properties from engine oil. Be sure to use the recommended oils.

Note 3: Hyper grease (G2-T, G2-TE) has a high performance.

When it is necessary to improve the lubricating ability of the grease in order to prevent squeaking of pins and bushings, the use of G2-T or G2-TE is recommended.

Note 4: Supercoolant (AF-NAC)

1) Coolant has the important function of anticorrosion as well as antifreeze.

Even in the areas where freezing is not an issue, the use of antifreeze coolant is essential.

Komatsu machines are supplied with Komatsu Supercoolant AF-NAC. Komatsu Supercoolant AF-NAC has excellent anticorrosion, antifreeze and cooling properties and can be used continuously for 2 years or 4000 hours. Komatsu Supercoolant AF-NAC is strongly recommended wherever available.

2) For details of the ratio when diluting super coolant with water, see "CLEAN INSIDE OF COOLING SYSTEM (PAGE 4-29)".

Supercoolant AF-NAC may be supplied in premix. In this case, always top off with premix solution. (never dilute with water)

3) To maintain the anticorrosion properties of Supercoolant AF-NAC, always keep the density of Supercoolant between 30% and 68%.

RECOMMENDED BRANDS, RECOMMENDED QUALITY FOR PRODUCTS OTHER THAN KOMATSU GENUINE OIL

When using commercially available oils other than Komatsu genuine oil, consult your Komatsu distributor.

STANDARD TIGHTENING TORQUES FOR BOLTS AND NUTS

TORQUE LIST

When tightening torques are not entered at concerned parts, tighten the metric nuts and bolts to the torque shown in the table below.

The tightening torque is determined by the width across the flats (b) of the nut and bolt.

If it is necessary to replace any nut or bolt, always use a Komatsu genuine part of the same size as the part that was replaced.

Please order nuts and bolts from your Komatsu distributor.

Thread diameter of bolt (a)(mm)	Width across flats (b)(mm)	Tightening torque					
		Target value			Service limit		
		Nm	kgm	lbft	Nm	kgm	lbft
6	10	13.2	1.35	9.8	11.8-14.7	1.2-1.5	8.7-10.8
8	13	31	3.2	23.1	27-34	2.8-3.5	20.3-25.3
10	17	66	6.7	48.5	59-74	6.0-7.5	43.4-54.2
12	19	113	11.5	83.2	98-123	10.0-12.5	72.3-90.4
14	22	177	18	130.2	157-196	16.0-20.0	115.7-144.7
16	24	279	28.5	206.1	245-309	25.0-31.5	180.8-227.8
18	27	382	39	282.1	343-425	35.0-43.5	253.2-314.6
20	30	549	56	405.0	490-608	50.0-62.0	361.7-448.4
22	32	745	76	549.7	662-829	67.5-84.5	488.2-611.2
24	36	927	94.5	683.5	824-1030	84.0-105.0	607.6-759.5
27	41	1320	135.0	976.5	1180-1470	120.0-150.0	868.0-1085.0
30	46	1720	175.0	1265.8	1520-1910	155.0-195.0	1121.1-1410.4
33	50	2210	225.0	1627.4	1960-2450	200.0-250.0	1446.6-1808.3
36	55	2750	280.0	2025.2	2450-3040	250.0-310.0	1808.3-2242.2
39	60	3280	335.0	2423.1	2890-3630	295.0-370.0	2133.7-2676.2

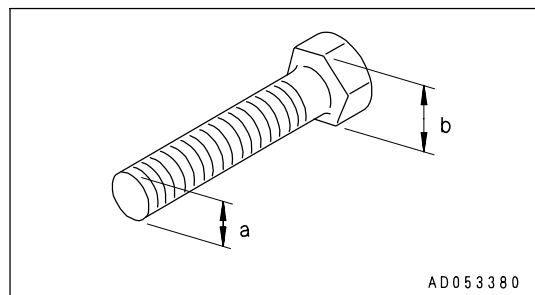

If parts made from plastic, such as panels, are tightened to an excessive torque, the tightened portion may break. Always keep to the standard tightening torque for nuts and bolts.

Apply the following table for Hydraulic Hose.

- Face seal

Nominal - No. of threads (a)	Width across flats (b) (mm)	Tightening torque					
		Target value			Permissible range		
		Nm	kgm	lbft	Nm	kgm	lbft
9/16 -18UNF	19	44	4.5	32.5	35 - 63	3.5 - 6.5	25.3 - 47.0
11/16 -16UN	22	74	7.5	54.2	54 - 93	5.5 - 9.5	39.8 - 68.7
13/16 -16UN	27	103	10.5	75.9	84 - 132	8.5 - 13.5	61.5 - 97.6
1 -14UNS	32	157	16.0	115.7	128 - 186	13.0 - 19.0	94.0 - 137.4
13/16 -12UN	36	216	22.0	159.1	177 - 245	18.0 - 25.0	130.2 - 180.8

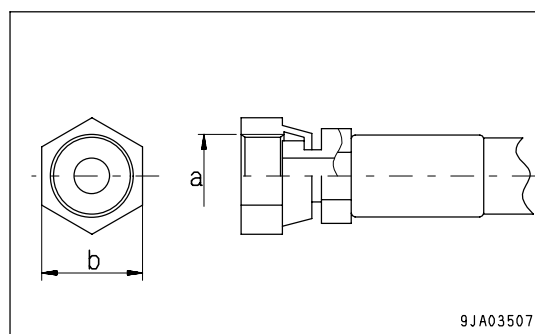

PERIODIC REPLACEMENT OF SAFETY CRITICAL PARTS

To ensure safety at all times when operating or driving the machine, the user of the machine must always carry out periodic maintenance. In addition, to further improve safety, the parts in the safety-critical parts list on the below must also be replaced at the specified interval. These parts are particularly closely connected to safety and fire prevention, so please contact your Komatsu distributor to have them replaced.

Material quality of these parts can change as time passes and they are likely to wear out or deteriorate. However, it is difficult to determine the extent of wear or deterioration at the time of periodic maintenance. Hence, it is required to replace them with new ones regardless of their condition after a certain period of usage. This is important to ensure that these parts maintain their full performance at all times.

Furthermore, should anything abnormal be found on any of these parts, replace it with a new one even if the periodic replacement time for the part has not yet arrived.

If any of the hose clamps show deterioration like deformation or cracking, replace the clamps at the same time as the hoses.

Also perform the checks with hydraulic hoses which need to be replaced periodically. Tighten all loose clamps and replace defective hoses, as required.

When replacing hoses, always replace O-rings, gaskets, and other such parts at the same time.

SAFETY CRITICAL PARTS

No.	Safety critical parts for periodic replacement	Replacement interval	Remarks
1	Fuel hose (strainer - fuel filter)	EVERY 4000 hours or 2 years, whichever comes sooner	
2	Fuel hose (fuel filter - fuel pump)		
3	Fuel hose (engine - fuel cooler)		
4	Fuel hose (fuel cooler - fuel tank)		
5	Rubber hose for brake piping		
6	High-pressure hose in steering oil pressure circuit (pump ↔ demand valve ↔ steering valve ↔ steering cylinder)		Replace as Ass'y
7	High-pressure hose in hoist circuit (pump ↔ demand valve ↔ hoist valve ↔ hoist cylinder)		
8	Hose at discharge side of retarder cooling pump		
9	Hose at discharge side of transmission pump		
10	Accumulator		Replace as Ass'y
11	Seat belt	Every 3 years	Replace

MAINTENANCE SCHEDULE CHART

MAINTENANCE SCHEDULE CHART

INITIAL 250 HOURS SERVICE (ONLY AFTER THE FIRST 250 HOURS)

Replace transmission valve oil filter element -----	4- 68
Change oil in transmission case, brake sub tank -----	4- 74
Replace transmission and rear brake cooling oil filter element -----	4- 77
Replace steering, hoist oil tank filter element -----	4- 83
Change oil in final drive case -----	4- 84
Change oil in differential case -----	4- 85
Change oil in steering, hoist oil tank -----	4- 86

WHEN REQUIRED

Check, clean or replace air cleaner -----	4- 23
Clean inside of cooling system -----	4- 29
Check level of window washer fluid, add fluid -----	4- 32
Clean air conditioner air filter -----	4- 32
Check refrigerant (gas) level -----	4- 33
Check dump body -----	4- 34
Check length of suspension cylinder, check oil level -----	4- 35
Bleeding air from fuel circuit -----	4- 37
Bleed air from rear brake -----	4- 40
Bleed air from front brake -----	4- 41
Bleed air from parking brake -----	4- 42
Clean, check radiator fins and after cooler fins -----	4- 43
Check play of output coupling of output shaft -----	4- 44
Selection and inspection of tires -----	4- 45

CHECK BEFORE STARTING

EVERY 250 HOURS SERVICE

Check oil level in differential case, add oil -----	4- 49
Check oil level in final drive case, add oil -----	4- 49
Lubrication -----	4- 50
Check drive shaft -----	4- 51
Check level of battery electrolyte -----	4- 52
Clean breathers -----	4- 55
Check frame -----	4- 57
Check braking capacity of foot brake -----	4- 58
Check braking capacity of retarder brake -----	4- 59
Check braking capacity of parking brake -----	4- 60
Check, clean automatic suspension -----	4- 61
Check of accumulator gas pressure -----	4- 62

EVERY 500 HOURS SERVICE

Change oil in engine oil pan, replace engine oil filter cartridge -----	4- 63
Replace fuel prefilter cartridge -----	4- 64
Replace fuel main filter cartridge -----	4- 66
Replace transmission valve oil filter element -----	4- 68
Check wear of front disc brake pads -----	4- 69
Check fan belt for wear and replace -----	4- 70
Check, replace compressor drive belt for alternator, air conditioner -----	4- 72

EVERY 1000 HOURS SERVICE

Replace corrosion resistor cartridge -----	4- 73
Change oil in transmission case, brake sub tank, wash strainer -----	4- 74
Replace transmission and rear brake cooling oil filter element -----	4- 77
Replace brake oil filter element -----	4- 78
Lubrication -----	4- 79
Check wear of rear brake disc -----	4- 80
Recover oil leaking from floating seal -----	4- 81
Check, grease compressor drive belt tension pulley assembly for alternator, air conditioner -----	4- 82
Check of engine air intake piping clamps for looseness -----	4- 82

EVERY 2000 HOURS SERVICE

Replace steering, hoist oil tank filter element -----	4- 83
Clean hydraulic tank strainer -----	4- 84
Change oil in final drive case -----	4- 84
Change oil in differential case -----	4- 85
Clean differential case breather -----	4- 85
Check alternator -----	4- 85
Check, adjust engine valve clearance -----	4- 85
Check accumulator gas pressure -----	4- 85

EVERY 4000 HOURS SERVICE

Change oil in steering, hoist oil tank -----	4- 86
Lubricate drive shaft -----	4- 86
Check starting motor -----	4- 87
Check water pump -----	4- 87
Check fan pulley and tension pulley -----	4- 87
Check accumulator -----	4- 87
Checking for looseness of high-pressure clamp, hardening of rubber -----	4- 88
Checking for missing fuel spray prevention cap, hardening of rubber -----	4- 89

EVERY 8000 HOURS SERVICE

Replace high-pressure piping clamp -----	4- 90
Replace fuel spray prevention cap -----	4- 90
Overhaul starting motor and alternator -----	4- 90

EVERY 15000 HOURS SERVICE

Check, replace steering A arm mounting bolt -----	4- 91
---	-------

SERVICE PROCEDURE

INITIAL 250 HOURS SERVICE (ONLY AFTER THE FIRST 250 HOURS)

Perform the following maintenance only after the first 250 hours.

- Replace transmission valve oil filter element
- Change oil in transmission case, brake sub tank
- Replace transmission and rear brake cooling oil filter element
- Replace steering, hoist oil tank filter element
- Change oil in final drive case
- Change oil in differential case
- Change oil in steering, hoist oil tank

For details of method of replacing or maintaining, see "EVERY 500 HOURS SERVICE (PAGE 4-63)", "EVERY 1000 HOURS SERVICE (PAGE 4-73)", "EVERY 2000 HOURS SERVICE (PAGE 4-83)", "EVERY 4000 HOURS SERVICE (PAGE 4-86)".

WHEN REQUIRED

CHECK, CLEAN OR REPLACE AIR CLEANER

After the outer element has been cleaned 6 times, or if the air cleaner element has been used for one year, replace the outer element, inner element, and O-ring. For details of the procedure for replacement, see "REPLACE ELEMENT (PAGE 4-27)".

After the outer element has been cleaned, if the maintenance caution lamp lights up and action code E01 and AIR FILTER are displayed on the character display at the same time immediately after operations start, replace the element even if the outer element has not been cleaned 6 times or the air cleaner element has not been used for one year.

CHECKING

NOTICE

Do not replace the element before the dust indicator reaches 7.5 kPa {0.76kg/cm²}. If it is cleaned frequently, the filtering effect of the air cleaner will drop, and this will reduce the service life of the engine.

1. Check if the dust indicator (1) displays 7.5 kPa {0.76kg/cm²}. If it is displaying 7.5 kPa {0.76kg/cm²}, clean the outer element.

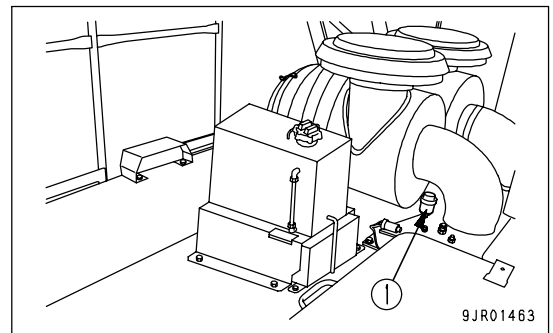

REMARK

Maintenance caution lamp (2) is on the machine monitor.

If the maintenance caution lamp lights up and E01 and AIR FILTER are displayed on character display (3), the air cleaner is clogged. If this happens, clean the air cleaner element.

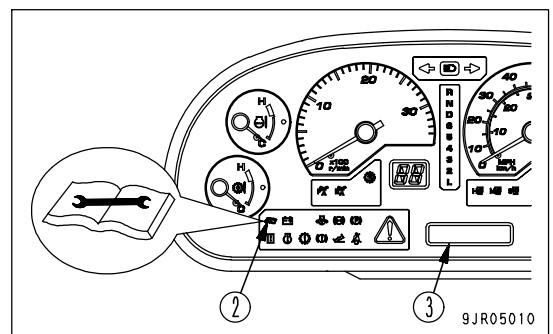

CLEAN OUTER ELEMENT

**WARNING**

- Dirt will fly if compressed air is used for cleaning. If dirt gets into your eyes it may cause blindness, and if you breathe in the dust it may damage your lungs. To prevent these problems, always wear safety glasses, dust mask, and other protective equipment.
- When pulling out the air cleaner element, make sure that you are standing on a firm place. If your footing is not secure when you carry out the operation, there is danger of falling and suffering injury.

NOTICE

When cleaning the element, clean only the outer element. Do not clean the inner element. There is danger that dirt and dust may get inside the engine when the outer element is being cleaned, and this will damage the engine.

1. Stop the engine.
2. Remove 6 hooks (5) of dust cup (4), then remove the dust cup.

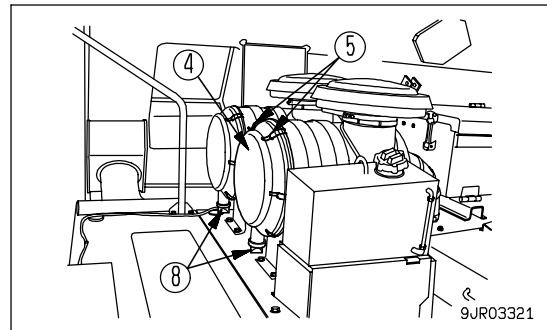

3. Hold outer element (6) with both hands, and move it up and down and to the left and right while pulling it out.
4. Hold inner element (7) so that it does not come out, and clean the inside of the air cleaner body with a dry cloth.
5. Use a dry cloth or compressed air to clean off the dirt stuck to dust cup (4) and vacuator valve (8).
6. Check that there are no cracks in the lip of the vacuator valve (8). If any cracks are found, replace with a new part.

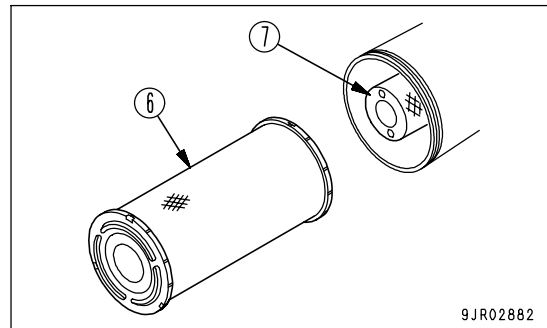

NOTICE

- If a damaged element is used, dust will pass the air cleaner filter and be sucked into the engine. Do not use any cleaning method that will damage the element. If the element is damaged, replace it with a new element.
- Never tap or hit the element against any other object when cleaning it.
- Do not use an element with damaged folds or a damaged gasket or seal.

7. Blow dry compressed air (0.69 MPa {7 kg/cm²}) from the inside of outer element (6) along the folds. Next, blow along the folds from the outside, then blow again from the inside.

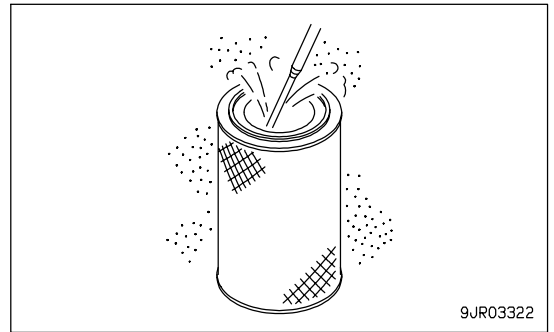

8. After cleaning, shine a light bulb from inside outer element (6) to check. If any holes or thin places are found, replace the outer element.

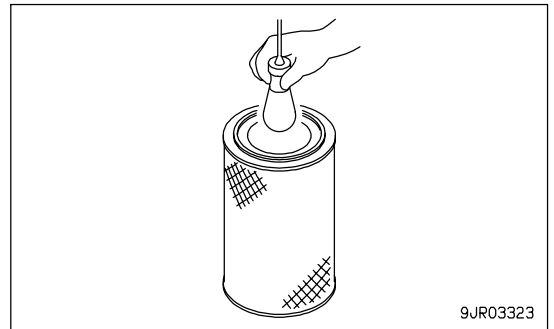

9. Install outer element (6) in the air cleaner body.

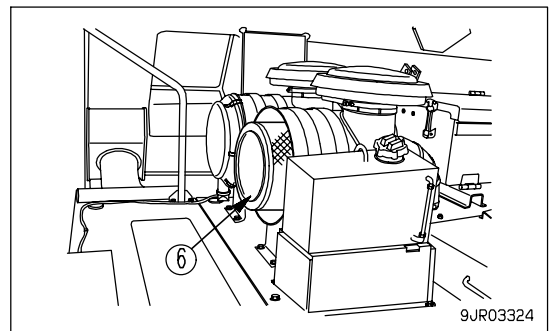

10. Check that O-ring (9) is fitted to dust cup (4). Next, set so that vacuator valve (8) of dust cup (4) is at the bottom, and insert it into the air cleaner body.

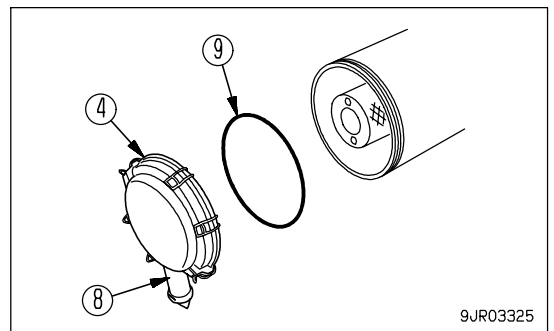

11. Clip hooks (5) of dust cup (4) to the protruding parts of the air cleaner body to lock in position.

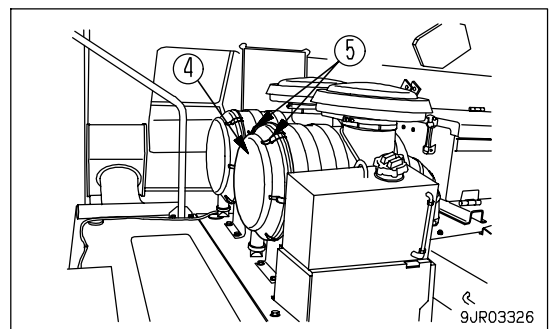

12. Push the head of dust indicator (1) to cancel the clogging display.

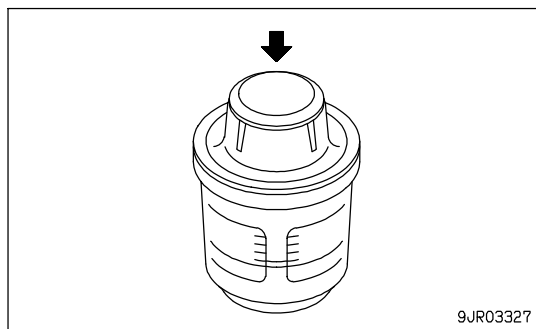
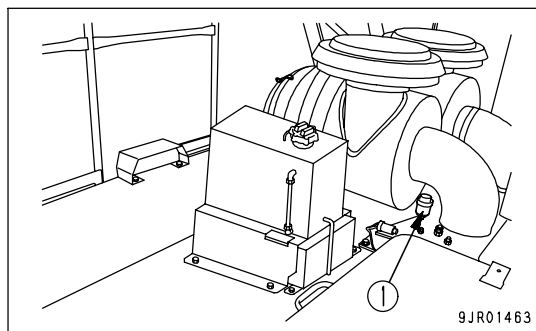

REPLACE ELEMENT

! WARNING

When pulling out the air cleaner element, make sure that you are standing on a firm place. If your footing is not secure when you carry out the operation, there is danger of falling and suffering injury.

1. Stop the engine.
2. Remove 6 hooks (5) of dust cup (4), then remove the dust cup.

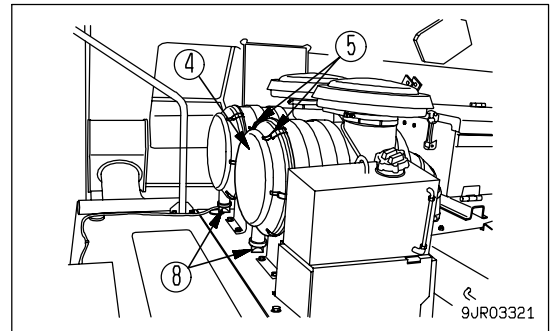

3. Hold outer element (6) with both hands, and move it up and down and to the left and right while pulling it out.
4. Hold inner element (7) so that it does not come out, and clean the inside of the air cleaner body with a dry cloth.
5. Use a dry cloth or compressed air to clean off the dirt stuck to dust cup (4) and vacuator valve (8).

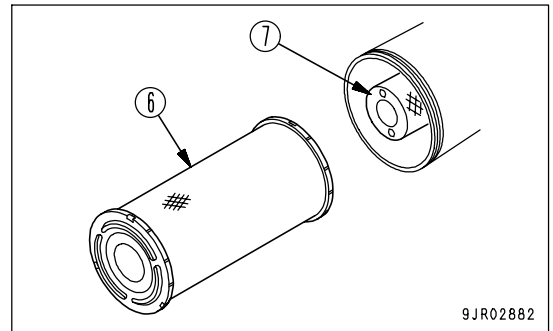

6. Check that there are no cracks in the lip of the vacuator valve (8). If any cracks are found, replace with a new part.
7. Pull out inner element (7) and install a new inner element.
8. Install outer element (6) in the air cleaner body.

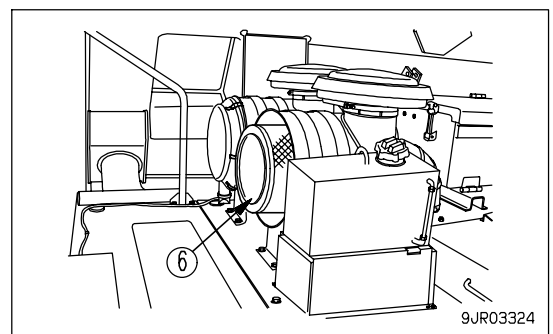

9. Replace O-ring (9) with a new part.

Next, set so that vacuator valve (8) of dust cup (4) is at the bottom, and insert it into the air cleaner body.

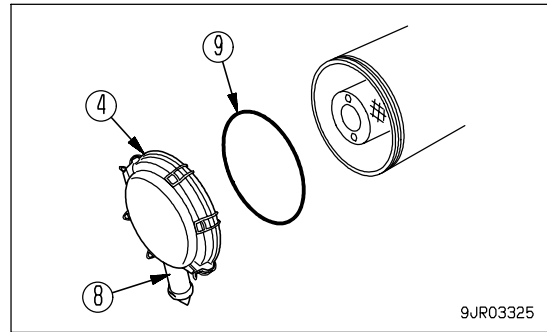

9JR03325

10. Clip hooks (5) of dust cup (4) to the protruding parts of the air cleaner body to lock in position.

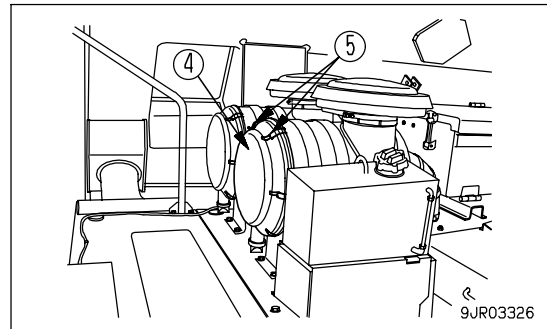

9JR03326

11. Push the head of dust indicator (1) to cancel the clogging display.

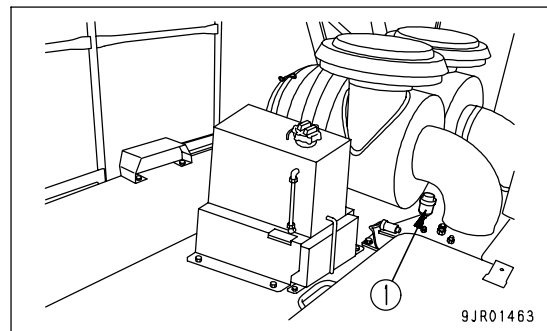

9JR01463

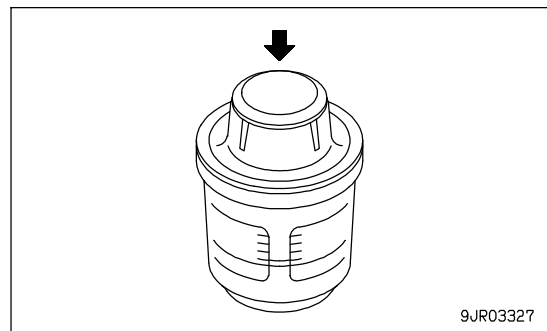

9JR03327

CLEAN INSIDE OF COOLING SYSTEM

 **WARNING**

- Immediately after the engine is stopped, the coolant is at high temperature and the inside of the radiator is under high-pressure. If the cap is removed under these conditions, boiling water will spurt out and cause burns. Always wait for the temperature to go down, then turn the cap slowly to release the internal pressure before removing the cap.
- To prevent the machine from moving while the radiator is being flushed, set the parking brake to the PARK position and the gear shift lever to the N position. If the machine moves, it may lead to serious personal injury.

Stop the machine on level ground when cleaning or changing the coolant.

Clean the inside of the cooling system, change the coolant according to the table below.

Antifreeze coolant	Interval for cleaning inside of cooling system and changing antifreeze coolant	Precautions for use
Komatsu supercoolant (AF-NAC)	Every two years or every 4000 hours whichever comes first	1*

*1: When using Komatsu Supercoolant (AF-NAC), there is no need to use a corrosion resistor. When no corrosion resistor is used, use the special cover (600-411-9000). Please consult your Komatsu distributor about the method of installing. When using corrosion resistor, use Komatsu genuine corrosion resistor. If you use another corrosion resistor, it may cause serious problems such as corrosion of the engine and parts of the cooling system that use light metals such as aluminum.

The coolant has the important function of preventing corrosion as well as preventing freezing. Even in the areas where freezing is not an issue, the use of antifreeze coolant is essential. Komatsu machines are supplied with Komatsu Supercoolant (AF-NAC). Komatsu Supercoolant (AF-NAC) has excellent anticorrosion, antifreeze and cooling properties and can be used continuously for 2 years or 4000 hours. As a basic rule, we do not recommend the use of any coolant other than Komatsu genuine supercoolant (AF-NAC). If you use another coolant, it may cause serious problems such as corrosion of the engine and parts of the cooling system that use light metals such as aluminum.

To maintain the anticorrosion properties of Supercoolant (AF-NAC), always keep the density of Supercoolant between 30% and 68%.

When deciding the ratio of antifreeze to water, check the lowest temperature in the past, and decide from the mixing table given below.

It is actually better to estimate and temperature about 10°C (18°F) lower when deciding the mixing ratio. The mixing ratio depends on the ambient temperature, but it should always be a minimum of 30% by volume (antifreeze/total amount of coolant x 100).

Even in areas where it is not necessary to prevent freezing, use Supercoolant (AF-NAC) at a mixing ratio of at least 30% to prevent corrosion of the cooling system.

The freezing temperature of undiluted antifreeze is -15°C (5°F). Do not store undiluted antifreeze at a temperature of below -15°C (5°F).

MIXING RATE OF WATER AND ANTIFREEZE

Min. atmospheric temperature	°C	-10	-15	-20	-25	-30
	°F	14	5	-4	-13	-22
Amount of antifreeze	Liters	47.1	56.6	64.4	72.3	78.5
	US gal	12.44	14.95	17.01	19.10	20.74
Amount of water	Liters	109.9	100.4	92.6	84.7	78.5
	US gal	29.04	26.53	24.47	22.38	20.74
Volume ratio	%	30	36	41	46	50

! WARNING

- Supercoolant contains substances that are toxic for humans. When handling coolant, wear rubber gloves and protective glasses. If Supercoolant gets in your eyes, wash your eyes, including the back of your eyelids, in large amounts of running water for at least 15 minutes. If there is severe pain or swelling, go to a doctor for treatment. If coolant gets on your skin, wash it off completely with large amounts of soap and water. If there is pain or any change can be seen in your appearance, go to a doctor for treatment.
- Supercoolant also contains substances that are toxic to the environment. When changing the cooling water or when repairing the radiator, do not drain the coolant into drainage ditches or spread it on the ground surface if Supercoolant has been added to the cooling water. After recovering cooling water which has had Supercoolant added, contact a specialist disposal company or your Komatsu distributor.
- Concentrated Supercoolant fluid may ignite. If you bring it close to a flame, it may cause fire. Do not use any flame close to concentrated Supercoolant.

Use antifreeze and appropriate water For diluting. (for details, see "COOLANT AND WATER FOR DILUTION (PAGE 4-11)")

We recommend the use of a super coolant density meter to control the mixing ratio.

1. Stop the engine and wait for the temperature of the coolant to go down.
2. Turn valve (1) on top of the corrosion resister to close.

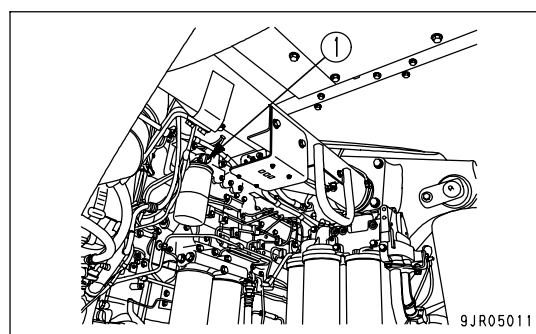

9JR05011

3. Turn radiator cap (2) slowly to remove it.
4. Open drain valve (3) at the bottom of the radiator and drain valve (4) of the oil cooler and drain the water.
5. After draining the water, close drain valves (3) and (4), and fill with city water.
6. When the radiator is full, start the engine, and run it at low idle. Keep the engine running at low idle for 10 minutes until the coolant temperature reaches more than 90°C (194°F).
7. Stop the engine, open drain valves (3) and (4), and drain the water. After draining the water, close them.

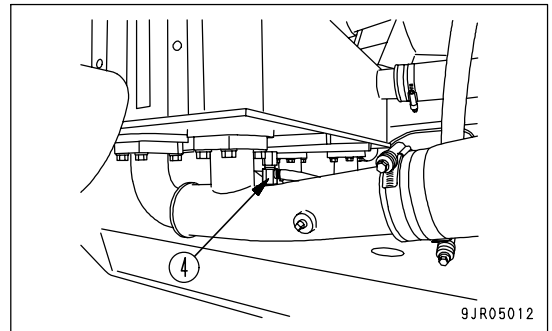
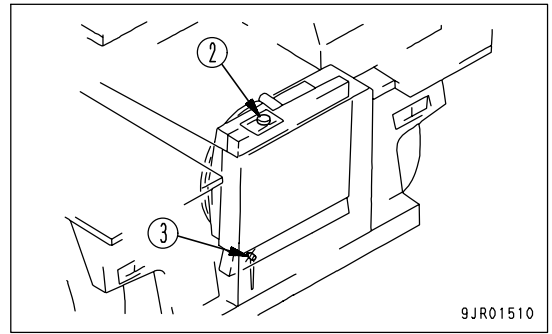

8. Replace the corrosion resistor, then turn valve (1) to open it. For replacing corrosion resistor, see "REPLACE CORROSION RESISTOR CARTRIDGE (PAGE 4-73)".
9. Add coolant mixed with antifreeze until it overflows from the water filler. Decide the proportions of antifreeze and water according to the table for the mixing rate of water and antifreeze.
10. To remove the air contained in the coolant, run the engine at low idle for 5 minutes, then run for another 5 minutes at high idle. (When doing this, leave the radiator cap OFF.)
11. Stop the engine. About 3 minutes later, supply the coolant up to the coolant filter, then close radiator cap.
12. Open drain valve (5) and drain the water from sub tank (6).
13. Flush the inside of sub tank (6) with tap water, then close drain valve (5).
14. Add water to sub tank (6) until the coolant level is between the FULL and LOW marks.

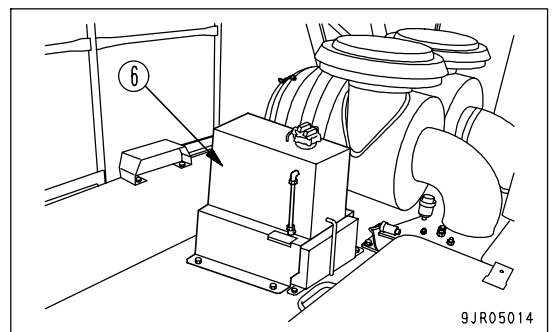
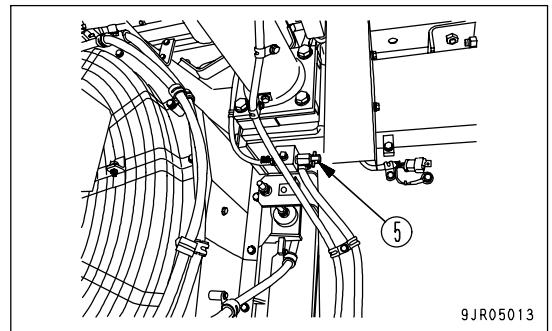

CHECK LEVEL OF WINDOW WASHER FLUID, ADD FLUID

If air gets into the window washer fluid when the window washer fluid is being sprayed out, check and add fluid.

Check the level of the fluid in window washer tank (1), and if it is low, fill with automobile window washer fluid.

Be careful not to let dirt or dust get in when adding fluid.

When operating at below freezing point, use fluid with antifreeze.

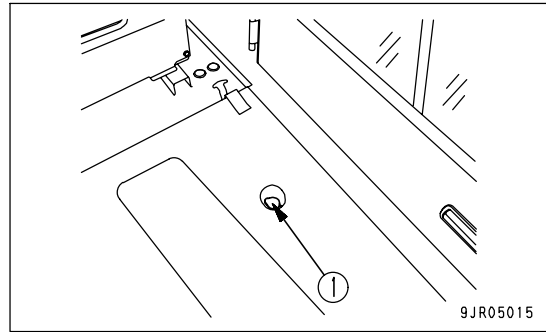

CLEAN AIR CONDITIONER AIR FILTER

If the air filter (FRESH air filter) at the suction port of the air conditioner unit or the air filter (circulated air filter) at the fresh air intake port become clogged, the cooling or heating capacity will drop, so clean the filters once a week.

1. Open cover (1) at the front face of the cab.
2. Pull out the air filter (FRESH air filter) and clean it with compressed air.

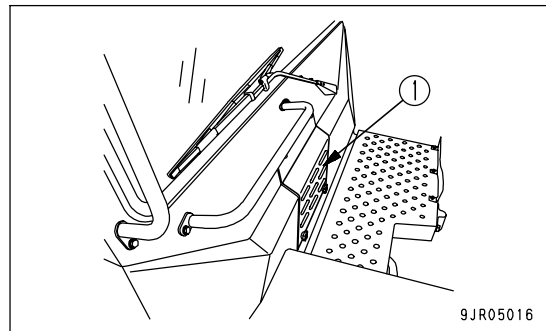

3. Open cover (2) at the front right of the operator's seat.
4. Pull out the air filter (recirculated air filter) in the air conditioner unit suction port at the end of the duct, and blow off the dust with a weak flow of compressed air or with a soft brush.

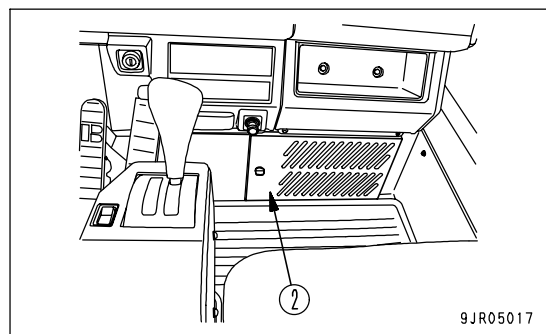

CHECK REFRIGERANT (GAS) LEVEL

! WARNING

- To prevent coming into contact with the coolant refrigerant, do not loosen any part in the refrigerant piping. If the refrigerant contacts your skin, it will cause frostbite; if it gets into your eyes, you will lose your eyesight.
- If refrigerant gets into your eyes, wash your eyes immediately in large amounts of running water for at least 15 minutes, then go to a doctor for treatment. If refrigerant gets on your skin, clothes, shoes, or socks, take them off immediately, and wash the affected places thoroughly with large amounts of water. If irritation still remains, go to a doctor for treatment.

If the cooling efficiency of the air conditioner is poor, there may be a lack of refrigerant (gas).

If this problem occurs, check sight glass (2) of receiver drier (1) on the left side inside the radiator guard.

Before carrying out inspection, set to the following conditions.

- Start the engine and run it at approx. 1,500 rpm.
- Turn the air conditioner ON/OFF switch to the ON position.
- Set the air flow to the maximum position.
- Set the temperature to the lowest position.
- Open the doors and windows fully.
- Turn the air conditioner switch ON.

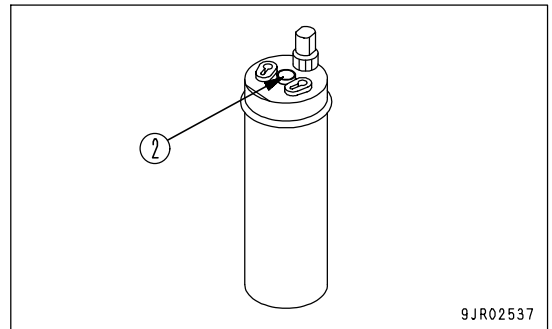
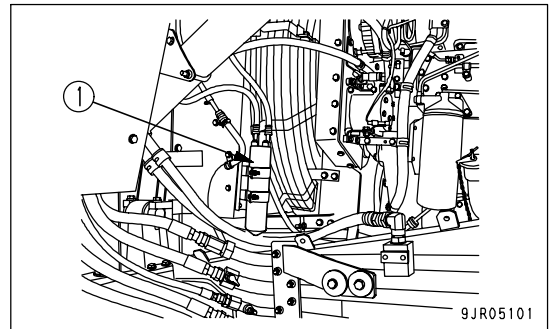

If the condition of sight glass (2) is "correct" as shown in the diagram on the right, the condition is normal. (After the air conditioner switch is turned ON, a small number of bubbles will be seen, but after that, the fluid becomes a transparent, milky white color.)

If the condition of sight glass (2) is "insufficient" as shown in the diagram on the right, there is lack of refrigerant, so ask your Komatsu distributor to charge with refrigerant. (After the air conditioner switch is turned ON, bubbles can be seen continuously.)

Refrigerant	Condition in sight glass
Correct	
Insufficient	

- A: Bubbles mixed with liquid refrigerant
- B: All refrigerant is clear liquid
- C: Oil and refrigerant are separated; liquid is thin milky white

CHECK DUMP BODY

Check that there are no cracks in the dump body.

1. Clean the dump body to make it easier to check.
2. Check all parts of the dump body for damage.

If any cracks or abnormal wear are found, carry out repairs.

Contact your Komatsu distributor for details of the repair procedure.

CHECK LENGTH OF SUSPENSION CYLINDER, CHECK OIL LEVEL

When traveling, if the unevenness of the road surface is transmitted directly to the chassis (the machine bounces or the cylinders retract and hit the stopper), carry out the following checks.

CHECK LENGTH OF CYLINDER

Front

Check that the bottom of the suspension cylinder cover is within range (A) shown by the arrow on the label when the machine is unloaded and on flat ground.

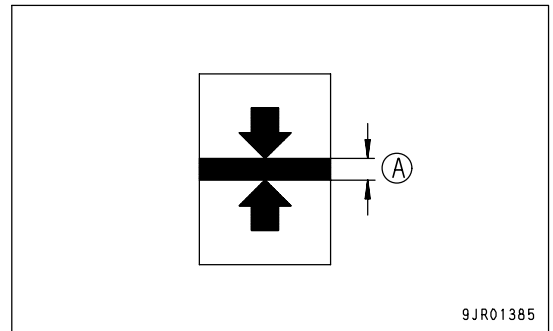

At the same time, when the machine is not loaded, remove cover (1), then measure dimension (B) from the shoulder of the rod head of the suspension cylinder to the top surface of the flange.

(B)	223 - 243 mm (8.8 - 9.6 in)
Reference (C)	441 - 461 mm (17.4 - 18.2 in)
Flange thickness (D)	50 mm (2.0 in)

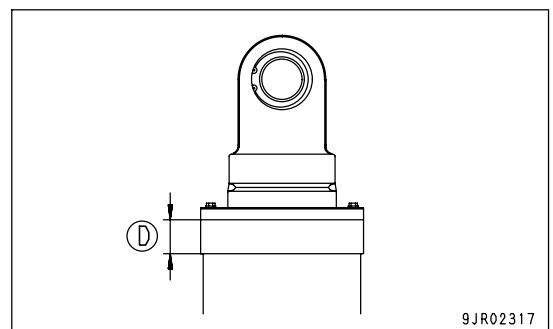
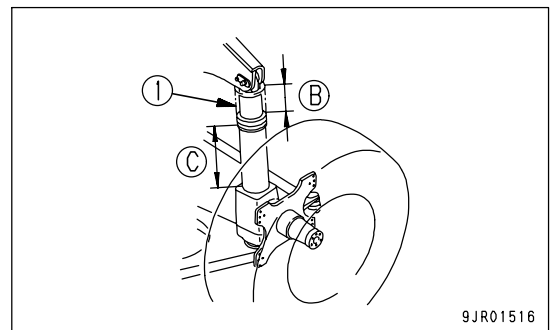

After checking, contact your Komatsu distributor for repairs if any problem is found.

Rear

Measure dimension (E) from the shoulder of the rod head of the suspension cylinder to the top surface of the flange.

(E)	166 - 186 mm (6.5 - 7.3 in)
Flange thickness (F)	65 mm (2.6 in)

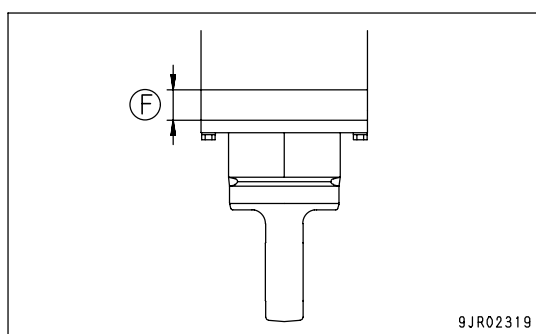
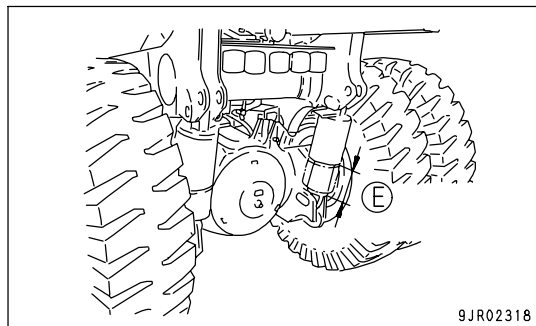

After checking, contact your Komatsu distributor for repairs if any problem is found.

BLEED AIR FROM FUEL CIRCUIT

This machine is equipped with an electric priming pump to bleed the air from the fuel circuit. In the following cases, use the procedure below to bleed the air.

- When fuel filter has been replaced
- When engine has run out of fuel
- When starting the engine for the first time after replacing the supply pump or modifying the piping or any other parts

PROCEDURE FOR BLEEDING AIR

WARNING

- For safety, make sure that there is nobody around the machine, and then start the engine. There is a possibility that the machine starts up all of sudden, causing a personal injury.
- When using the electric priming pump, do not loosen the air bleed plug for the fuel circuit. When the electric priming pump is operated, pressure is applied to the fuel circuit, so if the air bleed plug is loosened, fuel will spurt out and create a dangerous situation.

1. Turn the key in the starting switch to the OFF position and stop the engine.

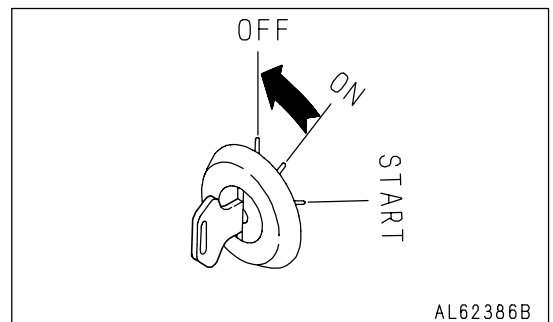

2. Check that fuel tank valve (1) is open.

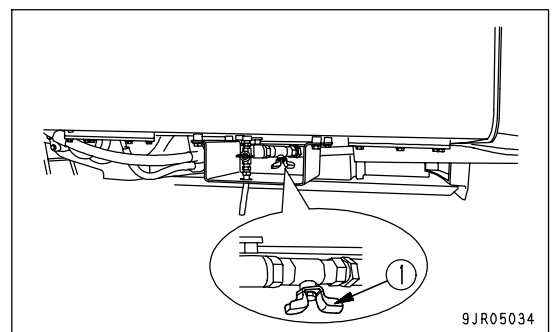

3. Open air bleeding valve (2).

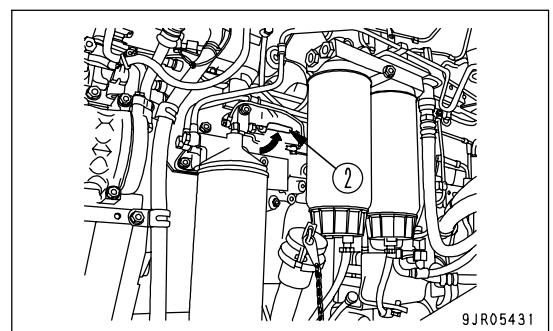

- Operate switch (3) of the electric priming pump to the ON position. Lamp (4) will flash and the electric priming pump will start.

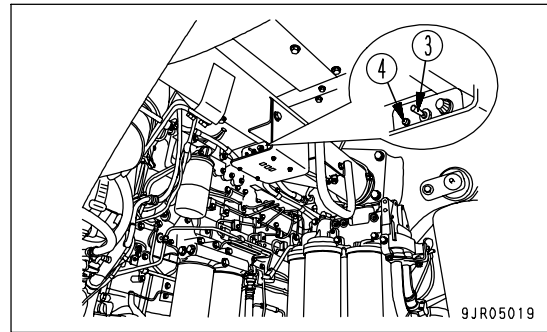

REMARK

- The electric priming pump switch has a built-in timer, and this actuates and stops the pump automatically.
- While the lamp is flashing, the electric priming pump will stop, but this does not indicate any abnormality.
- If the switch is turned to the OFF position when the lamp is lighted up, the lamp will go out and the electric priming pump will stop.

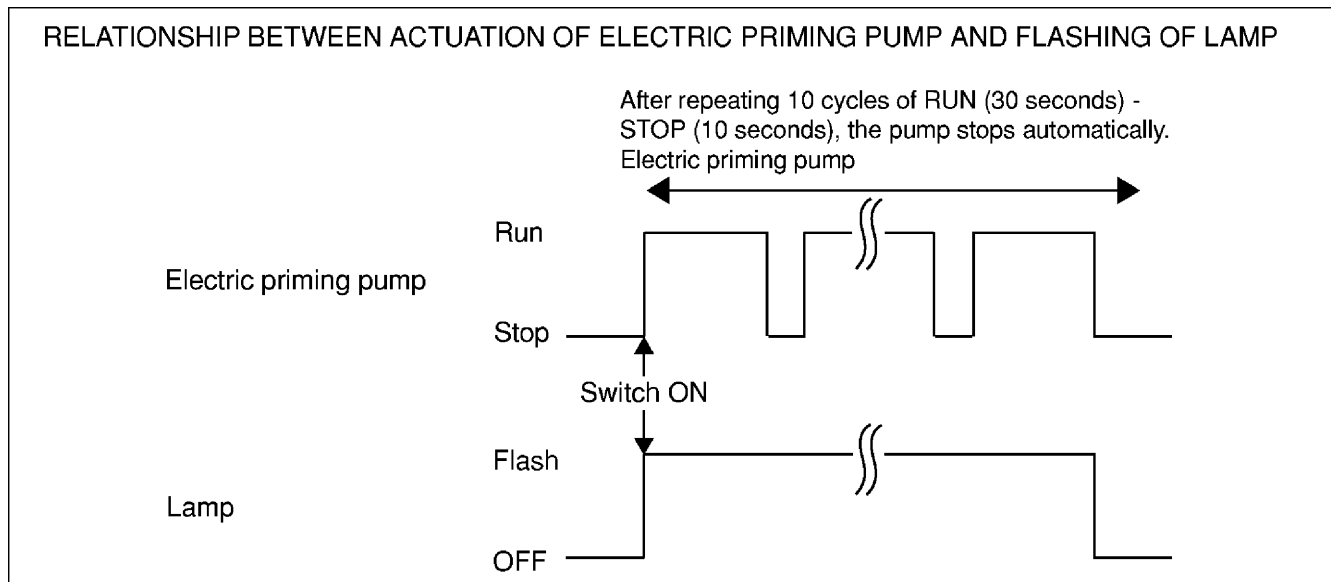

- When the specified time (approx. 7 minutes) has passed, lamp (4) automatically goes out and the electric priming pump stops.
- If the fuel has been drained from the fuel circuit, such as when the engine has run out of fuel and stopped, or maintenance has been carried out on the fuel hoses or tubes, or the supply pump has been replaced, turn the switch for the electric priming pump to the ON position again after the electric priming pump stops automatically (lamp goes out).
- When the lamp goes out, the air bleed operation is completed.

8. Close air bleeding valve (2).

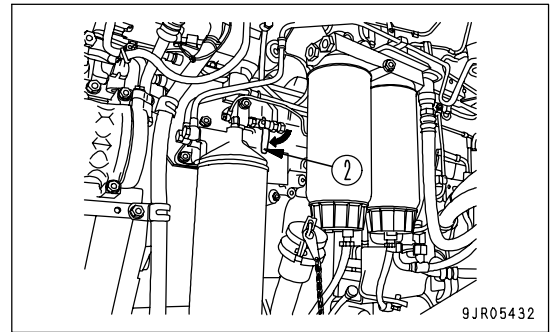

9. Start the engine. If the engine does not start, try again by following the steps below.

- 1) Check that air bleeding valve (2) is closed.
- 2) Tilt electric priming pump switch (3) to the ON position.
- 3) Try to start the engine while the electric priming pump is in operation. If the engine still does not start, wait for approx. 2 minutes, and then repeat steps 2) and 3).
- 4) After the engine has started, run the engine for approx. 5 minutes to bleed air from the fuel system completely.

NOTICE

Do not keep the starting motor rotating continuously for more than 20 seconds.

If the engine will not start, wait for at least 2 minutes before trying to start the engine again.

BLEED AIR FROM REAR BRAKE



WARNING

When bleeding the air, the brakes are released, so the machine may move and cause serious personal injury. When carrying out the air bleed operation, always park the machine on level ground and put blocks under the tires.

To make it easier to bleed the air, warm the oil up to a temperature of at least 40°C (104°F) before bleeding the air. Bleed the air from the rear brakes in the same way on both the left and right sides.

1. Start the engine.
2. Check that the oil in the transmission case is the specified level, and check if the brake oil pressure caution lamp is out.
3. Remove the cap installed to bleeder screw (1) of the slack adjuster, then insert a vinyl hose.
Prepare a container with oil in it and insert the other end of the hose approx. 50 mm (2.0 in) below the surface of the oil.
(Use any commercially available vinyl hose.)
4. Depress the brake pedal and loosen bleeder screw (1) approx. 3/4 turns. Keep the pedal depressed until no more bubbles come out from the vinyl hose.
5. Pull the retarder control lever and loosen bleeder screw (1) approx. 3/4 turns. Keep the retarder control lever depressed until no more bubbles come out from the vinyl hose.
6. After bleeding the air, tighten bleeder screw (1) securely and fit the cap.
7. The procedure for bleeder screw (2) of the rear brake is the same as for the slack adjuster (with Step 4 excluded).
8. Add oil. For details, see "CHECK OIL LEVEL IN TRANSMISSION CASE, ADD OIL (PAGE 3-71)".

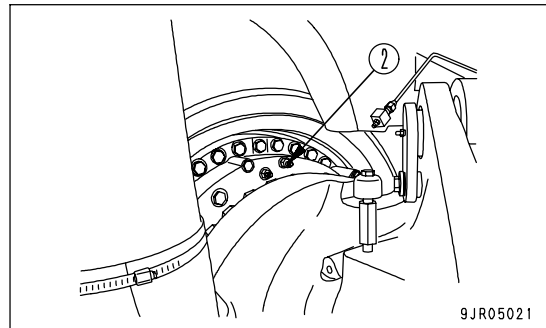
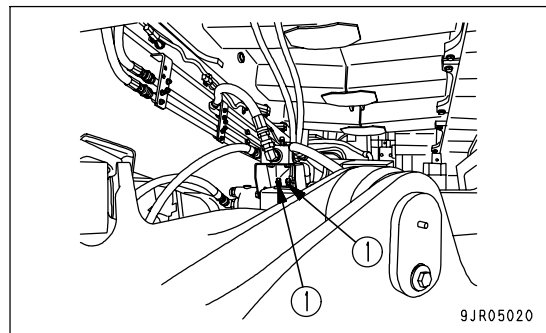

BLEED AIR FROM FRONT BRAKE**WARNING**

When bleeding the air, the brakes are released, so the machine may move and cause serious personal injury. When carrying out the air bleed operation, always park the machine on level ground and put blocks under the tires.

To make it easier to bleed the air, warm the oil up to a temperature of at least 40°C (104°F) before bleeding the air. Repeat the same procedure on the left and right sides.

When bleeding the air from the front brakes and rear brakes at the same time, bleed the air from the rear brakes first.

1. Start the engine.
2. Check that the oil in transmission case is the specified level, and check if the brake oil pressure caution lamp is out, and that the front brake OFF switch is at the OFF position.
3. Remove the cap of bleeder screw (1), then insert a vinyl hose (inside diameter: 8 mm (0.315 in)). Prepare a container with oil in it and insert the other end of the hose approx. 50 mm (2.0 in) into the oil. (Use any commercially available vinyl hose.)
4. Depress the brake pedal and loosen bleeder screw (1) approx. 3/4 turns. Keep the pedal depressed until no more bubbles come out from the vinyl hose.
5. After bleeding the air, tighten bleeder screw (1) securely and fit the cap.

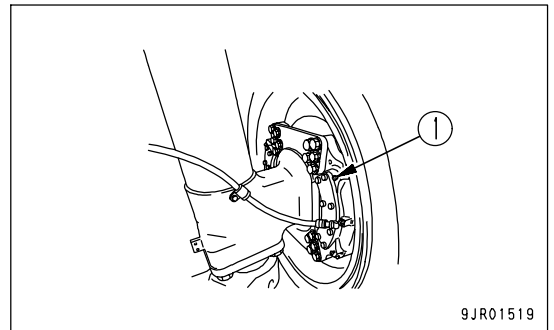

9JR01519

6. Add oil. For details, see "CHECK OIL LEVEL IN TRANSMISSION CASE, ADD OIL (PAGE 3-71)".

BLEED AIR FROM PARKING BRAKE**WARNING**

When bleeding the air, the brakes are released, so the machine may move and cause serious personal injury. When carrying out the air bleed operation, always park the machine on level ground and put blocks under the tires.

To make it easier to bleed the air, warm the oil up to a temperature of at least 40°C (104°F) before bleeding the air. Bleed the air from the parking brakes in the same way on both the left and right sides.

1. Start the engine.
2. Check that the oil in the transmission case is the specified level, and check if the brake oil pressure caution lamp is out.
3. Remove the cap of bleeder screw (1), install to the block at the top of the slack adjuster, then insert a vinyl hose. Prepare a container with oil in it and insert the other end of the hose approx. 50 mm (2.0 in) into the oil. (Use any commercially available vinyl hose.)
4. Put the retarder control lever, then set the parking brake switch to TRAVEL.
5. Loosen bleeder screw (1) approx. 3/4 turns. Continue until no more bubbles come out from vinyl hose.
6. After bleeding the air, tighten bleeder screw (1) securely and fit the cap.
7. The procedure for parking brake bleeder screw (2) is the same as for the block on top of the slack adjuster.
8. Add oil. For details, see "CHECK OIL LEVEL IN TRANSMISSION CASE, ADD OIL (PAGE 3-71)".

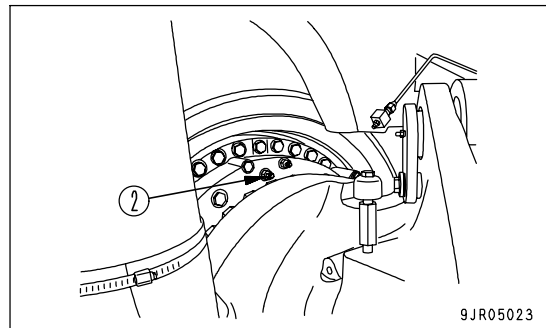
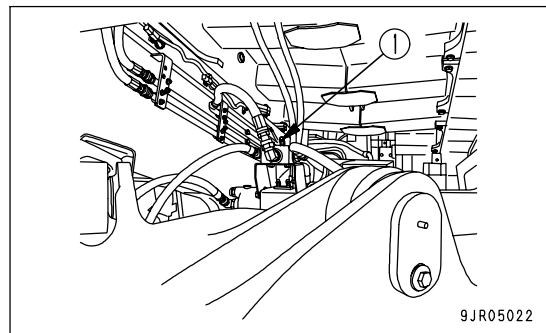

CLEAN, CHECK RADIATOR FINS AND AFTER COOLER FINS

! WARNING

If compressed air is used to carry out the cleaning, dust will fly. If dust gets into your eyes, you may lose your eyesight; if you breathe it in, it may affect your lungs. To prevent this, always wear protective glasses, anti-dust mask, and other protective equipment

If radiator fins (1) or aftercooler fins (2) become clogged or bent, it will cause overheating of the engine, carrying out inspection about clogged or vent of fin. When the clogged was found, clean the radiator fin. When vent of fin was found, please contact your Komatsu distributor for repair.

- Cleaning can be carried out by using jets of air, steam, or water, but be careful not to let the nozzle contact the fin.
- When using compressed air or steam, keep the nozzle at a right angle to the radiator and after cooler.
- Examine the rubber hose, and if any cracks or brittle places are found, replace the hose. In addition, check also for loose hose clamps.

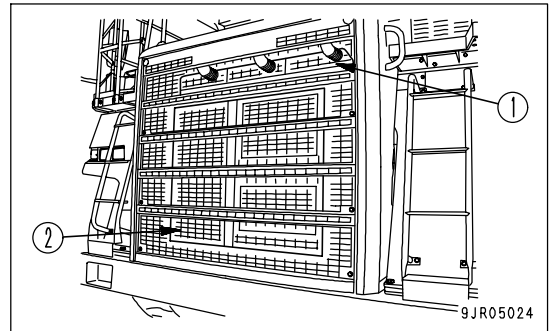

NOTICE

If steam jet nozzle (3) is brought too close to fins (4), the fins can be damaged, so keep a good distance in between when cleaning.

Use the following values as a benchmark.

- Jet pressure: Lower than 9.8 MPa (100 kg/cm²)
- Nozzle diameter: Less than 2 mm (0.08 in)
- Distance between nozzle and fin (A): More than 100 mm (4 in)

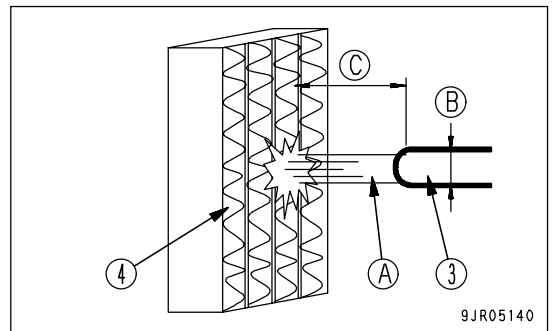

CHECK PLAY OF OUTPUT COUPLING OF OUTPUT SHAFT

**WARNING**

To prevent the machine from moving, set the parking brake switch to PARKING, stop the engine, then put blocks under the wheels.

If any abnormal noise occurs around the output shaft (1) or front drive shaft (2), the rubber inside the output shaft may be deteriorated or damaged, so check the play of the coupling (3) as follows.

1. Set wire (4) as shown in the diagram.
Using the tip of the wire as a benchmark, measure the amount of movement (L) of the coupling.
2. Using bar (5), rotate the coupling at a force of approx. 49 N {5 kg} in the direction around the circumference.
When doing this, mark the position of the wire.
3. Check that the engine fan is not rotating.

REMARK

If excessive force is used in rotating the coupling, the engine rotates freely and it becomes impossible to judge accurately.

4. Rotate the coupling in the reverse direction from Step 2.
When doing this, mark the position of the wire in the same way as in Step 2.

5. Measure the amount of movement (L) of the coupling using the marks made in Steps 2 and 4.

If amount of movement (L) is more than 15 mm (0.6 in), the rubber inside the output shaft may be deteriorated or damaged, so contact your Komatsu distributor and ask for disassembly and inspection of the internal parts of the output shaft.

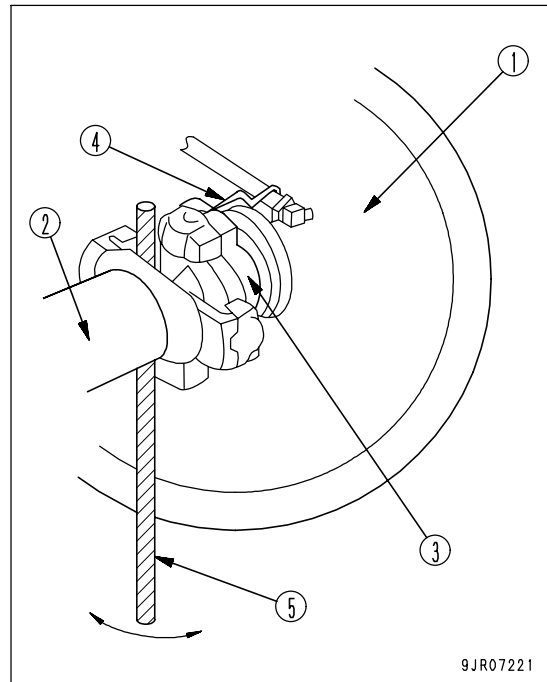

9JR07221

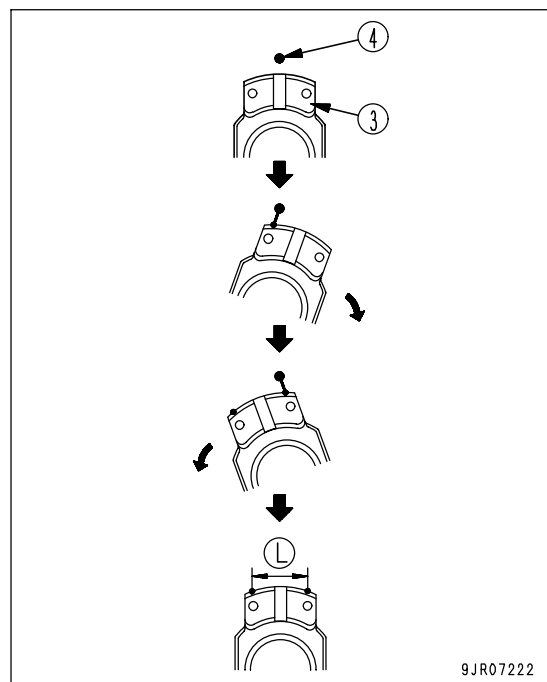

9JR07222

SELECTION AND INSPECTION OF TIRES

⚠ WARNING

If any mistake is made in handling the tire or rim, the tire may explode or be damaged, and the rim may fly off, causing damage or serious personal injury. Always do as follows.

- When carrying out inspection, disassembly, repair, or assembly of the tire, special equipment and special skill is needed, so always ask your specialist tire repair shop to carry out these operations.
- Do not carry out welding or light fires in the area close to tires. The heat will cause the internal pressure of the tire to rise and the rim may fly off.

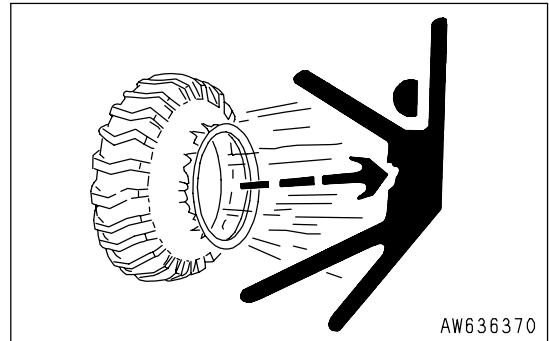

SELECTION OF TIRES

⚠ CAUTION

To maintain the performance and ensure the service life of the machine, tires must be selected to match the conditions of use and the weight of the attachment installed to the machine. Always use the tires specified by Komatsu and maintain the specified inflation pressure.

Select the tires according to the conditions of use and the weight of the attachments of the machine. Use the following table.

Since the travel speed indicated on the speedometer varies with the tire size, consult your Komatsu distributor when using optional tires.

	Max. load [kg (lb)]	Size	Operating model	Remarks
Front wheel	15500 (34178)	24.00-35-36PR	HD465: standard	Type 1 for construction equipment
	18500 (40793)	24.00R35 ★ ★	HD465: if equipped HD605: standard	
	18500 (40793)	24.00-35-48PR	HD605: if equipped	
Rear wheel	15500 (34178)	24.00-35-36PR	HD465: standard	
	18500 (40793)	24.00R35 ★ ★	HD465: if equipped HD605: standard	
	18500 (40793)	24.00-35-48PR	HD605: if equipped	

CHECK OF INFLATION PRESSURE OF TIRES AND INFLATION OF THEM

**WARNING**

If any mistake is made when inflating the tire, the tire may explode or be damaged, and the rim may fly off, causing serious personal injury. To ensure safety, always do as follows.

- When inflating the tire, do not let any person stand in the area around the tire.
- Before inflating the tire, check that there is no problem with the tire or rim. If there is a problem with the tire or rim and the tire is inflated, there is danger that the tire may burst and the rim may fly off.
- The side face of the tire is the area where the tire is damaged or the rim flies off. When inflating the tire set up a fence around the tire, avoid standing the side face of tire, and use an air chuck with a clip that can be fixed to the air valve.
- To prevent inflating the tires too much, measure the inflation pressure with an air gauge.

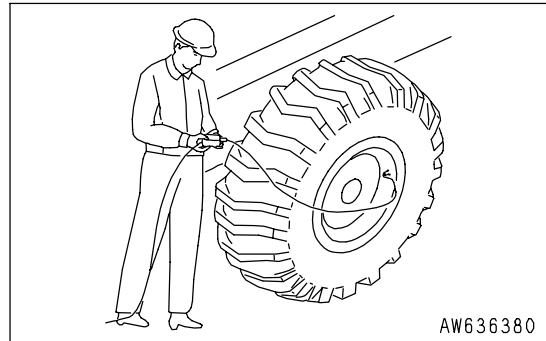

Check

**WARNING**

When traveling at high speed or when traveling with a heavy load, do not adjust the tire inflation pressure. Immediately after traveling at high speed, the measured tire pressure is higher than the proper pressure, so if it is adjusted, the inflation pressure will be too low. If the tire inflation pressure is low, it will cause damage to the tire and rim when the machine is traveling, and this may cause serious personal injury.

Measure the inflation pressure with a tire air gauge, while the tires are cool, before starting work.

Inflation of tires



WARNING

Always maintain the tire inflation pressure at the specified value. If the tire is not at the proper inflation pressure, the rim will be damaged. If the rim is damaged, there is danger that the ring may fly off when the tire is inflated and cause serious personal injury.

Adjust the inflation pressure properly.

When inflating a tire, use an air chuck which can be fixed to the air valve of the tire as shown in the figure. Do not work at the side face of tire but work on the tread side of the tire.

The proper inflation pressure is shown below.

- HD465-7

Tire size	Inflation pressure [MPa (kg/cm ² , PSI)]
24.00-35-36PR (standard)	0.47 to 0.50 (4.75 to 5.05, 67.4 to 71.7)
24.00R35 ★ ★ (if equipped)	0.69 to 0.72 (7.0 to 7.3, 99.4 to 104)

- HD605-7

Tire size	Inflation pressure [MPa (kg/cm ² , PSI)]
24.00R35 ★ ★ (standard)	0.69 to 0.72 (7.0 to 7.3, 99.4 to 104)
24.00-35-48PR (if equipped)	0.64 to 0.67 (6.5 to 6.8, 92.3 to 96.6)

PRECAUTIONS WHEN REPLACING TIRE

If the hub nuts (1) have been tightened again after replacing the tire, travel for 5 to 6 km, then tighten again to settle all the contacting parts.

In particular, there are more contacting parts on the rear wheels than on the front wheels, so it will take time for the parts to settle.

For this reason, repeat the tightening process for the first 50 hours after installation.

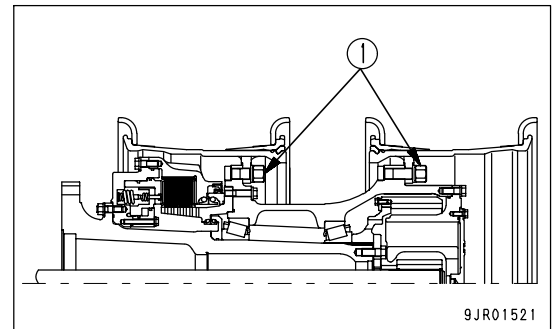

9JR01521

CHECK BEFORE STARTING

For details of the following items, see "CHECK BEFORE STARTING (PAGE 3-68)".

- Check coolant level, add coolant
- Check dust indicator
- Check oil level in engine oil pan, add oil
- Check oil level in transmission case, add oil
- Check oil level in steering and hoist oil tank, add oil
- Check oil level in brake sub-tank, add oil
- Check for leakage of oil from rear brake oil recovery tank breather
- Drain water, sediment from fuel tank
- Check level of fuel in fuel tank, add fuel
- Check wheel hub nuts, tighten
- Check central warning lamp, alarm buzzer, monitor lamps and meters
- Check braking effect
- Check braking capacity of secondary brake
- Check manual emergency steering
- Check auto-emergency steering
- Check backup alarm
- Check electric wiring
- Check inflation pressure of tires
- Check water separator
- Does body positioner operate normally?

EVERY 250 HOURS SERVICE

CHECK OIL LEVEL IN DIFFERENTIAL CASE, ADD OIL

! WARNING

- Immediately after the engine is stopped, the parts and oil are at high temperature, and there is danger that this may cause burns during the oil level check operation. Wait for the temperature to go down before starting the operation.
- When loosening the plug, loosen it slowly. Do not loosen it suddenly. The inside of the case is under high pressure, so if the plug is suddenly loosened, oil will spurt out and cause burns.

1. Remove plug (G). Then check that the oil level is near the bottom of the plug hole.
2. If the oil level is too low, add oil through the plug hole near the bottom of the plug hole.
3. Install plug (G).

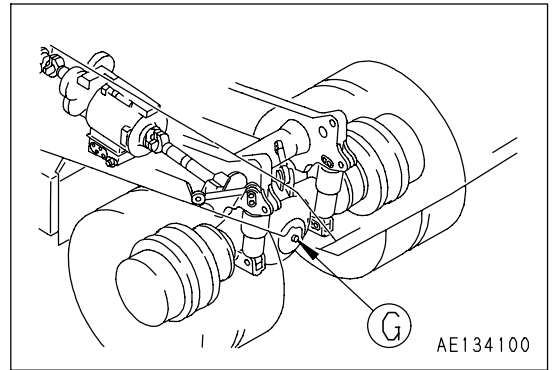

CHECK OIL LEVEL IN FINAL DRIVE CASE, ADD OIL

! WARNING

- Immediately after the engine is stopped, the parts and oil are at high temperature, and there is danger that this may cause burns during the oil level check operation. Wait for the temperature to go down before starting the operation.
- When loosening the plug, loosen it slowly. Do not loosen it suddenly. The inside of the case is under high pressure, so if the plug is suddenly loosened, oil will spurt out and cause burns.

1. Stop the machine so that the TOP casting mark is at the top and drain plug (P) is at the bottom.
2. Remove plug (G). Then check that the oil level is near the bottom of the plug hole.
3. If the oil level is too low, add oil through the plug hole near the bottom of the plug hole.
4. Install plug (G).

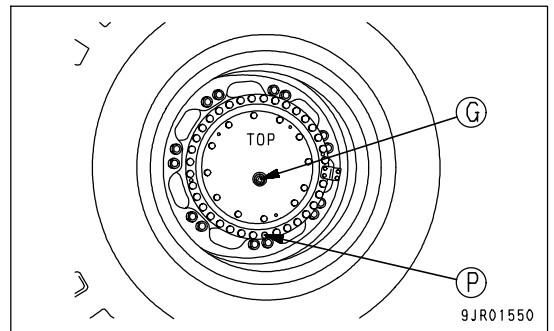

LUBRICATION

1. Stop the engine.
2. Using a grease pump, pump in grease through the grease fittings marked by the arrows.
3. After greasing, wipe off any old grease that was pushed out.

Carry out the greasing operation every day when operating in places where the grease flows out easily after traveling through mud or water.

(1) Dump body hinge pin (left and right: 1 place each)

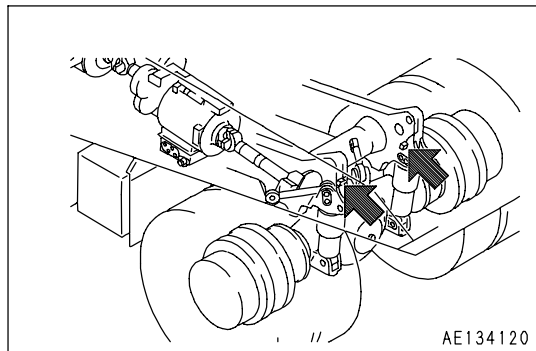

(2) Rear suspension (left and right: 2 places each)

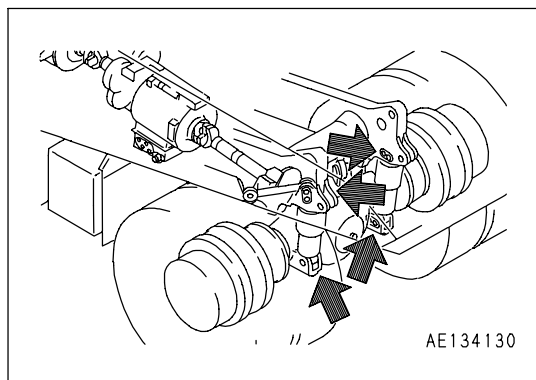

(3) Differential support (left and right: 4 places each)

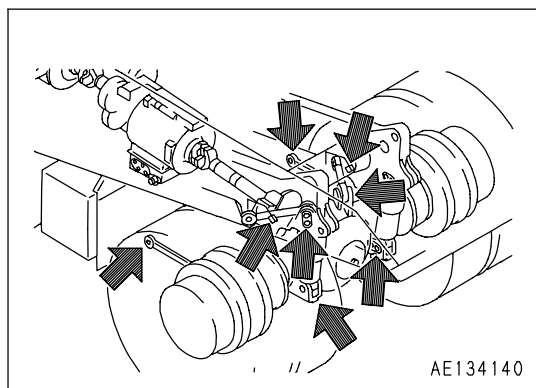

(4) Hoist cylinder pin (left and right: 2 places each)
Lower the dump body before greasing.

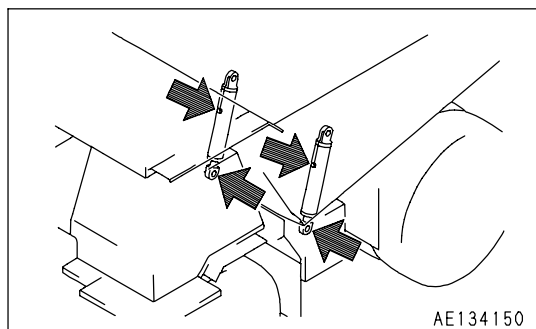

- (5) Front suspension (left and right: 1 places each)
Set the steering facing directly to the front before greasing.

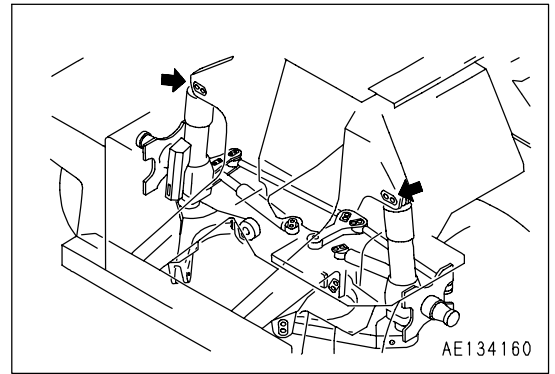

- (6) Steering cylinder pin (4 places)
- (7) Steering link pin (5 places)

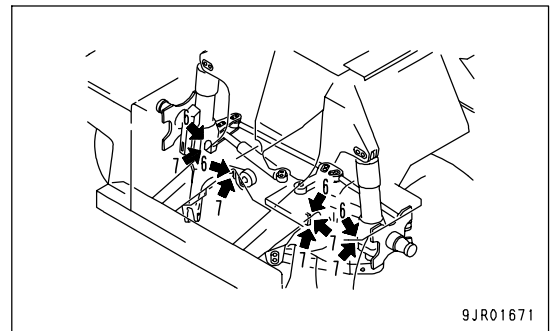

- (8) Steering linkage (left and right: 3 places each)

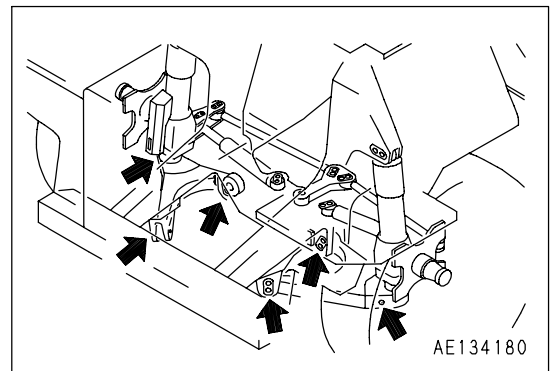

CHECK DRIVE SHAFT

If there is any problem, such as looseness of the drive shaft connection, play in the spline or bearing portion, or runout of the shaft, please contact your Komatsu distributor for repair.

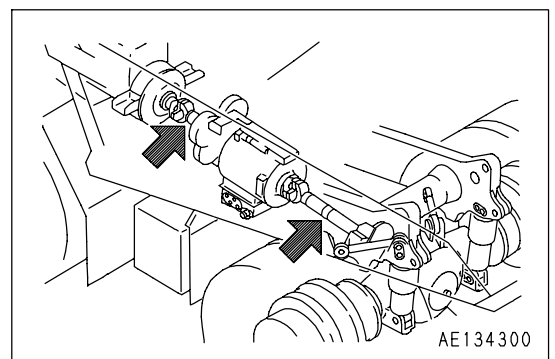

CHECK LEVEL OF BATTERY ELECTROLYTE

Carry out this procedure before operating the machine.



WARNING

- Do not use the battery when the level of the battery electrolyte is below the LOWER LEVEL line. If the battery is used when the electrolyte level is below the LOWER LEVEL line, the inside of the battery will deteriorate. In addition, a mixture of oxygen and hydrogen gas accumulates inside the battery. The deteriorated portion inside the battery becomes a source of fire and will cause the gas to ignite and explode.
- Do not bring any flame close to the battery. During the charging operation, hydrogen and oxygen gas are generated, so there is danger of explosion.
- If battery electrolyte (dilute sulphuric acid) gets in your eyes, you may lose your eyesight. Always wear protective glasses and rubber gloves when handling the battery. If battery electrolyte gets into your eyes, immediately wash your eyes with large amounts of fresh water for at least 15 minutes, and be sure to wash behind your eyelids. After that, get medical attention immediately.
- If battery electrolyte gets on your skin, it will cause chemical burns. If battery electrolyte gets on your skin, wash it off immediately with large amounts of water. When doing this, do not use any alkaline fluid as a neutralizer. If electrolyte gets on your clothes, wash it off in large amounts of water. Then take your clothes off and wash them further in large amounts of water. If you suffer any chemical burn, get medical attention immediately.
- Wipe all the dirt off the top surface of the battery with a damp cloth. If a dry cloth is used, it will generate static electricity. This will ignite the oxygen and hydrogen gas generated when charging the battery and cause an explosion.

NOTICE

If there is battery electrolyte on the machine, wash it off with water. The battery electrolyte is acid, so it will attack the paintwork and cause corrosion where it is in contact with the machine.

Inspect the battery electrolyte level at least once a month and follow the basic safety procedures given below.

WHEN CHECKING ELECTROLYTE LEVEL FROM SIDE OF BATTERY

If it is possible to check the electrolyte level from the side of the battery, check as follows.

1. Clean the around the electrolyte level lines with a wet cloth, and check that the electrolyte level is between the UPPER LEVEL(U. L.) and LOWER LEVEL (L. L.) lines.

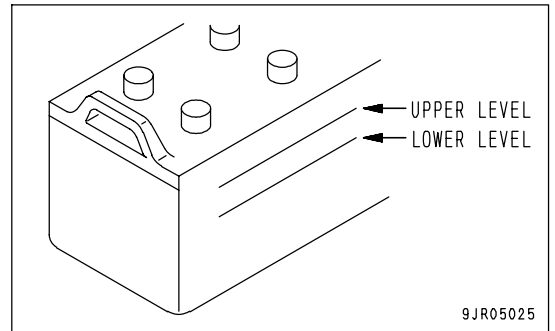

2. If the electrolyte level is below the midway point between the U.L. and L.L. lines, remove cap (1) and add distilled water to the U.L. line.
3. Afetr adding distilled water, tighten cap (1) securely.
4. If the top surface of the battery is dirty, clean it with a damp cloth.

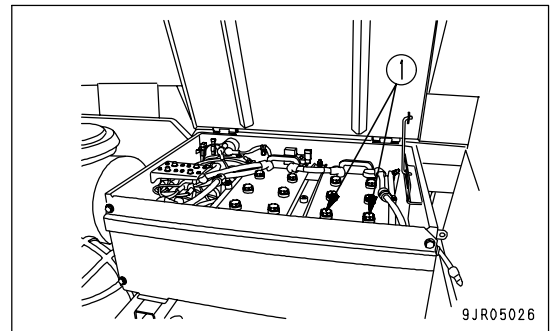

REMARK

If distilled water is added to above the U.L. line, use a syringe to lower the level to the U.L. line. Neutralize the removed fluid with baking soda (sodium bicarbonate), then flush it away with a large amount of water or consult your Komatsu distributor or battery maker.

WHEN IT IS IMPOSSIBLE TO CHECK ELECTROLYTE LEVEL FROM SIDE OF BATTERY

If it is impossible to check the electrolyte level from the side of the battery, or there is no display of the UPPER LEVEL line on the side of the battery, check as follows.

1. Remove cap (1) at the top of the battery, look through the water filler port, and check the electrolytes surface.
2. If the electrolyte does not reach the sleeve, add distilled water so that the level reaches the bottom of the sleeve (UPPER LEVEL line) without fail.

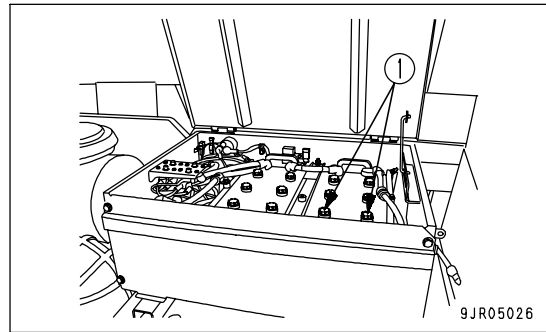

Use the diagram below for reference, and check if the electrolyte reaches the bottom of the sleeve.

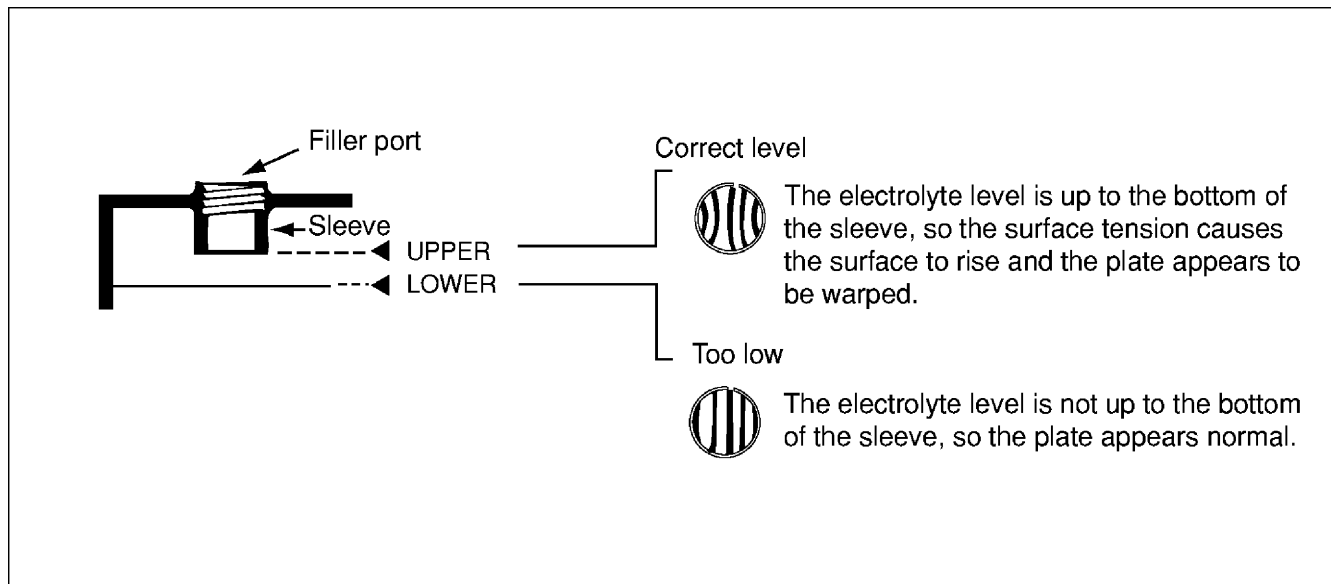

3. After adding distilled water, tighten cap (1) securely.
4. If the top surface of the battery is dirty, clean it with a damp cloth.

REMARK

If water is added to above the bottom tip of the sleeve, use a pipette to remove electrolyte. Neutralize the removed electrolyte with sodium bicarbonate, then flush it away with a large amount of water. If necessary, contact your Komatsu distributor or your battery maker.

WHEN IT IS POSSIBLE INDICATOR TO CHECK ELECTROLYTE LEVEL

(If equipped)

If it is possible to use and the indicator to check the electrolyte level, follow the instruction given.

CLEAN BREATHERS

Remove the mud and dirt from around the breathers, then remove the breathers and wash out the dirt with clean diesel oil or flushing oil.

- Transmission case (3 places)

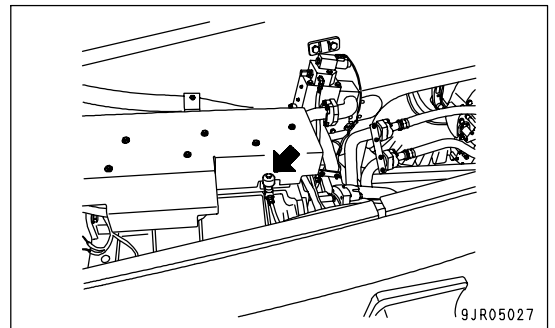
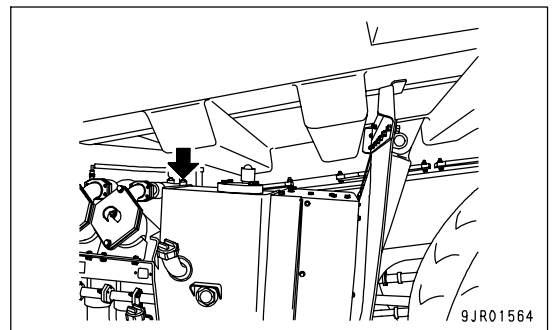
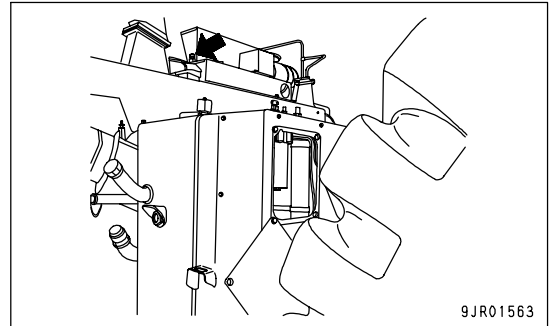

- Steering, hoist oil tank

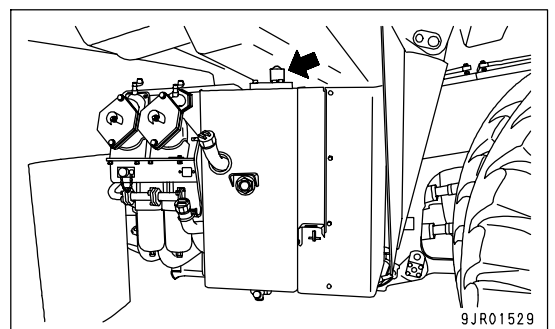

1. Remove nut (1), then remove cover (2) and wash element (3).
2. Install element (3), then install cover (2) and nut (1).

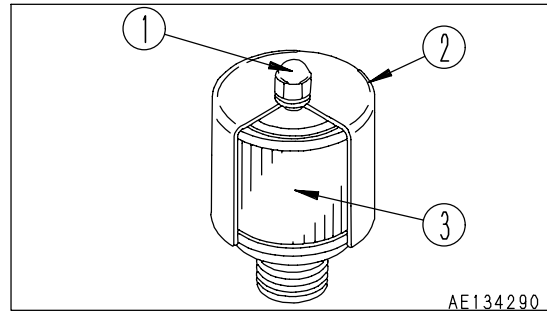

CHECK FRAME



DANGER

- Always carry out the operation to remove or insert the body pivot pin with at least two workers. This operation is carried out with the dump body raised, so if the dump body goes down during the operation, it will lead to serious injury or even death.
- When carrying out inspection with the dump body raised, always set the dump control lever to the HOLD position, set the dump control lever lock knob to the LOCK position, then insert the body pivot pin. If the body pivot pin is not inserted, the dump body may go down when the dump control lever is operated, and catch or cause serious injury or even death to the person carrying out the inspection.

1. Wash the frame to make it easier to check.
2. Check all parts of the frame for damage.

In particular, check the colored portions in the diagram and if any cracks or damage are found, repair the damage. Please contact your Komatsu distributor for details of the repair procedure.

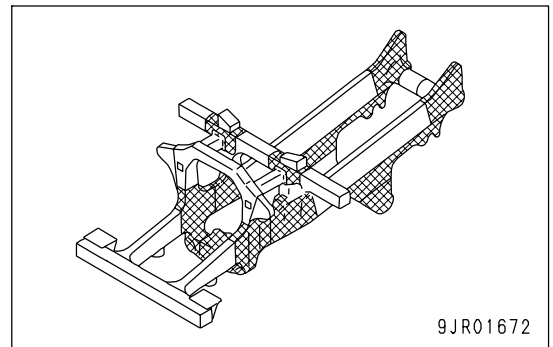

CHECK BRAKING CAPACITY OF FOOT BRAKE

**WARNING**

When checking the braking capacity of the foot brake, there is danger that the machine may suddenly move and be damaged or cause serious personal injury. Always do the following.

- Select a wide, flat area with sufficient distance to make it possible to stop the machine if it suddenly moves.
- If the machine suddenly moves when the braking capacity of the foot brake is being checked, reduce the engine speed immediately, move the gear shift lever to the N position, and set the parking brake to the PARKING position to stop the machine.
- If inspection is carried out when the dump body pilot lamp is lighted up and the shift indicator is at F1, there is danger of damage to the internal parts of the transmission.

When carrying out inspection, seat the dump body securely and check that the body pilot lamp has gone out. In addition, set the gear shift lever to the "D" position and check that the shift indicator shows F2.

Check the braking capacity of the foot brake as follows.

1. Stop the machine on flat ground and depress service brake (1).
2. Set shift lever (2) to the D position, gradually raise the engine speed, and check that the machine does not move even when the engine speed reaches 1870rpm. If the machine does not move, it is normal.
3. Lower the engine speed, set gear shift lever at N position, and then set parking brake valve lever at PARKING position. If any problem is found, ask Komatsu distributor for repair.

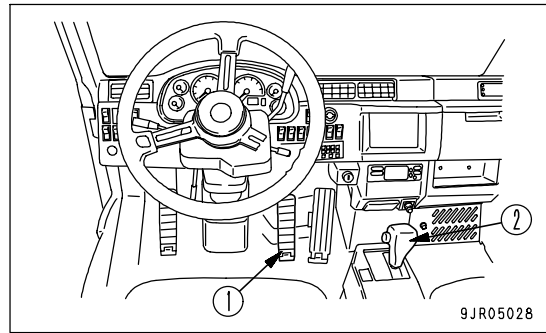
**NOTICE**

If the dump body is not seated and the parking brake is at "TRAVEL", the speed range is set to F1, even when the gear shift lever is at the "D" position.

CHECK BRAKING CAPACITY OF RETARDER BRAKE

! WARNING

When checking the braking capacity of the retarder brake, there is danger that the machine may suddenly move and be damaged or cause serious personal injury. Always do the following.

- Select a wide, flat area with sufficient distance to make it possible to stop the machine if it suddenly moves.
- If the machine suddenly moves when the braking capacity of the retarder brake is being checked, reduce the engine speed immediately, move the gear shift lever to the N position, and depress the foot brake to stop the machine.
- If inspection is carried out when the dump body pilot lamp is lighted up and the shift indicator is at F1, there is danger of damage to the internal parts of the transmission.

When carrying out inspection, seat the dump body securely and check that the body pilot lamp has gone out. In addition, set the gear shift lever to the "D" position and check that the shift indicator shows F2.

Check the braking capacity of the retarder brake as follows.

1. Stop the machine on flat ground and pull retarder control lever (1) fully.
2. Set shift lever (2) to the D position, gradually raise the engine speed, and check that the machine does not move even when the engine speed reaches 1400rpm. If the machine does not move, it is normal.
3. Lower the engine speed, set gear shift lever at N position. If any problem is found, ask your Komatsu distributor for repair.

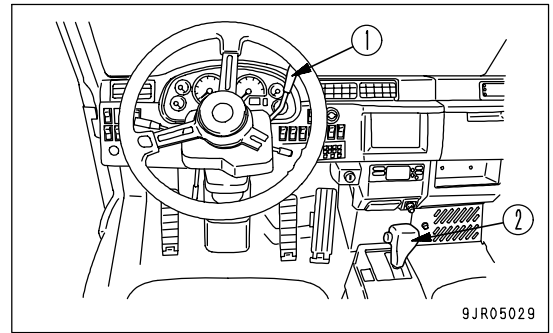

9JR05029

NOTICE

If the dump body is not seated and the parking brake is at "TRAVEL", the speed range is set to F1, even when the gear shift lever is at the "D" position.

CHECK BRAKING CAPACITY OF PARKING BRAKE



WARNING

When checking the braking capacity of the parking brake, there is danger that the machine may suddenly move and be damaged or cause serious personal injury. Always do the following.

- Select a wide, flat area with sufficient distance to make it possible to stop the machine if it suddenly moves.
- If the machine suddenly moves when the braking capacity of the parking brake is being checked, reduce the engine speed immediately, move the gear shift lever to the N position, and depress the foot brake to stop the machine.
- If inspection is carried out when the dump body pilot lamp is lighted up and the shift indicator is at F1, there is danger of damage to the internal parts of the transmission.

When carrying out inspection, seat the dump body securely and check that the body pilot lamp has gone out. In addition, set the gear shift lever to the "D" position and check that the shift indicator shows F2.

Check the braking capacity of the parking brake as follows.

1. Stop the machine on flat ground and set parking brake switch (1) to PARKING.
2. Set shift lever (2) to the D position, gradually raise the engine speed, and check that the machine does not move even when the engine speed reaches 1670rpm. If the machine does not move, it is normal.
3. Lower the engine speed, set gear shift lever at N position. If any problem is found, ask your Komatsu distributor for repair.

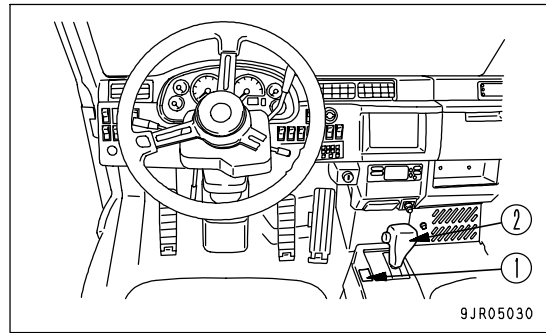

CHECK, CLEAN AUTOMATIC SUSPENSION

(If equipped)

! WARNING

When checking or cleaning the automatic suspension, always do as follows. If the machine suddenly moves during the inspection, there is danger that it may cause serious personal injury.

- One person should sit in the operator's seat so that the engine can be stopped at any time. All workers should be in communication all the time.
- Set the parking brake switch to the **PARKING** position, then put blocks under the tires to prevent the machine from moving.
- Do not touch the gear shift lever. Before operating the dump control lever, always give a signal to the other workers and have them move back to a safe place.

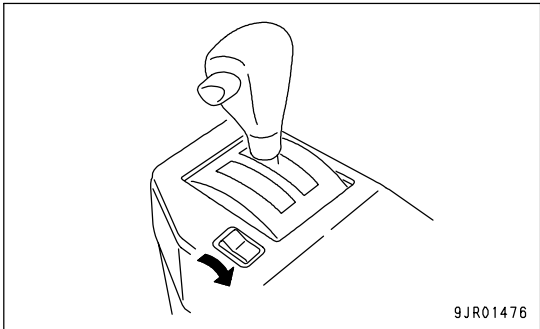
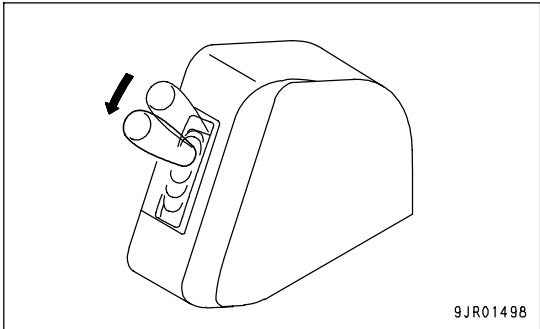

1. When bolts of inspection cover (1) are loosened and the cover is moved to the side. The inspection hole can be seen.

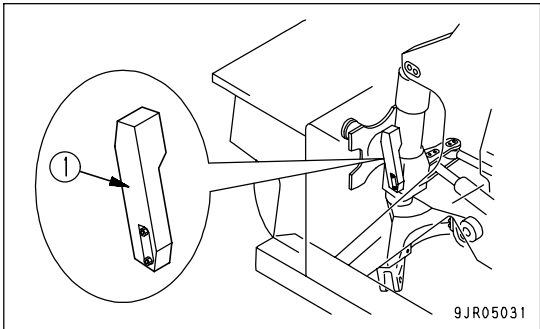

2. Check the position of the link.
 Check that it moves to the following positions:
 For normal travel when empty: soft (A)
 When the brake is depressed: medium (B)
 When the dump lever is at any position other than FLOAT: hard (C)

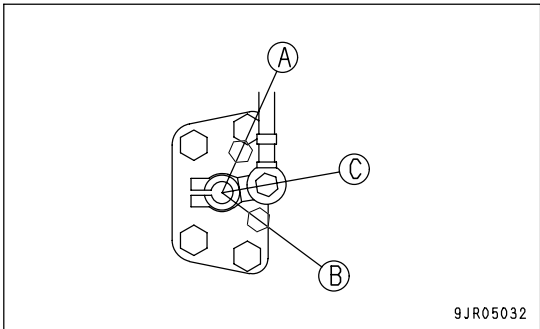

If any problem is found, please contact your Komatsu distributor for inspection and adjustment.

If operations are carried out on muddy or wet ground, mud will stick to the link, and the movement may become slow, so check and clean.

CHECK OF ACCUMULATOR GAS PRESSURE

For handling of the accumulator, see "HANDLING SUSPENSION CYLINDER, ACCUMULATOR, GAS SPRING (PAGE 2-36)".

REMARK

If the engine stops during travel, the brake can be operated with the oil pressure in the accumulator temporarily.

CHECK OF FUNCTION

1. Stop the machine on a flat place and set the parking brake switch to the PARKING position.
2. Start the engine and run it at medium speed for 1 minute, and then stop it.
3. Turn the starting switch to the ON position and depress the brake pedal several times. After the brake pedal is depressed some times, the brake oil pressure caution lamp lights up.
 - If the brake oil pressure caution lamp lights up when the brake pedal is depressed 4 times or less, the gas pressure in the accumulator may be low. Ask your Komatsu distributor for inspection.
 - If the brake oil pressure caution lamp does not light up when the brake pedal is depressed 5 times, the gas pressure in the accumulator is normal.

REMARK

Check the function within 5 minutes after stopping the engine. If the engine is kept stopped, the gas pressure in the accumulator lowers and cannot be checked.

EVERY 500 HOURS SERVICE

Maintenance for every 250 hours service should be carried out at the same time.

CHANGE OIL IN ENGINE OIL PAN, REPLACE ENGINE OIL FILTER CARTRIDGE

! WARNING

Immediately after the engine is stopped, the oil and parts are at high temperature, so there is danger of suffering burns during the operation. Wait for the temperature to go down before starting the operation.

- Refill capacity: 80 liters (21.14 US gal)
- Prepare a filter wrench

1. Remove drain plug (1), then install the drain hose in general tool.
2. Set a container in position to catch the oil, then loosen drain the valve (2) slowly to avoid getting oil on yourself, and drain the oil. Be careful not to loosen drain valve (2) too much. This will deform the stopper pin inside the valve.
3. Check the drained oil, and if there are excessive metal particles or foreign material, please contact your Komatsu distributor.
4. Remove the drain hose, then tighten drain valve (2) and drain plug (1).

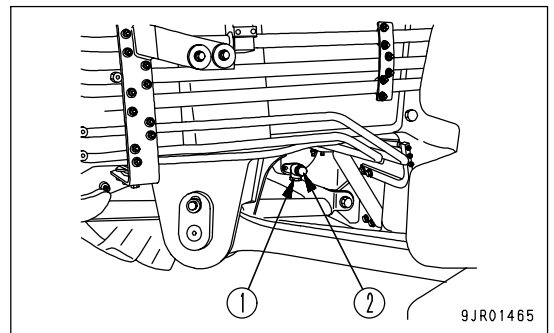

Tightening torque

Drain plug (1), drain valve (2): $68.6 \pm 9.8\text{Nm}$
 ($7 \pm 1 \text{ kgm}$, $50.6 \pm 7.2 \text{ lbft}$)

Using the filter wrench, turn 3 full-flow filter cartridges (3) to the left to remove them.

When doing this, to prevent getting oil on yourself, do not carry out this operation from immediately under the cartridge.

In particular, if this operation is carried out immediately after stopping the engine, a large amount of oil will come out, so wait for 10 minutes before starting the operation.

5. Clean the filter holder, fill the new filter cartridge with oil, then coat the seal and thread of the filter cartridge with oil (or coat thinly with grease) and install.
6. When installing the filter cartridge, tighten until the packing face is in contact with the filter holder, then tighten a further 3/4 - 1 turn.
7. Pour in the specified amount of engine oil from oil filler (F).
8. Run the engine for a short time at idle, then check the oil if it is filled up to a specified level. For details, see "CHECK OIL LEVEL IN ENGINE OIL PAN, ADD OIL (PAGE 3-70)".

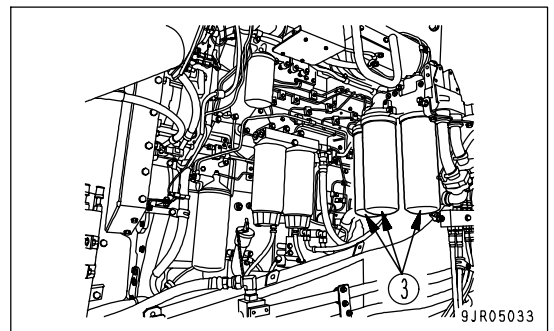

REPLACE FUEL PREFILTER CARTRIDGE



WARNING

- After the engine has been operated, all parts are at high temperature, so do not replace the filter immediately. Wait for all parts to cool down before starting the operation.
- High pressure is generated inside the engine fuel piping system when the engine is running. When replacing the filter, wait for at least 30 seconds after stopping the engine to let the internal pressure go down before replacing the filter.
- Do not bring any fire or flame close.

NOTICE

- Genuine Komatsu fuel filter cartridges use a special filter that has highly efficient filtering ability. When replacing the filter cartridge, always use a genuine Komatsu part.
 - The common rail fuel injection system used on this machine consists of more precise parts than the conventional injection pump and nozzle. If any part other than a genuine Komatsu filter cartridge is used, dust or dirt may get in and cause problems with the injection system. Always avoid using substitute parts.
 - When carrying out inspection or maintenance of the fuel system, pay more attention than normal to the entry of dirt. If dirt is stuck to any part, use fuel to wash it off completely.
- Prepare a container to catch drain fuel.
 - Prepare a filter wrench

1. Close supply valve (1) of the fuel tank.

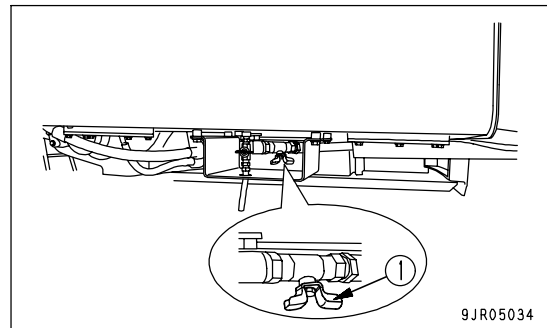

2. Set the container to catch the fuel under the filter cartridge (2).
3. Remove transparent cup (3) from the filter and inspect it. If it is broken or damaged, replace it with a new part.
4. Using a filter wrench, turn filter cartridge (2) counterclockwise to remove it.

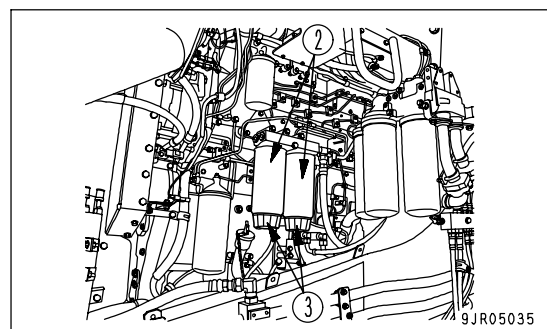

5. Clean transparent cup (3) and remove seal (4). Coat the new seal with clean fuel or oil.
6. Install transparent cup (3) to the new filter cartridge.
Tightening torque for cup: 10 Nm {1.0 kgm, 7.2 lbft}

NOTICE

It is not necessary to fill the filter cartridge with oil.

Cap (A) is installed to prevent dirt from entering the inside of the filter cartridge.

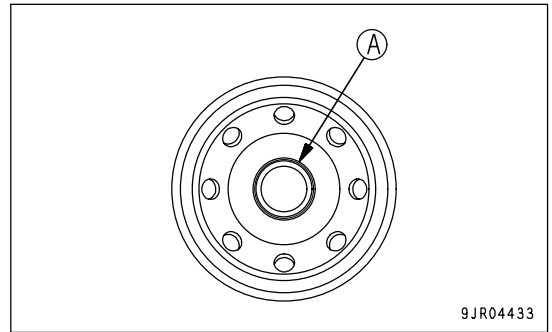

When replacing the filter cartridge, check that drain plug (5) at the bottom of transparent cup (3) is securely tightened.
(Tightening torque: 0.2-0.4 Nm {0.02 - 0.046 kgm, 0.1 - 0.3 lbft})

7. Clean the filter holder.
8. Coat the packing surface of the filter cartridge with oil.
9. Remove filter cartridge cap (A) and install to the filter holder.
10. When installing, tighten until the packing surface contacts the seal surface of the filter holder, then tighten it 3/4 of a turn.
If the filter cartridge is tightened too far, the packing will be damaged and this will lead to leakage of fuel. If the filter cartridge is too loose, fuel will also leak from the packing, so always tighten the correct amount.
11. Open fuel valve (1) on the fuel tank.

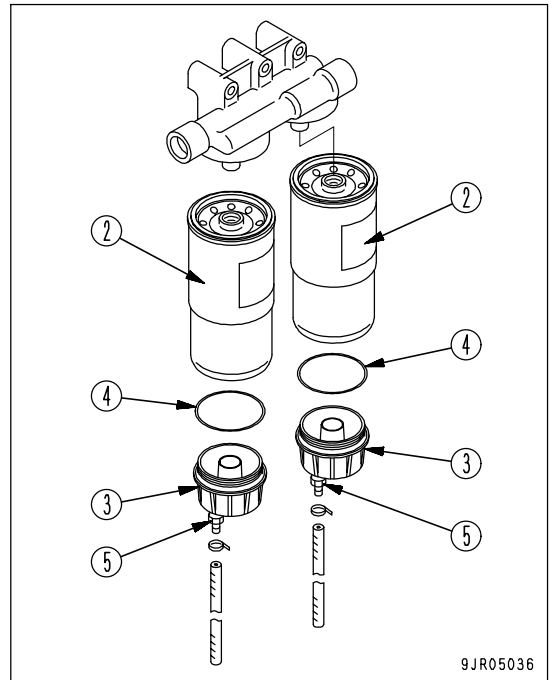

REPLACE FUEL MAIN FILTER CARTRIDGE



WARNING

- After the engine has been operated, all parts are at high temperature, so do not replace the filter immediately. Wait for all parts to cool down before starting the operation.
- High pressure is generated inside the engine fuel piping system when the engine is running. When replacing the filter, wait for at least 30 seconds after stopping the engine to let the internal pressure go down before replacing the filter.
- Do not bring any fire or flame close.

NOTICE

- Genuine Komatsu fuel filter cartridges use a special filter that has highly efficient filtering ability. When replacing the filter cartridge, always use a genuine Komatsu part.
 - The common rail fuel injection system used on this machine consists of more precise parts than the conventional injection pump and nozzle. If any part other than a genuine Komatsu filter cartridge is used, dust or dirt may get in and cause problems with the injection system. Always avoid using substitute parts.
 - When carrying out inspection or maintenance of the fuel system, pay more attention than normal to the entry of dirt. If dirt is stuck to any part, use fuel to wash it off completely.
- Prepare a container to catch drain fuel.
 - Prepare a filter wrench

1. Close supply valve (1) of the fuel tank.

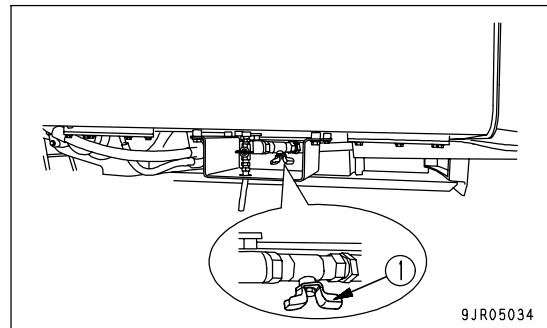

2. Set the container to catch the fuel under the filter cartridge (2).
3. Using a filter wrench, turn filter cartridge (2) counterclockwise to remove it.
4. Clean the filter holder.
5. Coat the packing surface of the filter cartridge with oil.

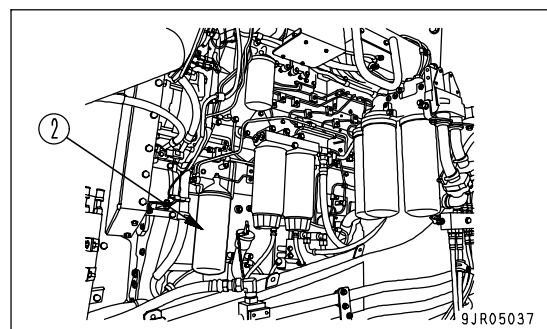

6. Remove filter cartridge cap (A) and install to the filter holder.

NOTICE

Do not fill the filter cartridge with fuel.

Cap (A) is installed to prevent dirt from entering the inside of the filter cartridge.

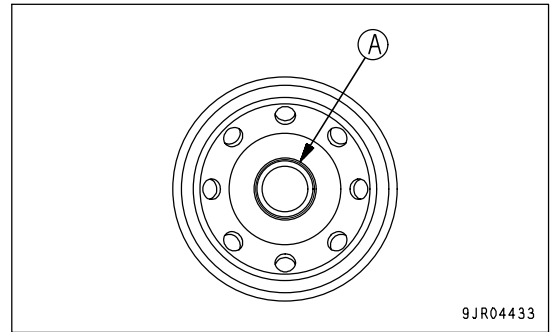

7. When installing, tighten until the packing surface contacts the seal surface of the filter holder, then tighten it 3/4 of a turn.
If the filter cartridge is tightened too far, the packing will be damaged and this will lead to leakage of fuel. If the filter cartridge is too loose, fuel will also leak from the packing, so always tighten the correct amount.
8. Open fuel valve (1) on the fuel tank.
9. After completing the replacement of fuel filter cartridge (2), bleed the air from the circuit. For details, see "BLEED AIR FROM FUEL CIRCUIT (PAGE 4-37)".
10. After replacing the filter cartridge, start the engine and check that there is no leakage of fuel from the filter seal surface. If any leakage of fuel is found, check that the filter cartridge is tightened properly. If the fuel still leaks, repeat Steps 1 - 3 to remove the filter cartridge, then check the packing surface for damage or embedded dirt. If any problem is found, replace the cartridge with a new part, then repeat Steps 4 - 8 to install the new cartridge.

REPLACE TRANSMISSION VALVE OIL FILTER ELEMENT

WARNING

Immediately after the engine is stopped, the oil and parts are at high temperature, so there is danger of suffering burns during the operation. Wait for the temperature to go down before starting the operation.

1. Set the container to catch the oil under the filter case.
2. Remove drain plug (1) at the bottom of the filter case, drain the oil, then tighten the plug again.
3. Loosen hexagonal portion (3) of case (2), then remove case (2).
4. Remove the element and clean the inside of the case.
5. Replace the filter gasket and O-ring with new parts. Coat the gasket and O-ring thinly with clean engine oil before installing.
6. Assemble the new element, then set the case in position and install it.

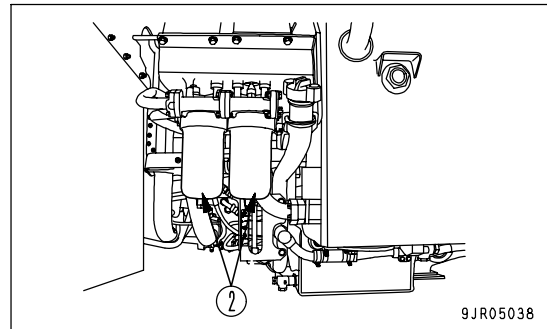

Tightening torque for drain: 49 to 58.8 Nm
(5 to 6 kgm, 36.2 to 43.4 lbft)

Tightening torque for case: 58.8 to 78.5 Nm
(6 to 8 kgm, 43.4 to 57.9 lbft)

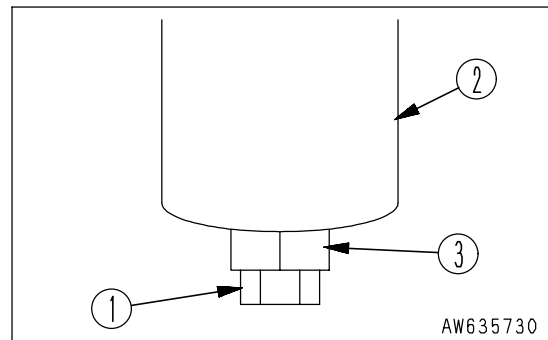

7. Run the engine for a short time at idling, then stop the engine, and check that the oil is up to the specified level. For details, see "CHECK OIL LEVEL IN TRANSMISSION CASE, ADD OIL (PAGE 3-71)".

Run the engine at high idling, and when the oil is warmed up, if the Maintenance caution lamp flashes, replace the element immediately.

CHECK WEAR OF FRONT DISC BRAKE PADS

! WARNING

Check the wear of the disc brakes carefully. If the disc exceeds the wear limit, the braking distance will become longer and it may become impossible to stop the machine within the desired distance. This may lead to serious personal injury.

Perform inspection EVERY 250 HOURS if the work site is covered by lots of earth and sand if it is at the location where the foot brake is frequently used.

1. Install the inspection gauge (2) into the wear inspection hole (1).
2. Check clearance between inspection gauge stepped portion (3) of gauge and caliper (4).

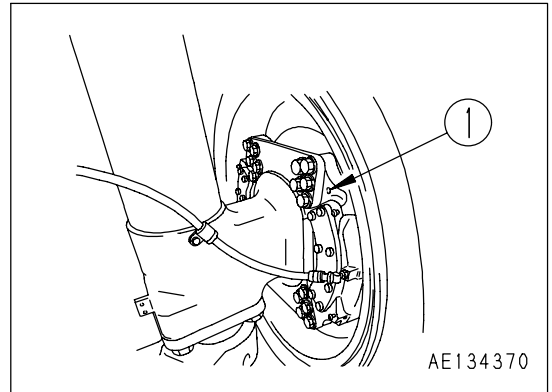

The wear limit where stepped portion (3) of gauge (2) contacts caliper (4) is 3 mm (0.1 in) (remaining thickness of pad), so replace pad (5).

- (A):Near wear limit
- (B):Wear limit reached, so replace pad

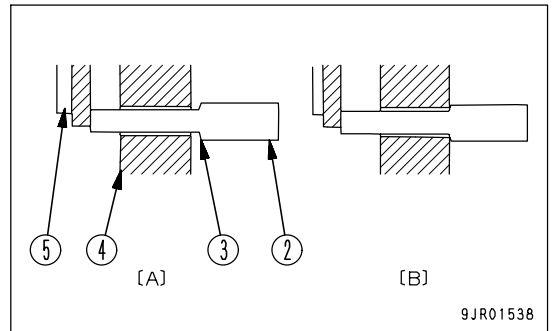

After the inspection, if it is necessary to change the pad, contact your Komatsu distributor.

Left and right wheels are not always the same in terms of the amount of wear of the pad. So, perform the inspection for both left and right. If either side shows the wear limit, be sure to change all 8 pads.

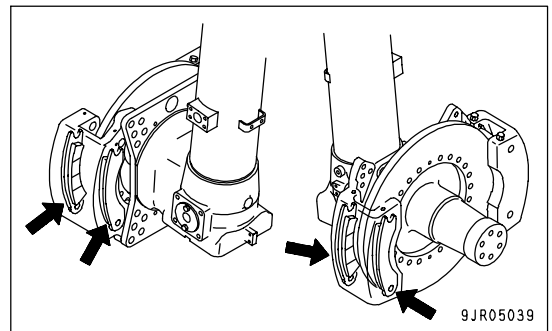

If the work is performed on the muddy and watery ground, the mud sticks to caliper or disc. Leaving the mud will increase the wear of pad, so wash out thoroughly with water.

CHECK FAN BELT FOR WEAR AND REPLACE

**WARNING**

When carrying out inspection and maintenance, always hang a "DO NOT OPERATE" warning sign on the gear shift lever. If anyone operates the machine when someone is carrying out inspection, that person may be caught in the rotating or moving parts of the machine and suffer serious injury.

In addition, there is danger of cutting your fingers off in the pulley groove.

Check the V-belt, and replace the V-belt if the condition is as follows.

- The V-belt is in contact with the bottom of the groove of each pulley
- The V-belt is worn and has sunk below the outside diameter of the pulley
- The V-belt is cracked or peeling

REPLACING

When replacing the V-belt, do as follows.

1. Loosen lock nut (1) and then loosen adjust screw (2).
2. Remove two bolts (3) and then loosen bolt (4) until bracket (5) can be moved.

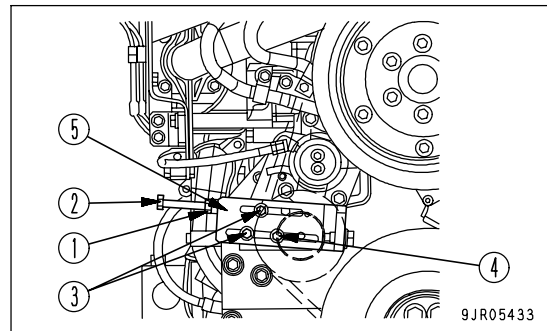

3. Push bracket (5) in as shown in the figure, tilt it up and then secure it with bolt (4) hard enough to stop it from moving.

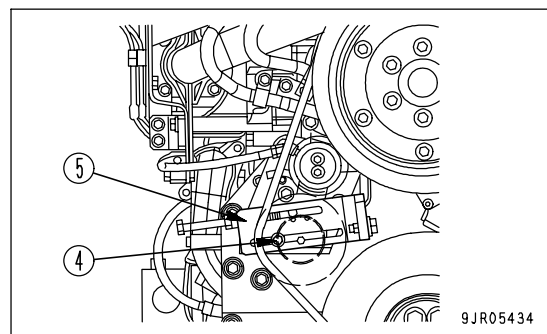

4. Disconnect the grease hose at portion (6), screw a bolt in tension pulley lever tapped hole (7) (M12 x 1.75) and pull the bolt down hard with a crowbar.
5. The tension pulley can be moved inward, so remove the present V belt.
6. Install a new V belt. And replace the V belt in a set.

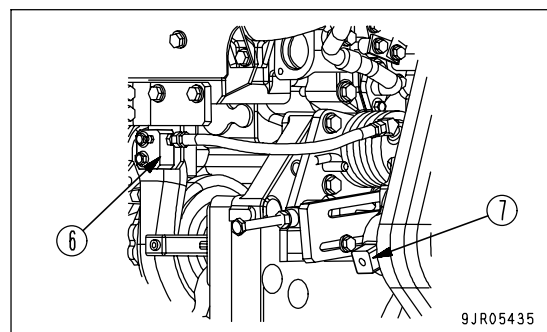
**NOTICE**

The V-belt stretches as it is used, so the length is different from that of a new belt. If new belts and old belts are used together, the load will be applied only to the new V-belt, and this may cause the V-belt to break.

- Loosen bolt (4), put bracket (5) back to the original position, install two bolts (3) and connect grease hose (6).

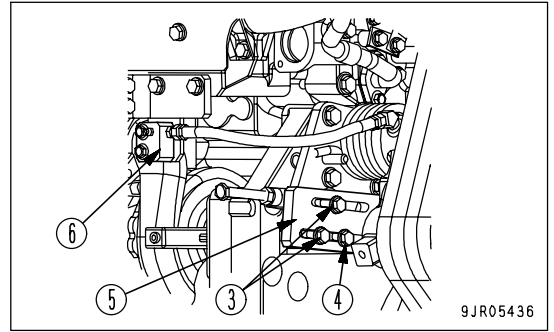

ADJUSTING

- Loosen three bolts (3) and (4) until bracket (5) can be moved.
- Pull bracket (5) back until it contacts tension pulley lever (7), and screw adjust screw (2) in until its tip comes to contact the bracket.
- After the screw tip contacts the bracket, screw adjust screw (2) in by two more turns and then tighten lock nut (1).
- Tighten three bolts (3) and (4) to secure bracket (5).
- Make an adjustment this way when the fan belt generates a squeaking noise.

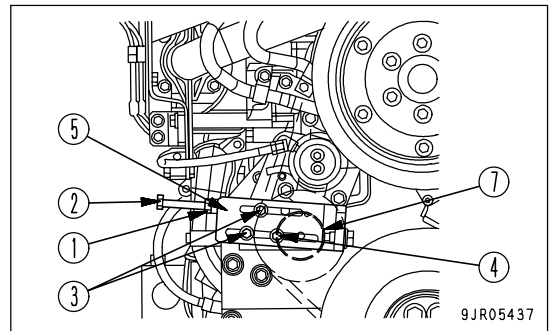

CHECK, REPLACE COMPRESSOR DRIVE BELT FOR ALTERNATOR, AIR CONDITIONER

CHECKING

If the alternator drive belt is in any of the following conditions, the belt must be replaced.

- When horizontal scratch (1) crosses vertical scratch (2)
- When there are tears (3) in part of the belt

In case (4) where there are horizontal scratches only, there is no need to replace the belt.

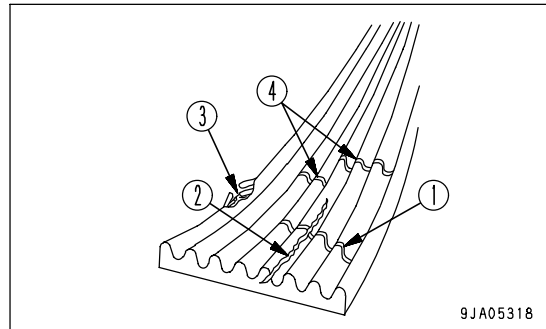

REPLACING

1. Remove 8 bolts (1), then remove cover (2).
2. Loosen locknut (4) of push bolt (3), then tighten push bolt (3) fully to push in tension pulley (5).
This will loosen belt (6).
3. Replace the belt.
4. Loosen push bolt (3) until approx. 90 mm (3.5 in) of the thread appears, then tighten the locknut (4).
5. Install cover (2), then install 8 bolts (1).

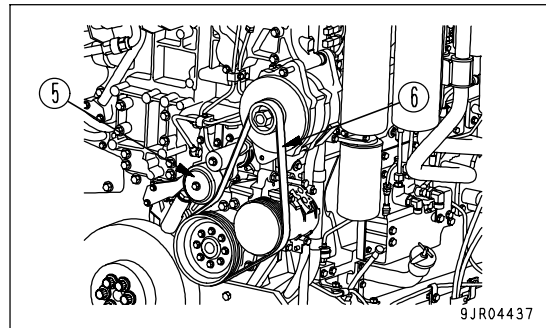
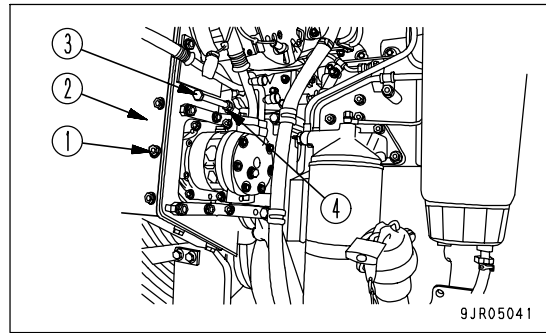

EVERY 1000 HOURS SERVICE

Carry out maintenance for EVERY 250 HOURS and EVERY 500 HOURS SERVICE at the same time.

REPLACE CORROSION RESISTOR CARTRIDGE



WARNING

Immediately after the engine is stopped, the oil and parts are at high temperature, so there is danger of suffering burns during the operation. Wait for the temperature to go down before starting the operation.

- Prepare a filter wrench

1. Turn valve (1) on top of the corrosion resistor to close.
2. Set the container to catch the water under the cartridge.
3. Using a filter wrench, remove cartridge (2).
4. Clean the filter holder, coat the steel surface of the new filter cartridge with clean engine oil, then install it.
5. When installing, tighten until the gasket contacts the seal surface of the filter holder, then tighten a further 2/3 turns.
If the filter cartridge is tightened too far, the gasket will be damaged and this will lead to leakage of water. If the filter is too loose, water will also leak from the gap at the gasket, so always tighten the correct amount.

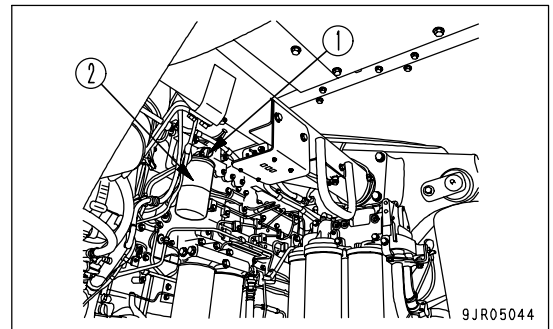

6. Open valve (1).
7. After replacing the cartridge, start the engine and check that there is no leakage of water from the filter seal surface. If there is any leakage of water, check the tightening of the filter cartridge.

CHANGE OIL IN TRANSMISSION CASE, BRAKE SUB TANK, WASH STRAINER

 **WARNING**

- Immediately after the engine is stopped, the parts and oil are at high temperature, and there is danger that this may cause burns during the oil level check operation. Wait for the temperature to go down before starting the operation.
- When loosening the plug, loosen it slowly. Do not loosen it suddenly. The inside of the case is under high pressure, so if the plug is suddenly loosened, oil will spurt out and cause burns.

- Refill capacity: 215 liters (56.8 US gal)

Change the oil every 1000 hours or every 10,000 km, whichever comes sooner.

Carry out the following items at the same time in order to drain oil completely.

- CHANGE OIL IN TRANSMISSION CASE, BRAKE SUB TANK, WASH STRAINER (PAGE 4-74)
- REPLACE TRANSMISSION AND REAR BRAKE COOLING OIL FILTER ELEMENT (PAGE 4-77)
- REPLACE BRAKE OIL FILTER ELEMENT (PAGE 4-78)

1. Stop the engine.
2. Set a container to catch the oil directly under the drain plug of the transmission case.
3. Remove drain plug (1).
4. Loosen drain valve (2) and drain the oil, then tighten the plug again.
5. Install drain plug (1).
6. Set a container to catch the oil directly under the drain plug of the brake sub tank.
7. Remove drain plug (3).
8. Loosen drain valve (4) and drain the oil. After draining the oil, tighten drain valve (4).
9. Install drain plug (3).
10. Remove bolts (5), then remove the cover (6) and take out strainer (7).
11. Remove any dirt stuck to the strainer, then wash in clean diesel fuel or flushing oil. If the strainer is damaged, replace it.
12. Install strainer (7).
13. Install cover (6), then tighten with bolts (5).

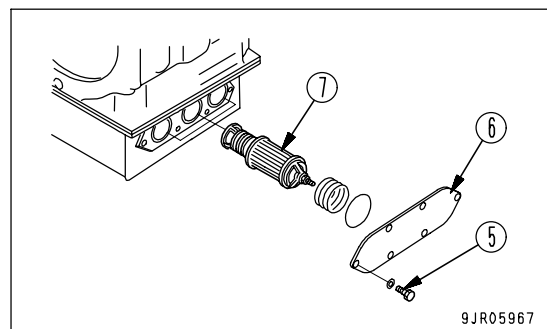
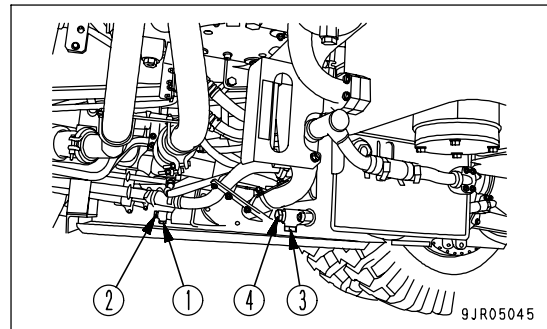

14. Remove plug (8).
If the plug is removed, it is easier to drain the oil from the brake chamber.

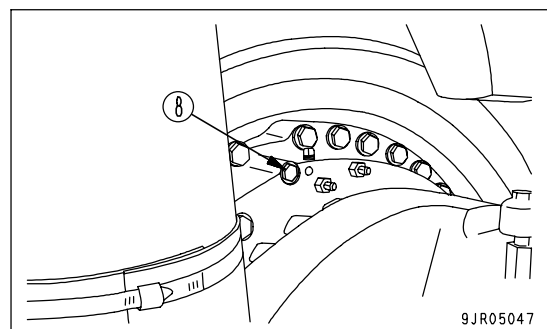

- Remove retader drain plug (9) and drain the oil from brake chamber.

NOTICE

Drain the oil from the brake chamber on both the left and right sides.

- After completely draining the oil from the brake chamber, install plug (8) and reterder drain plug (9).

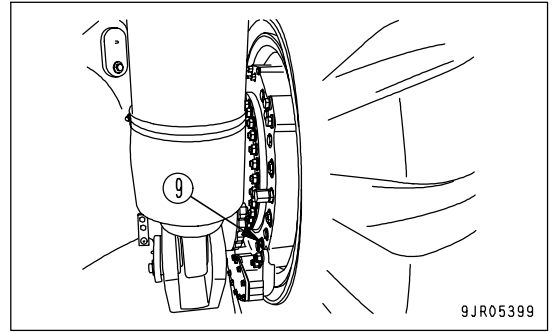

9JR05399

NOTICE

Do not start up the engine without the transmission being filled with oil. If the engine is started up while the transmission is empty or short of oil, the transmission hydraulic pump will suffer damage.

- Before starting the engine, add 170 liters (44.91 US gal) of oil through oil filler port (F).

When oil is added, the level will temporarily go above the oil level on sight gauge (G), but this does not indicate any abnormality.

- Start the engine and run at low idling.
- Add oil through oil filler port (F) until the oil level is between the H and L marks on sight gauge (G).

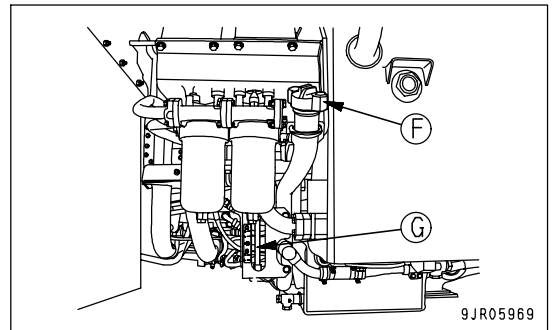

9JR05969

Make sure that the oil level in the brake oil tank does not go down below the mark in the sight gauge (H) while the engine is running at low idling. If the oil level goes down below (H) mark, stop the engine and raise the oil level in the brake oil tank.

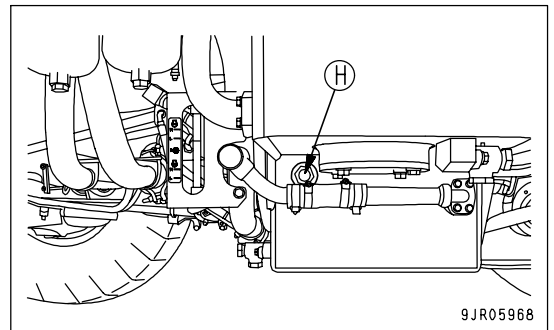

9JR05968

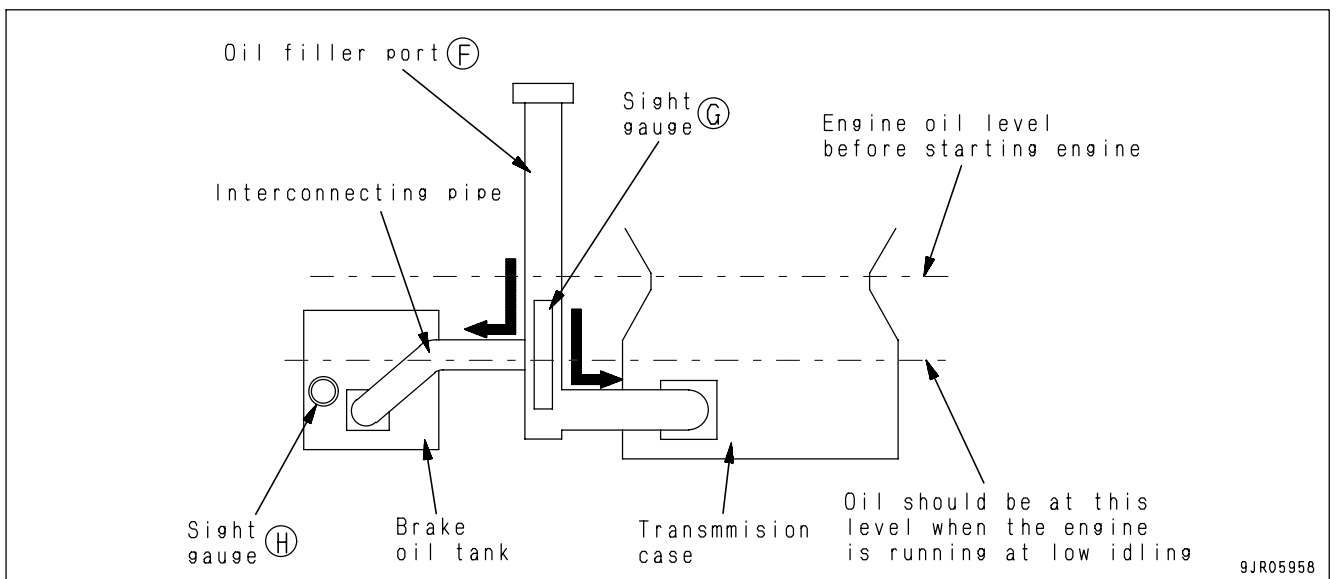

9JR05958

20. Remove the cap from bleeder screw (10) and insert a vinyl hose.

(Use a commercially available vinyl hose.)

21. Put the other end of the vinyl hose approx. 50 mm into a container of oil.

22. Loosen bleeder screw (10) approx. 3/4 turns and run the engine at low idling until no more bubbles come out from the vinyl hose.

23. When no more bubbles come out, tighten bleeder screw (10) securely, remove the vinyl hose, then install the cap.

24. Carry out the warming-up operation of the engine until the torque converter oil temperature gauge goes above 40°.

25. When the torque converter oil temperature gauge rises to 40°, bleed the air from the brakes.

Front brake: See "BLEED AIR FROM FRONT BRAKE (PAGE 4-41)".

Rear brake: See "BLEED AIR FROM REAR BRAKE (PAGE 4-40)".

Parking brake: See "BLEED AIR FROM PARKING BRAKE (PAGE 4-42)".

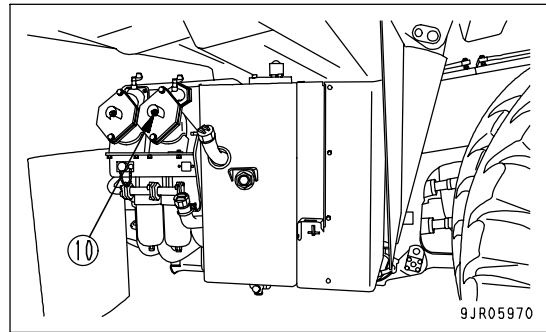

NOTICE

- Do not attempt to use the oil drained during air bleeding again. Such a practice can cause damage on the machine's tool and equipment.
- Make sure that the oil level in the brake oil tank does not go down below (H) level in the sight gauge during air bleeding. If it does, the brake oil pump could be damaged.

26. After finishing air bleeding, stop the engine (for 2 to 3 minutes), and adjust the oil level so that it reaches the specified level. For details, see "CHECK OIL LEVEL IN TRANSMISSION CASE, ADD OIL (PAGE 3-71)".

27. Check the oil level in the brake sub-tank and adjust the oil level so that it reaches the specified level. For details, see "CHECK OIL LEVEL IN BRAKE SUB-TANK, ADD OIL (PAGE 3-72)".

REPLACE TRANSMISSION AND REAR BRAKE COOLING OIL FILTER ELEMENT

! WARNING

- Immediately after the engine is stopped, the parts and oil are at high temperature, and there is danger that this may cause burns during the oil level check operation. Wait for the temperature to go down before starting the operation.
- When loosening the cap, do not loosen it suddenly. Loosen it gradually. The inside of the case is under high pressure, so if the cap is loosened suddenly, oil may spurt out and cause burns.

1. Turn the cap of oil filler (F) slowly to release the internal pressure, then remove the cap.
2. Remove bolt (1), then remove cover (2).

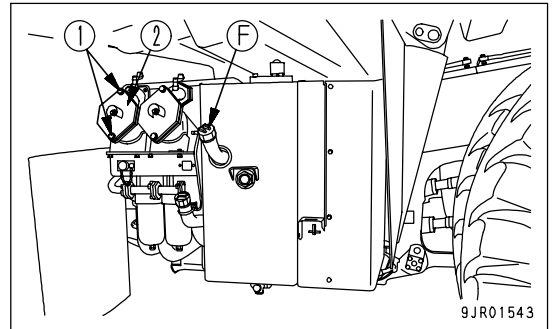

3. Remove O-ring (3), spring (4), valve (5), element (6), and the strainer (7), then wash the inside of the case and of the valve and strainer.
4. Prepare a new element, then install the strainer, element, valve, and spring.
5. Coat the O-ring thinly with clean oil, then install it.
6. Install cover (2) with bolts (1).

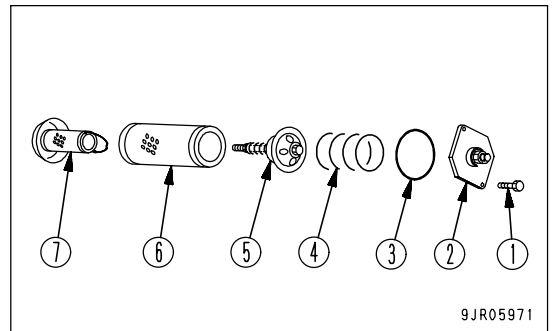

If the filter Maintenance caution lamp (if equipped) lights up when the engine water temperature gauge is in the white range and the engine is running at 1200 to 2100 rpm, replace the element immediately.

REPLACE BRAKE OIL FILTER ELEMENT

**WARNING**

- Immediately after the engine is stopped, the parts and oil are at high temperature, and there is danger that this may cause burns during the oil level check operation. Wait for the temperature to go down before starting the operation.
- When loosening the plug, loosen it slowly. Do not loosen it suddenly. The inside of the case is under high pressure, so if the plug is suddenly loosened, oil will spurt out and cause burns.

- Prepare a filter wrench

1. Stop the engine.
2. Depress the brake pedal at least 20 times to reduce the pressure inside the brake control accumulator to 0.

REMARK

When the pressure in the accumulator is released, the operating effort of the brake pedal becomes lighter and the oil pressure noise disappears.

3. Remove the bolt, then remove accumulator cover (1), and put a container to catch the drain oil under the brake oil filter.

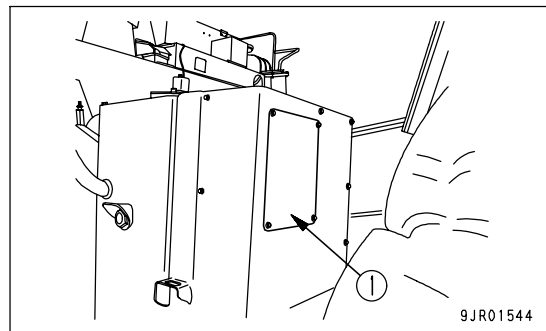

4. Use a wrench to turn the hexagonal portion at the bottom of the filter case, and remove filter case.

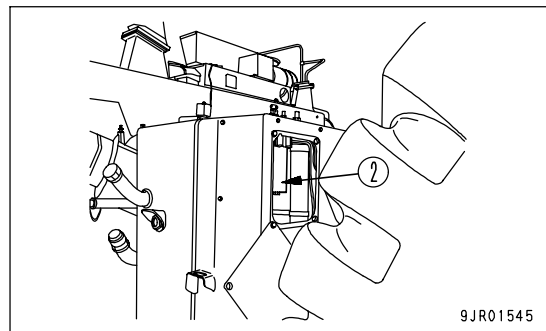

5. Take out the element (3) and wash the inside of filter case.
 6. Replace O-ring (4) and back-up ring (5) on the filter case with new parts, coat thinly with clean oil, then install it.
 7. Coat thinly with clean oil to new O-ring on new element.
 8. Assemble a element in filter case, install to filter head cover.
- Tightening torque: 78.4 - 98.0 Nm {8 - 10 kgm, 57.9 - 72.3 lbft}
9. Install accumulator cover (1).

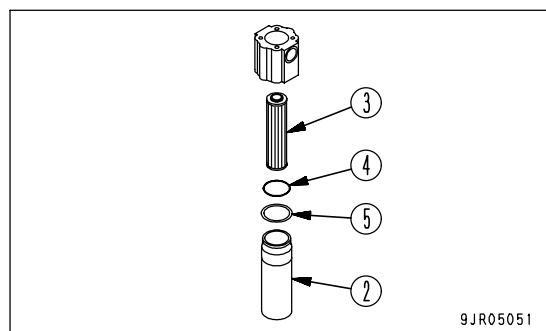

LUBRICATION

1. Stop the engine.
2. Using a grease pump, pump in grease through grease fittings marked by arrows.
3. After greasing, wipe off any old grease that was pushed out.

(1) Transmission mount (1 place)

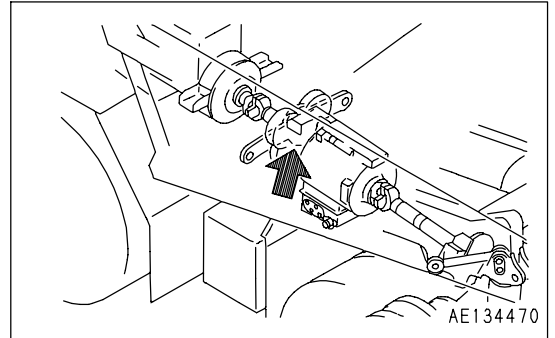

(2) Automatic suspension link (left and right: 1 place each)

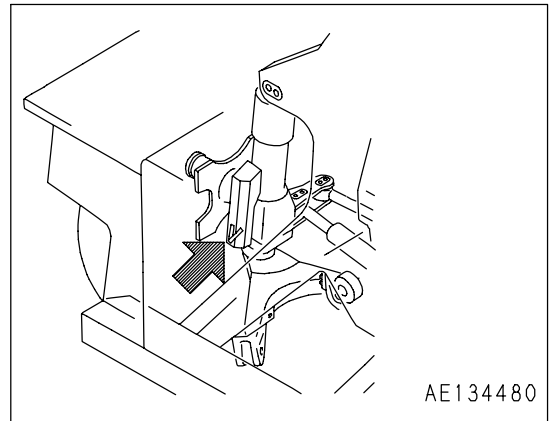

(3) Tension pulley and fan pulley (3 places)

Pump in grease through the grease fitting until grease oozes out from the seal.

NOTICE

Do not use air pressure or oil pressure to carry out high-pressure greasing.

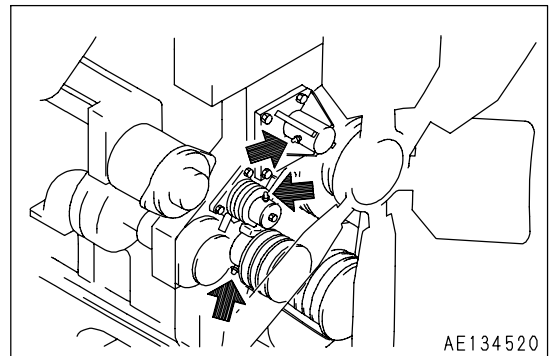

CHECK WEAR OF REAR BRAKE DISC

**WARNING**

- Immediately after the engine is stopped, the parts and oil are at high temperature, and there is danger that this may cause burns during the operation. Wait for the temperature to go down before starting the operation.
- Check the wear of the brake discs carefully. If the disc exceeds the wear limit, the braking distance will become longer and it may become impossible to stop the machine within the desired distance. This may lead to serious personal injury.

1. Stop the machine on level ground, set the parking brake switch to the PARKING position. Then check that the other brake are not applied.
2. Stop the engine.
3. Remove cap nut (1).

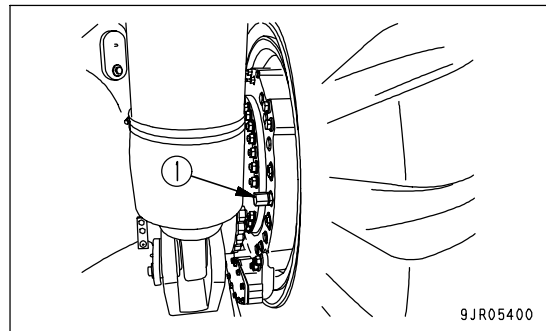

4. Push in until rod (2) of the gauge contacts the piston. Do not depress the brake pedal when doing this.
If slit (3) of rod (2) goes in beyond guide end face (4), it means that the disc has reached the wear limit.
If this happens, please contact your Komatsu distributor for inspection and maintenance.

5. Install cap nut (1) removed in Step 2.

Tightening torque: 128 to 186 Nm
(13 to 19 kgm, 94 to 137.4 lbft)

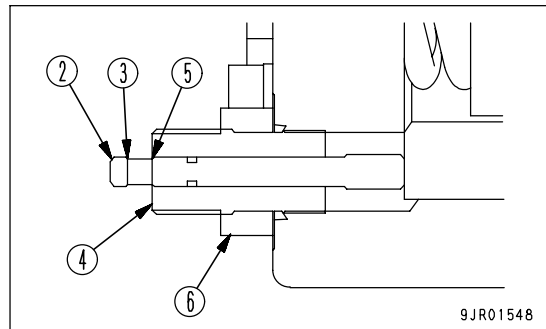
**REMARK**

- On a new machine, the position of the guide is adjusted so that slit (5) comes to guide end face (4), so do not loosen locknut (6) except when replacing the disc.
- When the engine is started and the rod is pushed in, the rod is pushed back by the brake cooling oil pressure, so carry out this operation with the engine stopped.

RECOVER OIL LEAKING FROM FLOATING SEAL**WARNING**

- The parts and oil are at high temperature immediately after the engine is stopped, and may cause serious burns. Wait for the temperature to go down before starting the operation.
- If there is still pressure remaining inside the case, the oil or plug may fly out.
Loosen the plug slowly to release the pressure.

Use the same procedure to recover the oil on the left and right sides.

1. Place a container to catch the oil under drain plug (P).
2. Remove drain plug (P), drain the oil, then tighten the plug again.

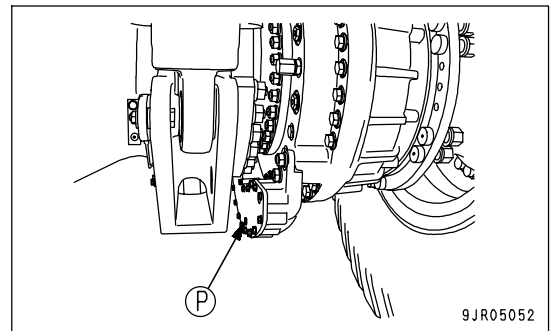

CHECK, GREASE COMPRESSOR DRIVE BELT TENSION PULLEY ASSEMBLY FOR ALTERNATOR, AIR CONDITIONER

CHECKING

Check the pulley for play and leakage of grease. If there is any abnormality, please contact your Komatsu distributor for disassembly and repair or replacement.

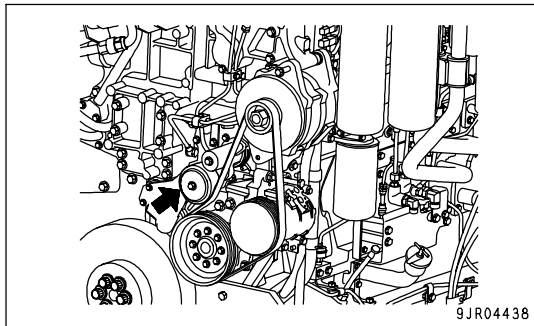

LUBRICATING

Using a grease pump, pump in grease through the grease fittings shown by arrow.

After greasing, wipe off any old grease that was pushed out.

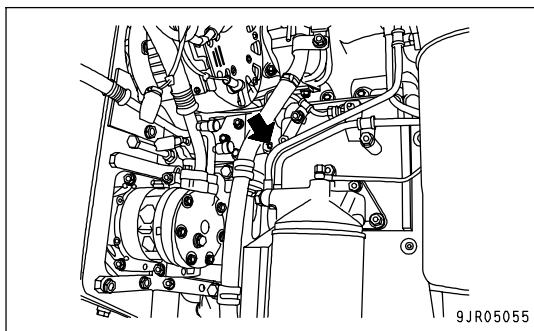

CHECK OF ENGINE AIR INTAKE PIPING CLAMPS FOR LOOSENESS

Check the clamps between the air cleaner, turbocharger, aftercooler, and engine for looseness. If any clamp is loosened, retighten it.

EVERY 2000 HOURS SERVICE

Carry out maintenance for EVERY 250 HOURS, EVERY 500 HOURS and EVERY 1000 HOURS SERVICE at the same time.

REPLACE STEERING, HOIST OIL TANK FILTER ELEMENT

WARNING

- Immediately after the engine is stopped, the parts and oil are at high temperature, and there is danger that this may cause burns during the oil level check operation. Wait for the temperature to go down before starting the operation.
- When loosening the cap, do not loosen it suddenly. Loosen it gradually. The inside of the case is under high pressure, so if the cap is loosened suddenly, oil may spurt out and cause burns.

1. Stop the engine.
2. Turn the cap of oil filler (F) slowly to release the internal pressure, then remove the cap.
3. Remove bolt (1), then remove cover (2).

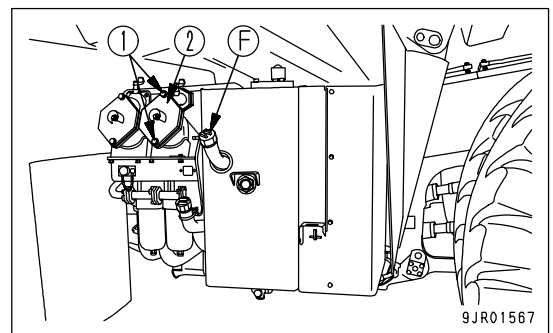

4. Remove O-ring (3), spring (4), valve (5), element (6), and the strainer (7), then wash the inside of the case and of the valve and strainer.
5. Prepare a new element, then install the strainer, element, valve, and spring.
6. Coat the O-ring thinly with clean oil, then install it.
7. Install cover (2) with bolts (1).

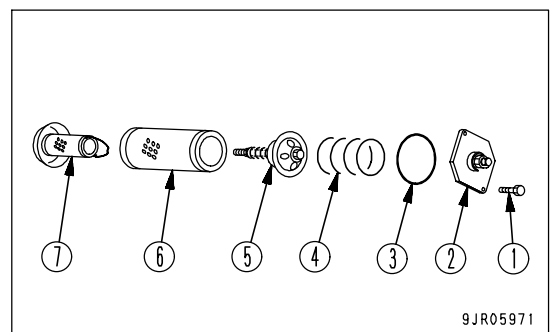

If the filter Maintenance caution lamp (if equipped) lights up when the engine water temperature gauge is in the white range and the engine is running at 1200 to 2100 rpm, replace the element immediately.

CLEAN HYDRAULIC TANK STRAINER



WARNING

- Immediately after the engine is stopped, the parts and oil are at high temperature, and there is danger that this may cause burns during the operation. Wait for the temperature to go down before starting the operation.
- When loosening the oil filler cap, do not loosen it suddenly. Loosen it gradually. The inside of the case is under high pressure, so if the oil filler cap is loosened suddenly, oil may spurt out and cause burns.

1. Lower the dump body and stop the engine.
2. Turn the cap of oil filler (F) slowly to release the internal pressure.
3. Remove plug (1) of the strainer (2 places) at the rear of the left front wheel.
4. Take the strainer out from strainer case (2), then wash it in clean diesel fuel.
5. Tighten the cap of oil filler (F).

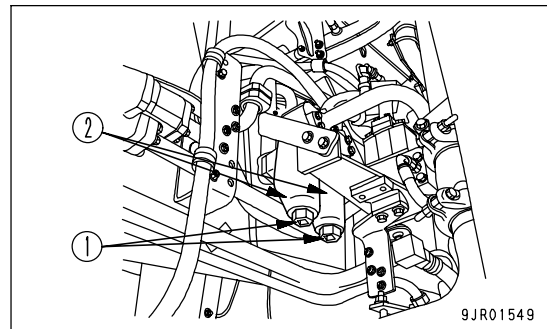
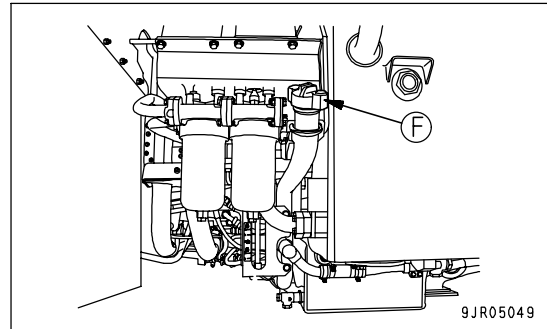

CHANGE OIL IN FINAL DRIVE CASE



WARNING

- Immediately after the engine is stopped, the parts and oil are at high temperature, and there is danger that this may cause burns during the oil level check operation. Wait for the temperature to go down before starting the operation.
- When loosening the plug, loosen it slowly. Do not loosen it suddenly. The inside of the case is under high pressure, so if the plug is suddenly loosened, oil will spurt out and cause burns.

- Refill capacity: Left, right 21 liters (5.6 US gal) each

1. Stop the machine so that the TOP casting mark is at the top and drain plug (P) is at the bottom.
2. Loosen drain plug (P) slowly to release the internal pressure, then remove it and drain the oil. After draining the oil, tighten the drain plug again.
3. Add oil through the hole for plug (G) to the specified level.
4. After adding oil, check that the oil is at the specified level. See "CHECK OIL LEVEL IN FINAL DRIVE CASE, ADD OIL (PAGE 4-49)".

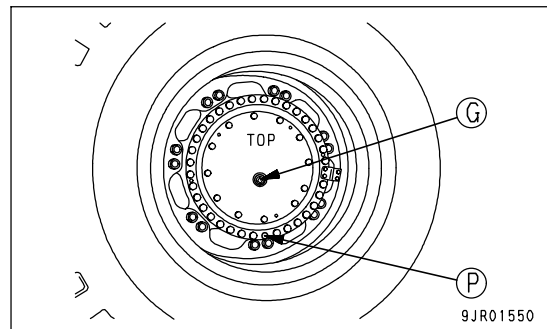

CHANGE OIL IN DIFFERENTIAL CASE

! WARNING

- Immediately after the engine is stopped, the parts and oil are at high temperature, and there is danger that this may cause burns during the oil level check operation. Wait for the temperature to go down before starting the operation.
- When loosening the plug, loosen it slowly. Do not loosen it suddenly. The inside of the case is under high pressure, so if the plug is suddenly loosened, oil will spurt out and cause burns.

- Refill capacity: 95 liters (25.1 US gal)

1. Loosen drain plug (P) slowly to release the internal pressure, then remove it and drain the oil. After draining the oil, tighten the drain plug again.
2. Add oil through the hole for plug (G) to the specified level.
3. After adding oil, check that the oil is at the specified level. See "CHECK OIL LEVEL IN DIFFERENTIAL CASE, ADD OIL (PAGE 4-49)".

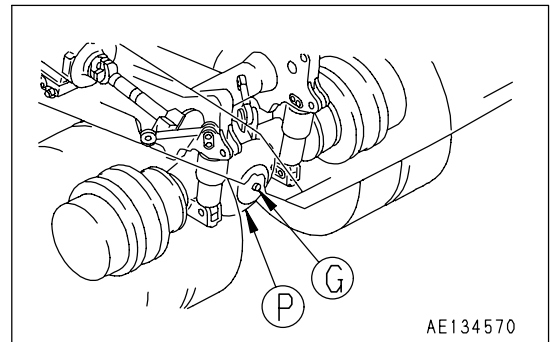

CLEAN DIFFERENTIAL CASE BREATHER

! WARNING

Immediately after the engine is stopped, the oil and parts are at high temperature, so there is danger of suffering burns during the operation. Wait for the temperature to go down before starting the operation.

1. Stop the engine.
2. Remove the mud and dirt from around the breather, then remove the breather.
3. Wash out the dirt from inside with clean diesel oil or flushing oil.
4. Install the breather.

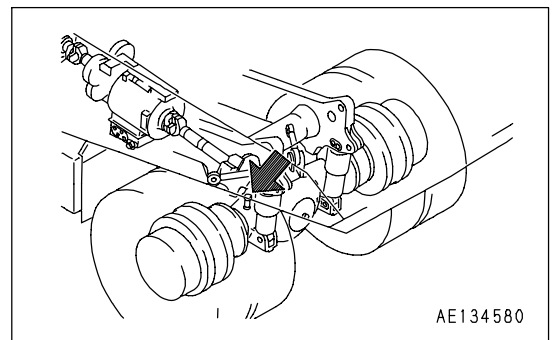

CHECK ALTERNATOR

The bearings may have run short of grease. Call your Komatsu distributor for an inspection and repairs.

CHECK, ADJUST ENGINE VALVE CLEARANCE

Special tools are needed for inspection and maintenance, so contact your Komatsu distributor.

CHECK ACCUMULATOR GAS PRESSURE

When carrying out the EVERY 2000 HOURS SERVICE or EVERY YEAR SERVICE or making periodic replacement of critical safety parts, please ask your Komatsu distributor to check the accumulator gas pressure.

EVERY 4000 HOURS SERVICE

Maintenance for every 250, 500, 1000 and 2000 hours service should be carried out at the same time.

CHANGE OIL IN STEERING, HOIST OIL TANK

WARNING

- Immediately after the engine is stopped, the parts and oil are at high temperature, and there is danger that this may cause burns during the operation. Wait for the temperature to go down before starting the operation.
- When loosening the oil filler cap, do not loosen it suddenly. Loosen it gradually. The inside of the case is under high pressure, so if the oil filler cap is loosened suddenly, oil may spurt out and cause burns.

- Refill capacity: 122 liters (32.2 US gal)

1. Lower the dump body.
2. Stop the engine.
3. Turn the cap of oil filler (F) slowly to release the internal pressure, then remove the cap.
4. Remove drain plug (1), then loosen drain plug (2) slowly to avoid getting oil on yourself, and drain the oil.
5. After draining, tighten the drain plug (1) and (2).
6. Pour in the specified amount of engine oil from oil filler (F).
7. After adding oil, check that the oil is at the specified level. See CHECK OIL LEVEL IN STEERING AND HOIST OIL TANK, ADD OIL (PAGE 3-71).

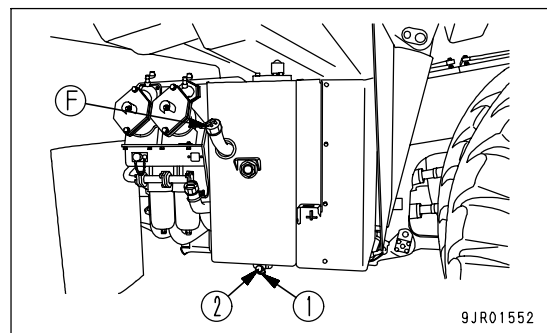

LUBRICATE DRIVE SHAFT

Carry out greasing every 4000 hours or every two years (whichever comes sooner).

1. Stop the engine.
2. Using a grease pump, pump in grease through the grease fittings marked by the arrows.
3. Grease the spider portion until grease comes out from the cap seal.
4. For the slide portion, continue greasing until grease comes out from vent.
5. After greasing, wipe off any old grease that was pushed out.

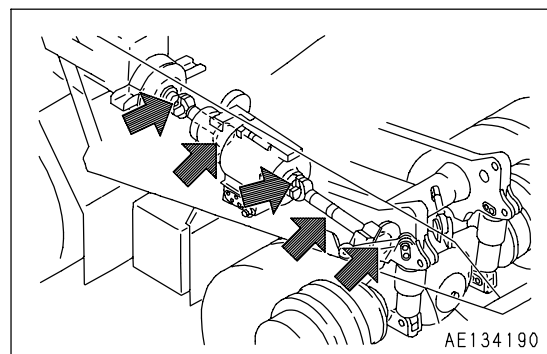

CHECK STARTING MOTOR

The brush may be worn or have no grease on the bearing, so contact your Komatsu distributor for inspection or repair.

If the engine is started frequently, carry out inspection every 1000 hours.

CHECK WATER PUMP

Check around the water pump for water leakage. If any part is leaking, ask your Komatsu distributor for inspection/repair.

CHECK FAN PULLEY AND TENSION PULLEY

Check for play of the pulley and leakage of grease. If any problem is found, please contact your Komatsu distributor.

CHECK ACCUMULATOR

At 4000 hours or 2 years, whichever comes sooner, ask your Komatsu distributor to replace the accumulator parts.

CHECKING FOR LOOSENESS OF HIGH-PRESSURE CLAMP, HARDENING OF RUBBER

Check visually and touch by hand to check that there are no loose mounting bolts for high-pressure piping clamps (1) - (20) in the diagram and no hardening of any rubber parts. If any problem is found, the part must be replaced. In this case, please ask your Komatsu distributor to carry out the replacement.

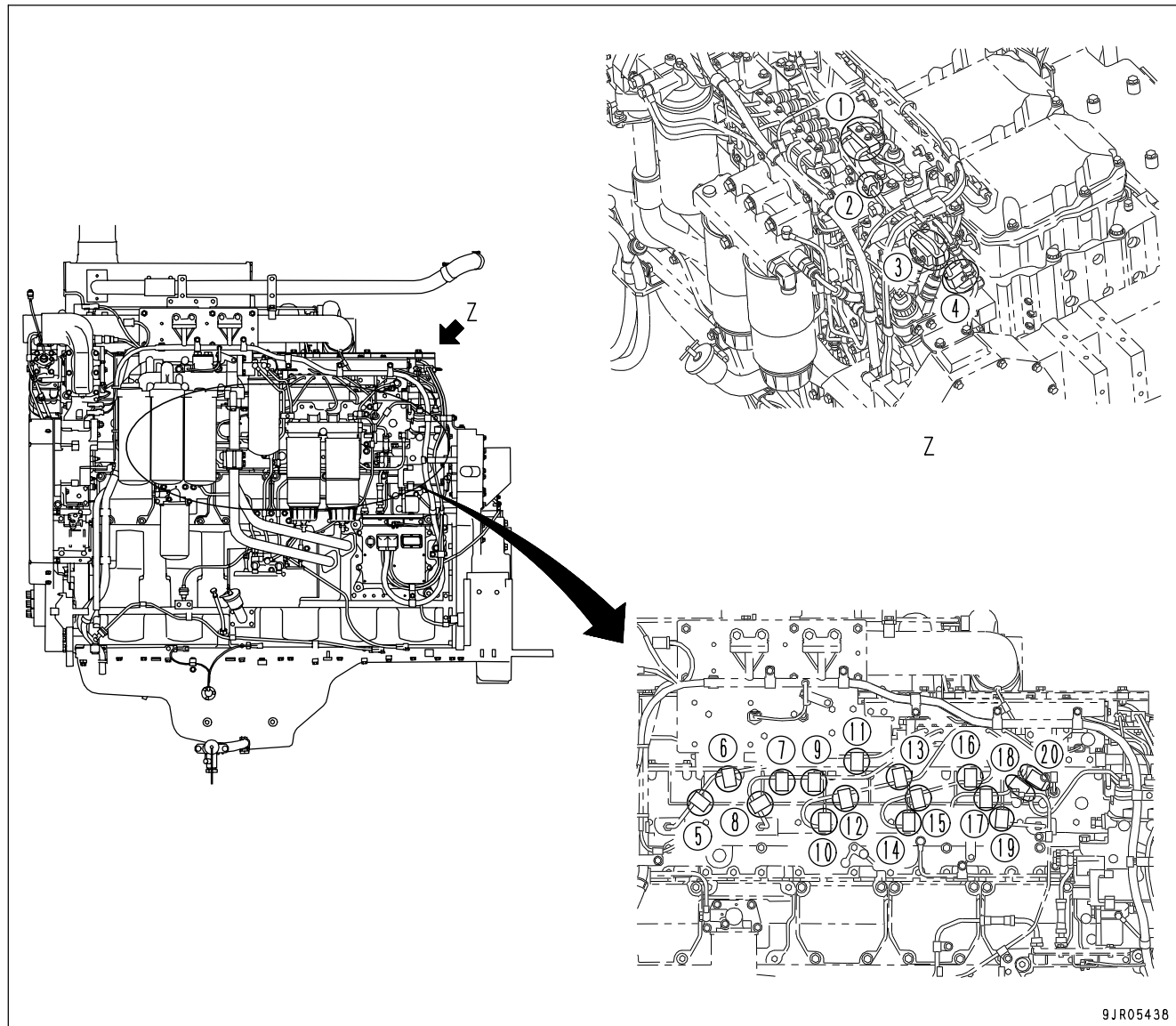

9JR05438

NOTICE

If the engine continues to be used when there are loose bolts, hardened rubber, or missing parts, there is danger of damage or breakage occurring due to vibration and wear at the connections of high-pressure piping. Always check that the proper high-pressure piping clamps are correctly installed.

CHECKING FOR MISSING FUEL SPRAY PREVENTION CAP, HARDENING OF RUBBER

Fuel spray prevention caps (1) - (5) are protective parts installed to prevent fire caused by fuel leaking and spraying out on to high temperature parts of the engine. Check visually that there are no missing caps or loose bolts, and feel with your finger to check that the rubber has not hardened. If there is any problem, the problem part must be replaced. Contact your Komatsu distributor for part replacement.

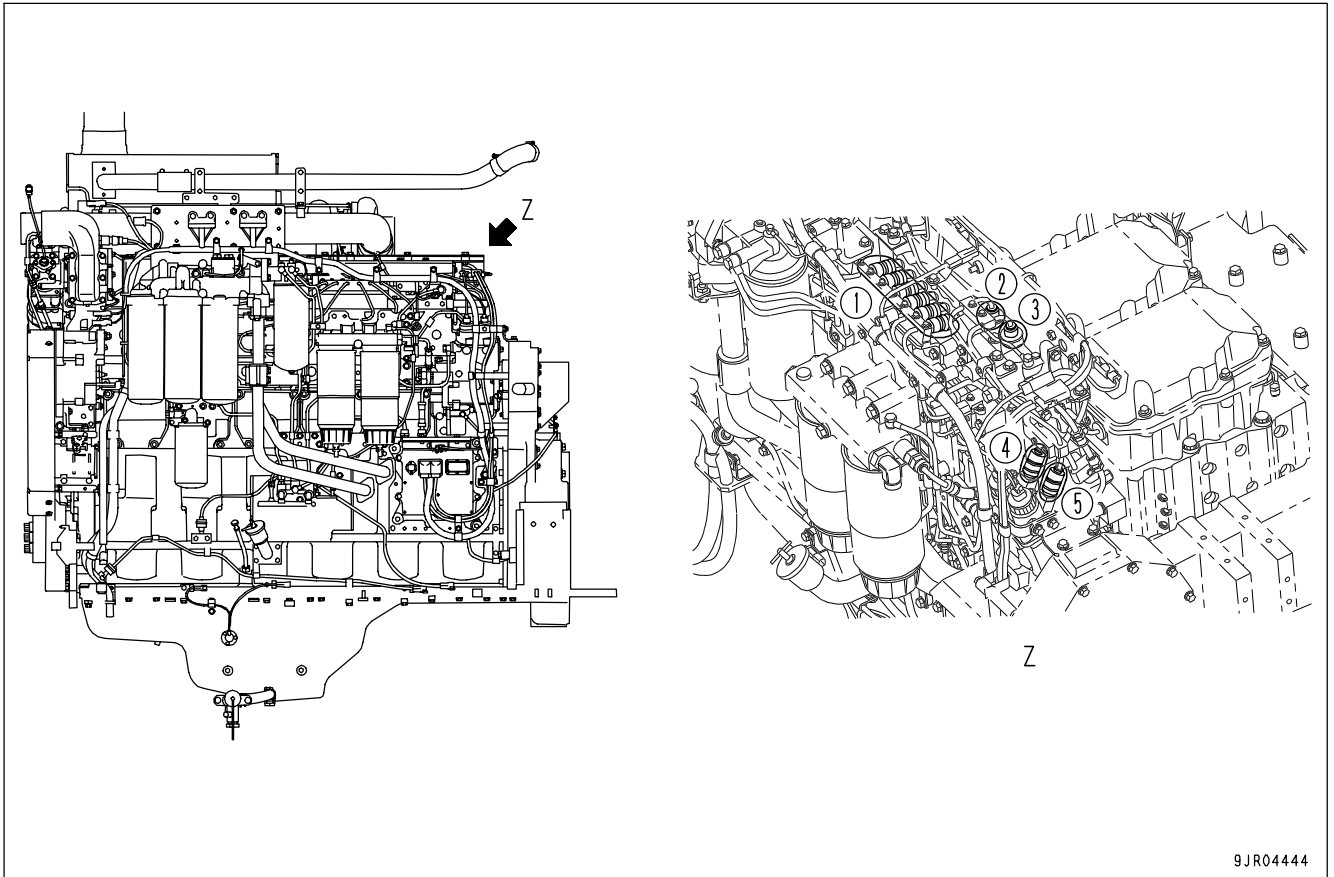

9JR04444

EVERY 8000 HOURS SERVICE

Maintenance for every 250, 500, 1000, 2000, and 4000 hours service should be carried out at the same time.

REPLACE HIGH-PRESSURE PIPING CLAMP

Ask your Komatsu distributor to carry out this work.

REPLACE FUEL SPRAY PREVENTION CAP

Ask your Komatsu distributor to carry out this work.

OVERHAUL STARTING MOTOR AND ALTERNATOR

Ask your Komatsu distributor to carry out this work.

EVERY 15000 HOURS SERVICE

Maintenance for every 250, 500, 1000, 2000, 4000 and 8000 hours of service should be performed at the same time.

CHECK, REPLACE STEERING A ARM MOUNTING BOLT

Check and replace the A arm mounting bolts, lock plate, and holder.

Please consult your Komatsu distributor when checking and replacing.

- (1) A arm
- (2) Front suspension
- (3) Lock plate
- (4) Bolt
- (5) Holder

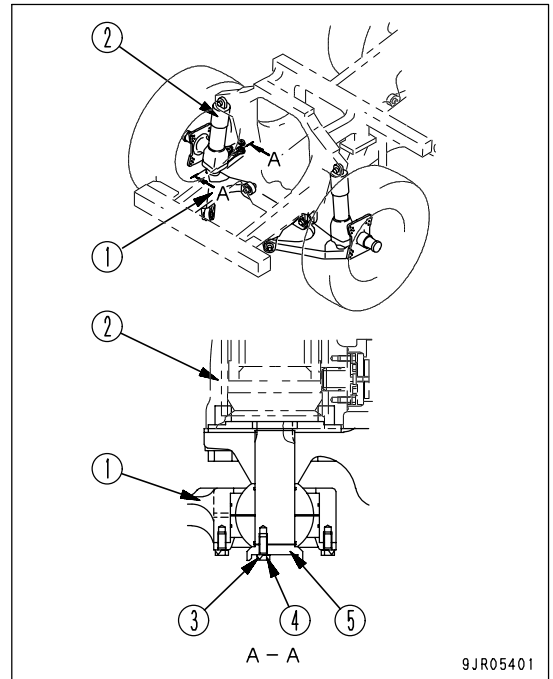

SPECIFICATIONS

SPECIFICATIONS

Item		Unit	HD465-7E0	HD605-7E0	
Overall weight (unladen weight + max. payload + 1 operator (75kg (165 lb)))		kg (lb)	98175 (216439)	109275 (240910)	
Unladen weight		kg (lb)	43100 (95019)	46200 (101854)	
Unladen weight (Without body)		kg (lb)	32370 (71376)	32780 (72280)	
Max. payload		kg (lb)	55000 (121275)	63000 (138915)	
Dump body capacity	Struck	m ³ (cu.yd)	25 (32.7)	29 (37.9)	
	Heaped (2 : 1)	m ³ (cu.yd)	34.2 (44.7)	40 (52.3)	
Dumping speed (at 2000 rpm) (raised)		sec	11.5		
Engine type		-	Komatsu SAA6D170E-5 diesel engine		
Flywheel horsepower of engine		kW (HP)/rpm	551 (740)/2,000		
Max. torque		Nm(kgm, lbft)/rpm	3324 (339, 2452)/1,400		
A	Overall length	mm (ft in)	9355 (30' 8")		
B	Overall height	mm (ft in)	4400 (14' 5")		
C	Overall height at dumping	mm (ft in)	8800 (28' 10")		
D	Overall width (from the right side view mirror stay to the left handrail)	mm (ft in)	5395 (17' 8")		
E	Min. ground clearance (bottom of rear axle)	mm (ft in)	604 (2' 0")		
Min. turning radius		mm (ft in)	8500 (27' 11")		
Travel speed	Forward	1st	km/h (MPH)	11.5 (7.1)	11.0 (6.8)
		2nd	km/h (MPH)	16.0 (9.9)	15.5 (9.6)
		3rd	km/h (MPH)	21.5 (13.4)	21.0 (13.0)
		4th	km/h (MPH)	29.5 (18.3)	29.0 (18.0)
		5th	km/h (MPH)	39.0 (24.2)	39.0 (24.2)
		6th	km/h (MPH)	52.5 (32.6)	52.5 (32.6)
		7th	km/h (MPH)	70.0 (43.5)	70.0 (43.5)
	Reverse	1st	km/h (MPH)	12.0 (7.5)	11.5 (7.1)
Temperature range when using		°C (°F)	-20 to 40 (-4 to 104)		

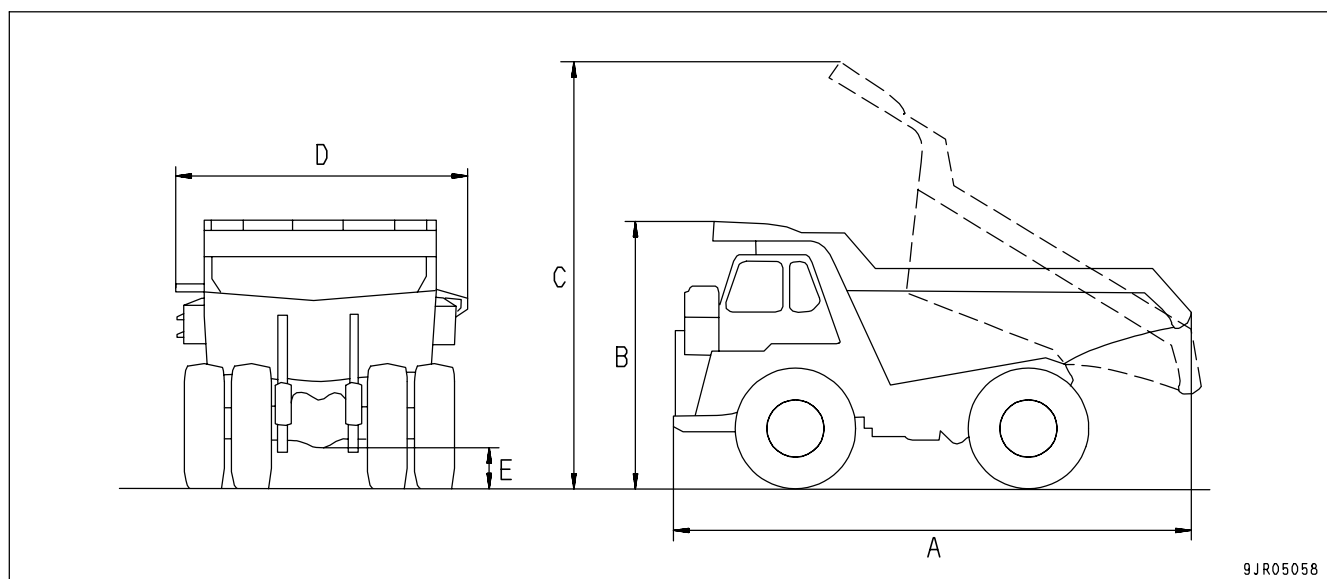

9JR05058

ATTACHMENTS, OPTIONS

Please read and make sure that you understand the SAFETY section before reading this section.

SELECTING DUMP BODY

Only HD465-7 can be selected.

Select the dump body from the following table.

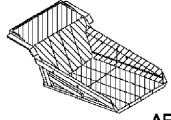
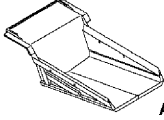
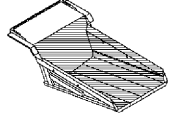
Purpose	Body type	Features	Body shape
Transporting rocks	Rock body	<ul style="list-style-type: none"> A liner is installed to the whole inside surface of the dump body to allow the loading of crushed rock, coal, or timber. Example: Coal mine 	 ※ AE134880
Transporting soil or sand	Linerless body	<ul style="list-style-type: none"> This is suitable for jobsites where soil or sand is loaded. No liner is installed. Example: Loading loose soil for landfills 	 ※ AE134890
(Special specification) Transporting rubble	Rubber liner body	<ul style="list-style-type: none"> This is suitable for jobsites where rubble or large rocks are loaded. A rubber liner is installed. This is also effective in reducing noise when loading. Example: Jobsites handling rubble 	 ※ AE134900

※: It is possible to install a side extension (if equipped) to these dump bodies.

HANDLING TACHOGRAPH (TCO20-90W)

EXPLANATION OF COMPONENTS

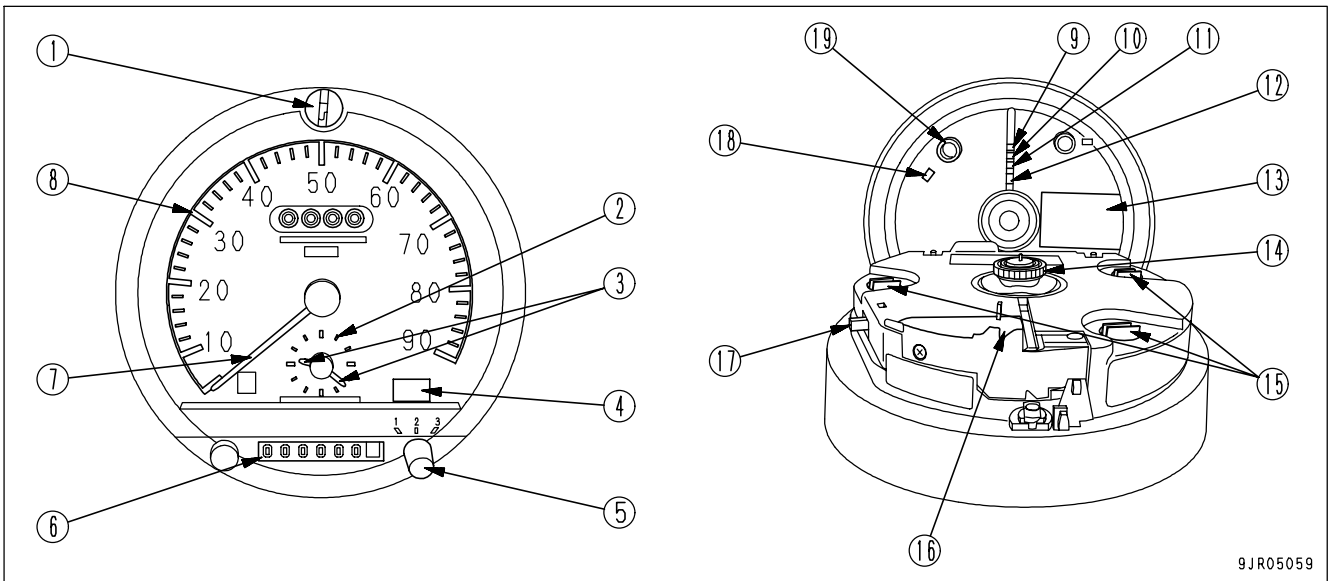

- (1) Keyhole
- (2) Clock scale
- (3) Clock hand
- (4) Model display label
- (5) Operator shift change knob
- (6) Odometer
- (7) Speed indicator
- (8) Speed scale
- (9) Speed recording indicator
- (10) Operator shift change recording indicator

- (11) Spare recording indicator
- (12) Odometer recording indicator
- (13) Nameplate
- (14) Crimped ring
- (15) Panel lighting lamps (x3)
- (16) Cutter
- (17) Time adjustment switch
- (18) Speed warning setup confirmation window
- (19) Speed warning setup adjustment screw

KEYHOLE

This keyhole (1) is the keyhole to use when opening the cover to replace the chart paper.

CLOCK SCALE

This clock scale (2) shows the minutes: each mark shows 1 minute.

CLOCK HAND

This hand (3) points to the hours.

MODEL DISPLAY LABEL

The tachograph model is written on this model display label (4).

OPERATOR SHIFT CHANGE KNOB

It is possible to divide into categories for 3 operators with this operator shift change knob (5).

Align the scale on the knob with the set scale (1, 2, 3).

ODOMETER

This odometer (6) shows the total distance (km) travelled by the machine. (It also calculates the distance traveled in reverse.)

The smallest display unit is 0.1 km.

SPEED INDICATOR

This speed indicator (7) shows the travel speed of the machine.

SPEED SCALE

This speed scale (8) is the scale to show the travel speed of the machine. The unit is km/h.

SPEED RECORDING INDICATOR

This speed recording indicator (9) records the travel speed of the machine at each moment on the chart paper.

OPERATOR SHIFT CHANGE RECORDING INDICATOR

This operator shift change recording indicator (10) records by filling in 3 types of width on the chart paper according to operation of the operator shift change knob.

SPARE RECORDING INDICATOR

This spare recording indicator (11) records the desired information (for example: loading, unloading) according to the switch (sold separately) installed on the outside.

ODOMETER RECORDING INDICATOR

This odometer recording indicator (12) records the distance traveled by the machine on the chart paper. One unit is 10 km.

NAMEPLATE

This nameplate (13) shows the model, authorization number, date of manufacture, manufacturing number, and serial number.

CRIMPED RING

This crimped ring (14) is used to secure the chart paper to the tachograph.

PANEL LIGHTING LAMPS

These panel lighting lamps (15) are the lamps do illuminate the gauges. (There are three lamps.)

CUTTER

This cutter (16) is the blade to cut the connecting tape of the chart paper.

TIME ADJUSTMENT SWITCH

This time adjustment switch (17) is used to adjust the hands of the clock.

SPEED WARNING SETUP CONFIRMATION WINDOW

This speed warning setup confirmation window (18) is the window to check the speed set by the speed warning setup adjustment screw.

SPEED WARNING SETUP ADJUSTMENT SCREW

This speed warning setup adjustment screw (19) is used to set the desired speed for the travel warning lamp to light up.

The range for the setting is 40 to 90 km/h.

METHOD OF USE

OPENING AND CLOSING COVER

- When closing the cover, align the cover and the case exactly, then apply the lock. If the cover is not closed securely, the speed indicator will not work properly.
- When opening the cover, do not use any excessive force on the cover. This will cause breakage of the cover support.
- When opening or closing the tachograph, use the key to open or close carefully.
- Always turn the key fully to the left when closing the cover. Do not close the cover if the key is in any other position. This will cause damage to the case or lock.

METHOD OF OPENING COVER

1. Insert the key in the keyhole (1).
2. Turn the key fully to the left, then pull lightly. The cover will open.

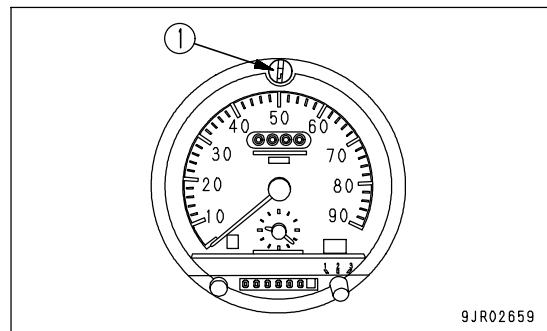

METHOD OF CLOSING COVER

1. Turn the key fully to the left, and use the key to close the cover carefully.
Check that the cover and case are correctly aligned.

REMARK

When the cover is closed, it will feel heavy, but this is not a problem.

2. Turn that the key fully to the right, then remove it. The cover will close.

SETTING TIME

- When adjusting the time, always turn so that the needle moves clockwise when setting. If the clock is fast, turn the needle back about 10 minutes, then move it forward to set the time. If this is not done, the time will not be set properly.
- Start the engine before adjusting the time.

1. Open up the tank cover.

2. Press the time adjusting switch to adjust the time.

REMARK

- When the time adjusting switch is pressed to the (A) position, the needle will advance; when it is pressed to the (B) position, the needle will move back.
- When the switch is pressed to the (A) position or (B) position, the indicator will move slowly for approx. 3 seconds, and then will move at high speed.

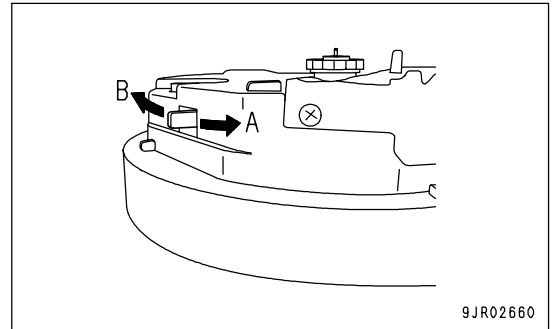

3. After setting the time, close the cover.

REPLACING CHART PAPER

CAUTION

When replacing the chart paper, do not touch the edge of the cutter. There is a protective cover, but there is still danger of cutting your finger by mistake.

- Always use Komatsu genuine chart paper. If any other chart paper is used, it may cause failure of the tachograph.
- When adjusting the time on the chart paper between 22:40 and 24:00, always set the cutter at the bottom of the first sheet of chart paper. If it is set wrongly, the speed indicator will catch and cause failure.
- Always start with the top sheet when using the chart paper. Do not cut the connecting tape to separate the chart paper and use one sheet at a time. This will cause the paper to catch and this will result in failure of the clock.
- Always remove and install the crimped ring by hand.

Always use Komatsu genuine chart paper (YZ762928-260).

Adjust the time before replacing the chart paper. If the time is adjusted after the chart paper is set in position, there will be a difference between the correct time and the set time for the chart paper.

Be careful not to bend the chart paper, damage the surface, or get water on the paper. It will become impossible to obtain a correct record.

1. Open up the tank cover.
2. Turn crimped ring (1) to the left, then move it up to remove it.
3. Always use a ballpoint pen to write the employee code, machine code, date, etc. on the new chart paper.

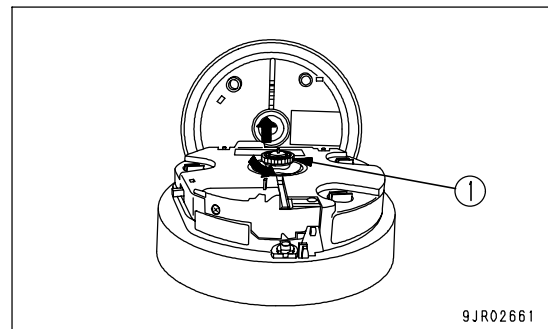

4. Insert the outside portion of the chart paper under cutter (2). Align with chart paper mount (3) of the tachograph and install the chart paper.
5. Turn the chart paper and align the present time position on the time scale on the chart paper with the time set mark (A) (red) on the tachograph.

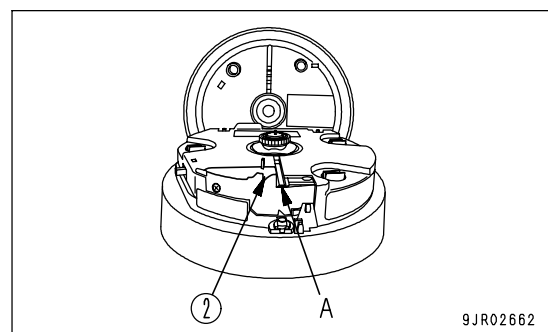

6. Set projecting portion (4) of the crimped ring at the bottom, and align with the groove of chart paper mount (3). Pressed crimped ring (1) down with your finger and turn it to the right to install it.

7. Close the cover.

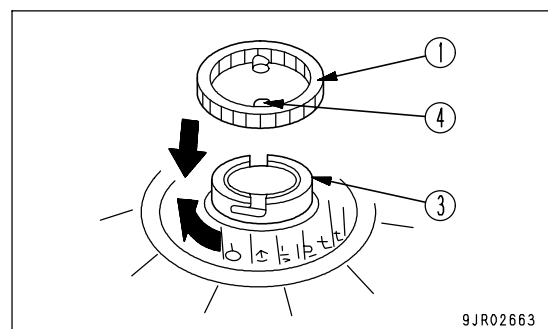

STORING CHART PAPER

Keep the chart paper in a place where there is no direct sunlight, where no water can get on the paper, and where there is no high humidity. Select a place where there is good ventilation and low humidity.

REPLACING LAMP

The tachograph illumination lamp is 24V. Never use a lamp of the wrong rating.

If the wrong lamp is used, the heat from the lamp will cause failure of the tachograph.

Part name	Color of socket	Rating
24V lamp	Dark brown	24V 1.4W

1. Open up the tank cover.
2. Insert a coin in the groove of lamp socket (1) and turn it to the left.
3. Remove lamp socket (1).
4. Align projecting portion (3) of the lamp socket with groove (2) of the tachograph lamp mount, then insert the lamp bulb.
5. Use a coin to turn lamp socket (1) to the right and secure the lamp socket in position.
6. Close the cover.

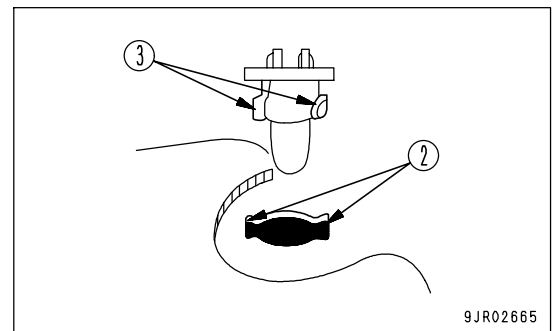
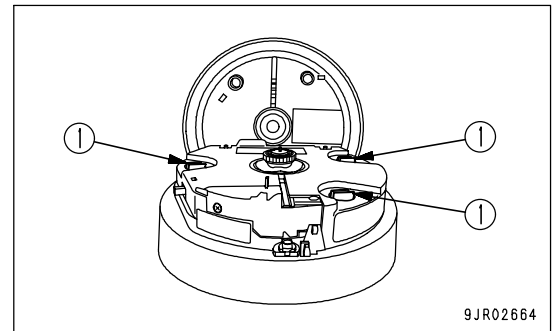

HANDLING AIR SUSPENSION SEAT

OPERATOR'S SEAT ADJUSTMENT

WARNING

- If you try to adjust the operator's seat during operations, the seat will move during the adjustment operation, and there is danger that this will cause mistaken operation which may lead to serious personal injury. Always stop the machine on level ground in a safe place before adjusting the operator's seat. Adjust the seat before starting to travel or when the operators change shifts.
- If the operator's seat is not in the proper position, it may be impossible to operate the brakes during an emergency, which may lead to serious personal injury. Always adjust the operator's seat so that it is possible to depress the brake pedal fully when sitting with your back against the backrest.
- If the operator's seat is not fixed in position, it may move if there is impact during operation. This may cause mistaken operation, which will lead to serious personal injury. After adjusting the operator's seat, move it lightly to check that it is securely held in position.

Adjust the operator's seat as follows.

This operator's seat uses the air compressor to adjust the weight, strength of the lumbar support, and strength of the side support. These items can be adjusted when the starting switch is ON.

FORE-AND-AFT ADJUSTMENT OF OPERATOR'S SEAT

1. Pull up lever (1) and slide the operator's seat to the front or rear.
2. Set the seat to the desired position, then release lever (1).
Fore-and-aft adjustment: 180 mm (10 mm x 18 stages)

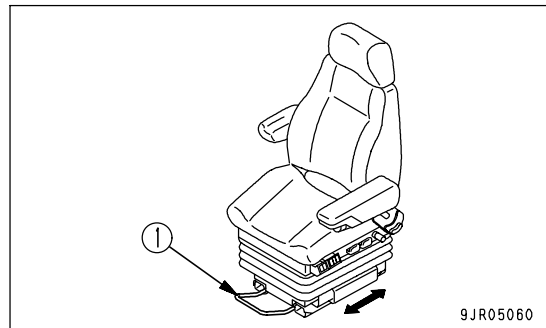

ADJUSTING OPERATOR'S SEAT ANGLE

BACKWARD

1. Pull up lever (2) and apply your weight to the rear of the seat cushion. The seat cushion will tilt to the rear.
2. Set the seat cushion to the desired angle, then release lever (2).

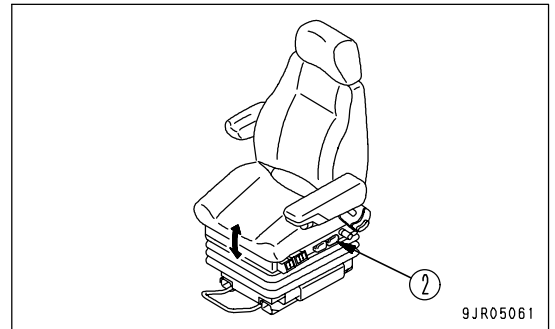

FORWARD

1. Push down lever (3) and apply your weight to the front of the seat cushion. The seat cushion will tilt to the front.
2. Set the seat cushion to the desired angle, then release lever (3).
Amount of adjustment: 11° to the front, 13° to the rear; total: 24° (front and rear, 3 stages each)

HEIGHT ADJUSTMENT OF OPERATOR'S SEAT

1. Pull levers (2) and (3) up to adjust the height of the seat cushion.
2. Set the seat cushion to the desired height, then release levers (2) and (3).
This adjustment procedure is also used for adjusting the seat angle, so adjust the seat angle as desired.
Height adjustment: 65 mm

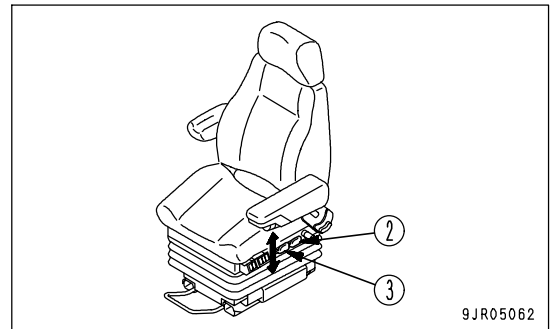

FORE-AND-AFT ADJUSTMENT OF SEAT CUSHION

1. Push lever (4) to the inside and adjust the seat cushion to the front or rear.
2. Set to the desired position, then release lever (4).
Fore-and-aft adjustment: 60 mm

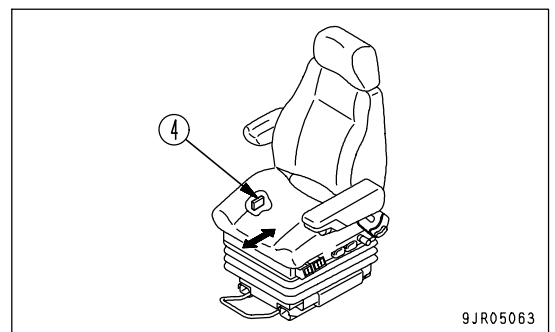

SETTING OPERATOR'S SEAT FOR OPERATOR'S WEIGHT

1. Turn the starting switch to the ON position.
2. With your body slightly raised, operate switch (5) and adjust the strength of the suspension.

Press the + portion to make the operator's seat suspension stronger.

Press the - portion to make the operator's seat suspension weaker.

Guideline for weight adjustment: 50 kg to 130 kg

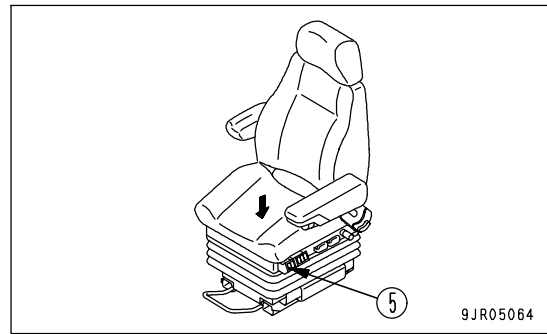

9JR05064

ADJUSTING RECLINING ANGLE OF BACK SEAT

1. Sit with your back pressed against the seatback, then pull up lever (6).
2. Push with your back to adjust the seatback to the desired angle, then release lever (6).

Adjustment amount: Forward tilt: Free

Rear tilt: 40° (2° x 20 stages)

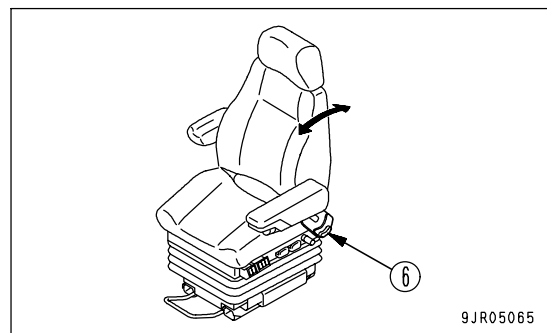

9JR05065

ADJUSTING HEADREST ANGLE

Tilt the headrest to the front or rear to set it to the desired angle.

Adjustment amount: Forward tilt: 13°

Rear tilt: 13°

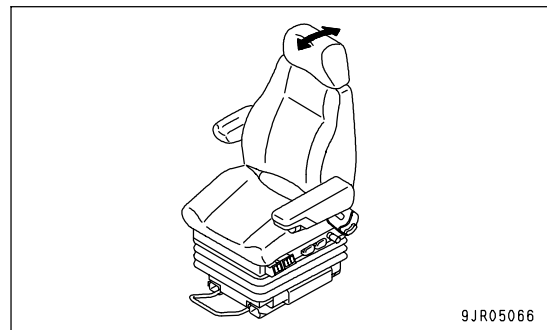

9JR05066

ADJUSTING HEADREST HEIGHT

Move the headrest up or down to adjust to the desired height.

When adjusting the headrest height, sit in the operator's seat and adjust so that the center portion of the headrest contacts the back of your head.

Amount of adjustment: 80 mm

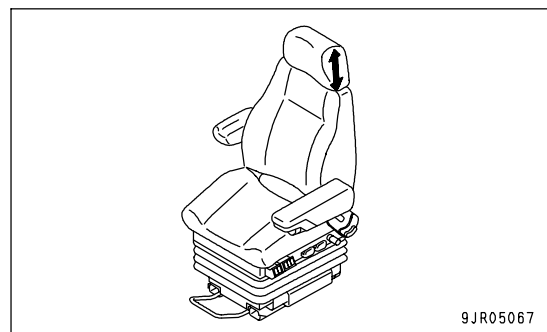

9JR05067

ADJUSTING ARMREST ANGLE

Turn knob (7) on the left armrest and adjust the angle of the left armrest.

Amount of adjustment:73° (front:54°; rear:19°)

REMARK

It is possible to make the armrest spring up. (Both left and right sides)

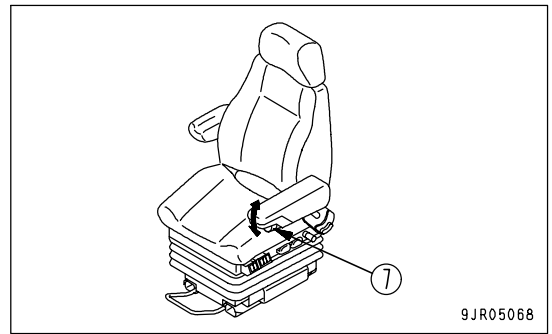

9JR05068

ADJUSTING LUNBAR SUPPORT TENSION

1. Turn the starting switch to the ON position.
2. Operate switch (8) to adjust the tension of the seatback to give the desired support to the upper part (A) of your lumbar region.
 - Press the + portion to make the operator's seat suspension stronger.
 - Press the - portion to make the operator's seat suspension weaker.
3. Operate switch (9) to adjust the tension of the seatback to give the desired support to the lower part (B) of your lumbar region.
 - Press the + portion to make the operator's seat suspension stronger.
 - Press the - portion to make the operator's seat suspension weaker.

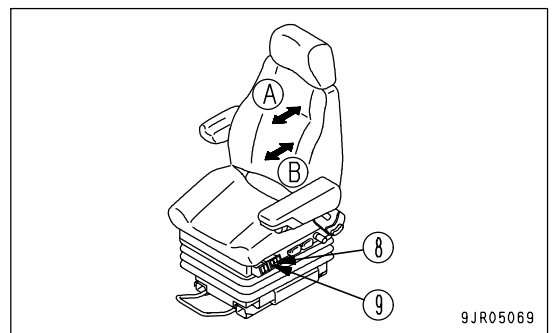

9JR05069

ADJUSTING SIDE SUPPORT TENSION

1. Turn the starting switch to the ON position.
2. Operate switch (10) to adjust the tension of the seatback to give the desired support to the left and right sides (A) of your lumbar region.
 - Press the + portion to make the operator's seat suspension stronger.
 - Press the - portion to make the operator's seat suspension weaker.

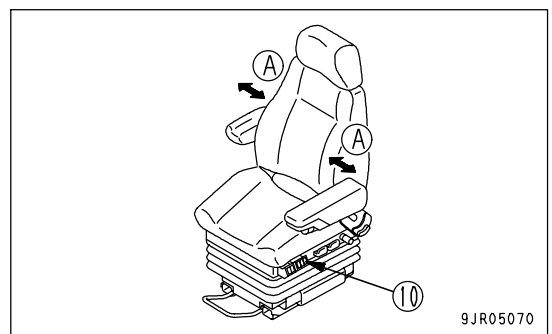

9JR05070

REMOVAL AND INSTALLATION OF HEADREST

REMOVAL

When replacing the headrest, remove it as follows.

1. Pull up the headrest to the position where it stops.
2. From the top of the seat back, turn stopper (1) (under the material at the top of the seat) of the headrest bar on one side in the direction of the arrow, and pull up the headrest.

When stopper (1) is turned, it will come out of groove (2).

3. Turn stopper (1) on the other side in the direction of the arrow, and pull up the headrest.

When both stoppers (1) come out of groove (2), the headrest can be removed.

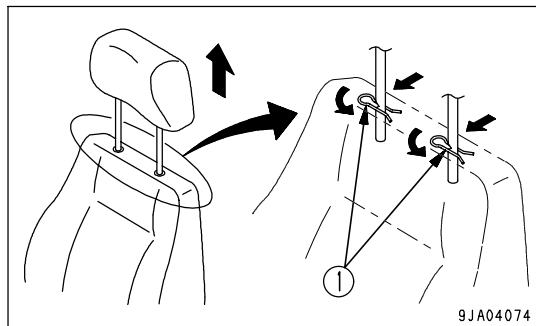

INSTALLATION

1. Insert the bars into the holes in the top of the seat and push down.

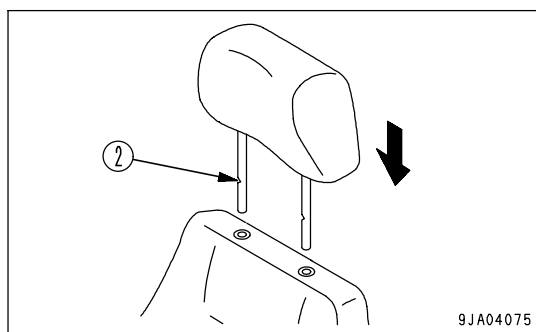

HANDLING AUTOMATIC SPIN REGULATOR (ASR)

ASR is a function to prevent slipping of the drive wheels caused by excessive torque. Accordingly, the machine can start and travel normally even on a bad or frozen road surface. If slipping of the drive shaft is detected, the ASR is actuated.

EXPLANATION OF COMPONENTS

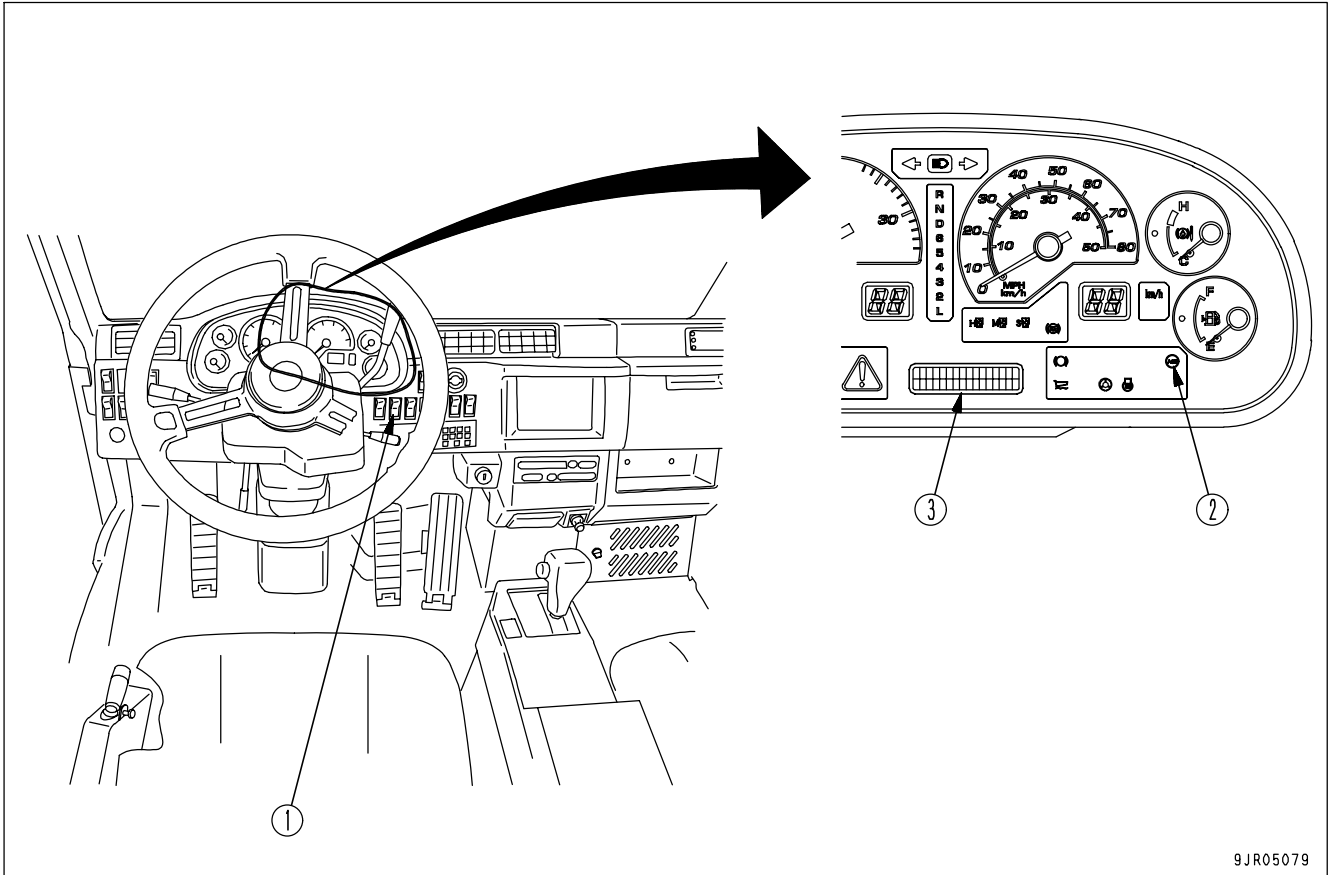

- (1) ASR switch
- (2) ASR actuation lamp

- (3) Character display

ASR SWITCH

This ASR switch (1) is used to switch the ASR system ON/OFF. When portion (A) of the switch is pressed, the ASR is actuated and the ASR actuation lamp on the machine monitor lights up. When portion (B) of the switch is pressed, the ASR is cancelled and the ASR actuation lamp on the machine monitor goes out.

When the head lamps are turned on, the icon inside portion (B) of the ASR switch lights up.

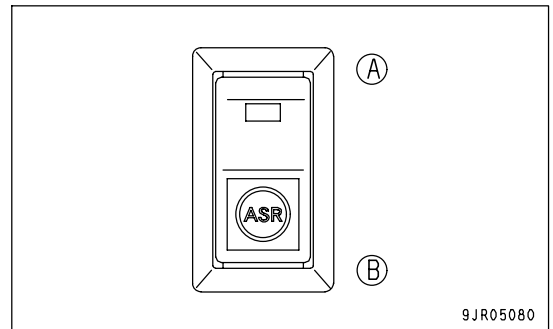

9JR05080

ASR ACTUATION LAMP

This ASR actuation lamp (2) lights up when the ASR switch is ON, and the system detects slipping of the rear wheels and actuates the ASR.

CHARACTER DISPLAY

If any problem occurs in the ASR system, the action code is displayed on this character display (3).

ACTUATION OF ASR SYSTEM

If slipping of the rear wheels is detected, the ASR system acts to prevent the machine from spinning. Use the ASR when traveling on poor road surfaces or road surfaces where the machine is likely to slip.

The ASR system can be actuated when the ASR switch is turned ON.

If the ASR system detects slipping of the rear wheels, the ASR is actuated to prevent the machine from spinning. When this happens, the ASR actuation lamp lights up.

The ASR system can be actuated when the travel speed is 0 to 30 km/h and the accelerator pedal is being depressed. If the accelerator pedal is released while the ASR system is being actuated, actuation of the ASR system stops.

If the retarder control lever is used to actuate the retarder when the ASR system is being actuated, actuation of the ASR system stops.

If the brake pedal is depressed when the ASR system is being actuated, actuation of the ASR system stops.

If any problem occurs in the ASR system and it becomes impossible to carry out control, the action code is displayed on the character display of the machine monitor, and actuation of the ASR system stops.

PRECAUTION WHEN USING ASR SYSTEM**WARNING**

- If any problem occurs in the system and it is impossible to carry out control properly, the action code is displayed on the character display of the machine monitor and actuation of the system stops. Move the machine quickly to a safe place, stop it, and turn the ASR switch OFF. Do not travel on slippery road surfaces with the ASR actuated.
 - On slippery road surfaces, it is impossible to control the turning of the machine even when the ASR is actuated. If the machine is turned, it may lead to serious personal injury. Even when the ASR is actuated, it is impossible to travel on frozen road surfaces.
-
- On road surfaces where it is possible to carry out normal travel even when the ASR switch is turned OFF, if the road surface is slippery, be extremely careful not to let the machine slip to the side.
 - If both rear wheels slip at the same speed, the ASR will not function. In this case, adjust the engine output with the accelerator pedal.

TROUBLESHOOTING

WHEN A PROBLEM OCCURS IN THE SYSTEM

This system is equipped with a self-diagnostic function and displays an action code on the character display of machine monitor. If any action code is displayed, move the machine to a safe place, and stop the machine. In addition check the code. For details, see "ACTION CODE (PAGE 3-152)". Please contact your Komatsu distributor for repair .

Failure code		Type of failure	Action
DLt3	KA	Disconnection in transmission output shaft speed sensor	ASR canceled
Dk11	KX	Failure in accelerator sensor system	ASR canceled
DX18	MA	Failure in ASR electromagnetic proportional pressure reducing valve (left) (valve is not actuated)	ASR canceled
DX18	K4	Failure in ASR electromagnetic proportional pressure reducing valve (left) (valve remains actuated)	ASR canceled
DX17	MA	Failure in ASR electromagnetic proportional pressure reducing valve (right) (valve is not actuated)	ASR canceled
DX17	M4	Failure in ASR electromagnetic proportional pressure reducing valve (right) (valve remains actuated)	ASR canceled
DX18	KA	Disconnection in output wiring of ASR electromagnetic proportional pressure reducing valve (left)	ASR canceled
DX18	KB	Short circuit in output wiring of ASR electromagnetic proportional pressure reducing valve (left)	ASR canceled
DX18	KY	Short circuit with chassis ground in output wiring of ASR electromagnetic proportional pressure reducing valve (left)	ASR canceled
DX17	KA	Disconnection in output wiring of ASR electromagnetic proportional pressure reducing valve (right)	ASR canceled
DX17	KB	Short circuit in output wiring of ASR electromagnetic proportional pressure reducing valve (right)	ASR canceled
DX17	KY	Short circuit with chassis ground in output wiring of ASR electromagnetic proportional pressure reducing valve (right)	ASR canceled
DLF9	KA	Disconnection in wheel speed sensor (RL)	ASR canceled
DLF8	KA	Disconnection in wheel speed sensor (RR)	ASR canceled
DLF9	LC	Failure in wheel speed sensor (RL) system	ASR canceled
DLF8	LC	Failure in wheel speed sensor (RR) system	ASR canceled
DLF3	LC	Failure in transmission output shaft sensor	ASR canceled
DDDA	KA	Disconnection in ASR system switch	ASR canceled
DDDA	KB	Short circuit with chassis ground in ASR system switch	ASR canceled
DK30	KX	Failure in steering angle potentiometer	Recognizes steering angle as 20° and continues ASR control
DWNB	KA	Disconnection in shut-off valve output wiring	ASR canceled
DWNB	KB	Short circuit in shut-off valve output wiring	ASR canceled
DWNB	KB	Short circuit with chassis ground in shut-off valve output wiring	ASR canceled
DWNB	MA	Failure in shut-off valve (valve is not actuated)	ASR canceled
DWNB	K4	Failure in shut-off valve (valve remains actuated)	ASR canceled

BLEEDING AIR FROM ASR CIRCUIT



WARNING

When bleeding the air, the brakes are released, so the machine may move and cause serious personal injury. When carrying out the air bleed operation, always park the machine on level ground and put blocks under the tires.

If the piping or valves in the ASR circuit have been replaced, bleed the air from the ASR circuit as follows.

1. Start the engine, check that the oil in the transmission case is the specified level, and check if the brake oil pressure caution lamp is out.
2. Turn the ASR switch ON.
3. Remove the cover behind the operator's seat, and connect connector TEST (1). The valve opens and oil pressure is applied to the ASR circuit.
4. Bleed the air from the rear brakes. For details, see MAINTENANCE, "BLEED AIR FROM REAR BRAKE (PAGE 4-40)".
5. 4. After completing the air-bleeding operation, remove connector TEST (1) and install the cover.

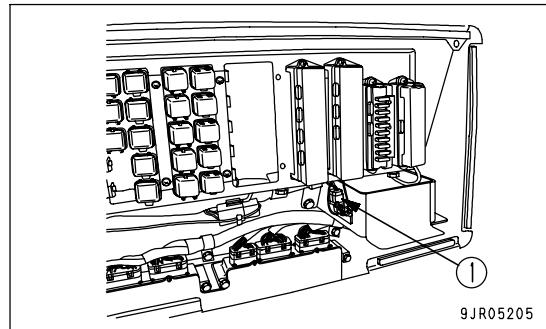

HANDLING ANTI SKID BRAKE SYSTEM (ABS)

The ABS (anti-skid brake system) is a brake system that ensures the steering ability and stable machine posture. It works by automatically suppressing the skidding caused by the wheels locking when the brakes are applied suddenly or are applied on snow-covered roads or other slippery road surfaces.

EXPLANATION OF COMPONENTS

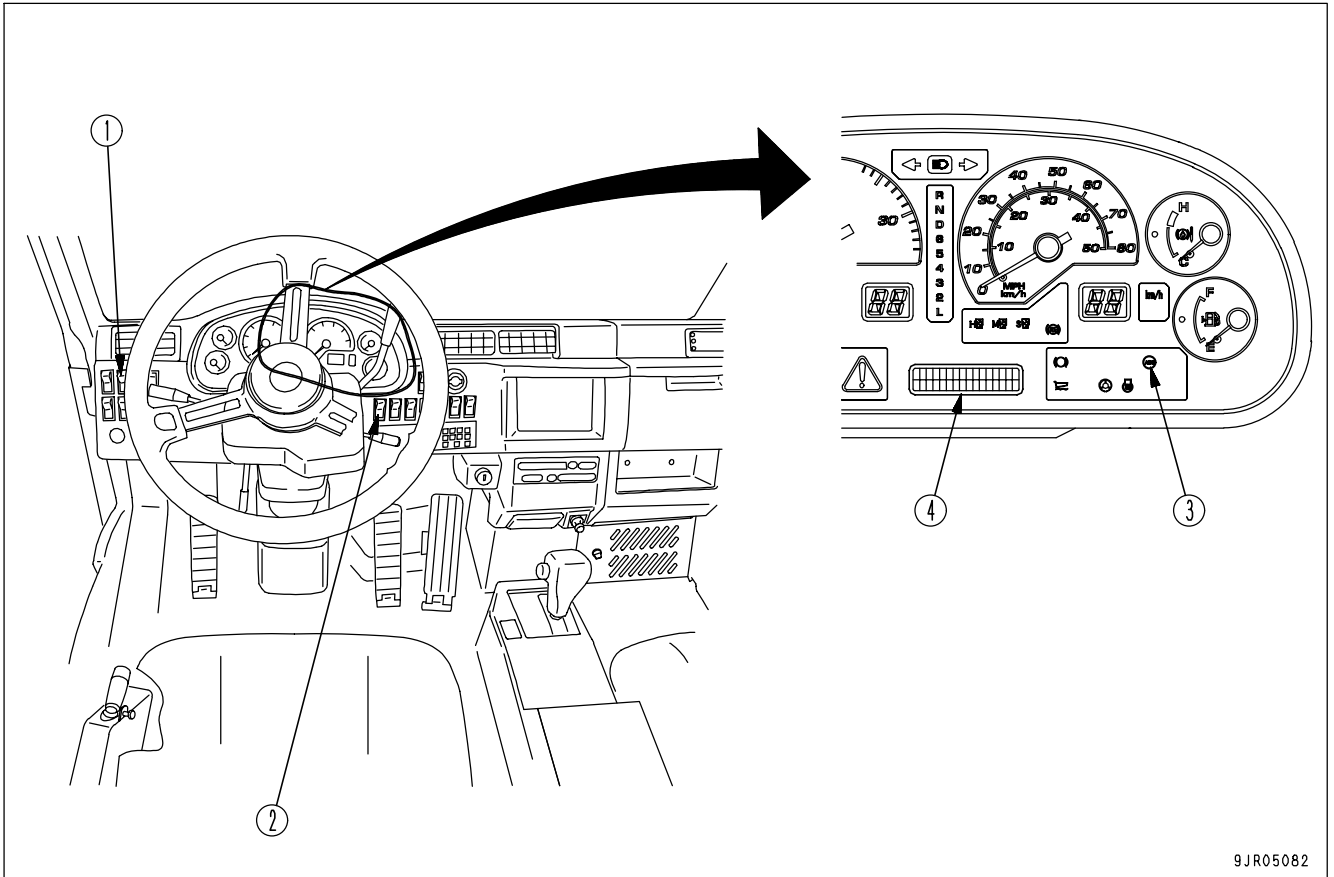

9JR05082

- (1) ABS system check switch
- (2) ABS main switch

- (3) ABS operation lamp
- (4) Character display

ABS SYSTEM CHECK SWITCH

Use this ABS system check switch (1) for the ABS system check carried out after starting the engine.

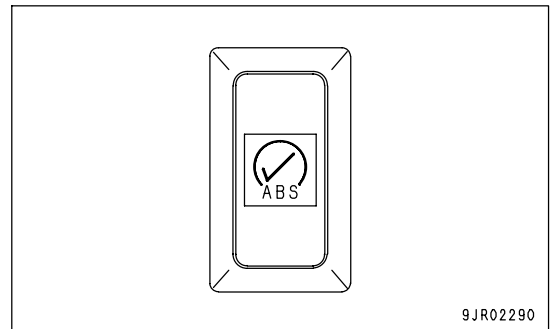

9JR02290

ABS MAIN SWITCH

Use this ABS switch (2) to switch the ABS system ON or OFF. When portion (A) of the switch is pressed, the ABS is actuated and the ABS actuation lamp on the machine monitor lights up. When portion (B) of the switch is pressed, the ABS is cancelled and the ABS actuation lamp on the machine monitor goes out.

When the head lamps are turned on, the icon inside portion (B) of the ABS switch lights up.

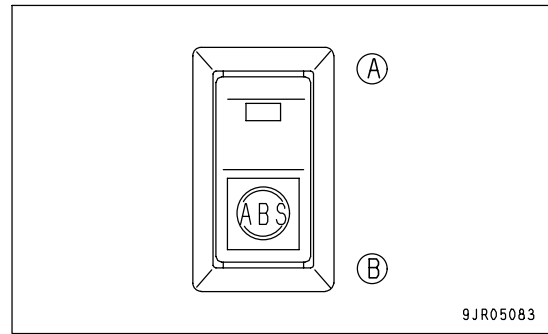
**ABS OPERATION LAMP**

This ABS actuation lamp (3) lights up when the ABS main switch is ON, and the system detects slipping caused by the wheels locking, and actuates the ABS.

CHARACTER DISPLAY

If any problem occurs in the ABS system, the action code is displayed on this character display (4).

ABS SYSTEM CHECK AFTER STARTING ENGINE

After starting the engine, check the ABS system.

1. Set the machine in the following condition.

If the machine is not in the following condition, the ABS system cannot be checked.

- Parking brake applied
- Brake oil pressure normal
- ABS main switch ON
- Action code is not displayed on character display.

2. Keep the brake pedal depressed until the ABS system check is completed.

3. Keep the ABS system check switch pressed for approx. 1 second.

The ABS operation lamp flashes and the ABS check system starts.

When any problem occurs in ABS system, the action code is displayed on character display. Check the error code. For details, see "TROUBLESHOOTING (PAGE 6-22)". Please your Komatsu distributor to carry out repair.

REMARK

The ABS system checks the ABS control valve, ABS cut valve, oil pressure switch, and oil pressure sensor. This check is completed in approx. 12 seconds.

4. When the flashing of the ABS operation lamp stops, the check is completed. Release the brake pedal.

OPERATION OF ABS

The ABS system automatically controls slipping caused by locking of the wheels, and shortens the braking distance. Use the ABS system when traveling on snow-covered or slippery road surfaces.

The ABS system can be actuated when the ABS switch is turned ON.

When the tires tend to lock, if the retarder control lever is operated, or the brake pedal is depressed, the ABS system is actuated. When this happens, the ABS actuation lamp lights up.

If the accelerator pedal is depressed, the ABS system is cancelled.

PRECAUTION WHEN USING ABS SYSTEM



WARNING

Even if the ABS system is used, the stopping distance on wet road surfaces is longer than the stopping distance on dry road surfaces. Reduce the travel speed when traveling on wet surfaces to reduce the stopping distance. If any mistake is made in the stopping distance, it may lead to serious personal injury.

- When traveling on roads with an extremely low friction coefficient (icy roads, etc.) or when traveling up or down a steep hill, it may not be possible to ensure safe travel even with the ABS installed. In such cases, carry out maintenance on the road surface before traveling on it.
- The ABS is not actuated when the retarder control lever or brake pedal are operated.
- After turning the ABS main switch ON, it takes a short time for the preparation of the ABS operation, so the ABS is not actuated for 2 seconds. Turn the ABS main switch ON beforehand if it is to be actuated.
- It is possible to carry out normal travel even when the ABS main switch is OFF. However, be extremely careful about the machine slipping to the side when traveling on slippery road surfaces.
- Even if there is a failure in the ABS system, it is possible to carry out normal travel. However, be extremely careful about the machine slipping to the side when traveling on slippery road surfaces. If any problem occurs in the ABS system, the system is automatically canceled, display the action code on character display. When ABS system canceled, so the condition become the same as for a machine which does not have the ABS installed.
- Even when the ABS system is installed, the secondary brake function is maintained, but when the secondary brake is actuated, even if the wheels lock, the ABS is not actuated.
- When equipping the machine with a wireless system, install it as far as possible from the system equipment and wiring. In addition, when equipping the machine with a wireless system, check carefully that the wireless and operating system do not break any laws regulating use of the airwaves.

TROUBLESHOOTING

This system is equipped with a self-diagnostic function and displays an action code on the character display of machine monitor. If any action code is displayed, move the machine to a safe place, and stop the machine. In addition check the code. For details, see "ACTION CODE (PAGE 3-152)". Please contact your Komatsu distributor for repair .

Failure code		Type of failure	Action
DBC0	KK	Drop in power source voltage	ABS canceled
DBC2	KK	Failure in the solenoid power source system	ABS canceled
DLF6	KA	Disconnection in wheel rotation sensor (FR)	ABS canceled
DLF7	KA	Disconnection in wheel rotation sensor (FL)	ABS canceled
dLF8	KA	Disconnection in wheel rotation sensor (RR)	ABS canceled
dLF9	KA	Disconnection in wheel rotation sensor (RL)	ABS canceled
DHU6	KX	Failure in ABS control valve pressure sensor (FR)	ABS canceled
DHU7	KX	Failure in ABS control valve pressure sensor (FL)	ABS canceled
DHU8	KX	Failure in ABS control valve pressure sensor (RR)	ABS canceled
DHU9	KX	Failure in ABS control valve pressure sensor (RL)	ABS canceled
dk11	KX	Failure in accelerator sensor	ABS canceled
DWND	KZ	Failure in ABS cut valve (F)	ABS canceled
DWNE	KZ	Failure in ABS cut valve (R)	ABS canceled
D1E5	KZ	Failure in ABS relay output system	ABS canceled
DX21	KA	Disconnection in ABS control valve (FR) output circuit	ABS canceled
DX21	KY	Short circuit in ABS control valve (FR) output circuit	ABS canceled
DX21	KB	Short circuit with ground in ABS control valve (FR) output circuit	ABS canceled
DX22	KA	Disconnection in ABS control valve (FL) output circuit	ABS canceled
DX22	KY	Short circuit in ABS control valve (FL) output circuit	ABS canceled
DX22	KB	Short circuit with ground in ABS control valve (FL) output circuit	ABS canceled
DX23	KA	Disconnection in ABS control valve (RR) output circuit	ABS canceled
DX23	KY	Short circuit in ABS control valve (RR) output circuit	ABS canceled
DX23	KB	Short circuit with ground in ABS control valve (RR) output circuit	ABS canceled
DX24	KA	Disconnection in ABS control valve (RL) output circuit	ABS canceled
DX24	KY	Short circuit in ABS control valve (RL) output circuit	ABS canceled
DX24	KB	Short circuit with ground in ABS control valve (RL) output circuit	ABS canceled
DBC9	KM	Problem in connector connection	ABS canceled
DBC3	KK	Drop in the battery direct power source voltage	Continue ABS control
DBC1	KK	Drop in the main power source voltage	ABS canceled
DDD9	KA	Disconnection in ABS system switch	ABS canceled
DDD9	KB	Short circuit in ABS system switch	ABS canceled
DX21	MA	Defective ABS control valve (FR)	ABS canceled
DX22	MA	Defective ABS control valve (FL)	ABS canceled
DWND	MA	Defective ABS cut valve (F)	ABS canceled
DX23	MA	Defective ABS control valve (RR)	ABS canceled
DX24	MA	Defective ABS control valve (RL)	ABS canceled
DWNE	MA	Defective ABS cut valve (R)	ABS canceled
DX25	MA	Defective ABS front wheel system control valve	ABS canceled
DX26	MA	Defective ABS rear wheel system control valve	ABS canceled

HANDLING PAYLOAD METER (VHMS BUILT-IN TYPE)

OUTLINE OF SYSTEM

The payload meter detects the signals from the pressure sensors, clinometer, body float detection, neutral detection, and travel speed detection, and uses the microcomputer built into the controller to calculate the payload. The calculated payload is displayed on the character display on the machine monitor; the external display lamps also display the payload condition.

The data stored in the payload meter can be downloaded to a personal computer using the separately sold special software. For details of the special software, please consult your Komatsu distributor.

To ensure accuracy when operating the system, apply the parking brake when dumping, set the gear shift lever to N, release the retarder brake, and set so that the machine and payload display are both stable before starting the dumping operation. If the machine is stopped suddenly at the dumping point, it will take time for the payload display to stabilize.

Always carry out dumping on flat ground.

- Payload display
(Character display)

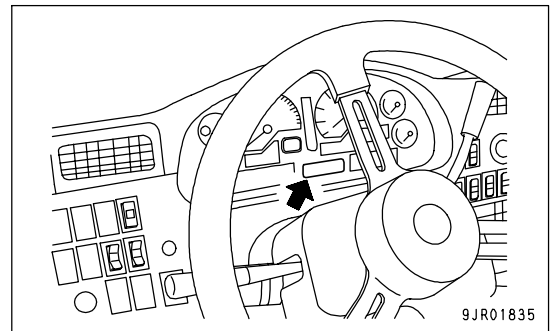

- External display lamps

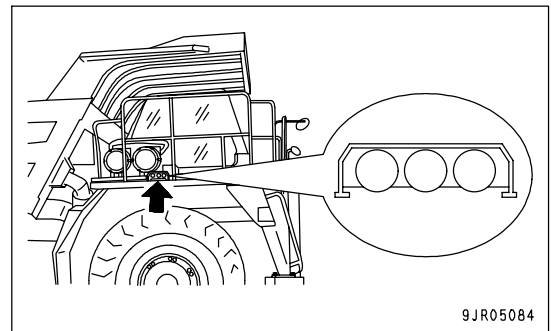

- Download connector inside cab
(end marked PLM)

When downloading, remove the connected cable. After completing the download operation, do not forget to restore the cable to its original position. If it is not restored, the download operation cannot be carried out from outside the operator's cab.

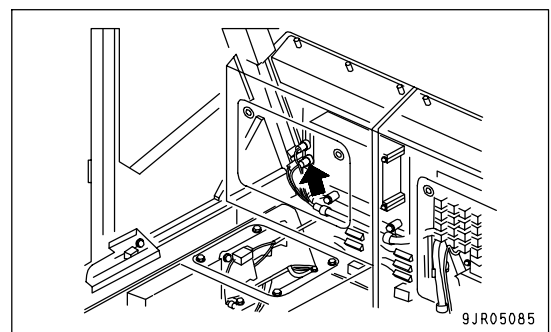

- Download connector outside the operator's cab
(end marked PLM)

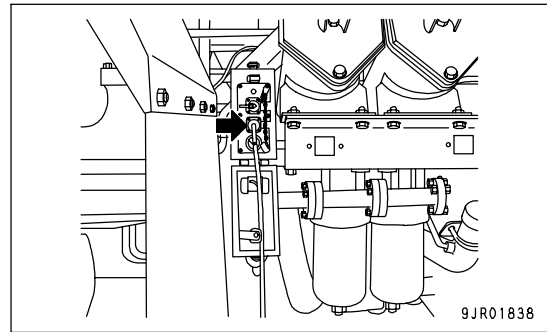

NORMAL OPERATION DISPLAY

Machine condition		Machine monitor display	External display lamps
When starting switch is ON		-	Light up for 30 sec
When empty	Stopped (*1)	Standard display (*2)	OFF
	Traveling	Standard display	OFF
During loading	Stopped	Payload display (*3)	Payload display
	Traveling	Standard display	OFF
When loaded	Stopped	Payload display	Payload display
	Traveling	Standard display	OFF
When dumping	Stopped	Payload display → standard display	Payload display → OFF
	Traveling	Standard display	OFF

(*1)"Stopped" means that the shift lever is at the N position and the travel speed signal is 0.

(*2)For details of the standard display on the machine monitor, see "DISPLAY OF CHARACTER DISPLAY (PAGE 3-28)" and "OTHER FUNCTIONS OF CHARACTER DISPLAY (PAGE 3-32)" in the explanation for components in the OPERATION section.

(*3)The machine starts off empty and is being loaded. It is necessary to wait for the load to go above approx. 15% of the max. payload and for the change in the load to stabilize when the machine is stopped.

- Example of payload display

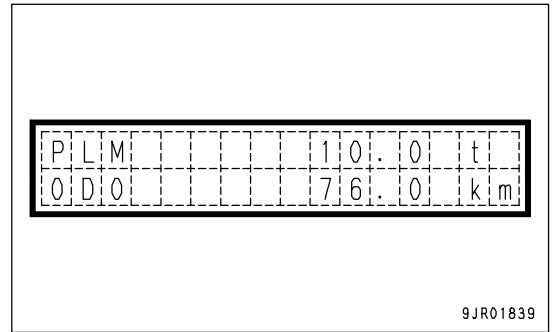

9JR01839

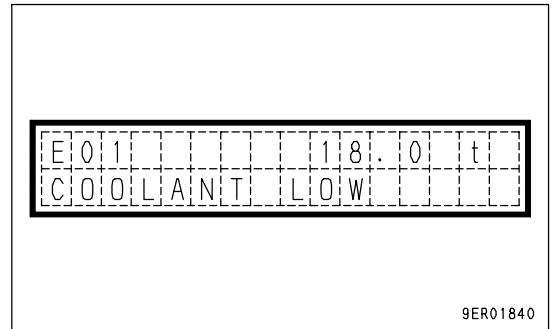

9ER01840

- Example of payload display when error occurs
If an error occurs in the suspension pressure sensors or in the clinometer sensor, it becomes impossible to calculate the payload, so [----] is displayed.
- When the machine is stopped during loading operations and when it is loaded, the service meter is not displayed on the character display.
If it is desired to display the service meter, keep the machine monitor inspection switch pressed. The software version and service meter will be displayed in turn on the bottom line of the character display.
- The payload at the loading point immediately after the loading operation may differ slightly from the display at the dumping point. This is caused by the effect of the friction in the suspension, and is impossible to remove. Even if the display value differs slightly according to the measurement point, it does not indicate any failure in the payload meter.

EXTERNAL DISPLAY LAMPS



If the red lamp lights up, the machine is overloaded. If the machine carries an excessive load, the machine will be damaged. To prevent overloading, continue loading until the yellow lamp lights up. If the red lamp flashes, stop loading immediately.

- The external lamps display the payload as follows.

	Color of lamp	HD465-7	HD605-7
1	Green	23.0 tons and up	31.5 tons and up
2	Yellow	41.4 tons and up	56.7 tons and up
3	Red	48.3 tons and up	63.0 tons and up

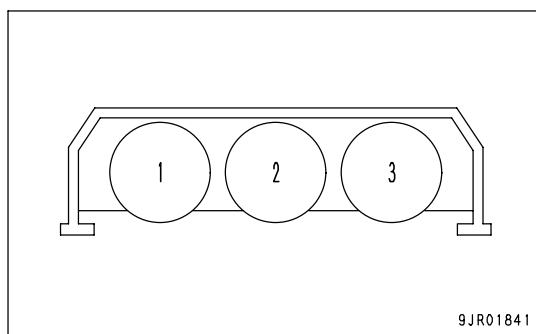

- If the red lamp lights, the machine is overloaded.

PREDICTED LOAD DISPLAY

- When the load changes in steps for each bucket loaded, the system estimates the total payload if one more bucket is loaded, payload meter estimates the predicted load and display the predicted load by flashing the lamp. When red lamp flashed, next load will carry over loading.
- The predicted load display and actual payload display are shown at the same time.

[Example: Case of HD465, expected number of bucket loads: 4]

- 1st bucket 11 tons
- 2nd bucket 11 tons (total: 22 tons)
- 3rd bucket 11 tons (total: 33 tons)
- 4th bucket 11 tons (total: 44 tons)

When the machine is loaded in this way, the external display lamps light up as shown in the chart below.

No. of loads	External display lamp	Remarks
1st bucket	<p>Green Yellow Red</p>	<ul style="list-style-type: none"> The weight actually loaded is 11 tons, so no lamp lights up. The predicted load is 22 tons, so no lamp flashes.
2nd bucket	<p>Green Yellow Red</p>	<ul style="list-style-type: none"> The weight actually loaded is 22 tons, so no lamp lights up. The predicted load is 33 tons, so the green lamp flashes.
3rd bucket	<p>Green Yellow Red</p>	<ul style="list-style-type: none"> The weight actually loaded is 33 tons, so the green lamp lights up. The predicted load is 44 tons, so the yellow lamp flashes.
4th bucket	<p>Green Yellow Red</p>	<ul style="list-style-type: none"> The weight actually loaded is 44 tons, so the green and yellow lamps light up. The predicted load is 55 tons, so the red lamp flashes.

PERFORMING CALIBRATION

Carry out calibration of payload meter at the following occasions.

- When the machine or payload meter are received
- Once every month
- When the suspension cylinder gas pressure and oil amount have been adjusted (when the suspension has been adjusted)
- When the suspension pressure sensor has been replaced
- When the machine has been modified and the weight of the machine when empty has changed more than 100 kg (221 lb)

METHOD OF PERFORMING CALIBRATION

- Carry out the calibration when traveling on a flat road surface.
- Carry out the calibration when traveling in a straight line (distance: approx. 100m (328 ft 1 in)). When traveling, maintain a speed of approx. 10 km/h (6.2 MPH).
- Do not carry out calibration if there is an existing error.
- Lower the dump body to seat it and set the dump lever to the FLOAT position before carrying out calibration. To confirm that the dump body is fully seated, check that the body pilot lamp is OFF.

1. Set the machine empty. When doing this, remove all the remaining soil inside the dump body.
2. Run in the machine.
3. With the engine still running, set the shift lever to the N position and stop the machine.
4. Using the following procedure, operate machine monitor mode selector switches 1 (1) and 2 (2) and carry out the preparatory work for calibration.

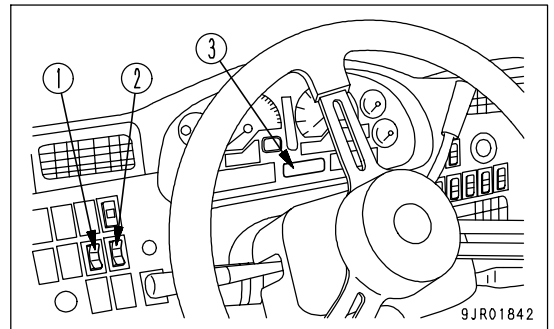

- 1) With the service meter/odometer value displayed on character display (3) of the machine monitor, press the (◇) of machine monitor selector switch 1 (1) to display the value for reverse travel.

For details of the method of displaying the reverse travel odometer, see "OTHER FUNCTIONS OF CHARACTER DISPLAY (PAGE 3-32)".

- 2) Press the (>) of machine monitor selector switch 2 (2) several times and display "PLM".

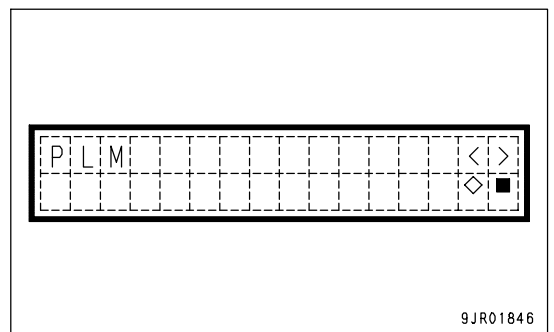

3) Press the (◇) of machine monitor selector switch 1 (1) and display CALIBRATION. Then, press the (◇) and check that the word CALIBRATION flashes.

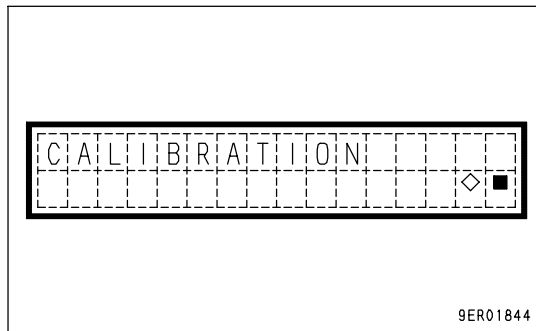

5. Drive the machine at a speed of 10 km/h (6.2 MPH).
 6. When the travel speed becomes stable, press the (◇) of machine monitor selector switch 1 (1) and display CALIBRATION. The word CALIBRATION flashes two or three times, and then the display on the right is given.

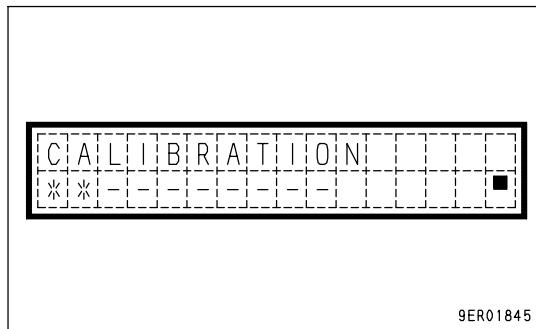

REMARK
 When canceling, press the (■) of machine monitor selector switch (1) when the display on the right is being given.

7. Continue traveling at a speed of 10 km/h (6.2 MPH). If the display on the right is given after approx. 30 seconds, the calibration is completed.

REMARK
 If the (■) of machine monitor selector switch (1) is kept pressed, the display returns to the service meter/odometer display.

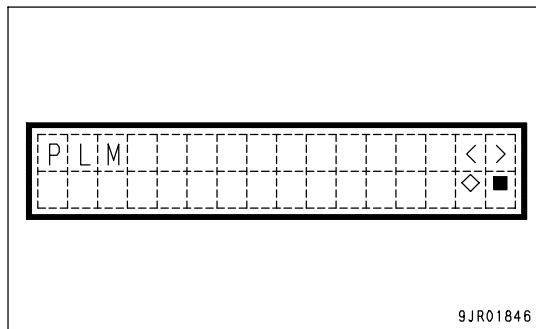

DATA STORED IN PAYLOAD METER

- The payload meter takes the cycle from one dumping operation to the next dumping operation as one cycle and records the data.

- Cycle data items

Date (month/day) of dumping	Time remaining stationary when loading
Time of dumping	Time traveling loaded
Machine ID	Distance traveled loaded
Open ID	Travel speed when loaded (max.)
Payload	Travel speed when loaded (ave.)

Time of traveling empty	Time remaining stationary when loaded
Distance traveled empty	Time taken to dump
Travel speed when empty (max.)	Speed limit
Travel speed when empty (ave.)	Warning items for each cycle
Time remaining stationary when empty	

- The maximum limit for stored cycle date is 2900 cycles. If 2900 cycles is exceeded, the old date is overwritten.
- Download the recorded data using the RS232C port of a personal computer which has the separately sold special software installed.

The downloaded date is saved in the specified location on the personal computer as a text file (CSV file). For details, see the instruction manual for the special software.

It is possible to check the downloaded data with a commercially available spreadsheet software that can read text files.

PROCEDURE WHEN DOWNLOADING

NOTICE

If any mistake is made in handling the cables and connectors, the cables or connectors may be damaged and it may become impossible to download the data. Always do as follows.

- Never pull the cable by force. This will damage the cable.
- Take precautions to prevent dirt from entering the connector. Do not leave the connector disconnected.

Download the recorded data to a personal computer which has the separately sold special software installed.

DOWNLOADING FROM DOWNLOAD CONNECTOR INSIDE CAB (REAR OF ASSISTANT'S SEAT)

1. Remove connector (1) at the end marked PLM, and connect the Download cable supplied with the special software.
2. Connect the other end of the cable to the RS232C port of the personal computer.
3. Turn the starting switch to the ON position.

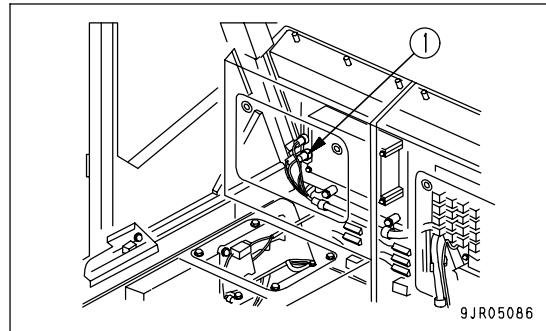

4. Start up the personal computer and use the special software to download the data.
The download software for the HD465/605 card type payload meter can be used as it is for the special software.
5. After completing the download operation, always return the cables to their original position.

DOWNLOADING FROM GROUND LEVEL DOWNLOAD BOX OUTSIDE CAB

**WARNING**

When downloading, set the parking brake switch to the PARKING position, return the gear shift lever to N, and set the dump control lever to the HOLD position. Then take action to prevent the machine from moving. If no action is taken, the machine may move and cause damage.

1. Turn the starting switch to the OFF position.
2. Open the ground level download box. Use the starting switch key to open or close the box.
3. Set switch (1) inside the box to the ON position. After a short time, display lamps (2) will light up.

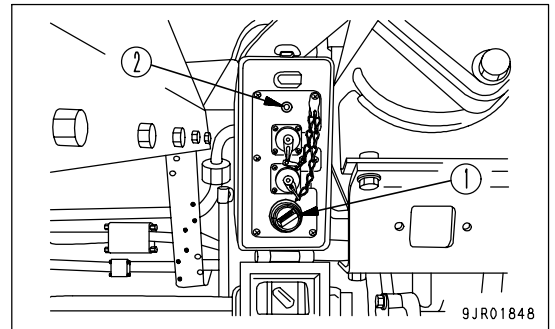

4. Connect the download cable supplied with the special software to the end marked PLM, Connect the other end of the cable to the RS232C port of the personal computer.
5. Start up the personal computer and use the special software to download the data. For details of the download operation, see "DOWNLOADING FROM DOWNLOAD CONNECTOR INSIDE CAB (REAR OF ASSISTANT'S SEAT) (PAGE 6-30)".

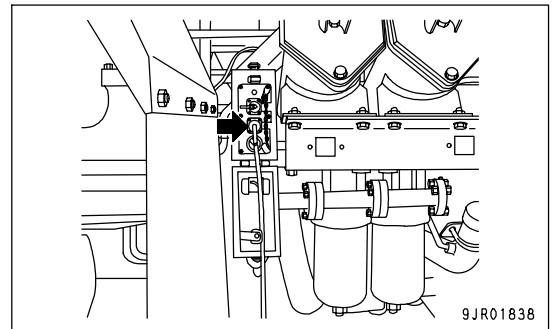

6. After completing the download operation, return the switch inside the box to the OFF position, then close the box securely.

DOWNLOAD SOFTWARE

For details of installing the software, see the instruction manual provided with the download software.

1. When the installation is completed, the icon shown in the diagram on the right is created.



2. Double click the icon. The download software is started and the screen shown in the diagram on the right is displayed. After that, screen [G1000] is displayed, so click [PLM].
[CARD] and [PMC] are not used, so do not click them.

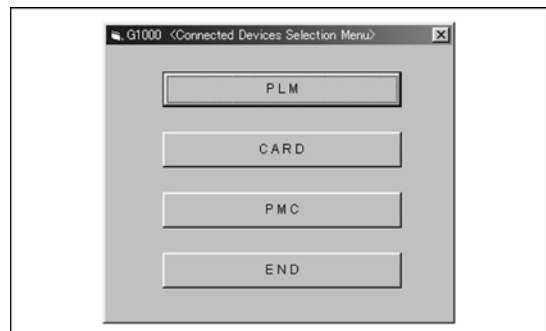
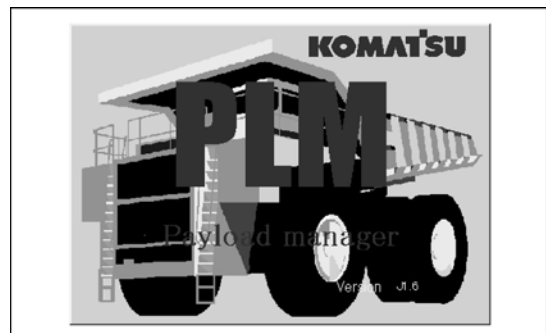

3. Click [Parameter Setting] on screen [G2000].
[PLM Remote Control] is not used, so do not click it.

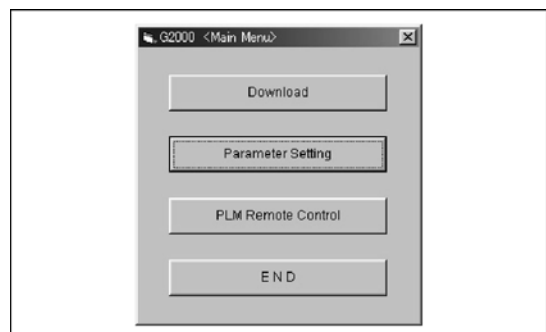

- Click [Unit Setting] on screen [G2200]. Screen [G2210] is displayed.
[User's Comment] is not used, so do not click it.



- On screen [G2210] it is possible to select the communication port (Com1, Com2), specify the destination for saving the downloaded data, specify the file name, and select the unit for the data. For details, see the instruction manual for the download software.
The files used for the HD465-7 and HD605-7 are the files for the summary and cycle data only, so put a check mark against [Summary Data File] and [Cycle Data File] in [File]. Once the setting is mode, there is no need to make any setting when the next download is carried out.
Click [Enter] to return to screen [G2200].

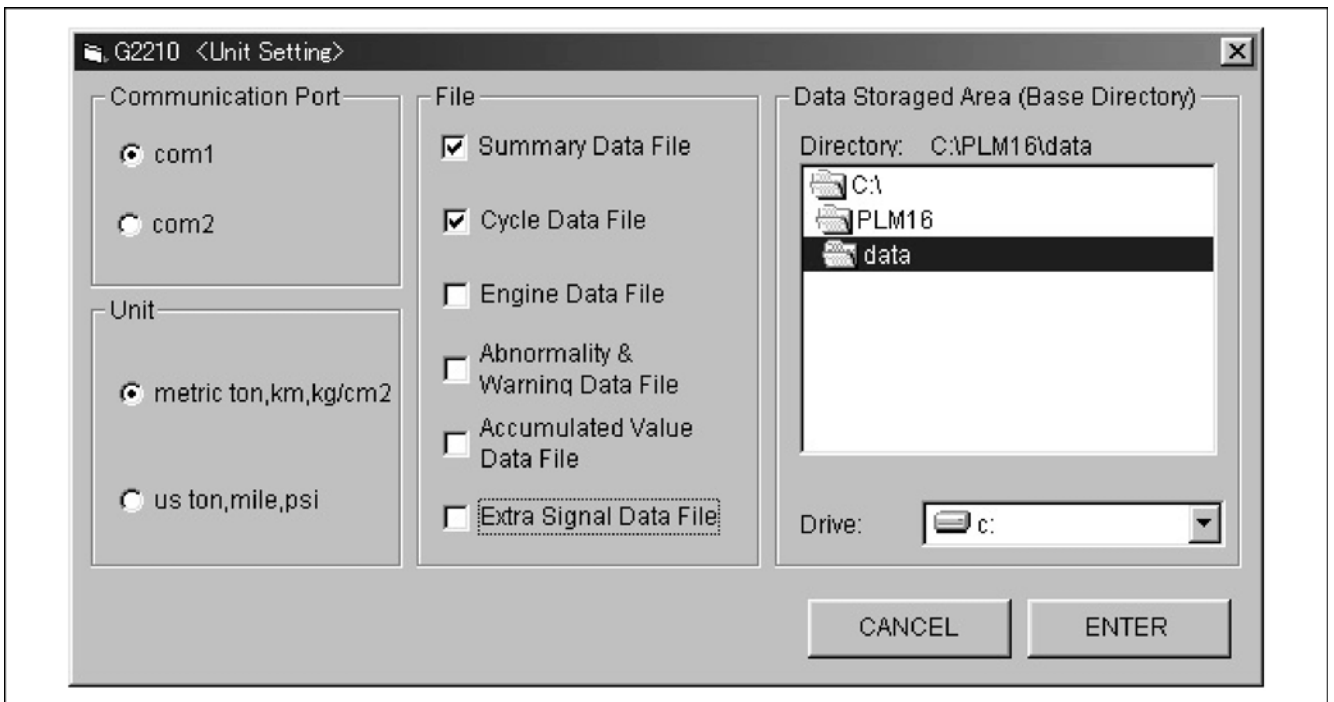

- On screen [G2200], click [BACK] to return to screen [G2000]
- Click [Download] on screen [G2000]. Screen [G2100] is displayed, so click [START] to download.
After completing the download operation, click the [X] at the top right of the screen to close the screen.



MACHINE ID, OPEN ID

It is possible to change the machine ID and open ID, which are cycle data items. When changing the machine Serial No. for the machine ID or the operator or type of load for the open ID, set the value specified by the customer beforehand to make it possible to use to check the operator and type of load for the applicable cycle afterwards.

METHOD OF SETTING MACHINE ID, OPEN ID

1. When the service meter/odometer is being displayed on the character display of the machine monitor, press the (◇) of machine monitor selector switch 1 to display reverse travel.
For details, see "OTHER FUNCTIONS OF CHARACTER DISPLAY (PAGE 3-32)".
2. Press the (>) of machine monitor selector switch 2 several times to display "PLM"

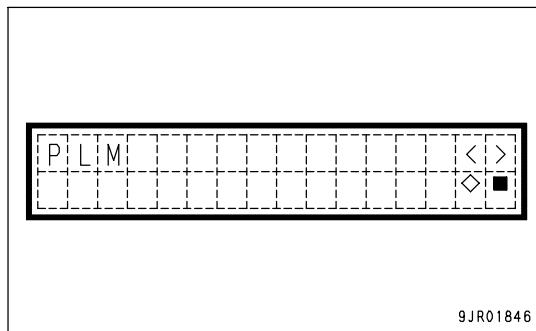

3. Press the (◇) of machine monitor selector switch 1 to display "CALIBRATION"

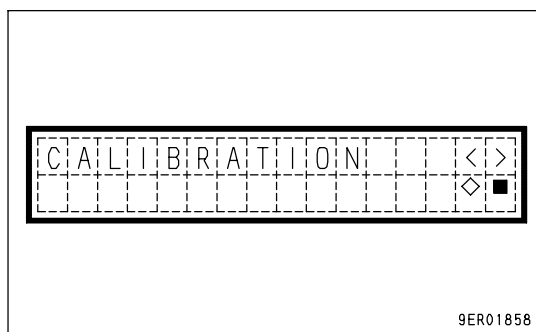

4. Press the (>) of machine monitor selector switch 2 to display the screen shown in the diagram on the right.
ID1 corresponds to the machine ID.
The present setting is displayed on the bottom line.

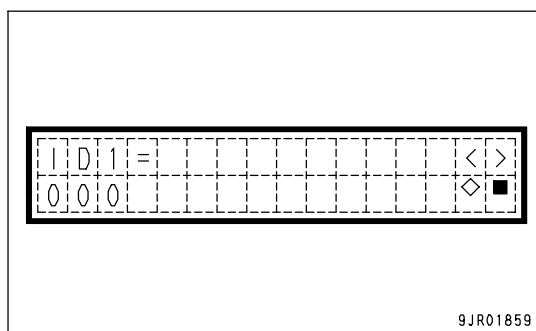

- Press the (◇) of machine monitor selector switch 1 to display the screen shown in the diagram on the right.

The available settings range from 0 to 200; input in order from the first digit. The place for insertion is marked by the cursor. Press the (<) or (>) of machine monitor selector switch 2 to select 0 to 9. After inputting the value, press the (◇) of machine monitor selector switch 1. The cursor will move to the next position.

Repeat this procedure to input the values for all the digits, then confirm the settings and return to the previous screen.

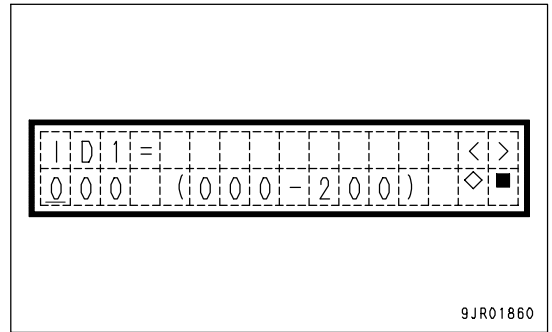

If the (■) of machine monitor mode selector switch 1 is pressed while inputting any value, the value will stay as it is and the cursor will move to the first digit. If any mistake is made in the input, input again from the first digit.

To abandon the input operation, press the (■) of machine monitor mode selector switch 1 again and return to the previous screen.

- When setting the open ID, press the (>) of machine monitor selector switch 2 at Step 4 to display the screen shown in the diagram on the right.

The procedure for setting is the same as for ID1 (machine ID).

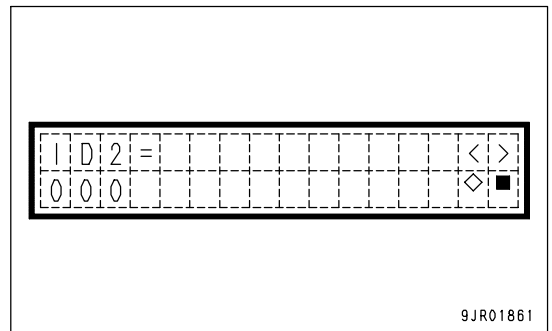

- Press the (■) of machine monitor selector switch 1 several times to return to the service meter/odometer display.

PAYLOAD (CYCLE DATA ITEM)

- The payload measurements, which are recorded as data, apply to the haul payload in the applicable cycle.
- There are the following two methods of confirming the haul payload.

1: At the dumping point, record the payload when the dump lever is moved from FLOAT to any position other than FLOAT.

2: Process the data sampled when traveling from the loading point to the dumping point, then confirm and record the haul payload when dumping.

When the machine is shipped from the factory, the same Method 1 is used as for the conventional card type payload meter (PLM II).

- The method for processing and confirming the payload in Step 2 above is useful if the dumping point is at an angle.

If you wish to change the method of confirming the haul payload, please ask your Komatsu distributor to carry out the change.

SERVICE FUNCTIONS

The following functions are available, but for normal use, there is no need to make any change. If it is necessary to change the setting, please consult your Komatsu distributor.

1. Setting travel distance needed to recognize completion of loading

The payload meter is set to judge that the loading is completed when the machine has traveled 160 m (524 ft 11 in) continuously from the loading point. If the dumping point is within 160 m (524 ft 11 in) from the loading point, the system will not judge that dumping has taken place, so the cycle data at that point will be incomplete. In cases where the loading point and the dumping point are extremely close, use this function to change to the setting for the travel distance needed to recognize the completion of loading.

2. Selecting method of confirming recorded payload

Use this function to change the selection of the method below to confirm the haul payload.

- 1) At the dumping point, record the payload when the dump lever is moved from FLOAT to any position other than FLOAT.
- 2) Process the data sampled when traveling from the loading point to the dumping point, then confirm and record the haul payload when dumping.

OTHERS

- If it is necessary to correct the data or time during the download operation, please consult your Komatsu distributor.
- If the payload and external display lamp display is different, or there is some error in the directory where the data is downloaded by the special software, there may be a mistake in the setting for the machine. In such a case, please consult your Komatsu distributor.
- Use a serial communication port (RS232C) to download the data. For computers without an RS232C port, it may be possible to use a third party USB-RS232C conversion adapter. (Part for operation check: IO DATA USB-RSAQ2) However, this does not guarantee the operation. In addition, the download software supports COM1 and COM2, so check which port it can be connected to.
- The payload meter has the function of communicating with the external equipment prepared by the customer. For details, please check with your Komatsu distributor. However, communications are carried out using the RS232C port for downloading, so in this case, it is impossible to download the data from the inside or outside of the cab.

If a card-type payload meter is installed to a machine with a built-in VHMS type payload meter, the VHMS type payload meter will not work.

HANDLING PAYLOAD METER II (CARD TYPE)

- The payload meter inputs the signals from the pressure sensors, clinometer (*1), body float detection, and neutral detection, and uses the built-in microcomputer to calculate the amount loaded. It then displays the calculated load on the panel display and also displays the load on the external display lamps.
(*1) This is not installed on the -60°C specification.
- The payload meter always carries out self-diagnosis of the system, and if any problem or warning occurs, it displays the content.
- It is also possible to use the switches on the payload meter itself to display the aggregate payload or total number of cycles from a certain time, and to forcibly display problem and warning items that are now occurring, or have already occurred and been restored to normal.
- The payload meter automatically records dump truck operation data, such as the payload, time, distance, and travel speed for each cycle, together with the time and date of starting or stopping the engine, time and date of the occurrence and remedy for problem or warnings, and the aggregate payload and total number of cycles from any given time.

These automatically recorded data are retained when the power is turned off, so it is possible to send (download) the data to a personal computer from the payload meter through a cable connected to the port (ANSI/EIA RS232C) inside the cab. In addition, it is also possible to display the dump truck operation data (based on these data) on the personal computer screen, to print it out, or to convert it to data for a spreadsheet (Lotus 1-2-3 or EXCEL).

Furthermore, if a memory card is inserted in the payload meter, these data can be written to the memory card and then read to a personal computer from the memory card, so the data can be processed in the same way as with cable communications using a personal computer.

REMARK

The personal computer software supplied by Komatsu is necessary for downloading the data, reading the data from a memory card to a personal computer, and processing the data. Please consult your Komatsu distributor.

- It is possible to set the machine ID, open ID, and travel speed limit for each payload meter (for each machine).

If a card-type payload meter is installed to a machine with a built-in VHMS type payload meter, the VHMS type payload meter will not work.

METHOD OF USING ACCURATELY

1. Recorded payload data

When the dump lever is operated from FLOAT to any position other than the FLOAT, the payload is recorded. The reason for this is the following two points.

- To measure the payload that has actually been carried
The payload can be measured more accurately by measuring the load that is actually dumped after subtracting the loss caused by spillage of the load during travel.
- The measurement is carried out based on the pressure of each suspension, and after the machine has traveled, the variation of the friction force at each place has been evened out, so it is possible to measure accurately.

When dumping the load, if the machine shakes and the payload display fluctuates, wait for the payload display to stabilize before dumping the load. (If the dump truck is stopped suddenly at the dumping point, it will take time for the payload display to stabilize.)

2. The payload display at the loading point (immediately after the loading) may be slightly less (1 to 5 tons) than the value displayed at the dumping point. This is caused by the differences in the friction force of the suspension, and it is impossible to remove this.

Even if the displayed value at the measurement location is slightly different, it is not caused by any failure in the payload meter.

GENERAL LOCATIONS

CONTROLLER SCREEN

When not inserting or removing memory card (7), always keep cover (6) closed.

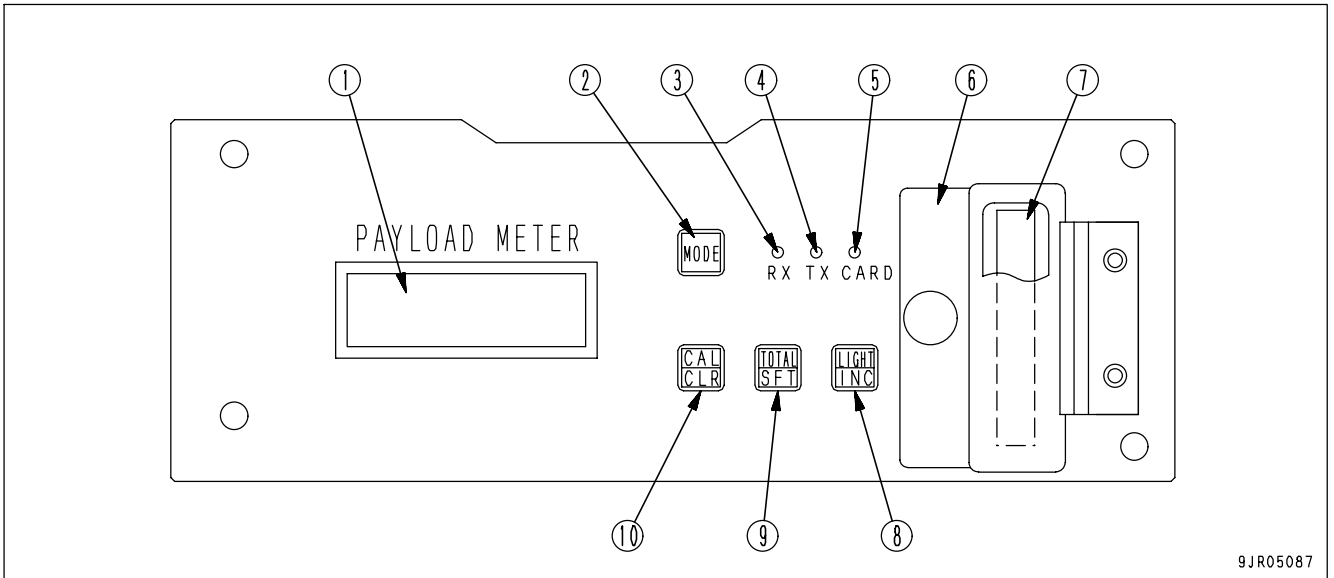

- | | |
|---|-------------------------------|
| (1) Display panel | (6) Cover |
| (2) MODE switch | (7) Memory card |
| (3) Reception pilot lamp (Rx busy) | (8) Light/increment switch |
| (4) Transmission pilot lamp (Tx busy) | (9) Total/shift switch |
| (5) Memory card access lamp (CARD busy) | (10) Calibration/clear switch |

REMARK

Transmission pilot lamp (4) lights up when the communication cable is not connected to the personal computer or when it is not properly connected.

LEFT FACE OF CONTROLLER

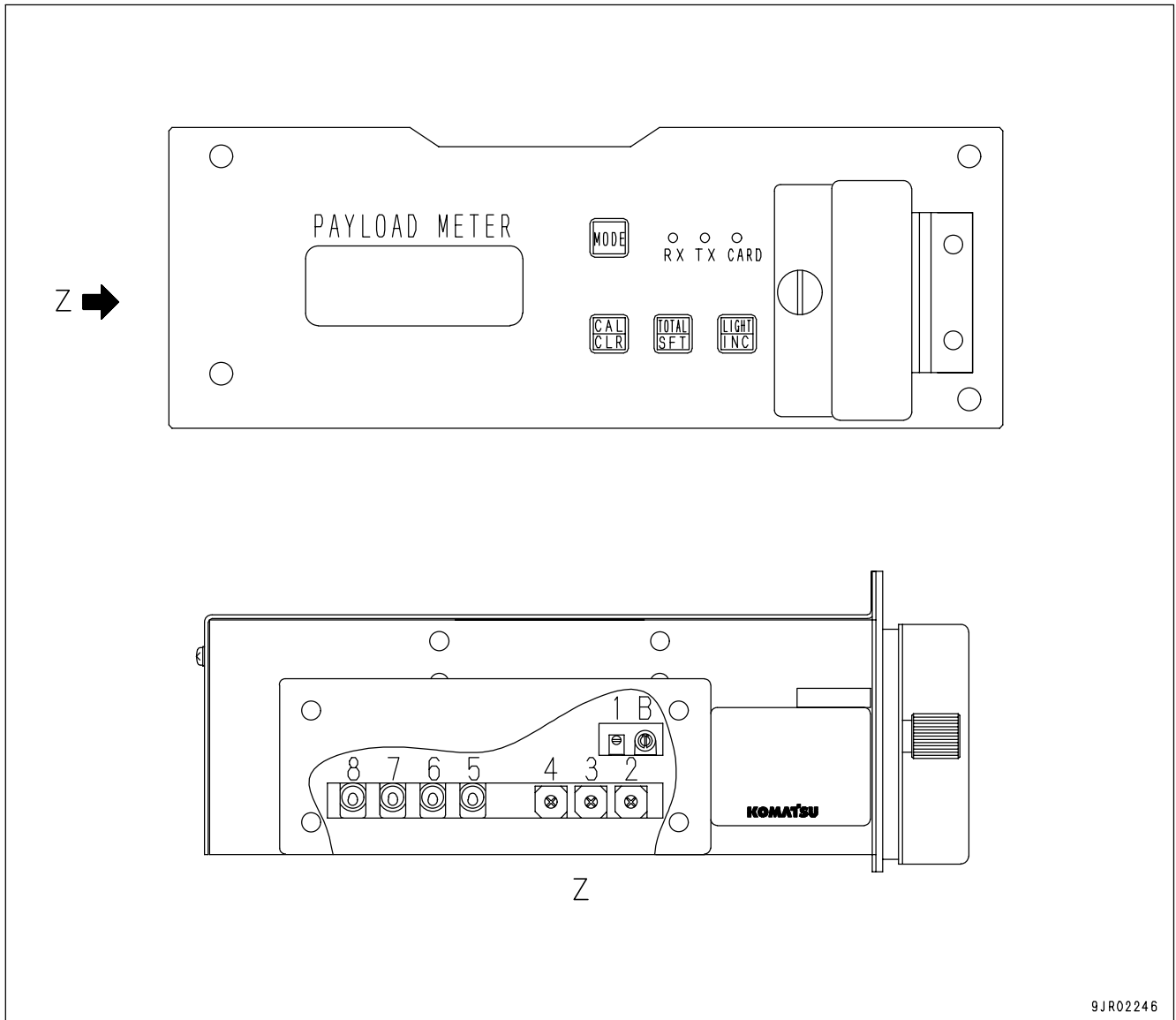

9JR02246

DETAILS OF SWITCHES ON LEFT SIDE

No.	Name	Type	Remarks
1	Payload gain adjustment trimmer	Rotary volume	-20% to 20% (Turn to left) - (Turn to right)
2	Speed regulation switch	0 - F Rotary switch	0: 107 % to 7: 100 % to F: 92 %
3	Distant regulation switch	0 - F Rotary switch	0: 107 % to 7: 100 % to F: 92 %
4	Model selection switch	0 - F Rotary switch	Refer to model selection chart
5	Use of memory-card switch	2-Stage selector switch	Up: not used; Down: used
6	Use of clinometer switch	2-Stage selector switch	Up: not used; Down: used
7	Mass unit setting switch	2-Stage selector switch	Up: metric tons; Down: short tons
8	Forced prohibition setting for switches	2-Stage selector switch	Up: permitted Down: prohibited According to permitted/prohibited setting table for switches
B	Buzzer volume regulation	Rotary volume	For MIN volume, turn to RIGHT For MAX volume, turn to LEFT

The switches on the left side are set when the machine is shipped from the factory.

Do not touch any switch except "7" and "B".

If you wish to adjust any switch except "7" and "B" to compensate the payload calculation value or speed or distance calculation value, please contact your Komatsu distributor.

REMARK

The weight is given in units of metric tons or short tons. The meaning of these units is as follows.

Metric ton: Unit for the metric system; one metric ton is 1000 kg

Short ton: Unit used in USA: 1 short ton is 907.18 kg

Model selection code chart for model selection switch

Model selection code display	Model / Type / Tire size / Engine		
0	HD1200-1 STD	Large-tire	Cummins engine
1	HD785-3 STD	Large-tire	Komatsu engine
2	HD465-5/-7 STD	Large-tire	Komatsu engine
3	HD325-6 STD	Large-tire	Komatsu engine
4		-	
5		-	
6	HD785-3 STD	Small-tire	Komatsu engine
7	HD465-5/-7 STD	Large-tire	Komatsu engine
8	HD405-6 Quarry	Large-tire	Komatsu engine
9	HD985-3/-5 STD	30.00-51	Komatsu engine
A	HD605-5/-7 Quarry	Large-tire	Komatsu engine
B	HD785-5 STD	Large-tire	Komatsu engine
C		-	
D		-	
E		-	
F		-	

PERMITTED/PROHIBITED SETTING TABLE FOR SWITCHES

Left side switch "5" Up (memory card not used)	Left side switch "8" Up (permitted)	Operation of all switches is permitted
	Left side switch "8" Down (prohibited)	Only calibration operation, data all clear, time and date setting operation are permitted
Left side switch "5" Down (memory card used)	Left side switch "8" Up (permitted)	Operation of all switches is permitted
	Left side switch "8" Down (prohibited)	Only calibration operation, data all clear, card dump, time and date setting operation are permitted

EXTERNAL DISPLAY LAMPS

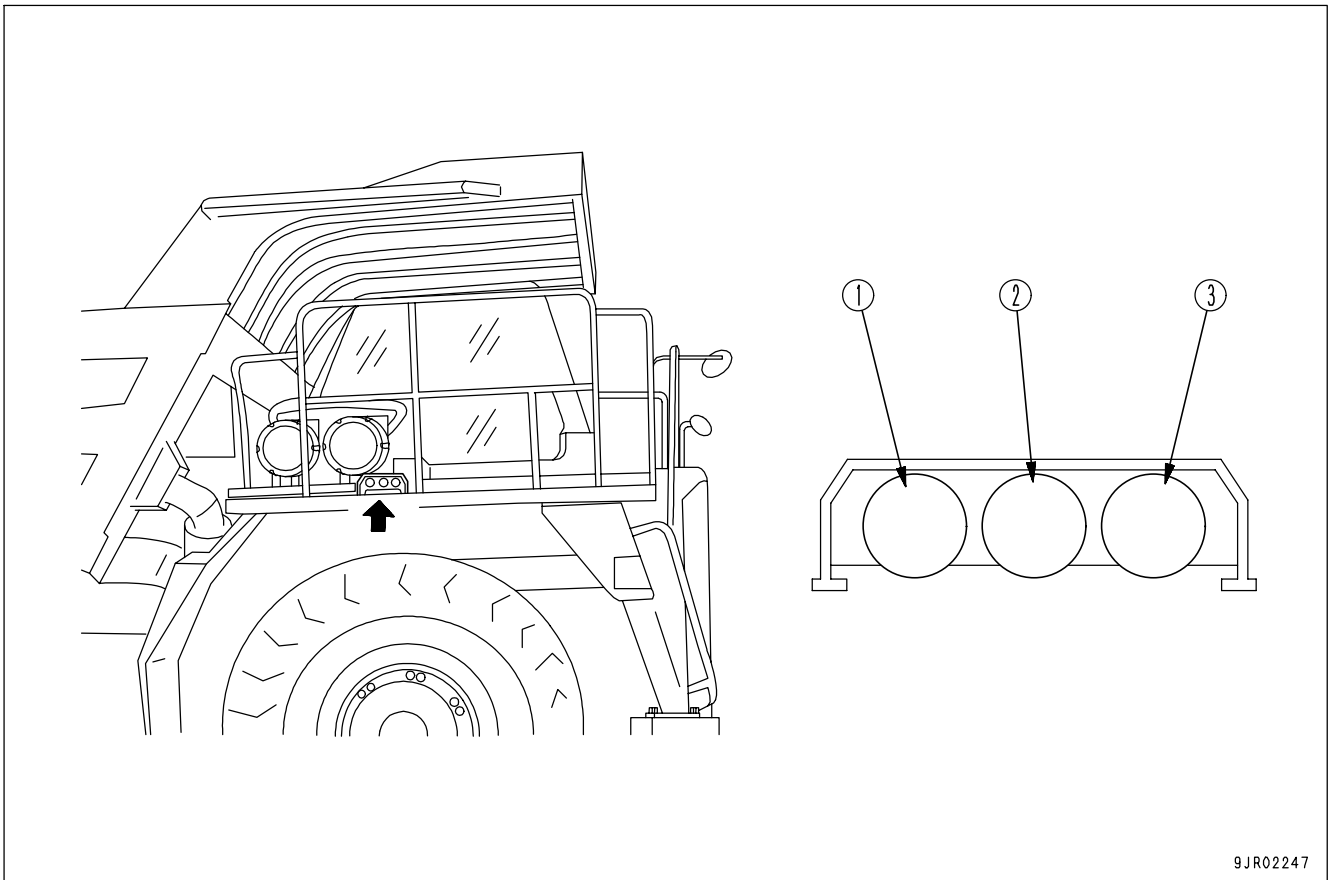

9JR02247

- (1) Green lamp
- (2) Yellow lamp
- (3) Red lamp

COMMUNICATIONS CABLE CONNECTION PORT FOR PERSONAL COMPUTER

- Download connector (side marked PLM)
 When downloading, remove the cable that is connected.
 After completing the download operation, always return the
 cable to its original position.

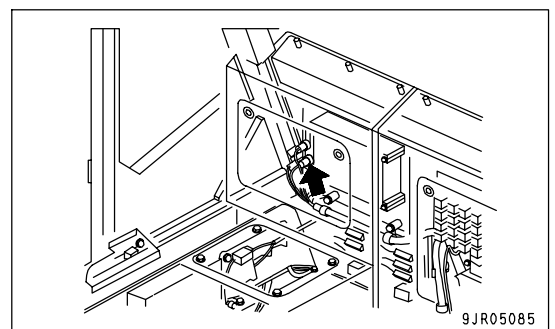

9JR05085

CONTENT OF DISPLAY (CONTROLLER, EXTERNAL DISPLAY LAMPS)

WHEN THE POWER IS ON

When the power is turned ON, the displays on the controller display and external display lamps are as follows.

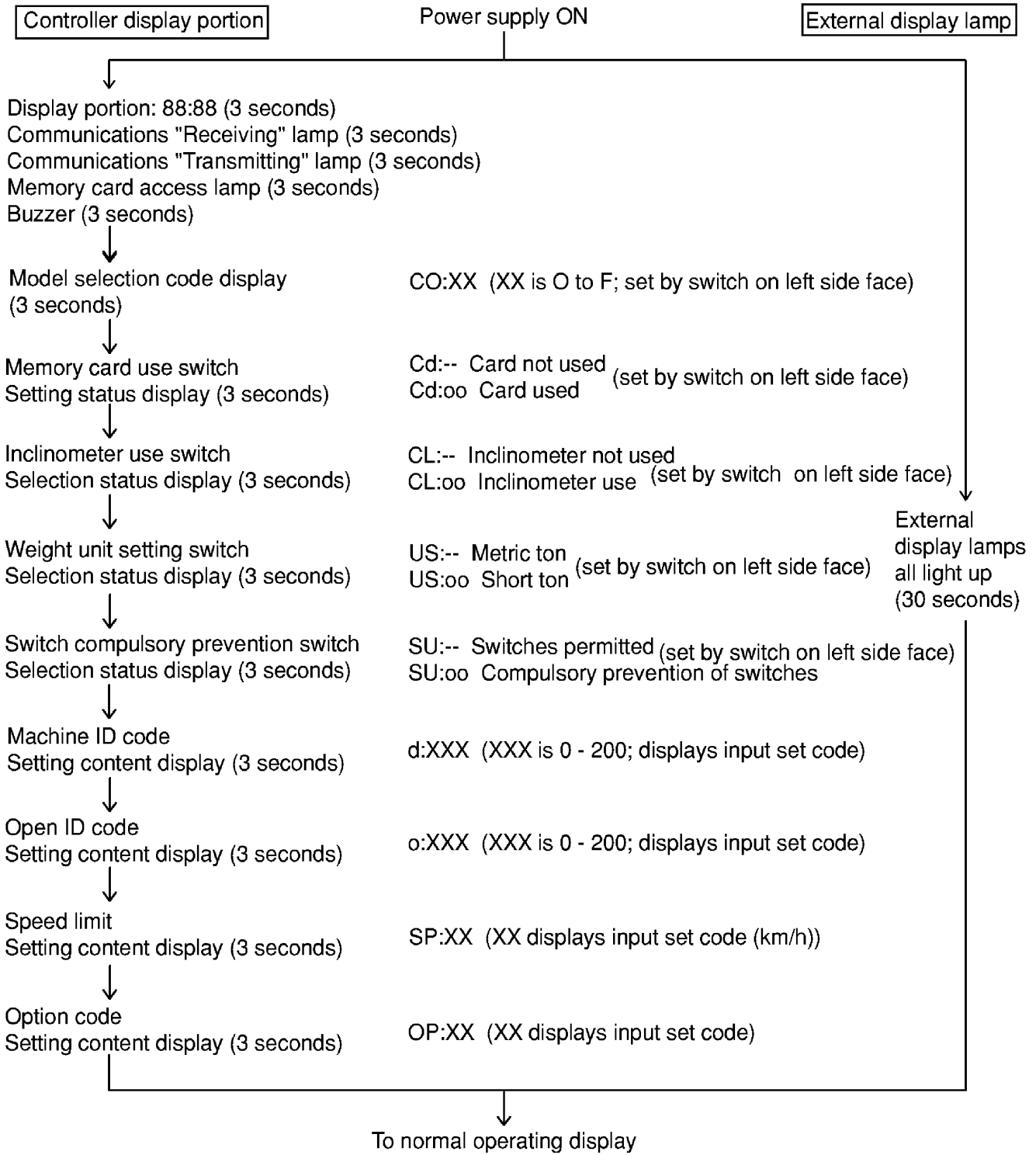

If the engine is started during this flow of displays, even if there are items remaining which should still be displayed, the display switches after several seconds to the display given during normal operations. The machine ID code, option ID code, speed limit, and option code, see "OPERATOR CHECK MODE (PAGE 6-59)".

DISPLAY DURING NORMAL OPERATIONS

Condition of machine		gear shift lever position	Dump lever position (*1)	Display panel	External display lamps
When empty	Stopped	N	FLOAT	Payload display (*2)	Payload display
	Traveling	Except N	FLOAT	Time display	OFF
During loading, until 50% of max. payload is reached	Stopped (*3)	N	FLOAT	Payload display	Payload display and display of estimate
	Traveling	Except N	FLOAT	Payload display	OFF
During loading, after 50% of max. payload is reached	Stopped	N	FLOAT	Payload display	Payload display and display of estimate
	Traveling (*4)	Except N	FLOAT	Travel distance displayed in units of meter from 0 to 160 m (every 5 m) -> sfter completion, time display	OFF
When loaded	Traveling	Except N	FLOAT		OFF
	Stopped (*5)	N	FLOAT	Payload display	Payload display
When dumping (*6)		N	FLOAT-> RAISE-> LOWER-> FLOAT	Total payload display (*7) goes out	OFF
When abnormality or warning is generated		-	-	See "PROBLEM AND WARNING DISPLAY (ERROR CODE)(6-77 PAGE)".	See "PROBLEM AND WARNING DISPLAY (ERROR CODE)(6-77 PAGE)".

See the next page for details of Notes *1 to *7.

- *1: Between the start of the loading operation and the start of the dumping operation, always keep the dump lever at the FLOAT position. If the dump lever is operated to any position other than FLOAT, the data will not be recorded when dumping, or the data will be recorded, but the data for time, distance, and speed will not be recorded accurately.
With the display, [b-FL] may be displayed instead of the total payload when dumping, and after completion of loading, the time display may be given instead of the distance display when starting to travel.
- *2: When the load is less than 50% of the maximum payload, 0 ton is displayed.
- *3: If there is no new load within 5 minutes from the time of the previous load:
Both the display panel and external display lamps will change to the display for "When empty, Stopped" in the table.
- *4: If the machine is stopped again before traveling 160 m, both the display panel and external display lamps will return to the display for "During loading, Stopped" in the table.
If the load is dumped before traveling 160 m, both the display panel and external display lamps will jump to the display for "When dumping" in the table.
- *5: If loading is carried out again when this happens:
Immediately after loading again, both the display panel and external display lamps will return to the display for "During loading, Stopped" in the table.
- *6: If the load that is dumped is not more than 50% of the maximum payload, the machine will not recognize that a load has been dumped. It will consider it only as a movement of the dump lever. (See *1)
- *7: The display for the total payload is given in units of 100 t (rounded to the nearest 100).
For the method of clearing the total payload (resetting of the measurement to 0), see "FORCED DISPLAY OF TOTAL PAYLOAD AND OVERALL NUMBER OF CYCLES (PAGE 6-57)".
When dumping, if the gear shift lever is at any position other than N, [b-FL] flashes. If the dump lever is at any position other than FLOAT from the beginning of the loading operation to the end of the dumping operation, the data will not be recorded accurately. (See *1)

The payload meter retains the existing condition when it is empty, during loading, and when it is loaded, even if the power is turned OFF, so when the operator starts operation again, the system starts from the existing machine condition.

NOTICE

If the operation is not carried out properly, the payload will not be measured correctly, so the payload meter data or external lamp display will not be correct. When the machine is unloaded, when it is stopped for loading, or when it is stopped when loaded, always place the gear shift lever at N.

In the following cases (1) to (4), the condition of the dump truck as seen by the payload meter will be different from the actual condition of the dump truck.

- (1) When a new controller has been installed
- (2) When the controller has been replaced
- (3) When the built-in battery has been replaced
- (4) In addition, if either of the following conditions should occur
 - o The external display lamps give the estimate display although no loading is taking place.
 - o The display gives the time display when loading even if more than 50% of the maximum payload is loaded and the machine starts to travel. (The distance display is not given when traveling 0 to 160 m. (0 to 524 ft 11 in))

In the case of (1), carry out calibration. For details, see "CARRYING OUT CALIBRATION (PAGE 6-56)".

In the case of (2), carry out calibration. For details, see "OPERATION WHEN ERROR CODE F.CAL IS DISPLAYED OR CONTROLLER HAS BEEN REPLACED (PAGE 6-87)".

In the case of (3), carry out calibration. For details, see "WHEN ERROR CODE F-09 IS DISPLAYED (PROCEDURE FOR REPLACING BATTERY) (PAGE 6-84)".

In the case of (4), carry out calibration. For details, see "CARRYING OUT CALIBRATION (PAGE 6-56)".

The payload meter will recognize the empty (stopped) condition. The cycle data recorded when dumping may be partly inaccurate.

- After starting dumping (operating the dump lever from FLOAT to RAISE), do not turn the power OFF within 5 seconds after completing the dumping (operating the dump lever from LOWER to FLOAT).
- Also, with operations other than dumping, do not turn the power OFF within 5 seconds after operating the dump lever to FLOAT from any position other than FLOAT.
- If the starting switch has been left at the ON position (power ON) for a long period without starting the engine, first turn the starting switch to the OFF position, then start the engine.
If the engine is started without turning the starting switch first to the OFF position, the time that the starting switch was at the ON position without starting the engine will also be calculated as part of the "Stopped, Empty" time or the "Stopped, Loaded" time.

EXTERNAL DISPLAY LAMPS

DISPLAY LEVEL FOR LAMPS



If the red lamp lights up, the machine is overloaded. If the machine carries an excessive load, the machine will be damaged. To prevent overloading, continue loading until the yellow lamp lights up. If the red lamp flashes, stop loading immediately.

- The external lamps display the payload as follows.

	Color of lamp	HD465-7	HD605-7
1	Green	23.0 tons and up	31.5 tons and up
2	Yellow	41.4 tons and up	56.7 tons and up
3	Red	48.3 tons and up	63.0 tons and up

- If the red lamp lights, the machine is overloaded.

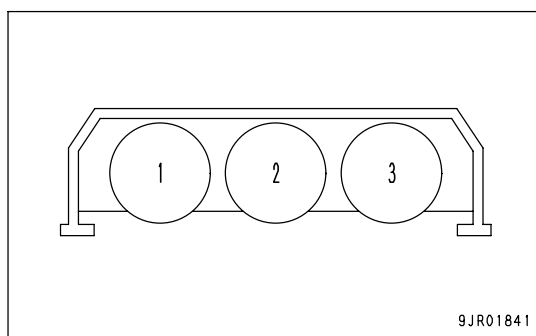

ESTIMATE DISPLAY

- When the load changes in steps for each bucket loaded, the system estimates the total payload if one more bucket is loaded, payload meter estimates the predicted load and display the predicted load by flashing the lamp. When red lamp flashed, next load will carry over loading.
 - The predicted load display and actual payload display are shown at the same time.
- [Example: Case of HD465, expected number of bucket loads: 4]

1st bucket 11 tons
 2nd bucket 11 tons (total: 22 tons)
 3rd bucket 11 tons (total: 33 tons)
 4th bucket 11 tons (total: 44 tons)

When the machine is loaded in this way, the external display lamps light up as shown in the chart below.

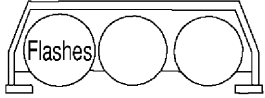
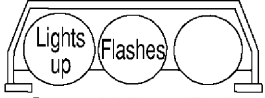
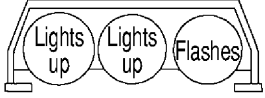
No. of loads	External display lamp	Remarks
1st bucket	 <p>Green Yellow Red</p>	<ul style="list-style-type: none"> • The weight actually loaded is 11 tons, so no lamp lights up. • The predicted load is 22 tons, so no lamp flashes.
2nd bucket	 <p>Green Yellow Red</p>	<ul style="list-style-type: none"> • The weight actually loaded is 22 tons, so no lamp lights up. • The predicted load is 33 tons, so the green lamp flashes.
3rd bucket	 <p>Green Yellow Red</p>	<ul style="list-style-type: none"> • The weight actually loaded is 33 tons, so the green lamp lights up. • The predicted load is 44 tons, so the yellow lamp flashes.
4th bucket	 <p>Green Yellow Red</p>	<ul style="list-style-type: none"> • The weight actually loaded is 44 tons, so the green and yellow lamps light up. • The predicted load is 55 tons, so the red lamp flashes.

DETAILS OF DATA STORED IN MEMORY OF PAYLOAD METER

The payload meter stores the data in this section in non-volatile memory.

This data are retained even when the power is switched OFF, so they can be used later as follows.

- (1) The data can be downloaded to a personal computer through a cable connected to the RS-232C port, and the personal computer can be used to display these data or to print them out using a printer. The data stored in the personal computer can be converted to a form that can be processed using Lotus 1-2-3 or Excel, so these data can be processed freely and used to make forms.
- (2) The data in the non-volatile RAM can be downloaded to a memory card inserted in the payload meter, and the data can be read from this memory card to a personal computer. After reading it to the personal computer, it can be processed in the same way as in Item (1).

REMARK

For details of the procedure for Items (1) and (2), please see the software manual provided with the personal computer.

CYCLE DATA

One cycle is taken as the time from the point where the load is dumped to the point where the next load is dumped, and the data between these two points are recorded.

The cycle data are sent to the memory every time the load is dumped.

The maximum number of cycles that can be stored in memory is 2900 cycles.

Item	Unit	Range	
Engine operation No.	Integer	1 - 65535	These show value, set value when dumping
Month	Month	1 - 12	
Day	Day	1 - 31	
Time Hour	Hour	0 - 23	
Time Min	Minute	0 - 59	
Machine ID	Integer	0 - 200	
Open ID	Integer	0 - 200	
Payload	MT or ST	0 - 6553.5	
Travel time when empty	MIN	0 - 6553.5	
Travel distance when empty	km	0 - 25.5	
Max. travel speed when empty	km/h	0 - 99	
Average travel speed when empty	km/h	0 - 99	
Stopping time when empty	MIN	0 - 6553.5	
Stopping time during loading	MIN	0 - 6553.5	
Travel time when loaded	MIN	0 - 6553.5	
Travel distance when loaded	km	0 - 25.5	
Max. travel speed when loaded	km/h	0 - 99	Shows set value when dumping
Average speed when loaded	km/h	0 - 99	
Stopping time when loaded	MIN	0 - 6553.5	See (*1)
Dumping time	MIN	0 - 25.5	
Speed limit	km/h	0 - 99	
Warning items for each cycle			

Analog spare 1			See (*2)
Max. electric potential	V	0 - 4.0	
Min. electric potential	V	0 - 4.0	
Average electric potential	V	0 - 4.0	
Analog spare 2			
Max. electric potential	V	0 - 4.0	
Min. electric potential	V	0 - 4.0	
Average electric potential	V	0 - 4.0	
Digital spare 1			
Times for Lo	Times	0 - 255	
Digital spare 2			
Times for Lo	Times	0 - 255	

(MT: Metric Ton; ST: Short Ton)

*1: Problems and warnings that occur during the cycle are displayed simply.
For details, see the output examples in the software manual.

*2: The data processing on the personal computer (display, printing, saving, etc.) is independent from the other data in the cycle data, and is handled as spare signal input data.

ENGINE ON/OFF DATA

When the engine is started or stopped, these data are recorded in memory.

The maximum limit for engine ON/OFF data is 115 sets of ON/OFF.

Item	Unit	Range	
Engine operation No.	Integer	1 - 65535	Consecutive numbers for engine operation (*1)
Year (last 2 digits)	Year	0 - 99] Shows when engine was switched ON
Month	Month	1 - 12	
Day	Day	1 - 31	
Time Hour	Hour	0 - 23	
Time Min	Minute	0 - 59	

Year (last 2 digits)	Year	0 - 99] Shows when engine was switched OFF
Month	Month	1 - 12	
Day	Day	1 - 31	
Time Hour	Hour	0 - 23	
Time Min	Minute	0 - 59	

Total payload	MT or ST	0 - 9999000	Total payload from time engine was switched ON to time engine was switched OFF
Overall number of cycles	Times	0 - 9999	

(MT: Metric Ton; ST: Short Ton)

*1: Every time starting switch ON position, the engine operation No. advances by one, and is recorded. The engine operation No. in the cycle data and the engine operation No. in the problem/warning data, which are recorded from the time the engine is switched ON to the time it is switched OFF, are all recorded as an equal value. As a result, when using a personal computer later to compile the data, it is possible to determine what time during the engine operation the cycle data or system problem refers to.

PROBLEM, WARNING DATA

When an problem or warning occurs or is restored in the payload meter system, these data are recorded in memory. The maximum limit for problem/warning data is 230 sets of occur/restore.

Item	Unit	Range	
Error code	-		See section on "PROBLEM AND WARNING DISPLAY (ERROR CODE)(6-77 PAGE)".
Engine operation No. when occurred	Integer	0 - 65535	(*1)
Number of times of occurrence since engine was switched ON	Times	1 - 255	
Year (last 2 digits)	Year	0 - 99] See section on problem/warning display (error code)
Month	Month	1 - 12	
Day	Day	1 - 31	
Time Hour	Hour	0 - 23	
Time Min	Minute	0 - 59	
Engine operation No. when restored	Integer	0 - 65535	
Year (last 2 digits)	Year	0 - 99] Shows when problem restored
Month	Month	1 - 12	
Day	Day	1 - 31	
Time Hour	Hour	0 - 23	
Time Min	Minute	0 - 59	

*1 *2: Every time the engine is switched ON, the engine operation No. advances by one, and is recorded. The engine operation No. in the cycle data and the engine operation No. in the problem/warning data, which are recorded from the time the engine is switched ON to the time it is switched OFF, are all recorded as an equal value. As a result, when using our personal computer later to compile the data, it is possible to determine what time during the engine operation the cycle data or system problem refers to.

When the engine operation No. is 0, it shows that the problem occurred or was restored when only the power was ON (starting switch key turned to ON), and the engine was not started.

TOTAL PAYLOAD, OVERALL NUMBER OF CYCLES DATA

- The total payload and overall number of cycles from any desired time are calculated and are recorded with each act of dumping.
- The calculation of both values is started from the point where the ZERO CLEAR switch is pressed for the total payload and overall number of cycles.
- Both total values can be displayed on the monitor panel by the using the operation given in "FORCED DISPLAY OF TOTAL PAYLOAD AND OVERALL NUMBER OF CYCLES (PAGE 6-57)". (See the same section for details of the method for ZERO CLEAR.)
The total payload is also displayed automatically when dumping.
- The maximum limit that can be recorded for the total payload and overall number of cycles is 999900.0 metric tons or short tons, and 9999 cycles.

Item	Unit	Range	
Total payload	MT or ST	0 - 999900.0] This shows the total value from the zero clear point Data and time shows time of zero clear operation
Overall number of cycles	Times	0 - 9999	
Year (last 2 digits)	Year	0 - 99	
Month	Month	1 - 12	
Day	Day	1 - 31	
Time Hour	Hour	0 - 23	
Time Min	Minute	0 - 59	

(MT: Metric Ton; ST: Short Ton)

OTHER DATA

Content	Item	Unit	Range	
Set data for operator check mode	Machine ID	Integer	0 - 200] Set using switch input operation For details, see section on operator check mode
	Open ID	Integer	0 - 200	
	Speed limit	km/h	0 - 99	
	Option code	Integer	0 - 11	
Calibration data	Year (last 2 digits)	Year	0 - 99] Data and time when calibration was carried out
	Month	Month	1 - 12	
	Day	Day	1 - 31	
	Time Hour	Hour	0 - 23	
	Time Min	Minute	0 - 59	
Data written by user	Data 1	-	20 characters] Comments which can be written freely to the payload meter. However, they can only be input using the cable communications from the personal computer. (See the software manual.)
	Data 2	-	20 characters	
	Data 3	-	20 characters	
	Data 4	-	20 characters	

OPERATION OF SWITCHES

By operating the switches on the payload meter, it is possible to force the following operations.

- "CARRYING OUT CALIBRATION (PAGE 6-56)"
- "FORCED DISPLAY OF TOTAL PAYLOAD AND OVERALL NUMBER OF CYCLES (PAGE 6-57)"
"FORCED DISPLAY OF PROBLEMS, WARNINGS WHEN THEY HAVE OCCURRED (PAGE 6-57)"
- "OPERATOR CHECK MODE (PAGE 6-59)"
 - (a) Memory card dump operation
 - (b) Data all clear operation
 - (c) Display of existing problems/warnings/restore status, status of input signals
 - (d) Machine ID setting
 - (e) Open ID setting
 - (f) Speed limit setting
 - (g) Option code setting
 - (h) Adjusting time, date
- "DIMMING LIGHTS ON MONITOR DISPLAY (PAGE 6-74)"
- "ADJUSTING BUZZER SOUND LEVEL (PAGE 6-74)"
- "SETTING MASS UNIT (SELECTING METRIC TON OR SHORT TON) (PAGE 6-74)"
- "SETTING FORCED PROHIBITION FOR SWITCHES (PAGE 6-74)"
- "SERVICE CHECK MODE (PAGE 6-75)"

CARRYING OUT CALIBRATION

WHEN CARRYING OUT CALIBRATION

Carry out calibration in the following cases.

- When delivering the machine, and once a month after that.
- When the oil and gas pressure for the suspension cylinder has been adjusted. (When the suspension is adjusted.)
- When the chassis has been modified and the mass of the machine when empty has changed more than 100 kilograms.
- When the suspension pressure sensor has been replaced.
- When anything else has been done to suspension related parts.
- When the condition of the machine as judged by the payload meter is different from the actual condition of the dump truck. (See the precautions for "DISPLAY DURING NORMAL OPERATIONS (PAGE 6-45)".)

METHOD OF CARRYING OUT CALIBRATION (METHOD OF OPERATION)

1. Empty the dump body. When doing this, remove all the mud that is stuck to the dump body.
2. Move the gear shift lever to the N position and keep CAL/CLR switch (1) pressed for at least 2 seconds. (The letters CAL flash.)
3. Drive the machine at a speed of 10 km/h (6.2 MPH).
4. When the travel speed reaches 10km/h (6.2 MPH), press CAL/CLR switch (1). In this condition, continue to drive the machine, and if the display changes to the time display after approx. 30 seconds, the procedure is completed.
5. Move the machine to a safe place and stop the engine.
6. Start the engine again.
7. Move the dump lever as follows: FLOAT -> RAISE -> LOWER -> FLOAT.

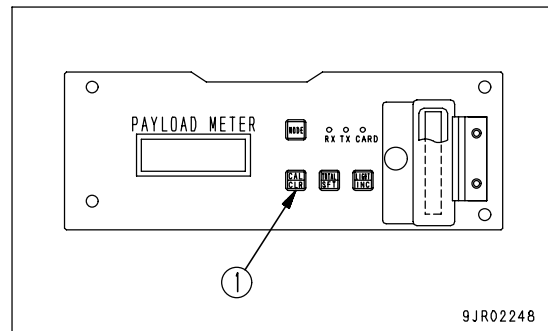

Step 5 to 7 are additional items to perform when installing new parts, but carry out these steps also to ensure accuracy.

- Carry out this operation on flat, level ground.
- Travel in a straight line. (Distance: approx. 100m (328 ft 1 in))
- When traveling, keep the travel speed to a range of 5 to 10 km/h (3.1 to 6.2 MPH).
The calibration date is stored in the memory, and is retained even if the power is switched OFF.
- If you want to stop calibration during the operation, when the letters CAL in Step 2 are flashing, press CAL/CLR switch (1) and the display will change from a flashing CAL to a flashing SCH. Press CAL/CLR switch (1) again and the display will return to the normal display.
During the normal operation display, calibration can be carried out when the dump lever is at the FLOAT position. However, if any errors have occurred on the machine, for some of the errors, it may be impossible to carry out calibration. For details, see "PROBLEM AND WARNING DISPLAY (ERROR CODE) (PAGE 6-77)".

FORCED DISPLAY OF TOTAL PAYLOAD AND OVERALL NUMBER OF CYCLES

FORCED DISPLAY OF PROBLEMS, WARNINGS WHEN THEY HAVE OCCURRED

- The payload meter displays the total payload when the load is dumped, but it is also possible to use the following operation to display the total payload and overall number of cycles.
- For the total payload and overall number of cycles, each time the load is dumped, its weight is added. Furthermore, it is possible to clear this figure and return the total to 0 at any time. However, when this operation is carried out, if any problem or warning has occurred, the error code for that problem or warning is displayed in turn. (During normal operation, only the item with the highest priority is displayed.)

Method for forced display operation

The forced display of the total payload and overall number of cycles, clear, and forced display of the warning codes during occurrence can only be carried out if the dump lever is at the FLOAT position during the normal operation display.

If any new problem or warning should occur during the display, the system will return automatically to the display during normal operation when this happens.

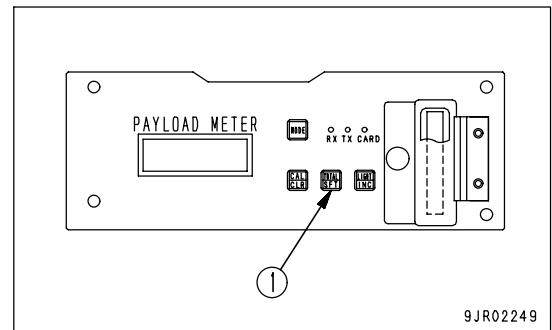

1. Press TOTAL/SFT switch (1).

2. If no problems or warnings are occurring at present

The total payload is displayed (100 t units, rounded to the nearest 100 t) (lights up).

1) Press TOTAL/SFT switch (1) again.

The overall number of cycles is displayed. (Unit: times) (lights up)

2) Press TOTAL/SFT switch (1) again.

":" is displayed (lights up) for 2 seconds, then the display returns to the display for normal operation.

3. If problems or warnings are occurring at present

The error code is displayed. (Flashes)

1) Press TOTAL/SFT switch (1) again.

If any other problem or warning is occurring at present, the next error code is displayed. (Flashes)

2) Press TOTAL/SFT switch (1) again.

If no other problem or warning is occurring at present, ":" is displayed (flashes) for 2 seconds, then the display returns to the normal operation display.

It is possible to clear all the data for total payload and overall number of cycles whenever desired.

After the values are cleared, the total payload and overall number of cycles are calculated again from 0.

REMARK

Before clearing the data, download the necessary data for the total payload and overall number of cycles to a personal computer or save the data to the memory card.

Method of clearing total payload and overall number of cycles

1. Press TOTAL/SFT switch (1) to display the total payload and overall number of cycles.
2. Keep CAL/CLR switch (2) pressed for at least 2 seconds.
The total payload or overall number of cycles display will flash.
3. Keep CAL/CLR switch (2) pressed again for at least 2 seconds.
After "0000" is displayed for 2 seconds, if the display returns to the normal operation display, the zero clear operation is completed.

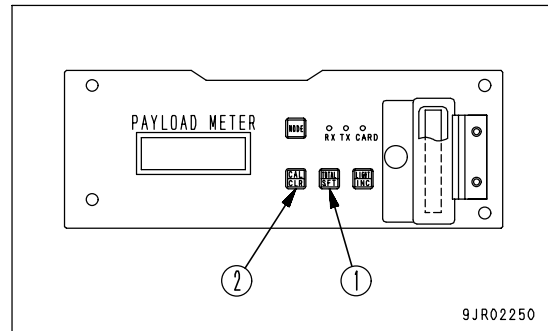
**REMARK**

- The zero clear operation for the total load and overall number of cycles is carried out at the same time. It is impossible to carry out the zero clear operation individually for only one of these items.
- The maximum limit for the total payload and overall number of cycles is as follows.
Total payload: 999900.0 t
Overall number of cycles: 9999 times
- If either the total payload or overall number of cycles goes above the set value, error code [H: FUL] is displayed.
- Carry out the zero clear operation for the total payload and overall number of cycles before error code [H:FUL] is displayed.
- If either the total payload or overall number of cycles exceeds the maximum limit, both values will be automatically cleared.
- Once error code [H:FUL] is displayed, it is impossible to forcibly clear the data or cancel the display until the value exceeds the limit and the data are automatically cleared.

OPERATOR CHECK MODE

By using the operator check mode, it is possible to forcibly display, set, or correct the following.

(a) Memory card dump

The data stored in the payload meter is written en bloc to the memory card installed in the payload meter.

REMARK

This function only works when switch "5" (memory card switch) on the left side face of the controller is set to "used."

(b) Data all clear

This forcibly erases all the cycle data, engine ON/OFF data, and problem and warning data.

The data for total payload and overall number of cycles are not cleared. For details, see "Method of clearing total payload and overall number of cycles (PAGE 6-58)".

REMARK

Before clearing the data, download the necessary data to a personal computer or carry out (a) Memory card dump.

(c) Display of existing problems/warnings/restore status, status of input signals

This distinguishes between problems and warnings that are now occurring and problems and warnings that have occurred in the past and have been restored to normal, and automatically displays the error code.

It also partially displays the condition of the signals from the sensors that are input to the payload meter.

(d) Machine ID setting

This is used when inputting, correcting, or setting the dump truck ID.

Available range for setting: 0 - 200

REMARK

There is no particular effect on the function of the payload meter if this is not set, but when using cable communications with the personal computer, communications cannot be carried out if the machine ID is not the same as the machine ID set in the personal computer.

(e) Open ID setting

This is used when inputting, correcting, or setting the desired ID.

Available range for setting: 0 - 200

There is no particular effect on the function of the payload meter if this is not set.

[Example of use of open ID]

Number to indicate location of work face

Operator ID number

(f) Speed limit setting

If there is a speed limit on the road that the dump truck uses, it is possible to display a warning on the payload meter if the dump truck exceeds that speed. This function is used when inputting, correcting, or setting the speed limit.

Available range for setting: 10 - 99 [km/h]

If the speed limit warning is not needed, set it to 99.

(g) Option code setting

This is used when inputting, correcting, or setting the options to give the desired baud rate for the cable communications function (RS-232C), ON/OFF for the PMC and TALKS (if equipped), and ON/OFF for the automatic transmission function. The code can be set as shown in the table below.

Option code	Communications baud rate (bit/sec)	Automatic transmission function	Option setting		
			TALKS setting	PMC setting	Data transmission type when completing dumping (when PMC is set)
0	9600	NO	NO	NO	-
1	9600	YES	NO	NO	-
2	1200	NO	NO	NO	-
3	1200	YES	NO	NO	-
4	9600	NO	YES	NO	-
5	9600	YES	YES	NO	-
6	1200	NO	YES	NO	-
7	1200	YES	YES	NO	-
8	9600	NO	YES	YES	Z1
9	9600	NO	YES	YES	Z2
10	9600	NO	NO	YES	Z1
11	9600	NO	NO	YES	Z2

When sending (downloading) the data stored in the payload meter to the personal computer using a communications cable, always set the option code to 0 or 2 before starting. (When PMC or TALKS are installed, set the option code to a number between 4 and 11.)

We recommend that you normally set the option code to 0.

(h) Adjusting time, date

Use this to set the time and date on the payload meter.

Of the functions in the operator check mode, the following can also be set from the personal computer using the personal computer download software supplied by Komatsu.

- Machine ID setting
- Open ID setting
- Speed limit setting
- Option code setting

Note that the option codes can only be changed from 0 to 2, from 4 to 6, or from 6 to 4.

- Adjusting time, date

For details, see the software manual.

METHOD OF OPERATION

The operator check mode is actuated when the dump lever is at the FLOAT position and the shift lever is at the N position during display for normal operations. However, it does not work during the period from the start of the loading operation to completion of the loading operation.

To operate the operator check mode, set the shift lever to the N position and the dump lever to the FLOAT position. If the levers are operated to any other position, the payload meter will return to the normal operation display, but the content set and input in the operator check mode may not be properly processed.

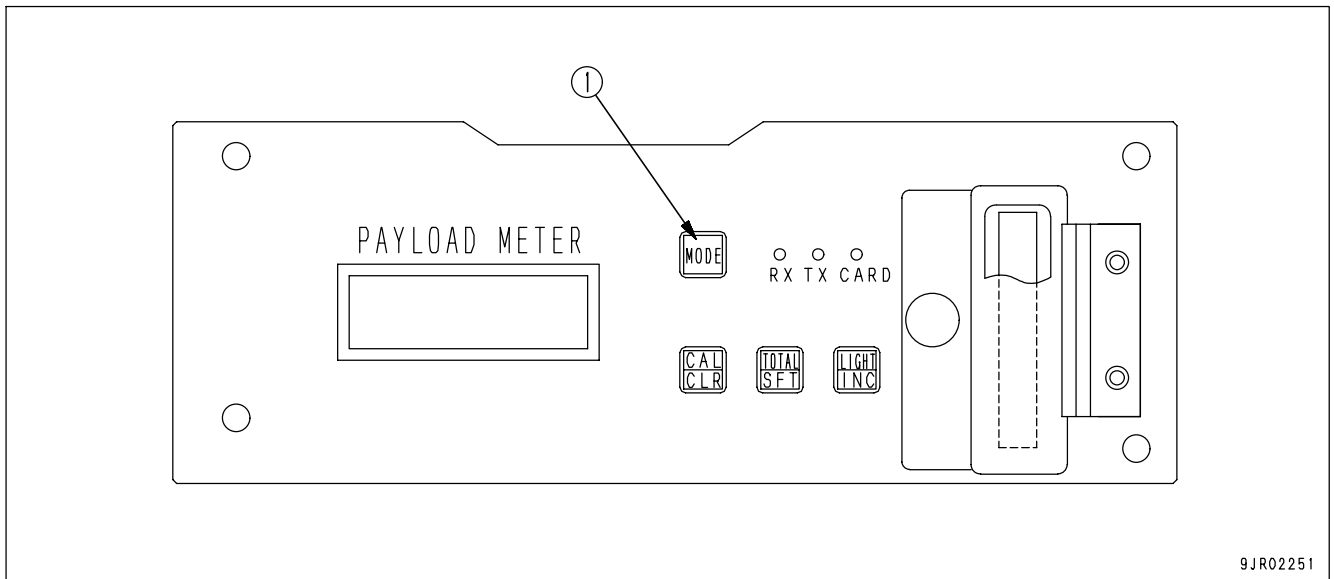

In the operator check mode, press MODE switch (1) to change the item. When the MODE switch (1) is pressed at the final item (time, date), it will return to the normal operation display.

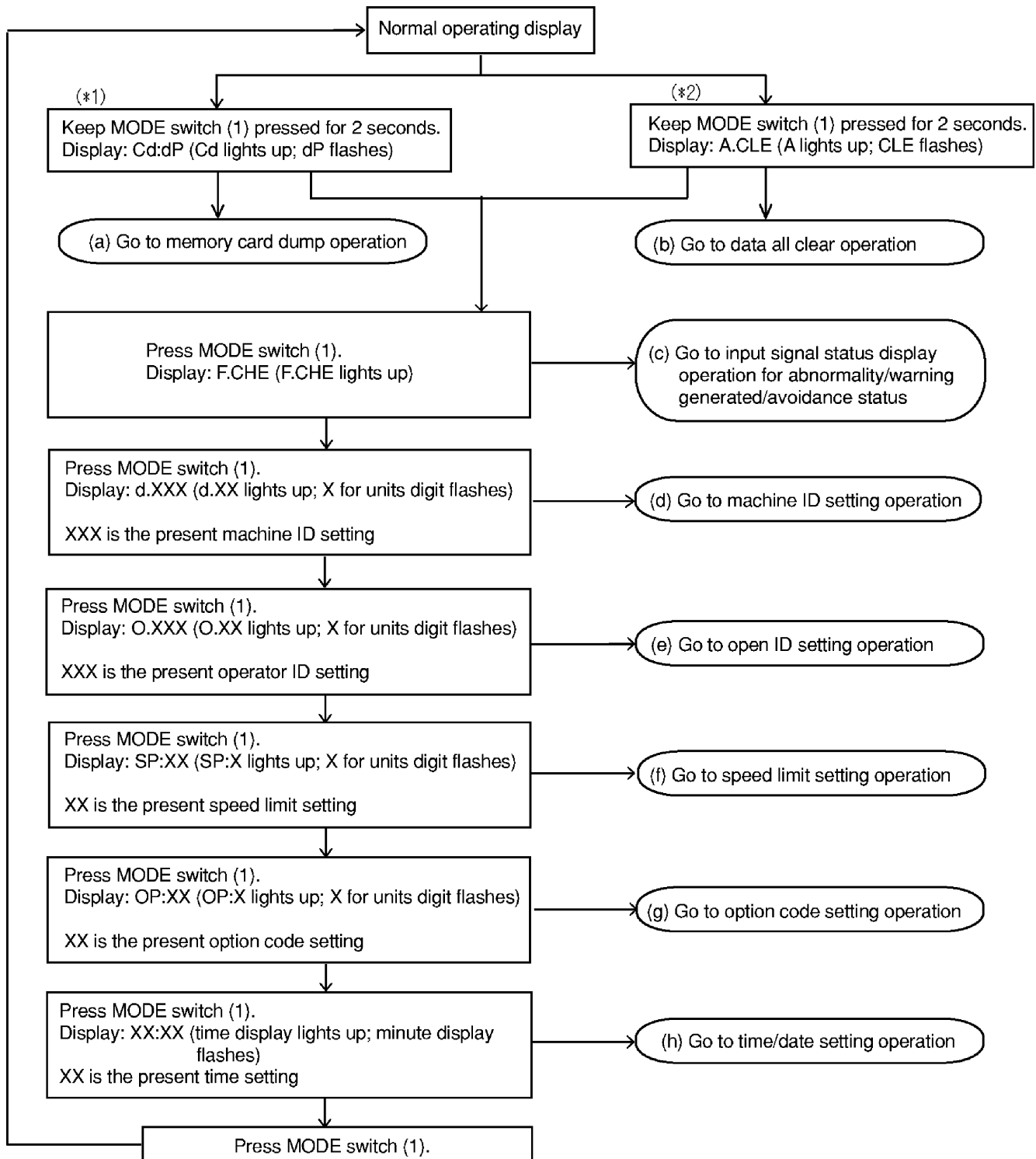

*1: This is actuated only when switch No. 5 (memory card switch) on the left side face of the controller is set to "used".

*2: This is actuated only when switch No. 5 (memory card switch) on the left side face of the controller is set to "not used".

(a) Memory card dump operation

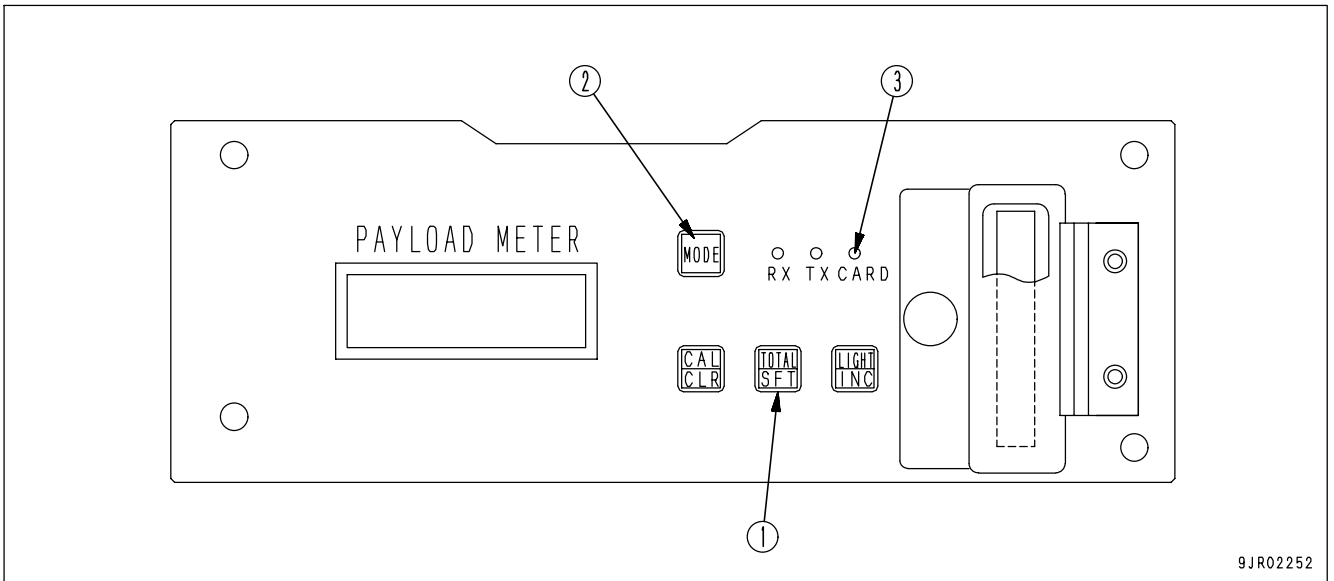

1. When the display is Cd:dP (Cd lights up, dP flashes), press TOTAL/SFT switch (1). The lighted up Cd display will change and start flashing.

REMARK

If you wish to stop the memory card dump operation when the display is Cd:dP (both Cd and dP are flashing), press MODE switch (2). The memory card dump operation is not carried out, and the display returns to the normal operation display.

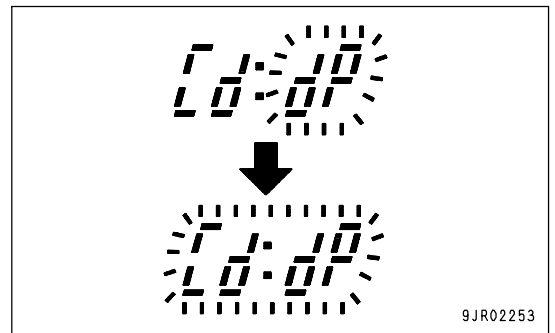

2. Press TOTAL/SFT switch (1) again.
The panel display goes out and memory card access lamp (3) lights up.
When the memory card dump operation is completed, it automatically returns to the normal operation display.

The memory card dump function works only when switch No. 5 (memory card switch) on the left side face of the controller is set to "used".

(b) Data all clear operation

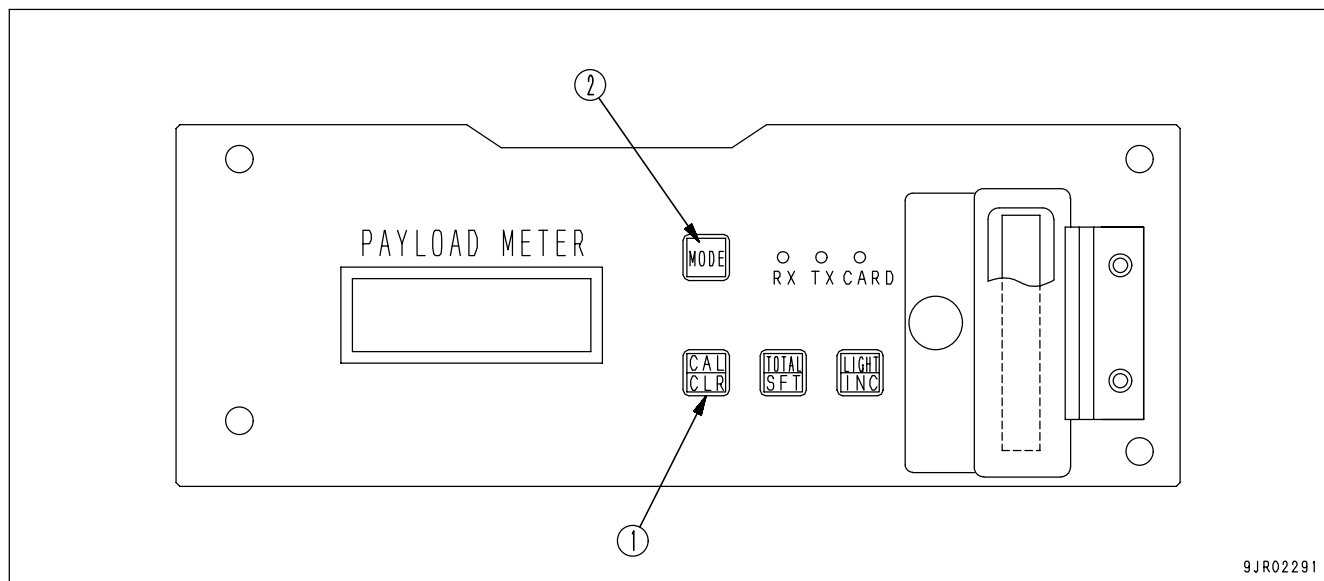

1. When the display is A.CLE (A lights up, CLE flashes), keep CAL/CLR switch (1) pressed for at least 2 seconds. The lighted up A display will change and start flashing.

REMARK

If you wish to stop the data all clear operation when the display is A.CLE (both A and CLE are flashing), press MODE switch (2). The data all clear operation is not carried out, and the display returns to the normal operation display.

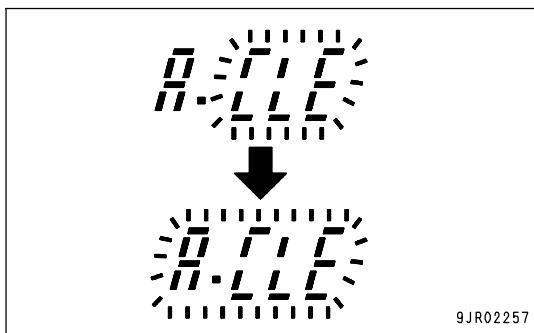

2. Keep CAL/CLR switch (1) pressed again for at least 2 seconds.

A.CLE lights up, and when the data clear operation is completed, the display automatically returns to the normal operation display.

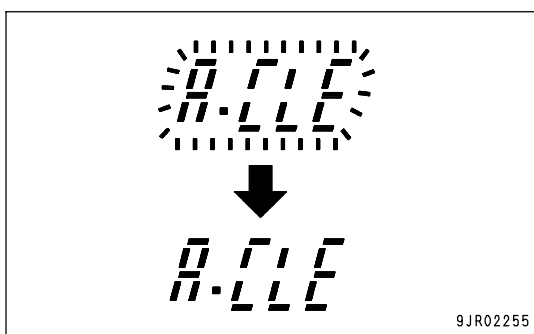

REMARK

Before clearing the data, download the necessary data to a personal computer or carry out (a) Memory card dump operation.

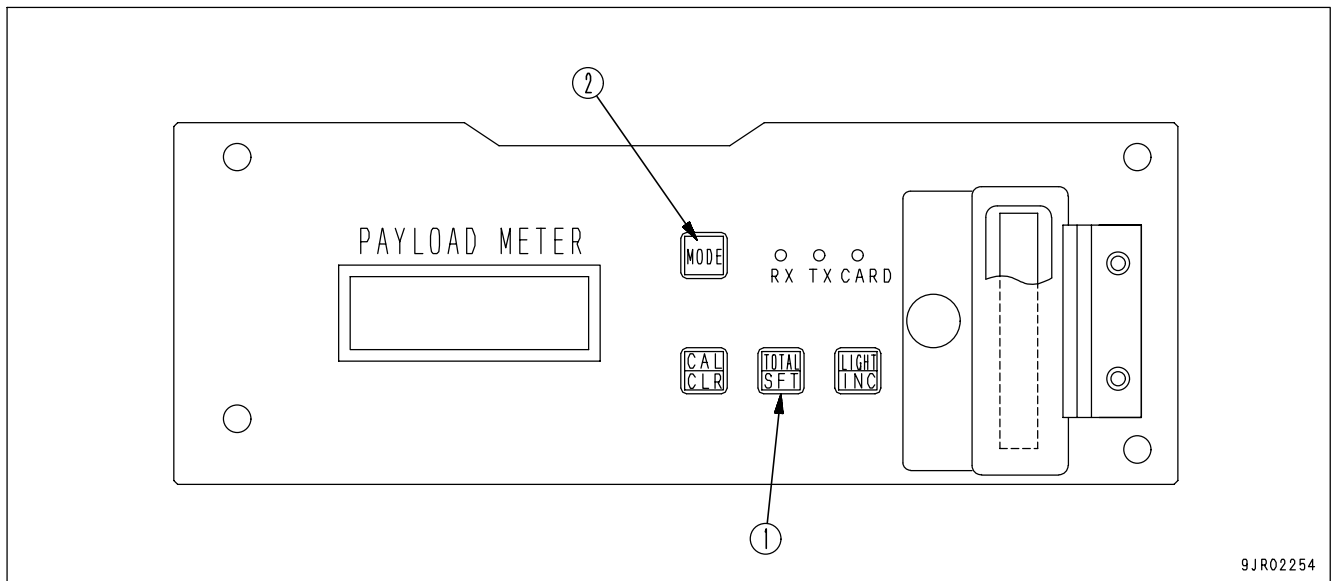
(c) Display of existing problems/warnings/restore status, status of input signals

1. When the display is F.CHE (flashing), press TOTAL/SFT switch (1). The existing problems or warnings will be shown as follows.
 - 1) If there are no existing problems or warnings, F.--- (flashing for 6 sec.) is displayed.
 - 2) If there are any existing problems or warnings, The error codes are displayed in turn. (The error codes flash for 6 sec. each.)

2. The system will then automatically proceed to the following display for problems and warnings that have occurred in the past.
 - 1) If no problems or warnings have occurred in the past (there is no record of occurrence or restoration in the payload meter), F.--- (flashing for 3 sec.) is displayed.
 - 2) If any problems or warnings have occurred in the past, but the condition has now been restored, The error codes are displayed in turn. (The error codes flash for 3 sec. each.) After all the error codes for problems that occurred in the past have been displayed, F.--- (lights up for 3 sec.) is displayed.

3. The system will then automatically proceed to the following display for sensor signals input to the payload meter.
 - 1) Condition of signal for gearshift lever position
 Display: C1:XX (lights up for 3 sec.)
 "N": C1:oo
 Other than "N" : C1:--
 - 2) Condition of signal for dump lever position
 Display: C2:XX (lights up for 3 sec.)
 FLOAT: C2:oo
 Other than FLOAT: C2:--
 - 3) Condition of signal for engine oil pressure
 Display: C3:XX (lights up for 3 sec.)
 Engine running: C3:oo
 Engine stopped: C3:--

- 4) Condition of signal for battery charge
Display: C4:XX (lights up for 3 sec.)
Engine running: C4:oo
Engine stopped: C4:--
 - 5) Condition of signal for analog spare input 1
Display: C5:XX (lights up for 3 seconds)
XX: Input signal (V)
 - 6) Condition of signal for analog spare input 2
Display: C6:XX (lights up for 3 seconds)
XX: Input signal (V)
 - 7) Condition of signal for digital spare input 1
Display: C7:XX (lights up for 3 sec.)
Hi: C7:oo
Lo: C7:--
 - 8) Condition of signal for digital spare input 2
Display: C8:XX (lights up for 3 sec.)
Hi: C8:oo
Lo: C8:--
4. With the display for Step 3.8), press TOTAL/SFT switch (1) and return again to Step 1.1) or Step 1.2).
5. If MODE switch (2) is pressed at any time from the display following Step 1.1) or Step 1.2) up to Step 3.8), the display will return to the normal operation display.

(d) Machine ID setting

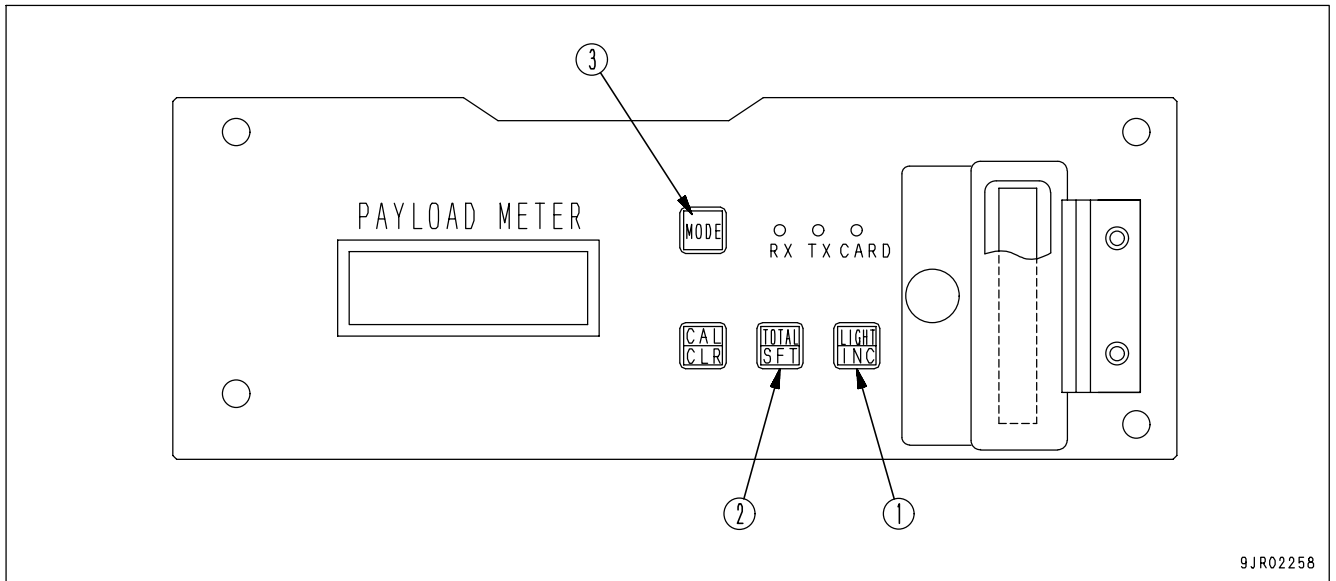

1. With the display at d.XXX (d.XX lights up, digit for units flashes), if it is necessary to correct the digit for the units, press LIGHT/INC switch (1) and correct the number.

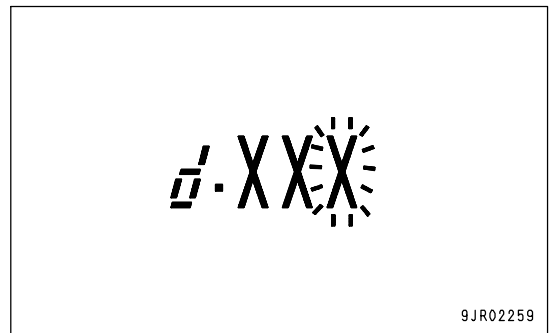

2. Press TOTAL/SFT switch (2).
The flashing digit in d.XXX moves one place to the left and it is possible to correct the digit for the tens.
If it is necessary to correct the digit for the tens, press LIGHT/INC switch (1) and correct the number.

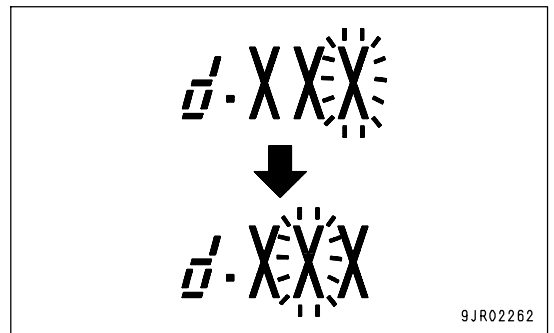

3. Press TOTAL/SFT switch (2).
The flashing digit in d.XXX moves one place to the left and it is possible to correct the digit for the hundreds.
If it is necessary to correct the digit for the hundreds, press LIGHT/INC switch (1) and correct the number.

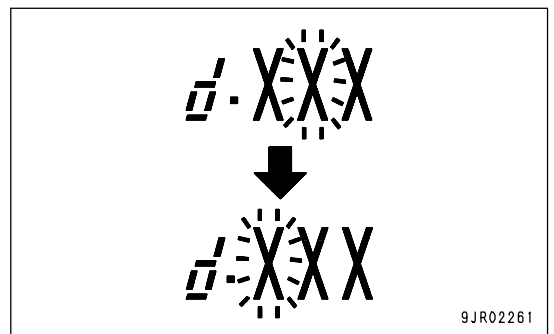

4. If TOTAL/SFT switch (2) is pressed again, the flashing digit will return to the digit for the units and it becomes possible to correct the units again.

5. After completing the correction of the Machine ID, press MODE switch (3). The display will return to the normal operation display.

If the number that has been input is not permitted, when MODE switch (3) is pressed, the display will return to Step 1.

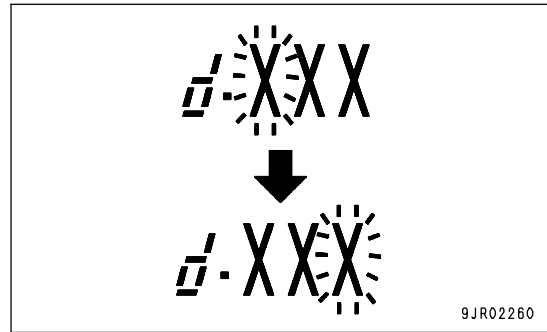

(e) Open ID setting

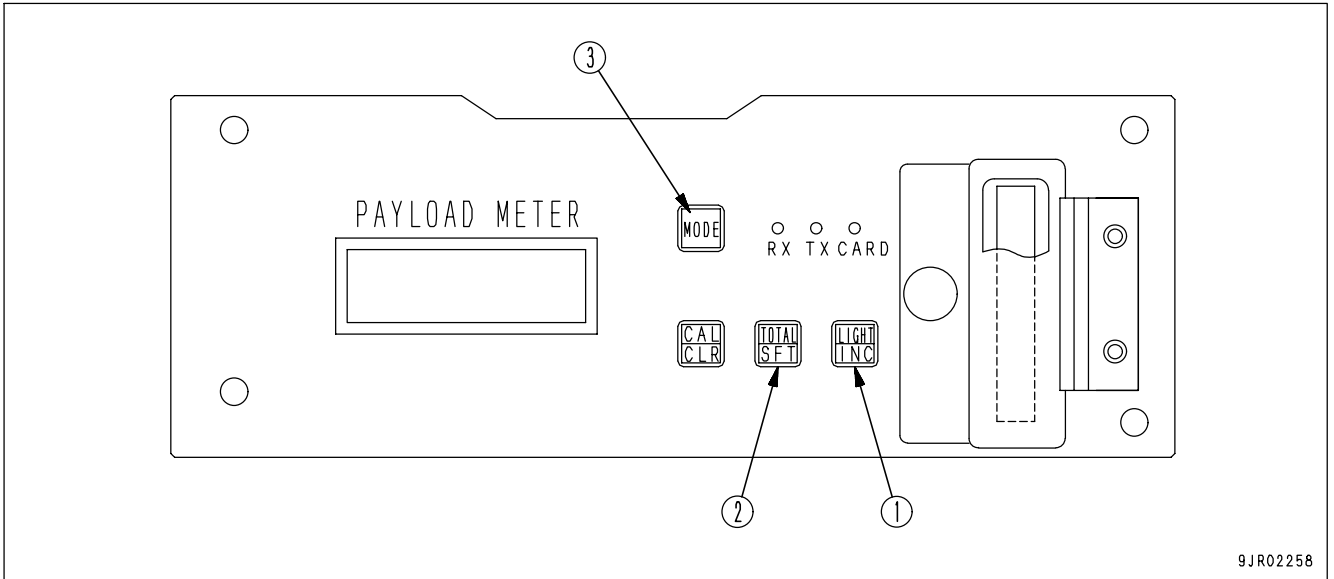

9JR02258

- 1. With the display at O.XXX (O.XX lights up, digit for units flashes), if it is necessary to correct the digit for the units, press LIGHT/INC switch (1) and correct the number.

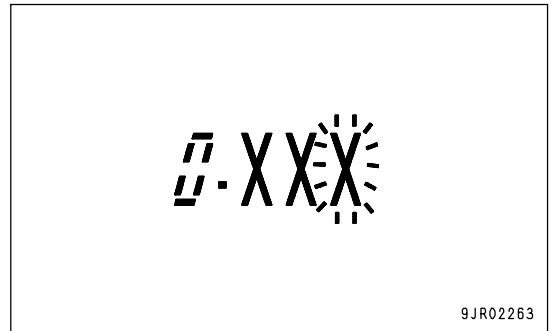

9JR02263

- 2. Press TOTAL/SFT switch (2).
The flashing digit in O.XXX moves one place to the left and it is possible to correct the digit for the tens.
If it is necessary to correct the digit for the tens, press LIGHT/INC switch (1) and correct the number.

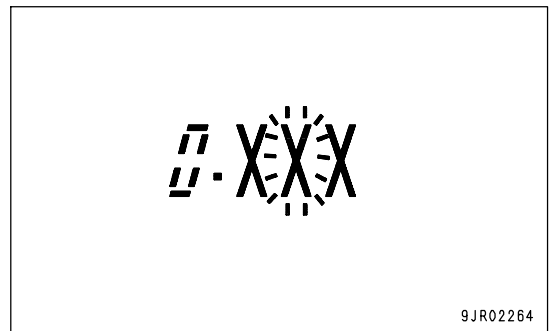

9JR02264

- 3. Press TOTAL/SFT switch (2).
The flashing digit in O.XXX moves one place to the left and it is possible to correct the digit for the hundreds.
If it is necessary to correct the digit for the hundreds, press LIGHT/INC switch (1) and correct the number.

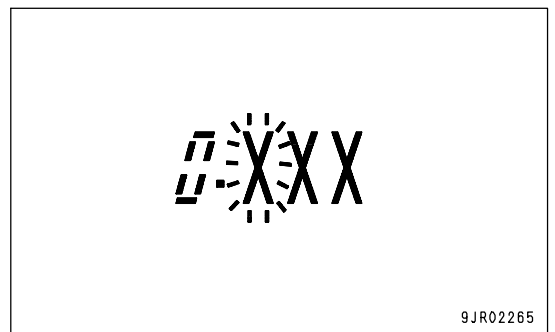

9JR02265

4. If TOTAL/SFT switch (2) is pressed again, the flashing digit will return to the digit for the units and it becomes possible to correct the units again.
5. After completing the correction of the Open ID, press MODE switch (3). The display will return to the normal operation display.
If the number that has been input is not permitted, when MODE switch (3) is pressed, the display will return to Step 1.

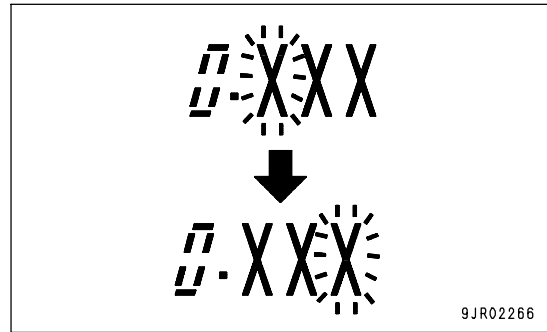

(f) Speed limit setting

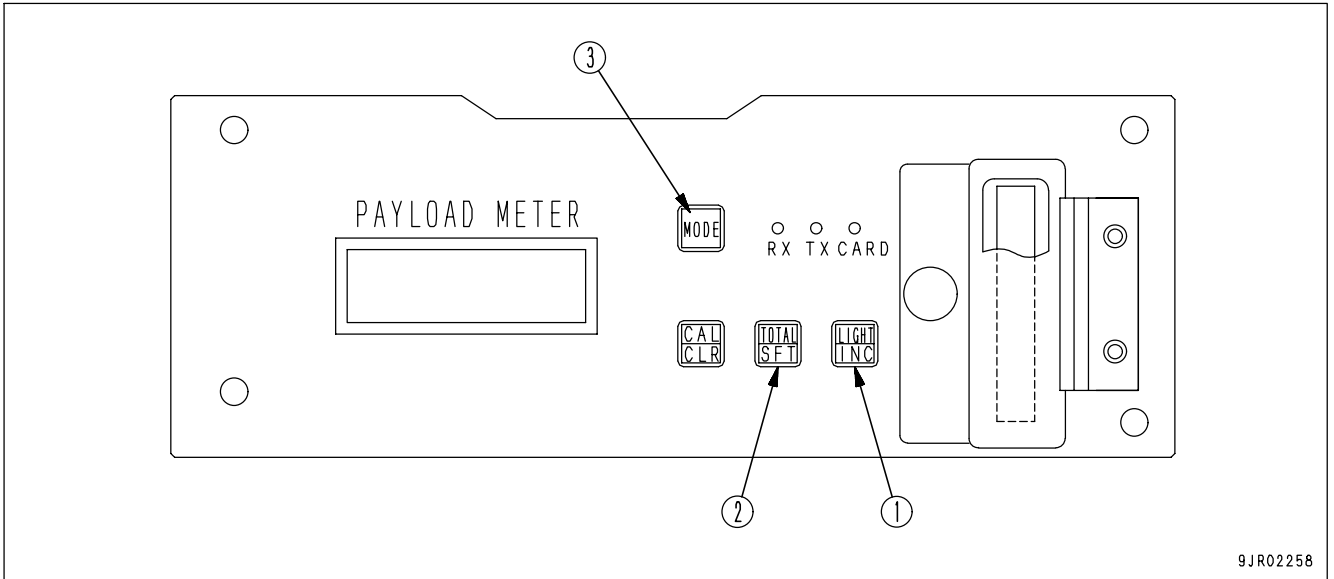

1. With the display at SP.XX (SP.X lights up, digit for units flashes), if it is necessary to correct the digit for the units, press LIGHT/INC switch (1) and correct the number.

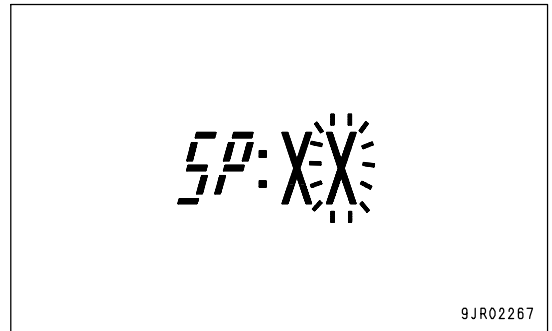

2. Press TOTAL/SFT switch (2).
The flashing digit in SP.XX moves one place to the left and it is possible to correct the digit for the tens.
If it is necessary to correct the digit for the tens, press LIGHT/INC switch (1) and correct the number.

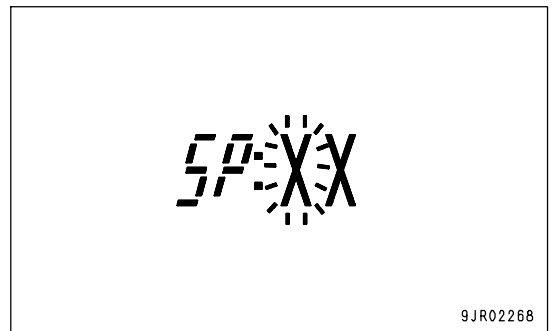

3. If TOTAL/SFT switch (2) is pressed again, the flashing digit will return to the digit for the units and it becomes possible to correct the units again.

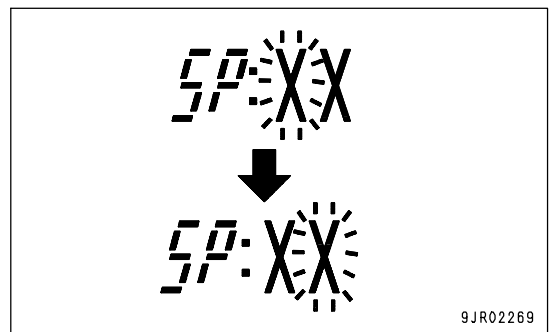

4. After completing the correction of the Speed Limit, press MODE switch (3). The display will return to the normal operation display.
If the number that has been input is not permitted, when MODE switch (3) is pressed, the display will return to Step 1.

(g) Option code setting

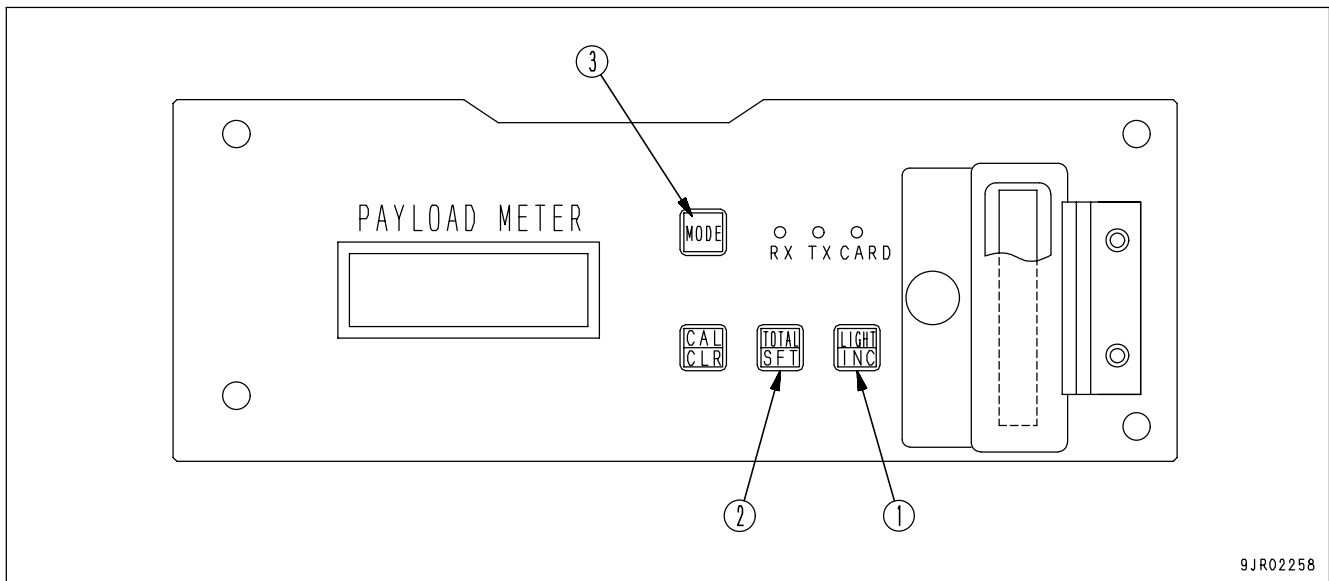

1. With the display at OP.XX (OP.X lights up, digit for units flashes), if it is necessary to correct the digit for the units, press LIGHT/INC switch (1) and correct the number.

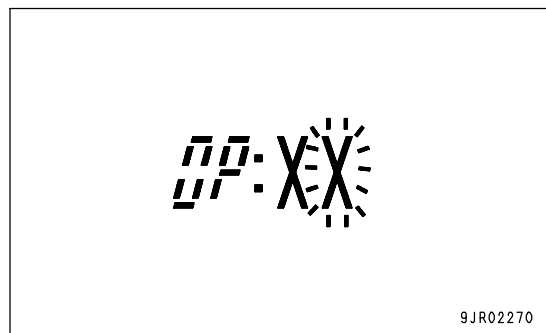

2. Press TOTAL/SFT switch (2).
The flashing digit in OP.XX moves one place to the left and it is possible to correct the digit for the tens.
If it is necessary to correct the digit for the tens, press LIGHT/INC switch (1) and correct the number.

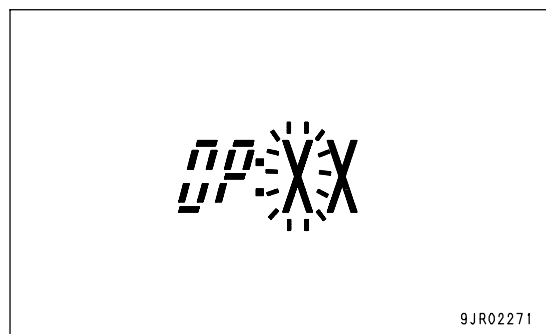

3. If TOTAL/SFT switch (2) is pressed again, the flashing digits will return to the digit for the units and it becomes possible to correct the units again.

4. After completing the correction of the Option Code, press MODE switch (3). The display will return to the normal operation display.
If the number that has been input is not permitted, when MODE switch (3) is pressed, the display will return to Step 1.

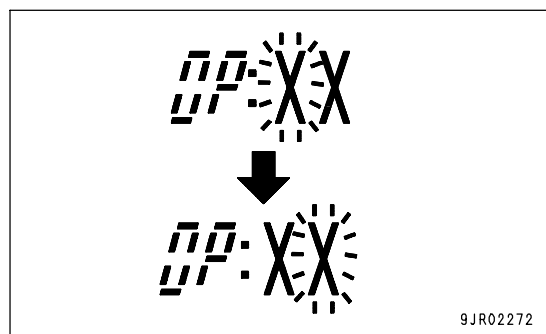

(h) Adjusting time, date

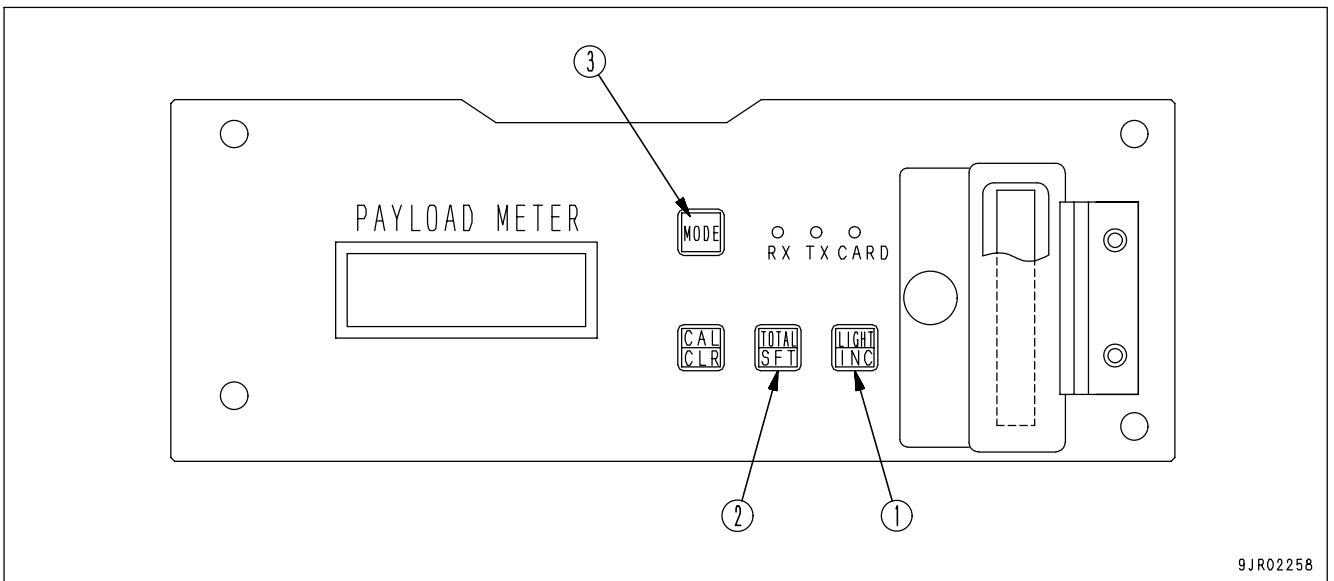

9JR02258

1. With the display at XX.XX (Time display lights up, Minute display flashes), if it is necessary to correct the minute display, press LIGHT/INC switch (1) and correct the number. Each time LIGHT/INC switch (1) is pressed, the number increases by "1".

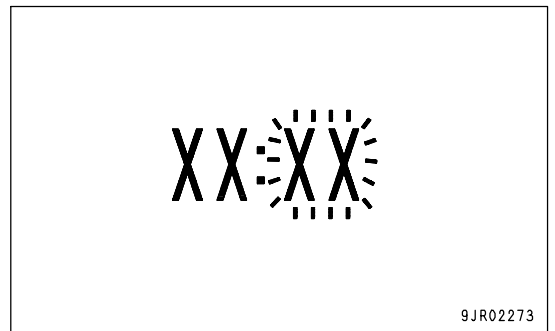

9JR02273

2. Press TOTAL/SFT switch (2). The flashing location moves from the minute display to the hour display and it is possible to correct the hour display. If it is necessary to correct the hour display, press LIGHT/INC switch (1) and correct the number. Display the time as a 24-hour clock.

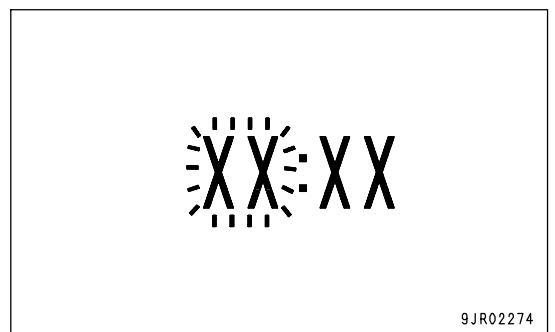

9JR02274

3. Each time TOTAL/SFT switch (2) is pressed, the flashing location will change Day, Month, Year. If it is necessary to correct, press LIGHT/INC switch (1) and correct the number.

4. When the year display is flashing, if TOTAL/SFT switch (2) is pressed again, the flashing location will return to the minute display and it becomes possible to correct the minute display again.

5. After completing the correction of the time and date, press MODE switch (3). The display will return to the normal operation display.

DIMMING LIGHTS ON MONITOR DISPLAY

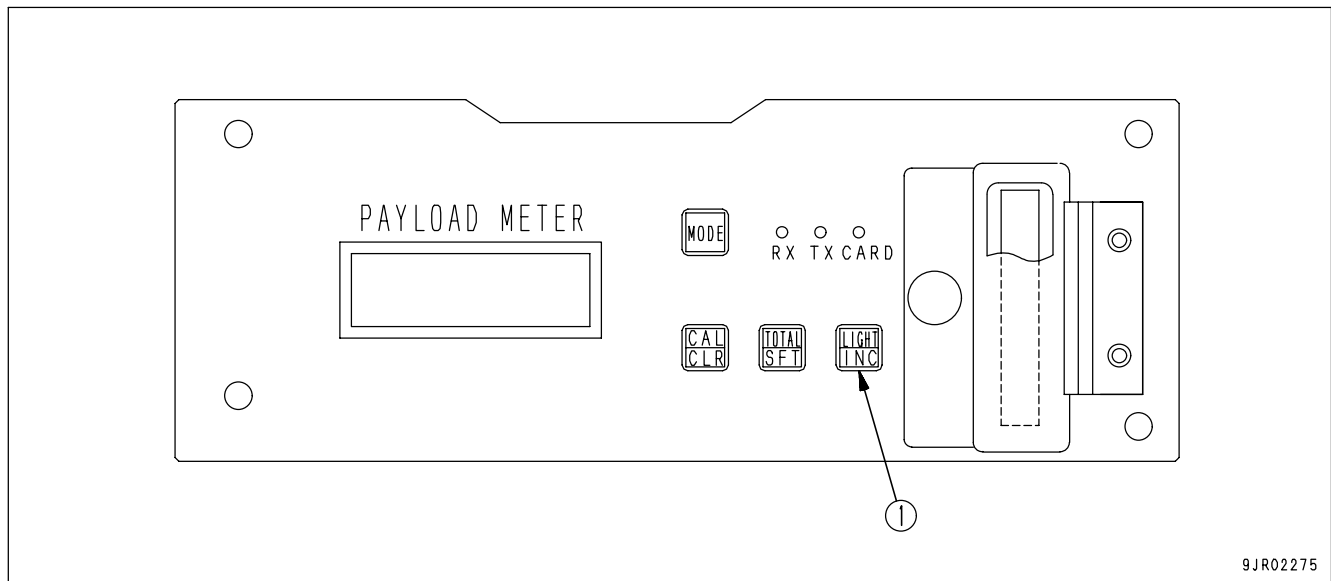

If you want to change the brightness of the monitor display, do as follows.

Press LIGHT/INC switch (1). Each time the switches pressed, the lighting will become one level darker; and if the switches pressed when that the lighting is darkest, it will return to the brightest level.

The brightness can be changed in ten stages.

If the switch is kept pressed, the brightness will change continuously.

ADJUSTING BUZZER SOUND LEVEL

For details, see "LEFT FACE OF CONTROLLER (PAGE 6-40)".

The switches on the left side are set when the machine is shipped from the factory.

Do not touch any switch except No.7 and No.B.

If you wish to adjust any switch except No.7 and No.B to compensate the payload calculation value or speed or distance calculation value, please contact your Komatsu distributor.

SETTING MASS UNIT (SELECTING METRIC TON OR SHORT TON)

For details, see "LEFT FACE OF CONTROLLER (PAGE 6-40)".

The payload display unit changes from the point where the setting for the mass unit is changed.

The values stored in the payload meter memory will also have the unit changed for any data put into memory from the time the setting is changed.

Is not possible to convert units or data already stored in payload meter memory, so before switching the units, we recommend that you download all the data to the personal computer or carry out the memory card dump.

The switches on the left side are set when the machine is shipped from the factory.

Do not touch any switch except No.7 and No.B.

If you wish to adjust any switch except No.7 and No.B to compensate the payload calculation value or speed or distance calculation value, please contact your Komatsu distributor.

SETTING FORCED PROHIBITION FOR SWITCHES

For details, see "LEFT FACE OF CONTROLLER (PAGE 6-40)".

In addition, when setting forced prohibition for the switches, please ask your Komatsu distributor.

SERVICE CHECK MODE

By operating the service check mode, it is possible to carry out display, setting, and correction forcibly of the following items.

If it is designed to correct the method of operation and setting, please ask your Komatsu distributor.

(a) Detailed display of calibration data

This display shows the data, suspension pressure, etc. for the latest calibration.

(b) Detailed display of payload calculation data (analog data)

The display shows the suspension pressure and machine angle when calculating the present payload.

(c) Memory card dump (service area)

This writes all the data displayed for (a) and (b) to the memory card installed in the body.

(d) Data all clear (service area)

This forcibly deletes (a) calibration data and (b) analog data, except for the latest calibration data.

(e) Input signal status display

This displays some of the signal status for the sensors input to the payload meter and the present recognition status display of the payload meter.

(f) Forced initialization

This forcibly deletes all the data in the payload meter.

(g) Extra payload setting when loading

The extra load for the payload can be forcibly input, corrected, or set when loading.

(h) Payload fixed display and cycle data recording, payload value setting

1. The payload fixed display

1) When TALKS is not set: Time that machine is stopped after traveling 160 m with at least 50% of set payload loaded until starting to dump

2) When TALKS is set: Time that machine is stopped from permission to move off until starting to dump

When displaying the payload in 1) or 2), it is possible to input, correct, or set the displayed payload and completion of loading (when traveling 160 m with at least 50% of the set payload loaded or when starting to dump), not the real-time payload.

2. Cycle data recording, switching payload value

If the payload fixed display in Item 1 above is applicable, this inputs, corrects, or sets the payload in the cycle data to the fixed display payload value.

(i) Setting loading completion recognition travel distance

This inputs, corrects, or sets the travel distance recognized as completion of loading by the payload meter.

(j) Setting loading start recognition payload

This inputs, corrects, or sets the payload recognized as the start of loading by the payload meter.

(k) Setting 0 ton display range

This inputs, corrects, or sets the range for the zero display on the payload display.

(l) Setting external display lamp display range

This inputs, corrects, or sets the payload range for the lamps to light up when displaying the payload.

Of the functions in the service check mode, the following can also be set from the personal computer using the personal computer download software supplied by Komatsu.

- Calibration data
- Payload calculation data (analog data)

PROBLEM AND WARNING DISPLAY (ERROR CODE)

The payload meter always carries out self-diagnosis of the system, and if any problem or warning occurs, it is displayed by the monitor panel and the external display lamps.

For details of the detection items and content of the display, see the problem/warning item chart

- If any problem or warning occurs, if it is within the timing possible for display, it is displayed on the monitor panel and the buzzer sounds for 3 seconds.
- If a problem or warning is currently being displayed, and another problem which has low priority for display occurs, if the timing possible for display overlaps, the newly occurring problem will be displayed and the buzzer will sound for 3 seconds.

Following this, the problems and warnings will be displayed according to the timing possible for display. If the timing possible for display overlaps, the problem with the higher display priority in the chart is displayed.

Priority of display	Content	Judgment standard	Content of error code display			Timing possible for display	Recording of problem and warning data (display code for personal computer software)	Remarks															
			Panel display	External display lamps	Display canceled																		
1	Dump lever not at FLOAT (except when dumping)	-	b-FL lights up	All flash	When problem is removed	Gear shift lever at N	-	-															
			b-FL lights up	-	When problem is removed				Gear shift lever at position other than N	-	-												
			Cd flashes	-	When problem is removed							Removal detection only for card dump	-	Detected only when card dump operation is run									
3	Drop in backup battery voltage	Defective contact or voltage below 2.7V	F-09 flashes	-	When problem is removed	Except when loading	Record (000-009)	Rated voltage:3.6V															
			See (*1)	-	See (*1)				Except when loading	Record (000-011)													
											-	-	-	-									
															-	-	-	-					
4	Cycle data memory FULL Engine ON/OFF data memory FULL Problem, warning data memory FULL Total payload, overall number of cycles data memory FULL	See (*1)	See (*1)	-	See (*1)	-	-																
								5	Disconnection at R terminal	Output with the engine running is less than 2V	F-18 flashes	All flash	When problem is removed	When engine is running	Record (000-018)								
																6	Problem in sensor power source (18V)	Output below 15V and power source voltage over 20V	F-20 flashes	All flash	When problem is removed	When normal	Record (000-020)

Priority of display	Content	Judgment standard	Content of error code display			Timing possible for display	Recording of problem and warning data (display code for personal computer software)	Remarks
			Panel display	External display lamps	Display canceled			
7	Short circuit or disconnection in front left suspension sensor system	Suspension pressure sensor input signal 0 kg/cm ² or below	F-21 flashes	All flash	When problem is removed	Record (000-021)	Calibration cannot be carried out when problem has occurred	
			F-22 flashes					
			F-23 flashes					
			F-24 flashes					
8	Short circuit or disconnection in front right suspension sensor system	Suspension pressure sensor input signal 200 kg/cm ² or above	F-25 flashes	All flash	When problem is removed	Record (000-025)	Calibration cannot be carried out when problem has occurred	
			F-26 flashes					
			F-27 flashes					
			F-28 flashes					
9	Short circuit or disconnection in rear left suspension sensor system	Suspension pressure sensor input signal 200 kg/cm ² or above	F-31 flashes	All flash	When problem is removed	Record (000-031)	Applicable only when clinometer switch is set to "used"	
			F-32 flashes					
10	Short circuit or disconnection in rear right suspension sensor system	Recorded data for calibration corrupted	F.CAL flashes	All flash	When problem is removed	Record (000-019)	Calculation of payload is stopped when problem has occurred	
11	Short circuit or disconnection in front left suspension sensor system							
12	Short circuit or disconnection in front right suspension sensor system							
13	Short circuit or disconnection in rear left suspension sensor system							
14	Short circuit or disconnection in rear right suspension sensor system							
15	Short circuit or disconnection in clinometer system							
16	Short circuit or disconnection in clinometer system							
17	Calibration not carried out or problem in RAM							

Priority of display	Content	Judgment standard	Content of error code display			Timing possible for display	Recording of problem and warning data (display code for personal computer software)	Remarks		
			Panel display	External display lamps	Display canceled					
18	Short circuit in No. 1 relay for external display lamps	When coil continuity is ON, relay coil is short circuited with power source	F-41 flashes	See Remarks column	When problem is removed	Except when loading (see Remarks column for details of external display lamps)	Record (000-041)	External lamps are actuated as follows		
19	Short circuit in No. 2 relay for external display lamps		F-42 flashes						Applicable lamps Machine stopped: Always ON When traveling: OFF	
20	Short circuit in No. 3 relay for external display lamps		F-43 flashes							
21	Short circuit in No. 4 relay for external display lamps		F-44 flashes							Other lamps When loading: Standard actuation When not loading Machine stopped: Flash When traveling: OFF
22	Short circuit in No. 5 relay for external display lamps		F-45 flashes							
23	Defective payload for cycle data (*2)		L bad flashes							
24	Exceeding speed limit	SP: SP flashes	-							
25	Defective communications or defective setting of option code	Travel speed exceeds set speed limit	F-71 flashes	-	When problem is removed	-	Record (000-071)	-		
			F-73 flashes						(000-073)	
			F-80 flashes						(000-080)	
			F-81 flashes						(000-081)	
			F-91 flashes						(000-091)	
			F-92 flashes						(000-092)	
			F-93 flashes						(000-093)	
			F-94 flashes						(000-094)	
			F-95 flashes						(000-095)	
			F-96 flashes						(000-096)	
F-97 flashes	(000-097)									
F-98 flashes	(000-098)									
F-99 flashes	(000-099)									

***1: Warning display when memory is full**

1. Cycle data

- 1) If more than 2600 cycles are recorded (less than 300 cycles remaining):

L: FUL flashes 7 times

: flashes 1 time

This is repeated.

- 2) If more than 2900 cycles are recorded (0 cycles remaining):

L: FUL lights up (3 sec.)

: flashes 1 time

This is repeated.

- 3) If more cycles are recorded, cycles 2901 and 2902 are recorded, but each time, the oldest cycle data is deleted in turn to make space to record the new cycle.

(The display stays the same as in condition 2.)

2. Engine ON/OFF data

- 1) If more than 105 sets are recorded (less than 10 sets remaining):

E: FUL flashes 7 times

: flashes 1 time

This is repeated 2 times, then the display goes out.

- 2) If more than 115 sets are recorded (0 sets remaining):

E: FUL lights up (3 sec.)

: flashes 1 time

This is repeated 2 times, then the display goes out.

- 3) If more sets are recorded, sets 116 and 117 are recorded, but each time, the oldest ON/OFF data is deleted in turn to make space to record the new set.

3. Problem and warning data

- 1) If more than 220 sets are recorded (less than 10 sets remaining):

F: FUL flashes 7 times (3 sec.)

: flashes 1 time

This is repeated.

- 2) If more than 230 sets are recorded (0 sets remaining):

F: FUL lights up (3 sec.)

: flashes 1 time

This is repeated.

- 3) If more problems or warnings are generated, sets 231 and 232 are recorded, but each time, the oldest problem and warning data are deleted in turn to make space to record the new set.

(The display stays the same as in condition 2.)

4. Data for total payload, overall number of cycles

1) If the overall number of cycles goes above 9994 (less than 5 times remaining) or the difference between the total payload recorded in memory and 999900 tons (maximum limit) is less than 5 times the rated payload:

H: FUL flashes 7 times (3 sec.)

: flashes

This is repeated.

2) If the overall number of cycles goes above 9997 (less than 2 times remaining) or the difference between the total payload recorded in memory and 999900 tons (maximum limit) is less than 2 times the rated payload:

H: FUL lights up (3 sec.)

: flashes 1 time

This is repeated.

3) If the overall number of cycles reaches 9999 times or the total payload exceeds 999900 tons, both the total payload and the overall number of cycles are cleared automatically. The data for both values are then calculated again from 0.

(The display returns to the normal operation display.)

5. To cancel the data FULL for Items 1 to 3, see "OPERATOR CHECK MODE (PAGE 6-59)". If data FULL is displayed for Item 4, it cannot be canceled until it is automatically cleared. Before the data FULL display appears, use the forced ZERO CLEAR to clear the data.

For details of the method of operation, see "FORCED DISPLAY OF TOTAL PAYLOAD AND OVERALL NUMBER OF CYCLES (PAGE 6-57)".

6. There is no order of priority for displays 1 to 4.

If multiple data 4 occur at the same time, they are displayed in order except during loading.

***2: Defective cycle data payload**

The payload meter carries out the detection of the payload based on the signal from the suspension pressure sensor. It is always carrying out this detection, but the result is somewhat inaccurate because of the dynamic friction of the suspension during loading and immediately after loading. To make the recorded payload more accurate, the payload meter records the payload by detecting the payload immediately before dumping, where the dynamic friction of the suspension while the machine is being loaded is canceled by traveling with the machine loaded, and this is written to the memory. (It is recorded as one part of the cycle data.)

NOTICE

If the machine is pitching when the load is dumped, an error will occur in the payload data. Always do as follows.

- When stopping the machine at the dumping point, avoid braking suddenly, mounting rocks or the blocks used to stop the wheels, or hitting things.
- When operating the dump lever to dump the load, stop the machine at the dumping point and wait for the pitching to stop before operating the lever.
(As a guideline, wait for at least 3 sec after stopping the machine before operating the dumped lever.)
- Make the dumping point as horizontal as possible, and makes the unevenness of the travel path as small as possible.

For this reason, if the dumping operation (operation of the dump lever) is carried out while the chassis is still pitching after the machine is stopped at the dumping point, the payload sent to the payload meter memory may not be accurate.

In addition, if the dump truck is stopped at the dumping point by braking suddenly, or if it mounts the blocks used to stop the wheels, or hits something and stops, the payload that is sent to the memory may not be accurate.

If the load is dumped while the machine is still pitching as in the conditions given above, the payload meter will display "Defective cycle data payload" in than the chart of Problem and Warning Items to warn the operator. In this case, the detected payload is also written to memory.

WHEN ERROR CODE F-09 IS DISPLAYED (PROCEDURE FOR REPLACING BATTERY)

The payload meter has an internal battery to prevent the recorded data from being deleted when the key in the starting switch is turned to the OFF position.

If the voltage of the battery drops, F-09 is displayed as an error message, so replace the battery as follows.

REPLACING BATTERY

NOTICE

If an error code is displayed, replace the battery within 48 hours. If it is not replaced, the recorded data will be lost.

- Parts to prepare
 - Crosshead screwdriver
 - New battery (581-86-55710)
- Remove your gloves when carrying out the operation.
- Be careful not to let any dirt or metal particles get inside the controller.
 - Be careful not to drop any nuts or washers inside the controller.



WARNING

When replacing the battery, turn the starting switch to the ON position but do not start the engine. If the engine starts, the machine may suddenly move during the operation, and this may lead to serious personal injury.

1. Turn the key in the starting switch to the ON position and download the data stored in the payload meter to a personal computer, or carry out the memory card dump operation.
2. Turn the key in the starting switch to the OFF position.
3. Remove 4 screws (1) (M6) holding the payload meter, then pull the payload meter to the front.
4. Remove the connector at the rear face.

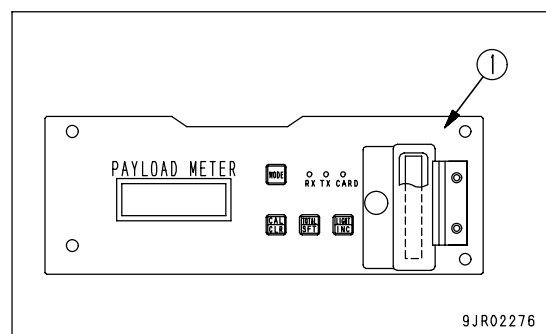

- Remove screws (3) (top surface: M3 x 6; rear face: M3 x 3) from the top cover of the payload meter, then remove top cover (2).

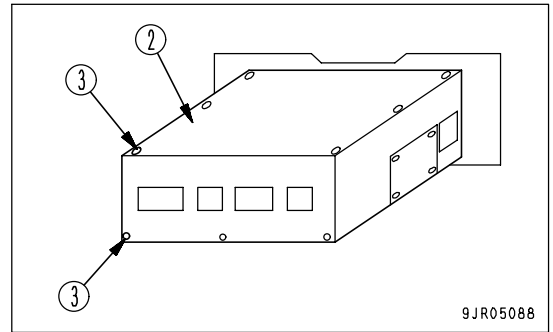

- Remove battery (5) from battery holder (4), then put it on top of a board.
Remove connector (6) after removing the battery from battery holder (4).
If it is attempted to use force to remove connector (6) when the battery is still in battery holder (4), there is danger that connector (6) may be damaged.

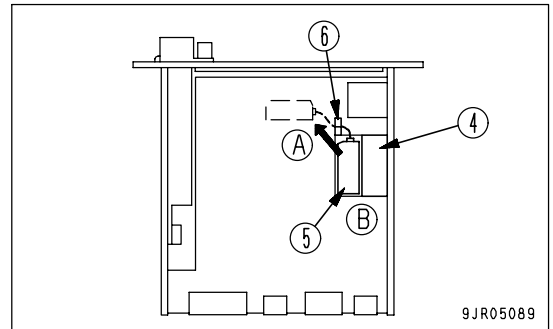

- Pull battery connector (6) straight out from the motherboard connector, then remove the battery (5).
- Insert the connector of the new battery straight into the connector of the motherboard.

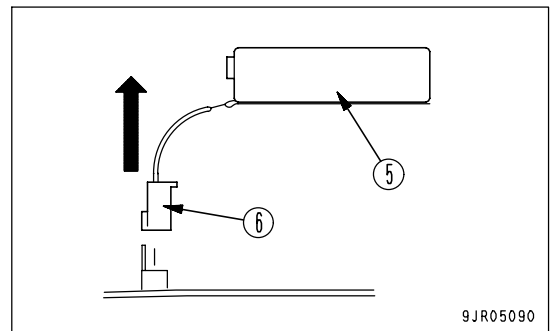

- Put the battery in the battery holder (4), and pass the wiring through the notch (7).
When doing this, insert the wiring into the bottom of the holder and pass it in through the notch.

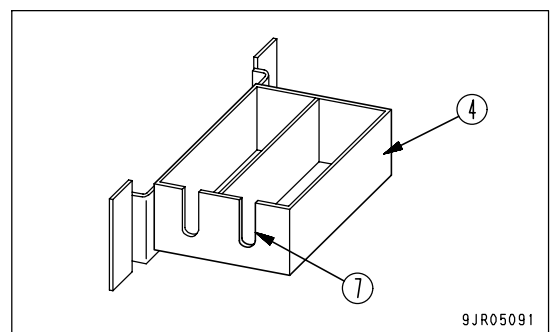

- Install top cover (2).
- Assemble the payload meter to its original position in the panel.

PROCEDURE AFTER REPLACING BATTERY

When the battery is replaced, the backup power for the non-volatile memory inside the payload meter is momentarily cut, so mistaken data (garbage) may enter the memory and cause mistakes in the payload meter's recognition of the condition of the machine.

To prevent removing this data, do as follows.

1. Turn the starting switch to the ON position. (F.CAL may flash.)
2. Using the operator check mode, set the machine ID, open ID, speed limit, option code, date and time.
3. Without turning the starting switch to OFF position, start the engine. (F.CAL may flash.)
4. Carry out calibration.
5. Load to near the rated payload, then dump the load.
6. Move the machine to a safe place, wait for at least 5 sec. after dumping the load in Step 5, then stop the engine.
7. Turn the starting switch to the ON position again.
Do not start the engine when doing this.
8. Carry out the DATA ALL CLEAR in the operator check mode.
9. Forcibly clear the date for the total payload and overall number of cycles.
With this operation, all the mistaken date inside the payload meter are cleared. Apart from the calibration date, all the date recorded in the Steps 1 to 6 (these date are all inaccurate date) are also deleted.
If this operation is carried out in the wrong order, the cycle date (beginning only) will be defective.
10. After the above operation is completed, the payload meter will function normally.

OPERATION WHEN ERROR CODE F.CAL IS DISPLAYED OR CONTROLLER HAS BEEN REPLACED

If F.CAL is displayed, mistaken data have probably been written to the memory inside the payload meter. In addition, when the controller is replaced, old data may be recorded to the new controller, or the machine condition recognised by the controller may be different from the actual condition. To prevent removing this data, do as follows.

1. Forcibly carry out initialization. For details, see "CARRYING OUT FORCED INITIALIZATION (PAGE 6-88)".
2. Using the operator check mode, set the machine ID, open ID, speed limit, option code, date and time.
3. Without turning the starting switch to the OFF position, start the engine. (F.CAL may flash.)
4. Carry out calibration.
5. Load to near the rated payload, then dump the load.
6. Move the machine to a safe place, wait for at least 5 sec. after dumping the load in Step 7, then stop the engine.
7. Turn the starting switch to the ON position again.
Do not start the engine when doing this.
8. Carry out the DATA ALL CLEAR in the operator check mode.
9. Forcibly clear the data for the total payload and overall number of cycles.
With this operation, all the mistaken data inside the payload meter are cleared. Apart from the calibration data, all the data recorded in the Steps 3 to 8 (these data are all inaccurate data) are also deleted.
If this operation is carried out in the wrong order, the cycle data (beginning only) will be defective.
After the above operation is completed, the payload meter will function normally.

CARRYING OUT FORCED INITIALIZATION

When this function is performed, all of the data recorded in the payload meter are deleted. Do not carry out this operation unless necessary.

Check the date and time before starting, and always be sure that the machine is empty.

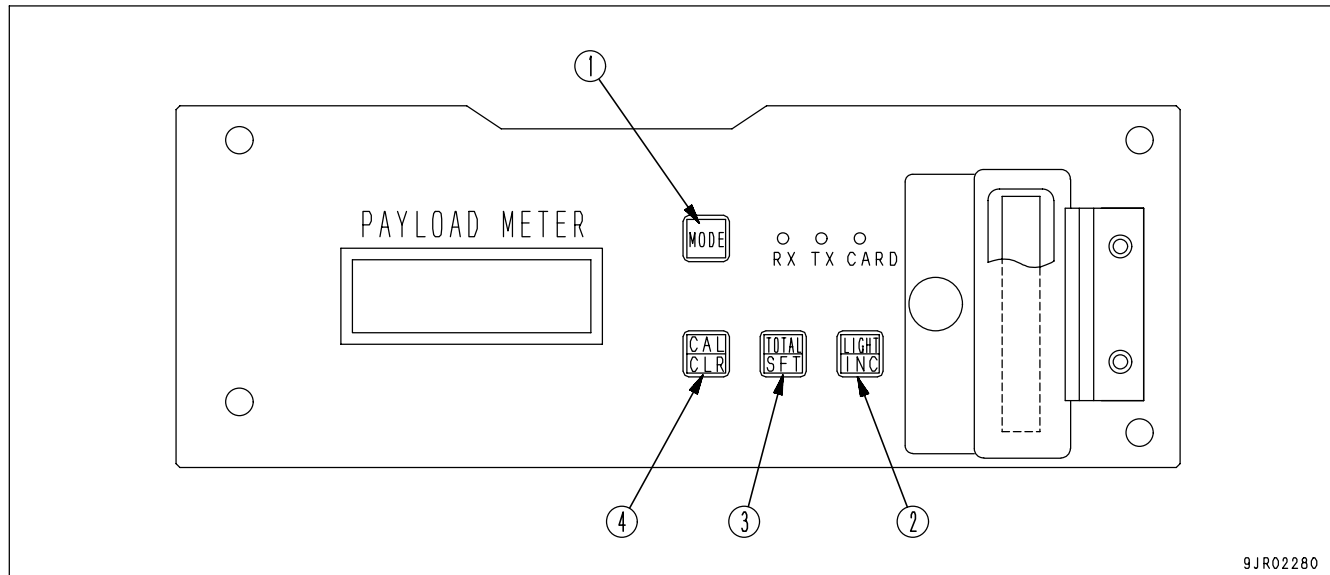

9JR02280

1. Turn the starting switch to the ON position.
2. In the normal display condition, keep MODE switch (1) and LIGHT/INC switch (2) pressed at the same time for at least 2 seconds.
CHEC will flash on the payload meter display.

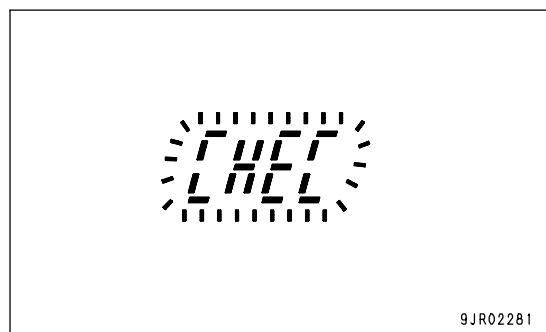

9JR02281

3. When CHEC is displayed, keep LIGHT/INC switch (2), TOTAL/SFT switch (3), and CAL/CLR switch (4) pressed at the same time for at least 2 seconds.
00:00 will flash on the display.

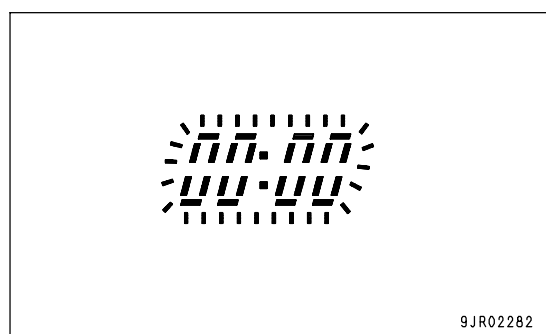

9JR02282

4. Keep CAL/CLR switch (4) pressed for at least 2 seconds.

The display changes to 00:00 (lights up for two seconds), and when the forced initialization is completed, it automatically displays F.CAL.

After this, carry out the procedure given in "OPERATION WHEN ERROR CODE F.CAL IS DISPLAYED OR CONTROLLER HAS BEEN REPLACED (PAGE 6-87)".

If it is desired to stop the forced initialization when 00:00 is flashing on the display, press MODE switch (1). The display will return to the flashing CHEC display without carrying out the forced initialization.

USE OF REAR VIEW MONITOR

! WARNING

- Never operate any of the switches while in running. If you do so, there is the fear that you may make an error in the truck operation, or neglect to watch the hauling road ahead for safety, and as a result cause a serious personal injury.
- The rear view monitor is an aid for checking obstacles in the rear. An image appearing on the monitor is limited. So when backing up the dump truck, be sure to make a visual check, not relying solely on the monitor.
- An image on the rear view monitor does not show an actual distance, so drive the dump truck slowly, when backing it up.

When the dump truck is backed up and the rear view monitor is set in operation, a monitor display enables the driver to check the rear for safety.

NAME AND FUNCTION OF EACH PART OF REAR VIEW MONITOR

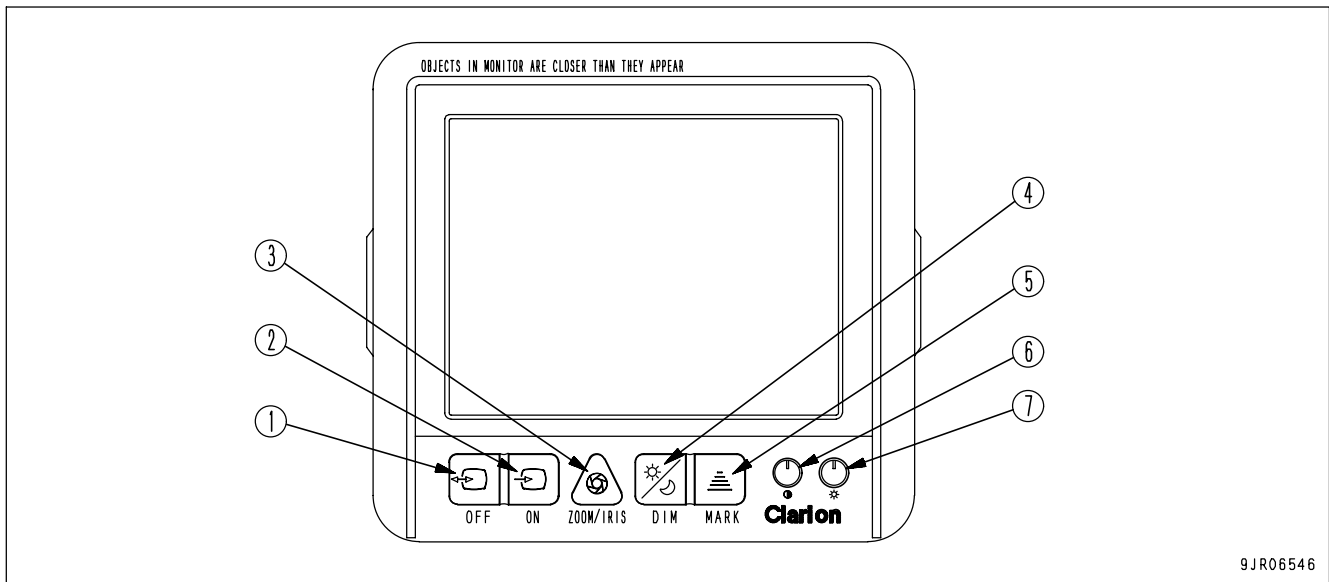

- | | |
|---|---|
| <p>(1) Auto Switch</p> <p>(2) Manual Switch</p> <p>(3) Zoom / Iris Switch (Reverse Light Compensation Switch)</p> | <p>(4) Bright / Dim Light Selector Switch</p> <p>(5) Mark Switch (not operable with this machine)</p> <p>(6) Contrast Adjustment Knob</p> <p>(7) Brightness Adjustment Knob</p> |
|---|---|

AUTO SWITCH

When an image of a camera is shown on the monitor display and this switch (1) is pressed, the camera image disappears and the display turns into a waiting condition.

When the gearshift lever is put into the "R" position while the display is in the waiting condition, an image of the rear view automatically appears.

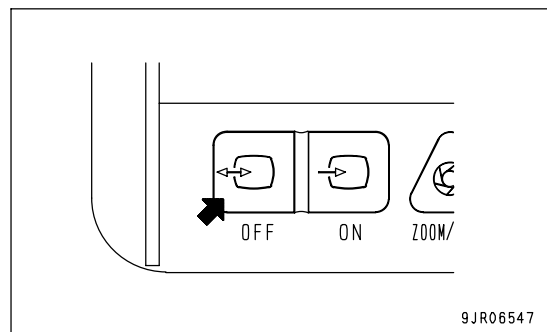

MANUAL SWITCH

When this switch (2) is pressed, an image of a camera appears on the monitor display.

At that time, a mark "CAM1" appears on the upper left side of the display and a figure "5" on the upper right side of the display.

REMARK

- When the manual switch is pressed to call an image and the operation is suspended thereafter, the image disappears in approx. 5 minutes, turning the display into a waiting condition. This is a function in case the operator forgets to switch off the display (timer function).
- The time until the monitor display is automatically switched off is shown on the upper right side of the display. It changes by minute and in the descending order as 5 → 4 → 3 → 2 → 1. Moreover, when the remaining time comes down to just 10 seconds before the monitor display goes off, the last figure "1" on the upper right side begins to flash.
- When the manual switch is pressed to call an image and it is pressed again while the image is shown on the monitor display, it remains on the display for approx. 5 more minutes from the moment the switch is pressed.
- When the gearshift lever is in the "R" position, the timer function does not work.

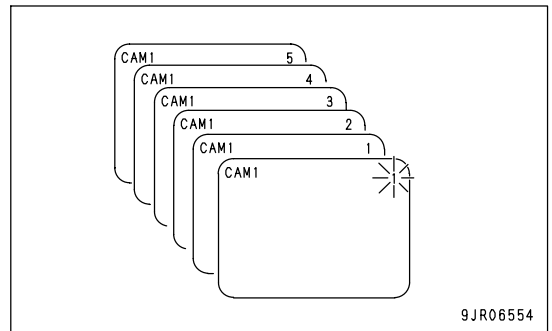
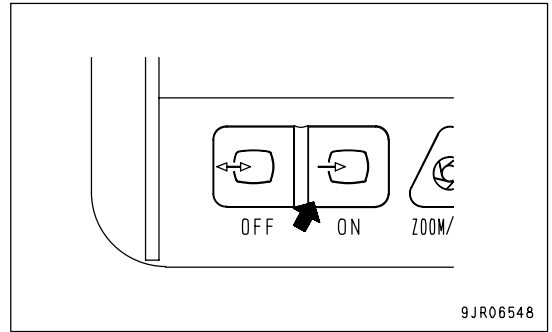

ZOOM/IRIS SWITCH (REVERSE LIGHT COMPENSATION SWITCH)

Zoom Function (press the switch)

By pressing this switch (3), an image on the monitor display can be enlarged by 1.4 times.

At that time, a mark of "ZOOM" is shown on the upper right side of the display.

When the switch is pressed again, "ZOOM" disappears and the display returns to the original image.

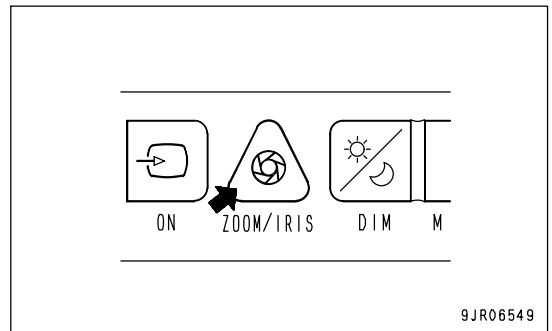

Iris Function (Reverse Light Compensation Function) (Keep the switch pressed for more than 1 second.)

! WARNING

When the iris function is activated (turned "ON"), the whole monitor display becomes brighter. As a result, some portion on the display becomes difficult to read or discern, while it is easy to do so with the iris function turned "OFF". Therefore do not use this function except when it is necessary to read or see a dim portion.

When it is difficult to see a monitor display due to a reverse light, keep this switch (3) for more than 1 second, and then the iris function (reverse light compensation function) is turned "ON", turning the display brighter and making it easier to see.

At that time, a mark of "IRIS" appears on the upper left side of the display.

If the switch is further kept pressed for more than 1 second, the iris function (reverse light compensation function) is turned "OFF" and "IRIS" mark goes off.

BRIGHT/DIM LIGHT SELECTOR SWITCH

When this switch is pressed, the brightness of the monitor display lowers.

A mark of "DIM" appears on the upper left side of the display then. When the switch is pressed again, the brightness returns to the original level, and "DIM" mark goes off.

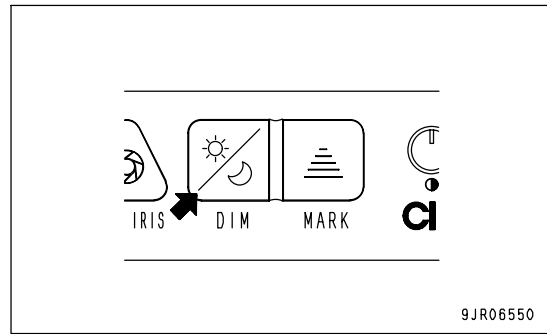

MARK SWITCH

The shown mark position does not correspond with the machine. Do not use this function.

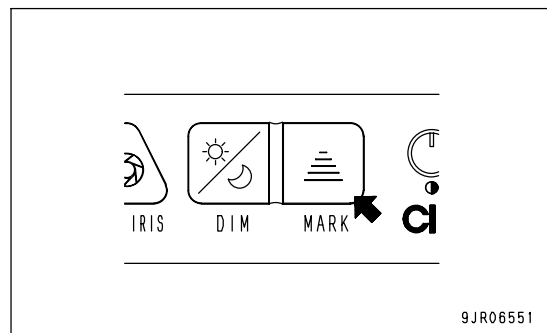

CONTRAST ADJUSTMENT KNOB

With this knob (6), contrast on the monitor display can be adjusted to be either stronger or weaker.

To side (A): Contrast becomes stronger.

To side (B): Contrast becomes weaker.

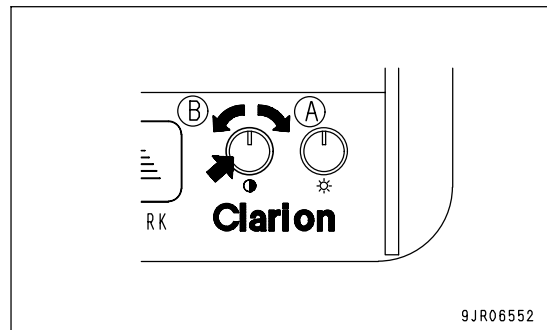

BRIGHTNESS ADJUSTMENT KNOB

With this knob (7), brightness (luminance) on the monitor display can be adjusted.

To side (A): Brightness increases.

To side (B): Brightness decreases.

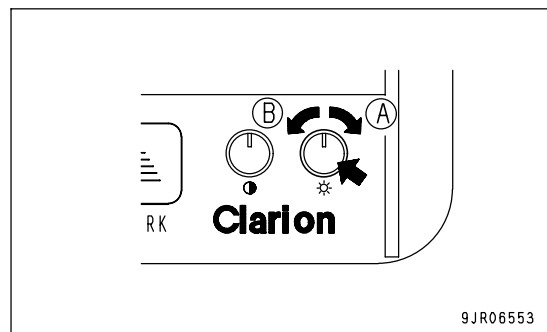

SETTING OF REAR VIEW MONITOR

HOW TO SET DISPLAY MODE

A mark of "CAM1", "DIM", "IRIS" and "ZOOM" appears on the upper left side of the monitor display, depending on the sort of ongoing operation.

Every mark is set to go off in approx. 2 seconds after it lights up (2- second display mode).

The display can be changed to a constantly lighted condition by the following method (continuous display mode).

1. Press mark switch (2) while pressing manual switch (1) at the same time.

A "Cam1" mark lights up on the upper left side of the monitor display, and the display mode changes to the continuous display mode.

2. When it is required to return to the 2- second display mode, press mark switch (2), while pressing manual switch (1) at the same time, the same way as in step 1 above.

After a "Cam1" mark remains lighted for approx. 2 seconds on the upper left side of the monitor display, only the mark disappears, and the display mode changes to the 2- second display mode.

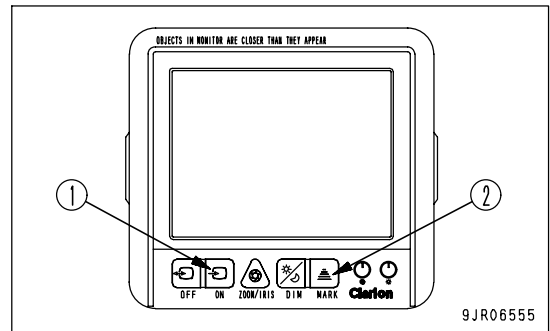

REMARK

In either case of the 2- second display mode and continuous display mode, the display remains lighted all the time in the remaining time after the mark goes off and before the monitor display goes off, too.

CAUTIONS WHEN USING REAR VIEW MONITOR

WARNING

- Do not attempt to disassemble or modify the monitor. There is a danger of electric shock or fire.
- Do not attempt to open the monitor backside cover. There is a danger of electric shock, as high voltage power is conducted internally.
- Do not use the monitor if it is suspected of defect. There is a fear of electric shock or fire, should it be used in spite of a defect. In that case, ask your Komatsu distributor for repair or replacement.
- In case a foreign material has got into the monitor or it gets wet, or if a smoke comes out of the monitor or it gives a bad smell, stop the use immediately. It poses a big danger to use the monitor when any such abnormality exists. In that case, consult your Komatsu distributor.
- When replacing a fuse, be sure to use one with the specified capacity of 3A. Should a fuse with a higher- than- specified capacity be used, it can cause fire.

- As a general rule, this product should be replaced after a total usage time of approximately 3000 hours (or approximately 3 years), though this may differ according to usage conditions.
- When cleaning the monitor, use dry soft cloth or wet cloth after having well wrung the water out. If it is very dirty, use neutral detergent. Do not use thinner or alcohol.
- Sometimes an image on the monitor display is blurred due to the camera lens being smeared. In that case, clean the camera lens with dry soft cloth or wet cloth after having well wrung the water out.

HANDLING DUMPING COUNTER

The dumping counter is an automatic counting function to count the number of loads that have been dumped.

The number of loads dumped is displayed on the character display.

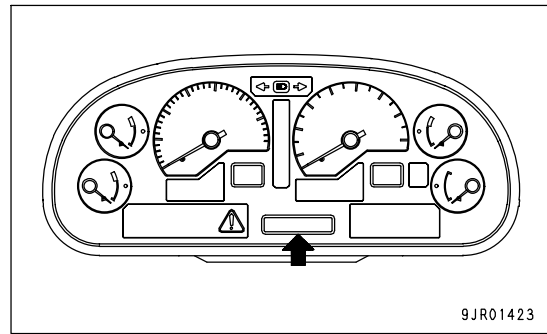

METHOD OF DISPLAYING, RESETTING DUMPING COUNTER

1. Check that the character display is showing the service meter/odometer, or the action code. If it is giving any other display, turn the starting switch OFF, then turn the starting switch to the ON position and wait for the above display to be given.
2. Press (◇) of machine monitor mode selector switch 1. The character display shows the dumping counter.

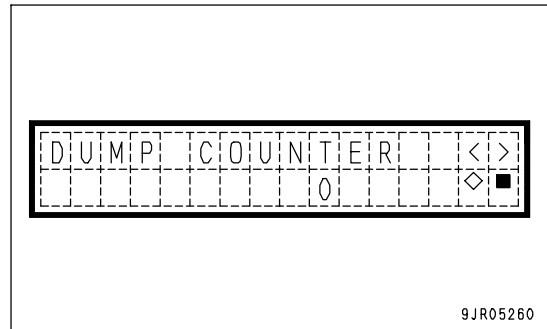

3. When resetting the number of loads dumped, press (◇) of machine monitor mode selector switch 1. The display shows the screen on the right.
4. Press (◇) of machine monitor mode selector switch 1. The number of loads dumped is reset and the display returns to the previous screen.

To abandon the resetting operation, press (■) of machine monitor mode selector switch 1 to return to the previous screen.

5. When completing the operation, press (■) of machine monitor mode selector switch 1 or turn the starting switch OFF.

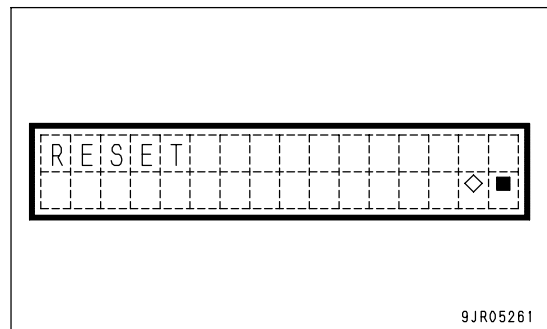

HANDLING BATTERY ISOLATOR



When the engine is running, do not operate the battery isolator switch to shut off the electrical circuit. When the circuit is shut off, electric noise is generated, and this may damage the electric circuit or the controllers.

The battery isolator prevents consumption of the battery power caused by short circuits or electrical leakage from the equipment during long-term storage.

When repairing any electrical circuit or carrying out welding operations, cut the battery isolator switch (at the position marked by the arrow in the diagram below) to prevent damage to the electrical circuit.

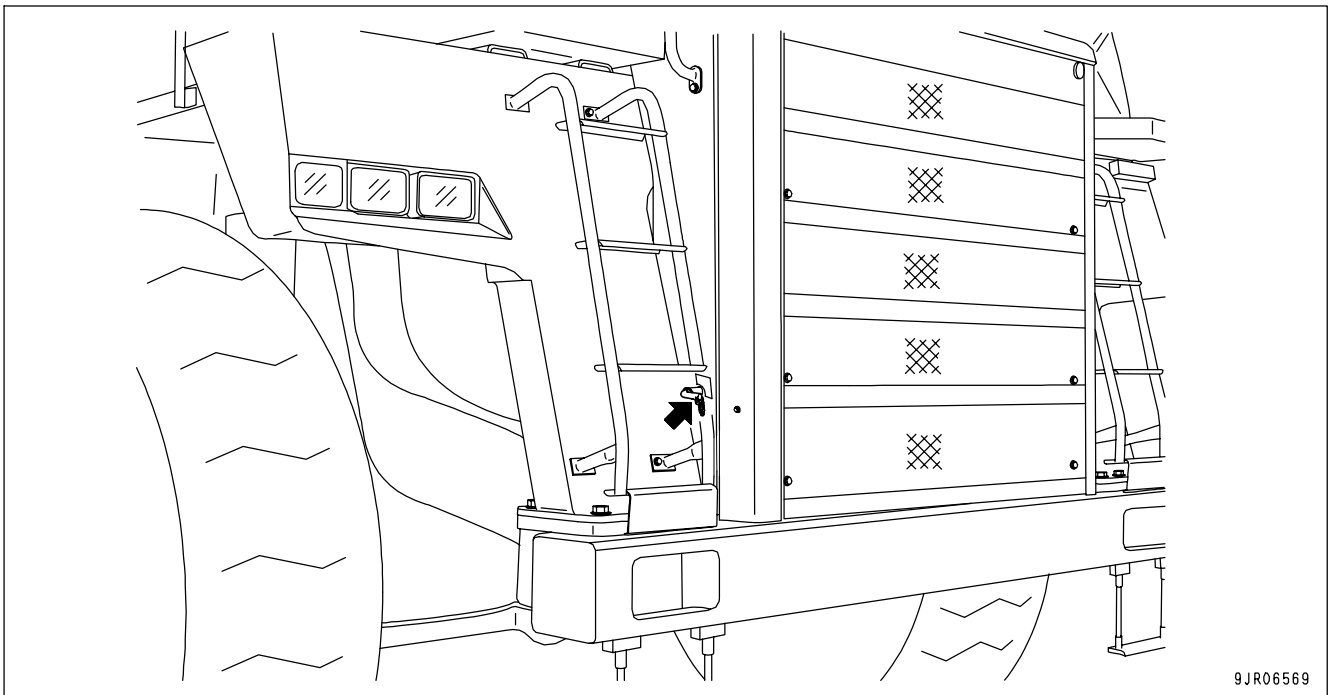

9JR06569

Position (A) (cut): Battery wiring is disconnected and no power flows to electric circuit.

The lever is disconnected from the switch.

Position (B) (connected): Battery wiring is connected and condition returns to normal.

The lever is fixed to the switch.

REMARK

Lever (1) can be removed at position (A). If lever (1) is separated from switch (2), align the protruding part of lever (1) with the groove in switch (2) and install.

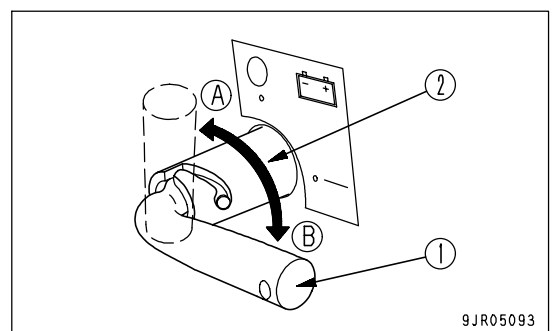

9JR05093

REMARK

- When the battery isolator switch is turned "OFF", the whole electrical system of the machine does not work.
- Preset memories in the radio, the clock in the monitor and radio broadcasting stations are lost. Preset them again at the next use.

NOTICE

In case the machine is equipped with VHMS, VHMS still continues to memorize data right after the engine starting switch key is turned "OFF". When turning the battery isolator switch "OFF", first check that VHMS operation indicator (1) (green) in the upper part of the battery isolator switch has gone off, and then turn off the switch.

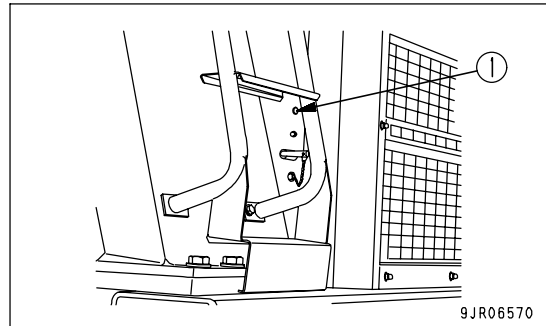

HANDLING MACHINES EQUIPPED WITH VHMS

- VHMS is a machine management system. When a communications terminal is installed, it is possible to transmit data.
- A contract is necessary before the VHMS communications terminal can be used. Any customers desiring to use the VHMS system should consult their Komatsu distributor.

VHMS INSTALLED, COMMUNICATIONS TERMINAL NOT INSTALLED

BASIC PRECAUTIONS



WARNING

- Never disassemble, repair, modify, or move the VHMS or cables. This may cause failure or fire on the VHMS equipment or the machine itself. (Your Komatsu distributor will carry out removal and installation of VHMS.)
- Do not allow cables or cords to become caught; do not damage or pull cables or cords by force. Short circuits or disconnected wires may cause failure or fire on the VHMS equipment or the machine itself.

REMARK

There is absolutely no need to inspect or operate the VHMS, but if any abnormality is found, please contact your Komatsu distributor.

VHMS AND COMMUNICATIONS TERMINAL INSTALLED

- The VHMS communications terminal is a wireless device using radio waves, so it is necessary to obtain authorization and conform to the laws of the country or territory where the machine equipped with the VHMS communications terminal is being used. Always contact your Komatsu distributor before selling or exporting any machine equipped with the VHMS communications terminal.
- When selling or exporting the machine or at other times when your Komatsu distributor considers it necessary, it may be necessary for your Komatsu distributor to remove the VHMS communications terminal or to carry out action to stop communications.
- If you do not obey the above precautions, neither Komatsu nor your Komatsu distributor can take any responsibility for any problem that is caused or for any loss that results.

BASIC PRECAUTIONS



WARNING

- Never disassemble, repair, modify, or move the VHMS, communications terminal, antenna, or cables. This may cause failure or fire on the VHMS communications terminal or the machine itself. (Your Komatsu distributor will carry out removal and installation of the VHMS and communications terminal.)
- Do not allow cables or cords to become caught; do not damage or pull cables or cords by force. Short circuits or disconnected wires may cause failure or fire on the VHMS communications terminal or the machine itself.
- For anyone wearing a pacemaker, make sure that the communications antenna is at least 22 cm from the pacemaker. The radio waves may have an adverse effect on the operation of the pacemaker.

NOTICE

- Please contact your Komatsu distributor before installing a top guard or other attachment that covers the antenna.
- Be careful not to get water on the communications terminal or wiring.

REMARK

- The communications terminal uses wireless communications, so it cannot be used inside tunnels, underground, inside buildings, or in mountain areas where radio waves cannot be received. Even when the machine is outside, it cannot be used in areas where the radio signal is weak or in areas outside the wireless communication service area.
- There is absolutely no need to inspect or operate the VHMS or communications terminal, but if any abnormality is found, please contact your Komatsu distributor.

PROCEDURE WHEN DOWNLOADING**WHEN DOWNLOADING FROM CONNECTOR INSIDE CAB (BEHIND ASSISTANT'S SEAT)**

1. Turn the starting switch to the ON position.
2. When downloading, remove download connector (1) and download.

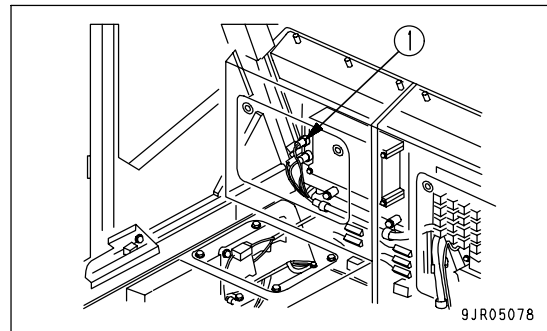
**WHEN DOWNLOADING FROM GROUND LEVEL DOWNLOAD BOX OUTSIDE CAB**

1. Turn the starting switch to the OFF position.
2. Use the starting switch to open the box.
3. Set switch (2) inside the box to the ON position.
When display lamp (3) lights up, the system is ready to download.
Start the download.
4. Close the box and lock it with the key.

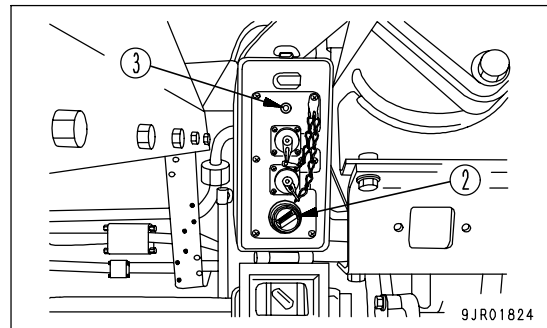
**CHECK BEFORE STARTING**

When using this machine, there is no particular need to operate this system, but be sure to carry out daily inspection in order to maintain the function and performance of the system. If there is any problem, please consult your Komatsu distributor.

1. Check for loose, damaged, or dirty mounts of the sensors or antenna.
2. Check for disconnected or damaged wiring harnesses, cables, or connectors.
3. Check for oil or gas leaks from the sensor mounts.

Inspect the following places.

Communication antenna (1) (if equipped)
Antenna pole (2) (if equipped)

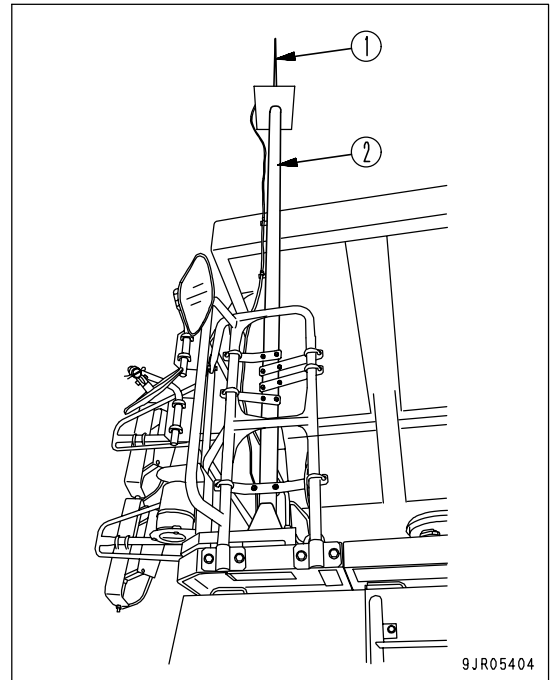

VHMS controller (3)

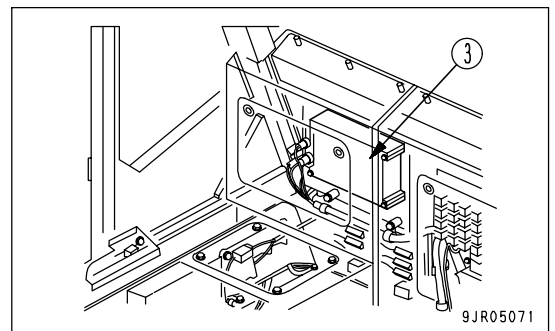

Orbcomm controller (4) (if equipped)

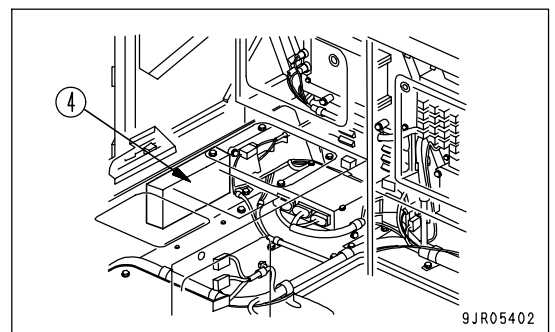

Download connector (5)

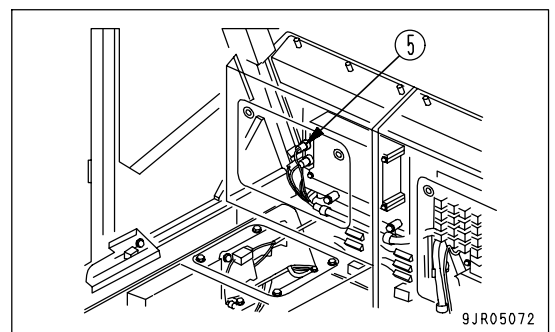

Ground level download box (6)

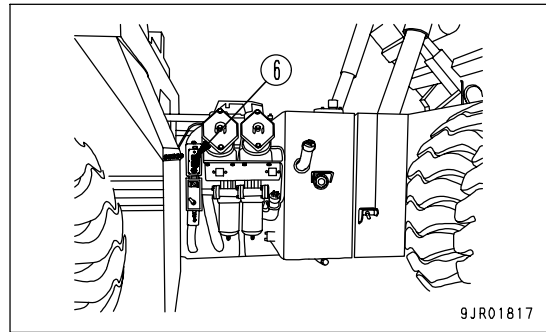

Blow-by sensor (7)

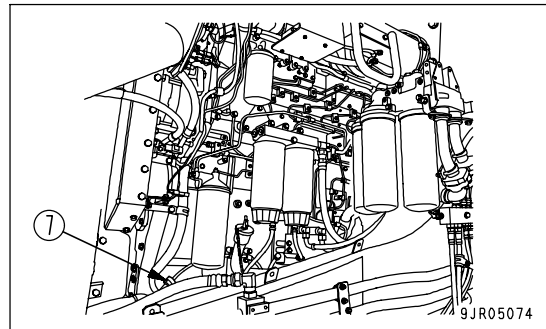

Exhaust temperature sensor (8)

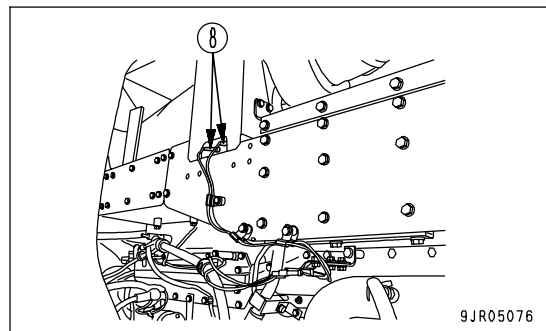

Ambient temperature sensor (9)
 Ambient temperature sensor (9) is inside box (A).
 Remove box (A) when carrying out inspection.

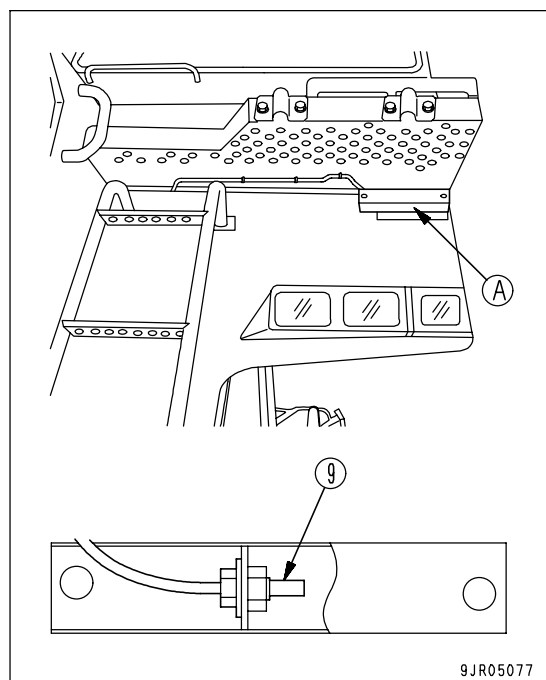

INDEX

<A>			
AIR CONDITIONER	3-	58	
			
BEFORE READING THIS MANUAL	1-	2	
BODY PIVOT PIN	3-	46	
<C>			
CAR RADIO	3-	51	
CAR STEREO	3-	53	
CHECK BEFORE STARTING ENGINE	3-	63	
CHECKS AFTER COMPLETION OF WORK	3-	117	
CHECKS AFTER STOPPING ENGINE	3-	118	
COLD WEATHER OPERATION	3-	131	
AFTER COLD WEATHER	3-	133	
PRECAUTIONS AFTER COMPLETION OF WORK	3-	133	
PRECAUTIONS FOR LOW TEMPERATURE	3-	131	
CONTROL LEVERS AND PEDALS	3-	10	
<D>			
DETERMINING AND MAINTAINING TRAVEL ROAD	3-	123	
DETERMINING TRAVEL ROAD	3-	123	
MAINTAINING TRAVEL ROAD	3-	123	
DISPLAY OF CHARACTER DISPLAY	3-	28	
DUMP OPERATIONS	3-	114	
DUST INDICATOR	3-	47	
<E>			
EXPLANATION OF COMPONENTS	3-	5	
<F>			
FUSES	3-	48	
<G>			
GENERAL PRECAUTIONS COMMON TO OPERATION AND MAINTENANCE	2-	12	
DO NOT GET CAUGHT IN DUMP BODY	2-	17	
FIRE PREVENTION	2-	14	
PRECAUTIONS BEFORE STARTING OPERATION	2-	12	
PRECAUTIONS RELATED TO ATTACHMENTS AND OPTIONS	2-	18	
PRECAUTIONS RELATED TO PROTECTIVE STRUCTURES	2-	17	
PRECAUTIONS WHEN GETTING ON OR OFF MACHINE	2-	15	
PRECAUTIONS WHEN RUNNING ENGINE INSIDE BUILDING	2-	18	
PREPARATIONS FOR SAFE OPERATION	2-	12	
UNAUTHORIZED MODIFICATION	2-	17	
GENERAL VIEW	3-	2	
DASHBOARD	3-	4	
GENERAL VIEW OF CONTROLS AND GAUGES	3-	3	
GENERAL VIEW OF MACHINE	3-	2	
GENERAL VIEW OF MACHINE	3-	5	
GUIDES TO MAINTENANCE	4-	2	
<H>			
HANDLING AIR SUSPENSION SEAT	6-	10	
OPERATOR'S SEAT ADJUSTMENT	6-	10	
REMOVAL AND INSTALLATION OF HEADREST	6-	14	
HANDLING ANTI SKID BRAKE SYSTEM (ABS)	6-	19	
ABS SYSTEM CHECK AFTER STARTING ENGINE	6-	20	
EXPLANATION OF COMPONENTS	6-	19	
OPERATION OF ABS	6-	21	
PRECAUTION WHEN USING ABS SYSTEM	6-	21	
TROUBLESHOOTING	6-	22	
HANDLING AUTOMATIC SPIN REGULATOR (ASR)	6-	15	
ACTUATION OF ASR SYSTEM	6-	16	
BLEEDING AIR FROM ASR CIRCUIT	6-	18	
EXPLANATION OF COMPONENTS	6-	15	
PRECAUTION WHEN USING ASR SYSTEM	6-	16	
TROUBLESHOOTING	6-	17	
HANDLING BATTERY ISOLATOR	6-	95	
HANDLING DUMPING COUNTER	6-	94	
HANDLING MACHINES EQUIPPED WITH VHMS	6-	97	
HANDLING PAYLOAD METER (VHMS BUILT-IN TYPE)	6-	23	
DATA STORED IN PAYLOAD METER	6-	29	
EXTERNAL DISPLAY LAMPS	6-	26	

MACHINE ID, OPEN ID -----	6- 34	LOCATION OF PLATES, TABLE TO ENTER SERIAL NO. AND DISTRIBUTOR -----	1- 7
NORMAL OPERATION DISPLAY -----	6- 24	PRODUCT IDENTIFICATION NUMBER (PIN)/MACHINE SERIAL NO. PLATE -----	1- 7
OTHERS -----	6- 36	SERVICE METER POSITION -----	1- 8
OUTLINE OF SYSTEM -----	6- 23	TABLE TO ENTER SERIAL NO. AND DISTRIBUTOR -----	1- 8
PAYLOAD (CYCLE DATA ITEM) -----	6- 36	LOCKING -----	3-118
PERFORMING CALIBRATION -----	6- 27	LONG-TERM STORAGE -----	3-134
PROCEDURE WHEN DOWNLOADING -----	6- 30	AFTER STORAGE -----	3-134
SERVICE FUNCTIONS -----	6- 36	BEFORE STORAGE -----	3-134
HANDLING PAYLOAD METER II (CARD TYPE) -----	6- 37	DURING STORAGE -----	3-134
CONTENT OF DISPLAY (CONTROLLER, EXTERNAL DISPLAY LAMPS) -----	6- 44	PRECAUTIONS BEFORE TRAVELING AFTER LONG-TERM STORAGE -----	3-134
DETAILS OF DATA STORED IN MEMORY OF PAYLOAD METER -----	6- 50	<M>	
EXTERNAL DISPLAY LAMPS -----	6- 48	MACHINE MONITOR -----	3- 15
GENERAL LOCATIONS -----	6- 39	MAINTENANCE SCHEDULE CHART -----	4- 20
METHOD OF USING ACCURATELY ----	6- 38	METHOD OF LIFTING MACHINE -----	3-128
OPERATION OF SWITCHES -----	6- 55	METHOD OF LOWERING DUMP BODY IN EMERGENCY -----	3-136
OPERATION WHEN ERROR CODE F.CAL IS DISPLAYED OR CONTROLLER HAS BEEN REPLACED -----	6- 87	METHOD OF SECURING MACHINE -----	3-127
PROBLEM AND WARNING DISPLAY (ERROR CODE) -----	6- 77	MOVING MACHINE OFF (FORWARD, REVERSE), STOPPING -----	3- 92
WHEN ERROR CODE F-09 IS DISPLAYED (PROCEDURE FOR REPLACING BATTERY) -----	6- 84	<O>	
HANDLING TACHOGRAPH (TCO20-90W) -----	6- 3	OPERATION -----	3- 63
EXPLANATION OF COMPONENTS -----	6- 3	OPERATIONS, CHECKS AFTER STARTING ENGINE -----	3- 91
METHOD OF USE -----	6- 6	OPERATOR'S CAB -----	3- 8
HANDLING TIRES -----	3-119	OTHER FUNCTIONS OF CHARACTER DISPLAY -----	3- 32
<I>		OUTLINE OF ELECTRIC SYSTEM -----	4- 13
IF TRANSMISSION HAS TROUBLE -----	3-135	<P>	
IMPORTANT SAFETY INFORMATION -----	2- 2	PARKING MACHINE -----	3-117
INTENDED USE -----	1- 6	PERIODIC REPLACEMENT OF SAFETY CRITICAL PARTS -----	4- 19
GENERAL VIEW AND DIRECTIONS OF MACHINE -----	1- 6	PRECAUTIONS FOR MAINTENANCE -----	2- 29
USE OF MACHINE -----	1- 6	PRECAUTIONS BEFORE STARTING INSPECTION AND MAINTENANCE -----	2- 29
VISIBILITY FROM OPERATOR'S SEAT -----	1- 6	PRECAUTIONS FOR INSPECTION AND MAINTENANCE -----	2- 33
<L>		TIRES -----	2- 38
LOADING OPERATIONS -----	3-113	PRECAUTIONS FOR OPERATION -----	2- 19
LOCATION OF FIRE EXTINGUISHER -----	3- 47	OPERATION -----	2- 23
		PRECAUTIONS FOR JOBSITE -----	2- 19

INDEX

STARTING ENGINE	2- 21	<T>	
TOWING	2- 28	TORQUE LIST	4- 18
TRANSPORTATION	2- 27	TRANSPORTATION	3-126
PRECAUTIONS FOR OPERATION	3-116	TRAVELING DOWNHILL	3-100
PRECAUTIONS WHEN		TROUBLESHOOTING	3-135
TRANSPORTING	3-126	ACTION IF FIRE OCCURS	3-146
		AFTER RUNNING OUT OF FUEL	3-135
<R>		IF BATTERY IS DISCHARGED	3-142
RECOMMENDED FUEL, COOLANT,		METHOD OF TOWING MACHINE	3-138
AND LUBRICANT	4- 15	OTHER TROUBLE	3-147
RECOMMENDED BRANDS,			
RECOMMENDED QUALITY FOR		<U>	
PRODUCTS OTHER THAN		USE OF REAR VIEW MONITOR	6- 90
KOMATSU GENUINE OIL	4- 17	CAUTIONS WHEN USING REAR	
USE OF FUEL, COOLANT AND		VIEW MONITOR	6- 93
LUBRICANTS ACCORDING TO		NAME AND FUNCTION OF EACH	
AMBIENT TEMPERATURE	4- 16	PART OF REAR VIEW MONITOR	6- 90
		SETTING OF REAR VIEW MONITOR ...	6- 93
<S>			
SAFETY CRITICAL PARTS	4- 19	<W>	
SAFETY INFORMATION	1- 5	WEAR PARTS	4- 14
SAFETY LABELS	2- 5	WEAR PARTS LIST	4- 14
POSITION FOR ATTACHING SAFETY			
LABELS	2- 6		
SECONDARY MATERIALS FOR			
OPERATION	4- 9		
HANDLING OIL, FUEL, COOLANT,			
AND PERFORMING OIL CLINIC	4- 9		
SELECTING DUMP BODY	6- 2		
SERVICE PROCEDURE	4- 22		
CHECK BEFORE STARTING	4- 48		
EVERY 1000 HOURS SERVICE	4- 73		
EVERY 15000 HOURS SERVICE	4- 91		
EVERY 2000 HOURS SERVICE	4- 83		
EVERY 250 HOURS SERVICE	4- 49		
EVERY 4000 HOURS SERVICE	4- 86		
EVERY 500 HOURS SERVICE	4- 63		
EVERY 8000 HOURS SERVICE	4- 90		
INITIAL 250 HOURS SERVICE (ONLY			
AFTER THE FIRST 250 HOURS)	4- 22		
WHEN REQUIRED	4- 23		
SHIFTING GEAR	3- 98		
SPECIFICATIONS	5- 2		
STANDARD TIGHTENING TORQUES			
FOR BOLTS AND NUTS	4- 18		
STARTING ENGINE	3- 88		
STEERING THE MACHINE	3-113		
STEPS FOR TRANSPORTATION	3-126		
STOPPING ENGINE	3- 91		
SWITCHES	3- 36		

HD465-7E0, HD605-7E0 DUMP TRUCK

Form No. TEN00138-08

©2008 KOMATSU
All Rights Reserved
Printed in Japan 09-08
