

Operation & Maintenance Manual

TEN00076-01

GALEO **PC138US-2** **PC138USLC-2** **HYDRAULIC EXCAVATOR**

SERIAL NUMBERS PC138US-5421 and up
PC138USLC-1695

⚠ WARNING

Unsafe use of this machine may cause serious injury or death. Operators and maintenance personnel must read this manual before operating or maintaining this machine. This manual should be kept near the machine for reference and periodically reviewed by all personnel who will come into contact with it.

NOTICE

Komatsu has Operation & Maintenance Manuals written in some other languages. If a foreign language manual is necessary, contact your local distributor for availability.

KOMATSU

FOREWORD

CALIFORNIA

Proposition 65 Warning

Diesel engine exhaust and some of its constituents are known to the State of California to cause cancer, birth defects, and other reproductive harm.

CALIFORNIA

Proposition 65 Warning

Battery posts, terminals and related accessories contain lead and lead compounds, chemicals known to the State of California to cause cancer and birth defects or other reproductive harm.

Wash hands after handling.

FOREWORD

This manual provides rules and guidelines which will help you use this machine safely and effectively. The precautions in this manual must be followed at all times when performing operation and maintenance. Most accidents are caused by the failure to follow fundamental safety rules for the operation and maintenance of machines. Accidents can be prevented by knowing beforehand conditions that may cause a hazard when performing operation and maintenance.



WARNING

Operators and maintenance personnel must always do as follows before beginning operation or maintenance.

- Always be sure to read and understand this manual thoroughly before performing operation and maintenance.
- Read the safety messages given in this manual and the safety labels affixed to the machine thoroughly and be sure that you understand them fully.

Keep this manual in the storage location for the operation and maintenance manual given below, and have all personnel read it periodically.

If this manual has been lost or has become dirty and cannot be read, request a replacement manual immediately from Komatsu or your Komatsu distributor.

If you sell the machine, be sure to give this manual to the new owners together with the machine.

Komatsu delivers machines that comply with all applicable regulations and standards of the country to which it has been shipped. If this machine has been purchased in another country or purchased from someone in another country, it may lack certain safety devices and specifications that are necessary for use in your country. If there is any question about whether your product complies with the applicable standards and regulations of your country, consult Komatsu or your Komatsu distributor before operating the machine.

Storage location for the Operation and Maintenance Manual:
A magazine box provided on the left side of operator's seat

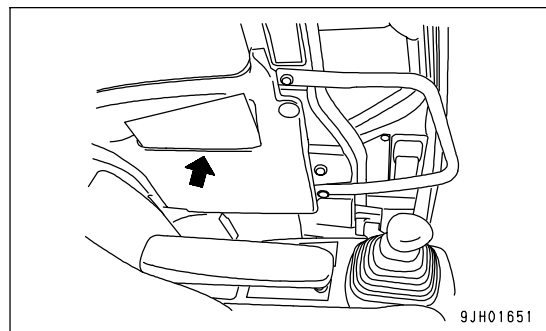

EMISSION CONTROL WARRANTY

EMISSION CONTROL WARRANTY STATEMENT (APPLIES TO CANADA ONLY)

1. Products Warranted

Komatsu America International Company, Komatsu Mining Systems Inc. and Komatsu Utility Corporation (collectively "Komatsu") produce and/or market products under brand names of Komatsu, Dresser, Dressta, Haulpak and Galion. This emissions warranty applies to new engines bearing the Komatsu name installed in these products and used in Canada in machines designed for industrial off-highway use. This warranty applies only to these engines produced on or after January 1, 2000. This warranty will be administered by Komatsu distribution in Canada.

2. Coverage

Komatsu warrants to the ultimate purchaser and each subsequent purchaser that the engine is designed, built and equipped so as to conform, at the time of sale by Komatsu, with all U.S. Federal emission regulations applicable at the time of manufacture and that it is free from defects in workmanship or material which would cause it not to meet these regulations within five years or 3,000 hours of operation, whichever occurs first, as measured from the date of delivery of the engine to the ultimate purchaser.

3. Limitations

Failures, other than those resulting from defects in materials or workmanship, are not covered by this warranty. Komatsu is not responsible for failures or damage resulting from what Komatsu determines to be abuse or neglect, including, but not limited to: operation without adequate coolant or lubricants; over fueling; over speeding; lack of maintenance of lubricating, cooling or intake systems; improper storage, starting, warm-up, run-in or shutdown practices; unauthorized modifications of the engine. Komatsu is also not responsible for failures caused by incorrect fuel or by water, dirt or other contaminants in the fuel. Komatsu is not responsible for non-engine repairs, "downtime" expense, related damage, fines, all business costs or other losses resulting from a warrantable failure.

KOMATSU IS NOT RESPONSIBLE FOR INCIDENTAL OR CONSEQUENTIAL DAMAGES.

This warranty, together with the express commercial warranties, are the sole warranties of Komatsu. **THERE ARE NO OTHER WARRANTIES, EXPRESS OR IMPLIED, OR OF MERCHANTABILITY OR FITNESS FOR A PARTICULAR PURPOSE.**

GARANTIE SUR LE CONTRÔLE DES ÉMISSIONS

ÉNONCÉ DE GARANTIE SUR LE CONTRÔLE DES ÉMISSIONS (APPLICABLE AU CANADA SEULEMENT):

1. Produits garantis:

Komatsu America International Company, Komatsu Mining Systems Inc. et Komatsu Utility Corporation (collectivement Komatsu) produisent et/ou font la mise en marché de produits portant les noms de marque Komatsu, Dresser, Dressta, Haulpak et Galion. Cette garantie sur les émissions s'applique à tous les nouveaux moteurs portant le nom Komatsu, installés dans ces produits et utilisés au Canada dans des machines conçues pour utilisation industrielle non-routière. Cette garantie s'applique seulement sur les moteurs produits à partir du 1er Janvier 2000. Cette garantie sera administrée par la distribution de Komatsu au Canada.

2. Couverture:

Komatsu garantit à l'acheteur ultime et chaque acheteur subséquent que le moteur est conçu, construit et équipé en toute conformité, au moment de la vente par Komatsu, avec toutes les Réglementations fédérales américaines sur les émissions applicables au moment de la fabrication et qu'il est exempt de défauts de construction ou de matériaux qui auraient pour effet de contrevenir à ces réglementations en dedans de 5 ans ou 3000 heures d'opération, mesuré à partir de la date de livraison du moteur au client ultime.

3. Limitations:

Les bris, autres que ceux résultant de défauts de matériaux ou de construction, ne sont pas couverts par cette Garantie. Komatsu n'est pas responsable pour bris ou dommages résultant de ce que Komatsu détermine comme étant de l'abus ou négligence, incluant mais ne se limitant pas à: l'opération sans lubrifiants ou agent refroidissants adéquats; la suralimentation d'essence; la survitesse; le manque d'entretien des systèmes de lubrification, de refroidissement ou d'entrée; de pratiques non-propices d'entreposage, de mise en marche, de réchauffement, de conditionnement ou d'arrêt; les modifications non-autorisées du moteur. De plus, Komatsu n'est pas responsable de bris causés par de l'essence inadéquate ou de l'eau, des saletés ou autres contaminants dans l'essence. Komatsu n'est pas responsable des réparations non-relées au moteur, des dépenses encourues suite aux temps d'arrêts, des dommages relatifs, amendes, et de tout autre coût d'affaires ou autres pertes résultant d'un bris couvert par la garantie.

KOMATSU N'EST PAS RESPONSABLE DES INCIDENTS OU DOMMAGES CONSÉQUENTS.

Cette garantie, ainsi que les garanties expresses commerciales, sont les seules garanties de Komatsu. **IL N'Y A AUCUNE AUTRE GARANTIE, EXPRESSE OU SOUS-ENTENDUE, MARCHANDABLE OU PROPICE A UNE UTILISATION PARTICULIÈRE.**

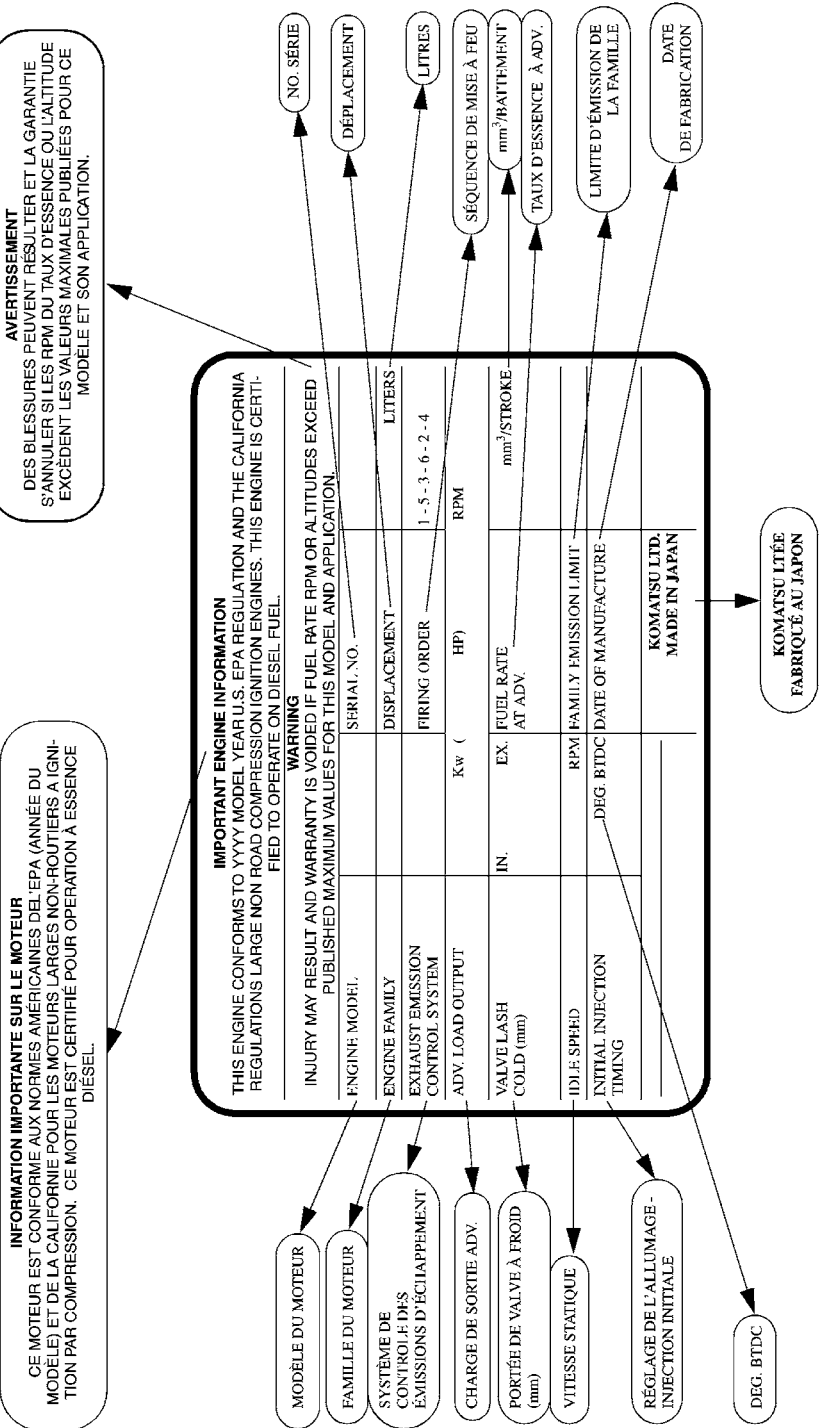

ENGINE DATAPLATE - ENGLISH / FRENCH



SAFETY INFORMATION

To enable you to use this machine safely, safety precautions and labels are given in this manual and affixed to the machine to give explanations of situations involving potential hazards and of the methods of avoiding such situations.

Signal words

The following signal words are used to inform you that there is a potential hazardous situation that may lead to personal injury or damage.

In this manual and on machine labels, the following signal words are used to express the potential level of hazard.

- | | |
|--|---|
|  DANGER | Indicates an imminently hazardous situation which, if not avoided, will result in death or serious injury. |
|  WARNING | Indicates a potentially hazardous situation which, if not avoided, could result in death or serious injury. |
|  CAUTION | Indicates a potentially hazardous situation which, if not avoided, may result in minor or moderate injury. This word is used also to alert against unsafe practices that may cause property damage. |

Example of safety message using signal word

 WARNING
When standing up from the operator's seat, always place the lock lever in the LOCK position. If you accidentally touch the control levers when they are not locked, this may cause a serious injury or death.

Other signal words

In addition to the above, the following signal words are used to indicate precautions that should be followed to protect the machine or to give information that is useful to know.

NOTICE This word is used for precautions that must be taken to avoid actions which could shorten the life of the machine.

REMARKS This word is used for information that is useful to know.

- Safety labels

Safety labels are affixed to the machine to inform the operator or maintenance worker on the spot when carrying out operation or maintenance of the machine that may involve hazard.

This machine uses "Safety labels using words" and "Safety labels using pictograms" to indicate safety procedures.

Example of safety label using words

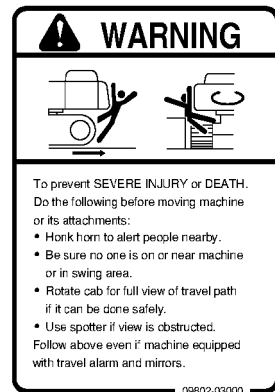

Part No

Safety labels using pictogram

Safety pictograms use a picture to express a level of hazardous condition equivalent to the signal word. These safety pictograms use pictures in order to let the operator or maintenance worker understand the level and type of hazardous condition at all times. Safety pictograms show the type of hazardous condition at the top or left side, and the method of avoiding the hazardous condition at the bottom or right side. In addition, the type of hazardous condition is displayed inside a triangle and the method of avoiding the hazardous condition is shown inside a circle.



Part No

Komatsu cannot predict every circumstance that might involve a potential hazard in operation and maintenance. Therefore, the safety messages in this manual and on the machine may not include all possible safety precautions. If any procedures or actions not specifically recommended or allowed in this manual are used, it is your responsibility to take the necessary steps to ensure safety.

In no event should you engage in prohibited uses or actions described in this manual.

The explanations, values, and illustrations in this manual were prepared based on the latest information available at that time. Continuing improvements in the design of this machine can lead to changes in detail which may not be reflected in this manual. Consult Komatsu or your Komatsu distributor for the latest available information of your machine or for questions regarding information in this manual.

The numbers in circles in the illustrations correspond to the numbers in () in the text. (For example: ① -> (1))

INTRODUCTION

This Komatsu machine is designed to be used mainly for the following work:

- Digging work
- Leveling work
- Ditching work
- Loading work
- Demolition work

See the section "RECOMMENDED APPLICATIONS (PAGE 3-94)" for further details.

DIRECTIONS OF MACHINE

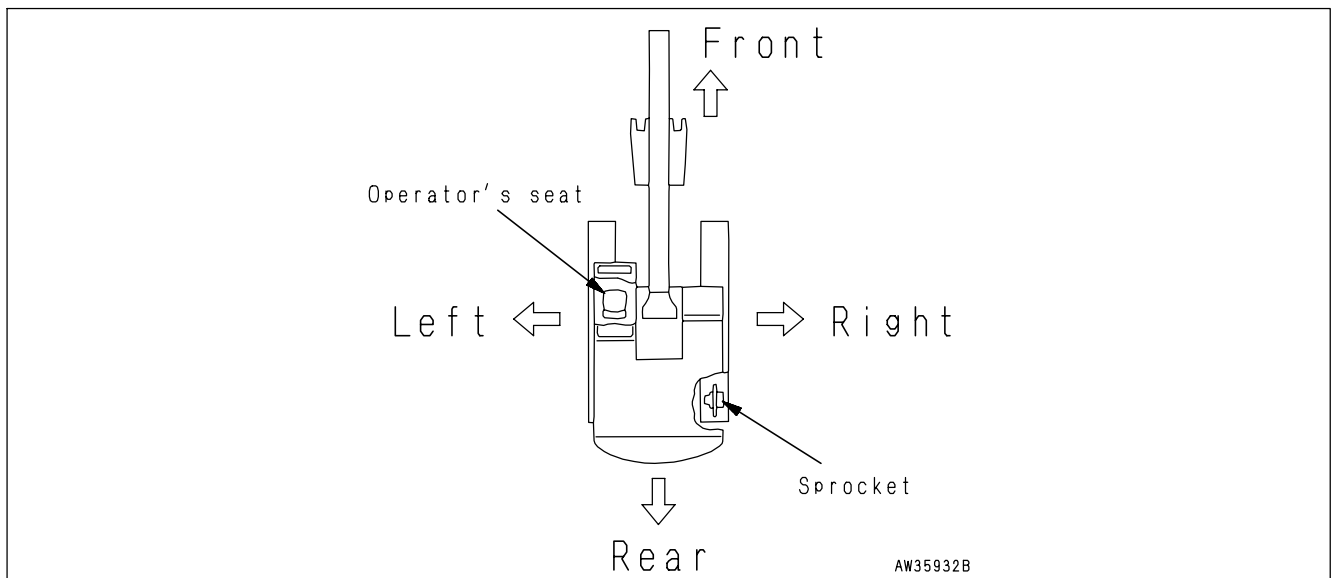

In this manual, the terms front, rear, left, and right refer to the travel direction as seen from the operator's seat when the operator's seat is facing the front and the sprocket is at the rear of the machine.

BREAKING-IN THE NEW MACHINE



CAUTION

Your Komatsu machine has been thoroughly adjusted and tested before shipment. However, operating the machine under severe conditions at the beginning can adversely affect the performance and shorten the machine life.

Be sure to break-in the machine for the initial 100 hours (as indicated by the service meter).

During break-in operations, follow the precautions described in this manual.

- Idle the engine for 5 minutes after starting it up.
- Avoid operation with heavy loads or at high speeds.
- Immediately after starting the engine, avoid sudden starts, sudden acceleration, unnecessary sudden stops, and sudden changes in direction.

PRODUCT INFORMATION

When requesting service or ordering replacement parts, please inform your Komatsu distributor of the following items.

PRODUCT IDENTIFICATION NUMBER (PIN)/MACHINE SERIAL NO. PLATE

On the bottom right of the operator's cab

The design of the nameplate differs according to the territory.

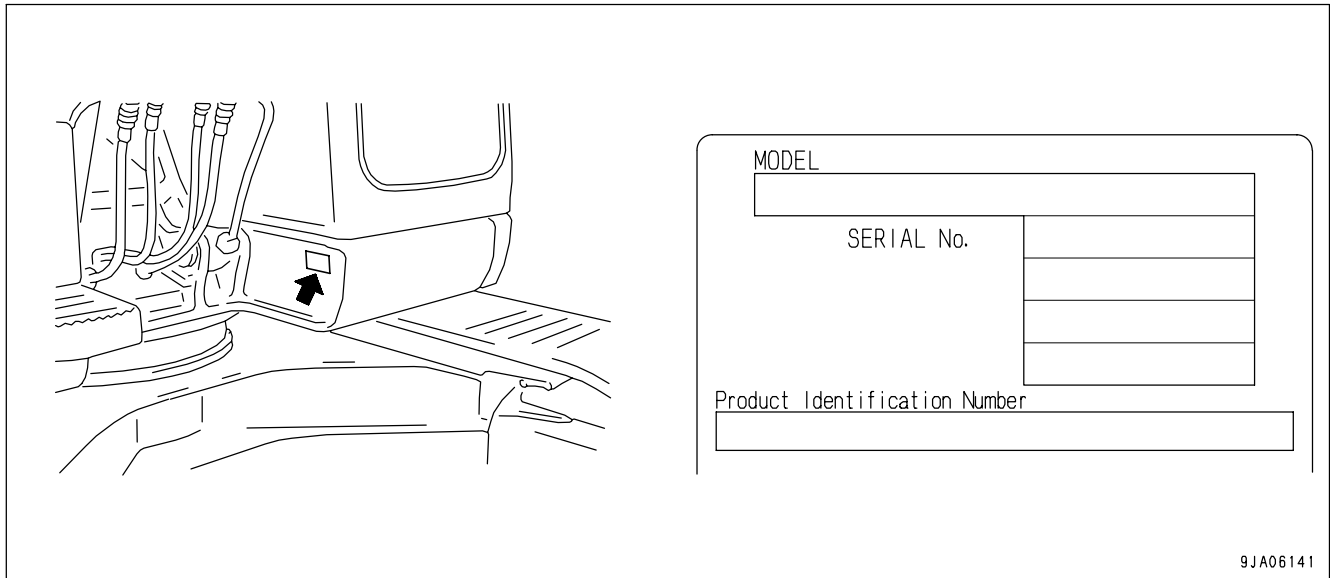

9JA06141

ENGINE SERIAL NUMBER PLATE AND ITS LOCATION

On the upper side of the engine cylinder head cover.

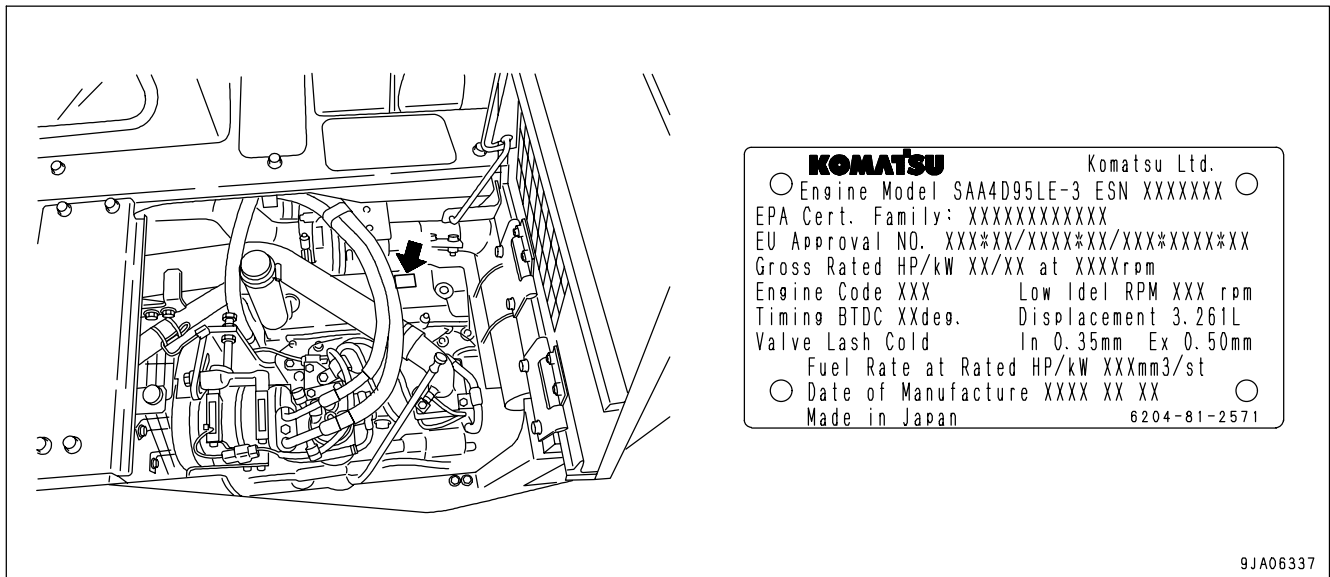

9JA06337

EPA NAMEPLATE

On the upper side of the engine cylinder head cover.

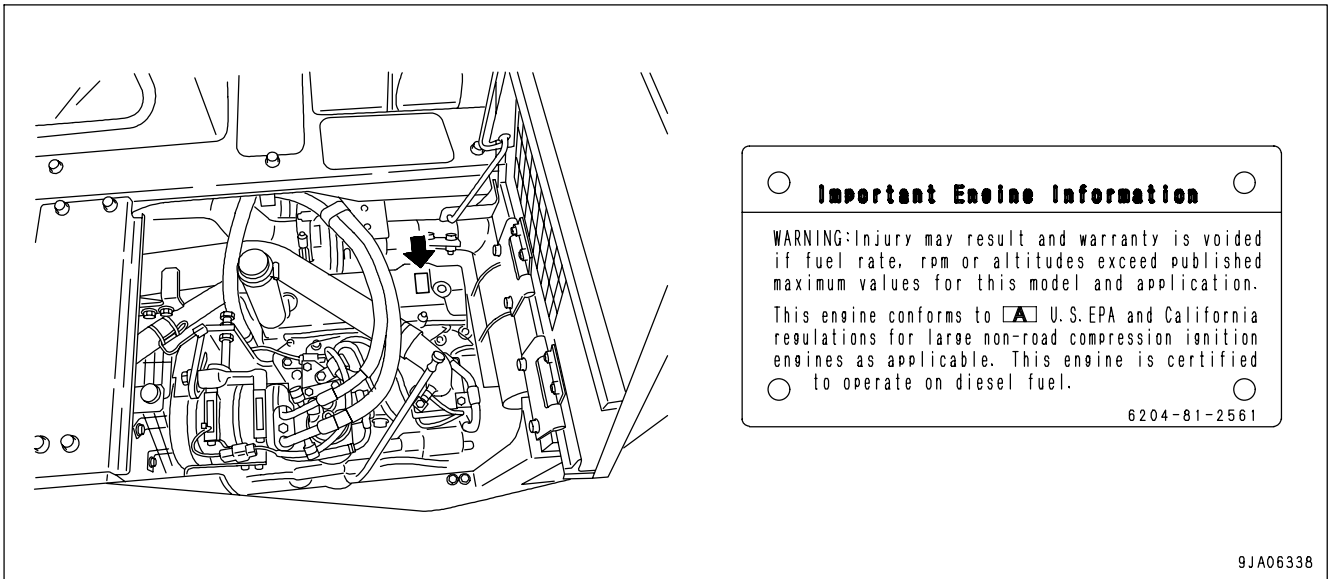

EPA: Environmental Protection Agency, U.S.A.

SERVICE METER LOCATION

On top of the machine monitor

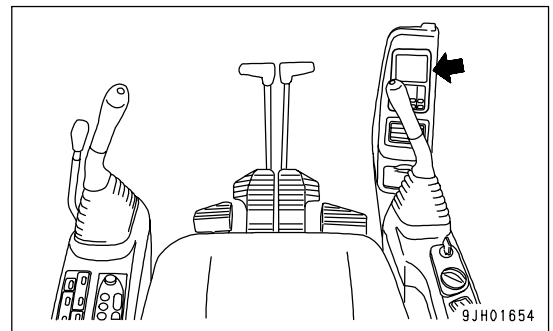

YOUR MACHINE SERIAL NUMBERS AND DISTRIBUTOR

Machine serial No.	
Engine serial No.	
Product identification number (PIN)	
Distributor name	
Address	-----

Service Personnel	
Phone/Fax	

CONTENTS

FOREWORD 1- 1

 FOREWORD 1- 2

 SAFETY INFORMATION 1- 5

 INTRODUCTION 1- 7

 DIRECTIONS OF MACHINE 1- 7

 BREAKING-IN THE NEW MACHINE 1- 7

 PRODUCT INFORMATION 1- 8

 PRODUCT IDENTIFICATION NUMBER (PIN)/MACHINE SERIAL NO. PLATE 1- 8

 ENGINE SERIAL NUMBER PLATE AND ITS LOCATION 1- 8

 EPA NAMEPLATE 1- 9

 SERVICE METER LOCATION 1- 9

 YOUR MACHINE SERIAL NUMBERS AND DISTRIBUTOR 1- 10

SAFETY 2- 1

 SAFETY INFORMATION 2- 2

 SAFETY LABELS 2- 4

 LOCATION OF SAFETY LABELS 2- 5

 SAFETY LABELS 2- 6

 SAFETY INFORMATION 2- 11

 SAFETY MACHINE OPERATION 2- 19

 STARTING ENGINE 2- 19

 OPERATION 2- 21

 TRANSPORTATION 2- 27

 BATTERY 2- 28

 TOWING 2- 30

 LIFTING OBJECTS WITH BUCKET 2- 31

 SAFETY MAINTENANCE INFORMATION 2- 32

OPERATION 3- 1

 MACHINE VIEW ILLUSTRATIONS 3- 2

 OVERALL MACHINE VIEW 3- 2

 CONTROLS AND GAUGES 3- 3

 DETAILED CONTROLS AND GAUGES 3- 4

 MONITORING SYSTEM 3- 4

 SWITCHES 3- 16

 CONTROL LEVERS AND PEDALS 3- 21

 SUN ROOF 3- 24

 WINDSHIELD 3- 25

 SLIDING DOOR 3- 30

 EMERGENCY ESCAPE HAMMER 3- 30

 CAP WITH LOCK 3- 32

 ENGINE HOOD 3- 33

 CAB REAR COVER 3- 34

 PUMP ROOM DOOR, BATTERY ROOM DOOR 3- 35

 DOOR AT FRONT OF TOOL BOX 3- 36

 FUZE 3- 37

 FUSIBLE LINK 3- 38

 AUXILIARY ELECTRIC POWER 3- 38

 CONTROLLERS 3- 39

 AIR CONDITIONER CONTROLS 3- 40

 RADIO 3- 45

OPERATION MANUAL STORAGE	3- 50
TOOL BOX	3- 50
GREASE PUMP HOLDER	3- 50
HOT AND COOL BOX	3- 50
ASHTRAY	3- 51
FIRE EXTINGUISHER	3- 51
MACHINE OPERATIONS AND CONTROLS	3- 52
BEFORE STARTING ENGINE	3- 52
STARTING ENGINE	3- 68
AFTER STARTING ENGINE	3- 73
STOPPING THE ENGINE	3- 76
MACHINE OPERATION	3- 77
STEERING THE MACHINE	3- 81
SWINGING	3- 83
WORK EQUIPMENT CONTROLS AND OPERATIONS	3- 84
WORKING MODE	3- 86
PROHIBITED OPERATIONS	3- 86
GENERAL OPERATION INFORMATION	3- 89
TRAVELING ON SLOPES	3- 91
ESCAPE FROM MUD	3- 93
RECOMMENDED APPLICATIONS	3- 94
BUCKET REPLACEMENT AND INVERSION	3- 96
PARKING MACHINE	3- 98
MACHINE INSPECTION AFTER DAILY WORK	3-100
LOCKING	3-100
ROAD LINERS	3-101
TRANSPORTATION	3-103
TRANSPORTATION PROCEDURE	3-103
LOADING AND UNLOADING WITH TRAILER	3-103
LIFTING MACHINE	3-110
COLD WEATHER OPERATION	3-112
COLD WEATHER OPERATION INFORMATION	3-112
AFTER DAILY WORK COMPLETION	3-114
AFTER COLD WEATHER SEASON	3-114
LONG TERM STORAGE	3-115
BEFORE STORAGE	3-115
DURING STORAGE	3-115
AFTER STORAGE	3-115
TROUBLES AND ACTIONS	3-116
RUNNING OUT OF FUEL	3-116
PHENOMENA THAT ARE NOT FAILURES	3-116
TOWING THE MACHINE	3-117
LIGHTWEIGHT TOWING HOOK	3-118
SEVERE JOB CONDITION	3-118
DISCHARGED BATTERY	3-119
OTHER TROUBLE	3-123
MAINTENANCE	4- 1
MAINTENANCE INFORMATION	4- 2
OUTLINE OF SERVICE	4- 4
HANDLING OIL, FUEL, COOLANT, AND PERFORMING OIL CLINIC	4- 4

ELECTRIC SYSTEM MAINTENANCE	4- 7
WEAR PARTS	4- 8
WEAR PARTS LIST	4- 8
RECOMMENDED FUEL, COOLANT, AND LUBRICANT	4- 9
USE OF FUEL, COOLANT AND LUBRICANTS ACCORDING TO AMBIENT TEMPERATURE ----	4- 10
RECOMMENDED BRANDS, RECOMMENDED QUALITY FOR PRODUCTS OTHER THAN KOMATSU GENUINE OIL	4- 11
TIGHTENING TORQUE SPECIFICATIONS	4- 12
TIGHTENING TORQUE LIST	4- 12
SAFETY CRITICAL PARTS	4- 13
SAFETY CRITICAL PARTS LIST	4- 13
MAINTENANCE SCHEDULE	4- 14
MAINTENANCE SCHEDULE CHART	4- 14
MAINTENANCE INTERVAL FOR HYDRAULIC BREAKER	4- 15
MAINTENANCE PROCEDURE	4- 16
INITIAL 250 HOURS MAINTENANCE (ONLY AFTER THE FIRST 250 HOURS)	4- 16
WHEN REQUIRED	4- 17
CHECK BEFORE STARTING	4- 42
EVERY 50 HOURS MAINTENANCE	4- 43
EVERY 100 HOURS MAINTENANCE	4- 44
EVERY 250 HOURS MAINTENANCE	4- 46
EVERY 500 HOURS MAINTENANCE	4- 51
EVERY 1000 HOURS MAINTENANCE	4- 59
EVERY 2000 HOURS MAINTENANCE	4- 62
EVERY 4000 HOURS MAINTENANCE	4- 68
EVERY 5000 HOURS MAINTENANCE	4- 69
SPECIFICATIONS	5- 1
SPECIFICATIONS	5- 2
ATTACHMENTS AND OPTIONS	6- 1
ATTACHMENTS AND OPTIONS - GENERAL INFORMATION	6- 2
SAFETY FIRST	6- 2
ATTACHMENT INSTALLATION	6- 3
BUCKET WITH HOOK	6- 4
HOOK CONDITION	6- 4
PROHIBITED OPERATIONS	6- 4
AIR CONDITIONER	6- 5
AIR CONDITIONER CONTROL PANEL	6- 5
AIR CONDITIONER CONTROLS	6- 10
AIR CONDITIONER MAINTENANCE	6- 10
MACHINE READY FOR ATTACHMENT	6- 11
LOCATIONS	6- 11
HYDRAULIC CIRCUIT	6- 14
ATTACHMENT REMOVAL AND INSTALLATION	6- 15
ATTACHMENT OPERATIONS	6- 19
LONG TERM STORAGE	6- 22
SPECIFICATIONS	6- 22
ATTACHMENT GUIDE	6- 23
OTHER ATTACHMENTS	6- 23
ATTACHMENT COMBINATIONS	6- 24
SELECTION OF TRACK SHOES	6- 25

RECOMMENDED ATTACHMENT OPERATIONS -----	6- 26
HYDRAULIC BREAKER -----	6- 26
CRUSHER -----	6- 31
INDEX -----	7- 1

SAFETY

WARNING

Please read and make sure that you fully understand the precautions described in this manual and the safety labels on the machine. When operating or servicing the machine, always follow these precautions strictly.

SAFETY INFORMATION

SAFETY LABELS	2- 4
LOCATION OF SAFETY LABELS	2- 5
SAFETY LABELS	2- 6
SAFETY INFORMATION	
Safety rules	2- 11
If problems are found	2- 11
Working wear and personal protective items	2- 11
Fire extinguisher and first aid kit	2- 11
Safety equipment	2- 11
Keep machine clean	2- 12
Keep operator's compartment clean	2- 12
Leaving operator's seat with lock	2- 12
Handrails and steps	2- 13
Mounting and dismounting	2- 13
No persons on attachments	2- 13
Do not get caught in articulated portion	2- 13
Burn prevention	2- 14
Fire prevention and explosion prevention	2- 14
Action if fire occurs	2- 15
Windshield washer fluid	2- 15
Falling objects, flying objects and intruding objects prevention	2- 15
Attachment installation	2- 16
Attachment combinations	2- 16
Cab window glasses	2- 16
Unauthorized modifications	2- 16
Safety at jobsite	2- 16
Working on loose ground	2- 17
Distance to high voltage cables	2- 17
Ensure good visibility	2- 17
Ventilation for enclosed area	2- 18
Signalman's signal and signs	2- 18
Emergency exit from operator's cab	2- 18
Asbestos dust hazard prevention	2- 18

SAFETY MACHINE OPERATION	2- 19
STARTING ENGINE	2- 19
Checks before starting engine	2- 19
Safety rules for starting engine	2- 19
Starting engine in cold weather	2- 20
OPERATION	2- 21
Checks before operation	2- 21
Safety rules for changing machine directions	2- 21
Safety rules for traveling	2- 22
Traveling on slopes	2- 23
Operations on slopes	2- 24
Prohibited operations	2- 24
Operations on snow	2- 25
Parking machine	2- 26
TRANSPORTATION	2- 27
Loading and unloading	2- 27
Shipping the machine	2- 27
BATTERY	2- 28
Battery hazard prevention	2- 28
Starting engine with booster cables	2- 29
TOWING	2- 30
Safety rules for towing	2- 30
LIFTING OBJECTS WITH BUCKET	2- 31
Safety rules for lifting objects	2- 31
 SAFETY MAINTENANCE INFORMATION	 2- 32
Warning tag	2- 32
Keep work place clean and tidy	2- 32
Appoint leader when working with others	2- 32
Stop engine before carrying out maintenance	2- 33
Two workers for maintenance when engine is running	2- 34
Proper tools	2- 34
Accumulator	2- 34
Personnel	2- 35
Attachments	2- 35
Work under the machine	2- 35
Noise	2- 35
When using hammer	2- 35
Welding works	2- 36
Removing battery terminals	2- 36
Safety first when using high-pressure grease to adjust track tension	2- 36
Do not disassemble recoil springs	2- 36
Safety rules for high-pressure oil	2- 37
Safety handling high-pressure hoses	2- 37
Waste materials	2- 37
Air conditioner maintenance	2- 37
Compressed air	2- 38
Periodic replacement of safety critical parts	2- 38

SAFETY LABELS

The following warning signs and safety labels are used on this machine.

- Be sure that you fully understand the correct position and content of labels.
- To ensure that the content of labels can be read properly, be sure that they are in the correct place and always keep them clean. When cleaning them, do not use organic solvents or gasoline. These may cause the labels to peel off.
- There are also other labels in addition to the warning signs and safety labels. Handle those labels in the same way.
- If the labels are damaged, lost, or cannot be read properly, replace them with new ones. For details of the part numbers for the labels, see this manual or the actual label, and place an order with Komatsu distributor.

LOCATION OF SAFETY LABELS

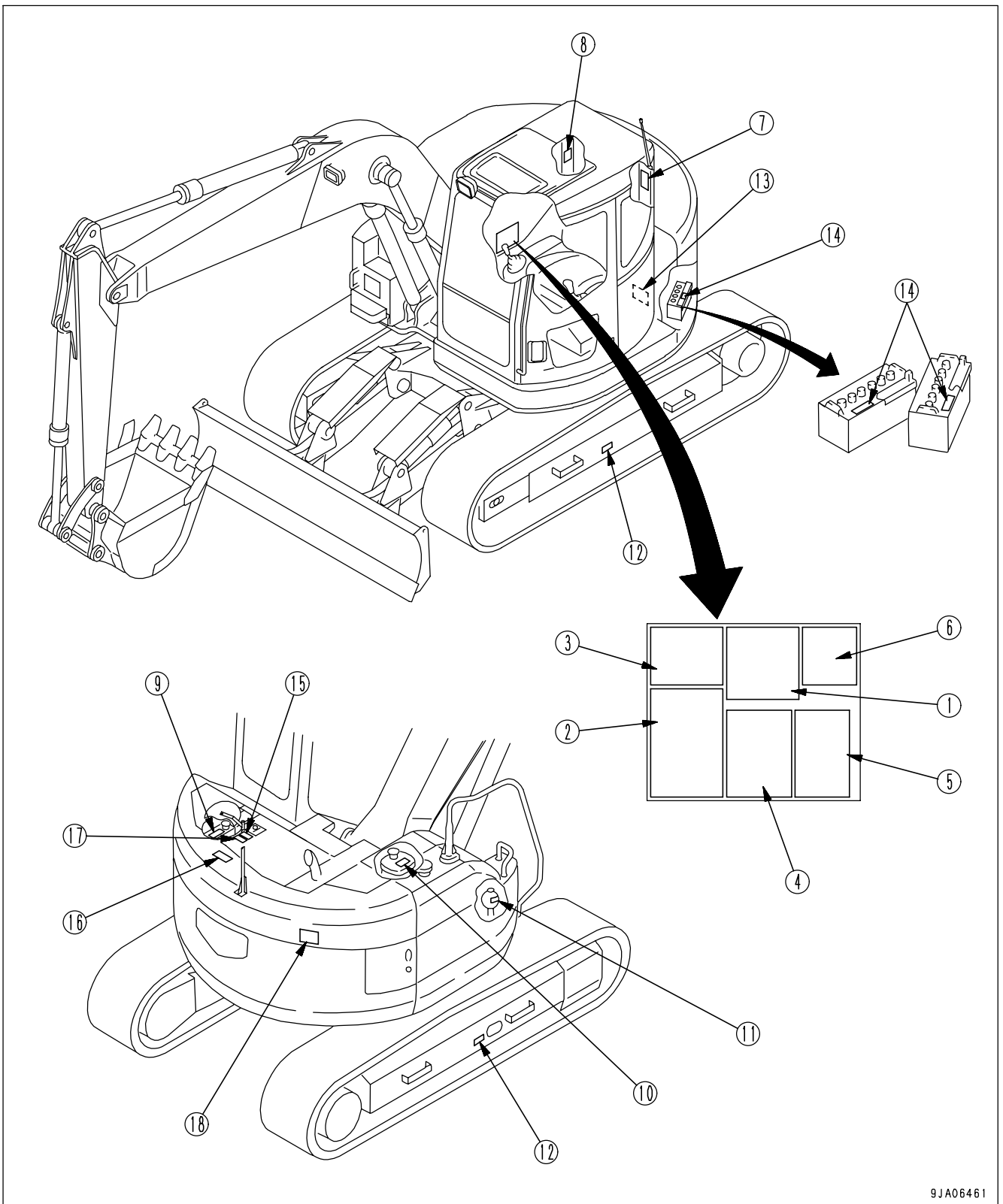

9JA06461

SAFETY LABELS

- (1) Caution before operating or maintaining machine
(09651-03001)



- (2) Caution before operating (09802-03000)

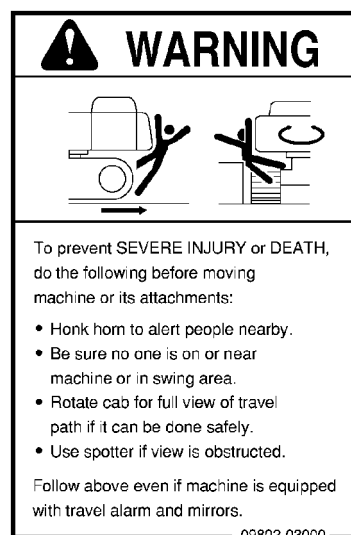

- (3) Caution for leaving operator's seat (09654-03001)



(4) Caution for going close to electric cables (09801-03001)

⚠ DANGER

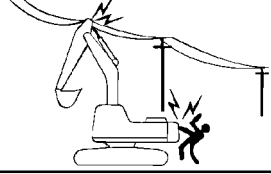

Hazardous voltage hazard.
Serious injury or death can occur if machine or attachments are not kept safe distance away from electric lines.

VOLTAGE		SAFE DISTANCE
LOW VOLTAGE	100V/200V	2m
	6.600V	2m
	22.000V	3m
SPECIAL HIGH VOLTAGE	66.000V	4m
	154.000V	5m
	187.000V	6m
	275.000V	7m
	500.000V	11m

09801-03001

(5) Caution for operating pattern (09822-03000)
Standard machine

⚠ WARNING

In order to prevent an accident resulting in injury or death caused by error-operation, confirm the machine motion and indicated operating pattern, when operating machines. Pay attention to the circumference and operate slowly when confirming the machine motion.

ISO pattern

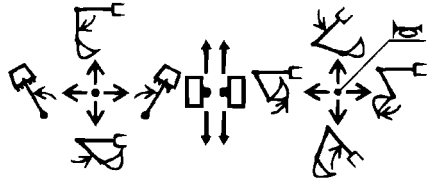

09822-03000

(6) Caution when opening or closing front window (09839-03000)

 WARNING
<p>To open or close the front or ceiling window, never stand up from the operator's seat before throwing the lock lever to the LOCK position.</p> <p>Inadvertently touching any of the working equipment control levers might cause the machine to start moving all of a sudden, probably resulting in a serious injury.</p> <p style="text-align: right;">09839-03000</p>

(7) Caution when stowing front window (09803-03000)

 WARNING
<p>When raising window, lock it in place with lock pins on both sides.</p> <p>Falling window can cause injury.</p> <p style="text-align: right;">09803-03000</p>

(8) Caution when window comes out or breaks (20U-98-21910)

 WARNING
<p>To prevent SEVERE INJURY or DEATH, follow instructions below :</p> <ul style="list-style-type: none"> • To avoid contact with boom, DO NOT lean outside right side window. • If right side window is broken or becomes dislodged, have it repaired immediately. <p style="text-align: right;">20U-98-21910</p>

(9) Caution with high-temperature coolant (09668-03001)

 WARNING
<p>Hot water hazard.</p> <p>To prevent hot water from spurting out:</p> <ul style="list-style-type: none"> • Turn engine off. • Allow water to cool. • Slowly loosen cap to relieve pressure before removing. <p style="text-align: right;">09668-03001</p>



(10) Caution with high-temperature hydraulic oil (09653-03001)

	WARNING
<p>Hot oil hazard.</p> <p>To prevent hot oil from spurting out:</p> <ul style="list-style-type: none"> • Turn engine off. • Allow oil to cool. • Slowly loosen cap to relieve pressure before removing. 	
09653-03001	

(11) Caution when handling accumulator (09659-53000)

	WARNING	<p>Explosion hazard</p> <ul style="list-style-type: none"> • Keep away from flame • Do not weld or drill
09659-53000		

(12) Caution when adjusting track tension (09657-03003)

	WARNING	
<p>Compressed spring lubricator and grease are under hazardous high pressure and can cause serious injury or death.</p> <ul style="list-style-type: none"> • When adjusting track tension, only turn lubricator ONE TURN, turning lubricator further could cause lubricator and grease to fly off and hurt you. See manual for adjustment instructions. • When loosening track shoe, if it does not loosen after turning lubricator ONE TURN, ask Komatsu dealer or distributor to disassemble. 		
09657-03003		

(13) Caution when handling cable (09808-03000)

	WARNING
<p>Improper use of booster cables and battery cables can cause an explosion resulting in serious injury or death.</p> <ul style="list-style-type: none"> • Follow instructions in manual when using booster cable and battery cables. 	
09808-03000	

(14) Caution when handling battery (09664-30082)

	WARNING
<p>EXPLOSIVE GASES Cigarettes, flames or sparks could cause battery to explode. Always shield eyes and face from battery. DO not charge or use booster cables or adjust post connections without proper instruction and training. KEEP VENT CAPS TIGHT AND LEVEL</p> <p>POISON causes severe burns Contains sulfuric acid. Avoid contact with skin, eyes or clothing. In event of accident flush with water and call a physician immediately. KEEP OUT OF REACH OF CHILDREN</p>	
09664-30082	

(15) Stop rotation during inspection and maintenance
(09667-03001)

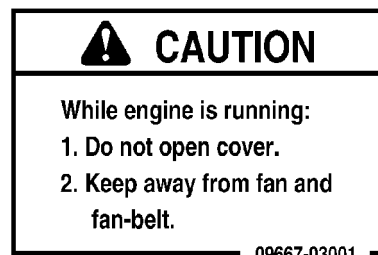

(16) Caution against falling (09805-03000)



(17) Caution against falling (09805-13000)



(18) Prohibition to enter swing range (09133-23000)



(19) Jump start prohibited (09842-A0481)
This safety label is fixed to the engine starting motor.

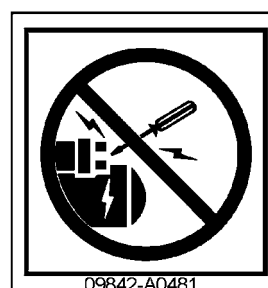

Start the engine only after sitting down in the operator's seat.

Do not attempt to start the engine by short-circuiting the engine starting circuit. Such an act may cause a serious bodily injury or fire.

The safety labels, (1) through (6) are a single seal. In replacement, place an order for it with Part No. 22U-00-21290.

SAFETY INFORMATION

SAFETY RULES

- Only trained and authorized personnel can operate and maintain the machine.
- Follow all safety rules, precautions and instructions when operating or performing maintenance on the machine.
- If you are under the influence of alcohol or medication, your ability to safely operate or repair your machine may be severely impaired putting yourself and everyone else on your jobsite in danger.
- When working with another operator or with a person on worksite traffic duty, be sure that all personnel understand all hand signals that are to be used.

IF PROBLEMS ARE FOUND

If you find any problems in the machine during operation or maintenance (noise, vibration, smell, incorrect gauges, smoke, oil leakage, etc., or any abnormal display on the warning devices or monitor), report to the person in charge and have the necessary action taken. Do not operate the machine until the problem has been corrected.

WORKING WEAR AND PERSONAL PROTECTIVE ITEMS

- Do not wear loose clothing and accessories. There is a hazard that they may catch on control levers or other protruding parts.
- If you have long hair and it hangs out from your hard hat, there is a hazard that it may get caught up in the machine, so tie your hair up and be careful not to let it get caught.
- Always wear a hard hat and safety shoes. If the nature of the work requires it, wear safety glasses, mask, gloves, ear plugs, and safety belt when operating or maintaining the machine.
- Check that all protective equipment functions properly before using it.

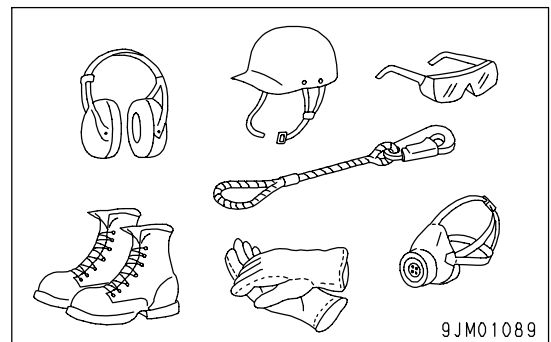

FIRE EXTINGUISHER AND FIRST AID KIT

Always follow the precautions below to prepare for action if any injury or fire should occur.

- Be sure that fire extinguishers have been provided and read the labels to ensure that you know how to use them in emergencies.
- Carry out periodic inspection and maintenance to ensure that the fire extinguisher can always be used.
- Provide a first aid kit in the storage point. Carry out periodic checks and add to the contents if necessary.

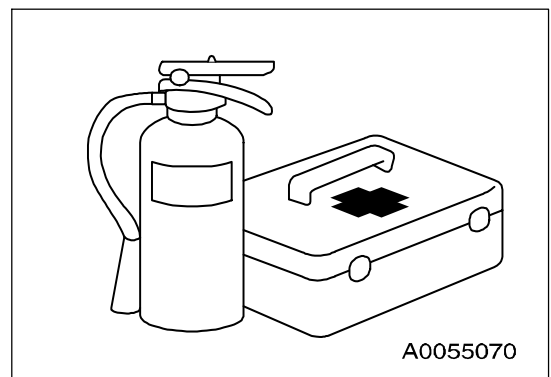

SAFETY EQUIPMENT

- Be sure that all guards and covers are in their proper position. Have guards and covers repaired immediately if they are damaged.
- Understand the method of use of safety features and use them properly.
- Never remove any safety features. Always keep them in good operating condition.

KEEP MACHINE CLEAN

- If water gets into the electrical system, there is a hazard that it will cause malfunctions or misoperation. Do not use water or steam to wash the electrical system (sensors, connectors).
- If inspection and maintenance is carried out when the machine is still dirty with mud or oil, there is a hazard that you will slip and fall, or that dirt or mud will get into your eyes. Always keep the machine clean.

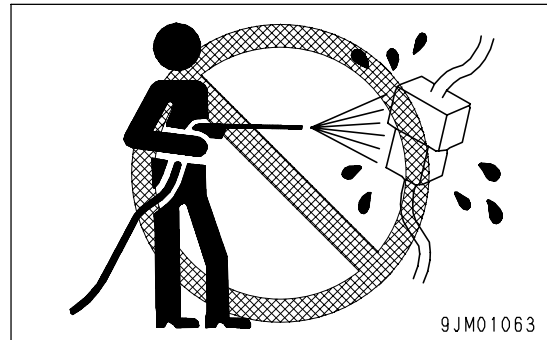
**KEEP OPERATOR'S COMPARTMENT CLEAN**

- When entering the operator's compartment, always remove all mud and oil from the soles of your shoes. If you operate the pedal with mud or oil affixed to your shoes, your foot may slip and this may cause a serious accident.
- Do not leave parts or tools lying around the operator's compartment.
- Do not stick suction pads to the window glass. Suction pads act as a lens and may cause fire.
- Do not use cellular telephones inside the operator's compartment when driving or operating the machine.
- Never bring any dangerous objects such as flammable or explosive items into the operator's compartment.

LEAVING OPERATOR'S SEAT WITH LOCK

- Before standing up from the operator's seat (such as when opening or closing the front window or roof window, or when removing or installing the bottom window, or when adjusting the operator's seat), lower the work equipment completely to the ground, set lock lever (1) securely to the LOCK position, then stop the engine. If you accidentally touch the levers when they are not locked, there is a hazard that the machine may suddenly move and cause serious injury or property damage.

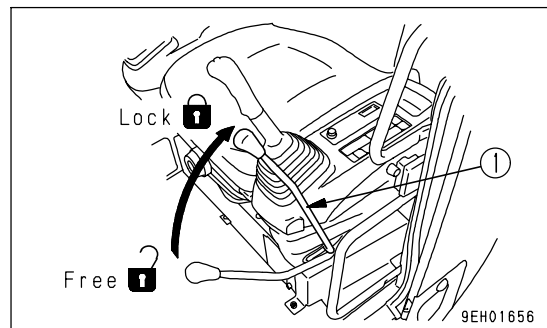

- When leaving the machine, always lower the work equipment completely to the ground, set lock lever (1) securely to the LOCK position, then stop the engine. Use the key to lock all the equipment. Always remove the key, take it with you, and keep it in the specified place.

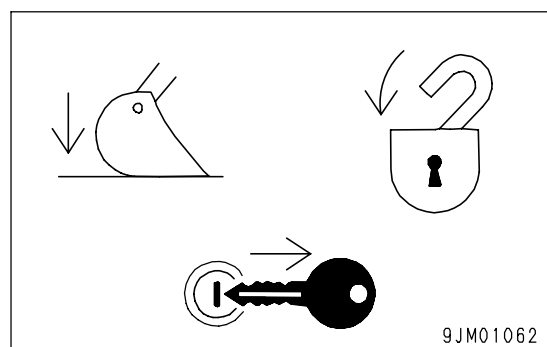

HANDRAILS AND STEPS

To prevent personal injury caused by slipping or falling off the machine, always do as follows.

- Use the handrails and steps marked by arrows in the diagram on the right when getting on or off the machine.

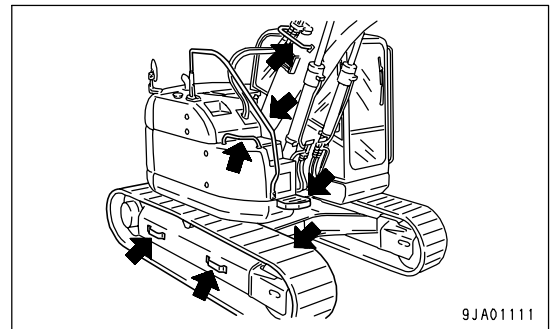
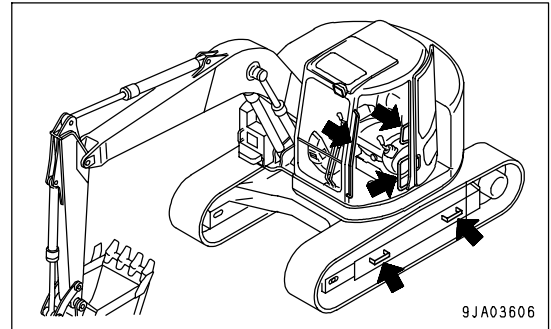

- To ensure safety, always face the machine and maintain three-point contact (both feet and one hand, or both hands and one foot) with the handrails and steps (including the track shoe) to ensure that you support yourself.
- Do not grip the control levers, or lock lever when getting on or off the machine.
- Never climb on the engine hood or covers where there are no non-slip pads.
- Before getting on or off the machine, check the handrails and steps (including the track shoe). If there is any oil, grease, or mud on the handrails or steps (including the track shoe), wipe it off immediately. Always keep these parts clean. Repair any damage and tighten any loose bolts.
- Do not get on or off the machine while holding tools in your hand.

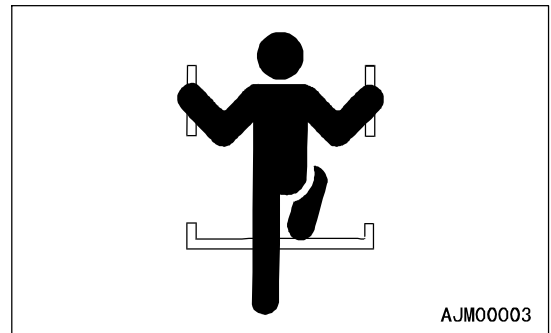

MOUNTING AND DISMOUNTING

- Never jump on or off the machine. Never get on or off a moving machine.
- If the machine starts to move when there is no operator on the machine, do not jump on to the machine and try to stop it.

NO PERSONS ON ATTACHMENTS

Never let anyone ride on the work equipment, or other attachments. There is a hazard of falling and suffering serious injury.

DO NOT GET CAUGHT IN ARTICULATED PORTION

The clearance around the work equipment will change according to the movement of the link. If you get caught, this may lead to serious personal injury. Do not allow anyone to approach any rotating or telescoping part.

BURN PREVENTION**Hot coolant**

- To prevent burns from hot water or steam spurting out when checking or draining the coolant, wait for the water to cool to a temperature where it is possible to touch the radiator cap by hand before starting the operation. Even when the coolant has cooled down, loosen the cap slowly to relieve the pressure inside the radiator before removing the cap.

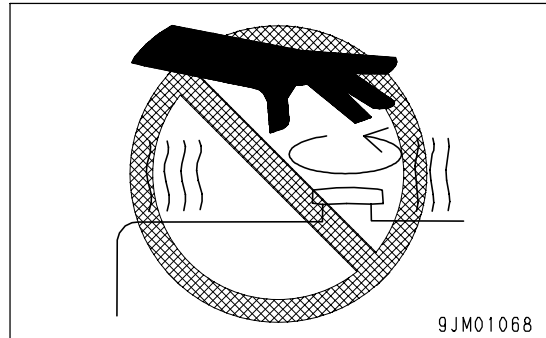
**Hot oil**

- To prevent burns from hot oil spurting out when checking or draining the oil, wait for the oil to cool to a temperature where it is possible to touch the cap or plug by hand before starting the operation. Even when the oil has cooled down, loosen the cap or plug slowly to relieve the internal pressure before removing the cap or plug.

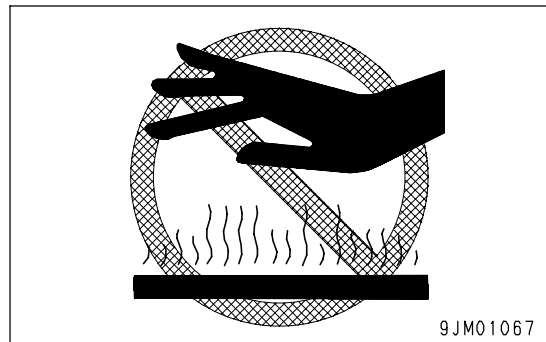
**FIRE PREVENTION AND EXPLOSION PREVENTION****• Fire caused by fuel or oil**

Fuel, oil, antifreeze, and window washer liquid are particularly flammable and can be hazardous. To prevent fire, always observe the following:

- Do not smoke or use any flame near fuel or oil.
- Stop the engine before refueling.
- Do not leave the machine while adding fuel or oil.
- Tighten all fuel and oil caps securely.
- Do not spill fuel on overheated surfaces or on parts of the electrical system.
- Use well-ventilated areas for adding or storing oil and fuel.
- Keep oil and fuel in the determined place and do not allow unauthorized persons to enter.
- After adding fuel or oil, wipe up any spilled fuel or oil.
- When carrying out grinding or welding work on the chassis, move any flammable materials to a safe place before starting.
- When washing parts with oil, use a non-flammable oil. Diesel oil and gasoline may catch fire, so do not use them.
- Put greasy rags and other flammable materials into a safe container to maintain safety at the work place.
- Do not weld or use a cutting torch to cut any pipes or tubes that contain flammable liquids.

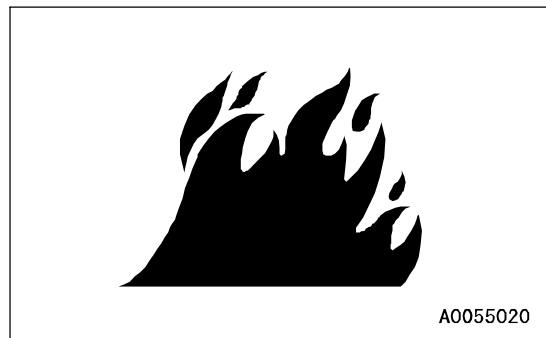
**• Fire caused by accumulation of flammable material.**

Remove any dry leaves, chips, pieces of paper, dust, or any other flammable materials accumulated or affixed around the engine, exhaust manifold, muffler, or battery, or inside the undercovers.

- **Fire coming from electric wiring**

Short circuits in the electrical system can cause fire.

- Always keep electric wiring connections clean and securely tightened.
- Check the wiring every day for looseness or damage. Tighten any loose connectors or wiring clamps. Repair or replace any damaged wiring.

- **Fire coming from hydraulic line**

Check that all the hose and tube clamps, guards, and cushions are securely fixed in position.

If they are loose, they may vibrate during operation and rub against other parts. This may lead to damage to the hoses, and cause high-pressure oil to spurt out, leading to fire damage or serious injury.

- **Explosion caused by lighting equipment**

- When checking fuel, oil, battery electrolyte, window washer fluid, or coolant, always use lighting with anti-explosion specifications. If such lighting equipment is not used, there is danger of explosion that may cause serious injury.
- When taking the electrical power for the lighting from the machine itself, follow the instructions in this manual.

ACTION IF FIRE OCCURS

If a fire occurs, escape from the machine as follows.

- Turn the start switch OFF to stop the engine.
- Use the handrails and steps to get off the machine.

WINDSHIELD WASHER FLUID

Use an ethyl alcohol base washer liquid.

Methyl alcohol base washer liquid may irritate your eyes, so do not use it.

FALLING OBJECTS, FLYING OBJECTS AND INTRUDING OBJECTS PREVENTION

On jobsites where there is a hazard that falling objects, flying objects, or intruding objects may hit or enter the operator's cab, consider the operating conditions and install the necessary guards to protect the operator.

- When carrying out demolition or breaker operations, install a front guard and use a laminated coating sheet on the front glass.
- When working in mines or quarries where there is a hazard of falling rock, install FOPS (Falling Objects Protective Structure) and a front guard, and use a laminated coating sheet on the front glass.
- When carrying out the above operations, always close the front window. In addition, always ensure that bystanders are a safe distance away and are not in hazard from falling or flying objects.
- The above recommendations assume that the conditions are for standard operations, but it may be necessary to add additional guards according to the operating conditions on the jobsite. Always contact your Komatsu distributor for advice.

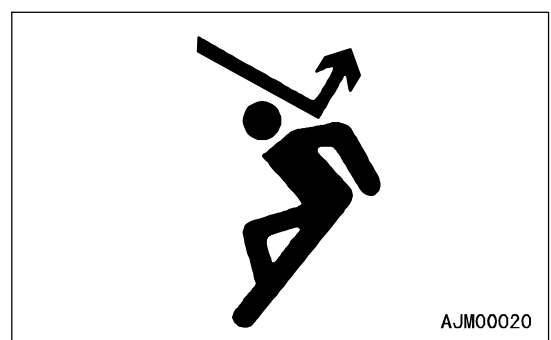
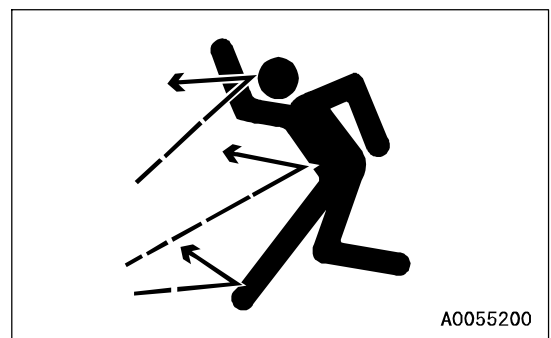

ATTACHMENT INSTALLATION

- When installing optional parts or attachments, there may be problems with safety or legal restrictions. Therefore contact your Komatsu distributor for advice.
- Any injuries, accidents, or product failures resulting from the use of unauthorized attachments or parts will not be the responsibility of Komatsu.
- When installing and using optional attachments, read the instruction manual for the attachment, and the general information related to attachments in this manual.

ATTACHMENT COMBINATIONS

Depending on the type or combination of work equipment, there is a hazard that the work equipment may hit the cab or other parts of the machine. Before using unfamiliar work equipment, check if there is any hazard of interference, and operate with caution.

CAB WINDOW GLASSES

- If a pane of the cab window on the work equipment side is broken, the work equipment may directly hit the operator. In that case, stop the machine immediately and replace the broken pane with new one.
- The ceiling window is made of organic glass (polycarbonate), and as such it is apt to break easily when receiving damage on the surface, thereby deteriorating its protective characteristic. If there is a crack or damage caused by a fallen rock, or when any sign of them is noticed, replace it with a new window.

UNAUTHORIZED MODIFICATIONS

Any modification made without authorization from Komatsu can create hazards. Before making a modification, consult your Komatsu distributor.

- Komatsu will not be responsible for any injuries, accidents, product failures or other property damages resulting from modifications made without authorization from Komatsu.

SAFETY AT JOBSITE

Before starting operations, thoroughly check the area for any unusual conditions that could be dangerous.

- When carrying out operations near combustible materials such as thatched roofs, dry leaves or dry grass, there is a hazard of fire, so be careful when operating.
- Check the terrain and condition of the ground at the worksite, and determine the safest method of operation. Do not operate where there is a hazard of landslides or falling rocks.
- If water lines, gas lines, or high-voltage electrical lines may be buried under the worksite, contact each utility and identify their locations. Be careful not to sever or damage any of these lines.
- Take action to prevent unauthorized people from approaching the jobsite.

When working on public roads, position flagmen and erect barriers to ensure the safety of passing traffic and pedestrians.

- When traveling or operating in shallow water or on soft ground, check the shape and condition of the bedrock, and the depth and speed of flow of the water before starting operations.

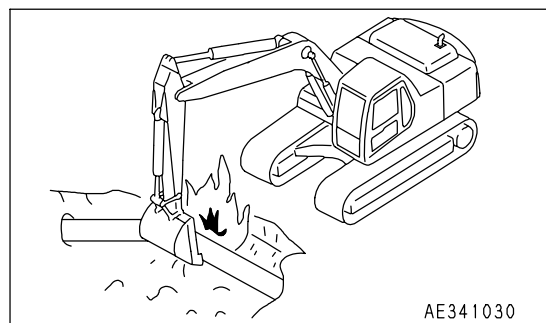

AE341030

WORKING ON LOOSE GROUND

- Avoid traveling or operating your machine too close to the edge of cliffs, overhangs, and deep ditches. The ground may be weak in such areas. If the ground should collapse under the weight or vibration of the machine, there is a hazard that the machine may fall or tip over. Remember that the soil after heavy rain or blasting or after earthquakes is weak in these areas.
- When working on embankments or near excavated ditches, there is a hazard that the weight and vibration of the machine will cause the soil to collapse. Before starting operations, take steps to ensure that the ground is safe and to prevent the machine from rolling over or falling.

DISTANCE TO HIGH VOLTAGE CABLES

Do not travel or operate the machine near electric cables. There is a hazard of electric shock, which may cause serious injury or property damage. On jobsites where the machine may go close to electric cables, always do as follows.

- Before starting work near electric cables, inform the local power company of the work to be performed, and ask them to take the necessary action.
- Even going close to high-voltage cables can cause electric shock, which may cause serious burns or even death. Always maintain a safe distance (see the table on the right) between the machine and the electric cable. Check with the local power company about safe operating procedure before starting operations.
- To prepare for any possible emergencies, wear rubber shoes and gloves. Lay a rubber sheet on top of the seat, and be careful not to touch the chassis with any exposed part of your body.
- Use a signalman to give warning if the machine approaches too close to the electric cables.
- When carrying out operations near high voltage cables, do not let anyone near the machine.
- If the machine should come too close or touch the electric cable, to prevent electric shock, the operator should not leave the operator’s compartment until it has been confirmed that the electricity has been shut off. Also, do not let anyone near the machine.

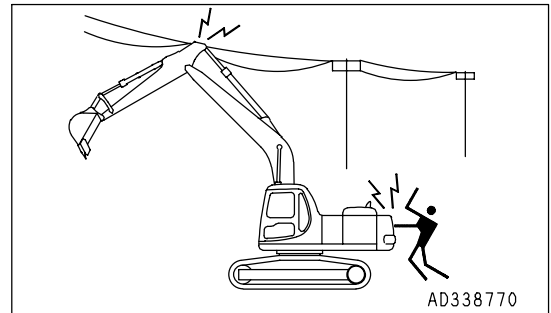

Voltage of Cables	Safety Distance
100 V - 200 V	Over 2 m (7 ft)
6,600 V	Over 2 m (7 ft)
22,000 V	Over 3 m (10 ft)
66,000 V	Over 4 m (14 ft)
154,000 V	Over 5 m (17 ft)
187,000 V	Over 6 m (20 ft)
275,000 V	Over 7 m (23 ft)
500,000 V	Over 11 m (36 ft)

ENSURE GOOD VISIBILITY

Check for any persons or obstacles in the area around the machine and check the conditions of the jobsite to ensure that operations and travel can be carried out safely. Always do as follows.

- When working in dark places, turn on the working lamp and front lamps installed to the machine, and set up additional lighting in the work area if necessary.
- Stop operations if the visibility is poor, such as in mist, snow, rain, or dust.

VENTILATION FOR ENCLOSED AREA

Exhaust fumes from the engine can kill.

- If it is necessary to start the engine within an enclosed area, or when handling fuel, flushing oil, or paint, open the doors and windows to ensure that adequate ventilation is provided to prevent gas poisoning.

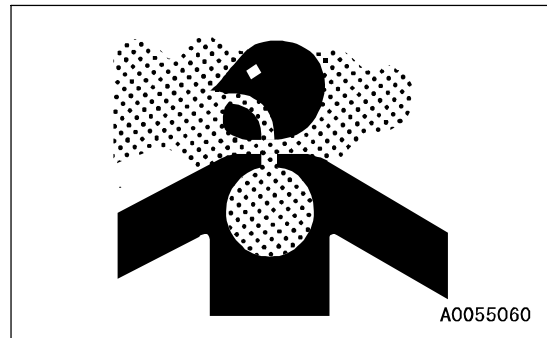
**SIGNALMAN'S SIGNAL AND SIGNS**

- Set up signs to inform of road shoulders and soft ground. If the visibility is not good, position a signalman if necessary. Operators should pay careful attention to the signs and follow the instructions from the signalman.
- Only one signalman should give signals.
- Make sure that all workers understand the meaning of all signals and signs before starting work.

EMERGENCY EXIT FROM OPERATOR'S CAB

If for any reason, it becomes impossible to open the cab door, use the hammer supplied to break the window and use it as an emergency escape.

For details, see "EMERGENCY ESCAPE HAMMER (PAGE 3-30)" in this manual.

- When escaping, remove all the pieces of glass from the window frame first and be careful not to cut yourself on the glass. Be careful also not to slip on the broken pieces of glass on the ground.

ASBESTOS DUST HAZARD PREVENTION

Asbestos dust in the air can cause lung cancer if it is inhaled. There is danger of inhaling asbestos when working on jobsites handling demolition work or work handling industrial waste. Always observe the following.

- Spray water to keep down the dust when cleaning. Do not use compressed air for cleaning.
- If there is danger that there may be asbestos dust in the air, always operate the machine from an upwind position. All workers should use an approved respirator.
- Do not allow other persons to approach during the operation.
- Always observe the rules and regulations for the work site and environmental standards.



This machine does not use asbestos, but there is a danger that imitation parts may contain asbestos, so always use genuine Komatsu parts.

SAFETY MACHINE OPERATION

STARTING ENGINE

If there is a warning tag hanging from the work equipment control lever, do not start the engine or touch the levers .

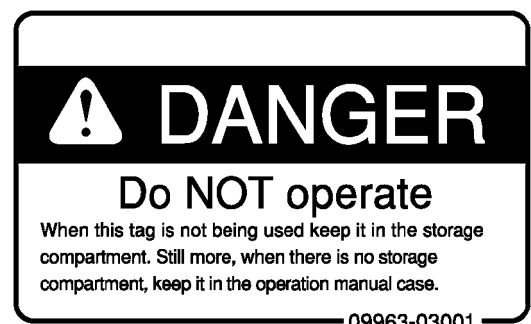
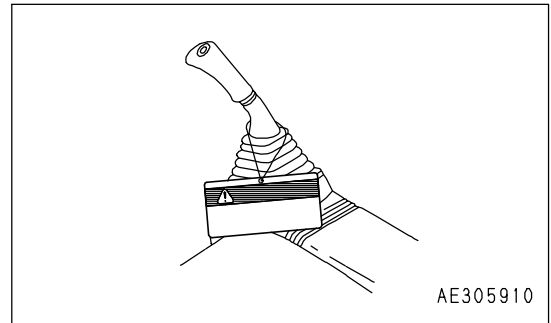

CHECKS BEFORE STARTING ENGINE

Carry out the following checks before starting the engine at the beginning of the day's work.

- Remove all dirt from the surface of the window glass to ensure a good view.
- Remove all dirt from the surface of the lens of the working lamps, and check that they light up correctly.
- Check the coolant level, fuel level, and oil level in engine oil pan, check for clogging of the air cleaner, and check for damage to the electric wiring.
- Adjust the operator's seat to a position where it is easy to carry out operations, and check that there is no damage or wear to the seat belt or mounting clamps.
- Check that the gauges work properly, check the angle of the lights and working lamps, and check that the control levers are all at the neutral position.
- Before starting the engine, make sure that the lock lever is in the LOCK position.
- Adjust the mirrors so that the rear of the machine can be seen clearly from the operator's seat. When adjusting, see "Rearview Mirrors (PAGE 3-62)".
- Check that there are no persons or obstacles above, below, or in the area around the machine.

SAFETY RULES FOR STARTING ENGINE

- Start and operate the machine only while seated.
- Do not attempt to start the engine by short-circuiting the engine starting circuit. Such an act may cause a serious bodily injury or fire.
- When starting the engine, sound the horn as a warning.
- Do not allow anyone apart from the operator to ride on the machine.

STARTING ENGINE IN COLD WEATHER

- Carry out the warming-up operation thoroughly. If the machine is not thoroughly warmed up before the control levers are operated, the reaction of the machine will be slow, and this may lead to unexpected accidents.
- If the battery electrolyte is frozen, do not charge the battery or start the engine with a different power source. There is a hazard that this will ignite the battery and cause the battery to explode. Before charging or starting the engine with a different power source, melt the battery electrolyte and check that there is no leakage of electrolyte before starting.

OPERATION

CHECKS BEFORE OPERATION

When carrying out the checks, move the machine to a wide area where there are no obstructions, and operate slowly. Do not allow anyone near the machine.

- Always fasten your seat belt.
- Check that the movement of the machine matches the display on the control pattern card. If it does not match, replace it immediately with the correct control pattern card.
- Check the operation of the work equipment, travel system and swing system.
- Check for any problem in the sound of the machine, vibration, heat, smell, or gauges; check also that there is no leakage of oil or fuel.
- If any problem is found, carry out repairs immediately.

SAFETY RULES FOR CHANGING MACHINE DIRECTIONS

- Before traveling, position the upper structure so that the sprocket is at the rear of the operator's cab. If the sprocket is at the front of the operator's cab, the machine makes a movement reverse to the control lever movement (for example, forward becomes reverse, and left becomes right). Be careful to avoid such a reverse movement of the machine.
- Before travelling, check again that there is no one in the surrounding area, and that there are no obstacles.
- Before travelling, sound the horn to warn people in the area.
- Always operate the machine only when seated.
- Do not allow anyone apart from the operator to ride on the machine.
- Check that the travel alarm (if equipped) works properly.
- Always lock the door and windows of the operator's compartment in position (open or closed).
On jobsites where there is a hazard of flying objects or of objects entering the operator's compartment, check that the door and windows are securely closed.
- If there is an area to the rear of the machine which cannot be seen, position a signal person. Take special care not to hit other machines or people when turning or swinging the machine.

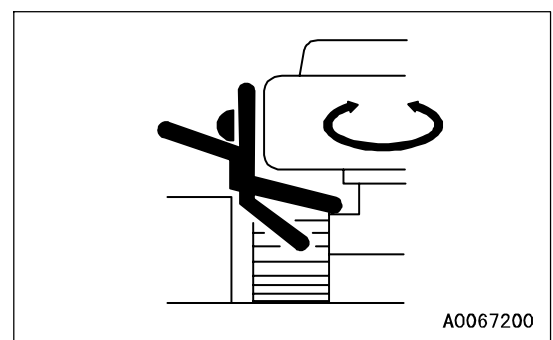
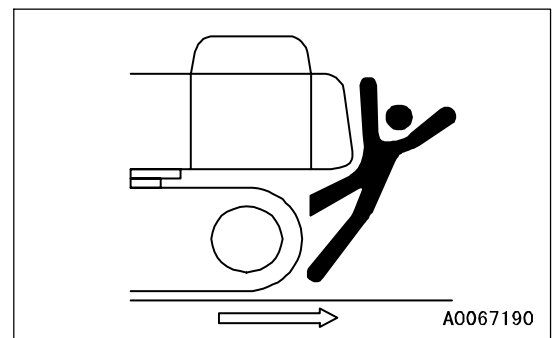
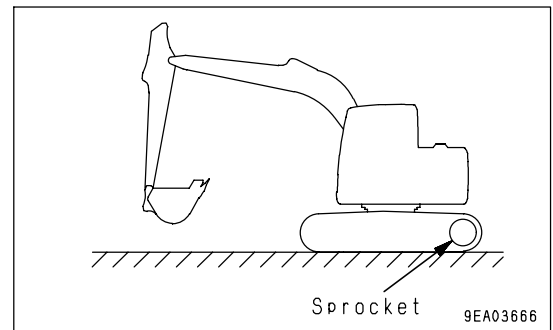

SAFETY RULES FOR TRAVELING

- It is dangerous to drive too fast, or to start suddenly, stop suddenly, or to turn sharply.
- When traveling on level ground, keep the work equipment at a height of 40 to 50 cm (16 to 20 in) from the ground.
- When traveling on rough ground, travel at low speed and do not operate the steering suddenly. There is danger that the machine may turn over. The work equipment may hit the ground surface and cause the machine to lose its balance, or may damage the machine or structures in the area.

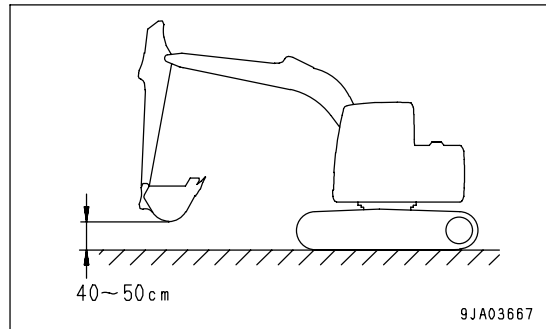

- Avoid traveling over obstacles when possible. If the machine has to travel over an obstacle, keep the work equipment close to the ground and travel at low speed. Never travel over obstacles which make the machine tilt strongly to one side.
- When traveling or carrying out operations, always keep a safe distance from people, structures, or other machines to avoid coming into contact with them.
- When passing over bridges or structures, check first that the structure is strong enough to support the weight of the machine. When traveling on public roads, check first with the relevant authorities and follow their instructions.
- When operating in tunnels, under bridges, under electric wires, or other places where the height is limited, operate slowly and be extremely careful not to let the work equipment hit anything.

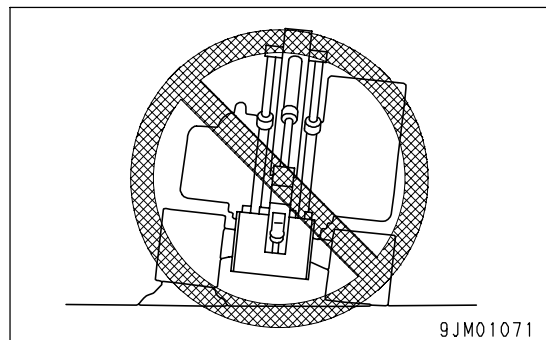

TRAVELING ON SLOPES

To prevent the machine from tipping over or slipping to the side, always do as follows.

- Keep the work equipment approx. 20 to 30 cm (8 to 12 in) above the ground. In case of emergency, lower the work equipment to the ground immediately to help stop the machine.
- When travel up slopes, set the operator's cab facing uphill, when travel down slopes, set the operator's cab facing downhill. Always check the firmness of the ground under the front of the machine when traveling.

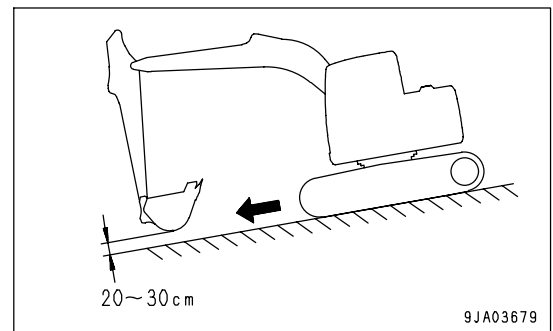
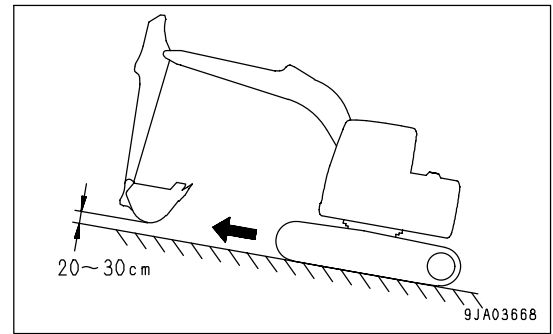

- When traveling up a steep slope, extend the work equipment to the front to improve the balance, keep the work equipment approximately 20 to 30 cm (8 to 12 in) above the ground, and travel at low speed.

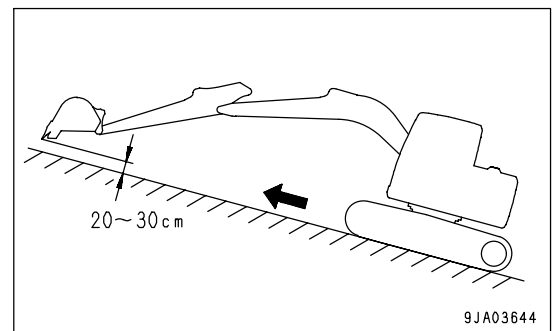

- When traveling downhill, lower the engine speed, keep the travel lever close to the neutral position, and travel at low speed.
- Always travel straight up or down a slope. Traveling at an angle or across the slope is extremely dangerous.
- Do not turn on slopes or travel across slopes. Always go down to a flat place to change the position of the machine, then travel on to the slope again.
- Travel on grass, fallen leaves, or wet steel plates with low speed. Even with slight slopes there is a hazard that the machine may slip.
- If the engine stops when the machine is traveling on a slope, move the control levers immediately to the neutral position and start the engine again.

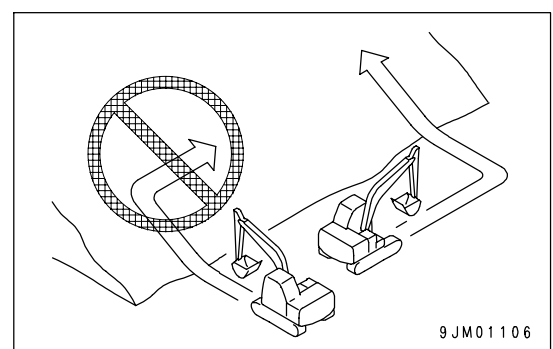

OPERATIONS ON SLOPES

- When working on slopes, there is a hazard that the machine may lose its balance and turn over when the swing or work equipment are operated. This may lead to serious injury or property damage, so always provide a stable place when carrying out these operations, and operate carefully.
- Do not swing the work equipment from the uphill side to the downhill side when the bucket is loaded. This operation is dangerous, and may cause the machine to tip over.
- If the machine has to be used on a slope, pile the soil to make a platform that will keep the machine as horizontal as possible.

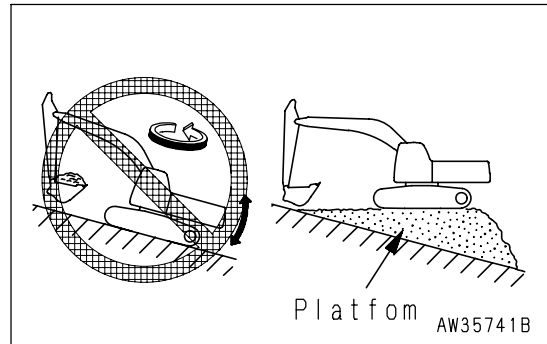
**PROHIBITED OPERATIONS**

- Never dig the work face under an overhang. There is a hazard that rocks may fall or that the overhang may collapse and fall on top of the machine.

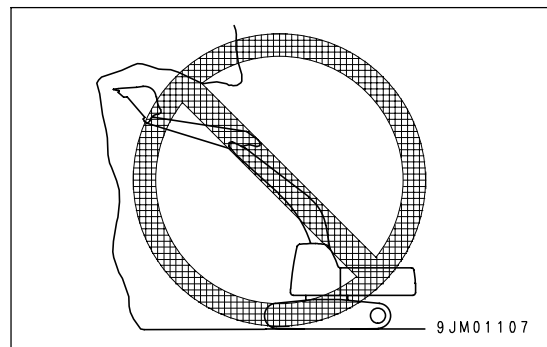

- Do not excavate too deeply under the front of the machine. The ground under the machine may collapse and cause the machine to fall.

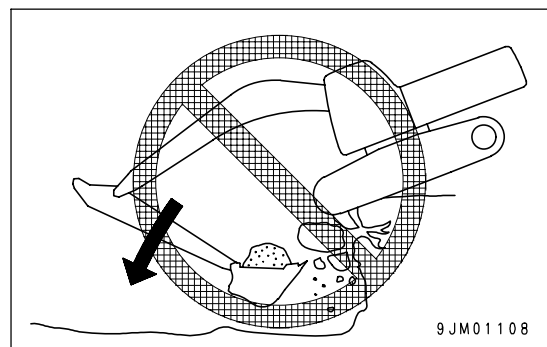

- To make it easier to escape if there is any problem, set the tracks at right angles to the road shoulder or cliff with the sprocket at the rear when carrying out operations.

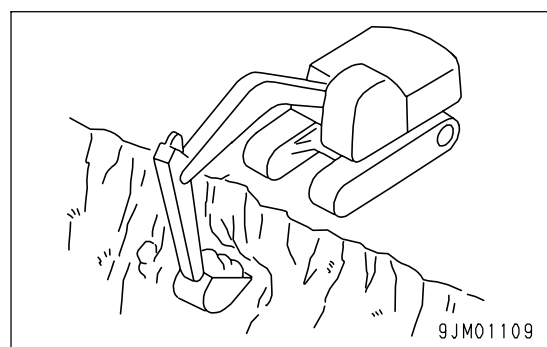

- Do not carry out demolition work under the machine. There is a hazard that the machine may become unstable and tip over.
- When working on or from the top of buildings or other structures, check the strength and the structure before starting operations. There is a hazard of the building collapsing and causing serious injury or damage.

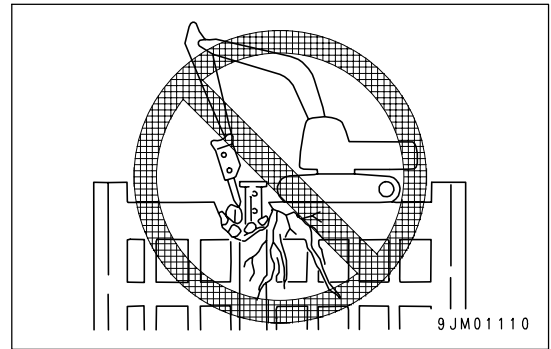

- When carrying out demolition work, do not carry out demolition above your head. There is a hazard of broken parts falling or of the building collapsing and causing serious injury or property damage.

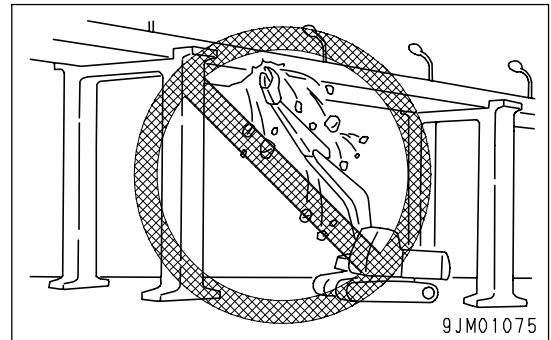

- Do not use the impact force of the work equipment for breaking work. There is a hazard of damage to the work equipment, or a hazard of serious personal injury being caused by flying pieces of broken materials, or of the machine tipping over due to reaction from the impact.
- Generally speaking, the machine is more liable to overturn when the work equipment is at the side than when it is at the front or rear.

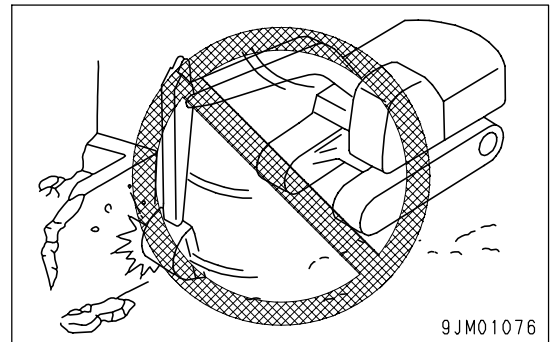

- When using a breaker or other heavy work equipment, there is a hazard of the machine losing its balance and tipping over. When operating on flat ground as well as on slopes.
 - Do not suddenly lower, swing, or stop the work equipment.
 - Do not suddenly extend or retract the boom cylinder. There is a hazard that impact will cause the machine to tip over.
- Do not pass the bucket over the head of other workers or over the operator's seat of dump trucks or other hauling equipment. The load may spill or the bucket may hit the dump truck and cause serious injury or property damage.

OPERATIONS ON SNOW

- Snow-covered or frozen surfaces are slippery, so be extremely careful when traveling or operating the machine, and do not operate the levers suddenly. Even a slight slope may cause the machine to slip, so be particularly careful when working on slopes.
- With frozen ground surfaces, the ground becomes soft when the temperature rises, and this may cause the machine to tip over.
- If the machine enters deep snow, there is a hazard that it may tip over or become buried in the snow. Be careful not to leave the road shoulder or to get trapped in a snow drift.
- When clearing snow, the road shoulder and objects placed beside the road are buried in the snow and cannot be seen. There is a hazard of the machine tipping over or hitting covered objects, so always carry out operations carefully.

PARKING MACHINE

- Park the machine on firm, level ground.
- Select a place where there is no hazard of falling rocks or landslides, or of flooding if the land is low.
- Lower the work equipment completely to the ground.

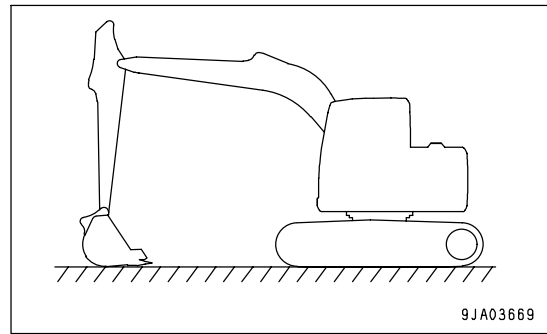

- When leaving the machine, set lock lever (1) to the LOCK position, then stop the engine.
- Always close the operator's cab door, and use the key to lock all the equipment in order to prevent any unauthorized person from moving the machine. Always remove the key, take it with you, and leave it in the specified place.
- If it is necessary to park the machine on a slope, always do as follows.
 - Set the bucket on the downhill side, then dig it into the ground.
 - Put blocks under the tracks to prevent the machine from moving.

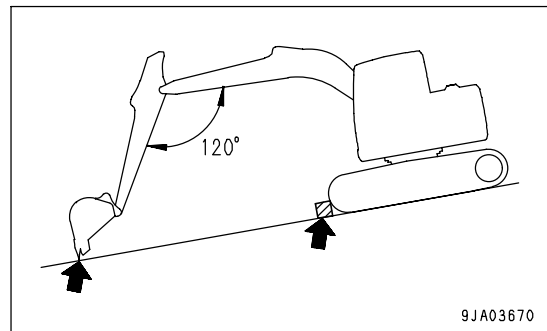
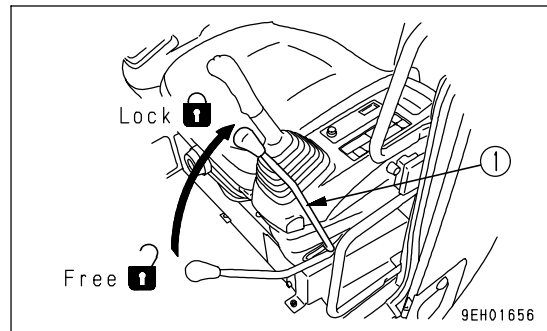

TRANSPORTATION

The machine can be divided into parts for transportation, so when transporting the machine, please contact your Komatsu distributor to have the work carried out.

LOADING AND UNLOADING

When loading or unloading the machine, mistaken operation may bring the hazard of the machine tipping over or falling, so particular care is necessary. Always do as follows.

- Perform loading and unloading on firm, level ground only. Maintain a safe distance from the edge of the road or cliff.
- Never use the work equipment to load or unload the machine. There is danger that the machine may fall or tip over.
- Always use ramps of adequate strength. Be sure that the ramps are wide, long, and thick enough to provide a safe loading slope. Take suitable steps to prevent the ramps from moving out of position or coming off.
- Be sure the ramp surface is clean and free of grease, oil, ice and loose materials. Remove dirt from machine-tracks. On a rainy day, in particular, be extremely careful since the ramp surface is slippery.
- Turn the auto-decelerator switch OFF (auto-deceleration function released).
- Run the engine at low speed and travel slowly.
- When on the ramps, do not operate any lever except for the travel lever.
- Never correct your steering on the ramps. If necessary, drive off the ramps, correct the direction, then enter the ramps again.
- The center of gravity of the machine will change suddenly at the joint between the ramps and the track or trailer, and there is danger of the machine losing its balance. Travel slowly over this point.
- When loading or unloading to an embankment or platform, make sure that it has suitable width, strength, and grade.
- When swinging the upper structure on the trailer, the trailer is unstable, so pull in the work equipment and swing slowly.
- For machines equipped with a cab, always lock the door after boarding the machine. If this is not done, the door may suddenly open during transportation.
Refer to "TRANSPORTATION (PAGE 3-103)".

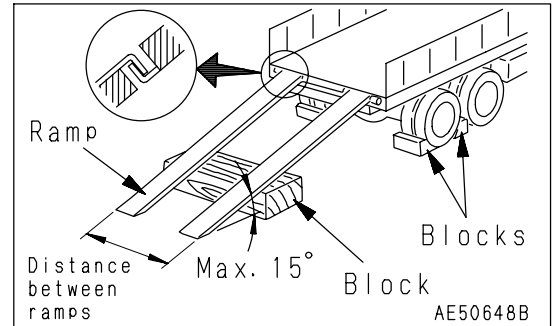

SHIPPING THE MACHINE

When shipping the machine on a trailer, do as follows.

- The weight, transportation height, and overall length of the machine differ according to the work equipment, so be sure to confirm the dimensions.
- When passing over bridges or structures on private land, check first that the structure is strong enough to support the weight of the machine. When traveling on public roads, check first with the relevant authorities and follow their instructions.
- For details of the shipping procedure, see "TRANSPORTATION (PAGE 3-103)" in the OPERATION section.

BATTERY

BATTERY HAZARD PREVENTION

Battery electrolyte contains sulphuric acid, and batteries generate flammable hydrogen gas, which may explode. Mistaken handling can lead to serious injury or fire. For this reason, always observe the following precautions.

- Do not use or charge the battery if the battery electrolyte level is below the LOWER LEVEL line. This may cause an explosion. Check the battery electrolyte level periodically and add distilled water to bring the electrolyte level to the UPPER LEVEL line.
- When working with batteries, always wear safety glasses and rubber gloves.
- Never smoke or use any flame near the battery.

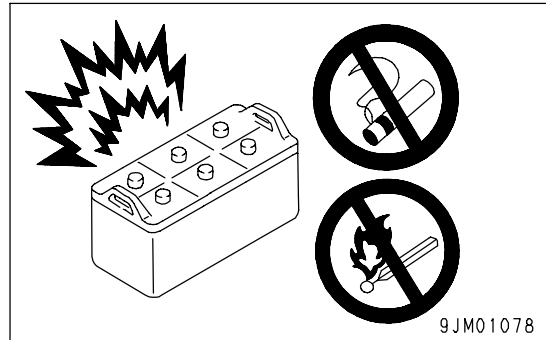

- If you spill acid on your clothes or skin, immediately flush the area with large amount of water.
- If acid gets into your eyes, flush them immediately with large amount of water and seek medical attention.

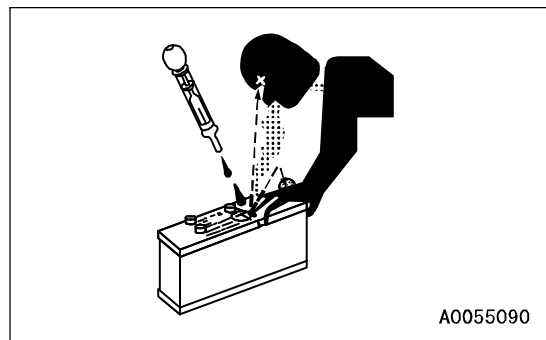

- Before working with batteries, turn the starting switch to the OFF position.

As there is a hazard that sparks will be generated, always do as follows.

- Do not let tools or other metal objects make any contact between the battery terminals. Do not leave tools or other metal objects lying around near the battery.
- Always disconnect the negative (-) terminal (ground side) first when removing the battery; when installing the battery, connect the positive (+) terminal first, and connect the ground last. Tighten the battery terminals securely.
- Flammable hydrogen gas is generated when the battery is charged, so remove the battery from the chassis, take it to a well-ventilated place, and remove the battery caps before charging it.
- Tighten the battery caps securely.
- Install the battery securely to the determined place.

STARTING ENGINE WITH BOOSTER CABLES

If any mistake is made in the method of connecting the booster cables, it may cause the battery to explode, so always do as follows.

- When starting with a booster cable, carry out the starting operation with two workers (one worker sitting in the operator's seat and the other working with the battery).
- When starting from another machine, do not allow the two machines to touch.
- When connecting the booster cables, turn the starting switch OFF position for both the normal machine and problem machine. There is a hazard that the machine will move when the power is connected.
- Be sure to connect the positive (+) cable first when installing the booster cables. Disconnect the negative (-) cable (ground side) first when removing them.
- When removing the booster cables, be careful not to let the booster cable clips touch each other or to let the clips touch the machine.
- Always wear safety glasses and rubber gloves when starting the engine with booster cables.
- When connecting a normal machine to a problem machine with booster cables, always use a normal machine with the same battery voltage as the problem machine.
- For details of the starting procedure when using booster cables, see "Starting Engine with Booster Cables (PAGE 3-121)" in the OPERATION section.

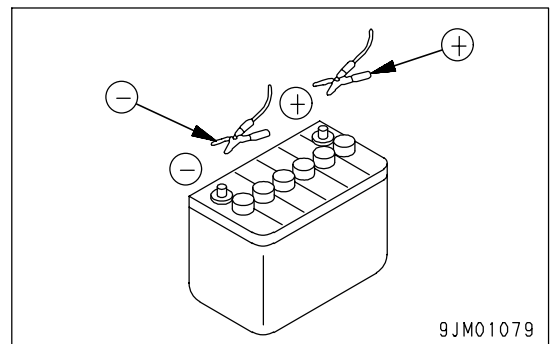
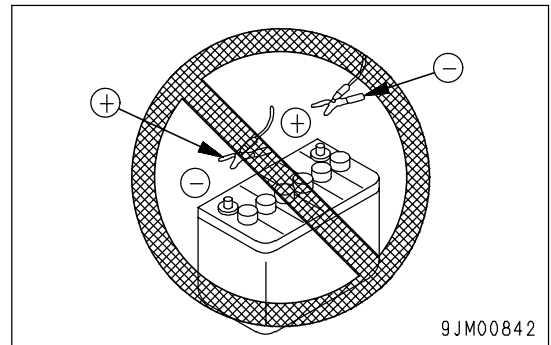

TOWING

SAFETY RULES FOR TOWING

Serious injury or death could result if a disabled machine is towed incorrectly or if there is a mistake in the selection or inspection of the wire rope.

For towing, see "TOWING THE MACHINE (PAGE 3-117)".

- Always be sure to check carefully that the capacity of the wire rope used for towing is ample for the weight of the towed machine.
- Never use a wire rope which has cut strands (A), reduced diameter (B), or kinks (C). There is danger that the rope may break during the towing operation.
- Always wear leather gloves when handling wire rope.
- Never tow a machine on a slope.
- During the towing operation, never stand between the towing machine and the machine being towed.
- Move the machine slowly and be sure not to apply any sudden load on the wire rope.

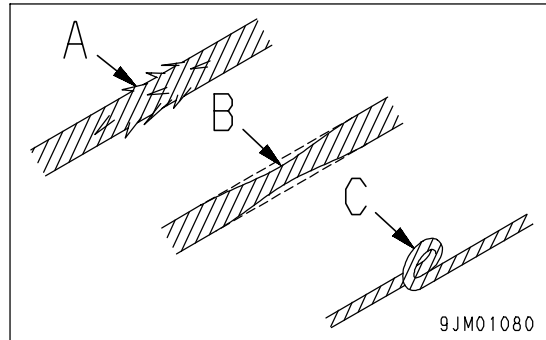

LIFTING OBJECTS WITH BUCKET

SAFETY RULES FOR LIFTING OBJECTS

- Do not carry out lifting work on slopes, soft ground, or other places where the machine is not stable.
- Use wire rope that conforms to the specified standard.
- Do not exceed the specified lifting load.

For details of the maximum lifting load permitted for this machine, see "BUCKET WITH HOOK (PAGE 6-4)".

- It is dangerous if the load hits any worker or structure. Always check carefully that the surrounding area is safe before swinging or turning the machine.
- Do not start, swing, or stop the machine suddenly. There is a hazard that the lifted load will swing.
- Do not pull the load to the side or in towards the machine.
- Do not leave the operator's seat when there is a raised load.

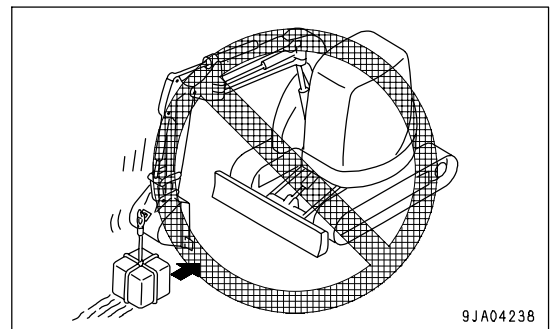
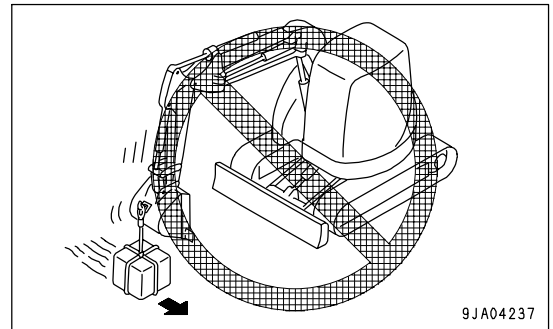

SAFETY MAINTENANCE INFORMATION

WARNING TAG

- Always attach the "DO NOT OPERATE" warning tag to the work equipment control lever in the operator's cab to alert others that you are performing service or maintenance on the machine. Attach additional warning tags around the machine if necessary. Warning tag Part No. 09963-03001
Keep this warning tag in the tool box while it is not used. If there is not the tool box, keep the tag in the operation manual pocket.
- If others start the engine, or touch or operate the work equipment control lever while you are performing service or maintenance, you could suffer serious injury or property damage.

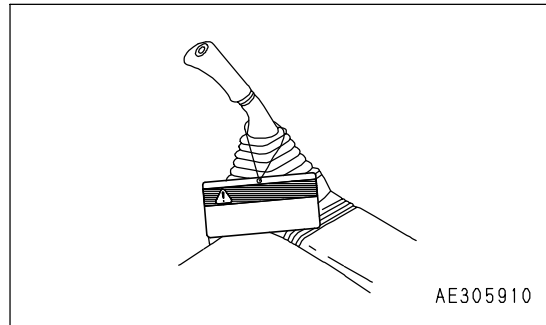

KEEP WORK PLACE CLEAN AND TIDY

- Do not leave hammers or other tools lying around in the work place. Wipe up all grease, oil, or other substances that will cause you to slip. Always keep the work place clean and tidy to enable you to carry out operations safely. If the work place is not kept clean and tidy, there is the danger that you will trip, slip, or fall over and injure yourself.
- When cleaning the ceiling window which is made of organic glass (polycarbonate), use tap water and avoid use of organic solvents for cleaning. An organic solvent like benzene, toluene or methanol can invite a chemical reaction like dissolution and decomposition on the window glass, deteriorating polycarbonate in use.

APPOINT LEADER WHEN WORKING WITH OTHERS

When repairing the machine or when removing and installing the work equipment, appoint a leader and follow his instructions during the operation.

When working with others, misunderstandings between workers can lead to serious accidents.

STOP ENGINE BEFORE CARRYING OUT MAINTENANCE

- Stop the machine on firm, level ground.
- Select a place where there is no hazard of falling rocks or landslides, or of flooding if the land is low.
- Lower the work equipment completely to the ground and stop the engine.

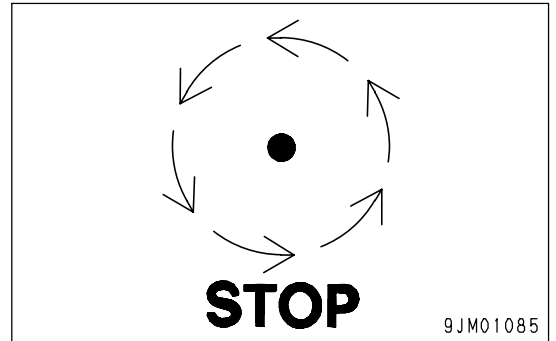

- Turn the engine starting switch to the ON position. Operate the work equipment control lever back and forth, and to the right and left, 2 to 3 times at the full stroke in order to release the residual pressure in the hydraulic circuit.

After releasing the pressure, move lock lever (1) to the LOCK position and turn the engine starting switch to the OFF position.

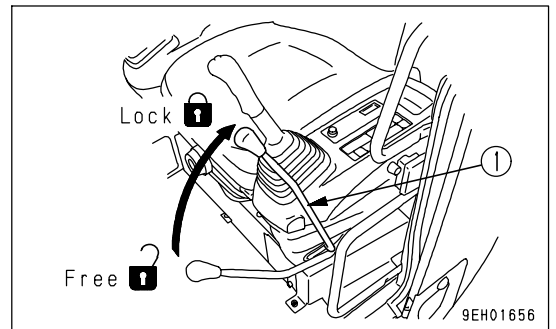

- Put blocks under the track to prevent the machine from moving.

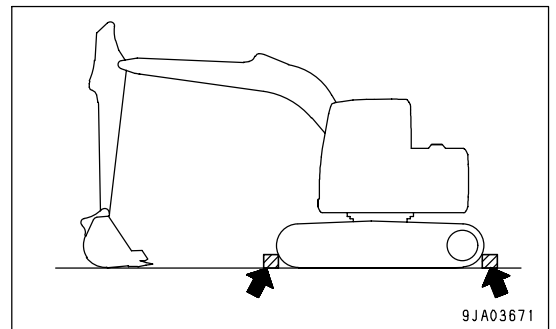

TWO WORKERS FOR MAINTENANCE WHEN ENGINE IS RUNNING

To prevent injury, do not carry out maintenance with the engine running. If maintenance must be carried out with the engine running, carry out the operation with at least two workers and do as follows.

- One worker must always sit in the operator's seat and be ready to stop the engine at any time. All workers must maintain contact with the other workers.

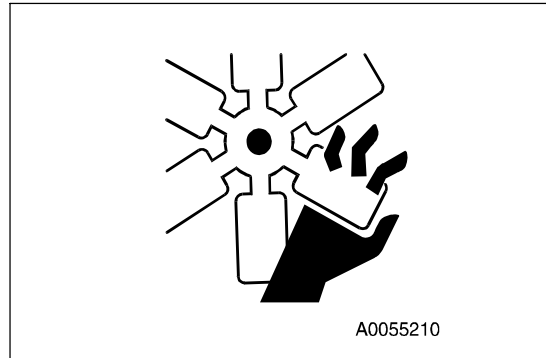

- Set lock lever (1) to the LOCK position.
- When carrying out operations near the fan, fan belt, or other rotating parts, there is a hazard of being caught in the parts, so be careful not to come close.
- Do not touch any control levers. If any control lever must be operated, give a signal to the other workers to warn them to move to a safe place.
- Never drop or insert tools or other objects into the fan or fan belt. Parts may break or be sent flying.

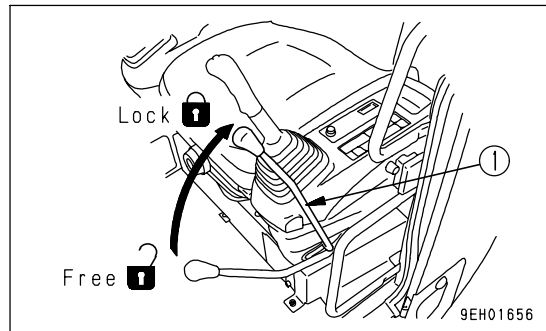
**PROPER TOOLS**

Use only tools suited to the task and be sure to use the tools correctly. Using damaged, low quality, faulty, makeshift tools or improper use of the tools could cause serious personal injury.

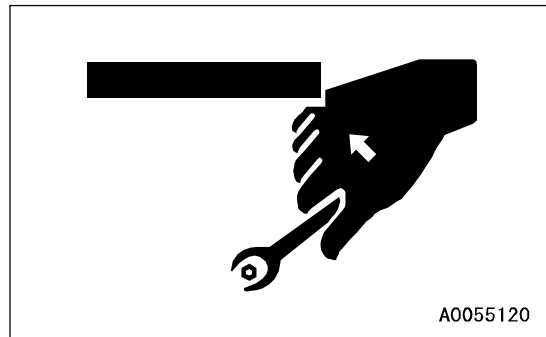
**ACCUMULATOR**

The accumulator is charged with high-pressure nitrogen gas. When handling the accumulator, careless procedure may cause an explosion which could lead to serious injury or property damage. For this reason, always observe the following precautions.

- Do not disassemble the accumulator.
- Do not bring it near flame or dispose of it in fire.
- Do not make holes in it, weld it, or use a cutting torch.
- Do not hit or roll the accumulator, or subject it to any impact.
- When disposing of the accumulator, the gas must be released. Please contact your Komatsu distributor to have this work performed.



PERSONNEL

Only authorized personnel can service and repair the machine. Do not allow unauthorized personnel into the area. If necessary, employ an observer.

ATTACHMENTS

- Appoint a leader before starting removal or installation operations for attachments.
- Place attachments that have been removed from the machine in a stable condition so that they do not fall. And take steps to prevent unauthorized persons from entering the storage area.

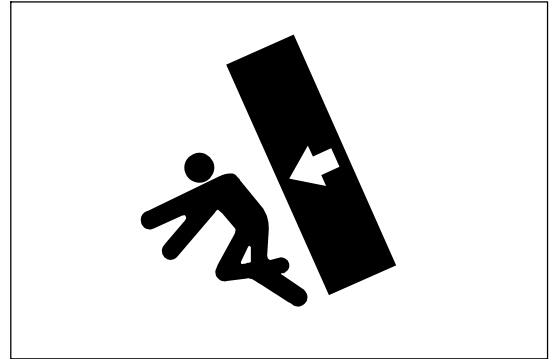
**WORK UNDER THE MACHINE**

- If it is necessary to go under the work equipment or the machine to carry out service and maintenance, support the work equipment and machine securely with blocks and stands strong enough to support the weight of the work equipment and machine.
- It is extremely dangerous to work under the machine if the track shoes are lifted off the ground and the machine is supported only with the work equipment. If any of the control levers is touched by accident, or there is damage occurring to the hydraulic piping, the work equipment or the machine will suddenly drop. This is extremely dangerous. Never work under the work equipment or the machine.

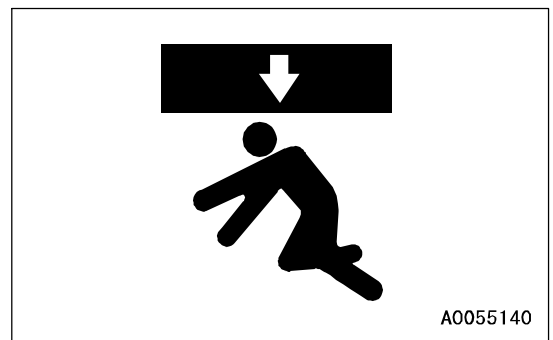
**NOISE**

When carrying out maintenance of the engine and you are exposed to noise for long periods of time, wear ear covers or ear plugs while working.

If the noise from the machine is too loud, it may cause temporary or permanent hearing problems.

WHEN USING HAMMER

When using a hammer, pins may fly out or metal particles may be scattered. This may lead to serious injury. Always do as follows.

- If hard metal parts such as pins, bucket teeth, cutting edges, or bearings are hit with a hammer, there is a hazard that pieces might be scattered and cause injury. Always wear safety glasses and gloves.
- When hitting pins or bucket teeth, there is a hazard that broken pieces might be sent flying and injure people in the surrounding area. Always check that there is no one in the surrounding area.

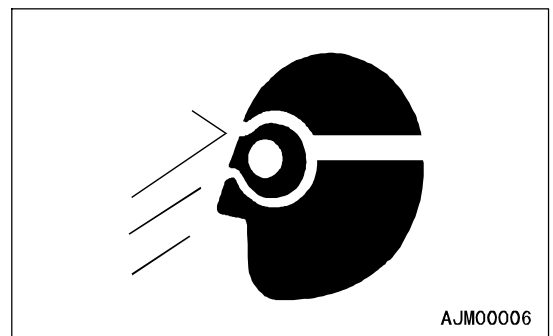

- There is a hazard that the pin hit with strong force may fly out and injure people in the surrounding area.

WELDING WORKS

Welding operations must always be carried out by a qualified welder and in a place equipped with proper equipment. There is a hazard of gas, fire, or electrocution when carrying out welding, so never allow any unqualified personnel to carry out welding.

REMOVING BATTERY TERMINALS

When repairing the electrical system or when carrying out electrical welding, remove the negative (-) terminal of the battery to prevent the flow of current.

SAFETY FIRST WHEN USING HIGH-PRESSURE GREASE TO ADJUST TRACK TENSION

- Grease is pumped into the track tension adjustment system under high pressure.
If the specified procedure for maintenance is not followed when making adjustment, grease drain plug (1) may fly out and cause serious injury or property damage.
- When loosening grease drain plug (1) to loosen the track tension, never loosen it more than one turn. Loosen the grease drain plug slowly.
- Never put your face, hands, feet, or any other part of your body close to grease drain plug (1).

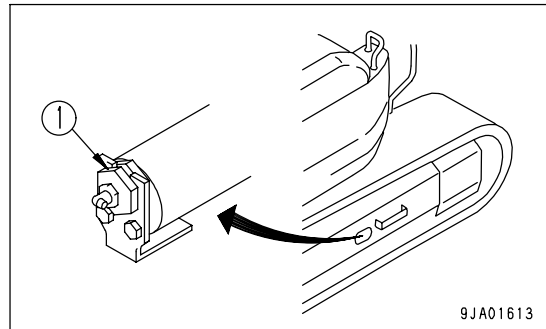
**DO NOT DISASSEMBLE RECOIL SPRINGS**

Never attempt to disassemble the recoils spring assembly. It contains a spring under high pressure which serves as a shock absorber for the idler. If it is disassembled by mistake, the spring will fly out and cause serious injury. When it becomes necessary to disassemble it, ask your Komatsu distributor to do the work.

SAFETY RULES FOR HIGH-PRESSURE OIL

The hydraulic system is always under internal pressure. When inspecting or replacing piping or hoses, always check that the pressure in the hydraulic circuit has been released. If the circuit is still under pressure, it will lead to serious injury, so always do as follows.

- For details of the method of releasing the pressure, see "METHOD OF RELEASING PRESSURE IN HYDRAULIC CIRCUIT (PAGE 4-66)". If the circuit is still under pressure, do not carry out any inspection or replacement operation.
- If there is any leakage from the piping or hoses, the surrounding area will be wet, so check for cracks in the piping and hoses and for swelling in the hoses.

When carry out inspection, wear safety glasses and leather gloves.

- There is a hazard that high-pressure oil leaking from small holes may penetrate your skin or cause blindness if it contacts your eyes directly. If you are hit by a jet of high-pressure oil and suffer injury to your skin or eyes, wash the place with clean water, and consult a doctor immediately for medical attention.

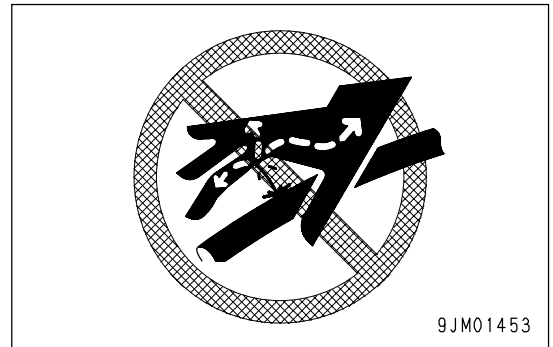

SAFETY HANDLING HIGH-PRESSURE HOSES

- If oil or fuel leaks from high-pressure hoses, it may cause fire or defective operation, which may lead to serious injury. If any loose bolts are found, stop work and tighten to the specified torque. If any damaged hoses are found, stop operations immediately and contact your Komatsu distributor.

Replace the hose if any of the following problems are found.

- Damaged or leaking hydraulic fitting.
- Frayed or cut covering or exposed reinforcement wire layer.
- Covering swollen in places.
- Twisted or crushed movable portion.
- Foreign material embedded in covering.

WASTE MATERIALS

To prevent pollution, pay careful attention to the method of disposing of waste materials.

- Always put oil drained from your machine in containers. Never drain oil directly onto the ground or dump into the sewage system, rivers, the sea, or lakes.
- Obey appropriate laws and regulations when disposing of harmful objects such as oil, fuel, coolant, solvent, filters, and batteries.

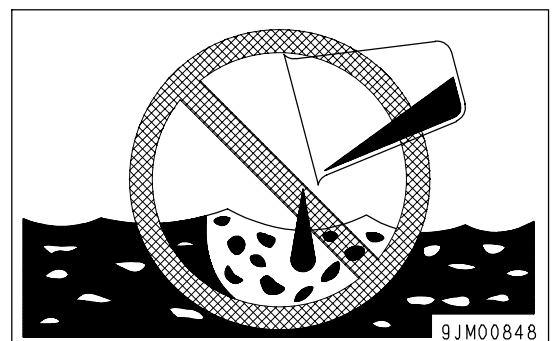

AIR CONDITIONER MAINTENANCE

If air conditioner refrigerant gets into your eyes, it may cause blindness; if it touches your skin, it may cause frostbite. Never touch refrigerant.

COMPRESSED AIR

- When carrying out cleaning with compressed air, there is a hazard of serious injury caused by flying particles.
- When using compressed air to clean elements or the radiator, always wear safety glasses, dust mask, gloves, and other protective equipment.

PERIODIC REPLACEMENT OF SAFETY CRITICAL PARTS

- For using the machine safely for an extended period of time, replace safety-critical parts like hoses and seat belts periodically.

Replacement of safety-critical parts: See "SAFETY CRITICAL PARTS (PAGE 4-13)".

- The material of these components naturally changes over time, and repeated use causes deterioration, wear, and fatigue. As a result, there is a hazard that these components may fail and cause serious injury or death. It is difficult to judge the remaining life of these components from external inspection or the feeling when operating, so always replace them at the specified interval.
- Replace or repair safety-critical parts if any defect is found, even when they have not reached the time specified interval.

OPERATION

WARNING

Please read and make sure that you understand the SAFETY section before reading this section.

MACHINE VIEW ILLUSTRATIONS

OVERALL MACHINE VIEW

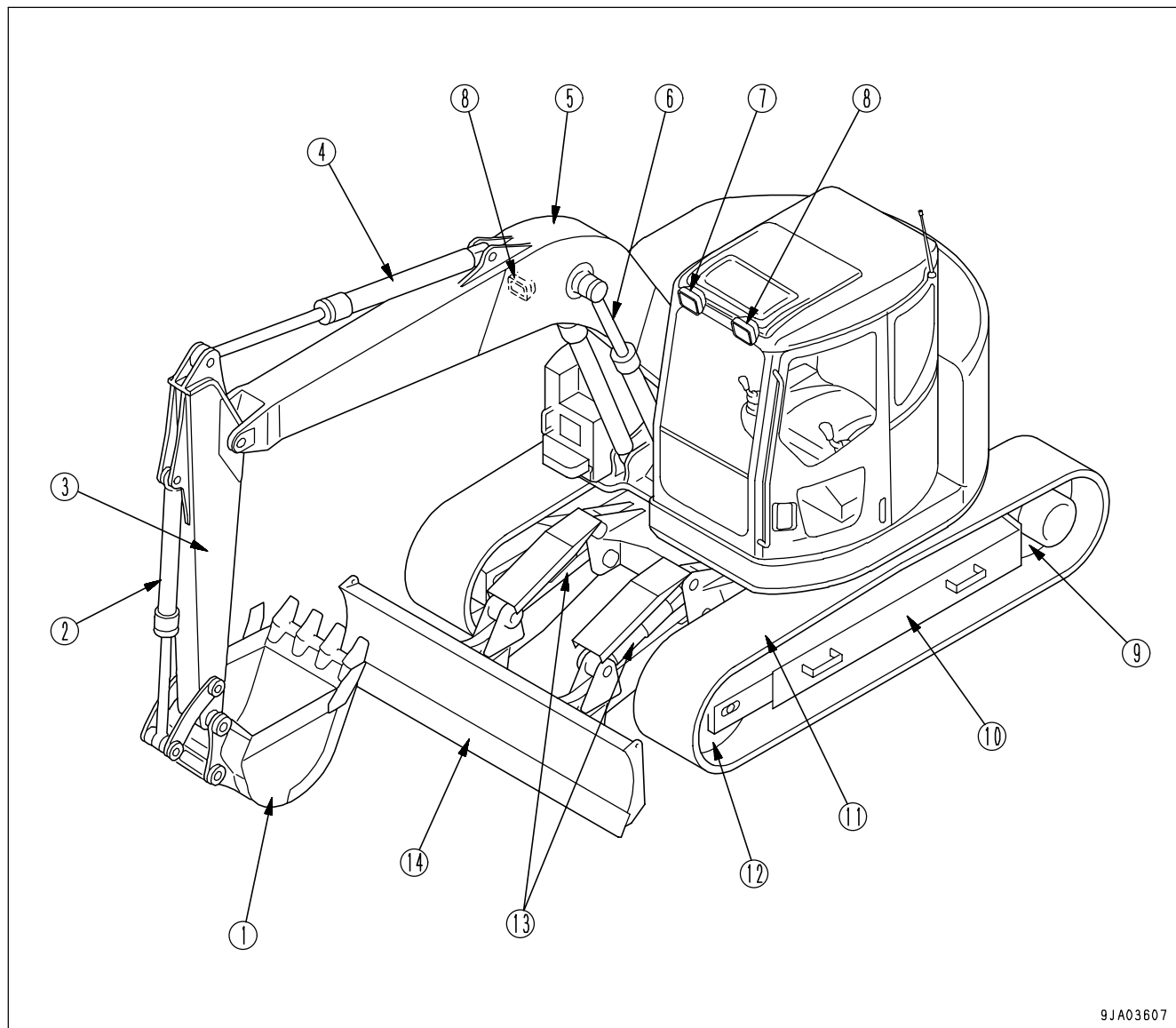

9JA03607

- | | |
|-----------------------------------|---|
| (1) Bucket | (8) Working lamp |
| (2) Bucket cylinder | (9) Sprocket |
| (3) Arm | (10) Track frame |
| (4) Arm cylinder | (11) Track shoe |
| (5) Boom | (12) Idler |
| (6) Boom cylinder | (13) Blade cylinder (blade specification) |
| (7) Additional lamp (if equipped) | (14) Blade (blade specification) |

CONTROLS AND GAUGES

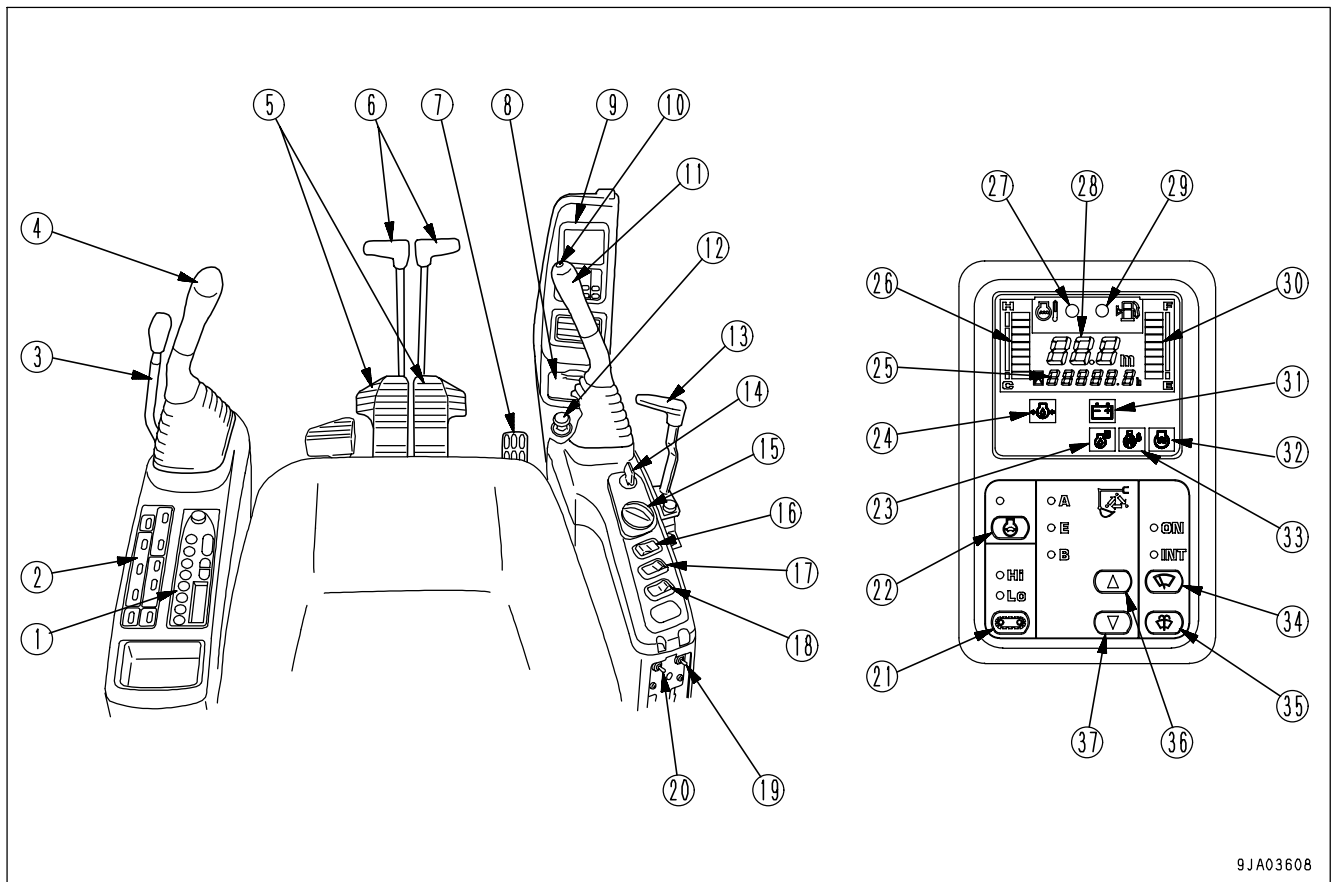

9JA03608

- | | |
|--|---|
| <ul style="list-style-type: none"> (1) Car radio (2) Air conditioner control panel (3) Lock lever (4) Left work equipment control lever (5) Travel pedals (6) Travel levers (7) Attachment control pedal (if equipped) (8) Ashtray (9) Machine monitor (10) Horn switch (11) Right work equipment control lever (12) Cigarette lighter (13) Blade control lever (blade specification) (14) Starting switch (15) Fuel control dial (16) Lamp switch (17) Alarm buzzer stop switch (18) Swing lock switch (19) Swing holding brake release switch | <ul style="list-style-type: none"> (20) Pump drive emergency switch (21) Travel speed selector switch (22) Auto-deceleration switch (23) Oil maintenance monitor (24) Engine oil pressure monitor (25) Service meter (26) Engine coolant temperature gauge (27) Engine coolant temperature monitor (28) Display (for failure display) (29) Fuel level monitor (30) Fuel gauge (31) Charge level monitor (32) Engine pre-heating monitor (33) Swing lock monitor (34) Wiper switch (35) Window washer switch (36) Working mode selector switch (△) (37) Working mode selector switch (▽) |
|--|---|

DETAILED CONTROLS AND GAUGES

The following is an explanation of devices needed for operating the machine.

To perform suitable operations correctly and safely, it is important to completely understand methods of operating the equipment, and the meanings of the displays.

MONITORING SYSTEM

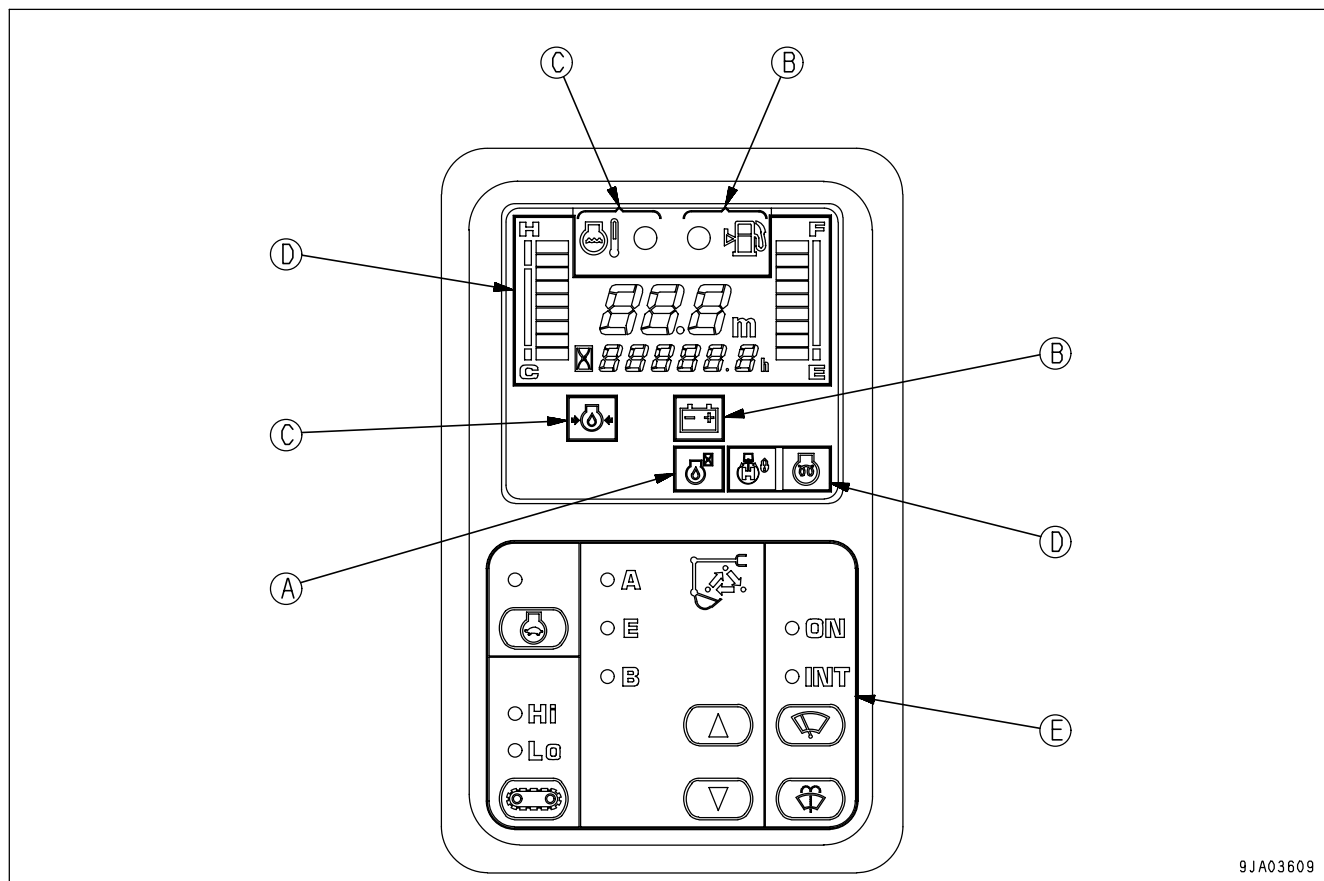

9JA03609

- A: Basic check monitors
- B: Caution monitors
- C: Emergency monitors

- D: Meter display portion
- E: Monitor switches portion

Basic Check Monitors



These monitors DO NOT ensure that the machine is in good condition. When performing checks before starting (daily checks), do not simply rely on the monitors. Always dismount the machine and check each item directly.

This displays the basic items to be checked before starting items that must be checked before starting the engine. If there is any problem, the monitor for the location of the problem will light up.

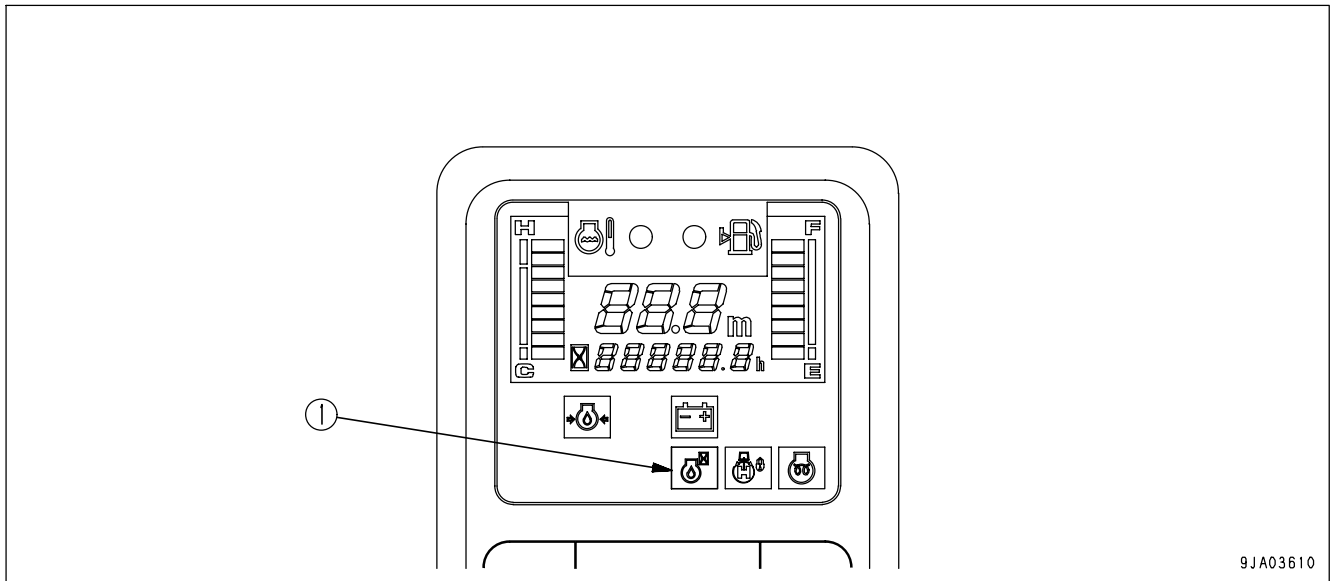

(1) Oil maintenance monitor

Oil Maintenance Monitor
(only for set machines)

This monitor (1) warns the operator if the set time passes after the engine oil was changed.

If the set time (125, 250, 500 H) passes after the engine oil is replaced, this lamp lights up. If the lamp lights up, change the engine oil.

If you want to change the set time for replacement of oil, please consult your Komatsu distributor.

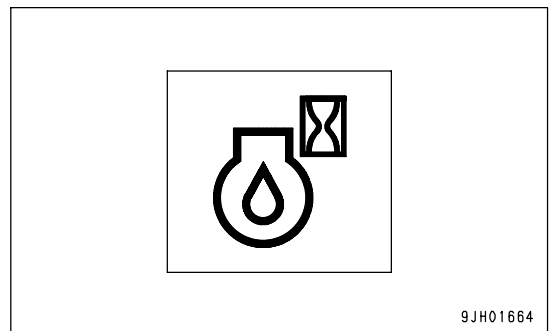

Caution Monitors

CAUTION

If the warning monitor flashes, check the problem point as soon as possible and carry out maintenance. Failure to repair the problem may cause to failure of the machine.

These are items which need to be observed while the engine is running. If any problem occurs, items which need to be repaired as soon as possible are displayed.

If there is any problem, the appropriate monitor lamp will flash to indicate the location of the problem.

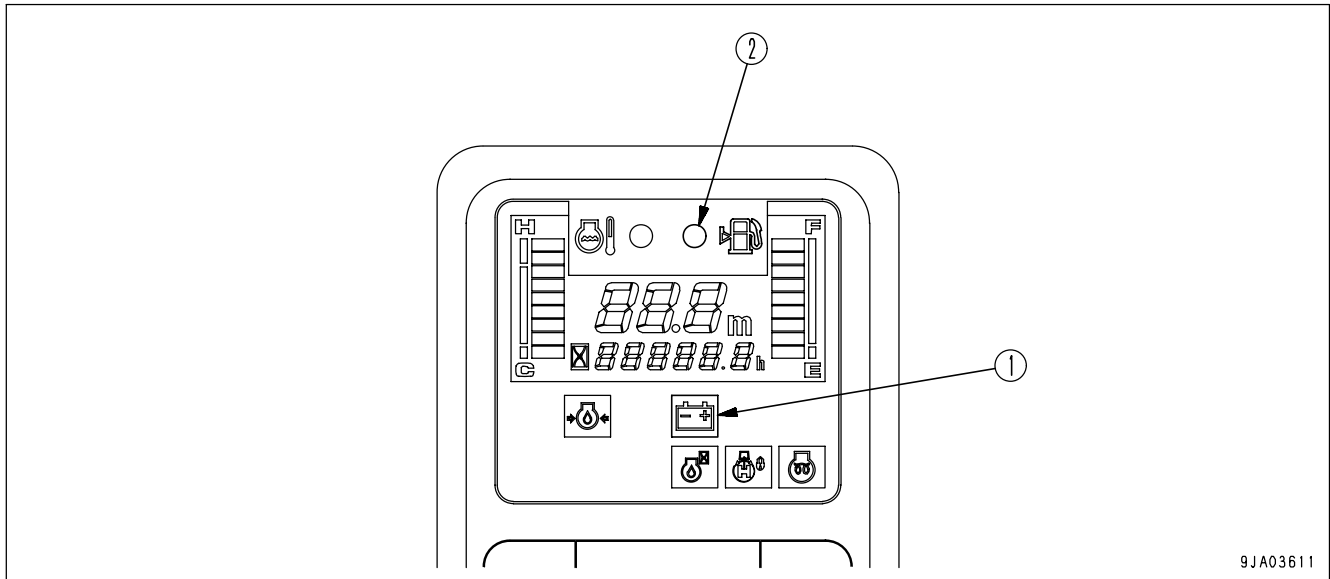

(1) Charge level monitor

(2) Fuel level monitor

Charge Level Monitor

This monitor (1) indicates a problem in the charging system while the engine is running.

If the monitor lamp flashes, check the V-belt tension. If any problem is found, see "OTHER TROUBLE (PAGE 3-123)".

REMARK

- This lamp will light up if the starting switch is turned ON when the engine is stopped, but this does not indicate any problem.
- When the engine is started or stopped with the starting switch at the ON position, the lamp may light up and the buzzer may sound momentarily, but this does not indicate any problem.

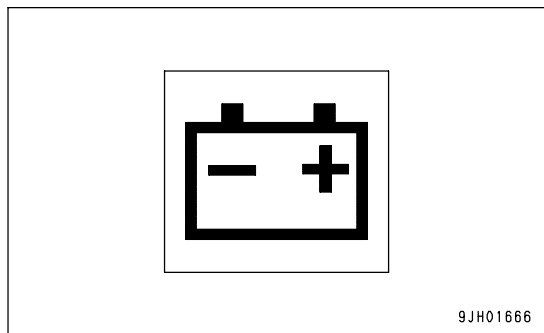

9JH01666

Fuel Level Monitor

This monitor (2) warns the operator the reduced fuel level in the fuel tank is low.

When the amount of the remaining fuel in the fuel tank reaches approx. 42 liters (11.10 US gal), this monitor lamp begins to flash. Lose no time in refueling.

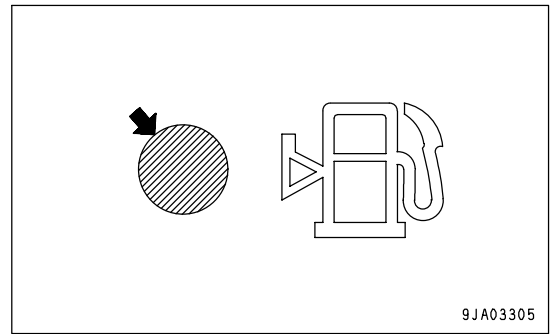

Emergency Monitors

CAUTION

If the monitor flashes, stop the engine immediately or run at low idle, then inspect the problem point immediately and repair the problem.

These are items which need to be observed when the engine is running. If there is any problem, the abnormal location on the monitor will lights up and the buzzer will sound. Carry out the necessary repairs immediately.

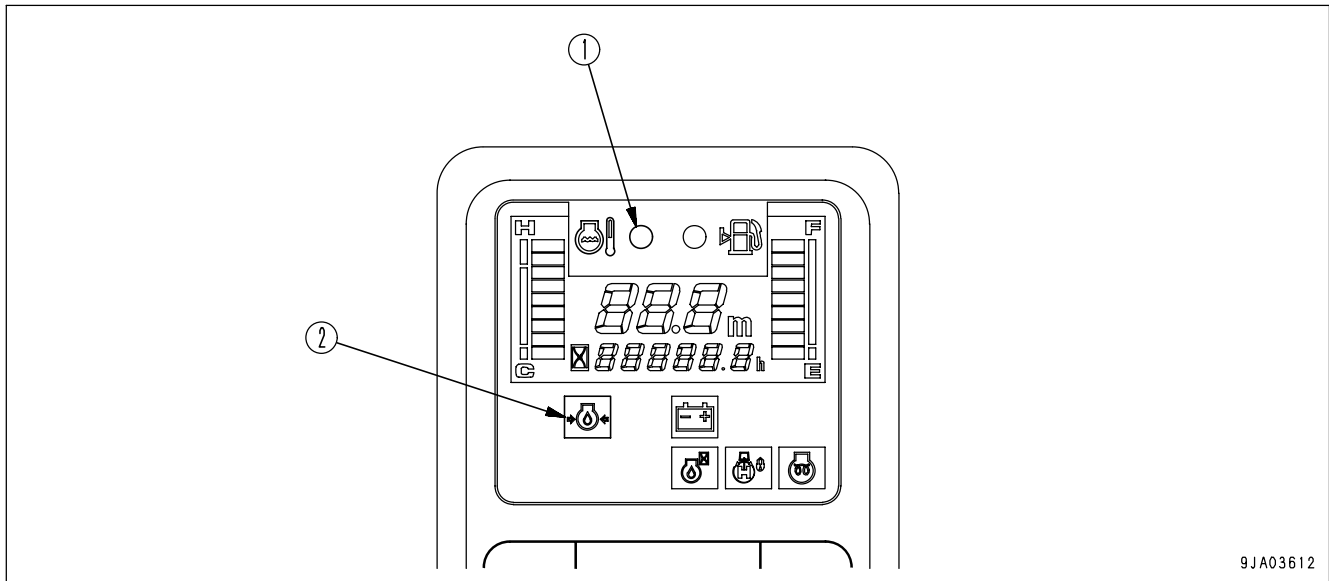

9JA03612

(1) Engine coolant temperature monitor

(2) Engine oil pressure monitor

Engine Coolant Temperature Monitor

This monitor (1) serves to warn against abnormal rise of the engine coolant temperature.

If the temperature of the engine coolant is too high, the monitor lamp flashes, and the overheat prevention system is automatically actuated to reduce the engine speed.

Stop operations and run the engine at low idle until the engine coolant temperature gauge enters the green range.

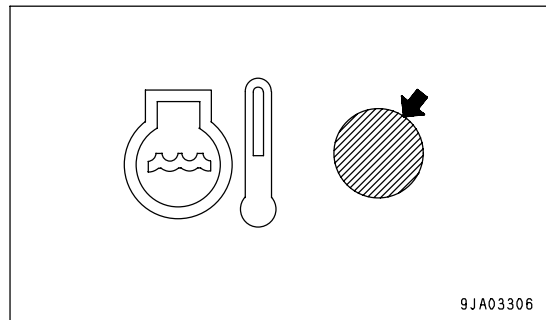

9JA03306

Engine Oil Pressure Monitor

If the engine lubricating pressure is below the normal value, this monitor (2) flashes. If it flashes, stop the engine, and check the oil level in the oil pan and lubricating system.

REMARK

- This lamp will light up if the starting switch is turned ON when the engine is stopped, but this does not indicate any problem.
- When the engine is started or stopped with the starting switch at the ON position, the lamp may light up and the buzzer may sound momentarily, but this does not indicate any problem.

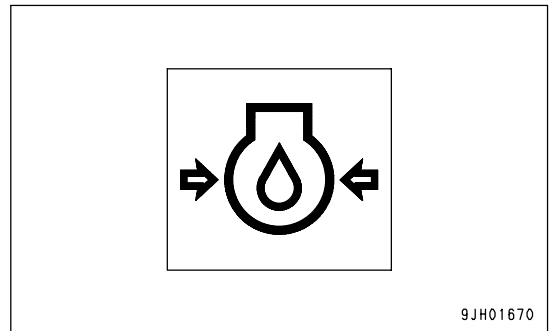

Meter Display Portion

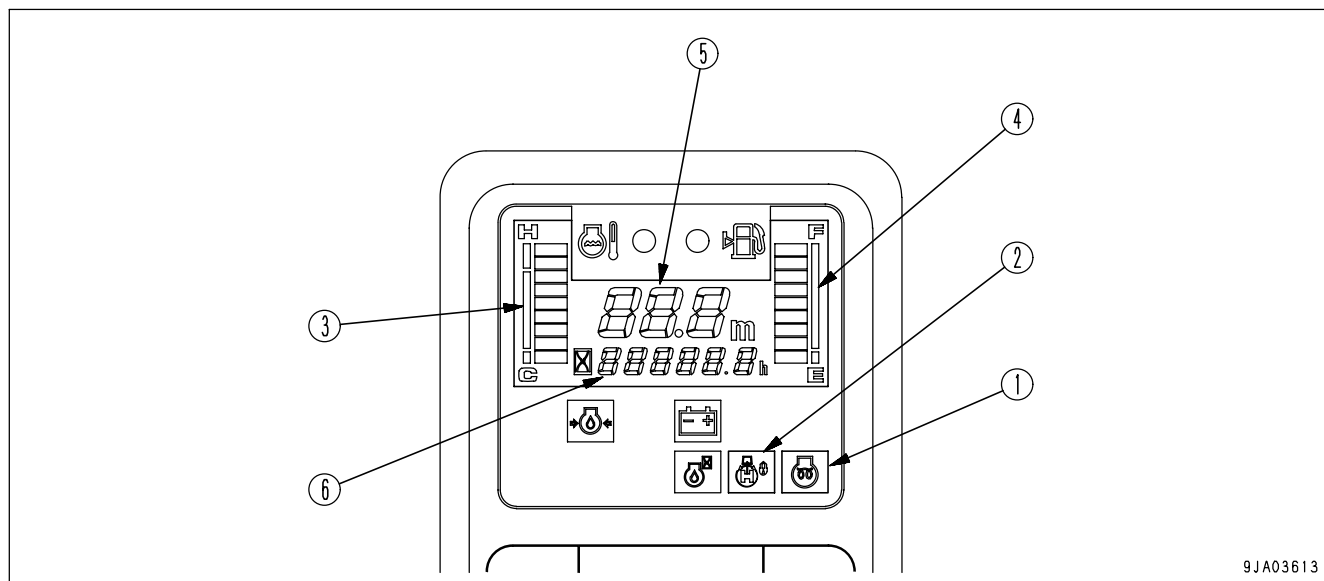

9JA03613

Pilot display

- (1) Engine pre-heating monitor
- (2) Swing lock monitor

Gauges and meter

- (3) Engine coolant temperature gauge
- (4) Fuel gauge
- (5) Display
- (6) Service meter

Pilot Display

When starting switch is ON, the pilot display lights up when display items are functioning.

Engine Pre-heating Monitor

This monitor (1) indicates the pre-heating time required when starting the engine at an ambient temperature below 0°C (32°F). The monitor lamp lights up when the engine starting switch is turned to the HEAT position and begins to flash after about 30 seconds to show that the pre-heating is completed. (The monitor lamp will go off after about 10 seconds)

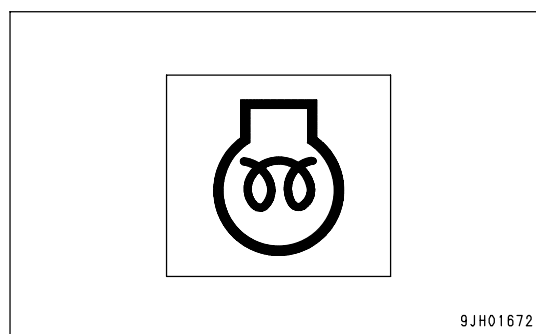

9JH01672

Swing Lock Monitor

This monitor (2) informs the operator that the swing lock is being actuated.

Actuated: Lights up

When the swing lock switch is turned ON (ACTUATED), the monitor lamp lights up.

When the swing holding brake release switch is turned on, this monitor lamp flashes.

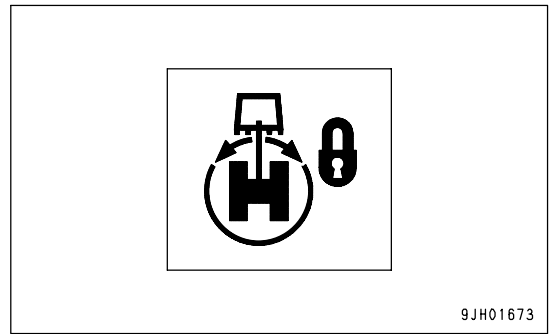

9JH01673

REMARK

The swing motor is equipped with a disc brake that mechanically stops the rotation. When the swing lock monitor is lighted up, the brake remains applied.

Gauges and Meter

Engine Coolant Temperature Gauge

When the red range (B) lights up during machine operation, the engine overheat preventive system is actuated.

The engine overheat preventive system functions in the following manner.

When segment (D) lights up:

Engine coolant temperature monitor lamp begins to flash.

When segment (E) lights up:

The engine speed is brought down to low idle, engine coolant temperature monitor lamp (F) begins to flash and the warning buzzer begins to sound.

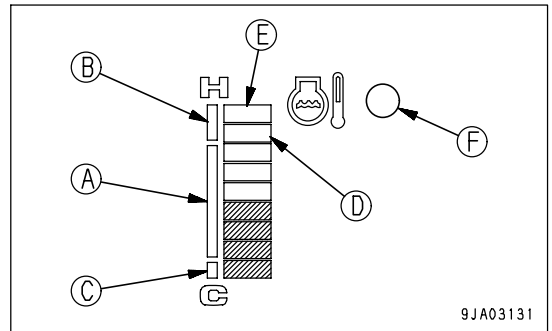

9JA03131

REMARK

- The engine overheat preventive system continues to function until the coolant temperature goes down to the level of green range (A).
- Engine coolant temperature monitor lamp (F) stops flashing, when the fuel adjusting dial is set at low idle, after the coolant temperature goes down to the level of green range (A).

If only white range (C) remains lit after starting the engine, warm up the engine until green range (A) lights up.

Fuel Gauge

This meter (4) shows the fuel level in the fuel tank. During normal operation, the lamp should light up in the green range (A).

If the lamp in the red range (B) flashes during operation, there is less than 42 liters (11.10 US gal) of fuel remaining, so check and add fuel.

The correct level may not be displayed for a short time after the starting switch is turned to the ON position, but this is not a problem.

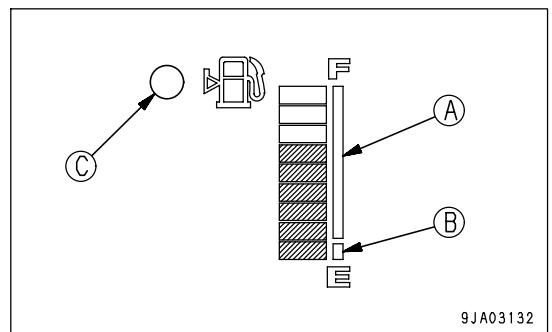

9JA03132

REMARK

When red range (B) in the fuel gauge lights up, fuel level monitor (C) begins to flash, too.

Display

This monitor (5) serves to display failure contents, if any problem occurs on the machine.

REMARK

If the machine has a problem, error information appears while the starting switch is ON. The monitor flashes and displays all error information sequentially.

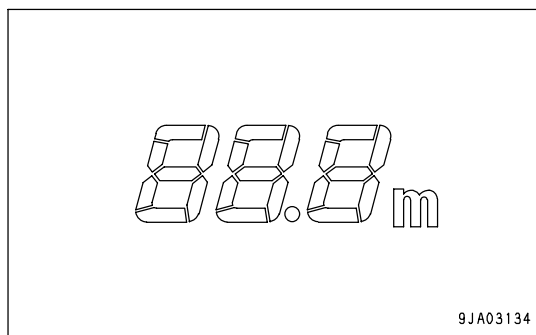

If the right displays flash, see "Electronic Control System (PAGE 3-127)".

Monitor indications	Error mode
E02	Pump control system error
E03	Swing brake system error
E05	Governor system error

Service Meter

This meter (6) shows the total operation hours of the machine. Set the periodic maintenance intervals using this display.

The service meter advances while the engine is running - even if the machine is not traveling.

The meter will advance by 1 for each 1/10 hour of operation regardless of the engine speed

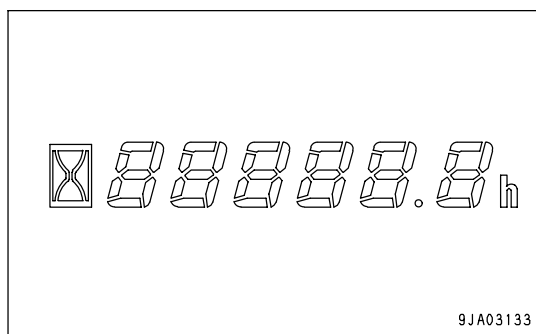

Monitor Switches Portion

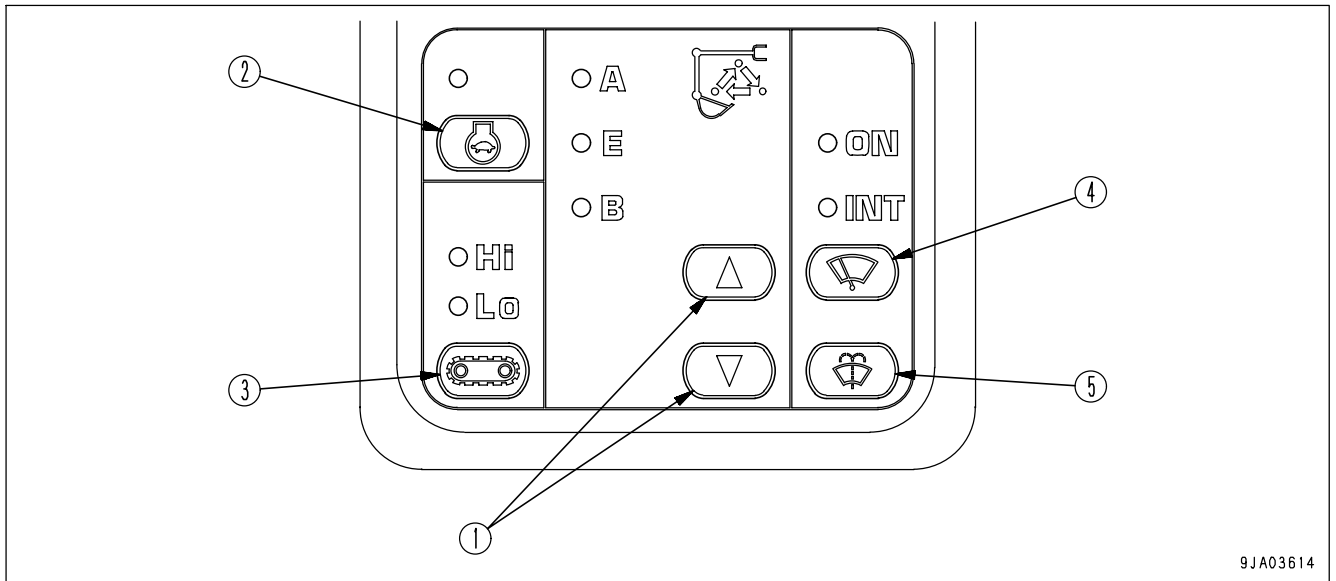

- (1) Working mode selector switch
- (2) Auto-deceleration switch
- (3) Travel speed selector switch
- (4) Wiper switch
- (5) Window washer switch

Working Mode Selector Switch

This switch (1) is used to set the power and movement of the work equipment.

Operations can be carried out more easily by selecting the mode to match the type of operation.

A lights up: A mode (for heavy-load operations)

E lights up: E mode (for operations with emphasis on fuel economy)

B lights up: B mode (for breaker operations)

For details on the use of this switch, refer to the section of "WORKING MODE (PAGE 3-86)".

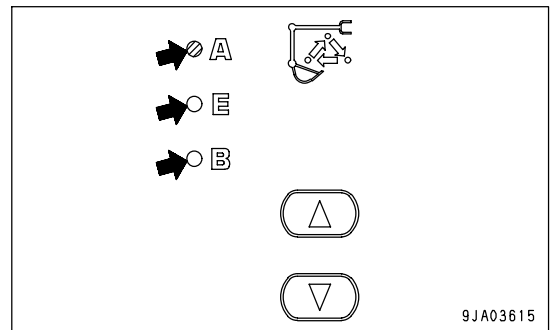

Auto-deceleration Switch

When this auto-deceleration switch button (2) is depressed, the auto-deceleration is actuated, if the control levers are in the neutral position, and the engine speed is automatically lowered to reduce fuel consumption.

The auto-deceleration lamp "ON": The auto-deceleration is actuated.

The auto-deceleration lamp "OFF": The auto-deceleration is released.

Every time the switch button is depressed, actuation and release alternate.

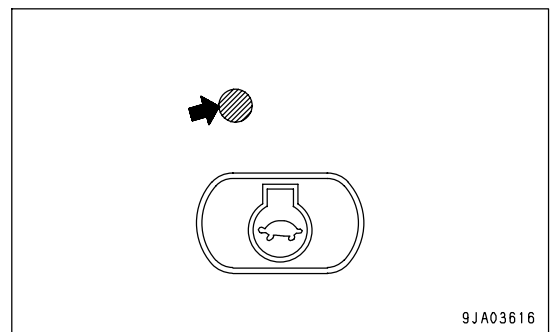

Travel Speed Selector Switch

WARNING

- When loading or unloading from a trailer, always travel at low speed (with travel speed selector switch (3) at the Lo position). Never operate travel speed selector switch (3) while loading or unloading.
- If the travel speed is switched between Hi and Lo when the machine is traveling, the machine may deviate to one side, even when traveling in a straight line.
Stop the machine before switching the travel speed.

This switch (3) is used to select high or low travel speed.

Lo position: Low speed travel

Hi position: High speed travel

The travel speed is changed every time the switch is depressed.

REMARK

- When the engine is started, it is automatically set to Lo speed travel.
- When traveling at high speed (Hi), if travel power is needed when traveling on soft ground or slopes, the travel speed is automatically set to low speed travel (Lo), so there is no need to operate this switch. On the monitor display, the Hi (high speed) lamp stays lighted up.

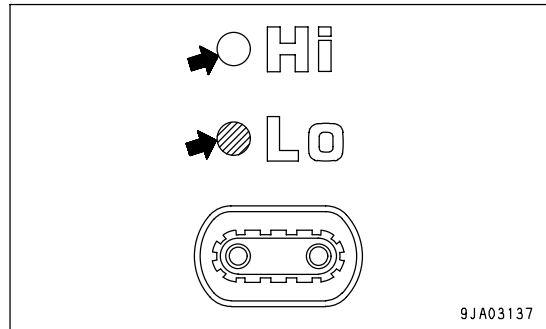

Wiper Switch

This switch (4) actuates the front window wiper.

ON lights up: The wiper works continuously.

INT lights up: The wiper works intermittently.

OFF: The wiper stops.

The wiper operation mode is changed in the order of stop -> intermittent -> continuous -> stop, every time the switch is depressed.

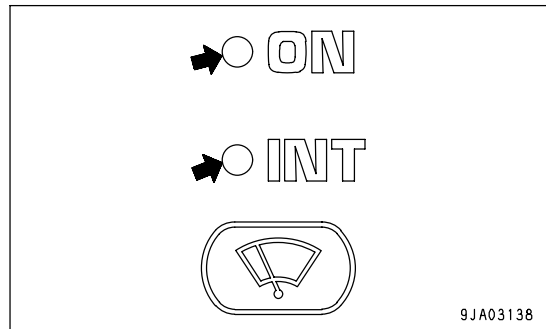

Window Washer Switch

This switch (5) is kept continuously pressed, window washer fluid is sprayed on the front glass. When the switch is released, the spray stops.

- If switch (5) is kept pressed when the wiper is stopped, the window washer fluid will spray, and at the same time, the wiper will be actuated continuously. When switch (5) is released, the wiper will continue to operate for 2 cycles, then stop.
- If the wiper is moving intermittently and switch (5) is kept pressed continuously, window washer fluid will spray, and at the same time, the wiper will be actuated continuously. When switch (5) is released, the wiper will continue to operate for 2 cycles, then return to intermittent operation.

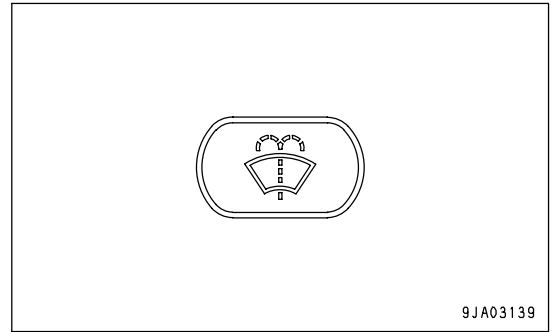

SWITCHES

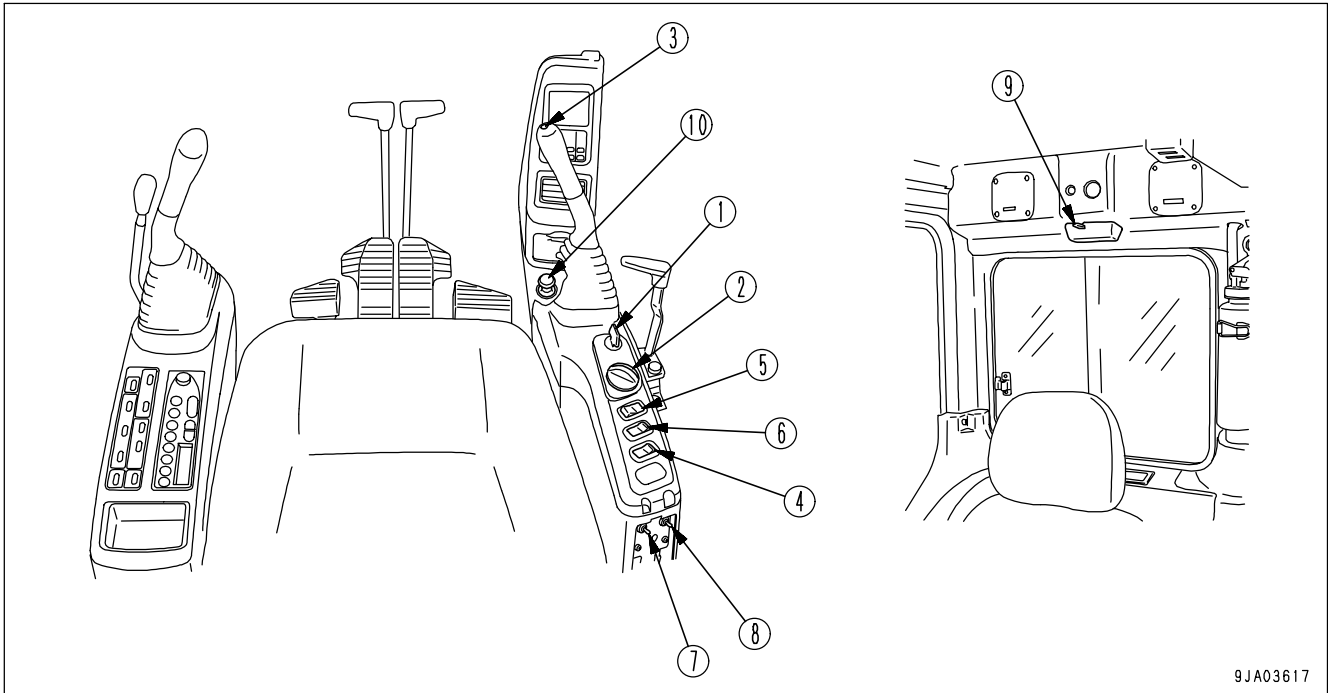

9JA03617

- (1) Starting switch
- (2) Fuel control dial
- (3) Horn switch
- (4) Swing lock switch
- (5) Lamp switch
- (6) Alarm buzzer stop switch
- (7) Pump drive emergency switch
- (8) Swing holding brake release switch
- (9) Room lamp switch
- (10) Cigarette lighter

Starting Switch

Starting switch (1) is used to start or stop the engine.

OFF position

The key can be inserted or withdrawn. The switches for the electric system except the room lamp and service meter are all turned off and the engine is stopped.

ON position

Electric current flows in the charging and lamp circuits. Keep the starting switch key at the ON position while the engine is running.

START position

This is the engine-start position. Keep the key at this position during cranking. Immediately after starting the engine, release the key. It will automatically return to the ON position.

HEAT (pre-heat) position

When starting engine in cold weather, set the key to this position. When the key is set to the HEAT position, the pre-heating monitor lights up. Keep the key at this position until the monitor lamp flashes. Immediately after the pre-heating monitor flashes, release the key. The key automatically returns to the OFF position. Then, start the engine by turning the key to the START position.

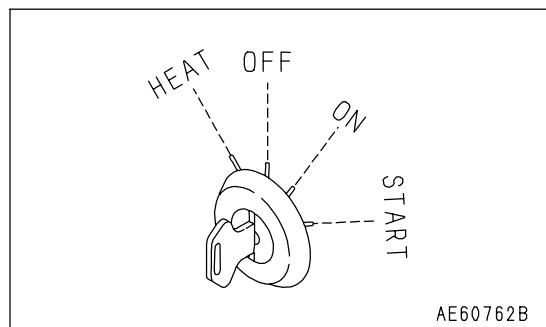

AE60762B

REMARK

The engine does not start, if the lock lever is not in the LOCK position. Make sure first that the lock lever is in the LOCK position, and then turn the engine starting switch.

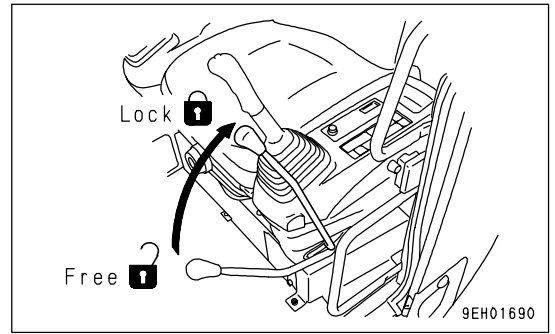

Fuel Control Dial

This dial (2) is used to control engine speed and output.

- (a) Low idle position: The dial is turned to the left (counterclockwise) fully.
- (b) High idle position: The dial is turned to the right (clockwise) fully.

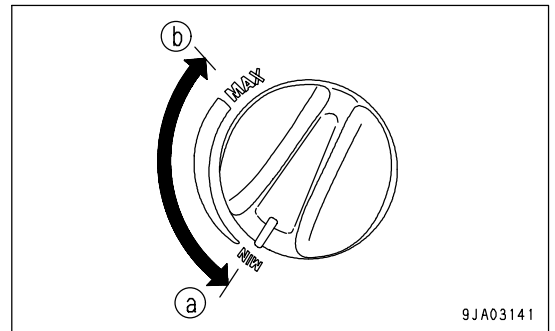

Horn Switch

Press switch (3) at the center of the knob of the right work equipment control lever to sound the horn.

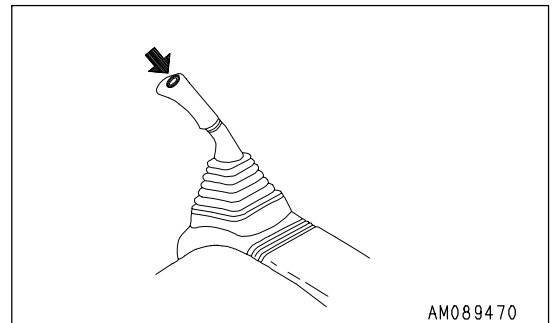

Swing Lock Switch

! WARNING

- When not using the swing operation, e.g. when traveling, put the swing lock switch to the OFF position.
- On slopes, even when the swing lock switch is at the ON position, the weight of the work equipment may cause the upper structure to swing if the swing control lever is operated in the downhill direction.

This switch (4) is used to lock the upper structure so that it cannot swing.

ON position (actuated):

The swing lock is always applied, and the upper structure will not swing even if the swing is operated. In this condition, the swing lock lamp lights up.

OFF position (canceled):

The swing lock is released, when operating the swing control lever, allowing the upper structure to swing.

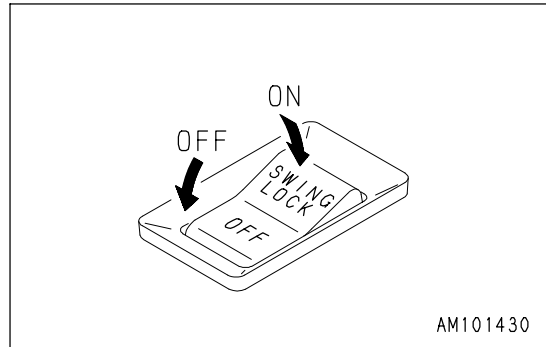

AM101430

Lamp Switch

This lights (5) up the working lamp and the panel lamp.

Position ON: Working lamp and panel lamp light up.

Position OFF: Lamps go off.

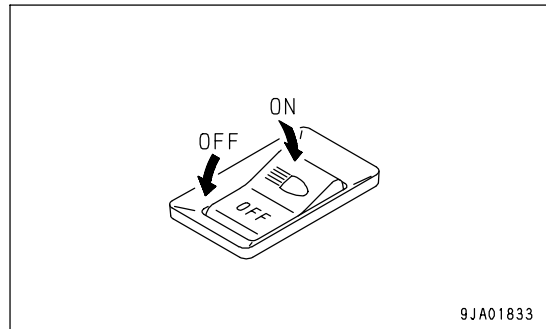

9JA01833

Alarm Buzzer Stop Switch

This switch (6) is used (when the engine is running) to stop the alarm buzzer when it has sounded to warn of a problem in a warning item.

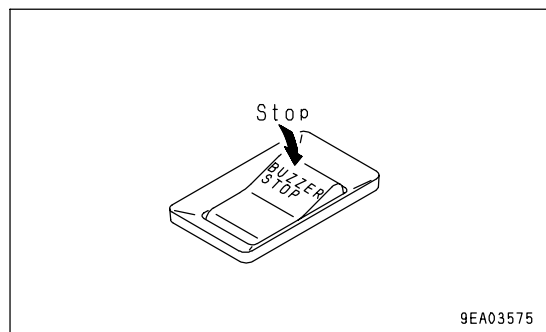

9EA03575

Emergency Pump Drive Switch

NOTICE

- This switch is provided to enable you to carry out operation temporarily, when any problem occurs on the pump control system. Do not use it except in emergency. Furthermore, remove the cause of the problem immediately.
- If this switch is depressed and moved to the EMERGENCY position by mistake, thereby engaging the machine in the work, while the machine is in normal condition, an "E02" mark is shown in the display.
If "E02" is displayed during the work, check that the switch is in the NORMAL position.

This switch (7) is used to make it possible to carry out operations temporarily if any problem should occur in the pump control system (when the display shows "E02").

- (a) EMERGENCY: When abnormal (move switch up)
(b) NORMAL: When normal (move switch down)

If the display shows "E02", move the switch up to make it possible to carry out work.

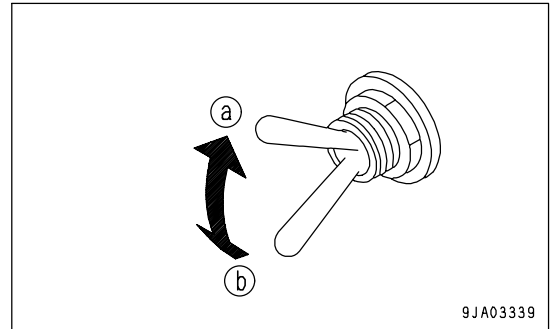

Swing Parking Brake Release Switch

NOTICE

This switch makes it possible to perform swing operations for a short even when there is a problem in the swing parking brake electric system. DO NOT use this switch except in emergencies. Repair the problem as soon as possible.

This switch (8) is used to make it possible to carry out operations temporarily if any problem should occur in the swing brake system (when the display shows "E03").

- (a) FREE: When abnormal (move switch up)
(b) NORMAL: When normal (move switch down)

- If the display shows "E03", move the switch up to make it possible to carry out work.
- When pushing this switch up to the FREE position, the swing lock monitor lamp begins to flash.

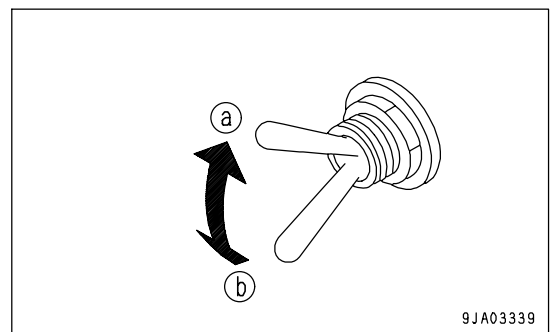

Room Lamp Switch

NOTICE

Be sure to switch the lamp to the OFF position after use.
 If the switch is left at the ON position, the battery will run down.

This switch (9) is used to light up the room lamp.
 ON position: Lights up
 OFF position: Goes off

REMARK

Even when the engine-starting switch is in the OFF position, the room lamp lights up, so do not forget to turn it off.

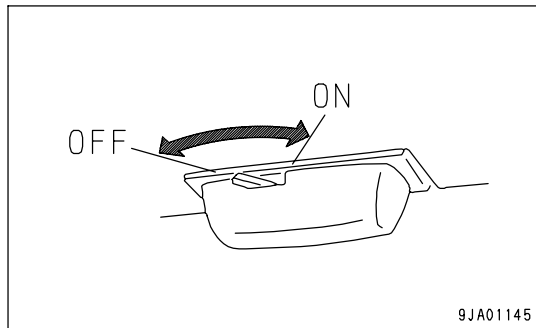

Cigarette Lighter

This switch (10) is used when lighting cigarettes. When the cigarette lighter is pushed in, it will return to its original position after several seconds, so pull it out to use it.
 If the cigarette lighter is removed, the socket can be used as a power source.

NOTICE

This cigarette lighter is of a 24 V type. Hence do not use this as a power source for electric equipment of 12 V type, otherwise they will likely be damaged.

The capacity of this cigarette lighter is 85 W (24 V x 3.5 A).

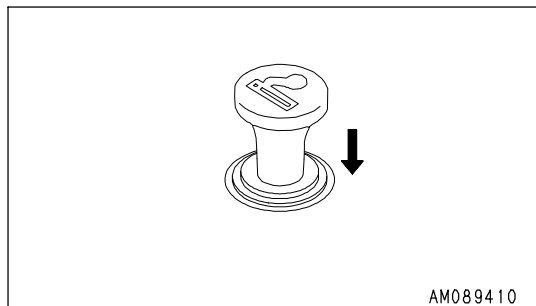

CONTROL LEVERS AND PEDALS

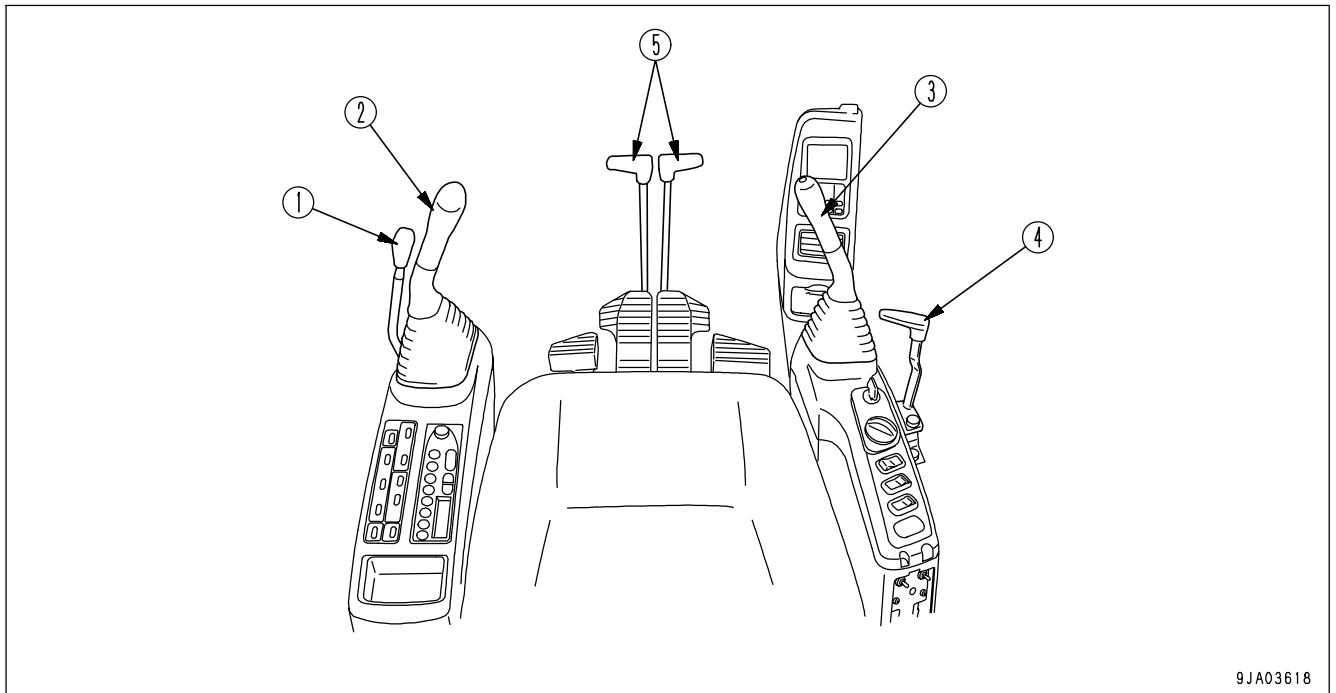

9JA03618

- | | |
|--|---|
| (1) Lock lever | (4) Blade control lever (blade specification) |
| (2) Left work equipment control lever | (5) Travel levers (with pedals) |
| (3) Right work equipment control lever | |

Lock Lever

**WARNING**

- When leaving the operator's compartment, set the lock lever securely to the LOCK position. If the lock lever is not at the LOCK position and the control levers are touched by mistake, it may lead to serious personal injury.
- Check that the condition of the lever is as shown in the diagram.
- When pulling the lock lever up, be careful not to touch the work equipment control lever.
When pushing the lock lever down, be careful not to touch the work equipment control lever.

This lever (1) is a locking device for locking operation of the work equipment and attachments, swing and travel.

The lever is put to the LOCK position, when it is pulled up.

This lock lever is of a hydraulic locking type. Even if it is put to the LOCK position, the work equipment control lever and travel control lever can be moved, but neither machine nor the work equipment moves.

REMARK

The engine does not start, if the lock lever is not in the LOCK position. Make sure first that the lock lever is in the LOCK position, and then turn the engine starting switch.

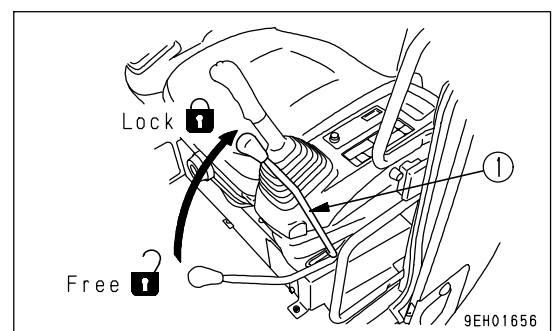

9EH01656

Work Equipment Control Lever

This left work equipment control lever (2) is used to operate the arm and upper structure.

Swing operation

- (a) Swing to right
- (b) Swing to left

Arm operation

- (c) Arm IN
- (d) Arm OUT

N (Neutral): The upper structure and arm are held in that position when they come to a stop and do not move.

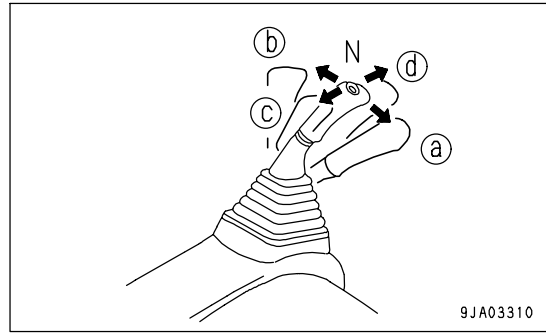

This right work equipment control lever (3) is used to operate the arm and upper structure.

Boom operation

- (e) RAISE
- (f) LOWER

Bucket operation

- (g) DUMP
- (h) CURL

N (Neutral): The boom and bucket are held in that position when they come to a stop and do not move.

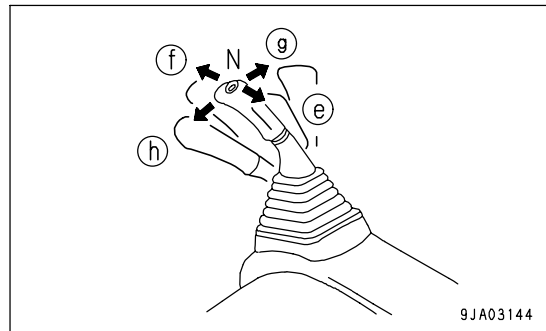

Blade Control Lever

(Only machines with blade specification)

This lever (4) is used to control the blade.

- (a): LOWER
- (b): RAISE

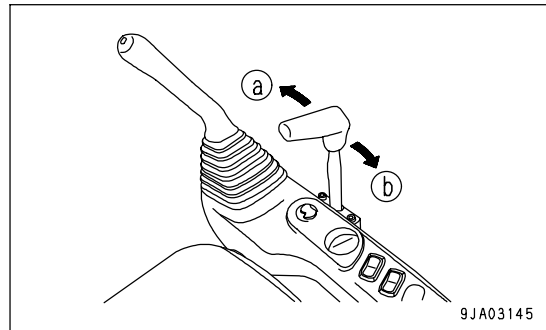

Travel Levers

! WARNING

- Do not put your foot on the pedal unless the machine is traveling. If you leave your foot on the pedal and press it by mistake, the machine will move suddenly, and this may lead to a serious accident. Do not rest a foot on the pedal except when traveling or steering the machine, using the pedal.
- If the track frame is facing the rear, the direction of travel operations will be reversed.
When operating the travel levers, check if the track frame is facing the front or the rear.
(If sprocket (A) is at the rear, the track frame is facing the front.)
- Take good care when traveling or steering the machine, using the pedal.

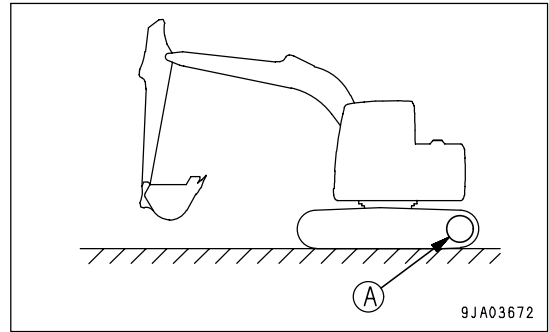

Use this lever (5) to change the direction of travel between forward and reverse. (): Pedal operation

(a) FORWARD: This lever is pushed forward
(This pedal is angled forward)

(b) REVERSE: This lever is pulled back
(The pedal is angled back)

N (Neutral): The machine stops

REMARK

Machines equipped with travel alarm (if equipped)
If the lever is shifted to the FORWARD or REVERSE position from the Neutral position, the alarm sounds to warn that the machine is starting to move.

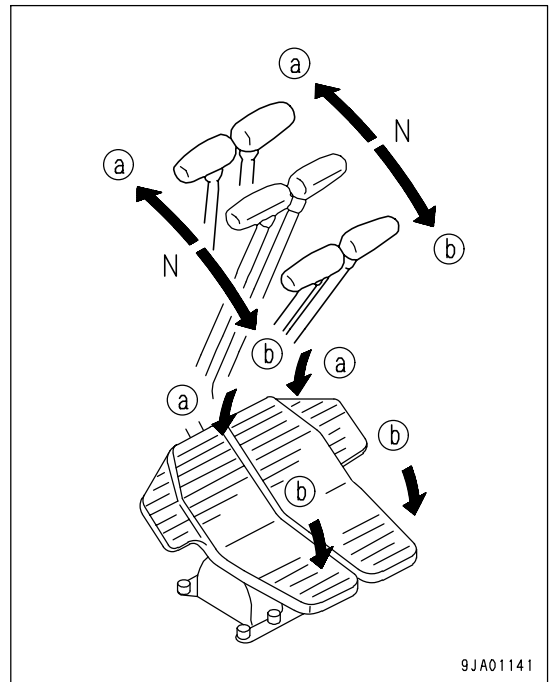

SUN ROOF

WARNING

- When leaving the operator's compartment, set the lock lever securely to the LOCK position.
If the control levers are not locked, and they are touched by mistake, this may lead to a serious accident.
- When opening or closing the roof hatch, carry out the operation on horizontal ground. If you open or close the hatch when the footing conditions are poor, there is danger that you may fall.

Opening

1. Set the lock lever securely to the LOCK position.

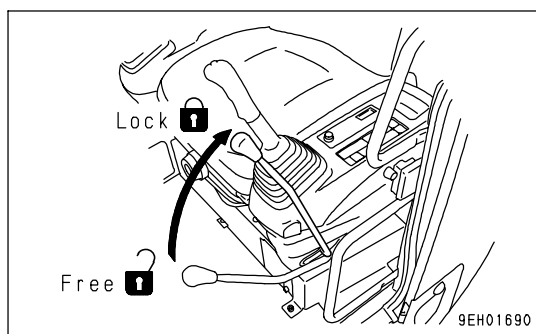

2. Release lock (A) provided on both side of the ceiling and check that it moves freely. Then push it up to open, holding handle (B).

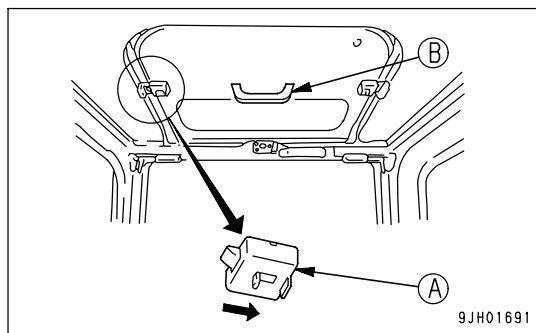

Closing

Pull the ceiling down, holding handle (B) and set locks (A). If the locks do not engage properly, open the ceiling once again and try to shut it.

WINDSHIELD

 **WARNING**

- When opening or closing the front window, bottom window, or door, always set the lock lever to the LOCK position.
If the control levers are not locked and they are touched by accident, this may lead to a serious accident.
- When opening or closing the window at the front of the cab, stop the machine on horizontal ground, lower the work equipment completely to the ground, stop the engine, then carry out the operation.
- When opening the front window, hold the grip securely with both hands, pull up, and do not let go until the automatic lock catch is locked.
- When closing the front window, hold the handle with your both hands and close it firmly.

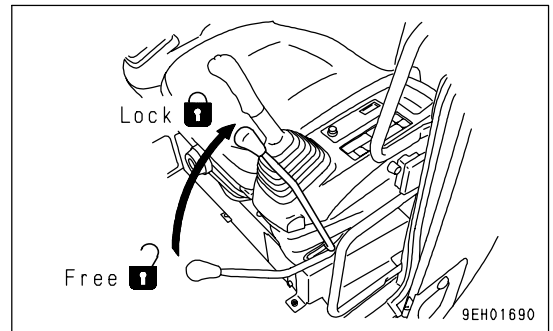

It is possible to stow (pull up) the front window in the roof of the operator's compartment.

Opening

1. Stop the machine on level ground, lower the work equipment completely to the ground, then stop the engine.
2. Set the lock lever securely to the LOCK position.
3. Check that the wiper blade is stowed in the right stay.

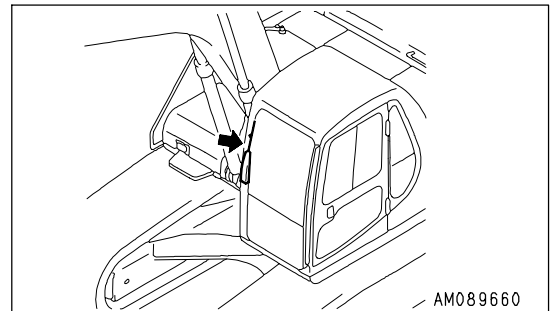

4. Grip handles (A) at the top right and left of the front window, and pull lock lever (B) toward yourself to release the lock at the top of the front window. The top of the front window will come out.

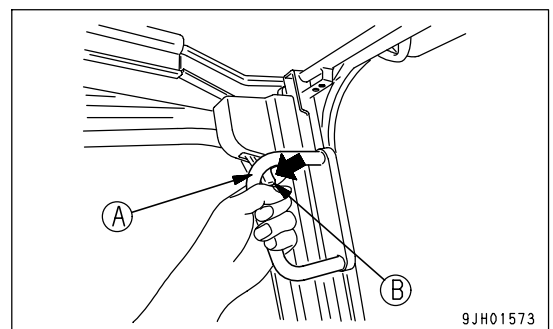
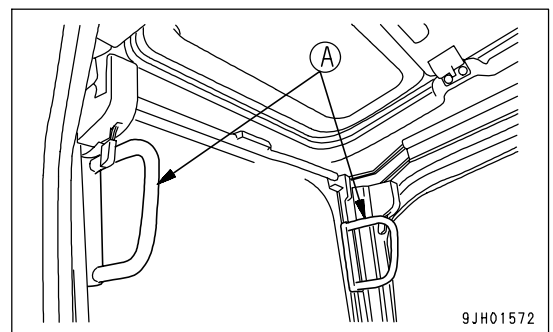

5. Hold lower knob (C) with your left hand from inside the operator's cab, and with your right hand, grip top knob (D), pull it up, and push it against lock catch (E) at the rear of the cab securely to lock the window.

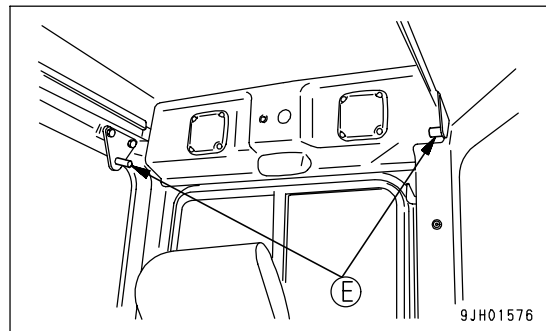
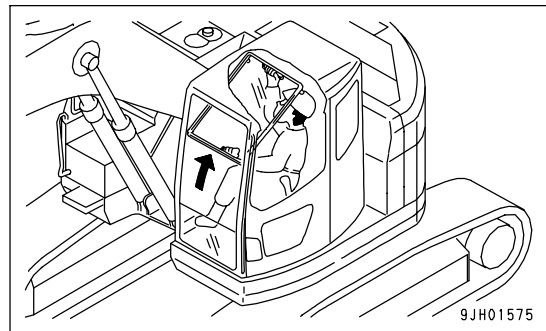
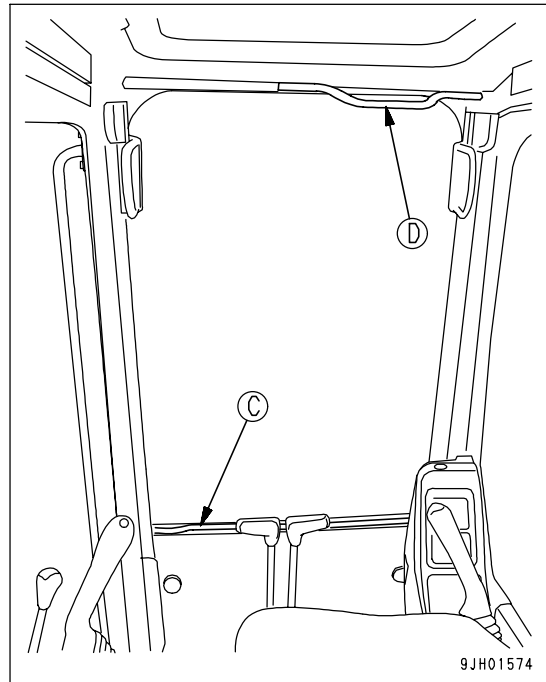

6. Check that lock lever (B) is securely in the LOCK position.

- The lock is engaged if the arrow on lock case (F) matches the position of the arrow on lock lever (B). Check visually.
- If the arrow on lock case (F) does not match the position of the arrow on lock lever (B), the lock is not engaged. Repeat the operation in Step 5 to engage the lock.

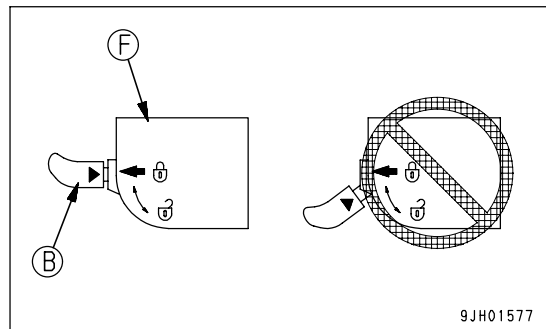

Closing

**WARNING**

When closing the window, lower it slowly and be careful not to get your hand caught.

1. Stop the machine on level ground, lower the work equipment completely to the ground, then stop the engine.
2. Set the lock lever securely to the LOCK position.

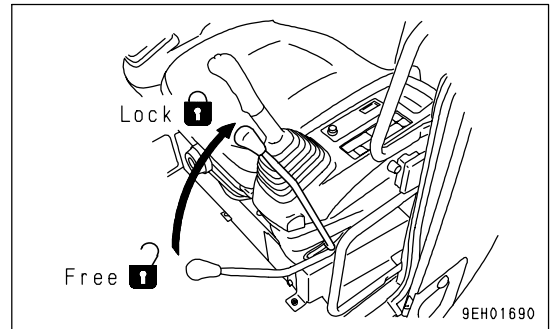

3. Grip left and right handles (A), and pull down lock lever (B) to release the lock.

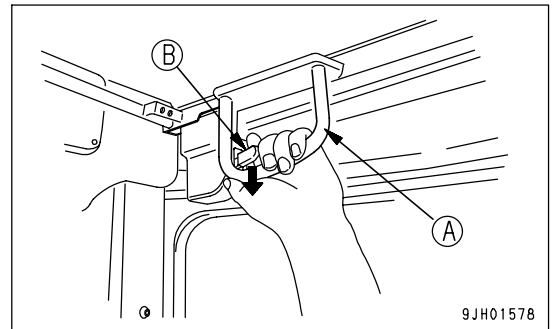

4. Grip handle (C) at the bottom of the front window with your left hand and handle (D) at the top with your right hand, push to the front, then lower slowly.

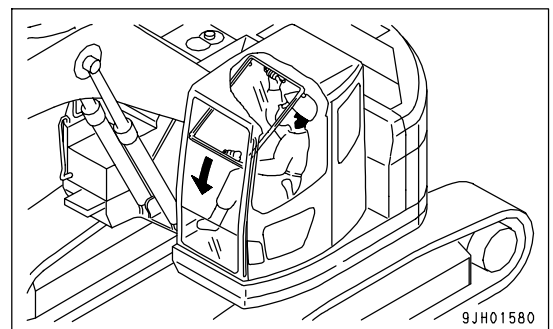
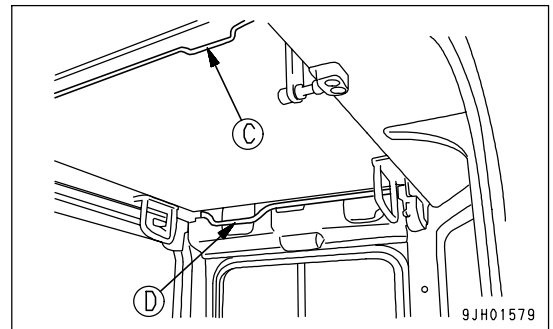

5. When the bottom of the window reaches the top of the bottom window, push the top of the window to the front to push it against left and right lock catches (G) and engage the lock.

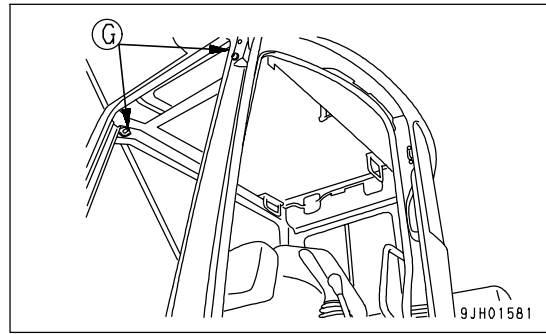

6. Check that lock lever (B) is securely at the LOCK position.
 - The lock is engaged if the arrow on lock case (F) matches the position of the arrow on lock lever (B). Check visually.
 - If the arrow on lock case (F) does not match the position of the arrow on lock lever (B), the lock is not engaged. Repeat the operation in Step 5 to engage the lock.

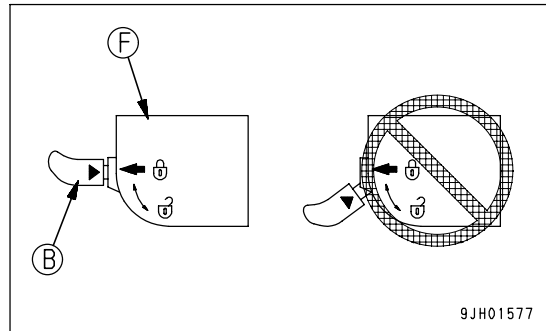

Removing Lower Windshield

1. Open the front window, then hold grip (A), pull up, and remove the bottom window.

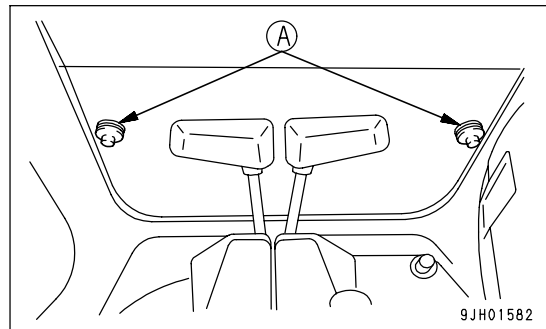

2. After removing the bottom window, stow it on the inside left of the operator's cab, then lock securely in position with lock lever (B). The procedure for stowing is as follows.

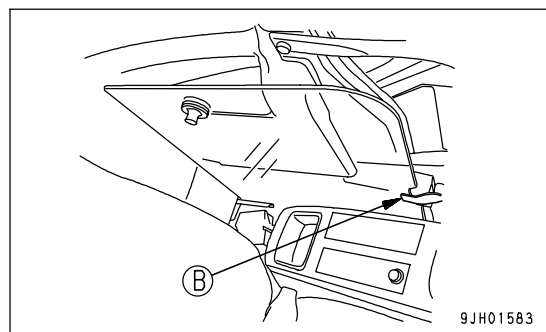

- 1) Set the hollow in the glass at the front face, set the protruding part of grip (A) on the inside, and insert between the left switch lever box and magazine box on the inside left of the operator's cab.

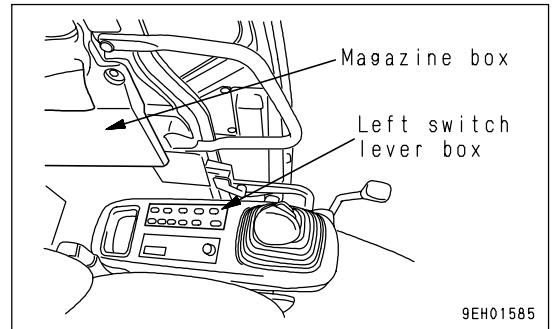
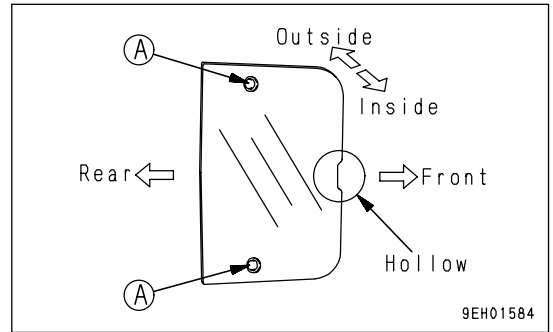

- 2) After inserting into groove (D) of the bottom frame rubber and rear frame rubber (A), push the bottom window against lock base (C).

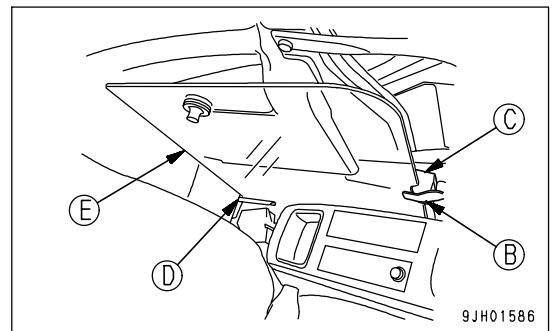

NOTICE

If the window rise up on lock base (C) or is not in contact with lock lever (B), and it is attempted to engage the lock by force, there is danger that the glass may break. Check before applying the lock.

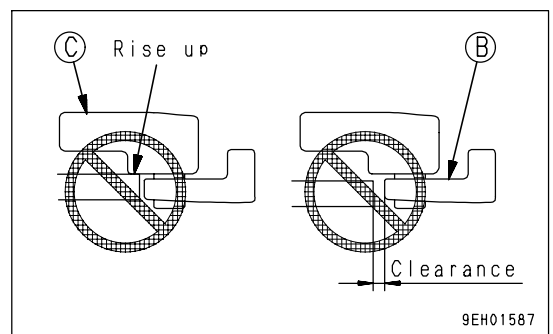

- 3) Set lock lever (B) to the LOCK (CLOSED) position.

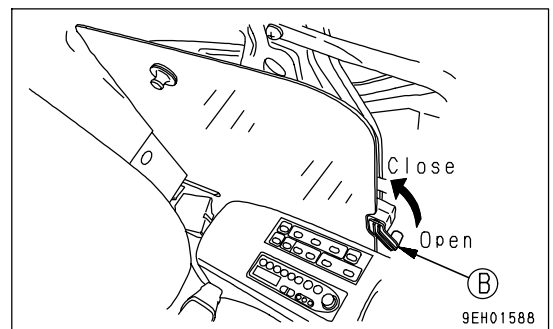

SLIDING DOOR

CAUTION

- Be sure to check that the sliding door is locked in position both when it is open and when it is closed.
- Always stop the machine on level ground when opening or closing the door.
If the door is opened or closed on a slope, there is danger that the operating effort will suddenly change. Do not open or close the door on slopes.
- When opening or closing the door, always use door handle (1) and knob (2).
- Be careful not to get your hands caught between the front pillar and center pillar.
- If there is anyone inside the cab, call out to that person before opening or closing the door.

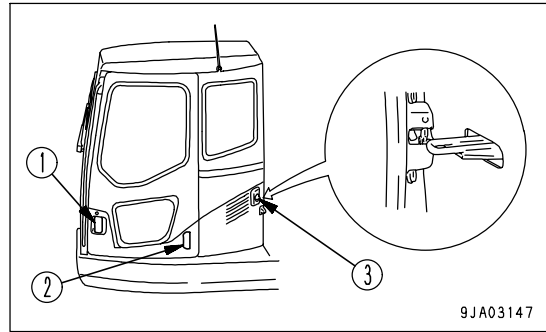

Door Lock

When closing the door, pull the handle back to remove lock (3), then pull the door to the front.

EMERGENCY ESCAPE HAMMER

CAUTION

- If it is necessary to break the window glass with the hammer, be extremely careful not to injure yourself on the flying pieces of broken glass.
- To prevent injury, remove the broken pieces of glass remaining in the frame before escaping through the window. Be careful also not to slip on the broken pieces of glass.

If it should become impossible to open the cab door for any reason, and it is necessary to make an emergency escape from the operator's compartment, use hammer (A) to escape.

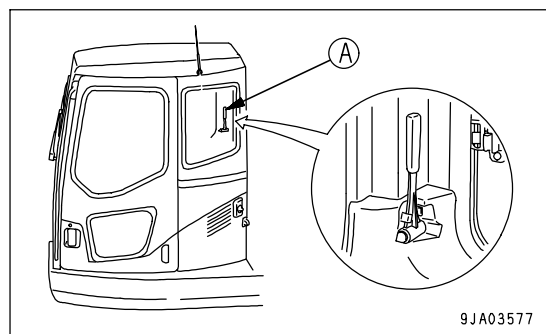

To escape from the operator's cab, use hammer (A) to break the glass and escape through the window.

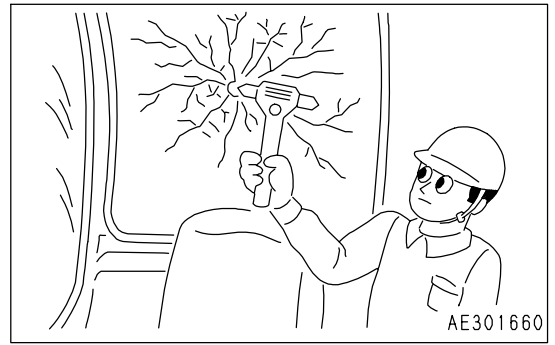

CAP WITH LOCK

Use the starting switch key to open and close the locks on the caps and covers.

For details of the locations of the caps and covers with locks, see "LOCKING (PAGE 3-100)".

Insert the key as far as it will go, then turn it. If the key is turned before it is inserted fully, it may break.

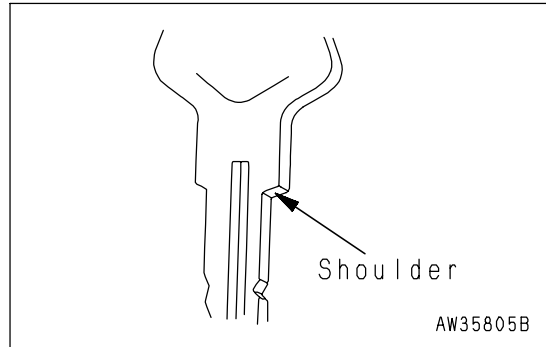

Opening and Closing Caps with Lock

Opening the Cap

1. Insert the key into the key slot.
2. Turn the key clockwise, align the key slot with the match mark on the cap, then open the cap.

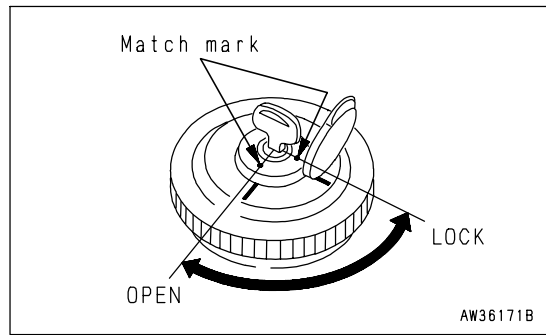

Locking the Cap

1. Turn the cap until tight, then insert the key into the key slot.
2. Turn the key counterclockwise and take the key out.

Opening and Closing Covers with Lock

Opening the Cover

1. Insert the key into the key slot.
2. Turn the key counterclockwise and open the cover by pulling the cover grip.

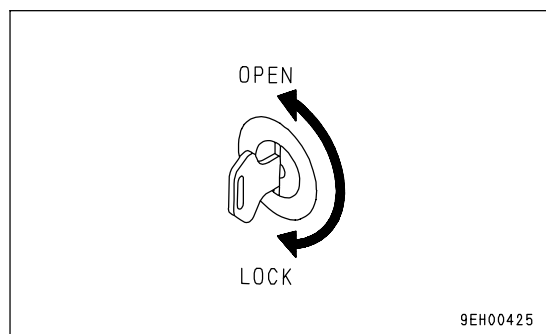

Locking the Cover

1. Close the cover and insert the key into the key slot.
2. Turn the key clockwise and take the key out.

ENGINE HOOD



CAUTION

When carrying out inspection and maintenance inside the engine hood, always use the hood support lever to hold the engine hood open.

NOTICE

Always keep the hood locked except when opening it.

1. Release lock (1) of the engine hood.
(For details see "Opening and Closing Covers with Lock (PAGE 3-32)".)
2. Locking can be released by pulling engine hood release lever (2).

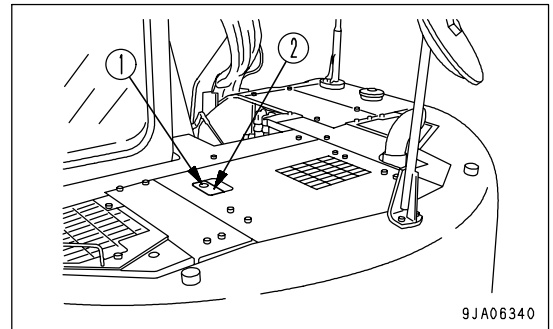

3. Pull up engine hood (3) and put engine hood support lever (4) in the position to secure the engine hood.
4. When closing engine hood (3), lower engine hood support lever (4) slowly to the sliding position and then lock the hood securely.
5. Do not forget to lock the engine hood.

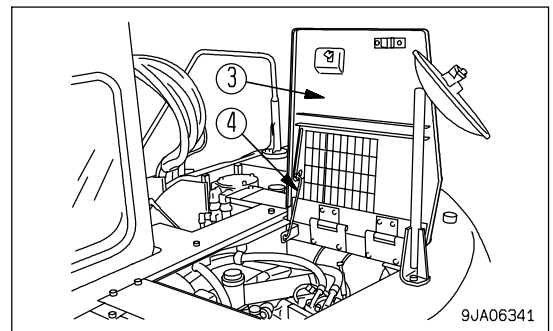

CAB REAR COVER



CAUTION

When carrying out inspection and maintenance inside the cover, always use the cover support lever to hold the cover open.

NOTICE

Except when opening the cover for some reason, always keep the cover locked.

1. Release lock (1) of the cover.
(For details see "Opening and Closing Covers with Lock (PAGE 3-32)".)
2. Put a finger in hook (2) and pull cover (3) open.

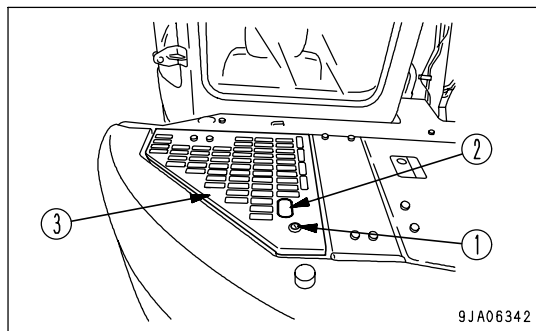

3. After opening the cover, set cover support lever (4) to hold the cover in position.
4. When closing cover (3), set cover support lever (4) to the slide position, and lower the cover slowly.
5. Lock the cover.

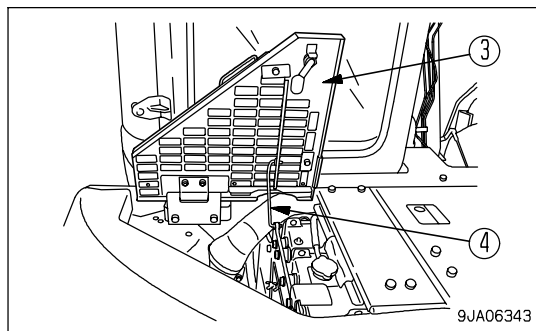

PUMP ROOM DOOR, BATTERY ROOM DOOR

**CAUTION**

When carrying out inspection and maintenance inside the door, always use the stopper to hold the door open.

NOTICE

Always keep the door locked except when opening it.

1. Release lock (1) of door.
(For details see "Opening and Closing Covers with Lock (PAGE 3-32)".)
2. Put a finger in hook (2) and pull door (3) open.

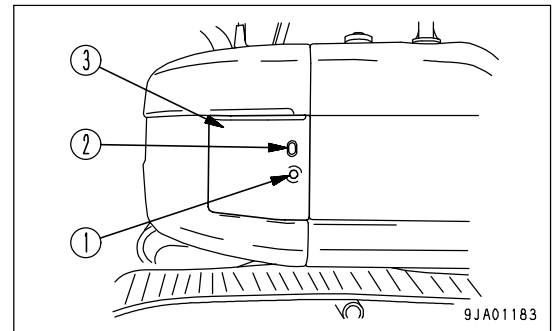

3. Remove stopper (4) from spring catch (5).
4. Set so that the cushion of stopper (4) contacts the outside circumference of the machine, then lower stopper (4).
5. When closing door (3), secure stopper (4) to spring catch (5), then close the door.
6. Do not forget to lock the door.

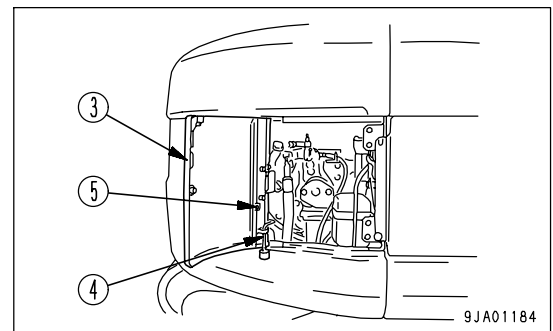
**REMARK**

The pump room door is on the right side of the machine; the battery room door is on the left side of the machine.

DOOR AT FRONT OF TOOL BOX

CAUTION

When carrying out inspection and maintenance inside the door, always use the stopper to hold the door open.

NOTICE

Always keep the door locked except when opening it.

1. Release lock (1) of door.
(For details see "Opening and Closing Covers with Lock (PAGE 3-32)".)
2. Pull door lever (2) to release the lock.

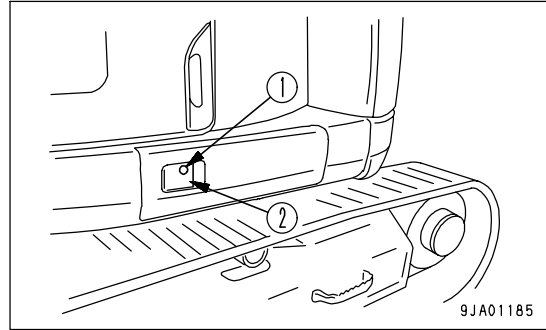

3. Pull door (3) to open it, remove door support lever (4) from spring catch (5), then insert the L-shaped portion in the hole in the frame.
4. To close door (3), lift up door support lever (4), fix it to spring catcher (5) and close it.
5. Do not forget to lock the door.

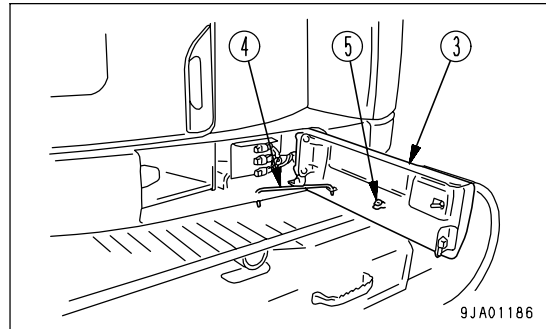

FUSE

NOTICE

Before replacing a fuse, be sure to turn off the starting switch.

The fuses protect the electrical equipment and wiring from burning out.

If the fuse becomes corroded, or white powder can be seen, or the fuse is loose in the fuse holder, replace the fuse.

Replace the fuse with another of the same capacity.

- The fuse box is provided behind the left console box.

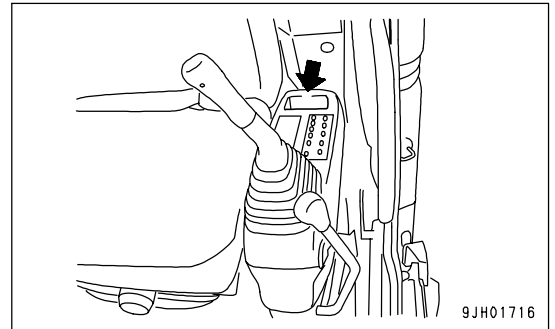

Fuse Capacities and Circuit Names

No.	Fuse capacity	Name of circuit
(1)	10A	Controller
(2)	10A	Solenoid valve
(3)	10A	Auxiliary electric power (1)
(4)	10A	Window washer, Cigarette lighter
(5)	5A	Horn
(6)	15A	Working lamp
(7)	10A	Radio
(8)	25A	Air conditioner unit
(9)	15A	Fuel control
(10)	5A	Swing brake
(11)	10A	Auxiliary electric power (2)
(12)	10A	PPC oil pressure lock solenoid
(13)	10A	Monitor panel
(14)	10A	Spare
(15)	15A	Key stop solenoid
(16)	5A	Radio back up
(17)	10A	Air conditioner back up
(18)	10A	Monitor (normal power source)
(19)	5A	Room lamp
(20)	30A	Starting switch

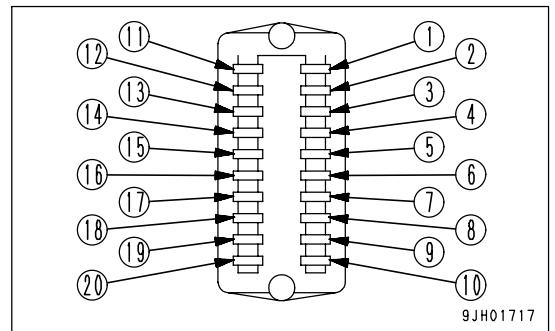

FUSIBLE LINK

If the starting motor does not move even when the starting switch is turned to the ON position, there is probably a break in the wire-shaped fusible link (1), so open the engine hood and check or replace.

REMARK

A fusible link refers to the large-sized fuse wiring installed in the high current flow portion of the circuit to protect electrical components and wiring from burning, in the same way as an ordinary fuse.

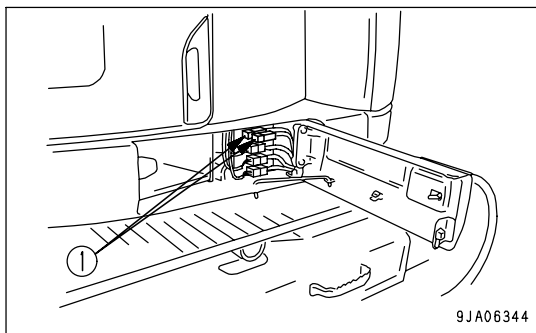

AUXILIARY ELECTRIC POWER

NOTICE

When installing electrical equipment not supplied by Komatsu, make sure that the equipment is 24 V specification with a maximum of 240 W (10 A or equivalent). When installing electrical equipment with a larger capacity, please consult your Komatsu distributor.

On both the left and right sides under the floor console, there are power takeoff connectors for optional equipment fixed to the wiring and held in position by tape. Remove the tape when using them. Use these connectors for taking off the power supply for components not supplied by Komatsu.

Left connector No: M30

Right connector No: M31

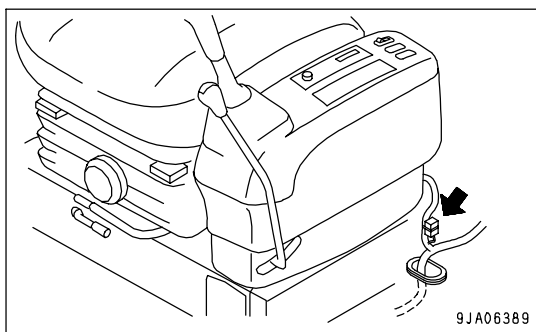
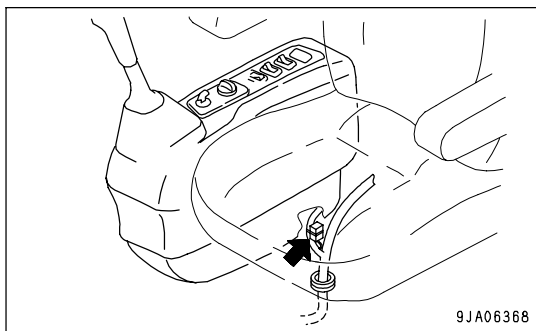

See the table below for the connection type of each connector. (Both left and right)

	M type housing (2-terminal)		Terminal		
	Body	Rear holder	AVS 0.5	AVS 0.85 - 2	AVS 3
Komatsu part No.	08056-00211	08056-00230	08056-00050	08056-00051	08056-00052

REMARK

Power may be sourced from the cigarette lighter, too. For the details, see the section of "Cigarette Lighter (PAGE 3-20)" in this manual.

CONTROLLERS

NOTICE

- Do not let water, mud, or juice spill on the controller. This will cause failures.
- If any problem occurs in the controller, do not repair it by yourself. Please contact your Komatsu distributor for repairs.

The controller is installed behind the operator's seat.

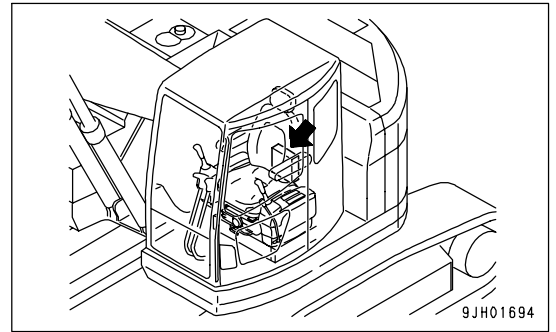

AIR CONDITIONER CONTROLS

Air Conditioner Control Panel

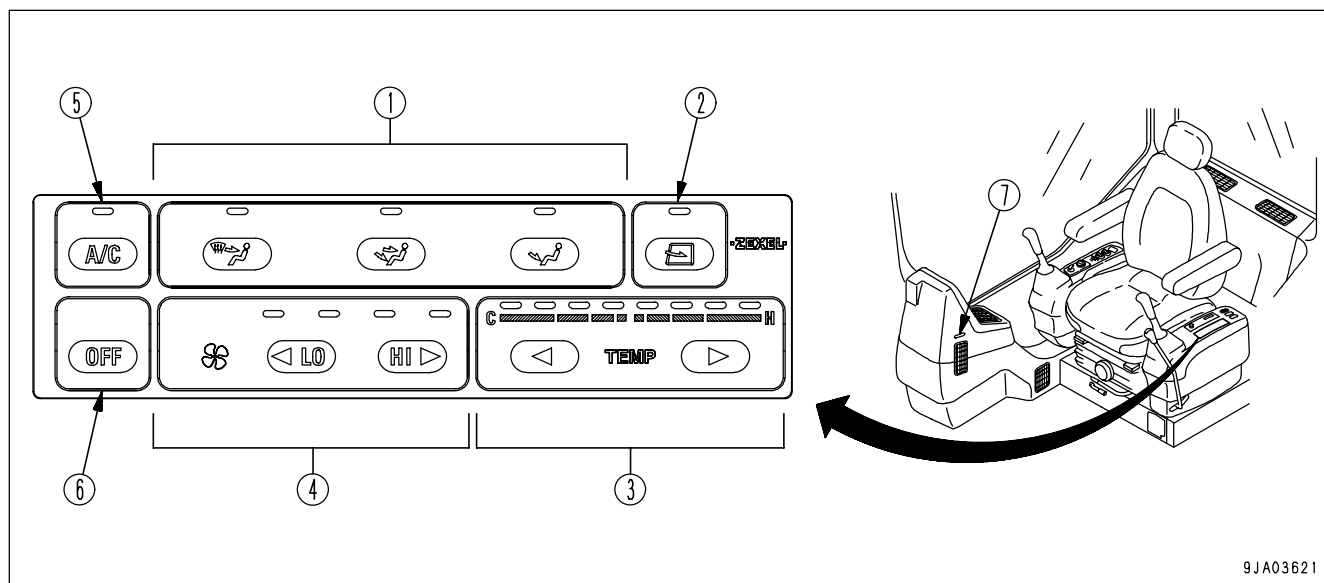

- (1) Vent selector switch
- (2) Air circulation selector switch (external/internal)
- (3) Temperature control switch
- (4) Air flow selector switch
- (5) Air conditioner switch
- (6) Off switch
- (7) Defroster selector lever

Vent Selector Switch (Air Flow to Upper Part of Body)

If this switch (1) is pressed, the air from the air conditioner is all directed to the face. This can be used to send a cool breeze to the face during hot weather.

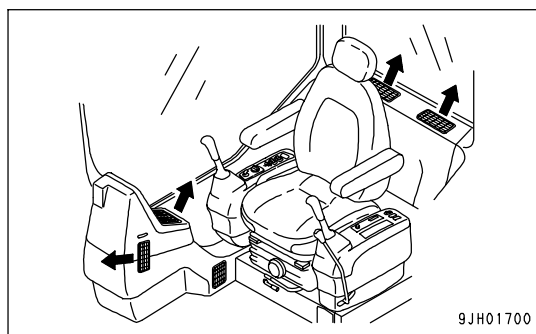
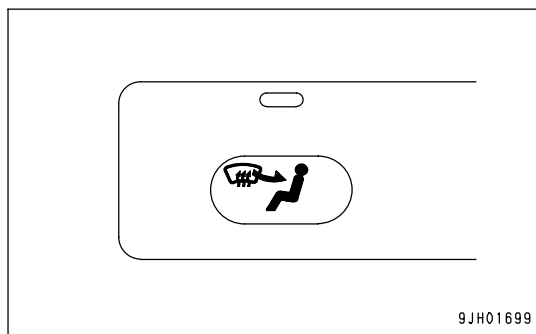

Vent Selector Switch (Air Flow to Upper Part of Body and Foot)

If this switch (1) is pressed, the air from the air conditioner is directed to the face and feet.

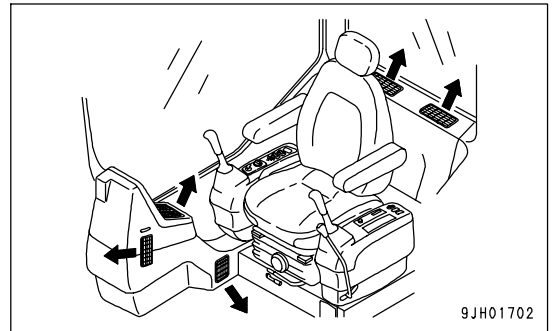
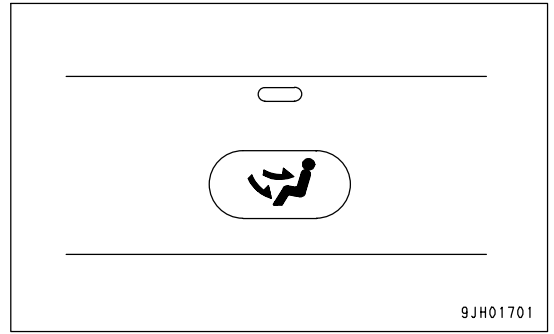

Vent Selector Switch (Air Flow to Foot)

If switch (1) is pressed, the air from the air conditioner is all directed to the feet.

This can be used to send warm air to the feet during cold weather.

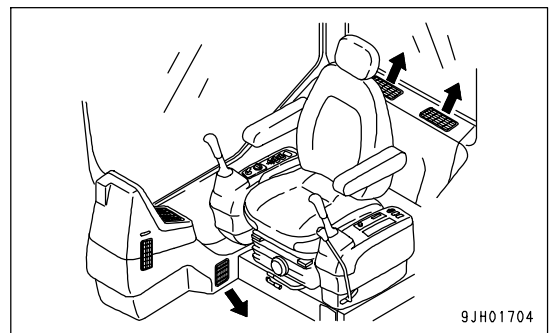
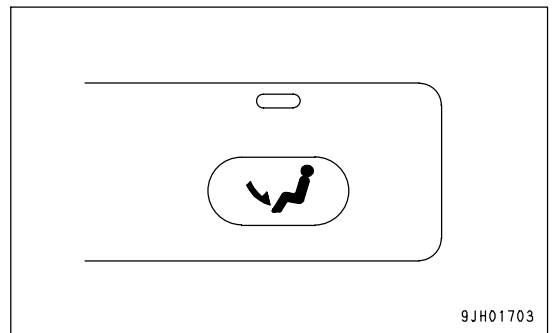

Air Circulation Selector Switch (External Air Circulation)

When switch (2) is pressed, fresh air is taken into the cab during heating or cooling.

This position is used to bring in clean fresh air into the cab or to remove the mist from the cab windows.

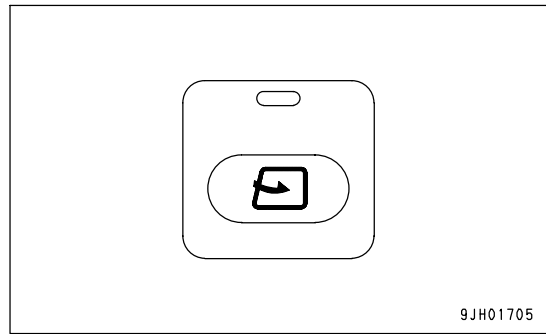

Air Circulation Selector Switch (Internal Air Circulation)

When switch (2) is pressed, the air inside the cab is recirculated and no fresh air is taken in from outside. This position is used when heating or cooling the cab quickly or when the outside air is dirty.

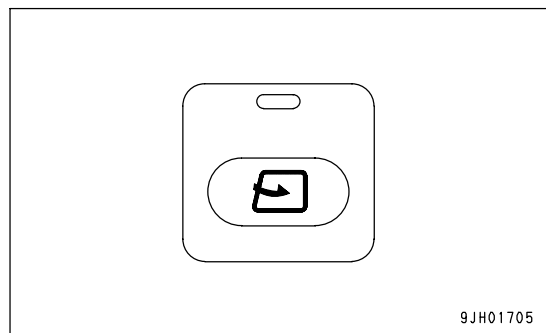

Temperature Control Switch

The closer to the "C" mark the lighting-up is in the range, the lower the room temperature is. Conversely the closer to the "H" mark the lighting-up is in the range, the higher the room temperature is. The indicator range is divided into 11 levels, but within each range the temperature changes steplessly.

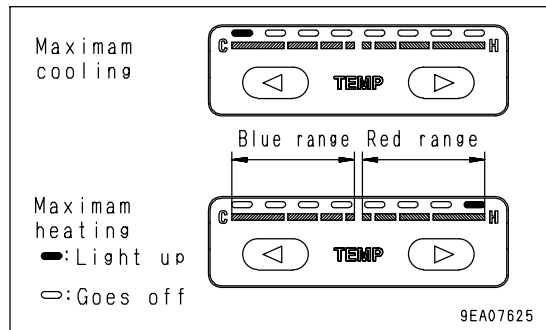

Temperature Control Switch (Cooling)

Use switch (3) to reduce the temperature.

Press this switch to reduce the temperature of the air sent from the air conditioner.

The more times the switch is pressed, the lower the temperature becomes, as the indicator light moves to the "C".

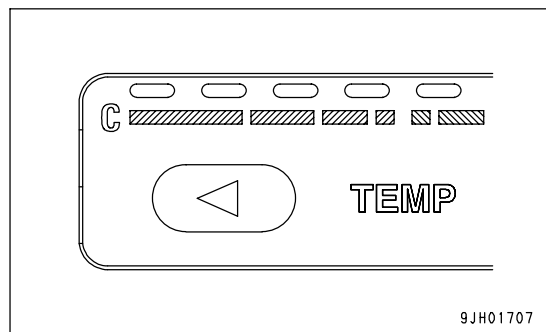

Temperature Control Switch (Heating)

Use switch (3) to increase the temperature.

Press this switch to increase the temperature of the air sent from the air conditioner.

The more times the switch is pressed, higher the temperature becomes, as the indicator light moves to the "H".

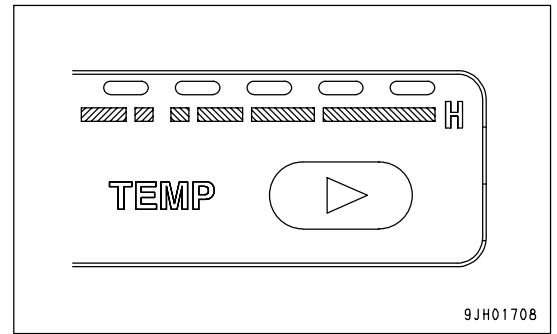

Air Flow Selector Switch

The further it is moved into the LO range (rear of machine), the smaller the air flow becomes; the further it is moved into the HI range (front of machine), the greater the air flow becomes.

The range is divided into 4 levels.

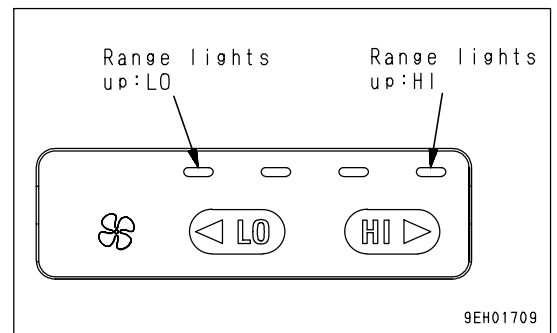

Air Flow Selector Switch (Low)

Switch (4) is used to set the flow of air from the air conditioner to Low.

Press this switch to reduce the air flow. The further it is moved into the LO range (rear of machine), the smaller the air flow becomes.

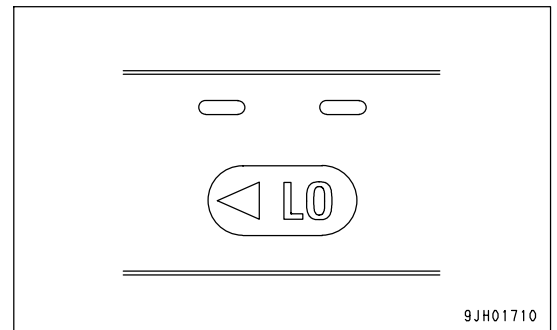

Air Flow Selector Switch (High)

This switch (4) it is used to adjust the amount of air flowing from the air conditioner vents.

To increase the air flow, press this switch. The more it is moved to the HI position (front of machine), the stronger the air flow becomes.

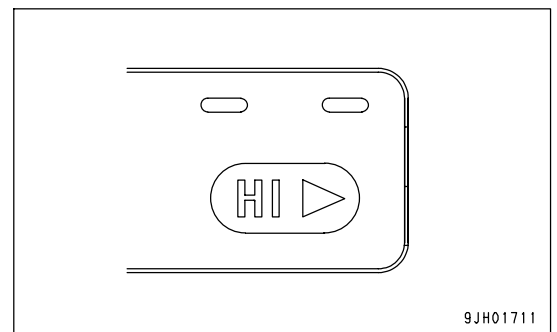

Air Conditioner Switch

Switch (5) is used to switch the air conditioner functions ON/OFF.

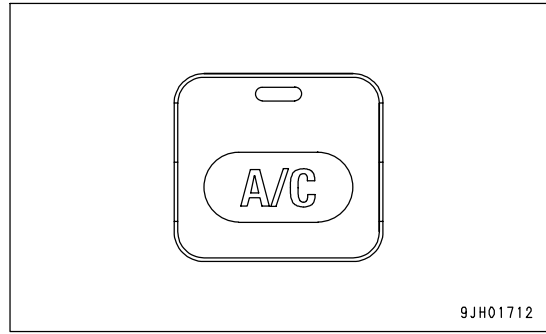

Off Switch

Switch (6) is used to stop operation of the fan.

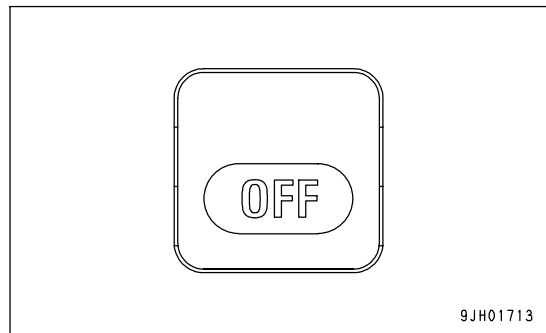

Defroster Selector Lever

Switch (7) is used to remove the mist from the front glass during cold or rainy weather.

Selector lever to front: To defroster (open)

Selector lever to rear: Closed

The defroster can be used when the vent selector switch is set to send air to the face or to the face and the feet.

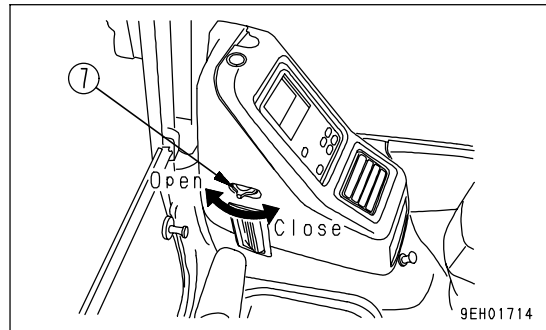

Use Air Conditioner with Care

Ventilation

- If you smoke when the air conditioner is on, the smoke may start to hurt your eyes, so open the window and turn the lever to FRESH for a while to remove the smoke while continuing the cooling.

When running the air conditioner for a long time, turn the lever to the FRESH position once an hour to carry out ventilation and cooling.

Temperature Control

- When the air conditioner is on, set the temperature so that it feels slightly cool when entering the cab (5 to 6°C (41 to 42.8°F) lower than the outside temperature). This temperature difference is considered to be the most suitable for your health, so always be careful to adjust the temperature properly.

Air Conditioner Maintenance

When carrying out inspection of a machine equipped with an air conditioner, see the "MAINTENANCE SCHEDULE CHART (PAGE 4-14)" and carry out inspection according to the table.

RADIO

Control Panel

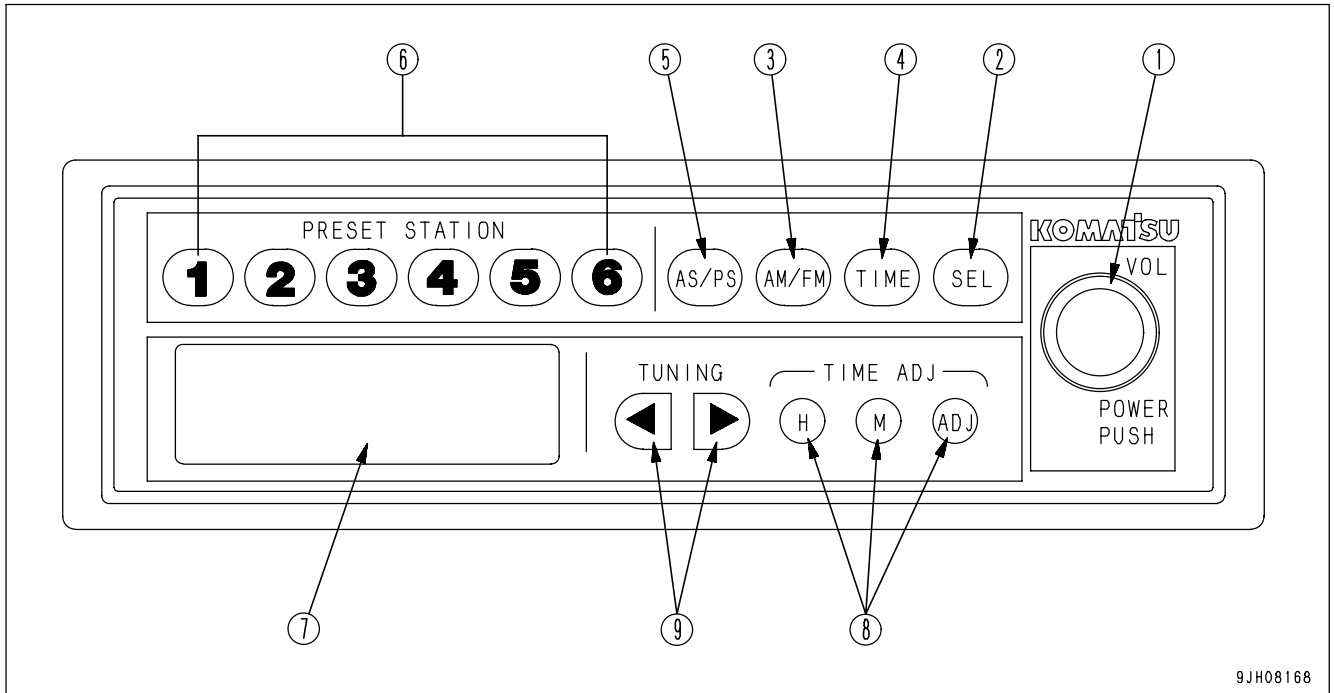

- | | |
|---|--|
| (1) Power switch, Volume control knob, Balance control knob | (5) AS/PS button |
| (2) SEL button | (6) Preset station buttons (1,2,3,4,5,6) |
| (3) FM/AM selection button | (7) Display |
| (4) Display selection button | (8) Time reset button |
| | (9) Tuning button |

Power switch, Volume control knob, Balance control knob

Press this knob (1) to turn the power for the radio on. The frequency is displayed on display (7). Press the knob again to turn the power off.

Turn the knob clockwise to increase the volume; press counterclockwise to reduce the volume. The range for the volume is VOL 0 - VOL 40.

SEL button

Each time this button (2) is pressed, the mode changes as follows: VOL (volume) → BAS (bass) → TRE (treble) → BAL (balance). The mode is displayed on display (7). For details of each mode, see "Method of Operating Mode (PAGE 3-48)".

FM/AM Selection Button (AM/FM)

Press this button (3) to select the desired band.

Each time the button is pressed, the band changes FM → AM → FM . . .

Display Selection Button (TIME)

On this machine, priority is given to the frequency display. When the frequency is being displayed, press button (4) and the display will show the present time for 5 seconds. After 5 seconds pass, the display returns automatically to the frequency display. If any button other than TIME ADJ (H, M, ADJ) is pressed within 5 seconds, the display returns to the frequency display. For details of the method of adjusting the time, see "Setting Correct Time (PAGE 3-48)".

AS/PS button

This button (5) actuates the auto store and preset scan functions.

- Auto store

If this button is pressed for more than 2 seconds during radio reception, a search is made automatically of the 6 station settings to find an unused preset number, and that frequency is stored in the preset memory.

- Preset scan

If this button is pressed within 2 seconds, it is possible to select one of the already preset stations. Wait for 6 sec. after pressing the button and then press the button again to select the next preset station. If it is impossible to receive the preset frequency, the selection advances after 1 second to the next preset station.

Preset Station Buttons (1, 2, 3, 4, 5, 6)

If this button (6) has been used to decide which stations to preset, it is possible to select the desired station at a touch. It is possible to preset 6 stations each for both AM and FM.

For details of the method of presetting the stations, see "Method of Setting with Preset Button (PAGE 3-47)".

Display

In this display (7), receiving band, frequency, preset No. and time are shown.

Time Reset Button

Use this button (8) when adjusting the time. For details of the method of adjusting the time, see "Setting Correct Time (PAGE 3-48)".

H: Hour

M: Minute

ADJ: Sets to 00 minutes

Tuning Button (TUNING)

Use this button (9) to change the frequency.

For further details, see "Method of Tuning (PAGE 3-47)"

Controls of Radio

Method of Setting with Preset Button

1. Press power switch (1) and display the frequency on display (7).
2. Use tuning button (9) to set to the desired frequency. There are two methods for tuning: auto tuning and manual tuning.
3. With the display (7) showing the desired frequency, keep the desired Preset button No pressed for at least 1.5 seconds. The reception sound will disappear, but when the presetting operation (saving to memory) is completed, the sound will appear again and the Preset No and frequency will be shown on the display to show that the presetting operation has been completed.

After completing the presetting, press Preset button (6) and release it within approx. 1.5 seconds. This will make it possible to receive the channel preset to that button. One channel each for AM and FM can be preset to each Preset button.

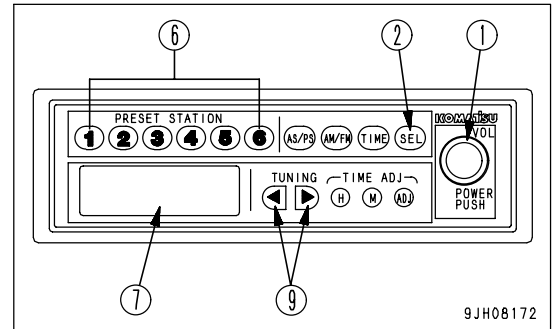

REMARK

It is also possible to save to the Preset button by using the auto store button.

Method of Tuning

1. Press power switch (1) and display the frequency on display (7).
2. Use tuning button (9) to set to the desired frequency. There are two methods for tuning: auto tuning and manual tuning.

- Manual tuning

Press tuning button (9) until the frequency is displayed on display (7).

< button: Frequency moves down

> button: Frequency moves up

When the frequency reaches the top or bottom frequency, it automatically continues as follows: Top → Bottom, or Bottom → Top.

- Auto tuning

Press tuning button (9) for at least 3 seconds. When a station is picked up, the tuning automatically stops. To search for the next station, press the tuning button again for at least 3 seconds.

< button: Frequency moves down

> button: Frequency moves up

If this button is pressed during auto tuning, the auto tuning will be cancelled and the setting will return to the frequency in use before the button was pressed.

Method of Operating Mode

- (BAS) Bass adjustment: When button (2) is pressed, BAS is displayed on display (7). If knob (1) is turned clockwise within 5 seconds, the bass sound is emphasized. If the knob is turned counterclockwise, the bass sound is reduced.
- (TRE) Treble adjustment: When button (2) pressed, TRE is displayed on display (7). If knob (1) is turned clockwise within 5 seconds, the treble sound is emphasized. If the knob is turned counterclockwise, the treble sound is reduced.
- (BAL) Balance adjustment: When button (2) is pressed, BAL is displayed on display (7). If knob (1) is turned clockwise within 5 seconds, the sound from the right speaker is increased. If the knob is turned counterclockwise, the sound from the left speaker is increased. When it is set to BAL 0, the sound from the left and right speakers is balanced.

REMARK

With each mode, the display is returned automatically to its original setting after 5 seconds.

Setting Correct Time

1. Press display selector button (4) to display the time.
After 5 seconds, the display will return to the frequency display and the time cannot be corrected. If this happens, press display selector button (4) again.
2. Press time adjustment button (8) to select Hour or Minute.
H button: Adjusts the hour (each time the button is pressed, the time advances by one hour)
M button: Adjusts the minute (each time the button is pressed, the time advances by one minute)
If the H or M button is kept pressed, the time will advance continuously until the button is released.
ADJ button: When the ADJ button is pressed, the time is reset as follows.
When display is 00 - 05 minutes, time is returned to 00 min. 00 sec. (No change in hour)
When display is 55 - 59 minutes, time is advanced to 00 min. 00 sec. (Hour advances)
When display is 06 - 54 minutes, time cannot be reset. (Time stays same)

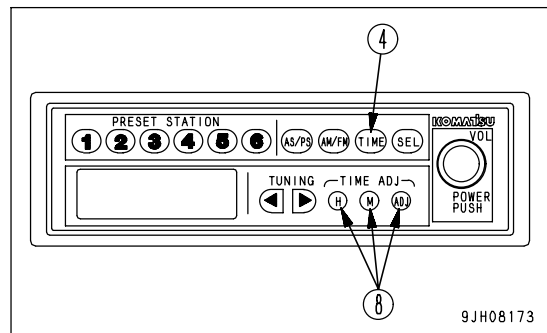

Example

- 10:05 → 10:00
- 10:59 → 11:00
- 10:26 → 10:26

Use the H, M, and ADJ buttons to set to the correct time.

Antenna

NOTICE

When transporting the machine or parking it in a garage, always fully retract the antenna to avoid the possibility of breakage.

If the receiving wave is weak or generates noise, extend the antenna. If the wave is too strong, adjust the sensitivity by retracting the antenna.

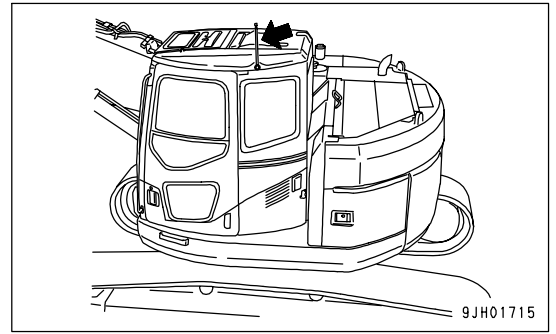

Use Radio with Care

- To ensure safety, always keep the sound to a level where it is possible to hear outside sounds during operation.
- If water gets into the speaker case or radio, it may lead to an unexpected failure, so be careful not to get water on the equipment.
- Do not wipe the scales or buttons with benzene, thinner, or any other solvent. Wipe with a soft dry cloth. Use a cloth soaked in alcohol if the equipment is extremely dirty.
- When the battery is replaced, the settings for the preset buttons are all cleared, so set them again.

OPERATION MANUAL STORAGE

A magazine box is provided on the left side of the operator's seat for safekeeping the operation and maintenance manual and oil chart.

Always keep the Operation and Maintenance Manual in this pocket so that it is possible to read it at any time.

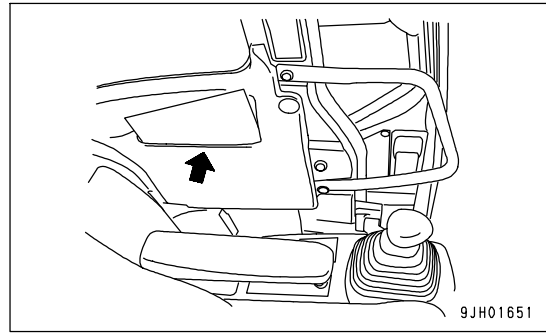

9JH01651

TOOL BOX

Open the door at the front of the tool box. The standard tool compartment is inside.

Put the tools in the supplied tool bag and store them in the tool compartment.

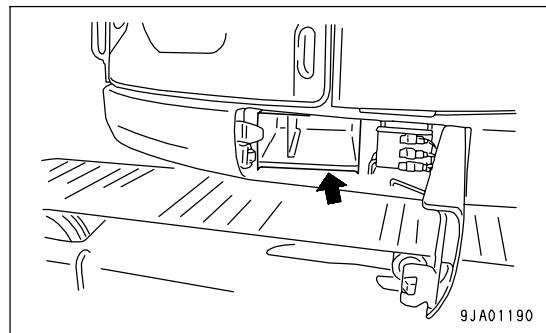

9JA01190

GREASE PUMP HOLDER

Open the door at the front of the tool box. The compartment to stow the grease pump is inside.

Pass the nozzle through the hole at the end, and push the grease gun holder fully in to store it.

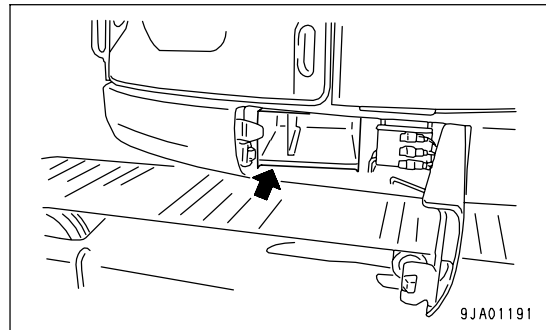

9JA01191

HOT AND COOL BOX

This is on the right side at the rear of the operator's seat. It is interconnected with the air conditioner: it stays warm when the heating is used, and stays cool when the cooling is used.

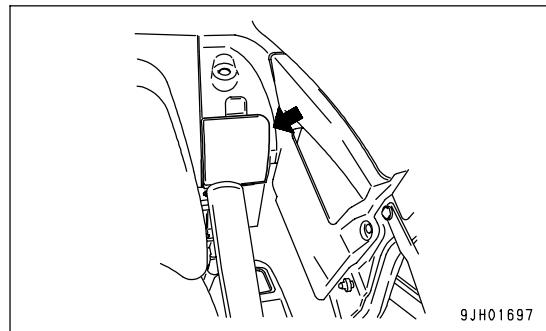

9JH01697

ASHTRAY

This is on the right front side of the operator's seat.

Be sure to extinguish your cigarette, then close the lid.

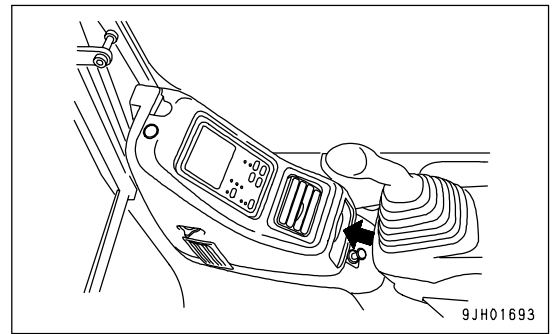
**FIRE EXTINGUISHER**

(If equipped)

A fire extinguisher is prepared at the rear part inside the operator's cab.

The directions are described on the nameplate affixed to it. Just in case, carefully read and grasp them beforehand.

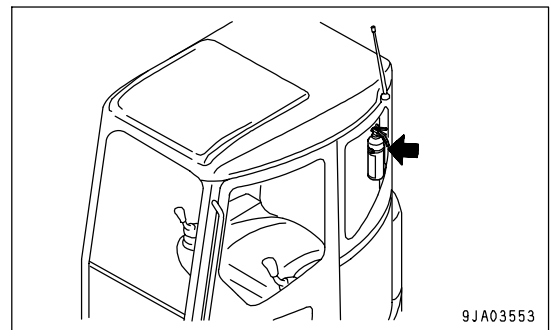

MACHINE OPERATIONS AND CONTROLS

BEFORE STARTING ENGINE

Walk-around Checks

Before starting the engine, look around and under the machine to check for loose nuts and bolts, or leakage of oil, fuel, or coolant, and check condition of the work equipment and hydraulic system. Also check for loose wiring and play, and accumulation of dust at places with high temperatures.



WARNING

Remove any flammable materials from around the battery, engine, muffler, turbocharger, or other high temperature engine parts. Leakage of fuel or oil will cause the machine to catch fire. Check carefully, be sure to repair any problem, or contact your Komatsu distributor.

If the machine is at an angle, reposition it level before checking.

Perform the following inspections and cleaning every day before starting engine for the day's work.

1. Check for damage, wear, play in work equipment, cylinders, linkage, and hoses.
Check that there are no cracks, excessive wear, or play in the work equipment, cylinders, linkage, or hoses. If any problem is found, repair it.
2. Remove dirt and debris from around the engine, battery, and radiator.
Check for dirt accumulated around the engine and radiator. Also check for flammable material (dry leaves, twigs, etc.) around the battery, engine muffler, turbocharger, or other high temperature engine parts. If any dirt or flammable materials are found, remove them.
3. Check for coolant and oil leakage around the engine
Check for oil leakage from the engine and coolant leaks from the cooling system. If any problem is found, repair it.
4. Check for oil leakage from hydraulic equipment, hydraulic tank, hoses, and joints
Check for oil leakage. If any problem is found, repair the area where oil is leaking.
5. Check the undercarriage (track, sprocket, idler, guard) for damage, wear, loose bolts, or leakage of oil from rollers.
If any problem is found, repair it.
6. Check for problems in handrails, steps, loose bolts.
If any problem is found, repair it. Tighten any loose bolts.
7. Check for problems in gauges and monitor
Check that there is no problem in the gauges and monitor in the operator's cab. If any problem is found, replace the parts. Clean off any dirt on the surface.
8. Checking window for damage and displacement
Check the window for any damage or displacement. If it is found broken or displaced, repair it. In particular, repairs must be made immediately, once stopping the machine, if the window is broken or displaced during operation. Do not attempt to continue to operate the machine without repair.

9. Clean, check rear view mirror
Check for damage to the rear view mirror. If damaged, replace it with a new mirror. Clean surface of the mirror and adjust angle so area at the rear can be seen from the operator's seat.
10. Seat belt and mounting clamps
Check for damage or wear to the seat belt and mounting clamps. If there is any damage, replace with new parts.
11. Check bucket with hook (if equipped) for damage.
Check for damage to the hook, guide, and hook mount. If any problem is found, contact your Komatsu distributor for repairs.

Checks Before Starting

Always check the items in this section before starting the engine each day.

Check Coolant Level, Add Coolant



WARNING

- Do not open the radiator cap unless necessary. Wait for the engine to cool down before checking the coolant in the sub-tank.
- Immediately after the engine is stopped, the coolant is at a high temperature and the radiator is under high internal pressure. If the cap is removed to check the coolant level in this condition, there is a hazard of burns. Wait for the temperature to go down, then turn the cap slowly to release the pressure before removing it.

1. Open the engine hood on the machine and check that the coolant level is between the FULL and LOW marks on radiator sub-tank (1) (shown in the diagram on the right).

If the water level is low, add water through the water filler of sub-tank (1) to the FULL level.

2. After adding coolant, tighten the cap securely.

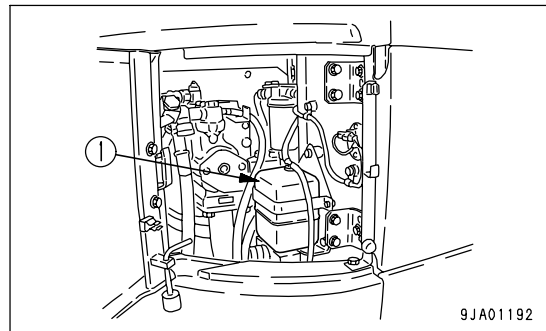

NOTICE

If the sub-tank is empty, there is probably leakage of water. After checking, repair any problem immediately. If no problem is found, check the level of the water in the radiator. If it is low, add water to the radiator, then add water to the sub-tank.

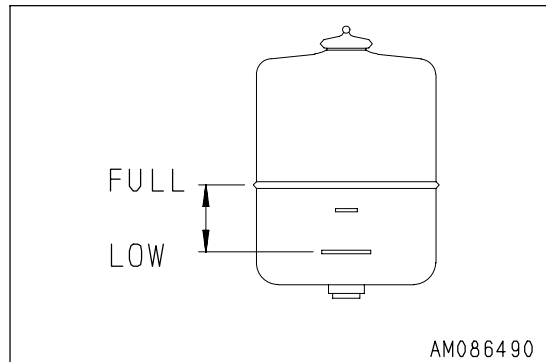

Check Oil Level in Engine Oil Pan, Add Oil

**WARNING**

Parts and oil are at high temperature immediately after the engine is stopped and may cause serious burns. Wait for the oil temperature to go down before performing this operation.

1. Open engine hood.
2. Remove dipstick (G) and wipe the oil off with a cloth.
3. Fully insert dipstick (G) into filler pipe (F), then remove it.

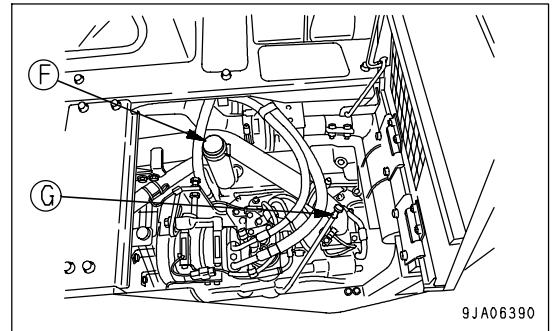

4. The oil level should be between the H and L marks on dipstick (G).
If the oil level is below the L mark, add oil through oil filler (F).

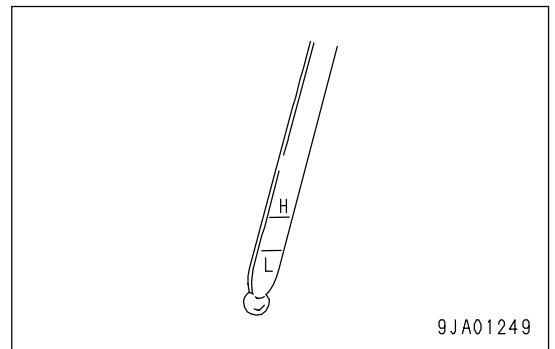

5. If the oil level is above the H mark, remove undercover (1), drain the excess engine oil from drain valve (P), then check the oil level again.
6. If the oil level is correct, tighten the oil filler cap securely and close the engine hood.

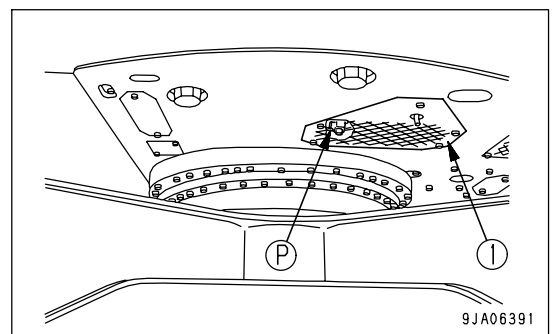
**REMARK**

- If the machine is at an angle, reposition it to level before checking.
- When checking the oil level after the engine has been operated, allow the engine to cool for 15 minutes before checking.

Check Fuel Level, Add Fuel

! WARNING

When adding fuel, never spill the fuel or let it overflow. It will cause fire.
 If any fuel has spilled, wipe it up completely. If fuel has spilled over soil or sand, remove that soil or sand.
 Fuel is highly flammable and dangerous. Never bring flames near fuel.

1. Insert the key into engine starting switch (1) and turn it to the ON position to light up monitor (2).

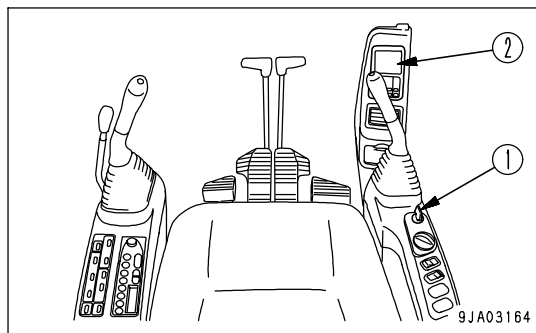

2. Check fuel gauge (3) for the remaining fuel amount.

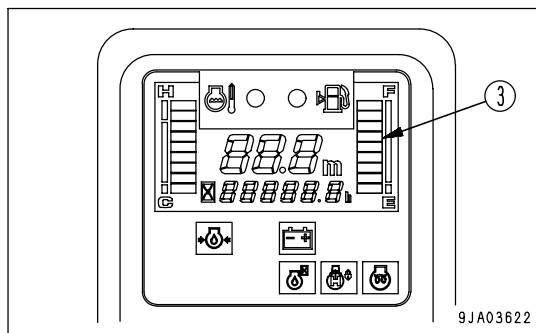

3. If fuel is found to be low, unscrew fuel filler cap (F) on the fuel tank and add fuel through the filler port until float gauge (G) comes up to the highest point.

Specified fuel amount in fuel tank: 195 liters (51.52 US gal)
 Position of tip of float gauge (G) when tank is full: Approx. 130 mm (5.1 in) from top surface of fuel tank

4. After adding fuel, push float gauge (G) straight down with fuel filter cap (F). Be careful not to get float gauge (G) caught in the tab (4) of fuel filler cap (F), and tighten fuel filler cap (F) securely.

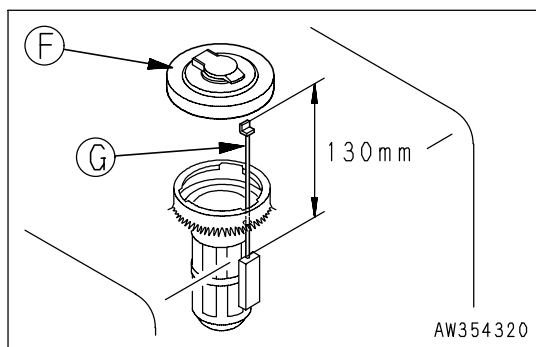
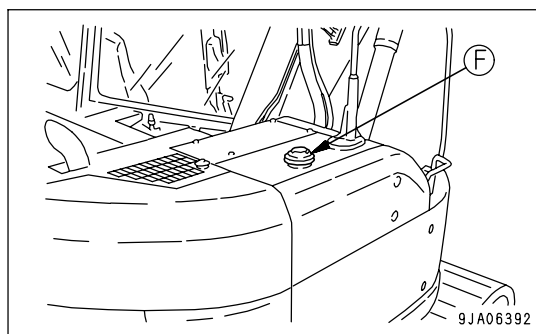

REMARK

If breather hole (5) on the cap is clogged, the pressure in the tank will drop and fuel will not flow.
Clean the hole from time to time.

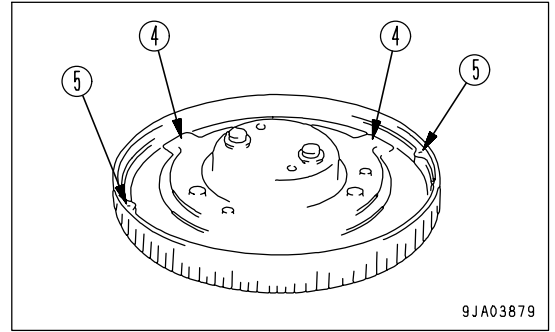

9JA03879

Check Oil Level in Hydraulic Tank, Add Oil

WARNING

- The parts and oil are at high temperature immediately after the engine is stopped, and may cause burns. Wait for the temperature to go down before starting the work.
- When removing the oil filler cap, turn it slowly to release the internal pressure, then remove it.

1. If the work equipment is not in the position shown in the diagram on the right, start the engine, run the engine at low speed, retract the arm and bucket cylinder rods fully, then lower the boom, set the bucket teeth in contact with the ground, and stop the engine.
2. Turn the starting switch to the ON position.
3. Within 15 seconds after stopping the engine, move each control lever (for work equipment and travel) to the full stroke in all directions to release the internal pressure.

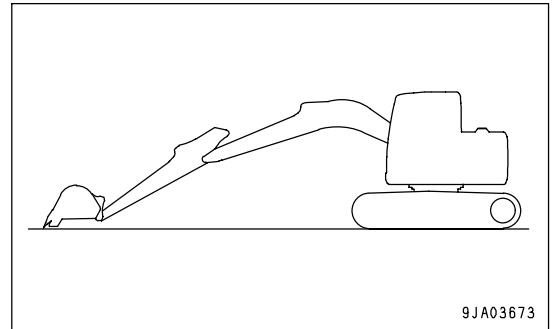

9JA03673

4. Open the door of the pump room on the right side of the machine, and check sight gauge (G). The oil level should be between the H and L lines.

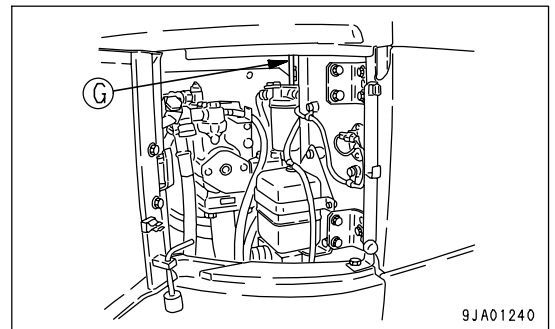

9JA01240

NOTICE

Do not add oil above the H line. This will damage the hydraulic circuit or cause the oil to spurt out.

If oil has been added above the H level, stop the upper structure so that the drain plug (P) under the hydraulic tank will be between both tracks, and stop the engine and wait for the hydraulic oil to cool down, then drain the excess oil from drain plug (P).

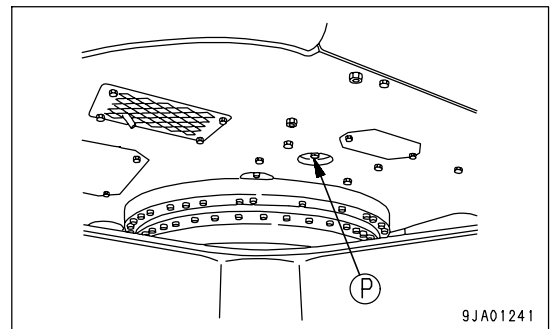

9JA01241

5. If the oil level is below the L line, add oil through oil filler (F) at the top of the hydraulic tank.

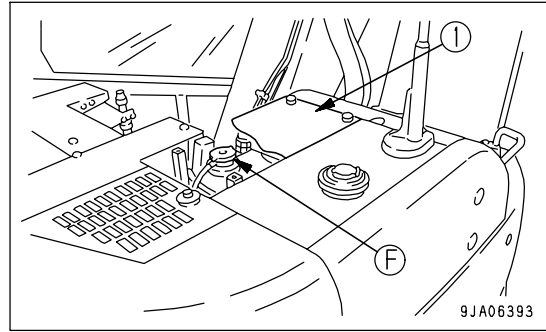

REMARK

The oil level will vary depending upon the oil temperature.

Accordingly, use the following as a guide:

- Before starting operation: Between H and L levels
(Oil temperature 10 to 30°C (50 to 86°F))
- Normal operation: Around H level
(Oil temperature 50 to 80°C (122 to 176°F))

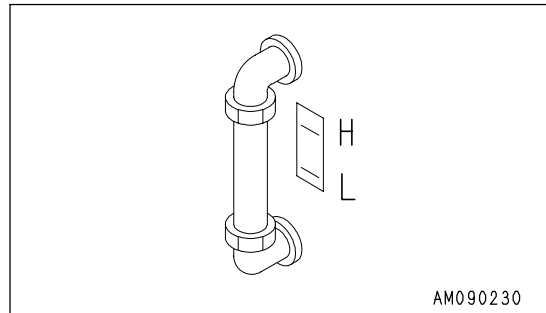

Check Dust Indicator

1. Open the cover at the rear of the cab and check that the red piston is not showing in the part of dust indicator (1) shown by the arrow.
2. If the red piston has appeared, clean or replace the element immediately.
For details of the method of cleaning the element, see "CHECK, CLEAN AND REPLACE AIR CLEANER ELEMENT (PAGE 4-17)".
3. After checking, cleaning, or replacing the air cleaner element, press the knob of dust indicator (1) to return the red piston to its original position.

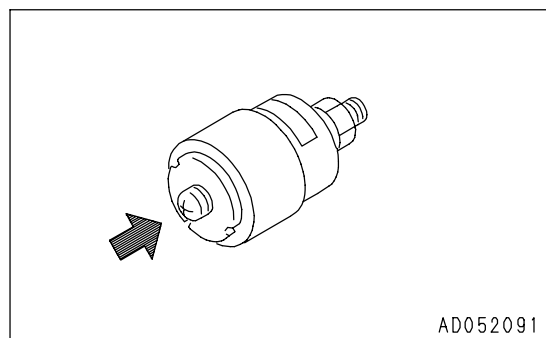
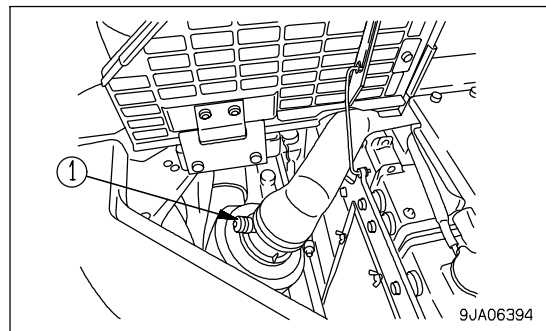

Check Water Separator

(If equipped)

The water separator separates water mixed in the fuel. If red ring (2) of water separator is at the bottom of case, there is no water. If float (2) is at or above red line (1), drain the water according to the following procedure.

1. Open the pump room door.
2. Loosen drain plug (3) at the bottom of the filter case and drain the water from inside.
3. When red ring (2) goes down to the bottom of the case, tighten drain plug (3).

Tightening torque: 2.9 to 3.9 N·m (0.3 to 0.4 kgf·m, 2.2 to 2.9 lbf·ft)

4. Drain any water or sediment from fuel tank. For details, see "DRAIN WATER FROM FUEL TANK (PAGE 4-43)".

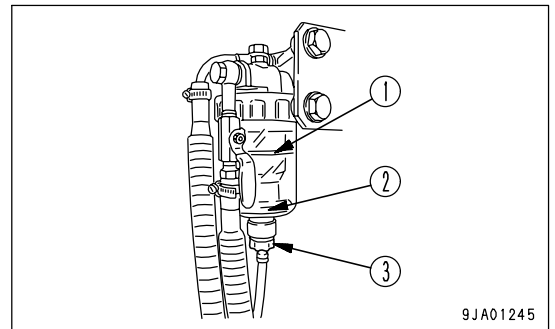
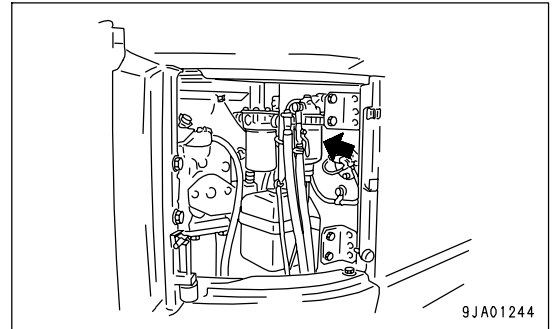

Check Electric Wiring



WARNING

- If the fuses frequently blow or if there are traces of short circuits in the electrical wiring, locate the cause and immediately perform repairs, or contact your Komatsu distributor for repairs.
- Keep the top surface of the battery clean and check the breather hole in the battery cap. If it is clogged with dirt or dust, wash the battery cap to clean the breather hole.

Check that there is no damage to the fuses; that fuses of the specified capacity are used; that there is no disconnection or trace of short-circuiting in the electric wiring and no damage to the covering. Check also that there is no loosened terminals. If any, tighten them.

Moreover, pay particular attention to the electric wiring when checking the battery, engine starting motor and alternator.

Be sure to check that there is no inflammable material accumulated around the battery. If any is found, remove immediately.

Check Function of Horn

1. Turn the starting switch to the ON position.

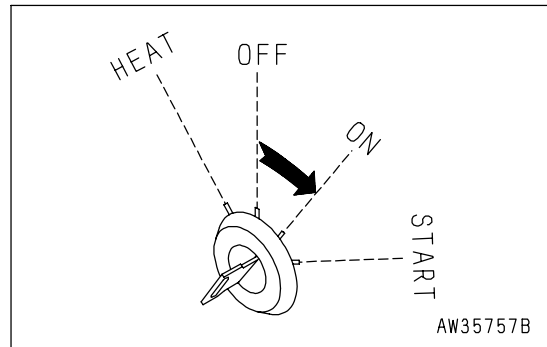

2. Confirm that the horn sounds immediately when the horn button is pressed.
If the horn does not sound, contact your Komatsu distributor for repair.

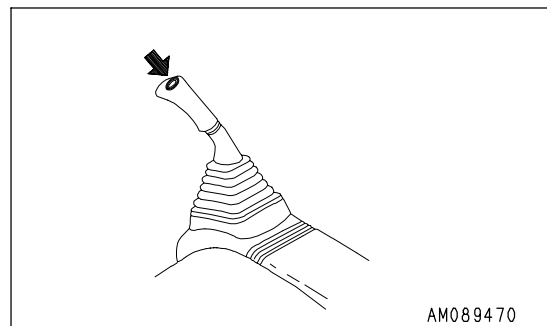

Adjustment



WARNING

- Adjust the seat position before starting operations or after changing the operator.
- Adjust the seat so that the control levers and switches can be operated freely and easily with the operator back against the backrest.

Seat Adjustment

(A) Fore-and-aft adjustment

Move lever (1) to the upper, set the operator's seat at the desired position, then release the lever.

Fore-and-aft adjustment: 50 mm (2.0 in)

(B) Adjusting reclining

REMARK

The seat can be reclined more when the seat is pushed to the front. The amount of reclining decreases as the seat is pushed back, so when moving the seat back, return the seatback to the upright position.

Pull up lever (2) and set the backrest to a position that is comfortable for operation, then release the lever.

Sit with your back against the seat backrest when adjusting. If your back is not against the backrest, the backrest may suddenly move forward.

(C) Adjusting armrest angle

Armrest (3) can be made to spring up by hand approx. 90°.

In addition, by turning the dial (4) at bottom of armrest by hand it is possible to make fine vertical adjustment of the armrest angle.

Armrest adjustment angle: 25°.

REMARK

If the seat back is tipped to the front without raising the armrest (3), the armrest will rise automatically.

(D) Overall fore-and-aft adjustment of seat

Move lever (5) to right. After the seat is set to the desired position, release the lever (5). In this case, the operator's seat, left and right control levers, and lock lever all slide together.

Fore-and-aft adjustment: 100 mm (3.9 in)

(E) Adjusting suspension

(Suspension seat)

Adjust the weight adjusting dial to your own weight by turning knob (6) under the operator's seat.

The weight can be adjusted to 50 to 120 kg (110 to 265 lb).

If you want to make the seat softer, turn the weight adjustment to a lower weight; if you want to make the seat harder, adjust to a higher weight. When operating on uneven surfaces, adjust the seat to a harder setting.

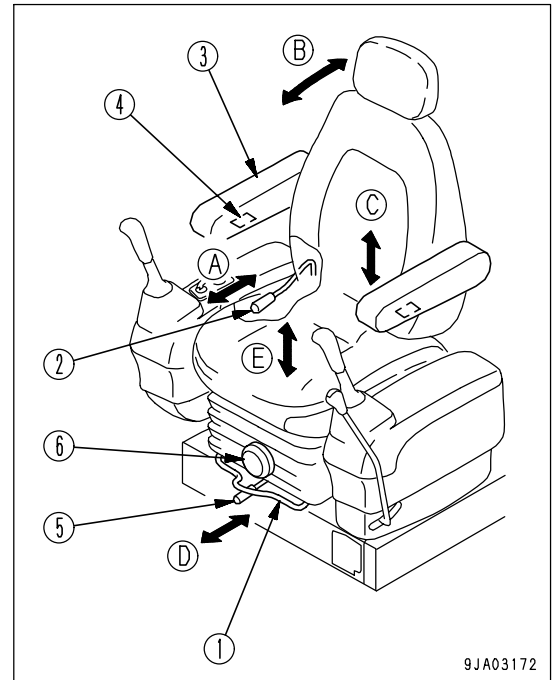

9JA03172

Rearview Mirrors

NOTICE

Depending on the direction of the mirror, it may extend outside the swing radius. (Approx. 60 mm (2.4 in))

Sit in the operator's seat and adjust the mirror so that it is possible to see the right side of the counterweight.

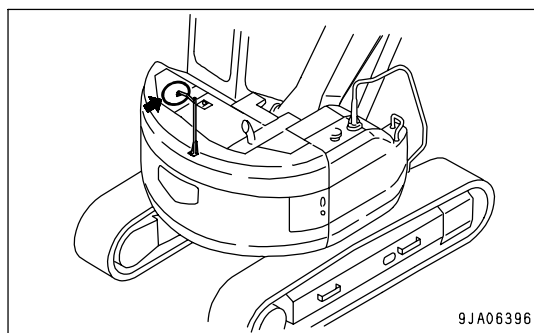

Seat Belt



WARNING

- Before fastening the seat belt, check that there is no problem in the securing brackets or belt. If there is any wear or damage, replace.
- Even if there appears to be no problem in the seat belt, replace the seat belt once every 3 years. The date of manufacture is woven on the reverse side of the belt.
- Adjust and fasten the seat belt before operating the machine.
- Always use the seat belt when operating the machine.
- Do not use the seat belt with either half of the belt twisted.

Check that the bolts of the clamp securing the belt to the chassis are not loose. Tighten them if they are loose. The tightening torque for the mounting bolt is 24.5 ± 4.9 N·m (2.5 ± 0.5 kgf·m, 18.1 ± 3.6 lbft). If the belt surface is scratched or frayed or if the fittings are broken or deformed, replace the seat belt unit.

Fastening and Removing

1. Adjust the seat so that the operator still feels that there is sufficient knee room when fully depressing the pedal while seated, with the operator's back against the backrest.
2. After adjusting the seat position, sit in the seat. Grip buckle (1) and tongue (2) in each hand and insert tongue (2) into buckle (1). Pull on the belt to confirm that the tongue is securely locked in the buckle.
3. Depress the red button on buckle (1) to unfasten the seat belt.

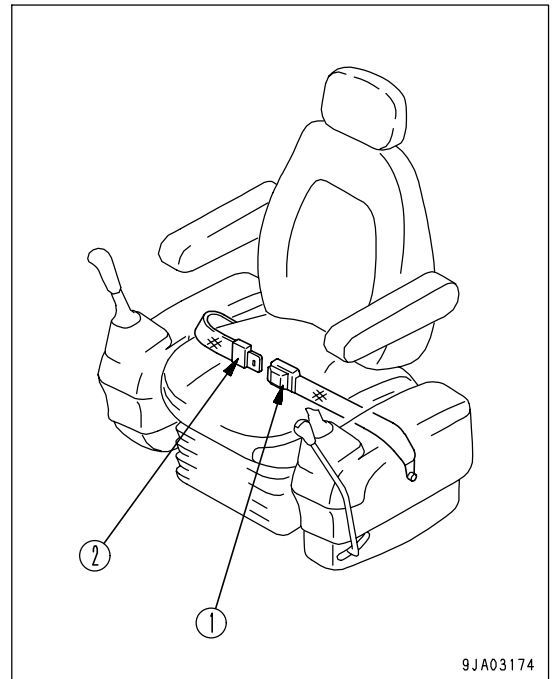

Fasten belt along your body without kinking it. Adjust the lengths of the belt on the tongue sides.

Seat Belt Adjustment

Shortening

Pull the free end on the tongue side.

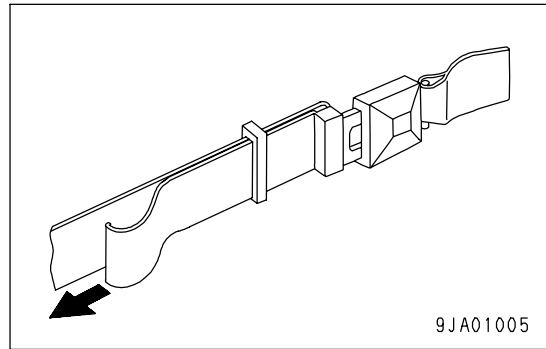

Lengthening

Pull the seat belt with a tongue in the direction perpendicular to the tongue.

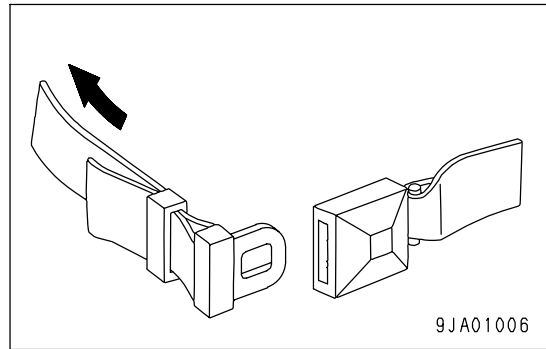

Wind-in Type Seat Belt

(If equipped)



WARNING

- Before fitting the seat belt, check that there is no problem in the belt mount bracket or mounting belt. If it is worn or damaged, replace the seat belt.
- Even if no problem can be seen in the belt, replace the seat belt every 3 years. The date of manufacture of the belt is shown on the back of the belt.
- Always wear the seat belt during operation.
- Fit the seat belt so that it is not twisted.

Fastening and Removing Seat Belt

This seat belt has a wind-in device, so it is not necessary to adjust the length.

Fastening seat belt

Hold grip (2) and pull the belt out from wind-in device (1), check that the belt is not twisted, then insert tongue (3) into buckle (4) securely.

When doing this, pull the belt lightly to check that it is properly locked.

Removing belt

Press button (5) in buckle (4), and remove tongue (3) from buckle (4).

The belt is automatically wound in, so hold grip (2) and return the belt slowly to wind-in device (1).

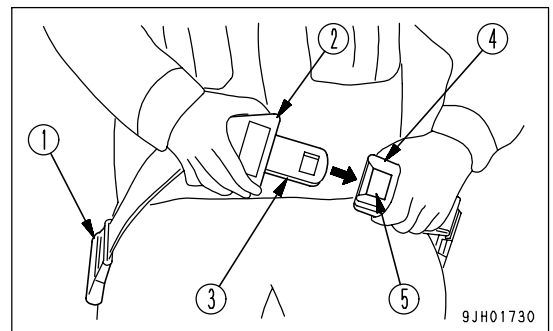

Operations Before Starting Engine

! WARNING

When standing up from the operator's seat, always set the lock lever to the LOCK position, regardless of whether the engine is running or stopped.

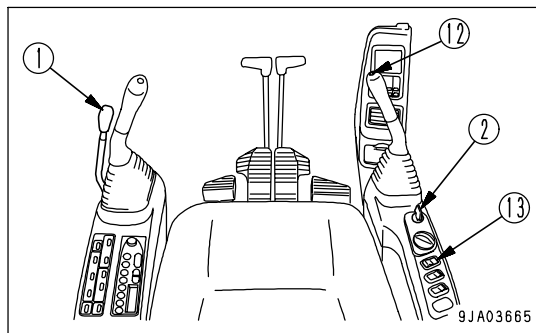

1. Check the lock lever (1) is at the LOCK position.

REMARK

The engine does not start, if the lock lever is not in the LOCK position.

2. Check that each control lever is in the NEUTRAL position.

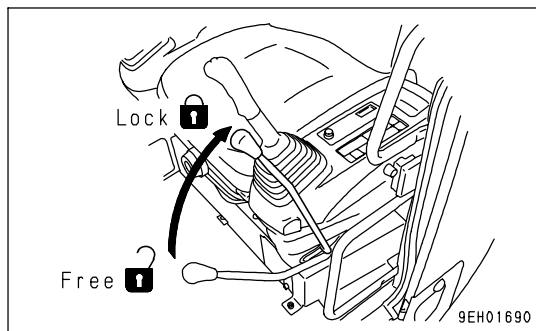

3. Insert the key in starting switch (2), turn the key to the ON position, then carry out the following checks.

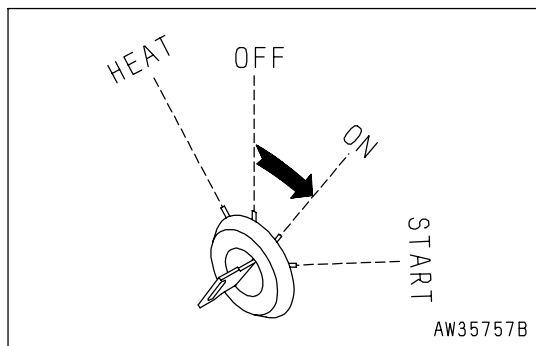

1) The buzzer will sound for approx. 1 sec, and the following monitors and gauges will light up for approx. 3 sec.

- Engine oil pressure monitor (3)
- Charge level monitor (4)
- Engine coolant temperature gauge (5)
- Engine coolant temperature monitor (6)
- Fuel level monitor (7)
- Fuel level gauge (8)
- Swing lock monitor (9)
- Engine pre-heating monitor (10)
- Oil maintenance monitor (11)

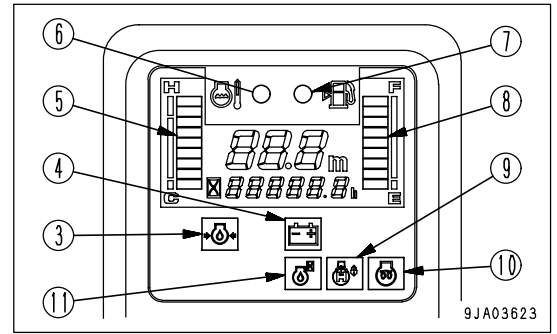

If the monitors or gauges do not light up or the buzzer does not sound, there is probably a blown bulb or disconnection, please contact your Komatsu distributor for repair.

After approx. 3 seconds, the following monitors and gauges will remain on and the others will go out.

- Engine oil pressure monitor (3)
- Charge level monitor (4)
- Engine coolant temperature gauge (5)
- Fuel level gauge (8)

2) Press horn switch (12) to confirm that the horn will sound.

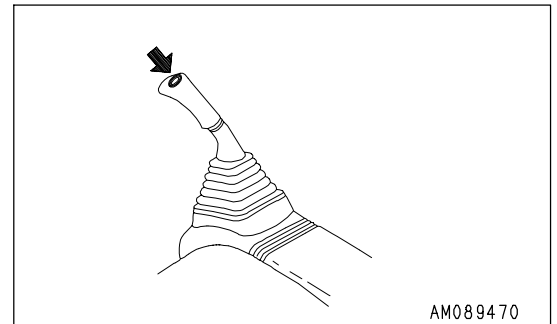

3) Press lamp switch (13) to turn on the working lamps. If it does not light up, there is probably a blown bulb or disconnection, so please contact your Komatsu distributor for repairs.

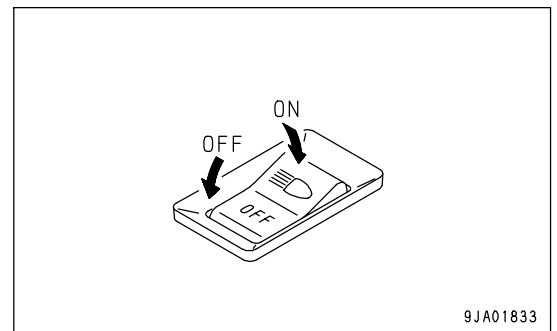

STARTING ENGINE

Normal Starting



WARNING

- Sit down in the operator's seat before starting the engine.
- Do not attempt to start the engine by short-circuiting the engine starting circuit. Such an act may cause serious bodily injury or fire.
- Check that there are no persons or obstacles in the surrounding area, then sound the horn and start the engine.
- Exhaust gas is toxic. When starting the engine in confined spaces, be particularly careful to ensure good ventilation.

NOTICE

- Do not try to start the engine with the fuel adjustment dial set near the full engine rotation. Otherwise the engine parts may be damaged.
- Do not keep the starting motor rotating continuously for more than 20 seconds.

If the engine will not start, wait for at least 2 minutes before trying to start the engine again.

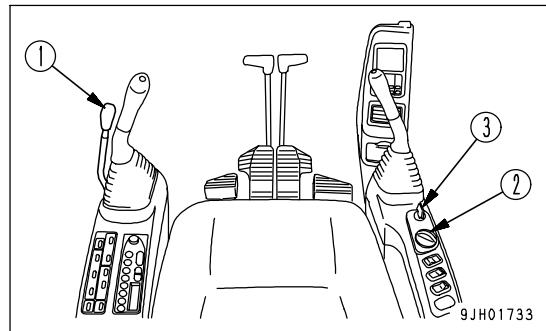

1. Check the lock lever (1) is at the LOCK position. If the lock lever is in the FREE position, the engine does not start.

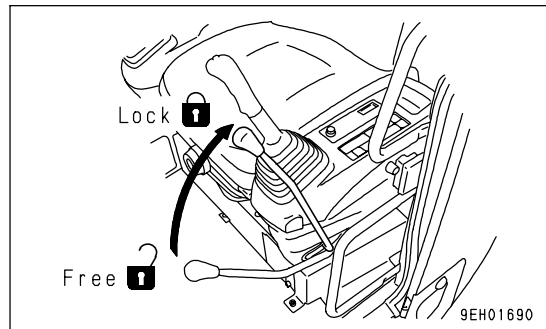

2. Set fuel control dial (2) at the low idle position.

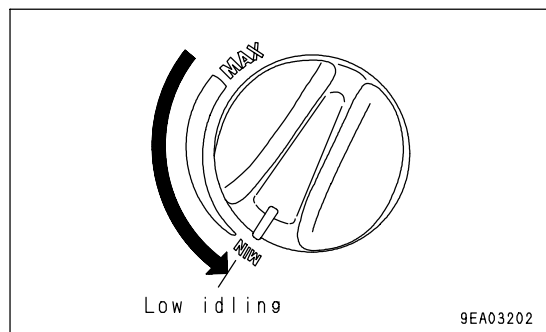

3. Turn the key in starting switch (3) to the START position. The engine will start.

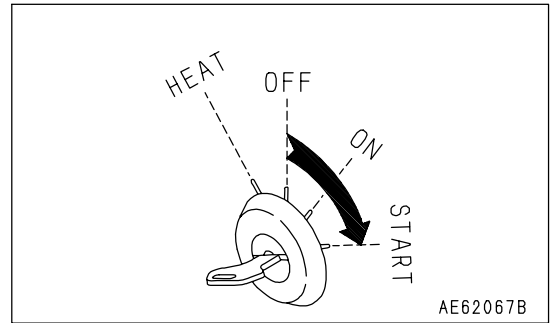

4. When the engine start, release the key in the starting switch (3). The key will return automatically to the ON position.

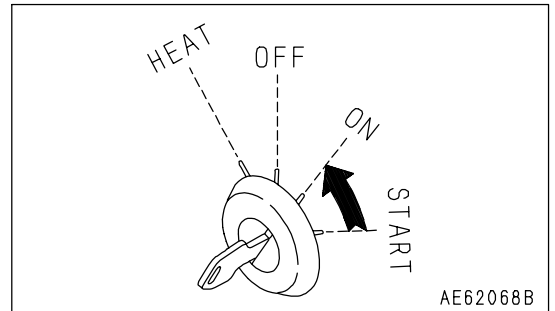

5. Keep the engine idle for the initial 15 seconds right after it has been started, and do not operate any control lever or the fuel adjustment dial during that time.
6. Check that battery charging level monitor (4) lamp and engine oil pressure monitor (5) lamp do not light up.

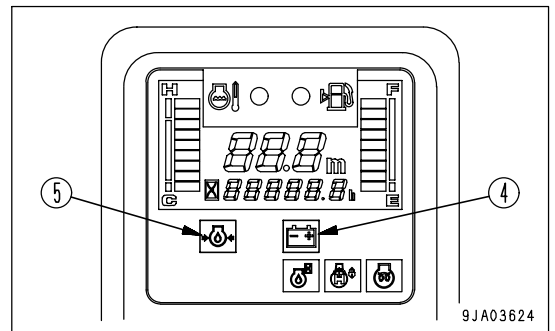

Starting Engine in Cold Weather



WARNING

- Start the engine only after sitting down in the operator's seat.
- Do not attempt to start the engine by short-circuiting the engine starting circuit. Such an act may cause a serious bodily injury or fire.
- Check that there are no persons or obstacles in the surrounding area, then sound the horn and start the engine.
- Never use starting aid fluids as they may cause explosions.
- Exhaust gas is toxic. When starting the engine in confined spaces, be particularly careful to ensure good ventilation.

NOTICE

- Do not try to start the engine with the fuel adjustment dial set near the full engine rotation. Otherwise the engine parts may be damaged.
- Do not keep the starting motor rotating continuously for more than 20 seconds.

If the engine fails to start, wait for about 2 minutes and repeat from Step 4.

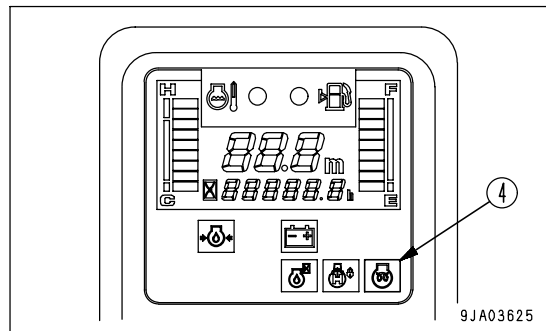
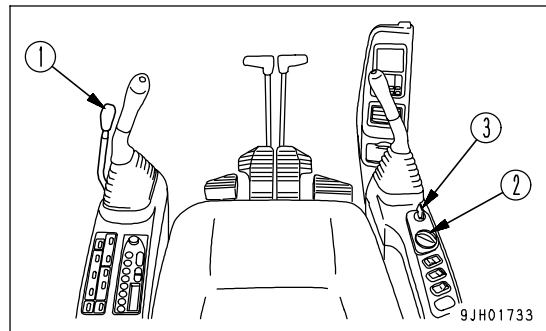

When starting in low temperatures, do as follows.

1. Check the lock lever (1) is at the LOCK position. If the lock lever is in the FREE position, the engine does not start.

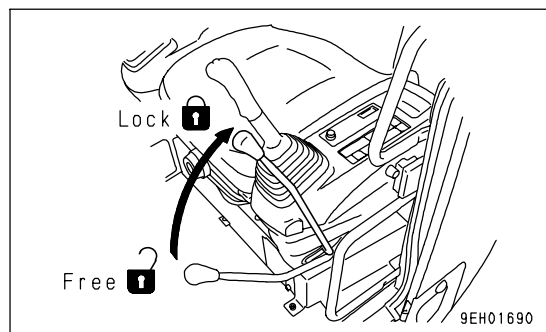

2. Before starting the engine, check that fuel control dial (2) is at the low position.

- Turn fuel control dial (2) to the center position between LOW IDLE and HIGH IDLE.

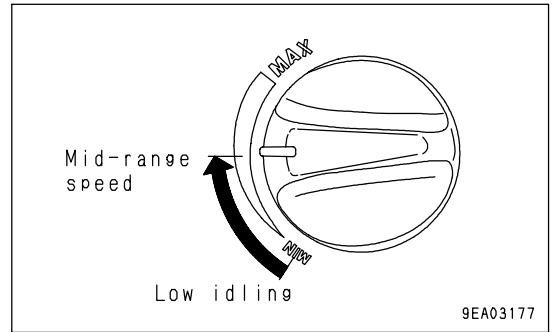

- Hold the key in starting switch (3) at the HEAT position, and check that pre-heating monitor (4) lights up. After about 30 seconds, pre-heating monitor (4) will flash 10 seconds to indicate that pre-heating is finished.

REMARK

The monitor and gauge also light up when the key is at the HEAT position, but this does not indicate any problem.

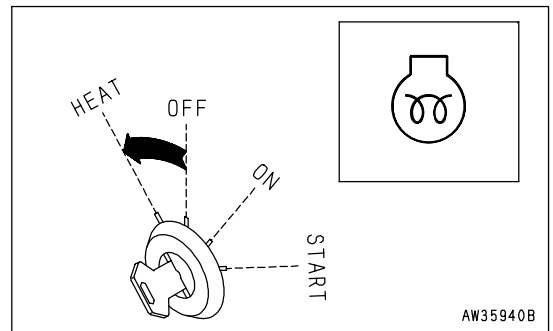

- When engine pre-heating monitor (4) goes off, turn the key in stating switch (3) to the START position to start the engine.

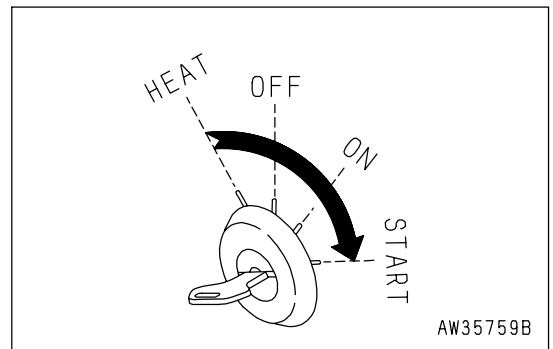

- When the engine start, release the key in the starting switch (3). The key will return automatically to the ON position.

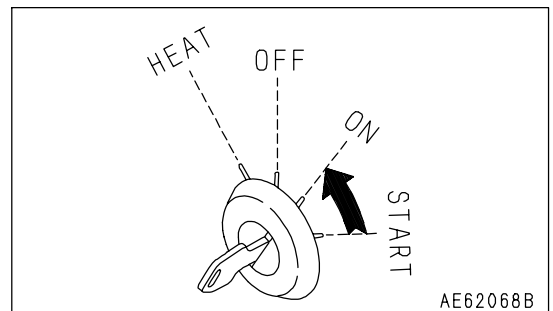

- Keep the engine idle for the initial 15 seconds right after it has been started, and do not operate any control lever or the fuel adjustment dial during that time.

8. Check that charge level monitor (5) and engine oil pressure monitor (6) goes off.

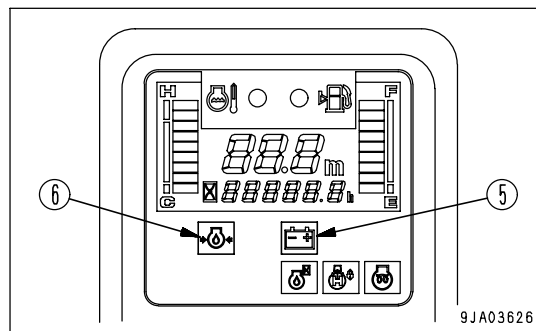

AFTER STARTING ENGINE



WARNING

- When a machine trouble such as emergency stop and abnormal movement occurs, turn the engine starting switch to the OFF position.
- If the work equipment is operated without warming the machine up sufficiently, the response of the work equipment to the movement of the control lever will be slow, and the work equipment may not move as the operator desires, so always carry out the warming-up operation. Particularly in cold areas, be sure to carry out the warming-up operation fully.

Warming-up Operation

NOTICE

- When the hydraulic oil is at a low temperature, do not carry out operations or move the levers suddenly. Always carry out the warm-up operation. This will help to extend the machine life.
Do not suddenly accelerate the engine before the warm-up operation is completed.
- Do not run the engine at low idle or high idle continuously for more than 20 minutes. This will cause leakage of oil from the turbocharger oil supply piping.
If it is necessary to run the engine at idle, apply a load from time to time or run the engine at a mid-range speed.

After starting the engine, do not immediately start operations. First, perform the following operations and checks.

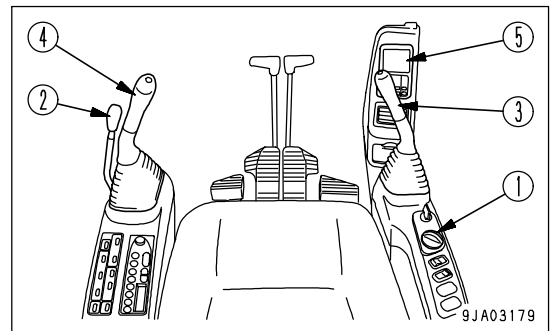

1. Turn fuel control dial (1) to the center position between LOW IDLE and HIGH IDLE and run the engine at medium speed for about 5 minutes with no load.

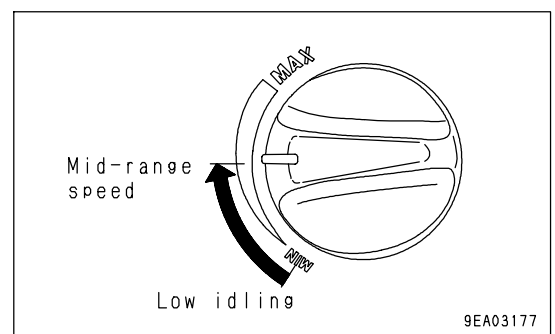

- Set lock lever (2) to the FREE position, and raise the bucket from the ground.

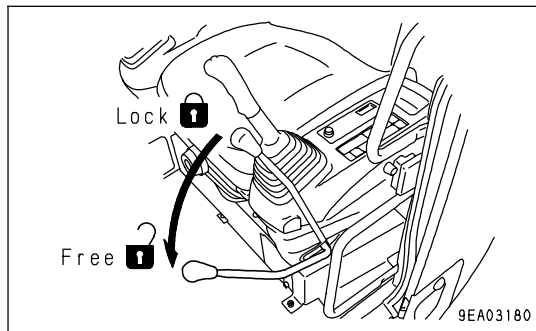

- Operate bucket control lever (3) and arm control lever (4) slowly to move the bucket cylinder and arm cylinder to the end of the stroke.
- Operate the bucket for 30 seconds and the arm for 30 seconds in turn fully for 5 minutes.

NOTICE

When the work equipment is retracted, take care that it does not interfere with the machine body or ground.

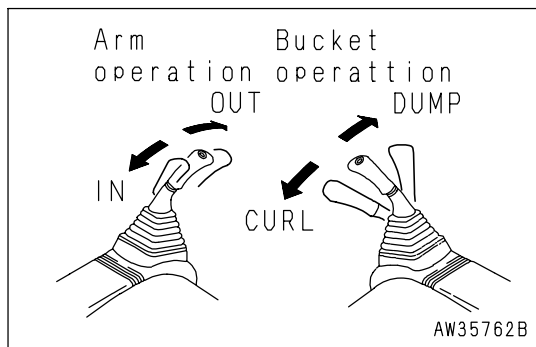

- After carrying out the warming-up operation, check that machine monitor (5) is in the following condition.

- Engine coolant temperature gauge (6): Inside green range
- Fuel gauge (7): Inside green range
- Engine coolant temperature monitor (8): OUT
- Engine oil pressure monitor (9): OUT
- Charge level monitor (10): OUT
- Fuel level monitor (11): OUT
- Pre-heating monitor (12): OUT
- Display (13): OUT

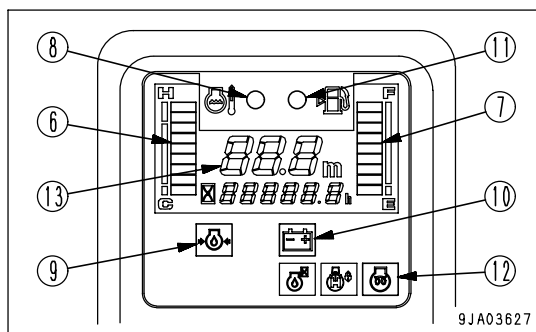

- Check for abnormal exhaust gas color, noise, or vibration. If any problem is found, contact your Komatsu distributor.
- Move lock lever (2) to the LOCK position and confirm that none of the operations for the control levers, work equipment, blade (if a blade is installed), swing and travel can be made.

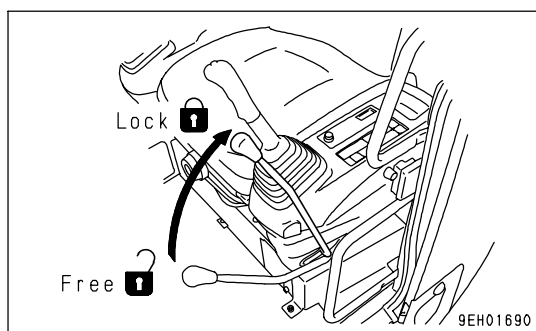

8. Turn working mode changing switch (14) in monitor panel (5) to the actual working mode.

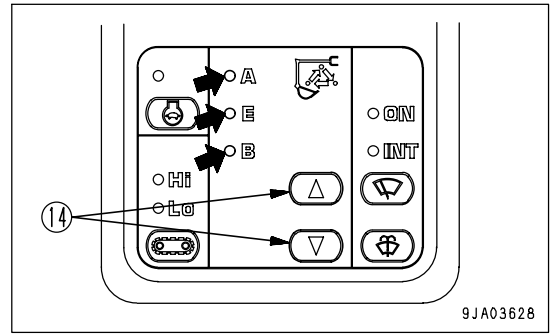

STOPPING THE ENGINE

NOTICE

If the engine is stopped abruptly, service life of component parts of the engine may be considerably reduced. Do not stop the engine abruptly except in an emergency. If the engine has overheated, do not try to stop it abruptly but run it at medium speed to allow it to cool down gradually, and then stop it.

1. Run the engine at low idle for about 5 minutes to cool down gradually.

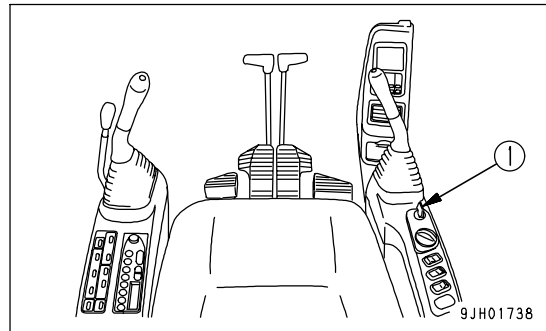

2. Turn the key of starting switch (1) to the OFF position to stop the engine.
3. Remove the key from starting switch (1).

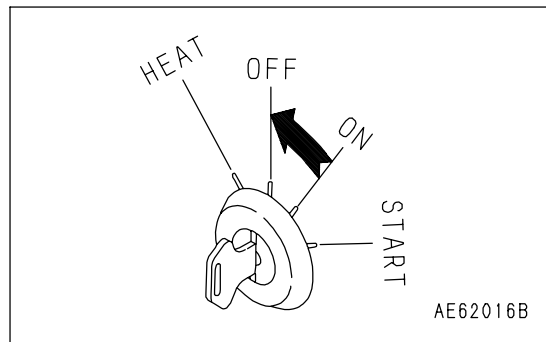

MACHINE OPERATION

! WARNING

- Before operating the travel levers, check the direction of the track frame. If the sprocket is at the front, the operation of the travel levers is reversed.
- When moving off, check that the area around the machine is safe, and sound the horn before moving.
- Clear all personnel from the machine and the area.
- Clear all obstacles from the path of the machine.
- Use extreme care when reversing the machine. Note there is an blind spot behind the machine.
- If the lever is moved inside the deceleration range, the engine speed will suddenly rise. Operate the levers carefully.
- For machines equipped with the travel alarm (if equipped), check that the alarm works properly.

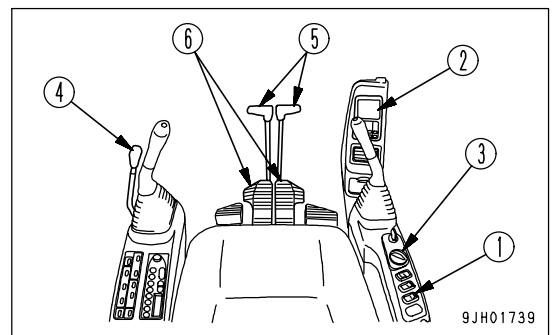

Preparations for Moving the Machine

1. Set swing lock switch (1) to the ON (actuated) position and confirm that swing lock monitor lamp (2) lights up.

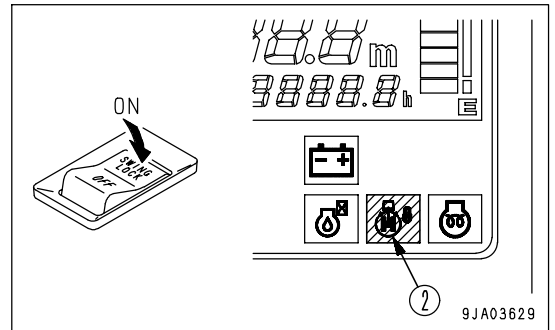

2. Turn fuel control dial (3) towards the full speed position to increase the engine speed.

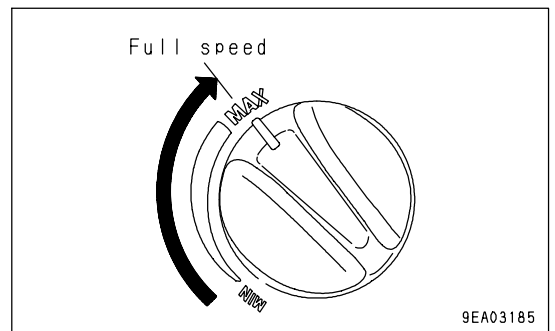

Moving Machine Forward

1. Set lock lever (4) to the FREE position, then raise the work equipment 40 to 50 cm (1.6 to 2.0 in) from the ground.

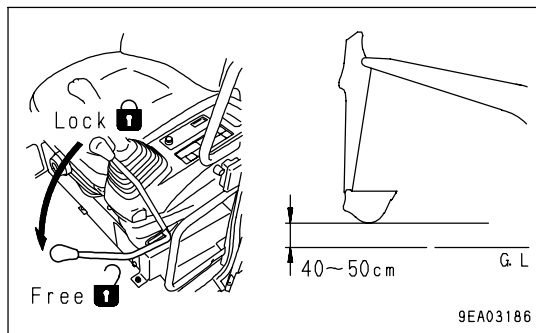

2. Raise the blade. (Blade specification only)
3. Operate right and left travel levers (5) or right and left travel pedals (6) as follows.

- When sprocket (A) is situated at the rear of the machine;
Start the machine either by pushing lever (5) forward slowly or by stepping on the front part of pedal (6) slowly.

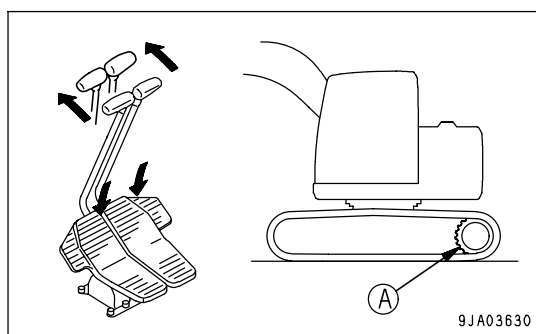

- When sprocket is situated at the front of the machine;
Start the machine either by pulling lever (5) back slowly or by stepping on the rear part of pedal (6) slowly.

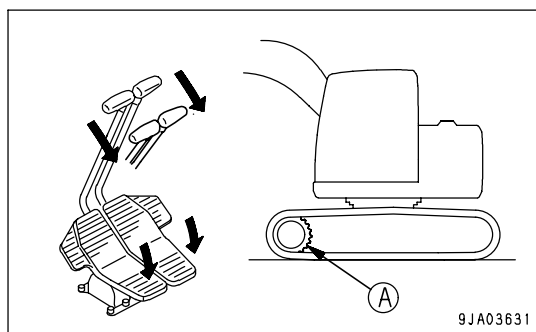

4. For machines equipped with a travel alarm (if equipped), check that the alarm sounds. If the alarm does not sound, please contact your Komatsu distributor for repair.

Moving Machine Backward

1. Set lock lever (4) to the FREE position, then raise the work equipment 40 to 50 cm (1.6 to 2.0 in) from the ground.

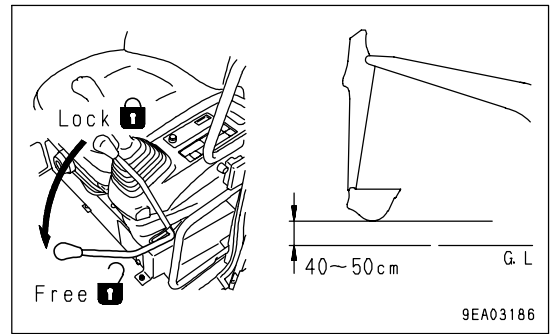

2. Raise the blade. (Blade specification only)
3. Operate right and left travel levers (5) or right and left travel pedals (6) as follows.

- When sprocket is situated at the rear of the machine; Start the machine either by pulling lever (5) back slowly or by stepping on the rear part of pedal (6) slowly.

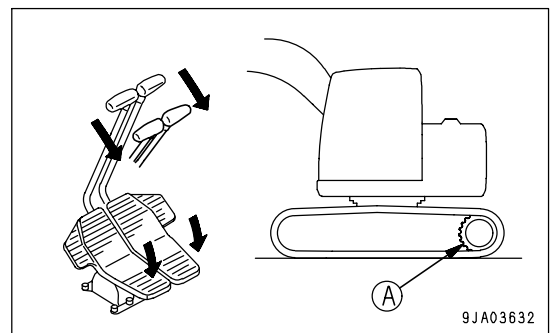

- When sprocket (A) is situated at the front of the machine; Start the machine either by pushing lever (5) forward slowly or by stepping on the front part of pedal (6) slowly.

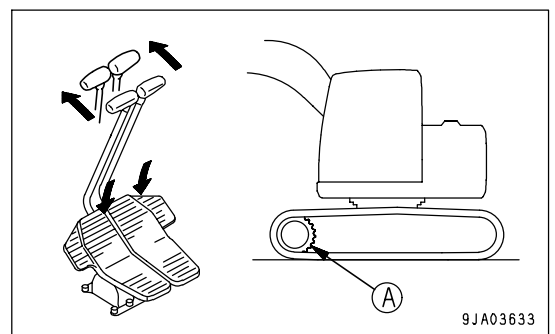

4. For machines equipped with a travel alarm (if equipped), check that the alarm sounds. If the alarm does not sound, please contact your Komatsu distributor for repair.

Stopping Machine



WARNING

Avoid stopping suddenly. Give yourself ample room when stopping.

Put the left and right travel levers (1) in the neutral position, then stop the machine.

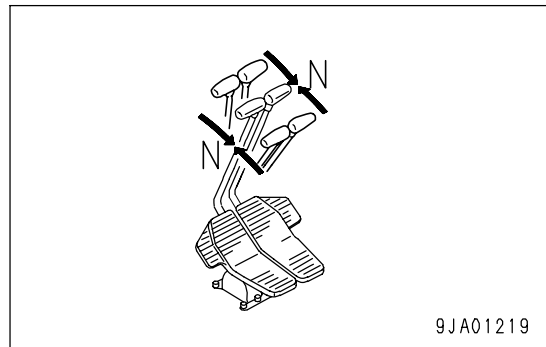
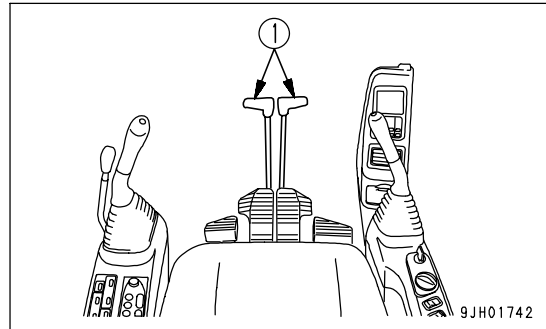

STEERING THE MACHINE

Steering

 **WARNING**

Before operating the travel levers, check the direction of the track frame (the position of the sprocket). If the sprocket is at the rear, the machine moves in the reverse direction to the operation of the travel levers.

Use the travel levers to change direction.
Avoid sudden changes of direction as much as possible.
Especially when performing counter-rotation (spin turn), stop the machine before turning.
Operate two travel levers (1) as follows.

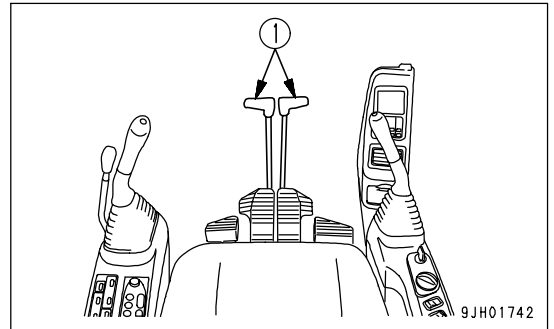

Steering the Machine when Stopped

When turning to the left:
Push the right travel lever forward to turn to the left when traveling forward; and pull it back to turn left when traveling in reverse.

REMARK
When turning to the right, operate the left travel lever in the same way.

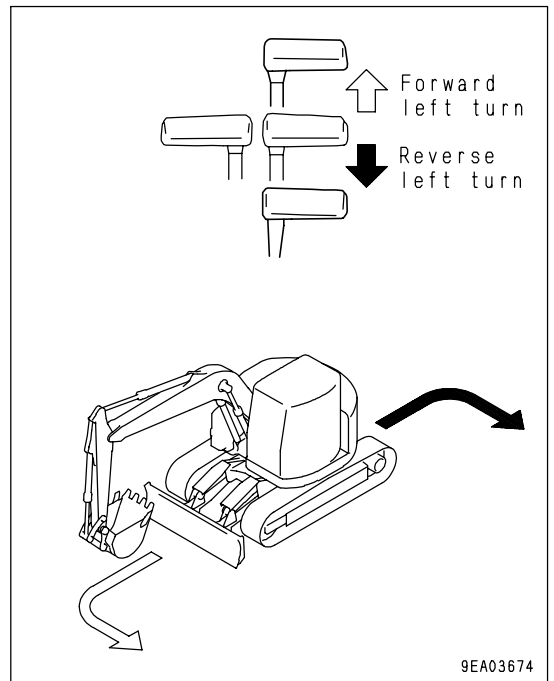

Changing Direction of the Machine

When turning to the left:

If the left travel lever is returned to the neutral position, the machine will turn to the left.

REMARK

When turning to the right, operate the right travel lever in the same way.

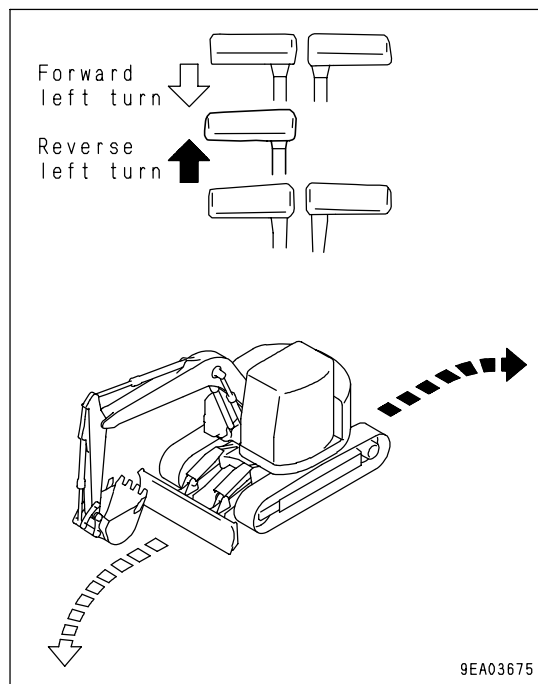

Counter-rotation Turn (Spin Turn)

When using counter-rotation (spin turn) to turn left, pull the left travel lever back and push the right travel lever forward.

REMARK

When using counter-rotation to turn right, pull the right travel lever back and push the left travel lever forward.

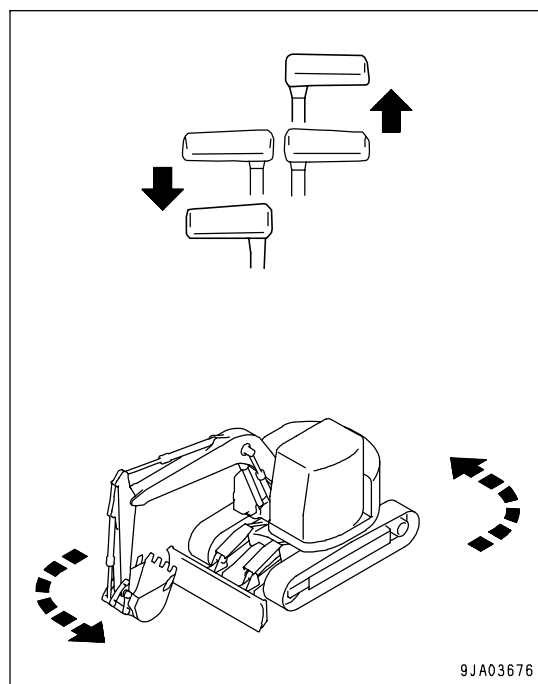

SWINGING

! WARNING

- The rear of the machine extends outside the track width. Check that the surrounding area is safe before swinging the upper structure.
- Operate the levers with care when the auto-decelerator is in use, because the engine speed sharply rises.

1. Before starting the swing operation, turn swing lock switch (1) OFF and check that swing lock monitor (2) has gone out.

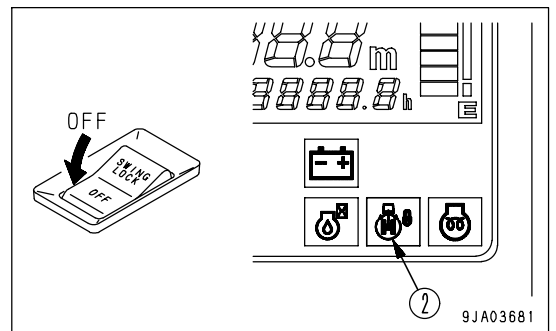
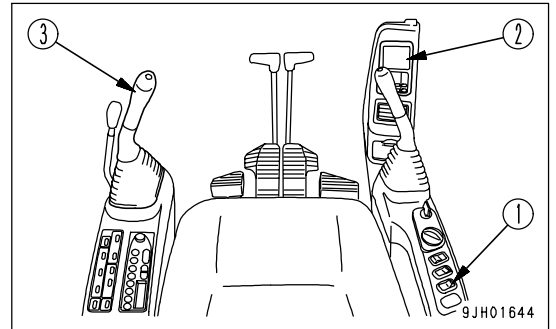

2. Operate left work equipment control lever (3) to swing the upper structure.
At the N position, the swing lock is applied.

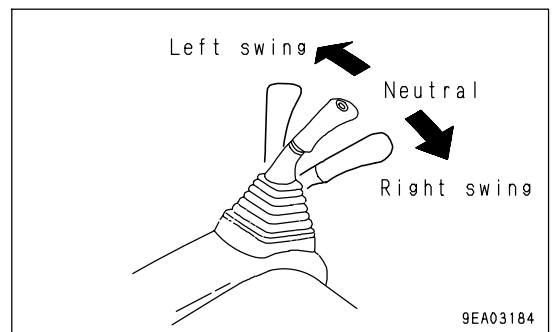

3. When swing operation is not required, set swing lock switch (1) to the ON position. This is a precaution for preventing the upper structure from swinging, when the left work equipment control lever is operated by mistake.

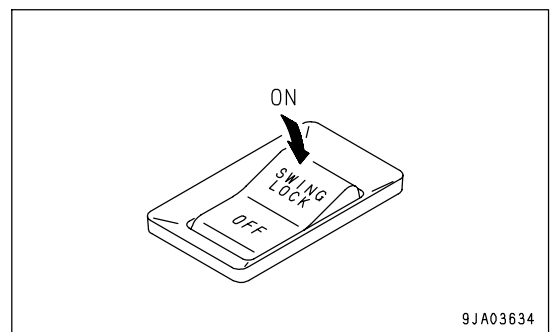

WORK EQUIPMENT CONTROLS AND OPERATIONS



WARNING

If the lever is operated when the auto-deceleration is being actuated, the engine speed will suddenly rise, so be careful when operating the lever.

Use the control levers to operate the work equipment.

Note that when the levers are released, they return to the HOLD position and the work equipment is held in that position.

- Arm control

Move the left work equipment control lever to the front or rear to operate the arm.

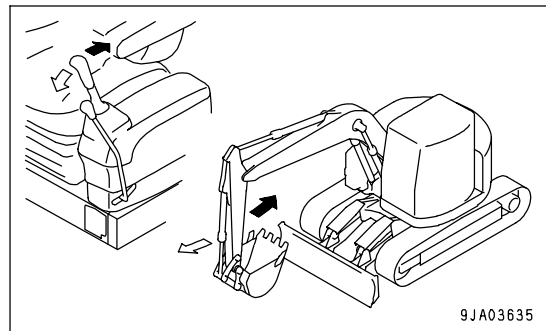

- Swing control

Move the left work equipment control lever to the left or right to swing the upper structure.

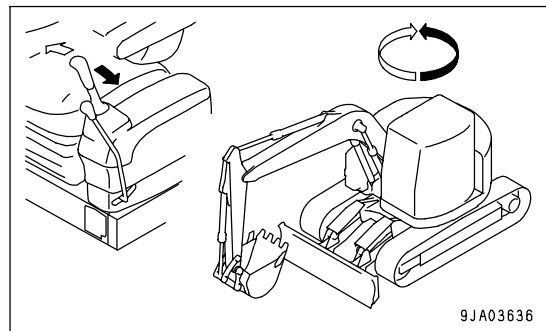

- Boom control

Move the right work equipment control lever to the front or rear to operate the boom.

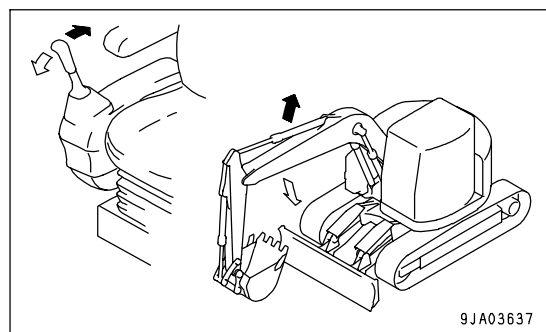

- Bucket control

Move the right work equipment control lever to the left or right to operate the bucket.

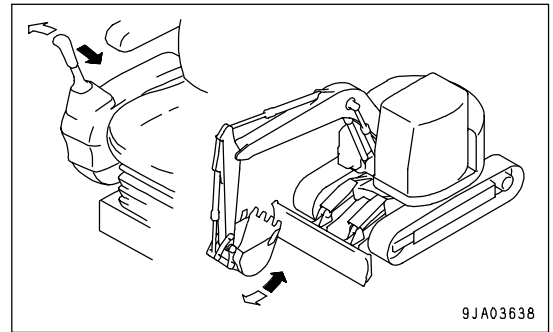

- Blade control (blade specification)

Move the lever on the right side of the operator's seat to the front or rear to operate the blade.

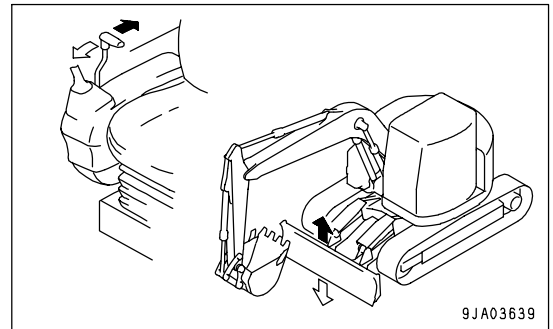

If the work equipment control levers are returned to the neutral position when the machine is stopped, even if the fuel control dial is set to FULL, the auto-deceleration mechanism will act to reduce the engine speed to a mid-range speed.

REMARK

If the levers are operated within 15 seconds after stopping the engine, it is possible to lower the work equipment to the ground.

In addition, the levers can also be operated to release any remaining pressure inside the hydraulic cylinder circuit.

WORKING MODE

The mode selector switch can be used to switch the mode to match operating conditions and purpose, thereby enabling work to be performed efficiently.

Make effective use of each mode as follows.

NOTICE

Do not use A mode when using a breaker. Otherwise the breaker will be damaged.

Every time switch (1) is pressed, the working mode shifts in the sequence of A -> B -> E -> A

Every time switch (2) is pressed, the working mode shifts in the sequence of A -> E -> B -> A

Use the working mode switch to set the mode to the most efficient mode to match the type of work.

Working mode	Applicable operations
A mode	Normal digging, loading operations
E mode	Normal digging, loading operations (For work with stress on fuel consumption ratio)
B mode	Breaker operations

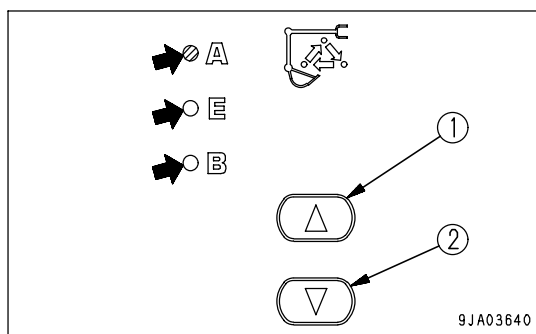

REMARK

- The A mode is automatically selected when starting the engine.
- If you desire automatic setting of E mode or B mode at the time of engine start-up, call your Komatsu distributor for the adjustment.

PROHIBITED OPERATIONS

WARNING

Do not attempt to operate the work equipment control lever, while the machine is traveling.

Operations Using Swing Force

Do not use the swing force to compact soil or break objects. This is not only dangerous, but will also drastically reduce the life of the machine.

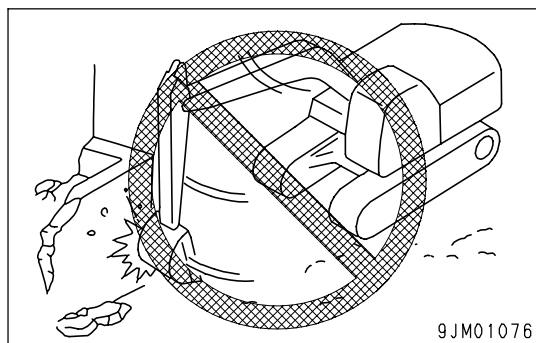

Operations Using Travel Force

Do not dig the bucket into the ground and use the travel force to carry out excavation. This will damage the machine or work equipment.

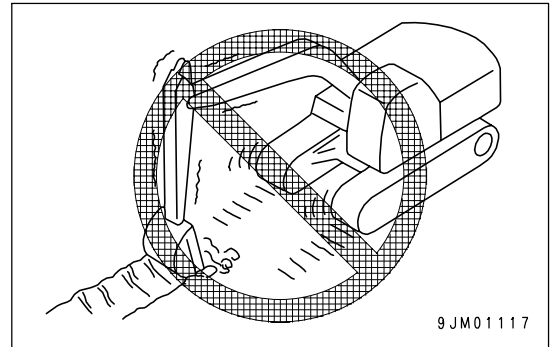
**Prohibition of Operations Using Hydraulic Cylinders to Stroke Ends**

If the work equipment is used with the cylinder rod operated to its stroke end, and given impact by some external force, the hydraulic cylinders will be damaged, causing personal injury. Avoid operations with the hydraulic cylinder fully retracted or fully extended.

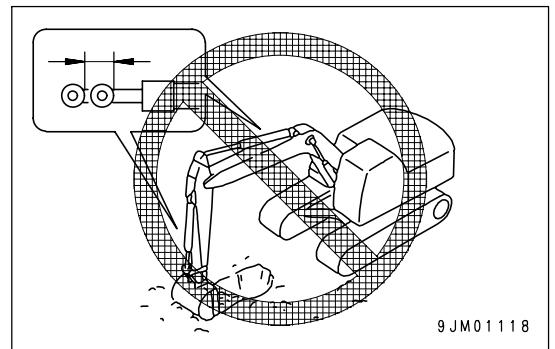

In particular, when using the crusher or other large attachment, if operations are carried out to the end of the stroke, excessive load will be brought to bear on the pins around the bucket and the bucket cylinder pin is, and there is danger that the pins may break.

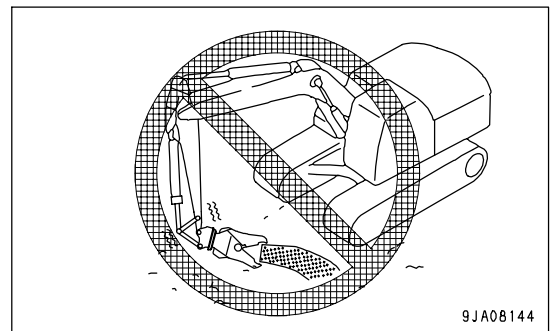
**Digging Hard Rocky Ground**

Do not attempt to directly excavate hard rocky ground with the work equipment. It is better to excavate it after breaking up by some other means. This will not only save the machine from damage but will make for better economy.

Operations Using Bucket Dropping Force

Do not use the dropping force of the machine for digging, or use the dropping force of the bucket as a pickaxe, breaker, or pile driver. This will markedly reduce the life of the machine.

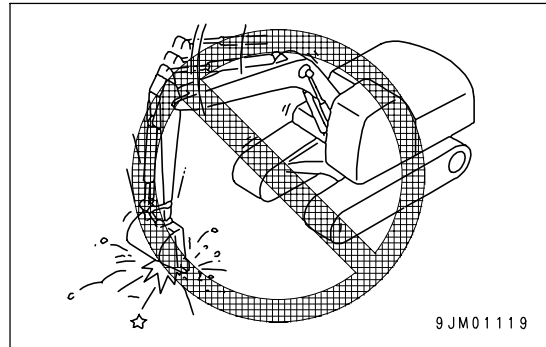

Operations Using Machine Dropping Force

Do not use the dropping force of the machine for digging.

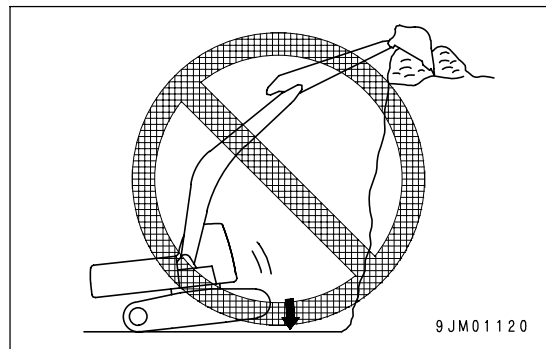

Sudden Lever Shifting High Speed Travel

- (1) Never carry out sudden lever shifting as this may cause sudden starting.
- (2) Avoid sudden lever shifting from forward to reverse (or from reverse to forward).
- (3) Avoid sudden lever shifting change such as sudden stopping from near top speed (lever release operation).

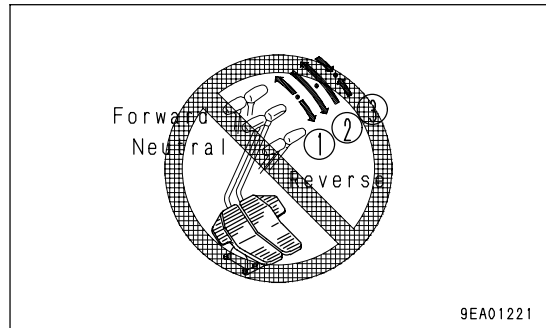

Support Blade on Both Sides

(Only machines with blade specification)

When using the blade as an outrigger, never support the machine with only one end of the blade.

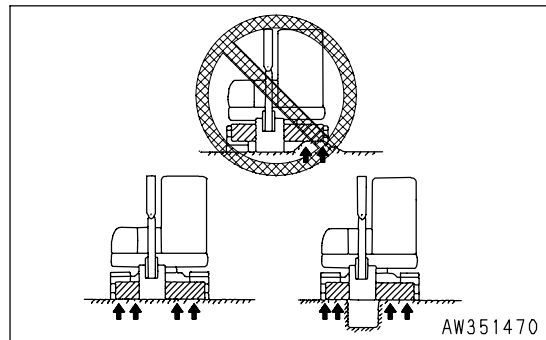

GENERAL OPERATION INFORMATION

Traveling

Traveling over boulders, tree stumps, or other obstacles will cause a big shock to the chassis (and in particular to the tracks), and this will cause damage to the machine. For this reason, always remove any obstacles or travel around them, or take other steps to avoid traveling over such obstacles as far as possible.

If there is no way to avoid traveling over an obstacle, reduce the travel speed, keep the work equipment close to the ground, and try to travel so that the center of the track passes over the obstacle.

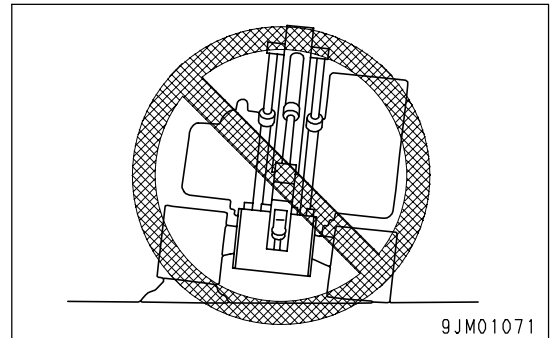

High Speed Travel

When traveling the machine on the rocky and rough ground or on a rough travel path strewn with stones, maintain slow speed (Lo lamp lights up). In traveling at high speed (Hi lamp lights up), meanwhile, travel the machine in such a way that the idlers face the traveling direction.

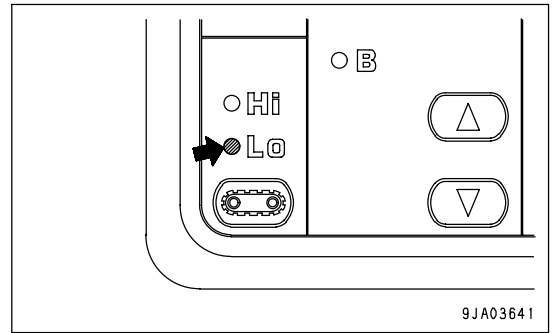

Folding in Work Equipment

(Only machines with blade specification)

When folding in the work equipment to the travel or transportation posture, be careful not to let the bucket hit the blade.

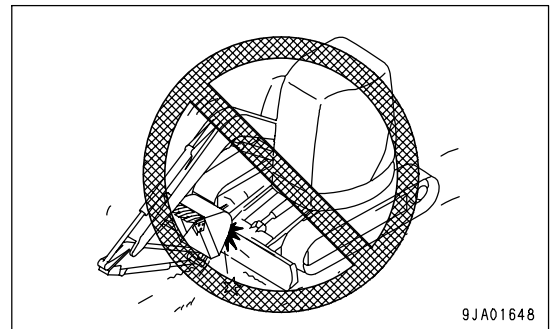

Avoid Hitting Blade

(Only machines with blade specification)

Be careful not to hit the blade against rocks or boulders. This will cause premature damage to the blade or cylinders.

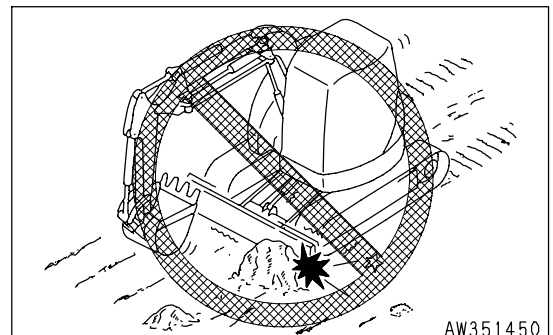

Blade During Backhoe Operations

(Only machines with blade specification)

When carrying out deep digging operations with the blade at the front, be careful not to the boom cylinder hit the blade. Always position the blade at the back unless it is needed at the front.

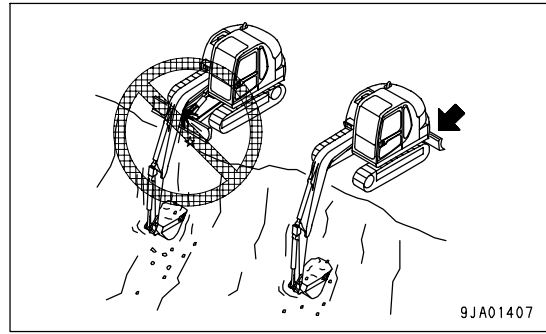

Permissible Water Depth

CAUTION

When driving the machine out of water, if the angle of the machine exceeds 15°, the rear of the upper structure will go under water, and water will be thrown up by the radiator fan. This may cause the fan to break. Be extremely careful when driving the machine out of water.

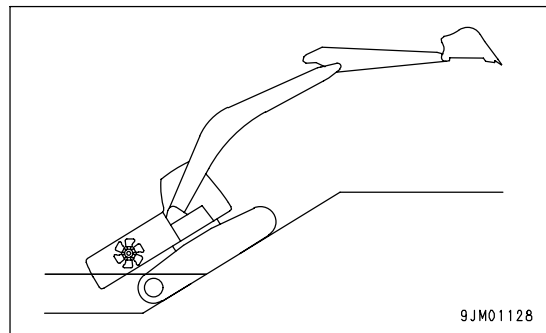

Do not drive the machine in water deeper than the center of carrier roller (1).

Supply grease to the parts which have been under water for a long time until the used grease is projected out of the bearings (around the bucket pin, in particular).

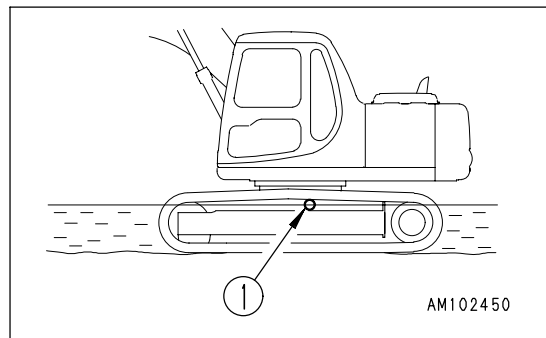

Digging Hard Rocky Ground

It is better to excavate hard rocky ground after breaking it up by some other means. This will not only reduce damage to the machine but make for better economy.

TRAVELING ON SLOPES

! WARNING

- Turning or operating the work equipment when working on slopes may cause the machine to lose its balance and turn over, so avoid such operations.
It is particularly dangerous to swing downhill when the bucket is loaded. If such operations have to be carried out, pile soil to make a platform on the slope so that the machine can be kept horizontal when operating.
- Do not travel up or down steep slopes. There is danger that the machine may turn over.
- When traveling, raise the bucket approx. 20 to 30 cm (8 to 12 in) from the ground.
Do not travel downhill in reverse.
- Never turn on slopes or travel across slopes.
Always go down to a flat place to perform these operations. It may be longer, but it will ensure safety.
- Always operate or travel in such a way that it is possible to stop safely at any time if the machine slips or becomes unstable.
- When traveling uphill, if the shoes slip or it is impossible to travel uphill using only the force of the tracks, do not use the pulling force of the arm to help the machine travel uphill. There is danger that the machine may turn over.

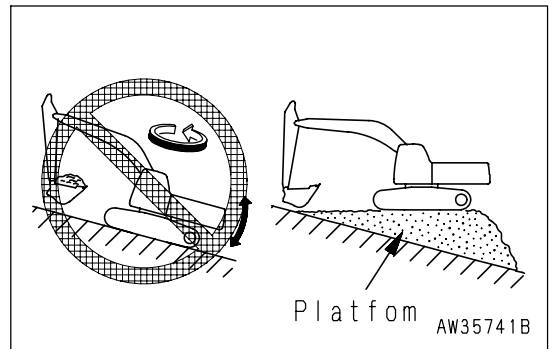
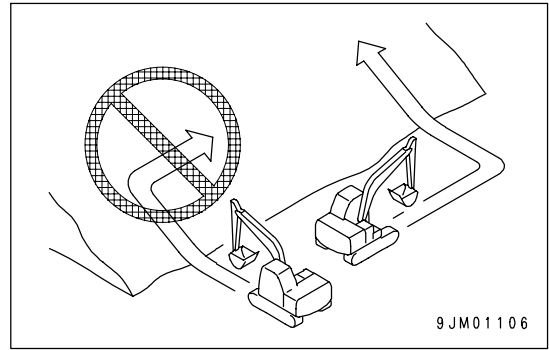

1. When traveling down steep hills, use the travel lever and fuel control dial to keep the travel speed low. When traveling down a steep hill of more than 15°, with the sprocket (1) side down, and set the work equipment to the posture shown in the diagram on the right, and lower the engine speed.

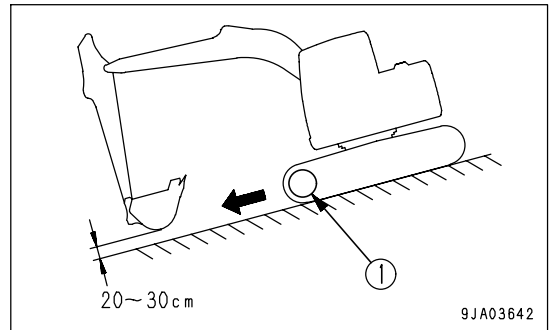

REMARK

Travel down fills with the sprocket (1) side down.
If the machine travels down with the sprocket (1) side up, the track tends to become loose, and that can cause skipping pitches.

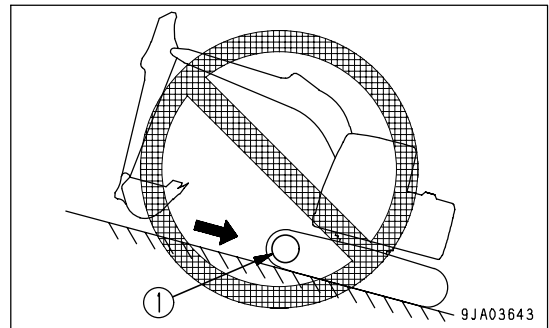

2. When traveling up a steep hill of more than 15°, set the work equipment to the posture shown in the diagram on the right.

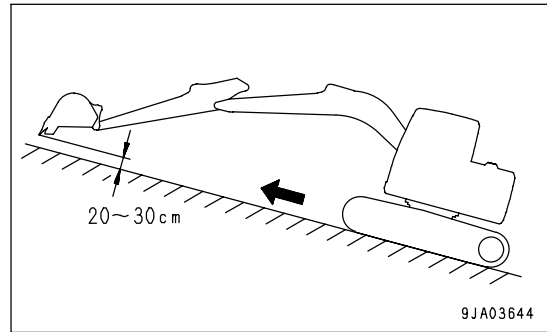

Traveling Downhill

Put the travel lever in the neutral position. This will cause the brake to be automatically applied.

Engine Stopped on Slope

If the engine stops when traveling uphill, move the travel levers to the neutral position, lower the bucket to the ground, stop the machine, then start the engine again.

Cab Doors on Slope

- If the engine stops when the machine is on a slope, never use the left work equipment control lever to carry out swing operations. The upper structure will swing under its own weight.
- Do not open or close the sliding door on slopes when traveling or operating. The operating effort may change suddenly.
Always keep the sliding door locked.
- Be extremely careful when opening or closing the sliding door when the machine is stopped on a slope. There is danger that the weight of the door may cause it to open or close suddenly.

ESCAPE FROM MUD

Always operate carefully to avoid getting stuck in mud. If the machine does get stuck in mud, do as follows to get the machine out.

Track on One Side Stuck

NOTICE

When using the boom or arm to raise the machine, always have the bottom of the bucket in contact with the ground. (Never push with the teeth). The angle between the boom and arm should be 90° to 110° .

The same applies when using the inverting bucket.

When only one side is stuck in mud, use the bucket to raise the track, then lay boards or logs and drive the machine out.

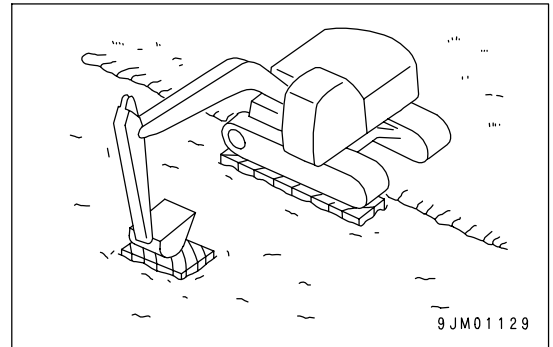

Tracks on Both Sides Stuck

If the track on both sides are in mud and the machine slips and cannot move, use the procedure given above to lay logs or timber. dig the bucket into the ground at the front, operate the arm in the same way as when digging, and set the travel lever to FORWARD to pull the machine out.

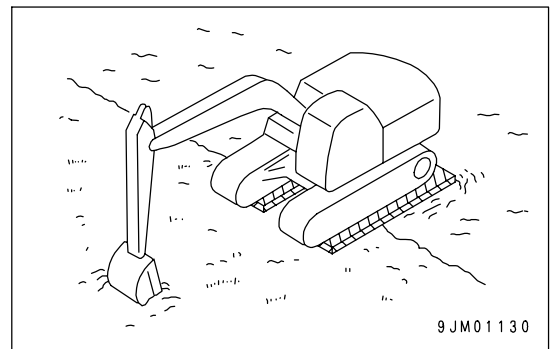

RECOMMENDED APPLICATIONS

In addition to the following, it is possible to further increase the range of applications by using various attachments.

Backhoe Work

A backhoe is suitable for excavating at a position lower than the machine.

When the condition of the machine is as shown in the diagram at right, each cylinder's maximum pushing excavation force is obtained when the bucket cylinder and link, arm cylinder and arm are at 90°.

When excavating, use this angle effectively to optimize your work efficiency.

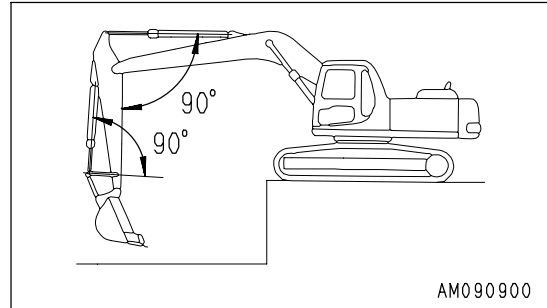

The range for excavating with the arm is from a 45° angle away from the machine to a 30° angle toward the machine.

There may be some differences depending on the digging depth, not try to keep within the above range rather than operating to the end of the cylinder stroke.

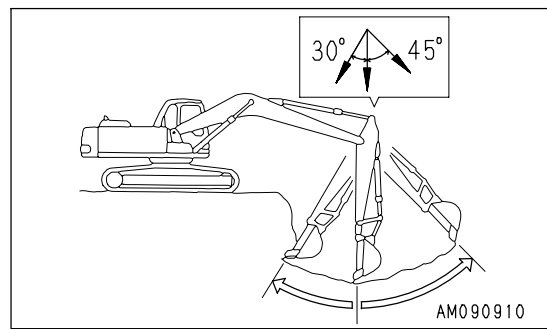

Shovel Work

A shovel is suitable for excavating at a position higher than the machine. Shovel work is performed by attaching the bucket in the reverse direction.

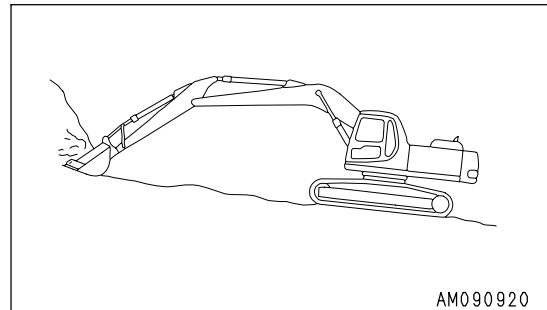

Ditching Work

Ditching work can be performed efficiently by attaching a bucket which matches the digging operation and then setting the tracks parallel to the line of the ditch to be excavated.

To excavate a wide ditch, first dig both sides and then finally remove the center portion.

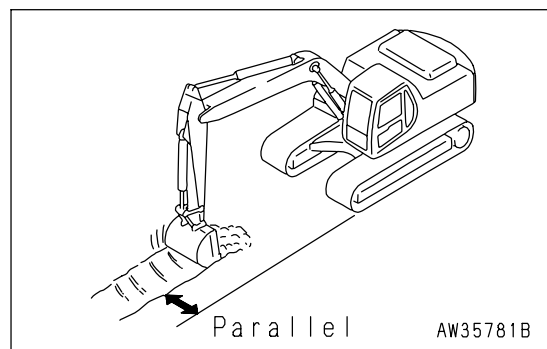

Loading Work

In places where the swing angle is narrow, work efficiency can be enhanced by locating the dump truck in a place easily visible to the operator.

Loading dump trucks is easier and the loading capacity is greater if the hydraulic excavator loads from the rear of the dump truck rather than from the side.

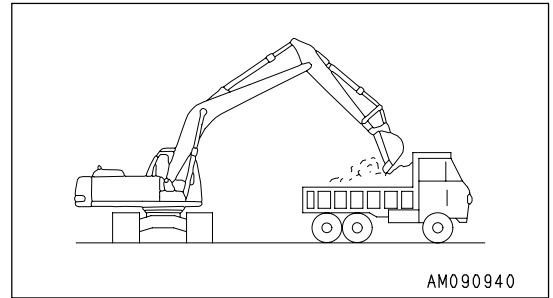

Refill and Finishing Work

(Only machines with blade specification)

When refilling after excavation and when smoothing the ground surface, use the blade.

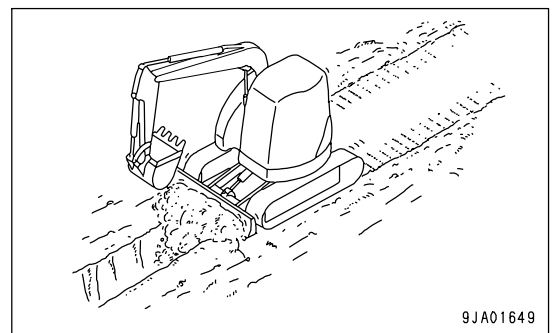

BUCKET REPLACEMENT AND INVERSION

WARNING

- When pins are knocked in with a hammer, pieces of metal may fly and cause serious injury. When carrying out this operation, always wear goggles, hard hat, gloves, and other protective equipment.
- When the bucket is removed, place it in a stable condition.
- If pins are hit with a strong force, there is a hazard that the pin may fly out and injure people in the surrounding area. Make sure that there is no one in the surrounding area before starting the operation.
- When removing the pins, do not stand behind the bucket. In addition, be extremely careful not to put your foot under the bucket while standing at the side for the work.
- When removing or inserting pins, be extremely careful not to get your fingers caught.
- Never insert your fingers into the pin holes when aligning the holes.

Stop the machine on a firm and flat surface and do the work. When performing joint work, appoint a lead and follow that person's instructions and signals.

Replacement

1. Place the bucket in contact with a flat surface.

REMARK

When removing the pins, place the bucket so that it is in light contact with the ground.

If the bucket is lowered strongly to the ground, the resistance will be increased and it will be difficult to remove the pins.

NOTICE

After removing the pins, make sure that mud or sand does not get on them. Dust seals are fitted at both ends of the bushings, be careful not to damage them.

2. Remove the double nut on the stopper bolt for arm pin (A) and link pin (B), remove the bolt, pull out arm pin (A) and link pin (B), and then remove the bucket.
3. Align the arm with holes (1) of the replacement bucket and the link with holes (2), then insert grease-coated pins (A) and (B) into hole (1) and hole (2) respectively.

REMARK

- Carry out installation in the reverse order to removal.
 - When installing the bucket, the O-rings are easily damaged, fit the O-rings on the boss of the arm end as shown in the diagram. When knocking the pin, move the O-ring down to the regular groove.
4. Install the stopper bolts and nuts for each pin, then grease the pin.

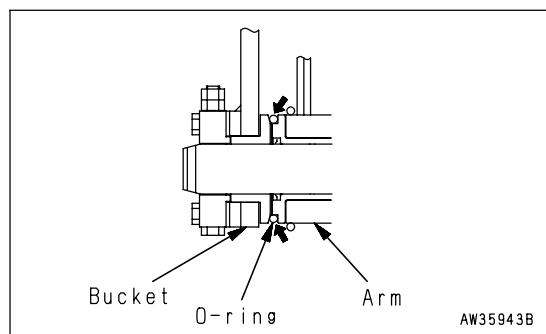
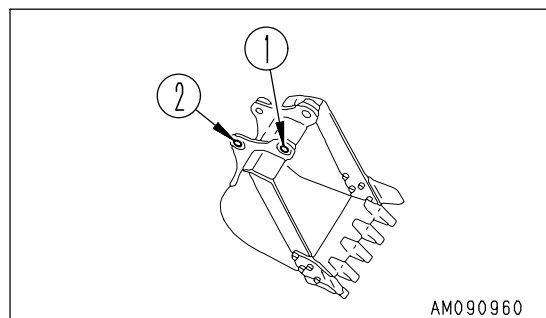
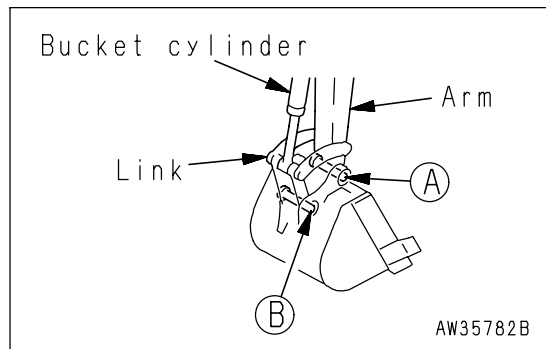

Inversion

WARNING

When reversing a bucket, there is the danger that the bucket tooth tip overruns the normal trajectory and interferes with the cab, thus causing a serious trouble. Pay good attention to the work when reversing a bucket so that the bucket and the cab may not interfere with each other.

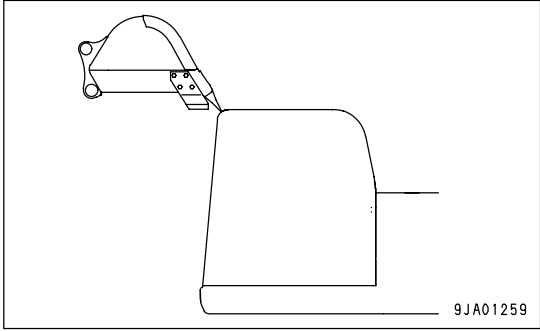

1. Place the bucket in contact with a flat surface.

REMARK

When removing the pins, place the bucket so that it is in light contact with the ground.

If the bucket is lowered strongly to the ground, the resistance will be increased and it will be difficult to remove the pins.

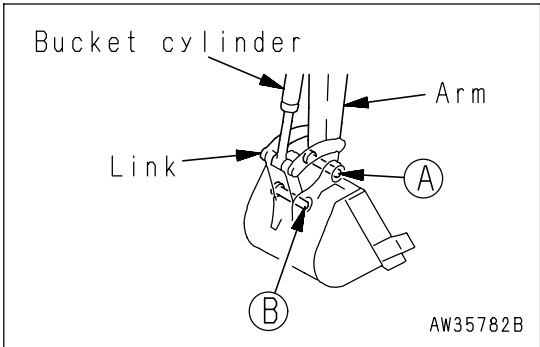

NOTICE

After removing the pins, make sure that mud or sand does not get on them. Dust seals are fitted at both ends of the bushings, be careful not to damage them.

2. Remove the double nut on the stopper bolt for arm pin (A) and link pin (B), remove the bolt, pull out arm pin (A) and link pin (B), and then remove the bucket.
3. Turn the removed bucket. After turning the bucket, align the arm with link mounting hole (1), then align the link with arm mounting hole (2) and install.
4. Align the arm with holes (1) of the replacement bucket and the link with holes (2), then insert grease-coated pins (A) and (B) into hole (1) and hole (2) respectively.

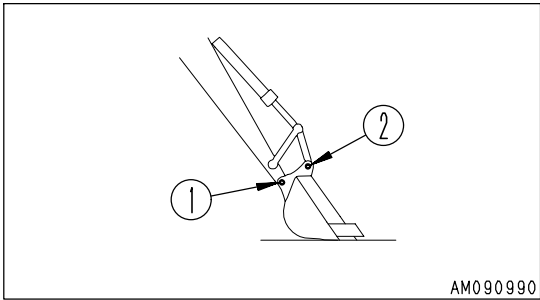
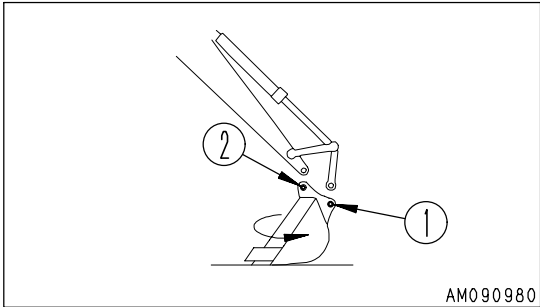

REMARK

Install the O-ring into retaining hole (1) of the arm and bucket. When installing the bucket, the O-rings are easily damaged, so fit the O-rings on the boss of the arm end as shown in the diagram on the right. When knocking in the pins, move the O-ring down to the regular groove.

5. Install the stopper bolts and nuts for each pin, then grease the pin.

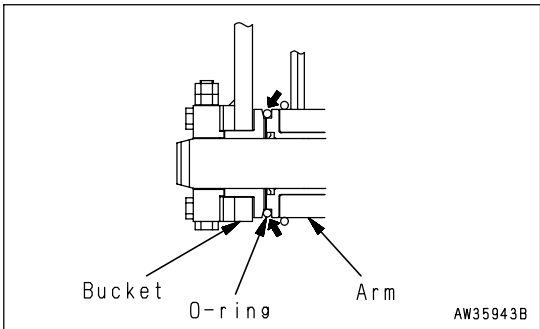

PARKING MACHINE

! WARNING

- Park the machine on the firm, level ground.
Avoid parking the machine on slopes.
If it is unavoidably necessary to park the machine on a slope, put blocks under the tracks and dig the work equipment into the ground surface to stop the machine from moving.
- If the control levers are touched by accident, the machine may move suddenly, and this may lead to a serious accident. Before standing up from the operator's seat, always set the lock lever securely to the LOCK position.
- Set the blade on the downhill side and lower it to the ground. (Blade specification only)

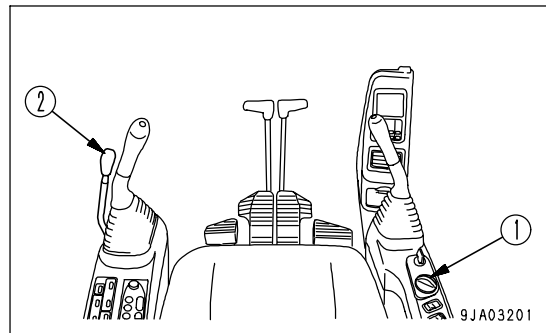
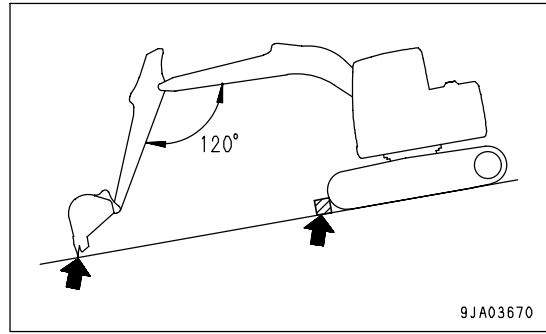

1. Stop the machine. For details, see "Stopping Machine (PAGE 3-80)".
2. Set fuel control dial (2) to the low idle position and lower the engine speed.

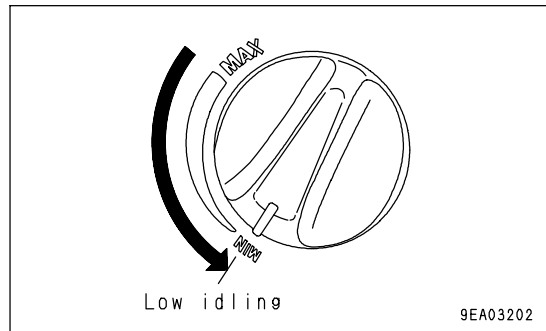

3. Lower the bucket horizontally until the bottom touches the ground.
4. Lower the blade to the ground. (Only machines with blade specification)

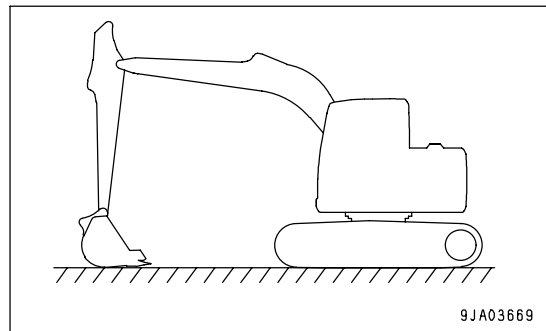

5. Set lock lever (2) in the LOCK position.

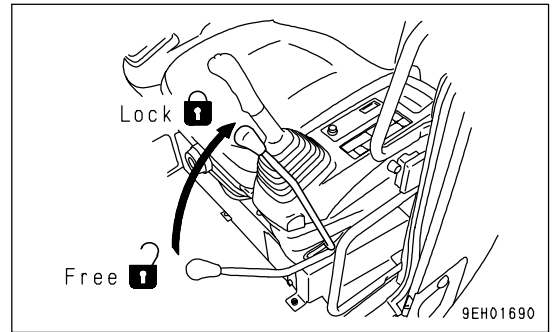

MACHINE INSPECTION AFTER DAILY WORK

Before Stopping Engine

Check the engine coolant temperature (1), engine oil pressure (2), and fuel level (3) on the machine monitor.

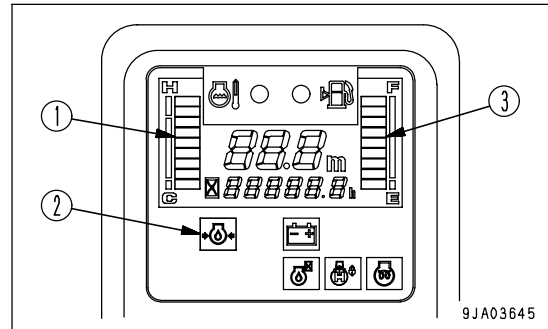

After Stopping Engine

1. Walk around the machine and check the work equipment, machine exterior, and undercarriage, also check for any leakage of oil or coolant. If any problems are found, repair them.
2. Fill the fuel tank.
3. Check the engine compartment for paper and debris. Clean out any paper and debris to avoid a fire hazard.
4. Remove any mud affixed to the undercarriage.

LOCKING

Always lock the following places.

- (1) Door of operator's cab
Always remember to close the window.
- (2) Fuel tank filler port
- (3) Engine hood
- (4) Cover at rear of cab
- (5) Battery room door
- (6) Pump room door
- (7) Door at front of tool box

REMARK

Use the starting switch key to lock and unlock all these places.

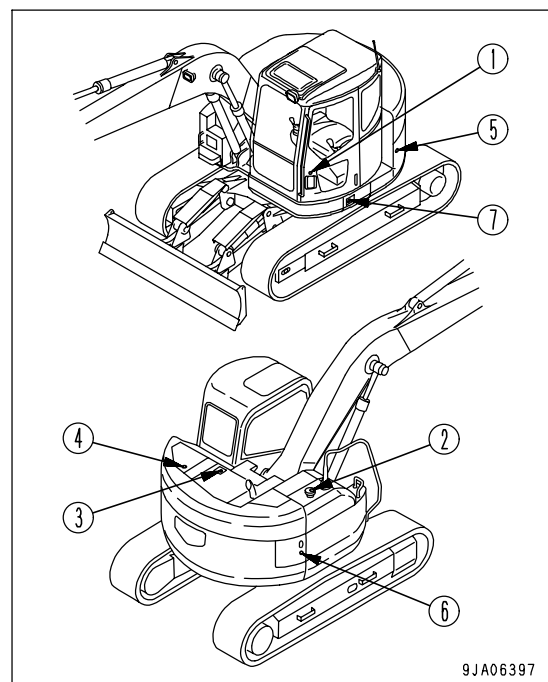

ROAD LINERS

(Machine equipped with road liner)

Road Liners Information

Road liner have excellent properties that are not found in steel shoes. However, if they are used in the same way as steel shoes, full use cannot be made of their advantages.

Be sure to operate without straining the rubber shoes in a way that matches the condition of the jobsite and the nature of the work.

Comparison of Road Liners and Metal Shoes

	Road liner	Steel shoe
Little vibration	◎	△
Smooth travel (No creaks)	○	○
Little noise	◎	△
No damage to paved surface	◎	△
Easily damage	○	◎
Strong drawbar pull	◎	◎

◎: Excellent

○: Good

△: Average

Considering the properties of the material used, rubber shoes and road liners offer various advantages. However, their weak point is lack of strength. Therefore, it is important to understand the advantages of rubber shoes and road liners, and to follow the precautions regarding handling and prohibited work. This will extend the life of the rubbershoes and road liners and will enable the machine to display the advantages of rubber shoes and road liners to the maximum. Before using rubber shoes and road liner, always read "Using Road Liners (PAGE 3-102)".

Warranty for Road Liners

It is important to inspect and maintain the tracks at the correct tension. Furthermore, these shoes must not be used near objects where they are likely to suffer damage, such as the corners of steel plates, U-shaped ditch liners, blocks, on crushed rock or the sharp edges of rocks, iron beams, or scrap iron.

Any damage resulting from the customer's mistaken use of the machine shall not be included in the scope of the warranty.

Using Road Liners

Prohibited Works

Do not carry out the following types of work.

- Carrying out operations and steering on crushed rock, extremely rough hard rock, steel beams, scrap iron, or near the edges of steel plates will cause damage to the rubber shoes and road liners.
- In places such as river beds where there are large numbers of large and small boulders, the stones may get caught and damage the rubber shoes and road liners or make the shoes come off. If dozing operations are carried out when the shoes are slipping, this will reduce the life of the rubber shoes and road liner.
- Be careful not to get oil, fuel, or chemical solvent on the rubber shoes and road liners. If such a substance should get on the shoes, remove it immediately. Furthermore, do not travel on road surfaces where oil has collected.
- When putting the machine into long-term storage (3 months or more), store the machine indoors where it is protected from direct sunlight or rain.
- Do not use the machine in high-temperature areas, such as areas where there is burning wood, steel plates that have been left under the hot sun, or places where asphalt has been laid.
- When the rubber parts of the road liner are so worn or broken that the head of the mounting bolts are scratched, replace the shoe immediately. If the bolt heads are broken, the bolt cannot be removed.
- When installing road liners, always install them to all links on both sides. If they are installed to only one part of the links, their durability will be greatly reduced.

Long Life Operations

Be careful of the following points when carrying out work.

- Avoid carrying out counterrotation turns on concrete surfaces. There is danger that the concrete surface will scrape off the rubber from the shoe.
- Avoid making sudden changes in direction. This may cause premature wear or damage to the rubber shoes and road liners.
- Avoid operating the steering when traveling over places where there is a big difference in height. When traveling over obstacles or places where there is a difference in height, drive the machine at right angles to the obstacle to prevent the shoes from coming off.
- If the machine has been raised using the bucket, lower it slowly.
- Avoid doing work with materials that produce oil when crushed (soy beans, corn, or remains of vegetables squeezed for oil); or wash the machine after use.
- Avoid handling materials that will attack the adhesion of the steel core, such as salt, ammonium sulphate, potassium chloride, potassium sulphate, or calcium superphosphate; or wash the machine after use.
- The adhesion of the core will be attacked by salt, so avoid using the machine in coastal areas.
- When handling salt, sugar, wheat, or soy beans, if there is any deep cut in the rubber shoes and road liners, these substances may get into the lugs or cut portion of the rubber. Always repair the rubber before use.
- Do not carry out work that involves scraping against walls or concrete embankments.
- Road liners slip extremely easily on snow or frozen roads. Be careful not to slip when traveling or working on slopes.
- The properties of road liners change when working in extremely cold places, and this will reduce the life of the rubber shoes and road liners.
- Because of the properties of rubber, use the road liners within a range of -25°C to $+65^{\circ}\text{C}$ (-13°F to $+149^{\circ}\text{F}$).
- When carrying out bucket operations, be careful not to damage the road liners with the bucket.

TRANSPORTATION

When transporting the machine, observe all related laws and regulations, and be careful to assure safety.

TRANSPORTATION PROCEDURE

Select the method of transportation to match the weight and dimensions given in "SPECIFICATIONS (PAGE 5-2)". Note that the weight and dimensions given in SPECIFICATIONS may differ according to the type of shoe or arm, or other attachments.

LOADING AND UNLOADING WITH TRAILER

WARNING

- Always turn the auto-deceleration switch OFF (cancel) during loading and unloading operations.
If the auto-deceleration switch is left ON, the machine may suddenly start moving.
- When loading a machine to a trailer or unloading from it, be sure to travel the machine at low speed. Never attempt to change the speed.
- Run the engine at low idle, set to low speed, and operate the machine slowly when loading or unloading.
- Select firm, level ground when loading or unloading the machine.
Maintain a safe distance from the edge of the road.
- Use ramps with ample width, length, thickness, and strength and install them at a maximum slope of 15°.
 - When using piled soil, compact the piled soil fully and take action to prevent the slope face from collapsing.
- Remove all mud and dirt from the machine tracks before starting in order to prevent the machine from slipping on the ramps.
Be sure that the ramp surface is clean and free of water, snow, ice, grease, or oil.
- Never correct your steering on the ramps. There is danger that the machine may turn over.
If necessary, drive off the ramps, correct the direction, then enter the ramps again.
- Do not use the work equipment for loading and unloading operations. It is dangerous.
- When on the ramps, do not operate any lever except the travel lever.
- The center of gravity of the machine will change suddenly at the joint between the ramps and the track or trailer, and there is danger of the machine losing its balance. Travel slowly over this point.
- When swinging the upper structure on the trailer, the trailer is unstable, so pull in the work equipment and swing slowly.
- If the sliding door of the cab is closed or open, always check that it is locked in position. The operating effort when opening or closing the door suddenly changes when the machine is on a ramp or platform, so never open or close the door in such conditions.

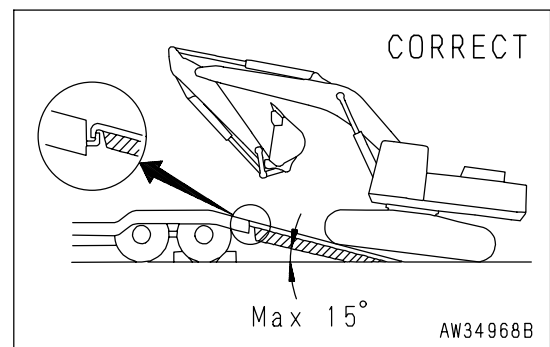
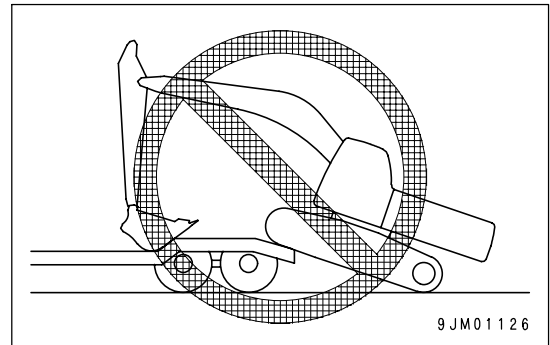

When loading or unloading, always use ramps or a platform. Proceed as follows.

Loading

1. Load and unload on firm level ground only.
 Maintain a safe distance from the edge of a road.
2. Properly apply the brakes on the trailer and put blocks under the tires to ensure that the trailer does not move.
 Make the slope of the ramps a maximum of 15°.

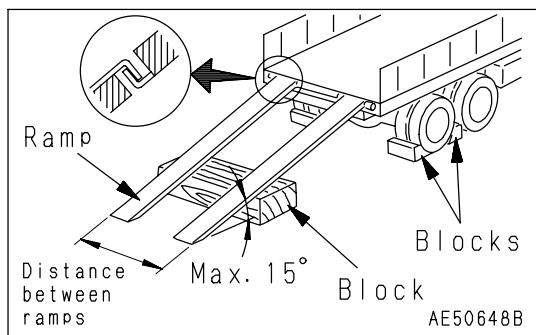

3. Turn the travel speed selector switch to low speed travel (Lo lamp lights up).

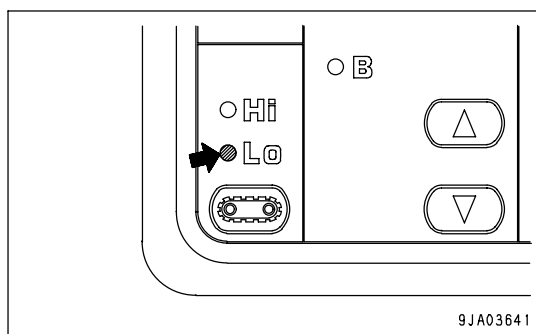

4. Turn the auto-decelerator switch to the RELEASE position (the lamp turns off).

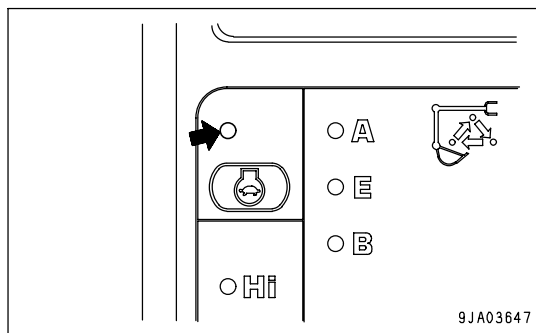

5. Run the engine at low speed.

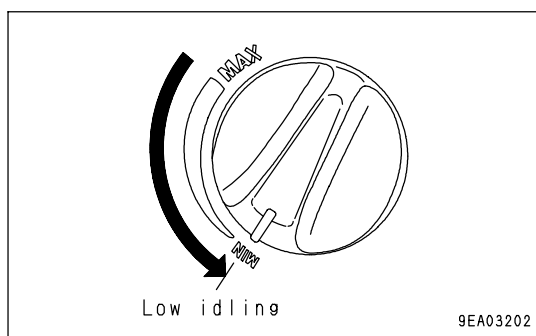

6. Turn the swing lock switch ON to apply the swing lock.

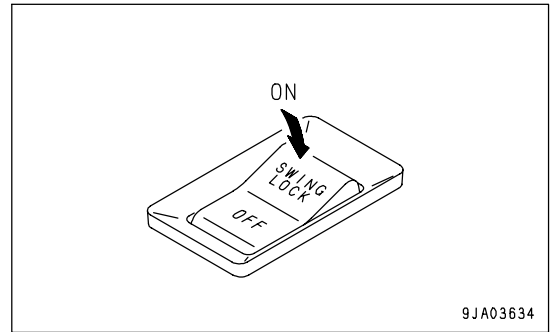

7. If the machine is equipped with work equipment, set the work equipment at the front, and travel forward to load it; if it has no work equipment, travel in reverse to load it. Follow instructions and signals of a conductor particularly when traveling in reverse.

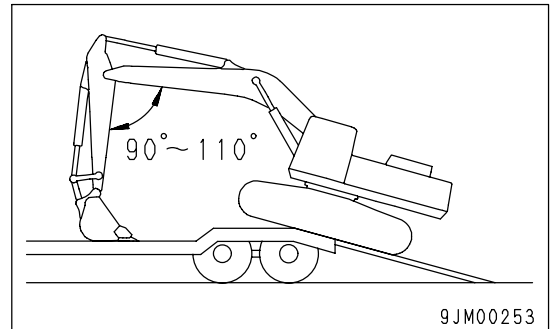

8. Before moving onto the ramps, make sure that the machine is positioned in a straight line with the ramps and that the centerline of the machine matches that of the trailer. Align the direction of travel with the ramps and travel slowly. Lower the work equipment as far as possible without causing interference.

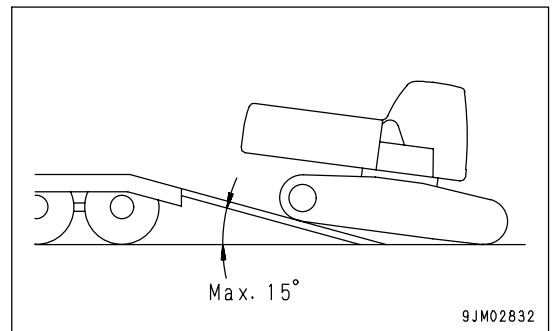

When on the ramps, operate only the travel lever. Do not operate any other lever.

9. Stop the machine, when it takes a level posture right above the rear wheels on the trailer bed.

10. Turn the swing lock switch OFF to release the swing lock, then swing the upper structure slowly 180°.

11. Move the machine forward slowly on the trailer. (A machine without work equipment will stay put)

12. Stop the machine at the specified position on the trailer.

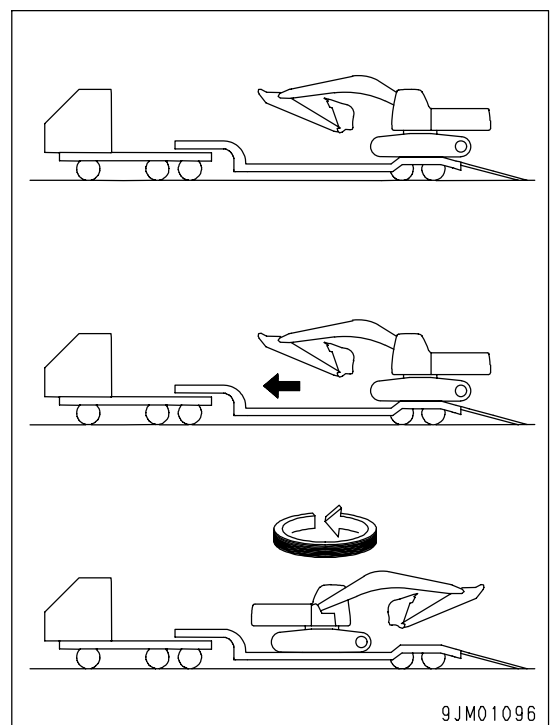

13. Turn the swing lock switch ON to apply the swing lock.

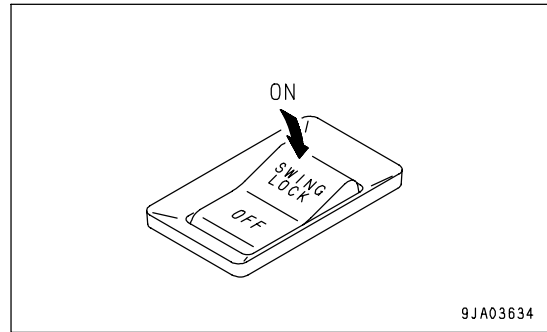

Securing Machine

After placing the machine on the specified position of the trailer, secure it according to the following procedure.

NOTICE

- Stow the antenna and other parts away. Reassemble the mirrors (for machines equipped with mirrors) so that they are within the width of the machine.
- To prevent damage to the bucket cylinder during transportation, fit a wooden block at one end of the bucket cylinder to prevent it from touching the floor.

Load the machine onto a trailer as follows:

1. Lower the blade. (Only machines with blade specification)
2. Extend the bucket and arm cylinders fully, then lower the boom slowly.

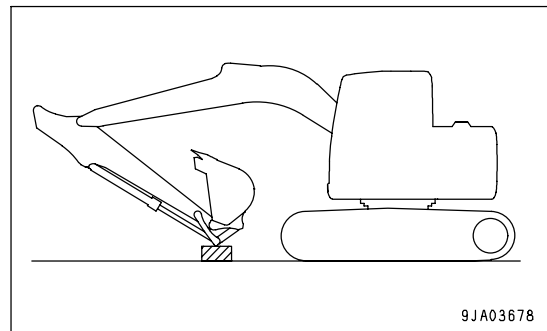

3. Set the lock lever securely to the LOCK position to lock the work equipment control levers.
4. Stop the engine, then remove the key from the starting switch.
5. Close all doors, windows, and covers.
Lock the covers, caps, and doors fitted with locks.

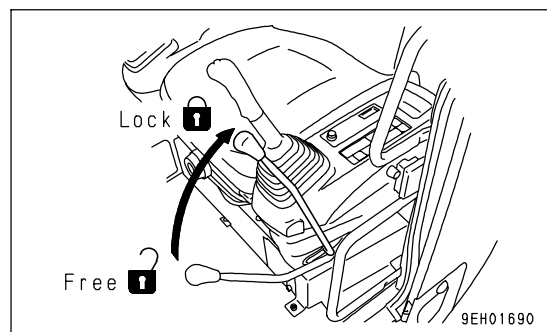

- Place blocks under both ends of the tracks to prevent the machine from moving during transportation, and secure the machine with chains or wire rope of suitable strength. Be particularly careful to secure the machine in position so that it does not slip to the side. When securing the machine, put blocks between the wire rope and the machine to prevent damage to the rope or machine.

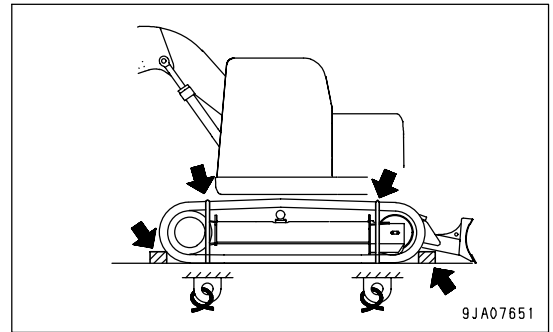

Unloading

- Load and unload on firm level ground only. Maintain a safe distance from the edge of a road.
- Properly apply the brakes on the trailer and put blocks under the tires to ensure that the trailer does not move. Make the slope of the ramps a maximum of 15°.
- Remove the chains and wire ropes fastening the machine.
- Start the engine. Warm the engine up fully.

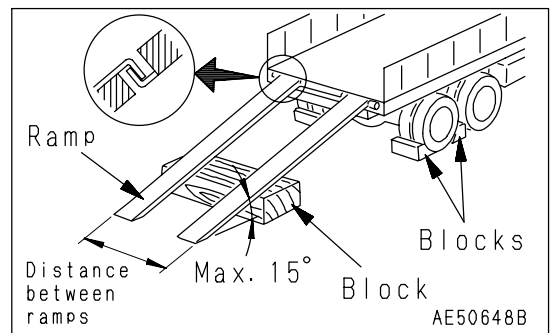

- Set the lock lever to the FREE position.

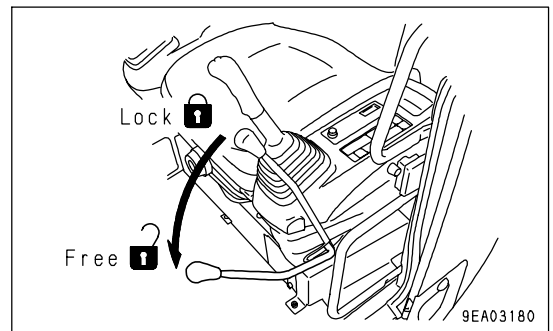

- Turn the travel speed selector switch to low speed travel (Lo lamp lights up).

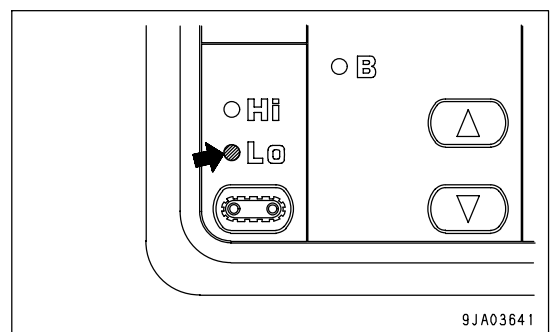

7. Turn the auto-decelerator switch to the RELEASE position (the lamp turns off).

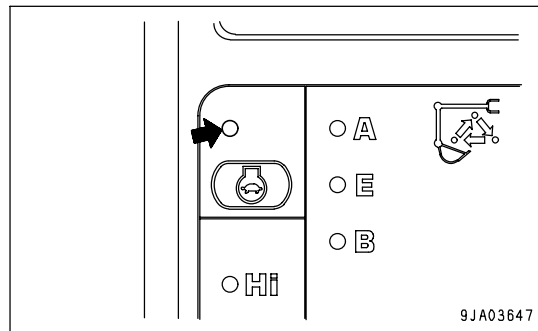

8. Run the engine at low speed.

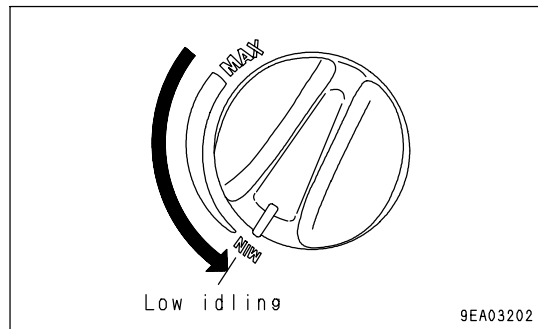

9. Turn the swing lock switch OFF to release the swing lock.

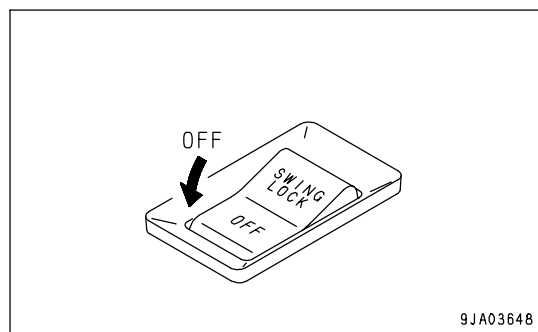

10. Raise the work equipment, pull in the arm under the boom, then move the machine slowly.

11. When the machine is horizontal on top of the rear wheels of the trailer, stop the machine.

NOTICE

- If the machine is unloaded with the arm pulled in, the work equipment will be damaged.
- When moving on to the ramps, to prevent damage to the hydraulic cylinders, do not let the bucket hit the ground.

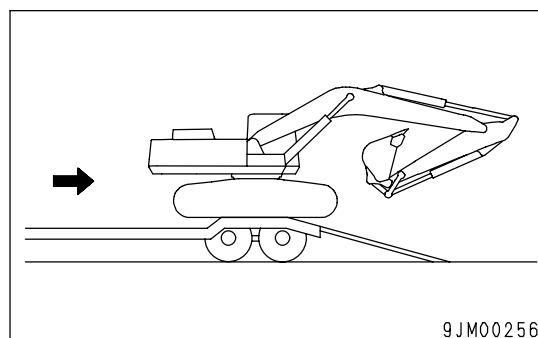

12. When moving from the rear of the trailer on to the ramps, set the angle of the arm and boom to 90° to 110° , lower the bucket to the ground, then move the machine slowly.

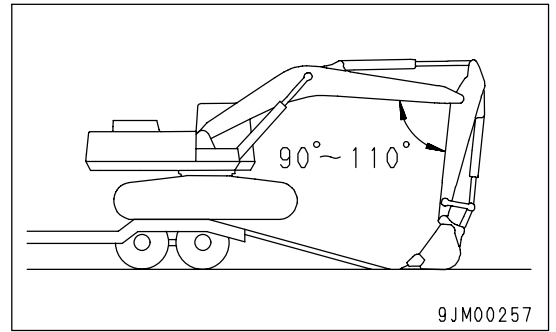

13. When moving down the ramps, operate the boom and arm slowly to lower the machine carefully until it is completely off the ramps.

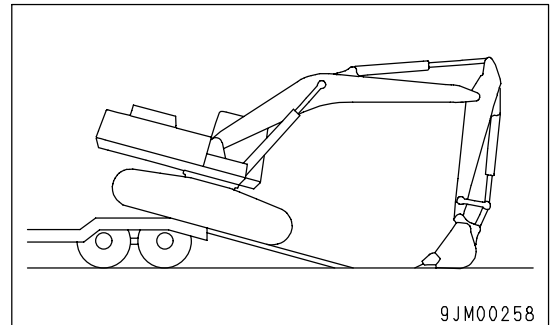

LIFTING MACHINE

**WARNING**

- The operator carrying out the lifting operation using a crane must be a properly qualified crane operator.
- Never raise the machine with any worker on it.
- Always make sure that the wire rope is of ample strength for the weight of this machine.
- When lifting, keep the machine horizontal.
- When carrying out lifting operations, set the lock lever to the LOCK position to prevent the machine from moving unexpectedly.
- Never go in the area under or around the machine when it is raised.
- There is a hazard that the machine may lose its balance.

Always use the posture given in the procedure below and use the proper lifting equipment to lift the machine.

NOTICE

The lifting procedure applies to machines with standard specifications.

The method of lifting differs according to attachments and options actually installed on the machine. For the proper lifting procedures, contact your Komatsu distributor.

For details of the weight, see "SPECIFICATIONS (PAGE 5-2)".

When lifting the machine, carry out the operation on flat ground as follows.

1. With a machine of blade specifications, turn the upper structure so that the work equipment will be on the side of sprocket (1).
2. Extend the bucket cylinder and arm cylinder fully, then lower the work equipment to the ground as shown in the diagram on the right using the boom cylinder.
3. Lower the blade to the ground. (Only machines with blade specification)

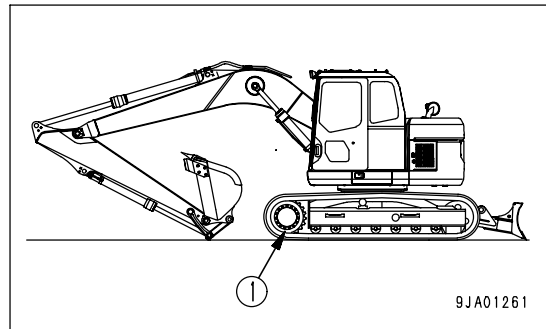

4. Set the lock lever securely to the LOCK position to lock the work equipment control levers.

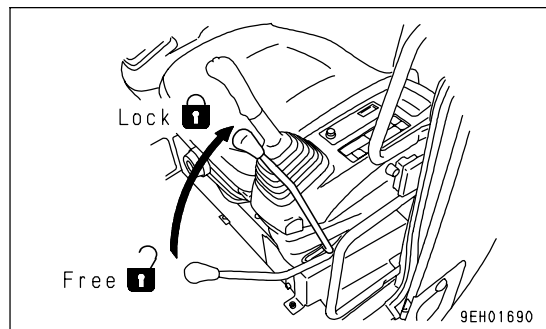

5. Stop the engine, check that there is nothing around the operator's compartment, then get off the machine. Close the cab door and front glass securely.

6. Pass wire ropes between the 1st and 2nd track rollers from the front and between the 1st and 2nd track rollers from the rear.
7. Put blocks between the wire rope and the machine to prevent damage to the rope or machine.
8. Set the lifting angle (A) of the wire rope to 30° to 40°, then lift the machine slowly.
9. After the machine comes off the ground, check the hook condition and the lifting posture, and then lift slowly.

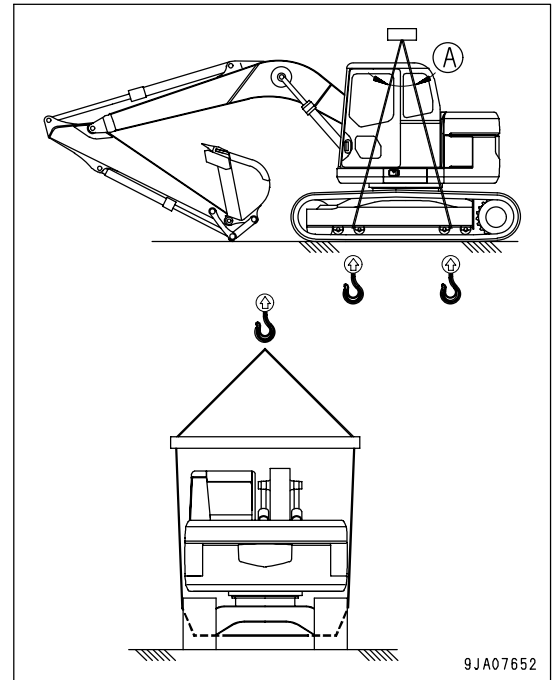

COLD WEATHER OPERATION

COLD WEATHER OPERATION INFORMATION

If the temperature becomes low, it becomes difficult to start the engine, and the coolant may freeze, so do as follows.

Fuel and Lubricants

Change to fuel and oil with low viscosity for all components. For details of the specified viscosity, see "RECOMMENDED FUEL, COOLANT, AND LUBRICANT (PAGE 4-9)".

Cooling System Coolant



WARNING

- Antifreeze is toxic. Be careful not to get it into your eyes or on your skin. If it should get into your eyes or on your skin, wash it off with large amounts of fresh water and see a doctor at once.
- When changing the coolant or when handling coolant containing antifreeze that has been drained when repairing the radiator, please contact your Komatsu distributor or request a specialist company to carry out the operation. Antifreeze is toxic. Do not let it flow into drainage ditches or spray it onto the ground surface.
- Antifreeze is flammable. Do not bring any flame close. Do not smoke when handling antifreeze.

NOTICE

- Use Komatsu Supercoolant wherever available, or use permanent type antifreeze coolant.
- Never use methanol, ethanol, or propanol-based antifreeze.
- Do not use any water leakage prevention agent, either alone, or in combination with antifreeze.
- Do not mix one brand of antifreeze with a different brand.

For details of the antifreeze mixture when changing the coolant, see "CLEAN INSIDE OF COOLING SYSTEM (PAGE 4-21)".

Battery



WARNING

- The battery generates flammable gas. Do not bring fire or sparks near the battery.
- Battery electrolyte is dangerous. If it gets in your eyes or on your skin, wash it off with a large amount of water and consult a doctor.
- Battery electrolyte dissolves paint. If it gets on the bodywork, wash it off immediately with water.
- If the battery electrolyte is frozen, do not charge the battery or start the engine with a different power source. There is danger that the battery may explode.
- Battery electrolyte is toxic. Do not let it flow into drainage ditches or spray it on to the ground surface.

When the ambient temperature drops, the capacity of the battery will also drop. If the battery charge ratio is low, the battery electrolyte may freeze. Maintain the battery charge as close as possible to 100%. Insulate it against cold temperature to ensure the machine can be started easily the next morning.

REMARK

Measure the specific gravity and calculate the charging rate from the following conversion table.

Charging Rate (%)	Electrolyte Temperature (°C)			
	20	0	-10	-20
100	1.28	1.29	1.30	1.31
90	1.26	1.27	1.28	1.29
80	1.24	1.25	1.26	1.27
75	1.23	1.24	1.25	1.26

- As the battery capacity drastically drops in low temperatures, cover or remove the battery from the machine, store the battery in a warm place, and install it again the next morning.
- If the electrolyte level is low, add distilled water in the morning before beginning work. Do not add water after the day's work to prevent diluted electrolyte in the battery from freezing during the night.

AFTER DAILY WORK COMPLETION



WARNING

Performing idle-running of the tracks is dangerous, stay well away from the tracks.

To prevent mud, water, or the undercarriage from freezing and making it impossible for the machine to move on the following morning, observe the following precautions.

- Remove all the mud and water from the machine body. In particular, wipe the hydraulic cylinder rods clean to prevent damage to the seal caused by mud, dirt, or drops of water on the rod from getting inside the seal.
- Park the machine on hard, dry ground.

If this is impossible, park the machine on boards.

The boards prevent the tracks from freezing to the ground, and allow the machine to be moved the next morning.

- Open the drain valve and drain any water collected in the fuel system to prevent it from freezing.
 - Fill the fuel tank to capacity. This minimizes moisture condensation in the tank when the temperature drops.
 - After operation in water or mud, remove water from undercarriage as described below to extend undercarriage service life.
1. Swing 90° with engine at low idle and bring the work equipment to the side of the track.
 2. Jack up the machine until the track is raised slightly from the ground. Rotate the track under no load. Repeat this procedure on both the left and right sides.

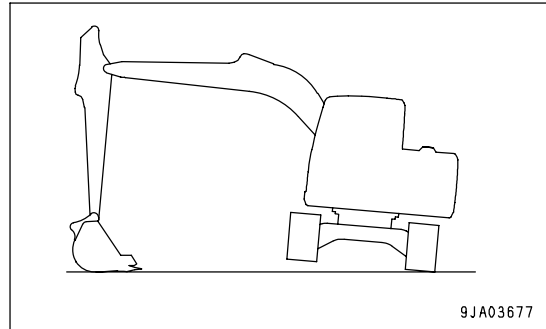

AFTER COLD WEATHER SEASON

When the season changes and the weather becomes warmer, do as follows.

- Replace the fuel and oil for all parts with oil of the viscosity specified.
For details, see "RECOMMENDED FUEL, COOLANT, AND LUBRICANT (PAGE 4-9)".

LONG TERM STORAGE

BEFORE STORAGE

NOTICE

When storing the machine (1 month or more), set the machine in the posture shown in the diagram on the right to protect the cylinder rod.
(To prevent rusting of the cylinder rod)

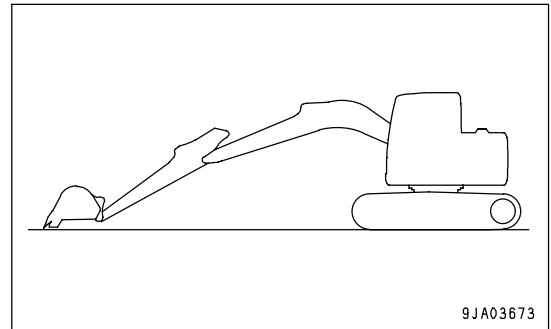

When keeping in long-term storage (more than one month), store as follows.

- Clean and wash all parts, then store the machine indoors. If the machine has to be stored outdoors, select level ground and cover the machine with canvas.
- Fill the fuel tank. This prevents moisture from collecting.
- Lubricate and change the oil before storage.
- Coat the exposed portion of the hydraulic cylinder piston rod with grease.
- Disconnect the negative terminals of the battery and cover it or remove it from the machine and store it separately.
- Lock each control lever and pedal with the lock lever and lock cover.
- Set the stop valve to the LOCK position on machines ready for attachments. Install the blind plugs to the elbows.
- Set the selector valve on the machines which can install attachments to the "Crusher or general attachment" position.
- To prevent corrosion, be sure to fill the cooling system with Supercoolant (AF-NAC) or permanent type antifreeze (density between 30% and 68%).

DURING STORAGE



WARNING

If it is necessary to perform the rust-prevention operation while the machine is indoors, open the doors and windows to improve ventilation and prevent gas poisoning.

- During storage, operate and move the machine for a short distance once a month so that a new film of oil will coat moving parts. At the same time, also charge the battery.
- For machines equipped with an air conditioner, run the air conditioner.

AFTER STORAGE

NOTICE

If the machine has been stored without carrying out the monthly rust-prevention operation, consult your Komatsu distributor before using it.

When using the machine after long-term storage, do as follows before using it.

- Wipe off the grease from the hydraulic cylinder rods.
- Add oil and grease at all lubrication points.
- When the machine is stored for a long period, moisture in the air will mix with the oil. Check the oil before and after starting the engine. If there is water in the oil, change all the oil.

TROUBLES AND ACTIONS

RUNNING OUT OF FUEL

When starting after running out of fuel, fill with fuel and bleed the air from the fuel system before starting.
For details on bleeding the air, see "REPLACE FUEL FILTER CARTRIDGE (PAGE 4-54)".

PHENOMENA THAT ARE NOT FAILURES

Note that the following phenomena are not failures:

- When the arm control lever is operated to the IN position and the work equipment is lowered under no load from a high position, the arm speed will drop momentarily when the arm is more or less at the vertical position.
- When the bucket control lever is operated to the CURL position and the work equipment is lowered under no load from a high position, the bucket speed will drop momentarily when the bucket teeth are more or less at the horizontal position.
- The bucket or arm will fluctuate by itself during heavy-duty digging operations.
- When starting or stopping the swing, noise will be emitted from the brake valve.
- When going down a steep slope at low speed, a noise will be emitted from the travel motor brake valve.

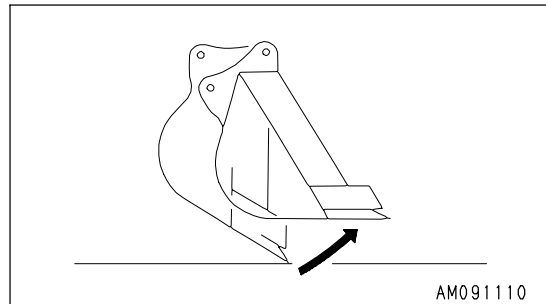
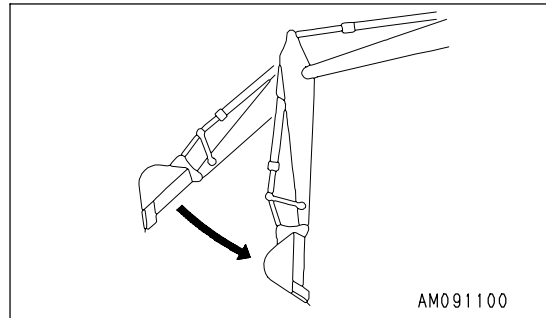

TOWING THE MACHINE

**WARNING**

Serious injury or death could result if a disabled machine is towed incorrectly or if there is a mistake in the selection or inspection of the wire rope.

- Always check that the wire rope used for towing has ample strength for the weight of the machine being towed.
- Never use a wire rope which has cut strands (A), reduced diameter (B), or kinks (C). There is danger that the rope may break during the towing operation.
- Always wear leather gloves when handling wire rope.
- Never tow a machine on a slope.
- During the towing operation, never stand between the towing machine and the machine being towed.
- Operate the machine slowly and be careful not to apply any sudden load to the wire rope.

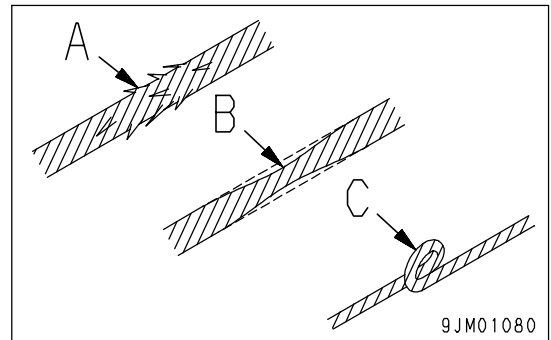

NOTICE

The maximum towing capacity for this machine is 9,710 kg (95,200 N).

Always carry out towing operations within the maximum towing capacity.

- If the machine sinks in mud and cannot get out under its own power, or if the drawbar pull of the excavator is being used to tow a heavy object, use a wire rope as shown in the diagram on the right.
- Place pieces of wood between wire ropes and body to prevent damage to ropes and body.
- Hold the wire rope level and direct it straight to the track frame.
- When towing a machine, travel at a speed of less than 1 km/h for a distance of only a few meters to a place that is suitable for carrying out repairs.

This is for use only in emergencies.

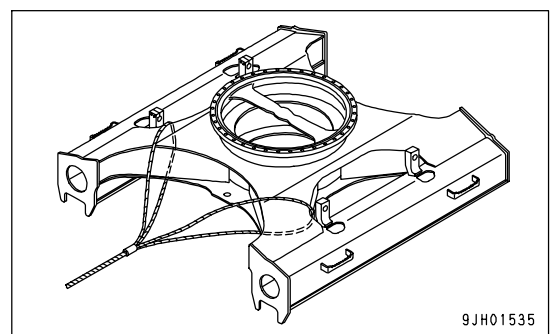
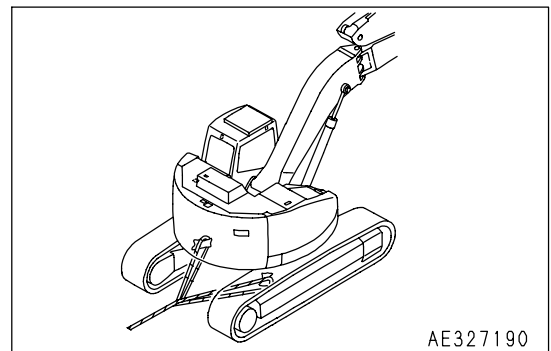

LIGHTWEIGHT TOWING HOOK



WARNING

- The shackle must always be used.
- Hold the wire rope level and direct it straight to the track frame.
- Move the machine slowly and be careful not to apply any sudden load to the wire rope.

There is a hole in the track frame to fit the shackle when towing light objects.

Permissible towing load: Max. 65,700 N (6,700 kg)

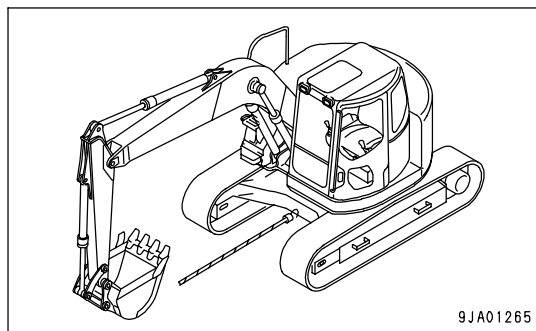

SEVERE JOB CONDITION

- When carrying out digging operations in water, if the work equipment mounting pin goes into the water, carry out greasing every time the operation is carried out.
- For heavy-duty operations and deep digging, carry out greasing of the work equipment mounting pins every time before operation.
After greasing, operate the boom, arm and bucket several times, then grease again.

DISCHARGED BATTERY

**WARNING**

- It is dangerous to charge a battery when mounted on a machine. Make sure that it is dismantled before charging.
 - When checking or handling the battery, stop the engine and turn the starting switch key to the OFF position.
 - The battery generates hydrogen gas, so there is a hazard of explosion. Do not bring lighted cigarettes near the battery, or do anything that will cause sparks.
 - Battery electrolyte is dilute sulfuric acid, and it will attack your clothes and skin. If it gets on your clothes or on your skin, immediately wash it off with a large amount of water. If it gets in your eyes, wash it out with fresh water and consult a doctor.
 - When handling batteries, always wear safety glasses and rubber gloves.
 - When removing the battery, first disconnect the cable from the ground (normally the negative (-) terminal). When installing, install the positive (+) terminal first.
- If a tool touches the positive terminal and the chassis, there is danger that it will cause a spark, so be extremely careful.
- If the terminals are loose, there is danger that the defective contact may generate sparks that will cause an explosion.
 - When removing or installing the terminals, check which is the positive (+) terminal and which is the negative (-) terminal.

When removing, disconnect the cable from the ground terminal first.

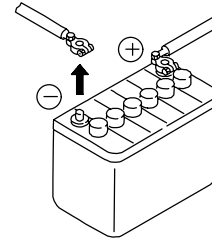

When installing, connect the cable to the positive ⊕ terminal first.

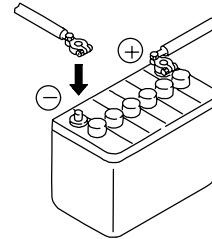

9EA00023

Battery Removal and Installation

Removal of Battery

1. Open the battery room door, then remove rubber cover (1) installed to the top of the battery.

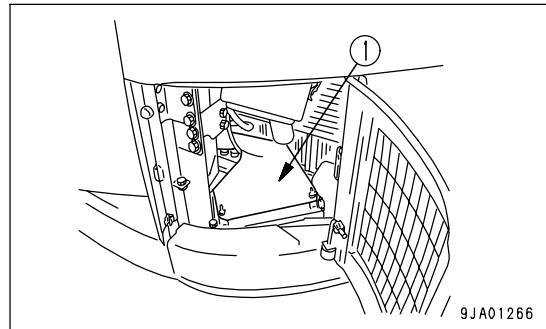

2. Remove cable (2) from the negative (-) terminal (ground).
3. Remove connection cable (4) and cable (3) from the positive (+) terminal.
4. Remove 4 mounting bolts (5), then remove mounting holder (6).
5. Pull the battery to the outside of the machine.

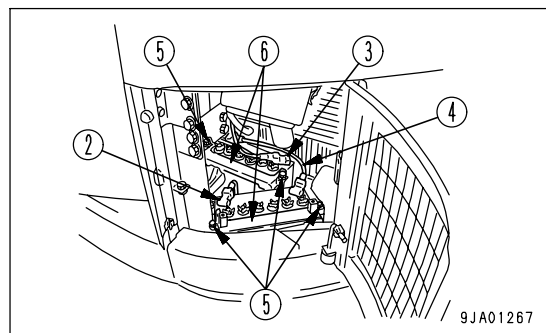

Installing of Battery

NOTICE

After securing the battery, check that it does not move. If it moves, tighten it again securely.

1. Place the battery in the specified position.
2. Secure the battery in position with mounting holder (6) and mounting bolts (5).
Tightening torque for mounting bolts: 9.8 to 14.7 N·m (1 to 1.5 kgf·m, 7.2 to 10.8 lbft)
3. Install cable (3) at the positive (+) terminal end.
4. Connect connection cable (4) from the (+) terminal.
5. Connect cable (2) to the negative (-) terminal end (ground).
6. Install rubber cover (1).

Battery Charges

When charging the battery, if the battery is not handled correctly, there is a hazard that the battery may explode. Always follow the instructions of "DISCHARGED BATTERY (PAGE 3-119)" and the instruction manual accompanying the charger, and do as follows.

- Set the voltage of the charger to match the voltage of the battery to be charged. If the correct voltage is not selected, the charger may overheat and cause an explosion.
- Connect the positive (+) charger clip of the charger to the positive (+) terminal of the battery, then connect the negative (-) charger clip of the charger to the negative (-) terminal of the battery. Be sure to attach the clips securely.
- Set the charging current to 1/10 of the value of the rated battery capacity; when carrying out rapid charging, set it to less than the rated battery capacity.
If the charger current is too high, the electrolyte will leak or dry up, and this may cause the battery to catch fire and explode.
- If the battery electrolyte is frozen, do not charge the battery or start the engine with a different power source. There is a danger that this will ignite the battery electrolyte and cause the battery to explode.
- Do not use or charge the battery if the battery electrolyte level is below the LOWER LEVEL line. This may cause an explosion. Check the battery electrolyte level periodically and add distilled water to bring the electrolyte level to the UPPER LEVEL line.

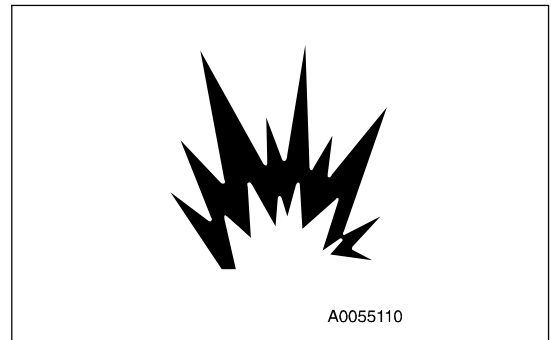

Starting Engine with Booster Cables

When starting the engine with a booster cable, do as follows:

Connecting and Disconnecting Booster Cables

WARNING

- When connecting the cables, never contact the positive (+) and negative (-) terminals.
- When starting the engine with a booster cable, always wear safety glasses.
- Be careful not to let the normal machine and problem machine contact each other. This prevents sparks from generating near the battery which could ignite the hydrogen gas given off by the battery. If hydrogen gas explodes, it could cause serious injury.
- Be careful not to make a mistake when connecting a booster cable. In the last connection (to the upper structure frame), a spark will be caused, connect the cable to a spot as far away from the battery as possible. (Avoid the work equipment, however, because it is not a good conductor)
- When removing the booster cable, exercise good care so that the booster cable clips may not contact each other, or they contact the chassis.

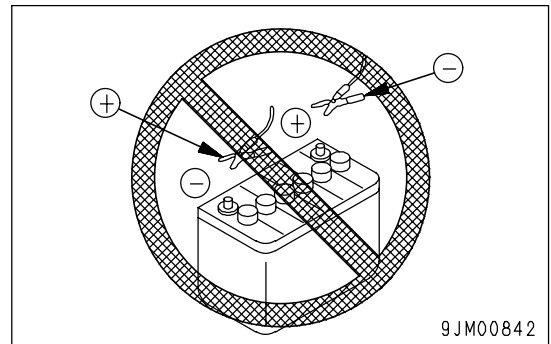

NOTICE

- The size of the booster cable and clip should be suitable for the battery size.
- The battery of the normal machine must be the same capacity as that of the engine to be started.
The starting system for this machine uses 24 V. For the normal machine, also use a 24 V battery.
- Check the cables and clips for damage or corrosion.
- Make sure that the cables and clips are firmly connected.
- Check that the lock levers of both machines are in the LOCK position.
- Check that each lever is in the NEUTRAL position.

Booster Cable Connection

Keep the starting switch of the normal machine and problem machine in the OFF position.

Connect the booster cable as follows, in the order of the numbers marked in the diagram.

1. Connect one clip of booster cable (A) to the positive (+) terminal of the problem machine.
2. Connect the other clip of booster cable (A) to the positive (+) terminal of the normal machine.
3. Connect one clip of booster cable (B) to the negative (-) terminal of the normal machine.
4. Connect the other clip of booster cable (B) to the upper structure frame of the problem machine.

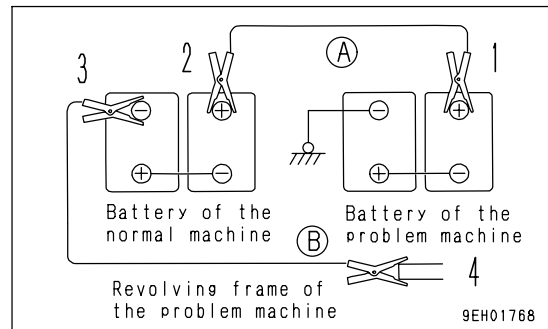
**Starting the Engine****CAUTION**

Always check that the lock lever is set to the LOCK position, regardless of whether the machine is working normally or has failed. Check also that all the control levers are at the HOLD or neutral position.

1. Make sure the clips are firmly connected to the battery terminals.
2. Start engine of the normal machine and run it at high idle speed.
3. Turn the starting switch of the problem machine to the START position and start the engine.
If the engine doesn't start at first, try again after 2 minutes or so.

Booster Cable Disconnection

After the engine has started, disconnect booster cables in the reverse order in which they were connected.

1. Remove one clip of booster cable (B) from the revolving frame of the problem machine.
2. Remove the other clip of booster cable (B) from the negative (-) terminal of the normal machine.
3. Remove one clip of booster cable (A) from the positive (+) terminal of the normal machine.
4. Remove the other clip of booster cable (A) from the positive (+) terminal of the problem machine.

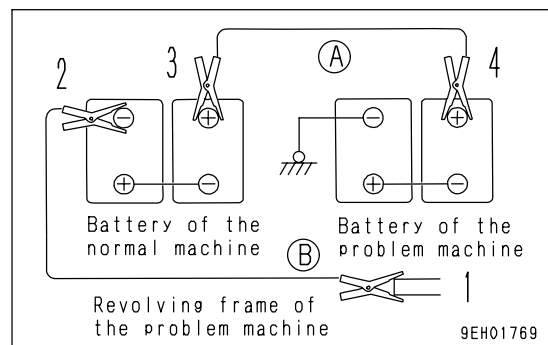

OTHER TROUBLE

Electrical System

- (): Always contact your Komatsu distributor when dealing with these items.
- In cases of problems or causes which are not listed below, contact your Komatsu distributor for repairs.

Problem	Main causes	Remedy
Lamp does not glow brightly even when the engine runs at high speed	• Defective wiring	(• Check, repair loose terminals, disconnections)
Lamp flickers while engine is running	• Defective adjustment of fan belt	(• Check, replace fan belt)
Charge level monitor does not go out even when engine is running	• Defective alternator	(• Replace)
Abnormal noise is generated from alternator	• Defective alternator	(• Replace)
Starting motor does not turn when starting switch is turned to ON	• Defective wiring • Defective starting motor	(• Check, repair) (• Replace)
Pinion of starting motor keeps going	• Insufficient battery charge	• Charge
Starting motor turns engine sluggishly	• Insufficient battery charge	• Charge
Starting motor disengages before engine starts	• Defective wiring Defective ring gear and pinion	(• Check, repair)
Pre-heating monitor does not light	• Defective wiring • Defective heater relay	(• Check, repair) (• Replace)
Oil pressure monitor does not light up when engine is stopped (starting switch at ON position)	• Defective monitor • Defective caution lamp switch	(• Replace) (• Replace)
When outside of electric heater is touched by hand, it is not warm	• Defective wiring • Disconnection in electric heater	(• Check, repair) (• Replace)

Chassis

- (): Always contact your Komatsu distributor when dealing with these items.
- In cases of problems or causes which are not listed below, contact your Komatsu distributor for repairs.

Problem	Main causes	Remedy
Speed of travel, swing, boom, arm and bucket is slow	<ul style="list-style-type: none"> • Lack of hydraulic oil 	<ul style="list-style-type: none"> • Adding oil to specified level,
Pump generates abnormal noise (Air sucked in)	<ul style="list-style-type: none"> • Hydraulic tank strainer element 	<ul style="list-style-type: none"> • Clean, see EVERY 2000
Excessive rise in hydraulic oil temperature	<ul style="list-style-type: none"> • Loose fan belt • Dirty oil cooler • Lack of hydraulic oil 	<ul style="list-style-type: none"> • Adjust fan belt tension, see EVERY 250 HOURS SERVICE • Clean. See EVERY 500 HOURS SERVICE • Add oil to specified level, see
Track comes off	<ul style="list-style-type: none"> • Track too loose 	<ul style="list-style-type: none"> • Adjusting track tension, see WHEN REQUIRED
Abnormal wear of sprocket		
Bucket rises slowly, dose not rise	<ul style="list-style-type: none"> • Lack of hydraulic oil 	<ul style="list-style-type: none"> • Adding oil to specified level,
Does not swing	<ul style="list-style-type: none"> • Forgotten to switch swing lock 	<ul style="list-style-type: none"> • Turn swing lock switch OFF

Engine

- (): Always contact your Komatsu distributor when dealing with these items.
- In cases of problems or causes which are not listed below, contact your Komatsu distributor for repairs.

Problem	Main causes	Remedy
Engine oil pressure monitor lights up	<ul style="list-style-type: none"> • Oil level low in oil pan (sucking air in) • Clogging oil filter cartridge • Defective tightening of oil pipe, pipe joint, oil leakage from damaged point • Defective engine oil pressure 	<ul style="list-style-type: none"> • Add oil to specified level, see CHECK BEFORE STARTING • Replace cartridge, see EVERY 500 HOURS SERVICE (• Check, repair) (• Replace sensor)
Steam spurts out from top of radiator (pressure valve)	<ul style="list-style-type: none"> • Coolant level low, leakage of water • Loose fan belt • Dirt scale accumulated in cooling system 	<ul style="list-style-type: none"> • Check, add coolant, repair, see CHECK BEFORE STARTING • Adjust fan belt tension, see EVERY 250 HOURS SERVICE • Change coolant, flush inside of cooling system, see WHEN REQUIRED
Red range of engine coolant temperature gauge lights up	<ul style="list-style-type: none"> • Clogging radiator fins or damages fins • Defective thermostat • Loose radiator filler cap (high altitude operations) 	<ul style="list-style-type: none"> • Clean or repair, see EVERY 500 HOURS SERVICE (• Replace thermostat) • Tightening cap or replace packing
Engine dose not start when starting motor is turned	<ul style="list-style-type: none"> • Lack of fuel • Air in fuel system • Defective fuel injection pump or defective nozzle • Starting motor cranks engine sluggishly • Pre-heating monitor dose not light up 	<ul style="list-style-type: none"> • Add fuel, see CHECK BEFORE STARTING • Repair place where air in sucked in, see EVERY 500 HOURS SERVICE (• Replace pump or nozzle) • See ELECTRICAL SYSTEM • See ELECTRICAL SYSTEM
Exhaust gas is white or blue	<ul style="list-style-type: none"> • Too mach oil in oil pan 	<ul style="list-style-type: none"> • Add oil to specified level, see CHECK BEFORE STARTING
Exhaust gas sometimes becomes black	<ul style="list-style-type: none"> • Clogging air cleaner element • Defective nozzle • Defective compression 	<ul style="list-style-type: none"> • Clean or replace, see WHEN REQUIRED (• Replace nozzle) (• See "Defective compression")
Combustion noise occasionally make breathing sound	<ul style="list-style-type: none"> • Defective nozzle 	<ul style="list-style-type: none"> (• Replace nozzle)

Problem	Main causes	Remedy
Abnormal noise generated (combustion or mechanical)	<ul style="list-style-type: none">• Low grade fuel being used• Overheating • Damage inside muffler	<ul style="list-style-type: none">• Change to specified fuel• See "Red range of engine coolant temperature gauge lights up"• Replace muffler
Engine stops while in work	<ul style="list-style-type: none">• Clogging feed pump pre-filter	<ul style="list-style-type: none">• Replace filter cartridge

Electronic Control System

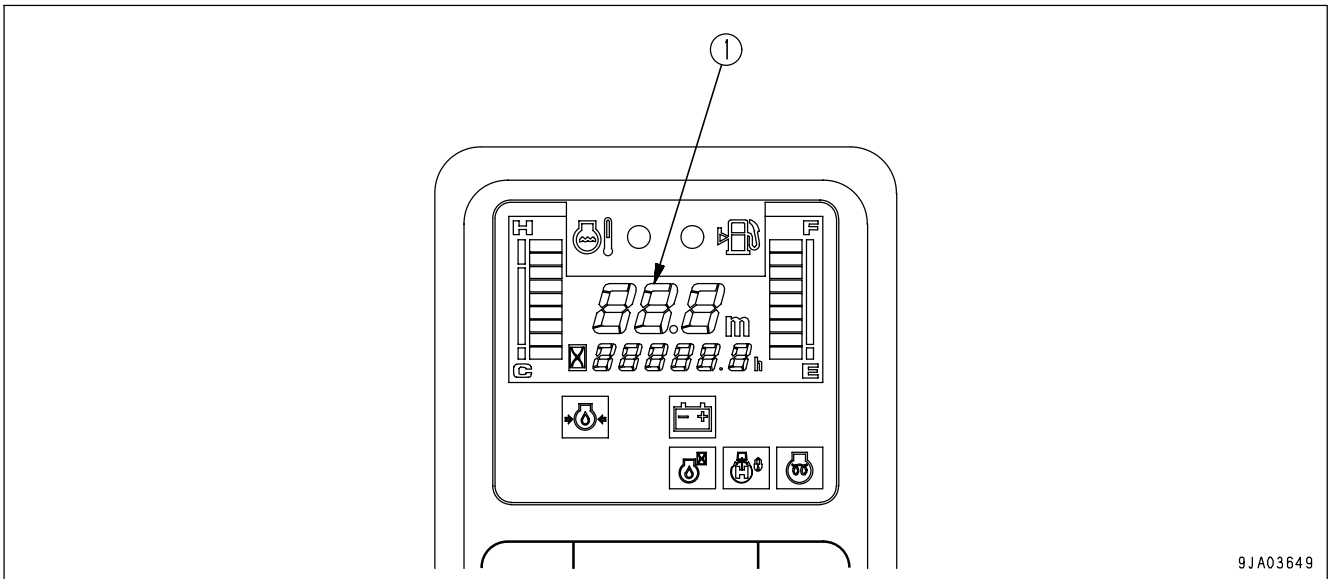

9J A03649

If an error code appears on machine monitor display (1) (normally displays TIME), follow the countermeasure table for the self-diagnosis as shown below.

Machine Monitoring System

Monitor display	Error mode	Countermeasure
E02	Pump control system error	If emergency pump drive switch is set to the ON position, operation can be carried out. However, immediately have the system inspected by your Komatsu distributor. (*)
E03	Swing brake system error	Turn the swing brake cancel switch ON to release the brake. Depending on the cause of the failure, it may be possible to release the brake. In any case, have the system inspected immediately by your Komatsu distributor. (*)
E05	Governor system error	Fuel adjusting dial is inoperative. Either or both of acceleration or deceleration cannot be operated, depending on a failure mode. In any case, call for inspection service immediately.
In the case where the monitor will not display error codes and work equipment operation and swing operation cannot be carried out.		Have the machine inspected immediately by your Komatsu distributor.

(*): For details of handling the emergency pump drive switch, swing holding brake cancel switch, and emergency work equipment actuation switch, see "SWITCHES (PAGE 3-16)".

MAINTENANCE

WARNING

Please read and make sure that you understand the SAFETY section before reading this section.

MAINTENANCE INFORMATION

Do not perform any inspection and maintenance operation that is not found in this manual.

Service Meter Reading

Check the service meter reading every day to see if the time has come for any necessary maintenance to be performed.

Komatsu Genuine Replacement Parts

Use Komatsu genuine parts specified in the Parts Book as replacement parts.

Komatsu Genuine Lubricants

Use Komatsu genuine oils and grease. Choose oils and grease with proper viscosities specified for ambient temperature.

Windshield Washer Fluid

Use automobile window washer fluid, and be careful not to let any dirt get into it.

Fresh and Clean Lubricants

Use clean oil and grease. Also, keep the containers of the oil and grease clean. Keep foreign materials away from oil and grease.

Check Drained Oil and Used Filter

After oil is changed or filters are replaced, check the old oil and filters for metal particles and foreign materials. If large quantity of metal particles or foreign materials are found, always report to the person in charge, and carry out suitable action.

Fuel Strainer

Do not remove the strainer from the filler port when adding fuel.

Welding Instructions

- Turn off the engine starting switch.
- Do not apply more than 200 V continuously.
- Connect grounding cable within 1 m (3.3 ft) of the area to be welded. If grounding cable is connected near instruments, connectors, etc., the instruments may malfunction.
- If a seal or bearing happens to come between the part being welded and grounding point, change the grounding point to avoid such parts.
- Do not use the area around the work equipment pins or the hydraulic cylinders as the grounding point.

Do not Drop Things Inside Machine

- When opening inspection windows or the oil filler port of the tank to carry out inspection, be careful not to drop nuts, bolts, or tools inside the machine.
If such things are dropped inside the machine, it may cause damage and/or malfunction of the machine, and will lead to failure. If you drop anything inside the machine, always remove it immediately.
- Do not put unnecessary things in your pockets. Carry only things which are necessary for inspection.

Dusty Jobsite

When working at dusty worksites, do as follows:

- Inspect the dust indicator frequently to see if the air cleaner is dirty or clogged.
- Clean the radiator core frequently to avoid clogging.
- Clean and replace the fuel filter frequently.
- Clean electrical components, especially the starting motor and alternator, to avoid accumulation of dust.
- When inspecting or changing the oil, move the machine to a place that is free of dust to prevent dirt from getting into the oil.

Avoid Mixing Lubricants

If a different brand or grade of oil has to be added, drain the old oil and replace all the oil with the new brand or grade of oil. Never mix different brand or grade of oil.

Locking the Inspection Covers

Lock inspection cover securely into position with the lock bar. If inspection or maintenance is performed with inspection cover not locked in position, there is a danger that it may be suddenly blow shut by the wind and cause injury to the worker.

Hydraulic System - Air Bleeding

When hydraulic equipment has been repaired or replaced, or the hydraulic piping has been removed and installed again, the air must be bled from the circuit. For details, see "BLEEDING AIR FROM HYDRAULIC SYSTEM (PAGE 4-40)".

Hydraulic Hose Installation

- When removing parts at locations where there are O-rings or gasket seals, clean the mounting surface, and replace with new parts.
When doing this, be careful not to forget to assemble the O-rings and gaskets.
- When installing the hoses, do not twist them or bend them sharply. If they are installed so, their service life will be shortened extremely and they may be damaged.

Checks After Inspection and Maintenance Works

If you forget to perform the checks after inspection and maintenance, unexpected problems may occur, and this may lead to serious injury or property damage. Always do the following:

- Checks after operation (with engine stopped)
 - Have any inspection and maintenance points been forgotten?
 - Have all inspection and maintenance items been performed correctly?
 - Have any tools or parts been dropped inside the machine? It is particularly dangerous if parts are dropped inside the machine and get caught in the lever linkage mechanism.
 - Are there any leakage of coolant or oil? Have all nuts and bolts been tightened?
- Checks when operating engine
 - For details of the checks when operating the engine, see "TWO WORKERS FOR MAINTENANCE WHEN ENGINE IS RUNNING (PAGE 2-34)" and pay careful attention to safety.
 - Are the inspection and maintenance items working properly?
 - Is there any leakage of fuel or oil when the engine speed is raised?

OUTLINE OF SERVICE

- Always use Komatsu genuine parts for replacement parts, grease or oil.
- When changing the oil or adding oil, do not mix different types of oil. When changing the type of oil, drain all the old oil and fill completely with the new oil. Always replace the filter at the same time. (There is no problem if the small amount of oil remaining in the piping mixes with the new oil.)
- Unless otherwise specified, when the machine is shipped from the factory, it is filled with the oil and coolant listed in the table below.

Item	Type
Engine oil pan	Engine oil EO15W40DH (Komatsu genuine parts)
Damper case	Powertrain oil TO30 (Komatsu genuine parts)
Swing machinery case	
Final drive case	
Hydraulic oil system	Powertrain oil TO10 (Komatsu genuine parts)
Radiator	Supercoolant AF-NAC (density: 30% or above) (Komatsu genuine parts)

HANDLING OIL, FUEL, COOLANT, AND PERFORMING OIL CLINIC

OIL

- Oil is used in the engine and hydraulic equipment under extremely severe conditions (high temperature, high pressure), and deteriorates with use.
Always use oil that matches the grade and maximum and minimum ambient temperatures recommended in the Operation and Maintenance Manual. Even if the oil is not dirty, always change the oil at the specified interval.
- Oil corresponds to blood in the human body, always be careful when handling it to prevent any impurities (water, metal particles, dirt, etc.) from getting in.
The majority of problems with the machine are caused by the entry of such impurities.
Take particular care not to let any impurities get in when storing or adding oil.
- Never mix oils of different grades or brands.
- Always add the specified amount of oil.
Having too much oil or too little oil are both causes of problems.
- If the oil in the work equipment is not clear, there is probably water or air getting into the circuit. In such cases, please contact your Komatsu distributor.
- When changing the oil, always replace the related filters at the same time.
- We recommend you have an analysis made of the oil periodically to check the condition of the machine. For those who wish to use this service, please contact your Komatsu distributor.
- When using commercially available oil, it may be necessary to reduce the oil change interval.
We recommend that you use the Komatsu oil clinic to carry out a detailed checks of the characteristics of the oil.

FUEL

- To prevent the moisture in the air from condensing and forming water inside the fuel tank, always fill the fuel tank after completing the day's work.
- The fuel pump is a precision instrument, and if fuel containing water or dirt is used, it cannot work properly.
- Be extremely careful not to let impurities get in when storing or adding fuel.
- Always use the fuel specified in the Operation and Maintenance Manual.
Fuel may congeal depending on the temperature when it is used (particularly in low temperature below -15°C (5 °F)). It is necessary to use the fuel that is suitable for the temperature.
- Before starting the engine, or when 10 minutes have passed after adding fuel, drain the sediment and water from the fuel tank.
- If the engine runs out of fuel, or if the filters have been replaced, it is necessary to bleed the air from the circuit.
- If there is any foreign material in the fuel tank, wash the tank and fuel system.

COOLANT AND WATER FOR DILUTION

- The coolant has the important function of preventing corrosion as well as preventing freezing.
Even in the areas where freezing is not an issue, the use of antifreeze coolant is essential.
Komatsu machines are supplied with Komatsu Supercoolant (AF-NAC). Komatsu Supercoolant (AF-NAC) has excellent anticorrosion, antifreeze and cooling properties and can be used continuously for 2 years or 4000 hours. Komatsu Supercoolant (AF-NAC) is strongly recommended wherever available.
- When diluting the antifreeze coolant, use distilled water or tap water (soft water).
Natural water, such as a river water or well water (hard water), contains large amounts of minerals (calcium, magnesium, etc.), and this makes it easier for scale to form inside the engine or radiator. Once scale is deposited inside the engine or radiator, it is extremely difficult to remove. It also causes overheating due to poor heat exchange, so when you dilute the coolant, we recommend that you use water with an overall hardness of less than 100 PPM.
- When using antifreeze, always observe the precautions given in the Operation and Maintenance Manual.
- Antifreeze coolant is flammable, so be sure to keep it away from flame.
- The ratio of Supercoolant (AF-NAC) to water differs according to the ambient temperature.
For details of the ratio when mixing, see "CLEAN INSIDE OF COOLING SYSTEM (PAGE 4-21)".
Supercoolant (AF-NAC) may be supplied in premix. In this case, never add diluting water.
- If the engine overheats, wait for the engine to cool before adding coolant.
- If the coolant level is low, it will cause overheating, and will also cause problems with corrosion due to air entering the coolant.

GREASE

- Grease is used to prevent seizure and noises at the joints.
- This construction equipment is used under heavy-duty conditions. Always use the recommended grease and follow the change intervals and recommended ambient temperatures given in this Operation and Maintenance Manual.
- The nipples not included in the maintenance section are nipples for overhaul, so they do not need grease.
If any part becomes stiff after being used for long time, add grease.
- Always wipe off all of the old grease that is pushed out when greasing.
Be particularly careful to wipe off the old grease in places where sand or dirt sticking in the grease would cause wear of the rotating parts.

CARRYING OUT KOWA (Komatsu Oil Wear Analysis)

KOWA is a maintenance service that makes it possible to prevent machine failures and downtime. With KOWA, the oil is periodically sampled and analyzed. This enables early detection of wear of the machine drive parts and other problems.

We strongly recommend you to use this service. The oil analysis is carried out at actual cost, so the cost is low, and the results of the analysis are reported together with recommendations which will reduce repair costs and machine downtime.

KOWA ANALYSIS ITEMS

- Measurement of density of metal wear particles
This uses an ICP (Inductively Coupled Plasma) analyzer to measure the density of iron, copper, and other metal wear particles in the oil.

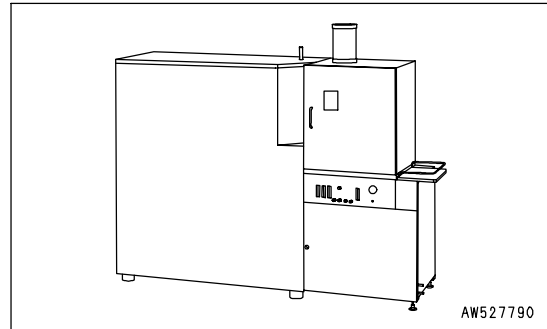

- Measurement of quantity of particles
This uses a particle quantifier index measurement machine to measure the quantity of iron particles of 5µ or more, enabling early detection of failures.

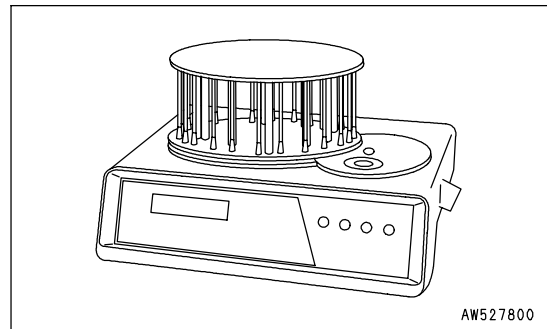

- Others
Measurements are made of items such as the ratio of water in the oil, density of the antifreeze coolant, ratio of fuel in the oil, and dynamic viscosity, enabling a highly precise diagnosis of the machine's health.

OIL SAMPLING

- Sampling interval
250 hours: Engine
500 hours: Other components
- Precautions when sampling
 - Make sure that the oil is well mixed before sampling.
 - Perform sampling at regular fixed intervals.
 - Do not perform sampling on rainy or windy days when water or dust can get into the oil.

For further details of KOWA, please contact your Komatsu distributor.

STORING OIL AND FUEL

- Keep indoors to prevent any water, dirt, or other impurities from getting in.
- When keeping drum cans for a long period, put the drum on its side so that the filler port of the drums is at the side to prevent moisture from being sucked in.
If drums have to be stored outside, cover them with a waterproof sheet or take other measures to protect them.
- To prevent any change in quality during long-term storage, be sure to use in the order of first in - first out (use the oldest oil or fuel first).

FILTERS

- Filters are extremely important safety parts. They prevent impurities in the fuel and air circuits from entering important equipment and causing problems.
Replace all filters periodically. For details, see the Operation and Maintenance Manual.
However, when working in severe conditions, replace the filters at shorter intervals according to the oil and fuel (sulfur content) being used.
- Never try to clean the filters (cartridge type) and use them again. Always replace with new filters.
- When replacing oil filters, check if any metal particles are attached to the old filter. If any metal particles are found, contact your Komatsu distributor.
- Do not open packs of spare filters until just before they are to be used.
- Always use Komatsu genuine filters.

ELECTRIC SYSTEM MAINTENANCE

- It is extremely dangerous if the electrical equipment becomes wet or the covering of the wiring is damaged. This will cause an electrical short circuit and may lead to malfunction of the machine. Do not wash the inside of the operator's cab with water. When washing the machine, be careful not to let water get into the electrical components.
- Service relating to the electric system is checking fan belt tension, checking damage or wear to the fan belt and checking battery fluid level.
- Never install any electric components other than those specified by Komatsu.
- External electro-magnetic interference may cause malfunction of the control system controller, before installing a radio receiver or other wireless equipment, contact your Komatsu distributor.
- When working at the seashore, carefully clean the electric system to prevent corrosion.
- When installing electrical equipment, connect it to the special power source connector.
Do not connect the optional power source to the fuse, starting switch, or battery relay.

WEAR PARTS

Replace filter elements, bucket teeth, and other wear parts at the specified interval or before they reach the wear limit.

Replacing wear parts correctly ensures more economical use of the machine.

When replacing parts, always use high-quality Komatsu genuine parts.

When ordering parts, the parts differ according to the serial number of the machine, so please inform your Komatsu distributor of the machine serial number.

WEAR PARTS LIST

The parts in parentheses are to be replaced at the same time.

Item	Part No.	Part Name	Q'ty	Replacement frequency
Engine oil filter	600-211-2110	Cartridge	1	EVERY 500 HOURS SERVICE
Fuel filter	600-311-7460	Cartridge	1	
Hydraulic tank breather	20Y-60-21470	Element	1	
Hydraulic oil filter	14X-60-31150 (07000-12135)	Element (O-ring)	1 (1)	EVERY 1000 HOURS SERVICE
Air cleaner	600-185-2100	Element assembly	1	-
Electric heater	6204-11-4850	Gasket	2	-
Bucket	205-70-74272 (205-70-74281) (205-70-74291)	Vertical pin type (Pin) (Lock)	4 (4) (4)	-
	205-70-19570 (09244-02496)	Horizontal pin type (Pin)	4 (4)	
	202-70-63161 202-70-63171 (208-32-11231) (01803-02228)	Side cutter (Left) Side cutter (Right) (Bolt) (Nut)	1 1 (8) (8)	
Reinforced blade (if equipped)	12F-70-31281	Edge (center portion)	1	-
	21Y-71-11221 (02090-11060) (02290-11016)	Edge (left, right) (Bolt) (Nut)	2 (24) (24)	

RECOMMENDED FUEL, COOLANT, AND LUBRICANT

- Komatsu genuine oils are adjusted to maintain the reliability and durability of Komatsu construction equipment and components.

In order to keep your machine in the best conditioner for long periods of time, it is essential to follow the instructions in this Operation and Maintenance Manual.

- Failure to follow these recommendations may result in shortened life or excess wear of the engine, power train, cooling system, and/or other components.
- Commercially available lubricant additives may be good for the machine, but they may also cause harm. Komatsu does not recommend any commercially available lubricant additive.
- Use the oil recommended according to the ambient temperature in the chart below.
- Specified capacity means the total amount of oil including the oil in the tank and the piping. Refill capacity means the amount of oil needed to refill the system during inspection and maintenance.
- When starting the engine in temperatures below 0°C (32°F), be sure to use the recommended multi-grade oil, even if the ambient temperature may become higher during the course of the day.
- If the machine is operated at a temperature below -20°C (-4°F), a separate device is needed, so consult your Komatsu distributor.
- When the fuel sulfur content is less than 0.5%, change the engine oil according to the period inspection table given in this Operation and Maintenance Manual.

If the fuel sulfur content is more than 0.5%, change the oil according to the following table.

Fuel sulfur content	Engine oil change interval
0.5 to 1.0%	1/2 of regular interval
Above 1.0%	1/4 of regular interval

USE OF FUEL, COOLANT AND LUBRICANTS ACCORDING TO AMBIENT TEMPERATURE

Reservoir	Fluid Type	Ambient Temperature, degrees Celsius									Recommended Komatsu Fluids
		-22 -30	-4 -20	14 -10	32 0	50 10	68 20	86 30	104 40	122°F 50°C	
Engine oil pan	Engine oil	SAE10W30									Komatsu EO10W30DH API CH-4 API CI-4
		SAE15W40									Komatsu EO15W40DH API CH-4 API CI-4
		SAE30DH									Komatsu EO30DH
Swing machinery case Final drive case PTO gear case or Damper case	Power train oil (Note.1)	TO30									TO30
Hydraulic System	Power train oil	TO10									TO10
	Hydraulic oil	HO46-HM									HO46-HM
	Engine oil	SAE10W30DH									Komatsu EO10W30DH
		SAE15W40DH									Komatsu EO15W40DH
Grease fitting	Hyperwhite grease (Note.2)	G2-T									G2-T
	Lithium EP grease	G2-LI									G2-LI
Cooling system	Supercoolant AF-NAC	AF-NAC (Note.3)									AF-NAC
Fuel tank	Diesel fuel	No.2-D									ASTM No.2-D
		No.1-D									ASTM No.1-D

- SAE: Society of Automotive Engineers
- ASTM: American Society of Testing and Material
- API: American Petroleum Institute

		Engine oil pan	Swing machinery case	Final drive case (each)	PTO gear case	Hydraulic system	Cooling system	Fuel tank
Specified capacity	Liters	11.5	2.5	2.5	0.75	120	14.2	195
	US gal	3.04	0.66	0.66	0.20	31.68	3.75	51.48
Refill capacity	Liters	11	2.5	2.5	0.75	69	-	-
	US gal	2.91	0.66	0.66	0.20	18.22	-	-

Note .1: Power train oil has different properties from engine oil. Be sure to use the recommended oil.

Note .2: Hyper white grease (G2-T) has a high performance.

When it is necessary to improve the lubricating ability of the grease in order to prevent squeaking of pins and bushings, the use of G2-T is recommended.

Note. 3: Supercoolant (AF-NAC)

1) The coolant has the important function of preventing corrosion as well as preventing freezing.

Even in the areas where freezing is not an issue, the use of antifreeze coolant is essential.

Komatsu machines are supplied with Komatsu Supercoolant (AF-NAC). Komatsu Supercoolant (AF-NAC) has excellent anticorrosion, antifreeze and cooling properties and can be used continuously for 2 years or 4000 hours. Komatsu Supercoolant (AF-NAC) is strongly recommended wherever available.

2) For details of the ratio when diluting super coolant with water, see "CLEAN INSIDE OF COOLING SYSTEM (PAGE 4-21)".

When the machine is shipped from the factory, it may be filled with coolant containing 30% or more Supercoolant (AF-NAC). In this case, no adjustment is needed for temperatures down to -10°C (14°F). (never dilute with water)

3) To maintain the anticorrosion properties of Supercoolant (AF-NAC), always keep the density of Supercoolant between 30% and 68%.

RECOMMENDED BRANDS, RECOMMENDED QUALITY FOR PRODUCTS OTHER THAN KOMATSU GENUINE OIL

When using commercially available oils other than Komatsu genuine oil, or when checking the latest specifications, refer to the Komatsu web page or consult your Komatsu distributor.

TIGHTENING TORQUE SPECIFICATIONS

TIGHTENING TORQUE LIST



If nuts, bolts, or other parts are not tightened to the specified torque, it will cause looseness or damage to the tightened parts, and this will cause failure of the machine or problems with operation.

Always pay careful attention when tightening parts.

Unless otherwise specified, tighten the metric nuts and bolts to the torque shown in the table below. If it is necessary to replace any nut or bolt, always use a Komatsu genuine part of the same size as the part that was replaced.

Thread diameter of bolt (a)(mm)	Width across flats (b)(mm)	Tightening torque					
		Target value			Service limit		
		N·m	kgf·m	lbft	N·m	kgf·m	lbft
6	10	13.2	1.35	9.8	11.8-14.7	1.2-1.5	8.7-10.8
8	13	31	3.2	23.1	27-34	2.8-3.5	20.3-25.3
10	17	66	6.7	48.5	59-74	6.0-7.5	43.4-54.2
12	19	113	11.5	83.2	98-123	10.0-12.5	72.3-90.4
14	22	172	17.5	126.6	153-190	15.5-19.5	112.1-141
16	24	260	26.5	191.7	235-285	23.5-29.5	170.0-213.4
18	27	360	37	267.6	320-400	33.0-41.0	238.7-296.6
20	30	510	52.3	378.3	455-565	46.5-58.0	336.3-419.5
22	32	688	70.3	508.5	610-765	62.5-78.0	452.1-564.2
24	36	883	90	651	785-980	80.0-100.0	578.6-723.3
27	41	1295	132.5	958.4	1150-1440	118.0-147.0	853.5-1063.3
30	46	1720	175.0	1265.8	1520-1910	155.0-195.0	1121.1-1410.4
33	50	2210	225.0	1627.4	1960-2450	200.0-250.0	1446.6-1808.3
36	55	2750	280.0	2025.2	2450-3040	250.0-310.0	1808.3-2242.2
39	60	3280	335.0	2423.1	2890-3630	295.0-370.0	2133.7-2676.2

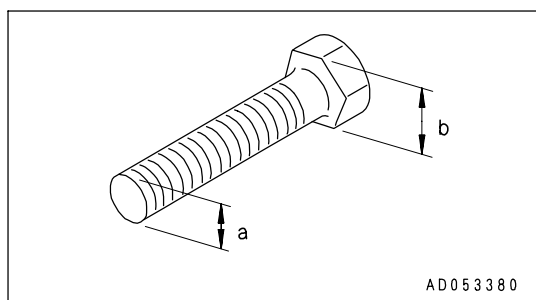

Apply the following table for Hydraulic Hose.

Nominal- No. of threads (a)	Width across flats (b) mm	Tightening torque (N·m (kgf·m, lbft))	
		Target valve	Permissible range
9/16 -18UNF	19	44 (4.5, 32.5)	34 - 54 (3.5 - 5.5, 25.3 - 39.8)
11/16 -16UN	22	74 (7.5, 54.2)	54 - 93 (5.5 - 9.5, 39.8 - 68.7)
13/16 -16UN	27	103 (10.5, 75.9)	84 - 132 (8.5 - 13.5, 61.5 - 97.6)
1 -14UNS	32	157 (16.0, 115.7)	128 - 186 (13.0 - 19.0, 94.0 - 137.4)
1-3/16 -12UN	36	216 (22.0, 159.1)	177 - 245 (18.0 - 25.0, 130.2 - 180.8)

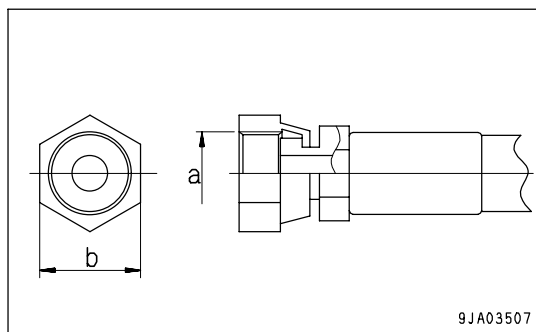

SAFETY CRITICAL PARTS

For using the machine safely for an extended period of time, you are required to periodically replace the safety (critical and fire prevention) related parts listed in the table of important parts on the following page.

Material quality of these parts can change as time passes and they are likely to wear out or deteriorate. However, it is difficult to determine the extent of wear or deterioration at the time of periodic maintenance. Hence, it is required to replace them with new ones regardless of their condition after a certain period of usage. This is important to ensure that these parts maintain their full performance at all times.

Furthermore, should anything abnormal be found on any of these parts, replace it with a new one even if the periodic replacement time for the part has not yet arrived.

If any of the hose clamps show deterioration like deformation or cracking, replace the clamps at the same time as the hoses.

Also perform the following checks with hydraulic hoses which need to be replaced periodically. Tighten all loose clamps and replace defective hoses, as required.

When replacing hoses, always replace O-rings, gaskets, and other such parts at the same time.

Have your Komatsu distributor replace the critical parts.

SAFETY CRITICAL PARTS LIST

No.	Safety critical parts for periodic replacment	Q'ty	Replacement interval
1	Fuel hose (fuel tank - injection pump)	2	Every 2 years or 4000 hours, whenever comes sooner
2	Spill hose (nozzle - fuel tank)	1	
3	Turbocharger lubricating hose	1	
4	Engine oil filter hose (engine - oil filter)	2	
5	Pump outlet hose (pump - control valve delivery hose)	1	
6	Pump outlet hose (pump - control valve PP hose)	1	
7	Pump outlet hose (pump - control valve LS hose)	1	
8	Work equipment hose (boom cylinder inlet port)	4	
9	Work equipment hose (bucket cylinder line - boom foot)	2	
10	Work equipment hose (bucket cylinder inlet port)	2	
11	Work equipment hose (arm cylinder line - boom foot)	2	
12	Work equipment hose (arm cylinder inlet port)	2	
13	Attachment additional line hose (boom foot)	2	
14	Attachment additional line hose (boom top)	2	
15	Swing line hose (swing motor inlet port)	2	
16	Main suction hose	1	
17	Air conditioner heater hose	2	
18	Seat belt	1	Every 3 years

MAINTENANCE SCHEDULE

If the machine is equipped with a hydraulic breaker, the maintenance schedule for some parts will be different. For details, see "MAINTENANCE INTERVAL FOR HYDRAULIC BREAKER (PAGE 4-15)" to confirm the correct maintenance schedule when carrying out maintenance.

MAINTENANCE SCHEDULE CHART

INITIAL 250 HOURS MAINTENANCE (ONLY AFTER THE FIRST 250 HOURS)

REPLACE FUEL FILTER CARTRIDGE ----- 4- 54

WHEN REQUIRED

CHECK, CLEAN AND REPLACE AIR CLEANER ELEMENT ----- 4- 17

CLEAN INSIDE OF COOLING SYSTEM ----- 4- 21

CHECK AND TIGHTEN TRACK SHOE BOLTS ----- 4- 24

CHECK AND ADJUST TRACK TENSION ----- 4- 25

CHECK ROAD LINERS ----- 4- 27

REPLACE ROAD LINERS ----- 4- 27

CHECK ELECTRICAL INTAKE AIR HEATER ----- 4- 27

REPLACE BUCKET TEETH (VERTICAL PIN TYPE) ----- 4- 28

REPLACE BUCKET TEETH (HORIZONTAL PIN TYPE) ----- 4- 31

ADJUST BUCKET CLEARANCE ----- 4- 32

CHECK WINDOW WASHER FLUID LEVEL, ADD FLUID ----- 4- 33

CHECK AND MAINTENANCE AIR CONDITIONER ----- 4- 34

CHECK, CLEAN AND LUBRICATE CAB SLIDE DOOR RAIL AND ROLLER ----- 4- 35

REPLACE BREAKER CIRCUIT ADDITIONAL OIL FILTER ELEMENT (IF EQUIPPED) ----- 4- 36

WASH WASHABLE FLOOR ----- 4- 37

BLEEDING AIR FROM HYDRAULIC SYSTEM ----- 4- 40

CHECKS BEFORE STARTING

EVERY 50 HOURS MAINTENANCE

DRAIN WATER FROM FUEL TANK ----- 4- 43

EVERY 100 HOURS MAINTENANCE

LUBRICATING ----- 4- 44

CHECK SWING MACHINERY CASE OIL, ADD OIL ----- 4- 45

EVERY 250 HOURS MAINTENANCE

CHECK OIL LEVEL IN FINAL DRIVE CASE, ADD OIL ----- 4- 46

CHECK LEVEL OF BATTERY ELECTROLYTE ----- 4- 47

CHECK AND ADJUST COOLING FAN BELT TENSION ----- 4- 49

CHECK AIR CONDITIONER COMPRESSOR BELT TENSION, ADJUST ----- 4- 50

EVERY 500 HOURS MAINTENANCE

LUBRICATING ----- 4- 51

CHANGE OIL IN ENGINE OIL PAN, REPLACE ENGINE OIL FILTER CARTRIDGE ----- 4- 53

REPLACE FUEL FILTER CARTRIDGE ----- 4- 54

CHECK SWING PINION GREASE LEVEL, ADD GREASE ----- 4- 55

LUBRICATE SWING CIRCLE ----- 4- 55

CLEAN, CHECK RADIATOR FINS, AIR COOLER FINS, OIL COOLER FINS, CONDENSER FINS ----- 4- 55

CLEAN AIR CONDITIONER FRESH/RECIRC FILTERS ----- 4- 56
 REPLACE BREATHER ELEMENT IN HYDRAULIC TANK ----- 4- 58

EVERY 1000 HOURS MAINTENANCE

CHANGE OIL IN SWING MACHINERY CASE ----- 4- 59
 CHANGE OIL IN FINAL DRIVE CASE ----- 4- 60
 REPLACE HYDRAULIC OIL FILTER ELEMENT ----- 4- 61
 CHECK ALL TIGHTENING PARTS OF TURBOCHARGER ----- 4- 61
 CHECK PLAY TURBOCHARGER ROTOR ----- 4- 61

EVERY 2000 HOURS MAINTENANCE

CHECK PTO GEAR CASE, ADD OIL ----- 4- 62
 CLEAN HYDRAULIC TANK STRAINER ----- 4- 63
 CLEAN, CHECK TURBOCHARGER ----- 4- 63
 CHECK ALTERNATOR, STARTING MOTOR ----- 4- 63
 CHECK ENGINE VALVE CLEARANCE, ADJUST ----- 4- 63
 CHECKING CHARGE PRESSURE OF NITROGEN GAS IN ACCUMULATOR (FOR CONTROL CIRCUIT) ----- 4- 64

EVERY 4000 HOURS MAINTENANCE

CHECK WATER PUMP ----- 4- 68
 REPLACE ACCUMULATOR (FOR CONTROL CIRCUIT) ----- 4- 68

EVERY 5000 HOURS MAINTENANCE

CHANGE OIL IN HYDRAULIC TANK ----- 4- 69

MAINTENANCE INTERVAL FOR HYDRAULIC BREAKER

For machine equipped with a hydraulic breaker, the hydraulic oil deteriorates faster than for normal bucket digging operations, so set the maintenance intervals as follows.

• **Replace hydraulic filter element**

On a new machine, replace the element after the first 100 to 150 hours, then carry out further replacement of the element according to the table on the right.

• **Change oil in hydraulic tank**

Change the oil according to the table on the right.

• **Replacing additional filter element for breaker (if equipped)**

Use a guideline of 250 hours for use of the breaker (operating ratio for the breaker: 50 % or more), and replace the element according to the table on the right.

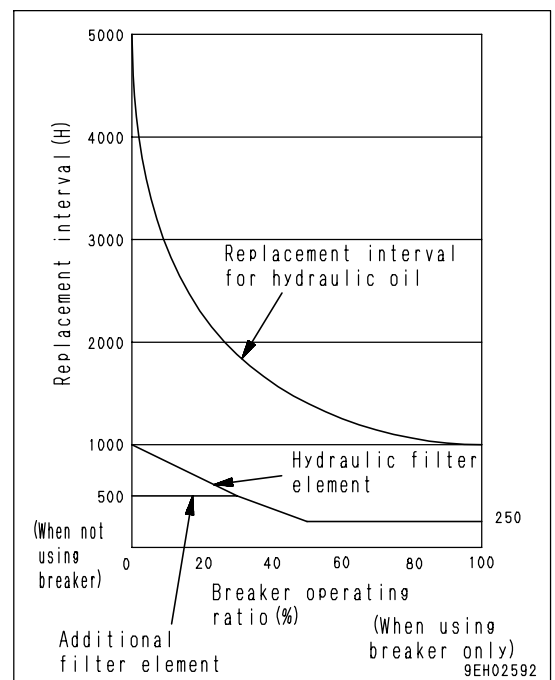

MAINTENANCE PROCEDURE

INITIAL 250 HOURS MAINTENANCE (ONLY AFTER THE FIRST 250 HOURS)

Carry out the following maintenance only after the first 250 hours of operation on new machines.

- Replace fuel filter cartridge

For details of the method of replacing or maintaining, see the section on EVERY 500 HOURS SERVICE.

WHEN REQUIRED

CHECK, CLEAN AND REPLACE AIR CLEANER ELEMENT



WARNING

- If inspection, cleaning, or maintenance is carried out with the engine running, dirt will get into the engine and damage it. Always stop the engine before carrying out these operations.
- When using compressed air, there is danger that dirt may be blown around and cause serious injury. Always use protective glasses, dust mask, and other protective equipment.

Checking

Open the rear cover of cab and check dust indicator (1). If a red piston shows in the transparent window, clean the air cleaner element.

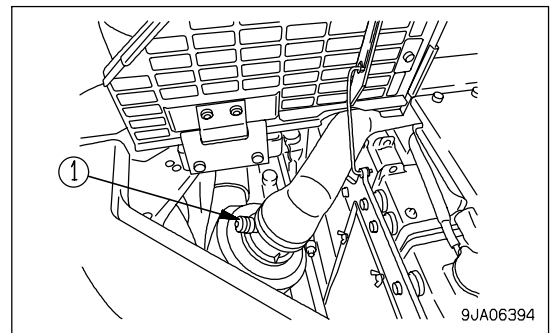

NOTICE

Do not clean the air cleaner element before the red piston in dust indicator (1) appears.

If the air cleaner element is cleaned frequently before the red piston in the dust indicator appears, the air cleaner cannot provide the proper performance and the cleaning efficiency is lowered.

Cleaning Outer Element

1. Open the battery room door on the left side of the machine, remove clips (2) at 3 places, then take out cover (3).

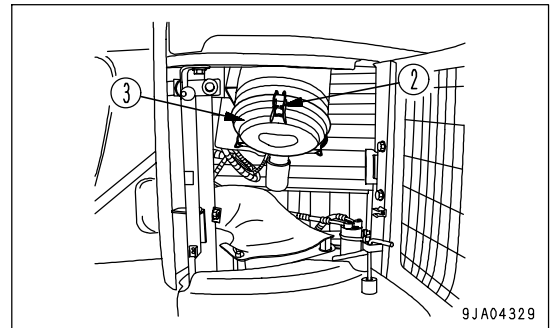

NOTICE

Never remove inner element (5). If it is removed, dust will enter and cause engine trouble.

2. Remove outer element (4).

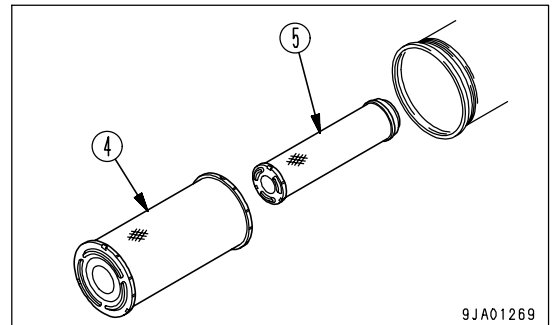

NOTICE

When cleaning cover (3), do not remove evacuator valve (6).

3. Clean the inside of the air cleaner body and the cover (3).

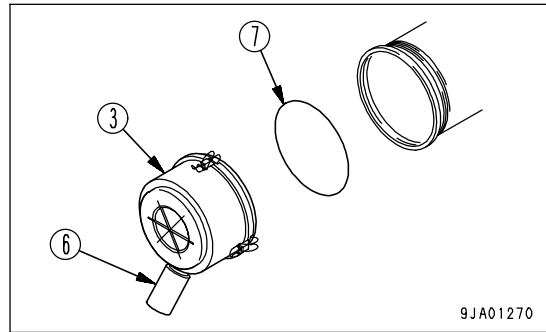

NOTICE

The inner element must not be used again even after cleaning. When replacing the outer element, replace the inner element at the same time.

4. Direct dry compressed air (Max. 0.69 MPa (7 kgf/cm², 99.4 PSI)) from the inside of the outer element along its folds. Then direct the compressed air from the outside along the folds, and again from the inside.

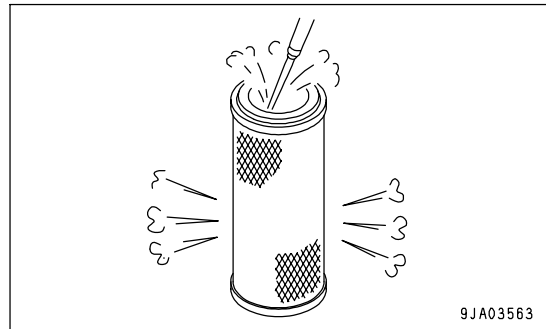

- 1) Replace any outer element which has been cleaned 6 times or used for 1 year. Replace the inner element at the same time.
- 2) Replace both inner and outer elements when the dust indicator red piston appears soon after installing the cleaned outer element even though it has not been cleaned 6 times.
- 3) Remove one seal from the element whenever the element has been cleaned.

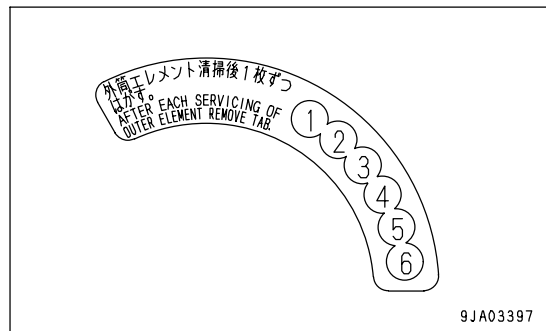

5. If small holes or thinner parts are found on the element when it is checked by shining a light through it after cleaning, replace the element.

NOTICE

When cleaning the element, do not hit it or beat it against something. Do not use an element whose folds or gasket or seal are damaged. Wrap unused element and store them in a dry place.

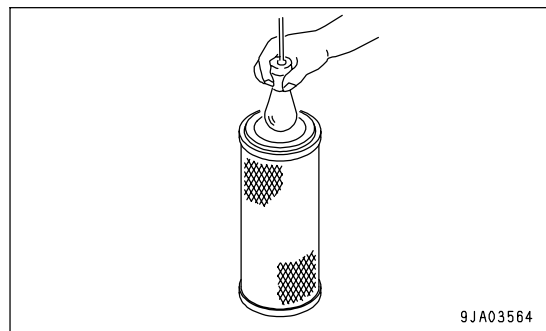

CAUTION

When installing the cover (3), check O-ring (7) and replace it if there are any scratches or damage.

6. Set the cleaned outer element in position, then secure cover (3) with mounting clips (2).

7. Press the button of dust indicator (1) to return the red piston to its original position.

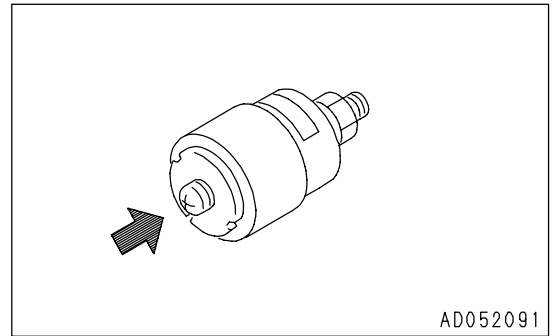

Replacing Element

1. Open the battery room door on the left side of the machine, remove clips (2) at 3 places, then take out cover (3).

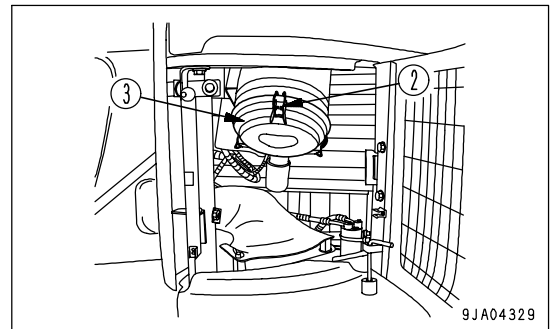

2. Remove outer element (4).
Do not remove inner element (5) at this time, however.

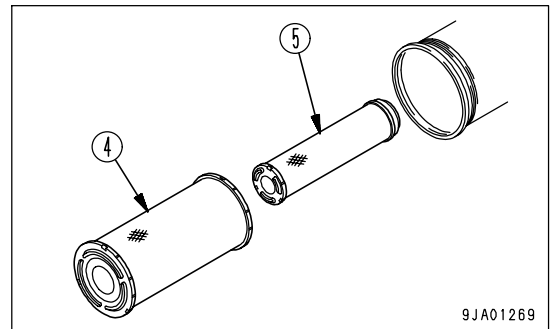

NOTICE

When cleaning cover (3), do not remove evacuator valve (6).

3. Clean the inside of the air cleaner body and the cover (3).

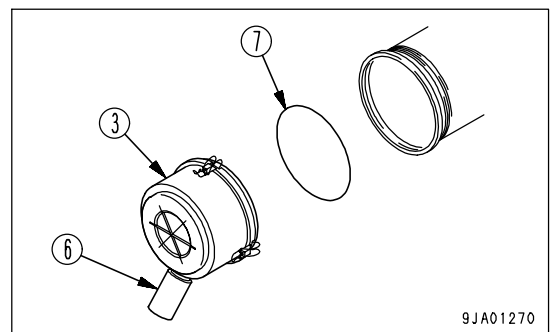

4. Remove inner element (5), then install a new inner element immediately.

 **CAUTION**

When installing the cover (3), check O-ring (7) and replace it if there are any scratches or damage.

5. Set the cleaned outer element in position, then secure cover (3) with mounting clips (2).

6. Replace the seal attached to cover (3) with new one.

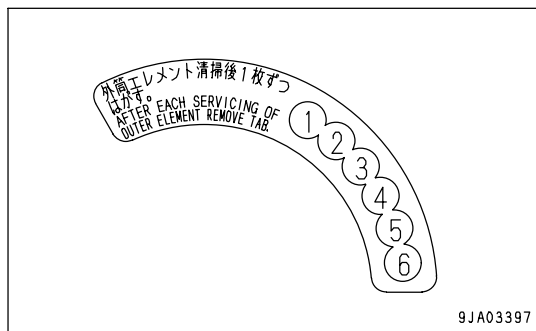

7. Return the red piston in the dust indicator (1) to its original position.

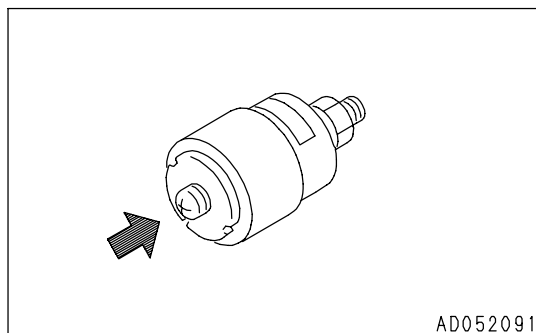

CLEAN INSIDE OF COOLING SYSTEM

 **WARNING**

- Immediately after the engine is stopped, the coolant is at a high temperature and the radiator is under high internal pressure. If the cap is removed to drain the coolant in this condition, there is a hazard of burns. Wait for the temperature to go down, then turn the cap slowly to release the pressure before removing it.
- Cleaning is carried out with the engine running. When standing up or leaving the operator's seat, set the lock lever to the LOCK position.
- For details of starting the engine, see "BEFORE STARTING ENGINE (PAGE 3-52)" and "STARTING ENGINE (PAGE 3-68)" in the OPERATION section.
- The engine is operated when washing, so it is dangerous if the machine moves when you are standing behind it. Never stand behind the machine when the engine is running.

Clean the inside of the cooling system, change the coolant according to the table below.

Antifreeze coolant	Interval of cleaning inside of cooling system and changing antifreeze coolant
Komatsu supercoolant (AF-NAC)	Every two years or every 4000 hours whichever comes first
Permanent type antifreeze (All-season type, *)	Every year (autumn) or every 2000 hours whichever comes first

*: Permanent type antifreeze shall meet the requirements of ASTM D3306-03.

Stop the machine on level ground when cleaning or changing the coolant.

The coolant has the important function of preventing corrosion as well as preventing freezing.

Even in the areas where freezing is not an issue, the use of antifreeze coolant is essential.

Komatsu machines are supplied with Komatsu Supercoolant (AF-NAC). Komatsu Supercoolant (AF-NAC) has excellent anticorrosion, antifreeze and cooling properties and can be used continuously for 2 years or 4000 hours. Komatsu Supercoolant (AF-NAC) is strongly recommended wherever available.

To maintain the anticorrosion properties of Supercoolant (AF-NAC), always keep the density of Supercoolant between 30% and 68%.

When deciding the ratio of antifreeze to water, check the lowest temperature in the past, and decide from the mixing table given below.

It is actually better to estimate and temperature about 10°C (18°F) lower when deciding the mixing ratio.

The mixing ratio depends on the ambient temperature, but it should always be a minimum of 30% by volume (antifreeze/total amount of coolant x 100).

The freezing temperature of undiluted antifreeze is -15°C (5°F). Do not store undiluted antifreeze at a temperature of below -15°C (5°F).

Mixing rate of water and antifreeze

Min. atmospheric temperature	°C	Above -10	-15	-20	-25	-30
	°F	Above 14	5	-4	-13	-22
Amount of antifreeze	Liters	4.3	5.0	5.7	6.4	7.1
	US gal	1.14	1.32	1.51	1.69	1.88
Amount of water	Liters	9.9	9.2	8.5	7.8	7.1
	US gal	2.61	2.43	2.24	2.06	1.87
Volume ratio	%	30	36	41	46	50

! WARNING

Antifreeze is flammable, so keep it away from flame.

Antifreeze is toxic. When removing the drain plug, be careful not to get water containing antifreeze on you. If it gets in your eyes, flush your eyes with large amount of fresh water and see a doctor at once.

Use antifreeze and appropriate water for diluting. (for details, see "COOLANT AND WATER FOR DILUTION (PAGE 4-5)")

We recommend use of an antifreeze density gauge to control the mixing proportions.

Prepare a container whose capacity is larger than the specified coolant volume to catch drained coolant.

Prepare a hose to supply antifreeze coolant and water.

1. Stop the engine.
2. Remove undercover (1) and cover (2) between the hydraulic tank and operator's cab, then put a container in position to catch the coolant.

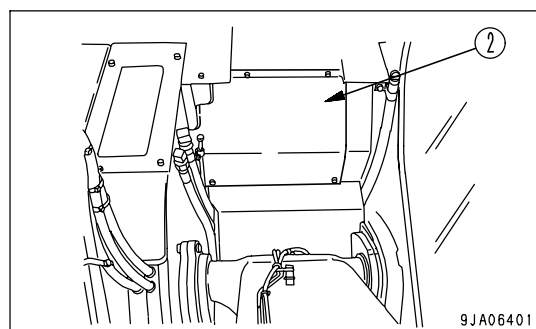
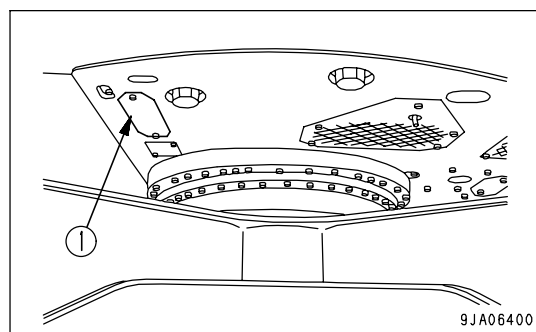

3. Check that the cooling water temperature has gone down enough to make it possible to touch the radiator cap surface by hand, then turn radiator cap (3) slowly until it contacts the stopper to release the pressure.
4. Following this, push radiator cap (3), turn it until it contacts the stopper, then remove it.
5. Open drain valve (4) at the bottom of the radiator and drain the water.
Remove drain plug (5) in the cylinder block and drain the water.
6. After draining the water, close drain valve (4) and tighten drain plug (5), then fill with city water.
7. When the radiator is full, start the engine, and run it at low idle. Keep the engine running at low idle for 10 minutes until the water temperature reaches more than 90°C (194°F).
8. Stop the engine, then open drain valve (4) and remove drain plug (5) to drain the water.

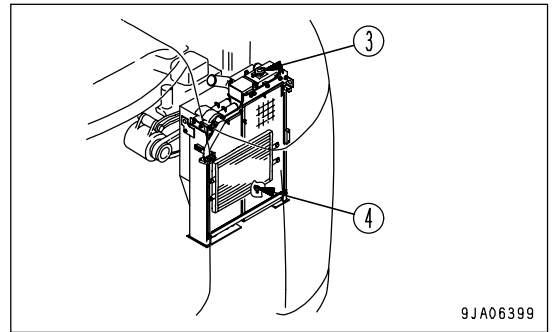

9JA06399

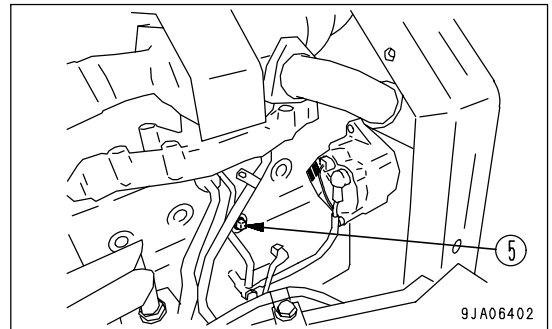

9JA06402

9. Close drain valve (4). Wind seal tapes onto drain plug (5), then tighten it.
10. Install covers (1) and (2).
11. Add coolant mixed with antifreeze until it overflows from the water filler.
Decide the proportions of antifreeze and water according to the table for the mixing rate of water and antifreeze.
12. To bleed the air from the cooling system, run the engine at low idle for 5 minutes, and for a further 5 minutes at high idle. (When doing this, leave the radiator cap off.)
13. Drain the coolant inside sub-tank (6), clean the inside of the sub-tank, then fill again with coolant to a point midway between the FULL and LOW marks.
14. Stop the engine, wait for approx. 3 minutes, then add coolant until the coolant level is near the coolant filler port, and tighten the cap. Check the coolant level and add coolant if necessary.

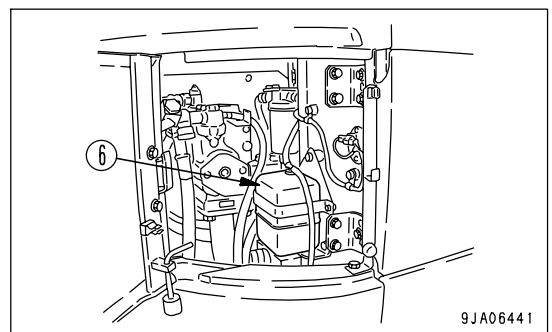

9JA06441

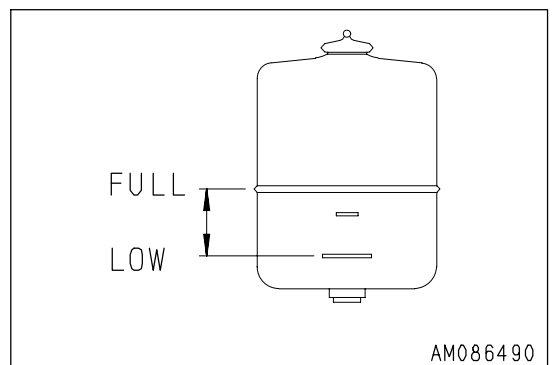

AM086490

CHECK AND TIGHTEN TRACK SHOE BOLTS

If the machine is used with track shoe bolts (1) loose, they will break, so tighten any loose bolts immediately.

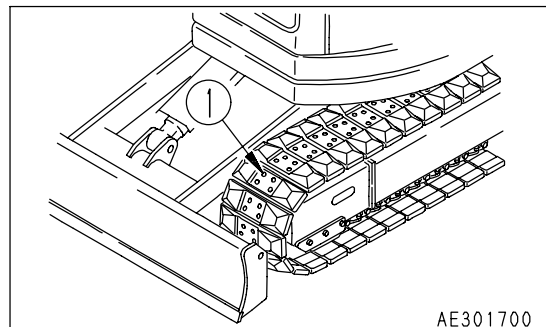
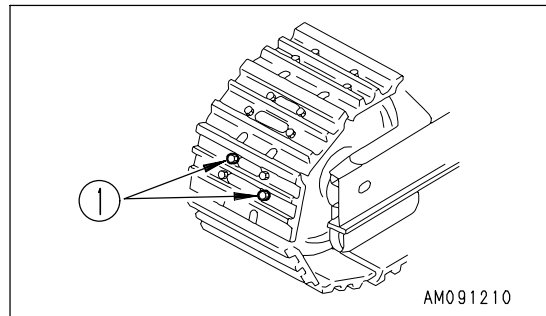

Tightening

1. First tighten to a tightening torque of $196 \pm 19.6 \text{ N}\cdot\text{m}$ ($20 \pm 2 \text{ kgf}\cdot\text{m}$, $144.7 \pm 14.5 \text{ lbf}\cdot\text{ft}$) then check that the nut and shoe are in close contact with the link contact surface.
2. After checking, tighten the angle of the shoe bolts a further $90^\circ \pm 10^\circ$ for steel shoes ($120^\circ \pm 10^\circ$ for swamp shoes) and $60^\circ \pm 10^\circ$ for road liners.

Order for Tightening

Tighten the bolts in the order shown in the diagram on the right. After tightening, check that the nut and shoe are in close contact with the link mating surface.

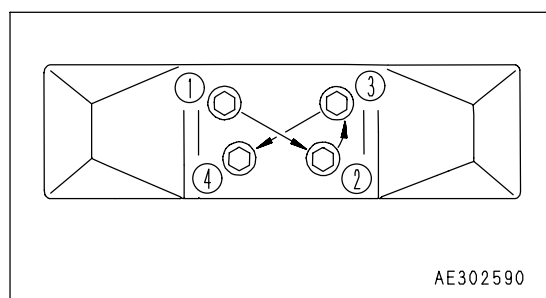
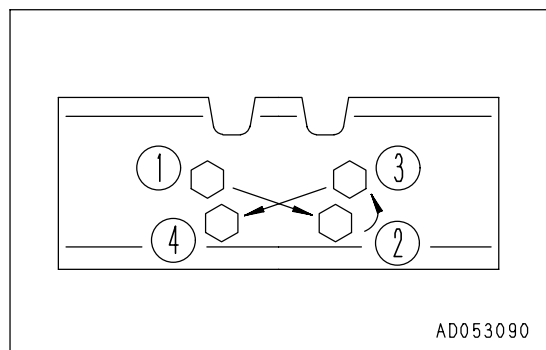

CHECK AND ADJUST TRACK TENSION

The wear of the pins and bushings on the undercarriage will vary with the working conditions and type of soil, so inspect the track tension frequently in order to maintain the standard tension.

Stop the machine on firm, horizontal ground when carrying out the inspection and maintenance.

Checking

1. Run the engine at low idle, move the machine forward a distance equal to the length of track on ground, then stop the machine.
2. Choose wooden block (3) that will reach from idler (1) to carrier roller (2), then place it on top of the track.
3. Measure the maximum deflection between the top surface of the track and the bottom surface of the wooden block.
 - Standard deflection
Deflection "a" should be 10 to 30 mm (0.4 to 1.2 in).

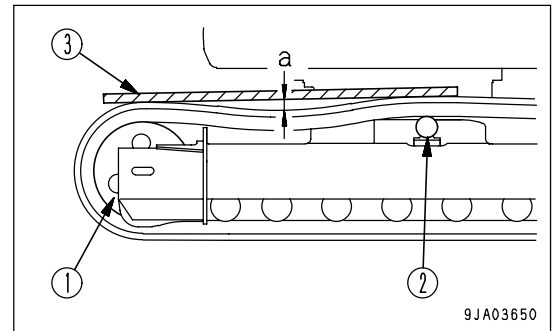

If the track tension is not at the standard value, adjust it in the following manner.

Adjustment

WARNING

There is danger of plug (1) flying out under the high internal pressure of the grease. Never loosen plug (1) more than 1 turn. Never loosen any part other than plug (1). Never put your face in the mounting direction of plug (1). If the track tension cannot be loosened with the procedure given here, please contact your Komatsu distributor.

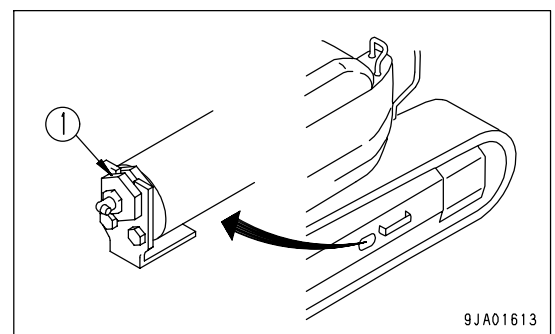

Increasing Track Tension

Prepare a grease pump.

1. Pump in grease through grease fitting (2) with a grease pump.
2. To check that the track tension is correct, run the engine at low idle, move the machine forward a distance equal to the length of track on ground, then stop the machine.
3. Check the track tension again, and if the tension is not correct, adjust it again.

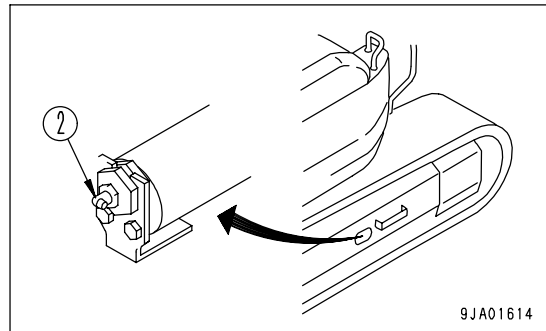

4. Continue to pump in grease until dimension (S) becomes zero (0). If the tension is still loose, the pin and bushing are excessively worn, so they must be either turned or replaced. Please contact your Komatsu distributor for repairs.

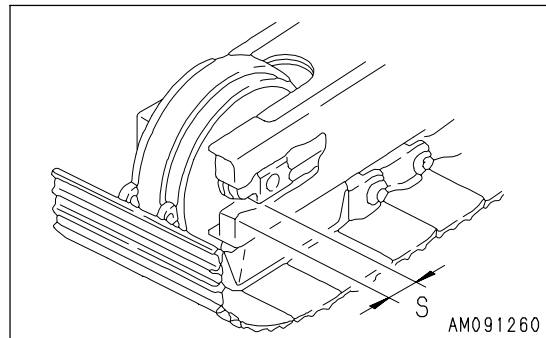

Loosening Track Tension



WARNING

It is extremely dangerous to release the grease by any method except the procedure given below.
If track tension is not relieved by this procedure, contact your Komatsu distributor for repairs.

1. Loosen plug (1) gradually to release the grease.
2. When loosening plug (1), turn it a maximum of one turn.
3. If the grease does not come out smoothly, move the machine forwards and backwards a short distance.
4. Tighten plug (1).
5. To check that the track tension is correct, run the engine at low idle, move the machine forward a distance equal to the length of track on ground, then stop the machine.
6. Check the track tension again, and if the tension is not correct, adjust it again.

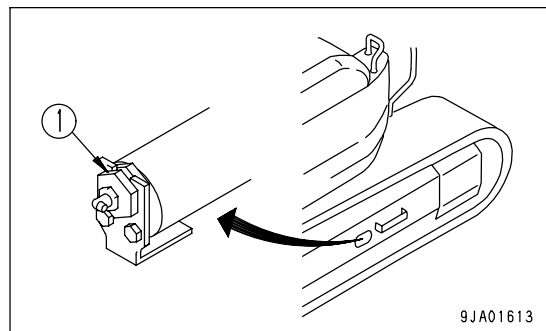

CHECK ROAD LINERS

(Machine equipped with road liner)

If the road liners are in the following condition, they must be repaired or replaced, so please contact your Komatsu distributor for repairs or replacement.

Lug Height

If lug height "a" is reduced by wear, the drawbar pull will drop.

If "a" is less than 5 mm (0.2 in), replace with a new part.

When making judgement whether to replace, repair, or continue using road liner, please contact your Komatsu distributor.

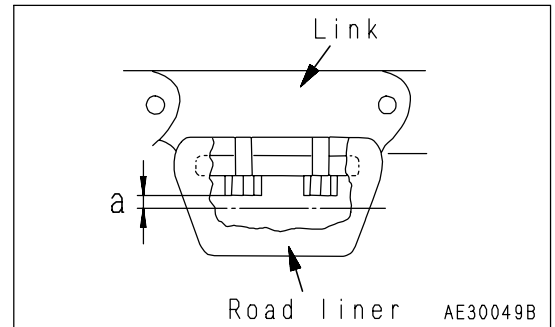

REPLACE ROAD LINERS

(Machine equipped with road liner)

- When replacing all the road liner for the machine, please contact your Komatsu distributor to have the replacement carried out.
- When replacing only part of the road liner, use the special road liner removal tool. Please order the tool from your Komatsu distributor.

CHECK ELECTRICAL INTAKE AIR HEATER

Before the start of the cold season (once a year), contact your Komatsu distributor to have the electrical intake air heater checked for dirt or disconnections.

REPLACE BUCKET TEETH (VERTICAL PIN TYPE)

WARNING

- It is dangerous if the work equipment moves by mistake when the teeth are being replaced.
Set the work equipment in a stable condition, then stop the engine and set the lock lever securely to the LOCK position.
- The pins can be knocked out only with strong force, so there is a hazard that the pin may fly out. Check that there is no one in the surrounding area.
- There is a hazard that fragments will fly during the replacement work, so always wear protective equipment like safety glasses and gloves.

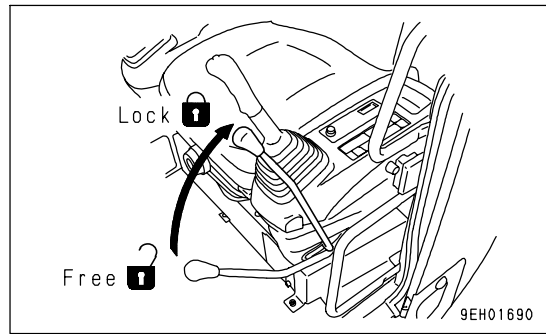

Replace the bucket teeth before the adapter starts to wear.

1. To make it possible to knock out the pin of tooth (1), set the bottom surface of the bucket on a block, check that the work equipment is in a stable condition, then set the lock lever to the LOCK position.
Set so that the bottom face of the bucket is horizontal.

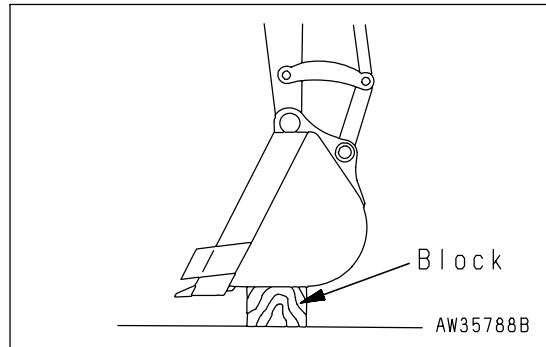

2. Use a hammer and drift to knock out lock pin (2). (If the drift is set against rubber pin lock (3) when it is hit, the rubber pin lock may break. Set it against the back of the pin.)
3. After removing lock pin (2) and rubber pin lock (3), check them.

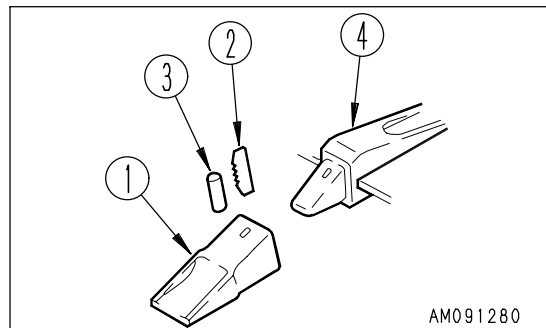

If lock pins (2) and rubber pin locks (3) with the following defects are used, the teeth may come off the bucket. Replace them with new ones.

- The lock pin is too short.

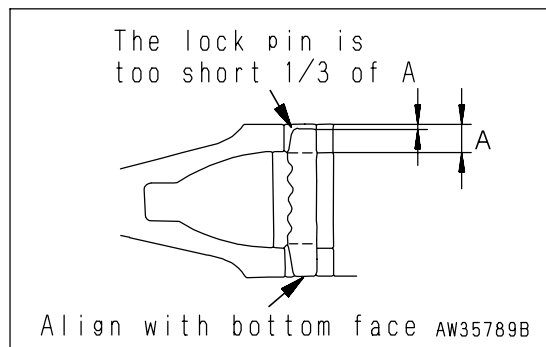

- The rubber of the rubber pin lock is torn, and the steel balls may come out.

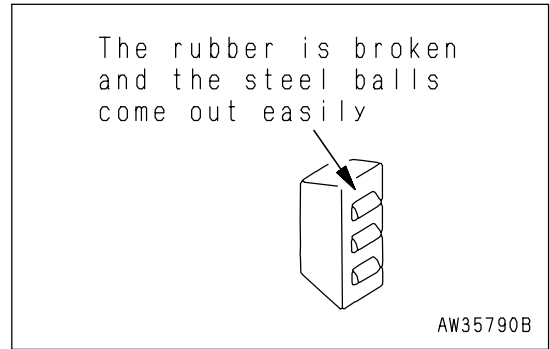

- The steel balls are buried when they are pressed by hand.

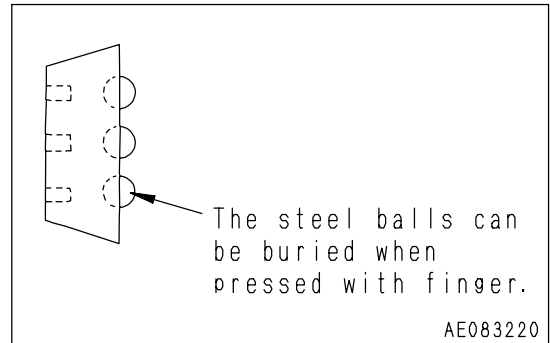

4. Clean the surface of adapter (4) and remove the soil with a knife.

5. Use your hand or a hammer to push rubber pin lock (3) into the hole of the adapter.

When doing this, be careful that the rubber pin lock (3) does not fly out from the adapter surface.

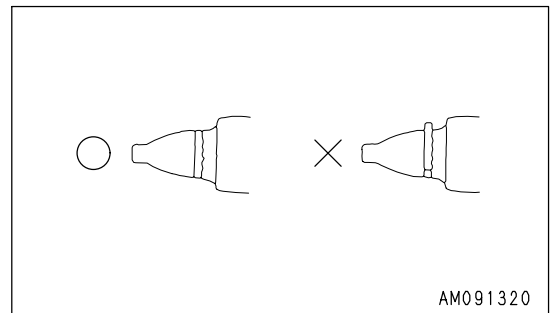

6. Clean the inside of teeth (1), then install it to adapter (4). If there is mud affixed to it or if there are protrusions, the teeth (1) will not enter the adapter properly, and there will not be proper contact at the mating portion.

7. Fit tooth (1) to adapter (4), and confirm that when the pointer is pressed strongly, the rear face of the hole for the pin of the teeth (1) is at the same level as the rear face of the hole for the pin of the adapter (4).

If the rear face of the hole for the pin of teeth (1) is protruding to the front from the rear face of the pin hole for adapter (4), do not try to knock the pin in.

There is something preventing teeth (1) from entering adapter (4) fully, so remove the obstruction. When teeth (1) enters adapter (4) fully, knock in lock pin (2).

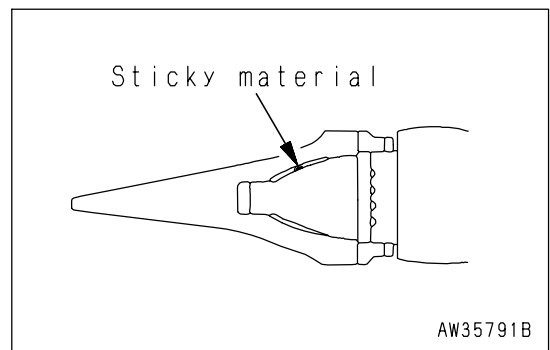

8. Insert lock pin (2) in the hole of the teeth (1) and hit it until its top is the same level as the surface of teeth (1).
9. After replacing a bucket tooth, always check the following.
 - 1) After the lock pin (2) has been knocked in completely, check that it is secured by the teeth (1) and surface.
 - 2) Lightly hit lock pin (2) in the reverse direction from which it was hit in.
 - 3) Lightly hit the tip of the teeth (1) from above and below, and hit its sides from right and left.
 - 4) Confirm that rubber pin lock (3) and lock pin (2) are set as shown in the figure.

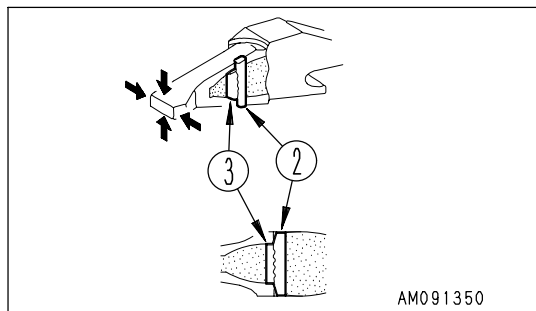
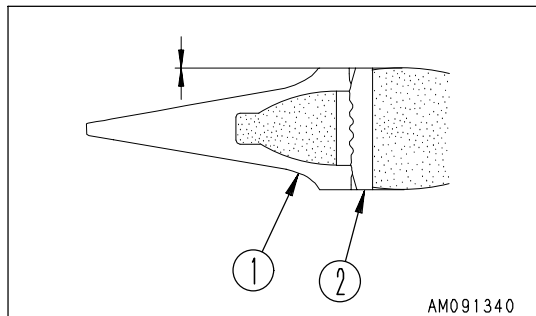

The life of the teeth can be lengthened and the frequency of its replacement can be reduced by turning it upside down so that it will wear evenly.

Replace the rubber pin lock and locking pin at the same time as replacing the teeth. This makes it possible to prevent the teeth from falling out.

REPLACE BUCKET TEETH (HORIZONTAL PIN TYPE)

WARNING

- It is dangerous if the work equipment moves by mistake when the teeth are being replaced.
Set the work equipment in a stable condition, then stop the engine and set the lock lever securely to the LOCK position.
- The pins can be knocked out only with strong force, so there is a hazard that the pin may fly out. Check that there is no one in the surrounding area.
- There is a hazard that fragments will fly during the replacement work, so always wear protective equipment like safety glasses and gloves.

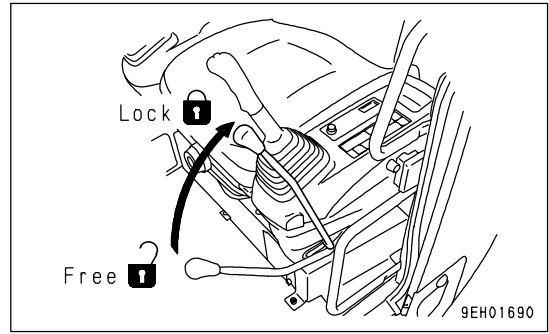

Replace the bucket teeth before the adapter starts to wear.

1. In order to enable tooth pin (1) to be pulled out, put a block under the bucket bottom and make sure that the work equipment rests on it securely. Then move the lock lever to the LOCK position. In that case ensure that the bucket is level on the block.

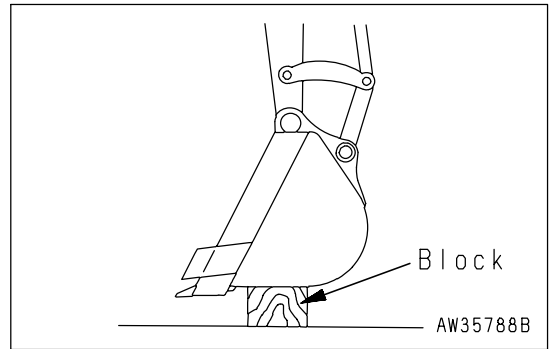

2. Place a bar on the head of pin (1), hit the bar with a hammer to knock out the pin, then remove tooth (2).

REMARK

- If the bucket teeth cannot be safely removed by this method, have your Komatsu distributor replace the bucket teeth.

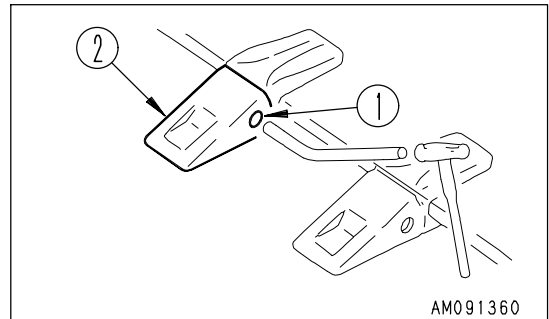

3. Clean the mounting face. Fit a new tooth (2) in the adapter, push in pin (1) partially by hand, then lock it with a hammer to install the tooth to the bucket.

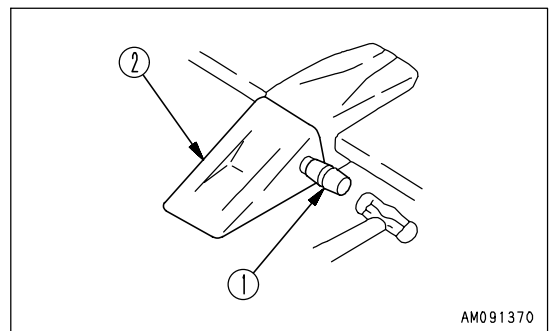

ADJUST BUCKET CLEARANCE

WARNING

It is dangerous if the work equipment moves by mistake while the bucket clearance is being adjusted.

Set the work equipment on the ground in a stable condition, then stop the engine and lock the lock lever without fail.

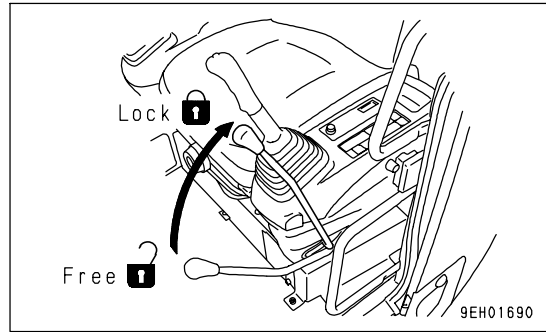

1. Set the work equipment in the position shown in the diagram on the right, then stop the engine and set the lock lever to the LOCK position (L).

2. Shift O-ring (1) of the linkage and measure the amount of clearance "a".

Measurement is easier if you move the bucket to one side (right side of the diagram) or the other so all the clearance can be measured in one place.

Use a gap (clearance) gauge for easy and accurate measurement.

3. Loosen 4 plate mounting bolts (2), and loosen plate (3).

The shim is a split type, so the operation can be carried out without removing the bolts.

4. Remove shim (4) corresponding to the amount of clearance "a" measured above.

[Example]

In the case of clearance of 3 mm (0.118 in), remove two 1.0 mm (0.039 in) shims and one 0.5 mm (0.020 in) shim. Play becomes 0.5 mm (0.020 in). For shim (4), two types of 1.0 mm (0.039 in) and 0.5 mm (0.020 in) are used.

When clearance a is smaller than one shim, do not carry out any maintenance.

5. Tighten the four bolts (2).

If the bolts (2) are too stiff to tighten, pull out pin stopper bolt (5) for easier tightening.

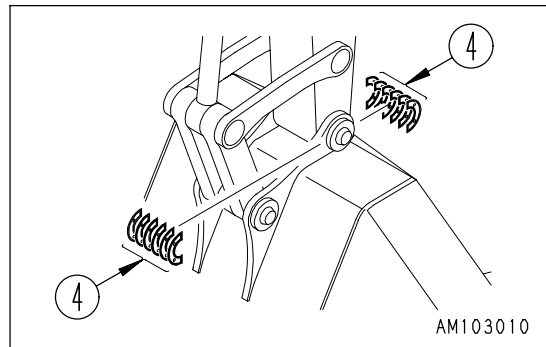
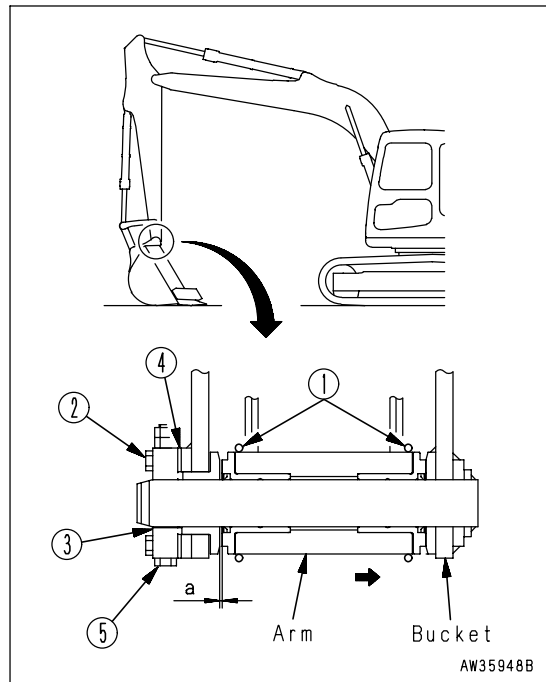

CHECK WINDOW WASHER FLUID LEVEL, ADD FLUID

If there is air in the window washer fluid, check the level of the fluid in window washer tank (1). Add automobile window washer fluid if necessary.

When adding fluid, be careful not to let any dust get in.

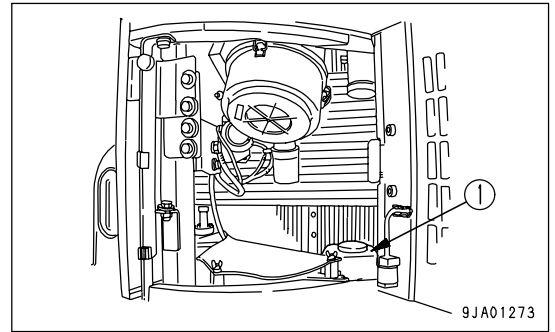

Mixture Ratio of Pure Washer Fluid and Water

The proportion differs according to the ambient temperature, so dilute the washer fluid with water to the following proportions before adding.

Area, season	Proportions	Freezing temperature
Normal	Washer fluid 1/3: water 2/3	-10°C (14°F)
Winter in cold area	Washer fluid 1/2 : water 1/2	-20°C (-4°F)
Winter in extremely cold area	Pure washer fluid	-30°C (-22°F)

There are two types depending on the freezing temperature:

-10°C (14°F) (general use) and -30°C (-22°F) (cold area use), select according to the area and season.

CHECK AND MAINTENANCE AIR CONDITIONER

Check Level of Refrigerant (gas)



WARNING

If the refrigerant used in the air conditioner gets into your eyes or on your hands, it may cause loss of sight or frostbite. Do not touch the refrigerant. Never loosen any part of the refrigerant circuit.

Do not bring any flame close to any point where the refrigerant gas is leaking.

If there is a lack of refrigerant (Freon 134a), the cooling performance will be poor.

When operating the cooler at high speed, there should be no bubbles in the sight glass (inspection window) mounted on the condenser unit receiver.

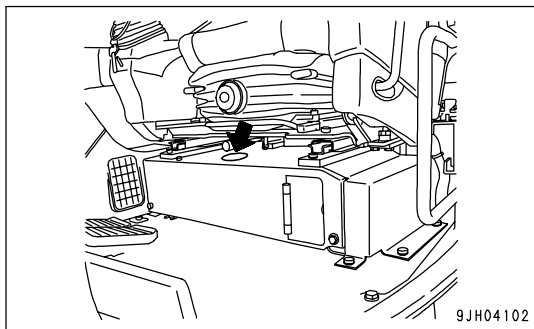

9JH04102

- No bubbles in refrigerant flow: Suitable
- Some bubbles in flow
(bubbles pass continuously): Lack of refrigerant
- Colorless, transparent: No refrigerant

REMARK

When there are bubbles, the refrigerant gas level is low, so contact your Komatsu distributors to have refrigerant added. If the air conditioner is run with the refrigerant gas level low, it will cause damage to the compressor.

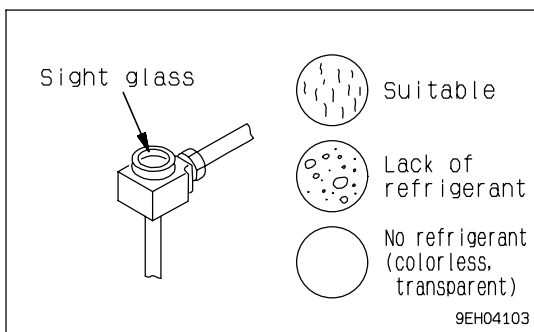

9EH04103

Inspection During Off Season

Even during the off-season, operate the air conditioner for 3 to 5 minutes once a month to maintain the oil film at all parts of the compressor.

Inspection and Maintenance Items

Check, maintenance items	Content of check, maintenance	Guideline for maintenance interval
Refrigerant (gas)	Charge amount	Twice a year (spring, autumn)
Air conditioner condenser	Clogged fins	Every 500 hours
Compressor	Operating condition	Every 4000 hours
V-belt	Damage, tension	Every 250 hours
Blower motor, fan	Operating condition (does it make abnormal noise?)	When required
Control mechanism	Operating condition (does it function normally?)	When required
Piping mounts	Mounting condition, looseness at tightening or connecting portions, leakage of gas, damage	When required

CHECK, CLEAN AND LUBRICATE CAB SLIDE DOOR RAIL AND ROLLER

Checking

When opening or closing the slide door, it may sometimes not slide smoothly due to mud stuck to the rail. In that case clean and lubricate slide door rail (1) and roller (2) at three points.

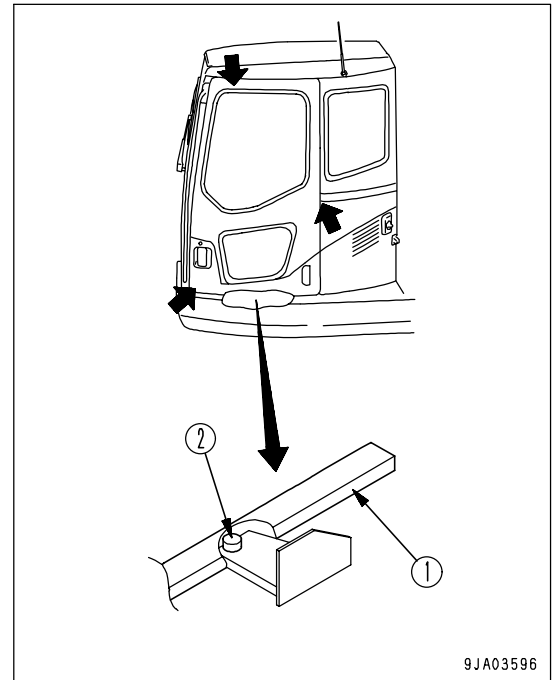

Cleaning

1. Open and close the door, and use a brush to remove any dirt from rail (1).
2. Use a cloth to wipe off any dirt from rail (1).

Greasing

NOTICE

Do not use high-viscosity oil for the lubricant. Use grease only.

1. Spray rail (1) and roller (2) thoroughly with lubricant.
2. After spraying with lubricant, slide the door and check that the door opens and closes smoothly.
If the movement is not smooth, contact your Komatsu distributor for repair.

REPLACE BREAKER CIRCUIT ADDITIONAL OIL FILTER ELEMENT

(If equipped)

WARNING

- After the engine is stopped, the parts and oil are at high temperature, so there is danger of burns. Wait for the temperature to go down before starting the operation.
- When removing the cap from oil filler port (F), turn it slowly to release the internal pressure, then remove it carefully.

NOTICE

For details of the replacement interval for the element, "MAINTENANCE INTERVAL FOR HYDRAULIC BREAKER (PAGE 4-15)".

- Prepare a container to catch the oil.
 1. Place a container under the filter element to catch the oil.
 2. Turn filter case (1) to the left to remove it, then take out element (2).
 3. Remove plug (3) from filter case (1).
 4. Clean the parts that were removed and install new element (2).
 5. When installing filter case (1) and plug (3), tighten to the tightening torque given below.

Tightening torque

Case (1): 58.8 to 78.5 N·m (6 to 8 kgf·m, 43.4 to 57.9 lbft)

Plug (3): 39.2 to 49.0 N·m (4 to 5 kgf·m, 28.9 to 36.2 lbft)

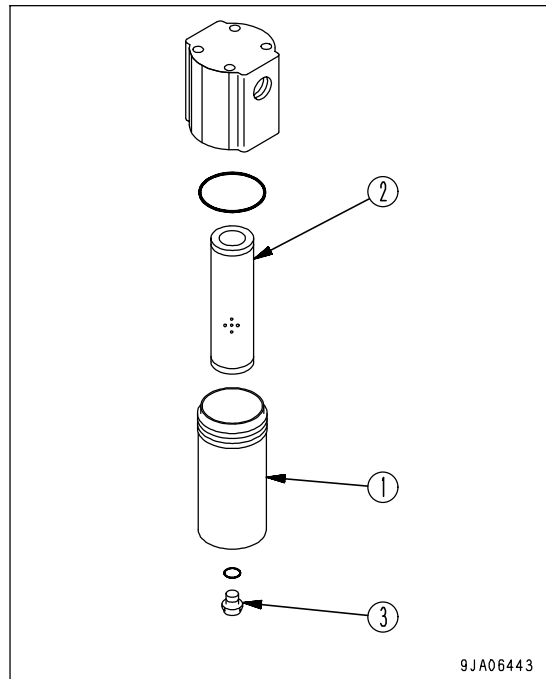
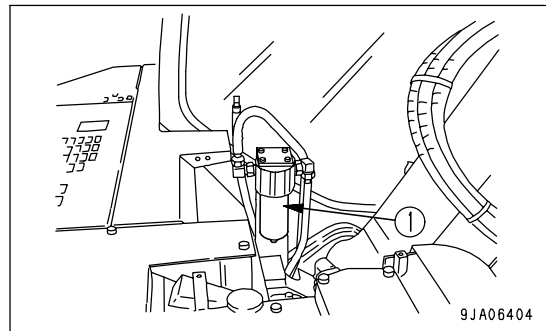

WASH WASHABLE FLOOR

With the washable floor, it is possible to flush out the dirt on the cab floor directly with water.

! WARNING

- When setting the machine at an angle, use strong blocks to stabilize the machine and be extremely careful when carrying out the operation.
- If the control levers are touched by mistake, the machine may suddenly move, and this may lead to a serious accident. Always set the lock lever securely to the LOCK position before standing up from the operator's seat.

NOTICE

While cleaning the cab floor, take care so that the connector, air conditioner main body and filters may not be splashed with water.

Method of Washing

1. Set the machine at an angle.
For details, see "Method of Setting Machine at Angle (PAGE 4-38)"
2. Swing the upper structure slowly so that water drain holes (1) in the cab floor are at a low position.

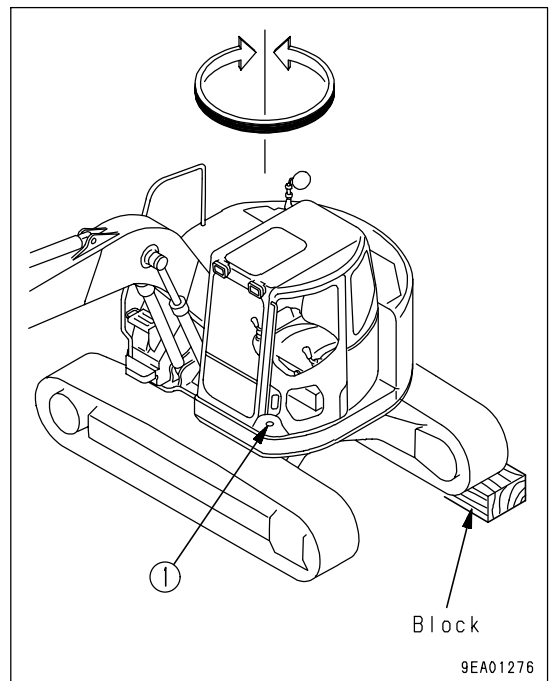

3. Lower the work equipment to the ground and set the machine in a stable condition.

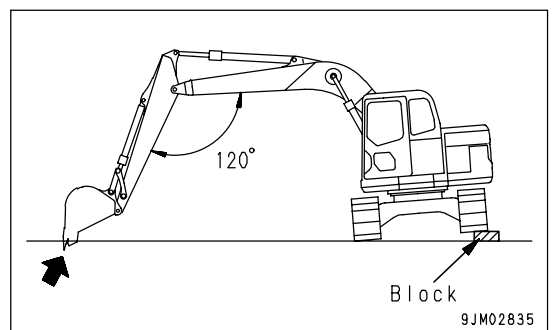

4. Set the lock lever to the LOCK position and stop the engine.

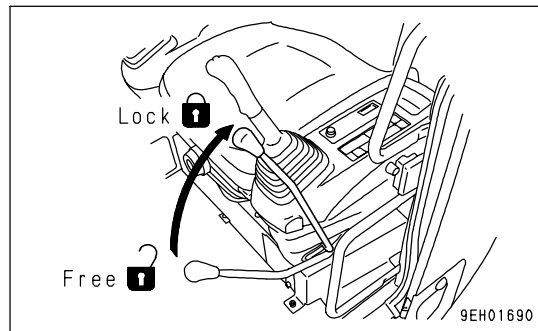

5. Remove the floor mat.

6. Flush out the dirt on the floor directly with water through water drain hole (1).

7. After completing the washing operation, install the floor mat.

Method of Setting Machine at Angle

Method Using Slope



Select a solid and smooth slope.

Always put blocks under the track to prevent the machine from moving, and dig the work equipment into the ground.

1. Stop the machine so that the work equipment is on the downhill side.
2. Put blocks under the track and dig the work equipment into the ground.

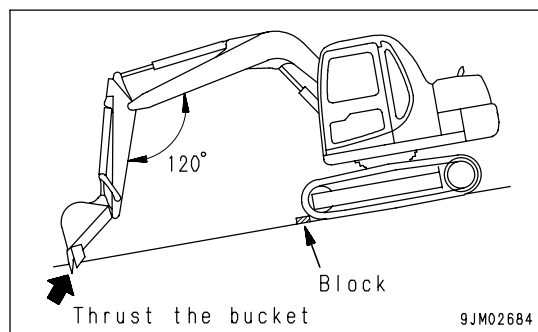

Method Using Block

 **WARNING**

Select a firm flat place.

Put strong blocks under the undercarriage to stabilize the machine and be extremely careful when carrying out the operation.

1. Raise the chassis with the boom and arm.
When doing this, operate the levers slowly.
2. Insert a block securely between the ground surface and the raised track and make sure that the machine is stable.

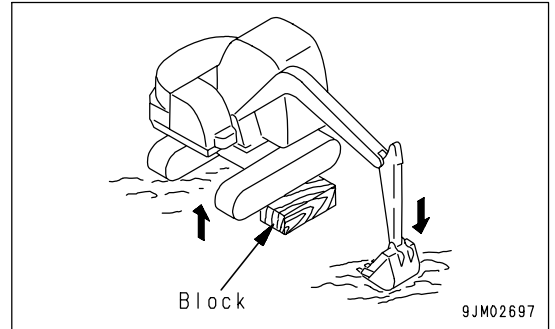

3. Raise the boom slowly and lower the machine.
When doing this, check that the machine is always stable.

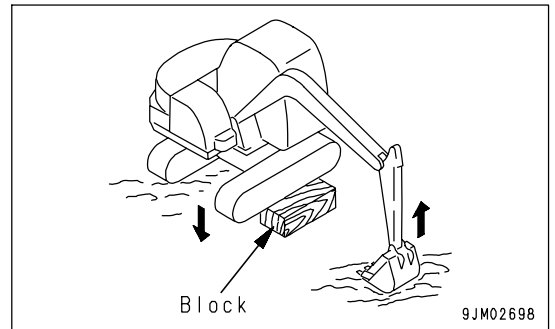

BLEEDING AIR FROM HYDRAULIC SYSTEM

For details, see "STARTING ENGINE (PAGE 3-68)". If it is necessary to refer to the items for starting the engine, moving the machine off, steering, or stopping, see the OPERATION section.

1. Bleeding air from pump

NOTICE

If the pump is operated without filling the pump case with hydraulic oil, there is danger that the pump may be prematurely damaged. Be sure to bleed the air completely.

- 1) Loosen air bleed plug (1) installed to the drain port and check that oil oozes out.
- 2) After completion of the air bleeding operation, tighten the air bleed plug (1).

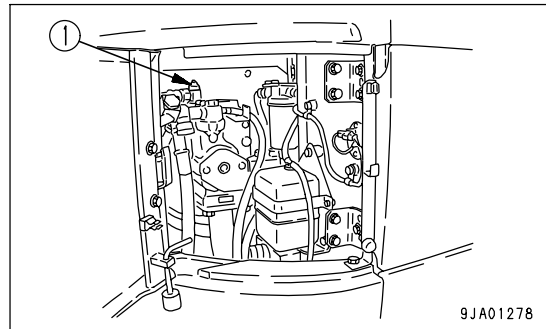

9JA01278

NOTICE

If the engine is run at high speed immediately after startup or a cylinder is pushed up to its stroke end, air taken inside the cylinder may cause damage to the piston packing.

2. Starting engine

Start the engine, referring to "STARTING ENGINE (PAGE 3-68)".

Run the engine at low idle for 10 minutes after starting, then start operations.

3. Bleeding air from cylinders

- 1) Run the engine at low idle, and extend and retract each cylinder 4 to 5 times, taking care that a cylinder is not moved to the end of its stroke. (Stop the cylinder approx. 100 mm (3.9 in) short of its stroke end)
- 2) Next, operate each cylinder 3 to 4 times to the end of its stroke.
- 3) Finally, operate each cylinder 4 to 5 times to the end of its stroke to completely remove the air.

4. Bleeding air from swing motor

(only after draining oil from swing motor case)

NOTICE

If the air is not bled from the swing motor, the motor bearings may be damaged.

- 1) Run the engine at low idle, Loosen air bleeding plug (2) and check that oil oozes out from air bleeding plug (2).

NOTICE

When doing this, do not operate the swing.

- 2) If no oil oozes out, stop the engine, remove air bleeding plug (2), then fill the motor case with hydraulic oil.

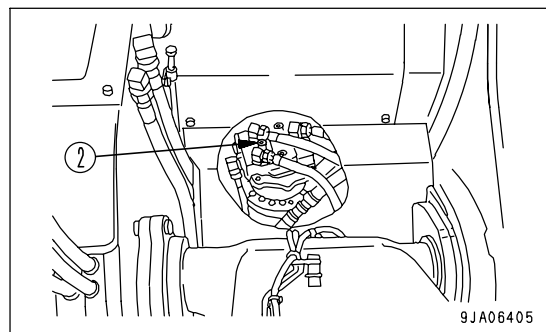

9JA06405

- 3) After completing the air bleed operation, tighten air bleeding plug (2).
- 4) Run the engine at low idle, and slowly swing the upper structure at least 2 times uniformly to the left and right.

5. Bleeding air from travel motor

(only when oil inside travel motor case has been drained)

- 1) Run the engine at low idle, remove hose (3) from port C, then when the oil has flowed out, tighten it again.
- 2) Run the engine at low idle and swing the work equipment 90° to bring it to the side of the track.
- 3) Jack up the machine until the track is raised slightly from the ground. Rotate the track under no load for 2 minutes. Repeat this procedure on both the left and right sides, and rotate the track equally both forward and in reverse.

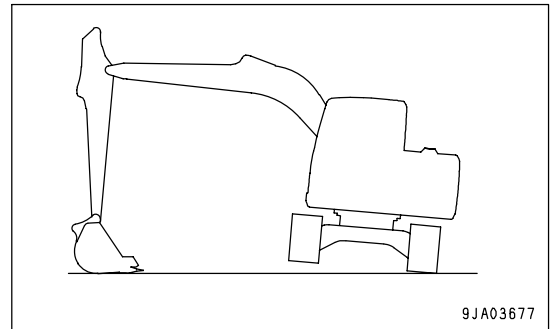
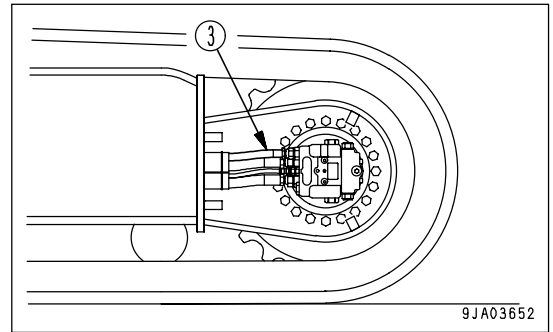

6. Bleeding air from attachment (when installed)

NOTICE

If the attachment maker specifies an air bleeding procedure for the attachment itself, follow the specified procedure to bleed the air.

If a breaker or other attachment has been installed, run the engine at low idle and operate the attachment pedal repeatedly (approx. 10 times) until the air has been bled from the attachment circuit.

NOTICE

- After completing the air bleeding operation, stop the engine, and leave the machine for 5 minutes before starting operations. This will remove the air bubbles in the oil inside the hydraulic cylinders.
- Check that there is no leakage of oil and wipe off any oil that has been spilled.

CHECK BEFORE STARTING

For details of the following items, see "Checks Before Starting (PAGE 3-54)" in the OPERATION section.

- Check coolant level, add coolant
- Check oil level in engine oil pan, add oil
- Check fuel level, add fuel
- Check oil level in hydraulic tank, add oil
- Check dust indicator
- Check water separator
- Check electric wiring
- Check function of horn

EVERY 50 HOURS MAINTENANCE

DRAIN WATER FROM FUEL TANK

NOTICE

- Never use trichlene for washing the inside of the tank. Use diesel fuel only.

Perform this check before operating the machine.

1. Open the pump room door on the right side of the machine.
2. Pass drain hose (1) (stowed at the top surface of the undercover) through hole (A) in the undercover.
3. Set a container under drain hose (1) to catch the drained fuel.
4. Open drain valve (2) at the rear of the fuel tank and drain the water and sediment accumulated at the bottom of the tank together with the fuel.
5. When only clean fuel comes out, close drain valve (2).
6. Remove drain hose (1) from hole (A) of the undercover and stow it at the top of the undercover.
7. Close the pump room door.

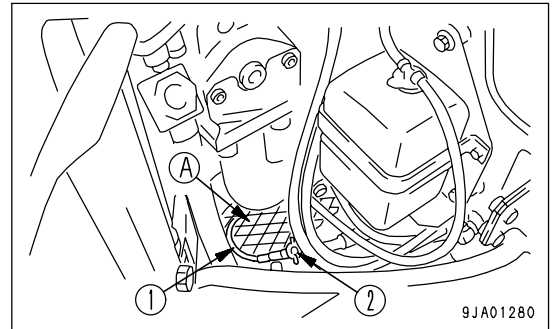

EVERY 100 HOURS MAINTENANCE

Maintenance for every 50 hours service should be carried out at the same time.

LUBRICATING

NOTICE

- If any abnormal noise is generated from any greasing point, carry out greasing regardless of the greasing interval.
- Carry out greasing every 10 hours for the first 50 hours on a new machine.
- After the machine was subjected to jobs in the water, be sure to grease the wet pins.

1. Set the machine to the greasing posture shown on the right, lower the work equipment to the ground, then stop the engine.
2. Using a grease pump, pump in grease through the grease fittings shown by arrows.
3. After greasing, wipe off any old grease that was pushed out.

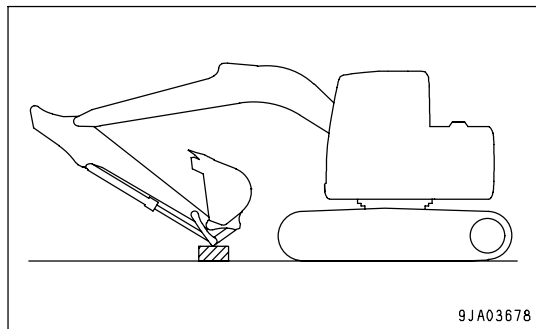

(1) Arm-Bucket coupling pin (1 place)

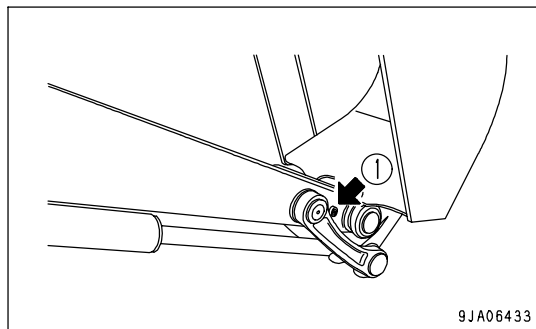

CHECK SWING MACHINERY CASE OIL, ADD OIL

! WARNING

The parts and oil are at high temperature after the engine is stopped, and may cause serious burns. Wait for the temperature to go down before starting the operation.

1. Remove dipstick (G) and wipe the oil from the dipstick with a cloth.
2. Fully insert dipstick (G) into the filler pipe.
3. When dipstick (G) is pulled out, if oil level is between the H and L marks of the gauge, oil level is proper.
4. If the oil does not reach the L mark on dipstick (G), remove the cap from oil filler (F), and add engine oil.

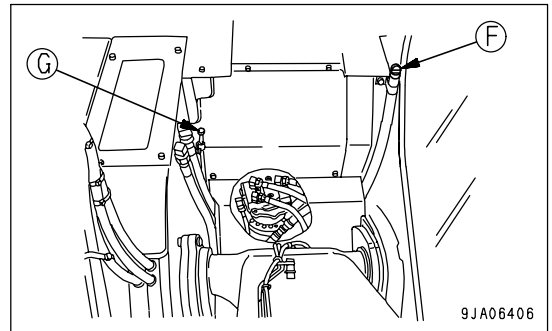

5. If the oil level exceeds the H mark on the oil level gauge, loosen drain plug (P) to drain the excess oil, after swinging the upper structure so that drain plug (P) comes between the right and left tracks.
6. After checking oil level or adding oil, insert the dipstick into the hole and install oil filler cap.

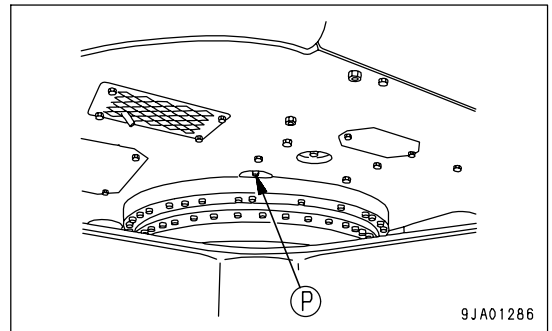

EVERY 250 HOURS MAINTENANCE

Maintenance for every 50 hours service should be carried out at the same time.

CHECK OIL LEVEL IN FINAL DRIVE CASE, ADD OIL

WARNING

- The oil is at high temperature immediately after the machine has been operated. Wait for the oil to cool down before starting the operation.
- If there is still pressure remaining inside the case, the oil or plug may fly out. Loosen the plug slowly to release the pressure.

- Prepare a container to catch drained oil.
- Prepare a hexagon wrench.

1. Set so that plug (F) is at the top, with plug (F) and plug (P) perpendicular to the ground.
2. Using a hexagonal wrench, remove plug (F) and check that the oil level is within a range from the bottom of the plug hole to a point 10 mm (0.4 in) below it.
3. If the oil level is low, add oil through the hole of plug (F). Add oil until oil overflows from the hole of plug (F).
4. After checking, install plug (F).

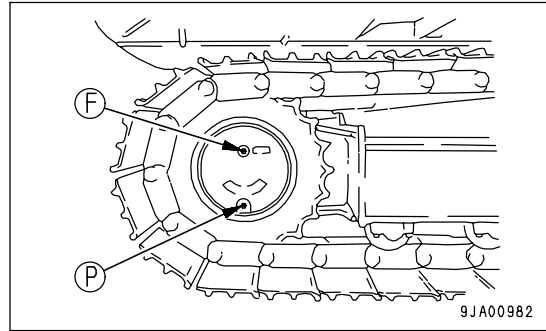

9JA00982

Large-capacity Final Drive

(If equipped)

1. Set so that plug (G) is at the top, with plug (G) and plug (P) perpendicular to the ground.
2. Remove plug (G) with a hexagonal wrench. Oil level should be near the bottom of the plug hole (G).
3. If the oil level is low, use a hexagonal wrench to remove plug (F), then add oil through the hole of plug (F). Add oil until the oil overflows from the hole in plug (G).
4. After checking the oil level, install plugs (F) and (G).

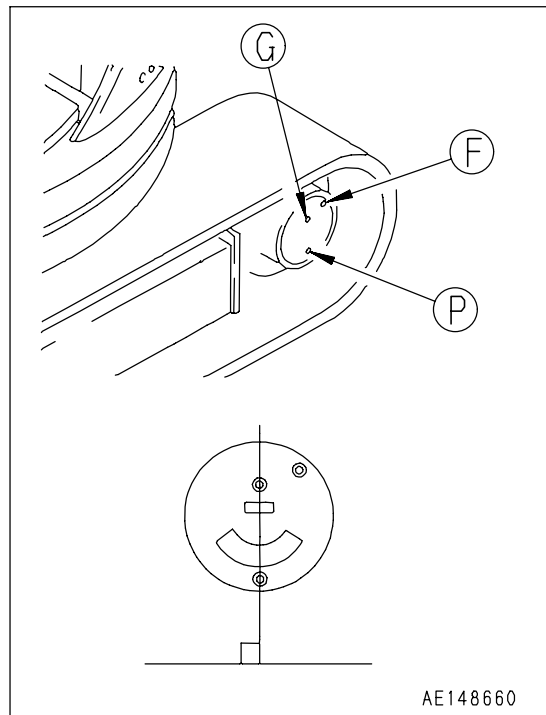

AE148660

CHECK LEVEL OF BATTERY ELECTROLYTE

Perform this check before operating the machine.



WARNING

- Do not use the battery if the battery electrolyte level is below the LOWER LEVEL line. This will accelerate deterioration of the inside of the battery and reduce the service life of the battery. In addition, it may cause an explosion.
- The battery generates flammable gas and there is danger of explosion, do not bring fire or sparks near the battery.
- Battery electrolyte is dangerous. If it gets in your eyes or on your skin, wash it off with a large amount of water and consult a doctor.
- When adding distilled water to the battery, do not allow the battery electrolyte to go above the UPPER LEVEL line. If the electrolyte level is too high, it may leak and cause damage to the paint surface or corrode other parts.

NOTICE

When adding distilled water in cold weather, add it before starting operations in the morning to prevent the electrolyte from freezing.

Inspect the battery electrolyte level at least once a month and follow the basic safety procedures given below.

When Checking Electrolyte Level from Side of Battery

If it is possible to check the electrolyte level from the side of the battery, check as follows.

1. Open the battery room door and remove sheet (1) installed above the battery.
2. Use a wet cloth to clean the area around the electrolyte level lines and check that the electrolyte level is between the UPPER LEVEL (U.L.) and LOWER LEVEL (L.L.) lines.
If the battery is wiped with a dry cloth, static electricity may cause a fire or explosion.

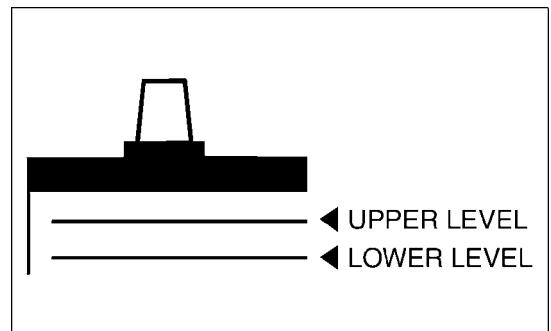

3. If the electrolyte level is below the midway point between the U.L and L.L lines, remove cap (2) and add distilled water to the U.L line.
4. After adding distilled water, tighten cap (2) securely.

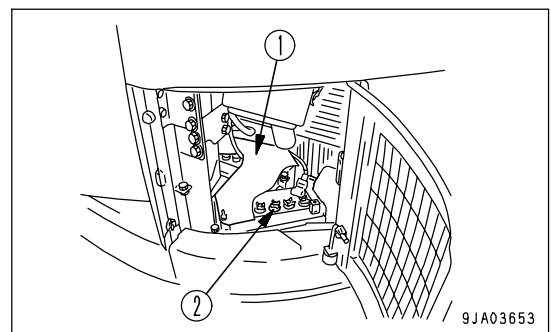

REMARK

If distilled water is added to above the U.L. line, use a syringe to lower the level to the U.L. line. Neutralize the removed fluid with baking soda (sodium bicarbonate), then flush it away with a large amount of water or consult your Komatsu distributor or battery maker.

When it is Impossible to Check Electrolyte Level from Side of Battery

If it is impossible to check the electrolyte level from the side of the battery, or there is no display of the UPPER LEVEL line on the side of the battery, check as follows.

1. Open the battery room door and remove sheet (1) installed above the battery.
2. Remove cap (2) at the top of the battery, look through the water filler port, and check the electrolyte surface. If the electrolyte does not reach the sleeve, add distilled water so that the level reaches the bottom of the sleeve (UPPER LEVEL line) without fail.

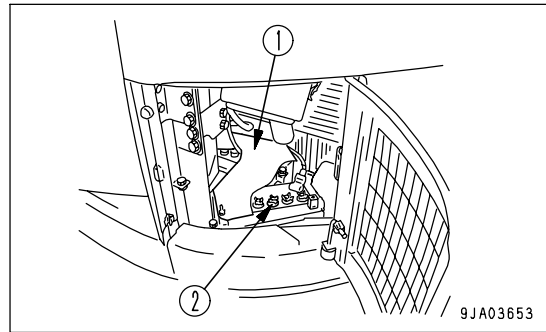

Use the diagram below for reference, and check if the electrolyte reaches the bottom of the sleeve.

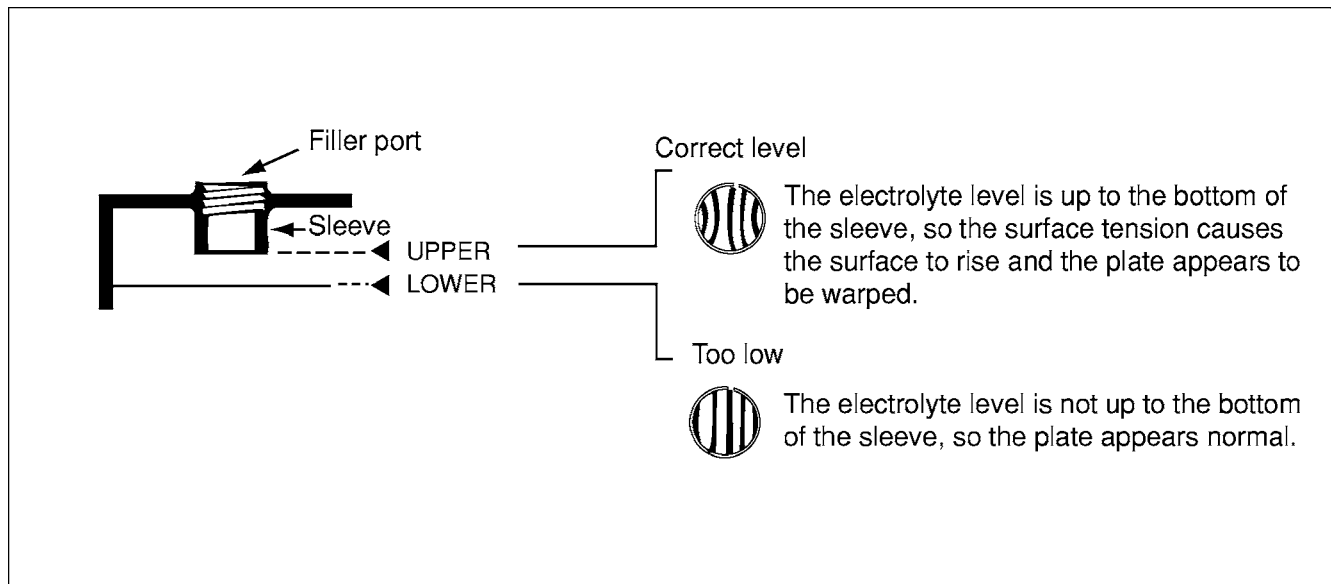

3. After adding distilled water, tighten cap (2) securely.

REMARK

If distilled water is added to above the bottom of the sleeve, use a syringe to lower the level to the bottom of the sleeve. Neutralize the removed fluid with baking soda (sodium bicarbonate), then flush it away with a large amount of water or consult your Komatsu distributor or battery maker.

When it is Possible to Use Indicator to Check Electrolyte Level

If it is possible to use an indicator to check the electrolyte level, follow the instructions given.

CHECK AND ADJUST COOLING FAN BELT TENSION

Checking

If deflection amount "a" shows approx. 8 mm (0.3 in) when the belt is pressed with a thumb of approx. 58.8 N (6 kgf) force at the midpoint between the alternator pulley and the fan pulley, then it is the standard deflection amount.

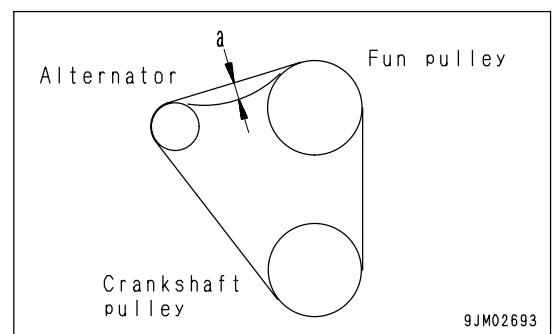
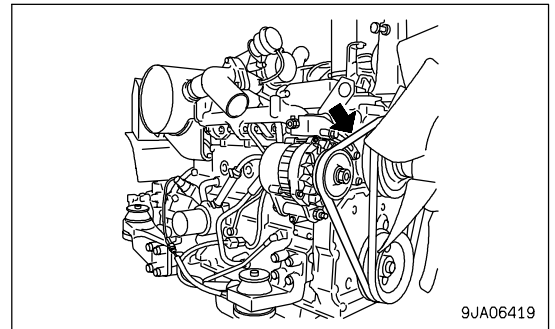

Adjustment

1. Remove cover (1) between the hydraulic tank and the operator's cab.

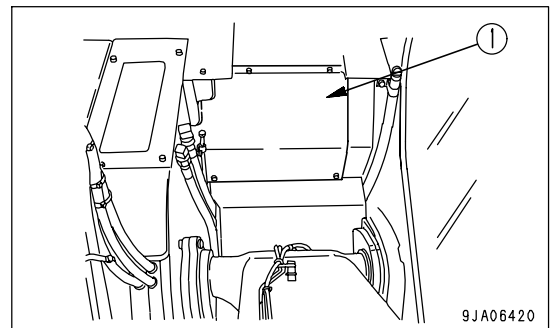

2. Loosen mounting bolt (3) of alternator (2).
3. Open the engine hood and loosen alternator lock bolt (4).
4. Turn tension bolt (5) of alternator (2) in the direction of loosening, and adjust the belt tension so that it is approx. 8 mm (0.315 in) (approx. 58.8 N (6 kgf)).

When doing this, do not touch double nut (6).

5. Tighten mounting bolt (3) and lock bolt (4).
6. Install cover (1).

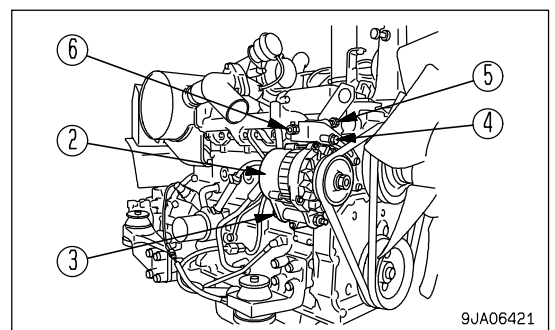

NOTICE

- Check each pulley for damage, wear of the V-groove, and wear of the V-belt. In particular, be sure to check that the V-belt is not touching the bottom of the V-groove.
- If the belt is stretched and there is no allowance for adjustment, or if it is cut or cracked, please contact your Komatsu distributor for replacement.

CHECK AIR CONDITIONER COMPRESSOR BELT TENSION, ADJUST

Checking

1. Press the belt at a point midway between the drive pulley (1) and compressor pulley (2) with a finger force of approx. 58.8 N (6 kgf) and check that the deflection is 5 to 8 mm (0.20 to 0.31 in).

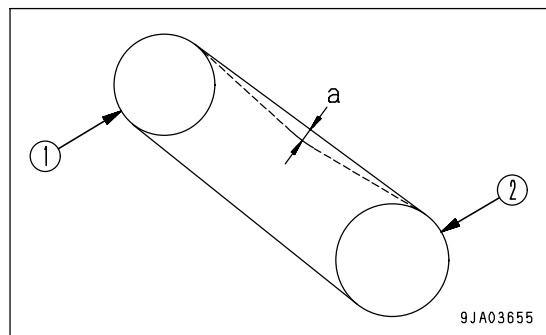
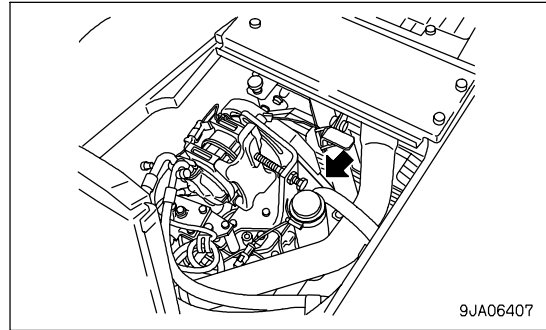

Adjustment

1. Loosen bolts (1) and (2).
 - Bracket (4) holds the compressor in place. When bolts (1) and (2) are loosened, bracket (4) moves with the bolt (2) securing position as a fulcrum.
2. Loosen nut (5) attached to the fixed bracket (3) and then tighten bolt (6).
 - Tighten bolt (6) so that the deflection of the belt will be 5 to 8 mm (0.20 to 0.31 in) (approx. 58.8N (6 kgf)).
3. Tighten bolts (1) and (2) to secure bracket (4).
4. Loosen bolt (6) to remove from bracket (4).
5. Tighten nut (5).

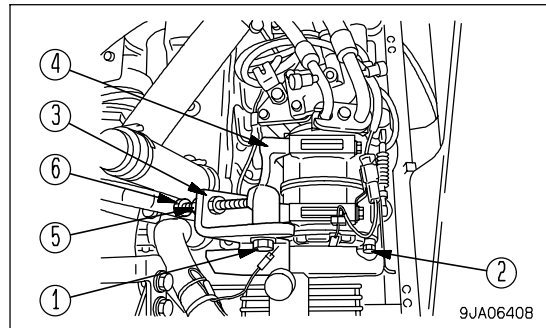

NOTICE

- Check each pulley for damage, wear of the V-groove, and wear of the V-belt. In particular, be sure to check that the V-belt is not touching the bottom of the V-groove.
- In case any of the following occurs, ask the Komatsu distributor in your territory to replace the belts with new ones.
 - The fan belt has elongated, leaving little allowance for adjustment.
 - A cut or crack is found on the belt.
 - Slipping or creaking sound is heard coming from the belt.
- When the new V-belt is set, readjust it after one hour of operation.

EVERY 500 HOURS MAINTENANCE

Maintenance for every 50, 100 and 250 hours service should be carried out at the same time.

LUBRICATING

NOTICE

- If any abnormal noise is generated from any greasing point, carry out greasing regardless of the greasing interval.
- Carry out greasing every 10 hours for the first 50 hours on a new machine.
- After the machine was subjected to jobs in the water, be sure to grease the wet pins.

1. Set the machine to the greasing posture shown on the right, lower the work equipment to the ground, then stop the engine.
2. Using a grease pump, pump in grease through the grease fittings shown by arrows.
3. After greasing, wipe off any old grease that was pushed out.

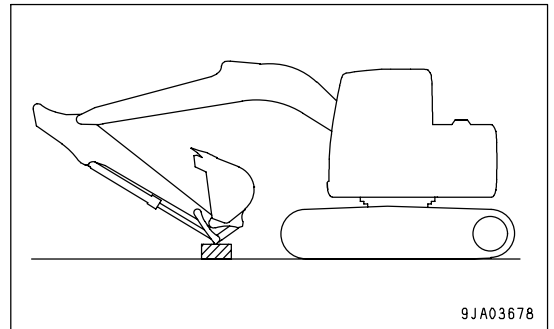

(1) Boom cylinder foot pin (2 places)

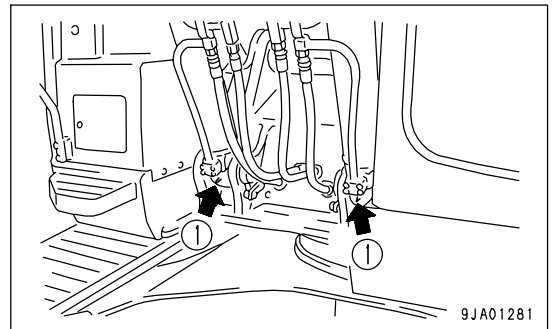

- (2) Boom foot pin (2 places)
- (3) Boom cylinder rod end pin (2 places)
- (4) Arm cylinder foot pin (1 place)

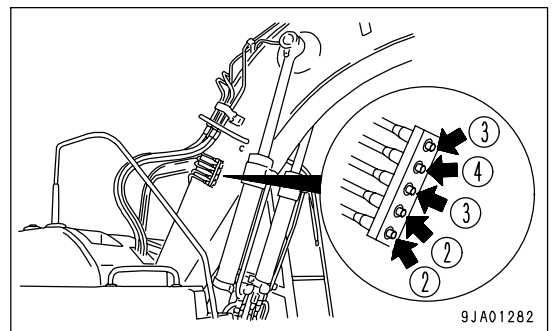

- (5) Boom-Arm coupling pin (1 place)
- (6) Arm cylinder rod end pin (1 place)
- (7) Bucket cylinder foot pin (1 place)

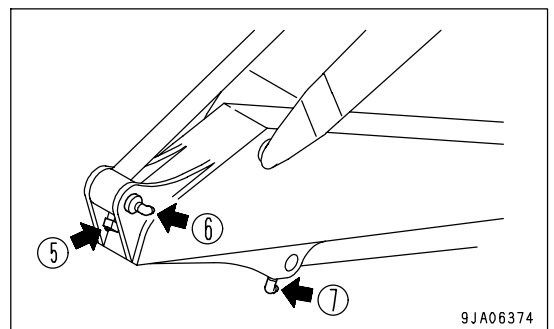

(8) Arm-Link coupling pin (1 place)

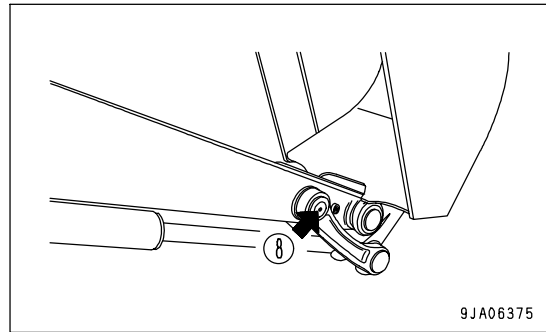

(9) Link connecting pin (1 place)
 (10) Bucket cylinder rod end (1 place)
 (11) Bucket-link connecting pin (2 places)

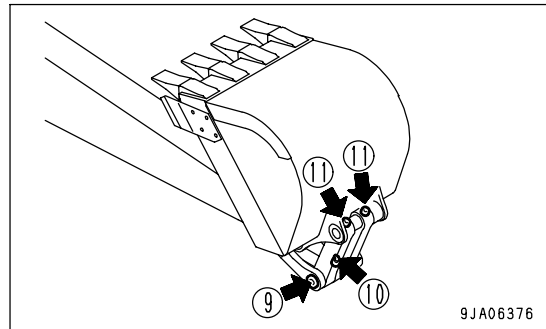

(12) Blade connecting pin (2 places)
 (13) Blade cylinder foot pin (2 places)
 (14) Blade cylinder rod end pin (2 places)

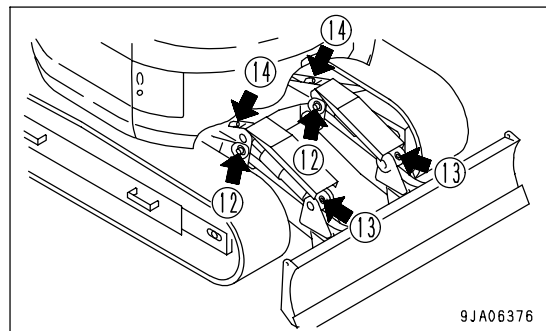

CHANGE OIL IN ENGINE OIL PAN, REPLACE ENGINE OIL FILTER CARTRIDGE

! WARNING

Parts and oil are at high temperature immediately after the engine is stopped and may cause serious burns. Wait for the oil temperature to go down before performing this operation.

- Oil pan refill amount: 11 liters (2.91 US gal)
- Prepare a filter wrench

1. Remove undercover (1) at the bottom of the machine, then set the container under drain valve (P) on the left side of the machine to catch the oil.
2. Loosen drain plug (P) and drain the oil. Be careful not to get oil on yourself.
3. Tighten drain plug (P).

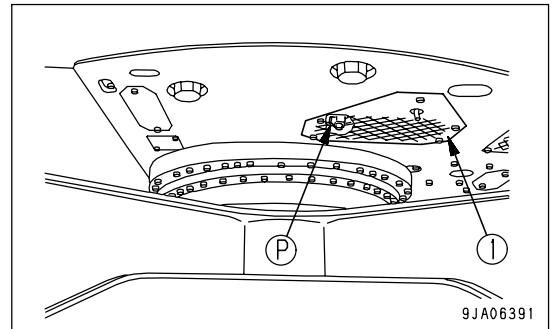

4. Open the pump room on the right side of the machine, then using the filter wrench, turn filter cartridge (2) to the left to remove it.
5. Clean the filter holder, fill the new filter cartridge with clean oil, coat the thread and packing portion of the new filter cartridge with oil (or coat thinly with grease), then install.

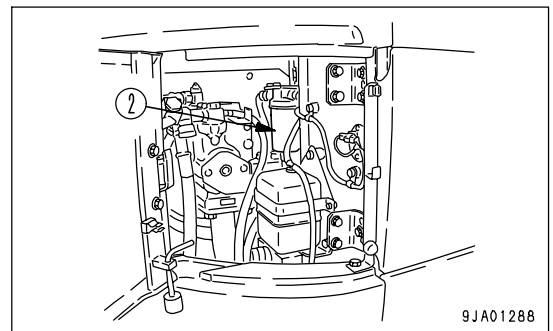

REMARK

Check that there is no old packing stuck to the filter holder. If there is any old packing stuck to the filter, it will cause leakage of oil.

6. When installing, tighten until the packing surface contacts the filter holder, then tighten a further 3/4 turn.
7. After replacing the filter cartridge, add oil through oil filler (F) until the oil level is between the H and L marks on the dipstick (G).
8. Run the engine at idle for a short time, then stop the engine, and check that the oil level is between the H and L marks on the dipstick. For details, see "Check Oil Level in Engine Oil Pan, Add Oil (PAGE 3-55)".

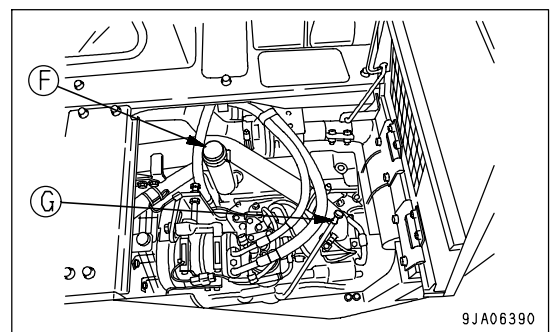

REPLACE FUEL FILTER CARTRIDGE

WARNING

- The engine is at high temperature immediately after the machine has been operated. Wait for the engine to cool down before replacing the filter.
- Do not bring fire or sparks near the fuel.

Prepare a filter wrench and a container to catch the fuel.

1. Set the container to catch the fuel under the filter cartridge.
2. Using a filter wrench, turn filter cartridge (1) counterclockwise on remove it.
3. Clean the filter holder. Fill a new filter cartridge with clean fuel. Coat the packing surface with engine oil. Then install the new cartridge into the filter holder.
4. When installing, screw in cartridge until seal comes in contact with sealing surface, then tighten approx. an additional 1/2 turn.

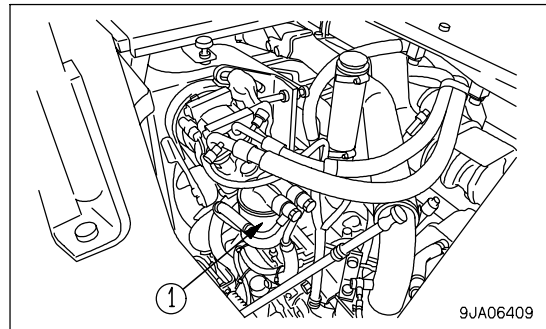

NOTICE

If the filter cartridge is tightened excessively, the packing will be damaged and fuel will leak. If the filter cartridge is too loose, fuel will also leak from the packing, so always tighten to the correct amount.

5. After replacing the fuel filter element, bleed air.
For details of the procedure, see "Air Bleeding (PAGE 4-54)".
6. After replacement of the filter cartridge, start the engine and check it for possible oil seepage from the filter seal. If oil leaks, check the filter cartridge tightening condition and retighten it. Should oil still leak, remove the filter cartridge again in the sequence of Item 1 and 2 above, and check the packing surface for any damage or whether some foreign material has got caught.
If any of the cases is noticed, replace the packing with new one and repeat the steps in Item 3 through 6 above.

Air Bleeding

1. Fill the fuel tank with fuel (to the position where the float is at the highest position).
2. Loosen air bleed plug (1) and joint bolt (2).
3. Loosen the knob of feed pump (3), then pump it up and down until no more bubbles come out with the fuel from the hole of air bleed plug (1).
4. Tighten joint bolt (2) and air bleed plug (1).

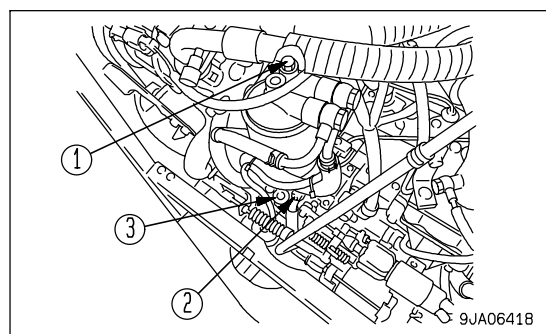

REMARK

Use the same procedure to operate the feed pump and bleed the air if the machine runs out of fuel.

CHECK SWING PINION GREASE LEVEL, ADD GREASE

- Prepare a scale.
- 1. Remove bolts (1) (2 bolts) on the top of the revolving frame and remove cover (2).
- 2. Insert a scale into the grease and check that the height of the grease in the portion where the pinion passes is at least 4 mm (0.2 in). Add more grease if necessary.
- 3. Check if the grease is milky white. If it is milky white, it is necessary to change the grease. Please contact your Komatsu distributor.
The total amount of grease is 10 liters (9.1 kg) (2.64 US gal, [20 lb]).
- 4. Install cover (2) with bolts (1).

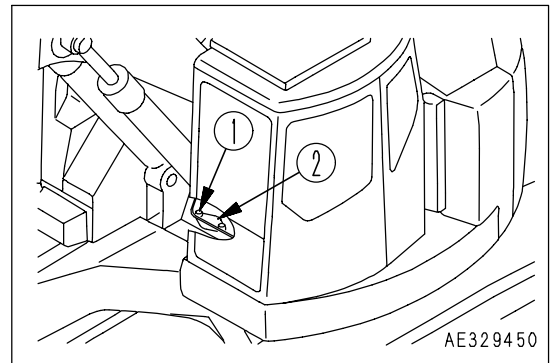

LUBRICATE SWING CIRCLE

1. Lower the work equipment to the ground.
2. Using a grease pump, pump in grease through the grease fittings shown by arrows. (2 places)
3. After greasing, wipe off any old grease that was pushed out.

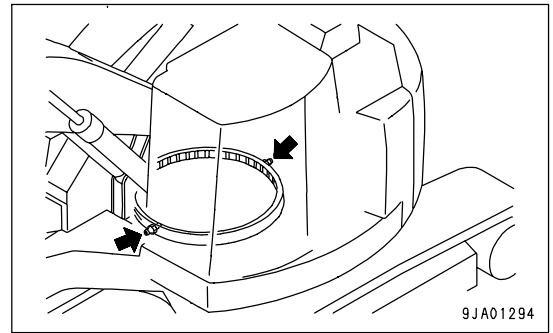

CLEAN, CHECK RADIATOR FINS, AIR COOLER FINS, OIL COOLER FINS, CONDENSER FINS

! WARNING

If compressed air, high-pressure water, or steam hit your body directly, or they cause dirt or dust to be blown up, there is a hazard of serious injury. Always use safety glasses, dust mask, or other protective equipment.

NOTICE

When use the compressed air, keep a distance from air nozzle, to prevents damage to the fins.
To prevent damage to the fins, apply compressed air from and appropriate distance. Damaged fins may cause water leakage or overheating. In a dusty site, check the fins daily, irrespective of the maintenance interval.

1. Open the cover at the rear of the cab and the battery room door at the left side of the machine.
2. Remove 4 wing screws (1) and remove net (2).
3. Use compressed air to clean the mud, dust, and leaves from the radiator fins, oil cooler fins, and condenser fins.
Steam or water may be used instead of compressed air.
4. Check the rubber hose. Replace with a new one if the hose is found to have cracks or to be hardened by aging.
Also, check hose clamps for looseness.

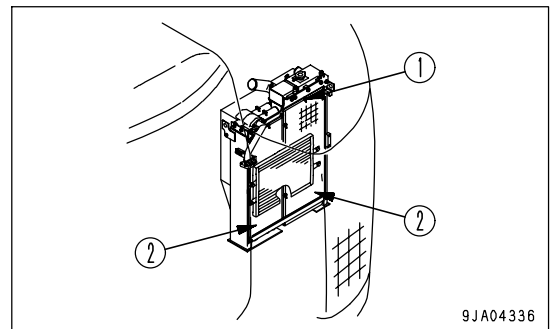

5. After completing inspection and cleaning, install net (2) to its original condition.

CLEAN AIR CONDITIONER FRESH/RECIRC FILTERS**WARNING**

If compressed air is used, there is danger that dirt may fly and cause personal injury.
Always wear protective glasses, dust mask, and other protective equipment.

NOTICE

- The guide for cleaning the filter is 500 hours, but if the machine is used on an extremely dusty jobsite, reduce the maintenance interval and clean the filter more frequently.
- When washing the floor, be careful not to get water on the air conditioner system.

Cleaning Reticulated Air Filter

1. Roll up floor mat (1) on the front left part of the floor in the operator's cab, and open cover (2).
2. Take out internal filter (3).
3. Clean internal filter (3) with compressed air. If there is oil stuck to the filter or it is extremely dirty, wash it in a neutral agent. After washing, dry it thoroughly before using it again.

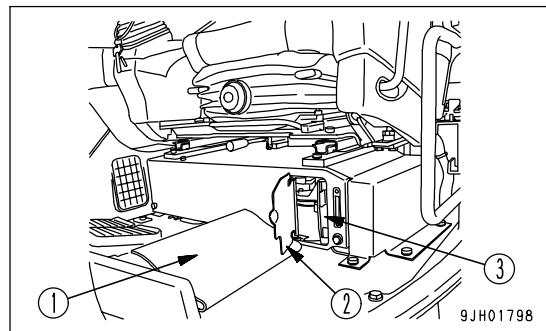
**REMARK**

If the clogging of the filter cannot be removed by blowing it with compressed air or washing in water, replace the filter with a new one.

4. Install cleaned filter (3), close cover (2) and spread floor mat (1) flat.

Cleaning Fresh Air Filter

1. Pull up pop-up rivet (4) of the air intake duct at the left rear of the operator's seat. Cover (5) will be released automatically.
2. Pull up external filter (6).
3. Clean external filter (6) by blowing it with compressed air. If there is oil stuck to the filter or it is extremely dirty, wash it in a neutral agent. After washing, dry it thoroughly before using it again.

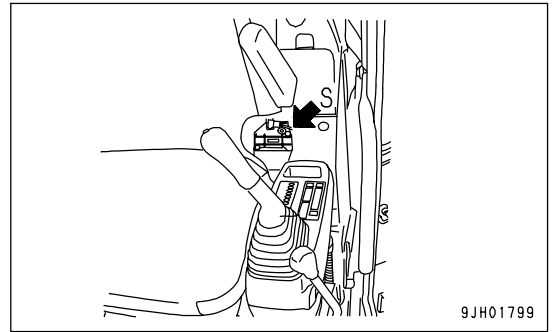

REMARK

If the clogging of the filter cannot be removed by blowing it with compressed air or washing in water, replace the filter with a new one.

4. Install cleaned filter (6) and then fix cover (5).

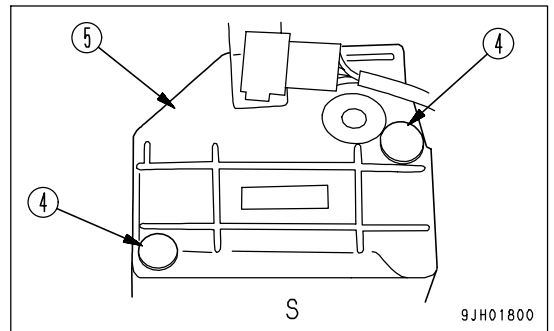

NOTICE

Insert filter (6), paying attention to the top and bottom sides.

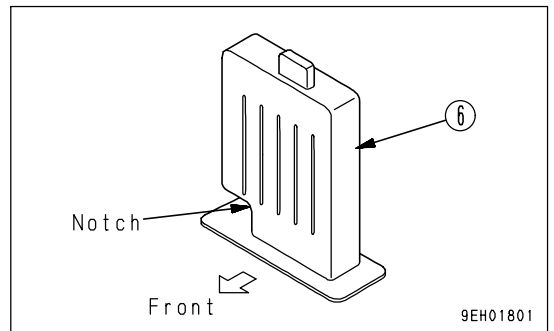

REPLACE BREATHER ELEMENT IN HYDRAULIC TANK

! WARNING

- The parts and oil are at high temperature immediately after the engine is stopped, and may cause burns. Wait for the temperature to go down before starting the work.
- When removing the oil filler cap, turn it slowly to release the internal pressure, then remove it.

1. Remove cover (1) at the top of the hydraulic tank.
Remove the cap of oil filler (F) over the hydraulic tank.

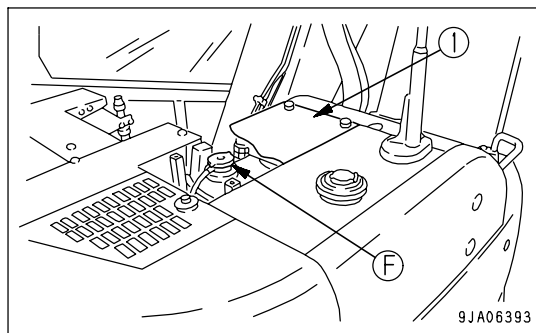

2. Replace element (2) inside the cap.

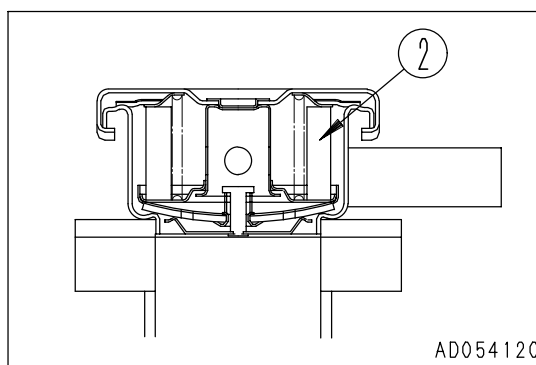

EVERY 1000 HOURS MAINTENANCE

Maintenance for every 50, 100, 250 and 500 hours service should be carried out at the same time.

CHANGE OIL IN SWING MACHINERY CASE



WARNING

The parts and oil are at high temperature after the engine is stopped, and may cause serious burns. Wait for the temperature to go down before starting the operation.

- Refill capacity: 2.5 liters (0.66 US gal)

1. Swing the upper structure so that drain plug (P) is between the left and right tracks.
2. Set an oil container under drain valve (P) at the bottom of the machine.
3. Remove drain plug (P) at the bottom of the machine, drain the oil, then tighten the drain plug again.

Tightening torque for drain plug: 44.1 to 93.1 N·m (4.5 to 9.5 kgf·m, 32.5 to 68.7 lbft)

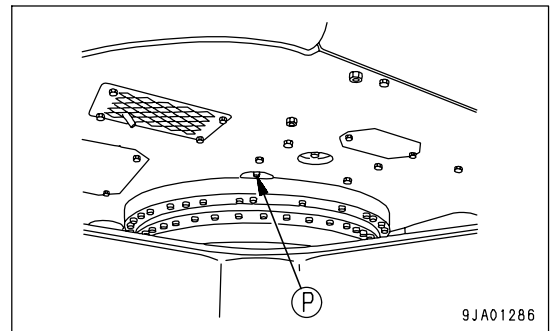

4. Remove dipstick (G) and the cap of oil filler (F), then add the specified amount of oil from oil filler (F).
5. Wipe off the oil on the dipstick with a cloth.
6. Fully insert dipstick (G) into filler pipe (F), then remove it.
7. The oil level should be between the H and L marks on oil level gauge (G). If the oil level is below the L mark, add oil through oil filler port (F).
8. If the oil is above the H mark, drain the excess oil from drain plug (P), then check the oil level again.

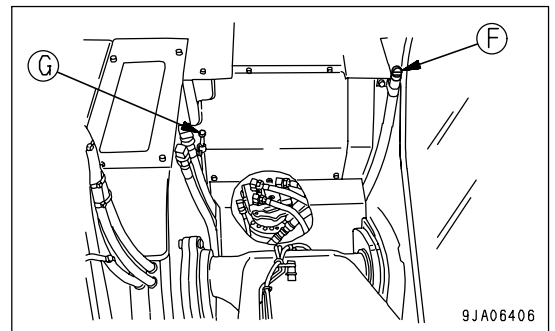

CHANGE OIL IN FINAL DRIVE CASE

! WARNING

- The oil is at high temperature immediately after the machine has been operated. Wait for the oil to cool down before starting the operation.
- If there is still pressure remaining inside the case, the oil or plug may fly out. Loosen the plug slowly to release the pressure.

- Refill capacity (each): 2.5 liters (0.66 US gal)
- Prepare a hexagon wrench

1. Set plug (F) at the top, with plug (F) and plug (P) perpendicular to the ground surface.
2. Set a container under plug (P) to catch the oil.
3. Remove plugs (P) and (F) with the hexagon wrench and drain the oil.
4. Tighten plug (P).
5. Add the replacement amount of oil through the hole of plug (F).
6. When the oil overflows from the hole of plug (F), install plug (F).

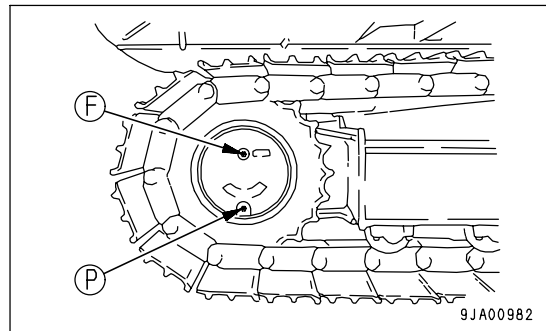

Large-capacity Final Drive

(If equipped)

1. Set so that plug (G) is at the top, with plug (G) and plug (P) perpendicular to the ground.
2. Set the container to catch oil under plug (P).
3. Remove plugs (P), (G) and (F) with hexagonal wench to drain the oil.
4. Tighten plug (P).
5. Add the replacement amount of oil through the hole of plug (F).
6. After the oil flows out of the hole plug (G), install plugs (G) and (F).

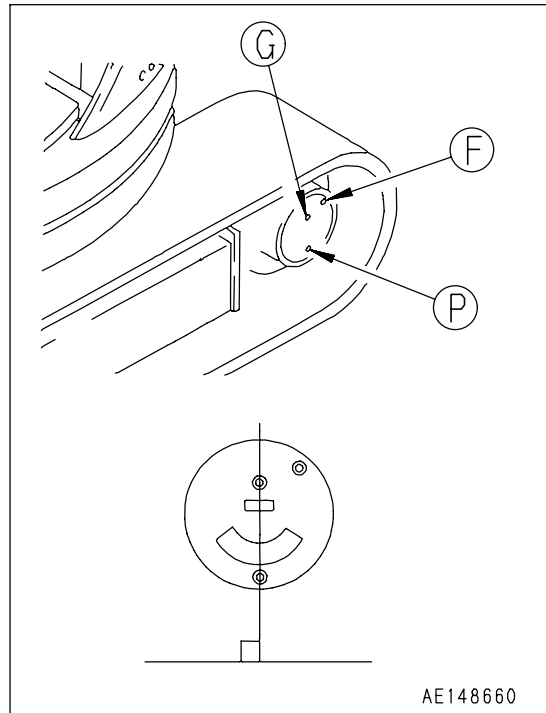

REPLACE HYDRAULIC OIL FILTER ELEMENT

! WARNING

- The parts and oil are at high temperature immediately after the engine is stopped, and may cause burns. Wait for the temperature to go down before starting the work.
- When removing the oil filler cap, turn it slowly to release the internal pressure, then remove it.

NOTICE

If the machine is equipped with a hydraulic breaker, the hydraulic oil will deteriorate much faster than during normal bucket operations. For details, see "MAINTENANCE INTERVAL FOR HYDRAULIC BREAKER (PAGE 4-15)" when carrying out maintenance.

1. Remove the cover at the top of the hydraulic tank.
2. Remove the cap from oil filler (F), and release the internal pressure.
3. Loosen 3 bolts, then remove cover (1). When doing this, the cover may fly out under the force of spring (2), so hold the cover down when removing the bolts.
4. After removing spring (2) and valve (3), take out element (4).
5. Clean the removed parts in diesel oil.
6. Install the new element in the place where old element (4) was installed.
7. Set valve (3) and spring (2) on top of the element.
8. Set cover (1) in position, push it down by hand, and install the cover with the mousing bolts.
9. Install the oil filler cap, then install the cover at the top of the hydraulic tank.
10. To bleed the air, start the engine according to "STARTING ENGINE (PAGE 3-68)" and run the engine at low idle for 10 minutes.
11. Stop the engine.

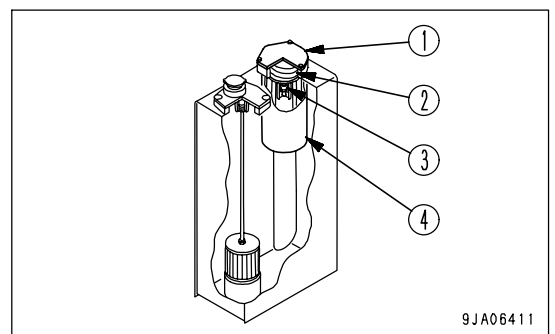
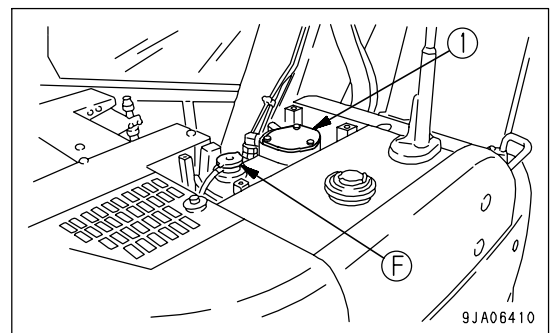

REMARK

Wait for at least 5 minutes after stopping the engine to eliminate bubbles in the oil inside the tank.

12. Check for oil leakage and wipe off any spilled oil.

CHECK ALL TIGHTENING PARTS OF TURBOCHARGER

Contact your Komatsu distributor to have the tightening portions checked.

CHECK PLAY TURBOCHARGER ROTOR

Contact your Komatsu distributor to have the rotor play checked.

EVERY 2000 HOURS MAINTENANCE

Maintenance for every 50, 100, 250, 500 and 1000 hours service should be carried out at the same time.

CHECK PTO GEAR CASE, ADD OIL



WARNING

Parts and oil are at high temperature immediately after the engine is stopped and may cause serious burns. Wait for the oil temperature to go down before performing this operation.

1. Swing the upper structure so that the PTO gear case is in the middle between the left and right tracks.
Stop the engine and set the lock lever to the LOCK position.
2. Remove undercover (1) at the bottom of the machine.

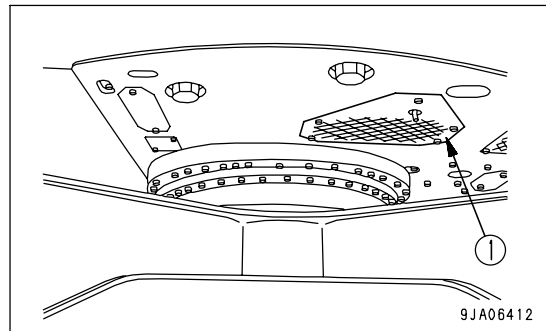

3. Remove oil inspection plug (G) and check that the oil is near the bottom of the plug hole.

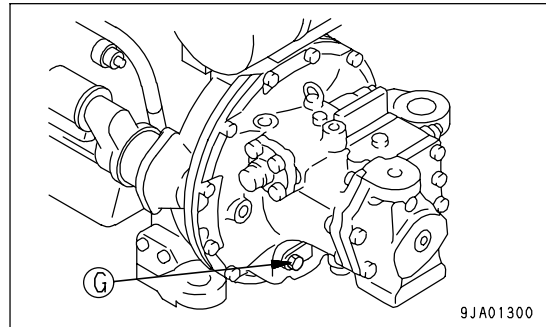

4. If the oil level is low, open the pump room door on the right side of the machine, remove the plug from oil filler (F), and add oil. Add oil until the oil level is close to the bottom of the hole of oil inspection plug (G).

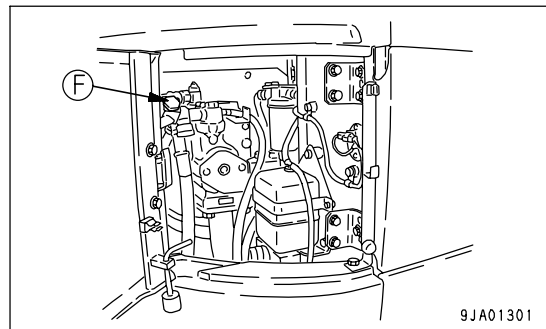

5. Install oil inspection plug (G) and the plug of oil filler (F).
6. Install cover (1).

CLEAN HYDRAULIC TANK STRAINER



WARNING

- The parts and oil are at high temperature immediately after the engine is stopped, and may cause burns. Wait for the temperature to go down before starting the work.
- When removing the oil filler cap, turn it slowly to release the internal pressure, then remove it.

1. Remove 4 bolts, then remove cover (1). When doing this, cover (1) may fly off because of the force of spring (2), keep the cover pushed down when removing the bolts.
2. Hold the top of rod (3) and pull up to remove spring (2) and strainer (4).
3. Remove any dirt stuck to strainer (4), then wash it in flushing oil. If strainer (4) is damaged, replace it with a new part.
4. When installing, insert strainer (4) into protruding part (5) of the tank, and assemble.
5. Install cover (1) with bolts.

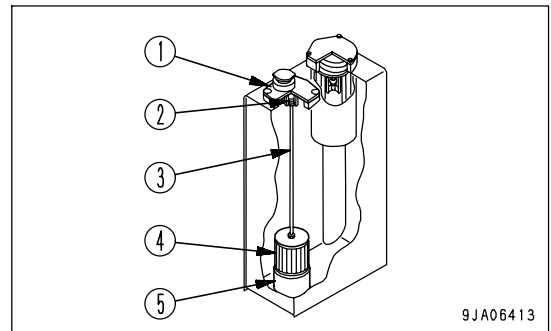

9JA06413

CLEAN, CHECK TURBOCHARGER

Contact your Komatsu distributor for cleaning and inspection.

CHECK ALTERNATOR, STARTING MOTOR

The brushes may be worn or the bearing may have run out of grease, contact your Komatsu distributor for inspection and repairs.

If the engine is started frequently, have this inspection carried out every 1000 hours.

CHECK ENGINE VALVE CLEARANCE, ADJUST

Special tools are needed for inspection and maintenance, please contact your Komatsu distributor.

CHECKING CHARGE PRESSURE OF NITROGEN GAS IN ACCUMULATOR (FOR CONTROL CIRCUIT)

WARNING

The accumulator is charged with high-pressure nitrogen gas, so mistaken operation may cause an explosion, which will lead to serious injury or damage. When handling the accumulator, always do as follows.

- The pressure in the hydraulic circuit cannot be completely removed. When removing the hydraulic equipment, do not stand in the direction that the oil spurts out when carrying out the operation. In addition, loosen the bolts slowly when carrying out the operation.
- Do not disassemble the accumulator.
- Do not bring it near flame or dispose of it in fire.
- Do not make holes in it or weld it.
- Do not hit it, roll it, or subject it to any impact.
- When disposing of the accumulator, the gas must be released. Please contact your Komatsu distributor to have this work carried out.

FUNCTION OF ACCUMULATOR

The accumulator stores the pressure in the control circuit. Even after the engine is stopped, the control circuit can be operated, so the following actions are possible.

- If the control lever is operated in the direction to lower the work equipment, it is possible for the work equipment to go down under its own weight.
- The pressure in the hydraulic circuit can be released.

The accumulator is installed to the position shown in the diagram on the right.

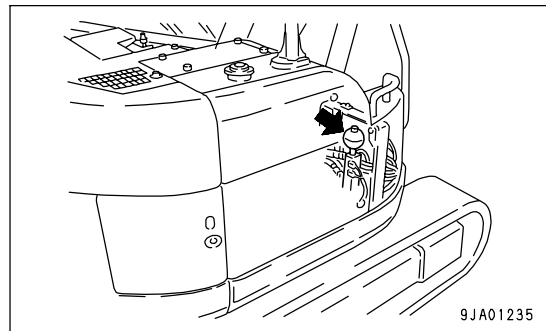

CHECKING FUNCTION OF ACCUMULATOR

Replace the accumulator every 2 years or every 4000 hours, whichever comes sooner.

Check the nitrogen gas charge pressure as follows.

1. Stop the machine on firm, level ground.
2. Set the work equipment to the maximum reach (arm fully extended and bucket fully dumped) and hold the work equipment at a position 1.5 m (4 ft 11 in) above the ground.

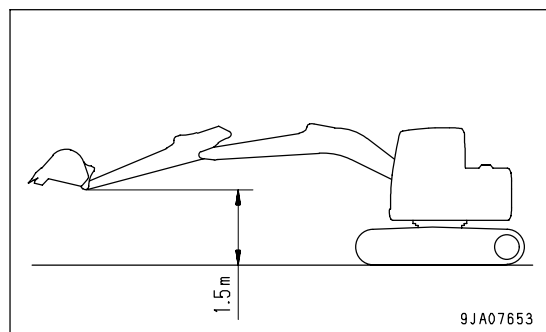

NOTICE

Carry out the following procedure to lower the work equipment to the ground within 15 seconds of stopping the engine.

When the engine stops, the pressure in the accumulator gradually goes down, so inspection can only be carried out immediately after the engine is stopped.

3. Keep the work equipment at the maximum reach, turn the starting switch to the OFF position, and stop the engine.
4. Turn the starting switch to the ON position.

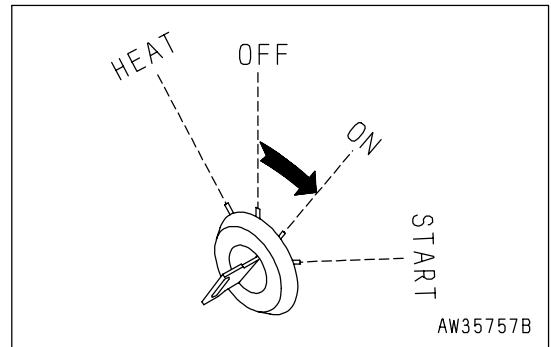

5. Set the lock lever to the FREE position.
6. Operate the work equipment control lever fully to the boom LOWER position.

REMARK

Check that the area around the machine is safe, then operate the work equipment control lever to the LOWER position.

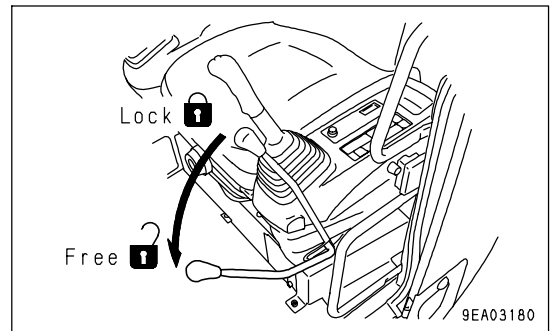

7. Check that the work equipment goes down to the ground under its own weight.
8. This completes the inspection.

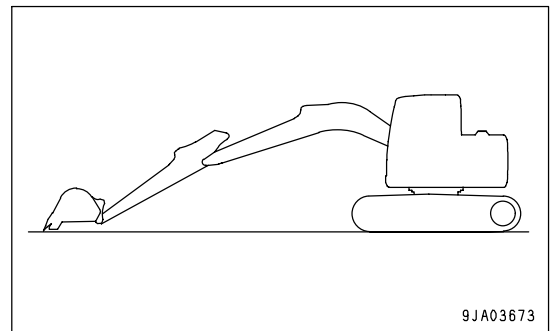

NOTICE

If the nitrogen gas charge pressure in the accumulator is low and operations are continued, it will become impossible to release the remaining pressure inside the hydraulic circuit if a failure occurs on the machine.

In the following cases, the charge pressure of the accumulator has gone down. Please contact your Komatsu distributor.

- Work equipment does not go down
- Stops while going down

METHOD OF RELEASING PRESSURE IN HYDRAULIC CIRCUIT

NOTICE

Carry out the following procedure to operate the work equipment control lever fully to the front, rear, left, and right within 15 seconds of stopping the engine.

When the engine stops, the pressure in the accumulator gradually goes down, so the pressure can only be released immediately after the engine is stopped.

1. Place the work equipment on the ground. Close the crusher attachment jaws, etc.
2. Stop the engine.

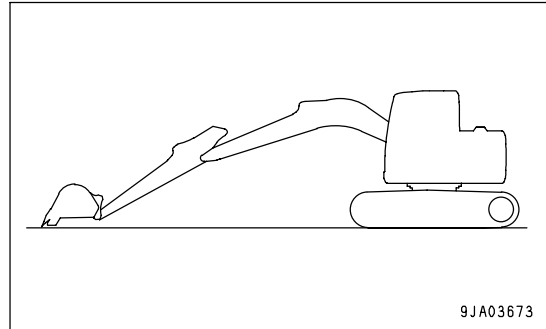

3. Turn the starting switch to the ON position.

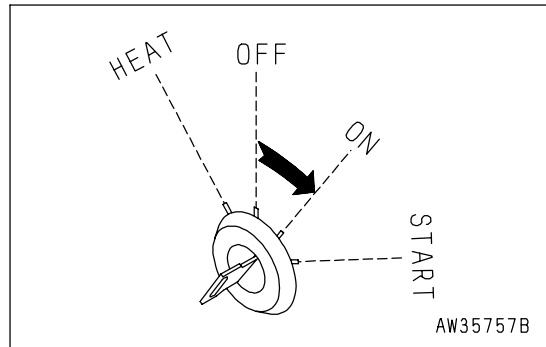

4. Set the lock lever to the FREE position, then operate each work equipment control lever and attachment control pedal (if equipped) fully to the front, rear, left, and right to release the pressure in the hydraulic circuit.

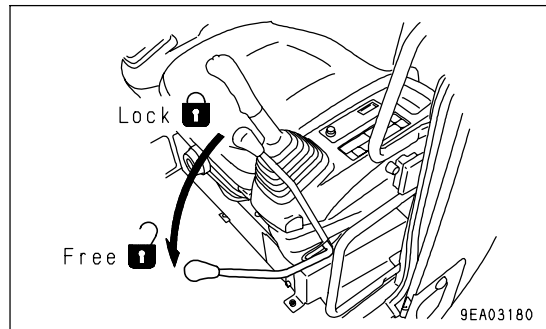

5. Set the lock lever to the LOCK position to lock the work equipment control levers and attachment control pedal (if equipped).

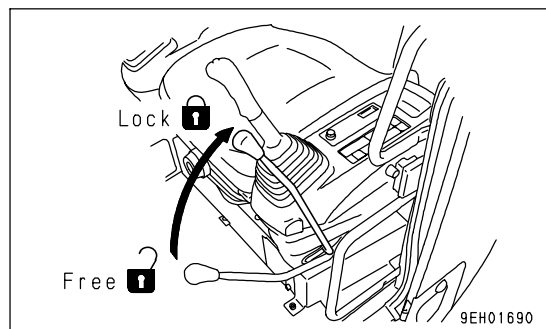

6. Remove cover (1) at the top surface of the hydraulic tank, then slowly loosen oil filler cap (F) to release the internal pressure.

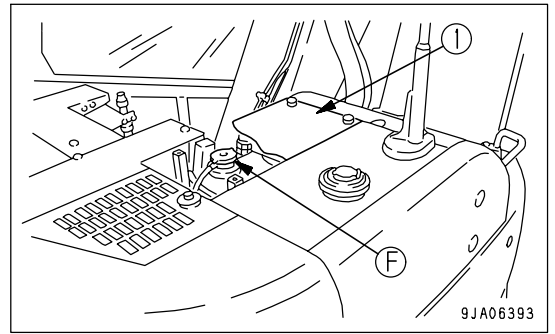

EVERY 4000 HOURS MAINTENANCE

Maintenance for every 50, 100, 250, 500, 1000 and 2000 hours service should be carried out at the same time.

CHECK WATER PUMP

Check that there is no play in the pulley, leakage of oil or water, or clogging of the drain hole. If any problem is found, please contact your Komatsu distributor for repairs or replacement.

REPLACE ACCUMULATOR (FOR CONTROL CIRCUIT)

Replace the accumulator every 2 years or every 4000 hours, whichever comes sooner.



WARNING

The accumulator is charged with high-pressure nitrogen gas, so mistaken operation may cause an explosion, which will lead to serious injury or damage. When handling the accumulator, always do as follows.

- The pressure in the hydraulic circuit cannot be completely removed. When removing the hydraulic equipment, do not stand in the direction that the oil spurts out when carrying out the operation. In addition, loosen the bolts slowly when carrying out the operation.
- Do not disassemble the accumulator.
- Do not bring it near flame or dispose of it in fire.
- Do not make holes in it or weld it.
- Do not hit it, roll it, or subject it to any impact.
- When disposing of the accumulator, the gas must be released. Please contact your Komatsu distributor to have this work carried out.

If operations are continued after the performance of the accumulator has dropped, it will be impossible to release the remaining pressure in the hydraulic circuit if there should be a failure on the machine. Please ask your Komatsu distributor to replace the accumulator.

The accumulator is installed to the position shown in the diagram on the right.

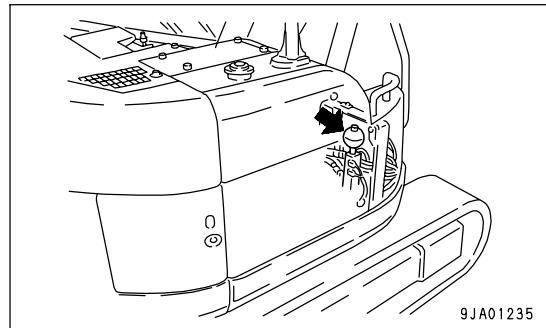

EVERY 5000 HOURS MAINTENANCE

Maintenance for every 50, 100, 250, 500 and 1000 hours service should be carried out at the same time.

CHANGE OIL IN HYDRAULIC TANK

 **WARNING**

- The parts and oil are at high temperature immediately after the engine is stopped, and may cause burns. Wait for the temperature to go down before starting the work.
- When removing the oil filler cap, turn it slowly to release the internal pressure, then remove it.

NOTICE

If the machine is equipped with a hydraulic breaker, the hydraulic oil will deteriorate much faster than during normal bucket operations. For details, see "MAINTENANCE INTERVAL FOR HYDRAULIC BREAKER (PAGE 4-15)" when carrying out maintenance.

- Refill, capacity: 69 liters (18.22 US gal)
 - Prepare a handle (for the socket wrench).
1. Swing so that the drain plug at the bottom of the hydraulic tank is in the middle between the left and right tracks.
 2. Retract the arm and bucket cylinders, then lower the boom and put the teeth in contact with the ground.
 3. Set the lock lever to the LOCK position and stop the engine.

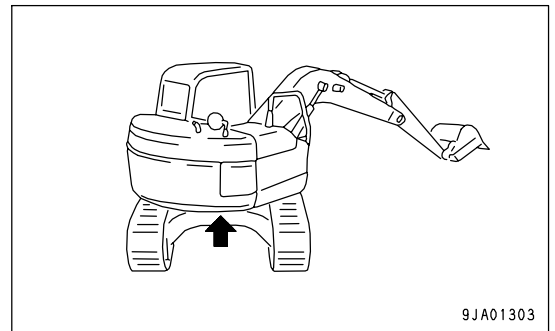

4. Remove cover (1) at the top of the hydraulic tank.
Remove the cap of oil filler (F) over the hydraulic tank.

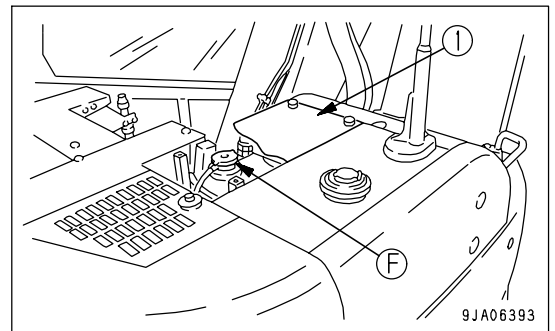

5. Set the oil container under the drain plug under the machine.
Using the handle, remove drain plug (P) and drain the oil.
Check the O-ring installed to plug (P), and if it is damaged, replace the O-ring. After draining the oil, tighten drain plug (P).
Tightening torque: 69 ± 10 N·m (7 ± 1 kgf·m, 51 ± 7 lbf·ft).

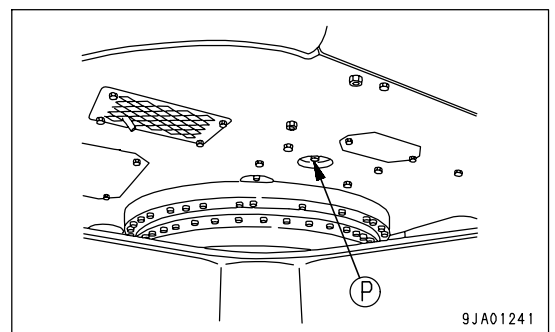

- Take care not to get oil on yourself when you remove drain plug (P).

6. Add the specified amount of new and clean oil through oil filler port (F). Check that the oil level is between H and L on the sight gauge.
For details of oil level check, see "Check Oil Level in Hydraulic Tank, Add Oil (PAGE 3-57)".

SPECIFICATIONS

SPECIFICATIONS

PC138US-2

	Item	Unit	Standard specification	Blade specification
	Operating weight	kg (lb)	13,400 (29,547)	14,050 (30,980)
	Bucket capacity	m ³ (cu.yd)	0.50 (0.65)	
	Name of engine	-	Komatsu SAA4D95LE-3-A diesel engine	
	Engine horsepower	kW (HP)/rpm	66.2 (88.7)/2,200	
A	Overall length (Standard specification)	mm (ft in)	7,260 (23' 10")	-
A'	Overall length (Blade specification)	mm (ft in)	-	7,970 (26' 2")
B	Overall height	mm (ft in)	2,850 (9' 4")	
C	Overall width	mm (ft in)	2,515 (8' 3")	
D	Track width	mm (ft in)	500 (1' 8")	
E	Tail swing radius	mm (ft in)	1,480 (4' 10")	
F	Length of track	mm (ft in)	3,610 (11' 10")	
G	Tumbler canter distance	mm (ft in)	2,880 (9' 5")	
H	Cab height	mm (ft in)	2,815 (9' 3")	
	Min. ground clearance	mm (ft in)	395 (1' 4")	
	Travel speed (Low/High)	km/h (MPH)	2.9/5.1 (1.8/3.2)	
	Continuous swing speed	rpm	11.0	

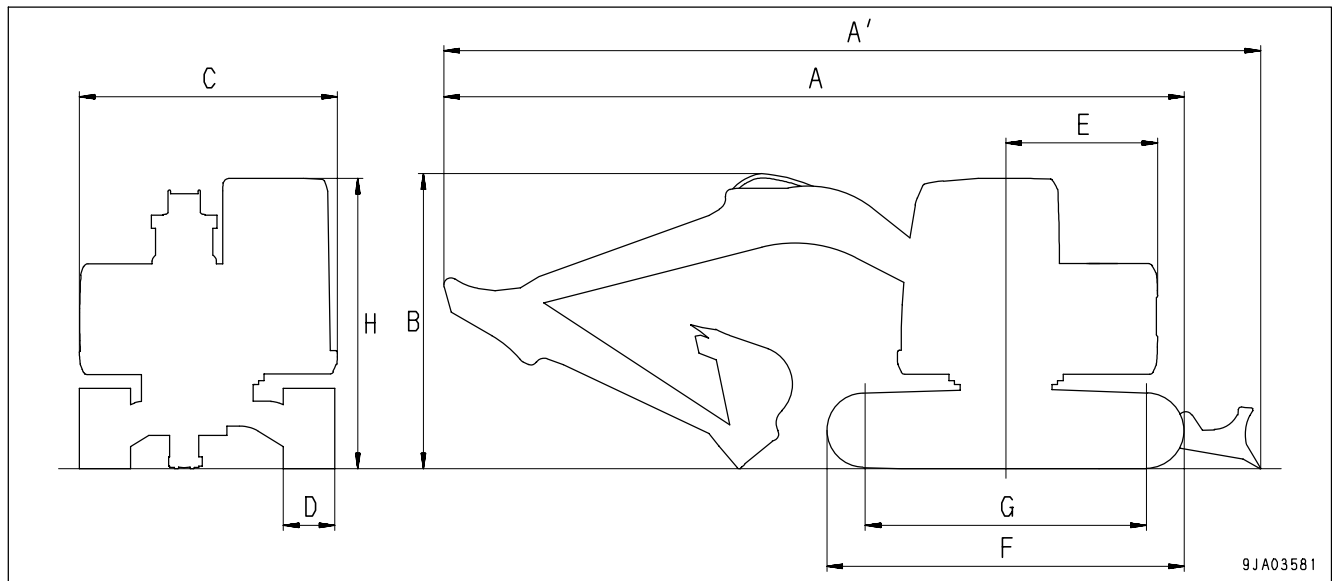

PC138USLC-2

	Item	Unit	Standard specification	Blade specification
	Operating weight	kg (lb)	14,000 (30,870)	14,370 (31,686)
	Bucket capacity	m ³ (cu.yd)	0.50 (0.65)	
	Name of engine	-	Komatsu SAA4D95LE-3-A diesel engine	
	Engine horsepower	kW (HP)/rpm	66.2 (88.7)/2,200	
A	Overall length (Standard specification)	mm (ft in)	7,390 (24' 3")	-
A'	Overall length (Blade specification)	mm (ft in)	-	8,035 (26' 4")
B	Overall height	mm (ft in)	2,850 (9' 4")	
C	Overall width	mm (ft in)	2,590 (8' 6")	-
C'	Overall width (Blade specification)	mm (ft in)	-	2,515 (8' 3")
D	Track width	mm (ft in)	600 (1' 12")	500 (1' 8")
E	Tail swing radius	mm (ft in)	1,480 (4' 10")	
F	Length of track	mm (ft in)	3,870 (12' 8")	
G	Tumbler canter distance	mm (ft in)	3,140 (10' 4")	
H	Cab height	mm (ft in)	2,815 (9' 3")	
	Min. ground clearance	mm (ft in)	395 (1' 4")	
	Travel speed (Low/High)	km/h (MPH)	2.9/5.1 (1.8/3.2)	
	Continuous swing speed	rpm	11.0	

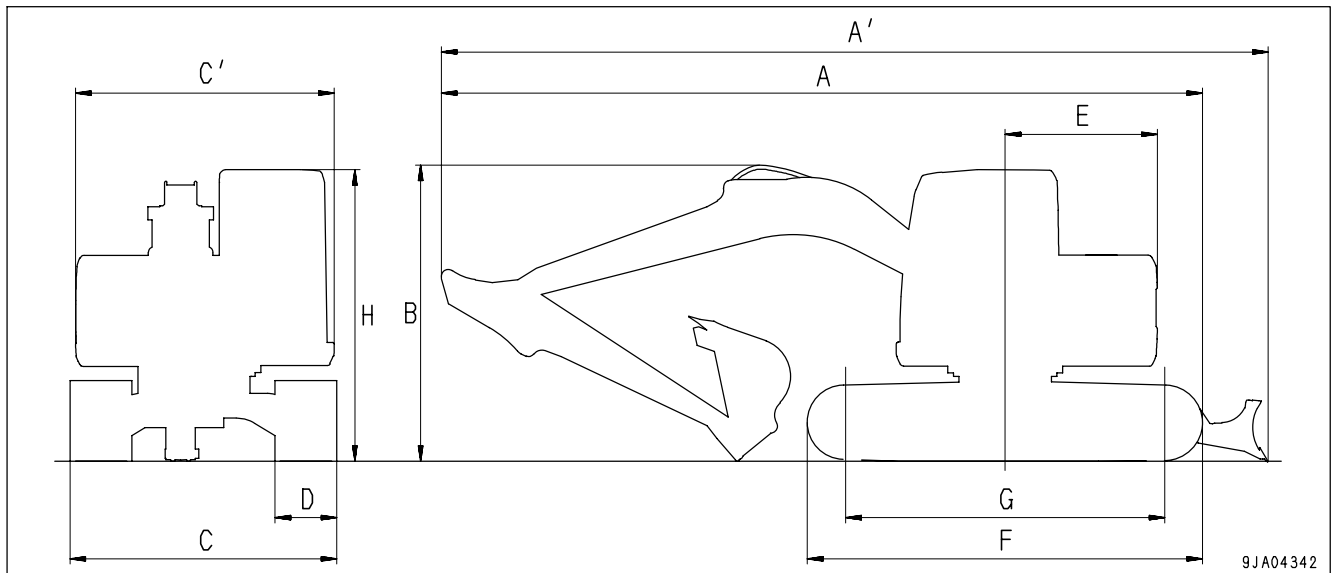

	Working ranges	Unit	PC138US-2	PC138USLC-2
A	Max. digging reach	mm (ft in)	8,300 (27' 3")	
B	Max. digging depth	mm (ft in)	5,480 (17' 2")	
C	Max. digging height	mm (ft in)	9,340 (30' 8")	
D	Max. vertical wall digging depth	mm (ft in)	4,900 (16' 1")	
E	Max. dumping height	mm (ft in)	6,840 (22' 5")	
F	Min. swing radius of work equipment	mm (ft in)	1,980 (6' 6")	
G	Max. reach ground level	mm (ft in)	8,180 (26' 10")	
H	Max. blade lifting height	mm (ft in)	470 (1' 7")	
I	Max. blade lowering depth	mm (ft in)	525 (1' 9")	490 (1' 7")

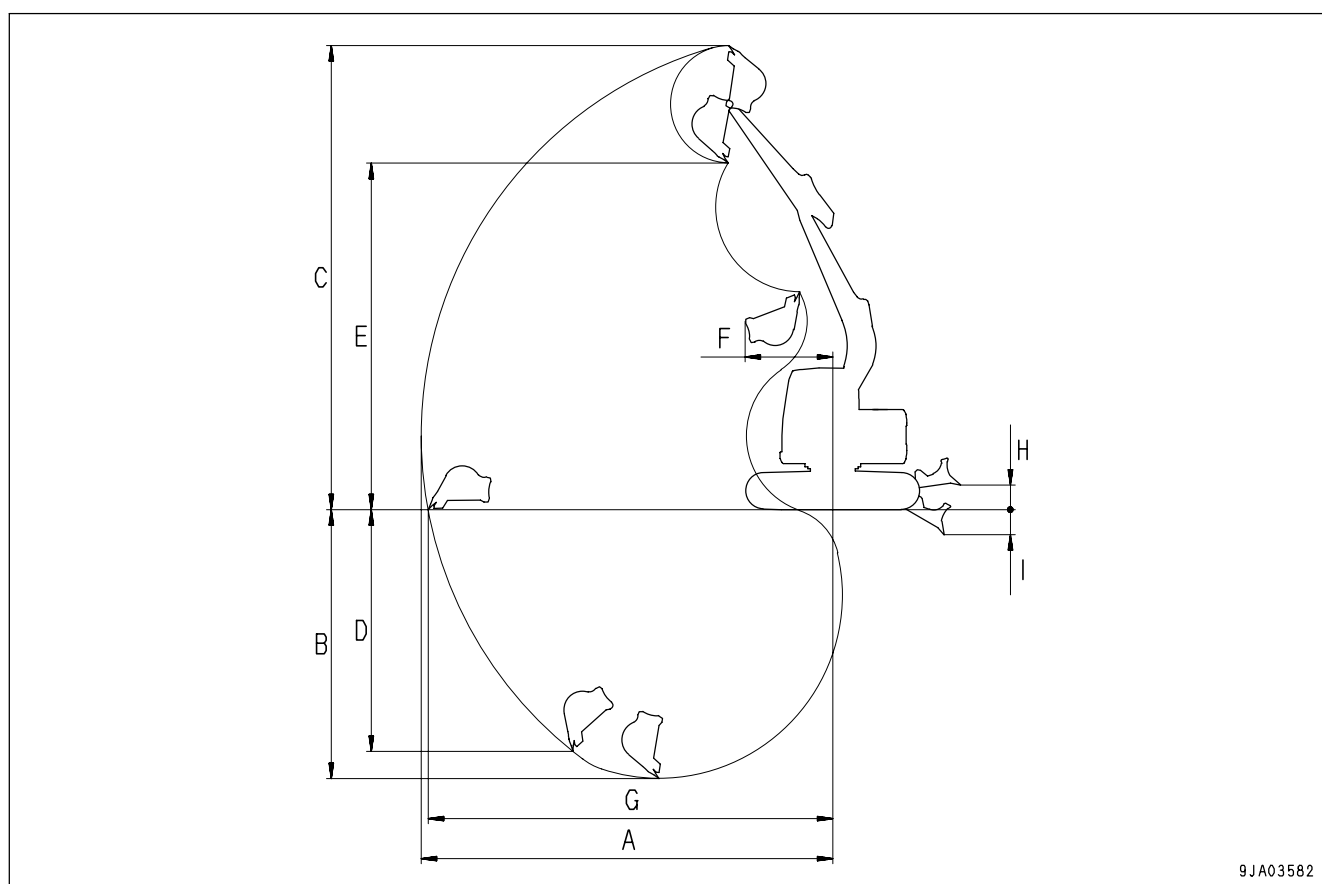

9JA03582

ATTACHMENTS, OPTIONS

 **WARNING**

Please read and make sure that you understand the SAFETY section before reading this section.

ATTACHMENTS AND OPTIONS - GENERAL INFORMATION

SAFETY FIRST

If attachments or options other than those authorized by Komatsu are installed, this will not only affect the life of the machine, but will also cause problems with safety.

When installing attachments not listed in this Operation and Maintenance Manual, contact your Komatsu distributor first.

If you do not contact Komatsu, we cannot accept any responsibility for any accidents or failures.



WARNING

General precautions

- Read the instruction manual for the attachment thoroughly, and do not use this attachment unless you are sure that you have understood the guides completely.
If you lose the instruction manual, always ask the manufacturer or your Komatsu distributor for a new copy.
- Depending on the attachment, install the necessary front guard on the machine.
- Depending on the attachment, the impact noise may make it difficult for fellow workers to transmit instructions for the operation. Before starting operation, decide a leader and determine the signals to be used.
- Do not carry out swinging operations to the side with a heavy load on the attachment. This is particularly dangerous on slopes.
- Comparing with a machine equipped with a bucket, a machine equipped with a breaker has a heavy load at the front of the work equipment and is unstable. To avoid a hazard of tipping over, do not carry out operations with the attachment swung to the side.
- When an attachment is installed, the swing range and center of gravity of the machine are different, and the machine may move in an unexpected way. Be sure that you understand the condition of the machine properly.
- Before starting operations, set up a fence around the machine to prevent people from entering.
Never operate the machine when there are people near the machine.
- To prevent serious accidents caused by misoperation, do not put your foot on the pedal except when operating the pedal.

Precautions for removal and installation operations

When removing or installing the attachments, obey the following precautions and take care to ensure safety during the operation.

- Carry out the removal and installation operation on a flat, firm ground surface.
- When the operation is carried out by two or more workers, determine the signals and follow these during the operation.
- When carrying heavy objects (more than 25 kg or 55 lb), use a crane.
- When removing heavy parts, always support the part before removing it.
When lifting such as heavy parts with a crane, always pay careful attention to the position of the center of gravity.
- It is dangerous to carry out operations with the load kept suspended. Always set the load on a stand, and check that it is safe.
- When removing or installing attachments, make sure that it is in a stable condition and will not fall over.
- Never go under a load suspended from a crane.
Always stand in a position that is safe even if the load should fall.

NOTICE

Qualifications are required to operate a crane. Never allow the crane to be operated by an unqualified person.

For details of removal and installation operations, contact your Komatsu distributor.

ATTACHMENT INSTALLATION

! WARNING

Long work equipment or heavy work equipment cause the machine to have poor stability, so there is danger of the machine losing its balance and tipping over when traveling down steep hills or when swinging on slopes. Never do any of the following. They are extremely dangerous.

- Traveling downhill with the work equipment raised
- Traveling across slopes
- Swinging upper structure on slopes
- If heavy-load work equipment is installed, there will be excessive overrun when swinging (the distance from operating to stop the swing to the point where the swing stops completely), so there is danger of mistaking the distance and hitting other objects.

Allow a margin to the stopping point when operating.

In addition, the hydraulic drift (the gradual downward movement caused by the weight of the work equipment when the work equipment is stopped in a raised condition) will also increase.

- If the correct procedure is not used when installing the boom and arm, it may lead to serious damage. Please consult your Komatsu distributor.
- When long work equipment is installed, the working range will suddenly become larger, so there is danger of mistaking the distance and hitting other objects. Allow an ample margin between the work equipment and surrounding obstacles when operating.

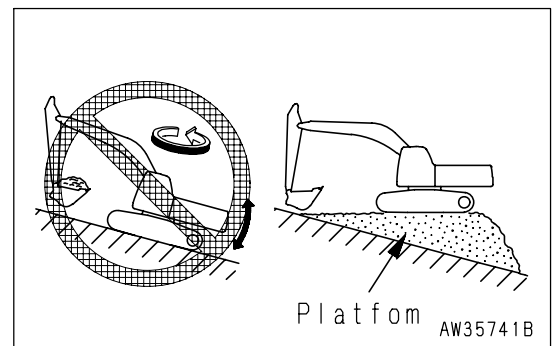
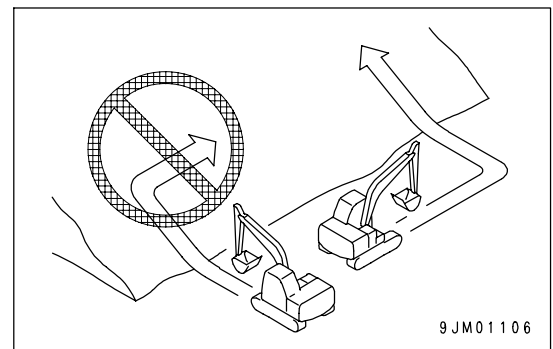
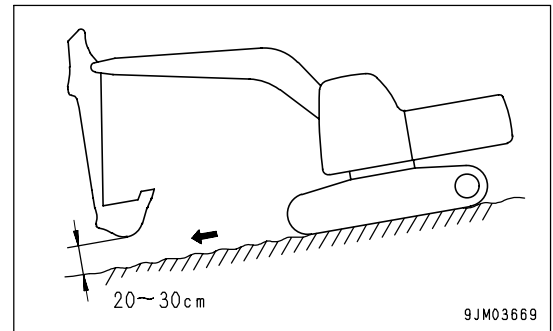

BUCKET WITH HOOK

HOOK CONDITION

Check that there is no damage to the hook, stopper, or hook mount. If there is any problem, contact your Komatsu distributor.

PROHIBITED OPERATIONS

Operations with Care

- Do not exceed the following loads when carrying out lifting operations.
 When standard arm is installed: 700 kg (1544 lb)
 When long arm is installed: 500 kg (1103 lb)
- It is dangerous if the load sways excessively. Lower the engine speed and operate the control levers slowly.
- The swing speed of this machine is 3 to 4 times the speed of a mobile crane. Be particularly careful to check that the surrounding area is safe when operating the swing.
- Check that there is no damage to the hook, stopper, and hook mount. If any problem is found, please contact your Komatsu distributor.
- Never travel the machine while lifting a load.
- Depending on the operating posture, there is danger that the wire or pulley may come off from the hook. To avoid these parts from coming off, pay careful attention to the angle of the hook. In addition, do not allow any person to come under or in the area around a raised load.
- If the bucket with hook is turned and used for operations, it will hit the arm during dumping operations, be careful when using it.
- If a hook is to be installed, please consult your Komatsu distributor.
- If you are planning to newly install a hook, contact your Komatsu distributor.

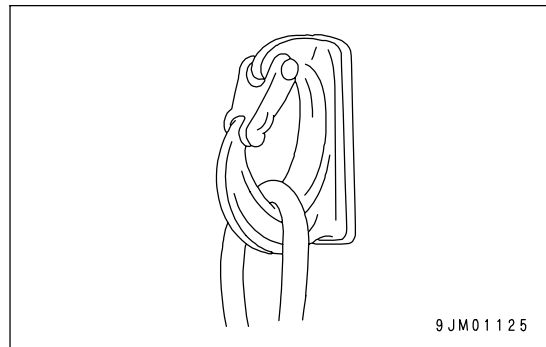
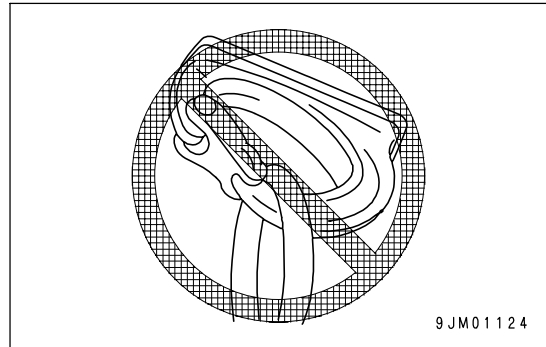

AIR CONDITIONER

(Auto air conditioner)

AIR CONDITIONER CONTROL PANEL

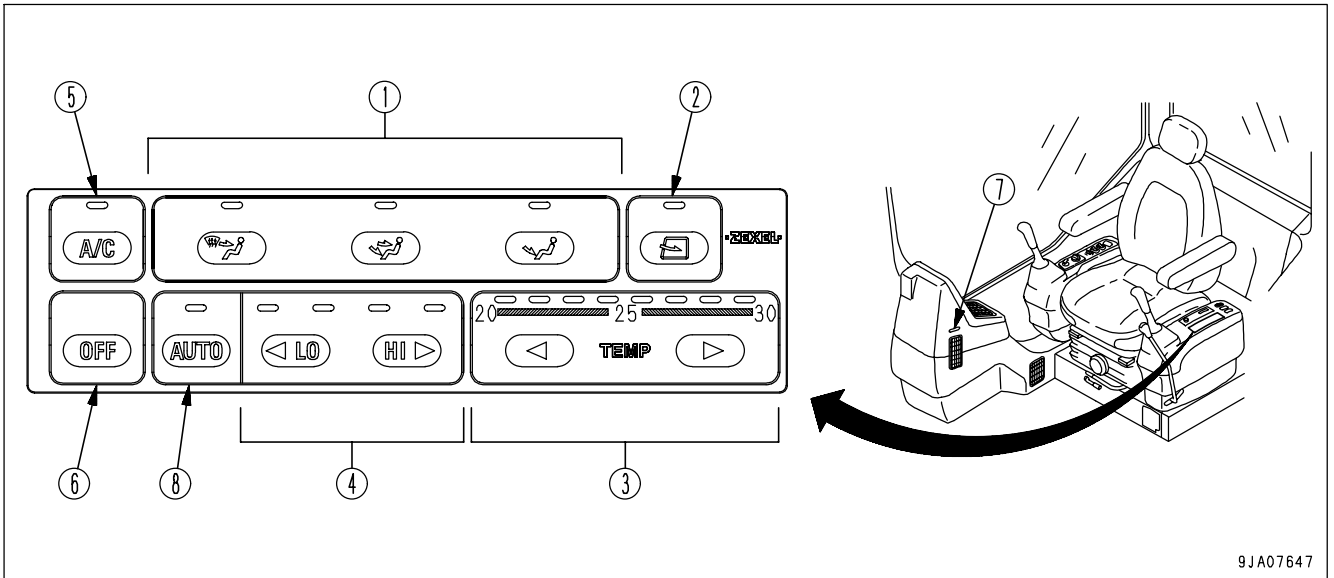

9JA07647

- | | |
|-------------------------------------|---------------------------------|
| (1) Vent selector switch | (5) Air conditioner switch |
| (2) Air circulation selector switch | (6) Off switch |
| (3) Temperature control switch | (7) Defroster selector lever |
| (4) Air flow selector switch | (8) Auto air conditioner switch |

Vent Selector Switch (Air Flow to Upper Part of Body)

If this switch (1) is pressed, the air from the air conditioner is all directed to the face. This can be used to send a cool breeze to the face during hot weather.

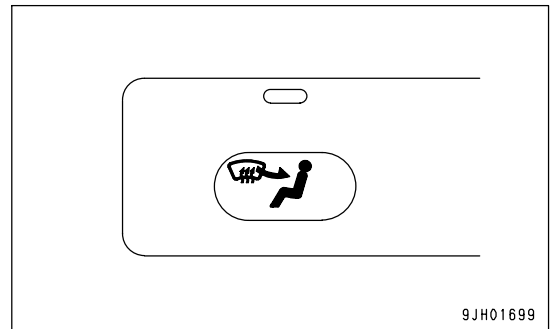

9JH01699

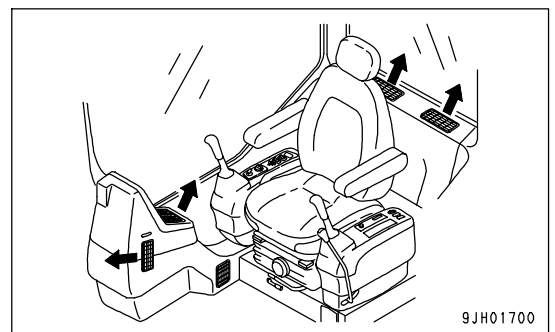

9JH01700

Vent Selector Switch (Air Flow to Upper Part of Body and Foot)

If this switch (1) is pressed, the air from the air conditioner is directed to the face and feet.

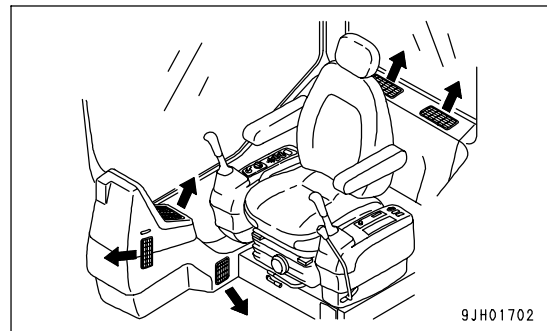
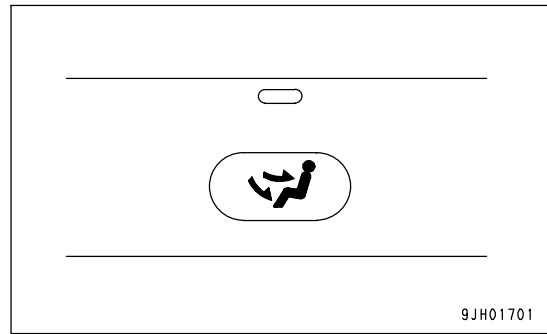

Vent Selector Switch (Air Flow to Foot)

If switch (1) is pressed, the air from the air conditioner is all directed to the feet.

This can be used to send warm air to the feet during cold weather.

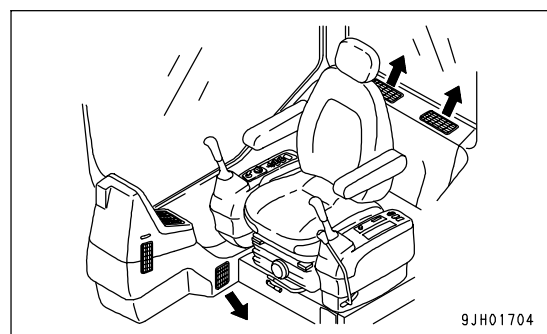
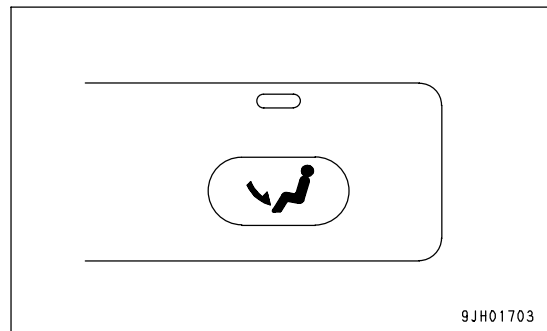

Air Circulation Selector Switch (External Air Circulation)

When switch (2) is pressed, fresh air is taken into the cab during heating or cooling.

This position is used to bring in clean fresh air into the cab or to remove the mist from the cab windows.

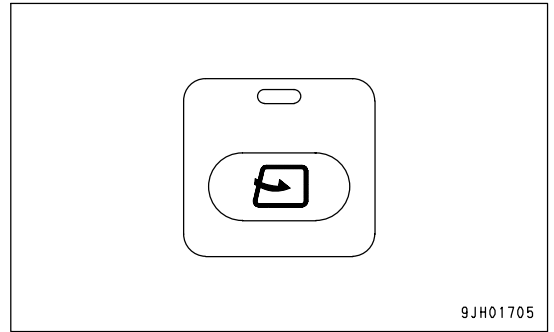

Air Circulation Selector Switch (Internal Air Circulation)

When switch (2) is pressed, the air inside the cab is recirculated and no fresh air is taken in from outside. This position is used when heating or cooling the cab quickly or when the outside air is dirty.

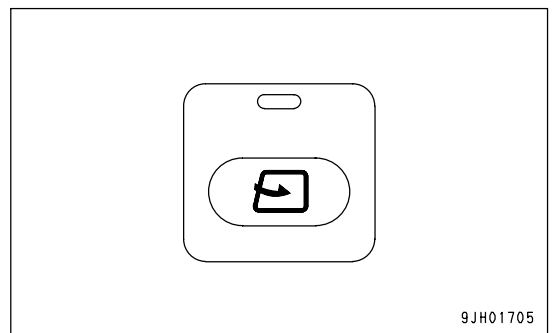

Temperature Control Switch

The closer the lighted lamp is to the "20" mark, the lower the temperature is. The closer the lighted lamp is to the "30" mark, the higher the temperature is.

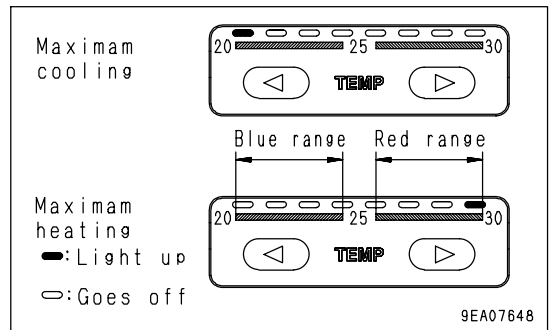

Temperature Control Switch (Cooling)

Use switch (3) to reduce the temperature.

Press this switch to reduce the temperature of the air sent from the air conditioner.

The more times the switch is pressed, the lower the temperature becomes, as the indicator light moves to the "20".

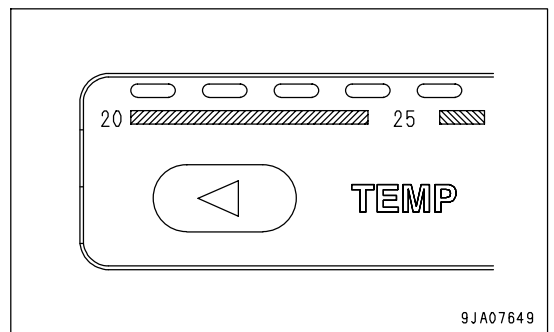

Temperature Control Switch (Heating)

Use switch (3) to increase the temperature.

Press this switch to increase the temperature of the air sent from the air conditioner.

The more times the switch is pressed, higher the temperature becomes, as the indicator light moves to the "30".

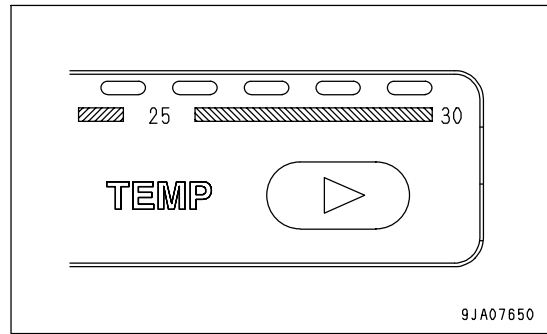

Air Flow Selector Switch

The further it is moved into the LO range (rear of machine), the smaller the air flow becomes; the further it is moved into the HI range (front of machine), the greater the air flow becomes.

The range is divided into 4 levels.

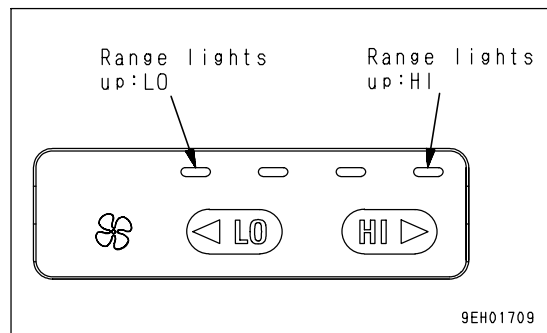

Air Flow Selector Switch (Low)

Switch (4) is used to set the flow of air from the air conditioner to Low.

Press this switch to reduce the air flow. The further it is moved into the LO range (rear of machine), the smaller the air flow becomes.

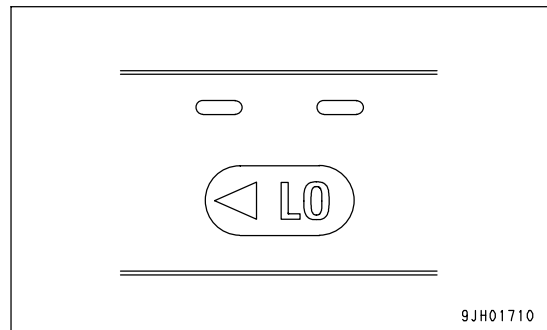

Air Flow Selector Switch (High)

This switch (4) it is used to adjust the amount of air flowing from the air conditioner vents.

To increase the air flow, press this switch. The more it is moved to the HI position (front of machine), the stronger the air flow becomes.

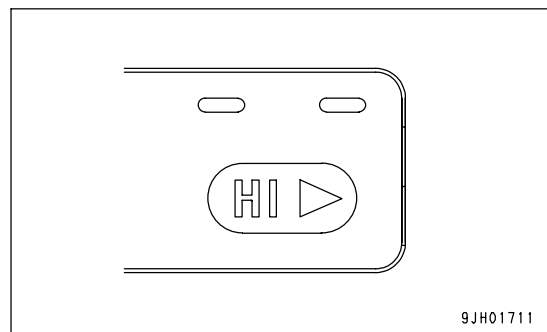

Air Conditioner Switch

Switch (5) is used to switch the air conditioner functions ON/OFF.

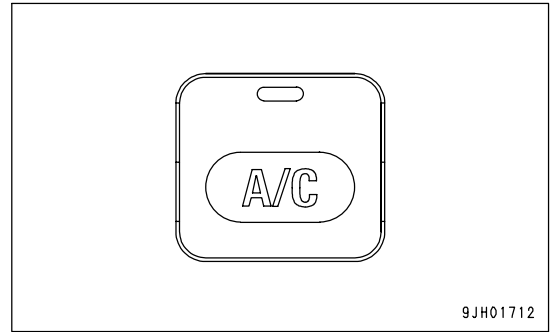

Off Switch

Switch (6) is used to stop operation of the fan.

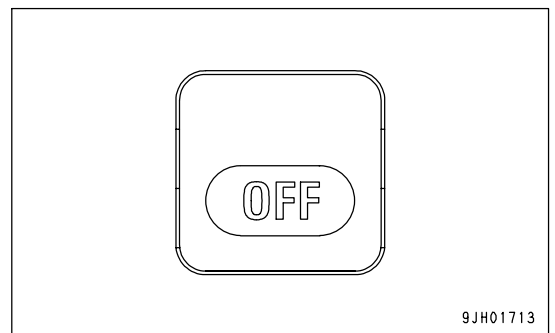

Defroster Selector Lever

Switch (7) is used to remove the mist from the front glass during cold or rainy weather.

Selector lever to front: To defroster (open)

Selector lever to rear: Closed

The defroster can be used when the vent selector switch is set to send air to the face or to the face and the feet.

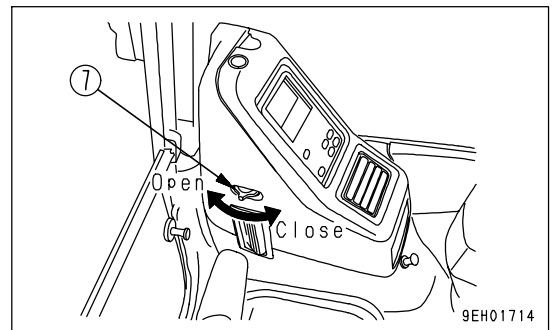

Auto Air Conditioner Switch

This switch (8) is used to automatically maintain the air temperature set by temperature control switch (3).

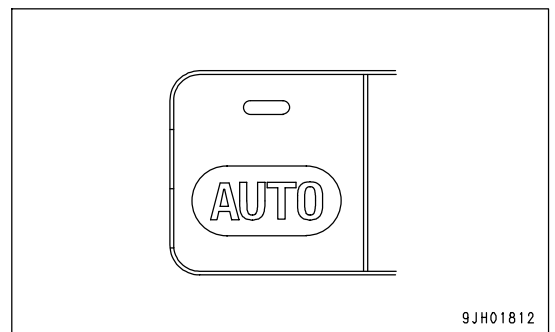

AIR CONDITIONER CONTROLS

Cooling

- If you smoke when the air conditioner is on, the smoke may start to hurt your eyes, so open the window and turn the lever to FRESH for a while to remove the smoke while continuing the cooling.

When running the air conditioner for a long time, turn the lever to the FRESH position once an hour to carry out ventilation and cooling.

Cooling with Care

- It is considered suitable for health reasons to set the cooling temperature so that it feels slightly cool when entering the cab (difference from outside temperature: 5 to 6°C (41 to 42.8°F)).

AIR CONDITIONER MAINTENANCE

When carrying out inspection of a machine equipped with an air conditioner, see the "MAINTENANCE SCHEDULE CHART (PAGE 4-14)" and carry out inspection according to the table.

MACHINE READY FOR ATTACHMENT

LOCATIONS

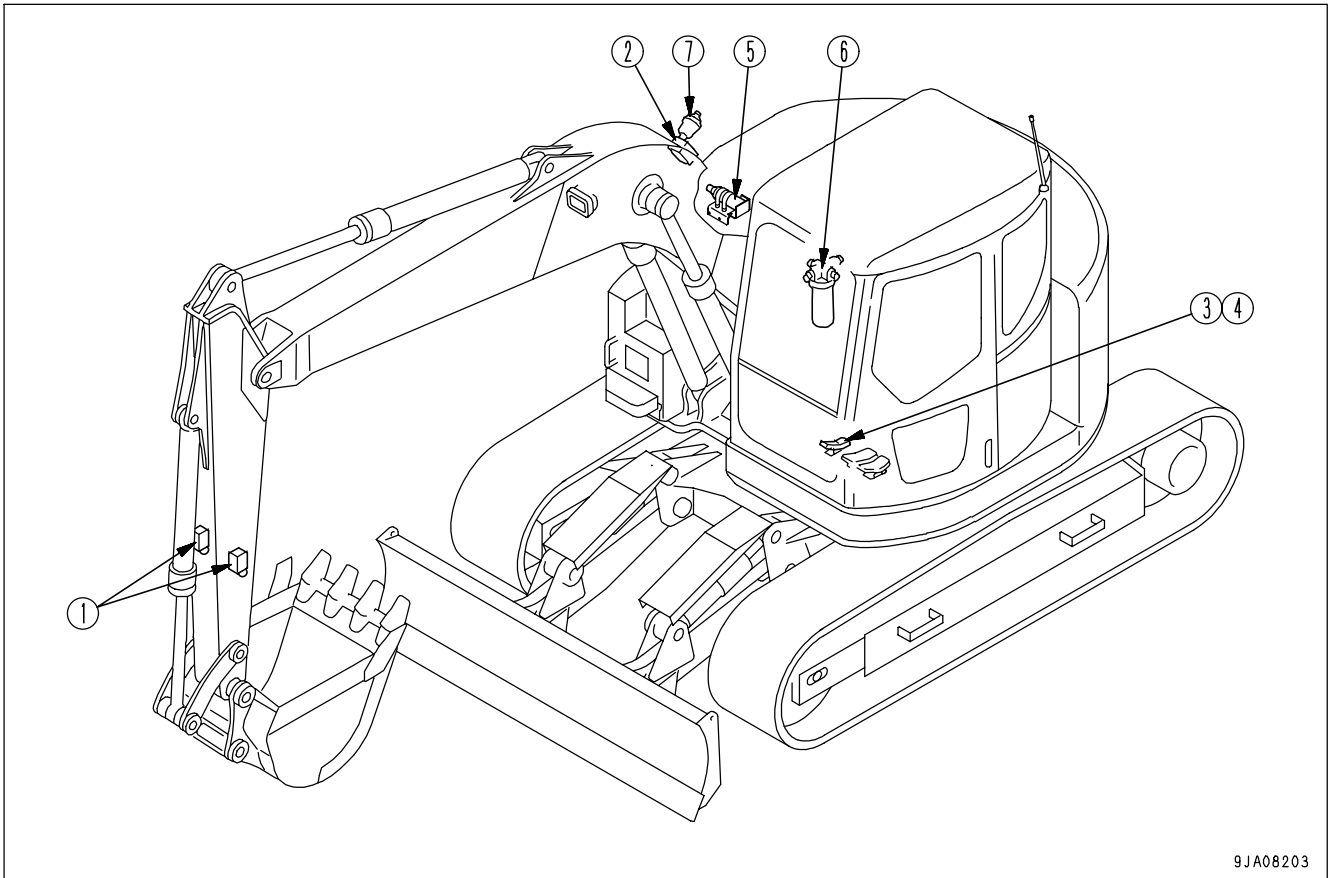

9JA08203

- | | |
|------------------------------|---|
| (1) Stop valve | (5) Accumulator (for attachment out circuit) |
| (2) Selector valve | (6) Breaker circuit additional oil filter |
| (3) Attachment control pedal | (7) Accumulator (for attachment return circuit) |
| (4) Lock pin | |

Stop Valve

This valve (1) stops the flow of the hydraulic oil.

(a) FREE: Hydraulic oil flows.

(b) LOCK: Hydraulic oil stops.

When removing or installing attachments, set this valve to the LOCK position.

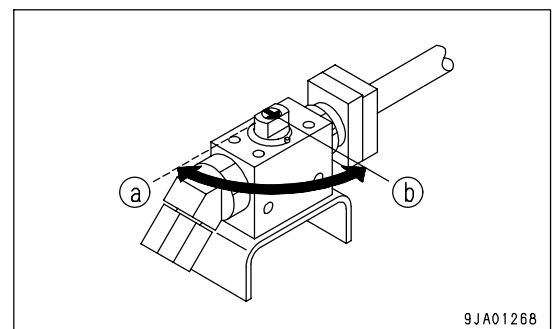

9JA01268

Selector Valve

This valve (2) selector the flow of the hydraulic oil.

Position (a) : When breaker is used

Position (b) : When general attachment is used (crusher, etc.)

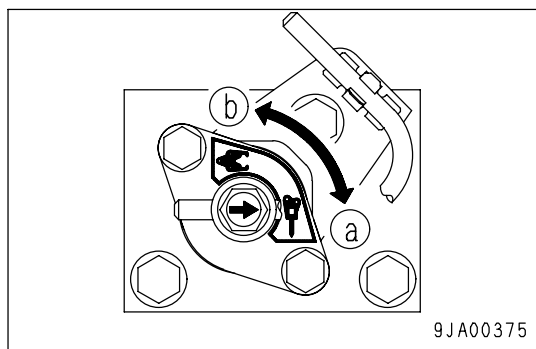

9JA00375

Attachment Control Pedal

This pedal (3) is used to operate the attachment.

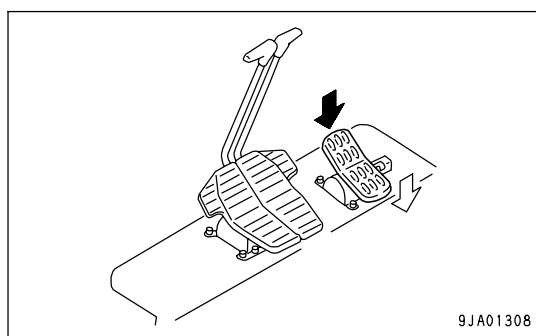

9JA01308

Lock Pin

This pin (4) locks the control pedal.

Position (a): Lock

Position (b): Pedal half stroke position (When using an attachment like the slide arm requiring a small flow rate or a breaker)

Position (c): Pedal full stroke position (When using an attachment like the crusher and power ripper requiring a large flow rate)

Keep the lock pin in the LOCK position when attachment is not used.

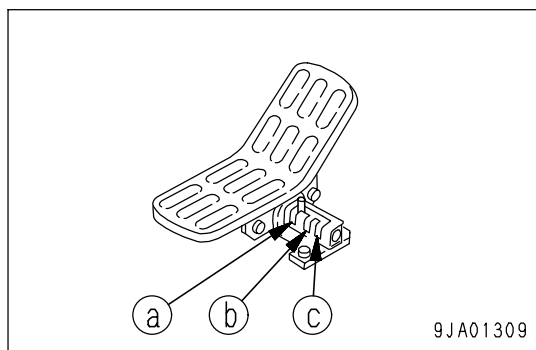

9JA01309

Accumulator (for Attachment Out Circuit)

(If equipped)

When a breaker is in use, this accumulator (5) serves to assure the number of breaker hammering by lowering pulsation in the hydraulic pump discharging pressure. Its another function is to protect the pump.

Consult each manufacturer of breaker to decide if an accumulator may well be installed on your machine.

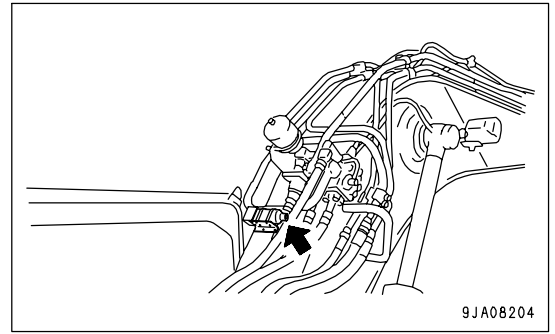

Table for Additional Circuit and Parts Required for Mounting Breaker

(○ white cirlet indicates an item necessary to install)

	Additional filter	Accumulator		Low-pressure safety valve	
		Attachment circuit	Control circuit	Main valve	Selector valve
Hydraulic breaker	○	○ (go/return)	○	○	○

- Cracking pressure of low-pressure safety valve
Main valve 24.53 MPa (250 kgf/cm², 3550.0 PSI)
Selector valve 17.17 MPa (175 kgf/cm², 2490.0 PSI)

Breaker Circuit Additional Oil Filter

This filter (6) is used to prevent deterioration of the hydraulic oil when using the breaker.

The oil flows through this only when the selector valve is at the breaker position.

NOTICE

Always install an additional filter in the return circuit on machines equipped with a hydraulic breaker.

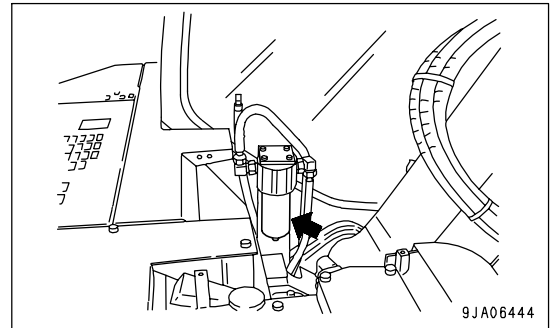

Accumulator (for Attachment Return Circuit)

(If equipped)

This accumulator (7) is installed to protect an oil cooler, when a breaker is used.

Consult each manufacturer of breaker to decide if an accumulator may well be installed in your machine.

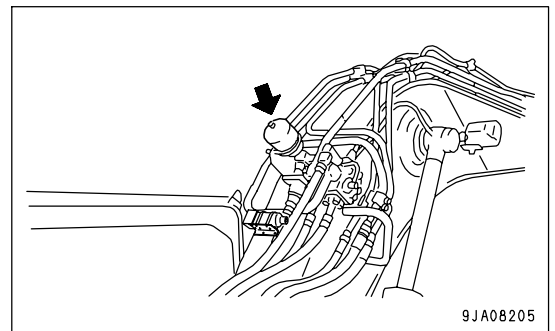

HYDRAULIC CIRCUIT

Hydraulic Circuit Connection

When connecting the attachment, connect the hydraulic circuit as follows.

One Line Attachment

1. Check that the stop valve is at the LOCK position, then remove the plug.
Be careful not to lose or damage any part that is removed.

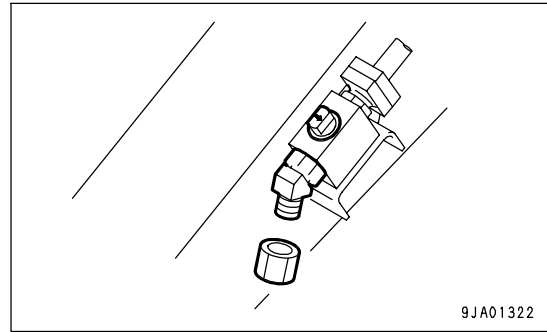

2. Connect the piping for the attachment provided by the attachment maker.
The dimensions on the stopper valve side are as indicated at right. For those on the attachment side, confer with each manufacturer of attachment and determine.

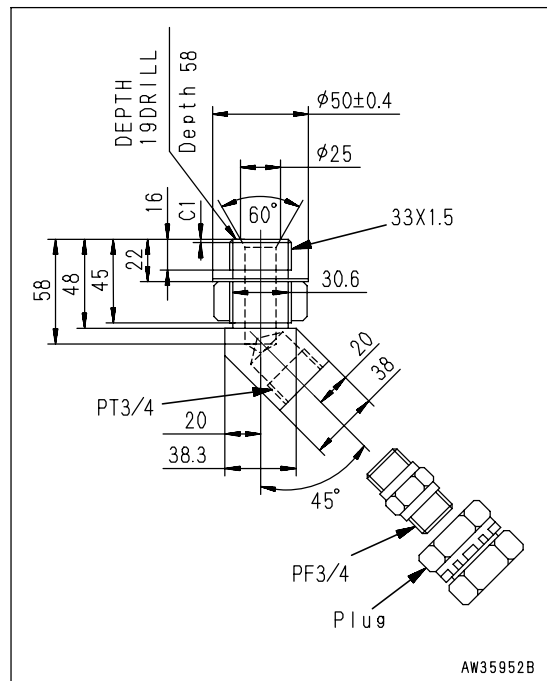

3. After connecting the piping, bleed the air from the circuit.
 - 1) Start the engine, referring to "STARTING ENGINE (PAGE 3-68)", and run it at low idle for the subsequent 10 minutes. Then proceed to the next work.
 - 2) Run the engine at low idle until the air in the attachment circuit is completely removed, then operate the attachment pedal repeatedly (approx. 10 times) to bleed the air.

NOTICE

If the attachment maker specifies an air bleeding procedure for the attachment itself, follow the specified procedure to bleed the air.

- 3) After completing the bleeding of the air, stop the engine, and wait for at least 5 minutes before starting operations. This will release the bubbles in the oil inside the tank.
- 4) Check that there is no oil leakage, and wipe off any oil that has been spilled.

ATTACHMENT REMOVAL AND INSTALLATION

Attachment Removal

1. Lower the attachment to the ground and stop the engine.
2. Turn the starting switch to ON position and push down the lock lever to FREE position.
3. Within 15 seconds after stopping the engine, move each control lever (for work equipment and travel) and attachment control pedal (if equipped) to the full stroke in all directions to release the internal pressure.

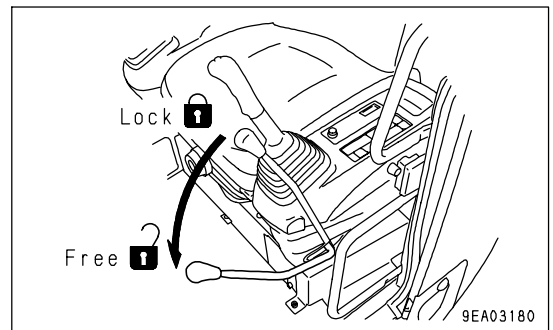
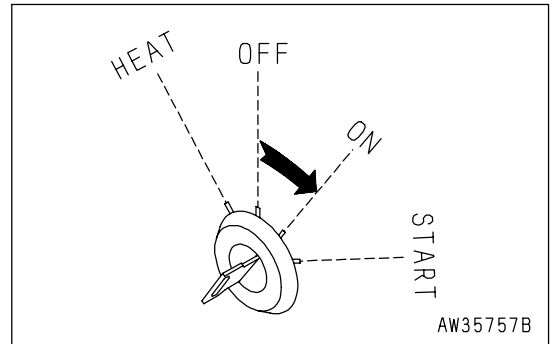

4. Set the lock lever to the LOCK position, then turn the starting switch to the OFF position.

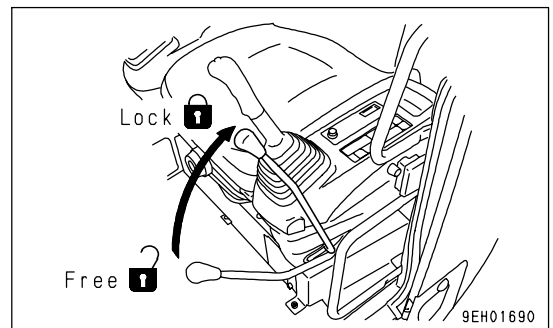

5. Remove cover (1) at the top surface of the hydraulic tank, then slowly loosen oil filler cap (F) to release the internal pressure.

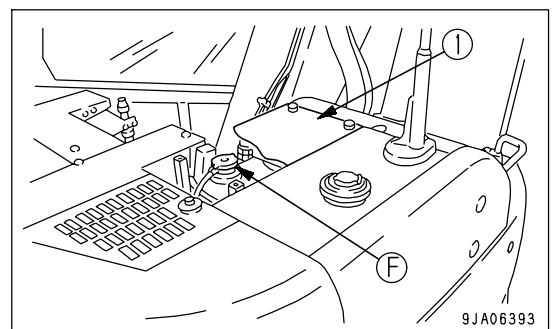

6. After checking that the oil temperature is low, turn the rotor of the stop valves installed to the inlet and outlet piping at the side of the arm to the OFF position.

7. Remove the hoses on the attachment side. Install the plugs to the two outlets.

The plugs are used to prevent the attachment from incorrect operation caused by mixing in of foreign matter. After the plugs are correctly installed, store the attachment.

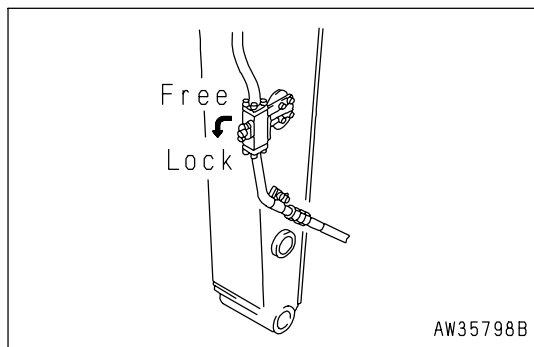

8. Pull out the mounting pins (2 places), remove the attachment, then install the bucket.

For details of the procedure for installing the bucket, see "BUCKET REPLACEMENT AND INVERSION (PAGE 3-96)".

9. After installing the bucket, check the oil level in the hydraulic tank.

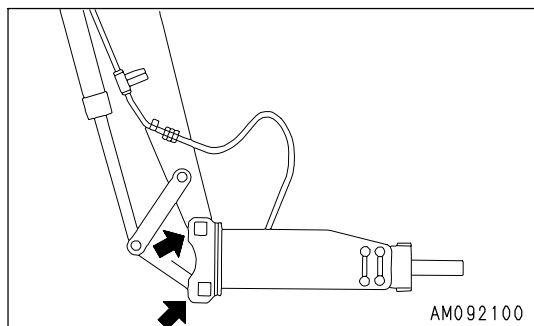

Attachment Installation

1. Remove the bucket.

For details of the procedure for removing the bucket, see "BUCKET REPLACEMENT AND INVERSION (PAGE 3-96)".

2. Place the attachment in a horizontal position, then install to the arm with pin (A) and then pin (B).

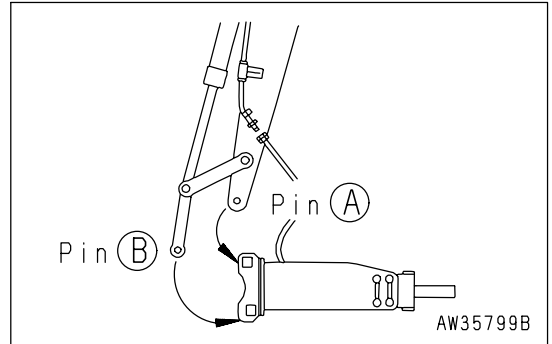

3. Turn the starting switch to ON position and push down the lock lever to FREE position.

4. Within 15 seconds after stopping the engine, move each control lever (for work equipment and travel) and attachment control pedal (if equipped) to the full stroke in all directions to release the internal pressure.

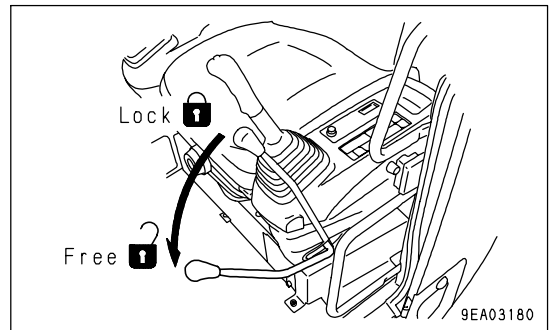
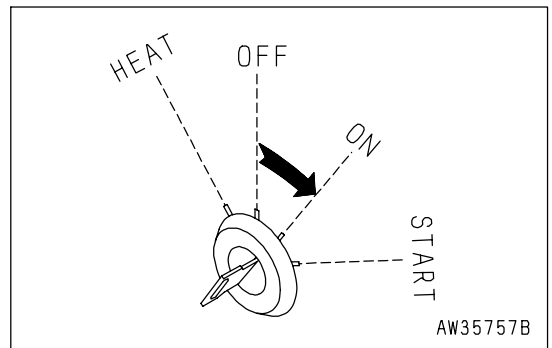

5. Set the lock lever to the LOCK position, then turn the starting switch to the OFF position.

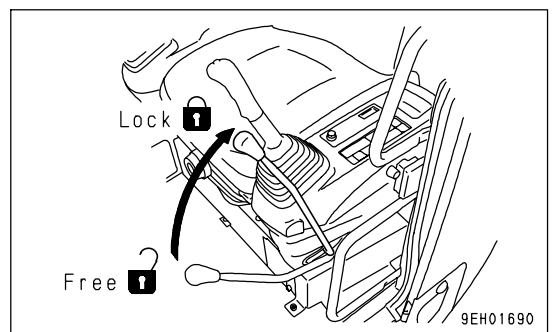

6. Remove cover (1) at the top surface of the hydraulic tank, then slowly loosen oil filler cap (F) to release the internal pressure.

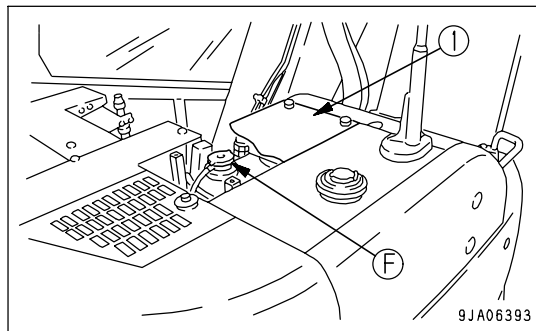

7. After checking that the oil temperature is low, remove the covers from the inlet port and outlet port (2 places). Be careful that no dirt or mud is stuck to the hose mouthpiece. If the O-ring is damaged, replace it with a new part.
8. Connect the hose at the attachment side. When doing this, check the direction of flow of the oil and be careful not to make any mistake.
9. Turn the rotor of the stop valves installed to the inlet and outlet piping at the side of the arm to the FREE position.
10. After installing the attachment, check the oil level in the hydraulic tank.

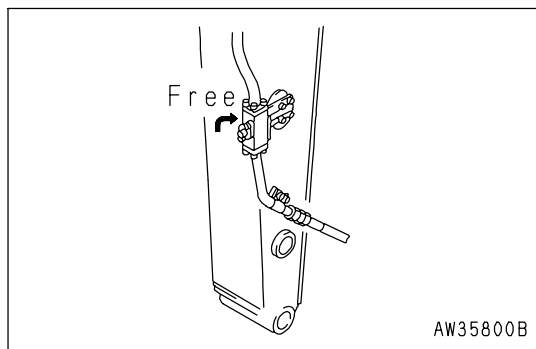

ATTACHMENT OPERATIONS

! WARNING

Do not put your foot on the pedal except when operating the pedal. If rest your foot on the pedal during operations, and it is depressed by accident, the attachment may move sudden and cause serious damage or injury.

Operate the attachment as follows.

When Using Breaker

1. If the pedal is depressed forward with lock pin (1) set at the full stroke position (c), the attachment begins to work.
2. After the work is finished, return the lock pin to the LOCK position (a) to lock the pedal.

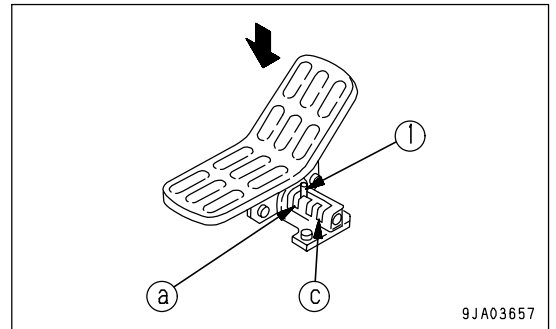

Set the working mode to B mode.

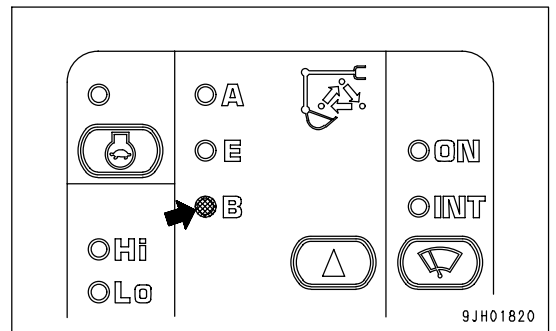

Precautions when Using

- Check that the stopper valve is in the FREE position.

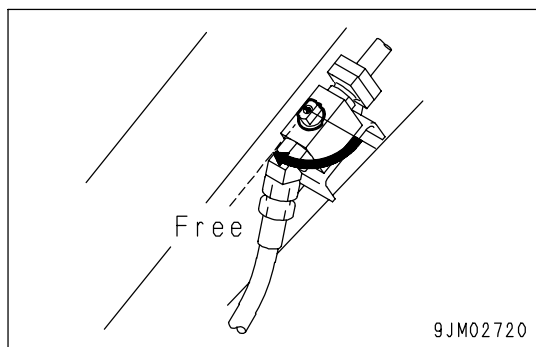

- Check that the selector valve is in the position for using the breaker.
- Check that selector valve locking bar (2) is properly installed at the position for breaker application.

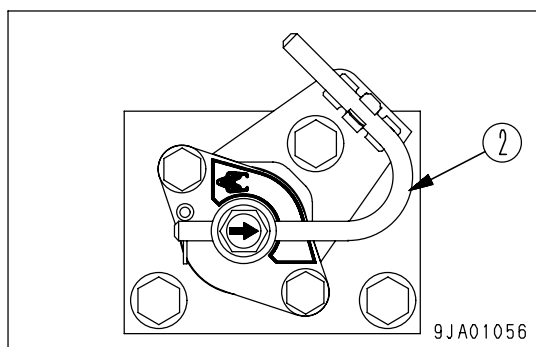

- Consult each manufacturer of breaker to decide if an accumulator for the breaker circuit may well be installed in your machine.
- For details of other precautions when handling the breaker, read and use correctly the instruction manual provided by the breaker manufacturer.
- When breaker is used, the hydraulic oil degrades faster than in normal operation. Shorten the maintenance interval of the hydraulic oil and filter element.

See "MAINTENANCE INTERVAL FOR HYDRAULIC BREAKER (PAGE 4-15)".

When Using General Attachment Such as Crusher

1. If the pedal is depressed with lock pin (1) set at the full stroke position (c), the attachment begins to work.
2. After the work is finished, return the lock pin to the LOCK position (a) to lock the pedal.

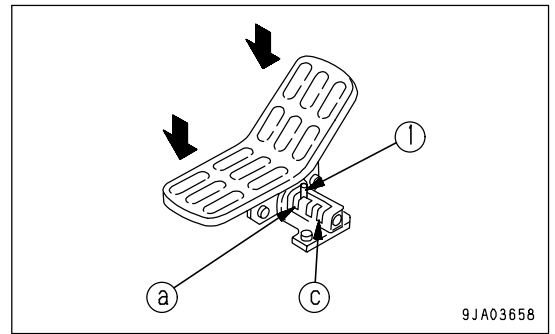

Precautions when Using

- Check that the stopper valve is in the FREE position.

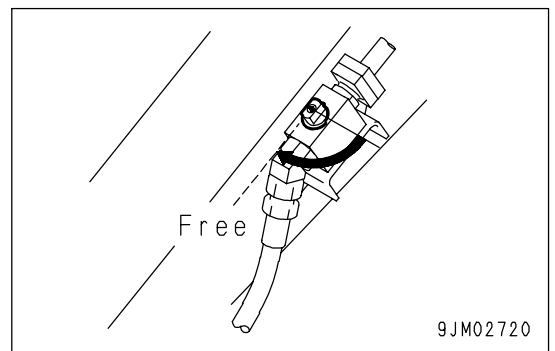

- Confirm that the selector valve is set to the position for general attachments such as the crusher.
- Check that selector valve locking bar (2) is properly installed at the position for general attachment application.

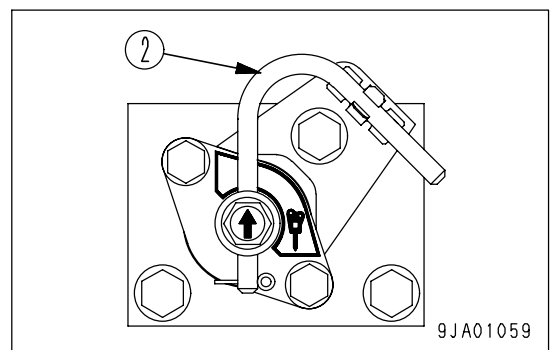

- For other precautions when using the attachment, see the instruction manual provided by the attachment manufacture.

LONG TERM STORAGE

If the equipment is not to be used for a long time, do as follows.

- Set the stop valve in the LOCK condition.
- Install a plug to the valve.
Install a plug to the stopvalve.
- Set the selector valve to the position for general attachments such as the crusher.
- Set the lock pin at the LOCK position.

If there is no breaker or general attachment installed, operating the pedal may cause overheating and other problems.

SPECIFICATIONS

Hydraulic specifications

- Oil flow

	Lock Pin position	Oil flow (liter/min)
(1)	Pedal lock	--
(2)	Half stroke	100
(3)	Full stroke	200

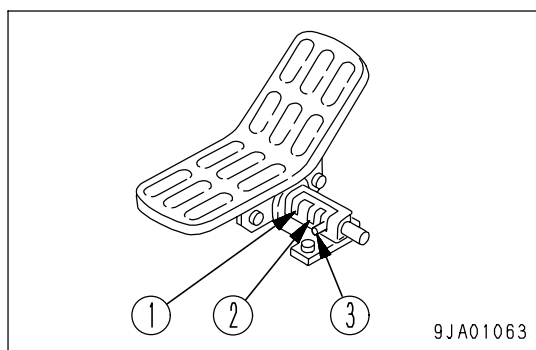

- Low pressure safety valve Cranking pressure
When using breaker: 17.17 MPa (175 kgf/cm², 2490.0 PSI)
When using other attachment: 24.53 MPa (250 kgf/cm², 3550.0 PSI)

ATTACHMENT GUIDE



WARNING

- Please read the instruction manual for the attachment and the sections of this manual related to attachments and options.
- When installing any attachment or option, there may be problems with safety, so please contact your Komatsu distributor before installing.
- Installing attachments or options without consulting your Komatsu distributor may not only cause problems with safety, but may also have an adverse effect on the operation of the machine and the life of the equipment.
- Any injuries, accidents, or damage resulting from the use of unauthorized attachments or options will not be the responsibility of Komatsu.

OTHER ATTACHMENTS

- Front half guard

This is to protect the operator. Always use this when operating on jobsites where there is danger from rocks or sand or other flying objects. (Breaker operations, etc.)

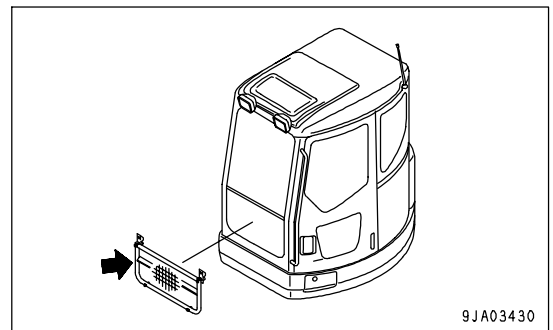

- Front full guard

This is to protect the operator. Always use this when operating on jobsites where there is danger from rocks or sand or other flying objects. (Demolition operations, etc.)

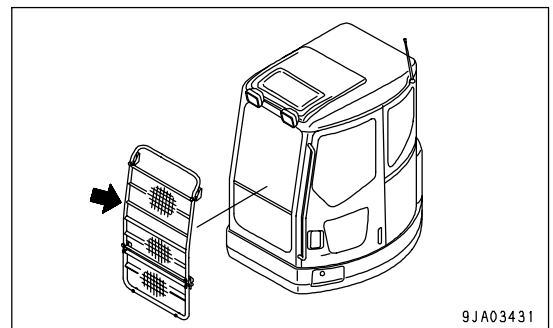

ATTACHMENT COMBINATIONS

**WARNING**

Depending on the type or combination of work equipment, there is danger that the work equipment may hit the cab or machine body.

When using unfamiliar work equipment for the first time, check before starting if there is any danger of interference, and operate with caution.

This is the combination table for attachments to install to the standard arm, short arm, or long arm.

○: Can be used

△: Can be used only for light duty work

×: Cannot be used

NOTICE

- When the long arm is equipped, if the bucket is pulled in to the machine body, the arm interferes with the body. Operate the long arm carefully.
- When the boom is fully lowered during oblique digging, the boom interferes with the undercarriage. Operate the boom carefully.

Categories of use

For general digging: Digging or loading sand, gravel, clay etc.

For light duty digging: Digging or loading dry, uncaked earth and sand, mud etc.

For loading work: Loading dry, loose earth and sand

- For digging or loading hard soil or soft rock, it is recommended that the strengthened bucket with high durability and high wear resistance be employed.

Name	Tooth mounting pin	Capacity m ³ (cu.yd) SAE/CECE	Outside width (bucket body) mm (in)	Outside width (side cutter) mm (in)	Use	Standard arm	Long arm	Short arm
Narrow bucket	Vertical	0.18/0.16 (0.24/0.21)	450 (17.7)	570 (22.5)	Narrow digging	○	○	○
Narrow bucket	Vertical Horizontal	0.29/0.26 (0.38/0.34)	600 (23.6)	720 (28.4)	Narrow digging	○	○	○
Narrow bucket	Vertical Horizontal	0.38/0.33 (0.50/0.43)	700 (27.6)	820 (32.3)	Narrow digging	○	○	○
Standard bucket	Vertical Horizontal	0.45/0.40 (0.59/0.52)	833 (32.8)	953 (37.5)	General digging	○	×	○
Reinforced bucket	Vertical Horizontal	0.50/0.45 (0.65/0.52)	859 (33.8)	979 (38.6)	Heavy-duty digging	○	×	○
Light duty bucket	Vertical Horizontal	0.50/0.45 (0.65/0.59)	859 (33.8)	979 (38.6)	General digging	○	×	△

SELECTION OF TRACK SHOES

Select the most suitable track shoe to match the operating conditions.

METHOD OF SELECTING SHOES

Check the category from the uses in the table below, then select the shoes from the table below that.

- Category of use B and C are the wide shoe, so there are limits on the use. Check the precautions for use, examine the conditions of use thoroughly, and use the optimum shoes for the situation.
- When selecting the shoe width, choose the narrowest shoes possible to bring the machine within the range where there is no problem regarding the machine flotation and ground contact pressure. If wider shoes than necessary are used, the load on the shoe will increase, this may cause problems such as bending of the shoe, cracking of the link, damage of the pin, and looseness of the shoe bolts.

Category	Use	Precautions when using
A	Rocky ground, riverbeds, normal soil	<ul style="list-style-type: none"> • On rough ground with large obstacles such as boulders or fallen trees, travel at low speed.
B	Normal soil, soft ground	<ul style="list-style-type: none"> • These shoes cannot be used on rough ground where there are large obstacles such as boulders or fallen trees. • Travel at high speed (Hi) only on flat ground. If it is impossible to avoid
C	Extremely soft ground (swamp)	<ul style="list-style-type: none"> • In the case of A and B, use only in places where the machine sinks and it is impossible to travel. • These shoes cannot be used on rough ground where there are large obstacles such as boulders or fallen trees. • Travel at high speed (Hi) only on flat ground. If it is impossible to avoid going over obstacles, travel slowly in low speed (Lo).
D	Paved road surfaces	<ul style="list-style-type: none"> • Be careful when using flat shoes on slopes. They have low gradeability.
E	Paved road surfaces	<ul style="list-style-type: none"> • To protect the road liner, always follow the precautions in Section

	PC138US		PC138USLC	
	Specification	Category	Specification	Category
Standard	500 mm (1 ft 8 in) Triple	A	600 mm (1 ft 12 in) Triple	B
Option	600 mm (1 ft 12 in) Triple	B	500 mm (1 ft 8 in) Triple	A
Option	700 mm (2 ft 4 in) Triple	C	500 mm (1 ft 8 in) Road liner	E
Option	500 mm (1 ft 8 in) Road liner	E		

RECOMMENDED ATTACHMENT OPERATIONS

Below described are instructions which must be followed without fail when doing the work using a hydraulic excavator equipped with an attachment.

NOTICE

Select the optimum model of attachment for a hydraulic excavator on which it is to be mounted.

- Depending on machine models of hydraulic excavator, the kind of attachments or the model of specific attachments that can be mounted will vary. Hence, consult your Komatsu distributor for the selection of optimum attachments.

HYDRAULIC BREAKER

Main Applications

- Crushed rock
- Demolition work
- Road construction

This attachment can be used for a wide range of applications including demolition of buildings, breaking up road surfaces or slag, tunnel work, rock crushing and breaking operations in quarries.

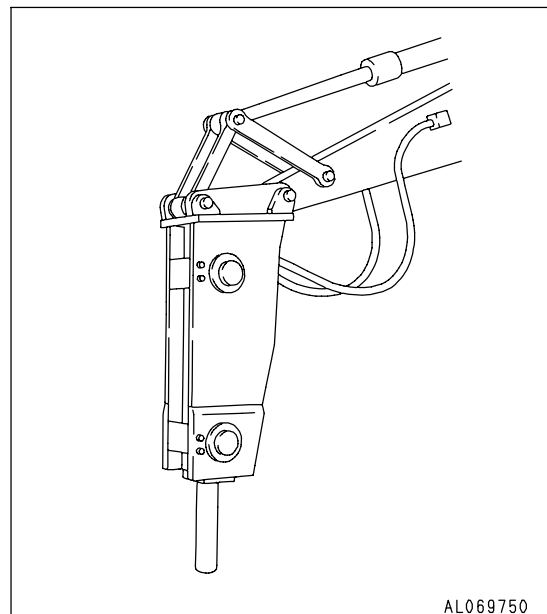

Keep the chisel pushed perpendicularly against the impact surface when carrying out breaking operations.

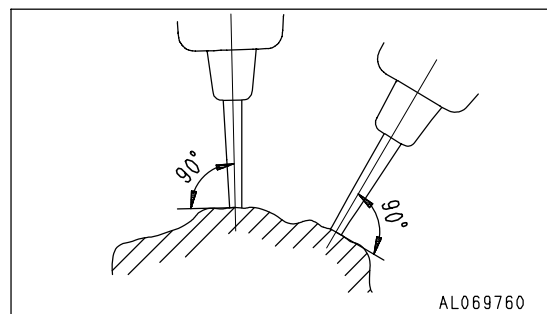

When applying impact, push the chisel against the impact surface and operate so that the chassis rises approx. 5 cm (2 in) off the ground. Do not let the machine come further off the ground than this amount.

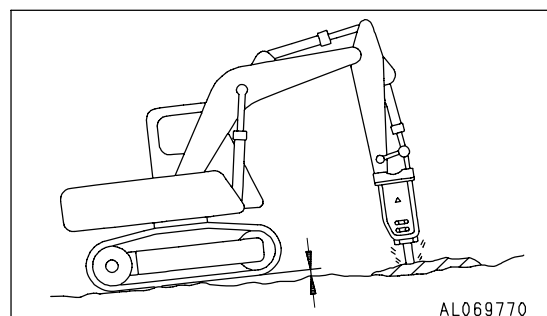

When applying continuous impact to the same impact surface, if the chisel does not penetrate or break the surface within 1 minute, change the point of impact and carry out breaking operations closer to the edge.

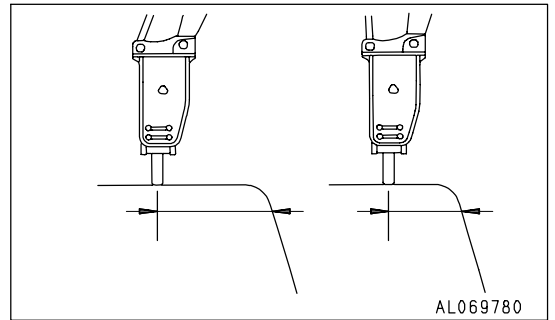

The direction of penetration of the chisel and the direction of the breaker body will gradually move out of line with each other, always adjust the bucket cylinder to keep them aligned.

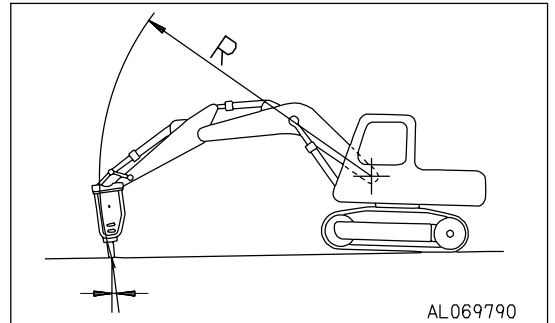

Always keep the chisel pressed against the impact surface properly to prevent using the impact force when there is no resistance.

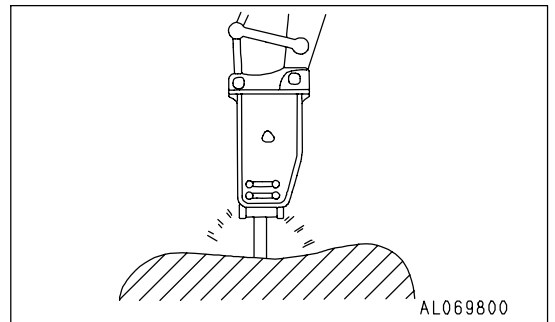

Prohibited Works

To ensure that the machine has a long life, and to ensure that operations are carried out in safety, do not operate the machine in any of the following ways.

- Do not operate the cylinder to the end of its stroke. Always leave a margin of at least 5 cm when using.

Using the mount to gather in pieces of rock

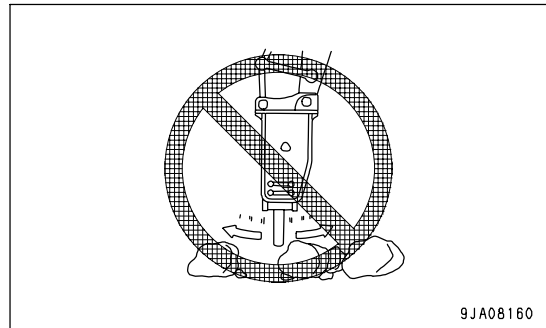

Operations using the swing force

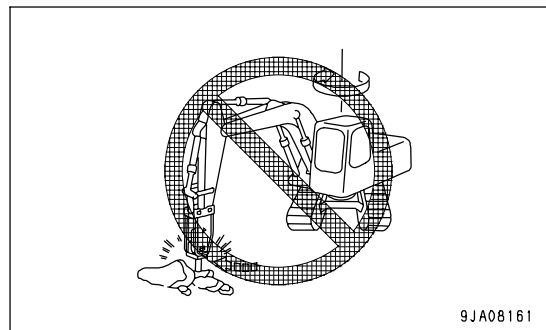

Moving the chisel while carrying out impacting operations

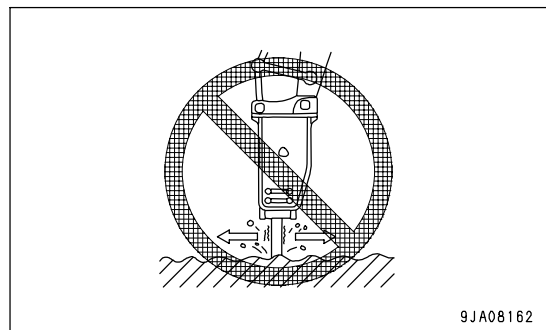

Holding the chisel horizontal or pointed up when carrying out impacting operations

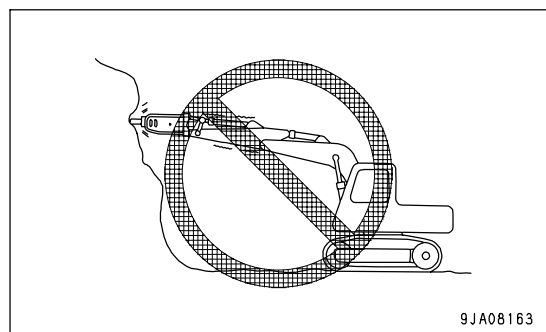

Operations in water

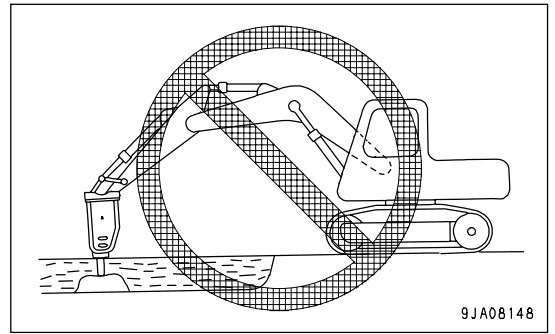

Twisting the chisel when it has penetrated the rock

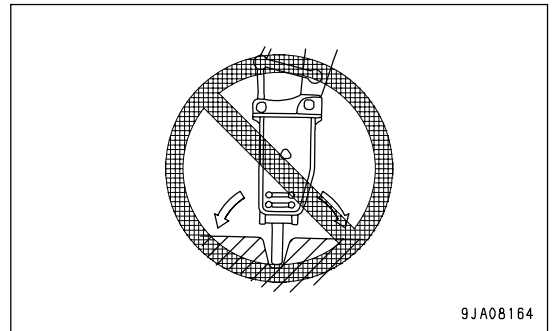

Pecking operations

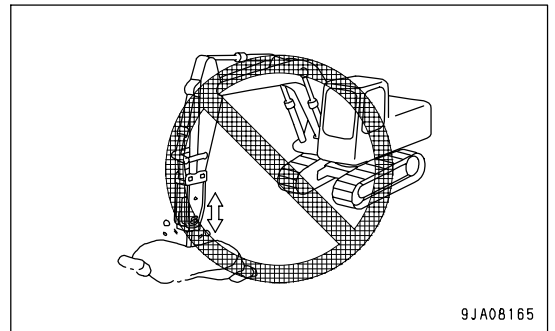

Extending the bucket cylinder fully and thrusting to raise the machine off the ground

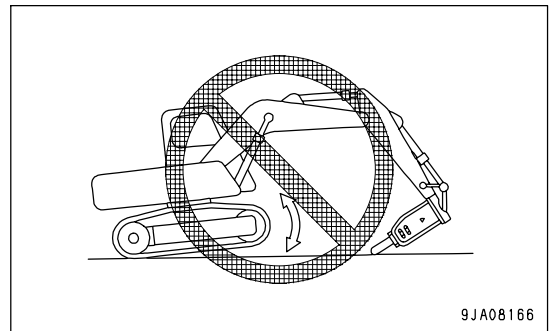

Operations using impact at end of hydraulic cylinder stroke

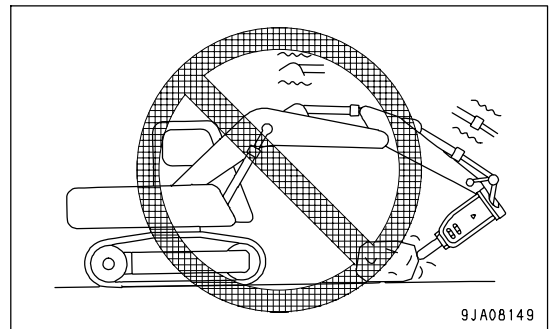

Greasing

Supply grease in the correct position.

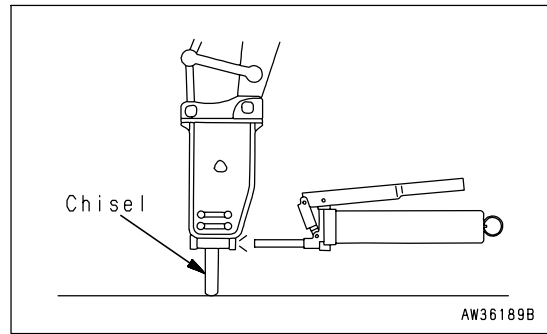

NOTICE

If the breaker is greased in an improper posture, it is filled with more grease than necessary. As a result, soil and sand will enter the hydraulic circuit and can damage the hydraulic components, while the breaker is in use. Therefore, be sure to grease the breaker, holding it in the right posture.

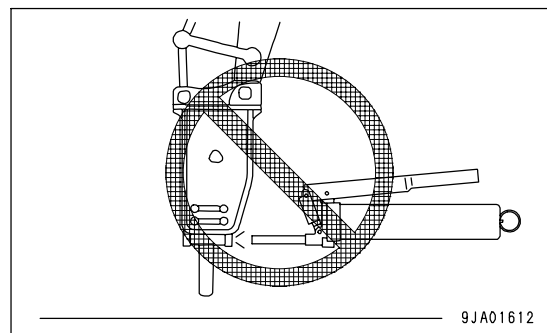
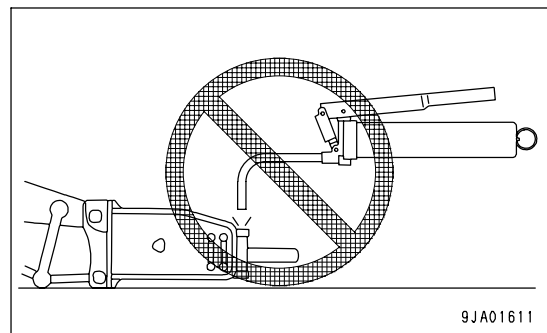

CRUSHER

CAUTION

When operations are carried out with a crusher installed, the nature of the operation and the fact that the crusher is heavier than the bucket means that the safety of the operation is less than when operating with the bucket.

Sudden operation may cause the machine to tip over, so avoid sudden operation. In addition, take steps to prevent any accident if the crushed material falls or flies around.

Main Applications

- Cutting reinforcement steel and rods
- Demolition of concrete structures

Prohibited Works

To ensure that the machine has a long life, and to ensure that operations are carried out in safety, do not operate the machine in any of the following ways.

- Do not operate the cylinder to the end of its stroke. Always leave a margin of at least 5 cm when using.

Operations with cylinder at stroke end

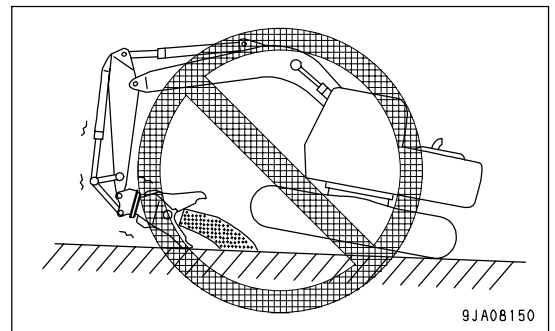

Operations with upper structure facing to side

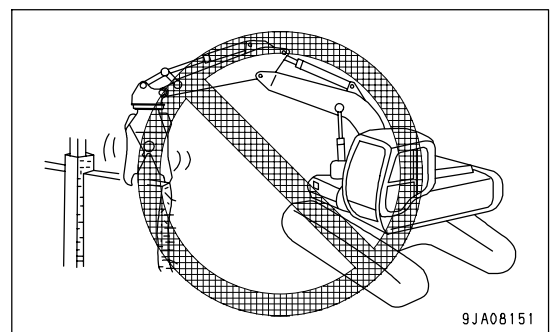

Sudden dropping, sudden stopping of crusher operation

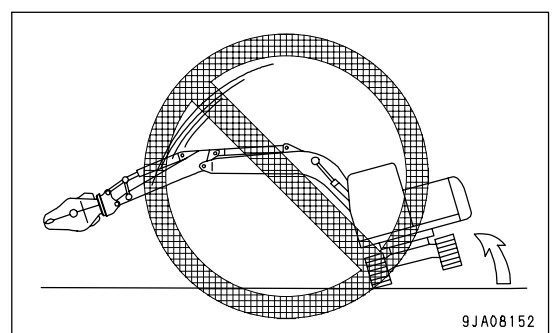

Operations where crushed material falls on top of machine

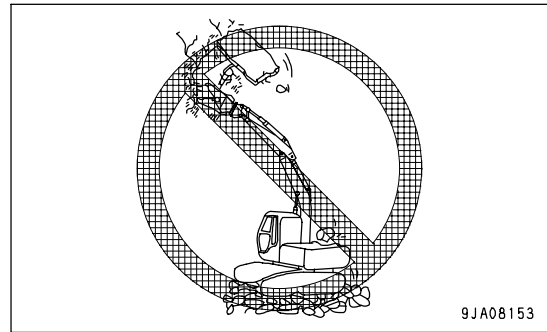

Operations on floors that will not withstand weight of machine or impact operations of crusher

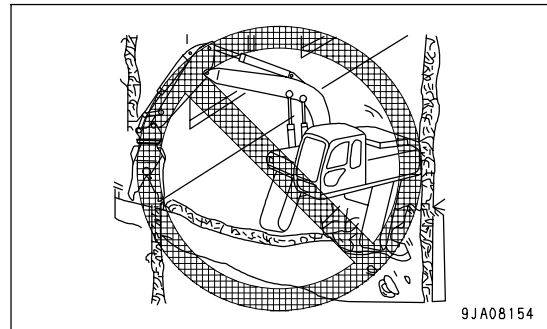

Operations under front of machine

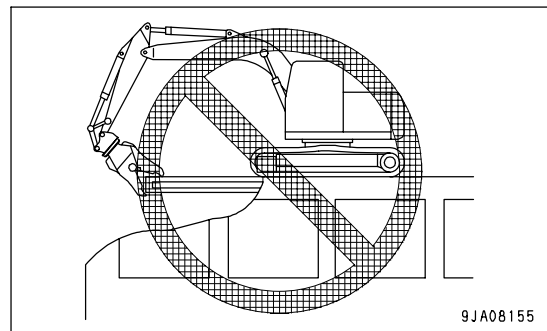

Operations with machine at an angle, such as when machine mounts rubble

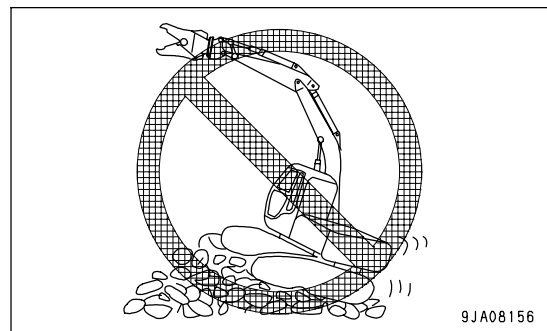

Operations using swing force or dropping force

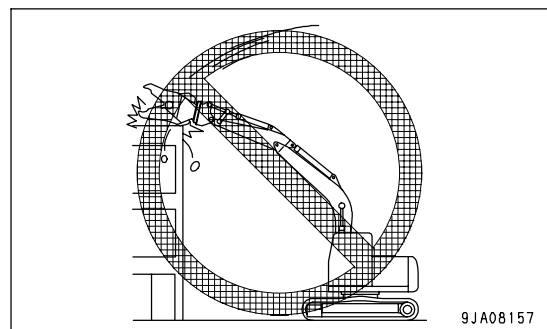

Operations at an angle to material being loaded
Digging the work equipment into the load at an angle will bring excessive force to bear on the work equipment and will damage the machine.

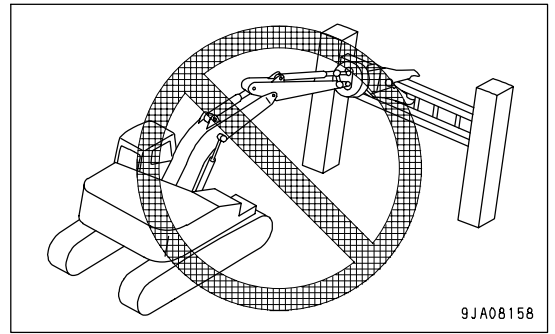

Operations suddenly extending bucket cylinder or arm cylinder.

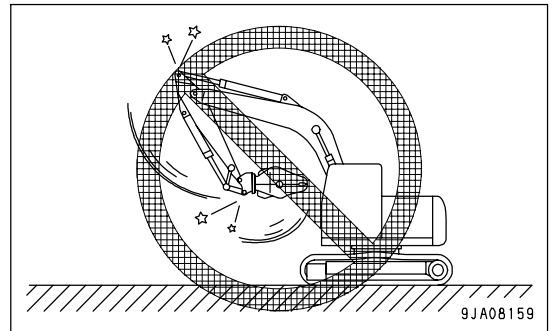

Operation suddenly raising boom cylinder

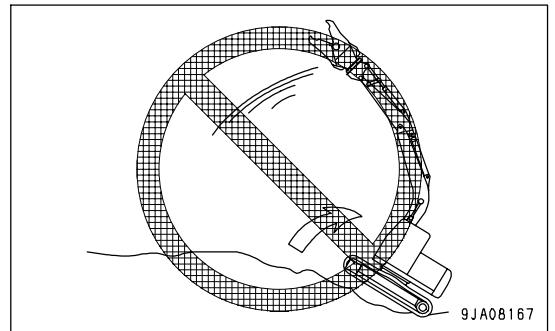

INDEX

<A>			
Air Conditioner	6-	5	
Air Conditioner Control Panel	6-	5	
Air Conditioner Controls	6-	10	
Air Conditioner Maintenance	6-	10	
Air Conditioner Controls	3-	40	
Ashtray	3-	51	
Attachment Guide	6-	23	
Attachment Combinations	6-	24	
Other Attachments	6-	23	
Selection of Track Shoes	6-	25	
Attachments and Options - General			
Information	6-	2	
Attachment Installation	6-	3	
Safety First	6-	2	
Auxiliary Electric Power	3-	38	
			
Breaking-In The New Machine	1-	7	
Bucket Replacement and Inversion	3-	96	
Bucket with Hook	6-	4	
Hook Condition	6-	4	
Prohibited Operations	6-	4	
<C>			
Cab Rear Cover	3-	34	
Cap with Lock	3-	32	
Cold Weather Operation	3-	112	
After Cold Weather Season	3-	114	
After Daily Work Completion	3-	114	
Cold Weather Operation Information	3-	112	
Control Levers and Pedals	3-	21	
Controllers	3-	39	
Controls and Gauges	3-	3	
<D>			
Detailed Controls and Gauges	3-	4	
Directions of Machine	1-	7	
Door at Front of Tool Box	3-	36	
<E>			
Electric System Maintenance	4-	7	
Emergency Escape Hammer	3-	30	
Engine, After Starting	3-	73	
Engine, Before Starting	3-	52	
Engine Hood	3-	33	
Engine Serial No. Plate and Its Location	1-	8	
Engine, Starting	3-	68	
Engine, Stopping the	3-	76	
EPA NAMEPLATE	1-	9	
Escape from Mud	3-	93	
<F>			
Fire Extinguisher	3-	51	
Foreword	1-	2	
Fuse	3-	37	
Fusible Link	3-	38	
<G>			
General Operation Information	3-	89	
Grease Pump Holder	3-	50	
<H>			
Handling Oil, Fuel, Coolant, and			
Performing Oil Clinic	4-	4	
Hot and Cool Box	3-	50	
<I>			
Introduction	1-	7	
<L>			
Locking	3-	100	
Long Term Storage	3-	115	
After Storage	3-	115	
Before Storage	3-	115	
During Storage	3-	115	
<M>			
Machine Inspection After Daily Work	3-	100	
Machine Operation	3-	77	
Machine Operations and Controls	3-	52	
Machine Ready for Attachment	6-	11	
Attachment Operations	6-	19	
Attachment Removal and Installation	6-	15	
Hydraulic Circuit	6-	14	
Locations	6-	11	
Long Term Storage	6-	22	
Specifications	6-	22	
Machine View Illustrations	3-	2	
Machine, Steering the	3-	81	
Maintenance Information	4-	2	
Maintenance Procedure	4-	16	
Check Before Starting	4-	42	
Every 50 Hours	4-	43	

Every 100 Hours -----	4- 44	Safety Information -----	2- 11
Every 250 Hours -----	4- 46	Safety Labels -----	2- 4
Every 500 Hours -----	4- 51	Location of Safety Labels -----	2- 5
Every 1000 Hours -----	4- 59	Safety Labels -----	2- 6
Every 2000 Hours -----	4- 62	Safety Machine Operation -----	2- 19
Every 4000 Hours -----	4- 68	Battery -----	2- 28
Every 5000 Hours -----	4- 69	Lifting Objects with Bucket -----	2- 31
Initial 250 Hours (First 250 Hours Only) --	4- 16	Operation -----	2- 21
When Required -----	4- 17	Starting Engine -----	2- 19
Maintenance Schedule -----	4- 14	Towing -----	2- 30
Maintenance Interval for Hydraulic		Transportation -----	2- 27
Breaker -----	4- 15	Safety Maintenance Information -----	2- 32
Maintenance Schedule Chart -----	4- 14	Service Meter Location -----	1- 9
Monitoring System -----	3- 4	Sliding Door -----	3- 30
		Specifications -----	5- 2
<O>		Sun Roof -----	3- 24
Operation Manual Storage -----	3- 50	Swinging -----	3- 83
Outline of Service -----	4- 4	Switches -----	3- 16
Overall Machine View -----	3- 2		
		<T>	
<P>		Tightening Torque Specifications -----	4- 12
Parking Machine -----	3- 98	Tightening Torque List -----	4- 12
Product Identification Number		Tool Box -----	3- 50
(PIN)/Machine Serial No. Plate -----	1- 8	Transportation -----	3-103
Product Information -----	1- 8	Lifting Machine -----	3-110
Prohibited Operations -----	3- 86	Loading and Unloading with Trailer -----	3-103
Pump Room Door, Battery Room Door -----	3- 35	Transportation Procedure -----	3-103
		Traveling on Slopes -----	3- 91
<R>		Troubles and Actions -----	3-116
Radio -----	3- 45	Battery, Discharged -----	3-119
Recommended Applications -----	3- 94	Lightweight Towing Hook -----	3-118
Recommended Attachment Operations -----	6- 26	Other Trouble -----	3-123
Crusher -----	6- 31	Phenomena That are Not Failures -----	3-116
Hydraulic Breaker -----	6- 26	Running Out of Fuel -----	3-116
Recommended Fuel, Coolant, and		Severe Job Condition -----	3-118
Lubricant -----	4- 9	Towing the Machine -----	3-117
Recommended Brands,			
Recommended Quality for Products		<W>	
other than Komatsu Genuine Oil -----	4- 11	Wear Parts -----	4- 8
Use of Fuel, Coolant and Lubricants		Wear Parts List -----	4- 8
According to Ambient Temperature -----	4- 10	Windshield -----	3- 25
Road Liners -----	3-101	Work Equipment Controls and Operations --	3- 84
		Working Mode -----	3- 86
<S>			
Safety Critical Parts -----	4- 13	<Y>	
Safety Critical Parts List -----	4- 13	Your Machine Serial Numbers And	
Safety Information -----	1- 5	Distributor -----	1- 10
Safety Information -----	2- 2		

PC138US-2, PC138USLC-2 GALEO HYDRAULIC EXCAVATOR

Form No. TEN00076-01

© 2006 KOMATSU
All Right Reserved
Printed in Japan 04-06
