

Operation & Maintenance Manual

SEAM035404T

PC128US-2

HYDRAULIC EXCAVATOR

SERIAL NUMBERS PC128US-6457 and up

WARNING

Unsafe use of this machine may cause serious injury or death. Operators and maintenance personnel must read this manual before operating or maintaining this machine. This manual should be kept near the machine for reference and periodically reviewed by all personnel who will come into contact with it.

NOTICE

Komatsu has Operation & Maintenance Manuals written in some other languages. If a foreign language manual is necessary, contact your local distributor for availability.

KOMATSU

FOREWORD

CALIFORNIA

Proposition 65 Warning

Diesel engine exhaust and some of its constituents are known to the State of California to cause cancer, birth defects, and other reproductive harm.

CALIFORNIA

Proposition 65 Warning

Battery posts, terminals and related accessories contain lead and lead compounds, chemicals known to the State of California to cause cancer and birth defects or other reproductive harm.

Wash hands after handling.

FOREWORD

This manual provides rules and guidelines which will help you use this machine safely and effectively. The precautions in this manual must be followed at all times when performing operation and maintenance. Most accidents are caused by the failure to follow fundamental safety rules for the operation and maintenance of machines. Accidents can be prevented by knowing beforehand conditions that may cause hazard when performing operation and maintenance.

WARNING

Operators and maintenance personnel must always do as follows before beginning operation or maintenance.

- **Always be sure to read and understand this manual thoroughly before performing operation and maintenance.**
- **Read the safety messages given in this manual and the safety labels affixed to the machine thoroughly and be sure that you understand them fully.**

Keep this manual at the storage location for the Operation and Maintenance Manual given below, and have all personnel read it periodically.

If this manual has been lost or has become dirty and cannot be read, request a replacement manual immediately from Komatsu or your Komatsu distributor.

If you sell the machine, be sure to give this manual to the new owners together with the machine.

Komatsu delivers machines that comply with all applicable regulations and standards of the country to which it has been shipped. If this machine has been purchased in another country or purchased from someone in another country, it may lack certain safety devices and specifications that are necessary for use in your country. If there is any question about whether your product complies with the applicable standards and regulations of your country, consult Komatsu or your Komatsu distributor before operating the machine.

Storage location for the Operation and Maintenance Manual:

Manual luggage box behind operator's seat

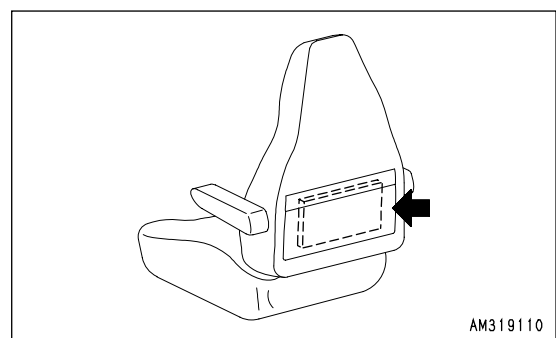

AM319110

EMISSION CONTROL WARRANTY

EMISSION CONTROL WARRANTY STATEMENT (APPLIES TO CANADA ONLY)

1. Products Warranted

Komatsu America International Company, Komatsu Mining Systems Inc. and Komatsu Utility Corporation (collectively "Komatsu") produce and/or market products under brand names of Komatsu, Dresser, Dressta, Haulpak and Galion. This emissions warranty applies to new engines bearing the Komatsu name installed in these products and used in Canada in machines designed for industrial off-highway use. This warranty applies only to these engines produced on or after January 1, 2000. This warranty will be administered by Komatsu distribution in Canada.

2. Coverage

Komatsu warrants to the ultimate purchaser and each subsequent purchaser that the engine is designed, built and equipped so as to conform, at the time of sale by Komatsu, with all U.S. Federal emission regulations applicable at the time of manufacture and that it is free from defects in workmanship or material which would cause it not to meet these regulations within five years or 3,000 hours of operation, whichever occurs first, as measured from the date of delivery of the engine to the ultimate purchaser.

3. Limitations

Failures, other than those resulting from defects in materials or workmanship, are not covered by this warranty. Komatsu is not responsible for failures or damage resulting from what Komatsu determines to be abuse or neglect, including, but not limited to: operation without adequate coolant or lubricants; over fueling; over speeding; lack of maintenance of lubricating, cooling or intake systems; improper storage, starting, warm-up, run-in or shutdown practices; unauthorized modifications of the engine. Komatsu is also not responsible for failures caused by incorrect fuel or by water, dirt or other contaminants in the fuel. Komatsu is not responsible for non-engine repairs, "downtime" expense, related damage, fines, all business costs or other losses resulting from a warrantable failure.

KOMATSU IS NOT RESPONSIBLE FOR INCIDENTAL OR CONSEQUENTIAL DAMAGES.

This warranty, together with the express commercial warranties, are the sole warranties of Komatsu. **THERE ARE NO OTHER WARRANTIES, EXPRESS OR IMPLIED, OR OF MERCHANTABILITY OR FITNESS FOR A PARTICULAR PURPOSE.**

GARANTIE SUR LE CONTRÔLE DES ÉMISSIONS

ÉNONCÉ DE GARANTIE SUR LE CONTRÔLE DES ÉMISSIONS (APPLICABLE AU CANADA SEULEMENT):

1. Produits garantis:

Komatsu America International Company, Komatsu Mining Systems Inc. et Komatsu Utility Corporation (collectivement Komatsu) produisent et/ou font la mise en marché de produits portant les noms de marque Komatsu, Dresser, Dressta, Haulpak et Galion. Cette garantie sur les émissions s'applique à tous les nouveaux moteurs portant le nom Komatsu, installés dans ces produits et utilisés au Canada dans des machines conçues pour utilisation industrielle non-routière. Cette garantie s'applique seulement sur les moteurs produits à partir du 1er Janvier 2000. Cette garantie sera administrée par la distribution de Komatsu au Canada.

2. Couverture:

Komatsu garantit à l'acheteur ultime et chaque acheteur subséquent que le moteur est conçu, construit et équipé en toute conformité, au moment de la vente par Komatsu, avec toutes les Réglementations fédérales américaines sur les émissions applicables au moment de la fabrication et qu'il est exempt de défauts de construction ou de matériaux qui auraient pour effet de contrevenir à ces réglementations en dedans de 5 ans ou 3000 heures d'opération, mesuré à partir de la date de livraison du moteur au client ultime.

3. Limitations:

Les bris, autres que ceux résultant de défauts de matériaux ou de construction, ne sont pas couverts par cette Garantie. Komatsu n'est pas responsable pour bris ou dommages résultant de ce que Komatsu détermine comme étant de l'abus ou négligence, incluant mais ne se limitant pas à: l'opération sans lubrifiants ou agent refroidissants adéquats; la suralimentation d'essence; la survitesse; le manque d'entretien des systèmes de lubrification, de refroidissement ou d'entrée; de pratiques non-propices d'entreposage, de mise en marche, de réchauffement, de conditionnement ou d'arrêt; les modifications non-autorisées du moteur. De plus, Komatsu n'est pas responsable de bris causés par de l'essence inadéquate ou de l'eau, des saletés ou autres contaminants dans l'essence. Komatsu n'est pas responsable des réparations non-relées au moteur, des dépenses encourues suite aux temps d'arrêts, des dommages relatifs, amendes, et de tout autre coût d'affaires ou autres pertes résultant d'un bris couvert par la garantie.

KOMATSU N'EST PAS RESPONSABLE DES INCIDENTS OU DOMMAGES CONSÉQUENTS.

Cette garantie, ainsi que les garanties expresses commerciales, sont les seules garanties de Komatsu. **IL N'Y A AUCUNE AUTRE GARANTIE, EXPRESSE OU SOUS-ENTENDUE, MARCHANDABLE OU PROPICE A UNE UTILISATION PARTICULIÈRE.**

INFORMATION IMPORTANTE SUR LE MOTEUR

CE MOTEUR EST CONFORME AUX NORMES AMÉRICAINES DEL'ÉPA (ANNÉE DU MODÈLE) ET DE LA CALIFORNIE POUR LES MOTEURS LARGES NON-ROUTIERS A IGNITION PAR COMPRESSION. CE MOTEUR EST CERTIFIÉ POUR OPERATION A ESSENCE DIÉSEL.

AVERTISSEMENT

DES BLESSURES PEUVENT RESULTER ET LA GARANTIE S'ANNULER SI LES RPM DU TAUX D'ESSENCE OU L'ALTITUDE EXCÈDENT LES VALEURS MAXIMALES PUBLIÉES POUR CE MODÈLE ET SON APPLICATION.

IMPORTANT ENGINE INFORMATION

THIS ENGINE CONFORMS TO YYYY MODEL YEAR U.S. EPA REGULATION AND THE CALIFORNIA REGULATIONS LARGE NON ROAD COMPRESSION IGNITION ENGINES. THIS ENGINE IS CERTIFIED TO OPERATE ON DIESEL FUEL.

WARNING
INJURY MAY RESULT AND WARRANTY IS VOIDED IF FUEL RATE RPM OR ALTITUDES EXCEED PUBLISHED MAXIMUM VALUES FOR THIS MODEL AND APPLICATION.

ENGINE MODEL	SERIAL NO.	DISPLACEMENT	LITERS
ENGINE FAMILY		FIRING ORDER	1 - 5 - 3 - 6 - 2 - 4
EXHAUST EMISSION CONTROL SYSTEM			
ADV. LOAD OUTPUT	Kw (HP)		RPM
VALVE LASH COLD (mm)	IN.	EX. FUEL RATE AT ADV.	mm ³ /STROKE
IDLE SPEED		FAMILY EMISSION LIMIT	
INITIAL INJECTION TIMING	DEG. BTDC	DATE OF MANUFACTURE	
		KOMATSU LTD. MADE IN JAPAN	

MODÈLE DU MOTEUR

FAMILLE DU MOTEUR

SYSTÈME DE CONTROLE DES ÉMISSIONS D'ÉCHAPPEMENT

CHARGE DE SORTIE ADV.

PORTÉE DE VALVE À FROID (mm)

VITESSE STATIQUE

RÉGLAGE DE L'ALLUMAGE - INJECTION INITIALE

DEG. BTDC

NO. SÉRIE

DÉPLACEMENT

LITRES

SÉQUENCE DE MISE À FEU

mm³/BATTEMENT

TAUX D'ESSENCE À ADV.

LIMITE D'ÉMISSION DE LA FAMILLE

DATE DE FABRICATION

KOMATSU LTD.
FABRIQUÉ AU JAPON

ENGINE DATAPLATE - ENGLISH / FRENCH

SAFETY INFORMATION

To enable you to use this machine safely, safety precautions and labels are given in this manual and affixed to the machine to give explanations of situations involving potential hazards and of the methods of avoiding such situations.

Signal words

The following signal words are used to inform you that there is a potential hazardous situation that may lead to personal injury or damage.

In this manual and on machine labels, the following signal words are used to express the potential level of hazard.

⚠ DANGER Indicates an imminently hazardous situation which, if not avoided, will result in death or serious injury. This signal word is to be limited to most extreme situations.

⚠ WARNING Indicates a potentially hazardous situation which, if not avoided, could result in death or serious injury.

⚠ CAUTION Indicates a potentially hazardous situation which, if not avoided, may result in minor or moderate injury. It may also be used to alert against unsafe practices.

Example of safety message using signal word

⚠ WARNING

**To avoid hitting unlocked operation levers, lower equipment to ground and move SAFETY LOCK LEVER (located near seat) to LOCK position before starting up from operator's seat.
Sudden and unwanted machine movement can cause serious injury or death.**

Other signal words

In addition to the above, the following signal words are used to indicate precautions that should be followed to protect the machine or to give information that is useful to know.

NOTICE This word is used for precautions that must be taken to avoid actions which could shorten the life of the machine.

REMARK This gives information that is useful to know.

Safety labels

Safety labels are affixed to the machine to inform the operator or maintenance worker on the spot when carrying out operation or maintenance of the machine that may involve hazard.

This machine uses "Safety labels using words" and "Safety labels using pictograms" to indicate safety procedures.

Example of safety label using words

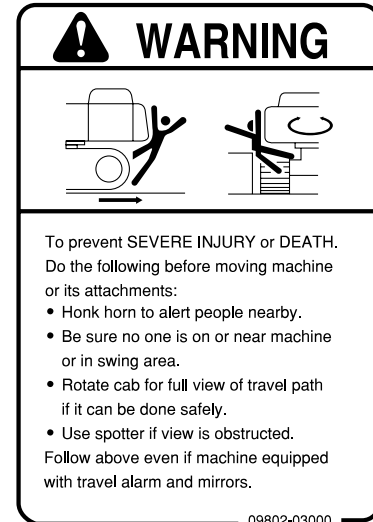

Part No.

Safety labels using pictogram

Safety pictograms use a picture to express a level of hazardous condition equivalent to the signal word. These safety pictograms use pictures in order to let the operator or maintenance worker understand the level and type of hazardous condition at all times. Safety pictograms show the type of hazardous condition at the top or left side, and the method of avoiding the hazardous condition at the bottom or right side. In addition, the type of hazardous condition is displayed inside a triangle and the method of avoiding the hazardous condition is shown inside a circle.



Part No.

Komatsu cannot predict every circumstance that might involve a potential hazard in operation and maintenance. Therefore, the safety messages in this manual and on the machine may not include all possible safety precautions. If any procedures or actions not specifically recommended or allowed in this manual are used, it is your responsibility to take the necessary steps to ensure safety.

In no event should you engage in prohibited uses or actions described in this manual.

The explanations, values, and illustrations in this manual were prepared based on the latest information available at that time. Continuing improvements in the design of this machine can lead to changes in detail which may not be reflected in this manual. Consult Komatsu or your Komatsu distributor for the latest available information of your machine or for questions regarding information in this manual.

The numbers in circles in the illustrations correspond to the numbers in () in the text. (For example: ① → (1))

INTRODUCTION

This Komatsu HYDRAULIC EXCAVATOR is designed to be used mainly for the following works:

- Digging work
- Leveling work
- Ditching work
- Loading work
- Demolition work

See the section "RECOMMENDED APPLICATIONS (PAGE 3-79)" for further details.

DIRECTIONS OF MACHINE

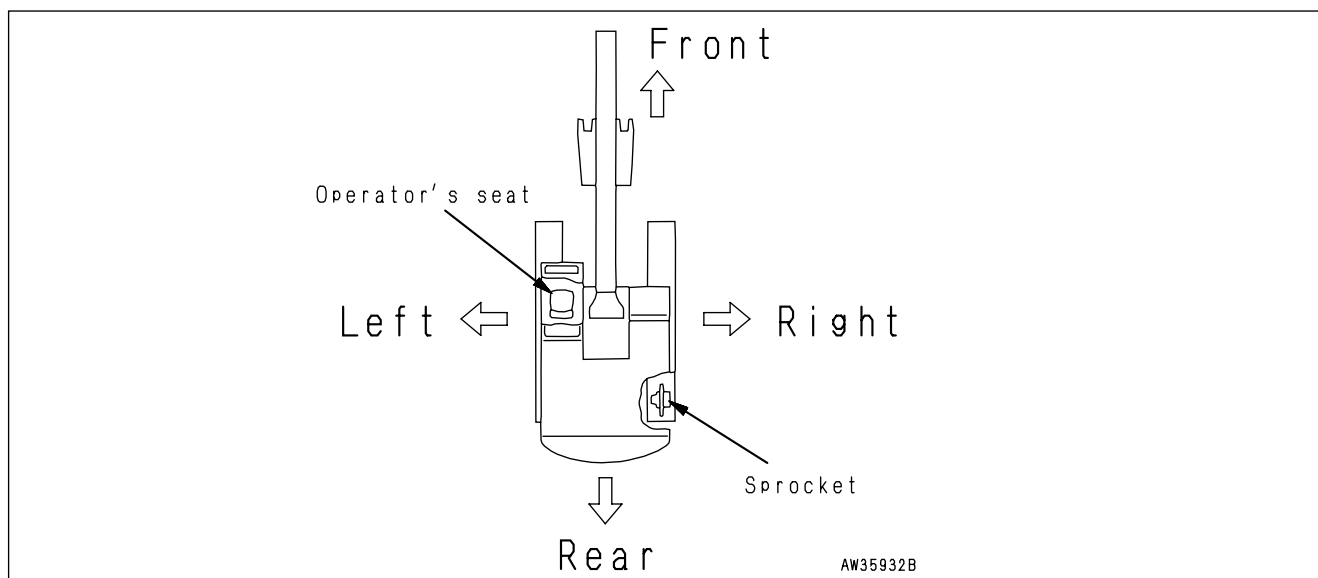

In this manual, the terms front, rear, left, and right refer to the travel direction as seen from the operator's cab when the operator's cab is facing the front and the sprocket is at the rear of the machine.

PRODUCT INFORMATION

When requesting service or ordering replacement parts, please inform your Komatsu distributor of the following items.

MACHINE SERIAL NUMBER PLATE AND ITS LOCATION

On the bottom right of the operator's cab

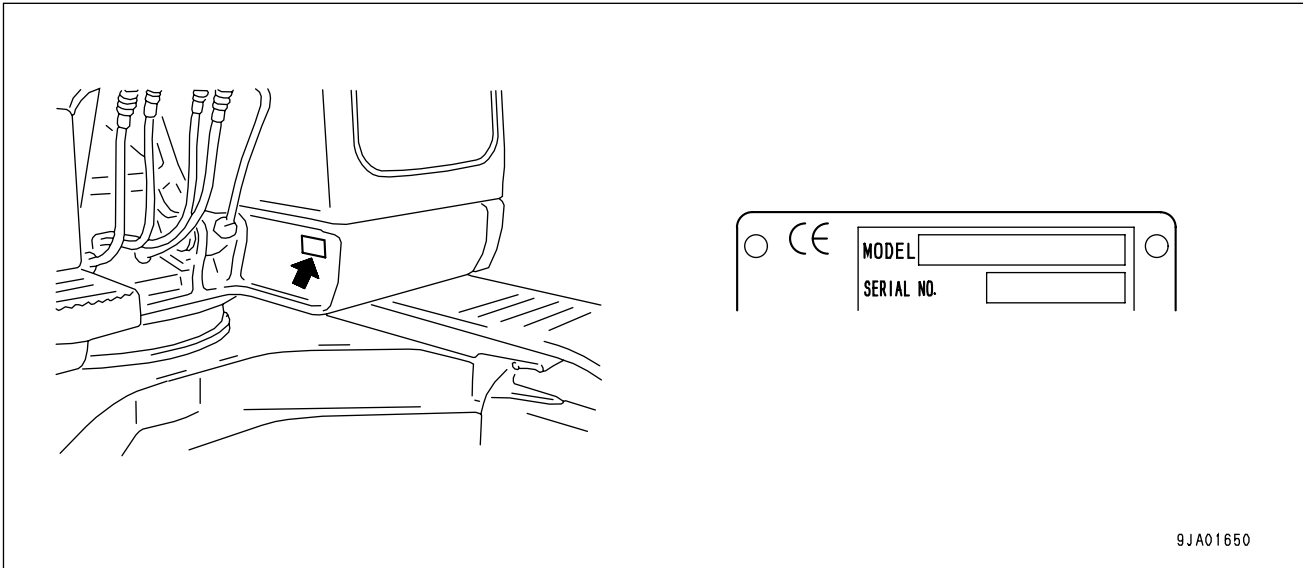

ENGINE SERIAL NUMBER PLATE AND ITS LOCATION

On the upper side of the engine cylinder head cover

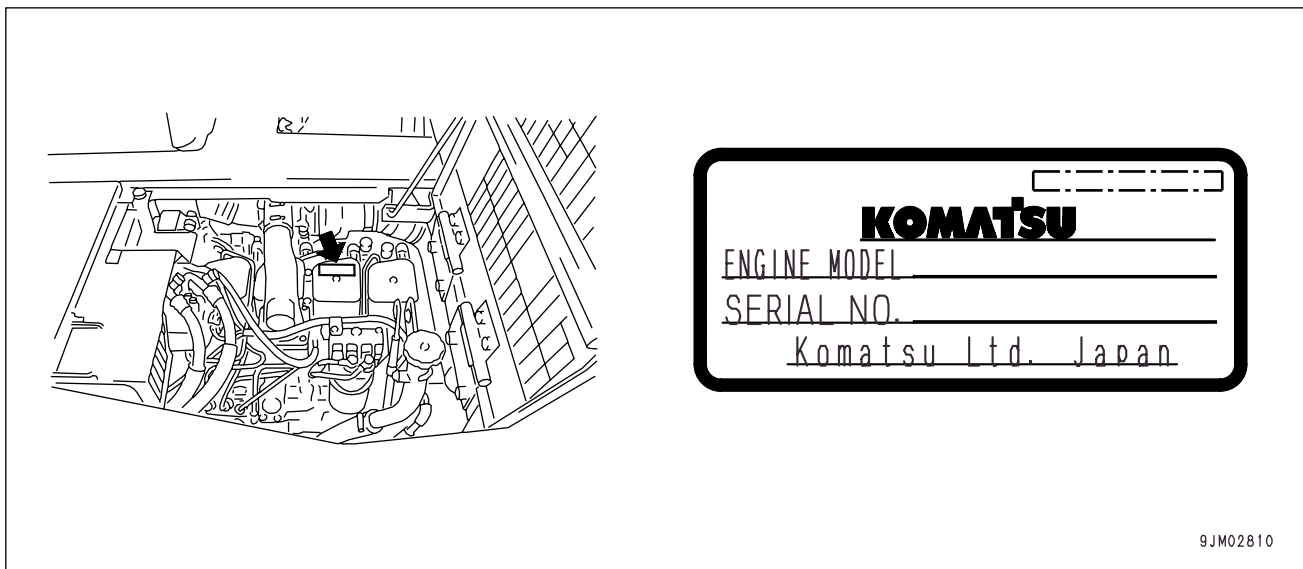

EMISSION CONTROL INFORMATION LABEL

On the upper side of the engine cylinder head cover.

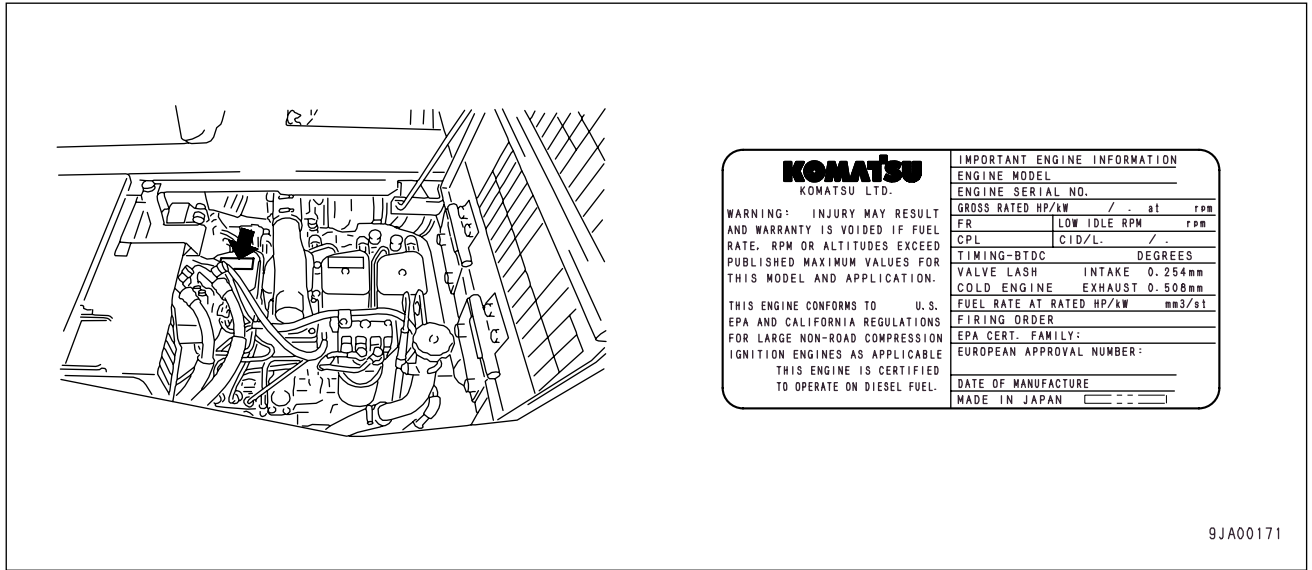

EPA:Environmental Protection Agency,U.S.A.

SERVICE METER LOCATION

On top of the machine monitor

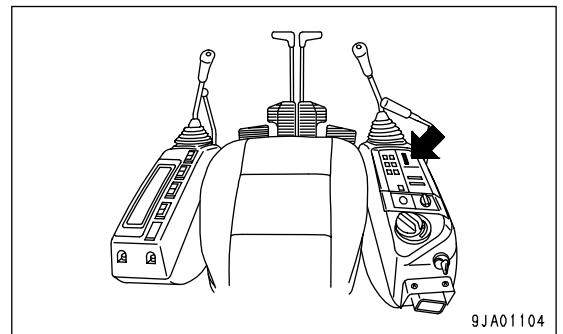

YOUR MACHINE SERIAL NUMBERS AND DISTRIBUTOR

Machine serial No.	
Engine serial No.	
Distributor name	
Address	-----

Service Personal	-----
Phone/Fax	-----

CONTENTS

FOREWORD

FOREWORD	1-2
SAFETY INFORMATION	1-5
INTRODUCTION	1-7
DIRECTIONS OF MACHINE	1-7
PRODUCT INFORMATION	1-8
MACHINE SERIAL NUMBER PLATE AND ITS LOCATION	1-8
ENGINE SERIAL NUMBER PLATE AND ITS LOCATION	1-8
EMISSION CONTROL INFORMATION LABEL	1-9
SERVICE METER LOCATION	1-9
YOUR MACHINE SERIAL NUMBERS AND DISTRIBUTOR	1-9

SAFETY

SAFETY INFORMATION	2-2
POSITION FOR ATTACHING SAFETY LABELS	2-4
POSITION FOR ATTACHING SAFETY LABELS	2-5
SAFETY LABELS	2-6
SAFETY INFORMATION	2-11
SAFETY MACHINE OPERATION	2-20
STARTING ENGINE	2-20
OPERATION	2-22
TRANSPORTATION	2-28
BATTERY	2-30
TOWING	2-32
LIFTING OBJECTS WITH BUCKET	2-33
SAFETY MAINTENANCE INFORMATION	2-34

OPERATION

GENERAL VIEW	3-2
GENERAL VIEW OF MACHINE	3-2
GENERAL VIEW CONTROLS AND GAUGES	3-3
EXPLANATION OF COMPONENTS	3-4
MACHINE MONITOR	3-4

SWITCHES	3-10
CONTROL LEVERS, PEDALS	3-16
FRONT WINDOW	3-20
SLIDING DOOR	3-23
REAR WINDOW	3-24
HAMMER FOR EMERGENCY ESCAPE	3-24
CAP, COVER WITH LOCK	3-25
ENGINE HOOD	3-26
CAB REAR COVER	3-27
PUMP ROOM DOOR, BATTERY ROOM DOOR	3-28
DOOR AT FRONT OF TOOL BOX	3-29
FUSE	3-30
FUSIBLELINK	3-30
POWER SOURCE FOR OPTION	3-31
CONTROLLER	3-31
HANDLING AIR CONDITIONER	3-32
CAR RADIO	3-35
HANDLING ACCUMULATOR	3-40
OPERATION AND MAINTENANCE MANUAL HOLDER	3-41
TOOL COMPARTMENT	3-41
GREASE GUN HOLDER	3-41
ASHTRAY	3-41
MACHINE OPERATIONS AND CONTROLS	3-42
BEFORE STARTING ENGINE	3-42
STARTING ENGINE	3-55
AFTER STARTING ENGINE	3-58
STOPPING THE ENGINE	3-61
CHECK AFTER SHUT OFF ENGINE	3-61
MACHINE OPERATION	3-62
STEERING THE MACHINE	3-66
SWINGING	3-68
WORK EQUIPMENT CONTROLS AND OPERATIONS	3-69
PROHIBITED OPERATIONS	3-71
GENERAL OPERATION INFORMATION	3-75
TRAVELING ON SLOPES	3-76
ESCAPE FROM MUD	3-78
RECOMMENDED APPLICATIONS	3-79
REPLACEMENT AND INVERSION OF BUCKET	3-81
PARKING MACHINE	3-85
CHECK AFTER FINISHING WORK	3-86
LOCKING	3-87
HANDLING ROAD LINER	3-88
TRANSPORTATION	3-90
TRANSPORTATION PROCEDURE	3-90
LOADING AND UNLOADING WITH TRAILER	3-91
LIFTING MACHINE	3-97

COLD WEATHER OPERATION 3-99

 COLD WEATHER OPERATION INFORMATION..... 3-99

 AFTER DAILY WORK COMPLETION 3-101

 AFTER COLD WEATHER SEASON 3-102

LONG TERM STORAGE 3-103

 BEFORE STORAGE..... 3-103

 DURING STORAGE 3-103

 AFTER STORAGE..... 3-104

TROUBLESHOOTING..... 3-105

 AFTER RUNNING OUT OF FUEL..... 3-105

 PHENOMENA THAT ARE NOT FAILURES..... 3-105

 TOWING THE MACHINE 3-106

 LIGHTWEIGHT TOWING HOOK..... 3-106

 PRECAUTIONS ON PARTICULAR JOBSITES 3-106

 DISCHARGED BATTERY 3-107

 OTHER TROUBLE 3-112

MAINTENANCE

MAINTENANCE INFORMATION 4-2

LUBRICANTS, COOLANT AND FILTERS 4-5

 OUTLINE OF OIL, FUEL, COOLANT 4-5

 ELECTRIC SYSTEM MAINTENANCE 4-7

 HANDLING HYDRAULIC SYSTEM..... 4-7

WEAR PARTS LIST 4-9

USE OF FUEL, COOLANT AND LUBRICANTS ACCORDING TO AMBIENT TEMPERATURE..... 4-10

 PROPER SELECTION OF FUEL, COOLANT AND LUBRICANTS 4-10

TIGHTENING TORQUE SPECIFICATIONS 4-14

 TIGHTENING TORQUE LIST..... 4-14

PERIODIC REPLACEMENT OF SAFETY CRITICAL PARTS 4-15

 SAFETY CRITICAL PARTS..... 4-15

MAINTENANCE SCHEDULE..... 4-16

 MAINTENANCE SCHEDULE CHART..... 4-16

 MAINTENANCE INTERVAL FOR HYDRAULIC BREAKER..... 4-18

MAINTENANCE PROCEDURE..... 4-19

 INITIAL 250 HOURS MAINTENANCE (ONLY AFTER THE FIRST 250 HOURS) 4-19

 WHEN REQUIRED 4-20

 CHECK BEFORE STARTING 4-44

 EVERY 50 HOURS MAINTENANCE..... 4-45

 EVERY 100 HOURS MAINTENANCE..... 4-46

EVERY 250 HOURS MAINTENANCE.....	4-49
EVERY 500 HOURS MAINTENANCE.....	4-54
EVERY 1000 HOURS MAINTENANCE.....	4-59
EVERY 2000 HOURS MAINTENANCE.....	4-61
EVERY 4000 HOURS MAINTENANCE.....	4-63
EVERY 5000 HOURS MAINTENANCE.....	4-64

SPECIFICATIONS

SPECIFICATIONS.....	5-2
---------------------	-----

ATTACHMENTS AND OPTIONS

GENERAL PRECAUTIONS	6-2
PRECAUTIONS RELATED TO SAFETY	6-2
PRECAUTIONS WHEN INSTALLING ATTACHMENTS.....	6-4
HANDLING BUCKET WITH HOOK	6-5
CHECKING FOR DAMAGE TO BUCKET WITH HOOK	6-5
PROHIBITED OPERATIONS	6-5
HANDLING CAR HEATER	6-6
EXPLANATION OF COMPONENTS.....	6-6
PREPARING CAR HEATER.....	6-6
MACHINES READY FOR ATTACHMENTS	6-7
EXPLANATION OF COMPONENTS.....	6-7
HYDRAULIC CIRCUIT.....	6-10
ATTACHMENT MOUNTING/DISMOUNTING PROCEDURE	6-11
OPERATION.....	6-13
LONG-TERM STORAGE.....	6-15
SPECIFICATIONS.....	6-15
INTRODUCTION OF ATTACHMENTS	6-16
SPECIFICATION, USE.....	6-16
ATTACHMENT INSTALLATION COMBINATION TABLE	6-17
ATTACHMENT COMBINATIONS.....	6-17
RECOMMENDED ATTACHMENT OPERATIONS	6-18
HYDRAULIC BREAKER.....	6-18
INDEX	7-1

SAFETY

WARNING

Please be sure that you fully understand this manual and the precautions related to safety for the machine. When operating or servicing the machine, always follow these precautions strictly.

SAFETY INFORMATION

POSITION FOR ATTACHING SAFETY LABELS	2-4
POSITION FOR ATTACHING SAFETY LABELS	2-5
SAFETY LABELS	2-6
SAFETY INFORMATION	2-11
SAFETY RULES	2-11
IF ABNORMALITIES ARE FOUND	2-11
WORKING WEAR AND PERSONAL PROTECTIVE ITEMS	2-11
FIRE EXTINGUISHER AND FIRST AID KIT	2-11
SAFETY EQUIPMENT	2-12
KEEP MACHINE CLEAN	2-12
KEEP OPERATOR'S COMPARTMENT CLEAN	2-12
LEAVING OPERATOR'S SEAT WITH LOCK	2-12
HANDRAILS AND STEPS	2-13
MOUNTING AND DISMOUNTING	2-14
NO PERSONS ON ATTACHMENTS	2-14
BURN PREVENTION	2-14
FIRE PREVENTION AND EXPLOSION PREVENTION	2-15
ACTION IF FIRE OCCURS	2-16
WINDSHIELD WASHER FLUID	2-16
FALLING OBJECTS, FLYING OBJECTS AND INTRUDING OBJECTS PREVENTION	2-16
ATTACHMENT INSTALLATION	2-16
ATTACHMENT COMBINATIONS	2-17
CAB WIDOW GLASSES	2-17
UNAUTHORIZED MODIFICATIONS	2-17
SAFETY AT JOBSITE	2-17
WORKING ON LOOSE GROUND	2-17
DISTANCE TO HIGH VOLTAGE CABLES	2-18
ENSURE GOOD VISIBILITY	2-18
VENTILATION FOR ENCLOSED AREA	2-19
SIGNALMAN'S SIGNAL AND SIGNS	2-19
EMERGENCY EXIT FROM OPERATOR'S CAB	2-19
ASBESTOS DUST HAZARD PREVENTION	2-19

SAFETY MACHINE OPERATION	2-20
BEFORE STARTING ENGINE	2-20
CHECKS BEFORE STARTING ENGINE	2-20
SAFETY RULES FOR STARTING ENGINE	2-21
STARTING ENGINE IN COLD WEATHER	2-21
AFTER STARTING ENGINE	2-22
CHECKS AFTER STARTING ENGINE	2-22
SAFETY RULES FOR CHANGING MACHINE DIRECTIONS	2-22
SAFETY RULES FOR TRAVELING	2-23
TRAVELING ON SLOPES	2-24
OPERATIONS ON SLOPES	2-25
PROHIBITED OPERATIONS	2-25
OPERATIONS ON SNOW	2-27
PARKING MACHINE	2-27
TRANSPORTATION	2-28
LOADING AND UNLOADING	2-28
SHIPPING THE MACHINE	2-29
BATTERY	2-30
BATTERY HAZARD PREVENTION	2-30
STARTING ENGINE WITH BOOSTER CABLES	2-31
TOWING	2-32
SAFETY RULES FOR TOWING	2-32
LIFTING OBJECTS WITH BUCKET	2-33
SAFETY RULES FOR LIFTING OBJECTS	2-33
SAFETY MAINTENANCE INFORMATION	2-34
WARNING TAG	2-34
KEEP WORK PLACE CLEAN AND TIDY	2-34
APPOINT LEADER WHEN WORKING WITH OTHERS	2-34
STOP ENGINE BEFORE CARRYING OUT MAINTENANCE	2-35
TWO WORKERS FOR MAINTENANCE WHEN ENGINE IS RUNNING	2-36
PROPER TOOLS	2-36
ACCUMULATOR	2-37
PERSONNEL	2-37
ATTACHMENTS	2-37
WORK UNDER THE MACHINE	2-37
NOISE	2-38
WHEN USING HAMMER	2-38
WELDING WORKS	2-38
REMOVING BATTERY TERMINALS	2-38
SAFETY FIRST WHEN USING HIGH-PRESSURE GREASE TO ADJUST TRACK TENSION	2-39
DO NOT DISASSEMBLE RECOIL SPRINGS	2-39
SAFETY RULES FOR HIGH-PRESSURE OIL	2-39
SAFETY HANDLING HIGH-PRESSURE HOSES	2-40
WASTE MATERIALS	2-40
AIR CONDITIONER MAINTENANCE	2-40
COMPRESSED AIR	2-40
PERIODIC REPLACEMENT OF SAFETY CRITICAL PARTS	2-41

POSITION FOR ATTACHING SAFETY LABELS

The following warning signs and safety labels are used on this machine.

- Be sure that you fully understand the correct position and content of labels.
- To ensure that the content of labels can be read properly. Be sure that they are in the correct place and always keep them clean. When cleaning them, do not use organic solvents or gasoline, there may cause the labels to peel off.
- There are also other labels in addition to the warning signs and safety labels. Handle those labels in the same way.
- If the labels are damaged, lost, or cannot be read properly, replace them with new ones. For details of the part numbers for the labels, see this manual or the actual label, and place an order with Komatsu distributor.

POSITION FOR ATTACHING SAFETY LABELS

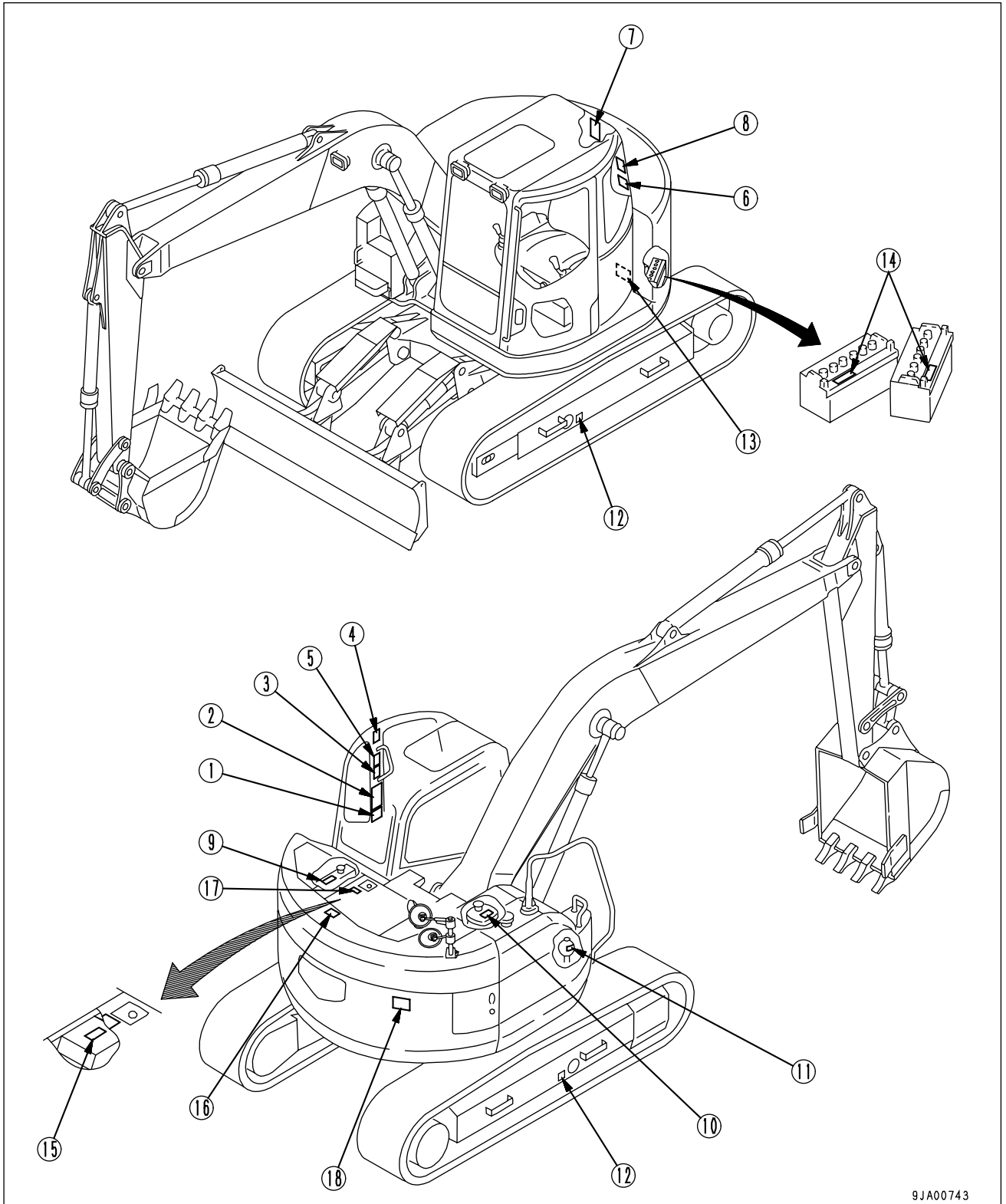

9JA00743

SAFETY LABELS

(1) Precautions for operation, inspection and maintenance (09651-03001)

⚠ WARNING

Improper operation and maintenance can cause serious injury or death.

Read manual and labels before operation and maintenance. Follow instructions and warnings in manual and in labels on machine.

Keep manual in machine cab near operator.
Contact Komatsu distributor for a replacement manual.

09651-03001

(2) Precautions for operation (09802-03000)

⚠ WARNING

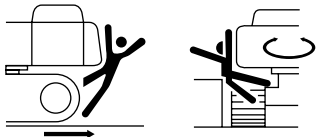

To prevent SEVERE INJURY or DEATH. Do the following before moving machine or its attachments:

- Honk horn to alert people nearby.
- Be sure no one is on or near machine or in swing area.
- Rotate cab for full view of travel path if it can be done safely.
- Use spotter if view is obstructed.

Follow above even if machine equipped with travel alarm and mirrors.

09802-03000

(3) Precautions for leaving the operator's seat (09654-03001)

⚠ WARNING

To avoid hitting unlocked operation levers, lower equipment to ground and move SAFETY LOCK LEVER (located near seat) to LOCK position before standing up from operator's seat.

Sudden and unwanted machine movement can cause serious injury or death.

09654-03001

(4) Precautions for going close to electric cables (09801-03001)

⚠ DANGER

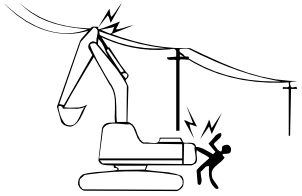

Hazardous voltage hazard. Serious injury or death can occur if machine or attachments are not kept safe distance away from electric lines.

VOLTAGE		SAFE DISTANCE
LOW VOLTAGE	100V 200V	2m
	6,600V	2m
	22,000V	3m
SPECIAL HIGH VOLTAGE	66,000V	4m
	154,000V	5m
	187,000V	6m
	275,000V	7m
	500,000V	11m

09801-03001

(5) Precautions for operating pattern (09822-03000)

(6) Precautions for opening the window (09839-03000)



WARNING

In order to prevent an accident resulting in injury or death caused by error-operation, confirm the machine motion and indicated operating pattern, when operating machines. Pay attention to the circumference and operate slowly when confirming the machine motion.

ISO pattern

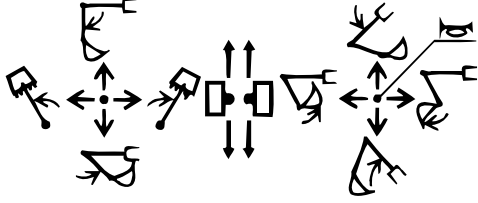

09822-03000



WARNING

To avoid hitting unlocked operation levers, lower equipment to ground and move SAFETY LOCK LEVER (located near seat) to LOCK position before standing up from operator's seat, for the purpose of such as opening window and leaving the machine.

Sudden and unwanted machine movement can cause serious injury or death.

09839-03000

(7) Precautions for stowage (09803-03000)

(8) Precautions for broken or becomes dislodged to the window (20U-98-21910)



WARNING

When raising window, lock it in place with lock pins on both sides.

Falling window can cause injury.

09803-03000



WARNING

To prevent SEVERE INJURY or DEATH, follow Instructions below :

- To avoid contact with boom, DO NOT lean outside right side window.
- If right slide window is broken or becomes dislodged, have it repaired immediately.

20U-98-21910

(9) Precautions for high-temperature cooling water (09668-03001)

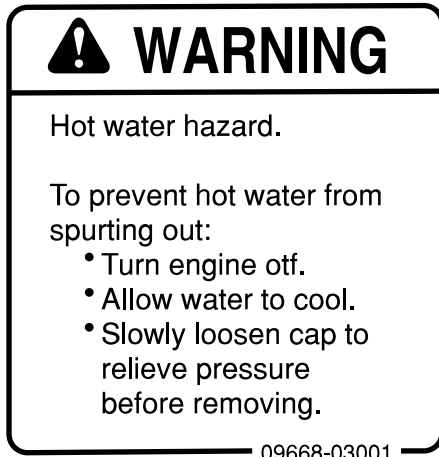

(10) Precautions for high-temperature hydraulic oil (09653-03001)

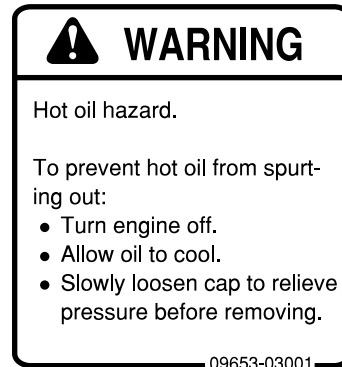

(11) Precautions for handling accumulator (09659-53000)



(12) Precautions for check and adjust track tension (09657-03003)

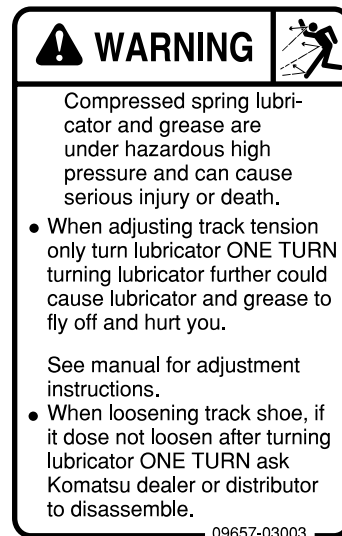

(13) Precautions for handling electric wires
(09808-03000)

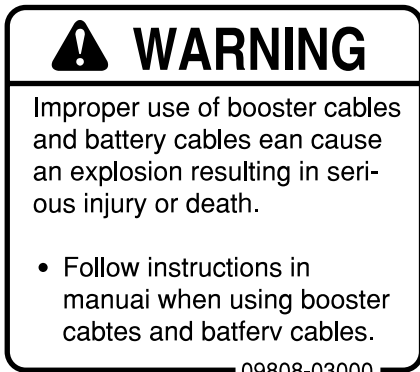

(14) Precautions when handling battery
(09664-30082)

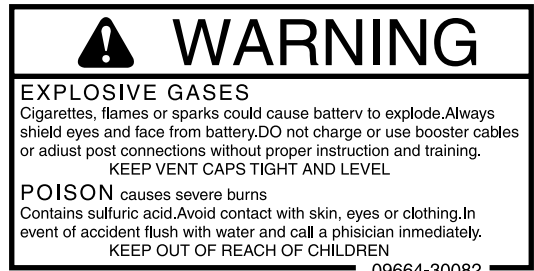

(15) Precautions for opening engine hood
(09667-03001)

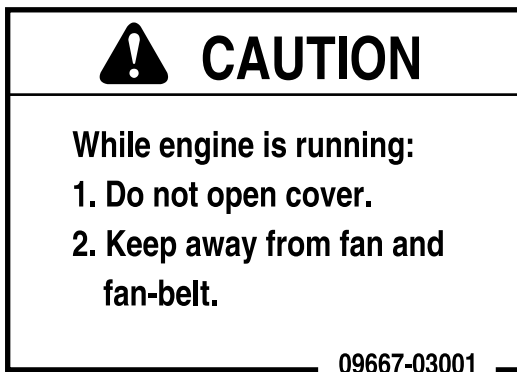

(16) Precautions for avoiding falling down
(09805-23000)



(17) Precautions for avoiding falling down
(09805-13000)



(18) Prohibited to enter range of swing
(09133-23000)



(19) Warning for battery (09664-30082)

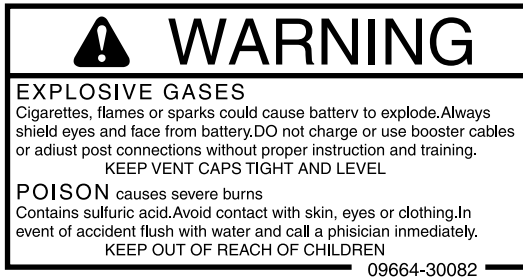

(This plate is stick on the machine by the battery maker.)

SAFETY INFORMATION

SAFETY RULES

- Only trained and authorized personnel can operate and maintain the machine.
- Follow all safety rules, precautions and instructions when operating or performing maintenance on the machine.
- If you are under the influence of alcohol or medication, your ability to safely operate or repair your machine may be severely impaired putting yourself and everyone else on your jobsite in danger.
- When working with another operator or with a person on worksite traffic duty, be sure that all personnel understand all hand signals that are to be used.

IF ABNORMALITIES ARE FOUND

If you find any abnormality in the machine during operation or maintenance (noise, vibration, smell, incorrect gauges, smoke, oil leakage, etc., or any abnormal display on the warning devices or monitor), report to the person in charge and have the necessary action taken. Do not operate the machine until the abnormality has been corrected.

WORKING WEAR AND PERSONAL PROTECTIVE ITEMS

- Do not wear loose clothing and accessories. There is a hazard that they may catch on control levers or other protruding parts.
- If you have long hair and it hangs out from your hard hat, there is a hazard that it may get caught up in the machine, so tie your hair up and be careful not to let it get caught.
- Always wear a hard hat and safety shoes. If the nature of the work requires it, wear safety glasses, mask, gloves, ear plugs, and safety belt when operating or maintaining the machine.
- Check that all protective equipment functions properly before using it.

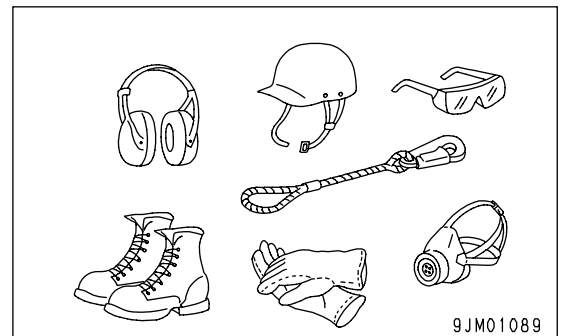

FIRE EXTINGUISHER AND FIRST AID KIT

Always follow the precautions below to prepare for action if any injury or fire should occur.

- Be sure that fire extinguishers have been provided and read the labels to ensure that you know how to use them in emergencies.
- Carry out periodic inspection and maintenance to ensure that the fire extinguisher can always be used.
- Provide a first aid kit at the storage point. Carry out periodic checks and add to the contents if necessary.

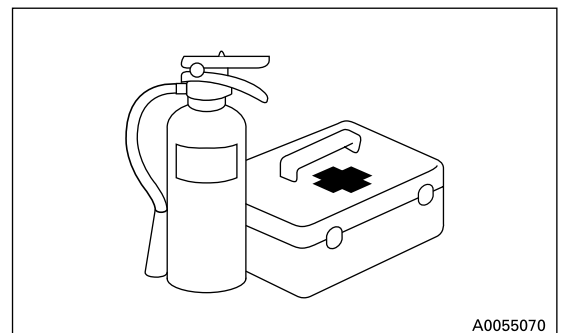

SAFETY EQUIPMENT

- Be sure that all guards and covers are in their proper position. Have guards and covers repaired immediately if they are damaged.
- Understand the method of use of safety features and use them properly.
- Never remove any safety features. Always keep them in good operating condition.

KEEP MACHINE CLEAN

- If water gets into the electrical system, there is a hazard that it will cause malfunctions or misoperation. Do not use water or steam to wash the electrical system (sensors, connectors).
- If inspection and maintenance is carried out when the machine is still dirty with mud or oil, there is a hazard that you will slip and fall, or that dirt or mud will get into your eyes. Always keep the machine clean.

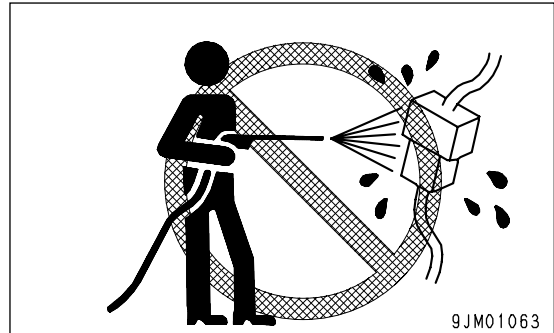

KEEP OPERATOR'S COMPARTMENT CLEAN

- When entering the operator's compartment, always remove all mud and oil from the soles of your shoes. If you operate the pedal with mud or oil affixed to your shoes, your foot may slip and this may cause a serious accident.
- Do not leave parts or tools lying around the operator's compartment.
- Do not stick suction pads to the window glass. Suction pads act as a lens and may cause fire.
- Do not use cellular telephones inside the operator's compartment when driving or operating the machine.
- Never bring any dangerous objects such as flammable or explosive items into the operator's cab.

LEAVING OPERATOR'S SEAT WITH LOCK

- Before standing up from the operator's seat (such as when opening or closing the front window or roof window, or when removing or installing the bottom window, or when adjusting the operator's seat), lower the work equipment completely to the ground, set safety lock lever (1) securely to the LOCK position, then stop the engine. If you accidentally touch the levers when they are not locked, there is a hazard that the machine may suddenly move and cause serious injury or property damage.

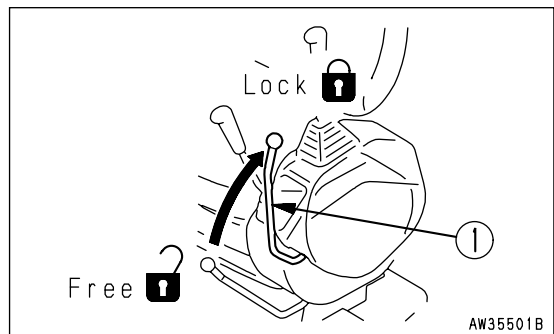

- When leaving the machine, always lower the work equipment completely to the ground, set safety lock lever (1) securely to the LOCK position, then stop the engine. Use the key to lock all the equipment. Always remove the key, take it with you, and keep it in the specified place.

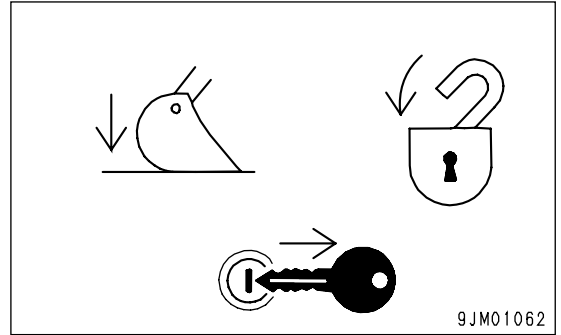

HANDRAILS AND STEPS

To prevent personal injury caused by slipping or falling off the machine, always do as follows.

- Use the handrails and steps marked by arrows in the diagram on the right when getting on or off the machine.

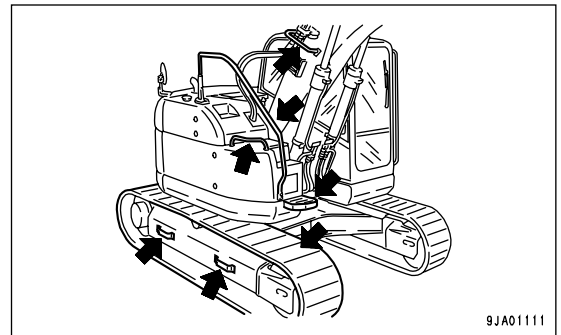
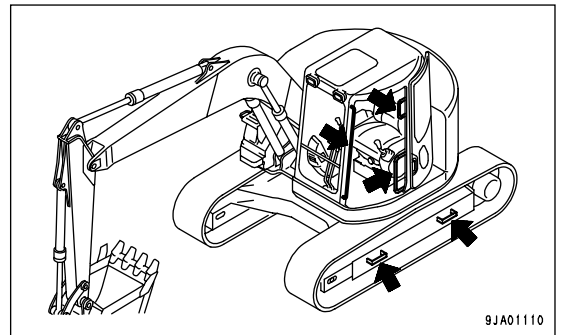

- To ensure safety, always face the machine and maintain three-point contact (both feet and one hand, or both hands and one foot) with the handrails and steps (including the track shoe) to ensure that you support yourself.
- Do not grip the control levers when getting on or off the machine.
- Use only the inspection path fitted with non-slip pads when climbing on top of the machine. Never climb on the engine hood or covers where there are no non-slip pads.

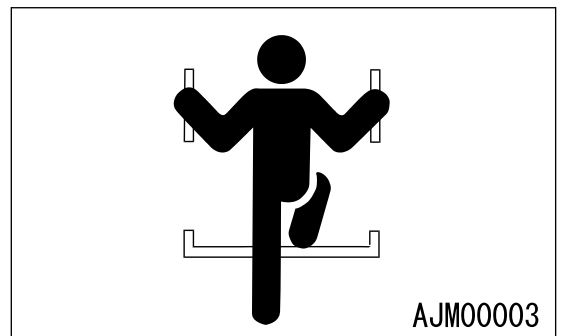

- Before getting on or off the machine, check the handrails and steps (including the track shoe). If there is any oil, grease, or mud on the handrails or steps (including the track shoe), wipe it off immediately. Always keep these parts clean. Repair any damage and tighten any loose bolts.
- Do not get on or off the machine while holding tools in your hand.

CRUSHING OR CUTTING PREVENTION

Do not put your hand, arm or any other part of your body between movable parts such as the work equipment and cylinders, or between the machine and work equipment. When the work equipment is operated, the clearance will change and this may lead to serious damage or personal injury.

MOUNTING AND DISMOUNTING

- Never jump on or off the machine. Never get on or off a moving machine.
- If the machine starts to move when there is no operator on the machine, do not jump on to the machine and try to stop it.

NO PERSONS ON ATTACHMENTS

Never let anyone ride on the bucket, grapple, clamshell, or other attachments. There is a hazard of falling and suffering serious injury.

BURN PREVENTION

Hot coolant

- To prevent burns from hot water or steam spurting out when checking or draining the coolant, wait for the water to cool to a temperature where it is possible to touch the radiator cap by hand before starting the operation. Even when the coolant has cooled down, loosen the cap slowly to relieve the pressure inside the radiator before removing the cap.

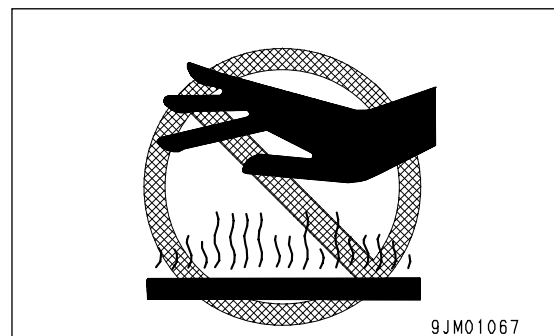

Hot oil

- To prevent burns from oil spurting out or from contact with hot parts when checking or draining the oil, wait for the oil to cool to a temperature where it is possible to touch the cap or plug by hand before starting the operation. Even when the oil has cooled down, loosen the cap or plug slowly to relieve the internal pressure before removing the cap or plug.

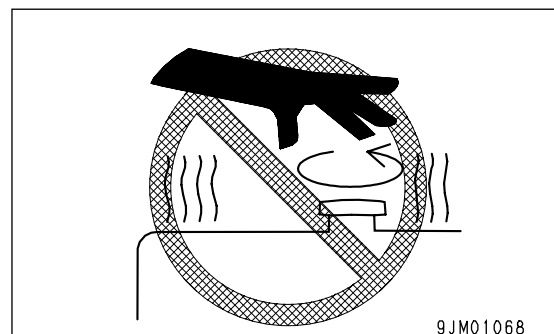

FIRE PREVENTION AND EXPLOSION PREVENTION

● Fire caused by fuel or oil

Fuel, oil, antifreeze, and window washer liquid are particularly flammable and can be hazardous. To prevent fire, always observe the following:

- Do not smoke or use any flame near fuel or oil.
- Stop the engine before refueling.
- Do not leave the machine while adding fuel or oil.
- Tighten all fuel and oil caps securely.
- Do not spill fuel on overheated surfaces or on parts of the electrical system.
- Use well-ventilated areas for adding or storing oil and fuel.
- Keep oil and fuel in the determined place and do not allow unauthorized persons to enter.
- After adding fuel or oil, wipe up any spilled fuel or oil.
- When carrying out grinding or welding work on the chassis, move any flammable materials to a safe place before starting.
- When washing parts with oil, use a non-flammable oil. Diesel oil and gasoline may catch fire, so do not use them.
- Put greasy rags and other flammable materials into a safe container to maintain safety at the work place.
- Do not weld or use a cutting torch to cut any pipes or tubes that contain flammable liquids.

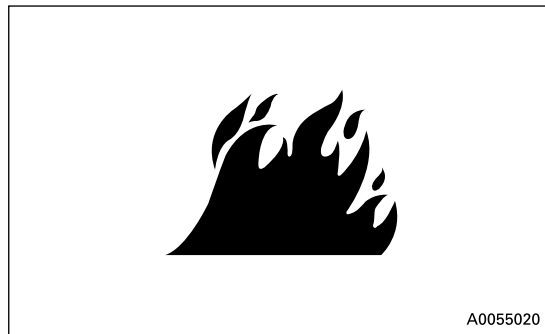

● Fire caused by accumulation of flammable material.

- Remove any dry leaves, chips, pieces of paper, dust, or any other flammable materials accumulated or affixed around the engine, exhaust manifold, muffler, or battery, or inside the undercovers.

● Fire coming from electric wiring

Short circuits in the electrical system can cause fire.

- Always keep electric wiring connections clean and securely tightened.
- Check the wiring every day for looseness or damage. Tighten any loose connectors or wiring clamps. Repair or replace any damaged wiring.

● Fire coming from hydraulic line

Check that all the hose and tube clamps, guards, and cushions are securely fixed in position.

If they are loose, they may vibrate during operation and rub against other parts. This may lead to damage to the hoses, and cause high-pressure oil to spurt out, leading to fire damage or serious injury.

● Explosion caused by lighting equipment

- When checking fuel, oil, battery electrolyte, window washer fluid, or coolant, use explosion-proof lighting. If you do not use explosion-proof lighting, there is a hazard of serious injury or damage caused by explosion.
- When taking the electrical power for the lighting from the machine, follow the instructions in this manual.

ACTION IF FIRE OCCURS

If a fire occurs, escape from the machine as follows.

- Turn the starting switch OFF and stop the engine.
- Use the handrails and steps to get off the machine.

WINDSHIELD WASHER FLUID

Use an ethyl alcohol base washer liquid. Methyl alcohol base washer liquid may irritate your eyes, so do not use it.

FALLING OBJECTS, FLYING OBJECTS AND INTRUDING OBJECTS PREVENTION

On jobsites where there is a hazard that falling objects, flying objects, or intruding objects may hit or enter the operator's cab, consider the operating conditions and install the necessary guards to protect the operator.

- When carrying out demolition or breaker operations, install a front guard and use a laminated coating sheet on the front glass.
- When carrying out operations in mines, quarries, or other places where there is danger of falling rocks, fit FOPS and a front guard, and stick a laminated coating sheet to the front glass.
- When carrying out the above operations, always close the front window. In addition, always ensure that bystanders are a safe distance away and are not in hazard from falling or flying objects.
- The above recommendations assume that the conditions are for standard operations, but it may be necessary to add additional guards according to the operating conditions on the jobsite.
Always contact your Komatsu distributor for advice.

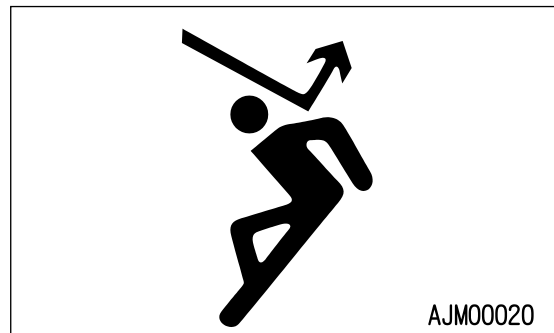

ATTACHMENT INSTALLATION

- When installing optional parts or attachments, there may be problems with safety or legal restrictions, so please contact your Komatsu distributor for advice.
- Any injuries, accidents, or product failures resulting from the use of unauthorized attachments or parts will not be the responsibility of Komatsu.
- When installing and using optional attachments, read the instruction manual for the attachment, and the general information related to attachments in this manual.

ATTACHMENT COMBINATIONS

Depending on the type or combination of work equipment, there is a hazard that the work equipment may hit the cab or other parts of the machine. Before using unfamiliar work equipment, check if there is any hazard of interference, and operate with caution.

CAB WIDOW GLASSES

If the cab glass on the work equipment side is broken, there is a hazard that the work equipment may contact the operator's body directly. Stop operation immediately and replace the glass.

UNAUTHORIZED MODIFICATIONS

Any modification made without authorization from Komatsu can create hazards. Before making a modification, consult your Komatsu distributor.

- Komatsu will not be responsible for any injuries, accidents, or product failures resulting from modifications made without authorization from Komatsu.

SAFETY AT JOBSITE

Before starting operations, thoroughly check the area for any unusual conditions that could be dangerous.

- When carrying out operations near combustible materials such as thatched roofs, dry leaves or dry grass, there is a hazard of fire, so be careful when operating.
- Check the terrain and condition of the ground at the worksite, and determine the safest method of operation. Do not carry out operations at places where there is a hazard of landslides or falling rocks.
- If water lines, gas lines, or high-voltage electrical lines may be buried under the worksite, contact each utility and identify their locations. Be careful not to sever or damage any of these lines.
- Take necessary measures to prevent any unauthorized person from entering the operating area.
- When traveling or operating in shallow water or on soft ground, check the shape and condition of the bedrock, and the depth and speed of flow of the water before starting operations.

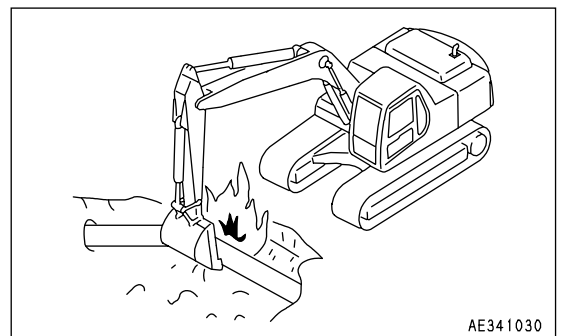

WORKING ON LOOSE GROUND

- Avoid traveling or operating your machine too close to the edge of cliffs, overhangs, and deep ditches. The ground may be weak in such areas. If the ground should collapse under the weight or vibration of the machine, there is a hazard that the machine may fall or tip over. Remember that the soil after heavy rain or blasting or after earthquakes is weak in these areas.
- When working on embankments or near excavated ditches, there is a hazard that the weight and vibration of the machine will cause the soil to collapse. Before starting operations, take steps to ensure that the ground is safe and to prevent the machine from rolling over or falling.

DISTANCE TO HIGH VOLTAGE CABLES

Do not travel or operate the machine near electric cables. There is a hazard of electric shock, which may cause serious injury or property damage. On jobsites where the machine may go close to electric cables, always do as follows.

- Before starting work near electric cables, inform the local power company of the work to be performed, and ask them to take the necessary action.
- Even going close to high-voltage cables can cause electric shock, which may cause serious burns or even death. Always maintain a safe distance (see the table on the right) between the machine and the electric cable. Check with the local power company about safe operating procedure before starting operations.
- To prepare for any possible emergencies, wear rubber shoes and gloves. Lay a rubber sheet on top of the seat, and be careful not to touch the chassis with any exposed part of your body.
- Use a signalman to give warning if the machine approaches too close to the electric cables.
- When carrying out operations near high voltage cables, do not let anyone come close to the machine.
- If the machine should come too close or touch the electric cable, to prevent electric shock, the operator should not leave the operator's compartment until it has been confirmed that the electricity has been shut off. Also, do not let anyone come close to the machine.

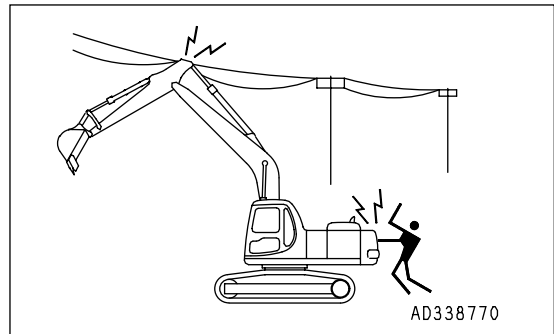

	Voltage	Min. safety distance
Low voltage	100V 200V	2m
	6,600V	2m
Very high voltage	22,000V	3m
	66,000V	4m
	154,000V	5m
	187,000V	6m
	275,000V	7m
	500,000V	11m

ENSURE GOOD VISIBILITY

- Check for any persons or obstacles in the area around the machine and check the conditions of the jobsite to ensure that operations and travel can be carried out safely. Always do as follows.
 - Position a signalman if there are areas at the rear of the machine where the visibility is not good.
 - When working in dark places, turn on the working lamp and front lamps installed to the machine, and set up additional lighting in the work area if necessary.
 - Stop operations if the visibility is poor, such as in mist, snow, rain, or dust.

VENTILATION FOR ENCLOSED AREA

Exhaust fumes from the engine can kill.

- If it is necessary to start the engine within an enclosed area, or when handling fuel, flushing oil, or paint, open the doors and windows to ensure that adequate ventilation is provided to prevent gas poisoning.

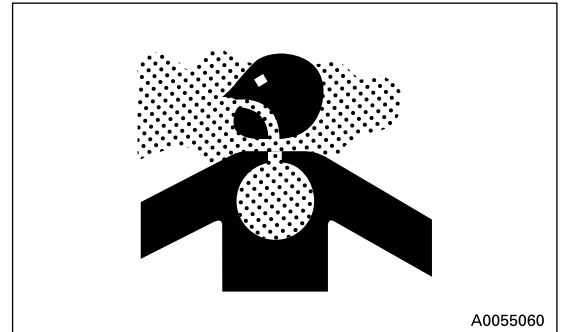

SIGNALMAN'S SIGNAL AND SIGNS

- Set up signs to inform of road shoulders and soft ground. If the visibility is not good, position a signalman if necessary. Operators should pay careful attention to the signs and follow the instructions from the signalman.
- Only one signalman should give signals.
- Make sure that all workers understand the meaning of all signals and signs before starting work.

EMERGENCY EXIT FROM OPERATOR'S CAB

If any accident should happen and it becomes impossible to open the door, use the hammer supplied to break the window and use it as an emergency escape.

For details, see "HAMMER FOR EMERGENCY ESCAPE (PAGE 3-24)" in this manual.

- When escaping, remove all the pieces of glass from window frame first and be careful not to cut yourself on the glass. Be careful also not to slip on the broken pieces of glass on the ground around the machine.

ASBESTOS DUST HAZARD PREVENTION

Asbestos dust in the air can cause lung cancer if it is inhaled. There is danger of inhaling asbestos when working on jobsites handling demolition work or work handling industrial waste. Always observe the following.

- Spray water to keep down the dust when cleaning. Do not use compressed air for cleaning.
- If there is danger that there may be asbestos dust in the air, always operate the machine from an upwind position. All workers should use an approved respirator.
- Do not allow other persons to approach during the operation.
- Always observe the rules and regulations for the work site and environmental standards.

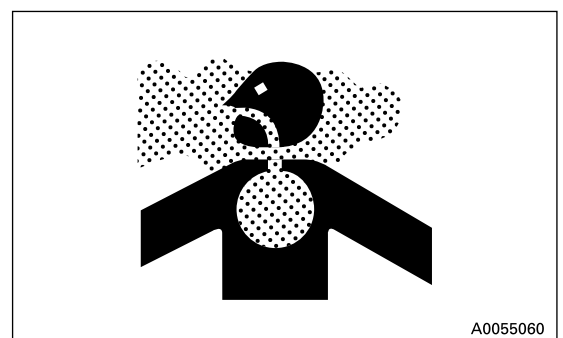

This machine does not use asbestos, but there is a danger that imitation parts may contain asbestos, so always use genuine Komatsu parts.

SAFETY MACHINE OPERATION

STARTING ENGINE

If there is a warning tag hanging from the work equipment control lever, do not start the engine or touch the levers.

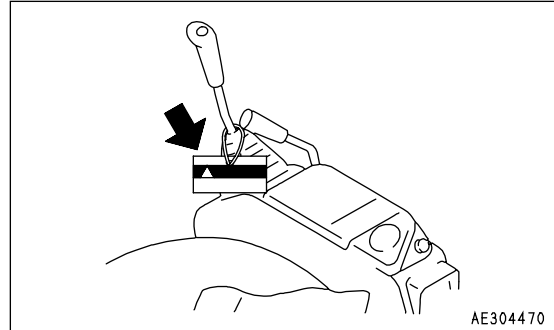

CHECKS BEFORE STARTING ENGINE

Carry out the following checks before starting the engine at the beginning of the day's work.

- Remove all dirt from the surface of the window glass to ensure a good view.
- Remove all dirt from the surface of the lens of the front lamps and working lamps, and check that they light up correctly.
- Check the coolant level, fuel level, and oil level in engine oil pan, check for clogging of the air cleaner, and check for damage to the electric wiring.
- Adjust the operator's seat to a position where it is easy to carry out operations, and check that there is no damage or wear to the seat belt or mounting clamps.
- Check that the gauges work properly, check the angle of the lights and working lamps, and check that the control levers are all at the neutral position.
- Before starting the engine, check that the safety lock lever is at the LOCK position.
- Adjust the mirrors so that the rear of the machine can be seen clearly from the operator's seat. When adjusting, see "REARVIEW MIRRORS (PAGE 3-50)".
- Check that there are no persons or obstacles above, below, or in the area around the machine.

SAFETY RULES FOR STARTING ENGINE

- When starting the engine, sound the horn as a warning.
- Start and operate the machine only while seated.
- Do not allow anyone apart from the operator to ride on the machine.
- Do not short circuit the starting motor circuit to start the engine. It is not only dangerous, but will also cause damage to the equipment.

STARTING ENGINE IN COLD WEATHER

- Carry out the warming-up operation thoroughly. If the machine is not thoroughly warmed up before the control levers are operated, the reaction of the machine will be slow, and this may lead to unexpected accidents.
- If the battery electrolyte is frozen, do not charge the battery or start the engine with a different power source. There is a hazard that this will ignite the battery. Before charging or starting the engine with a different power source, melt the battery electrolyte and check for frost and leakage of battery electrolyte before starting.

OPERATION

CHECKS AFTER STARTING ENGINE

When carrying out the checks, move the machine to a wide area where there are no obstructions, and operate slowly. Do not allow anyone near the machine.

- Always fasten your seat belt.
- Check that the movement of the machine matches the display on the control pattern card. If it does not match, replace it immediately with the correct control pattern card.
- Check the operation of the gauges and equipment, and check the operation of the bucket, arm, boom, travel system, swing system, and steering system.
- Check for any abnormality in the sound of the machine, vibration, heat, smell, or gauges; check also that there is no leakage of oil or fuel.
- If any abnormality is found, carry out repairs immediately.

SAFETY RULES FOR CHANGING MACHINE DIRECTIONS

- Position the upper structure so that the sprocket is at the rear of the operator's cab before traveling. If the sprocket is at the front of the operator's cab, the direction of operations is reversed (for example, forward becomes reverse, and left becomes right).
- Before travelling, check again that there is no one in the surrounding area, and that there are no obstacles.
- Before travelling, sound the horn to warn people in the area.
- Always operate the machine only when seated.
- Do not allow anyone apart from the operator to ride on the machine.
- Check that the travel alarm (if equipped) works properly.
- Always lock the door and windows of the operator's compartment in position (open or closed). On jobsites where there is a hazard of flying objects or of objects entering the operator's compartment, check that the door and windows are securely closed.
- If there is an area to the rear of the machine which cannot be seen, position a signal person. Take special care not to hit other machines or people when turning or swinging the machine.

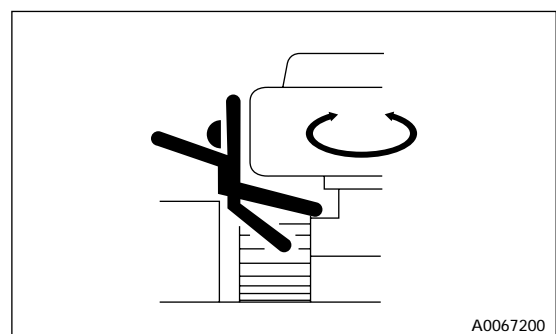
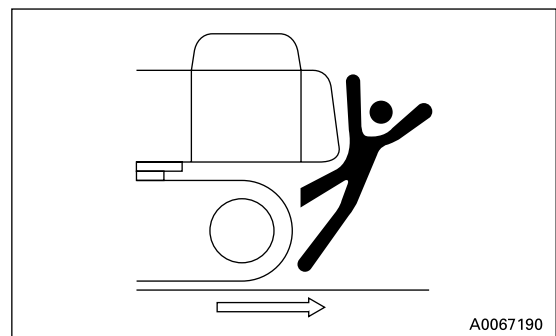
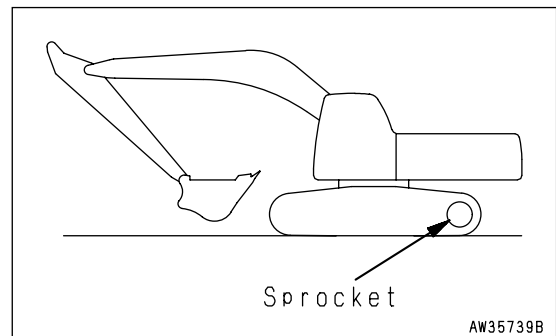

Always be sure to carry out the above precautions even when the machine is equipped with mirrors.

SAFETY RULES FOR TRAVELING

- It is dangerous to drive too fast, or to start suddenly, stop suddenly, or to turn sharply.
- When traveling on level ground, pull in the work equipment and keep it at a height of 40 to 50cm (16 to 20 in) from the ground.
- When traveling on rough ground, travel at low speed and do not operate the steering suddenly. There is danger that the machine may turn over. The work equipment may hit the ground surface and cause the machine to lose its balance, or may damage the machine or structures in the area.
- Avoid traveling over obstacles when possible. If the machine has to travel over an obstacle, keep the work equipment close to the ground and travel at low speed. Never travel over obstacles which make the machine tilt strongly to one side.
- When traveling or carrying out operations, always keep a safe distance from people, structures, or other machines to avoid coming into contact with them.
- When passing over bridges or structures, check first that the structure is strong enough to support the weight of the machine.
When traveling on public roads, check first with the relevant authorities and follow their instructions.
- When operating in tunnels, under bridges, under electric wires, or other places where the height is limited, operate slowly and be extremely careful not to let the work equipment hit anything.

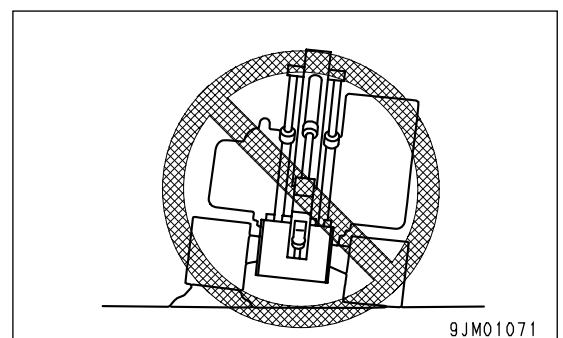
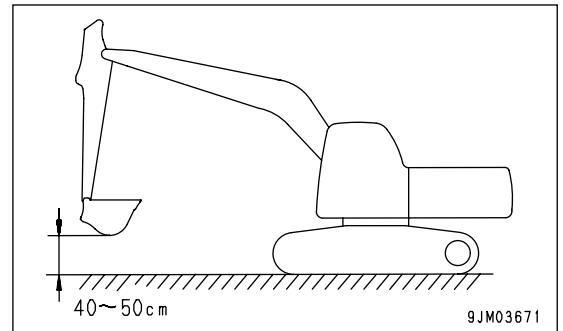

TRAVELING ON SLOPES

To prevent the machine from tipping over or slipping to the side, always do as follows.

- When traveling on slopes, keep the work equipment approximately 20 to 30cm (8 to 12 in) above the ground. In case of emergency, quickly lower the work equipment to the ground immediately to help stop the machine.
- When travel up slopes, set the operator's cab facing uphill, when travel down slopes, set the operator's cab facing downhill.
Always check the firmness of the ground under the front of the machine when traveling.

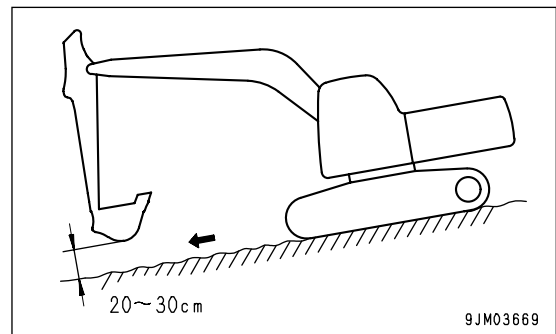
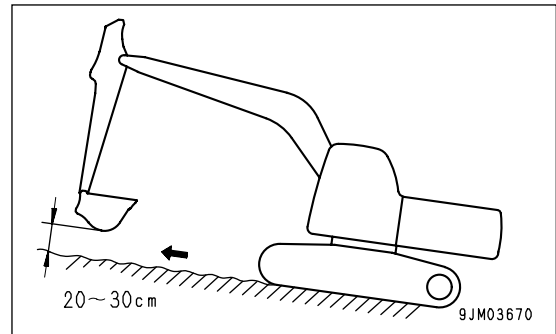

- When traveling up a steep slope, extend the work equipment to the front to improve the balance, keep the work equipment approximately 20 to 30cm (8 to 12 in) above the ground, and travel at low speed.
- When traveling downhill, lower the engine speed, keep the travel lever close to the neutral position, and travel at low speed.

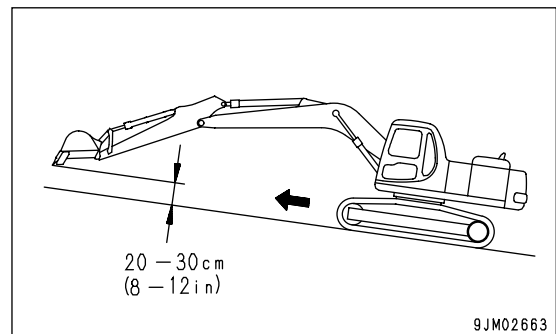

- Always travel straight up or down a slope. Traveling at an angle or across the slope is extremely dangerous.
- Do not turn on slopes or travel across slopes. Always go down to a flat place to change the position of the machine, then travel on to the slope again.
- Travel on grass, fallen leaves, or wet steel plates with low speed. Even with slight slopes there is a hazard that the machine may slip.
- If the engine stops when the machine is traveling on a slope, move the control levers immediately to the neutral position and start the engine again.

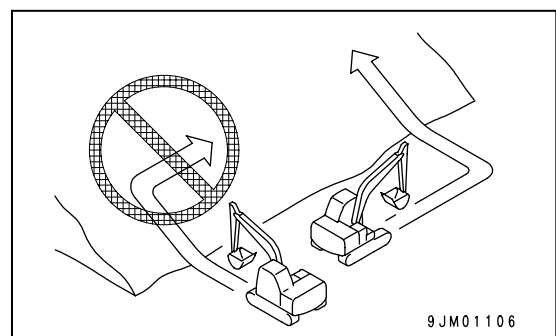

OPERATIONS ON SLOPES

- When working on slopes, there is a hazard that the machine may lose its balance and turn over when the swing or work equipment are operated. This may lead to serious injury or property damage, so always provide a stable place when carrying out these operations, and operate carefully.
- Do not swing the work equipment from the uphill side to the downhill side when the bucket is loaded. This operation is dangerous, and may cause the machine to tip over.
- If the machine has to be used on a slope, pile the soil to make a platform that will keep the machine as horizontal as possible.

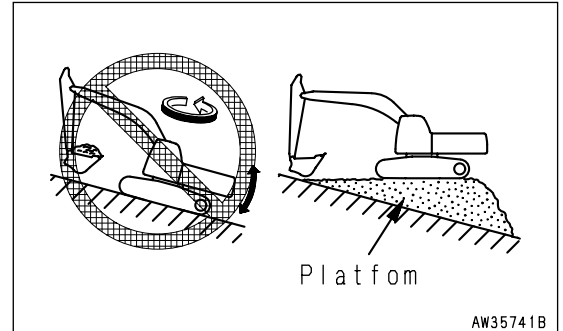

PROHIBITED OPERATIONS

- Never dig the work face under an overhang. There is a hazard that rocks may fall or that the overhang may collapse and fall on top of the machine.

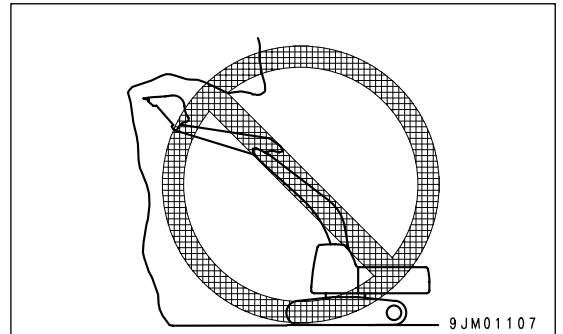

- Do not excavate too deeply under the front of the machine. The ground under the machine may collapse and cause the machine to fall.

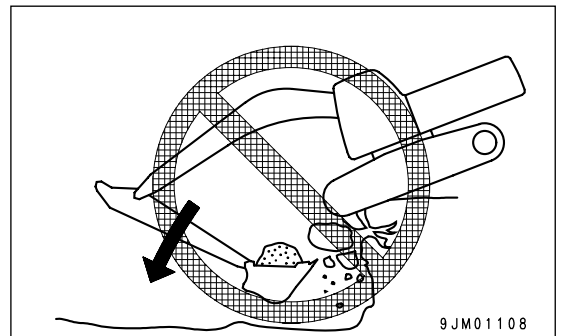

- To make it easier to escape if there is any problem, set the tracks at right angles to the road shoulder or cliff with the sprocket at the rear when carrying out digging operations.

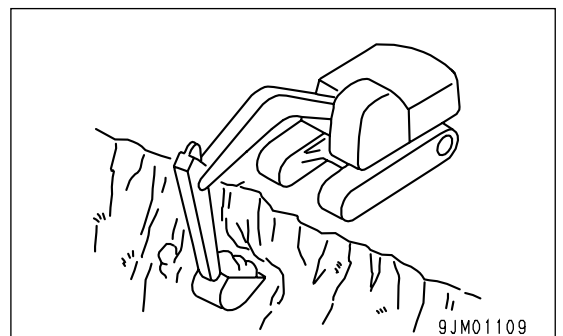

- Do not carry out demolition work under the machine. There is a hazard that the machine may become unstable and tip over.
- When working on or from the top of buildings or other structures, check the strength and the structure before starting operations. There is a hazard of the building collapsing and causing serious injury or damage.

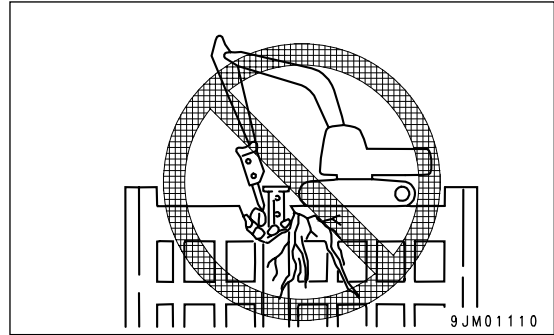

- When carrying out demolition work, do not carry out demolition above your head. There is a hazard of broken parts falling or of the building collapsing and causing serious injury or property damage.

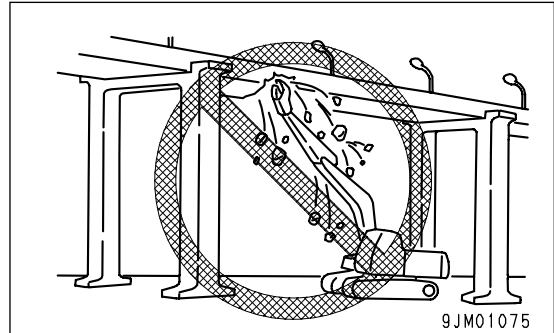

- Do not use the impact force of the work equipment for breaking work. There is a hazard of personal injury or property damage being caused by flying pieces of broken material or damage to the work equipment.
- Generally speaking, the machine is more liable to overturn when the work equipment is at the side than when it is at the front or rear.

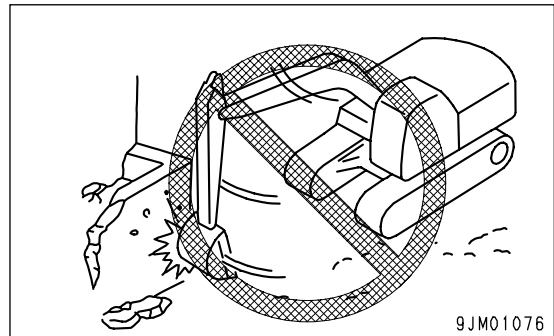

- When using a breaker or other heavy work equipment, there is a hazard of the machine losing its balance and tipping over. When operating on flat ground as well as on slopes.
 - Do not suddenly lower, swing, or stop the work equipment.
 - Do not suddenly extend or retract the boom cylinder. There is a hazard that impact will cause the machine to tip over.
- Do not pass the bucket over the head of other workers or over the operator's seat of dump trucks or other hauling equipment. The load may spill or the bucket may hit the dump truck and cause serious injury or property damage.

OPERATIONS ON SNOW

- Snow-covered or frozen surfaces are slippery, so be extremely careful when traveling or operating the machine, and do not operate the levers suddenly. Even a slight slope may cause the machine to slip, so be particularly careful when working on slopes.
- With frozen ground surfaces, the ground becomes soft when the temperature rises, and this may cause the machine to tip over.
- If the machine enters deep snow, there is a hazard that it may tip over or become buried in the snow. Be careful not to leave the road shoulder or to get trapped in a snow drift.
- When clearing snow, the road shoulder and objects placed beside the road are buried in the snow and cannot be seen. There is a hazard of the machine tipping over or hitting covered objects, so always carry out operations carefully.

PARKING MACHINE

- Park the machine on firm, level ground.
- Select a place where there is no hazard of falling rocks or landslides, or of flooding if the land is low.
- Lower the work equipment completely to the ground.
- When leaving the machine, set safety lock lever (1) to the LOCK position, then stop the engine.
- Always close the operator's cab door, and use the key to lock all the equipment in order to prevent any unauthorized person from moving the machine. Always remove the key, take it with you, and leave it in the specified place.
- If it is necessary to park the machine on a slope, always do as follows.
 - Set the bucket on the downhill side, then dig it into the ground.
 - Put blocks under the tracks to prevent the machine from moving.

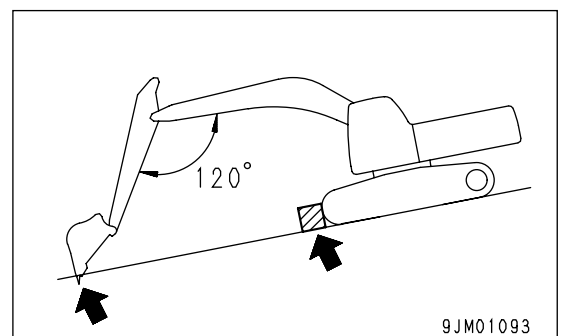
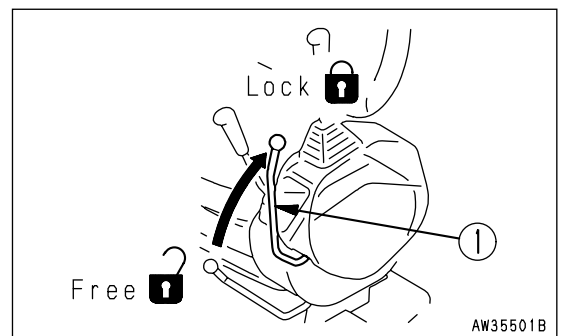
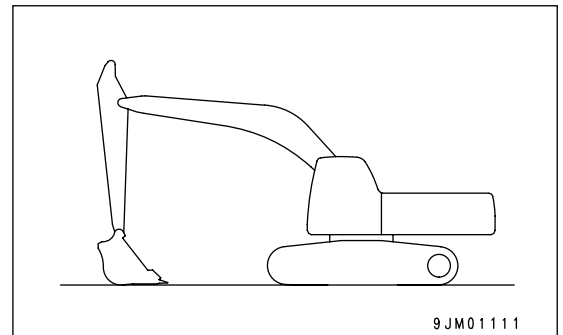

TRANSPORTATION

LOADING AND UNLOADING

When loading or unloading the machine, mistaken operation may bring the hazard of the machine tipping over or falling, so particular care is necessary. Always do as follows.

- Perform loading and unloading on firm, level ground only. Maintain a safe distance from the edge of the road or cliff.
- Never use the work equipment to load or unload the machine. There is danger that the machine may fall or tip over.
- Always use ramps of adequate strength. Be sure that the ramps are wide, long, and thick enough to provide a safe loading slope. Take suitable steps to prevent the ramps from moving out of position or coming off.
- Be sure the ramp surface is clean and free of grease, oil, ice and loose materials. Remove dirt from machine-tracks. On a rainy day, in particular, take extremely careful since the ramp surface is slippery.
- Run the engine at low speed, and operate the machine slowly.
- Never correct your steering on the ramps. If necessary, drive off the ramps, correct the direction, then enter the ramps again.
- When on the ramps, do not operate any lever except for the travel lever.
- The center of gravity of the machine will change suddenly at the joint between the ramps and the track or trailer, and there is danger of the machine losing its balance. Travel slowly over this point.
- When loading or unloading to an embankment or platform, make sure that it has suitable width, strength, and grade.
- When swinging the upper structure on the trailer, the trailer is unstable, so pull in the work equipment and swing slowly. And turn swing lock switch ON to apply swing lock after loading machine.
- For machines equipped with a cab, always lock the door after loading the machine. If this is not done, the door may suddenly open during transportation.
- After loading, block the machine tracks and secure the machine with tie-downs.

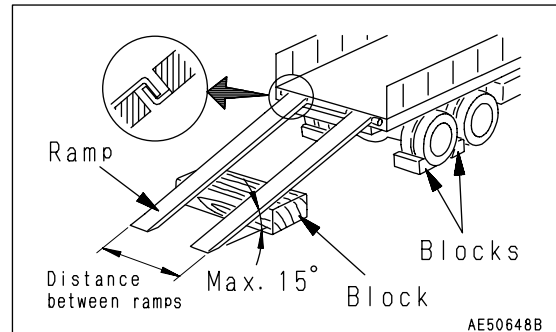

SHIPPING THE MACHINE

When shipping the machine on a trailer, do as follows.

- Investigate all state and local laws governing the weight, width, and length of a load. If necessary, disassemble the work equipment. The width, height and weight of the load differ according to the work equipment, so take this into account when determining the shipping route.
- When passing over bridges or structures on private land, check first that the structure is strong enough to support the weight of the machine. When traveling on public roads, check first with the relevant authorities and follow their instructions.
- For details of the shipping procedure, see TRANSPORTATION (PAGE 3-90) in the OPERATION section.

BATTERY

BATTERY HAZARD PREVENTION

Battery electrolyte contains sulphuric acid, and batteries generate flammable hydrogen gas, which may explode.

Mistaken handling can lead to serious injury or fire. For this reason, always observe the following precautions.

- Do not use or charge the battery if the battery electrolyte level is below the LOWER LEVEL line. This may cause an explosion. Always check the battery electrolyte level periodically and add distilled water to bring the electrolyte level to the UPPER LEVEL line.
- When working with batteries, always wear safety glasses and rubber gloves.
- Never smoke or use any flame near the battery.

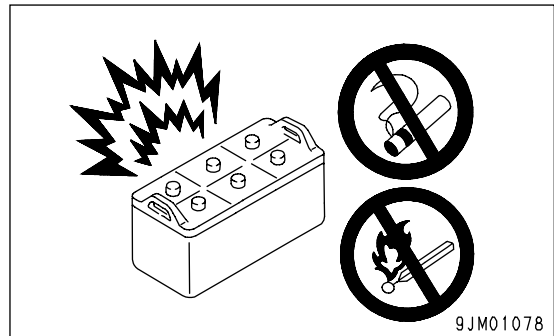

- If you spill acid on your clothes or skin, immediately flush the area with large amounts of water.
- If acid gets into your eyes, flush them immediately with large quantities of water and seek medical attention.

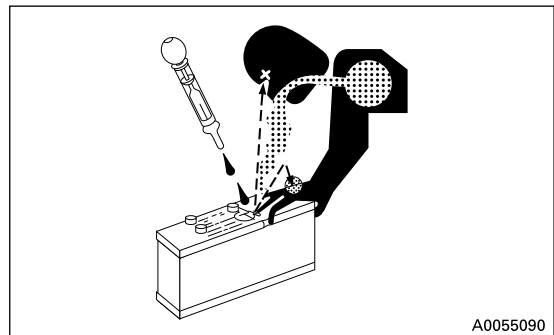

- Before working with batteries, turn the starting switch to the OFF position.

As there is a hazard that sparks will be generated, always do as follows.

- Do not let tools or other metal objects make any contact between the battery terminals. Do not leave tools or other metal objects lying around near the battery.
- Always disconnect the negative (-) terminal (ground side) first when removing the battery; when installing the battery, connect the positive (+) terminal first, and connect the ground last. Tighten the battery terminals securely.
- Flammable hydrogen gas is generated when the battery is charged, so remove the battery from the chassis, take it to a well-ventilated place, and remove the battery caps before charging it.
- Tighten the battery caps securely.
- Install the battery securely to the determined place.

STARTING ENGINE WITH BOOSTER CABLES

If any mistake is made in the method of connecting the booster cables, it may cause the battery to explode, so always do as follows.

- When starting with a booster cable, carry out the starting operation with two workers (one worker sitting in the operator's seat and the other working with the battery).
- When starting from another machine, do not allow the two machines to touch.
- When connecting the booster cables, turn the starting switch OFF for both the normal machine and problem machine. There is a hazard that the machine will move when the power is connected.
- Be sure to connect the positive (+) cable first when installing the booster cables. Disconnect the ground or negative (-) cable (ground side) first when removing them.
- When removing the booster cables, be careful not to let the booster cable clips touch each other or to let the clips touch the machine.
- Always wear safety goggles and rubber gloves when starting the engine with booster cables.
- When connecting a normal machine to a problem machine with booster cables, always use a normal machine with the same battery voltage as the problem machine.
- For details of the starting procedure when using booster cables, see STARTING ENGINE WITH BOOSTER CABLES (PAGE 3-110) in the OPERATION section.

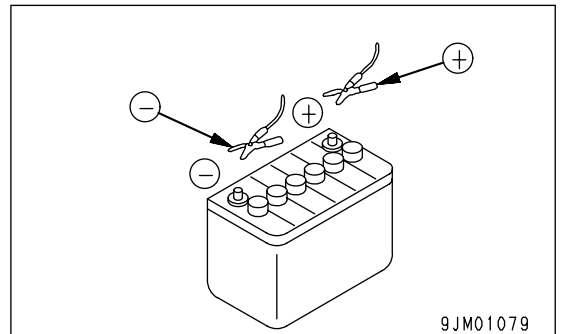
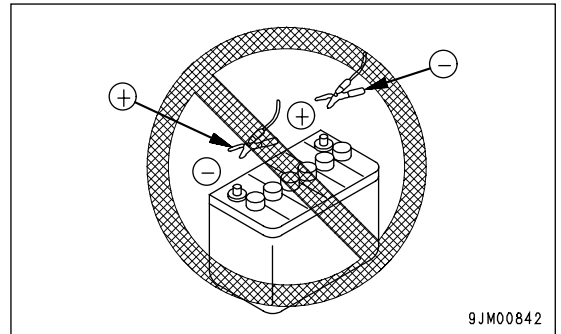

TOWING

SAFETY RULES FOR TOWING

Serious injury or death could result if a disabled machine is towed incorrectly or if there is a mistake in the selection or inspection of the wire rope.

When towing, always use the method given in TOWING THE MACHINE (PAGE 3-106) in the OPERATION section.

- Always wear leather gloves when handling wire rope.
- During the towing operation, never stand between the towing machine and the machine being towed.
- Never tow a machine on a slope.
- Never use a wire rope which has cut strands (A), reduced diameter (B), or kinks (C). There is danger that the rope may break during the towing operation.

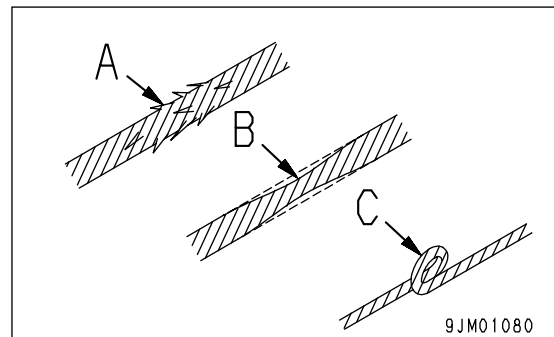

LIFTING OBJECTS WITH BUCKET

SAFETY RULES FOR LIFTING OBJECTS

- Do not carry out lifting work on slopes, soft ground, or other places where the machine is not stable.
- Use wire rope that conforms to the specified standard.
- Do not exceed the specified lifting load.
For details of the maximum lifting load permitted for this machine, see HANDLING BUCKET WITH HOOK (PAGE 6-5).
- It is dangerous if the load hits any worker or structure. Always check carefully that the surrounding area is safe before swinging or turning the machine.
- Do not start, swing, or stop the machine suddenly. There is a hazard that the lifted load will swing.
- Do not pull the load to the side or in towards the machine.
- Do not leave the operator's seat when there is a raised load.

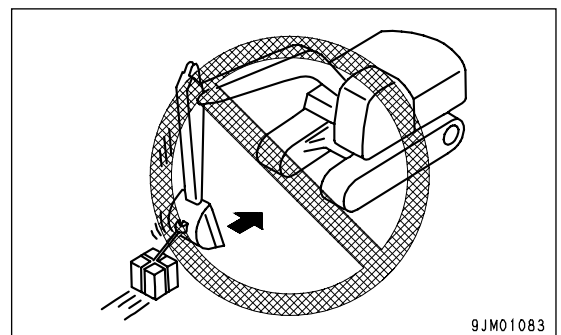
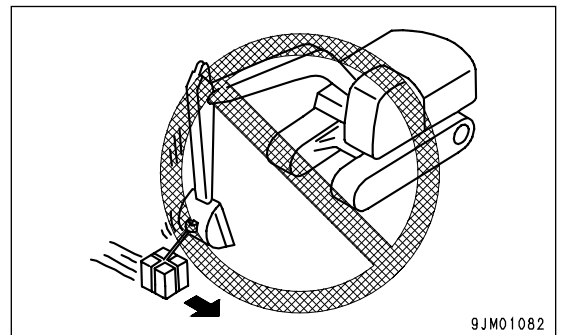

SAFETY MAINTENANCE INFORMATION

WARNING TAG

- Always attach the "DO NOT OPERATE" warning tag to the work equipment control lever in the operator's cab to alert others that you are performing service or maintenance on the machine.
Attach additional warning tags around the machine if necessary.
Warning tag Part No. 09963-03001
Keep this warning tag in the tool box while it is not used. If there is not the tool box, keep the tag in the operation manual pocket.
- If others start the engine, or touch or operate the work equipment control lever while you are performing service or maintenance, you could suffer serious injury or property damage.

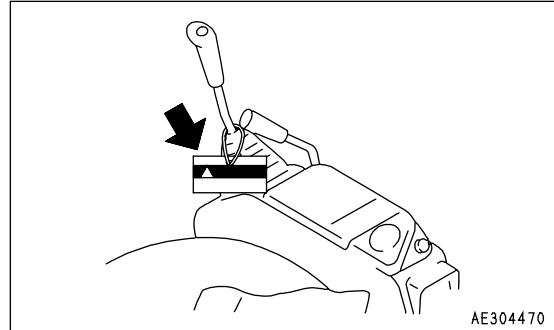

KEEP WORK PLACE CLEAN AND TIDY

- Do not leave hammers or other tools lying around in the work place. Wipe up all grease, oil, or other substances that will cause you to slip. Always keep the work place clean and tidy to enable you to carry out operations safely.
If the work place is not kept clean and tidy, there is the danger that you will trip, slip, or fall over and injure yourself.

APPOINT LEADER WHEN WORKING WITH OTHERS

- When repairing the machine or when removing and installing the work equipment, appoint a leader and follow his instructions during the operation.
When working with others, misunderstandings between workers can lead to serious accidents.

STOP ENGINE BEFORE CARRYING OUT MAINTENANCE

- Stop the machine on firm, level ground.
- Select a place where there is no danger of falling rocks, landslides, or flooding.
- Lower the work equipment completely to the ground and stop the engine.
- Turn the starting switch to the ON position to send current flowing through the circuit.
- Put blocks under the track to prevent the machine from moving.

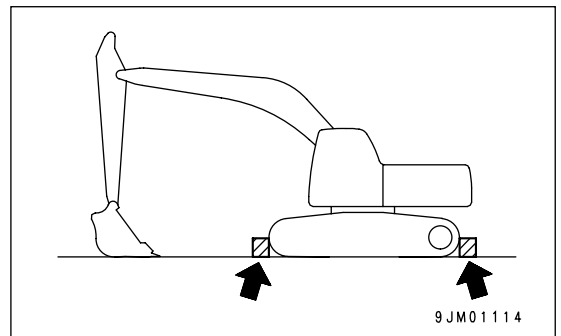
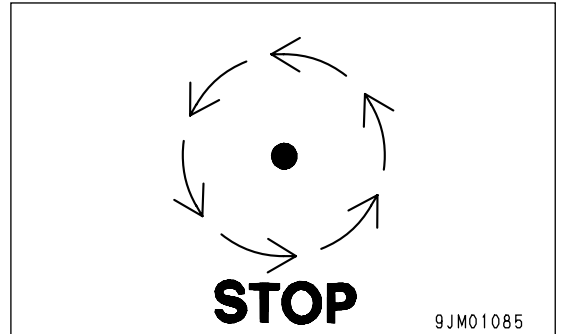

TWO WORKERS FOR MAINTENANCE WHEN ENGINE IS RUNNING

To prevent injury, do not carry out maintenance with the engine running. If maintenance must be carried out with the engine running, carry out the operation with at least two workers and do as follows.

- One worker must always sit in the operator's seat and be ready to stop the engine at any time. All workers must maintain contact with the other workers.
- Set safety lock lever (1) to the LOCK position.
- When carrying out operations near the fan, fan belt, or other rotating parts, there is a hazard of being caught in the parts, so be extremely careful.
- Do not touch any control levers. If any control lever must be operated, always give a signal to the other workers to warn them to move to a safe place.
- Never drop or insert tools or other objects into the fan or fan belt.
Parts may break or be sent flying.

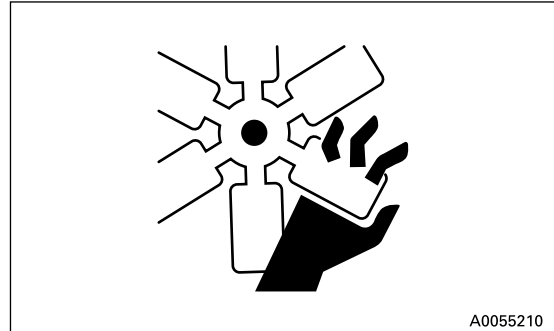

A0055210

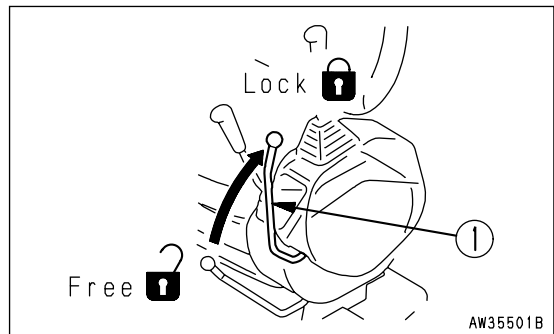

AW35501B

PROPER TOOLS

Use only tools suited to the task and be sure to use the tools correctly. Using damaged, low quality, faulty, makeshift tools or improper use of the tools could cause serious personal injury.

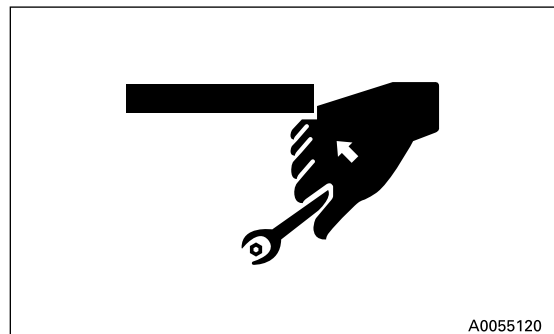

A0055120

ACCUMULATOR

The accumulator is charged with high-pressure nitrogen gas.

When handling the accumulator, careless procedure may cause an explosion which could lead to serious injury or property damage. For this reason, always observe the following precautions.

- Do not disassemble the accumulator.
- Do not bring it near flame or dispose of it in fire.
- Do not make holes in it, weld it, or use a cutting torch.
- Do not hit or roll the accumulator, or subject it to any impact.
- When disposing of the accumulator, the gas must be released. Please contact your Komatsu distributor to have this work performed.



PERSONNEL

Only authorized personnel can service and repair the machine. Do not allow unauthorized personnel into the area.

If necessary, employ an observer.

ATTACHMENTS

- Appoint a leader before starting removal or installation operations for attachments.
- Place attachments that have been removed from the machine in a stable condition so that they do not fall. And take steps to prevent unauthorized persons from entering the storage area.



WORK UNDER THE MACHINE

- If it is necessary to go under the work equipment or the machine to carry out service and maintenance, support the work equipment and machine securely with blocks and stands strong enough to support the weight of the work equipment and machine.
- It is extremely dangerous to work under the machine if the track shoes are off the ground and the machine is supported only by the work equipment. If the control levers are touched by mistake, or there is a hazard to the hydraulic line, the work equipment or the machine may suddenly descend. This is extremely dangerous. Never work under the machine if the machine is not properly supported by blocks or stands.



NOISE

If the noise from the machine is too loud, it may cause temporary or permanent hearing problems.

When carrying out maintenance of the engine and you are exposed to noise for long periods of time, wear ear covers or ear plugs while working.

WHEN USING HAMMER

When using a hammer, pins may fly out or metal particles may be scattered. This may lead to serious injury. Always do as follows.

- If hard metal parts such as pins, bucket teeth, cutting edges, or bearings are hit with a hammer, there is a hazard that pieces might be scattered and cause injury. Always wear safety goggles and gloves.
- When hitting pins or bucket teeth, there is a hazard that broken pieces might be sent flying and injure people in the surrounding area. Always check that there is no one in the surrounding area.
- If pins are hit with strong force, there is a hazard that the pin may fly out and injure people in the surrounding area.

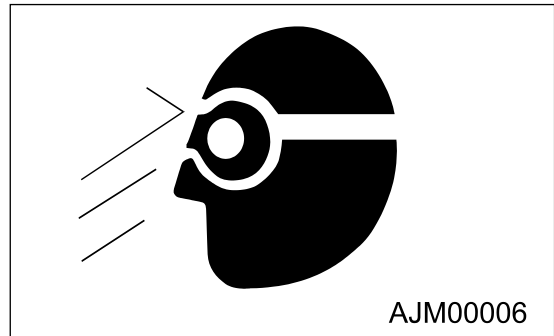

WELDING WORKS

Welding operations must always be carried out by a qualified welder and in a place equipped with a proper equipment. There is a hazard of fire or electrocution when carrying out welding, so never allow any unqualified personnel to carry out welding.

REMOVING BATTERY TERMINALS

When repairing the electrical system or when carrying out electrical welding, remove the negative (-) terminal of the battery to prevent the flow of current.

SAFETY FIRST WHEN USING HIGH-PRESSURE GREASE TO ADJUST TRACK TENSION

- Grease is pumped into the track tension adjustment system under high pressure. If the specified procedure for maintenance is not followed when making adjustment, grease drain plug (1) may fly out and cause serious injury or property damage.
- When loosening grease drain plug (1) to loosen the track tension, never loosen it more than one turn. Loosen the grease drain plug slowly.
- Never put your face, hands, feet, or any other part of your body close to grease drain plug (1).

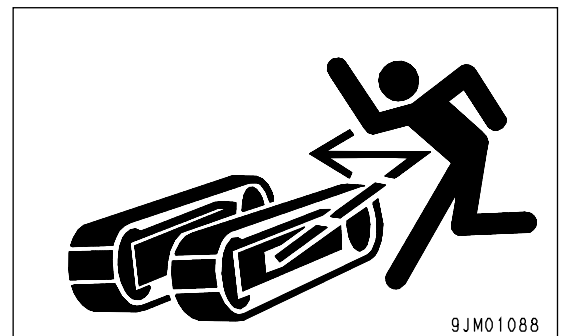
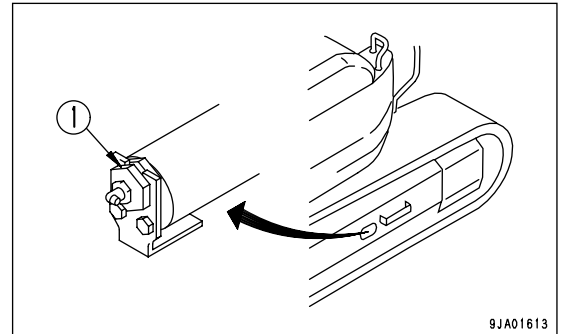

DO NOT DISASSEMBLE RECOIL SPRINGS

The recoil spring assembly is used to reduce the impact on the idler. It contains a spring under high pressure, so if it is disassembled by mistake, the spring will fly out and cause serious injury or even death. Never disassemble the recoil spring.

SAFETY RULES FOR HIGH-PRESSURE OIL

The hydraulic system is always under internal pressure. When inspecting or replacing piping or hoses, always check that the pressure in the hydraulic circuit has been released. If the circuit is still under pressure, it will lead to serious injury or property damage, so always do as follows.

- Do not carry out inspection or replacement work when the hydraulic system is under pressure.
- If there is any leakage from the piping or hoses, the surrounding area will be wet, so check for cracks in the piping and hoses and for swelling in the hoses.
When carry out inspection, wear safety glasses and leather gloves.
- There is a hazard that high-pressure oil leaking from small holes may penetrate your skin or cause blindness if it contacts your eyes directly. If you are hit by a jet of high-pressure oil and suffer injury to your skin or eyes, wash the place with clean water, and consult a doctor immediately for medical attention.

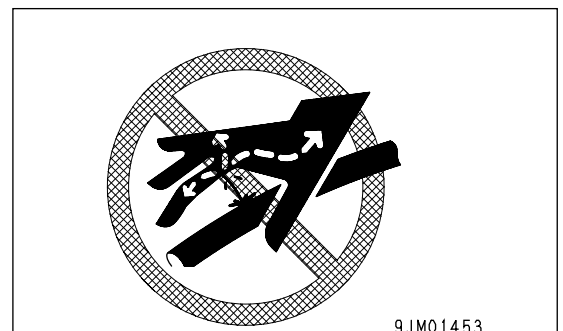

SAFETY HANDLING HIGH-PRESSURE HOSES

- If oil or fuel leaks from high-pressure hoses, it may cause fire or defective operation, which may lead to serious injury or property damage. If any loose bolts are found, stop work and tighten to the specified torque. If any damaged hoses are found, stop operations immediately and contact your Komatsu distributor.

Replace the hose if any of the following problems are found.

- Damaged or leaking hydraulic fitting.
- Frayed or cut covering or exposed reinforcement layer of wire.
- Covering swollen in places.
- Twisted or crushed movable portion.
- Foreign material embedded in covering.

WASTE MATERIALS

To prevent pollution, pay careful attention to the method of disposing of waste materials.

- Always put oil drained from your machine in containers. Never drain oil directly onto the ground or dump into the sewage system, rivers, the sea, or lakes.
- Obey appropriate laws and regulations when disposing of harmful objects such as oil, fuel, coolant, solvent, filters, and batteries.

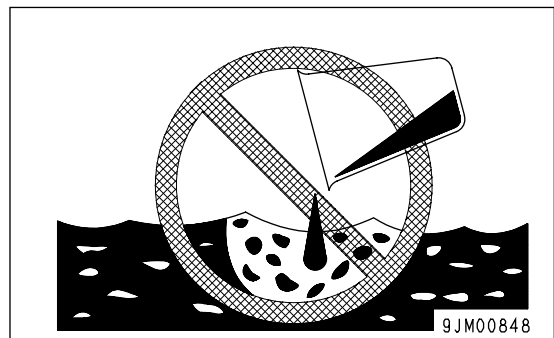

AIR CONDITIONER MAINTENANCE

If air conditioner refrigerant gets into your eyes, it may cause blindness; if it touches your skin, it may cause frost-bite.

Never touch refrigerant.

COMPRESSED AIR

- When carrying out cleaning with compressed air, there is a hazard of serious injury or property damage caused by flying particles.
- When using compressed air to clean elements or the radiator, always wear safety goggles, dust mask, gloves, and other protective equipment.

PERIODIC REPLACEMENT OF SAFETY CRITICAL PARTS

- In order for the machine to be operated safely for a long time, it is necessary to add oil and to carry out service and maintenance at periodic intervals. In order to further increase safety, components with a strong relationship to safety, such as hoses and seat belts, must be replaced at periodic intervals.
Replacement of safety critical parts: See "SAFETY CRITICAL PARTS (PAGE 4-15)".
- The material of these components naturally changes over time, and repeated use causes deterioration, wear, and fatigue. As a result, there is a hazard that these components may fail and cause serious injury or property damage. It is difficult to judge the remaining life of these components from external inspection or the feeling when operating, so always replace them at the specified interval.
- Replace or repair safety critical parts if any defect is found, even when they have not reached the time specified interval.

OPERATION

 **WARNING**

Please read and make sure that you understand the safety volume before reading this section.

GENERAL VIEW

GENERAL VIEW OF MACHINE

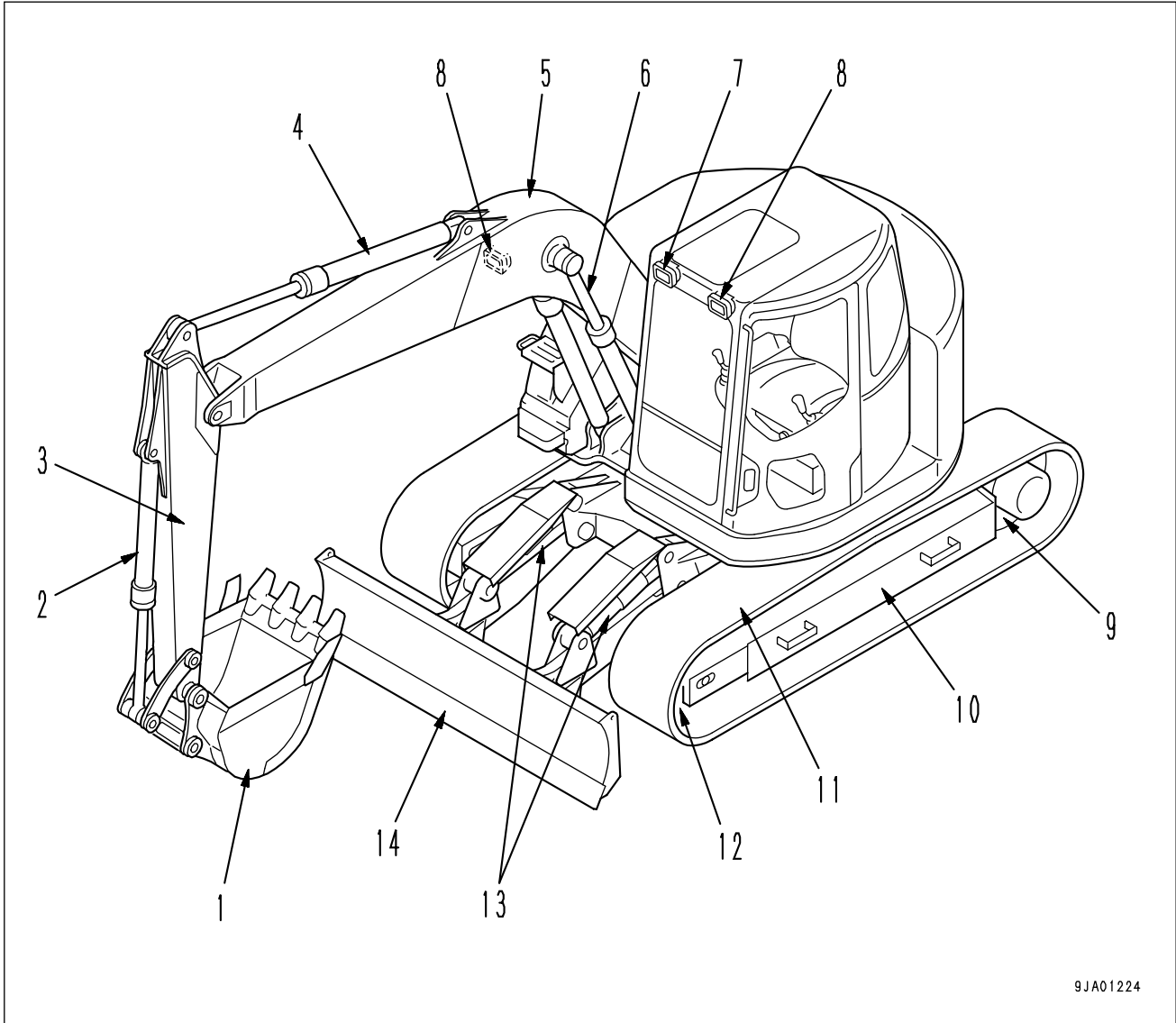

9JA01224

- | | |
|---------------------|-----------------------------------------------------------------|
| (1) Bucket | (10) Track frame |
| (2) Bucket cylinder | (11) Track shoe |
| (3) Arm | (12) Idler |
| (4) Arm cylinder | (13) Blade cylinder
(Only machines with blade specification) |
| (5) Boom | (14) Front blade
(Only machines with blade specification) |
| (6) Boom cylinder | |
| (7) Additional lamp | |
| (8) Working lamp | |
| (9) Sprocket | |

GENERAL VIEW CONTROLS AND GAUGES

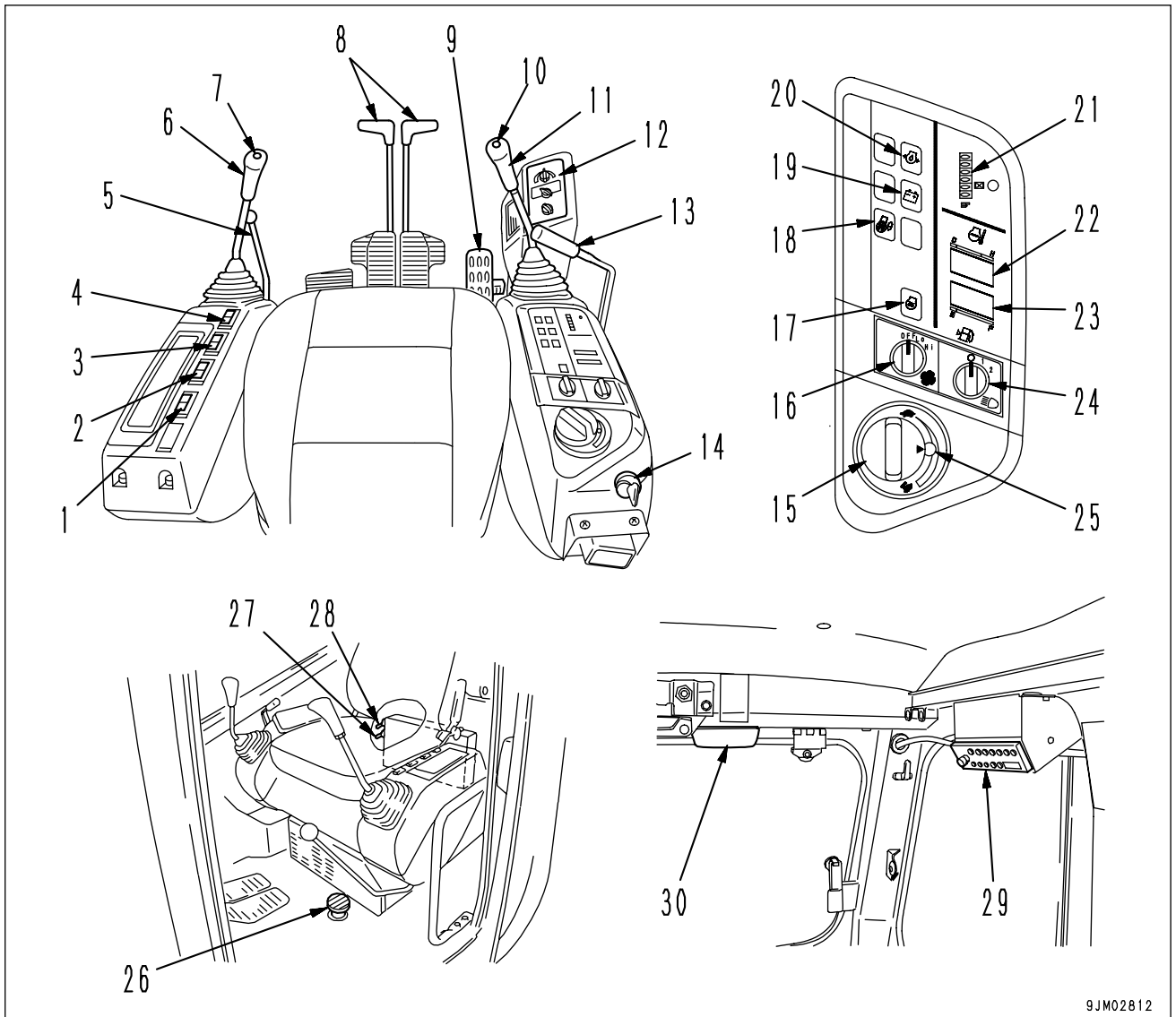

9JM02812

- | | |
|------------------------------------------|------------------------------------------|
| (1) Additional light switch | (16) Heater switch (if equipped) |
| (2) Wiper switch | (17) Preheating monitor |
| (3) Swing lock switch | (18) Swing lock monitor |
| (4) Travel speed switch | (19) Charge monitor |
| (5) Safety lock levers | (20) Engine oil pressure monitor |
| (6) Left work equipment control lever | (21) Service meter |
| (7) Swift deceleration switch | (22) Engine coolant temperature gauge |
| (8) Travel levers | (23) Fuel gauge |
| (9) Attachment control pedal | (24) Lamp switch |
| (10) Horn switch | (25) Swift deceleration pilot lamp |
| (11) Right work equipment switch | (26) Traveling accelerator pedal |
| (12) Airconditioner control panel | (only machines with blade specification) |
| (13) Blade control lever | (27) Swing brake cancel switch |
| (only machines with blade specification) | (28) Emergency pump drive switch |
| (14) Starting switch | (29) Car radio |
| (15) Fuel control dial | (30) Room lamp switch |

EXPLANATION OF COMPONENTS

The following is an explanation of the devices needed for operating the machine.

To carry out suitable operations correctly and safely, it is important to understand fully the methods of operating the equipment and the meanings of the displays.

MACHINE MONITOR

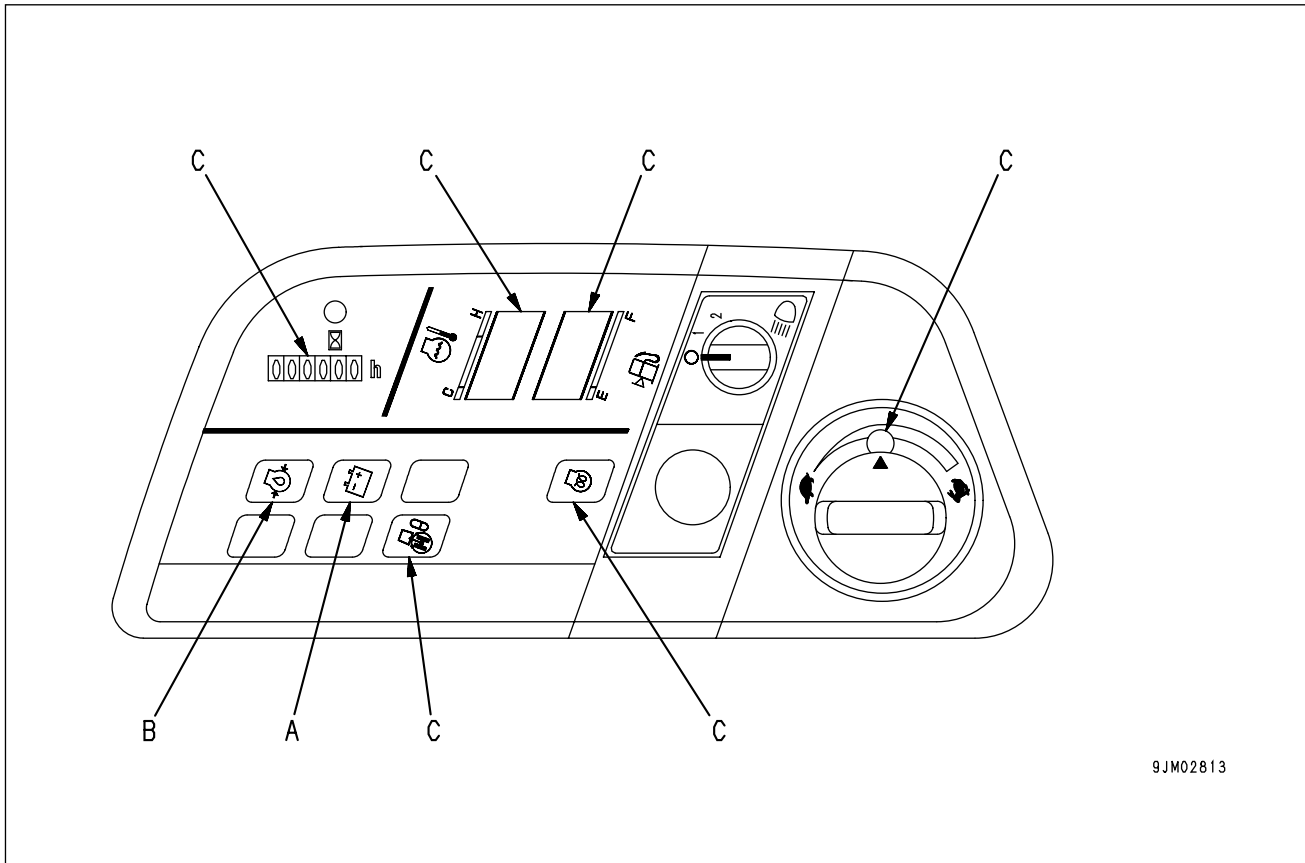

9JM02813

A:Caution Items

C:Meter Display Portion

B:Emergency Stop Items

CAUTION ITEMS

⚠ CAUTION

If the warning monitor flashes or lights up, carry out inspection and maintenance of the appropriate point as soon as possible.

If the problem is not corrected, it may lead to failure of the machine.

These are items which need to be observed when the engine is running. If any abnormality occurs, the item needing immediate repair is displayed. If there is any abnormality, the abnormal location on the monitor will flash or light up.

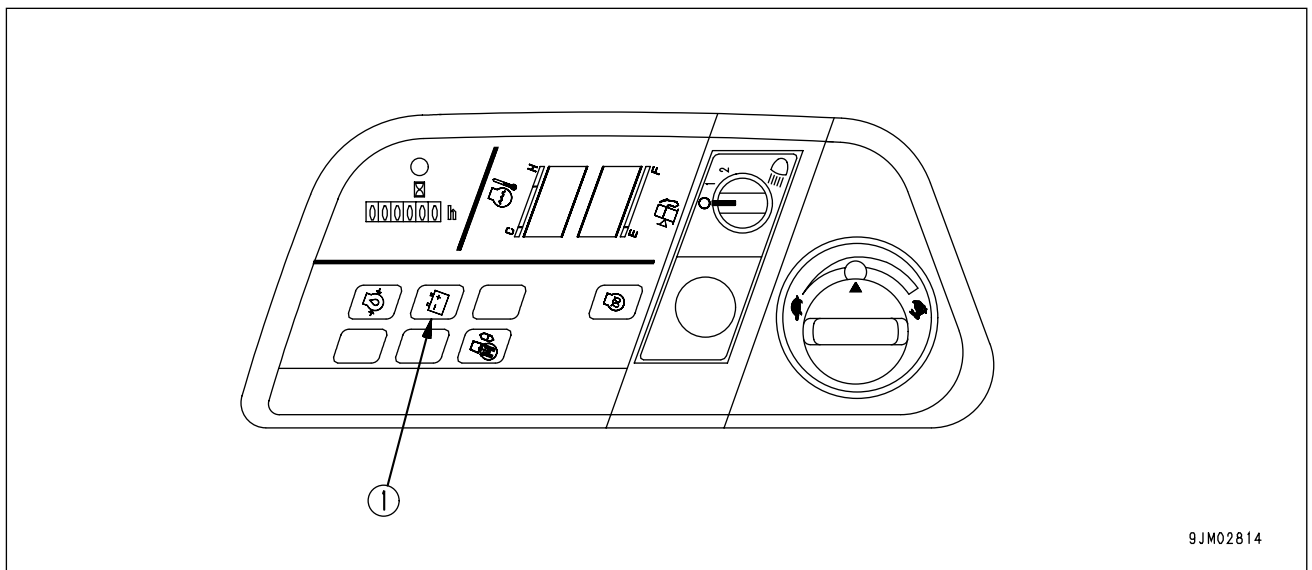

(1) Charge Level Monitor

CHARGE LEVEL MONITOR

This monitor(1) indicates an abnormality in the charging system while the engine is running.

If the monitor lamp flashes, check the V-belt tension. If any abnormality is found, see "OTHER TROUBLE (PAGE 3-112)".

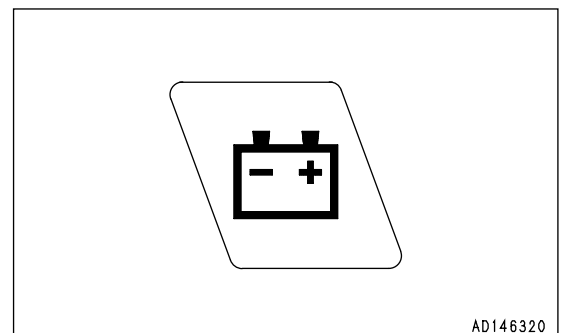

REMARK

- While the starting switch is ON, the lamp will remain lit and will go off once the engine is started.
- When the engine is started or stopped with the starting switch at the ON position, the lamp may light up and the buzzer may sound momentarily, but this does not indicate any abnormality.

EMERGENCY STOP ITEMS

⚠ CAUTION

If the monitor flashes, stop the engine immediately or run at low idling, then inspect the problem point immediately and repair the problem.

These are items which need to be observed when the engine is running. If there is any abnormality, the abnormal location on the monitor will flash and the buzzer will sound. Carry out the necessary repairs immediately.

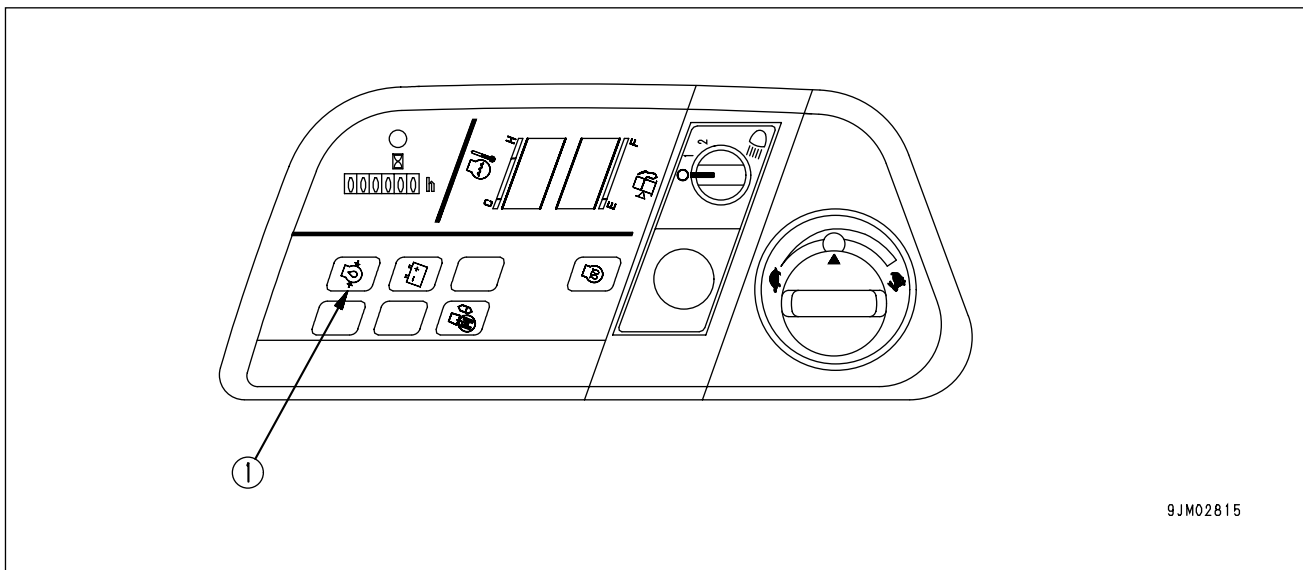

(1)Engine Oil Pressure Monitor

ENGINE OIL PRESSURE MONITOR

If the engine lubricating pressure is below the normal value, this monitor (1) lights up and the buzzer sounds. If it lights up, stop the engine, and check the oil level in the oil pan and lubricating system.

REMARK

- While the starting switch is ON, the lamp will remain lit and will go off once the engine is started.
- When the engine is started or stopped with the starting switch at the ON position, the lamp may light up and the buzzer may sound momentarily, but this does not indicate any abnormality.

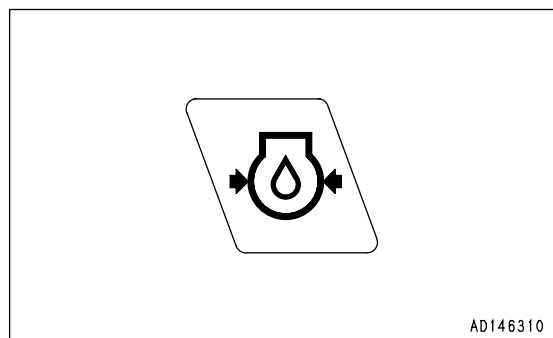

METER DISPLAY PORTION

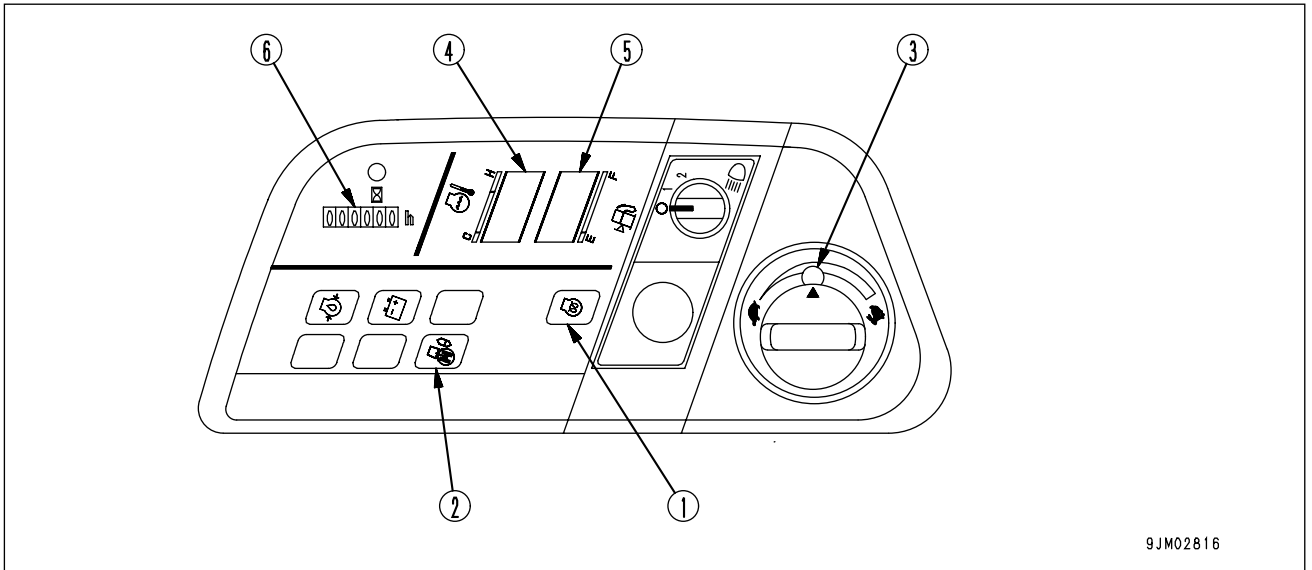

9JM02816

Pilot Display

- (1) Engine Pre-heating Monitor
- (2) Swing Lock Monitor
- (3) Swift Deceleration Display Lamp

Gauges And Meter

- (4) Engine Coolant Temperature Gauge
- (5) Fuel Gauge
- (6) Service Meter

PILOT DISPLAY

When the starting switch is ON, the pilot display lights up when the display items are functioning.

ENGINE PRE-HEATING MONITOR

This monitor lamp(1) indicates the pre-heating time required when starting the engine at an ambient temperature below 0°C (32°F).

The monitor lamp lights when the starting switch is turned to HEAT position and flashes after about 30 seconds to show that the pre-heating is completed. (The monitor lamp will go off after about 10 seconds.)

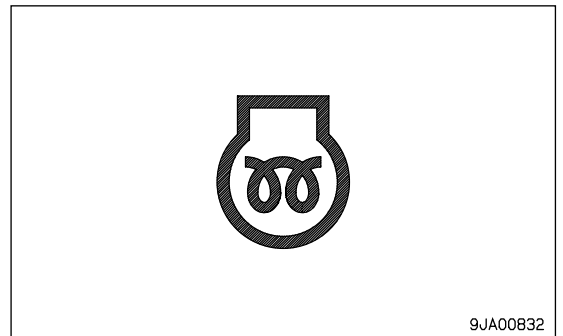

9JA00832

SWING LOCK MONITOR

This monitor (2) informs the operator that the swing lock is being actuated.

Actuated: Lights up

When the swing lock switch is turned ON (ACTUATED), the monitor lamp lights up.

REMARK

The swing motor is equipped with a disc brake that mechanically stops the rotation. When the swing lock monitor lamp is lighted up, the brake remains applied.

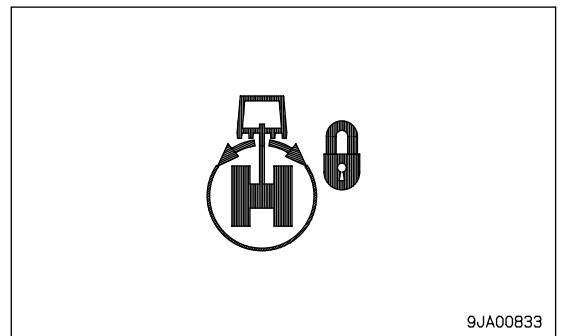

9JA00833

SWIFT DECELERATION DISPLAY LAMP

This monitor(3) informs the operator that the swift deceleration function is being actuated.

Actuated: Lights up
 Canceled: Goes out

When the swift deceleration switch is pressed, the swift deceleration display lamp lights up. When it is pressed again, the lamp goes out.

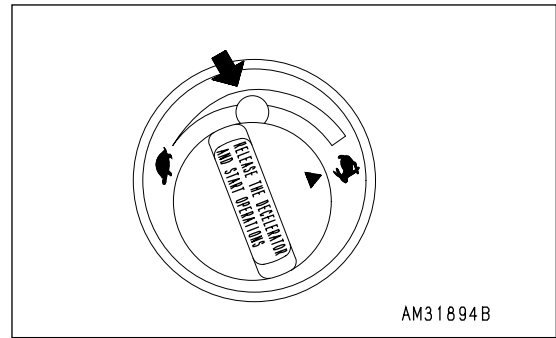

REMARK

When the swift deceleration display lamp is lighted up, the engine speed remains at low idling even if the fuel control dial is operated.

GAUGES AND METER

ENGINE COOLANT TEMPERATURE GAUGE

This meter(4) shows the engine cooling water temperature. During normal operation, the lamp should light up in the green range.

If the lamp in the red range lights up during operation, run the engine at low idling and wait for the temperature to go down to the green range.

After starting the engine, warm up it until the green range lights up.

REMARK

If the water temperature reaches the right edge, the lamp flashes and the buzzer sounds.

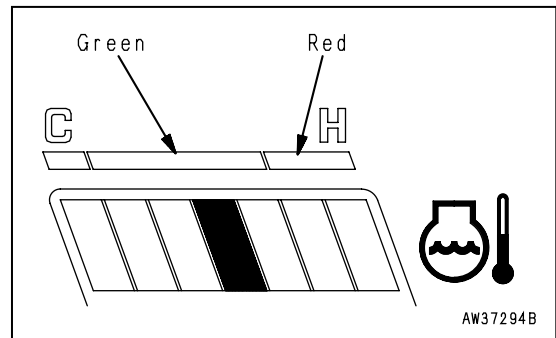

FUEL GAUGE

This meter(5) shows the fuel level in the fuel tank. During normal operation, the lamp should light up in the green range.

If the lamp in the red range flashes during operation, there is less than 50 liters (13.20 US gal) of fuel remaining, so check and add fuel.

The correct level may not be displayed for a short time after the starting switch is turned to the ON position, but this is not an abnormality.

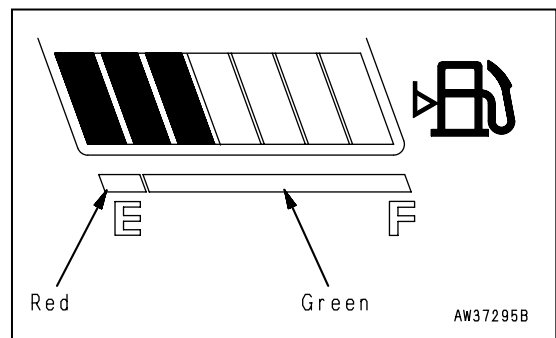

SERVICE METER

This meter(6) shows the total operation hours of the machine. Set the periodic maintenance intervals using this display. The service meter advances while the engine is running - even if the machine is not traveling.

While the engine is running, operation display (A) at the top inside of the meter will light to show that the meter is advancing.

The meter will advance by 1/10 for each hour of operation regardless of the engine speed.

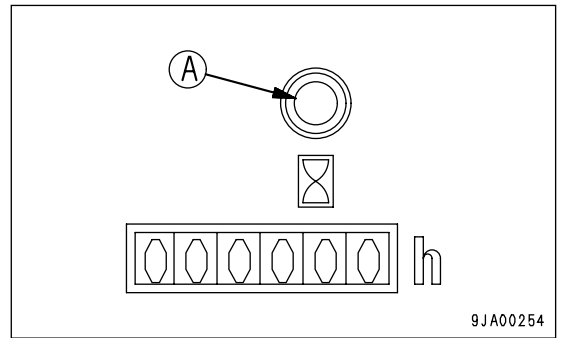

SWITCHES

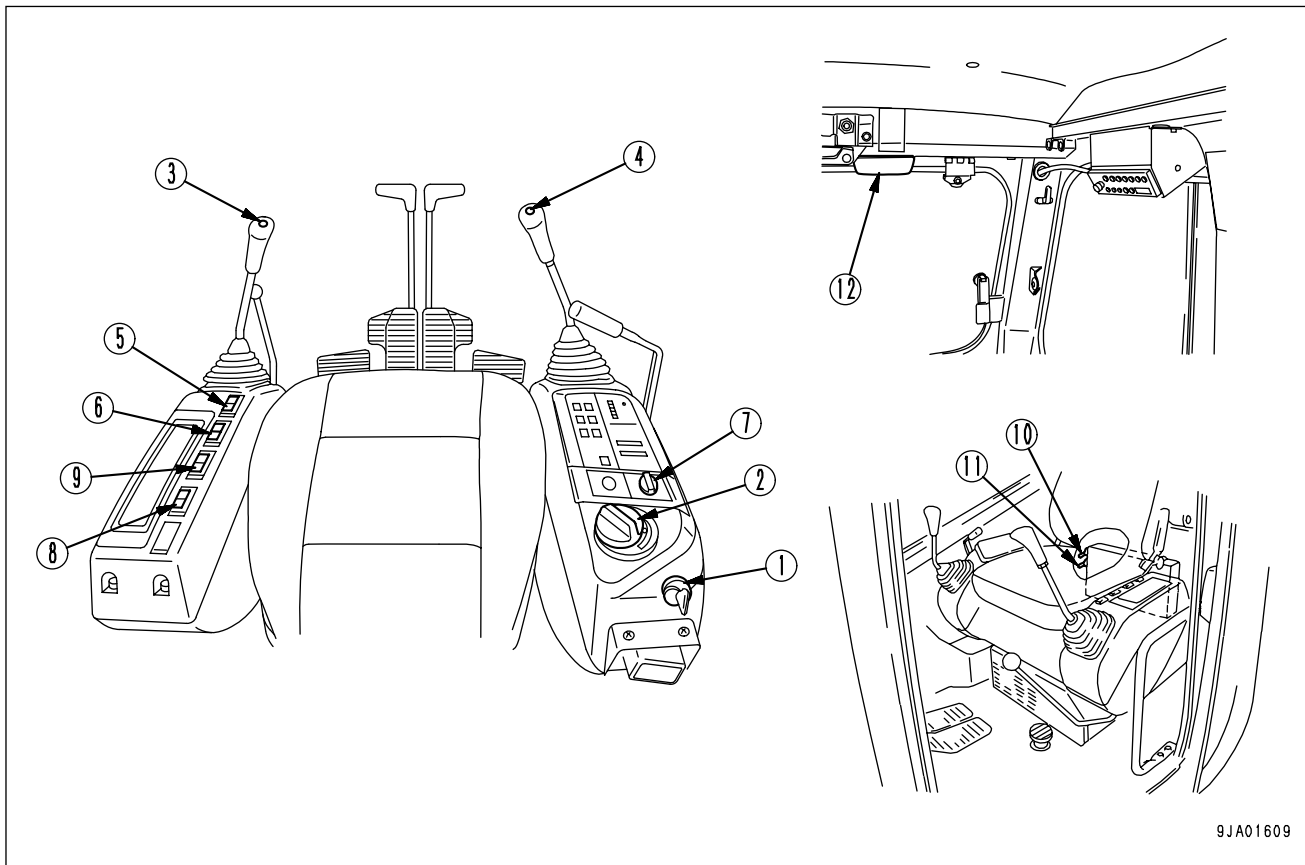

9JA01609

- | | |
|----------------------------------|----------------------------------|
| (1) Starting Switch | (7) Lamp Switch |
| (2) Fuel Control Dial | (8) Additional light Switch |
| (3) Swift Deceleration Switch | (9) Wiper Switch |
| (4) Horn Switch | (10) Emergency pump drive Switch |
| (5) Travel Speed Selector Switch | (11) Swing Brake Cancel Switch |
| (6) Swing Lock Switch | (12) Room Lamp Switch |

STARTING SWITCH

This switch (1) is used to start or stop the engine.

OFF position

The key can be inserted or withdrawn. The switches for the electric system are all turned off and the engine is stopped.

ON position

Electric current flows in the charging and lamp circuits. Keep the starting switch key at the ON position while the engine is running.

START position

This is the engine-start position. Keep the key at this position during cranking. Immediately after starting the engine, release the key. It will automatically return to the ON position.

HEAT (preheat) position

When starting the engine in winter, set the key to this position. When the key is set to the HEAT position, the pre-heating monitor lights up. Keep the key at this position until the monitor lamp flashes. Immediately after the pre-heating monitor flashes, release the key. The key automatically returns to the OFF position. Then, start the engine by turning the key to the START position.

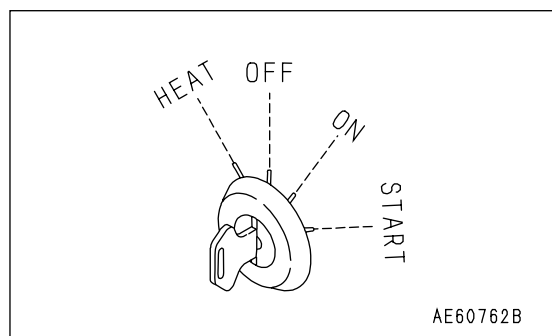

AE60762B

FUEL CONTROL DIAL

This dial(2) is used to control the engine speed and output.

- (a) Low idling position: The dial is turned to the left (counter-clockwise)
- (b) High idling position: The dial is turned to the right (clockwise)

REMARK

When the swift deceleration display lamp is lighted up, the engine speed will remain at low idling even if the dial is operated. To restore the engine speed, press the swift deceleration switch on the left control lever to cancel the deceleration function.

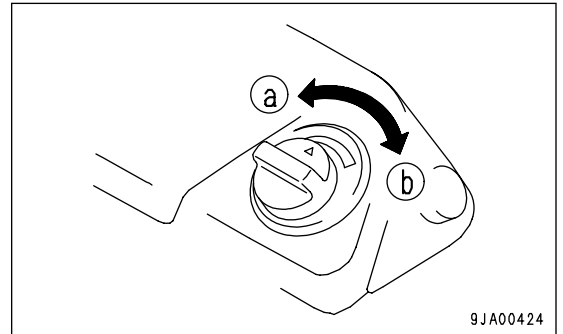

SWIFT DECELERATION SWITCH

⚠ WARNING

Always return the work equipment and travel levers to the neutral position before operating the swift deceleration switch. If the switch is operated when any lever is being operated, the engine torque will suddenly change.

This switch (3) is used to activate the system to lower the engine speed and reduce the fuel consumption when the engine output is not required, such as when the travel levers and left and right work equipment control levers are at the neutral position.

When the swift deceleration switch in the center of the knob of the left work equipment control lever is pressed, the swift deceleration pilot lamp lights up and the engine speed goes down to low idling.

When the swift deceleration switch is pressed again, the deceleration pilot lamp goes out, and the engine speed returns to the speed set by the fuel control dial.

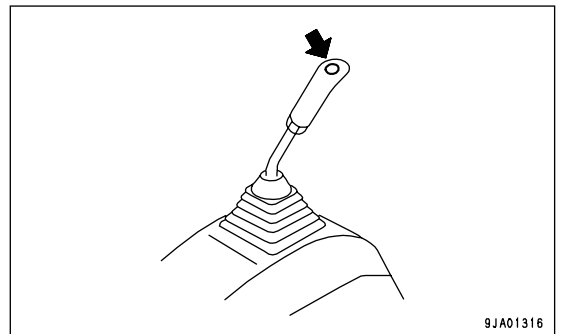

REMARK

- When the fuel control lever is at the low idling position, the engine speed will not go down any lower even if this switch is pressed.
- If the engine speed does not rise, it is possible that this switch is ON. Look at the swift deceleration pilot lamp to check the condition of the switch.
- If the starting switch is turned OFF when the swift deceleration switch is ON, the deceleration function is canceled.

HORN SWITCH

When the button(4) at the tip of the right work equipment control lever is pressed, the horn will sound.

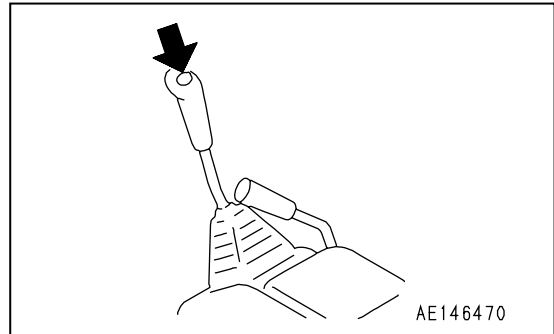

TRAVEL SPEED SELECTOR SWITCH

WARNING

- When loading or unloading from a trailer, always travel at low speed. Never operate the travel speed selector switch during the loading or unloading operation.
- If the travel speed is switched between high and low when the machine is traveling, the machine may deviate to one side, even when traveling in a straight line. Stop the machine before switching the travel speed.

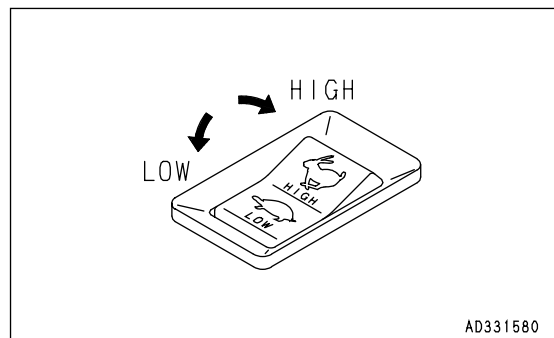

This switch(5) is used to select high or low travel speed.

LOW position: Low speed travel

HIGH position: Traveling under own power

When the switch is set to the HIGH position, the engine speed and pump pressure are detected, and are automatically switched to provide a travel speed that matches the operation.

SWING LOCK SWITCH

⚠ WARNING

- When traveling or when not using the swing operation, apply the swing lock.
- On slopes, even when the swing lock switch is at the ON position, the weight of the work equipment may cause the upper structure to swing if the swing control lever is operated in the downhill direction.

This switch (6) is used to lock the upper structure so that it cannot swing.

ON position (actuated): The swing lock is always applied, and the upper structure will not swing even if the swing is operated. In this condition, the swing lock lamp lights up.

OFF position (canceled): The swing lock is applied only when the swing control lever is at neutral; when the swing control lever is operated, it is canceled. The swing lock is actuated approx. 4 seconds after the swing lever is placed in neutral.

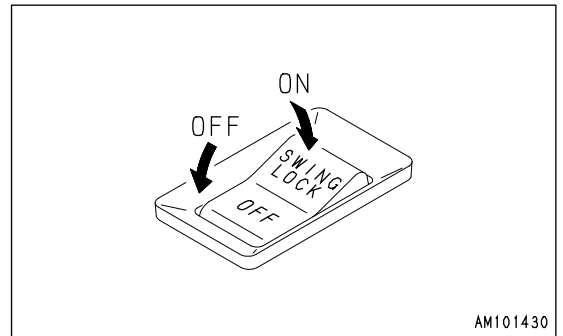

LAMP SWITCH

This switch (7) is used to light up the front lamps and gauge lighting.

- Position (1): Instrument panel lighting lights up.
- Position (2): Instrument panel lighting and front lamps light up.
- OFF position: Lighting is turned OFF

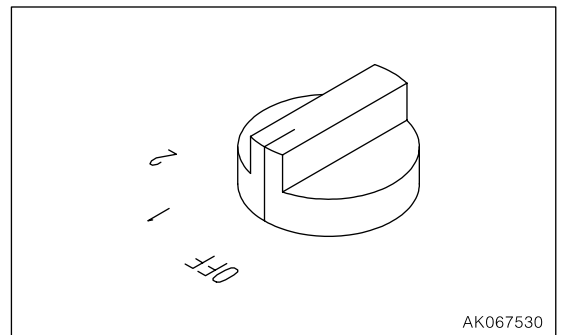

ADDITIONAL LIGHT SWITCH

This switch (8) is used to light up the lamp on the upper right side of the cab.

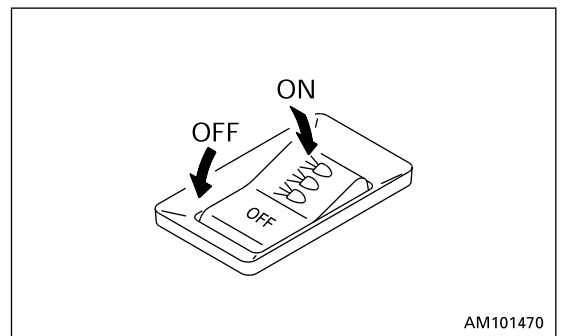

WIPER SWITCH

This switch (9) actuates the front window wiper.

- (a)OFF: The wiper stops.
- (b)ON: The wiper moves continuously.
- (c)Window washer fluid is sprayed out:When the switch is released, it returns to (b).
- (d)Window washer fluid is sprayed out:When the switch is released, it returns to (a).

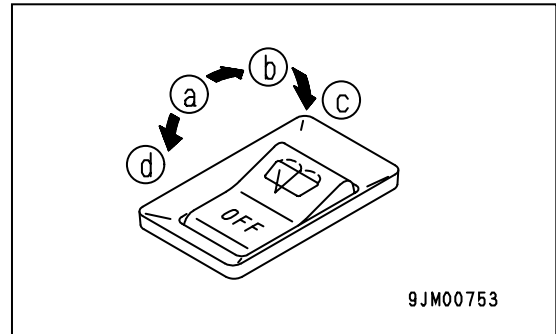

EMERGENCY PUMP DRIVE SWITCH

NOTICE

This switch is installed to make it possible to carry out operation temporarily if any abnormality should occur in the pump control system. It is not intended for permanent use. Repair the cause of the abnormality immediately.

This switch (10) is used to make it possible to carry out operations temporarily if any abnormality should occur in the pump control system.

- When normal: Move switch down
- When abnormal: Move switch up

Move the switch up to make it possible to carry out work.

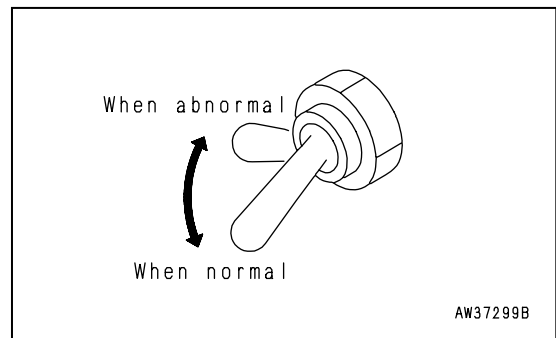

SWING BRAKE CANCEL SWITCH

NOTICE

This switch is installed to make it possible to carry out operation temporarily if any abnormality should occur in the swing brake system. It is not intended for permanent use. Repair the cause of the abnormality immediately.

This switch (11) is used to make it possible to carry out operations temporarily if any abnormality should occur in the swing brake system.

- When normal: Move switch down
- When abnormal: Move switch up

Move the switch up to make it possible to carry out work.

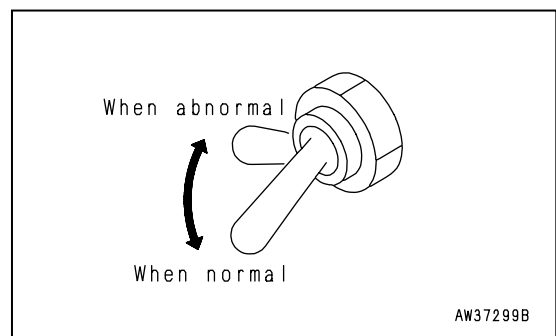

ROOM LAMP SWITCH

NOTICE

Be sure to switch the lamp to the **OFF** position after use.

If the switch is left at the **ON** position, the battery will run down.

This switch (12) is used to light up the room lamp.

ON position: Lights up

OFF position: Goes out

It will also light up even when the engine is not running.

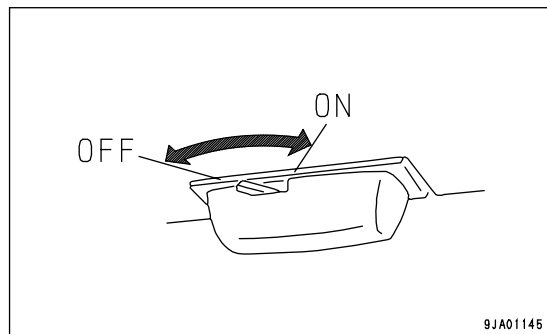

CONTROL LEVERS, PEDALS

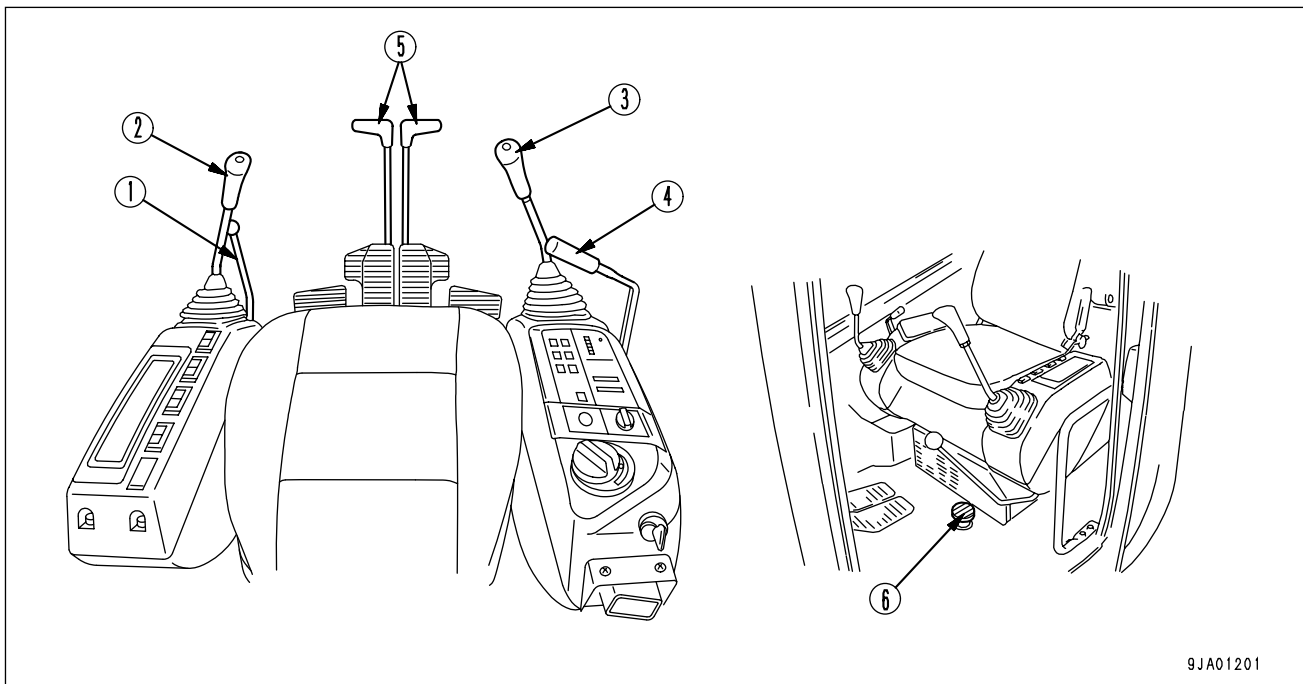

- | | |
|------------------------------------------|------------------------------------------------|
| (1) Safety Lock Lever | (5) Travel Levers (Machines with travel pedal) |
| (2) Left Work Equipment Control Lever | (6) Traveling Accelerator Pedal |
| (3) Right Work Equipment Control Lever | (only machines with blade specification) |
| (4) Blade Control Lever | |
| (only machines with blade specification) | |

SAFETY LOCK LEVER

⚠ WARNING

- When leaving the operator’s compartment, set the safety lock lever securely to the LOCK position. If the safety lock lever is not at the LOCK position and the control levers are touched by mistake, it may lead to serious personal injury.
- If the safety lock lever is not placed securely at the LOCK position, the control lever may move and cause a serious accident or injury. Check that the condition of the lever is as shown in the diagram.
- When pulling the safety lock lever up, be careful not to touch the work equipment control lever.
- When pushing the safety lock lever down, be careful not to touch the work equipment control lever.

Lever (1) is a device to lock the work equipment, swing, travel, and blade control levers.

Pull the lever up to apply the lock.

This lock lever is a hydraulic lock, so even if it is in the lock position, the work equipment control lever and travel lever will move, but the work equipment, travel motor, and swing motor will not work.

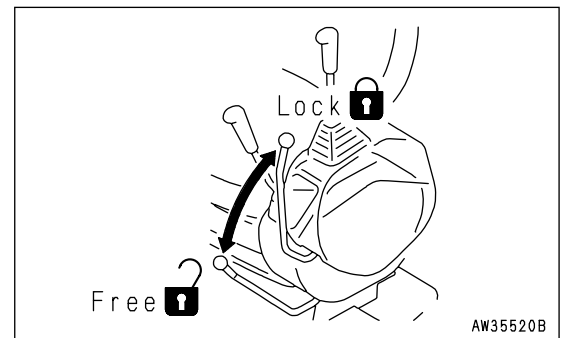

WORK EQUIPMENT CONTROL LEVER

(with auto-deceleration device)

This Left work equipment control lever (2) is used to operate the arm and upper structure.

Arm operation Swing operation

- (a) Arm OUT
- (b) Arm IN
- (c) Swing to right
- (d) Swing to left

N (Neutral): The upper structure and arm are held in position and do not move.

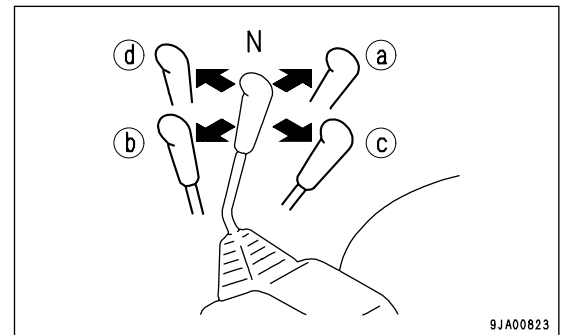

This Right work equipment control lever(3) is used to operate the arm and upper structure.

Boom operation Bucket operation

- (e) RAISE
- (f) LOWER
- (g) DUMP
- (h) CURL

N (Neutral): The boom and bucket are held in position and do not move.

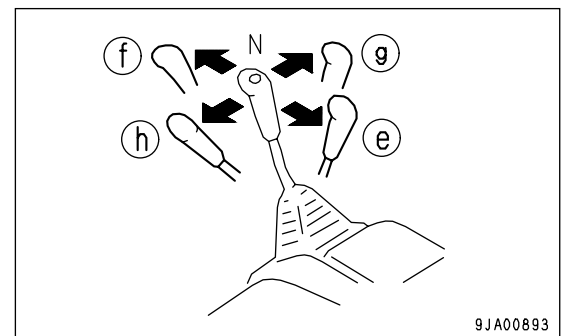

BLADE CONTROL LEVER

(Only machines with blade specification)

This lever (4) is used to control the blade.

- (a) :LOWER
- (b) :RAISE

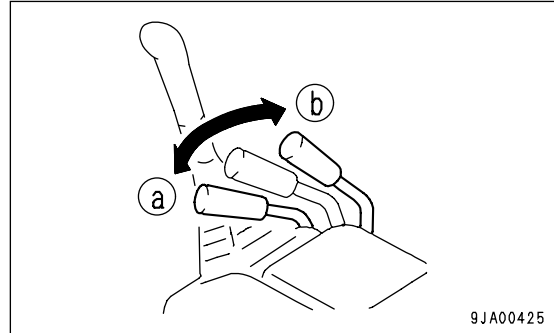

TRAVEL LEVERS

⚠ WARNING

- Do not put your foot on the pedal unless the machine is traveling. If you leave your foot on the pedal and press it by mistake, the machine will move suddenly, and this may lead to a serious accident.
- With the track frame facing to the rear, the machine will move in the reverse direction by forward traveling and in the forward direction by reverse traveling. When the travel lever is used, check to see if the track frame is facing forward or backward. (If the sprocket is located to the rear, the track frame is facing forward.)

- (1) FORWARD:
The lever is pushed forward
(The pedal is angled forward)
- (2) REVERSE:
The lever is pulled back
(The pedal is angled back)

N (Neutral): The machine stops

() : This indicates operation of the pedal.

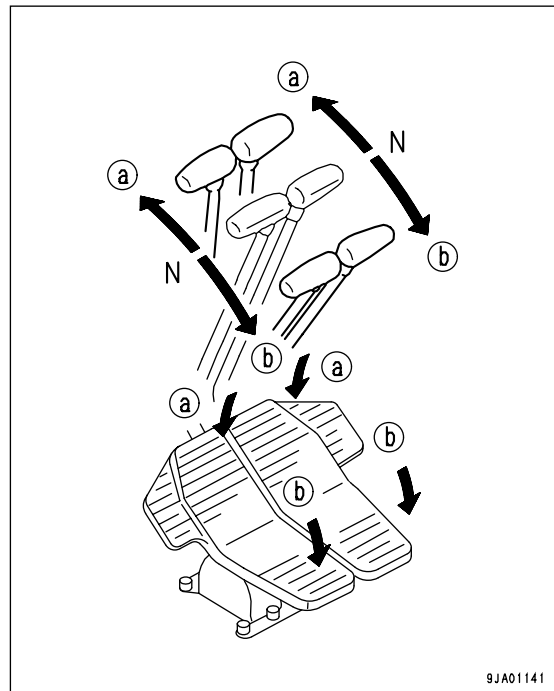

REMARK

Machines equipped with travel alarm (If equipped)

If the lever is shifted to the advance or reverse position from the neutral position, the alarm sounds to warn that the machine is starting to advance.

TRAVELING ACCELERATOR PEDAL

If the pedal (6) is depressed, the machine speed will increase.

3.2km/h (2.0MPH) to 5.1km/h (3.2MPH) (when engine is at full throttle)

REMARK

This pedal functions only when the travel speed selector switch is in LOW position.

When the travel speed selector switch is at the HIGH position, the travel speed is automatically switched, so the machine speed will not change even if the pedal is depressed.

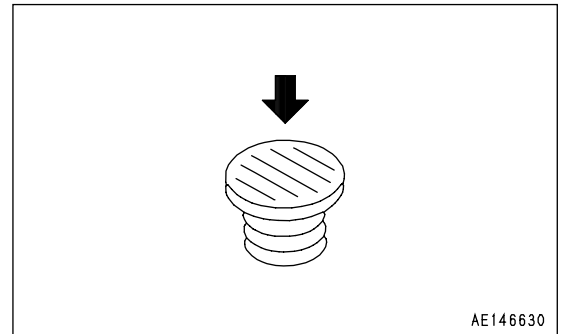

CEILING WINDOW

⚠ WARNING

When leaving the operator's compartment, set the safety lock lever securely to the LOCK position. If the control levers are not locked, and they are touched by mistake, this may lead to a serious accident.

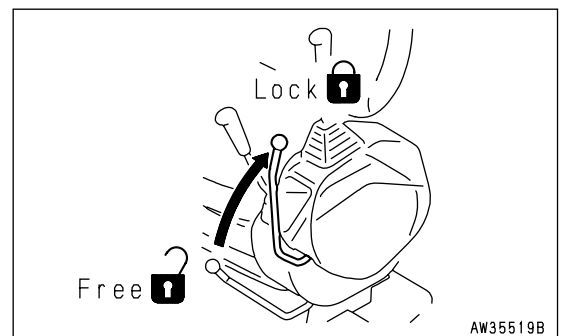

When opening

1. Lock the safety lock lever securely.
2. Check for any ceiling window movement by pulling lock knob (2) located on front side, then push up and open the ceiling window grasping grip (1).

When closing

Close the ceiling window grasping grip (1) and lock it with lock knob (2). If the lock cannot be applied, open and close the ceiling window again.

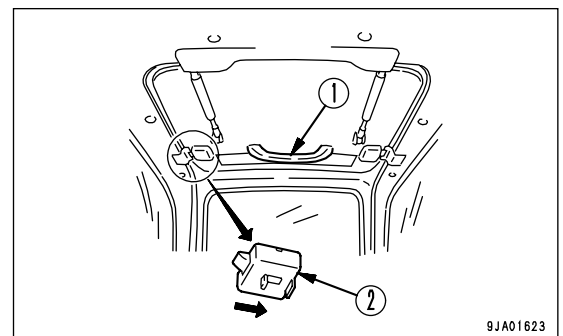

FRONT WINDOW

⚠ WARNING

- When opening or closing the ceiling window, front window, bottom window, or door, always set the safety lock lever to the LOCK position. If the control levers are not locked and they are touched by accident, this may lead to a serious accident.
- When opening the front window, hold the grip securely with both hands, pull up, and do not let go until the automatic lock catch is locked.
- When the front window is open, there is danger that it will fall, so always lock it with left and right lock pins (A).
- When closing the front window, the window will move quicker under its own weight. Hold the grips securely with both hands when closing it.

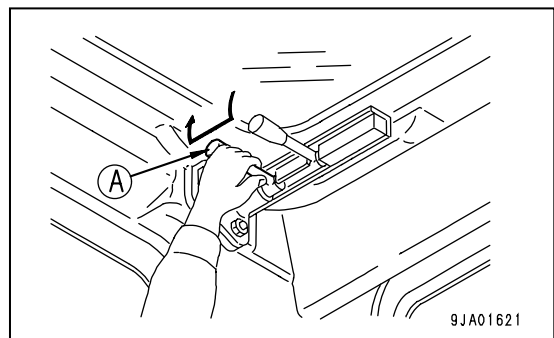
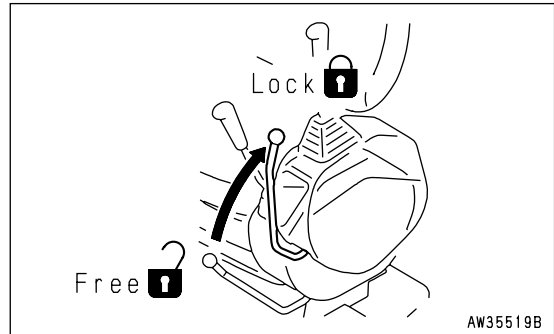

It is possible to store (pull up) the front window (top) in the roof of the operator's compartment.

When opening

⚠ WARNING

When the front window is open, there is danger that it will fall, so always lock it with left and right lock pins (A).

1. Place the work equipment on flat ground and stop the engine.
2. Securely lock the safety lock lever.

NOTICE

Always disconnect the socket before opening the front window. If the front window is opened with the wiring still connected, the wiring may be broken.

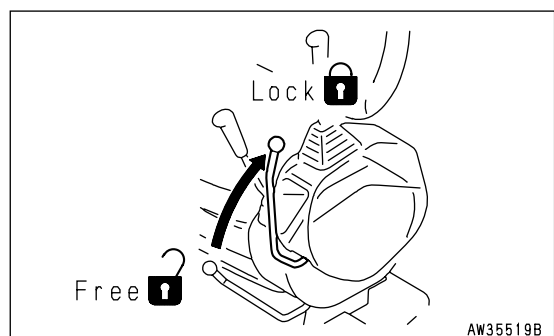

OPERATION

EXPLANATION OF COMPONENTS

3. Pull lock pins (A) at the top left and right sides of the front window to the inside to release the lock.

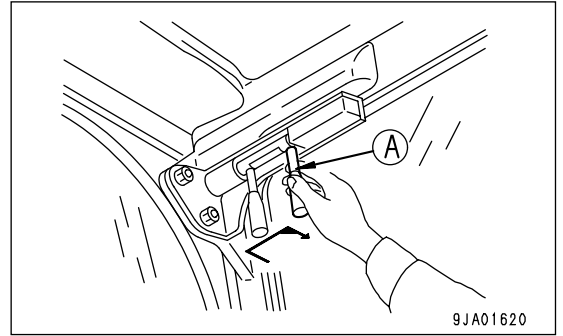

4. Hold the top grip with your right hand, pull it to the front to remove the top of the front window from the frame, then set it on the rail of the top roller.

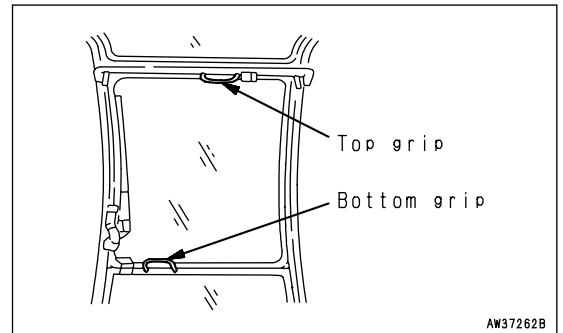

5. From the inside of the operator's cab, hold the bottom grip with the left hand and the top grip with the right hand, pull up the window, and push it in fully until it is locked by catch (C).

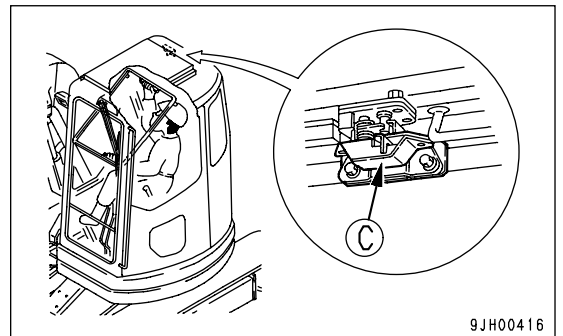

6. Lock with lock pins (A) on the left and right sides.

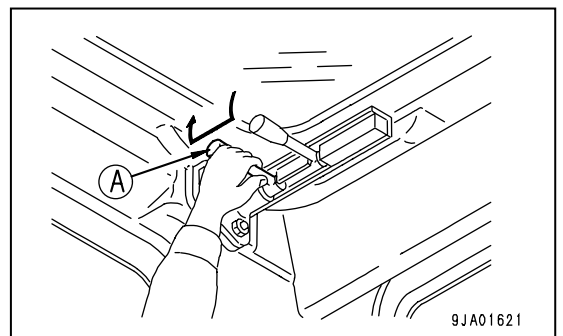

When closing

⚠ WARNING

When closing the window, lower it slowly and be careful not to get your hand caught.

1. Place the work equipment on flat ground and stop the engine.
2. Securely lock the safety lock lever.

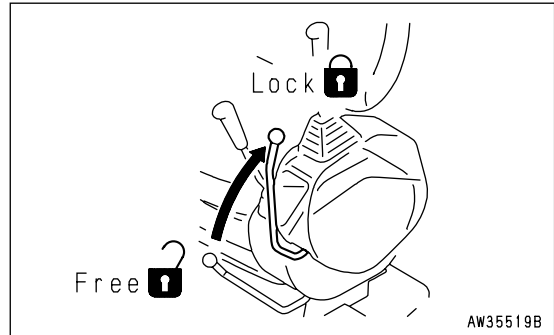

3. Release the lock pin (A).

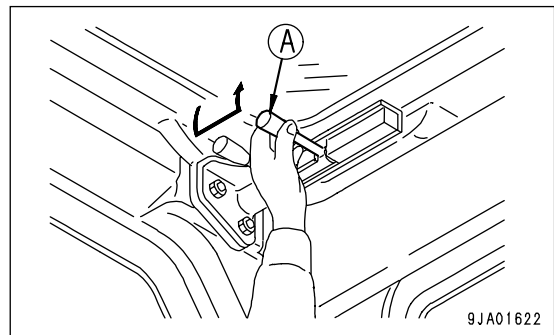

4. Hold the grip at the bottom of the front window with your left hand and the grip at the top with your right hand, release the lock of catch (C) with your right thumb, then pull the top grip slowly and lower the front window. When releasing the lock of catch (C), push release lever (D) in the direction of the arrow to release the lock.

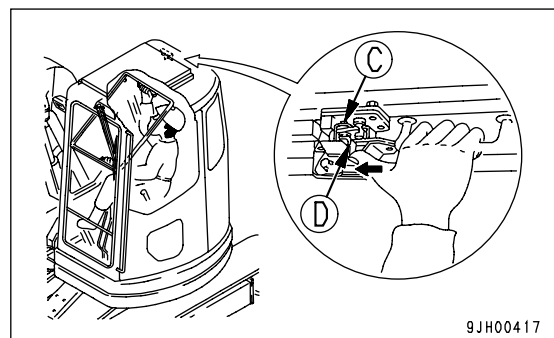

5. Lock securely with lock pins (A) at the left and right sides.

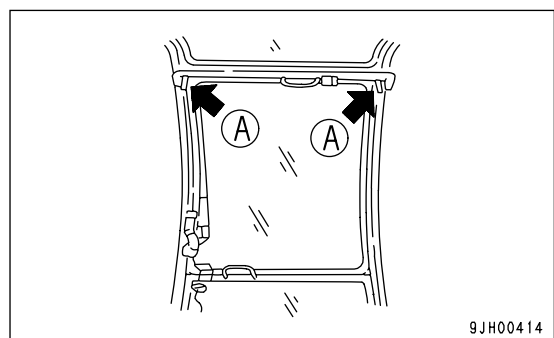

Removing front window (bottom)

With the front window open, remove lock pins (E), and the bottom part of the front window can be removed.

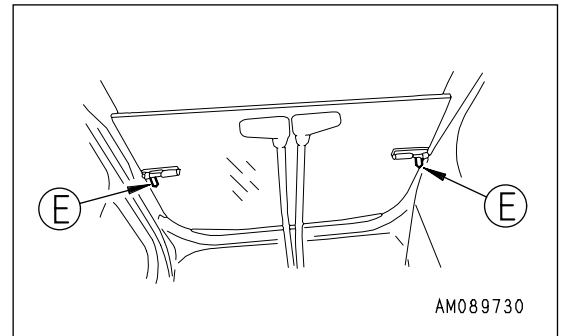

Store the removed bottom part of the front window at the rear of the operator's cab and lock with lock pins (E).

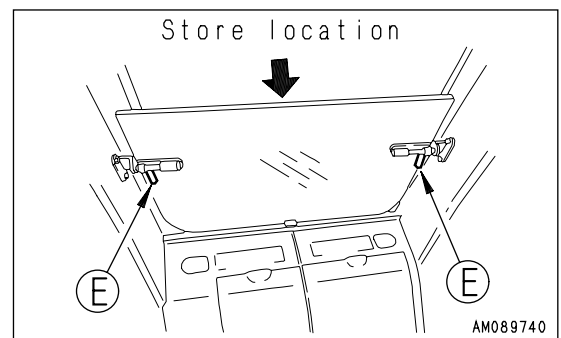

SLIDING DOOR

⚠ CAUTION

- Always check that the sliding door is locked in position, both when it is open and when it is closed.
- Always stop the machine on level ground before opening or closing the door. If the door is opened or closed on a slope, there will be a sudden change in the operating effort, and this may cause personal injury.
- When opening or closing the door, always hold door handle (1) and grip (2).
- Be careful not to get your hand caught at the front pillar or center pillar.
- If there is someone inside the cab, always call out before opening or closing the door.

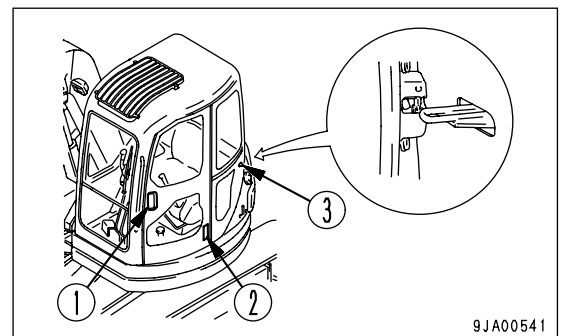

Door lock

When closing the door, pull the handle back to remove lock (3), then pull the door to the front.

REAR WINDOW

It is possible to open the rear window.

Lock the window securely in position with the lever lock.

To open the rear window, open the left and right locks, then push the rear window up to the rear.

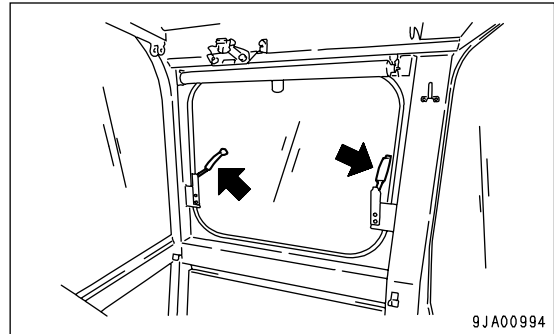

HAMMER FOR EMERGENCY ESCAPE

NOTICE

To prevent injury from pieces of glass, remove all the broken glass from the window frame. Be careful also not to slip on the broken glass that has fallen to the ground.

If it should become impossible to open the cab door for any reason, and it is necessary to make an emergency escape from the operator's compartment, use hammer (1) to escape.

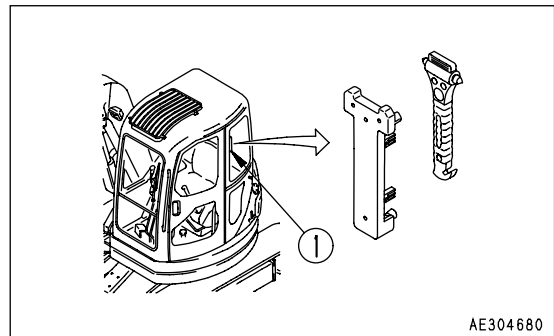

To escape from the operator's cab, use hammer (1) to break the glass and escape through the window.

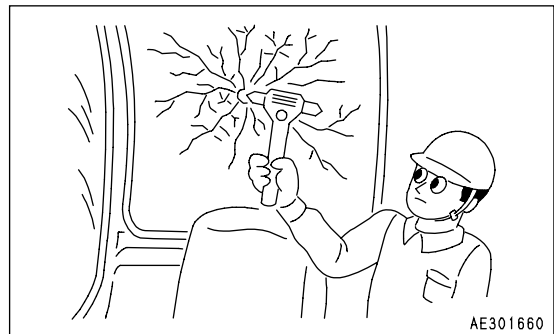

CAP, COVER WITH LOCK

There are locks fitted to the fuel tank filler port, operator's cab, engine hood, door in front of the tool box, pump room door (right side of machine), inspection window at the front right of the machine, cover at the rear of the cab, and the battery room door (left side of machine). Use the starting switch key to lock or unlock the caps and covers.

Insert the key as far as it will go, then turn it. If the key is turned before it is inserted fully, it may break.

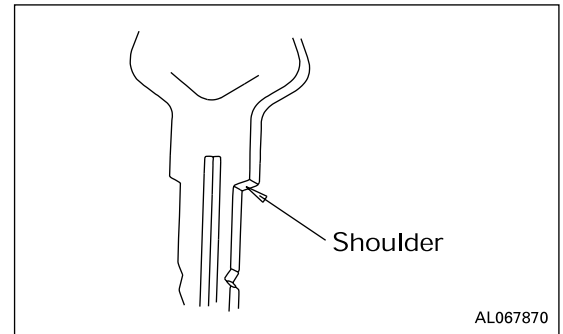

METHOD OF OPENING AND CLOSING CAP WITH LOCK

To open the cap (For the fuel tank filler port)

1. Insert the key into the cap.
Insert the key as far as it will go. If the key is turned before it is inserted all the way, it may break.
2. Turn the key clockwise, align the match mark on the cap with the rotor groove, then remove the cap.

To lock the cap

1. Turn the cap into place.
2. Turn the key counterclockwise and take the key out.

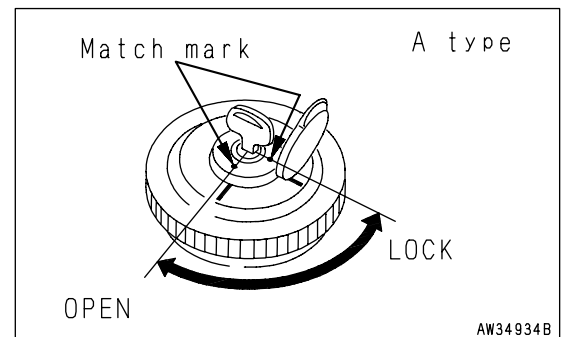

METHOD OF OPENING AND CLOSING COVER WITH LOCK

To open the cover (locked cover)

1. Insert the key into the key slot.
2. Turn the key counterclockwise and open the cover by pulling the cover grip.

To lock the cover

1. Close the cover and insert the key into the key slot.
2. Turn the key clockwise and take the key out.

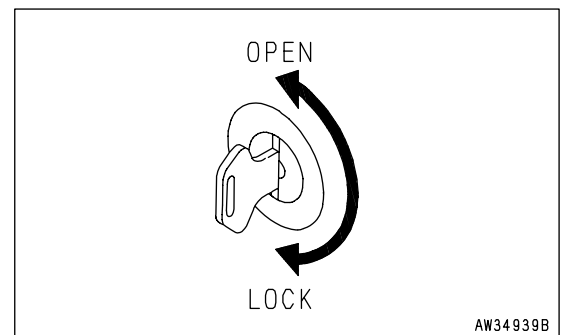

ENGINE HOOD

⚠ CAUTION

When carrying out inspection and maintenance inside the engine hood, always use the hood support lever to hold the engine hood open.

NOTICE

Always keep the hood locked except when opening it.

1. Release lock (1) of the engine hood.
For details, see "CAP, COVER WITH LOCK (PAGE 3-25)".
2. Pull engine hood release lever (2) to release the lock.
3. Pull up engine hood (3) and set hood support lever (4) to hold the engine hood in position.
4. When closing engine hood (3), set hood support lever (4) to the slide position, lower the engine hood slowly, and apply the lock securely.
5. Lock the engine hood.

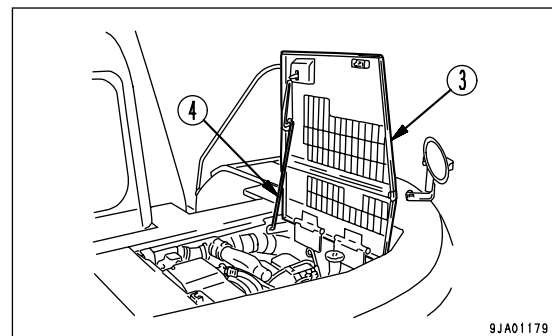
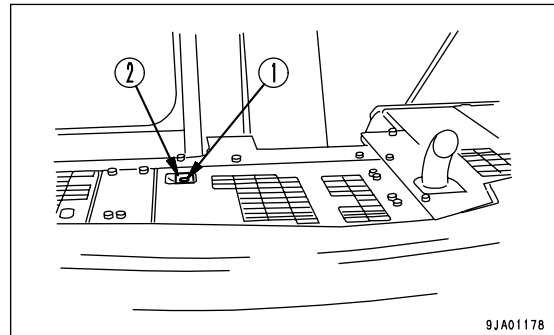

CAB REAR COVER

CAUTION

When carrying out inspection and maintenance inside the cover, always use the cover support lever to hold the cover open.

NOTICE

Always keep the cover locked except when opening it.

1. Release lock (1) of the cover.
For details, see "CAP, COVER WITH LOCK (PAGE 3-25)".
2. Hook your finger in catch (2) and open cover (3).
3. After opening the cover, set cover support lever (4) to hold the cover in position.
4. When closing cover (3), set cover support lever (4) to the slide position, and lower the cover slowly.
5. Lock the cover.

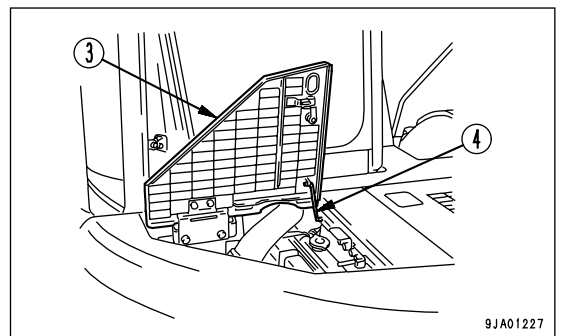
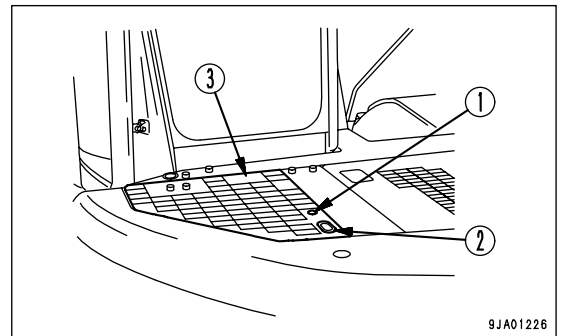

PUMP ROOM DOOR, BATTERY ROOM DOOR

⚠ CAUTION

When carrying out inspection and maintenance inside the door, always use the stopper to hold the door open.

NOTICE

Always keep the door locked except when opening it.

1. Release lock (1) of the door.
For details, see "CAP, COVER WITH LOCK (PAGE 3-25)".
2. Hook your finger in catch (2) and open door (3).
3. Remove stopper (4) from spring catch (5).
4. Set so that the cushion of stopper (4) contacts the outside circumference of the machine, then lower stopper (4).
5. When closing door (3), secure stopper (4) to spring catch (5), then close the door.
6. Lock the door.

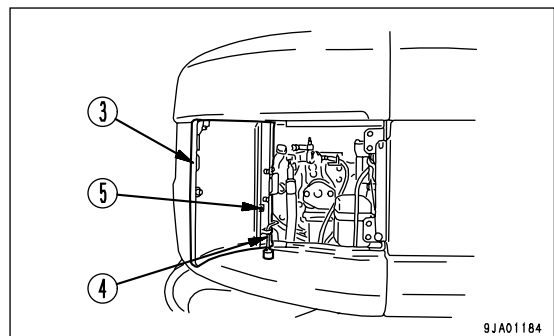
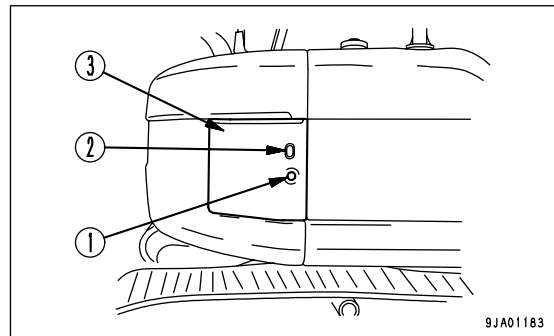

REMARK

The pump room door is on the right side of the machine; the battery room door is on the left side of the machine.

DOOR AT FRONT OF TOOL BOX

⚠ CAUTION

When carrying out inspection and maintenance inside the door, always use the stopper to hold the door open.

NOTICE

Always keep the door locked except when opening it.

1. Release lock (1) of the door.
For details, see "CAP, COVER WITH LOCK (PAGE 3-25)".
2. Pull door lever (2) to release the lock.
3. Pull door (3) to open it, remove door support lever (4) from spring catch (5), then insert the L-shaped portion in the hole in the frame.
4. When closing door (3), lift up door support lever (4), secure it to the spring catch, then close the door.
5. Lock the door.

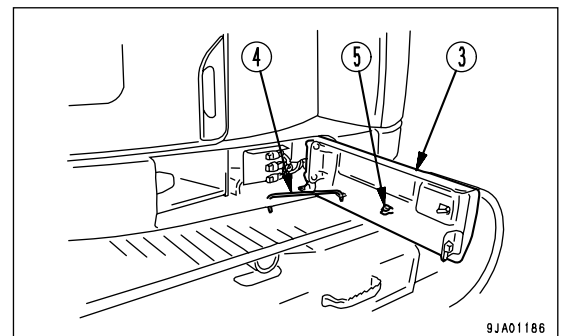
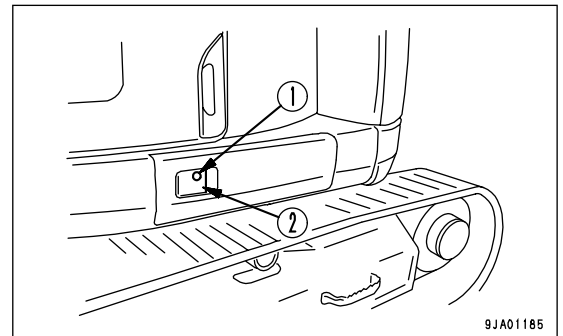

FUSE

NOTICE

Before replacing a fuse, be sure to turn off the starting switch.

The fuses protect the electrical equipment and wiring from burning out.

If the fuse becomes corroded, or white powder can be seen, or the fuse is loose in the fuse holder, replace the fuse.

Replace the fuse with another of the same capacity.

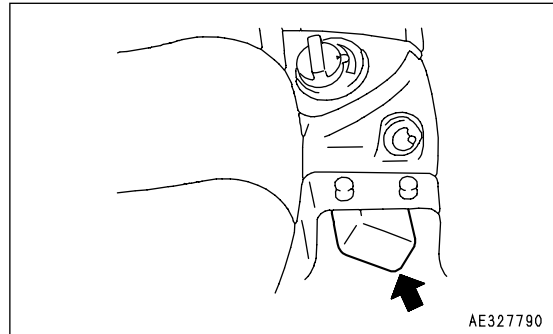

FUSE CAPACITIES AND CIRCUIT NAMES

	Fuse capacity	Name of circuit
(1)	30 A	Room lamp, radio (back-up), starting motor terminal B (stop solenoid)
(2)	20 A	Alarm buzzer, monitor panel, solenoid, pump adjuster
(3)	20 A	Wiper, radio, horn, window washer, throttle actuator
(4)	10 A	Light
(5)	15 A	Heater, additional lamp (if equipped), rear working lamp
(6)	20 A	Air conditioner, travel alarm (if equipped), limit switch, 2- stage relief solenoid
(7)	15 A	Spare fuse
(8)	20 A	Spare fuse
(9)	30 A	Spare fuse

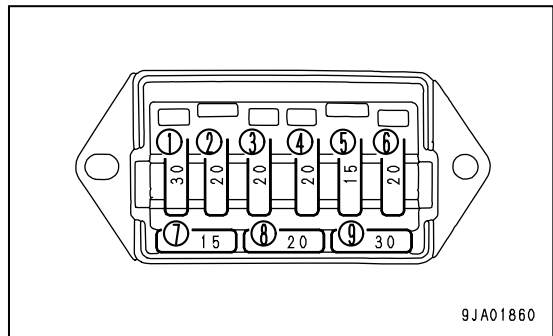

FUSIBLELINK

If the starting motor does not move even when the starting switch is turned to the ON position, there is probably a break in the wire-shaped fusible link (1), so open the engine hood and check or replace.

REMARK

A fusible link refers to the large-sized fuse wiring installed in the high current flow portion of the circuit to protect electrical components and wiring from burning, in the same way as an ordinary fuse.

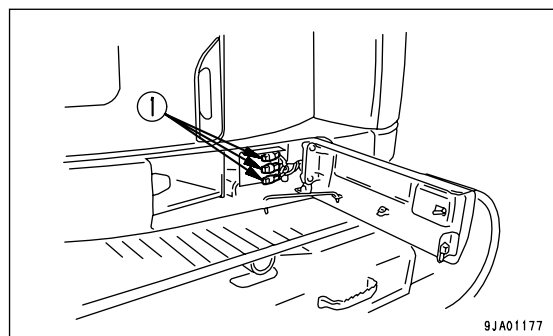

POWER SOURCE FOR OPTION

NOTICE

When installing electrical equipment not supplied by Komatsu, use 24 V specification with a maximum of 85 W (equivalent to 3.5 A). If equipment is to be installed with a capacity greater than this, please consult your Komatsu distributor.

Connector(1) (connector No. M31) for taking off the power supplied for optional equipment is at the bottom rear of the box for the right work equipment control lever.

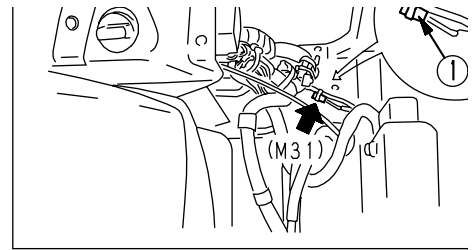

REMARK

Connector(1) is secured by band(2), so take it out when using it. After use, secure it to its original position with the band.

The connector types are shown in the table below.

	M type housing		Terminal		
	Body	Rear holder	AVS 0.5	M.AVS 0.85-2	M.AVS3
Komatsu part No.	08056-00211	08056-00230	08056-00050	08056-00051	08056-00052

CONTROLLER

NOTICE

- Never splash or spill water, mud or drink over the controllers as this may cause a fault.
- If a fault occurs in the controller, do not attempt repair, but consult your Komatsu distributor.

The work equipment control system controller is installed behind the operator's seat.

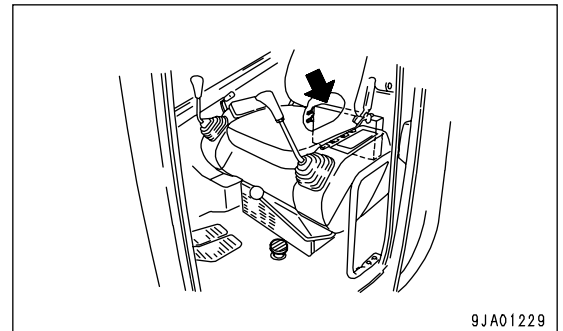

HANDLING AIR CONDITIONER

GENERAL LOCATIONS OF CONTROL PANEL

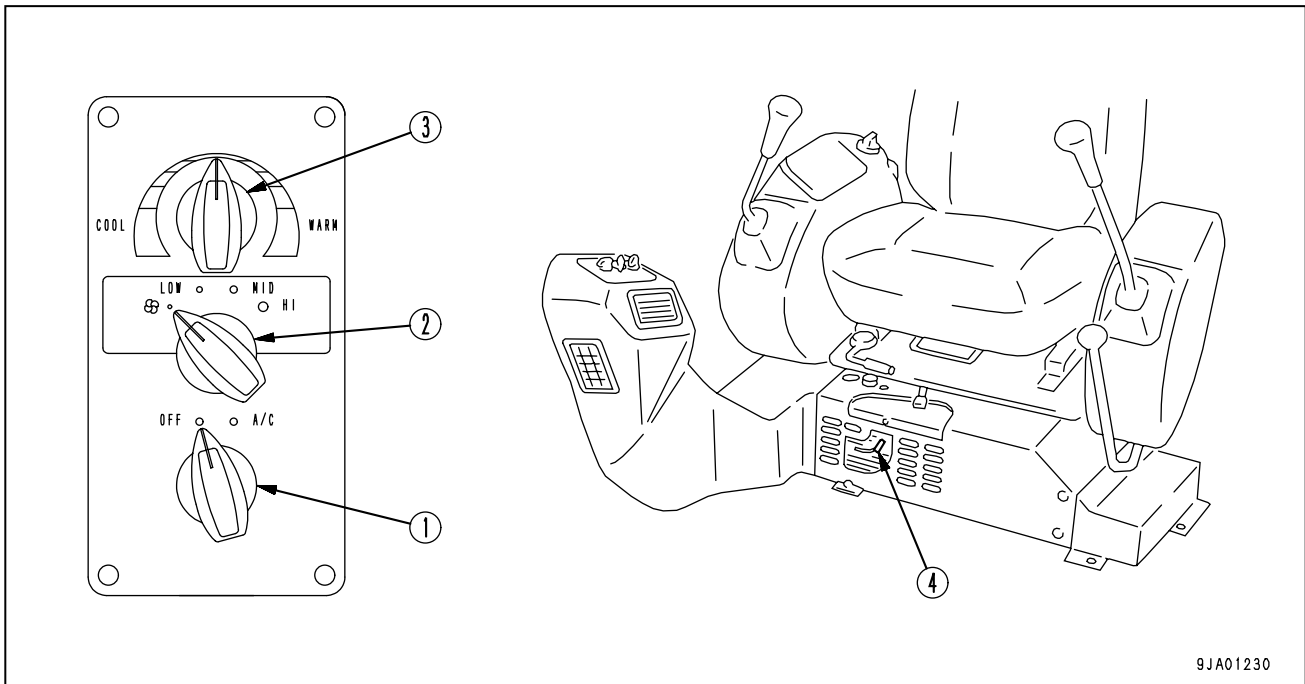

9JA01230

- (1) Air conditioner switch
- (2) Air flow selector switch
- (3) Temperature control switch
- (4) Vent selector lever

AIR CONDITIONER SWITCH

This switch(1) is used to operate the air conditioner.

A/C: Actuated
 OFF: Stopped

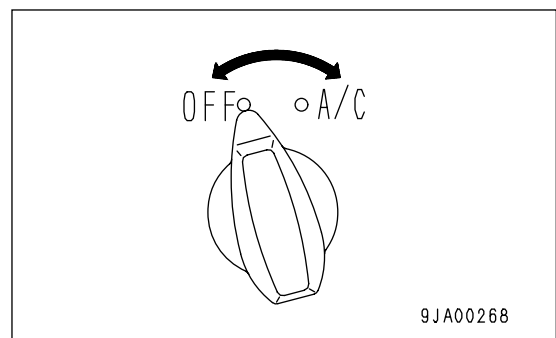

9JA00268

AIR FLOW SELECTOR SWITCH

The air flow can be set to three levels with this switch (2).

- (a): Air flow OFF
- (b) LOW: Air flow LOW
- (c) MID: Air flow MID
- (d) HI: Air flow HI

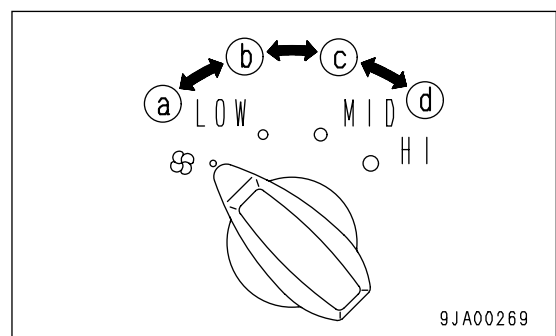

9JA00269

TEMPERATURE CONTROL SWITCH

This switch (3) is used to adjust the temperature.
 Turn the switch to adjust the temperature as follows.
 Turn to LEFT to LOWER temperature.
 Turn to RIGHT to RAISE temperature.

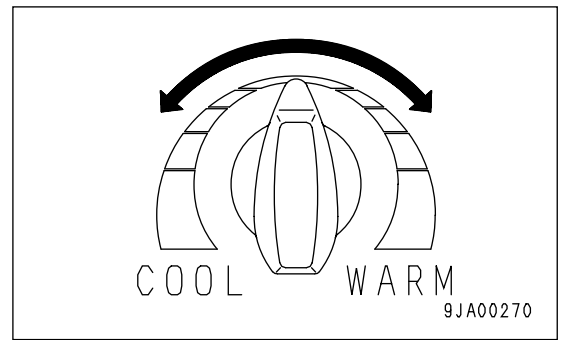

VENT SELECTOR LEVER (FEET + UPPER BODY)

This lever (4) can be used to select the vent to match the purpose of use.

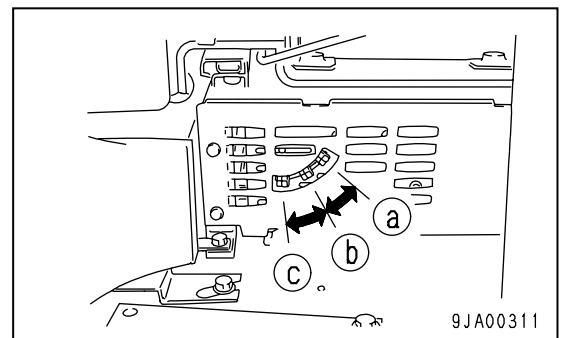

(a): Send air to feet

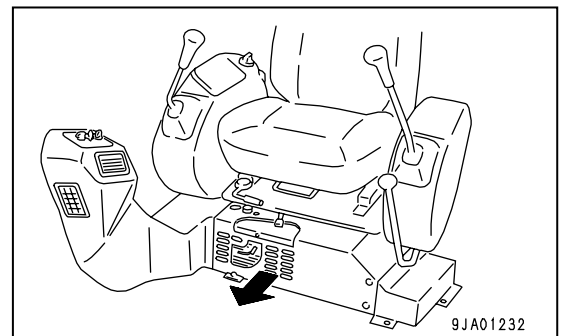

(b): Send air to feet and upper body at same time

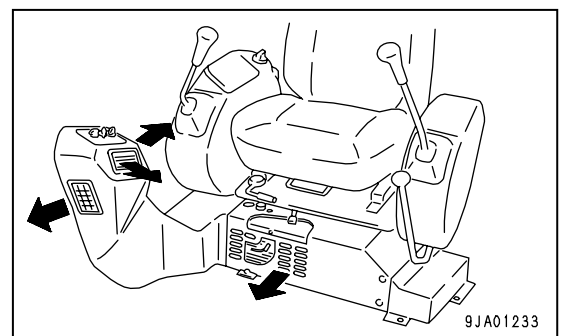

(c): Send air to upper body

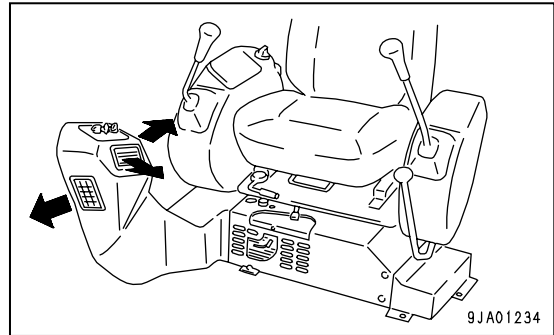

PRECAUTIONS WHEN USING AIR CONDITIONER

Ventilate the cab from time to time when using the cooler.

- If you smoke when the cooler is on, the smoke may start to hurt your eyes, so open the window and carry out ventilation and cooling for a short time to remove the smoke.
- When running the air conditioner for a long time, carry out ventilation and cooling together once an hour.

Be careful not to make the temperature in the cab too low.

- When the cooler is on, set the temperature so that it feels slightly cool when entering the cab (5 - 6°C lower than the outside temperature). This temperature difference is considered to be the most suitable for your health, so always be careful to adjust the temperature properly.

CHECK, MAINTAIN MACHINE EQUIPPED WITH AIR CONDITIONER

When carrying out inspection of a machine equipped with an air conditioner, see the MAINTENANCE SCHEDULE CHART (PAGE 4-16) and carry out inspection according to the table.

CAR RADIO

EXPLANATION OF COMPONENTS

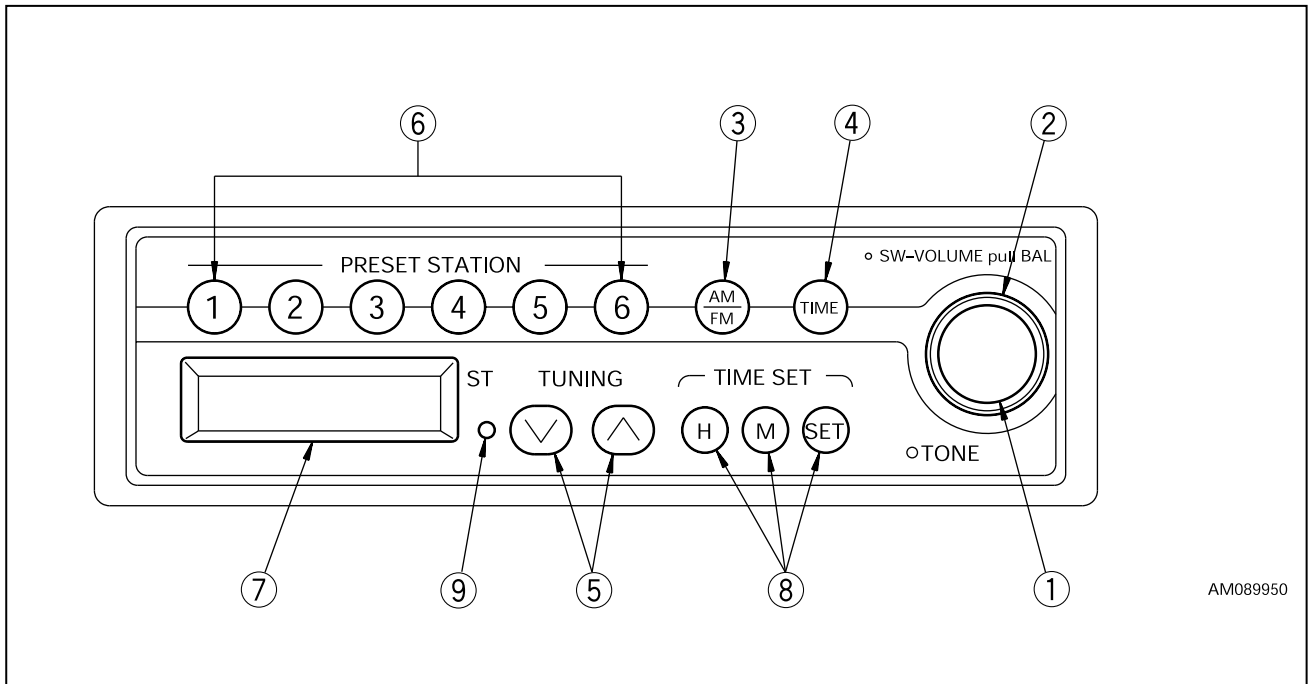

AM089950

POWER SWITCH/VOLUME CONTROL KNOB (SW-VOLUME) BALANCE (Pull BAL)

Press this knob to turn the power for the radio on. The frequency is displayed on display (7). Press again to turn the power off.

Turn the knob to adjust the volume as follows.

Turn **CLOCKWISE** to **INCREASE** volume

Turn **COUNTERCLOCKWISE** to **REDUCE** volume

If the knob is pulled until it locks, it can be turned to the left or right to adjust the balance of the left and right speakers.

Turn **CLOCKWISE** to increase volume from **RIGHT** speaker

Turn **COUNTERCLOCKWISE** to increase volume from **LEFT** speaker

After adjusting the left and right balance, press lightly to return the knob to its original position. (If it is left pulled out, the overall volume cannot be adjusted.)

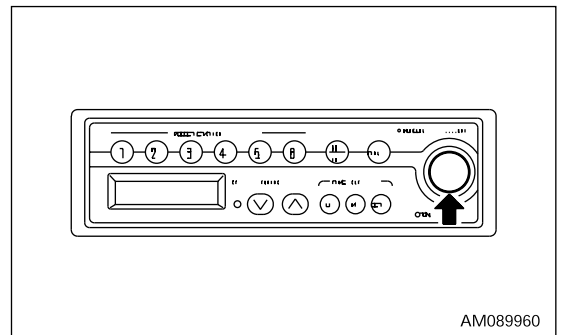

AM089960

tone control knob

Turn the knob to adjust the tone as follows.

Turn CLOCKWISE to emphasize the high sounds

Turn COUNTERCLOCKWISE to suppress the high sounds

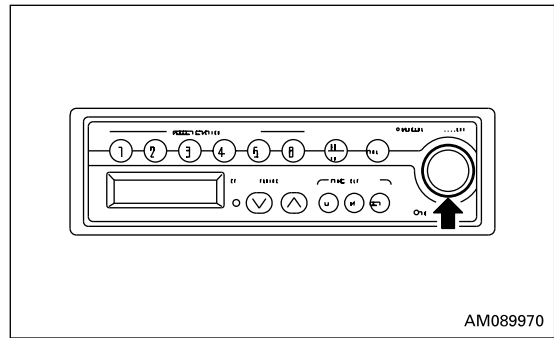

FM/AM selector button (AM/FM)

Press this button and select the desired band.

Each time the button is pressed, it switches AM → FM → AM ...

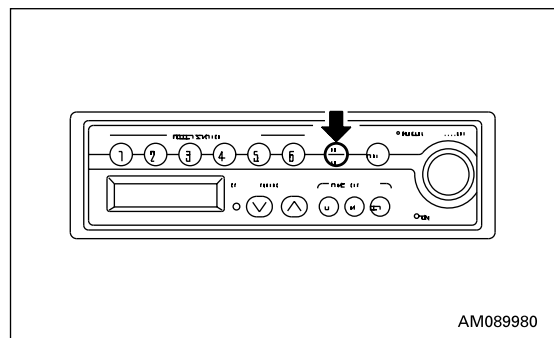

display selector button (TIME)

This equipment gives priority to the frequency display. If the button is pressed when the frequency is displayed, display will give the present time for 5 seconds. After 5 seconds pass, the display will automatically return to the frequency display. If any button other than TIME SET (H, M, SET) is pressed within the 5 seconds, the display will return to the frequency display.

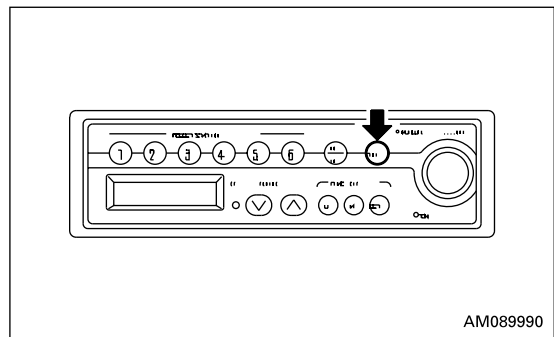

MANUAL TUNING (MANUAL)

Use the buttons to change the frequency.

Up button (∧): Each time the button is pressed, the frequency will go up in steps (FM: 0.1 MHz, AM: 9 kHz).

Down button (∨): Each time the button is pressed, the frequency will go down in steps (FM: 0.1 MHz, AM: 9 kHz).

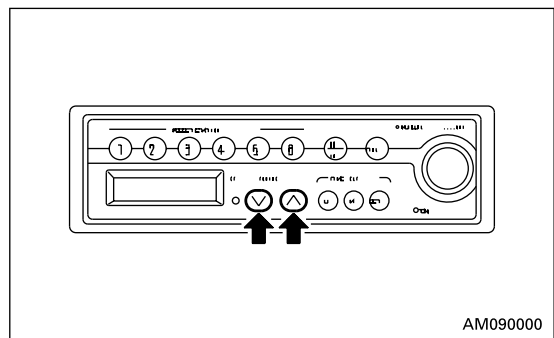

PRESET BUTTONS (1, 2, 3, 4, 5, 6) (PRESET STATION)

If these buttons are set to the frequency of the desired broadcasting station, the station can be selected at a touch.

For details of the method of presetting, see "METHOD OF OPERATION (PAGE 3-38)".

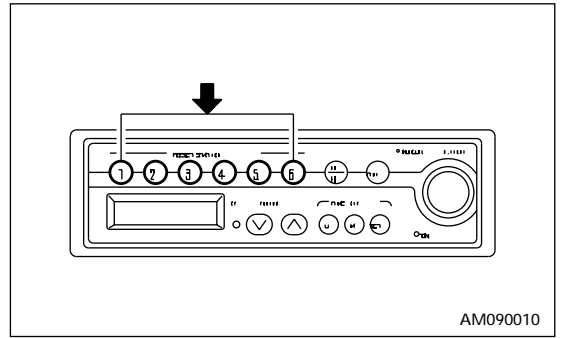

DISPLAY

The reception band, frequency, preset number, and time are displayed.

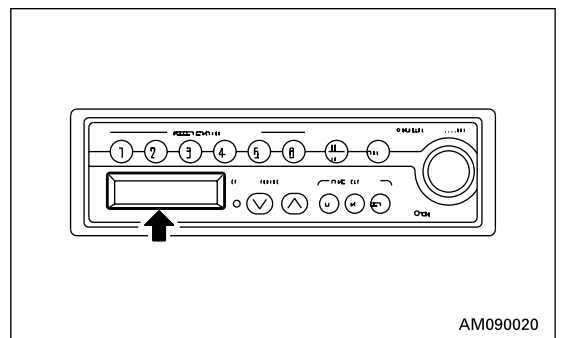

TIME CORRECTION BUTTON

This is used to correct the time.

- H : Hour
- M : Minute
- SET : Sets to start of hour (00 minutes)

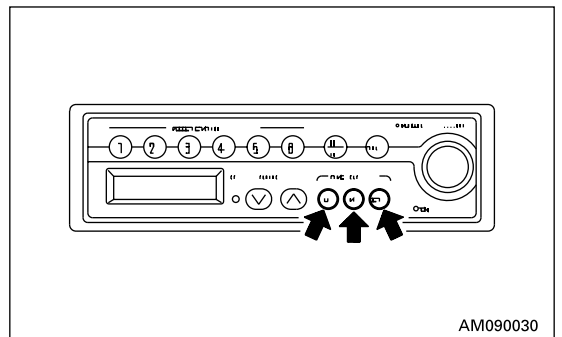

STEREO INDICATOR (ST)

This lamp lights up when a stereo broadcasting is picked up when receiving an FM broadcasting station.

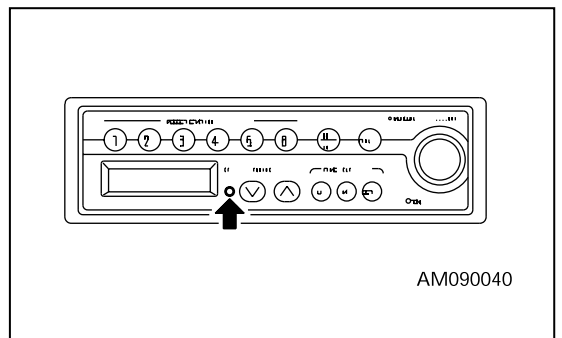

METHOD OF OPERATION

METHOD OF SETTING PRESET BUTTONS

1. Press power switch (1) and display the frequency on display (7).
2. Turn the tuning button (manual, auto) to adjust to the desired frequency.
3. Select a preset button to use for recording the frequency setting, and keep that button pressed for at least 1.5 seconds. The sound will disappear, but when the setting is recorded, the sound will appear and the preset number will appear on display (7) to show that the station has been preset.
After completion of presetting, press preset button (6), and release it within approx. 1.5 seconds. The setting will change to the frequency of the broadcasting station recorded for that button. One AM station and one FM station can be recorded for each preset button.

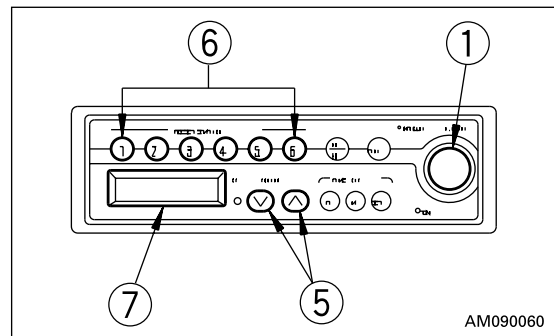

AM090060

MANUAL TUNING

Press tuning button (5) and set to the desired frequency.

Each time the button is pressed, the frequency will move up or down in steps of 9 kHz (AM) or 0.1 MHz (FM).

∨ button: Move to a higher frequency station

∧ button: Move to a lower frequency station

- If the frequency reaches the top or bottom limit, it will automatically change as follows: top limit → bottom limit, or bottom limit → top limit

AUTOMATIC TUNING

Keep tuning button (5) pressed for at least 0.5 seconds. When a broadcasting station is picked up, it will automatically stop. To search for the next station, press tuning button (5) again for at least 0.5 seconds.

∨ button: Move to a higher frequency station

∧ button: Move to a lower frequency station

- If tuning button (5) is pressed during auto tuning, the auto tuning will be canceled and the frequency at the point where it is canceled will be picked up.

SETTING CORRECT TIME

1. Press display selector button (4) to display the time.
 After 5 seconds, the display will return to the frequency display and the time cannot be corrected. If this happens, press display selector button (4) again.

2. Press time adjustment button (8) and adjust the hour and minute.

H button: Adjusts hour (advances one hour each time it is pressed)

M button: Adjusts minute (advances one minute each time it is pressed)

If the H or M button are kept pressed, the time will advance continuously until the button is released.

SET button: Sets to start of hour (when it is pressed, the minute returns to 00)

If the minute display is between 0 and 05, and the SET button is pressed, the minute reading will return to 00. If it is pressed when the minute display is between 55 and 59, the minute display will return to 00 and the hour will advance by 1.

Example 10:05 → 10:00

10:59 → 11:00

10:26 → 10:26

Press the H, M, and SET buttons to set to the correct time.

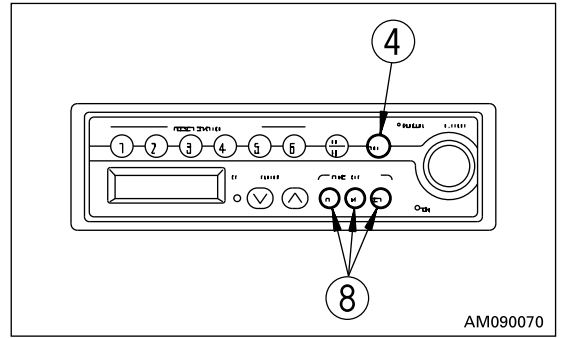

ANTENNA

If the receiving wave is weak or generates noise, extend the antenna. If the wave is too strong, adjust the sensitivity by retracting the antenna.

NOTICE

When transporting the machine or parking it in a garage, always fully retract the antenna to avoid the possibility of breakage.

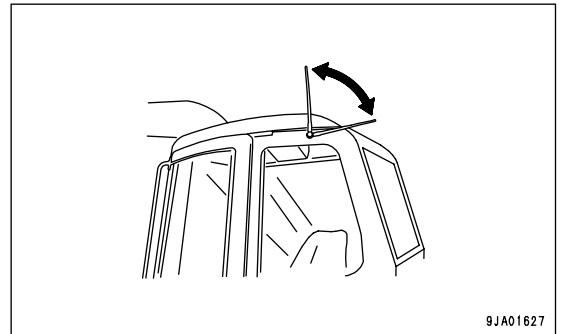

PRECAUTIONS WHEN USING

- To ensure safety, always keep the sound to a level where it is possible to hear outside sounds during operation.
- If water gets into the speaker case or radio, it may lead to an unexpected failure, so be careful not to get water on the equipment.
- Do not wipe the scales or buttons with benzene, thinner, or any other solvent. Wipe with a soft dry cloth. Use a cloth soaked in alcohol if the equipment is extremely dirty.
- When the battery is replaced, the settings for the preset buttons are all cleared, so set them again.

HANDLING ACCUMULATOR

⚠ WARNING

The accumulator is charged with high-pressure nitrogen gas, so mistaken operation may cause an explosion which will lead to serious injury or damage. When handling the accumulator, always do as follows.

- Do not disassemble the accumulator.
- Do not bring it near flame or dispose of it in fire.
- Do not make holes in it or weld it.
- Do not hit it, roll it, or subject it to any impact.
- When disposing of the accumulator, the gas must be released. Please contact your Komatsu distributor to have this work carried out.

The machine is equipped with an accumulator in the control circuit. The accumulator in the control circuit is a device to store pressure, and when this accumulator is installed, it is possible to operate the control circuit for a short time even after the engine is stopped. Therefore, it is possible to lower the work equipment under its own weight by operating the control lever in the direction to lower the work equipment.

The accumulator is installed in the position shown in the diagram on the right.

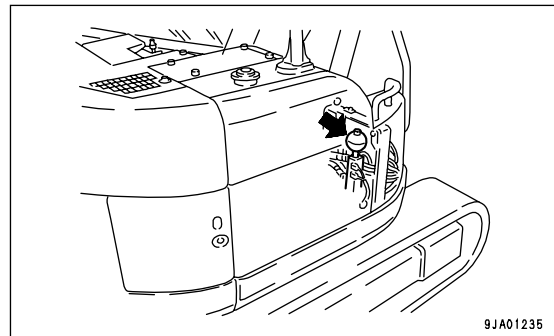

9JA01235

METHOD OF RELEASING PRESSURE IN CONTROL CIRCUIT ON MACHINE EQUIPPED WITH ACCUMULATOR

1. Lower the work equipment to the ground, then close the crusher or other attachment.
2. Stop the engine.
3. Turn the key in the starting switch to the ON position again to let electric current flow in the circuits.
4. Set the safety lock lever to the FREE position, then operate the work equipment control levers and attachment control pedal (if equipped) backwards and forwards, and to the right and left to the full stroke to release the pressure in the control circuit.
5. Set the safety lock lever to the LOCK position to lock the control levers and attachment control pedal.
6. Turn the starting switch to the OFF position.

OPERATION AND MAINTENANCE MANUAL HOLDER

There is a pocket in the rear of the operator's seat to hold the Operation and Maintenance Manual.

Always keep the Operation and Maintenance Manual in this pocket so that it is possible to read it at any time.

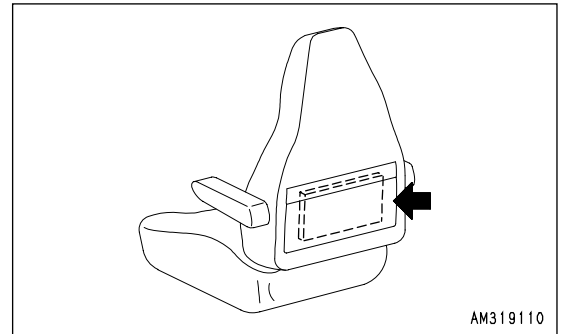

TOOL COMPARTMENT

Open the door at the front of the tool box. The standard tool compartment is inside.

Put the tools in the supplied tool bag and store them in the tool compartment.

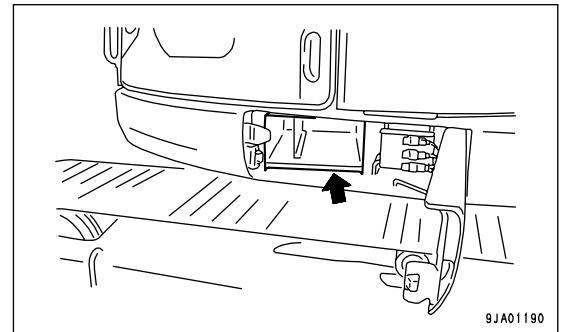

GREASE GUN HOLDER

Open the door at the front of the tool box. The compartment to stow the grease gun is inside.

Pass the nozzle through the hole at the end, and push the grease gun holder fully in to store it.

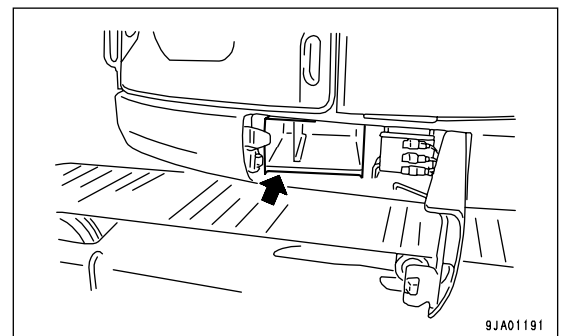

ASHTRAY

This is a magnet type, so it can be fitted at any place as desired.

Be sure to extinguish your cigarette, then close the lid.

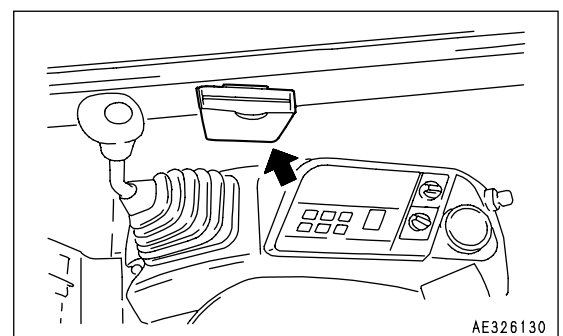

MACHINE OPERATIONS AND CONTROLS

BEFORE STARTING ENGINE

WALK-AROUND CHECKS

Before starting the engine, look around the machine and under the machine to check for loose nuts or bolts, or leakage of oil, fuel, or coolant, and check the condition of the work equipment and hydraulic system. Check also for loose wiring, play, and accumulation of dust at places which reach high temperatures.

WARNING

Remove any flammable materials from around the battery or engine muffler, or other high temperature engine parts. Leakage of fuel or oil will cause the machine to catch fire. Check carefully, and be sure to repair any abnormalities, or please contact your Komatsu distributor.

Always check the items in this section before starting the engine each day.

1. Check for damage, wear, play in work equipment, cylinders, linkage, hoses

Check that there are no cracks, excessive wear, or play in the work equipment, cylinders, linkage, or hoses. If any abnormality is found, repair it.

2. Remove dirt and dust from around engine, battery, radiator

Check if there is any dirt or dust accumulated around the engine or radiator. Check also if there is any flammable material (dead leaves, twigs, grass, etc.) accumulated around the battery or high temperature engine parts, such as the engine muffler or turbocharger. Remove all such dirt or flammable material.

3. Check for leakage of water or oil around engine

Check that there is no leakage of oil from the engine or leakage of water from the cooling system. If any abnormality is found, repair it.

4. Check for oil leakage from hydraulic equipment, hydraulic tank, hoses, joints

Check that there is no oil leakage. If any abnormality is found, repair the place where the oil is leaking.

5. Check the undercarriage (track, sprocket, idler, guard) for damage, wear, loose bolts, or leakage of oil from rollers

6. Check for damage to handrail, loose bolts

Repair any damage and tighten any loose.

7. Check for damage to gauges, monitor, loose bolts

Check that there is no damage to the gauges and monitor in the operator's cab. If any abnormality is found, replace the parts. Clean off any dirt on the surface.

8. Clean rear view mirror, check for damage

Check that there is no damage to the rear view mirror. If it is damaged, replace it with a new mirror. Clean the surface of the mirror and adjust the angle so that the view to the rear can be seen from the operator's seat.

9. Seat belt option and mounting clamps

Check that there is no abnormality in the seat belt or mounting clamps. If there is any damage, replace with new parts.

10. Check bucket with hook for damage.

Check the hook, catcher and hook foot for damage. If damage is found, contact your Komatsu distributor for repair.

CHECKS BEFORE STARTING

Always carry out the items of the checks in this section before starting the engine.

CHECK COOLANT LEVEL, ADD WATER

WARNING

- Do not open the radiator cap unless necessary. When checking the coolant, always wait for the engine to cool down and check the sub tank.
- Immediately after the engine is stopped, the coolant is at a high temperature and the radiator is under high internal pressure. If the cap is removed to drain the coolant in this condition, there is a hazard of burns. Wait for the temperature to go down, then turn the cap slowly to release the pressure before removing it.

1. Open the engine hood on the machine and check that the cooling water level is between the FULL and LOW marks on radiator reserve tank (1) (shown in the diagram on the right).
If the water level is low, add water through the water filler of reserve tank (1) to the FULL level.
2. After adding water, tighten the caps securely.
3. If the sub tank is empty, there is probably leakage of water.
After inspecting, repair any abnormality immediately. If there is no abnormality, check the water level in the radiator. If the water level is low, add water to the radiator, then fill the reserve tank (1).

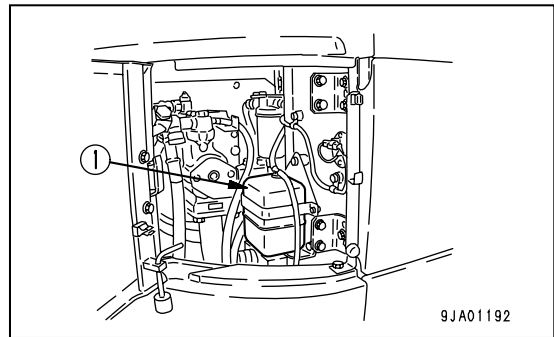

9JA01192

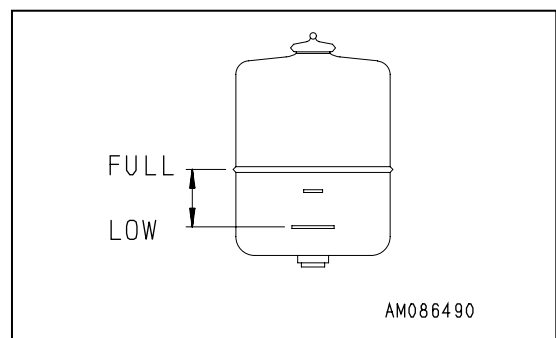

AM086490

CHECK OIL LEVEL IN ENGINE OIL PAN, ADD OIL

⚠ WARNING

The parts and oil are at high temperature after the engine is stopped, and may cause serious burns. Wait for the temperature to go down before starting the operation.

1. Open the engine hood on the machine.
2. Remove dipstick (G) and wipe the oil off with a cloth.
3. Insert dipstick (G) fully in the oil filler pipe, then take it out again.

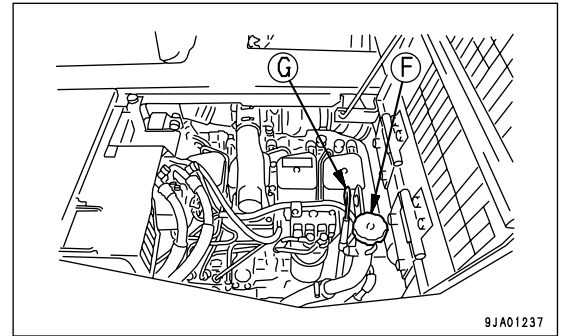

4. The oil level should be between the H and L marks on dipstick (G).
If the oil level is below the L mark, add engine oil through oil filler (F).
5. If the oil level is above the H mark, remove undercover (1), drain the excess engine oil from drain valve (P), then check the oil level again.

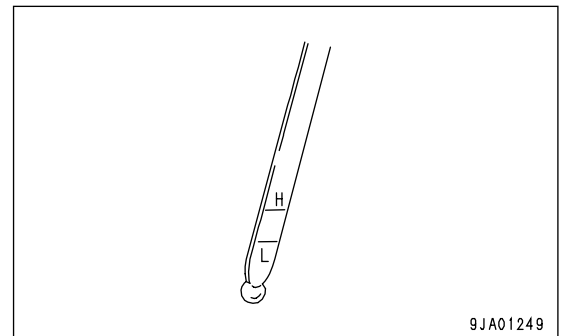

6. If the oil level is correct, tighten the oil filler cap securely and close the engine hood.

REMARK

When checking the oil level after the engine has been operated, wait for at least 15 minutes after stopping the engine before checking.

If the machine is at an angle, make it horizontal before checking.

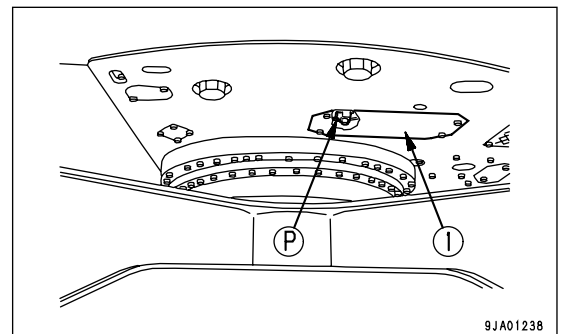

CHECK FUEL LEVEL, ADD FUEL

⚠ WARNING

Be careful not to let the fuel overflow when adding fuel. This may cause a fire.

Wipe up all fuel that is spilled. If there is sand where the fuel is spilled, remove all the sand. Fuel is flammable and dangerous. Keep it away from any flame.

1. Open fuel filler cap (F) of the fuel tank.
2. When fuel filler cap (F) is opened, float gauge (G) will rise according to the fuel level. Check that the fuel tank is full. Check by looking into the tank and by using float gauge (G).

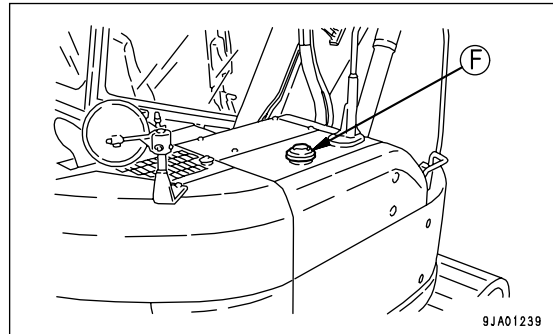

3. If the tank is not full, add fuel through the fuel filler until float gauge (G) rises to the maximum position. Fuel tank capacity: 195 liters (51.48 US gal)
Position of tip of float gauge (G) when tank is full: Approx. 130 mm (5.1 in) from top surface of fuel tank

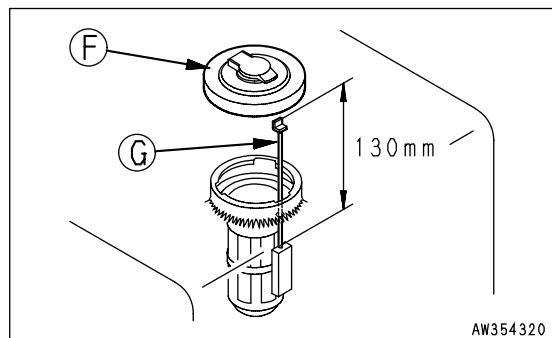

4. After adding fuel, push float gauge (G) straight down with fuel filler cap (F). Be careful not to get float gauge (G) caught in the tab of fuel filler cap (F), and tighten fuel filler cap (F) securely.

REMARK

If breather hole (1) on the cap is clogged, the pressure in the tank will drop and fuel will not flow. Clean the hole from time to time.

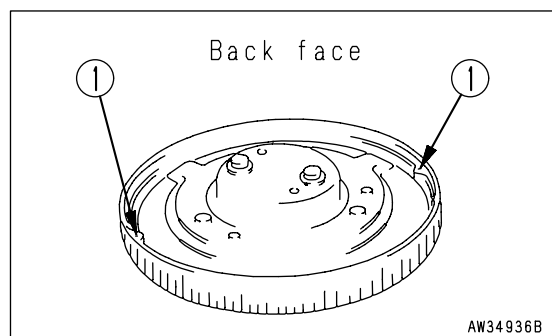

CHECK OIL LEVEL IN HYDRAULIC TANK, ADD OIL

⚠ WARNING

When removing the oil filler cap, oil may spurt out, so turn the cap slowly to release the internal pressure before removing the cap.

1. If the work equipment is not in the condition shown in the diagram on the right, start the engine, run the engine at low speed, retract the arm and bucket cylinders, then lower the boom, set the bucket teeth in contact with the ground, and stop the engine.
2. Within 15 seconds after stopping the engine, move each control lever (for work equipment and travel) to the full stroke in all directions to release the internal pressure.
3. Open the door of the pump room on the right side of the machine and check sight gauge (G). The oil level should be between the H and L lines.

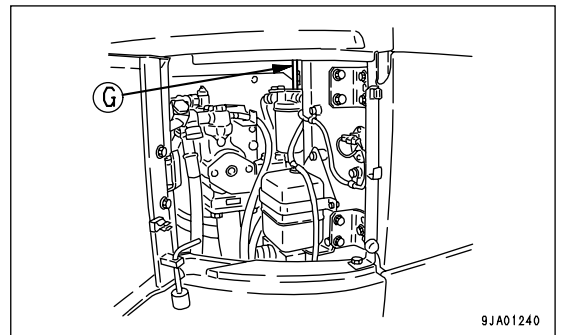
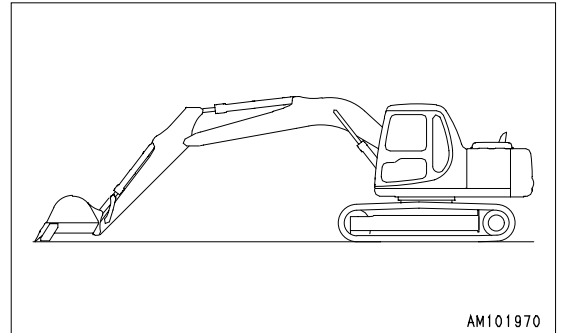

NOTICE

Do not add oil above the H line. This will damage the hydraulic circuit or cause the oil to spurt out. If oil has been added to above the H level, stop the engine and wait for the hydraulic oil to cool down, then drain the excess oil from drain plug (P).

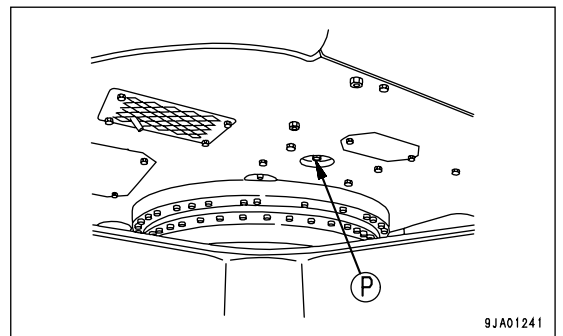

4. If the oil level is below the L line, add oil through oil filler (F) at the top of the hydraulic tank.

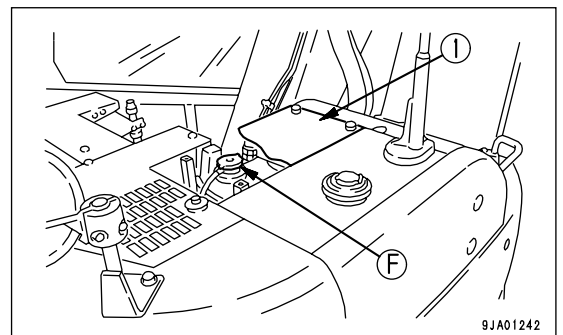

REMARK

The oil level will vary depending upon the oil temperature. Accordingly, use the following as a guide:

- Before operation: around L level
(Oil temperature 10 to 30°C (50 to 86°F))
- Normal operation: around H level
(Oil temperature 50 to 80°C (122 to 176°F))

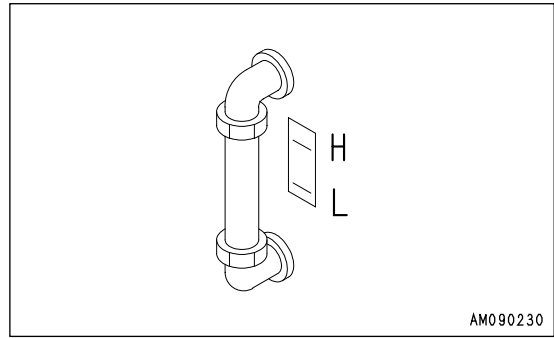

CHECK DUST INDICATOR

1. Open the cover at the rear of the cab and check that the red piston is not showing in the part of dust indicator (1) shown by the arrow.
2. If the red piston has appeared, clean or replace the element immediately.
For details of the method of cleaning the element, see "CHECK, CLEAN AND REPLACE AIR CLEANER ELEMENT (PAGE 4-20)".
3. After checking, cleaning, and replacing, press the knob of dust indicator (1) to return the red piston to its original position.

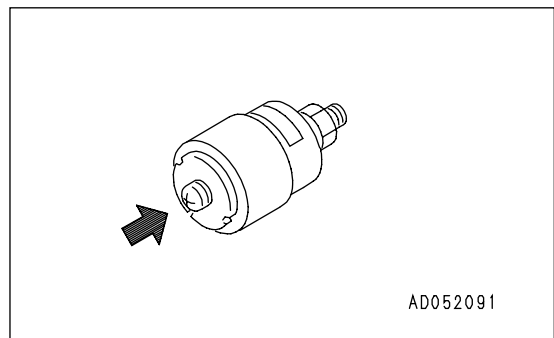
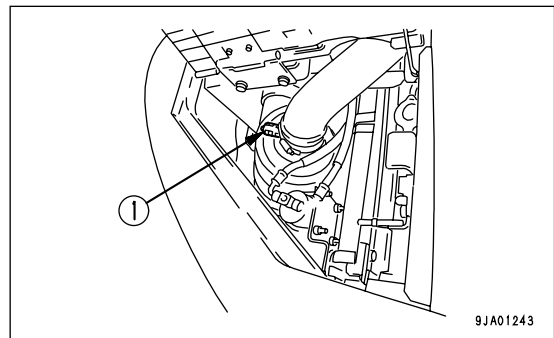

CHECK ELECTRIC WIRINGS

⚠ WARNING

- If the fuses frequently blow or if there are traces of short circuits on the electrical wiring, locate the cause immediately and carry out repairs, or contact your Komatsu distributor for repairs.
- If flammable materials (dead leaves, twigs, dry grass, etc.) accumulate around the battery, they will cause fire, so always remove such material immediately.
- Keep the top surface of the battery clean and check the breather hole in the battery cap. If it is clogged with dirt or dust, wash the battery cap to clean the breather hole.

Check for damage and wrong capacity of the fuse and any sign of disconnection or short circuit in the electric wiring. Check also for loose terminals and tighten any loose parts.

Check the wiring of the "battery", "starting motor" and "alternator" carefully in particular.

When carrying out walk-around checks or checks before starting, always check if there is any accumulation of flammable material around the battery, and remove such flammable material.

Please contact your Komatsu distributor for investigation and correction of the cause.

CHECK FUNCTION OF HORN

1. Turn the starting switch to the ON position.
2. Confirm that the horn sounds without delay when the horn button is pressed. If the horn does not sound, ask your Komatsu distributor for repair.

CHECK FOR WATER AND SEDIMENT IN WATER SEPARATOR, DRAIN WATER

The water separator separates water mixed in the fuel. If float (2) is at or above red line (1), drain the water according to the following procedure.

1. Open the pump room door.
2. Loosen drain plug (3) at the bottom of the filter case and drain the water from inside.
3. When red ring (1) goes down to the bottom of the case, tighten drain plug (3).
Tightening torque: 2.9 to 3.9 N•m
(0.3 to 0.4 kgf•m, 2.2 to 2.9 lbft)
4. Drain the water and sediment from the fuel tank.
For details, see "DRAIN WATER AND SEDIMENT FROM FUEL TANK (PAGE 4-45)".

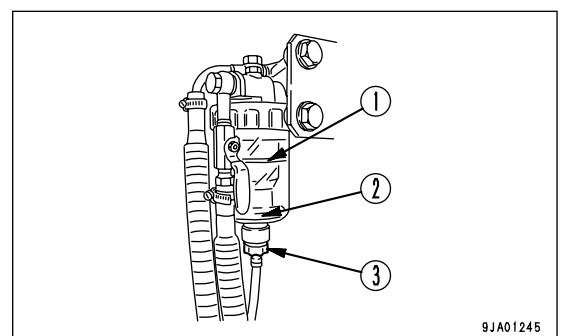
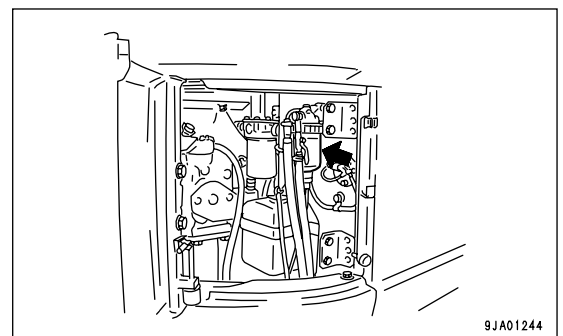

ADJUST BEFORE OPERATION

⚠ WARNING

- Adjust the seat position before starting operations or after changing the operator.
- Adjust the seat so that the brake pedal can be depressed fully with the operator's back against the backrest.

A: Fore-and-aft adjustment

Move lever (1) to right. After the seat is set to the desired position, release the lever.

Adjustable distance: 100 mm (3.9 in) in 10 steps

B: Adjusting reclining

NOTICE

The seat can be reclined to a large angle when the seat is pushed fully forward, but the reclining angle is reduced when the seat is moved back, so when moving the seat to the rear, return the seat back to its original position.

Pull lever (2) and set the seat back to a position which is comfortable for operation, then release the lever.

Sit with your back against the seat back when adjusting. If your back is not touching the seat back, the seat back may suddenly move forward.

C: Adjusting armrest angle

Armrest (3) can be made to spring up by hand approx. 90°.

D: Overall fore-and-aft adjustment of seat

Pull up lever (4), set to the desired position, then release the lever. In this case, the operator's seat, left and right control levers, and safety lock lever all slide together.

Fore-and-aft adjustment: 80 mm (3.2 in)

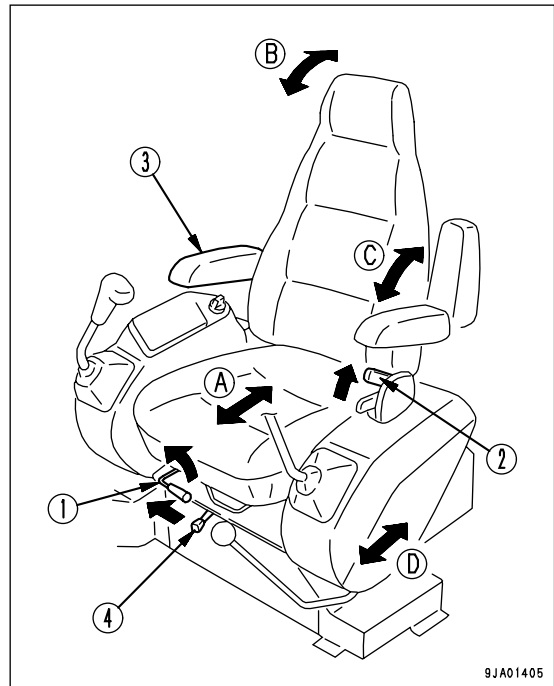

REARVIEW MIRRORS

Loosen nut (1) and bolt (2) of the mirror mount, then adjust the mirror so that it is possible to see clearly the area to the rear left and right of the machine. These are a blind spots from the operator's seat.

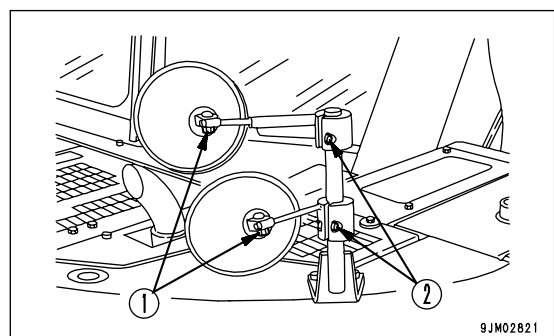

SEAT BELT

WARNING

- Before fitting the seat belt, check that there is no abnormality in the belt mount bracket or mounting belt. If it is worn or damaged, replace the seat belt.
- Even if no abnormality can be seen in the belt, replace the seat belt every 3 years. The date of manufacture of the belt is shown on the back of the belt.
- Adjust the seat belt and fit it before starting operations.
- Always wear the seat belt during operations.
- Fit the seat belt so that it is not twisted.

Check the mounting bolts of the belt fitting on the machine body for looseness, and re-tighten them if necessary.

The tightening torque for the mounting bolt is $24.5 \pm 4.9 \text{ N}\cdot\text{m}$ ($2.5 \pm 0.5 \text{ kgf}\cdot\text{m}$, $18.1 \pm 3.6 \text{ lbft}$).

If the belt surface is scratched or frayed or if the fittings are broken or deformed, replace the seat belt unit.

FASTENING AND REMOVING

1. Sit in the seat with your back against the seat back, and adjust the belt so that it is easy to carry out operations.
2. After adjusting the seat position, sit in the seat. Grip buckle (1) and tongue (2) in each hand and insert tongue (2) into buckle (1). Confirm by pulling the belt that the tongue is securely locked to the buckle.
3. When removing the belt, raise the tip of the lever of buckle (1) to release the belt.

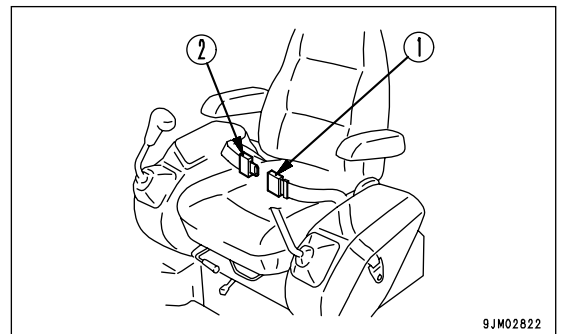

Fasten belt along your body without kinking it. Adjust the lengths of the belt on both the buckle and the tongue sides so that the buckle is located at the mid-point of your body front.

SEAT BELT ADJUSTMENT

Shortening

Pull the free end of the belt on either the buckle body or tongue side.

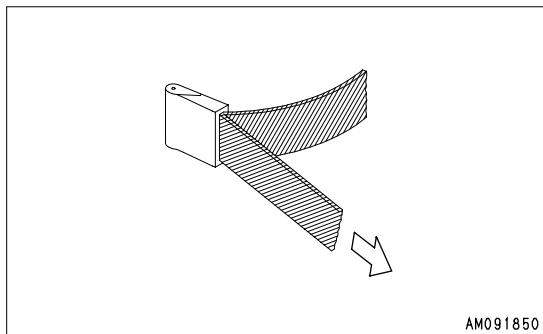

Lengthening

Pull the belt while holding it at a right angle to the buckle or tongue.

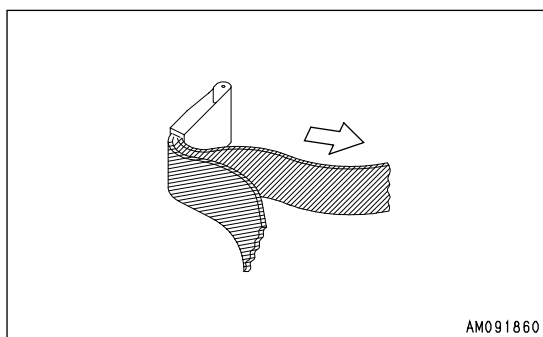

OPERATIONS BEFORE STARTING ENGINE

⚠ WARNING

- When starting the engine, check that the safety lock lever is securely at the LOCK position. If the control levers are not locked and they are touched by accident when starting the engine, the work equipment may move unexpectedly, and this may lead to a serious accident.
- When standing up from the operator's seat, always set the safety lock lever to the LOCK position, regardless of whether the engine is running or stopped.

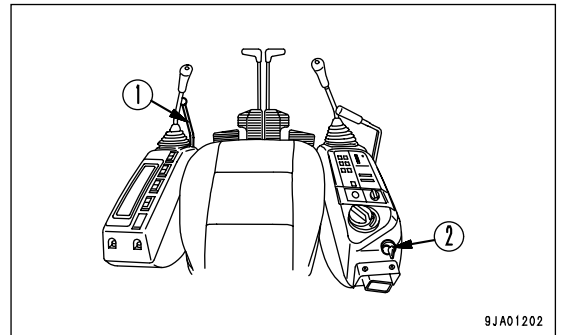

1. Check that safety lock lever (1) is at the LOCK position.
2. Check the position of each lever.

Set the control lever to the neutral position.
When starting the engine, never touch the knob button.

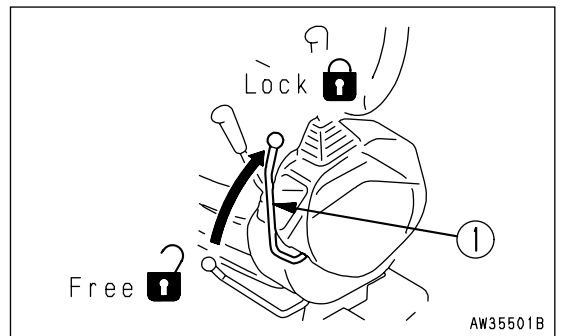

3. Insert the key in starting switch (2), turn the key to the ON position, then carry out the following checks.
 - 1) The buzzer will sound for approx. 1 sec, and the following monitors and gauges will light up for approx. 3 sec.
 - Charge level monitor (3)
 - Engine oil pressure monitor (4)
 - Swing lock monitor (5)
 - Engine water temperature gauge (6)
 - Fuel gauge (7)

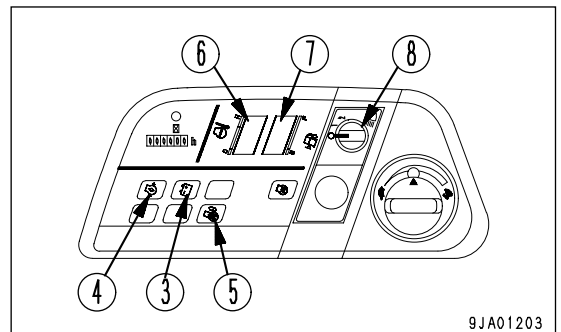
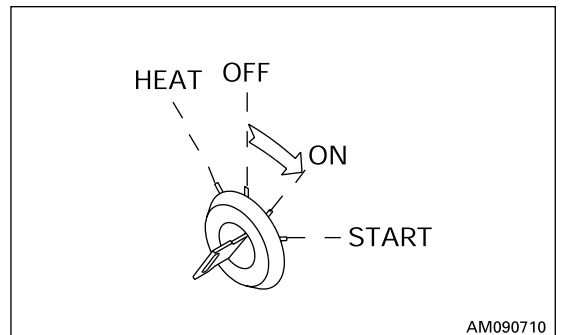

If the monitors or gauges do not light up or the buzzer does not sound, there is probably a broken bulb or disconnection in the monitor wiring, so contact your Komatsu distributor for repairs.

After approx. 3 sec, the following gauges will remain on and the other monitors will go out.

- Charge level monitor (3)
- Engine oil pressure monitor (4)
- Engine water temperature gauge (6)
- Fuel gauge (7)

- 2) Press lamp switch(8) to turn on the head lamps. If it does not light up, there is probably a blown bulb or disconnection, so please contact your Komatsu distributor for repairs.

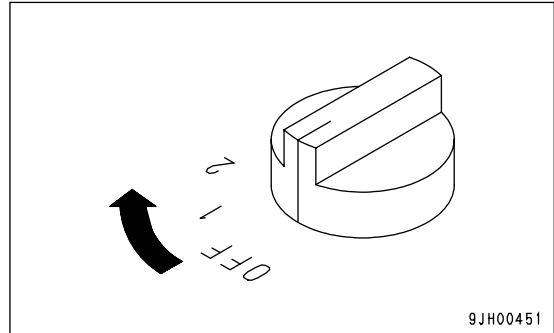

STARTING ENGINE

NORMAL STARTING

WARNING

- Check that there are no persons or obstacles in the surrounding area, then sound the horn and start the engine.
- Exhaust gas is toxic. When starting the engine in confined spaces, be particularly careful to ensure good ventilation.

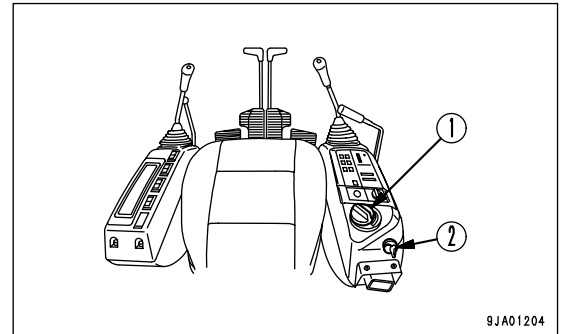

NOTICE

- If the fuel control dial is at the FULL position, the engine will pick up suddenly and this will damage the engine parts, so always set the fuel control dial to the mid-range or low position.
- Do not keep the starting motor rotating continuously for more than 20 seconds. If the engine will not start, wait for at least two minutes before trying to start the engine again.

1. Before starting the engine, check that fuel control dial (1) is at the low idling position.
2. Turn fuel control dial (1) to the center position between LOW IDLING and HIGH IDLING.

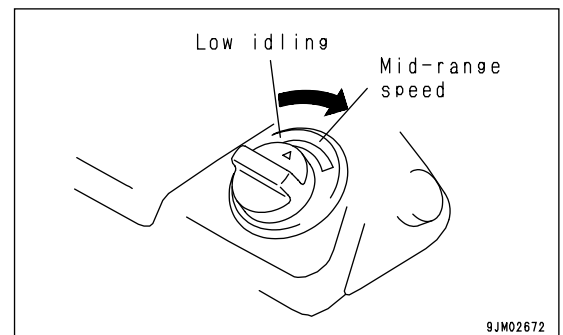

3. Turn the key in starting switch (2) to the START position. The engine will start.

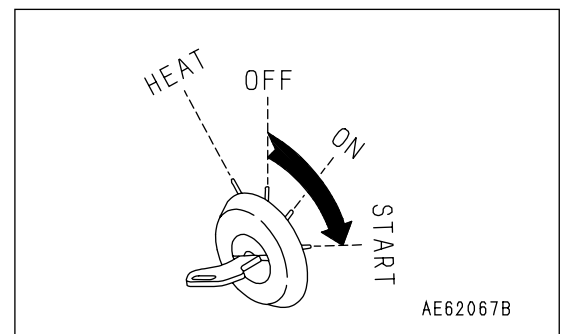

4. When the engine starts, release the key in starting switch (2).
The key will return automatically to the ON position.

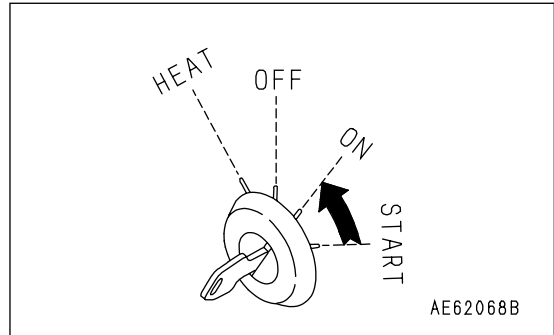

5. Continue idling for 15 seconds after the engine starts. During this time, do not operate the control levers or fuel control dial.

STARTING ENGINE IN COLD WEATHER

⚠ WARNING

- Check that there are no persons or obstacles in the surrounding area, then sound the horn and start the engine.
- Never use starting aid fluids as they may cause explosions.

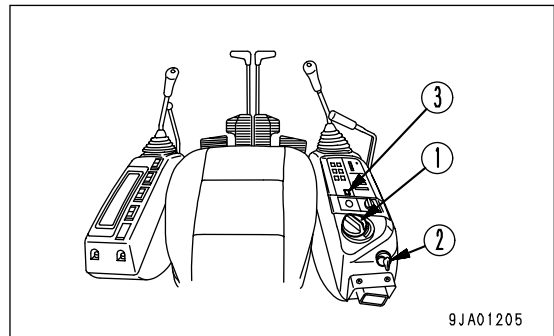

NOTICE

- If the fuel control dial is at the FULL position, the engine will pick up suddenly and this will damage the engine parts, so always set the fuel control dial to the mid-range or low position.
- Do not keep the starting motor rotating continuously for more than 20 seconds.
If the engine will not start, wait for at least two minutes before trying to start the engine again.

When starting in low temperatures, do as follows.

1. Before starting the engine, check that fuel control dial (1) is at the low idling position.
2. Turn fuel control dial (1) to the center position between LOW IDLING and HIGH IDLING.

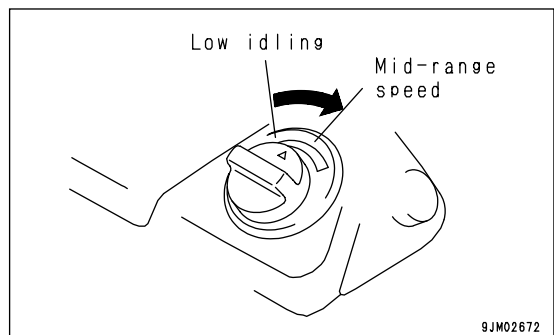

3. Hold the key in starting switch (2) at the HEAT position, and check that preheating monitor (3) lights up. After about 30 seconds, preheating monitor lamp (3) will flash to indicate that preheating is finished.

REMARK

The monitor and gauge also light up when the key is at the HEAT position, but this does not indicate any abnormality.

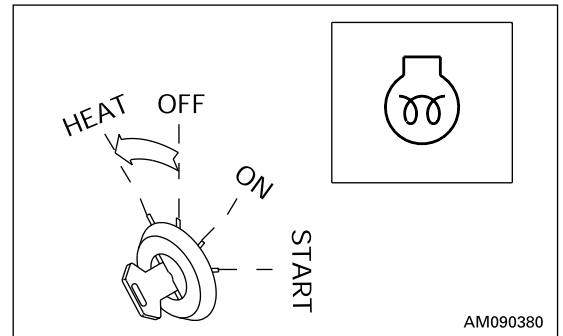

4. When preheating monitor (3) goes out, turn the key in starting switch (2) to the START position to start the engine.

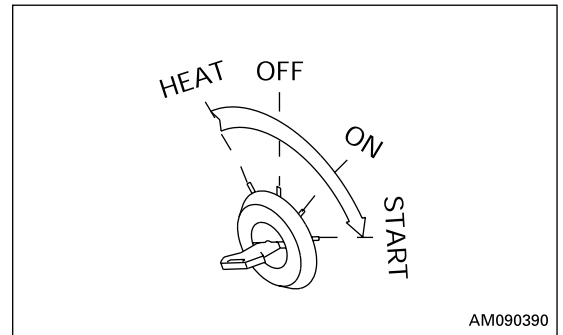

5. When the engine starts, release the key in starting switch (2). The key will return automatically to the ON position.

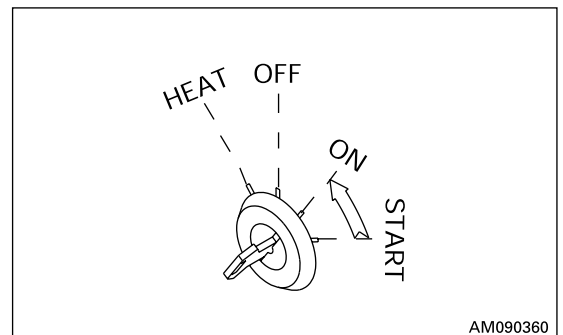

6. Continue idling for 15 seconds after the engine starts. During this time, do not operate the control levers or fuel control dial.

AFTER STARTING ENGINE

WARNING

- **Emergency stop**
If there has been any abnormal actuation or trouble, turn the starting switch key to the OFF position.
- If the work equipment is operated without warming the machine up sufficiently, the response of the work equipment to the movement of the control lever will be slow, and the work equipment may not move as the operator desires, so always carry out the warming-up operation. Particularly in cold areas, be sure to carry out the warming-up operation fully.

BREAKING-IN THE NEW MACHINE

CAUTION

Your Komatsu machine has been thoroughly adjusted and tested before shipment. However, operating the machine under severe conditions at the beginning can adversely affect the performance and shorten the machine life.

Be sure to running-in the machine for the initial 100 hours (as indicated by the service meter). During running-in operations, follow the precautions described in this manual.

- Idle the engine for 5 minutes after starting it up.
- Avoid operation with heavy loads or at high speeds.
- Avoid sudden starts, sudden acceleration, sudden steering and sudden stops except in cases of emergency.

WARMING-UP OPERATION

NOTICE

- When the hydraulic oil is at a low temperature, do not carry out operations or move the levers suddenly. Always carry out the warming-up operation. This will help to extend the machine life.
- Do not suddenly accelerate the engine before the warming-up operation is completed. Do not run the engine at low idling or high idling continuously for more than 20 minutes. This will cause leakage of oil from the turbocharger oil supply piping. If it is necessary to run the engine at idling, apply a load from time to time or run the engine at a mid-range speed.

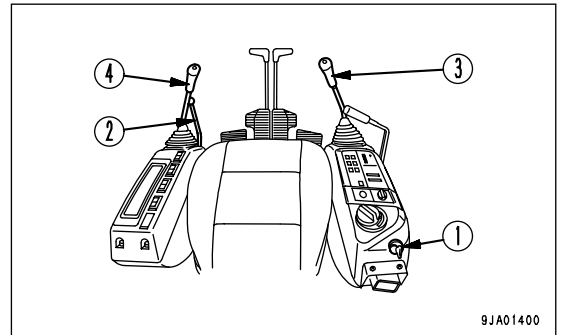

After starting the engine, do not immediately start operations. First, carry out the following operations and checks.

1. Turn fuel control dial (1) to the center position between LOW IDLING and HIGH IDLING and run the engine at medium speed for about 5 minutes with no load.

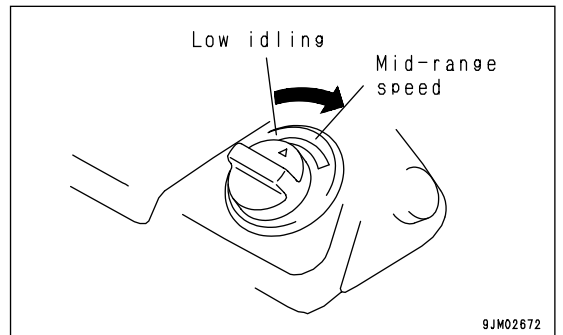

2. Set safety lock lever (2) to the FREE position, and raise the bucket from the ground.

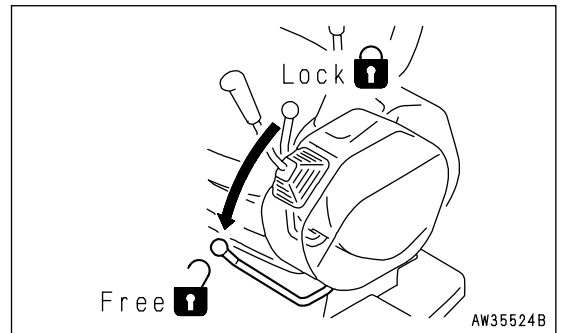

3. Operate bucket control lever (3) and arm control lever (4) slowly to move the bucket cylinder and arm cylinder to the end of the stroke.

NOTICE

When the work equipment is retracted, take care that it does not interfere with the machine body or ground.

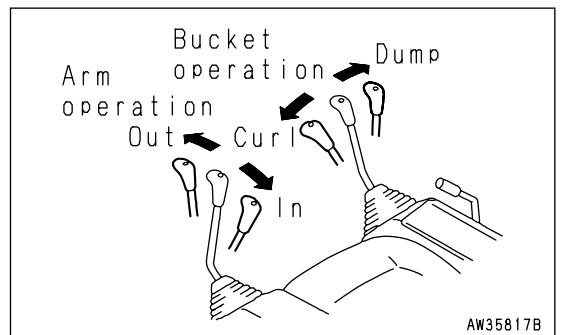

4. Carry out bucket and arm operation for 5 minutes at full stroke, alternating between bucket operation and arm operation at 30 second intervals.

5. After carrying out the warming-up operation, check that each gauge and monitor lamp is in the following condition.
 - Engine water temperature gauge (6): Inside green range
 - Fuel gauge (7): Inside green range
 - Engine oil pressure monitor (8): OUT
 - Charge level monitor (9): OUT

6. Check that there is no abnormal exhaust gas color, noise, or vibration. If any abnormality is found, repair it.

7. Set lock lever (2) to the LOCK position and check that it is impossible to operate the swing and work equipment with the left and right work equipment control levers.

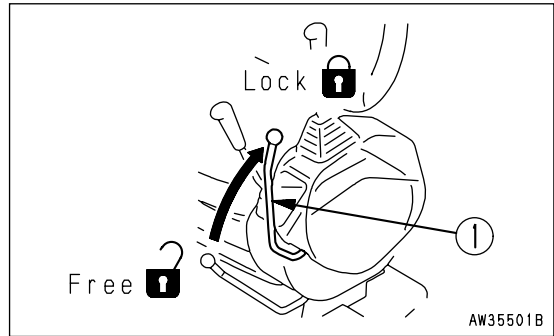
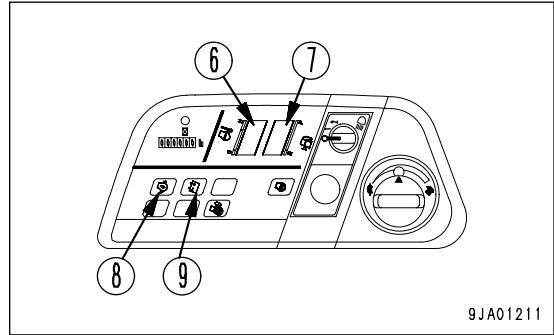

STOPPING THE ENGINE

NOTICE

If the engine is abruptly stopped before it has cooled down, engine life may be greatly shortened. Consequently, do not abruptly stop the engine apart from an emergency.

In particular, if the engine has overheated, do not abruptly stop it but run it at medium speed to allow it to cool gradually, then stop it.

1. Run the engine at low idling speed for about 5 minutes to allow it to gradually cool down.

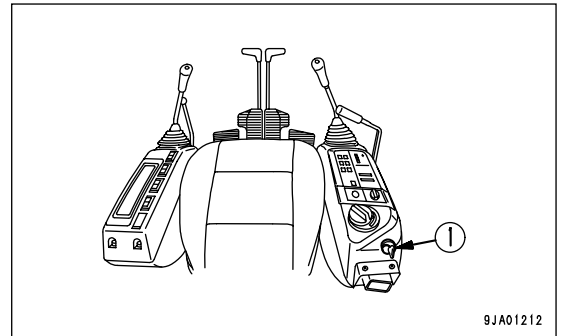

2. Turn the key in starting switch (1) to the OFF position and stop the engine.
3. Remove the key from starting switch (1).

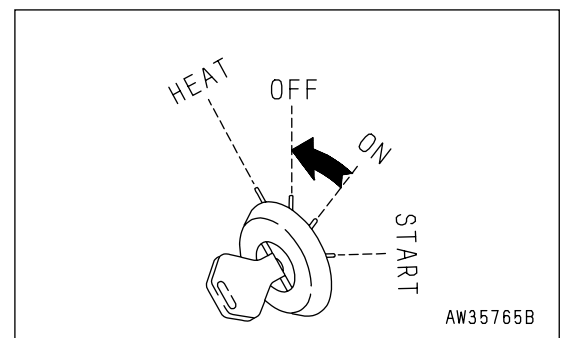

CHECK AFTER SHUT OFF ENGINE

1. Walk around the machine and check the work equipment, machine exterior, and undercarriage, and check also for leakage of oil or water. If any abnormalities are found, repair them.
2. Fill the fuel tank.
3. Check the engine compartment for paper and debris. Clean out any paper and debris to avoid a fire hazard.
4. Remove any mud affixed to the undercarriage.

MACHINE OPERATION

PREPARATIONS FOR MOVING THE MACHINE OFF

WARNING

- Before operating the steering levers, check the direction of the track frame.
If the sprocket is at the front, the operation of the travel levers is reversed.
- When moving off, check that the area around the machine is safe, and sound the horn before moving.
- Do not allow anyone in the area around the machine.
- Remove all obstacles from the travel path of the machine.
- The rear of the machine is a blind spot, so be particularly careful when travel in reverse.
- For machines equipped with a travel alarm (if equipped), check that the warning equipment works properly.

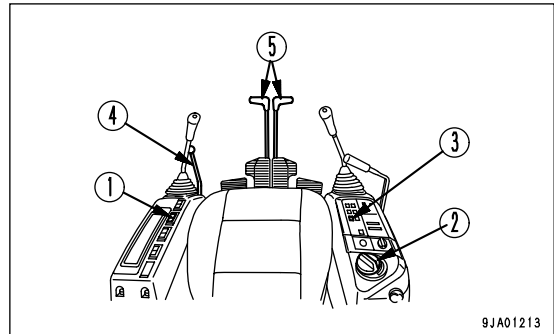

1. Set swing lock switch (1) to the ON (actuated) position and confirm that swing lock monitor lamp (2) lights up.

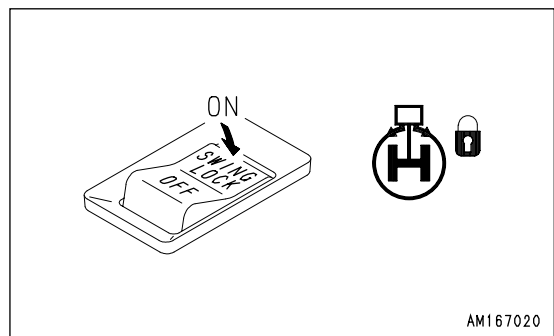

2. Turn fuel control dial (3) towards the full speed position to increase the engine speed.

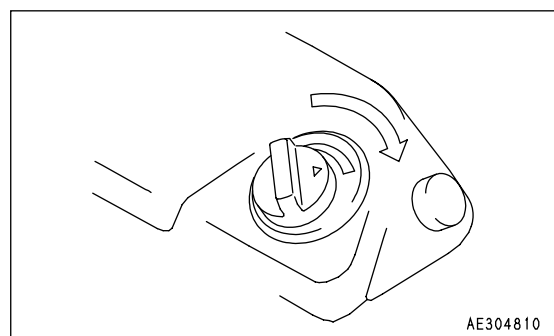

MOVING MACHINE FORWARD

1. Set safety lock lever (4) in the FREE position, fold the work equipment, and raise it 40 to 50 cm (16 to 20 in) from the ground.

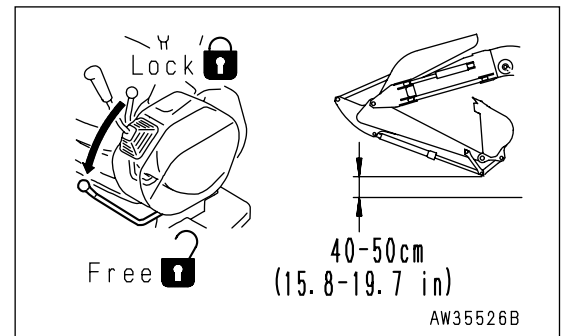

2. Operate right and left travel levers (5) as follows.

- When the sprocket is at the rear of the machine

Push levers (5) forward slowly to move the machine off.

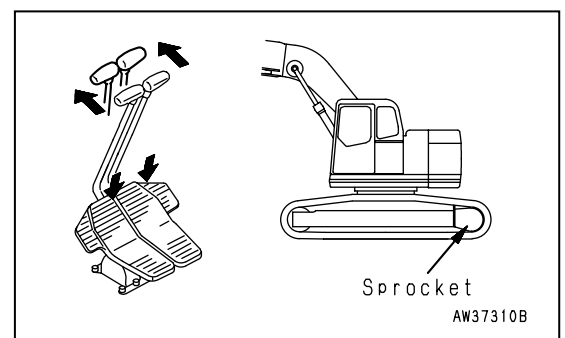

- When the sprocket is at the front of the machine

Pull levers (5) backward slowly to move the machine off.

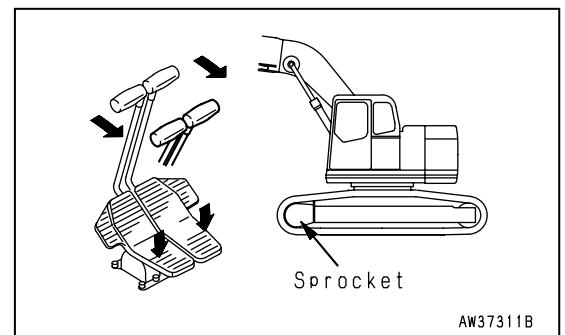

3. For machines equipped with a travel alarm, check that the alarm sounds. If the alarm does not sound, please contact your Komatsu distributor for repairs.

MOVING MACHINE BACKWARD

1. Set safety lock lever (4) in the FREE position, fold the work equipment, and raise it 40 to 50 cm (16 to 20 in) from the ground.

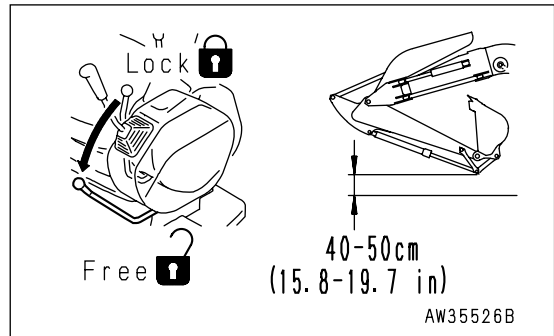

2. Operate right and left travel levers (5) as follows.

- When the sprocket is at the rear of the machine

Pull levers (5) backward slowly to move the machine off.

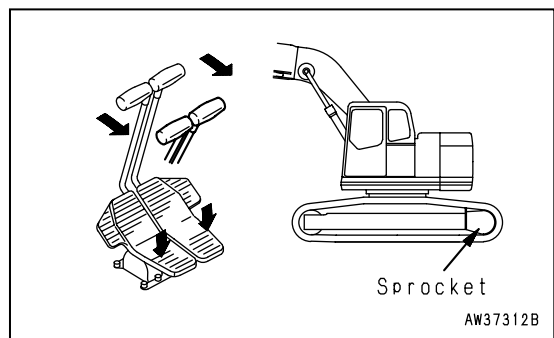

- When the sprocket is at the front of the machine

Push levers (5) forward slowly to move the machine off.

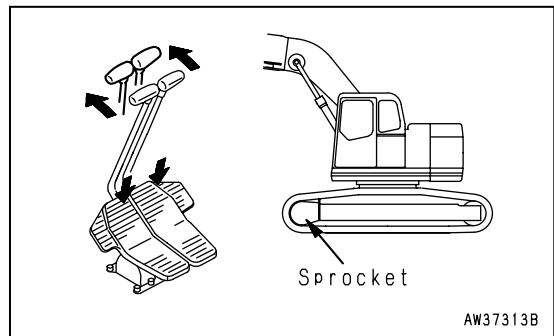

3. For machines equipped with a travel alarm, check that the alarm sounds. If the alarm does not sound, please contact your Komatsu distributor for repairs.

STOPPING MACHINE

WARNING

Avoid stopping suddenly. Give yourself ample room when stopping.

1. Put the left and right travel levers (1) in the neutral position, then stop the machine.

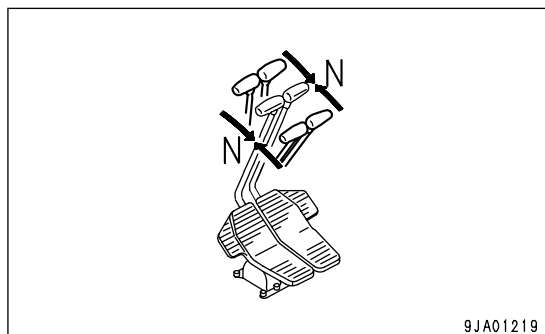
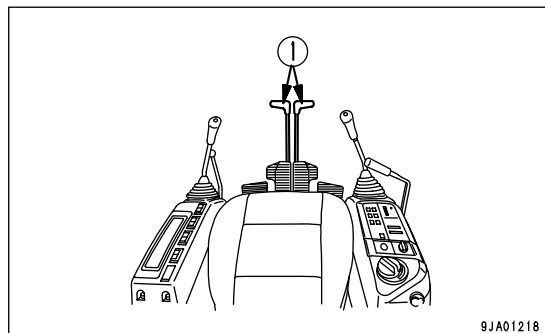

STEERING THE MACHINE

Steering

⚠ WARNING

Before operating the travel levers, check the position of the sprocket. If the sprocket is at the front, the operation of the travel levers is reversed.

Use the travel levers to change direction.

Avoid sudden changes of direction as far as possible. In particular, when carrying out counter-rotation (spin turn), stop the machine first before turning.

Operate two travel levers (1) as follows.

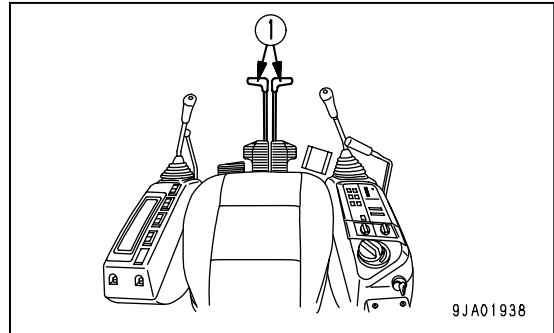

Steering the Machine when Stopped

When turning to the left:

Push the right travel lever forward to turn to the left when traveling forward; and pull it back to turn left when traveling in reverse.

REMARK

When turning to the right, operate the left travel lever in the same way.

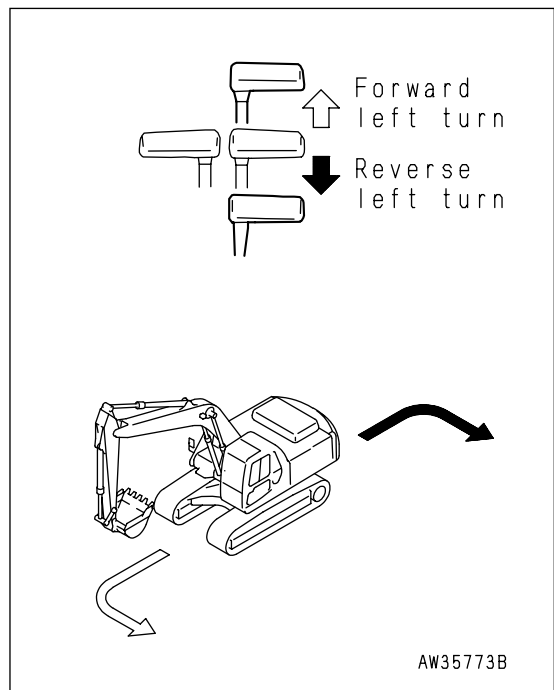

Changing Direction of the Machine

When turning to the left:

If the left travel lever is returned to the neutral position, the machine will turn to the left.

REMARK

When turning to the right, operate the right travel lever in the same way.

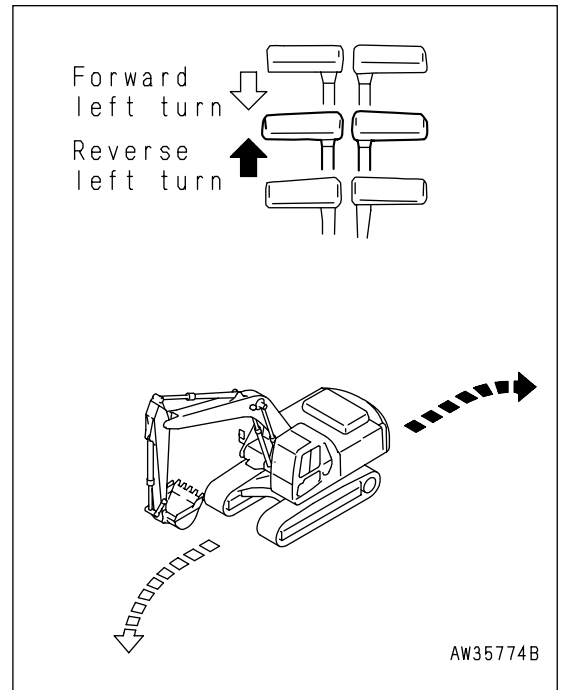

Counter-rotation Turn (Spin Turn)

When using counter-rotation (spin turn) to turn left, pull the left travel lever back and push the right travel lever forward.

REMARK

When using counter-rotation to turn right, pull the right travel lever back and push the left travel lever forward.

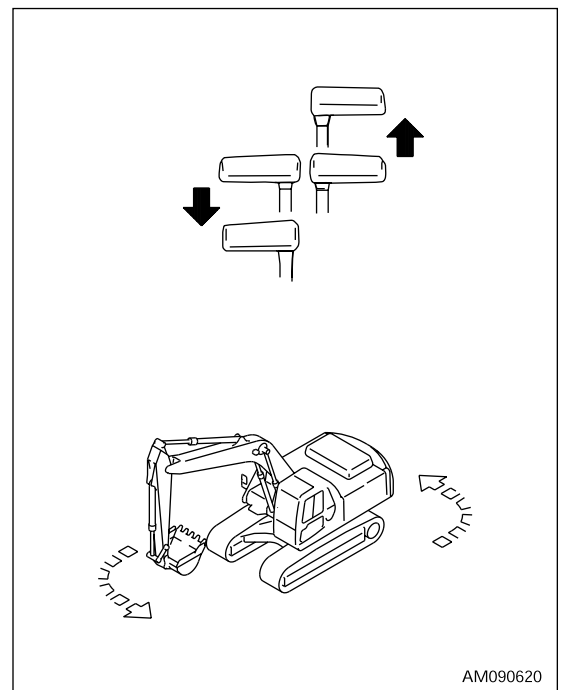

SWINGING

⚠ WARNING

- The rear of the machine extends outside the track width. Check that the surrounding area is safe before swinging the upper structure.
- Check that swing lock monitor is not lighted up.
- If the swing control lever is operated quickly, the upper structure will move quickly; if it is operated slowly, the upper structure will move slowly.

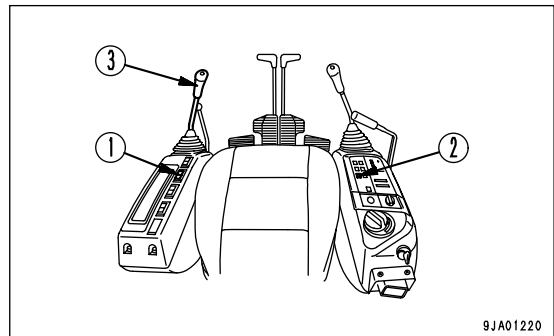

1. Before operating the swing, turn swing lock switch (1) OFF.

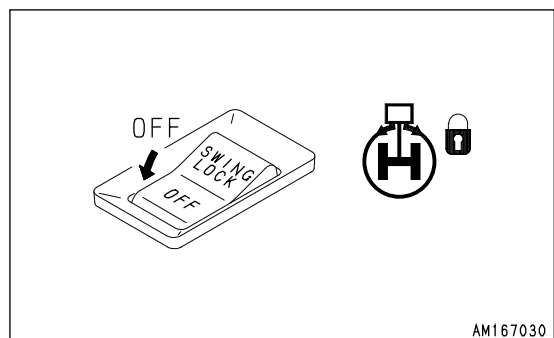

2. Operate left work equipment control lever (1) to operate the swing.
At the N position, the spring brake is applied.

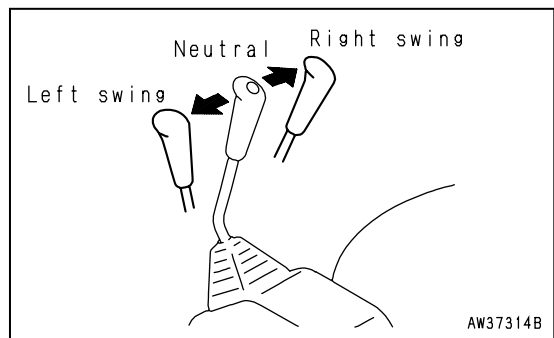

3. When not carrying out swing operations, set swing lock switch (1) to the ON (SWING LOCK) position. This will prevent the upper structure from swinging even if the left work equipment control lever is operated by mistake to the swing position.

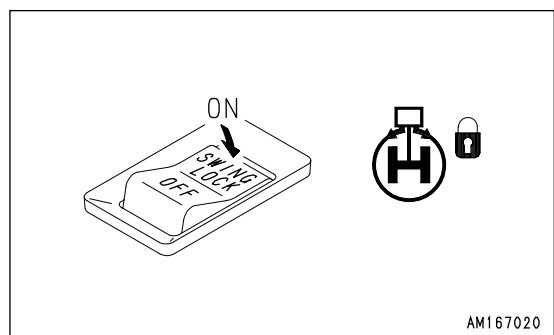

WORK EQUIPMENT CONTROLS AND OPERATIONS

WARNING

If the work equipment control lever is operated quickly, the work equipment will move quickly; and if it is operated slowly, the work equipment will move slowly.

Use the control levers to operate the work equipment.

Note that when the levers are released, they return to the HOLD position and the work equipment is held in that position.

- Arm control

Move the left work equipment control lever to the front or rear to operate the arm.

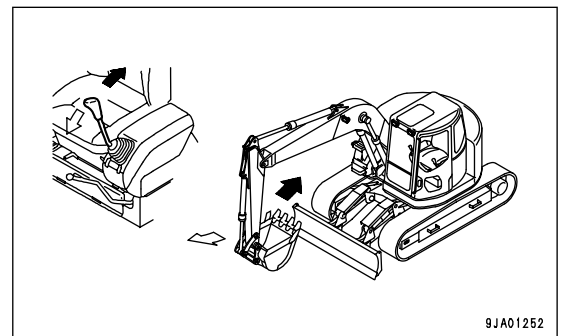

- Swing control

Move the left work equipment control lever to the left or right to swing the upper structure.

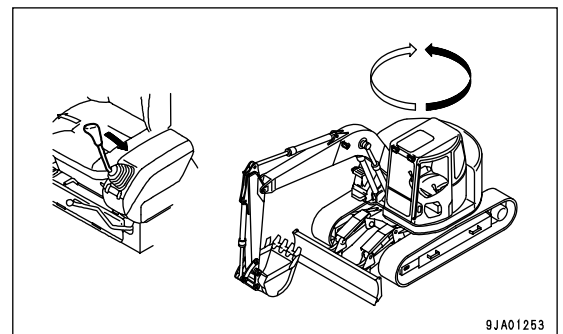

- Boom control

Move the right work equipment control lever to the front or rear to operate the boom.

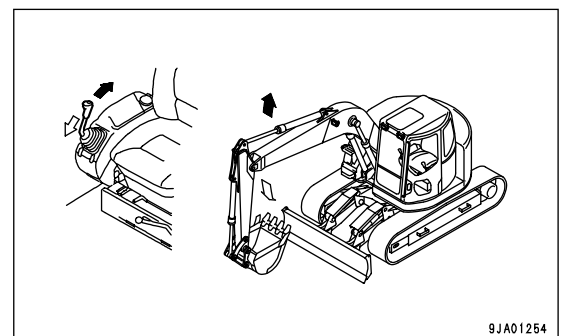

- Bucket control

Move the right work equipment control lever to the left or right to operate the bucket.

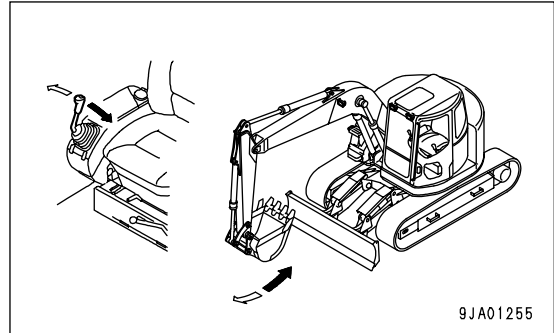

- Blade control (blade specification)

Move the lever on the right side of the operator's seat to the front or rear to operate the blade.

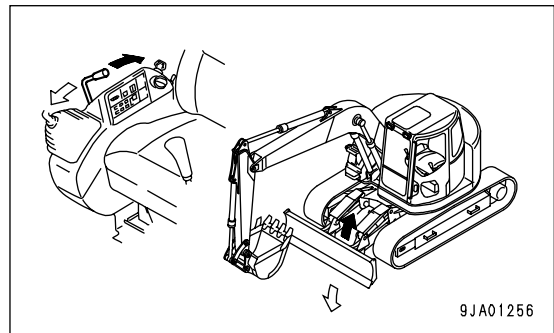

PROHIBITED OPERATIONS

WARNING

If it is necessary to operate the work equipment control lever when the machine is traveling, stop the machine, then operate the control lever.

OPERATIONS USING SWING FORCE

Do not use the swing force to compact soil or break objects. This is not only dangerous, but will also markedly reduce the life of the machine.

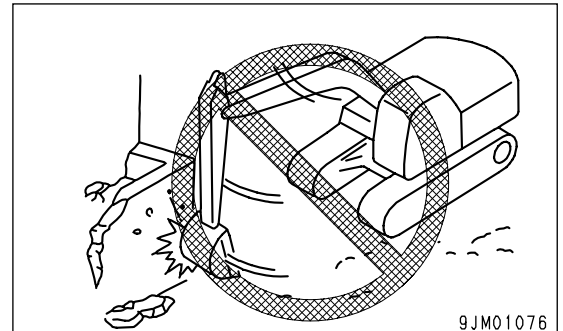

OPERATIONS USING TRAVEL FORCE

Do not dig the bucket into the ground and use the travel force to carry out excavation. This will damage the machine or work equipment.

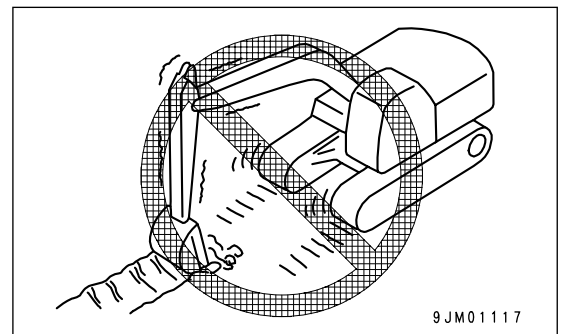

OPERATIONS USING HYDRAULIC CYLINDER STROKE ENDS

If the cylinder is used when the cylinder rod has been operated to the end of its stroke during operations, external force will cause impact to the work equipment, and this will damage the hydraulic cylinders. Avoid carrying out operations with the hydraulic cylinder fully retracted or fully extended.

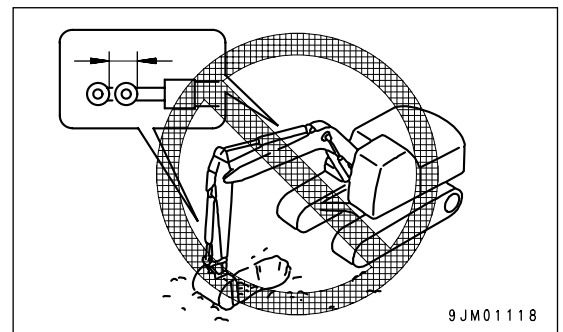

OPERATIONS USING BUCKET DROPPING FORCE

Do not use the dropping force of the machine for digging, or use the dropping force of the bucket as a pickaxe, breaker, or pile driver.

This will markedly reduce the life of the machine.

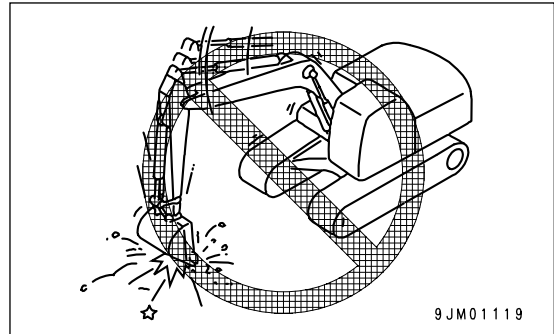

OPERATIONS USING MACHINE DROPPING FORCE

Do not use the dropping force of the machine for digging.

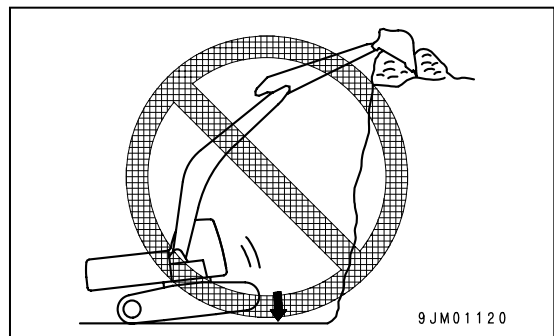

DIGGING HARD ROCKY GROUND

It is better to excavate hard rocky ground after breaking it up by some other means. This will not only reduce damage to the machine but make for better economy.

SUDDEN LEVER SHIFTING HIGH SPEED TRAVEL

- (1) Never carry out sudden lever shifting as this may cause sudden starting.
- (2) Avoid sudden lever shifting from forward to reverse (or from reverse to forward).
- (3) Avoid sudden lever shifting change such as sudden stopping from near top speed (lever release operation).

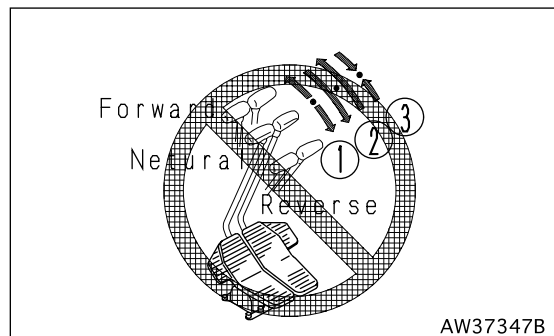

AVOID HITTING BLADE

(Only machines with blade specification)

Be careful not to hit the blade against rocks or boulders. This will cause premature damage to the blade or cylinders.

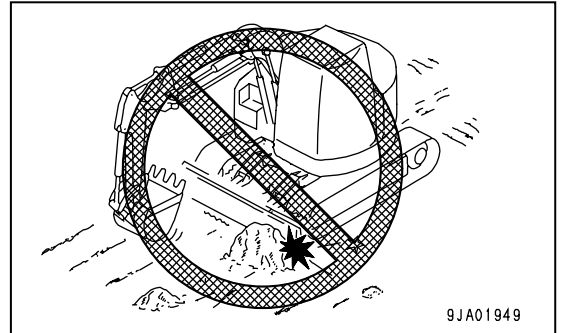

FOLDING IN WORK EQUIPMENT

(Only machines with blade specification)

When folding in the work equipment to the travel or transportation posture, be careful not to let the bucket hit the blade.

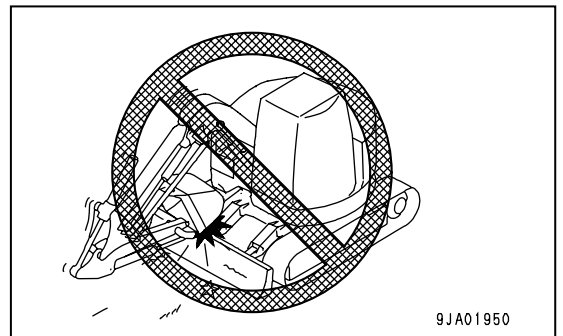

SUPPORT BLADE ON BOTH SIDES

(Only machines with blade specification)

When using the blade as an outrigger, never support the machine with only one end of the blade.

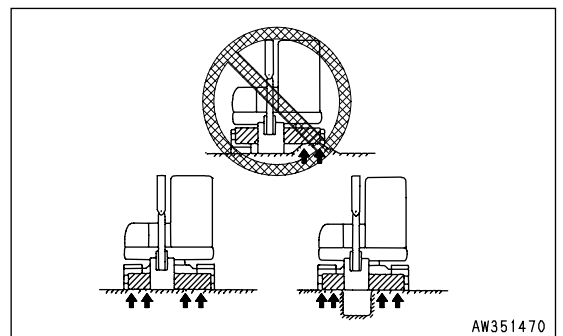

BLADE DURING BACKHOE OPERATIONS

(Only machines with blade specification)

When carrying out deep digging operations with the blade at the front, be careful not to let the boom cylinder hit the blade. Always position the blade at the back unless it is needed at the front.

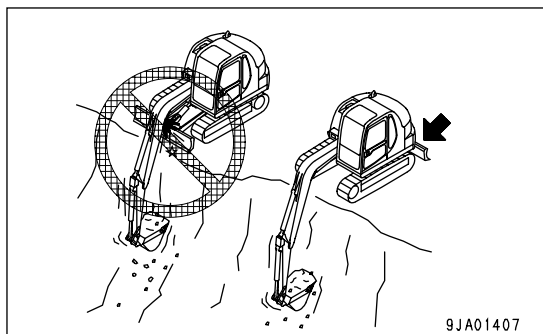

GENERAL OPERATION INFORMATION

TRAVELING

When traveling over obstacles such as boulders or tree stumps, the machine (in particular, the undercarriage) is subjected to a large shock, so reduce the travel speed and travel over the obstacle at the center of the tracks. As far as possible, remove such obstacles or avoid traveling over them.

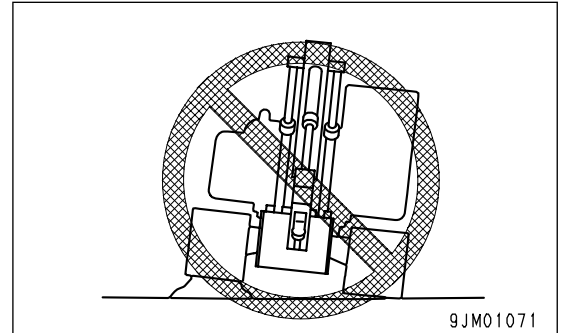

HIGH SPEED TRAVEL

On uneven roadbeds such as rock beds or uneven roads with large locks, travel at Lo speed. When Hi-speed traveling, set the idler in the forward direction.

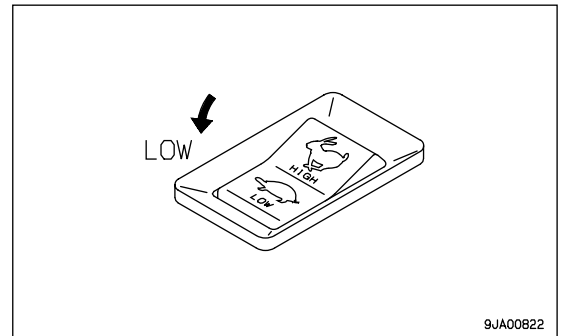

PERMISSIBLE WATER DEPTH

CAUTION
When driving the machine out of water, if the angle of the machine exceeds 15°, the rear of the upper structure will go under water, and water will be thrown up by the radiator fan. This may cause the fan to break. Be extremely careful when driving the machine out of water.

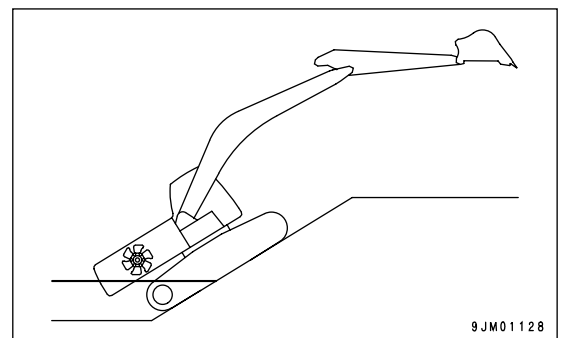

Do not drive the machine in water deeper than of the center of carrier roller(1).

Supply grease to the parts which have been under water for a long time until the used grease is projected out of the bearings (around the bucket pin, in particular).

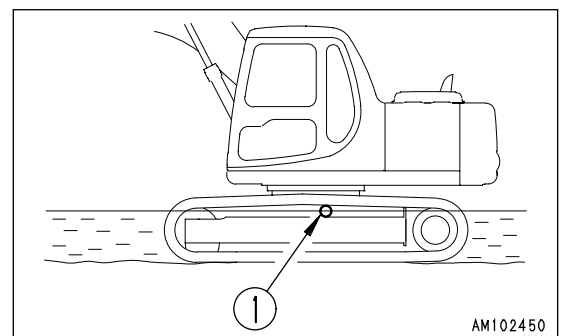

TRAVELING ON SLOPES

WARNING

When traveling, raise the bucket approx. 20 to 30cm (8 to 12 in) from the ground.

Do not travel downhill in reverse.

- When traveling over ridges or other obstacles, keep the work equipment close to the ground and travel slowly.
- Never turn on slopes or travel across slopes. Always go down to a flat place to perform these operations. It may be longer, but it will ensure safety.
- Always operate or travel in such a way that it is possible to stop safely at any time if the machine slips or becomes unstable.
- Turning or operating the work equipment when working on slopes may cause the machine to lose its balance and turn over, so avoid such operations. It is particularly dangerous to swing downhill when the bucket is loaded. If such operations have to be carried out, pile soil to make a platform on the slope so that the machine can be kept horizontal when operating.
- Do not travel up or down steep slopes. There is danger that the machine may turn over.
- When traveling uphill, if the shoes slip or it is impossible to travel uphill using only the force of the tracks, do not use the pulling force of the arm to help the machine travel uphill. There is danger that the machine may turn over.

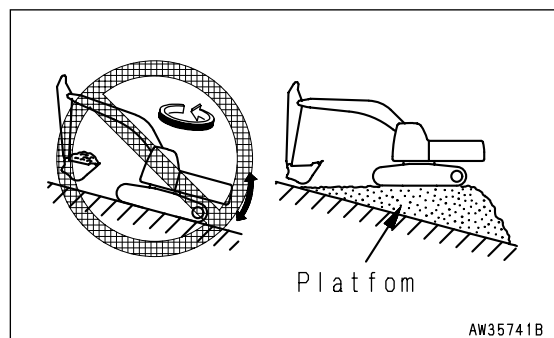
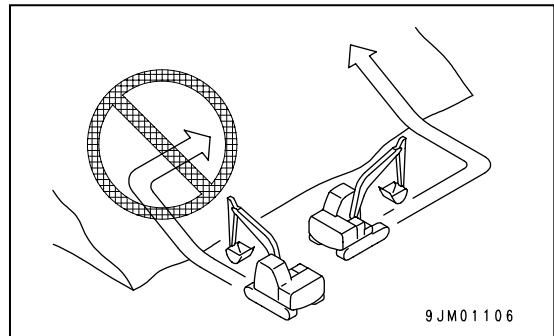

1. When traveling down steep hills, use the travel lever and fuel control lever to keep the travel speed low. When traveling down a steep hill of more than 15°, set the work equipment to the posture shown in the diagram on the right, and lower the engine speed.

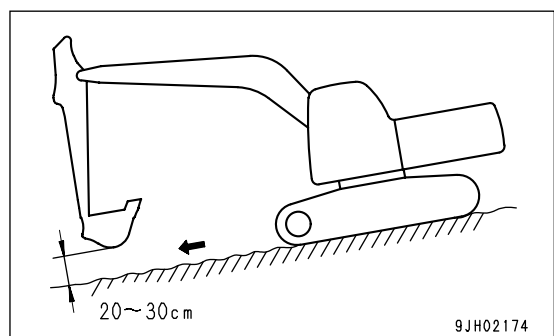

REMARK

Travel down fills with the sprocket side down.
If the machine travels down with the sprocket side up, the track tends to become loose, and that can cause skipping pitches.

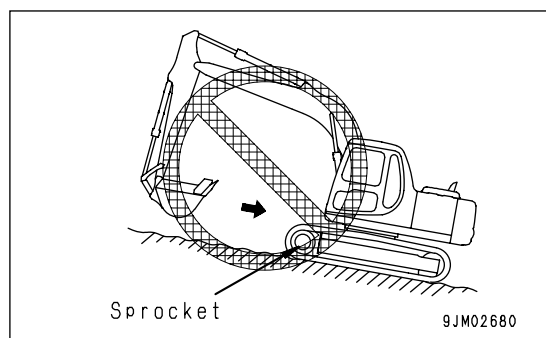

2. When traveling up a steep hill of more than 15°, set the work equipment to the posture shown in the diagram on the right.

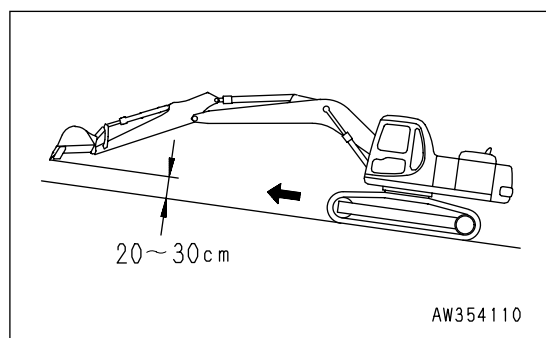
**TRAVELING DOWNHILL**

To brake the machine during downhill runs, put the travel lever in the neutral position. This will cause the brake to be automatically applied.

IF SHOES SLIP

When traveling uphill, if the shoes slip or it is impossible to travel uphill using the force of the track only, it is possible to use the pulling force of the arm to help the machine travel uphill.

ENGINE STOPPED ON SLOPE

If the engine stops when traveling uphill, move the all levers to the neutral position, then start the engine again.

PRECAUTIONS ON SLOPES

- If the engine stops when the machine is on a slope, never use the left work equipment control lever to carry out swing operations. The upper structure will swing under its own weight.
- Do not open or close the sliding door when traveling or operating on slopes. The operating force may change suddenly.
Always set the sliding door to the LOCK position.
- Be extremely careful when opening or closing the sliding door when the machine is stopped. The weight of the door may cause the door to open or close suddenly.

ESCAPE FROM MUD

Always operate carefully to avoid getting affixed in mud. If the machine does get affixed in mud, do as follows to get the machine out.

STUCK ONE SIDE OF TRACK

NOTICE

When using the boom or arm to raise the machine, always have the bottom of the bucket in contact with the ground. (Never push with the teeth). The angle between the boom and arm should be 90° to 110° . The same applies when using the inverting bucket.

When only one side is stuck in mud, use the bucket to raise the track, then lay boards or logs and drive the machine out. If necessary, put a board under the bucket also.

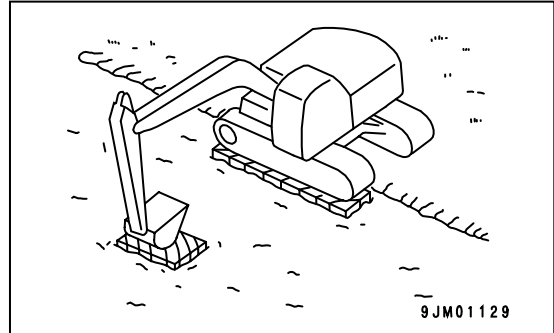

STUCK BOTH SIDES OF TRACKS

When the tracks on both sides are stuck in mud and the machine will not move, lay boards as explained above, and dig the bucket into the ground in front. Then pull in the arm as in normal digging operations and put the travel levers in the FORWARD position to pull the machine out.

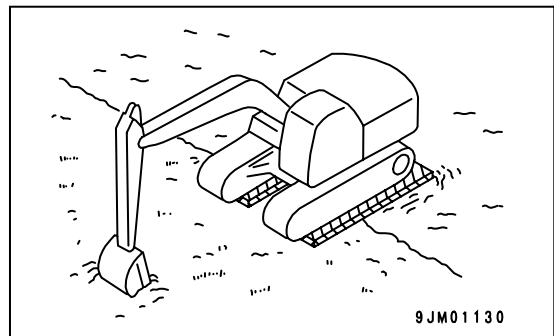

RECOMMENDED APPLICATIONS

In addition to the following, it is possible to further increase the range of applications by using various attachments.

BACKHOE WORK

A backhoe is suitable for excavating at a position lower than the machine.

When the condition of the machine is as shown in the diagram at right, each cylinder's maximum pushing excavation force is obtained when the bucket cylinder and link, arm cylinder and arm are at 90°.

When excavating, use this angle effectively to optimize your work efficiency.

The range for excavating with the arm is from a 45° angle away from the machine to a 30° angle toward the machine.

There may be some differences depending on the excavation depth, but try to stay within the above range rather than operating the cylinder is the end of its stroke.

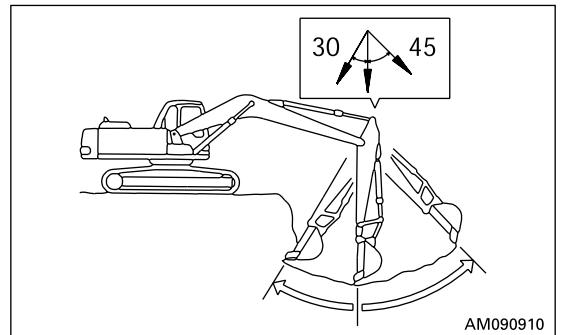
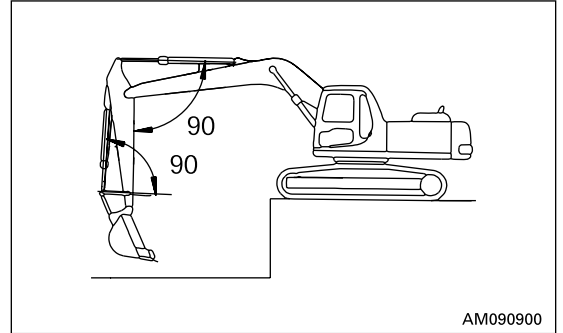

SHOVEL WORK

A shovel is suitable for excavating at a position higher than the machine. Shovel work is performed by attaching the bucket in the reverse direction.

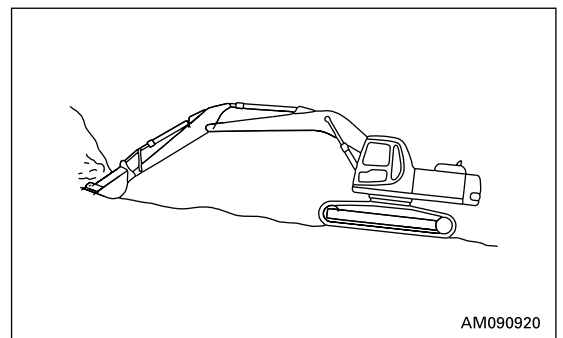

DITCHING WORK

Ditching work can be performed efficiently by attaching a bucket to match the width of the ditch and then setting the tracks parallel to the line of the ditch to be excavated.

To excavate a wide ditch, first dig out both sides and then finally remove the center portion.

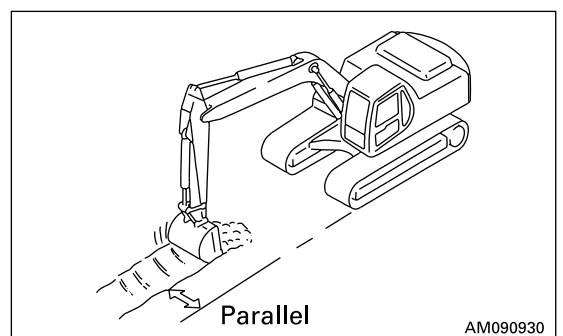

LOADING WORK

In places where the swing angle is small, work efficiency can be enhanced by locating the dump truck in a place easily visible to the operator.

Loading is easier and capacity greater if you begin from the front of the dump truck body than if loading is done from the side.

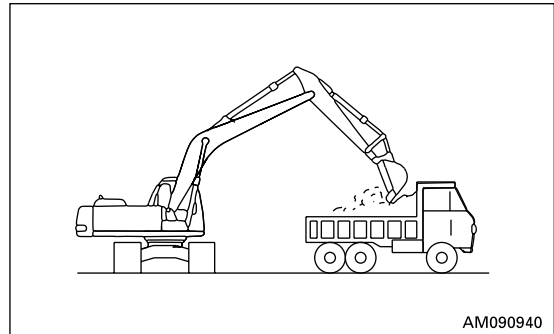

SMOOTHING WORK

When refilling after excavation and when smoothing the ground surface, use the blade.

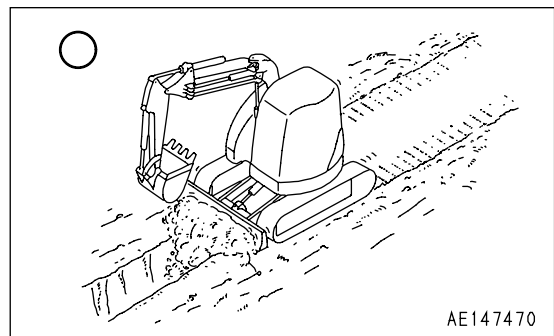

REPLACEMENT AND INVERSION OF BUCKET

⚠ WARNING

- When the pin is knocked in with a hammer, pieces of metal may fly into your eyes and cause serious injury.
When carrying out this operation, always wear goggles, hard hat, gloves, and other protective equipment.
- When the bucket is removed, place it in a stable condition.
- If the pins are hit with force, the pin may fly and injure people in the surrounding area, so check that the surrounding area is safe.
- When removing the pin, be extremely careful not to stand behind the bucket or to put your foot or any part of your body behind the bucket from the side.
- When removing or installing the pin, be extremely careful not to get your hands caught.
- Never put your fingers in the pin holes when aligning the holes.

Stop the machine on a firm, flat surface. When performing joint work, make clear signals to each other and work carefully for safety's sake.

REPLACEMENT

1. Place the bucket in contact with a flat surface.

REMARK

When removing the pins, place the bucket so that it is in light contact with the ground.

If the bucket is lowered strongly to the ground, the resistance will be increased and it will be difficult to remove the pins.

2. Remove the stopper bolts and nuts, then remove pins (A) and (B), and remove the bucket.

NOTICE

After removing the pins, make sure that they do not become contaminated with sand or mud and that the seals of bushing on both sides do not become damaged.

3. Align the arm with holes (1) and the link with holes (2), then coat with grease and install pins (A) and (B).

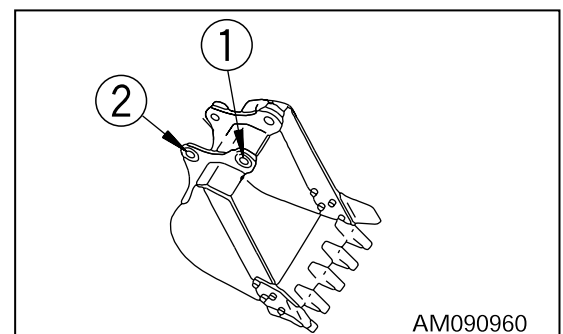
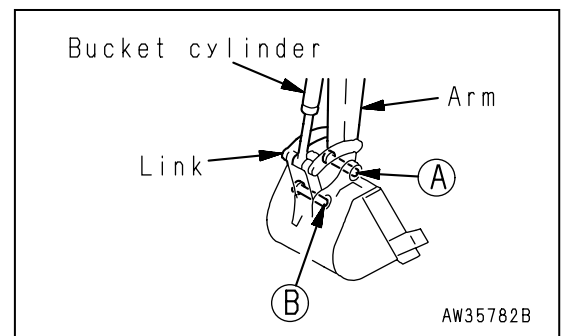

REMARK

When installing the bucket, the O-rings are easily damaged, so fit the O-rings on the boss of the arm end as shown in the diagram. When knocking in the pins, move the O-ring down to the regular groove.

4. Install the stopper bolts and nuts for each pin, then grease the pin.

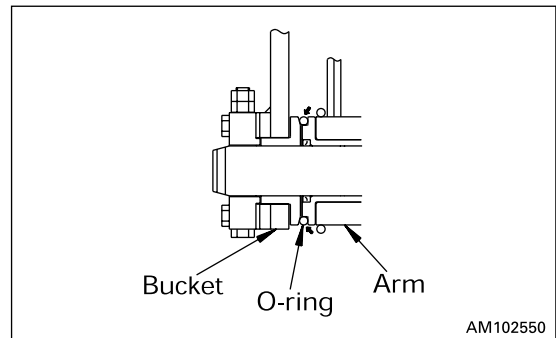

INVERSION

⚠ WARNING

When reversing the bucket, there is danger that the track of the bucket edge will extend outside the normal line. It may hit the cab and cause a serious accident. When the bucket is reversed, pay careful attention during operations to prevent the bucket from hitting the cab.

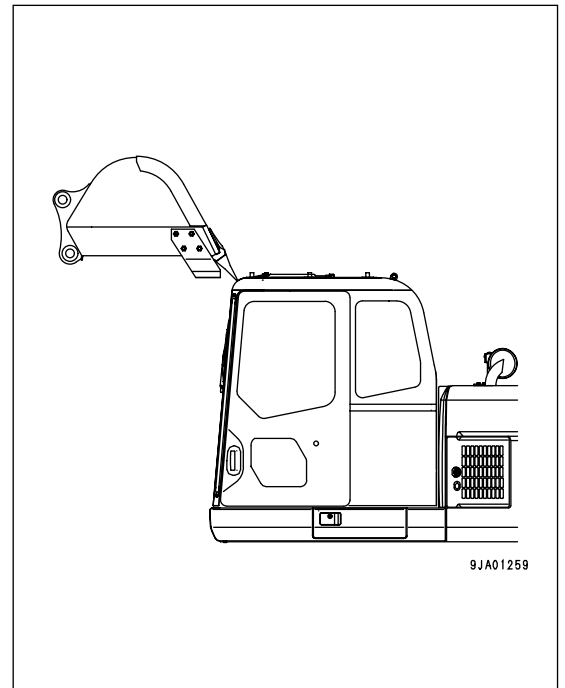

1. Place the bucket in contact with a flat surface.

REMARK

When removing the pins, place the bucket so that it is in light contact with the ground. If the bucket is lowered strongly to the ground, the resistance will be increased and it will be difficult to remove the pins.

2. Remove the stopper bolts and nuts, then remove pins (A) and (B), and remove the bucket.

NOTICE

After removing the pins, make sure that they do not become contaminated with sand or mud and that the seals of bushing on both sides do not become damaged.

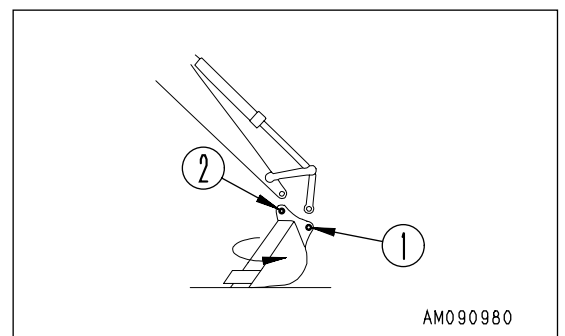
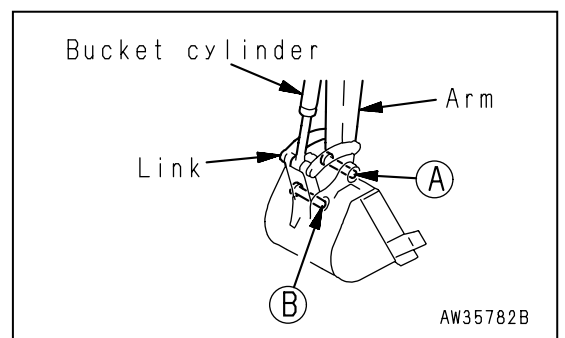

3. Install the bucket inversely.
After the bucket is inverted, correct the inclination and direction of the retaining pin holes (1) and (2) and stabilize the bucket securely.
4. Align the arm with holes (1) and the link with holes (2), then coat with grease and install pins (A) and (B).

REMARK

When installing the bucket, the O-rings are easily damaged, so fit the O-rings on the boss of the arm end as shown in the diagram. When knocking in the pins, move the O-ring down to the regular groove.

5. Install the stopper bolts and nuts for each pin, then grease the pin.

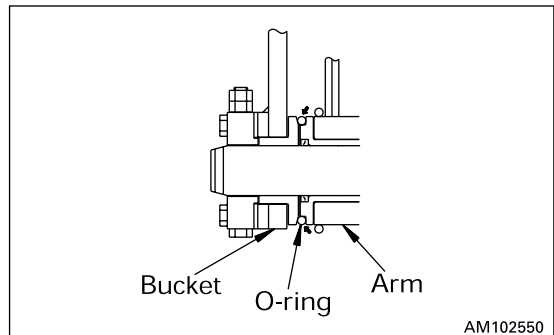
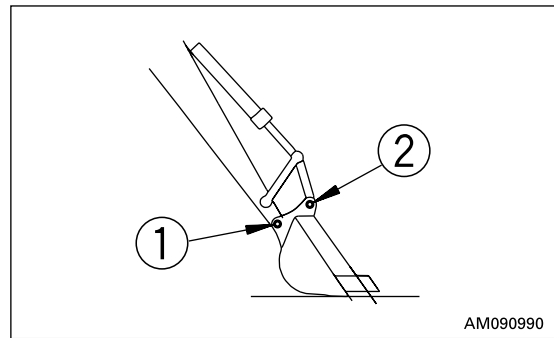

PARKING MACHINE

⚠ WARNING

- Avoid stopping suddenly. Give yourself ample room when stopping.
- When stopping the machine, select flat hard ground and avoid dangerous places. If it is unavoidably necessary to park the machine on a slope, insert blocks underneath the track shoes. As an additional safety measure, thrust the bucket into the ground.
- If the control lever is touched by accident, the work equipment or the machine may move suddenly, and this may lead to a serious accident. Before leaving the operator's compartment, always set the safety lock lever securely to LOCK position.

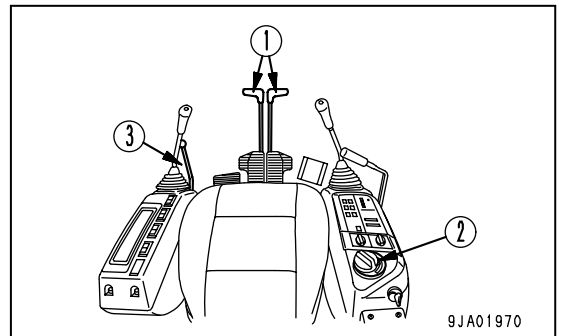
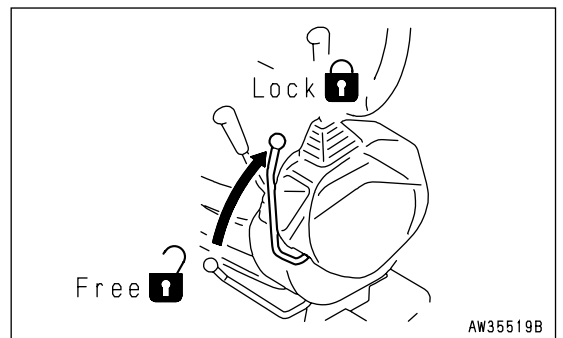
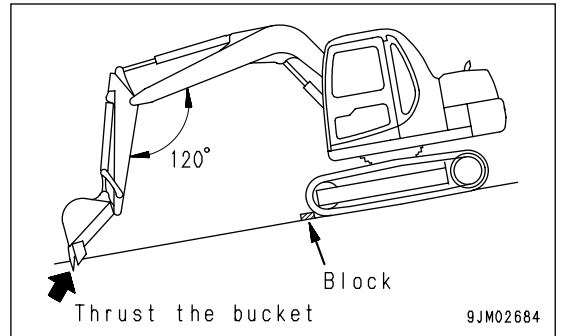

1. Put left and right travel levers (1) in the neutral position. The machine stops.

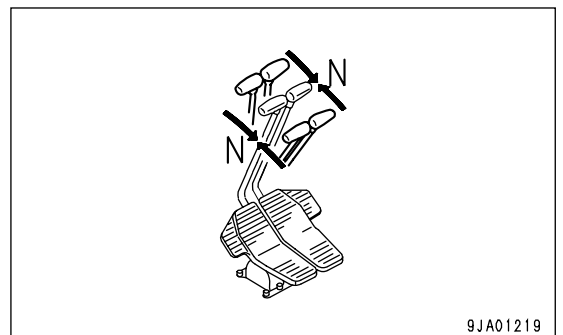

- 2. Lower the engine speed to low idling by fuel control dial (2) .

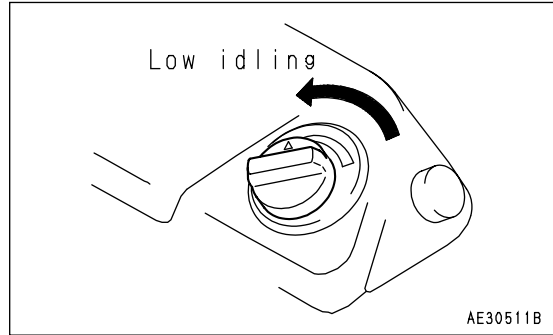

- 3. Lower the bucket horizontally until the bottom touches the ground.

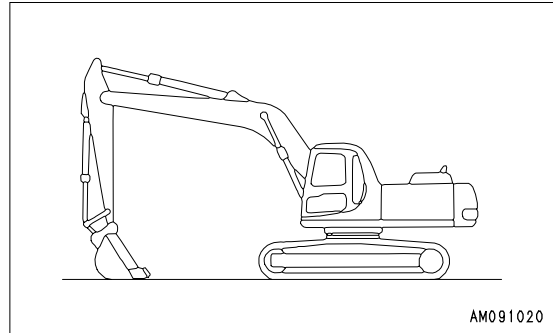

- 4. Set safety lock lever (3) in the LOCK position.

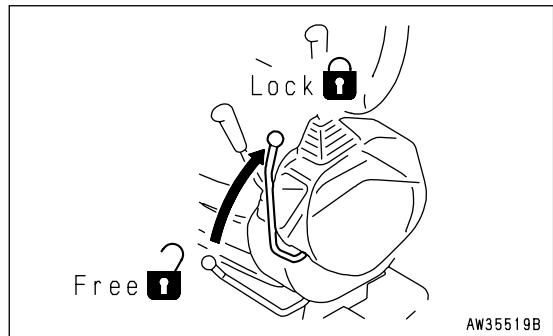

CHECK AFTER FINISHING WORK

Check the engine water temperature(1), engine oil pressure(2), and fuel level(3) on the machine monitor.

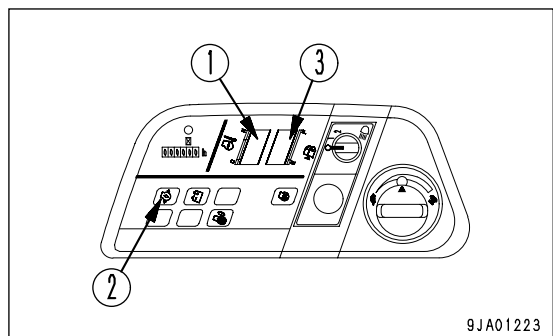

LOCKING

Always lock the following places.

- (1) Door of operator's cab
Always remember to close the window.
- (2) Fuel tank filler port
- (3) Engine hood
- (4) Cover at rear of cab
- (5) Battery room door
- (6) Pump room door
- (7) Door at front of tool box
- (8) Inspection window at front right of machine

REMARK

Use the starting switch key to open and close all these places.

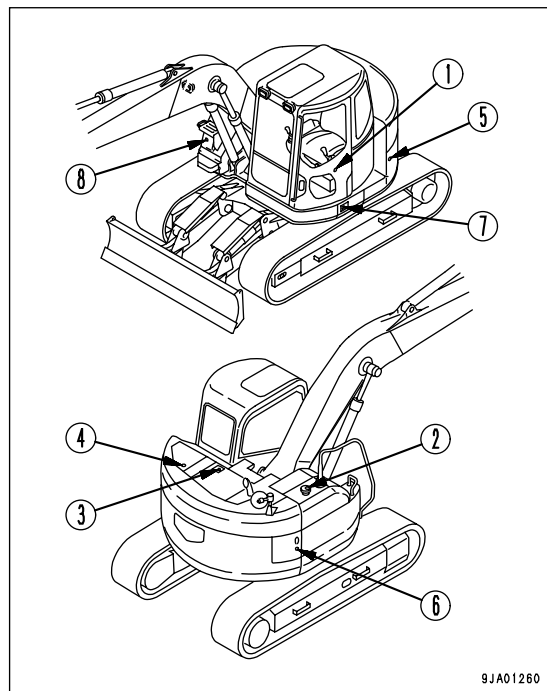

9JA01260

HANDLING ROAD LINER

(Machine equipped with road liner)

ROAD LINERS INFORMATION

Road liner have excellent properties that are not found in steel shoes. However, if they are used in the same way as steel shoes, full use cannot be made of their advantages.

Be sure to operate without straining the rubber shoes in a way that matches the condition of the jobsite and the nature of the work.

Comparison Among Rubber Shoes

	Road liner	Steel shoe
Little vibration	Excellent	Average
Smooth travel (No creaks)	Good	Good
Little noise	Excellent	Average
No damage to paved surface	Excellent	Average
Easy to handle	Average	Average
Easily damage	Good	Excellent
Strong drawber pull	Excellent	Excellent

Considering the properties of the material used, rubber shoes and road liners offer various advantages. However, their weak point is lack of strength. Therefore, it is important to understand the advantages of rubber shoes and road liners, and to follow the precautions regarding handling and prohibited work. This will extend the life of the rubbershoes and road liners and will enable the machine to display the advantages of rubber shoes and road liners to the maximum. Before using rubber shoes and road liner, always read "USING ROAD LINERS (PAGE 3-89)".

WARRANTY FOR ROAD LINERS

It is important to inspect and maintain the tracks at the correct tension. Furthermore, these shoes must not be used near objects where they are likely to suffer damage, such as the corners of steel plates, U-shaped ditch liners, blocks, on crushed rock or the sharp edges of rocks, iron beams, or scrap iron.

Any damage resulting from the customer's mistaken use of the machine shall not be included in the scope of the warranty.

USING ROAD LINERS

PROHIBITED WORKS

Do not carry out the following types of work.

- Carrying out operations and steering on crushed rock, extremely rough hard rock, steel beams, scrap iron, or near the edges of steel plates will cause damage to the rubber shoes and road liners.
- In places such as river beds where there are large numbers of large and small boulders, the stones may get caught and damage the rubber shoes and road liners or make the shoes come off. If dozing operations are carried out when the shoes are slipping, this will reduce the life of the rubber shoes and road liner.
- Be careful not to get oil, fuel, or chemical solvent on the rubber shoes and road liners. If such a substance should get on the shoes, remove it immediately. Furthermore, do not travel on road surfaces where oil has collected.
- When putting the machine into long-term storage (3 months or more), store the machine indoors where it is protected from direct sunlight or rain.
- Do not use the machine in high-temperature areas, such as areas where there is burning wood, steel plates that have been left under the hot sun, or places where asphalt has been laid.
- When the rubber parts of the road liner are so worn or broken that the head of the mounting bolts are scratched, replace the shoe immediately. If the bolt heads are broken, the bolt cannot be removed.
- When installing road liners, always install them to all links on both sides. If they are installed to only one part of the links, their durability will be greatly reduced.

LONG LIFE OPERATIONS

Be careful of the following points when carrying out work.

- Avoid carrying out counter-rotation turns on concrete surfaces.
- Avoid making sudden changes in direction. This may cause premature wear or damage to the rubber shoes and road liners.
- If the machine has been raised using the bucket, lower it slowly.
- Avoid doing work with materials that produce oil when crushed (soya beans, corn, or remains of vegetables squeezed for oil); or wash the machine after use.
- Avoid handling materials that will attack the adhesion of the steel core, such as salt, ammonium sulphate, potassium chloride, potassium sulphate, or calcium superphosphate; or wash the machine after use.
- The adhesion of the core will be attacked by salt, so avoid using the machine in coastal areas.
- When handling salt, sugar, wheat, or soya beans, if there is any deep cut in the rubber shoes and road liners, these substances may get into the lugs or cut portion of the rubber. Always repair the rubber before use.
- Do not carry out work that involves scraping against walls or concrete embankments.
- Rubber shoes and road liners slip extremely easily on snow or frozen roads. Be careful not to slip when traveling or working on slopes.
- The properties of rubber shoes and road liners change when working in extremely cold places, and this will reduce the life of the rubber shoes and road liners.
- Because of the properties of rubber, use the road liners within a range of -25°C to +65°C (-13°F to +149°F).
- When carrying out bucket operations, be careful not to damage the rubber shoes and road liners with the bucket.

TRANSPORTATION

When transporting the machine, observe all related laws and regulations, and be careful to assure safety.

TRANSPORTATION PROCEDURE

As a basic rule, transport the machine by trailer.

Select the trailer to match the weight and dimensions given in "SPECIFICATIONS (PAGE 5-2)".

Note that the value for the weight and transportation dimensions given in SPECIFICATIONS may differ according to the type of shoe or type of arm or other attachments.

LOADING AND UNLOADING WITH TRAILER

⚠ WARNING

- When loading or unloading on to a trailer, set to low speed, and do not operate the travel speed selector switch during the operation.
- Run the engine at low idling, set to low speed, and operate the machine slowly when loading or unloading.
- Select firm, level ground when loading or unloading the machine.
Maintain a safe distance from the edge of the road.
- Use ramps with ample width, length, thickness, and strength and install them at a maximum slope of 15°. When using piled soil, compact the piled soil fully and take action to prevent the slope face from collapsing.
- Remove all mud and dirt from the machine tracks before starting in order to prevent the machine from slipping on the ramps.
Be sure that the ramp surface is clean and free of water, snow, ice, grease, or oil.
- Never correct your steering on the ramps. There is danger that the machine may turn over.
If necessary, drive off the ramps, correct the direction, then enter the ramps again.
- Do not use use the work equipment for loading and unloading operations. It is dangerous.
- When on the ramps, do not operate any lever except the travel lever.
- The center of gravity of the machine will change suddenly at the joint between the ramps and the track or trailer, and there is danger of the machine losing its balance. Travel slowly over this point.
- When swinging the upper structure on the trailer, the trailer is unstable, so pull in the work equipment and swing slowly.
- If the sliding door of the cab is closed or open, always check that it is locked in position. The operating effort when opening or closing the door suddenly changes when the machine is on a ramp or platform, so never open or close the door in such conditions.

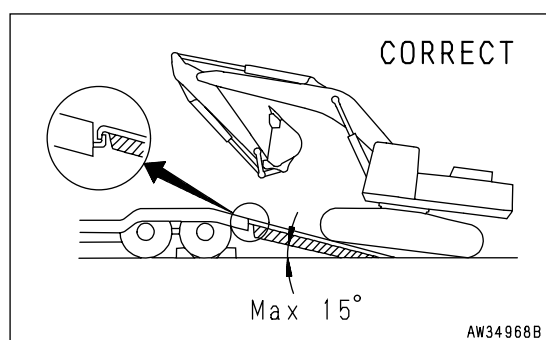
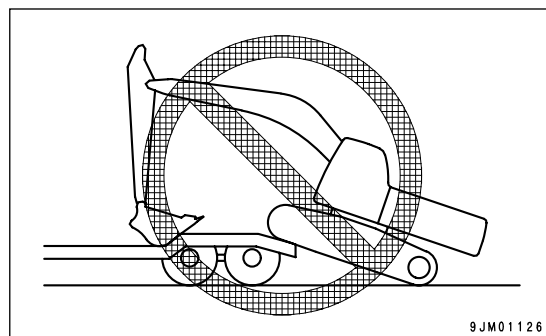

When loading or unloading, always use ramps or a platform and carry out the operation as follows.

LOADING

1. Perform loading and unloading on firm, level ground only. Maintain a safe distance from the edge of a road.
2. Properly apply the brakes on the trailer and put blocks under the tires to ensure that the trailer does not move. Then fix the ramps in line with the centers of the trailer and the machine.
Be sure that the two sides are at the same level as one another.
Make the slope of the ramps a maximum of 15°.
Set the distance between the ramps to match the center of the tracks.

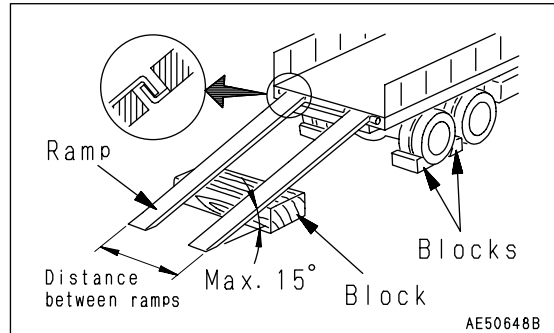

3. Set the travel speed selector switch to the LOW position.

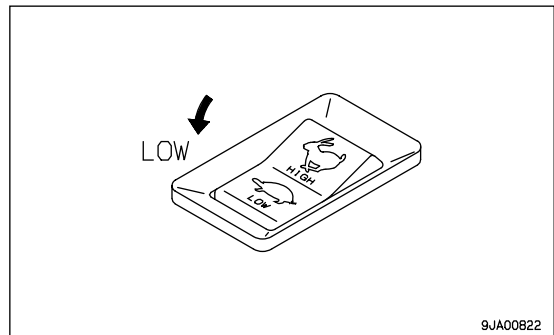

4. Lower the engine speed to low idling fuel control dial.

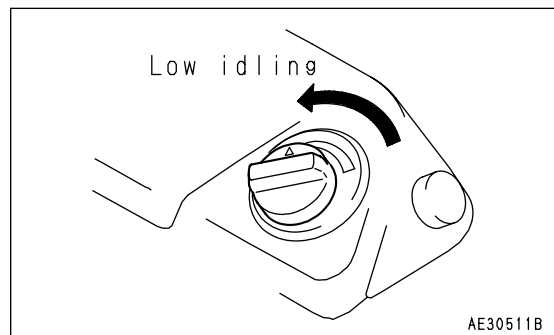

5. Do not operate the travel boost pedal. (Only machines with blade specification)

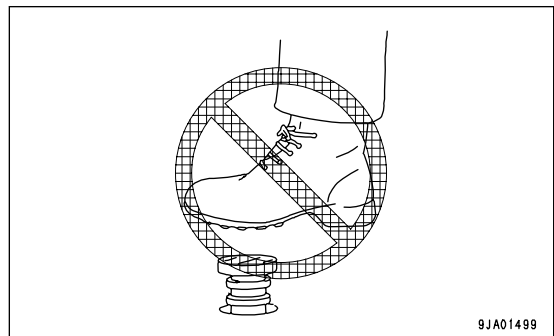

- Turn the swing lock switch OFF to release the swing lock.

NOTICE

Check that swing lock monitor goes out at the same time.

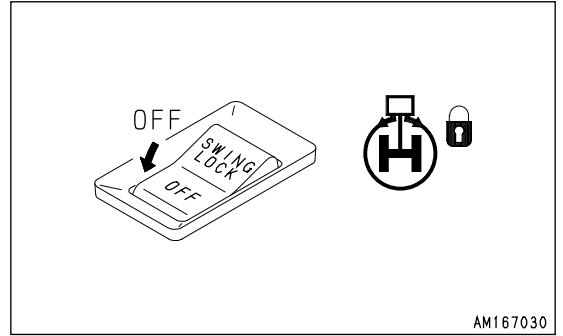

- If the machine is equipped with work equipment, set the work equipment at the front, and travel forward to load it; if it has no work equipment, travel in reverse to load it.

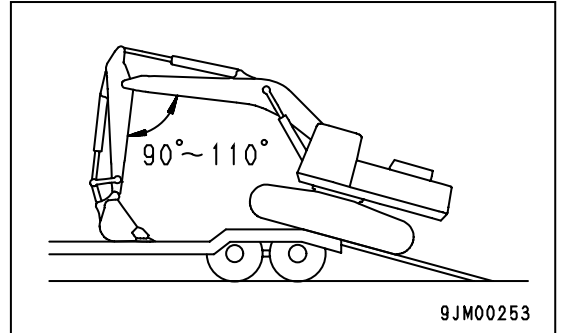

- Align the direction of travel with the ramps and travel slowly. Lower the work equipment as far as possible without causing interference. When on the ramps, operate only the travel lever. Do not operate any other lever or pedal.

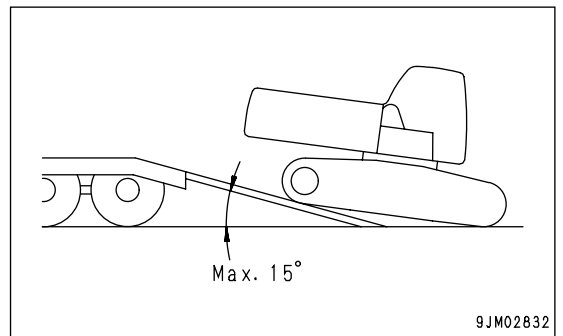

- When the machine travels over the rear wheels of the trailer, it will become unstable, so travel slowly and carefully. (Never change the direction of the machine under any circumstances.)
- When the machine passes the raised area above the rear wheels, it will tilt to the front, so be extremely careful not to let the work equipment hit the body of the trailer, then travel forward to the specified position.
- Turn the swing lock switch OFF to release the swing lock, then swing the upper structure slowly 180°.
- Stop the machine at the specified position on the trailer.

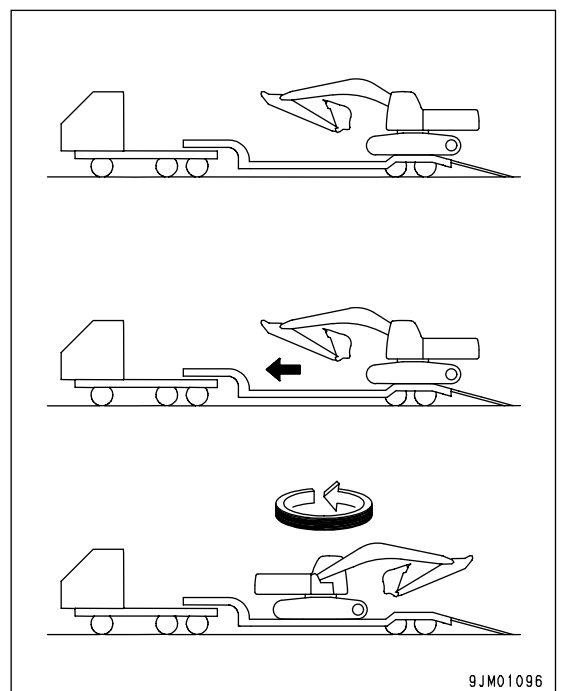

SECURING MACHINE

NOTICE

To prevent damage to the bucket cylinder during transportation, fit a wooden block at one end of the bucket cylinder to prevent it from touching the floor.

Load the machine on to a trailer as follows.

1. Lower the blade (only machines with blade specification).
2. Extend the bucket and arm cylinders fully, then lower the boom slowly.
3. Stop the engine, then remove the key from the starting switch.

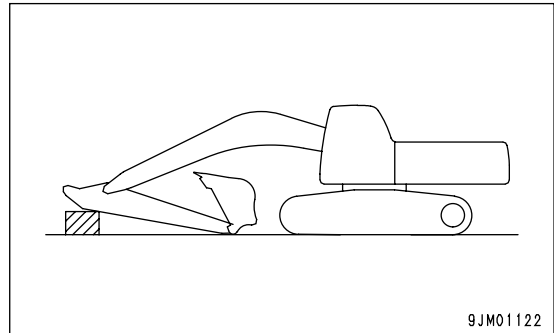

4. Lock the control levers securely with the safety lock lever.
5. Close all doors, windows, and covers.
Lock the cover caps and doors fitted with locks.

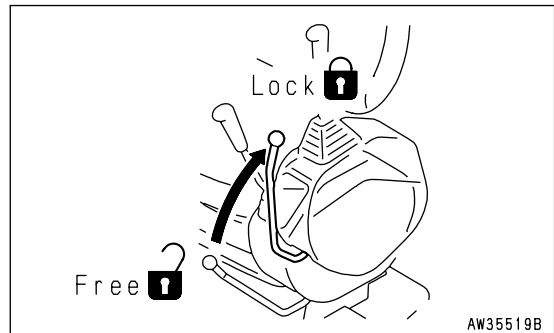

6. Put blocks under both ends of the tracks to prevent the machine from moving during transportation, and tie the machine down securely with chains or wire rope of suitable strength.
Be particularly careful to fix the machine in position securely so that it does not slip to the side.

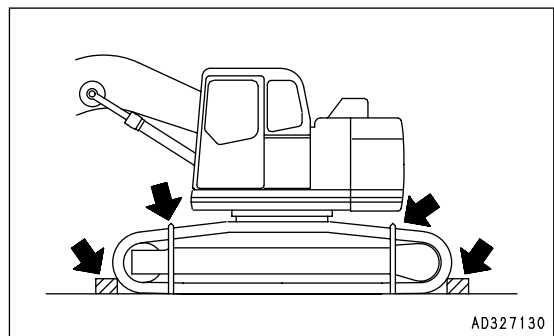

UNLOADING

1. Perform loading and unloading on firm, level ground only. Maintain a safe distance from the edge of a road.
2. Properly apply the brakes on the trailer and put blocks under the tires to ensure that the trailer does not move. Then fix the ramps in line with the centers of the trailer and the machine.
Be sure that the two sides are at the same level as one another.
Make the slope of the ramps a maximum of 15°.
Set the distance between the ramps to match the center of the tracks.

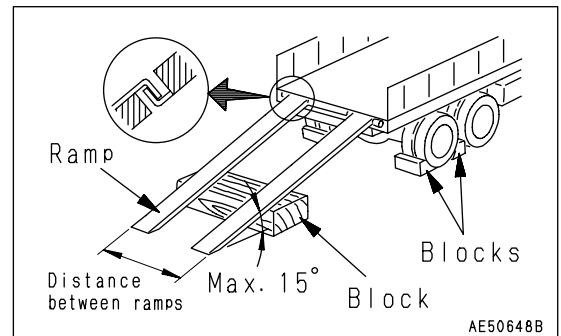

3. Remove the chains or wire rope holding the machine.
4. Start the engine.
Warm the engine up fully.
5. Set the safety lock lever to the FREE position.

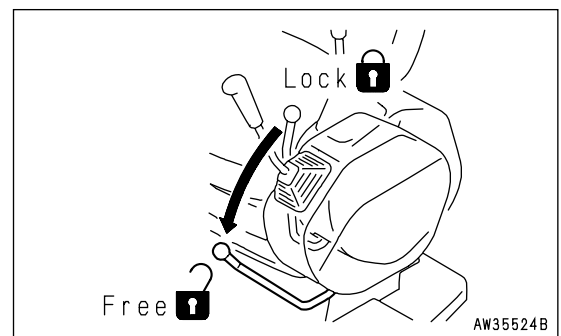

6. Set the travel speed selector switch to the LOW position.

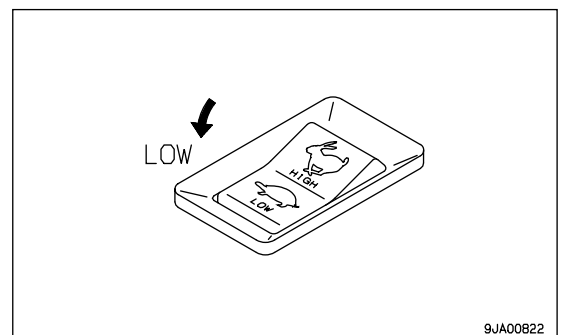

7. Set fuel control dial (1) at the LOW IDLING position.

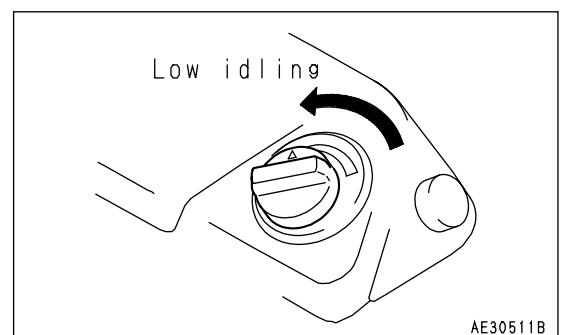

- 8. Do not operate the travel boost pedal.
(Only machines with blade specification)

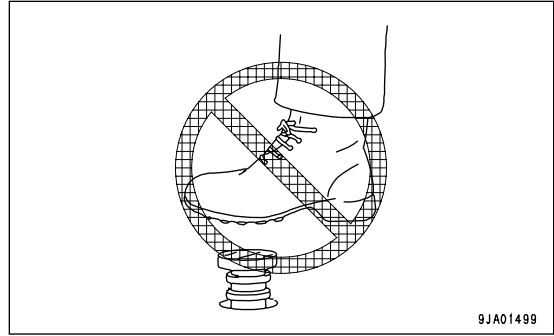

- 9. Turn the swing lock switch OFF to release the swing lock.

NOTICE

Check that swing lock monitor goes out at the same time.

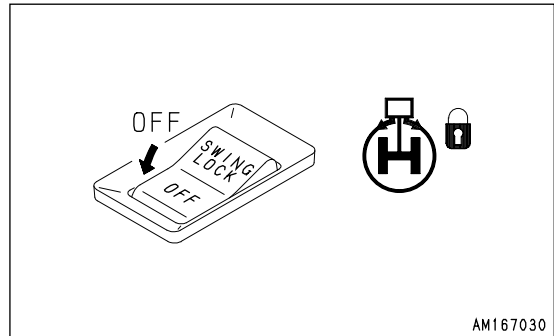

- 10. Raise the work equipment, pull in the arm under the boom, then move the machine slowly.
- 11. When the machine is horizontal on top of the rear wheels of the trailer, stop the machine.

NOTICE

- If the machine is unloaded with the arm pulled in, the work equipment will be damaged.
- When moving on to the ramps, to prevent damage to the hydraulic cylinders, do not let the bucket hit the ground.

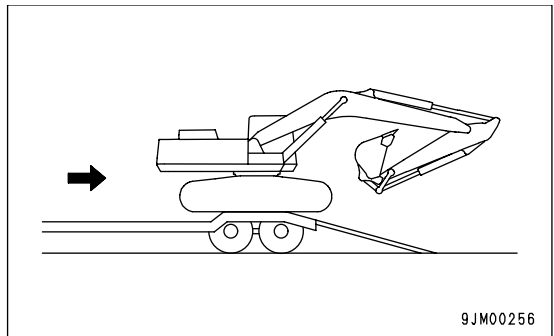

- 12. When moving from the rear of the trailer on to the ramps, set the angle of the arm and boom to 90 - 110°, lower the bucket to the ground, then move the machine slowly.

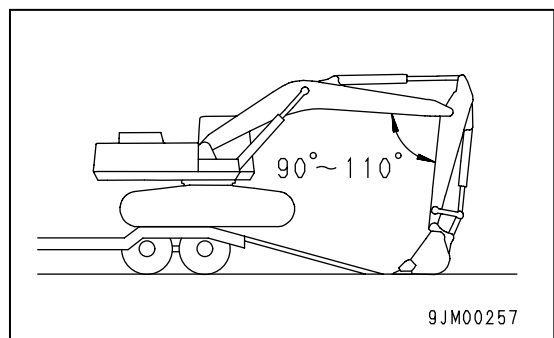

- 13. When moving down the ramps, operate the boom and arm slowly to lower the machine carefully until it is completely off the ramps.

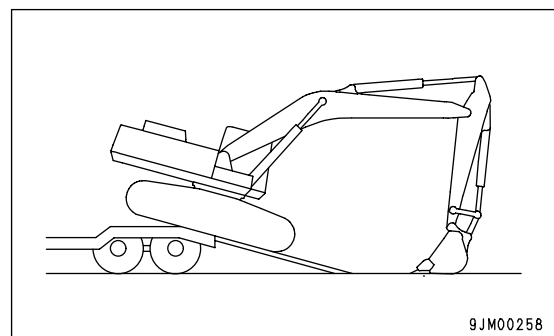

LIFTING MACHINE

WARNING

- Never raise the machine with any worker on it.
- Always make sure that the wire rope used for lifting the machine is of ample strength for the weight of the machine.
- Never try to lift the machine in any posture other than the posture given in the procedure below. There is a hazard that the machine may lose its balance.
- Never lift the machine with the upper structure swung to the side. Swing the work equipment so that it is at the sprocket end and set the undercarriage and upper structure parallel before lifting.
- When lifting, keep the machine horizontal.
- It is dangerous to go under the machine when it is raised. Never go under the machine in such cases.

STANDARD SPECIFICATION MACHINE

NOTICE

The lifting procedure applies to machines with standard specifications.

The method of lifting differs according to the attachments and options actually installed. In such cases, please contact your Komatsu distributor for information.

When lifting the machine, carry out the operation on flat ground as follows.

For details of the weight, see SPECIFICATIONS (PAGE 5-2).

When lifting the machine, carry out the operation on flat ground as follows.

1. Swing the upper structure so that the work equipment is at sprocket (1) end.

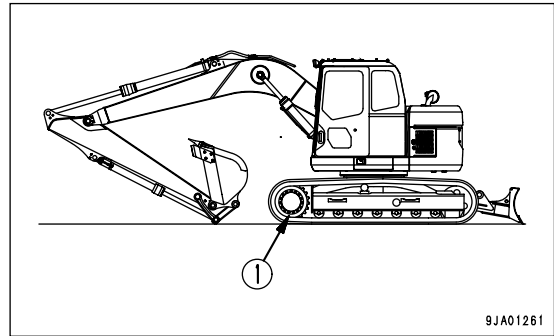

2. Extend the bucket cylinder and arm cylinder fully, then lower the work equipment to the ground as shown in the diagram on the right using the boom cylinder.
3. Stop the engine, check that there is nothing around the operator's compartment, then get off the machine. Close the cab door and front glass securely.
4. Pass wire ropes between the 1st and 2nd track rollers from the front and between the 1st and 2nd track rollers from the rear.
5. Set the lifting angle of the wire rope to 30° to 40°, then lift the machine slowly.
6. After the machine comes off the ground, check carefully that the machine is balanced, then lift slowly.

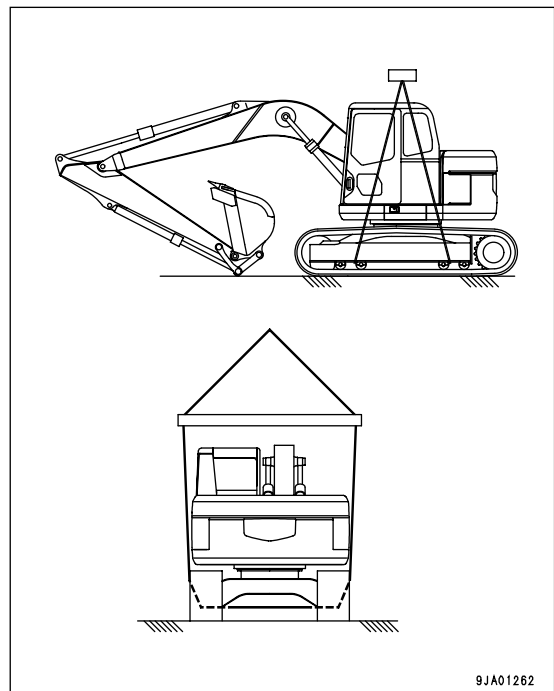

COLD WEATHER OPERATION

COLD WEATHER OPERATION INFORMATION

If the temperature becomes low, it becomes difficult to start the engine, and the coolant may freeze, so do as follows.

FUEL AND LUBRICANTS

Change to fuel and oil with low viscosity for all components. For details of the specified viscosity, see "USE OF FUEL, COOLANT AND LUBRICANTS ACCORDING TO AMBIENT TEMPERATURE (PAGE 4-10)".

COOLING SYSTEM COOLANT

WARNING

- Antifreeze is toxic. Be careful not to get it into your eyes or on your skin. If it should get into your eyes or on your skin, wash it off with large quantities of fresh water and see a doctor at once.
- Antifreeze is toxic. Be extremely careful when handling it. When replacing coolant containing antifreeze or when handling coolant when repairing the radiator, contact your Komatsu distributor or ask your local antifreeze dealer. Be careful not to let the water flow into drainage ditches or spray on to the ground surface.
- Antifreeze is flammable, so do not bring any flame close. Do not smoke when handling antifreeze.

NOTICE

- Never use methanol, ethanol or propanol based antifreeze.
- Absolutely avoid using any water leak preventing agent irrespective of weather it is used independently or mixed with an antifreeze.
- Do not mix one antifreeze with a different brand.

For details of the antifreeze mixture when changing the coolant, see "CLEAN INSIDE OF COOLING SYSTEM (PAGE 4-23)".

REMARK

Where no permanent antifreeze is available, an ethylene glycol antifreeze without corrosion inhibitor may be used only for the cold season. In this case, clean the cooling system twice a year (in spring and autumn). When refilling the cooling system, add antifreeze in autumn, but do not add any in spring.

For details of the antifreeze mixture when changing the coolant, see "CLEAN INSIDE OF COOLING SYSTEM (PAGE 4-23)".

BATTERY

WARNING

- The battery generates flammable gas, so do not bring fire or sparks near the battery.
- Battery electrolyte is dangerous. If it gets in your eyes or on your skin, wash it off with large amounts of water, and consult a doctor.
- Battery electrolyte dissolves paint. If it gets on to the bodywork, wash it off immediately with water.
- If the battery electrolyte is frozen, do not charge the battery or start the engine with a different power source. There is danger that the battery may explode.

When the ambient temperature drops, the capacity of the battery will also drop. If the battery charge ratio is low, the battery electrolyte may freeze. Maintain the battery charge as close as possible to 100%, and insulate it against cold temperature so that the machine can be started easily the next morning.

REMARK

Measure the specific gravity and calculate the rate of charge from the following conversion table.

Temp. of fluid Rate of charge	20°C	0°C	-10°C	-20°C
100	1.28	1.29	1.30	1.31
90	1.26	1.27	1.28	1.29
80	1.24	1.25	1.26	1.27
75	1.23	1.24	1.25	1.26

- As the battery capacity drops markedly in low temperatures, cover the battery or remove it from the machine, keep it in a warm place, and install it again the next morning.
- If the electrolyte level is low, add distilled water in the morning before beginning work. Do not add the water after the day's work so as to prevent fluid in the battery from freezing in the night.

AFTER DAILY WORK COMPLETION

WARNING

- Performing idle-running of the tracks is dangerous, so stay well away from the tracks.
- After completion of operations, fill the fuel tank to prevent the formation of water caused by condensation of moisture in the empty space in the tank when the temperature goes down.

To prevent mud, water, or the undercarriage from freezing and making it impossible for the machine to move on the following morning, always observe the following precautions.

- Mud and water on the machine body should be completely removed. This is to prevent damage to the seal caused by mud or dirt getting inside the seal with frozen drops of water.
- Park the machine on hard, dry ground.

If this is impossible, park the machine on wooden boards.

The boards help protect the tracks from being frozen in soil and the machine can start next morning.

- Open the drain valve and drain any water collected in the fuel system to prevent it from freezing.
 - After operation in water or mud, remove water from undercarriage as described below to extend undercarriage service life.
1. Swing 90° with engine at low idling and bring the work equipment to the side of the track.
 2. Jack up the machine until the track is raised slightly from the ground. Rotate the track under no load. Repeat this procedure on both the left and right sides.

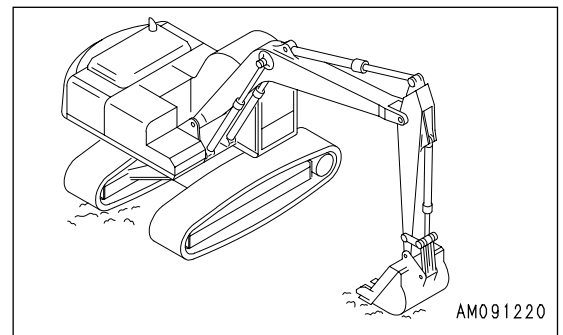

AFTER COLD WEATHER SEASON

When season changes and the weather becomes warmer, do as follows.

- Replace the fuel and oil for all parts with oil of the viscosity specified.

For details, see "USE OF FUEL, COOLANT AND LUBRICANTS ACCORDING TO AMBIENT TEMPERATURE (PAGE 4-10)".

- If for any reason permanent antifreeze cannot be used, and an ethyl glycol base antifreeze (winter, one season type) is used instead, or if no antifreeze is used, drain the cooling system completely, then clean out the inside of the cooling system thoroughly, and fill with fresh soft water.

LONG TERM STORAGE

BEFORE STORAGE

NOTICE

When storing the machine, set the machine in the posture shown in the diagram on the right to protect the cylinder rod.

(To prevent rusting of the cylinder rod)

When putting the machine in storage for a long time, do as follows.

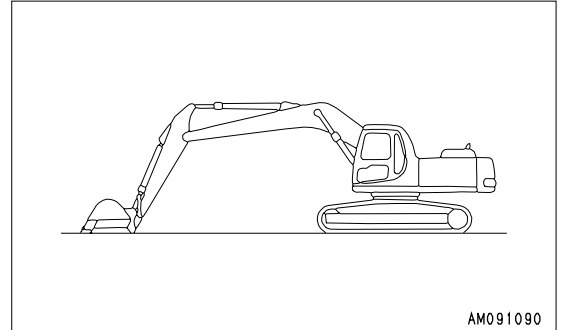

- Clean and wash all parts, then store the machine indoors. If the machine has to be stored outdoors, select level ground and cover the machine with a sheet.
- Completely fill the fuel tank, lubricate and change the oil before storage.
- Apply a thin coat of grease to the metal surface of the hydraulic piston rods.
- Disconnect the negative terminals of the battery and cover it or remove it from the machine and store it separately.
- If the ambient temperature is expected to drop below 0°C (32°F), always add antifreeze to the cooling water.
- Lock each control lever and pedal with the lock lever and pedal lock.
- Set the stop valve to the LOCK position on machines which can install attachments. Install a plug in the elbow.
- Set the selector valve on the machines which can install attachments to the "Crusher or general attachment" position.

DURING STORAGE

WARNING

If it is unavoidably necessary to carry out the rust-preventive operation while the machine is indoors, open the doors and windows to improve ventilation and prevent gas poisoning.

- During storage, always operate the machine once a month so that a new film of oil will be coated over movable parts and component surfaces. At the same time, also charge the battery.
- For machines equipped with an air conditioner, run the air conditioner.
- Rotate the tracks.

AFTER STORAGE

NOTICE

If the machine is to be used when the monthly rust prevention operation has not been carried out, please contact your Komatsu distributor.

When using the machine after long-term storage, do as follows before using it.

- Wipe off all the grease coating the hydraulic cylinder rods.
- Add oil and grease to all places.
- When the machine has been stored for a long time, the moisture in the atmosphere will get into the oil. Check the oil at all parts before and after starting the engine. If there is water in the oil, change all the oil.

TROUBLESHOOTING

AFTER RUNNING OUT OF FUEL

When starting after running out of fuel, fill with fuel and bleed the air from the fuel system before starting.

For details of bleeding the air, see "REPLACE FUEL FILTER CARTRIDGE (PAGE 4-54)".

PHENOMENA THAT ARE NOT FAILURES

Note that the following phenomena are not failures:

- When the arm is pulled in, the speed of movement will drop momentarily when the arm is more or less vertical.

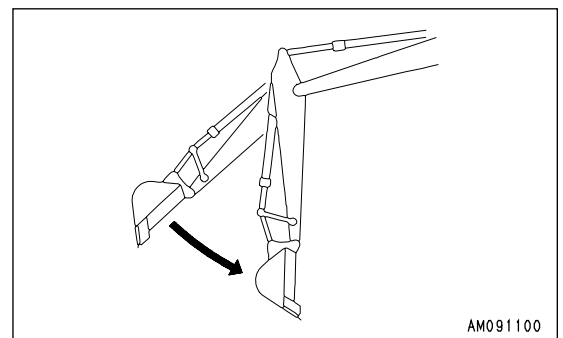

- The arm speed will drop momentarily when the bucket teeth are more or less horizontal.

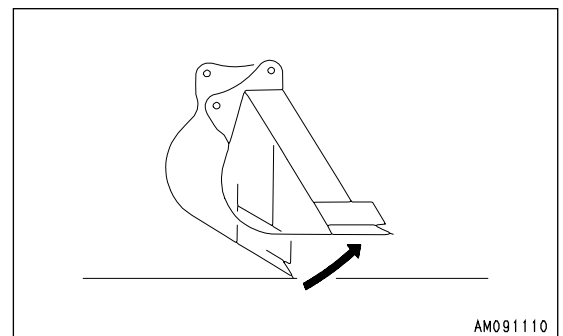

- When starting or stopping the swing, noise will be emitted from the brake valve.
- When going down a steep slope at low speed, a noise will be emitted from the travel motor.

TOWING THE MACHINE

⚠ WARNING

- When towing the machine, use a wire rope that has ample strength for the weight of the machine that is being towed.
- Do not apply a sudden load to the wire rope.

If the machine sinks in mud and cannot get out under its own power, or if the drawbar pull of the excavator is being used to tow a heavy object, use a wire rope as shown in the diagram on the right.

Place pieces of wood between wire ropes and body to prevent damage to ropes and body.

At this time, never use the hook for light-weight towing.

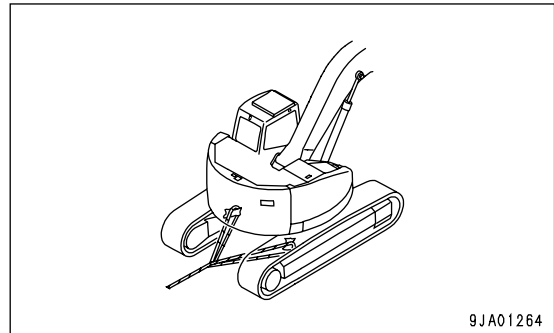

LIGHTWEIGHT TOWING HOOK

⚠ WARNING

- The shackle must always be used.
- Hold the rope level and direct it straight to the track frame.
- Move the machine slowly in the Lo mode.

The track frame has been equipped with a hook to pass the shackle for towing light objects.

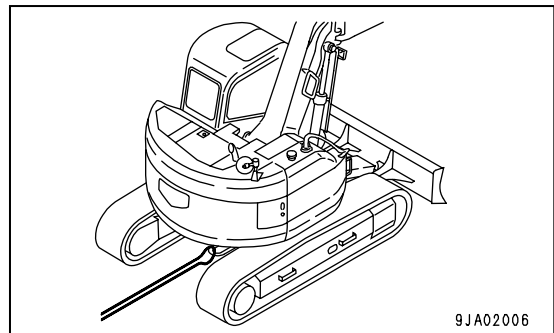

PRECAUTIONS ON PARTICULAR JOBSITES

- When carrying out digging operations in water, if the work equipment mounting pin goes into the water, carry out greasing every time the operation is carried out.
- For heavy-duty operations and deep digging, carry out greasing of the work equipment mounting pins every time before operation.

After greasing, operate the boom, arm, bucket, and blade several times, then grease again.

DISCHARGED BATTERY

⚠ WARNING

- It is dangerous to charge the battery while it is still mounted on the machine. Always remove the battery before charging it.
- When checking or handling the battery, stop the engine and turn the starting switch key to the OFF position.
- The battery generates hydrogen gas, so there is a hazard of explosion. Do not bring lighted cigarettes near the battery, or do anything that will cause sparks.
- Battery electrolyte is dilute sulphuric acid, and it will attack your clothes and skin. If it gets on your clothes or on your skin, wash it immediately off with large amounts of water. If it gets in your eyes, wash it out with fresh water, and consult a doctor.
- When handling batteries, always wear protective goggles and rubber gloves.
- When removing the battery, first disconnect the cable from the ground (normally the negative (-) terminal). When installing, install the positive (+) terminal first. If a tool touches the positive terminal and the chassis, there is danger that it will cause a spark, so be extremely careful.
- If the terminals are loose, there is danger that the defective contact may generate sparks that will cause an explosion.
- When installing the terminals, install them tightly. When removing or installing the terminals, check which is the positive (+) terminal and which is the negative (-) terminal.
- Green rust around the terminals is a cause of self-discharge of the battery. Polish the terminals with sandpaper. After removing the rust, coat the terminals thinly with grease before installing.

When removing, disconnect the cable from the ground terminal first.

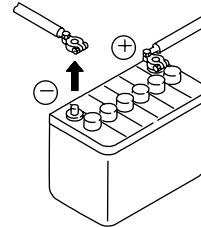

When installing, connect the cable to the positive (+) terminal first.

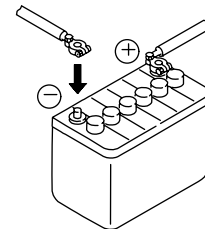

AW35946B

REMOVAL AND INSTALLATION OF BATTERY

Removal of battery

1. Open the battery room door, then remove rubber cover (1) installed to the top of the battery.
2. Remove cable (2) from the negative (-) terminal (ground).
3. Remove connection cable (4) and cable (3) from the positive (+) terminal.
4. Remove 4 mounting bolts (5), then remove mounting holder (6).
5. Remove the battery to the outside of the machine.

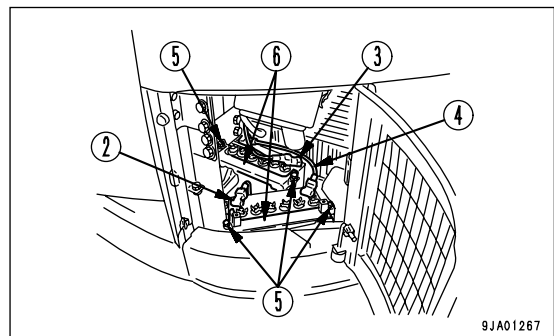
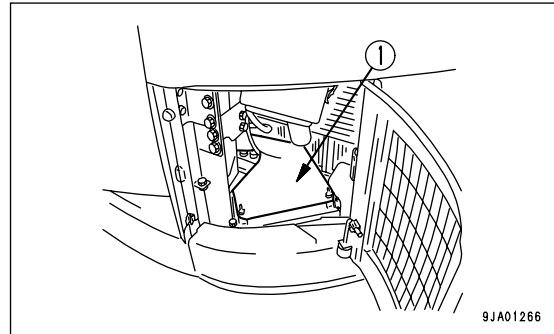

Installing battery

NOTICE

After fixing the battery in position, check that it does not move. If it moves, install it again.

1. Set the battery in the specified position.
2. Secure the battery in position with mounting holder (6) and mounting bolts (5).
Tightening torque for mounting bolts: 9.8 to 14.7 N•m (1 to 1.5 kgf•m, 7.2 to 10.8 lbf•ft)
3. Install cable (3) at the positive (+) terminal end.
4. Connect connection cable (4) from the positive (+) terminal end.
5. Connect cable (2) to the negative (-) terminal end (ground).
6. Install rubber cover (1).

BATTERY CHARGES

When charging the battery, there is danger that the battery may explode if it is handled wrongly, so follow the instructions in "OTHER TROUBLE (PAGE 3-112)" and the instruction manual supplied with the charger, and be sure to observe the following precautions.

- Set the voltage of the charger to match the voltage of the battery to be charged. If the voltage is not selected correctly, the charger may overheat and cause an explosion.
- Connect the positive (+) charger clip of the charger to the positive (+) terminal of the battery, then connect the negative (-) charger clip of the charger to the negative (-) terminal of the battery. Be sure to fix the clips securely.
- Set the charging current to 1/10 of the value of the rated battery capacity; when carrying out rapid charging, set it to less than the rated battery capacity.
If the charger current is too high, the electrolyte will leak or dry up, and this may cause the battery to catch fire and explode.
- If the battery electrolyte is frozen, do not charge the battery or start the engine with a different power source. There is a hazard that this will ignite the battery electrolyte and cause the battery to explode.
- Do not use or charge the battery if the battery electrolyte level is below the LOWER LEVEL line. This may cause an explosion. Always check the battery electrolyte level periodically and add distilled water to bring the electrolyte level to the UPPER LEVEL line.

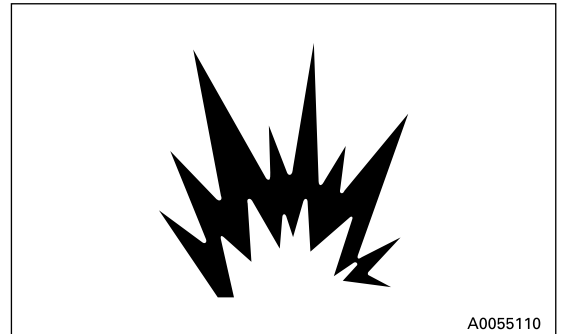

STARTING ENGINE WITH BOOSTER CABLES

When starting the engine with a booster cable, do as follows:

CONNECTING AND DISCONNECTING BOOSTER CABLES

⚠ WARNING

- When connecting the cables, never contact the positive (+) and negative (-) terminals.
- When starting the engine with a booster cable, always wear safety glasses.
- Be careful not to let the normal machine and problem machine contact each other. This prevents sparks from generating near the battery which could ignite the hydrogen gas given off by the battery. If hydrogen gas explodes, it could cause serious injury.
- Make sure that there is no mistake in the booster cable connections.
The final connection is to the revolving frame, but sparks will be generated when this is done, so connect to a place as far as possible from the battery. (However, avoid connecting the cable to the work equipment, as conduction is poor.)
- Use care when removing the cables from the machine that has been started. To avoid hydrogen explosion, do not allow the cable ends to contact each other or the machine.

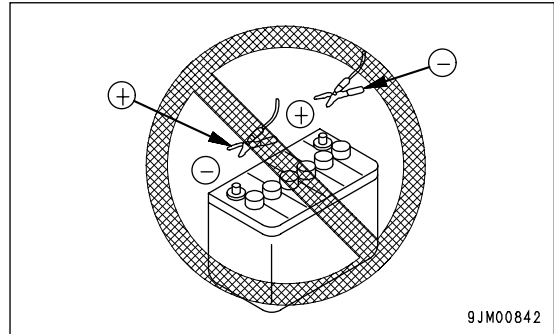

NOTICE

- The size of the booster cable and clip should be suitable for the battery size.
- The battery of the normal machine must be the same capacity as that of the engine to be started.
- Check the cables and clips for damage or corrosion.
- Make sure that the cables and clips are firmly connected.
- Check that the safety lock levers and parking brake levers of both machine are in the LOCK position.
- Check that each lever is in the NEUTRAL position.

BOOSTER CABLE CONNECTION

Keep the starting switch of the normal machine and problem machine are both at the OFF position.

Connect the booster cable as follows, in the order of the numbers marked in the diagram.

1. Make sure that the starting switches of the normal machine and problem machine are both at the OFF position.
2. Connect one clip of booster cable (A) to the positive (+) terminal of the problem machine.
3. Connect the other clip of booster cable (A) to the positive (+) terminal of the normal machine.
4. Connect one clip of booster cable (B) to the negative (-) terminal of the normal machine.
5. Connect the other clip of booster cable (B) to the engine block of the problem machine.

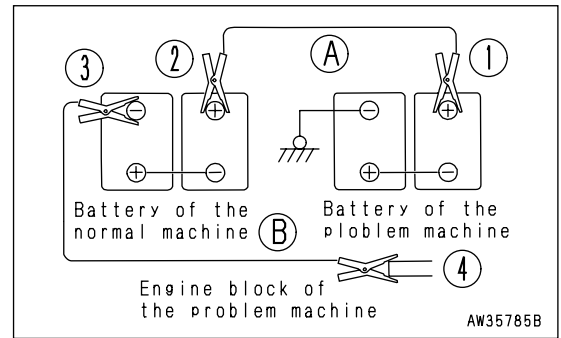

STARTING THE ENGINE

⚠ CAUTION

Always check that the safety lock lever is set to the LOCK position, regardless of whether the machine is working normally or has failed. Check also that all the control levers are at the HOLD or neutral position.

1. Make sure the clips are firmly connected to the battery terminals.
2. Start the engine of the normal machine and keep it to run at high idling speed.
3. Turn the starting switch of the problem machine to the START position and start the engine. If the engine doesn't start at first, try again after 2 minutes or so.

BOOSTER CABLE DISCONNECTION

After the engine has started, disconnect the booster cables in the reverse of the order in which they were connected.

1. Remove one clip of booster cable (B) from the engine block of the problem machine.
2. Remove the other clip of booster cable (B) from the negative (-) terminal of the normal machine.
3. Remove one clip of booster cable (A) from the positive (+) terminal of the normal machine.
4. Remove the other clip of booster cable (A) from the positive (+) terminal of the problem machine.

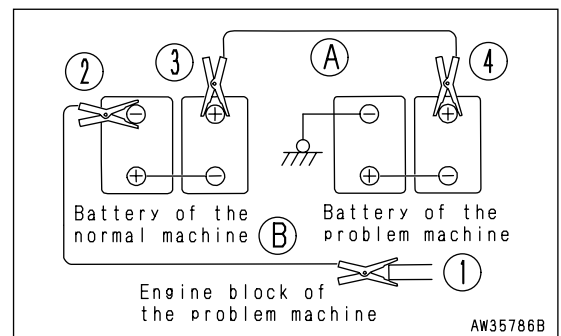

OTHER TROUBLE

ELECTRICAL SYSTEM

- (): Always contact your Komatsu distributor when dealing with these items.
- In cases of abnormalities or causes which are not listed below, please contact your Komatsu distributor for repairs.

Problem	Main causes	Remedy
Lamp does not glow brightly even when the engine runs at high speed	● Defective wiring	(● Check, repair loose terminals, disconnections)
Lamp flickers while engine is running	● Defective adjustment of fan belt tension	● Adjust fan belt tension For details, see EVERY 250 HOURS SERVICE
Charge level monitor does not go out even when engine is running	● Defective alternator ● Defective wiring	(● Replace) (● Check, repair)
Abnormal noise is generated from alternator	● Defective alternator	(● Replace)
Starting motor does not turn when starting switch is turned to ON	● Defective wiring ● Defective starting motor ● Insufficient battery charge	(● Check, repair) (● Replace) ● Charge
Pinion of starting motor keeps going and out	● Insufficient battery charge ● Defective safety relay	● Charge (● Replace)
Starting motor turns engine sluggishly	● Insufficient battery charge ● Defective starting motor	● Charge (● Replace)
Starting motor disengages before engine starts	● Defective wiring ● Insufficient battery charge	(● Check, repair) ● Charge
Pre-heating monitor does not light	● Defective wiring ● Defective heater relay ● Defective monitor	(● Check, repair) (● Replace) (● Replace)
Oil pressure monitor does not light up when engine is stopped (starting switch at ON position)	● Defective monitor ● Defective caution lamp switch	(● Replace) (● Replace)
Outside of electrical heater is not warm when touched by hand	● Defective wiring ● Disconnection in electric heater ● Defective operation of heater relay switch	(● Check, repair) (● Replace) (● Replace)

CHASSIS

- (): Always contact your Komatsu distributor when dealing with these items.
- In cases of abnormalities or causes which are not listed below, please contact your Komatsu distributor for repairs.

Problem	Main causes	Remedy
Speed of travel, swing, boom, arm, bucket is slow	<ul style="list-style-type: none"> ● Lack of hydraulic oil 	<ul style="list-style-type: none"> ● Add oil to specified level, see CHECK BEFORE STARTING
Pump generates abnormal noise	<ul style="list-style-type: none"> ● Clogged element in hydraulic tank strainer 	<ul style="list-style-type: none"> ● Clean, see EVERY 2000 HOURS SERVICE
Excessive rise in hydraulic oil temperature	<ul style="list-style-type: none"> ● Loose fan belt ● Dirty oil cooler ● Lack of hydraulic oil 	<ul style="list-style-type: none"> ● Adjust fan belt tension, EVERY 1000 HOURS SERVICE ● Clean, see EVERY 500 HOURS SERVICE ● Add oil to specified level, see CHECK BEFORE STARTING
Track comes off	<ul style="list-style-type: none"> ● Track too loose 	<ul style="list-style-type: none"> ● Adjust track tension, see WHEN REQUIRED
Abnormal wear of sprocket		
Bucket rises slowly, does not rise	<ul style="list-style-type: none"> ● Lack of hydraulic oil 	<ul style="list-style-type: none"> ● Add oil to specified level, CHECK BEFORE STARTING
Does not swing	<ul style="list-style-type: none"> ● Swing lock switch still applied 	<ul style="list-style-type: none"> ● Turn swing lock switch OFF

ENGINE

- (): Always contact your Komatsu distributor when dealing with these items.
- In cases of abnormalities or causes which are not listed below, please contact your Komatsu distributor for repairs.

Problem	Main causes	Remedy
Engine oil pressure monitor lights up	<ul style="list-style-type: none"> ● Engine oil pan oil level is low (sucking in air) ● Clogged oil filter cartridge ● Defective tightening of oil pipe, pipe joint, oil leakage from damaged point ● Defective engine oil pressure sensor ● Defective monitor 	<ul style="list-style-type: none"> ● Add oil to specified level, see CHECK BEFORE STARTING ● Replace cartridge, see EVERY 250 HOURS SERVICE (● Check, repair) (● Replace sensor) (● Replace)
Steam spurts out from top of radiator (pressure valve)	<ul style="list-style-type: none"> ● Cooling water level low, leakage of water ● Loose fan belt ● Dirt or scale accumulated in cooling system 	<ul style="list-style-type: none"> ● Check, add water, repair, see CHECK BEFORE STARTING ● Adjust fan belt tension. For details, see EVERY 250 HOURS SERVICE. ● Change coolant, flush inside of cooling system, see WHEN REQUIRED
Radiator water level monitor lights up	<ul style="list-style-type: none"> ● Clogged radiator fins or damaged fins ● Defective thermostat ● Loose radiator filler cap (high-altitude operations) ● Defective water level sensor ● Defective monitor 	<ul style="list-style-type: none"> ● Clean or repair, see EVERY 500 HOURS SERVICE (● Replace thermostat) ● Tighten cap or replace packing (● Replace sensor) (● Replace sensor)
Engine does not start when starting motor is turned	<ul style="list-style-type: none"> ● Lack of fuel ● Air in fuel system ● Defective fuel injection pump or defective nozzle ● Starting motor cranks engine sluggishly ● Preheating monitor does not light up ● Defective compression <ul style="list-style-type: none"> ○ Defective valve clearance 	<ul style="list-style-type: none"> ● Add fuel, see CHECK BEFORE STARTING ● Repair place where air is sucked in, see EVERY 500 HOURS SERVICE (● Replace pump or nozzle) ● See ELECTRICAL SYSTEM ● See ELECTRICAL SYSTEM (● Adjust valve clearance)
Exhaust gas is white or blue	<ul style="list-style-type: none"> ● Too much oil in oil pan ● Improper fuel 	<ul style="list-style-type: none"> ● Set oil to specified level, see CHECK BEFORE STARTING ● Change to specified fuel

Problem	Main causes	Remedy
Exhaust gas occasionally turns black	<ul style="list-style-type: none"> ● Clogged air cleaner element ● Defective nozzle ● Defective compression ● Defective turbocharger 	<ul style="list-style-type: none"> ● Clean or replace, see WHEN REQUIRED (● Replace nozzle) (● See defective compression above) ● Clean or replace turbocharger
Combustion noise occasionally make breathing sound	<ul style="list-style-type: none"> ● Defective nozzle 	<ul style="list-style-type: none"> (● Replace nozzle)
Abnormal noise generated (combustion or mechanical)	<ul style="list-style-type: none"> ● Low-grade fuel being used ● Overheating ● Damage inside muffler ● Excessive valve clearance 	<ul style="list-style-type: none"> ● Change to specified fuel ● Refer to "Radiator water level monitor lights up" as above ● Replace muffler (● Adjust clearance)

MAINTENANCE

 **WARNING**

Please read and make sure that you understand the safety volume before reading this section.

MAINTENANCE INFORMATION

Do not carry out any inspection and maintenance operation that is not found in this manual.

SERVICE METER READING

Check the service meter reading every day to see if the time has come for any necessary maintenance to be carried out.

KOMATSU GENUINE REPLACEMENT PARTS

Use Komatsu genuine parts specified in the Parts Book as replacement parts.

KOMATSU GENUINE LUBRICANTS

Use Komatsu genuine oils and grease. Choose oils and grease with proper viscosities specified for ambient temperature.

WINDSHIELD WASHER FLUID

Use automobile windshield washer fluid, and be sure not to let any dirt get into it.

FRESH AND CLEAN LUBRICANTS

Use clean oil and grease. Also, keep the containers of the oil and grease clean. Keep foreign materials away from oil and grease.

CHECK DRAINED OIL AND USED FILTER

After oil is changed or filters are replaced, check the old oil and filters for metal particles and foreign materials. If large quantities of metal particles or foreign materials are found, always report to the person in charge, and carry out suitable action.

FUEL STRAINER

If your machine is equipped with a fuel strainer, do not remove it while fueling.

WELDING INSTRUCTIONS

- Turn off the engine starting switch.
- Do not apply more than 200V continuously.
- Connect grounding cable within 1m (3.3 ft) from the area to be welded. If grounding cable is connected near instruments, connectors, etc., the instruments may have troubles.
- Avoid seals or bearings from being between the area to be welded and the position of grounding point.
- Do not use the area around the work equipment pins or the hydraulic cylinders as the grounding point.

DO NOT DROP THINGS INSIDE MACHINE

- When opening inspection windows or the oil filler port of the tank to carry out inspection, be careful not to drop nuts, bolts, or tools inside the machine.
If such things are dropped inside the machine, it will cause damage and malfunction of the machine, and will lead to failure. If you drop anything inside the machine, always remove it immediately.
- Do not put unnecessary things in your pockets. Carry only things which are necessary for inspection.

DUSTY JOBSITE

When working at dusty worksites, do as follows:

- Check the clogging of the air cleaner more frequently with the dust indicator. Clean the air cleaner element more frequently.
- Clean the radiator core frequently to avoid clogging.
- Clean and replace the fuel filter frequently.
- Clean electrical components, especially the starting motor and alternator, to avoid accumulation of dust.
- When inspecting or changing the oil, move the machine to a place that is free of dust to prevent dirt from getting into the oil.

AVOID MIXING LUBRICANTS

Never mix different kinds of oil. If a different type of oil has to be added, drain the old oil and replace all the oil with the new type of oil.

LOCKING THE INSPECTION COVERS

When carrying out maintenance with the inspection cover open, lock it in position securely with a lock bar. If inspection or maintenance is carried out with the inspection cover open and not locked in position, there is a hazard that it may be suddenly blown shut by the wind and cause injury to the worker.

HYDRAULIC SYSTEM - AIR BLEEDING

When hydraulic equipment has been repaired or replaced, or the hydraulic piping has been removed and installed again, the air must be bled from the circuit. For details, see "BLEEDING AIR FROM HYDRAULIC SYSTEM (PAGE 4-41)".

HYDRAULIC HOSE INSTALLATION

- When removing parts at locations where there are O-rings or gasket seals, clean the mounting surface, and replace with new parts.

When doing this, be careful not to forget to assemble the O-rings and gaskets.

- When installing the hoses, do not twist them or bend them into loops with a small radius.

This will cause damage to the hose and markedly reduce its service life.

CHECKS AFTER INSPECTION AND MAINTENANCE WORKS

If you forget to carry out the checks after inspection and maintenance, unexpected problems may occur, and this may lead to serious injury or property damage. Always do as follows.

- Checks after operation (with engine stopped)
 - Have any inspection and maintenance points been forgotten?
 - Have all inspection and maintenance items been carried out correctly?
 - Have any tools or parts been dropped inside the machine? It is particularly dangerous if parts are dropped inside machine and get caught in the lever linkage mechanism.
 - Is there any leakage of water or oil? Have all the bolts been tightened?
- Checks when operating engine
 - For details of the checks when operating the engine, see "TWO WORKERS FOR MAINTENANCE WHEN ENGINE IS RUNNING (PAGE 2-36)" and pay careful attention to safety.
 - Are the inspection and maintenance items working properly?
 - Is there any leakage of oil when the engine speed is raised and load is applied to the oil pressure?

SELECTING FUEL AND LUBRICANTS TO MATCH AMBIENT TEMPERATURE

It is necessary to use fuel and lubricants that match the ambient temperature.

For details, see "USE OF FUEL, COOLANT AND LUBRICANTS ACCORDING TO AMBIENT TEMPERATURE (PAGE 4-10)".

LUBRICANTS, COOLANT AND FILTERS

OUTLINE OF OIL, FUEL, COOLANT

OIL

- Oil is used in the engine and work equipment under extremely severe conditions (high temperature, high pressure), and is deteriorates with use.

Always use oil that matches the grade and temperature for use given in the Operation and Maintenance Manual.

Even if the oil is not dirty, always change the oil after the specified interval.

- Oil corresponds to blood in the human body, so always be careful when handling it to prevent any impurities (water, metal particles, dirt, etc.) from getting in.

The majority of problems with machine are caused by the entry of such impurities.

Take particular care not to let any impurities get in when storing or adding oil.

- Never mix oils of different grades or brands.
- Always add the specified amount of oil.
Having too much oil or too little oil are both causes of problems.
- If the oil in the work equipment is not clear, there is probably water or air getting into the circuit. In such cases, please contact your Komatsu distributor.
- When changing the oil, always replace the related filters at the same time.
- We recommend you to have an analysis made of the oil periodically to check the condition of the machine. For those who wish to use this service, please contact your Komatsu distributor.

FUEL

- The fuel pump is a precision instrument, and if fuel containing water or dirt is used, it cannot work properly.
- Be extremely careful not to let impurities get in when storing or adding fuel.
- Always use the fuel specified in the Operation and Maintenance Manual.

Fuel may congeal depending on the temperature when it is used (particularly in low temperature below -15°C (5°F)), so it is necessary to change to a fuel that matches the temperature.

- To prevent the moisture in the air from condensing and forming water inside the fuel tank, always fill the fuel tank after completing the day's work.
- Before starting the engine, or when 10 minutes have passed after adding fuel, drain the sediment and water from the fuel tank.
- If the engine runs out of fuel, or if the filters have been replaced, it is necessary to bleed the air from the circuit.

COOLING SYSTEM COOLANT

- River water contains large amounts of calcium and other impurities, so if it is used, scale will stick to the engine and radiator, and this will cause defective heat exchange and overheating.

Do not use water that is not suitable for drinking.

- When using anti-freeze, always observe the precautions given in the Operation and Maintenance Manual.
- Komatsu machines are supplied with Komatsu specified anti-freeze in the coolant.

This anti-freeze is effective in preventing corrosion of the cooling system.

The anti-freeze can be used continuously for 2 years or 4000 hours. Therefore, it can be used as it is even in hot areas.

- Anti-freeze is flammable, so be extremely careful not to expose it to flame or fire.
- The ratio for the mixture of water and anti-freeze differs according to the ambient temperature.

For details of the ratio, see "CLEAN INSIDE OF COOLING SYSTEM (PAGE 4-23)".

- If the engine overheats, wait for the engine to cool before adding coolant.
- In addition to causing overheating, lack of cooling water also causes corrosion of the cooling circuit due to entry of air.

GREASE

- Grease is used to prevent twisting and noise at the joints.
- The nipples not included in the MAINTENANCE section are nipples used when overhauling, so they do not need grease.

If any part becomes stiff or generates noise after being used for a long time, grease it.

- Always wipe off all of the old grease that is pushed out when greasing.

Be particularly careful to wipe off the old grease in places where sand or dirt sticking in the grease would cause wear of the rotating parts.

OIL AND FUEL STORAGE

- Keep indoors to prevent any water, dirt, or other impurities from getting in.
- When keeping drum cans for a long period, put the drum on its side so that the filler port of the drum can is at the side. (To prevent moisture from being sucked in)
If drum cans have to be stored outside, cover them with a waterproof sheet or take other measures to protect them.
- To prevent any change in quality during long-term storage, be sure to use in the order of first in - first out (use the oldest oil or fuel first).

FILTERS

- Filters are extremely important safety parts. They prevent impurities in the fuel and air circuits from entering important equipment and causing problems.

Replace all filters periodically. For details, see the Operation and Maintenance Manual.

However, when working in severe conditions, replace the filters at shorter intervals according to the oil and fuel (sulfur content) being used.

- Never try to clean the filters (cartridge type) and use them again. Always replace with new filters.
- When replacing oil filters, check if any metal particles are affixed to the old filter. If any metal particles are found, please contact your Komatsu distributor.
- Do not open packs of spare filters until just before they are to be used.
- Always use Komatsu genuine filters.

ELECTRIC SYSTEM MAINTENANCE

- It is extremely dangerous if the electrical equipment becomes wet or the covering of the wiring is damaged. This will cause electrical leakage and may lead to malfunction of the machine. Do not wash the inside of the operator's cab with water. When washing the machine, be careful not to let water get into the electrical components.
- Service relating to the electric system is check of fan belt tension, check of damage or wear in the fan belt and check of battery fluid level.
- Never install any electric components other than there specified by Komatsu.
- External electrical interference may cause malfunction of the control system controller, so before installing a radio receiver or other wireless equipment, please contact your Komatsu distributor.
- When working at the seashore, carefully clean the electric system to prevent corrosion.
- When installing an operator's cab cooler or any other electrical equipment, connect it to an independent power source connector. The optional power source must never be connected to the fuse, starting switch, or battery relay.

HANDLING HYDRAULIC SYSTEM

- During and after operations, the hydraulic system is at high temperature. During operations, it is also under high pressure, so always pay careful attention to the following when carrying out inspection and maintenance of the hydraulic system.
- Stop the machine on level ground, lower the bucket to the ground, and set so that there is no pressure on the cylinder circuit.
- Always stop the engine.
- Immediately after operations, the hydraulic oil and lubricating oil are under pressure and at high temperature, so always wait for the temperature to go down before starting maintenance.
- Even when the temperature goes down, there may still internal pressure, so when loosening plugs, screws, or hose connections, do not stand directly in front, and loosen gradually to release the internal pressure before removing.

- When carrying out inspection or maintenance of the hydraulic circuits, always bleed the air to release the internal pressure.
- Inspection or maintenance consists of checking the hydraulic oil level, replacing the filters, and changing the hydraulic oil.
- When removing high-pressure hoses, check that the O-ring is not damaged. If it is damaged, replace it.

WEAR PARTS LIST

Wear parts such as the filter element, bucket tooth, etc. are to be replaced at the time of periodic maintenance or before their abrasion limits.

The wear parts should be changed correctly in order to use the machine economically.

For part change, Komatsu genuine parts of excellent quality should be used.

When ordering parts, please check the part number in the parts book.

The parts in parentheses are to be replaced at the same time.

Item	Part No.	Part Name	Q'ty	Replacement frequency
Engine oil filter	6735-51-5140	Cartridge	1	Every 250 hours service
Fuel filter	6732-71-6110	Cartridge	1	Every 500 hours service
Hydraulic oil filter	07063-51100 (07000-15155)	Element (O-ring)	1 (1)	Every 500 hours service
Air cleaner	600-185-2100	Element assembly	1	-
Additional filter for breaker (if equipped)	203-973-5820	Element (O-ring)	1	-
Electric heater	6732-11-4811	Gasket	2	-
Bucket	205-70-74272 (205-70-74281) (205-70-74291)	Vertical pin type Tooth (Pin) (Lock)	4 (4) (4)	-
	205-70-19570 (09244-02496)	Horizontal pin type Tooth (Pin)	4 (4)	
	202-70-63161 202-70-63171 (208-32-11231) (01803-02228)	Cutter (left) Cutter (right) (Bolt) (Nut)	1 1 (8) (8)	

USE OF FUEL, COOLANT AND LUBRICANTS ACCORDING TO AMBIENT TEMPERATURE

PROPER SELECTION OF FUEL, COOLANT AND LUBRICANTS

RESERVOIR	KIND OF FLUID	AMBIENT TEMPERATURE										CAPACITY	
		-22	-4	14	32	50	68	86	104	122°F	Specified	Refill	
		-30	-20	-10	0	10	20	30	40	50°C			
Engine oil pan	Engine oil	SAE30CD					17.5 liters 4.62 US gal	17 liters 4.49 US gal					
		SAE 10W											
		SAE 10W-30											
		SAE 15W-40											
Swing machinery case												2.5 liters 0.66 US gal	2.5 liters 0.66 US gal
Final drive case (each)		SAE 30					2.5 liters 0.66 US gal	2.5 liters 0.66 US gal					
PTO gear case												0.75 liters 0.20 US gal	0.75 liters 0.20 US gal
Hydraulic system		SAE 10W					120 liters 31.68 US gal	69 liters 18.22 US gal					
		SAE 10W-30											
		SAE 15W-40											
Fuel tank	Diesel fuel	ASTM D975 No.2							195 liters 51.48 US gal	-			
		*											
Grease fitting	Grease	NLGI No. 2										-	-
Cooling system	Water	Add antifreeze										18.2 liters 4.80 US gal	-

*ASTM D975 No. 1

REMARK

- When fuel sulphur content is less than 0.5%, change oil in the oil pan every periodic maintenance hours described in this manual.
Change oil according to the following table if fuel sulphur content is above 0.5%.

Fuel sulphur content	Change interval of oil in engine oil pan
0.5 to 1.0%	1/2 of regular interval
Above 1.0%	1/4 of regular interval

- When starting the engine in an atmospheric temperature of lower than 0°C, be sure to use engine oil of SAE10W, SAE10W-30 and SAE15W-40, even though an atmospheric temperature goes up to 10°C more or less in the day time.
- Use API classification CD as engine oil and if API classification CC, reduce the engine oil change interval to half.
- There is no problem if single grade oil is mixed with multigrade oil (SAE10W-30, 15W-40), but be sure to add single grade oil that matches the temperature in the table.
- We recommend Komatsu genuine oil which has been specifically formulated and approved for use in engine and hydraulic work equipment applications.

Specified capacity: Total amount of oil including oil for components and oil in piping.

Refill capacity: Amount of oil needed to refill system during normal inspection and maintenance.

ASTM: American Society of Testing and Material

SAE: Society of Automotive Engineers

API: American Petroleum Institute

No.	Supplier	Engine Oil [CD or CE] SAE10W, 30, 40 10W30, 15W40 (The 15W40 oil marked * is CE.)	Gear Oil [GL-4 or GL-5] SAE80, 90, 140	Grease [Lithium-Base] NLGI No.2	Anti-freeze Coolant [Ethylene Glycol Base] Permanent Type
1	KOMATSU	EO10-CD EO30-CD EO10-30CD EO15-40CD	GO90 GO140	G2-LI G2-LI-S	AF-ACL AF-PTL AF-PT(Winter, one season type)
2	AGIP	Diesel sigma S super dieselmulti- grade *Sigma turbo	Rotra MP	GR MU/EP	-
3	AMOCO	*Amoco 300	Multi-purpose gear oil	PYKON premium grease	-
4	ARCO	*Arcofleet S3 plus	Arco HD gear oil	Litholine HEP 2 Arco EP moly D	-
5	BP	Vanellus C3	Gear oil EP Hypogear EP	Energrease LS-EP2	Antifreeze
6	CALTEX	*RPM delo 400 RPM delo 450	Universal thuban Universal thuban EP	Marfak all purpose 2 Ultra-duty grease 2	AF engine coolant
7	CASTROL	*Turbomax *RX super CRD	EP EPX Hypoy Hypoy B Hypoy C	MS3 Spheerol EPL2	Anti-freeze
8	CHEVRON	*Delo 400	Universal gear	Ultra-duty grease 2	-
9	CONOCO	*Fleet motor oil	Universal gear lubricant	Super-sta grease	-
10	ELF	Multiperformance 3C Performance 3C	-	Tranself EP Tranself EP type 2	Glacelf
11	EXXON (ESSO)	Essolube D3 *Essolube XD-3 *Essolube XD-3 Extra *Esso heavy duty Exxon heavy duty	Gear oil GP Gear oil GX	Beacon EP2	All season coolant
12	GULF	Super duty motor oil *Super duty plus	Multi-purpose gear lubricant	Gulfcrown EP2 Gulfcrown EP special	Antifreeze and coolant
13	MOBIL	Delvac 1300 *Delvac super 10W-30, 15W-40	Mobilube GX Mobilube HD	Mobilux EP2 Mobilgrease 77 Mobilgrease special	-
14	PENNZOIL	*Superme duty fleet motor oil	Multi-purpose 4092 Multi-purpose 4140	Multi-purpose white grease 705 707L White-bearing grease	Anti-freeze and summer coolant

MAINTENANCE
USE OF FUEL, COOLANT AND LUBRICANTS ACCORDING TO AMBIENT TEMPERATURE

No.	Supplier	Engine Oil [CD or CE] SAE10W, 30, 40 10W30, 15W40 (The 15W40 oil marked * is CE.)	Gear Oil [GL-4 or GL-5] SAE80, 90, 140	Grease [Lithium-Base] NLGI No.2	Anti-freeze Coolant [Ethylene Glycol Base] Permanent Type
15	PETROFINA	FINA kappa TD	FINA potonic N FINA potonic NE	FINA marson EPL2	FINA tamidor
16	SHELL	Rimura X	Spirax EP Spirax heavy duty	Albania EP grease	-
17	SUN	-	Sunoco GL5 gear oil	Sunoco ultra pres- tige 2EP Sun prestige 742	Sunoco antifreeze and summer cool- ant
18	TEXACO	*Ursa super plus Ursa premium	Multigear	Multifak EP2 Starplex 2	Coda 2055 startex antifreeze coolant
19	TOTAL	Rubia S *Rubia X	Total EP Total Transmission TM	Multis EP2	Antigal/antifreeze
20	UNION	*Guardol	MP gear lube LS	Unoba EP	-
21	VEEDOL	*Turbostar *Diesel star MDC	Multigear Multigear B Multigear C	-	Antifreeze

TIGHTENING TORQUE SPECIFICATIONS

TIGHTENING TORQUE LIST

⚠ CAUTION

If nuts, bolts, or other parts are not tightened to the specified torque, it will cause looseness or damage to the tightened parts, and this will cause failure of the machine or problems with operation. Always pay careful attention when tightening parts.

Unless otherwise specified, tighten the metric nuts and bolts to the torque shown in the table below.

The tightening torque is determined by the width across the flats of the nut and bolt.

If it is necessary to replace any nut or bolt, always use a Komatsu genuine part of the same size as the part that was replaced.

Thread diameter a(mm)	Width across flat b(mm)	Tightening torque					
		Target value			Service limit		
		N•m	kgf•m	lbft	N•m	kgf•m	lbft
6	10	13.2	1.35	9.8	11.8 - 14.7	1.2 - 1.5	8.7 - 10.8
8	13	31	3.2	23.1	27 - 34	2.8 - 3.5	20.3 - 25.3
10	17	66	6.7	48.5	59 - 74	6.0 - 7.5	43.4 - 54.2
12	19	11	11.5	83.2	98 - 123	10.0 - 12.5	72.3 - 90.4
14	22	177	18	130.2	157 - 196	16.0 - 20.0	115.7 - 144.7
16	24	279	28.5	206.1	245 - 309	25.0 - 31.5	180.8 - 227.8
18	27	382	39	282.1	343 - 425	35.0 - 43.5	253.2 - 314.6
20	30	549	56	405.0	490 - 608	50.0 - 62.0	361.7 - 448.4
22	32	745	76	549.7	662 - 829	67.5 - 84.5	488.2 - 611.2
24	36	927	94.5	683.5	824 - 1030	84.0 - 105.0	607.6 - 759.5
27	41	1320	135.0	976.5	1180 - 1470	120.0 - 150.0	868.0 - 1085.0
30	46	1720	175.0	1265.8	1520 - 1910	155.0 - 195.0	1121.1 - 1410.4
33	50	2210	225.0	1627.4	1960 - 2450	200.0 - 250.0	1446.6 - 1808.3
36	55	2750	280.0	2025.2	2450 - 3040	250.0 - 310.0	1808.3 - 2242.2
39	60	3280	335.0	2423.1	2890 - 3630	295.0 - 370.0	2133.7 - 2676.2

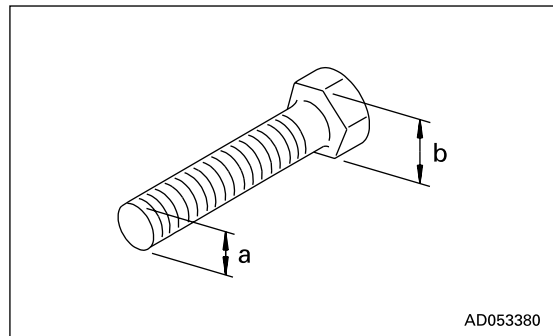

Apply the following table for Hydraulic Hose.

Thread diameter a(mm)	Width across flat b(mm)	Tightening torque					
		Target value			Service limit		
		N•m	kgf•m	lbft	N•m	kgf•m	lbft
14	19	29.4	3.0	21.7	27.5 - 39.2	2.8 - 4.0	20.3 - 28.9
18	24	78.5	8.0	57.3	58.8 - 98.1	6.0 - 10.0	43.4 - 72.3
22	27	117.7	12.0	86.8	88.3 - 137.3	9.0 - 14.0	65.1 - 101.3
24	32	147.1	15.0	108.5	117.7 - 176.5	12.0 - 18.0	86.8 - 130.2
30	36	215.7	22.0	159.1	176.5 - 245.2	18.0 - 25.0	130.2 - 180.8
33	41	255.0	26.0	188.1	215.7 - 284.4	22.0 - 29.0	159.1 - 209.8

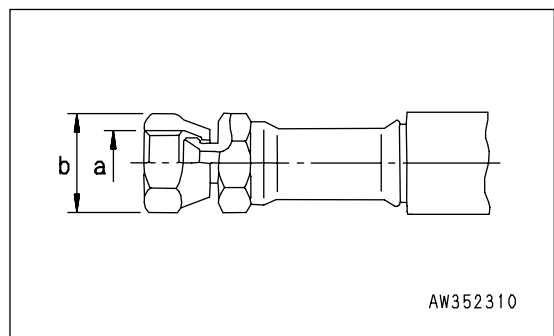

PERIODIC REPLACEMENT OF SAFETY CRITICAL PARTS

To ensure safety at all times when operating or driving the machine, the user of the machine must always carry out periodic maintenance. In addition, to further improve safety, the user should also carry out periodic replacement of the parts given in the table. These parts are particularly closely connected to safety and fire prevention.

With these parts, the material changes as time passed, or they easily wear or deteriorate. However, it is difficult to judge the condition of the parts simply by periodic maintenance, so they should always be replaced after a fixed time has passed, regardless of their condition. This is necessary to ensure that they always maintain their function completely.

However, if these parts show any abnormality before the replacement interval has passed, they should be repaired or replaced immediately.

If the hose clamps show any deterioration, such as deformation or cracking, replace the clamps at the same as the hoses.

When replacing the hoses, always replace the O-rings, gaskets, and other such parts at the same time.

Ask your Komatsu distributor to replace the safety critical parts.

SAFETY CRITICAL PARTS

No.	Safety critical parts for periodic replacement	Q'ty	Replacement interval
1	Fuel hose (Fuel tank - Fuel injection pump)	2	Every 2 years or 4000 hours, whichever comes sooner
2	Spill hose (Nozzle - Fuel tank)	1	
3	Turbocharger lubricating oil hose	1	
4	Engine oil filter hose (Engine - Oil filter)	2	
5	Pump outlet hose (Pump - Control valve)	1	
6	Work equipment hose (Boom cylinder inlet)	4	
7	Work equipment hose (Bucket cylinder line - Boom foot section)	2	
8	Work equipment hose (Bucket cylinder inlet)	2	
9	Work equipment hose (Arm cylinder line - Boom foot section)	2	
10	Work equipment hose (Arm cylinder inlet)	2	
11	Additional attachment line hose (Boom foot section)	2	
12	Additional attachment line hose (Boom top section)	2	
13	Swing line hose (Swing motor inlet)	2	
14	Main suction hose	1	
15	Heater hose	2	
16	Seat belt	1	Every 3 years

MAINTENANCE SCHEDULE

If the machine is equipped with a hydraulic breaker, the maintenance schedule for some parts will be different. For details, see "MAINTENANCE INTERVAL FOR HYDRAULIC BREAKER (PAGE 4-18)" to confirm the correct maintenance schedule when carrying out maintenance.

MAINTENANCE SCHEDULE CHART

Initial 250 Hours Maintenance (Only after the first 250 hours)

REPLACE FUEL FILTER CARTRIDGE 4-54
 CHECK ENGINE VALVE CLEARANCE, ADJUST 4-62

When Required

CHECK, CLEAN AND REPLACE AIR CLEANER ELEMENT 4-20
 CLEAN INSIDE OF COOLING SYSTEM 4-23
 CHECK AND TIGHTEN TRACK SHOE BOLTS 4-26
 CHECK AND ADJUST TRACK TENSION 4-28
 CHECK ROAD LINER (MACHINES EQUIPPED WITH ROAD LINER) 4-30
 CHECK ELECTRICAL INTAKE AIR HEATER 4-30
 REPLACE BUCKET TEETH (VERTICAL PIN TYPE) 4-31
 REPLACE BUCKET TEETH (HORIZONTAL PIN TYPE) 4-34
 ADJUST BUCKET CLEARANCE 4-35
 CHECK WINDOW WASHER FLUID LEVEL, ADD FLUID 4-36
 CHECK AND ADJUST AIR CONDITIONER (ONLY MACHINES EQUIPPED WITH AIR CONDITIONER) 4-37
 REPLACE ADDITIONAL BREAKER FILTER ELEMENT (IF EQUIPPED) 4-38
 WASHING WASHABLE FLOOR 4-39
 BLEEDING AIR FROM HYDRAULIC SYSTEM 4-41
 METHOD FOR RELEASING INTERNAL PRESSURE IN HYDRAULIC CIRCUIT 4-43

Checks Before Starting

Every 50 Hours Maintenance

DRAIN WATER AND SEDIMENT FROM FUEL TANK 4-45

Every 100 Hours Maintenance

LUBRICATING 4-46
 CHECK OIL LEVEL IN SWING MACHINERY CASE, ADD OIL 4-48

Every 250 Hours Maintenance

CHECK OIL LEVEL IN FINAL DRIVE CASE, ADD OIL..... 4-49

CHECK LEVEL OF BATTERY ELECTROLYTE 4-50

CHANGE OIL IN ENGINE OIL PAN, REPLACE ENGINE OIL FILTER CARTRIDGE 4-51

CHECK, ADJUST TENSION OF AIR CONDITIONER COMPRESSOR BELT 4-52

Every 500 Hours Maintenance

REPLACE FUEL FILTER CARTRIDGE 4-54

CHECK SWING PINION GREASE LEVEL, ADD GREASE 4-55

LUBRICATE SWING CIRCLE (2 POINTS) 4-55

CLEAN AND INSPECT RADIATOR FINS, OIL COOLER FINS AND CONDENSER FINS
(ONLY FOR MACHINES EQUIPPED WITH AIR CONDITIONER)..... 4-55

CLEAN INTERNAL AND EXTERNAL AIR FILTERS OF AIR CONDITIONER SYSTEM
(ONLY FOR MACHINES EQUIPPED WITH AIR CONDITIONER)..... 4-56

REPLACE HYDRAULIC FILTER ELEMENT 4-58

Every 1000 Hours Maintenance

CHANGE OIL IN SWING MACHINERY CASE 4-59

CHANGE OIL IN FINAL DRIVE CASE 4-60

CHECK ALL TIGHTENING PARTS OF TURBOCHARGER..... 4-60

CHECK PLAY OF TURBOCHARGER ROTOR 4-60

CHECK FAN BELT TENSION AND REPLACE FAN BELT 4-60

Every 2000 Hours Maintenance

CHECK OIL LEVEL IN PTO GEAR CASE, ADD OIL 4-61

CLEAN HYDRAULIC TANK STRAINER..... 4-62

CLEAN, CHECK TURBOCHARGER 4-62

CHECK ALTERNATOR, STARTING MOTOR..... 4-62

CHECK ENGINE VALVE CLEARANCE, ADJUST..... 4-62

Every 4000 Hours Maintenance

CHECK WATER PUMP..... 4-63

Every 5000 Hours Maintenance

CHANGE OIL IN HYDRAULIC TANK 4-64

MAINTENANCE INTERVAL FOR HYDRAULIC BREAKER

For machine equipped with a hydraulic breaker, the hydraulic oil deteriorates faster than for normal bucket digging operations, so set the maintenance intervals as follows.

REPLACING HYDRAULIC ELEMENT

- On new machines, replace the element after the first 100 to 150 hours, then carry out further replacement of the element according to the table on the right.

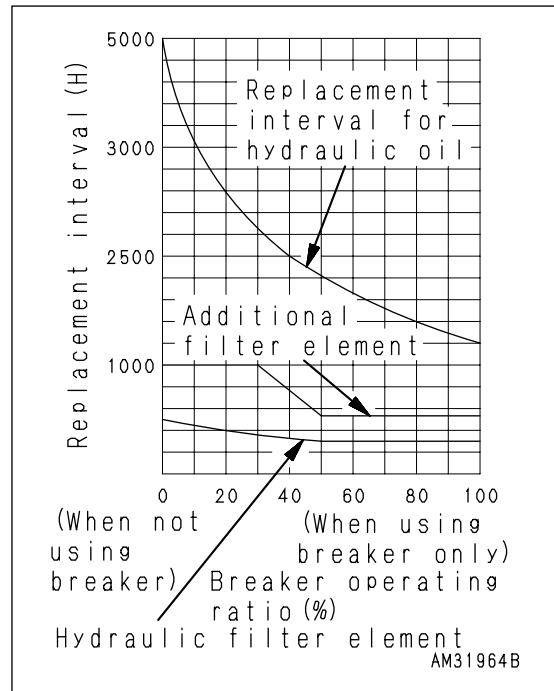

CHANGING OIL IN HYDRAULIC TANK

- Change the oil according to the table on the right.

REPLACING ADDITIONAL FILTER ELEMENT FOR BREAKER

- Use a guideline of 250 hours for use of the breaker (operating ratio for the breaker: 50 % or more), and replace the element according to the table on the right.

MAINTENANCE PROCEDURE

INITIAL 250 HOURS MAINTENANCE (ONLY AFTER THE FIRST 250 HOURS)

Carry out the following maintenance only after the first 250 hours of operation on new machines.

- Replace Fuel Filter Cartridge
- Check and adjust engine valve clearance

Special tools are needed for inspection and maintenance, so contact your Komatsu distributor.

For details of the method of replacing or maintaining, see the section on EVERY 500 HOURS and 2000 HOURS SERVICE.

WHEN REQUIRED

CHECK, CLEAN AND REPLACE AIR CLEANER ELEMENT

⚠ WARNING

- If inspection, cleaning, or maintenance is carried out with the engine running, dirt will get into the engine and the engine will suffer damage. Always stop the engine before carrying out these operations.
- When using compressed air, there is danger that dirt may be blown around and cause serious injury. Always use safety glasses, dust mask, and other protective equipment.

Checking

Whenever the red piston in dust indicator (1) appears, clean the air cleaner element.

NOTICE

Do not clean the air cleaner element before the red piston in dust indicator (1) appears.

If the air cleaner element is cleaned frequently before the red piston in the dust indicator appears, the air cleaner cannot provide the proper performance and the cleaning efficiency is lowered.

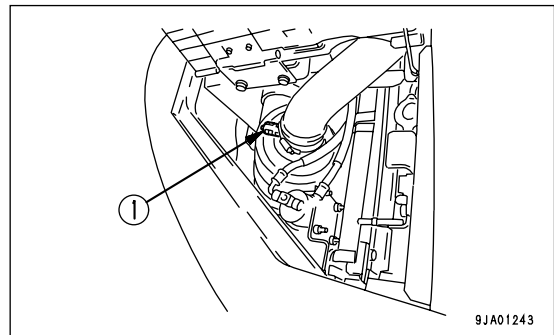

Cleaning the outer element

1. Open the battery room door on the left side of the machine, remove clips (2) at 3 places, then take out dust cup (3).

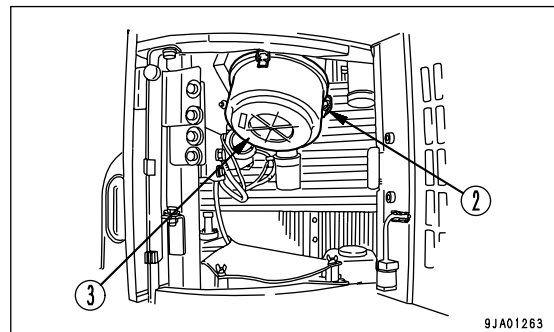

NOTICE

Never remove inner element (5). Dust will get in and cause failure of the engine.

2. Remove outer element (4).

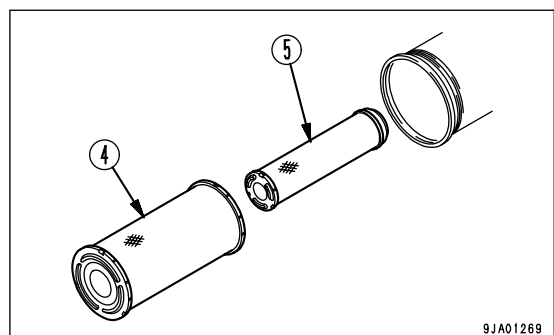

NOTICE

When cleaning the dust cup, do not remove evacuator valve (6).

3. Clean the inside of the air cleaner body and the dust cap.

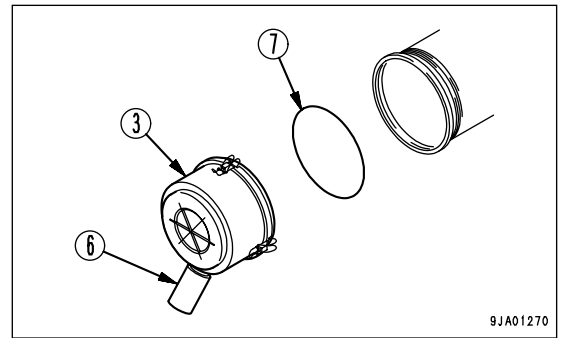

NOTICE

Do not clean the inner element and use it again. When replacing the outer element, replace the inner element with a new part at the same time.

4. Direct dry compressed air (Max. 0.69 MPa (7 kgf/cm²)) from the inside of the outer element along its folds. Then blow with air along the folds from the outside, and finally blow again from the inside.
 - 1) Replace any outer element which has been cleaned 6 times or used for one year. Replace the inner element at the same time.
 - 2) Replace both the inner and outer elements if the dust indicator shows red immediately after the outer element is cleaned, even if the element has not been cleaned 6 times.
5. After cleaning the element, shine an electric light bulb from the inside and check for small holes or thin parts on the element. If such parts are found, replace the element.

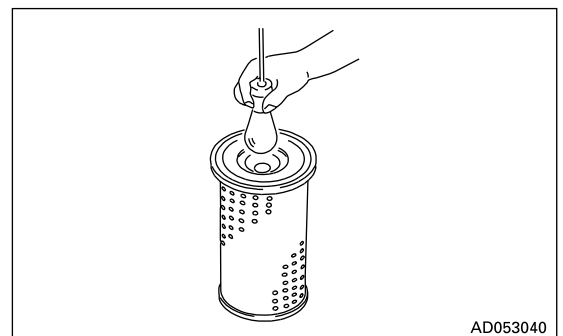
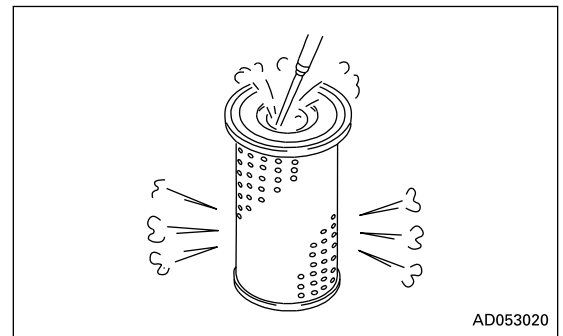

NOTICE

When cleaning the element, do not hit it or beat it against anything. Do not use any element if its folds or gasket or seal are damaged.

6. Set the cleaned outer element in position, then secure dust cup (3) with mounting clips (2).

⚠ CAUTION

When installing the dust cup, check O-ring (7) and replace it if there are any scratches or damage.

7. Press the button to return the red piston in the dust indicator to its original position.

Replacing inner element

1. Open the battery room door on the left side of the machine, remove clips (2) at 3 places, then take out the dust cup.

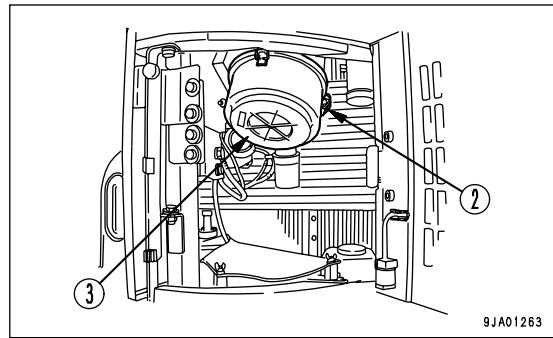

2. Remove outer element (4). Do not remove inner element (5) at this point.

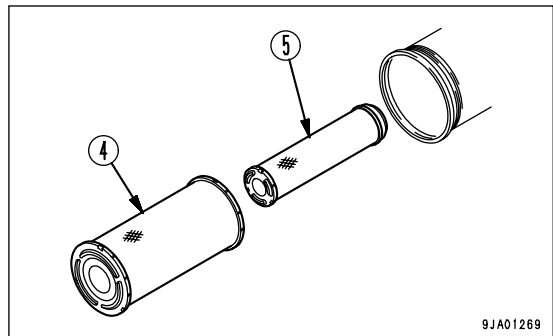

NOTICE

When cleaning the dust cup, do not remove evacuator valve (6).

3. Clean the inside of the air cleaner body and the dust cap.
4. Remove inner element (5) and quickly install a new inner element.
5. Set the cleaned outer element in position, then secure dust cup (3) with mounting clips (2).

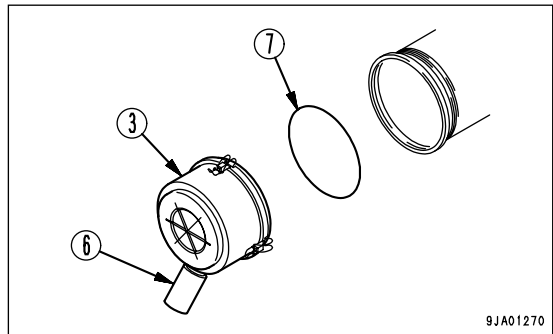

⚠ CAUTION

When installing the dust cup, check O-ring (7) and replace it if there are any scratches or damage.

6. Press the button to return the red piston in the dust indicator to its original position.

CLEAN INSIDE OF COOLING SYSTEM

WARNING

- Immediately after the engine is stopped, the coolant is at a high temperature and the radiator is under high internal pressure. If the cap is removed to drain the coolant in this condition, there is a hazard of burns. Wait for the temperature to go down, then turn the cap slowly to release the pressure before removing it.
- Cleaning is carried out with the engine running. When standing up or leaving the operator's seat, set the safety lock lever to the LOCK position.
- For details of starting the engine, see "BEFORE STARTING ENGINE (PAGE 3-42)" and "STARTING ENGINE (PAGE 3-55)" in the OPERATION section.
- There is danger of touching the fan if the undercover is left removed. Never enter behind the machine when the engine is running.

Clean the inside of the cooling system, change the coolant and replace the corrosion resistor agent KI according to the table below.

Kind of coolant	Cleaning inside of cooling system and changing coolant	Adding corrosion resistor agent KI
Permanent type anti-freeze (All season type)	Every year (autumn) or every 2000 hours whichever comes first	Every 1000 hours and when cleaning the inside of the cooling system and when changing coolant.
Nom permanent type antifreeze containing ethylene glycol (winter, one season type)	Every 6 months (spring, autumn) (Drain antifreeze in spring, add antifreeze in autumn)	
When not using anti-freeze	Every 6 months or every 1000 hours whichever comes first	

Stop the machine on level ground when cleaning or changing the coolant.

Use a permanent type of antifreeze.

If, for some reason, it is impossible to use permanent type antifreeze, use an antifreeze containing ethylene glycol.

Super Coolant (AF-ACL) has an anti-corrosion effect as well as an antifreeze effect.

The ratio of antifreeze to water depends on the ambient temperature, but to obtain the corrosion resistance effect, a minimum ratio of 30% by volume is necessary.

In areas where the water is hard, always add Komatsu genuine corrosion resistor agent KI. One packet of corrosion resistor agent contains 100g (0.22 lb). The standard density of the mixture should be 7g/liters (0.065 oz/US gal).

When deciding the ratio of antifreeze to water, check the lowest temperature in the past, and decide from the mixing rate table given below.

It is actually better to estimate a temperature about 10°C (50°F) lower when deciding the mixing rate.

Mixing rate of water and antifreeze

Min. atmospheric temperature	°C	-10	-15	-20	-25	-30
	°F	14	5	-4	-13	-22
Amount of antifreeze	liters	5.5	6.6	7.5	8.4	9.1
	US gal	1.45	1.74	1.98	2.22	2.40
Amount of water	liters	12.7	11.6	10.7	9.8	9.1
	US gal	3.35	3.06	2.82	2.59	2.40

⚠ WARNING

Antifreeze is flammable, so keep it away from flame.

Antifreeze is toxic. When removing the drain plug, be careful not to get water containing antifreeze on you. If it gets in your eyes, flush your eyes with large quantities of fresh water and see a doctor at once.

Use city water for the cooling water.

If river water, well water or other such water supply must be used, contact your Komatsu distributor.

We recommend use of an antifreeze density gauge to control the mixing proportions.

- Prepare a container to catch drained coolant: Min 17 liters (4.49 US gal) capacity.

Prepare a hose to supply water.

1. Stop the engine.
2. Turn radiator cap (1) slowly and remove it.
3. Remove the undercover, then set the container under drain valve (2) and drain plug (3) to catch the coolant mixture.
Open drain valve (2) at the bottom of the radiator and drain the coolant. Then open drain plug (3) in the cylinder block and drain the coolant.
4. After draining the coolant, close drain valve (2) and drain plug (3), and fill with city water. When the radiator is full, start the engine and run at low idling to raise the temperature to at least 90°C, then continue to run for approx. 10 minutes.
5. Stop the engine, open drain valve (2) and drain plug (3), and drain the water.
6. After draining the water, clean the radiator with detergent. For the cleaning method, follow the instruction of detergent.

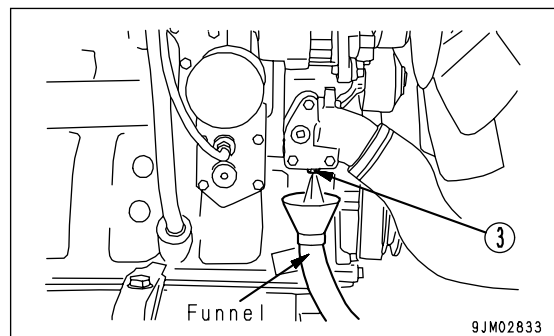
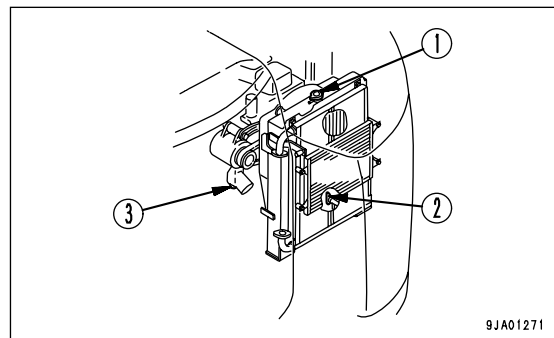

7. Close drain valve (2), then wrap drain plug (3) with sealing tape and close it.
8. Install the undercover.

9. Add water through the water filler up to the filler port.
10. Run the engine idle at a low speed for 5 minutes, then at a high speed for 5 minutes to bleed air mixed in the cooling water. (At this time, keep the water filler cap removed.)
11. After draining off the cooling water of reserve tank (4) , clean the inside of the reserve tank and refill the water between FULL and LOW level.
12. Stop the engine and tighten the cap. Check the coolant level, and add water if the level is low.

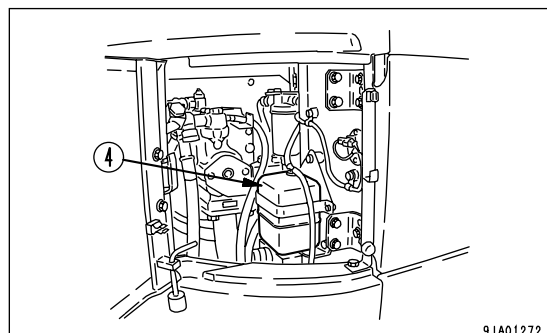

9JA01272

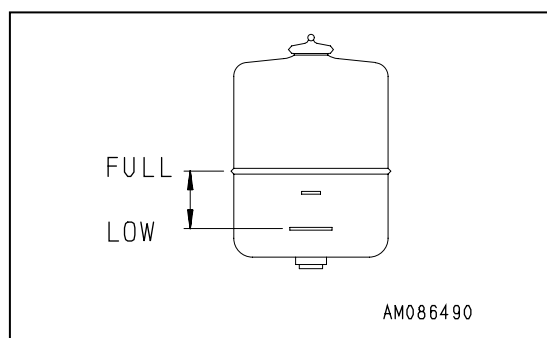

AM086490

CHECK AND TIGHTEN TRACK SHOE BOLTS

If the machine is used with track shoe bolts (1) loose, they will break, so tighten any loose bolts immediately.

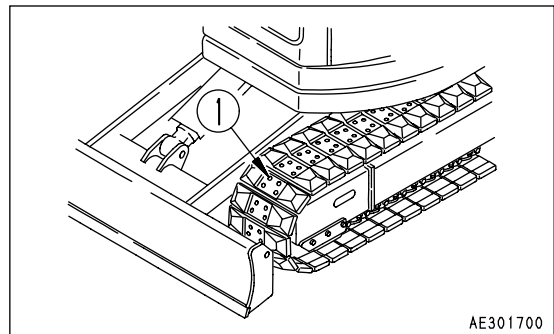
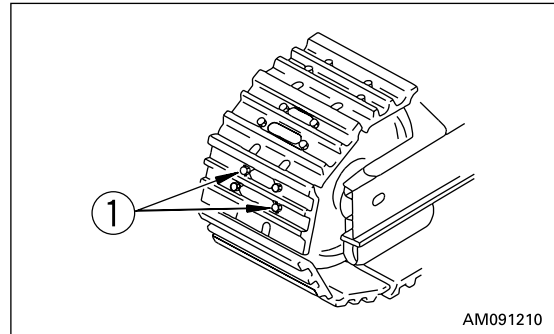

Method for tightening

- Track shoe

1. First tighten to a tightening torque of 490 ± 49 Nm (50 ± 5 kgf•m, 360 ± 36 lbft) then check that the nut and shoe are in close contact with the link contact surface.
2. After checking, tighten a further $120^\circ \pm 10^\circ$.

- Road liner

1. Tighten to a tightening torque of 549 ± 59 Nm (56 ± 6 kgf•m, 405 ± 43 lbft). After tightening, check that the nut and shoe are in close contact with the link contact surface.
2. After checking, tighten a further $60^\circ \pm 10^\circ$.

Order for tightening

Tighten the bolts in the order shown in the diagram on the right. After tightening, check that the nut and shoe are in close contact with the link mating surface.

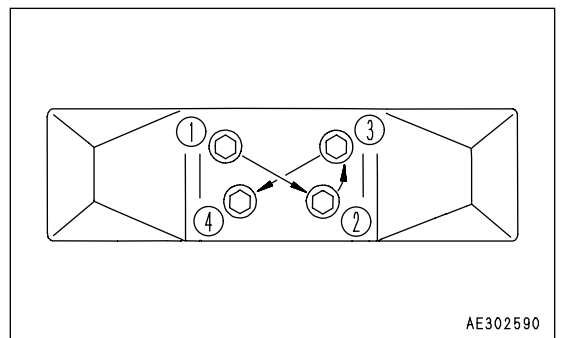
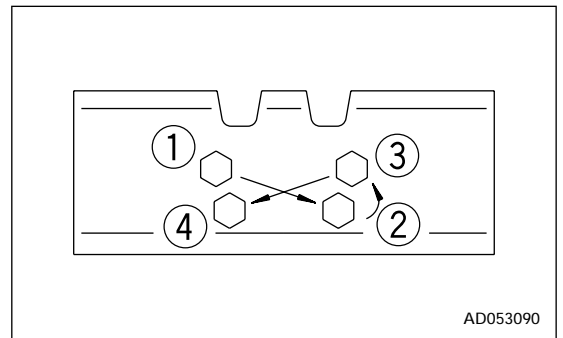

CHECK AND ADJUST TRACK TENSION

⚠ WARNING

- The track tension is checked with the machine raised, so it is extremely dangerous if the machine comes down by mistake during the inspection. Stop the engine and set the safety lock lever to the LOCK position to prevent the machine from moving.
Never put any part of your body under the track or track frame while measuring, and be extremely careful when taking the measurements.
- For details of starting the engine and operating the work equipment, see "BEFORE STARTING ENGINE (PAGE 3-42)", "STARTING ENGINE (PAGE 3-55)", "AFTER STARTING ENGINE (PAGE 3-58)", and "WORK EQUIPMENT CONTROLS AND OPERATIONS (PAGE 3-69)" in the OPERATION section.

The condition of wear of the undercarriage pins and bushings differs according to the working conditions and type of soil, so check the track tension regularly and be sure to maintain it at the standard value.

Carry out the inspection and maintenance under the same conditions as normal operations (with mud clogging the parts normally clogged by mud).

Inspection

1. Raise the chassis with the boom and arm.
When doing this, operate the levers slowly.
2. Measure the clearance between the bottom of the track frame and the top of the track shoe at a position that is safe even if the chassis should come down.

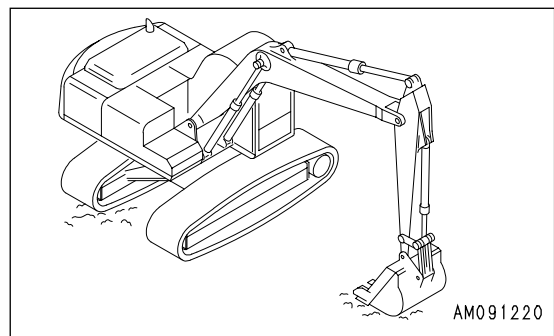

Standard clearance: 230 ± 10 mm (9.2 ± 0.4 in)

Places to measure

4th track roller from sprocket

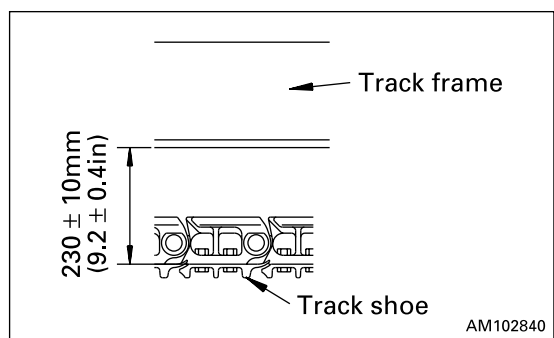

If the track tension is not at the standard value, adjust it in the following manner.

Adjustment

⚠ WARNING

There is danger of plug (1) flying out under the high internal pressure of the grease. Never loosen plug (1) more than 1 turn.

Never loosen any part other than plug (1). Never put your face in the mounting direction of plug (1).

If the track tension cannot be loosened with the procedure given here, please contact your Komatsu distributor.

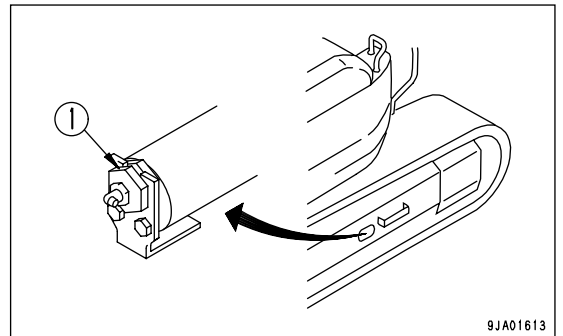

When increasing tension

Prepare a grease gun.

1. Pump in grease through grease fitting (2) with a grease gun.
2. To check that the tension is correct, move the machine slowly forward (7 - 8 m (23 ft - 26 ft 3 in)).
3. Check the track tension again, and if the tension is not correct, adjust it again.
4. Continue to pump in grease until dimension S becomes zero (0). If the tension is still loose, the pin and bushing are excessively worn, so they must be either turned or replaced. Please contact your Komatsu distributor for repairs.

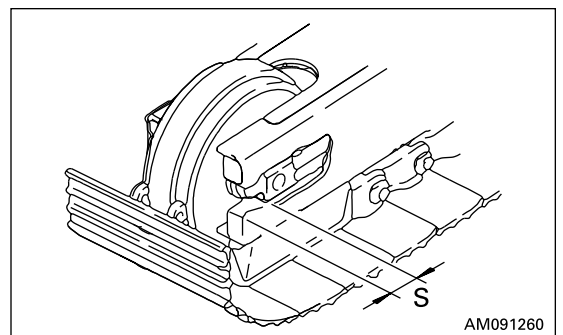
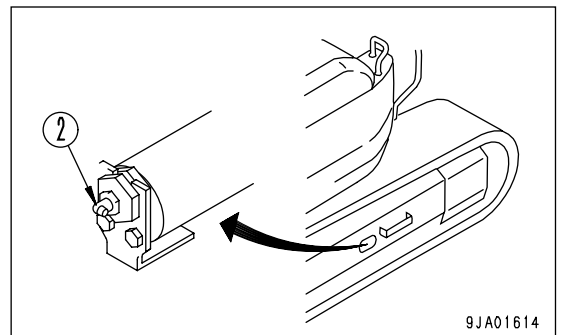

When loosening tension

⚠ WARNING

It is extremely dangerous to release the grease by any method except the procedure given below.

If the track tension is not relieved by this procedure, please contact your Komatsu distributor for repairs.

1. Loosen plug (1) gradually to release the grease.
2. Turn plug (1) a maximum of one turn.
3. If the grease does not come out smoothly, move the machine forwards and backwards a short distance.
4. Tighten plug (1).
5. To check that the tension is correct, move the machine slowly forward (7 - 8 m (23 ft - 26 ft 3 in)).
6. Check the track tension again, and if the tension is not correct, adjust it again.

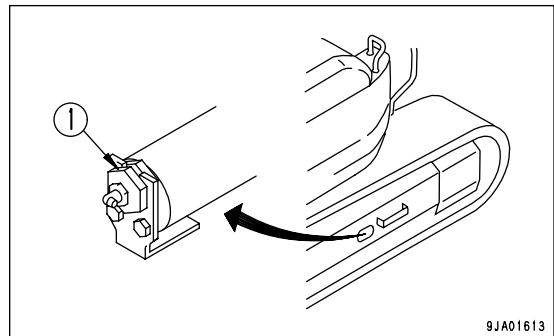

CHECK ROAD LINER (MACHINES EQUIPPED WITH ROAD LINER)

If the road liner are in the following condition, they must be repaired or replaced, so please contact your Komatsu distributor for repair or replacement.

Height of lug

- If lug height "a" is reduced by wear, the drawbar pull will drop. If "a" is less than 5 mm (0.2 in), replace with a new part.

When making judgement whether to replace, repair, or continue using road liner, please contact your Komatsu distributor.

Replace road liner

- When all the road liners of the machine need to be replaced, ask your Komatsu distributor to replace them.
- When only some of the road liners need to be replaced, replace them by using the road liner replacing tools. Order the tools from your Komatsu distributor.

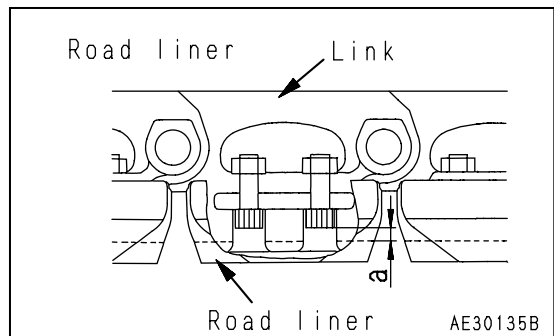

CHECK ELECTRICAL INTAKE AIR HEATER

Before the start of the cold season (once a year), contact your Komatsu distributor to have the electrical intake air heater repaired or checked for dirt or disconnections.

REPLACE BUCKET TEETH (VERTICAL PIN TYPE)

Replace the point before the adapter starts to wear.

⚠ WARNING

- It is dangerous if the work equipment moves by mistake when the teeth are being replaced. Set the work equipment in a stable condition, then stop the engine and apply the locks securely to the levers.
- If the locking pin is knocked out with excessive force, there is a hazard that the pin may fly out. Check that there is no one in the surrounding area.
- Pieces will often fly during the replacement operation, so always wear safety glasses, gloves, and other protective equipment.

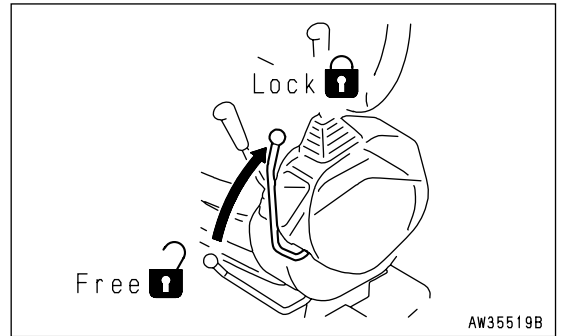

1. To make it possible to knock out the pin of tooth (1), set the bottom surface of the bucket on a block, check that the work equipment is in a stable condition, then set the safety lock lever to the LOCK position. Set so that the bottom face of the bucket is horizontal.
2. Use a hammer and drift to knock out lock pin (2). (If the drift is set against rubber pin lock (3) when it is hit, the rubber pin lock may break. Set it against the back of the pin.)
3. After removing lock pin (2) and rubber pin lock (3), check them.
If lock pins and rubber pin locks with the following defects are used, the teeth may come off the bucket. Replace them with new ones.

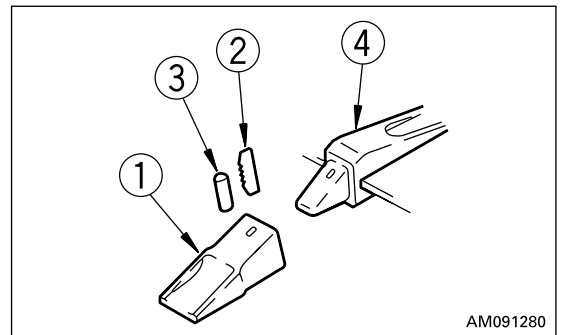
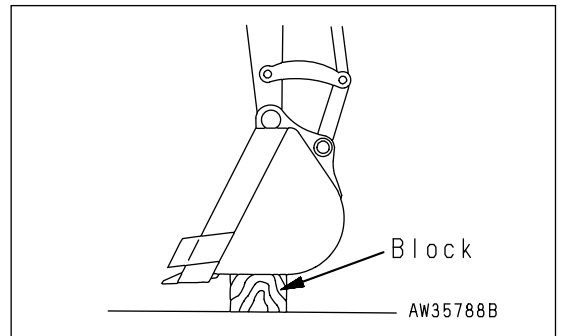

- The lock pin is too short.

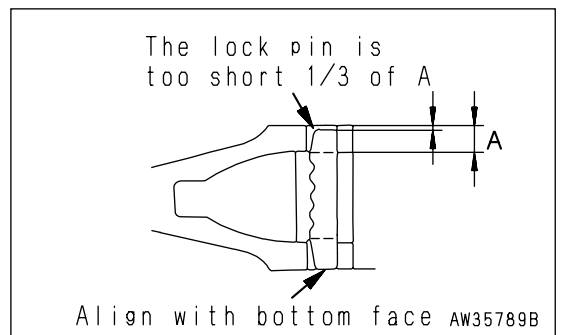

- The rubber of the rubber pin lock is torn, and the steel balls may come out.

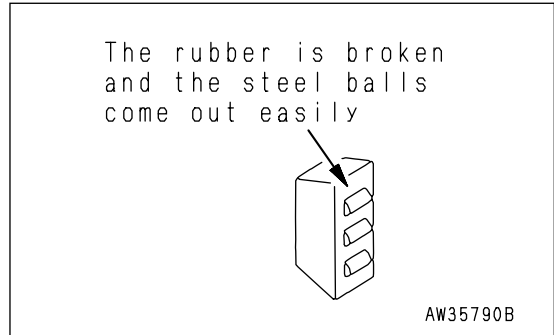

- The steel balls are buried when they are pressed by hand.

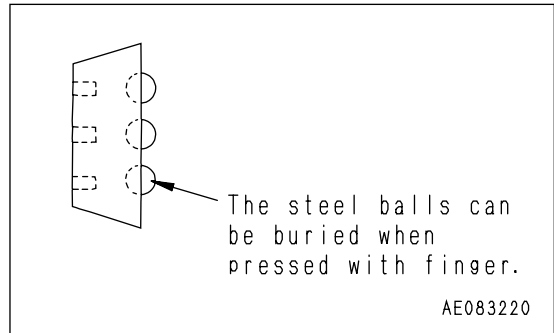

4. Clean the surface of adapter (4) and remove the soil with a knife.
5. Use your hand or a hammer to push rubber pin lock (3) into the hole of the adapter.
When doing this, be careful that the rubber pin lock does not fly out from the adapter surface.
6. Clean the inside of teeth (1), then install it to adapter (4).
If there is mud affixed to it or if there are protrusions, the teeth will not enter the adapter properly, and there will not be proper contact at the mating portion.

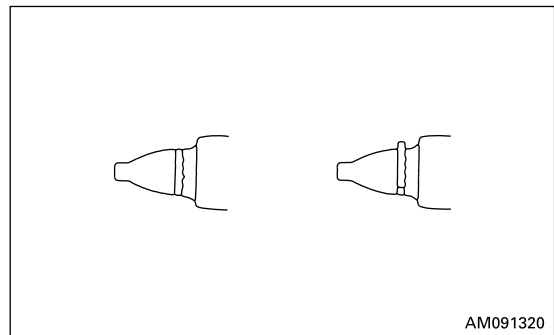

7. Fit teeth (1) to adapter (4), and confirm that when the pointer is pressed strongly, the rear face of the hole for the pin of the teeth (1) is at the same level as the rear face of the hole for the pin of the adapter.
If the rear face of the hole for the pin of teeth (1) is protruding to the front from the rear face of the pin hole for adapter (4), do not try to knock the pin in.

There is something preventing teeth (1) from entering adapter (4) fully, so remove the obstruction. When teeth (1) enters adapter (4) fully, knock in lock pin (2).

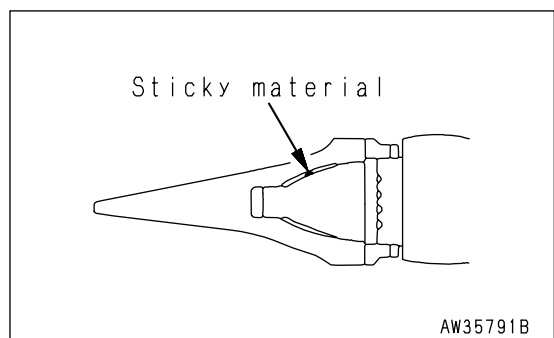

8. Insert lock pin (2) in the hole of the teeth and hit it until its top is the same level as the surface of teeth (1).

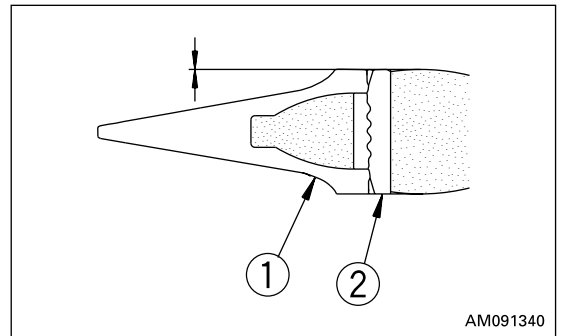

9. After replacing a bucket tooth, always check the following.
 - 1) After the lock pin has been knocked in completely, check that it is secured by the point and surface.
 - 2) Lightly hit lock pin (2) in the reverse direction from which it was hit in.
 - 3) Lightly hit the tip of the point from above and below, and hit its sides from right and left.
 - 4) Confirm that rubber pin lock (3) and lock pin (2) are set as shown in the figure.

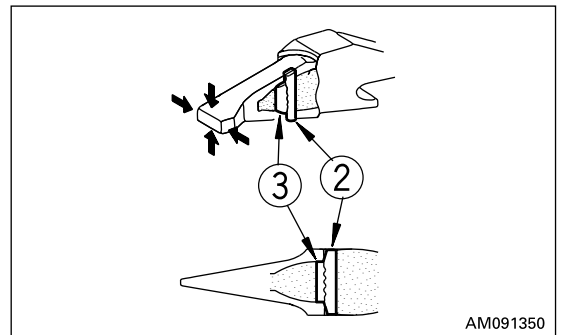

The life of the teeth can be lengthened and the frequency of its replacement can be reduced by turning it upside down so that it will wear evenly.

Replace the rubber pin lock and locking pin at the same time as replacing the teeth. This makes it possible to prevent the teeth from falling out.

REPLACE BUCKET TEETH (HORIZONTAL PIN TYPE)

Replace the teeth before the wear reaches the adapter.

WARNING

- It is dangerous if the work equipment moves by mistake when the teeth are being replaced. Set the work equipment in a stable condition, then stop the engine and apply the locks securely to the levers.
- If the locking pin is knocked out with excessive force, there is a hazard that the pin may fly out. Check that there is no one in the surrounding area.
- Pieces will often fly during the replacement operation, so always wear safety glasses, gloves, and other protective equipment.

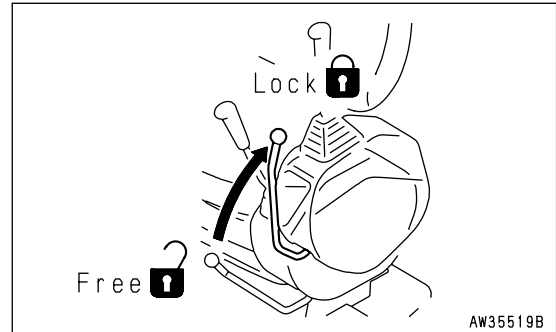

1. Set the bottom of the bucket on a block to make it possible to remove pin (1), check that the work equipment is stable, then set the safety lock lever to the LOCK position. Set so that the bottom of the bucket is horizontal.

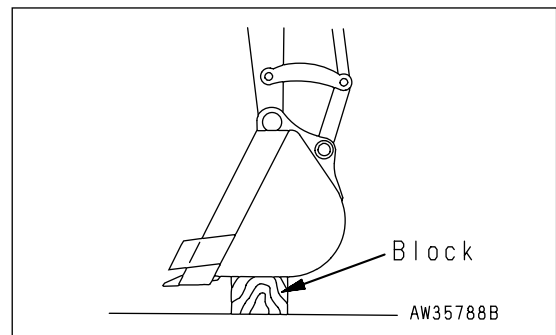

2. Place a bar on the pin head and strike the bar with a hammer to knock out pin (1). Remove tooth (2).

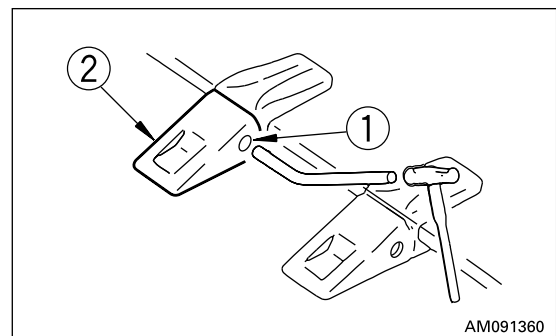

REMARK

Use a round bar with a smaller diameter than that of the pin.

3. Clean the mounting face. Fit a new tooth (2) in the adapter, push in pin (1) partially by hand, then lock it with a hammer to install the tooth to the bucket.

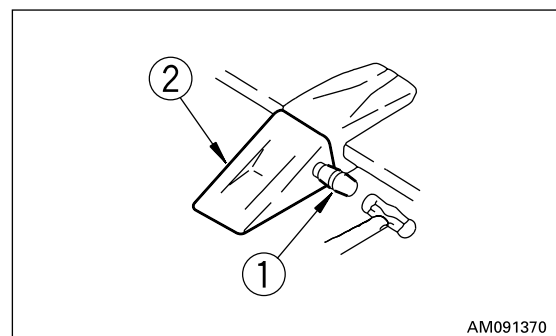

ADJUST BUCKET CLEARANCE

⚠ WARNING

It is dangerous if the work equipment moves by mistake when the clearance is being adjusted.

Set the work equipment in a stable condition, then stop the engine and lock the safety lock lever securely.

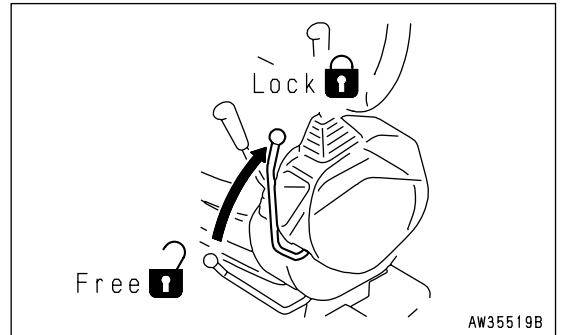

1. Set the work equipment to the position shown in the diagram at right, stop the engine and set the lock lever to the locked position.
2. Shift O-ring (1) of the linkage and measure the amount of play "a".
Measurement is easier if you move the bucket to one side or the other so all the play can be measured in one place.

Use a gap (clearance) gauge for easy and accurate measurement.

3. Loosen the four plate fixing bolts (2) and loosen plate (3). Because it uses split shims, you can carry out the operation without removing the bolts entirely.
4. Remove shim (4) corresponding to the amount of play "a" measured above.

[Example]

In the case of play of 3 mm, remove two 1.0 mm shims and one 0.5 mm shim. Play becomes 0.5 mm. For shim (4), two types of 1.0 mm and 0.5 mm are used.

When play a is smaller than one shim, do not carry out any maintenance.

5. Tighten the four bolts (2).
If the bolts (2) are too stiff to tighten, pull out pin stopper bolt (5) for easier tightening.

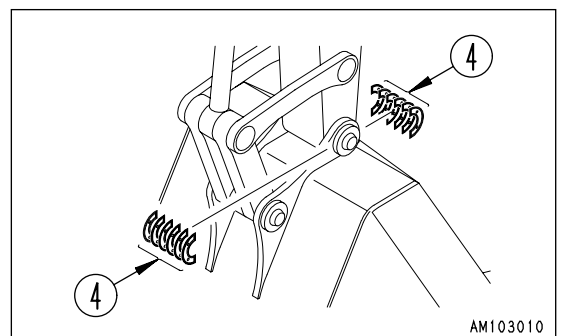
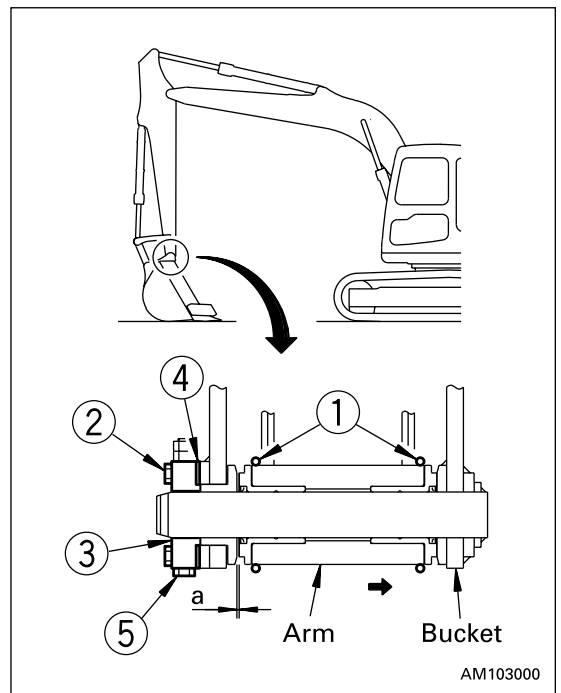

CHECK WINDOW WASHER FLUID LEVEL, ADD FLUID

If there is air in the window washer fluid, check the level of the fluid in window washer tank (1). Add automobile window washer fluid if necessary.

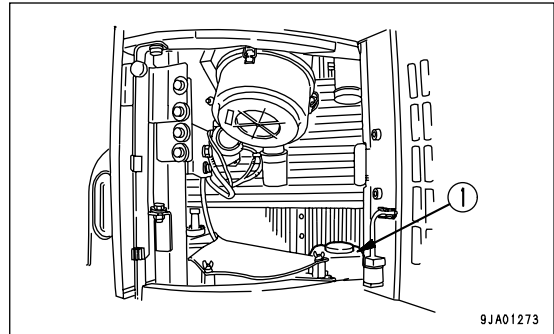

9JA01273

When adding fluid, be careful not to let any dust get in.

Mixture ratio of pure washer fluid and water

Since the ratio should be varied depending on atmospheric temperature, replenish washer fluid at the following mixture ratio, taking temperature into account.

Operation area and season	Mixture ratio	Freezing temperature
Normal	Pure washer fluid 1/3: water 2/3	- 10°C (14°F)
Winter in cold region	Pure washer fluid 1/2: water 1/2	- 20°C (- 4°F)
Winter in extremely cold region	Pure washer fluid	- 30°C (- 22°F)

Pure washer fluid comes in two types: for -10°C (14°F) (for general use) and for -30°C (-22°F) (cold regions).

Use pure washer fluid according to operation area and season.

CHECK AND ADJUST AIR CONDITIONER (ONLY MACHINES EQUIPPED WITH AIR CONDITIONER)

CHECK LEVEL OF REFRIGERANT (GAS)

⚠ WARNING

If the refrigerant used in the cooler gets into your eyes or on your hands, it may cause loss of sight or frostbite. Do not touch the refrigerant. Never loosen any part of the refrigerant circuit.
Do not bring any flame close to any point where the refrigerant gas is leaking.

If there is a lack of refrigerant (Freon 134a), the cooling performance will be poor.

When operating the cooler at high speed, there should be no bubbles in the sight glass (inspection window) mounted on the condenser unit receiver.

- No bubbles in refrigerant flow: Correct
- Bubbles in refrigerant flow (bubbles continuously pass through): Refrigerant level low
- Colorless, transparent: No refrigerant

REMARK

When there are bubbles, the refrigerant gas level is low, so contact your refrigerant dealer to have refrigerant added. If the air conditioner is run with the refrigerant gas level low, it will cause damage to the compressor.

Check in off-season

When not being used for a long period, operate the cooler for 3 to 5 minutes once a month to supply lubricant to each component of the compressor.

Inspection and maintenance items list for cooler

Inspection and maintenance items	Contents	Maintenance interval
Refrigerant (gas)	Filling quantity	Twice a year; spring and autumn
Condenser	Clogging of fin	Every 500 hours
Compressor	Function	Every 4000 hours
V belt	Damage and tension	Every 250 hours
Blower motor and fan	Function (Check for abnormal sound)	When required
Control mechanism	Function (Check for normal function)	When required
Piping for connection	Installation condition looseness of tightening connection portions gas leakage, damage	When required

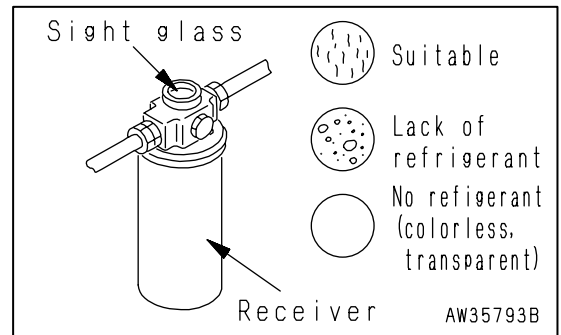
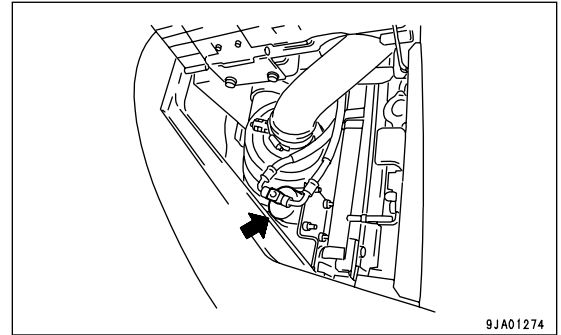

REPLACE ADDITIONAL BREAKER FILTER ELEMENT (IF EQUIPPED)

⚠ WARNING

Immediately after operating the engine, all parts still retain high temperature. Never replace the filter in such condition. Replace it only after each part has sufficiently cooled.

- Prepare a container for draining off oil.
 1. Place the container under the filter element.
 2. Turn filter case (1) counterclockwise to remove it. Remove element (2) from the case.
 3. Unscrew plug (3) from filter case (1).
 4. Clean the removed parts. Mount a new element (2) and O-ring (4).
 5. After the case reaches the filter holder, additionally tighten the case by more than a 1/2 turn.

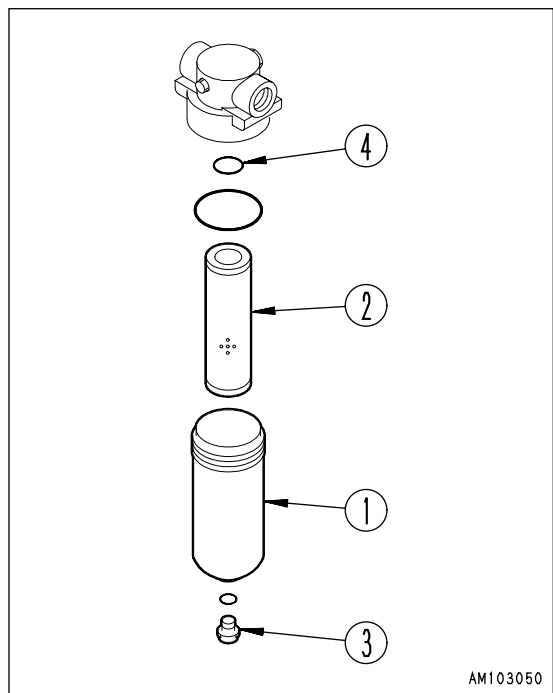
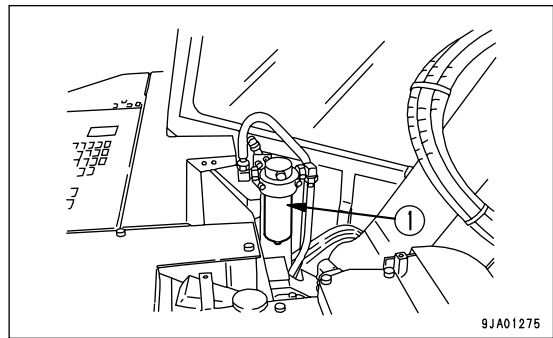

WASHING WASHABLE FLOOR

With the washable floor, the dirt on the cab floor can be washed off directly with water.

WARNING

- When setting the machine at an angle, use strong blocks to stabilize the machine and be extremely careful when carrying out the operation.
- If the control levers are touched by mistake, the work equipment or machine may suddenly move, and this may lead to a serious accident. Always set the safety lock lever securely to the LOCK position before standing up from the operator's seat.

With the washable floor, it is possible to flush out the dirt on the cab floor directly with water.

Method of washing

1. Set the machine at an angle.
For details, see "METHOD OF SETTING MACHINE ANGLE (PAGE 4-40)".
2. Swing the upper structure slowly so that water drain holes (1) in the cab floor are at a low position.

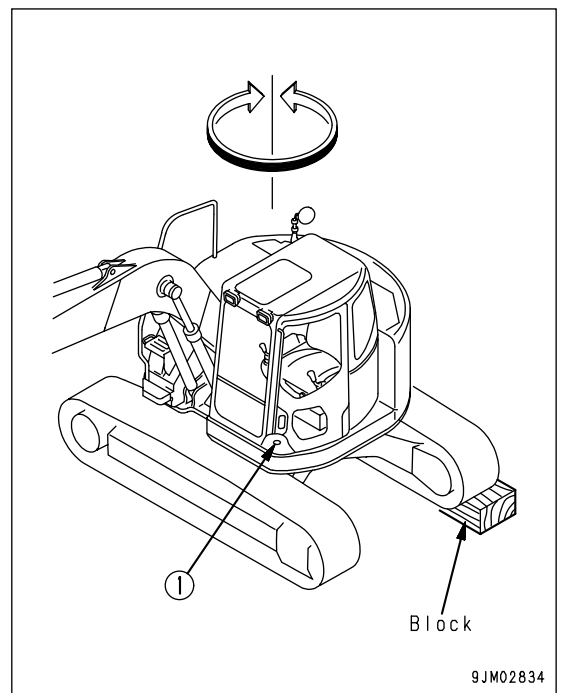

3. Lower the work equipment to the ground and set the machine in a stable condition.

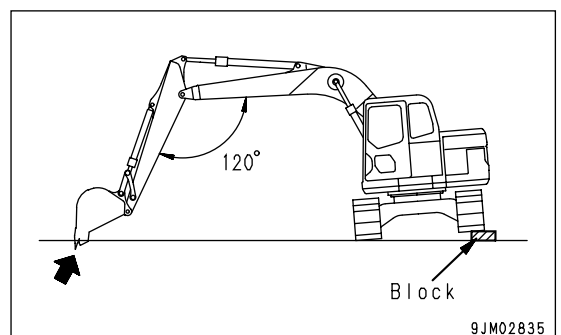

4. Set the safety lock lever to the LOCK position, then stop the engine.

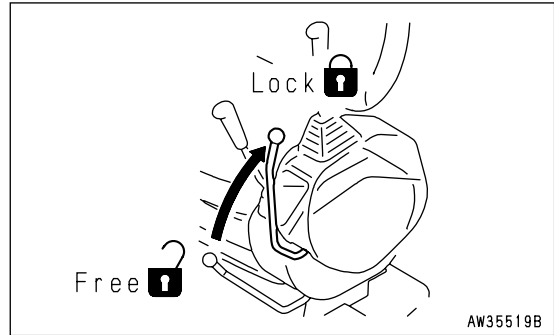

5. Remove the floor mat.
6. Flush out the dirt on the floor directly with water through water drain hole (1).
7. After completing the washing operation, install the floor mat.

METHOD OF SETTING MACHINE ANGLE

Method Using Slope

⚠ WARNING

Select a firm flat place.

Always put blocks under the track to prevent the machine from moving, and dig the work equipment into the ground.

1. Stop the machine so that the work equipment is on the downhill side.
2. Put blocks under the track and dig the work equipment into the ground.

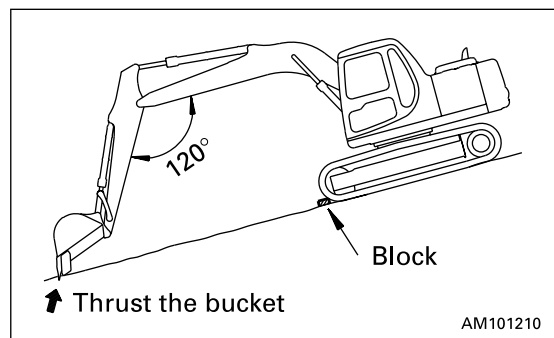

Method Using Block

⚠ WARNING

Select a firm flat place.

Put strong blocks under the undercarriage to stabilize the machine and be extremely careful when carrying out the operation.

1. Raise the chassis with the boom and arm. When doing this, operate the levers slowly.
2. Insert a block securely between the ground surface and the raised track and make sure that the machine is stable.

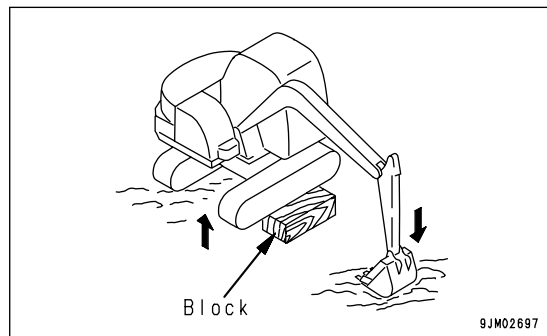

3. Raise the boom slowly and lower the machine. When doing this, check that the machine is always stable.

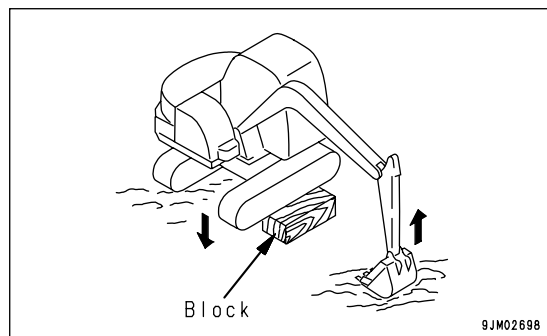

BLEEDING AIR FROM HYDRAULIC SYSTEM

For details, see "STARTING ENGINE (PAGE 3-55)". If it is necessary to refer to the items for starting the engine, moving the machine off, steering, or stopping, see the OPERATION section.

1. Bleeding air from pump
 - 1) Loosen air bleed plug (1) installed to the drain port and check that oil oozes out (air bleeding is completed).
 - 2) After completion of the air bleeding operation, tighten the air bleed plug.

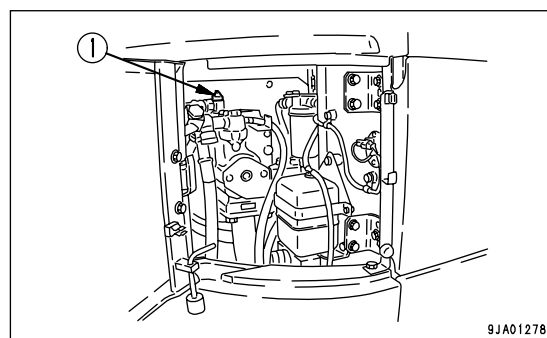

NOTICE

If the pump is run when the pump case is not full of oil, there will be abnormal generation of heat, and this will lead to premature failure of the pump.

2. Starting engine

Start the engine. For details, see STARTING ENGINE (PAGE 3-55).

Run the engine at low idling for 10 minutes after starting, then start operations.

3. Bleeding air from cylinders
 - 1) Run the engine at a mid-range speed (1650rpm) and extend and retract the cylinders 4 to 5 times to a point 100 mm(3.9in) from the end of the stroke. (Be careful not to operate to the end of the stroke.)
 - 2) Next, operate each cylinder 3 to 4 times to the end of its stroke.
 - 3) Finally, operate each cylinder 4 to 5 times to the end of its stroke to completely remove the air.

NOTICE

If the engine is run immediately at high speed or the cylinder is operated to the end of its stroke, the air inside the cylinder may cause damage to the piston packing.

4. Bleeding air from swing motor
(only after draining oil from swing motor case)
 - 1) Run the engine at low idling, Loosen air bleeding plug (1) and check that oil oozes out from air bleeding plug (1).

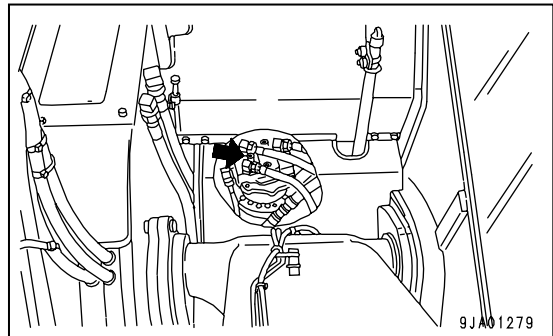

NOTICE

When doing this, do not operate the swing.

- 2) If no oil oozes out, stop the engine, remove air bleeding plug (1), then fill the motor case with hydraulic oil.
- 3) After completing the air bleed operation, tighten air bleeding plug (1).
- 4) Run the engine at low idling, and slowly swing the upper structure at least 2 times uniformly to the left and right.

NOTICE

If the air is not bled from the swing motor, the motor bearings may be damaged.

5. Bleeding air from travel motor (only when oil inside travel motor case has been drained)
 - 1) Run the engine at low idling, remove hose (1) from port C, then when the oil has flowed out, tighten it again.

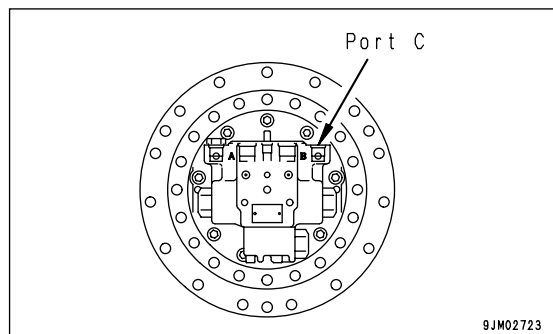
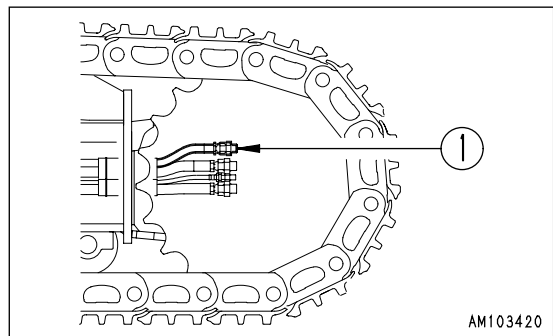

- 2) Run the engine at low idling and swing the work equipment 90° to bring it to the side of the track.
- 3) Jack up the machine until the track is raised slightly from the ground. Rotate the track under no load for 2 minutes.
Repeat this procedure on both the left and right sides, and rotate the track equally both forward and in reverse.

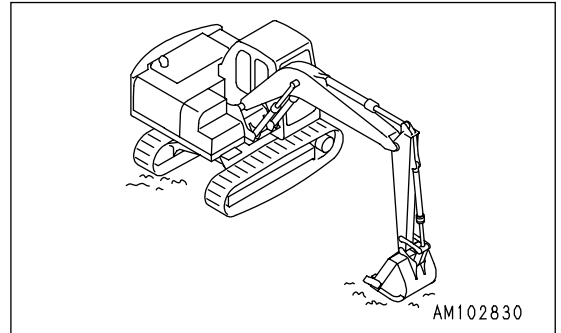

6. Bleeding air from attachment (when installed)
If a breaker or other attachment has been installed, run the engine at low idling and operate the attachment pedal repeatedly (approx. 10 times) until the air has been bled from the attachment circuit.

NOTICE

- If the method of bleeding the air from the attachment itself is specified by the manufacturer, bleed the air according to the specified procedure.
- After completing the air bleeding operation, stop the engine, and leave the machine for 5 minutes before starting operations. This will remove the air bubbles in the oil inside the hydraulic cylinders.
- Check that there is no leakage of oil and wipe off any oil that has been spilled.

METHOD FOR RELEASING INTERNAL PRESSURE IN HYDRAULIC CIRCUIT

⚠ WARNING

- The hydraulic circuit is always under pressure, so release the pressure inside the circuit before inspecting or replacing the piping or hoses. If the pressure is not released, high-pressure oil will spurt out and may cause serious personal injury.
- The parts and oil are at high temperature after the engine is stopped, and may cause serious burns. Wait for the temperature to go down before starting the operation.
- When the oil filler cap is removed, oil may spurt out, so turn the cap slowly to release the internal pressure before removing the cap.

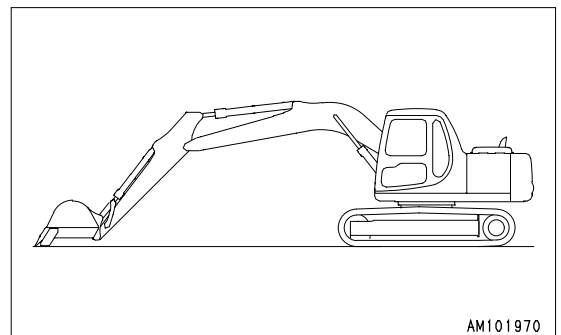

1. Stop the machine on horizontal, firm ground.
2. Within 15 seconds after stopping the engine, turn the starting switch to the ON position, then operate the control levers (work equipment, travel) and attachment control pedal (if equipped) the full stroke in all directions to release the internal pressure.
3. Remove cover (1) at the top surface of the hydraulic tank, then slowly loosen oil filler cap (F) to release the internal pressure.

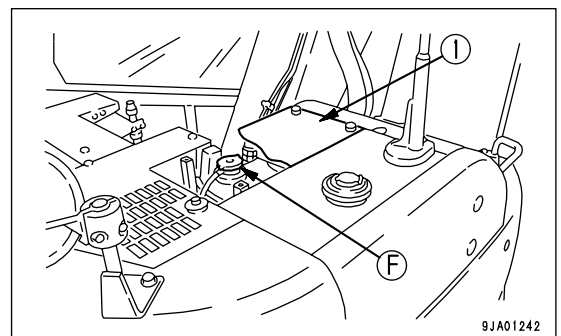

CHECK BEFORE STARTING

For details of the following items, see "CHECKS BEFORE STARTING (PAGE 3-44)" in the OPERATION section.

- Check coolant level, add water
- Check oil level in engine oil pan, add oil
- Check fuel level, add fuel
- Check oil level in hydraulic tank, add oil
- Check dust indicator
- Check electric wirings
- Check function of horn

EVERY 50 HOURS MAINTENANCE

DRAIN WATER AND SEDIMENT FROM FUEL TANK

NOTICE

Never use trichloroethylene for washing the inside of the tank.

Carry out this operation before starting to operate the machine.

1. Open the pump room door on the right side of the machine.
2. Pass drain hose (1) (stowed at the top surface of the undercover) through hole (A) in the undercover.
3. Set a container under drain hose (1) to catch the drained fuel.
4. Open drain valve (2) at the rear of the fuel tank and drain the water and sediment accumulated at the bottom of the tank together with the fuel.
5. When clean fuel comes out, close drain valve (2).
6. Remove drain hose (1) from hole (A) of the undercover and stow it at the top of the undercover.
7. Close the pump room door.

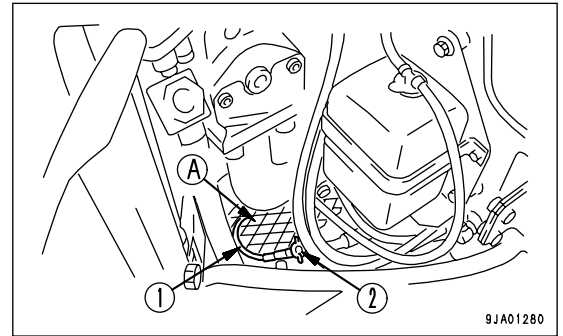

EVERY 100 HOURS MAINTENANCE

Maintenance for every 50 hours service should be carried out at the same time.

LUBRICATING

NOTICE

- If any abnormal noise is generated from any greasing point, carry out greasing regardless of the greasing interval.
- Carry out greasing of greasing points 1 - 7 every 10 hours for the first 100 hours on a new machine.

1. Set the work equipment in the greasing posture below, then lower the work equipment to the ground and stop the engine.
2. Using a grease pump, pump in grease through the grease fittings shown by arrows.
3. After greasing, wipe off any old grease that was pushed out.

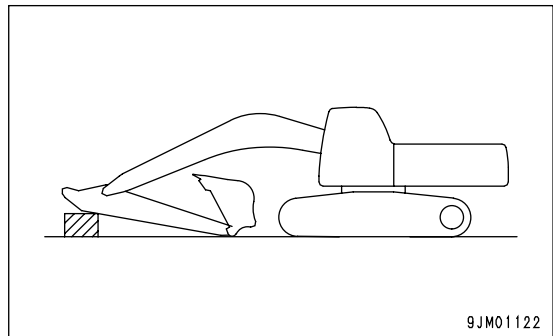

- (1) Boom cylinder foot pin (2 points)

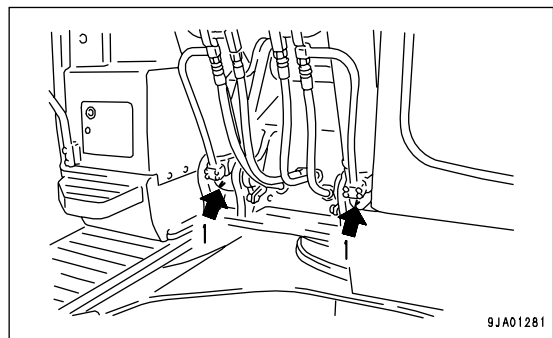

- (2) Boom foot pin (2 points)
- (3) Boom cylinder rod end (2 points)
- (4) Arm cylinder foot pin (1 point)

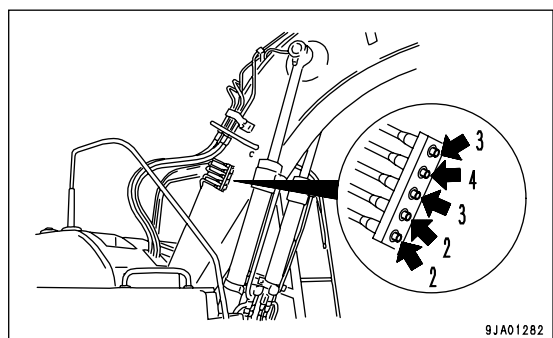

- (5) Boom-Arm coupling pin (1 point)
- (6) Arm cylinder rod end (1 point)
- (7) Bucket cylinder foot pin (1 point)

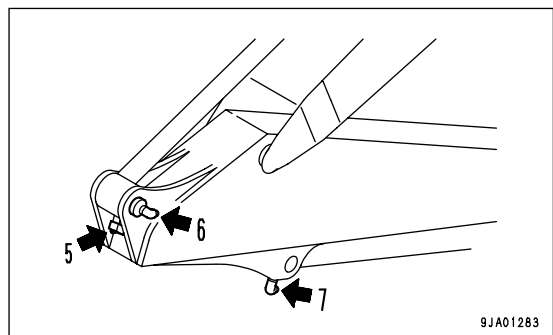

- (8) Arm-Link coupling pin (1 point)
- (9) Arm-Bucket coupling pin (1 point)

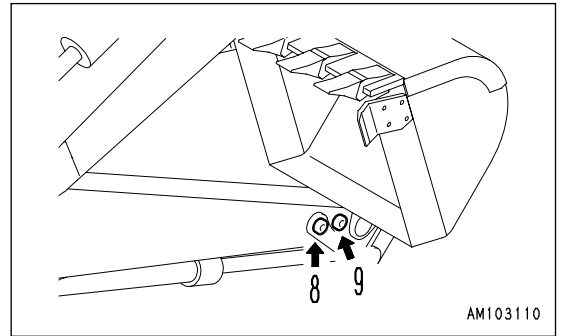

- (10) Link coupling pin (1 point)
- (11) Bucket cylinder rod end (1 point)
- (12) Bucket-Link coupling pin (2 points)

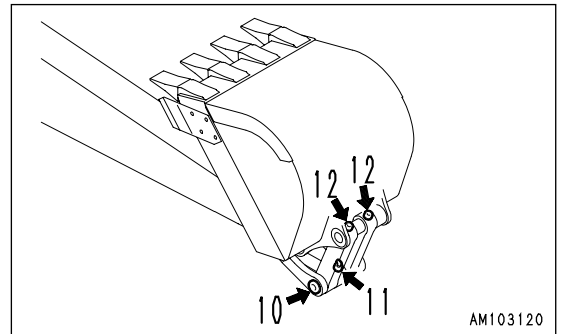

(Only machines with blade specification)

- (13) Blade cylinder rod end (1 point)
- (14) Blade cylinder foot pin (1 point)
- (15) Blade foot pin (2 points)

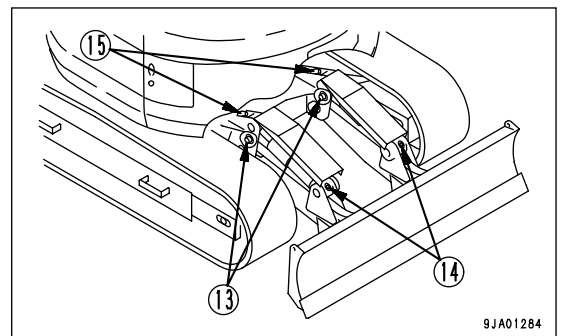

CHECK OIL LEVEL IN SWING MACHINERY CASE, ADD OIL

⚠ WARNING

The parts and oil are at high temperature after the engine is stopped, and may cause serious burns. Wait for the temperature to go down before starting the operation.

1. Remove dipstick (G) and wipe the oil from the dipstick with a cloth.
2. Insert dipstick (G) fully in the guide.
3. When dipstick (G) is pulled out, if the oil level is between the H and L marks of the gauge, oil level is proper.
4. If the oil does not reach the L mark on dipstick (G), add engine oil through dipstick insertion hole (F). When refilling, remove bleeding plug (1).
5. If the oil level exceeds the H mark on the dipstick, loosen drain plug (P) to drain the excess oil.
6. After checking oil level or adding oil, insert the dipstick into the hole and install air bleeding plug (1).

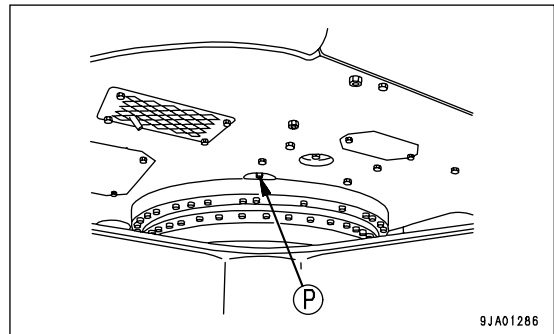
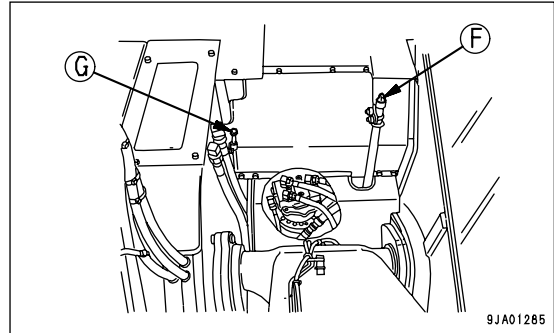

EVERY 250 HOURS MAINTENANCE

Maintenance for every 50 hours service should be carried out at the same time.

CHECK OIL LEVEL IN FINAL DRIVE CASE, ADD OIL

WARNING

- The parts and oil are at high temperature after the engine is stopped, and may cause serious burns. Wait for the temperature to go down before starting the operation.
- If there is still pressure remaining inside the case, the oil or plug may fly out. Loosen the plug slowly to release the pressure.

- Prepare a hexagonal wrench.
 1. Set so that plug (F) is at the top, with plug (F) and plug (P) perpendicular to the ground.
 2. Using a hexagonal wrench, remove plug (F) and check that the oil level is within a range from the bottom of the plug hole to a point 10 mm(0.4 in) below it.
 3. If the oil level is too low, install plug (F), operate the travel levers, and drive forward or in reverse to rotate the sprocket one turn. Then repeat Step 2 to check again.
 4. If the oil level is still too low, add engine oil through the hole in plug (F) until the oil overflows.
 5. After checking, install plug (F).

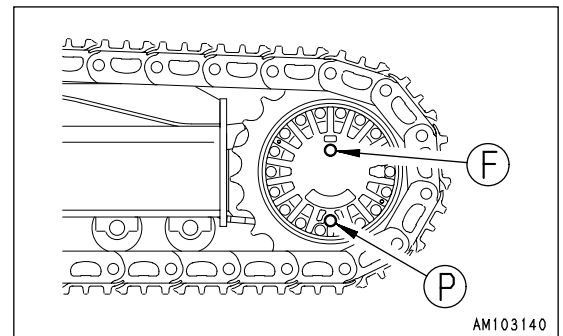

CHECK LEVEL OF BATTERY ELECTROLYTE

WARNING

- The battery generates flammable gas, and there is danger of explosion, so do not bring fire or sparks near the battery.
- Battery electrolyte is dangerous. If it gets in your eyes or on your skin, wash it off with large amounts of water, and consult a doctor.
- Do not use or charge the battery if the battery electrolyte level is below the LOWER LEVEL line. This may cause an explosion.
- Always check the battery electrolyte level periodically and add distilled water to bring the electrolyte level to the UPPER LEVEL line.

Carry out this operation before starting to operate the machine.

1. Open the battery room door on the left side of the machine.
2. Remove cap (2) and if the electrolyte is not at the maximum level (A), add distilled water.
 UPPER LEVEL (A): Bottom surface of skirt (3) of filler plug.
 LOWER LEVEL (B): 15 mm (0.6 in) above plate (4).
 - Do not add distilled water above UPPER LEVEL (A). This will cause leakage of electrolyte.
 - Do not use or charge the battery if the battery electrolyte level is below LOWER LEVEL (B). It may cause an explosion.
 If the electrolyte has spilled, add dilute sulfuric acid.
3. Clean the vents of the battery caps, then close the caps securely.
 Keep the top of the battery clean and wipe it with a wet cloth.

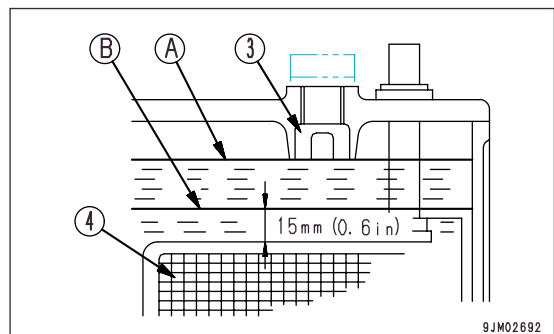
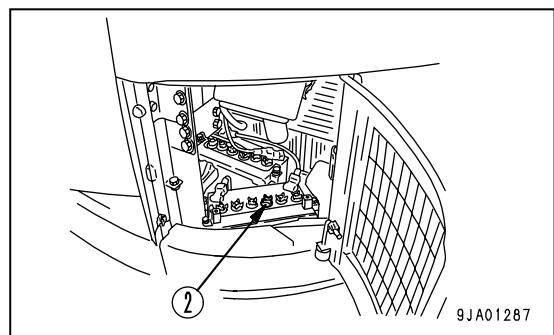
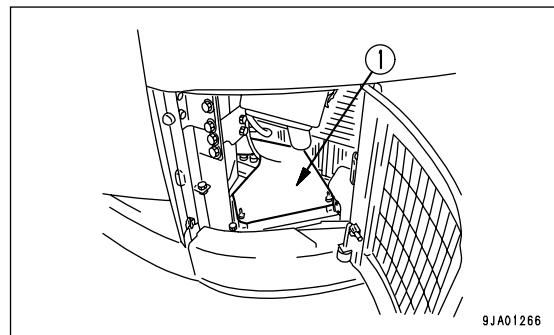

NOTICE

Add distilled water before starting work on the next day to prevent it from freezing.

CHANGE OIL IN ENGINE OIL PAN, REPLACE ENGINE OIL FILTER CARTRIDGE

⚠ WARNING

The parts and oil are at high temperature after the engine is stopped, and may cause serious burns. Wait for the temperature to go down before starting the operation.

Prepare the following:

- Container to catch drained oil: Min. 17 liters (4.49 US gal) capacity
 - Refill capacity of oil pan: 17 liters (4.49 US gal)
 - Filter wrench
1. Remove undercover (1) at the bottom of the machine, then set the container under drain valve (P) on the left side of the machine to catch the oil.
 2. Loosen drain plug (P) and drain the oil. Be careful not to get oil on yourself.
 3. Tighten drain plug (P).
 4. Open the pump room on the right side of the machine, then using the filter wrench, turn filter cartridge (2) to the left to remove it.
 5. Clean the filter holder, fill the new filter cartridge with clean engine oil, coat the packing surface and thread of the filter cartridge with engine oil (or coat it thinly with grease), then install the filter cartridge to the filter holder.

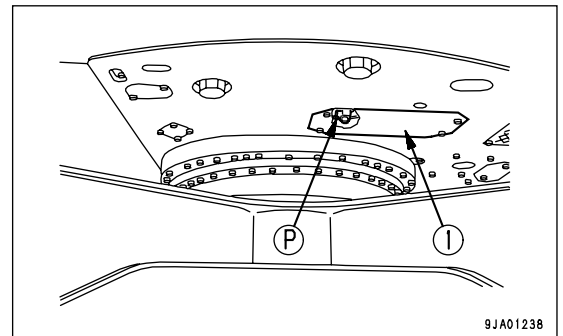

9JA01238

REMARK

Check that there is no old packing stuck to the filter holder. If there is any old packing remaining, it will cause oil leakage.

6. When installing, tighten until the packing surface contacts the filter holder, then tighten a further 3/4 turn.
7. After replacing the filter cartridge, add engine oil through oil filler port (F) so that the oil level is between the H and L marks on dipstick (G).
8. Run the engine at idling for a short time, then stop the engine and check again that the oil level is between the H and L marks on dipstick (G).
For details, see "CHECK OIL LEVEL IN ENGINE OIL PAN, ADD OIL (PAGE 3-45)".

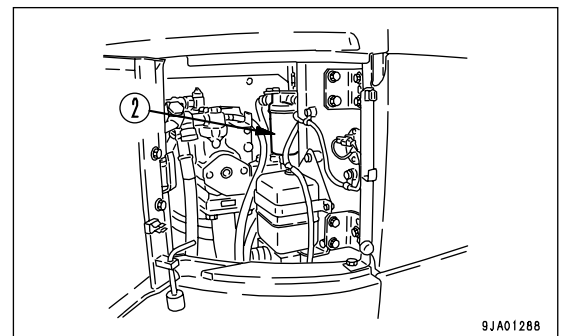

9JA01288

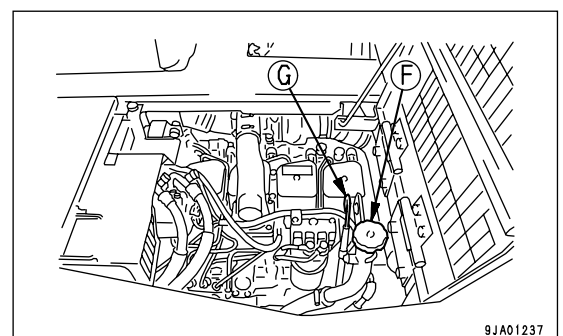

9JA01237

CHECK, ADJUST TENSION OF AIR CONDITIONER COMPRESSOR BELT

WARNING

If the fan guard has been removed, always be sure to install it again.
 If it is left removed, you may touch the belt and fan by accident and suffer serious injury.

Checking

1. Open the engine hood and remove fan guard (1).

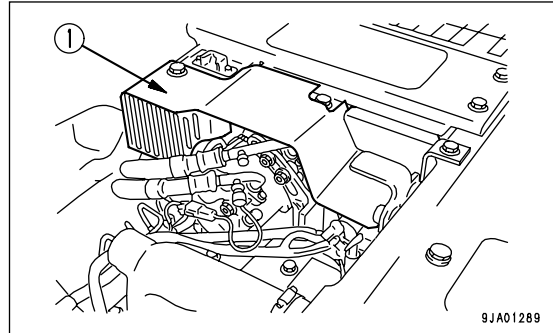

2. Press the belt at a point midway between the drive pulley and compressor pulley with a finger force of approx. 58.8 N (6 kgf) and check that the deflection is 5 - 8 mm (0.20 in - 0.31 in).

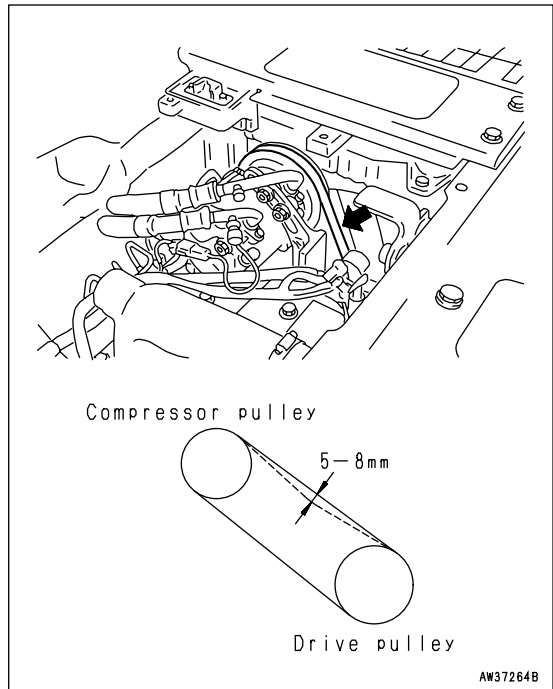

3. After completion of the inspection, install fan guard (1).

Adjusting

1. Remove fan guard (1).
2. Insert a bar between compressor (2) and the bracket (3) to fix compressor (2) in position. When fixing in position, put a piece of wood between the bar and compressor (2) to prevent damage to compressor (2).

NOTICE

When loosening bolt (4), be careful not to damage piping (6) of the air conditioner.

3. Loosen bolts (4) and (5).
4. Move compressor (2) with the tension adjusting bar so that the deflection of the belt will be 5 - 8 mm (approx. 58.8N(6kgf)).
5. Tighten bolts (4) and (5) to secure compressor (2). Then, take out the tension adjusting bar.
6. Check each pulley for damage, wear of the V-groove, and wear of the V-belt. In particular, be sure to check that the V-belt is not touching the bottom of the V-groove.
7. Replace belt if it has stretched, leaving no allowance for adjustment, or if there is a cut or crack on V-belt.

REMARK

When the new V-belt is set, readjust it after operation for an hour.

8. After completion of the adjustment, install fan guard (1).

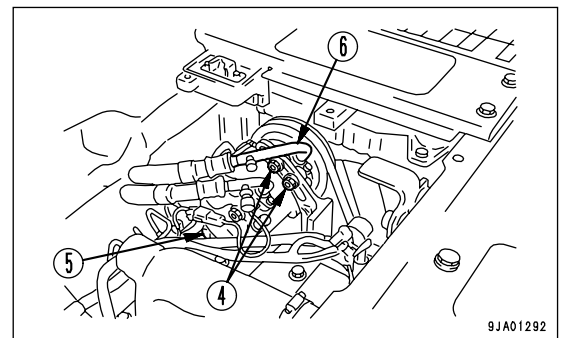
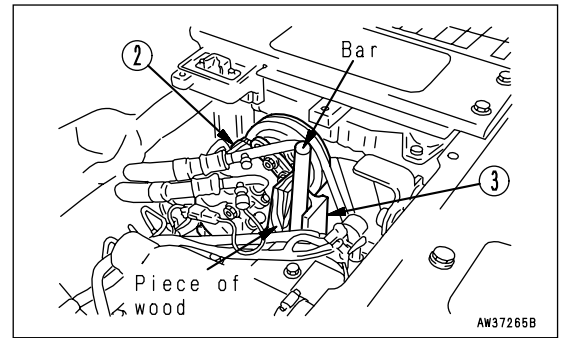

EVERY 500 HOURS MAINTENANCE

Maintenance for every 50, 100 and 250 hours service should be carried out at the same time.

REPLACE FUEL FILTER CARTRIDGE

⚠ WARNING

- The parts are at high temperature immediately after the engine has been operated. Wait for all parts to cool down before replacing the filter.
- Do not bring fire or sparks near the fuel.

Prepare a filter wrench and a container to catch the fuel.

1. Set the container to catch the fuel under the filter cartridge.
2. Using a filter wrench, turn filter cartridge (1) counterclockwise to remove it.
3. Clean the filter holder, fill a new filter cartridge with clean fuel, coat the packing surface with engine oil, then install it to the filter holder.
4. After bringing the packing surface into contact with the seal surface of the filter holder, tighten it a further 2/3 turns.

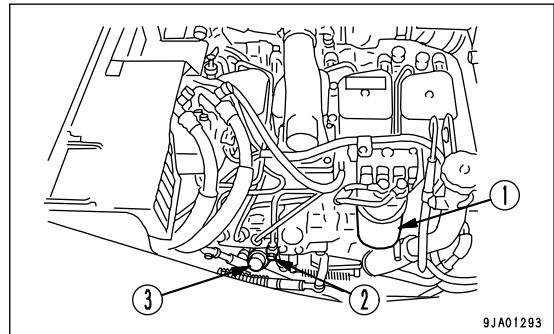

NOTICE

If the filter cartridge is tightened too far, the packing will be damaged and this will lead to leakage of fuel. If the filter cartridge is too loose, fuel will also leak from the packing, so always tighten to the correct amount.

5. After replacing the fuel filter cartridge, bleed the air from the system. Bleed the air as follows.
6. Fill the fuel tank with fuel (to the position where the float is at the highest position).
7. After replacing filter cartridge (1), loosen air bleed plug (2).
8. Loosen the knob of feed pump (3), pump it up and down, and continue to make the fuel overflow until no more bubbles come out from joint bolt (2).
9. Tighten joint bolt (2).
Always use a genuine Komatsu filter cartridge.
After replacing the filter cartridge, start the engine and check for any leakage of oil from the filter seal surface.

CHECK SWING PINION GREASE LEVEL, ADD GREASE

Prepare a scale.

1. Remove bolts (1) (2 bolts) on the top of the revolving frame and remove cover (2).
2. Insert a scale into the grease and check that the height of the grease in the portion where the pinion passes is at least 4 mm (0.2 in). Add more grease if necessary.
3. Check if the grease is milky white. If it is milky white, it is necessary to change the grease. Please contact your Komatsu distributor.

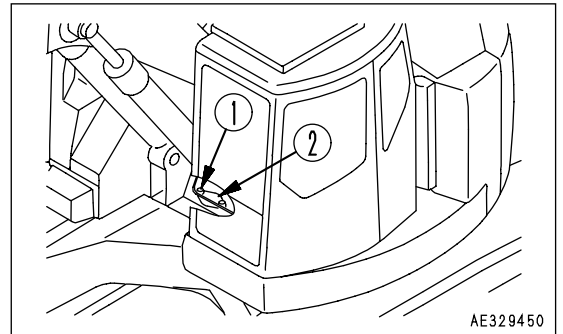

The total amount of grease is 10 liters (9.1 kg) (2.64 US gal, [20 lb]).

4. Install cover (2) with bolts (1).

LUBRICATE SWING CIRCLE (2 POINTS)

1. Lower the work equipment to the ground.
2. Using a grease gun, pump in grease through the grease fittings shown by arrows.
3. After greasing, wipe off all the old grease that was pushed out.

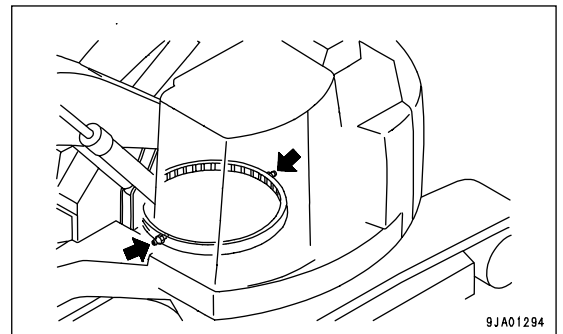

CLEAN AND INSPECT RADIATOR FINS, OIL COOLER FINS AND CONDENSER FINS (ONLY FOR MACHINES EQUIPPED WITH AIR CONDITIONER)

WARNING

If compressed air, high-pressure water, or steam hit your body directly, or they cause dirt or dust to be blown up, there is a hazard of serious injury. Always use safety glasses, dust mask, or other protective equipment.

NOTICE

When using compressed air, if the nozzle is brought too near the fins, the fins may be damaged. Carry out the cleaning from a reasonable distance to prevent damage to the fins.

Do not direct the jet directly at the core. If the fins are damaged, it will cause leakage of water and overheating. On dusty jobsites, carry out this inspection every day, regardless of the maintenance interval.

1. Open the cover at the rear of the cab and the battery room door at the left side of the machine.
2. Use compressed air to clean the mud, dust, and leaves from the radiator fins, oil cooler fins, and condenser fins. Steam or water may be used instead of compressed air.
3. Check the rubber hose. Replace with a new one if the hose is found to have cracks or to be hardened by ageing. Further, check hose clamps for looseness.

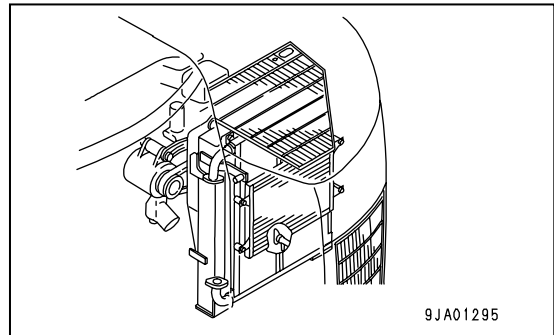

CLEAN INTERNAL AND EXTERNAL AIR FILTERS OF AIR CONDITIONER SYSTEM (ONLY FOR MACHINES EQUIPPED WITH AIR CONDITIONER)

WARNING

If compressed air, high-pressure water, or steam hit your body directly, or they cause dirt or dust to be blown up, there is a hazard of serious injury. Always use safety glasses, dust mask, or other protective equipment.

NOTICE

- The guide for cleaning the filter is 500 hours, but if the machine is used on an extremely dusty jobsite, reduce the maintenance interval and clean the filter more frequently.
- When washing the floor, be careful not to get water on the air conditioner system.

1. Remove cover (1).
2. Loosen wingnut (1), remove cover (2), then pull filter (3) out to the front to remove it.
3. Clean filter (3) with compressed air. If there is oil stuck to the filter or it is extremely dirty, wash it in a neutral agent. After washing, dry it thoroughly before using it again.
4. Clean sponge filter (4) (1 each installed at the front and rear) in the same way.

REMARK

If the clogging of the filter cannot be removed by blowing with compressed air or washing in water, replace the filter with a new part.

5. Install cleaned filter (4) and sponge filter (5).
6. Install cover (3) with wing nut (2).
7. Install cover (1).

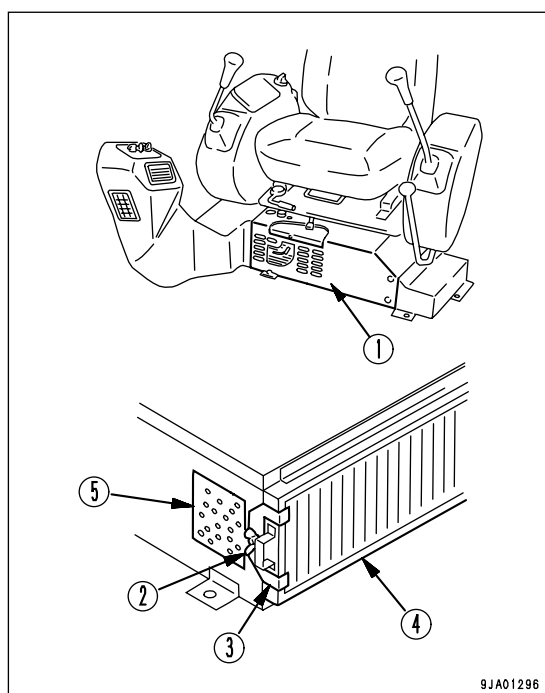

9JA01296

REPLACE HYDRAULIC FILTER ELEMENT

⚠ WARNING

- The parts and oil are at high temperature after the engine is stopped, and may cause serious burns. Wait for the temperature to go down before cleaning the hydraulic tank strainer.
- When the oil filler cap is removed, oil may spurt out, so turn the cap slowly to release the internal pressure, then remove it carefully.

NOTICE

If the machine is equipped with a hydraulic breaker, the hydraulic oil will deteriorate much faster than during normal bucket operations. For details, see "MAINTENANCE INTERVAL FOR HYDRAULIC BREAKER (PAGE 4-18)" when carrying out maintenance.

1. Remove the cover at the top of the hydraulic tank.
2. Remove the cap from oil filler (F), and release the internal pressure.
3. Loosen 4 bolts, then remove cover (1). When doing this, the cover may fly out under the force of spring (2), so hold the cover down when removing the bolts.
4. After removing spring (2) and valve (3), take out element (4).
5. Clean the removed parts in diesel oil.
6. Install the new element in the place where old element (4) was installed.
7. Set valve (3) and spring (2) on top of the element.
8. Set cover (1) in position, push it down by hand, and install the cover with the mounting bolts.
9. Install the oil filler cap, then install the cover at the top of the hydraulic tank.
10. To bleed the air, start the engine according to "STARTING ENGINE (PAGE 3-55)" and run the engine at low idling for 10 minutes.
11. Stop the engine.

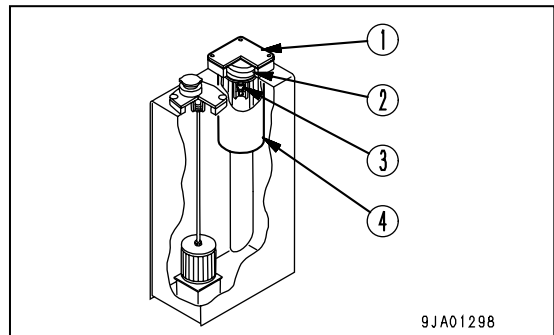
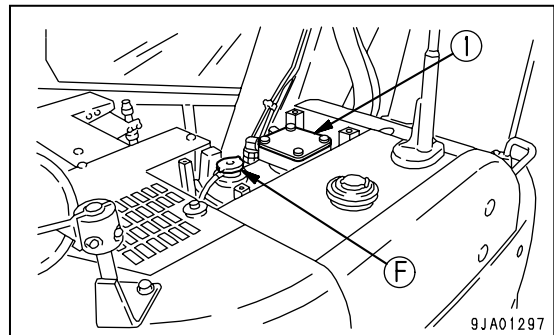

REMARK

Wait for at least 5 minutes after stopping the engine to eliminate bubbles in the oil inside the tank.

12. Check for oil leakage and wipe off any spilled oil.

EVERY 1000 HOURS MAINTENANCE

Maintenance for every 50, 100, 250 and 500 hours service should be carried out at the same time.

CHANGE OIL IN SWING MACHINERY CASE

WARNING

The parts and oil are at high temperature after the engine is stopped, and may cause serious burns. Wait for the temperature to go down before starting the operation.

- Container to catch drained oil: Min. 2.5 liters capacity
 - Refill capacity: 2.5 liters (0.66 US gal)
1. Set an oil container under drain valve (P) under the machine body.
 2. Loosen drain valve (P) under the body, drain the oil, then tighten the drain valve again.
 3. Remove drain plug (P) at the bottom of the machine, drain the oil, then tighten the drain plug again.
Tightening torque for drain plug: 44.1 to 93.1 N•m
(4.5 to 9.5 kgf•m,
32.5 to 68.7 lbft)
 4. Remove dipstick (G) and the cap of oil filler (F), then add the specified amount of engine oil from oil filler (F).
 5. Wipe off oil on the dipstick with a cloth.
 6. Insert dipstick (G) into the gauge pipe thoroughly and then pull out it again.
 7. When the oil level is between the H and L marks, on dipstick (G), it is normal. If the oil does not reach the L mark, add more oil through oil filler (F).
 8. If the oil level exceeds the H mark, drain the excess engine oil from drain valve (P), and check the oil level again.

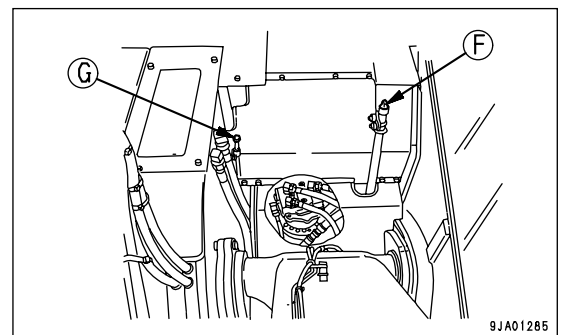
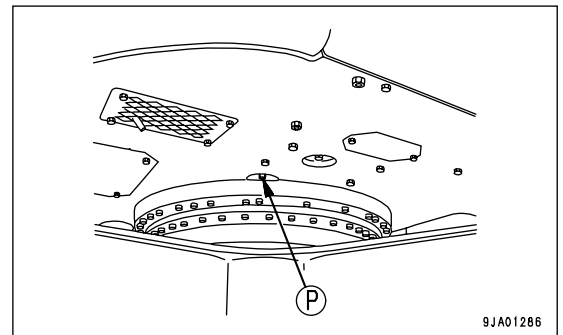

CHANGE OIL IN FINAL DRIVE CASE

WARNING

- The oil is at high temperature after the engine is stopped. Wait for the temperature to go down before starting the operation.
- If there is pressure remaining inside the case, the oil or plug may fly out. Loosen the plug slowly to release the pressure.

- Container to catch drained oil: Min. 2.5 liters capacity
 - Refill capacity (each): 2.5 liters (0.66 US gal)
 - Hexagon wrench (Width across flats: 8 mm (0.3 in))
1. Set plug (F) at the top, with plug (F) and plug (P) perpendicular to the ground surface.
 2. Set a container under plug (P) to catch the oil.
 3. Remove plugs (P) and (F) with the hexagon wrench and drain the oil.

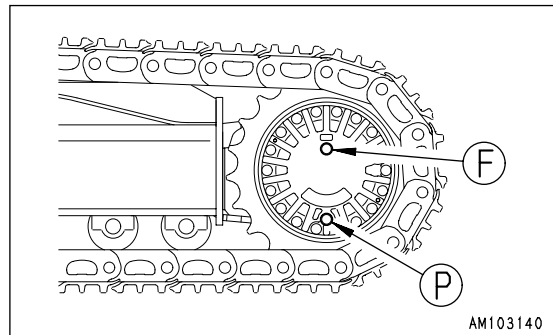

REMARK

Check the O-rings in the plugs for damage. If necessary, replace with new ones.

4. Tighten plug (P).
5. Add engine oil through the hole of plug (F).
6. When the oil overflows from the hole of plug (F), install plug (F).

CHECK ALL TIGHTENING PARTS OF TURBOCHARGER

Contact your Komatsu distributor to have the tightening portions checked.

CHECK PLAY OF TURBOCHARGER ROTOR

Ask Komatsu distributor to check the play of the turbocharger rotor.

CHECK FAN BELT TENSION AND REPLACE FAN BELT

Special tools are required for inspection and replacement of the fan belt. Contact your Komatsu distributors for inspection and replacement.

EVERY 2000 HOURS MAINTENANCE

Maintenance for every 50, 100, 250, 500 and 1000 hours service should be carried out at the same time.

CHECK OIL LEVEL IN PTO GEAR CASE, ADD OIL

WARNING

The parts and oil are at high temperature after the engine is stopped, and may cause serious burns. Wait for the temperature to go down before starting the operation.

1. Swing the upper structure so that the PTO gear case is in the middle between the left and right tracks. Stop the engine and set the safety lock lever to the LOCK position.
2. Remove undercover (1) at the bottom of the machine.

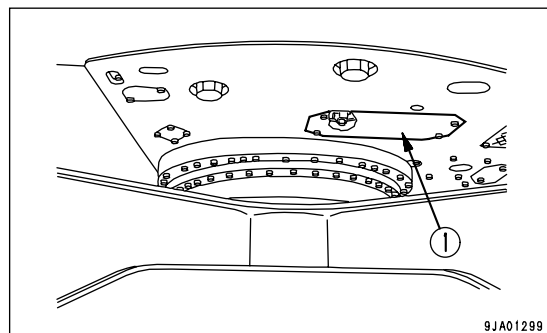

3. Remove oil inspection plug (G) and check that the oil is near the bottom of the plug hole.

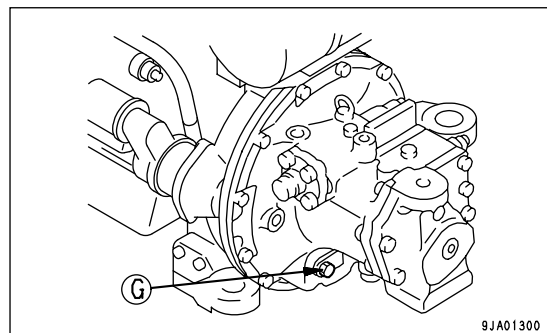

4. If the oil level is low, open the pump room door on the right side of the machine, remove the plug from oil filler (F), and add oil. Add oil until the oil level is close to the bottom of the hole of oil inspection plug (G).

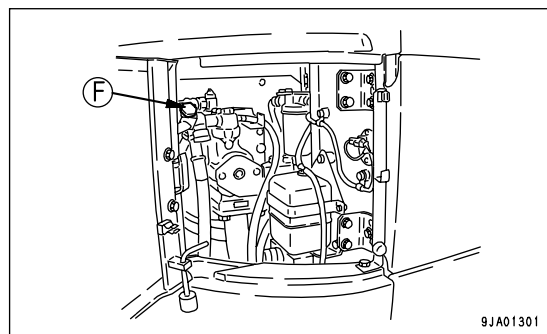

5. Install oil inspection plug (G) and the plug of oil filler (F).
6. Install cover (1).

CLEAN HYDRAULIC TANK STRAINER

WARNING

- The parts and oil are at high temperature after the engine is stopped, and may cause serious burns. Wait for the temperature to go down before cleaning the hydraulic tank strainer.
- When the oil filler cap is removed, oil may spurt out, so turn the cap slowly to release the internal pressure, then remove it carefully.

1. Loosen 4 bolts, then remove cover (1).
When doing this, the cover may fly out under the force of spring 2, so push the cover down when removing the bolts.
2. Pull up the top of rod (3), and remove spring (2) and strainer (4).
3. Remove the dirt stuck to strainer (4), then wash it in clean diesel oil or flushing oil.
If strainer (4) is damaged, replace it with a new one.
4. Refit strainer (4) by inserting it into tank projecting part (5).
5. Install cover (1) with bolts.

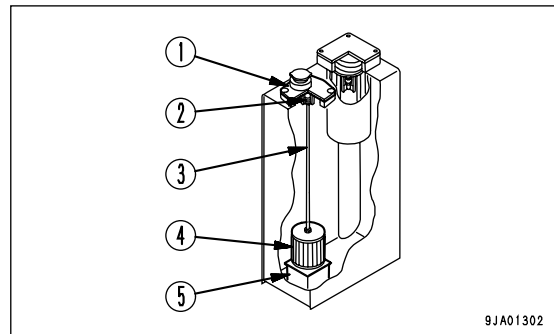

CLEAN, CHECK TURBOCHARGER

Contact your Komatsu distributor for cleaning or inspection.

CHECK ALTERNATOR, STARTING MOTOR

The brush may be worn, or the bearing may have run out of grease, so contact your Komatsu distributor for inspection or repair.

If the engine is started frequently, carry out inspection every 1000 hours.

CHECK ENGINE VALVE CLEARANCE, ADJUST

As special tool is required for removing and adjusting the parts, you shall request Komatsu distributor for service.

EVERY 4000 HOURS MAINTENENCE

Maintenance for every 50, 100, 250, 500, 1000 and 2000 hours service should be carried out at the same time.

CHECK WATER PUMP

Since the pulley may have play, oil may leak, water may leak and the drain hole may be clogged, contact your Komatsu distributor for inspection, overhaul or replacement.

EVERY 5000 HOURS MAINTENANCE

Maintenance for every 50, 100, 250, 500 and 1000 hours service should be carried out at the same time.

CHANGE OIL IN HYDRAULIC TANK

⚠ WARNING

The oil is at high temperature immediately after the machine has been operated. Wait for the oil to cool down before changing the oil.

When removing the oil filler cap, turn it slowly to release the internal pressure, then remove it carefully.

NOTICE

If the machine is equipped with a hydraulic breaker, the hydraulic oil will deteriorate much faster than during normal bucket operations. For details, see "MAINTENANCE INTERVAL FOR HYDRAULIC BREAKER (PAGE 4-18)" when carrying out maintenance.

Prepare the following.

- Container to catch drained oil: min. 69 liters capacity
 - Refill, capacity: 69 liters (18.22 US gal)
 - Prepare a handle for the socket wrench set.
1. Swing the upper structure so that the drain plug under the hydraulic tank comes at the middle of the left or right track.
 2. Retract the arm and bucket cylinders to the stroke end, then lower the boom and put the bucket teeth in contact with the ground.
 3. Lock the safety lock lever and stop the engine.
 4. Remove cover (1) at the top of the hydraulic tank.
Remove the cap of oil filler (F) over the hydraulic tank.

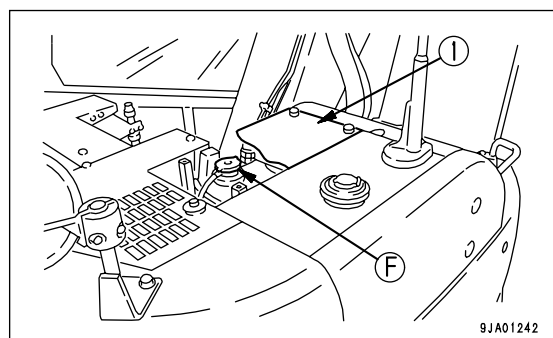
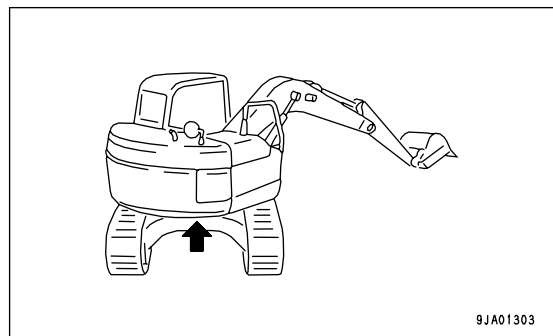

5. Set the oil container under the drain plug under the machine. Using the handle, remove drain plug (P) and drain the oil.
Check the O-ring installed to plug (P), and if it is damaged, replace the O-ring. After draining the oil, tighten drain plug (P).
Tightening torque: $69 \pm 10 \text{ N}\cdot\text{m}$ ($7 \pm 1 \text{ kgf}\cdot\text{m}$, $51 \pm 7 \text{ lbft}$).

When removing drain plug (P), be careful not to get oil on yourself.

6. Add the specified amount of engine oil through oil filler port (F).
Check that the oil level is between H and L on the sight gauge.

For details of the method of bleeding the air, see "CHECK OIL LEVEL IN HYDRAULIC TANK, ADD OIL (PAGE 3-47)".

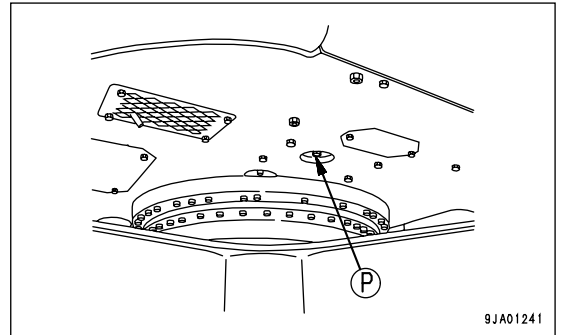

SPECIFICATIONS

SPECIFICATIONS

	Item	Unit	PC128US-2	PC128US-2 blade specification
	Operating weight	kg (lb)	13,100 (28,886)	13,600 (29,988)
	Bucket capacity	m ³ (cu.yd)	0.45 (0.58)	
	Name of engine		KOMATSU S4D102E diesel engine	
	Engine horsepower	kW (HP)/rpm	64 (86) / 2,200	
A	Overall length	mm (ft in)	7,220 (23'8")	
A'	Overall length (Blade specification)	mm (ft in)	7,955 (26'1")	
B	Overall height	mm (ft in)	2,850 (9'4")	
C	Overall width	mm (ft in)	2,590 (8'6")	
D	Track width	mm (ft in)	600 (1'12")	
E	Height of cab	mm (ft in)	2,730 (8'11")	
F	Radius of upper structure	mm (ft in)	1,480 (4'10")	
G	Length of track	mm (ft in)	3,480 (11'5")	
H	Tumbler center distance	mm (ft in)	2,750 (9')	
	Min. ground clearance	mm (ft in)	390 (1'2")	
	Travel speed (Low/High)	km/h (MPH)	3.2/5.1 (2/3.1)	
	Swing speed	rpm	10.5	

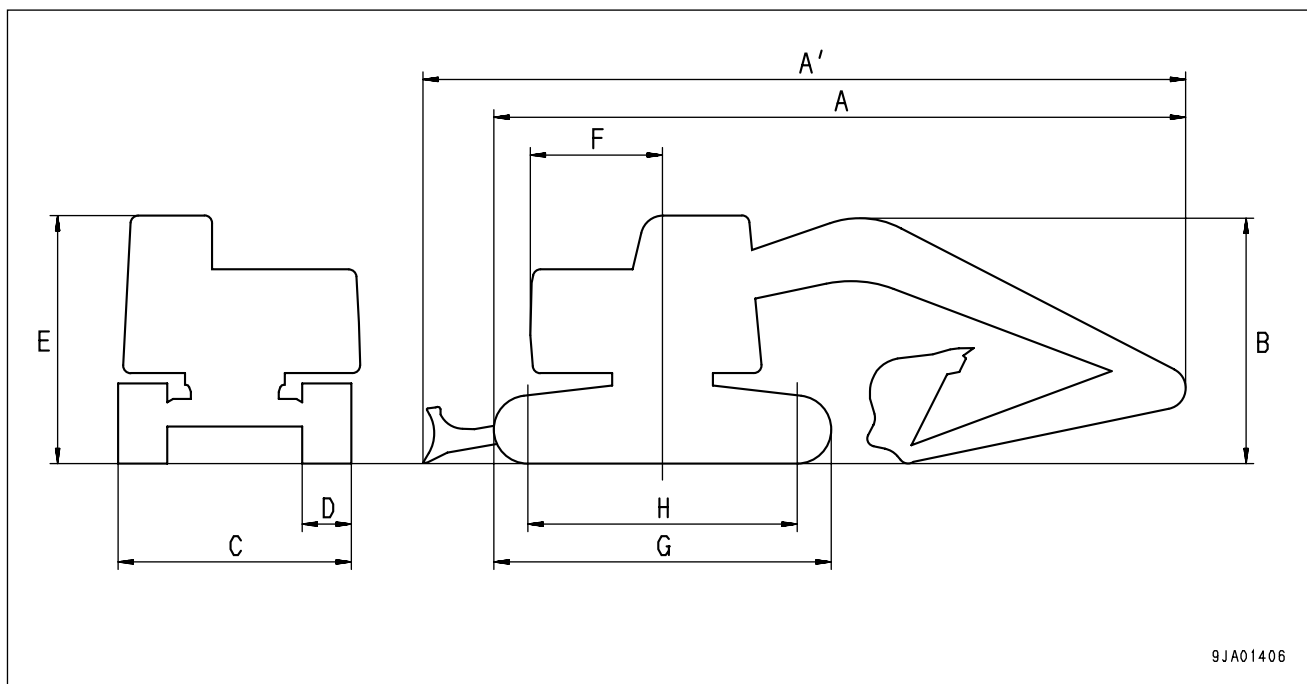

9JA01406

	Working ranges	Unit	PC128US-2
A	Max. digging reach	mm (ft in)	8230 (27')
B	Max. digging depth	mm (ft in)	5445 (17'10")
C	Max. digging height	mm (ft in)	9220 (30'3")
D	Max. vertical wall depth	mm (ft in)	4900 (16'1")
E	Max. dumping height	mm (ft in)	6870 (22'6")
F	Min. dumping height	mm (ft in)	-
G	Max. reach at ground level	mm (ft in)	8110 (26'7")

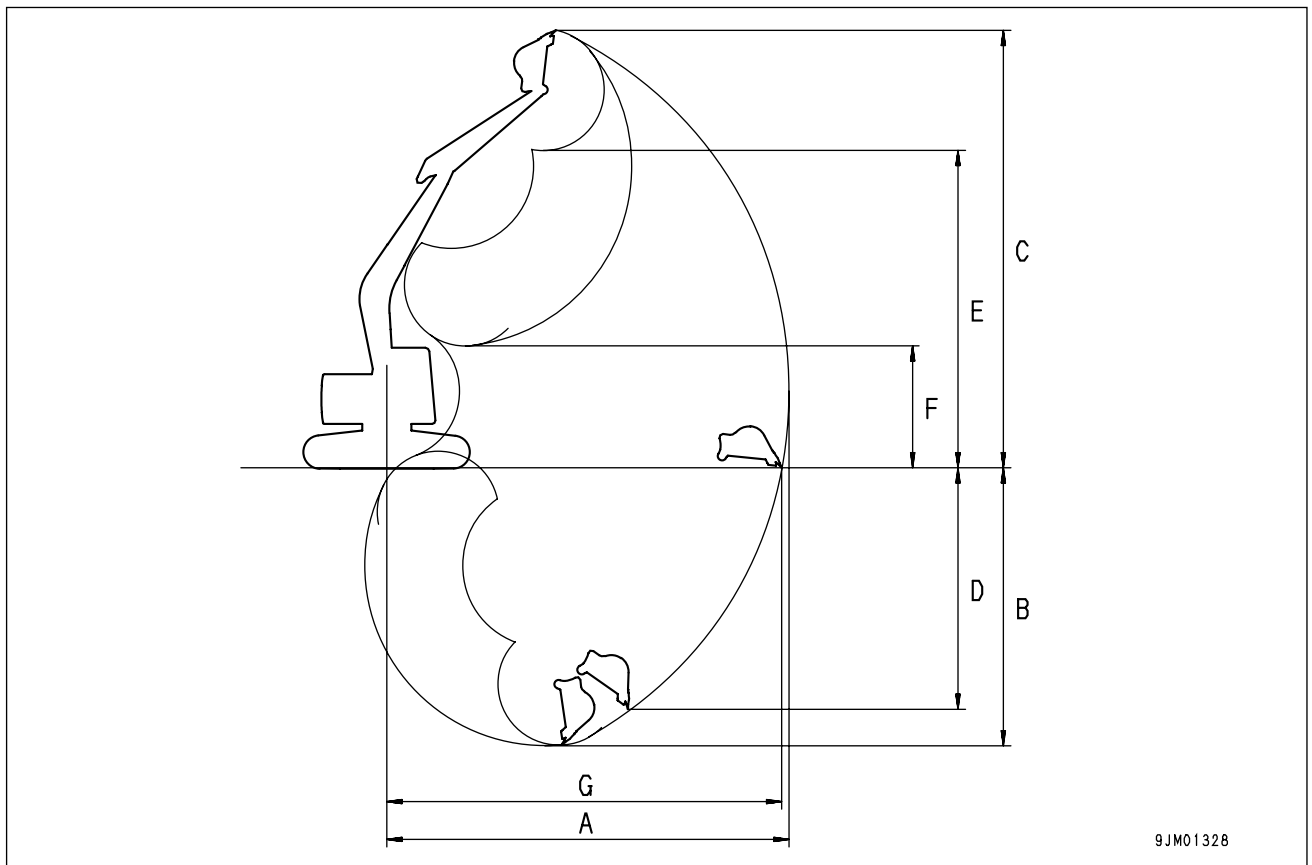

ATTACHMENTS AND OPTIONS

 **WARNING**

Please read and make sure that you understand the safety volume before reading this section.

GENERAL PRECAUTIONS

PRECAUTIONS RELATED TO SAFETY

If attachments or options other than those authorized by Komatsu are installed, this will not only affect the life of the machine, but will also cause problems with safety.

When installing attachments not listed in this Operation and Maintenance Manual, contact your Komatsu distributor first.

If you do not contact Komatsu, we cannot accept any responsibility for any accidents or failures.

WARNING

General precautions

- **Read the instruction manual for the attachment thoroughly, and do not use this attachment unless you are sure that you have understood the guides completely.**
If you lose the instruction manual, always ask the manufacturer or attachment sales company for a new copy.
- **Depending on the attachment, install the necessary front guard to the machine.**
- **Depending on the attachment, the impact noise may make it difficult for fellow workers to transmit instructions for the operation. Before starting operation, decide a leader and determine the signals to be used.**
- **Do not carry out swinging operations to the side with a heavy load on the attachment. This is particularly dangerous on slopes.**
- **Compared with a machine equipped with a bucket, a machine equipped with a breaker has a heavy load at the front of the work equipment and is unstable. To avoid the danger of tipping over, do not carry out operations with the attachment swung to the side.**
- **When an attachment is installed, the swing range and center of gravity of the machine are different, and the machine may move in an unexpected way. Be sure that you understand the condition of the machine properly.**
- **Before starting operations, set up a fence around the machine to prevent people from entering. Never operate the machine when there are people near the machine.**
- **To prevent serious accidents caused by misoperation, do not put your foot on the pedal except when operating the pedal.**

⚠ WARNING**Precautions for removal and installation operations**

When removing or installing the attachment, always do as follows to ensure safety in the operation.

- Carry out the removal and installation operation on firm, level ground.
- When carrying out the operation with two or more workers, determine the signals and follow these during the operation.
- Always use a crane when you lift or carrying heavy objects (more than 25kg or 55 lb).
- When removing heavy components, always support the component before removing it. When lifting with a crane, be particularly careful about the position of the center of gravity.
- It is dangerous to carry out operations with a load left raised by a crane. Always prepare a stand and ensure that the condition is safe.
- When leaving an attachment removed or when installing the attachment, make sure that it is in a stable condition and cannot fall over.
- Never go under a load raised by a crane. Stay in a safe place where there is no danger if the load should fall.

NOTICE

Qualifications are required to operate a crane. Never allow the crane to be operated by an unqualified person.

For details of removal and installation operations, contact your Komatsu distributor.

PRECAUTIONS WHEN INSTALLING ATTACHMENTS

WARNING

Long work equipment reduces the stability of the machine, so if the swing is operated on a slope, or when going down a steep hill, the machine may lose its balance and overturn.

The following operations are particularly dangerous, so never operate the machine in these ways.

- Traveling downhill with the work equipment raised
- Traveling across slopes
- Swing operations on slopes
- If heavy work equipment is installed, the overrun of the swing becomes greater (the distance from the point where the operator operates the control levers to stop the swing to the point where the upper structure stops completely), so there is danger of mistaking the distance and hitting something.
Always operate so that there is an ample margin to the stopping point.
Furthermore, the hydraulic drift also becomes larger (when the work equipment is stopped in mid-air, it will gradually move down under its own weight).
- Always follow the correct procedure when installing the boom and arm.
If the correct procedure is not followed, this may lead to serious damage or injury, so consult your Komatsu distributor before carrying out installation.

If long work equipment is installed, the working range will suddenly become larger, so there is danger of mistaking the distance and hitting something.
Always operate the work equipment so that there is ample space from any obstacles in the area.

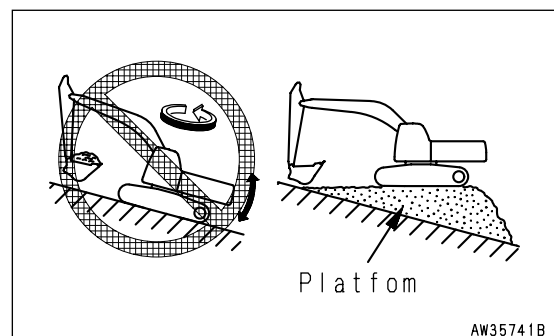
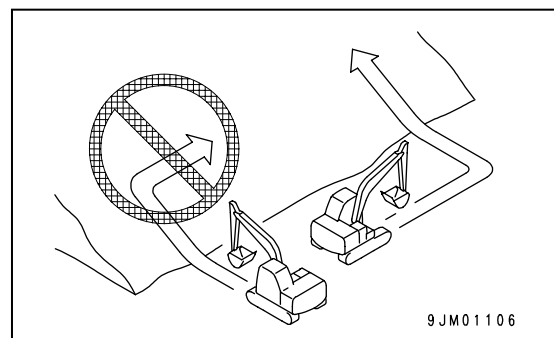
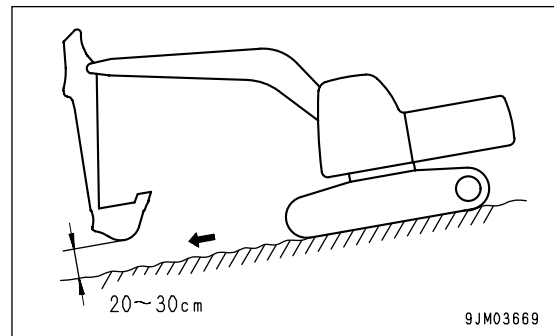

HANDLING BUCKET WITH HOOK

CHECKING FOR DAMAGE TO BUCKET WITH HOOK

Check that there is no damage to the hook, stopper, or hook mount. If there is any abnormality, contact your Komatsu distributor.

PROHIBITED OPERATIONS

PRECAUTIONS DURING OPERATIONS

- When carrying out lifting operations, reduce the engine speed and use the lifting operation mode.
- Depending on the posture of the work equipment, there is the danger that the wire or load may slip off the hook.

Always be careful to maintain the correct hook angle to prevent this from happening.

- Never steer the machine while lifting a load.
- If the bucket with hook is turned and used for operations, it will hit the arm during dumping operations, so be careful when using it.

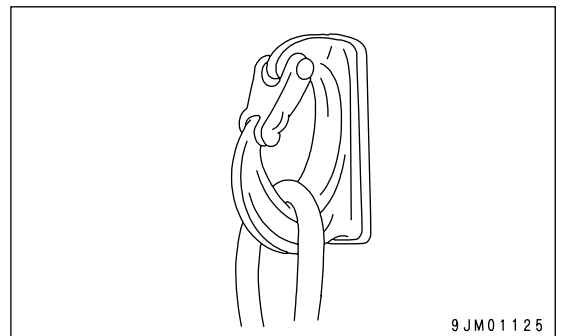
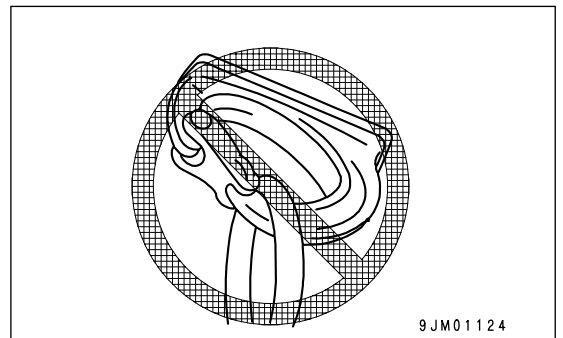

- If you are planning to install a hook, contact your Komatsu distributor.

HANDLING CAR HEATER

EXPLANATION OF COMPONENTS

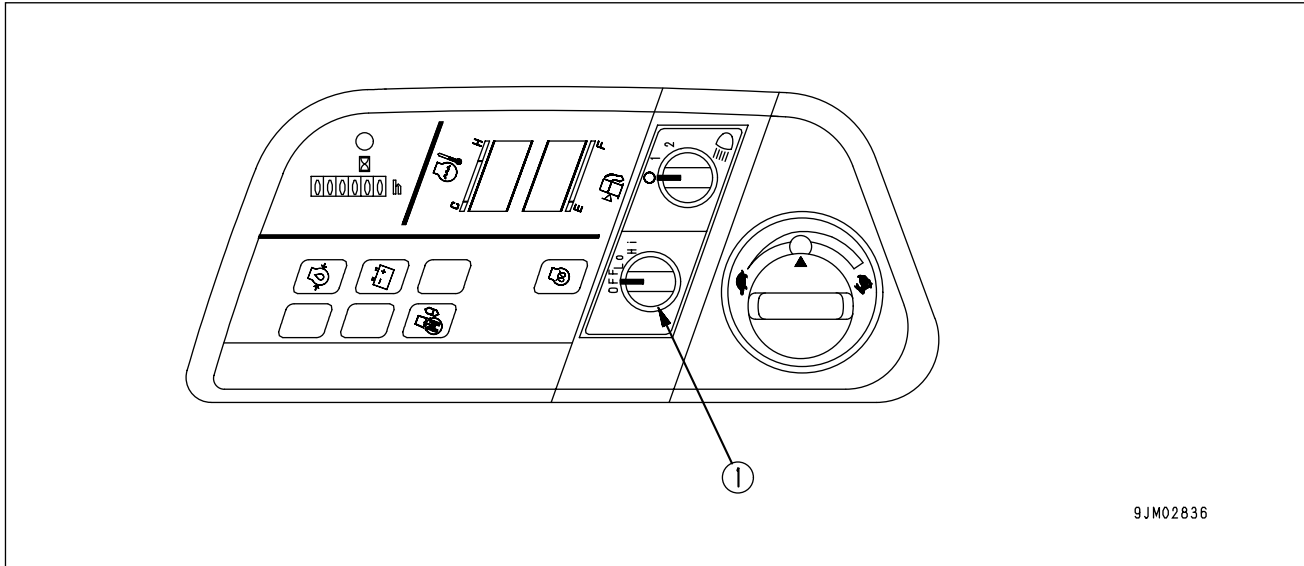

9JM02836

The car heater utilizes the water heated by the engine. Use the car heater when the engine coolant is warmed.

CAR HEATER FAN SWITCH

This switch(1) adjusts air-flow in 2 steps.

- Hi : Strong
- Lo : Weak
- OFF : Car heater turned off.

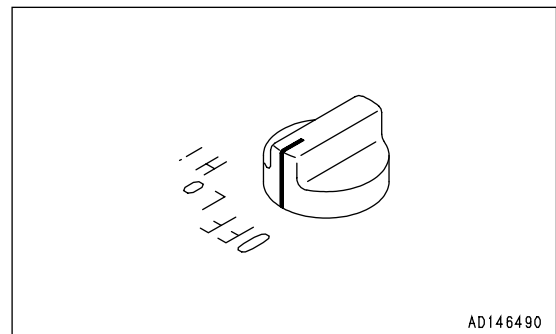

AD146490

PREPARING CAR HEATER

If the ambient temperature drops, use the cab heater.

When using the cab heater, turn valve (1) on the water pump counterclockwise to open it.

When leaving the cab heater unused for a long time, turn valve (1) clockwise to close it.

REMARK

On machines equipped with the air conditioner system, always open valve (1).

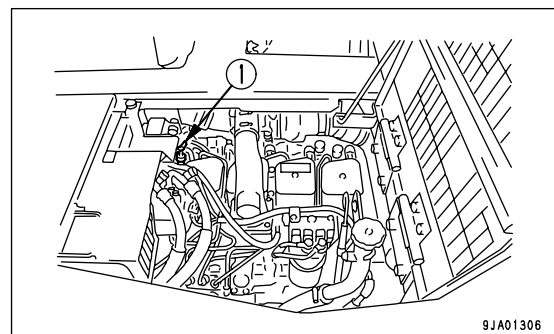

9JA01306

MACHINES READY FOR ATTACHMENTS

EXPLANATION OF COMPONENTS

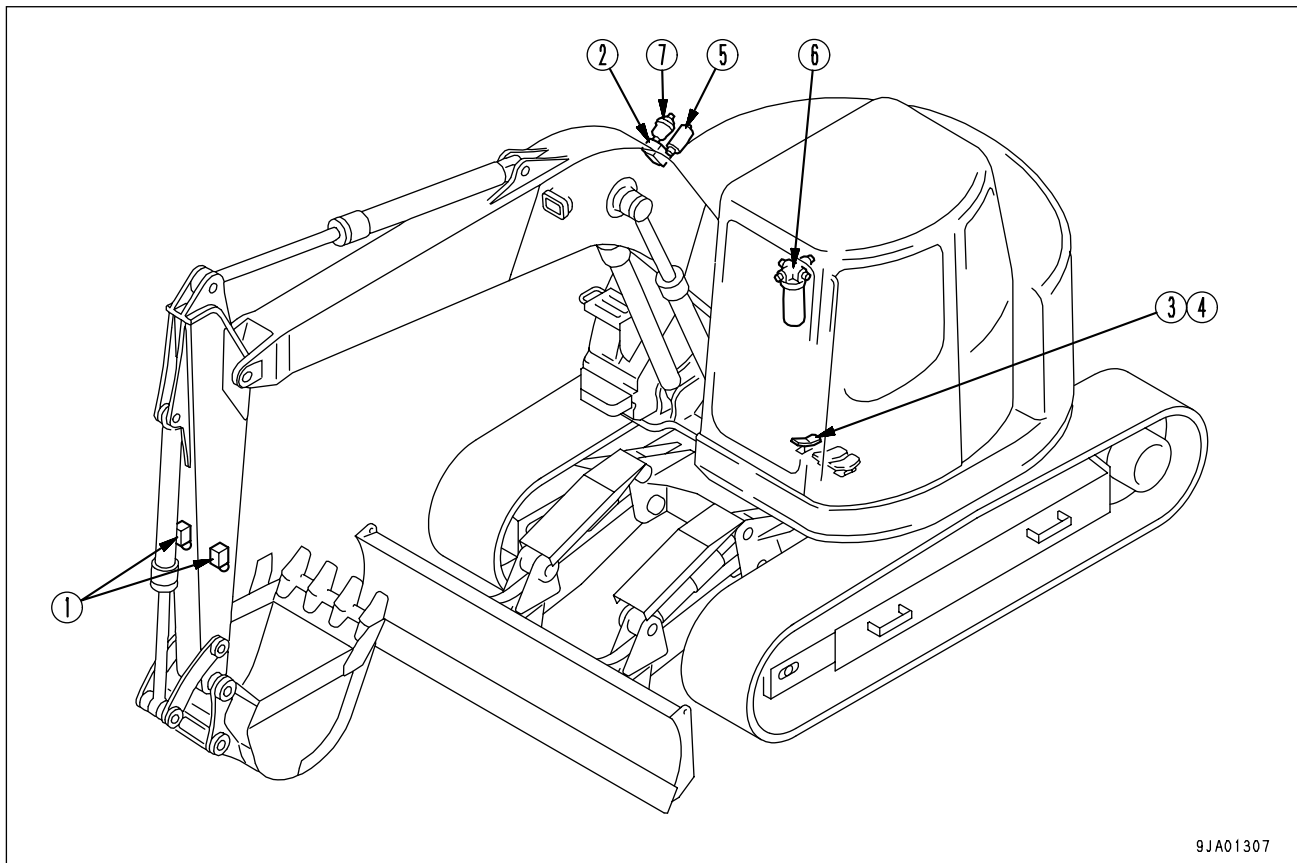

9JA01307

- (1) Stop valve
- (2) Selector valve
- (3) Attachment control pedal
- (4) Lock pin
- (5) Accumulator (for attachment out circuit)
- (6) Additional filter for breaker
- (7) Accumulator (for attachment return circuit)

STOP VALVE

This valve (1) stops the flow of the hydraulic oil.

- (a) FREE: Hydraulic oil flows
- (b) LOCK: Hydraulic oil stops

Set this valve to the LOCK position when removing or installing attachments.

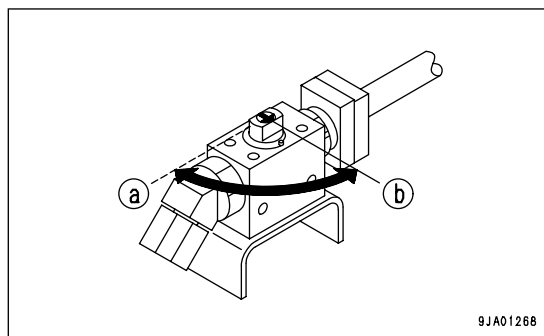

9JA01268

SELECTOR VALVE

This valve (2) selector the flow of the hydraulic oil.

Position (a): When breaker is used

Position (b): When general attachment is used (crusher, etc.)

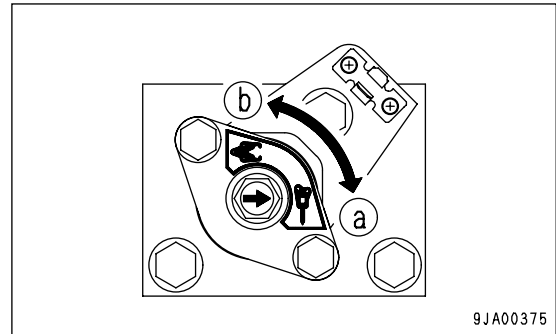

ATTACHMENT CONTROL PEDAL

This pedal is used to operate the attachment.

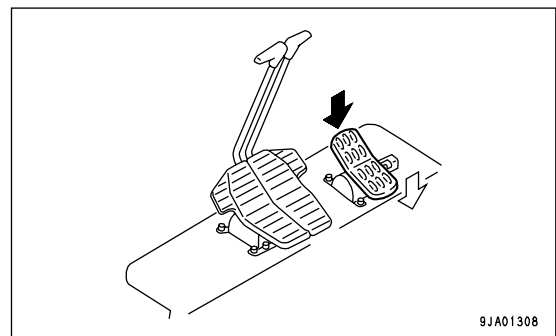

LOCK PIN

This is used to lock the control pedal.

Position (a): lock

Position (b): Pedal half stroke position (when using a breaker, slide arm, or other attachment using a small flow)

Position (c): Pedal full stroke position (when using a crusher, power ripper, or other attachment using a large flow)

Set the lock pin at the lock position when attachment is not used.

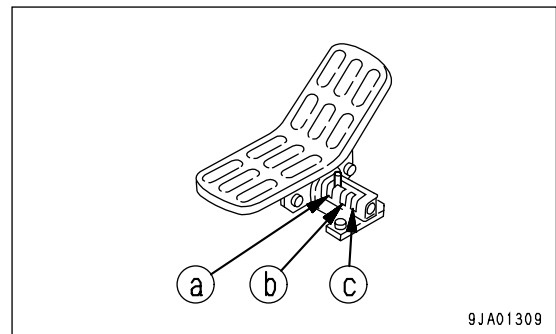

ACCUMULATOR (FOR ATTACHMENT OUT CIRCUIT) (IF EQUIPPED)

Accumulator (5) is installed to ensure the number of blows of the breaker when the pump discharge pressure pulse drops when the breaker is used. It also acts to protect the pump.

Consult with your attachment maker to decide if it is possible to install the accumulator.

Table of additional circuits, parts supplied with breaker

(○: These parts must be installed)

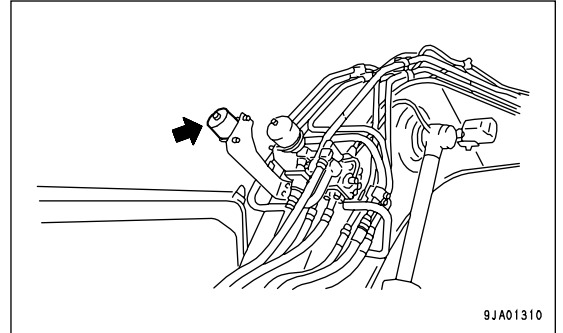

	Additional filter	Accumulator		Low-pressure safety valve	
		Attachment circuit	Control circuit	Main valve	Selector valve
Hydraulic breaker	○	○ (Attachment out/ return circuit)	○	○	○

- Low-pressure safety valve cracking pressure

Main valve: 24.53 MPa (250 kg/cm²)

Selector valve: 17.17 MPa (175 kg/cm²)

ADDITIONAL FILTER FOR BREAKER

This filter (6) prevents deterioration of the hydraulic oil when the breaker is used.

Oil flows only when the selector valve is turned to the breaker position.

NOTICE

When installing a breaker, always install an additional filter to the return circuit.

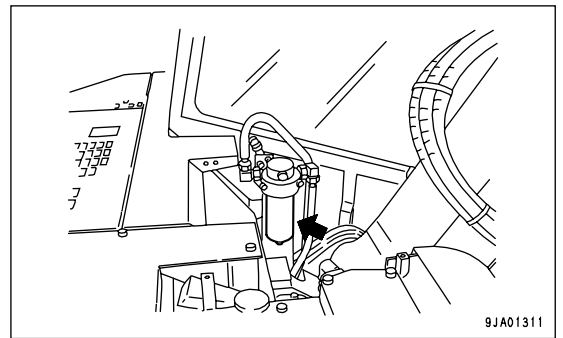

ACCUMULATOR (FOR ATTACHMENT RETURN CIRCUIT) (option)

This accumulator (7) is installed to protect the oil cooler when the breaker is used.

Consult with your attachment maker to decide if it is necessary to install the accumulator.

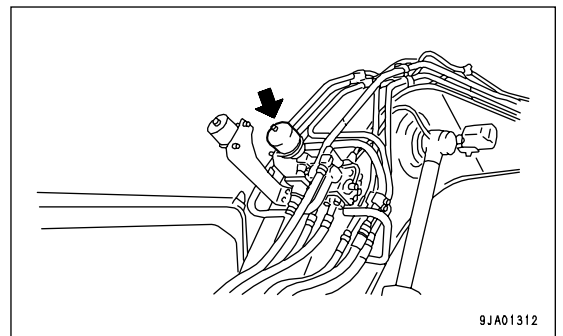

HYDRAULIC CIRCUIT

HYDRAULIC CIRCUIT CONNECTION

When connecting the attachment, connect the hydraulic circuit as follows.

One Line Attachment

1. Check that the stop valve is locked, then remove plug. Be careful not to lose or damage any parts that are removed.
2. Connect the attachment piping supplied by the attachment manufacturer.
Depending on the piping for the attachment, it may be necessary to remove nipple.
The dimensions for nipple 2 and elbow 3 for the attachment at the stop valve end are as shown in the diagram on the right; for details of the dimensions at the attachment end, please consult the attachment manufacturer.
3. After connecting the piping, bleed the air from the circuit.
 - 1) Start the engine and run it at low idling for 10 minutes. For details, see "STARTING ENGINE (PAGE 3-55)". Then carry out the following operation.
 - 2) Run the engine at low idling until the air in the attachment circuit is completely removed, then operate the attachment pedal repeatedly (approx. 10 times) to bleed the air.

NOTICE

If the attachment maker specifies an air bleeding procedure for the attachment itself, follow the specified procedure to bleed the air.

- 3) After completing the bleeding of the air, stop the engine, and wait for at least 5 minutes before starting operations.
This will release the bubbles in the oil inside the tank.
- 4) Check that there is no oil leakage, and wipe off any oil that has been spilled.

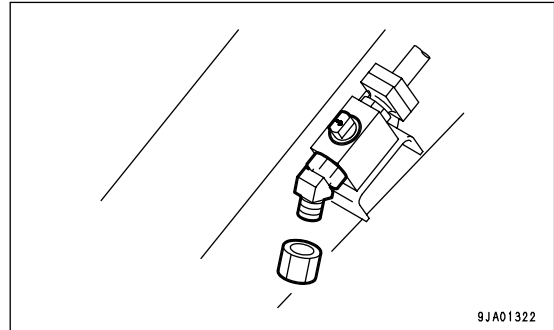

9JA01322

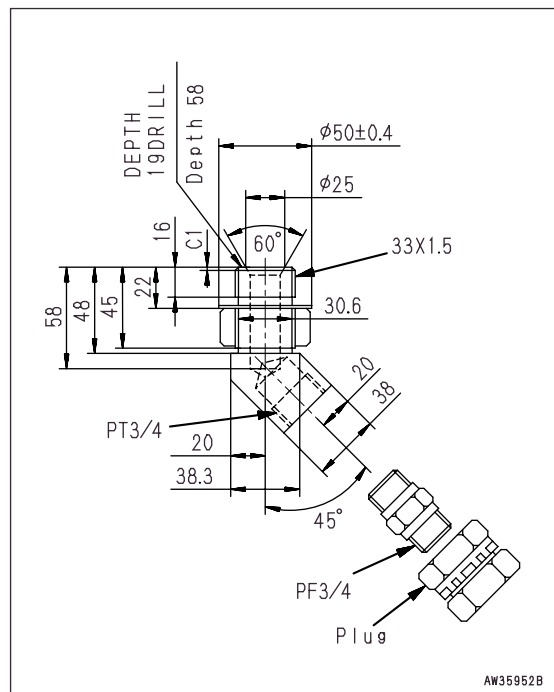

AW35952B

ATTACHMENT MOUNTING/DISMOUNTING PROCEDURE

DISMOUNTING PROCEDURE

1. Place the attachment on the ground and stop the engine.
2. After stopping the engine, operate each work equipment control lever and the attachment control pedal back and forth, left and right at full stroke 2 to 3 times to eliminate the internal pressure in the hydraulic circuit.
3. After confirming low oil temperature, turn the rotor of the stop valve connected to the inlet and outlet piping on the arm side face toward the lock side.
4. Remove the hoses on the attachment side. Install the blind plugs to the two outlets.

The blind plugs are used to prevent the attachment from incorrect operation caused by mixing in of foreign matter. After the plugs are correctly installed, store the attachment.

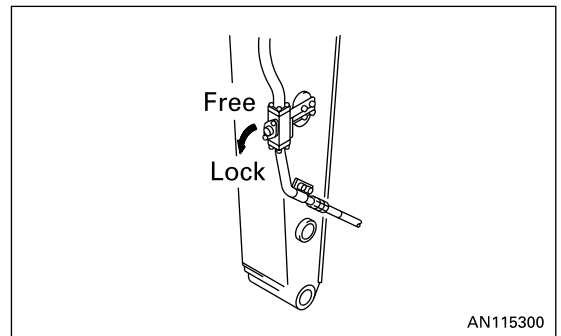

5. Dismount the attachment by removing the retaining pins (2 pins). Then, mount the bucket. For the bucket mounting procedure, see "REPLACEMENT AND INVERSION OF BUCKET (PAGE 3-81)".
6. After the bucket is mounted, check the hydraulic oil level.

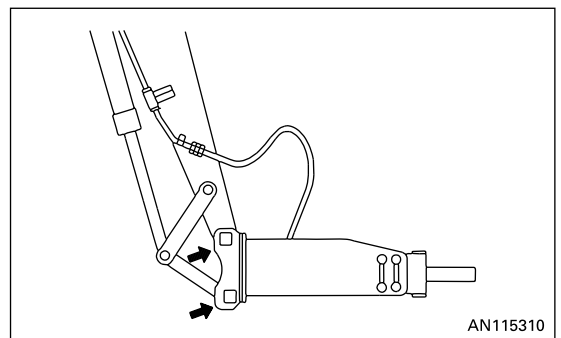

MOUNTING PROCEDURE

1. Remove the bucket.
For bucket dismounting procedure, see "REPLACEMENT AND INVERSION OF BUCKET (PAGE 3-81)".
2. Place the attachment on a flat place, install pins (A) and (B) to the arm in that order.
3. After mounting the attachment, stop the engine. Operate each work equipment control lever and the attachment control pedal to full stroke back and forth, right and left to eliminate the internal pressure in the hydraulic circuit.
4. After confirming low oil temperature, remove the blind plug from the outlet and inlet port respectively.

Take care that no dust, mud etc. adheres to the hose mouse-piece portions.

If O-ring is damaged, replace it with a new one.

5. Turn the rotor of the stop valve connected to the inlet and outlet piping on the arm side face toward the free side.
6. Confirm that oil level in the hydraulic oil tank is correct, after mounting the attachment.

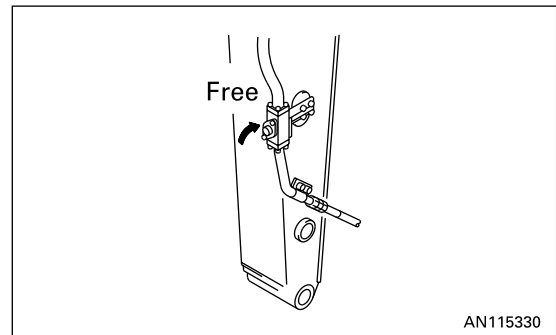
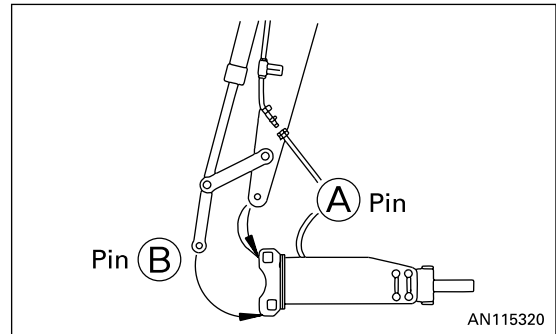

OPERATION

⚠ WARNING

Do not put your foot on the pedal except when operating the pedal. If rest your foot on the pedal during operations, and it is depressed by accident, the attachment may move suddenly and cause serious damage or injury.

The operation of the attachment is as follows.

WHEN USING BREAKER

NOTICE

If breaker operations are carried out with lock pin (1) at full stroke position (c), it will cause overheating and damage to the hydraulic equipment. Never carry out breaker operations with the pin in this position.

1. Set lock pin (1) to half stroke position (b) and operate the pedal to the front to operate the breaker.
2. After completion of operations, set the lock pin to LOCK position (a) to lock the pedal.

Precautions when using

- Check that the stop valve is at the FREE position.
- Check that the selector valve is at the position for using the breaker.
- Check that stopper bar (2) of the selector valve is installed to the breaker position.
- Consult with the attachment manufacturer as to whether the accumulator is required for the attachment circuit or not.
- For other precautions when using the breaker, see the instruction manual provided by the breaker manufacturer.
- When the breaker is used, the hydraulic oil degrades faster than in normal operation. Shorten the maintenance interval of the hydraulic oil and filter element. See "MAINTENANCE INTERVAL FOR HYDRAULIC BREAKER (PAGE 4-18)".

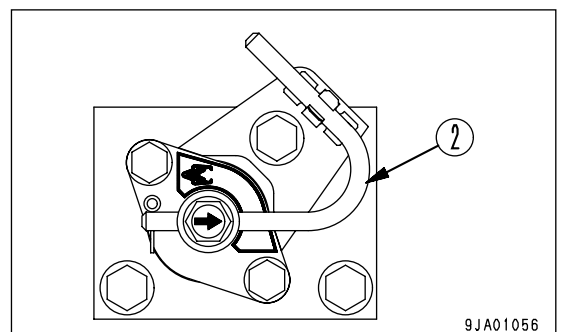
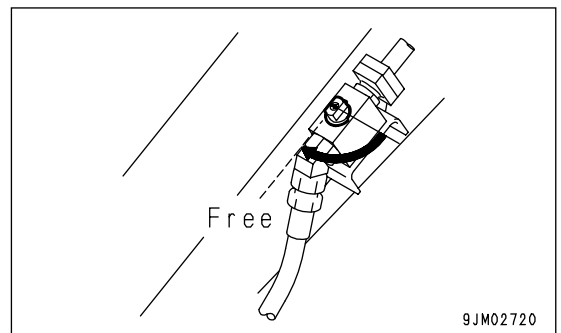
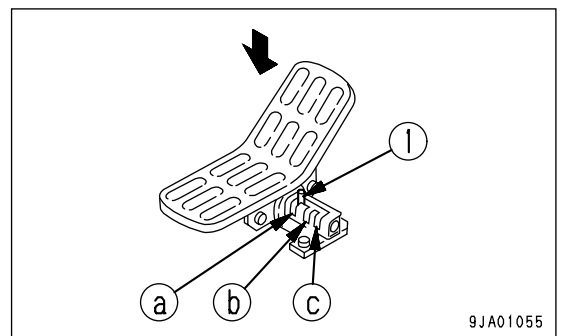

WHEN USING GENERAL ATTACHMENT SUCH AS CRUSHER

1. Set lock pin (1) to the full stroke position (c) and operate the pedal to operate the breaker.
2. After completion of operations, set the lock pin to LOCK position (a) to lock the pedal.

Precautions when using

- Check that the stop valve is at the FREE position.
- Confirm that the selector valve is set to the position for general attachments such as the crusher.

For details of the oil path, see "HYDRAULIC CIRCUIT (PAGE 6-10)".

- For other precautions when using the attachment, see the instruction manual provided by the attachment manufacturer.
- Check that stopper bar (2) of the selector valve is installed to the breaker position.

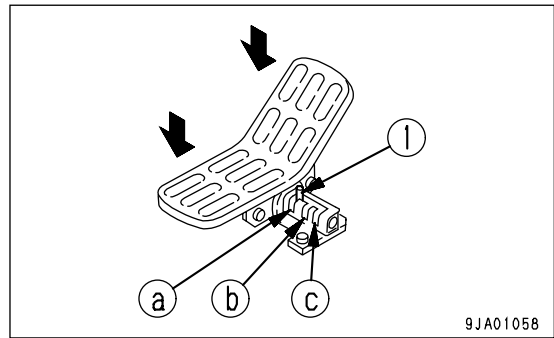

9JA01058

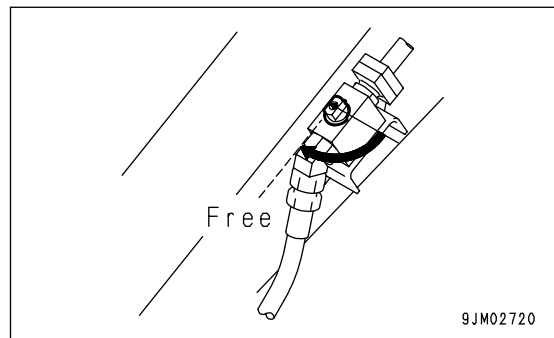

9JM02720

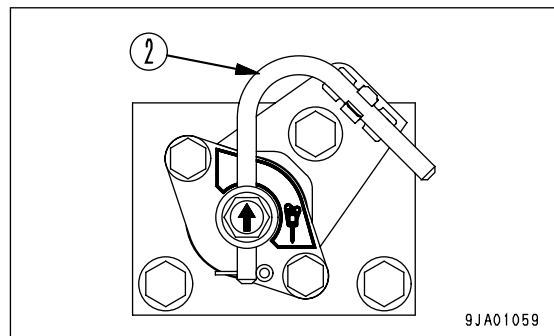

9JA01059

LONG-TERM STORAGE

If the equipment is not to be used for a long period, do as follows.

- Set the stop valve to the LOCK position.
- Install the blind plugs and O-rings to the valves.
- Set the selector valve to the "when not use" position.
- Lock the lock pin to the lock position.

If the pedal is operated when there is no breaker or general attachment installed, it will cause overheating and other problems.

SPECIFICATIONS

Hydraulic specifications

- Flow

Lock pin position		Flow
1	Pedal lock	-
2	Half stroke	100 liters (26.40 US gal)/min
3	Full stroke	200 liters (52.80 US gal)/min

- Safety valve cracking pressure

When using breaker: 17.17 MPa (175 kg/cm², 2485 PSI)

When using other attachments: 24.53 MPa (250 kg/cm², 3550 PSI)

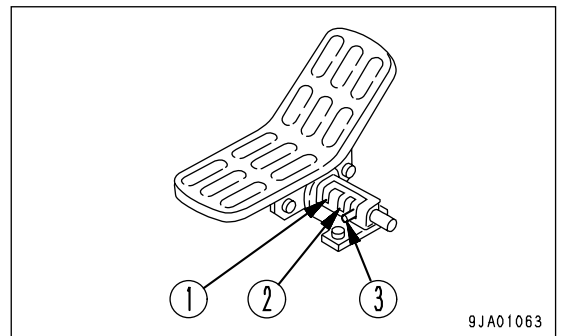

INTRODUCTION OF ATTACHMENTS

SPECIFICATION, USE

⚠ WARNING

- When installing and using an optional attachment, read the instruction manual for the attachment and the information related to attachments in this manual.
- When installing optional parts or attachments, there may be problems with safety, so contact your Komatsu distributor for advice.
- Do not use optional parts or attachments that are not authorized by Komatsu or your Komatsu distributor. Use of unauthorized attachments could create a safety problem and adversely affect the proper operation and useful life of the machine.
- Any injuries, accidents, product failures, or damage resulting from the use of unauthorized attachments will not be the responsibility of Komatsu.

INTRODUCTION OF OPTIONAL PARTS AND ATTACHMENTS

- Overhead guard
This is to protect the operator. Always use this when operating on jobsites where there is danger from rocks or other light falling objects.
- Front half guard
This is to protect the operator. Always use this when operating on jobsites where there is danger from rocks or sand or other flying objects. (Breaker operations, etc.)
- Front full guard
This is to protect the operator. Always use this when operating on jobsites where there is danger from rocks or sand or other flying objects. (Demolition work, etc.)

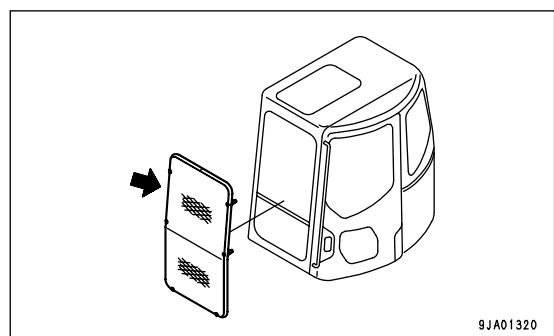
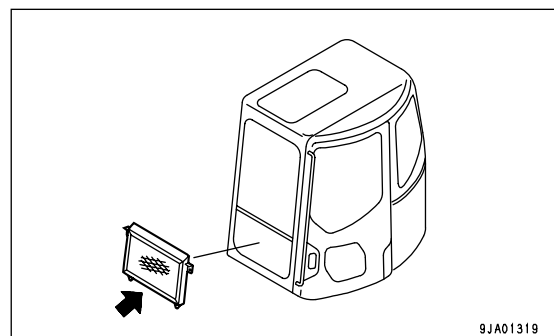
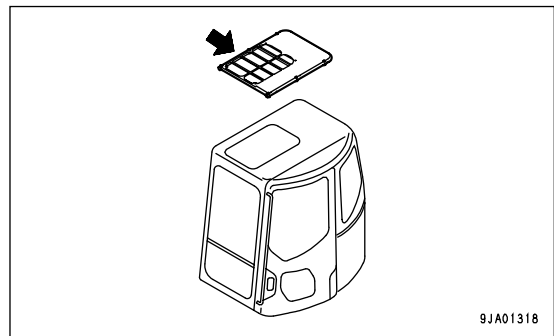

ATTACHMENT INSTALLATION COMBINATION TABLE

⚠ WARNING

Depending on the type or combination of work equipment, there is danger that the work equipment may hit the cab or machine body.

When using unfamiliar work equipment for the first time, check before starting if there is any danger of interference, and operate with caution.

ATTACHMENT COMBINATIONS

This table lists the combination of attachments which can be installed to the standard arm, short arm and long arm.

○ : Can be used

△ : Can be used only for light-duty work

× : Cannot be used

NOTICE

- When the long arm is equipped, if the bucket is pulled in to the machine body, the arm interferes with the body. Operate the long arm carefully.
- When the boom is fully lowered during oblique digging, the boom interferes with the undercarriage. Operate the boom carefully.

Categories of use

For general digging: Digging or loading sand, gravel, clay etc.

For light duty digging: Digging or loading dry, uncaked earth and sand, mud etc.

For loading work: Loading dry, loose earth and sand

Name	Tooth mounting pin	Capacity (m ³) SAE/CECE	Outside width (bucket body) (mm)	Outside width (side cutter) (mm)	Use	Standard arm	Short arm	Long arm
Narrow bucket	Vertical	0.18/0.16	450 (18")	570 (22")	Narrow digging	○	○	○
Narrow bucket	Vertical Horizontal	0.28/0.26	600 (24")	720 (28")	Narrow digging	○	○	○
Narrow bucket	Vertical Horizontal	0.36/0.33	700 (28")	820 (32")	Narrow digging	○	○	○
Standard bucket	Vertical Horizontal	0.44/0.40	833 (33")	953 (38")	General digging	○	○	×
Strengthened bucket	Vertical Horizontal	0.44/0.40	833 (33")	953 (38")	Heavy duty digging	○	○	×
Strengthened bucket	Vertical Horizontal	0.50/0.45	859 (34")	979 (39")	Heavy duty digging	○	○	×
Light duty bucket	Vertical Horizontal	0.55/0.50	859 (34")	-	General digging	○	○	×
Light duty bucket	Vertical Horizontal	0.60/0.55	1000 (39")	-	Loading	×	△	×

RECOMMENDED ATTACHMENT OPERATIONS

This section describes the necessary precautions to be observed when operating a hydraulic excavator equipped with an attachment.

NOTICE

Select the attachment most suited to the machine body.

- The machine models to which attachments can be mounted vary. For selection of attachment and machine model, consult your Komatsu distributor.

HYDRAULIC BREAKER

MAIN APPLICATIONS

- Crushed rock
- Demolition work
- Road construction

This attachment can be used for a wide range of work including demolition of buildings, breaking up of road surfaces, tunnel work, breaking up slag, rock crushing, and breaking operations in quarries.

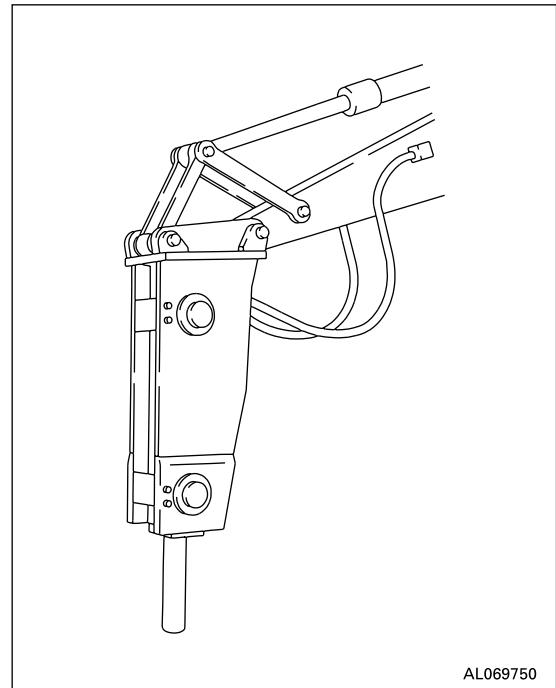

Keep the chisel pushed perpendicularly against the impact surface when carrying out breaking operations.

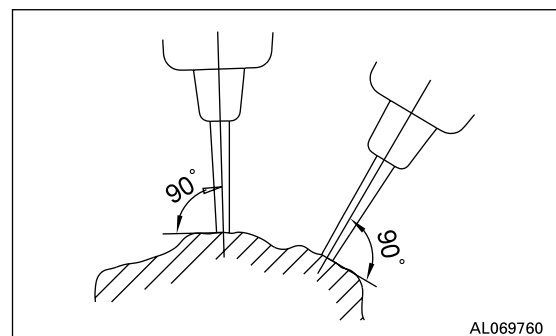

When applying impact, push the chisel against the impact surface and operate so that the chassis rises approx. 5 cm (2 in) off the ground. Do not let the machine come further off the ground than this amount.

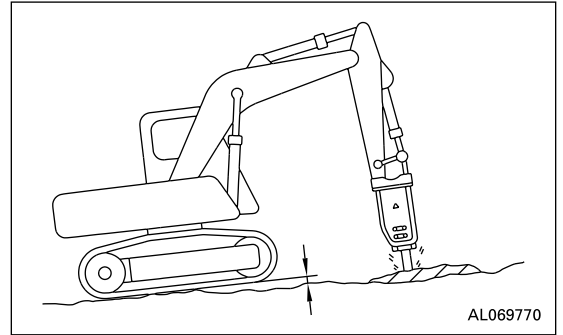

When applying continuous impact to the same impact surface, if the chisel does not penetrate or break the surface within 1 minute, change the point of impact and carry out breaking operations closer to the edge.

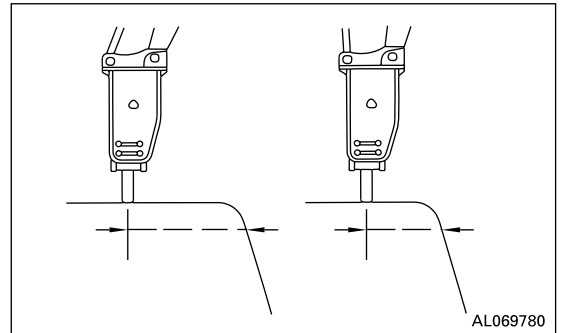

The direction of penetration of the chisel and the direction of the breaker body will gradually move out of line with each other, so always adjust the bucket cylinder to keep them aligned.

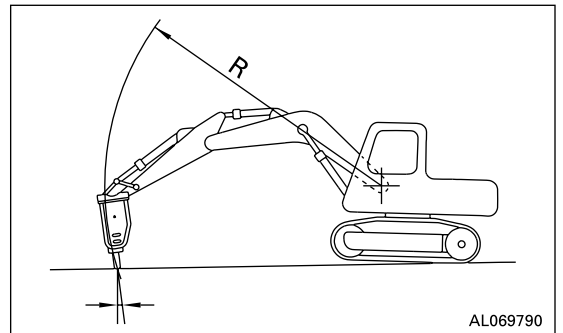

Always keep the chisel pressed against the impact surface properly to prevent using the impact force when there is no resistance.

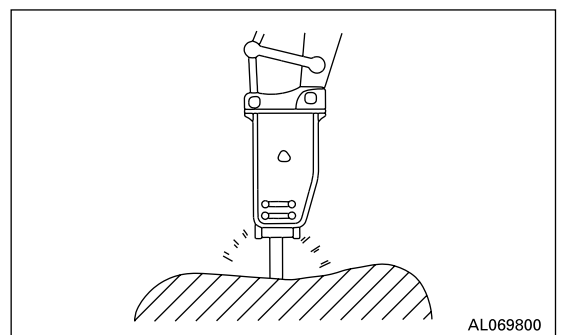

PROHIBITED WORKS

To ensure that the machine has a long life, and to ensure that operations are carried out in safety, do not operate the machine in any of the following ways.

- Do not operate all cylinders to the end of their strokes. Always leave approx. 5 cm (2 in) to spare.

Using the mount to gather in pieces of rock

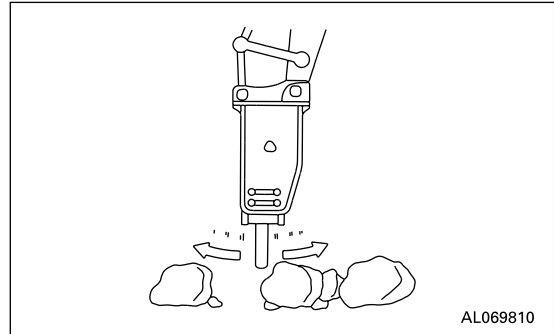

Operations using the swing force

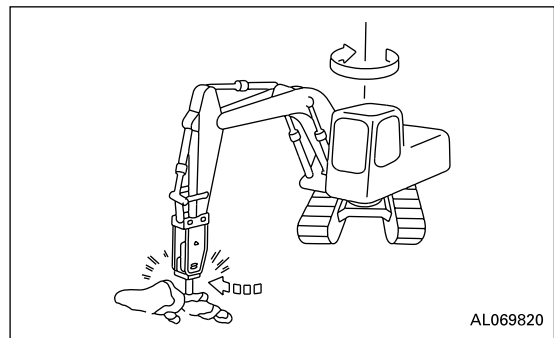

Moving the chisel while carrying out impacting operations

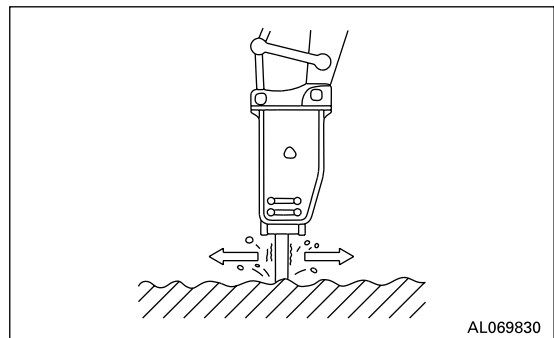

Applying impact horizontally or in upward direction

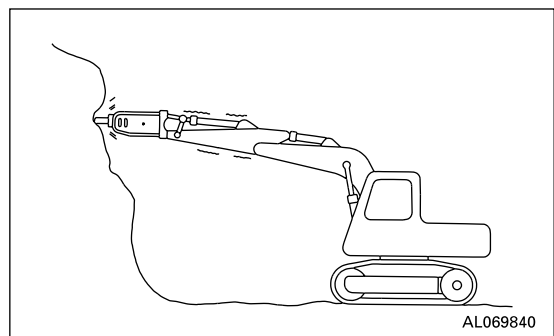

Twisting the chisel when it has penetrated the rock

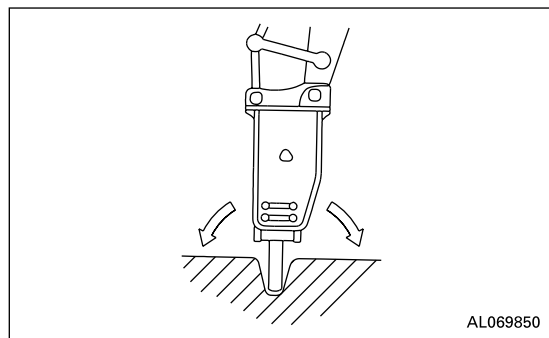

Pecking operations

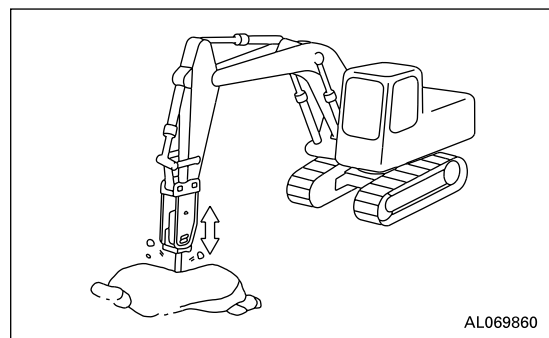

Extending the bucket cylinder fully and thrusting to raise the machine off the ground

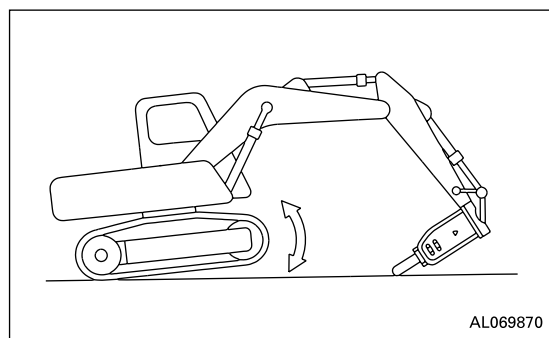

GREASING POSITION FOR HYDRAULIC BREAKER

Supply grease in the correct position.

NOTICE

If grease is supplied in an incorrect position, the breaker is filled with more grease than necessary. As a result, soil and sand will enter the hydraulic circuit and can damage the hydraulic devices while the breaker is used. Accordingly, be sure to supply grease in the correct position.

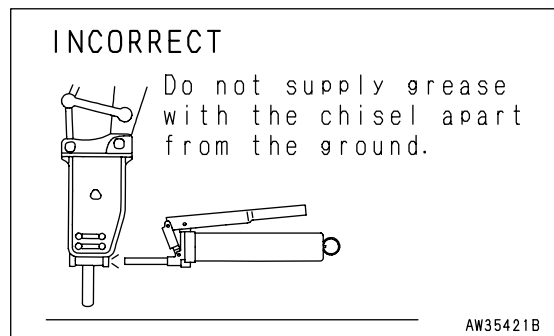
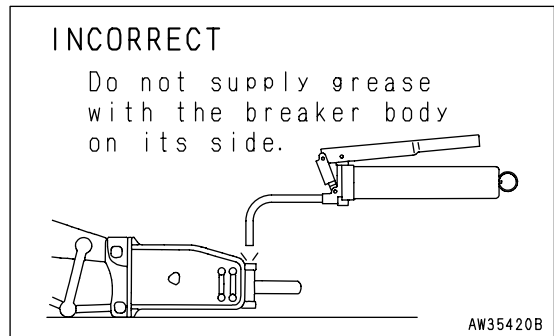
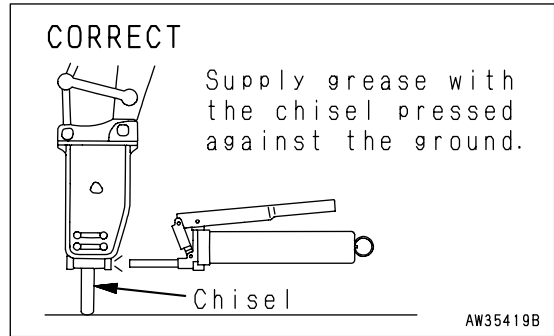

INDEX

A

AFTER COLD WEATHER SEASON	3-102
AFTER DAILY WORK COMPLETION	3-101
AFTER RUNNING OUT OF FUEL	3-105
AFTER STARTING ENGINE	3-58
AFTER STORAGE	3-104
ASHTRAY	3-41
ATTACHMENT COMBINATIONS	6-17
ATTACHMENT INSTALLATION COMBINATION TABLE	6-17

B

BATTERY	2-30
BEFORE STARTING ENGINE	3-42
BEFORE STORAGE	3-103

C

CAB REAR COVER	3-27
CAP, COVER WITH LOCK	3-25
CAR RADIO	3-35
CHECK AFTER FINISHING WORK	3-86
CHECK AFTER SHUT OFF ENGINE	3-61
CHECK BEFORE STARTING	4-44
CHECKING FOR DAMAGE TO BUCKET WITH HOOK	6-5
COLD WEATHER OPERATION	3-99
COLD WEATHER OPERATION INFORMATION ...3- 99	
CONTROL LEVERS, PEDALS	3-16
CONTROLLER	3-31

D

DIRECTIONS OF MACHINE	1-7
DISCHARGED BATTERY	3-107
DOOR AT FRONT OF TOOL BOX	3-29
DURING STORAGE	3-103

E

ELECTRIC SYSTEM MAINTENANCE	4-7
EMISSION CONTROL INFORMATION LABEL	1-9
ENGINE HOOD	3-26
ENGINE SERIAL NUMBER PLATE AND ITS LOCATION	1-8
ESCAPE FROM MUD	3-78
EVERY 100 HOURS MAINTENANCE	4-46
EVERY 1000 HOURS MAINTENANCE	4-59
EVERY 2000 HOURS MAINTENANCE	4-61
EVERY 250 HOURS MAINTENANCE	4-49
EVERY 4000 HOURS MAINTENANCE	4-63
EVERY 50 HOURS MAINTENANCE	4-45

EVERY 500 HOURS MAINTENANCE	4-54
EVERY 5000 HOURS MAINTENANCE	4-64
EXPLANATION OF COMPONENTS	3-4, 6-6, 6-7

F

FOREWORD	1-2
FRONT WINDOW	3-20
FUSE	3-30
FUSIBLELINK	3-30

G

GENERAL OPERATION INFORMATION	3-75
GENERAL PRECAUTIONS	6-2
GENERAL VIEW	3-2
GENERAL VIEW CONTROLS AND GAUGES	3-3
GENERAL VIEW OF MACHINE	3-2
GREASE GUN HOLDER	3-41

H

HAMMER FOR EMERGENCY ESCAPE	3-24
HANDLING ACCUMULATOR	3-40
HANDLING AIR CONDITIONER	3-32
HANDLING BUCKET WITH HOOK	6-5
HANDLING CAR HEATER	6-6
HANDLING ROAD LINER	3-88
HYDRAULIC BREAKER	6-18

I

INITIAL 250 HOURS MAINTENANCE (ONLY AFTER THE FIRST 250 HOURS)	4-19
INTRODUCTION	1-7
INTRODUCTION OF ATTACHMENTS	6-16

L

LIFTING MACHINE	3-97
LIFTING OBJECTS WITH BUCKET	2-33
LIGHTWEIGHT TOWING HOOK	3-106
LOADING AND UNLOADING WITH TRAILER ..	3-91
LOCKING	3-87
LONG TERM STORAGE	3-103
LUBRICANTS, COOLANT AND FILTERS	4-5

M

MACHINE MONITOR	3-4
MACHINE OPERATION	3-62
MACHINE OPERATIONS AND CONTROLS	3-42
MACHINE SERIAL NUMBER PLATE AND ITS LOCATION	1-8

MACHINES READY FOR ATTACHMENTS6-7
 MAINTENANCE INFORMATION4-2
 MAINTENANCE INTERVAL FOR HYDRAULIC
 BREAKER4-18
 MAINTENANCE PROCEDURE4-19
 MAINTENANCE SCHEDULE4-16
 MAINTENANCE SCHEDULE CHART4-16

O

OPERATION AND MAINTENANCE MANUAL
 HOLDER3-41
 OTHER TROUBLE3-112
 OUTLINE OF OIL, FUEL, COOLANT4-5

P

PARKING MACHINE3-85
 PERIODIC REPLACEMENT OF SAFETY CRITICAL
 PARTS4-15
 PHENOMENA THAT ARE NOT FAILURES3-105
 POSITION FOR ATTACHING SAFETY LABELS 2-4,
 2-5
 POWER SOURCE FOR OPTION3-31
 PRECAUTIONS ON PARTICULAR JOBSITES 3-106
 PRECAUTIONS RELATED TO SAFETY6-2
 PRECAUTIONS WHEN INSTALLING
 ATTACHMENTS6-4
 PREPARING CAR HEATER6-6
 PRODUCT INFORMATION1-8
 PROHIBITED OPERATIONS3-71, 6-5
 PROPER SELECTION OF FUEL, COOLANT AND
 LUBRICANTS4-10
 PUMP ROOM DOOR, BATTERY ROOM DOOR 3-28

R

REAR WINDOW3-24
 RECOMMENDED APPLICATIONS3-79
 RECOMMENDED ATTACHMENT OPERATIONS .6-
 18
 REPLACEMENT AND INVERSION OF BUCKET ..3-
 81

S

SAFETY CRITICAL PARTS4-15
 SAFETY INFORMATION 1-5, 2-2, 2-11
 SAFETY LABELS2-6
 SAFETY MACHINE OPERATION2-20
 SAFETY MAINTENANCE INFORMATION2-34
 SERVICE METER LOCATION1-9
 SLIDING DOOR3-23
 SPECIFICATION, USE6-16
 SPECIFICATIONS5-2
 STARTING ENGINE3-55
 STEERING THE MACHINE3-66
 STOPPING THE ENGINE3-61
 SWINGING3-68
 SWITCHES3-10

T

TIGHTENING TORQUE LIST 4-14
 TIGHTENING TORQUE SPECIFICATIONS 4-14
 TOOL COMPARTMENT3-41
 TOWING2-32
 TOWING THE MACHINE3-106
 TRANSPORTATION2-28, 3-90
 TRANSPORTATION PROCEDURE3-90
 TRAVELING ON SLOPES3-76
 TROUBLESHOOTING3-105

U

USE OF FUEL, COOLANT AND LUBRICANTS
 ACCORDING TO AMBIENT TEMPERATURE .. 4-
 10

W

WEAR PARTS LIST4-9
 WHEN REQUIRED4-20
 WORK EQUIPMENT CONTROLS AND
 OPERATIONS3-69

Y

YOUR MACHINE SERIAL NUMBERS AND
 DISTRIBUTOR1-9

PC128US-2 HYDRAULIC EXCAVATOR

Form No. SEAM035404T

©2001 **KOMATSU**
All Rights Reserved
Printed in Japan 04-01
