

Operation & Maintenance Manual

VEAM950200

WA75-3

WHEEL LOADER

SERIAL NUMBER

HA950051 and up



WARNING

Unsafe use of this machine may cause serious injury or death. Operators and maintenance personnel must read this manual before operating or maintaining this machine. This manual should be kept inside the cab for reference and periodically reviewed by all personnel who will come into contact with the machine.

CALIFORNIA

Proposition 65 Warning

Diesel engine exhaust and some of its constituents are known to the State of California to cause cancer, birth defects and other reproductive harm.

KOMATSU

Operation & Maintenance Manual

VEAM950200

WA75-3

WHEEL LOADER

SERIAL NUMBER

HA950051 and up

This material is proprietary to Komatsu Hanomag Aktiengesellschaft and is not to be reproduced, used, or disclosed except in accordance with written authorization from Komatsu America International Company.

It is our policy to improve our products whenever it is possible and practical to do so. We reserve the right to make changes or add improvements at any time without incurring any obligation to install such changes on products sold previously.

Due to this continuous program of research and development, periodic revisions may be made to this publication. It is recommended that customers contact their distributor for information on the latest revision.

PRODUCT PUBLICATIONS INFORMATION

VARIOUS PRODUCT PARTS & SERVICE PUBLICATIONS ARE AVAILABLE TO ALL **KOMATSU** CONSTRUCTION. EQUIPMENT OWNERS, INCLUDING OPERATION & MAINTENANCE MANUALS, PARTS BOOKS AND SHOP MANUALS.

SPECIAL PUBLICATIONS SUCH AS SERVICE TOOL, AIR CONDITIONING, AND TURBOCHARGER SHOP MANUALS ARE ALSO AVAILABLE AS WELL AS SELECTED OPERATION & MAINTENANCE AND SHOP MANUALS IN FOREIGN LANGUAGES.

THE PUBLICATIONS LISTED BELOW ARE AVAILABLE FOR THIS PARTICULAR MACHINE(S).

DESCRIPTION	FORM NUMBER
PARTS BOOK - PAPER:	
Engine and Chassis.....	VZPB179502
PARTS BOOK - MICROFICHE:	
Engine and Chassis.....	VZPM179502
OPERATION & MAINTENANCE MANUAL:	
Chassis	VEAM950200
SHOP MANUAL:	
Engine	YMHINSHI-H8013
Chassis	VEBM950101
SAFETY MANUAL:	WLT70-1

PARTS AND SERVICE PUBLICATIONS CAN ONLY BE ACQUIRED BY AUTHORIZED KOMATSU DISTRIBUTORS, USING THE KOMATSU AMERICA INTERNATIONAL COMPANY PARTS INVENTORY PROCESSING SYSTEM (PIPS).

IF THE PIPS SYSTEM IS NOT AVAILABLE AT THE DISTRIBUTOR LOCATION, THEN THE FOLLOWING REQUISITION FOR TECHNICAL SERVICE PUBLICATIONS AND SERVICE FORMS CAN BE USED. FORM KDC91D IS SHOWN ON THE REVERSE SIDE OF THIS PAGE.

REQUISITION FOR TECHNICAL SERVICE PUBLICATIONS AND SERVICE FORMS

COMPLETE FORM

AND RETURN TO —> **Komatsu America International Company**

440 North Fairway Drive
 Vernon Hills, IL 60061-8112 U.S.A.
 Attn: Technical Publications
 Fax No. (847) 970-4186
 Tel No. (847) 970-5887

SHIP TO →	COMPANY NAME	
	ATTN.	PURCHASE ORDER NO.
	STREET ADDRESS	
TYPE or PRINT ONLY →	CITY, STATE, ZIP CODE	ORDER DATE
	COUNTRY	

PHONE NO.	FAX NO.	SHIPPING METHOD	DISTR/BRANCH CODE
-----------	---------	-----------------	-------------------

IMPORTANT - TO ASSURE SHIPMENT OF THE CORRECT PUBLICATION(S), THE MODEL NUMBER AND MACHINE SERIAL NUMBER MUST BE SHOWN.

QTY.	PUBLICATION FORM NO.	PARTS BOOK ↓ P-PAPER M-MICROFICHE	PUBLICATION DESCRIPTION	MODEL NUMBER	SERIAL NUMBER

TABLE OF CONTENTS

INTRODUCTION

1.	FORWORD	2
2.	SAFETY INFORMATION	3
3.	INTRODUCTION	4
3.1	• FEATURES	4
3.2	• BREAKING IN A NEW MACHINE	4
4.	LOCATION OF PLATES, TABLE TO ENTER SERIAL NO. AND DISTRIBUTOR	5
4.1	• MACHINE SERIAL NO. PLATE POSITION	5
4.2	• ENGINE SERIAL NO. PLATE POSITION	5
4.3	• TABLE TO ENTER SERIAL NO. AND DISTRIBUTOR	5
5.	WHY YOU SHOULD READ THESE OPERATING INSTRUCTIONS	6
6.	NOTES ON SAFETY REGULATIONS	7
6.1	• CORRECT USE	7
6.2	• SAFETY NOTES IN THE OPERATING INSTRUCTIONS	7
7.	EQUIPMENT	8

LOADING AND TRANSPORTING THE MACHINE

8.	LOADING AND TRANSPORTING THE MACHINE	12
8.1	• SECURING THE ARTICULATED STEERING	12
8.2	• LIFTING THE MACHINE	12
8.3	• DRIVING MACHINE ONTO LOADING AREA OF TRANSPORT VEHICLE	14
8.4	• SECURING THE MACHINE DURING TRANSPORT	15
8.5	• AFTER TRANSPORT	15

SAFETY

9.	GENERAL SAFETY MEASURES	19
9.1	• SAFETY INSTRUCTIONS	19
9.2	• SAFETY DEVICES	19
9.3	• EMERGENCY EXIT	19
9.4	• CLOTHING AND PERSONAL PROTECTION	20
9.5	• MACHINE MODIFICATIONS	20
9.6	• BEFORE YOU LEAVE THE DRIVER'S SEAT	20
9.7	• MOUNTING AND DISMOUNTING	20
9.8	• FIRE PREVENTION AND FIRE FIGHTING	21
9.8.1	•• FIRE EXTINGUISHER AND FIRST-AID KIT	22
9.9	• PROTECTION AGAINST ASBESTOS DUST	22
9.10	• PROTECTION AGAINST INJURIES	23
9.11	• WORKING AT HIGH TEMPERATURES	23
9.12	• ROLL-OVER PROTECTION SYSTEM (ROPS)	24
9.13	• ATTACHMENT FOR PROTECTION AGAINST FALLING OBJECTS (FOPS)	24
9.14	• ATTACHMENTS	24
9.15	• BATTERY	25
10.	SAFETY MEASURES DURING OPERATION	26
10.1	• BEFORE YOU START THE ENGINE	26
10.1.1	•• WORKPLACE SAFETY	26
10.1.2	•• IN THE DRIVER'S CAB	26
10.1.3	•• IN-DOOR OPERATION	27
10.1.4	•• GAS, DUST, AND INFLAMMABLE VAPOURS	27

10.1.5	•• MIRRORS, WINDOWS, AND LIGHTING	27
10.2	• MACHINE OPERATION	28
10.2.1	•• BEFORE YOU START THE ENGINE	28
10.2.2	•• REVERSING	28
10.2.3	•• DRIVING	29
10.2.4	•• DRIVING ON SLOPES	29
10.2.5	•• EMERGENCY LOWERING SYSTEM	30
10.2.6	•• WORKING CLOSE TO OVERHEAD POWER TRANSMISSION LINES	30
10.2.7	•• LOADING	31
10.2.8	•• GOOD VISION	31
10.2.9	•• WORKING ON SNOW	31
10.2.10	•• HEIGHT LIMITATION	31
10.2.11	•• BRAKES	32
10.2.12	•• WORKING ON LOOSE SOIL	32
10.2.13	•• WORKING WITH THE FORKLIFT TRUCK ATTACHMENT	33
10.2.14	•• PARKING THE MACHINE	34
10.3	• TRANSPORT	35
10.3.1	•• LOADING AND UNLOADING THE MACHINE	35
10.3.2	•• TRANSPORT	35
11.	SAFETY MEASURES DURING MAINTENANCE	36
11.1	• PERSONNEL	36
11.2	• PRIOR TO START OF MAINTENANCE MEASURES	36
11.2.1	•• WARNING SIGN	36
11.2.2	•• TOOLS	36
11.2.3	•• SAFETY-RELATED PARTS	36
11.2.4	•• PRIOR TO START OF INSPECTION AND MAINTENANCE	37
11.2.5	•• SECURING THE ARTICULATED STEERING	37
11.2.6	•• SUPPORTING THE WORK UNIT	37
11.3	• DURING MAINTENANCE	38
11.3.1	•• ATTACHMENTS	38
11.3.2	•• WORKING UNDER THE MACHINE	38
11.3.3	•• KEEPING THE MACHINE CLEAN	38
11.3.4	•• SPECIFIC MEASURES	38
11.3.5	•• REFUELING AND TOPPING OFF OIL	39
11.3.6	•• COOLANT	39
11.3.7	•• USE OF LIGHTING	40
11.3.8	•• HIGH-PRESSURE HOSES	40
11.3.9	•• HANDLING HIGH-PRESSURE OIL	40
11.3.10	•• FAN AND BELTS	41
11.3.11	•• WASTE MATERIAL	41
11.4	• TIRES	42
11.4.1	•• STORING TIRES	42
12.	LABELING	43
12.1	• POSITION OF SAFETY LABELS	43
12.2	• POSITION OF STANDARD LABELS	45

CONTROLS AND INDICATORS

13.	GENERAL VIEW OF MACHINE	48
14.	CONTROLS AND INDICATORS	49
14.1	• GENERAL VIEW	49
14.1.1	•• SWITCHES AND CONTROLS	50
14.2	• INSTRUMENT PANEL	51
14.3	• WARNING LIGHTS	52
14.4	• CONTROL LAMPS	55
14.5	• MEASURING INDICATORS	58
14.6	• SWITCHES	60
14.7	• CONTROL LEVERS, PEDALS	66
14.8	• ARTICULATED STEERING CATCH	71
14.9	• TRACTION DEVICE	71
14.10	• SOCKET	71
14.11	• DOOR UNLOCKING SYSTEM	72
14.12	• ALARM HORN FOR REVERSE DRIVING	72

OPERATION

15.	RUNNING IN THE MACHINE	74
16.	PREPARING THE MACHINE START	75
16.1	• VISUAL CHECKS	75
16.1.1	•• BEFORE YOU START THE ENGINE	75
16.1.2	•• BEFORE STARTING WORKING WITH THE MACHINE	75
17.	ADJUSTMENTS PRIOR TO MACHINE START	77
17.1	• ADJUSTING THE DRIVER'S SEAT	77
17.2	• ADJUSTING THE STEERING COLUMN	78
17.3	• ADJUSTING THE ARMREST	78
17.4	• ADJUSTING THE REAR-VIEW MIRRORS	78
17.5	• ADJUSTING THE HEATING AND VENTILATION SYSTEM	79
17.5.1	•• ADJUSTING THE VENTILATION SYSTEM	79
17.5.2	•• ADJUSTING THE HEATING SYSTEM	79
17.6	• PUTTING ON THE SAFETY BELT	80
17.6.1	•• PUTTING ON THE SAFETY BELT	80
17.6.2	•• TAKING OFF THE SAFETY BELT	80
18.	STARTING AND SWITCHING OFF THE ENGINE	81
18.1	• STARTING THE ENGINE	81
18.1.1	•• WARMING UP THE ENGINE	82
18.2	• SWITCHING OFF THE ENGINE	83
19.	DRIVING	84
19.1	• START-UP	84
19.1.1	•• STARTING THE MACHINE ON SLOPES	85
19.2	• CHANGING THE DRIVING DIRECTION	85
19.3	• REVERSE DRIVING	86
19.4	• TURNING	86
19.4.1	•• TURNING ON SLOPES, EMBANKMENTS OR HILL FLANKS	86
19.5	• BRAKING	87
19.5.1	•• PULLING THE PARKING BRAKE	87
19.5.2	•• RELEASING THE PARKING BRAKE	87
19.5.3	•• BRAKING WITH THE SERVICE BRAKE	87
19.5.4	•• IF THE SERVICE BRAKE BREAKS DOWN	87

19.5.5	•• BRAKING ON SLOPES	88
19.6	• STOPPING	88
19.6.1	•• PARKING THE MACHINE ON A SLOPE	88
19.7	• LONGER-DISTANCE DRIVING	89
20.	OPERATING THE MACHINE	90
20.1	• PREPARING THE WORK EQUIPMENT	90
20.1.1	•• SELECTING A WORK UNIT	90
20.1.2	•• PICKING UP THE WORK UNIT (EXCEPT MULTI-PURPOSE BUCKET)	90
20.1.3	•• REMOVING THE WORK UNIT	91
20.1.4	•• PICKING UP THE MULTI-PURPOSE BUCKET	91
20.1.5	•• REMOVING THE MULTI-PURPOSE BUCKET	93
20.2	• TIRE SERVICE LIFE	94
20.2.1	•• LEVEL INDICATOR FOR THE BUCKET	94
20.3	• LOADING	95
20.3.1	•• REMOVING PILED UP SOIL	95
20.3.2	•• EXCAVATION WORKS	97
20.4	• TRANSPORTING	98
20.5	• DUMPING / UNLOADING	98
20.5.1	•• LOADING IN DIAGONAL DIRECTION	98
20.5.2	•• V-SHAPED LOADING	99
20.5.3	•• PILING UP MATERIAL	99
20.6	• PLANING	100
20.6.1	•• FILLING UP	100
20.6.2	•• TAKING OFF SOIL	100
20.6.3	•• CUTTING THE GROUND	100
20.7	• WORKING WITH THE FORKLIFT TRUCK ATTACHMENT	101
20.7.1	•• PICKING UP THE LOAD	101
20.8	• PRECAUTIONS FOR SPECIAL OPERATIONS	102
20.8.1	•• WORKING IN WATER	102
20.8.2	•• WORKING ON SNOW	102
20.8.3	•• DUMPING ON STEEP SLOPES	102
20.8.4	•• WORKING IN THE VICINITY OF ELECTRICAL OVERHEAD LINES	102
20.8.5	•• OPERATION ON SLOPES	102
20.8.6	•• WORKING ON LOOSE SOIL	102
20.9	• AFTER THE WORK IS FINISHED	102
20.10	• INSTRUCTIONS FOR WINTER OPERATION	103
20.10.1	•• BEFORE THE COLD SEASON	103
20.10.2	•• AFTER OPERATION	103
20.10.3	•• AFTER THE COLD SEASON	103
20.11	• LONGER STANDSTILL PERIODS OF THE MACHINE	103
20.11.1	•• BEFORE THE STANDSTILL	103
20.11.2	•• DURING THE STANDSTILL	104
20.11.3	•• AFTER THE STANDSTILL	104
 TROUBLESHOOTING		
21.	TROUBLESHOOTING	106
21.1	• WARNING LIGHTS AND INDICATORS	106
21.2	• ELECTRICAL SYSTEM	107
21.3	• ENGINE	108
21.4	• HYDRAULIC SYSTEM	111

21.5	• BRAKES	113
21.6	• AXLES	114
21.7	• EMERGENCY STEERING CHARACTERISTICS	115
21.8	• EMERGENCY LOWERING SYSTEM	115
21.9	• STARTING THE ENGINE WITH A BATTERY JUMPER CABLE	116
21.9.1	•• CONNECTING THE JUMPER CABLE	116
21.10	• STARTING THE ENGINE	117
21.10.1	•• DISCONNECTING THE BATTERY JUMPER CABLE	117
21.11	• TOWING THE MACHINE	118
21.12	• TOWING A MACHINE WITH DEFECTIVE BRAKES	119

MAINTENANCE

22.	MAINTENANCE BASICS	122
22.1	• PREPARING THE MACHINE FOR MAINTENANCE	122
22.2	• CLEANING THE MACHINE	123
22.2.1	•• PRECAUTIONARY MEASURES WHEN CLEANING THE MACHINE	123
22.2.2	•• FIRE PREVENTION	123
22.3	• WORKING-AREA-DEPENDENT MAINTENANCE	123
22.3.1	•• MUDDY OR WET WORKING AREAS	123
22.3.2	•• DUSTY WORKING AREAS	123
22.4	• LUBRICANTS AND OPERATING AGENTS	124
22.4.1	•• DRAINING HOT LUBRICANTS AND FLUIDS	124
22.4.2	•• CHECKING THE OIL LEVEL AND CHANGING OIL	124
22.4.3	•• CHANGING FILTERS	124
22.4.4	•• REFUELLING AND TOPPING OFF OIL	124
22.4.5	•• OIL	124
22.4.6	•• LUBRICATING GREASE	125
22.4.7	•• BIODEGRADABLE HYDRAULIC OIL AND LUBRICATING GREASE	125
22.4.8	•• FUEL	125
22.4.9	•• STORAGE OF OIL AND FUEL	125
22.4.10	•• COOLANTS	126
22.4.11	•• WINDSCREEN WASHER LIQUID	126
22.4.12	•• TABLE OF LUBRICANTS AND OPERATING AGENTS	128
22.4.13	•• LUBRICATION CHART	129
22.5	• REPLACING SAFETY-RELATED PARTS	130
22.5.1	•• WELDING INSTRUCTIONS	130
22.6	• SPARE PARTS AND CONSUMABLE COMPONENTS	131
22.7	• ELECTRICAL SYSTEM	132
22.7.1	•• FUSES	132
22.7.2	•• FUSE ASSIGNMENT	132
22.7.3	•• SLOW-BLOWING FUSES	133
22.8	• TIRES	134
22.8.1	•• TIRE COMPONENTS	134
22.8.2	•• CHECKING THE TIRES	134
22.8.3	•• CHECKING THE TIRE PRESSURE	134
22.9	• TOOLS	136
22.10	• TORQUE FOR STANDARD NUTS AND BOLTS	137

23.	MAINTENANCE SCHEDULE	139
24.	MAINTENANCE PRIOR TO START	141
24.1	• VISUAL CHECKS	141
24.2	• COOLING SYSTEM, CHECKING THE COOLANT LEVEL, TOPPING OFF COOLANT	141
24.3	• ENGINE, CHECKING THE OIL LEVEL, TOPPING OFF OIL	142
24.4	• ENGINE, DRAINING OFF OIL	143
24.5	• CHECKING THE FUEL LEVEL, REFUELING	144
24.6	• CHECKING THE CONTROLS	145
24.7	• CHECKING THE PARKING BRAKE	146
24.7.1	• • TEST CONDITIONS	146
24.7.2	• • TEST PROCEDURE	146
24.8	• CHECKING THE SERVICE BRAKE	146
24.9	• CHECKING THE ELECTRICAL CONNECTIONS	147
24.10	• OTHER MAINTENANCE MEASURES PRIOR TO START	147
25.	MAINTENANCE EVERY 10 OPERATING HOURS	148
25.1	• LUBRICATION	148
26.	MAINTENANCE AFTER THE FIRST 50 OPERATING HOURS	149
26.1	• ENGINE, CHANGING OIL AND REPLACING THE OIL FILTER CARTRIDGE	149
26.1.1	• • REPLACING THE OIL FILTER CARTRIDGE	150
26.2	• V-BELT, CHECKING THE CONDITION	151
26.3	• V-BELT, CHECKING AND ADJUSTING THE TENSION	151
26.4	• HYDRAULIC SYSTEM, REPLACING THE FILTER INSERT	152
26.5	• CHECKING AND TIGHTENING THE WHEEL NUTS	153
26.6	• FRONT AND REAR AXLE, CHANGING OIL	154
26.6.1	• • PLANET GEAR	154
26.6.2	• • DIFFERENTIAL	154
26.7	• TRANSFER GEAR - CHANGING OIL	155
27.	MAINTENANCE EVERY 50 OPERATING HOURS	156
27.1	• CHECKING THE COOLING SYSTEM, COOLANT LEVEL IN THE RADIATOR AND EXPANSION TANK	156
27.2	• DRAINING OFF WATER AND DIRT DEPOSITS FROM THE FUEL TANK	157
27.3	• CHECKING THE SERVICE BRAKE AND OIL LEVEL, REFILLING OIL	157
27.4	• CHECKING THE BATTERY AND ACID LEVEL	158
27.4.1	• • RE-CHARGING A BUILT-IN BATTERY	159
27.5	• LUBRICATION	160
27.5.1	• • LUBRICATING POINTS OF THE WORK EQUIPMENT	160
28.	MAINTENANCE EVERY 100 OPERATING HOURS	161
28.1	• DRAINING THE WATER SEPARATOR, REMOVING WATER AND DIRT DEPOSITS	161
29.	MAINTENANCE EVERY 250 OPERATING HOURS	162
29.1	• CHANGING THE ENGINE OIL AND OIL FILTER CARTRIDGE	162
29.2	• CHECKING THE V-BELT CONDITION	162
29.3	• CHECKING AND ADJUSTING THE V-BELT TENSION	162
29.4	• LUBRICATION	162
29.4.1	• • LUBRICATING POINTS OF THE STEERING CYLINDER	162
29.5	• FRONT AND REAR AXLE, CHECKING THE OIL LEVEL	163
29.5.1	• • PLANET GEAR	163
29.5.2	• • DIFFERENTIAL	163
29.6	• AIR FILTER, REMOVING AND RE-INSTALLING THE FILTER INSERT, CHECKING AND CLEANING THE FILTER INSERT	164
29.6.1	• • STRUCTURE OF THE AIR FILTER	164
29.6.2	• • MAINTENANCE DEMAND	164

29.6.3	•• REMOVING THE FILTER CARTRIDGE	164
29.6.4	•• CLEANING OR EXCHANGING THE FILTER CARTRIDGE	165
29.6.5	•• CHECKING THE FILTER CARTRIDGE	166
29.6.6	•• ASSEMBLING THE AIR FILTER CARTRIDGE	166
29.7	• CLEANING THE RADIATOR SEGMENTS	166
30.	MAINTENANCE EVERY 500 OPERATING HOURS	167
30.1	• CHANGING THE FUEL FILTER AND FILTER ELEMENT	167
30.1.1	•• BLEEDING THE FUEL SYSTEM	168
30.2	• CHANGING THE FILTER CARTRIDGE OF THE HYDRAULIC SYSTEM	169
30.3	• CLEANING THE WATER SEPARATOR	169
30.4	• LUBRICATION	170
30.5	• TRANSFER GEAR, CHECKING THE OIL LEVEL AND REFILLING OIL	170
30.6	• AIR FILTER, REPLACING THE FILTER INSERT, REPLACING THE SAFETY FILTER	171
30.6.1	•• REPLACING THE FILTER INSERT	171
30.6.2	•• REPLACING THE SAFETY FILTER	171
31.	MAINTENANCE EVERY 1000 OPERATING HOURS	172
31.1	• COOLING SYSTEM, EXCHANGING COOLANT AND CLEANING THE SYSTEM	172
31.1.1	•• DRAINING OFF THE COOLANT	172
31.1.2	•• CLEANING THE COOLING SYSTEM	173
31.1.3	•• FILLING OFF COOLANT	173
31.2	• FRONT AXLE, OIL CHANGE	174
31.3	• REAR AXLE, OIL CHANGE	174
31.4	• TRANSFER GEAR, OIL CHANGE	174
31.5	• SERVICE BRAKE	174
31.5.1	•• CHANGING OIL	174
31.5.2	•• CHECKING TUBES AND LINES	174
31.5.3	•• CHECKING THE BRAKE DISKS FOR WEAR AND TEAR	174
31.5.4	•• ADJUSTING THE CLEARANCE OF THE BRAKE DISKS	174
31.6	• CHECKING AND ADJUSTING SYSTEM PRESSURES	174
31.7	• CHECKING AND ADJUSTING THE VALVE CLEARANCE	174
31.8	• CHECKING AND ADJUSTING THE INJECTION NOZZLES, NOZZLE PRESSURE AND FUEL-JET PATTERN	174
32.	MAINTENANCE EVERY 2000 OPERATING HOURS	175
32.1	• HYDRAULIC SYSTEM, OIL CHANGE	175
32.2	• BLEEDING THE HYDRAULIC OIL TANK	176
32.3	• COOLING SYSTEM, CHECKING THE ANTIFREEZE CONTENT OF THE COOLANT	176
32.4	• CHECKING THE COOLING SYSTEM	176
32.5	• CHECKING THE FUEL PUMP	176
32.6	• CHECKING THE FUEL AND COOLANT TUBES, REPLACING THE TUBES (IF REQUIRED) ..	176
32.7	• CHECKING THE WATER PUMP	177
32.8	• CHECKING AND ADJUSTING THE FUEL INJECTION AND INJECTION TIME	177
32.9	• ENGINE, INTAKE VALVES AND OUTLET VALVES - GRINDING IN THE VALVE BASES	177

TECHNICAL DATA

33.	TECHNICAL DATA	180
33.1	• NOISE EMISSION LEVELS	181
33.2	• VIBRATION LEVEL	181
33.3	• LIMIT VALUES FOR SLOPES	182
33.3.1	•• MAXIMUM SLOPE ANGLE FOR OPERATING THE MACHINE	182
33.3.2	•• TILTING/TIPPING ANGLE	182

INTRODUCTION

1. FORWARD

This manual describes procedures for operation, handling, lubrication, maintenance, checking, and adjustment. It will help the operator and maintenance personnel realize peak performance through effective, economical and safe machine operation and maintenance.

Keep this manual handy and have all personnel read it periodically. If this manual is lost or becomes dirty and can not be read, request a replacement manual from your local distributor.

If you sell the machine, be sure to give this manual to the new owner.

Continuing improvements in the design of this machine can lead to changes in detail, which may not be reflected in this manual. Consult your local distributor or Komatsu America International Company for the latest available information on your machine or for questions regarding information in this manual.



WARNING

- **Improper operation and maintenance of this machine can be hazardous and could result in serious injury or death.**
 - **Operators and maintenance personnel must read this manual thoroughly before operating or maintaining this machine.**
 - **This manual should be kept near the machine for reference and periodically reviewed by all personnel who come across it.**
 - **Some actions involved in operation and maintenance can cause a serious accident, if they are not performed in the manner described in this manual.**
 - **The procedures and precautions given in this manual apply only to intended uses of the machine. If you use your machine for any unintended uses that are not specifically prohibited, you must be sure that it is safe for you and others. In no event should you or others engage in prohibited uses or actions as described in this manual.**
 - **Komatsu America International Company delivers machines that comply with all applicable regulations and standards of the country to which it has been shipped. If this machine has been purchased in another country or purchase from someone in another country, it may lack certain safety features and specifications that are necessary for use in your country. If there is any question about whether your product complies with the applicable standards and regulations or your country, consult your local distributor or Komatsu America International Company before operating the machine.**
 - **The description of safety is given in "2. Safety Information" and in chapter "Safety".**
-

2. SAFETY INFORMATION

Most accidents are caused by the failure to follow fundamental safety rules for the operation and maintenance of machines. To avoid accidents, read, understand and follow all precautions and warnings in this manual and on the machine before performing maintenance and machine operations.

To identify safety messages in this manual and on machine product graphics, the following signal words are used.



DANGER

- This word is used on safety messages and product graphics where there is a high probability of serious injury or death if the hazard is not avoided. These safety messages and product graphics usually describe precautions that must be taken to avoid the hazard. Failure to avoid this hazard may also result in serious damage to the machine.
-



WARNING

- This word is used on safety messages and product graphics where there is a potentially dangerous situation, which could result in serious injury or death if the hazard is not avoided. These safety messages and product graphics usually describe precautions that must be taken to avoid the hazard. Failure to avoid this hazard may also result in serious damage to the machine.
-



CAUTION

- This word is used on safety messages and product graphics for hazards, which could result in minor or moderate injury if the hazard is not avoided. These safety messages and product graphics might also use this word for hazards where the only result could be damage to the machine.
-



NOTE

- This word is used for precautions that must be taken to avoid actions, which could shorten the life of the machine.
-



IMPORTANT

- This word is used for important additional information.
-

Safety precautions are described in chapter "Safety".

Komatsu America International Company cannot predict every circumstance that might involve a potential hazard in operation and maintenance. Therefore the safety message in this manual and on the machine may not include all possible safety precautions. If any procedures, tools, actions, work method, or operating technique not specifically recommended or allowed in this manual are used, you must be sure that you and others can do such procedures and actions safely and without damaging the machine. If you are unsure about the safety of some procedures, contact your local distributor or Komatsu America International Company.

3. INTRODUCTION

3.1 FEATURES

- Maximum flexibility of usefulness.
- Improved sealing for reduced noise, low vibration cab.
- Console and adjustable steering column with unencumbered foot area provides a comfortable feeling.
- Light touch lever operations through use of electrical transmission control lever.
- Pleasant operators compartment with low vibration and noise levels.
- Excellent view from the cabin to all sides.
- Engine hood opens fully for ease of maintenance.
- Safety lock lever for work equipment.
- New engine that meets exhaust gas emission of 96 EPA & carb.

3.2 BREAKING IN A NEW MACHINE

Your machine has been thoroughly adjusted and tested before shipment. However, operating the machine under severe conditions at the beginning can adversely affect the performance and shorten the machine life. Be sure to break in the machine for the initial 100 hours.

During breaking in:

- After starting, let the engine idle for 5 minutes to allow proper engine warm-up prior to actual operation.
- Avoid operation with heavy loads or at high speeds.
- Avoid sudden starts or acceleration, unnecessarily abrupt stops and sharp steering except in cases of emergency.

The precautions given in this manual for operating, maintenance, and safety procedures are only those that apply when this product is used for the specified purpose. If the machine is used for a purpose that is not listed in this manual, Komatsu America International Company cannot bear any responsibility for safety. All consideration of safety in such operations is the responsibility of the user.

Operations that are prohibited in this manual must never be carried out under any circumstance.

4. LOCATION OF PLATES, TABLE TO ENTER SERIAL NO. AND DISTRIBUTOR

4.1 MACHINE SERIAL NO. PLATE POSITION

1 - POSITION OF PLATE

On the center right of the front frame.

2 - POSITION OF STAMP

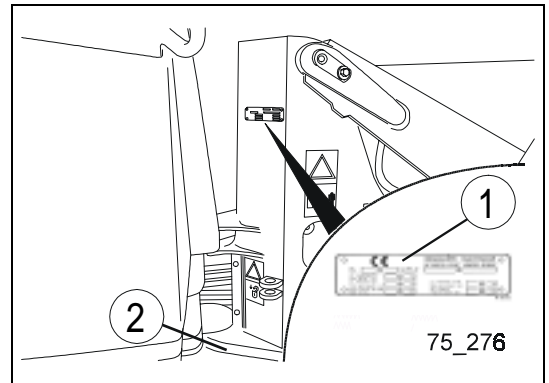

4.2 ENGINE SERIAL NO. PLATE POSITION

1 - POSITION OF PLATE

2 - POSITION OF EPA - LABEL

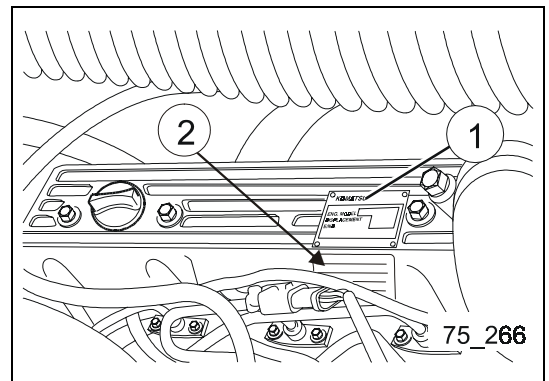

4.3 TABLE TO ENTER SERIAL NO. AND DISTRIBUTOR

Machine serial No.:	
Engine serial No.:	
Distributor name:	
Address:	Phone:
	Fax:
Service personnel for your machine:	

REMARKS

5. WHY YOU SHOULD READ THESE OPERATING INSTRUCTIONS

The machine must be operated, cleaned, and maintained very carefully to ensure safe and troublefree operation. If you operate the machine correctly, these operating instructions will help you to avoid injuries and damage to property. To ensure this, these operating instructions take into account all applicable legal regulations and directives; the operating instructions comprise the following information:

- Notes on the Operating Instructions
- Notes on Transport
- Notes on Safety Regulations
- Operating Instructions
- Troubleshooting
- Maintenance Instructions
- Technical Data
- Notes on Lubricants and Operating Agents

The operating instructions are part of the machine and must always be available at hand in the machine. If the operating instructions have been lost or if they have become unreadable, because they are dirty, you may receive a new copy from Komatsu or your local Komatsu dealer. If the machine is resold, the operating instructions, and the licence are to be handed over to the new owner.

The owner of the machine has to ensure that:

- **all persons driving the machine have the legally required minimum age and are physically and mentally fit to perform the tasks they are charged with.**
- **all persons in charge with operating or maintaining the machine are appropriately instructed before operation or maintenance is started. They must have completely read and understood these operating instructions. In particular, this applies to the following section "6. Notes on Safety Regulations" and the chapter "Safety".**
- **all persons driving the machine have read the accompanying leaflet "Notes on Operation of Komatsu Construction Machines in Public Traffic".**
- **the machine is correctly operated.**
- **the machine is not improperly modified.**

Please note:

If the owner modifies safety-related parts of the machine, the certificate of conformity of the manufacturer will lapse and the person who has performed the modification has to issue a new certificate. Should you have any questions concerning this point, please do not hesitate to ask your local Komatsu dealer.

Our continuous effort to improve the machine's design may lead to changes of machine details. However, the introduction of these improvements does not oblige us to perform them on machines which have already been delivered and are already in use.

If these improvements result in minor changes, these minor changes will not be described in the operating instructions. Should you require new available information about your machine or have any questions concerning the information given in the operating instructions, please do not hesitate to contact either Komatsu America International Company or your local Komatsu dealer.

These operating instructions may refer to attachments and special equipment not available from your local Komatsu dealer. Should you require attachments or special equipment, ask your local Komatsu dealer.

6. NOTES ON SAFETY REGULATIONS

The procedures and precautionary measures concerning operation and maintenance only apply on the provision that the machine is used as intended.

6.1 CORRECT USE

A loader is a machine which has its own drive and which is moving on either tracks or wheels. By moving in forward direction, a loader can load material or cut the ground with the work unit (use of bucket) provided for loading which is attached to its front.

The standard working cycle of a loader comprises filling and lifting the loading bucket, transporting material, and emptying the loading bucket.

If you use the machine for any other purpose than specified above, we will not accept any responsibility for safety. All considerations concerning safety will then be up to the owner or the operating and maintenance personnel. In any case, neither you nor any other person are/is authorised to perform work and functions explicitly prohibited in these operating instructions.

6.2 SAFETY NOTES IN THE OPERATING INSTRUCTIONS

Most accidents are caused by disregard of basic safety regulations during operation and maintenance of machines. In order to avoid accidents and thus damage to persons and property, read all applicable safety notes and warnings in these operating instructions and on the machine, before you start operation or maintenance of the machine and always adhere to these safety notes and warnings.

The chapter "Safety" contains a summary of all safety notes applying to this machine. We cannot, however, predict all circumstances resulting in potentially dangerous situations when operating and maintaining the machine. For this reason, it may be possible that the safety notes in these operating instructions and on the machine do not comprise all possible safety measures. If procedures or measures are required which are not recommended or approved, you must ensure that performing them is neither dangerous nor involving potential damage to the machine. Should you have any doubt concerning safety of a procedure, either directly contact Komatsu America International Company or your local Komatsu dealer.

7. EQUIPMENT

EQUIPMENT					
	1	2	3	4	-
WA 75-3	Type	Part No.	Volume cuft (m ³)	Hydr. pressure bar	Weight lb (kg)
Bucket	WA75-3	42U-70-12040	28.268 (0,8)	205	736 (334)
		42U-70-12050	28.268 (0,8)	205	789 (358)
		42U-70-12201	26.5 (0,75)	205	1257 (570)
		42U-70-12140	35.335 (1,0)	205	842 (382)
		42U-70-12150	44.169 (1,25)	205	904 (410)

KOMATSU HANOMAG
AKTIEGESELLSCHAFT HANNOVER-GERMANY

Typ Type	①		
Teile Nr. Part number	②		
Volumen Volume	③	m ³	m ³
Tragfähigkeit Load capacity		kg	kg
Hydr. Druck Hydr. pressure	④	bar	bar

R567a

1 - Typ
Type

2 - Teile Nr.
Part number

3 - Volumen
Volume

4 - Hydr. Druck
Hydr. pressure

EQUIPMENT						
	1	2	3	4	5	-
WA 75-3	Type	Part No.	Work load of fork carrier STD lb (kg)	Work load of fork carrier with CTW lb (kg)	Hydr. pressure bar	Weight lb (kg)
Fork carrier	WA75-3	42U-70-12080	*) 4189 (1900) **) 3197 (1450)	*) 4409 (2000) **) 3030 (1500)	205	267 (121)

*) Standing security 80% of the tipping load on firm and level ground

**) Standing security 60% of the tipping load on uneven ground

KOMATSU HANOMAG
AKTIEGESELLSCHAFT HANNOVER-GERMANY

Typ Type	①	①	
Teile Nr. Part number	②		
Volumen Volume	m ³	m ³	
Tragfähigkeit Load capacity	③ kg	④ kg	R567b
Hydr. Druck Hydr. pressure	⑤ bar	bar	

1- Typ
Type

2- Teile Nr.
Part number

3- Tragfähigkeit STD
STD load capacity

4- Tragfähigkeit mit CTW
Load capacity incl. CTW

5- Hydr. Druck
Hydr. pressure

EQUIPMENT

**LOADING AND
TRANSPORTING THE
MACHINE**

8. LOADING AND TRANSPORTING THE MACHINE

If you have to transport the machine over far distances, use an appropriate transport vehicle. You may either lift or drive the machine onto an appropriate transport vehicle via loading ramp (also refer to "10. Safety Measures during Operation"). Before transporting machine, check the following: roads and bridges are wide enough, clearance heights on tunnels etc. are adequate and **carrying** capacities of roads and bridges are sufficient.

8.1 SECURING THE ARTICULATED STEERING

Secure the articulated steering before you lift up the machine or start to perform repair measures.

- 1- Set the machine to straight driving.
- 2- Loosen the spring bolt and remove the bolt.
- 3- Turn the locking bar from position '1' to position '2'.
 '1' Articulated steering unlocked
 '2' Articulated steering locked
- 4- Insert the bolt and secure it with the spring bolt.

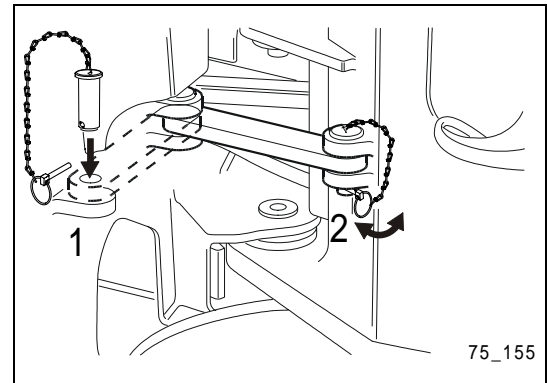

8.2 LIFTING THE MACHINE



DANGER

- Failure to heed the following warnings may result in serious injury or even death.



DANGER

- **Danger of pinching!** An unlocked articulated steering may suddenly move!
Secure the articulated steering before you lift up the machine.
- **Danger of accidents!** Carrying wire ropes with insufficient carrying capacities may tear so that the machine may fall down!
Only lift up the machine using carrying wire ropes with sufficient carrying capacities.
- **Hoisting equipment with insufficient carrying capacities may suddenly bend and cause severe accidents!**
Only use hoisting equipment capable of carrying the machine's operating weight.
- **Objects lying on the machine may fall down and cause injuries when the machine is lifted up!**
Remove all loose objects from the machine before you lift up the machine.



CAUTION

- **Incorrectly attached wire ropes may damage the machine!**
- **Only fasten the eye hooks of the carrying wire ropes at the marked attachment points.**

There are two attachment points each at the front part and the rear part of the machine. These attachment points are shown in the following figure.

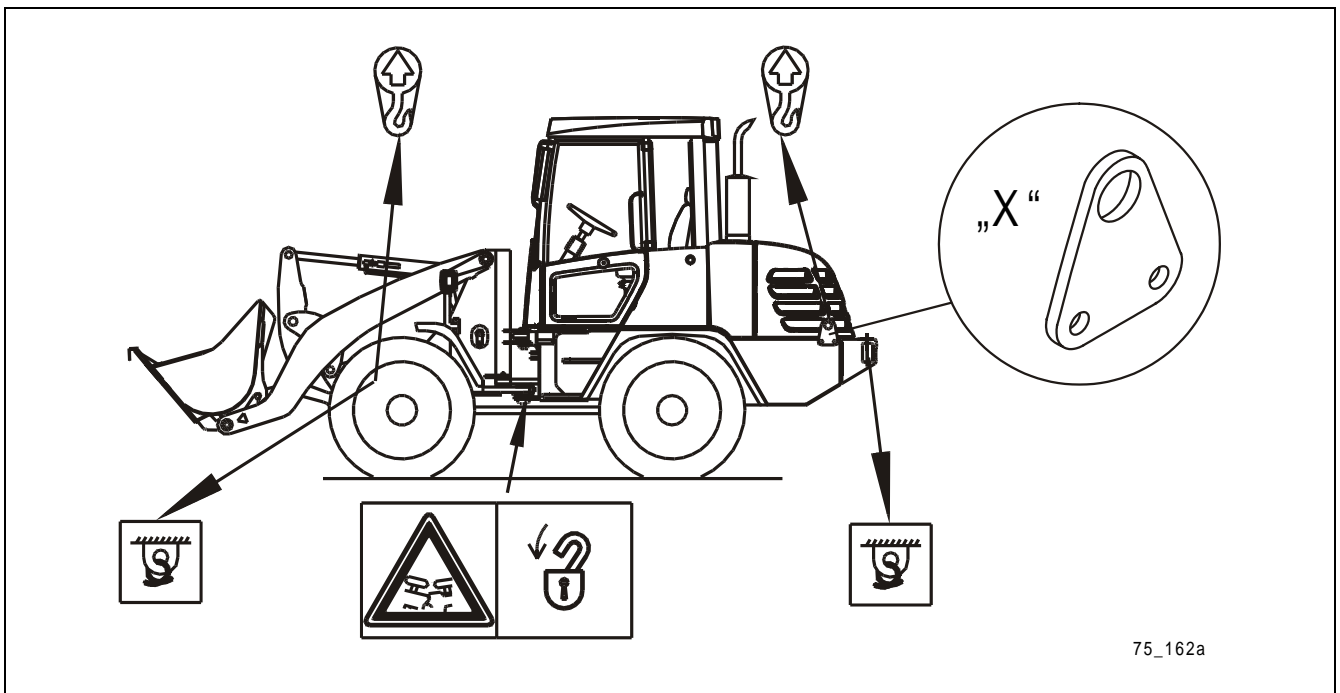

Information signs attached to the machine indicate the attachment points. To avoid damage to the machine, attach the eye hooks only to the attachment points.

Machine equipment „X“:

- 2 Brackets, P/N. 42U-98-12A10
- 4 Screws M16 X 40, Strength class 10.9, P/N. 01016-51640

Screws mounted in the rear frame, inside.

Tightening torque: 280 Nm

When selecting the lifting equipment, take the operating weight of the machine into account. Insufficient carrying capacities of the lifting equipment may cause severe accidents. Also use carrying wire ropes with appropriate carrying capacities for the operating weight of the machine. Carrying wire ropes with insufficient carrying capacities may tear when the machine is lifted up and cause severe accidents. The operating weight of the machine depends on the attached bucket. You find the operating weights of the machine in the chapter "33. Technical Data".

8.3 DRIVING MACHINE ONTO LOADING AREA OF TRANSPORT VEHICLE



- If the transport vehicle or the loading ramp starts skidding while you are driving up the loading ramp, the machine may fall off the ramp and cause severe accidents! Secure the transport vehicle against accidental movement. Secure the wheels of the low bed loader with wheel chocks or wedges.

The transport vehicle for the machine must have an appropriate work load. The operating weight of the machine depends on the attached equipment. The operating weights of the machine can be found in the respective table in the chapter "33. Technical Data".

The articulated steering must be unlocked before the machine is driven onto the transport vehicle to ensure that the machine remains steerable. Remove any mud, snow, or ice adhering to the wheels to ensure that you can drive onto the ramps without danger of skidding. Do not load the machine via landing stage unless you have checked that the landing stage is broad enough and that its strength is sufficient to carry the load.

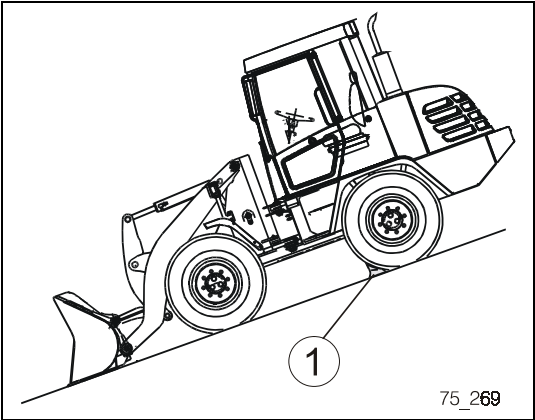

The loading ramps (3) must be aligned to the wheel tracks (5) of the machine. The loading ramps must be secured in such a way that they cannot slip while the machine is being loaded. Support the loading ramps by placing support blocks (2) under both ramps. Make sure that the transport vehicle may neither tip over, start to skid, or roll away while you are driving it onto the transport vehicle. Secure the wheels of the low bed loader with wheel chocks (1) or wedges.

Position the machine straight in front of the loading ramp and slowly drive up the loading ramp. Do not perform steering movements on the ramp. If required, drive off the ramp, correct the position of the machine on the ground and drive up the ramp again.

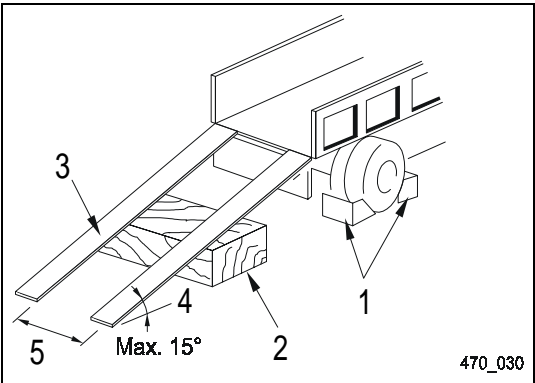

8.4 SECURING THE MACHINE DURING TRANSPORT



DANGER

- If the machine is insufficiently secured, it may start to skid or fall off the transport vehicle and cause severe accidents!

Always secure the machine with ropes and wheel chocks or wedges to avoid falling down and skidding.



CAUTION

- Stay wire ropes that are incorrectly attached may damage the machine!
Only fasten the eye hooks of the stay wire ropes at the marked attachment points.
-

When the machine is on the loading area of the transport vehicle, secure the articulated steering as described in the chapter "8.1 Securing the Articulated Steering". Then, block the wheels of the machine with wheel chocks or wedges and secure the machine with wire ropes in such a way that it will neither start to skid nor tip over during transport. To avoid damage to the machine, only fasten the eye hooks of the stay wire ropes at the marked attachment points. The attachment points to be used are the two eye hooks at the front frame and the tie bolt at the rear frame of the machine. The positions of the attachment points are shown in the figure on the previous page.

8.5 AFTER TRANSPORT

After transport, remove all securing devices, such as wheel chocks or wedges and wire ropes. Remove the catch of the articulated steering before you drive the machine off the transport vehicle. For this purpose, reverse the steps 1 through 4 described in the chapter "8.1 Securing the Articulated Steering".

LOADING AND TRANSPORTING THE MACHINE

SAFETY

Safety



DANGER

- **Failure to adhere to these safety instructions can lead to serious injury or death!
Read and adhere to all safety instructions.**
-

This chapter also contains safety instructions for special equipment and attachments.

9. GENERAL SAFETY MEASURES

9.1 SAFETY INSTRUCTIONS

- Do not operate or service the machine unless you have been trained and are authorized to do so.
- Always adhere to all instructions, measures, and safety instructions when operating or servicing the machine.
- When working together with other persons, agree beforehand on all hand signals that you want to use to avoid accidents due to misunderstandings.

9.2 SAFETY DEVICES

- Check that all safety devices and covers of the machine are correctly installed.
- Ensure that damaged safety devices and covers are repaired before you start the machine.
- Use all safety devices as prescribed, e.g. the safety lever for the work hydraulic system (see opposite figure) and the safety belt.

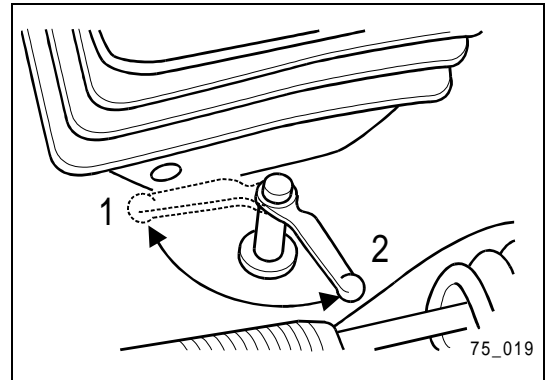

- You must not remove any safety device, such as the protective grid above the ventilator (see opposite figure). These devices must always be kept in a perfect condition.

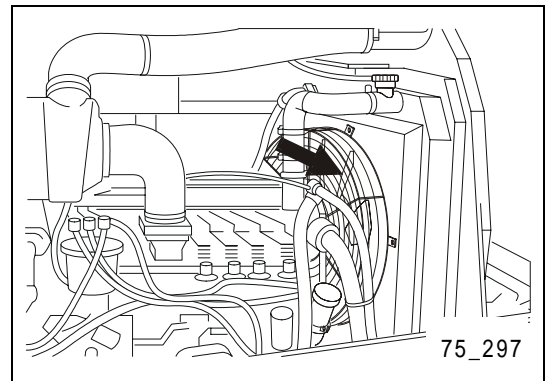

9.3 EMERGENCY EXIT

In an emergency situation, you can use the door on the right-hand side of the driver's cab (seen from the driving direction) as an emergency exit.

9.4 CLOTHING AND PERSONAL PROTECTION

- Do not wear loose-fitting clothing, jewellery, or open long hair. There is danger that you get caught by control elements or moving parts leading to serious injuries.
- Immediately replace clothing stained with highly inflammable substances.
- When operating and servicing the machine, wear the appropriate protective equipment, e.g. safety helmet, safety goggles, safety shoes, dust protection mask, and safety gloves.
- Always wear safety goggles, safety helmet, and protective clothing, if it is likely that chippings or splinters will be produced while operating the machine (e.g. when removing or driving in bolts or cleaning with compressed air).
- Ensure that no unauthorised person is within the danger zone.

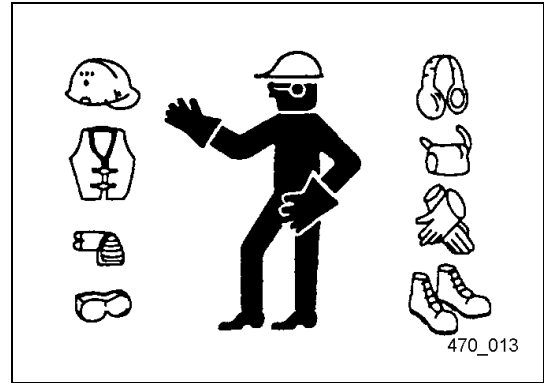

9.5 MACHINE MODIFICATIONS

- Komatsu will not be liable for modifications performed without prior expressed consent by the manufacturer.
- Komatsu will not be liable for any injuries or damage resulting from unapproved modifications.

9.6 BEFORE YOU LEAVE THE DRIVER'S SEAT

- 1- Lower the work unit onto the ground.
- 2- Use the safety lever to secure the work hydraulic system against unintentional operation (lever position '1'). If the lever for the hydraulic system is not secured and accidentally touched, uncontrolled movements of the work unit may lead to accidents with severe injuries or damage.
- 3- Switch off the engine.
- 4- Remove the ignition key before you leave the driver's seat. Store the ignition key in a safe place.
- 5- Close the cabin door.

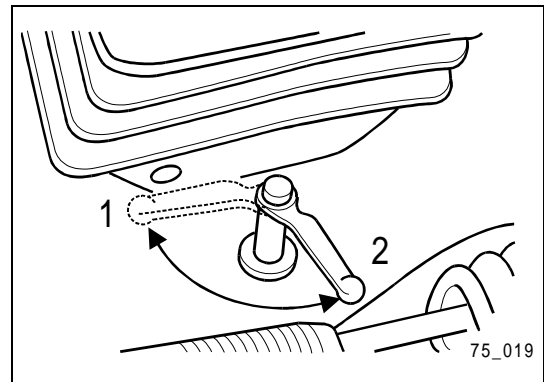

9.7 MOUNTING AND DISMOUNTING

- Do not jump on or off the machine. Do not mount on or dismount from a moving machine.
- Always use the handle bars and tread steps for mounting or dismounting the machine. Do not hold onto the control levers while mounting and dismounting.
- To ensure safe hold, hold the handle bar with one hand and stand on the tread steps with both feet. Optionally, stand on the tread steps with one foot and hold the handle bars with both hands.
- To reach the left rear mudguard for checking of the coolant level, set one foot into the driver's cab and use it as the fourth step. Dismount backwards.

9.8 FIRE PREVENTION AND FIRE FIGHTING

- Fuel, oil, and antifreezing compound are highly inflammable and could cause a fire.
- Do not approach inflammable material with naked light.
- Prior to refuelling, switch off the engine and stop smoking.
- Refuelling and refilling of oil are to be performed in sufficiently ventilated places.
- Store oil and fuel in special places appropriate for this purpose. Ensure that unauthorised persons do not have access to these places.
- Tightly close all cover caps.
- Check the fuel system, the lubrication system, and the hydraulic system for leaks. Have leaks repaired. Remove any excess oil, fuel, or other inflammable substances.
- Carefully and completely remove wooden chippings, leaves, paper, and other highly inflammable materials that may have collected in the engine compartment, since they could cause a fire.
- A fully operational fire extinguisher must be available at hand.
- The fire extinguisher is located in the compartment under the driver's seat.
- Do not operate the machine in the vicinity of naked light.

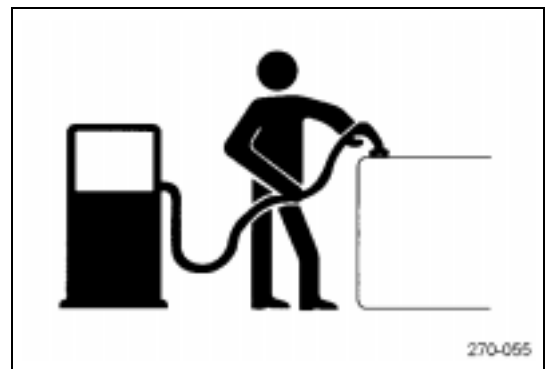

9.8.1 FIRE EXTINGUISHER AND FIRST-AID KIT

- If, in the course of certain operations, there is danger of fire, fire extinguishers must be at hand. Familiarise with the use of the fire extinguishers. The fire extinguisher is located in the compartment under the driver's seat.
- Inform yourself on measures to be taken in the event of a fire.

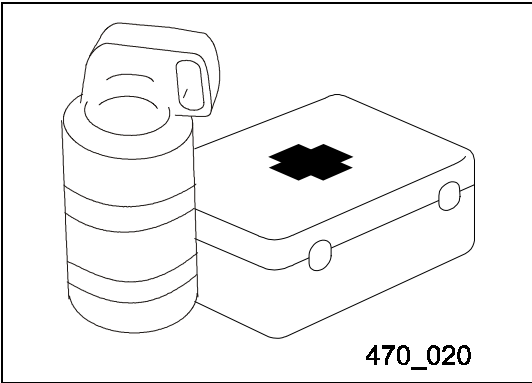

- The first-aid kit is located in the compartment under the driver's seat next to the fire extinguisher.
- Make sure that you know all telephone numbers of the persons that you need to contact in an emergency.

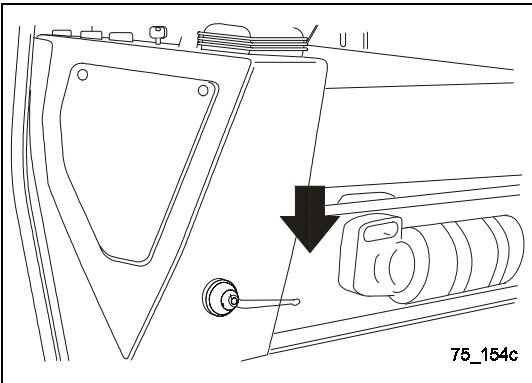

9.9 PROTECTION AGAINST ASBESTOS DUST

Asbestos dust is a health hazard if breathed in. This machine is free of any parts containing asbestos.

When handling material that may contain asbestos fibres, strictly adhere to all legal instructions and regulations. Furthermore, adhere to the following protective measures for your own protection:

- Work, if possible, with a following wind.
- While working, wear an approved dust protection mask.
- After work, clean the machine with water to minimise formation of dust. Do not use compressed air for cleaning.

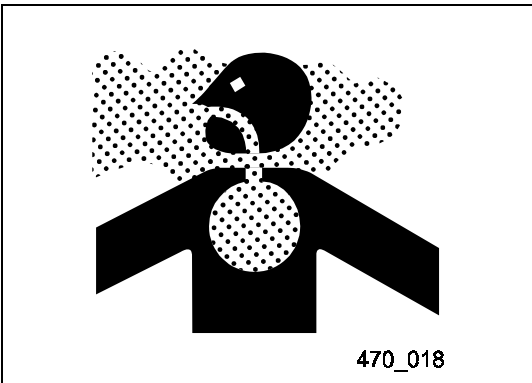

9.10 PROTECTION AGAINST INJURIES

Do not insert any part of your body in the operating range of moving parts, such as work unit and cylinder, or machine and work unit. Never stand in a hazardous area. Distances vary when the work unit or steering are operated, this may lead to serious injuries.

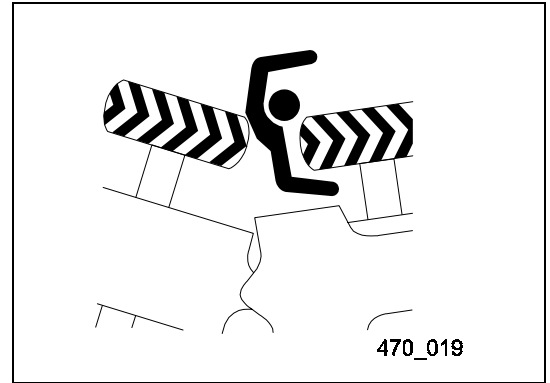

9.11 WORKING AT HIGH TEMPERATURES

- Directly after operating the machine, the engine coolant, the engine oil, and the hydraulic oil are extremely hot and under pressure. Do not try to unscrew caps, drain water or oil, or replace filters directly after operating the machine, since this may lead to severe burns due to hot fluids or hot machine parts. Wait until the temperature has fallen. Strictly adhere to the described procedures when performing the required measures.
- Lower the work equipment.
- Switch off the engine and wait for the radiator to cool down before you unscrew the radiator cap. Slowly turn the radiator cap until it reaches the first catch to let the pressure escape. Then, proceed turning the cap further and remove it. If you do not let the pressure escape, boiling water may spurt out when you remove the radiator cap.
- Switch off the engine. Allow the hydraulic oil to cool down before you unscrew the cap of the hydraulic tank to drain the hydraulic oil. Slowly turn the cap of the hydraulic tank to let the pressure escape from the tank. If you do not let the pressure escape, oil may spurt out when you remove the cap of the hydraulic tank.

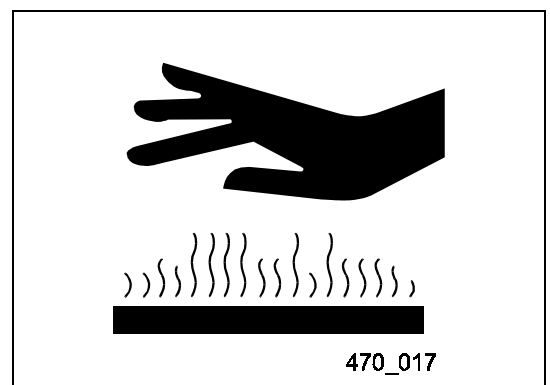

9.12 ROLL-OVER PROTECTION SYSTEM (ROPS)

- The roll-over protection system (ROPS) protects the operator and absorbs load and impact energy, if the machine should roll over.
- The ROPS is a fixed component of the cab. The machine must not be operated without this roll-over protection system.
- If, however, the ROPS is modified, damaged, or repaired without permission, its stability is impaired. In this case, the ROPS must be replaced, since its correct function can no longer be guaranteed.
- The ROPS can only provide maximum protection, if the driver wears the safety belt correctly. For this reason, the safety belt is to be worn when the machine is in operation.

9.13 ATTACHMENT FOR PROTECTION AGAINST FALLING OBJECTS (FOPS)



IMPORTANT

- **FOPS is a fixed component of the cab.**
-

When you work on a site where there is danger of falling rocks or other objects, the machines must be equipped with a FOPS. If the FOPS is modified without permission or damaged, its stability is impaired. In this case, the FOPS must be replaced, since its correct function can no longer be guaranteed.

9.14 ATTACHMENTS

Prior to assembly and operation of an additional attachment, read the attachment's manual and strictly adhere to the instructions on assembly and operation.

- Do not use attachments that have not been approved of by Komatsu or the local Komatsu dealer. If you use attachments which have not been approved of, safety, correct operation, and service life of the machine may be impaired.
- Komatsu are not liable for injuries, accidents, and damage resulting from the use of attachments that have not been approved.

9.15 BATTERY

The batteries are filled with sulphuric acid (battery acid).

- **Always** wear safety goggles when handling batteries.
- Contact of battery acid with eyes can cause blindness. If acid should get into your eyes, immediately rinse your eyes with ample water and call for medical help. Rinse your eyes with water until a doctor arrives or you are able to visit an ophthalmologist or go to a hospital.
- Sulphuric acid that gets into contact with skin or clothing may cause acid burns. Immediately rinse the area that has come into contact with the acid with ample water.
- When working in the area of the battery, your hands may unintentionally get in touch with acid. For this reason, do not touch your eyes while working in the area of the battery. Always wash your hands after work.
- Batteries produce detonating gas. Detonating gas is extremely **explosive** and may be ignited even by the smallest spark.
- Do **not** disconnect the battery while the engine is still running.
- Prior to start of work on batteries, set the start switch to '0'. Set the main switch of the battery (if installed) to 'Off'.
- Avoid any short-circuits via the poles or the pole terminals of the battery due to unintentional touching with metal objects, such as tools.
- When removing or inserting the battery, note which of the poles is the positive (+) and which is the negative (-) one. Always disconnect the mass cable first and reconnect it last.
- Tightly fasten the pole terminals. Loose pole terminals may produce sparks and thus cause explosions. Ensure that the cover of the positive pole (+) is always mounted.
- Tighten the cover caps.
- When repairing the electrical system or performing electric welding, disconnect the negative (-) pole terminal from the battery to interrupt the electric circuit.

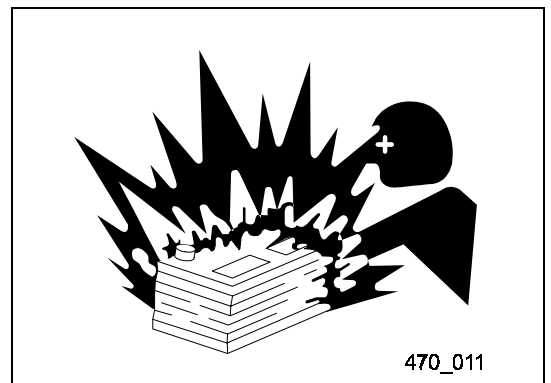
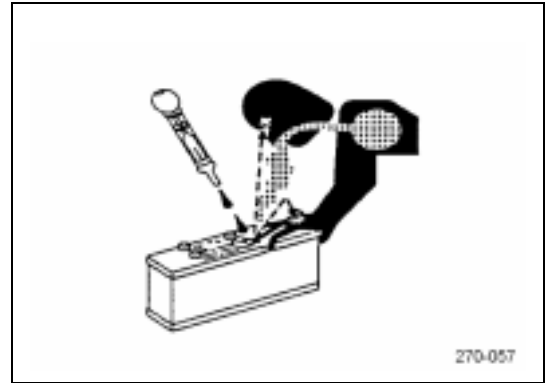

10. SAFETY MEASURES DURING OPERATION

10.1 BEFORE YOU START THE ENGINE

10.1.1 WORKPLACE SAFETY

- Before you start operation, check the working area for dangerous working conditions.
- Inspect the surface of the soil in the working area and determine the optimum and safest procedure.
- Determine the required safety measures against dangers on public roads in co-operation with the owners, users, and responsible authorities.
- On sites where there are underground water pipes, gas pipes, or conduits for high voltage cables, contact the responsible supply company to determine the lines' positions. Ensure that these facilities will not be damaged.
- When working with water or crossing sand banks, first check the subsoil and depth and flow rate of water. Ensure that the permitted water depth will not be exceeded.

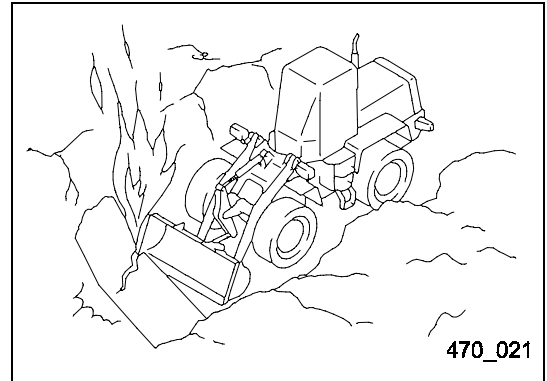

10.1.2 IN THE DRIVER'S CAB

- Do not leave any tools or spare parts lying around in the cab. These may actuate, damage, or block control levers, pedals, or switches. Store these parts in the tool box.
- Keep the cab floor, the control elements, the tread steps, and the handrails free of oil, grease, and excessive dirt.
- Immediately repair any damage. Tighten loose screw connections.
- Check the safety belt, the belt buckle, and the fastening elements for damage and wear. Replace worn or damaged parts.

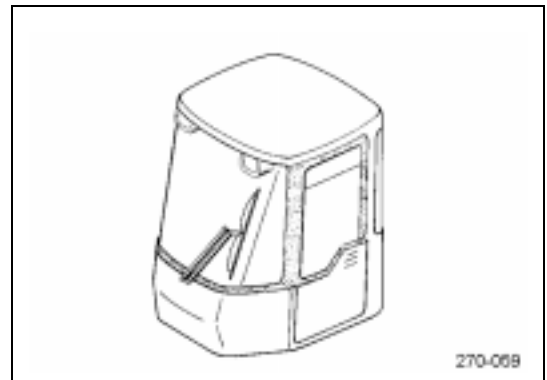

10.1.3 IN-DOOR OPERATION

Do not operate machines in-door unless these areas are sufficiently ventilated (e.g. workshops).

Caution - Danger of intoxication!

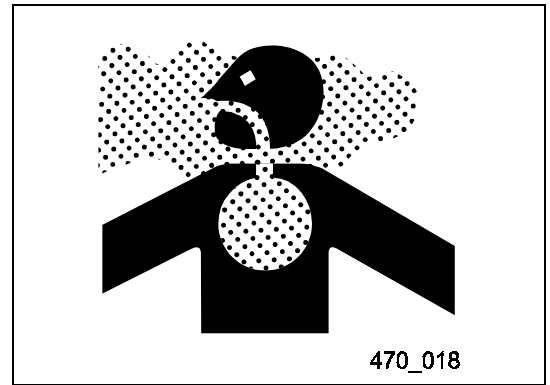

10.1.4 GAS, DUST, AND INFLAMMABLE VAPOURS

Do not operate combustion engines in an environment that may contain inflammable gases or vapours. These gases, dusts, or vapours may ignite or be sucked in by the suction system, thus causing a rise in engine speed or an exceeding of the engine's maximum rpm. This may lead to a fire, an explosion, and major damage to property. It may also happen that the engine cannot be switched off anymore. Also refer to chapter "10.1.3 In-Door Operation".

10.1.5 MIRRORS, WINDOWS, AND LIGHTING

- Clean the windows and the headlights to ensure maximum sight.
- Adjust the rear-view mirror in such a way that you have an excellent view of the rear from the driver's seat. Keep the mirrors clean.
- Ensure that the complete lighting system operates properly and that it is correctly adjusted.
- Immediately replace broken window panes by new ones.

10.2 MACHINE OPERATION

10.2.1 BEFORE YOU START THE ENGINE

- Walk around the machine to check whether persons or objects are in the way before you get on the machine.
- Do not start the engine, if a warning sign has been attached to the control lever or another point.
- Sound the horn just before you start the engine.
- Start and operate the machine only from the driver's seat.
- Apart from the operator, no other person is permitted in the driver's cab or in the vicinity of the machine.
- If the machine is provided with a reversing warning system, you must ensure that it operates correctly.
- Before you start the machine, check that the articulated steering is unlocked (position '1') and that the locking bar is attached to the frame by means of bolts and spring bolts.
- Always wear the safety belt when operating the machine.

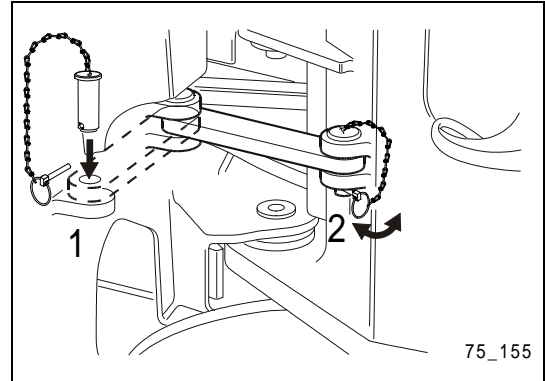

10.2.2 REVERSING

These rules must be observed for all machines, i.e. also for those machines equipped with a reversing warning system:

- Check that there is nobody near the machine or in the way.
- Before you start reversing, sound the horn to warn persons within or near the operating area.
- When working in potentially dangerous areas or areas with obstructed view, ask another person to regulate and supervise traffic.

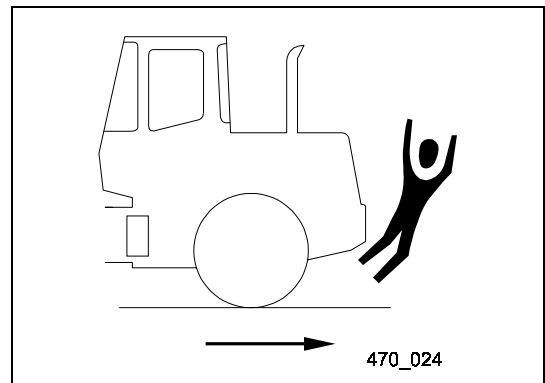

10.2.3 DRIVING

- When driving, set the bucket to the transport position. The bucket is in its transport position when the transport position markings on frame and boom are aligned in parallel.
- When driving on uneven ground, drive slowly and avoid sudden steering movements.
- If the engine goes out while driving or if the hydraulic pump breaks down, you may no longer steer the machine. An emergency steering system will only be available, if the machine is moved with a speed of min. 1.24 mph (2 km/h) (1.24 mph is the max. permitted towing speed).

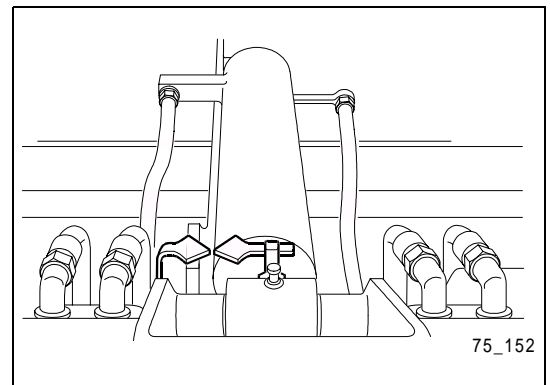
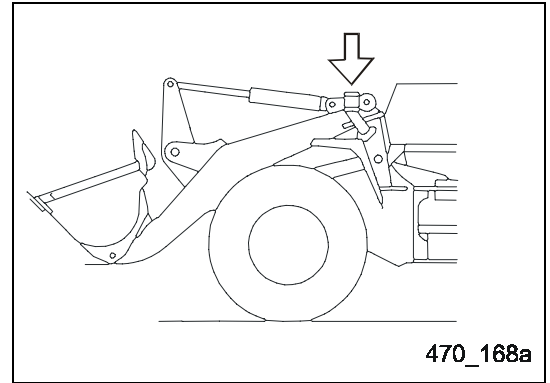

10.2.4 DRIVING ON SLOPES

- Keep sufficient distance to ridges and steep slopes. There is danger of the machine tipping over or sliding down on steep slopes, embankments, or hill flanks. The limiting values are defined in chapter "33.3 Limit Values for Slopes".
- To keep the centre of gravity as low as possible when driving on slopes, embankments, and hill flanks, you must set the bucket to a position just above the ground (approx. 7.87 in (200 mm) to 11.8 in (300 mm)). In an emergency, quickly lower the bucket to the ground to stabilize the machine.
- Do not turn on a slope or drive across a slope. Turn or cross the section only on level ground.
- When driving on slopes, avoid driving on grass, fallen leaves, or steel plates. Driving sideways on these surfaces may result in the machine sliding. Drive very slowly and carefully.
- When driving down a slope, use the braking power of the engine and drive slowly.
- If the engine stops while you are driving on a slope, immediately apply the service brake to stop the machine. Then apply the parking brake. Lower the work unit.
- When driving on a hill with a load, drive uphill: in forward direction
downhill: in reverse direction

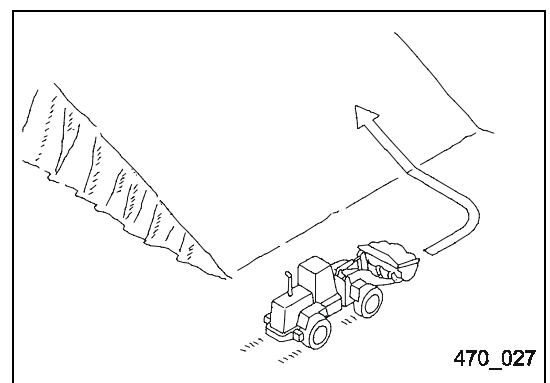
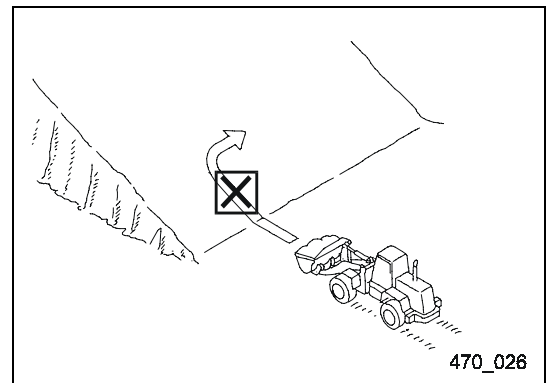

10.2.5 EMERGENCY LOWERING SYSTEM

When the engine is in operation or not in operation, you may lower the work unit with the emergency lowering system.

- Ensure that nobody is standing under the work unit.

Likewise you may release the rest pressure in the hydraulic circuit.

- Turn the lever of the emergency lowering system to position '2'.
The work unit is lowered, or the rest pressure is released.
- Turn the lever of the emergency lowering system back to position '1'.

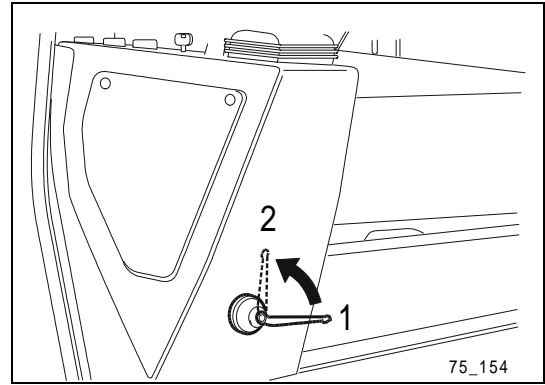

10.2.6 WORKING CLOSE TO OVERHEAD POWER TRANSMISSION LINES

- A voltage overspill may occur, if you or the machine get too close to overhead power transmission lines. For this reason, always heed the required safety distance between the machine and the overhead power transmission lines.

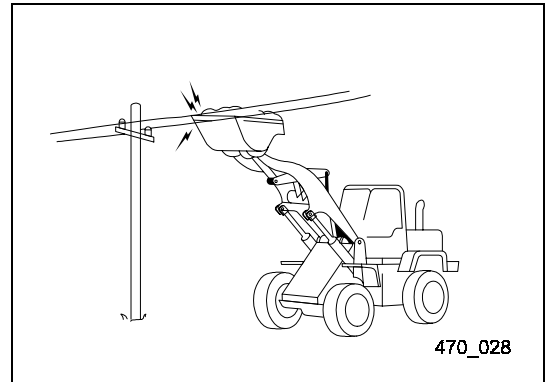

	Voltage	Min. Safety Distance	
Low voltage	100-200 V	7 ft	2 m
	6,600 V	7 ft	2 m
Very high voltage	22,000 V	10 ft	3 m
	66,000 V	14 ft	4 m
	154,000 V	17 ft	5 m
	187,000 V	20 ft	6 m
	275,000 V	23 ft	7 m
	500,000 V	36 ft	11 m

- Before you start work, obtain information about line voltages from your supply company.
- When estimating the distance, take into account all possible movements of the machine, the work unit, and the line. An uneven surface may result in the machine swaying, or wind may move the lines, etc..

- Should the work unit come into contact with a power transmission line, proceed as follows:
 - 1- Do not leave the driver's cab. The driver's cab is a "Faraday cage" protecting you from electric shock.
 - 2- Warn other persons and tell them to stay far away from both the power line and your machine.
 - 3- Try to move the machine out of the range of influence of the overhead power transmission line by moving it away from the line, moving away the work unit, etc.
 - 4- Have the power in the line switched off.

10.2.7 LOADING

- Proceed as follows to fill embankments, to backfill ditches, or to deposit earth over the edge of a hill:
 - 1- First, dump a heap of earth in front of the hill.
 - 2- Fill the bucket with earth again and drive the machine into the heap of earth. Dump the bucket contents behind the first heap of earth.
- The load is relieved very suddenly when the heap of earth is pushed over the edge of the hill or when the machine reaches the edge of the hill. If this happens, the driving speed may suddenly increase. For this reason, drive particularly slowly and carefully at these points.
- If possible, perform all load operations with a following wind to protect yourself against dust and impaired vision.
- Avoid sudden starts, turns, or stops when the bucket is full.

10.2.8 GOOD VISION

- When working in dark areas, switch on the working lights of the machine and provide additional lighting for the working area.
- If vision is impaired, e.g. due to mist, snow, or rain, interrupt work and wait until vision has improved to such an extent that safe work is ensured again.

10.2.9 WORKING ON SNOW

- When working on snow or ice-covered surfaces, there is danger of the machine starting to skid even at a very flat angle. For this reason, drive slowly and avoid sudden starts, turns, or stops.
- Very often snow hides the edges of roads and other objects. For this reason, proceed very carefully when removing snow.
- When driving on hill flanks covered with snow do not brake abruptly to stop the machine. To stop the machine, lower the bucket onto the ground.
- The load may vary considerably, depending on the structure of the snow. For this reason, reduce the load and pay attention that the machine does not start to skid.

10.2.10 HEIGHT LIMITATION

When working in areas with height limitations, e.g. in tunnels, beneath bridges or power transmission lines, or in garages, pay attention that the work unit does not touch or damage these facilities.

10.2.11 BRAKES

- Use the brake pedal only for braking, do not use the brake pedal as a foot rest.
- When you are driving downhill, you can use the braking force of the engine by reducing the speed (rpm) of the engine. If required, you can additionally press down the braking pedal for braking.

10.2.12 WORKING ON LOOSE SOIL

Do not drive the machine too close to edges of hills, overhangs, and deep ditches. If the soil starts to sag at these locations, the machine may tip over, fall down, or roll over, thus injuring you severely. Take into account that the soil is wet and soft after heavy rainfall, or very loose after blasting.

10.2.13 WORKING WITH THE FORKLIFT TRUCK ATTACHMENT

- Check daily, before starting operation, the fork tines of the machine for visual damages (e.g. fissures, cracks, wear and tear). Also the protective device preventing unintentional removing or shifting of the fork tines may have no defects. Never work with a damaged forklift truck attachment.
- Before inserting the forklift truck attachment into the quick-change unit, check whether it is properly locked in.
- Make sure that the gaps between the individual fork tines are sufficient.
- Never exceed the maximum permitted loading capacity of the forklift truck attachment. It depends on the condition of the ground on which the work is to be performed and the stroke height. The centre of gravity of the load lies 19.685 in (500 mm) from the fork back and from the fork tines (see drawing).
- Transports pallets only one at a time. If you are instructed by the responsible colleague to transport more pallets, which are also piled up, you must make sure in any case that the pallet parts under which the forklift truck attachment is gripping for transporting are in perfect condition. The overall height of the pallet pile must not exceed 7 ft (2 m).
- Make sure that the fork tines are adapted to the length of the load. Move the fork tines so far under the load that the load comes to a rest at the fork back.
- If you are transporting a load which is impairing your sight on the route, you must drive the machine into a direction in which you have free sight. If it cannot be avoided, drive backwards. If this is not possible, ask a colleague to assist you by clearing your way and indicating to you any obstacle. In this case, drive very slowly and extremely careful.
- During transporting, lower the boom to its transport position. Both red arrows of the transport position marking on the lifting cylinder (see adjacent figure) must be next to each other. Incline the load slightly to the back during the transport. You may only lift the load above the pile during the lowering or lifting procedure.
- Always drive slowly when you are transporting loads (speed range 1).
- If you are driving on slopes or hills, transport the load always in such a way that it is facing uphill.
- The boom performs a semicircular movement during lifting. Lift the boom to the desired transporting height only shortly before approaching the deposit surface. This prevents that the load is damaged during the lifting.
- Lower the forklift truck attachment completely to the ground before quitting the driver's cab.

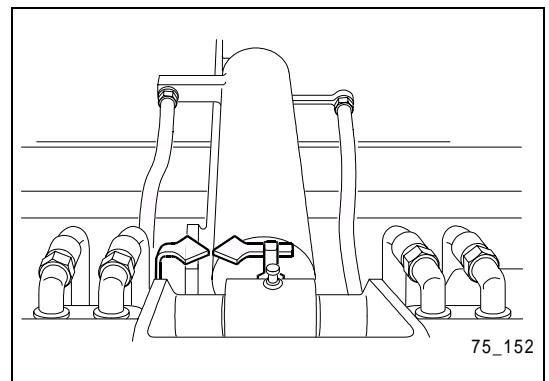
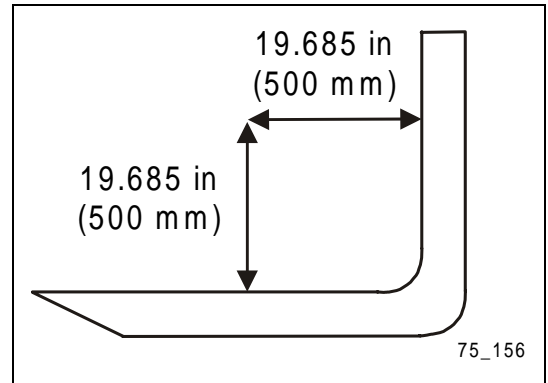

10.2.14 PARKING THE MACHINE

- If possible, park the machine on an even surface. If you have to park the machine on a slope, you must park the machine with the work unit pointing down the slope. Lower the work unit (1) until it firmly touches the ground, or let the cutting edge of the bucket sink deeply into the soil. Block the wheels with wheel chocks (2) to ensure that the machine cannot roll away.
- When parking the machine on public roads, ensure that it does not obstruct traffic. Put up signal lamps and required warning signs to ensure that passing traffic can clearly see the machine.
- Adhere to all regulations on parking vehicles and securing building sites.
- Before you leave the machine, completely lower the work unit onto the ground. Secure the control lever of the work hydraulic system against accidental operation. Switch off the motor. Lock all points that can be locked and store the key in a safe place.

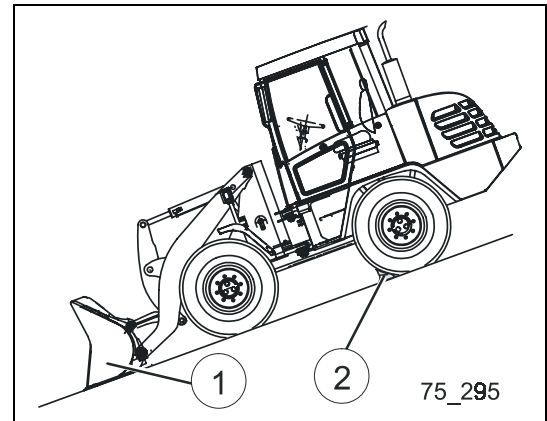

10.3 TRANSPORT

10.3.1 LOADING AND UNLOADING THE MACHINE

Loading and unloading is potentially dangerous. For this reason, proceed with extreme care.

- Load and unload the machine only on solid and level ground. Keep a safety distance to the edge of the road.
- Block the wheels of the transport vehicle (1) and place support blocks (2) under both ramps before driving the machine onto the transport vehicle.
- Only use ramps (3) with appropriate carrying capacities and widths. The ramps must be long enough to ensure that the maximum loading gradient (4) of 15% is not exceeded.
- Ensure that the ramps are positioned and fastened safely and that both sides have the same height. Set the distance between the ramps to the distance between the wheel tracks (5).
- Ensure that the surfaces of the ramps are clean and free of grease, oil, ice, and loose material. Remove any dirt adhering to the wheels.
- When loading and unloading the machine, keep the engine speed low and drive slowly.
- Do not carry out steering movements on the ramps. If required, drive off the ramps again, correct alignment of the machine, and drive up again.
- After loading, i.e. when the machine is on the transport vehicle, apply the parking brake.
- Block the wheels of the machine with wheel chocks.
- Set the steering wheel of the machine to straight driving.
- Secure the articulated steering with the locking bar. Position '1' Articulated steering unlocked. Position '2' Articulated steering locked. Always secure the locking bar with the bolt and the spring bolt in both positions.
- Secure the machine on the transport vehicle by means of appropriate fastening equipment. Only use the attachment points on the machine for lifting and securing. For safety reasons, do not use any other points for fastening (e.g. axle, cardan shaft, articulated steering, bucket teeth, or strapping around the cab).

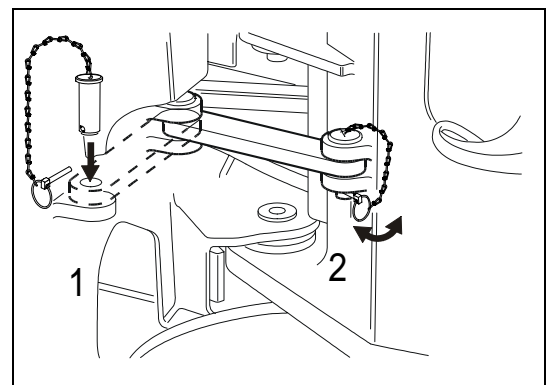
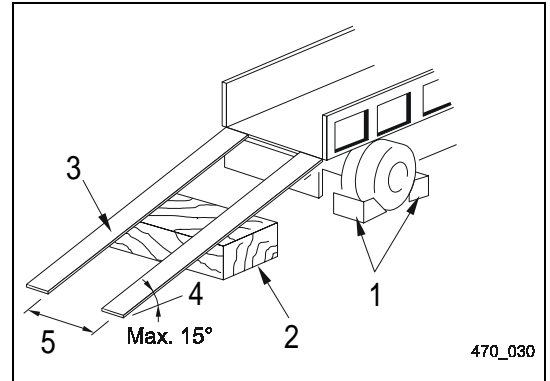

10.3.2 TRANSPORT

- When moving the machine on a transport vehicle, adhere to all applicable motor vehicle traffic regulations.
- Determine the transport route, taking into account the width, length, height, and weight of the load and, if necessary, have this approved by the responsible authorities.

11. SAFETY MEASURES DURING MAINTENANCE

11.1 PERSONNEL

Do not service or repair the machine unless you are an appropriately qualified technician or have been appropriately instructed by a qualified technician.

11.2 PRIOR TO START OF MAINTENANCE MEASURES

11.2.1 WARNING SIGN

While the machine is being serviced, the engine must not be started and the control elements must not be actuated without prior agreement, since this could cause accidents with serious injury.

Always attach the **warning sign** to the control lever for the work hydraulic system to warn other persons that work is being performed on the machine. If required, put up additional warning signs around the machine.

You may purchase these warning signs from your Komatsu dealer.

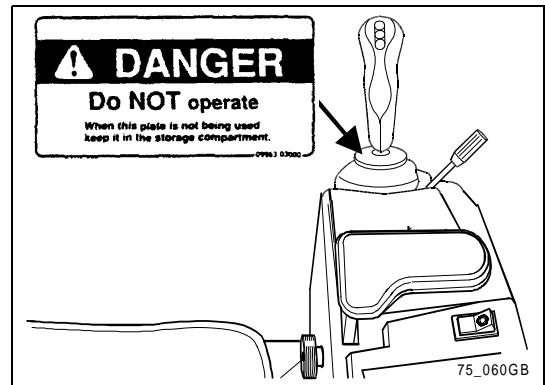

11.2.2 TOOLS

Only use tools which are suitable for the task you want to carry out. If you use damaged or makeshift tools or tools which are of inferior quality, injuries may occur.

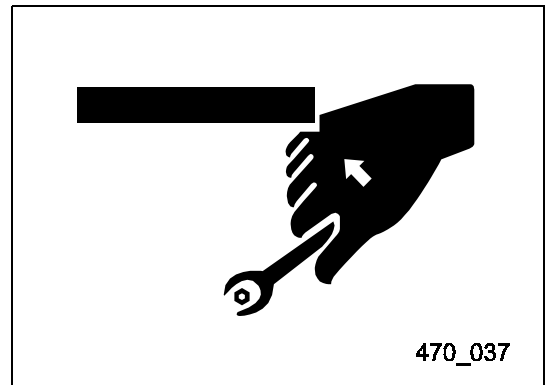

11.2.3 SAFETY-RELATED PARTS

The quality of these parts is subject to normal wear and tear. For this reason, replace safety-related parts by new ones at regular intervals, regardless of whether they are defective or not.

Safety-related parts are:

Fuel system: fuel hose, overflow hose, and tank cap

Hydraulic system: all hydraulic hoses

Immediately replace defective parts, even if the interval for replacement has not elapsed.

Replace hydraulic hoses every 6 years.

11.2.4 PRIOR TO START OF INSPECTION AND MAINTENANCE

Prior to start of inspection and maintenance operations, park the machine on solid, even ground. Lower the work unit. Switch off the engine (start switch to position '0') and safeguard the machine.

If the engine has to be running during maintenance, e.g. for pressure checks of the hydraulic system, proceed with particular care. Perform such measures with two persons with whom you have arranged clear hand signs beforehand.

One person must be seated on the driver's seat to ensure that the engine can be immediately switched off, if required. This person must always ask the second person before actuating the control levers.

The person performing the maintenance measures must take care not to touch or get caught by moving parts.

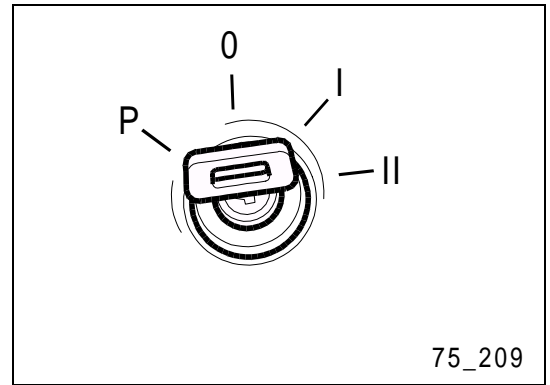

11.2.5 SECURING THE ARTICULATED STEERING

Before starting maintenance, secure the articulated steering against accidental movement using the locking bar (position '2').

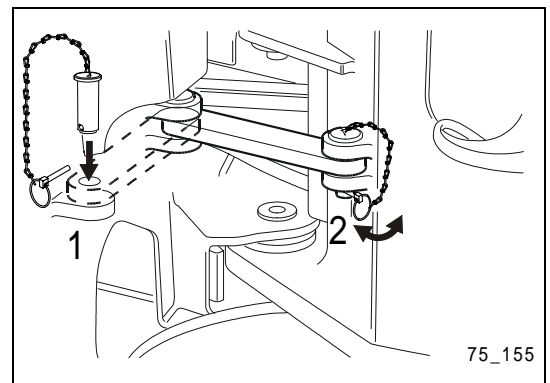

11.2.6 SUPPORTING THE WORK UNIT

Before work under a lifted work unit is started, the work unit must be supported to ensure safety. For this purpose, use a support block. In addition, set the control lever for the work hydraulic unit to its neutral 'HOLD' position and secure it with the safety lever.

If the area under the boom is to be cleaned and a support has not been erected, the machine must be parked as follows:

- 1 - Park the machine on even ground.
- 2 - Apply the parking brake.
- 3 - Place wheel chocks in front of the wheels to prevent the machine from rolling away.
- 4 - Lower the cutting edge or the teeth of the completely empty bucket onto the ground.

These steps are only permitted for cleaning measures.

11.3 DURING MAINTENANCE

11.3.1 ATTACHMENTS

Attachments removed from the machine must be stored in a safe location and in such a way that they cannot tip over.

Caution - risk of injury!



11.3.2 WORKING UNDER THE MACHINE

- Always lower all movable work units onto the ground or set them to their lowest positions before you start to perform maintenance or repair measures under the machine.
- Block the wheels of the machine using wheel chocks.
- Do not work under a machine that is not appropriately supported.



11.3.3 KEEPING THE MACHINE CLEAN

- Always keep the machine clean and tidy.
- Oil, grease, and tools lying around involve danger, since they may cause slipping or tripping over.
- Do not clean sensors, plugs, and the interior of the driver's cab with water or steam. If water seeps into the electric system, there is danger of uncontrolled and unintentional movement of the machine which may cause accidents.

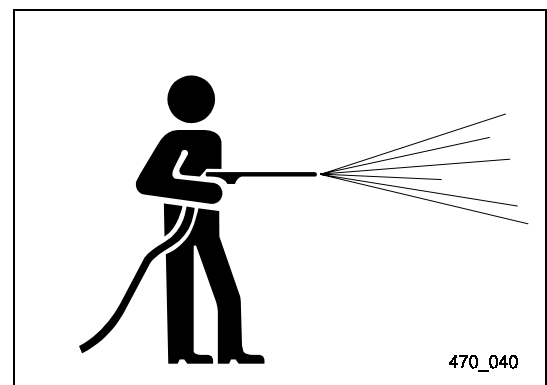

11.3.4 SPECIFIC MEASURES

Always wear appropriate safety clothes and safety goggles when you perform grinding, welding, use a sledge hammer or perform similar work.

11.3.5 REFUELING AND TOPPING OFF OIL

- Spilled fuel or oil involves danger of slipping and fire. For this reason, immediately remove any spilled liquid.
- Always refuel and top off oil in a place that is sufficiently ventilated.
- After refueling and topping off, close the filling openings with cover caps.
- Do not use fuel for rinsing or cleaning of components.
- Ensure that neither oil nor fuel can seep into the soil or water. Dispose of used substances according to the relevant environmental regulations.
- If the machine is provided with a fuel sieve in the tank opening, do not remove this fuel sieve before you start refueling.

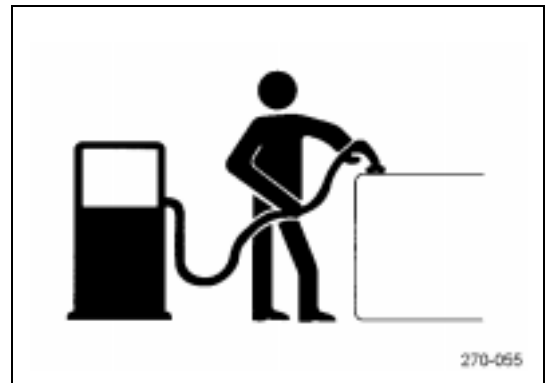

11.3.6 COOLANT

- The machine is provided with an aluminium radiator. Use coolants only in the prescribed mixing ratio.
- Caution, antifreeze is highly inflammable.
- To check the coolant level, first switch off the engine and wait for the cooling system to cool down. Then, check the coolant level in the expansion tank.
- Slowly unscrew the cap to let the pressure escape.
- If required, top up water in the expansion tank.

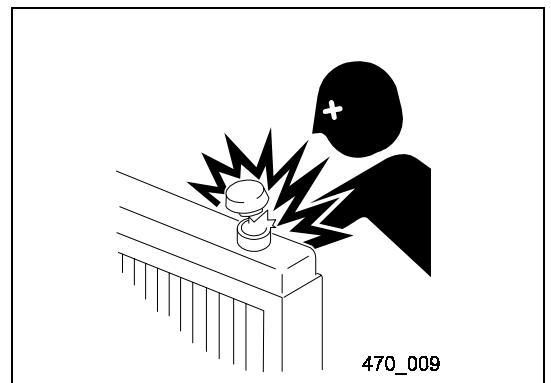

11.3.7 USE OF LIGHTING

Always use explosion-proof lighting when checking fuel, oil, coolant, or battery acid.

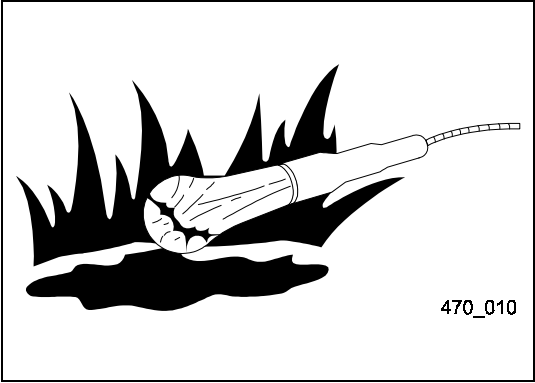

11.3.8 HIGH-PRESSURE HOSES

Neither bend high-pressure hoses nor hit them with hard objects. Do not use piping or hoses with fissures, cracks, or bends, since they may burst during operation.

Immediately replace any loose or damaged fuel or oil hoses. Leaking fuel or oil involves danger of fire and slipping.

Replace all hoses every six years at the latest.

11.3.9 HANDLING HIGH-PRESSURE OIL

- Always take into account that the hydraulic lines are subjected to high pressure.
- Do not top up oil, drain oil, or perform maintenance or inspection measures unless the work unit is completely lowered and the system is depressurised.
- If oil comes out under high pressure, this involves danger of an oil jet penetrating the skin or getting into the eyes. For this reason, always wear safety goggles and thick safety gloves, and use a piece of cardboard or wood when checking for oil leaks.
- If you have been hit by an oil jet, immediately go and see a doctor and explain what has happened.



11.3.10 FAN AND BELTS

- Always keep sufficient distance from rotating parts and pay attention that nothing gets within the operating range of rotating parts.
- There is danger that parts getting caught by the fan or the belt are cut off or hurled away.
- Do not wear loose clothing, neckerchiefs or the like, or open, long hair that might get caught.

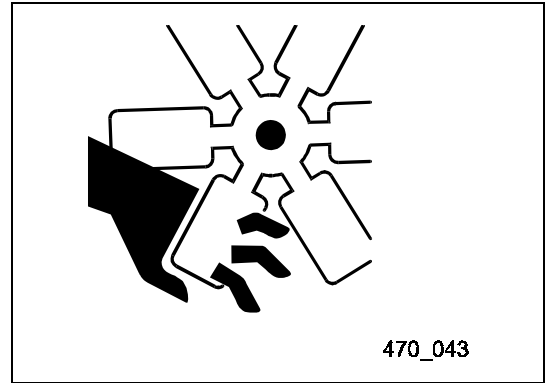

11.3.11 WASTE MATERIAL

- Do not pour used oil into the sewage system, rivers, etc.
- Collect used oil of the machine in appropriate containers. Do not let oil flow out onto the ground.
- Adhere to all applicable laws and regulations when disposing of harmful substances, such as oil, fuel, coolant, solvents, filters, batteries, etc.

11.4 TIRES

Handling of Tires (also refer to chapter "20.2 Tire Service Life").

Tires may burst and the resulting blast wave or parts whirling around may cause severe injury or damage. Make sure that the applicable procedures for servicing and replacing of wheels or tires are fully understood and that only correct procedures are used.

To ensure safety and reduce wear and tear, always adhere to the following instructions:

- Inflate tires up to the defined pressure. If the tire pressure is too low, the tires may heat up and burst. If the tire pressure is too high, there is also danger that the tire may burst.
- If a tire heats up considerably, inflammable gases are produced. A burning tire may burst very easily, thus spreading fire over a large area.
- Check the tire pressure when the tires are still cold. Do not let off pressure, when the pressure in a warm tire has increased.
- Do not light a fire and do not perform welding near the tire.
- Keep the working area free of pointed or sharp objects that may damage the tire.
- Avoid any overload.



The values for the tire pressure and for the permitted speed correspond to the manufacturer specifications and refer to standard operations. If you want to perform special operations, contact the local Komatsu dealer or the tire manufacturer.

11.4.1 STORING TIRES

- Basically, tires must be stored in a protected room that cannot be accessed by unauthorised persons.
- Place the tires on an even surface and incline them 60° to 70° (2) against a solid stopper. Secure the tires with wheel chocks (1) so that they cannot roll away, tip over, or slip.
- If, however, a tire tips over despite this safety measure, do not try to stop it, but get out of the way as quickly as possible, since tires for construction machines are very heavy and may cause serious injuries.

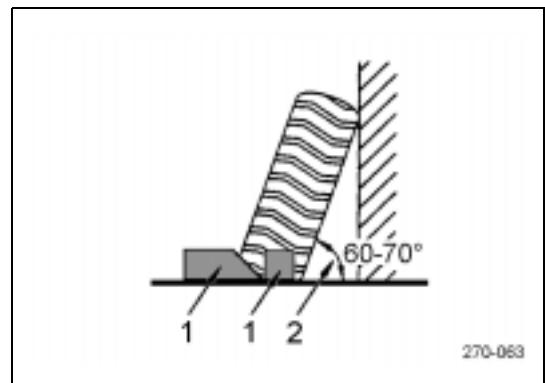

12. LABELING

- All safety labels must be kept clean all times. Missing or damaged safety labels must be replaced.

12.1 POSITION OF SAFETY LABELS

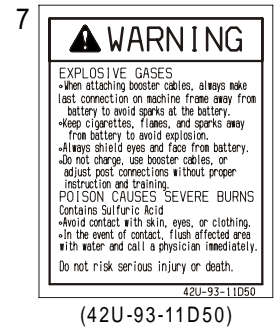
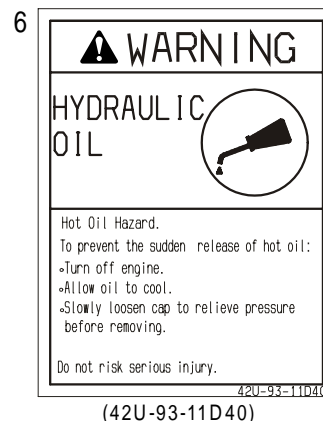
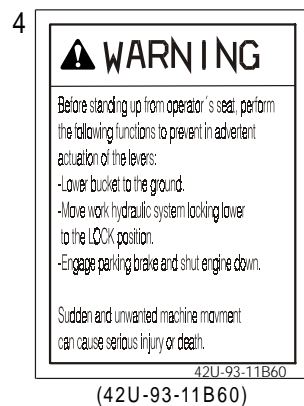
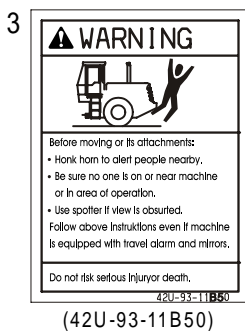
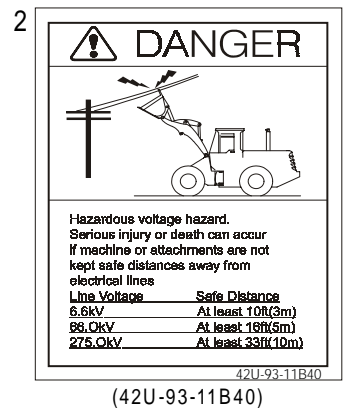
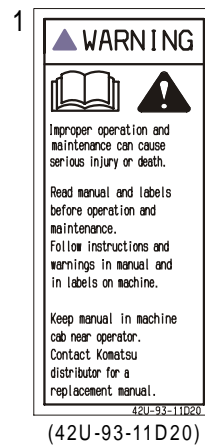
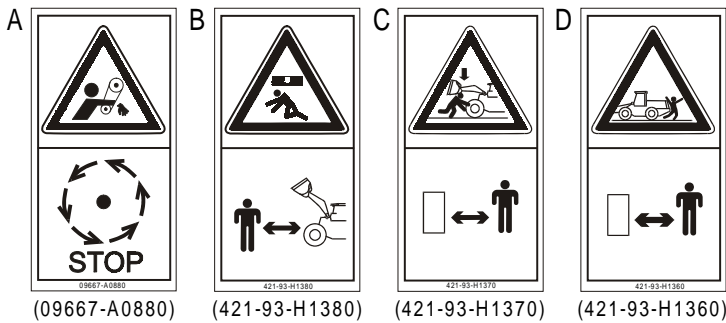
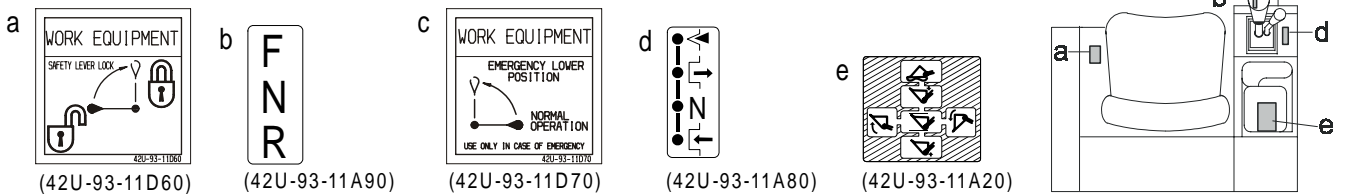
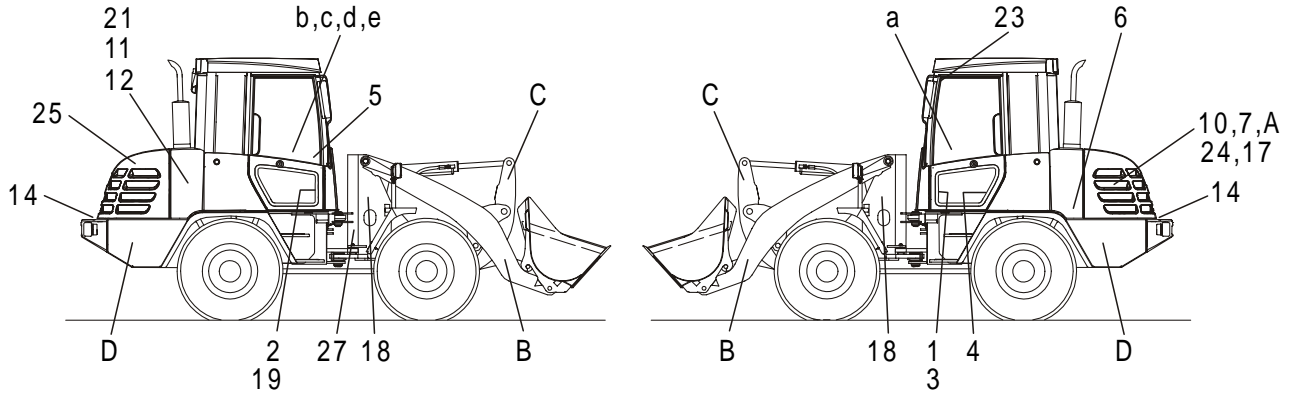

LABELING

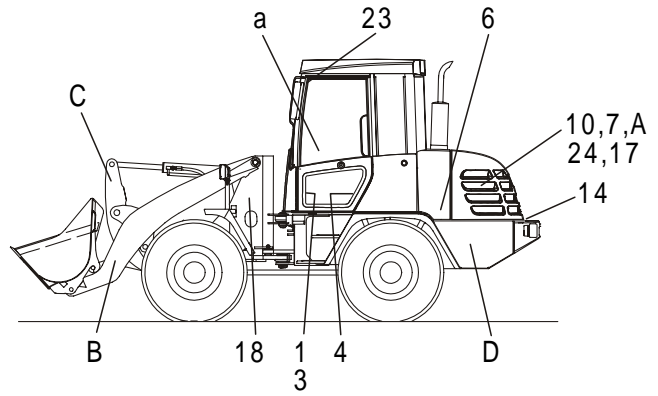
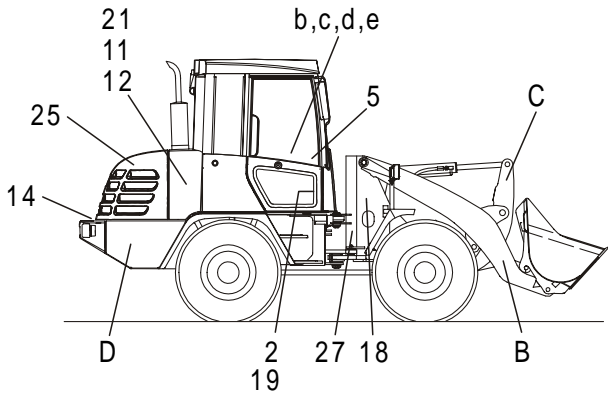

10

IMPORTANT
<ul style="list-style-type: none"> • Element must be kept free of cracks and oil. • For cleaning and replacement of elements, refer to the Operator's Manual. • Do not put oil into this cleaner.
42U-93-11B70

(42U-93-11B70)

11

WARNING
Hot Water Hazard
To prevent the sudden release of hot water:
<ul style="list-style-type: none"> • Turn off engine • Allow water to cool • Slowly loosen cap to relieve pressure before removing.
Do not risk serious injury.
42U-93-11B80

(42U-93-11B80)

12

FUEL DIESEL FUEL ONLY
Refer to your Operation and Maintenance Manual for instructions on draining fuel tank.
42U-93-11B90

(42U-93-11B90)

14

WARNING
NEVER STAND, SIT, OR IN ANY WAY TRANSPORT PEOPLE OR MATERIALS ON THIS HOOD. DO NOT RISK SEVERE PERSONAL INJURY OR DEATH.
42U-93-11C10

(42U-93-11C10)

17

WARNING
WHILE ENGINE IS RUNNING:
<ol style="list-style-type: none"> 1. Do not open cover. 2. Keep away from fan and fan belt.
Do not risk serious injury.
42U-93-11C20

(42U-93-11C20)

18

DANGER
CRUSH HAZARD; KEEP CLEAR - Operate machine from operator's seat ONLY. - During operations, never place yourself in articulated area of machine. Do not risk serious injury or death.
42U-93-11C30

(42U-93-11C30)

19

WARNING
ALWAYS USE SEAT BELT.
Avoid being crushed - DO NOT jump if machine tips. Do not risk serious injury or death.
42U-93-11C40

(42U-93-11C40)

20

WARNING
Block wheels to prevent machine movement. Do not risk serious injury or death.
42U-93-11C50

(42U-93-11C50)

21

DANGER
Start only from operator's seat with park brake engaged and the machine in neutral. Do not risk serious injury or death.
42U-93-11C60

(42U-93-11C60)

23

CAUTION
DO NOT WELD ONTO ROPS STRUCTURE. If any damage is sustained to ROPS structure, contact your local Komatsu dealer immediately.
42U-93-11C70

(42U-93-11C70)

24

WARNING
Use only the prescribed brake fluid listed in the Operator's manual. Using an unauthorized brake fluid could result in brake failure. Do not risk serious injury or death.
42U-93-11C80

(42U-93-11C80)

25

WARNING
DO NOT USE ETHER
Engine equipped with electric heater. Using ether as a starting aid may cause explosion. Do not risk serious injury or death.
42U-93-11C90

(42U-93-11C90)

27

WARNING
If articulated steering locking bar is unlocked, machine can jackknife unexpectedly when it is being transported or hoisted. - Always lock locking bar when machine is being transported or hoisted. - If necessary, lock locking bar during servicing or maintenance. Do not risk serious injury or death.
42U-93-11D10

(42U-93-11D10)

12.2 POSITION OF STANDARD LABELS

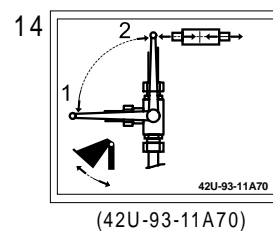
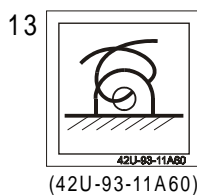
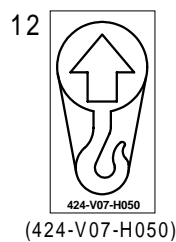
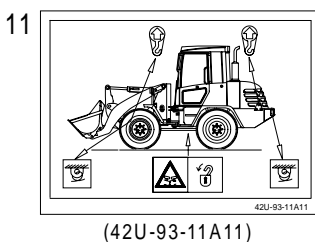
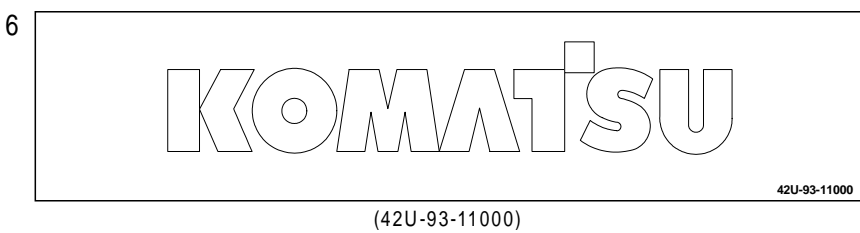
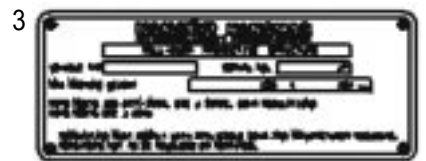
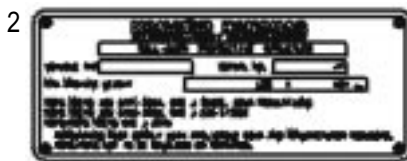
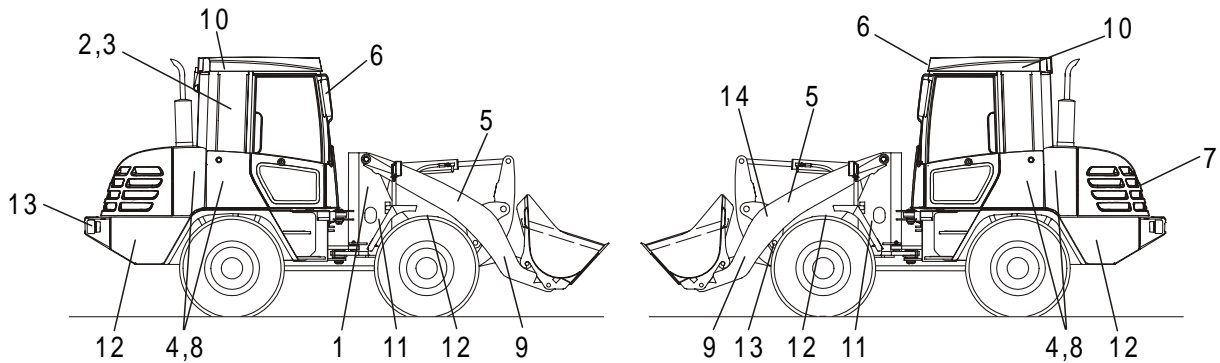

CONTROLS AND INDICATORS

13. GENERAL VIEW OF MACHINE

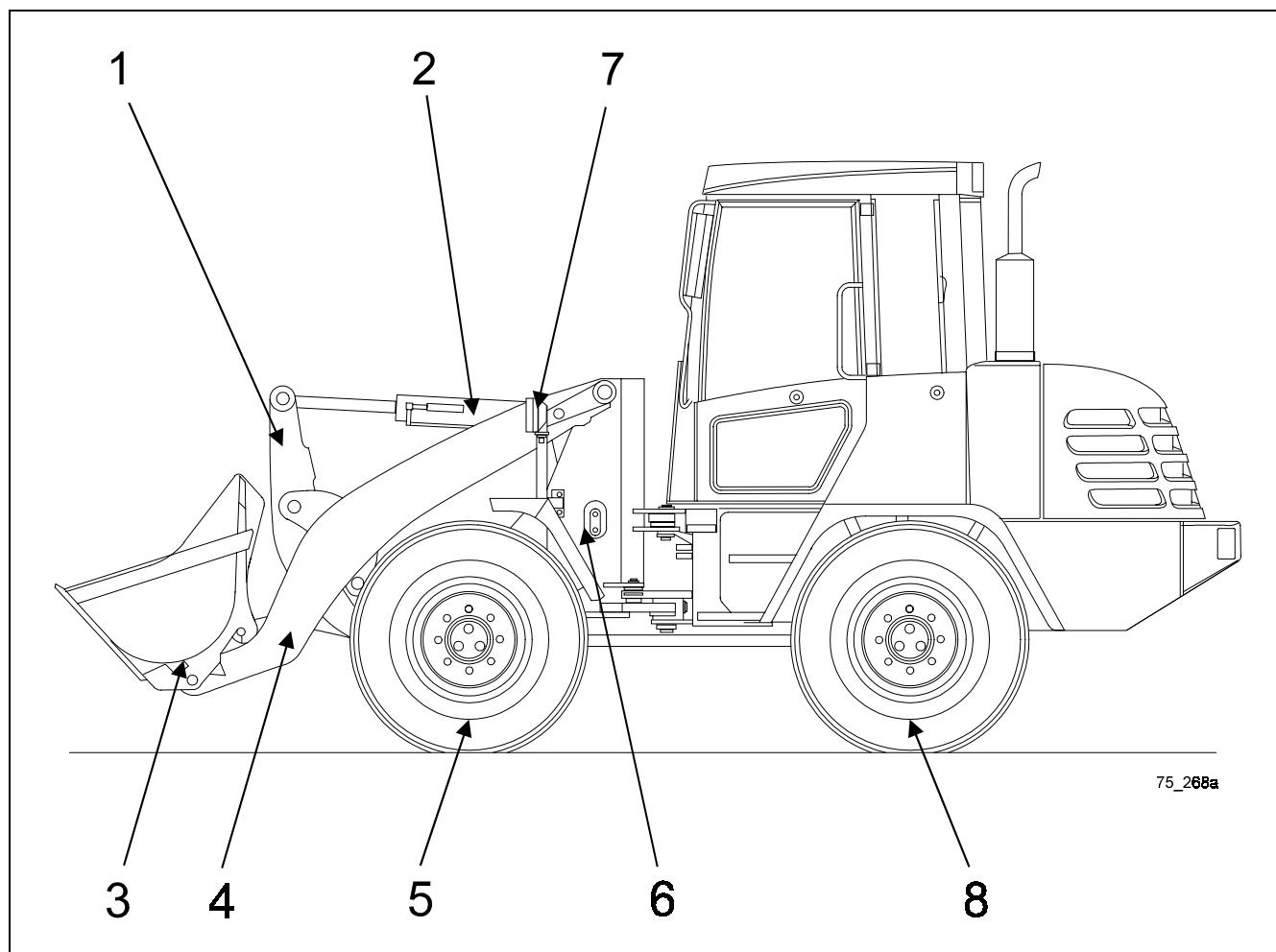

- 1- Rocker arm
- 2- Bucket cylinder
- 3- Bucket
- 4- Boom
- 5- Front wheel

- 6- Lift cylinder
- 7- Head lamp
Direction indicator
- 8- Rear wheel

14. CONTROLS AND INDICATORS

14.1 GENERAL VIEW

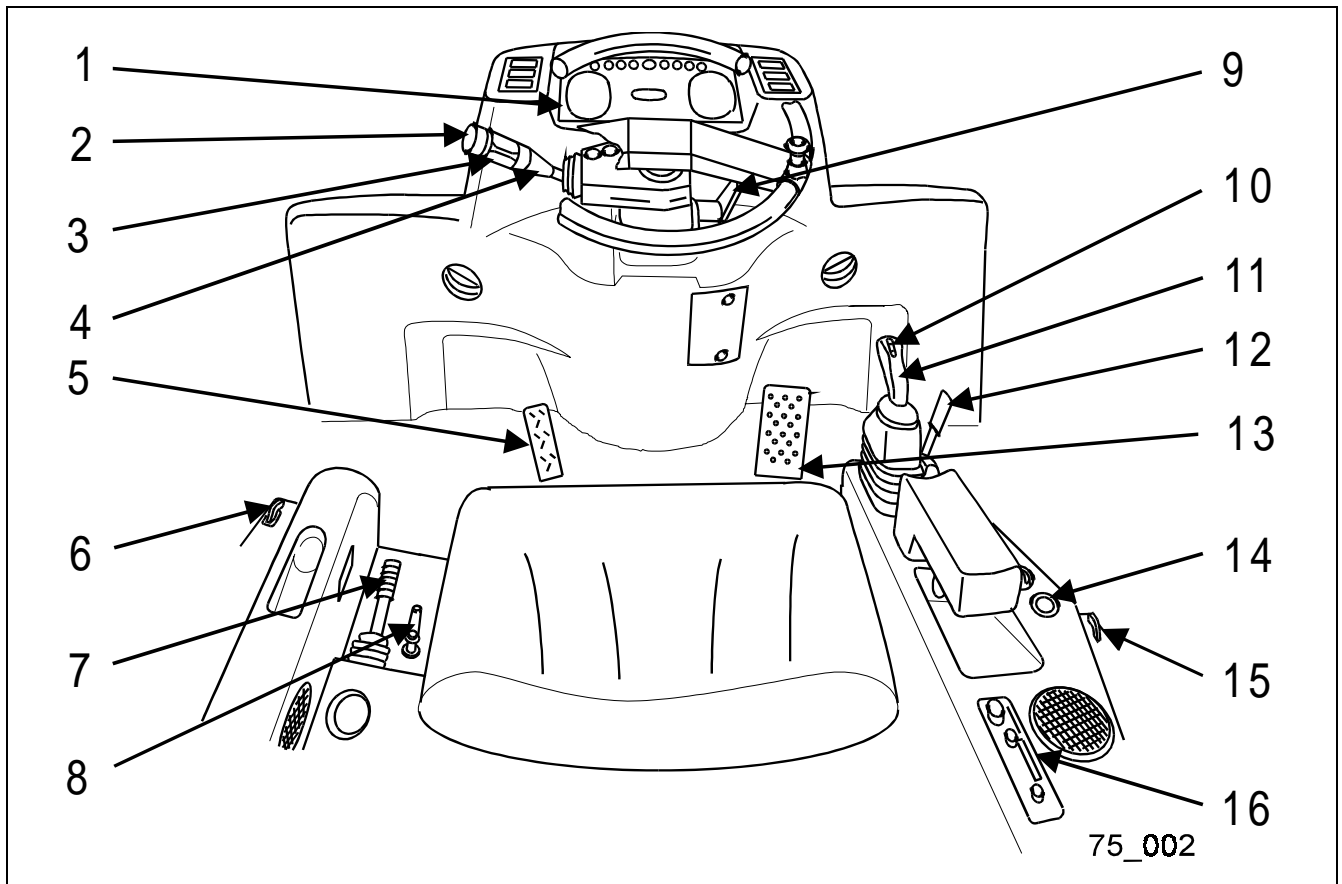

- 1- Instrument panel
- 2- Horn button
- 3- Light switch
- 4- Direction indicator lever
- 5- Inch-brake pedal
- 6- Unlocking system of left door
- 7- Parking brake
- 8- Safety lever for work hydraulic system
- 9- Steering column adjustment
- 10- Driving direction switch
- 11- Multifunctional lever
- 12- Control lever for special equipment
- 13- Accelerator pedal
- 14- Socket
- 15- Unlocking system of right door
- 16- Car radio (Option)
- 17- Lever of emergency lowering system

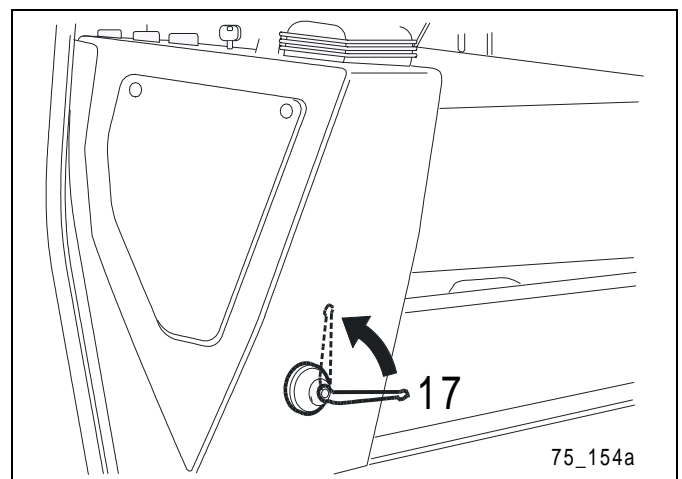

14.1.1 SWITCHES AND CONTROLS

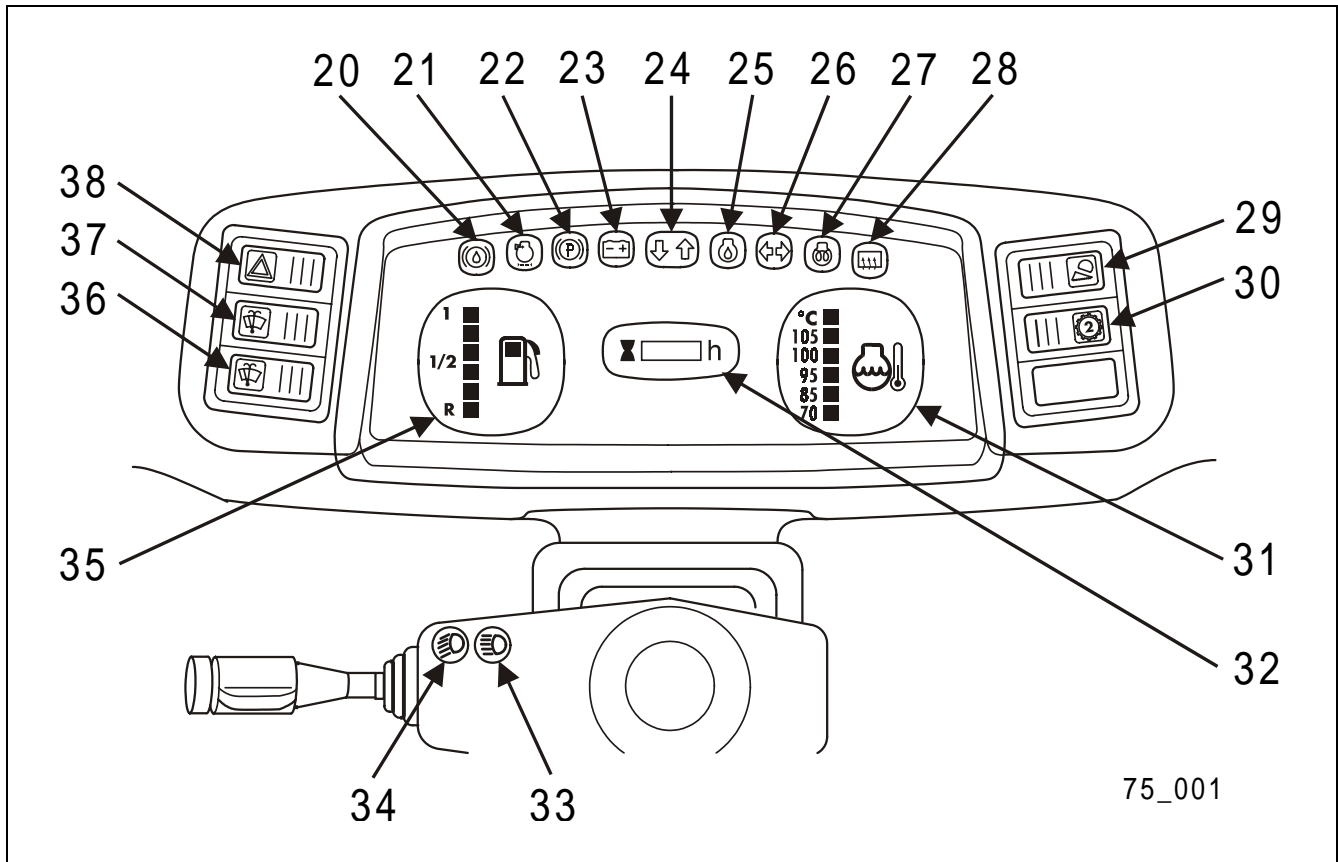

75_001

- 20 - Brake fluid warning light
- 21 - Air filter warning light
- 22 - Parking brake warning light
- 23 - Charging current warning light
- 24 - Driving direction switch indicators
- 25 - Engine oil-pressure warning light
- 26 - Direction indicator control lamp
- 27 - Air preheater control lamp
- 28 - Heated rear windscreen indicator
- 29 - Working lights switch and control lamp
- 30 - Driving range switch and control lamp for speed up to 12.43 mph (20 km/h)
- 31 - Coolant temperature indicator
- 32 - Operating hour meter
- 33 - High beam control lamp
- 34 - Low beam control lamp
- 35 - Fuel supply indicator
- 36 - Rear windscreen wiper switch and washer
- 37 - Front windscreen wiper switch and washer
- 38 - Hazard flasher switch and control lamp

14.2 INSTRUMENT PANEL

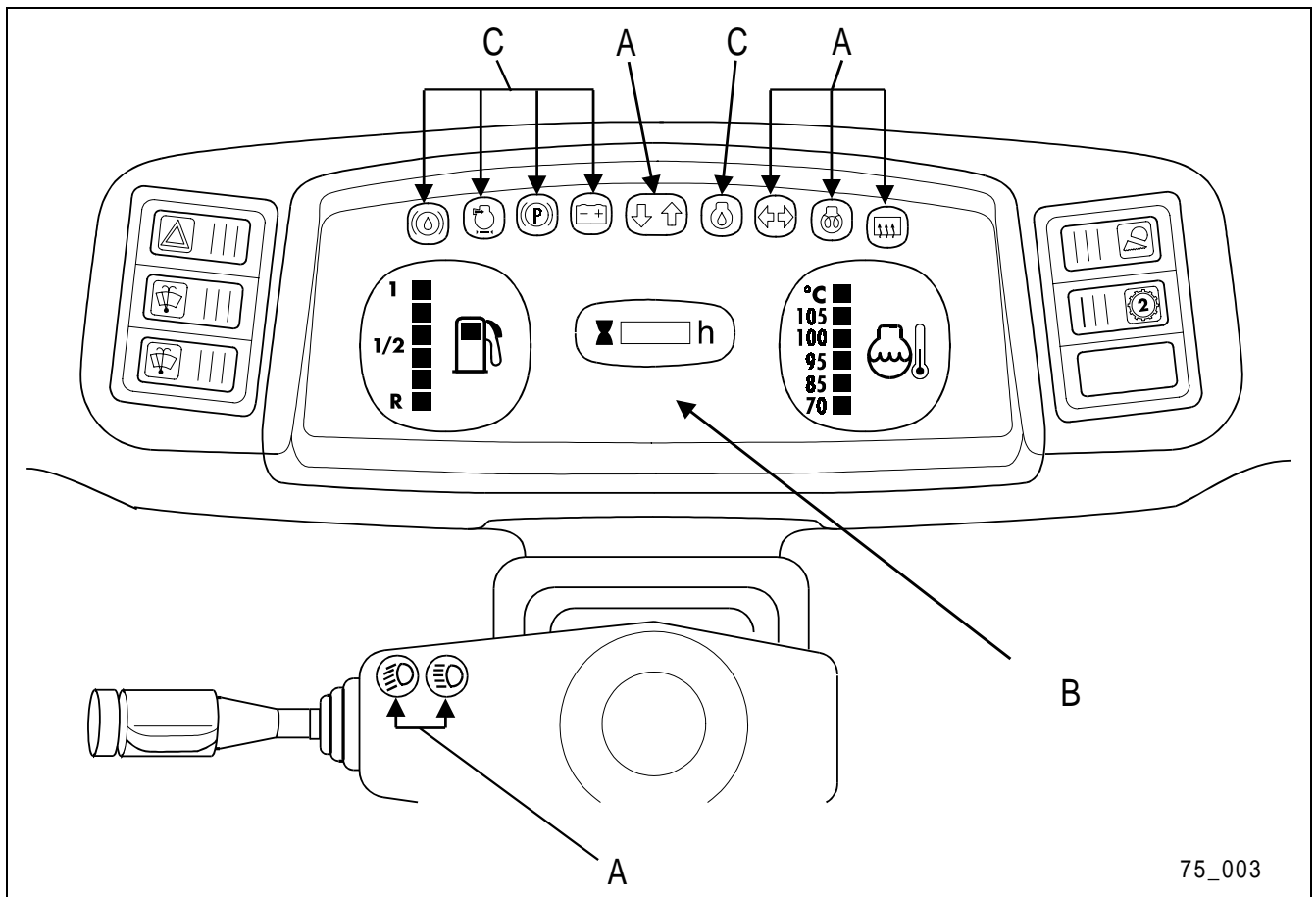

The instrument panel can be divided in

- (A) Control lamps
- (B) Measuring indicators
- (C) Warning lights

In the following sections of this chapter, all elements required for an efficient machine operation are explained in detail.

CONTROL LAMPS

This group comprises the control lamps for high beam, low beam, heated rear windscreen, air preheater, direction indicator and driving direction switch.

MEASURING INDICATORS

This group comprises the fuel gauge, the operating hour meter and the temperature indicator of the coolant.

WARNING LIGHTS

This group comprises the warning lights for charging current, parking brake, air filter, engine oil-pressure and brake fluid supply.

14.3 WARNING LIGHTS

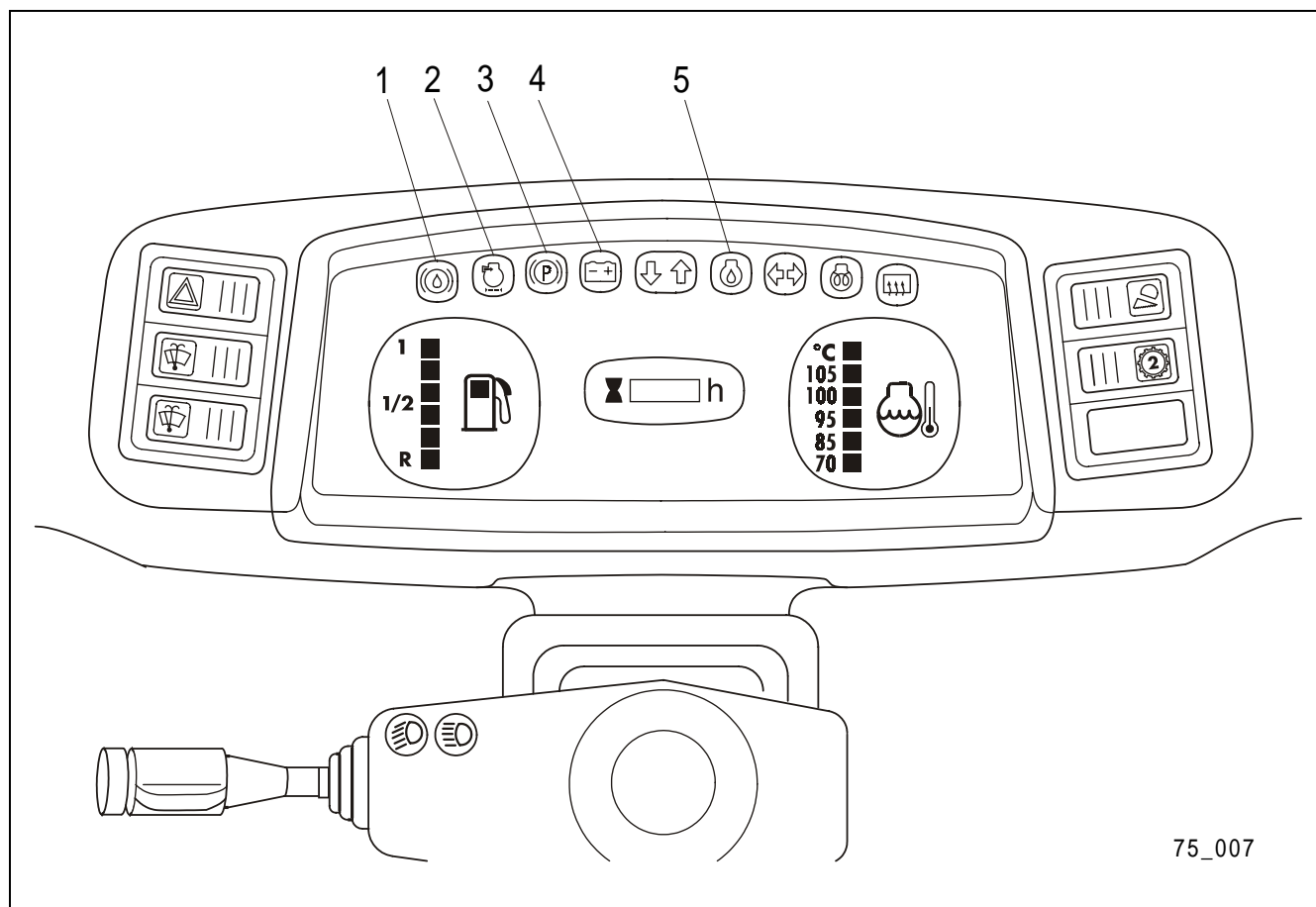

75_007

- 1 - Brake fluid warning light
- 2 - Air filter warning light
- 3 - Parking brake warning light
- 4 - Charging current warning light
- 5 - Engine oil-pressure warning light

1 - BRAKE FLUID WARNING LIGHT

If the brake fluid supply is too low, the brake fluid warning light lights up in red.

In this case you must immediately stop the machine and switch off the engine. Proceed as described in chapter "21. Troubleshooting".

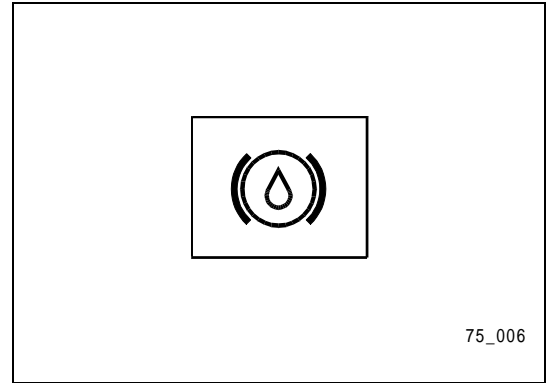
**2 - AIR FILTER WARNING LIGHT**

If the air filter is polluted, the air filter warning light lights up in red. In this case, you must clean or exchange the air filter. Proceed as described in chapter "29. Maintenance Every 250 Operating Hours", air filter section.

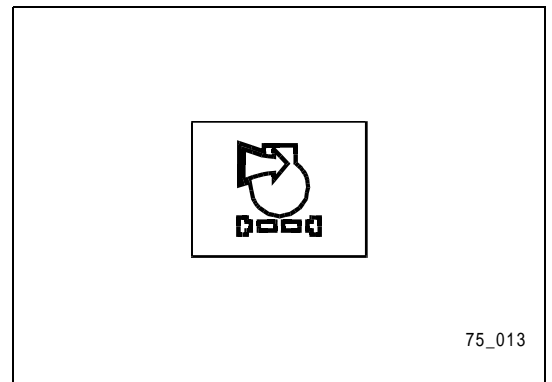
**3 - PARKING BRAKE WARNING LIGHT**

The parking brake warning light lights up in red if you set the start switch to the operating position 'I' while the parking brake is applied. In addition, the acoustic warning sounds if you set the driving direction switch to forward or reverse driving with the parking brake applied.

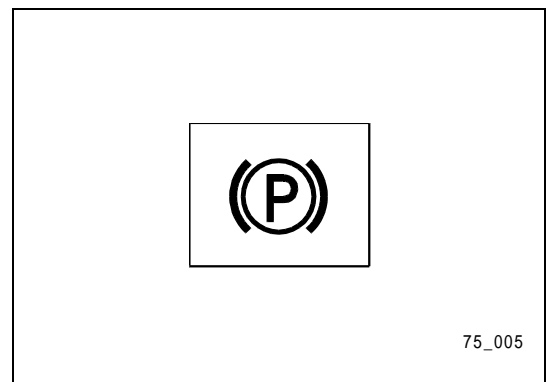
**4 - CHARGING CURRENT WARNING LIGHT**

Before you start up the engine:

The charging current warning light must light up if you set the start switch to the operating position 'I'.

With the engine running:

As soon as the engine runs, the generator starts to generate current and to charge the battery. At the same time, the charging current warning light will go out. A fault is present, if the charging current warning light does not go out while the engine is running.

In the latter case, proceed as described in chapter "21. Troubleshooting".

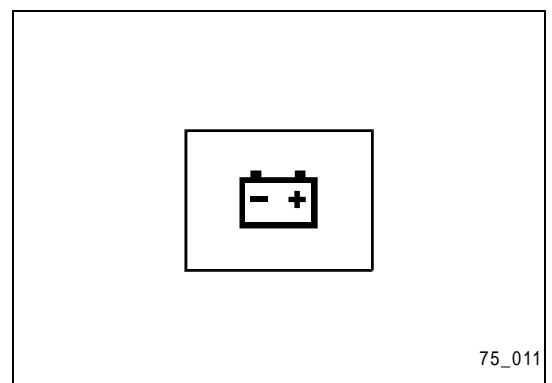

5 - ENGINE OIL-PRESSURE WARNING LIGHT

Before you start up the engine:

The engine oil-pressure warning light must light up if you set the start switch to the operating position 'I'. At the same time, the acoustic warner will sound.

With the engine running:

After starting the engine, the lubricating pressure builds up and the lamp goes out. If the engine oil-pressure warning light does not go out with the engine running or if it suddenly lights up during operation, while the acoustic warner sounds at the same time, a fault has occurred in the oil-pressure system.

In both cases, you must immediately stop the machine and switch off the engine. Proceed as described in the chapter "21. Troubleshooting".

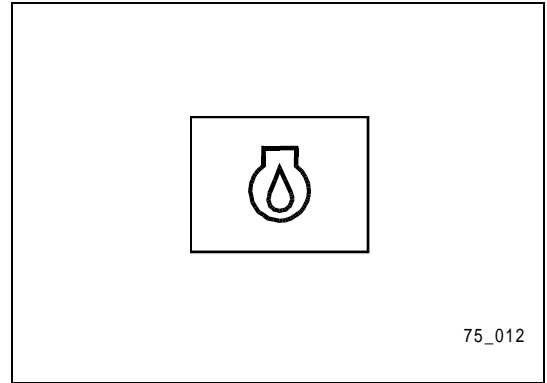

14.4 CONTROL LAMPS

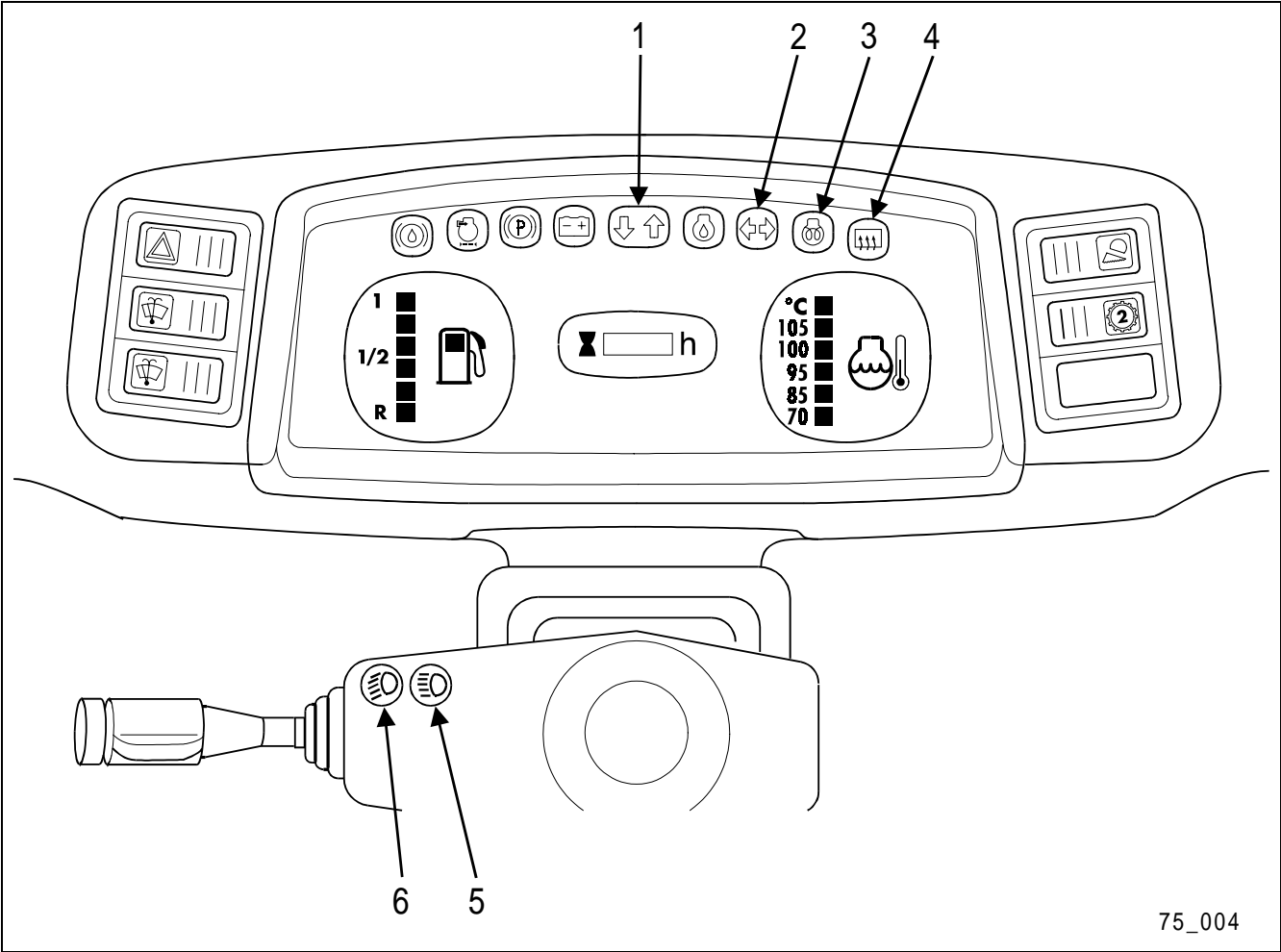

75_004

- 1 - Driving direction switch indicator
- 2 - Direction indicator control lamp
- 3 - Air preheater control lamp
- 4 - Heated rear windscreen indicator
- 5 - High beam control lamp
- 6 - Low beam control lamp

1 - DRIVING DIRECTION SWITCH INDICATORS

The indicators of the driving direction switch indicate which driving direction you have selected:

left arrow lights up: Machine drives backwards (driving direction switch in 'R' position)

right arrow lights up: Machine drives forward (driving direction switch in 'F' position)

If the driving direction switch is set to the 'N' neutral position, both control lamps will go out.

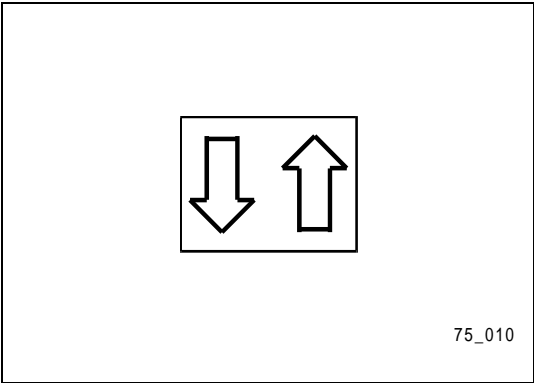

2 - DIRECTION INDICATOR CONTROL LAMP

The direction indicator control lamp flashes if you have switched on the right or left direction indicators or the hazard flashers.

If the direction indicator control lamp flashes in very short intervals, a fault has occurred in the direction indicator system. In this case, proceed as described in chapter "21. Troubleshooting".

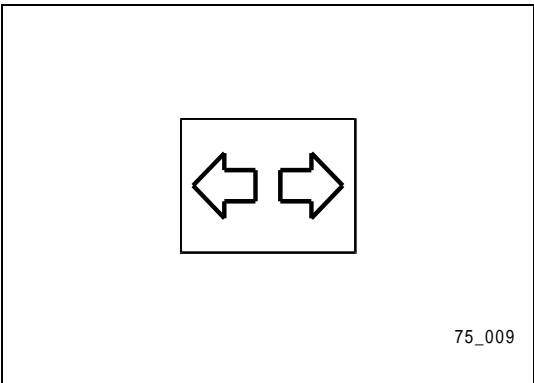

3 - AIR PREHEATER CONTROL LAMP

The control lamp lights up, if you set the start switch to the operating position 'I' and if the air preheater is running. It will go out if the heating cycle is over. The running period of the air preheater depends on the ambient temperature. You can start the engine, after the control lamp has gone out.

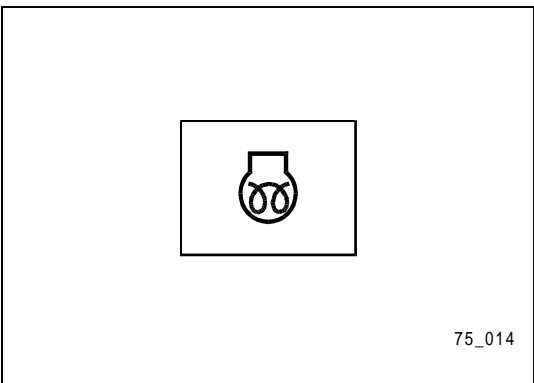

4 - HEATED REAR WINDSCREEN INDICATOR

The control lamp of the heated rear windscreen lights up, if you have switched on the heated rear windscreen.

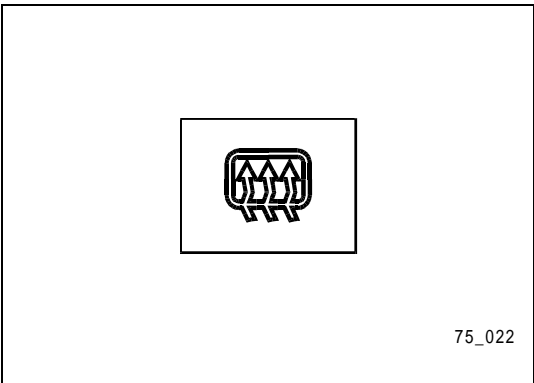

5 - HIGH BEAM CONTROL LAMP

The high beam control lamp lights up if you change from low beam to high beam. It also lights up if you flash your lights.

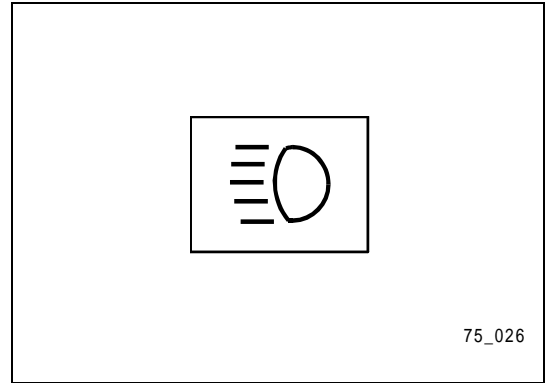

6 - LOW BEAM CONTROL LAMP

The low beam control lamp lights up when you switch on the low beam.

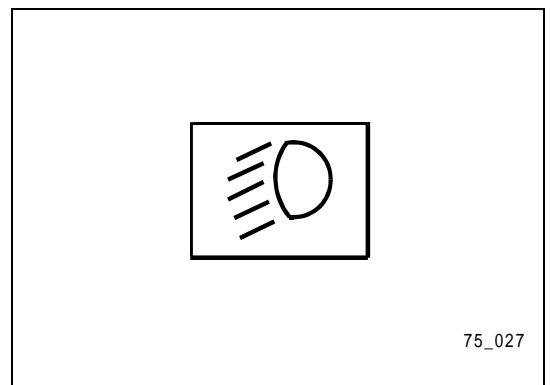

14.5 MEASURING INDICATORS

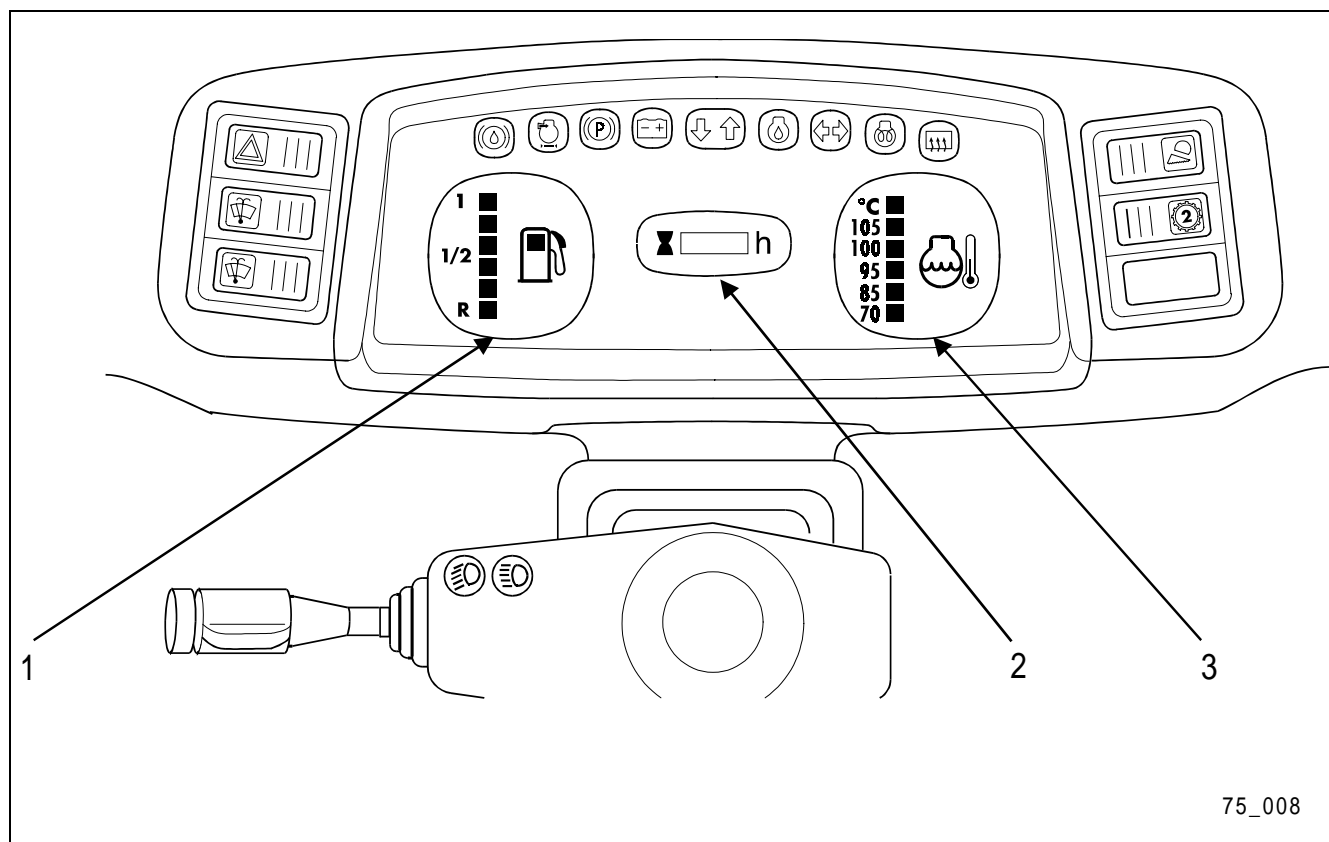

75_008

- 1 - Fuel level indicator
- 2 - Operating hour meter
- 3 - Coolant temperature indicator

1 - FUEL LEVEL INDICATOR

If you set the start switch to the operating position 'I', the fuel gauge indicates the available fuel supply.

1: The tank is full

R: The tank is in the critical range

During operation, it is recommended to keep the fuel supply between 'R' and '1'. If only the lowest 'R' LED lights up, it is time to refill fuel. If there is no electric contact between the fuel gauge and the fuel level indicator, only the top LED lights up.

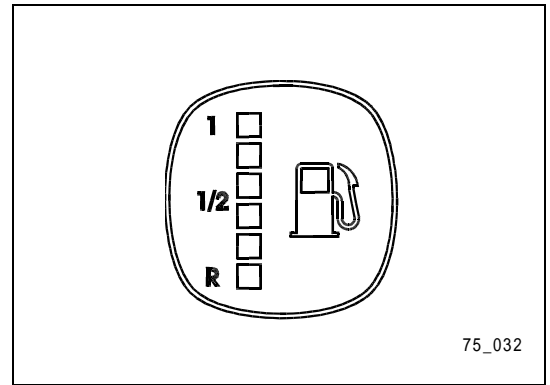

2 - OPERATING HOUR METER

The operating hour meter indicates the total hours of operation. It only counts the hours with the engine running, no matter whether the machine is actually driving or not. If the operating hour meter is ON, the symbol on top of the operating hour meter is flashing.

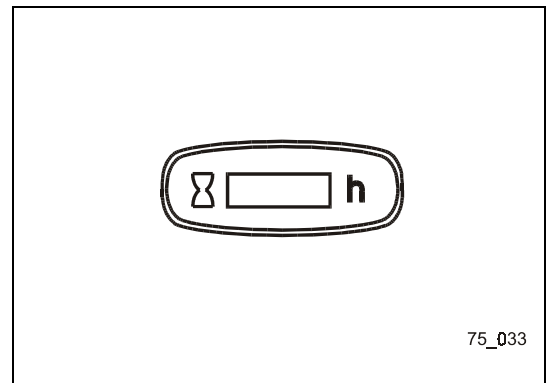

3 - COOLANT TEMPERATURE INDICATOR

The coolant temperature indicator shows the temperature of the coolant. If you set the power switch to the 'I' position with the coolant being warmer than 70° C, the temperature indicator will show the current coolant temperature. If the temperature is normal during operation, the green range of the temperature indicator lights up. If the coolant is too hot, the top red LED of the temperature indicator starts to flash. At the same time, the acoustic warner starts to sound.

In this case, you must stop the machine and let the engine run idle at medium speed until the indicator returns to the green range. Proceed as described in chapter "21. Troubleshooting". If there is no electric contact applied to the sensor, only the top LED lights up.

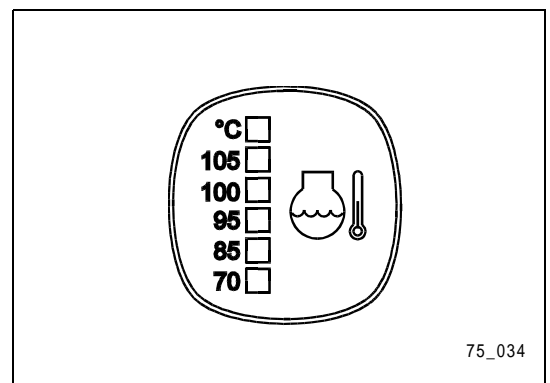

14.6 SWITCHES

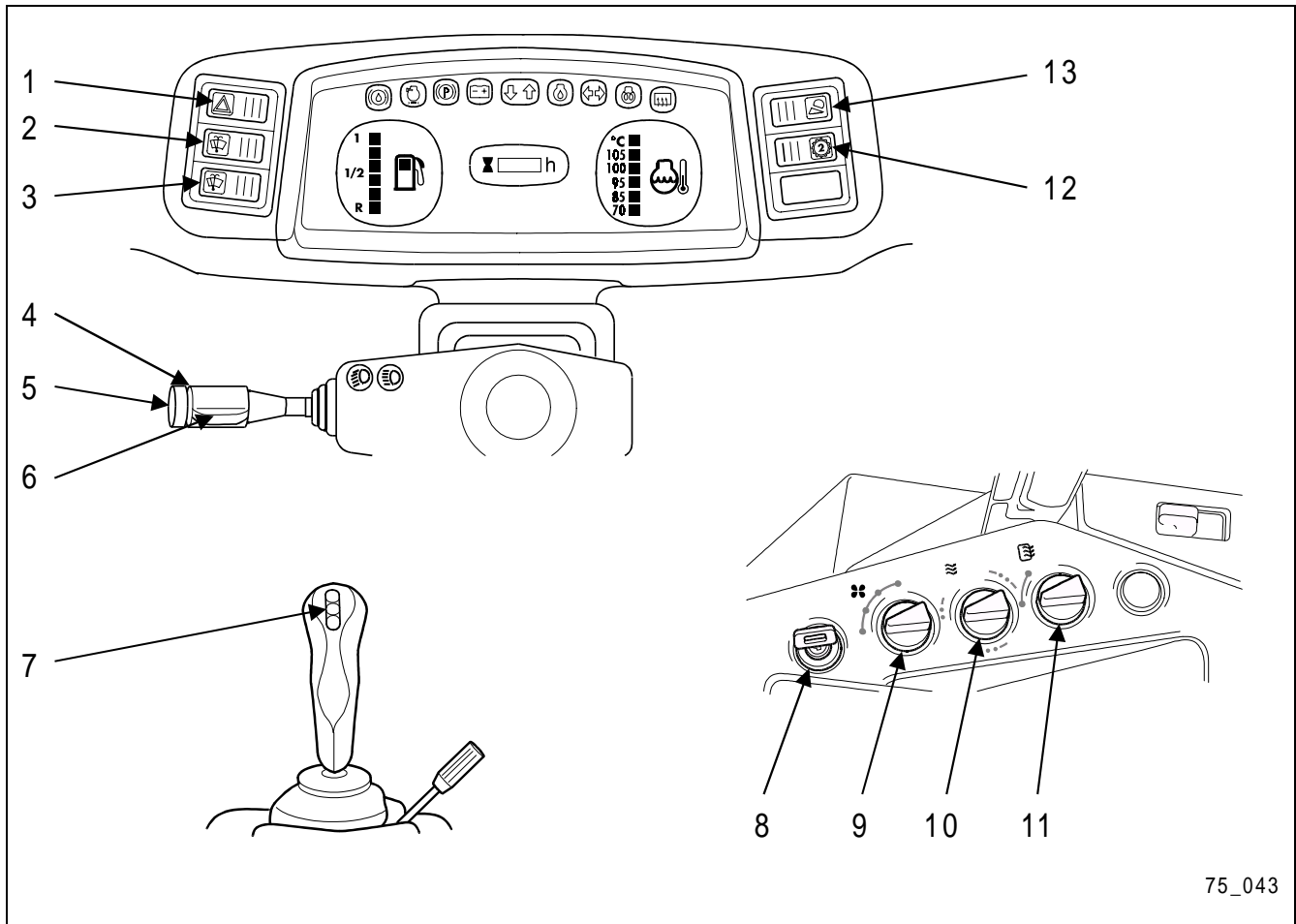

- 1- Switch and control lamp of hazard flashers
- 2- Switch of front windscreen wiper and washer
- 3- Switch of rear windscreen wiper and washer
- 4- Direction indicator lever
- 5- Horn button
- 6- Light switch
- 7- Driving direction switch
- 8- Start switch
- 9- Fan rotary switch, for ventilation and heating
- 10- Heating temperature switch
- 11- Heated rear windscreen switch
- 12- Switch and control lamp for driving range up to 12.43 mph (20 km/h)
- 13- Working lights switch and control lamp
- 14- Switch for inside lighting (without fig.)
- 15- Battery main switch (option, without fig.)

1 - HAZARD FLASHER SWITCH

This switch is used to switch on/off the hazard flasher.

**NOTE**

- You may switch on the hazard flasher only in an emergency situation.

If you switch on the hazard flasher, all direction indicators of the machine will start to flash. At the same time, the control lamp of the hazard flasher switch and the direction indicator control lamp start to flash.

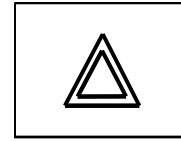

75_028

2 - SWITCH OF FRONT WINDSCREEN WIPER AND WASHER

This switch is used to switch on/off the front windscreen wiper and washer. The switch has two switching stages:

Switching stage 1 locks in permanently and is used to switch on/off the windscreen wiper.

If you hold the switch pressed in switching stage 2, the windscreen washer is only operated for the time you keep the switch pressed.

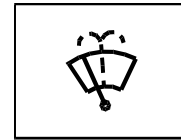

75_029

3 - SWITCH OF REAR WINDSCREEN WIPER AND WASHER

This switch is used to switch on/off the rear windscreen wiper and washer. The switch has two switching stages:

Switching stage 1 locks in permanently and is used to switch on/off the windscreen wiper.

If you hold the switch pressed in switching stage 2, the windscreen washer is only operated for the time you keep the switch pressed.

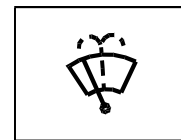

75_029

4 - DIRECTION INDICATOR LEVER

The direction indicator lever is used to switch on/off the direction indicators.

Switching on the right direction indicators: Press direction indicator lever to the front '1'

Switching on the left direction indicators: Draw direction indicator lever to the back '2'

After you have passed the bend, the direction indicator lever automatically returns to its home position and the direction indicator will be switched off.

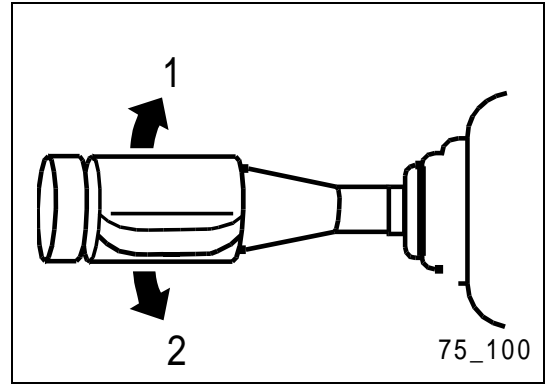

5 - HORN BUTTON

The horn sounds when you press the horn button.

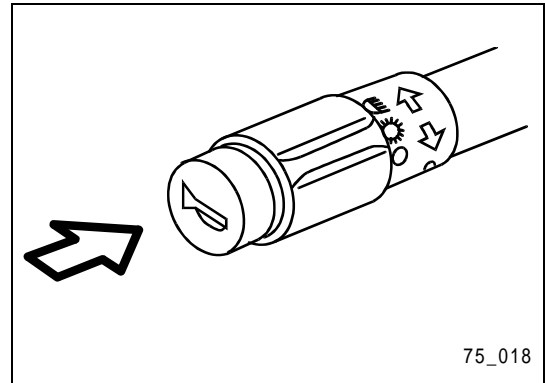

6 - LIGHT SWITCH

The light switch is used to switch on/off the main headlights, the side lamps and the taillights.

Switching off the lights

Switch in '0' position

Switching on the parking light

Turn the light switch to the front until it reaches position '1'. The side lamps and the taillights light up.

Switching on the low beam

Continue to turn the light switch until it reaches position '2'. All lights which were already switched on in position '1' (parking light) remain lit. In addition, the low beam is switched on. The low beam control lamp lights up.

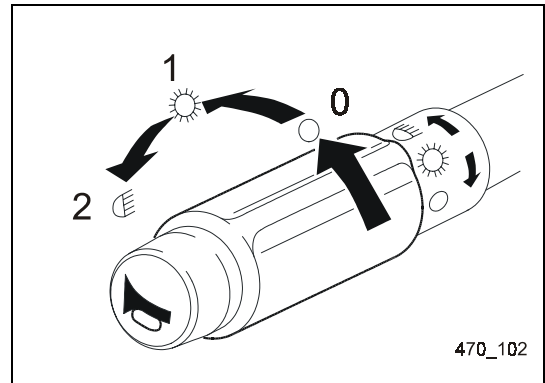

How to flash one's lights (high beam)

In order to flash your lights, you need to draw the lever briefly in the direction of the steering wheel. The high beam is only switched on as long as you draw the lever. The high beam control lamp will also light up for that time.

Switching on the high beam

In order to switch on the high beam you must press the lever completely down. In this position the lever locks in and the high beam control lamp lights up.

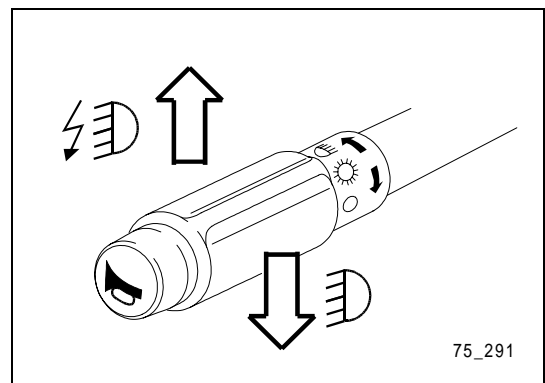

7 - DRIVING DIRECTION SWITCH

You can change the driving direction of the machine with the driving direction switch.

Position 'F': Forward driving

Position 'N': Neutral position

Position 'R': Reverse driving



NOTE

- You can only start the engine if the driving direction switch is switched to the neutral position 'N'.

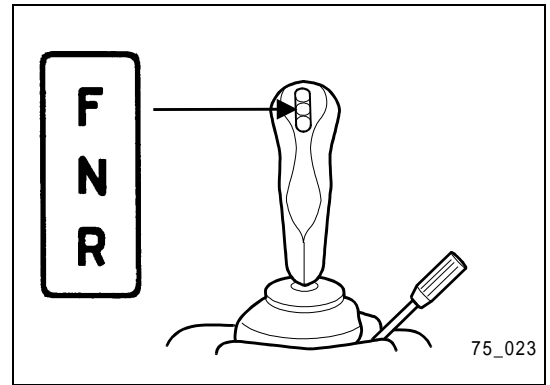

8 - START SWITCH

You can start and switch off the engine with the start switch.

'P': Parking Position

'0': Stop position

In this position, the engine is switched off, permitting you to remove the ignition key. All functional circuits are interrupted in the stop position.

'I': Operating position

The control lamps light up in the operating position 'I' and the air preheater is in operation. All functional circuits are activated. The ignition key remains in this position with the engine running.

'II': Start position

In start position 'II', the engine starts up.



IMPORTANT

- You may only start the engine, if the driving direction switch is set to the neutral position 'N'.

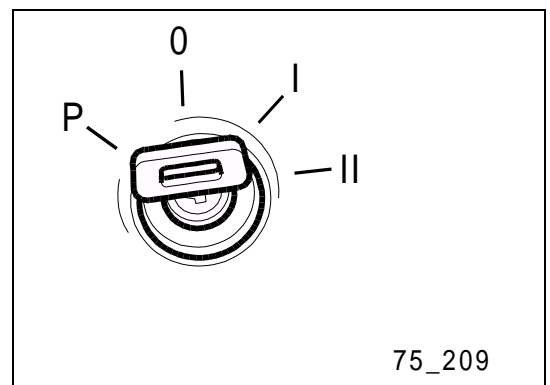

9 - FAN ROTARY SWITCH FOR VENTILATION AND HEATING

This rotary switch permits to regulate the fan step by step.

- Switch setting 1: Fan off
- Switch setting 2: Low air flow
- Switch setting 3: Medium air flow
- Switch setting 4: High air flow

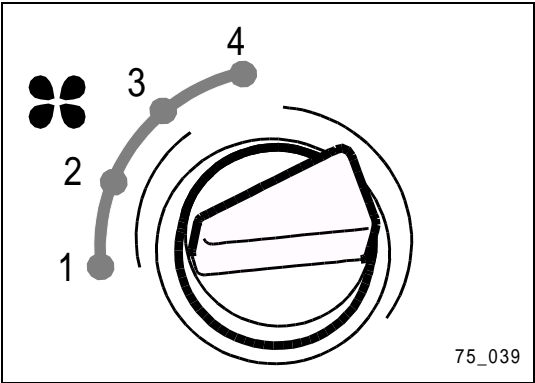

10 - TEMPERATURE ROTARY SWITCH

The temperature rotary switch permits to adjust continuously the capacity of the heating system from 'cold' (heating OFF) to 'warm'.

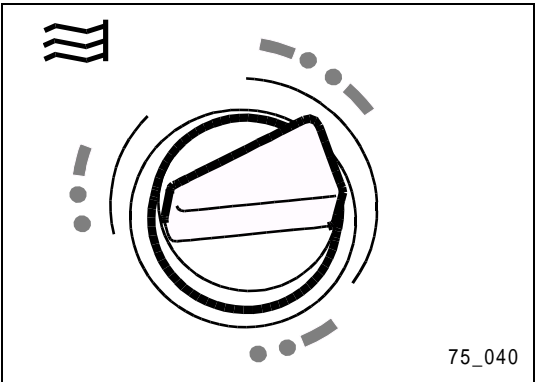

11 - HEATED REAR WINDSCREEN SWITCH

This rotary switch is used to switch on/off the heated rear windscreen.

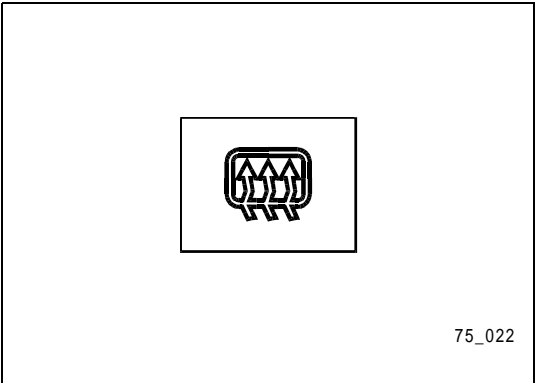

12 - SWITCH FOR DRIVING RANGE UP TO 12.43 mph (20 km/h)

This switch is used to change between the machine's two speed ranges. If you operate the switch, the machine will drive in speed range 2 (up to 12.43 mph (20 km/h)). If the switch is set to OFF, the machine drives in speed range 1 (up to 4.66 mph (7,5 km/h)).

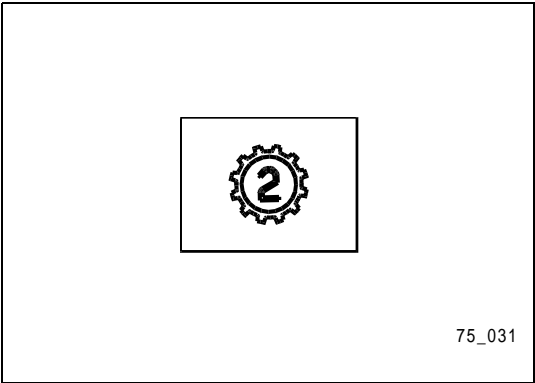

13 - WORKING LIGHTS SWITCH**CAUTION**

- **The front working lights may blind oncoming traffic!
Before driving on public roads, turn off the working lights.**

This switch is used to switch on/off the working lights.

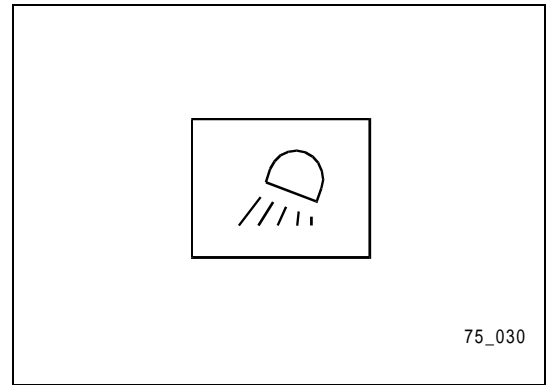
**14 - SWITCH FOR INSIDE LIGHTING**

The inside lighting has three different switch settings:

- Switch setting 1: Steady light
- Switch setting 0: Off
- Switch setting 2: Steady light

**NOTE**

- **You can also switch on the inside lighting, if the start switch is in stop position '0'. For this reason, switch off the inside lighting before you leave the driver's cab.**

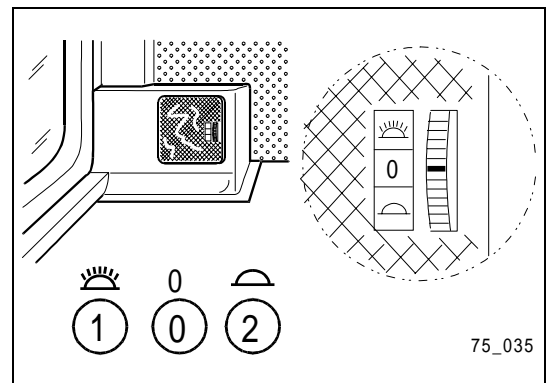
**15 - BATTERY MAIN SWITCH (OPTION)****NOTE**

- **Do not operate the battery main switch with the engine running!**

The battery main switch (1) disconnects the power supply of the machine's electrical system. The switch is situated next to the battery in the rear section of the machine.

If the machine is to be taken out of service for a longer time, you must switch off the battery main switch and remove the ignition key.

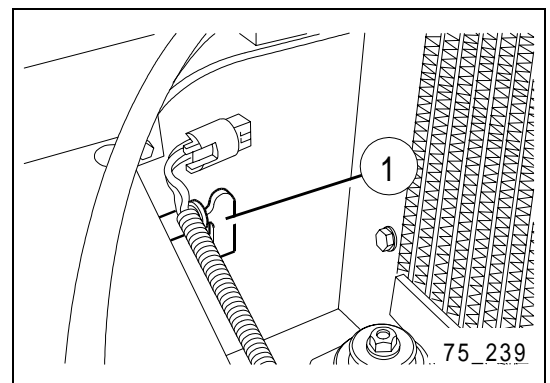

14.7 CONTROL LEVERS, PEDALS

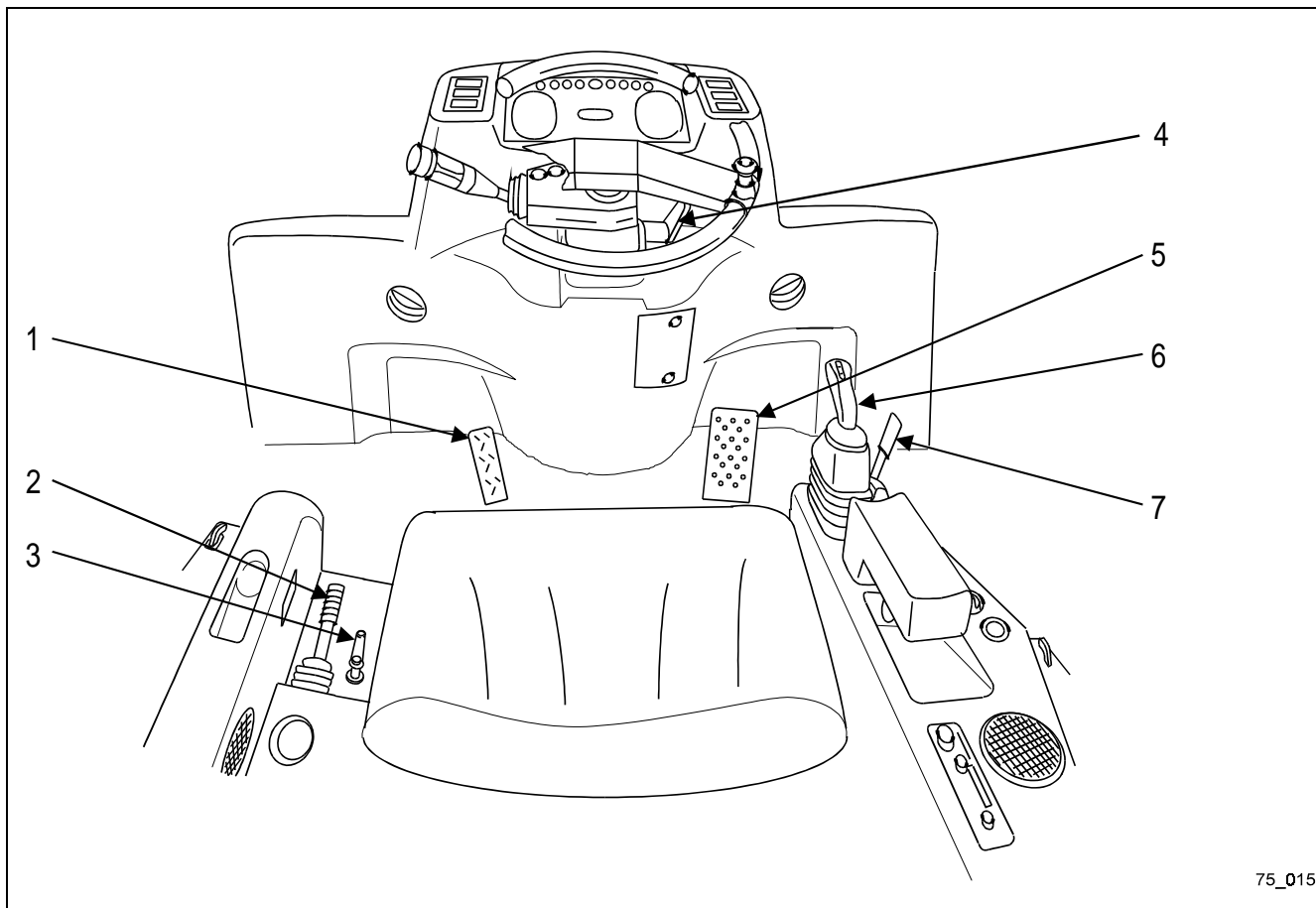

75_015

- 1- Brake pedal
- 2- Parking brake
- 3- Safety lever to close or open the work hydraulic system
- 4- Steering column adjustment
- 5- Accelerator pedal
- 6- Multifunctional lever
- 7- Control lever for special equipment
- 8- Switching lever for bucket (without fig.)

1 - BRAKE PEDAL



CAUTION

- If you are driving downhill, let the engine run and use the braking effect of the engine. If required, brake additionally using the brake pedal.
- **Danger of accidents due to unintentional braking!**
Do not use the brake pedal as a foot rest.

The brake is operated via a combined brake/inch pedal. The brake has an effect on the two multi-disk brakes in the rear axle. The inching exerts an additional braking effect on the hydrostatic drive system.

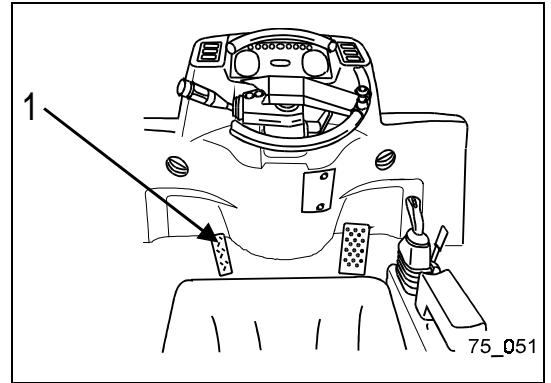

2 - PARKING BRAKE

The parking brake is a mechanical device for operating the two multi-disk brakes in the rear axle.

As soon as you pull the parking brake lever from its normal position, the braking action comes into effect. If the start switch is set to the 'I' operating position, the parking brake warning light lights up in the instrument panel. The machine will drive again, if you re-loosen the parking brake.



IMPORTANT

- You cannot start the machine with the parking brake being applied. If you set the driving direction parking switch to the 'F' position (forward driving) or 'R' (reversing) with the parking brake still being applied, the alarm buzzer will sound.

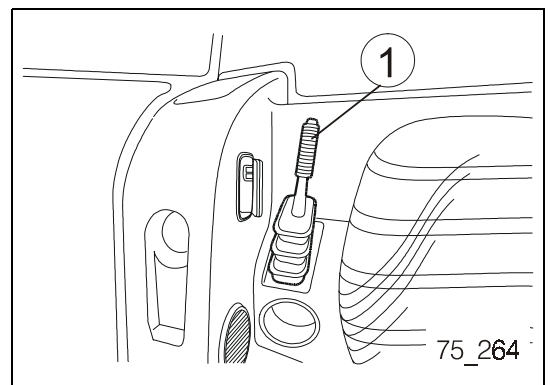

3 - SAFETY LEVER FOR THE WORK HYDRAULIC SYSTEM

The safety lever for the work hydraulic system protects the work hydraulic system against unintentional activation. Before driving on streets or beginning maintenance operations, it is required to block the work hydraulic system with this safety lever.

Position '1': Control lever secured

Position '2': Operating position

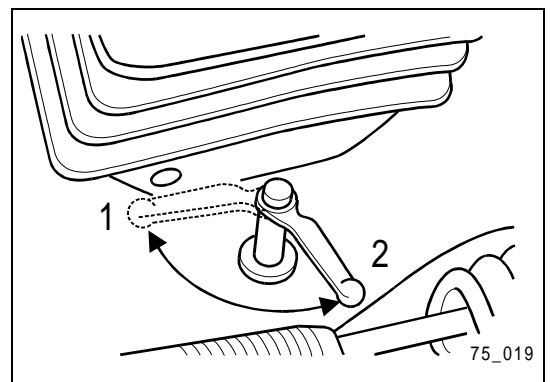

4 - STEERING COLUMN ADJUSTMENT

The lever for adjusting the steering column position permits to incline the steering column smoothly in two directions (front or back). The adjustment range is 4.92 in (125 mm).

Proceed as described in chapter "17. Adjustments Prior to Machine Start".

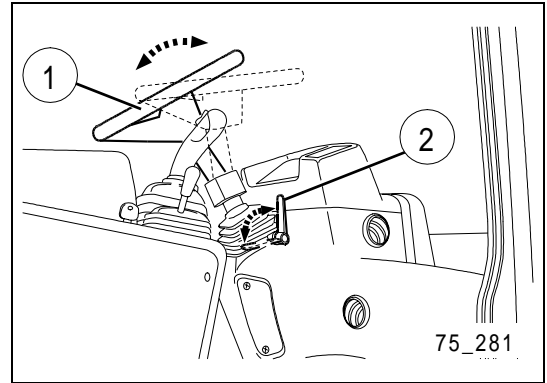

5 - ACCELERATOR PEDAL

The accelerator pedal regulates the speed (r.p.m.) and performance of the engine.

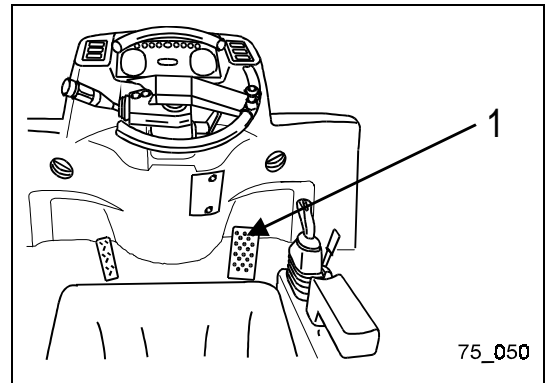

6 - MULTIFUNCTIONAL LEVER FOR THE WORK HYDRAULIC SYSTEM

The work unit is operated with the multifunctional lever. The multifunctional lever has 6 positions which control the work unit as follows:

SW Floating position  The multifunctional lever is locked in this position. The floating position is provided for planing operations (removing subsoil). In this switch position, the work unit is lowered by its own weight, and can be freely operated by external parties.

S Lowering  The boom is lowered in this position.

0 Paused  The boom is held in position.

H Lifting  If you draw the multifunctional lever further in the direction of 'H' (lifting), the lever is locked in this position until the boom has reached the top limit stop. Then, the multifunctional lever automatically returns to the '0' position (Paused).

E Bucket curl  If you draw the multifunctional lever to position 'E' (Bucket curl), it is locked in this position until the bucket has reached the limit stop. Then, the multifunctional lever automatically returns to position '0' (paused).

A Dumping  In this position, the bucket is dumped.

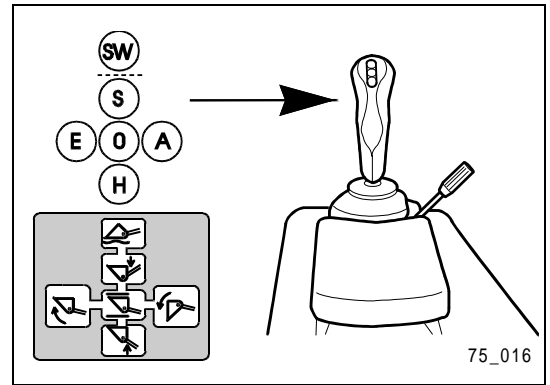

7 - CONTROL LEVER FOR SPECIAL EQUIPMENT

The control lever for special equipment has three switch settings whose functions depend on the type of the used special equipment.

If the standard bucket, the light-weight material bucket or the forklift truck attachment is attached to the quick-change unit, the control lever for special equipment provides the following functions:

- Position '1': Locking pins for work unit are drawn in
- Position '0': Neutral position (locking pins are drawn in; you can pick up the work unit in this position)
- Position '2': Locking pins for work unit are extended

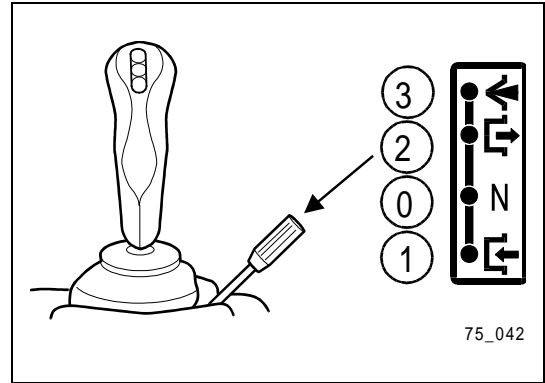

If the multi-purpose bucket is attached to the quick-change unit, the control lever has the functional assignment described above. If the switching lever for the bucket is in position '1', the multi-purpose bucket is active. You can then operate the multi-purpose bucket via the control lever for special equipment. It then has the following functions:

- Position '1': Close multi-purpose bucket
- Position '0': Neutral position
- Position '2': Open multi-purpose bucket

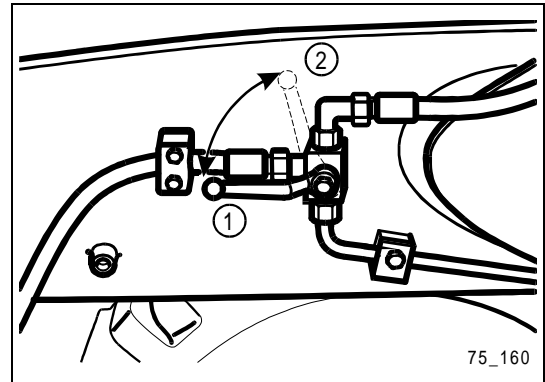

If you use attachments requiring a steady oil flow (e.g. brush, snow remover), the control lever has the following functions:

- Position '1': Work unit turns backwards
- Position '0': Neutral position
- Position '2': Work unit turns forward
- Position '3': Work unit turns forward in permanent operation (locks in)

For permanent operation, you must set the control lever to position '3'. The control lever locks in this position.

 **NOTE**

- **Without connected special equipment, you must not set the control lever for special equipment to switch settings '1', '2' or '3'. If you do not heed this note, the work hydraulic system will operate in order to counteract overpressure thus unnecessarily heating up the oil.**

8 - SWITCHING LEVER OF BUCKET

If you have the multi-purpose bucket attached to the machine, you can use this switching lever to change the function assignment of the control lever for special equipment (see "(7) Control lever for special equipment").

- Position '1': the control lever for special equipment operates the multi-purpose bucket.
- Position '2': the control lever for special equipment operates the quick-change unit.

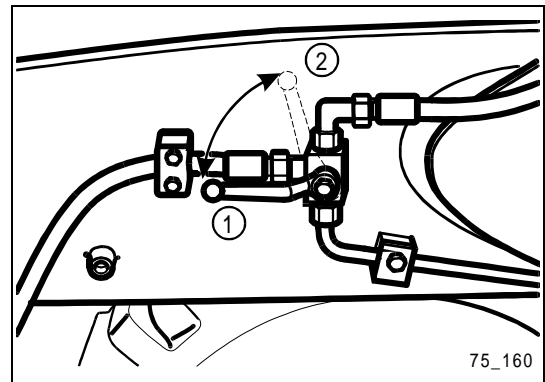

14.8 ARTICULATED STEERING CATCH

The articulated steering catch is used to join rigidly the front and rear part of the machine, thus preventing the articulated steering from bending. You must block the articulated steering before the machine is hoisted or before repairs or maintenance operations are being performed.

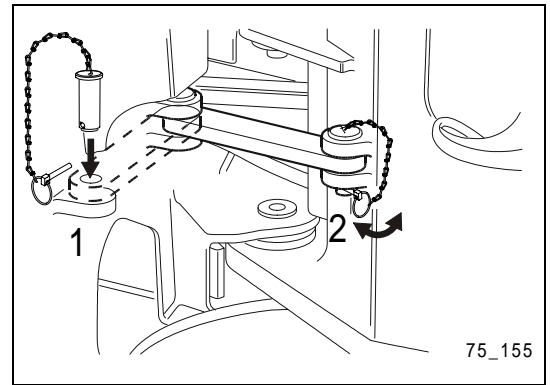

14.9 TRACTION DEVICE

You can use the traction device (hitch) to tow off, e.g., another machine or trailer. You must also fix the machine at the tie bolt during transport. Always secure the bolt of the traction device, which is fixed to a chain, with the spring bolt.

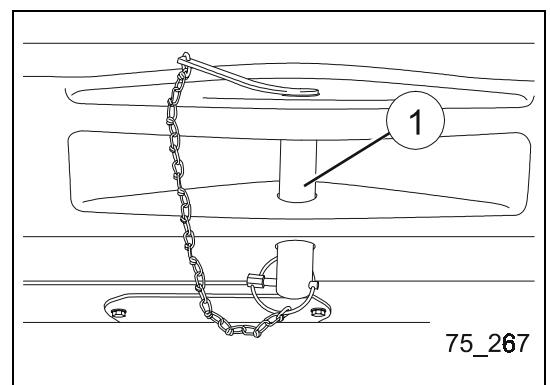

14.10 SOCKET



CAUTION

- **Danger of accidents!**
Electrical devices may interfere with the on-board electronics. For this reason, connect only the working lamp to the socket.

You may connect a working lamp to the socket (1).

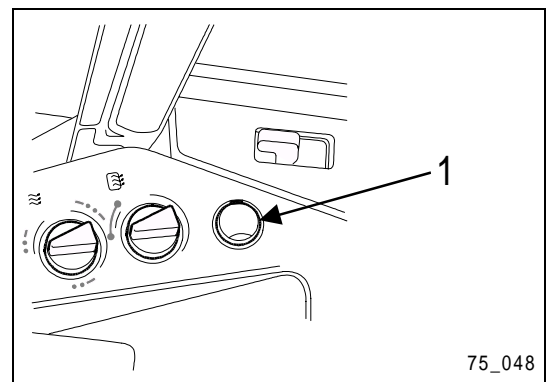

14.11 DOOR UNLOCKING SYSTEM

Both doors have a locking mechanism which locks in if you open the door completely to prevent the door from closing while driving. In order to be able to close the door, you must draw the respective door unlocking system (1) to the back.

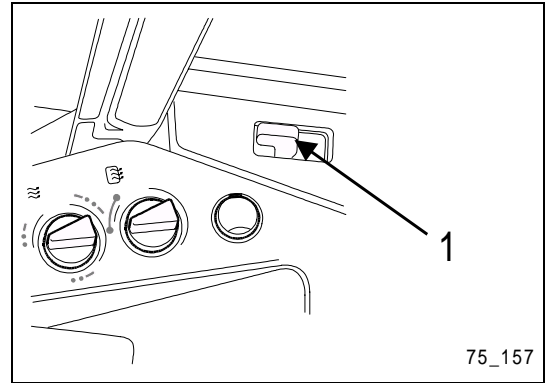

14.12 ALARM HORN FOR REVERSE DRIVING

The horn sounds if you have set the driving direction switch to the reverse/backwards position.

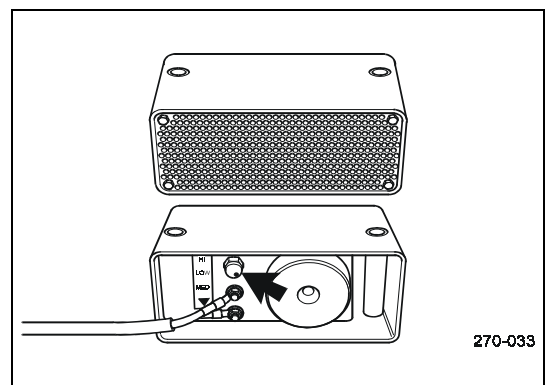

OPERATION

15. RUNNING IN THE MACHINE

Before shipment, each machine was carefully checked and adjusted. A machine which is to be run in for the first time has to be treated with utmost care during its first 100 operating hours. If the machine is used for work involving loads exceeding the specified maximum load valid for the running-in period, its performance may be prematurely impaired and its service life may be shortened. A new machine must be run in and serviced very carefully and thoroughly. The following points are particularly important:

- After the engine has been started, it must run in idle for 5 minutes.
- Operation with heavy loads or at high speeds is to be avoided.
- Sudden starts, sudden acceleration, jerky steering and stopping is to be avoided; this does not apply to emergency situations.

Note that particular maintenance measures apply only to a machine during its running-in period (see also chapter "Maintenance").

16. PREPARING THE MACHINE START

16.1 VISUAL CHECKS

(also refer to chapter "24. Maintenance Prior to Start")



WARNING

- **Danger of fire! Oil or fuel leaking out or accumulated combustible materials may catch fire at hot parts of the machine, e.g. the exhaust pipe!**
Prior to starting the machine, check the oil and fuel lines for leaks and immediately repair any leaks. Store combustible material in a safe place.
-

16.1.1 BEFORE YOU START THE ENGINE

Check that there are no loose nuts or screws lying around the machine. Check that neither oil, nor fuel nor coolant are leaking out. Check the condition of the work unit and the hydraulic system. Check that there are no loose cables and accumulated dirt. Remove accumulated dirt and eliminate faults.

16.1.2 BEFORE STARTING WORKING WITH THE MACHINE

Perform daily the following measures:

1 - CHECK WORK UNIT

Check work unit, cylinder, connecting rods, and hoses for cracks, premature wear and tear, and play. Repair damaged parts.

2 - REMOVE DIRT AND DUST

Check the area around the engine and the radiator for accumulated dirt or dust. Additionally check whether combustible material has accumulated near the battery or near hot parts of the machine, e.g. the exhaust. Remove completely any accumulated dirt or dust.

3 - CHECK ENGINE AND COOLING SYSTEM

Check that there is no oil leaking out of the engine and that the cooling system and the fuel supply system are not leaking. Repair damaged parts.

4 - CHECK THE GEAR UNIT, AXLES, HYDRAULIC TANK AND HOSES AND THE CONNECTING POINTS

Check whether oil is leaking out of the transfer box gearing, axles, hydraulic tank and hoses, and connecting points. Repair damaged parts.

5 - CHECK BRAKE HOSES

Check that there is no oil leaking out at the brake hoses. Repair damaged parts.

6 - CHECK WHEELS

Check the tires for cracks, damages and wear and tear. Check the wheel rims and lock rings for cracks, damage, and wear and tear. Tighten loose wheel nuts. Repair damaged parts. Replace missing valve caps.

7 - CHECK HANDRAILS

Check handrails for damage and loose screws. Repair damaged parts and tighten loose screws.

8 - CHECK MEASURING AND CONTROL INDICATORS

Check measuring and control indicators for damage and loose screw connections. Replace defective parts. Remove dirt from surfaces.

9 - CHECK AIR FILTER

Check the fastening screws of the air filter. Tighten loose screws.

10 - CHECK BATTERY TERMINALS

Tighten loose battery terminals.

11 - CHECK SAFETY BELT



WARNING

- **Danger of injury! A damaged safety belt or a safety belt that has been stretched in an accident does no longer protect you!**
Have the safety belt replaced by an expert, if it is damaged or if the machine has been involved in an accident.
-

The belt must not be twisted or caught between parts, nor must it chafe at sharp edges. The socket for the lock tongue must not be blocked by paper or the like, since this will make engaging of the lock tongue impossible.

Keep the belt clean and check that the belt fixings are tightly fastened.

Replace the safety belt, if the belt or the belt fixings are damaged or deformed.

12 - CHECK ROPS

Check whether screws are loose or damaged. Have loose screws tightened and damaged screws replaced by a Komatsu dealer. Loose screws must only be tightened with the specified tightening torque. Damaged screws must only be replaced by original parts.

13 - CHECK CAB WINDOWS

Prior to start of work, clean the cab windows.

14 - PERFORM THE OPERATIONS INDICATED IN CHAPTER "24. Maintenance Prior to Start".

(See also "23. Maintenance Schedule").

17. ADJUSTMENTS PRIOR TO MACHINE START

17.1 ADJUSTING THE DRIVER'S SEAT

After each change of the driver, re-adjust the driver's seat. Before you start operation, check that the seat is adjusted in such a way that you can fully floor the brake pedal when you lean against the backrest. Proceed as follows to adjust the seat according to your requirements:

1 - WEIGHT ADJUSTMENT

Turn the handwheel (3) to set the vibration absorbing system to the weight of the driver.

2 - ADJUSTMENT OF HORIZONTAL POSITION

To adjust the horizontal seating position, pull the lever (4) and slide the seat forward or backward. To lock the position of the seat, release the lever again.

3/4 - ADJUSTING HEIGHT AND ANGLE OF INCLINATION

You may adjust the height and the angle of inclination of the driver's seat with the spring-supported levers (1) and (2). Use lever (2) to set the front part of the seat, use lever (1) to set the rear part of the seat.

Adjusting the seat's height

Adjust the front and the rear section of the seat uniformly. For this purpose, pull lever (2) and hold it in this position. To lift up the front part of the seat, it is necessary to relieve your weight from the front section of the seat cushion by standing up. Then, sit down on the front part in order to press down the front section of the seat. Release the lever if you have reached the right position. The seat is now locked in its position.

Then, pull lever (1) and hold it in this position. To lift up the rear part of the seat, it is necessary to relieve your weight from the rear section of the seat cushion by standing up. Then, sit down on the rear part in order to press down the rear section of the seat. Release the lever if you have reached the right position. The seat is now locked in its position.

Adjusting the angle of inclination of the seat

Adjust the front and rear section of the seat with different settings. Proceed as described above.

5 - ADJUSTING THE BACKREST

To adjust the position of the backrest, slightly lean against the backrest, pull lever (5) and hold it in this position. Relieve the backrest in order to bend it to the front. Press it to the back in order to bend it to the back. Release lever (5) if the backrest is in the desired position. The backrest will lock in automatically in this position.

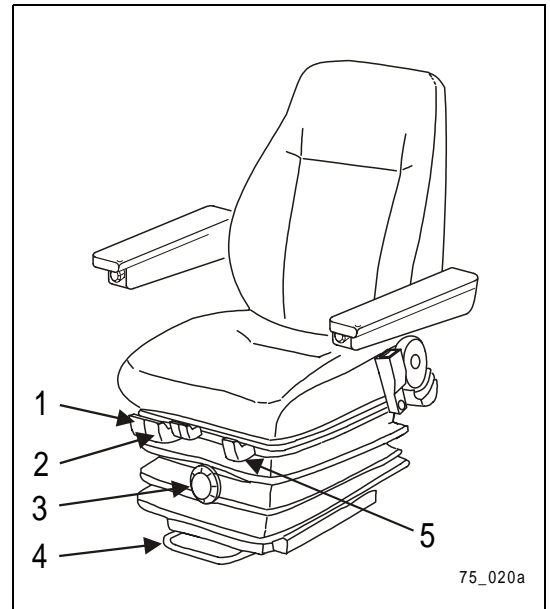

17.2 ADJUSTING THE STEERING COLUMN



WARNING

- Do not change the angle of inclination of the steering column while you are driving, since this may lead to severe accidents!
- Stop the machine, before you change the angle of inclination of the steering column.

You may use this lever for continuous adjustment of the steering column's (1) angle of inclination. (Adjustment range 4.92 in (125 mm)).

Proceed as follows:

- 1- Push down the locking lever (2).
- 2- Adjust it in such a way that you can reach the steering wheel from a comfortable seating position while at the same time having an optimum view of the work unit. Hold the steering wheel in this position.
- 3- Pull up the locking lever again to lock the steering column in this position.

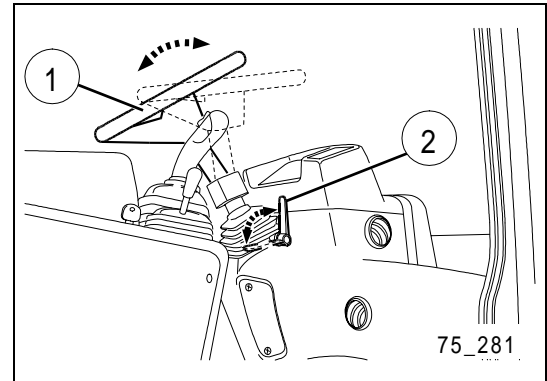

17.3 ADJUSTING THE ARMREST

Proceed as follows to adjust the height of the armrest (1):

- 1- Loosen the screw (2).
- 2- Either pull out or push back the armrest to reach the multi-functional lever. Your forearm should rest on the armrest at an angle of 90° to your upper arm.
- 3- Re-tighten the screw.

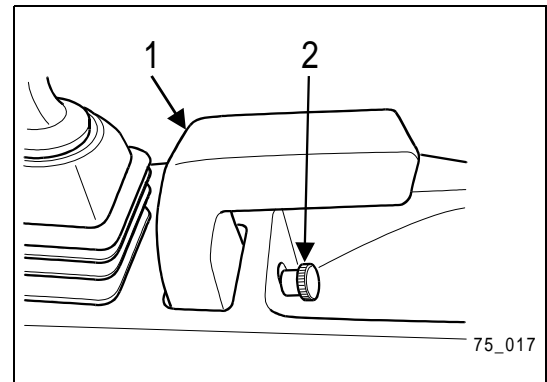

17.4 ADJUSTING THE REAR-VIEW MIRRORS

Sit down on the driver's seat and adjust the rear-view mirrors to their required positions. You should be able to view the traffic coming from behind without having to change your seating position.

17.5 ADJUSTING THE HEATING AND VENTILATION SYSTEM

17.5.1 ADJUSTING THE VENTILATION SYSTEM

When the ventilation system is operated, air is blown into the driver's cab. If the cabin is closed, a light overpressure is built up, preventing dust from outside to settle down in the cab. To increase the volume of filtered fresh air, you can open the ventilation grid a little.

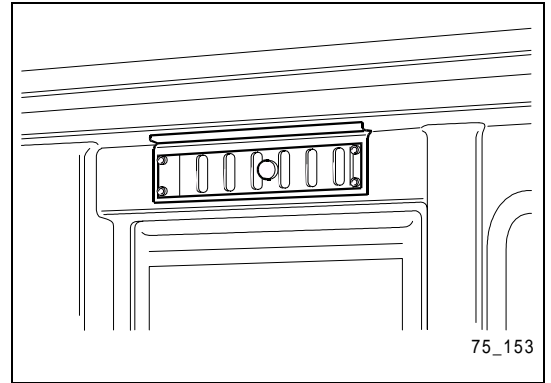

The air is distributed via the air ventilation nozzles (1 and 2) on the left-hand and right-hand side of the steering column. You may open or close the nozzles individually. The exhaust direction can be varied using the diffusing disks. You can direct the air ventilation nozzles (1) onto the front windshield and the air ventilation nozzles (2) onto the side windows.

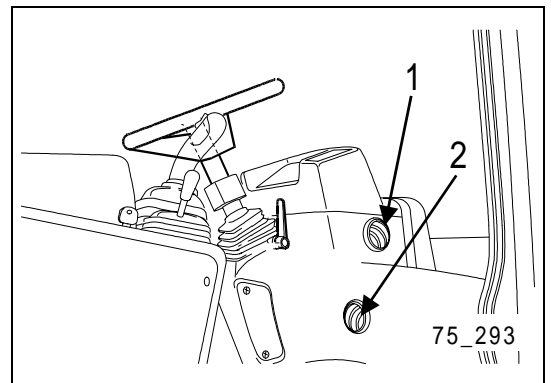

17.5.2 ADJUSTING THE HEATING SYSTEM

IMPORTANT

- The heating capacity depends on the coolant temperature of the engine. Full heating capacity is only realised, if the engine is completely warmed up.

You can realize maximum heating inside the cabin, if you open all air ventilation nozzles, set the temperature rotary switch to maximum heating power while switching on the fan with its highest level.

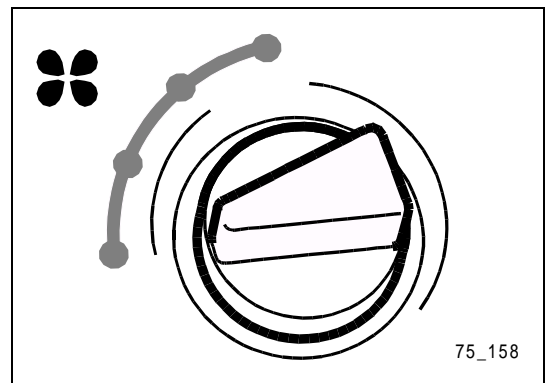

You may realize a comfortable temperature, if you open all air ventilation nozzles, set the temperature rotary switch to a comfortable temperature and set the fan to an appropriately low air throughput.

To cool down the temperature inside the cabin, open all air ventilation nozzles, set the temperature rotary switch to position 'Cold' and set the fan to its highest level.

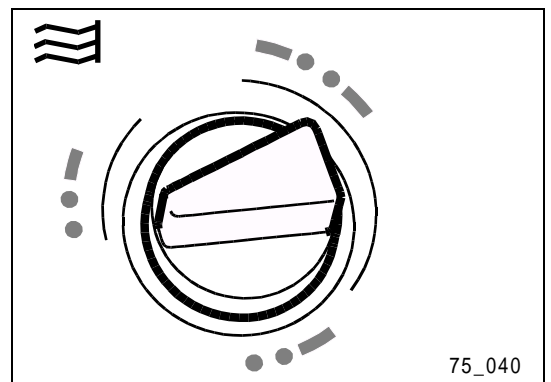

To prevent premature tiredness due to lack of oxygen, it is recommended to open the door a little from time to time and to lock it in this position. Optionally, you may leave open the ventilation grid above the side window.

17.6 PUTTING ON THE SAFETY BELT



WARNING

- **Danger of injury!** A damaged safety belt, a safety belt that has been stretched in an accident, or a safety belt the belt fixings or fastening screws of which have not been mounted correctly will not protect you sufficiently in case of accident! Replace the safety belt, if it is damaged, or if the machine has been involved in an accident. Check that the belt fixings and fastening screws are in perfect condition, before you fasten the safety belt.
 - **If you have not put on the safety belt and are involved in an accident, this may lead to severe injury or even death!**
Fasten the safety belt, before you start work and do not take it off during work. Put on the safety belt in such a way that it is not twisted and fits tightly.
-

The machine is provided with a lap belt which is automatically rolling up. When pulled slowly, automatic belts ensure full freedom of action, but block immediately, if you suddenly brake or accelerate, or if you drive downhill or take corners.

17.6.1 PUTTING ON THE SAFETY BELT

- 1- Sit down on the driver's seat.
- 2- Slowly and continuously pull out the belt.
- 3- Insert the lock tongue into the lock socket until the lock engages.
- 4- Then, pull the belt to check whether or not the lock tongue is fully engaged.



IMPORTANT

- **The belt cannot be pulled out unless it is completely wound up.**
-

17.6.2 TAKING OFF THE SAFETY BELT

Press the orange button to release the lock of the safety belt and allow the belt to wind up.

18. STARTING AND SWITCHING OFF THE ENGINE

18.1 STARTING THE ENGINE

- 1- Ensure parking brake is engaged.
- 2- Set the drive direction switch to its neutral position 'N'.



NOTE

- You may only start the engine, if the driving direction switch is set to the neutral position 'N'.



CAUTION

- Unintentional start-up of the engine may lead to severe accidents!
Before starting up the engine, make sure that there are no persons or obstacles near the engine. In addition, sound the horn before you start the engine.

- 3- Turn the ignition key into the operating position 'I'. The fuel supply (1) is indicated. The charging current (3) and engine oil-pressure (4) warning lights light up. The parking brake (2) warning light lights up, if the parking brake is pulled. The air preheater (5) control lamp lights up, if the air preheater is in operation.



IMPORTANT

- The running period of the air preheater depends on the ambient temperature. If the ambient temperature is low, the preheating process may take more time.

- 4- Press down slightly the accelerator pedal.
- 5- If the control lamp of the air preheater has gone out, you can turn the ignition key to the start position 'II' in order to start up the engine.



NOTE

- Do not operate the starter for longer than 15 seconds. If the engine does not start up, wait at least two minutes before trying a restart. If the engine does not start up after several tries, find out the cause using the information indicated in the chapter "21. Troubleshooting".

- 6- Release the ignition key as soon as the engine started. It automatically returns to the operating position 'I'.
- 7- Check whether all warning lights have gone out.

For starting up the engine in cold weather, see section: "20.10 Instructions for Winter Operation".

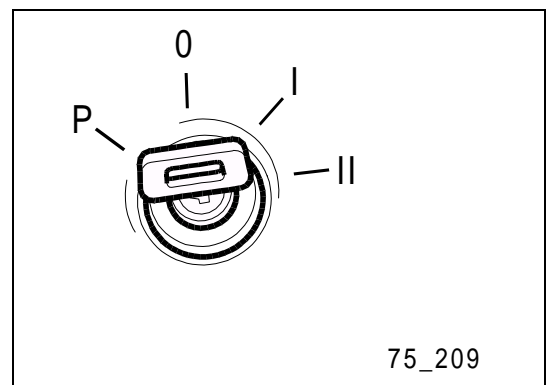
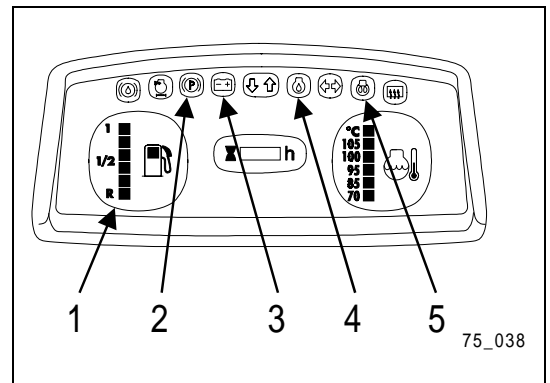
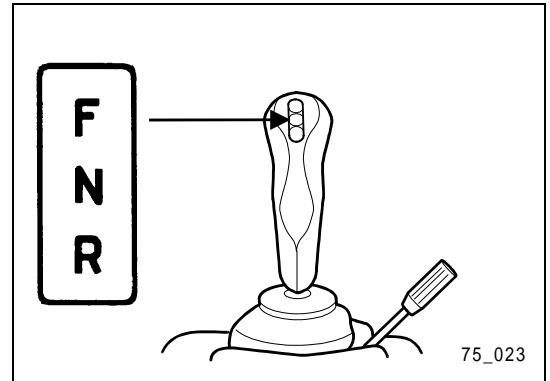

18.1.1 WARMING UP THE ENGINE



NOTE

- You must not accelerate the engine abruptly before the warm-up phase is finished.
- Do not let the engine run idle for longer than 20 minutes at its lower or top speed. If it is necessary to let the engine run idle for a longer time, you must load the engine briefly from time to time or let it run idle at medium speed.

Do not immediately begin with work after starting the engine. Prior to operation, perform the following preparations and checks:

- 1- Press down slightly the accelerator pedal and let the engine run without load at medium speed for approx. 5 minutes.
- 2- Proceed as follows in order to heat up the hydraulic oil at low ambient temperatures:
 Allow the engine to run consistently during the warm-up phase. For warming the hydraulic oil, reset the multi-function lever for the work hydraulic system in short intervals from position '0' (holding) into position 'E' (tip-in position). Then reset it to its '0' position. Make sure not to exceed the maximum time (10 seconds) permitted for the multi-function lever in the tip-in position.
- 3- While the engine is warming up, observe all measuring instruments and warning lights and eliminate immediately any fault.
- 4- Let the engine run with lightweight load further until the engine coolant temperature indicator (1) lights up in the green range.
- 5- Ensure that the exhaust gas colour is normal and that the exhaust pipe produces neither abnormal noises nor vibrations. Eliminate possible defects.

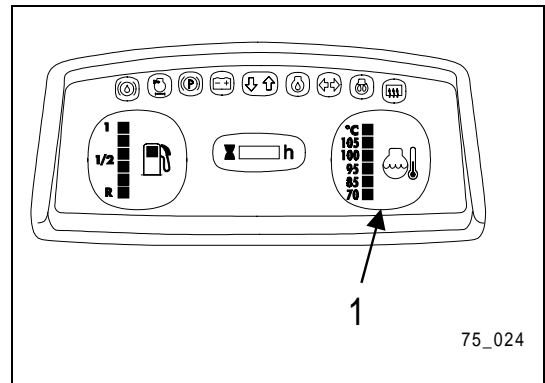
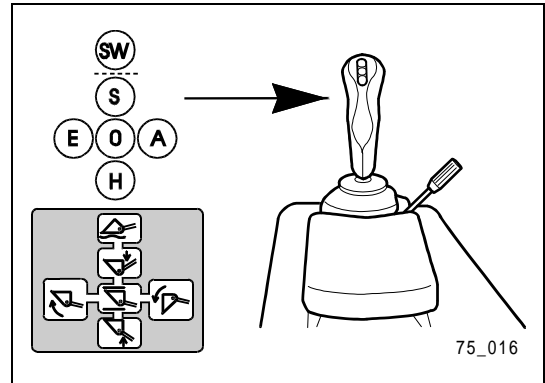

18.2 SWITCHING OFF THE ENGINE

 **NOTE**

- If you switch off the engine abruptly after heavy operations without prior cool-down period, the service life of the engine may be severely impaired. It is recommended to switch off the engine abruptly only in the event of an emergency.

- 1- Check the temperature of the engine with the help of the coolant temperature indicator (1).
- 2- If the engine is overheated, you must let it run at medium speed or 5 minutes before you switch it off, so that the engine can cool down sufficiently.
- 3- Lower the work unit.
- 4- Turn the ignition key into its stop position '0' in order to switch off the engine.
- 5- Pull the ignition key from the start switch.

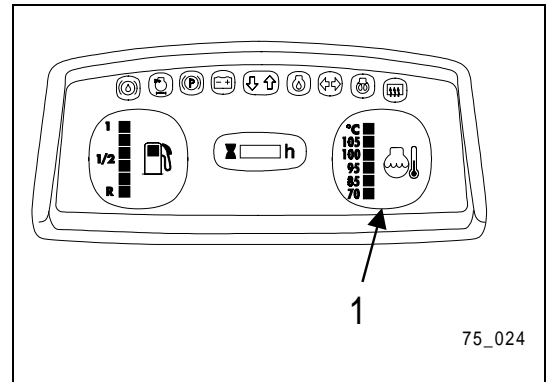

19. DRIVING

19.1 START-UP



- Careless driving may lead to accidents!
- Before starting to drive, ensure that no persons are near the machine and sound the horn before you start to drive.

- 1- Start up the engine as described in chapter "18.1 Starting the Engine".
- 2- Release the work hydraulic system by setting the locking lever of the work hydraulic system to position '2'.
- 3- Raise the work unit to its transport position. If the work unit is in transport position, the two red arrows of the transport position marking on the lifting cylinder are next to each other.
- 4- Press down the brake pedal and hold it in this position.

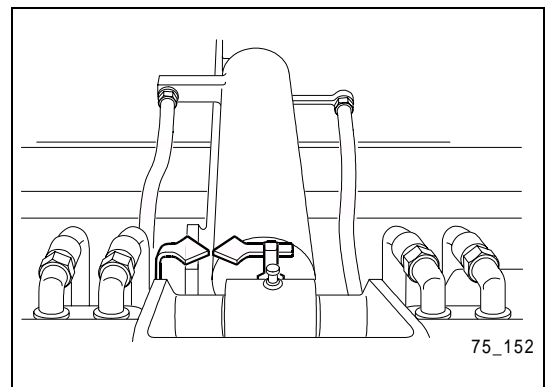
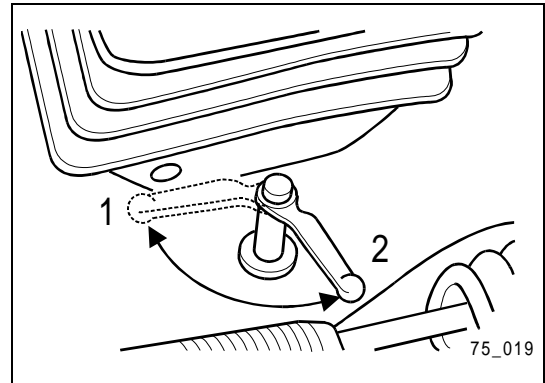

- 5- Release the parking brake. Press the celebration adjustment knob to this at the parking brake lever. Press down the locking button of the parking brake lever. Then, release the locking button. The parking brake warning light goes out.

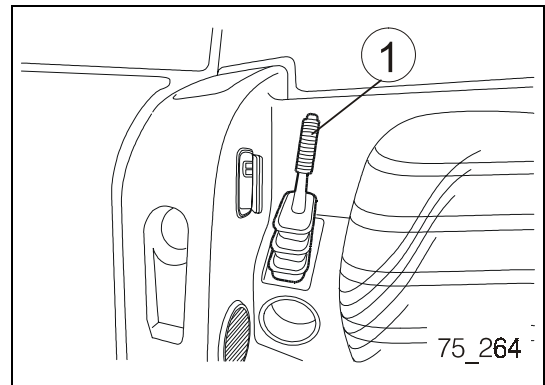

- 6- Set the drive direction switch to the desired direction setting.
Position 'F' Driving forward
Position 'N' Neutral
Position 'R' Reversing



- If you set the drive direction switch in to forward or reverse driving, without having released the parking brake, the horn will sound.

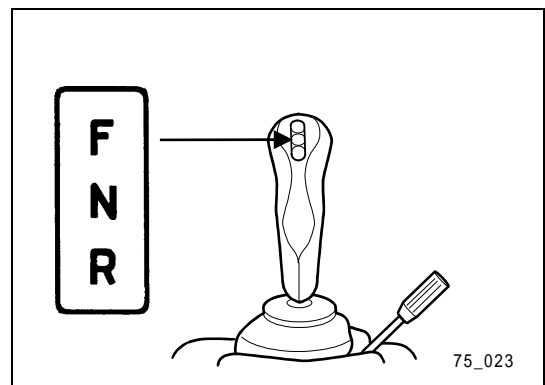

- 7- Release the brake pedal and press down the accelerator pedal at the same time in order to start the machine.

19.1.1 STARTING THE MACHINE ON SLOPES



CAUTION

- **Careless driving may lead to accidents!**
Before starting up, ensure that no persons are near the machine and sound the horn before driving.

- 1- Start up the engine as described in chapter "18. Starting and Switching Off the Engine".
- 2- Make sure that the parking brake is pulled. The parking brake warning light lights up.
- 3- Press down the brake pedal.
- 4- Release the parking brake.
- 5- Set the drive direction switch to the desired direction setting.

Position 'F'	Driving forward
Position 'N'	Neutral
Position 'R'	Reversing
- 6- Press down the accelerator pedal and release slowly the brake pedal at the same time in order to start the machine.

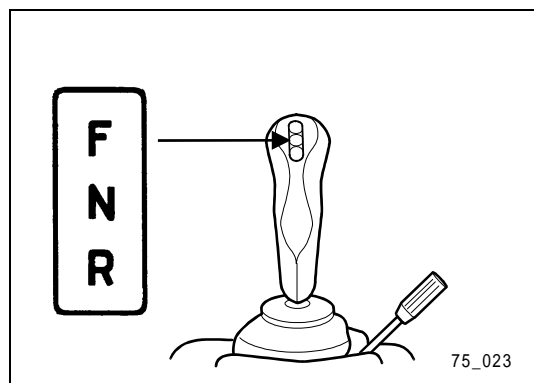

19.2 CHANGING THE DRIVING DIRECTION



WARNING

- **Careless changes of the driving direction may cause severe accidents!**
Before you change the driving direction from forward to reverse driving or vice versa, you must make sure that no persons or obstacles are in your way.



CAUTION

- **The engine may be damaged if you are driving at a high speed and then change abruptly from forward to reverse driving or vice versa!**
Brake until the machine has nearly come to a standstill before you change the driving direction.

The drive direction switch is used to switch between forward and reverse gear or vice versa. The machine may still roll, if you change the driving direction.

- | | |
|--------------|-----------------|
| Position 'F' | Driving forward |
| Position 'N' | Neutral |
| Position 'R' | Reversing |

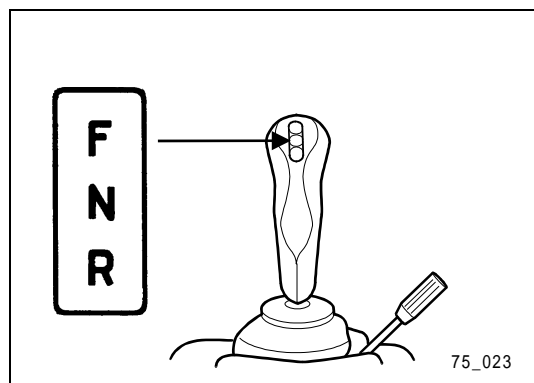

19.3 REVERSE DRIVING

The machine can drive forward or backwards (reversing) at the same speed. Before driving backwards, pay particularly care, that nobody is in your way. If necessary, rely on another person for aid. Sound the horn before starting to drive to make sure, that anybody who might be in your way is appropriately warned.

While driving backwards, turn your head into the driving direction. It is not sufficient to rely on the rear view mirrors.

19.4 TURNING



- **The machine may fall over if you turn abruptly at a high speed!**

If the engine is stopped during operation, does it affect braking and the servo-assisted steering will be deactivated. You may then only steer the machine with considerably higher effort.

19.4.1 TURNING ON SLOPES, EMBANKMENTS OR HILL FLANKS

Keep sufficient distance to ridges and steep slopes. There is danger of the machine tipping over or sliding down on steep slopes, embankments, or hill flanks. The limit values are defined in chapter "33.3 Limit Values for Slopes".

Do not turn on a slope or drive across a slope. Turn or cross the section only level ground. When driving on slopes, avoid driving on grass, fallen leaves, or steel plates. Driving sideways on these surface types may result in the machine sliding. For this reason, drive very slowly and carefully.

To keep the centre of gravity as low as possible when driving on slopes, embankments, and hill flanks, you must set the bucket to a position just above the ground (approx. 7.87 in (200 mm) to 11.8 in (300 mm)). In the event of an emergency, lower the bucket on the ground in order to stabilise the machine.

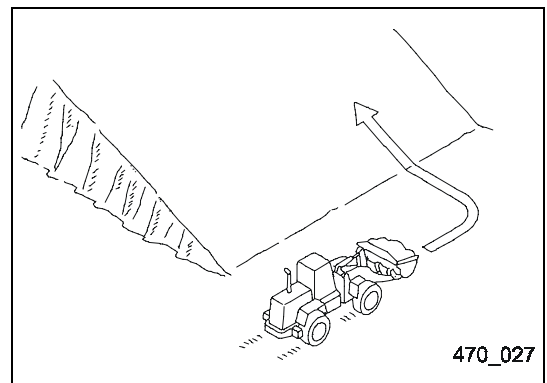
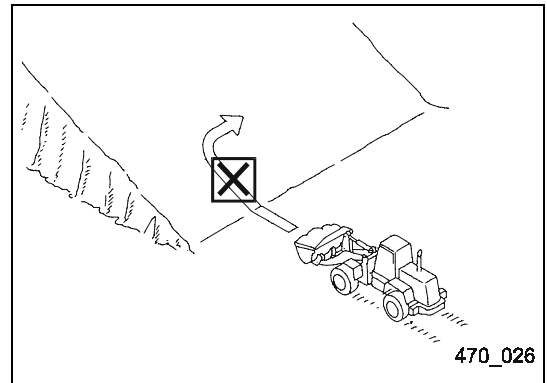

19.5 BRAKING

While driving, you may reduce your speed with the service brake (1). After the machine has stopped, you must secure it with the parking brake (2).

19.5.1 PULLING THE PARKING BRAKE

- 1 - Press the locking button.
- 2 - Pull up the parking brake lever.
- 3 - Release the locking button. The control lamp of the parking brake lights up.

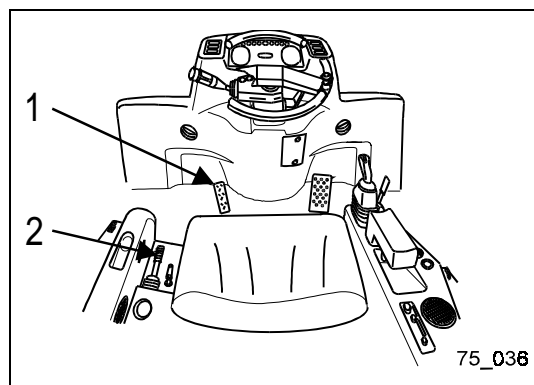

19.5.2 RELEASING THE PARKING BRAKE

- 1 - Lift up the parking brake lever a little.
- 2 - Press the locking button.
- 3 - Push the parking brake lever down.
- 4 - Release the locking button. The control lamp of the parking brake goes out.

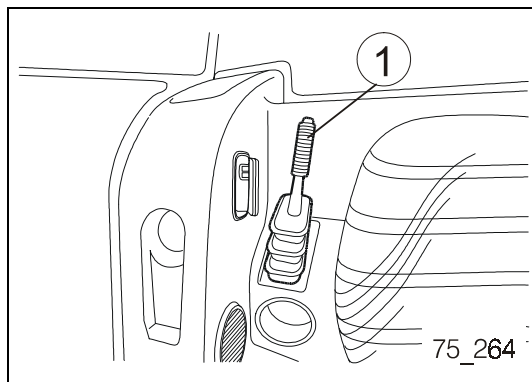

19.5.3 BRAKING WITH THE SERVICE BRAKE

If the braking delay is not sufficient by relieving the pressure from the accelerator pedal, you must brake the machine with the service brake. For this purpose, press down the brake pedal.

The service brake (1) can also be used to adapt the driving speed to the respective driving and operating situation (2), independent of the accelerator pedal position.

If it is required to press down the accelerator pedal completely, in order to be able to use the full-load output of the engine of the work hydraulic system, you can nevertheless use the brake pedal to reduce the speed of the machine or to stop it completely.

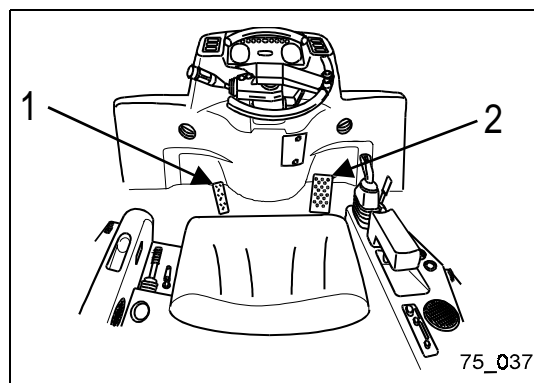

19.5.4 IF THE SERVICE BRAKE BREAKS DOWN

If the machine is not stopped after pressing down the brake pedal, you must use the parking brake.

19.5.5 BRAKING ON SLOPES



CAUTION

- **The service brake may overheat and be damaged while driving downhill!**
Let the engine run while driving downhill. If required, brake in addition using the brake pedal.
- **Danger of accidents due to unintentional braking!**
Do not use the brake pedal as a foot rest.

If you use the service brake too often while driving downhill, it may overheat and be damaged. You can avoid this by driving downhill in the lower speed range and by using the braking effect of the engine. (In the lower speed range the driving range switch will be switched off and the control lamp will go out.)

19.6 STOPPING

Avoid abrupt stopping. Proceed as follows, if you want to stop the machine:

- 1- Release the accelerator pedal and press down the brake pedal.
- 2- Set the drive direction switch into its neutral position 'N'.
- 3- Apply the parking brake.
- 4- Lower the work unit onto the ground.



WARNING

- **Unintentional moving of the equipment may lead to accidents!**
Before you leave the cab, turn the locking lever for the work hydraulic system into position '1'. As a result, the work hydraulic system is blocked.

- 5- Protect the work hydraulic system against unintentional activation by turning the locking lever of the work hydraulic system into position '1'.

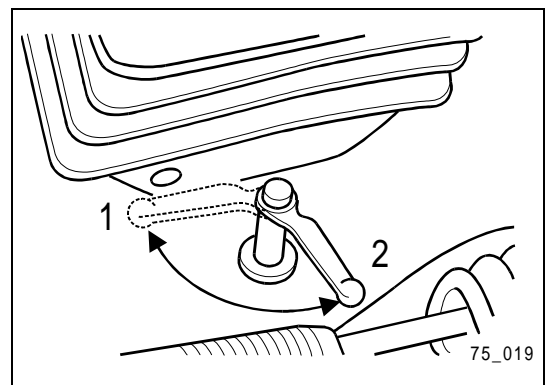
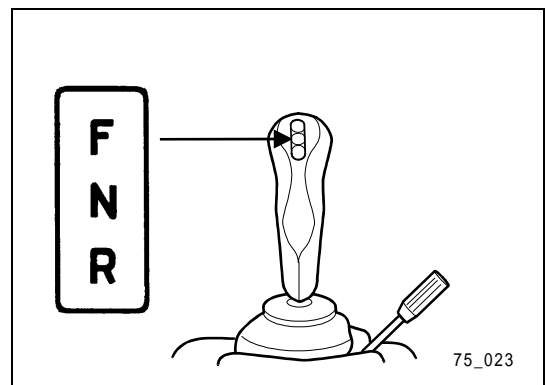

19.6.1 PARKING THE MACHINE ON A SLOPE

Whenever possible, stop the machine on level ground. If you have to park the machine on a slope, it is required that you park it in such a way that the front section (work unit) points downhill. Lower the work unit onto the ground. Block the wheels with wheel chocks (1).

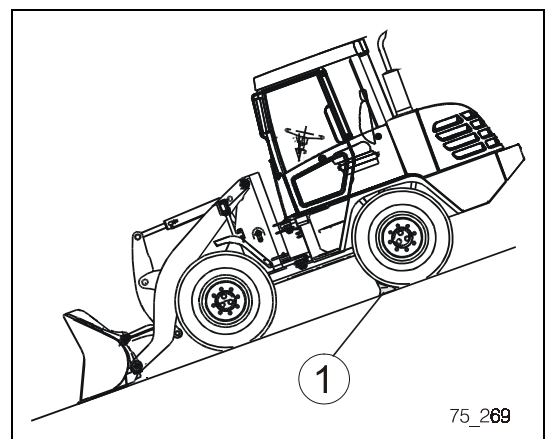

19.7 LONGER-DISTANCE DRIVING

If the machine is driven over long routes at a high speed and without having adapted the tire pressure, the tires will become very hot. This leads to premature wear and tear of the tires which should be avoided if possible. Adhere to the following instructions if you must drive the machine over a long distance:

- Perform all pre-start checks before starting to drive (see chapter "16. Preparing the Machine Start").
- Fix supplementary hand tools before starting to drive.
- The required tire pressure, the driving speed or the tire type may vary depending on the condition or structure of the road to be used. Contact the responsible Komatsu trader or the tire dealer to obtain the required information.
- The required tire pressure can be found in the tires and tire pressure table in chapter "22. Maintenance Basics".
- Check the tire pressure before driving with the tires being cold.
- Lower the work unit to its transport position and move it completely to its rear limit stop position.
- Always drive with empty bucket or empty forklift truck attachment.
- Adhere to the valid motor vehicle traffic regulations and drive very careful. Make sure that the working lights and the warning beacon are turned off while driving on public roads.
- Make a break of 30 minutes after driving for one hour. Check the tires and all particularly strained parts during driving on public roads whether they are still fully functioning or damaged.

20. OPERATING THE MACHINE

20.1 PREPARING THE WORK EQUIPMENT

20.1.1 SELECTING A WORK UNIT

Refer to chapter "7. Equipment" for information on the work units registered.

20.1.2 PICKING UP THE WORK UNIT (EXCEPT MULTI-PURPOSE BUCKET)

Connect the multi-purpose bucket as described in section „Picking up the multi-purpose bucket“ (see next page).

- 1- Make sure that the change-over lever for the additional control unit is in position '2' (fig. 75_160).
- 2- Start the engine.
- 3- Unlock the quick-change unit by setting the control lever for special equipment into position '1' (fig. 75_042).
- 4- Lift the boom slightly by setting the multi-function lever into position 'H' (fig. 75_016).
- 5- Tilt the quick-change unit slightly to the front by setting the multi-function lever into position 'A' (fig. 75_016).
- 6- Drive the machine to the work unit until the quick-change unit (3) is below the pickup hooks of the work unit. Then, lift the boom until the work unit catches the quick-change unit (fig. 75_280).
- 7- Tip in the quick-change unit until the work unit is connected to the limit stops on the the quick-change unit by setting the multi-function lever into position 'E' (fig. 75_016).
- 8- Lock the quick-change unit by setting the control lever for special equipment into position '2' (fig. 75_042).
The interlocking pins (4) will then be visible (fig. 75_280).

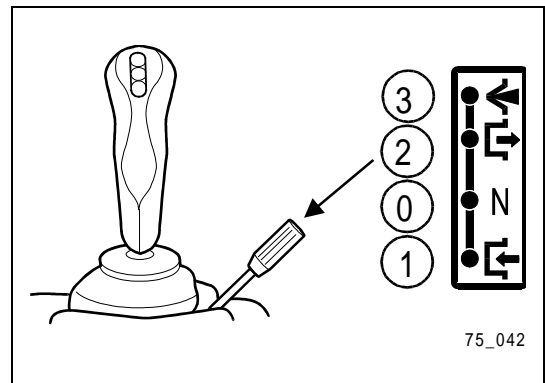
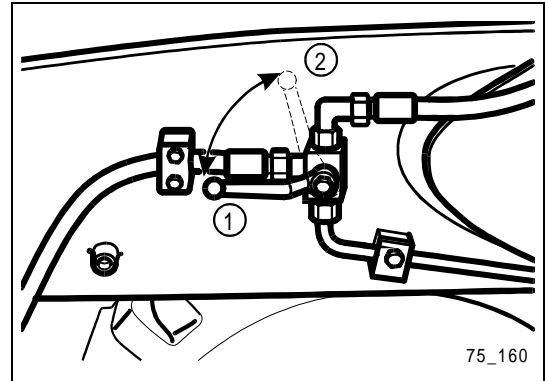

WARNING

- **If the work unit is not properly attached, it can suddenly fall down and cause severe accidents! Carefully lift the work unit and check whether it is completely locked in by slowly tipping it in and then dumping it.**

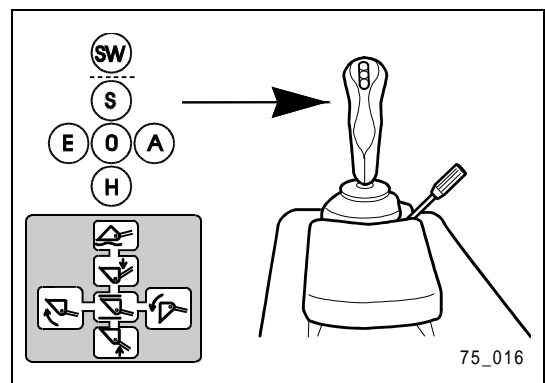

- 9- Check whether the work unit is completely locked in by tipping it in and then dumping it.

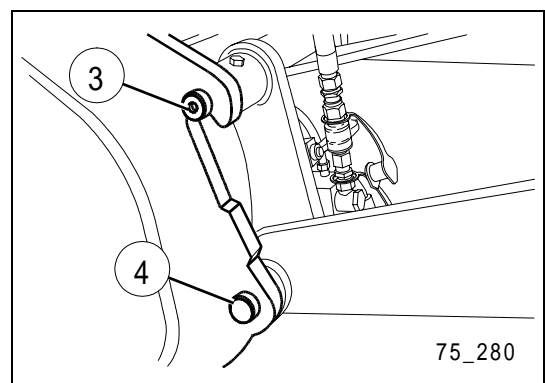

20.1.3 REMOVING THE WORK UNIT

- 1- Lower the work unit onto level ground.
- 2- Unlock the quick-change unit by setting the control lever for special equipment into position '1' (fig. 75_042).
- 3- Set the quick-change unit into the dumping position 'A' (fig. 75_016) using the multi-function lever, until the quick-change unit is unhooked of the pickup hooks of the work unit.
- 4- Make sure that nobody is behind the machine and drive the machine away from the work unit.

20.1.4 PICKING UP THE MULTI-PURPOSE BUCKET

- 1- Set the change-over lever for the additional control unit into position '2' (fig. 75_160).
- 2- Start the engine.
- 3- Unlock the quick-change unit by setting the control lever for special equipment into position '1' (fig. 75_042).
- 4- Lift the boom slightly by setting the multi-function lever into position 'H' (fig. 75_016).
- 5- Tilt the quick-change unit slightly to the front by setting the multi-function lever into position 'A' (fig. 75_016).
- 6- Drive the machine to the work unit until the quick-change unit (1) is below the pickup hooks of the work unit. Then, lift the boom until the work unit catches the quick-change unit.
- 7- Tip in the quick-change unit until the work unit is connected to the limit stops on the the quick-change unit by setting the multi-function lever into position 'E' (fig. 75_016).
- 8- Lock the quick-change unit by setting the control lever for special equipment into position '2' (fig. 75_042).

 **IMPORTANT**

- **Unlock the quick-change unit again by setting the control lever for special equipment into position '1' (fig. 75_042) in order to remove the pressure from the additional control circuit.**

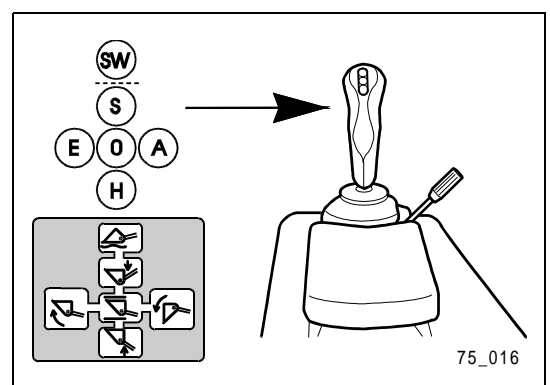
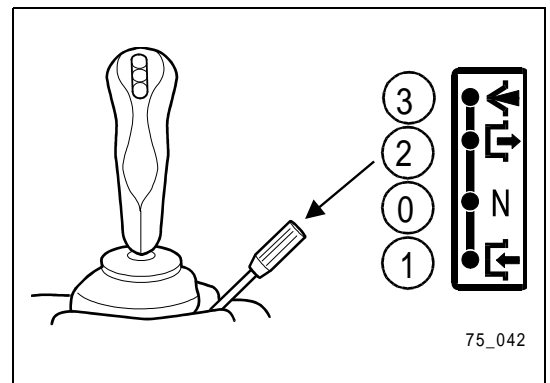

OPERATING THE MACHINE

- 9- Connect the hydraulic hoses of the multi-purpose bucket to the quick attach couplers (2) (fig. 75_161) and (3) (fig. 75_275).
- 10- Lock the quick-change unit by setting the control lever for special equipment into position '2' (fig. 75_042).

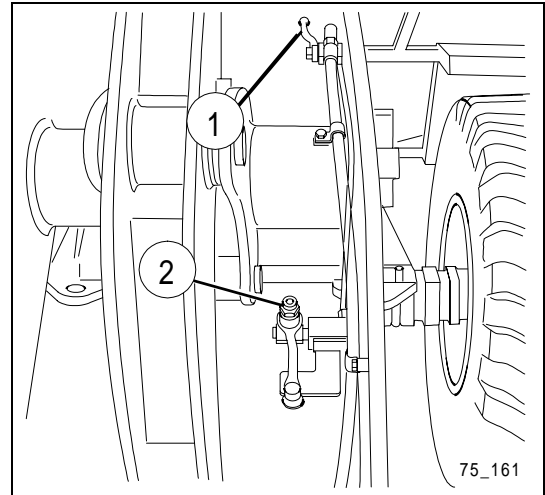

- 11- Set the change-over lever for the additional control circuit into position '1' (fig. 75_160). You can now operate the multi-purpose bucket with the control lever for special equipment (fig. 75_042).

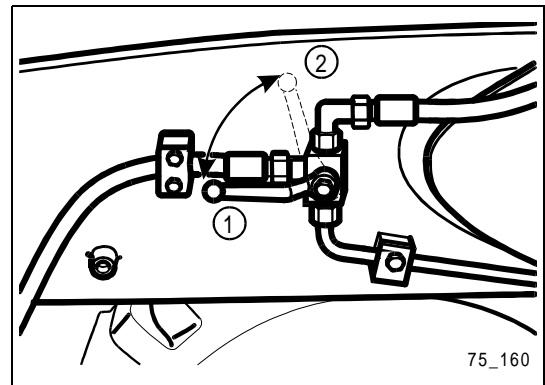

- Position '1': Close multi-purpose bucket
- Position '0': Neutral position
- Position '2': Open multi-purpose bucket

! WARNING

- If the work unit is not properly attached, it can suddenly fall down and cause severe accidents. Carefully lift the work unit and check whether it is completely locked in by slowly tipping it in and then dumping it.

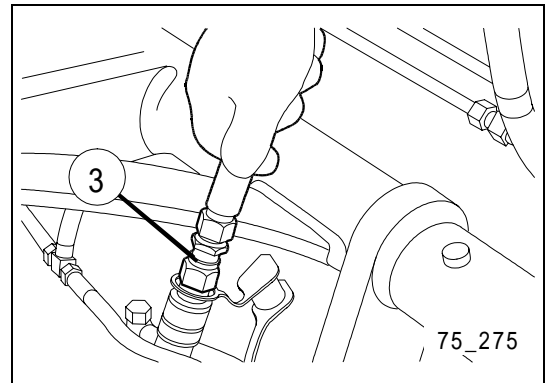

- 12- Check whether the work unit is completely locked in by tipping it in and then dumping it.

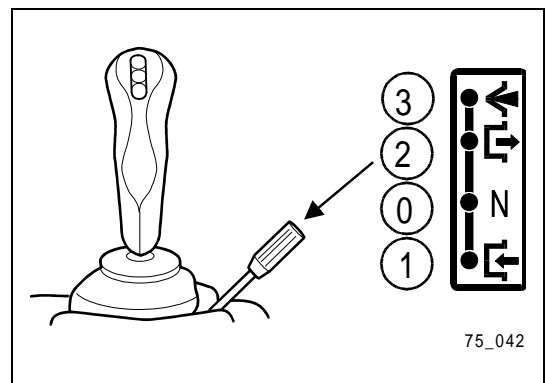

20.1.5 REMOVING THE MULTI-PURPOSE BUCKET

- 1 - Lower the multi-purpose bucket onto level ground.
- 2 - Turn the change-over lever for the additional control circuit to position '2' (fig. 75_160).
- 3 - Unlock the quick-change unit by setting the control lever for special equipment into position '1' (fig. 75_042).
- 4 - Loosen the hydraulic hoses of the multi-purpose bucket from the quick attach couplers.
- 5 - Set the quick-change unit into the dumping position 'A' (fig. 75_016) using the multi-function lever, until the quick-change unit is unhooked of the pickup hooks of the work unit.
- 6 - Make sure that nobody is behind the machine and drive the machine away from the work unit.

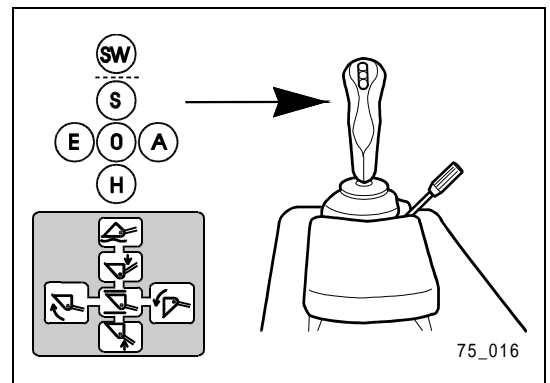
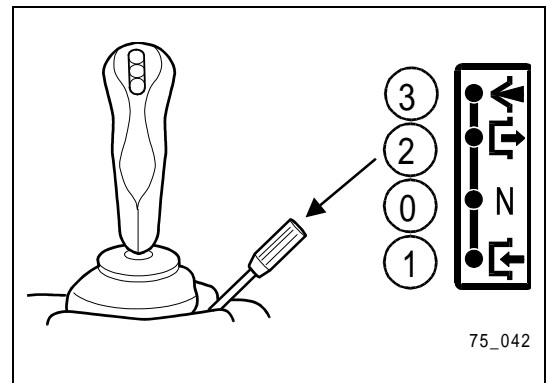
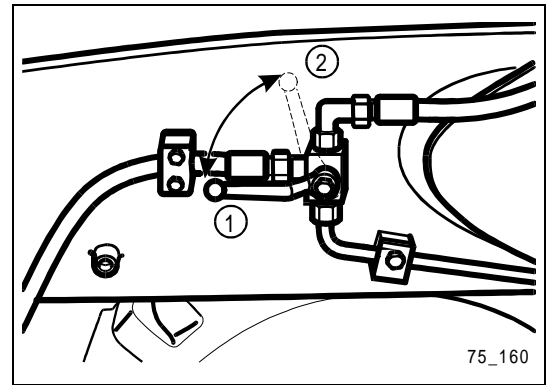

20.2 TIRE SERVICE LIFE

Removing piles of loose soil or rock debris may cause premature wear and tear of the tires due to cracks and small fissures. As a result, the service life of the tires is reduced. Proceed as follows to avoid unnecessary wear and tear of the tires:

- Try to work on level ground and remove any rocks and large stones which are sticking out of the surface.
- Always drive in straight direction into the pile or slope. This ensures that you have always the largest intrusive force while reducing tire wear and tear at the same time.
- For removing operations, lift the bucket as soon as you drive into the pile or slope. This procedure permits to increase the load of the front wheels, prevents slipway of the front wheels and reduces wear and tear of the tires.
- Lower the bucket slowly onto the ground. If the bucket touches the ground too fast, the front wheels may be lifted from the ground, thus leading to premature wear and tear of the rear tires.
- To prevent the front wheels from skidding, it is recommended to set the ground pressure of the front wheels as high as possible. Therefore, immediately lift the bucket a little after running into the pile or slope.

20.2.1 LEVEL INDICATOR FOR THE BUCKET

On both sides of the bucket the upper edges (see arrow) are arranged in parallel to the bucket edge and can be used as a level indicator for the bucket.

You can recognize the position of the cutting edge of the bucket from the driver's seat with the help of the level indicators.

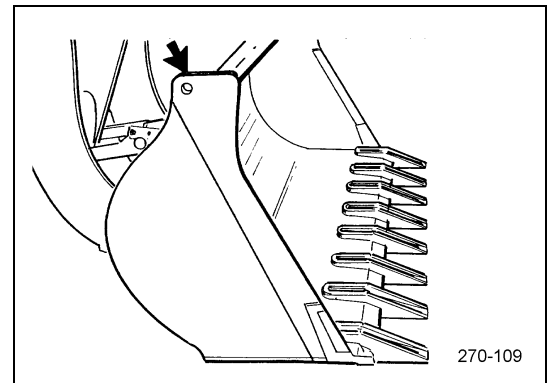

20.3 LOADING



CAUTION

- **Danger of accidents! The machine may fall over if you transport a load with the bucket lifted too high! Lower the bucket during transporting loads in order to lower the centre of gravity of the machine.**

The loading operation of wheel loaders is based on the following principle:

Removing or digging → Transport → Dumping

In the following sections, the individual operation steps of this operating cycle are explained.

20.3.1 REMOVING PILED UP SOIL



CAUTION

- **If you perform removal operations with the machine being in an unbalanced position, you may damage the articulated steering and the cardan shaft! Always drive into the material which you want to remove in straight direction.**

For removal operations, adhere to the instructions in chapter "20.2 Tire Service Life". For removal operations, proceed as follows:

- 1- Drive in straight line to the piled up soil.
- 2- While driving forward, lower the bucket rapidly until it reaches a height of approx. 11.8 in (30 cm) over the ground and hold the bucket in this position.



NOTE

- **If the bucket touches the ground, the front wheels may be lifted from the ground, resulting in premature wear and tear of the rear wheels.**

- 3- Then, proceed with slowly lowering the bucket onto the ground.
- 4- Brake right in front of the material to be removed using the service brake, while pressing down the accelerator pedal at the same time.

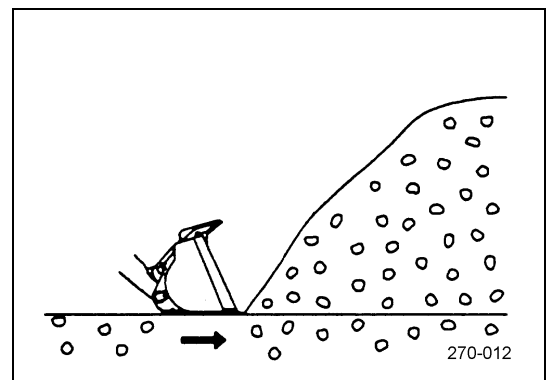
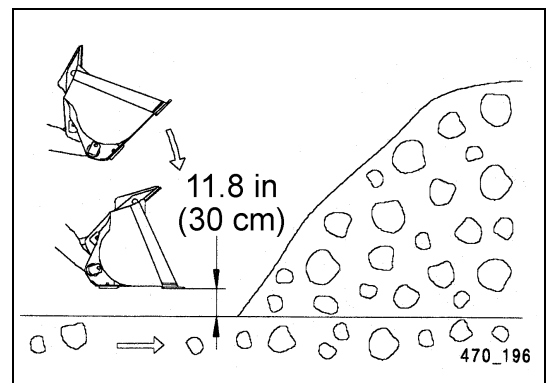

OPERATING THE MACHINE

- 5- Press down the accelerator pedal and drive the bucket into the material to be removed. In order to remove the material, it is required that you align horizontally the cutting edge of the bucket while driving into the material. When you are loading rock debris, it is necessary to lower the bucket slightly.

While removing rock debris, ensure that no rock gets under the bucket. This may lead to the front wheels being lifted from the ground, thus resulting in premature wear and tear of the rear wheels.

Always hold the load in the centre of the bucket. If the load is shifted to one side, the equilibrium of the machine will be impaired.

- 6- To prevent that the bucket digs in too deep into the material to be removed, you must lift the boom while driving into the material. Lifting the boom ensures a sufficient thrust force.

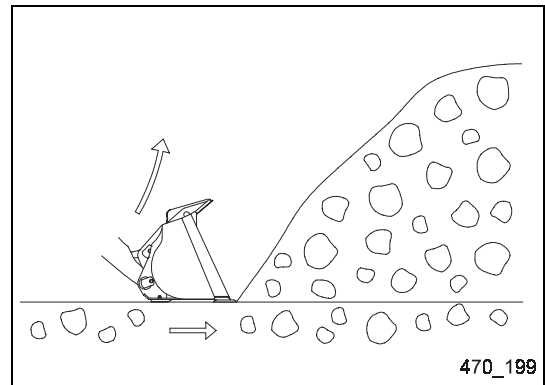
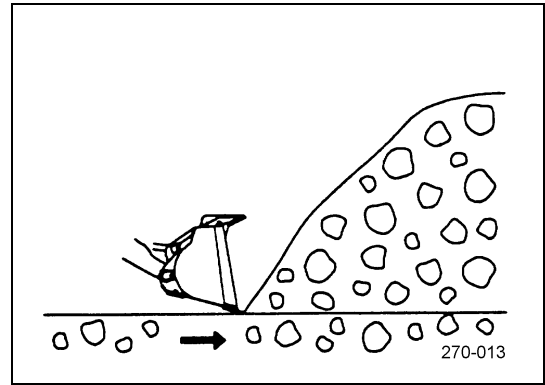

- 7- Tip in the bucket.

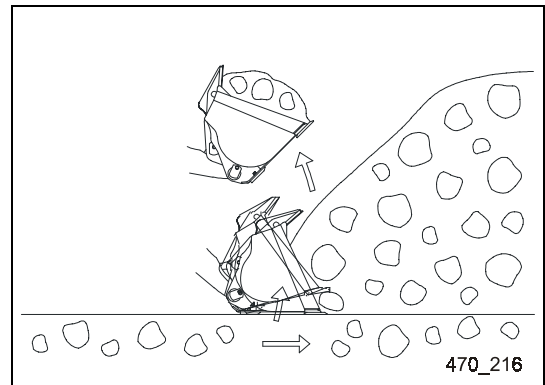

- 8- If there is too much material inside the bucket, you must briefly tip it in, dump it and lower it in order to reduce the load and to prevent that you lose the load during the transport.

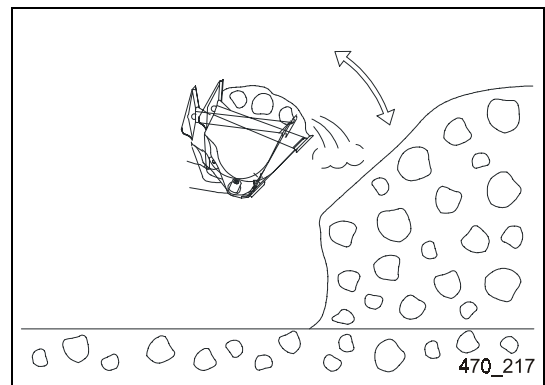

20.3.2 EXCAVATION WORKS

During excavation works, ensure that you do not load the bucket only on one side, since the equilibrium of the machine may be impaired.

- 1- Drive up to the soil heap in a straight line.
- 2- Slow down the machine using the service brake while keeping the accelerator pedal pressed down at the same time.
- 3- Bend the bucket edge slightly down.

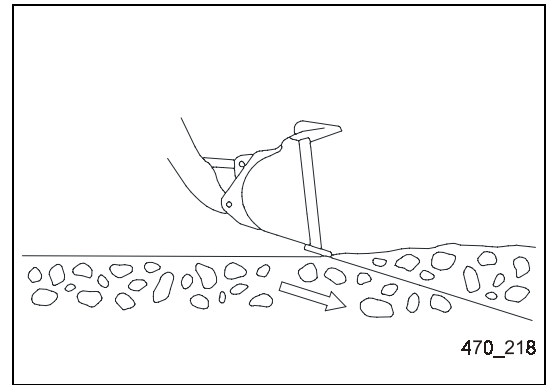

- 4- While driving forward, move slightly the multi-function lever of the boom in order to remove only a thin layer of the surface of the soil to be removed.

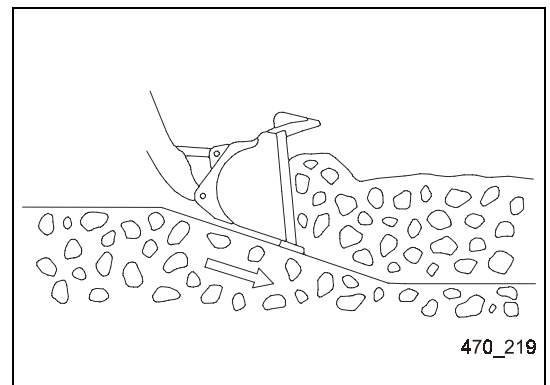

- 5- Move the multi-function lever of the boom slightly up and down to reduce the resistance during driving forward. While removing, ensure that the digging force is not applied only on one side of the bucket.

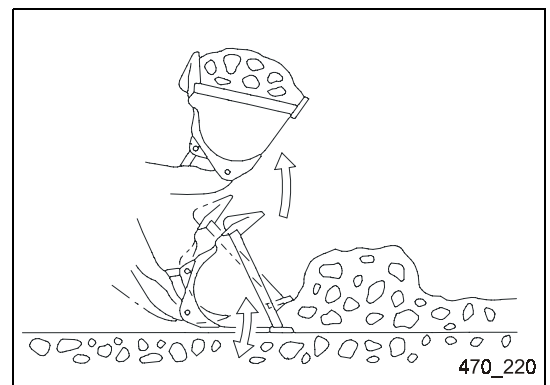

20.4 TRANSPORTING

Make sure that the transport route is in perfect condition and that nobody is in your way. Remove any rocks or large stones which have fallen down out of the operating range (see chapter "20.2 Tire Service Life"). Hold the bucket in tip-in position. Lower the boom to its transport position. If the boom is in transport position, the two red arrows of the transport position marking on the lifting cylinder will be next to each other.

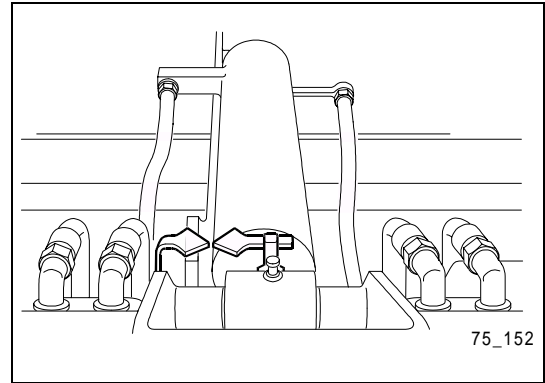

20.5 DUMPING / UNLOADING

Always select the dumping/unloading type with the smallest turning circle and driving effort in order to work as efficiently as possible.

WARNING

- **Danger of accidents! If you turn or brake abruptly with the lifted load, the load may fall out of the bucket and cause accidents!**
- **Turn slowly with the load lifted and brake cautiously.**

CAUTION

- **The bucket and the machine will be damaged if you drive into a heap of soil or rocks with high speed!**
- **Drive slowly into a heap of soil or rocks.**

NOTE

- **Avoid any excessive shaking of the bucket. Always operate with respect to the condition of the tires (see chapter "20.2 Tire Service Life").**

20.5.1 LOADING IN DIAGONAL DIRECTION

Align the machine in rectangular position to the heap. Drive the machine backwards in straight line after you have filled the bucket. Then, let the dump truck drive between heap and machine. Drive up to the dump truck and unload the material.

This operation requires not much time and considerably reduces the cycle time.

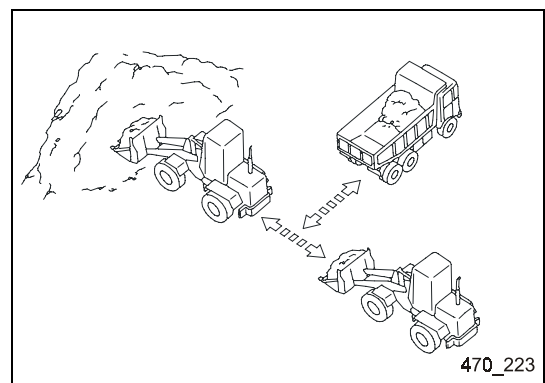

20.5.2 V-SHAPED LOADING

Position the dump truck in such a way that the angle between the dump and the dump truck is approx. 60°. Fill the bucket and shake it. This leads to a better distribution of the cargo in the bucket and prevents that material falls down to the back. Drive the machine backwards from the heap and align the machine with the dump truck. Raise the bucket to its maximum height. Drive up forward to the dump truck and unload the material.

If you keep the turning angle of the machine as small as possible, the work can be performed more efficiently.

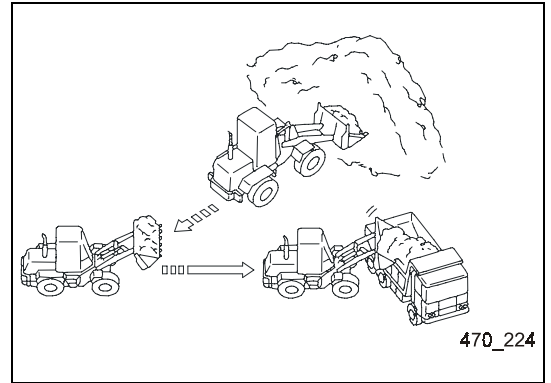

20.5.3 PILING UP MATERIAL

Do not position the bucket in its maximum tip-in or dumping position while piling up material. Instead, use the required mining angle. The rear counterweight must not touch the ground.

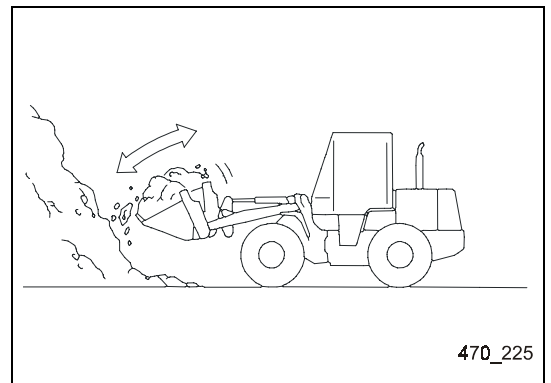

20.6 PLANING

Planing operations are required for levelling the ground. For this purpose, a straight bucket without claws is suitable. Planing includes two operation steps - filling up and taking off ground.

20.6.1 FILLING UP

It may be necessary to fill up the uneven ground in front of the machine with soil. Proceed as follows:



NOTE

- For fill-up operations, lower the bucket max. by 15° to the front.
-

Fill the bucket with soil. Drive slowly forward with the machine and distribute the soil little by little from the bucket. If you must fill up particularly large uneven surfaces, you should place additional soil in front of the bucket, which will be distributed when the machine is driving forward.

20.6.2 TAKING OFF SOIL

If the surface is filled up, you may level the ground.



WARNING

- **Danger of accidents! Careless reverse driving may lead to severe accidents!**
Before you drive backwards, make sure that nobody is behind the machine. Warn persons who are in your way by sounding the horn.
-

Lower the bucket slightly. Drive backwards and draw the bucket over the ground.

In order to receive a particularly even surface, you must lower the boom to its floating position. Drive slowly backwards and draw the bucket with its plane underside over the ground.

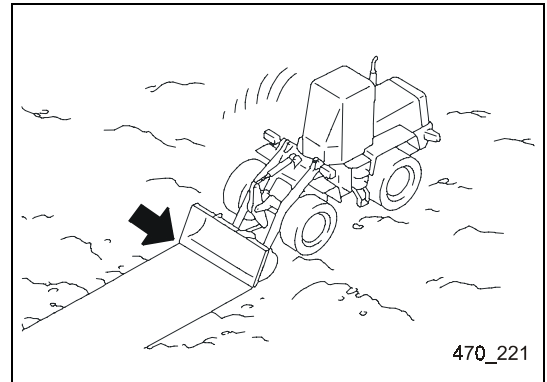

20.6.3 CUTTING THE GROUND

Cutting the ground is a special type of planing. It is used to wear off the top layer of soil.



CAUTION

- **The bucket teeth and bucket are damaged if you mine with the bucket in dumping position!**
For prospecting operations, align the underside of the bucket until it is in parallel to the ground surface.
-

Always drive in the lower speed range while cutting ground.

20.7 WORKING WITH THE FORKLIFT TRUCK ATTACHMENT

Operations with an forklift truck attachment on a wheel loader differ from operations with the bucket or a forklift truck. Take into account the following notes and the instructions specified in the chapter "Safety":

- Do not take up loads which are so high that you cannot see onto the route.
- Hold the fork tines of the forklift truck attachment as horizontal as possible when you take up the load.
- During the ride, hold the load as low as possible in order to have free sight onto the route.
- Always drive slowly (speed range 1) with the load.
- The boom performs a semicircular stroke while performing the lifting movement. Raise the boom only immediately in front of the place at which you want to unload to the desired height. This prevents that you damage the load during lifting it.
- Hold the forklift truck attachment as horizontal as possible during piling up.

20.7.1 PICKING UP THE LOAD

- 1- Approach slowly the load to be picked up.



CAUTION

- **Danger of accidents! If the load does not lie in the centre of gravity, the stability of the machine is impaired. Drive under the load until it is touching the fork back of the forklift truck attachment.**

- 2- Drive so far under the load until it touches the fork back of the forklift truck attachment.
- 3- Tip in slightly the forklift truck attachment so that the load cannot fall down.
- 4- Lower the boom to its transport position. The two red arrows of the transport position marking on the lifting cylinder will then be next to each other.
- 5- Then lift the load to the appropriate height only shortly before you reach the stacking surface. Raise the load a little higher than necessary.
- 6- Set the load surface slowly and from above onto the stacking.
- 7- Slowly lower the boom so far that you can pull out the fork tines below the load.
- 8- Make sure that nobody is behind the machine and drive off backwards from the deposit surface.

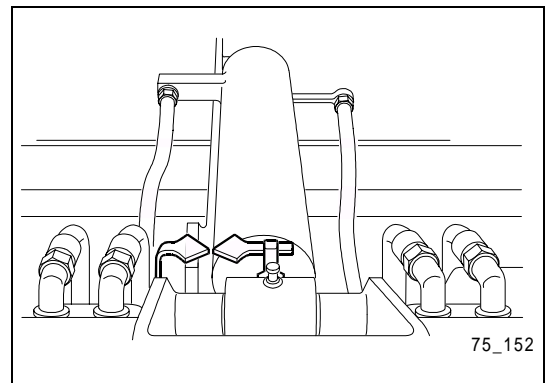
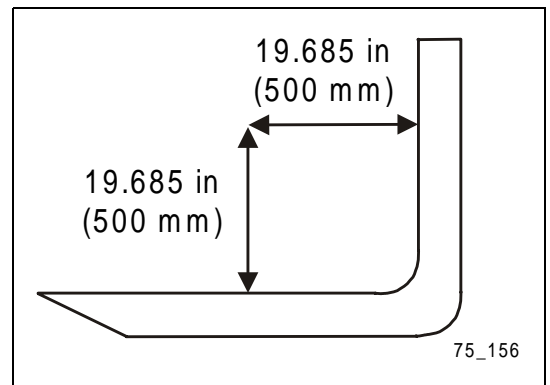

20.8 PRECAUTIONS FOR SPECIAL OPERATIONS

20.8.1 WORKING IN WATER

While operating in water or on swampy ground, the water must not reach the underside of the axle housing. Wash the machine after the work has been finished and check the lubricating points.

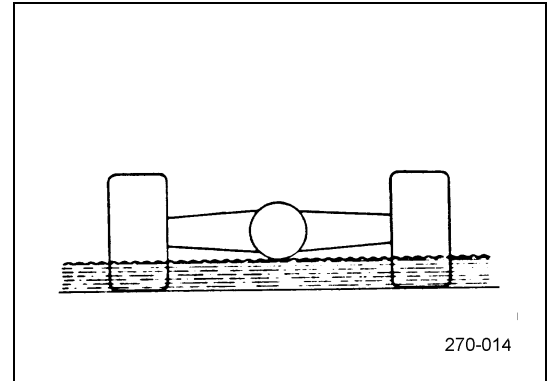

20.8.2 WORKING ON SNOW

Adhere to the instructions in the chapter "Safety", "10.2.9 Working On Snow".

20.8.3 DUMPING ON STEEP SLOPES

Adhere to the instructions indicated in the chapter "Safety", "10.2.7 Loading".

20.8.4 WORKING IN THE VICINITY OF ELECTRICAL OVERHEAD LINES

Adhere to the instructions indicated in the chapter "Safety", "10.2.6 Working Close to Overhead Power Transmission Lines".

20.8.5 OPERATION ON SLOPES

Adhere to the instructions indicated in the chapter "Safety", "10.2.4 Driving On Slopes".

20.8.6 WORKING ON LOOSE SOIL

Adhere to the instructions indicated in the chapter "Safety", "10.2.12 Working On Loose Soil".

20.9 AFTER THE WORK IS FINISHED

- 1- Walk around the machine and visually inspect the work unit, the car body and the chassis. In addition, pay attention to emerging oil and water. Eliminate immediately any fault or defect.
- 2- Fill up the fuel tank.
- 3- Remove highly flammable material from the engine room since it represents a fire risk.
- 4- Clean roughly the chassis landing gear.

20.10 INSTRUCTIONS FOR WINTER OPERATION

20.10.1 BEFORE THE COLD SEASON

Before the cold season begins, you should perform the following preparatory measures to ensure troublefree operation also in the winter months.

- The machine is provided with a aluminium radiator. Therefore, the cooling system must be set to -34.6°F (-37°C) for the whole year.
- Use oils with the prescribed viscosities which are suitable for the cold weather to be expected in your region (see chapter "22.4 Lubricants and Operating Agents").
- Fill up with winter diesel fuel. At low temperatures, paraffin deposits of diesel fuel may block the filters and lines (see chapter "22.4 Lubricants and Operating Agents").
- If the injection system, the starter, the battery and the generator are in perfect condition, it is ensured that the engine can be easily started and that the machine can be operated troublefree even in extremely cold weather. Let these important components be checked at an authorised garage before the winter starts.
- Insufficient compression pressure impairs the start-up behaviour of the engine, especially at low temperatures. Let the compression pressure be measured at an authorised garage.
- If the speed is continuously increased, the starter may remain switched on until the engine finally starts up.
- Let the engine warm up with increased idle speed for some minutes before starting to work. During the warm-up phase, operate the hydraulics devices several times without load.
- Add a standard antifreeze to the water in the windshield washer assy. If required, add 25 vol. % of alcohol (spirit) to the water.

20.10.2 AFTER OPERATION

Realise the following actions to make sure that the machine can be started the next time without problems:

- Remove mud and water from the car body. This prevents that sealings are damaged due to freezing.
- Park the machine on hard and dry ground. If this is not possible, you must park the machine on wooden planks. The planks prevent that the wheels are freezing to the ground.
- Drain off collected water from the fuel system.
- The battery capacity drops clearly at low temperatures. Therefore, dismount the battery in frost periods and store it in a warm place. Re-install it the next morning, before starting to work.

20.10.3 AFTER THE COLD SEASON

If the weather becomes warmer, you must fill up the prescribed fuel and use oils with prescribed viscosities (see table "22.4 Lubricants and Operating Agents").

20.11 LONGER STANDSTILL PERIODS OF THE MACHINE

20.11.1 BEFORE THE STANDSTILL

Perform the following actions, if the machine is to be taken out of service over a longer period of time:

- Clean the entire machine, including the engine room, and let it dry.
- If possible park the machine at a dry, roofed location. A supplementary cover with a canvas cover is recommended.
If the machine must be parked outside, you need to put wooden planks on the ground on which the machine is to be parked and covered with a canvas cover.
- Fill up the fuel tank. Lubricate the machine and change the oils.
- Apply a thin grease film to the piston rods of the hydraulic cylinders.
- Disconnect the negative terminals of the battery. Cover the battery or remove it and store filled up and completely charged it in a dry room which is frost-free in winter.
- Check whether the coolant is set to a temperature of -34.6°F (-37° C). Refill antifreeze, if necessary.

20.11.2 DURING THE STANDSTILL

Perform the following actions in order to keep the machine in operating condition during the standstill:



WARNING

- **Danger of poisoning, if the engine is going to be run indoors!**
Prior to starting engine indoors, ensure that there is sufficient ventilation in the facility. Failure to do so could result in serious injury or even death.
-

- Let the engine run once a month.
- Wipe away the grease from the piston rods of the hydraulic cylinders.
- Drive the machine over a short distance so that the movable parts are re-coated with an oil film.
- Recharge the battery.

20.11.3 AFTER THE STANDSTILL



NOTE

- **If the machine was not moved once a month, contact the local Komatsu dealer to arrange a maintenance appointment.**
-

After a longer standstill period, perform the following works before starting up the machine:

- Remove the grease from the piston rods of the hydraulic cylinders.
- Check the oil levels and, if necessary, refill oil. Lubricate the machine.

TROUBLESHOOTING

21. TROUBLESHOOTING

Have all malfunctions and causes of malfunctions that are not given in the tables below remedied by your local Komatsu dealer.

21.1 WARNING LIGHTS AND INDICATORS

The following list contains the troubleshooting tables with explanations of warning lights and indicators:

Charging current warning light	see "21.2 Electrical System"
Engine oil pressure warning light	see "21.3 Engine"
Brake oil warning light	see "21.5 Brakes"
Air filter warning light	see "21.3 Engine"
Parking brake warning light	see "21.5 Brakes"
Coolant temperature indicator	see "21.3 Engine"
Fuel level indicator	see "21.3 Engine"

21.2 ELECTRICAL SYSTEM

ELECTRICAL SYSTEM		
FAULT	CAUSES	REMEDY
Warning light charging current: warning light charging current is off, when the engine is switched off and the start switch is set to its operating position 'I'	Electrical connection without function	*) Check terminals, connections, and cables
Warning light charging current: warning light charging current does not go out when engine is running	Electrical connection without function	*) Check terminals, connections, and cables
	Generator without function	*) Check function of generator; replace defective generator
	Tension of generator drive belt too low	Increase tension of drive belt
Generator produces unusual noise	Generator defective	Replace generator
Starter does not start the engine	Electrical connection without function	*) Check terminals, connections, and cables
	Battery charge insufficient	Re-charge battery *) Check function of battery; replace defective battery
Starter pinion repeatedly engages and disengages	Battery charge insufficient	Re-charge battery
	Starter defective	*) Replace starter
Starter turns engine only slowly	Battery charge insufficient	Re-charge battery
	Starter defective	*) Replace starter
Starter disengages before engine is started	Battery charge insufficient	Re-charge battery
	Starter defective	*) Replace starter

*) These measures must be performed by your local Komatsu dealer.

21.3 ENGINE

ENGINE		
FAULT	CAUSES	REMEDY
Warning light engine oil pressure: with the engine running the warning light is on and an acoustic alarm signal is given	Oil level in engine too low	Top up engine oil
	Engine oil filter (filter cartridge) dirty	Replace engine oil filter (filter cartridge)
	Lines or hoses of engine lubricating system damaged	Check lines and hoses (visual check: oil leaks) *) Replace defective lines and hoses
	Line or hose connections of engine lubricating system leaky	Check line and hose connections (visual check: oil leaks) *) Repair leaky line and hose connections
	Oil pressure switch without function	*) Check function of oil pressure switch; replace defective oil pressure switch
Vapour is let off at the pressure valve of the radiator cap	Coolant level in radiator too low	Top up coolant (ensure correct mixing ratio)
Coolant level too low	Leaks in the cooling system	Check lines and hoses (visual check: coolant leaks) *) Replace defective lines and hoses

*) These measures must be performed by your local Komatsu dealer.

ENGINE (CONTINUED)		
FAULT	CAUSES	REMEDY
Temperature display coolant: temperature display coolant in red zone, top LED is flashing, acoustic alarm is given	Engine has run too hot	Let engine run idle without load until it has cooled down sufficiently and the coolant temperature indicator is within the green range.
	Tension of fan's drive belt too low	Tension drive belt
	Internal surface of engine cooling system furred or dirty	*) Clean internal surface of engine cooling system
	Radiator (radiator surfaces, fins) dirty	Clean radiator (radiator surfaces, fins)
	Thermostat without function	*) Check function of thermostat; replace defective thermostat
	Radiator cap either defective or loose	Replace defective radiator cap; re-tighten loose radiator cap
Coolant temperature indicator: with the engine at operating temperature, the temperature display coolant does not indicate a temperature	Temperature indicator without function	*) Check function of temperature indicator; replace defective temperature indicator
Engine does not start up	Fuel tank empty	Refill fuel and bleed fuel system
	Air in fuel system	Bleed fuel system
	Injection pump or injection nozzles without function	*) Replace injection pump or injection nozzles
	Starting speed too low	See "Electrical System"
	Engine compression too low	*) Check tappet clearance
Exhaust fume colour white or blue	Oil level in engine too high	Correct oil level
	Wrong fuel	Use prescribed fuel
Exhaust fume colour temporarily black	Air filter insert dirty	Clean or replace air filter insert
	Injection nozzle defective	*) Replace injection nozzles
	Engine compression too low	*) Check tappet clearance

*) These measures must be performed by your local Komatsu dealer.

ENGINE (CONTINUED)		
FAULT	CAUSES	REMEDY
Temporarily, combustion sounds like breathing	Injection nozzles defective	*) Replace injection nozzles
Unusual combustion noise	Wrong fuel	Use prescribed fuel
	Engine temperature too high (engine overheated)	Allow engine to cool down See "Engine - Coolant temperature indicator"
Unusual mechanical noise	Defective silencer	*) Replace silencer
	Tappet clearance too wide	*) Adjust tappet clearance
Engine does not start or stops during operation and the top LED of the fuel supply indicator is flashing	Fuel tank empty	Refill fuel and bleed fuel system
Warning light air filter: warning light air filter is on when engine is running	Air filter or filter insert dirty	Clean or replace filter insert of air filter

*) These measures must be performed by your local Komatsu dealer.

21.4 HYDRAULIC SYSTEM

HYDROSTATIC DRIVE UNIT		
FAULT	CAUSES	REMEDY
Machine does not drive	Parking brake applied	Release parking brake
	Driving direction switch in position 'N'	'Set driving direction switch to either position 'F' or 'R'
	Driving direction switch without function	*) Check function of driving direction switch
	Oil level in hydraulic oil tank too low	Top off hydraulic oil
Machine does only drive slowly and performance is poor	Hydrostatic motor motor does not swivel	Check hydrostatic motor for contamination; clean dirty hydraulic motor *) Check function of hydrostatic motor
	On-off-valve without function	*) Check function of on-off valve; replace defective on-off-valve
	Hydrostatic pump defective	*) Replace hydrostatic pump
	Wrong control pressure	*) Check control pressure; reset, if required
	Wrong high pressure	*) Check high pressure; reset, if required
	Inch valve defective or set incorrectly	*) Check setting of inch valve *) Replace defective inch valve
	Hydraulic filter dirty	Replace filter element of hydraulic filter
	Switching relay without function	*) Check function of switching relay; repair or replace defective switching relay
Hydrostatic drive unit overheated	Faulty operation of charge pump	*) Check function (pressure) of charge pump
	Hydraulic oil radiator (radiator surfaces, fins) dirty	Clean hydraulic oil radiator (radiator surfaces, fins)
	Faulty fan operation	Check tension of drive belt
	Hydraulic filter dirty	Replace filter element of hydraulic filter
	Oil level in hydraulic oil tank either too high or too low	Correct oil level in hydraulic oil tank

*) These measures must be performed by your local Komatsu dealer.

HYDROSTATIC DRIVE UNIT (CONTINUED)		
FAULT	CAUSES	REMEDY
Unusual noise	Oil level in hydraulic oil tank too low	Top off hydraulic oil
	Inclusions of air in lines and units of the hydraulic system (faulty bleeding)	Bleed hydraulic system

WORK HYDRAULIC SYSTEM		
FAULT	CAUSES	REMEDY
Lifting power too low	Oil level in hydraulic tank too low	Top off hydraulic oil
Lifting power too slow	Filter insert of hydraulic oil filter dirty	Replace filter insert of hydraulic oil filter
Air bubbles in hydraulic oil	Wrong hydraulic oil quality	Fill in prescribed hydraulic oil
	Oil level in hydraulic oil tank too low	Top off hydraulic oil
Cylinders move jerky	Oil level in hydraulic oil tank too low	Top off hydraulic oil

*) These measures must be performed by your local Komatsu dealer.

21.5 BRAKES

BRAKE		
FAULT	CAUSES	REMEDY
Brake has no effect	Multi-disks of brake worn	*) Replace multi-disks of brake
	Air in brake system	*) Bleed brake system
Warning light brake oil reserve: warning light brake oil reserve is on	Brake oil level in brake oil tank too low	Top off brake oil Check brake system for damage and leaks (visual check: brake oil leaks)

PARKING BRAKE		
FAULT	CAUSES	REMEDY
Brake is ineffective	Parking brake's brake lever is too loose	*) Adjust parking brake
	Brake's multi-disks are worn	*) Replace multi-disks

STEERING		
FAULT	CAUSES	REMEDY
Steering reacts slowly	Hydraulic system operates improperly	*) Check function of hydraulic system
Steering wobbles	Clearance of steering cylinder bolt too large	*) Check fastenings of steering cylinder; replace defective cylinder bolts
	Faulty operation of hydraulic system	*) Check function of hydraulic system

*) These measures must be performed by your local Komatsu dealer.

21.6 AXLES

AXLES		
FAULT	CAUSES	REMEDY
Noise	Oil level in axle too low	Top off oil

*) These measures must be performed by your local Komatsu dealer.

21.7 EMERGENCY STEERING CHARACTERISTICS

If the engine breaks down during driving, you may proceed with steering the machine. However, you will need considerable more effort.

If the engine breaks down, immediately drive to the roadside, switch on the hazard flasher and secure the machine.

21.8 EMERGENCY LOWERING SYSTEM

When the engine is in operation or not in operation, you may lower the work unit with the emergency lowering system.

- 1 - Ensure that nobody is standing under the work unit.

Likewise you may release the rest pressure in the hydraulic circuit.

- 2 - Turn the lever of the emergency lowering system to position '2'.
The work unit is lowered, or the rest pressure is released.
- 3 - Turn the lever of the emergency lowering system back to position '1'.

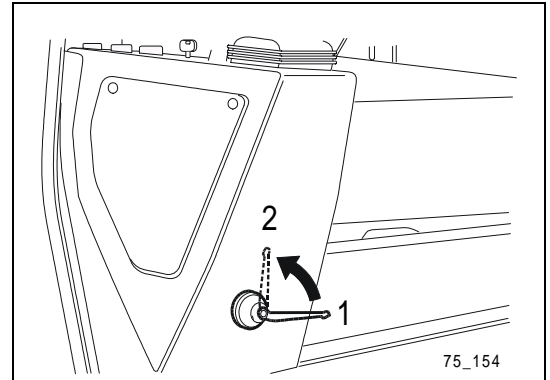

21.9 STARTING THE ENGINE WITH A BATTERY JUMPER CABLE



NOTE

- The current-supplying battery and the discharged battery must have identical nominal voltages.
 - The capacity of the current-supplying battery must not be significantly lower than the capacity of the discharged battery.
 - The cross-sections of the battery jumper cable and the cable clamps must be suitable for the battery type.
-

21.9.1 CONNECTING THE JUMPER CABLE



CAUTION

- A short-circuit may damage parts of the electrical system. A short-circuit may occur, if:
 - the positive (+) and negative (-) clamps touch each other when you connect them to the battery, or if they are conductively connected (e.g. by a tool),
 - the operational and the defective machine touch each other and current is already flowing when the positive poles are connected,
 - a clamp slips off and touches the machine!
 - Firmly connect the clamps. When connecting and disconnecting the cables, pay attention that
 - the cable ends neither touch each other nor the machine,
 - the two machines do not touch each other.
-

- 1- Turn the start switch of the defective machine to '0' (OFF).
- 2- Connect one clamp of the battery jumper cable to the positive terminal (+) of the discharged battery.
- 3- Connect the other clamp of the battery jumper cable to the positive terminal (+) of the charged battery.
- 4- Connect one clamp of the battery jumper cable to the negative terminal (-) of the charged battery.



WARNING

- **Danger of explosion! When you connect the last clamp to the engine block of the defective machine, sparks are produced which may ignite the gas produced in the battery!**
Connect the last clamp as far away from the battery as possible.
-

- 5- Connect the other clamp of the battery jumper cable to the engine block of the machine with the discharged battery.

21.10 STARTING THE ENGINE

The engine of the machine with the charged battery must run at high idle-running speed. Start the engine of the machine with the discharged battery. If the engine does not start up immediately, wait at least two minutes, before you make a second attempt.

21.10.1 DISCONNECTING THE BATTERY JUMPER CABLE



CAUTION

- **Danger of short-circuit! When disconnecting the cables, pay attention not to let the cable ends touch each other or the machine. When the cable ends touch each other or the machine, a short-circuit is produced which may damage parts of the electrical system!**
When disconnecting the cables, pay attention not to let the cable ends touch each other or the machine.
-

After starting of the engine, disconnect the battery jumper cables by reversing the steps you performed to connect the cables.

- 1- Disconnect one clamp of the battery jumper cable from the engine block.
- 2- Disconnect the other clamp of the battery jumper cable from the negative terminal (-) of the charged battery.
- 3- Disconnect the clamp of the battery jumper cable from the positive terminal (+) of the charged battery.
- 4- Disconnect the other clamp of the battery jumper cable from the positive terminal (+) of the discharged battery.

21.11 TOWING THE MACHINE



WARNING

- Towing with a tractor of insufficient weight may cause accidents!
Perform towing using a machine weighing at least as much as the machine that you want to tow off.



CAUTION

- Towing to start the engine will damage the hydrostatic drive system!
Do not give the machine a tow to start the engine. This will not start the engine, but may damage the hydrostatic drive system.

To avoid damage to the hydrostatic drive system, do not tow the machine for more than 0,6 miles (1000 m). The towing speed must not exceed 1.2 mph (2 km/h).

Perform towing using a machine weighing at least as much as the machine that you want to tow off. Connect both machines with appropriate towing attachments.



CAUTION

- Towing attachments fastened to inappropriate points may damage the machine!
Only fasten the towing attachment to the points provided for this purpose.

At the front part of the machine, fasten the towing attachment at the marked eyes. At the rear part of the machine, fasten the towing attachment at the hitch.

Before you tow a machine with a hydrostatic drive system, establish a short-circuit connection between the high-pressure side and the low-pressure side of the variable pump. For this purpose, turn the high-pressure valves in the valve block about 2 revolutions. Proceed as follows:

- 1- Set the driving-direction switch to position 'N'.
- 2- Loosen both screws (1) and remove the cover plate (2).
- 3- Remove protecting caps from the valves.
- 4- Hold the valve (3) in position, using a wrench.
- 5- Loosen the counter-nut (4) and re-insert the threaded stud (5) clockwise, using a hexagonal socket head wrench, until it reaches the top edge of the counter-nut (4).
- 6- Re-tighten firmly the counter-nut (4). Perform these operations on both valves.

After towing another machine loosen the counter-nut (4) and the threaded stud (5) by turning it anti-clockwise until it reaches the limit stop. Hold the valve (3) in position using a wrench and re-tighten firmly the counter-nut (4). Perform these operations on both valves.

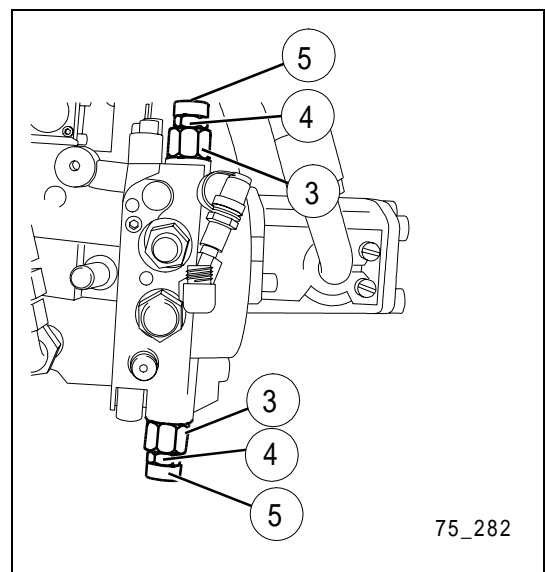
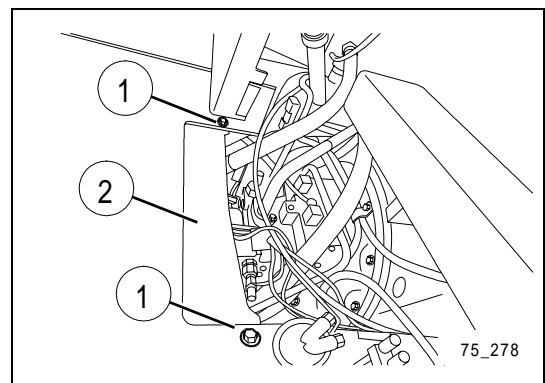
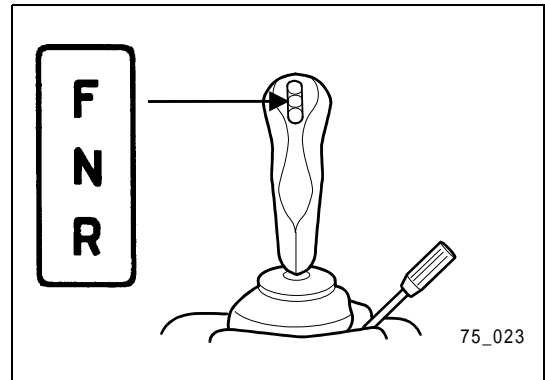

**NOTE**

- **When the engine is switched off, the power-assisted steering is not operational, i.e. you have to apply much more force to steer the machine.**
-

If you lift up the rear axle of the machine with a lorry-mounted crane, you can tow off the machine over longer distances and at speeds exceeding 1.2 mph (2 km/h). Before you do this you must, however, remove the cardan shaft of the front axle. In addition, secure the articulated steering with the locking bar, in the same way as it is required for transport of the machine on a low bed loader or by train.

21.12 TOWING A MACHINE WITH DEFECTIVE BRAKES

**WARNING**

- **If the brakes of the machine that you want to give a tow are defective, uncontrolled movement of the machine may cause a crash while it is being towed!**
Always use two machines to tow off a machine with defective brakes. Connect all three machines with appropriate towing attachments.

If you want to tow a machine with defective brakes, or if you have to tow a machine driving downhill, use two machines for towing. Attach the machine that you want to give a tow to a larger machine with sufficient tractive and braking force. Attach a second machine to the rear part of the machine that you want to give a tow. In this way, you avoid uncontrolled movement of the machine.

Towing can be performed under various conditions. Thus, it is impossible to determine all the requirements that may apply to a particular condition. When towing on an even and horizontal surface, the tractive force that you need is much less than the tractive force that you need when towing on a slope or uneven surface.

Please ask your local Komatsu dealer for details, if you want to give a particular machine a tow.

MAINTENANCE

22. MAINTENANCE BASICS



CAUTION

- **Maintenance work must only be performed by trained and qualified personnel. Also refer to chapter "Safety Measures During Maintenance".**

To ensure troublefree operation of the machine, it must be serviced at regular intervals. Control daily the operating hour meter to determine which of the maintenance measures is required.

When performing maintenance work, do not keep loose items in your pockets. Loose items could fall into the machine during maintenance work.

22.1 PREPARING THE MACHINE FOR MAINTENANCE

Before you start maintenance or repair work, position the machine as follows, unless stated otherwise:

- 1- Park the machine on solid and level ground.
- 2- Set the machine to the specified position for maintenance and repair.
- 3- Lower the work unit to the ground and position it as shown in the drawing.
- 4- Set all control levers to either the neutral or the hold position '0'.
- 5- Turn the safety lever of the work hydraulic system to position '1'.
- 6- Take out the start key and store it in a safe place.
- 7- Apply the parking brake.
- 8- Apply the warning sign you received together with the tools at the start switch.
- 9- Put wheel chocks in front and behind the wheels.
- 10- Secure the articulated steering with the articulated steering catch.
- 11- If required, remove dirt.

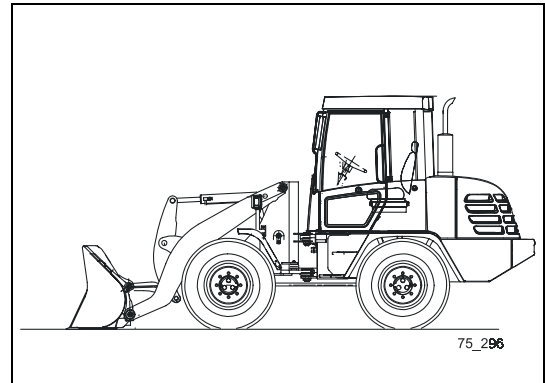

22.2 CLEANING THE MACHINE

Always keep the machine clean. Ensure that grease nipples, air vent holes, and oil level indicators are always clean. Avoid contamination of operating agents with impurities. This will reduce malfunctions to a minimum.



WARNING

- **If somebody accidentally lowers the bucket while cleaning is being performed under the boom, this may lead to severe accidents!**
Before you start performing cleaning work under the boom, either support the bucket or lower it onto the ground.
-

If you have to perform cleaning work under the boom and you cannot support the bucket, park and secure the machine as follows:

- 1- Park the machine on level ground.
- 2- Apply the parking brake.
- 3- Place wheel chocks in front of the wheels to prevent the machine from rolling away.
- 4- With the bucket in its dumping position, lower the bucket onto the ground with either its cutting edge or teeth.

22.2.1 PRECAUTIONARY MEASURES WHEN CLEANING THE MACHINE

- Do not point a water or steam jet directly at the radiator.
- Pay attention that water does not get into the electrical system.

22.2.2 FIRE PREVENTION

Do not use any highly inflammable cleaning agents for cleaning of parts.

If – by way of exception – you have to use inflammable cleaning agents, keep the cleaning agent away from fire and do not smoke while you are working.

22.3 WORKING-AREA-DEPENDENT MAINTENANCE

22.3.1 MUDDY OR WET WORKING AREAS

- Immediately clean the machine after work to protect the components against corrosion.
- Perform maintenance and lubrication measures more frequently when working in areas with unfavourable working conditions.
- If the machine is used in water, lubricate bolts daily - see page 148 and page 162.

22.3.2 DUSTY WORKING AREAS

Adhere to the following measures when working in dusty working areas:

- Pay attention to the warning lamp of the air filter to detect a blocked air filter insert in time. In addition, clean the air filter insert more frequently than specified in the maintenance schedule.
- Frequently clean the external surfaces of the radiator to ensure unobstructed flow of air.
- Replace the fuel filter cartridge more frequently than specified in the maintenance schedule.
- Clean all electrical components, especially the starter and the generator.

22.4 LUBRICANTS AND OPERATING AGENTS

22.4.1 DRAINING HOT LUBRICANTS AND FLUIDS

There is danger of scalding, when you drain off hot oils or hot coolant and remove the corresponding filters immediately after you have switched off the engine. For this reason, wait until the engine has cooled down to approx. 60° C, before you start to perform maintenance work.

Do not remove oils when the engine is cold.

22.4.2 CHECKING THE OIL LEVEL AND CHANGING OIL

Check the oil level and change the oil and oil filter in a dust-free place to avoid contamination of service fluids by undesired material.

After an oil change or oil filter change, check the oil and oil filter for an unusual high number of metal parts or other undesired material. In case you detect an unusual high contamination, inform your responsible Komatsu dealer.

22.4.3 CHANGING FILTERS

Filters avoid introduction of undesired material into the individual cycles and the equipment where they may cause malfunctions.

- Regularly replace all filters. For details refer to "23. Maintenance Schedule" for the proper interval.
- Replace the filters more often, if you work under difficult conditions, depending on the oil and fuel that you use (e.g. high sulphur content).
- Do not try to clean filter cartridges for re-use. Always replace used filter cartridges by new ones.
- Do not open the packages containing the spare filters unless you will mount them immediately.
- Always use genuine Komatsu filters.

22.4.4 REFUELLING AND TOPPING OFF OIL

Always refuel and top off oil in a sufficiently ventilated place. If the machine is equipped with a fuel strainer in the tank filler neck, do not remove the fuel strainer when refuelling. After refuelling or topping up of oil, close the filler openings again.

Spilled fuel or oil involve danger of slipping and fire. For this reason, immediately remove any spilled fuel or oil.

Do not let oil or fuel seep into soil or water. Dispose of oil and fuel according to applicable environmental regulations.

22.4.5 OIL

The oil in the engine and the hydraulic system is subjected to extreme conditions (high temperatures, high pressure). Thus, its quality deteriorates the longer it is used.

- Always use the types of oil specified for the particular use and temperature in the operating and maintenance instructions. Always adhere to the specified intervals for oil changes.
- Pay particular attention not to contaminate oil and grease when topping them up. A lot of malfunctions are caused by contaminated oil.
- Do not mix oils of different types or makes.
- Always top off with the required volume of oil. If the volume of oil used for topping up is too high or too low, this may lead to malfunctions.
- If the oil in the work hydraulic system is milky, it is very likely that there is either water or air present within the system. In this case, inform the responsible Komatsu dealer.
- Always replace the oil filter when you perform an oil change.
- We recommend that you have the engine oil and the hydraulic oil checked at regular intervals by the responsible Komatsu dealer to get an impression of the machine's condition.

22.4.6 LUBRICATING GREASE

Lubricating grease reduces wear and operating noise.

- The grease nipples not specified in the "23. Maintenance Schedule" are only to be used for overhauling purposes; for this reason, they do not have to be lubricated.
- To prolong service life lubricate all moving parts.
- Remove old grease which is pressed out during lubrication. Ensure that the lubricating grease is not contaminated with sand or dirt, since this would result in premature wear and tear.

22.4.7 BIODEGRADABLE HYDRAULIC OIL AND LUBRICATING GREASE

Biodegradable hydraulic oil and lubricating grease - based on synthetic esters - can be used for Komatsu machines. Please contact our factory representatives for information about the products which suit best your type of application which are approved by Komatsu.

22.4.8 FUEL

The fuel injection pump is a precision device. If the fuel in the fuel injection pump contains water or dirt, this will damage the fuel injection pump.

- Proceed with utmost care when storing or refuelling, to avoid intrusion of impurities into the fuel.
- Always use the fuel specified in the operating and maintenance manuals.
- If the temperature of diesel fuel falls below 5°F (-15°C), paraffin may precipitate, blocking filters and hoses. For this reason, always use a diesel fuel appropriate for these temperatures.
- To prevent humidity from condensing in the fuel tank, always refill the fuel tank after daily work has been finished.
- After refuelling, wait at least ten minutes before draining off dirt precipitations and water. Swirled up impurities will precipitate again during this period of time.
- If the fuel tank has been „run empty" or filters have been replaced, ventilate the fuel system. Refer to chapter "30. Maintenance Every 500 Operating Hours".
- If you use fuels with a sulphur content between 0.5 and 1.0%, cut in half the interval for an oil change. If you use fuels with a sulphur content of over 1.0%, quarter the interval for an oil change.

22.4.9 STORAGE OF OIL AND FUEL

- Store oil and fuel in-doors in sufficiently ventilated rooms to avoid contamination with water, dirt, or other impurities.
- Position barrels which you want to store over longer periods of time sideways. Store them in such way that the feed opening is on the side. In this way, you avoid formation of humidity in the barrel.
- Cover barrels that you want to store in the open with a watertight foil or take other appropriate measures to protect the barrels.
- To avoid a negative influence on the quality during long-time storage, always proceed according to the "first in - first out" principle, i.e. use first that oil or fuel which is stored longest.

22.4.10 COOLANTS

- Always prepare coolants as described in the maintenance instructions.
- River water contains large amounts of calcium and other substances. If you use river water, scale will deposit in both the engine and the radiator, impairing heat exchange, which may lead to overheating.
- Only use drinking water.
- Always adhere to the information given in the operating and maintenance instructions when using antifreeze.
- Our machines are delivered with original Komatsu antifreeze. This antifreeze does, among other things, protect against corrosion in the cooling system, it lubricates moving parts, and it increases the coolant's boiling point. For this reason, it must also be used when working in hot working areas.
- Antifreeze is highly inflammable. For this reason, take care that antifreeze does not come into contact with naked light.
- If the coolant level is too low, the air in the cooling system may lead to overheating and corrosion in the cooling system.
- If the engine is overheated and you have to top off coolant, allow the engine to cool down before you fill in the coolant.

22.4.11 WINDSCREEN WASHER LIQUID

Only use clean windscreen washer liquid approved for use in automobiles.

Blank for Technical Reason

22.4.12 TABLE OF LUBRICANTS AND OPERATING AGENTS

WA75-3	LUBRICANTS AND OPERATING AGENTS BI-CODES*), SPECIFICATIONS, AND FILLING VOLUMES					
	Lubricants and Service Fluids	BI-Codes	Quality Classes	Temperature Ranges	Viscosity Classes	Filling Volume in Litres approx.
Engine	Engine Oil EO	EO 1540 A EO 1030 A NRS	CCMC D4 or, if not available: API CE or API CF-4 ²⁾	-15° to 45° C -20° to 30° C -15° to 20° C	SAE 15W-40 ¹⁾ SAE 10W-30 SAE 05W-30	9.4
Transfer Gear Box	Gear Oil GO	GO 90 LS	API-GL5 +LS or MIL-L-2105D+LS	-	SAE 90LS	1
Front Axle	Gear Oil GO	GO 90 LS	API-GL5 +LS or MIL-L-2105D+LS	-	SAE 90 LS ¹⁾ SAE 85W-90LS SAE 80W-90LS	Planet Gear: 2 x 0.9 Differential: 4.3
Rear Axle	Gear Oil GO	GO 90 LS	API-GL5 +LS or MIL-L-2105D+LS	-	SAE 90 LS ¹⁾ SAE 85W-90LS SAE 80W-90LS	Planet Gear: 2 x 0.9 Differential: 4.7
Hydraulic System, Steering	Hydraulic Oil HYD	HYD 0530 HYD 1030 HYD 1540	HVLP HVLP D	15° to 20° C -20° to 30° C -15° to 45° C	ISO VG 46 ¹⁾ ISO VG 68 ISO VG 100	95
	or Engine Oil EO	EO 1540 A EO 1030 A NRS	CCMC D4 or, if not available: API CE or API CF -4 ²⁾	-15° to 45° C -20° to 30° C -15° to 20° C	SAE 15W-40 ¹⁾ SAE 10W-30 SAE 05W-30	
	or Hydraulic Oil BIO-E-HYD	BIO-E-HYD 0530	HEES (acc. to VDMA fluid technology)	-15° to 20° C	ISO VG 46	
Service Brake	Automatic Transmission Gear Oil	ATF	ATF, Type A, Suffix A	-	-	0.6
Cooling System	Long-Time Coolant	SP-C	Antifreeze and Corrosion Protection	Proportion of Mixture: 50% Coolant : 50% Water Min. Freeze Proofing: -34° C		12.25
Fuel Tank	Diesel Fuel ³⁾	CFPP Class B CFPP Class D CFPP Class E CFPP Class F	DIN-EN 590	up to 0°C up to -10°C up to -15°C up to -20°C		90
Grease Nipple	Lithiumsoap-Based Multi-Purpose Grease	MPG-A	KP2N-20	-	NLGI 2	

The specified filling volumes represent approximate values; the testing devices are binding. The selection of a viscosity class depends on the ambient temperature prevailing over a longer period of time. The temperature limits are to be regarded as guiding values; for a brief period, the actual temperature may be higher or lower than these guiding values.

¹⁾ Factory filling

²⁾ If engine oil of either the API CE or the API CF - 4 specification is not available, engine oil of either the API CC or the API CD specification may be used. In these cases, the oil change intervals must be cut in halves.

³⁾ If fuels with a sulphur content between 0.5 and 1.0 % are used, the oil change intervals for the engine must be cut in halves; if the sulphur content exceeds 1.0 %, the oil change intervals must be quartered.

*) BI-codes are the "standard lubricants" (Regelschmierstoffe) for construction machinery and vehicles of the Hauptverband der Deutschen Bauindustrie e.V. (BI) (head association of the German construction industry). The brochure "Regelschmierstoffe für Baumaschinen- und Fahrzeuge" (standard lubricants for construction machinery and vehicles) can be obtained from bookstores or the German Bauverlag GmbH Wiesbaden und Berlin under the ISBN-No. 3-7625-3102-1.

22.4.13 LUBRICATION CHART

WA 65/75/85-3 LUBRICATION CHART

CHECK · ADD
CHANGE

					LUBRI-CATION POINT
DAILY	1	DISPLAY			1
	2	FUEL LEVEL	F		1
	3	ENGINE OIL	EO		1
	4	COOLANT	CL		1
	5	BRAKE	ATF		1
	6	HYDRAULIC SYSTEM	HO		1
10h	7	ARTICULATED JOINT	G		3
50h	8	LIFT CYLINDER PIN	G		2
	9	DUMP CYLINDER PIN			2
	10	LIFT ARM PIVOT PIN			4
	11	BELLCRANK PIN			1
	12	QUICK COUPLER		3	
	5	BRAKE SYSTEM	ATF		1
	13	FUEL TANK			1
250h	14	FUEL PRE-FILTER			1
	15	STEERING CYLINDER PIN	G		2
	16	UNIVERSAL SHAFT			2
	17	FRONT AXLE	AXO		3
	18	REAR AXLE			3
	19	GEARBOX			1
	20	AIR CLEANER			1
	*21	ENGINE OIL	EO	OM	1

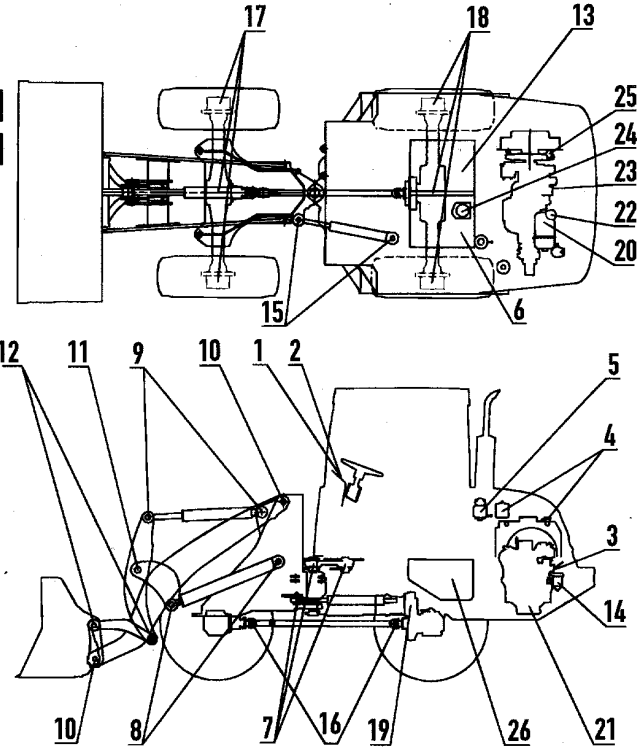

					LUBRI-CATION POINT
500h	*22	FUEL FILTER			1
	20	AIR CLEANER			1
	23	ENGINE OIL FILTER			1
	*24	HYDRAULIC OIL FILTER			1
1000h	25	COOLING SYSTEM	CL	OM	1
	*17	FRONT AXLE	AXO	OM	3
	*18	REAR AXLE		OM	3
	*19	GEARBOX		OM	1
	5	BRAKE OIL	ATF	OM	1
2000h	26	HYDRAULIC OIL	HO	OM	1

1. LUBRICATION INTERVALS ARE BASED ON THE SERVICE METER READING.
 2. ABBREVIATIONS
 EO: ENGINE OIL G: LITHIUM GREASE NO.2 F: DIESEL FUEL
 AXO: AXLE OIL CL: COOLING LIQUID HO: HYDRAULIC OIL
 OM: OPERATOR'S MANUAL
 FOR THE BRANDS OF EO, F AND AXO, REFER TO THE OPERATION AND MAINTENANCE MANUAL.
 3. NUMBERS AT THE LEFT SIDE OF THE CHART INDICATE THE NUMBER OF MAINTENANCE POINTS. REFER TO THE ABOVE ILLUSTRATION.
 4. ITEMS MARKED * SHOULD BE PERFORMED IN THE FIRST SERVICE FOR NEW CARS 50-HOURS DRIVING.
 5. REFER TO THE OPERATION AND MAINTENANCE MANUAL FOR DETAILS.

42U-93-11400

22.5 REPLACING SAFETY-RELATED PARTS



WARNING

- **Worn safety-related parts may cause accidents!**
Have parts which are important for machine safety and fire protection replaced at your local Komatsu dealer at regular intervals.
-

Have the following parts replaced at your local Komatsu dealer at regular intervals, even if they are not visibly worn:

- Have the safety belt replaced at least every three years.
- Do not use hoses longer than six years under normal operating conditions. Have hoses replaced, if you detect one of the following damages:
 - damage to the outer layer reaching down to the lining,
 - embrittlement of the outer layer,
 - deformations that do not correspond to the normal shape of the installed hose, when the hose is pressurised and depressurised,
 - leaks,
 - damage to hose fittings or connections between fittings and hoses,
 - damage due to storage (the storage time for hoses should not exceed two years).

When replacing hoses, do not forget to replace also all accessory O-rings, gaskets, and similar parts.

22.5.1 WELDING INSTRUCTIONS

- Set the engine start switch to switching position '0' (OFF).
- Apply only briefly a voltage of more than 200 V.
- Connect the earthing cable at a distance of max. 3.28 ft (1 m) to the area to be welded.
- There must be no gaskets or bearings between the welding area and the mass point.
- There must be a minimum distance of 3.28 ft (1 m) between the welding area and the battery.
- Do not weld lines or pipes containing fuel or oil.

22.6 SPARE PARTS AND CONSUMABLE COMPONENTS

- Replace parts which are subjected to wear and tear, such as filter elements, air filter insert, etc., when performing the regular maintenance work or when the limiting value for wear and tear and contamination is reached.
- Perform this work at regular intervals and as prescribed to ensure an efficient use of the machine.
- Only use original Komatsu spare parts.
- After removing the gaskets, clean the sealing surfaces. Replace gaskets and O-rings with new ones. Pay attention not to forget any gaskets and O-rings when re-assembling the parts.
- Use the part numbers specified in the spare parts catalogue for ordering of spare parts.

Position	Part No.	Part Designation	Quant.	Replacement Interval
Engine Oil Filter	YM129150-35151	Cartridge	1	First maintenance after 50 operating hours Maintenance every 250 operating hours
Fuel Filter	YM19000-55600	Cartridge	1	Maintenance every 500 operating hours
Hydraulic Oil Filter	42U-62-13150 (42U-62-H0P01) (42U-62-H0P02)	Filter Element (O-Ring) (O-Ring)	1 (1) (1)	First maintenance after 50 operating hours Maintenance every 500 operating hours
Engine Valve Cover Gasket	YM129902-01330 YM24311-000120	Gasket O-Ring	1 1	Maintenance every 1000 operating hours
Air Filter	42U-01-H0P01 42U-01-H0P02	Filter Insert Safety Filter	1 1	Maintenance every 500 operating hours

22.7 ELECTRICAL SYSTEM

- Do not remove or modify electrical components installed in the machine.
- Only install Komatsu Utility Corporation approved electrical components.
- When cleaning the machine or during heavy rainfall, pay attention that water does not get into the electrical system.
- If the wiring is wet or the insulation damaged, insulation faults will occur in the electrical system leading to dangerous malfunctions of the machine.
- When working in coastal areas, clean the system very thoroughly to avoid corrosion.
- Do not connect an external power source to fuses, the start switch, or the battery relay.
- **Maintenance of the electrical system comprises:**
 - 1- Checking the tension of the generator belt,
 - 2- Checking the generator belt for damage and wear, and
 - 3- Checking the acid level in the battery.

22.7.1 FUSES



CAUTION

- **Parts of the electrical system may be damaged, if you replace fuses with the ignition switched on! Turn the start switch to switching position '0' (OFF), before starting to replace fuses.**
- **Fuses with wrong amperages may cause fires due to electrical faults or may immediately blow again! Only replace defective fuses with fuses of the same rating.**

The fuses protect the electrical system. Replace defective, corroded, or loose fuses.

The fuses are located under the cover. To access the fuses, remove the screws fixing the cover and remove the cover. Then remove the cover caps of the fuse boxes.

22.7.2 FUSE ASSIGNMENT

1	Starter, stop magnet, socket	10A	Solenoid valves gear unit	10A
2	Inside lighting, radio	10A	Direction indicator, horn	10A
3	Hazard flasher	10A	Instrument lighting	10A
4	Windscreen wiper and windscreen washer front and rear	20A	Working light	20A
5	Brake light, reversing warning system, warning beacon	10A	Side lamp left, lamp registration number	10A
6	Fan, ventilation, heating	20A	Side lamp right	10A
7	Heated rear windscreen	20A	High beam	10A
8	Tank sensor, solenoid valves high speed-motor, ALS (option)	10A	Low beam	10A

22.7.3 SLOW-BLOWING FUSES

If the power supply fails, the reason for this may be that one of the slow-blowing fuses (1) has blown. Check the electrical system and replace defective fuses.

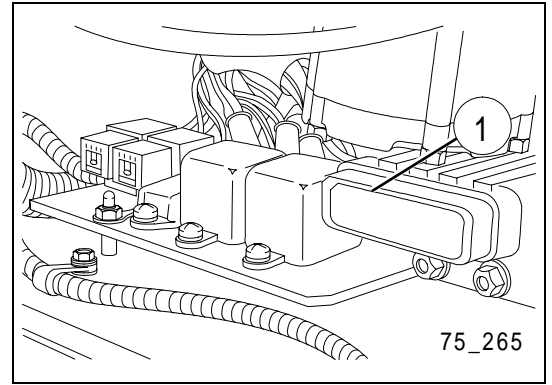

- F3 80A: Main Power Supply / Starter
- F4 50A: Intake Air Heater
- F5 30A: Engine Stop
- F6 70A: not assigned

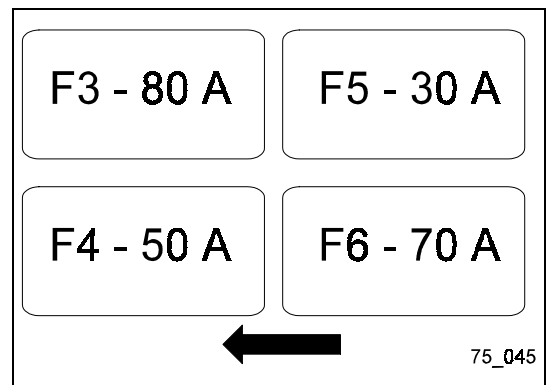

22.8 TIRES

22.8.1 TIRE COMPONENTS

- 1- Steel Cord Belt
- 2- Radial Carcass
- 3- Bead Core
- 4- Liner
- 5- Diagonal Carcass
- 6- Bead Cores

22.8.2 CHECKING THE TIRES

Particularly after work on rocky surfaces, check the tires for damage, wear and tear, and fissures. Tighten loose screws and nuts. For reasons of safety, replace the tires, if you detect one or several of the following faults:

- The bead core (3) is torn or buckled.
- The tire is excessively worn and more than a quarter of the carcass (5), not the liner (4), is exposed.
- The damage to the carcass (5) exceeds one third of the tire width.
- The single plies of the tire are separated.
- Radial fissures down to the carcass (5).
- Deformation or damage to such an extent that the tire cannot be used anymore.

22.8.3 CHECKING THE TIRE PRESSURE

When checking the tire pressure, pay attention to fissures, peeling, and unusual wear and tear. Remove nails, pieces of metal, and other undesired material from the tire.



WARNING

- **If the tire bursts or if the parts of a rim consisting of several parts come apart while the tire is being inflated, parts of the tire or rim may cause injury or damage to property!**
Use a tire-inflating hose with clamping device to inflate the tire. The hose must be long enough to ensure that you can stand erect next to the tire's tread. Stand next to the tire's tread when you inflate the tire. Before you inflate a removed tire, secure it by means of ropes, chains, or a protecting cage.
- **Improper work at tires and rims may cause severe injury or damage to property due to the high tire pressure!**
Repairs at wheels and tires must only be performed by trained experts.

The service life and performance of a tire depend very much on the tire pressure. Only correct tire pressures will protect the tires from damage.

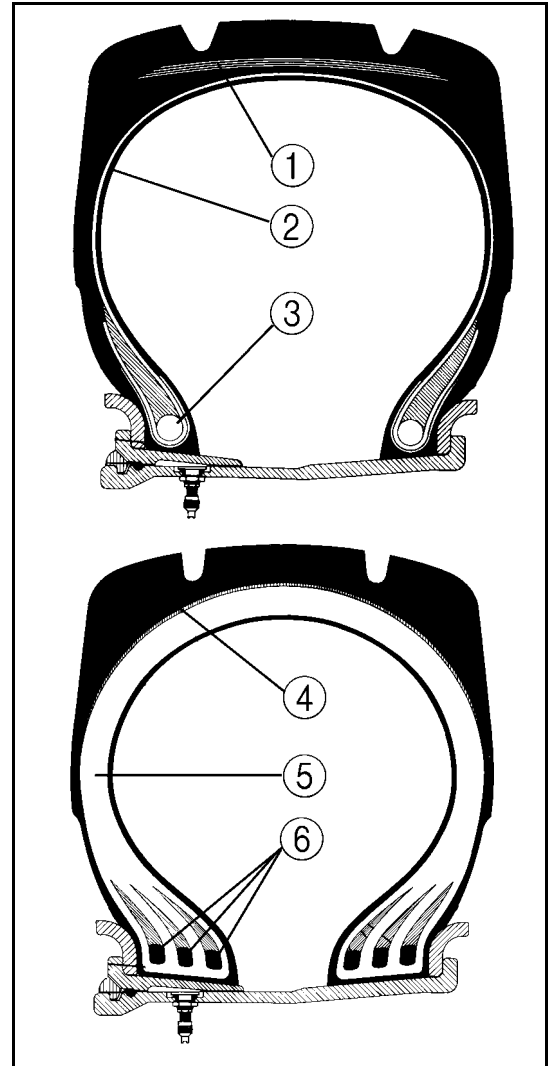

 **NOTE**

- Check that the machine is unloaded before you check the tire pressure.
- Prior to start of work, measure the tire pressure of the cold tires.

If the tire pressure is too low, the tire will be overloaded. If the tire pressure is too high, this will lead to formation of notches in the tire resulting in bursting of the tire when it is subjected to shock load. To avoid such damage, set the pressure of the tires according to the values given in the following table. If you are not sure, ask your tire dealer.

Do not deflate the tire when the tire pressure increases due to a rise in temperature. For this reason, check and set the tire pressure before you start work, i.e. when the tires are still cold.

TIRES			RECOMMENDED TIRE PRESSURE							
			on public roads				during operation			
Manufacturer	Size	Type	Front axle		Rear axle		Front axle		Rear axle	
			bar	psi	bar	psi	bar	psi	bar	psi
DUNLOP	12.5 - 20 MPT	10 PR TG32	1.5	22	1.75	26	2.75	40	1.5	22
DUNLOP	335/80 R20 EM	SP T9	1.5	22	2.25	33	3.0	44	1.5	22
DUNLOP	405/70 R18 EM	SP T9	1.5	22	2.0	29	2.5	37	1.5	22
DUNLOP	14.5 - 20 MPT	10 PR E91	1.5	22	1.75	26	2.0	29	1.5	22
MICHELIN	335/80 R20	X M27 TL	1.0	14.5	1.75	26	2.5	37	1.75	26
MICHELIN	405/70 R20	X M27 TL	1.0	14.5	1.5	22	2.25	33	1.5	22
MICHELIN	375/75 R20	X M27 TL	1.0	14.5	1.5	22	2.25	33	1.5	22
BRIDGE-STONE	17.5/65 - 20	10PR FG	1.0	14.5	1.2	17.5	2.0	29	1.5	22

If the tires are too soft, increase the tire pressure accordingly. The following degree of resilience (tire loaded/unloaded) of the front tires can be used as the guideline for the visual check.

- Transport of normal loads (horizontal position of boom): approx. 15 - 25%.
- Digging (rear wheels lifted off the ground): approx. 25-30%.

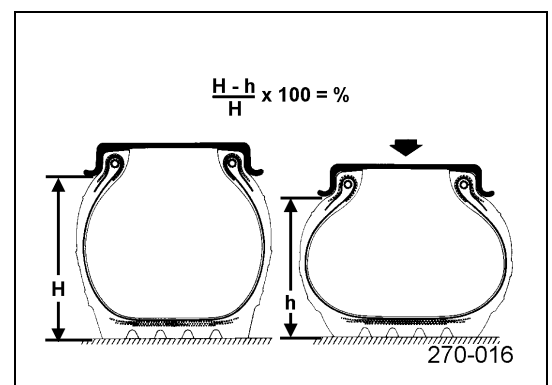

22.9 TOOLS

No.	Designation	Part No.	Remark
1	Set of Double-Ended Ring Spanners	42T-09-H0450 42T-09-H0460 42T-09-H0470 42T-09-H0440	Spanner Openings: 8/10 mm 13/15 mm 17/19 mm 24/27 mm
2	Screwdriver	421-98-H1120	
3	Screwdriver	421-98-H1110	
4	Hammer	421-98-H1140	
5	Bag	421-98-H1130	
6	Lever Type Hand Gun (Grease)	424-98-H1010	

22.10 TORQUE FOR STANDARD NUTS AND BOLTS

Provided that no other values are given, tighten the metric screws with a strength value of 10.9 and the nuts with a strength value of 10 applying the torques given in the tables.

The torque that must be applied depends on the diameter of the thread (a) and the size of the spanner (b) of both the nut and the screw.

Always replace nuts and screws by original parts. Dimensions and quality of replaced parts and original parts must be identical.



NOTE

- Do not apply excessive torque to plastic parts. Tighten plastic parts only manually.

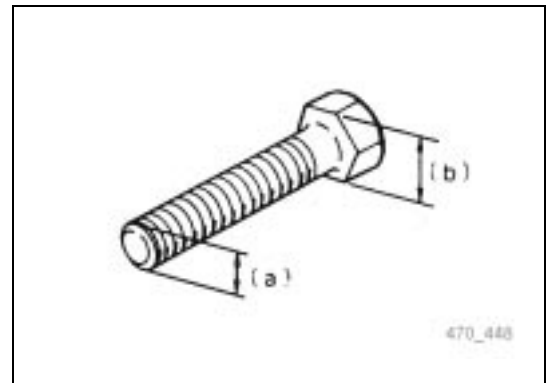

METRIC BOLTS COARSE-PITCH-THREAD - TENSILE STRENGTH CLASS 10.9					
Thread diameter of bolt mm	Width across flat mm	Steel		Aluminium Cast	
		Nm	kpm	Nm	kpm
(a)	(b)				
M6	10	14	1.4	7.7	0.77
M8	13	35	3.5	19.0	1.9
M10	17 (15)	70	7.0	37.0	3.7
M12	19	115	11.5	64.0	6.4
M14	22	185	18.5	101.5	10.15
M16	24	280	28.0	158.0	15.8
M18	27	390	39.0	218.0	21.8
M20	30	560	56.0	306.5	30.65
M22	32	750	75.0	416.0	41.6
M24	36	960	96.0	528.5	52.85
M27	41	1400	140.0	774.0	77.4
M30	46	1900	190.0	1053.0	105.3
M33	50	2600	260.0	-	-
M36	55	3300	330.0	-	-
M39	60	4300	430.0	-	-

METRIC FINE SCREW THREAD - TENSILE STRENGTH CLASS 10.9					
Thread diameter of bolt mm	Width across flat mm	Steel		Aluminium Cast	
		Nm	kpm	Nm	kpm
(a)	(b)				
M8 x 1	13	35	3.5	20.0	2.0
M10 x 1	17 (15)	75	7.5	42.0	4.2
M10 x 1.25	17 (15)	70	7.0	39.0	3.9
M12 x 1.25	19	125	12.5	70.0	7.0
M12 x 1.5	19	120	12.0	67.0	6.7
M14 x 1.5	22	200	20.0	110.0	11.0
M16 x 1.5	24	300	30.0	167.5	16.75
M18 x 1.5	27	440	44.0	243.0	24.3
M18 x 2	27	420	42.0	230.0	23.0
M20 x 1.5	30	620	62.0	338.5	33.85
M20 x 2	30	-	-	322.5	32.25
M22 x 1.5	32	820	82.0	454.5	45.45
M22 x 2	32	-	-	436.0	43.6
M24 x 1.5	36	1090	109.0	596.0	59.6
M24 x 2	36	1040	104.0	573.0	57.3
M27 x 2	41	1500	150.0	832.0	83.2
M30 x 2	46	2120	212.0	1158.0	115.8
M33 x 2	50	2800	280.0	-	-
M36 x 3	55	3500	350.0	-	-
M39 x 3	60	4600	460.0	-	-

23. MAINTENANCE SCHEDULE

24.	MAINTENANCE PRIOR TO START	141
24.1	• VISUAL CHECKS	141
24.2	• COOLING SYSTEM, CHECKING THE COOLANT LEVEL, TOPPING OFF COOLANT	141
24.3	• ENGINE, CHECKING THE OIL LEVEL, TOPPING OFF OIL	142
24.4	• ENGINE, DRAINING OFF OIL	143
24.5	• CHECKING THE FUEL LEVEL, REFUELING	144
24.6	• CHECKING THE CONTROLS	145
24.7	• CHECKING THE PARKING BRAKE	146
24.7.1	•• TEST CONDITIONS	146
24.7.2	•• TEST PROCEDURE	146
24.8	• CHECKING THE SERVICE BRAKE	146
24.9	• CHECKING THE ELECTRICAL CONNECTIONS	147
24.10	• OTHER MAINTENANCE MEASURES PRIOR TO START	147
25.	MAINTENANCE EVERY 10 OPERATING HOURS	148
25.1	• LUBRICATION	148
26.	MAINTENANCE AFTER THE FIRST 50 OPERATING HOURS	149
26.1	• ENGINE, CHANGING OIL AND REPLACING THE OIL FILTER CARTRIDGE	149
26.1.1	•• REPLACING THE OIL FILTER CARTRIDGE	150
26.2	• V-BELT, CHECKING THE CONDITION	151
26.3	• V-BELT, CHECKING AND ADJUSTING THE TENSION	151
26.4	• HYDRAULIC SYSTEM, REPLACING THE FILTER INSERT	152
26.5	• CHECKING AND TIGHTENING THE WHEEL NUTS	153
26.6	• FRONT AND REAR AXLE, CHANGING OIL	154
26.6.1	•• PLANET GEAR	154
26.6.2	•• DIFFERENTIAL	154
26.7	• TRANSFER GEAR - CHANGING OIL	155
27.	MAINTENANCE EVERY 50 OPERATING HOURS	156
27.1	• CHECKING THE COOLING SYSTEM, COOLANT LEVEL IN THE RADIATOR AND EXPANSION TANK	156
27.2	• DRAINING OFF WATER AND DIRT DEPOSITS FROM THE FUEL TANK	157
27.3	• CHECKING THE SERVICE BRAKE AND OIL LEVEL, REFILLING OIL	157
27.4	• CHECKING THE BATTERY AND ACID LEVEL	158
27.4.1	•• RE-CHARGING A BUILT-IN BATTERY	159
27.5	• LUBRICATION	160
27.5.1	•• LUBRICATING POINTS OF THE WORK EQUIPMENT	160
28.	MAINTENANCE EVERY 100 OPERATING HOURS	161
28.1	• DRAINING THE WATER SEPARATOR, REMOVING WATER AND DIRT DEPOSITS	161
29.	MAINTENANCE EVERY 250 OPERATING HOURS	162
29.1	• CHANGING THE ENGINE OIL AND OIL FILTER CARTRIDGE	162
29.2	• CHECKING THE V-BELT CONDITION	162
29.3	• CHECKING AND ADJUSTING THE V-BELT TENSION	162
29.4	• LUBRICATION	162
29.4.1	•• LUBRICATING POINTS OF THE STEERING CYLINDER	162
29.5	• FRONT AND REAR AXLE, CHECKING THE OIL LEVEL	163
29.5.1	•• PLANET GEAR	163
29.5.2	•• DIFFERENTIAL	163
29.6	• AIR FILTER, REMOVING AND RE-INSTALLING THE FILTER INSERT, CHECKING AND CLEANING THE FILTER INSERT	164
29.6.1	•• STRUCTURE OF THE AIR FILTER	164

MAINTENANCE SCHEDULE

29.6.2	•• MAINTENANCE DEMAND	164
29.6.3	•• REMOVING THE FILTER CARTRIDGE	164
29.6.4	•• CLEANING OR EXCHANGING THE FILTER CARTRIDGE	165
29.6.5	•• CHECKING THE FILTER CARTRIDGE	166
29.6.6	•• ASSEMBLING THE AIR FILTER CARTRIDGE	166
29.7	• CLEANING THE RADIATOR SEGMENTS	166
30.	MAINTENANCE EVERY 500 OPERATING HOURS	167
30.1	• CHANGING THE FUEL FILTER AND FILTER ELEMENT	167
30.1.1	•• BLEEDING THE FUEL SYSTEM	168
30.2	• CHANGING THE FILTER CARTRIDGE OF THE HYDRAULIC SYSTEM	169
30.3	• CLEANING THE WATER SEPARATOR	169
30.4	• LUBRICATION	170
30.5	• TRANSFER GEAR, CHECKING THE OIL LEVEL AND REFILLING OIL	170
30.6	• AIR FILTER, REPLACING THE FILTER INSERT, REPLACING THE SAFETY FILTER	171
30.6.1	•• REPLACING THE FILTER INSERT	171
30.6.2	•• REPLACING THE SAFETY FILTER	171
31.	MAINTENANCE EVERY 1000 OPERATING HOURS	172
31.1	• COOLING SYSTEM, EXCHANGING COOLANT AND CLEANING THE SYSTEM	172
31.1.1	•• DRAINING OFF THE COOLANT	172
31.1.2	•• CLEANING THE COOLING SYSTEM	173
31.1.3	•• FILLING OFF COOLANT	173
31.2	• FRONT AXLE, OIL CHANGE	174
31.3	• REAR AXLE, OIL CHANGE	174
31.4	• TRANSFER GEAR, OIL CHANGE	174
31.5	• SERVICE BRAKE	174
31.5.1	•• CHANGING OIL	174
31.5.2	•• CHECKING TUBES AND LINES	174
31.5.3	•• CHECKING THE BRAKE DISKS FOR WEAR AND TEAR	174
31.5.4	•• ADJUSTING THE CLEARANCE OF THE BRAKE DISKS	174
31.6	• CHECKING AND ADJUSTING SYSTEM PRESSURES	174
31.7	• CHECKING AND ADJUSTING THE VALVE CLEARANCE	174
31.8	• CHECKING AND ADJUSTING THE INJECTION NOZZLES, NOZZLE PRESSURE AND FUEL-JET PATTERN	174
32.	MAINTENANCE EVERY 2000 OPERATING HOURS	175
32.1	• HYDRAULIC SYSTEM, OIL CHANGE	175
32.2	• BLEEDING THE HYDRAULIC OIL TANK	176
32.3	• COOLING SYSTEM, CHECKING THE ANTIFREEZE CONTENT OF THE COOLANT	176
32.4	• CHECKING THE COOLING SYSTEM	176
32.5	• CHECKING THE FUEL PUMP	176
32.6	• CHECKING THE FUEL AND COOLANT TUBES, REPLACING THE TUBES (IF REQUIRED)	176
32.7	• CHECKING THE WATER PUMP	177
32.8	• CHECKING AND ADJUSTING THE FUEL INJECTION AND INJECTION TIME	177
32.9	• ENGINE, INTAKE VALVES AND OUTLET VALVES - GRINDING IN THE VALVE BASES	177

24. MAINTENANCE PRIOR TO START

24.1 VISUAL CHECKS

(refer to chapter "16. Preparing the Machine Start")

24.2 COOLING SYSTEM, CHECKING THE COOLANT LEVEL, TOPPING OFF COOLANT



CAUTION

- A wrong water/coolant mixing ratio will damage the radiator!
Always mix water and coolant in the ratio 50:50. This also applies to countries with a hot climate.
- Danger of fire! Coolant may be ignited by a hot engine!
Do not top off coolant, unless the engine has cooled down sufficiently.

- 1- Open the engine hood.
- 2- Check whether the coolant level in the expansion tank is between the FULL and LOW markings.
If the coolant level does not reach up to the LOW marking, top off coolant when the engine is cold.
- 3- Remove the cover cap of the overflow tank.
- 4- Top coolant until the level reaches up to the FULL marking.
- 5- After topping, firmly close the cover cap.
If the expansion tank is empty again after a short period of time, immediately have the cooling system checked for leaks and have any leaks repaired in the garage.

If the sub-tank must be topped, the coolant level in the cooler has to be checked.

(See chapter "27. Maintenance Every 50 Operating Hours")

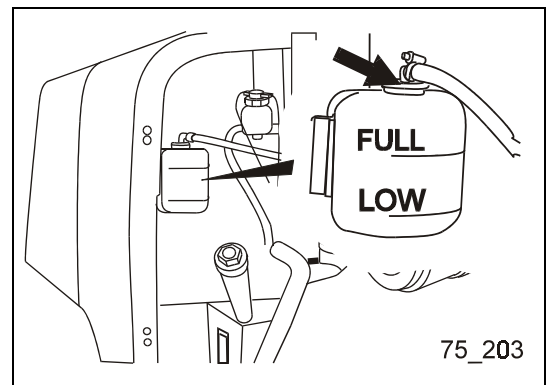

24.3 ENGINE, CHECKING THE OIL LEVEL, TOPPING OFF OIL

 **NOTE**

- After you have switched off the engine, wait at least 5 minutes before you check the engine oil level. The machine must stand on an even surface.

- 1- Pull out the oil dipstick (1) and wipe off the oil with a clean cloth.
- 2- Completely re-insert the oil dipstick and pull it out again after a few seconds. The oil level must be between the (H) and (L) markings on the oil dipstick.
- 3- If the oil level does not reach up to the (L) marking, top off engine oil.

For detailed information on recommended oils, see section "22.4 Lubricants and Operating Agents".

 **NOTE**

- Add only enough oil as needed - do not overfill.

- 4- Wait three minutes before you check the oil level again.
If the oil level is above the (H) marking, drain off some oil (see section "Engine, Draining Off Oil").
- 5- Close the oil filler (2).

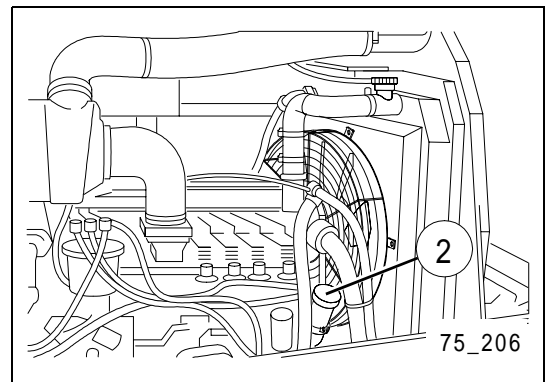
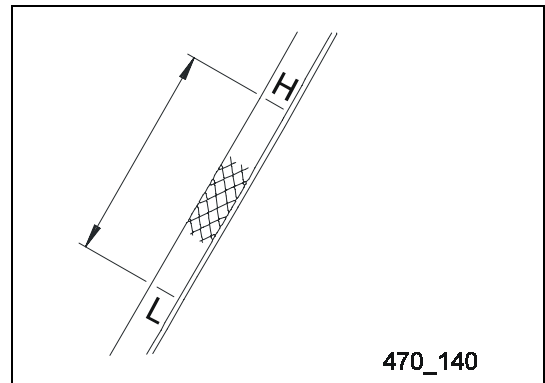
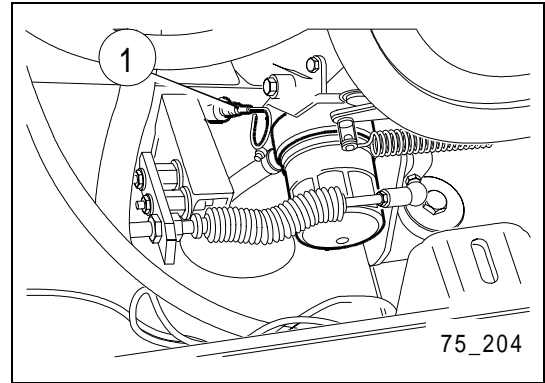

24.4 ENGINE, DRAINING OFF OIL

If you have topped off too much oil, you must drain off the excess oil. Have an oil trough with a sufficient capacity ready.

- 1- Loosen the screw (1) at the bottom cover plate (2) and swivel the cover plate to the side.
- 2- Put the oil trough to pan.
- 3- Remove the cover cap (3) of the drain screw.
- 4- Unscrew the drain screw (4).
- 5- Let the excess oil flow off.
- 6- Screw in the drain screw.
- 7- Check the oil level again.
- 8- Put on the cover cap.
- 9- Fasten the bottom cover plate with the screw.

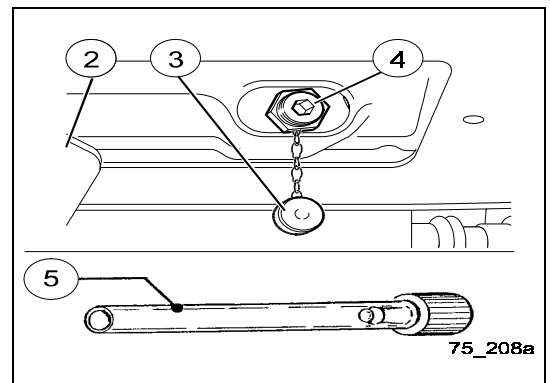
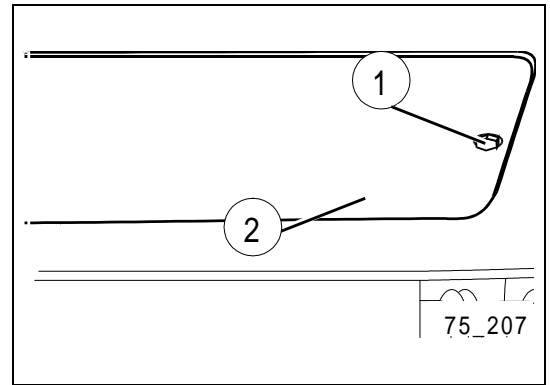

24.5 CHECKING THE FUEL LEVEL, REFUELING



- **Danger of fire! Fuel that has spilled over may ignite! Immediately remove fuel that has spilled over.**

- 1- Turn the start switch to the operating position 'I' and check the fuel level indicated on the fuel level indicator.
A - fuel tank full
B - fuel tank half-full
- 2- Then, return the start switch to the stop position '0'.
- 3- If required, refuel via the filler (1).
For detailed information on fuels, see section "22.4 Lubricants and Operating Agents".
- 4- After refueling, firmly close the filler.

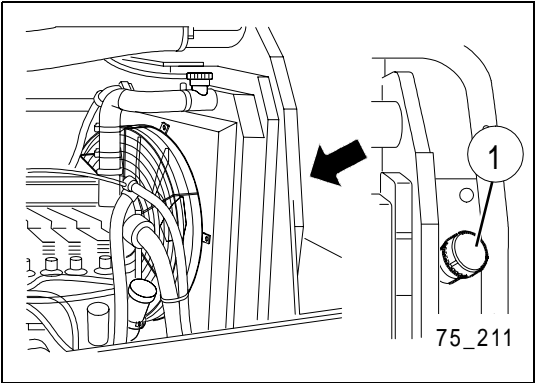
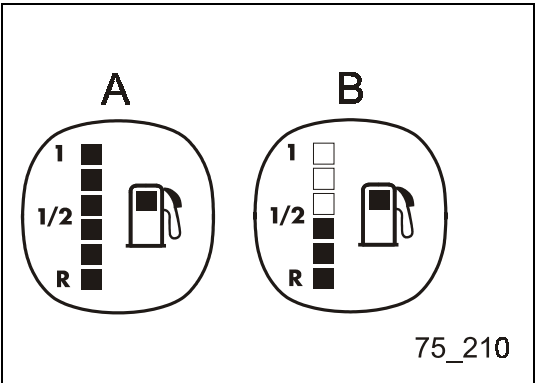
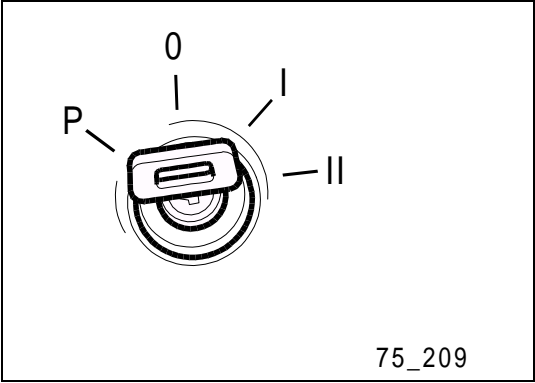

24.6 CHECKING THE CONTROLS

- 1 - Turn the start switch to the operating position 'I'.
An alarm buzzer sounds until the machine is started.
- 2 - Check that the following alarm and control indicators are on until the engine is started:
 - Charging current (1)
 - Engine oil level (2)
 - Parking brake (3)
 - Intake air preheater (4)
- 3 - Check that the fuel level indicator (5) indicates the fuel level in the fuel tank.



NOTE

- Contact your local Komatsu dealer, if one or several of the indicators do not light up.

Do not only use the indicators to perform the checks prior to start. Always perform the work described as regular maintenance, too.

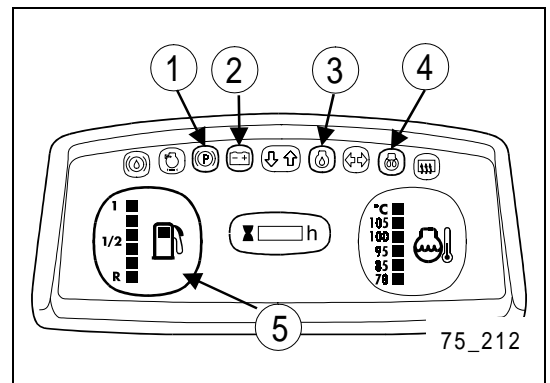
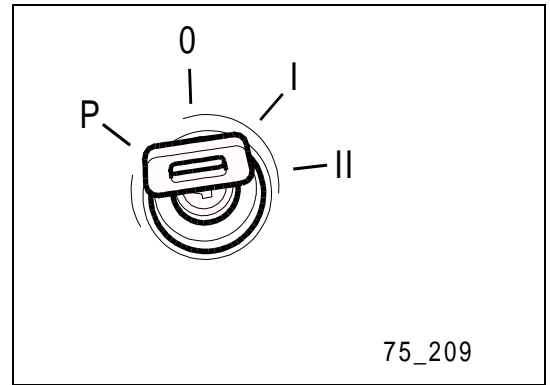

24.7 CHECKING THE PARKING BRAKE

24.7.1 TEST CONDITIONS

- Tire pressure: according to specification
- Road surface: dry, solid surface with a gradient of 18%
- Machine: ready for operation

24.7.2 TEST PROCEDURE

- 1- Start the engine, set the machine to straight driving, and drive the machine with an empty bucket up a gradient of 18%.
- 2- Stop the machine with the service brake and do not release your foot again to keep the service brake applied.
- 3- Lower the bucket.
- 4- Set the driving direction switch (1) to its neutral position 'N'.
- 5- Switch off the engine.
- 6- Apply the parking brake (2) and slowly release the pedal of the service brake.
The machine must stand still.

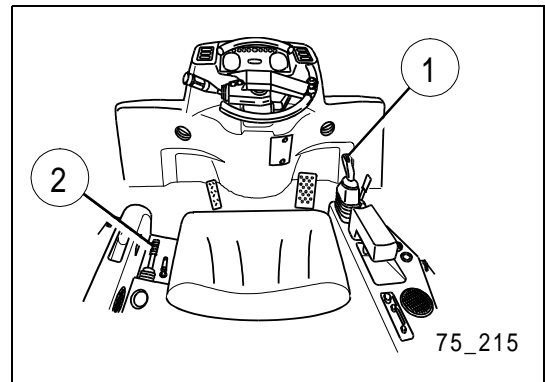
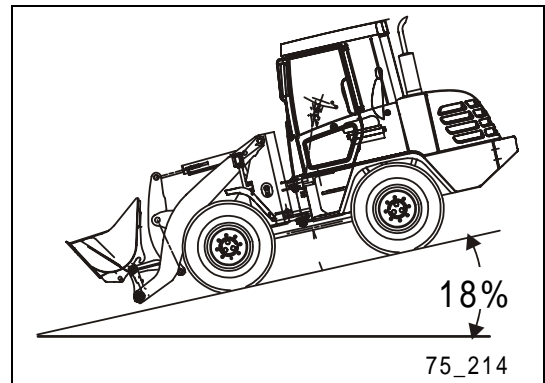
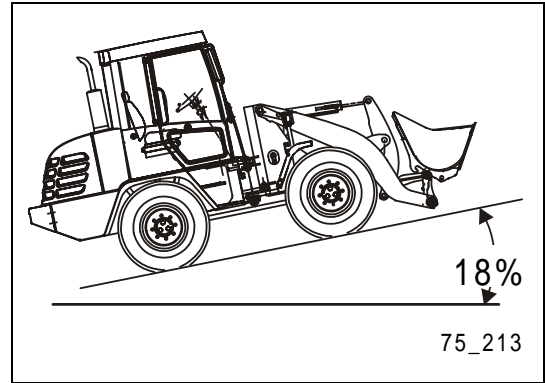

24.8 CHECKING THE SERVICE BRAKE



WARNING

- **Danger of accidents!**
Always put on the safety belt.

Drive the machine at maximum speed on a dry and even road and apply the service brake. For this purpose, release the accelerator pedal and quickly step on the brake pedal. The braking distance must not exceed 17 ft (5 m).

24.9 CHECKING THE ELECTRICAL CONNECTIONS



CAUTION

- **Danger of ignition! Inflammable material (leaves, twigs, grass, etc.) may ignite within the electrical system!**
Remove inflammable material from the electrical system.



NOTE

- **If a fuse blows, or if there are any signs of a short-circuit within the electrical system, inform your local Komatsu dealer.**

Regularly check that the terminals are fastened tightly, retighten loose terminals.

24.10 OTHER MAINTENANCE MEASURES PRIOR TO START

- Check that the brake oil level reaches up to the marking.
- Check that the contacts at the float of the brake oil container are tightened correctly.
- Check that the lighting equipment operates correctly; check it for dirt and damage.
- Check the measuring instruments.
- Check both the horn and the reversing warning horn.
- Check both clearance and operation of the steering wheel.
- Check the function of the rear-view mirror; check it for dirt and damage.

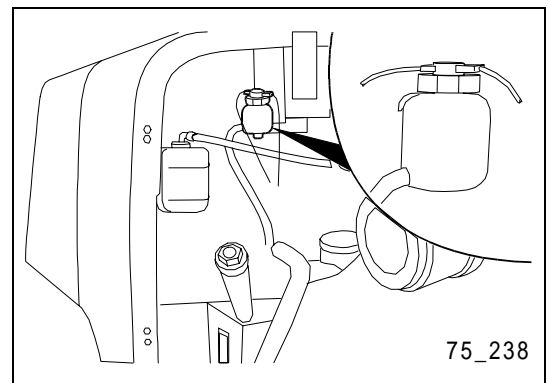

25. MAINTENANCE EVERY 10 OPERATING HOURS

25.1 LUBRICATION



DANGER

- There is danger of severe accidents, if you perform maintenance work at a machine that has not been parked and secured correctly!
Park the machine on a solid, even surface and secure it, before you start to perform maintenance work.

- 1- Before you start maintenance work, park and secure the machine as described in the chapter "11.2 Prior to Start of Maintenance Measures".
- 2- Clean the grease nipples marked by arrows.
- 3- Use a grease gun to fill the grease nipples with a sufficient volume of lubricating grease.
Articulated steering (3 points)
- 4- Remove the used lubricating grease that is pressed out of the bearings.



NOTE

- Perform lubrication more frequently, when working in a continually wet or salty environment.

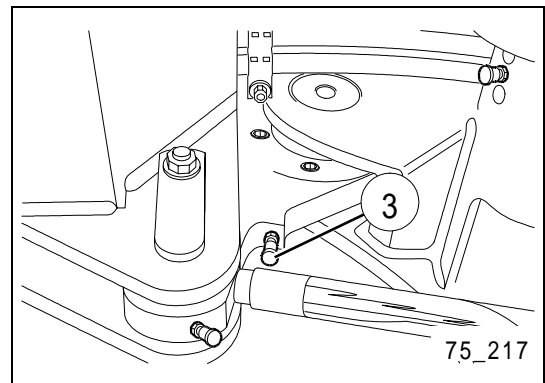
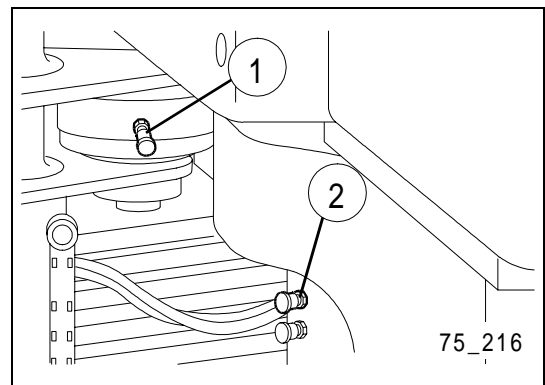
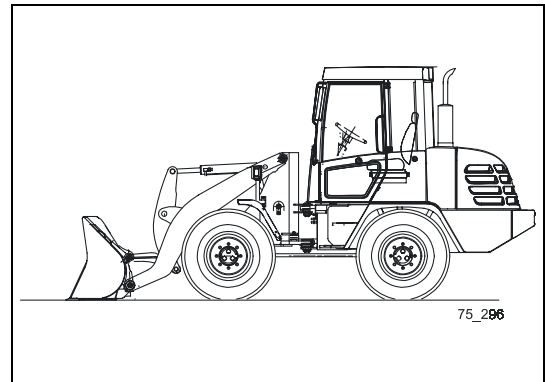

26. MAINTENANCE AFTER THE FIRST 50 OPERATING HOURS

All maintenance operations to be performed after 10 hours of operation also fall into this maintenance category.

26.1 ENGINE, CHANGING OIL AND REPLACING THE OIL FILTER CARTRIDGE



WARNING

- Frequent skin contact with used engine oil may cause skin lesions!
Thoroughly remove any engine oil adhering to your skin.
- Hot engine oil may cause scalding!
Wear rubber gloves and place the oil trough under the discharge opening in such a way that you do not get in contact with the oil when it is running out.



NOTE

- Do not perform an oil change, unless the engine is switched off and at operating temperature.



DANGER

- There is danger of severe accidents, if you perform maintenance work at a machine that has not been parked and secured correctly!
Park the machine on a solid, even surface and secure it, before you start to perform maintenance work.

- 1- Before you start maintenance work, park and secure the machine as described in the chapter "22.1 Preparing the Machine for Maintenance".
- 2- Loosen the screw (1) at the bottom cover plate (2) and swivel the cover plate to the side.
- 3- Put the oil trough under the drain screw (4).
- 4- Remove the cover cap (3) of the drain screw.
- 5- Screw the drain hose (5) onto the drain plug (4).
This will at the same time cause the drain valve to open.
- 6- Let the oil drain off into the oil trough.
- 7- Check the removed oil for metal parts or undesired material.
If the oil contains such particles, inform the local Komatsu dealer.
- 8- Remove the drain hose (5), this will cause the drain valve (4) to close.
- 9- Screw on the cover cap (3).
- 10- Fasten the bottom cover plate with the screw.

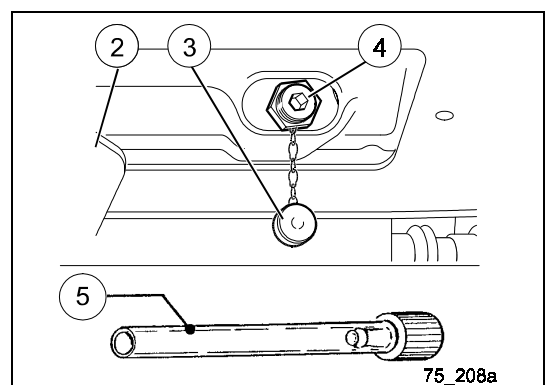
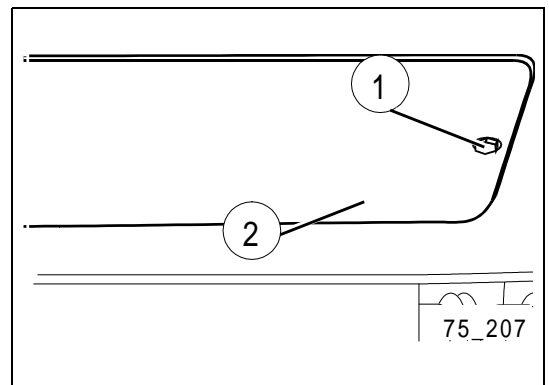

26.1.1 REPLACING THE OIL FILTER CARTRIDGE

- 11- Turn the filter screwdriver counterclockwise to unscrew the filter cartridge (1).
- 12- Clean the filter holder. Completely fill up the new filter cartridge with engine oil. Slightly oil both the gasket and the thread of the cartridge with engine oil. Screw in the filter cartridge again.
- 13- When installing the filter cartridge, make sure that the sealing surface of the cartridge slightly touches the filter holder. Then, tighten the filter cartridge according to the filter manufacturer's specification.
- 14- After replacing the filter cartridge, fill in clean engine oil until the oil level reaches up to the (H) marking on the oil dipstick. For details on recommended engine oils see section "22.4 Lubricants and Operating Agents".
- 15- Close the oil filler (2).
- 16- Let the engine run in idle for about five minutes and check whether oil is leaking out.
- 17- Switch off the engine.
- 18- Wait about ten minutes, then check the oil level again. The oil level must be between the 'H' and 'L' markings on the oil dipstick.
For further details see section "24. Maintenance Prior to Start".

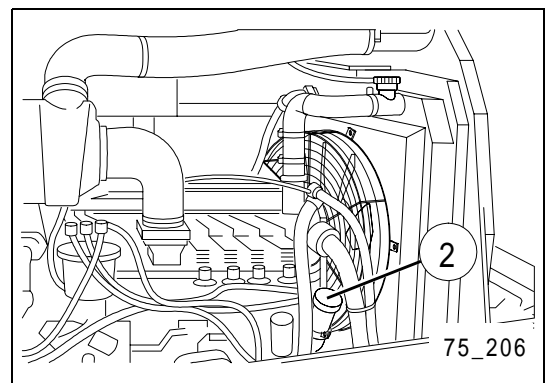
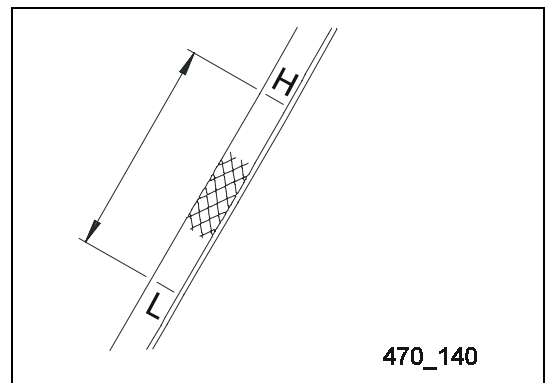
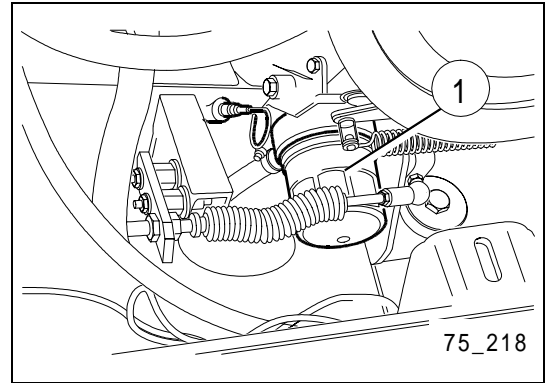

26.2 V-BELT, CHECKING THE CONDITION

Check the drive belt for fissures. Transversal fissures in direction of the belt width are permitted. Longitudinal fissures in direction of the belt length crossing transversal fissures, missing parts, or damaged tissue layers are not permitted. In these cases, replace the drive belt.

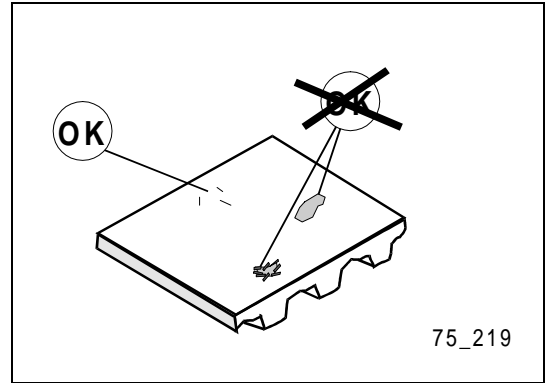

26.3 V-BELT, CHECKING AND ADJUSTING THE TENSION



DANGER

- **There is danger of severe accidents, if you perform maintenance work at a machine that has not been parked and secured correctly!**
Park the machine on a solid, even surface and secure it, before you start to perform maintenance work.

1- Before you start maintenance work, park and secure the machine as described in the chapter "22.1 Preparing the Machine for Maintenance".



WARNING

- **Danger of injuries! When the engine is in operation, there is danger of severe injuries by moving parts within the engine compartment!**
Do not work within the engine compartment, while the engine is in operation.

2- Press down the V-belt in the middle of the longest straight part. You should be able to press the V-belt down about 0.394 in (10 mm) to 0.591 in (15 mm).

If you can press down the V-belt more than 0.394 in (10 mm) to 0.591 in (15 mm), adjust the tension as follows:

- 3- Loosen the fastening screw (1) at the generator.
- 4- Loosen the connecting screw (2) between the generator and the guide rail.
- 5- Loosen the fastening screw (3) at the guide rail.
- 6- Tilt the generator to adjust the tension of the V-belt.
- 7- Fasten the generator and the guide rail.
- 8- Check the tension of the V-belt and re-adjust it, if required.

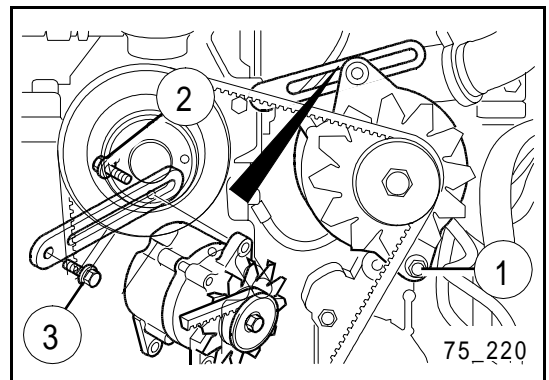

26.4 HYDRAULIC SYSTEM, REPLACING THE FILTER INSERT



WARNING

- **Frequent contact between used hydraulic oil and skin may cause skin lesions and other physical damage! Wear rubber gloves when changing the filter. Thoroughly wash off any hydraulic oil adhering to your skin.**

- 1- Lower the work equipment onto the floor.
- 2- Park the machine.
- 3- Turn the inlet and ventilation screw (1) several revolutions to let the pressure escape.
- 4- Clean the surface of the filter cap (2) and the area around the filter cap.
- 5- Unscrew the filter cap.
- 6- Pull out the filter element (3) at the handle (4) .
- 7- Pull the filter element off the handle and dispose of the filter element.
- 8- Clean the inner surface of the filter housing. Before you start cleaning, check that there is no undesired material in the filter housing.
- 9- Put the handle onto the new filter element.
- 10- Insert the new filter element into the housing.
- 11- Screw on the filter cap and tighten it with 2.039 kgm (20 Nm).
- 12- Ventilate the system at the tank according to the specification (see "32.2 Bleeding the Hydraulic Oil Tank").
- 13- Perform a test run and check that the system is tight.

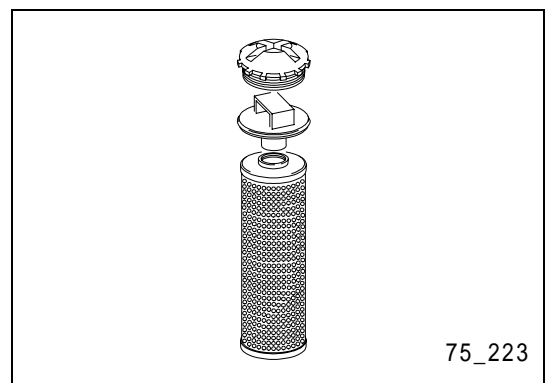
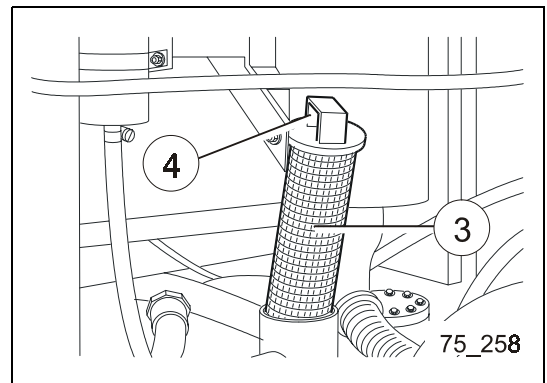
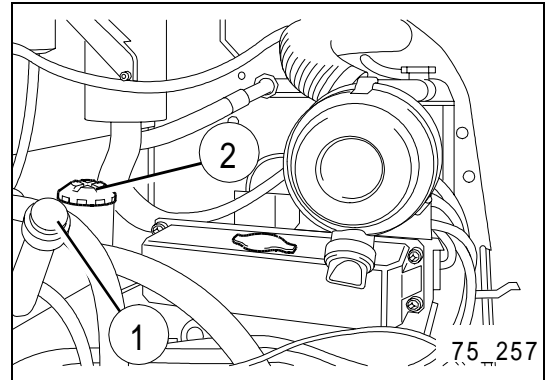

26.5 CHECKING AND TIGHTENING THE WHEEL NUTS



WARNING

- **Loose wheel nuts may cause severe accidents!**
Regularly check and tighten the wheel nuts.
-

Retight loose nuts.

Tightening torque: 45.89 kgm to 50.989 kgm
(450 - 500 Nm)



NOTE

- **If a threaded bolt breaks, replace all threaded bolts of the respective wheel.**
-

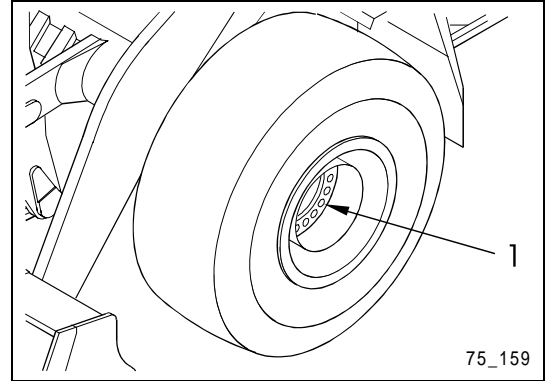

26.6 FRONT AND REAR AXLE, CHANGING OIL



WARNING

- **Frequent contact between used hydraulic oil and skin may cause skin lesions and other physical damage! Wear rubber gloves when changing the oil. Thoroughly wash off any hydraulic oil adhering to your skin.**



DANGER

- **There is danger of severe accidents, if you perform maintenance work at a machine that has not been parked and secured correctly! Park the machine on a solid, even surface and secure it, before you start to perform maintenance work.**

Before you start maintenance work, park and secure the machine as described in the chapter "22.1 Preparing the Machine for Maintenance".

26.6.1 PLANET GEAR

- 1- Move the machine until the check drill hole (1) of the planet gear at the wheel that you want to check is in its bottom position.
- 2- Put the oil trough under the oil discharge hole.
- 3- Unscrew the screw plug (1) and let the oil flow off.
- 4- Turn the wheel to bring the drill hole of the planet gear into horizontal position.
- 5- Top up the planet gear with oil, until the oil reaches up to the bottom edge of the check drill hole.
- 6- Clean the screw plug and replace the gaskets.
- 7- Re-tighten firmly the screw plug.
- 8- Change the oil in the planet gear for the other wheel as described under the points 3 through 7.

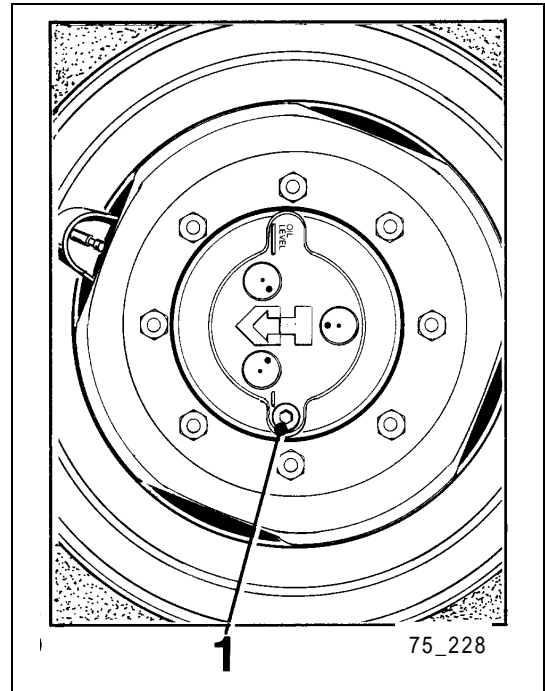

26.6.2 DIFFERENTIAL

- 1- Unscrew the screw plugs (1) and (2) at the front axle and let the oil flow off.
- 2- Clean the screw plugs and replace the gaskets.
- 3- Re-tighten firmly the screw plug.
- 4- Top up with oil, until the oil reaches up to the bottom edge of the check drill hole of screw plug (2).
- 5- Re-tighten firmly the screw plug (2).
- 6- Unscrew the screw plugs (4) and (5) at the rear axle and let the oil flow off. Then, proceed as described under points 2 through 5 in the section dealing with the front axle.

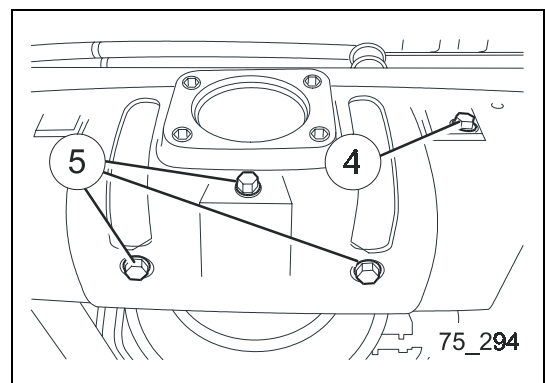
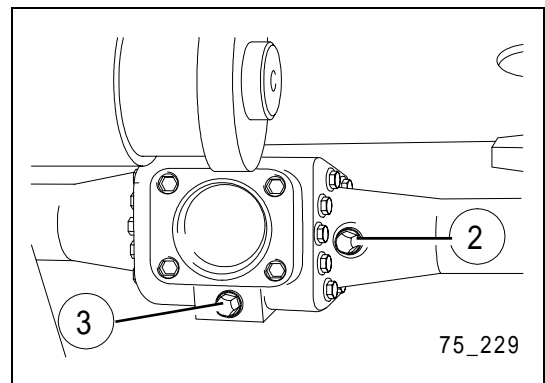

26.7 TRANSFER GEAR - CHANGING OIL



WARNING

- Frequent contact between used hydraulic oil and skin may cause skin lesions and other physical damage!
Wear rubber gloves when changing the oil. Thoroughly wash off any hydraulic oil adhering to your skin.
- Hot engine oil may cause scalding!
Wear rubber gloves and place the oil trough under the discharge hole in such a way that you do not get in contact with the oil when it is running out.



DANGER

- There is danger of severe accidents, if you perform maintenance work at a machine that has not been parked and secured correctly!
Park the machine on a solid, even surface and secure it, before you start to perform maintenance work.

Have an oil trough with a sufficient capacity ready.

Perform an oil change with the gear unit at operating temperature.

- 1- Before you start maintenance work, park and secure the machine as described in the chapter "22.1 Preparing the Machine for Maintenance".
- 2- Clean the surfaces of the screw plugs (1) and (2) and the area around the screw plugs.
- 3- Unscrew the screw plugs.
- 4- Let the oil flow off.
- 5- Clean the screw plugs and replace the gaskets.
- 6- Tightly screw in the screw plug (2).
- 7- Fill in oil via the check drill hole (1), until the oil reaches up to the bottom edge of the check drill hole.
- 8- Tightly screw in the screw plug (1).

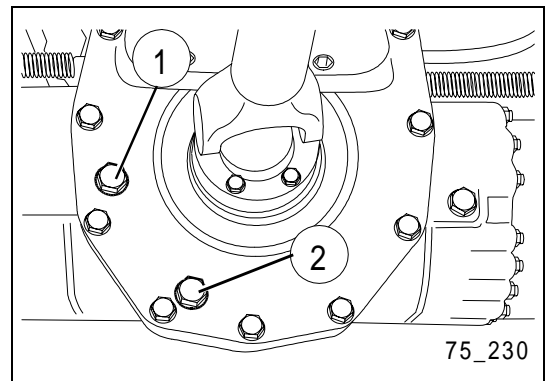

27. MAINTENANCE EVERY 50 OPERATING HOURS

All maintenance operations to be performed after 10 hours of operation also fall into this maintenance category.

27.1 CHECKING THE COOLING SYSTEM, COOLANT LEVEL IN THE RADIATOR AND EXPANSION TANK



WARNING

- **Danger of scalding!** The coolant is pressurized when the engine is hot. Hot coolant can spray out, when opening the radiator cap.
Check the coolant level only, when the engine has cooled down. Somewhat turn the cap (arrow) slowly to release the pressure.



DANGER

- **Fire!** The anti-freeze can ignite when it contacts hot engine parts.
Wait until the engine has cooled before topping off with anti-freeze.

- 1- Stop the engine and let it cool down.
- 2- Open the engine cover.
- 3- Turn the radiator cap (arrow) slowly to the first stop and let the pressure escape. Then press the cap down and turn further to remove.
- 4- Check that the radiator is filled up to the overflow with coolant. If not then top off to the overflow with coolant.
- 5- After topping off, fit the radiator cap and tighten.
- 6- Check that the coolant level in the expansion tank is between the marks full and low.
- 7- Top off to the full mark if required.
- 8- After topping off, refit the tank cap and tighten.

When coolant has been topped off:

- Start the engine and fully open the heater.
- Run the engine until warm. Check points 1 to 5 again.



NOTE

- If coolant has to be topped off regularly in the radiator or expansion tank, then the system should be checked by your local Komatsu dealer and repaired if required.

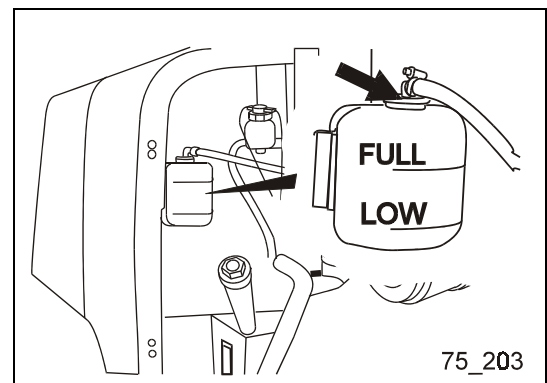
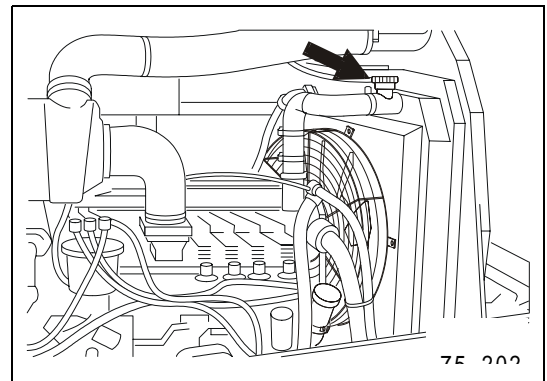

27.2 DRAINING OFF WATER AND DIRT DEPOSITS FROM THE FUEL TANK

- 1- Place a container under the drain plug of the fuel tank (see arrow).
- 2- Open the drain plug, drain off water and dirt.
- 3- Close the drain plug when clean fuel starts to leak out.

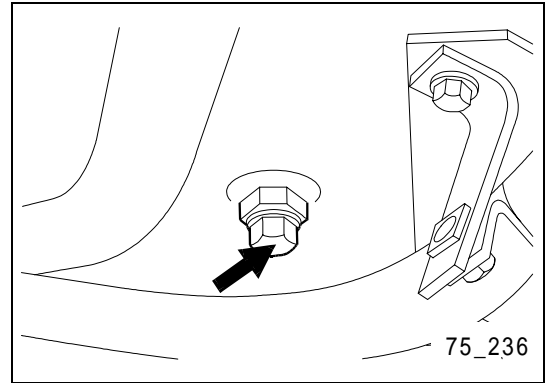

27.3 CHECKING THE SERVICE BRAKE AND OIL LEVEL, REFILLING OIL



WARNING

- **Danger of accidents! If the oil level is too low, the service brake may break down!**
If the brake fluid supply control lamp (1) lights up, you must immediately stop and check the oil level.



CAUTION

- **Danger of accidents! If you use usually available brake fluid for filling up, the operational efficiency of the brake system may be impaired!**
Use only the prescribed oil for filling up! Do not use brake fluid! Pay attention to utmost cleanness!

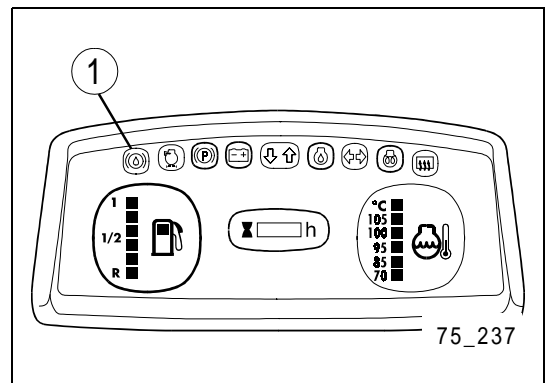

- 1- For maintenance operations, park and secure machine as described in chapter "22.1 Preparing the Machine for Maintenance".
- 2- Check the brake fluid level at the expansion tank. The oil level must be 0.394 in (10 mm) to 0.787 in (20 mm) below the upper edge of the expansion tank (marking).
- 3- If the oil level is too low, fill prescribed oil into the expansion tank.
For detailed specifications, see section "22.4 Lubricants and Operating Agents".
- 4- If you detect a significant oil loss, inform your local Komatsu dealer.

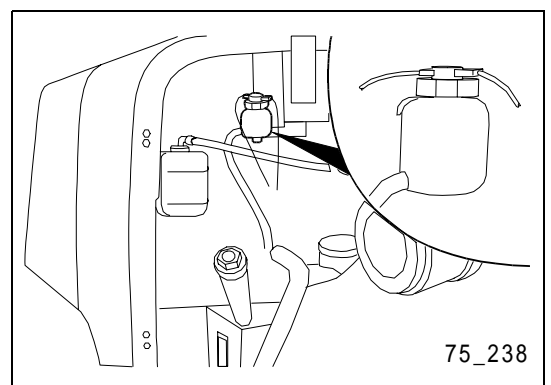

27.4 CHECKING THE BATTERY AND ACID LEVEL



DANGER

- **Danger of injury!** The battery contains highly toxic battery acid which may squirt out and burn your eyes!
Use goggles and rubber gloves if you work on the battery. Immediately rinse your eyes or skin using plenty of water and immediately seek medical attention.
- **Gases which may explode can form inside in the battery!**
Do not come with open fire or sparks into proximity of the battery. Do not smoke.

- 1- For maintenance operations, park and secure the machine as described in chapter "22.1 Preparing the Machine for Maintenance".
- 2- Check the battery and pole terminals for proper fit.
- 3- Clean the environment of the plugs.
- 4- Remove all plugs and check whether the battery acid is at the acid level markings. Refill distilled water if the acid level is too low.



NOTE

- **In cold weather, refill distilled water only immediately before starting the machine. The water can then mix with the battery acid and does not freeze.**

- 5- Measure the specific density of the battery acid and read off the battery charging using the following conversion table.

BATTERY	TEMPERATURE			
	20°C / 68°F	5°C / 41°F	-10°C / 14°F	-25°C / -13°F
Charge	Specific density (kg/l)			
full	1.28	1.29	1.30	1.31
half empty	1.20	1.21	1.22	1.23
empty	1.12	1.13	1.14	1.15

- 6- Recharge insufficiently charged batteries.
- 7- Lock the cells with the cleaned plugs. Re-Charging the Battery

27.4.1 RE-CHARGING A BUILT-IN BATTERY

- Disconnect the cable of the negative pole before re-charging or pull the battery main switch, in order to interrupt the power supply. Otherwise, the alternator will be damaged due to high voltage peaks.
- Remove all battery plugs before re-charging to ensure sufficient ventilation. To prevent gas explosions, do not come near the battery with fire and do not produce any sparks.
- Interrupt the charging process if the temperature of the battery acid exceeds 113°F (45° C).
- Switch off the battery charger, as soon as the battery is re-charged.
If the battery is overloaded, the following situations may occur:
 - 1 - The battery may be overheated
 - 2 - Decrease in the battery acid volume
 - 3 - Damage of the electrode plates.
- Do not mix up the cables (positive (+) and negative (-)).
- Before performing maintenance operations, remove all cables from the battery poles. Only exceptions: acid level check or the measurement of the specific density.

27.5 LUBRICATION

27.5.1 LUBRICATING POINTS OF THE WORK EQUIPMENT



DANGER

- If you perform maintenance operations at a machine which is not properly parked and secured, severe accidents may occur!
Park the machine on firm, level ground and secure it before starting the maintenance operations.

- 1- Park and secure machine for the maintenance operations as described in chapter "22.1 Preparing the Machine for Maintenance".
- 2- Clean the grease nipples which are indicated by the arrows.
- 3- Use a grease gun to press sufficient grease into the grease nipples.

Lifting cylinder (1)	(2 locations)
Rocker arm (2)	(1 location)
Boom (3)	(2 locations)
Tipping cylinder (4)	(2 locations)
Quick-change unit (5)	(3 locations)
Clamshell bucket (6)	(3 locations)

- 4- Remove the old grease which is extruding at the bearings.



NOTE

- If you operate in humid conditions or in a salty environment, you must reduce the lubricating intervals.

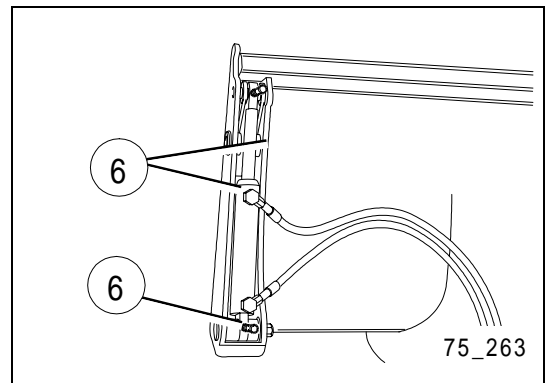
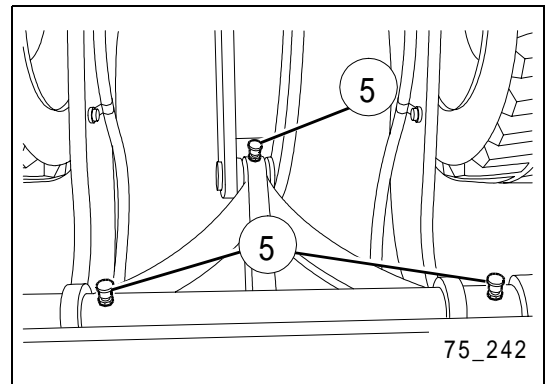
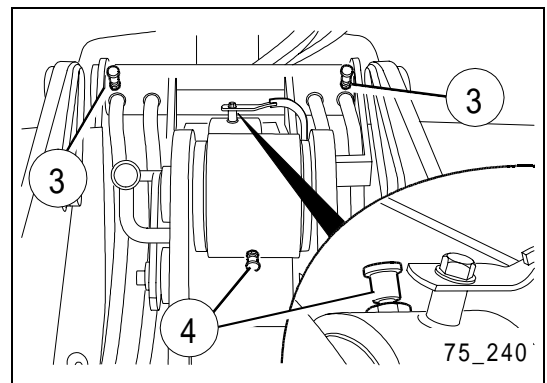
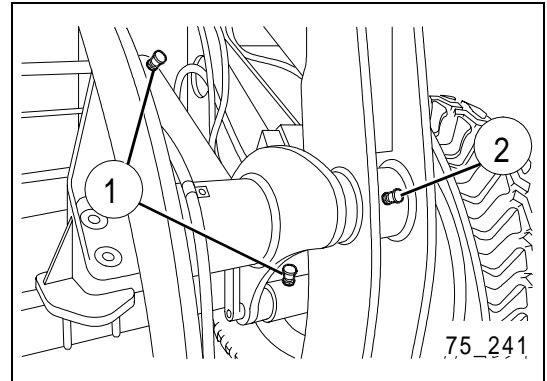

28. MAINTENANCE EVERY 100 OPERATING HOURS

All maintenance operations to be performed after 10 and 50 hours of operation fall also into this maintenance category.

28.1 DRAINING THE WATER SEPARATOR, REMOVING WATER AND DIRT DEPOSITS

Keep a container ready for collecting the liquid from the water separator (1).

- 1 - Screw out the drain plug (2).
- 2 - Let the water run off.
- 3 - Screw in the drain plug and tight it.
- 4 - Check for tightness.

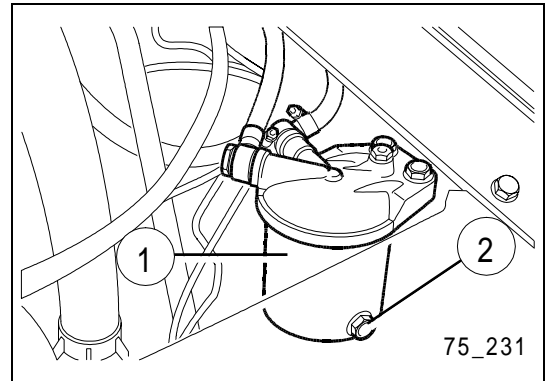

29. MAINTENANCE EVERY 250 OPERATING HOURS

All maintenance operations to be performed after 10, 50 and 100 hours of operation also fall into this maintenance category.

29.1 CHANGING THE ENGINE OIL AND OIL FILTER CARTRIDGE

See chapter "26. Maintenance After the First 50 Operating Hours".

29.2 CHECKING THE V-BELT CONDITION

See chapter "26. Maintenance After the First 50 Operating Hours".

29.3 CHECKING AND ADJUSTING THE V-BELT TENSION

See chapter "26. Maintenance After the First 50 Operating Hours".

29.4 LUBRICATION

29.4.1 LUBRICATING POINTS OF THE STEERING CYLINDER



DANGER

- If you perform maintenance operations at a machine which is not properly parked and secured, severe accidents may occur!

Park the machine on firm, level ground and secure it before starting the maintenance operations.

- 1- For maintenance operations, park the machine as described in chapter "22.1 Preparing the Machine for Maintenance".
- 2- Clean the grease nipples which are indicated by the arrows.
- 3- Use a grease gun to press sufficient grease into the grease nipples.
- 4- Remove the old grease which is extruding at the bearings.

Front steering cylinder (1)	(1location)
Rear steering cylinder (2)	(1 location)

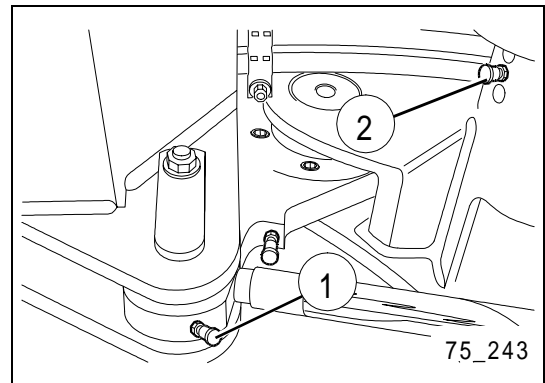

NOTE

- If you operate in humid conditions or in a salty environment, you must reduce the lubricating intervals.

29.5 FRONT AND REAR AXLE, CHECKING THE OIL LEVEL



- There is danger of severe accidents, if you perform maintenance work at a machine that has not been parked and secured correctly!
Park the machine on a solid, even surface and secure it, before you start to perform maintenance work.

Before you start maintenance work, park and secure the machine as described in the chapter "22.1 Preparing the Machine for Maintenance".

29.5.1 PLANET GEAR

- 1- Move the machine until the oil level marking at the planetary gearing of the wheel which you are checking is in horizontal position.
- 2- Unscrew the locking screw (1) of the drill hole.
- 3- Check the oil level. The oil level must reach up to the bottom edge of the check drill hole.
- 4- If the oil level is too low, top off oil via the check drill hole of the screw plug.
For details on recommended oils, see section "22.4 Lubricants and Operating Agents".
- 5- Tightly screw in the screw plug.
- 6- Check the oil level at the other wheel of the front and rear axle. For this purpose, proceed as described under points 2 through 5.

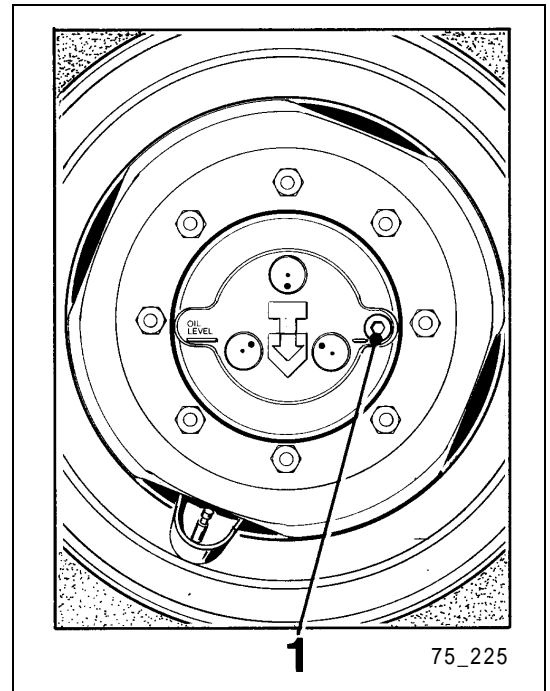

29.5.2 DIFFERENTIAL

- 1- Unscrew the locking screw (2) of the drill hole at the front axle. Check the oil level as described under points 3 through 5 in section "29.5.1 Planet gear".
- 2- Unscrew the locking screw (2) of the drill hole at the rear axle. Check the oil level as described under points 3 through 5 in section "29.5.1 Planet gear".

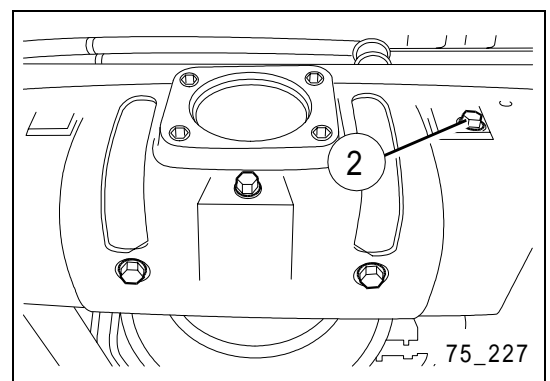
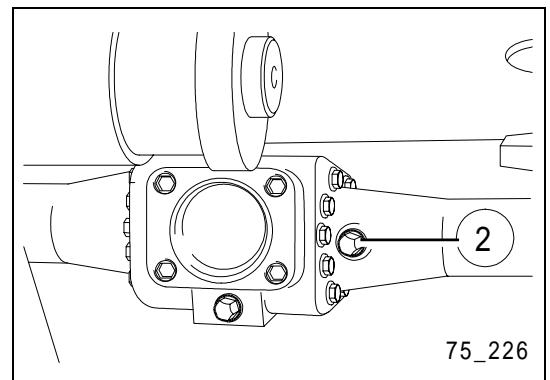

29.6 AIR FILTER, REMOVING AND RE-INSTALLING THE FILTER INSERT, CHECKING AND CLEANING THE FILTER INSERT

29.6.1 STRUCTURE OF THE AIR FILTER

The air filter consists of the air filter housing, the dust exhaust valve, the filter cartridge and the safety filter.

29.6.2 MAINTENANCE DEMAND

If the air filter warning indicator (1) lights up, the air filter cartridge is dirty. You must clean or exchange it immediately.

The filter insert has to be checked for perfect condition and be cleaned every 250 operating hours, no matter whether the control light is lit or not. If the filter insert is damaged or deformed, it must be exchanged.

A dirty safety filter indicates that the filter cartridge is damaged. In this case, both - filter cartridge and safety filter - must be exchanged.

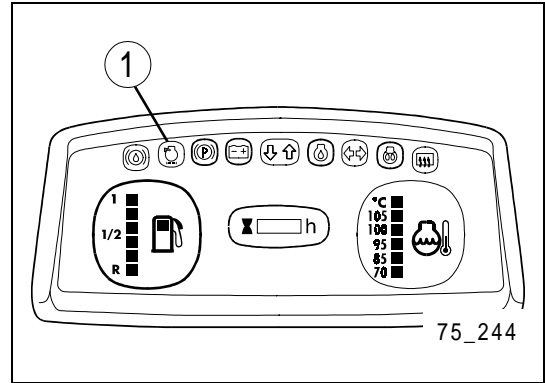

29.6.3 REMOVING THE FILTER CARTRIDGE



WARNING

- **Danger of injury! When the engine is running, you may hurt yourself on the movable components inside the engine room!**
Do not perform any operation in the engine room with the engine running!

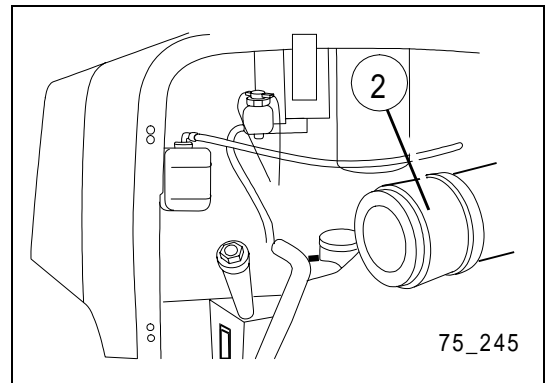

- 1- For maintenance operations, park and secure machine as described in chapter "22.1 Preparing the Machine for Maintenance".
- 2- Open the twistlocks on the cover of the air filter housing (2).
- 3- Remove the cover of air filter housing.
- 4- Pull out the filter cartridge (3).

Clean thoroughly the interior of the filter housing with a cloth.

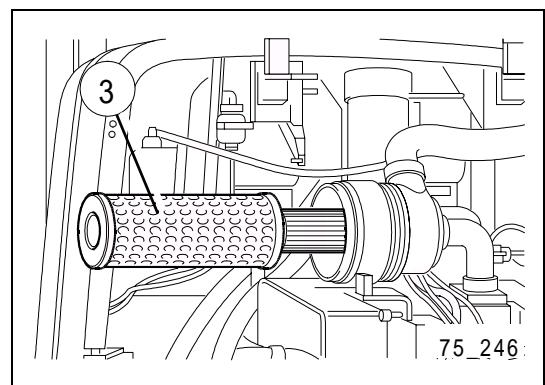

29.6.4 CLEANING OR EXCHANGING THE FILTER CARTRIDGE

Depending on the degree of contamination, the air-filter insert can be cleaned using compressed air or water to which a mild detergent can be added.



NOTE

- The air-filter insert must be replaced, if the air-filter control light lights up only short time after cleaning.
- Do not clean the safety filter (refer to chapter "30.6 Air Filter, Replacing the Filter Insert, Replacing the Safety Filter").

a) *Cleaning with compressed air*



CAUTION

- Whirled up dust particles may hurt the eyes!
Use goggles if you clean the filter cartridges with compressed air.
- Dangerous dust particles may irritate the lung!
Use a dust-protection mask if you clean the filter cartridges with compressed air.

Blow out the air filter cartridge with dry compressed air (max. 6 bars) starting with the interior and then proceeding to the outside. The air nozzle is to be moved up and down the paper with a minimum distance of 1.181 in (3 cm). You can stop the cleaning if no more dust comes out.

Do not clean the cartridge by hitting it or by beating it against other objects.

b) *Cleaning with water and cleaning agents*

After the dust has been blown out, the filter cartridge can also be additionally cleaned using warm water with a mild cleaning agent max. 122°F (50°C) to remove adhering oil, grease, soot, etc. For this purpose, swing the cartridge back and forth in the solution.

Then, rinse the filter cartridge with clean water starting with the inside and then proceeding to the outside (max. 3 bars) and let it dry at a temperature of max. 122°F (50°C).

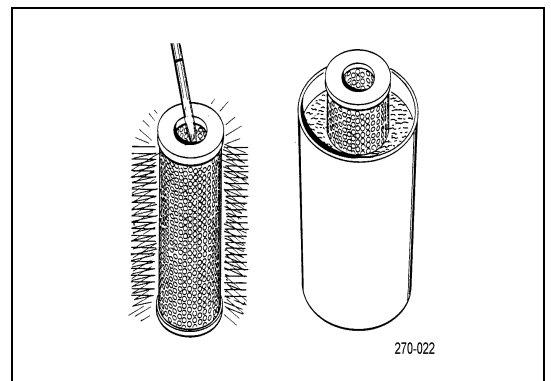

29.6.5 CHECKING THE FILTER CARTRIDGE

Usually, it is required to check each air filter cartridge before it is re-installed. For this purpose, insert a lamp into the cartridge and visually check the filter paper against the transmitted light. If you detect small holes or spots on which the paper is thin, the insert is defective and must be replaced.

Check filter cartridges for damaged seals.



- Also new filter cartridges must be checked before they are assembled.

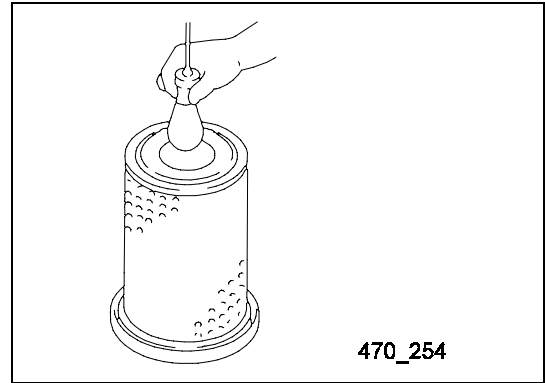

29.6.6 ASSEMBLING THE AIR FILTER CARTRIDGE

- 1- Check the safety filter for proper fit.
- 2- Insert the filter cartridge into filter housing in such a way that the seal of the insert locks firmly on the collar of the housing rear panel.
- 3- Assemble the air filter cap.



- If the control lamp lights up again after a short time, you must replace both, the air filter cartridge and the safety filter.

29.7 CLEANING THE RADIATOR SEGMENTS

The radiator segments must be checked daily and cleaned with compressed air, if required.



- Do not hold the compressed air nozzle or water nozzle too close to the radiator segments. Do not use a scrubber for cleaning since the plates may be damaged.

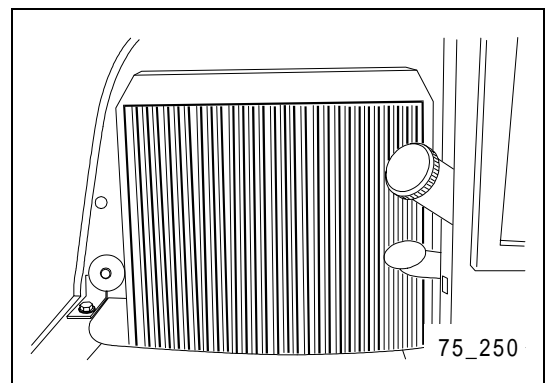

30. MAINTENANCE EVERY 500 OPERATING HOURS

All maintenance operations to be performed after 10, 50, 100 and 250 hours of operation also fall into this maintenance category.

30.1 CHANGING THE FUEL FILTER AND FILTER ELEMENT



DANGER

- **Danger of fire! Fuel may ignite on hot surfaces!**
Only change the filter elements if the engine has sufficiently cooled down. Stay away with open fire or sparks while handling with fuel. Do not smoke.

- 1- For maintenance operations, park and secure machine as described in chapter "22.1 Preparing the Machine for Maintenance".
- 2- Clean the area around the fuel filter (1).
- 3- Unscrew the filter element counterclockwise with the filter screwdriver.
- 4- Clean the filter head.
- 5- Fill up the new filter element with clean fuel.
- 6- Lubricate the sealing faces of the filter element lightly with engine oil.
- 7- During reassembly, re-tighten the filter element manually, until the seal is fitting. Then re-tighten the filter element.
 (Consider the specifications of the filter manufacturer on the filter).
- 8- Then purge the fuel system.
 (see section "30.1.1 Bleeding the Fuel System").
- 9- Start the engine and check for leaks.

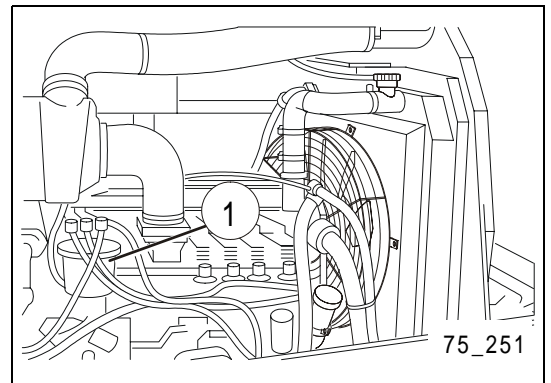

30.1.1 BLEEDING THE FUEL SYSTEM



DANGER

- Fuel in the injection system is under pressure. Use goggles and rubber gloves if you work on the injection pump. If you are hit by a high-pressure fuel stream, immediately seek medical attention.

- 1- For maintenance operations, park and secure machine as described in chapter "22.1 Preparing the Machine for Maintenance".
- 2- Loosen the vent screw (1) at the water separator.
- 3- Unlock the fuel pump (2) by pressing the cover down and swivelling it out of the way.
- 4- Operate fuel pump until bubble-free fuel leaks out at the vent screw.
- 5- Re-tighten the vent screw.
- 6- Loosen the vent screw (4) at the fuel filter (3).
- 7- Operate the fuel pump until bubble-free fuel leaks out at the vent screw.
- 8- Re-tighten vent screw.
- 9- Re-lock the cover of the fuel pump.

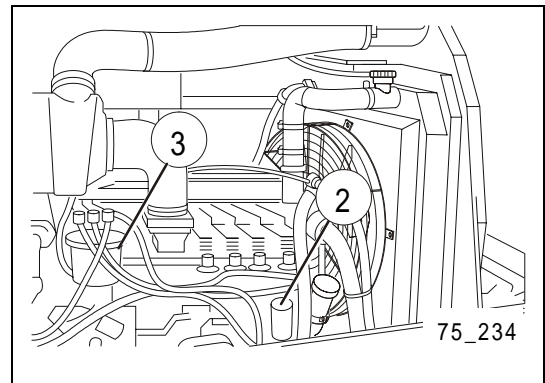
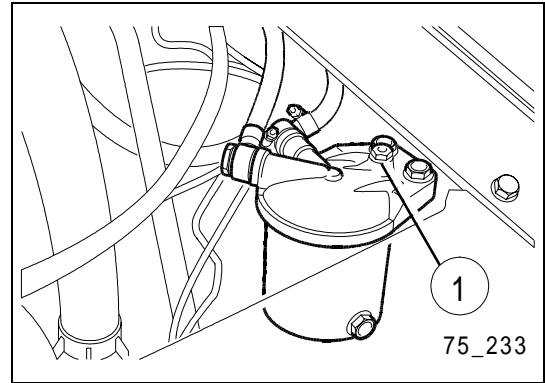

WARNING

- Danger of injury! When the engine is running, you may hurt yourself on the movable components inside the engine room. Do not perform any operation in the engine room with the engine running.

- 10- Start up the engine and bleed the lines, one after the other, while engine is running until the engine is running regularly.



IMPORTANT

- If the fuel system has run empty during driving, or if repairs or maintenance operations are to be performed, it is necessary to bleed the system.

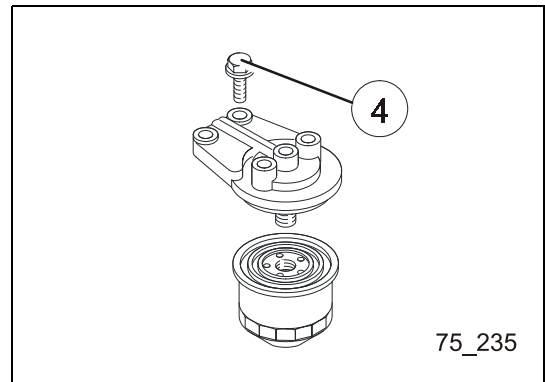

30.2 CHANGING THE FILTER CARTRIDGE OF THE HYDRAULIC SYSTEM

See chapter „Maintenance After the First 50 Operating Hours“.

30.3 CLEANING THE WATER SEPARATOR

Keep a container ready for collecting the liquid from the water separator (1).

- 1 - Loosen the drain plug (2).
- 2 - Let the water and fuel run off.
- 3 - Loosen the screw (4) at the bottom side.
- 4 - Remove the housing (5) from the cover.
- 5 - Remove the gasket (6).
- 6 - Remove the filter element (7), the gasket (8) and the spiral spring (9).
- 7 - Remove water and dirt from the housing.
- 8 - Clean the filter element and blow-dry it with compressed air.
- 9 - Check the filter element and replace it, if it is damaged.
- 10 - Re-insert the spiral spring, the gasket (8) and the filter element.
- 11 - Position the gasket (6) and the housing.
- 12 - Insert a new o-ring (10).
- 13 - Re-tighten the drain plug at the bottom side.
- 14 - Remove the attachment screw (3).
- 15 - Fill up the water separator with fuel.
- 16 - Re-tighten firmly the attachment screw.

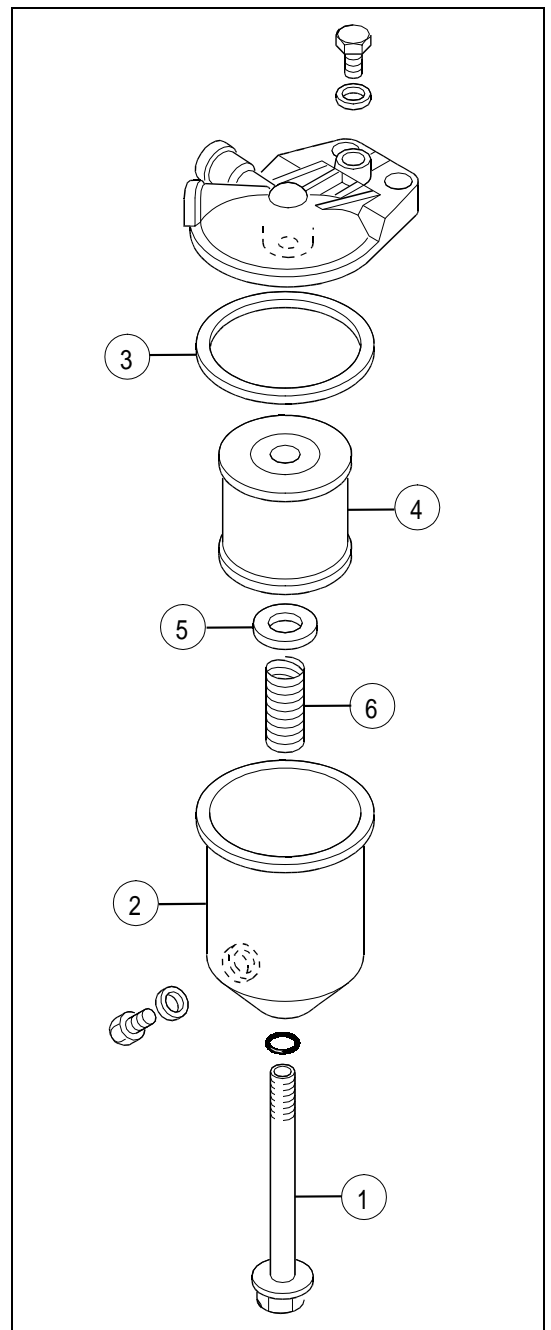
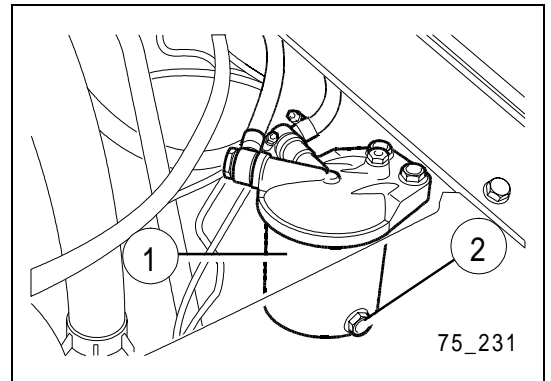

30.4 LUBRICATION



DANGER

- **If you perform maintenance operations at a machine which is not properly parked and secured, severe accidents may occur!**
Park the machine on firm, level ground and secure it before starting the maintenance operations.

-
- 1- For maintenance operations, park and secure machine as described in chapter "22.1 Preparing the Machine for Maintenance".
 - 2- Clean the grease nipples.
 - 3- Use a grease gun to press sufficient grease into the grease nipples.
 - 4- Remove the old grease which is extruding at the bearings.
 - Door hinges (4 locations)
 - Bonnet hinges (2 locations)

30.5 TRANSFER GEAR, CHECKING THE OIL LEVEL AND REFILLING OIL



NOTE

- **If the engine is not running, the oil level in the transfer box can significantly rise. Therefore, only check the gear oil level with the engine running idle at operating temperature. The gearshift assembly must be in neutral position.**



DANGER

- **Danger of injury! When the engine is running, you may hurt yourself on the movable components inside the engine room!**
Do not perform any operation in the engine room with the engine running.

-
- 1- For maintenance operations, park and secure machine as described in chapter "22.1 Preparing the Machine for Maintenance".
 - 2- Clean the screw plug (1) and the adjacent environment.
 - 3- Unscrew the screw plug.
 - 4- Check the oil level. The oil level must be at the lower edge of the control drill hole of the screw plug.
 - 5- If the oil level is too low, fill up with oil using the control drill hole of the screw plug.
 - 6- Clean the screw plug and insert a new packing ring.
 - 7- Re-tighten firmly the screw plug.

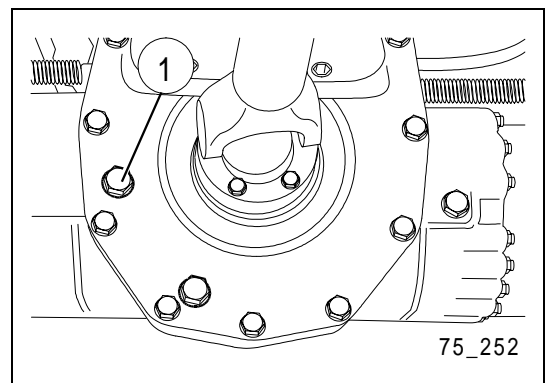

30.6 AIR FILTER, REPLACING THE FILTER INSERT, REPLACING THE SAFETY FILTER

30.6.1 REPLACING THE FILTER INSERT



NOTE

- If the filter element is replaced for the third time in sequence, it is required to replace also the safety filter.

- 1- Open the air filter and remove the air-filter insert (1). Proceed as described in chapter "29.6 Air Filter, Removing and Re-Installing the Filter Insert, Checking and Cleaning the Filter Insert".
- 2- Use a lamp to check the new air filter for damages.
- 3- Re-install the air-filter insert as described in chapter "29.6 Air Filter, Removing and Re-Installing the Filter Insert, Checking and Cleaning the Filter Insert".

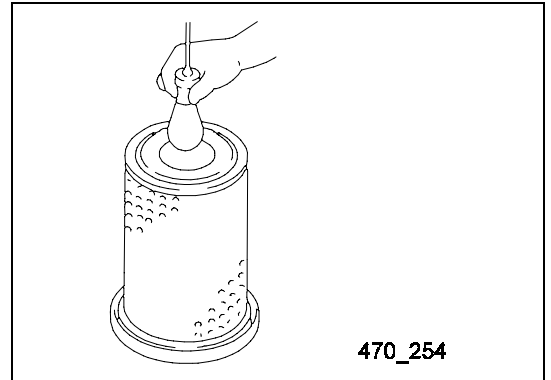

30.6.2 REPLACING THE SAFETY FILTER



NOTE

- If the filter element is replaced for the third time in sequence, it is required to replace also the safety filter.

- 1- Open the air filter and remove the air-filter insert (1). Proceed as described in chapter "29.6 Air Filter, Removing and Re-Installing the Filter Insert, Checking and Cleaning the Filter Insert".
- 2- Pull out the safety filter (2).
- 3- In order to prevent that dust enters the interior of the engine, it is required to the air aspiration opening of the engine with a clean cloth or similar.
- 4- Clean the interior of the air-filter enclosure and **remove the cloth from the air aspiration opening.**
- 5- Use a lamp to check the new safety filter for damages. If it is in perfect condition, press it firmly into place.
- 6- Re-install the air-filter insert as described in chapter "29.6 Air Filter, Removing and Re-Installing the Filter Insert, Checking and Cleaning the Filter Insert".

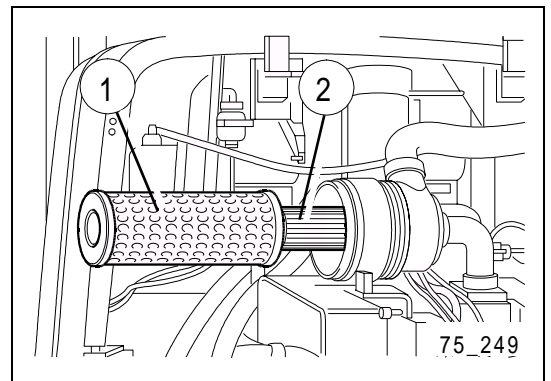

31. MAINTENANCE EVERY 1000 OPERATING HOURS

All maintenance operations to be performed after 10, 50, 100, 250 and 500 hours of operation fall also into this maintenance category.

31.1 COOLING SYSTEM, EXCHANGING COOLANT AND CLEANING THE SYSTEM



WARNING

- **Danger of being burnt! The coolant is under pressure if the engine is hot. Hot coolant may squirt out during opening.**

Check the coolant level only after the engine has sufficiently cooled down. Open the cover of the radiator (arrow) by turning it slowly so that the pressure can escape.



DANGER

- **Danger of fire! Antifreeze may ignite at the hot engine! Wait until the engine has cooled down, before refilling antifreeze.**



NOTE

- **The coolant must be exchanged after max. of two years.**
- **While preparing the coolant, make sure to adhere to the prescribed mixing proportions to ensure a freezing protection up to -34.6°F (-37°C)! This is also valid for areas with moderate climate.**

The coolant has to consist of 50 vol.% coolant additive and 50 vol.% water. Only monoethylene glycol and diethylene glycol are permitted as coolant additives which are both contained in commercially available standard coolants.

If the water contains too much lime, the cooling system may be impaired. In this case, use a mixture of potable water and distilled or deionized water.

31.1.1 DRAINING OFF THE COOLANT

- 1- Switch off the engine and let it cool down.
- 2- Turn the radiator cap (arrow) slowly to the side, up to the first fixed stop, and let the pressure escape. Then press down the cover, while proceeding with swivelling. Then, remove the cover.
- 3- Stretch a tube onto the drain opening (1) of the discharge cock and insert the other tube end into the collecting container.
- 4- Open the discharge cock and let the coolant run off.
- 5- Close the discharge cock.

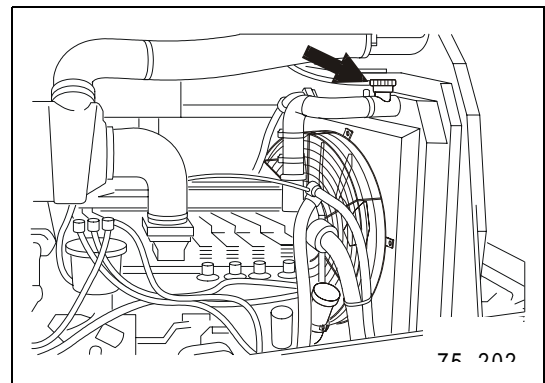
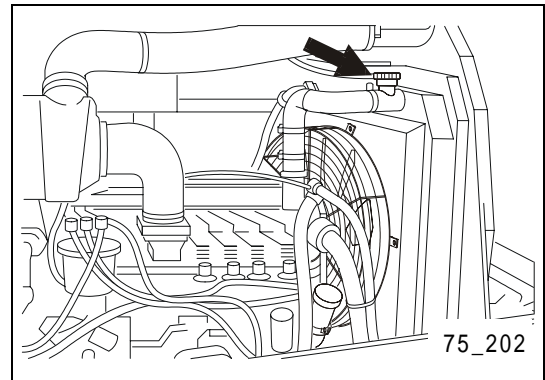

31.1.2 CLEANING THE COOLING SYSTEM



- **The cooling system may only be filled slowly since otherwise the included air cannot escape completely. After filling up, wait approx. 3 minutes and refill liquid, if required.**

- 6- Fill up the cooling system slowly with cleaning fluid (Adhere to the specifications of the cleaning agent manufacturer).
- 7- With the radiator cap opened, let the engine run for 5 minutes with a coolant temperature of approx. 176°F (80°C).
- 8- After the cleaning, switch off the engine and open the drain valve to let the entire cooling system run empty. Re-lock the drain valve and slowly fill the cooling system with clean water.
- 9- Let the engine run for five minutes with a coolant temperature of approx. 176°F (80° C).
- 10- Then, let the cooling system run empty again. If the extruding water is not clean, the cooling system must be re-flushed until the extruding water is clean.
- 11- Close the drain valve.

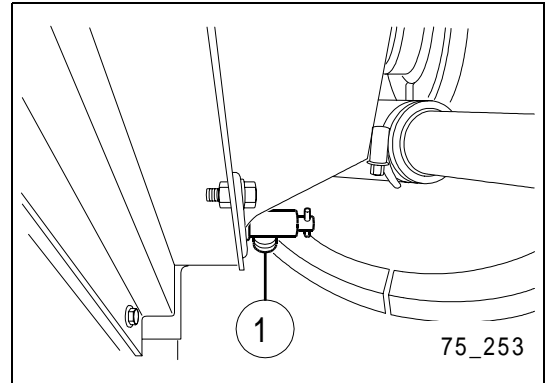

31.1.3 FILLING OFF COOLANT

- 12- Empty and clean the expansion tank.
- 13- Prepare the coolant as prescribed.
- 14- Fill off the coolant slowly into the cooling system up to the overflow shoot of the radiator.
- 15- To bleed the cooling system while the radiator cap is removed, let the engine run idle for five minutes with its lower speed (rpm) and then for another five minutes with its top speed. Fill off with coolant if the coolant level in the radiator is dropping.
- 16- Switch off the engine, wait approx. three minutes and then refill coolant up to overflow shoot of the radiator. Re-lock the radiator.
- 17- Fill off coolant into the expansion tank, until the coolant level is between the FULL and LOW markings.

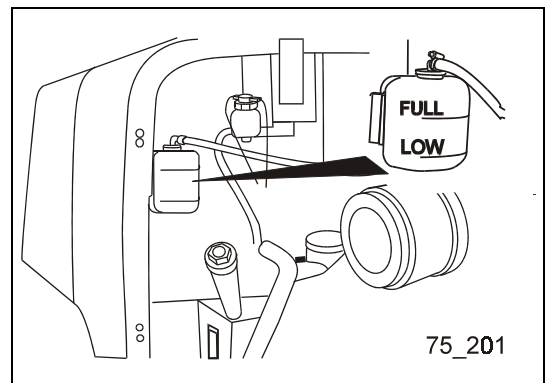

31.2 FRONT AXLE, OIL CHANGE

See chapter "26. Maintenance After the First 50 Operating Hours".

31.3 REAR AXLE, OIL CHANGE

See chapter "26. Maintenance After the First 50 Operating Hours".

31.4 TRANSFER GEAR, OIL CHANGE

See chapter "26. Maintenance After the First 50 Operating Hours".

31.5 SERVICE BRAKE



NOTE

- All repairs on the brake system must be performed by your local Komatsu dealer.
-

31.5.1 CHANGING OIL

31.5.2 CHECKING TUBES AND LINES

31.5.3 CHECKING THE BRAKE DISKS FOR WEAR AND TEAR

31.5.4 ADJUSTING THE CLEARANCE OF THE BRAKE DISKS

31.6 CHECKING AND ADJUSTING SYSTEM PRESSURES



NOTE

- All repairs on the brake system must be performed by your local Komatsu dealer.
-

31.7 CHECKING AND ADJUSTING THE VALVE CLEARANCE



NOTE

- Have the valve play checked and adjusted at your local Komatsu dealer.
-

31.8 CHECKING AND ADJUSTING THE INJECTION NOZZLES, NOZZLE PRESSURE AND FUEL-JET PATTERN



NOTE

- Have the nozzle pressure of the injection nozzles and the fuel-jet pattern checked and adjusted at your local Komatsu dealer.
-

32. MAINTENANCE EVERY 2000 OPERATING HOURS

All maintenance operations to be performed after 10, 50, 100, 250, 500 and 1000 hours of operation also fall into this maintenance category.

32.1 HYDRAULIC SYSTEM, OIL CHANGE



WARNING

- Frequent skin contact with used hydraulic oil may cause skin damages and other injuries!
Use rubber gloves for exchanging the filter. Wash any spilled hydraulic oil thoroughly from your skin.
- Danger of being burnt! The hydraulics tank is under pressure. Hot hydraulic oil may squirt out and cause injuries!
Use rubber gloves and hold the oil trough under the discharge hole in such a way that you cannot come into contact with the extruding oil.

Keep a collecting container with sufficient capacity ready.

- 1- Park the machine on level ground.
- 2- Lower the work unit onto the ground.
- 3- Switch off the engine.
- 4- Secure the articulated steering with the articulated steering lock (1).
- 5- Unlock the feeding and ventilation screw (2) by turning it slowly to let the pressure escape.
- 6- Loosen the screw plug (4) of the hydraulic oil tank and let the oil run off.
- 7- Re-tighten the screw plug with its seal being in perfect condition.
- 8- Unscrew the feeding and ventilation screw.
- 9- Fill up oil until the oil level is between the center and top edge of the inspection glass (3).
- 10- Start up the engine.
- 11- Raise and lower the work equipment several times, while operating the bucket at the same time.
- 12- Lower the bucket onto the ground and bring it into mining position.
- 13- Check the oil level with the engine running idle in its low speed position.
- 14- Ventilate the hydraulic oil tank (see section "32.2 Bleeding the Hydraulic Oil Tank").



NOTE

- Do not fill up with too much hydraulic oil! Otherwise, the pressure in the hydraulic oil container increases to very dangerous levels.

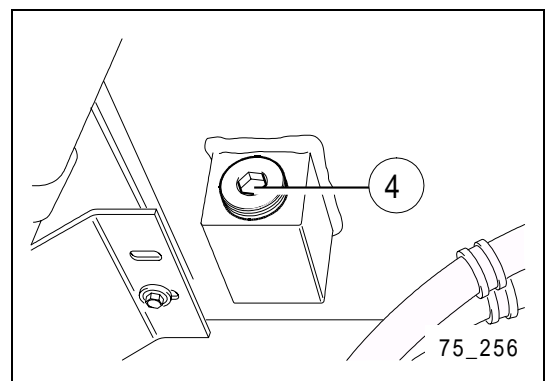
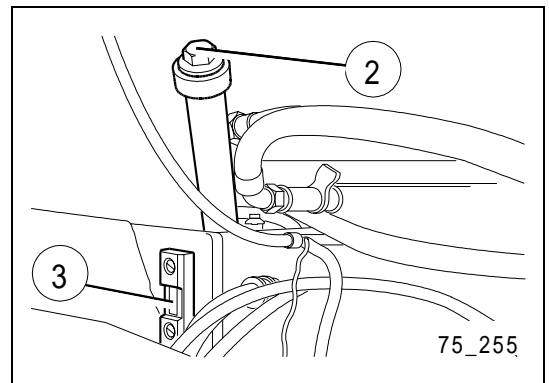
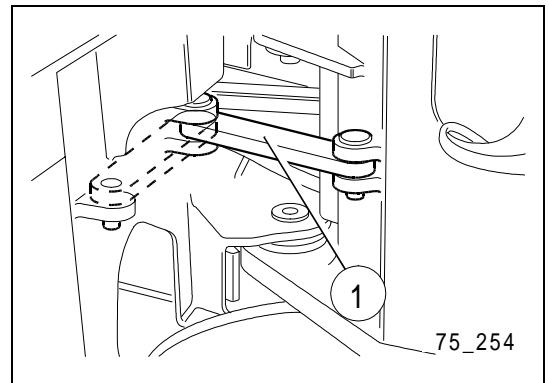

32.2 BLEEDING THE HYDRAULIC OIL TANK

- 1- Loosen the feeding and ventilation screw by turning it a couple of rotations.
- 2- Start up the engine.
- 3- Bring the boom into its highest position.
- 4- Bring bucket into its tip-in position (up to its limit stop).
- 5- Re-tighten the feeding and ventilation screw.

32.3 COOLING SYSTEM, CHECKING THE ANTIFREEZE CONTENT OF THE COOLANT

Check the antifreeze content of the coolant. The mixing proportion must always be adjusted to a temperature of -34.6°F (-37°C) - even in areas with moderate climate. During filling up, pay attention to the prescribed mixing proportion.



- The coolant must contain antifreeze in all climate regions. The antifreeze does not only decrease the freezing point but also increases the boiling point. It lubricates movable components and lip seals and prevents corrosion and foam formation.
-

32.4 CHECKING THE COOLING SYSTEM



- Let the cooling system check be performed at your local Komatsu dealer.
-

32.5 CHECKING THE FUEL PUMP



- Let the fuel pump be checked at your local Komatsu dealer.
-

32.6 CHECKING THE FUEL AND COOLANT TUBES, REPLACING THE TUBES (IF REQUIRED)



- Have the fuel and coolant tubes checked and replaced, if required, at your local Komatsu dealer.
-

32.7 CHECKING THE WATER PUMP



- Let the water pump be checked at your local Komatsu dealer.
-

32.8 CHECKING AND ADJUSTING THE FUEL INJECTION AND INJECTION TIME



- Let the injection time be checked at your local Komatsu dealer.
-

32.9 ENGINE, INTAKE VALVES AND OUTLET VALVES - GRINDING IN THE VALVE BASES



- Have these operations performed at your local Komatsu dealer.
-

MAINTENANCE EVERY 2000 OPERATING HOURS

TECHNICAL DATA

33. TECHNICAL DATA

SPECIFICATIONS		
Engine	Model	Komatsu 4D 98E - 1 HC
	Engine Output (ISO 9249)	42.5 kW (57.3 Hp) / 2600 rpm
	Torque, max. (ISO 9249)	190 - 210 Nm / 1600 rpm
	Starter Motor	12 V - 2.3 kW
	Alternator	12 V - 60 A
	Battery	12 V - 92 Ah
Travel Speed forward and reverse	1st	4.66 mph (7.5 km/h)
	2nd	11.81 mph (19.0 km/h)
Tractive force, max.		37.4 kN
Turning radius	Outside Counterweight	12 ft 4 in (3750 mm)
	Outer Edge Bucket, Standard	13 ft 10 in (4210 mm)
Bucket, Standard		28.268 cuft (0.8 m ³)
Operating weight	Includes Standard Bucket and Operator with 75 kg	10692 lb (4850 kg)

33.1 NOISE EMISSION LEVELS

Sound pressure level	$L_{pA} = 73 \text{ dB/A}$
Sound power level	$L_{WA} = 97 \text{ dB/A}$

No alterations may be made to the machine which could have an influence on the noise emission levels

33.2 VIBRATION LEVEL

When used for its intended purpose, levels of vibration for the earthworking machine transmitted from the operator's seat are lower or equal to the test vibrations for the relative machinery class in compliance with ISO 7096. The effective value of acceleration of the upper limbs is less than 8.2 ft/s^2 (2.5 m/s^2). The effective value of acceleration for the body is less than 2.5 ft/s^2 (0.76 m/s^2). These values have been measured at a representative machine in compliance with the directions ISO 2631/1-1505349-SAEJ1166.

33.3 LIMIT VALUES FOR SLOPES

33.3.1 MAXIMUM SLOPE ANGLE FOR OPERATING THE MACHINE

If operating the machine on a slope, its angle must not exceed 30° uphill, downhill or sideways. If you angle the machine at more than 30° during operation, the motor, transmission, hydraulic system or axles, will not be supplied with sufficient oil and can be damaged.

- A uphill 30°
- B downhill 30°
- C sideways 30°

33.3.2 TILTING/TIPPING ANGLE

The tilting/tipping angle is a calculated value. It represents the angle at which the machine at rest can stand on a slope without tipping over. You must not work with the machine in positions exceeding these angles as the engine, transmission, hydraulic system or axles, will not be supplied with sufficient oil and can be damaged.

- A uphill with workload 54°
uphill without workload 33°
- B downhill with workload 39°
downhill without workload 55.5°
- C sideways with workload 40.5°
sideways without workload 39°

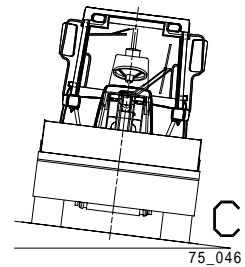
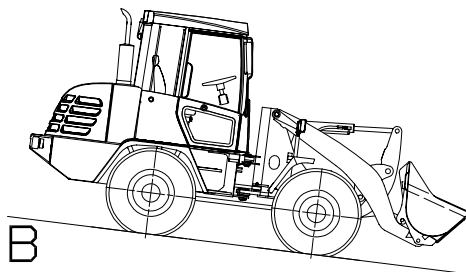
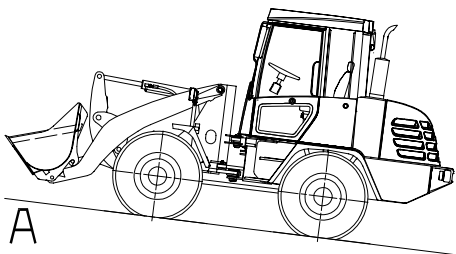

KOMATSU

© 1999 Komatsu Hanomag Aktiengesellschaft
All Rights Reserved
Printed in Europe
03.99