

Operation & Maintenance Manual

BULLDOZER

D475A-5

SERIAL NUMBERS 20001 and up

NOTICE

Komatsu has Operation & Maintenance Manuals written in some other languages . If a foreign language manual is necessary , contact your local distributor for availability .

WARNING

Unsafe use of this machine may cause serious injury or Death. Operators and maintenance personnel must read this manual before operating or maintaining this machine. This manual should be kept near the machine for reference and periodically reviewed by all personnel who will come into contact with it .

KOMATSU

FOREWORD

CALIFORNIA

Proposition 65 Warning

Diesel engine exhaust and some of its constituents are known to the State of California to cause cancer, birth defects, and other reproductive harm.

CALIFORNIA

Proposition 65 Warning

Battery posts, terminals and related accessories contain lead and lead compounds, chemicals known to the State of California to cause cancer and birth defects or other reproductive harm.

Wash hands after handling.

FOREWORD

This manual provides rules and guidelines which will help you use this machine safely and effectively. The precautions in this manual must be followed at all times when performing operation and maintenance. Most accidents are caused by the failure to follow fundamental safety rules for the operation and maintenance of machines. Accidents can be prevented by knowing beforehand conditions that may cause a hazard when performing operation and maintenance.



WARNING

Operators and maintenance personnel must always do as follows before beginning operation or maintenance.

- Always be sure to read and understand this manual thoroughly before performing operation and maintenance.
- Read the safety messages given in this manual and the safety labels affixed to the machine thoroughly and be sure that you understand them fully.

Keep this manual in the storage location for the operation and maintenance manual given below, and have all personnel read it periodically.

If this manual has been lost or has become dirty and cannot be read, request a replacement manual immediately from Komatsu or your Komatsu distributor.

If you sell the machine, be sure to give this manual to the new owners together with the machine.

Komatsu delivers machines that comply with all applicable regulations and standards of the country to which it has been shipped. If this machine has been purchased in another country or purchased from someone in another country, it may lack certain safety devices and specifications that are necessary for use in your country. If there is any question about whether your product complies with the applicable standards and regulations of your country, consult Komatsu or your Komatsu distributor before operating the machine.

Location to keep operation & maintenance manual
In door pocket inside of cab door

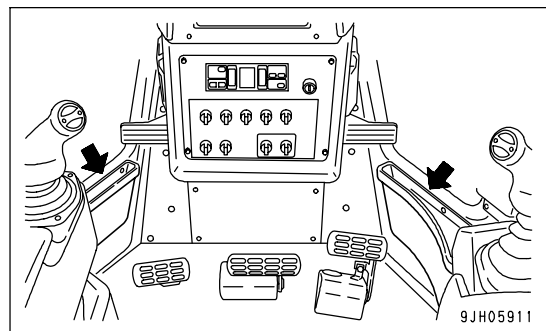

EMISSION CONTROL WARRANTY**EMISSION CONTROL WARRANTY STATEMENT (APPLIES TO CANADA ONLY)****1. Products Warranted**

Komatsu America International Company, Komatsu Mining Systems Inc. and Komatsu Utility Corporation (collectively "Komatsu") produce and/or market products under brand names of Komatsu, Dresser, Dressta, Haulpak and Galion. This emissions warranty applies to new engines bearing the Komatsu name installed in these products and used in Canada in machines designed for industrial off-highway use. This warranty applies only to these engines produced on or after January 1, 2000. This warranty will be administered by Komatsu distribution in Canada.

2. Coverage

Komatsu warrants to the ultimate purchaser and each subsequent purchaser that the engine is designed, built and equipped so as to conform, at the time of sale by Komatsu, with all U.S. Federal emission regulations applicable at the time of manufacture and that it is free from defects in workmanship or material which would cause it not to meet these regulations within five years or 3,000 hours of operation, whichever occurs first, as measured from the date of delivery of the engine to the ultimate purchaser.

3. Limitations

Failures, other than those resulting from defects in materials or workmanship, are not covered by this warranty. Komatsu is not responsible for failures or damage resulting from what Komatsu determines to be abuse or neglect, including, but not limited to: operation without adequate coolant or lubricants; over fueling; over speeding; lack of maintenance of lubricating, cooling or intake systems; improper storage, starting, warm-up, run-in or shutdown practices; unauthorized modifications of the engine. Komatsu is also not responsible for failures caused by incorrect fuel or by water, dirt or other contaminants in the fuel. Komatsu is not responsible for non-engine repairs, "downtime" expense, related damage, fines, all business costs or other losses resulting from a warrantable failure.

KOMATSU IS NOT RESPONSIBLE FOR INCIDENTAL OR CONSEQUENTIAL DAMAGES.

This warranty, together with the express commercial warranties, are the sole warranties of Komatsu. **THERE ARE NO OTHER WARRANTIES, EXPRESS OR IMPLIED, OR OF MERCHANTABILITY OR FITNESS FOR A PARTICULAR PURPOSE.**

GARANTIE SUR LE CONTRÔLE DES ÉMISSIONS**ÉNONCÉ DE GARANTIE SUR LE CONTRÔLE DES ÉMISSIONS (APPLICABLE AU CANADA SEULEMENT):****1. Produits garantis:**

Komatsu America International Company, Komatsu Mining Systems Inc. et Komatsu Utility Corporation (collectivement Komatsu) produisent et/ou font la mise en marché de produits portant les noms de marque Komatsu, Dresser, Dressta, Haulpak et Galion. Cette garantie sur les émissions s'applique à tous les nouveaux moteurs portant le nom Komatsu, installés dans ces produits et utilisés au Canada dans des machines conçues pour utilisation industrielle non-roulière. Cette garantie s'applique seulement sur les moteurs produits à partir du 1er Janvier 2000. Cette garantie sera administrée par la distribution de Komatsu au Canada.

2. Couverture:

Komatsu garantit à l'acheteur ultime et chaque acheteur subséquent que le moteur est conçu, construit et équipé en toute conformité, au moment de la vente par Komatsu, avec toutes les Réglementations fédérales américaines sur les émissions applicables au moment de la fabrication et qu'il est exempt de défauts de construction ou de matériaux qui auraient pour effet de contrevenir à ces réglementations en dedans de 5 ans ou 3000 heures d'opération, mesuré à partir de la date de livraison du moteur au client ultime.

3. Limitations:

Les bris, autres que ceux résultant de défauts de matériaux ou de construction, ne sont pas couverts par cette Garantie. Komatsu n'est pas responsable pour bris ou dommages résultant de ce que Komatsu détermine comme étant de l'abus ou négligence, incluant mais ne se limitant pas à: l'opération sans lubrifiants ou agent refroidissants adéquats; la suralimentation d'essence; la survitesse; le manque d'entretien des systèmes de lubrification, de refroidissement ou d'entrée; de pratiques non-propices d'entreposage, de mise en marche, de réchauffement, de conditionnement ou d'arrêt; les modifications non-autorisées du moteur. De plus, Komatsu n'est pas responsable de bris causés par de l'essence inadéquate ou de l'eau, des saletés ou autres contaminants dans l'essence. Komatsu n'est pas responsable des réparations non-relées au moteur, des dépenses encourues suite aux temps d'arrêts, des dommages relatifs, amendes, et de tout autre coût d'affaires ou autres pertes résultant d'un bris couvert par la garantie.

KOMATSU N'EST PAS RESPONSABLE DES INCIDENTS OU DOMMAGES CONSÉQUENTS.

Cette garantie, ainsi que les garanties expresses commerciales, sont les seules garanties de Komatsu. **IL N'Y A AUCUNE AUTRE GARANTIE, EXPRESSE OU SOUS-ENTENDUE, MARCHANDABLE OU PROPICE A UNE UTILISATION PARTICULIÈRE.**

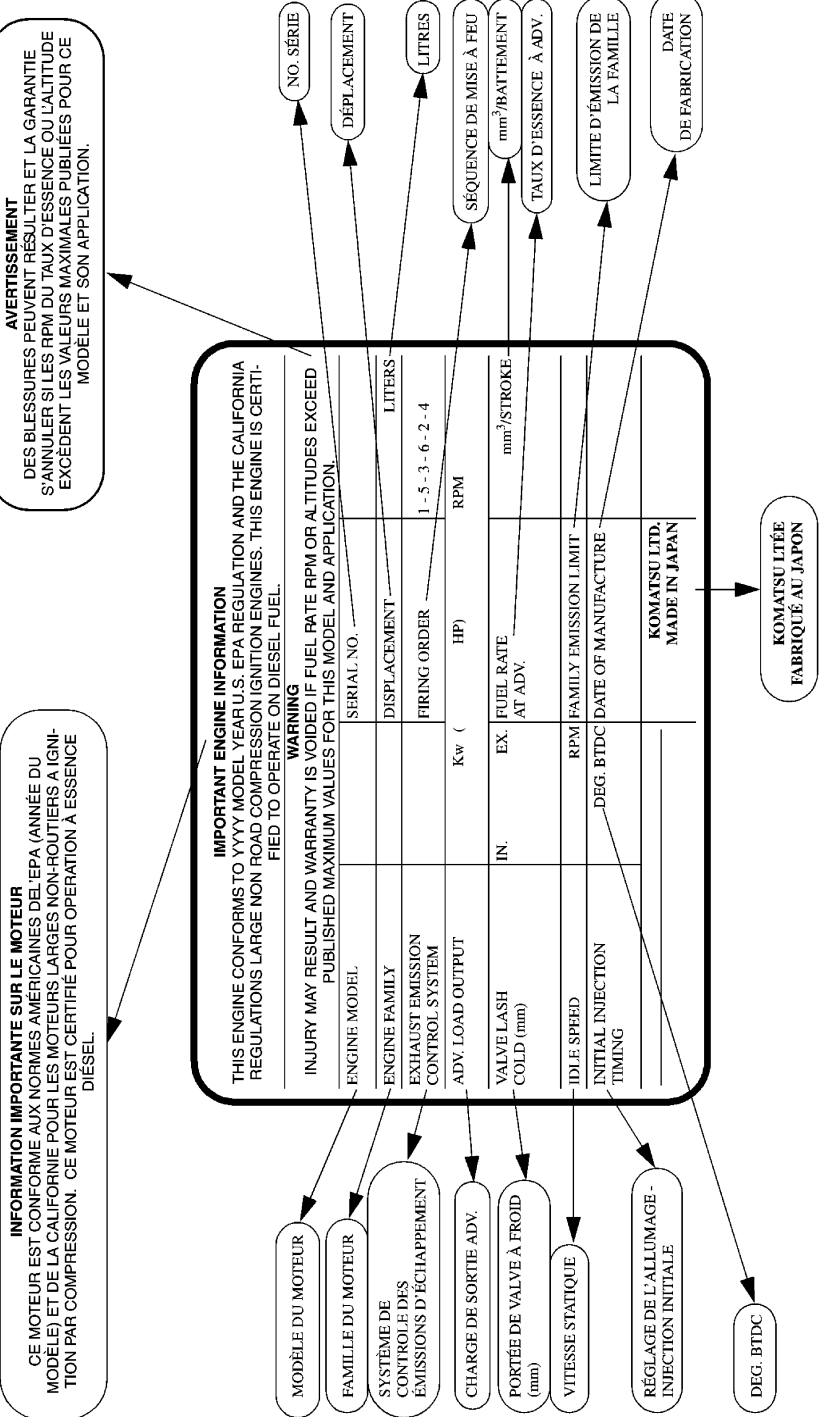

ENGINE DATAPLATE - ENGLISH / FRENCH



SAFETY INFORMATION

To enable you to use this machine safely, safety precautions and labels are given in this manual and affixed to the machine to give explanations of situations involving potential hazards and of the methods of avoiding such situations.

Signal words

The following signal words are used to inform you that there is a potential hazardous situation that may lead to personal injury or damage.

In this manual and on machine labels, the following signal words are used to express the potential level of hazard.

- | | |
|--|---|
|  DANGER | Indicates an imminently hazardous situation which, if not avoided, will result in death or serious injury. |
|  WARNING | Indicates a potentially hazardous situation which, if not avoided, could result in death or serious injury. |
|  CAUTION | Indicates a potentially hazardous situation which, if not avoided, may result in minor or moderate injury. This word is used also to alert against unsafe practices that may cause property damage. |

Example of safety message using signal word

 WARNING
When standing up from the operator's seat, always place the lock lever in the LOCK position. If you accidentally touch the control levers when they are not locked, this may cause a serious injury or death.

Other signal words

In addition to the above, the following signal words are used to indicate precautions that should be followed to protect the machine or to give information that is useful to know.

NOTICE This word is used for precautions that must be taken to avoid actions which could shorten the life of the machine.

REMARKS This word is used for information that is useful to know.

- Safety labels

Safety labels are affixed to the machine to inform the operator or maintenance worker on the spot when carrying out operation or maintenance of the machine that may involve hazard.

This machine uses "Safety labels using words" and "Safety labels using pictograms" to indicate safety procedures.

Example of safety label using words

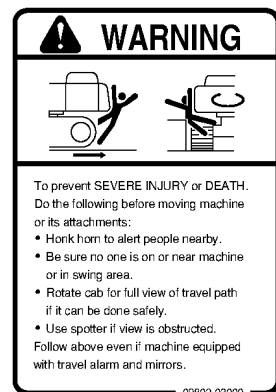

Part No

Safety labels using pictogram

Safety pictograms use a picture to express a level of hazardous condition equivalent to the signal word. These safety pictograms use pictures in order to let the operator or maintenance worker understand the level and type of hazardous condition at all times. Safety pictograms show the type of hazardous condition at the top or left side, and the method of avoiding the hazardous condition at the bottom or right side. In addition, the type of hazardous condition is displayed inside a triangle and the method of avoiding the hazardous condition is shown inside a circle.



Part No

Komatsu cannot predict every circumstance that might involve a potential hazard in operation and maintenance. Therefore, the safety messages in this manual and on the machine may not include all possible safety precautions. If any procedures or actions not specifically recommended or allowed in this manual are used, it is your responsibility to take the necessary steps to ensure safety.

In no event should you engage in prohibited uses or actions described in this manual.

The explanations, values, and illustrations in this manual were prepared based on the latest information available at that time. Continuing improvements in the design of this machine can lead to changes in detail which may not be reflected in this manual. Consult Komatsu or your Komatsu distributor for the latest available information of your machine or for questions regarding information in this manual.

The numbers in circles in the illustrations correspond to the numbers in () in the text. (For example: ① → (1))

INTRODUCTION

This Komatsu machine is designed to be used mainly for the following work:

- Dozing
- Cutting into hard or frozen ground or ditching
- Felling trees, removing stumps
- Pushing
- Ripping

For further details, see "WORK POSSIBLE USING BULLDOZER (PAGE 3-138)" and "RIPPER OPERATION (PAGE 3-145)".

FRONT/REAR, LEFT/RIGHT DIRECTIONS OF MACHINE

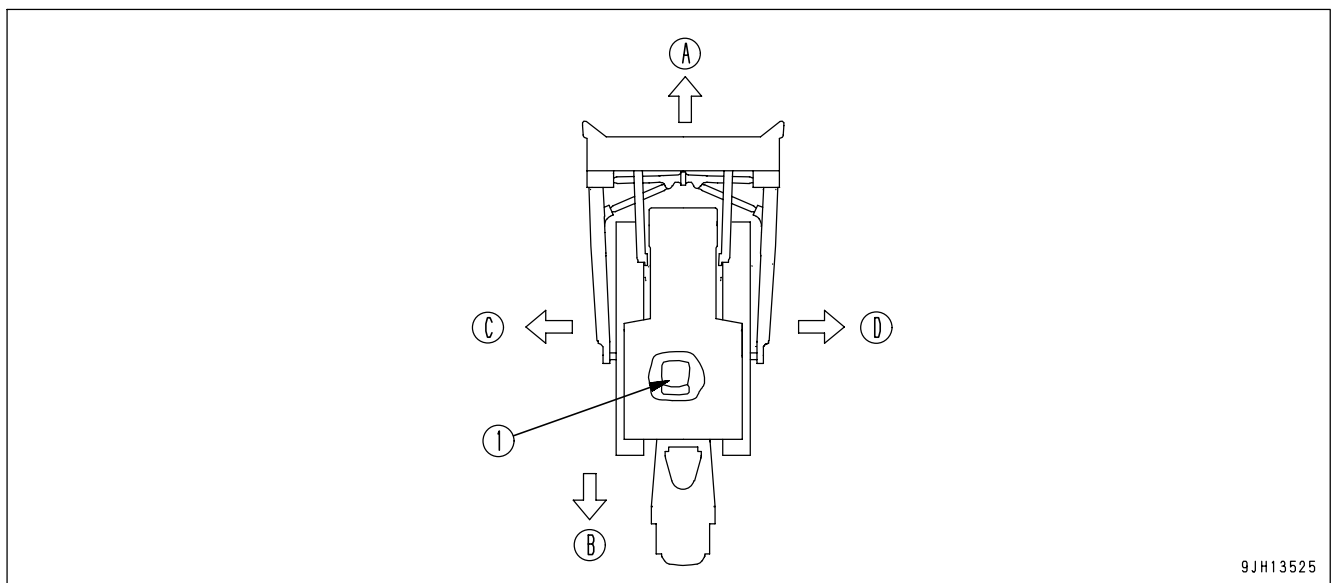

- | | |
|---------------------|-----------|
| (1) Operator's seat | (C) Left |
| (A) Front | (D) Right |
| (B) Rear | |

In this manual, the terms front, rear, left, and right refer to the travel direction as seen from the operator's seat when the operator's seat is facing the front.

BREAKING IN THE MACHINE

NOTICE

Your Komatsu machine has been thoroughly adjusted and tested before shipment from the factory. However, operating the machine under full load before breaking the machine in can adversely affect the performance and shorten the machine life. Be sure to break in the machine for the initial 100 hours (as indicated on the service meter).

Make sure that you fully understand the content of this manual, and pay careful attention to the following points when breaking in the machine.

- Run the engine at idle for 15 seconds after starting it. During this time, do not operate the control levers or fuel control dial.
- Idle the engine for 5 minutes after starting it up.
- Avoid operation with heavy loads or at high speeds.
- Immediately after starting the engine, avoid sudden starts, sudden acceleration, unnecessary sudden stops, and sudden changes in direction.

NECESSARY INFORMATION

When requesting service or ordering replacement parts, please inform your Komatsu distributor of the following items.

PRODUCT IDENTIFICATION NUMBER (PIN), MACHINE SERIAL NO. PLATE

This is inside the console box on the left side of the operator's seat.

The design of the nameplate differs according to the territory.

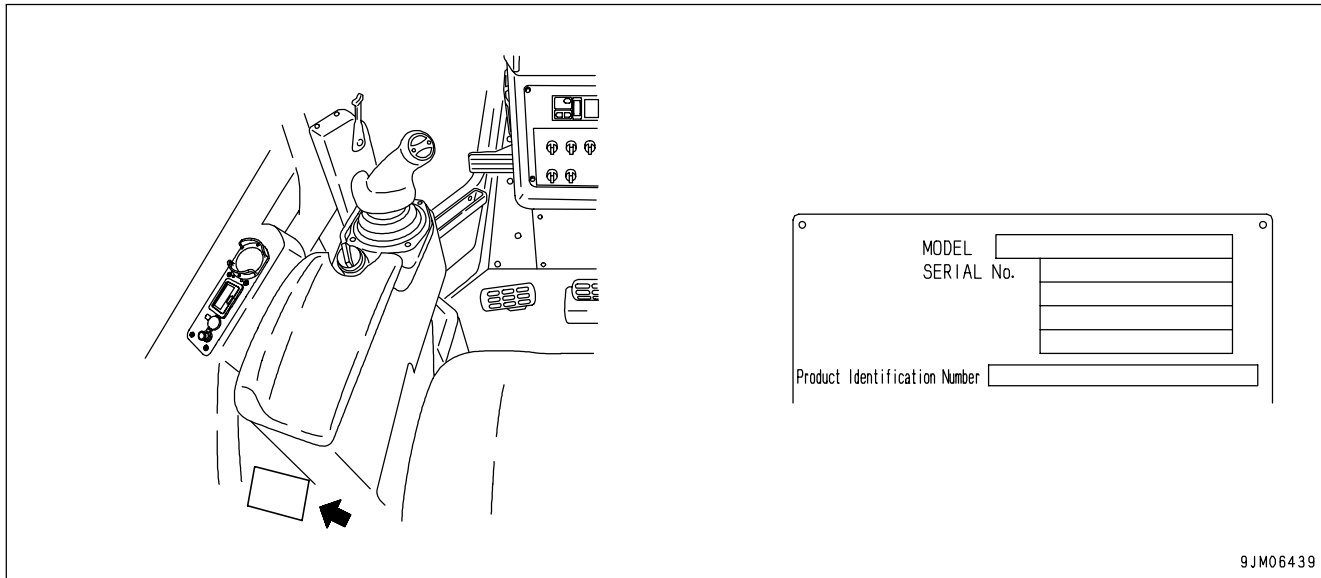

EPA REGULATIONS, ENGINE NUMBER PLATE

The usual plate and EPA plate are on the left side face of the engine at the air intake manifold.

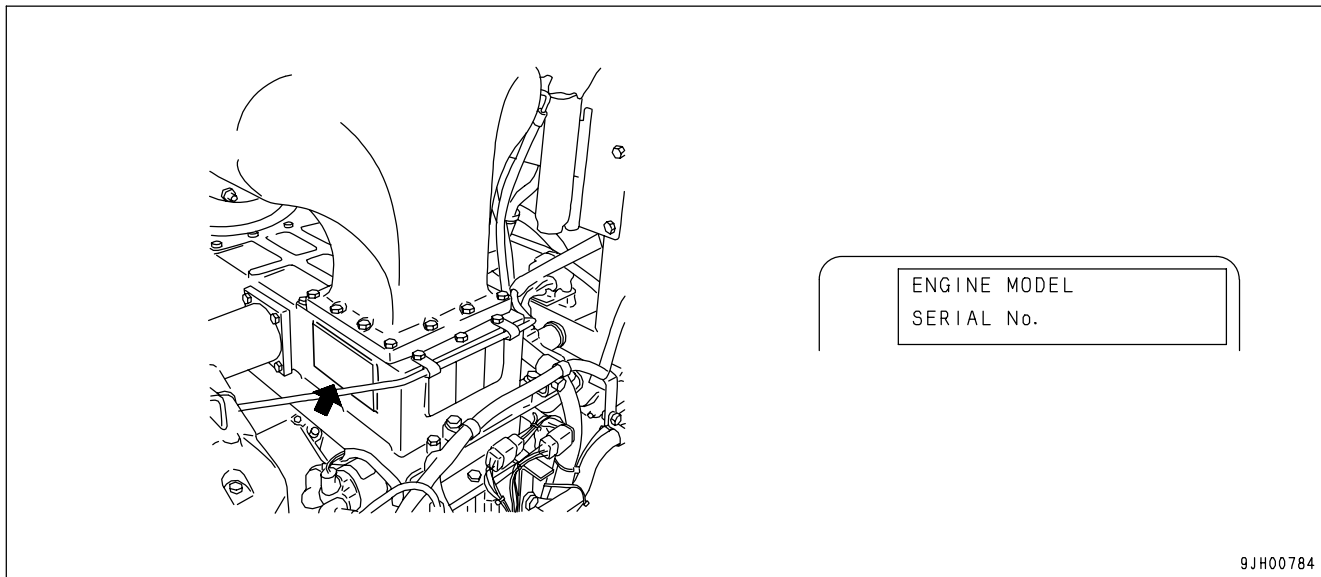

EPA: Environmental Protection Agency, U.S.A.

BLADE SERIAL NO. PLATE POSITION

This is located on the upper right of blade back surface.

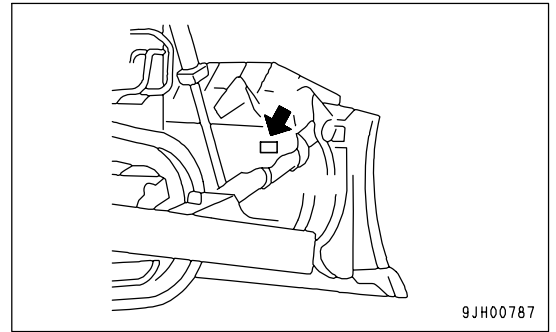
**RIPPER SERIAL NO. PLATE POSITION**

This is located on the left side surface of ripper beam.

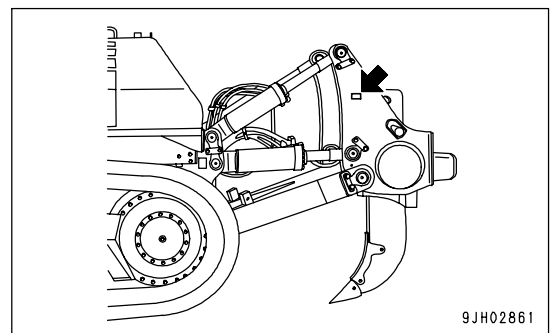
**POSITION OF SERVICE METER**

On top of the machine monitor

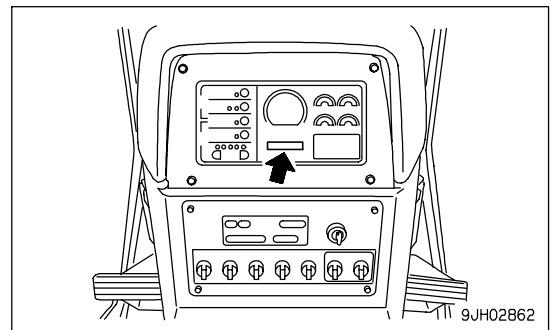

TABLE TO ENTER SERIAL NO. AND DISTRIBUTOR

Machine serial No.	
Engine serial No.	
Product identification number (PIN)	
Distributor name	
Address	-----

Service Personnel	
Phone/Fax	

CONTENTS

FOREWORD	1- 1
FOREWORD	1- 2
SAFETY INFORMATION	1- 5
INTRODUCTION	1- 7
FRONT/REAR, LEFT/RIGHT DIRECTIONS OF MACHINE	1- 7
BREAKING IN THE MACHINE	1- 7
NECESSARY INFORMATION	1- 8
PRODUCT IDENTIFICATION NUMBER (PIN), MACHINE SERIAL NO. PLATE	1- 8
EPA REGULATIONS, ENGINE NUMBER PLATE	1- 8
BLADE SERIAL NO. PLATE POSITION	1- 9
RIPPER SERIAL NO. PLATE POSITION	1- 9
POSITION OF SERVICE METER	1- 9
TABLE TO ENTER SERIAL NO. AND DISTRIBUTOR	1- 10
SAFETY	2- 1
SAFETY	2- 2
SAFETY LABELS	2- 4
POSITIONS OF SAFETY PICTOGRAMS	2- 4
SAFETY LABELS	2- 5
GENERAL PRECAUTIONS	2- 8
PRECAUTIONS FOR OPERATION	2- 17
BEFORE STARTING ENGINE	2- 17
OPERATION	2- 19
TRANSPORTATION	2- 23
BATTERY	2- 24
TOWING	2- 26
PRECAUTIONS FOR MAINTENANCE	2- 27
OPERATION	3- 1
GENERAL VIEW	3- 2
GENERAL VIEW OF MACHINE	3- 2
GENERAL VIEW OF CONTROLS AND GAUGES	3- 3
EXPLANATION OF COMPONENTS	3- 5
FRONT PANEL	3- 5
SWITCHES	3- 36
CONTROL LEVERS, PEDALS	3- 41
DUST INDICATOR	3- 49
POWER SOURCE	3- 50
FUSE BOX	3- 51
DOOR OPEN LOCK	3- 55
SASH GLASS INTERMEDIATE LOCK	3- 55
DOOR POCKET	3- 56
ASHTRAY	3- 56
TOOL BOX	3- 56
CLEAN INTERIOR OF CAB	3- 56
CAR STEREO, HANDLING	3- 57
AIR CONDITIONER, HANDLING	3- 66
ACCUMULATOR, HANDLING	3- 83
HANDLING MACHINES EQUIPPED WITH VHMS	3- 84
OPERATION	3- 86
CHECK BEFORE STARTING ENGINE, ADJUST	3- 86

STARTING ENGINE	3-107
OPERATIONS AND CHECKS AFTER STARTING ENGINE	3-115
STOPPING ENGINE	3-118
CHECK AFTER STOPPING ENGINE	3-118
MOVING MACHINE	3-119
STOPPING MACHINE	3-121
SHIFTING GEAR	3-122
SHIFTING BETWEEN FORWARD AND REVERSE	3-127
STEERING MACHINE	3-129
PRECAUTIONS FOR OPERATION	3-133
PARKING MACHINE	3-135
CHECK AFTER FINISHING WORK	3-137
LOCKING	3-137
WORK POSSIBLE USING BULLDOZER	3-138
EFFECTIVE USE OF MODE SELECTION SYSTEM	3-140
RIPPER OPERATION	3-145
OPERATING METHOD FOR RIPPING OPERATIONS	3-148
ADJUSTING POSTURE OF WORK EQUIPMENT	3-152
TIPS FOR LONGER UNDERCARRIAGE LIFE	3-155
TRANSPORTATION	3-157
TRANSPORTATION PROCEDURE	3-157
LOADING, UNLOADING WORK	3-157
METHOD OF LIFTING MACHINE	3-160
PRECAUTIONS FOR TRANSPORTATION	3-161
TRAVELING ON ROADS	3-161
REMOVAL OF CAB	3-162
INSTALLATION OF CAB	3-165
INSTALLATION OF ROPS	3-166
COLD WEATHER OPERATION	3-167
PRECAUTIONS FOR LOW TEMPERATURE	3-167
AFTER COMPLETION OF WORK	3-169
AFTER COLD WEATHER	3-169
LONG-TERM STORAGE	3-170
BEFORE STORAGE	3-170
DURING STORAGE	3-170
AFTER STORAGE	3-170
STARTING MACHINE AFTER LONG-TERM STORAGE	3-170
TROUBLESHOOTING	3-171
AFTER RUNNING OUT OF FUEL	3-171
METHOD OF TOWING MACHINE	3-173
IF BATTERY IS DISCHARGED	3-174
OTHER TROUBLE	3-178
WHEN MODE SELECTION SYSTEM FLASHES	3-183
MAINTENANCE	4- 1
GUIDES TO MAINTENANCE	4- 2
OUTLINES OF SERVICE	4- 5
HANDLING OIL, FUEL, COOLANT, AND PERFORMING OIL CLINIC	4- 5
OUTLINE OF ELECTRIC SYSTEM	4- 8
HANDLING HYDRAULIC RELATED EQUIPMENT	4- 9

WEAR PARTS	4- 10
WEAR PARTS LIST	4- 10
RECOMMENDED FUEL, COOLANT, AND LUBRICANT	4- 12
RECOMMENDED BRANDS, RECOMMENDED QUALITY FOR PRODUCTS OTHER THAN KOMATSU GENUINE OIL	4- 14
STANDARD TIGHTENING TORQUES FOR BOLTS AND NUTS	4- 15
TORQUE LIST	4- 15
PERIODIC REPLACEMENT OF SAFETY CRITICAL PARTS	4- 16
SAFETY CRITICAL PARTS	4- 17
MAINTENANCE SCHEDULE CHART	4- 19
MAINTENANCE SCHEDULE CHART	4- 19
SERVICE PROCEDURE	4- 21
INITIAL 250 HOURS SERVICE (ONLY AFTER THE FIRST 250 HOURS) WHEN REQUIRED	4- 21
CHECK BEFORE STARTING	4- 47
EVERY 250 HOURS SERVICE	4- 48
EVERY 500 HOURS SERVICE	4- 56
EVERY 1000 HOURS SERVICE	4- 61
EVERY 2000 HOURS SERVICE	4- 66
EVERY 4000 HOURS SERVICE	4- 72
SPECIFICATIONS	5- 1
SPECIFICATIONS	5- 2
ATTACHMENTS, OPTIONS	6- 1
GENERAL PRECAUTIONS	6- 2
PRECAUTIONS RELATED TO SAFETY	6- 2
SELECTION OF TRACK SHOE	6- 3
SELECTION OF TRACK SHOES	6- 3
PROCEDURE FOR SELECTING RIPPER POINT	6- 4
CAP WITH LOCK, HANDLING	6- 5
METHOD OF OPENING AND CLOSING CAP WITH LOCK	6- 5
EFFECTIVE METHOD OF OPERATION FOR DUAL TILT DOZER	6- 6
BLADE CONDITION	6- 6
DOZING WORK	6- 8
LEVELING (SPREADING) OPERATION	6- 11
DITCHING OPERATION	6- 11
BOULDER RAISING OPERATION	6- 11
SIDE-CUTTING OPERATIONS	6- 12
HORIZONTAL DOZING OPERATIONS FROM SIDE SLOPE (ROUGH GROUND)	6- 12
SHOE SLIP CONTROL	6- 13
MODE SELECTION SWITCH PANEL (SHOE SLIP CONTROL)	6- 13
EFFECTIVE USE OF MODE SELECTION SYSTEM	6- 14
IF MODE SELECTION SYSTEM FLASHES	6- 20
INDEX	7- 1

SAFETY

WARNING

Please read and make sure that you fully understand the precautions described in this manual and the safety labels on the machine. When operating or servicing the machine, always follow these precautions strictly.

SAFETY

Safety Labels	2-	4
Positions of Safety Pictograms	2-	4
Safety Labels	2-	5
General Precautions	2-	8
Safety Rules	2-	8
If Abnormalities are Found	2-	8
Clothing and Personal Protective Items	2-	8
Fire Extinguisher and First Aid Kit	2-	8
Safety Features	2-	8
Keep Machine Clean	2-	9
Inside Operator's Compartment	2-	9
Precautions when Working in High Places	2-	10
Always Apply Lock when Leaving Operator's Seat	2-	9
Handrails and Steps	2-	10
Mounting and Dismounting	2-	10
No People on Attachments	2-	10
Crushing or Cutting Prevention	2-	11
Prevention of Burns	2-	11
Fire Prevention	2-	12
Action if Fire Occurs	2-	13
Window Washer Liquid	2-	13
Precautions when using ROPS	2-	13
Precautions for Attachments	2-	13
Cab Window Glasses	2-	13
Unauthorized Modification	2-	13
Safety at Worksite	2-	14
Working on Loose Ground	2-	14
Do not Go Close to High-Voltage Cables	2-	15
Ensure Good Visibility	2-	15
Ventilation for Enclosed Areas	2-	16
Checking Signalman's Signals and Signs	2-	16
Be Careful About Asbestos Dust	2-	16

Precautions for Operation	2- 17
Before Starting Engine	2- 17
Checks Before Starting Engine	2- 17
Precautions when Starting	2- 17
Precautions in Cold Areas	2- 17
Operation	2- 19
Checks Before Operation	2- 19
Precautions for Moving Machine Forward or in Reverse	2- 19
Precautions when Traveling	2- 20
Traveling on Slopes	2- 21
Prohibited Operations	2- 21
Using Brakes	2- 21
Operate Carefully on Snow	2- 21
Parking Machine	2- 22
Transportation	2- 23
Loading and unloading	2- 23
Shipping	2- 23
Battery	2- 24
Battery Hazard Prevention	2- 24
Starting with Booster Cable	2- 25
Towing	2- 26
When Towing	2- 26
Precautions for Maintenance	2- 27
Warning Tag	2- 27
Keep Work Place Clean and Tidy	2- 27
Appoint Leader when Working with Others	2- 27
Stop Engine Before Carrying Out Inspection and Maintenance	2- 28
Two Workers for Maintenance when Engine is Running	2- 29
Proper Tools	2- 29
Handling Accumulator	2- 30
Personnel	2- 30
Attachments	2- 30
Work Under the Machine	2- 31
Noise	2- 31
Precautions when Using Hammer	2- 31
Repair Welding	2- 31
Removing Battery Terminal	2- 31
Precautions when Using High-Pressure Grease to Adjust Track Tension	2- 32
Do not Disassemble Recoil Spring	2- 32
Precaution with High-Pressure Oil	2- 33
Precaution for High Fuel Pressure	2- 33
Handling High-Pressure Hoses	2- 33
Precaution for High Voltage	2- 33
Waste Material	2- 34
Maintenance for Air Conditioner	2- 34
Compressed Air	2- 34
Periodic Replacement of Safety Critical Parts	2- 34

SAFETY LABELS

The following warning signs and safety labels are used on this machine.

- Be sure that you fully understand the correct position and content of labels.
- To ensure that the content of labels can be read properly, be sure that they are in the correct place and always keep them clean. When cleaning them, do not use organic solvents or gasoline. These may cause the labels to peel off.
- There are also other labels in addition to the warning signs and safety labels. Handle those labels in the same way.
- If the labels are damaged, lost, or cannot be read properly, replace them with new ones. For details of the part numbers for the labels, see this manual or the actual label, and place an order with Komatsu distributor.

POSITIONS OF SAFETY PICTOGRAMS

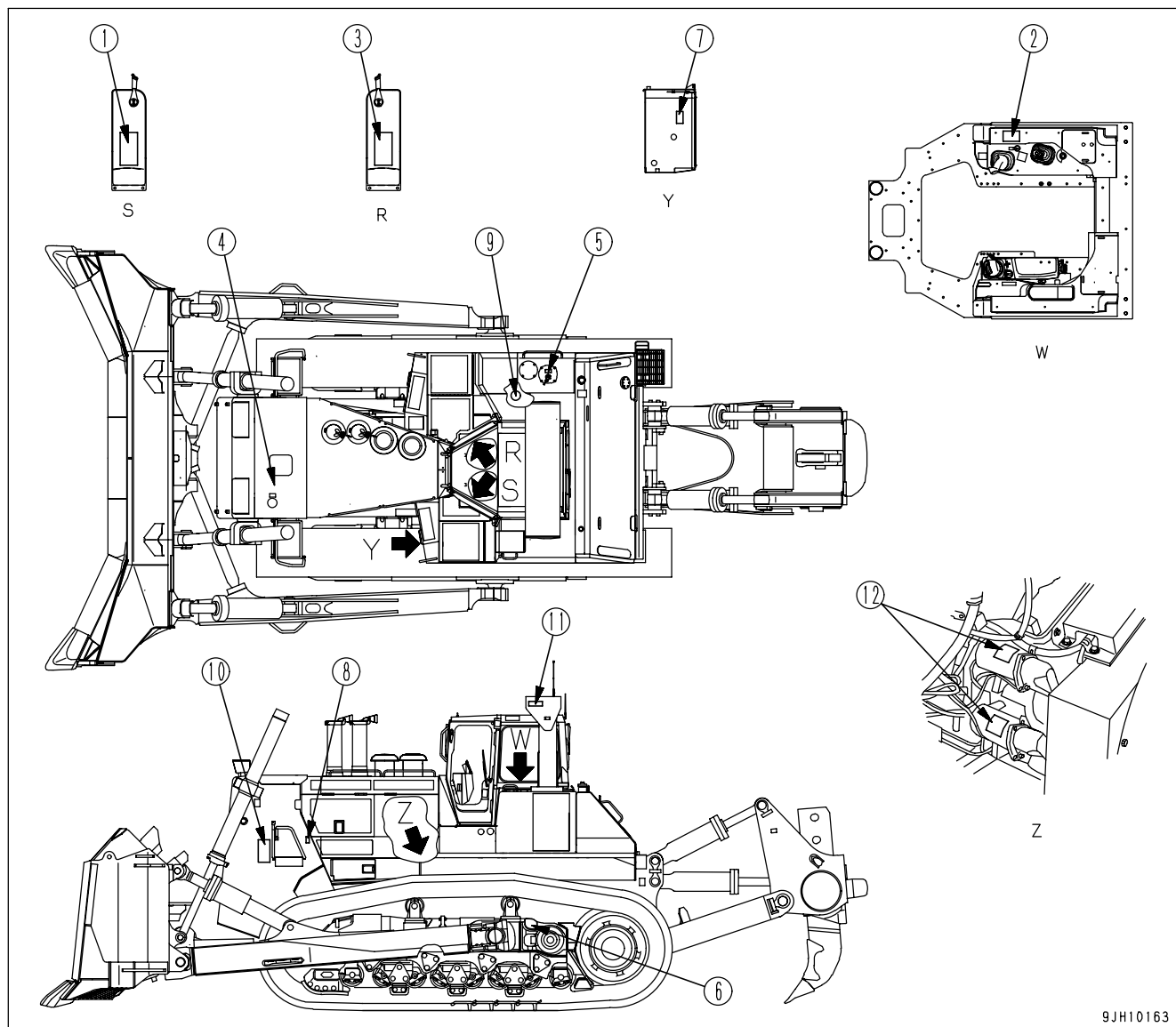

9JH10163

SAFETY LABELS

- (1) Caution before operating or maintaining machine
(09651-03001)



- (2) Caution before moving in reverse (09802-13000)

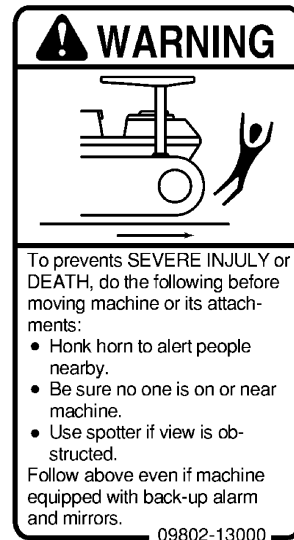

- (3) Caution for leaving operator's seat (09654-33001)

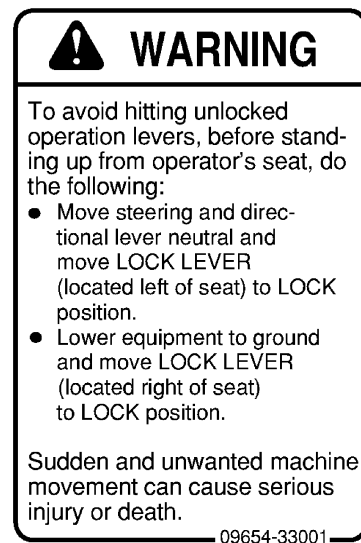

(4) Caution for high-temperature coolant (09668-03001)



(5) Caution for high-temperature hydraulic oil (09653-03001)



(6) Caution for check and adjust track tension (195-98-22931)



(7) Caution for handling electric wires (09808-03000)

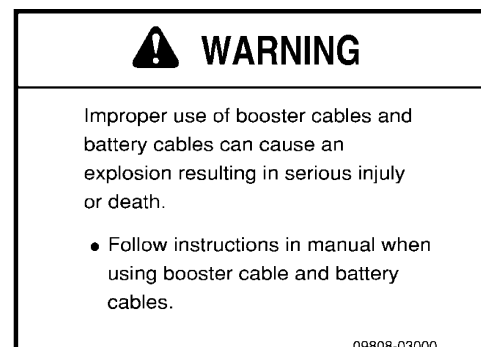

(8) Caution for engine running (09667-03001)



(9) Caution for handling accumulator (09659-53000)



(10) Caution for approach when machine moving (09812-03000)



(11) Warning for ROPS (09620-30201)

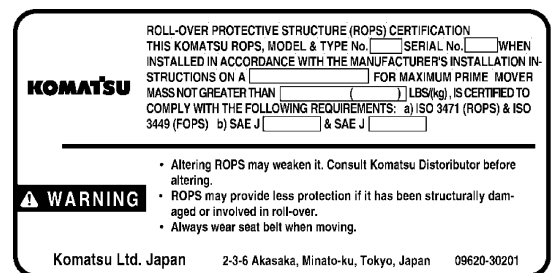

(12) Prohibition of jump start (09842-A0481)



Start the engine only after sitting down in the operator's seat.

Do not attempt to start the engine by short-circuiting the engine starting circuit. Such an act may cause a serious bodily injury or fire.

GENERAL PRECAUTIONS

SAFETY RULES

- Only trained and authorized personnel can operate and maintain the machine.
- Follow all safety rules, precautions and instructions in this manual when operating or performing maintenance on the machine.
- If you are not feeling well, or if you are under the influence of alcohol or medication, your ability to safely operate or repair your machine may be severely impaired, putting yourself and everyone else on your job site in danger.
- When working with another operator or with the person on the worksite traffic duty, discuss the content of the operation beforehand and use the determined signals when carrying out the operation.

IF ABNORMALITIES ARE FOUND

If you find any problems in the machine during operation or maintenance (noise, vibration, smell, incorrect gauges, smoke, oil leakage, etc., or any abnormal display on the warning devices or monitor), report to the person in charge and have the necessary action taken. Do not operate the machine until the problem has been corrected.

CLOTHING AND PERSONAL PROTECTIVE ITEMS

- Do not wear loose clothing and accessories. There is a hazard that they may catch on control levers or other protruding parts.
- If you have long hair and it hangs out from your hard hat, there is a hazard that it may get caught up in the machine, so tie your hair up and be careful not to let it get caught.
- Always wear a hard hat and safety shoes. If the nature of the work requires it, wear safety glasses, mask, gloves, ear plugs, and safety belt when operating or maintaining the machine.
- Check that all protective equipment functions properly before using it.

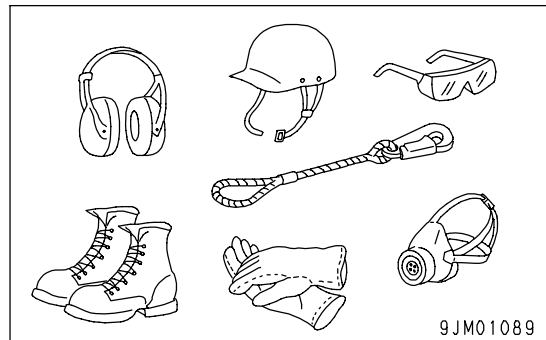

FIRE EXTINGUISHER AND FIRST AID KIT

Always follow the precautions below to prepare for action if any injury or fire should occur.

- Be sure that fire extinguishers have been provided and read the labels to ensure that you know how to use them in emergencies.
- Carry out periodic inspection and maintenance to ensure that the fire extinguisher can always be used.
- Provide a first aid kit in the storage point. Carry out periodic checks and add to the contents if necessary.

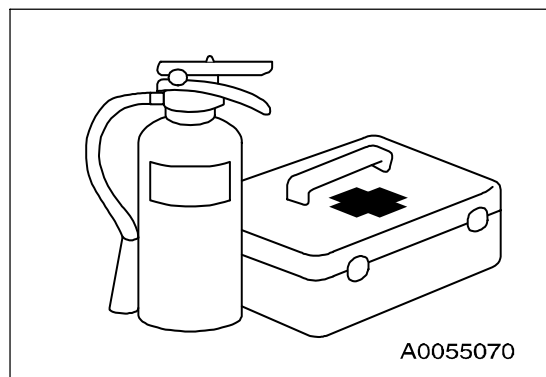

SAFETY FEATURES

- Be sure that all guards, covers and mirrors are in their proper position. Have guards and covers repaired immediately if they are damaged.
- Understand the method of use of safety features and use them properly.
- Never remove any safety features. Always keep them in good operating condition.

KEEP MACHINE CLEAN

- If water gets into the electrical system, there is a hazard that it will cause malfunctions or misoperation. Do not use water or steam to wash the electrical system (sensors, connectors).
- If inspection and maintenance is carried out when the machine is still dirty with mud or oil, there is a hazard that you will slip and fall, or that dirt or mud will get into your eyes. Always keep the machine clean.

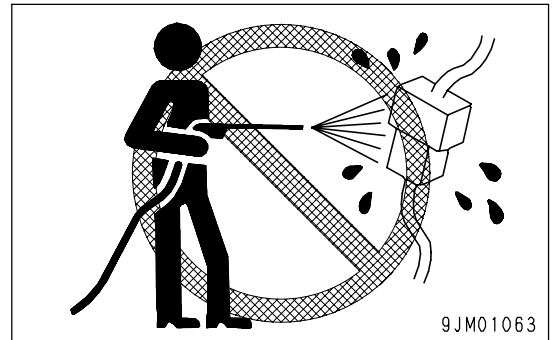
**INSIDE OPERATOR'S COMPARTMENT**

- When entering the operator's compartment, always remove all mud and oil from the soles of your shoes. If you operate the pedal with mud or oil affixed to your shoes, your foot may slip and this may cause a serious accident.
- Do not leave parts or tools lying around the operator's compartment.
- Do not stick suction pads to the window glass. Suction pads act as a lens and may cause fire.
- Do not use cellular telephones inside the operator's compartment when driving or operating the machine.
- Never bring any dangerous objects such as flammable or explosive items into the operator's compartment.

ALWAYS APPLY LOCK WHEN LEAVING OPERATOR'S SEAT

- Before standing up from the operator's seat, lower the work equipment completely to the ground, set work equipment lock lever (1) and parking brake lever (2) securely to the LOCK position (L), then stop the engine.

If you accidentally touch the levers when they are not locked, there is a hazard that the machine may suddenly move and cause serious injury or property damage.

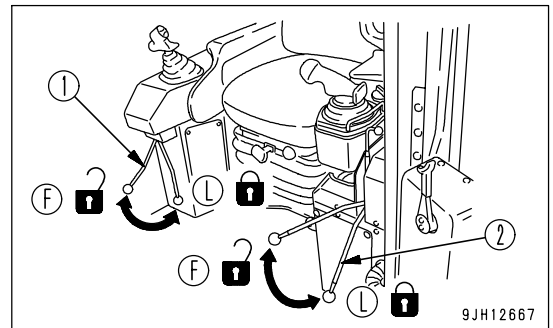

- When leaving the machine, always lower the work equipment completely to the ground, set work equipment lock lever and parking brake lever securely to the LOCK position, then stop the engine. Use the key to lock all the equipment. Always remove the key, take it with you, and keep it in the specified place.

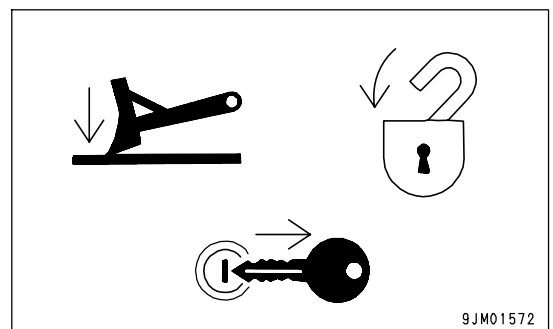

HANDRAILS AND STEPS

To prevent personal injury caused by slipping or falling off the machine, always do as follows.

- Use the parts marked by arrow A in the diagrams when getting on or off the machine.
Never use the parts marked by arrow B when getting on or off the machine. Use them only when moving along the top of the track or when checking or carrying out maintenance inside the side cover, or when filling the tank with oil.
- Never jump on or off the machine. In particular, never get on or off a moving machine. This may cause serious injury.

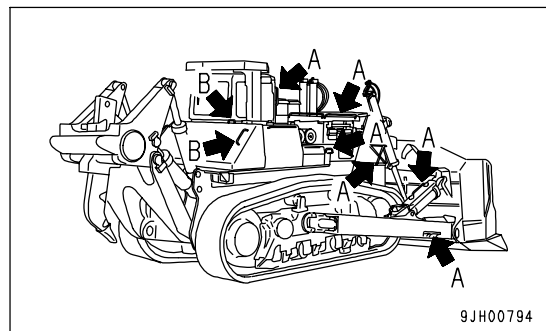
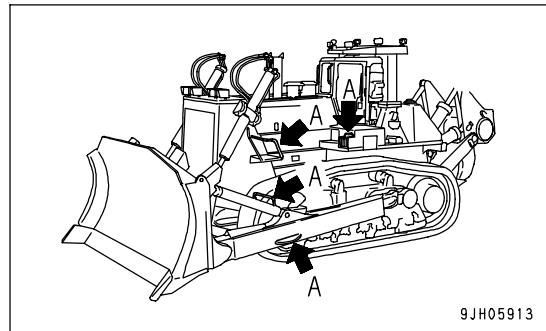

- To ensure safety, always face the machine and maintain three-point contact (both feet and one hand, or both hands and one foot) with the handrails and steps (including the track shoe) to ensure that you support yourself.
- Do not grip the control levers, or work equipment lock lever when getting on or off the machine.

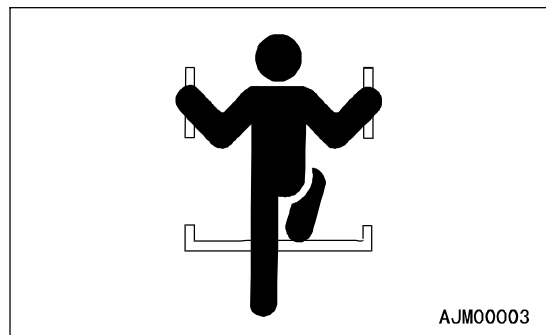

- Never climb on the engine hood or covers where there are no non-slip pads.
- Before getting on or off the machine, check the handrails and steps (including the track shoe). If there is any oil, grease, or mud on the handrails or steps (including the track shoe), wipe it off immediately. Always keep these parts clean. Repair any damage and tighten any loose bolts.
- Do not get on or off the machine while holding tools in your hand.

PRECAUTIONS WHEN WORKING IN HIGH PLACES

When working at high places, use a step ladder or other stand to ensure that the work can be carried out safely.

MOUNTING AND DISMOUNTING

- Never jump on or off the machine. Never get on or off a moving machine.
- If the machine starts to move when there is no operator on the machine, do not jump on to the machine and try to stop it.

NO PEOPLE ON ATTACHMENTS

Never let anyone ride on the work equipment, or other attachments. There is a hazard of falling and suffering serious injury.

CRUSHING OR CUTTING PREVENTION

The clearance around the work equipment will change according to the movement of the link. If you get caught, this may lead to serious personal injury. Do not allow anyone to approach any rotating or telescoping part.

PREVENTION OF BURNS**Hot coolant**

- To prevent burns from hot water or steam spurting out when checking or draining the coolant, wait for the water to cool to a temperature where it is possible to touch the radiator cap by hand before starting the operation. Even when the coolant has cooled down, loosen the cap slowly to relieve the pressure inside the radiator before removing the cap.

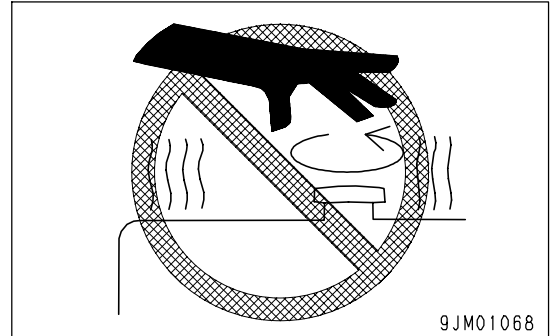
**Hot oil**

- To prevent burns from hot oil spurting out when checking or draining the oil, wait for the oil to cool to a temperature where it is possible to touch the cap or plug by hand before starting the operation. Even when the oil has cooled down, loosen the cap or plug slowly to relieve the internal pressure before removing the cap or plug.

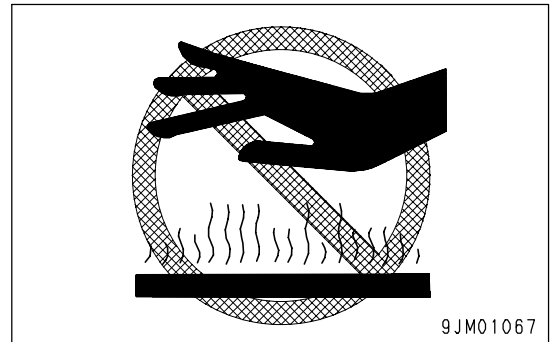

FIRE PREVENTION

- **Fire caused by fuel or oil**

Fuel, oil, antifreeze, and window washer liquid are particularly flammable and can be hazardous. To prevent fire, always observe the following:

- Do not smoke or use any flame near fuel or oil.
- Stop the engine before refueling.
- Do not leave the machine while adding fuel or oil.
- Tighten all fuel and oil caps securely.
- Do not spill fuel on overheated surfaces or on parts of the electrical system.
- Use well-ventilated areas for adding or storing oil and fuel.
- Keep oil and fuel in the determined place and do not allow unauthorized persons to enter.
- After adding fuel or oil, wipe up any spilled fuel or oil.
- When carrying out grinding or welding work on the chassis, move any flammable materials to a safe place before starting.
- When washing parts with oil, use a non-flammable oil. Diesel oil and gasoline may catch fire, so do not use them.
- Put greasy rags and other flammable materials into a safe container to maintain safety at the work place.
- Do not weld or use a cutting torch to cut any pipes or tubes that contain flammable liquids.

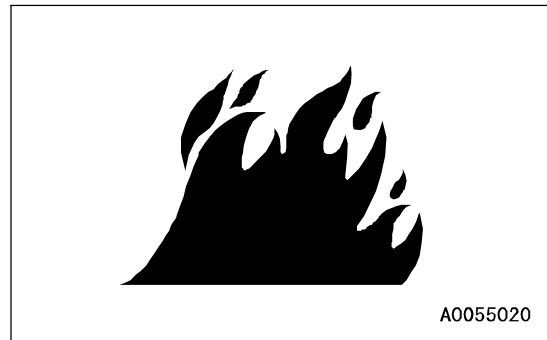

- **Fire caused by accumulation of flammable material.**

- Prevention of fire around high-temperature parts or electrical parts
Remove any flammable materials, such as dry leaves, chips, paper, or coal dust that are accumulated around the engine, exhaust manifold, muffler, or battery.
- Prevention of fire spreading from outside machine
To prevent fire caused by sparks from fires, remove any flammable materials such as dry leaves, chips, paper, or coal dust that are accumulated near the cooling system (radiator, oil cooler) or inside the undercover.

- **Fire coming from electric wiring**

Short circuits in the electrical system can cause fire.

- Always keep electric wiring connections clean and securely tightened.
- Check the wiring every day for looseness or damage. Tighten any loose connectors or wiring clamps. Repair or replace any damaged wiring.

- **Fire coming from hydraulic line**

Check that all the hose and tube clamps, guards, and cushions are securely fixed in position.

If they are loose, they may vibrate during operation and rub against other parts. This may lead to damage to the hoses, and cause high-pressure oil to spurt out, leading to fire damage or serious injury.

- **Explosion caused by lighting equipment**

- When checking fuel, oil, battery electrolyte, window washer fluid, or coolant, always use lighting with anti-explosion specifications. If such lighting equipment is not used, there is danger of explosion that may cause serious injury.
- When taking the electrical power for the lighting from the machine itself, follow the instructions in this manual.

ACTION IF FIRE OCCURS

If a fire occurs, escape from the machine as follows.

- Turn the start switch OFF to stop the engine.
- Use the handrails and steps to get off the machine.

WINDOW WASHER LIQUID

Use an ethyl alcohol base washer liquid.

Methyl alcohol base washer liquid may irritate your eyes, so do not use it.

PRECAUTIONS WHEN USING ROPS (Roll Over Protective Structure)

Install ROPS when working in places where there is danger of falling rocks, such as in mines and quarries, or in places where there is danger of rolling over.

- If ROPS is installed, do not remove it when operating the machine.
- ROPS is installed to protect the operator when machine rolls over. When machine rolls over, ROPS supports its weight and absorbs its impact energy.

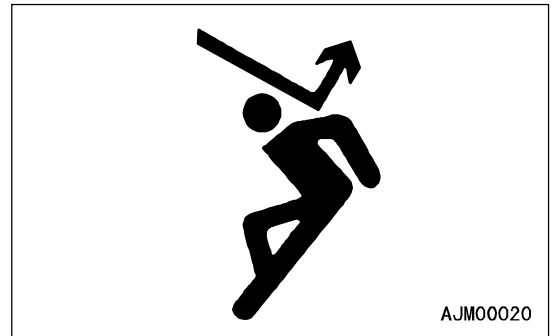

- If ROPS is modified, its strength may lower. When modifying it, consult your Komatsu distributor.
- If ROPS is deformed by falling objects or by rolling over, its strength lowers and its design functions cannot be maintained. In this case, be sure to ask your Komatsu distributor about repair method.

Even when the ROPS is installed, if you do not fasten your seat belt securely, it cannot protect you properly. Always fasten your seat belt when operating the machine.

PRECAUTIONS FOR ATTACHMENTS

- When installing optional parts or attachments, there may be problems with safety or legal restrictions. Therefore contact your Komatsu distributor for advice.
- Any injuries, accidents, product failures or other property damages resulting from the use of unauthorized attachments or parts will not be the responsibility of Komatsu.
- When installing and using optional attachments, read the instruction manual for the attachment, and the general information related to attachments in this manual.

CAB WINDOW GLASSES

If the cab glass on the work equipment side is broken, there is a hazard that the work equipment may contact the operator's body directly. Stop operation immediately and replace the glass.

UNAUTHORIZED MODIFICATION

If this machine is modified without permission from Komatsu, there is danger that problems may occur with safety and that this may lead to serious personal injury. Modifications may have an adverse effect on items such as machine strength and visibility. Before making any modifications, please consult your Komatsu distributor. Komatsu cannot take any responsibility for accidents, failures, or damage caused by modifications not authorized by Komatsu.

SAFETY AT WORKSITE

Before starting operations, thoroughly check the area for any unusual conditions that could be dangerous.

- When carrying out operations near combustible materials such as thatched roofs, dry leaves or dry grass, there is a hazard of fire, so be careful when operating.
- Check the terrain and condition of the ground at the worksite, and determine the safest method of operation. Do not operate where there is a hazard of landslides or falling rocks.
- If water lines, gas lines, or high-voltage electrical lines may be buried under the worksite, contact each utility and identify their locations. Be careful not to sever or damage any of these lines.
- Take necessary measures to prevent any unauthorized person from entering the operating area.
- In particular, if you need to operate on a road, protect pedestrian and cars by designating a person for worksite traffic duty or by installing fences around the worksite.
- When traveling or operating in shallow water or on soft ground, check the shape and condition of the bedrock, and the depth and speed of flow of the water before starting operations.

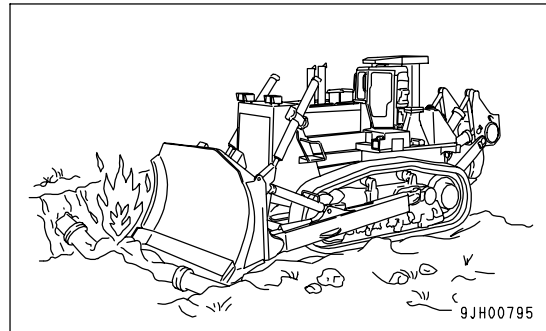
**WORKING ON LOOSE GROUND**

- Avoid traveling or operating your machine too close to the edge of cliffs, overhangs, and deep ditches. The ground may be weak in such areas. If the ground should collapse under the weight or vibration of the machine, there is a hazard that the machine may fall or tip over. Remember that the soil after heavy rain or blasting or after earthquakes is weak in these areas.
- When working on embankments or near excavated ditches, there is a hazard that the weight and vibration of the machine will cause the soil to collapse. Before starting operations, take steps to ensure that the ground is safe and to prevent the machine from rolling over or falling.

DO NOT GO CLOSE TO HIGH-VOLTAGE CABLES

Do not travel or operate the machine near electric cables. There is a hazard of electric shock, which may cause serious personal injury or death. On jobsites where the machine may go close to electric cables, always do as follows.

- Before starting work near electric cables, inform the local power company of the work to be performed, and ask them to take the necessary action.

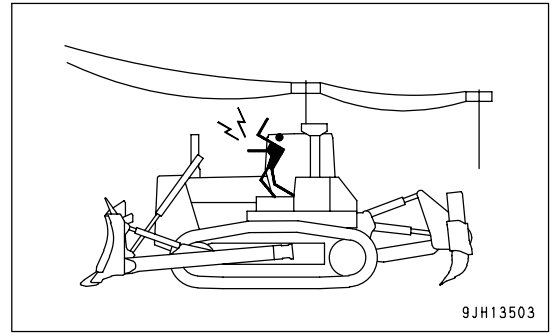

- Even going close to high-voltage cables can cause electric shock, which may cause serious burns or even death. Always maintain a safe distance (see the table on the right) between the machine and the electric cable. Check with the local power company about safe operating procedure before starting operations.
- To prepare for any possible emergencies, wear rubber shoes and gloves. Lay a rubber sheet on top of the seat, and be careful not to touch the chassis with any exposed part of your body.

- Use a signalman to give warning if the machine approaches too close to the electric cables.
- When carrying out operations near high voltage cables, do not let anyone near the machine.
- If the machine should come too close or touch the electric cable, to prevent electric shock, the operator should not leave the operator's compartment until it has been confirmed that the electricity has been shut off. Also, do not let anyone near the machine.

Voltage of Cables	Safety Distance
100 V - 200 V	Over 2 m (7 ft)
6,600 V	Over 2 m (7 ft)
22,000 V	Over 3 m (10 ft)
66,000 V	Over 4 m (14 ft)
154,000 V	Over 5 m (17 ft)
187,000 V	Over 6 m (20 ft)
275,000 V	Over 7 m (23 ft)
500,000 V	Over 11 m (36 ft)

ENSURE GOOD VISIBILITY

This machine is equipped with mirrors to improve the visibility, but even with mirrors, there are places, which cannot be seen from the operator's seat, so always be careful when operating.

When operating or traveling in places with poor visibility, if it is impossible to confirm the condition of the job side or obstacle is in the area around the machine, there is danger that the machine may suffer damage or the operator may suffer serious personal injury. When operating or traveling in places with poor visibility, always observe the following items strictly.

- If the visibility cannot be sufficiently assured, position a flagman if necessary. The operator should pay careful attention to the signs and follow the instructions of the flagman.
- The signals should be given only by one flagman.
- When working in dark places, turn on the working lamps and front lamps of the machine, and if necessary, set up additional lighting in the area.
- Stop operations if there is poor visibility, such as in fog, snow, rain, or sand storms.
- Check the mirrors on the machine before starting operations every day. Clean off any dirt and adjust the view to ensure good visibility.

VENTILATION FOR ENCLOSED AREAS

Exhaust fumes from the engine can kill.

- If it is necessary to start the engine within an enclosed area, or when handling fuel, flushing oil, or paint, open the doors and windows to ensure that adequate ventilation is provided to prevent gas poisoning.

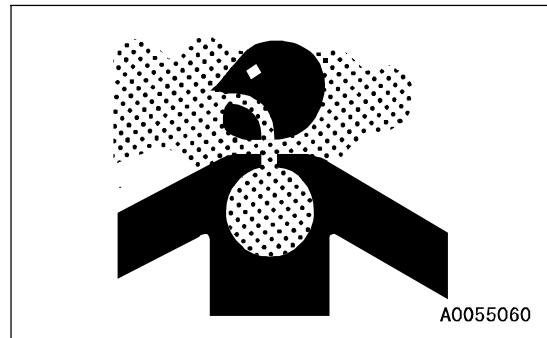
**CHECKING SIGNALMAN'S SIGNALS AND SIGNS**

- Set up signs to inform of road shoulders and soft ground. If the visibility is not good, position a signalman if necessary. Operators should pay careful attention to the signs and follow the instructions from the signalman.
- Only one signalman should give signals.
- Make sure that all workers understand the meaning of all signals and signs before starting work.

BE CAREFUL ABOUT ASBESTOS DUST

Asbestos dust in the air can cause lung cancer if it is inhaled. There is danger of inhaling asbestos when working on jobsites handling demolition work or work handling industrial waste. Always observe the following.

- Spray water to keep down the dust when cleaning. Do not use compressed air for cleaning.
- If there is danger that there may be asbestos dust in the air, always operate the machine from an upwind position. All workers should use an approved respirator.
- Do not allow other persons to approach during the operation.
- Always observe the rules and regulations for the work site and environmental standards.

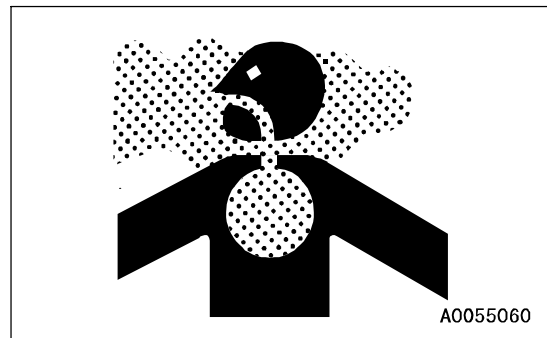

This machine does not use asbestos, but there is a danger that imitation parts may contain asbestos, so always use genuine Komatsu parts.

PRECAUTIONS FOR OPERATION

BEFORE STARTING ENGINE

If there is a warning tag hanging from the work equipment control lever, do not start the engine or touch the levers.

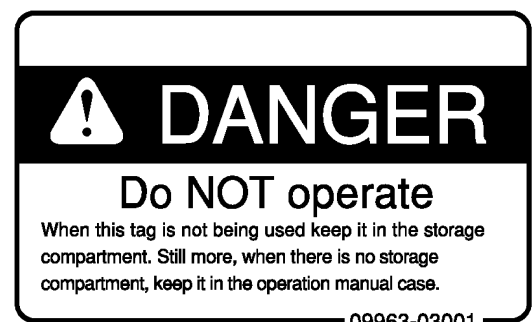
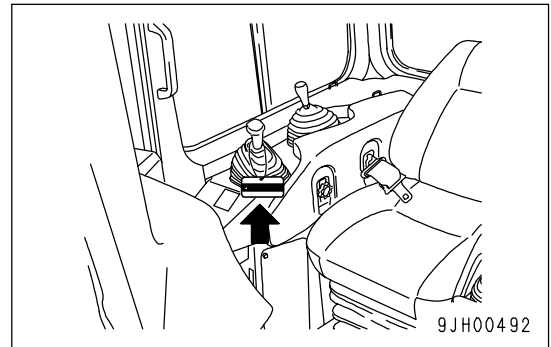

CHECKS BEFORE STARTING ENGINE

Carry out the following checks before starting the engine at the beginning of the day's work.

- Completely remove all flammable materials accumulated around the engine and battery, and remove any dirt from the windows, mirrors, handrails and steps.
- Remove all dirt from the surface of the lens of the front lamps and working lamps, and check that they light up correctly.
- Check the coolant level, fuel level, and oil level in engine oil pan, check for clogging of the air cleaner, and check for damage to the electric wiring.
- Adjust the operator's seat to a position where it is easy to carry out operations, and check that there is no damage or wear to the seat belt or mounting clamps.
- Check the operation of the instruments and gauges, check the angle of the mirror, and check that the control levers are all at the Neutral position.
- When starting the engine, check that the parking lever and work equipment lock lever are at the LOCK position.
- Adjust the mirrors so that you can get a good rear-view from the operator's seat.
For the details of adjustment, see "ADJUST MIRROR (PAGE 3-102)".
- Check that there are no persons or obstacles above, below, or in the area around the machine.

PRECAUTIONS WHEN STARTING

- Start and operate the machine only while seated.
- When starting the engine, sound the horn as a warning.
- Do not attempt to start the engine by short-circuiting the engine starting circuit. Such an act may cause a serious bodily injury or fire.
- Do not allow anyone apart from the operator to ride on the machine.

PRECAUTIONS IN COLD AREAS

- Carry out the warming-up operation thoroughly. If the machine is not thoroughly warmed up before the control levers are operated, the reaction of the machine will be slow, and this may lead to unexpected accidents.
- If the battery electrolyte is frozen, do not charge the battery or start the engine with a different power source. There is a hazard that this will ignite the battery and cause the battery to explode. Before charging or starting the engine with a different power source, melt the battery electrolyte and check that there is no leakage of electrolyte before starting.

OPERATION

CHECKS BEFORE OPERATION

When carrying out the checks, move the machine to a wide area where there are no obstructions, and operate slowly. Do not allow anyone near the machine.

- Always fasten your seat belt.
- Check the operation of travel, steering and brake systems, and work equipment control system.
- Check for any problem in the sound of the machine, vibration, heat, smell, or gauges; check also that there is no leakage of oil or fuel.
- If any problem is found, carry out repairs immediately.

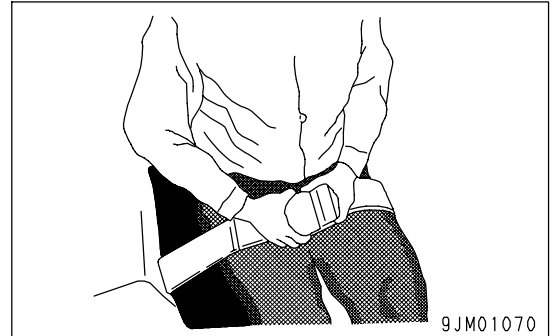

PRECAUTIONS FOR MOVING MACHINE FORWARD OR IN REVERSE

- Before travelling, check again that there is no one in the surrounding area, and that there are no obstacles.
- Before travelling, sound the horn to warn people in the area.
- Always operate the machine only when seated.
- Do not allow anyone apart from the operator to ride on the machine.
- Check that the backup alarm (alarm buzzer when machine travels in reverse) works properly.
- Always lock the door and windows of the operator's compartment in position (open or closed).

On jobsites where there is a hazard of flying objects or of objects entering the operator's compartment, check that the door and windows are securely closed.

- If there is an area to the rear of the machine where the visibility is obstructed, use a flagman. Be extremely careful not to hit anything and drive the machine slowly.

Always be sure to carry out the above precautions even when the machine is equipped with mirrors.

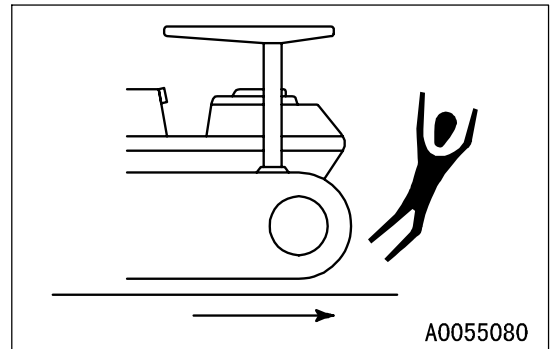

PRECAUTIONS WHEN TRAVELING

- Never turn the starting switch to the OFF position when traveling. It is dangerous if the engine stops when the machine is traveling. When the engine is off, it is impossible to operate the steering. Apply the brakes and stop the machine immediately, if the engine stops.
- When traveling on flat ground, keep the work equipment 40 to 50 cm (16 to 20 in) high above the ground.
- When traveling on rough ground, travel at low speed and do not operate the steering suddenly. There is danger that the machine may turn over. The work equipment may hit the ground surface and cause the machine to lose its balance, or may damage the machine or structures in the area.

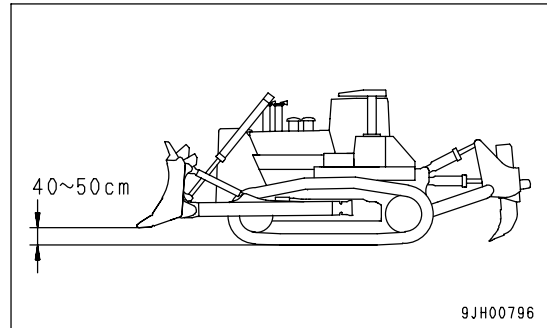

- Avoid traveling over obstacles when possible. If the machine has to travel over an obstacle, keep the work equipment close to the ground and travel at low speed. Never travel over obstacles which make the machine tilt strongly to one side.
- When traveling or carrying out operations, always keep a safe distance from people, structures, or other machines to avoid coming into contact with them.

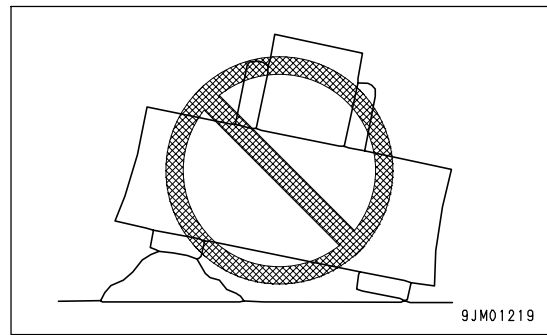

- When passing over bridges or structures, check first that the structure is strong enough to support the weight of the machine. When traveling on public roads, check first with the relevant authorities and follow their instructions.
- When operating in tunnels, under bridges, under electric wires, or other places where the height is limited, operate slowly and be extremely careful not to let the machine body or work equipment hit anything.
- Do not approach the edge of a cliff carelessly. When dropping soil over a cliff for banking or reclamation, leave soil of one scoop at the edge of the cliff and push it with the next scoop.
- When the machine passes over the top of a hill or when a load is dumped over a cliff, the load is suddenly reduced, and there is danger that the travel speed rises suddenly. To prevent this, lower the travel speed.
- If the machine moves with only either side of the blade loaded, its tail may swing. Take care.

TRAVELING ON SLOPES

To prevent the machine from tipping over or slipping to the side, always do as follows.

- When traveling on slopes, keep the blade approximately 20 to 30 cm (8 to 12 in) above the ground. In case of emergency, quickly lower the blade to the ground to help the machine to stop. Apply the brake and use the engine as a brake, if necessary.
- Always travel straight up or down a slope. Traveling at an angle or across the slope is extremely dangerous.

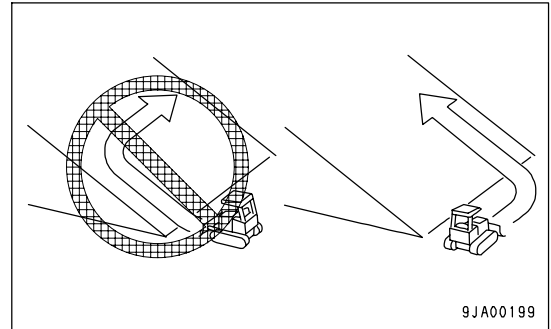

- Do not turn on slopes or travel across slopes. Always go down to a flat place to change the position of the machine, then travel on to the slope again.
- Travel on grass, fallen leaves, or wet steel plates with low speed. Even with slight slopes there is a hazard that the machine may slip.
- When driving down a slope, never shift gear or place the transmission in neutral. The engine brake cannot be used and this creates a dangerous condition. Always travel downhill in the same speed range as when traveling uphill. When operating on slopes of a grade of more than 15°, use F1 or R1.
- When turning on a downhill ground, lower the travel speed.

PROHIBITED OPERATIONS

- To make it easier to escape if there is any problem, set the tracks at right angles to the road shoulder or cliff with the sprocket at the rear when carrying out operations.
- When operating the machine, take care that it will not exceed its performance values such as stability, maximum using load, etc. to prevent rolling of the machine caused by an overload and disasters caused by breakage of the work equipment.

USING BRAKES

- When the machine is traveling, do not rest your foot on the brake pedal. If you travel with your foot resting on the pedal, the brake will always be applied, and this will cause the brakes to overheat and fail.
- Do not depress the brake pedal repeatedly if not necessary. If this is neglected, the brake will be overheated and will not work when required.
- When traveling downhill, use the braking force of the engine.

OPERATE CAREFULLY ON SNOW

- Snow-covered or frozen surfaces are slippery, so be extremely careful when traveling or operating the machine, and do not operate the levers suddenly. Even a slight slope may cause the machine to slip, so be particularly careful when working on slopes.
- With frozen ground surfaces, the ground becomes soft when the temperature rises, and this may cause the machine to tip over or make it impossible for the machine to escape.
- If the machine enters deep snow, there is a hazard that it may tip over or become buried in the snow. Be careful not to leave the road shoulder or to get trapped in a snow drift.
- When clearing snow, the road shoulder and objects placed beside the road are buried in the snow and cannot be seen. There is a hazard of the machine tipping over or hitting covered objects, so always carry out operations carefully.
- When traveling on snow-covered slopes, never apply the brakes suddenly. Reduce the speed and use the engine as a brake while applying the foot brake intermittently (depress the brake intermittently several times). If necessary, lower the blade to the ground to stop the machine.

PARKING MACHINE

- Park the machine on level ground where there is no danger of falling rocks or landslides, or of flooding if the land is low, and lower the work equipment to the ground.
- If it is necessary to park the machine on a slope, set the blocks (1) under the tracks to prevent the machine from moving, then dig the Point (2) of work equipment into the ground.
- After stopping the engine, operate the right work equipment control lever several times to the RAISE and LOWER positions to release the remaining pressure in the hydraulic circuit.

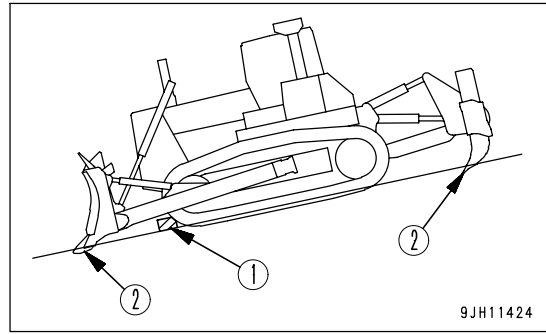

- When leaving the machine, set work equipment lock lever (1) and parking brake lever (2) to the LOCK position (L), then stop the engine.
- Always close the operator's cab door, and use the key to lock all the equipment in order to prevent any unauthorized person from moving the machine. Always remove the key, take it with you, and leave it in the specified place.

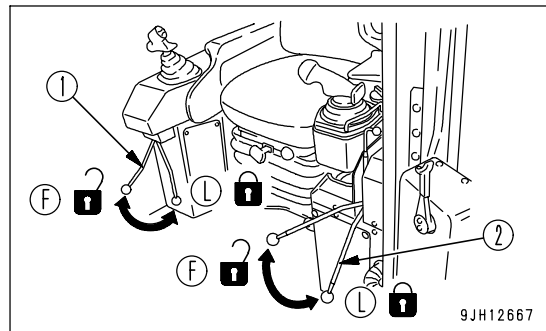

TRANSPORTATION

The machine can be divided into parts for transportation, so when transporting the machine, please contact your Komatsu distributor to have the work carried out.

LOADING AND UNLOADING

When loading or unloading the machine, mistaken operation may bring the hazard of the machine tipping over or falling, so particular care is necessary. Always do as follows.

- Perform loading and unloading on firm, level ground only. Maintain a safe distance from the edge of the road or cliff.
- Never use the work equipment to load or unload the machine. There is danger that the machine may fall or tip over.
- Always use ramps of adequate strength. Be sure that the ramps are wide, long, and thick enough to provide a safe loading slope. Take suitable steps to prevent the ramps from moving out of position or coming off.

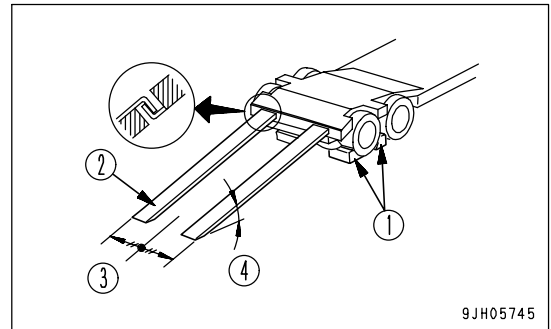

- (1) Blocks
- (2) Ramp
- (3) Centerline of trailer
- (4) Angle of ramps: Max. 15°

- Be sure the ramp surface is clean and free of grease, oil, ice and loose materials. Remove dirt from machine-tracks. On a rainy day, in particular, be extremely careful since the ramp surface is slippery.
- Run the engine at low speed and travel slowly.
- When on the ramps, do not operate any lever except for the travel lever.
- Never correct your steering on the ramps. If necessary, drive off the ramps, correct the direction, then enter the ramps again.
- The center of gravity of the machine will change suddenly at the joint between the ramps and the track or trailer, and there is danger of the machine losing its balance. Travel slowly over this point.
- When loading or unloading to an embankment or platform, make sure that it has suitable width, strength, and grade.
- For machines equipped with a cab, always lock the door after boarding the machine. If this is not done, the door may suddenly open during transportation. Refer to "TRANSPORTATION (PAGE 3-157)".

SHIPPING

When shipping the machine on a trailer, do as follows.

- The weight, transportation height, and overall length of the machine differ according to the work equipment, so be sure to confirm the dimensions.
- When passing over bridges or structures on private land, check first that the structure is strong enough to support the weight of the machine. When traveling on public roads, check first with the relevant authorities and follow their instructions.
- For details of the shipping procedure, see "TRANSPORTATION (PAGE 3-157)" in the OPERATION section.

BATTERY

BATTERY HAZARD PREVENTION

Battery electrolyte contains sulphuric acid, and batteries generate flammable hydrogen gas, which may explode. Mistaken handling can lead to serious injury or fire. For this reason, always observe the following precautions.

- When the battery electrolyte is below LOWER LEVEL, don't either use or charge the battery. Otherwise, that may cause explosion. Always carry out periodic checks of the battery electrolyte, and add distilled water up to UPPER LEVEL.

For the method of checking the battery electrolyte, see "CHECK LEVEL OF BATTERY ELECTROLYTE (PAGE 4-51)".

- When working with batteries, always wear safety glasses and rubber gloves.
- Never smoke or use any flame near the battery.

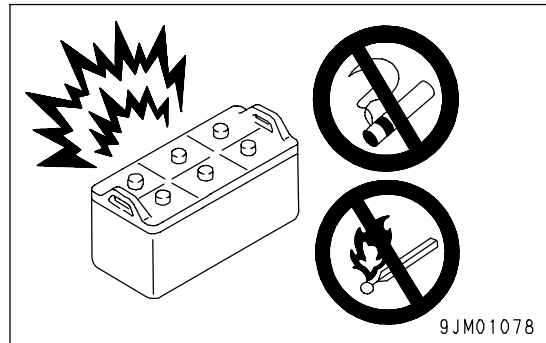

- If you spill acid on your clothes or skin, immediately flush the area with large amount of water.
- If acid gets into your eyes, flush them immediately with large amount of water and seek medical attention.
- Before working with batteries, turn the starting switch to the OFF position.

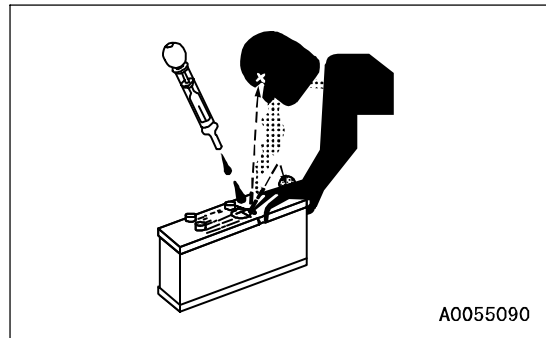

As there is a hazard that sparks will be generated, always do as follows.

- Do not let tools or other metal objects make any contact between the battery terminals. Do not leave tools or other metal objects lying around near the battery.
- When disconnecting the battery terminals, wait for approx. one minute after turning off the engine starting switch key, and be sure to disconnect the grounding terminal (negative (-) terminal) first. Conversely, when connecting them, begin with the positive (+) terminal and then the grounding (-) terminal. Make sure that all the terminals are connected securely.
- Tighten the battery terminals securely.
- Flammable hydrogen gas is generated when the battery is charged, so remove the battery from the chassis, take it to a well-ventilated place, and remove the battery caps before charging it.
- Tighten the battery caps securely.
- Install the battery securely to the determined place.

STARTING WITH BOOSTER CABLE

If any mistake is made in the method of connecting the booster cables, it may cause the battery to explode, so always do as follows.

- When starting with a booster cable, carry out the starting operation with two workers (one worker sitting in the operator's seat and the other working with the battery).
- When starting from another machine, do not allow the two machines to touch.

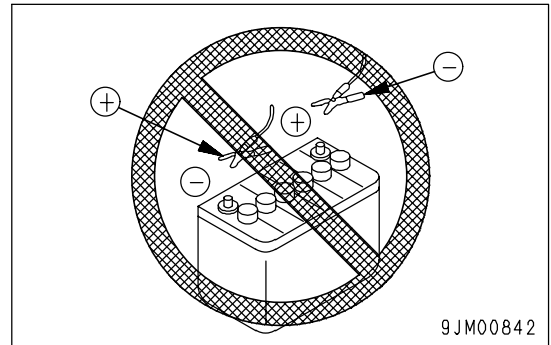

- When connecting the booster cables, turn the starting switch OFF position for both the normal machine and problem machine. There is a hazard that the machine will move when the power is connected.
- Be sure to connect the positive (+) cable first when installing the booster cables. Disconnect the negative (-) cable (ground side) first when removing them.

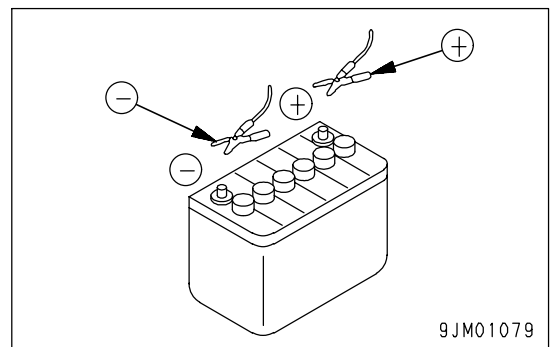

- When removing the booster cables, be careful not to let the booster cable clips touch each other or to let the clips touch the machine.
- Always wear safety glasses and rubber gloves when starting the engine with booster cables.
- When connecting a normal machine to a problem machine with booster cables, always use a normal machine with the same battery voltage as the problem machine.
- For the procedure of starting the engine with booster cables, see "STARTING ENGINE WITH BOOSTER CABLE (PAGE 3-176)".

TOWING

WHEN TOWING

Serious injury or death could result if a disabled machine is towed incorrectly or if there is a mistake in the selection or inspection of the wire rope.

For towing, see "METHOD OF TOWING MACHINE (PAGE 3-173)".

- Always check that the wire rope used for towing has ample strength for the weight of the machine being towed.
- Never use a wire rope which has cut strands (A), reduced diameter (B), or kinks (C). There is danger that the rope may break during the towing operation.

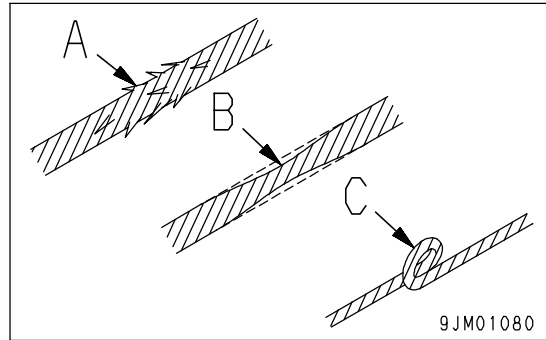

- Always wear leather gloves when handling wire rope.
- Never tow a machine on a slope.
- During the towing operation, never stand between the towing machine and the machine being towed.
- Operate the machine slowly and be careful not to apply any sudden load to the wire rope.

PRECAUTIONS FOR MAINTENANCE

WARNING TAG

- Always attach the "DO NOT OPERATE" warning tag to the work equipment control lever in the operator's cab to alert others that you are performing service or maintenance on the machine. Attach additional warning tags around the machine if necessary. Warning tag Part No. 09963-03001. Keep the tag in the operation manual pocket.
- If others start the engine, or touch or operate the work equipment control lever while you are performing service or maintenance, you could suffer serious injury or property damage.

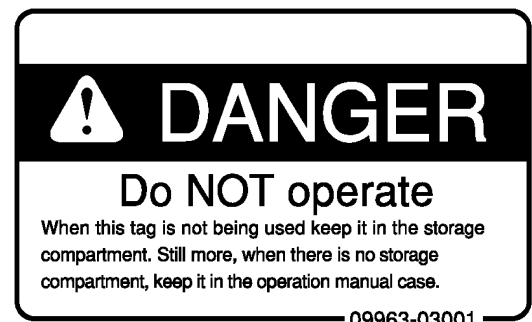
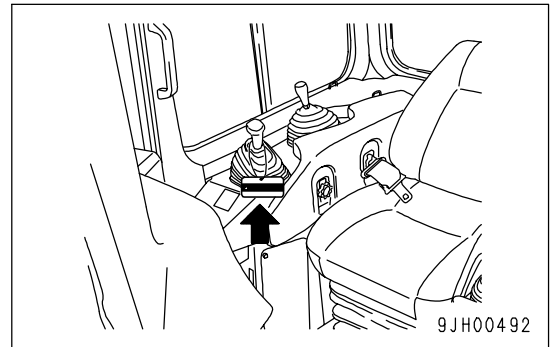

KEEP WORK PLACE CLEAN AND TIDY

- Do not leave hammers or other tools lying around in the work place. Wipe up all grease, oil, or other substances that will cause you to slip. Always keep the work place clean and tidy to enable you to carry out operations safely. If the work place is not kept clean and tidy, there is the danger that you will trip, slip, or fall over and injure yourself.

APPOINT LEADER WHEN WORKING WITH OTHERS

- When repairing the machine or when removing and installing the work equipment, appoint a leader and follow his instructions during the operation.

STOP ENGINE BEFORE CARRYING OUT INSPECTION AND MAINTENANCE

- Stop the machine on firm, level ground.
- Select a place where there is no hazard of landslides, falling rocks, or flooding.
- Lower the work equipment completely to the ground and stop the engine.

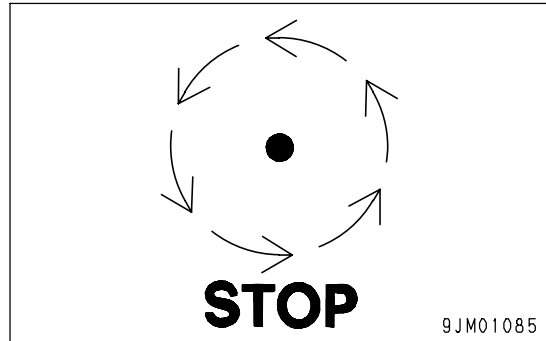

- Turn the starting switch to the ON position. Operate the work equipment control lever back and forth, left and right at the full stroke 2 to 3 times to eliminate the remaining internal pressure in the hydraulic circuit, and then push up work equipment lock lever (1) and parking brake lever (2) to the LOCK position (L).

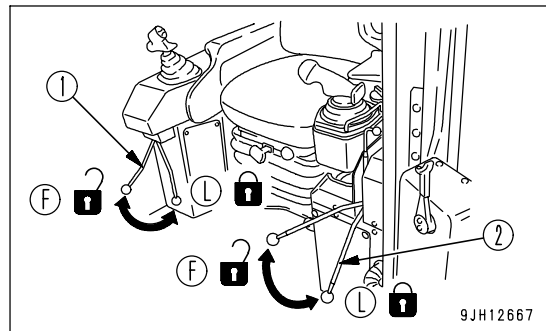

- Check that the battery relay is off and main power is not conducted. (Wait for approx. one minute after turning off the engine starting switch key and press the horn switch. If the horn does not sound, it is not activated.)
- Put blocks (1) under the track to prevent the machine from moving.

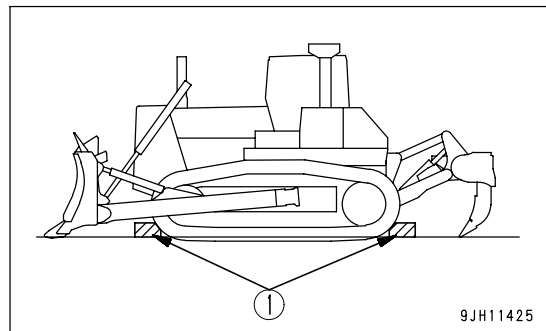

TWO WORKERS FOR MAINTENANCE WHEN ENGINE IS RUNNING

To prevent personal injury, do not carry out maintenance with the engine running. If maintenance must be carried out with the engine running, carry out the operation with at least two workers and do as follows.

- One worker must always sit in the operator's seat and be ready to stop the engine at any time. All workers must maintain contact with the other workers.
- Set work equipment lock lever (1) and parking brake lever (2) to the LOCK position (L) to prevent the work equipment from moving.
- Do not touch any control levers. If any control lever must be operated, give a signal to the other workers to warn them to move to a safe place.

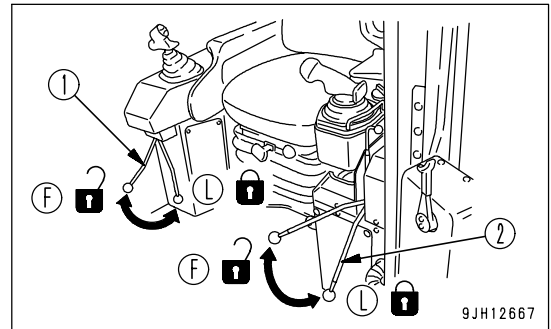

- When carrying out operations near the fan, fan belt, or other rotating parts, there is a hazard of being caught in the parts, so be careful not to come close.
- Never drop or insert tools or other objects into the fan or fan belt. Parts may break or be sent flying.

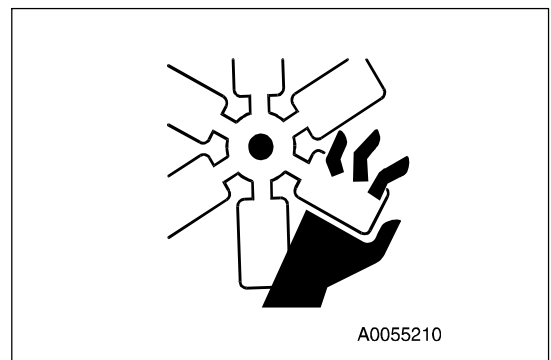
**PROPER TOOLS**

Use only tools suited to the task and be sure to use the tools correctly. Using damaged, low quality, faulty, makeshift tools or improper use of the tools could cause serious personal injury.

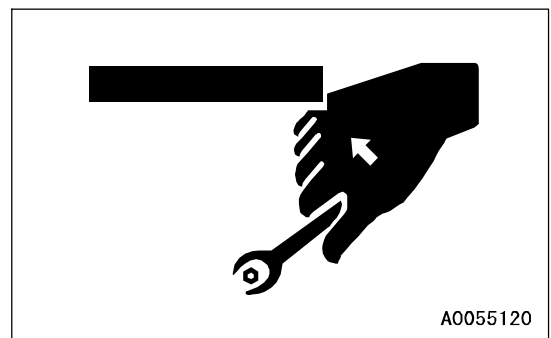

HANDLING ACCUMULATOR

- On machines equipped with an accumulator, for a short time after the engine is stopped, if the blade control lever is moved to the LOWER position, the work equipment will move down under its own weight.

After stopping the engine, always place the work equipment lock lever and parking lever in the LOCK position.

- When releasing the pressure inside the work equipment circuit on machines equipped with an accumulator, follow the procedure given in the following section.

Method of releasing pressure : See "ACCUMULATOR, HANDLING (PAGE 3-83)".

The accumulator is charged with high-pressure nitrogen gas. When handling the accumulator, careless procedure may cause an explosion which could lead to serious injury or property damage. For this reason, always observe the following precautions.

- Do not disassemble the accumulator.
- Do not bring it near flame or dispose of it in fire.
- Do not make holes in it, weld it, or use a cutting torch.
- Do not hit or roll the accumulator, or subject it to any impact.
- When disposing of the accumulator, the gas must be released.

Please contact your Komatsu distributor to have this work performed.



PERSONNEL

Do not allow any unauthorized personnel into the area when servicing the machine. If necessary, employ a guard.

ATTACHMENTS

- Appoint a leader before starting removal or installation operations for attachments.
- Place attachments that have been removed from the machine in a stable condition so that they do not fall. And take steps to prevent unauthorized persons from entering the storage area.



WORK UNDER THE MACHINE

- If it is necessary to go under the work equipment or the machine to carry out service and maintenance, support the work equipment and machine securely with blocks and stands strong enough to support the weight of the work equipment and machine.



- It is extremely dangerous to work under the machine if the track shoes are lifted off the ground and the machine is supported only with the work equipment. If any of the control levers is touched by accident, or there is damage occurring to the hydraulic piping, the work equipment or the machine will suddenly drop. This is extremely dangerous. Never work under the work equipment or the machine.

NOISE

When carrying out maintenance of the engine and you are exposed to noise for long periods of time, wear ear covers or ear plugs while working.

If the noise from the machine is too loud, it may cause temporary or permanent hearing problems.

PRECAUTIONS WHEN USING HAMMER

When using a hammer, pins may fly out or metal particles may be scattered. This may lead to serious injury. Always do as follows.

- If hard metal parts such as pins, bucket teeth, cutting edges, or bearings are hit with a hammer, there is a hazard that pieces might be scattered and cause serious personal injury or death. Always wear safety glasses and gloves.
- When hitting pins or bucket teeth, there is a hazard that broken pieces might be sent flying and injure people in the surrounding area. Always check that there is no one in the surrounding area.
- There is a hazard that the pin hit with strong force may fly out and injure people in the surrounding area.

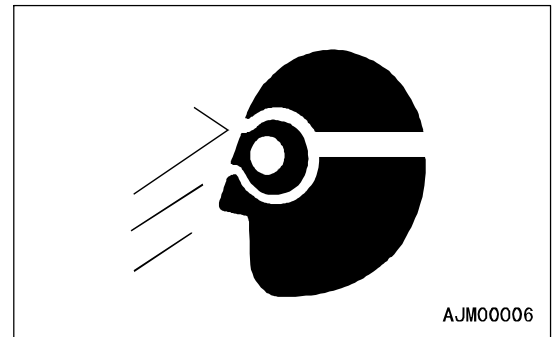
**REPAIR WELDING**

Welding operations must always be carried out by a qualified welder and in a place equipped with proper equipment. There is a hazard of gas, fire, or electrocution when carrying out welding, so never allow any unqualified personnel to carry out welding.

REMOVING BATTERY TERMINAL

When repairing or welding the electrical system, wait for approx. one minute after turning off the engine starting switch key, and then disconnect the negative (-) terminal of the battery to stop the flow of electricity.

PRECAUTIONS WHEN USING HIGH-PRESSURE GREASE TO ADJUST TRACK TENSION

- Grease is pumped into the track tension adjustment system under high pressure. If the specified procedure for maintenance is not followed when making adjustment, grease drain valve (1) may fly out and cause serious injury or damage.

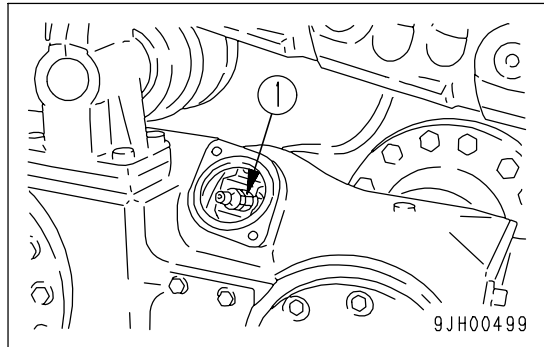

- When loosening grease drain valve (1) to loosen track tension, never loosen it more than one turn. In doing so, loosen the valve slowly.
- Never put your face, hands, feet, or any other part of your body directly in front of grease drain valve (1).



DO NOT DISASSEMBLE RECOIL SPRING

Never attempt to disassemble the recoils spring assembly. It contains a spring under high pressure which serves as a shock absorber for the idler. If it is disassembled by mistake, the spring will fly out and cause serious injury. When it becomes necessary to disassemble it, ask your Komatsu distributor to do the work.

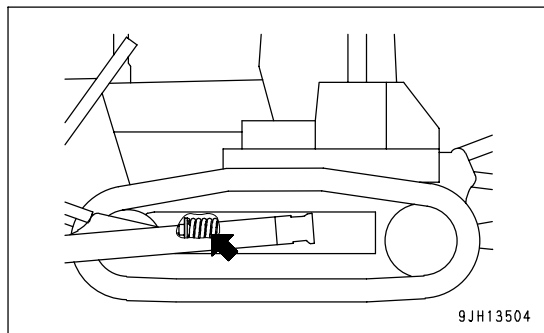

PRECAUTION WITH HIGH-PRESSURE OIL

The hydraulic system is always under internal pressure. When inspecting or replacing piping or hoses, always check that the pressure in the hydraulic circuit has been released. If the circuit is still under pressure, it will lead to serious personal injury, so always do as follows.

- Do not carry out inspection or replacement work when the hydraulic system is under pressure.
- If there is any leakage from the piping or hoses, the surrounding area will be wet, so check for cracks in the piping and hoses and for swelling in the hoses.

When carry out inspection, wear safety glasses and leather gloves.

- There is a hazard that high-pressure oil leaking from small holes may penetrate your skin or cause blindness if it contacts your eyes directly. If you are hit by a jet of high-pressure oil and suffer injury to your skin or eyes, wash the place with clean water, and consult a doctor immediately for medical attention.

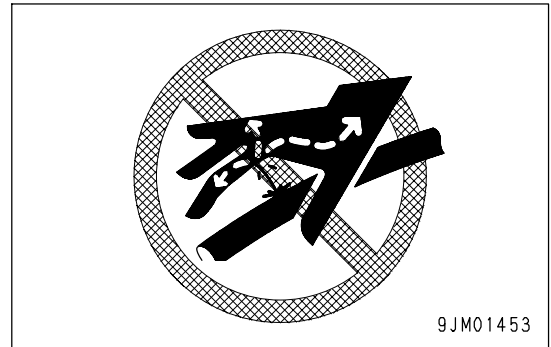
**PRECAUTION FOR HIGH FUEL PRESSURE**

High pressure is generated inside the engine fuel piping when the engine is running. When carrying out inspection or maintenance of the fuel piping system, wait for at least 30 seconds after stopping the engine to let the internal pressure go down before starting inspection or maintenance.

HANDLING HIGH-PRESSURE HOSES

- If oil or fuel leaks from high-pressure hoses, it may cause fire or defective operation, which may lead to serious injury. If any loose bolts are found, stop work and tighten to the specified torque. If any damaged hoses are found, stop operations immediately and contact your Komatsu distributor.

Replace the hose if any of the following problems are found.

- Damaged or leaking hydraulic fitting.
- Frayed or cut covering or exposed reinforcement wire layer.
- Covering swollen in places.
- Twisted or crushed movable portion.
- Foreign material embedded in covering.

PRECAUTION FOR HIGH VOLTAGE

When the engine is running or immediately after it has stopped, high voltage is generated at the injector terminal and inside the engine controller, so there is danger of electrocution. Never touch the injector terminal or the inside of the engine controller.

If it is necessary to touch the injector terminal or the inside of the engine controller, please contact your Komatsu distributor.

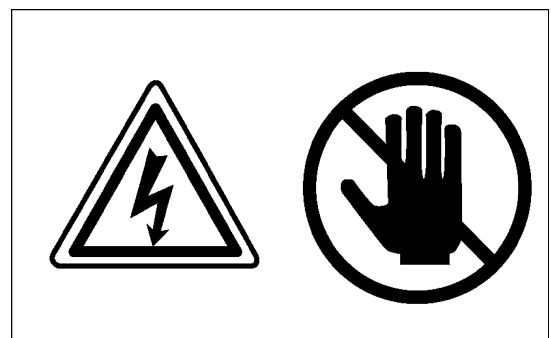

WASTE MATERIAL

To prevent pollution, pay careful attention to the method of disposing of waste materials.

- Always put oil drained from your machine in containers. Never drain oil directly onto the ground or dump into the sewage system, rivers, the sea, or lakes.
- Obey appropriate laws and regulations when disposing of harmful objects such as oil, fuel, coolant, solvent, filters, and batteries.

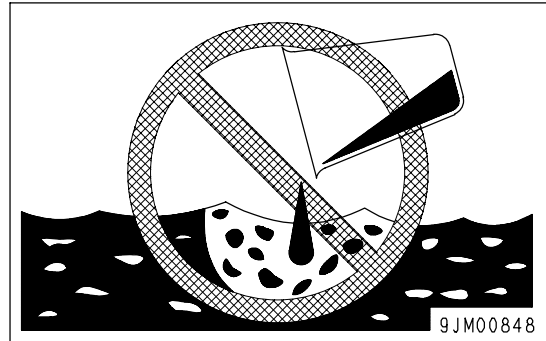
**MAINTENANCE FOR AIR CONDITIONER**

If air conditioner refrigerant gets into your eyes, it may cause blindness; if it touches your skin, it may cause frostbite. Never touch refrigerant.

COMPRESSED AIR

- When carrying out cleaning with compressed air, there is a hazard of serious injury caused by flying particles.
- When using compressed air to clean elements or the radiator, always wear safety glasses, dust mask, gloves, and other protective equipment.

PERIODIC REPLACEMENT OF SAFETY CRITICAL PARTS

- For using the machine safely for an extended period of time, replace safety-critical parts like hoses and seat belts periodically.

Replacement of safety-critical parts: See "PERIODIC REPLACEMENT OF SAFETY CRITICAL PARTS (PAGE 4-16)".

- The material of these components naturally changes over time, and repeated use causes deterioration, wear, and fatigue. As a result, there is a hazard that these components may fail and cause serious injury or death. It is difficult to judge the remaining life of these components from external inspection or the feeling when operating, so always replace them at the specified interval.
- Replace or repair safety-critical parts if any defect is found, even when they have not reached the specified replacement time.

OPERATION

WARNING

Please read and make sure that you understand the SAFETY section before reading this section.

GENERAL VIEW

GENERAL VIEW OF MACHINE

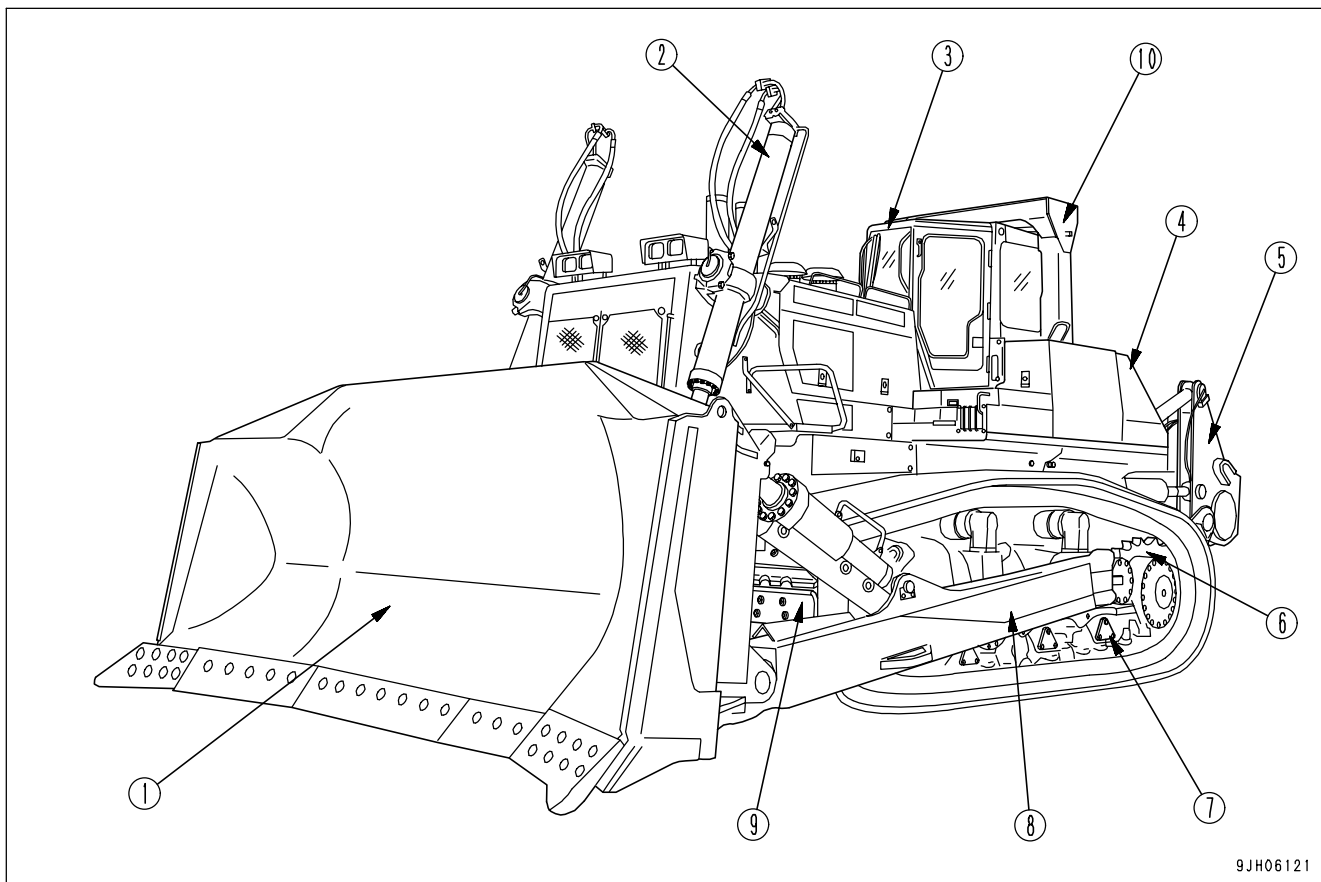

9JH06121

- | | |
|-------------------------|-----------------|
| (1) Blade | (6) Sprocket |
| (2) Blade lift cylinder | (7) Track frame |
| (3) Cab | (8) Frame |
| (4) Fuel tank | (9) Track shoe |
| (5) Ripper | (10) ROPS |

GENERAL VIEW OF CONTROLS AND GAUGES

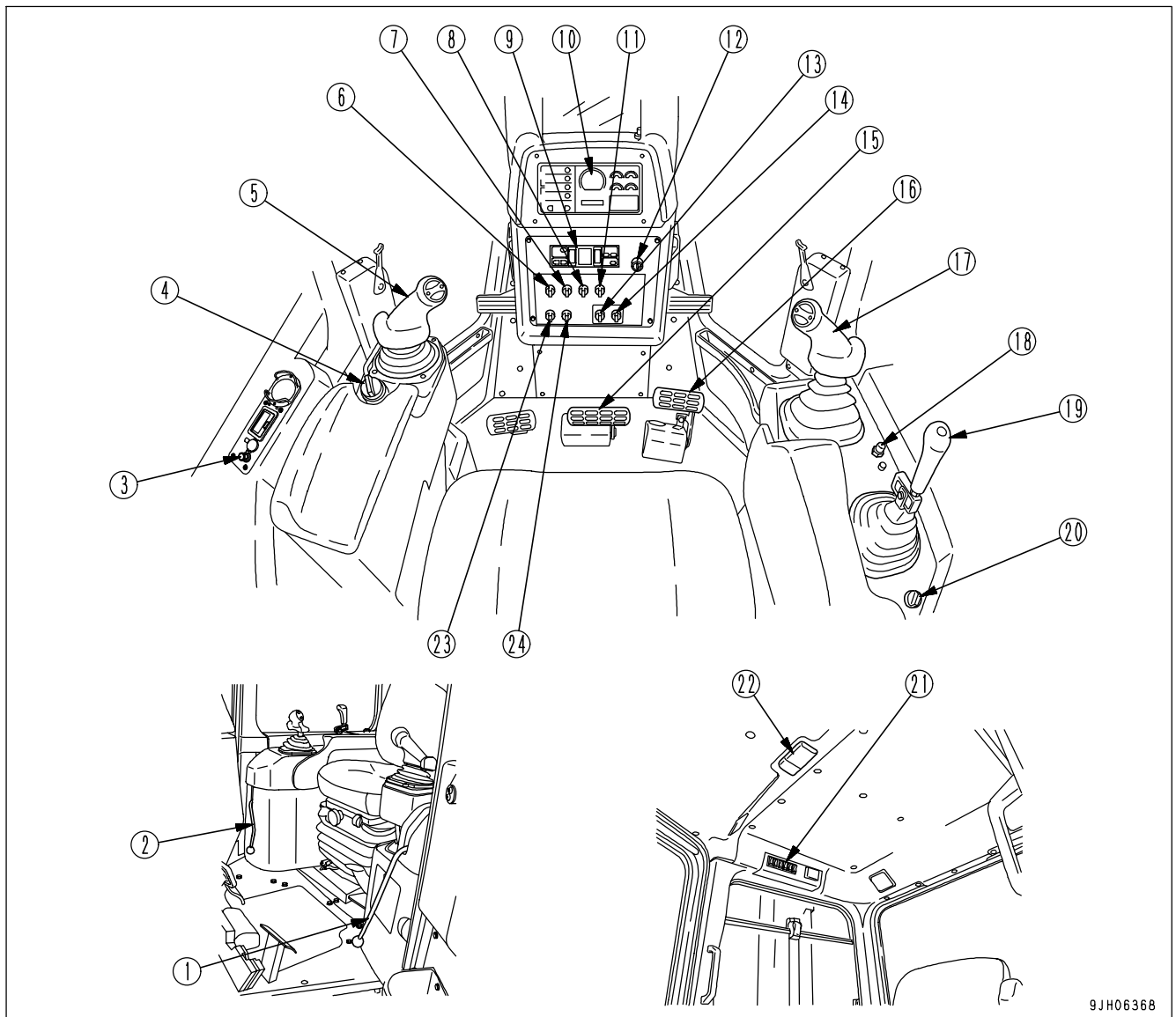

9JH06368

- | | |
|--|--|
| (1) Parking lever | (12) Starting switch |
| (2) Work equipment lock lever | (13) Information switch |
| (3) Cigarette lighter | (14) Buzzer cancel switch |
| (4) Fuel control dial | (15) Brake pedal |
| (5) Joystick
(Steering, directional and gear shift lever) | (16) Deceleration pedal |
| (6) Front lamp, working lamp switch | (17) Blade control lever |
| (7) Rear lamp switch | (18) Horn switch |
| (8) Fan rotation selector switch | (19) Ripper control lever |
| (9) Air conditioner panel or heater panel | (20) Pin puller control switch (if equipped) |
| (10) Display panel A
(speed range display, engine speed) | (21) Wiper switch |
| (11) Auto shift down switch | (22) Room lamp switch |
| | (23) Extra strong wind flow switch |
| | (24) Additional heater switch (if equipped) |

FRONT PANEL

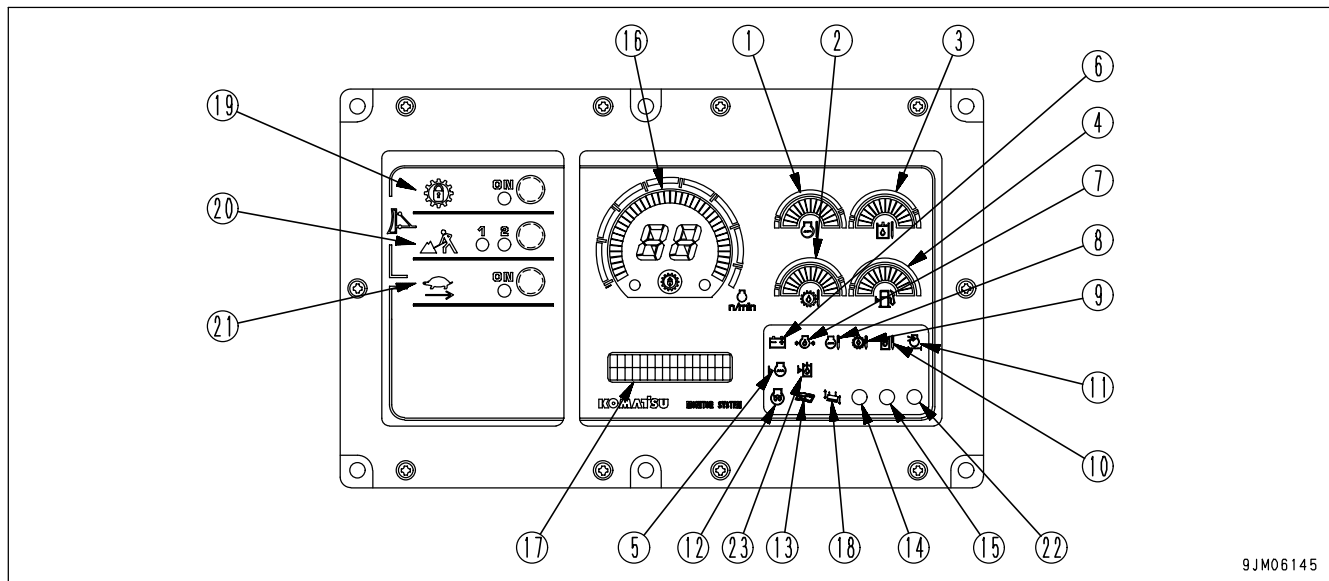

9JM06145

- | | |
|--|---|
| (1) Engine coolant temperature gauge | (13) Maintenance caution lamp |
| (2) Power train oil temperature gauge | (14) Warning lamp |
| (3) Hydraulic oil temperature gauge | (15) Filter, oil change interval lamp |
| (4) Fuel gauge | (16) Display panel A |
| (5) Radiator coolant level check lamp | (speed range display, engine speed) |
| (6) Charge level monitor | (17) Display panel B (multi-information) |
| (7) Engine oil pressure caution lamp | (18) Dual/single tilt selector display lamp |
| (8) Engine coolant temperature caution lamp | (19) Lock up mode switch |
| (9) Power train oil temperature caution lamp | (20) Economy mode switch |
| (10) Hydraulic oil temperature caution lamp | (21) Reverse slow mode selector lamp |
| (11) Air cleaner clogging caution lamp | (22) Fan operation confirmation lamp |
| (12) Engine pre-heating pilot lamp | (23) Hydraulic oil level caution lamp (if equipped) |

EXPLANATION OF COMPONENTS

The following is an explanation of devices needed for operating the machine.

To perform suitable operations correctly and safely, it is important to completely understand methods of operating the equipment, and the meanings of the displays.

FRONT PANEL

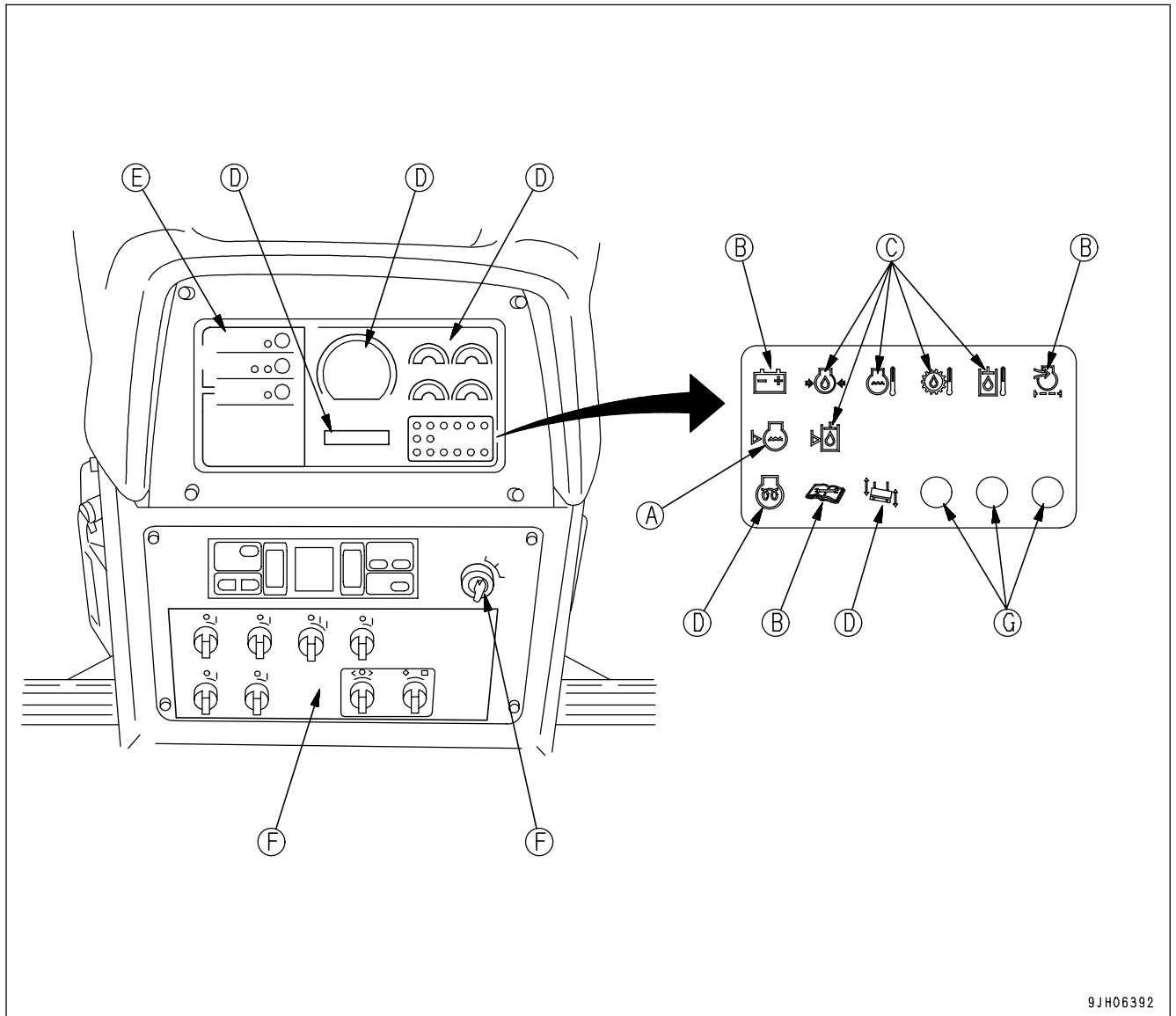

9JH06392

- (A) Check monitor group
- (B) Caution monitor group
- (C) Emergency caution items
- (D) Meter group
- (E) Mode selection switch group
- (F) Switches
- (G) Lamps

A: Check monitor group (for details, see "CHECK MONITOR GROUP (PAGE 3-7)")

Before the engine is started, the basic items among the check before starting items that must be checked are displayed.

If there is any abnormality, the caution lamp for the location of the abnormality flashes.

NOTICE

When carrying out checks before starting, do not simply rely on the monitor. Always refer to the periodic maintenance items or "OPERATION (PAGE 3-86)" to carry out the checks.

B: Caution monitor group (See "CAUTION MONITOR GROUP (PAGE 3-9)")



If the caution lamp for any of these items flashes, check and repair the appropriate item as soon as possible.

These are items which need to be observed when the engine is running. If any problem occurs, the item needing immediate repair is displayed. If there is any problem, the problem location on the caution lamp will flash.

C: Emergency caution items (for details, see "EMERGENCY CAUTION ITEMS (PAGE 3-11)")



If the caution lamp for any of these items flashes, stop the engine immediately or run it at low idling, and take the following action.

This displays the abnormal items that action must be taken on immediately the engine is running.

If there is any abnormality, the monitor showing the location of the abnormality will flash and the alarm buzzer will sound.

D. Meter group (see "METER GROUP (PAGE 3-14)")

This consists of the engine pre-heating pilot lamp, power train oil temperature gauge, engine coolant temperature gauge, hydraulic oil temperature gauge, fuel level gauge, dual/single selector display lamp, display panel A (speed range display, engine speed) and display panel B (multi-information).

E: Mode selection switch group (see "MODE SELECTION SWITCH GROUP (PAGE 3-19)")

This consists of the lock-up mode switch, economy mode selector switch, shoe slip control switch, rockbed selection mode selector switch, and slow reverse mode selector switch.

F. Switches (see "SWITCHES (PAGE 3-21)")

This consists of the starting switch, buzzer cancel switch, front lamp/working lamp switch, rear lamp switch, fan rotation selector switch, auto shift down switch, auto pitch back switch, information switch, extra strong wind flow switch, and additional heater switch.

G. Lamps (see "LAMPS (PAGE 3-25)".)

This consists of the warning lamp, filter/oil change interval lamp, and fan operation confirmation lamp.

CHECK MONITOR GROUP

NOTICE

- When performing the check before starting, do not rely only on these monitors. Always refer to "OPERATION (PAGE 3-86)" to perform these checks.
- Park the machine on level ground and then check the monitor lamps.
- Confirm that monitor lamps light up about 2 seconds after the starting switch is turned to the ON position. If any monitor lamp does not light, contact your Komatsu distributor to inspect and repair.

REMARK

- When the starting switch is turned to the ON position, before starting the engine, the caution lamps flash for 2 seconds, the warning lamps light up for 2 seconds, and the alarm buzzer sounds for 2 seconds.
- The caution lamps cannot be checked for any malfunction until at least 5 seconds after the engine has been stopped.

This displays the basic items among the check before starting items that must be checked before starting the engine. If there is any abnormality, the caution lamp for that location will flash.

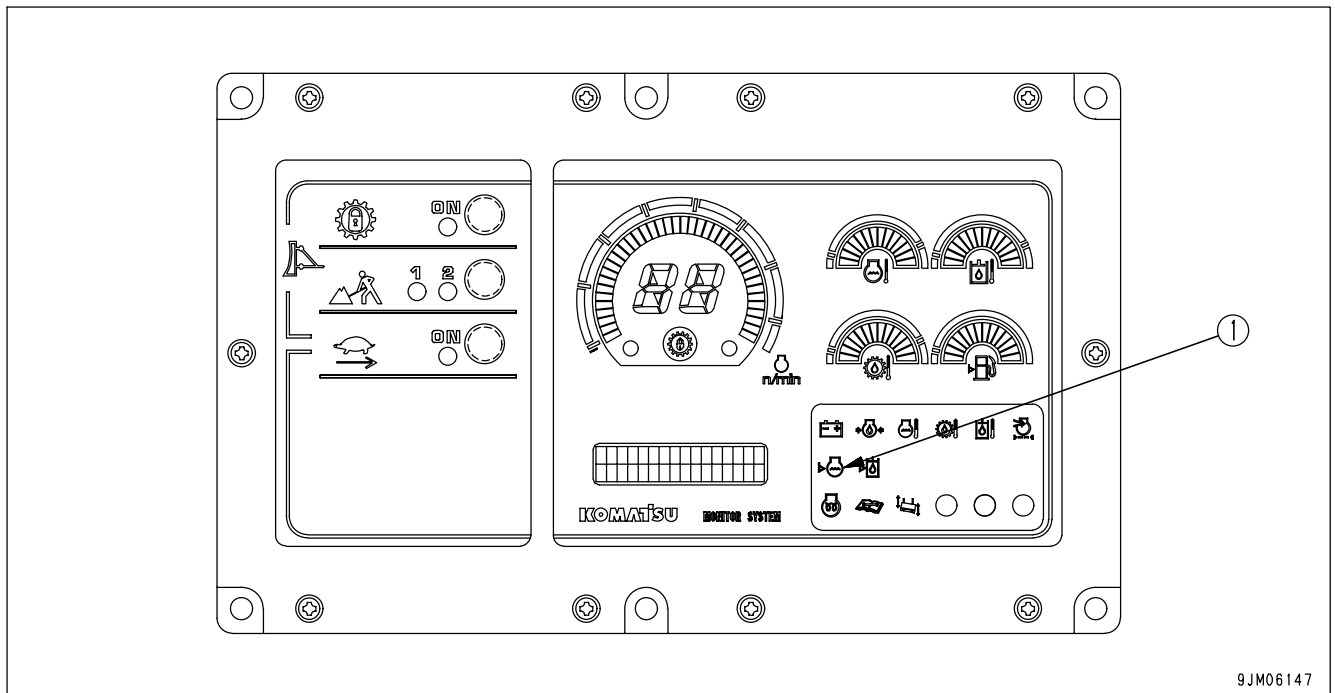

(1) Radiator coolant level caution lamp

RADIATOR COOLANT LEVEL CAUTION LAMP

Lamp (1) warns the operator that the coolant level in the main and sub radiators has gone down.

If the lamp flashes, check the coolant level in the main and sub radiators, and add coolant.

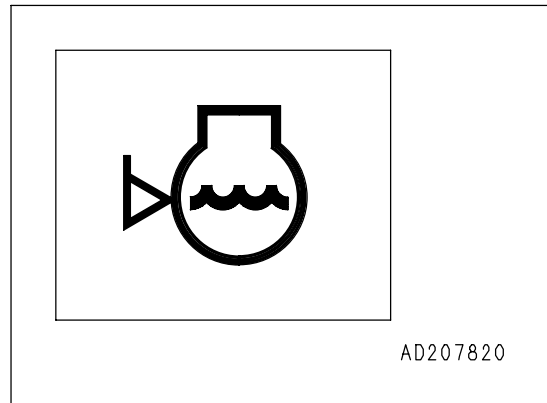

CAUTION MONITOR GROUP



If these caution lamps flash, check and repair the appropriate location as soon as possible.

NOTICE

- Park the machine on level ground and check the monitor lamps.
- Confirm that monitor lamps light up about 2 seconds after the starting switch is turned to the ON position. If any monitor lamp does not light, contact your Komatsu distributor to inspect and repair.

These are items which need to be observed when the engine is running. If any problem occurs, the item needing immediate repair is displayed. If there is any problem, the problem location on the caution lamp will flash.

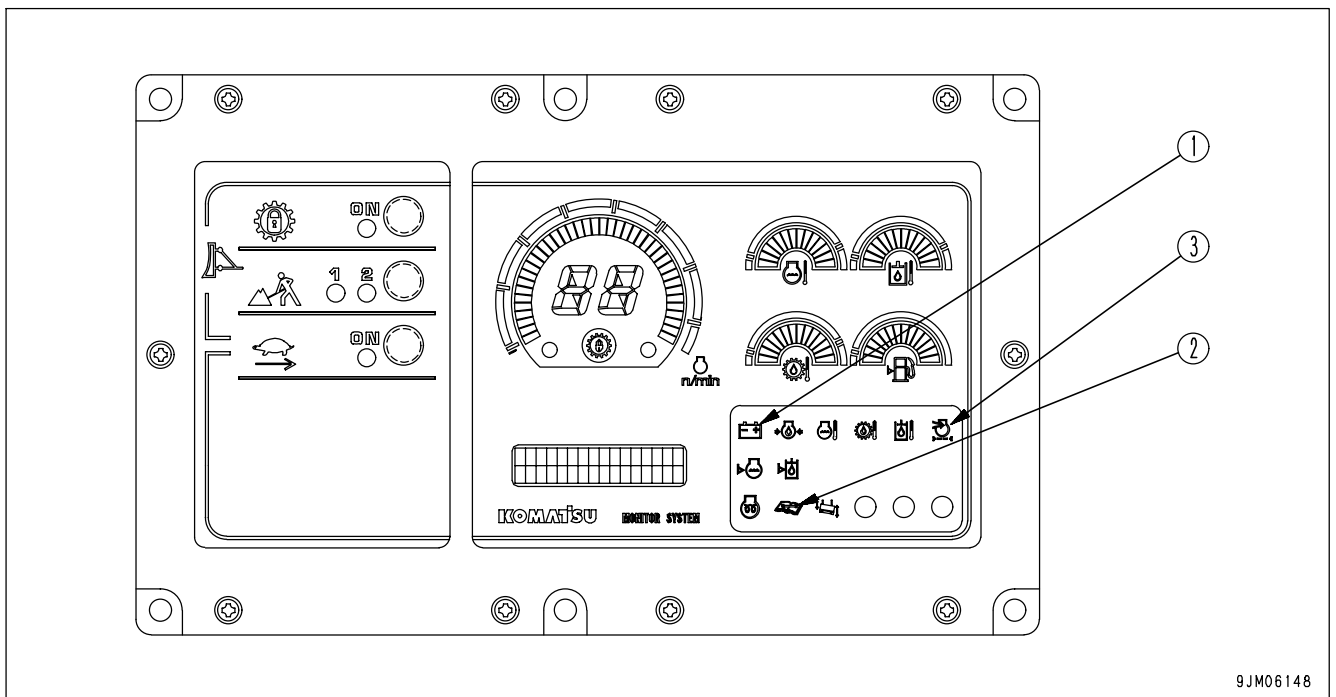

- (1) Charge level caution lamp
- (2) Maintenance caution lamp
- (3) Air cleaner clogging caution lamp

CHARGE LEVEL CAUTION LAMP

Lamp (1) indicates an abnormality in the charging system while the engine is running.

If the monitor lamp flashes, check the V-belt tension. If any abnormality is found, see "OTHER TROUBLE (PAGE 3-178)".

REMARK

This monitor lamp lights when the starting switch is turned to ON immediately after the engine is started or immediately before the engine is stopped. It does not indicate a problem.

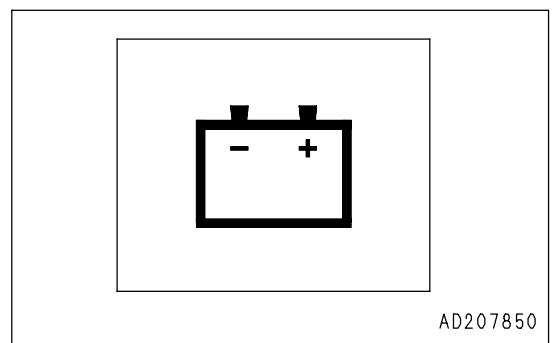

MAINTENANCE CAUTION LAMP

Monitor (2) flashes when the filter or oil change interval has been reached. DISPLAY PANEL B (Multi-information) (PAGE 3-18) to the maintenance mode and check or replace the applicable filter or oil.

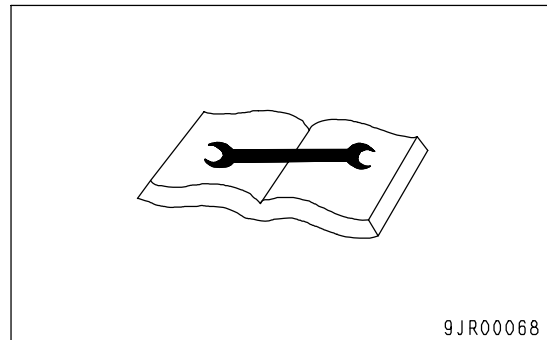
**AIR CLEANER CLOGGING CAUTION LAMP**

Lamp (3) warns operator that the air cleaner is clogged. If it flashes, stop the engine, check and clean the air cleaner.

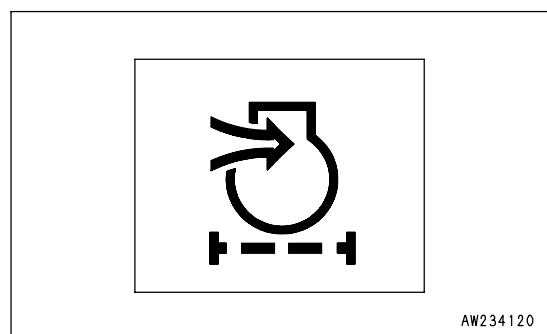

EMERGENCY CAUTION ITEMS

CAUTION

If the caution lamp for any of these items flashes, stop the engine immediately or run it at low idling, and take the following action.

NOTICE

- Park the machine on level ground and check the monitor lamps.
- Confirm that these caution lamps light for about 3 seconds after the starting switch is turned to ON. If any monitor lamp does not light, have your Komatsu distributor inspect and repair it.

These items need to be observed while the engine is running. If any abnormality occurs, items that need to be repaired immediately are displayed.

If there is any abnormality, alarm buzzer sounds intermittently and the abnormal location on the caution lamp will flash.

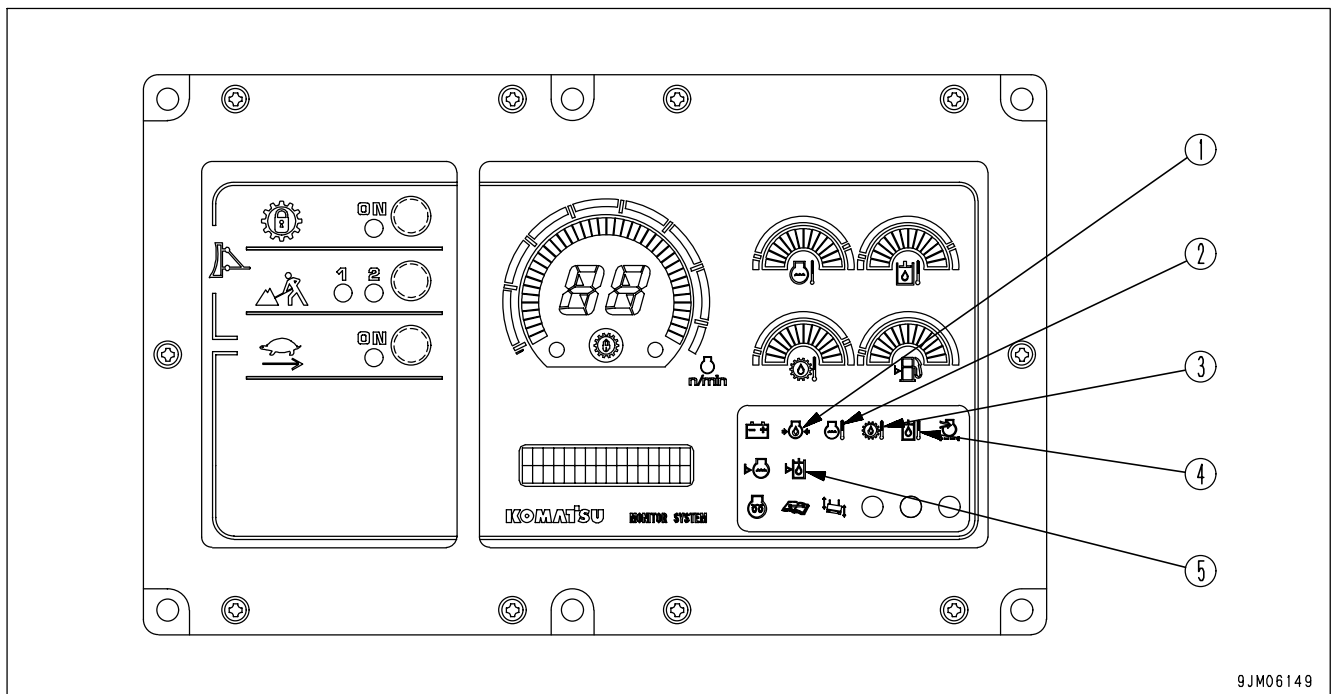

9JM06149

- | | |
|--|--|
| (1) Engine oil pressure caution lamp | (4) Hydraulic oil temperature caution lamp |
| (2) Engine coolant temperature caution lamp | (5) Hydraulic oil level caution lamp |
| (3) Power train oil temperature caution lamp | |

ENGINE OIL PRESSURE CAUTION LAMP

This lamp (1) indicates low engine oil pressure.

If the monitor lamp flashes, stop the engine and check it immediately.

REMARK

The alarm buzzer sounds, when the starting switch is turned to ON immediately after the engine oil has been changed. It does not indicate a problem.

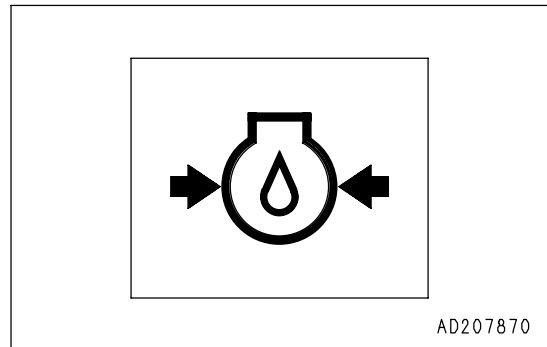
**ENGINE COOLANT TEMPERATURE CAUTION LAMP**

This lamp (2) indicates a rise in the coolant temperature.

When the monitor lamp flashes, run the engine at low idle speed until green range of the engine coolant temperature gauge lights.

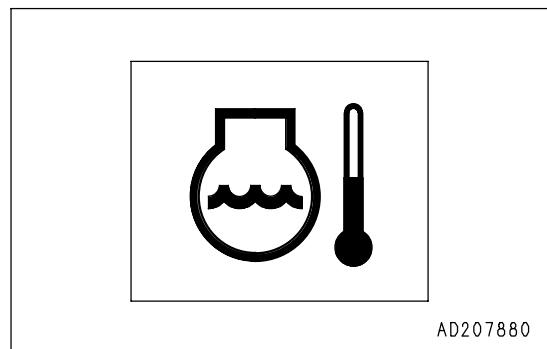
**POWER TRAIN OIL TEMPERATURE CAUTION LAMP**

Lamp (3) warns operator that the torque converter outlet port oil temperature has risen.

If it flashes, run the engine at low idling until the power train oil temperature gauge goes down to the green range.

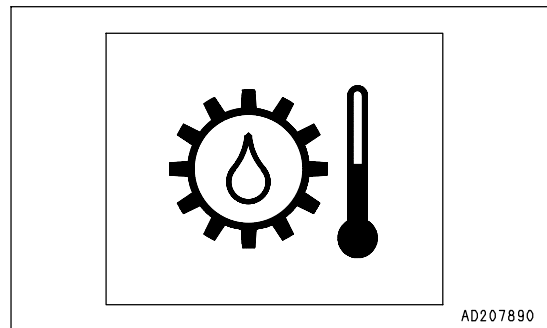
**HYDRAULIC OIL TEMPERATURE CAUTION LAMP**

Lamp (4) indicates a rise in the hydraulic oil temperature.

When the monitor lamp flashes, stop the machine and run the engine at the low idling speed until oil temperature falls.

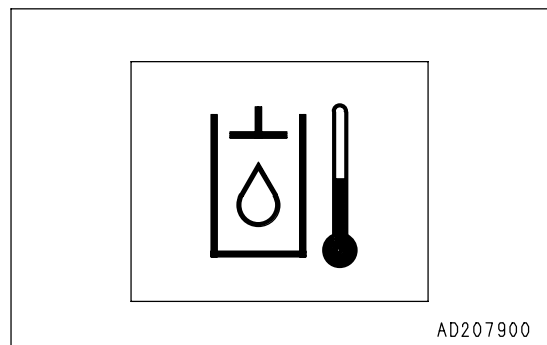

HYDRAULIC OIL LEVEL CAUTION LAMP

This lamp (5) warns the operator that the level of the hydraulic oil in the hydraulic tank has gone down.

If the lamp flashes, check the level of the hydraulic oil in the hydraulic tank, and add oil.

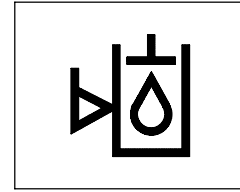

9JM05197

METER GROUP

NOTICE

While the engine is at rest, turn the starting switch to the ON position to see if the engine coolant temperature gauge, power train oil temperature gauge, fuel level gauge, and monitor lamps all light up.

If they do not, have your Komatsu distributor inspect and repair it.

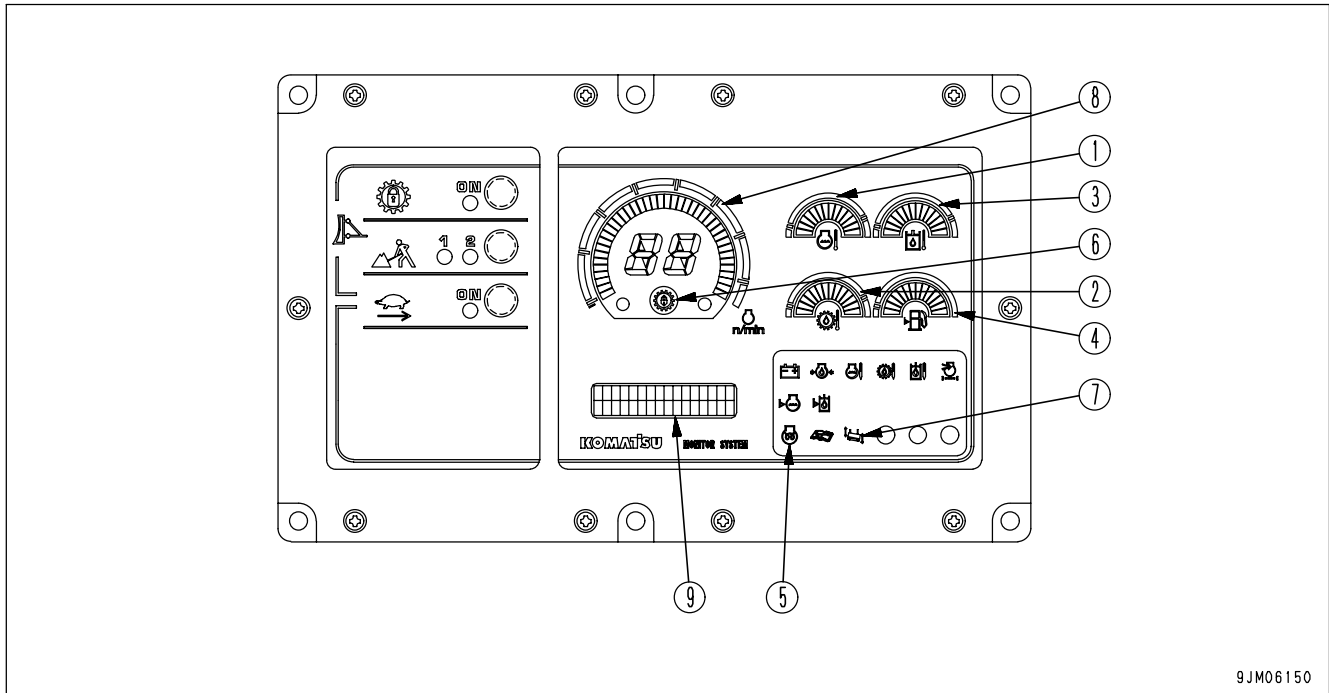

9JM06150

- | | |
|---|---|
| (1) Engine coolant temperature gauge | (7) Dual/single tilt selector display lamp
(dual tilt dozer specification) |
| (2) Power train oil temperature gauge | (8) Display panel A
(speed range display, engine speed) |
| (3) Hydraulic oil temperature gauge | (9) Display panel B (multi-information) |
| (4) Fuel level gauge | |
| (5) Engine pre-heating pilot lamp | |
| (6) Torque converter lock up pilot lamp | |

ENGINE COOLANT TEMPERATURE GAUGE

Gauge (1) indicates temperature of the engine coolant.

If the temperature is normal during operation, green range (B) will light.

If red range (C) lights during operation, move the fuel control dial to lower engine speed to approx. 3/4 of the full speed, and run until the coolant temperature enters green range (B).

During operation, if red range (C) lights, engine coolant temperature monitor flashes and the alarm buzzer sounds, stop the machine and run at low idle until coolant temperature enters green range (B).

(A): White range

(B): Green range

(C): Red range

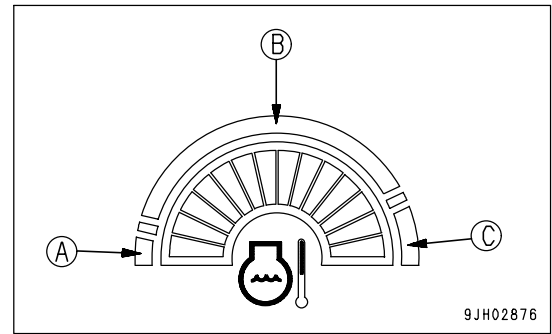
**NOTICE**

If the coolant temperature gauge often enters red range (C), check the radiator for clogging.

POWER TRAIN OIL TEMPERATURE GAUGE

Gauge (2) indicates the torque converter outlet oil temperature.

If the temperature is normal during operation, green range (B) will light.

If red range (C) lights up during operation, move the fuel control dial to lower engine speed to approx. 3/4 of the full speed, reduce the load and run until the oil temperature enters green range (B).

If red range (C) lights up, the power train oil temperature caution lamp flashes and the alarm buzzer sounds during operations, stop the machine, and run the engine at low idling until the oil temperature goes down to green range (B).

(A): White range

(B): Green range

(C): Red range

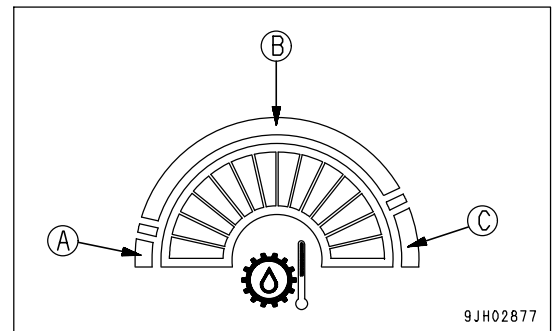
**NOTICE**

If the power train oil temperature gauge often enters red range (C), shift down one speed range to reduce the load on the power train when operating.

HYDRAULIC OIL TEMPERATURE GAUGE

Gauge (3) indicates the hydraulic oil temperature.

If the temperature is normal during operation, green range (B) will light.

If red range (C) lights up during operation, move the fuel control dial down to approx. 3/4 of the full speed, reduce the load, and run until the oil temperature enters green range (B). If the oil temperatures does not enter green range (B) even when the load is reduced, stop the work equipment control lever and run until the oil temperature enters green range (B).

(A): White range

(B): Green range

(C): Red range

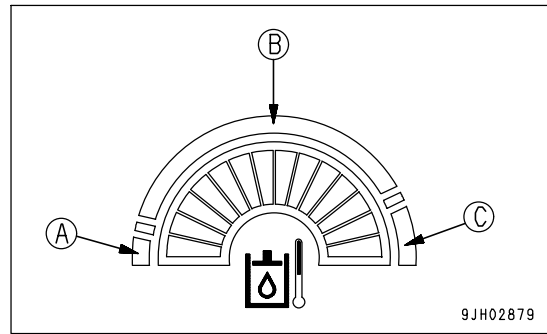
**FUEL LEVEL GAUGE**

Gauge (4) fuel level in the fuel tank.

During normal operation, the green range (B) should be lit.

If red range (A) lights up during operation, add fuel immediately. If this is not done, the engine speed will become irregular or an error display will be shown on the monitor.

(A): Red range

(B): Green range

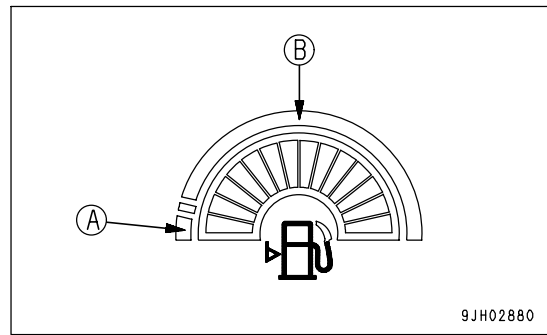
**REMARK**

- The display is not proportional to the amount of fuel remaining.
- If only the red range (A) lights up, there is less than 270 liters (71.34 US gal) of fuel remaining.

ENGINE PRE-HEATING PILOT LAMP

Lamp (5) indicates that engine is being pre-heated by the electrical heater during cold weather.

The engine controller detects the coolant temperature and automatically actuates pre-heating in low temperatures when starting the engine.

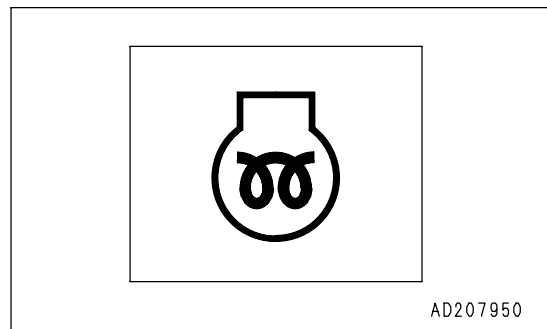

TORQUE CONVERTER LOCK UP PILOT LAMP

Lamp (6) lights up when the torque converter has been automatically locked up (when transmission is set to direct drive) after lock up switch for the monitor lamp has been turned ON. The lamp goes out when torque converter drive is being used.

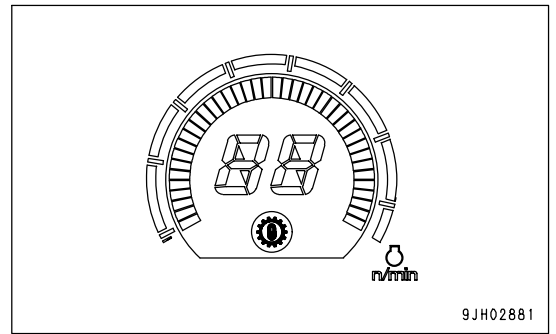

DUAL/SINGLE TILT SELECTOR DISPLAY LAMP

(Dual tilt dozer specification)

Lamp (7) lights green when the dual/single selector switch on the work equipment control lever is set to DUAL.

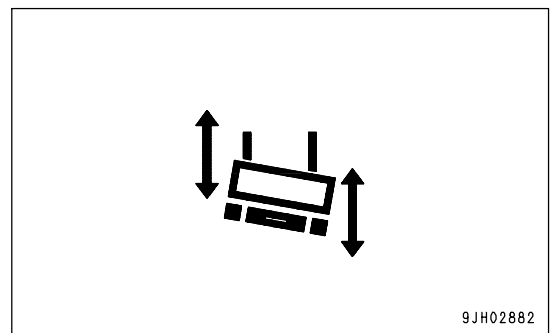

DISPLAY PANEL A (speed range display, engine speed)

Meter (8) displays transmission speed range being used on the machine and engine speed.

- When the transmission is in 1st FORWARD, the display shows F1, and when it is in 1st REVERSE, the display shows R1.
- The peripheral bar graph indicates the engine speed. When the red range lights up during running, shift the gear to a lower speed to run the engine at a speed within the green range.

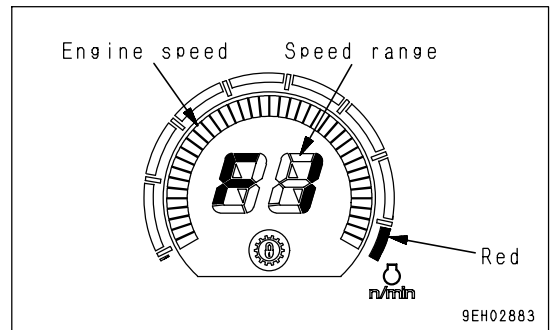

DISPLAY PANEL B (Multi-information)

This monitor (9) displays information related to the condition of the machine on the top and bottom lines of the display portion. The content of the display can be switched by operating the service mode selector switch.

(1) Operating mode (normal operation screen)

Use this mode when operating the machine.

REMARK

When starting switch is turned from the OFF position to the ON position, the multi-information is set to the operating mode.

The shift mode selected by operation of the "GEARSHIFTING USING SHIFT MODE SELECTION (PAGE 3-123)" through the shift mode selection is displayed on the left side of the monitor.

The total operating hours of the machine is displayed at the bottom right of the monitor. (Use the service meter function display to set the interval for periodic maintenance.)

When the engine is running, the service meter advances, even if the machine is not moving.

When the engine is running, the hourglass mark pilot display at the side of the meter lights up to show that the meter is advancing.

The meter advances by 1 for every hour of operation, regardless of the engine speed.

If there is a failure in the machine, the failure code is also displayed on the top line. If a failure code is displayed, carry out the remedy given in "OTHER TROUBLE (PAGE 3-178)".

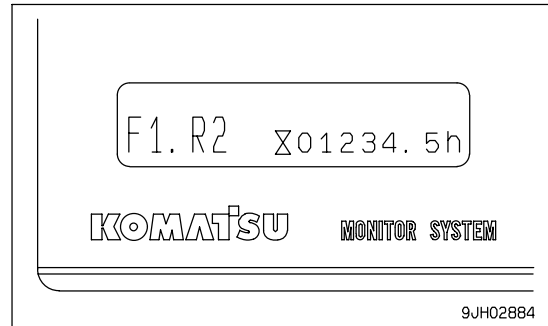
**(2) Maintenance mode**

The maintenance mode is displayed by continuing to turn the buzzer cancel switch in the \diamond direction for 2.5 seconds.

For details, see "METHOD OF USING DISPLAY PANEL B (Multi-information) (PAGE 3-27)".

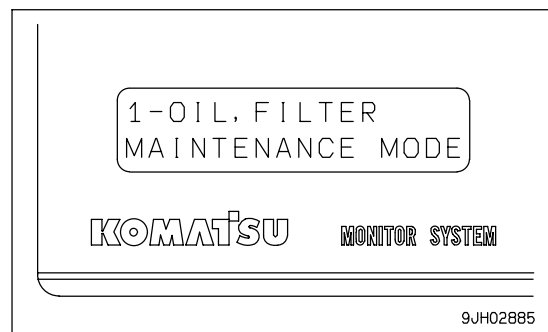

MODE SELECTION SWITCH GROUP

- Press each mode switch to turn it ON or OFF and to select the mode.
- For details of setting the mode to use, see "EFFECTIVE USE OF MODE SELECTION SYSTEM (PAGE 3-140)".
- It is impossible to use any combination of the lock up mode and any other mode.
- The economy mode, reverse slow mode, and shoe slip control mode can be used independently or in combination.

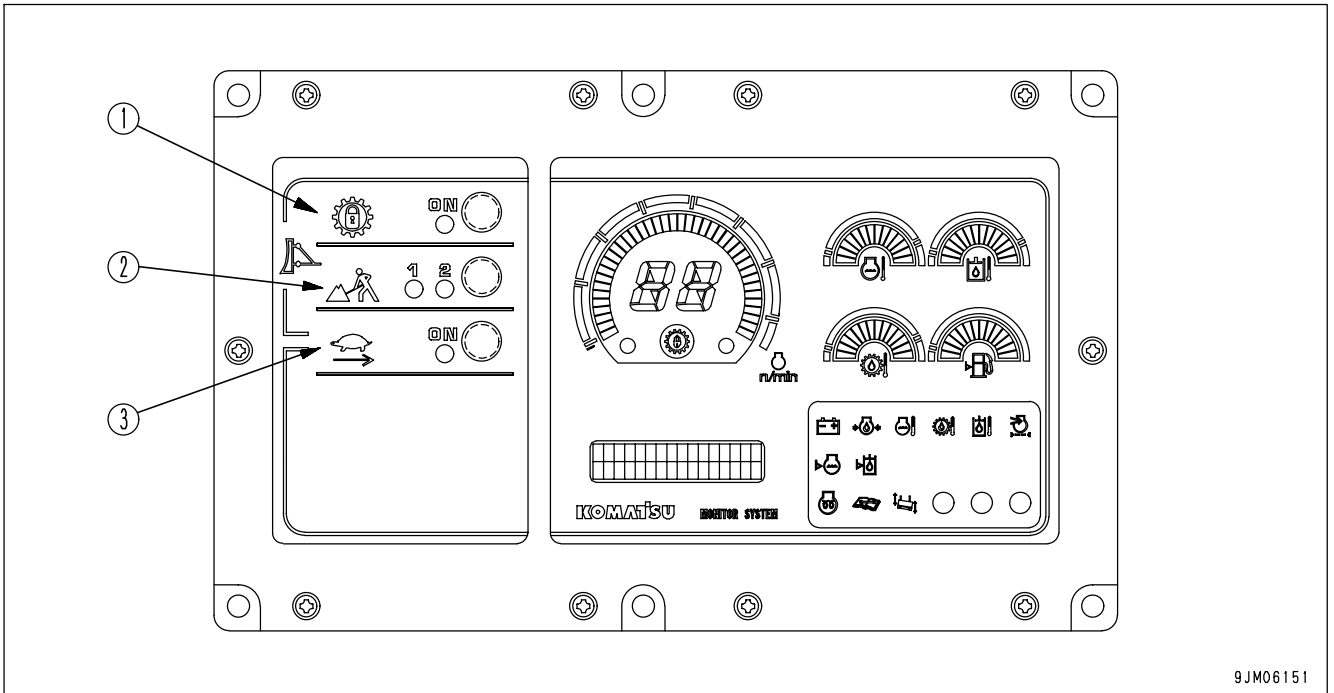

- (1) Lock up mode switch
- (2) Economy mode switch
- (3) Reverse slow mode selector switch

Selecting mode to match the type of work and quality of rock and soil makes to perform operations effectively.

Dozing		Ripping	
Lock up mode	Economy mode	Reverse slow mode	Shoe slip control
○	×	×	×
×	○	○	○

○: Possible to use ×: Compound use not possible

LOCK UP MODE SWITCH

Switch (1) is used when more power is needed rather than high production (such as when dozing loose soil).

The drive is switched between torque converter drive and direct drive according to the load. When it is ON, the lamp lights up.

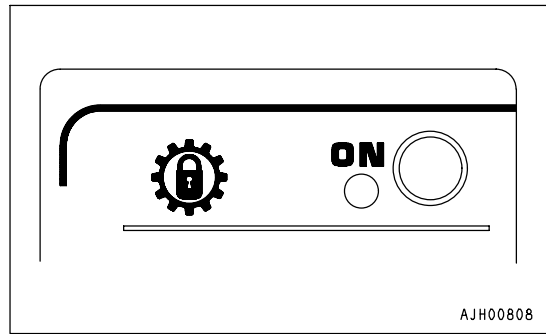

ECONOMY MODE SWITCH

Switch (2) is used for hauling work after ripping or for dozing blasted rock.

When the system is OFF, if the switch is pressed once, mode [1] lights up, and if it is pressed again, mode [2] lights up.

Select the mode according to the type of rock.

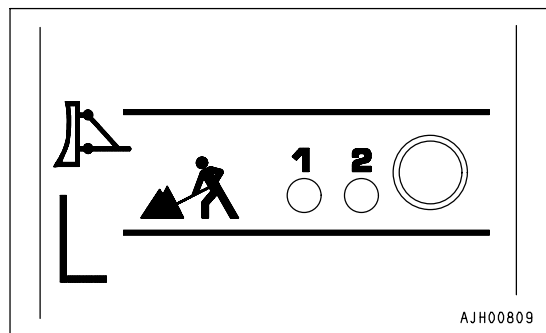

REVERSE SLOW MODE SELECTOR SWITCH

Switch (3) is used to make small reductions in the travel speed when traveling in R1, R2, or R3.

When it is turned ON, the lamp lights up.

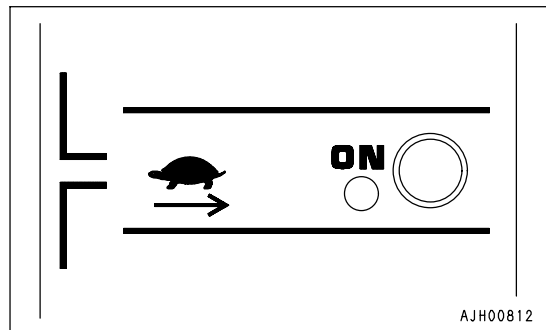

SWITCHES

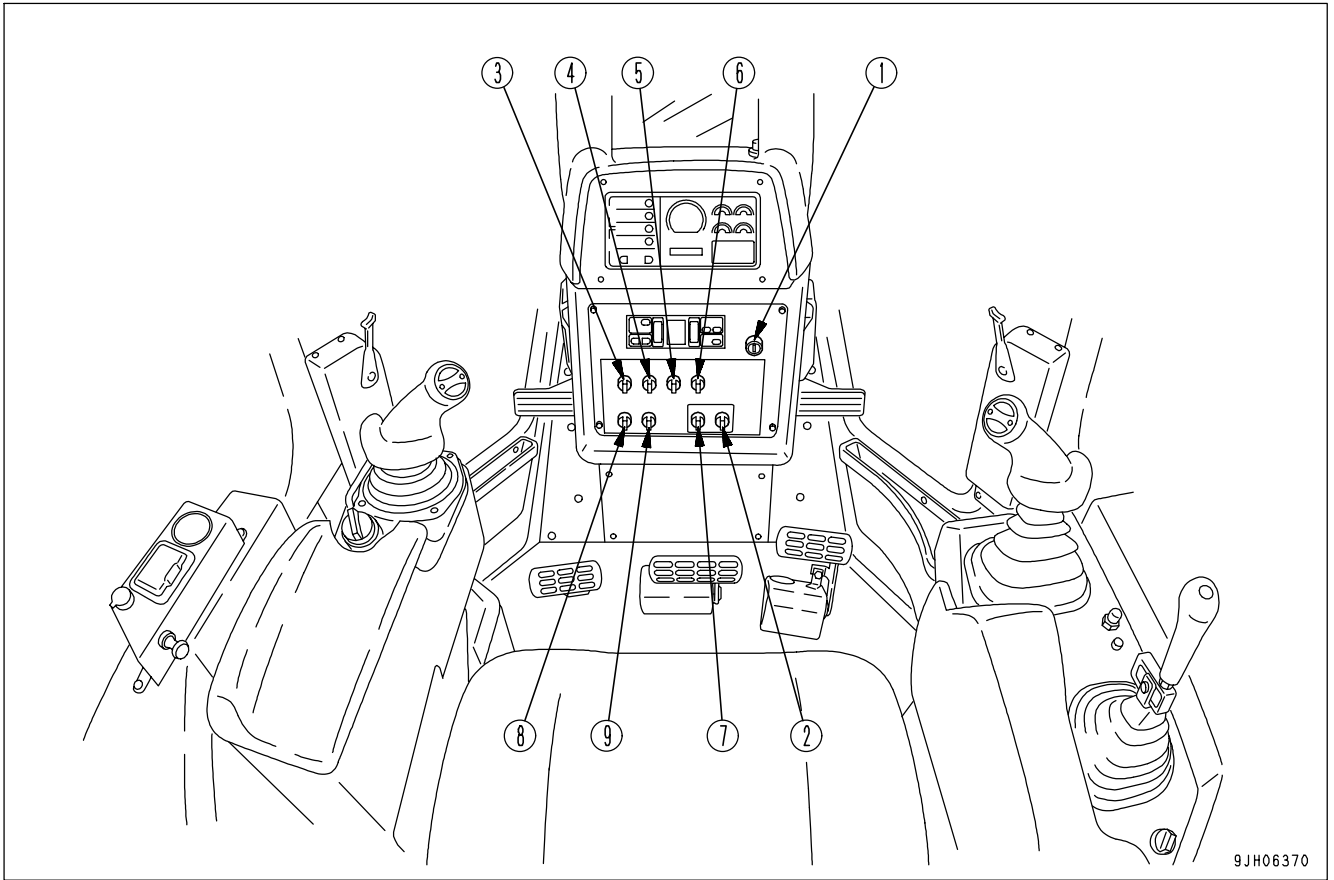

9JH06370

- | | |
|------------------------------------|--|
| (1) Starting switch | (6) Auto shift down switch |
| (2) Buzzer cancel switch | (7) Information switch |
| (3) Front lamp/working lamp switch | (8) Extra strong wind flow switch |
| (4) Rear lamp switch | (9) Additional heater switch (if equipped) |
| (5) Fan rotation selector switch | |

STARTING SWITCH

Switch (1) is used to start the engine.

OFF

Key insertion-withdrawal position. None of electrical circuits activate.

ON

Charging and electric device circuits activate. Keep key in the ON position after starting.

START

In this key position, the starting motor will crank the engine. Immediately after starting the engine, release the key which will automatically return to the ON position.

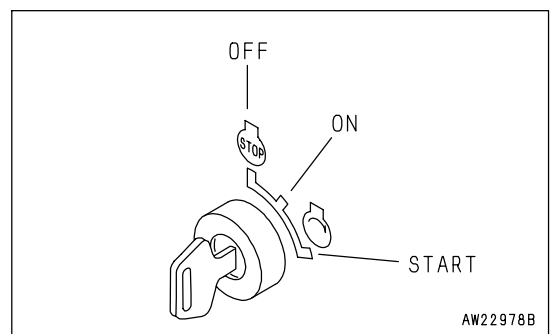

AW22978B

BUZZER CANCEL SWITCH

When switch (2) is operated to the left or right, the alarm buzzer stops.

When the information monitor is in the maintenance mode, switch (2) can be operated to move the cursor left or right.

(a) position: Cancel

(c) position: Select

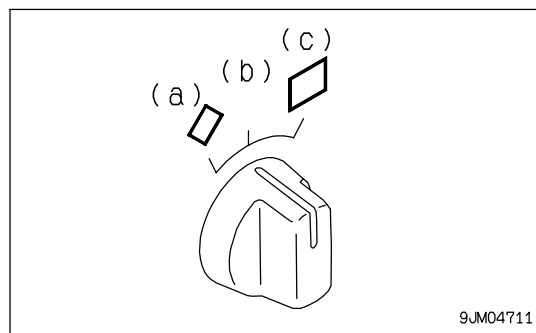

9JM04711

FRONT LAMP/WORKING LAMP SWITCH

Switch (3) lights up when the front lamp, left and right working lamps located on the front fender, and panel lamp light up.

(a) OFF position: Goes out

(b) ON position: Lights up

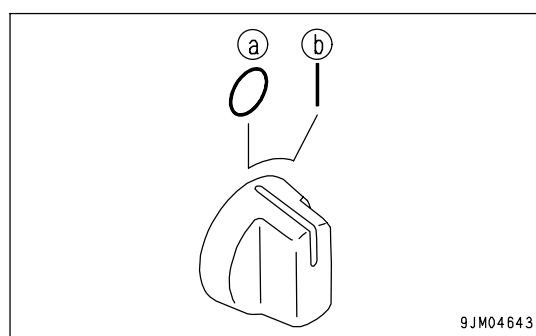

9JM04643

REAR LAMP SWITCH

Switch (4) lights up the rear lamp.

(a) OFF position: goes off

(b) ON position: lights up

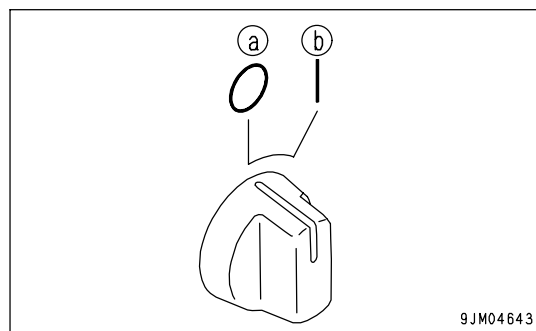

9JM04643

FAN ROTATION SELECTOR SWITCH

Switch (5) is used to select the normal, reverse, or clean mode for the fan.

Position (a): Normal mode

Position (b): Reverse mode

Position (c): Clean mode

The reverse mode is used in cold weather to maintain the temperature; the clean mode is used to blow the dirt out when cleaning the radiator.

In the clean mode, the fan normally rotates at 100% speed.

Always stop the engine before operating the fan rotation selector switch.

If the fan rotation selector switch is operated when the engine is running, the fan operation confirmation lamp flashes to inform the operator that the fan rotation cannot be switched. When rotating the fan in the clean mode, open the engine room side cover.

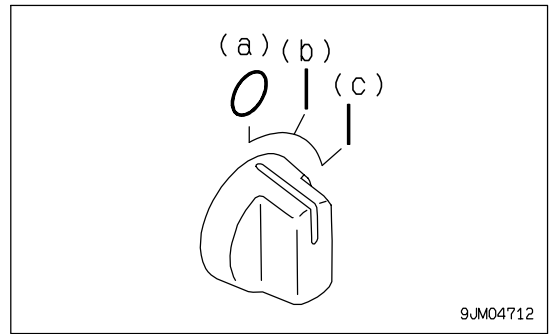

9JM04712

AUTO SHIFT DOWN SWITCH

If switch (6) is turned to the right when the travel speed has gone down because of load condition when traveling, the transmission is automatically shifted to low speed.

Position (a) (OFF): Auto shift down is canceled

Position (b) (ON): Transmission automatically shifts to low speed

For details, see "AUTO SHIFT DOWN OPERATION (PAGE 3-125)".

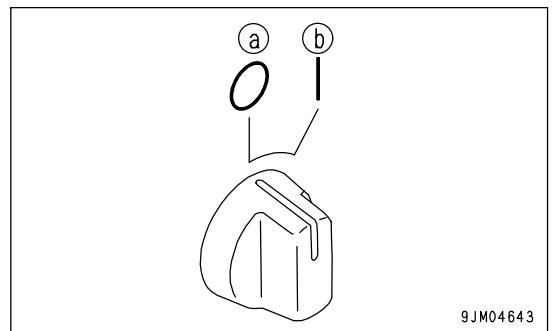

9JM04643

INFORMATION SWITCH

This switch (7) is used to carry out the switching of the information monitor display mode and the switching of the cursor with the maintenance mode.

(a) position: Cursor moves to left

(c) position: Cursor moves to right

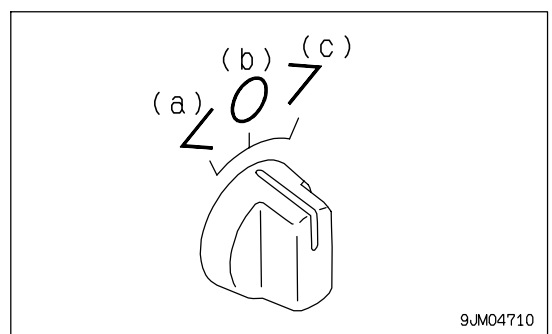

9JM04710

EXTRA STRONG WIND FLOW SWITCH

Switch (8) is used to provide a stronger wind flow than for the normal HIGH position.

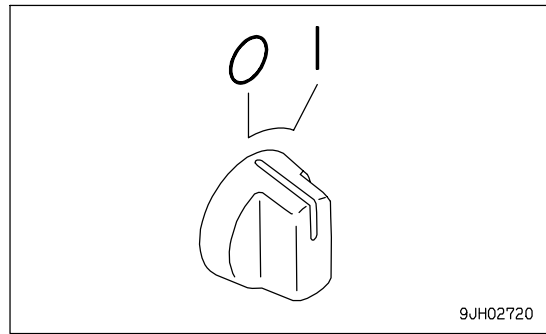
**ADDITIONAL HEATER SWITCH**

(If equipped)

Switch (9) actuates the hot water heater.

Position (a): Hot water heater OFF

Position (b): Hot water heater LOW (ON)

Position (c): Hot water heater HIGH (ON)

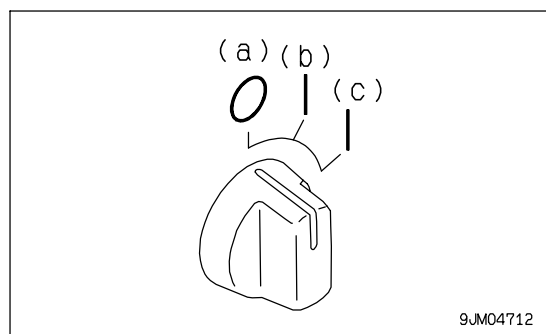

LAMPS

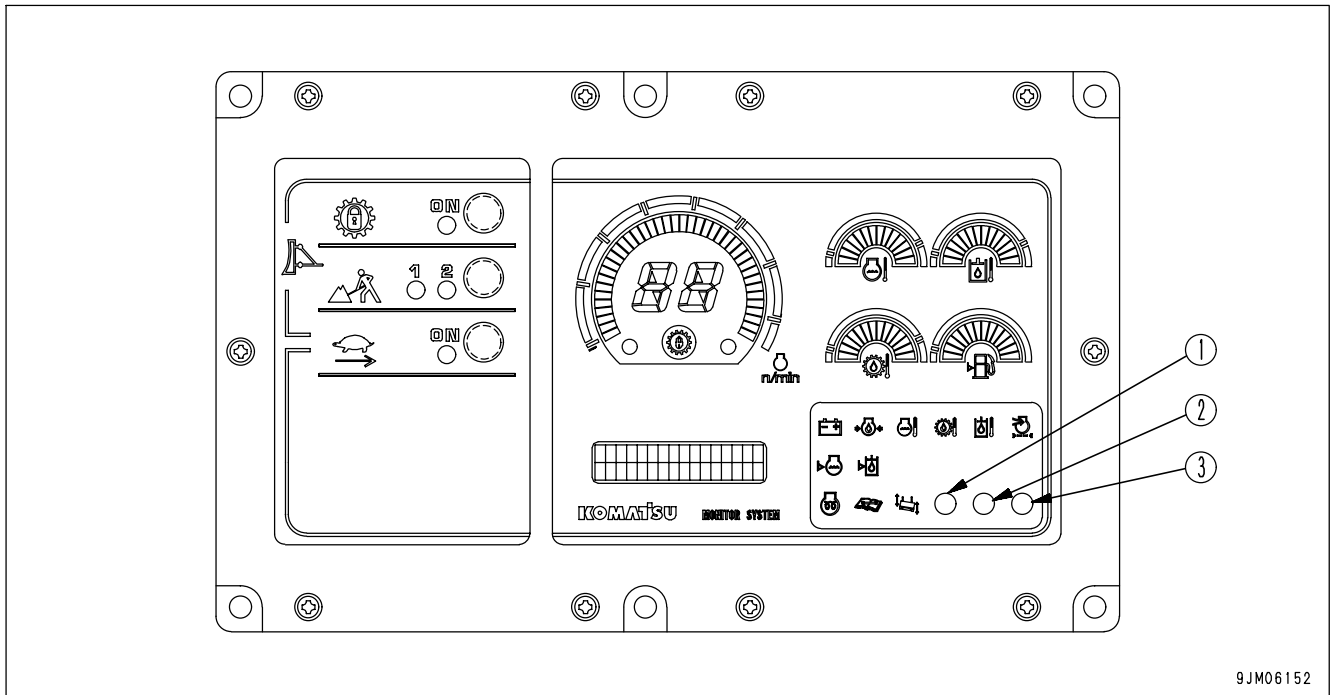

(1) Warning lamp

(2) Filter/oil change interval lamp

(3) Fan operation confirmation lamp

WARNING LAMP

NOTICE

If alarm buzzer sounds, stop work immediately and perform inspection and maintenance of the appropriate point.

When the caution lamp for the CAUTION (B) and CAUTION (C) groups on the machine monitor system flashes, and an abnormality has occurred in the electronic control system, lamp (1) also flashes at the same time.

If the lamp flashes, check the monitor panel to locate the abnormality.

When the monitor inside the CAUTION (C) group flashes, the alarm buzzer also sounds continuously.

See "FRONT PANEL (PAGE 3-5)".

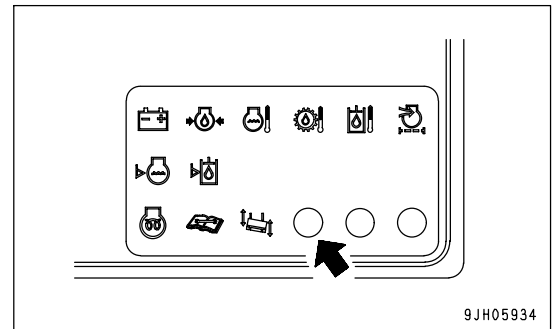

9JH05934

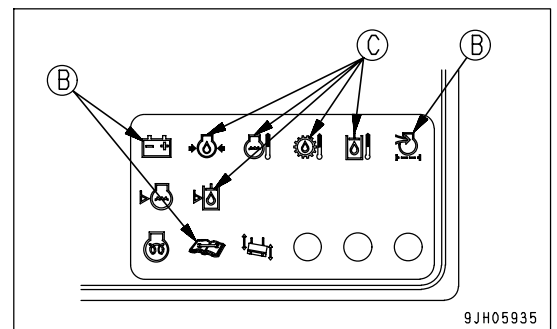

9JH05935

FILTER/OIL CHANGE INTERVAL LAMP

Lamp (2) lights when it comes near the time for replacing the filter or oil.

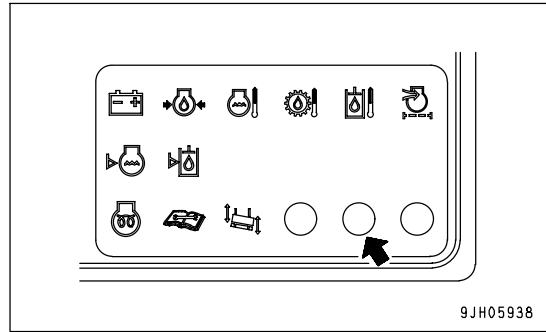
**FAN OPERATION CONFIRMATION LAMP**

If fan rotation selector switch (3) is in reverse mode or clean mode and the starting switch is turned to the ON position, this lamp lights up to warn the operator that the fan is rotating in reverse direction. When starting switch is turned to the START position, the lamp goes out.

If the fan rotation selector switch is operated when the engine is running, this lamp flashes to warn the operator that the fan operation cannot be switched.

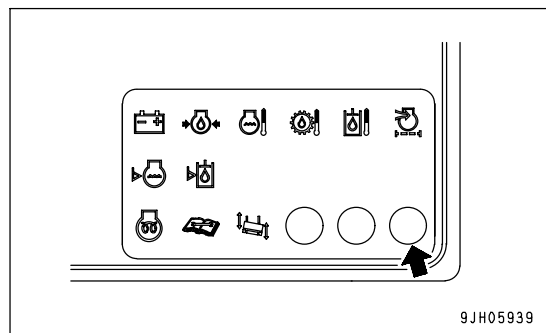

METHOD OF USING DISPLAY PANEL B (Multi-information)

EXPLANATION OF MODES AND CONTROLS

- Display panel B (1) has the function of displaying the following four types of mode. (The diagram on the right shows the normal screen before the mode display.)

Maintenance mode

This displays the time for replacing the filters or oil.

PM clinic auxiliary mode

This displays the engine speed and the oil pressure in the hydraulic circuits.

Fault display mode

This displays the fault code related to the electronic control.

Adjustment mode

This adjusts the brightness and contrast of the display.

- There are variations (sub-items) in the four types of mode. For an explanation of the variations, see the following items.

METHOD OF USING MAINTENANCE MODE (PAGE 3-29)

METHOD OF USING PM CLINIC AUXILIARY MODE (PAGE 3-31)

METHOD OF USING FAULT CODE DISPLAY MODE (PAGE 3-32)

METHOD OF USING USER ADJUST MODE (PAGE 3-33)

- Each mode is operated by using information switch (2) and buzzer cancel switch (3) on the dashboard in front of the operator's seat.

After operating the switch, release the switch, and the switch will return automatically to the center position as shown in the diagram on the right.

The functions of each position of the switches are as follows.

<: Moves mode to left

>: Moves mode to right

◇: Selects mode

□: Cancels mode

- The four types of mode can be selected in a cycle by operating information switch (2) to > and < to give the following sequence: Maintenance mode ←→ PM clinic auxiliary mode ←→ Fault code display mode ←→ Adjustment mode ←→ Maintenance mode.
- From the normal mode before giving the mode display, if buzzer cancel switch (3) is operated to ◇ and held for 2.5 seconds, the maintenance mode is displayed. After that, if information switch (2) is operated to >, the mode changes to the PM clinic auxiliary mode. If information switch (2) is operated to <, the mode changes to the user adjust mode.
- When any mode is being displayed, if the buzzer cancel switch is operated to □, the screen returns the normal screen shown before the mode display.

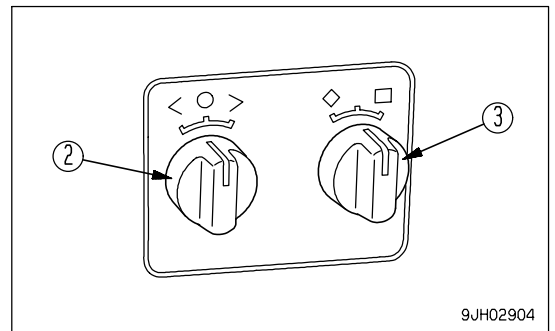
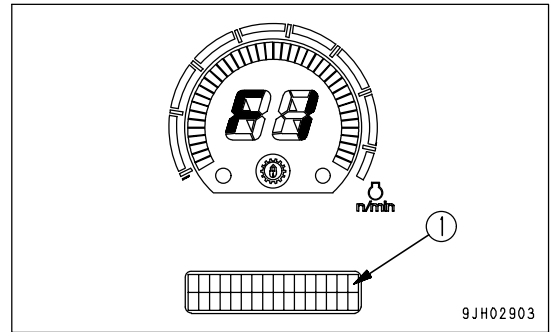

METHOD OF SELECTING MODES

1. When moving from the normal operation display to a user mode, the maintenance mode is displayed. Use the controls to change the mode as follows.

- > position: Go to PM clinic auxiliary mode
- < position: Go to user adjust mode
- position: Go to normal operation screen
- ◇ position: Go to maintenance mode selection screen.

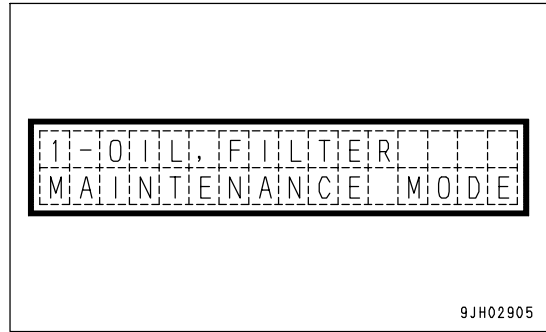

2. The diagram on the right shows the screen display for the PM clinic auxiliary mode. Use the controls to change the mode as follows.

- > position: Go to fault code display mode
- < position: Go to maintenance mode
- position: Go to normal operation screen
- ◇ position: Go to PM clinic auxiliary mode selection item screen

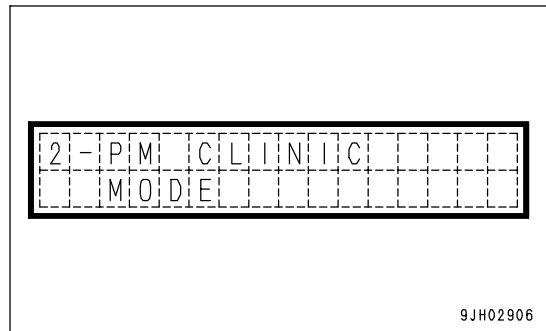

3. The diagram on the right shows the screen display for the fault code display mode. Use the controls to change the mode as follows.

- > position: Go to adjustment mode
- < position: Go to PM clinic auxiliary mode
- position: Go to normal operation screen
- ◇ position: Go to fault code selection item screen

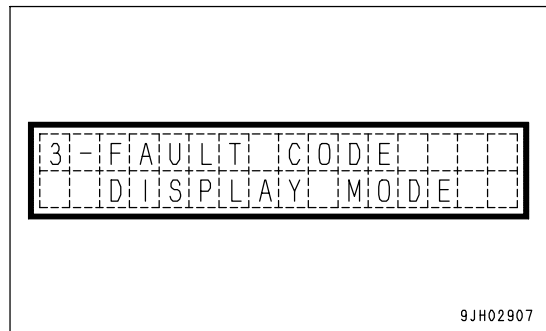

4. The diagram on the right shows the screen display for the user adjust mode. Use the controls to change the mode as follows.

- > position: Go to maintenance mode
- < position: Go to fault code display mode
- position: Go to normal operation screen
- ◇ position: Go to user adjust mode selection item screen

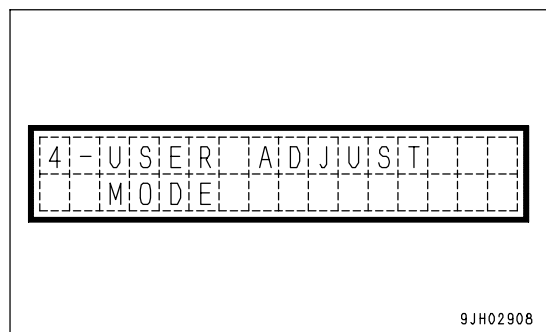

METHOD OF USING MAINTENANCE MODE

NOTICE

This function is only a guideline. If dirty oil or filters are found during daily maintenance, replace them immediately. If the controllers or monitor panel are replaced, the timer for this function will not work properly. Contact your Komatsu distributor for replacement.

The maintenance mode shows the replacement interval for the oil filters and oil on the monitor.

The content of the display is as follows.

- (1) The item is displayed.
- (2) The time remaining until replacement is displayed.
- (3) The number of times that replacement has been made until now is displayed.

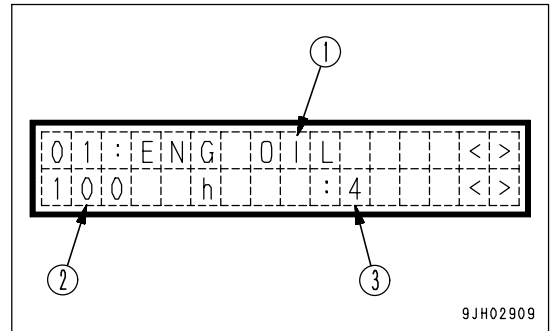

The display items can be displayed in order by operating the information switch to the left or right (<, >).

	Display	Item	1st replacement interval	2nd and following replacement intervals
1.	01: ENG OIL	Engine oil	500h	500h
2.	02: ENG FLT	Engine oil filter	500h	500h
3.	03: FUEL. FLT	Fuel filter	500h	500h
4.	04: HYD FLT	Hydraulic oil filter	250h	2000h
5.	06: CORR RES	Corrosion resistor	1000h	1000h
6.	18: BYPS FLT	Bypass filter *	0h	0h
7.	07: DAMP OIL	Damper oil	2000h	2000h
8.	08: F/D OIL	Final drive oil	250h	2000h
9.	10: HYD OIL	Hydraulic oil	250h	2000h
10.	19: POWL OIL	Power train oil	250h	1000h
11.	20: POWL FLT	Power train oil filter	250h	500h
12.	12: HSS FLT	HSS charge filter *	0h	0h

The item marked * is displayed in the above table, but is not used on this machine.

When the oil or filter has been replaced, select the applicable item, then operate the buzzer cancel switch to \diamond .

The screen will ask if you want to display the replacement history. Operate the information switch to select YES, then operate the buzzer cancel switch to \diamond . The replacement account will increase by 1, the replacement interval will be reset, and the oil, filter change interval lamp will go out.

When this is done, if the maintenance caution lamp does not go out, there is another item close to the replacement time, so check the situation.

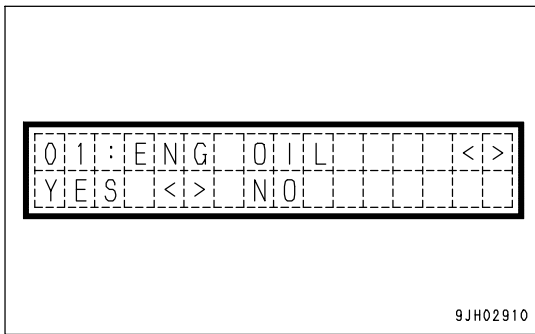

REMARK

To return to the function selection mode, operate the buzzer cancel switch to \square .

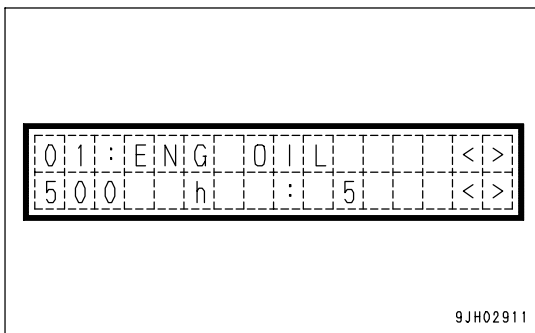

METHOD OF USING PM CLINIC AUXILIARY MODE

**CAUTION**

When moving the work equipment or setting the transmission to the travel position for carrying out measurements, check carefully that the situation is safe.

The PM clinic auxiliary mode displays the engine speed, hydraulic oil pressure, and other items on display panel B. Display panel B displays the item on the top line (1), and the measured value on the bottom line (2).

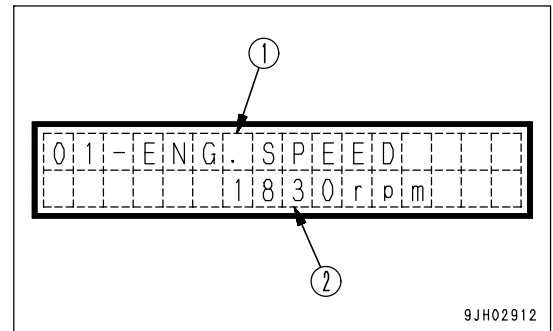

The display items consist of the six items in the table below.
The items can be selected by operating the information switch (<, >).

Display	Item	Measured value
01-ENG.SPEED	Engine speed	Speed (rpm)
02-HYD.PUMP PRES F	Hydraulic oil pressure (F pump)	Pressure (MPa)
03-HYD.PUMP PRES R	Hydraulic oil pressure (R pump)	Pressure (MPa)
04-BATTERY VOLT	Battery voltage	Voltage (mV)

REMARK

- Items such as the engine speed fluctuate and are difficult to see during the measurement. In such cases, operate the buzzer cancel switch to \diamond . This makes it possible to hold the display of the value.
- To cancel this mode, operate the buzzer cancel switch again to \diamond .
- To return to the function selection mode, operate the buzzer cancel switch to \square .

METHOD OF USING FAULT CODE DISPLAY MODE

NOTICE

The fault items observed by this function are connected with the electronic control, so even if a fault code is not displayed, there is probably some problem with the machine. If the operator feels any problem with the machine, the machine should be stopped immediately and checked.

When any disconnection or short circuit in any sensor is detected, the location and fault code are displayed by a 6-digit code on display panel B. When contacting your Komatsu distributor, inform your distributor of the code at the same time.

If the failure observation function has not determined the condition of the machine, the display is as shown in the diagram on the right.

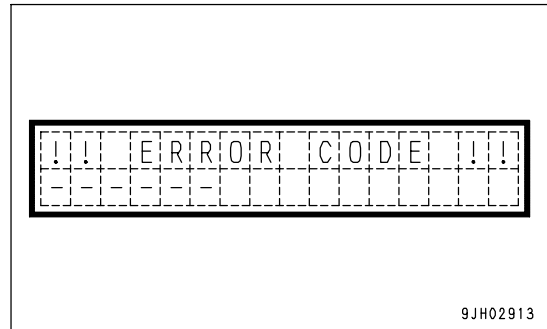

With this function, existing failures can be displayed up to a maximum of 20 items.

If multiple failures are occurring, the display automatically changes every 2 seconds, so check the code.

The display is shown repeatedly.

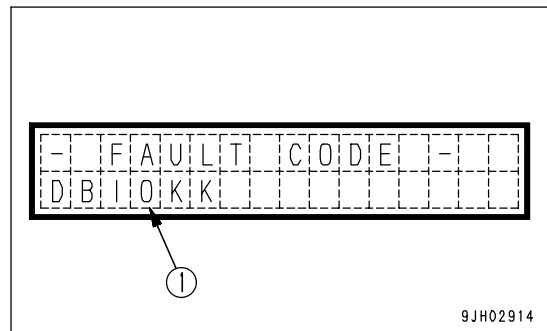

REMARK

To return to the function selection mode, operate the buzzer cancel switch to .

METHOD OF USING USER ADJUST MODE

With the user adjust mode, the brightness of the panel screen backlighting and the contrast of the liquid crystal panel can be changed, or the cooling fan can be set to maximum speed to clean the radiator when it is clogged.

These are displayed on display panel B.

1. Adjusting backlighting of liquid crystal display

The diagram on the right is the mode for adjusting the brightness of the backlighting of the liquid crystal panel. On this screen, operate the buzzer cancel switch to ◇ to switch to the screen to adjust the brightness.

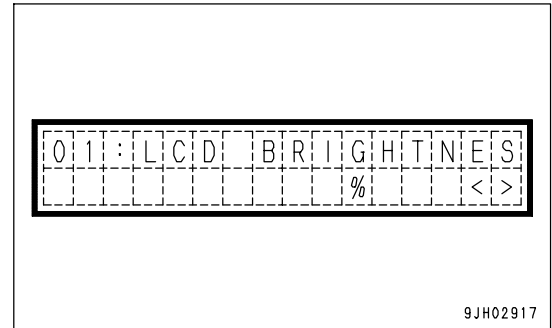

The brightness can be adjusted by operating the information switch.

The higher the number, the brighter the screen becomes; the lower the number, the darker the screen becomes.

> position: Number increases

< position: Number decreases

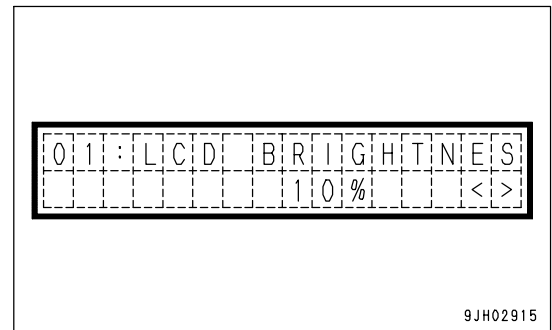

When the buzzer cancel switch is operated to ◇, the brightness of the liquid crystal display backlighting is set.

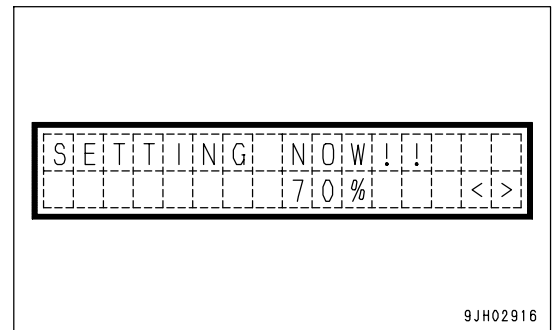

2. Adjusting backlighting of message display

The diagram on the right is the mode for adjusting the brightness of the backlighting of the message display. On the screen, operate the buzzer cancel switch to ◇ to switch to the screen for adjusting the brightness.

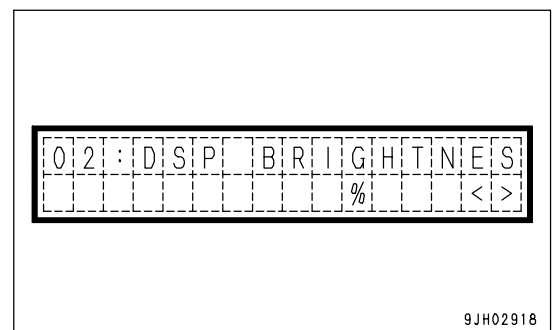

The brightness can be adjusted by operating the information switch.

The higher the number, the brighter the screen becomes; the lower the number, the darker the screen becomes.

- > position: Number increases
- < position: Number decreases

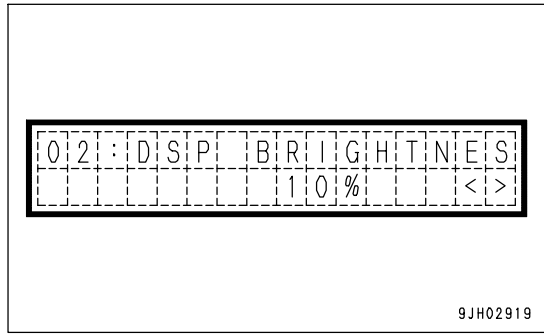

When the buzzer cancel switch is operated to ◇, the brightness of the message display backlighting is set.

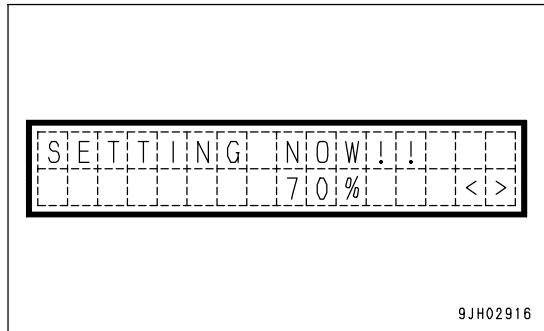

3. Adjusting contrast of liquid crystal message display

The diagram on the right is the mode for adjusting the contrast of the liquid crystal message display.

On this screen, operate the buzzer cancel switch to ◇ to switch to the screen to adjust the contrast.

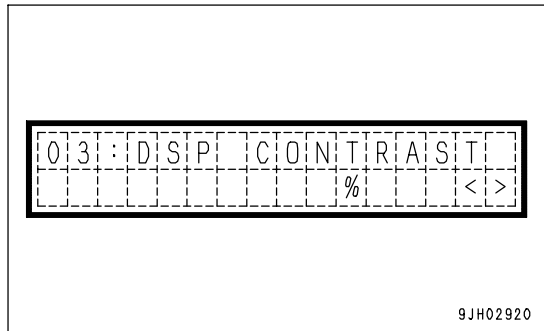

The contrast can be adjusted by operating the information switch. The higher the number, the darker the screen becomes; the lower the number, the lighter the screen becomes.

- > position: Number increases
- < position: Number decreases

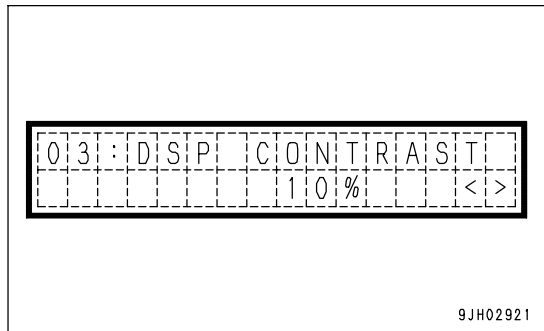

When the buzzer cancel switch is operated to ◇, the contrast of the liquid crystal display is set.

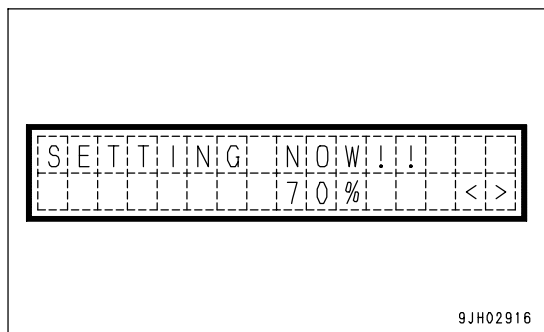

4. Setting blade tilt angle limit

The diagram on the right shows the mode for setting the blade tilt angle limit. Please contact your Komatsu distributor when using this function.

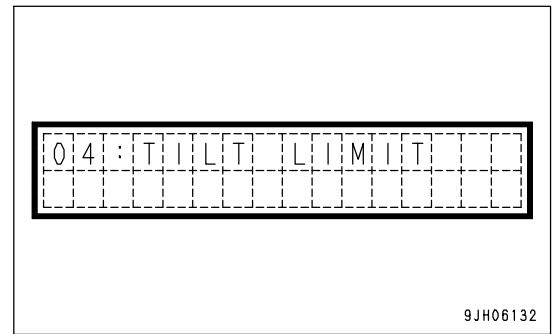

5. Mode to rotate cooling fan at maximum speed

The diagram on the right is the mode for rotating the cooling fan at maximum speed. On this screen, operate the buzzer cancel switch to \diamond to rotate the cooling fan at the maximum speed.

Note that this mode is effective only when the display in the diagram on the right is being given. After leaving this mode, the screen returns to the normal mode.

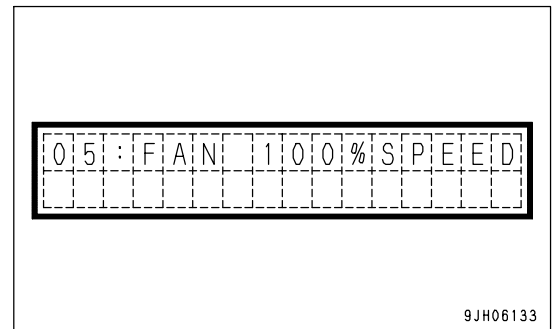

6. Prelube mode

The diagram on the right shows the mode for machines equipped with the prelube system. Please contact your Komatsu distributor when using this function.

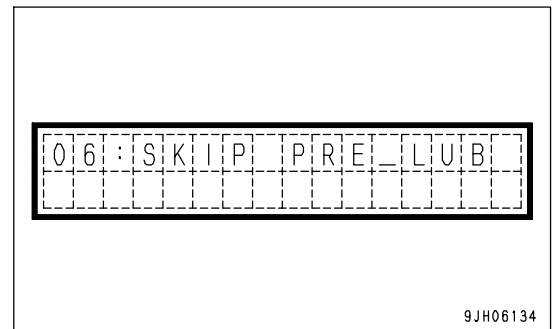
**REMARK**

- To return to the function selection mode, operate the buzzer cancel switch to \square .
- The brightness of the backlighting of the monitor panel differs according to whether the front lamp is lit or not. Entering this mode when the front lamps are lit makes it possible to adjust the brightness when the front lamps are lit. In the same way, entering this mode when the front lamps are not lit makes it possible to adjust the brightness when the front lamps are not lit.

SWITCHES

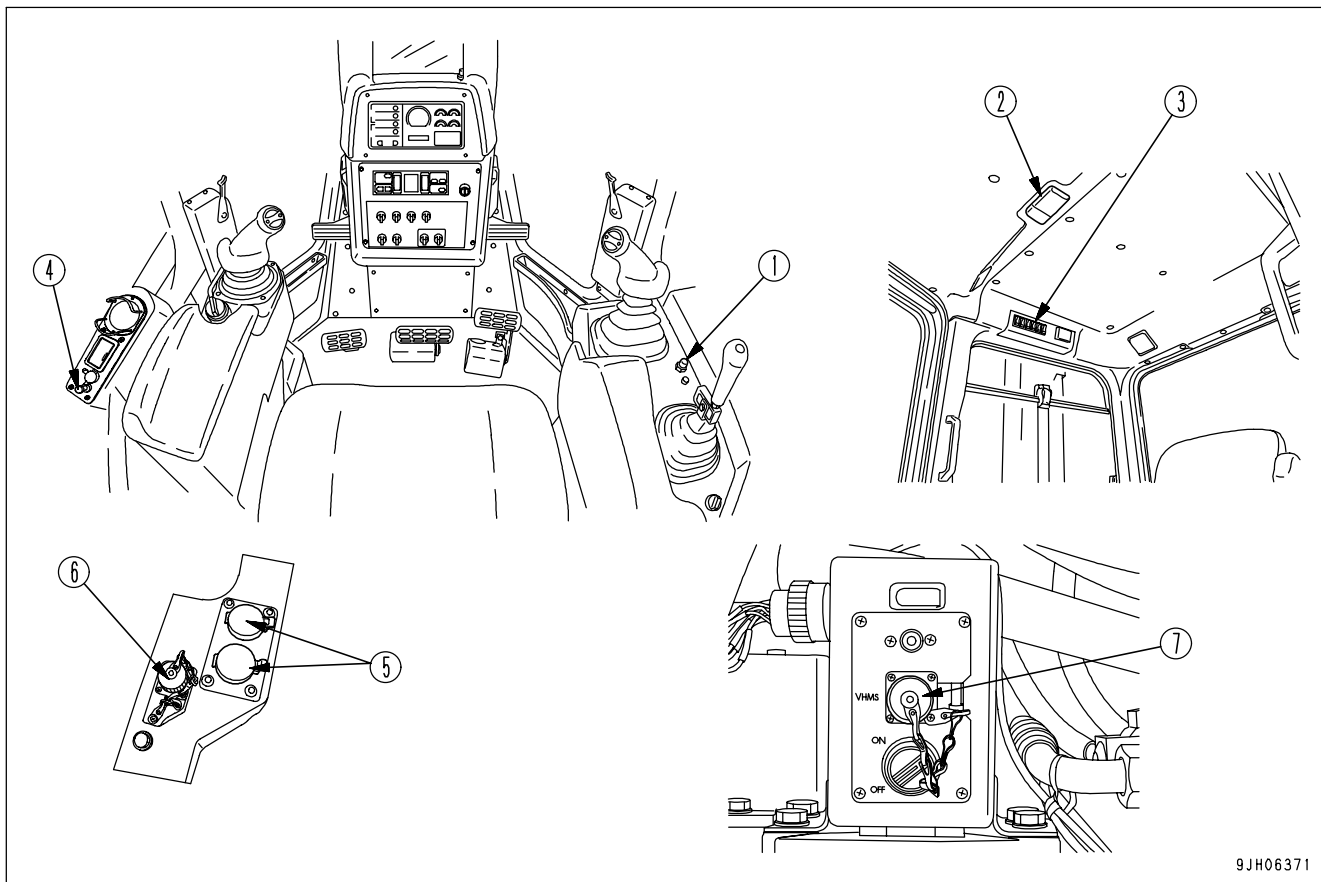

9JH06371

- (1) Horn switch
- (2) Room lamp switch
- (3) Wiper switch
- (4) Cigarette lighter
- (5) Accessory socket
- (6) Connector for VHMS download
- (7) Connector for VHMS download

HORN SWITCH

The horn sounds when button (1) at rear of the blade control lever on the right side of operator's seat is pressed.

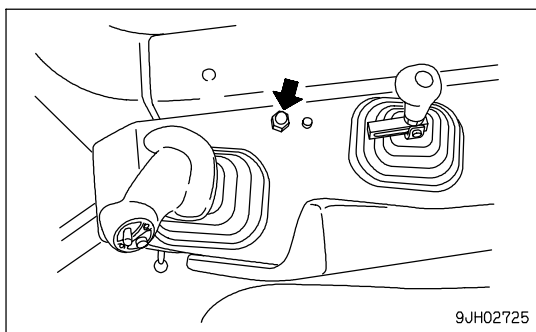

9JH02725

ROOM LAMP SWITCH

Switch (2) lights the room lamp.

ON position: Lamp lights up

OFF position: Lamp is out

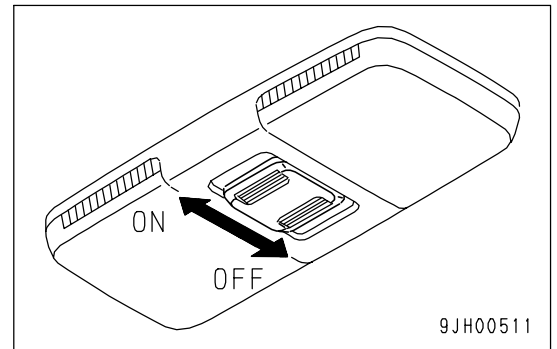

WIPER SWITCH

Switch (3) activates the wipers.

The wiper switches are as follows:

- (A) L.H. door
- (B) Front window
- (C) R.H. door
- (D) Rear window

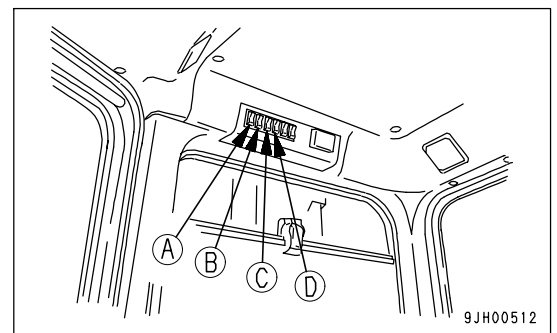

On machines with the double wiper specification, operate the switches on left door (A) and right door (C) to operate the wipers at the top and bottom of the door simultaneously.

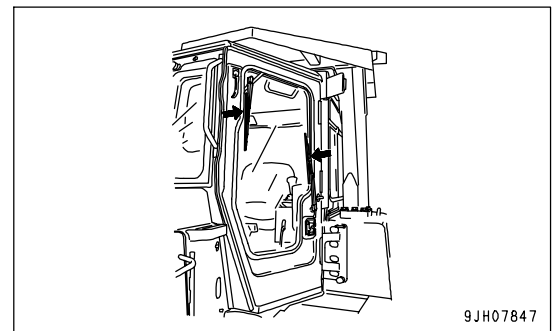

This is also used as the window washer switch.

The switch is operated as follows.

- Window washer only
 - Keep the switch pressed to the OFF position to spray out water.

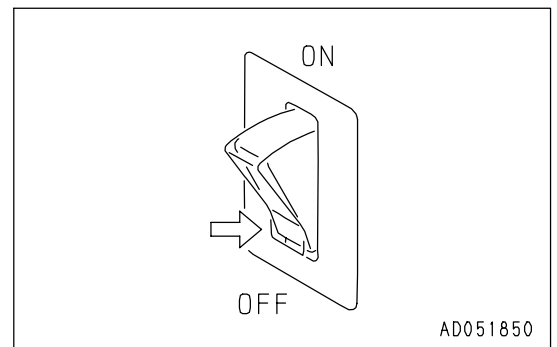

- Wiper only

If this is switched on, the wiper will start.

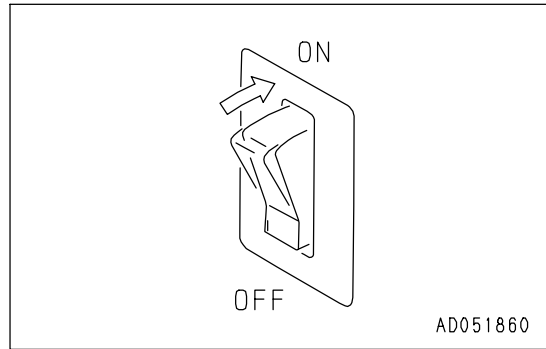

- Wiper and window washer

If this is kept pressed to the ON position while the wiper is working, water will be sprayed out.

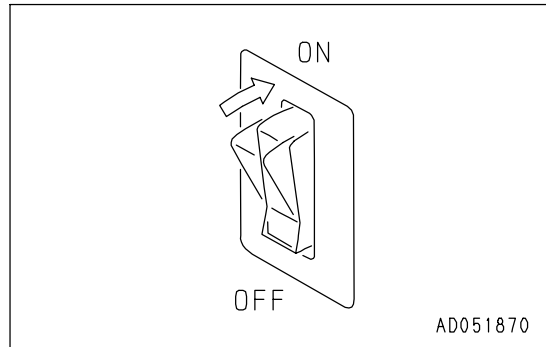

REMARK

When installing the cab, check the colors of the washer tank and window washer hoses, and be sure to connect correctly.

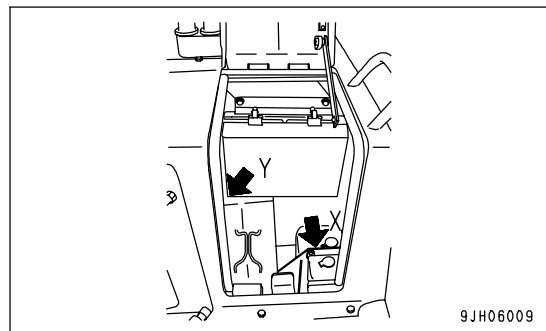

- (a) Front of machine
- (b) Front (no color)
- (c) Rear (black)
- (d) Left side (blue)
- (e) Right side (red)

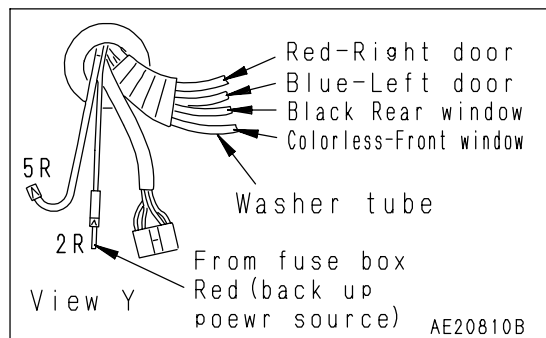
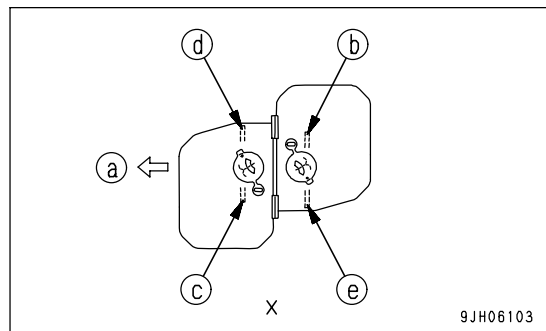

CIGARETTE LIGHTER

This lighter (4) is used to light cigarettes.

When the cigarette lighter is pushed in, it will return to its original position after a few seconds, so take it out to light your cigarette. If the cigarette lighter is removed, the socket can be used as a power source.

NOTICE

This cigarette lighter is 24V. Do not use it as the power supply for 12V equipment. This will cause failure of the equipment. The capacity of the cigarette lighter is 120W (24V x 5A).

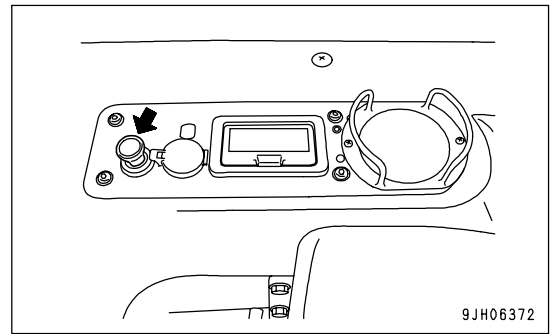

ACCESSORY SOCKET

Socket (5) is used as the power source for a wireless device or other 12V equipment.

With both Type (A) and Type (B) electricity flows only when the ignition switch is at the ON position.

The capacity for both Types (A) and (B) is 60W (12V x 5A).

REMARK

This socket is under the left armrest.

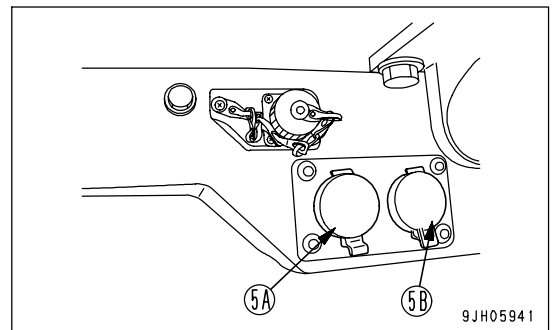

CONNECTOR FOR VHMS DOWNLOAD

It is possible to download the VHMS data using connector (6),(7).

When using this connector, consult your Komatsu distributor.

REMARK

This connector is under the left armrest and in the download box under the fuel tank at the rear of the machine.

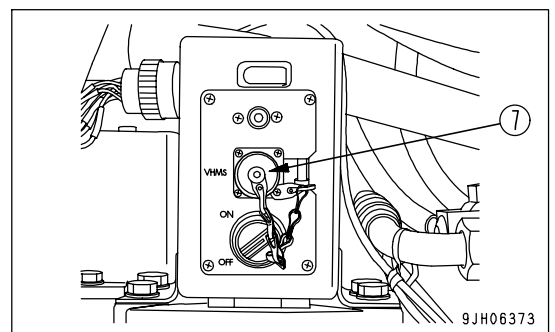
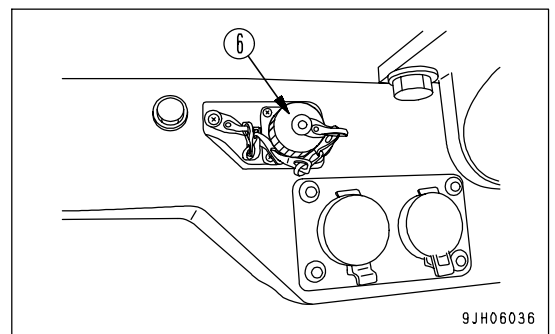

OPTION SWITCHES

These switches are used respectively for the following additional lamps and rotating lamp.

(E) (e): Additional front lamp switch

(F) (f): Additional rear lamp switch

(G) (g): Rotating lamp

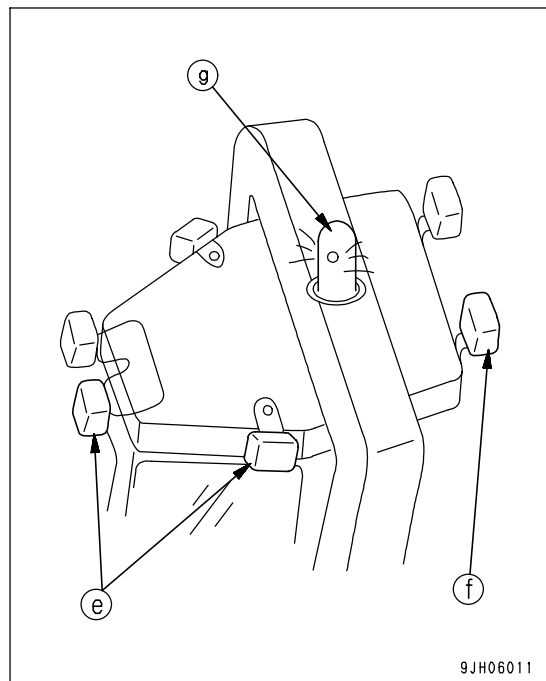
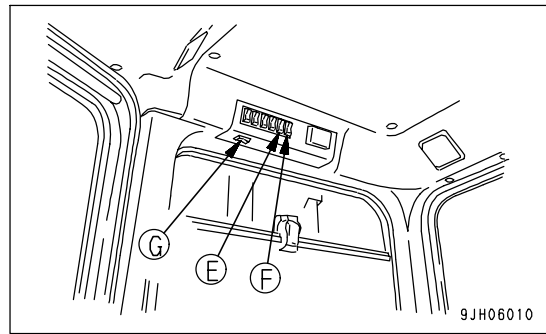

CONTROL LEVERS, PEDALS

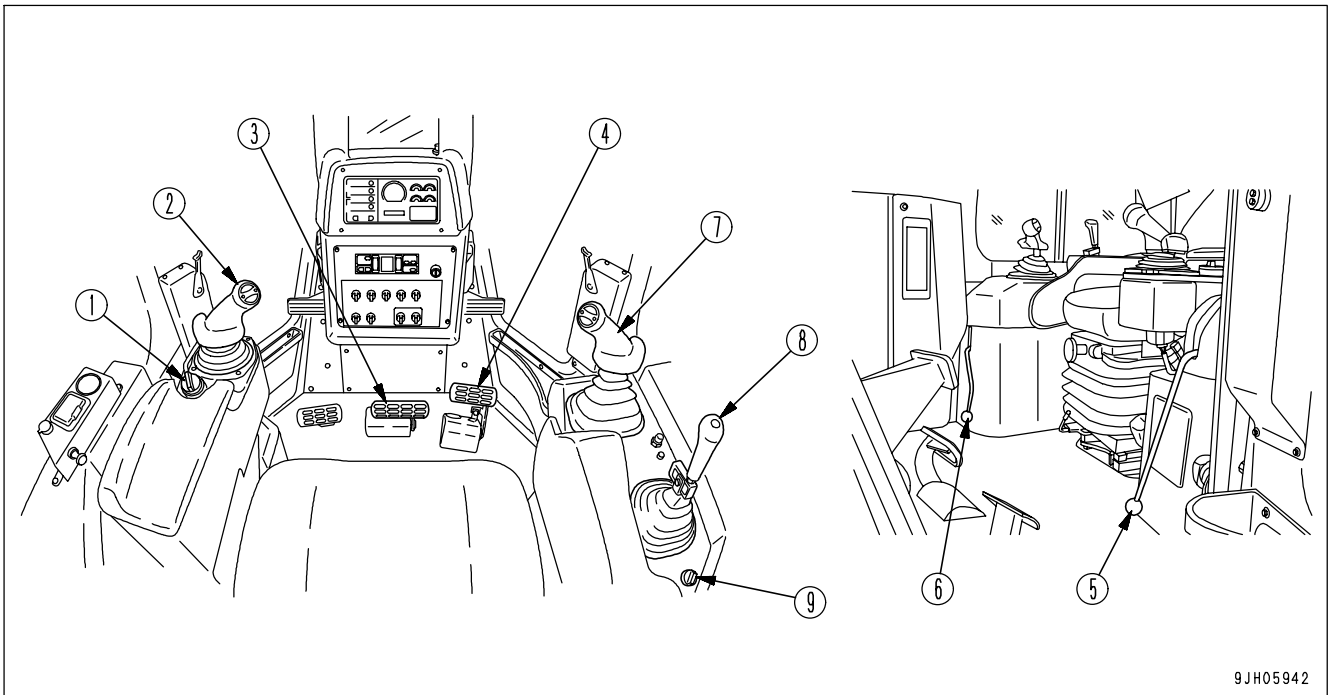

9JH05942

- | | |
|--|-------------------------------|
| (1) Fuel control dial | (5) Parking lever |
| (2) Joystick
(steering, directional and gear shift lever) | (6) Work equipment lock lever |
| (3) Brake pedal | (7) Blade control lever |
| (4) Deceleration pedal | (8) Ripper control lever |
| | (9) Pin puller control switch |

FUEL CONTROL DIAL

Dial (1) is used to control the engine speed and output.

- (a) Low idling position: Turn fully to the left
- (b) High idling position: Turn fully to the right

REMARK

To stop the engine, turn the starting switch to the OFF position.

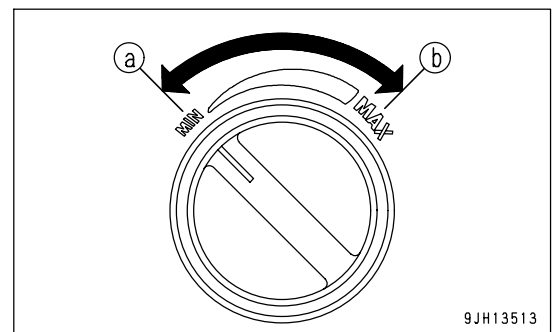

9JH13513

JOYSTICK (STEERING, DIRECTIONAL AND GEAR SHIFT LEVER)

(PCSS lever)

Lever (2) is used to switch direction of travel and to steer the machine.

REMARK

PCCS: Palm command control system

- **Forward-reverse shifting**

Position (a): FORWARD

Position (b): REVERSE

Position N: Neutral

Move to the front to drive forward; move to the rear to drive in reverse.

- **Steering**

Position (L): Left turn

Position (R): Right turn

With the lever moved to the front or rear, operate the lever partially to the left or right to turn the machine. The machine will turn gradually in the same direction as the lever is operated.

If the lever is moved fully to the left or right, the machine will turn in a small radius.

REMARK

- If the lever is released when steering the machine, the lever will return to the (a) position or the (b) position and the machine will be returned to straight movement.

- **Gear shifting**

When the steering, directional, and gearshift lever is at the FORWARD or REVERSE position and switch (c) or switch (d) is pushed, the transmission speed will change.

UP switch (c): Each time the switch is pressed, the transmission will shift up one speed.

DOWN switch (d): Each time the switch is pressed, the transmission will shift down one speed.

For details of the maximum speed in each speed range, see "SPECIFICATIONS (PAGE 5-2)".

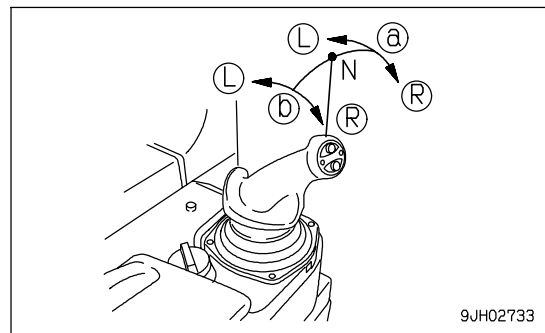

9JH02733

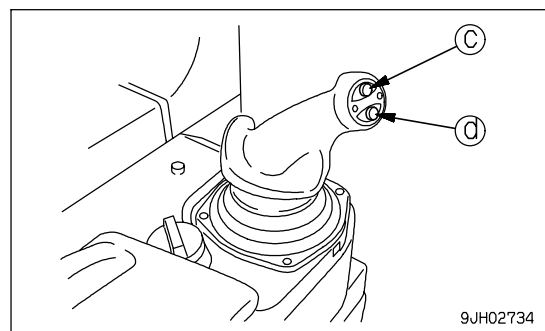

9JH02734

REMARK

- When the transmission is shifted, the speed range being used is displayed on the display panel on the monitor panel.

Example:

Neutral: N is displayed on the display panel.

FORWARD 2nd: F2 is displayed on the display panel.

REVERSE 3rd: R3 is displayed on the display panel.

When the parking lever is locked, P is displayed.

- For details of the gearshift operation using the shift mode, see "SHIFTING GEAR (PAGE 3-122)". Shift mode selection means the operation to set the selected speed range beforehand in the N position.

BRAKE PEDAL

! WARNING

Do not place your foot on this pedal unnecessarily.

Depress the pedal (3) to apply the right and left brakes.

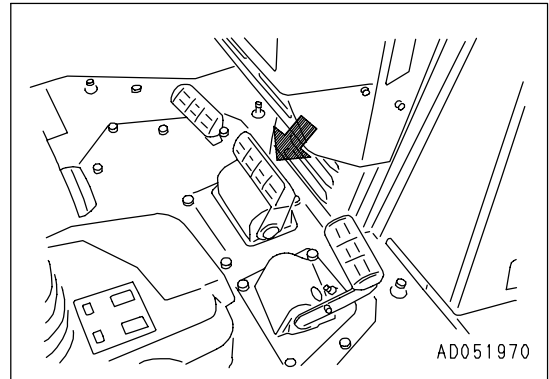

DECELERATOR PEDAL

! WARNING

- Do not rest your foot on the pedal if you are not using it.
- When passing over the top of a slope or when dumping soil from a cliff, the load on the machine will suddenly be reduced and the travel speed will increase. This situation is dangerous, so use the decelerator pedal to reduce the travel speed of the machine

Pedal (4) is used when reducing engine speed or stopping the machine.

When switching between forward and reverse, or when stopping the machine, use this pedal to reduce speed.

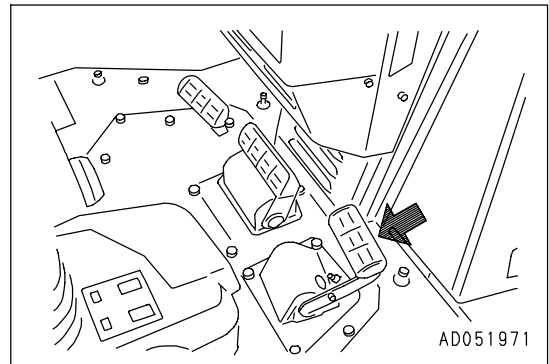

REMARK

When operating the decelerator pedal, there may be a particular noise, but there is no problem with quality or durability.

PARKING LEVER

! WARNING

When parking the machine, always set the parking brake lever to the LOCK position.

This lever (5) is used to apply the parking brake.

REMARK

- Before moving the parking brake lever to the LOCK position, return the steering, directional, and gearshift lever to the N position.
- When starting the engine, if the parking brake lever is not in the LOCK position, the limit switch is actuated and it is impossible to start the engine.

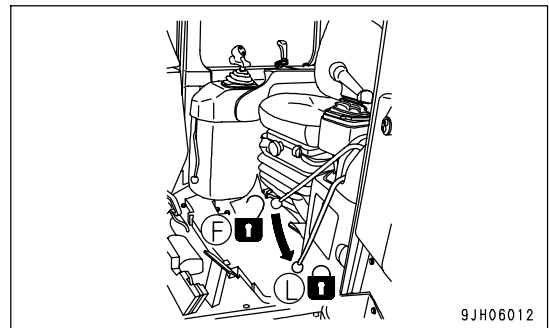

WORK EQUIPMENT LOCK LEVER

**WARNING**

- When standing up from the operator's seat, always move the work equipment lock lever securely to the LOCK position. If the blade control and ripper control levers are not locked and are touched by accident, it may lead to serious injury or damage.
- If the work equipment lock lever is not completely in the LOCK position, the lock may not be applied. Check that it is in the position shown in the diagram.
- When parking the machine or when performing maintenance, always lower the blade or ripper to the ground, then set the work equipment lock lever to the LOCK position.

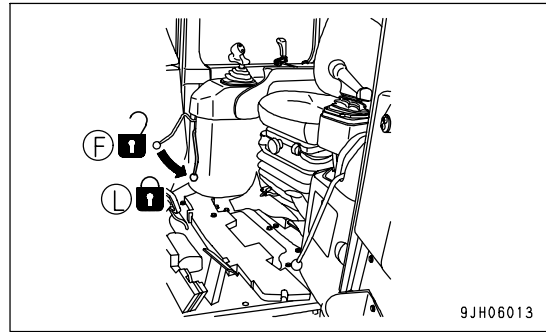

Lever (6) is a device to lock the blade control and ripper control levers.

When it is set to the LOCK position, the TILT, RAISE, LOWER, and FLOAT operations are locked.

REMARK

When starting the engine, to ensure safety, always set the work equipment lock lever to the LOCK position.

BLADE CONTROL LEVER

Lever (7) is used to operate the blade.
Single tiltdozer

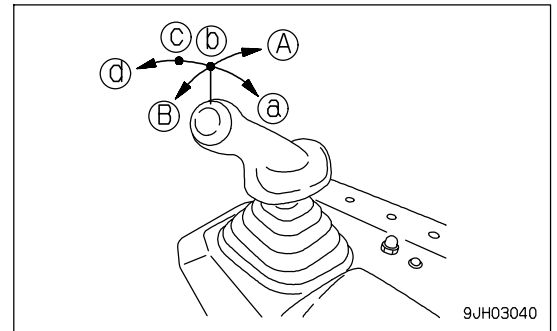

Lever (7) is used to raise or tilt the blade.

- Lifting control
- (a) RAISE:
- (b) HOLD: Blade is stopped and held in this position.
- (c) LOWER:
- (d) FLOAT: Blade will move freely according to external force.

REMARK

When released from FLOAT position, this lever (7) will not return to HOLD position, so it must be returned to HOLD by hand.

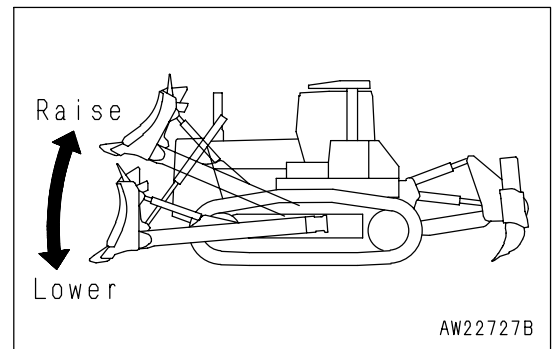

- Tilting control
- (A) RIGHT TILT
- (B) LEFT TILT

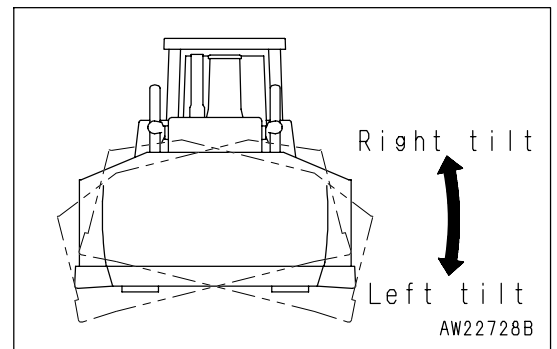

DUAL TILTDOZER

Operate the tilt switch to the (D) position.

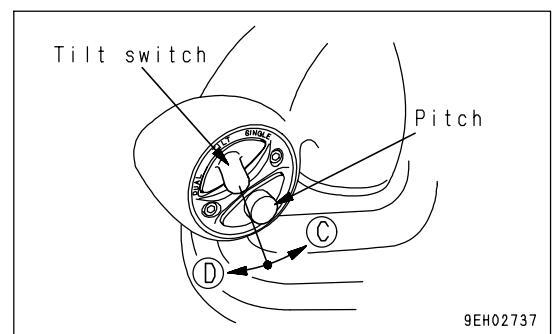

Lever (7) is used to raise or tilt the blade.

- Lifting control

- (a) RAISE:
- (b) HOLD: Blade is stopped and held in this position.
- (c) LOWER:
- (d) FLOAT: Blade will move freely according to external force.

REMARK

When released from FLOAT position, this lever (7) will not return to HOLD position, so it must be returned to HOLD by hand.

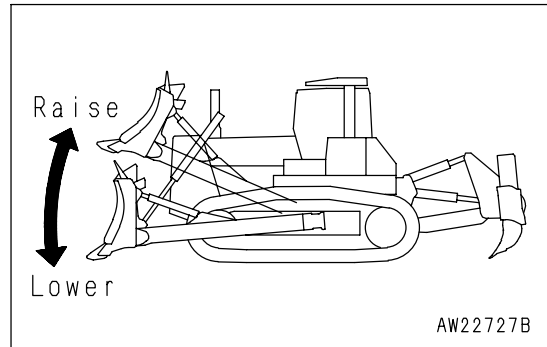
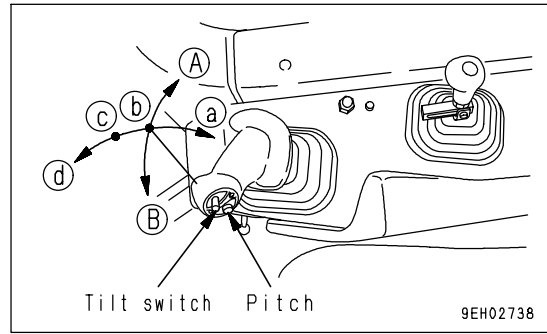

- TILT OPERATION

- (A) RIGHT TILT
- (B) LEFT TILT

REMARK

- With the dual tilt operation, a larger amount of tilt can be obtained than with the single tilt operation.
- With the dual tilt operation, the blade can be operated to RAISE, HOLD, or LOWER.

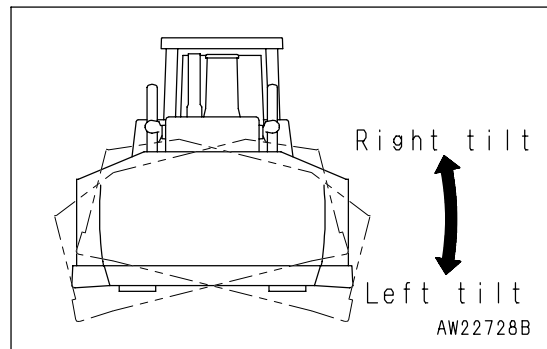

- Single tilt operation

Operate the tilt switch to the (C) position.

- (A) RIGHT TILT
- (B) LEFT TILT

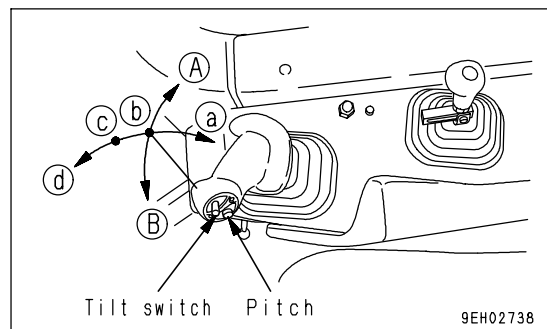
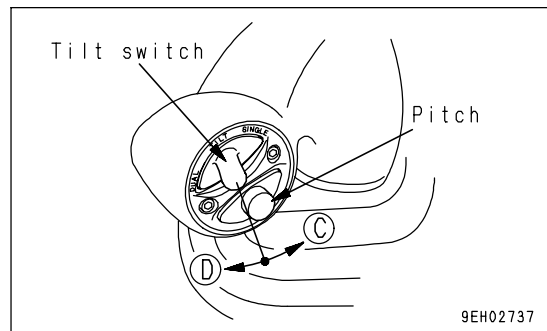

- Pitch control

Rear pitch (cutting angle reduced)

Carry out operation (B) with the pitch button pressed.

Forward pitch (cutting angle increased)

Carry out operation (A) with the pitch button pressed.

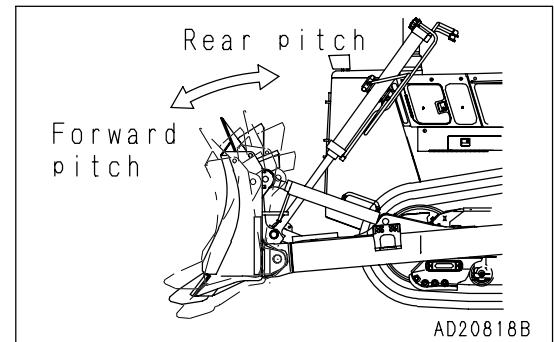

REMARK

- With the pitch operation, the blade can be operated to any of RAISE, HOLD, or LOWER.
- For details of the effective use of the dual tilt dozer, see "EFFECTIVE METHOD OF OPERATION FOR DUAL TILT DOZER (PAGE 6-6)".
- To operate the pitch, keep the pitch button pressed and operate the blade control lever to the left or right to start the operation.
- The pitch is the priority circuit, so if the pitch button is pressed during single tilt operation, the pitch will be actuated.

RIPPER CONTROL LEVER

(For variable ripper)

Lever (8) is used to operate the ripper.

- (a) RAISE
- (b) HOLD: Ripper is stopped and held in the same position.
- (c) LOWER
- (A) Digging angle reduced: Cutting angle (α) becomes smaller.
- (B) Digging angle increased: Cutting angle (α) becomes larger.

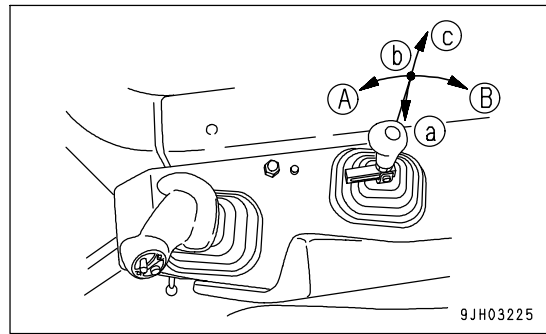

9JH03225

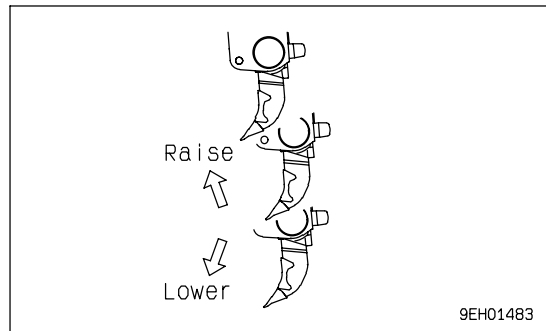

9EH01483

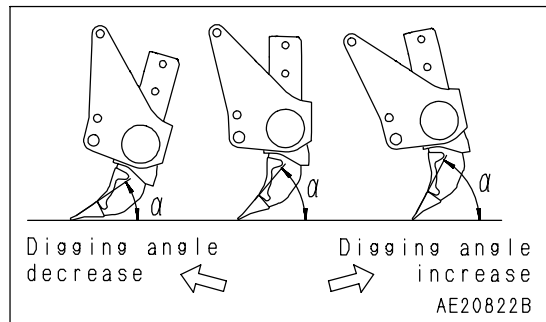

AE20822B

ADJUSTING FRONT-REAR POSITION OF RIPPER CONTROL LEVER

(Range of adjustment: ± 40 mm (1.6 in))

Lever (8) position can be adjusted to best suit the operator's physique. Follow the steps below for the adjustment.

- Adjustment within range of 40 mm (1.6 in) from neutral to rear
 1. Loosen lock nut (1) with a wrench.
 2. Set lever (2) to the optimum position.
 3. Tighten lock bolt (1) with the wrench to hold lever (2) in position.

- Adjustment within range of 40 mm (1.6 in) from neutral to front
 1. Remove lock bolt (1) with a wrench.
 2. Remove lever (2) and reverse it 180°
 3. Install lever (2) to lever (5), then set it to the optimum position.
 4. Tighten lock bolt (1) with the wrench to hold lever (2) in position.
 5. Loosen nut (3).
 6. Reverse knob 180°.
 7. Tighten nut (3).

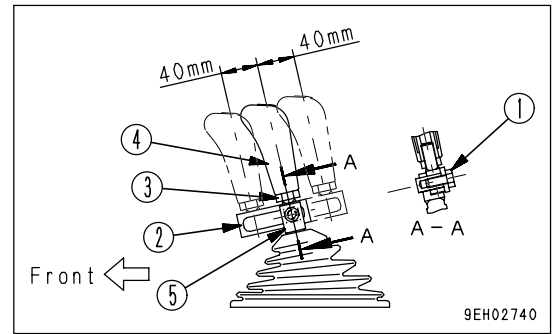

PIN PULLER CONTROL SWITCH (IF EQUIPPED)

Switch (9) is used to operate the pin puller.

- (a) PULL OUT: Pin is pulled out.
- (b) PUSH IN: Pin is pushed in.

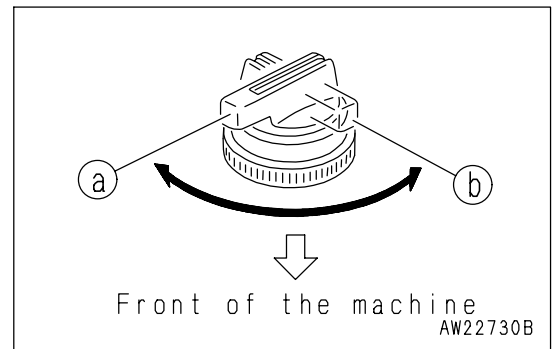

DUST INDICATOR

This is on the air cleaner bracket inside the engine room.

This device indicates that the air cleaner element is clogged.

For details on how to clean the element, see "CHECK, CLEAN AND REPLACE AIR CLEANER ELEMENT (PAGE 4-26)".

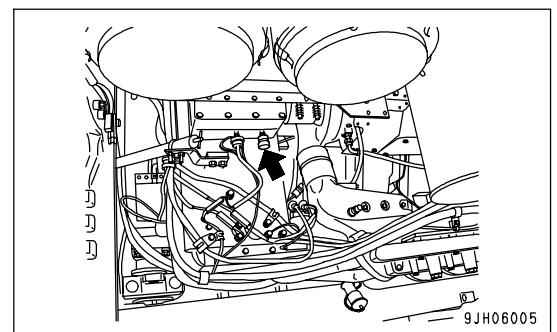

POWER SOURCE

The cigarette lighter socket (1) can be used as a power source for 24V equipment and the accessory socket (2) can be used for 12V equipment.

NOTICE

The cigarette lighter is 24V. Do not use it as the power source for 12V equipment.

The capacity of the cigarette lighter is 120W (24V x 5A).

There are 2 accessory sockets. Their capacity is 60W (12V x 5A).

These 2 accessory sockets only provide power when the starting switch is ON.

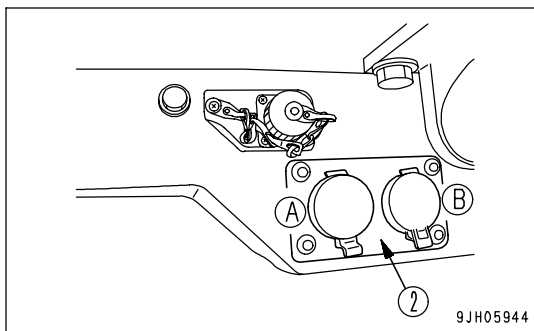
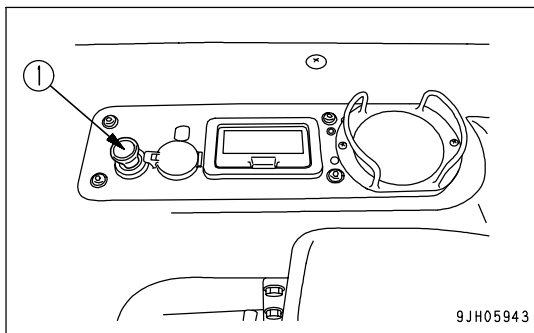

FUSE BOX

NOTICE

Before replacing a fuse, be sure to turn starting switch to the OFF position.

Fuses protect the electrical equipment and wiring from burning out.

If a fuse becomes corroded, or white powder can be seen, or a fuse is loose in the holder, replace the fuse.

Replace a fuse with another of the same capacity.

- Chassis

Open the fuse inspection cover at the bottom front left of the operator's compartment. Fuse box I is installed inside.

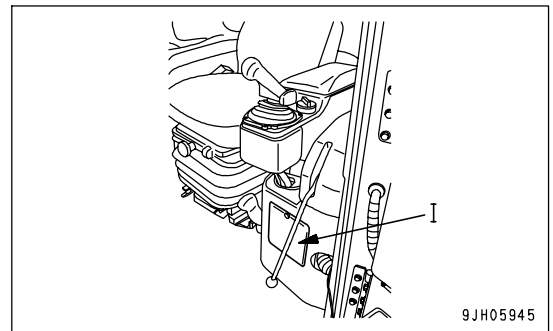

- (1) Fuse box fs1
- (2) Fuse box fs2
- (3) Fuse box fs4
- (4) Circuit breaker

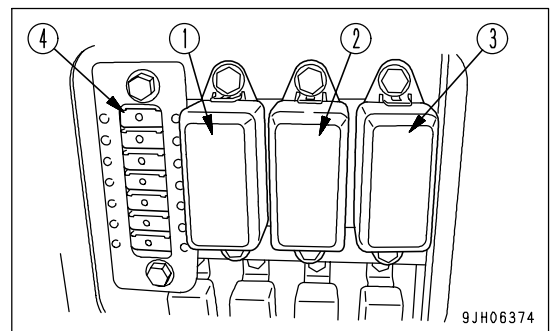

- Cab (machines equipped with cab)

Fuse box II is installed at the bottom of the overhead panel.

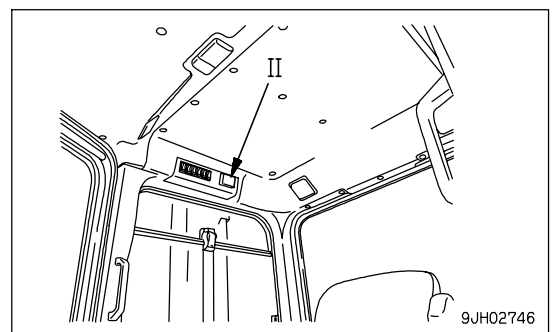

CIRCUIT BREAKER

- If the starting switch does not work, open the circuit breaker box and check.
- If excessive current flows through the circuit breaker, it cuts off the electric circuit to prevent damage to the electrical components and wiring.
- To restore the electric circuit after it has been cut off, push in reset button (1). (This springs out when the circuit is cut off.) If the electric circuit is normal, reset button (1) will stay pushed in. If it comes out immediately when it is pushed in, the electric circuit must be checked.

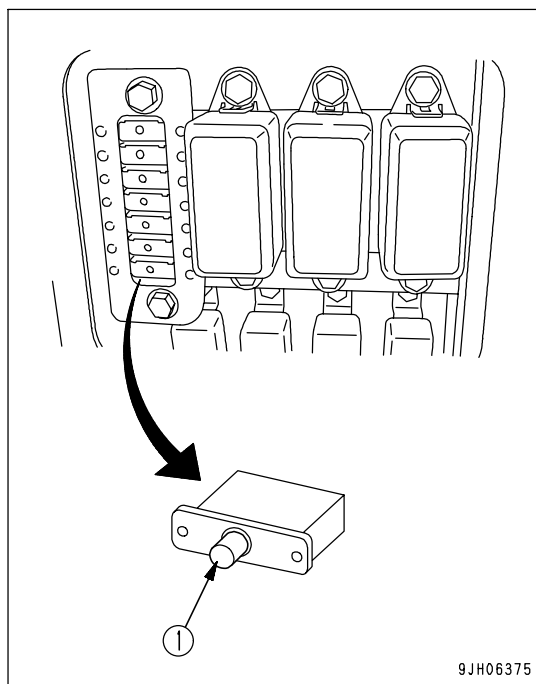

9JH06375

No	Capacity	Circuit
(1)	20A	Steering controller
(2)	20A	Monitor panel
(3)	20A	Transmission controller
(4)	20A	Air conditioner
(5)	20A	Front lamp
(6)	20A	Starting switch
(7)	20A	Rear lamp

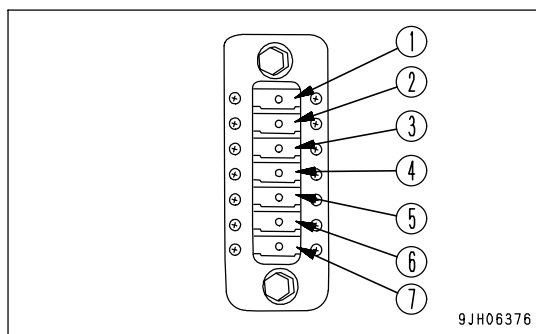

9JH06376

REMARK

The circuit breaker is a device installed in electric circuits where a large current flows. It is installed to protect the electric circuit. It protects the electric components and wiring from damage caused by an abnormal current in the same way as a normal fuse. After repairing and restoring the location of the abnormality, there is no need to replace the breaker. It can be used again.

FUSE CAPACITY AND NAME OF CIRCUIT

FUSE BOX I

(1) Fuse box fs1

NO.	Fuse capacity	Name of circuit
1	20A	Not used
2	20A	Permanently ON power source
3	10A	Not used
4	10A	Not used
5	20A	VHMS permanently ON power source

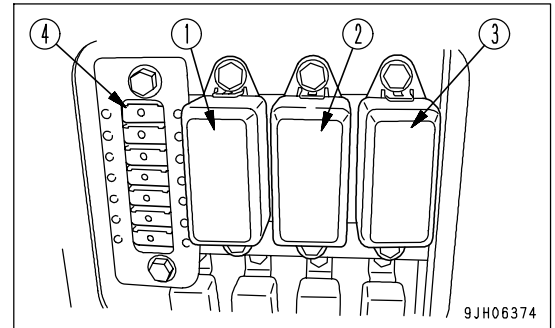

(2) Fuse box fs2

NO.	Fuse capacity	Name of circuit
1	20A	Spare power source (1)
2	20A	Auxiliary blower power source
3	20A	Additional heater power source
4	20A	Working lamp
5	20A	Rear lamp

(3) Fuse box fs4

NO.	Fuse capacity	Name of circuit
1	20A	Back-up alarm, pin puller
2	20A	Spare power source (2)
3	20A	VHMS controller
4	20A	Electrical intake air heater, Horn
5	20A	Spare ACC signal

FUSE BOX II

NO.	Fuse capacity	Name of circuit
(1)	10A	Car radio, cigarette lighter, room lamp
(2)	10A	Rear wiper
(3)	10A	R.H. wiper
(4)	10A	Front wiper
(5)	10A	L.H. wiper
(6)	20A	Additional front lamp
(7)	20A	Additional rear lamp, revolving lamp
(8)	-	Spare
(9)	-	Spare
(10)	10A	Radio memory

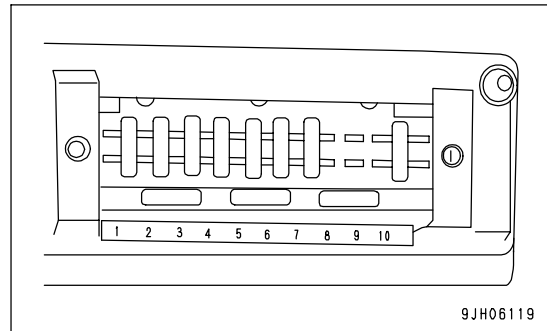

CIRCUIT BREAKER FOR MAIN POWER SUPPLY

- If the starting motor does not crank, even when the starting switch is turned to the ON position, open the battery box and check breakers (A) and (B).
- If there is a surge of current, the circuit breaker shuts off the circuit to protect the electrical components and wiring from damage.

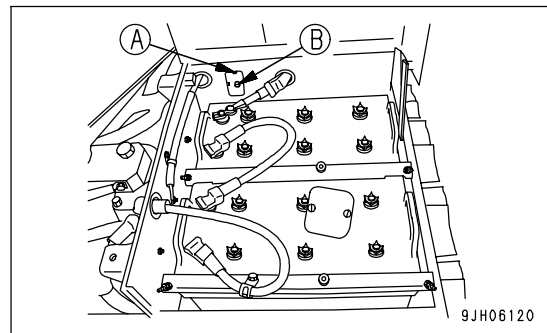

- Turn the starting switch to the OFF position and reset the circuit breaker.
- When resetting the electrical circuit after it has been shut off, press the reset button 5 to 10 minutes after the circuit has been shut off. When the electrical circuit has been shut off, the operation of the reset button is heavier than when the circuit is normal. The height of the reset button is the same, regardless of whether the circuit has been shut off or has been reset, so make note of the effort of the reset button when resetting the circuit.
- Do not keep the circuit breaker reset button longer than necessary.
- If the starting motor does not work even when the circuit breaker has been reset, contact your Komatsu distributor.

REMARK

The capacity of circuit breakers (A) and (B) is as follows.

(A): 30A (for regular cab power supply)

(B): 105A (for general power supply)

DOOR OPEN LOCK

Use this when you want to keep the door held open.

1. Push the door against door catch (1). The door will be held by the door catch.

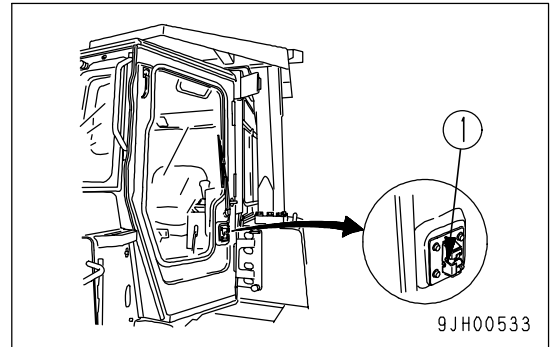

2. To release the door, move lever (2) inside the cab forward. This will release the catch.

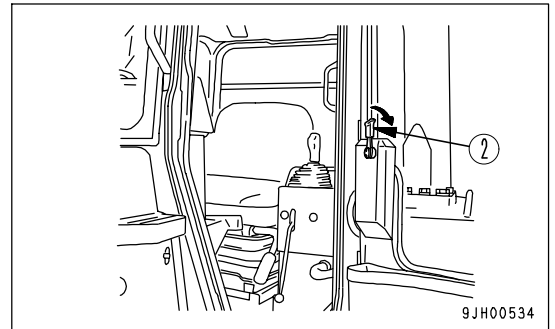

NOTICE

- When keeping the door open, fix it securely to the catch.
- Always close the door when traveling or carrying out operations. Leaving the door open will cause the door to break.
- Keep the door locked open securely. The door may swing closed because of the vibration.

SASH GLASS INTERMEDIATE LOCK

When working with the cab sash glass open, use this lock to prevent the glass from chattering.

- When the lever is in the FREE position, the glass can be opened or closed.
- When the lever is moved to the LOCK (up or down) position, the glass is fixed in position.
- If the glass is not held securely, set the lever in the FREE position and rotate clockwise to strengthen the holding power.
- To reduce the holding power, turn counterclockwise.

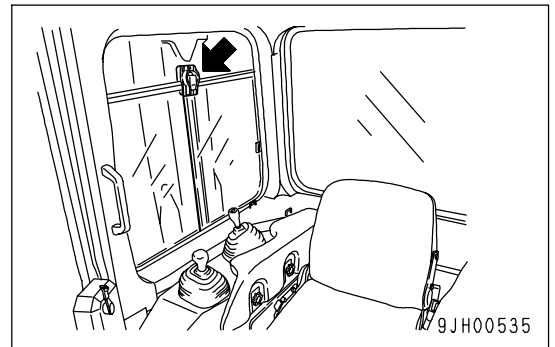

NOTICE

Always close the window when traveling or carrying out operations. Leaving the window open will cause the window to break.

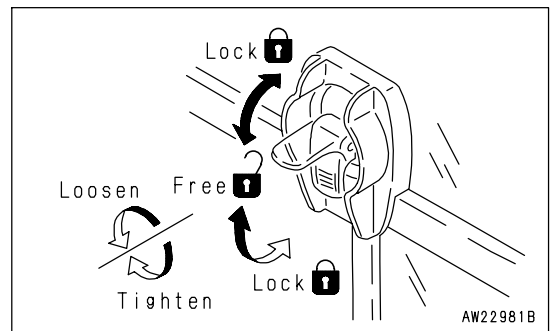

DOOR POCKET

This is inside the left and right doors. Use it for keeping things.
Do not put the heavy tools or other heavy objects in it.
If the pocket is dirty, loosen three bolts (1), then remove the pocket and rinse it.

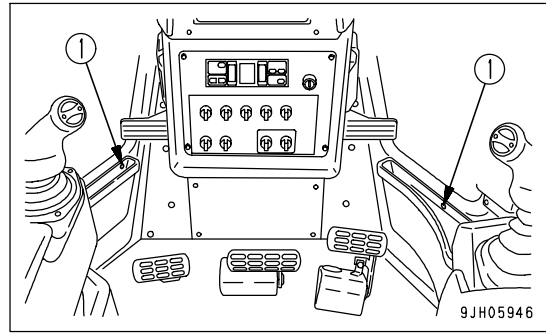

ASHTRAY

This is on the left side of the operator's seat.
Always make sure that you extinguish the cigarette before closing the lid.

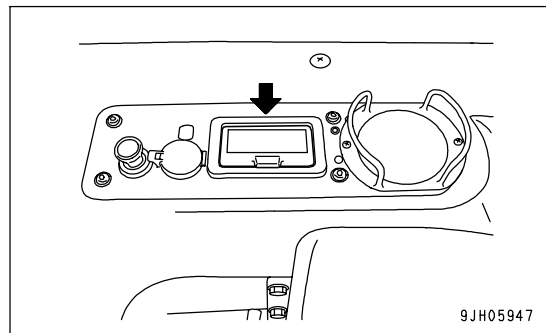

TOOL BOX

This is inside the front of the right fender.
It is used for storing tools.

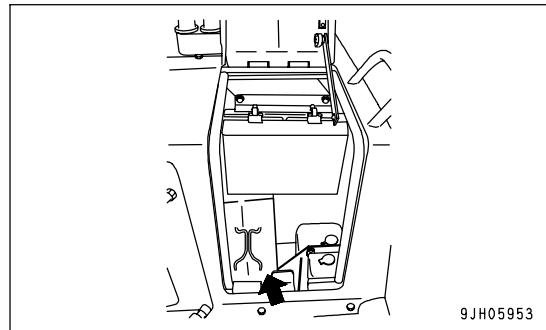

CLEAN INTERIOR OF CAB

If there is any oil or dirt stuck to cab interior (1) and (2), apply a neutral detergent to a cloth and dab to remove the dirt, then wash with water.
After washing with water, dry completely and assemble.

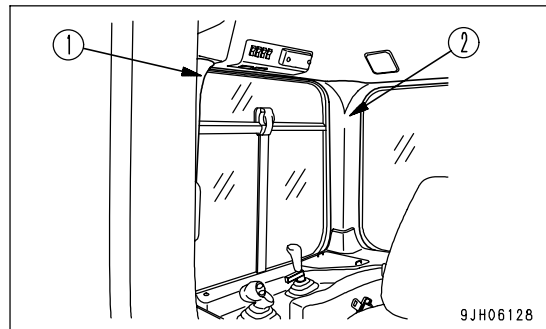

CAR STEREO, HANDLING

EXPLANATION OF COMPONENTS

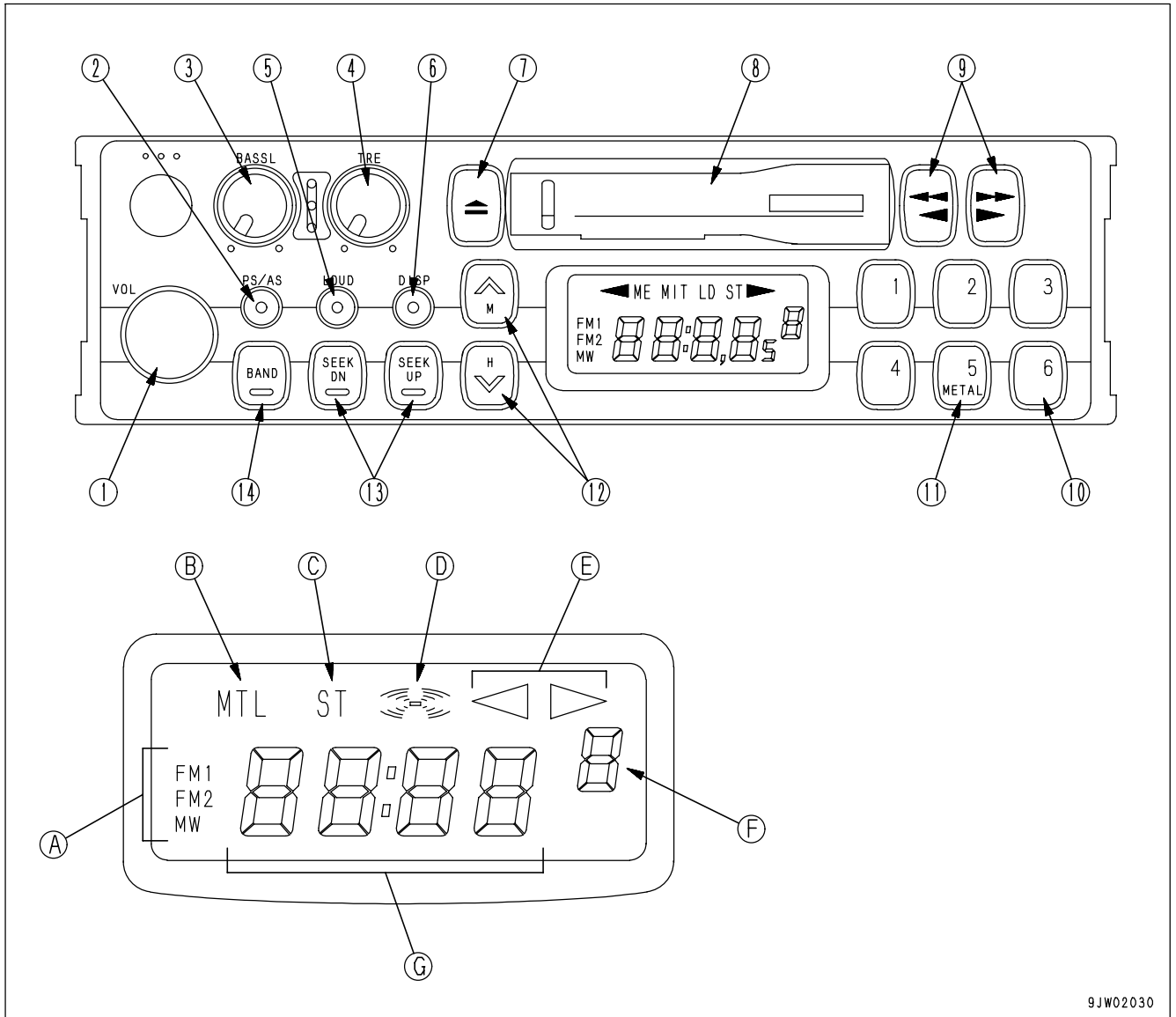

- | | |
|--|----------------------------------|
| (1) Power switch/volume | (8) Cassette door |
| (2) Auto-store/preset scan button | (9) Fast forward, rewind buttons |
| (3) Bass control knob | (10) Preset buttons |
| (4) Treble control knob | (11) Metal tape button |
| (5) Loudness button | (12) Manual tuning buttons |
| (6) Time/radio display selector button | (13) Seek tuning buttons |
| (7) Tape eject button | (14) Band selector button |
| (A) Band display | (E) Tape direction display |
| (B) Metal tape display | (F) Preset channel display |
| (C) FM stereo reception display | (G) Time/frequency display |
| (D) Loudness display | |

9JW02030

POWER SWITCH/VOLUME

Turn this knob (1) to the right until it clicks to turn the power on.
Turn it further to increase the volume.

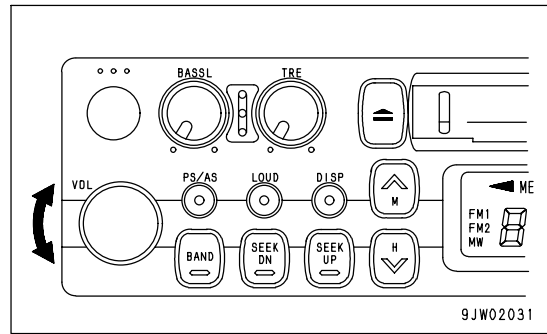

AUTO-STORE/PRESET SCAN BUTTON

Use this button (2) to actuate the preset scan and auto-store functions.

- Auto-store
Each time this button is pressed for more than 2 seconds while in radio reception, this auto-store function automatically starts to search for the desired station within a receivable band, and memorize the frequency in the preset memory. During this scanning process, the frequency shown in the right side of display continues to change. This indicates that each frequency is memorized in the auto-store.

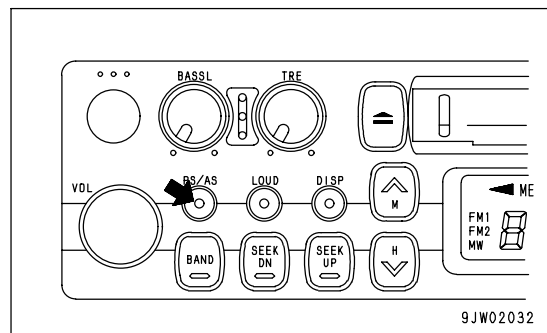

REMARK

The auto-store function cannot be used when the channel display is flashing.
When the display is flashing, the preset scan function is being used.

BASS CONTROL KNOB

Turn this button (3) to the left to reduce the low tones; turn it to the right to emphasize the low tones.
Direction (a): Low tone reduced
Direction (b): Low tone emphasized

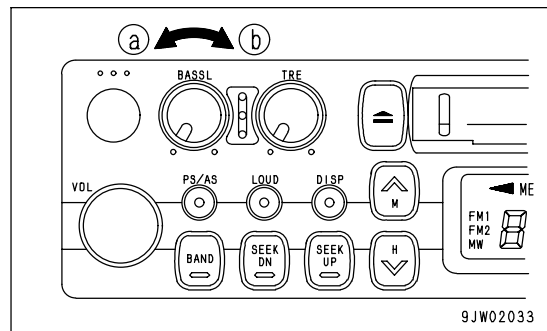

TREBLE CONTROL KNOB

Turn this button (4) to the left to reduce the low tones; turn it to the right to emphasize the high tones.

Direction (a): High tone reduced

Direction (b): High tone emphasized

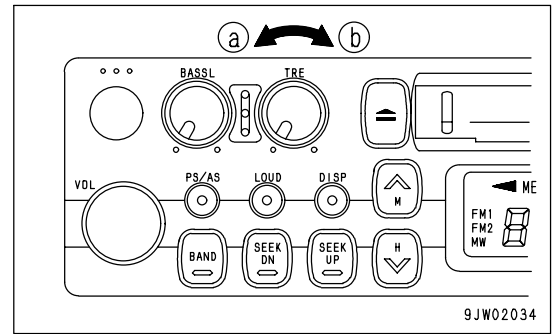

LOUDNESS BUTTON

This button (5) is used when playing at low volume. It makes it possible to hear more easily by emphasizing the low tone when the low tones are weak.

Push button: Actuated (ON)

Push button again: Canceled (OFF)

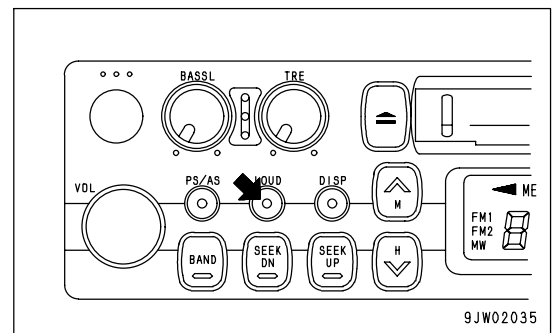

TIME/RADIO DISPLAY SELECTOR BUTTON

This button (6) is used to switch between the "Radio/tape display" and the "Time display".

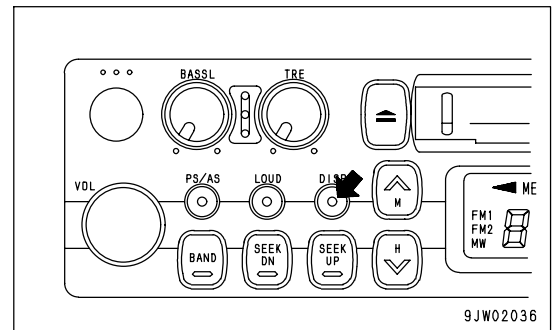

• Correcting time

Press the button to set to the time display.

(A) Correcting hour :

Keep the DISP button pressed and press the bottom tuning button (H) to correct the hour.

(B) Correcting minute :

Keep the DISP button pressed and press the top tuning button (M) to correct the minute.

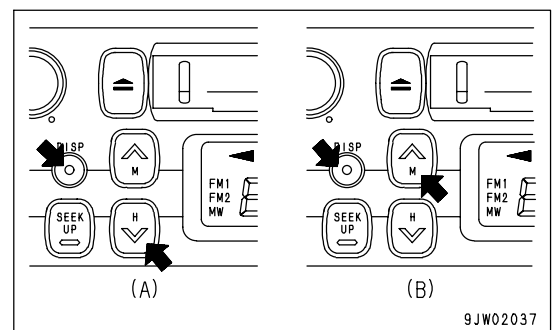

TAPE EJECT BUTTON

This button (7) is used to stop the tape and to eject the cassette. When this button is pressed, the tape is ejected and the radio plays.

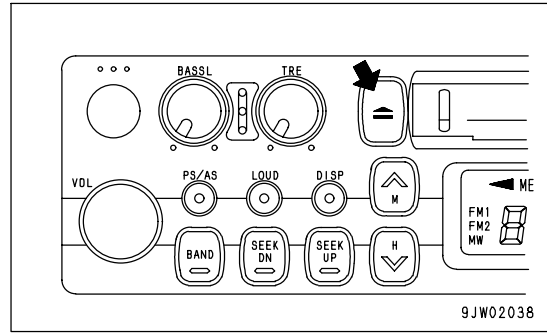

CASSETTE DOOR

Set the cassette with the exposed portion of the tape on the right side and insert it through the cassette door (8).

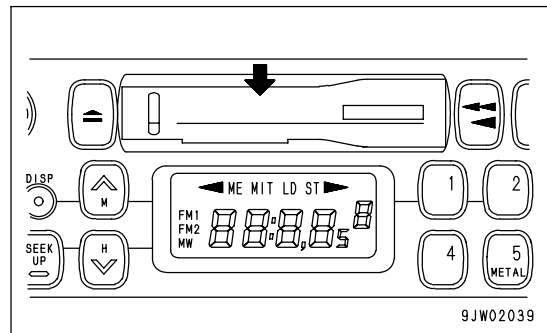

FAST FORWARD, REWIND BUTTONS

These buttons (9) are used to fast-forward or rewind the tape.

- Fast forward/rewind

If you press the button pointing in the same direction as the arrow indicating the direction of play, the tape will be fast forwarded; if you press the button pointing in the opposite direction, the tape will be rewound.

To stop the tape, lightly press the button that is not locked. The fast forward or rewind operation will be canceled.

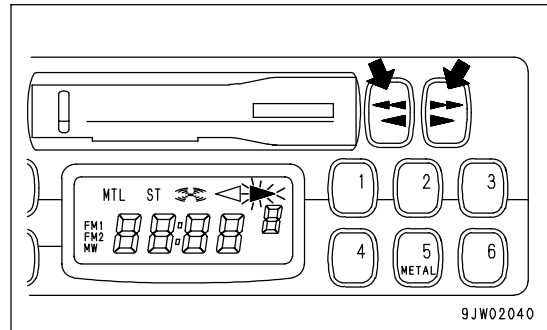

PRESET BUTTONS

These buttons (10) are used to call up the broadcast station frequencies preset in memory for each of buttons No. 1 to No. 6. It is possible to preset 18 stations (FM: 12; AM: 6) with these buttons.

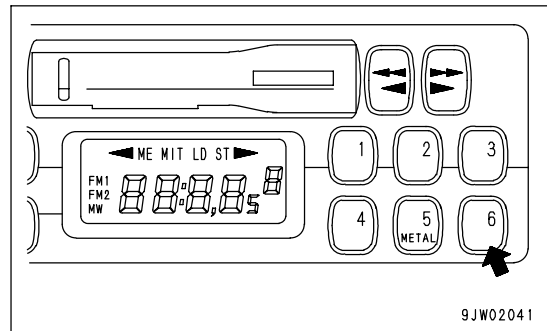

METAL TAPE BUTTON

(used also for preset button No. 5)

This button (11) is used when playing a metal or chrome tape. This button is also used for preset button No. 5. When it is pressed, "MTL" appears on the display.

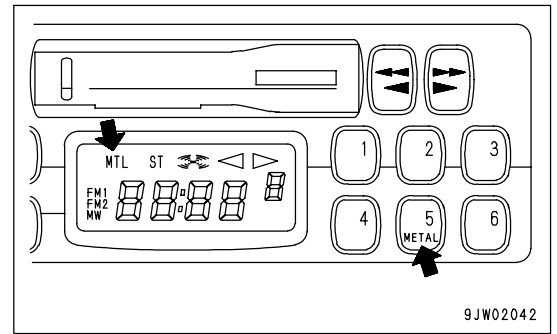

MANUAL TUNING BUTTONS

These buttons (12) are used for manual tuning.

When "TUN ^" button is pressed, the frequency goes up 9 kHz for AM or 0.1 MHz for FM; when "TUN v" button is pressed, the frequency goes down 9 kHz for AM or 0.1 MHz for FM.

If the button is pressed down and held, the frequency will change continuously.

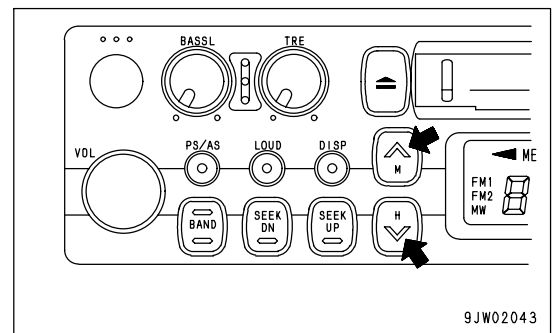

SEEK TUNING BUTTONS

These buttons (13) are used to seek tuning.

When the "SEEK UP" button is pressed, the search automatically goes up; when the "SEEK DN" button is pressed, the search automatically goes down.

When the next station that can be received is found, it automatically stops.

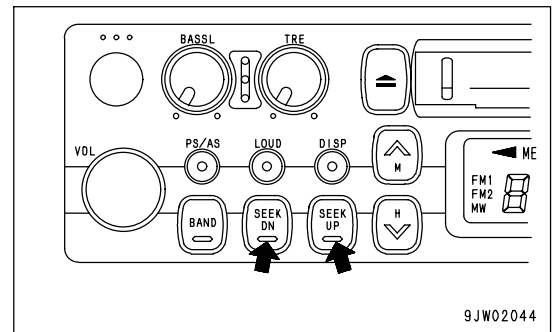

BAND SELECTOR BUTTON

When this button (14) is pressed, the band is switched between FM1, FM2, and MW (AM). The band is shown on the display.

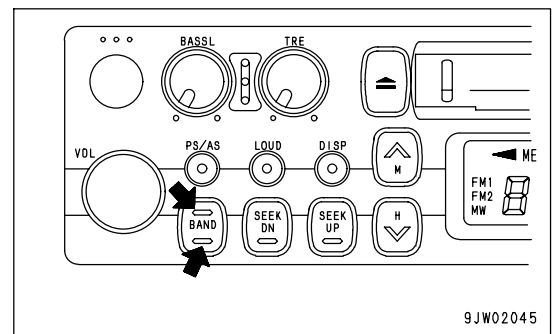

METHOD OF OPERATION

METHOD OF SETTING PRESET BUTTONS

To listen to a preset station, use band selector button (1) to select AM, FM1, or FM2, then press the preset switch number to listen to the desired station.

It is possible to preset six AM stations and 12 FM stations (FM1: 6, FM2: 6).

1. If you are playing a cassette, press the tape eject button to stop the tape.
2. Select the station to be preset.
Use band selector button (1) to select MW (AM), FM1, or FM2, then use the manual tuning button to select the frequency of the broadcasting station.
3. Press manual memory button (2) or seek tuning button (3).
4. Press preset button (4) of the number to be preset for 2 seconds while the frequency display is being shown on the display. (The preset channel and frequency are displayed and the presetting is completed).
5. Repeat Steps 2 to 4 to preset other stations.

REMARK

- Use Steps 2 to 4 also when changing the setting of a preset switch to another station.
- When the power is disconnected, such as when the battery is replaced, all the settings are deleted, so preset the stations again.

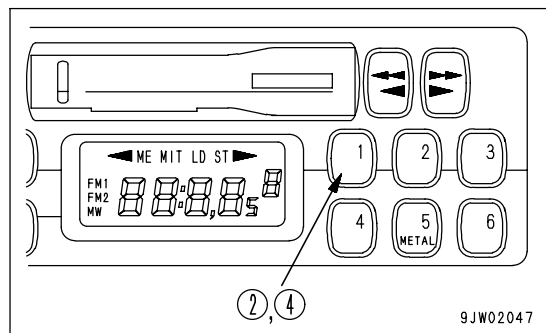
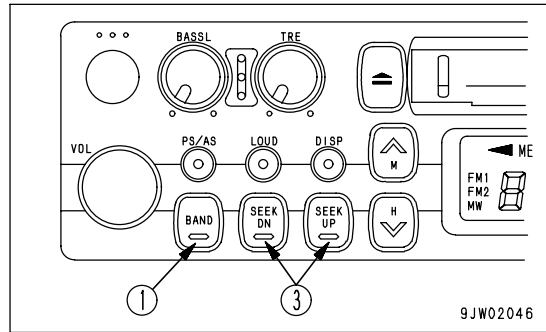

MANUAL MEMORY BUTTON

Select the station to be preset with manual tuning button (1) or seek tuning button (2), then keep button No.1 to button No.6 of button (3) pressed for 2 seconds while the frequency is being displayed to preset the station.

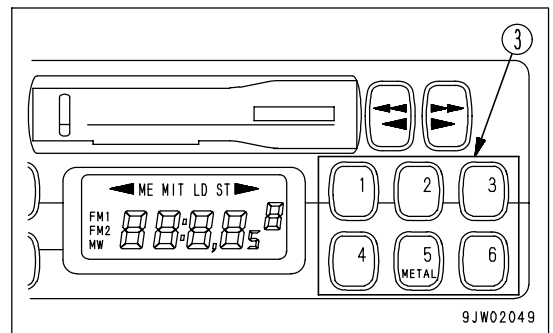
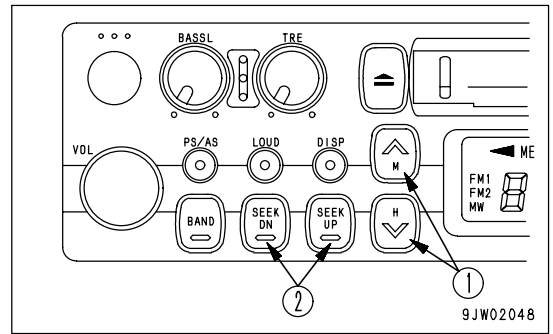

LISTENING TO RADIO

1. Turn the starting switch ON, then turn power switch (1) ON.
2. Set band selector button (2) to AM or FM.
3. Select the station with the preset buttons or manual tuning button (3).
4. Adjust the volume, balance, and tone as desired.
5. When turning the radio OFF, turn power switch (1) to the left until it clicks.

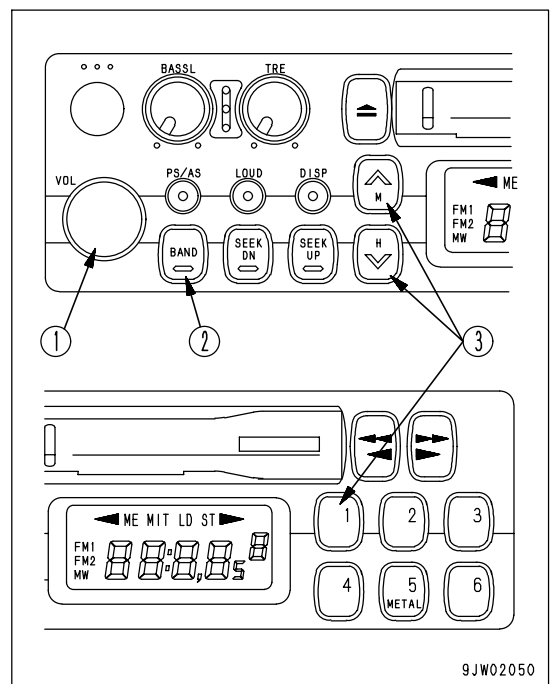

REMARK

- To switch to the radio when listening to a cassette, press the cassette eject button to stop the tape.
- If you insert a cassette when listening to the radio, the tape will start to play.

LISTENING TO CASSETTE TAPE

- 1. Turn the starting switch ON, then turn power switch (1) ON.
- 2. Set the cassette with the exposed portion of the tape on the right side and push it past the cassette door. The tape will automatically start playing.

If the arrow indicating the direction of play is pointing to the right, the top side is being played; if the arrow is pointing to the left, the bottom side is being played.

When the tape reaches the end, it is automatically reversed and the other side starts to play.

- 3. When finished with the tape, press the cassette eject button to eject the tape and automatically switch to the radio.

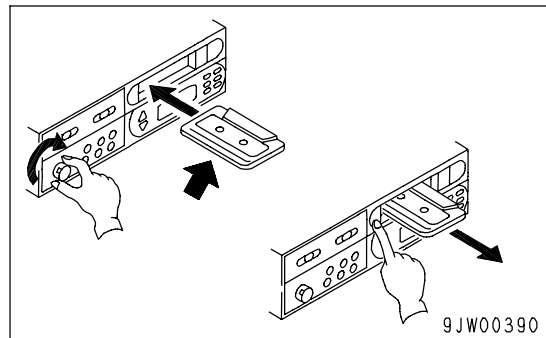
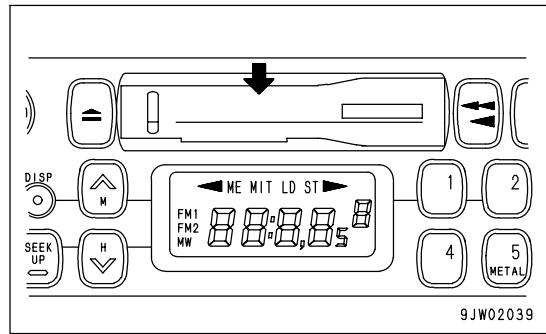

REVERSING TAPE

When listening to the tape, press both FAST FORWARD, REWIND buttons (A) and (B) at the same time lightly.

When this is done, the tape direction display will be reversed.

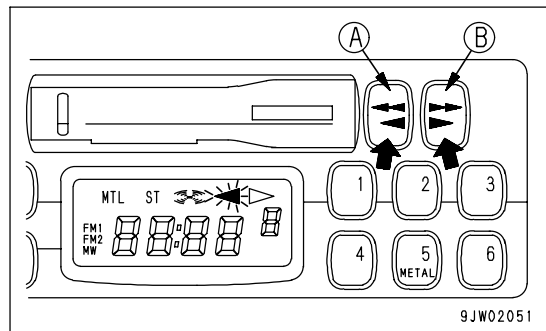

PRECAUTION WHEN USING**WARNING**

- If a voltage greater than the specified voltage is input, it may cause fire, electrocution, or other failure. Never input any voltage other than the specified voltage.
- Places inside the radio are under high voltage. Do not remove the cover.
- Do not carry out any modifications. This may cause fire, electrocution, or other failure.
- If the sound cannot be heard, nothing is displayed, or any other problem occurs, turn off the power switch and ask your Komatsu distributor to make repairs without delay.

- Stow the antenna when traveling in places with low overhead clearance.
- To ensure safety during operations, keep the volume at a level where it is possible to hear other machines.
- If water gets inside the speaker case or radio (auto tuning), it may cause a serious problem, take care not to let water get in these items.
- Do not wipe the scales or buttons with solvent such as benzene or thinner. Wipe with a dry soft cloth. If the dirt cannot be removed easily, soak the cloth with alcohol.

NOTICE**Handling cassette tape**

- Clean the tape head approx. once a month with a commercially available head cleaning tape.
- Do not leave the tape any place where it is exposed to direct sunlight, any place that is excessively dusty, or any place where there is a magnetic field.
- Do not use 120-minute tapes. The tape is thin and it easily gets caught up inside the machine.
- If the tape is slack, it easily gets caught up inside the machine. Use a pencil to wind in the tape to remove any slack.
- Do not use any cassette tape if the label has started to come off. It may cause defective rotation, or it may be impossible to get the tape out of the machine.

AIR CONDITIONER, HANDLING

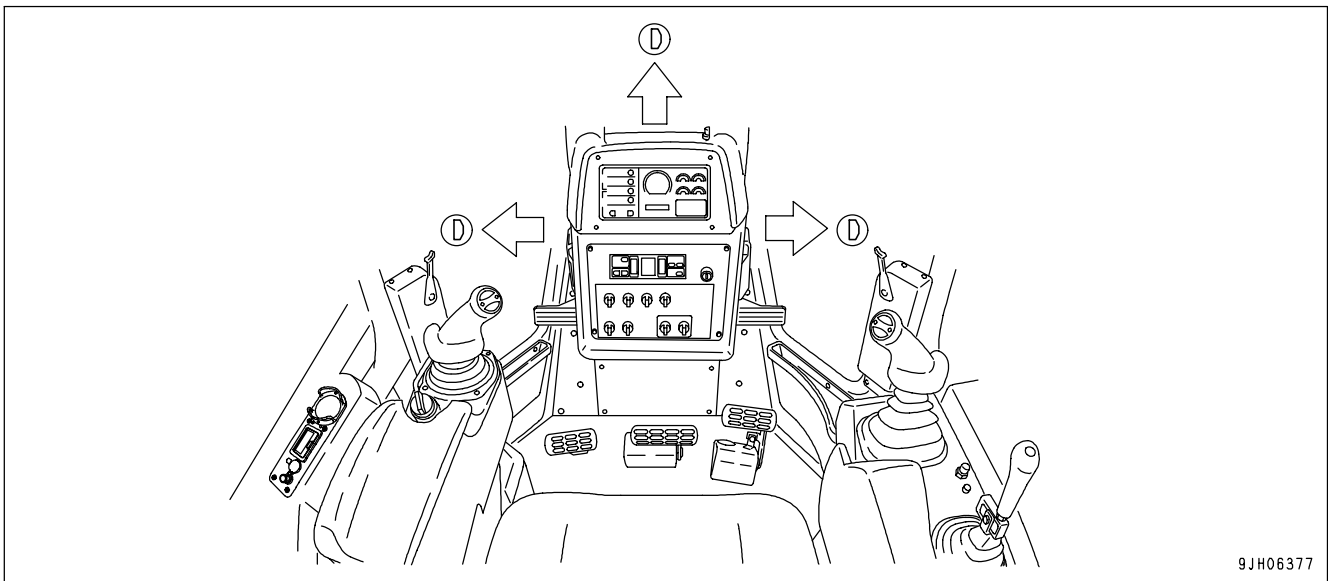
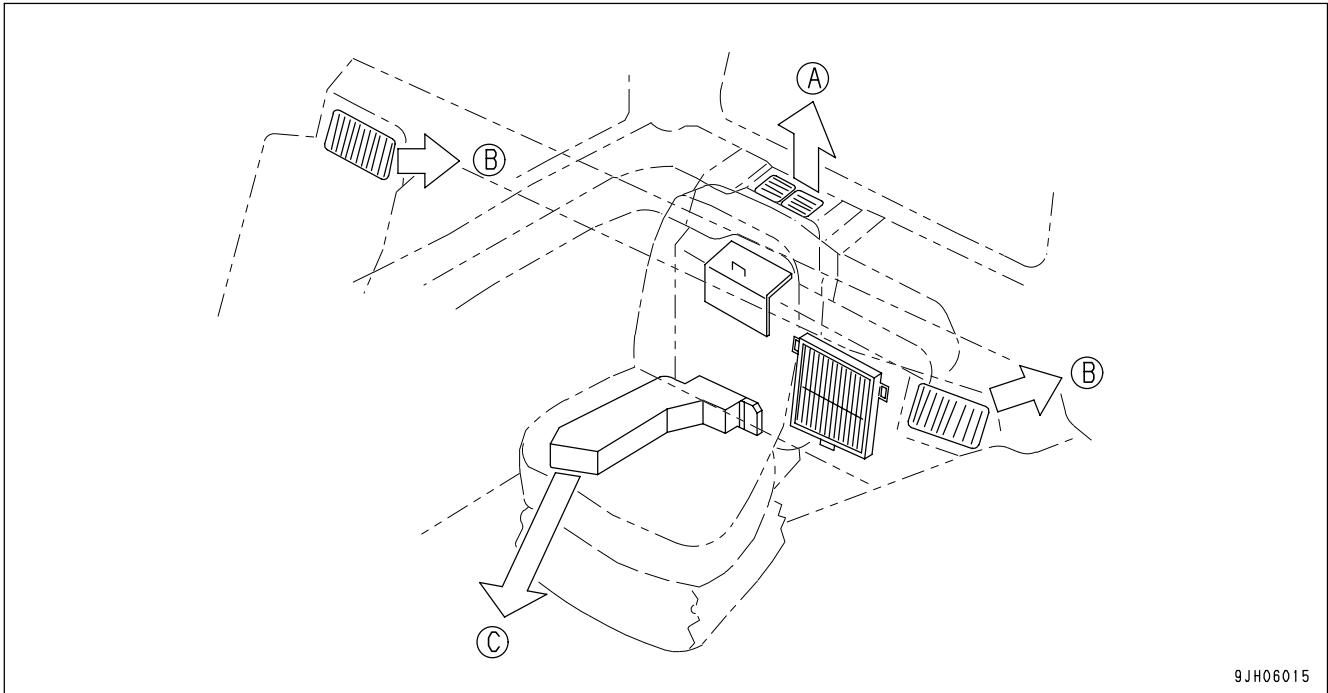

The air conditioner is installed behind the operator's seat. The vents blow out cool air or hot air to cool or heat the cab.

Location of vents

- (A) Rear vent
- (B) Front vent (ceiling)
- (C) Foot vent
- (D) Defroster vent

REMARK

- Vents (A) and (B) have louvers to make it possible to change the direction of the airflow as desired.
- Vent (D) can be opened and closed manually.

GENERAL LOCATIONS OF CONTROL PANEL

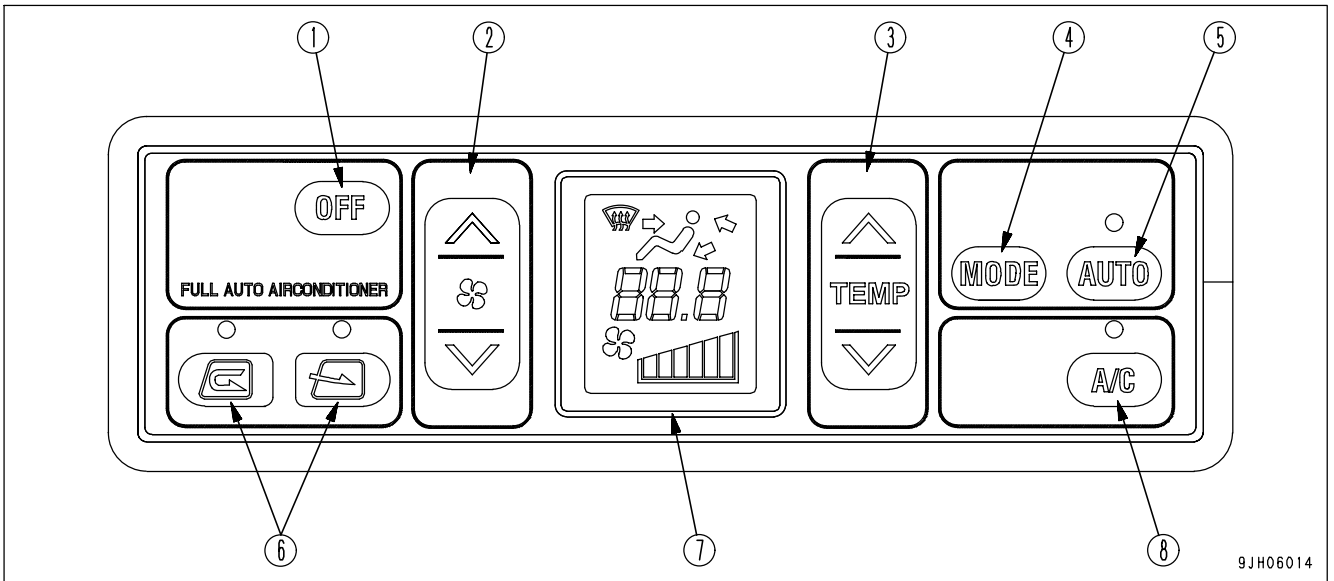

- | | |
|--------------------------------|----------------------------------|
| (1) OFF switch | (5) Auto switch |
| (2) Fan switch | (6) RECIRC/FRESH selector switch |
| (3) Temperature control switch | (7) Display monitor |
| (4) Vent selector switch | (8) Air conditioner switch |

OFF Switch

Switch (1) is used to stop the fan and air conditioner.

- When OFF switch (1) is pressed, the set temperature and air flow display on display monitor (7), the lamps above auto switch (5), and air conditioner (8) go out, and operation stops.



Fan Switch

Switch (2) is used to adjust the air flow.

The air flow can be adjusted to six levels.

- Press the ^ switch to increase the air flow; press the v switch to reduce the air flow.
- During auto operation, the air flow is automatically adjusted.

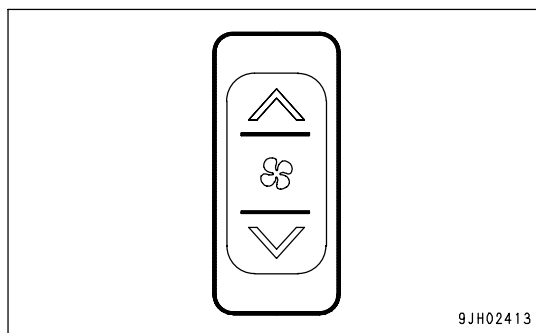

A: Liquid crystal display

B: Air flow

a: Air flow "low"

b: Air flow "medium 1"

c: Air flow "medium 2"

d: Air flow "medium 3"

e: Air flow "medium 4"

f: Air flow "high"

A	B
	a
	b
	c
	d
	e
	f

Temperature Control Switch

Switch (3) is used to control temperature inside the cab. The temperature can be set between 18°C (64.4°F) and 32°C (89.6°F).

- Press the ^ switch to raise the set temperature; press the v switch to lower the set temperature.
- The temperature is generally set at 25°C (77°F).
- The temperature can be set in stages of 0.5°C (0.9°F).

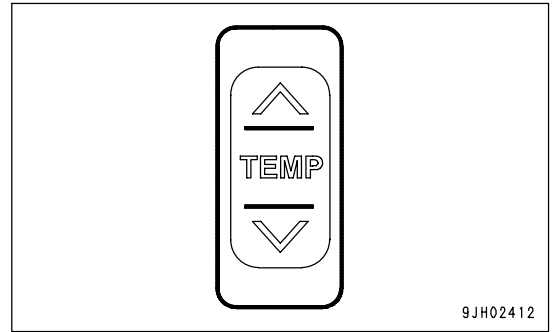

<Monitor display and the function>

Monitor display °C	Set temperature
18.0	Max. cooling
18.5 to 31.5	Adjusts temperature inside cab to set temperature
32.0	Max. heating

REMARK

If the mode is set to auto mode and the temperature setting is set to 18.0 °C (64.4 °F) or 32.0 °C (89.6 °F), the air flow from the fan is always set to HIGH and does not change even when the set temperature is reached.

Vent Selector Switch

Switch (4) is used to select the vents.

- When switch (4) is pressed, the display on monitor display (7) switches and air blows out from the vents displayed.
- During automatic operation, the vents are automatically selected.

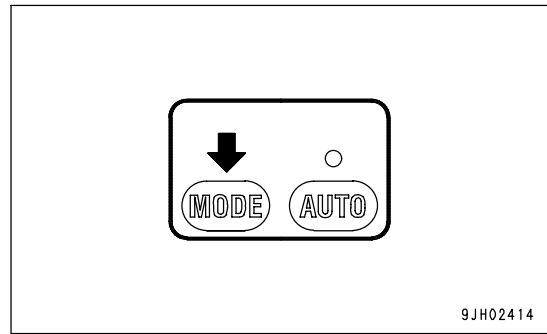

Liquid crystal display	Vent mode	Vent				Remarks
		(A)	(B)	(C)	(D)	
	Front and rear vents (including defroster vent)	○	○		(○)	—
	Front, rear, and foot vents (including defroster vent)	○	○	○	(○)	—
	Foot vent			○		—
	Front, foot vents (including defroster vent)		○	○	(○)	Cannot be selected for automatic operation
	Front vents (including defroster vent)		○		(○)	Cannot be selected for automatic operation

Note 1: Air blows out from vents marked ○

Note 2: The defroster vents can be opened or closed manually with the vent lever.

Auto Switch

With switch (5), the air flow, vents, and air source (RECIRC/FRESH) are automatically selected according to the set temperature.

- When auto switch (5) is pressed, the lamp above the auto switch lights up.
- Press switch (5), then use temperature control switch (3) to set the temperature, and run the air conditioner under automatic control.
- When the control is switched from automatic operation to manual operation, it is possible to operate the to change air flow, vents, and air source (RECIRC/FRESH). When manual control is used, lamp above the auto switch goes out.

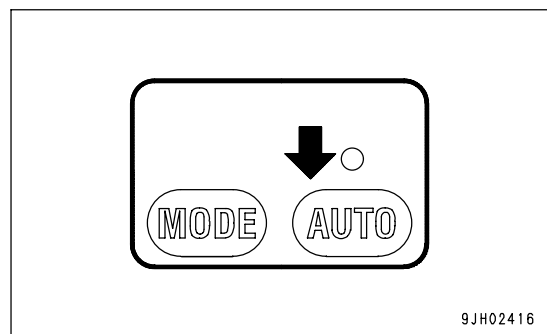

REMARK

When Auto Mode is selected, if the set temperature is set to 18.0 °C (64.4 °F) or 32.0 °C (89.6 °F), the air flow is always set to High, but this is not a problem.

RECIRC/FRESH Selector Switch

Switch (6) is used to switch the air source between recirculation of the air inside the cab and intake of fresh air from the outside.

- When switch (6) is pressed, the lamp above the selector switch lights up to show that air is being blown out.
- During automatic operation, the selection of inside air (RECIRC) and outside air (FRESH) is performed automatically.

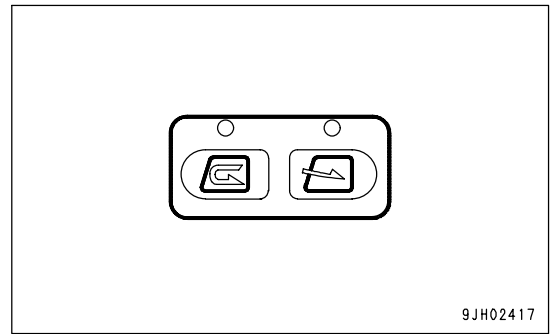

9JH02417

RECIRC	Outside air is shut off and only air inside the cab is circulated. Use this setting to perform rapid cooling of the cab or when outside air is dirty.
FRESH	Outside air is taken into the cab. Use this setting to take in fresh air when performing demisting.

Display Monitor

Monitor (7) displays the status of temperature setting (a), air flow (b), and vents (c).

- When OFF switch (1) is pressed, the display of temperature setting (a) and air flow (b) goes out, and operation stops.

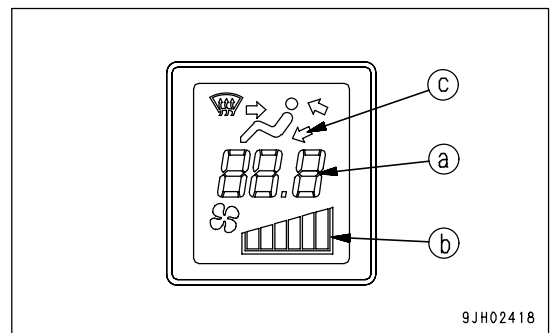

9JH02418

Air Conditioner Switch

Switch (8) is used to turn the air conditioner (cooling, dehumidifying, heating) ON or OFF.

- When the fan is actuated (display (b) is shown) and air conditioner switch (8) is pressed, the air conditioner is switched ON, lamp above the air conditioner switch lights up, and the air conditioner starts.

When switch (8) is pressed again, the air conditioner is switched OFF, lamp above the air conditioner switch goes out, and the air conditioner stops.

- Air conditioner cannot be operated while the fan is off.

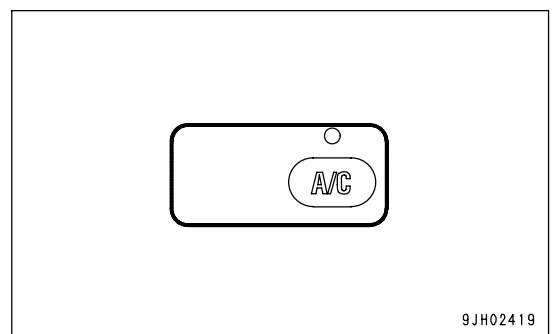

9JH02419

METHOD OF OPERATION

The air conditioner can be operated automatically or manually. Select the method of operation as desired.

Automatic Operation

1. Turn auto switch (5) ON.

- The lamp above switch (5) lights up.
- The set temperature (a) and air flow (b) are displayed on the monitor.

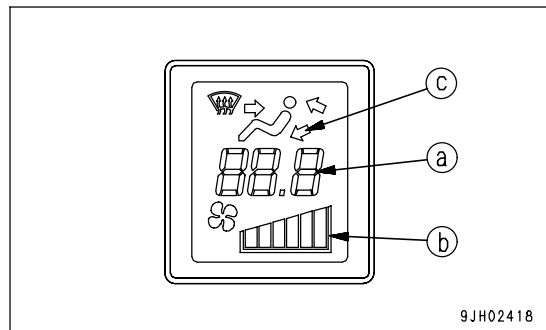
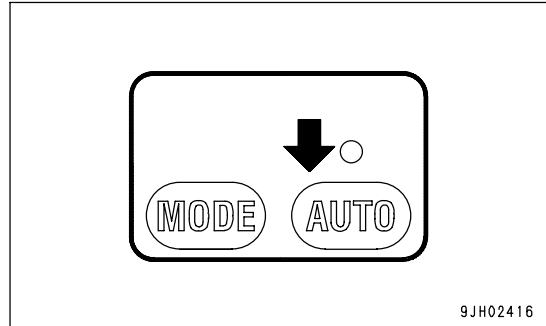

2. Use temperature set switch (3) to set to the desired temperature. The air flow, combination of vents, and selection of fresh or recirculated air is automatically selected according to the set temperature, and the air conditioner is operated automatically to provide the set temperature.

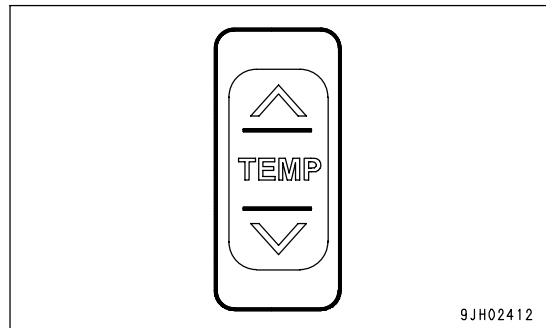

REMARK

When vent display monitor (c) displays (d) or (e), and engine coolant temperature is low, the air flow is automatically limited to prevent cold air from blowing out.

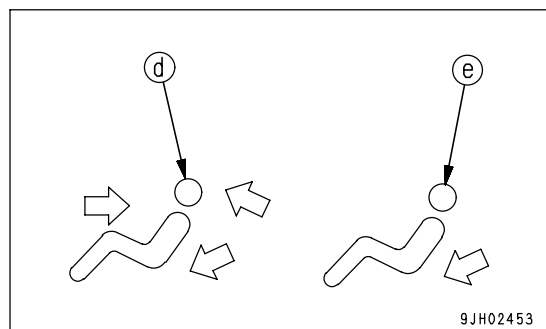

Stopping Automatic Operation

Press OFF switch (1). The displays for temperature setting (a) and air flow (b) on monitor (7), and lamps above auto switch (5) and air conditioner switch (8) go out, the operation stops.



Manual Operation

1. Press fan switch (2) and adjust the air flow. When doing this, check that temperature setting (a) and air flow (b) are displayed on monitor (7).

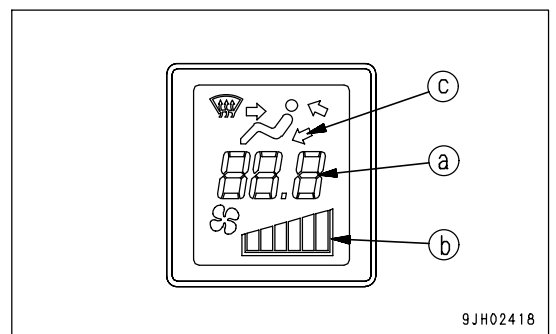
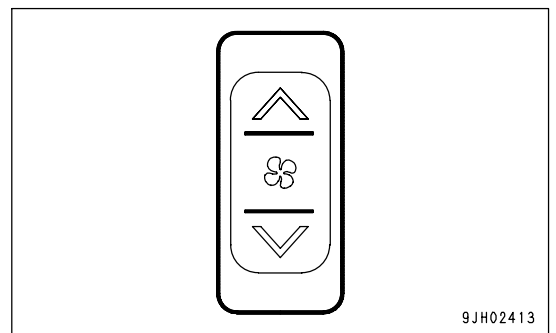

2. Turn air conditioner switch (8) ON. Check that the lamp above air conditioner switch lights up.

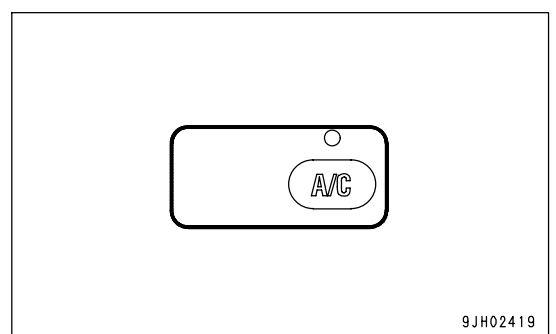

3. Press temperature setting switch (3) and adjust temperature inside the cab.

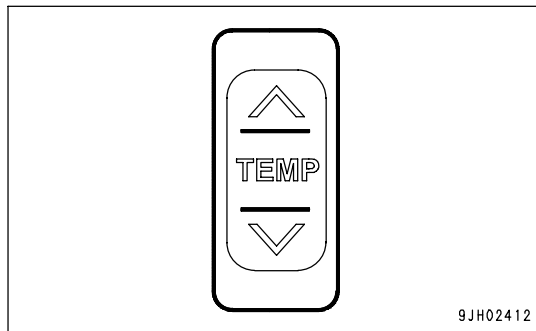

4. Press vent selector switch (4) and select the desired vents. When this is done, the display for vent (c) of the display monitor changes according to the selection.

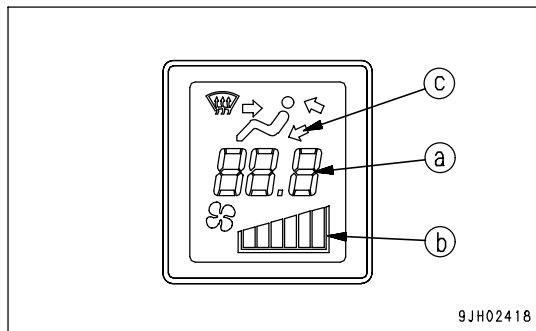
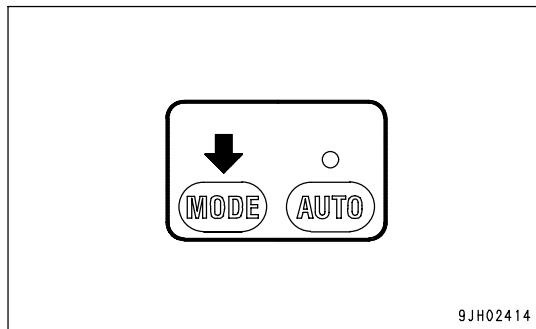

5. Press RECIRC/FRESH selector switch (6) and select recirculation of the air inside the cab (RECIRC) or intake of fresh air from outside (FRESH).

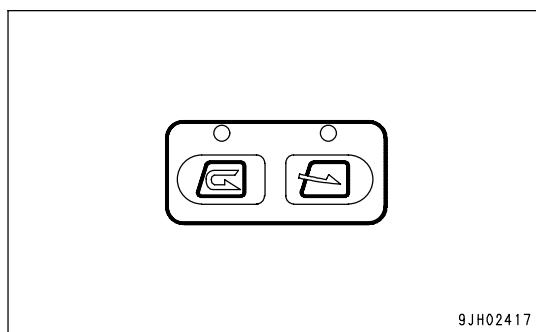

Stopping Manual Operation

Press OFF switch (1). The displays for temperature setting (a) and air flow (b) on monitor (7), and lamps above auto switch (5) and air conditioner switch (8) go out, the operation stops.



Operation with Cold Air to Face and Warm Air to Feet

To operate with cold air blowing to the face and warm air blowing to the feet, set as follows.

1. Press fan switch (2) and adjust the air flow. When doing this, check that temperature setting (a) and air flow (b) are displayed on monitor (7).

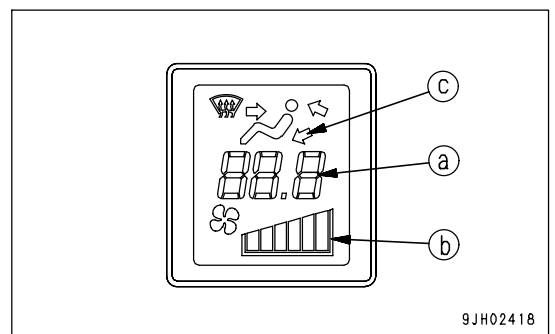
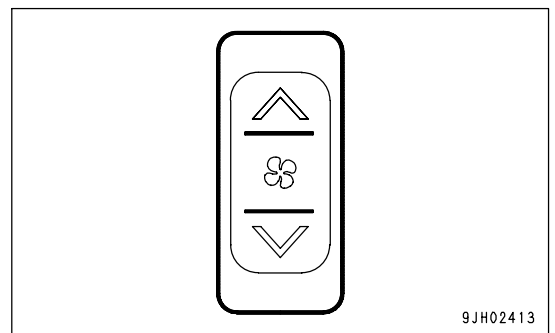

2. Press vent selector switch (4) and set the vent display on the display monitor to the display shown in the diagram on the right.

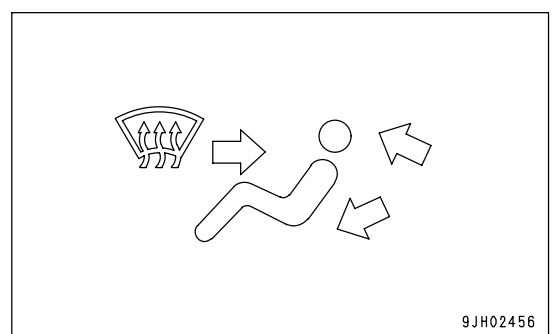

3. Turn air conditioner switch (8) ON. Check that the lamp above air conditioner switch lights up.

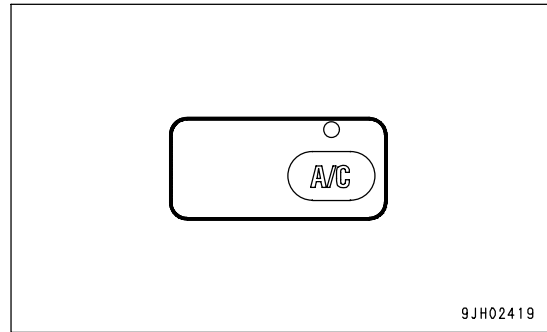

4. Adjust fan switch (2), temperature setting switch (3) and RECIRC/FRESH selector switch (6) to the desired positions.

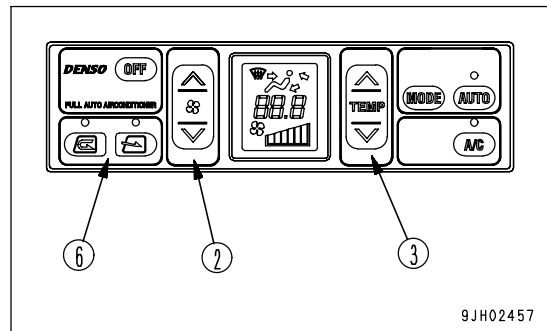

Defroster Operation

1. Press fan switch (2) and adjust the air flow. When doing this, check that temperature setting (a) and air flow (b) are displayed on monitor (7).

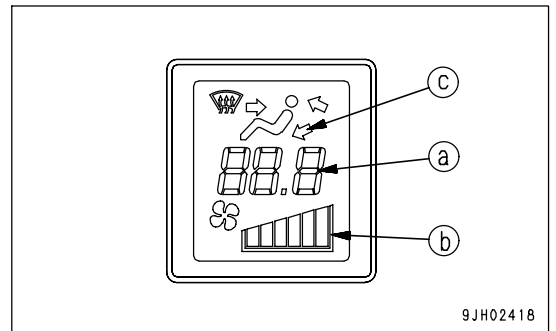
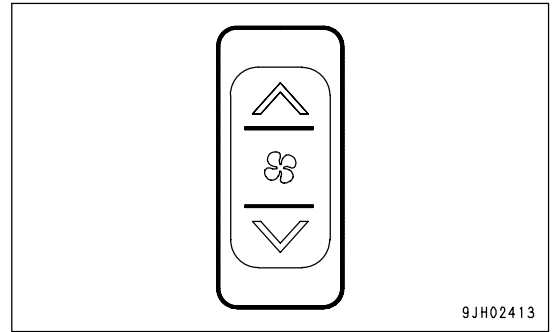

2. Press vent selector switch (4) and set vent display on the display monitor to (f) or (g) as shown in diagram on the right.

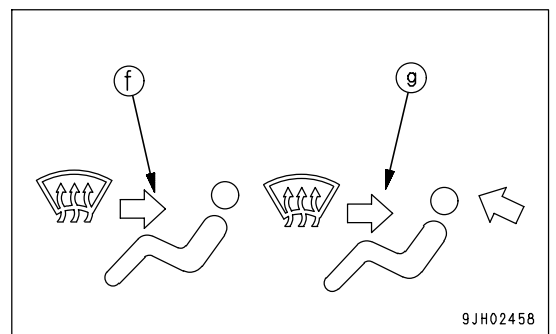
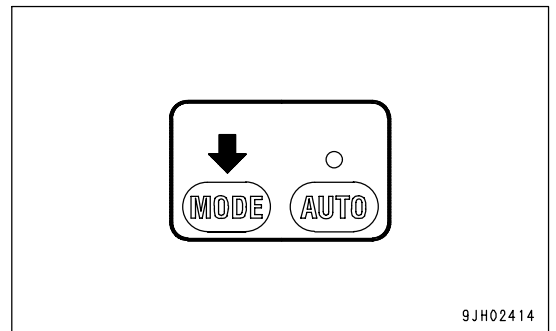

3. Press RECIRC/FRESH selector switch (6) and set it to take in fresh air.

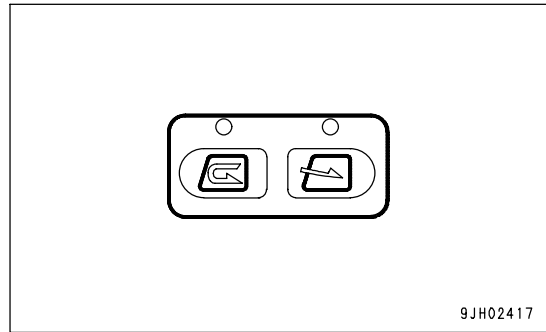

4. Press temperature setting switch (3) and set temperature on the display (7) monitor to maximum heating.

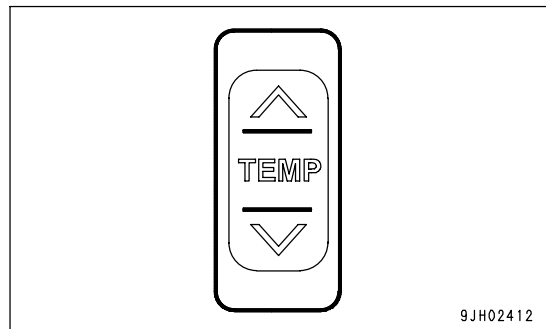

When operating in the rainy season or when it is desired to remove the mist from the window glass or to dehumidify the air, turn air conditioner switch (8) ON.

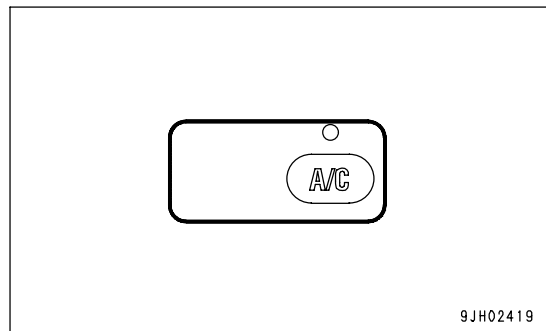

OTHER FUNCTIONS

Self-diagnostic Function

It is possible to perform troubleshooting of various sensors and equipment used on the air conditioner.

1. Press OFF switch (1). The temperature setting and air flow display on the liquid crystal display portion go out and operation stops.
2. If the "∨" and "∧" parts of temperature setting switch (3) are kept pressed at the same time for at least 3 seconds, the troubleshooting mode is displayed on the liquid crystal display portion.

<Monitor display and failure mode>

Display	Failure mode
E--	No failure
E11	Disconnection in recirculated air sensor
E12	Short circuit in recirculated air sensor
E13	Disconnection in fresh air sensor
E14	Short circuit in fresh air sensor
E15	Disconnection in coolant temperature sensor
E16	Short circuit in coolant temperature sensor
E18	Short circuit in sunlight sensor
E21	Disconnection in vent sensor
E22	Short circuit in vent sensor
E43	Problem in vent damper
E44	Problem in air mix damper
E45	Problem in RECIRC/FRESH air damper
E51	Problem in refrigerant pressure

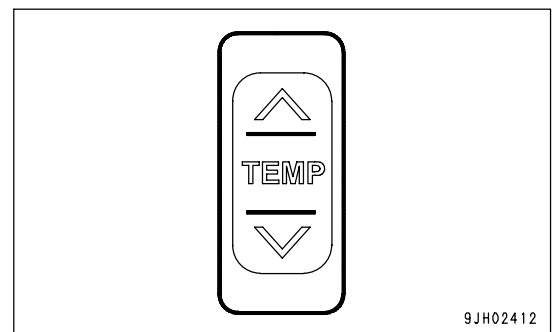

- When more than one failure is detected, press the "∨" or "∧" portion of temperature setting switch (3) to display the failures in turn.
- After completing the troubleshooting, press OFF switch (1) again to return to the normal display.

If any problem is detected by the self-diagnostic function, contact your Komatsu distributor perform inspection and repair.

Function to Switch Set Temperature Display Between Fahrenheit and Celsius

It is possible to switch the set temperature display between °F and °C.

If the "∨" and "∧" portions of temperature setting switch (3) are pressed at the same time for more than 5 seconds while the fan is running, the temperature display will switch between °F and °C. (Note that the unit is not displayed.)

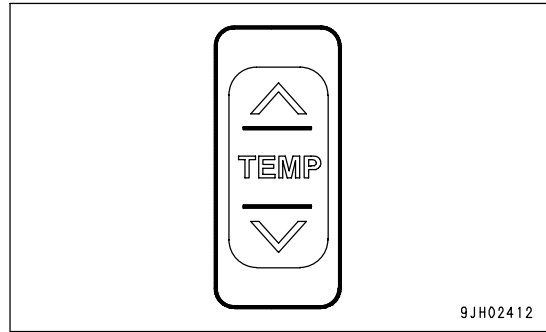

	Liquid crystal display range
°C	18.0 to 32.0
°F	63 to 91

Extra Strong Wind Flow Function

It is possible to provide a stronger wind flow than for the normal HIGH position.

Use switch (2) to set to HIGH, then turn the extra strong wind flow switch ON. When the extra strong wind flow switch is turned ON, the airflow from the front and the dashboard vents is increased.

PRECAUTIONS WHEN USING AIR CONDITIONER

WHEN CARRYING OUT COOLING, VENTILATE THE CAB FROM TIME TO TIME

- If you smoke when using the air conditioner, your eyes may start to itch or burn, therefore ventilate the cab every so often to remove the smoke.
- When the air conditioner is used for long periods, carry out ventilation once every hour.

BE CAREFUL NOT TO COOL TOO MUCH

- For reasons of health, it is recommended that the cab should feel pleasantly cool when you enter it from the outside (5 to 6°C (9.0 to 10.8°F) lower than the outside temperature). Pay attention to the temperature when carrying out cooling.

SET SO THAT COLD AIR DOES NOT DIRECTLY BLOW ONTO THE GLASS SURFACE

- If the left and right vents in the dashboard are turned so that cold air plays directly on the cab door glass, moisture will condense on the outside of the cab door glass and reduce the visibility. (This occurs particularly in high temperatures.)
If this happens, operate the louvers of the vents to direct the air upward and stop it from blowing directly on the glass surface.

CHECKS DURING OFF-SEASON

Even during the off-season, run the compressor at low speed for several minutes once a week to prevent the loss of the oil film on the lubricated parts of the compressor. (Run the engine at low speed and set the temperature control lever to the central position.)

REMARK

When the ambient temperature is low, if the compressor is suddenly run at high speed, it may cause failure of the compressor. Note that the system is set so that the compressor will not run when the cooler switch is turned on, if the ambient temperature is less than 2 to 6.5°C (35.6 to 43.7°F).

PROCEDURE FOR REPLACING RECEIVER

Replace the receiver once every 2 years.

After replacing the receiver, add compressor oil. Turn the receiver at an angle and measure the oil remaining inside the receiver, then add the same amount of oil (Denso Oil 6) to fill the receiver.

REMARK

- The replacement interval may become shorter depending on the conditions during use.
- If the receiver is used when the moisture absorption limit of the desiccant has been exceeded, the refrigerant circuit may become blocked and cause the compressor to break down.

PRECAUTIONS WHEN REPLACING RECEIVER

- If the receiver is left for more than 15 minutes with the blind cover removed, the moisture in the air will be absorbed, and this will reduce the life of the desiccant. If you remove the blind cover, connect the piping quickly, evacuate the system and fill with refrigerant.
- When removing the refrigerant from the refrigerant circuit, release it gradually from the low pressure side to prevent oil from flowing out.

CHECK COMPRESSOR BELT TENSION AND REFRIGERANT (GAS) LEVEL

If the compressor belt is loose, or the refrigerant level is low, cooling is not carried out efficiently.

For details, see "WHEN REQUIRED (PAGE 4-22)".

CLEANING AIR FILTER

If the air filter for the FRESH or RECIRC air intake becomes clogged, the cooling or heating capacity will drop.

To prevent this, clean the air filter with compressed air once a week.

For details of the cleaning method, see "WHEN REQUIRED (PAGE 4-22)".

EFFECTIVE USE OF AIR CONDITIONER

When it is Desired to Cool Inside of Cab Quickly

If the machine is left in the sun in the middle of summer, the temperature inside the cab may become extremely high. If this happens and it is desired to cool the cab quickly, first open all the doors and windows to remove all the hot air, then turn the air conditioner on.

After starting the engine, press auto switch (5) and use temperature setting switch (3) to set the temperature to 18.0. Run the engine at a slightly higher speed for 2 or 3 minutes, then close the doors and windows.

When the temperature inside the cab goes down, adjust to the desired temperature.

When Window is Misted

In the rainy season, when the humidity inside the cab is high, if the windows mist up, run the air conditioner to remove the mist. When the outside air is extremely humid, if the temperature inside the cab is too low, the outside of the glass may mist up. If this happens, adjust the set temperature or stop the air conditioner to adjust the temperature inside the cab.

Action when not Using Air Conditioner

At times of the year when the air conditioner is not used, run the air conditioner for several minutes with the engine at low speed once a month to maintain the lubricating oil film on all parts of the compressor. (Running in of air conditioner)

In winter, when the temperature inside the cab is low, the air conditioner may not work. If this happens, use a heater to raise the temperature inside the cab and run the air conditioner.

NOTICE

- When running the air conditioner, always start with the engine running at low speed. Never start the air conditioner when the engine is running at high speed. It will cause failure of the air conditioner.
- If water gets into the control panel or sunlight sensor, it may lead to unexpected failure, be careful not to let water get on these parts. In addition, never bring any flame near these parts.
- For the auto function of the air conditioner to work properly, always keep the sunlight sensor clean and do not leave anything around the sunlight sensor that may interfere with its sensor function.

ACCUMULATOR, HANDLING



WARNING

On machines equipped with an accumulator, for a short time after the engine is stopped, if the work equipment control lever is moved to the LOWER position, the work equipment will move down under its own weight.

After stopping the engine, always place the work equipment lock lever and parking lever in the LOCK position.

The accumulator is charged with high-pressure nitrogen gas, so improper operation may cause an explosion which will lead to serious injury or damage. When handling the accumulator, always do as follows:

- Pressure in the control circuit cannot be completely removed. When removing the hydraulic equipment, do not stand in the direction that oil spurts out when performing the operation.
- Loosen the bolts slowly.
- Do not disassemble the accumulator.
- Do not bring it near flame or dispose of it in fire.
- Do not make holes in it or weld it.
- Do not hit it, roll it, or subject it to any impact.
- When disposing of the accumulator, the gas must be released. Contact your Komatsu distributor for proper disposal.

The accumulator is a device to store the pressure in the control circuit, and when it is installed, the control circuit can be operated for a short time even after the engine is stopped.

Therefore, if the control lever is moved in the direction to lower the work equipment, it is possible for the work equipment to move under its own weight.

The accumulator is installed in the position shown in the diagram on the right.

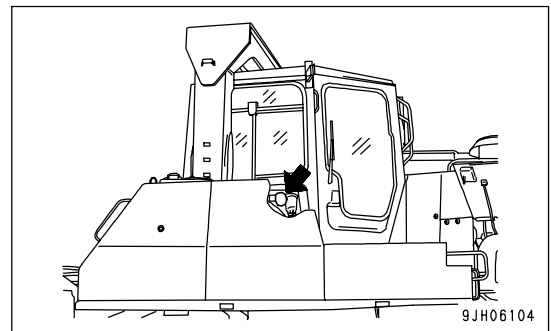

METHOD OF RELEASING PRESSURE IN OPERATING CIRCUIT ON MACHINE EQUIPPED WITH ACCUMULATOR

1. Lower the work equipment and stop the engine.
2. After stopping the engine, operate control lever full strokes to the front, rear, left, and right to release pressure inside the work equipment circuit.

However, the pressure cannot be completely released, so if accumulator in the work equipment circuit is removed, loosen the screws slowly, and never stand in the direction oil spurts out.

HANDLING MACHINES EQUIPPED WITH VHMS

- VHMS is a machine management system. When a communications terminal is installed, it is possible to transmit data.
- A contract is necessary before the VHMS communications terminal can be used. Any customers desiring to use the VHMS system should consult their Komatsu distributor.

VHMS INSTALLED, COMMUNICATIONS TERMINAL NOT INSTALLED

BASIC PRECAUTIONS



WARNING

- Never disassemble, repair, modify, or move the VHMS, antenna, or cables. This may cause failure or fire on the VHMS equipment or the machine itself. (Your Komatsu distributor will carry out removal and installation of VHMS.)
- Do not allow cables or cords to become caught; do not damage or pull cables or cords by force. Short circuits or disconnected wires may cause failure or fire on the VHMS equipment or the machine itself.

REMARK

There is absolutely no need to inspect or operate the VHMS, but if any abnormality is found, please contact your Komatsu distributor.

VHMS AND COMMUNICATIONS TERMINAL INSTALLED

- The VHMS equipment is a wireless device using radio waves, so it is necessary to obtain authorization and conform to the laws of the country or territory where the machine equipped with VHMS is being used. Always contact your Komatsu distributor before selling or exporting any machine equipped with VHMS.
- When selling or exporting the machine or at other times when your Komatsu distributor considers it necessary, it may be necessary for your Komatsu distributor to remove the VHMS equipment or to carry out action to stop communications.
- If you do not obey the above precautions, neither Komatsu nor your Komatsu distributor can take any responsibility for any problem that is caused or for any loss that results.

BASIC PRECAUTIONS



WARNING

- Never disassemble, repair, modify, or move the VHMS, terminal, antenna, or cables. This may cause failure or fire on the VHMS equipment or the machine itself. (Your Komatsu distributor will carry out removal and installation of the VHMS and terminal.)
- Do not allow cables or cords to become caught; do not damage or pull cables or cords by force. Short circuits or disconnected wires may cause failure or fire on the VHMS equipment or the machine itself.
- For anyone wearing a pacemaker, make sure that the communications antenna is at least 22 cm from the pacemaker. The radio waves may have an adverse effect on the operation of the pacemaker.

NOTICE

- Please contact your Komatsu distributor before installing a top guard or other attachment that covers the antenna.
- Be careful not to get water on the communications terminal or wiring.

REMARK

- The communications terminal uses wireless communications, so it cannot be used inside tunnels, underground, inside buildings, or in mountain areas where radio waves cannot be received. Even when the machine is outside, it cannot be used in areas where the radio signal is weak or in areas outside the wireless communication service area.
- There is absolutely no need to inspect or operate the VHMS or communications terminal, but if any abnormality is found, please contact your Komatsu distributor.

OPERATION

CHECK BEFORE STARTING ENGINE, ADJUST

WALK-AROUND CHECK

Before starting the engine, walk around the machine and look at the underside of chassis for anything unusual like loose bolts and nuts, leakage of fuel, oil and coolant. Also check the condition of the work equipment and the hydraulic system.

Also check for loose wiring, play, and collection of dust at places that reach high temperature.



WARNING

- Leakage of oil or fuel, or accumulation of flammable material around high temperature parts, such as the engine muffler or turbocharger, may cause fire.
Check carefully, and if any abnormality is found, repair it or contact your Komatsu distributor.
- Do not get on or off the machine from the rear. Using this position is dangerous because it is easy to slip and you cannot be seen from the operator's compartment. Always use the handrail and step at the side when getting on or off the machine.

Perform the following inspections and cleaning every day before starting engine for the day's work.

1. Check for damage, wear, play in work equipment, cylinders, linkage, hoses
Check for cracks, excessive wear, play in work equipment, cylinders, linkage, and hoses. If any problem is found, repair it.
2. Remove dirt and debris from around the engine, battery, and radiator.
Check for dirt accumulated around the engine and radiator. Also check for flammable material (dry leaves, twigs, etc.) around the battery, engine muffler, turbocharger, or other high temperature engine parts. If any dirt or flammable materials are found, remove them.
For the method of removing dirt from the radiator, see "CLEAN AND CHECK RADIATOR FINS (PAGE 4-35)".
3. Check for coolant and oil leakage around the engine
Check for oil leakage from the engine and coolant leaks from the cooling system. If any problem is found, repair it.
4. Check for leakage from fuel line.
Check that there is no leakage of fuel or damage to the hoses and tubes. If any problem is found, carry out repairs.
5. Check for leakage of oil from power train case, final drive case, hydraulic tank, hose, joints
Check that there is no oil leakage. If any abnormality is found, repair the place where the oil is leaking.
Check for leakage of oil from the undercover. Check the ground for traces of oil leakage.
6. Check the undercarriage (track, sprocket, idler, guard) for damage, wear, loose bolts, or leakage of oil from rollers.
If any problem is found, repair it.
7. Check for problems in handrails, steps, loose bolts.
If any problem is found, repair it. Tighten any loose bolts.

8. Check for damage to gauges, lamps on the instrument panel, and loose bolts
Check for damage to the panel, gauges, and lamps. Replace any damaged parts. Clean off any dirt on the surface.
9. Check and cleaning of the rear view mirrors
Check the rear view mirrors for breakage, and replace any broken one. Clean the surface of each mirror and adjust the angle so that the rear view can be seen clearly from the operator's platform.
10. Seat belt and mounting clamps
Check for damage or wear to the seat belt and mounting clamps. If there is any damage, replace with new parts.

CHECK BEFORE STARTING

Always check the items in this section before starting the engine each day.

CHECK MACHINE MONITOR

1. Turn starting switch (1) to the ON position.
2. Check that the monitor and gauges light for 3 seconds, and the alarm buzzer sounds for 1 seconds.

REMARK

If the lamps do not light up, there may be a failure or disconnection in the monitor, please contact your Komatsu distributor.

NOTICE

Do not simply use the monitor to carry out the check before starting. Always carry out the check before starting according to the procedure on the following pages.

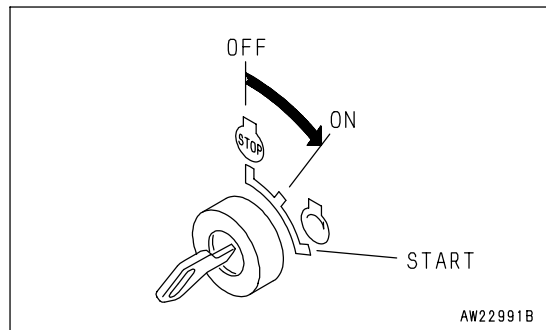
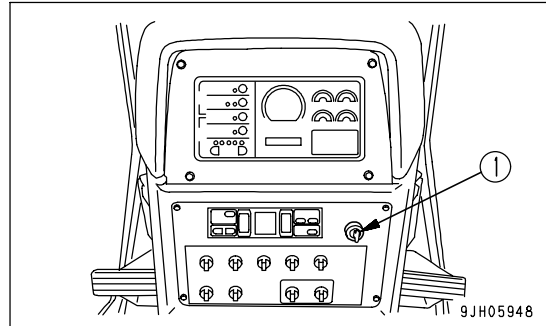

CHECK COOLANT LEVEL, ADD COOLANT

**WARNING**

Do not remove caps (1) or (2) while coolant is hot. Hot coolant may spurt out and cause serious injury.

When removing cap (1) or (2) wait until the coolant temperature goes down and loosen caps slowly to release radiator pressure, then remove the caps.

1. Open the side cover on left side of the machine and check that the coolant level in reserve tank (3) is between the FULL and LOW lines. If the coolant level is low, add coolant as follows.
2. When adding coolant, add through both caps (1) and (2). Check that the coolant is above bottom of the strainer as shown in diagram on the right. At the same time add coolant to the FULL line in the reserve tank through cap (3).
3. To refill the radiator, first stop the engine and pour coolant until it reaches the top of the filler opening. Then start the engine, after idling for 5 minutes recheck the coolant level, add coolant if necessary.
4. After adding coolant, tighten radiator caps (1) and (2), then tighten reserve tank cap (3).
5. If the volume of coolant added is more than usual, check for possible cooling system leaks.
Do not rely solely on the monitor for checking the coolant level.

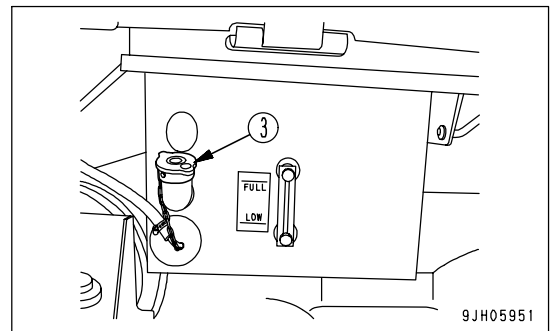
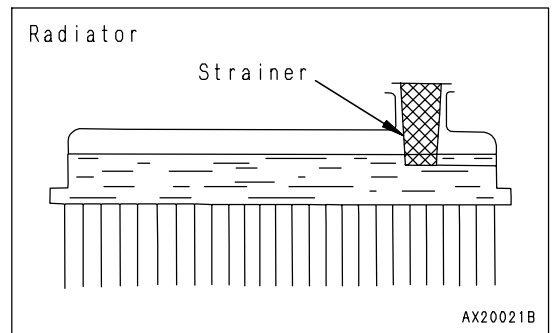
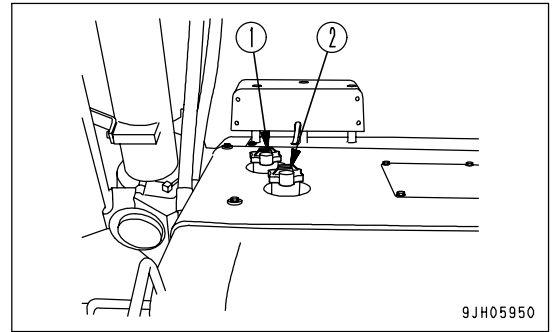

CHECK FUEL LEVEL, ADD FUEL

! WARNING

When adding fuel, never let the fuel overflow. This may cause a fire. If the fuel is spilt, wipe it off completely.

1. Turn the starting switch to the ON position and check the fuel level with fuel gauge (G) on the monitor panel.
After checking, turn the switch back to the OFF position.

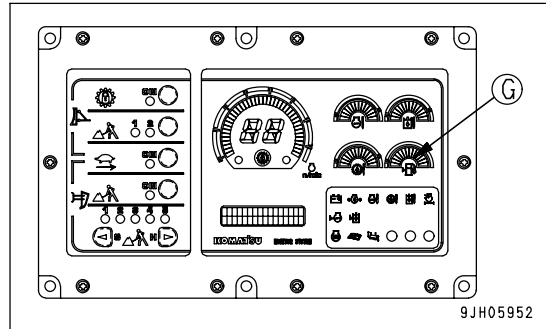

2. After completing work, fill the fuel tank through fuel filler port (F).
Check the fuel level with the fuel gauge at the fuel filler port.
3. After adding fuel, tighten the cap securely.
Fuel capacity: 1670 liters (441.21 US gal)

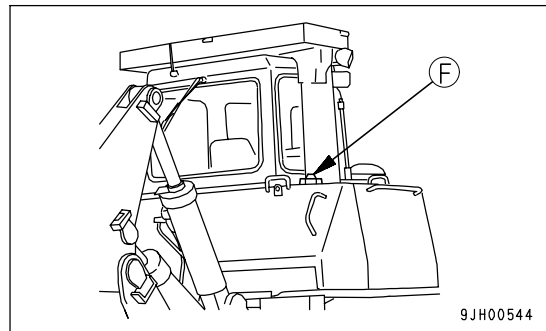

REMARK

- When dozing on a grade, make sure there is plenty of fuel in the tank so that the engine fuel line does not become aerated.
- If breather hole (1) on the cap is clogged, the pressure in the tank will drop and fuel will not flow.
Clean the hole from time to time.

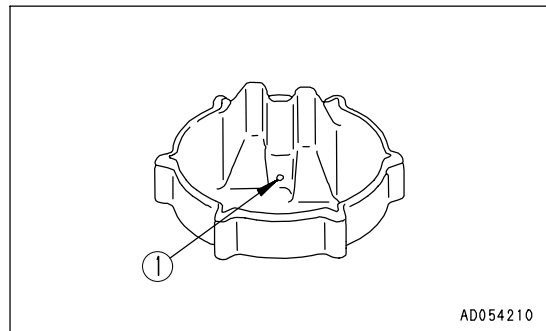

CHECK OIL LEVEL IN ENGINE OIL PAN, ADD OIL

**WARNING**

Parts and oil are at high temperature immediately after the engine is stopped and may cause serious burns. Wait for the oil temperature to go down before performing this operation.

1. Open the engine side cover on the right side of the chassis.
2. Remove dipstick (G), and wipe the oil off with a cloth.
3. Fully insert dipstick (G) into filler pipe (F), then remove it.

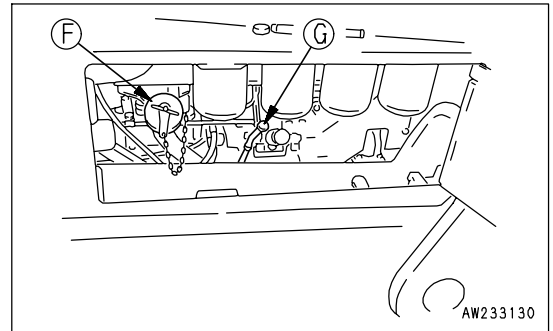

4. The oil level should be between the H and L marks on the ENGINE STOPPED side of dipstick (G).
If the oil level is below the L mark, add oil through oil filler (F).

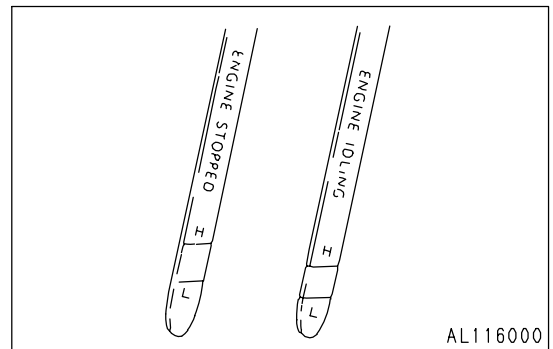

5. If the oil is above the H mark, remove drain plug (1), loosen drain valve (2) to drain the excess oil, then check the oil level again.
6. If the oil level is correct, tighten the oil filler cap securely and close the engine side cover.

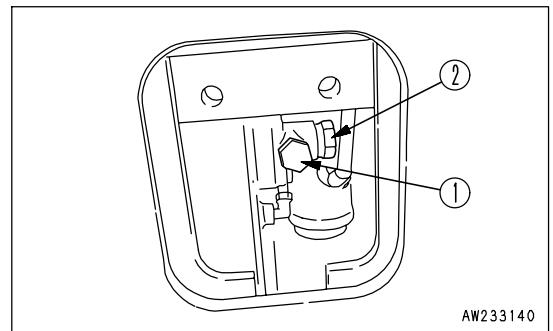
**REMARK**

- When checking the oil level after the engine has been operated, wait for at least 15 minutes after stopping the engine before checking.
- If the machine is at an angle make it horizontal before checking.
- When adding oil, remove the dipstick from the holder to release the air inside the crankcase.
- The dipstick is marked with the levels for "ENGINE STOPPED" on one side and "ENGINE IDLING" on the other side.

It is also possible to check the oil level with the engine idling, but be sure to remember the following points.

- Check oil when the engine coolant temperature gauge is within the green range.
- Read the dipstick on its reverse side marked with "ENGINE IDLING".

CHECK OIL LEVEL IN POWER TRAIN CASE (INCL. TRANSMISSION, TORQUE CONVERTER AND BEVEL GEAR CASES), ADD OIL

1. Start the engine and run at idling for 5 minutes, then check the oil level with the COLD side of dipstick (G).
Remove dipstick (G), and wipe the oil off with a cloth.
2. Fully insert dipstick (G) into filler pipe (F), then remove it.
3. The oil level should be between the H and L marks on dipstick (G).
If the oil level is below the L mark, add oil through oil filler (F).

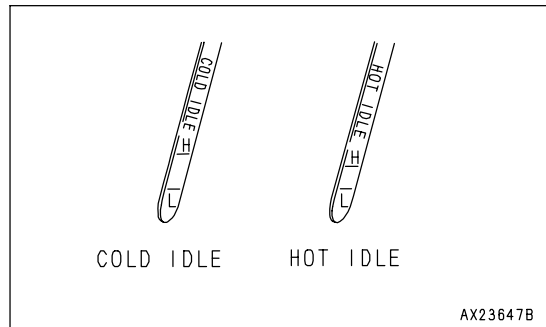
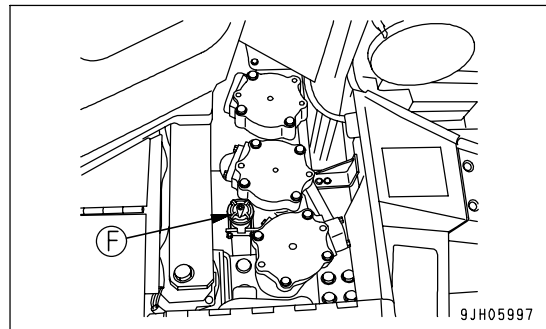
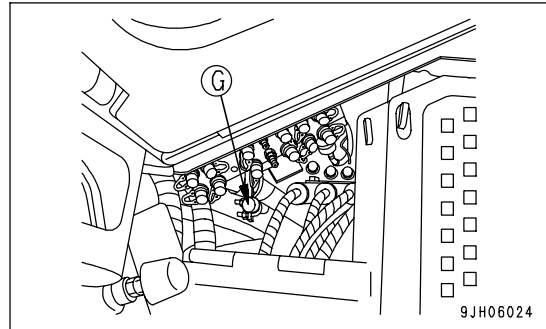

4. If the oil is above the H mark, pull out hose (1), and loosen drain plug (2) to drain the excess oil, then check the oil level again.
5. If the oil level is correct, tighten the oil filter cap securely.

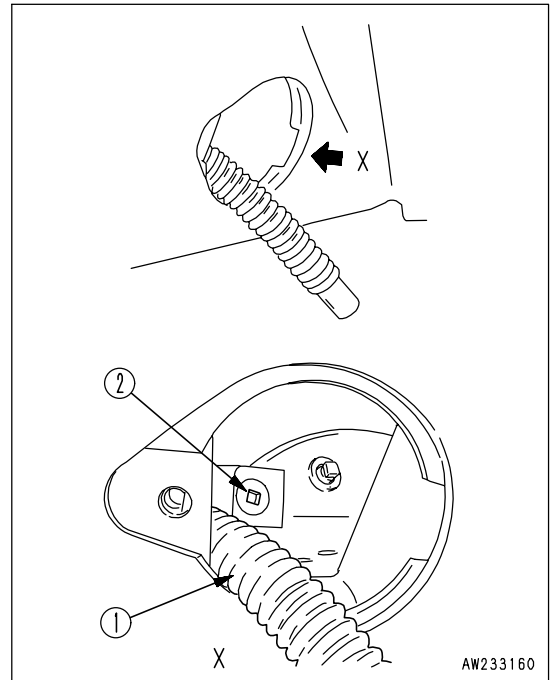
**REMARK**

- If the machine is at an angle, make it horizontal before checking.
- When the engine is stopped, the oil level will rise, so it is impossible to check the oil level correctly.
- When checking during operation or after operation, run the engine at idling and measure with the HOT side of dipstick (G). However, reading on the HOT side should be treated only as a guideline because of big changes in the power train oil temperature.
- The oil level should be checked when running the engine at idling within 60 minutes after finishing operations.
- When working on a slope of more than 20°, check that the oil is up to the H level.

CHECK DAMPER CASE OIL LEVEL, ADD OIL

1. Remove dipstick (G), and wipe the oil off with a cloth.
2. Fully insert dipstick (G) into filler pipe (F), then remove it.
3. The oil level should be between the H and L marks on dipstick (G).

If the oil is below the L mark, add oil through the dipstick holder.

4. If the oil is above the H mark, drain the excess oil from drain plug. After draining the oil, check the oil level again.

REMARK

- Check the oil level with the engine stopped.
- When checking the oil level, if the machine is at an angle, move it to a horizontal position before checking.

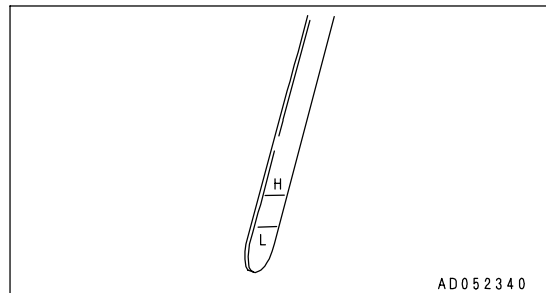
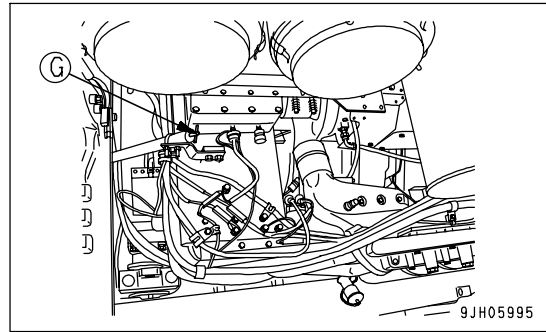
**CHECK BRAKE PEDAL TRAVEL**

Drive the machine, depress the brake pedal, and check that the machine stops.

CHECK DUST INDICATOR

1. Check for the yellow piston overlapping the red zone on the dust indicator (1).
2. If the yellow piston is overlapping the red zone, clean or replace the element immediately.

For details of the method of cleaning the element, see "CHECK, CLEAN AND REPLACE AIR CLEANER ELEMENT (PAGE 4-26)".

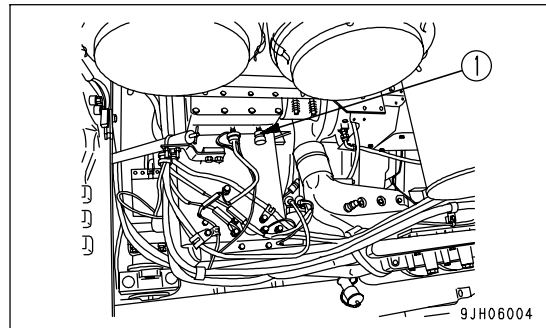

3. After checking, cleaning, and replacing, press the knob of dust indicator (1) to return the yellow piston to its original position.
 - In environments where the rubber deteriorates quickly or the surface becomes damaged (in direct sunlight, dusty areas, etc.), replace before it becomes dirty and it becomes difficult to judge the condition.

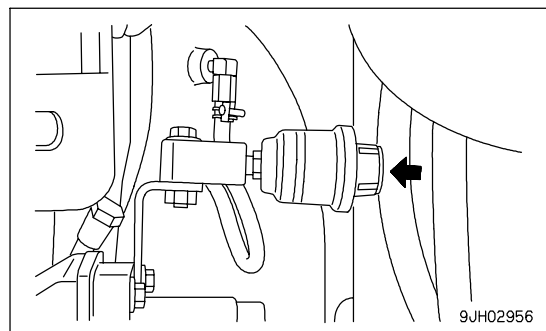

CHECK OIL LEVEL IN HYDRAULIC TANK, ADD OIL

WARNING

- When removing the oil filler cap, oil may spurt out, so stop the engine and wait for the oil temperature to go down, then turn the cap slowly to release the internal pressure before removing the cap.
- If oil has been added to above the H mark, stop the engine and wait for the hydraulic oil to cool down. Then remove drain plug (P), loosen drain valve (1), and drain the excess oil.

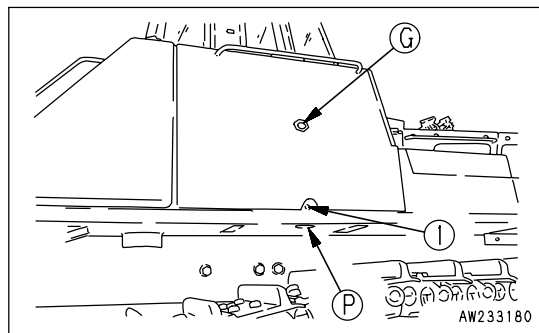

1. Lower blade to the ground and stop the engine. Wait for 5 minutes before checking oil level. Oil level should be between the H and L in sight gauge (G).

NOTICE

If the oil level is above the H line, do not add oil. Doing so may lead to damage to the oil pressure circuit and spouting out of oil.

2. If the level is below the L mark, add oil through oil filler (F).

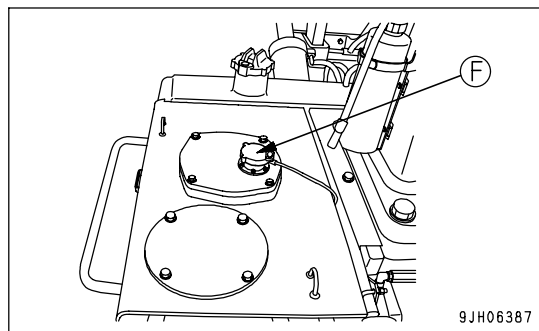

REMARK

When inspecting, if the machine is at an angle, move it to a level place to carry out the check.

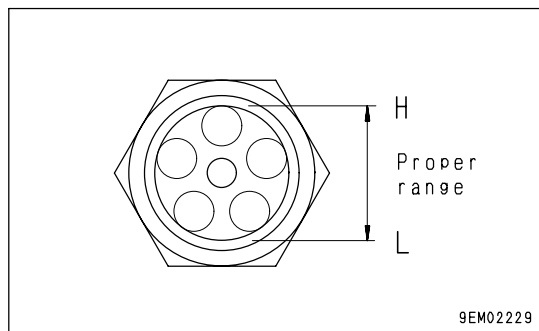

CHECK ELECTRIC WIRING

 **WARNING**

- If fuses are frequently blown or if there is a short circuit in the electrical wiring, locate the cause and repair or contact your Komatsu distributor.
- Accumulation of flammable material (dead leaves, twigs, grass, etc.) around the battery may cause fire, so always check and remove such material.
- Keep the top surface of the battery clean and check the breather hole in the battery cap. If it is clogged with dirt or dust, wash the battery cap to clear the breather hole.

Check for damage and wrong capacity of the fuse and any sign of disconnection or short circuit in the electric wiring. Check also for loose terminals and tighten any loose parts.

Check the wiring of the "battery", "starting motor" and "alternator" carefully in particular.

Always check if there is any accumulation of flammable material around the battery, and remove such flammable material.

Please contact your Komatsu distributor for investigation and correction of the cause.

CHECK THAT LAMPS LIGHT UP

1. Turn starting switch key to the ON position.

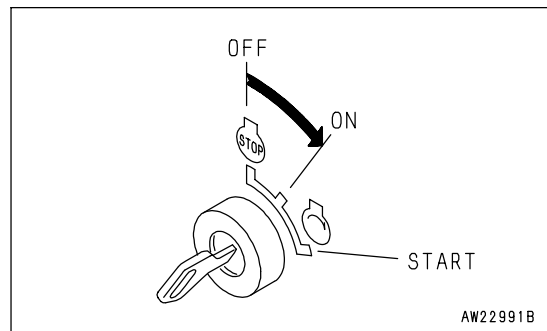

2. Turn the front lamp and working lamp switch to the ON (b) position, make sure the lamps light up.

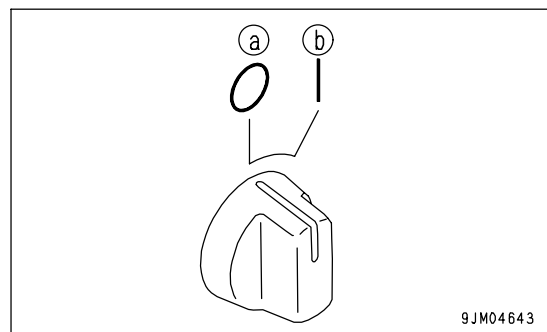

3. Turn the rear lamp switch to the ON (b) position, make sure the lamps on the left and right fenders light. If the lamps do not light, check for a broken bulb or disconnected wire, contact your Komatsu distributor for repairs.

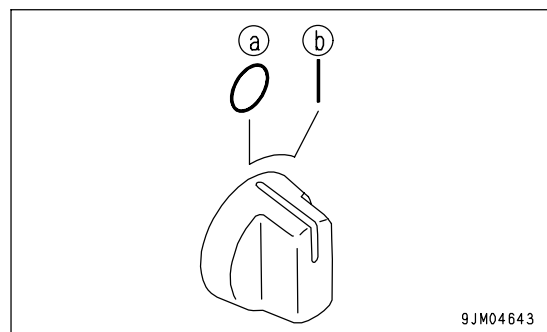

CHECK HORN SOUND

1. Turn starting switch key to the ON position.

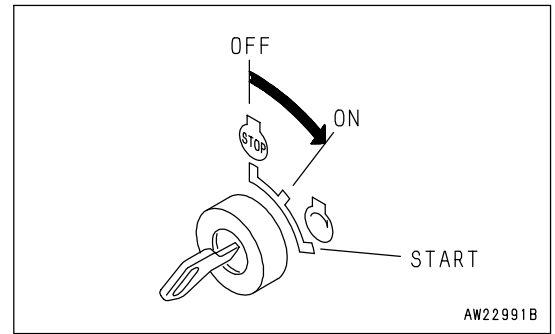

2. Push the horn switch and check that the horn sounds.

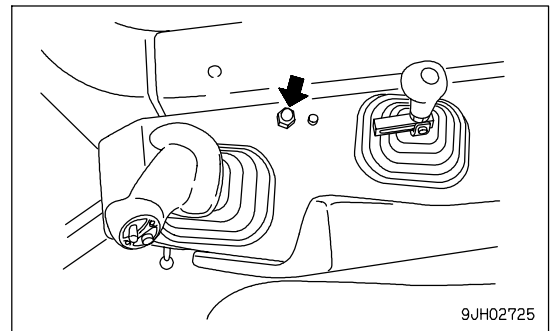

CHECK BACKUP ALARM SOUND

1. Turn starting switch to the ON position (B).

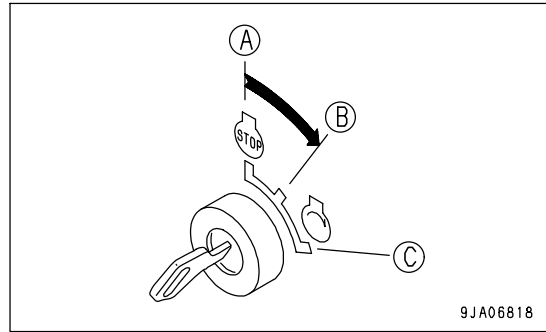

2. Set parking brake lever to the FREE position (F).

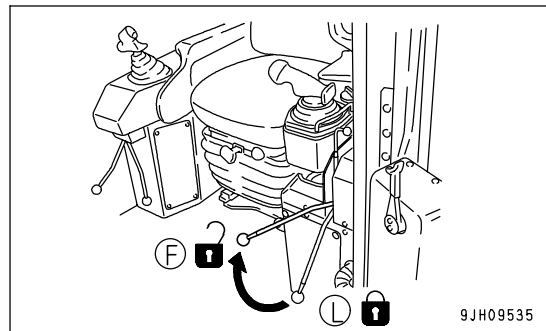

3. While depressing the brake pedal, set joystick to the REVERSE position (b).

The buzzer must sound immediately.

Buzzer will continue to sound until the joystick is moved to NEUTRAL position (N) or FORWARD position (a).

4. As soon as it is confirmed that the buzzer is working properly, set the joystick to the NEUTRAL position (N), put the parking brake lever to the LOCK position (L), and then release the brake pedal.

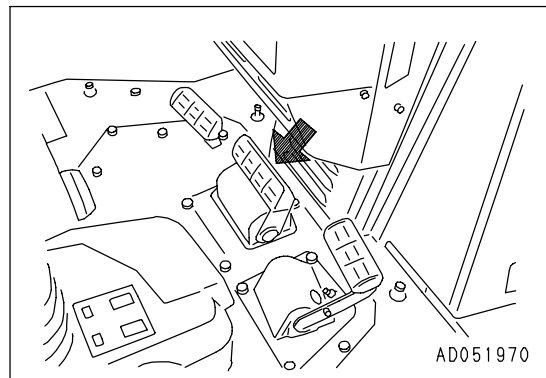

AD051970

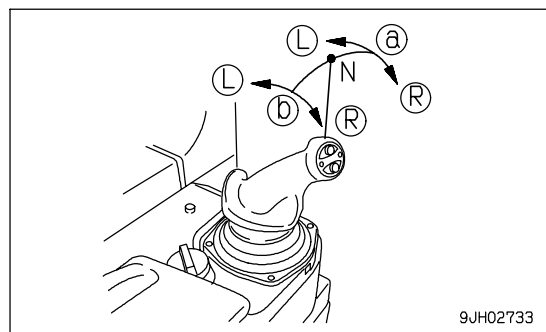

ADJUSTMENT

ADJUSTING OPERATOR'S SEAT

! WARNING

- Adjust the seat position at the beginning of each shift or when operators change.
- Adjust seat so the brake pedal can be completely depressed with the operator's back against the backrest.

(A) Fore-and-aft adjustment

Pull lever (1), set the seat to a position where it is easy to operate, then release the lever.

Fore-aft adjustment: 200 mm (7.9 in) (10 stages)

(B) Weight and height adjustment of seat

- Turn knob (2) under the seat so that weight adjustment indicator (3) displays the green range. The height can be adjusted by turning the knob (2) while the green range is displayed.
- Turn the knob clockwise to raise the seat and turn the knob counterclockwise to lower the seat.

Height adjustment range: stepless, 75 mm (3 in)

Weight adjustment range: 50 to 130 kg (110 to 237 lb)

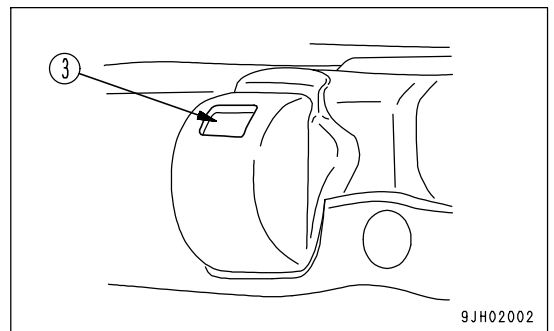
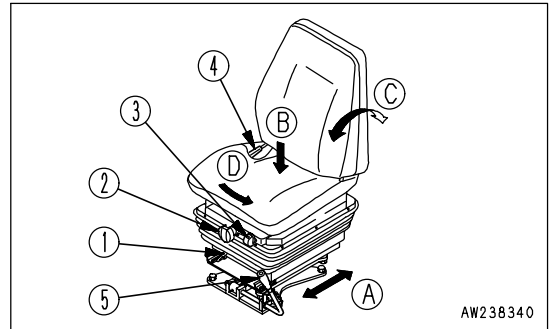

(C) Adjust reclining angle

REMARK

When the seat is pushed forward, the available reclining angle becomes greater; when the seat is pushed back, the available reclining angle becomes smaller. When moving the backrest, return the backrest to its original position before moving the seat.

Pull up lever (4), set the seatback to a position where it is easy to operate, then release the lever.

(D) Adjusting direction of seat

Pull up lever (5) to unlock the seat. The seat can then be turned 15° to the right.

After changing the direction of the seat, return the lever securely to lock the seat.

- Change the direction of the seat to the right for the ease of operation of the ripper.

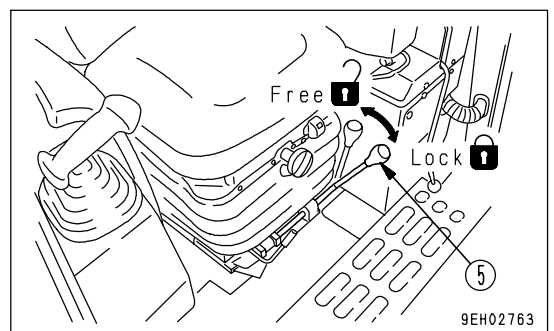

REMARK

If the direction of the seat is changed, the steering, directional, and gearshift lever is also interconnected and changes direction.

(E) Adjusting angle of seat

Pull up lever (6) to release the lock, then adjust the seat angle.

(Front 6°, rear 13°)

1. To raise the angle of the seat at the front, keep the lever pulled and apply your weight to the seat backrest.
2. To lower the angle of the seat at the front, keep the lever pulled and apply your weight to the front of the seat.

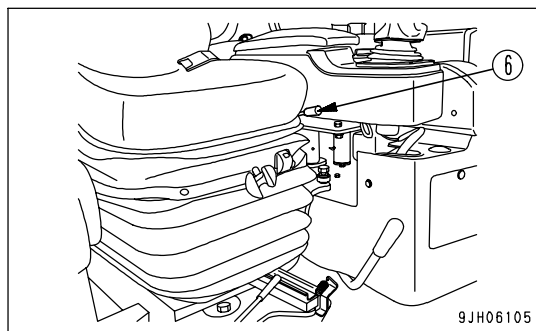

USING SEAT BELT

Always install a seat belt on machines equipped with ROPS.

**WARNING**

- Before fastening the seat belt, inspect the securing brackets and belt for abnormal conditions. Replace any worn or damaged seat belt or the securing brackets.
- Even no problem can be seen with the belt, always replace the seatbelt once every three years. The date of manufacture is given on the rear side of the belt.
- Adjust and fasten the seat belt before operating the machine.
- Always use the seat belt when operating the machine.
- Fit the seat belt across your lap without twisting.

FASTEN THE BELT AND REMOVE IT

1. Sit on the seat, depress the brake pedal fully, and adjust the seat so that your back is pressed against the backrest.
2. After adjusting the seat position, adjust tether belt (1). Tense the tether belt and install it when there is no one sitting on the seat.
3. Sit on the seat and hold tongue (4) connected to wind-in mechanism (2) and pull out the belt slowly so that the belt will cover your abdomen sufficiently.
4. Insert tongue (4) in buckle (3) until it clicks. The belt is pulled back into wind-in mechanism (2) until it is fitted to your abdomen. The belt is locked under this condition and cannot be extended anymore. Fit the belt to your abdomen without twisting it.

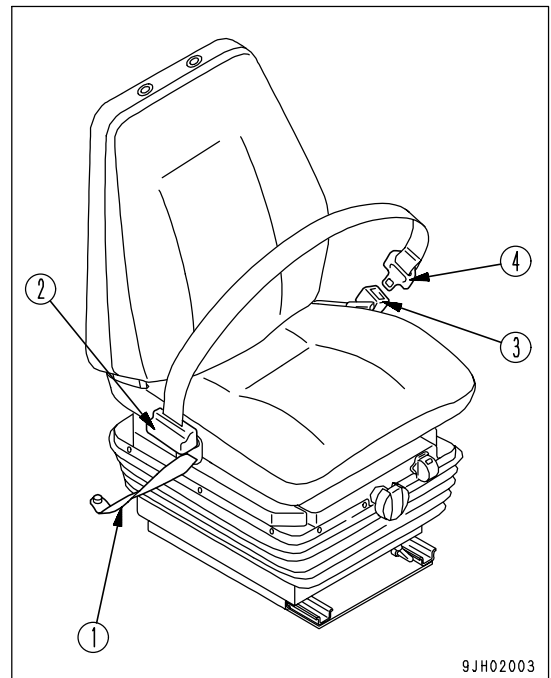

9JH02003

REMARK

If the belt is locked before the tongue is inserted in the buckle, let it return to the wind-in mechanism, then repeat the above procedure from the start.

5. Pull the belt to check that it is securely locked in position.
6. When removing the belt, press the red button on buckle (3). The belt will automatically retract.

Check that the bolts of the clamp securing the belt to the chassis are not loose. Tighten them if they are loose. Tightening torque: 24.5 ± 4.9 Nm (2.5 ± 0.5 kgm, 18.1 ± 3.6 lbft)

If the seat belt is scratched or frayed, if any fittings are broken or deformed from long service, replace the seat belt immediately.

ADJUST MIRROR

Loosen nut (1) of the mirror and adjust the mirror to a position where it gives the best view from the operator's seat.

In particular, be sure to adjust the mirror so that people at the rear left or right of the machine can be seen clearly.

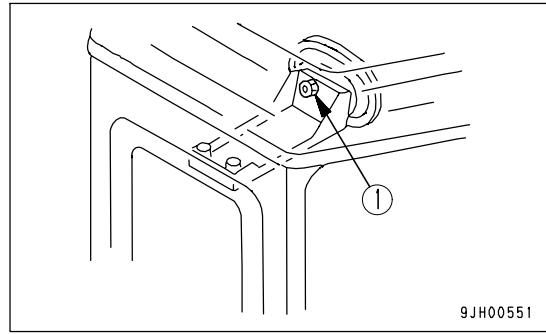

ADJUST JOYSTICK (PCCS LEVER)



After moving case (2) in order to adjust the position of the steering, directional, and gearshift lever, secure lock lever (1) into the notched hole, making sure it is in the LOCK position. If it is not completely locked, the steering, directional, and gearshift lever may unexpectedly move and cause damage, serious injury, or death.

The steering, directional, and speed lever (wrist control type single lever: joystick) can be adjusted by 100 mm (3.9 in) in 5 stages to the front or rear. Adjust to the most suitable position to match the adjustment of the operator's seat.

1. Pull up lock lever (1) to the FREE position at the rear of case (2) on left side of the operator's compartment.

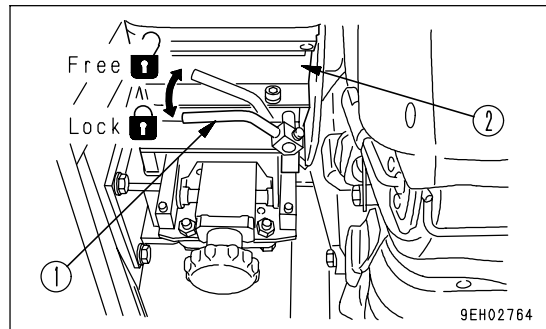

2. With lock lever (1) pulled up, use your other hand to grip the front of case (2), then move it forward with your left and right hands. The joystick moves with case (2).
3. Move case (2) to the desired position until a click is heard. Then pull up lock lever (1) and release it. Lock lever (1) automatically returns to the LOCK position.

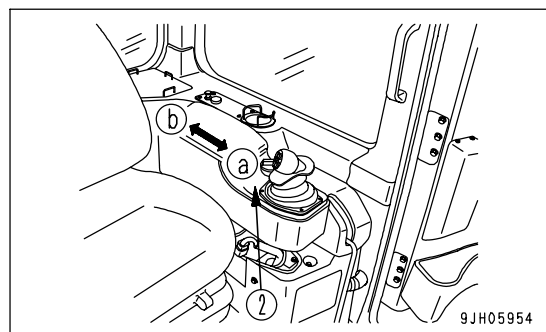

REMARK

PCCS: Palm command control system

ADJUST ARMREST

The height of the armrest on the left and right sides of the operator's seat can be adjusted to 3 positions. After adjusting the operator's seat, adjust the armrest to a suitable height.

ADJUST ARMREST (RIGHT)

Armrest (1) on the right side of the operator's cab part can be adjusted up 30 mm (1.2 in) or down 30 mm (1.2 in) based on the standard height (center) in three stages.

1. Loosen knob (2) (2 places).

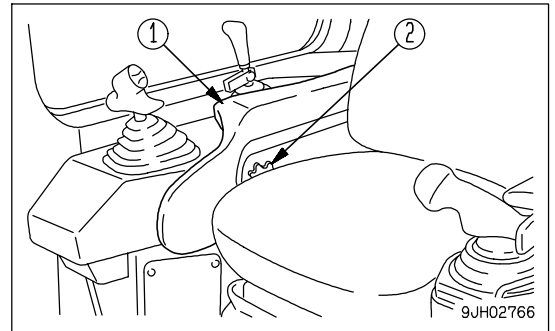

2. Move the armrest on the operator's seat to the front, then align the position of the 3 holes (high, middle, low).
3. Tighten knob (2) securely.

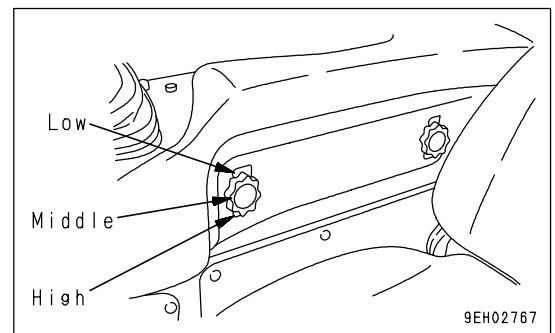

ADJUST ARMREST (LEFT)

The armrest on the left side of the operator's compartment can be adjusted to 2 heights.

1. When adjusting height of both armrest and case

It is possible to effortlessly adjust the standard height up 50 mm (2 in) or down 50 mm (2 in).

The steering, directional, and gearshift lever moves as a unit.

Turn up/down left adjustment knob (1) to adjust the height.

Turn the knob to adjust as follows.

Turn **CLOCKWISE** to move **UP**

Turn **COUNTERCLOCKWISE** to move **DOWN**

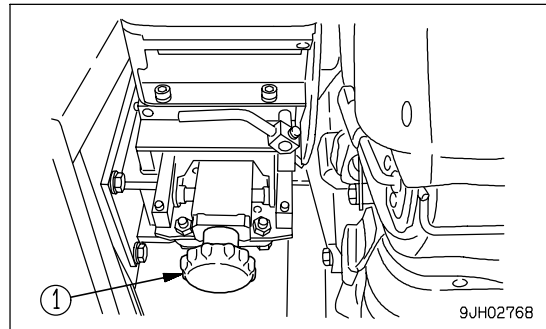

2. When adjusting height of armrest only

It is possible to effortlessly adjust up to 36 mm (1.4 in) upward from the armrest and case contact surface.

The steering, directional, and gearshift lever does not move.

Open the armrest, and turn knob (2) counterclockwise to adjust the height.

Only the armrest will move up. After adjusting it to the desired height, close the armrest.

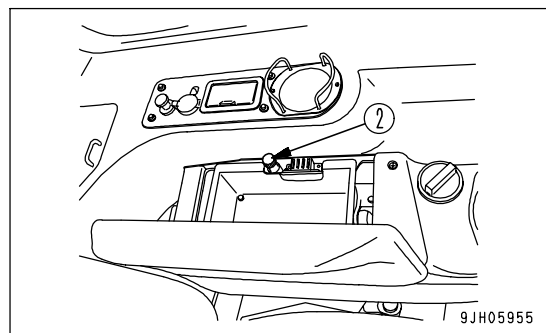

3. By carefully adjusting to match the operator's physique, it is possible to operate the travel lever correctly (with fine control and smooth steering) and comfortably (with little fatigue), so adjust the armrest as follows:

1) Sit in the operator's seat, grip the travel lever, and turn up-down adjustment knob (1) to adjust the height of the console assembly to a position where the elbow matches the top surface of the armrest as shown in the diagram on the right.

2) Next, operate the travel lever to the left and right, and turn knob (2) to adjust the height of the armrest to match the thickness of the operator's arm so that it is possible to operate smoothly to the left and right using the elbow and the support at the front.

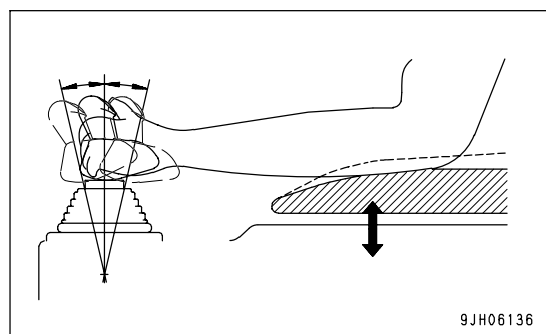
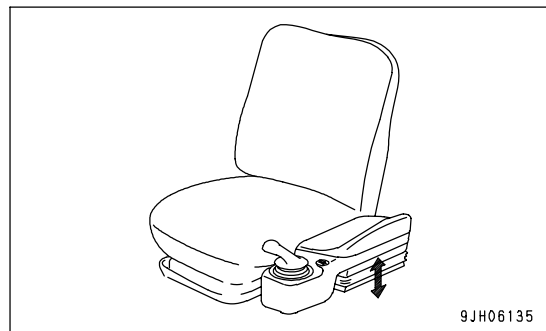

OPERATIONS AND CHECKS BEFORE STARTING ENGINE

⚠ WARNING

- When starting the engine, check and make sure the work equipment lock lever (4) and parking brake lever (1) are secured in the LOCK position.
If the control levers are not locked and they are touched by accident when starting the engine, the work equipment may move unexpectedly, and this may lead to a serious injury or death.
- When standing up from the operator's seat, always set the work equipment lock lever (4) and parking brake lever (1) to the LOCK position, regardless of whether the engine is running or stopped.

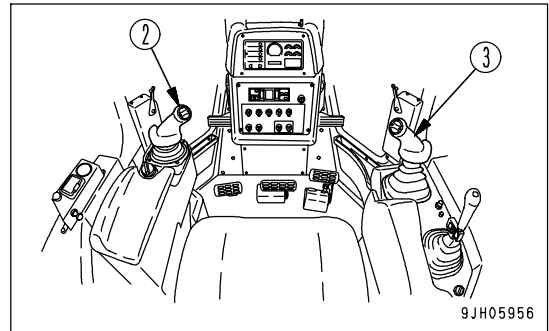
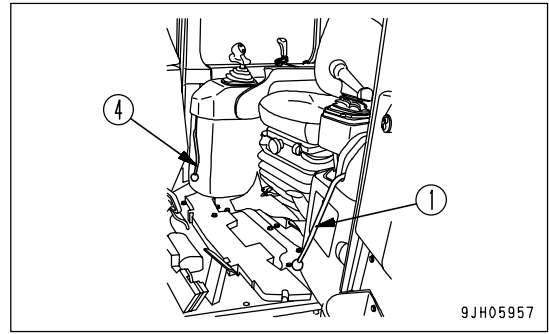

1. Check that parking lever (1) is locked. If this lever is not in the LOCK position, the engine will not start.

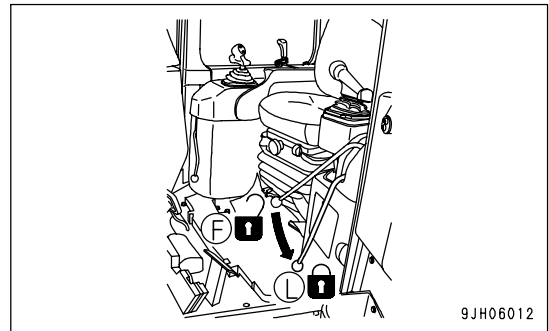

2. Check that joystick (2) is in the N (neutral) position.

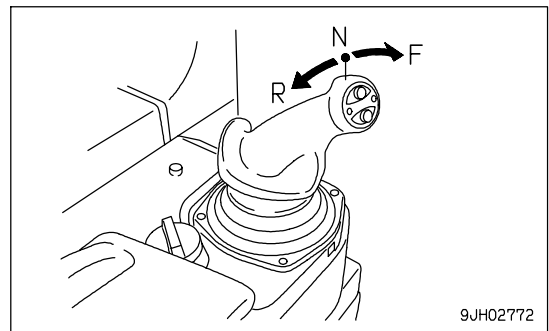

REMARK

The engine cannot be started if joystick (steering, directional, and gearshift lever) (2) is not in the N position. If joystick (steering, directional, and gearshift lever) (2) is in F or R, the letter P on display panel A will flash.

3. Check that the blade is lowered to the ground and that blade control lever (3) is in the HOLD position. If it is in the FLOAT position, the engine will not start.

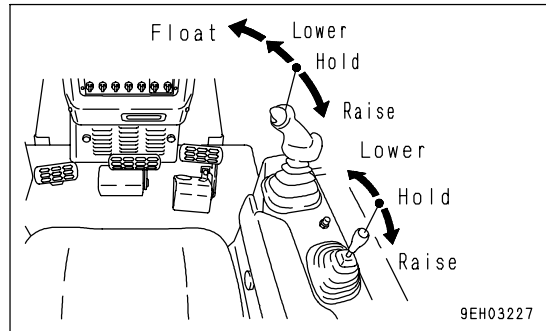
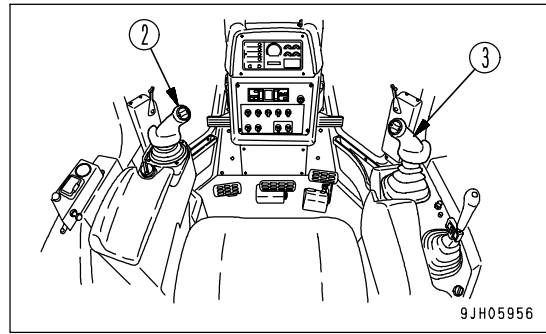

4. Check that the ripper is lowered to the ground.
5. Check that work equipment lock lever (4) is locked. If work equipment lock lever (4) is locked, the blade control lever is returned to the HOLD position even if it is in the FLOAT position.

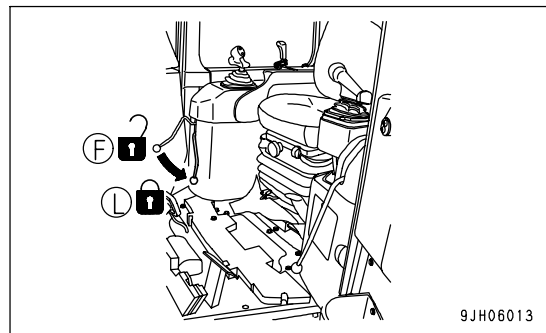

STARTING ENGINE

NORMAL STARTING

WARNING

- Check that there are no persons or obstacles in the surrounding area, then sound the horn and start the engine.
- Exhaust gas is toxic. When starting the engine in confined spaces, be particularly careful to ensure good ventilation.

NOTICE

Do not keep the starting motor rotating continuously for more than 20 seconds.

If the engine will not start, wait for at least 2 minutes before trying to start the engine again.

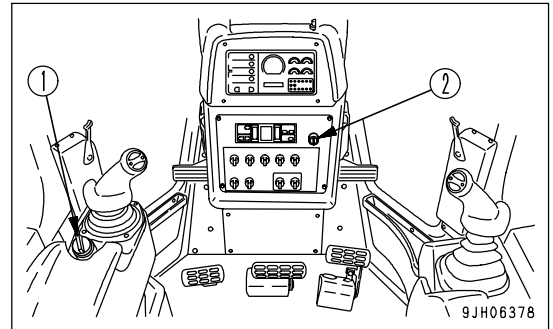

1. Turn fuel control dial (1) a little toward you from the MIN position.

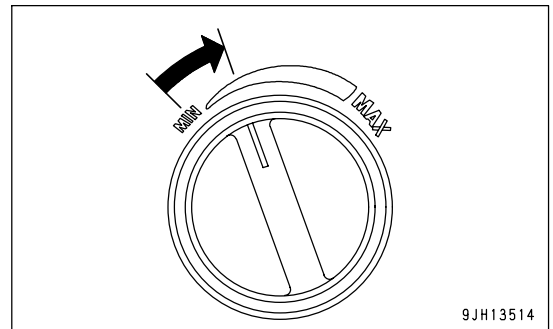

2. Turn the key of starting switch (2) to the START position.

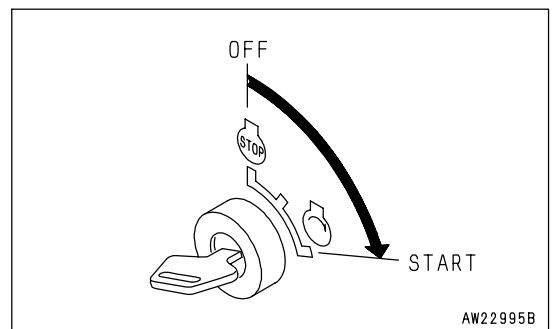

3. When engine is started, release the key of starting switch (2) and the key will return automatically to ON.

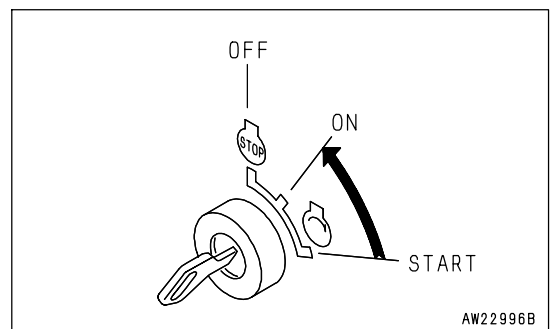

STARTING IN COLD WEATHER

**WARNING**

- Always sit in the operator's seat when starting the engine.
- Do not short circuit the starting motor circuit to start the engine. There is danger that this may cause serious personal injury or fire.
- Check that there is no person or obstacle in the surrounding area, then sound the horn before starting the engine.
- Never use any starting aid fluid to start the engine. There is danger that it may cause an explosion.
- Exhaust gas is poisonous. Always ensure that there is good ventilation before starting the engine in an enclosed place.

NOTICE

- Do not crank the starting motor continuously for more than 20 seconds. If the engine does not start, wait for 2 minutes, then repeat procedure from step 2.
- Before starting the engine, check that the fuel control dial is at the low idle (MIN) position.
- If the fuel control dial is at the FULL position (MAX), the engine will accelerate suddenly and cause damage to the engine parts, so set it to an intermediate or low speed position.

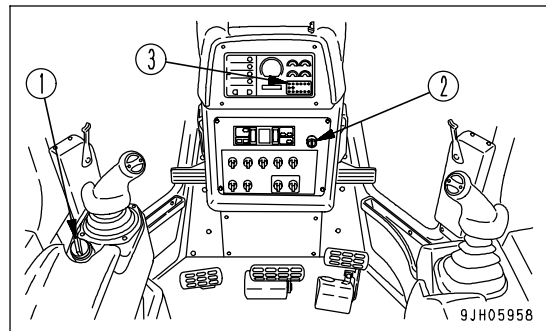

1. Turn fuel control dial (1) to the center position between LOW IDLE (MIN) and HIGH IDLE (MAX).

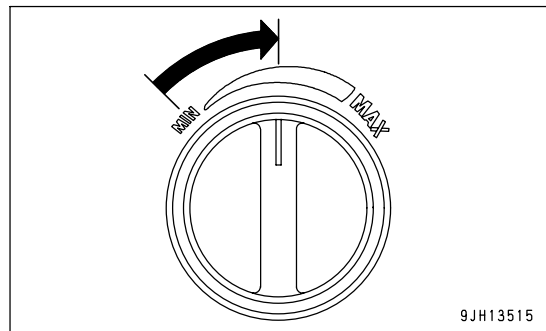

2. Turn the key of starting switch (2) to the START position.

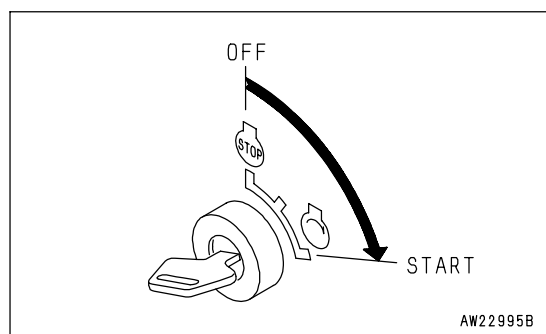

3. Check that engine pre-heating pilot lamp (3) on the monitor panel lights up.
If the engine pre-heating pilot lamp does not light, go to step 5.

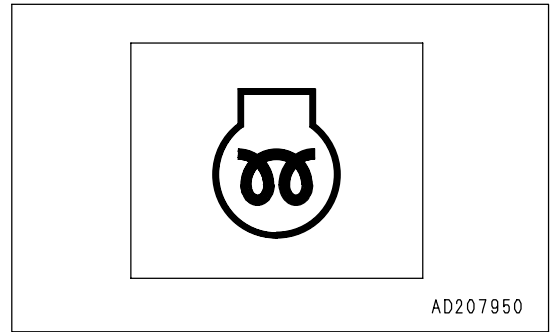

4. Keep in this condition until engine pre-heating pilot lamp (3) goes out.
(Pre-heating is completed after approx. 12 seconds, and the lamp goes out.)

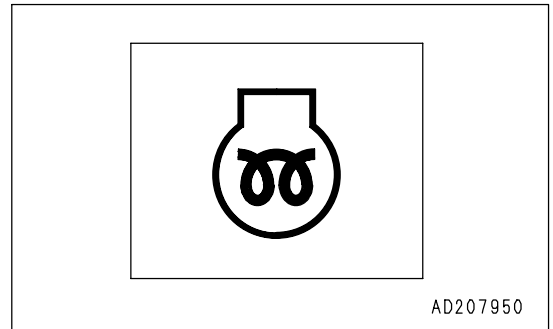

5. When engine pre-heating pilot lamp (3) goes off, turn the key of starting switch (2) to the START position to crank the engine.
The time that engine pre-heating pilot lamp (3) stays on changes according to the ambient temperature as shown in the table below.

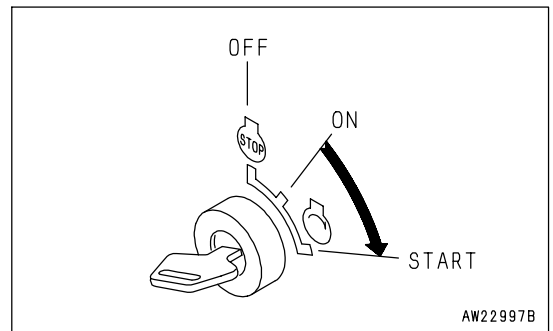

Ambient temperature	Pre-heat time
0°C to -10°C (32°F to 14°F)	0 to 15 seconds
-10°C to -20°C (14°F to -4°F)	15 to 30 seconds
-20°C to -30°C (-4°F to -22°F)	30 to 45 seconds
-30°C to (-22°F to)	45 seconds

6. When the engine starts, release the key in starting switch (2).
The key will automatically return to the ON position.

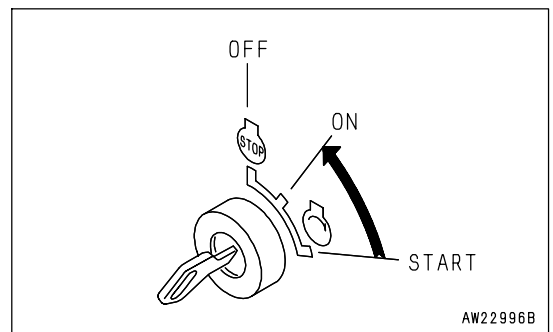

REMARK

Immediately after starting the engine, run the engine at idling, and do not operate the accelerator pedal or work equipment during this time.

Guideline for idling time

- Cold weather: At least 15 seconds
- When first starting engine after changing oil or replacing engine oil filter: 20 seconds

7. When the engine rotation stabilizes, set fuel control dial (1) to low idle (MIN) position, then perform the warming-up operation.

REMARK

- Regardless of the ambient temperature, if the key in starting switch (2) is turned from the OFF position to the left, engine pre-heating pilot lamp (3) will light and pre-heating will start. (Pre-heating continues while the starting switch is being held to the left.)

For details of pre-heating times, see the table in step 5.

- During the pre-heating operation, engine pre-heating pilot lamp (3) lights to show that preheating is being performed.

Pre-heating is completed within 45 seconds.

- If the engine does not start after pre-heating, wait for 2 minutes, then repeat starting procedure from step 2.

STARTING ENGINE ON MACHINES WITH PRELUBE SYSTEM

**WARNING**

- Always sit in the operator's seat when starting the engine.
- Do not short circuit the starting motor circuit to start the engine. There is danger that this may cause serious personal injury or fire.
- Check that there is no person or obstacle in the surrounding area, then sound the horn before starting the engine.
- Never use any starting aid fluid to start the engine. There is danger that it may cause an explosion.
- Exhaust gas is poisonous. Always ensure that there is good ventilation before starting the engine in an enclosed place.

NOTICE

- Do not crank the starting motor continuously for more than 20 seconds. If the engine does not start, wait for 2 minutes, then repeat procedure from step 2.
- Before starting the engine, check that the fuel control dial is at the low idle (MIN) position.
- If the fuel control dial is at the FULL position (MAX), the engine will accelerate suddenly and cause damage to the engine parts, so set it to an intermediate or low speed position.

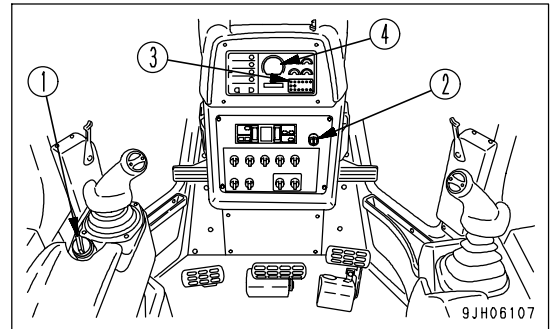

1. Turn fuel control dial (1) to the center position between LOW IDLE (MIN) and HIGH IDLE (MAX).

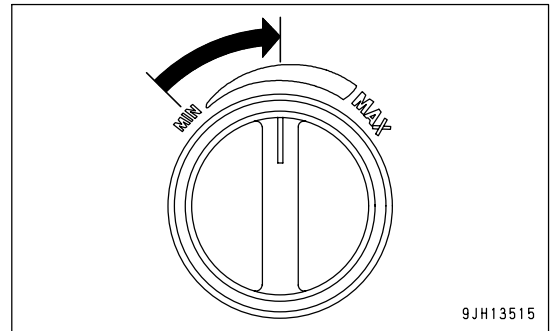

2. Turn the key of starting switch (2) to the START position.

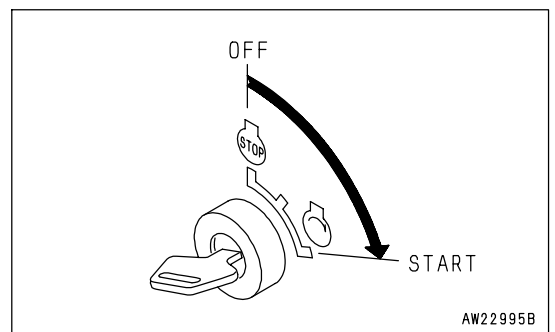

3. Monitor panel speed range display (4) changes as shown on the right.

- (A): Lock lever at safety position
- (B): Flashes: Prelube needed

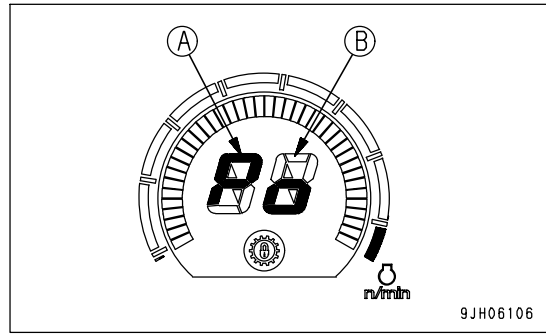

4. Turn the key in starting switch (2) to the START (C) position, then return it to the ON (D) position. If the key is released while it is at the START (C) position, the key automatically returns to the ON (D) position.

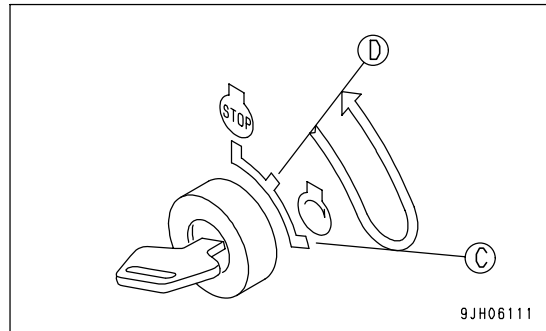

5. Monitor panel speed range display (4) changes as shown on the right, indicates the prelube operation is being performed.

- (B): Lights up: Prelube operation taking place

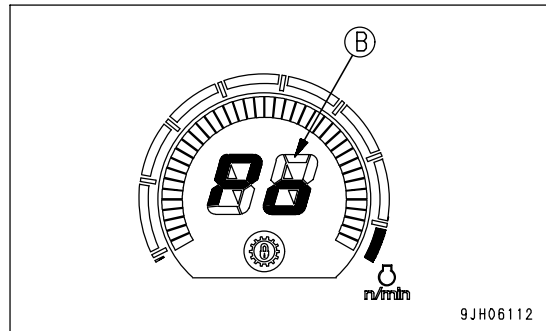

6. The prelube operation is completed in approx. 5 to 60 seconds. When this happens, monitor panel speed range display (4) changes as shown on the right.

(The time for the prelube operation changes according to the ambient temperature and the engine oil temperature.)

Goes out: Prelube operation completed

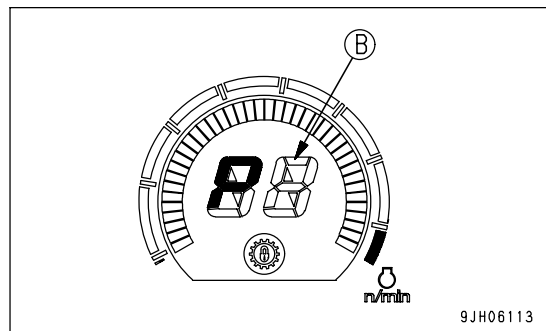

7. Check that engine pre-heating pilot lamp (3) on the monitor panel lights up.

If the preheating lamp pilot lamp does not light, go on to step 9.

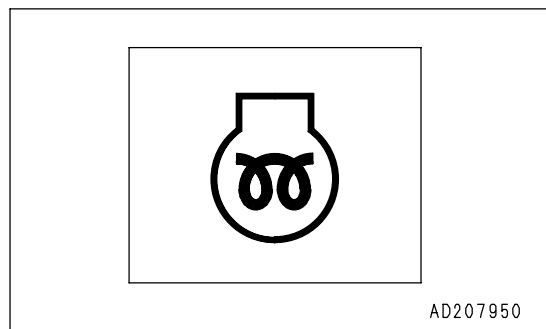

8. Keep in this condition until engine pre-heating pilot lamp (3) goes out.
 (Pre-heating is completed after approx. 12 seconds, and the lamp goes out.)

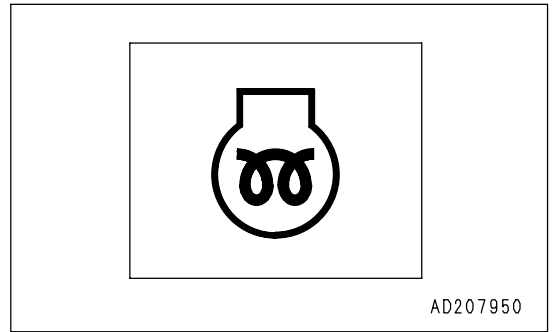

9. When engine pre-heating pilot lamp (3) goes off, turn the key of starting switch (2) to the START position to crank the engine. The time that engine pre-heating pilot lamp (3) stays on changes according to the ambient temperature as shown in the table below.

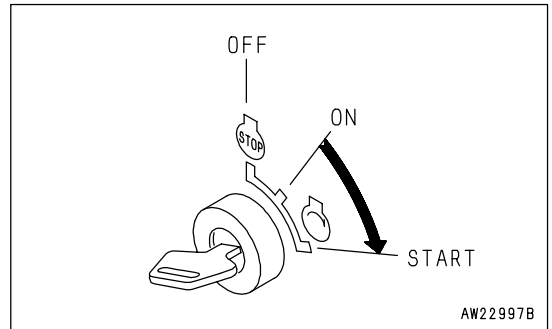

Ambient temperature	Pre-heat time
0°C to -10°C (32°F to 14°F)	0 to 15 seconds
-10°C to -20°C (14°F to -4°F)	15 to 30 seconds
-20°C to -30°C (-4°F to -22°F)	30 to 45 seconds
-30°C to (-22°F to)	45 seconds

10. When the engine starts, release the key in starting switch (2). The key will automatically return to the ON position.

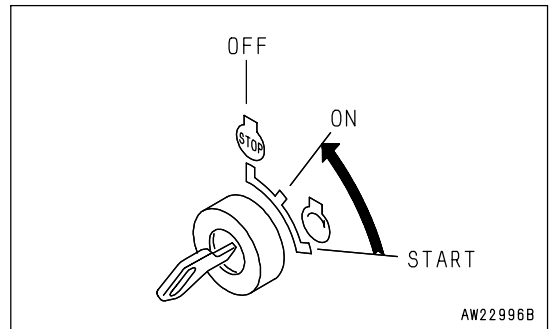

REMARK

Immediately after starting the engine, run the engine at idling, and do not operate the accelerator pedal or work equipment during this time.

Guideline for idling time

- Cold weather: At least 15 seconds
- When first starting engine after changing oil or replacing engine oil filter: 20 seconds

11. When the engine rotation stabilizes, set fuel control dial (1) to low idle (MIN) position, then perform the warming-up operation.

REMARK

- Regardless of the ambient temperature, if the key in starting switch (2) is turned from the OFF position to the left, engine pre-heating pilot lamp (3) will light and pre-heating will start. (Pre-heating continues while the starting switch is being held to the left.)
For details of pre-heating times, see the table in step 9.
- During the pre-heating operation, engine pre-heating pilot lamp (3) lights to show that preheating is being performed.
Pre-heating is completed within 45 seconds.
- If the engine does not start after pre-heating and prelube, wait for 2 minutes, then repeat starting procedure from step 2.
- If it is left for more than 60 seconds in same condition as step 4, speed range display (4) will return to the condition in step 2.
- If the operation is not correct as shown below, please contact your Komatsu distributor.

Problem	Speed range display	Main causes
Engine does not start	PE (Flashes)	Disconnected oil pressure switch Failure in starter motor Failure in starter motor relay
After the prelube operation, it returns again to the Prelube needed position	Po (Flashes)	Does not reach specified oil pressure in 60 seconds

OPERATIONS AND CHECKS AFTER STARTING ENGINE

! WARNING

- If there has been any Emergency stop, abnormal actuation or trouble, turn the starting switch key to the OFF position.
- If the work equipment is operated without sufficiently warming the machine up, response of the work equipment to movement of the control lever will be slow, and the work equipment may not respond as the operator desires, so always perform the warming-up operation. Particularly in cold areas, be sure the warming-up operation is completed.

WARMING UP OPERATIONS

NOTICE

- Do not perform operations or suddenly operate the levers when the hydraulic oil is at a low temperature. Always perform the warming-up operation until the hydraulic oil temperature monitor displays the green range. This will help extend the machine life.
Do not suddenly accelerate the engine before the machine reaches full operating temperature.
- Do not run the engine at low or high idle for more than 20 minutes. This will cause oil leaks from the turbocharger oil supply piping.
If it is necessary to run the engine at idling, apply a load from time to time or run the engine at a mid-range speed.
- If engine oil pressure caution lamp (3) flashes or the buzzer sounds intermittently, stop the engine and check for the cause.

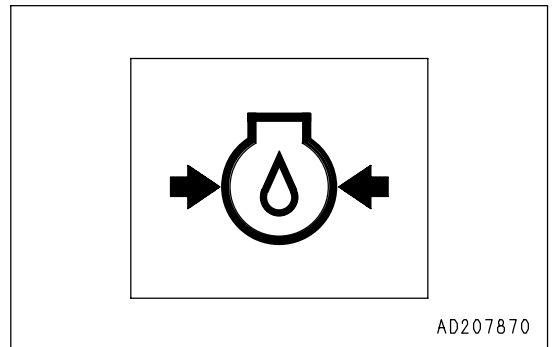
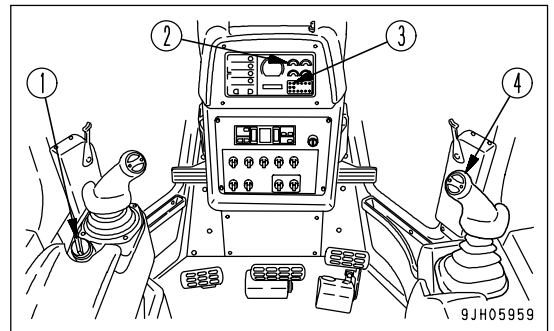

1. Turn fuel control dial (1) to the center position between LOW IDLING (MIN) and HIGH IDLING (MAX) and run the engine at medium speed for about 5 minutes with no load.

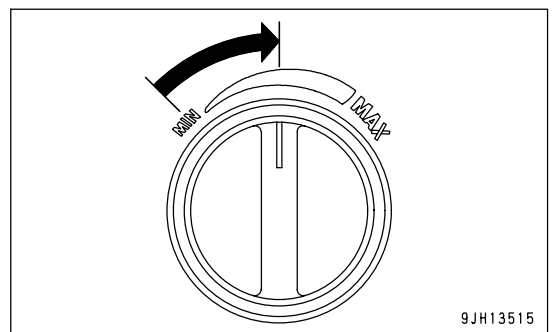

2. After warm-up is completed, check gauges and caution lamps for proper operation. If any problem is found, repair it.

Continue to run the engine under a light load until engine coolant temperature gauge indicator (2) is within the green range (B).

(A): White range

(B): Green range

(C): Red range

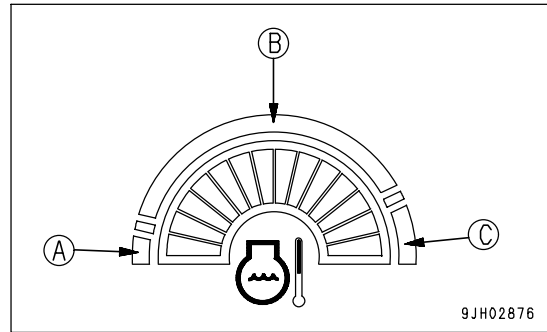

3. Check for abnormal exhaust gas color, noise, or vibration. If any problem is found, contact your Komatsu distributor.

IN COLD AREAS

1. Turn fuel control dial (1) to the center position between low idling (MIN) and high idling (MAX) positions and run the engine at a mid-range speed for 10 minutes under no load.

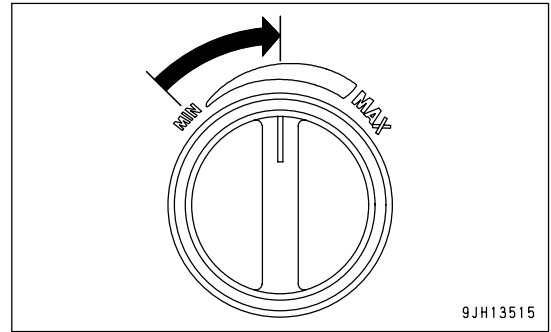

2. Operate blade control lever (4) to the RAISE position, then keep the blade raised to the maximum height and continue to relieve the circuit for 10 minutes.
3. Finally, operate blade control lever (4) and ripper control lever to operate the blade and ripper cylinders several times. If the oil temperature in the work equipment is not properly raised, there will be a time lag in the response of the work equipment and steering.

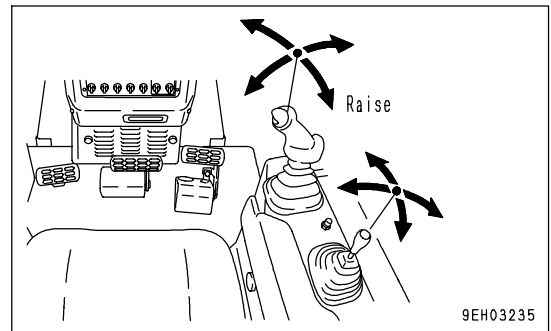

4. After warm-up is completed, check gauges and caution lamps for proper operation. If any problem is found, repair it.

Continue to run the engine under a light load until engine coolant temperature gauge indicator (2) is within the green range (B).

(A): White range

(B): Green range

(C): Red range

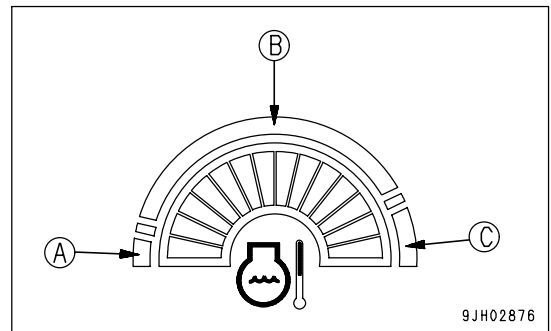

REMARK

If the power train oil temperature is not raised sufficiently, it will take longer to accelerate to the maximum speed.

5. Check for abnormal exhaust gas color, noise, or vibration. If any problem is found, contact your Komatsu distributor.

STOPPING ENGINE

NOTICE

If the engine is stopped without allowing it to cool down, there is danger that the service life of various parts of the engine will be reduced. Except in emergencies, never stop the engine suddenly.

If the engine overheats, do not stop it suddenly. Run it at low speed to allow it to cool down gradually, then stop it.

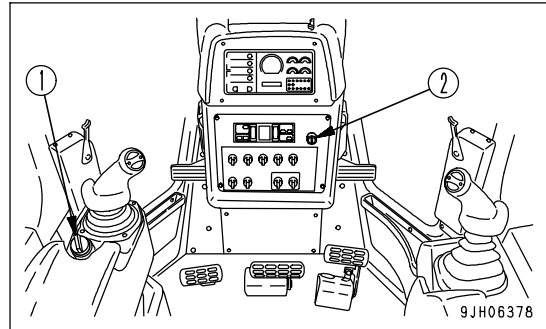

1. Turn fuel control dial (1) in the low idling (MIN) positions and run the engine at low idling speed for 5 minutes to allow the engine to gradually cool down.

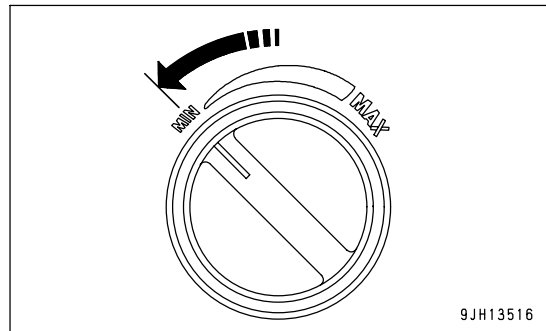

2. Turn the key in starting switch (2) to the OFF position. The engine will stop.

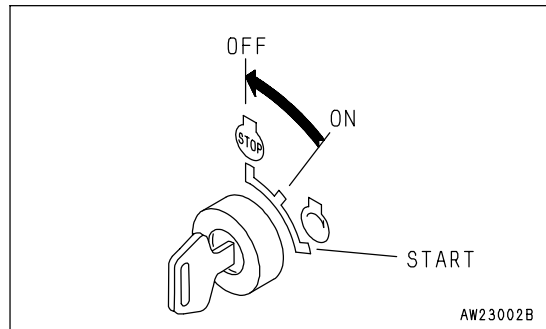

3. Remove the key from starting switch (2).

CHECK AFTER STOPPING ENGINE

1. Walk around the machine and check the work equipment, machine exterior, and undercarriage, also check for any leakage of oil or coolant. If any problems are found, repair them.
2. Fill the fuel tank.
3. Check the engine compartment for paper and debris. Clean out any paper and debris to avoid a fire hazard.
4. Remove any mud affixed to the undercarriage.

MOVING MACHINE

WARNING

- Before moving the machine, check that the area around the machine is safe, and always sound the horn before moving. Do not allow anyone to enter the area around the machine. The rear of the machine is a blind spot, so be extremely careful when traveling in reverse.
- When moving the machine down a slope, always keep brake pedal (8) depressed, even after releasing parking brake lever (1).
- When moving the machine up a steep slope, turn fuel control dial (5) to high idling (MAX) position and run the engine at full speed, and keep brake pedal (8) and decelerator pedal (6) depressed. Then operate steering, directional, and gearshift lever (4) from the N (neutral) position to the direction of travel and slowly release brake pedal (8). When the travel speed rises, slowly release decelerator pedal (6).

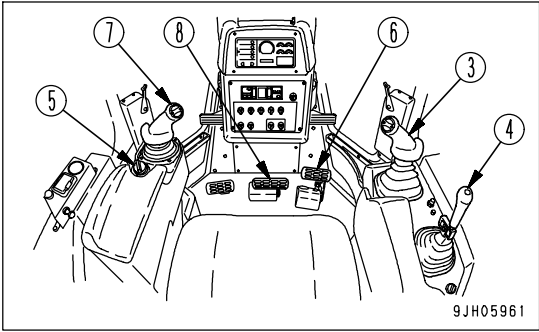
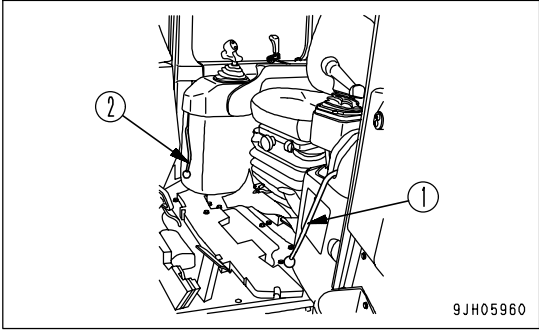

1. Set parking brake lever (1) to the FREE position.

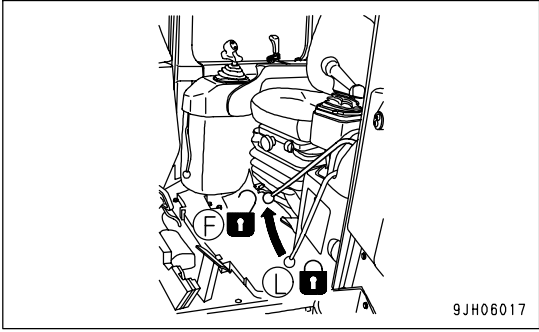

2. Set work equipment lock lever (2) for blade control lever (3) and ripper control lever (4) to the FREE position.

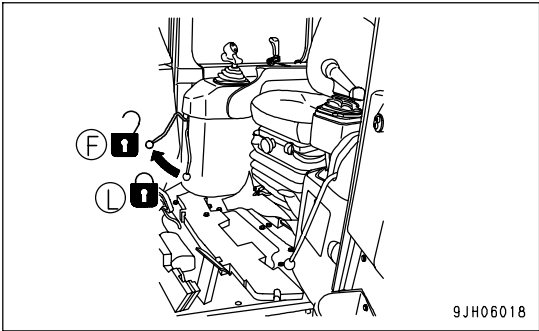

- 3. Operate blade control lever (3) and ripper control lever (4) to the RAISE position, raise the blade 40 - 50 cm (15.8 - 19.7 in) from the ground, and raise the ripper to the maximum height.

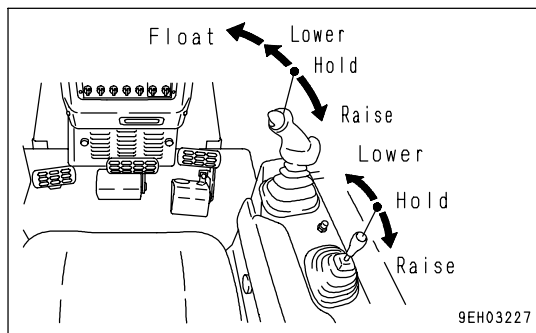

- 4. Turn fuel control dial (5) to the full speed (MAX) position, raise the engine speed, and fully depress decelerator pedal (6).

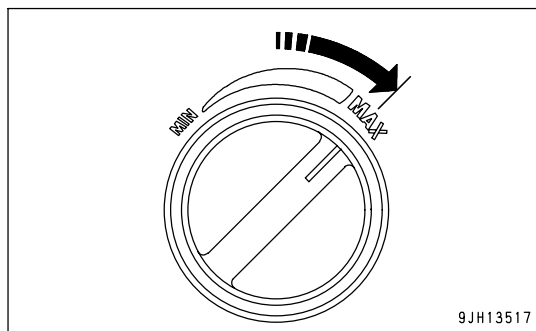

- 5. Move joystick to the F (FORWARD) or R (REVERSE) position, gradually release decelerator pedal (6) and allow the machine to move.

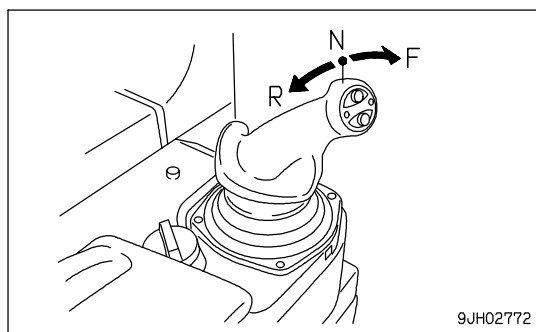

STOPPING MACHINE

⚠ WARNING

- Avoid stopping suddenly. Give yourself ample room when stopping.
- When stopping the machine, select flat hard ground and avoid dangerous places. If it is unavoidably necessary to park the machine on a slope, place the parking brake lever (1) in the LOCK position and insert blocks underneath the track shoes. As an additional safety measure, thrust the blade into the ground.
- If the work equipment control lever is touched by accident, the work equipment may suddenly move, and may cause damage, serious injury, or death. Before leaving the operator's seat, always secure work equipment lock lever (2) in the LOCK position.

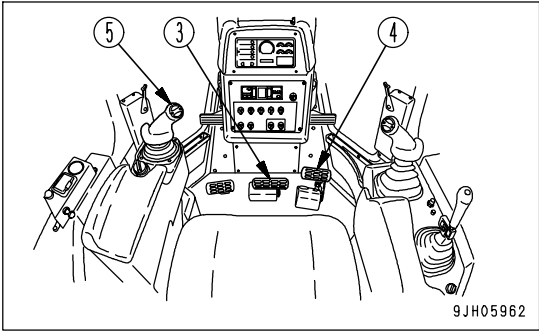
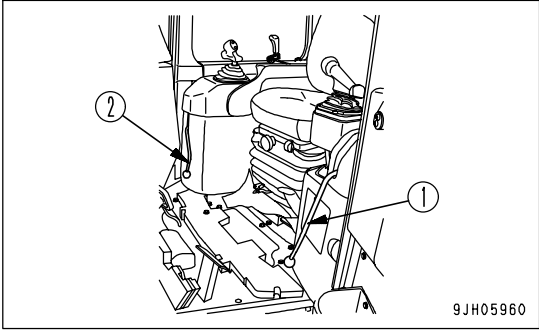

1. Depress brake pedal (3) to apply the brake.

NOTICE

If the brake is depressed when the engine speed or travel speed is high, the brake disc may make a slipping sound. Normally, depress decelerator pedal (4) to reduce the engine speed and travel speed before depressing the brake.

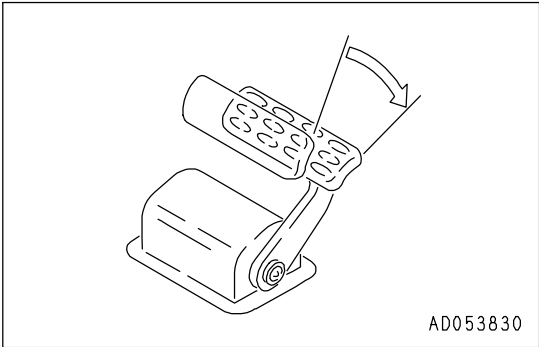

2. Set joystick (5) in the neutral position.

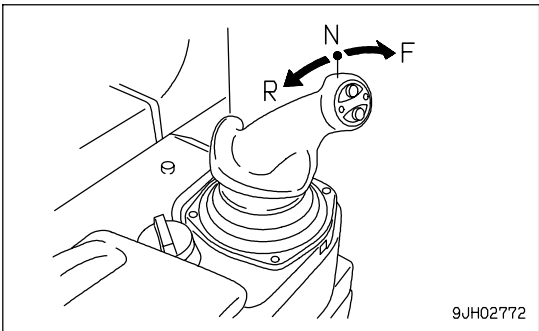

SHIFTING GEAR

The machine does not have to be stopped to shift gears.

1. Move steering, forward-reverse, gear shift lever (1) to the desired gear position to shift gears.

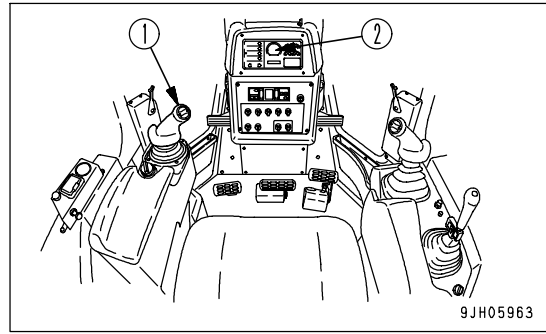

GEAR SHIFTING

- When the joystick is at the FORWARD or REVERSE position and switch (a) or switch (b) is pushed, the transmission speed will change.
 UP switch (a): Each time the switch is pressed, the transmission will shift up one speed.
 DOWN switch (b): Each time the switch is pressed, the transmission will shift down one speed.

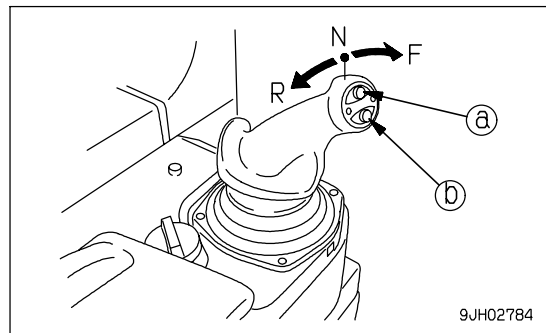

- When the lever is moved to the forward (to set to FORWARD) from the N position, the transmission shifts to F1.
 If the UP switch is pressed once when the transmission is in F1, the transmission shifts to F2.
 If the UP switch is pressed once when the transmission is in F2, the transmission shifts to F3.
 If the DOWN switch is pressed once when the transmission is in F3, the transmission shifts to F2.
 If the DOWN switch is pressed once when the transmission is in F2, the transmission shifts to F1.
- When the lever is moved to the rear (to set to REVERSE) from the N position, the transmission shifts to R1.
 If the UP switch is pressed once when the transmission is in R1, the transmission shifts to R2.
 If the UP switch is pressed once when the transmission is in R2, the transmission shifts to R3.
 If the DOWN switch is pressed once when the transmission is in R3, the transmission shifts to R2.
 If the DOWN switch is pressed once when the transmission is in R2, the transmission shifts to R1,

For details of the maximum speed in each speed range, see "SPECIFICATIONS (PAGE 5-2)".

REMARK

The speed range in use is displayed on the panel display according to the gearshift operation.

For example:

- Neutral: N is displayed on the display panel A (2)
- FORWARD 2nd: F2 is displayed on the display panel A (2)
- REVERSE 3rd: R3 is displayed on the display panel A (2)
- When the parking brake lever is locked, P is displayed.

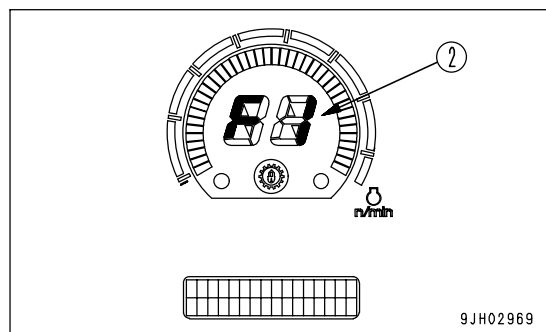

GEARSHIFTING USING SHIFT MODE SELECTION

- Shift mode selection means that the selected speed range is displayed in the N position before starting.
- When the joystick is in the N position, if UP switch (a) or DOWN switch (b) is pressed, the shift mode selection can be carried out.

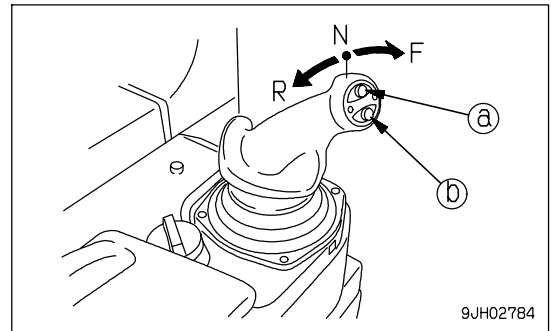

- The selected shift mode is displayed on display panel B (multi-information) of the monitor panel.

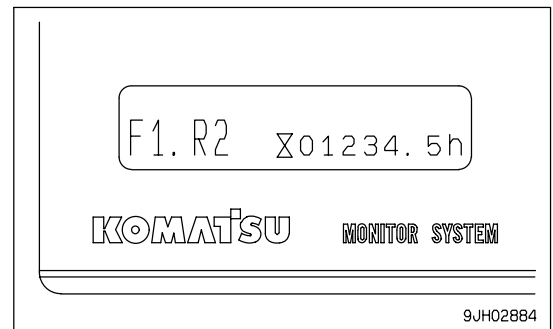

- Shift operation when [F1-R2] mode is set

When the steering, directional, and speed lever is in the N position, if the up switch is pressed once, the mode is set to [F1-R2] mode. After that, if the steering, directional, and speed lever is operated forward (forward travel operation), the transmission is shifted to F1. If it is moved back (reverse travel operation), the transmission is shifted to R2.

- Shift operation when [F2-R2] mode is set

When the steering, directional, and speed lever is in the N position, if the up switch is pressed twice, the mode is set to [F2-R2] mode. After that, if the steering, directional, and speed lever is operated forward (forward travel operation), the transmission is shifted to F2. If it is moved back (reverse travel operation), the transmission is shifted to R2.

REMARK

Even when the transmission is set to [F1-R1] mode, [F1-R2] mode, or [F2-R2] mode, if the UP switch or DOWN switch is operated, this will be given priority and manual operation can be carried out.

For example:

After the [F1-R2] mode has been set, if the joystick is operated forward (to set to FORWARD), the speed range is set to F1. However, if the lever is kept operated forward and UP switch (a) is pressed once, the speed range will shift to F2; if the UP switch is pressed twice, the speed range will shift to F3. When the transmission is in F3 and DOWN switch (b) is pressed once, the speed range will shift to F2; if the DOWN switch is pressed twice, the speed range will shift to F1.

On the other hand, if the joystick is operated to the rear (to set to REVERSE), the speed range is automatically switched R1 → R2. However, if the lever is kept operated to the rear and UP switch (a) is pressed once, the speed range will shift to R3; if the DOWN switch (b) is pressed once, the speed range will shift to R1.

However, the setting stays in the [F1-R2] mode. If the steering, directional, and gearshift lever is returned to N and then operated forward (to set to FORWARD), the speed range is set to F1; if the lever is operated to the rear (to set to REVERSE), the speed range is automatically switched R1 → R2.

REMARK

The default setting is [F1-R1].

After the starting switch is turned OFF, the shift mode returns to the default setting [F1-R1].

AUTO SHIFT DOWN OPERATION

If the travel speed has gone down because of the load condition when traveling, the transmission is automatically shifted to low speed. Set auto shift down switch (2) on the instrument panel in front of the operator's seat to the b (ON) position to actuate the auto shift.

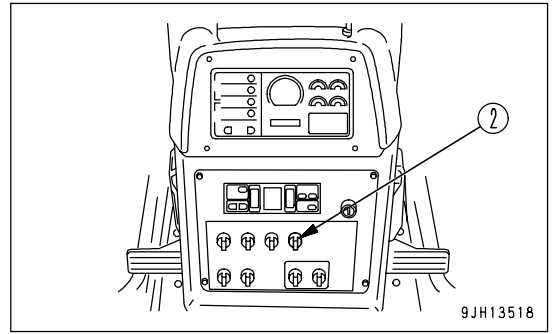

OFF position (a): Automatically canceled

ON position (b): Automatically shifted down to lower speed range

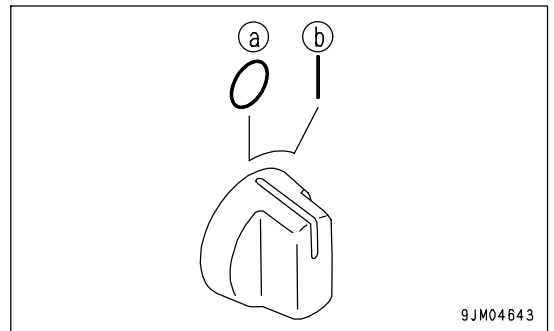

The transmission is automatically shifted down F2 → F1, F3 → F2, R2 → R1, R3 → R2.

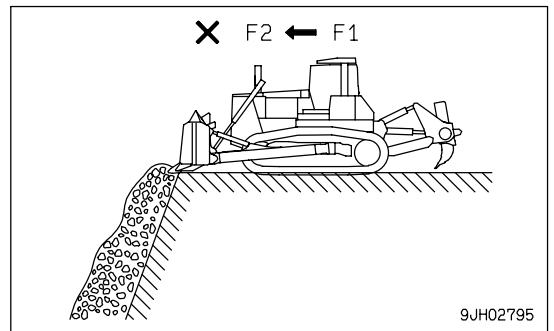

REMARK

- For safety reasons, during auto shift down, the transmission is prevented from shifting up.
- If it is desired to shift up, use manual control and press the UP button on the steering, directional, and gearshift lever.

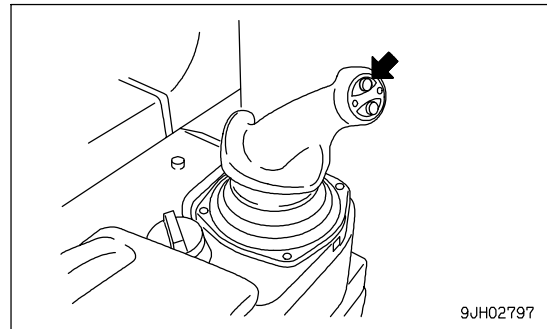
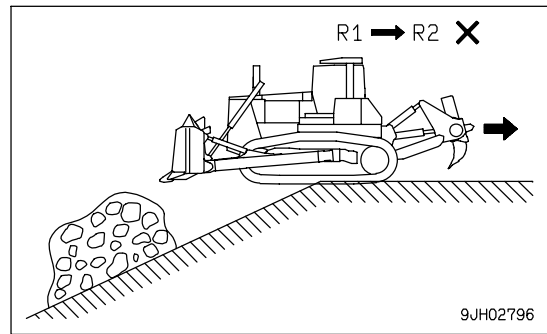

SHIFTING BETWEEN FORWARD AND REVERSE

! WARNING

When switching between FORWARD and REVERSE, first check that the direction of travel is safe.

! CAUTION

There is no need to stop the machine even when switching between FORWARD and REVERSE.

To increase safety, operator comfort, and the life of the transmission, leave the engine running at full speed, and always depress the decelerator pedal to lower the engine speed.

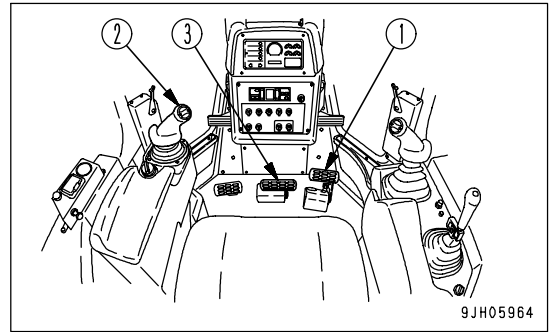

9JH05964

1. Depress decelerator pedal (1) to reduce the engine speed.

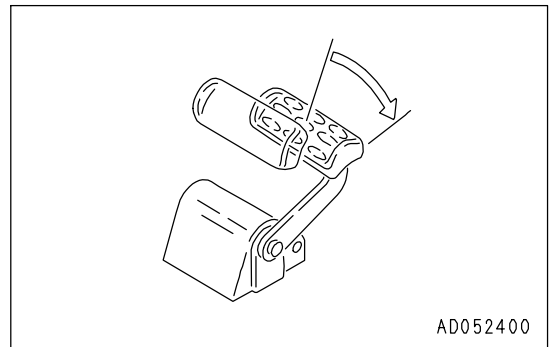

AD052400

2. Move joystick (2) to the neutral position, reduce the speed, then depress brake pedal (3) and stop the machine.

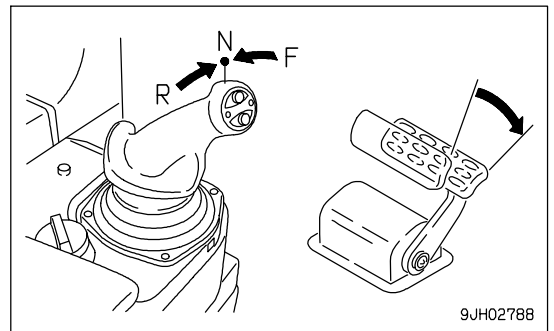

9JH02788

3. After depressing decelerator pedal (1), move steering, forward-reverse, gear shift lever (2) to the desired position.

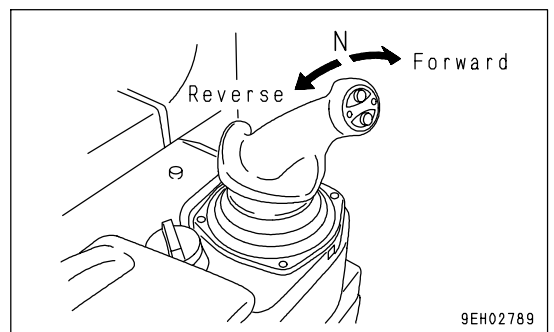

9EH02789

4. Release decelerator pedal (1) and raise the engine speed.

REMARK

When the joystick is placed in REVERSE, the backup alarm will sound.

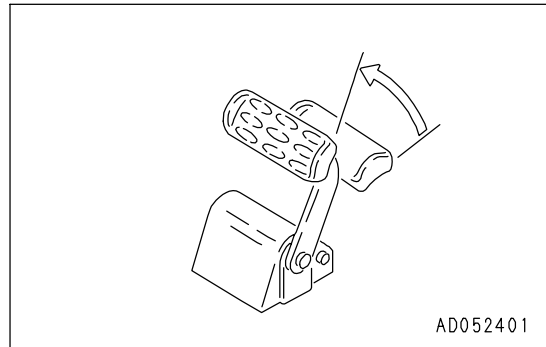

STEERING MACHINE



WARNING

- Avoid as much as possible turning the machine on a slope.
The machine will tend to slip sideways. Particular care should be taken on soft or clay soil.
- Never make a pivot turn at high speed.

NORMAL TURNING

To turn the machine while traveling, incline steering, forward-reverse, gear shift lever (1) in the direction of the turn.

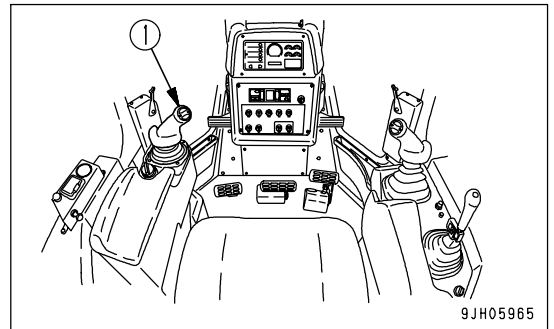

TURNING GRADUALLY TO LEFT WHILE TRAVELING FORWARD

If the joystick is pushed forward and moved partially to the left (L), the steering clutch is disengaged and the machine turns gradually to the left.

When turning gradually to the right, push the joystick forward, and move it partially to the right.
Do the same when traveling in reverse.

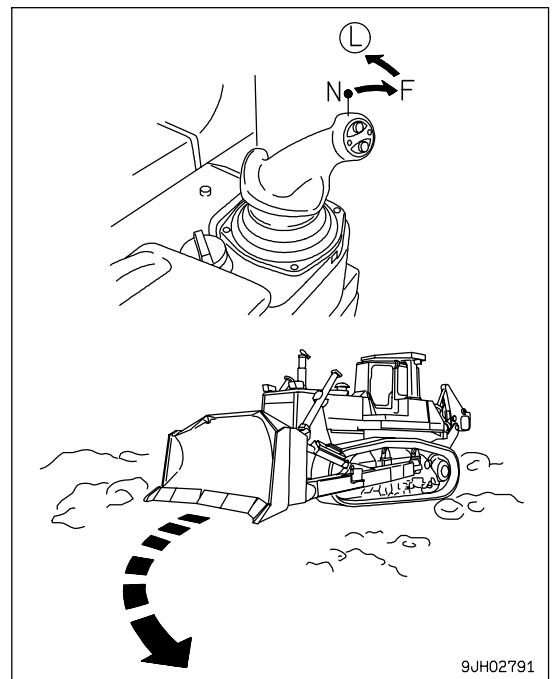

MAKING SHARP TURNS TO LEFT WHILE TRAVELING FORWARD

If the joystick is pushed forward and moved fully to the left (L), the steering clutch is disengaged, the brake is applied, and the machine turns sharply to the left.

REMARK

When making sharp turns to the right, push the joystick forward, and move it fully to the right.

Do the same when traveling in reverse.

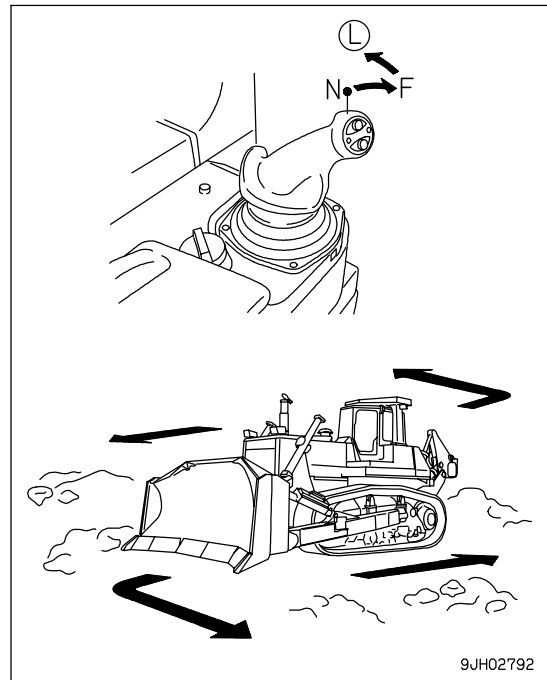

TURNING WHILE DESCENDING A SLOPE

With machines that can carry out counter rotation turns, on steep downhill slopes where the machine may travel under its own weight, or on downhill slopes where it is being pushed by a towed machine, the machine will not steer in the opposite direction, so do as follows.

REMARK

Cross steering means the phenomenon that the machine turns in the opposite direction to the actual steering direction.

TURNING GRADUALLY TO LEFT WHILE TRAVELING FORWARD

If the joystick (1) is pushed forward and moved partially to the left (L), the machine turns gradually to the left.

REMARK

When making gradual turns to the right, push the joystick (1) forward, and move it partially to the right. Do the same when traveling in reverse.

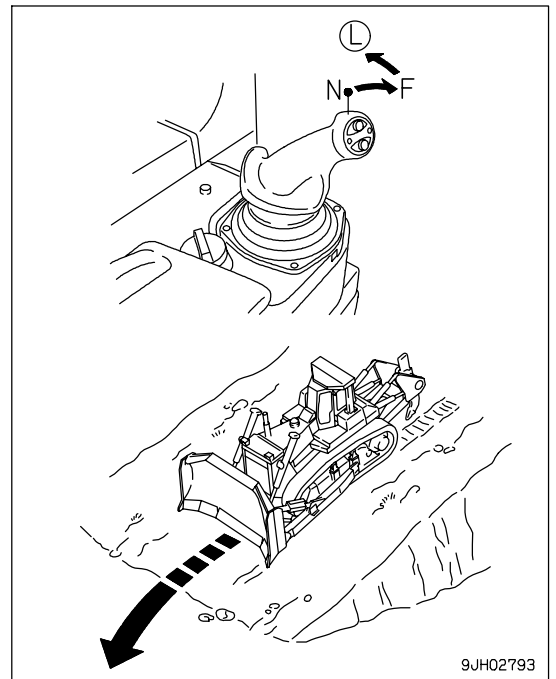

MAKING SHARP TURNS TO LEFT WHILE TRAVELING FORWARD

Operate the steering, directional, and gearshift lever forward and fully to the left (L). The machine will turn to the left.

REMARK

To make spin turns to the right, operate the steering, directional, and gearshift lever forward and fully to the right. The machine will turn to the right.

The same conditions apply when traveling in reverse.

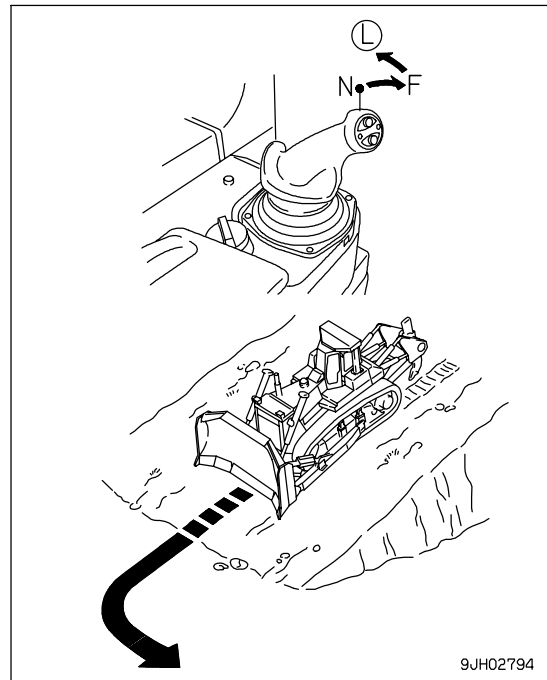

PRECAUTIONS FOR OPERATION

PAY ATTENTION TO GAUGES

If the red range of the power train oil temperature gauge lights up during operation, reduce the load and wait for the temperature to go down.

PERMISSIBLE WATER DEPTH

When operating in water, always keep top surface of the track frame above the surface of the water.

Also, be careful that the engine cooling fan will not come in contact with water. The fan can be damaged.

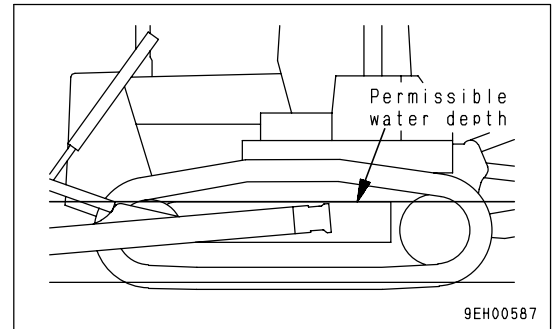

PRECAUTIONS WHEN TRAVELING FOR A LONG TIME

Avoid operating the machine at high speed for a long time, otherwise the temperature of hydraulic oil sharply rises, and that can cause oil leakage from the track rollers or final drive and lower durability.

If there is no way to avoid operating the machine at high speed for a long time, stop the machine every one hour for 30 minutes and let the track rollers and final drive cool off before starting up the machine again.

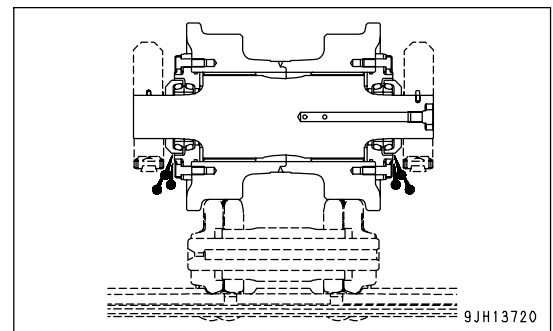

PRECAUTIONS WHEN TRAVELING UP OR DOWN HILLS

METHOD OF USING DECELERATOR PEDAL

When stepping on the decelerator pedal while going uphill, climbing ability will be reduced and the machine will stop. Furthermore, the engine may stall.

USE ENGINE AS BRAKE

When going downhill, move steering, forward-reverse, gear shift lever into low speed to run engine at slow speed and travel down slope using the engine as a brake.

Do not move the steering, forward-reverse, gear shift lever to the NEUTRAL position.

When traveling down hills of more than 15°, shift down to 1st speed (R1 or F1).

BRAKING WHEN TRAVELING DOWNHILL

While descending a slope using the engine as a brake, also apply the brakes.

Failure to brake may result in overrunning, causing engine trouble.

PRECAUTIONS ON SLOPE

BE CAREFUL OF FUEL LEVEL

If the fuel level in the fuel tank becomes low when working on slopes, the engine may suck in air because of the angle of the machine or the swaying of the machine. This makes the engine stop, so be careful not to let the fuel level in the fuel tank become too low.

BE CAREFUL OF OIL LEVEL

When operating machine on sloped areas of more than 20°, fill all appropriate components with oil to H level.

PRECAUTIONS WHEN ENGINE STOPS ON SLOPE

If the engine stops while working or traveling on a hill, immediately depress the brake pedal to bring the machine to a complete stop.

METHOD OF USING BRAKES

The following actions cause premature damage to the brakes, so avoid such operations.

- Using emergency brake at full speed
- Using brake with engine running at full speed in first gear (F1, R1) (Machine stall condition)

REMARK

Always depress the decelerator pedal to lower the engine speed before actuating the brakes.

PROHIBITED TO KEEP THE DOOR OPEN DURING OPERATIONS

Always keep the door closed when traveling or carrying out operations.

If the door is open, there is danger of damage from obstacles or strong vibration.

IT IS PROHIBITED TO MODIFY THE CAB GLASS IN ANY WAY THAT WILL OBSTRUCT THE VIEW

- For safety reasons, do not install anything on the cab glass that will obstruct the view.
- Always keep the glass clean to ensure safety during operations.

PRECAUTIONS FOR BLIND SPOTS CAUSED BY CAB STAY AND ROPS STAY



WARNING

The cab stay and ROPS stay cause blind spots.

When operating, always be sure to check carefully that there is no obstacle or worker in the surrounding area.

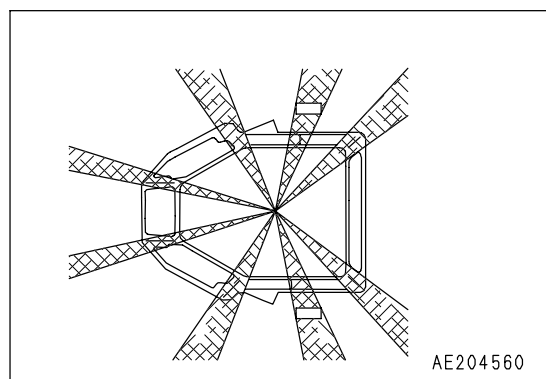

PARKING MACHINE

⚠ WARNING

- Avoid stopping suddenly. Give yourself ample room when stopping.
- When stopping the machine, select flat hard ground and avoid dangerous places. If it is unavoidably necessary to park the machine on a slope, place the parking lever (4) in the LOCK position and insert blocks underneath the track shoes. As an additional safety measure, thrust the blade into the ground.
- If the work equipment control lever is touched by accident, the work equipment may suddenly move, and may cause damage, serious injury, or death. Before leaving the operator's seat, always secure work equipment lock lever (7) in the LOCK position.

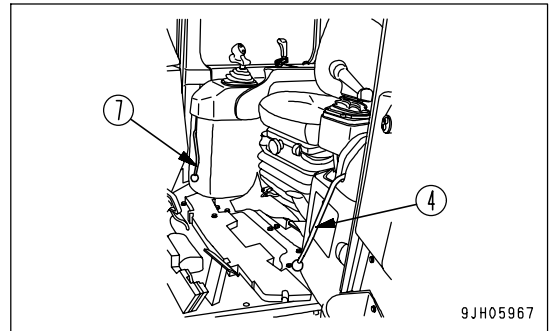
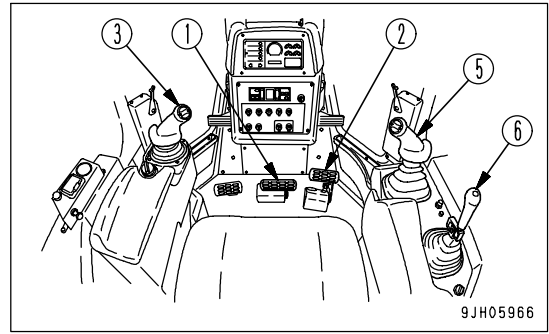

1. Depress brake pedal (1) to stop the machine.

NOTICE

If the brake pedal is depressed when the engine speed or machine travel speed is high, the brake disc may produce a slipping sound. When depressing the brake pedal, usually depress decelerator pedal (2) to reduce the engine speed and machine travel speed.

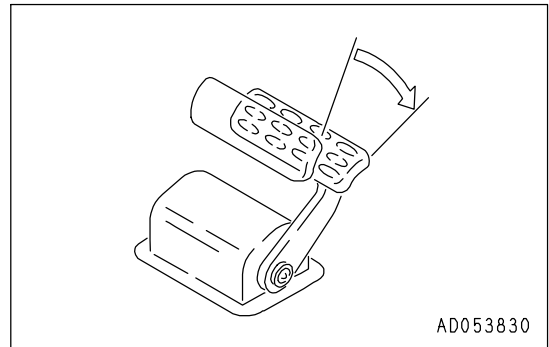

2. Place joystick (3) at the neutral position and set the speed range to 1st.

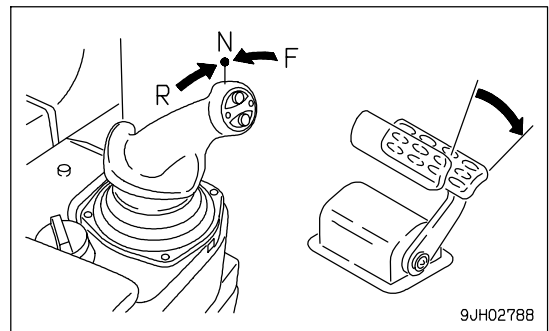

3. Operate parking lever (4) to lock the brakes.

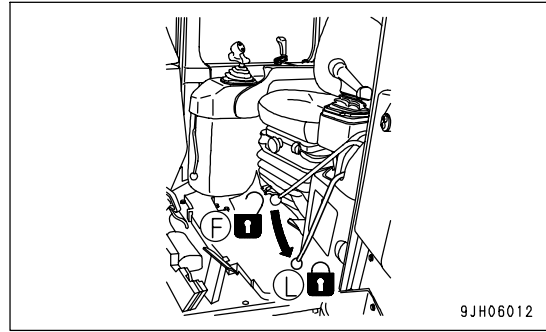

4. Operate blade control lever (5) and ripper control lever (6) to the LOWER position, and lower the blade and ripper to the ground.

5. Set blade control lever (5) and ripper control lever (6) to the HOLD position.

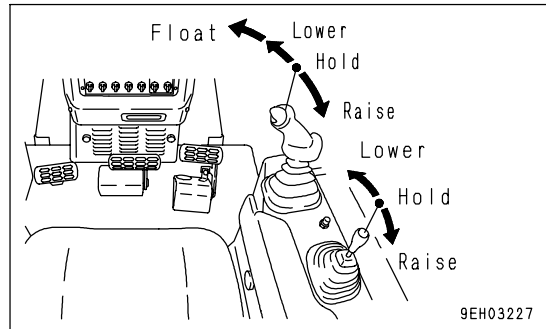

6. Set work equipment lock lever (7) for blade control lever (5) and ripper control lever (6) to the FREE position.

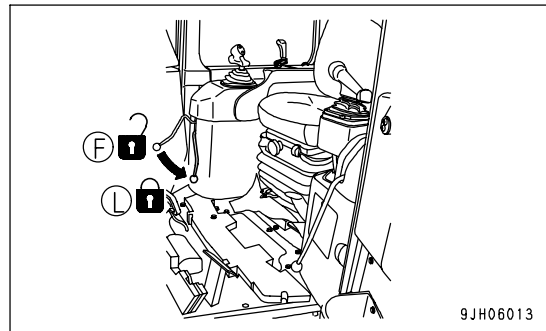

CHECK AFTER FINISHING WORK

Use the meters and caution lamps to check the engine coolant temperature, engine oil pressure, fuel, and power train oil temperature.

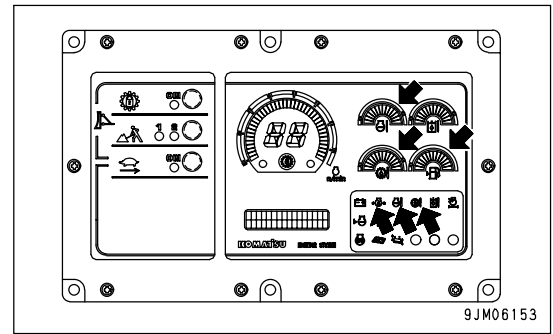

LOCKING

Places that can be locked with the starting switch key.

To prevent vandalism, there are locks in the following places.

- Right and left engine side cover (1)
(left side: 2 places, right side: 2 places)
- Fresh air filter inspection cover (left) (2)
- Cab door opener (3)
- Lock-type caps (4) (if equipped)
 - Radiator cap
 - Fuel tank cap
 - Hydraulic tank cap
 - Power train oil filler pipe cap
- Battery inspection cover (5), (6)
- Tool box inspection cover (7)

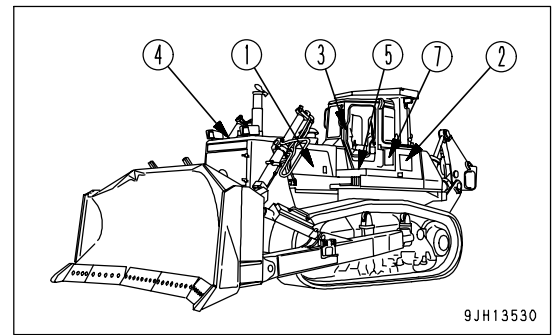

REMARK

It is possible to fit commercially available locks to the following place.

- Power train central pressure inspection, power train oil level inspection cover (8)

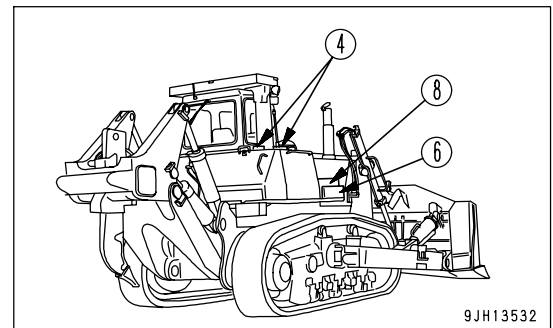

WORK POSSIBLE USING BULLDOZER

In addition to the following, it is possible to further increase the range of applications by using various attachments.

DOZING

A bulldozer digs and transports dirt in a forward direction. Slope excavation can always be most effectively carried out by proceeding from the top downward.

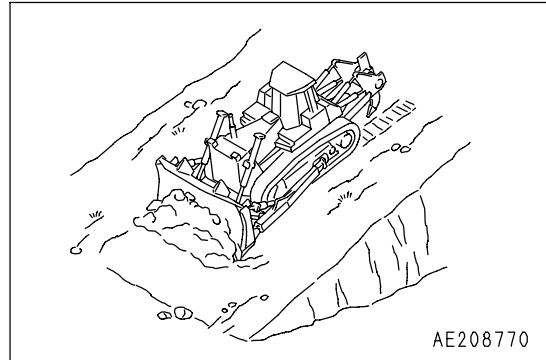

CUTTING INTO HARD OR FROZEN GROUND OR DITCHING

For digging and ditch excavation of hard or frozen ground tilt the blade. Even hard ground can be dug effectively by a tilted or angled blade.

If the ground is harder, use a ripper attachment for better efficiency.

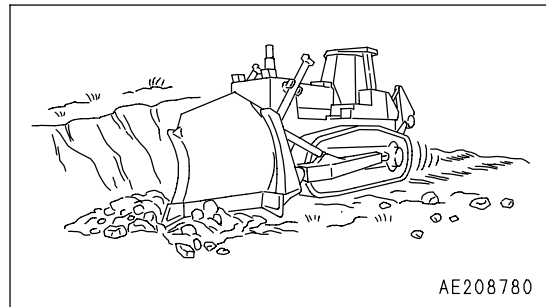

FELLING TREES, REMOVING STUMPS

NOTICE

Do not up root trees or stumps or fell trees by angling or tilting the blade.

For trees with a diameter of 10 to 30 cm (3.9 to 11.8 in), raise the blade high and push 2 or 3 times to fell the tree.

Next, travel in reverse, and dig the corner of the blade into the ground to cut and dig up the roots.

When doing this, never hit the tree at high speed or apply shock to fell the tree.

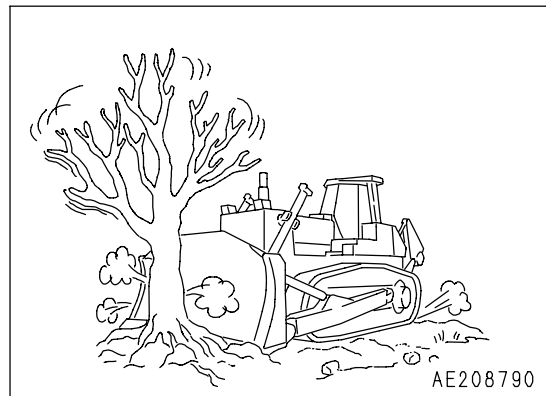

PUSHER OPERATIONS

- When carrying out pusher operations, always install a pusher plate.
- When approaching the other machine, depress the decelerator pedal to reduce the engine speed and approach slowly. After coming into contact, raise the travel speed slowly and push with full power.

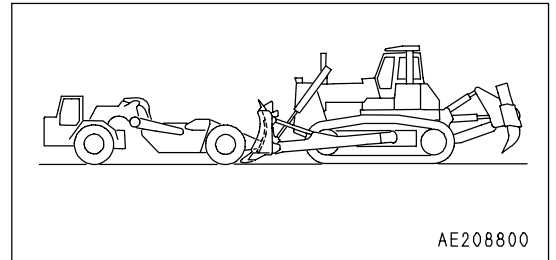

SMOOTHING

NOTICE

Avoid smoothing on rocky or stony ground. It can damage the blade.

When finishing the ground surface to a smooth finish after digging or filling operations, keep a full load of soil in the blade and operate the blade up or down in small movements while traveling forward. When leveling windrows or ruts left by the tracks, set the blade to the FLOAT position, travel at low speed in reverse and drag the blade over the ground surface.

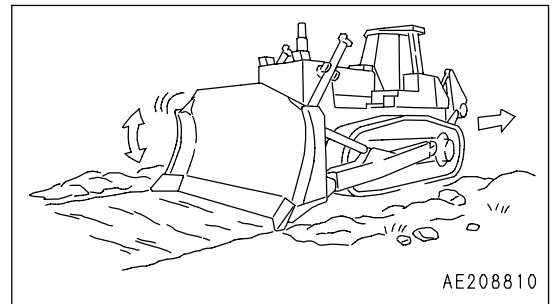

EFFECTIVE USE OF MODE SELECTION SYSTEM

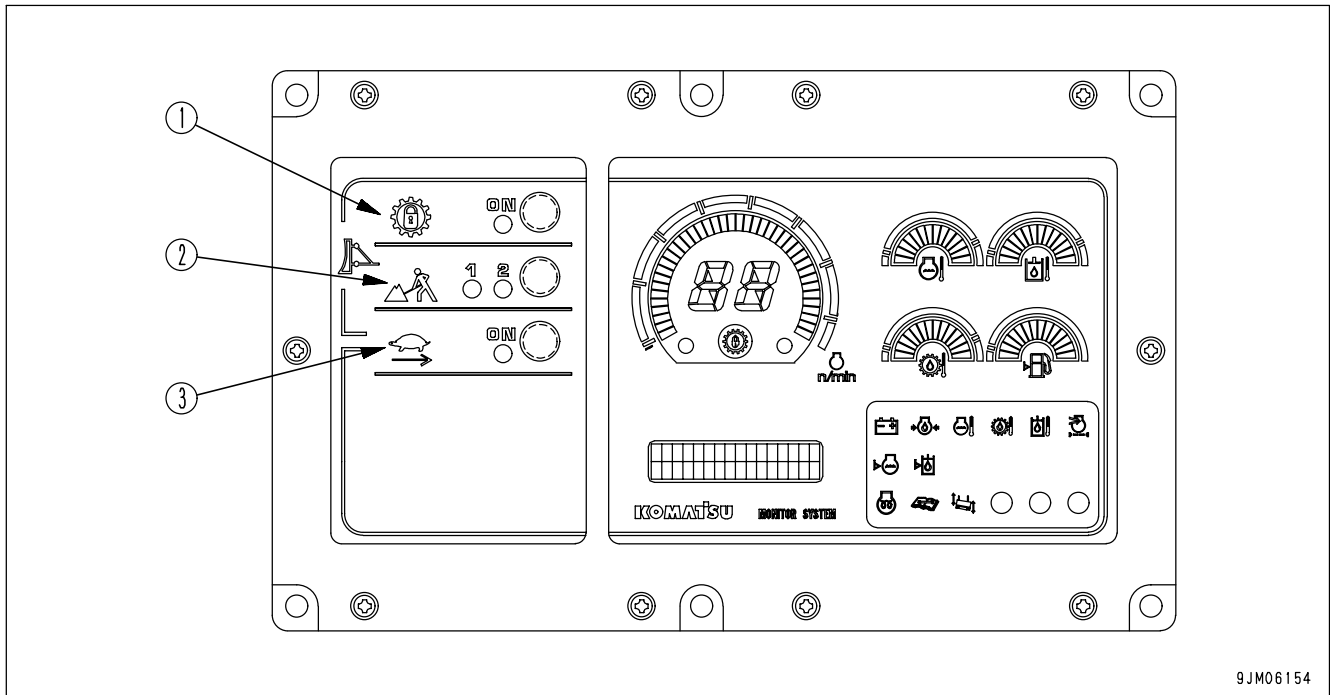

9JM06154

- (1) Lock up mode switch
- (2) Economy mode selector switch
- (3) Reverse slow mode selector switch

Selecting mode to match the type of work and quality of rock and soil makes to perform operations effectively. For the machine that is solely used for crushed rocks, it can be done that when the ignition switch is turned ON, all mode switches are turned ON. Contact your Komatsu distributor for such modification of the switches. When all the mode selection switches are off, the selection is suitable for conventional digging and dozing of bedrock.

The condition when all the mode selection switches are off is called the standard mode.

It is impossible to use any combination of the lock-up mode and any other mode.

The economy mode, reverse slow mode, and shoe slip control mode can be used independently or in combination.

Dozing		Ripping
Lock up mode	Economy mode	Reverse slow mode
○	×	×
×	○	○

○: Possible to use ×: Compound use not possible

SELECTION OF MODE

DOZING OPERATIONS

LOCK UP MODE

By using the lock up mode, the travel speed increases, the operating efficiency is improved, and the fuel consumption is also reduced.

- Speed ranges that can be used: All speed ranges
- Applicable operations: Dozing loose material (suitable for long-distance hauling operations)

When the lock up mode is turned ON, direct drive or torque converter drive are automatically selected according to the load.

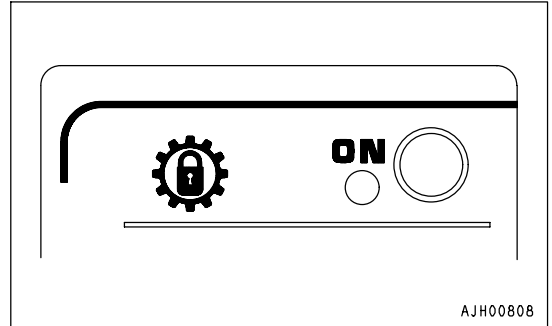

(Example)

- Slot dozing operations

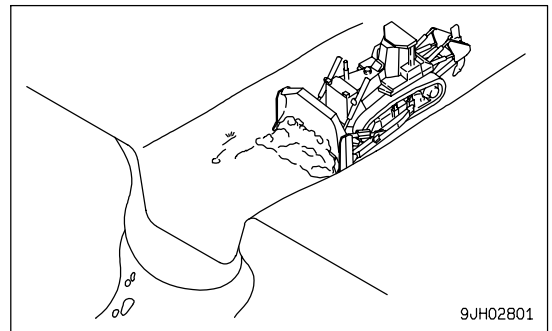

- Hillside dozing operations

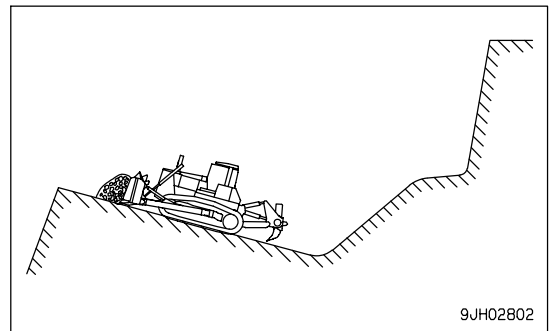

REMARK

- If dozing operations power carried out on a slope of an angle of more than 15°, the lock up may easily be canceled, so operations are easier to carry out in the standard mode.
- For normal ripping operations, if the lock up mode is used, the lock up will repeatedly switch between ON and OFF, so use the standard mode.
- Even with ripping operations, if the ground is extremely soft, the lock up mode can be used.

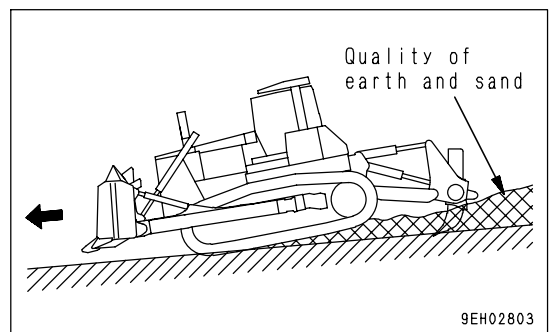

ECONOMY MODE

Using the economy mode makes it possible to reduce wasteful shoe slippage and to reduce the fuel consumption.

- Speed ranges that can be used: F1
- Applicable operations: Hauling after ripping, dozing blasted rock, smoothing.

When the economy mode is turned ON, it is automatically set to [1]. Carry out dozing operations in this condition, then set to [2] and carry out operations. From this test, select the matching that gives power and low shoe slip ratio (frequency of deceleration operation).

Mode [1] is set to approx. 90% of full power and mode [2] is set to approx 70%.

(Example)

- Fine leveling operations

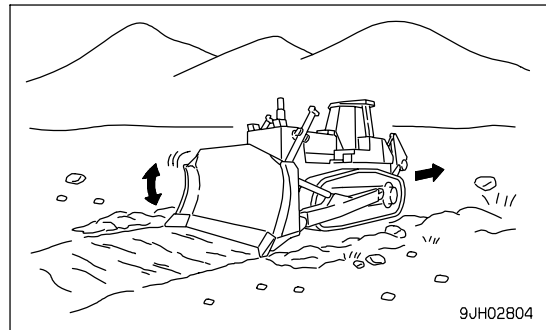
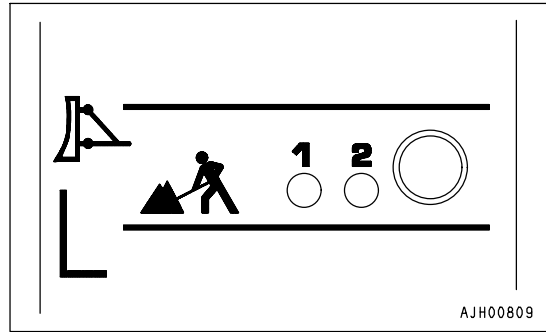

- Ripping and dozing operations

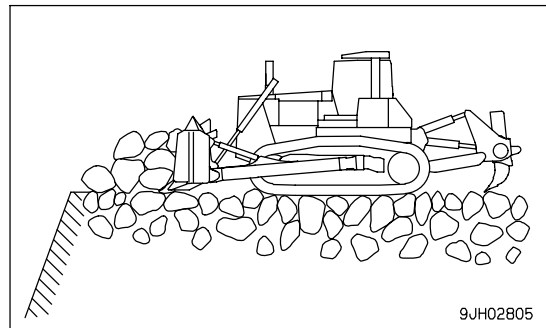

REVERSE SLOW MODE

This reduces the travel speed when traveling in reverse, reduces the frequency of operating the decelerator pedal, and improves the riding comfort for the operator.

- Speed ranges that can be used: R1, 2, 3
- Applicable operations: Travelling on bedrock

Use this mode to reduce the travel speed when traveling in R1, R2, or R3.

When the reverse slow mode is ON, the travel speed is set to approx. 80% of the full travel speed.

Use this mode to reduce the travel speed when traveling in reverse after ripping and dozing bedrock or when traveling in reverse after dozing on steep slopes. The travel speed differs in each mode according to whether it is used in combination with the economy mode.

When traveling on bedrock, if it is felt that the travel speed when traveling in reverse is too high, turn the reverse slow mode ON.

This will reduce the travel speed when traveling in reverse.

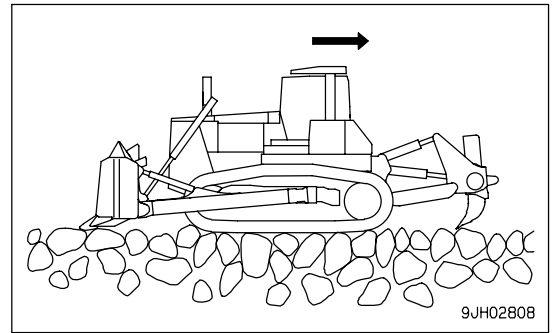
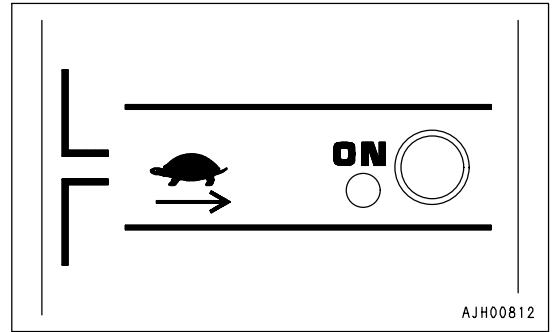

When traveling down slopes, if it is felt that the travel speed when traveling in reverse is too high, turn the reverse slow mode ON.

This will reduce the travel speed when traveling in reverse.

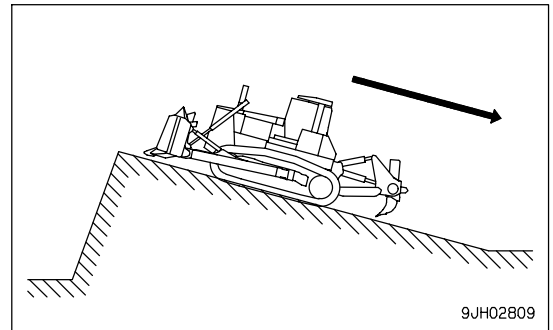

PROCEDURE FOR SELECTING MODE ACCORDING TO NATURE OR NEEDS TO WORK

Use the table below to select the mode that matches the nature or needs of the operation.

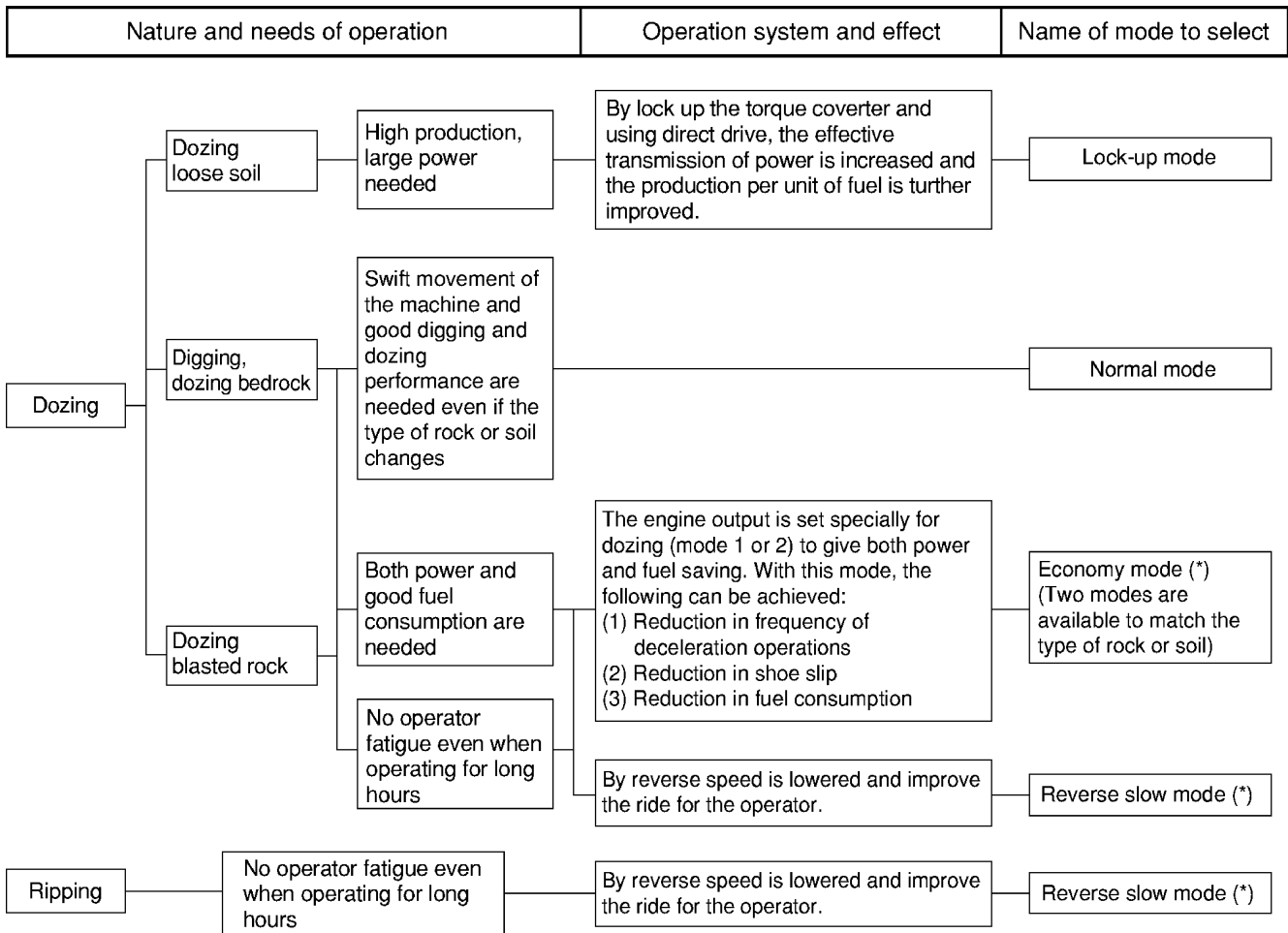

(*): The dozing economy mode and reverse slow mode can all be selected independently or in combination. In addition, it is possible to select and correct as needed, so it is possible to achieve precise matching for various types of operation.

RIPPER OPERATION

EFFECTIVE METHOD OF USE

- The optimum digging angle for the shank is when the shank is perpendicular to the ground (ripping angle: 45° to 50°).
- In comparatively soft rock (seismic velocity: 1500 m/s or below), it is also possible to carry out ripping with the shank tilted to the rear.
- On comparatively hard rock, if ripping is carried out with the shank tilted to the rear, there will be excessive wear of the point of tip (1), and the self-sharpening ability will be lost.
- During ripping operations, if the shoes slip because of boulders or resistance from the bedrock, use the tilt cylinder. When picking up a stone, advance the machine at a fixed gear speed (F1 or F2).

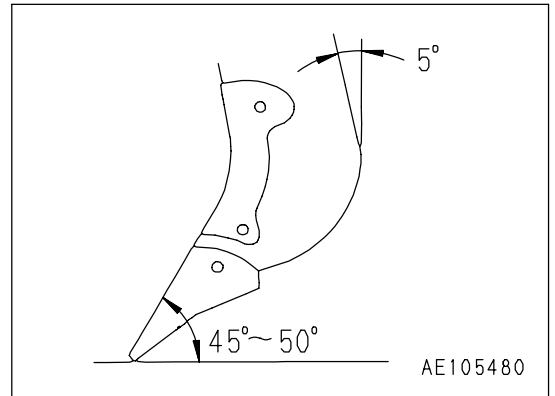

REMARK

- When raising boulders or digging up rockbed, do not put the transmission in neutral. If the transmission is in neutral, the reaction of the tilt cylinder will push the machine back. Always operate the machine with the transmission in FORWARD.
- Choosing a suitable ripper point to match the type of rock is one of the most important elements in using the ripper effectively. Ripper points are available for different types of rock, so select the most suitable ripper point from the list. For details, see "PROCEDURE FOR SELECTING RIPPER POINT (PAGE 6-4)".

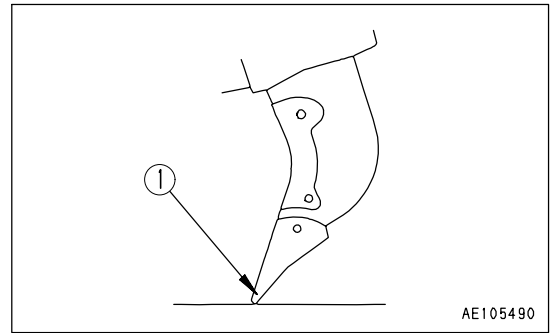

DIGGING UP BOULDERS OR ROCKBED

During ripper operations, if stubborn boulders or rockbed cause the travel speed to become slower, operate the tilt cylinder to dig up the boulder/rockbed.

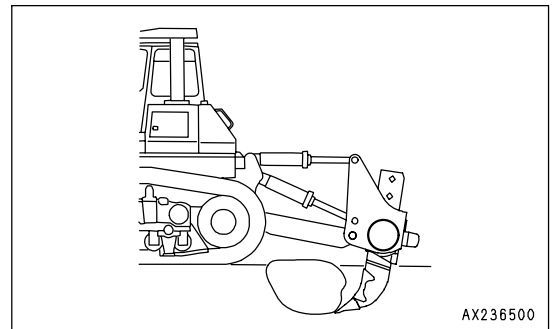

OPERATING ON SLOPES

When using the variable ripper, adjust the length of the tilt cylinder to select dimension L.

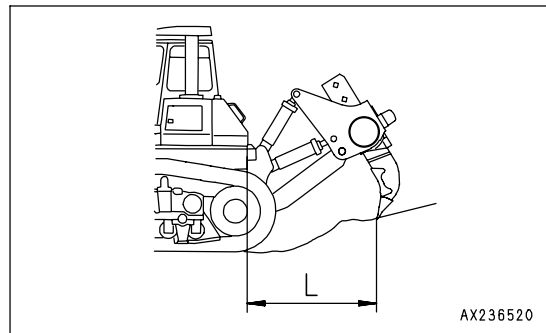
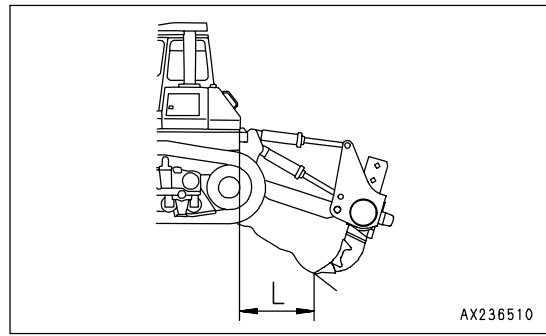

METHOD OF OPERATING PIN PULLER

1. Stop the machine in a safe place and lower the shank to the ground.
2. Operate the pin puller controller switch to the PULL OUT position and remove the mounting pin.
3. Move the ripper up or down to set to the desired shank position.

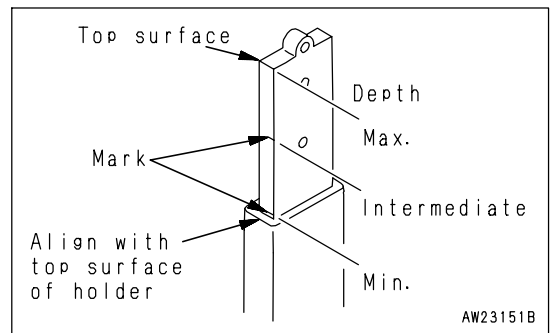
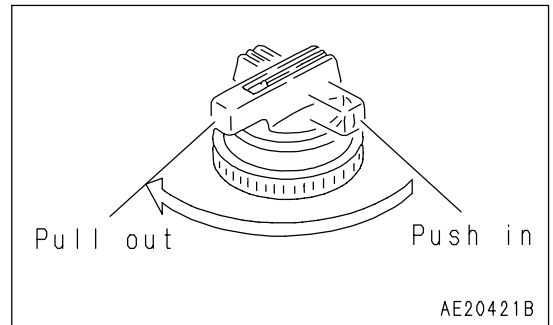

4. Operate the pin puller control switch to insert the mounting pin.
If the pin does not match the position of the hole in the shank, set the pin puller control switch to the PUSH IN position and slowly move the ripper up or down.

REMARK

When raising the pin position to increase the digging depth, use a long protector to prevent wear of the shank.

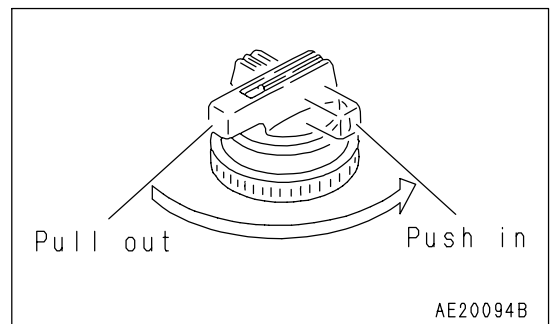

OPERATING METHOD FOR RIPPING OPERATIONS

BASIC OPERATING METHOD

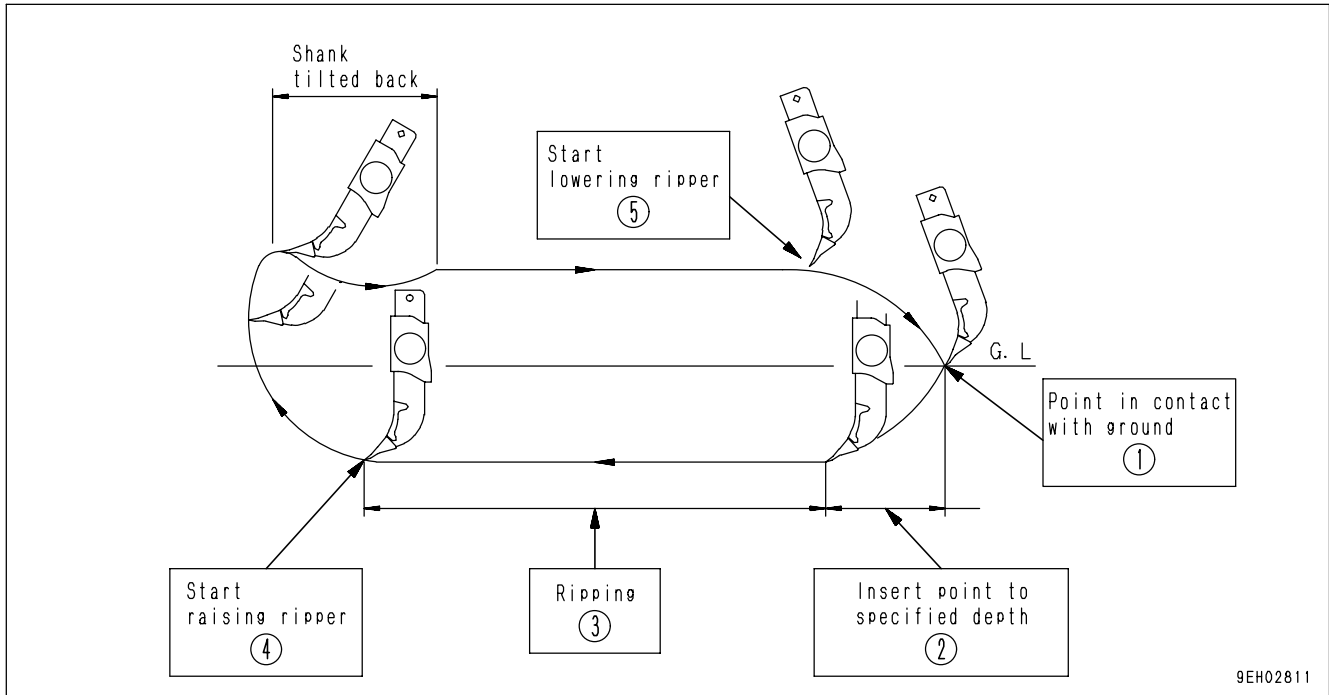

TRACK OF RIPPER SHANK

Carry out the ripping operation as follows, passing through the points shown in the diagram above.

- (1) Tilt the ripper back, lower the ripper point to the ground that the place to begin ripping, and raise the rear of the machine.
- (2) To press the decelerator pedal and lower the engine speed, set the speed range to F1, and tilt the ripper to insert the point to the specified depth.
- (3) When the ripper point reaches the specified depth, raise the engine speed to full speed and travel forward. Tilt the shank and carry out ripping. If the circuit is relieved even when the shank is tilted, change the shank mounting hole to the hole below and reduce the ripping depth.
- (4) After completing the ripping, travel forward, raise the shank from the bed rock, then travel in reverse.
- (5) While traveling in reverse, tilt the ripper back, and when the starting point for the ripping is reached, lower the ripper.

REMARK

- If the ripper is applied with the rear of the machine raised from the ground, the drawbar pull will be low, so the ripping efficiency will be reduced.
- If the ripping depth is kept constant, there will be no unevenness, and this will increase the efficiency of the dozing operation.

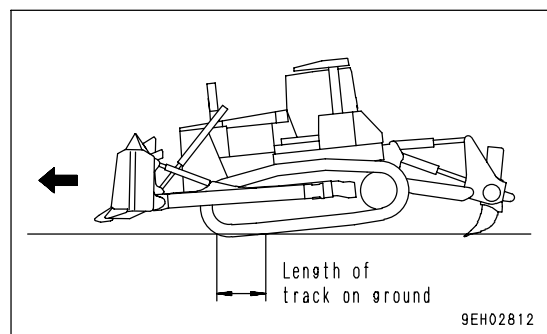

RIPPING BY CLIFFS

- When carrying out ripping at the edge of a cliff, tilt the ripper back to make depth (L) longer.
- Depress the decelerator pedal, drive slowly forward, and when the ripper point contacts the cliff, tilt the ripper.

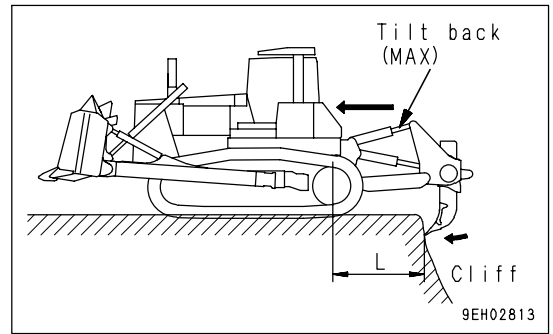

RIPPING BY SLOPE FACES

(Giant ripper)

- When carrying out ripping work at the edge of slope faces, make the ripper tilt back angle small, and if there is an area where the slope face has not been ripped, apply the ripper diagonally.

REMARK

In the case of the multi-shank ripper, carry out ripping at right angles to the slope face.

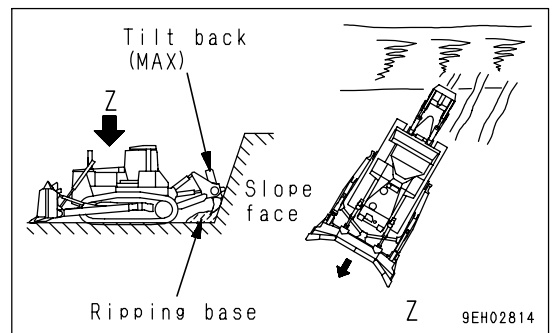

Cross ripping

- On jobsites with hard bedrock, for rocks and boulders which are impossible to break or dig up with one ripping pass, carry out the second ripping pass at right angles to the first ripping direction.
- At the edge of cliffs, where it is impossible to apply the ripper in a cross direction, make the space between the shanks smaller and carry out ripping.

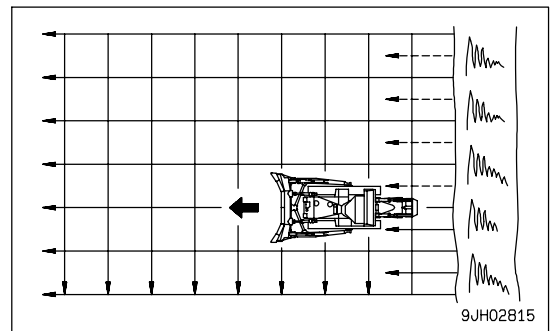

- During the ripping operation, if there is any hard bedrock, carry out ripping in the opposite direction to the direction where the ripper was applied. If it is still impossible to break up the rock, break up the area around the bedrock a little at the time.
- When carrying out concentrated ripping of hard bedrock, the work efficiency is high if the ripper is applied to the whole of the digging face.

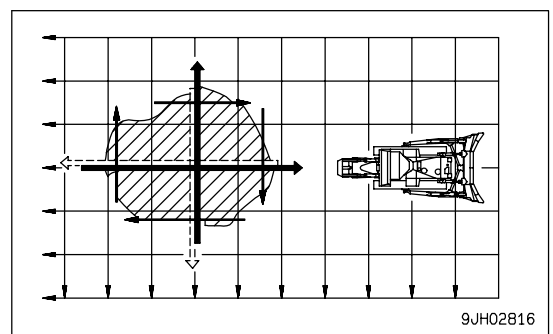

DIGGING UP BOULDERS

During the ripping operation, if boulders are found which are difficult to break and shoe slippage occurs, dig up the boulder as follows.

1. Depress the decelerator pedal and lower the engine speed to a point where there is no shoe slippage.

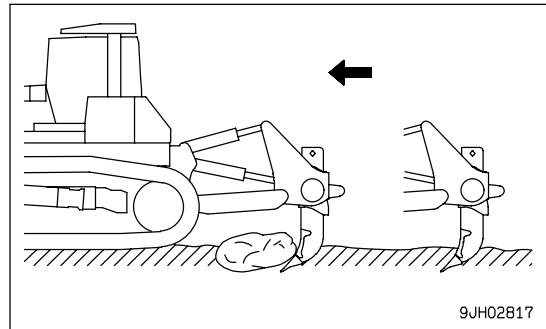

2. Operate the ripper lever to the TILT position and carry out ripping and digging.

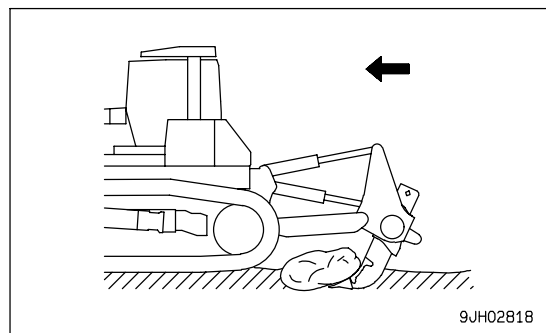

3. If there are boulders which are impossible to break or dig up with the tilt operation, move forward slightly and tilt the shank back, then operate the tilt again and dig up the boulder.

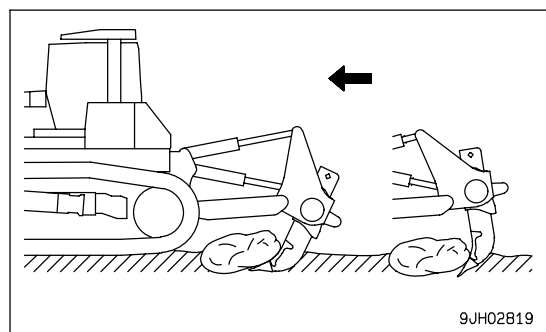

4. Even when the operation in Step 3 is repeated, if it is impossible to break or dig up the boulder, drive back about 10 cm, raise the shank, avoid the rock or boulder that cannot be ripped, then drive forward and start ripping again.

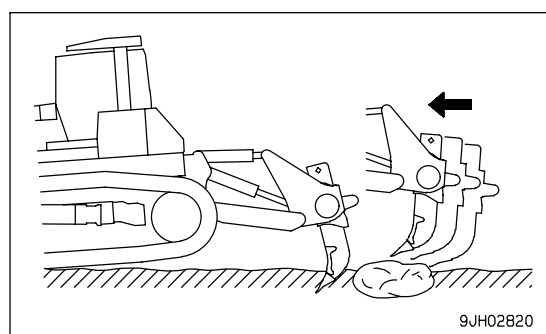

PRECAUTIONS WHEN RIPPING

- For the digging angle when ripping, set so that the top of the shank is perpendicular, then lower the ripper.
- Do not carry out ripping for long periods with the shank tilted back. The tip of the point will wear to a round shape.

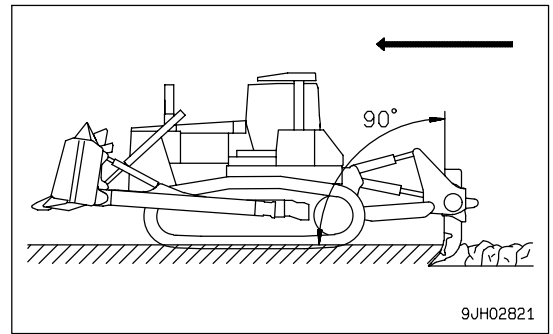

- Do not change the direction of travel during the ripping operation. This will cause breakage of the shank. When changing the direction of travel, remove the shanks from the ground before turning.

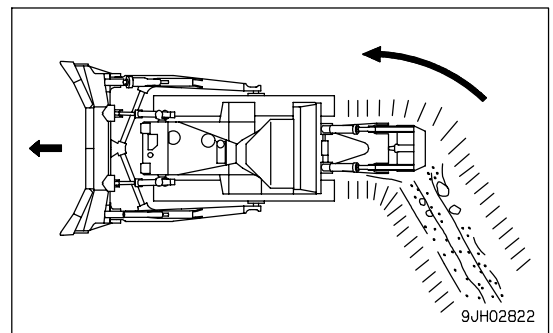

- Never drive in reverse when the ripper point is inserted in the bedrock. The pin installing the point will break and the point will fall off.
Move the machine forward, and raise ripper slowly.

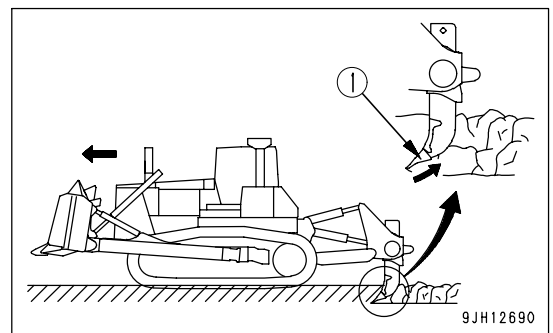

- After ripping, if the broken rock is comparatively large, avoid traveling over the ripping path (2) when traveling in reverse. When traveling in reverse (3), check the rear carefully to avoid hitting any large rocks. As far as possible, choose level ground to travel over.

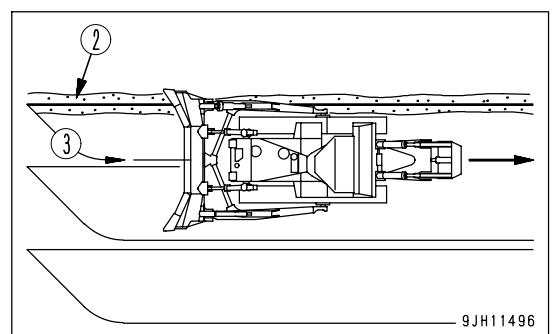

ADJUSTING POSTURE OF WORK EQUIPMENT



WARNING

When adjusting, it is dangerous if the work equipment is moved by mistake. Set the work equipment in a safe condition, then stop the engine and lock the work equipment securely with the work equipment lock lever.

BLADE ADJUSTMENT

TILTING THE TILTDOZER

NOTICE

The maximum amount of tilt is 900 mm (2.9 ft).

(When the semi-U blade is used.)

Be sure not to exceed 900 mm (2.9 ft) for the tilt.

Tilt exceeding the maximum limit imposes unnecessary forces onto sections. This may cause damage to the machine.

The following tilt amount can be obtained by operating the blade control lever.

Right side: 600 mm (23.6 in) or more

Left side: 600 mm (23.6 in) or more

If an even greater tilt is necessary, do as follows.

Use rod (2) installed to the left brace to turn brace (1) and change the length (ℓ) of the brace. This makes it possible to obtain a maximum tilt of 900 mm (2.9 ft).

- Standard distance (ℓ) between joints is 1845 mm (6.0 ft).

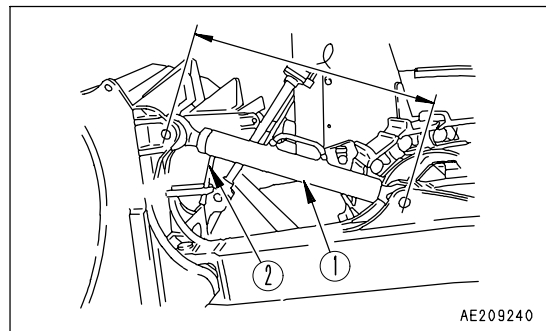

ADJUSTING BRACE

**WARNING**

If maintenance is carried out with the engine running, always have one worker sitting in the operator's seat while another worker carries out the maintenance. Both workers must mutually confirm the safety during the operation.

Adjustment can be carried out more easily if the engine is started, the inching operation used to carry out tilting to the left and right, and the blade shaken up and down while turning the brace handle (1).

- When extending the brace

It is easy to carry out the adjustment if the blade is set on top of a block and the brace handle is turned.

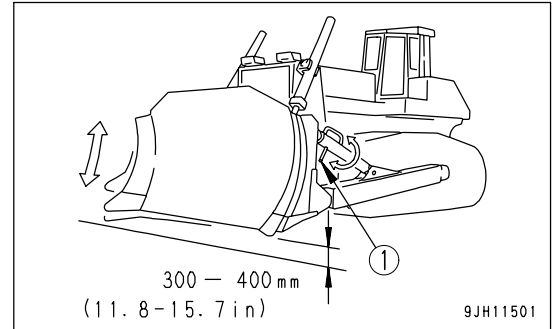
**REMARK**

When operated in this way, the blade is tilted, so the handle gradually becomes heavier. When this happens, return the blade from the tilt position to the horizontal position and turn the handle again according to the procedure given above.

SHIM ADJUSTMENT

Adjust the thickness of shim so that the ball joint play (4 places) in the axial direction (shown by the arrow) does not exceed 1 mm (0.04 in).

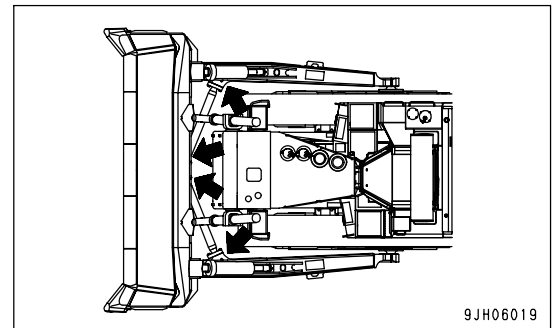

1. Remove shim (1) and tighten bolts (2) to eliminate the ball joint play.
2. Measure clearance "A" and remove bolts (2).
3. Install shim (1) having its thickness of "A" mm to "A + 1" mm ("A" in. to "A + 0.04" in) in place with bolts 2.
4. Confirm that ball joint can move smoothly after tightening bolts.

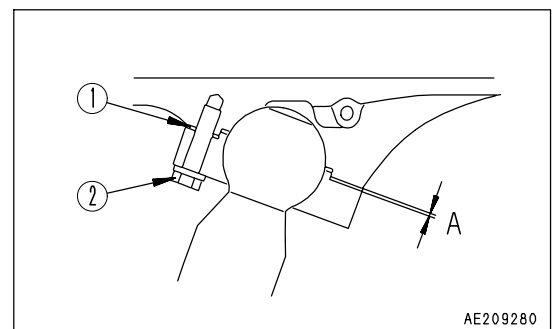

ADJUSTING RIPPER

ADJUSTING DIGGING DEPTH

Mounting pin holes are provided in the shank and these are used according to the desired digging depth. For normal use, use the bottom hole, and when particularly deep digging is needed, use the top hole.

For the method of changing the depth of digging, see "METHOD OF OPERATING PIN PULLER (PAGE 3-147)".

1. Place a pointed object on the tip of pin (1), then hit with a hammer to remove from the opposite side.
2. Remove pin (2) and change the position of the shank hole.
3. Insert pin (1) partially by hand then knock it in with a hammer.
 - The pin is made of one piece, so insert it partially by hand then knock it in with a hammer.
 - When a giant ripper is installed, use the pin puller.
 For details, see "METHOD OF OPERATING PIN PULLER (PAGE 3-147)".

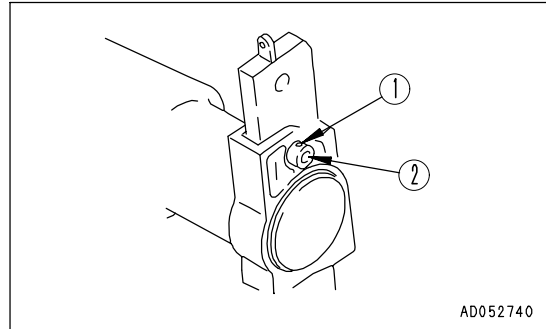

REPLACING POINT AND PROTECTOR

To protect the shank, if the protector and point installed to the tip are worn, replace them.

Place a pin remover on the pin marked by the arrow, then hit with a hammer to remove from the opposite side.

REMARK

The pin is a unitized type, so insert the pin partially by hand, then knock it in fully with a hammer.

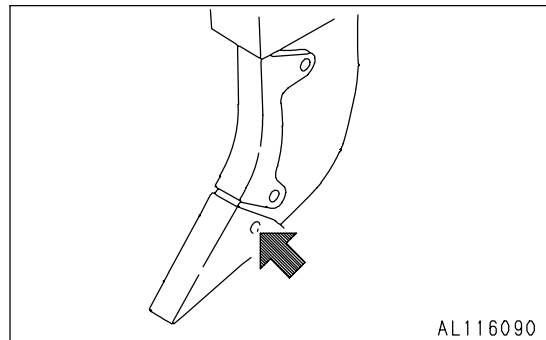

TIPS FOR LONGER UNDERCARRIAGE LIFE

Undercarriage life greatly varies depending on operation method, inspection and maintenance. For most efficient operation, keep the following point in mind.

OPERATION METHOD

- Select the track shoe that best suits the type of soil to be encountered in service.
Consult your Komatsu distributor when selecting track shoes.
- Do not allow shoe slippage to occur during operation. If slippage occurs, reduce load to the blade until slipping stops.
- Avoid sudden starts, acceleration or stops, unnecessary high speeds and sharp turns.
- Always operate machine in a straight line whenever possible. When making turns, be careful not to allow the machine to stay to one side, so operation in both turning directions can be done properly. Make turns with the largest possible radius.
- Prior to operation, clear boulders and obstacles to prevent machine from riding over them while operating.
- On a slope, operate the machine parallel to the inclination of the slope. Do not operate across the slope. Also when stopping the machine on a slope, the machine should face the top of the slope.
- When ground inclines to the left or right during digging operations, do not continue to dig with the incline. Move the machine back to level ground and start to dig again.
- Do not force the machine to carry out work that exceeds its working capability. Such work includes cases where the idler or sprocket come off the ground when the machine meets obstacles that resist the power of the machine during dozing or ripping operations.

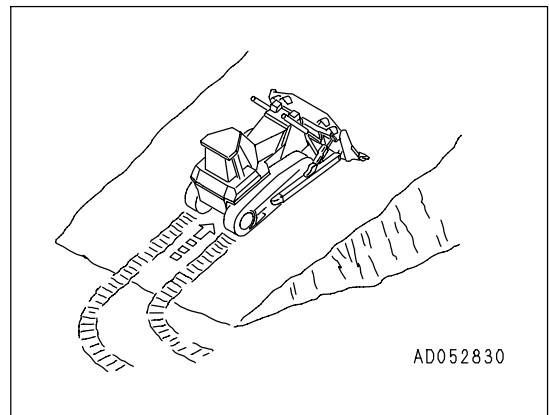

INSPECTION AND ADJUSTING

- Properly adjust track tension.
Tension should be measured at clearance (A) shown in the diagram - usually 20 to 30 mm (0.8 to 1.2 in) at this point. For rocky terrain, tighten tracks slightly. In clay or sandy areas, slightly loosen them. (For inspection and adjustment procedures, refer to "CHECK AND ADJUST TRACK TENSION (PAGE 4-28)").
- Check idler rollers for oil leakage as well as for loose bolts and nuts. If any trouble is detected, repair immediately.
- Check the clearance between the idler guide plate and the track frame. If clearance (B) increases, idler may develop side motion and tracks may come off. (For inspection and adjustment procedures, refer to "ADJUST IDLER CLEARANCE (PAGE 4-32)").

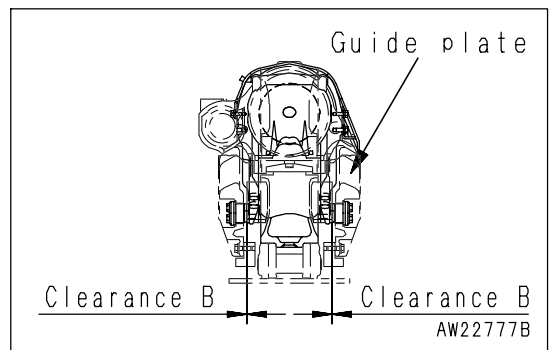
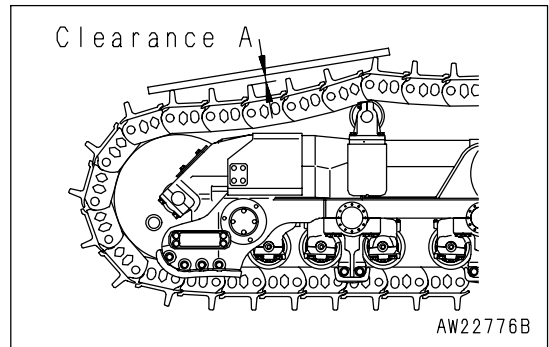

INSPECTION AND REPAIR

Frequent inspection and prompt repair will reduce repair costs.

The following items for inspection will serve as a guide to maintenance service of each undercarriage part. Perform periodical inspection and contact the Komatsu distributor in your area when machine has approached repairable limits and reversing limits.

MEASURING HEIGHT OF GROUSER

- After taking up slack in track shoes, measure height at center of shoe as shown below.

Standard height (h): 105 mm (4.1 in)

Repair limit (h): 35 mm (1.4 in)

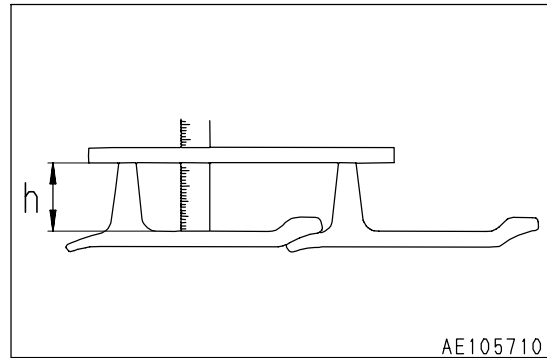

MEASURING OUTSIDE DIAMETER OF TRACK ROLLER

1. Measure the outside diameter of the tread (dimension A).

(1) Double flange roller

Standard dimension (A): 300 mm (11.8 in)

Repair limit (A): 246 mm (9.7 in)

(2) Single flange roller

Standard dimension (A): 300 mm (11.8 in)

Repair limit (A): 230 mm (9.1 in)

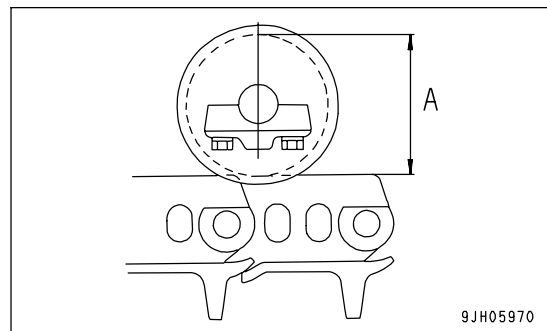

TRANSPORTATION

When transporting the machine, observe all related laws and regulations, and be careful to assure safety.

TRANSPORTATION PROCEDURE

A trailer should be used for transporting the machine.

LOADING, UNLOADING WORK



WARNING

- Make sure the ramp has sufficient width, length and thickness to enable the machine to be safely loaded and unloaded. If the ramp sags appreciably, reinforce it with blocks, etc.
- When loading and unloading the machine, park the trailer on a flat firm roadbed. Keep a fairly long distance between the road shoulder and the machine.
- Remove the mud from the undercarriage to prevent the machine from slipping to the side on slopes. Be sure the ramp surface is clean and free of grease, oil, ice and loose materials.
- Never change the direction of travel when on the ramps. If it is necessary to change direction, drive off the ramps and correct the direction, then drive on to the ramps again.

When loading or unloading, always use ramps or a platform. Proceed as follows.

LOADING

1. Load and unload on firm level ground only.
Maintain a safe distance from the edge of a road.
2. Apply the trailer brakes securely, then put blocks (1) under the tires to prevent the trailer from moving.
 - Set left and right ramps (2) parallel to each other and equally spaced to the left and right of center (3) of the trailer. Make angle of installation (4) a maximum of 15°. If the ramps bend a large amount under the weight of the machine, put blocks under the ramps to prevent them from bending.
3. Set parking brake lever to the FREE position (F).
4. Set the transmission in the 1st gear and run the engine at low idle.
5. Set the travel direction toward the ramps and drive slowly.
6. The center of gravity of the machine shifts suddenly at the border between the ramps and trailer, and the machine is unbalanced and becomes dangerous. Accordingly, pass the border slowly.
7. Stop the machine at the specified position on the trailer.

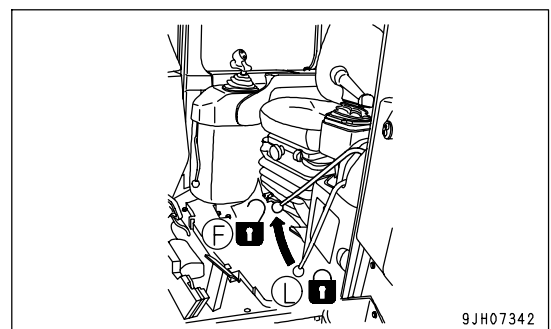
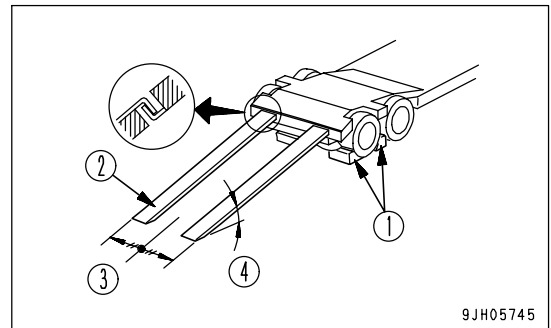

SECURING MACHINE

NOTICE

Stow the antenna away.

Load the machine onto a trailer as follows:

1. Lower the work equipment slowly.
(When transporting with work equipment installed)
2. Set the work equipment lock lever to the LOCK position (L) securely.
(When transporting with work equipment installed)

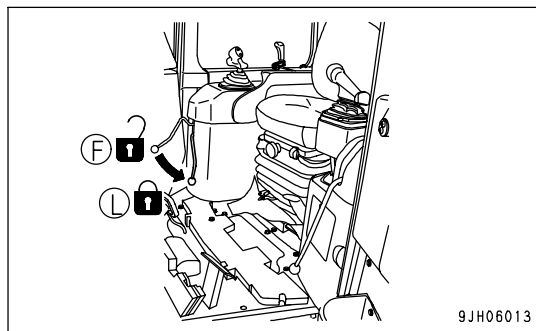

3. Set the parking brake lever to the LOCK position (L) securely.
4. Stop the engine, then remove the key from the starting switch.

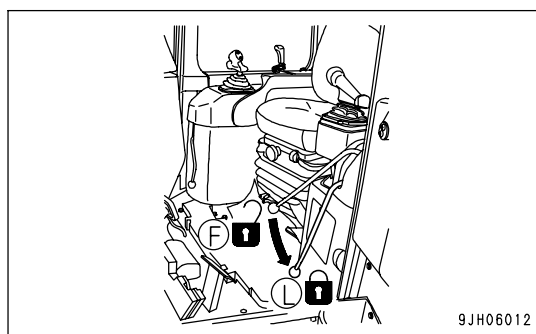

5. Place blocks under both ends of the tracks to prevent the machine from moving during transportation, and secure the machine with chains or wire rope of suitable strength. Be particularly careful to secure the machine in position so it does not slip to the side.

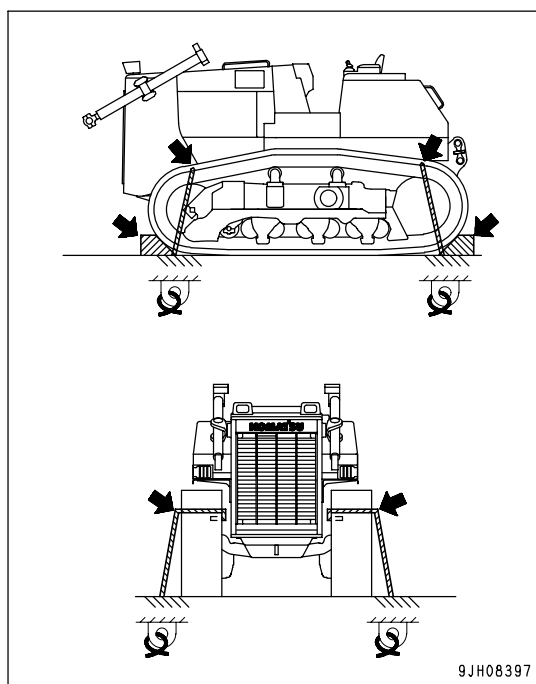

UNLOADING

1. Load and unload on firm level ground only. Maintain a safe distance from the edge of a road.
2. Apply the trailer brakes securely, then put blocks (1) under the tires to prevent the trailer from moving.
 - Set left and right ramps (2) parallel to each other and equally spaced to the left and right of center (3) of the trailer. Make angle of installation (4) a maximum of 15°. If the ramps bend a large amount under the weight of the machine, put blocks under the ramps to prevent them from bending.
3. Remove the chains and wire ropes fastening the machine.
4. Start the engine.
 - Warm the engine up fully.
5. Set main work equipment lock lever to FREE position (F), and raise the work equipment.
 - (When transporting with work equipment installed)

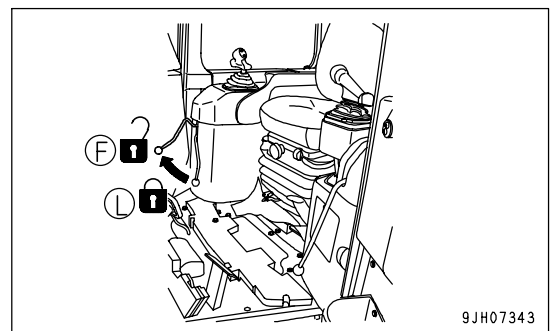
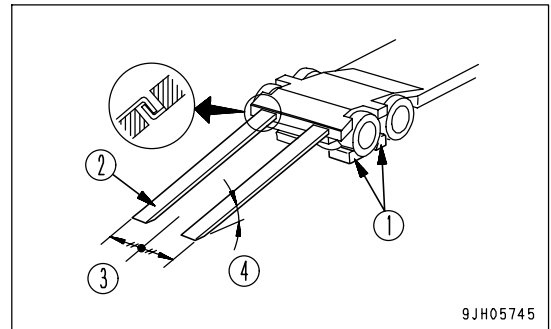

6. Set parking brake lever to the FREE position (F).
7. Set the transmission in the 1st gear and run the engine at low idle.
8. Set the travel direction toward the ramps and drive slowly.
9. The center of gravity of the machine shifts suddenly at the border between the ramps and trailer, and the machine is unbalanced and becomes dangerous. Accordingly, pass the border slowly.
10. Drive down the ramps slowly and carefully until the machine leaves the ramps perfectly.

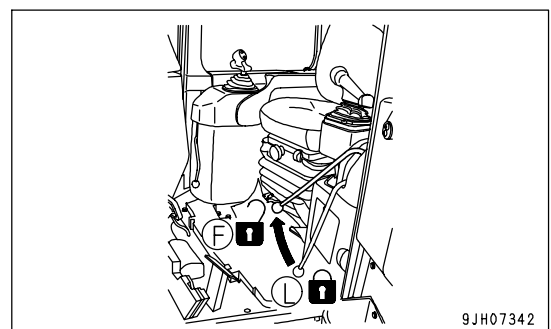

METHOD OF LIFTING MACHINE



WARNING

- The operator carrying out the lifting operation using a crane must be a properly qualified crane operator.
- Never raise the machine with any worker on it.
- Always make sure that the wire rope is of ample strength for the weight of this machine.
- When lifting, keep the machine horizontal.
- When carrying out lifting operations, set the work equipment lock lever and parking brake lever to the LOCK position to prevent the machine from moving unexpectedly.
- Never enter the area under or around a raised machine.

Never try to lift the machine in any posture other than the posture given in the procedure below or using lifting equipment other than in the procedure below.

There is a hazard that the machine may lose its balance.

NOTICE

This method of lifting applies to the standard specification machine.

The method of lifting differs according to the attachments and options installed.

For details of the procedure for machines that are not the standard specification, please consult your Komatsu distributor.

When lifting the machine, stop it on a level place, then observe the following procedure.

1. Set the work equipment lock lever to the LOCK position (L) securely.

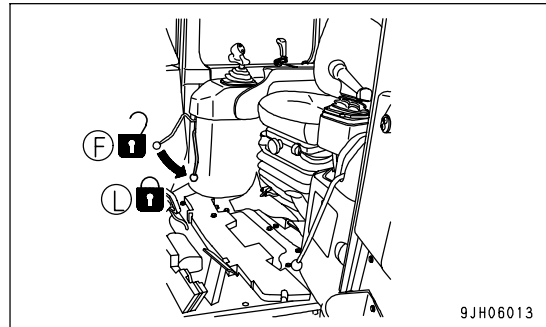

2. Set the parking brake lever to the LOCK position (L) securely.

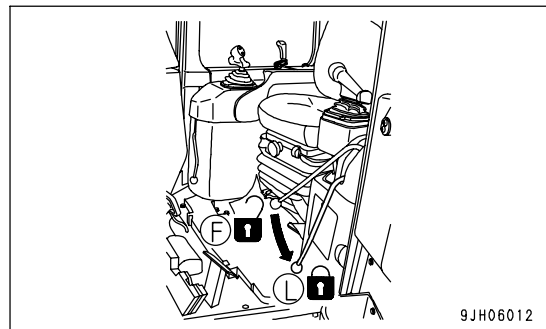

3. Stop the engine.

NOTICE

- Use protectors to prevent the wire rope from being cut on sharp corners and to prevent the wire rope from cutting into the machine bodywork.
 - When using a spreader bar, select an ample width to prevent contact with the machine.
4. Install wire ropes, slings, etc. matched to the weight of the machine to the lifting points as shown in the diagram on the right.
 5. After setting the wire ropes, lift up the machine and stop at 100 to 200 mm (3.9 to 7.9 in) above the ground, and check that the wire ropes are not slack and the machine is level, then lift up slowly.

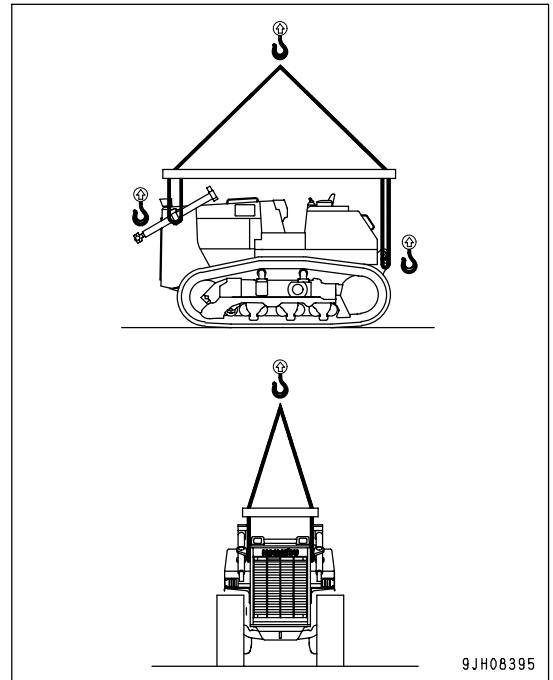

PRECAUTIONS FOR TRANSPORTATION

 **WARNING**

Determine the route for transporting the machine by taking into account the width, height and weight of the machine.

Obey all state and local laws governing the weight, width and length of a load. Observe all regulations governing wide loads.

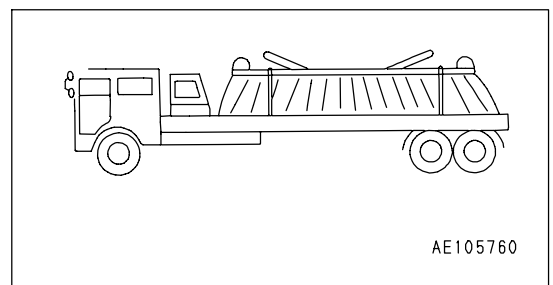
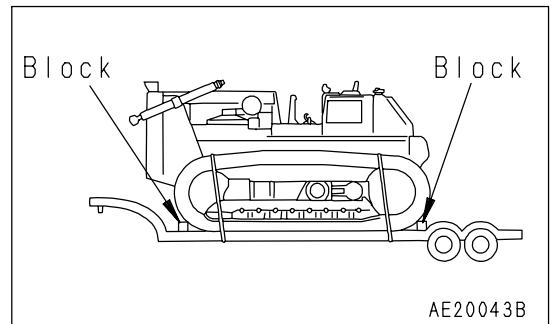

TRAVELING ON ROADS

- When traveling on paved roads, use flat shoes to protect their surface. Even when travelling a short distance, always place boards to protect the road surface.

REMARK

Note that the asphalt road becomes soft in summer.

REMOVAL OF CAB

(Machine equipped with cab)

If it is necessary to remove the cab for transporting, disconnect the washer hoses, cab power source, and washer motor wiring from the socket before removing the cab.

1. Remove the cab wiring harness connector and washer hose.
 - 1) Pull the grommet portion in towards the cab from the hole in the machine cover, then remove.
 - 2) Disconnect 4 washer hoses and the wiring (single wires x 2, 4-pin plug x 1) from the socket.

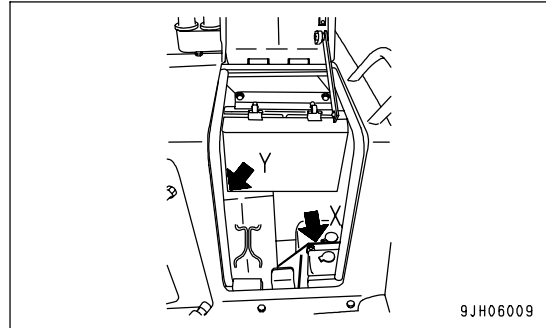

- After removing, cover the washer hoses with a vinyl bag to prevent any dirt or dust from entering.
- Before removing the cab, measure the clearance between the cab and each lever (joystick and blade control lever, etc.). Note the measurements to use as a standard when installing the cab again.

(1)	Washer tube	Red-Right door Blue-Left door Black-Rear window Colorless-Front window
(2)	Power source of cab	5R-ACC power source of cab 2R-Back up power source
(3)	4-pin socket	For washer motor

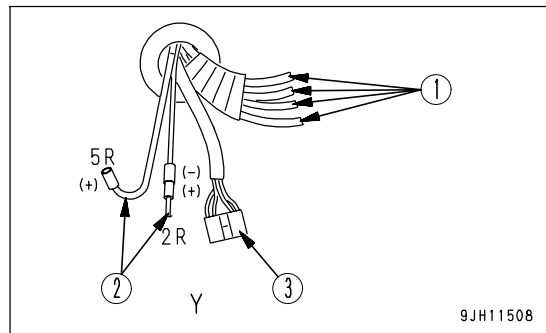

2. Removing covers inside cab

- 1) Use a screwdriver to push tab (A) in from the side and remove louver (1).
- 2) Remove ashtray assembly (2).
Remove the connector for the cigarette lighter power supply.
- 3) Remove rubber sheet (3), and pull it out as it is.
- 4) Remove the clip, then remove decoration (4).
- 5) Remove decoration lower plate (5).
- 6) Remove front cover (6).
Remove connector (11) of sunlight sensor (10) also.
- 7) Remove entrance cover (7).
- 8) Remove high mount foot rest (8).
- 9) Remove cover (9).

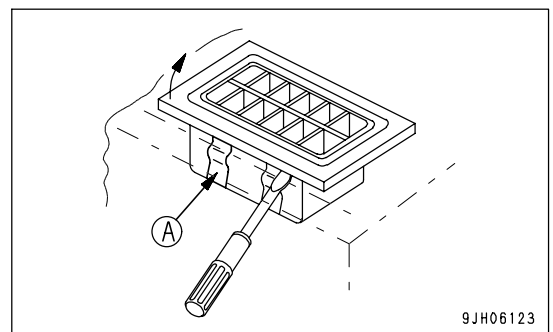
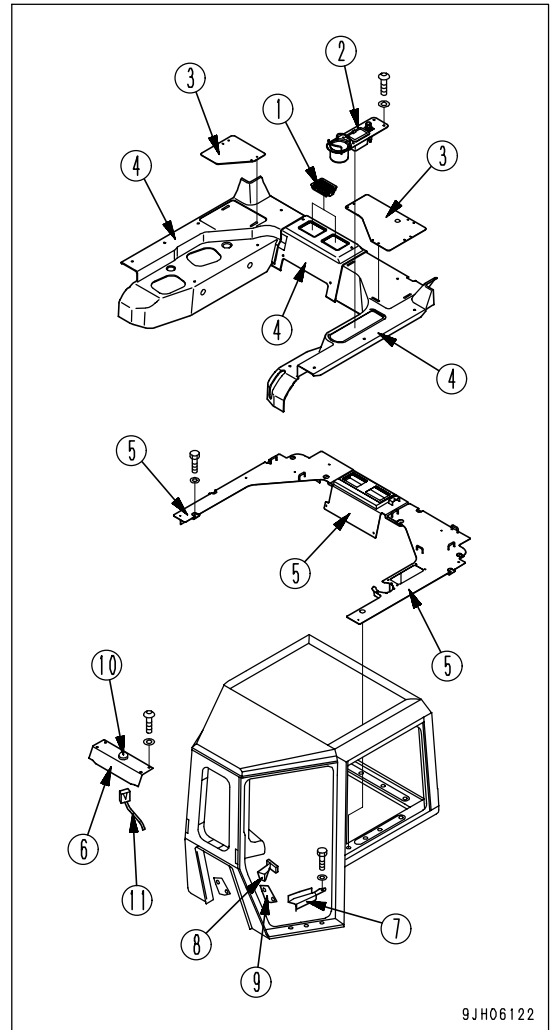

3. Remove the cab mount bolts.
Remove the bolts marked (A) - (U) shown on the right.

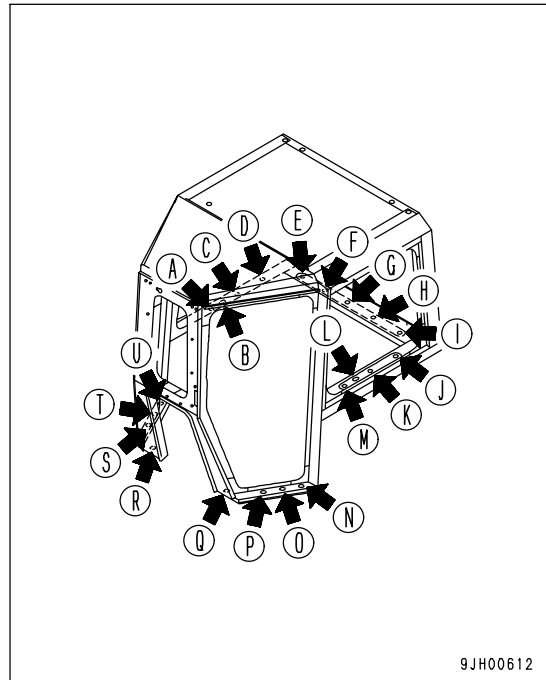

4. Raise the cab and lower it.
After inserting eyebolts into the roof, fit to the lifting hook, then lift up and lower.

Weight of cab: Approx. 470 kg (1,036 lb)
(MSHA glass specification machine: Approx. 530 kg (1,169 lb))

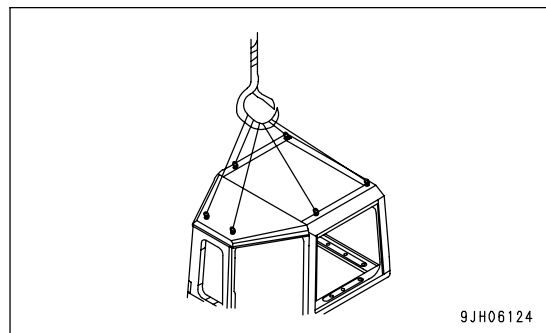

INSTALLATION OF CAB

1. Replacing cab seals

- 1) Raise the cab to replace the seal at the mating surface of the operator's cab assembly.
 - Weight of cab: Approx. 470 kg (1,036 lb)
(MSHA glass specification machine: Approx. 530 kg (1,169 lb))
- 2) Remove all the old seal with a scraper.
- 3) Remove any dirt or oil from the mounting surface of seal (A).
- 4) Remove the paper backing from the new seal, then stick it in the same position as the old seal.
The new seal is longer the necessary, so cut off the excess portion.

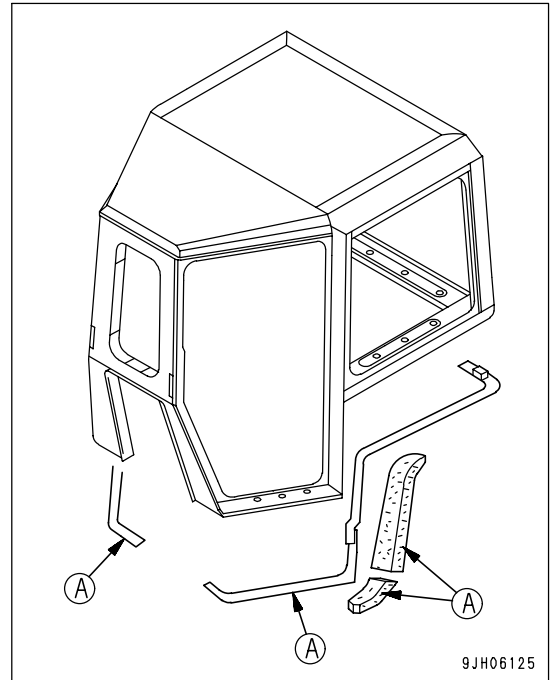

2. Replacing dashboard seal

- 1) Remove the old seal and replace it with a new seal.
- 2) Coat the outside of the seal with grease (G2-Li).
(This is to make sliding easier and prevent deformation of the seal when the cab is installed.)

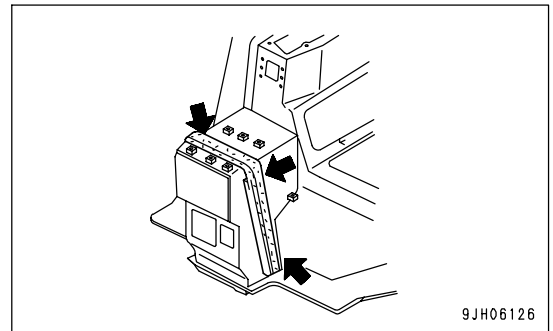

3. Reinstalling cab

Install the cab parts in the opposite order to removal.
Connect all parts that were disconnected.

- 1) Lower the cab slowly on top of the floor frame.
- 2) Align the cab with the floor frame, then install bolts and washers in holes (A) - (U).
Do not completely tighten the bolts. Screw them in 3 or 4 turns.
- 3) Tighten the bolts in holes (N) - (U) fully.
Tighten in the order (N), (U), (Q), (R), (O), (T), (P), (S).
- 4) Tighten bolts (A) to (M) completely.
- 5) connect the cab wiring harness connector and washer hoses in reverse order of removal.
- 6) Install covers inside the cab in reverse order of removal.

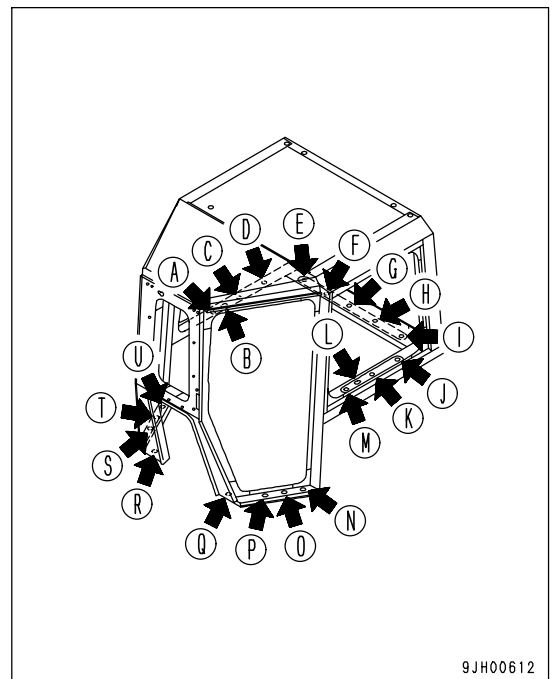

INSTALLATION OF ROPS

Tighten the bolts securely to the following torque.

- All 16 bolts: 1960 to 2450 Nm (200 to 250 kgm, 1447 to 1808 lbft)

COLD WEATHER OPERATION

PRECAUTIONS FOR LOW TEMPERATURE

If the temperature becomes low, it becomes difficult to start the engine, and the coolant may freeze, so do as follows.

FUEL AND LUBRICANTS

Change to oil with low viscosity for all components. For details of the specified viscosity, see "RECOMMENDED FUEL, COOLANT, AND LUBRICANT (PAGE 4-12)".

COOLANT



WARNING

- Antifreeze is toxic. Be careful not to get it into your eyes or on your skin. If it should get into your eyes or on your skin, wash it off with large amounts of fresh water and see a doctor at once.
- When changing the coolant or when handling coolant containing antifreeze that has been drained when repairing the radiator, please contact your Komatsu distributor or request a specialist company to carry out the operation. Antifreeze is toxic. Do not let it flow into drainage ditches or spray it onto the ground surface.
- Antifreeze is flammable. Do not bring any flame close. Do not smoke when handling antifreeze.

NOTICE

- Use Komatsu Supercoolant (AF-NAC) wherever available, or use permanent type antifreeze coolant.
- Never use methanol, ethanol, or propanol-based antifreeze.
- Do not use any water leakage prevention agent, either alone, or in combination with antifreeze.
- Do not mix one brand of antifreeze with a different brand.
- When using Komatsu super coolant (AF-NAC), there is no need to use a corrosion resistor. For details, see "CLEAN INSIDE OF COOLING SYSTEM (PAGE 4-22)".

For details of the antifreeze mixture when changing the coolant, see "CLEAN INSIDE OF COOLING SYSTEM (PAGE 4-22)".

BATTERY

 **WARNING**

- The battery generates flammable gas. Do not bring fire or sparks near the battery.
- Battery electrolyte is dangerous. If it gets in your eyes or on your skin, wash it off with a large amount of water and consult a doctor.
- Battery electrolyte dissolves paint. If it gets on the bodywork, wash it off immediately with water.
- If the battery electrolyte is frozen, do not charge the battery or start the engine with a different power source. There is danger that the battery may explode.
- Battery electrolyte is toxic. Do not let it flow into drainage ditches or spray it on to the ground surface.

When the ambient temperature drops, the capacity of the battery will also drop. If the battery charge ratio is low, the battery electrolyte may freeze. Maintain the battery charge as close as possible to 100%. Insulate it against cold temperature to ensure the machine can be started easily the next morning.

REMARK

Measure the specific gravity and calculate the charging rate from the following conversion table.

Charging Rate (%)	Electrolyte Temperature	20°C (68°F)	0°C (32°F)	-10°C (14°F)	-20°C (-4°F)
	100		1.28	1.29	1.30
90		1.26	1.27	1.28	1.29
80		1.24	1.25	1.26	1.27
75		1.23	1.24	1.25	1.26

- As the battery capacity drastically drops in low temperatures, cover or remove the battery from the machine, store the battery in a warm place, and install it again the next morning.
- If the electrolyte level is low, add distilled water in the morning before beginning work. Do not add water after the day's work to prevent diluted electrolyte in the battery from freezing during the night.

AFTER COMPLETION OF WORK



WARNING

Performing idle-running of the tracks is dangerous, stay well away from the tracks.

To prevent mud, water, or the undercarriage from freezing and making it impossible for the machine to move on the following morning, observe the following precautions.

- Remove all the mud and water from the machine body. In particular, wipe the hydraulic cylinder rods clean to prevent damage to the seal caused by mud, dirt, or drops of water on the rod from getting inside the seal.
- Park the machine on hard, dry ground.

If this is impossible, park the machine on boards.

The boards prevent the tracks from freezing to the ground, and allow the machine to be moved the next morning.

- Open the drain valve and drain any water collected in the fuel system to prevent it from freezing.
- Fill the fuel tank to capacity. This minimizes moisture condensation in the tank when the temperature drops.
- After operation in water or mud, remove water from undercarriage as described below to extend undercarriage service life.

AFTER COLD WEATHER

When the season changes and the weather becomes warmer, do as follows.

- Replace the fuel and oil for all parts with oil of the viscosity specified.
For details, see "RECOMMENDED FUEL, COOLANT, AND LUBRICANT (PAGE 4-12)".
- If for any reason permanent antifreeze cannot be used, and an ethylene glycol base antifreeze (winter, one season type) is used instead, or if no antifreeze is used, drain the cooling system completely. Thoroughly flush out the cooling system and fill it with fresh coolant.
- When it is unnecessary to use the automatic starting aid (APS) (When the ambient temperature is above 15°C (59°F)), Always keep the fuel valve closed.

LONG-TERM STORAGE

BEFORE STORAGE

When putting the machine in storage for a long time (more than one month), do as follows.

- Clean and wash all parts, then store the machine indoors. If the machine has to be stored outdoors, select level ground and cover the machine with canvas.
- Completely fill the fuel tank. This prevents moisture from collecting.
- Lubricate and change the oil before storage.
- Coat the exposed portion of the hydraulic cylinder piston rod with grease.
- Disconnect the negative terminals of the battery and cover it, or remove it from the machine and store it separately.
- Place all control levers at the neutral position, set the work equipment lock lever and parking brake lever to the lock position, and set the fuel control dial to the low idling position.

DURING STORAGE



WARNING

If it is necessary to perform the rust-prevention operation while the machine is indoors, open the doors and windows to improve ventilation and prevent gas poisoning.

- During storage, operate and move the machine for a short distance once a month so that a new film of oil will coat moving parts. At the same time, also charge the battery.
- When operating the work equipment, wipe off all the grease from the hydraulic cylinder rods.
- If the machine is equipped with an air conditioner, operate the air conditioner for 3 to 5 minutes once a month to lubricate all parts of the air conditioner compressor. Always run the engine at low idle when doing this. In addition, check the refrigerant level twice a year.

AFTER STORAGE

NOTICE

If the machine has been stored without carrying out the monthly rust-prevention operation, consult your Komatsu distributor before using it.

When using the machine after long-term storage, do as follows before using it.

- Wipe off the grease from the hydraulic cylinder rods.
- Add oil and grease at all lubrication points.
- When the machine is stored for a long period, moisture in the air will mix with the oil. Check the oil before and after starting the engine. If there is water in the oil, change all the oil.

STARTING MACHINE AFTER LONG-TERM STORAGE

When starting the engine after the machine has been in storage for a long period, carry out the warming-up operation thoroughly. For details, see the procedure in "WARMING UP OPERATIONS (PAGE 3-115)".

TROUBLESHOOTING

AFTER RUNNING OUT OF FUEL

When starting after running out of fuel, fill the filter cartridge with fuel and bleed the air from the fuel system before starting.

PROCEDURE FOR BLEEDING AIR



WARNING

When air bleed plug at the top of the fuel filter head or supply pump air breather are removed, the system is still under pressure, so fuel may spurt out. Loosen these parts slowly before opening them.

1. Remove the fuel filter cartridge, fill the filter case with fuel, then install again.

NOTICE

- If no clean fuel is available, bleed the air with priming pump (3) without removing the fuel cartridge.

NOTICE

- When filling with fuel, use clean fuel and be careful not to let any dust or dirt get in. Portion (B) at the center is the clean side, so be particularly careful not to let any dust or dirt get in.
- When adding fuel, always add from small hole (A) at eight places on the dirty side.

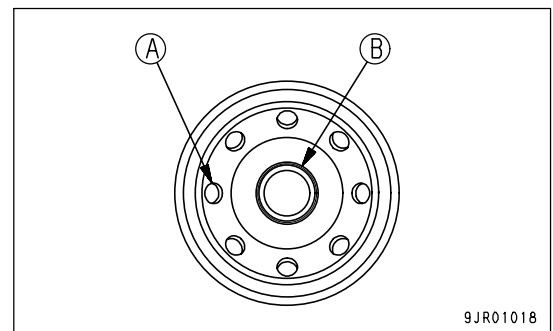

9JR01018

2. Loosen air bleed plug (2) at the top of the fuel filter head and open fuel supply valve (1) at the bottom of the fuel tank.
 3. Loosen the knob of priming pump (3), pump the knob, and check that fuel comes out from air bleed plug (2). After checking, tighten the plug.
- Tightening torque: 7.8 to 9.8 Nm (0.8 to 1 kgm, 5.8 to 7.2 lbft)

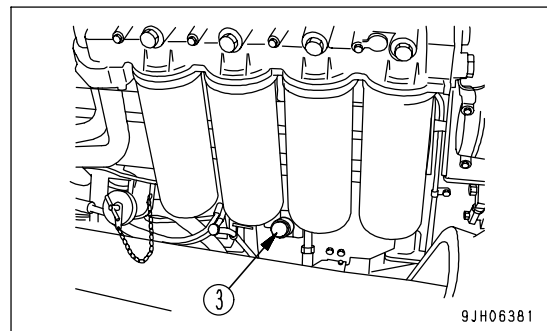
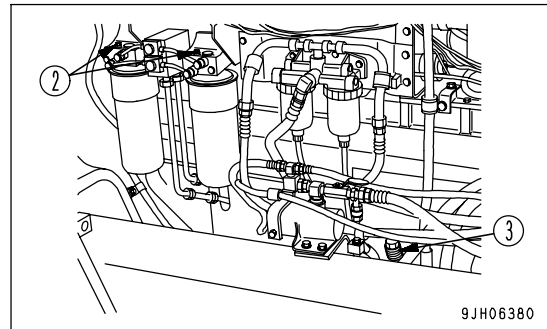
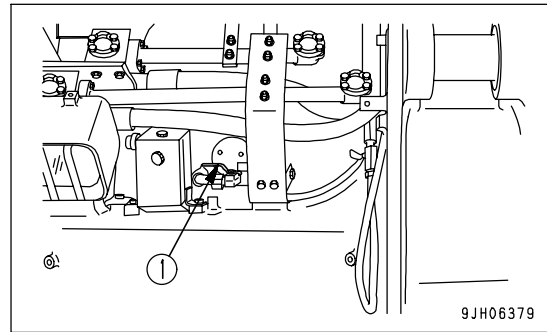

4. Push the knob of priming pump (3) in and tighten it.
5. If the air is not bled properly, return to Step 3 and bleed the air again.
6. For normal starting operations, turn key in the starting switch to the START position to start the engine.

METHOD OF TOWING MACHINE

WARNING

Serious injury or death could result if a disabled machine is towed incorrectly or if there is a mistake in the selection or inspection of the wire rope.

- Always check that the wire rope used for towing has ample strength for the weight of the machine being towed.
- Never use a wire rope which has cut strands (A), reduced diameter (B), or kinks (C). There is danger that the rope may break during the towing operation.
- Always wear leather gloves when handling wire rope.
- Never tow a machine on a slope.
- During the towing operation, never stand between the towing machine and the machine being towed.
- Operate the machine slowly and be careful not to apply any sudden load to the wire rope.

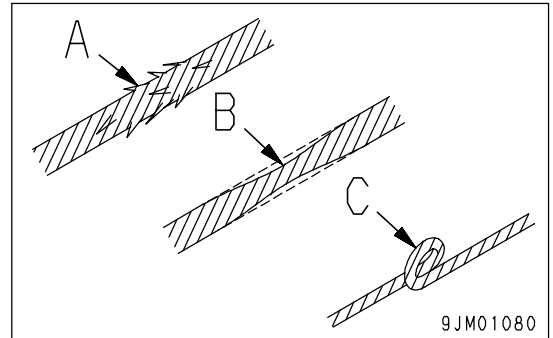

NOTICE

The max. allowable drawbar pull of this machine is 755,110 N (77,000 kg). Do not attempt to pull anything beyond this limit.

- If the machine is stuck in mud and cannot escape under its own power, or when towing a heavy object, fit wire to the towing hook as shown in the diagram on the right, or if the machine is equipped with a counterweight, fit the wire to the towing hook on the counterweight and tow the machine.
- When towing a machine, travel at a speed of less than 1 km/h for a distance of only a few meters to a place that is suitable for carrying out repairs.

This is for use only in emergencies.

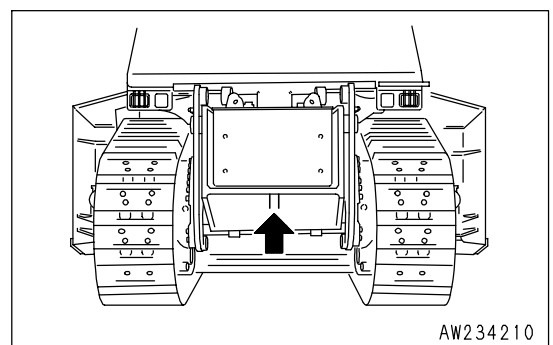
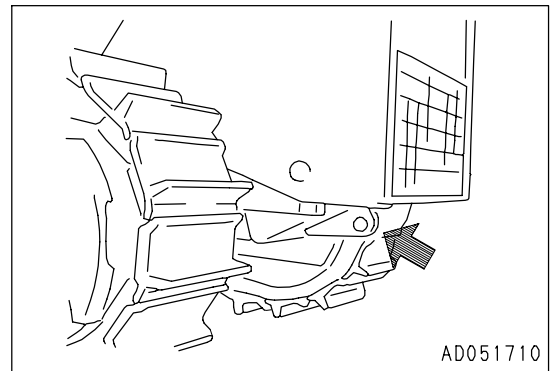

IF BATTERY IS DISCHARGED



WARNING

- It is dangerous to charge a battery when mounted on a machine. Make sure that it is dismantled before charging.
- When checking or handling the battery, stop the engine and turn the starting switch key to the OFF position.
- The battery generates hydrogen gas, so there is a hazard of explosion. Do not bring lighted cigarettes near the battery, or do anything that will cause sparks.
- Battery electrolyte is dilute sulfuric acid, and it will attack your clothes and skin. If it gets on your clothes or on your skin, immediately wash it off with a large amount of water. If it gets in your eyes, wash it out with fresh water and consult a doctor.
- When handling batteries, always wear safety glasses and rubber gloves.
- When removing the battery, first disconnect the cable from the ground (normally the negative (-) terminal). When installing, install the positive (+) terminal first.
If a tool touches the positive terminal and the chassis, there is danger that it will cause a spark, so be extremely careful.
- If the terminals are loose, there is danger that the defective contact may generate sparks that will cause an explosion.
- When removing or installing the terminals, check which is the positive (+) terminal and which is the negative (-) terminal.

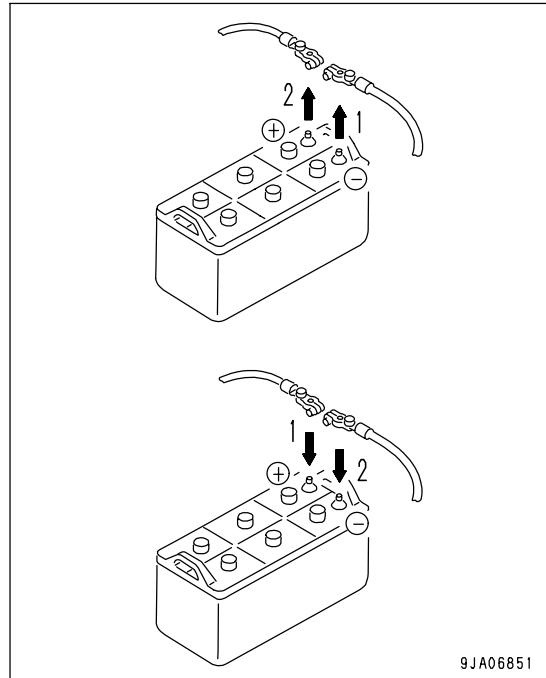

9JA06851

REMOVAL AND INSTALLATION OF BATTERY

- Before removing the battery, remove the ground cable (normally connected to the negative (-) terminal).
If any tool touches between the positive terminal and the chassis, there is a hazard of sparks being generated.
- When installing the battery, connect the ground cable last.
- When replacing the battery, secure it with battery hold-down.
Tightening torque: Tightening battery terminal: 9.8 to 14.7 Nm (1 to 1.5 kgm, 7.2 to 10.8 lbf)

REMOVAL, INSTALLATION OF BATTERY CABLE

1. Open battery cover (1).

There are batteries at 2 places (left and right).

2. Before removing the battery, remove the ground cable (normally connected to the negative (-) terminal). If any tool touches between the positive terminal and the chassis, there is danger of sparks being generated. Loosen the nut of the terminal and remove the wires from the battery.
3. When installing the battery, connect the ground cable last.
Insert the hole of the terminal on the battery and tighten the nut.
Tightening torque: 9.8 to 19.6 Nm (1 to 2 kgm, 7.2 to 14.5 lbf)
4. Close battery cover (1).

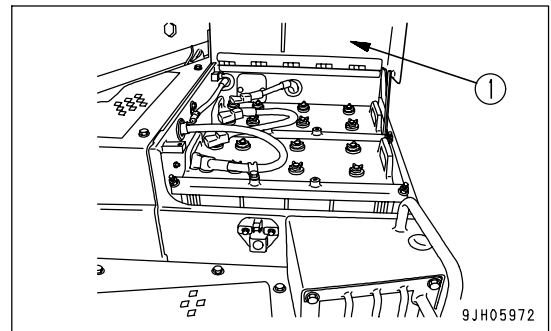
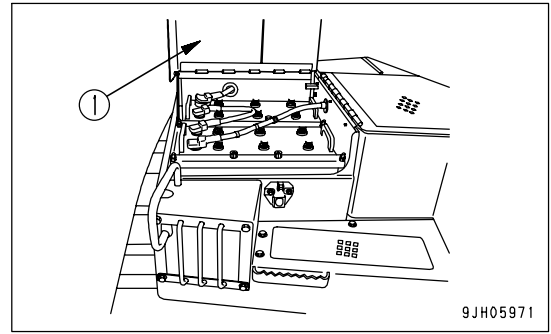
**PRECAUTIONS WHEN CHARGING BATTERY**

When charging the battery, if the battery is not handled correctly, there is danger that the battery may explode. Always follow the instructions in "IF BATTERY IS DISCHARGED (PAGE 3-174)" and the instruction manual accompanying the charger, and do as follows.

- Set the voltage of the charger to match the voltage of the battery to be charged. If the correct voltage is not selected, the charger may overheat and cause an explosion.
- Connect the positive (+) charger clip of the charger to the positive (+) terminal of the battery, then connect the negative (-) charger clip of the charger to the negative (-) terminal of the battery. Be sure to attach the clips securely.
- Set the charging current to 1/10 of the value of the rated battery capacity; when carrying out rapid charging, set it to less than the rated battery capacity.
If the charger current is too high, the electrolyte will leak or dry up, and this may cause the battery to catch fire and explode.
- If the battery electrolyte is frozen, do not charge the battery or start the engine with a different power source. There is a danger that this will ignite the battery electrolyte and cause the battery to explode.
- Do not use or charge the battery if the battery electrolyte level is below the LOWER LEVEL line. This may cause an explosion. Check the battery electrolyte level periodically and add distilled water to bring the electrolyte level to the UPPER LEVEL line.

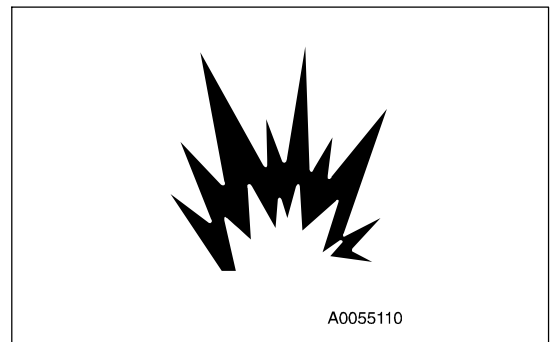

STARTING ENGINE WITH BOOSTER CABLE

When starting the engine with a booster cable, do as follows.

PRECAUTIONS WHEN CONNECTING AND DISCONNECTING BOOSTER CABLE



WARNING

- When connecting the cables, never contact the positive (+) and negative (-) terminals.
- When starting the engine with a booster cable, wear safety glasses and rubber gloves.
- Be careful not to let the normal machine and problem machine contact each other. This prevents sparks from generating near the battery which could ignite the hydrogen gas given off by the battery.
- Make sure that there is no mistake in the booster cable connections. The final connection is to the engine block of the problem machine, but sparks will be generated when this is done, so connect to a place as far as possible from the battery.
- When disconnecting the booster cable, take care not to bring the clips in contact with each other or with the machine body.

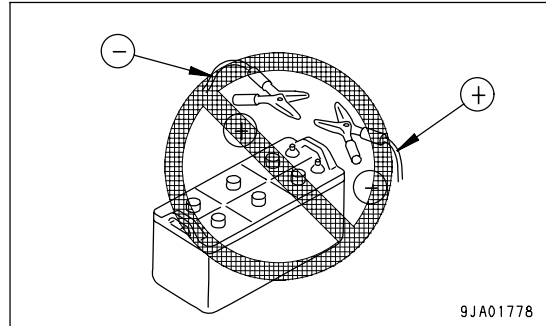

NOTICE

- The starting system for this machine uses 24V. For the normal machine, also use a 24V battery.
- The size of the booster cable and clip should be suitable for the battery size.
- The battery of the normal machine must be the same capacity as that of the engine to be started.
- Check the cables and clips for damage or corrosion.
- Make sure that the cables and clips are firmly connected.
- Check that the lock levers and parking brake levers of both machine are in the LOCK position.
- Check that each lever is in the NEUTRAL position.

CONNECTING THE BOOSTER CABLES

Keep the starting switch of the normal machine and problem machine in the OFF position.

Connect the booster cable as follows, in the order of the numbers marked in the diagram.

1. Connect the clip of booster cable (A) to the positive (+) terminal of battery (C) on the problem machine.
2. Connect the clip at the other end of booster cable (A) to the positive (+) terminal of battery (D) on the normal machine.
3. Connect the clip of booster cable (B) to the negative (-) terminal of battery (D) on the normal machine.
4. Connect the clip at the other end of booster cable (B) to engine block (E) on the problem machine.

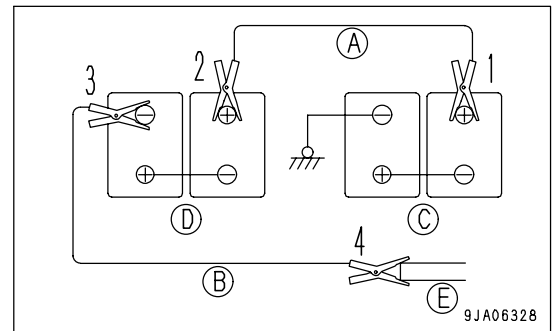

STARTING THE ENGINE



WARNING

Always check that the work equipment lock lever and Parking brake lever is set to the LOCK position, regardless of whether the machine is working normally or has failed. Check also that all the control levers are in the HOLD or NEUTRAL position.

1. Make sure the clips are firmly connected to the battery terminals.
2. Start engine of the normal machine and run it at high idle speed.
3. Turn the starting switch of the problem machine to the START position and start the engine.
If the engine doesn't start at first, try again after 2 minutes or so.

DISCONNECTING THE BOOSTER CABLES

After the engine has started, disconnect the booster cables in the reverse of the order in which they were connected.

1. Remove the clip of booster cable (B) from engine block (E) on the problem machine.
2. Remove the clip of booster cable (B) from the negative (-) terminal of battery (D) on the normal machine.
3. Remove the clip of booster cable (A) from the positive (+) terminal of battery (D) on the normal machine.
4. Remove the clip of booster cable (A) from the positive (+) terminal of battery (C) on the problem machine.

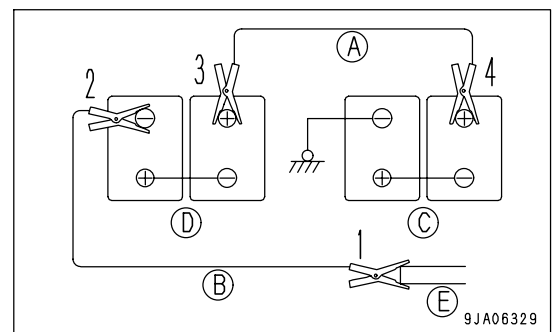

OTHER TROUBLE

ELECTRICAL SYSTEM

- (): Always contact your Komatsu distributor when dealing with these items.
- In cases of problems or causes which are not listed below, contact your Komatsu distributor for repairs.

Problem	Main cause	Remedy
Lamp does not glow brightly even when the engine runs at high speed	• Defective wiring	(• Check, repair loose terminals, disconnections Check fuses and diodes in fuse box)
Lamp flickers while engine is running	• Defective adjustment of fan belt tension	• Adjust fan belt tension For details, see EVERY 250 HOURS SERVICE
Charge lamp does not go out even when engine is running	• Defective alternator • Defective wiring	(• Replace) (• Check, repair Check fuse, diode in fuse box)
Abnormal noise is generated from alternator	• Defective alternator	(• Replace)
Starting motor does not crank when starting switch is turned ON	• Defective wiring • Insufficient battery charge	(• Check, repair) • Charge
Pinion of starting motor keeps going in and out	• Insufficient battery charge	• Charge
Starting motor turns engine sluggishly	• Insufficient battery charge • Defective starting motor	• Charge (• Replace)
Starting motor disengages before engine starts	• Defective wiring • Insufficient battery charge	(• Check, repair) • Charge
Engine pre-heating monitor lamp does not light up (When the temperature of the engine coolant exceed 20°C (68°F), this condition is normal)	• Defective wiring • Defective timer • Defective monitor • Disconnection in glow plug	(• Check, repair) (• Replace) (• Replace) (• Replace)
Air conditioner operation is defective	• Blown fuse • Insufficient battery charge • Defective air conditioner switch • Defective blower switch • Defective compressor	(• Check, repair) • Charge (• Replace air conditioner switch) (• Replace blower switch) (• Replace)
Blade does not pitch when pitch operation is carried out (dual tilt specification machine only)	• Defective wiring • Defective switch • Defective solenoid valve	(• Check, repair) (• Replace) (• Replace)

MONITOR PANEL

When an error code appears on the display panel B (multi-information), take appropriate remedies based upon the table below.

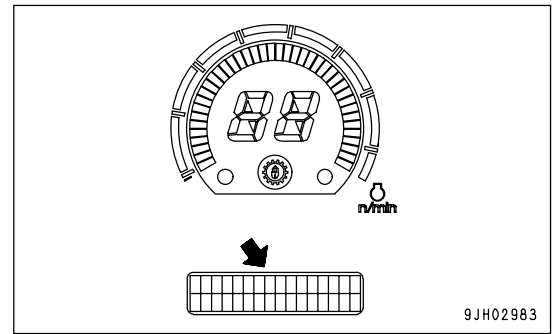

Abnormality code	Abnormality	Method of displaying abnormality	Remedy
E01	<ul style="list-style-type: none"> • Lock up torque converter does not come ON • Dual tilt does not work 	Abnormality code and service hour are displayed in turn on service meter portion	The automatic functions stop and some functions stop, but it is still possible to carry out operations. Please contact your Komatsu distributor immediately for repairs.
E02	<ul style="list-style-type: none"> • Tilt limit does not work • Does not shift up or shift down • Pitch does not work 	Abnormality code and service hour are displayed in turn on service meter portion, caution lamp flashes, buzzer sounds	If user stops engine and then starts again, operations are possible without limit functions. However, user must be careful. Please contact your Komatsu distributor immediately for repairs.
E03+CALL	<ul style="list-style-type: none"> • Number of speed ranges that can be used is limited • Engine does not run at full speed • Excessive shock when shifting gear • Turning ability becomes poor • Excessive braking shock • Abnormal engine coolant temperature sensor 	Abnormality code and service hour are displayed in turn on service meter portion, caution lamp flashes, buzzer sounds	Move machine to a safe place, then contact your Komatsu distributor immediately for repairs.
E04+CALL	<ul style="list-style-type: none"> • Engine control impossible • Travel impossible • Machine does not stop 	Abnormality code and service hour are displayed in turn on service meter portion, caution lamp flashes, buzzer sounds	Stop machine, then contact your Komatsu distributor immediately for repairs.

CHASSIS

- (): Always contact your Komatsu distributor when dealing with these items.
- In cases of problems or causes which are not listed below, contact your Komatsu distributor for repairs.

Problem	Main causes	Remedy
Torque converter oil pressure does not rise	<ul style="list-style-type: none"> • Improper tightening of oil pipe or pipe joint, air leaking in because of damage, oil leakage • Wear, gouging of gear pump • Lack of oil in transmission case • Clogged oil filter element strainer in transmission case 	<ul style="list-style-type: none"> • Inspect, repair (• Check, replace) • Add oil to specified level. See Checks before starting • Clean. See EVERY 500 HOURS SERVICE
Torque converter overheats	<ul style="list-style-type: none"> • Clogged radiator • Engine coolant temperature too high • Clogged oil cooler • Oil pressure too low • Low circulation of oil due to worn gear pump 	<ul style="list-style-type: none"> • Clean, wash radiator core • See Engine Related (• Clean or replace) • See Torque converter oil pressure does not rise (• Replace gear pump)
Torque converter oil temperature gauge does not work	<ul style="list-style-type: none"> • Defective oil temperature gauge • Defective connection of wiring 	<ul style="list-style-type: none"> (• Replace oil temperature gauge) (• Check, repair)
Lacks drawbar pull	<ul style="list-style-type: none"> • Lack of engine horsepower • Torque converter oil pressure too low • Steering clutch slipping 	<ul style="list-style-type: none"> • See Engine Related • See Torque converter oil pressure does not rise (• Inspect, repair)
Machine does not move when steering, directional, speed lever is placed in FORWARD	<ul style="list-style-type: none"> • Lack of oil in the steering clutch case • Oil pressure in transmission does not rise • Steering clutch slipping • Wear, gouging of gear pump • Clogged oil strainer element in steering clutch case • Defective wiring of steering, directional, speed lever • Parking brake is at LOCK 	<ul style="list-style-type: none"> • Add oil to specified level. See Checks before starting • See Torque converter oil pressure does not rise (• Check, repair) • Clean. See EVERY 1000 HOURS SERVICE • Check wiring • Set parking brake to FREE position
Machine does not turn when steering is operated	<ul style="list-style-type: none"> • Defective wiring of steering, directional, speed lever 	<ul style="list-style-type: none"> (• Check wiring)
Machine does not stop when brake pedal is depressed	<ul style="list-style-type: none"> • Defective brake adjustment • Defective brake pedal wiring 	<ul style="list-style-type: none"> (• Adjust linkage, adjust brake pressure) (• Check wiring)

Problem	Main causes	Remedy
Track comes off	<ul style="list-style-type: none"> • Track shoe assembly too loose 	<ul style="list-style-type: none"> • Adjust track tension. See WHEN REQUIRED
Abnormal wear of sprocket	<ul style="list-style-type: none"> • Track shoe assembly too loose or too tight 	<ul style="list-style-type: none"> • Adjust track tension. See WHEN REQUIRED
Blade lifting speed is slow or does not rise (or blade tilting speed is slow)	<ul style="list-style-type: none"> • Lack of hydraulic oil • Defective hydraulic switch • Work equipment lock lever is at LOCK position 	<ul style="list-style-type: none"> • Add oil to specified level. See EVERY 250 HOURS SERVICE • Replace • Set lock lever to FREE position
Ripper movement is slow	<ul style="list-style-type: none"> • Lack of hydraulic oil • Work equipment lock lever is at LOCK position 	<ul style="list-style-type: none"> • Add oil to specified level. See EVERY 250 HOURS SERVICE • Set lock lever to FREE position
Ripper lacks power	<ul style="list-style-type: none"> • Leakage of oil from piping 	(• Tighten piping)

ENGINE

- (): Always contact your Komatsu distributor when dealing with these items.
- In cases of problems or causes which are not listed below, contact your Komatsu distributor for repairs.

Problem	Main causes	Remedy
Engine oil pressure monitor flashes when engine speed is raised after completion of warm-up	<ul style="list-style-type: none"> • Engine oil pan oil level is low (sucking in air) • Clogged oil filter cartridge • Defective tightening of oil pipe joint, oil leakage from damaged part • Defective monitor panel 	<ul style="list-style-type: none"> • Add oil to specified level, see CHECK BEFORE STARTING • Replace cartridge, see EVERY 500 HOURS SERVICE (• Check, repair) (• Replace)
Steam is emitted from top part of radiator (pressure valve)	<ul style="list-style-type: none"> • Coolant level low, leakage • Dirt or scale accumulated in cooling system 	<ul style="list-style-type: none"> • Add coolant, repair, see CHECK BEFORE STARTING • Change coolant, clean inside of cooling system, see WHEN REQUIRED
Engine coolant temperature monitor flashes	<ul style="list-style-type: none"> • Clogged radiator fin or damaged fin • Defective thermostat • Loose radiator filler cap (high altitude operation) • Defective monitor panel 	<ul style="list-style-type: none"> • Clean or repair, see WHEN REQUIRED (• Replace thermostat) • Tighten cap or replace packing (• Replace)
Engine does not start when starting motor is turned	<ul style="list-style-type: none"> • Lack of fuel • Air in fuel system • No fuel in fuel filter • Starting motor cranks engine sluggishly • Defective valve clearance 	<ul style="list-style-type: none"> • Add fuel, see CHECK BEFORE STARTING • Repair place where air is sucked in (• Replace pump or nozzle) • See ELECTRICAL SYSTEM (• Adjust valve clearance)
Exhaust gas is white or blue	<ul style="list-style-type: none"> • Too much oil in oil pan • Improper fuel 	<ul style="list-style-type: none"> • Add oil to specified level, see CHECK BEFORE STARTING • Change to specified fuel
Exhaust gas occasionally turns black	<ul style="list-style-type: none"> • Clogged air cleaner element • Defective nozzle • Defective compression • Defective turbocharger 	<ul style="list-style-type: none"> • Clean or replace, see WHEN REQUIRED (• Replace nozzle) (• Adjust valve clearance) (• Clean or replace,turbocharger)
Combustion noise occasionally makes breathing sound	<ul style="list-style-type: none"> • Defective compression 	<ul style="list-style-type: none"> (• Replace nozzle)
Abnormal noise generated (combustion or mechanical)	<ul style="list-style-type: none"> • Low grade fuel being used • Overheating • Damage inside muffler • Excessive valve clearance 	<ul style="list-style-type: none"> • Change to specified fuel • See item "Engine coolant temperature monitor remains lit" (• Replace muffler) (• Adjust valve clearance)

WHEN MODE SELECTION SYSTEM FLASHES

If the caution lamp flashes, or it becomes impossible to control the engine speed with the fuel control dial or decelerator pedal, stop operation immediately, check the monitor panel display, then contact your Komatsu distributor for repairs.

In addition to the above problems, if any of the problems in the table below occur, there is probably an abnormality in the work equipment lever switch, transmission speed range sensor, or other part, so please contact your Komatsu distributor for repairs.

Mode	Operation	Problem
Shoe slip control	Ripping	<ul style="list-style-type: none"> • When shoes slip, power is not throttled down • No control is carried out when shoes slip • When slippage stops, it takes time for power to be restored • It becomes more difficult to break rocks by operating lever to TILT or RAISE • Travel speed becomes slower when shank penetrates ground • Travel speed is slow, lacks drawbar pull • No feeling of control, engine stays at full or partial speed • Machine jumps when starting ripping
Economy	Dozing	<ul style="list-style-type: none"> • Engine speed changes, difficult to carry out work • No feeling of control, engine stays at full or partial speed
Reverse slow	Reverse travel	<ul style="list-style-type: none"> • Ripper lifting speed is slow • Travel speed in Reverse Slow is fast
Lock-up	All operations	<ul style="list-style-type: none"> • Lock-up does not work • Excessive shock when shifting gear
-	Travel under own power	<ul style="list-style-type: none"> • Engine runs at partial speed when traveling under own power

MAINTENANCE

WARNING

Please read and make sure that you understand the SAFETY section before reading this section.

GUIDES TO MAINTENANCE

Do not perform any inspection and maintenance operation that is not found in this manual.

CHECK SERVICE METER:

Check the service meter reading every day to see if the time has come for any necessary maintenance to be performed.

KOMATSU GENUINE REPLACEMENT PARTS:

Use Komatsu genuine parts specified in the Parts Book as replacement parts.

KOMATSU GENUINE OILS:

For lubrication of the machine, use the Komatsu genuine lubricants. Moreover use oil of the specified viscosity according to the ambient temperature.

ALWAYS USE CLEAN WASHER FLUID:

Use automobile window washer fluid, and be careful not to let any dirt get into it.

CLEAN OIL AND GREASE:

Use clean oil and grease. Also, keep the containers of the oil and grease clean. Keep foreign materials away from oil and grease.

CHECK FOREIGN MATERIAL IN DRAINED OIL:

After oil is changed or filters are replaced, check the old oil and filters for metal particles and foreign materials. If large quantity of metal particles or foreign materials are found, always report to the person in charge, and carry out suitable action.

FUEL STRAINER:

If your machine is equipped with a fuel strainer, do not remove it while fueling.

WELDING INSTRUCTIONS:

- Cut off power. Wait for approx. one minute after turning off the engine starting switch key, and then disconnect the negative (-) terminal of the battery.
- Do not apply more than 200 V continuously.
- Connect grounding cable within 1 m (3.3 ft) of the area to be welded. If grounding cable is connected near instruments, connectors, etc., the instruments may malfunction.
- If a seal or bearing happens to come between the part being welded and grounding point, change the grounding point to avoid such parts.
- Do not use the area around the work equipment pins or the hydraulic cylinders as the grounding point.

OBJECTS IN YOUR POCKETS:

- When opening inspection windows or the oil filler port of the tank to carry out inspection, be careful not to drop nuts, bolts, or tools inside the machine.
If such things are dropped inside the machine, it may cause damage and/or malfunction of the machine, and will lead to failure. If you drop anything inside the machine, always remove it immediately.
- Do not put unnecessary things in your pockets. Carry only things which are necessary for inspection.

DUSTY WORKSITES:

When working at dusty worksites, do as follows:

- Clean the radiator fins and other parts of the heat exchange equipment more frequently, and take care not to let the fins become clogged.
- Replace the fuel filter more frequently.
- Clean electrical components, especially the starting motor and alternator, to avoid accumulation of dust.
- When checking and replacing the oil or filters, move the machine to a place where there is no dust and take care to prevent dust from entering the system.

AVOID MIXING OILS:

If a different brand or grade of oil has to be added, drain the old oil and replace all the oil with the new brand or grade of oil. Never mix different brand or grade of oil.

LOCKING INSPECTION COVERS:

Lock inspection cover securely into position with the lock bar. If inspection or maintenance is performed with inspection cover not locked in position, there is a danger that it may be suddenly blow shut by the wind and cause injury to the worker.

BLEEDING AIR:

When hydraulic equipment has been repaired or replaced, or the hydraulic piping has been removed and installed again, the air must be bled from the circuit. For details, see "BLEEDING AIR IN HYDRAULIC SYSTEM (PAGE 4-43)".

PRECAUTIONS WHEN INSTALLING HYDRAULIC HOSES:

- When removing parts at locations where there are O-rings or gasket seals, clean the mounting surface, and replace with new parts.
When doing this, be careful not to forget to assemble the O-rings and gaskets.
- When installing the hoses, do not twist them or bend them sharply. If they are installed so, their service life will be shortened extremely and they may be damaged.

CONTROLLER:

The controller for the machine monitor may be actuated mistakenly by radio wave interference from the outside, so when installing any radio control equipment to the machine, please consult your Komatsu distributor.

CHECKS AFTER INSPECTION AND MAINTENANCE:

If you forget to perform the checks after inspection and maintenance, unexpected problems may occur, and this may lead to serious injury or property damage. Always do the following:

- Checks after operation (with engine stopped)
 - Have any inspection and maintenance points been forgotten?
 - Have all inspection and maintenance items been performed correctly?
 - Have any tools or parts been dropped inside the machine? It is particularly dangerous if parts are dropped inside the machine and get caught in the lever linkage mechanism.
 - Are there any leakage of coolant or oil? Have all nuts and bolts been tightened?
- Checks when operating engine
 - For details of the checks when operating the engine, see "PROPER TOOLS (PAGE 2-29)" and pay careful attention to safety.
 - Are the inspection and maintenance items working properly?
 - Is there any leakage of fuel or oil when the engine speed is raised?

PRECAUTIONS WHEN OPENING AND CLOSING ENGINE SIDE COVER:

- When standing on track to open the engine side cover, adopt a standing position, hold the side cover with both thumbs, and open it slowly with your other fingers.

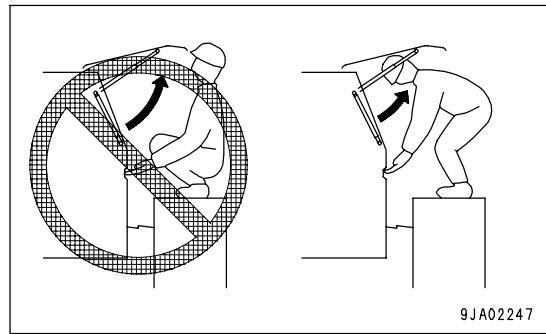

OUTLINES OF SERVICE

- Always use Komatsu genuine parts for replacement parts, grease or oil.
- When changing the oil or adding oil, do not mix different types of oil. When changing the type of oil, drain all the old oil and fill completely with the new oil. Always replace the filter at the same time. (There is no problem if the small amount of oil remaining in the piping mixes with the new oil.)
- Unless otherwise specified, when the machine is shipped from the factory, it is filled with the oil and coolant listed in the table below.

Item	Type
Engine oil pan	Engine oil EO15W40DH (Komatsu genuine parts)
Damper case	Powertrain oil TO30 (Komatsu genuine parts)
Power train oil pan	
Final drive case	
Hydraulic oil system	Powertrain oil TO10 (Komatsu genuine parts)
Radiator	Supercoolant AF-NAC (density: 30% or above) (Komatsu genuine parts)

HANDLING OIL, FUEL, COOLANT, AND PERFORMING OIL CLINIC

OIL

- Oil is used in the engine and hydraulic equipment under extremely severe conditions (high temperature, high pressure), and deteriorates with use.
Always use oil that matches the grade and maximum and minimum ambient temperatures recommended in the Operation and Maintenance Manual. Even if the oil is not dirty, always change the oil at the specified interval.
- Oil corresponds to blood in the human body, always be careful when handling it to prevent any impurities (water, metal particles, dirt, etc.) from getting in.
The majority of problems with the machine are caused by the entry of such impurities.
Take particular care not to let any impurities get in when storing or adding oil.
- Never mix oils of different grades or brands.
- Always add the specified amount of oil.
Having too much oil or too little oil are both causes of problems.
- If the oil in the work equipment is not clear, there is probably water or air getting into the circuit. In such cases, please contact your Komatsu distributor.
- When changing the oil, always replace the related filters at the same time.
- We recommend you have an analysis made of the oil periodically to check the condition of the machine. For those who wish to use this service, please contact your Komatsu distributor.
- When using commercially available oil, it may be necessary to reduce the oil change interval.
We recommend that you use the Komatsu oil clinic to carry out a detailed checks of the characteristics of the oil.

FUEL

- To prevent the moisture in the air from condensing and forming water inside the fuel tank, always fill the fuel tank after completing the day's work.
- The fuel pump is a precision instrument, and if fuel containing water or dirt is used, it cannot work properly.
- Be extremely careful not to let impurities get in when storing or adding fuel.
- Always use the fuel specified for the temperature in the Operation and Maintenance Manual.
 - If the fuel is used at temperatures lower than the specified temperature (particularly at temperatures below -15 °C (5°F), the fuel will solidify.
 - If the fuel is used at temperatures higher than the specified temperature, the viscosity will drop, and this may result in problems such as a drop in output.
- Before starting the engine, or when 10 minutes have passed after adding fuel, drain the sediment and water from the fuel tank.
- If the engine runs out of fuel, or if the filters have been replaced, it is necessary to bleed the air from the circuit.
- If there is any foreign material in the fuel tank, wash the tank and fuel system.

NOTICE

Always use diesel oil for the fuel.

To ensure good fuel consumption characteristics and exhaust gas characteristics, the engine mounted on this machine uses an electronically controlled high-pressure fuel injection device. This device requires high precision parts and lubrication, so if low viscosity fuel with low lubricating ability is used, the durability may drop markedly.

COOLANT AND WATER FOR DILUTION

- The coolant has the important function of preventing corrosion as well as preventing freezing. Even in the areas where freezing is not an issue, the use of antifreeze coolant is essential. Komatsu machines are supplied with Komatsu Supercoolant (AF-NAC). Komatsu Supercoolant (AF-NAC) has excellent anticorrosion, antifreeze and cooling properties and can be used continuously for 2 years or 4000 hours. Komatsu Supercoolant (AF-NAC) is strongly recommended wherever available.
- When using Komatsu super coolant (AF-NAC), there is no need to use a corrosion resistor. For details, see "CLEAN INSIDE OF COOLING SYSTEM (PAGE 4-22)".
- When diluting the antifreeze coolant, use distilled water or tap water (soft water). Natural water, such as a river water or well water (hard water), contains large amounts of minerals (calcium, magnesium, etc.), and this makes it easier for scale to form inside the engine or radiator. Once scale is deposited inside the engine or radiator, it is extremely difficult to remove. It also causes overheating due to poor heat exchange, so when you dilute the coolant, we recommend that you use water with an overall hardness of less than 100 PPM.
- When using antifreeze, always observe the precautions given in the Operation and Maintenance Manual.
- Antifreeze coolant is flammable, so be sure to keep it away from flame.
- The ratio of Supercoolant (AF-NAC) to water differs according to the ambient temperature. For details of the ratio when mixing, see "CLEAN INSIDE OF COOLING SYSTEM (PAGE 4-22)". Supercoolant (AF-NAC) may be supplied already mixed. In such cases, never dilute with water.
- If the engine overheats, wait for the engine to cool before adding coolant.
- If the coolant level is low, it will cause overheating, and will also cause problems with corrosion due to air entering the coolant.

GREASE

- Grease is used to prevent seizure and noises at the joints.
- This construction equipment is used under heavy-duty conditions. Always use the recommended grease and follow the change intervals and recommended ambient temperatures given in this Operation and Maintenance Manual.
- It is recommended to shorten the lubrication interval when the machine is operated under hard working conditions or in a dusty or wet jobsite.
- Grease fittings not listed in the inspection and maintenance section are grease fittings that are used at the time of overhaul, so there is no need to grease these points.

When using the machine after it has been in storage for a long time, carry out greasing if there is any stiffness or screeching.

- Always wipe off all of the old grease that is pushed out when greasing.
Be particularly careful to wipe off the old grease in places where sand or dirt sticking in the grease would cause wear of the rotating parts.

CARRYING OUT KOWA (Komatsu Oil Wear Analysis)

KOWA is a maintenance service that makes it possible to prevent machine failures and downtime. With KOWA, the oil is periodically sampled and analyzed. This enables early detection of wear of the machine drive parts and other problems.

We strongly recommend you to use this service. The oil analysis is carried out at actual cost, so the cost is low, and the results of the analysis are reported together with recommendations which will reduce repair costs and machine downtime.

KOWA ANALYSIS ITEMS

- Measurement of density of metal wear particles
This uses an ICP (Inductively Coupled Plasma) analyzer to measure the density of iron, copper, and other metal wear particles in the oil.

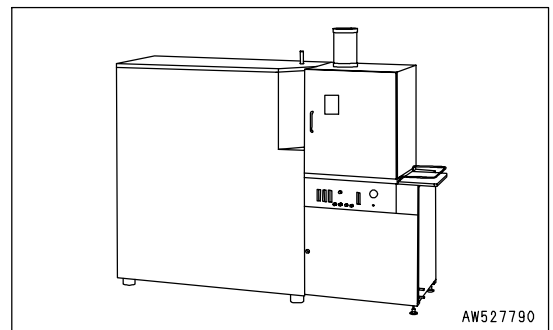

- Measurement of quantity of particles
This uses a PQI (Particle Quantifier Index) measurer to measure the quantity of iron particles of 5µm or more, enabling early detection of failures.

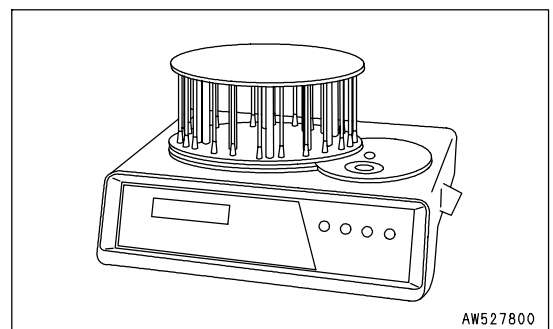

- Others
Measurements are made of items such as the ratio of water in the oil, density of the antifreeze coolant, ratio of fuel in the oil, and dynamic viscosity, enabling a highly precise diagnosis of the machine's health.

OIL SAMPLING

- Sampling interval
250 hours: Engine
500 hours: Other components
- Precautions when sampling
 - Make sure that the oil is well mixed before sampling.
 - Perform sampling at regular fixed intervals.
 - Do not perform sampling on rainy or windy days when water or dust can get into the oil.

For further details of KOWA, please contact your Komatsu distributor.

STORING OIL AND FUEL

- Keep indoors to prevent any water, dirt, or other impurities from getting in.
- When keeping drum cans for a long period, put the drum on its side so that the filler port of the drums is at the side to prevent moisture from being sucked in.
If drums have to be stored outside, cover them with a waterproof sheet or take other measures to protect them.
- To prevent any change in quality during long-term storage, be sure to use in the order of first in - first out (use the oldest oil or fuel first).

FILTERS

- Filters are extremely important safety parts. They prevent impurities in the fuel and air circuits from entering important equipment and causing problems.
Replace all filters periodically. For details, see the Operation and Maintenance Manual.
However, when working in severe conditions, replace the filters at shorter intervals according to the oil and fuel (sulfur content) being used.
- Never try to clean the filters (cartridge type) and use them again. Always replace with new filters.
- When replacing oil filters, check if any metal particles are attached to the old filter. If any metal particles are found, contact your Komatsu distributor.
- Do not open packs of spare filters until just before they are to be used.
- Use of Komatsu genuine filter elements is strongly recommended.

OUTLINE OF ELECTRIC SYSTEM

- It is extremely dangerous if the electrical equipment becomes wet or the covering of the wiring is damaged. This will cause an electrical short circuit and may lead to malfunction of the machine. Do not wash the inside of the operator's cab with water. When washing the machine, be careful not to let water get into the electrical components.
- Service relating to the electric system is checking fan belt tension, checking damage or wear to the fan belt and checking battery fluid level.
- Never install any electric components other than those specified by Komatsu.
- External electro-magnetic interference may cause malfunction of the control system controller, before installing a radio receiver or other wireless equipment, contact your Komatsu distributor.
- When working at the seashore, carefully clean the electric system to prevent corrosion.
- When installing electrical equipment, connect it to the special power source connector.
Do not connect the optional power source to the fuse, starting switch, or battery relay.

HANDLING HYDRAULIC RELATED EQUIPMENT

- During operations and after completion of operations, the hydraulic equipment is at a high temperature. During operations, it is also under high pressure, so when carrying out inspection and maintenance of hydraulic related equipment, be careful of the following points.
 - Stop the machine on flat ground, lower the work equipment completely to the ground, and carry out the operation so that there is no pressure on the cylinder circuits.
 - Always stop the engine.
 - Immediately after stopping operations, the hydraulic oil and lubricating oil is at high temperature and high pressure, so wait for the oil temperature to go down before starting maintenance.
Even after the temperature has gone down, some parts may still be under internal pressure, so when loosening plugs, bolts, or hose connections, do not stand directly in front of the parts, and loosen slowly to release the internal pressure before removing.
 - When carrying out inspection and maintenance of the hydraulic circuit, always release the air in the hydraulic tank to remove the internal pressure.
- Inspection and maintenance include checking the hydraulic system for oil level, replacement of filter elements and replacement of hydraulic oil.
- If high-pressure hoses have been removed, check that there is no damage to the O-rings. If any damage is found, replace the O-ring.
- When the hydraulic oil filter elements or strainers are cleaned or replaced, or when any hydraulic component has been repaired or replaced, or when a hydraulic piping has been disconnected, bleeding air from the hydraulic system is required.
- The accumulator is charged with high-pressure nitrogen gas, and it is extremely dangerous if it is handled incorrectly. For details of the method of handling, see "ACCUMULATOR, HANDLING (PAGE 3-83)".

WEAR PARTS

Replace wear parts such as the filter element or cutting edge at the time of periodic maintenance or before they reach the wear limit. The wear parts should be replaced correctly in order to ensure more economic use of the machine. When replacing parts, always use Komatsu genuine parts.

As a result of our continuous efforts to improve product quality, the part number may change, so inform your Komatsu distributor of the machine serial number and check for the latest part number when ordering parts.

WEAR PARTS LIST

The parts in parentheses are to be replaced at the same time.

Item	Part No.	Part name	Weight kg (lb)	Q'ty	Replacement interval	
Engine oil filter	600-211-1340	Cartridge	-	4	Ever 500 hours	
Transmission filter	07063-01142 (07000-E5165)	Element (O-ring)	- -	1 (1)		
Transmission lubricating filter	07063-01142 (07000-E5165)	Element (O-ring)	- -	1 (1)		
Torque converter filter	07063-01142 (07000-E5165)	Element (O-ring)	- -	1 (1)		
Fuel filter	600-311-7132	Cartridge	-	2		
Hydraulic tank breather element	20Y-06-21470	Element	-	1		
Main corrosion resistor	600-411-1171	Cartridge	-	2	Every 1000 hours	
Sub corrosion resistor	600-411-1151	Cartridge	-	1		
Hydraulic oil filter	208-60-71120 (07000-15210)	Element (O-ring)	- -	1 (2)	Every 2000 hours	
Air cleaner	600-185-6100	Element assembly	-	2		
	600-185-6110	Outer element	-	2		
	600-185-6120	Inner element	-	2		
Blade	Semi U-dozer	198-71-31540	Cutting edge	114.2(252)	2	-
		198-71-31550	Cutting edge	157.5(347)	3	
		(198-71-21850)	(Bolt)	-	(26)	
		(198-71-21890)	(Washer)	-	(26)	
		(198-71-21911)	(Nut)	-	(26)	
		198-71-31520	End bit (left)	148.0(326)	1	
		198-71-31530	End bit (right)	148.0(326)	1	
		(198-71-21870)	(Bolt)	-	(8)	
		(198-71-21860)	(Bolt)	-	(8)	
		(198-71-21880)	(Boss)	-	(8)	
	(198-71-21890)	(Washer)	-	(8)		
	(198-71-21911)	(Nut)	-	(16)		
	Full U-dozer	198-71-31540	Cutting edge	114.2	2	
		198-71-31550	Cutting edge	157.5	3	
		(198-71-21850)	(Bolt)	-	(34)	
		(198-71-21890)	(Washer)	-	(34)	
		(198-71-21911)	(Nut)	-	(34)	
		198-71-31520	End bit (left)	148.0	1	
		198-71-31530	End bit (right)	148.0	1	
		(198-71-21870)	(Bolt)	-	(8)	
(198-71-21860)		(Bolt)	-	(8)		
(198-71-21880)		(Boss)	-	(8)		
(198-71-21890)	(Washer)	-	(8)			
(198-71-21911)	(Nut)	-	(16)			

Item		Part No.	Part name	Weight kg (lb)	Q'ty	Replacement interval
Ripper	(Variable giant ripper)	198-78-21330	Protector	38.5(85)	1	-
		195-78-21340	Point	34.3(76)	1	
		(198-71-21410)	(Pin assembly)	-	(3)	
	(Variable multi ripper)	198-78-21330	Protector	38.5(85)	3	
		195-78-21340	Point	34.3(76)	3	
		(198-71-21410)	(Pin assembly)	-	(9)	

NOTICE

When handling parts that weigh more than 25 kg (55 lb), remember that they are heavy objects, and take the necessary care.

RECOMMENDED FUEL, COOLANT, AND LUBRICANT

- Komatsu genuine oils are adjusted to maintain the reliability and durability of Komatsu construction equipment and components.

In order to keep your machine in the best conditioner for long periods of time, it is essential to follow the instructions in this Operation and Maintenance Manual.

- Failure to follow these recommendations may result in shortened life or excess wear of the engine, power train, cooling system, and/or other components.
- Commercially available lubricant additives may be good for the machine, but they may also cause harm. Komatsu does not recommend any commercially available lubricant additive.
- Use the oil recommended according to the ambient temperature in the chart below.
- Specified capacity means the total amount of oil including the oil in the tank and the piping. Refill capacity means the amount of oil needed to refill the system during inspection and maintenance.
- When starting the engine in temperatures below 0°C (32°F), be sure to use the recommended multi-grade oil, even if the ambient temperature may become higher during the course of the day.
- If the machine is operated at a temperature below -20°C (-4°F), a separate device is needed, so consult your Komatsu distributor.
- When the fuel sulfur content is less than 0.5%, change the engine oil according to the period inspection table given in this Operation and Maintenance Manual.

If the fuel sulfur content is more than 0.5%, change the oil according to the following table.

Sulfur content (%)	Oil change interval
Less than 0.5	500 hours
0.5 - 1.0	250 hours
1.0 and up	Not recommendable (*)

* If these fuels are used, there is danger that serious trouble may occur because of early deterioration of the engine oil or early wear of the internal parts of the engine. If the local situation makes it necessary to use these fuels, always remember the following.

- 1) Be sure to check Total Basic Number (TBN) of oil frequently by TBN handy checker etc., and change oil based on the result.
- 2) Always be aware that oil change interval is extremely shorter than standard.
- 3) Be sure to carry out periodic engine inspection by distributor's expert since change interval of periodic replacement parts and overhaul interval are also shorter.

Reservoir	Fluid Type	Ambient Temperature, degrees Celsius										Recommended Komatsu Fluids	
		-22	-4	14	32	50	68	86	104	122°F			
		-30	-20	-10	0	10	20	30	40	50°C			
Engine oil pan	Engine oil	(Note.1)										Komatsu EOS0W30	
		(Note.1)										Komatsu EOS5W40	
		(Note.1)										Komatsu EO10W30-DH	
		(Note.1)										Komatsu EO15W40-DH	
		(Note.1)										Komatsu EO30-DH	
Damper case	Powertrain oil (Note.2)	(Note.1)										TO30	
Power train oil pan (incl. Transmission,torque converter and bevel gear case)	Powertrain oil	(Note.1)										TO10	
		(Note.1)										TO30	
Final drive case (each)	Gear oil	(Note.1)										GO75W90	
		(Note.1)										GO85W140	
Hydraulic system	Powertrain oil	(Note.1)										TOS5W30	
		(Note.1)										TO10	
	Hydraulic oil	(Note.1)										HO46-HM	
		Engine oil	(Note.1)										Komatsu EO10W30-DH
(Note.1)										Komatsu EO15W40-DH			
Grease fitting	Hyper grease (Note.3)	(Note.1)										G2-T,G2-TE	
	Lithium EP grease	(Note.1)										G2-LI	
Cooling system	Coolant (Note.4)	(Note.1)										Supercoolant AF-NAC	
Fuel tank	Diesel fuel	(Note.1)										ASTM Grade No.1-D S15 ASTM Grade No.1-D S500	
		(Note.1)										ASTM Grade No.2-D S15 ASTM Grade No.2-D S500	

• ASTM: American Society of Testing and Material

		Engine oil pan	Power train oil pan (incl. transmission, torque converter and bevel gear cassettes)	Damper case	Final drive case (each)	Hydraulic system	Fuel tank	Cooling system	
								Main circuit	Sub circuit
Specified amount	Liters	126	410	2.2	75	420	1670	210	35
	US gal	33.29	108.32	0.58	19.82	110.96	441.21	55.48	9.25
Refill capacity	Liters	121	210	2.2	75	170	-	-	-
	US gal	31.97	55.48	0.58	19.82	44.91	-	-	-

NOTICE

Always use diesel oil for the fuel.

To ensure good fuel consumption characteristics and exhaust gas characteristics, the engine mounted on this machine uses an electronically controlled high-pressure fuel injection device. This device requires high precision parts and lubrication, so if low viscosity fuel with low lubricating ability is used, the durability may drop markedly.

Note 1: HTHS (High-Temperature High-Shear Viscosity 150°C), specified by ASTM D4741 must be equal to or higher than 3.5 mPa-S. Komatsu EOS0W30 and EOS5W40 are the most suitable oils.

Note 2: Powertrain oil has different properties from engine oil. Be sure to use the recommended oils.

Note 3: Hyper grease (G2-T, G2-TE) has a high performance.

When it is necessary to improve the lubricating ability of the grease in order to prevent squeaking of pins and bushings, the use of G2-T or G2-TE is recommended.

Note. 4: Supercoolant (AF-NAC)

1) Coolant has the important function of anticorrosion as well as antifreeze.

Even in the areas where freezing is not an issue, the use of antifreeze coolant is essential.

Komatsu machines are supplied with Komatsu Supercoolant AF-NAC. Komatsu Supercoolant AF-NAC has excellent anticorrosion, antifreeze and cooling properties and can be used continuously for 2 years or 4000 hours. Komatsu Supercoolant AF-NAC is strongly recommended wherever available.

2) For details of the ratio when diluting super coolant with water, see "CLEAN INSIDE OF COOLING SYSTEM (PAGE 4-22)".

Supercoolant AF-NAC may be supplied in premix . In this case, always top off with premix solution. (never dilute with water)

3) To maintain the anticorrosion properties of Supercoolant AF-NAC, always keep the density of Supercoolant between 30% and 68%.

RECOMMENDED BRANDS, RECOMMENDED QUALITY FOR PRODUCTS OTHER THAN KOMATSU GENUINE OIL

When using commercially available oils other than Komatsu genuine oil, consult your Komatsu distributor.

STANDARD TIGHTENING TORQUES FOR BOLTS AND NUTS

TORQUE LIST



If nuts, bolts, or other parts are not tightened to the specified torque, it will cause looseness or damage to the tightened parts, and this will cause failure of the machine or problems with operation.

Always pay careful attention when tightening parts.

Unless otherwise specified, tighten the metric nuts and bolts to the torque shown in the table below. If it is necessary to replace any nut or bolt, always use a Komatsu genuine part of the same size as the part that was replaced.

Thread diameter of bolt (a)(mm)	Width across flats (b)(mm)	Tightening torque					
		Target value			Service limit		
		Nm	kgm	lbft	Nm	kgm	lbft
6	10	13.2	1.35	9.8	11.8-14.7	1.2-1.5	8.7-10.8
8	13	31	3.2	23.1	27-34	2.8-3.5	20.3-25.3
10	17	66	6.7	48.5	59-74	6.0-7.5	43.4-54.2
12	19	113	11.5	83.2	98-123	10.0-12.5	72.3-90.4
14	22	177	18	130.2	157-196	16.0-20.0	115.7-144.7
16	24	279	28.5	206.1	245-309	25.0-31.5	180.8-227.8
18	27	382	39	282.1	343-425	35.0-43.5	253.2-314.6
20	30	549	56	405.0	490-608	50.0-62.0	361.7-448.4
22	32	745	76	549.7	662-829	67.5-84.5	488.2-611.2
24	36	927	94.5	683.5	824-1030	84.0-105.0	607.6-759.5
27	41	1320	135.0	976.5	1180-1470	120.0-150.0	868.0-1085.0
30	46	1720	175.0	1265.8	1520-1910	155.0-195.0	1121.1-1410.4
33	50	2210	225.0	1627.4	1960-2450	200.0-250.0	1446.6-1808.3
36	55	2750	280.0	2025.2	2450-3040	250.0-310.0	1808.3-2242.2
39	60	3280	335.0	2423.1	2890-3630	295.0-370.0	2133.7-2676.2

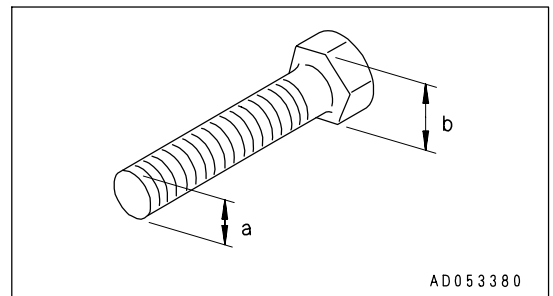

Apply the following table for Hydraulic Hose.

Nominal- No. of threads (a)	Width across flats (b) mm	Tightening torque					
		Target valve			Permissible range		
		Nm	kgm	lbft	Nm	kgm	lbft
9/16 -18UNF	19	44	4.5	32.5	34 - 54	3.5 - 5.5	25.3 - 39.8
11/16 -16UN	22	74	7.5	54.2	54 - 93	5.5 - 9.5	39.8 - 68.7
13/16 -16UN	27	103	10.5	75.9	84 - 132	8.5 - 13.5	61.5 - 97.6
1 -14UNS	32	157	16.0	115.7	128 - 186	13.0 - 19.0	94.0 - 137.4
1 3/16 -12UN	36	216	22.0	159.1	177 - 245	18.0 - 25.0	130.2 - 180.8

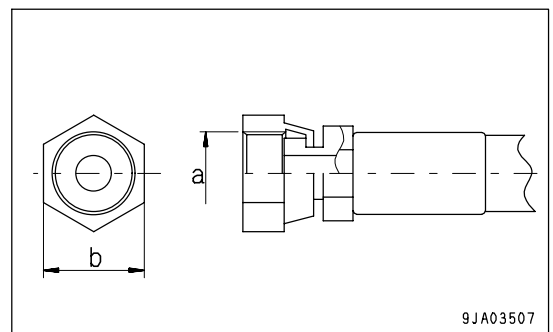

PERIODIC REPLACEMENT OF SAFETY CRITICAL PARTS

For using the machine safely for an extended period of time, you are required to periodically replace the safety (critical and fire prevention) related parts listed in the table of important parts on the following page.

Material quality of these parts can change as time passes and they are likely to wear out or deteriorate. However, it is difficult to determine the extent of wear or deterioration at the time of periodic maintenance. Hence, it is required to replace them with new ones regardless of their condition after a certain period of usage. This is important to ensure that these parts maintain their full performance at all times.

Furthermore, should anything abnormal be found on any of these parts, replace it with a new one even if the periodic replacement time for the part has not yet arrived.

If any of the hose clamps show deterioration like deformation or cracking, replace the clamps at the same time as the hoses.

Also perform the following checks with hydraulic hoses which need to be replaced periodically. Tighten all loose clamps and replace defective hoses, as required.

When replacing hoses, always replace O-rings, gaskets, and other such parts at the same time.

Have your Komatsu distributor replace the critical parts.

SAFETY CRITICAL PARTS

NO.	Periodic replacement parts	Q'ty		Replacement interval
		Single	Dual,SD	
1	Fuel hose (spill hose between nozzles)	4	4	Every 2 years or every 4000 hours, whichever comes sooner
2	Turbocharger oil supply hose	2	2	
3	Fuel hose (nozzle - fuel return hose)	1	1	
4	Fuel hose (fuel filter - injection pump)	2	2	
5	Fuel hose (feed pump - fuel return hose)	1	1	
6	Hose between torque converter oil cooler - steering case	1	1	
7	Power train pressure detection hose assembly	1	1	
8	Fuel hose (fuel tank - fuel strainer)	3	3	
9	Fuel hose (fuel return)	1	1	
10	Hose between torque converter outlet port - torque converter oil cooler	1	1	
11	Fuel hose (fuel strainer - feed pump)	1	1	
12	Hose between main valve - ripper relay tube	4	4	
13	Hose between ripper relay tube - ripper divider lock	4	4	
14	Hose between ripper divider block - ripper lift cylinder	4	4	
15	Hose between ripper divider block - ripper tilt cylinder	4	4	
16	Hose between main valve - tank	2	2	
17	Hose between PPC accumulator - PPC lock valve	1	1	
18	Hose between PPC lock valve - blade PPC valve	1	1	
19	Hose between PPC lock valve - ripper PPC valve	1	1	
20	Hose between self-pressure reduction valve - main valve	1	1	
21	Hose between self-pressure reduction valve - PPC basic pressure divider block	1	1	
22	Hose between PPC basic pressure divider block - PPC accumulator	1	1	
23	Hose between PPC basic pressure divider block - blade relay block	-	1	
24	Hose between PPC basic pressure divider block - EPC divider block	1	1	
25	Hose between EPC divider block - hydraulic pump	1	1	
26	Hose between EPC divider block - fan pump	2	2	
27	Hose between EPC divider block - pump merge-divider valve	1	1	
28	Hose between blade PPC valve - blade relay block	4	4	
29	Blade relay block - main valve	4	6	
30	Hose between blade PPC valve - PPC drain relay block	1	1	
31	Hose between ripper PPC valve - ripper relay block	4	4	
32	Hose between ripper relay block - main valve	4	4	
33	Hose between ripper PPC valve - PPC drain relay block	1	1	
34	Hose between blade relay block - PPC drain relay block	-	1	

NO.	Periodic replacement parts	Q'ty		Replacement interval
		Single	Dual,SD	
35	Hose between pump merge-divider valve - PPC drain relay block	-	1	Every 2 years or every 4000 hours, whichever comes sooner
36	Hose between PPC drain relay block - tank	1	1	
37	Pump merge-divider valve - tank	-	1	
38	Hose between hydraulic pump - main valve	6	6	
39	Hose between hydraulic pump - tank	1	1	
40	Hose between main valve - blade lift divider block	4	4	
41	Hose between blade lift divider block - relay tube	2	2	
42	Hose between relay tube - blade lift cylinder	2	2	
43	Hose between main low valve - blade tilt relay block	2	4	
44	Hose between fan pump - tank	2	2	
45	Hose between fan pump LPV30 - fan pump discharge merge block	1	1	
46	Hose between fan pump discharge merge block - fan motor	2	2	
47	Hose between fan motor - tank	3	3	
48	Hose between fan motor - hydraulic cooler	2	2	
49	Hydraulic cooler - bypass valve	1	1	
50	Hose between hydraulic cooler - tank	2	2	
51	Seat belt	1	1	

MAINTENANCE SCHEDULE CHART

MAINTENANCE SCHEDULE CHART

INITIAL 250 HOURS SERVICE (ONLY AFTER THE FIRST 250 HOURS)

REPLACE TRANSMISSION FILTER ELEMENT, TRANSMISSION LUBRICATION FILTER ELEMENT AND TORQUE CONVERTER OIL FILTER ELEMENT -----	4- 59
CHANGE OIL IN POWER TRAIN CASE, CLEAN STRAINERS (INCL. TRANSMISSION CASE, TORQUE CONVERTER CASE AND BEVEL GEAR CASE) -----	4- 61
CHANGE OIL IN HYDRAULIC TANK, REPLACE HYDRAULIC OIL FILTER ELEMENT, CLEAN HYDRAULIC TANK STRAINER -----	4- 66
CHANGE OIL IN FINAL DRIVE CASE -----	4- 68

WHEN REQUIRED

CLEAN INSIDE OF COOLING SYSTEM -----	4- 22
CHECK, CLEAN AND REPLACE AIR CLEANER ELEMENT -----	4- 26
CHECK TRACK TENSION -----	4- 28
CHECK AND TIGHTEN TRACK SHOE BOLTS -----	4- 31
ADJUST IDLER CLEARANCE -----	4- 32
REVERSE AND REPLACE THE END BITS AND CUTTING EDGES -----	4- 33
CLEAN, CHECK RADIATOR FINS -----	4- 35
CLEAN FUEL TANK STRAINER -----	4- 36
DRAIN WATER AND SEDIMENT IN FUEL TANK -----	4- 36
CLEAN STEERING CLUTCH CASE BREATHER -----	4- 36
CHECK UNDERCARRIAGE OIL -----	4- 37
CLEAN AIR CONDITIONER AIR FILTER (FRESH/RECIRC FILTER) -----	4- 38
REPLACE AIR CONDITIONER BELT -----	4- 38
CLEAN, CHECK HYDRAULIC COOLER FINS -----	4- 38
CHECK, ADJUST AIR CONDITIONER -----	4- 39
LUBRICATE DOOR HINGE -----	4- 40
CHECK DOOR LATCH -----	4- 40
CHECK DOOR LOCK STRIKER -----	4- 41
REPLACE DOOR DAMPER -----	4- 41
CHECK WINDOW WASHER FLUID LEVEL, ADD FLUID -----	4- 41
REPLACE WIPER BLADE -----	4- 42
BLEEDING AIR IN HYDRAULIC SYSTEM -----	4- 43
CHECK ELECTRICAL INTAKE AIR HEATER -----	4- 44
LUBRICATING -----	4- 44

CHECK BEFORE STARTING

EVERY 250 HOURS SERVICE

LUBRICATING ----- 4- 48
 CHECK ALTERNATOR DRIVE BELT TENSION, ADJUST ----- 4- 50
 CHECK LEVEL OF BATTERY ELECTROLYTE ----- 4- 51
 CHECK BRAKE PERFORMANCE ----- 4- 54
 CHECK OIL LEVEL IN DAMPER CASE, ADD OIL ----- 4- 55

EVERY 500 HOURS SERVICE

CHANGE OIL IN ENGINE OIL PAN, REPLACE ENGINE OIL FILTER CARTRIDGE ----- 4- 56
 REPLACE FUEL FILTER CARTRIDGE ----- 4- 57
 REPLACE TRANSMISSION FILTER ELEMENT, TRANSMISSION LUBRICATION FILTER ELEMENT
 AND TORQUE CONVERTER OIL FILTER ELEMENT ----- 4- 59
 CHECK OIL LEVEL IN FINAL DRIVE CASE, ADD OIL ----- 4- 60
 REPLACE HYDRAULIC TANK BREATHER ELEMENT ----- 4- 60

EVERY 1000 HOURS SERVICE

CHANGE OIL IN POWER TRAIN CASE, CLEAN STRAINERS (INCL. TRANSMISSION CASE,
 TORQUE CONVERTER CASE AND BEVEL GEAR CASE) ----- 4- 61
 CHECK, CLEAN FUEL STRAINER ----- 4- 63
 CHECK FOR LOOSE ROPS MOUNT BOLTS ----- 4- 63
 REPLACE MAIN CORROSION RESISTOR CARTRIDGE AND SUB CORROSION RESISTOR
 CARTRIDGE ----- 4- 64
 REPLACE AIR CONDITIONER AIR FILTER (FRESH, RECIRC FILTER) ----- 4- 64
 CHECK TIGHTENING PARTS OF TURBOCHARGER ----- 4- 65

EVERY 2000 HOURS SERVICE

CHANGE OIL IN HYDRAULIC TANK, REPLACE HYDRAULIC OIL FILTER ELEMENT, CLEAN
 HYDRAULIC TANK STRAINER ----- 4- 66
 CHANGE OIL IN FINAL DRIVE CASE ----- 4- 68
 CHANGE OIL IN DAMPER CASE AND BREATHER FILTER, CLEAN DAMPER BREATHER ----- 4- 69
 CHECK PIVOT BEARING OIL LEVEL, ADD OIL ----- 4- 70
 CHECK OIL LEVEL IN RECOIL SPRING, ASSIST CYLINDER CASE, ADD OIL ----- 4- 70
 CLEAN ENGINE BREATHER ELEMENT ----- 4- 71
 CHECK ALTERNATOR, STARTING MOTOR ----- 4- 71
 CHECK ENGINE VALVE CLEARANCE, ADJUST ----- 4- 71

EVERY 4000 HOURS SERVICE

CHECK WATER PUMP ----- 4- 72
 CHECK VIBRATION DAMPER ----- 4- 72
 CLEAN, CHECK TURBOCHARGER ----- 4- 72
 CHECK PLAY OF TURBOCHARGER ROTOR ----- 4- 72
 CHECK MAIN FRAME, WORK EQUIPMENT (BLADE, RIPPER) ----- 4- 73

SERVICE PROCEDURE

INITIAL 250 HOURS SERVICE (ONLY AFTER THE FIRST 250 HOURS)

Perform the following maintenance only after the first 250 hours.

- Replace transmission filter element, transmission lubrication filter element and torque converter oil filter element
- Change oil in power train case, clean strainers (incl. transmission case, torque converter case and bevel gear case)
- Change oil in hydraulic tank, replace hydraulic oil filter element, clean hydraulic tank strainer
- Change oil in final drive case

For details of the method of replacing or maintaining, see the section on EVERY 500 HOURS, 1000 HOURS and 2000 HOURS SERVICE.

WHEN REQUIRED

CLEAN INSIDE OF COOLING SYSTEM



WARNING

- Immediately after the engine is stopped, the coolant is at a high temperature and the radiator is under high internal pressure. If the cap is removed to drain the coolant in this condition, there is a hazard of burns. Wait for the temperature to go down, then turn the cap slowly to release the pressure before removing it.
- Cleaning is carried out with the engine running. When standing up or leaving the operator's seat, set the work equipment lock lever and the parking brake lever to the LOCK position.
- For details of starting the engine, see "CHECK BEFORE STARTING ENGINE, ADJUST (PAGE 3-86)" and "STARTING ENGINE (PAGE 3-107)" in the OPERATION section.
- Never enter front the machine when the engine is running.
There is danger of touching the fan.

Stop the machine on level ground when cleaning or changing the coolant.

Clean the inside of the cooling system, change the coolant and replace the corrosion resistor according to the table below.

Antifreeze coolant	Interval for cleaning inside of cooling system and changing antifreeze coolant	Replacing corrosion resistor
Komatsu supercoolant (AF-NAC)	Every two years or every 4000 hours whichever comes first	unnecessary
Permanent type antifreeze (All-season type, *)	Every year (autumn) or every 2000 hours whichever comes first	Every 1000 hours and when cleaning the inside of the cooling system and when changing coolant

*: Permanent type antifreeze shall meet the requirements of ASTM D3306-03.

The coolant has the important function of preventing corrosion as well as preventing freezing.

Even in the areas where freezing is not an issue, the use of antifreeze coolant is essential.

Komatsu machines are supplied with Komatsu Supercoolant (AF-NAC). Komatsu Supercoolant (AF-NAC) has excellent anticorrosion, antifreeze and cooling properties and can be used continuously for 2 years or 4000 hours. Komatsu Supercoolant (AF-NAC) is strongly recommended wherever available.

When using Komatsu Supercoolant (AF-NAC), there is no need to use a corrosion resistor.

When no corrosion resistor is used, use the special cover (600-411-9000). Please consult your Komatsu distributor about the method of installing.

To maintain the anticorrosion properties of Supercoolant (AF-NAC), always keep the density of Supercoolant between 30% and 68%.

When deciding the ratio of antifreeze to water, check the lowest temperature in the past, and decide from the mixing table given below.

It is actually better to estimate and temperature about 10°C (18°F) lower when deciding the mixing ratio.

The mixing ratio depends on the ambient temperature, but it should always be a minimum of 30% by volume (antifreeze/total amount of coolant x 100).

Even in areas where it is not necessary to prevent freezing, use Supercoolant (AF-NAC) at a mixing ratio of at least 30% to prevent corrosion of the cooling system.

The freezing temperature of undiluted antifreeze is -15°C (5°F). Do not store undiluted antifreeze at a temperature of below -15°C (5°F).

Mixing rate of water and antifreeze

Min. atmospheric temperature	°C	Above -10	-15	-20	-25	-30	-35	-40
	°F	14	5	-4	-13	-22	-31	-40
Amount of antifreeze	Liters	73.5	88.0	100.5	113.0	122.5	132.3	142.0
	US gal	19.42	23.25	26.55	29.85	32.36	34.95	37.52
Amount of water	Liters	171.5	157.0	144.5	132.0	122.5	112.7	103.0
	US gal	45.31	41.48	38.18	34.88	32.37	29.78	27.21
Volume ratio (%)		30	36	41	46	50	54	58

 **WARNING**

- Antifreeze is flammable, so keep it away from flame.
Antifreeze is toxic. When open the drain valve, be careful not to get water containing antifreeze on you. If it gets in your eyes, flush your eyes with large amount of fresh water and see a doctor at once.
- When changing the coolant or draining the coolant from the radiator before carrying out repairs, ask a specialist company to handle any coolant containing antifreeze, or contact your Komatsu distributor. Antifreeze is toxic, so never pour it into drainage water ditches or drain it onto the ground surface.

Use antifreeze and appropriate water for diluting. (for details, see "COOLANT AND WATER FOR DILUTION (PAGE 4-6)")

Use city water for the coolant.

If river water, well water or other such water supply must be used, contact your Komatsu distributor.

We recommend use of an antifreeze density gauge to control the mixing proportions.

Prepare a container whose capacity is larger than the specified coolant volume to catch drained coolant.

Prepare a hose to supply antifreeze coolant and water.

1. Stop the machine on level ground, then stop the engine.

2. Stop the engine, wait for the coolant to cool completely, then turn valve (3) of main corrosion resistor (1) and sub corrosion resistor (2) to the Close stopper position.

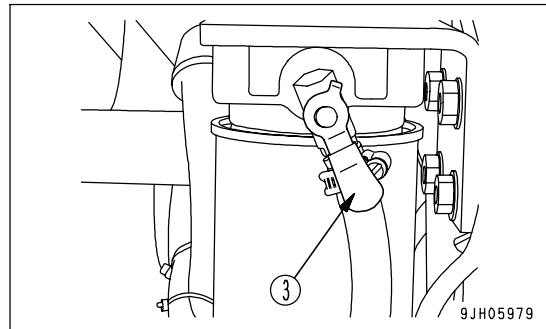
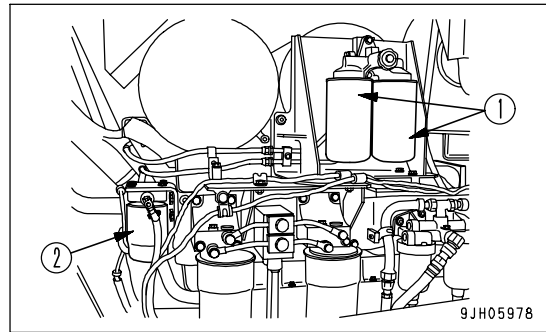

3. Turn main radiator cap (4) and sub radiator cap (5) slowly, and remove.

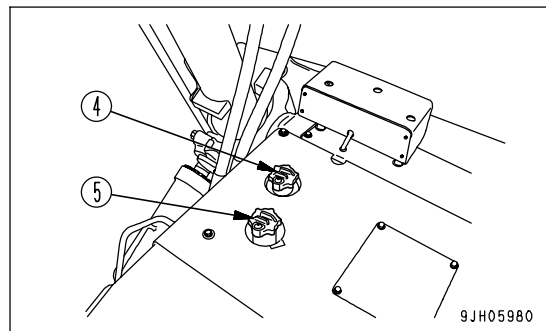

4. Prepare a container to catch the drained coolant, then open main radiator drain valves (6) and (7) at the bottom of the radiator and drain valve (8) of the sub-radiator, and drain the water.
5. After draining the water, close drain valves (6), (7), and (8), then fill with city water.
6. When the radiator is filled with water, start the engine, run at low idling, raise the water temperature to at least 90 °C, then run the engine for approx. 10 minutes.
7. Open drain valves (6), (7), and (8), and drain the water.
8. After draining the water, flush the system with a flushing agent. For details of the flushing method, see the instructions on the flushing agent.
9. Open drain valves (6), (7), and (8).

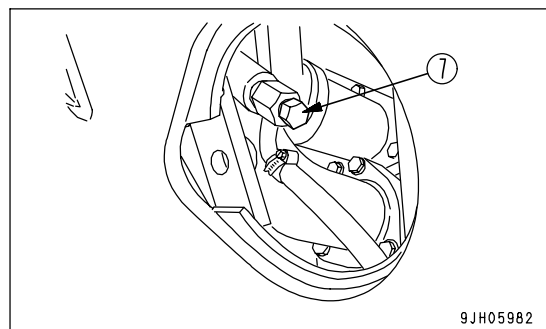
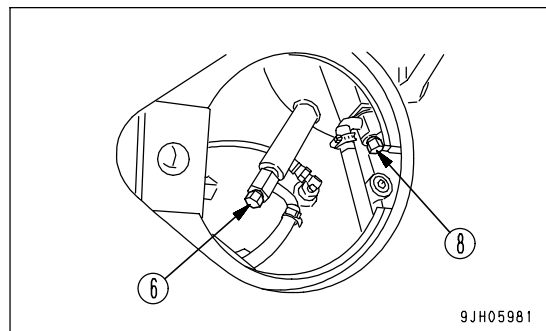

10. Replace the corrosion resistor, then open each valve (3).

For details of the method of replacing the corrosion resistor, see "REPLACE MAIN CORROSION RESISTOR CARTRIDGE AND SUB CORROSION RESISTOR CARTRIDGE (PAGE 4-64)".

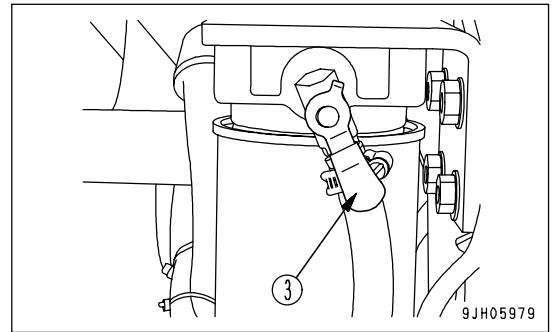

11. Add city water until the water overflows from the water filler port.
12. To bleed the air from the cooling system, run the engine at low idle for 5 minutes, and for a further 5 minutes at high idle. (When doing this, leave the radiator cap off.)
13. Open cap (9) of the coolant reserve tank, add water to the specified level, then tighten cap (9). For details, see "CHECK COOLANT LEVEL, ADD COOLANT (PAGE 3-89)".

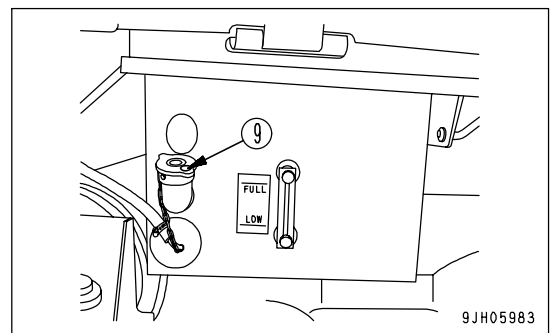

14. Stop the engine, wait for approx. 3 minutes, then add city water to near the mouth of the filler port, and tighten caps (4) and (5).

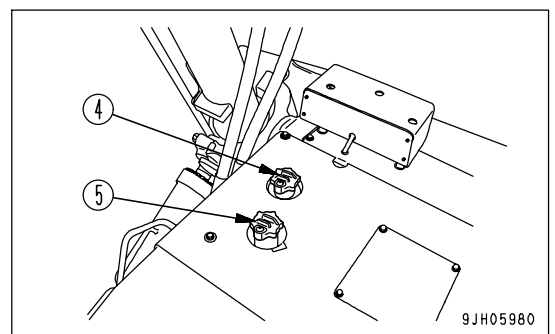

CHECK, CLEAN AND REPLACE AIR CLEANER ELEMENT

WARNING

- Always wear protective glasses, dust mask, or other protective equipment.
- When removing the air cleaner element from the air cleaner body, it is dangerous to pull it out by force.
When working at high places or where the foothold is poor, be careful not to fall because of the reaction when pulling out the outer element.

CHECKING

If the internal yellow piston overlaps the red zone on the outside diameter of dust indicator (1), clean the air cleaner element. After cleaning, press the reset button to reset the piston.

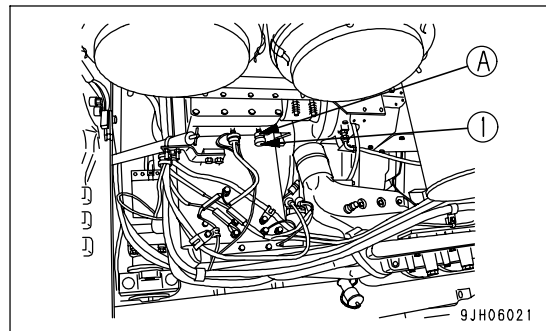

NOTICE

Always wait for the yellow piston in the dust indicator to overlap the red zone on the outside before cleaning the element.

If the element is cleaned frequently before the yellow piston in the dust indicator overlaps the red zone on the outside, the air cleaner will be unable to display its normal performance and the cleaning effect will become poor.

In addition, the frequency of dust stuck to the element falling inside the inner element during the cleaning operation will increase.

CLEANING OR REPLACING OUTER ELEMENT

NOTICE

Before and after cleaning the element, do not leave or keep it in direct sunlight.

1. Remove 6 hooks (2), then remove cover (3).
Remove outer element.
2. Hold the outer element, rock it lightly up and down and to the left and right, and rotate the element to the left and right to pull it out.

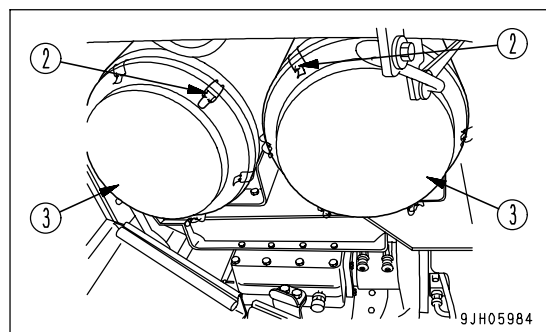

NOTICE

- Never remove the inner element. It will allow dirt to enter and cause failure of the engine.
 - Do not use a screwdriver or any other tool.
3. After removing the outer element, cover the air connector inside the air cleaner body with a clean cloth or tape to prevent dirt or dust from entering.

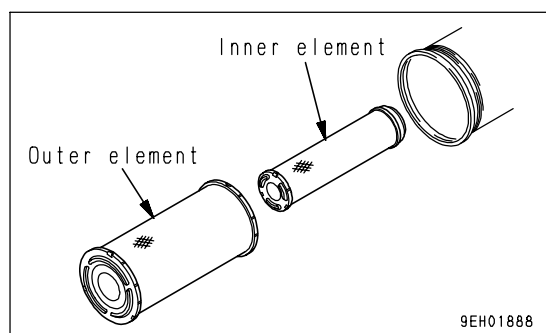

4. Use a clean cloth or brush to remove the dirt stuck to the cover and the inside of the air cleaner body.
5. Direct dry compressed air (Max. 0.69 MPa (7 kg/cm², 99.4 PSI)) from the inside of the outer element along its folds. Then direct the compressed air from the outside along the folds, and again from the inside.
 - 1) Check that the inner element is not loose. If it is loose, insert it securely.
 - 2) If the yellow piston overlaps the outer element red zone immediately after the outer element is cleaned, replace the inner and outer elements.
6. Remove the cloth or tape cover installed in Step 3.
7. If small holes or thinner parts are found on the element when it is checked with an electric bulb after cleaning and drying, replace the element.

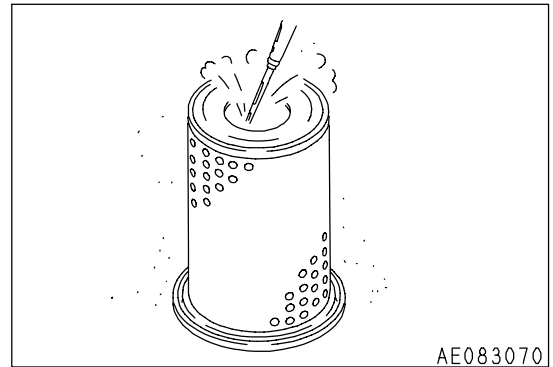

NOTICE

- When cleaning the element, do not hit or beat it against anything.
- Do not use an element whose folds or gasket or seal are damaged.

8. After replacing the element, press the dust indicator button to reset it.
The yellow piston will return to its original position.

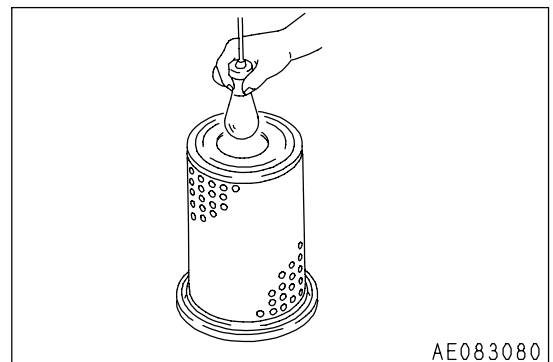

REPLACING INNER ELEMENT

1. First remove the outer element, and then remove the inner element.
2. Cover the air connector side (outlet side) with a clean cloth or tape.
3. Clean the air cleaner body interior, then remove the cover installed in Step 2.
4. Fit a new inner element to the connector.
Do not clean and reinstall an inner element.
5. Install the outer element and the cover.

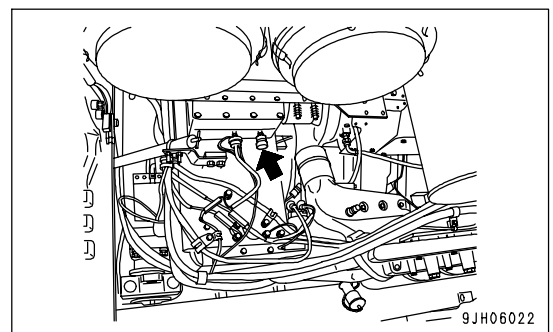

CHECK AND ADJUST TRACK TENSION

The wear of pins and bushings on the undercarriage will vary with the working conditions and types of soil. It is thus necessary to continually inspect the track tension so as to maintain the standard tension.

Carry out the check and adjustment under the same conditions as when operating (on jobsites where the track becomes clogged with mud, measure with the track clogged with mud).

INSPECTION

Stop the machine on level ground (stop with the transmission in FORWARD without applying the brake). Then place a straight bar on the track shoes between the carrier roller and the idler as shown in the figure, and measure the clearance between the bar and the grouser at the midpoint. If the clearance (A) is 20 to 30 mm (0.79 to 1.18 in), the tension is standard.

If the track tension is not at the standard value, adjust it in the following manner.

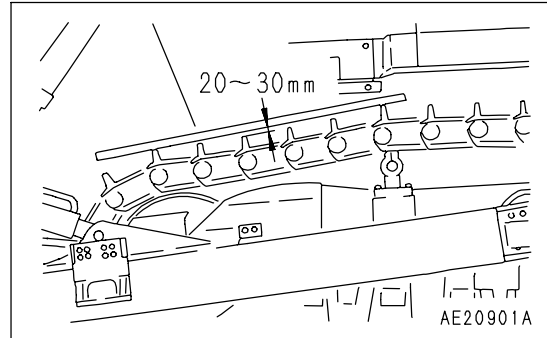

ADJUSTMENT

⚠ WARNING

Grease inside the adjusting mechanism is under high pressure. Grease coming from plug (4) under pressure can penetrate the body causing injury or death. For this reason, do not loosen plug (4) more than one turn. Do not loosen any part other than plug (4). Furthermore, do not bring your face in front of the grease fitting. If track tension is not relieved by this procedure, contact your Komatsu distributor for repairs.

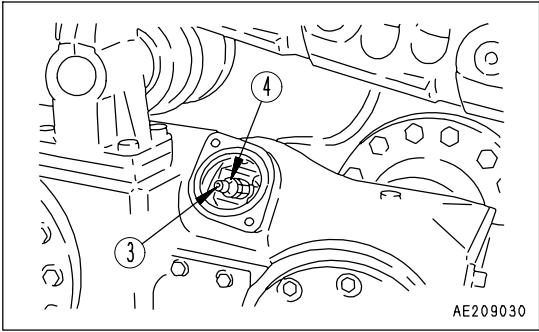
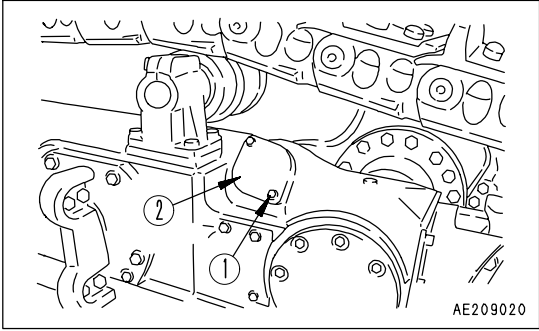

WHEN INCREASING TENSION

1. First remove the bolt (1) and then remove the cover (2).

NOTICE

- When removing cover (2), be careful not to let any dirt get inside.
- There is a safety label stuck to the back of cover (2). Be careful not to damage the safety label.

2. Pump in grease through the grease fitting (3) with a grease pump.
3. To check that the correct tension has been achieved, move the machine backwards and forwards.
4. Check the track tension again, and if the tension is not correct, adjust it again.
5. Continue to pump in grease until (S) becomes 480 mm (18.9 in). If the tension is still loose, the pin and bushing are excessively worn, so they must be either turned or replaced. Contact your Komatsu distributor for repairs.

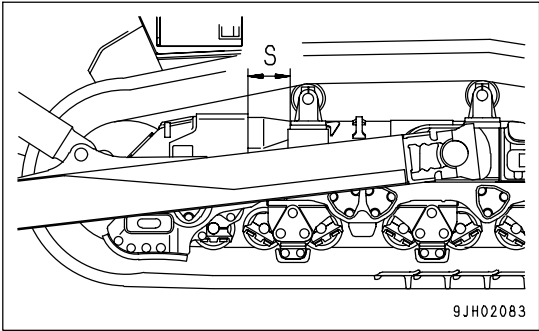

WHEN LOOSENING TENSION

**WARNING**

It is extremely dangerous to release the grease by any method except the procedure given below.
If track tension is not relieved by this procedure, contact your Komatsu distributor for repairs.

1. Remove both bolts (1), then remove cover (2).

NOTICE

- When removing cover (2), be careful not to let any dirt get inside.
- There is a safety label stuck to the back of cover (2). Be careful not to damage the safety label.

2. Loosen plug (4) gradually to release the grease.
3. Turn plug (4) a maximum of one turn.
4. If the grease does not come out smoothly, move the machine backwards and forwards a short distance.
5. Tighten plug (4).
6. To check that the correct tension has been achieved, move the machine backwards and forwards.
7. Check the track tension again, and if the tension is not correct, adjust it again.

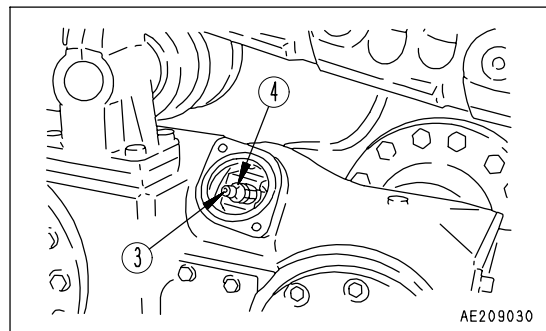
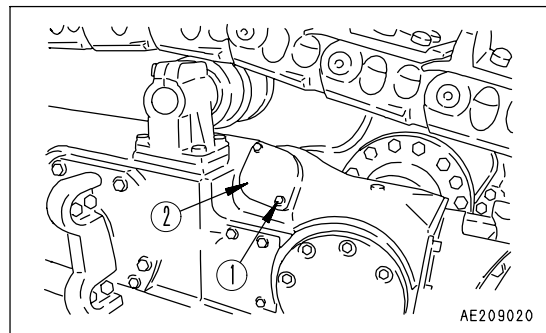

WHEN REMOVING TRACK

**WARNING**

Depending on the situation, the operation to remove the track may be extremely dangerous.
Before removing the track, if the procedure "WHEN LOOSENING TENSION (PAGE 4-30)" does not loosen the track tension, contact your Komatsu distributor for repairs.

CHECK AND TIGHTEN TRACK SHOE BOLTS

If the machine is used with track shoe bolts being loose, they will break, so tighten any loose bolts immediately.

METHOD OF TIGHTENING SHOE BOLT

1. First tighten to a tightening torque of $980 \pm 98 \text{ Nm}$ ($100 \pm 10 \text{ kgm}$, $723.3 \pm 72.3 \text{ lbft}$) and then check that the link contact surfaces are in close contact.
2. After checking, tighten a further $180^\circ \pm 10^\circ$.

METHOD OF TIGHTENING MASTER LINK CONNECTING BOLT

1. Tighten first to a tightening torque of $980 \pm 98 \text{ Nm}$ ($100 \pm 10 \text{ kgm}$, $723.3 \pm 72.3 \text{ lbft}$), then check that the link mating surface is in close contact.
2. After checking, tighten a further $180^\circ \pm 10^\circ$.

ORDER FOR TIGHTENING

Tighten the bolts in the order shown in the diagram on the right.

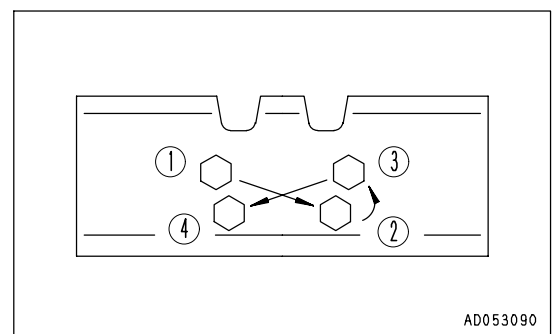

ADJUST IDLER CLEARANCE

The idler moves forward and backward under external pressure when this happens, side guide (1) and guide plate (2) become worn.

As they become worn, there is side play in the idler, or the idler turns at an angle, causing the track to come off or resulting in uneven wear, so adjust as follows.

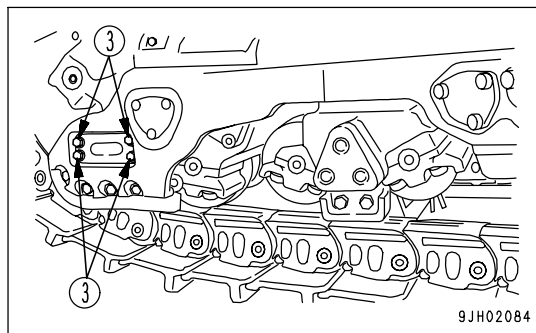

ADJUSTMENT

1. Drive the machine for 8 to 12 m (24.4 to 36.6 ft) on flat ground, then measure clearance A (4 places: left, right, inside outside) between the track frame and side guide (1).
2. If clearance A is more than 3 mm (0.1 in), remove bolt (3), then take out shim (4), and adjust to that the clearance on one side is less than 0.5 mm (0.02 in).

REMARK

There are two types of shim (thickness: 0.5 mm (0.02 in) and 1.0 mm (0.04 in)).

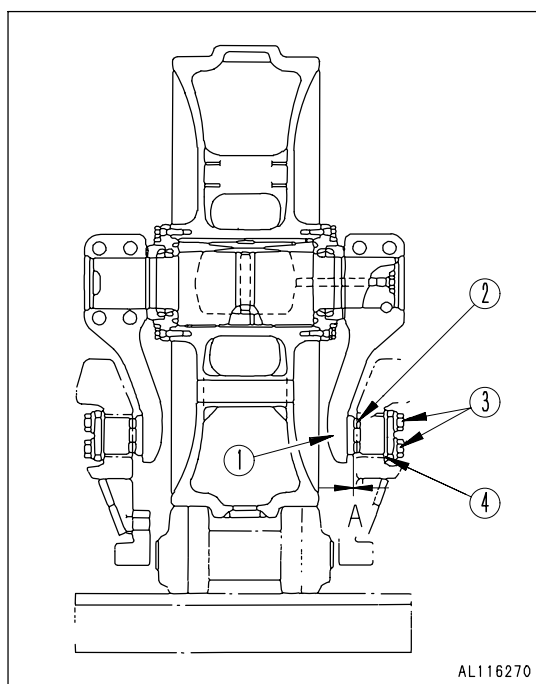

REVERSE AND REPLACE THE END BITS AND CUTTING EDGES

WARNING

It is dangerous if the work equipment moves by mistake when the cutting edges and end bits are being reversed or replaced. Set the work equipment in a stable condition, then stop the engine and lock the blade control lever securely with the work equipment lock lever.

Reverse or replace the end bits and cutting edges before it is worn out to the blade end.

1. Raise the blade to a proper height, position a block under the frame to prevent the blade from falling.
2. Operate the work equipment lock lever to the LOCK position.

If the cutting edge and the end bit on both sides are worn out, replace with new one.

If the mounting surface is worn, correct it before turning or replacing the end bits.

3. Loosen nut (1) and remove bolt (2). Then remove the cutting edge and the end bit and clean the mounting surface.

4. Reverse or replace the cutting edge and the end bit when worn out.

If bolt (1) and nut (2) are damaged, replace them with new ones at the same time.

5. Install the edge to the blade, then tighten partially. Drop the blade three to five times on to the ground or rock to remove any play in bolt (2), then tighten it to the correct tightening torque. When installing end bit (3), put top surface (4) of the end bit in close contact with stopper (5), then tighten with the bolts.

- Tightening torque: $3340 \pm 373 \text{ Nm}$ ($341 \pm 38 \text{ kgm}$, $2466.3 \pm 274.8 \text{ lbft}$)

6. After several hours of running, retorque the nuts.

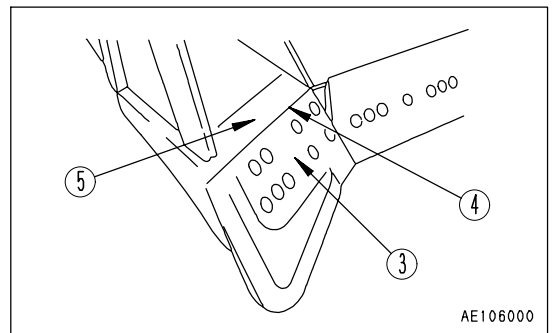
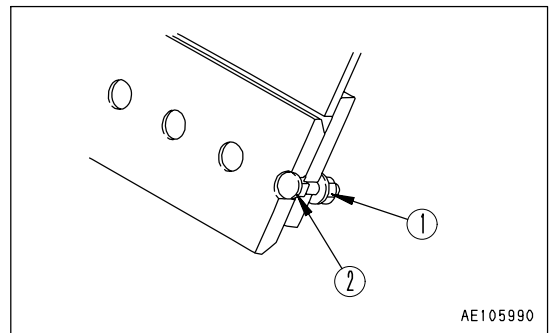

REMARK

The tightening operation is easier if the power wrench that has been supplied is used.

When the nut is rusted and is removed by gas cutting, cut on both side (6) of the nut as shown in the diagram.

Be careful not to damage seat surface (7).

If it is damaged, repair it. Be careful not to get spatter on the mounting surface.

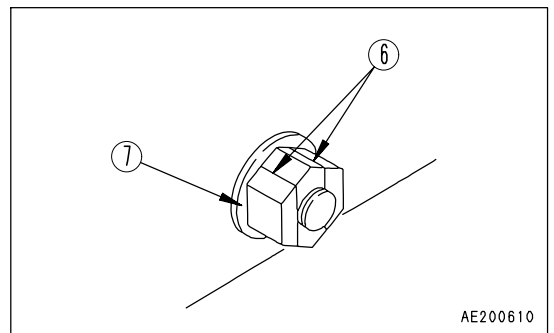

METHOD OF USING POWER WRENCH

The power wrench set is equipped with a special socket.

This socket is designed to grip the nuts and prevent the wrench set from pulling out. This means that tightening can be performed by one worker.

This socket has a double construction, and is designed so that the outside can rotate 30°

It is used as follows.

1. Align the hexagons of the inside socket and outside socket, the insert the nut that is to be tightened or loosened.
2. After inserting the nut, turn the outside socket 30° clockwise. When this is done, the outside socket will catch the notch in the nut seat surface, and the wrench will not come off.
3. Put the reaction arm in contact with the blade rib, and tighten or loosen.
4. Turn the outside socket counterclockwise, and remove the wrench.

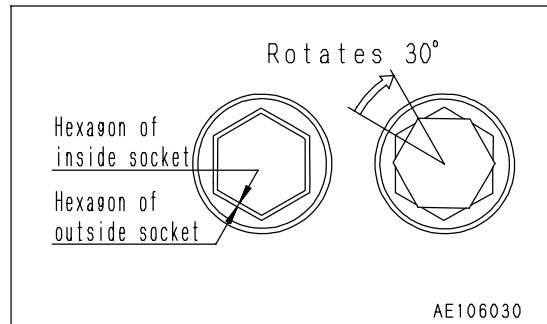
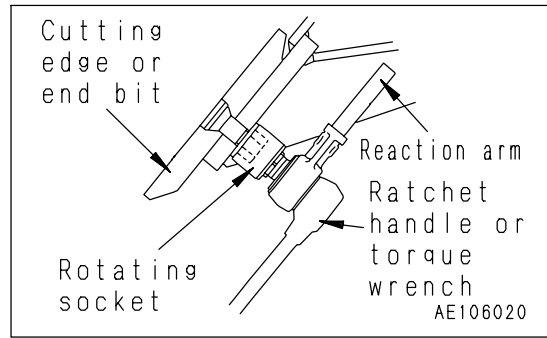

CLEAN AND CHECK RADIATOR FINS

 **WARNING**

Always stop the engine and check that it is not rotating before starting cleaning or inspection. When rotating the fan, always close the radiator grill to make it impossible to touch the fan.

If the radiator fins are clogged or dirty, clean and inspect them.

1. Remove four bolts (1) at corners of grill (2), then open the grill.

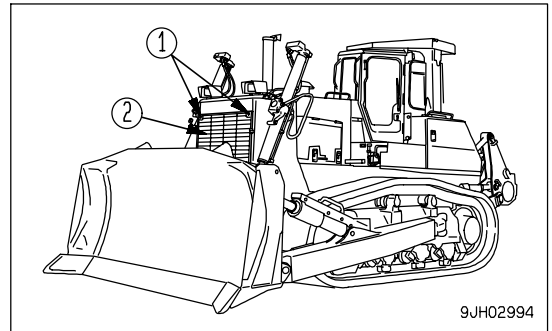

2. Clean the radiator fins clogged with mud, dust and leaves with compressed air. Steam or water may be used instead of compressed air.

REMARK

Check the hydraulic cooler hoses. If any hose is cracked or hardened by age, replace with a new hose. Also check and tighten all loose hose clamps.

When cleaning the radiator fins, reverse the rotation of the fan and change the direction of the air flow. Open the engine room side cover, set the fan rotation selector switch to the CLN position, then start the engine.

The fan rotates at 100% speed in reverse and cleans the fins. The fan rotation selector switch cannot be operated when the engine is running.

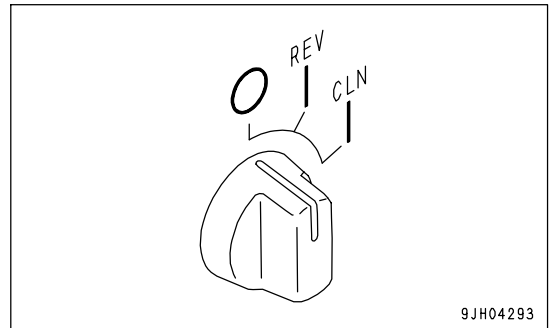

REMARK

Use compressed air to blow off any dirt embedded in the radiator fins. It is also possible to blow with compressed air from the side holes on both sides (3) of the radiator guard.

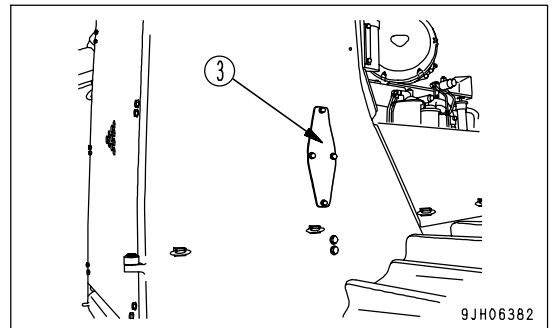

CLEAN FUEL TANK STRAINER

Clean the strainer if there is any dirt collected in it.
 Remove the filler cap (1) of the fuel tank and take out strainer.
 If the strainer is dirty, clean it with diesel fuel.

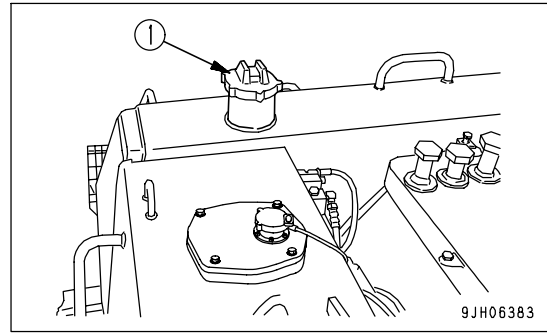

DRAIN WATER AND SEDIMENT IN FUEL TANK

Carry out this procedure after the machine has been at rest for a long time and after a long spell of rainy days.
 Loosen valve (1) at the bottom of the fuel tank, and drain the water and sediment collected at the bottom of the tank together with the fuel.

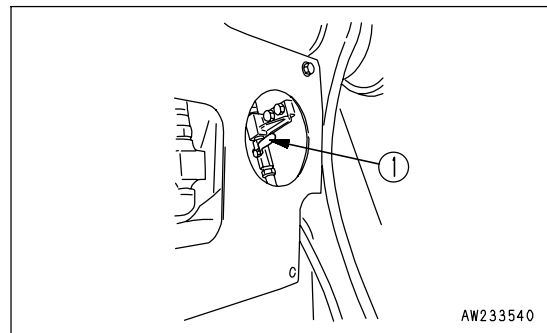

CLEAN STEERING CLUTCH CASE BREATHER

1. Open the rear cover.
2. Remove bolts (1), then remove cover (2).

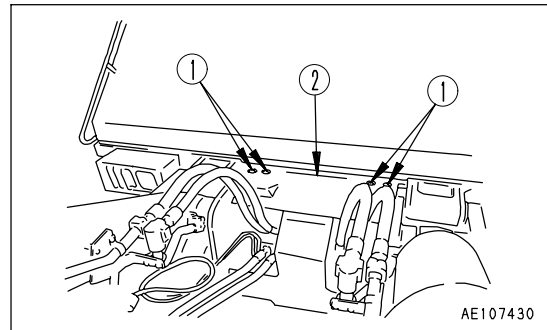

3. Remove breather (3) on steering clutch case, remove any dirt stuck to the breather, then wash with clean diesel oil or flushing oil.

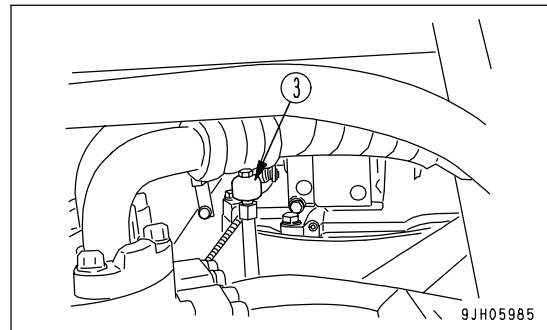

CHECK UNDERCARRIAGE OIL

Stop the machine on level ground, and check for any reduction in the oil at the idler (portion P), track roller (portion Q), and carrier roller (portion R).

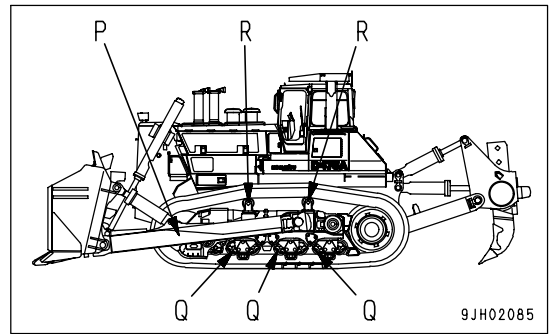

1. Loosen seal bolt (1) slowly and check if oil oozes out from the thread. If oil oozes out, the oil level has not gone down, so tighten the bolt.
2. If no oil comes out even when seal bolt is removed, the oil level is low. Contact your Komatsu distributor for repairs.

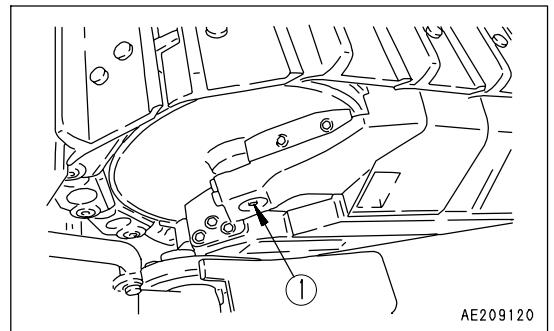

REMARK

Bogie shaft seal bolt (1) is located on both the inside and outside.

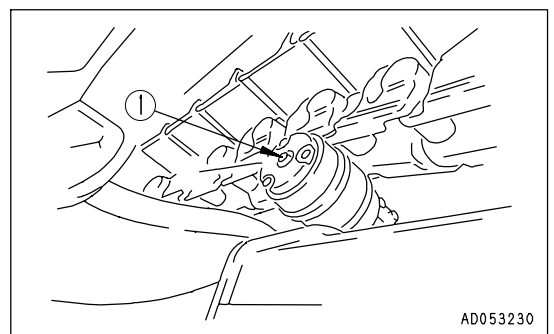
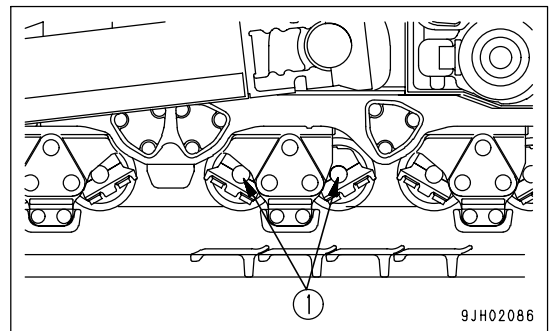

CLEAN AIR CONDITIONER AIR FILTER (FRESH/RECIRC FILTER)

Clean the air conditioner air filter if it becomes clogged or if there is dirt or oil stuck to it.

1. Open inspection cover (1) and remove fresh air filter (2).
2. Remove RECIRC filter (3) at the rear of the cab.
3. Use compressed air to clean filters (2) and (3).

If there is any oil stuck to the filter or it is extremely dirty, wash it in water containing a neutral agent.

After washing with water, dry the filter thoroughly and use it again.

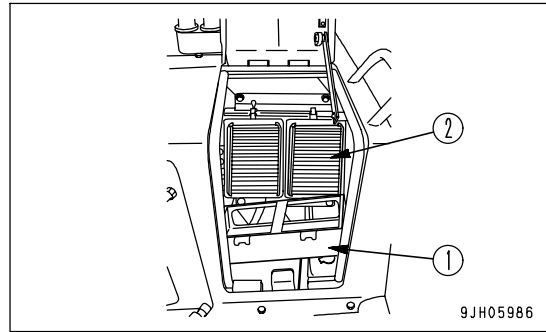

9JH05986

REMARK

If the filters cannot be cleaned with air or in water, replace them with new ones.

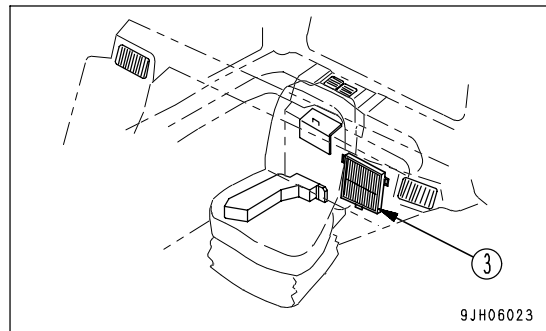

9JH06023

REPLACE AIR CONDITIONER BELT

1. Loosen 3 bolts (1) and lock nut (2), then move compressor (3) to the side.
2. Replace the V-belt.

- When adjusting the V-belt, do not push the compressor directly with a bar. Use adjust nut (4).

Tighten adjust nut (4) and bolts (1), and apply tension to the V-belt. The standard deflection for the V-belt is approx. 18 to 22 mm (0.71 to 0.88 in) when the belt is pushed by thumb (approx. 58.8 N {6 kg}) at a point midway between the air compressor pulley and fan pulley.

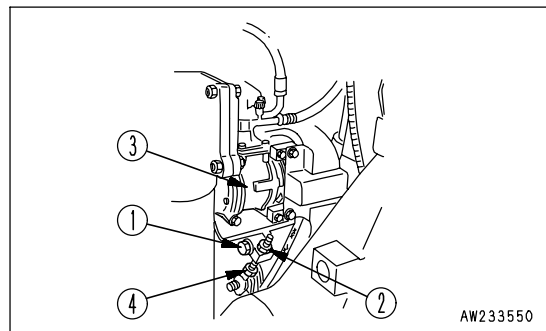

AW233550

CLEAN AND CHECK HYDRAULIC COOLER FINS

If the hydraulic cooler fins are clogged or there is dirt caught in the fins, clean and check the fins.

1. Open the inspection cover on the right.
2. Use compressed air to remove the mud, dirt, and leaves clogging the hydraulic cooler fins. Steam or water may be used instead of compressed air.

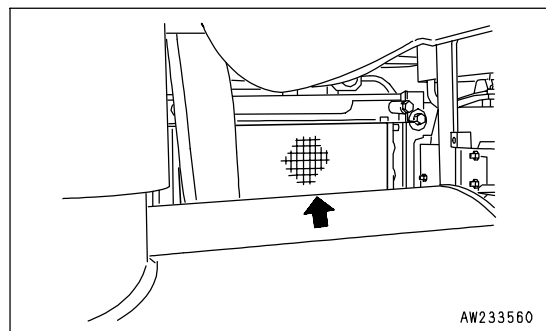

AW233560

REMARK

Check the hydraulic cooler hoses. If any hose is cracked or hardened by age, replace with a new hose. Also check and tighten all loose hose clamps.

CHECK AND ADJUST AIR CONDITIONER

CHECK TENSION OF COMPRESSOR BELT

If the belt is loose, it will slip and the cooling effect will be reduced. From time to time, press a point midway between the drive pulley and compressor pulley with your finger (approx. 58.8 N {6 kg}) and check that the tension is 15 to 18 mm (0.6 to 0.7 in).

When the belt is new, there will be initial elongation, so always adjust again after 2 or 3 days.

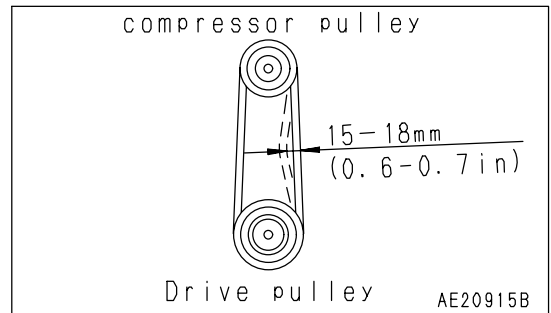

CHECK LEVEL OF REFRIGERANT(GAS)

! WARNING

- When handling refrigerant gas, always follow local laws and regulations.
- The refrigerant used in the cooler is colorless and odorless and does not harm the atmosphere, but if the liquid gets into your eyes or on your hands, it may cause loss of sight or frostbite, so never loosen any part of the refrigerant circuit.

If the level of the refrigerant (gas) is low, the cooling effect will be reduced. Run the engine at high idle, and check the flow of the refrigerant in the refrigerant circuit through the sight glass of the receiver when the cooler is running at high speed.

- No bubbles in refrigerant flow: Suitable
- Some bubbles in flow (bubbles pass continuously): Lack of refrigerant
- Colorless, transparent: No refrigerant

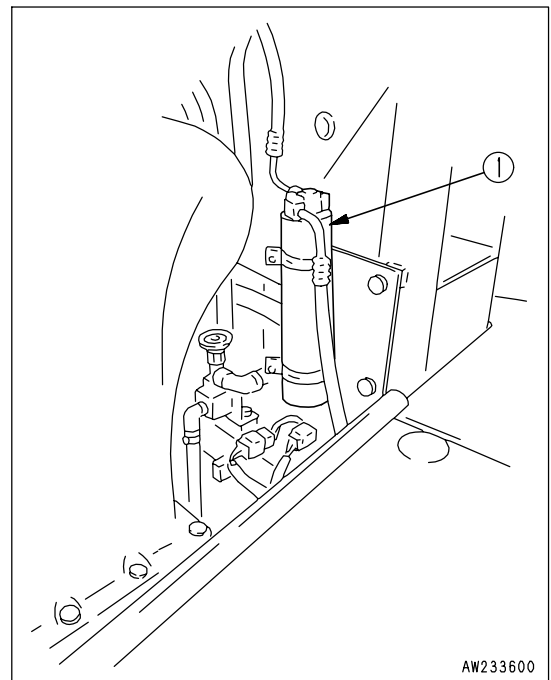

REMARK

- When there are bubbles, the refrigerant gas level is low, so contact your refrigerant dealer to have refrigerant added. If the air conditioner is run with the refrigerant gas level low, it will cause damage to the compressor.
- New Freon R134a is used as the refrigerant.

Charge amount of air conditioner refrigerant (gas): 1100 g

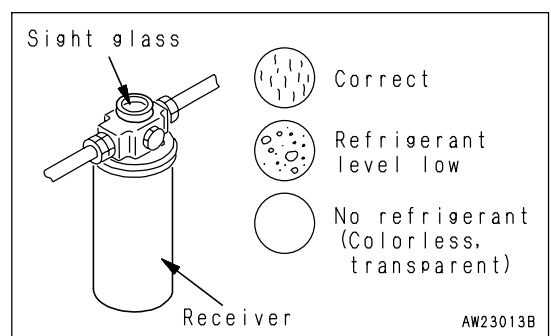

LUBRICATE DOOR HINGE

If the door makes a squeaking noise when it is opened or closed, spray lubricant in through the split in the hinge bushing.
If the bushing is worn, replace the hinge.

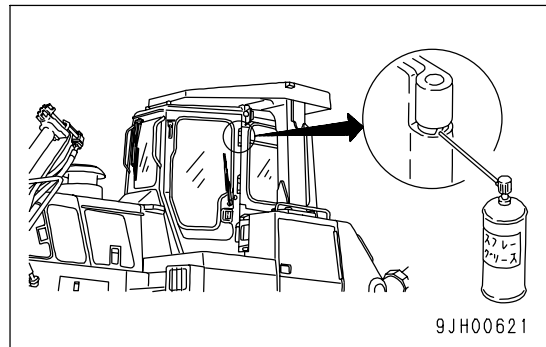

9JH00621

CHECK DOOR LATCH



WARNING

If the control lever is touched by accident during checking, the machine moves off suddenly, and this may lead to serious injury or death.
Before checking door latch, stop the engine and set the parking lever securely to the LOCK position.

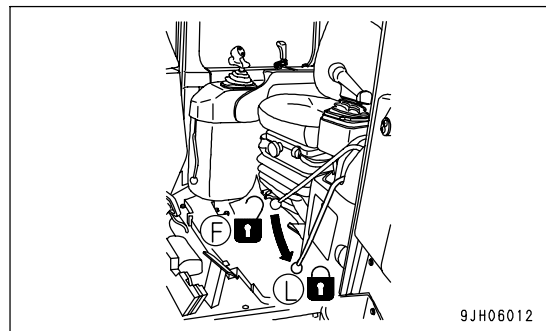

9JH06012

Check

Hold the door open-locked, and check that there is still grease inside the latch. If the amount of grease is low or there is no more grease, coat the inside of the latch with grease from portion (1).

REMARK

If there is no more grease inside the latch, the movement will become poor because of dust inside the latch, and the handle may be stiff when opening the door.

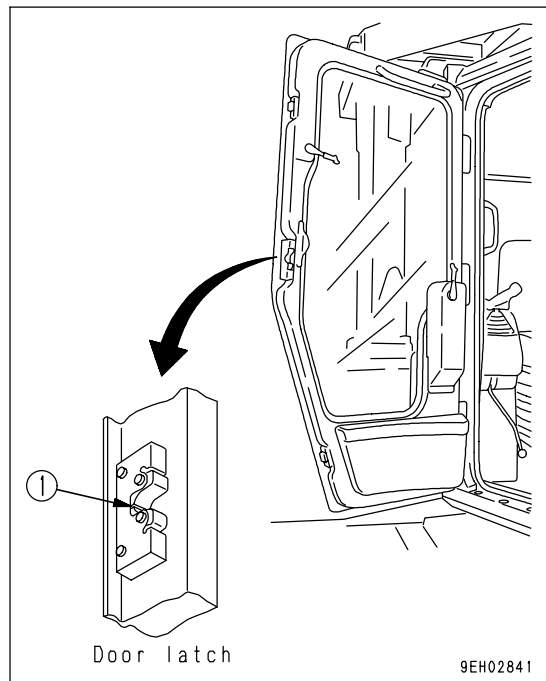

9EH02841

CHECK DOOR LOCK STRIKER

If the wear of the door lock striker exceeds 0.5 mm (0.02 in), replace the striker. If it is used at it is, the play will increase and this may result in breakage of the hinge or door lock.

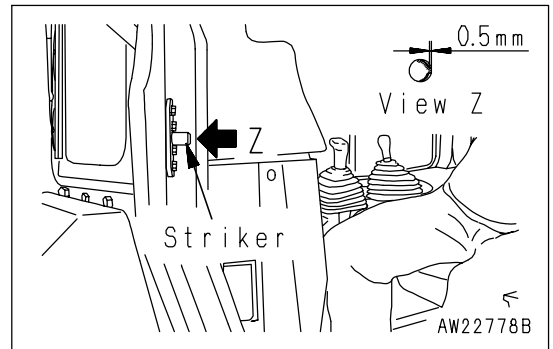

REPLACE DOOR DAMPER

If the depth of the door damper rubber groove is less than 2 mm (0.08 in), replace the damper.

There are two dampers each at the top and bottom on the left and right doors.

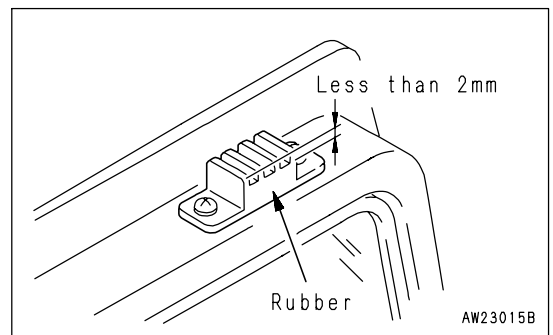

CHECK WINDOW WASHER FLUID LEVEL, ADD FLUID

If there is air in the window washer fluid, check the level and add fluid.

Open the battery cover, check the level of the fluid in window washer tank (1), and if it is low, add automobile window washer fluid.

When adding fluid, be careful not to let any dust get in.

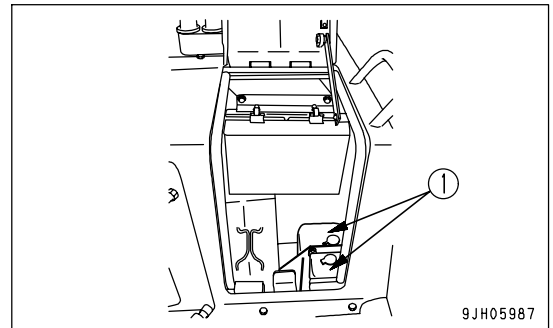

REPLACE WIPER BLADE

If the blade is damaged, it will not wipe the window clean, so replace the blade.

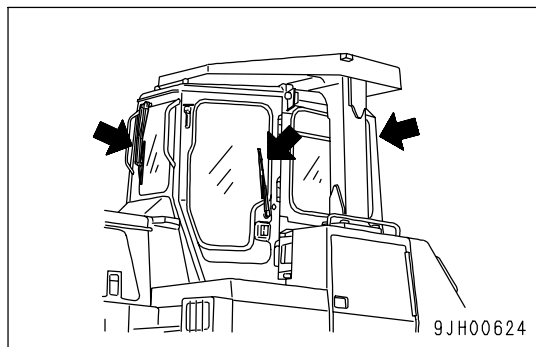

REPLACEMENT

FRONT, REAR WIPER

1. Remove screw (1), then remove the blade.
2. Install a new blade, then tighten screw (1) securely.

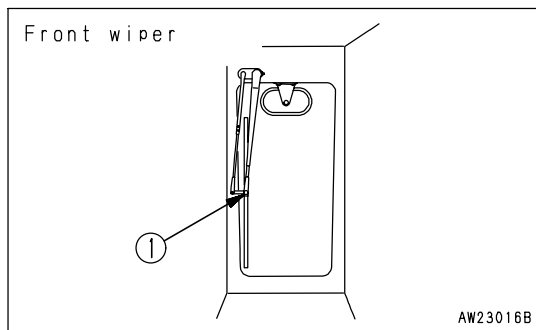

REAR WIPER

1. Remove E-ring (1).
The blade can then be removed.
2. Install a new blade, then install securely with E-ring (1).

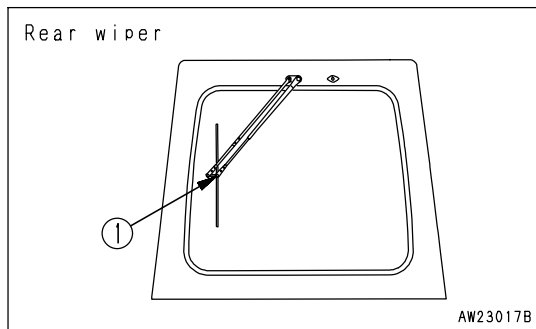

DOOR WIPER

1. It is hooked at portion (A), so move the blade in the direction of the arrow to remove it.
2. Install the new blade and hook it securely.

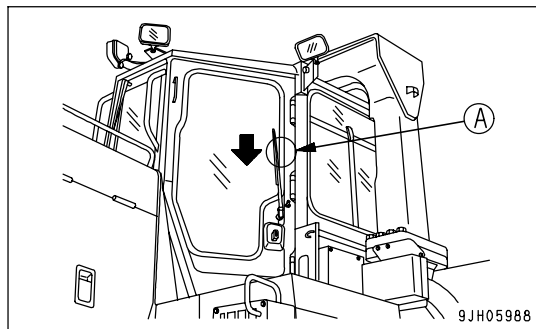

BLEEDING AIR IN HYDRAULIC SYSTEM

See "OPERATIONS AND CHECKS AFTER STARTING ENGINE (PAGE 3-115)".

Since the engine must be started and the blade must be operated, see OPERATION.

NOTICE

If the engine is run at high speed immediately after startup or a cylinder is pushed up to its stroke end, air taken inside the cylinder may cause damage to the piston packing.

1. Bleeding air from cylinders

- 1) Run the engine at low idle, and extend and retract each cylinder 4 to 5 times, taking care that a cylinder is not moved to the end of its stroke. (Stop the cylinder approx. 100 mm (3.9 in) short of its stroke end)
- 2) Next, operate each cylinder 3 to 4 times to the end of its stroke.
- 3) Finally, operate each cylinder 4 to 5 times to the end of its stroke to completely remove the air.

CHECK ELECTRICAL INTAKE AIR HEATER

Check before the cold season starts (once a year).

Remove the electric heater from the engine intake manifold and check for wire disconnections and dirt clinging to it.

When checking and installing the electric heater, replace its gasket with a new one.

LUBRICATING

1. Lower the work equipment to the ground, then stop the engine.
2. Using a grease pump, pump in grease through the grease fittings shown by arrows.
3. After greasing, wipe off any old grease that was pushed out.

Fuel control (1 place)

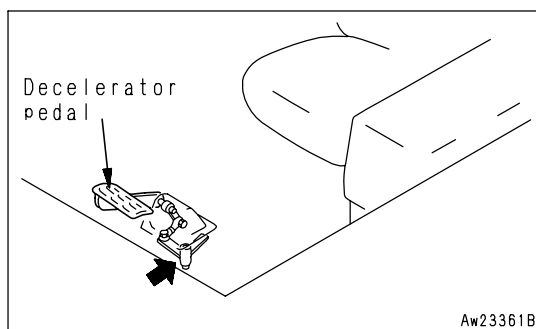

Steering, directional, gearshift lever rotating link (4 places)

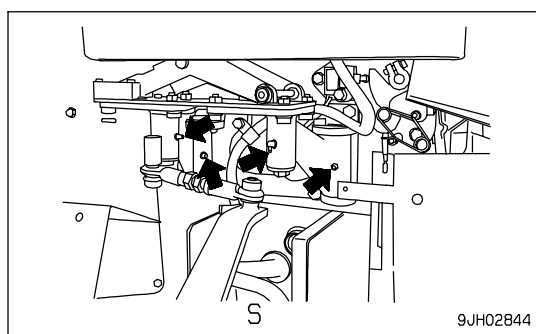
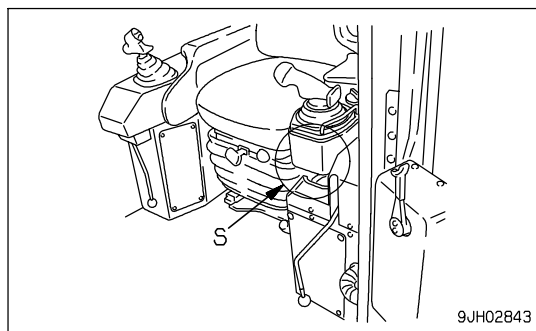

Brake pedal (3 places)

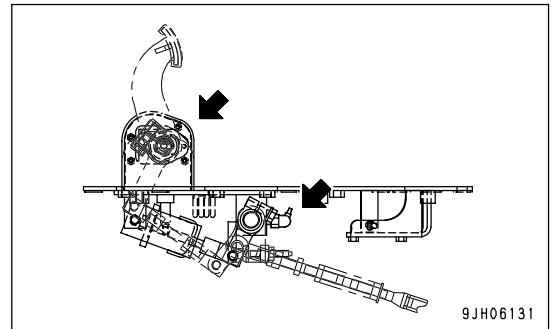
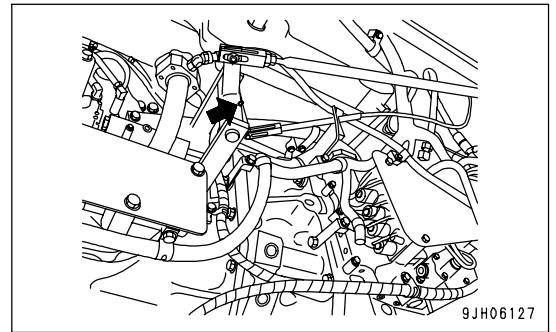

Universal joint (2 places)

⚠ WARNING

The undercover is heavy. Never try to open or close the cover when directly beneath it. When removing bolts(2), carry out the work from the rear of the cover so that you can easily get out of the way.

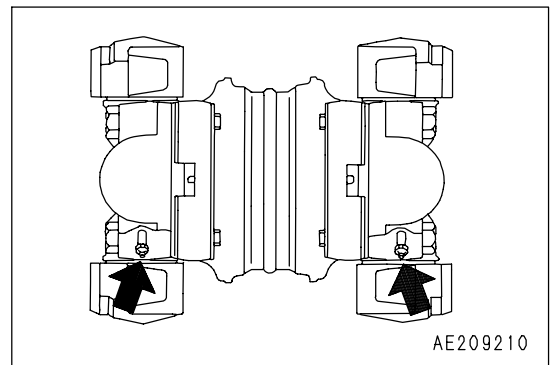

Remove inspection cover (3) of the undercover on the rear bottom of the chassis as follows.

- 1) Remove 2 bolts (1) at the front of the machine.
 - 2) Support the cover with your elbow while gradually removing 2 bolts (2) at the rear of the machine.
 - 3) Lower the cover gradually to open it.
- (A) Rear of machine

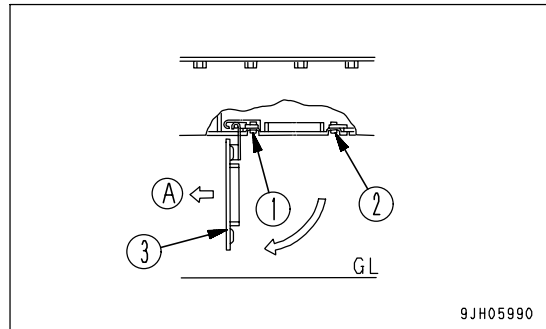
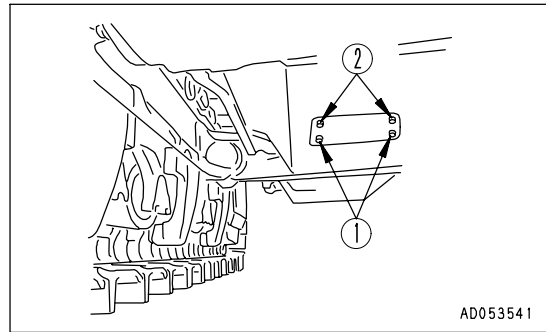

CHECK BEFORE STARTING

For details of the following items, see "CHECK BEFORE STARTING (PAGE 3-88)".

- Check machine monitor
- Check coolant level, add coolant
- Check fuel level, add fuel
- Check oil level in engine oil pan, add oil
- Check oil level in power train case (incl. transmission, torque converter and bevel gear cases), add oil
- Check damper case oil level, add oil
- Check brake pedal travel
- Check dust indicator
- Check oil level in hydraulic tank, add oil
- Check electric wiring
- Check that lamps light up
- Check horn sound
- Check backup alarm sound
- Adjusting operator's seat
- Using seat belt
- Adjust mirror
- Adjust joystick
- Adjust armrest

EVERY 250 HOURS SERVICE

LUBRICATING

1. Lower the work equipment to the ground, then stop the engine.
2. Using a grease pump, pump in grease through the grease fittings shown by arrows.
3. After greasing, wipe off any old grease that was pushed out.

- (1) Blade lift cylinder support yoke (4 places)
- (2) Blade lift cylinder support shaft (2 places)

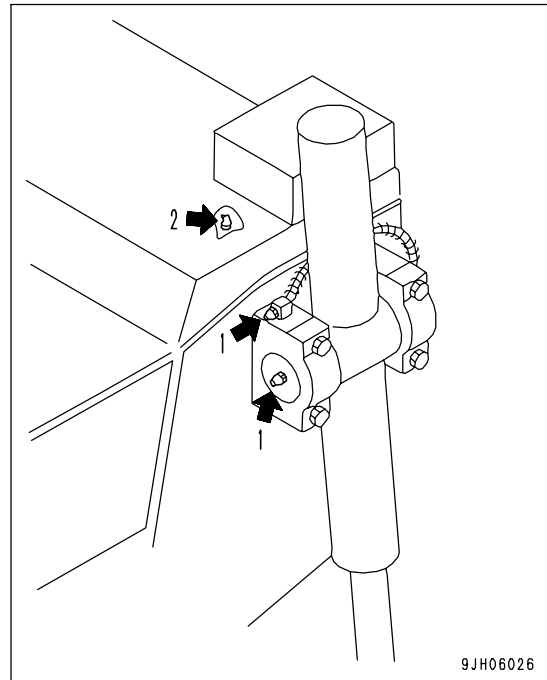

- (3) Blade arm ball joint (5 places) - Semi U
- Blade arm ball joint (4 places) - U
- (4) Brace screw (2 places)

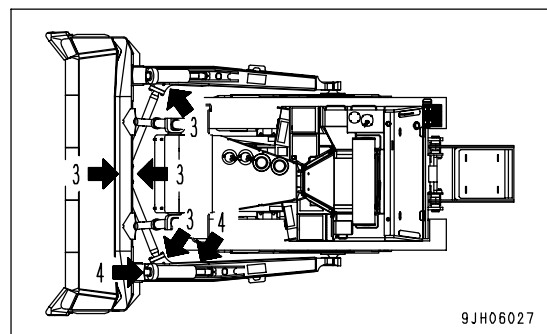

- (5) Ripper tilt cylinder bottom pin (2 places)
 - (6) Ripper lift cylinder bottom pin (2 places)
 - (7) Ripper tilt cylinder rod end pin (2 places)
 - (8) Ripper lift cylinder rod end pin (2 places)
 - (9) Ripper arm pin (front) (2 places)
 - (10) Ripper arm pin (rear) (2 places)
- The illustration on the right shows Giant Ripper (if equipped).

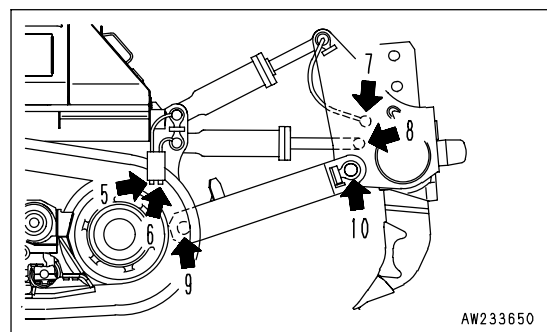

(11) Equalizer bar side shaft (2 places)

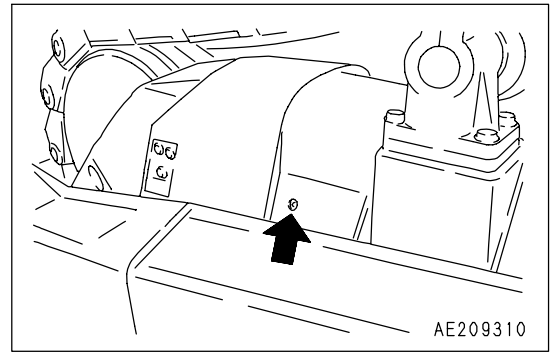

(12) Suspension (equalizer bar center shaft) (1 place)

1. Carry out greasing of the suspension (equalizer bar center shaft) through the grease fittings marked by arrows.
2. Pump the greasing lever up and down 3 - 5 times.

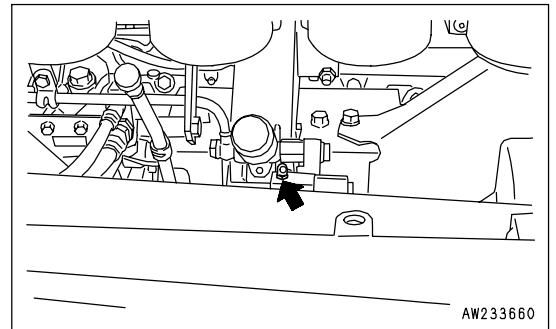

CHECK ALTERNATOR DRIVE BELT TENSION, ADJUST**CHECKING**

The standard deflection for the drive belt is approx. 15 mm (0.59 in) when pressed by thumb (approx. 58.8 N {6 kg}) at a point midway between the drive pulley and alternator pulley.

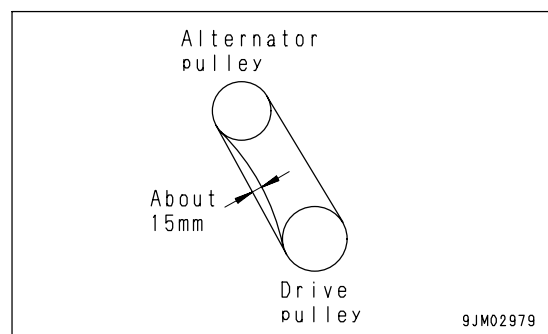
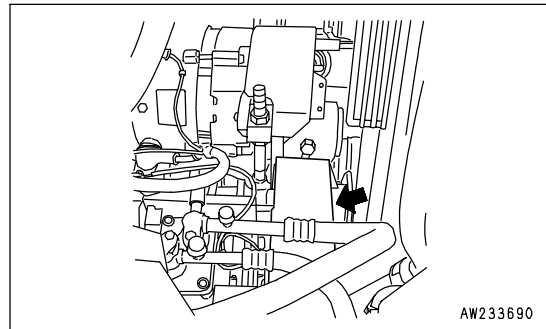
**ADJUSTING**

1. Loosen bolts and nuts (1), (2) and (3).
2. Turn nut (4) clockwise, then move alternator (5) to adjust the belt tension so that the deflection is approx. 15 mm (0.59 in) when pushed with a force of 6 kg.

REMARK

When adjusting the belt tension, never push the alternator directly with a bar. If it is necessary to push the alternator, insert a piece of wood in-between and push it with a bar.

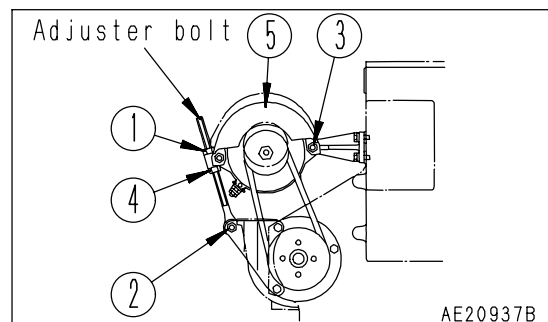

3. Tighten the bolts and nuts (1), (2) and (3) to fix alternator (5) in position.
4. Check for damage to the pulleys, and wear of the V-groove and V-belt. Be particularly careful to check that the V-belt is not in contact with the bottom of the V-groove.
5. If any belt has stretched and there is no allowance for adjustment, or if there are cuts or cracks on any belt, replace the belt.
6. After replacing the belt, operate for one hour, then adjust again.

CHECK LEVEL OF BATTERY ELECTROLYTE

Carry out this procedure before operating the machine.

! WARNING

- Do not use the battery if the battery electrolyte level is below the LOWER LEVEL line. This will accelerate deterioration of the inside of the battery and reduce the service life of the battery. In addition, it may cause an explosion.
- The battery generates flammable gas and there is danger of explosion, do not bring fire or sparks near the battery.
- Battery electrolyte is dangerous. If it gets in your eyes or on your skin, wash it off with a large amount of water and consult a doctor.

NOTICE

- When adding distilled water to the battery, do not allow the battery electrolyte to go above the UPPER LEVEL line. If the electrolyte level is too high, it may leak and cause damage to the paint surface or corrode other parts.
- When adding distilled water in cold weather, add it before starting operations in the morning to prevent the electrolyte from freezing.

Inspect the battery electrolyte level at least once a month and follow the basic safety procedures given below.

Open covers (1) on the left and right sides of the machine. The batteries are mounted at portion (A).

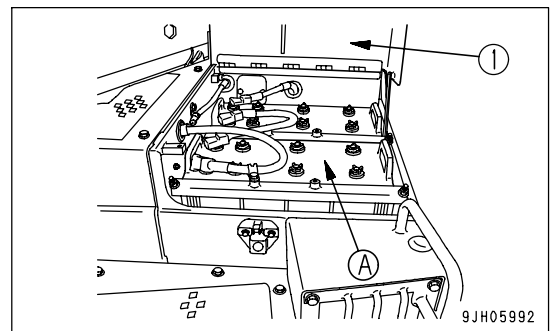
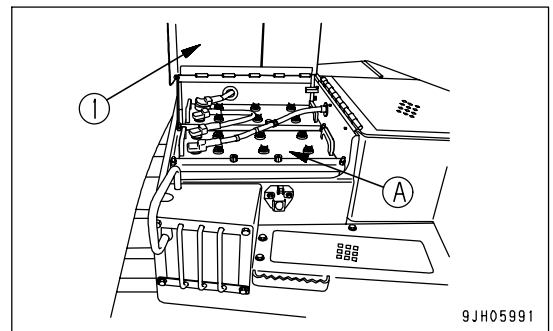

WHEN CHECKING ELECTROLYTE LEVEL FROM SIDE OF BATTERY

If it is possible to check the electrolyte level from the side of the battery, check as follows.

1. Use a wet cloth to clean the area around the electrolyte level lines and check that the electrolyte level is between the UPPER LEVEL (U.L.) and LOWER LEVEL (L.L.) lines.
If the battery is wiped with a dry cloth, static electricity may cause a fire or explosion.

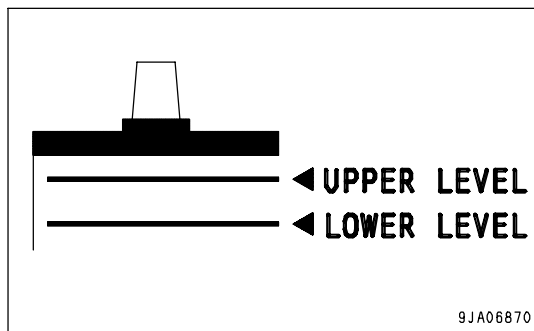

2. If the electrolyte level is below the midway point between the UPPER LEVEL (U.L.) and LOWER LEVEL (L.L.) lines, remove cap (2) and add distilled water to the U.L. line.
3. After adding distilled water, tighten cap (2) securely.

REMARK

If distilled water is added to above the UPPER LEVEL (U.L.) line, use a syringe to lower the level to the UPPER LEVEL (U.L.) line. Neutralize the removed fluid with baking soda (sodium bicarbonate), then flush it away with a large amount of water or consult your Komatsu distributor or battery maker.

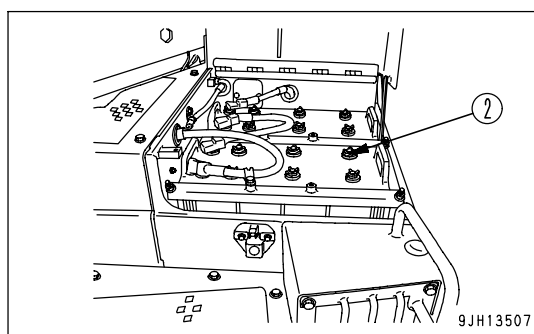

WHEN IT IS IMPOSSIBLE TO CHECK ELECTROLYTE LEVEL FROM SIDE OF BATTERY

If it is impossible to check the electrolyte level from the side of the battery, or there is no display of the UPPER LEVEL line on the side of the battery, check as follows.

1. Remove cap (2) at the top of the battery, look through the water filler port (3), and check the electrolyte surface. If the electrolyte does not reach the sleeve (4), add distilled water so that the level reaches the bottom of the sleeve (UPPER LEVEL line) without fail.
 - (A) Suitable level: Electrolyte level is up to bottom of sleeve, so surface tension causes electrolyte surface to bulge and poles appear bent.
 - (B) Low: Electrolyte level is not up to bottom of sleeve, so poles appear straight and not bent.
2. After adding distilled water, tighten cap (2) securely.

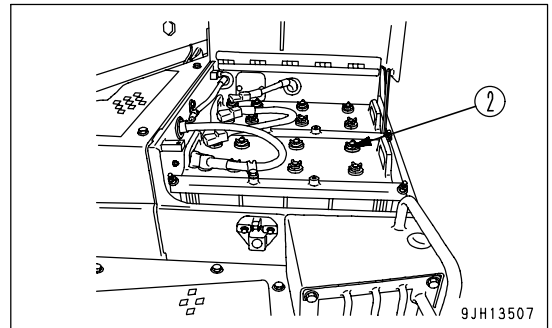

REMARK

If water is added to above the bottom tip of the sleeve, use a pipette to remove electrolyte. Neutralize the removed electrolyte with sodium bicarbonate, then flush it away with a large amount of water. If necessary, contact your Komatsu distributor or your battery maker.

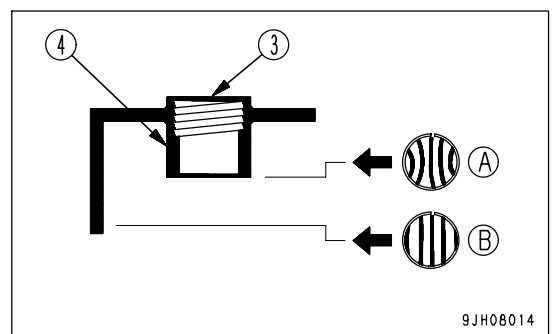

WHEN IT IS POSSIBLE TO USE INDICATOR TO CHECK ELECTROLYTE LEVEL

If it is possible to use an indicator to check the electrolyte level, follow the instructions given.

CHECK BRAKE PERFORMANCE

**WARNING**

If the machine moves during the following operation, please contact your Komatsu distributor for repairs immediately.

NOTICE

Set the steering, directional, speed lever to 1st and depress the brake pedal. Run the engine at low speed. Do not run it at full speed; this will cause damage to the machine.

Before starting the engine, check that the area around the machine is safe, then do as follows:

1. Start the engine.
2. After completing the warm-up operation, set fuel control dial (3) to the SLOW position.
3. Set work equipment lock lever (1) to the FREE position then operate blade control lever (6) and ripper control lever (7) to raise the blade and ripper.
Leave the work equipment lock lever (1) in the FREE position.
4. Set parking lever (2) to the FREE position.
5. Depress brake pedal (5), set steering, directional, speed lever (4) to FORWARD, then press the shift-up button to set to 2nd.
6. Operate fuel control dial (3) and gradually raise the engine speed to full throttle. (Keep the brake pedal depressed.)
7. Check that the machine does not move. This indicates that brake performance is normal.

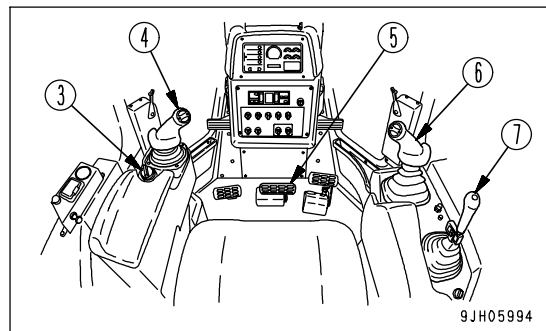
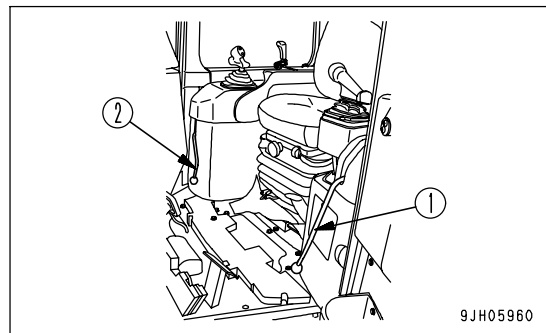

CHECK OIL LEVEL IN DAMPER CASE, ADD OIL

1. Open the engine side cover on the right side of the machine.
2. Remove dipstick (G) and wipe the oil off with a cloth.
3. Fully insert dipstick (G) into filler pipe (F), then remove it.
4. The oil should be between the H and L marks on dipstick (G).
If the oil is below the L mark, add oil through the dipstick insertion port.

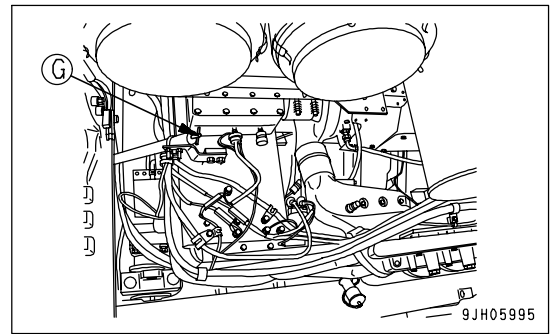

5. If the oil is above the H mark, open inspection cover (2) in the center of the bottom face of the power train case, drain the excess oil from engine damper drain plug (P) (this can be seen towards the front of the machine from the inspection window), then check the oil level again.

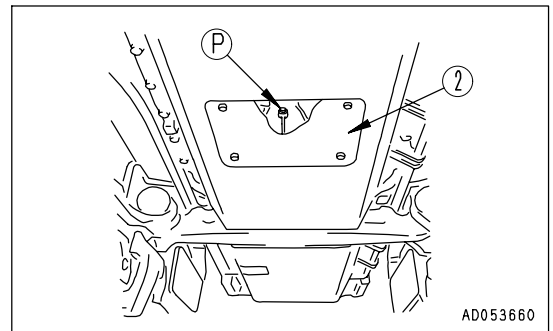

REMARK

- Check the oil level while the engine is stopped.
- If the machine is inclined, set it in a level position before checking the oil level.

EVERY 500 HOURS SERVICE

Maintenance for every 250 hours should be performed at the same time.

CHANGE OIL IN ENGINE OIL PAN, REPLACE ENGINE OIL FILTER CARTRIDGE



WARNING

The oil is at high temperature after the engine has been operated, so never change the oil immediately after finishing operations. Wait for the oil to cool down before changing it.

- Use a venturi component type for the engine oil filter.
- Prepare a socket wrench and filter wrench.
- Refill capacity: 121 liters (31.97 US gal)

1. Open cover under the chassis. Set a container to catch oil under drain valve (2).

2. Remove drain plug (1) and slowly open drain valve (2), and drain the oil.

Take care not to open drain valve (2) so much that the stopper pin in the valve is distorted.

Tightening torque for drain plug (1): 68.6 ± 9.81 Nm
(7 ± 1 kgm, 50.6 ± 7.2 lbft)

Tightening torque for drain valve (2): 63.7 ± 14.7 Nm (6.5 ± 1.5 kgm, 47.0 ± 10.8 lbft)

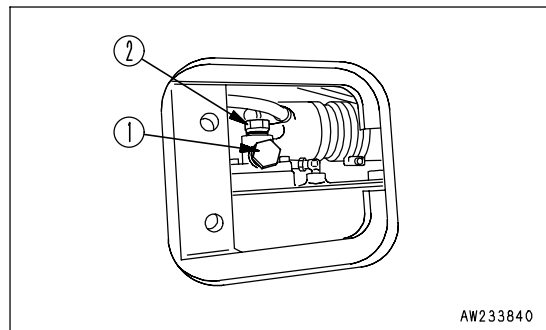

3. Check the drained oil, if there is excessive metal particles or foreign material, contact your Komatsu distributor.

4. Close drain valve (2) and insert and tighten drain plug (1).

5. Use a filter wrench and remove each filter cartridge (3) in turn, starting from the front of the machine.

6. Clean the filter holder, fill the new filter cartridge with engine oil, coat the packing surface and thread with engine oil (or coat it thinly with grease), then install the filter cartridge.

7. When installing the filter cartridge, bring the packing surface into contact with the filter holder, then tighten a further 3/4 to 1 turn.

8. After replacing the filter cartridge, add engine oil through oil filler port (F) until the oil level is between the H and L marks on the dipstick.

9. Run the engine at idling for a short time, then stop the engine, and check that the oil level is between the H and L marks on the dipstick. For details, see "CHECK OIL LEVEL IN ENGINE OIL PAN, ADD OIL (PAGE 3-91)".

Even if the machine has not been operated for 500 hours, the oil and filter cartridge must be replaced when the machine has been operated for 12 months.

In the same way, even if the machine has not been operated for 12 months, the oil and filter cartridge must be replaced when the machine has been operated for 500 hours.

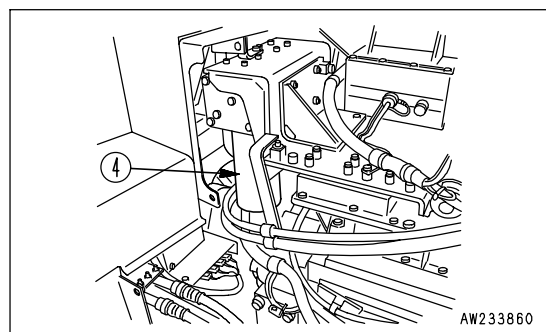
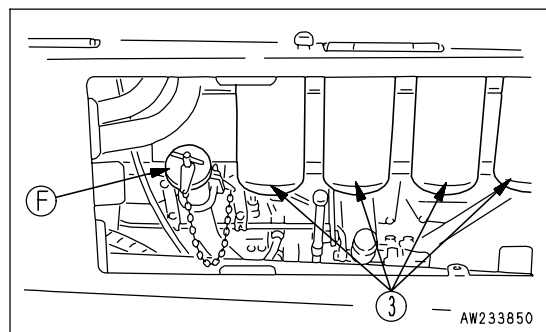

REPLACE FUEL FILTER CARTRIDGE

Prepare a filter wrench and a container to catch the fuel.

WARNING

- Engine is at high temperature immediately after the machine has been operated. Wait for engine to cool down before replacing the filter.
- Do not bring fire or sparks near the fuel.
- When bleeding the air, be careful not to let the fuel overflow. It may cause a fire.

NOTICE

- Genuine Komatsu fuel filter cartridges use a special filter that has highly efficient filtering ability. When replacing the filter cartridge, always use a genuine Komatsu part.
- The common rail fuel injection system used on this machine consists of more precise parts than the conventional injection pump and nozzle.
If any part other than a genuine Komatsu filter cartridge is used, dust or dirt may get in and cause problems with the injection system. Always avoid using substitute parts.
- When carrying out inspection or maintenance of the fuel system, pay more attention than normal to the entry of dirt. If dirt is stuck to any part, use fuel to wash it off completely.

1. Set the container under the filter cartridge to catch the drained oil.
2. Close valve (1) of fuel strainer part.
3. Using a filter wrench, turn filter cartridge (2) counterclockwise to remove it.
4. Clean the filter holder, fill a new filter cartridge with clean fuel, coat the packing surface with oil, then install it to the filter holder.
5. When installing tighten until the packing surface contacts the seal surface of the filter holder, then tighten 3/4 to 1 turn.
If the filter cartridge is tightened too far, the packing will be damaged and this will lead to leakage of fuel. If the filter cartridge is too loose, fuel will also leak from the packing, so always tighten to the correct amount.
6. Open valve (1) of fuel strainer and loosen air bleeding plug (3).
7. Loosen the knob of priming pump (4), move it up and down, and continue until no more bubbles come out with the fuel from air bleed plug (3).
8. Tighten air bleed plug (3), push in the knob of priming pump (4), then tighten it.

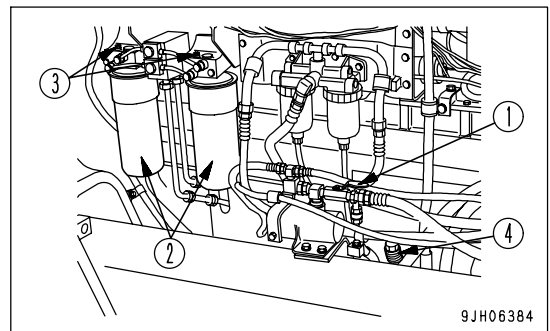

9. After replacing the filter cartridge, start the engine and check for leakage from the filter seal surface.

REMARK

When only the filter cartridge is replaced, it is enough to bleed the air only from the filter head. If the fuel piping is removed, bleed the air from injection pump air bleed plug (6).

Fuel injection pump air bleed plug (6) is on the left and right sides of the engine.

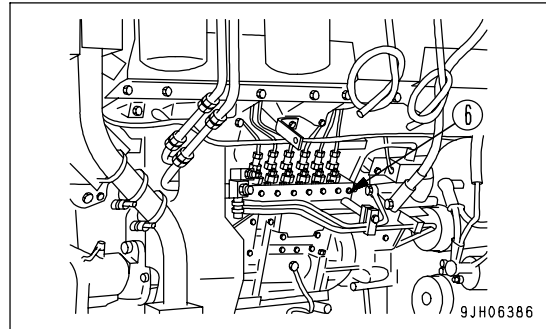

REPLACE TRANSMISSION FILTER ELEMENT, TRANSMISSION LUBRICATION FILTER ELEMENT AND TORQUE CONVERTER OIL FILTER ELEMENT

! WARNING

Before opening the filter cases, depress the brake pedal several times to release the pressure, then lock the brake pedal. If there is still pressure inside the filter, the oil may spurt out.

1. Remove the floor cover on right side fender.
 - (A) Torque converter oil filter
 - (B) Transmission lubrication filter
 - (C) Transmission filter
 - (F) Direction of advance

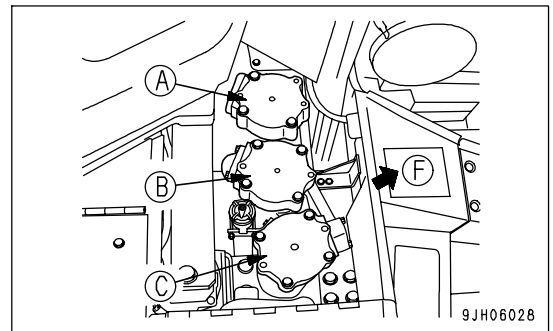

2. Remove mounting bolt (1) of the filter, then remove cover (2).
3. Take out element (3).
4. Clean inside of the case and the removed parts, then install a new element.
Replace the O-ring with a new one.

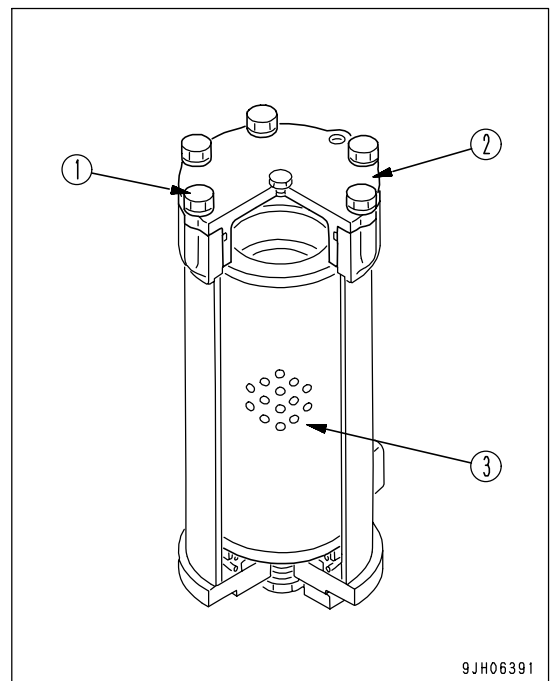

CHECK OIL LEVEL IN FINAL DRIVE CASE, ADD OIL

! WARNING

There is danger that oil may spurt out under internal pressure, so stand to the side, and gradually turn the plug to release internal pressure before removing the plug.

1. Place the machine on a horizontal place.
2. Remove oil level plug (G) and check the oil level. The oil level should be within a range from the bottom edge of the plug hole to 20 mm (0.8 in) down from the hole.

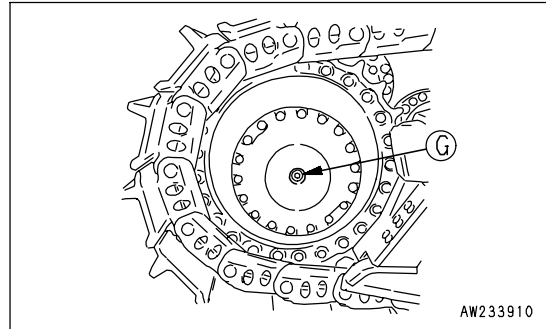

3. If the oil level is still too low, add oil through oil filter plug hole (F) until the oil overflows. Before removing oil plug (F), remove all the mud and dirt from around oil filler plug (F). Be careful not to let any dirt or sand get in when adding oil.

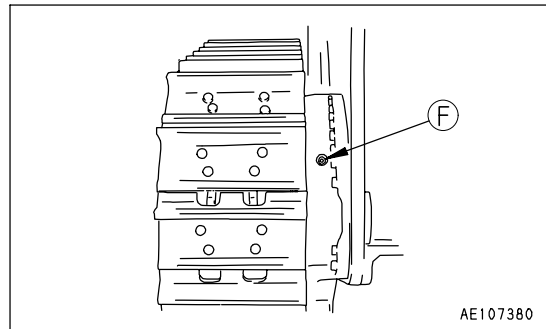

REPLACE HYDRAULIC TANK BREATHER ELEMENT

! WARNING

Replace the element when the oil is cold. When removing breather cap (1), turn it slowly to release the internal pressure before removing it.

1. Remove breather cap (1) on the top of the hydraulic tank.
2. Replace element (2) inside the cap.

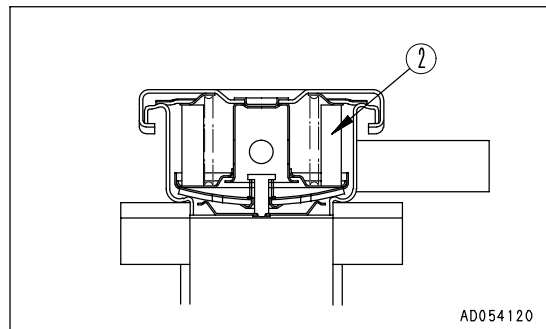
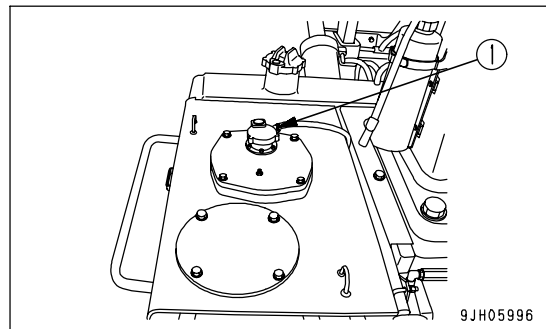

EVERY 1000 HOURS SERVICE

Maintenance for every 250 and 500 hours service should be carried out at the same time.

CHANGE OIL IN POWER TRAIN CASE, CLEAN STRAINERS (INCL. TRANSMISSION CASE, TORQUE CONVERTER CASE AND BEVEL GEAR CASE)

! WARNING

- The oil is at high temperature immediately after the machine has been operated. Wait for the oil to cool down before starting the operation.
- The undercover is heavy. Never open and close operation right below the undercover. When removing bolts, work behind the right below and be ready for escaping at any time.

- Refill capacity: 210 liters (55.48 US gal)

1. Remove the cover on the bottom of the rear body.
2. Pull out hose (1), then loosen drain plug (2) and drain the oil.
3. After draining the oil, tighten drain plug (2).
4. Insert hose (1) inside the cover, then install the cover.

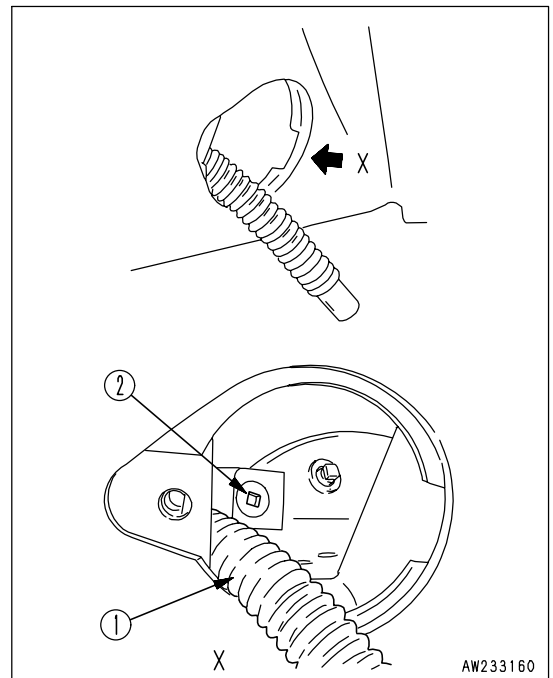

5. Remove the cover on left fender, remove bolts (3) and case (4).
6. Take out strainer (5) and magnet (6).

If any damage to strainer (5) or magnet (6) is found, replace with a new one.

7. Loosen bolt (7), then divide into strainer (5) and magnet (6).
Tightening torque of bolt (7): 46 to 59 Nm (4.7 to 5.9 kgm, 34 to 43 lbf)

8. Remove all dirt from strainer, then wash in clean diesel oil or flushing oil.

Clean the case interior and the removed parts.

9. Install the strainers to their original position.

10. After installing, replace the element in the power train oil filter.
For details, see "EVERY 500 HOURS SERVICE (PAGE 4-56)".

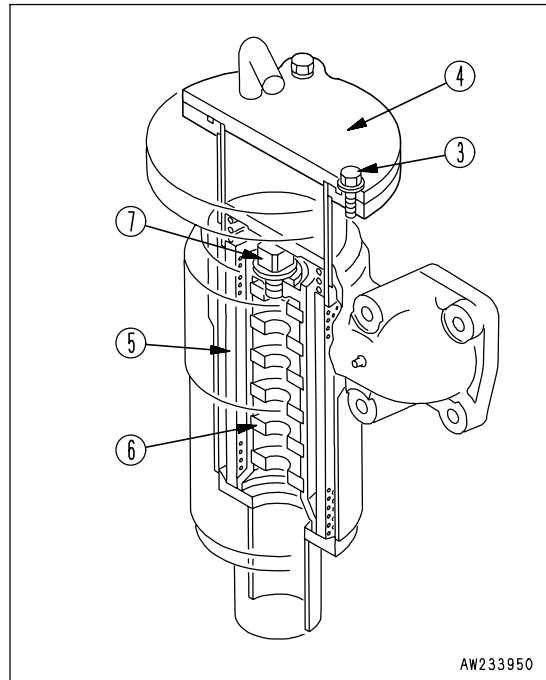
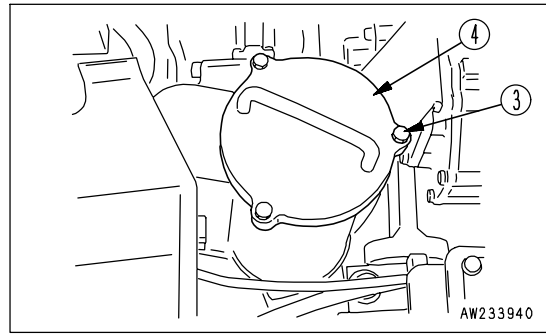

11. Refill the specified quantity of oil through oil filler (F).

12. Check that the oil is at the specified level.

For details, see "CHECK OIL LEVEL IN POWER TRAIN CASE (INCL. TRANSMISSION, TORQUE CONVERTER AND BEVEL GEAR CASES), ADD OIL (PAGE 3-92)".

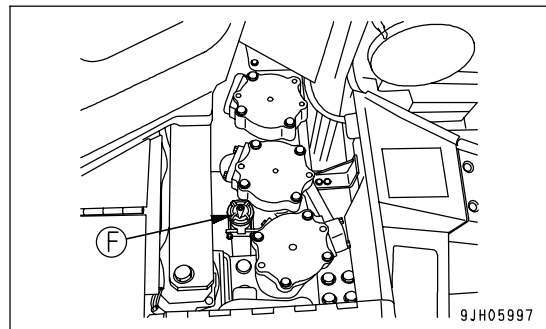

CHECK, CLEAN FUEL STRAINER

1. Tighten valve (1).
2. Remove cap (2), and wash the strainer and strainer case.
The strainer forms one unit with the cap.
3. After checking and cleaning, set the strainer in the case, then tighten cap (2).
4. After installing, open valve (1).

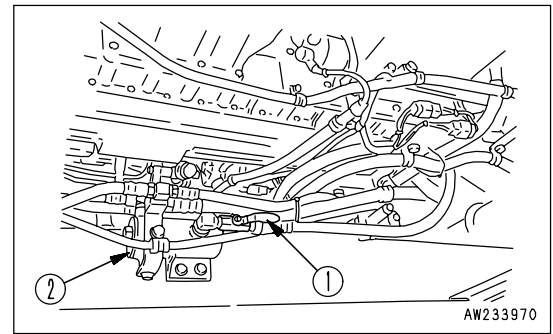
**CHECK FOR LOOSE ROPS MOUNT BOLTS**

Check for loose and damaged bolts. If any loose bolt is found, tighten to a torque of 1960 to 2450 Nm (200 to 250 kgm, 1446.6 to 1808.3 lbft).

If any damaged bolt is found, replace the bolt with a genuine Komatsu bolt.

REPLACE MAIN CORROSION RESISTOR CARTRIDGE AND SUB CORROSION RESISTOR CARTRIDGE

WARNING

If the engine has been operated, all parts will be at a high temperature, so never try to replace the cartridge immediately after stopping the engine.

Always wait for the engine and other parts to cool down.

- Container to catch drained coolant
- Prepare a filter wrench for fuel filter element.

1. Close main corrosion resistor valve (1) and sub corrosion resistor valve (2).
2. Set a container to catch the coolant under the cartridge.
3. Use a filter wrench and remove cartridge (3).
4. Clean the filter holder, coat the packing surface and thread of the new cartridge with oil, then install it to the filter holder.
5. When installing, tighten until the packing surface contacts the seal surface of the filter holder, then tighten it up 2/3 of a turn. If the filter cartridge is tightened too far, the packing will be damaged and this will lead to leakage of coolant. If the filter cartridge is too loose, coolant will also leak from the packing, so always tighten to the correct amount.
6. Open valves (1) and (2).
7. After replacing the cartridge, start the engine and check for any coolant leakage from the filter seal surface. If there is any leakage, check if the cartridge is tightened properly.

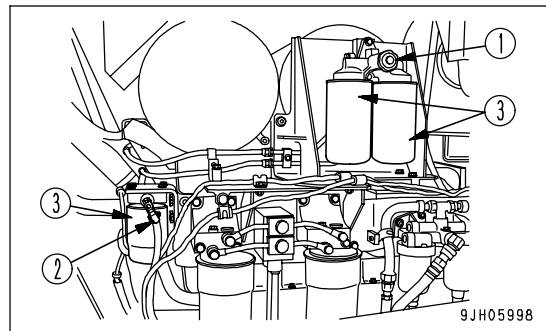

REPLACE AIR CONDITIONER AIR FILTER (FRESH, RECIRC FILTER)

Replace the air conditioner air filters every 1000 hours.

If the air conditioner air filter becomes clogged or there is dirt or oil stuck to it, replace it with a new part if necessary.

1. Open inspection cover (1) and remove fresh air filter (2).
2. Remove RECIRC filter (3) at the rear of the cab.
3. Replace filters (2) and (3).

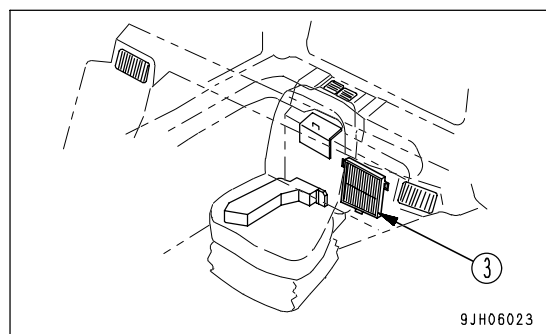
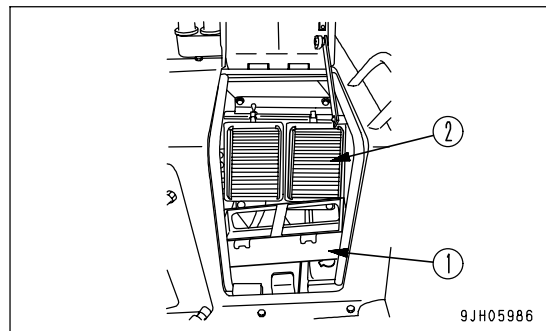

CHECK TIGHTENING PARTS OF TURBOCHARGER

Contact your Komatsu distributor to have the tightening portions checked.

EVERY 2000 HOURS SERVICE

Maintenance for every 250, 500 and 1000 hours service should be carried out at the same time.

CHANGE OIL IN HYDRAULIC TANK, REPLACE HYDRAULIC OIL FILTER ELEMENT, CLEAN HYDRAULIC TANK STRAINER**WARNING**

- The oil is at high temperature immediately after the machine has been operated. Wait for the oil to cool down before changing the oil.
- When removing the oil filler cap (F), turn it slowly to release the internal pressure, then remove it carefully.

- Refill capacity: 170 liters (44.91 US gal)

1. Lower the blade and ripper on the ground securely, stop the engine and slowly turn the cap of oil filler (F) to release the internal pressure. Then, remove the cap.

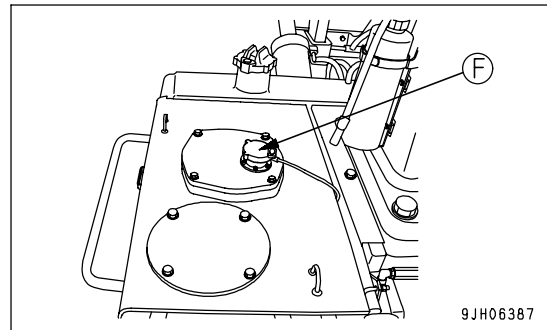

2. Remove drain plug (1) at the bottom of the tank and loosen drain valve (2). After draining the oil, tighten drain plug (1) and drain valve (2). When loosening drain valve (1), be careful not to get oil on yourself.

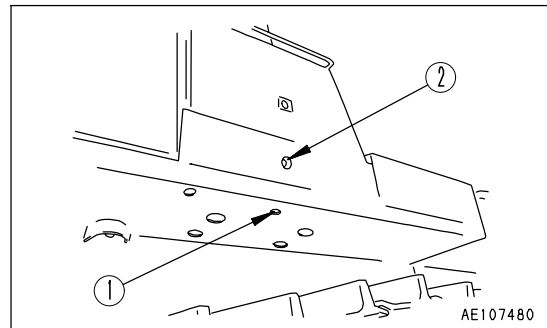

3. Remove bolts (3), then remove cover (4), and take out element (5).
4. Clean the inside of case and removed parts and install a new element.

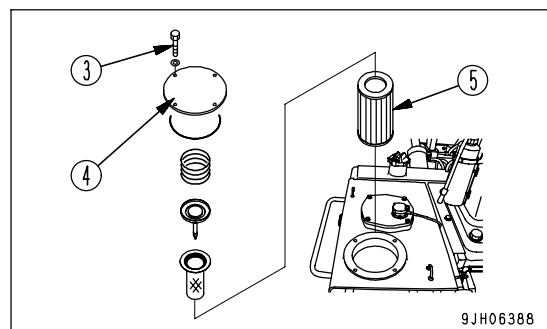

5. Remove bolts (6), then remove cover (7) and take out the strainer.
6. Wash strainer (8) in clean diesel oil or flushing oil.
7. Install strainer (8) to its original position.
8. Add oil through oil filler port (F) to the specified level.
9. After adding oil, check that the oil is at the specified level. For details, see "CHECK OIL LEVEL IN HYDRAULIC TANK, ADD OIL (PAGE 3-95)".

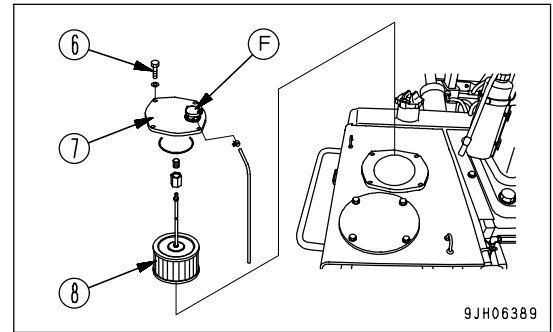

CHANGE OIL IN FINAL DRIVE CASE

**WARNING**

- The oil is at high temperature immediately after the machine has been operated. Wait for the oil to cool down before starting the operation.
- There is danger that oil spouts out due to the internal pressure. When removing the plug, work from the side, turn the plug slowly to release the internal pressure, and remove it carefully.

- Refill capacity: 75 liters (19.82 US gal)

1. Remove oil filler plug (F), then remove drain plug (1) and level plug (G), and drain the oil.

Remove all the mud and dirt from around oil filler plug (F) before removing it. Be careful not to let any dirt or sand get in when adding oil.

2. After draining the oil, tighten the drain plug (1).
3. Remove level plug (G), refill oil from oil filler plug hole (F) until the oil overflows the level plug hole. After refilling, tighten the plugs.

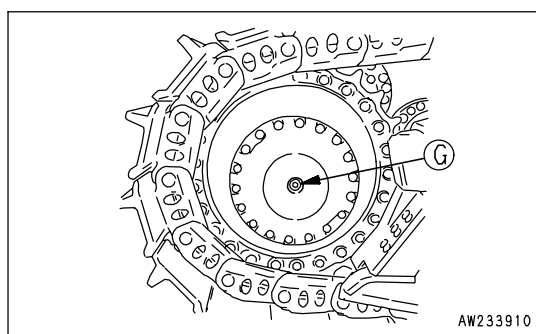
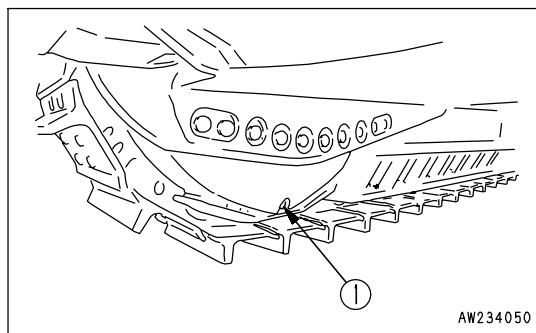
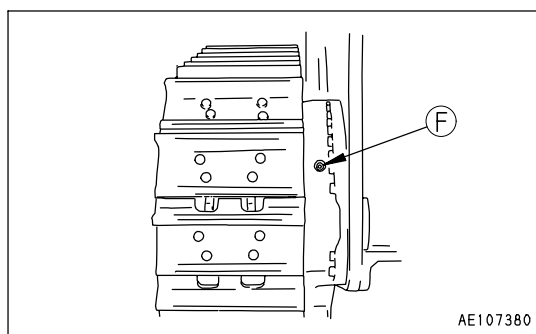

CHANGE OIL IN DAMPER CASE AND BREATHER FILTER, CLEAN DAMPER BREATHER

WARNING

The oil is at high temperature immediately after the machine has been operated. Wait for the oil to cool down before changing the oil.

- Refill capacity: 2.2 liters (0.58 US gal)

1. Remove breather (4) at the top of the damper.
2. Wash out dust remaining inside of breather with diesel oil and flushing oil.
3. Install breather (4) to the original position.

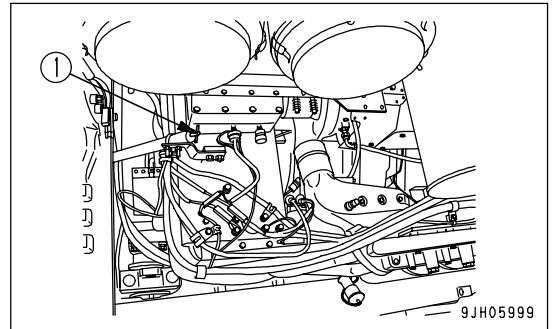

4. Remove slit plate (3), breather filter (5) and holder (6) on the upper part of the damper cover.
5. Wipe off dusts stuck to the slit plate and holder and then wash them with clean light oil or detergent liquid. Replace the filter with a new one.
6. Open the inspection cover under the chassis.
7. Remove drain plug (2) slowly to avoid getting oil on yourself, and drain the oil. After draining the oil, tighten plug (2).
8. Pull out dipstick (1), and add oil to the specified level through oil filler.
9. Check that the oil level is between the H and L marks on dipstick. For details, see "CHECK OIL LEVEL IN DAMPER CASE, ADD OIL (PAGE 4-55)".
10. Close the inspection cover.

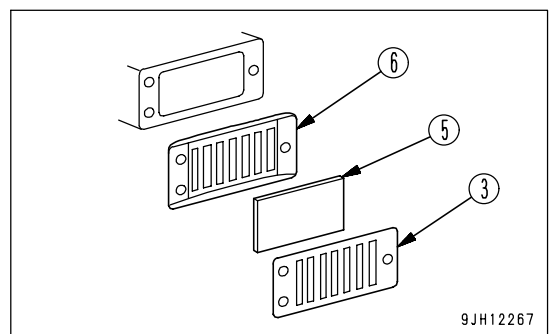
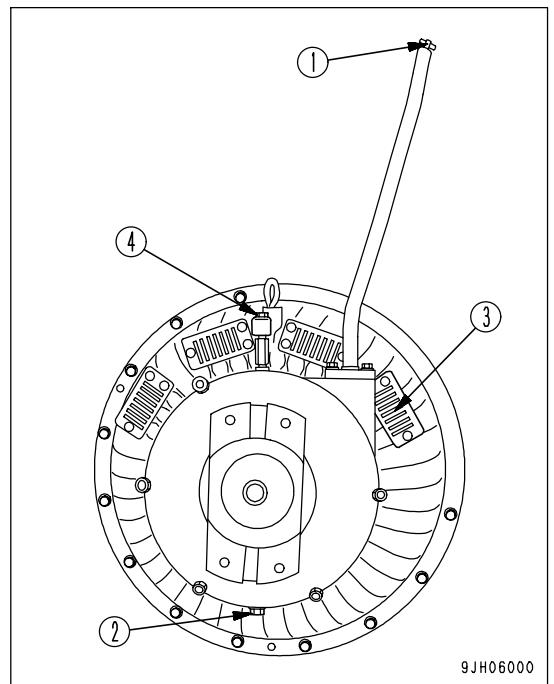

CHECK PIVOT BEARING OIL LEVEL, ADD OIL

1. Remove plug (1).

When removing plug (1), be careful not to let dirt or dust get it.

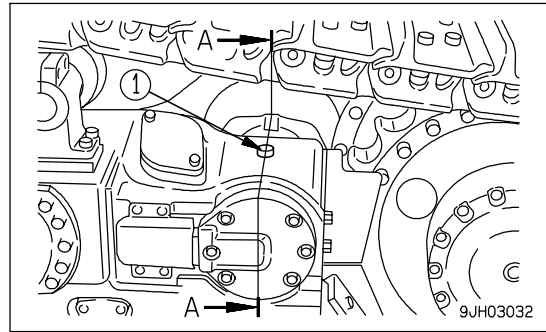

2. Check that the oil is at the level shown in the diagram. If the oil level (2) is low, add engine oil through the hole of plug (1). Use class CD SAE 30 engine oil regardless of the ambient temperature.

(B): 10 to 30 mm (0.4 to 1.2 in)

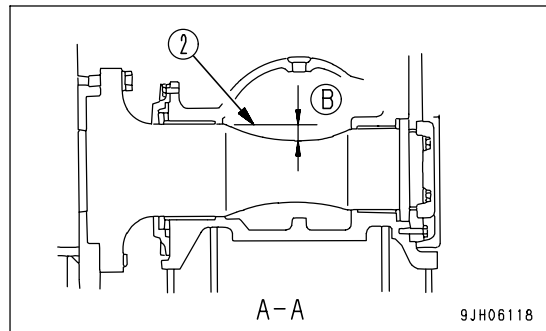

CHECK OIL LEVEL IN RECOIL SPRING, ASSIST CYLINDER CASE, ADD OIL

1. Remove bolts (1), then remove cover (2).

When removing the cover, be careful not to let dirt or sand get in.

2. Loosen the plug and confirm that the internal pressure is released.

Insert a scale and check that the oil level is 90 to 110 mm (3.6 to 4.4 in) from the bottom edge of the inspection port.

If the oil is insufficient, add oil.

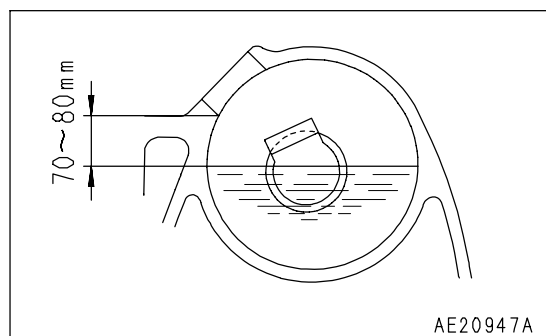
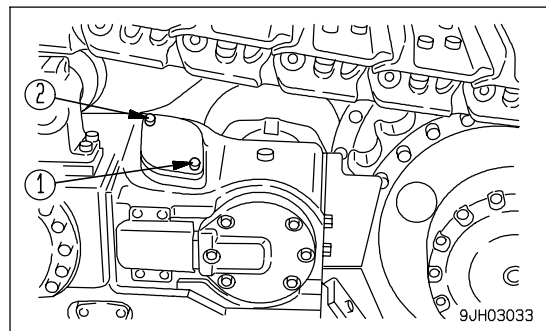

CLEAN ENGINE BREATHER ELEMENT

1. Loosen clamp (1), then remove the hose.
2. Remove bolt (2), then remove breather (3).
3. Rinse the whole breather in diesel oil or flushing oil. Dry with compressed air, then install it.
4. Check the breather hose, and if any deteriorated oil is stuck to the inside, replace the hose with a new hose.

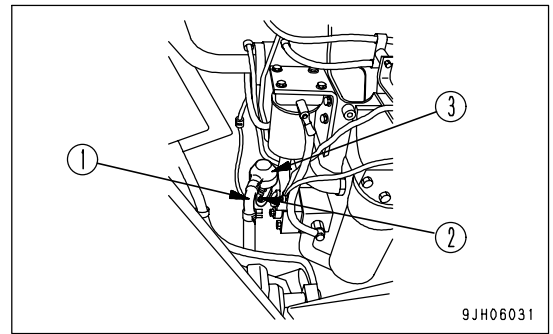

REMARK

The engine breather element is at the front end on top of the engine (behind the radiator).

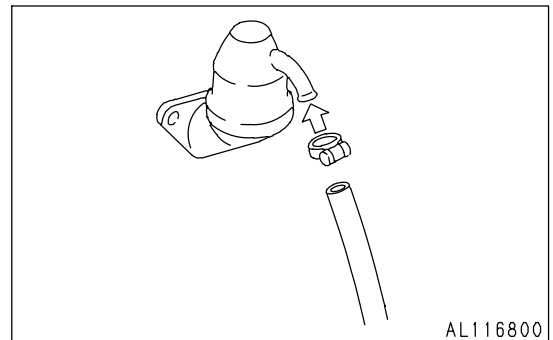

CHECK ALTERNATOR, STARTING MOTOR

The brushes may be worn or the bearing may have run out of grease, contact your Komatsu distributor for inspection and repairs.

If the engine is started frequently, have this inspection carried out every 1000 hours.

CHECK ENGINE VALVE CLEARANCE, ADJUST

Special tools are required for removal and adjustment of the parts, have your Komatsu distributor perform this service.

EVERY 4000 HOURS SERVICE

Maintenance for every 250, 500, 1000 and 2000 hours service should be carried out at the same time.

CHECK WATER PUMP

Check for oil and coolant leakage, or clogging of the drain hole. If any abnormality is found, contact your Komatsu distributor for disassembly, repair, or replacement.

CHECK VIBRATION DAMPER

Check decrease of damper fluid, dent or out-of-flat. If there is any abnormality, contact Komatsu distributor for repair.

CLEAN, CHECK TURBOCHARGER

Contact your Komatsu distributor for cleaning or inspection.

CHECK PLAY OF TURBOCHARGER ROTOR

Contact your Komatsu distributor to have the rotor play checked.

CHECK MAIN FRAME, WORK EQUIPMENT (BLADE, RIPPER)

Check after the first 4000 hours, and every 1000 hours after that.

- Preparation

Wipe off all the mud that is stuck around portions (A) - (L) of the work equipment and frame to make it easier to carry out the check.

- Visual check

Carefully check the base material of the steel casting and welding at portions (A) - (L), and check that there is no damage.

If any cracks or other damage is found, repair them.

Contact your Komatsu distributor for details of the repair procedure.

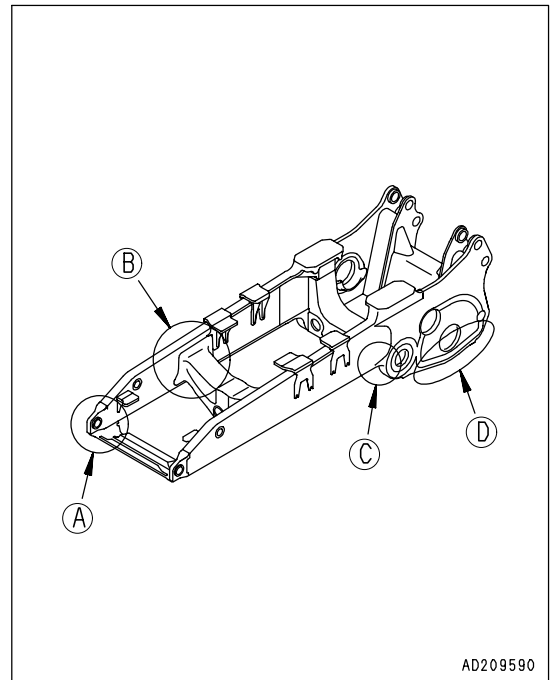

AD209590

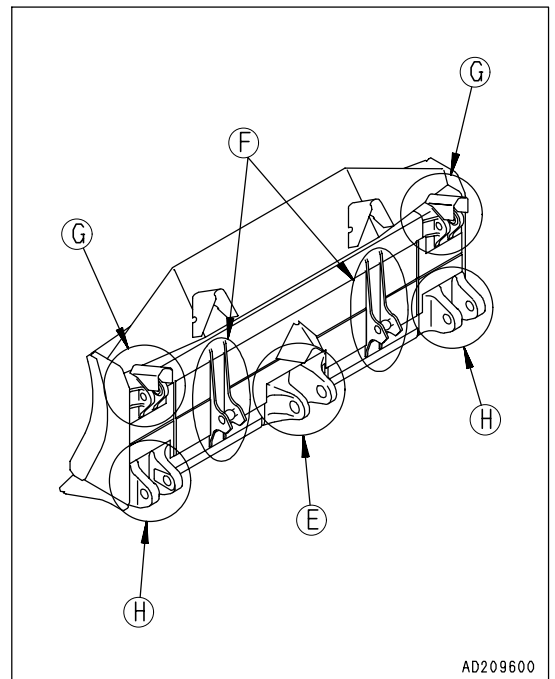

AD209600

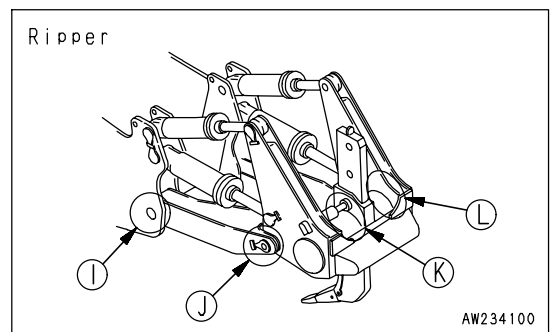

AW234100

SPECIFICATIONS

SPECIFICATIONS

Item		Unit	D475A-5	
Operating weight (without operator)		kg (lb)	103,900 (229,100) *1	
Blade (straight tilt dozer) Weight of attachment (incl. cylinder)		kg (lb)	14,600 (32,193)	
Ripper Weight of attachment		kg (lb)	9,720 (21,433)	
Engine model		-	Komatsu SDA12V140E-1 diesel engine	
Engine flywheel horsepower		kW(HP)/rpm	641 (860)/2000	
A	Overall length	mm (ft in)	11,560 (37' 11")	
B	Overall height	mm (ft in)	4,600 (15' 1")	
C	Overall width	mm (ft in)	5,265 (17' 3")	
	Travel speed (1st/2nd/3rd)	Forward	km/h (MPH)	3.5/6.3/10.9 (2.2/3.9/6.8)
		Reverse	km/h (MPH)	4.7/8.4/14.3 (2.9/5.2/8.9)

*1: With straight tilt dozer, multi ripper, ROPS cab, air conditioner

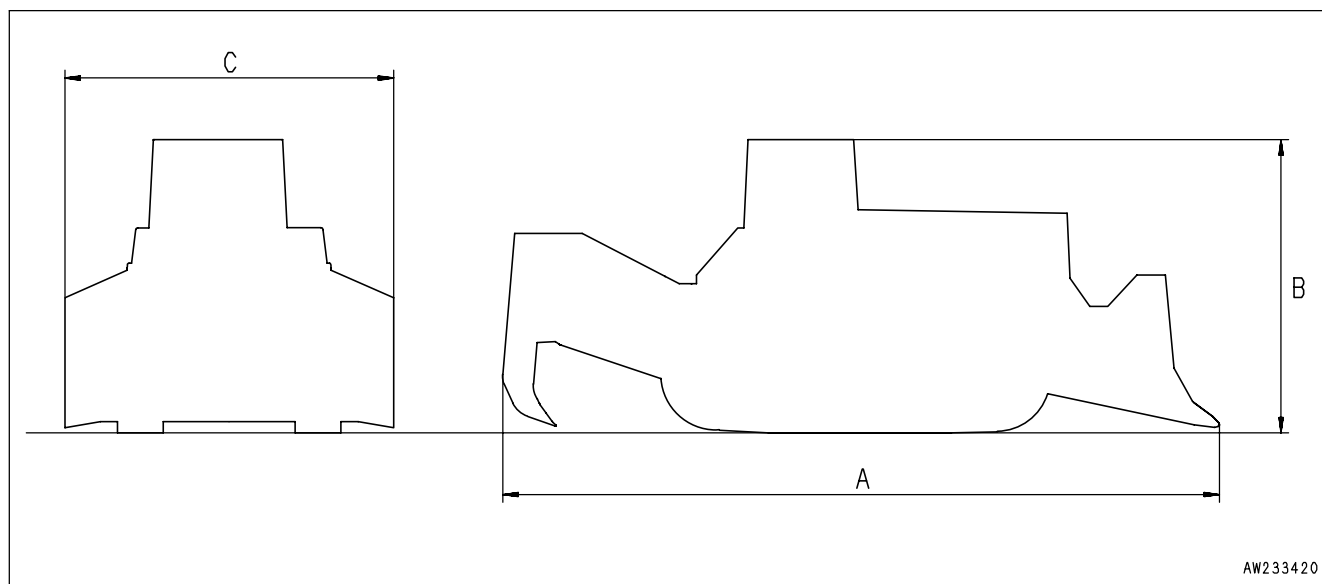

AW233420

ATTACHMENTS, OPTIONS

 **WARNING**

Please read and make sure that you understand the SAFETY section before reading this section.

GENERAL PRECAUTIONS

PRECAUTIONS RELATED TO SAFETY

If attachments or options other than those authorized by Komatsu are installed, this will not only affect the life of the machine, but will also cause problems with safety.

When installing attachments not listed in this Operation and Maintenance Manual, contact your Komatsu distributor first.

If you do not contact Komatsu, we cannot accept any responsibility for any accidents or failures.



WARNING

General precautions

- Read the instruction manual for the attachment carefully, and do not use the machine before you understand the operation method completely.

If you lose the instruction manual, be sure to order another copy from your Komatsu distributor.

- To prevent serious personal injury caused by misoperation, place your foot on the pedal only when operating the pedal.

Precautions for removal and installation

When removing or installing an attachment, observe the following items and work safely.

- Select a firm, level surface when installing or removing an attachment.
- When working in cooperation with one or more other workers, decide signs and observe them when carrying out the operation.
- When carrying a heavy part (25 kg (55 lb) or more), use a crane.
- When removing a heavy part, always place a support in position before removing it.

When lifting a load with a crane, be particularly careful of the center of gravity.

- It is dangerous to carry out operations when the load has been raised by a crane. Always lower the load onto a stand and check that it is safe.
- When leaving an attachment removed or installing it, place it in a stable position to prevent it from falling over.
- Never go under a load raised by a crane.

Always stand in a place which is safe even if the load should fall.

NOTICE

Qualifications are required to operate a crane. Never allow the crane to be operated by an unqualified person.

For details of removal and installation operations, contact your Komatsu distributor.

SELECTION OF TRACK SHOE

SELECTION OF TRACK SHOES

Select suitable track shoes to match the operating conditions.

METHOD OF SELECTING SHOES

If a wider shoe than necessary is used, the load on the track will increase, and this will cause the shoes to bend, links to crack, pins to break, shoe bolts to come loose, and various other problems.

Category	Use	Precautions when using	Track shoe width
A	Bedrock, normal soil	This shoe can be used for a wide range of work from crushed rock to general civil engineering work such as reclamation of residential land. There is no particular limit to its use.	710 mm (28 in)
B	Normal soil	Use this shoe for general soil, such as where the main work is pusher work, and stripping the overburden for coal mines. This shoe can be used on bedrock. On jobsites where there are rocks in the soil, be careful to avoid letting the machine mount the rocks.	810 mm (32 in)
C	Soft soil	Use this shoe on soft ground where the shoe in category "B" sinks into the ground. Do not use this shoe on jobsites where there are rocks in the soil.	910 mm (36 in)

PROCEDURE FOR SELECTING RIPPER POINT

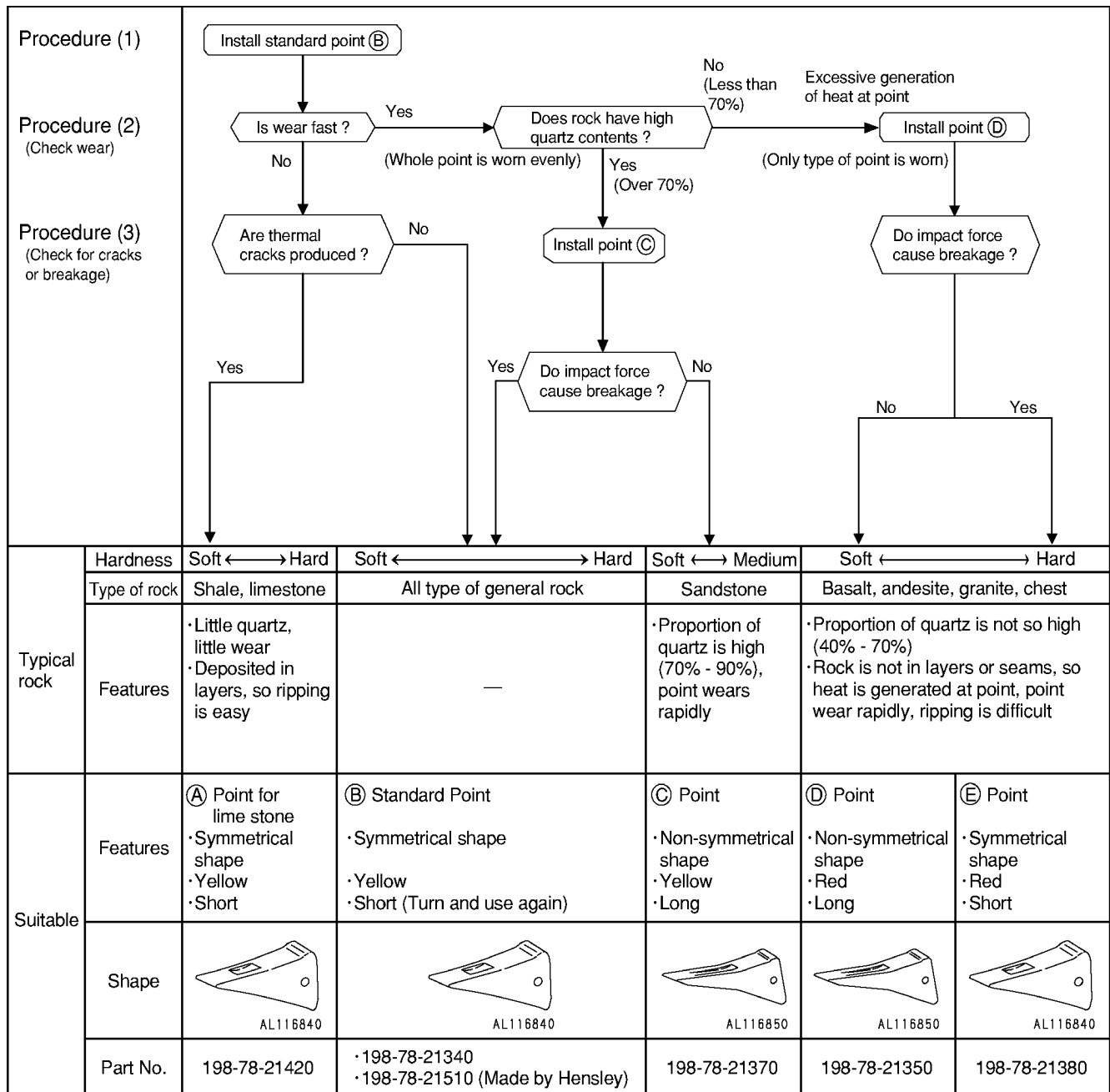

REMARK

- A symmetrical ripper point is suited to a terrain of hard rocks because it recovers penetrability by turning the point after the penetrability drops due to its worn tip.
- Ripper points usually lose their hardness when they undergo intense heat generated by a contact with rocks during the use. In this respect, red ripper points are suited to a terrain of hard rocks where those others are likely to slip during the use, because red ones are made of materials whose hardness less lowers under intense heat, compared with yellow ripper points.
- Where an amount of wear on a ripper point is limited, a heat- originated (thermal) crack on the point surface is not readily removed, and the point itself can break with the crack as a starting point. For this reason, ripper points for limestone are suited to a jobsite where they are comparatively free of wear.

CAP WITH LOCK, HANDLING

METHOD OF OPENING AND CLOSING CAP WITH LOCK

Lock-type caps are available for the radiator water filler, fuel tank filler cap, power train case oil filler cap, hydraulic tank oil filler cap, and hydraulic tank breather cap. The method of opening or closing the cap is as follows:

TO OPEN THE CAP

1. Insert the key. Make sure that you have inserted the key fully before turning it. If the key is turned when only partially inserted, it may break.
2. Turn the key counterclockwise to align the match mark on the cap with the rotor groove, then turn the cap slowly. When a click is heard, the lock is released, enabling the cap to be opened.

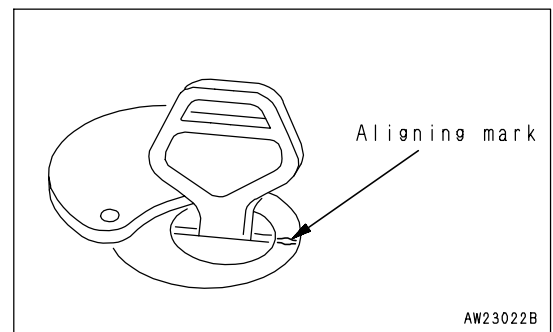
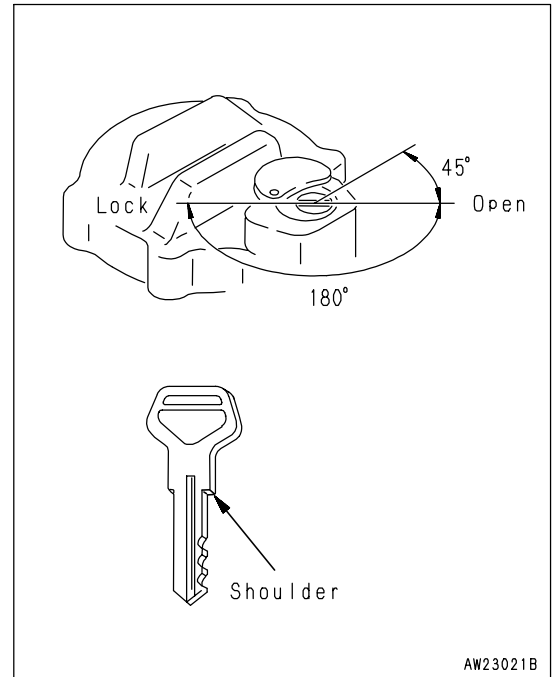

TO LOCK THE CAP

1. Turn the cap into place.
2. Turn the key clockwise and take the key out.

EFFECTIVE METHOD OF OPERATION FOR DUAL TILT DOZER

BLADE CONDITION

SINGLE TILT

Operate single/dual tilt selector switch to the SINGLE position, then operate the tilt.

Applicable operation

- Normal operations

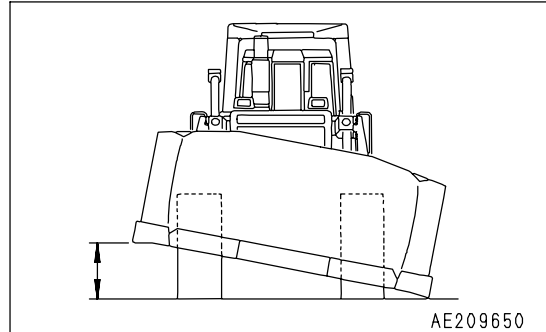

DUAL TILT

Operate single/dual tilt selector switch to the DUAL position, then operate the tilt.

Applicable operation

- Side cutting operations (high places)
- Horizontal dozing operations from side slope (rough ground)
- Ditching work

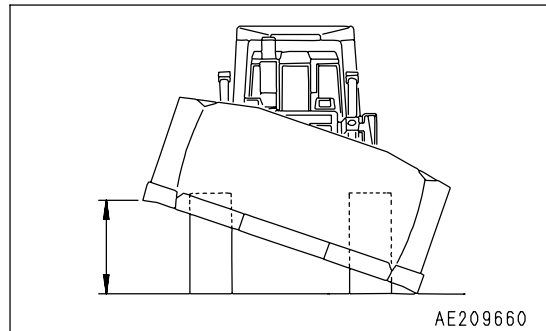

R PITCH (PITCH BACK)

Keep the pitch button pushed in and operate the left tilt.

Applicable operation

- Hauling
- Dozing soft soil (filling)
- Leveling operations (spreading)
- Side-cutting operations

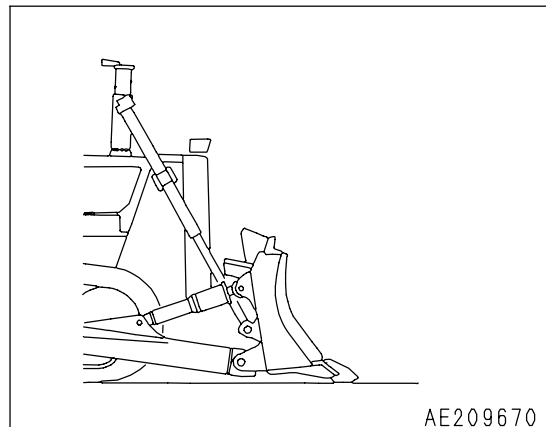

S PITCH (STANDARD)

Normal operations

Applicable operation

- Normal operations

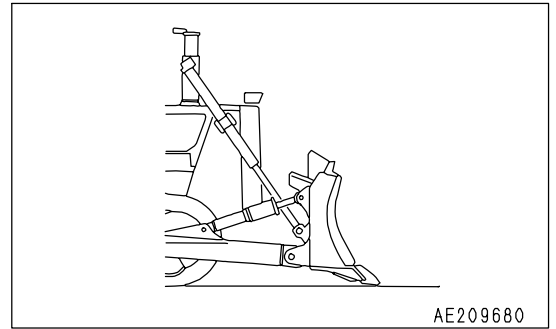

F PITCH (PITCH DUMP)

Keep the pitch button pushed in and operate the right tilt.

Applicable operation

- Digging natural ground and bed-rock (digging hard soil)
- Pushing soil over cliffs
- Pushing-up soil
(Reduces spillage of soil over the top surface of the blade, and reduces amount of soil carried back)

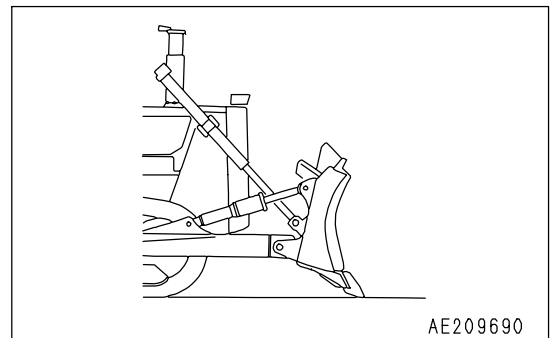

DOZING WORK

DOZING ON LEVEL GROUND, OR DOWNHILL

NATURAL GROUND, BEDROCK

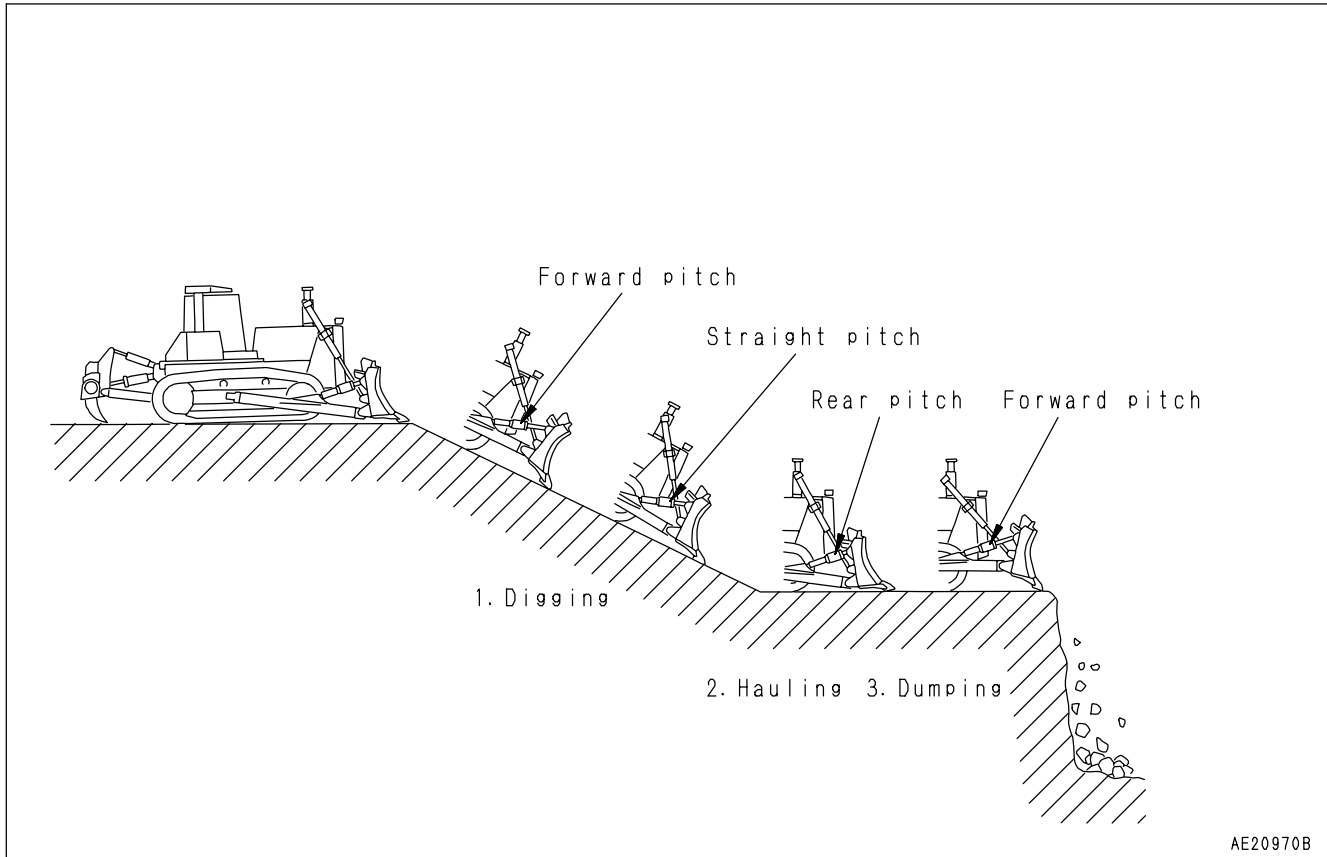

WARNING

If you feel that the situation is dangerous when dumping the soil, for safety reasons, use two movements to push the soil over the edge.

1. Dig with the F (Front) pitch, and when the load on the blade is approx. 80%, return to S (Straight) pitch and continue digging.
2. Set to R (Rear) pitch which gives a larger load, and haul the soil. Adjust the cutting angle to the most effective angle for rolling the soil.
3. Use F pitch to dump the soil.

FILLING, SOFT SOIL

Carry out digging in R pitch or S pitch, and haul in R pitch.

REMARK

If the digging is carried out in R pitch, there is no sudden digging into the soil, and the operation can be carried out smoothly.

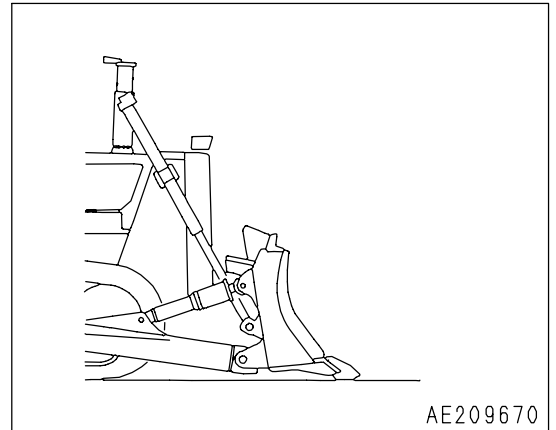

AE209670

HARD SOIL (HARD CLAY, SHALE, ETC.)

If digging is carried out in F pitch, and the chassis is raised and the blade is tilted, the end bit will dig in better.

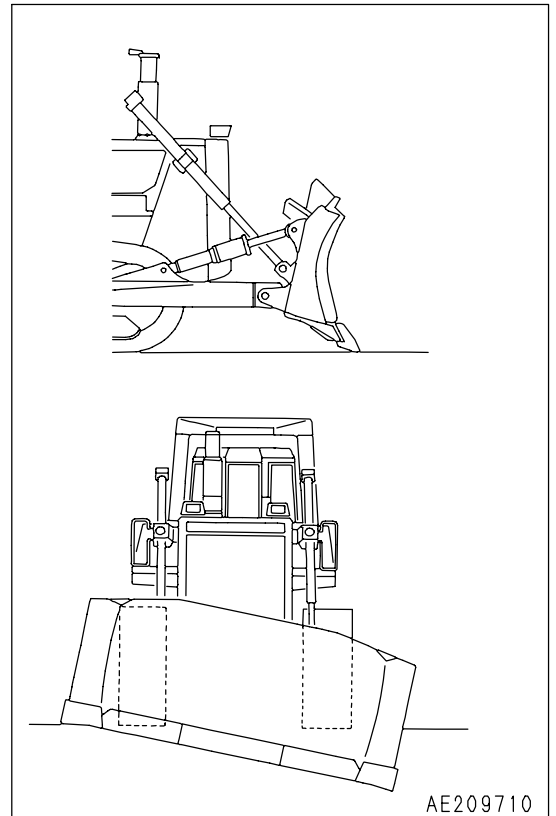

AE209710

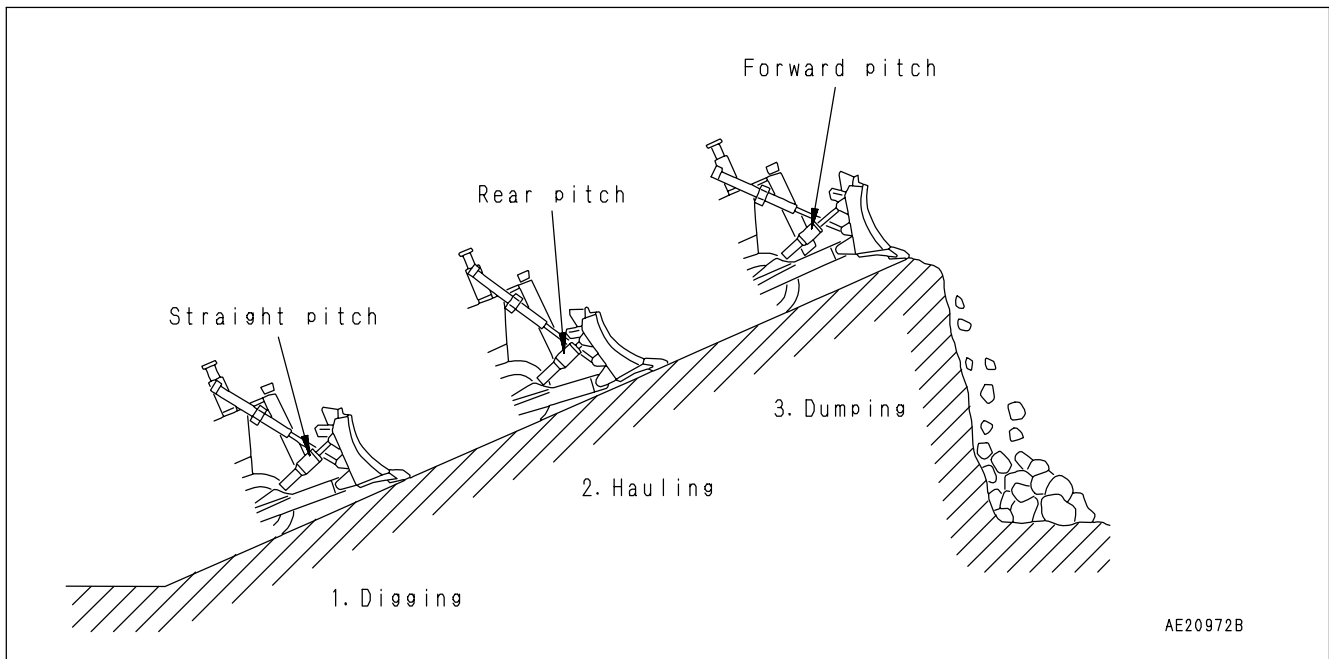
PUSHING-UP SOIL**1. Dig with S pitch.**

When digging gradually, use R pitch.

If the ground is hard, use F pitch.

2. Haul with R pitch.

If there is any spillage of soil over the top of the blade, change to S pitch.

3. Dump the soil with F pitch.

This dumps the soil more effectively, and less soil is carried back.

LEVELING (SPREADING) OPERATION

Carry out this operation with R itch.

When carry out this operation with R pitch, the end bit does not dig in, and the ground can be leveled (or the soil can be spread smoothly.)

REMARK

If the tilt cylinder is moved completely to the end of its stroke, the tilt operation cannot be carried out on one side, so move the cylinder back slightly from the end of its stroke to the S pitch position.

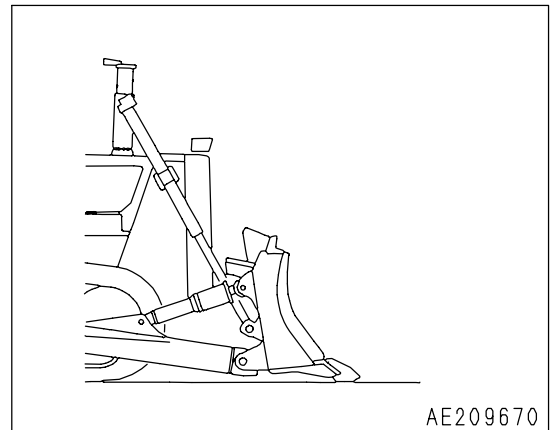

DITCHING OPERATION

If the dual tilt is used, the digging width becomes smaller and a deeper ditch can be dug.

If R pitch is used, the digging can be carried out gradually, and this reduces the unevenness.

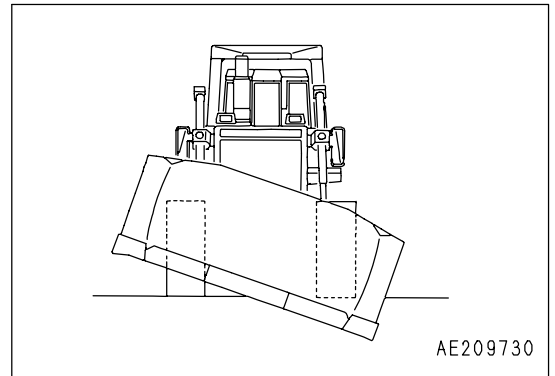

BOULDER RAISING OPERATION

Because the dual tilt greatly increases the amount of tilt, the blade can dig in deep and hook under the boulder. In addition, the operating stroke is large, so operations to raise boulders can be carried out effectively.

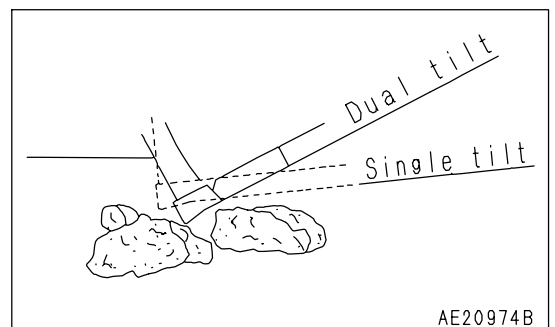

SIDE-CUTTING OPERATIONS

Carry out this operation in R pitch, and set the end face of the end bit in contact with the rock face to carry out cutting.

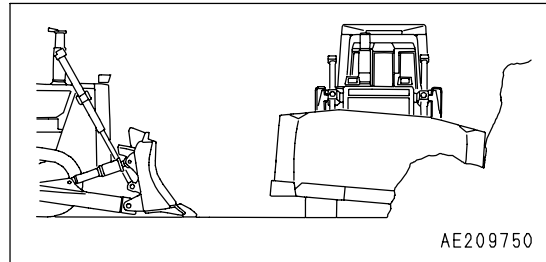

REMARK

With the dual tilt it is possible to increase the amount of tilt and to carry out side-cutting operations on higher walls.

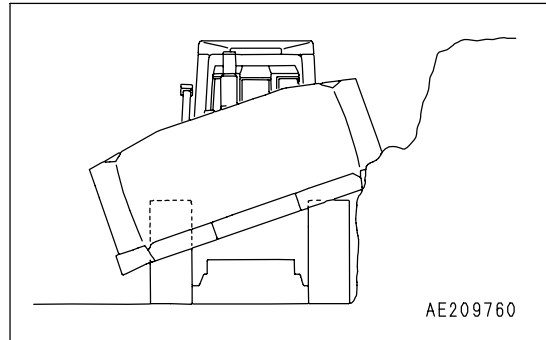

HORIZONTAL DOZING OPERATIONS FROM SIDE SLOPE (ROUGH GROUND)

The dual tilt can give a larger amount of tilt, so when dozing from a side slope, this is effective because the chassis becomes horizontal after a short digging distance.

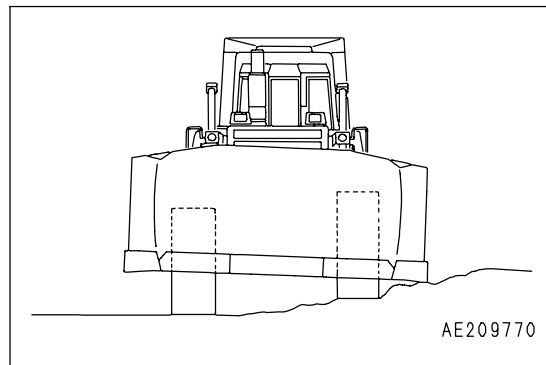

SHOE SLIP CONTROL

MODE SELECTION SWITCH PANEL (SHOE SLIP CONTROL)

- Press each mode switch to turn it ON or OFF and to select the mode.
- For details of setting the mode to use, see "EFFECTIVE USE OF MODE SELECTION SYSTEM (PAGE 3-140)".
- The economy mode, reverse slow mode, and shoe slip control mode can be used independently or in combination.

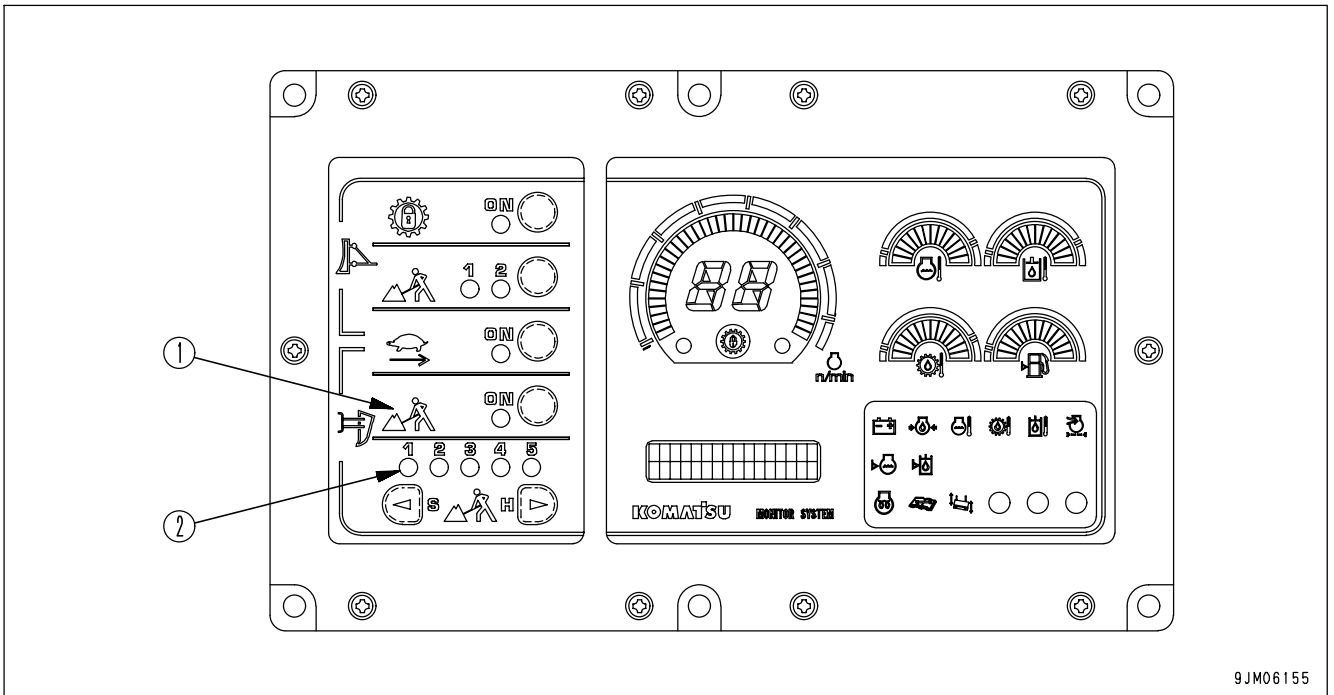

(1) Shoe slip control switch

(2) Rock selection mode selector switch

SHOE SLIP CONTROL SWITCH

This switch (1) is used for ripping operations. When it is switched ON, the lamp lights up.

NOTICE

If the shoe slip control is switched ON, the rock selection mode is automatically set to [3], so switch the rock selection mode to match the type of rock.

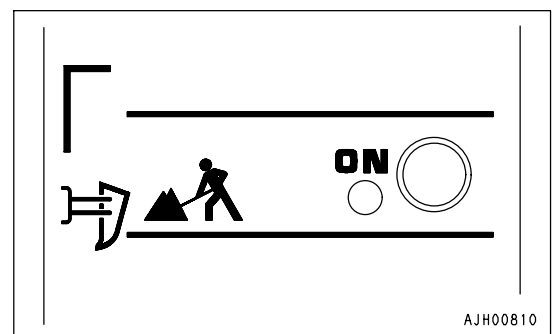

ROCK SELECTION MODE SELECTOR SWITCH

Using this switch (2) during ripping operations, turn the shoe slip control ON and select mode [1] - [5] according to the shoe slip ratio.

The lamp for the selected mode lights up.

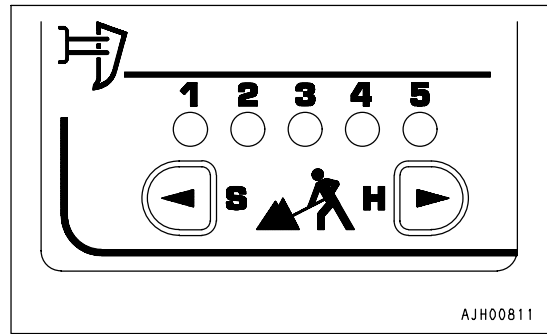

EFFECTIVE USE OF MODE SELECTION SYSTEM

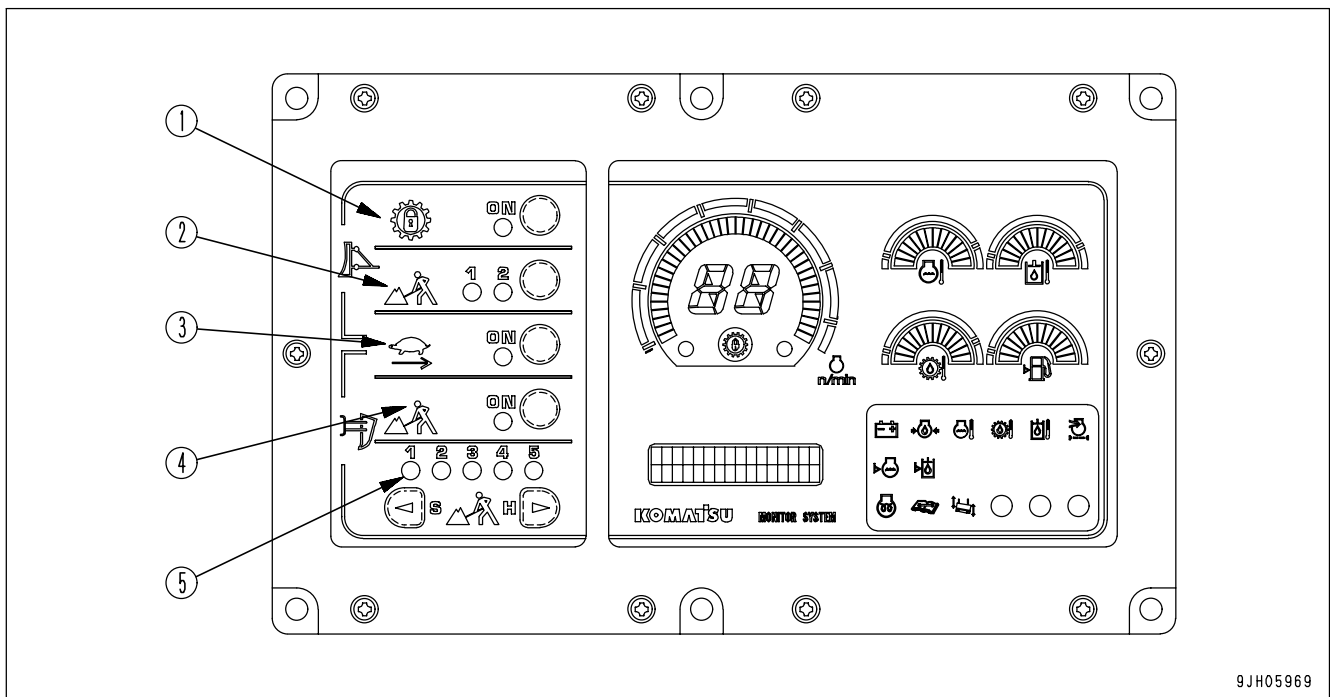

- (1) Lock up mode switch
- (2) Economy mode selector switch
- (3) Reverse slow mode selector switch
- (4) Shoe slip control switch
- (5) Rock selection mode selector switch

Selecting mode to match the type of work and quality of rock and soil makes to perform operations effectively. The condition when all the mode selection switches are off is called the standard mode.

It is impossible to use any combination of the lock-up mode and any other mode.

The economy mode, reverse slow mode, and shoe slip control mode can be used independently or in combination.

Dozing		Ripping	
Lock up mode	Economy mode	Reverse slow mode	Shoe slip control
○	×	×	×
×	○	○	○

○: Possible to use ×: Compound use not possible

SELECTION OF MODE

DOZING OPERATIONS

LOCK UP MODE

By using the lock up mode, the travel speed increases, the operating efficiency is improved, and the fuel consumption is also reduced.

- Speed ranges that can be used: All speed ranges
- Applicable operations: Dozing loose material (suitable for long-distance hauling operations)

When the lock up mode is turned ON, direct drive or torque converter drive are automatically selected according to the load.

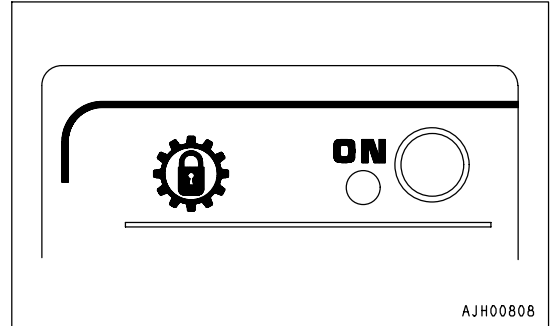

(Example)

- Slot dozing operations

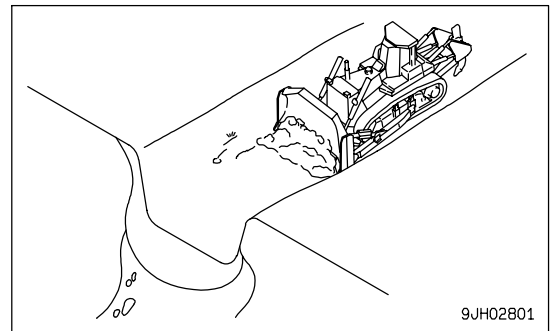

- Hillside dozing operations

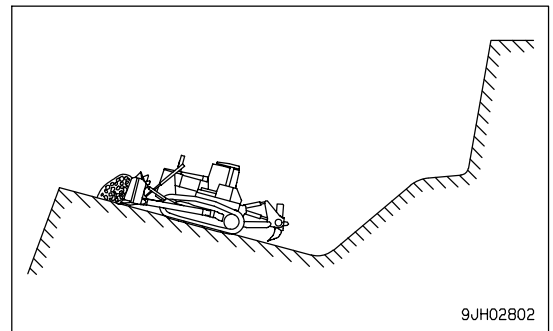

REMARK

- If dozing operations are carried out on a slope of more than 15 °, the lock-up tends to be canceled, so operations are easier to carry out in the standard mode.
- For normal ripping operations, if the lock-up mode is used, the lock-up will switch repeatedly between ON and OFF, so use the standard mode or shoe slip control mode.
- Even with ripping operations, if the ground is extremely soft, the lock-up mode can be used.

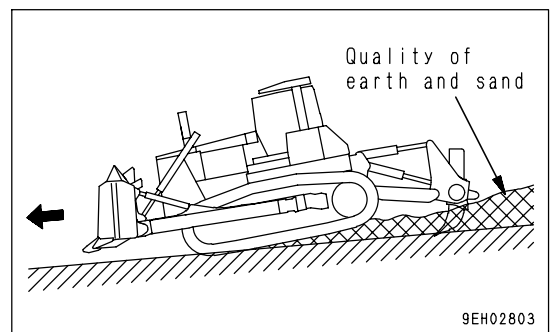

ECONOMY MODE

Using the economy mode makes it possible to reduce wasteful shoe slippage and to reduce the fuel consumption.

- Speed ranges that can be used: F1
- Applicable operations: Hauling after ripping, dozing blasted rock, smoothing.

When the economy mode is turned ON, it is automatically set to [1]. Carry out dozing operations in this condition, then set to [2] and carry out operations. From this test, select the matching that gives power and low shoe slip ratio (frequency of deceleration operation).

Mode [1] is set to approx. 90% of full power and mode [2] is set to approx 70%.

(Example)

- Fine leveling operations

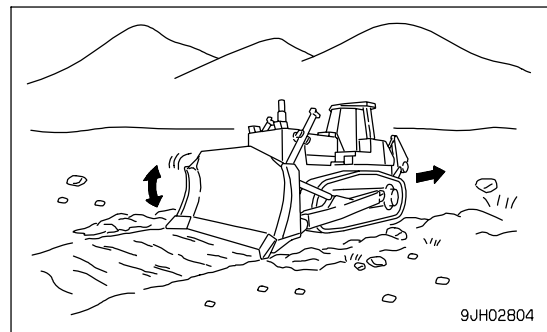
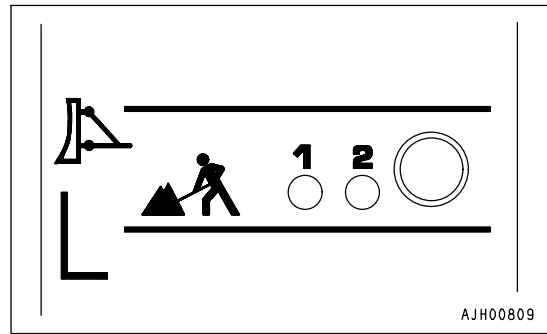

- Ripping and dozing operations

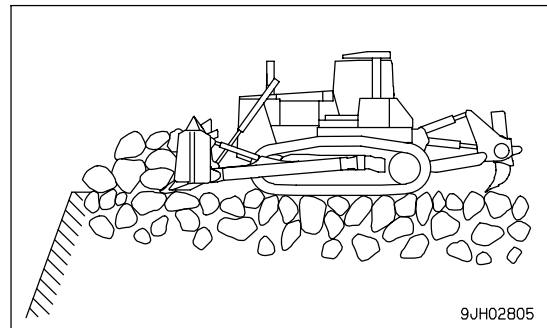
**REMARK**

- If the shoe slip control switch is turned ON and the ripper is lowered during dozing operations in the standard mode, the system will enter the shoe slip control mode. If this happens, return to the N position, set the speed range to F1, and this will return to the standard mode.
- If the economy mode and shoe slip control switches are turned ON and the ripper is lowered during dozing operations in the economy mode, the system will enter the shoe slip control mode. If this happens, return to the N position, set the speed range to F1, and this will return to the standard mode.

RIPPING OPERATIONS

SHOE SLIP CONTROL

This makes it possible to reduce the frequency of operation of the decelerator pedal by the operator, and contributes to reduction in operator fatigue. It also prevents wasteful shoe slippage, improves the service life of the undercarriage, and reduces fuel consumption.

- Speed ranges that can be used: F1
- Applicable operations: Ripping

In normal ripping operations, the operator uses the decelerator pedal to control the engine speed while carrying out ripping. If the shoe slip control is turned ON, the shoe slip control system aids the operator in carrying out this control.

When the shoe slip control switch is turned ON, the rock selection mode is automatically set to [3].

Carry out operations in this condition, and if the shoe slip ratio is too high, press a switch in the hard direction to set the mode to [4] or [5].

If the shoe slip ratio is low and there seems to be lack of power, press the switch in the soft direction to set the mode to [2] or [1].

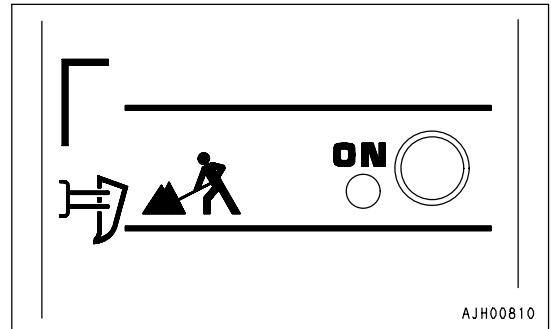

AJH00810

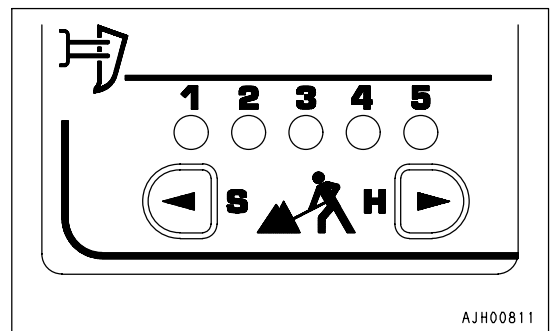

AJH00811

REMARK

- After the joystick is set to F1, the shoe slip control starts when the ripper lever is operated to LOWER or TILT. Even when the operation alternates between dozing and ripping, there is no need to turn the switch ON or OFF.
- With this system, if shoe slippage occurs during ripping operations, the engine speed is lowered to prevent wasteful shoe slippage.

If shoe slippage occurs during ripping operations and the engine speed goes down, if the ripper lever is operated to TILT IN or RAISE, the engine speed will rise (output is increased) to make it easier to carry out breaking operations.

- When carrying out ripping operations on hard rock, if the rear of the machine comes off the ground and there is sudden shoe slippage, it is possible to reduce the shoe slippage by operating the ripper to LOWER and reducing the engine speed.

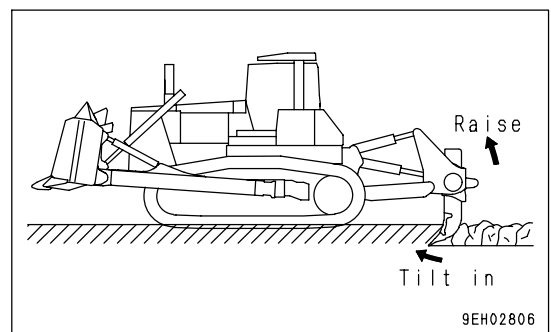

9EH02806

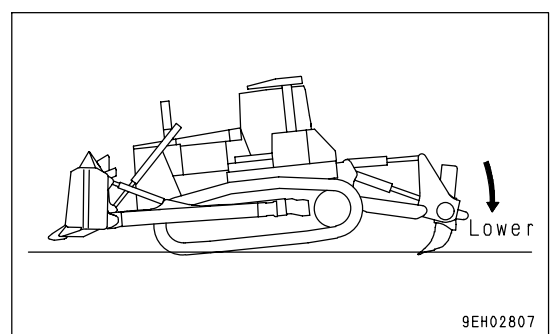

9EH02807

REVERSE SLOW MODE

This reduces the travel speed when traveling in reverse, reduces the frequency of operating the decelerator pedal, and improves the riding comfort for the operator.

- Speed ranges that can be used: R1, 2, 3

(If this mode is only necessary when traveling in R2 or R3, it is possible to change the setting of the service mode. To do this, please contact your Komatsu distributor.)

- Applicable operations: Traveling on bedrock, traveling down steep hills

Use this mode to reduce the travel speed when traveling in R1, R2, or R3.

When the reverse slow mode is ON, the travel speed is set to approx. 80% of the full travel speed.

Use this mode to reduce the travel speed when traveling in reverse after ripping and dozing bedrock or when traveling in reverse after dozing on steep slopes. The travel speed differs in each mode according to whether it is used in combination with the economy mode or with shoe slip control.

When using shoe slip control, the travel speed for bedrock setting modes [1] - [5] is set at approx. 70 - 90% of the full travel speed.

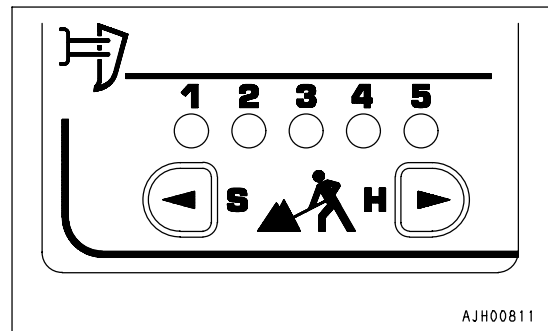
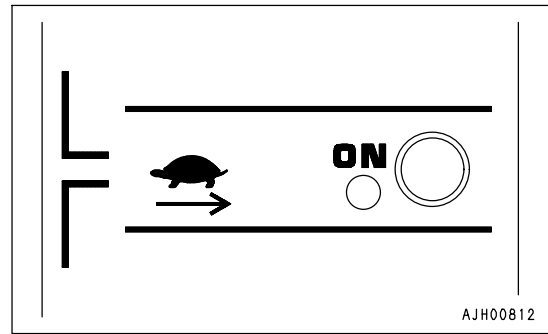

When traveling on bedrock, if it is felt that the travel speed when traveling in reverse is too high, turn the reverse slow mode ON. This will reduce the travel speed when traveling in reverse.

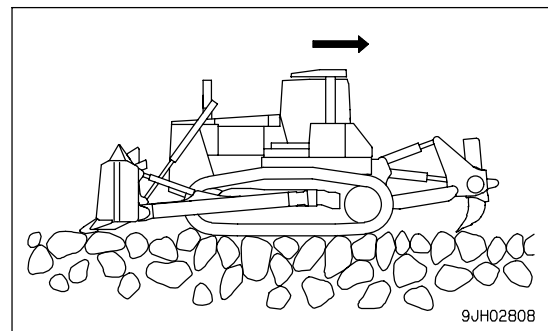

When traveling down slopes, if it is felt that the travel speed when traveling in reverse is too high, turn the reverse slow mode ON. This will reduce the travel speed when traveling in reverse.

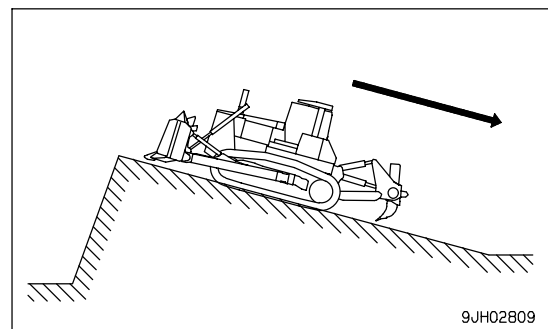

PROCEDURE FOR SELECTING MODE ACCORDING TO NATURE OR NEEDS TO WORK

Use the table below to select the mode that matches the nature or needs of the operation.

Nature and needs of operation		Operation system and effect	Name of mode to select
Dozing	Dozing loose soil	High production, large power needed	By lock up the torque converter and using direct drive, the effective transmission of power is increased and the production per unit of fuel is further improved.
	Digging, dozing bedrock	Swift movement of the machine and good digging and dozing performance are needed even if the type of rock or soil changes	
	Dozing blasted rock	Both power and good fuel consumption are needed	The engine output is set specially for dozing (mode 1 or 2) to give both power and fuel saving. With this mode, the following can be achieved: (1) Reduction in frequency of deceleration operations (2) Reduction in shoe slip (3) Reduction in fuel consumption
		No operator fatigue even when operating for long hours	By reverse speed is lowered and improve the ride for the operator.
Ripping	No operator fatigue even when operating for long hours		By reverse speed is lowered and improve the ride for the operator.
	Easy to operate	The following items are always detected: (1) Engine out put (2) Drawber pull (3) Shoe slip ratio If any of these values goes too high, the engine out put is aotomatically controlled to the oputimum for the sctual operation. As a result, the following are achieved: ·No need for deceleration operation ·No need for the operator to watch for shoe slipping ·Reduce in shoe slippage Inaddition, a selection of five modes is available to cover a wide range of rock conditions (hardness). The power can be iselcted to match the type of rock, so it is possible to achieve both power and reduction in fuel consumption.	Shoe slip control mode (*)
	Both power and reduced fuel consumption are desired		
	Lower repair costs for undercarriage		

(*): The dozing economy mode, reverse slow mode, and ripping shoe slip control mode can all be selected independently or in combination. In addition, it is possible to select and correct as needed, so it is possible to achieve precise matching for various types of operation.

IF MODE SELECTION SYSTEM FLASHES

If the caution lamp flashes, or it becomes impossible to control the engine speed with the fuel control dial or decelerator pedal, stop operation immediately, check the monitor panel display, then contact your Komatsu distributor for repairs.

In addition to the above problems, if any of the problems in the table below occur, there is probably an abnormality in the work equipment lever switch, transmission speed range sensor, or other part, so please contact your Komatsu distributor for repairs.

Mode	Operation	Abnormality
Shoe slip control	Ripping	<ul style="list-style-type: none"> • When shoe slip occurs, it is impossible to throttle power • Even when there is shoe slippage, it is impossible to control • After slippage stops, it takes a long time for power to recover • It becomes difficult to break rock by operating lever to TILT or RAISE • Travel speed increases when shank is inserted • Travel speed is slow and drawbar pull is lacking • No sense of control, engine stays at full or partial • Chassis flies when starting ripping

INDEX

<A>		EPA REGULATIONS, ENGINE NUMBER	
ACCUMULATOR, HANDLING -----	3- 83	PLATE -----	1- 8
ADJUSTING POSTURE OF WORK		EXPLANATION OF COMPONENTS -----	3- 5
EQUIPMENT -----	3-152	<F>	
AIR CONDITIONER, HANDLING -----	3- 66	FOREWORD -----	1- 2
ASHTRAY -----	3- 56	FRONT PANEL -----	3- 5
		FRONT/REAR, LEFT/RIGHT	
BLADE SERIAL NO. PLATE POSITION ----	1- 9	DIRECTIONS OF MACHINE -----	1- 7
BREAKING IN THE MACHINE -----	1- 7	FUSE BOX -----	3- 51
<C>		<G>	
CAP WITH LOCK, HANDLING -----	6- 5	GENERAL PRECAUTIONS -----	2- 8
METHOD OF OPENING AND		GENERAL PRECAUTIONS -----	6- 2
CLOSING CAP WITH LOCK -----	6- 5	PRECAUTIONS RELATED TO	
CAR STEREO, HANDLING -----	3- 57	SAFETY -----	6- 2
CHECK AFTER FINISHING WORK -----	3-137	GENERAL VIEW -----	3- 2
CHECK AFTER STOPPING ENGINE -----	3-118	GENERAL VIEW OF CONTROLS AND	
CHECK BEFORE STARTING ENGINE,		GAUGES -----	3- 3
ADJUST -----	3- 86	GENERAL VIEW OF MACHINE -----	3- 2
COLD WEATHER OPERATION -----	3-167	GUIDES TO MAINTENANCE -----	4- 2
AFTER COLD WEATHER -----	3-169	<H>	
AFTER COMPLETION OF WORK -----	3-169	HANDLING HYDRAULIC RELATED	
PRECAUTIONS FOR LOW		EQUIPMENT -----	4- 9
TEMPERATURE -----	3-167	HANDLING MACHINES EQUIPPED	
CONTROL LEVERS, PEDALS -----	3- 41	WITH VHMS -----	3- 84
<D>		HANDLING OIL, FUEL, COOLANT, AND	
DOOR OPEN LOCK -----	3- 55	PERFORMING OIL CLINIC -----	4- 5
DOOR POCKET -----	3- 56	<I>	
DUST INDICATOR -----	3- 49	INSTALLATION OF CAB -----	3-165
<E>		INTRODUCTION -----	1- 7
EFFECTIVE METHOD OF OPERATION		<L>	
FOR DUAL TILT DOZER -----	6- 6	LOADING, UNLOADING WORK -----	3-157
BLADE CONDITION -----	6- 6	LOCKING -----	3-137
BOULDER RAISING OPERATION -----	6- 11	LONG-TERM STORAGE -----	3-170
DITCHING OPERATION -----	6- 11	AFTER STORAGE -----	3-170
DOZING WORK -----	6- 8	BEFORE STORAGE -----	3-170
HORIZONTAL DOZING		DURING STORAGE -----	3-170
OPERATIONS FROM SIDE SLOPE		STARTING MACHINE AFTER	
(ROUGH GROUND) -----	6- 12	LONG-TERM STORAGE -----	3-170
LEVELING (SPREADING)		<M>	
OPERATION -----	6- 11	<N>	
SIDE-CUTTING OPERATIONS -----	6- 12	<O>	
EFFECTIVE USE OF MODE		<P>	
SELECTION SYSTEM -----	3-140	<Q>	

<M>					
MAINTENANCE SCHEDULE CHART -----	4-	19		SAFETY LABELS -----	2- 4
METHOD OF LIFTING MACHINE -----	3-	160		POSITIONS OF SAFETY	
MOVING MACHINE -----	3-	119		PICTOGRAMS -----	2- 4
				SASH GLASS INTERMEDIATE LOCK -----	3- 55
<N>				SELECTION OF TRACK SHOE -----	6- 3
NECESSARY INFORMATION -----	1-	8		SELECTION OF TRACK SHOES -----	6- 3
				SERVICE PROCEDURE -----	4- 21
<O>				CHECK BEFORE STARTING -----	4- 47
OPERATING METHOD FOR RIPPING				EVERY 1000 HOURS SERVICE -----	4- 61
OPERATIONS -----	3-	148		EVERY 2000 HOURS SERVICE -----	4- 66
OPERATION -----	3-	86		EVERY 250 HOURS SERVICE -----	4- 48
OPERATIONS AND CHECKS AFTER				EVERY 4000 HOURS SERVICE -----	4- 72
STARTING ENGINE -----	3-	115		EVERY 500 HOURS SERVICE -----	4- 56
OUTLINE OF ELECTRIC SYSTEM -----	4-	8		INITIAL 250 HOURS SERVICE (ONLY	
OUTLINES OF SERVICE -----	4-	5		AFTER THE FIRST 250 HOURS) -----	4- 21
				WHEN REQUIRED -----	4- 22
<P>				SHIFTING BETWEEN FORWARD AND	
PARKING MACHINE -----	3-	135		REVERSE -----	3-127
PERIODIC REPLACEMENT OF SAFETY				SHIFTING GEAR -----	3-122
CRITICAL PARTS -----	4-	16		SHOE SLIP CONTROL -----	6- 13
POSITION OF SERVICE METER -----	1-	9		EFFECTIVE USE OF MODE	
POWER SOURCE -----	3-	50		SELECTION SYSTEM -----	6- 14
PRECAUTIONS FOR MAINTENANCE -----	2-	27		IF MODE SELECTION SYSTEM	
PRECAUTIONS FOR OPERATION -----	2-	17		FLASHES -----	6- 20
BATTERY -----	2-	24		MODE SELECTION SWITCH PANEL	
OPERATION -----	2-	19		(SHOE SLIP CONTROL) -----	6- 13
TOWING -----	2-	26		SPECIFICATIONS -----	5- 2
TRANSPORTATION -----	2-	23		STANDARD TIGHTENING TORQUES	
PRECAUTIONS FOR OPERATION -----	3-	133		FOR BOLTS AND NUTS -----	4- 15
PRECAUTIONS FOR				STARTING ENGINE -----	3-107
TRANSPORTATION -----	3-	161		STEERING MACHINE -----	3-129
PROCEDURE FOR SELECTING				STOPPING ENGINE -----	3-118
RIPPER POINT -----	6-	4		STOPPING MACHINE -----	3-121
PRODUCT IDENTIFICATION NUMBER				SWITCHES -----	3- 36
(PIN), MACHINE SERIAL NO. PLATE -----	1-	8			
				<T>	
<R>				TABLE TO ENTER SERIAL NO. AND	
RECOMMENDED FUEL, COOLANT,				DISTRIBUTOR -----	1- 10
AND LUBRICANT -----	4-	12		TIPS FOR LONGER UNDERCARRIAGE	
REMOVAL OF CAB -----	3-	162		LIFE -----	3-155
RIPPER OPERATION -----	3-	145		TOOL BOX -----	3- 56
RIPPER SERIAL NO. PLATE POSITION ---	1-	9		TORQUE LIST -----	4- 15
				TRANSPORTATION -----	3-157
<S>				TRANSPORTATION PROCEDURE -----	3-157
SAFETY -----	2-	2		TRAVELING ON ROADS -----	3-161
SAFETY CRITICAL PARTS -----	4-	17		TROUBLESHOOTING -----	3-171
SAFETY INFORMATION -----	1-	5		AFTER RUNNING OUT OF FUEL -----	3-171
				IF BATTERY IS DISCHARGED -----	3-174

INDEX

METHOD OF TOWING MACHINE ----- 3-173
OTHER TROUBLE ----- 3-178
WHEN MODE SELECTION SYSTEM
FLASHES ----- 3-183

<W>

WEAR PARTS ----- 4- 10
WEAR PARTS LIST ----- 4- 10
WORK POSSIBLE USING BULLDOZER --- 3-138

D475A-5 BULLDOZER
Form No. TEN00018-05

©2007 KOMATSU
All Rights Reserved
Printed in Japan 11-07
