

Operation & Maintenance Manual

MOTOR GRADER

GD655-5

SERIAL NUMBERS 55001 and up

ecot3

⚠ WARNING

Unsafe use of this machine may cause serious injury or death. Operators and maintenance personnel must read this manual before operating or maintaining this machine. This manual should be kept near the machine for reference and periodically reviewed by all personnel who will come into contact with it.

NOTICE

Komatsu has Operation & Maintenance Manuals written in some other languages. If a foreign language manual is necessary, contact your local distributor for availability.

KOMATSU

FOREWORD

CALIFORNIA

Proposition 65 Warning

Diesel engine exhaust and some of its constituents are known to the State of California to cause cancer, birth defects, and other reproductive harm.

CALIFORNIA

Proposition 65 Warning

Battery posts, terminals and related accessories contain lead and lead compounds, chemicals known to the State of California to cause cancer and birth defects or other reproductive harm.

Wash hands after handling.

BEFORE READING THIS MANUAL

This manual gives details of the operation and methods of inspection and maintenance for this machine that must be obeyed in order to use the machine safely. Most accidents are caused by the failure to follow fundamental safety rules for the operation and maintenance of machines.

Read, understand and follow all precautions and warnings in this manual and on the machine before performing operation and maintenance. Failure to do so may result in serious injury or death.

Komatsu cannot predict every circumstance that might involve a potential hazard when the machine is used. Therefore, the safety messages in this manual and on the machine may not include all possible safety precautions. If you carry out any operation, inspection, or maintenance under conditions that are not described in this manual, understand that it is your responsibility to take the necessary precautions to ensure safety. In no event should you or others engage in the prohibited uses or actions described in this manual. Improper operation and maintenance of the machine can be hazardous and could result in serious injury or death.

If you sell the machine, be sure to give this manual to the new owner together with the machine.

Always keep this Operation and Maintenance Manual in the location shown on the right so that all relevant personnel can read it at any time.

Storage location for the Operation and Maintenance Manual:
Pocket at rear of operator's seat

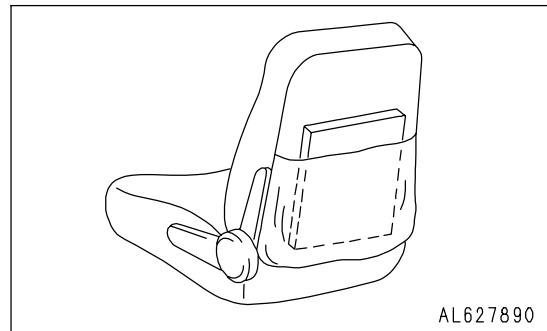

If this manual is lost or damaged, contact your distributor immediately to arrange for its replacement. For details regarding the machine serial No. you will need to provide your Komatsu distributor, see "TABLE TO ENTER SERIAL NO. AND DISTRIBUTOR (PAGE 1-7)".

This manual uses the international units (SI) for units of measurement. For reference, units that have been used in the past are given in ().

The explanations, values, and illustrations in this manual have been prepared based on the latest information available as of the date of its publication. Continuing improvements in the design of this machine may lead to additional changes that are not reflected in this manual. Consult Komatsu or your Komatsu distributor for the latest available information concerning your machine or with questions regarding information contained in this manual.

- The numbers in circles in the illustrations correspond to the numbers in () in the text.

(For example: ① → (1))



Komatsu delivers machines that comply with all applicable regulations and standards of the country to which it has been shipped. If this machine has been purchased in another country, it may lack certain safety devices and specifications that are necessary for use in your country. If there is any question about whether your product complies with the applicable standards and regulations of your country, consult Komatsu or your Komatsu distributor before operating the machine.

SAFETY INFORMATION

To enable you to use the machine safely, and to prevent injury to operators, service personnel or bystanders, the precautions and warnings included in this manual and the safety signs attached to the machine must always be followed.

To identify important safety messages in the manual and on the machine labels, the following signal words are used.

The "Safety Alert Symbol" identifies important safety messages on machines, in manuals, and elsewhere. When you see this symbol, be alert to the risk of personal injury or death. Follow the instructions in the safety message.

- | | |
|--------------------------------------------------------------------------------------------------|------------------------------------------------------------------------------------------------------------------------------------|
|  DANGER | This signal word indicates an imminently hazardous situation which, if not avoided, will result in death or serious injury. |
|  WARNING | This signal word indicates a potentially hazardous situation which, if not avoided, could result in death or serious injury. |
|  CAUTION | This signal word indicates a potentially hazardous situation exists which, if not avoided, may result in minor or moderate injury. |

The following signal words are used to alert you to information that must be followed to avoid damage to the machine.

- | | |
|----------------|--------------------------------------------------------------------------------------------------------------------------|
| NOTICE | This precaution is given where the machine may be damaged or the service life reduced if the precaution is not followed. |
| REMARKS | This word is used for information that is useful to know. |

INTENDED USE

USE OF MACHINE

This Komatsu machine is designed to be used mainly for the following work:

- Smoothing
- Repair and maintenance of gravel roads
- Snow-clearing operations
- Ditch digging
- Cutting slope faces
- Excavating operations
- Mixed operations
- Spreading operations

See the section "WORK WHICH CAN BE CARRIED OUT USING A MOTOR GRADER (PAGE 3-129)" for further details.

DIRECTIONS OF MACHINE

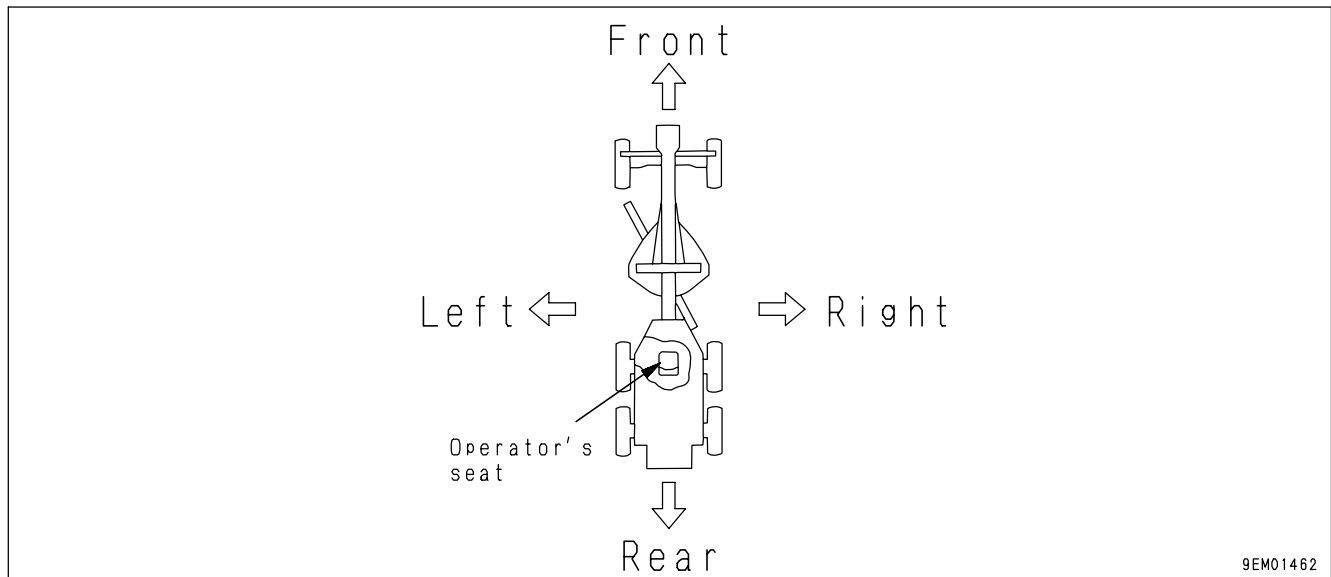

In this manual, the directions of the machine (front, rear, left, right) are determined according to the view from the operator's seat in the direction of travel (front) of the machine.

VISIBILITY FROM OPERATOR'S SEAT

The visibility standards (ISO 5006) for this machine require a view shown in the diagram below.

VISIBILITY IN IMMEDIATE AREA

The visibility of this machine in the area 1 m from the outside surface of the machine at a height of 1.5 m is shown in the diagram below. The hatched area (A) shows the area where the view is blocked by part of the machine when mirrors or other aids to visibility are installed as standard. Please be fully aware that there are places that cannot be seen when operating the machine.

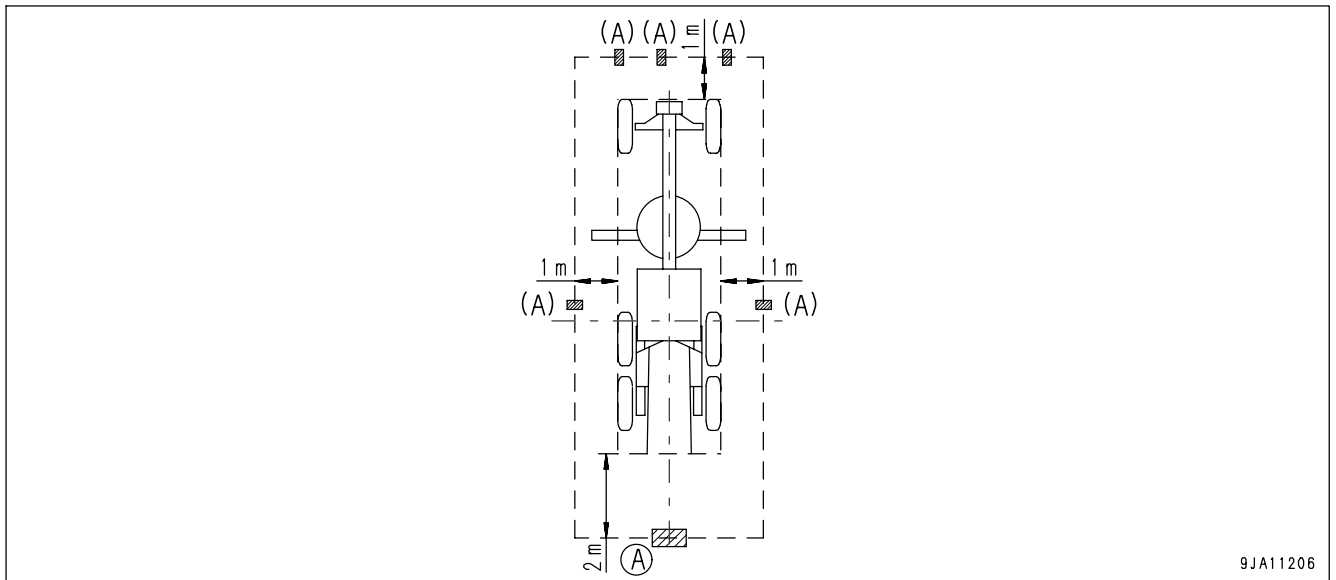

12-M RADIUS VISIBILITY

The visibility at a radius of 12 m from the machine is as shown in the diagram below. The hatched areas (B) show the areas where the view is blocked when mirrors or other aids to visibility are installed as standard. Please be fully aware that there are places that cannot be seen when operating the machine.

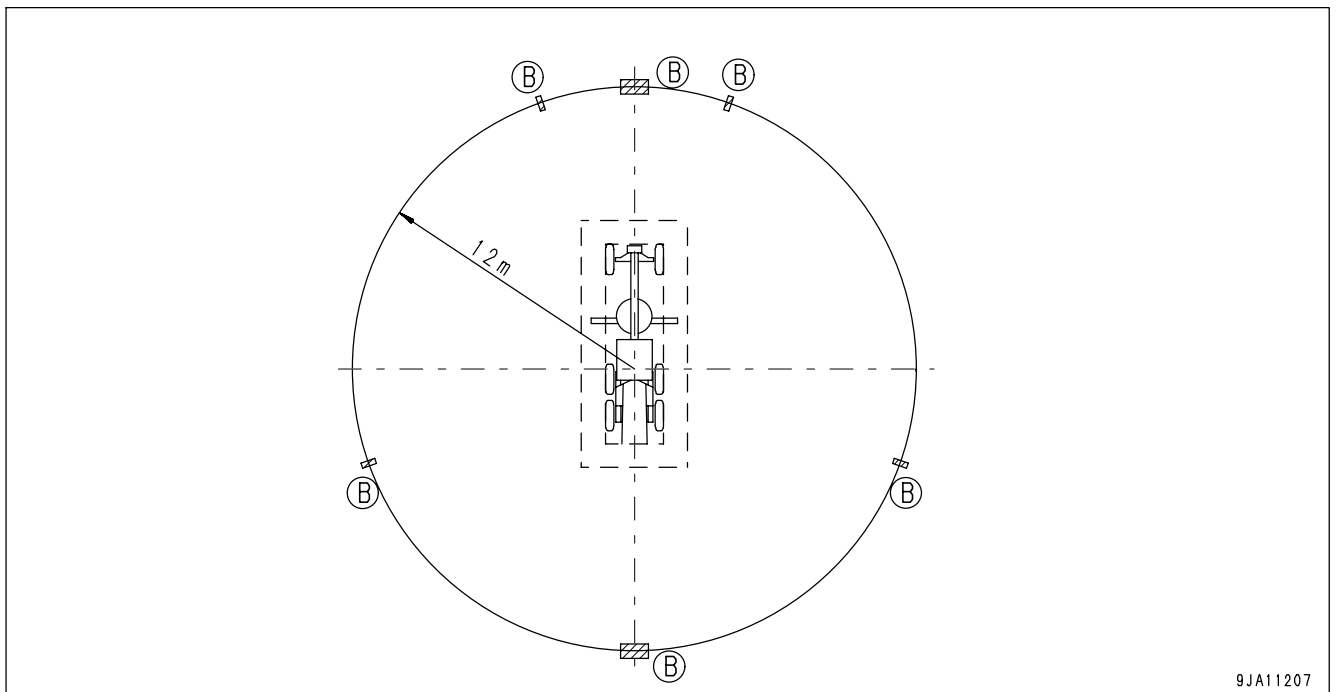

LOCATION OF PLATES, TABLE TO ENTER SERIAL NO. AND DISTRIBUTOR

When requesting service or ordering replacement parts, please inform your Komatsu distributor of the following items.

PRODUCT IDENTIFICATION NUMBER (PIN)/MACHINE SERIAL NO. PLATE

This is at the front of the rear frame on the left side of the machine.
The design of the nameplate differs according to the territory.

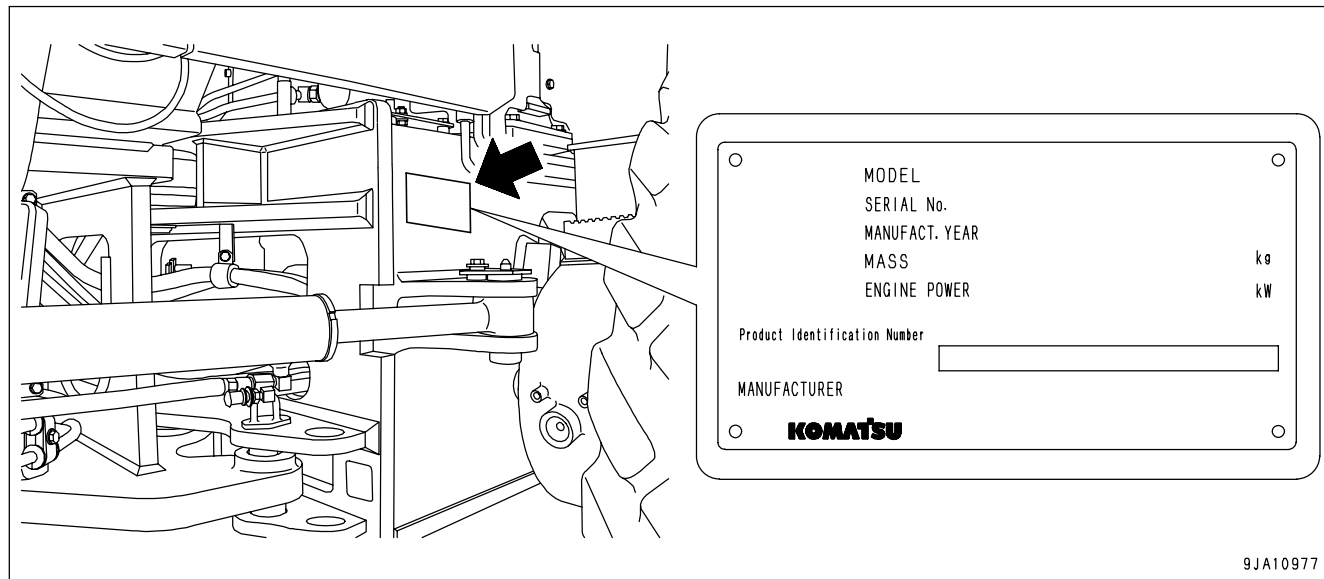

9JA10977

EPA REGULATIONS, ENGINE NUMBER PLATE

This is on the oil cooler at the side face of the engine cylinder block at the right side of machine.

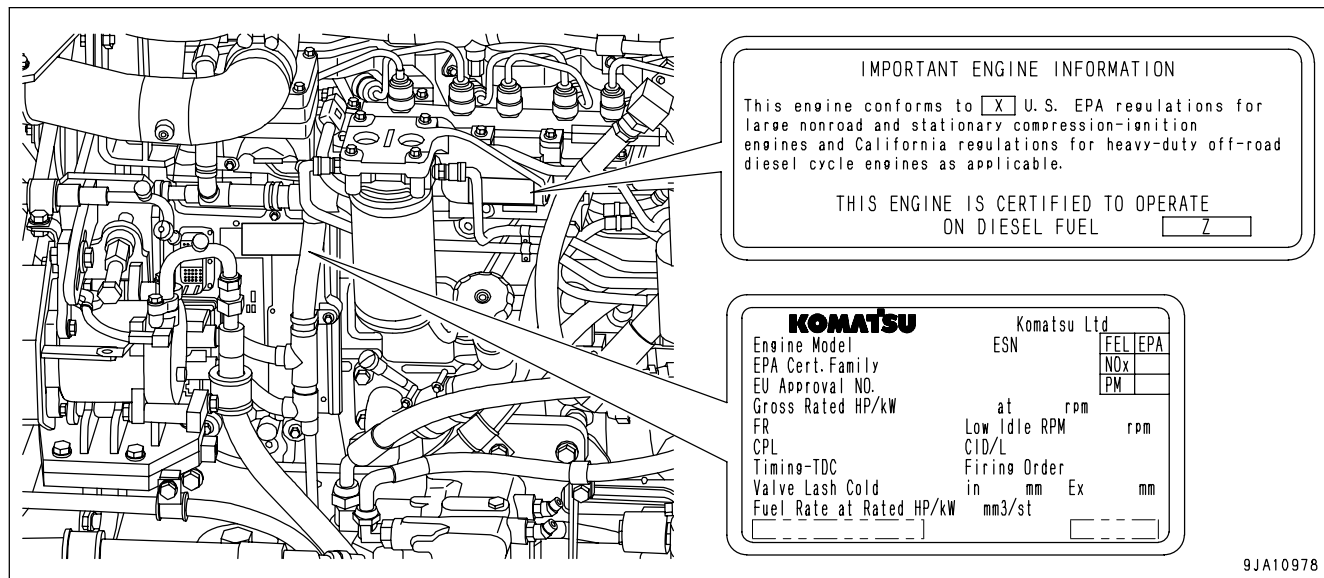

9JA10978

EPA: Environmental Protection Agency, U.S.A.

SERVICE METER POSITION

The service meter is displayed on the character display of the machine monitor.

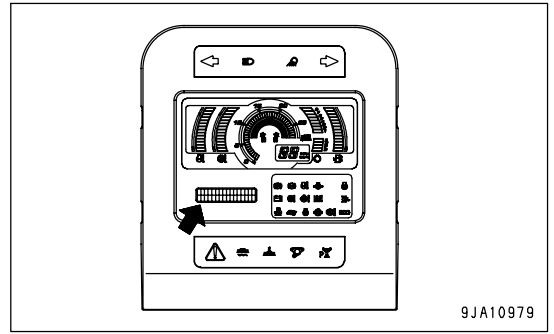

TABLE TO ENTER SERIAL NO. AND DISTRIBUTOR

Machine serial No.	
Engine serial No.	
Distributor name	
Address	-----

Service Personnel	-----
Phone/Fax	-----

CONTENTS

FOREWORD	1- 1
BEFORE READING THIS MANUAL	1- 2
SAFETY INFORMATION	1- 3
INTENDED USE	1- 4
USE OF MACHINE	1- 4
DIRECTIONS OF MACHINE	1- 4
VISIBILITY FROM OPERATOR'S SEAT	1- 5
LOCATION OF PLATES, TABLE TO ENTER SERIAL NO. AND DISTRIBUTOR	1- 6
PRODUCT IDENTIFICATION NUMBER (PIN)/MACHINE SERIAL NO. PLATE	1- 6
EPA REGULATIONS, ENGINE NUMBER PLATE	1- 6
SERVICE METER POSITION	1- 7
TABLE TO ENTER SERIAL NO. AND DISTRIBUTOR	1- 7
SAFETY	2- 1
SAFETY INFORMATION	2- 2
SAFETY LABELS	2- 5
POSITION FOR ATTACHING SAFETY LABELS	2- 6
SAFETY LABELS	2- 7
GENERAL PRECAUTIONS COMMON TO OPERATION AND MAINTENANCE	2- 13
PRECAUTIONS BEFORE STARTING OPERATION	2- 13
PREPARATIONS FOR SAFE OPERATION	2- 13
FIRE PREVENTION	2- 15
PRECAUTIONS WHEN GETTING ON OR OFF MACHINE	2- 16
DO NOT GET CAUGHT IN WORK EQUIPMENT	2- 18
PRECAUTIONS RELATED TO PROTECTIVE STRUCTURES	2- 18
UNAUTHORIZED MODIFICATION	2- 19
PRECAUTIONS RELATED TO ATTACHMENTS AND OPTIONS	2- 19
PRECAUTIONS WHEN RUNNING ENGINE INSIDE BUILDING	2- 19
PRECAUTIONS FOR OPERATION	2- 20
PRECAUTIONS FOR JOBSITE	2- 20
STARTING ENGINE	2- 22
OPERATION	2- 25
TRANSPORTATION	2- 29
TOWING	2- 30
PRECAUTIONS FOR MAINTENANCE	2- 31
PRECAUTIONS BEFORE STARTING INSPECTION AND MAINTENANCE	2- 31
PRECAUTIONS FOR INSPECTION AND MAINTENANCE	2- 35
TIRES	2- 40
OPERATION	3- 1
GENERAL VIEW	3- 2
GENERAL VIEW OF MACHINE	3- 2
GENERAL VIEW OF CONTROLS AND GAUGES	3- 3
EXPLANATION OF COMPONENTS	3- 6
MONITOR PANEL	3- 6
OTHER FUNCTIONS OF MACHINE MONITOR	3- 26
SWITCHES	3- 34
CONTROL LEVERS, PEDALS	3- 51
DUST INDICATOR	3- 63
ARTICULATE LOCK PIN	3- 63
FUSE BOX	3- 64

SLOW BLOW FUSE	3- 65
ELECTRIC POWER TAKEOFF	3- 66
HANDLING BATTERY DISCONNECTOR SWITCH	3- 67
OPENING, CLOSING CAB DOORS	3- 68
BACKUP ALARM	3- 69
AM/FM RADIO	3- 70
AIR CONDITIONER	3- 76
OPERATION MANUAL STORAGE	3- 80
TOOL BOX	3- 80
GREASE PUMP HOLDER	3- 81
CUP HOLDER	3- 81
ASHTRAY	3- 81
FIRE EXTINGUISHER	3- 81
HANDLING MACHINES EQUIPPED WITH KOMTRAX	3- 82
OPERATION	3- 83
CHECK BEFORE STARTING ENGINE	3- 83
STARTING ENGINE	3-101
OPERATIONS, CHECKS AFTER STARTING ENGINE	3-104
STOPPING ENGINE	3-106
CHECK AFTER STOPPING ENGINE	3-106
TRAVELING POSTURE FOR MACHINE	3-107
MOVING MACHINE OFF (FORWARD, REVERSE, SHIFTING GEAR), STOPPING	3-108
TURNING MACHINE	3-119
OPERATING WORK EQUIPMENT	3-122
WORK WHICH CAN BE CARRIED OUT USING A MOTOR GRADER	3-129
PRECAUTIONS WHEN OPERATION	3-150
ADJUSTING WORK EQUIPMENT POSTURE	3-155
PARKING MACHINE	3-164
CHECKS AFTER COMPLETION OF OPERATION	3-166
LOCKING	3-167
HANDLING THE TIRES	3-168
COMBINATION OF SNOW RADIAL TIRE AND CHAIN	3-169
TRANSPORTATION	3-170
STEPS FOR TRANSPORTATION	3-170
LOADING, UNLOADING WORK	3-170
PRECAUTIONS FOR LOADING	3-171
LIFTING MACHINE	3-172
COLD WEATHER OPERATION	3-174
PRECAUTIONS FOR LOW TEMPERATURE	3-174
CAUTIONS AFTER COMPLETION OF WORK	3-175
AFTER COLD WEATHER	3-175
LONG-TERM STORAGE	3-176
BEFORE STORAGE	3-176
DURING STORAGE	3-176
AFTER STORAGE	3-176
TROUBLESHOOTING	3-177
AFTER RUNNING OUT OF FUEL	3-177
WHEN LEANING PIPING IS DAMAGED	3-177
TOWING THE MACHINE	3-178
IF BATTERY IS DISCHARGED	3-180

IF THE GEAR SHIFT LEVER OF THE TRANSMISSION HAS ANY TROUBLE -----	3-183
METHODS OF LOWERING WORK EQUIPMENTS AFTER THE ENGINE STOPS (RELEASE OF THE HYDRAULIC CIRCUIT PRESSURE FOR WORK EQUIPMENTS) -----	3-184
OTHER TROUBLE -----	3-186
MAINTENANCE -----	4- 1
GUIDES TO MAINTENANCE -----	4- 2
OUTLINES OF SERVICE -----	4- 4
HANDLING OIL, FUEL, COOLANT, AND PERFORMING OIL CLINIC -----	4- 4
RELATING TO ELECTRIC SYSTEM -----	4- 7
WEAR PARTS -----	4- 8
WEAR PARTS LIST -----	4- 8
RECOMMENDED FUEL, COOLANT, AND LUBRICANT -----	4- 10
USE OF FUEL, COOLANT AND LUBRICANTS ACCORDING TO AMBIENT TEMPERATURE ----	4- 11
RECOMMENDED BRANDS, RECOMMENDED QUALITY FOR PRODUCTS OTHER THAN KOMATSU GENUINE OIL -----	4- 12
STANDARD TIGHTENING TORQUES FOR BOLTS AND NUTS -----	4- 13
TORQUE LIST -----	4- 13
PERIODIC REPLACEMENT OF CRITICAL PARTS -----	4- 14
CRITICAL PARTS -----	4- 14
MAINTENANCE SCHEDULE CHART -----	4- 15
MAINTENANCE SCHEDULE CHART -----	4- 15
SERVICE PROCEDURE -----	4- 17
INITIAL 250 HOURS SERVICE (only after the first 250 hours) -----	4- 17
WHEN REQUIRED -----	4- 18
CHECK BEFORE STARTING -----	4- 39
EVERY 50 HOURS SERVICE -----	4- 40
EVERY 250 HOURS SERVICE -----	4- 43
EVERY 500 HOURS SERVICE -----	4- 55
EVERY 1000 HOURS SERVICE -----	4- 61
EVERY 2000 HOURS SERVICE -----	4- 69
EVERY 4000 HOURS SERVICE -----	4- 75
EVERY 8000 HOURS SERVICE -----	4- 77
SPECIFICATIONS -----	5- 1
SPECIFICATIONS -----	5- 2
ATTACHMENTS, OPTIONS -----	6- 1
HANDLING BLADE ACCUMULATOR -----	6- 2
FEATURES OF BLADE ACCUMULATOR -----	6- 2
METHOD OF OPERATING BLADE ACCUMULATOR -----	6- 3
INDEX -----	7- 1

SAFETY

WARNING

Please read and make sure that you fully understand the precautions described in this manual and the safety labels on the machine. When operating or servicing the machine, always follow these precautions strictly.

SAFETY INFORMATION

SAFETY LABELS	2- 5
POSITION FOR ATTACHING SAFETY LABELS	2- 6
SAFETY LABELS	2- 7
GENERAL PRECAUTIONS COMMON TO OPERATION AND MAINTENANCE	2- 13
PRECAUTIONS BEFORE STARTING OPERATION	2- 13
ENSURING SAFE OPERATION	2- 13
UNDERSTANDING THE MACHINE	2- 13
PREPARATIONS FOR SAFE OPERATION	2- 13
PRECAUTIONS REGARDING SAFETY-RELATED EQUIPMENT	2- 13
INSPECTING MACHINE	2- 13
WEAR WELL-FITTING CLOTHES AND PROTECTIVE EQUIPMENT	2- 13
KEEP MACHINE CLEAN	2- 14
PRECAUTIONS INSIDE OPERATOR'S COMPARTMENT	2- 14
PROVIDE FIRE EXTINGUISHER AND FIRST AID KIT	2- 14
IF ANY PROBLEM IS FOUND	2- 14
FIRE PREVENTION	2- 15
ACTION IF FIRE OCCURS	2- 15
PRECAUTIONS TO PREVENT FIRE	2- 15
PRECAUTIONS WHEN GETTING ON OR OFF MACHINE	2- 16
USE HANDRAILS AND STEPS WHEN GETTING ON OR OFF MACHINE	2- 16
NO JUMPING ON OR OFF MACHINE	2- 16
NO PEOPLE ON ATTACHMENTS	2- 16
PRECAUTIONS WHEN STANDING UP FROM OPERATOR'S SEAT	2- 17
PRECAUTIONS WHEN LEAVING MACHINE	2- 17
EMERGENCY EXIT FROM OPERATOR'S CAB	2- 17
PRECAUTIONS WHEN CLEANING CAB GLASS AND CAB-MOUNTED WORKING LAMP (IF EQUIPPED)	2- 18
DO NOT GET CAUGHT IN WORK EQUIPMENT	2- 18
PRECAUTIONS RELATED TO PROTECTIVE STRUCTURES	2- 18
UNAUTHORIZED MODIFICATION	2- 19
PRECAUTIONS RELATED TO ATTACHMENTS AND OPTIONS	2- 19
PRECAUTIONS WHEN RUNNING ENGINE INSIDE BUILDING	2- 19

PRECAUTIONS FOR OPERATION	2- 20
PRECAUTIONS FOR JOBSITE	2- 20
INVESTIGATE AND CONFIRM JOBSITE CONDITIONS	2- 20
WORKING ON LOOSE GROUND	2- 20
DO NOT GO CLOSE TO HIGH-VOLTAGE CABLES	2- 21
ENSURE GOOD VISIBILITY	2- 21
CHECKING SIGNS AND SIGNALMAN'S SIGNALS	2- 21
BEWARE OF ASBESTOS DUST	2- 22
STARTING ENGINE	2- 22
USE WARNING TAGS	2- 22
INSPECTION AND MAINTENANCE BEFORE STARTING ENGINE	2- 23
PRECAUTIONS WHEN STARTING ENGINE	2- 23
PRECAUTIONS IN COLD AREAS	2- 24
STARTING WITH BOOSTER CABLES	2- 24
OPERATION	2- 25
CHECKS BEFORE OPERATION	2- 25
PRECAUTIONS WHEN TRAVELING IN FORWARD OR REVERSE	2- 25
PRECAUTIONS WHEN TRAVELING	2- 26
TRAVELING ON SLOPES	2- 27
PRECAUTIONS WHEN OPERATING	2- 27
OPERATING ON SLOPES	2- 27
PROHIBITED OPERATIONS	2- 27
TRAVELING ON SNOW-COVERED OR FROZEN SURFACES	2- 28
PARKING MACHINE	2- 28
TRANSPORTATION	2- 29
LOADING AND UNLOADING	2- 29
TOWING	2- 30
PRECAUTIONS WHEN TOWING	2- 30

PRECAUTIONS FOR MAINTENANCE	2- 31
PRECAUTIONS BEFORE STARTING INSPECTION AND MAINTENANCE	2- 31
DISPLAY WARNING TAG DURING INSPECTION AND MAINTENANCE	2- 31
KEEP WORKPLACE CLEAN AND TIDY	2- 31
SELECT SUITABLE PLACE FOR INSPECTION AND MAINTENANCE	2- 31
ONLY AUTHORIZED PERSONNEL	2- 31
APPOINT LEADER WHEN WORKING WITH OTHERS	2- 31
STOP ENGINE BEFORE CARRYING OUT INSPECTION AND MAINTENANCE	2- 32
TWO WORKERS FOR INSPECTION AND MAINTENANCE WHEN ENGINE IS RUNNING	2- 33
INSTALLING, REMOVING, OR STORING ATTACHMENTS	2- 33
PRECAUTIONS WHEN WORKING AT HIGH PLACES	2- 34
PRECAUTIONS WHEN WORKING ON TOP OF MACHINE	2- 34
PRECAUTIONS WHEN WORKING UNDER MACHINE	2- 34
PROPER TOOLS	2- 34
PRECAUTIONS FOR INSPECTION AND MAINTENANCE	2- 35
PRECAUTIONS WHEN WELDING	2- 35
HANDLING BATTERY	2- 35
PRECAUTIONS WHEN USING HAMMER	2- 36
PRECAUTIONS WITH HIGH-TEMPERATURE COOLANT	2- 36
PRECAUTIONS WITH HIGH-TEMPERATURE OIL	2- 37
PRECAUTIONS WITH HIGH-PRESSURE OIL	2- 37
PRECAUTIONS WITH HIGH-PRESSURE FUEL	2- 37
HANDLING HIGH-PRESSURE HOSES AND PIPING	2- 37
NOISE	2- 38
HANDLING ACCUMULATOR AND GAS SPRING	2- 38
PRECAUTIONS WITH COMPRESSED AIR	2- 38
MAINTENANCE OF AIR CONDITIONER	2- 38
DISPOSING OF WASTE MATERIALS	2- 38
METHOD OF SELECTING WINDOW WASHER FLUID	2- 38
PERIODIC REPLACEMENT OF SAFETY CRITICAL PARTS	2- 39
TIRES	2- 40
HANDLING TIRES	2- 40
PRECAUTIONS WHEN STORING TIRES	2- 41

SAFETY LABELS

The following warning signs and safety labels are used on this machine.

- Be sure that you fully understand the correct position and content of labels.
- To ensure that the content of labels can be read properly, be sure that they are in the correct place and always keep them clean. When cleaning them, do not use organic solvents or gasoline. These may cause the labels to peel off.
- There are also other labels in addition to the warning signs and safety labels. Handle those labels in the same way.
- If the labels are damaged, lost, or cannot be read properly, replace them with new ones. For details of the part numbers for the labels, see this manual or the actual label, and place an order with Komatsu distributor.

POSITION FOR ATTACHING SAFETY LABELS

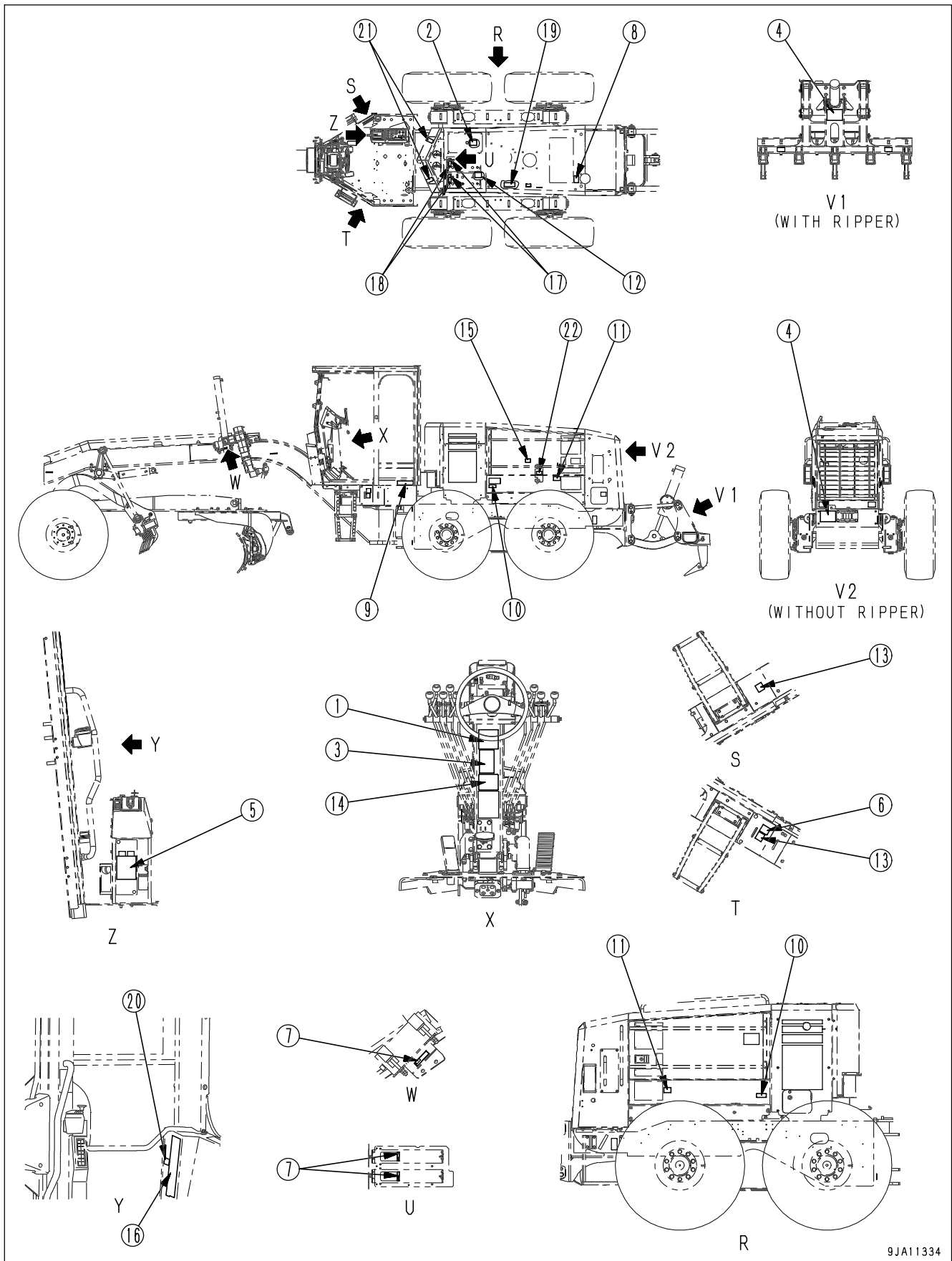

9JA11334

SAFETY LABELS

(1) Caution before operating (09651-03001)

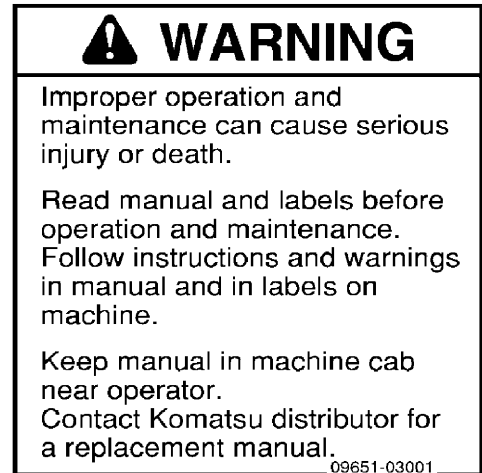

(2) Caution for opening hydraulic cap (09653-03001)



(3) Caution when driving in reverse (09802-43000)

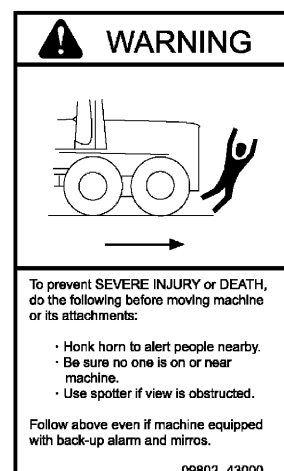

(4) Danger when approaching (09812-13000)



(5) Warning for high voltage (09801-43001)

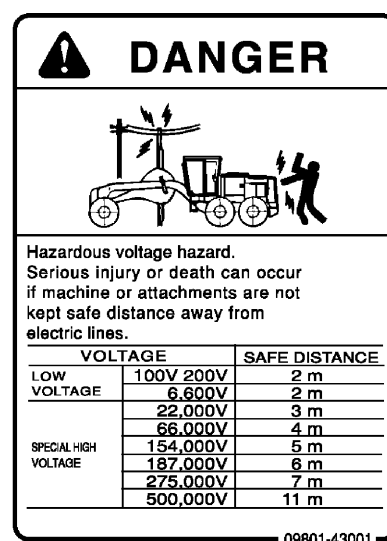

(6) Articulate lock (09161-33000)

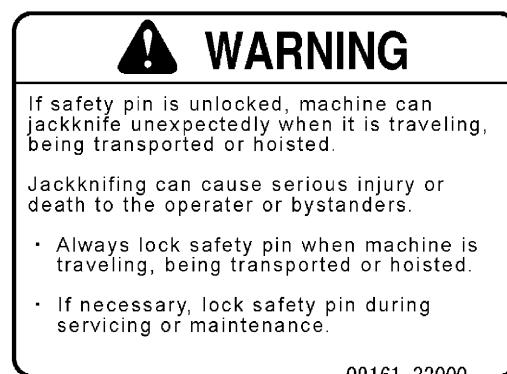

(7) Caution for handling accumulator (09659-53000)



(8) Warning for hot cooling water (09668-03001)



(9) Roll-over protective structure (09620-A2000)

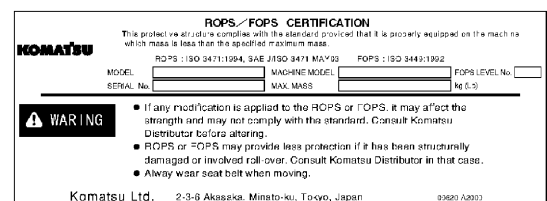

(10) Prohibited to walk (23B-53-31740)



(11) Caution when engine running (09667-03001)

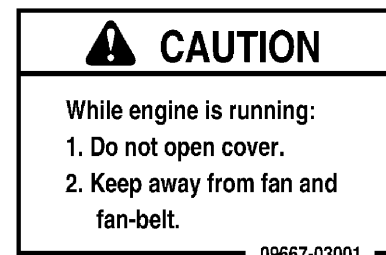

(12) Caution when handling booster cable and battery cable (09808-03000)

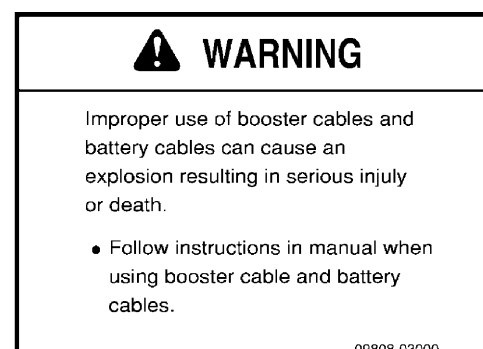

(13) Prohibited to enter (09162-33000)

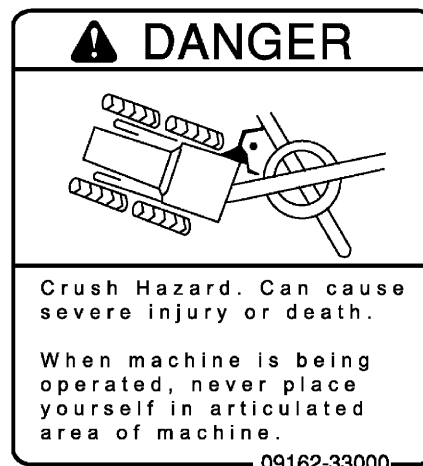

(14) Caution when startling and traveling
(23B-53-31740)

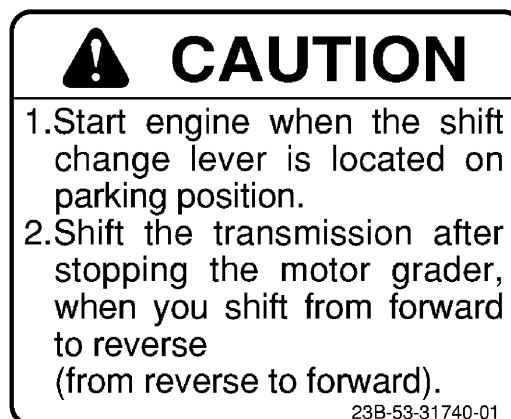

(15) Exhaust pipe is hot ! (09817-A0753)

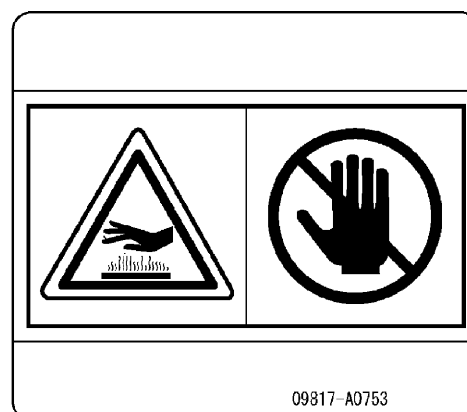

Sign indicates a burn hazard from touching heated parts, such as engine, motor, or muffler during or right after operation.

Never touch when hot.

(16) Caution in carrying out gear shift, downhill travel, brake operation, and bank pin operation (23B-53-71170)

<p>WARNING</p> <ul style="list-style-type: none"> Use braking effect of engine to retard machine speed while traveling downhill by downshifting transmission. Gear selection is restricted by shift inhibitor to prevent engine over speeding. Machine speed may have to be reduced with service brakes before transmission shift inhibitor will allow entry into gear selected. 	<p>Maximum Machine Travel Speed at Down Shift</p>	
	GEAR	
	F2→F1	2.8 mph
	F3→F2	4.0 mph
	F4→F3	5.6 mph
	F5→F4	8.1 mph
	F6→F5	12.4 mph
	F7→F6	18.0 mph
F8→F7	24.5 mph	
<ul style="list-style-type: none"> Do not risk brake loss by using service brakes as a retarder. Never travel downhill with transmission in neutral or with clutch disengaged. <p>DO NOT RISK SERIOUS BODILY INJURY OR DEATH</p>		
<p>CAUTION</p>	<ul style="list-style-type: none"> In "MANU" downshift manually. In "T/C AUTO" the transmission auto shift program will downshift as needed to 4th gear. If lower gears are required shift down manually. Do not put foot on the brake pedal continuously especially when travelling downhill. Brake may burn out. Before changing from "T/C AUTO" mode, stop machine, shift lever to "N" position, and idle engine at low speed. Do not use the brake frequently with the hand throttle set at high engine RPM. Brake may burn out. 	
	<p>WARNING</p> <p>Always lower the blade to the ground before removing the bank-control lock pin. If the blade is raised, it may fall, possibly causing serious injury or death.</p>	

23B-53-71170

(17) Precautions when handling battery
(This plate is stick on the machine by the battery maker.)

<p>火気厳禁 メガネ着用 こども禁止 破損注意 説明書熟読 爆発注意</p> <p>●水素ガス発生、取扱いを誤ると引火爆発の恐れあり ●工具等でショートやスパークをさせない。充電は風通しのよい所で行う ●ブースターケーブルの使用は取扱説明書に按ず ●バッテリー液(硫酸)で失明ややけどの恐れあり ●液がつかいたらすぐに多量の水で洗い、目の場合は医師の治療を受ける ●爆発の恐れあり、液面はLOWER以下で使用しない ●液漏れの恐れあり、UPPER以上に補水しない</p>	
<p>危険</p> <p>DANGER KEEP SPARKS, FLAME, CIGARETTES AWAY. ÉLOIGENZ LES ÉTINCELLES, FLAMME, CIGARETTES.</p>	<p>公称電圧 12V</p>

(18) Caution when handling battery (09664-30011)

<p>⚠ DANGER/POISON EXPLOSIVE GASES Cigarettes, flames or sparks could cause battery to explode. Always shield eyes and face from battery. Do not charge or use booster cables or adjust post connections without order instruction and training. KEEP VENT CAPS TIGHT AND LEVEL. Poison causes severe burns. Contains sulfuric acid. In event of accident flush with water and call a physician immediately. KEEP OUT OF REACH OF CHILDREN.</p>

(19) Jump start prohibited (09842-A0481)
Safety label (19) is stick on the starting motor.



Start the engine only after sitting down in the operator's seat.

Do not attempt to start the engine by short-circuiting the engine starting circuit. Such an act may cause a serious bodily injury or fire.

(20) Warning when removing bank-control lock pin (09819-03000)

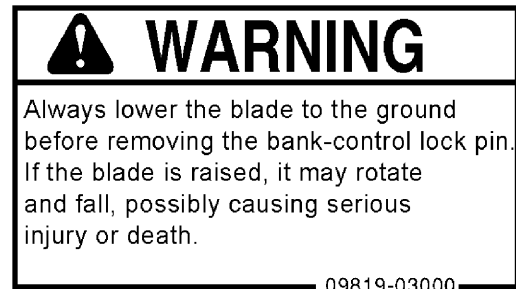

(21) Caution to prevent falling (09805-13000)



(22) Caution for rotating parts (09667-23001)



GENERAL PRECAUTIONS COMMON TO OPERATION AND MAINTENANCE

Mistakes in operation, inspection, or maintenance may result in serious personal injury or death. Before carrying out operation, inspection, or maintenance, always read this manual and the safety labels on the machine carefully and obey the warnings.

PRECAUTIONS BEFORE STARTING OPERATION

ENSURING SAFE OPERATION

- Only trained and authorized personnel can operate and maintain the machine.
- Follow all safety rules, precautions and instructions in this manual when operating or performing maintenance on the machine.
- If you are not feeling well or you are feeling stressed, or if you are under the influence of alcohol or medication, your ability to safely operate or repair your machine may be severely impaired, putting yourself and everyone else on your job site in danger.
- When working with another operator or with the person on the worksite traffic duty, discuss the content of the operation beforehand and use the determined signals when carrying out the operation.

UNDERSTANDING THE MACHINE

Before operating the machine, read this manual thoroughly. If there are any places in this manual that you do not understand, ask the person in charge of safety to give an explanation.

PREPARATIONS FOR SAFE OPERATION

PRECAUTIONS REGARDING SAFETY-RELATED EQUIPMENT

- Be sure that all guards, covers and mirrors are in their proper position. Have guards and covers repaired immediately if they are damaged.
- Understand the method of use of safety features and use them properly.
- Never remove any safety features. Always keep them in good operating condition.

INSPECTING MACHINE

Check the machine before starting operations. If any abnormality is found, do not operate the machine until repairs of the problem location have been completed.

WEAR WELL-FITTING CLOTHES AND PROTECTIVE EQUIPMENT

- Do not wear loose clothes or any accessories. If these catch on the control levers or protruding parts, there is danger that it may cause the machine to move unexpectedly.
- Always wear a hard hat and safety shoes. If the nature of the work requires it, wear safety glasses, mask, gloves, ear plugs, and safety belt when operating or maintaining the machine.
- If you have long hair and it hangs out from your hard hat, there is a hazard that it may get caught up in the machine, so tie your hair up and be careful not to let it get caught.
- Check that all protective equipment functions properly before using it.

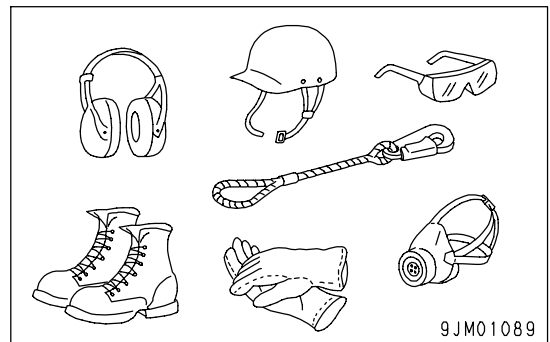

KEEP MACHINE CLEAN

- If you get on or off the machine or carry out inspection and maintenance when the machine is dirty with mud or oil, there is a hazard that you will slip and fall. Wipe off any mud or oil from the machine. Always keep the machine clean.
- If water gets into the electrical system, there is a hazard that it will cause malfunctions or misoperation. If there is any misoperation, there is danger that the machine may move unexpectedly and cause serious personal injury or death. When washing the machine with water or steam, do not allow the water or steam to come into direct contact with electrical components.

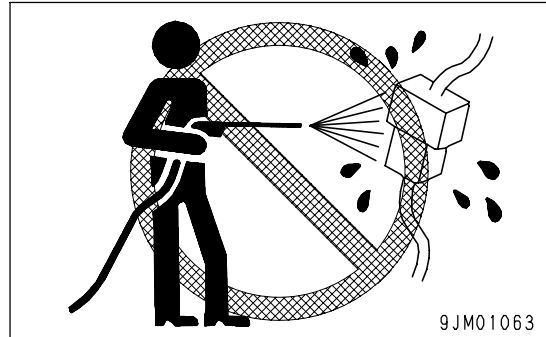
**PRECAUTIONS INSIDE OPERATOR'S COMPARTMENT**

- When entering the operator's compartment, always remove all mud and oil from the soles of your shoes. If you operate the pedal with mud or oil affixed to your shoes, your foot may slip and this may cause a serious accident.
- Do not leave tools or a machine parts lying around inside the operator's compartment. If tools or parts get into the control devices, it may obstruct operation and cause the machine to move unexpectedly, resulting in serious personal injury or death.
- Do not stick suction pads to the window glass. Suction pads act as a lens and may cause fire.
- Do not use a cell phone when driving or operating the machine. This may lead to mistakes in operation, which could cause serious personal injury or death.
- Never bring any dangerous objects such as flammable or explosive items into the operator's compartment.

PROVIDE FIRE EXTINGUISHER AND FIRST AID KIT

Always follow the precautions below to prepare for action if any injury or fire should occur.

- Be sure that fire extinguishers have been provided and read the labels to ensure that you know how to use them in emergencies.
- Carry out periodic inspection and maintenance to ensure that the fire extinguisher can always be used.
- Provide a first aid kit in the storage point. Carry out periodic checks and add to the contents if necessary.

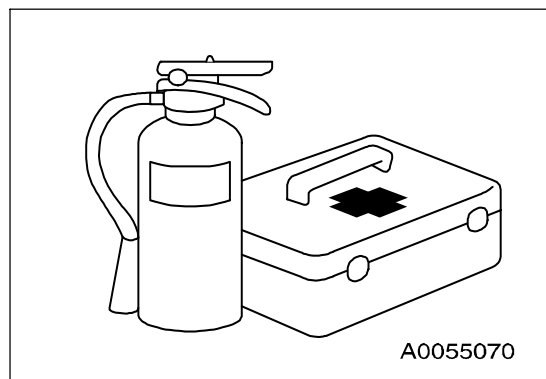
**IF ANY PROBLEM IS FOUND**

If you find any problems in the machine during operation or maintenance (noise, vibration, smell, incorrect gauges, smoke, oil leakage, etc., or any abnormal display on the warning devices or monitor), report to the person in charge and have the necessary action taken. Do not operate the machine until the problem has been corrected.

FIRE PREVENTION

ACTION IF FIRE OCCURS

- Turn the start switch OFF to stop the engine.
- Use the handrails and steps to get off the machine.
- Do not jump off the machine. There is the danger of falling and suffering serious injury.

PRECAUTIONS TO PREVENT FIRE

• Fire caused by fuel, oil, antifreeze, or window washer fluid

Do not bring any flame or fire close to flammable substances such as fuel, oil, antifreeze, or window washer fluid. There is danger that they may catch fire. To prevent fire, always observe the following:

- Do not smoke or use any flame near fuel or other flammable substances.
- Stop the engine before adding fuel.
- Do not leave the machine when adding fuel or oil.
- Tighten all fuel and oil caps securely.
- Be careful not to spill fuel on overheated surfaces or on parts of the electrical system.
- After adding fuel or oil, wipe up any spilled fuel or oil.
- Put greasy rags and other flammable materials into a safe container to maintain safety at the workplace.
- When washing parts with oil, use a non-flammable oil. Do not use diesel oil or gasoline. There is danger that they may catch fire.
- Do not weld or use a cutting torch to cut any pipes or tubes that contain flammable liquids.
- Determine well-ventilated areas for storing oil and fuel. Keep the oil and fuel in the determined place and do not allow unauthorized persons to enter.
- When carrying out grinding or welding work on the machine, move any flammable materials to a safe place before starting.

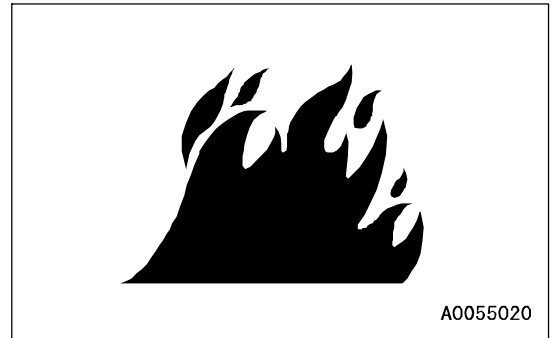

• Fire caused by accumulation of flammable material.

Remove any dry leaves, chips, pieces of paper, coal dust, or any other flammable materials accumulated or affixed around the engine, exhaust manifold, muffler, or battery, or inside the undercovers.

• Fire coming from electric wiring

Short circuits in the electrical system can cause fire. To prevent fire, always observe the following.

- Keep all electric wiring connections clean and securely tightened.
- Check the wiring every day for looseness or damage. Tighten any loose connectors or wiring clamps. Repair or replace any damaged wiring.

• Fire coming from piping

Check that all the hose and tube clamps, guards, and cushions are securely fixed in position.

If they are loose, they may vibrate during operation and rub against other parts. There is danger that this may lead to damage to the hoses and cause high-pressure oil to spurt out, leading to fire, serious personal injury or death.

- **Explosion caused by lighting equipment**

- When checking fuel, oil, battery electrolyte, or coolant, always use lighting with anti-explosion specifications.

PRECAUTIONS WHEN GETTING ON OR OFF MACHINE

USE HANDRAILS AND STEPS WHEN GETTING ON OR OFF MACHINE

To prevent personal injury caused by slipping or falling off the machine, always do as follows.

- Use the handrails and steps marked by arrows in the diagram on the right when getting on or off the machine.

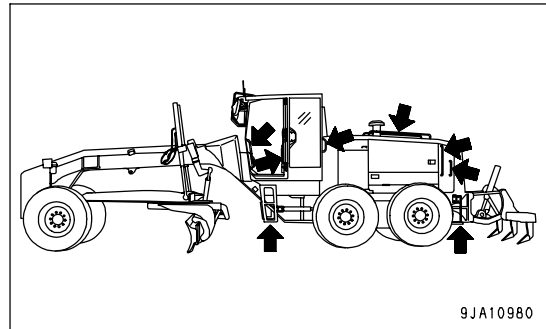

- Always face the machine and maintain at least three-point contact (both feet and one hand, or both hands and one foot) with the handrail and steps to ensure that you support yourself.

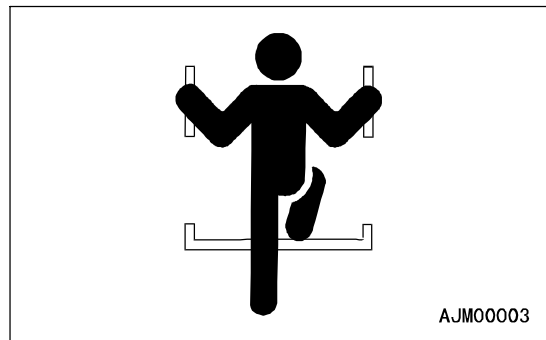

- Before getting on or off the machine, check the handrails and steps, and if there is any oil, grease, or mud on them, wipe it off immediately. In addition, repair any damage and tighten any loose bolts.
- Do not grip the control levers when getting on or off the machine.
- Never climb on the engine hood or covers where there are no non-slip pads.
- Do not get on or off the machine while holding tools in your hand.

NO JUMPING ON OR OFF MACHINE

- Never jump on or off the machine. Never get on or off a moving machine.
- If the machine starts to move when there is no operator on the machine, do not jump on to the machine and try to stop it.

NO PEOPLE ON ATTACHMENTS

Never let anyone ride on the work equipment or other attachments. There is a hazard of falling and suffering serious personal injury or death.

PRECAUTIONS WHEN STANDING UP FROM OPERATOR'S SEAT

Before standing up from the operator's seat, such as when adjusting the position of the seat, always lower the work equipment completely to the ground, set gearshift lever (1) to the P (Parking) position, then stop the engine.

If the control levers are touched by mistake, the machine may suddenly move and cause serious personal injury or death.

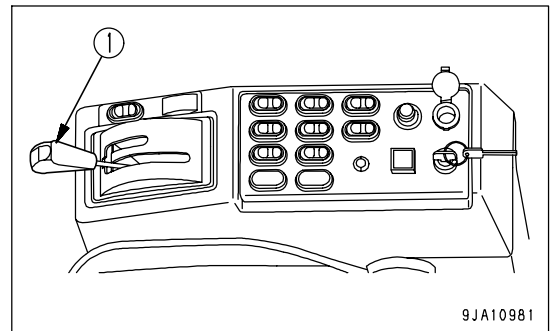
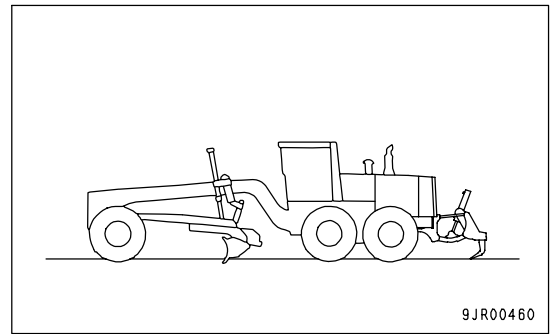
**PRECAUTIONS WHEN LEAVING MACHINE**

If the proper procedures are not taken when parking the machine, the machine may suddenly move off by itself, and this may lead to serious personal injury or death. Always do the following.

- When leaving the machine, always lower the work equipment completely to the ground, set gearshift lever (1) to the P (Parking) position, then stop the engine.
Use the key to lock all the equipment. Always remove the key, take it with you, and keep it in the specified place.
- To ensure that there is enough space to get on or off the machine, raise the steering column fully when getting off the machine.

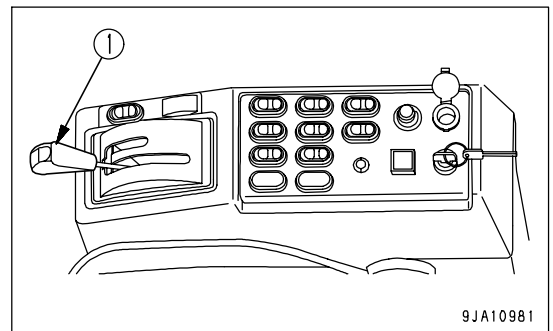
**EMERGENCY EXIT FROM OPERATOR'S CAB**

Machines equipped with a cab have doors on the left and right sides. If the door on the one side does not open, escape from the door on the other side.

PRECAUTIONS WHEN CLEANING CAB GLASS AND CAB-MOUNTED WORKING LAMP (IF EQUIPPED)

Working on the frame, tire, or hood is very dangerous.

Be sure to carry out the cleaning operation from the ground by using a handled mop, etc.

Clean the cab glass to ensure good visibility during operations.

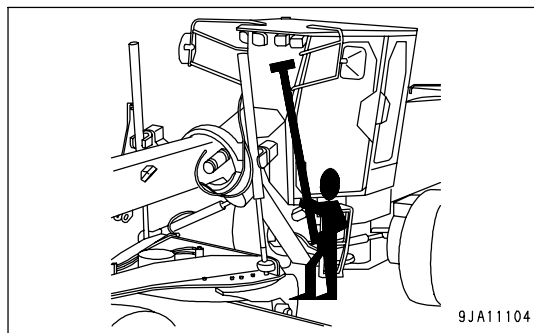
**DO NOT GET CAUGHT IN WORK EQUIPMENT**

The clearance in the area around the work equipment changes according to the movement of the link. If you get caught, you may suffer serious personal injury or death. Do not allow anyone to come close to any rotating or extending/retracting portion.

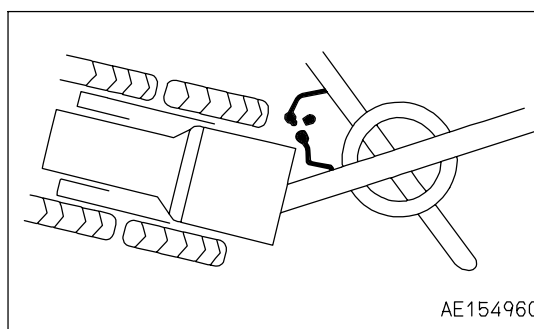
**PRECAUTIONS RELATED TO PROTECTIVE STRUCTURES**

The operator's compartment is equipped with a structure (such as ROPS, FOPS) to protect the operator by absorbing the impact energy. As for the machine equipped with ROPS, if the machine weight (mass) exceeds the certified value (shown on the ROLL-OVER PROTECTIVE STRUCTURE (ROPS) CERTIFICATION plate), ROPS will not be able to fulfill its function. Do not increase machine weight beyond the certified value by modifying the machine or by installing attachments to the machine. Also, if the function of the protective equipment is impeded, the protective equipment will not be able to protect the operator, and the operator may suffer injury or death. Always observe the following.

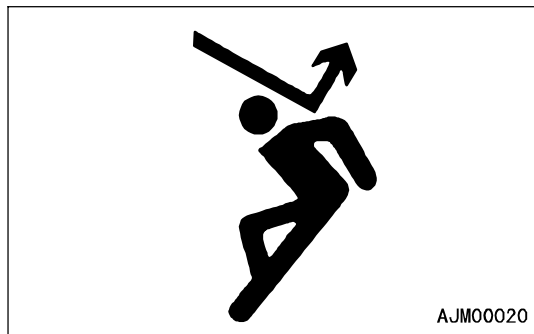

- If the machine is equipped with a protective structure, do not remove the protective structure and carry out operations without it.
- If the protective structure is welded, or holes are drilled in it, or it is modified in any other way, its strength may drop. Consult your Komatsu distributor before carrying out any modifications.
- If the protective structure is damaged or deformed by falling objects or by rolling over, its strength will be reduced and it will not be able to fulfill its function properly. In such cases, always contact your Komatsu distributor for advice on the method of repair.
- Even if the protective structure is installed, always fasten your seat belt properly when operating the machine. If you do not fasten your seatbelt properly, it cannot display its effect.

UNAUTHORIZED MODIFICATION

- Komatsu will not be responsible for any injuries, accidents, product failures or other property damages resulting from modifications made without authorization from Komatsu.
- Any modification made without authorization from Komatsu can create hazards. Before making a modification, consult your Komatsu distributor.

PRECAUTIONS RELATED TO ATTACHMENTS AND OPTIONS

- Any injuries, accidents, product failures or other property damages resulting from the use of unauthorized attachments or parts will not be the responsibility of Komatsu.
- When installing optional parts or attachments, there may be problems with safety or legal restrictions. Therefore contact your Komatsu distributor for advice.
- When installing and using optional attachments, read the instruction manual for the attachment, and the general information related to attachments in this manual.

PRECAUTIONS WHEN RUNNING ENGINE INSIDE BUILDING

The engine exhaust gas contains substances that may damage your health or even cause death. Start or operate the engine in a place where there is good ventilation. If the engine or machine must be operated inside a building or under ground, where the ventilation is poor, take steps to ensure that the engine exhaust gas is removed and that ample fresh air is brought in.

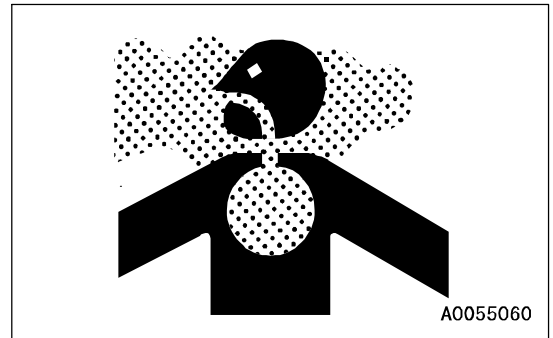

PRECAUTIONS FOR OPERATION

PRECAUTIONS FOR JOBSITE

INVESTIGATE AND CONFIRM JOBSITE CONDITIONS

On the jobsite, there are various hidden dangers that may lead to personal injury or death. Before starting operations, always check the following to confirm that there is no danger on the jobsite.

- When carrying out operations near combustible materials such as thatched roofs, dry leaves or dry grass, there is a hazard of fire, so be careful when operating.
- Check the terrain and condition of the ground at the worksite, and determine the safest method of operation. Do not operate where there is a hazard of landslides or falling rocks.
- If water lines, gas lines, or high-voltage electrical lines may be buried under the worksite, contact each utility and identify their locations. Be careful not to sever or damage any of these lines.
- Take necessary measures to prevent any unauthorized person from entering the operating area.
- In particular, if you need to operate on a road, protect pedestrian and cars by designating a person for worksite traffic duty or by installing fences around the worksite.
- When traveling or operating in water or on soft ground, check the water depth, speed of the current, bedrock, and shape of the ground beforehand and avoid any place that will obstruct travel.
- Maintain the travel path on the jobsite so that there is no obstruction to travel operations.

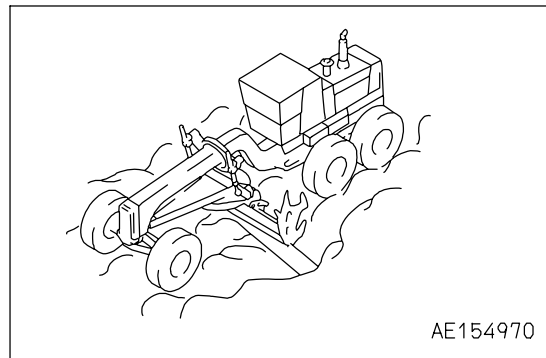

WORKING ON LOOSE GROUND

- Avoid traveling or operating your machine too close to the edge of cliffs, overhangs, and deep ditches. The ground may be weak in such areas. If the ground should collapse under the weight or vibration of the machine, there is a hazard that the machine may fall or tip over. Remember that the soil after heavy rain or blasting or after earthquakes is weak in these areas.
- When working on embankments or near excavated ditches, there is a hazard that the weight and vibration of the machine will cause the soil to collapse. Before starting operations, take steps to ensure that the ground is safe and to prevent the machine from rolling over or falling.

DO NOT GO CLOSE TO HIGH-VOLTAGE CABLES

Do not travel or operate the machine near electric cables. There is a hazard of electric shock, which may cause serious personal injury or death. On jobsites where the machine may go close to electric cables, always do as follows.

- Before starting work near electric cables, inform the local power company of the work to be performed, and ask them to take the necessary action.

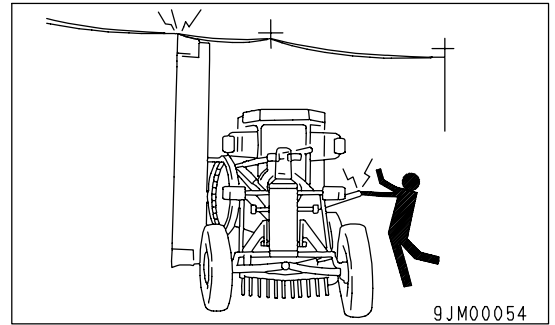

- Even going close to high-voltage cables can cause electric shock, which may cause serious burns or even death. Always maintain a safe distance (see the table on the right) between the machine and the electric cable. Check with the local power company about safe operating procedure before starting operations.
- To prepare for any possible emergencies, wear rubber shoes and gloves. Lay a rubber sheet on top of the seat, and be careful not to touch the chassis with any exposed part of your body.
- Use a signalman to give warning if the machine approaches too close to the electric cables.
- When carrying out operations near high voltage cables, do not let anyone near the machine.
- If the machine should come too close or touch the electric cable, to prevent electric shock, the operator should not leave the operator's compartment until it has been confirmed that the electricity has been shut off. Also, do not let anyone near the machine.

Voltage of Cables	Safety Distance
100V - 200V	Over 2 m (7 ft)
6,600V	Over 2 m (7 ft)
22,000V	Over 3 m (10 ft)
66,000V	Over 4 m (14 ft)
154,000V	Over 5 m (17 ft)
187,000V	Over 6 m (20 ft)
275,000V	Over 7 m (23 ft)
500,000V	Over 11 m (36 ft)

ENSURE GOOD VISIBILITY

This machine is equipped with mirrors to ensure good visibility, but even then there are places that cannot be seen from the operator's seat, so be careful when operating.

When traveling or carrying out operations in places with poor visibility, it is impossible to check for obstacles in the area around the machine and to check the condition of the jobsite. This leads to danger of serious personal injury or death. When traveling or carrying out operations in places with poor visibility, always observe the following.

- Position a signalman if there are areas where the visibility is not good.
- Only one signalman should give signals.
- When working in dark places, turn on the working lamp and front lamps installed to the machine, and set up additional lighting in the work area if necessary.
- Stop operations if the visibility is poor, such as in mist, snow, rain, or dust.
- When checking the mirrors installed to the machine, remove all dirt and adjust the angle of the mirror to ensure good visibility.

CHECKING SIGNS AND SIGNALMAN'S SIGNALS

- Set up signs to inform of road shoulders and soft ground. If the visibility is not good, position a signalman if necessary. Operators should pay careful attention to the signs and follow the instructions from the signalman.
- Only one signalman should give signals.
- Make sure that all workers understand the meaning of all signals and signs before starting work.

BEWARE OF ASBESTOS DUST

Asbestos dust in the air can cause lung cancer if it is inhaled. There is danger of inhaling asbestos when working on jobsites handling demolition work or work handling industrial waste. Always observe the following.

- Spray water to keep down the dust.
- Do not use compressed air.
- If there is danger that there may be asbestos dust in the air, always operate the machine from an upwind position, and make sure that all workers operate on the upwind side.
- All workers should use anti-dust masks.
- Do not allow other persons to approach during the operation.
- Always observe the rules and regulations for the work site and environmental standards.

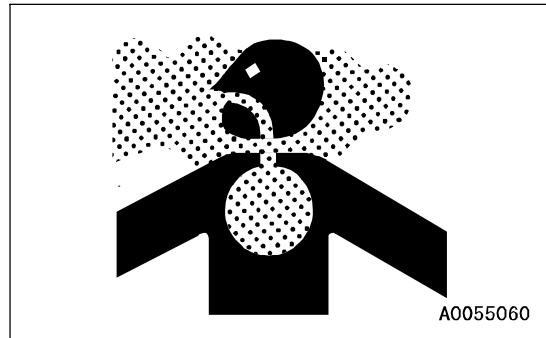

This machine does not use asbestos, but there is a danger that imitation parts may contain asbestos, so always use genuine Komatsu parts.

STARTING ENGINE

USE WARNING TAGS

If there is any "DANGER! Do NOT operate!" warning tag displayed, it means that someone is carrying out inspection and maintenance of the machine. If the warning sign is ignored and the machine is operated, there is danger that the person carrying out inspection or maintenance may be caught in the rotating parts or moving parts and suffer serious personal injury or death. Do not start the engine or touch the levers.

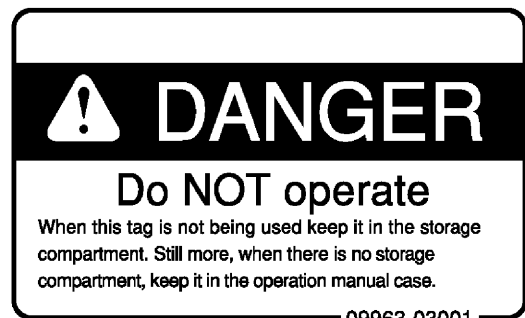
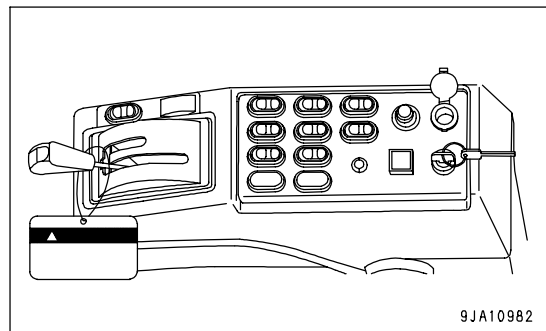

INSPECTION AND MAINTENANCE BEFORE STARTING ENGINE

Carry out the following checks before starting the engine at the beginning of the day's work to ensure that there is no problem with the operation of the machine. If this inspection is not carried out properly problems may occur with the operation of the machine, and there is danger that this may lead to serious personal injury or death.

- Remove all dirt from the surface of the window glass to ensure a good view.
- Carry out the "WALK-AROUND CHECK (PAGE 3-83)".
- Remove all dirt from the surface of the lens of the front lamps, working lamps, and rear combination lamp, and check that they light up correctly.
- Check the coolant level, fuel level, and oil level in engine oil pan, check for clogging of the air cleaner, and check for damage to the electric wiring.
- Check that there is no mud or dust accumulated around the movable parts of the accelerator pedal or brake pedal, and check that the pedals work properly.
- Adjust the operator's seat to a position where it is easy to carry out operations, and check that there is no damage or wear to the seat belt or mounting clamps.
- Check that the gauges work properly, check the angle of the mirror, and check that the control levers are all at the Neutral position.
- Before starting the engine, check that the gearshift lever is at the P (Parking) position.
- Adjust the mirrors so that you can get a good rear-view from the operator's seat.
For the details of adjustment, see "ADJUSTING MIRROR (PAGE 3-98)".
- Check that there are no persons or obstacles above, below, or in the area around the machine.
- If the operation requires use of the articulation, set the articulate lock pin (1) is at the FREE position (F).
- Before traveling on roads, check that the articulation lock pin (1) is at the LOCK position (L).

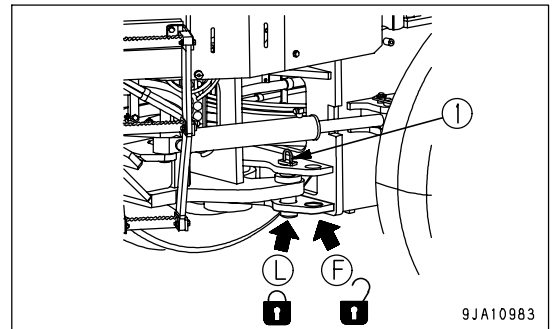

- If leaning stopper (2) is inserted, remove it and keep it in the toolbox.

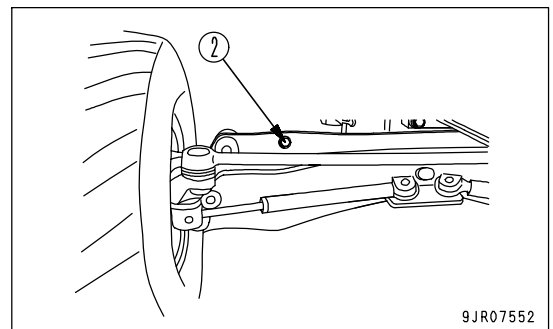
**PRECAUTIONS WHEN STARTING ENGINE**

- Start and operate the machine only while seated.
- When starting the engine, sound the horn as a warning.
- Do not allow anyone apart from the operator to ride on the machine.
- Do not attempt to start the engine by short-circuiting the engine starting circuit. This may cause fire, serious personal injury or death.
- Check that the backup alarm (alarm buzzer when machine travels in reverse) works properly.

PRECAUTIONS IN COLD AREAS

- Carry out the warming-up operation thoroughly. If the machine is not thoroughly warmed up before the control levers are operated, the reaction of the machine will be slow, and this may lead to unexpected accidents.
- If the battery electrolyte is frozen, do not charge the battery or start the engine with a different power source. There is a hazard that this will ignite the battery and cause the battery to explode. Before charging or starting the engine with a different power source, melt the battery electrolyte and check that there is no leakage of electrolyte before starting.

STARTING WITH BOOSTER CABLES

If any mistake is made in the method of connecting the booster cables, it may cause the battery to explode, so always do as follows.

- Always wear safety goggles and rubber gloves when starting the engine with booster cable.
- When connecting a normal machine to a problem machine with booster cables, always use a normal machine with the same battery voltage as the problem machine.
- When starting with a booster cable, carry out the starting operation with two workers (one worker sitting in the operator's seat and the other working with the battery).
- When starting from another machine, do not allow the two machines to touch.
- When connecting the booster cables, turn the starting switch to the OFF position for both the normal machine and problem machine. There is a hazard that the machine will move when the power is connected.
- Be sure to connect the positive (+) cable first when installing the booster cables. Disconnect the negative (-) cable (ground side) first when removing them.
- When removing the booster cables, be careful not to let the booster cable clips touch each other or to let the clips touch the machine.
- For details of the starting procedure when using booster cables, see "STARTING ENGINE WITH BOOSTER CABLE (PAGE 3-182)" in the OPERATION section.

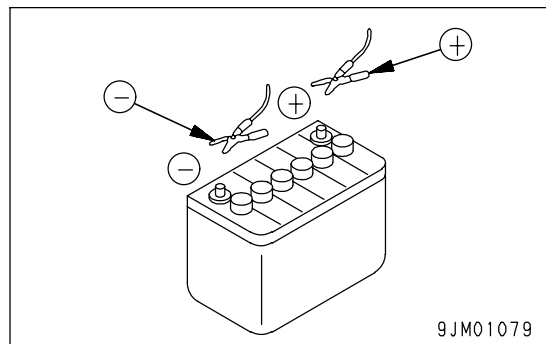
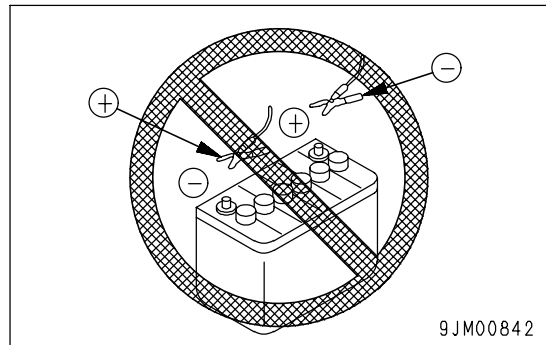

OPERATION

CHECKS BEFORE OPERATION

If the checks before starting are not carried out properly, the machine will be unable to display its full performance, and there is also danger that it may lead to serious personal injury or death.

When carrying out the checks, move the machine to a wide area where there are no obstructions, and pay careful attention to the surrounding area. Do not allow anyone near the machine.

- Always wear the seatbelt. There is danger that you may be thrown out of the operator's seat and suffer serious injury when the brakes are applied suddenly.
- Check the operation of travel, steering and brake systems, and work equipment control system.
- Check for any problem in the sound of the machine, vibration, heat, smell, or gauges; check also that there is no leakage of oil or fuel.
- If any problem is found, carry out repairs immediately.
- If the operation requires use of the articulation, set the articulate lock pin (1) is at the FREE position (F).
- Before traveling on roads, check that the articulation lock pin (1) is at the LOCK position (L).

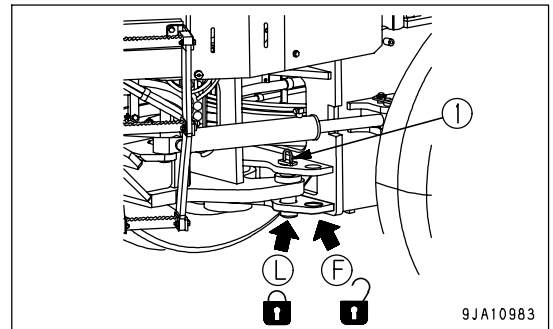
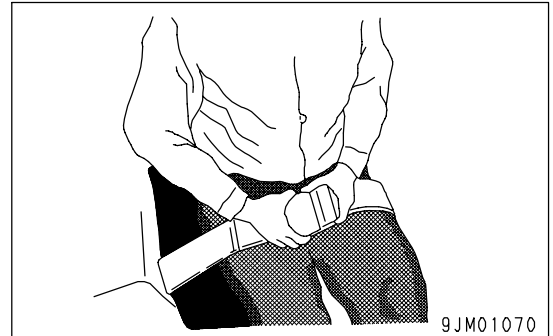

PRECAUTIONS WHEN TRAVELING IN FORWARD OR REVERSE

- Lock the cab door and windows securely, both when they are open and when they are closed.
- Do not allow anyone apart from the operator to ride on the machine.
- If there are any persons in the area around the machine, there is danger that they may be hit or caught by the machine, and this may lead to serious personal injury or death. Always observe the following before traveling.
 - Always operate the machine only when seated.
 - Before moving off, check again that there is no person or obstruction in the surrounding area.
 - Before moving, sound the horn to warn people in the surrounding area.
 - Check that the backup alarm (alarm buzzer when machine travels in reverse) works properly.
 - If there is an area to the rear of the machine which cannot be seen, position a signalman.

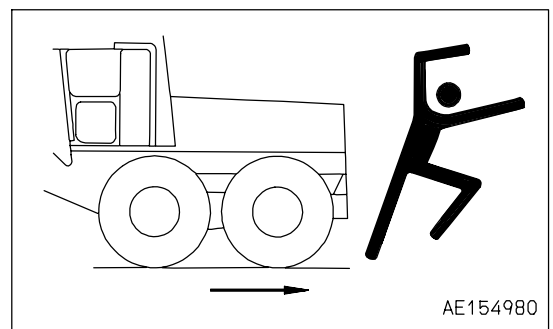

Always be sure to carry out the above precautions even when the machine is equipped with mirrors.

PRECAUTIONS WHEN TRAVELING

- Never turn the key in the starting switch to the OFF position. It is dangerous if the engine stops when the machine is traveling, because the steering becomes heavy. There is danger that this will cause misoperation of the steering wheel and may lead to serious personal injury or death. If the engine stops, depress the brake pedal immediately to stop the machine.
- When traveling or carrying out operations, always keep a safe distance from people, structures, or other machines to avoid coming into contact with them.
- When traveling on flat ground, keep the work equipment 30 - 50 cm (12 - 20 in) above the ground. If the work equipment is too close to the ground surface, the work equipment may contact the ground and cause the machine to tip over.

It is necessary to operate the work equipment control lever, stop the machine first, then operate the control lever.

- When traveling on rough ground, travel at low speed and do not operate the steering suddenly. There is danger that the machine may turn over. The work equipment may hit the ground surface and cause the machine to lose its balance, or may damage the machine or structures in the area.
- Operate carefully when the wheels are leaning. It is prohibited to travel on roads with the wheels leaning.

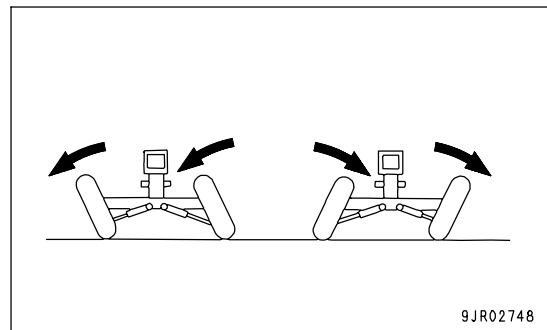

- Travel at a maximum speed of 10 km/h (6.2 MPH) when using the articulation. If the articulation is used when traveling at a speed of over 10 km/h (6.2 MPH), there is danger that the machine may overturn. Never use the articulation at speeds of over 10 km/h (6.2 MPH).

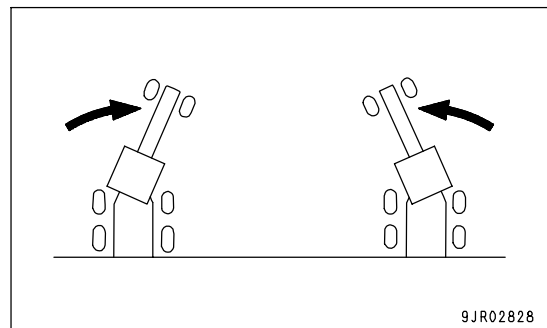

- When traveling or carrying out operations, always keep a safe distance from people, structures, or other machines to avoid coming into contact with them.
- When passing over bridges or structures, check first that the structure is strong enough to support the mass of the machine.
- When operating in tunnels, under bridges, under electric wires, or other places where the height is limited, operate slowly and be extremely careful not to let the machine body or work equipment hit anything.
- If you drive the machine at high speed continuously for a long time, the tires will overheat and the internal pressure will become abnormally high. This may cause the tires to burst. If a tire bursts, it produces an extremely large destructive force, and this may cause serious injury. When traveling continuously, travel for 2 hours or 80 km, then rest for 30 minutes. Next, travel for 2 hours, then rest for 1 hour, or contact your Komatsu distributor. If you are going to travel continuously, please consult your Komatsu distributor.

- Do not move the gear shift lever to the N position when traveling on level ground or when traveling downhill. Always keep the transmission in the gear when traveling. Failure to do this may cause the following problems.
 - There is danger that the steering will become heavy and that it will be impossible to use the braking force of the engine.
 - Damage may be caused to the transmission or other parts of the power train, and there is danger that this may lead to unexpected accidents.
- Always keep the operator's cab door closed during operations. Unexpected scattered objects possibly enter the operator's cab. On rainy days, rain and mud possibly enter the cab, too.

TRAVELING ON SLOPES

To prevent the machine from tipping over or slipping to the side, always do as follows.

- Always travel straight up or down a slope. Traveling at an angle or across the slope is extremely dangerous.
- Do not turn on slopes or travel across slopes. Always go down to a flat place to change the position of the machine, then travel on to the slope again.
- Travel on grass, fallen leaves, or wet steel plates with low speed. Even with slight slopes there is a hazard that the machine may slip.
- If the engine stops, depress the brake pedal immediately, lower the blade, set the gearshift lever to the P (Parking) position, and stop the machine.
- When traveling downhill, never shift gear or place the transmission at neutral. It is dangerous not to use the braking force of the engine. Always place the transmission in a low gear before starting to travel downhill.
- When traveling downhill, travel slowly. If necessary, use the braking force of the engine together with the brake pedal to control the travel speed.
- When traveling on slopes with the body articulated, always set the front wheels on the downhill side. If the front wheels are on the uphill side, there is increased danger that the machine will tip over.

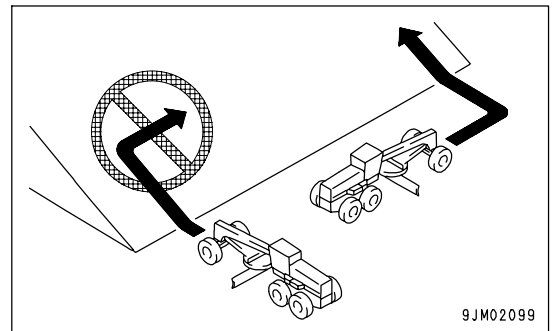

PRECAUTIONS WHEN OPERATING

- When operating in tunnels, under bridges, under electric wires, or other places where the height is limited, be extremely careful not to let the machine body or work equipment hit anything.
- To prevent accidents caused by hitting other objects, always operate the machine at a speed which is safe for operation, particular in confined spaces, indoors, and in places where there are other machines.
- Check that there is no person other than the operator within the range of flying objects caused by the operation.

OPERATING ON SLOPES

- Do not articulate the machine fully on steep slopes. There is danger that the machine may tip over.
- When working on slopes, control the machine speed with the accelerator pedal.

PROHIBITED OPERATIONS

If the machine rolls over or falls, or the ground at the working point collapses, it may lead to serious personal injury or death. Always observe the following precautions.

- When operating at the bottom of a cliff, there is danger that the soil may collapse or that rocks may fall. Never operate in such places.
- The edge of cliffs or road shoulders may easily collapse, and there is danger of falling. Do not go close to such places.
- Avoid sudden starts, sudden stops, and sudden steering.

TRAVELING ON SNOW-COVERED OR FROZEN SURFACES

- Snow-covered or frozen surfaces are slippery, so be extremely careful when traveling or operating the machine, and do not operate the levers suddenly. Even a slight slope may cause the machine to slip, so be particularly careful when working on slopes.
- With frozen ground surfaces, the ground becomes soft when the temperature rises, and this may cause the machine to tip over or make it impossible for the machine to escape.
- When traveling on snow-covered roads, always fit tire chains.
- If the machine enters deep snow, there is a hazard that it may tip over or become buried in the snow. Be careful not to leave the road shoulder or to get trapped in a snow drift.
- When clearing snow, the road shoulder and objects placed beside the road are buried in the snow and cannot be seen. There is a hazard of the machine tipping over or hitting covered objects, so always carry out operations carefully.
- When traveling on snow-covered slopes, never apply the foot brake suddenly. Reduce the speed and use the engine as a brake while applying the foot brake intermittently (depress the brake intermittently several times). If necessary, lower the work equipment to the ground to stop the machine.

PARKING MACHINE

- Park the machine on firm, level ground.
- Select a place where there is no hazard of landslides, falling rocks, or flooding.
- Lower the work equipment completely to the ground.

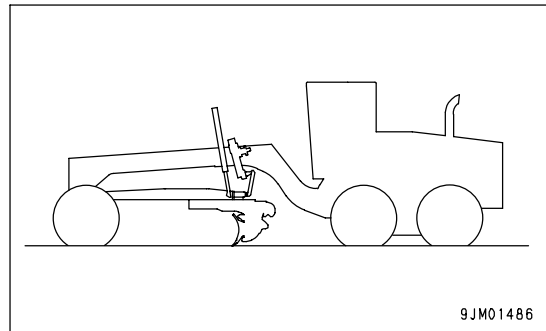

- When leaving the machine, set gearshift lever (1) to the P (Parking) position, then stop the engine.
- Always close the operator's cab door, and use the key to lock all the equipment in order to prevent any unauthorized person from moving the machine. Always remove the key, take it with you, and leave it in the specified place.

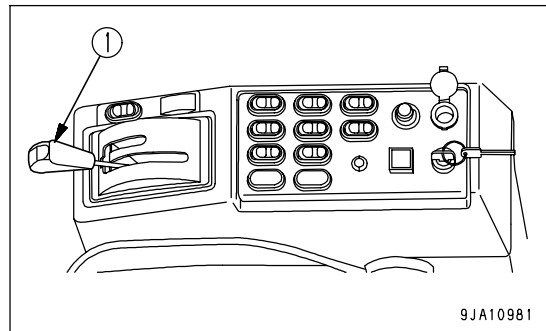

- If it is necessary to park the machine on a slope, set blocks under the wheels to prevent the machine from moving.

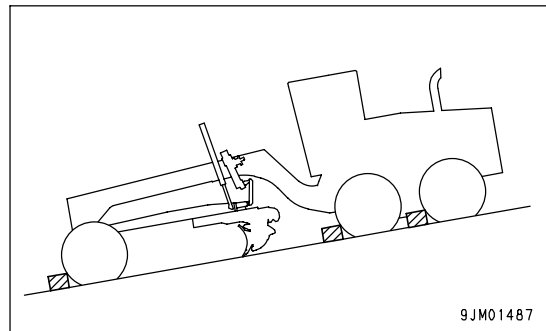

TRANSPORTATION

When the machine is transported on a trailer, there is danger of serious personal injury or death during transportation. Always do as follows.

- Always check the machine dimensions carefully. Depending on the work equipment installed, the machine weight, transportation height, and overall length may differ.
- Check beforehand that all bridges and other structures on the transportation route are strong enough to withstand the combined weight of the transporter and the machine being transported.
- When traveling on public roads, apply to the local authorities to obtain permission to transport the machine.
- The machine can be divided into parts for transportation, so when transporting the machine, please contact your Komatsu distributor to have the work carried out.
- Lock the frame with the articulate lock pin to prevent the machine from articulating.
- Lock the front axle with the leaning stopper to prevent the front tires from falling down.
- For details of the procedure for transporting the machine, see "TRANSPORTATION (PAGE 3-170)".

LOADING AND UNLOADING

When loading or unloading the machine, mistaken operation may bring the hazard of the machine tipping over or falling, so particular care is necessary. Always do as follows.

- Perform loading and unloading on firm, level ground only. Maintain a safe distance from the edge of the road or cliff.
- Always use ramps of adequate strength. Be sure that the ramps are wide, long, and thick enough to provide a safe loading slope. Take suitable steps to prevent the ramps from moving out of position or coming off.
- Be sure the ramp surface is clean and free of grease, oil, ice and loose materials. Remove dirt from the tire of the machine. On a rainy day, in particular, be extremely careful since the ramp surface is slippery.
- Run the engine at low idling and drive the machine slowly at low speed.
- Never correct your steering on the ramps. If necessary, drive off the ramps, correct the direction, then enter the ramps again.
- When loading or unloading to an embankment or platform, make sure that it has suitable width, strength, and grade.
- For machines equipped with a cab, always lock the door after boarding the machine. If this is not done, the door may suddenly open during transportation.

Refer to "TRANSPORTATION (PAGE 3-170)".

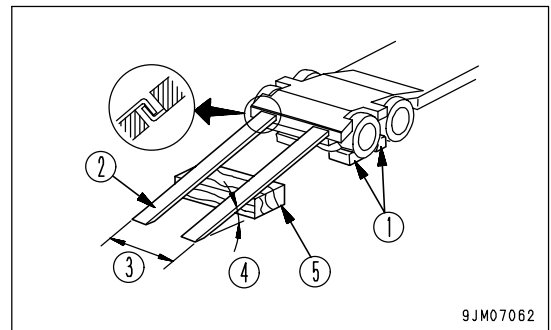

- (1) Blocks
- (2) Ramp
- (3) Width of ramps: Same width as tiers
- (4) Angle of ramps: Max. 15°
- (5) Block

9JM07062

TOWING

PRECAUTIONS WHEN TOWING

Always use the correct towing equipment and towing method. Any mistake in the selection of the wire rope or towing bar or in the method of towing a disabled machine may lead to serious personal injury or death.

For towing, see "TOWING THE MACHINE (PAGE 3-178)".

- Always confirm that the wire rope or drawbar used for towing has ample strength for the weight of the machine being towed.
- Never use a wire rope which has cut strands (A), reduced diameter (B), or kinks (C). There is danger that the rope may break during the towing operation.
- Always wear leather gloves when handling wire rope.
- Never tow a machine on a slope.
- During the towing operation, never stand between the towing machine and the machine being towed.

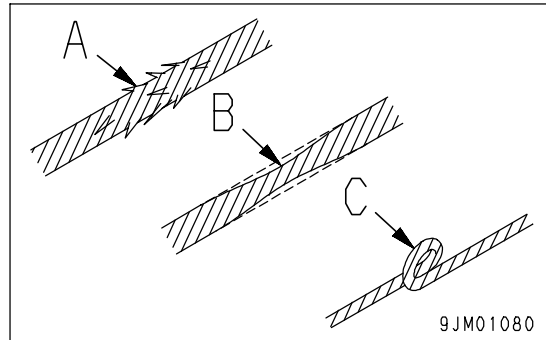

(If not equipped with ripper)

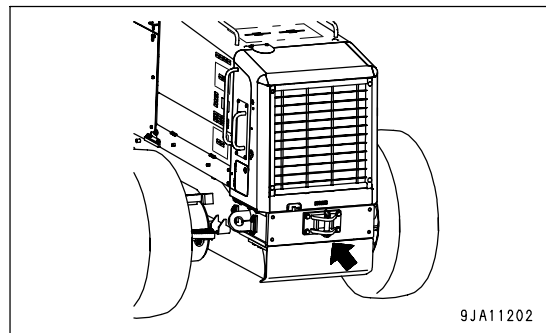

(If equipped with ripper)

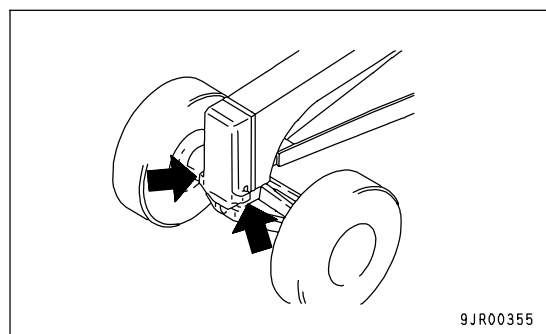
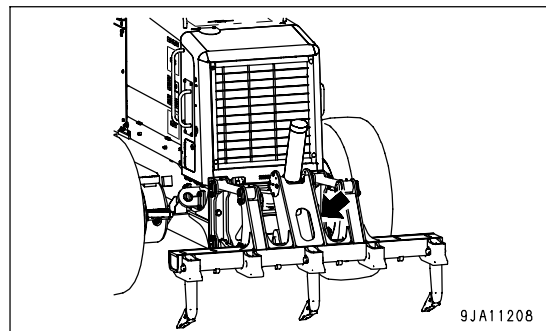

PRECAUTIONS FOR MAINTENANCE

PRECAUTIONS BEFORE STARTING INSPECTION AND MAINTENANCE

DISPLAY WARNING TAG DURING INSPECTION AND MAINTENANCE

Always display the "DANGER! Do NOT operate" warning tag during the inspection and maintenance. If there is any "DANGER! Do NOT operate!" warning tag displayed, it means that someone is carrying out inspection and maintenance of the machine. If the warning sign is ignored and the machine is operated, there is danger that the person carrying out inspection or maintenance may be caught in the rotating parts or moving parts and suffer serious personal injury or death. Do not start the engine or touch the levers.

- If necessary, put up signs around the machine also.
Warning tag part number: 09963-03001
When not using this warning tag, keep it in the toolbox.
If there is no toolbox, keep it in the pocket for the Operation and Maintenance Manual

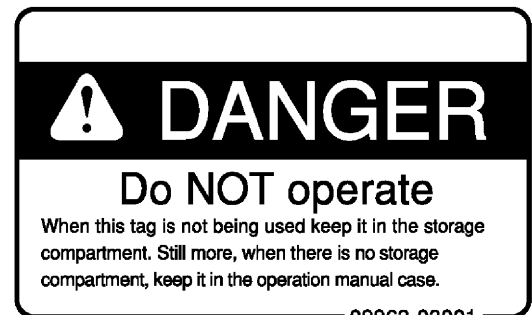
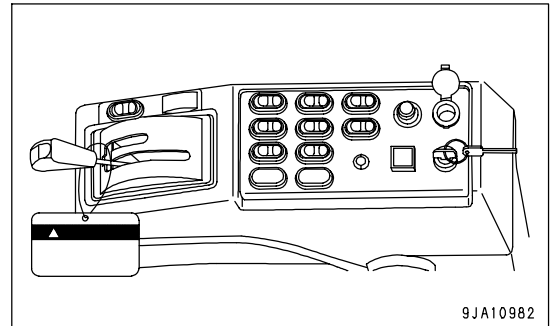

KEEP WORKPLACE CLEAN AND TIDY

Do not leave hammers or other tools lying around in the work place. Wipe up all grease, oil, or other substances that will cause you to slip. Always keep the work place clean and tidy to enable you to carry out operations safely. If the work place is not kept clean and tidy, there is the danger that you will trip, slip, or fall over and injure yourself.

SELECT SUITABLE PLACE FOR INSPECTION AND MAINTENANCE

- Stop the machine on firm, level ground.
- Select a place where there is no hazard of landslides, falling rocks, or flooding.

ONLY AUTHORIZED PERSONNEL

Do not allow any unauthorized personnel into the area when servicing the machine. If necessary, employ a guard.

APPOINT LEADER WHEN WORKING WITH OTHERS

When repairing the machine or when removing and installing the work equipment, appoint a leader and follow his instructions during the operation.

STOP ENGINE BEFORE CARRYING OUT INSPECTION AND MAINTENANCE

- Lower the work equipment completely to the ground and stop the engine before performing any inspection and maintenance.
- To return the oil inside the accumulator to the tank, stop the engine and then depress the brake pedal approximately 20 times.

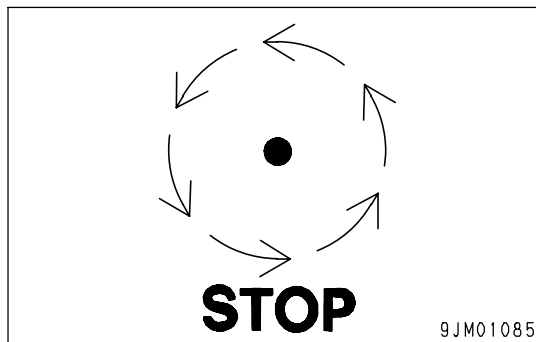

- After stopping the engine, operate the left and right blade lift cylinder control levers fully to the RAISE and LOWER positions 2 or 3 times to release the pressure remaining in the hydraulic circuit, then set gearshift lever (1) to the P (Parking) position.
- In case of a machine having a blade accumulator, stop the engine, then turn the starting switch ON, and, while the accumulator is kept "ON", operate the right and left blade lift cylinder control levers to release the pressure.

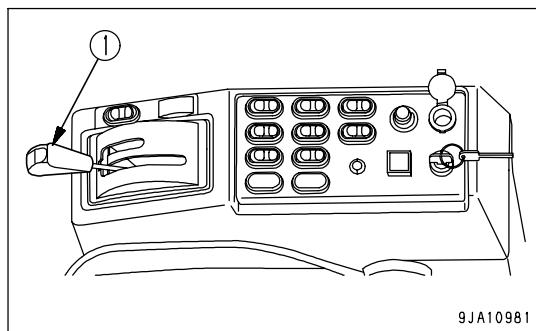
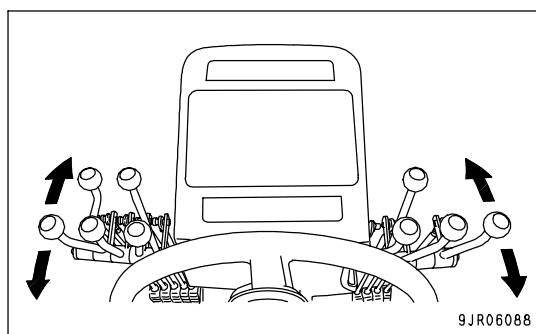

- Put blocks under the front and rear of the tires.

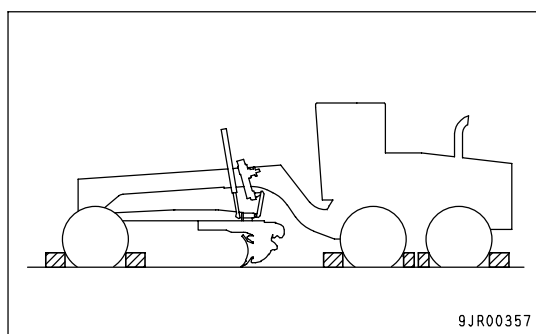

- To prevent the machine from articulating, set the articulation lock pin (2) to the LOCK position (L).

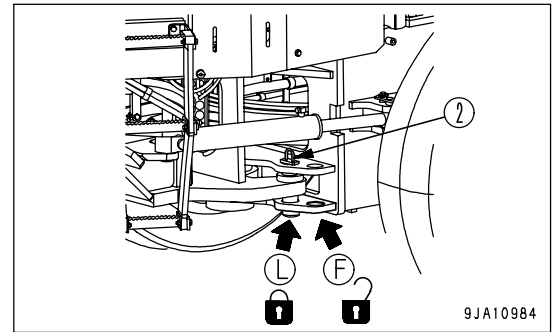

TWO WORKERS FOR INSPECTION AND MAINTENANCE WHEN ENGINE IS RUNNING

To prevent personal injury, do not carry out maintenance with the engine running. If maintenance must be carried out with the engine running, carry out the operation with at least two workers and do as follows.

- One worker must always sit in the operator's seat and be ready to stop the engine at any time. All workers must maintain contact with the other workers.
- When carrying out operations near the fan, fan belt, or other rotating parts, there is a hazard of being caught in the parts, so be careful not to come close.
- Never drop or insert tools or other objects into the fan, fan belt, or other rotating parts. There is danger that they may contact the rotating parts and break or be sent flying.

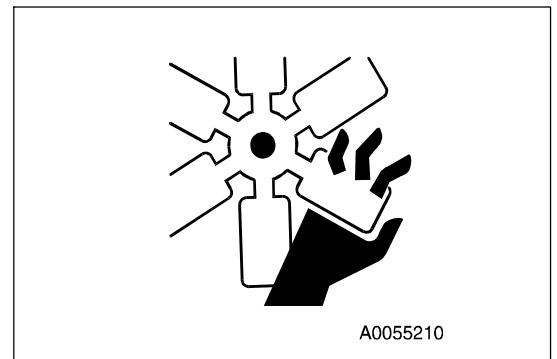

- Place speed lever (1) at the P (parking) position to prevent the machine from moving.
- Be careful not to touch the control levers or steering equipment. If the control levers must be operated, always give a signal to your partner and have your partner withdraw to a safe place.

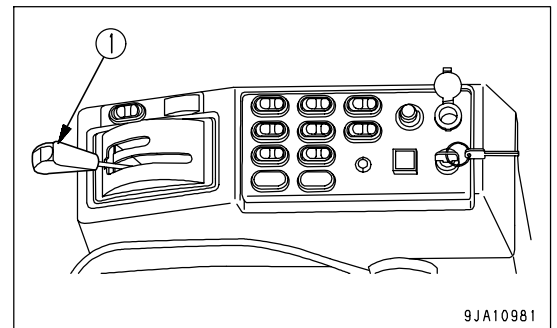

INSTALLING, REMOVING, OR STORING ATTACHMENTS

- Appoint a leader before starting removal or installation operations for attachments.
- Place attachments that have been removed from the machine in a stable condition so that they do not fall. And take steps to prevent unauthorized persons from entering the storage area.



PRECAUTIONS WHEN WORKING AT HIGH PLACES

When working at high places, use a step ladder or other stand to ensure that the work can be carried out safely.

PRECAUTIONS WHEN WORKING ON TOP OF MACHINE

- Clean up the machine to prevent falling off when performing maintenance, always do as follows.
 - Do not spill oil or grease.
 - Do not scatter the tools.
 - Be careful at the time of the walk on the step.
 - Remove mud and the oils and fats kind of the bottom of shoes.
- Never jump off the machine. When getting on or off the machine, maintain at least three-point contact (both feet and one hand, or both hands and one foot) with the handrail and steps to ensure that you support yourself.
- To prevent personal injury caused by slipping or falling off the machine, never climb on the engine hood or covers except the check passage with non-slip pads.



PRECAUTIONS WHEN WORKING UNDER MACHINE

- Make sure the hoists or jacks you use are in good repair and strong enough to handle the weight of the component. Never use jacks at places where the machine is damaged, bent, or twisted. Never use frayed, twisted or pinched wire rope. Never use bent or distorted hooks.
- If it is necessary to raise the work equipment or the machine and then go under it to carry out inspection or maintenance, support the work equipment and machine securely with blocks and stands strong enough to support the weight of the work equipment and machine.
 If the work equipment and machine are not supported, there is a hazard that they may come down and that this may lead to serious personal injury or death.
- Never use concrete blocks for supports. They can collapse under even light loads.

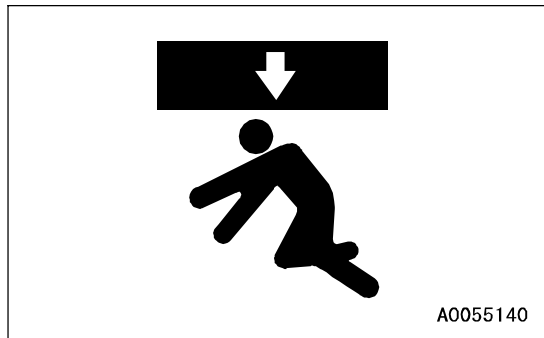

PROPER TOOLS

Use only tools suited to the task and be sure to use the tools correctly. Using damaged, deformed, or low quality tools, or making improper use of the tools may cause serious personal injury.

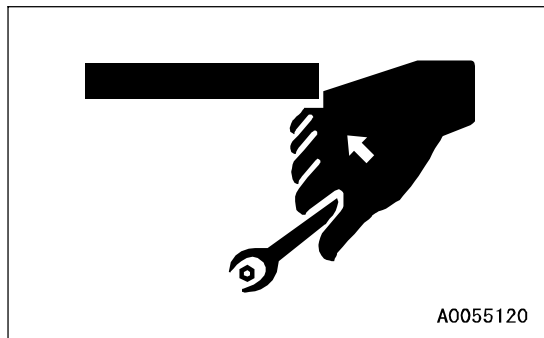

PRECAUTIONS FOR INSPECTION AND MAINTENANCE

PRECAUTIONS WHEN WELDING

Welding operations must always be carried out by a qualified welder and in a place equipped with proper equipment. There is a hazard of gas, fire, or electrocution when carrying out welding, so never allow any unqualified personnel to carry out welding.

HANDLING BATTERY

Before inspecting or handling the battery, turn the key in the starting switch to the OFF position.

- When installing the battery disconnecter switch, turn the battery disconnecter switch to the OFF position. For details, see "HANDLING BATTERY DISCONNECTOR SWITCH (PAGE 3-67)".

- **Danger of battery exploding**

When the battery is being charged, flammable hydrogen gas is generated and may explode. In addition, the battery electrolyte includes dilute sulphuric acid. Any mistake in handling may cause serious personal injury, explosion, or fire, so always observe the following.

- Do not use or charge the battery if the battery electrolyte is below the LOWER LEVEL mark. This will cause explosion. Always carry out periodic inspection of the battery electrolyte level, and add distilled water (or commercially available battery filler solution) to the UPPER LEVEL mark.
- Do not smoke or bring any flame close to the battery.
- Hydrogen gas is generated when the battery is being charged, so remove the battery from the machine, take it to a well-ventilated place, remove the battery caps, then carry out the charging.
- After charging, tighten the battery caps securely.

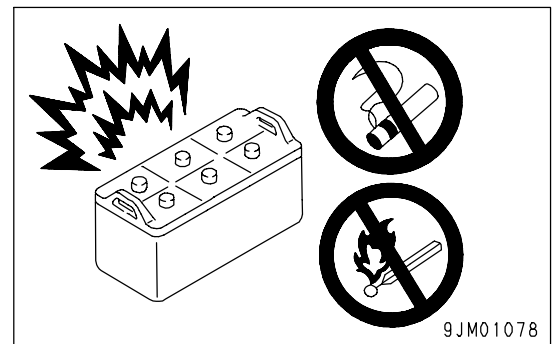

- **Danger from dilute sulphuric acid**

When the battery is being charged, flammable hydrogen gas is generated and may explode. In addition, the battery electrolyte includes dilute sulphuric acid. Any mistake in handling may cause serious personal injury, explosion, or fire, so always observe the following.

- When handling the battery, always wear protective goggles and rubber gloves.
- If battery electrolyte gets into your eyes, immediately wash your eyes with large amounts of fresh water. After that, get medical attention immediately.
- If battery electrolyte gets on your clothes or skin, wash it off immediately with large amounts of water.

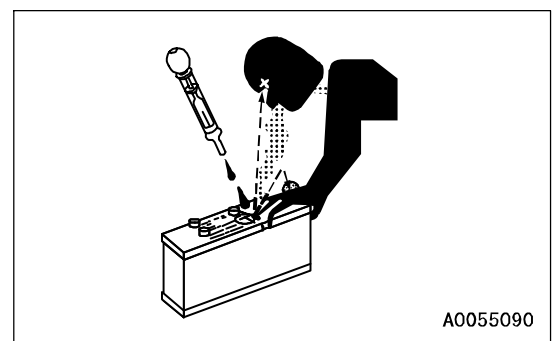

• **Removing battery cables**

Before repairing the electrical system or carrying out electrical welding, turn the starting switch OFF. Wait for approx. 1 minute, then remove the negative (-) battery cable to stop the flow of electricity.

- For machines equipped with a battery disconnect switch, set the battery disconnect switch to the OFF position.

For details, see "HANDLING BATTERY DISCONNECTOR SWITCH (PAGE 3-67)".

• **Danger of sparks**

There is hazard that sparks will be generated, so always observe the following.

- Do not let tools or other metal objects make any contact between the battery cables. Do not leave tools lying around near the battery.
- When removing the battery cables, remove the ground cable (negative (-) cable) first. When installing, connect the positive (+) cable first, then connect the ground. Tighten the battery cable terminals securely.
- Secure the battery firmly in the specified position.

PRECAUTIONS WHEN USING HAMMER

When using a hammer, pins may fly out or metal particles may be scattered. This may lead to serious personal injury or death. Always do as follows.

- When hitting pins or bucket teeth, there is a hazard that broken pieces might be sent flying and injure people in the surrounding area. Always check that there is no one in the surrounding area.
- If hard metal parts such as pins, bucket teeth, cutting edges, or bearings are hit with a hammer, there is a hazard that pieces might be scattered and cause serious personal injury or death. Always wear safety glasses and gloves.
- If the pin is hit with strong force, there is a hazard that it may fly out and injure people in the surrounding area. Do not allow anyone to enter the surrounding area.

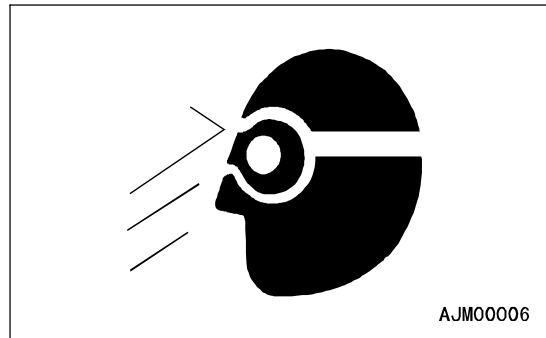

PRECAUTIONS WITH HIGH-TEMPERATURE COOLANT

To prevent burns from boiling water or steam spurting out when checking or draining the coolant, wait for the coolant to cool down to a temperature where the radiator cap can be touched by hand. Then loosen the cap slowly to release the pressure inside the radiator, and remove the cap.

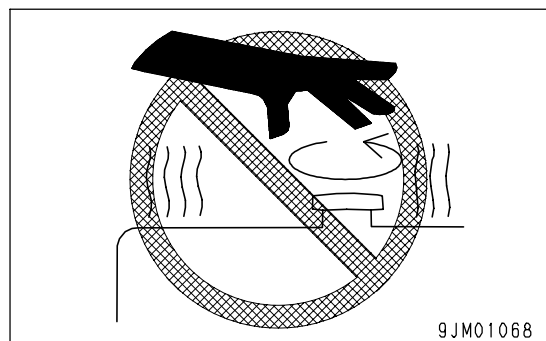

PRECAUTIONS WITH HIGH-TEMPERATURE OIL

To prevent burns from hot oil spurting out or from touching high-temperature parts when checking or draining the oil, wait for the oil to cool down to a temperature where the cap or plug can be touched by hand. Then loosen the cap or plug slowly to release the internal pressure and remove the cap or plug.

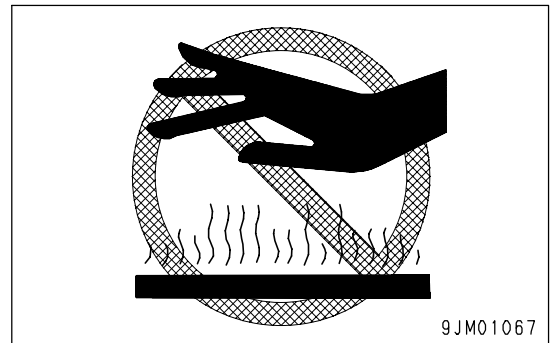
**PRECAUTIONS WITH HIGH-PRESSURE OIL**

The hydraulic system is always under internal pressure. In addition, the fuel piping is also under internal pressure when the engine is running and immediately after the engine is stopped. When carrying out inspection or replacement of the piping or hoses, check that the internal pressure in the circuit has been released. If this is not done, it may lead to serious personal injury or death. Always do as follows.

- Do not carry out inspection or replacement work with the circuit under pressure. Always release the pressure before starting. For details, see "TWO WORKERS FOR INSPECTION AND MAINTENANCE WHEN ENGINE IS RUNNING (PAGE 2-33)".
- If there is any leakage from the piping or hoses, the surrounding area will be wet, so check for cracks in the piping and hoses and for swelling in the hoses.

When carry out inspection, wear safety glasses and leather gloves.

- There is a hazard that high-pressure oil leaking from small holes may penetrate your skin or cause loss of sight if it contacts your skin or eyes directly. If you are hit by a jet of high-pressure oil and suffer injury to your skin or eyes, wash the place with clean water, and consult a doctor immediately for medical attention.

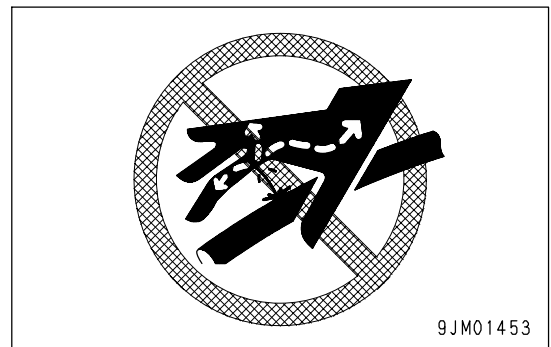
**PRECAUTIONS WITH HIGH-PRESSURE FUEL**

When the engine is running, high-pressure is generated in the engine fuel piping. When carrying out inspection or maintenance of the fuel piping system, stop the engine and wait for at least 30 seconds to allow the internal pressure to go down before starting the operation.

HANDLING HIGH-PRESSURE HOSES AND PIPING

- If oil or fuel leaks from high-pressure hoses or piping, it may cause fire or misoperation, and lead to serious personal injury, or death. If the hose or piping mounts are loose or oil or fuel is found to be leaking from the mount, stop operations and tighten to the specified torque.

If any damaged or deformed hoses or piping are found, please consult your Komatsu distributor.

Replace the hose if any of the following problems are found.

- Damaged hose or deformed hydraulic fitting.
- Frayed or cut covering or exposed reinforcement wire layer.
- Covering swollen in places.
- Twisted or crushed movable portion.
- Foreign material embedded in covering.

NOISE

When carrying out maintenance of the engine and you are exposed to noise for long periods of time, wear ear covers or ear plugs while working.

If the noise from the machine is too loud, it may cause temporary or permanent hearing problems.

HANDLING ACCUMULATOR AND GAS SPRING

The accumulator and gas spring are charged with high-pressure nitrogen gas. If the accumulator is handled mistakenly, it may cause an explosion that could lead to serious personal injury or death. For this reason, always observe the following precautions.

- Do not disassemble the accumulator.
- Do not bring it near flame or dispose of it in fire.
- Do not make holes in it, weld it, or use a cutting torch.
- Do not hit or roll the accumulator, or subject it to any impact.
- When disposing of the accumulator, the gas must be released.
Please contact your Komatsu distributor to have this work performed.



PRECAUTIONS WITH COMPRESSED AIR

- When carrying out cleaning with compressed air, there is a hazard of serious personal injury caused by flying dust or particles.
- When using compressed air to clean the filter element or radiator, wear safety glasses, anti-dust mask, gloves, and other protective equipment.

MAINTENANCE OF AIR CONDITIONER

If air conditioner refrigerant gets into your eyes, it may cause loss of sight; if it contacts your skin, it may cause frostbite. Never loosen any parts of the cooling circuit.

DISPOSING OF WASTE MATERIALS

To prevent pollution, pay careful attention to the method of disposing of waste materials.

- Always put oil drained from your machine in containers. Never drain oil directly onto the ground or dump into the sewage system, rivers, the sea, or lakes.
- Obey appropriate laws and regulations when disposing of harmful objects such as oil, fuel, coolant, solvent, filters, and batteries.

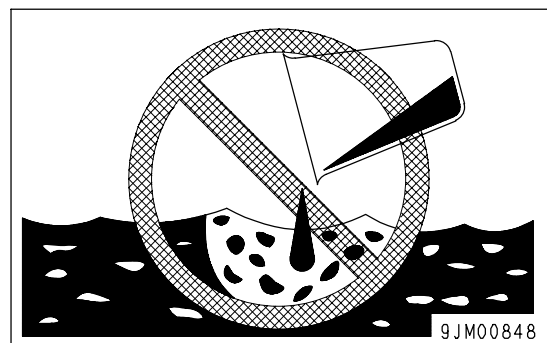

METHOD OF SELECTING WINDOW WASHER FLUID

Use an ethyl alcohol base washer liquid.

Methyl alcohol base washer liquid may irritate your eyes, so do not use it.

PERIODIC REPLACEMENT OF SAFETY CRITICAL PARTS

- For using the machine safely for an extended period of time, replace safety-critical parts like hoses and seat belts periodically.

Replacement of safety-critical parts: See "PERIODIC REPLACEMENT OF CRITICAL PARTS (PAGE 4-14)".

- The material of these components naturally changes over time, and repeated use causes deterioration, wear, and fatigue. As a result, there is a hazard that these components may fail and cause serious personal injury or death. It is difficult to judge the remaining life of these components from external inspection or the feeling when operating, so always replace them at the specified interval.
- Replace or repair safety-critical parts if any defect is found, even when they have not reached the specified replacement time.

TIRES

HANDLING TIRES

If tires or rims are handled mistakenly, there is danger that the tire may explode or be damaged, or that the rim may fly off and cause serious personal injury or death.

To maintain safety, always do as follows.

- Maintenance, disassembly, repair, and assembly of the tires and rims requires special equipment and special technology, so always ask your Komatsu distributor to carry out these operations.
- Always use the tires specified by Komatsu and maintain the specified inflation pressure.

Suitable tire inflation pressure: see "HANDLING THE TIRES (PAGE 3-168)"

- When pumping up the tires, check that no other person is standing near the tire, and install an air chuck with a clip that can be secured to the air valve.

To prevent the tire inflation pressure from becoming too high, measure the pressure from time to time with an air gauge while pumping up the tire.

- If the tire pressure goes down abnormally or the rim parts do not fit the tire, there is a problem with the tire or rim parts. Always contact your Komatsu distributor for repairs.
- If the rim parts are not fitted properly when the tire is being pumped up, there is danger that the rim parts may fly off, so set up a protective fence around the tire, and do not stand directly in front of the rim. Stand beside the tread when pumping up the tire.
- Do not adjust the tire inflation pressure immediately after traveling at high speed or carrying out operations under heavy load.
- Never carry out welding or light a fire near the tire.
- Always release all pressure from a single tire or from both tires of a dual assembly prior to removing any rim components.
- Before removing the tire from the machine for repairs, remove the valve partially to release the air from the tire, then remove the tire.

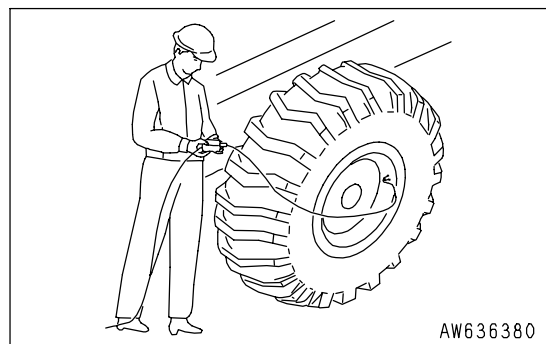
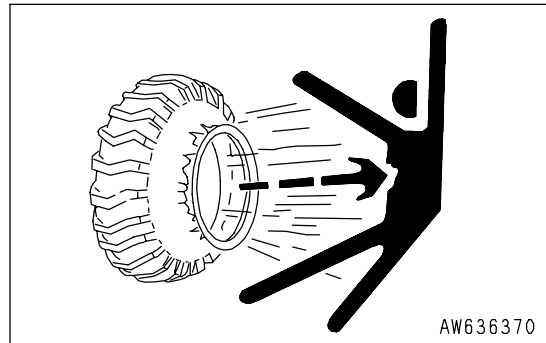

PRECAUTIONS WHEN STORING TIRES

Tires for construction equipment are extremely heavy, it may lead to serious personal injury or death. To maintain safety, always do as follows.

- As a basic rule, store the tires in a warehouse which unauthorized persons cannot enter.
If the tires must be stored outside, always erect a fence and put up "No Entry" signs.
- Stand the tire on level ground, and block it securely so that it cannot roll or fall over if any person should touch it.
Do not lay the tire on its side. This will deform the tire and cause it to deteriorate.
- If the tire should fall over, do not attempt to stop it. Get out of the way quickly.

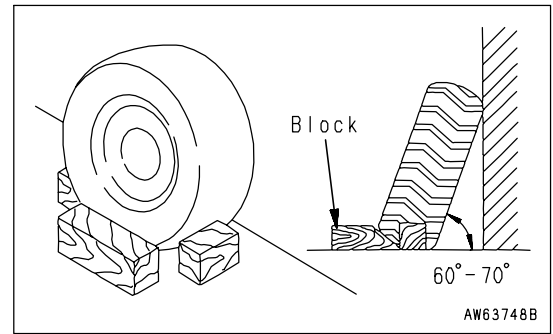

OPERATION

WARNING

Please read and make sure that you understand the SAFETY section before reading this section.

GENERAL VIEW

GENERAL VIEW OF MACHINE

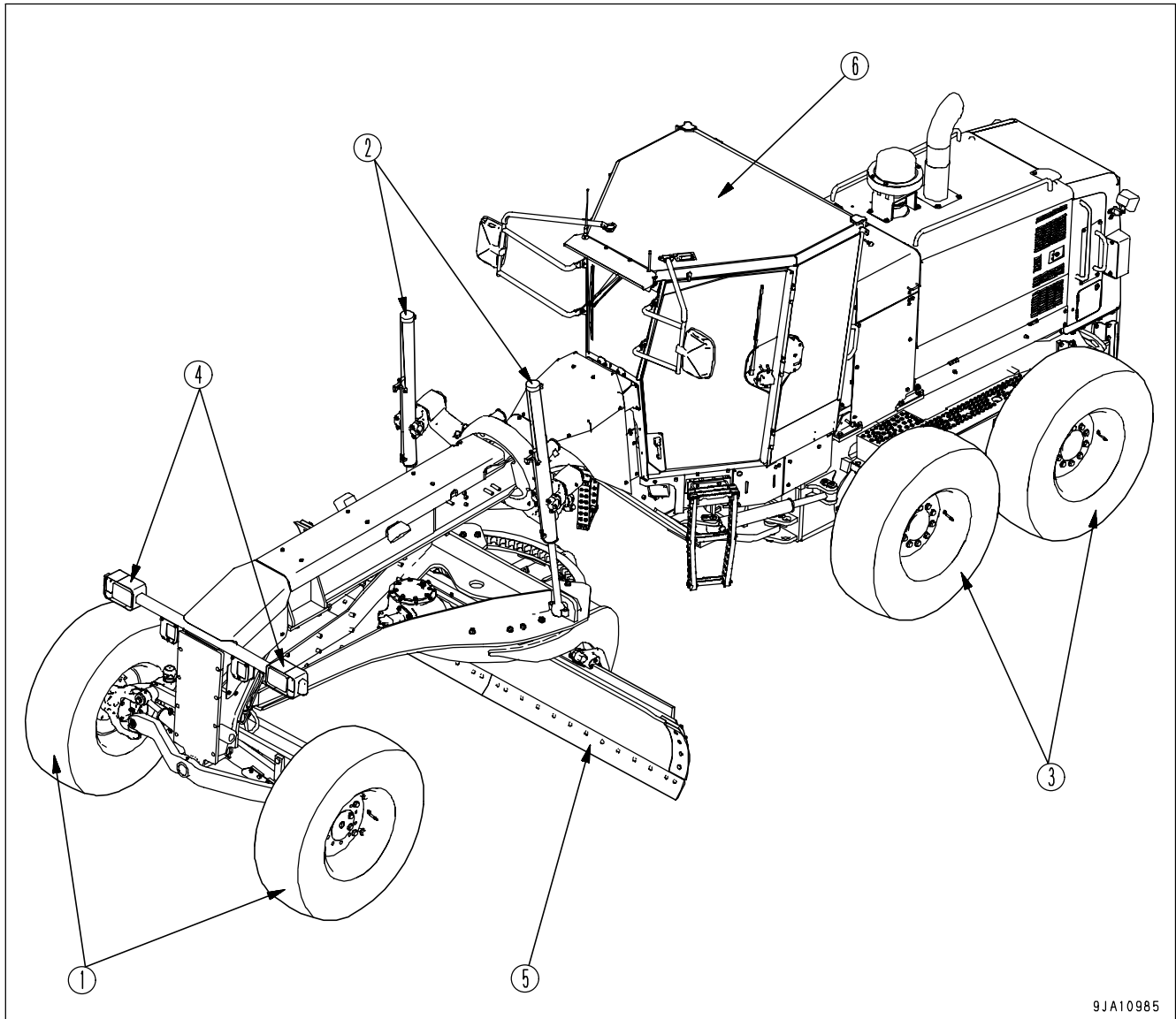

9JA10985

- | | |
|-------------------------|---------------|
| (1) Front wheel | (4) Head lamp |
| (2) Blade lift cylinder | (5) Blade |
| (3) Rear wheel | (6) Cab |

GENERAL VIEW OF CONTROLS AND GAUGES

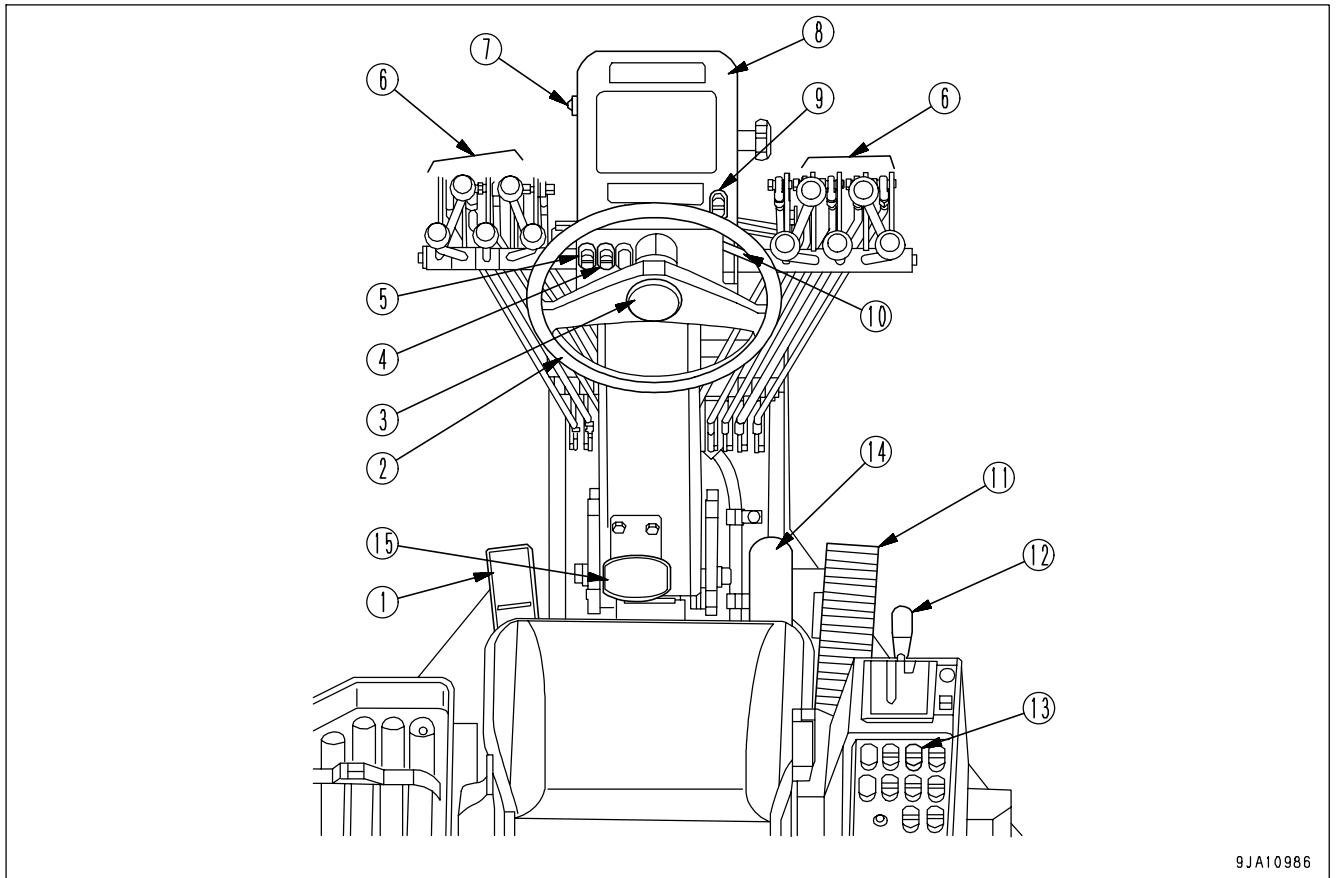

- | | |
|--------------------------------------------|--------------------------------------------|
| (1) Inching pedal | (9) Differential lock switch (if equipped) |
| (2) Steering wheel | (10) Turn signal lever |
| (3) Horn button | (11) Accelerator pedal |
| (4) Machine monitor mode selector switch 2 | (12) Gear shift lever |
| (5) Machine monitor mode selector switch 1 | (13) Right side panel |
| (6) Work equipment control lever | (14) Brake pedal |
| (7) Dimmer switch | (15) Steering console tilt pedal |
| (8) Machine monitor | |

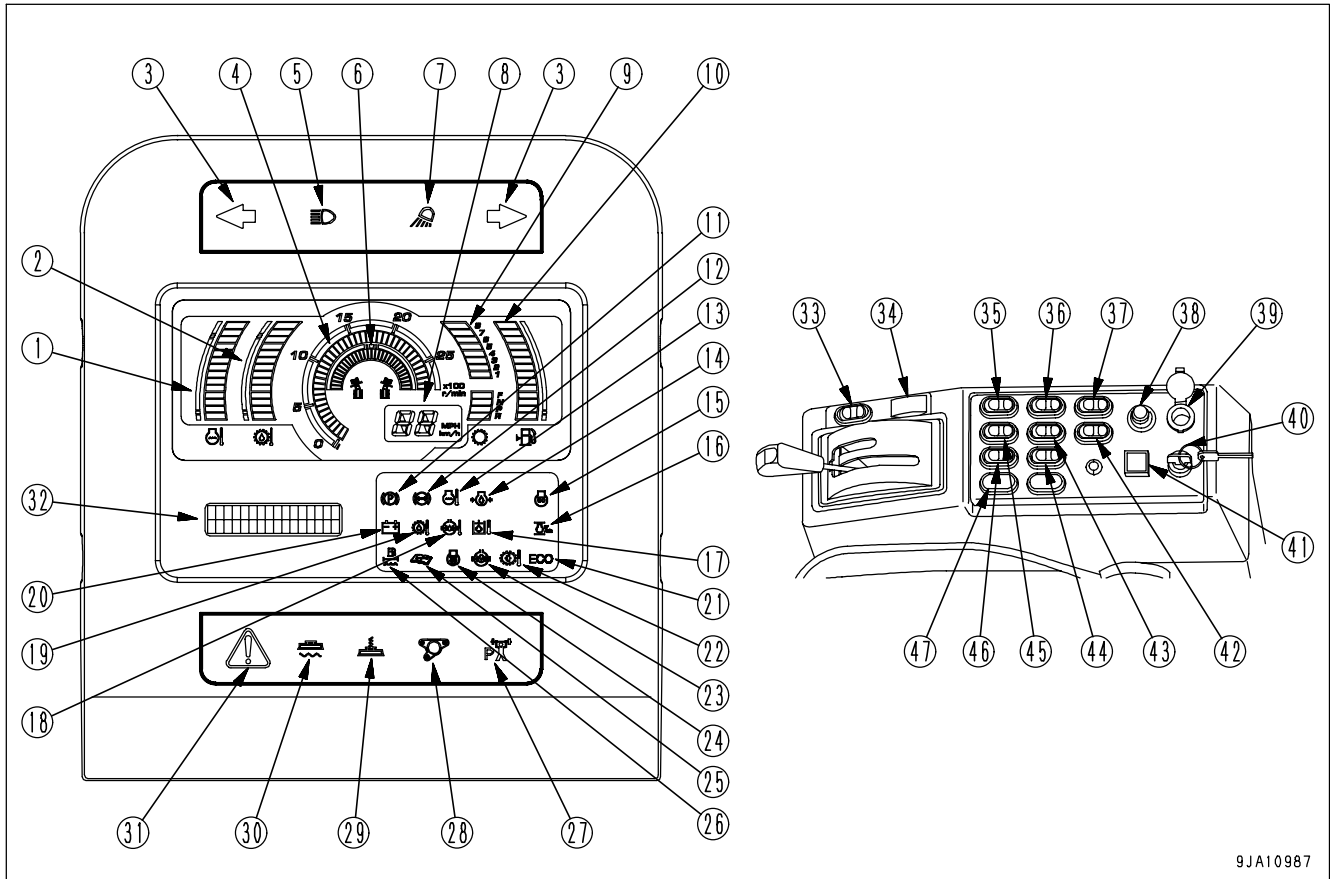

9JA10987

Machine monitor

- (1) Engine coolant temperature gauge
- (2) Torque converter oil temperature gauge
- (3) Turn signal pilot lamp
- (4) Engine tachometer
- (5) Head lamp high beam pilot lamp
- (6) Articulation gauge
- (7) Working lamp pilot lamp
- (8) Speedometer
- (9) Shift indicator
- (10) Fuel gauge
- (11) Parking brake pilot lamp
- (12) Brake oil pressure caution lamp
- (13) Engine water temperature caution lamp
- (14) Engine oil pressure caution lamp
- (15) Engine preheating pilot lamp
- (16) RPM set pilot lamp
- (17) Hydraulic oil temperature caution lamp
- (18) Differential oil temperature caution lamp (if equipped)
- (19) Torque converter oil temperature caution lamp
- (20) Battery charge circuit caution lamp
- (21) Economy operation display lamp
- (22) Inching clutch overheat caution lamp
- (23) Differential lock pilot lamp (if equipped)
- (24) Cooling fan reverse rotation pilot lamp
- (25) Maintenance caution lamp
- (26) Water separator monitor
- (27) P mode pilot lamp
- (28) Lift arm lock pin pilot lamp
- (29) Blade accumulator pilot lamp (if equipped)
- (30) Blade float pilot lamp
- (31) Central caution lamp
- (32) Character display
- (33) [Control button]
- (34) [Control button]
- (35) [Control button]
- (36) [Control button]
- (37) [Control button]
- (38) [Control button]
- (39) [Control button]
- (40) [Control button]
- (41) [Control button]
- (42) [Control button]
- (43) [Control button]
- (44) [Control button]
- (45) [Control button]
- (46) [Control button]
- (47) [Control button]

Right side panel

- (33) RPM SET mode selector switch
- (34) RPM SET switch
- (35) Blade accumulator switch (if equipped)
- (36) Rear working lamp switch
- (37) Cooling fan reverse rotation switch
- (38) Cigarette lighter
- (39) 12 V electric power takeoff
- (40) Starting switch
- (41) Lift arm lock switch
- (42) Power mode selector switch
- (43) Front working lamp switch
- (44) Front lamp switch
- (45) Transmission mode selector switch
- (46) Hazard lamp switch
- (47) Additional car heater switch (if equipped)

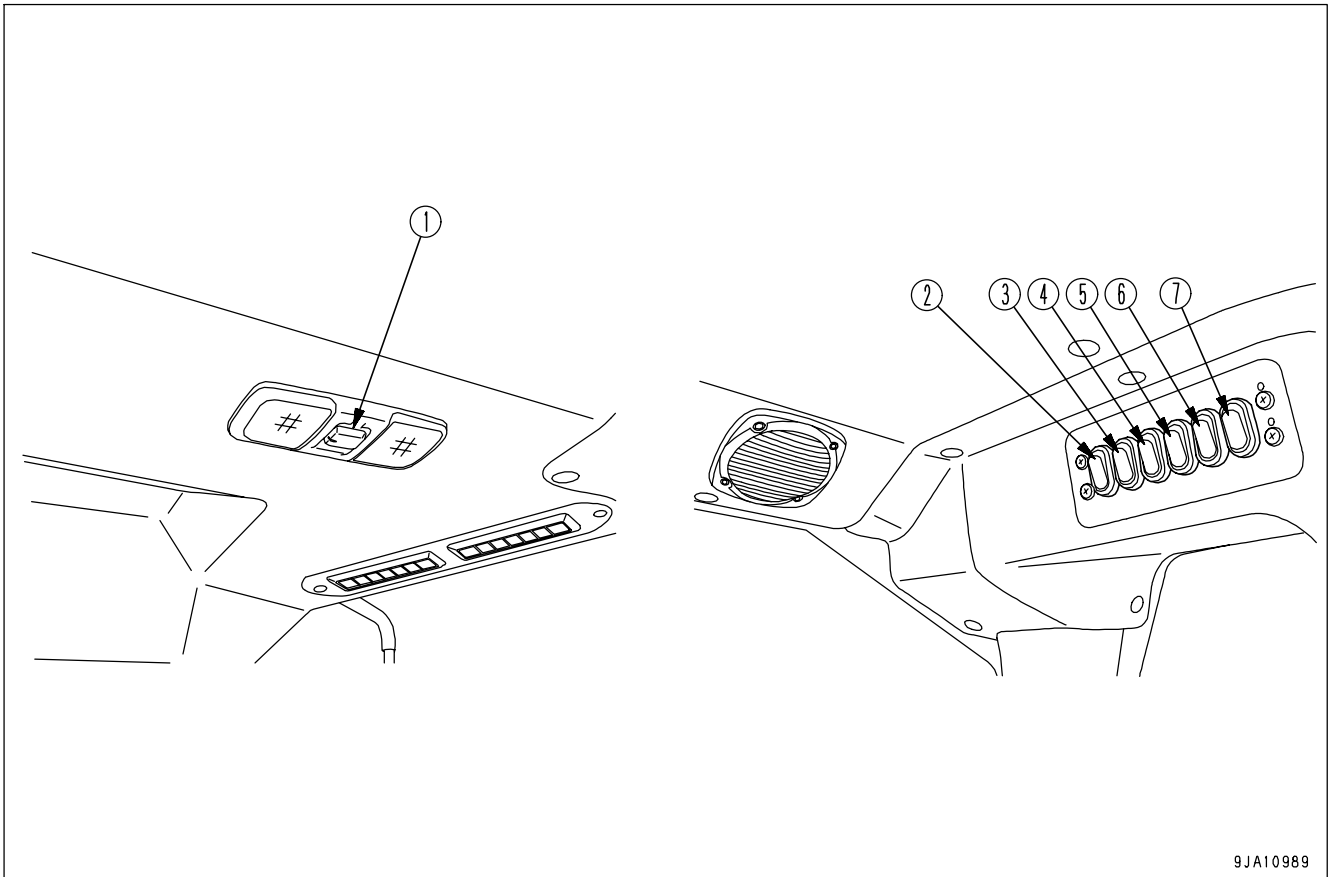

Top right inside cab

- (1) Room lamp switch

Top left inside cab

- (2) Intermittent wiper switch
- (3) Rear wiper switch
- (4) Door wiper switch
- (5) Front wiper switch
- (6) Yellow rotating lamp switch (if equipped)
- (7) Cab-mounted working lamp switch (if equipped)

EXPLANATION OF COMPONENTS

The following is an explanation of devices needed for operating the machine.

To perform suitable operations correctly and safely, it is important to completely understand methods of operating the equipment, and the meanings of the displays.

MONITOR PANEL

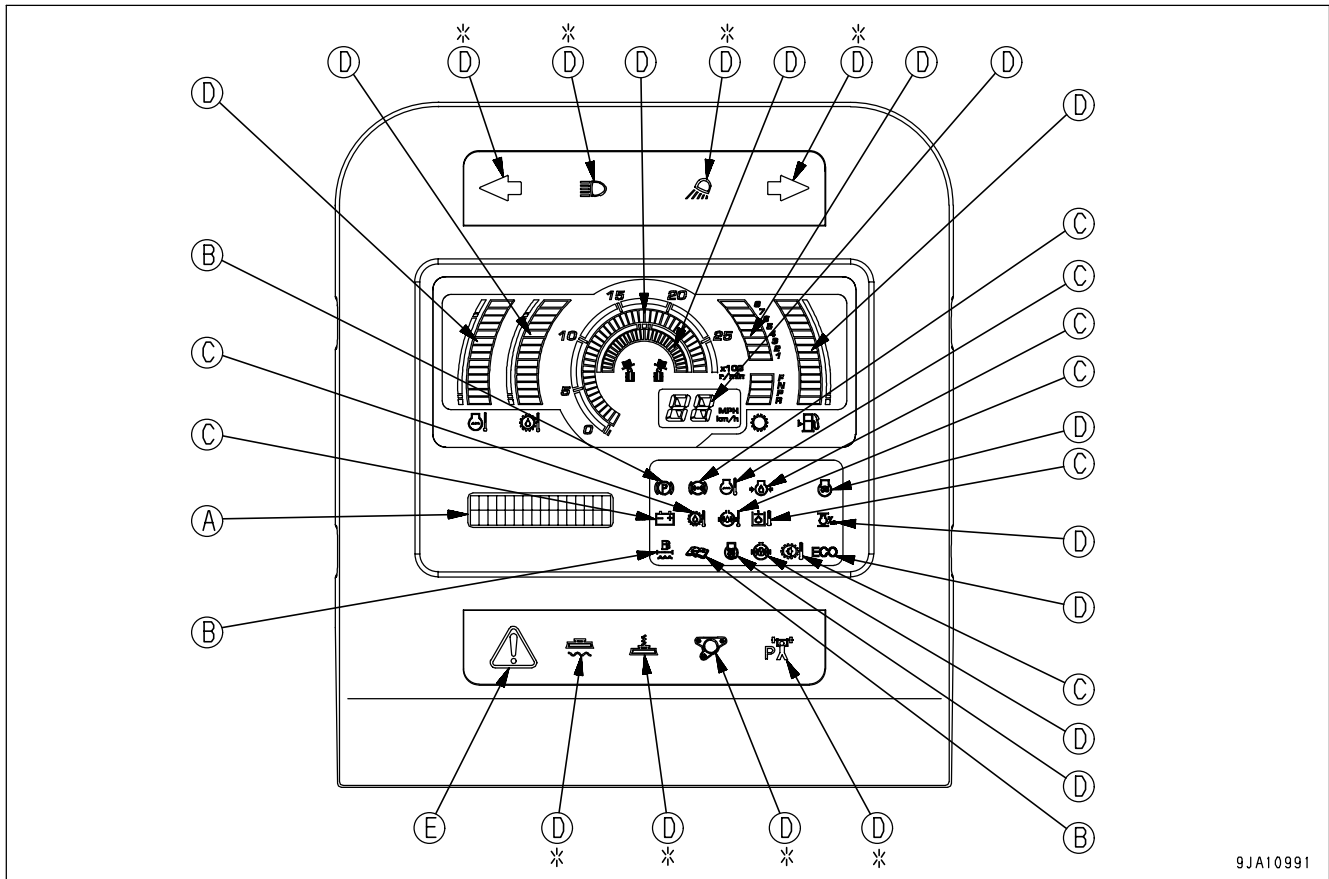

9JA10991

- | | |
|-------------------------|---------------------------|
| (A) Character display | (D) Meter display portion |
| (B) Caution items | (E) Central warning lamp |
| (C) Emergency stop item | |

NOTICE

When the starting switch is turned to the ON position before starting the engine, a system check is carried out for 3 seconds.

- The centralized warning lamp lights up for 2 seconds, and then goes out.
- The alarm buzzer sounds for 2 seconds, and then stops.
- The monitor lamp lights up for 2 seconds, and then goes out for 1 second. (Except items marked with *)
- The speedometer displays "88" for 2 seconds, and then goes out for 1 second.
- After the system check has been carried out for 3 seconds, the meters start operation.
- The character display displays "KOMATSU" for 3 seconds.
- If any lamp or other part does not work, there is probably a failure or disconnection, so ask your Komatsu distributor to carry out inspection.

CHARACTER DISPLAY

Normally, the service meter/odometer is displayed on the character display.

If the machine has failed, or if there has been excessive load on the machine, or if it is necessary to carry out inspection and maintenance, an action code is displayed to recommend suitable action.

When the time for replacing the filter or changing the oil is reached, after completion of the system check with the starting switch at the ON position, the maintenance caution lamps flash or light up, and at the same time, the filter or oil to be replaced is displayed.

NOTICE

Information regarding the failure of the machine or maintenance is displayed on the character display when the starting switch is at the ON position, check the display to confirm that there is no problem before starting to travel.

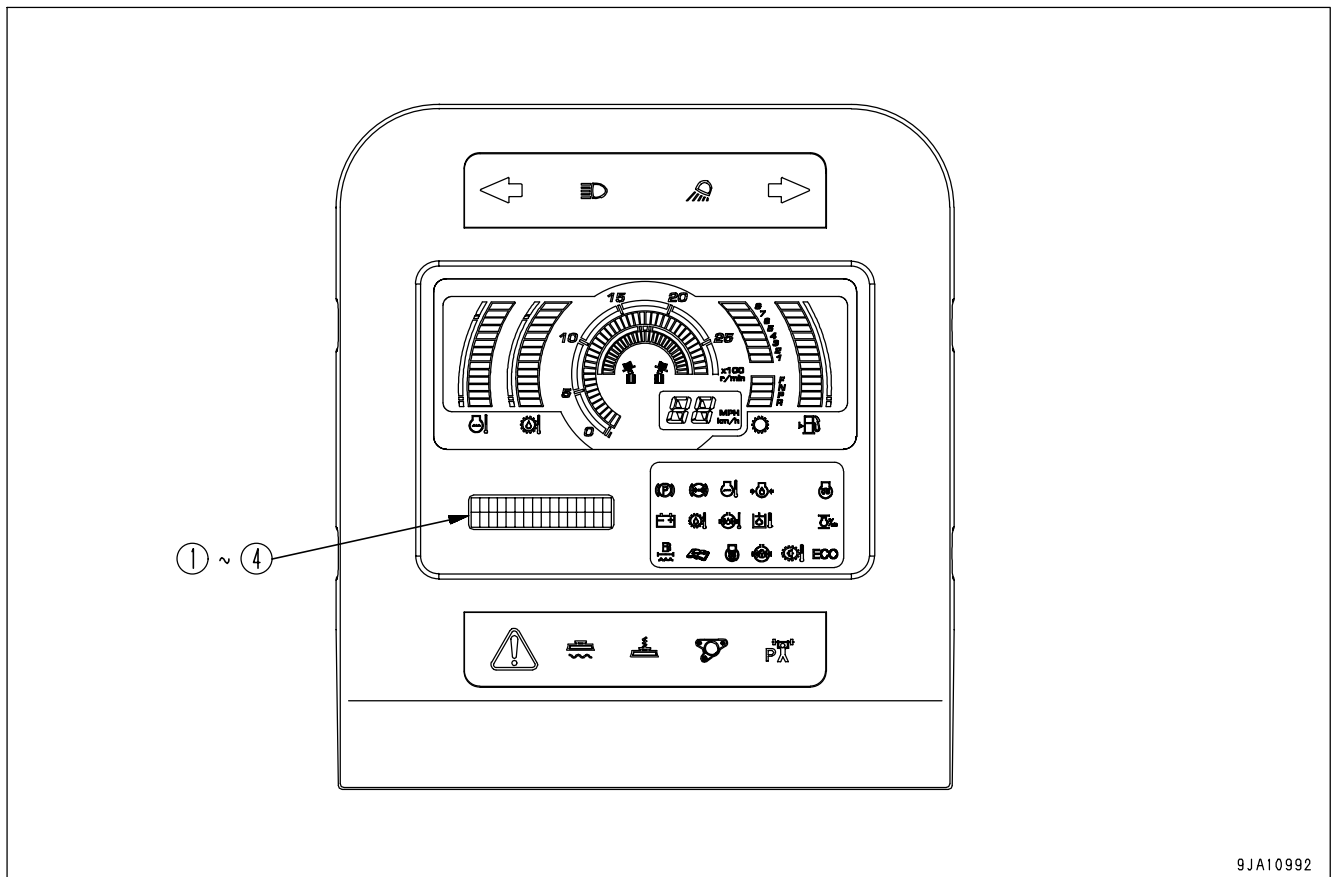

- (1) Service meter
- (2) Odometer

- (3) Action code display
- (4) Filter, oil replacement time display

SERVICE METER

This display (1) shows the total amount of time that the machine has been operated.

If the engine is running, the service meter advances, even if the machine is not moving.

The meter reading advances by 1 for every one hour of operation, regardless of the engine speed.

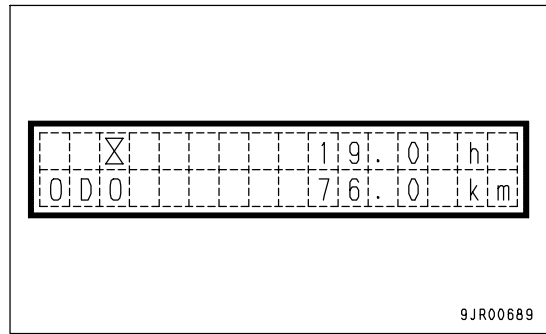

9JR00689

Even if the starting switch is OFF, the service meter gives a display while the top (◇) of machine monitor mode selector switch 1 is being pressed.

NOTICE

When the starting switch is at the OFF position, if the service meter is displayed even though the top (◇) of machine monitor mode selector switch 1 is not being pressed, there is probably a failure in the machine, so please contact your Komatsu distributor for inspection.

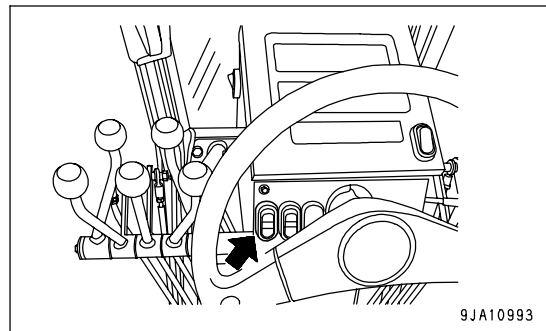

9JA10993

ODOMETER

This display (2) shows the total distance that the machine has traveled in units of km.

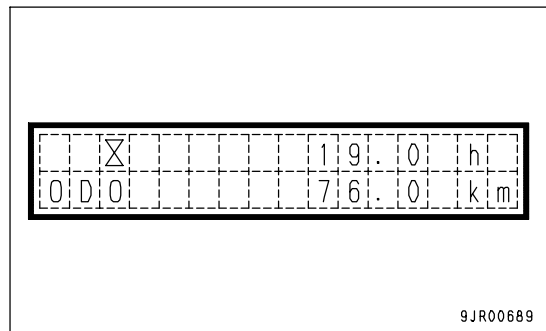

9JR00689

Even if the starting switch is OFF, the odometer gives a display while the top (◇) of machine monitor mode selector switch 1 is being pressed.

NOTICE

When the starting switch is at the OFF position, if the total distance is displayed even although the top (◇) of machine monitor mode selector switch 1 is not being pressed, there is probably a failure in the machine, so please contact your Komatsu distributor for inspection.

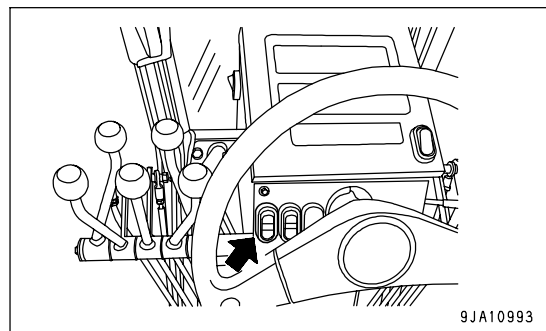

9JA10993

ACTION CODE DISPLAY



If action code E03 is displayed, stop the machine immediately and ask your Komatsu distributor to carry out repairs.

If the machine has failed, or if there has been excessive load on the machine, or if it is necessary to carry out inspection and maintenance, an action code is displayed on this panel (3) to recommend suitable action. If more than one failure occurs at the same time, the most important action code is displayed. The order of importance, starting from the highest, is E03, E02, and E01. If failures of equal importance occur at the same time, the latest one is displayed.

When action codes E02 or E03 occur, the alarm buzzer sounds intermittently and the central warning lamp lights up.

E03

If code E03 is displayed, stop the machine immediately, check the failure code, then ask your Komatsu distributor to carry out repairs. For details of the method of displaying the failure code, see "FAILURE CODES (PAGE 3-192)".

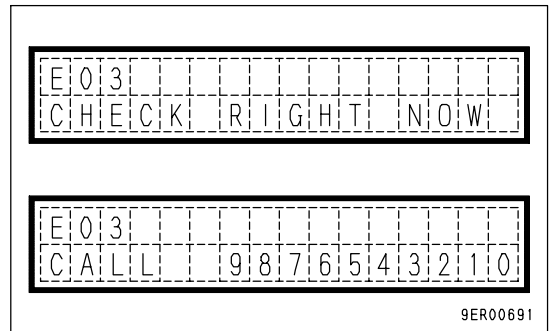

REMARK

- "E03" is displayed on the top line of the character display, and "CHECK RIGHT NOW" and "CALL" are displayed in turn for 3 seconds each on the bottom line.
- On the right side of the "CALL" display, a telephone number is displayed. If no telephone number has been set, this space is blank. For details of the method of setting the telephone number, see "INPUT METHOD FOR TELEPHONE NUMBER (PAGE 3-31)".

E02

If an overrun related display is given, reduce the engine speed and machine speed while continuing operations.

If an overheat related display is given, stop the machine and run at the engine at a mid-range speed under no load.

After taking the above action, if an action code is displayed, check the failure code and ask your Komatsu distributor to carry out repairs.

For details of the method of displaying the failure code, see "FAILURE CODES (PAGE 3-192)".

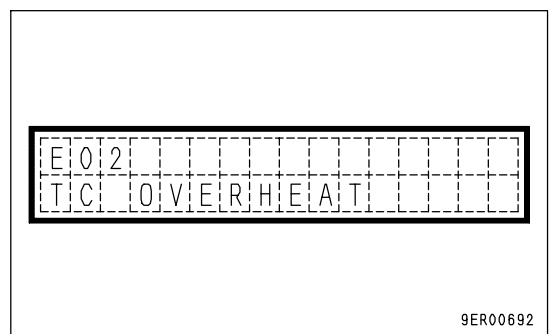

REMARK

The top line of the character display displays "E02" and the bottom line displays the condition of the machine related to overrun or overheat.

E01

If the maintenance location is displayed and the maintenance caution lamp lights up, carry out inspection and maintenance for the item given after completing the day's operations or when the operators change shifts.

If "MAINTENANCE" is displayed together with E01, check the failure code and ask for repairs to be carried out.

For details of the method of displaying the failure code, see "FAILURE CODES (PAGE 3-192)".

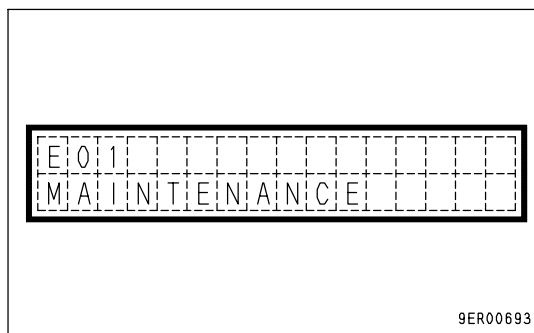
**REMARK**

The top line of the character display displays "E01" and the bottom line displays "MAINTENANCE" or displays the location needing inspection, filling, or replacing.

FILTER, OIL REPLACEMENT TIME DISPLAY

After the system check is completed, this display (4) displays the filter and type of oil for 30 seconds for items where the replacement interval is close. When this happens, the maintenance caution lamp also flashes or lights up.

If any filter or oil has been replaced, reset the replacement time. For details, see "RESET METHOD FOR FILTER, OIL REPLACEMENT TIME (PAGE 3-30)".

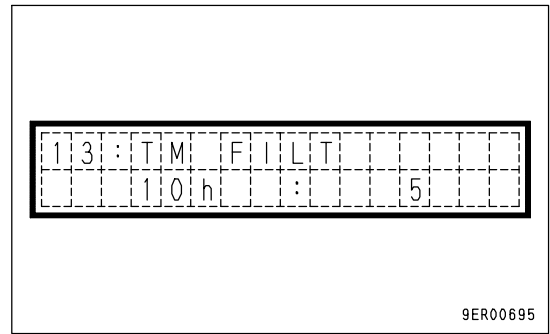

REMARK

- The top line of the character display shows the name and ID number of the item needing replacement. The line at the bottom shows the remaining time until replacement and the total number of times the item has been replaced.
- After giving the display for 30 seconds, the display does not appear again until the starting switch is turned again to the ON position.
- If the action code is being displayed, the message in the diagram above is not displayed on the character display.
- If there two or more items to be displayed, they are displayed every three seconds.
- If there are more than 10 items to be displayed, all the items are displayed once each.
- The display is given when the time reaches 30 hours before the filter and oil replacement interval.
- When the replacement interval approaches, the maintenance caution lamp flashes, and if the replacement interval has passed, the lamp lights up.

Items for display of filter, oil replacement time

Item	Replacement interval (H)	Character display	ID number
Engine oil	500	ENGOIL	01
Engine oil filter	500	ENGFILT	02
Fuel prefilter	500	P FUEL FILT	41
Fuel main filter	1000	FUEL FILT	03
Hydraulic filter	1000	HYD FILT	04
Transmission oil	1000	TM OIL	12
Transmission oil filter	1000	TM FILT	13
Final drive case	1000	AXLE OIL	15
Hydraulic oil	2000	HYD OIL	10
Circle case oil	2000	CR CASE OIL	36
Tandem case oil	2000	TD CASE OIL	37

REMARK

See the section below for details of procedure for replacing the filter and oil.

- Engine oil
"CHANGE OIL IN ENGINE OIL PAN, REPLACE ENGINE OIL FILTER CARTRIDGE (PAGE 4-55)"
- Engine oil filter
"CHANGE OIL IN ENGINE OIL PAN, REPLACE ENGINE OIL FILTER CARTRIDGE (PAGE 4-55)"
- Fuel prefilter
"REPLACE FUEL PRE-FILTER CARTRIDGE (PAGE 4-56)"
- Fuel main filter
"REPLACE FUEL MAIN FILTER CARTRIDGE (PAGE 4-61)"
- Hydraulic filter
"REPLACE HYDRAULIC TANK FILTER ELEMENT (PAGE 4-65)"
- Transmission oil
"CHANGE OIL IN TRANSMISSION CASE, CLEAN STRAINER (PAGE 4-63)"
- Transmission oil filter
"REPLACE TRANSMISSION OIL FILTER CARTRIDGE (PAGE 4-62)"
- Final drive case oil
"CHANGE OIL IN FINAL DRIVE CASE (PAGE 4-64)"
- Hydraulic oil
"CHANGE OIL IN HYDRAULIC TANK, CLEAN STRAINER (PAGE 4-69)"
- Circle reverse gear case oil
"CHANGE OIL IN CIRCLE REVERSE GEAR CASE (PAGE 4-71)"
- Tandem case oil
"CHANGE OIL IN TANDEM DRIVE CASE (PAGE 4-72)"

CAUTION ITEMS

! CAUTION

If the monitor lights up during travel, inspect the location of the problem quickly and take the necessary action.

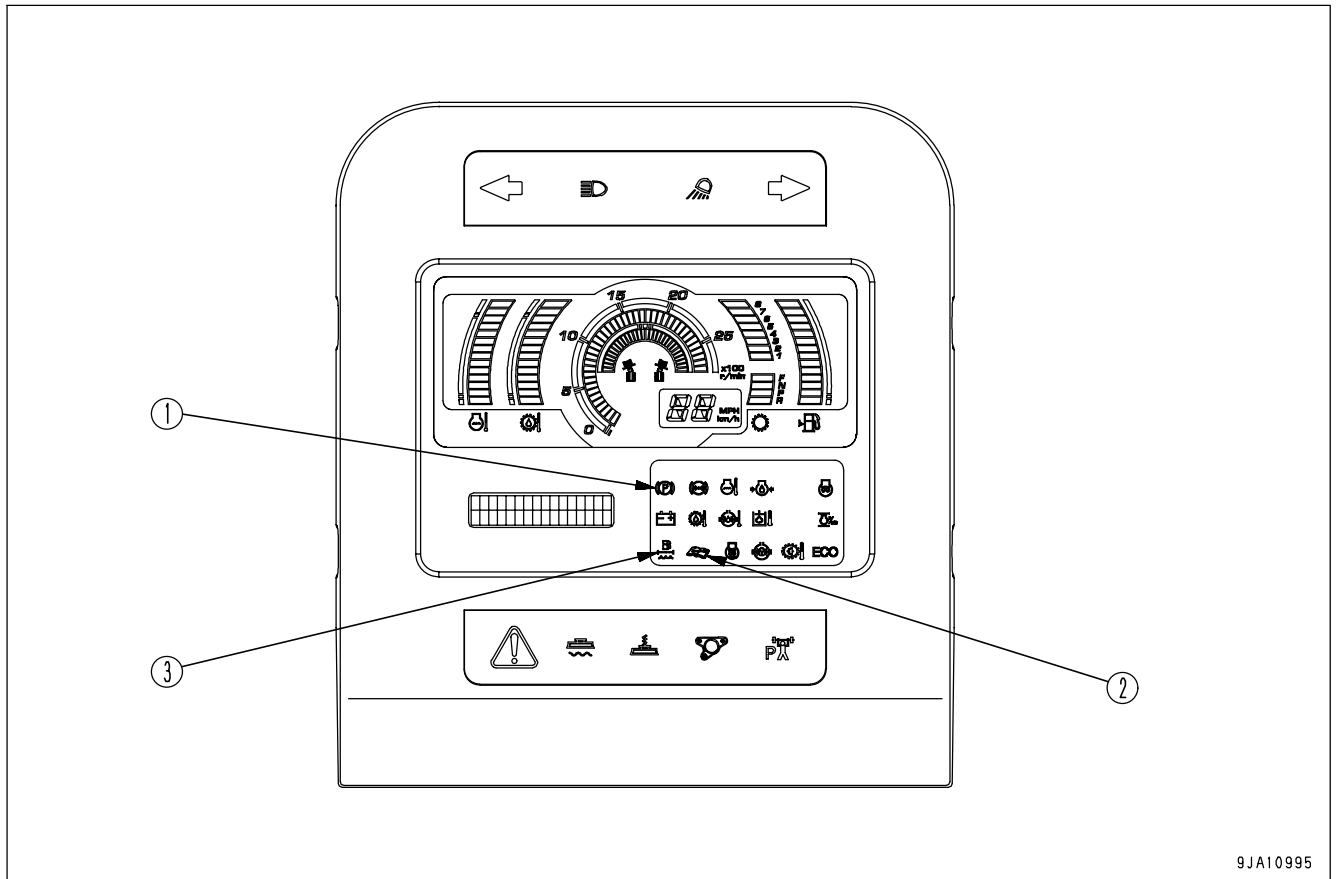

9JA10995

- (1) Parking brake pilot lamp
- (2) Maintenance caution lamp

- (3) Water separator monitor

PARKING BRAKE PILOT LAMP

This monitor (1) lights up when the parking brake has been applied.

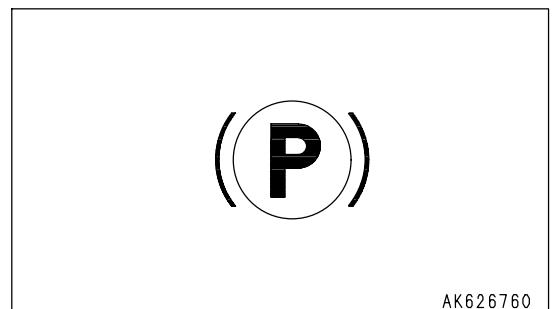

AK626760

MAINTENANCE CAUTION LAMP

**CAUTION**

If the caution monitor lamp lights up, repair the problem as soon as possible.

When the starting switch is turned ON, this monitor (2) flashes or lights up for approximately 30 seconds after the system check has been completed if the oil change time is close.

REMARK

The maintenance caution lamp flashes when there are less than 30 hours to the replacement time, and after the replacement time has passed, it stays on.

For details of the items covered by filter and oil replacement, see "FILTER, OIL REPLACEMENT TIME DISPLAY (PAGE 3-11)".

In addition, this lamp lights up when the air cleaner element is clogged. At this time, "AIR FILTER" is displayed on the character display.

Clean or replace the air cleaner element.

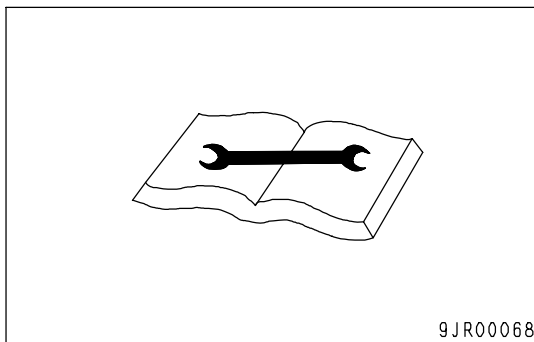

9JR00068

WATER SEPARATOR MONITOR

This monitor (3) lights up red to inform the operator that the water separator is full of water. If monitor (3) lights up red, stop the engine and drain the water from the water separator.

For details of the method of draining the water from the water separator, see "DRAIN WATER FROM FUEL PRE-FILTER (PAGE 4-25)".

REMARK

The water separator forms one unit with the fuel pre-filter. It is at the bottom of the fuel pre-filter and can be removed.

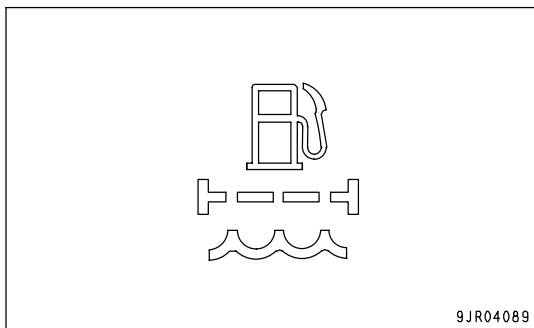

9JR04089

EMERGENCY STOP ITEMS

! CAUTION

If the monitor lights up, stop operations immediately, then check the corresponding area and carry out the action.

If any problem is found in the emergency stop items, the alarm buzzer will sound intermittently, and the monitor for the location of the problem and the central warning lamp will light up.

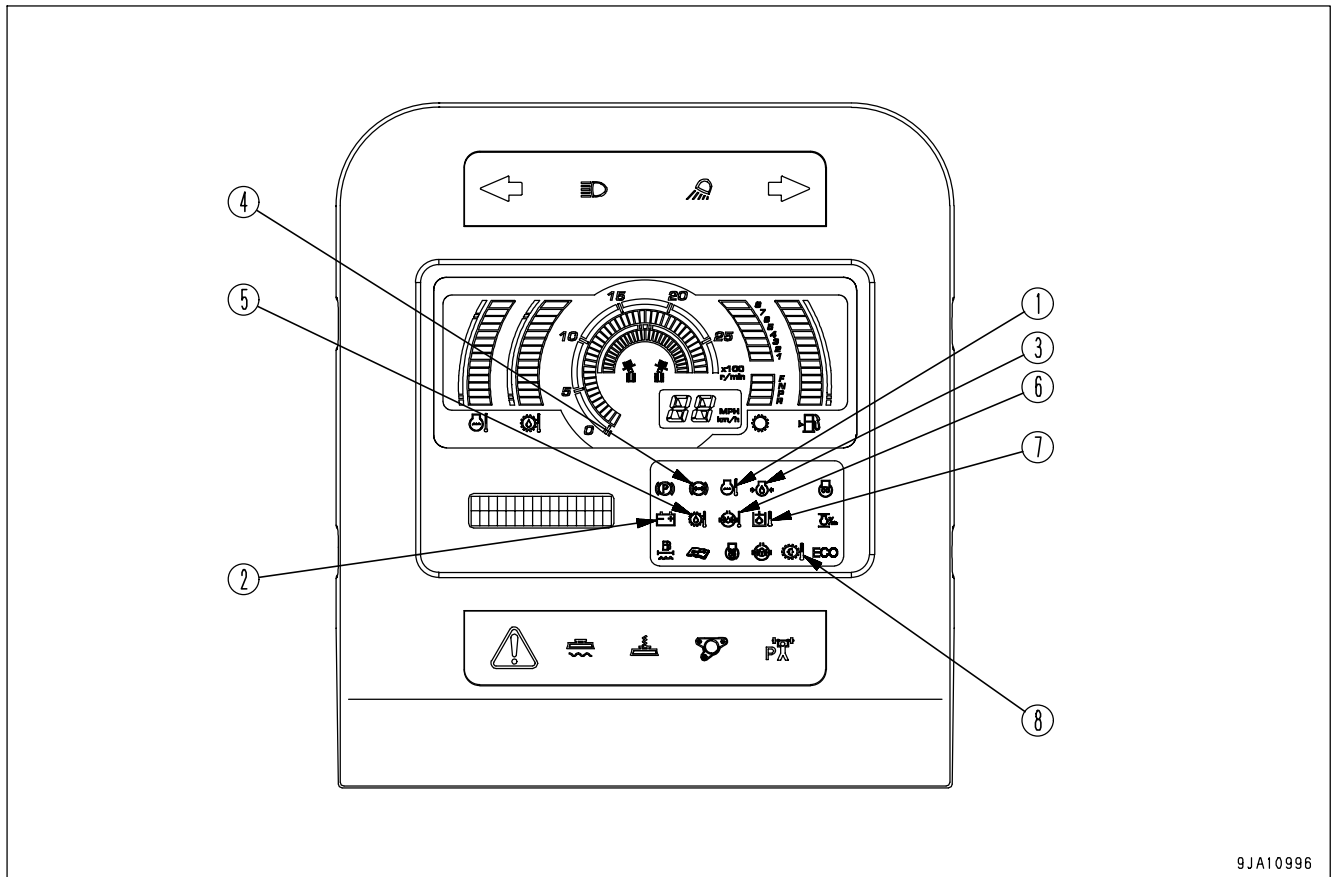

9JA10996

- | | |
|---------------------------------------------------|----------------------------------------------------------------|
| (1) Engine water temperature caution lamp | (6) Differential oil temperature caution lamp
(if equipped) |
| (2) Battery charge circuit caution lamp | (7) Hydraulic oil temperature caution lamp |
| (3) Engine oil pressure caution lamp | (8) Inching clutch overheat caution lamp |
| (4) Brake oil pressure caution lamp | |
| (5) Torque converter oil temperature caution lamp | |

ENGINE WATER TEMPERATURE CAUTION LAMP

This monitor (1) warns the operator that the engine coolant temperature has risen.

When it lights up, "E02 ENGINE OVERHEAT" is displayed on the character display at the same time, and the engine output is automatically limited.

Run the engine under no load at a mid-range speed until the lamp goes out.

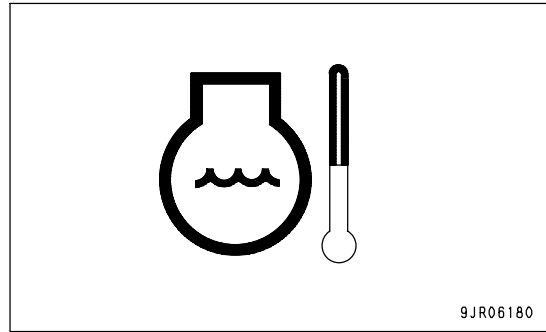
**BATTERY CHARGE CIRCUIT CAUTION LAMP**

When the engine is running, this monitor (2) informs the operator that there is an abnormality in the charging system.

When it lights up, "E03 CHECK RIGHT NOW" is displayed on the character display at the same time. Move the machine immediately to a safe place, stop the machine, then stop the engine and inspect the charging system.

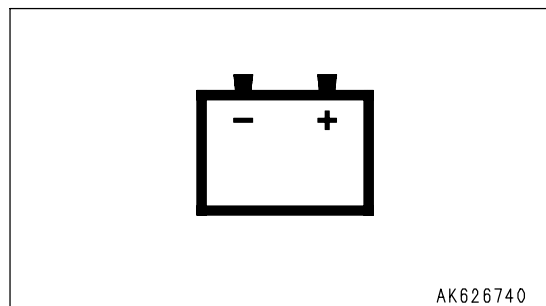
**ENGINE OIL PRESSURE CAUTION LAMP**

This monitor (3) warns the operator that the engine lubricating oil pressure has dropped.

When it lights up, "E03 CHECK RIGHT NOW" is displayed on the character display at the same time, and the engine output is automatically limited.

Move the machine immediately to a safe place, stop the machine, then stop the engine and carry out inspection.

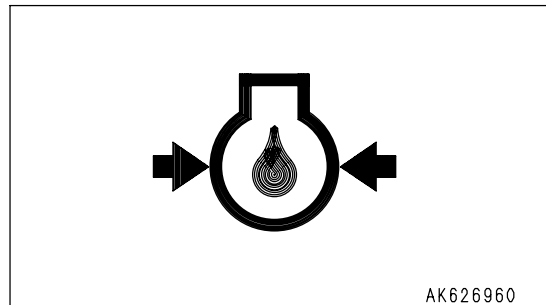
**BRAKE OIL PRESSURE CAUTION LAMP**

This monitor (4) lights up if the oil pressure in the brake circuit goes below the specified value. When the engine is stopped, the central warning lamp does not light up and the alarm buzzer does not sound.

After starting the engine, if the brake oil pressure is still below the specified value even after 30 seconds have passed, "E03 CHECK RIGHT NOW" is displayed on the character display at the same time. Move the machine immediately to a safe place, stop the machine, then stop the engine and carry out inspection.

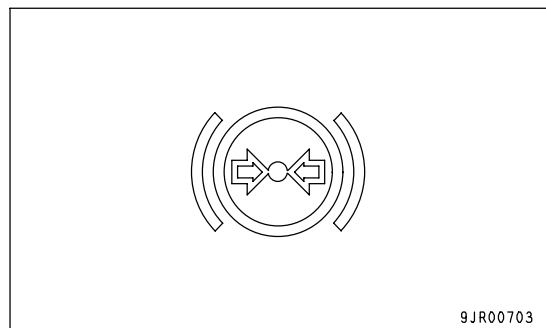

TORQUE CONVERTER OIL TEMPERATURE CAUTION LAMP

This monitor (5) warns the operator that the torque converter oil temperature has risen.

When it lights up, "E02 TC OVERHEAT" is displayed on the character display at the same time.

Move the machine immediately to a safe place, stop the machine, then move the gear shift lever to P (Parking) and run the engine under no load at a mid-range speed until the lamp goes out.

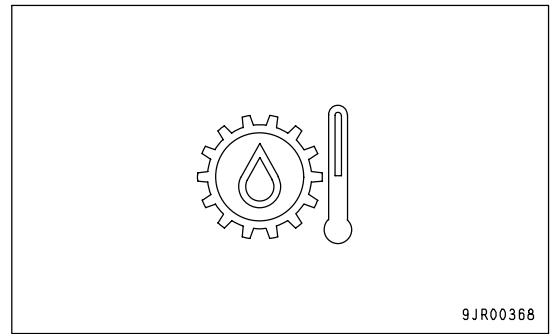
**DIFFERENTIAL OIL TEMPERATURE CAUTION LAMP**

(If equipped)

This monitor (6) warns the operator that the differential oil temperature has risen.

When the lamp lights up, "E02 DIFF OVERHEAT" is displayed on the character display at the same time. Cancel the differential lock, move the machine to a safe place, set the gear shift lever to the P (PARKING) position, and run at the engine at low speed under no load until the lamp goes out.

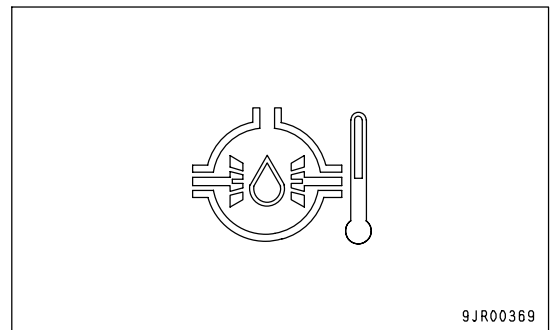
**HYDRAULIC OIL TEMPERATURE CAUTION LAMP**

This monitor (7) warns the operator that the hydraulic oil temperature rose. When the lamp lights up, "E02 HYD OVERHEAT" is displayed on the character display at the same time. Place the machine still in a safe place, stop the engine, and check.

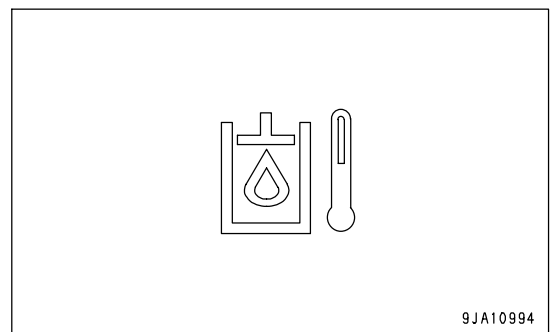

INCHING CLUTCH OVERHEAT CAUTION LAMP

This monitor (8) warns the operator that the clutch temperature in the transmission rose due to partially applied clutch operations.

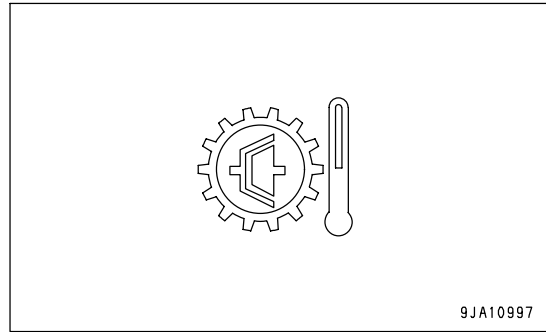

- Measures to be taken when the inching clutch overheat caution lamp lights up
 1. Set the gear shift lever to N (NEUTRAL) position immediately.
 2. Release the inching pedal.
 3. Depress the brake pedal.
 4. Even after the inching clutch overheat caution lamp goes out, keep the engine running at medium speed (1200 - 1400 rpm) for at least 1 minute, placing the gear shift lever in N (NEUTRAL) position, to cool down the clutch.

NOTICE

- When the inching clutch overheat caution lamp lights up, be sure to set the gear shift lever to N (NEUTRAL) position and then release the inching pedal.

If releasing the inching pedal without setting the gear shift lever to N (NEUTRAL) position, the clutch temperature rises further depending on the clutch engaging condition.
- Lighting of the inching clutch overheat caution lamp is likely to indicate that excessive loads are being applied.

Lower the engine speed, lighten the load on the blade, etc., and see the effect.

METER GROUP

PILOT DISPLAY

When starting switch is ON, the pilot display lights up when display items are functioning.

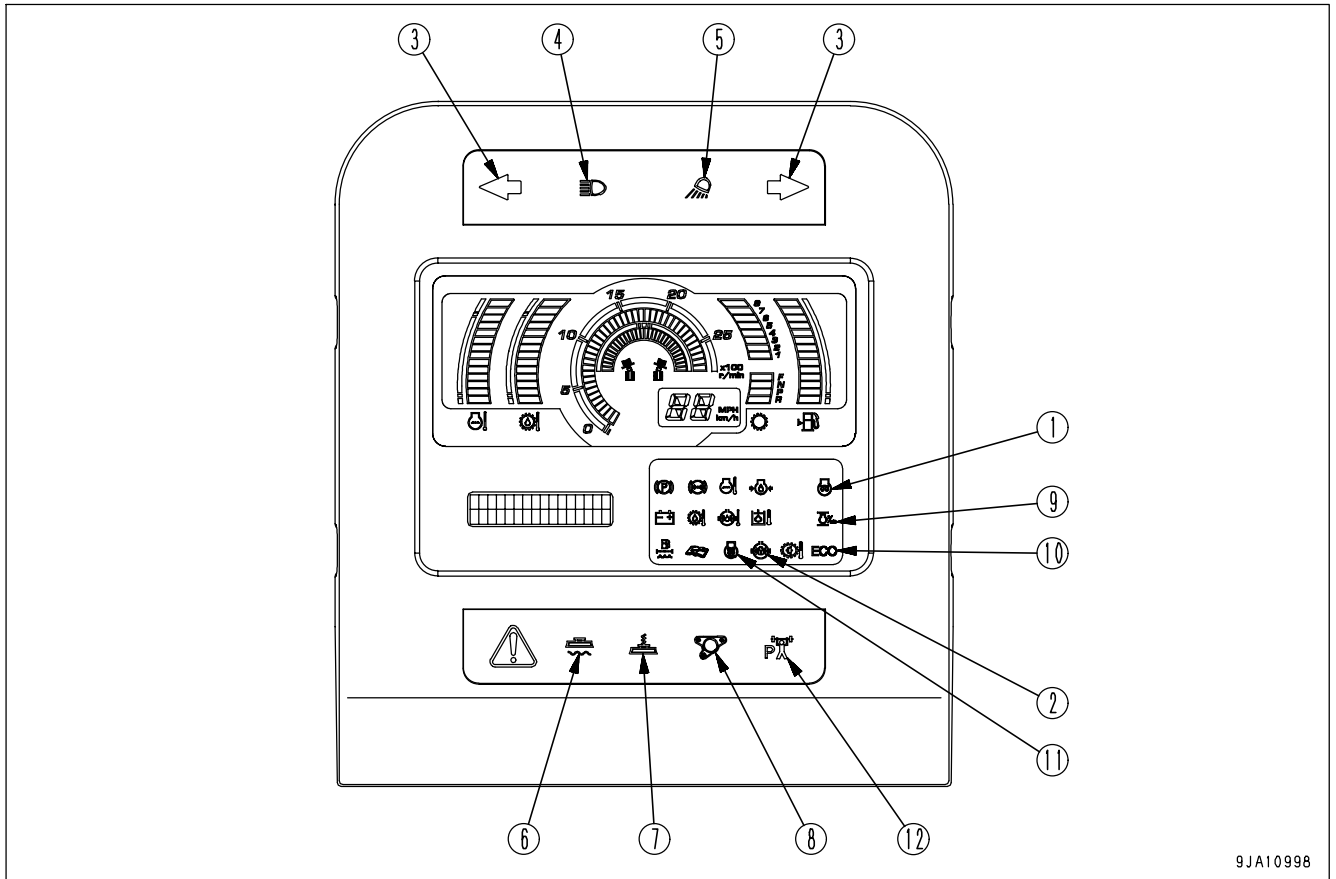

9JA10998

- (1) Engine preheating pilot lamp
- (2) Differential lock pilot lamp (if equipped)
- (3) Turn signal pilot lamp
- (4) Head lamp high beam pilot lamp
- (5) Working lamp pilot lamp
- (6) Blade float pilot lamp
- (7) Blade accumulator pilot lamp (if equipped)
- (8) Lift arm lock pin pilot lamp
- (9) RPM SET pilot lamp
- (10) Economy operation display lamp
- (11) Cooling fan reverse rotation pilot lamp
- (12) P mode pilot lamp

ENGINE PREHEATING PILOT LAMP

This monitor (1) lights up when the engine preheating electrical heater is actuated.

When the starting switch is turned to the ON position in cold areas, this lamp lights up. It goes out after 5 - 45 seconds to inform the operator that the preheating has been completed.

In addition, this monitor lights up when the starting switch is turned to the HEAT position.

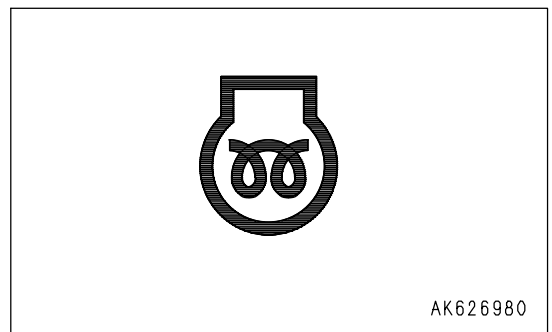

AK626980

DIFFERENTIAL LOCK PILOT LAMP

(If equipped)

This monitor (2) lights up when the differential lock switch is set to differential lock.

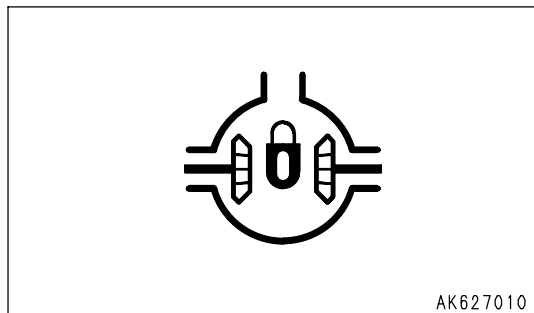
**TURN SIGNAL PILOT LAMP**

This monitor (3) flashes at the same time when the turn signal lamp (hazard display lamp) flashes.

REMARK

If there is a disconnection in the turn signal lamp (hazard display lamp), the flashing interval becomes shorter.

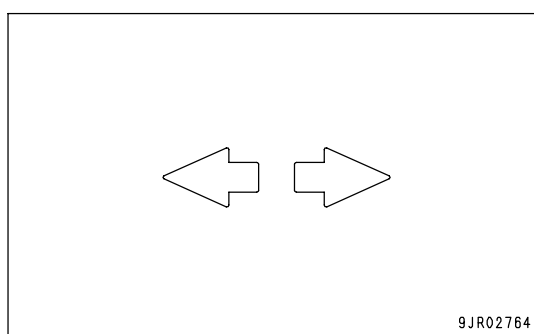
**HEAD LAMP HIGH BEAM PILOT LAMP**

This monitor (4) lights up when the head lamp is set to high beam.

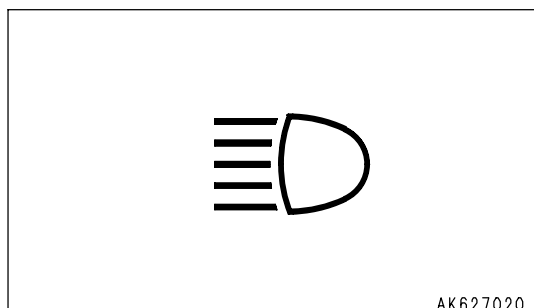
**WORKING LAMP PILOT LAMP**

This monitor (5) lights up when the working lamp is turned on.

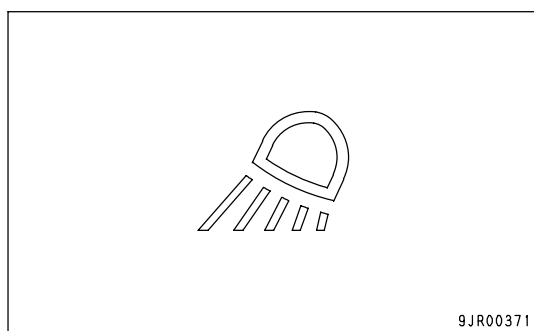

BLADE FLOAT PILOT LAMP

This monitor (6) lights up when the right and left blade lift cylinder control levers are set to the FLOAT position.

When this monitor is lighting, the engine does not start even if the starting switch is turned to the START position.

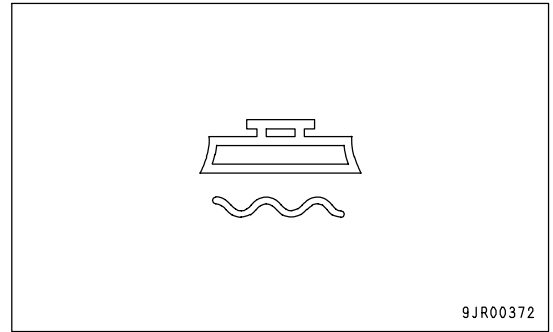
**BLADE ACCUMULATOR PILOT LAMP**

(If equipped)

This monitor (7) lights up when the blade accumulator switch is pressed to the accumulator side.

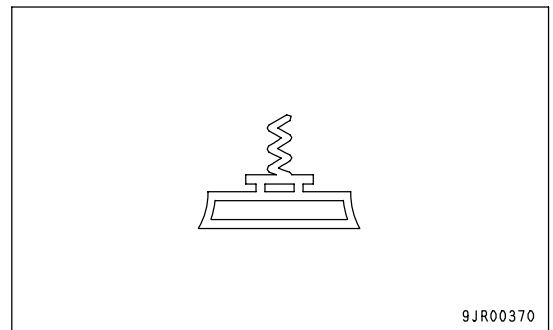
**LIFT ARM LOCK PIN PILOT LAMP**

This monitor (8) lights up when the lift arm lock switch is pressed (pin removal).

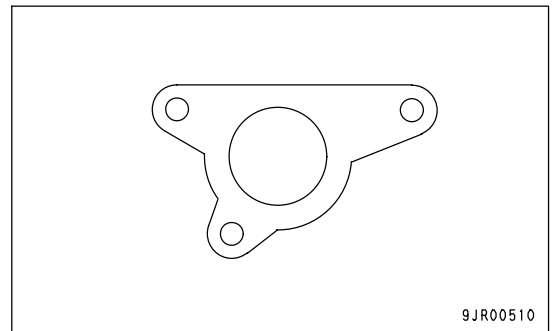
**RPM SET PILOT LAMP**

This monitor (9) lights up when the RPM SET switch is pushed to the front (SET/ACCEL) and the opening angle of the accelerator is set.

The lamp also lights up if the brake pedal or accelerator pedal are depressed and the setting is temporarily cancelled after the setting has been made.

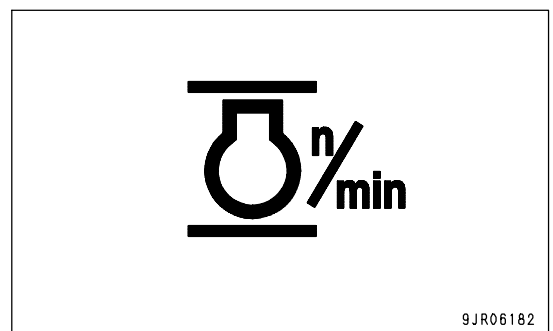

ECONOMY OPERATION DISPLAY LAMP

This monitor (10) lights up during economy operations.

As this monitor lights up and goes out in conjunction with the accelerator pedal, use it as an indicator of energy saving operations.

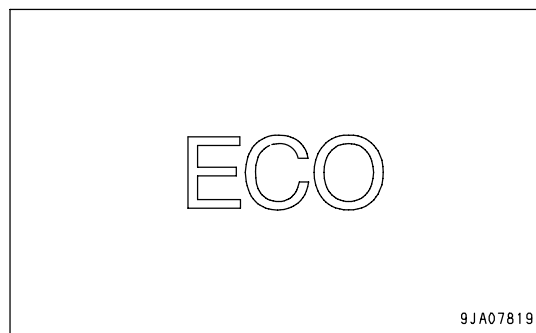
**COOLING FAN REVERSE ROTATION PILOT LAMP**

This monitor (11) lights up when the cooling fan is rotating in reverse after the cooling fan reverse rotation switch is operated.

In addition, this monitor flashes during switch-over from normal rotation to reverse rotation and from reverse rotation to normal rotation.

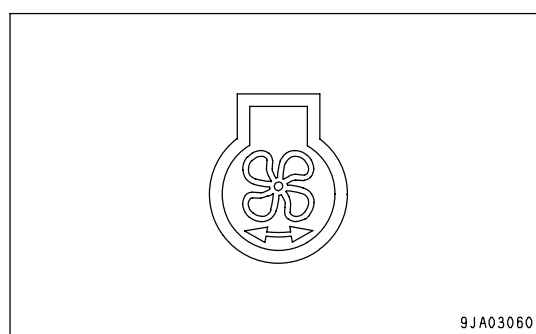
**P MODE PILOT LAMP**

This monitor (12) lights up when the P mode is selected.

Use the power mode selector switch to select the P mode.

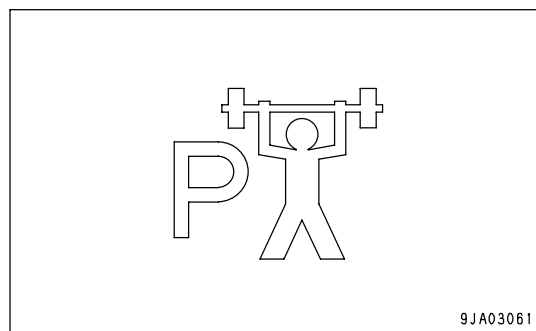

METERS

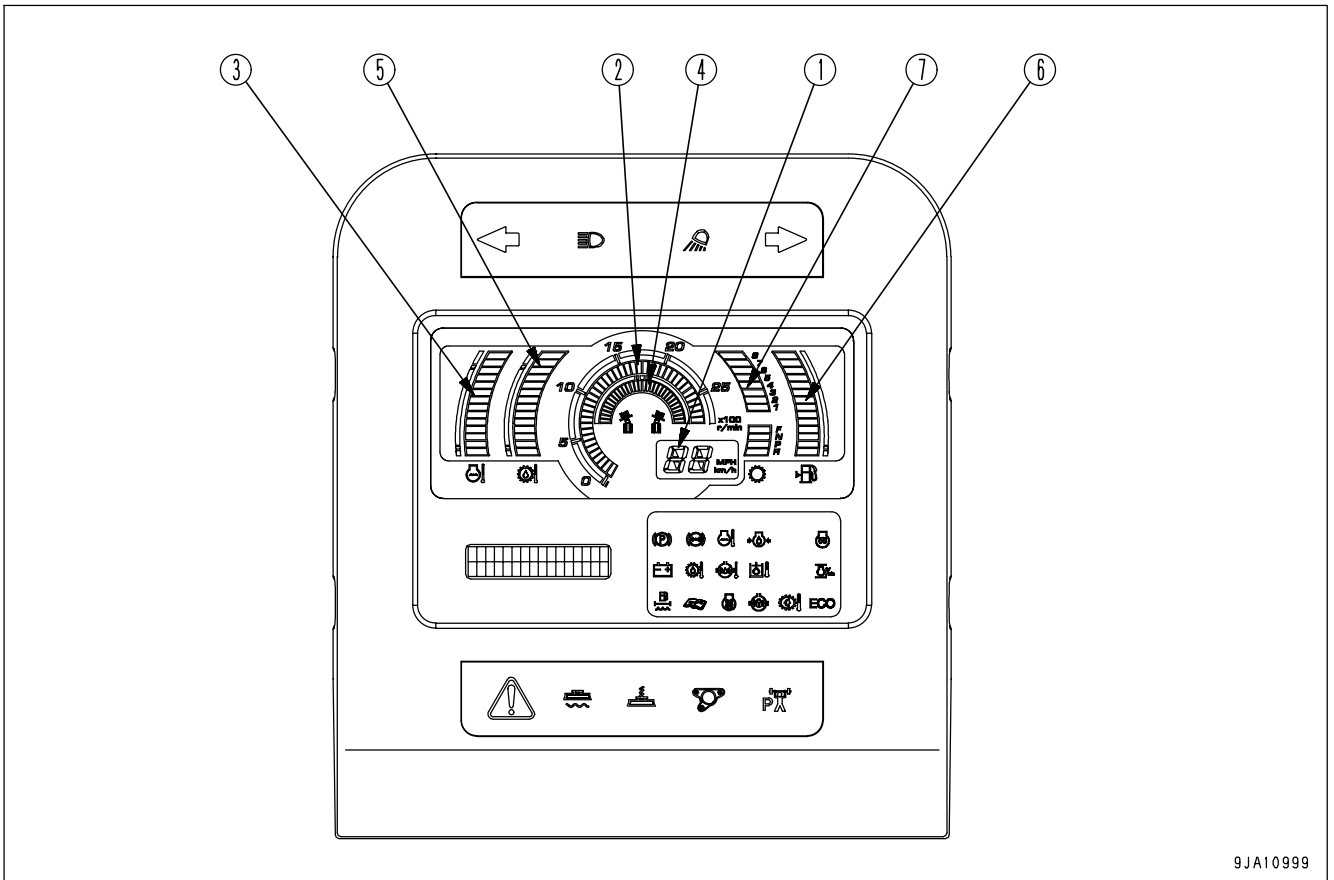

9JA10999

- (1) Speedometer
- (2) Engine tachometer
- (3) Engine coolant temperature gauge
- (4) Articulation gauge
- (5) Torque converter oil temperature gauge
- (6) Fuel gauge
- (7) Shift indicator

SPEEDOMETER

This meter (1) indicates the travel speed of the machine.

When it is changed to the shift indicator display, the shift position is displayed.

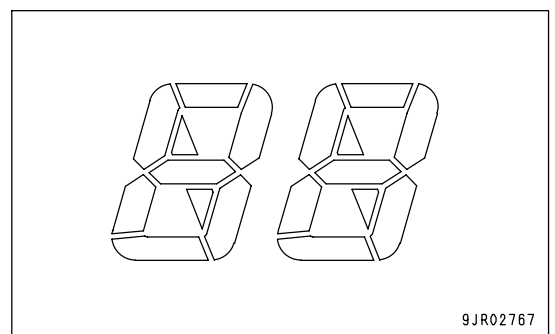

9JR02767

ENGINE TACHOMETER

This meter (2) indicates the engine speed.

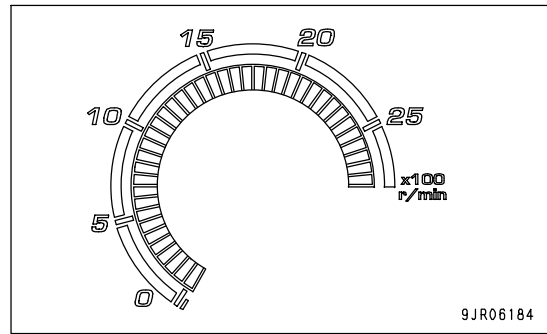

ENGINE COOLANT TEMPERATURE GAUGE

This meter (3) shows the engine coolant temperature.

During operations, the indicator should be in green range (B).

If it enters red range (C) during operations, at the same time, the alarm buzzer sounds, the central warning lamp lights up, and "E02 ENGINE OVERHEAT" is displayed on the character display. Run the engine under no load at a mid-range speed and wait until the indicator enters the green range. In addition, when the indicator enters the red range, the engine output is automatically limited.

(A): White range

(B): Green range

(C): Red range

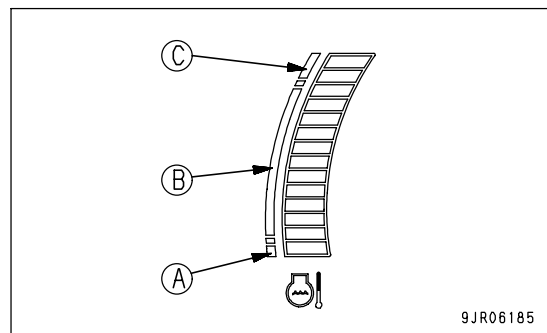

ARTICULATION GAUGE

This meter (4) shows the angle between the front frame and rear frame.

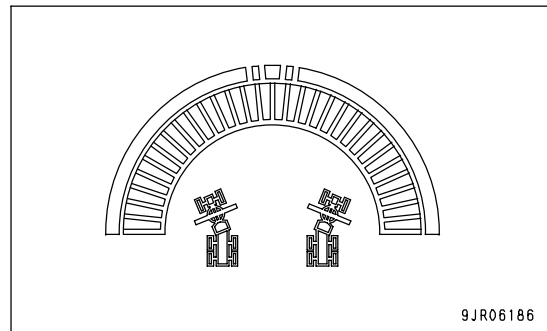

TORQUE CONVERTER OIL TEMPERATURE GAUGE

This meter (5) shows the torque converter oil temperature.

During operations, the indicator should be in green range (B).

If it enters red range (C) during operations, at the same time, the alarm buzzer sounds, the central warning lamp lights up, and "E02 TC OVERHEAT" is displayed on the character display. Run the engine under no load at a mid-range speed and wait until the indicator enters the green range.

(A): White range

(B): Green range

(C): Red range

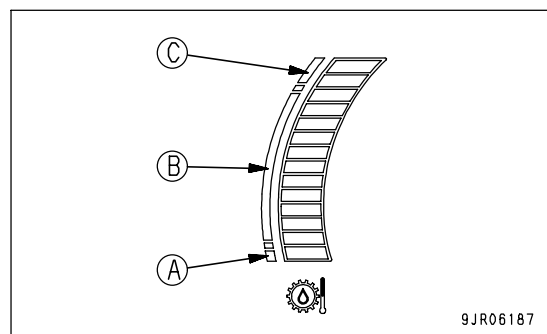

FUEL GAUGE

This meter (6) shows the fuel level in the fuel tank.

During operations, the indicator should be in green range (B).

If it enters red range (A) during operations, it indicates that the remaining amount of fuel is low. If it comes close to the red range, add fuel as soon as possible.

(A): Red range

(B): Green range

Fuel tank capacity: 416 liters (109.91 US gal)

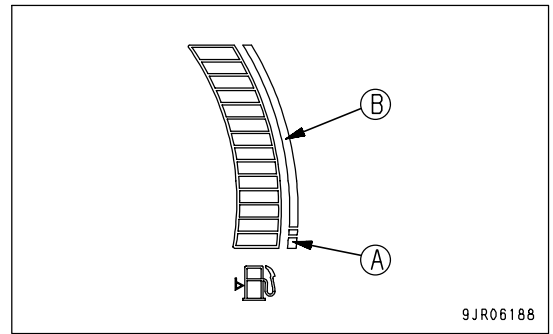
**SHIFT INDICATOR**

This meter (7) indicates the shift range (speed range) of the transmission.

When the gear shift lever is at N (Neutral) or P (Parking), the shift range (1 - 8) is not indicated.

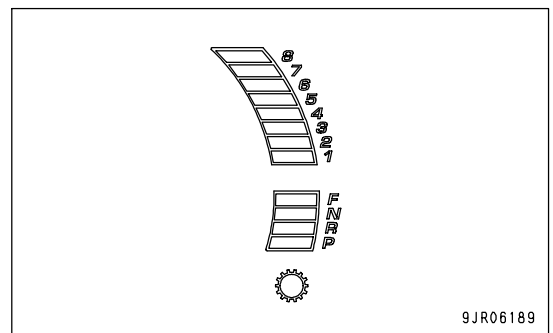
**CENTRAL CAUTION LAMP**

When the machine is in any of the following conditions, this lamp lights up and the alarm buzzer sounds intermittently at the same time:

- When an abnormality occurs in any emergency stop item
- When action code "E02" or "E03" is displayed on the character display
- When attempting to start the engine while the gear shift lever is not in the P position
- When the clutch temperature rises during inching operations



OTHER FUNCTIONS OF MACHINE MONITOR

The machine monitor also has the following functions. Use them if necessary.

When the (◇) portion of the machine monitor mode selector switch 1 (1) is pressed from the standard screen (service meter/odometer display) or warning screen (action code display), the display changes to "OPERATION INFO". Press the (>) or (<) portion of the machine monitor mode selector switch 2 (2) and move to the following menus.

To return from each menu to the standard screen, press the (■) portion of the machine monitor mode selector switch 1 (1).

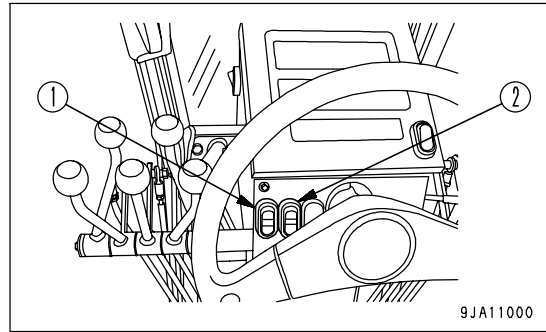

Overall menu

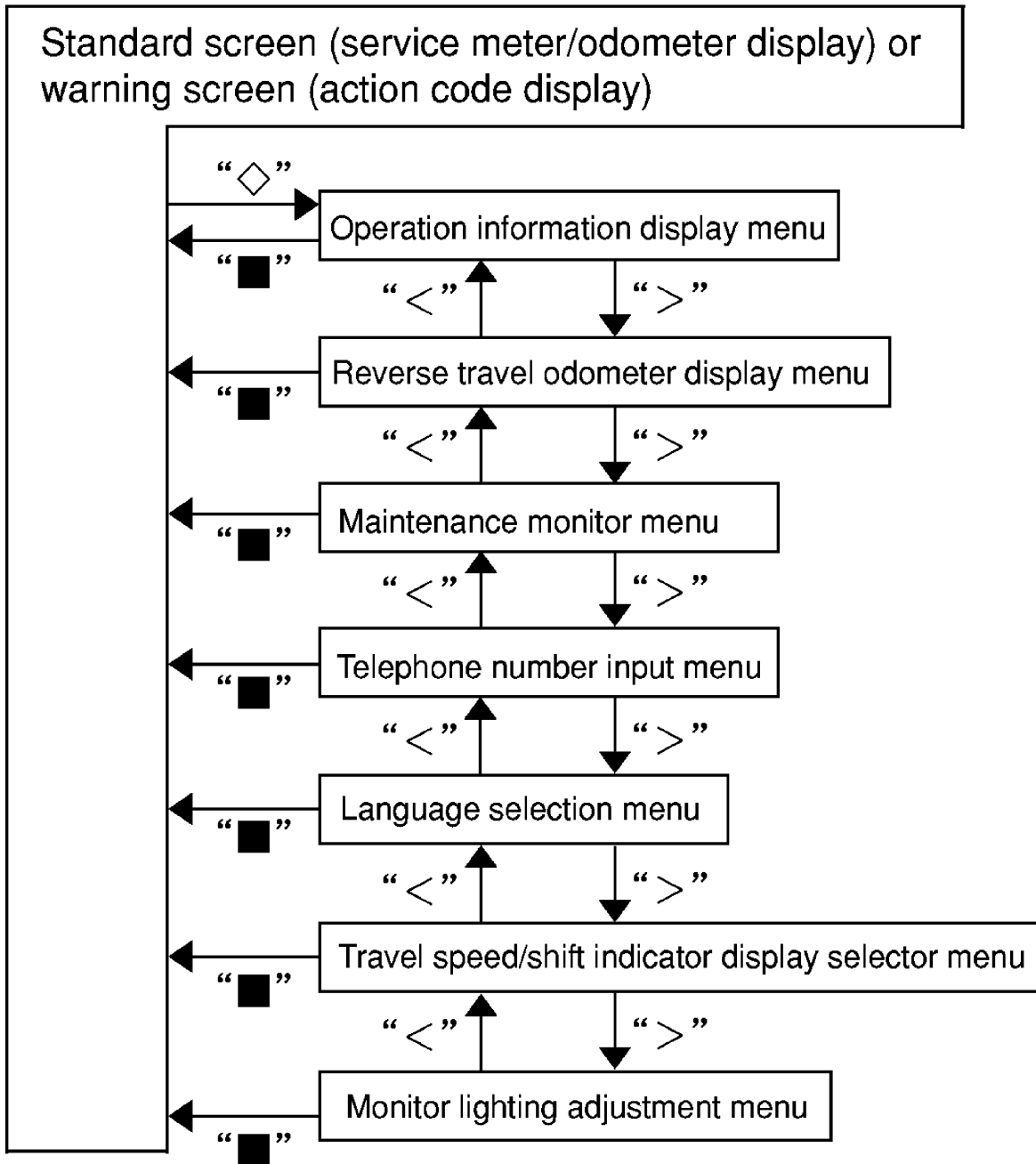

Standard screen

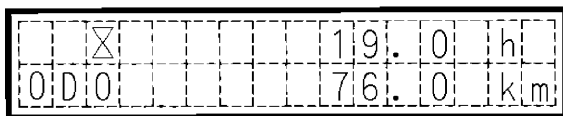

Operation information display menu



- ◊、■ : Machine monitor mode selector switch 1
- >、< : Machine monitor mode selector switch 2

DISPLAY METHOD OF OPERATION INFORMATION (FUEL CONSUMPTION)

Use to confirm the fuel consumption.

- 1. Check that the character display is showing the service meter/odometer, or the action code. If it is giving any other display, turn the starting switch OFF, then turn the starting switch to the ON position and wait for the above display to be given.
- 2. Press the (<>) of the machine monitor mode selector switch 1 and display "OPERATION INFO".
To finish as it is, press the (■) of the machine monitor mode selector switch 1 or turn the starting switch OFF.

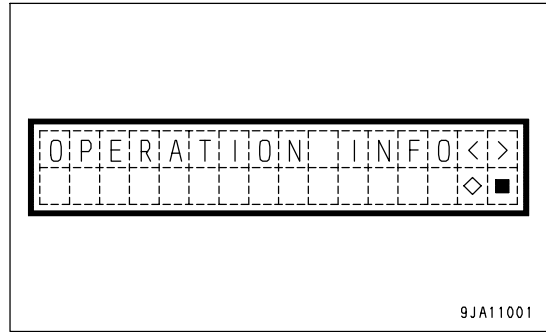

- 3. Press the (<>) of the machine monitor mode selector switch 1.
The fuel consumption per km or per mile (L/km or L/mile) after the previous reset and the average fuel consumption per hour (L/h) after the previous reset are displayed.
To finish as it is, press the (■) of the machine monitor mode selector switch 1 or turn the starting switch OFF.

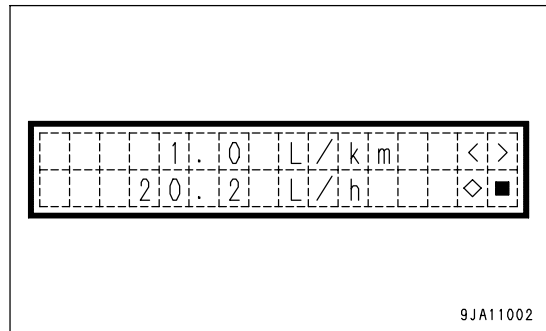

- 4. Press the (>) of the machine monitor mode selector switch 2.
The cumulative fuel consumption (L) after the previous reset and the travel distance (km or mile) after the previous reset are displayed.
To return to one screen before, press the (<) of the machine monitor mode selector switch 2.
To finish as it is, press the (■) of the machine monitor mode selector switch 1 or turn the starting switch OFF.

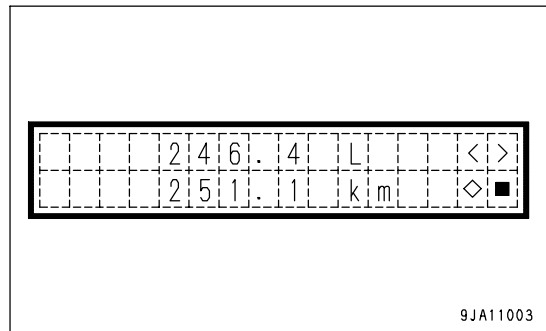

- 5. Press the (>) of the machine monitor mode selector switch 2.
The cumulative fuel consumption (L) after the previous reset and the elapsed time (h) after the previous reset are displayed.
To return to one screen before, press the (<) of the machine monitor mode selector switch 2.
To finish as it is, press the (■) of the machine monitor mode selector switch 1 or turn the starting switch OFF.

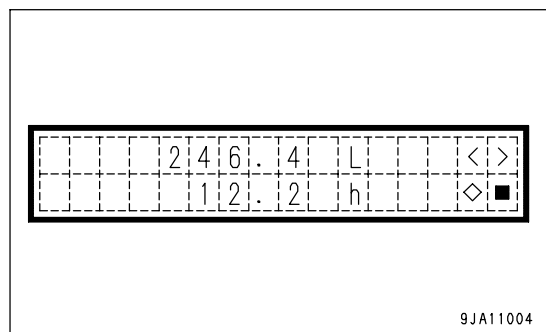

6. When the (◇) of the machine monitor mode selector switch 1 is pressed on the screen of procedure 3 - 5, the screen in the right figure is shown. When the (◇) of the machine monitor mode selector switch 1 is pressed again, the value on the screen of procedure 3 - 5 is reset and the screen of procedure 2 is displayed.
- To finish as it is without resetting, press the (■) of the machine monitor mode selector switch 1 or turn the starting switch OFF.

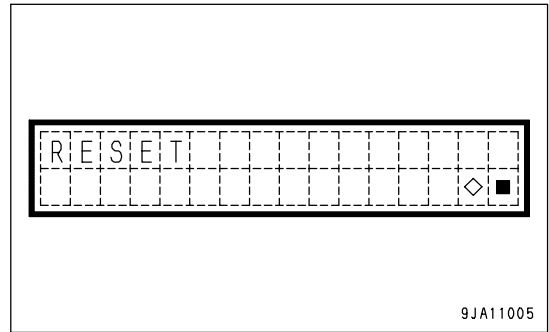

DISPLAY METHOD FOR REVERSE TRAVEL ODOMETER

Use this when checking the total travel distance in reverse.

1. Check that the character display is showing the service meter/odometer, or the action code. If it is giving any other display, turn the starting switch OFF, then turn the starting switch to the ON position and wait for the above display to be given.
2. Press the (◇) of the machine monitor mode selector switch 1 and display "OPERATION INFO".
3. Press the (>) of the machine monitor mode selector switch 2. It displays the reverse travel odometer.
4. When completing the operation, press (■) of machine monitor mode selector switch 1 or turn the starting switch OFF.

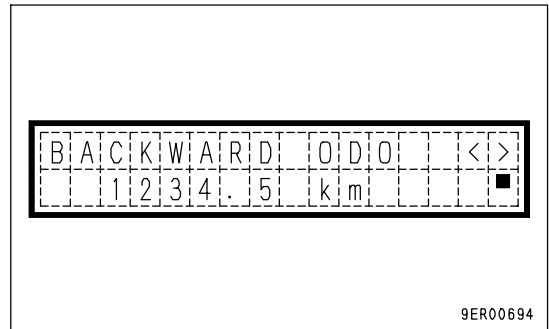

RESET METHOD FOR FILTER, OIL REPLACEMENT TIME

The filter and oil replacement time is displayed on the character display, so if the filter and oil have been replaced, reset the filter and oil change time.

- 1. Press the (◇) of the machine monitor mode selector switch 1 and display "OPERATION INFO".
- 2. Press part (>) or (<) of machine monitor mode selector switch 2 to display "MAINTENANCE MONITOR".

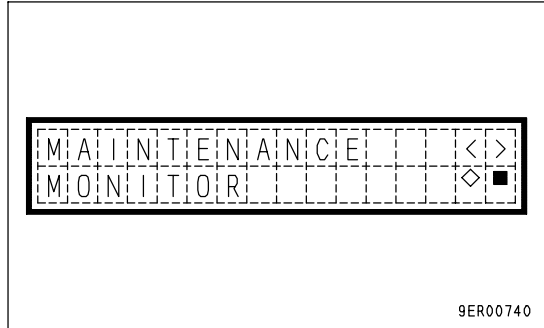

- 3. Press the (◇) of machine monitor mode selector switch 1. It will change to the display in the diagram on the right. The bottom line shows two items: the replacement time on the left and the total number of times the item has been replaced on the right.
- 4. Press the (>) or (<) of machine monitor mode selector switch 2 to display the item to be reset.

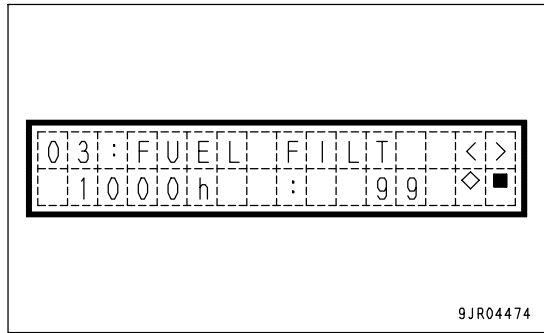

- 5. Press the (◇) of machine monitor mode selector switch 1. It will change to the display in the diagram on the right. The top line shows [Reset] and [Item to be reset] in turn.
- 6. When resetting the replacement time, press the (>) or (<) of machine monitor mode selector switch 2 and move the cursor to "YES", then press (■) of machine monitor mode selector switch 1. The system is reset and the screen returns to the previous screen. To abort the resetting procedure, move the cursor to "NO", then press (■) of machine monitor mode selector switch 1.

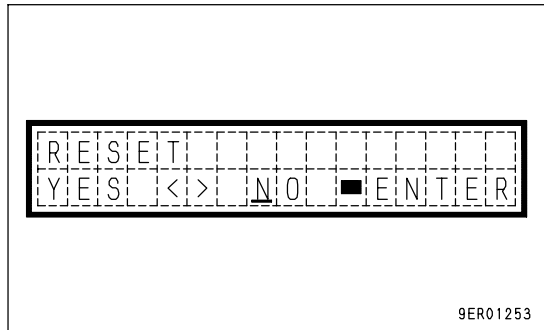

- 7. When resetting the replacement time for another item, carry out the procedure from Step 4. After completing, press (■) of machine monitor mode selector switch 1 twice or turn the starting switch OFF.

INPUT METHOD FOR TELEPHONE NUMBER

When an error for action code "E03" occurs, it is possible to display the telephone number.

1. Press the (◇) of the machine monitor mode selector switch 1 and display "OPERATION INFO".
2. Press the (>) or (<) portion of the machine monitor mode selector switch 2 to display "TEL".

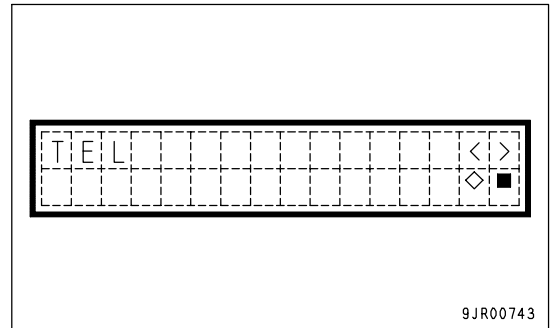

3. Press (◇) of machine monitor mode selector switch 1. It will change to the display in the diagram on the right.

Once the telephone number is input, the input number will be displayed next time.

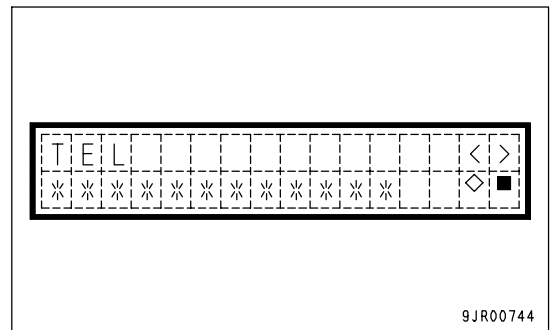

4. A maximum of 12 digits can be displayed for the telephone number. Input in order from the first digit. The cursor is displayed at the input position. Press the (>) or (<) of machine monitor mode selector switch 2 and select the number to input from "0 - 9". For spaces, input "*".

After inputting the desired number, press the (◇) of machine monitor mode selector switch 1. The cursor moves to the position for the next number.

5. Repeat the procedure in Step 4 until the last digit. At the last digit, press (◇) of machine monitor mode selector switch 1 to return to the previous screen.
If there is a mistake in the input or the input is to be stopped, press (■) of machine monitor mode selector switch 1 to return to the previous screen.
6. When completing the operation, press (■) of machine monitor mode selector switch 1 twice or turn the starting switch OFF.

METHOD FOR SELECTING LANGUAGE

Use this when switching the language displayed on the character display.

1. Press the (◇) of the machine monitor mode selector switch 1 and display "OPERATION INFO".
2. Press part (>) or (<) of machine monitor mode selector switch 2 to display "LANGUAGE".

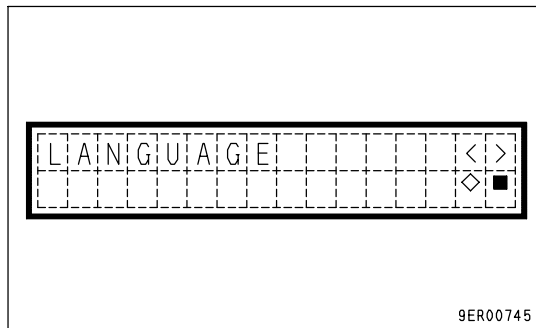

3. Press the (◇) of machine monitor mode selector switch 1. The presently selected language is displayed.
4. Press the (>) or (<) portion of the machine monitor mode selector switch 2 to select the desired language.

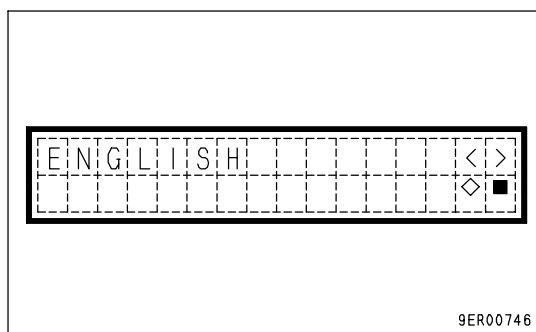

The available languages are English, Japanese, German, French, Italian, Spanish, and Swedish.

Language	Display
English	ENGLISH
Japanese	日本語
German	DEUTSCH
French	FRANCAIS
Italian	ITALIANO
Spanish	Español
Swedish	SVENSKA

5. When the (◇) of machine monitor mode selector switch 1 is pressed, the language is set and the screen returns to the previous screen.
6. When completing the operation, press (■) of machine monitor mode selector switch 1 twice or turn the starting switch OFF.

METHOD OF SWITCHING SPEEDOMETER/SHIFT INDICATOR

1. Press the (◇) of the machine monitor mode selector switch 1 and display "OPERATION INFO".
2. Press the (>) or (<) of machine monitor mode selector switch 2 to display "SELECT SPEEDOMETER" ("SELECT SHIFT INDIC" if the shift indicator is being displayed).
3. Press the (◇) of the machine monitor mode selector switch 1. The screen switches from the speedometer display to the shift indicator display (or from the shift indicator display to the speedometer display if the shift indicator is being displayed), and the screen returns to the service meter/odometer display. When completing the operation, press (■) or turn the starting switch OFF.

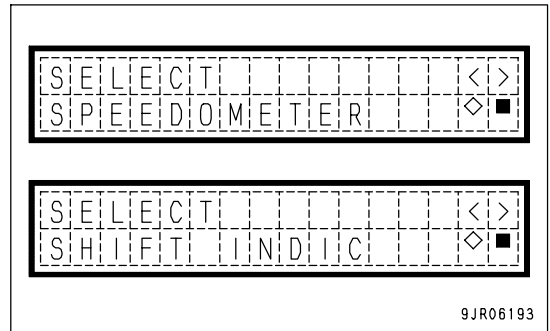

METHOD OF ADJUSTING MONITOR BRIGHTNESS

1. Press the (◇) of the machine monitor mode selector switch 1 and display "OPERATION INFO".
2. Press part (>) or (<) of machine monitor mode selector switch 2 to display "BRIGHTNESS ADJUST".

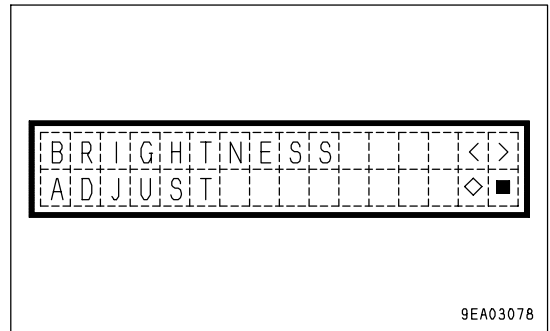

3. Press the (◇) of machine monitor mode selector switch 1 to move to the screen for selecting the item for the brightness to be adjusted.

LCD1: Adjustment of brightness for item other than the character display

LCD2: Adjustment of brightness of character display

Press (>) or (<) to select LCD1 or LCD2.

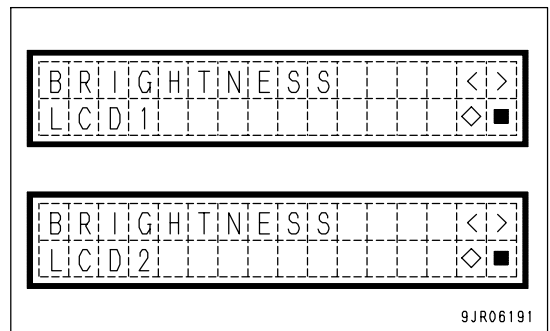

4. After selecting the display for LCD1 or LCD2, press the (◇) of machine monitor mode selector switch 1 to move to the adjustment screen.
5. Press the (>) or (<) of machine monitor mode selector switch 2. The (■) mark will move to the left or right and the brightness will change.
6. After selecting the desired brightness, press the (■) of machine monitor mode selector switch 1 to confirm the selection. The screen will return automatically to LCD1/LCD2 selection screen (Step 3 above), so go onto the next adjustment.

When completing the operation, press (■) or turn the starting switch OFF.

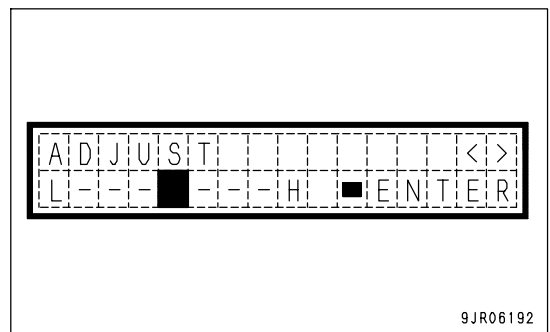

SWITCHES

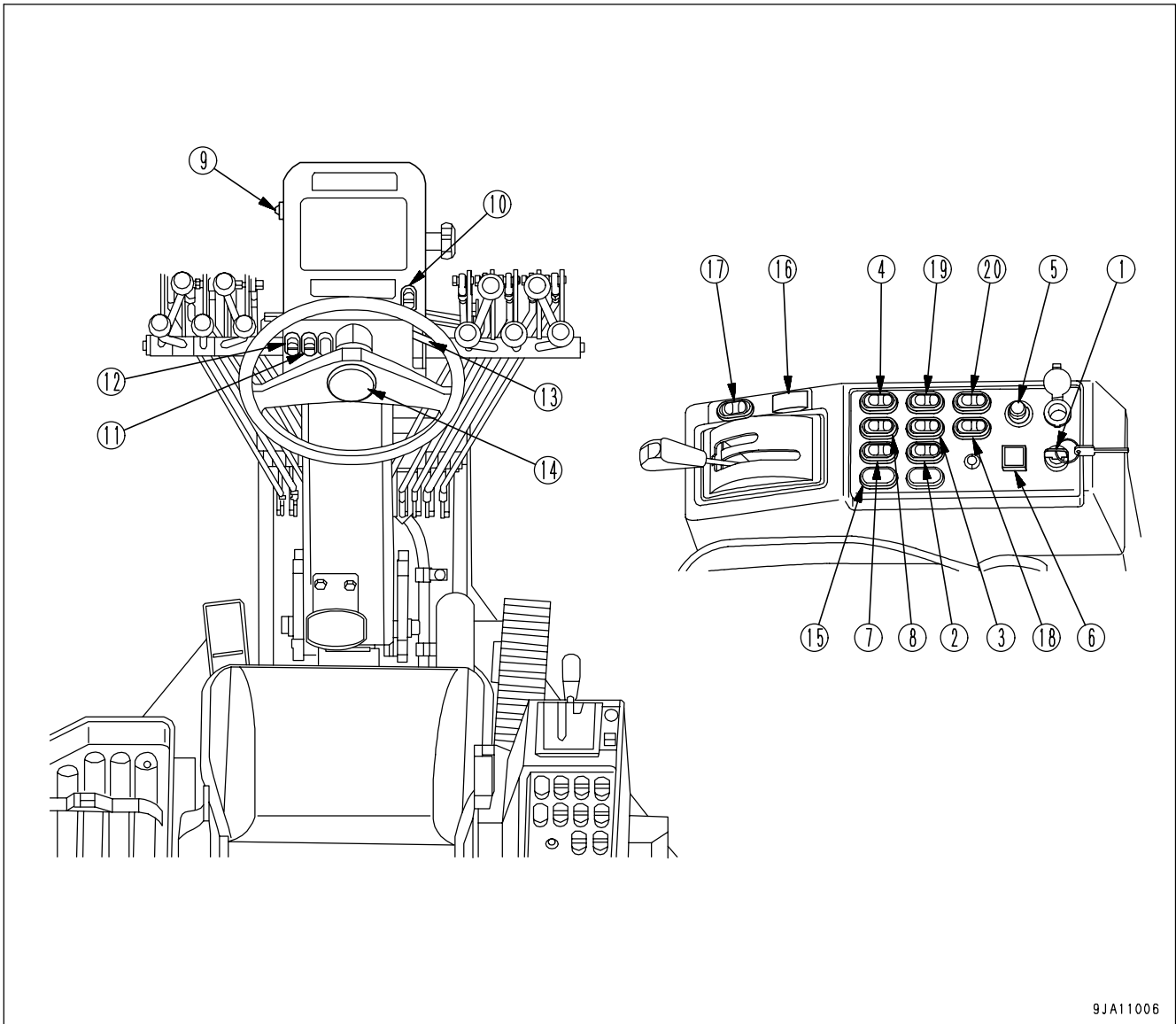

9JA11006

- | | |
|---------------------------------------------|-------------------------------------------------|
| (1) Starting switch | (11) Machine monitor mode selector switch 2 |
| (2) Front lamp switch | (12) Machine monitor mode selector switch 1 |
| (3) Front working lamp switch | (13) Turn signal lever |
| (4) Blade accumulator switch (if equipped) | (14) Horn button |
| (5) Cigarette lighter | (15) Additional car heater switch (if equipped) |
| (6) Lift arm lock switch | (16) RPM SET switch |
| (7) Hazard lamp switch | (17) RPM SET mode selector switch |
| (8) Transmission mode selector switch | (18) Power mode selector switch |
| (9) Dimmer switch | (19) Rear working lamp switch |
| (10) Differential lock switch (if equipped) | (20) Cooling fan reverse rotation switch |

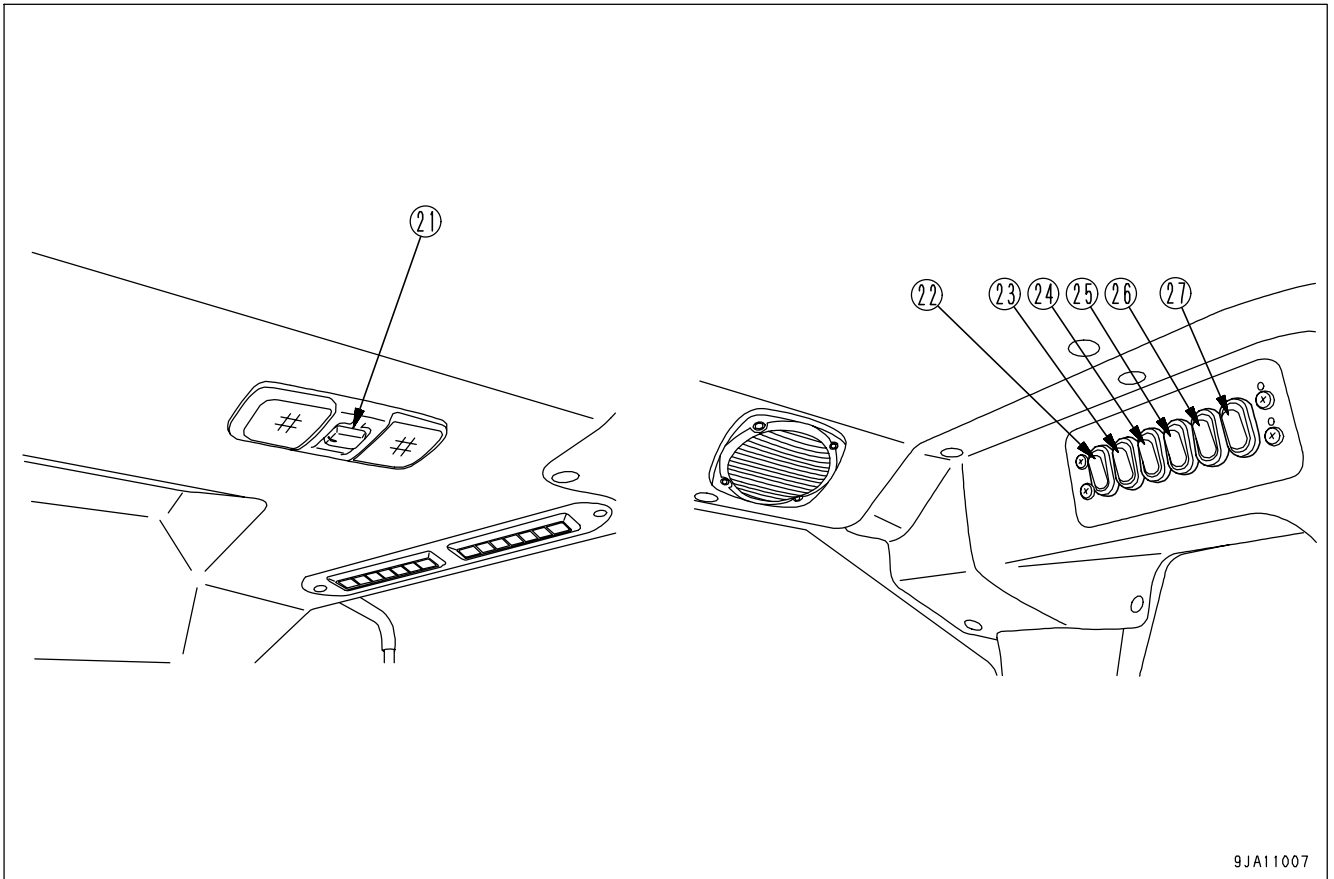

9JA11007

Top right inside cab
 (21) Room lamp switch

Top left inside cab
 (22) Intermittent wiper switch
 (23) Rear wiper switch
 (24) Door wiper switch
 (25) Front wiper switch
 (26) Yellow rotating lamp switch (if equipped)
 (27) Cab-mounted working lamp switch (if equipped)

STARTING SWITCH

Starting switch (1) is used to start or stop the engine.

(A): OFF position

The key can be inserted or withdrawn. Switches for the electrical system (except room lamp), are all turned off and the engine is stopped.

(B): ON position

Electric current flows through the charging and lamp circuits. Keep starting switch key in the ON position while the engine is running.

In cold weather, if the starting switch is turned to the ON position (B), preheating is automatically started and the engine preheating pilot lamp lights up. After the preheating is completed, the engine preheating pilot lamp goes out. The time that the engine preheating pilot lamp stays lighted up depends on the ambient temperature as shown in the table below.

Ambient temperature	Lighting time
Above -4 °C	0 seconds
-4 °C to -15 °C	5 seconds to 30 seconds
Below -15 °C	30 seconds

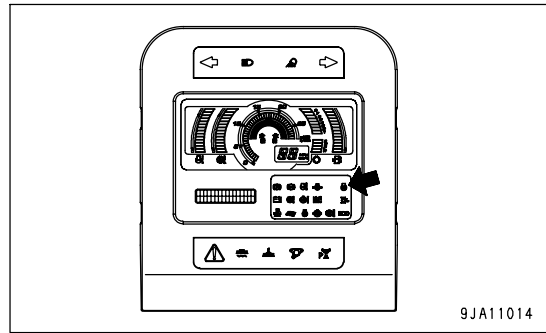
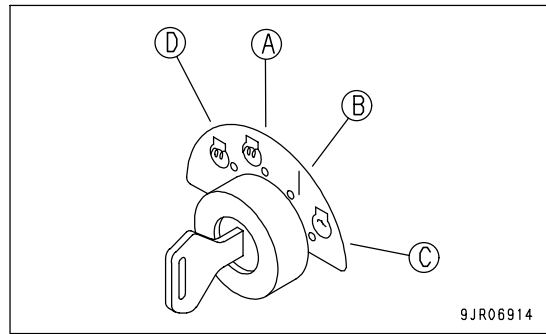

(C): START position

This is the engine-start position. Keep the key at this position during cranking. Immediately after starting the engine, release the key. It will automatically return to the ON position (B).

(D): HEAT position

Set to this position when starting the engine manually in cold weather.

When turning the key to the HEAT position (D), the engine preheating pilot lamp lights up. As the key returns automatically to the OFF position (A) when released, immediately turn to the START position (C) to start the engine. Hold the key in the HEAT position (D) within 5 - 30 seconds only.

REMARK

When turning the key to B (ON) position at cold seasons, engine pre-heating starts automatically. As the necessity of automatic pre-heating is judged by the outdoor air temperature, starting the engine is sometimes difficult if the engine is colder than the outdoor temperature. Only in such case, turn the key to D (HEAT) position and manually preheat.

FRONT LAMP SWITCH

Use this switch (2) to light up the front lamps, side clearance lamps and tail lamps.

Position (A): Front lamps light up in addition to lamps at position (B).

Position (B): Side clearance lamps and tail lamps light up

Position (C): OFF

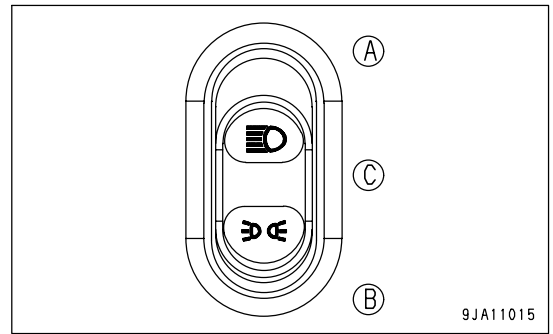

FRONT WORKING LAMP SWITCH

This switch (3) is used to light up the front working lamp.

Position (A): Working lamp lights up

Position (B): OFF

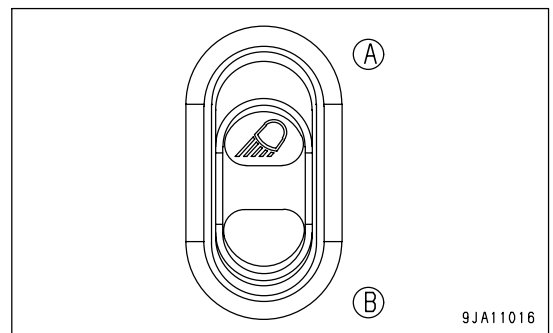

BLADE ACCUMULATOR SWITCH

(If equipped)

This switch (4) is used to actuate the blade accumulator.

Position (A): Blade accumulator ON

Position (B): OFF

REMARK

- The blade accumulator is effective in leveling road surfaces on jobsites where there are many rocks or when clearing compressed snow.

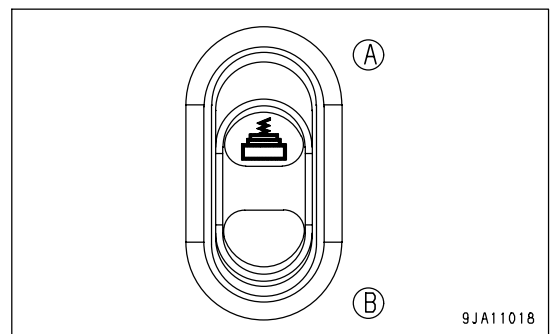

CIGARETTE LIGHTER

This cigarette lighter (5) is used to light cigarettes. When the cigarette lighter is pushed in, it will return to its original position after several seconds, so pull it out and use it to light your cigarette.

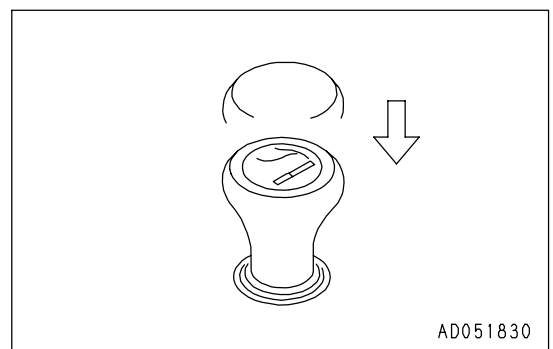

LIFT ARM LOCK SWITCH

This switch (6) is used to remove or insert the lifter lock pin.

This switch is used when setting the blade to the bank cut posture or shoulder reach posture. Press the switch to remove the pin, and press the switch again to return the switch and insert the pin.

A cover is provided to prevent accidental operations. Before pressing the switch, open the cover.

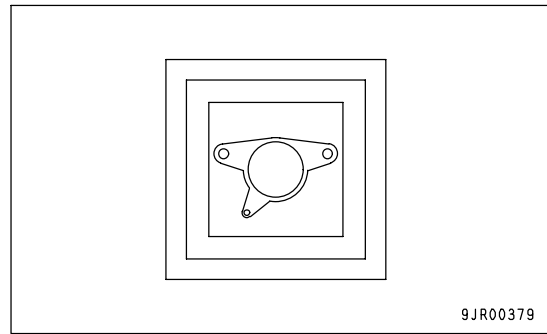
**HAZARD LAMP SWITCH****WARNING**

Never use the hazard lamp except in emergencies. If it is used while traveling when there is no problem, it may cause misunderstanding for drivers of other vehicles.

Use this switch (7) only in emergencies such as the case when having to park on a road due to a failure, etc.

Position (A): All turn signal lamps and turn signal pilot lamps flash.

Position (B): OFF

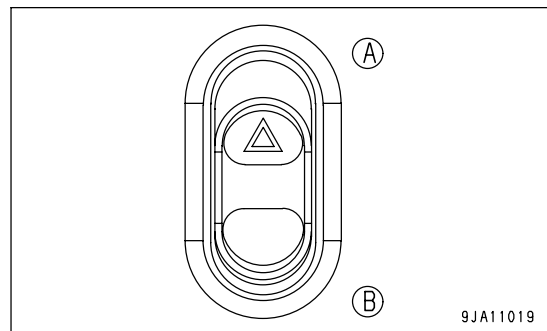

TRANSMISSION MODE SELECTOR SWITCH

**CAUTION**

- When switching from torque converter Auto mode to Manual mode, set the gear shift lever to N (NEUTRAL) position while the machine stops, set the engine to low idling, and then switch over.
- When starting the machine off after switching over the mode, observe the items in "MOVING MACHINE OFF (FORWARD, REVERSE, SHIFTING GEAR), STOPPING (PAGE 3-108)".

This model has a TORQFLOW transmission with lockup clutch.

By using this switch (8), changeover between torque converter Auto mode and Manual mode can be carried out. While selecting torque converter Auto mode, machine operations are easier and the automatic gear shift is also available.

Position (A) (T/C AUTO): Torque converter Auto mode

When carrying out work as the easy-to-operate torque converter machine with automatic transmission functions, select torque converter Auto mode. At F5 or higher gear speeds, the gear shift is automatically operated in lockup state which has high transmission efficiency.

Inching operations are not necessary, and operations of only the brake pedal and accelerator pedal enable the optimum work.

Torque converter Auto mode is suitable for the following works:

- Work during which loads fluctuate widely and the engine speed is significantly lowered
- Snow clearing work or any other work carried out at F5 or higher gear speeds
- Long distance travel
- Work carried out at very low speeds

Position (B) (MANU): Manual mode

When carrying out work with the same operating feeling as the conventional direct power shift (hydroshift), select Manual mode.

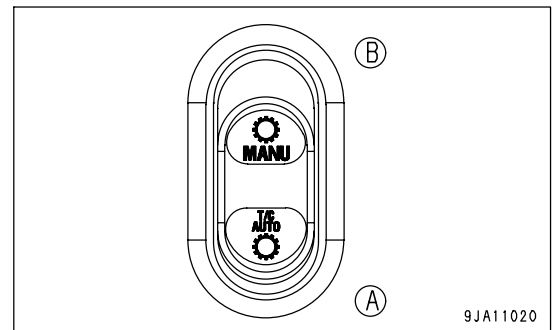

		Position of gear shift lever							
		F1	F2	F3	F4	F5	F6	F7	F8
T/C AUTO	Gear speed	F1	○						
		F2		○					
		F3			○				
		F4				○	○	○	○
		F5					⊕	⊕	⊕
		F6						⊕	⊕
		F7						⊕	⊕
		F8							⊕

		Position of gear shift lever			
		R1	R2	R3	R4
Gear speed	R1	○			
	R2		○	○	○
	R3			⊕	⊕
	R4				⊕

		Position of gear shift lever							
		F1	F2	F3	F4	F5	F6	F7	F8
MANU	Gear speed	F1	●						
		F2		●					
		F3			●				
		F4				●			
		F5					●		
		F6						●	
		F7							●
		F8							●

		Position of gear shift lever			
		R1	R2	R3	R4
Gear speed	R1	○			
	R2		○	○	○
	R3			⊕	⊕
	R4				⊕

- : In lockup state (torque converter is not in use)
- ⊕ : As the machine speed increases, torque converter state changes to lockup state.
- : In torque converter state
- ↕ : Automatic gear shift

REMARK

- Even in Manual mode, no engine stall occurs as this model has the linked control of torque converter and direct drive.
- When working at F1 and low idling of engine during selection of torque converter Auto mode, the machine can travel at very slow speeds through acceleration and brake operations.
- When selecting torque converter Auto mode and F5 - F8 of the gear shift lever, the machine starts off at F4 in torque converter state and thereafter the gear speeds automatically change up to the selected one as appropriate.
- When traveling reverse (R1 - R4), the gear shifts in Manual mode are made in the same manner as in torque converter Auto mode.
- When selecting torque converter Auto mode and R3 - R4 of the gear shift lever for reverse travels, the machine starts off at R2 in torque converter state and thereafter the gear speeds automatically change up to the selected one as appropriate.
- Even if operating the gear shift lever when traveling at high speeds, the gear shift is not actuated as long as there is possibility of overrun of the engine. After the machine slows down to a speed at which the engine never overruns, the gear speed automatically changes to the selected one.

NOTICE

Be cautious as some operations possibly apply excessive loads to the lockup clutch and cause failures.

- When the torque converter is stalling in torque converter Auto mode, do not switch to Manual mode.
- Carry out laden moving (starting of the machine with its blade loaded) in Manual mode at F3 or lower gear speeds.
- Before making directional selections halfway on a slope in Manual mode, be sure to stop the machine by applying the brake even when traveling at low speeds.
- Do not make gear shifts halfway on a steep slope in Manual mode.
When entering a slope in Manual mode, select a gear speed suitable for the slope angle and then enter.

DIMMER SWITCH

This switch (9) is used to switch the head lamps between high beam and low beam.

Position (A): High beam

Position (B): Low beam

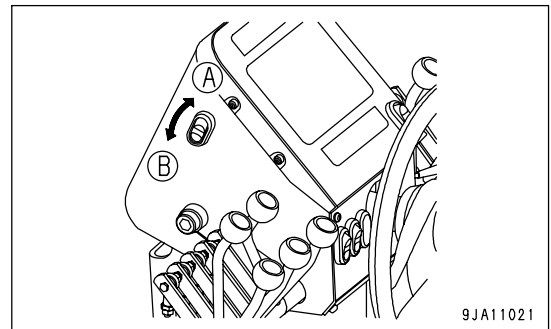

DIFFERENTIAL LOCK SWITCH

(If equipped)

**CAUTION**

- To protect the differential device, operate the differential lock switch when the machine is stopping.
Do not operate it when traveling or turning.
- Do not use the differential lock when travelling at high speeds.
- If a tire on either side slips, lower the engine speed and, after confirming that no tire is slipping, operate the differential lock.

This switch (10) is used to actuate the differential lock.

Position (A): Differential lock actuated

Position (B): OFF

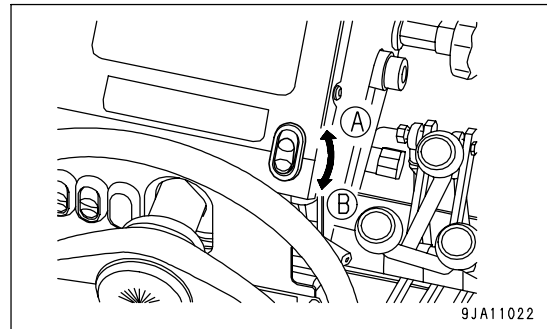

Differential lock OFF: To be used normally.

This gives smooth traveling and turning, prevents damage to road surfaces, and reduces the wear of tires.

Differential lock ON: To be used for travelling straight on wet roads or soft ground.

By rotating tires on the right and left sides at the same speed, the one-sided tire slippage can be prevented.

Avoid using on roads of high wear resistance. It possibly damages the machine seriously.

- The differential lock can enhance the straight traveling performance of machines.
It also enables the maximum use of drawbar pull.
- Use the differential lock on slopes, soft ground, wet roads, etc.
It helps to prevent the one-sided tire slippage.
- For operations such as steering and traveling, turn the differential lock OFF.
The wear of tires is reduced. In addition, road surfaces are less damaged.
- When turning on a road having high wear resistance against tires such as concrete road, set the differential lock OFF.
The wear of tires is reduced and the machine can turn smoothly.

MACHINE MONITOR MODE SELECTOR SWITCH 2

This switch (11) is used to switch the function of the character display.

When the switch is released, it automatically returns to its original position.

The basic operations are as follows.

Position (A): Use this position when going to the next screen or advancing the cursor or going up to the next number when inputting numerals.

Position (B): Use this position when going back to the previous screen or returning the cursor or going down to the next number when inputting numerals.

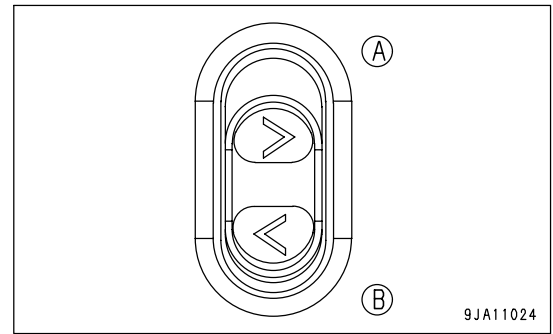
**MACHINE MONITOR MODE SELECTOR SWITCH 1**

This switch (12) is used to switch the function of the character display.

When the switch is released, it automatically returns to its original position.

The basic operation is as follows.

Position (A): Use this position to select (confirm) each mode or operation.

Position (B): Use this position to cancel each mode or operation.

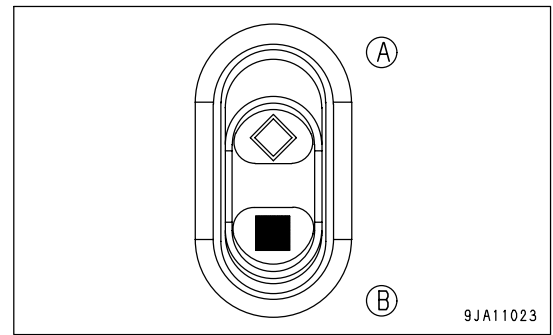
**TURN SIGNAL LEVER**

Use this lever (13) to operate the turn signal lamp.

Position (A): Left turn (move the lever up)

Position (B): Right turn (move the lever down)

When moving the lever, the turn signal pilot lamp also flashes.

The lever does not return automatically to its original position when the steering wheel returns to the straight traveling position. Return the lever manually.

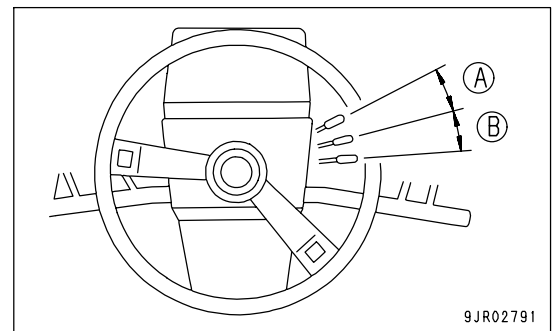
**HORN BUTTON**

When horn button (14) in the center of the steering wheel is pressed, the horn will sound.

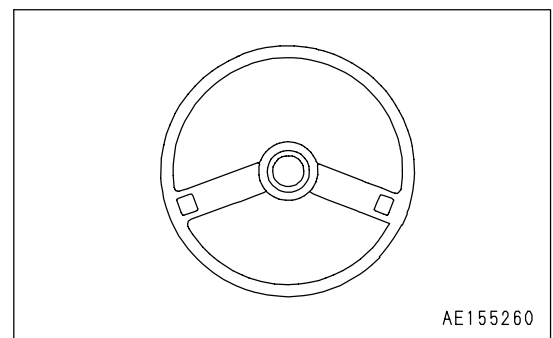

ADDITIONAL CAR HEATER SWITCH

(If equipped)

Use this switch (15) to turn the heater ON/OFF and to regulate the air flow (2 stages).

Position (A): ON, low air flow

Position (B): OFF

Position (C): ON, high air flow

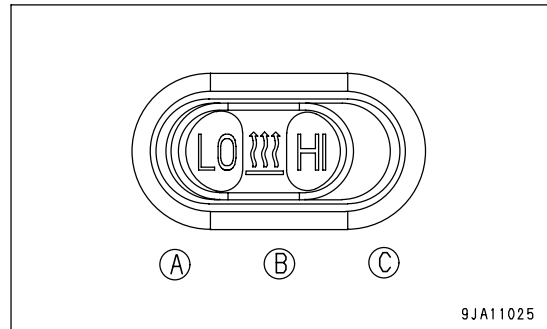
**RPM SET SWITCH**

Use this switch (16) when setting or adjusting the angle of the accelerator.

Position (A) (push front): SET/ACCEL

If this switch is pushed forward when the accelerator pedal has been depressed to give the necessary engine speed, the opening angle of the accelerator at that point is maintained and the RPM SET pilot lamp on the machine monitor lights up.

Once the accelerator opening angle has been set, if the front of the switch is pushed, the accelerator opening angle will increase by approx. 7% each time the switch is pressed.

If the front of the switch is kept pushed, the opening angle will increase 50% each second.

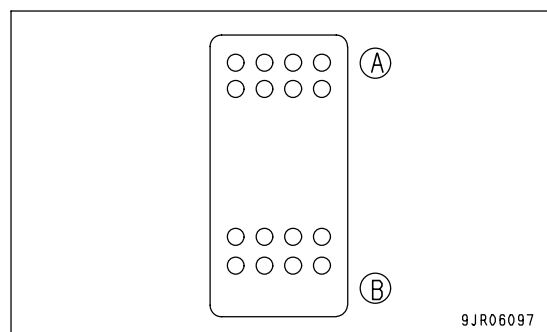

Position (B) (push back): RESUME/DECEL

Once the accelerator opening angle has been set, if the back of the switch is pushed, the accelerator opening angle will decrease by approx. 7% each time the switch is pressed.

If the back of the switch is kept pushed, the opening angle will decrease 50% each second.

Once the accelerator opening angle has been set in the Auto mode, if the back of the switch is pushed in the temporary cancel condition, the accelerator opening angle will be restored to the position before the temporary cancel.

RPM SET MODE SELECTOR SWITCH

This switch (17) is used to switch the power for the RPM SET system ON-OFF and to select the RPM SET mode.

Position (A): The automatic mode is selected and the indicator on the (A) side of the switch lights up.

Position (B): OFF

The electric power for the RPM SET system is shut off and the indicator of the switch goes out.

Position (C): The manual mode is selected and the indicator on the (C) side of the switch lights up.

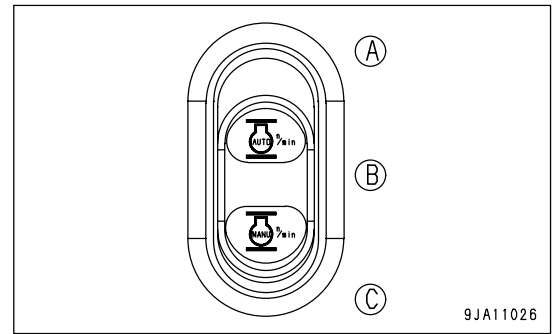
**REMARK**

- Use the RPM SET mode selector switch only for ON/OFF operations of the electric power for the RPM SET system.
Use the RPM SET switch to set the engine speed.
- When cancelling or not using the RPM SET system, turn the RPM SET mode selector switch OFF.
- After starting the engine, the power remains OFF wherever the position of this switch is. If starting the engine when the switch is in the position (A) or (C), turn it OFF once and then press the position (A) or (C) again.

AUTO mode

Once the accelerator opening angle has been set, it can be canceled by operating the accelerator pedal or brake pedal.

If the back of the switch is pushed (RESUME/DECEL) in the temporary cancel condition, the accelerator opening angle will be restored to the position before the temporary cancel.

- After the accelerator opening angle has been set and the accelerator pedal is fully released, if the accelerator pedal is depressed beyond the set opening angle, the engine speed will rise and the setting is temporarily canceled. During temporary cancel, the engine speed follows only the accelerator pedal.
- If the accelerator pedal opening angle is set and the brake pedal is depressed, the setting is temporarily canceled and the engine speed follows only the accelerator pedal.

REMARK

- If the temporary cancel is actuated, the machine monitor RPM SET pilot lamp lights up.
- If the temporary cancel is actuated and the front of the RPM SET switch (SET/ACCEL) is pressed, the accelerator opening angle at that point is maintained as the new value for the accelerator opening angle.
- If the temporary cancel is actuated and the engine stops, the accelerator opening angle saved in memory is deleted, and it cannot be restored even if the back of the switch (RESUME/DECEL) is depressed.

MANUAL mode

Once the accelerator opening angle has been set, it is retained until the switch is turned OFF.

After the accelerator opening angle is set, if the accelerator pedal is depressed beyond the set opening angle, the engine speed will rise.

If the accelerator pedal is released, the opening angle of the accelerator returns to the set opening angle.

The accelerator opening angle is not released even when the brake pedal is depressed.

! WARNING

Do not depress the brake pedal while the engine is set to run at high speeds.

Mode	Auto mode	Manual mode
Set	Push front of RPM SET switch (SET/ACCEL)	Push front of RPM SET switch (SET/ACCEL)
Cancel	Turn RPM SET mode selector switch OFF	Turn RPM SET mode selector switch OFF
Temporary cancel	1. Depress accelerator pedal 2. Depress brake pedal	-
Recovery from temporary release	Press back of RPM SET switch (RESUME/DECEL)	-

POWER MODE SELECTOR SWITCH

This switch (18) can be used to switch the engine output to match the purpose of the operation.

When the P mode is selected, the P mode pilot lamp on the machine monitor lights up.

Position (A): E mode (use this mode when operating or when traveling on flat ground)

Position (B): P mode (use this mode when traveling at high speeds or when travelling on uphill)

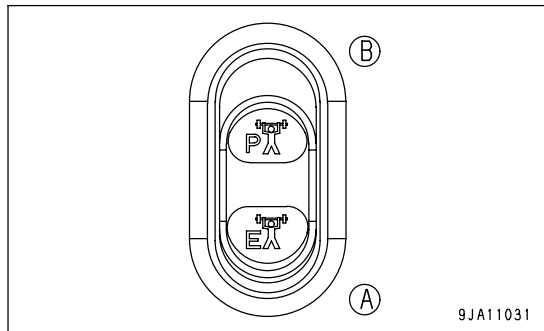

9JA11031

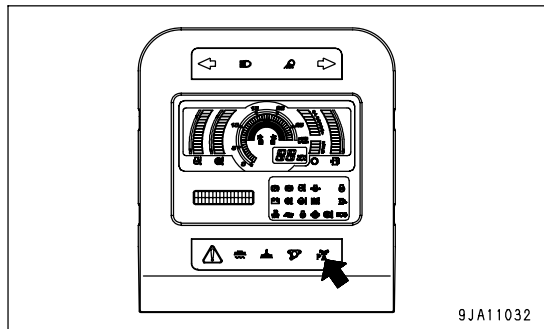

9JA11032

REMARK

- To carry out operations with effective fuel consumption, normally set to the E mode.
The maximum engine speed is set lower in E mode than in P mode, but it can display ample power and can also display good fuel consumption in working or traveling on flat ground.
- Set to the P mode if large drawbar pull is required when carrying out operations or traveling on slopes or if high speeds are required when traveling on flat ground or uphill.

REAR WORKING LAMP SWITCH

This switch (19) is used to light up the rear working lamp.

Position (A): Working lamp lights up

Position (B): OFF

REMARK

The rear working lamp lights up only when the front working lamp is lighting.

In case the front working lamp is OFF, the rear lamp does not light up even when the rear working lamp switch is set to the position (A).

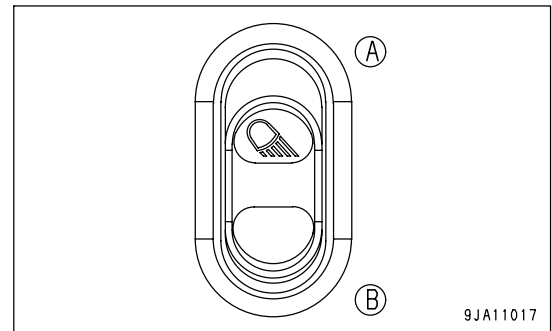
**COOLING FAN REVERSE ROTATION SWITCH**

Use this switch (20) to rotate the cooling fan in reverse to clean the radiator.

When operating the switch, run the engine at low idle.

Position (A): Reverse rotation switch ON

When the fan is rotating in the normal direction, if the switch is pressed once, the fan rotates in reverse; if the switch is pressed again, the fan rotates in the normal direction.

When the fan is rotating in the reverse direction, the cooling fan reverse rotation pilot lamp on the machine monitor lights up. For procedures of the cleaning, see the item in "CLEAN RADIATOR FINS AND COOLER FINS (PAGE 4-30)".

Position (B): OFF (Neutral)

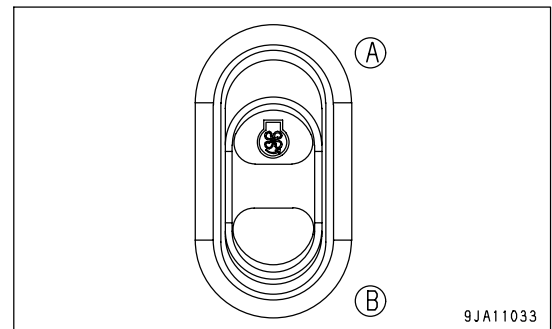
**REMARK**

- The reverse rotation of the fan can be used only when the gear shift lever is in P (PARKING) position.
- When the direction of fan rotation switches over, the reverse rotation pilot lamp flashes.
- To protect the machine, the direction of fan rotation does not switch over in some cases during high load operations or in low temperatures. (For details, see the conditions for switching the fan rotation.)
- When the engine stops, the fan rotation returns to the normal direction.
- When the switch is set to A (REVERSE ROTATION ON) position and the switch is released, it returns to B (OFF (NEUTRAL)) position. Even if the switch is not pressed continuously at A position, the fan rotates in reverse. Be sure to release the switch.
- When the fan is rotating in reverse, if the engine coolant temperature, hydraulic oil temperature, or torque converter oil temperature overheats (the caution lamp for the oil temperature gauge on the machine monitor lights up), the reverse rotation of the fan is forcibly stopped and the fan returns to rotation in the normal direction.

Conditions for switching fan rotation

Switching from normal rotation to reverse rotation

The fan will switch from normal rotation to reverse rotation only if all the following conditions are fulfilled.

If the direction is switched, the cooling fan reverse rotation pilot lamp on the machine monitor will change from flashing and will stay lighted up.

If all the conditions are not fulfilled, the fan direction will not change.

If the direction is not switched, the cooling fan reverse rotation pilot lamp on the machine monitor will continue to flash.

Conditions

- Position (A) of the cooling fan reverse rotation switch is pressed once.
- The engine speed is between low idling speed and 1200 rpm.
- The engine coolant temperature is less than 90°C (The indicator of the engine coolant temperature gauge is at scale of 8th or less of the bar graph).
- The torque converter oil temperature is less than 100°C (The display of the torque converter oil temperature gauge is within the green range).
- At least 30 seconds passed after the engine started.
- The gear shift lever is placed in P (PARKING) position.

Switching from reverse rotation to normal rotation

The fan will switch from reverse rotation to normal rotation if any of the following conditions are fulfilled.

If the direction is switched, the cooling fan reverse rotation pilot lamp on the machine monitor will change as follows: Lighted up -> flashing -> OFF.

If none of the conditions are fulfilled, the fan direction will not change.

If the direction is not switched, the cooling fan reverse rotation pilot lamp on the machine monitor will change from being lighted up to flashing and will continue to flash.

Conditions

- The engine speed becomes less than 1200 rpm in 10 minutes after the fan starts to rotate in reverse.
- When pressing the position (A) of the cooling fan reverse rotation switch again during reverse rotation of the fan, the engine speed becomes less than 1200 rpm.

ROOM LAMP SWITCH

This switch (21) is used to light up the room lamp.

Position (A): OFF

Position (B): Lights up when cab door is opened

Position (C): ON

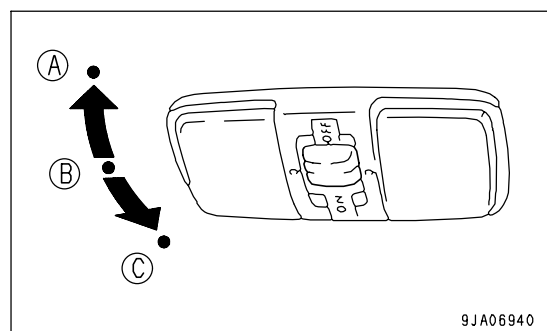

9JA06940

INTERMITTENT WIPER SWITCH

This switch (22) actuates the front wiper, rear wiper, and door wiper intermittently.

Position (A): Wipers are actuated intermittently

Position (B): OFF

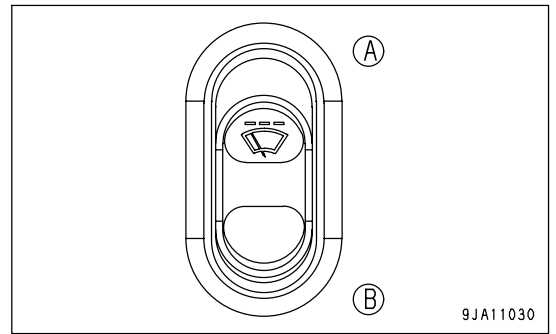

REAR WIPER SWITCH

This switch (23) actuates the rear wipers.

Position (A): Wipers operate and washer fluid is sprayed

Position (B): Wipers operate

Position (C): OFF

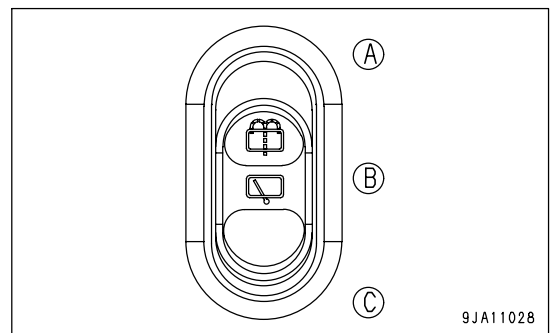

DOOR WIPER SWITCH

This switch (24) actuates the door wipers.

Position (A): Wipers operate and washer fluid is sprayed

Position (B): Wipers operate

Position (C): OFF

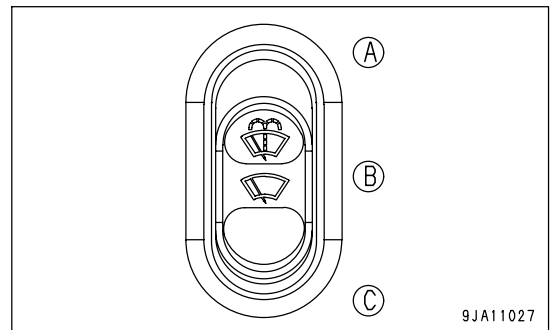

FRONT WIPER SWITCH

This switch (25) actuates the front wipers.

Position (A): Wipers operate and washer fluid is sprayed

Position (B): Wipers operate

Position (C): OFF

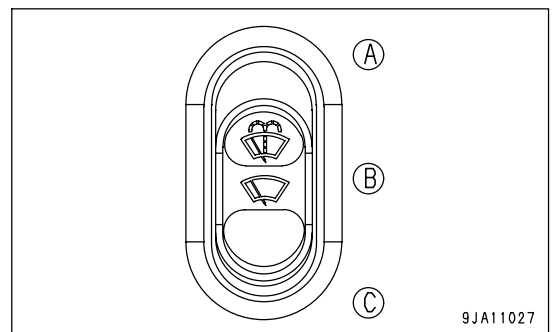

YELLOW ROTATING LAMP SWITCH

(If equipped)

This switch (26) is used to light up.

Position (A): Rotating lamp lights up

Position (B): OFF

REMARK

Use the yellow rotating lamp when carrying out operations. Follow the guidance of the supervisor when using.

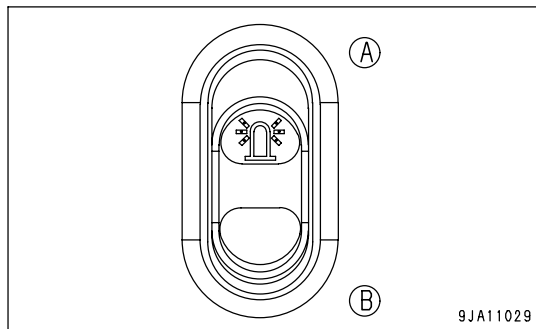

CAB-MOUNTED WORKING LAMP SWITCH

(If equipped)

This switch (27) is used to light up the cab-mounted working lamp.

Position (A): Working lamp lights up

Position (B): OFF

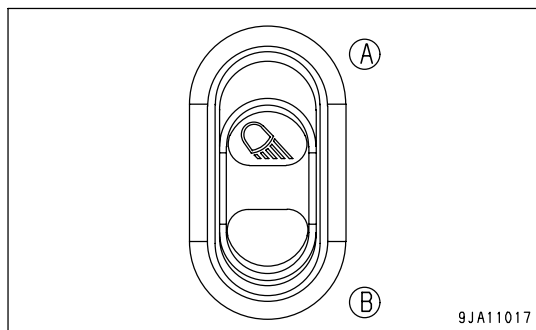

CONTROL LEVERS, PEDALS

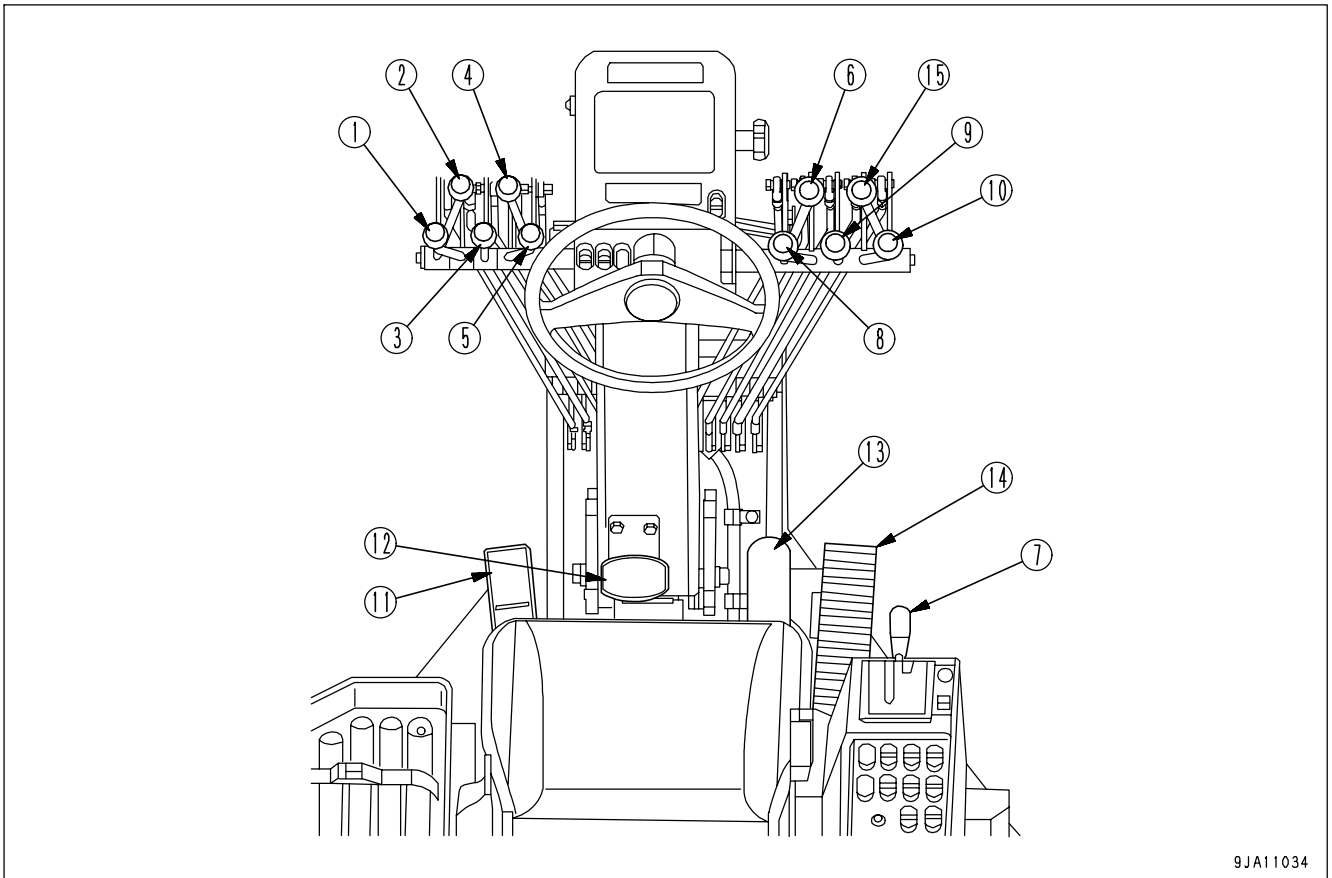

9JA11034

- | | |
|--------------------------------------------------|---------------------------------------------------|
| (1) Left blade lift cylinder control lever | (8) Drawbar side shift control lever |
| (2) Ripper/Scarifier control lever (if equipped) | (9) Leaning control lever |
| (3) Blade side shift control lever | (10) Right blade lift cylinder control lever |
| (4) Power tilt control lever | (11) Inching pedal |
| (5) Blade rotation control lever | (12) Steering console tilt pedal |
| (6) Articulate control lever | (13) Brake pedal |
| (7) Gear shift lever | (14) Accelerator pedal |
| | (15) Front attachment control lever (if equipped) |

LEFT BLADE LIFT CYLINDER CONTROL LEVER

This lever (1) operates the left blade lift cylinder.

- (A) LOWER: The left side of the blade goes down.
- (B) HOLD: The blade stops and is held in the same position.
- (C) RAISE: The left side of the blade goes up.
- (D) FLOAT: The blade moves freely according to the external force.

REMARK

- Even after releasing the lever in D (FLOAT) position, it does not return to B (HOLD) position. Return it manually.
- D (FLOAT) position is effective for removal of fresh snow.

NOTICE

Before starting the engine, be sure to return the lever to B (HOLD) position.

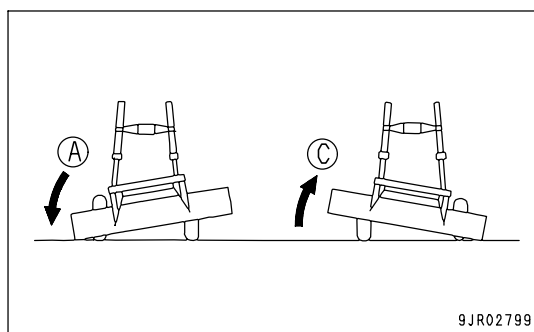
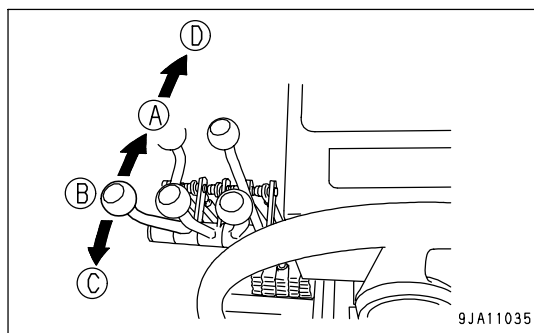

RIPPER/SCARIFIER CONTROL LEVER

(If equipped)

This lever (2) is used to operate the ripper or scarifier.

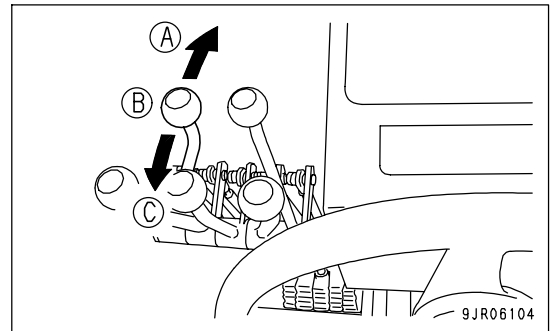

When the machine is equipped with a ripper

- (A) LOWER: The ripper is lowered.
- (B) HOLD: The ripper is stopped and held in position.
- (C) RAISE: The ripper is raised.

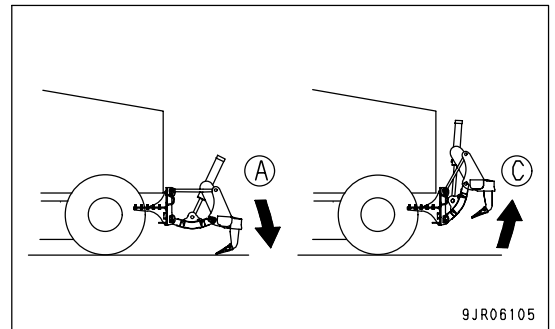

When the machine is equipped with a scarifier

- (A) LOWER: The scarifier is lowered.
- (B) HOLD: The scarifier is stopped and held in position.
- (C) RAISE: The scarifier is raised.

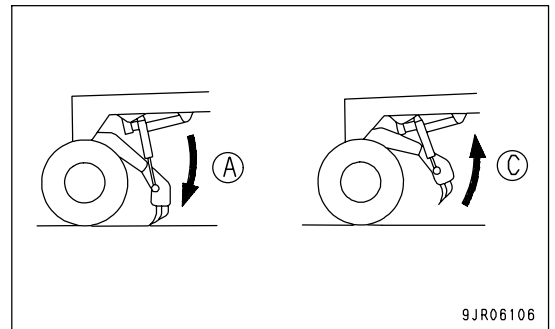

BLADE SIDE SHIFT CONTROL LEVER

This lever (3) shifts the blade to the side.

- (A) LEFT SHIFT: The blade is shifted to the left position.
- (B) HOLD: The blade stops and is held in the same position.
- (C) RIGHT SHIFT: The blade is shifted to the right.

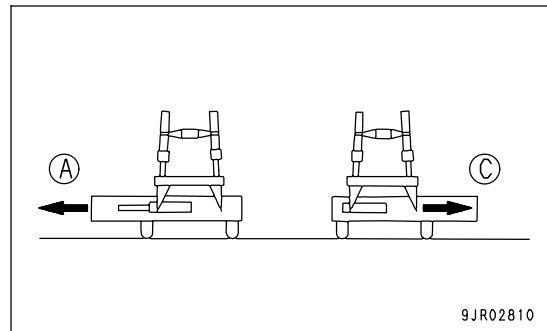
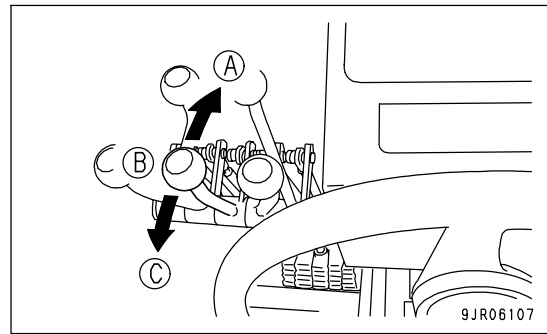

POWER TILT CONTROL LEVER

This lever (4) changes the cutting angle of the blade.

- (A) Max. cutting angle: This makes the blade cutting angle bigger. This is effective when operating on hard ground.
- (B) HOLD: The blade stops and is held in the same position.
- (C) Min. cutting angle: This makes the blade cutting angle smaller. This is effective when operating on soft ground.

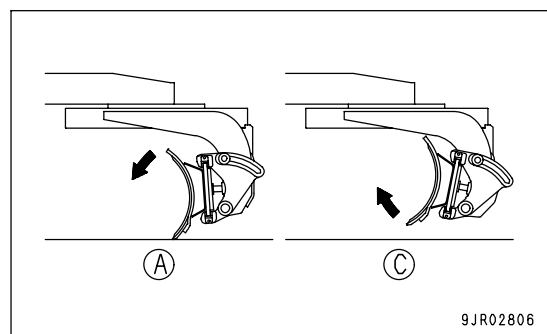
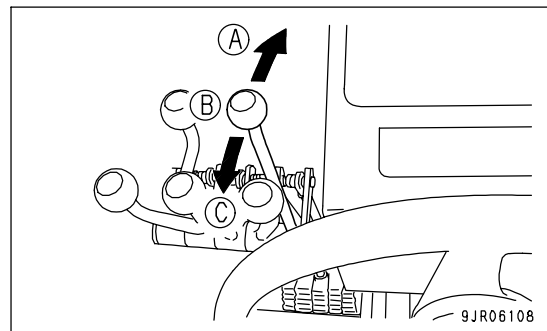

BLADE ROTATION CONTROL LEVER**NOTICE**

To prevent damage to the tires, be careful not to let the blade hit the tires when rotating the blade.

This lever (5) rotates the blade.

(A) RIGHT ROTATION: The blade is rotated to the left.

(B) HOLD: The blade stops and is held in the same position.

(C) LEFT ROTATION: The blade is rotated to the right.

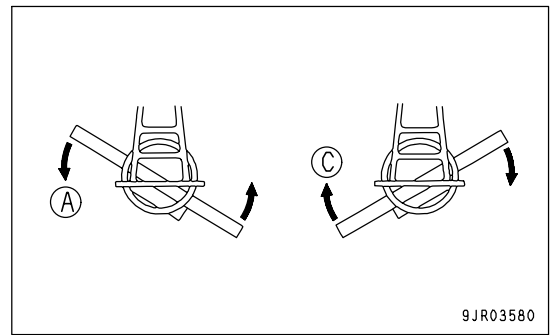
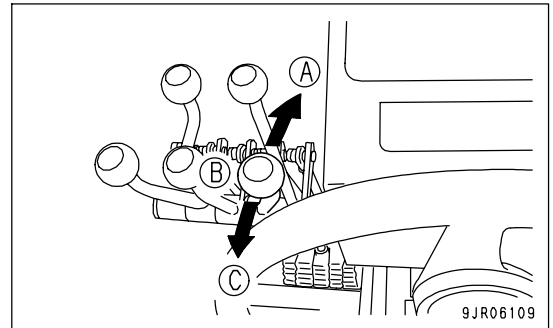

ARTICULATE CONTROL LEVER

**WARNING**

Operate this lever only when traveling at a speed of below 10 km/h (6.2 MPH). If the articulation is operated at a speed of over 10 km/h (6.2 MPH), there is danger that the machine may overturn.

NOTICE

To prevent damage to the tires, be careful not to let the blade hit the tires when articulating the machine.

This lever (6) is used to operate the articulation.

(A) LEFT TURN: The machine articulates to the left.

(B) HOLD: The articulation is kept in the same condition.

(C) RIGHT TURN: The machine articulates to the right.

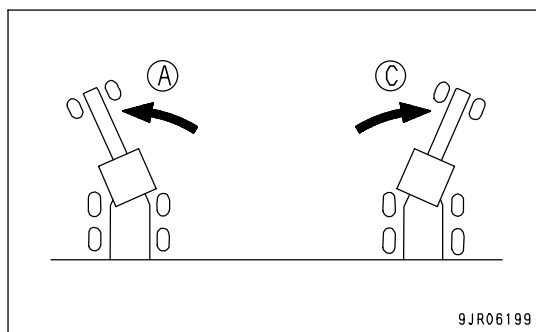
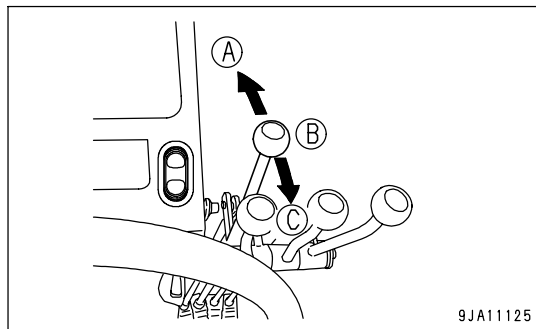

GEAR SHIFT LEVER

 **WARNING**

When leaving the operator's seat, be sure to return the gear shift lever to P (PARKING) position.

Even after setting the gear shift lever to P (PARKING) position, keep the brake pedal depressed until the parking brake pilot lamp lights up, to avoid dangers.

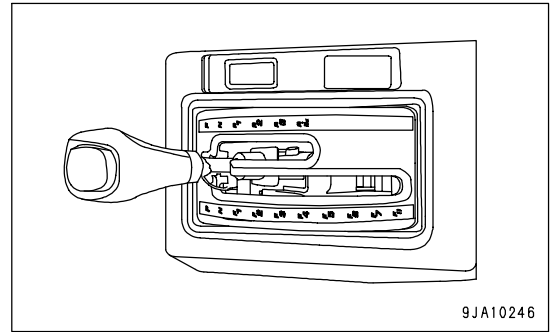

Use this lever (7) to select the transmission speeds.

The transmission has 8 FORWARD and 4 REVERSE speeds, and the gear is shifted simply by setting the gear shift lever to the desired position.

By setting the gear shift lever to P (PARKING) position, the parking brake is applied and the parking brake pilot lamp lights up.

NOTICE

- Except in emergencies, do not set to P (PARKING) position to apply the brake during travels. The parking brake is possibly damaged, causing serious accidents. Only after the machine stops, use the parking brake.
- In case the parking brake was used as emergency brake during travels due to avoidable reasons, ask your Komatsu distributor to check the abnormality in the parking brake.

REMARK

- Set the gear shift lever to P (PARKING) position before starting the engine.
- The gear shift pattern differs according to the position of the transmission mode selector switch. For details, see the items in "TRANSMISSION MODE SELECTOR SWITCH (PAGE 3-39)".
- To protect the transmission, the gear-speed skip preventive function is provided.

DRAWBAR SIDE SHIFT CONTROL LEVER

This lever (8) shifts the drawbar to the side.

- (A) LEFT SHIFT: The drawbar is shifted to the left.
- (B) HOLD: The drawbar stops and is held in the same position.
- (C) RIGHT SHIFT: The drawbar is shifted to the right.

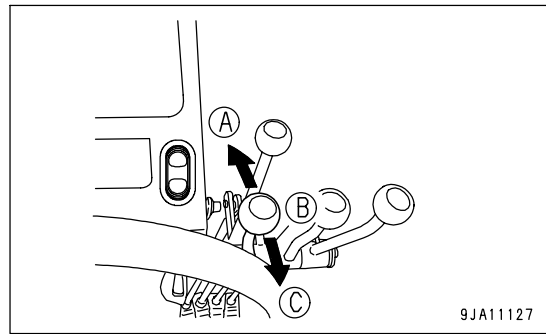

9JA11127

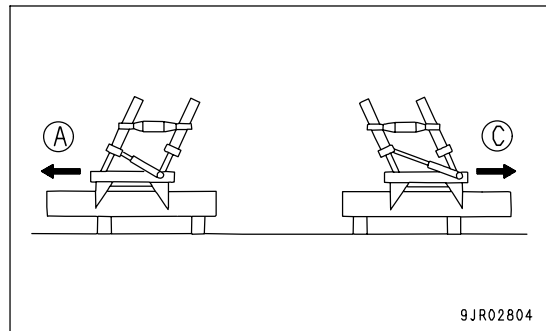

9JR02804

LEANING CONTROL LEVER

This lever (9) is used to operate the leaning.

- (A) LEFT TURN: The tires lean to the left.
- (B) HOLD: The leaning is kept in the same condition.
- (C) RIGHT TURN: The tires lean to the right.

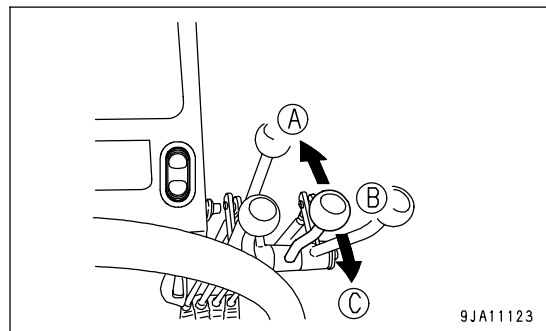

9JA11123

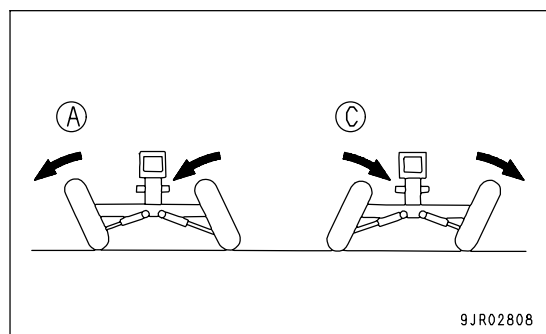

9JR02808

RIGHT BLADE LIFT CYLINDER CONTROL LEVER

This lever (10) operates the right blade lift cylinder.

- (A) LOWER: The right side of the blade goes down.
- (B) HOLD: The blade stops and is held in the same position.
- (C) RAISE: The right side of the blade goes up.
- (D) FLOAT: The blade moves freely according to the external force.

REMARK

- Even after releasing the lever in D (FLOAT) position, it does not return to B (HOLD) position. Return it manually.
- D (FLOAT) position is effective for removal of fresh snow.

NOTICE

Before starting the engine, be sure to return the lever to B (HOLD) position.

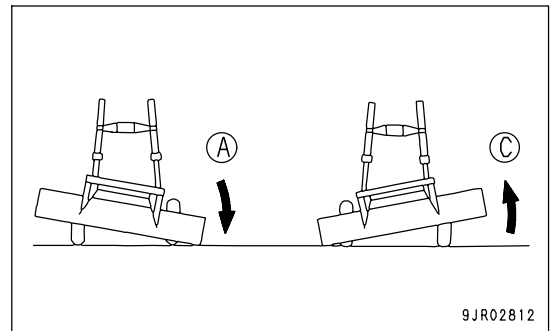
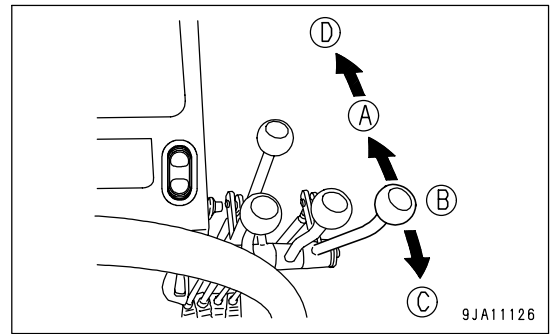

INCHING PEDAL

CAUTION

- Never continue stopping the machine on a slope for a long time, keeping the inching clutch slipping.
When stopping on a slope, set the gear shift lever to P (PARKING) position.
- If not necessary, do not put your foot on this pedal.

NOTICE

- Long time inching operations raise the clutch temperature excessively and cause the seizure or abnormal wear.
In case the clutch temperature rose excessively during inching operations, the inching clutch overheat caution is issued. (The inching clutch overheat caution lamp and the centralized warning lamp light up, and the alarm buzzer sounds intermittently.)
- For the measures to be taken when the inching clutch overheat caution lamp lights up, see the items in "INCHING CLUTCH OVERHEAT CAUTION LAMP (PAGE 3-18)".
- Avoid the following operations as they possibly cause issuance of the inching clutch overheat caution:
 - 1) Continuous use of the inching pedal for a long time. As a target, the continuation of using the inching pedal is within 10 seconds.
 - 2) Operation of continuously repeated "depression" and "release" of the inching pedal within a short time.
Issuance of the inching clutch overheat caution is likely to indicate that large loads are applied.
 - 3) Operation of the inching pedal while large loads are applied.
Issuance of the inching clutch overheat caution is likely to indicate that large loads are applied.
In this case, take such measures as lowering the engine speed, lightening loads on the blade, etc.

This pedal (11) cuts off the power from the engine.

When depressing the pedal, the power is cut off.

Use this pedal when stopping the machine, starting the machine off, or when shifting the direction between forward and reverse.

When the transmission is in F1 - F4 or in R1 or R2, operating this pedal makes it possible to make fine movements of the machine, which are suitable for light load operations such as road surface finishing.

REMARK

- It is not necessary to operate the inching pedal when shifting gears.
When making gear shifts, operate the gear shift lever, not depressing the inching pedal.
- The duration of inching operations until issuance of the inching overheat caution, if issued, is uncertain.

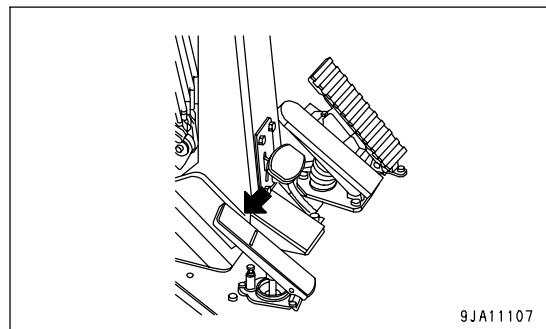

STEERING CONSOLE TILT PEDAL

This pedal (12) can be used to adjust the angle of the steering console steplessly.

Depress the tilt pedal, move the steering console to the desired position, then release the pedal.

REMARK

The steering wheel, instrument panel, and work equipment control levers also move forward or backward at the same time.

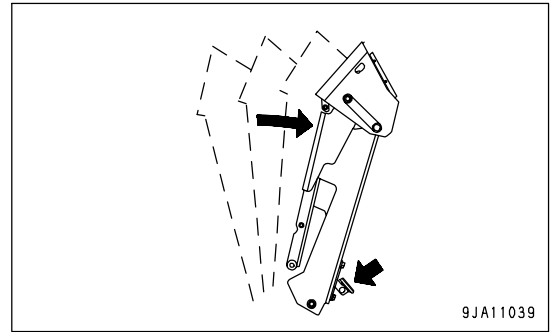
**BRAKE PEDAL****WARNING**

Do not place your foot on this pedal unnecessarily.

This pedal (13) is used to apply the wheel brakes.

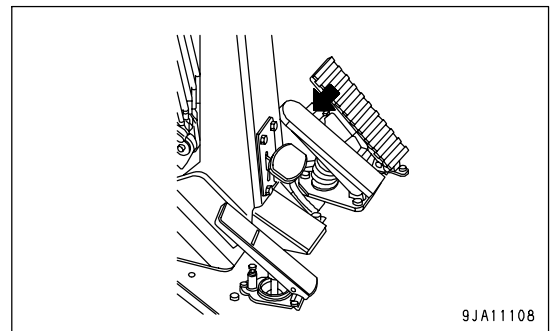
**ACCELERATOR PEDAL**

This pedal (14) adjusts the engine speed.

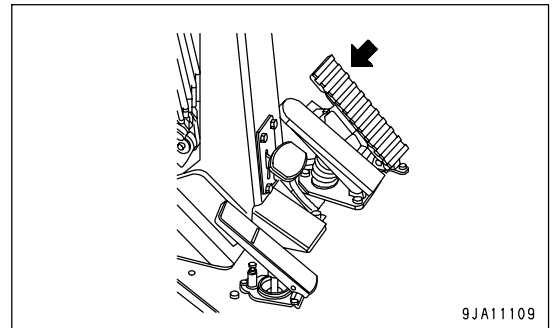

FRONT ATTACHMENT CONTROL LEVER

(If equipped)

This lever (15) is used to operate the front attachment.

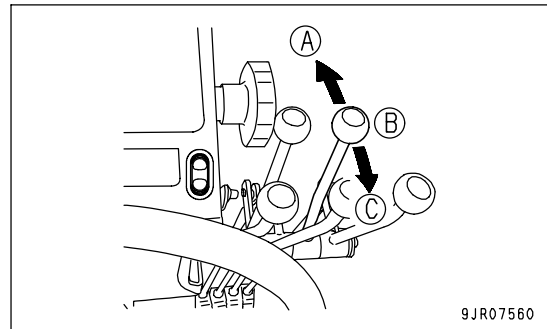

When the machine is equipped with a front blade

(A) LOWER: The front blade is lowered.

(B) HOLD: The front blade is stopped and held in position.

(C) RAISE: The front blade is raised.

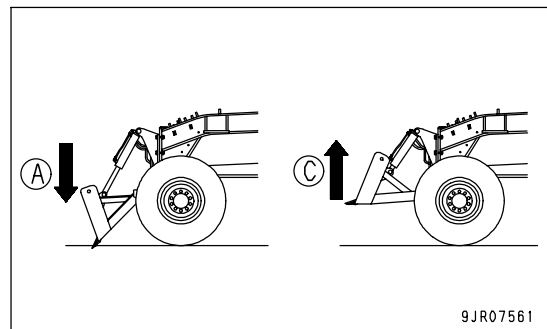

DUST INDICATOR

This device checks the condition of clogging of the air cleaner element.

It displays five levels for the amount of clogging.

When the yellow display panel showing the clogging reaches the red line, clean the element.

After cleaning the element, press the reset button to return the yellow display panel to its original position.

REMARK

When air cleaning element is clogged, the maintenance caution lamp lights up.

Although the lamp goes out automatically after cleaning, resetting of the dust indicator is necessary.

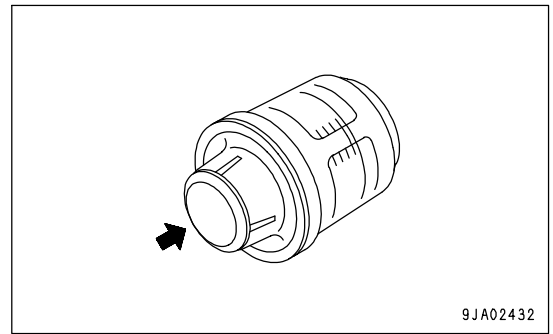

ARTICULATE LOCK PIN

WARNING

- When servicing or transporting the machine always use this lock pin.
- For normal travel, always use the lock pin.

For general travel, maintenance, or transportation, insert this pin in LOCK position (L) to lock the front frame and rear frame and prevent the machine from articulating.

When articulating the machine, stow the pin at FREE position (F).

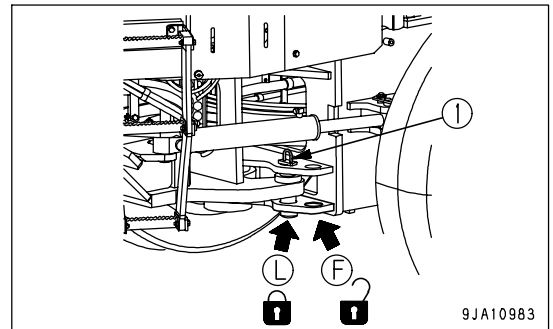

FUSE BOX



WARNING

If the fuse blows again immediately after it is replaced, please contact your Komatsu distributor.

NOTICE

Before replacing a fuse, be sure to cut the power off (turn the starting switch OFF and the battery connect switch OFF).

The fuses protect the electrical equipment and wiring from burning out.

If the fuse becomes corroded, or white powder can be seen, or the fuse is loose in the fuse holder, replace the fuse.

Remove the cover, and replace the fuse.

Replace the fuse with another of the same capacity.

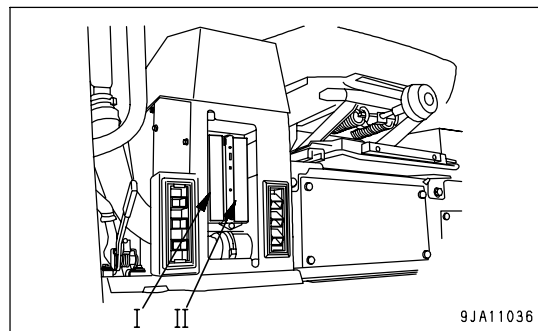

9JA11036

FUSE CAPACITY AND NAME OF CIRCUIT

Fuse I

No.	Capacity	Name of circuit
1	10A	Monitor
2	15A	Key switch
3	10A	Constant power source for transmission controller
4	10A	Hazard lamp
5	15A	Cab-mounted working lamp
6	10A	Turn signal lamp
7	15A	Solenoid
8	10A	Cigarette lighter
9	15A	Rear working lamp
10	15A	Front working lamp
11	10A	Transmission controller
12	15A	Head lamp
13	10A	Back lamp, Stop lamp
14	10A	Horn
15	5A	Engine controller

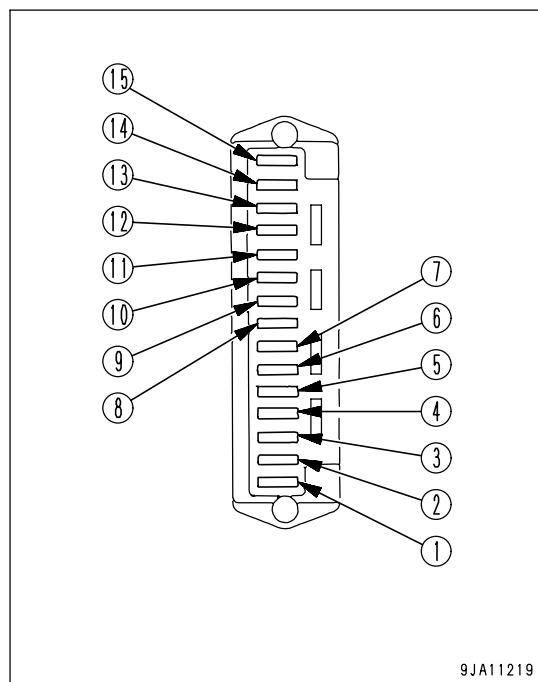

9JA11219

Fuse II

No.	Capacity	Name of circuit
1	20A	Air conditioner blower
2	10A	Constant power source for cab
3	10A	Room lamp
4	30A	Constant power source for engine controller
5	10A	Option (Heater)
6	10A	Option (12 V converter)
7	5A	Radio
8	5A	Air conditioner compressor, Clutch
9	10A	Illumination
10		
11	5A	Air conditioner controller
12	15A	Cab-mounted working lamp
13	10A	Yellow rotating lamp, Fan
14	20A	Door wiper
15	20A	Front wiper, Rear wiper

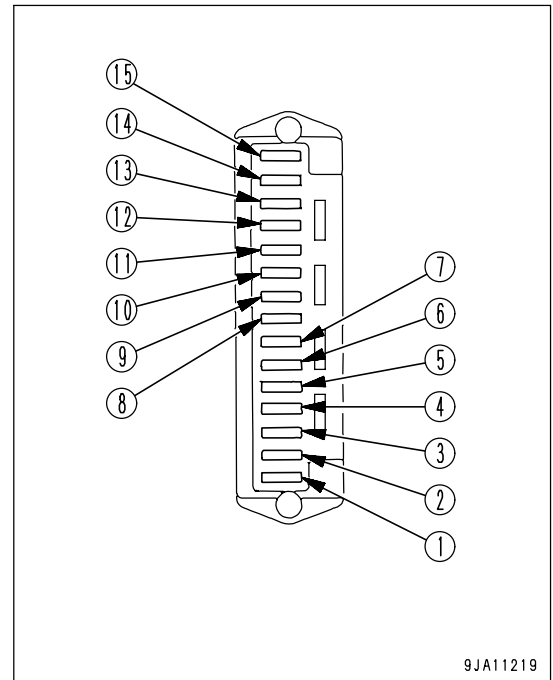

9JA11219

SLOW BLOW FUSE

If the power does not come on when turning the starting switch ON, the slow blow fuse may burn out. Check and replace it.

The slow blow fuse is located inside of the battery box and beside the engine on the left side of the machine.

SLOW BLOW FUSE

- (1)60A : Main fuse for the secondary power source
- (2)30A : Main fuse for the stationary power source
- (3)120A : Heater relay (Intake air heater)
- (4)120A : Alternator main fuse

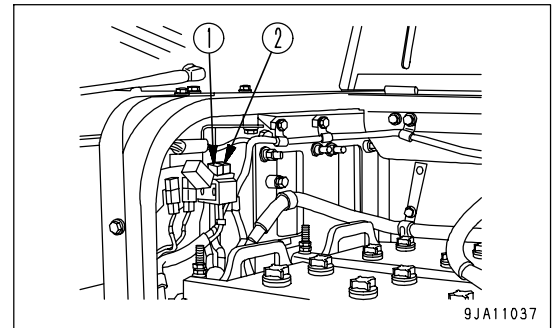

9JA11037

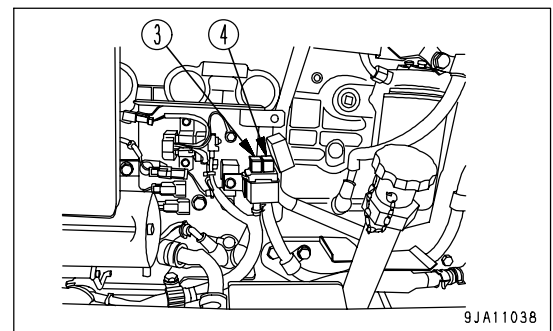

9JA11038

ELECTRIC POWER TAKEOFF

The cigarette lighter socket (1) can be used as a power source for 24V equipment and the accessory socket (2) can be used for 12V equipment.

NOTICE

The cigarette lighter is 24 V. Do not use it as the power source for 12 V equipments.

The capacity of the cigarette lighter is 120 W (24 V x 5 A).

The capacity of the accessory socket is 120 W (12 V x 10 A).

Power is provided only when the starting switch is ON.

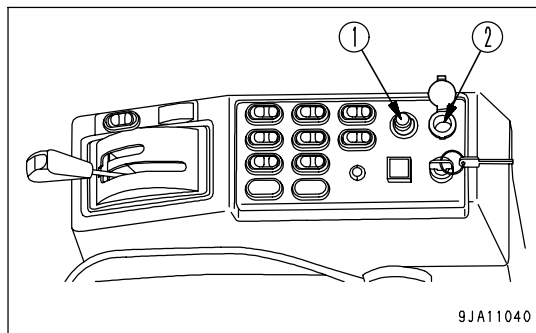

HANDLING BATTERY DISCONNECTOR SWITCH

This switch cuts the flow of electricity from the battery.
This is inside the battery box on the left side of the machine.

NOTICE

When the battery disconnect switch is turned OFF, the memory and chronometric functions in the radio are reset. In addition, communications through KOMTRAX become unavailable.

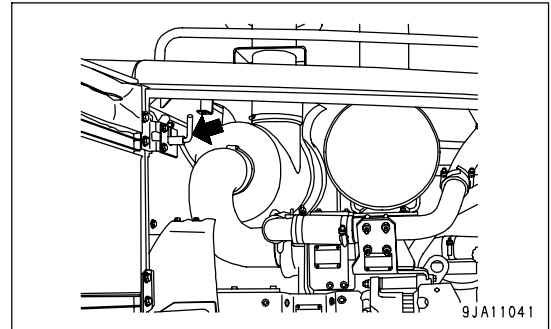

EXPLANATION OF COMPONENTS

BATTERY DISCONNECTOR SWITCH

(A): OFF position

The switch key can be inserted or removed, and the flow of electricity is cut off. Turn to this position at least 1 minute after the engine stops.

(B): ON position

Electricity flows from the battery to the circuits.
Always set to this position before operating the machine.

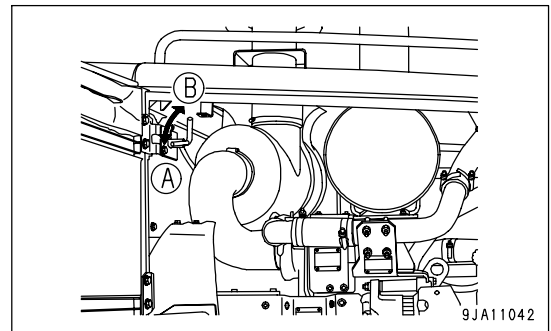

HANDLING



WARNING

Do not turn the battery disconnect switch OFF when the engine is running or immediately after the engine is stopped. There is danger that this may cause serious damage to the electrical system.

In the following cases, set the battery disconnect switch to the OFF position.

- When machine is put into long-term storage (1 month or more)
- When electrical system is to be repaired
- When carrying out electric welding
- When inspecting or handling battery
- When replacing fuse or slow blow fuse

OPENING, CLOSING CAB DOORS



CAUTION

- Be sure to open or close the door on level ground.
Avoid opening or closing the door on a slope. There is a danger that the operating effort changes suddenly. In addition, carefully open or close when it is windy around the machine.
- When locking the door in opening state, be sure to lock from the ground. It is automatically locked when opened to the end.
- Be careful not to get your hands caught by the front pillar or center pillar.
- In case of operating the door from the ground when there is any person inside the cab, call out a warning before opening or closing the door.

WHEN OPENING

When opening the door from the ground, grasp the door handle (1) and press the release button (2).

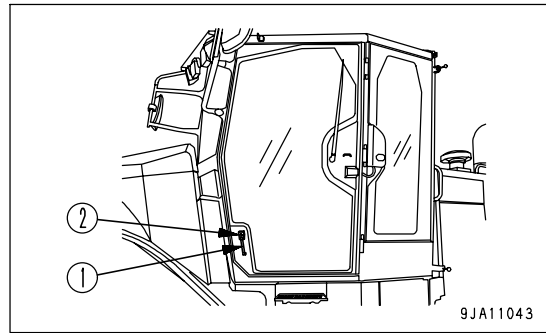

When opening the door from inside of the cab, grasp the door handle (3) and press the release button (4).
Be careful as the door tends to open by its own weight.

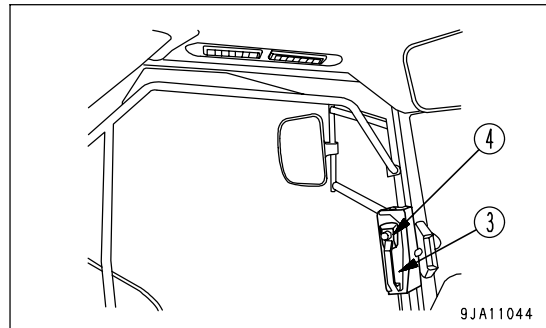

WHEN CLOSING

When closing the door from the ground, depress the release lever (5). The door locked in opening state is released. As the door starts closing at the same time as released, hold the door by hand and close.

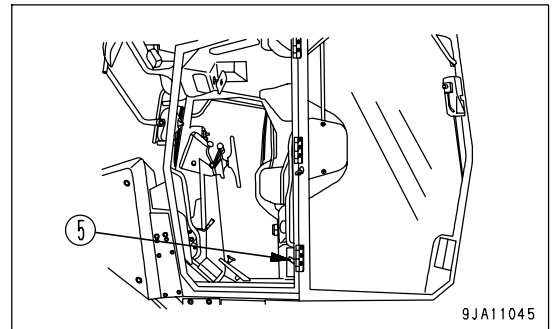

When closing the door from inside of the cab, confirm that there are no person and other obstacles around the machine and press the release knob (6).

The door locked in opening state is released. The door starts closing at the same time as released.

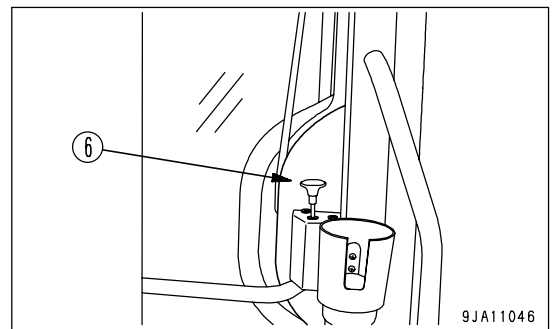

Grasp the handle (7) on the upper part of the door and pull it to firmly close.

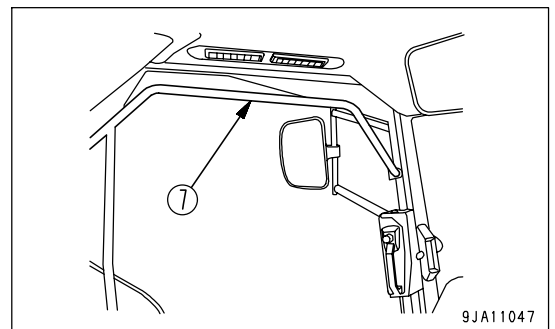

BACKUP ALARM

This alarm sounds at the same time as the gear shift lever is set to the reverse side. Use the alarm to warn persons behind the machine when the machine travels in reverse.

AM/FM RADIO

EXPLANATION OF COMPONENTS

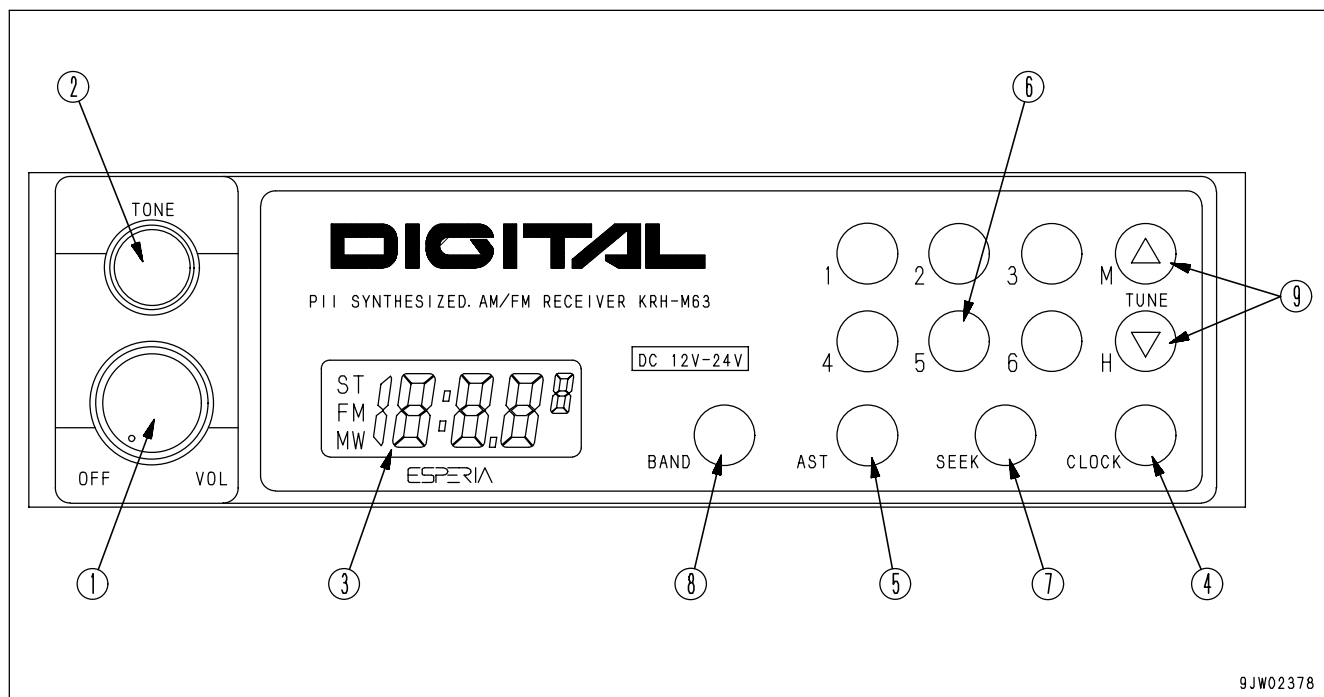

9JW02378

- (1) Power switch/Volume
- (2) Tone control knob
- (3) Display
- (4) Clock button/Displaying frequency
- (5) AST
- (6) Preset switch
- (7) Seek
- (8) Band selector switch
- (9) Tuning switch

POWER SWITCH/VOLUME

When this switch (1) is turned to the right, it clicks and the power is turned on. If it is turned further, the speaker volume is adjusted.

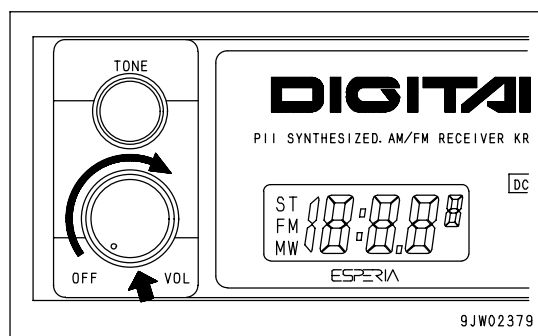

9JW02379

TONE CONTROL KNOB

If this knob (2) is turned to the right, the high tone is emphasized;
if it is turned to the left, the high tone is reduced.

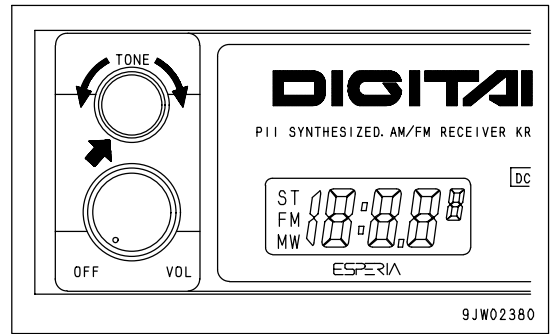

DISPLAY

This display (3) shows the radio reception frequency and the operating mode.

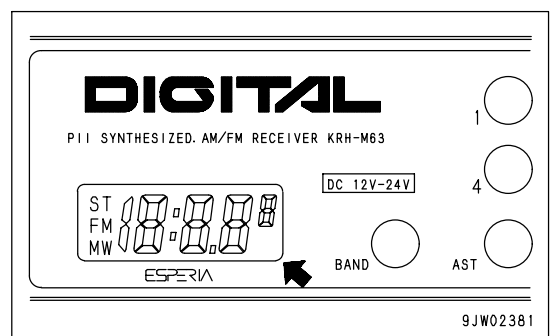

CLOCK BUTTON/DISPLAYING FREQUENCY

When this button (4) is pressed, the display changes to the time.
If it is pressed again, it displays the frequency.

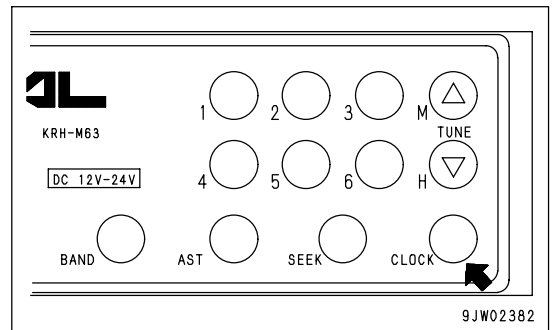

AST

When this button (5) is pressed, the preset stations are called up in turn.

When the desired broadcasting station is reached, press the button again to stop it.

If the button is kept pressed continuously for 2 seconds, it is set to auto memory.

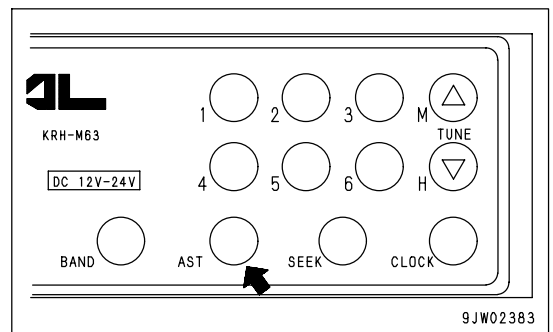

PRESET SWITCH

With this switch (6), each button can be preset to one station each for FM and MW (AM). (For details of the method of presetting, see Section "METHOD OF PRESETTING STATION (PAGE 3-74)".)

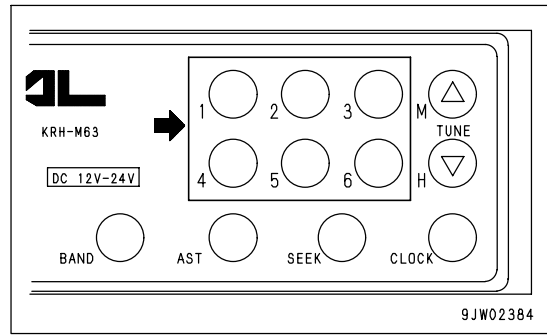

SEEK

When this switch (7) ("SEEK") is pressed, it automatically searches for stations that can be received, and when it receives a station, it stops.

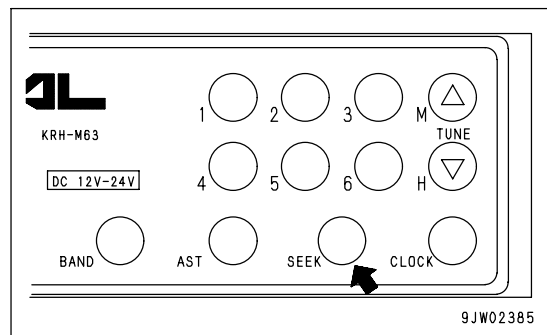

BAND SELECTOR SWITCH

When this switch (8) ("BAND") is pressed, the band is switched between FM and MW (AM).

The reception band and frequency are displayed on the display.

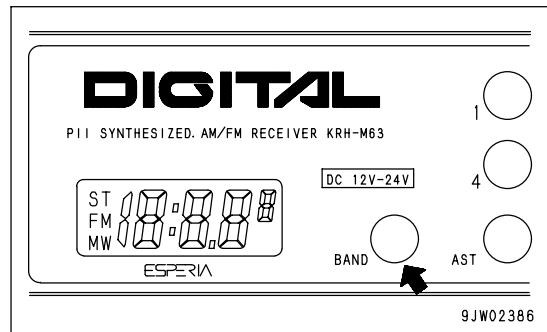

TUNING SWITCH

When the "TUNE" button Δ of switch (9) is pressed, the frequency goes up; when the ∇ button is pressed, the frequency goes down. If it is kept pressed, the frequency changes continuously.

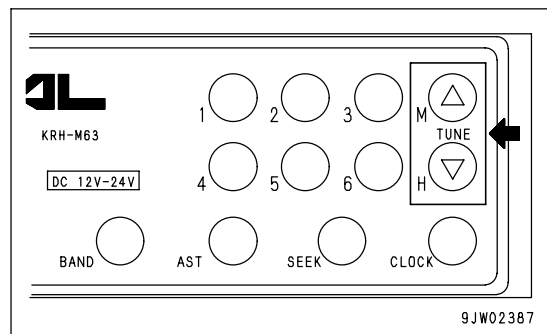

METHOD OF OPERATION

LISTENING TO RADIO

1. Turn radio power switch (1) ON.
2. "BAND" switch (2) is used to select MW (AM) or FM.
3. Use the preset switch or tuning switch (3) to select the station.
4. Adjust the volume and tone as desired.
5. To turn the radio OFF, turn VOL knob (1) to the left until a click is heard.

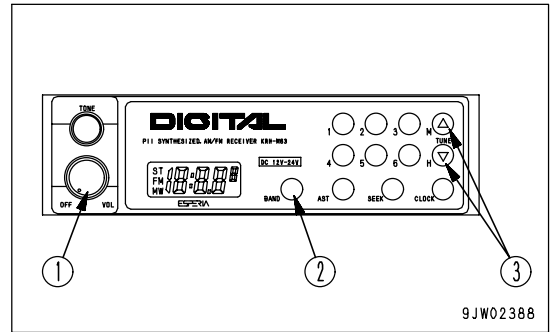

METHOD FOR SELECTING STATION AUTOMATICALLY

When the "SEEK" switch is pressed, it moves up to higher frequencies and when it finds a station that can be received, it stops automatically.

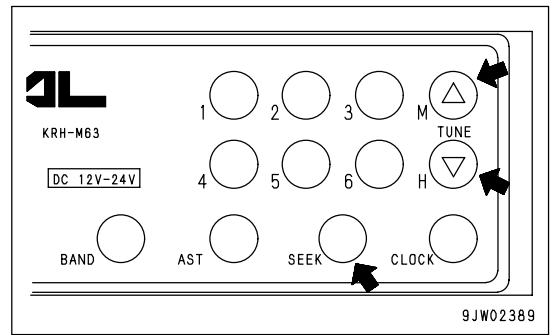

METHOD FOR SELECTING STATION MANUALLY

When the TUNE button Δ is pressed, the frequency goes up; when the ∇ button is pressed, the frequency goes down. If it is kept pressed, the frequency changes continuously.

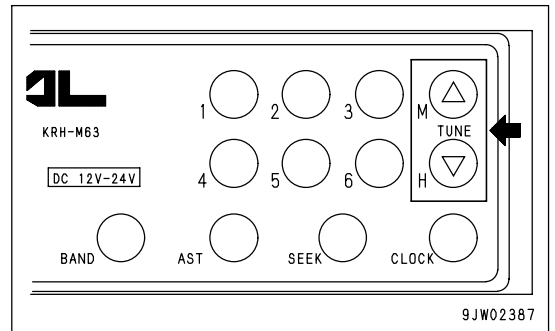

METHOD OF PRESETTING STATION

1. Select the desired preset station.

Use the "BAND" button to select MW (AM) or FM, and use the "TUNE" button to select the frequency of the broadcasting station.

2. Decide the number of the button to be preset, and keep it pressed for 2 seconds. The number of the button will be displayed and the presetting is completed.

3. Repeat Steps 1 to 2 to preset other broadcasting stations.

- To change the setting of a preset switch to another station, repeat Steps 1 to 2.
- If the battery is replaced or the power is switched off, all the preset settings are deleted. Carry out the presetting operation again.
- It is possible to preset 6 AM (MW) stations and 6 FM stations.

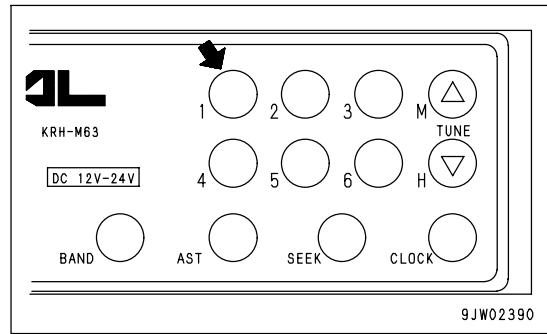

METHOD OF USING AUTO MEMORY

If the "AST" button is pressed for 2 seconds, the broadcasting stations that can be received in the area are called up in turn, and the broadcasting stations are automatically saved in the preset memory.

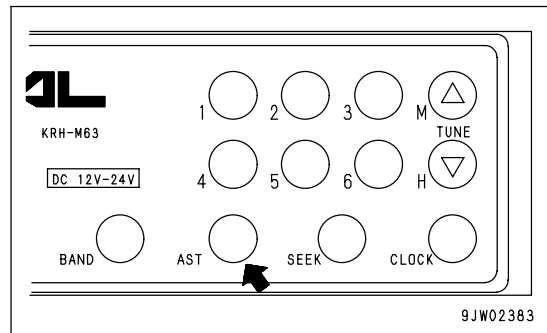

AUTOMATIC SWITCHING OF MONAURAL/STEREO RECEPTION

If the reception of the FM stereo broadcast being received is weak (when you are far from the broadcasting station or are surrounded by hills), the radio is automatically switched from stereo to monaural to reduce the interference. When the stereo broadcast becomes stronger, it automatically switches back to stereo broadcasting.

METHOD OF SETTING TIME

1. Turn radio power (1) ON. If the display (2) is set to a frequency, press TIME button (3) to display the time.
2. With TIME button (3) kept pressed:
 - Press Δ button (4) to set the minutes.
 - Press ∇ button (5) to set the hours.

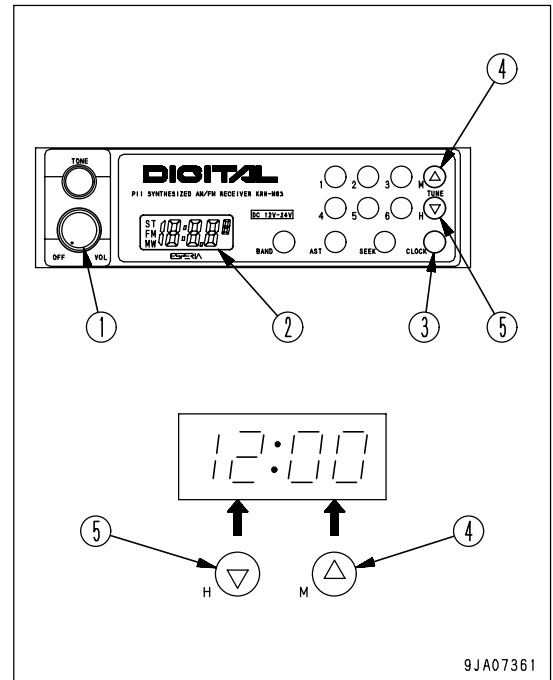
**PRECAUTIONS WHEN USING**

- Stow the antenna when traveling in places with low overhead clearance.
- To ensure safety, always keep the sound to a level where it is possible to hear outside sounds during operation.
- If water gets into the speaker case or radio, it may lead to an unexpected failure, so be careful not to get water on the equipment.
- Do not wipe the scales or buttons with solvent such as benzene or thinner. Wipe with a dry soft cloth. If the dirt cannot be removed easily, soak the cloth with alcohol.

AIR CONDITIONER

By taking fresh air into the cab through a filter, it is possible to raise the pressure inside the cab. This makes it possible to provide a pleasant working environment even on dusty jobsites.

LOCATIONS AND FUNCTIONS OF CONTROL PANEL

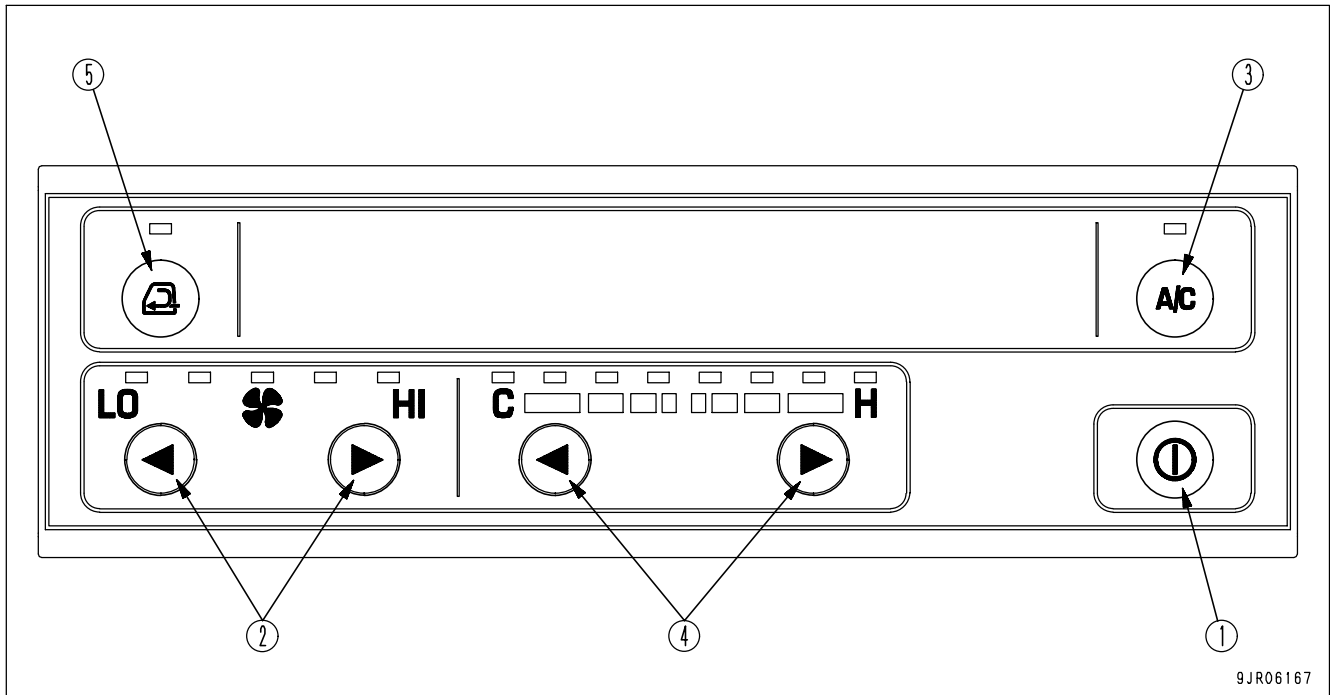

- (1) Main power switch
- (2) Fan switch
- (3) Air conditioner switch
- (4) Temperature control switch
- (5) FRESH/RECIRC selector switch

MAIN POWER SWITCH

Use the switch (1) to turn the main power of the air conditioner ON/OFF.

Press this switch to operate the fan.

Press the switch again to turn it off and stop the fan.

(If the switch is turned ON again, operation will start under the conditions being used when the switch was last turned OFF.)

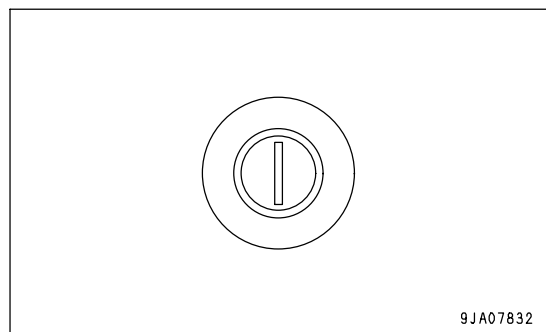

FAN SWITCH

Use this switch (2) to adjust the air flow from the fan.

The air flow can be adjusted to 5 stages.

When this switch (A) is pressed, the air flow increases; when switch (B) is pressed, the air flow decreases.

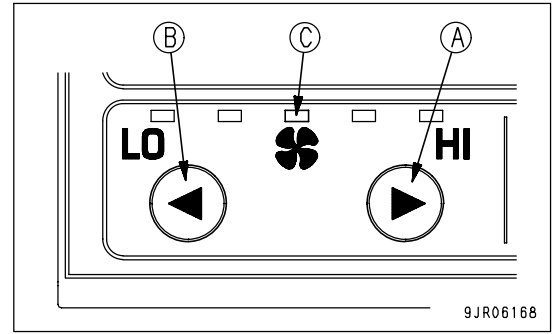

LED display (C) shows the position set for the air flow.

Air flow	LED display
Lo	
M ₁	
M ₂	
M ₃	
Hi	

AIR CONDITIONER SWITCH

Use this switch (3) to actuate and stop the cooling and dehumidifying-heating function.

Turn the main power switch ON, then press the air conditioner switch. The air conditioner comes on and LED display (A) lights up.

When the switch is pressed again, the switch goes OFF and LED display (A) goes out.

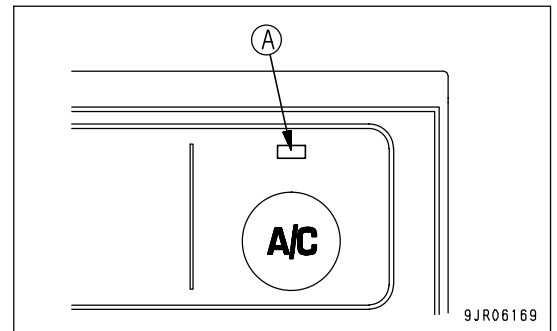

TEMPERATURE CONTROL SWITCH

Use this switch (4) to adjust the temperature between low temperature and high temperature.

When switch (A) is pressed, the temperature of the air blowing out becomes higher; when switch (B) is pressed, the temperature of the air blowing out becomes lower.

LED display (C) shows the position set for the temperature adjustment.

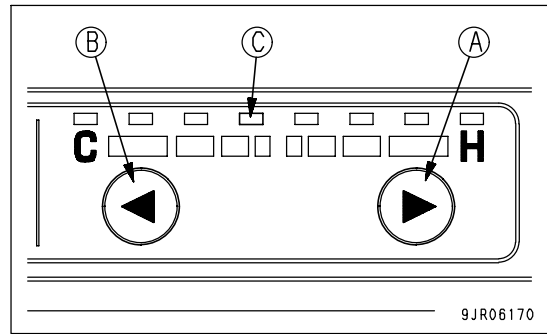
**FRESH/RECIRC SELECTOR SWITCH**

Use this switch (5) to switch between recirculation of the air inside the cab and intake of fresh air from outside.

When this switch is pressed, the system is set to recirculation of air inside the cab and LED display (A) lights up.

If the switch is pressed again, the system switches to intake of fresh air from outside and LED display (A) goes out.

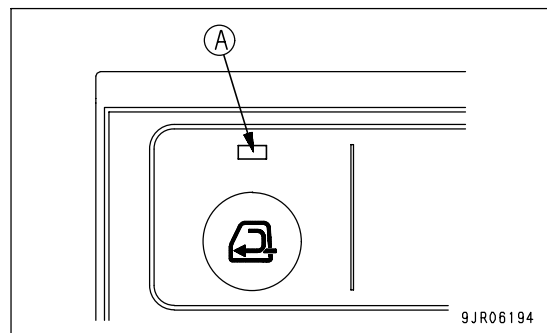
**Recirculation of air inside cab**

Only the air inside the cab is circulated. Use this setting when carrying out quick cooling or heating of the cab or when the outside air is dirty.

Intake of fresh air from outside

Air from the outside is taken into the cab. Use this setting when taking in fresh air from outside or when removing the mist from the windows.

METHOD OF OPERATION

COOLING OPERATION

1. Press main power switch (1) of the air conditioner to turn the power ON.
2. Press fan switch (2) and set the air flow to "Hi".
3. Press temperature control switch (3) to set the LED display to the COOL side.
4. Press air conditioner switch (4) to turn the air conditioner switch ON.
5. Press RECIRC/FRESH selector switch (5) to select RECIRC.
6. When the temperature inside the cab goes down, use the temperature control switch and the fan switch to set to the desired temperature.

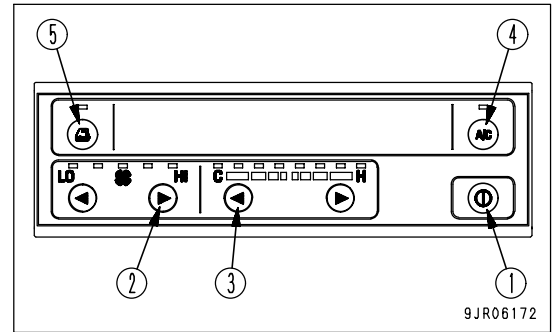

REMARK

If the temperature control switch is pressed to set the LED display to the COOL side, and the air conditioner is run for a long time with the air flow or set to "Lo", there is a slight possibility that the evaporator may freeze. If no cold air comes out, turn air conditioner switch (4) OFF, raise the temperature setting, run for a short time with the air flow at "Hi", then turn the air conditioner switch ON again.

HEATING OPERATION

1. Press main power switch (1) of the air conditioner to turn the power ON.
2. Press fan switch (2) and set the air flow to "Hi".
3. Press temperature control switch (3) to set the LED display to the HOT side.
4. Press RECIRC/FRESH selector switch (4) to select FRESH.
5. When the temperature inside the cab goes up, use the temperature control switch and the fan switch to set to the desired temperature.

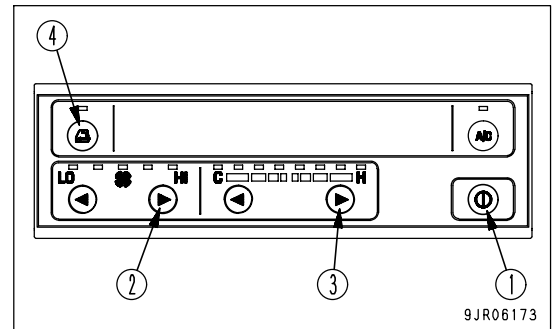

REMARK

Heating is carried out using the engine cooling water, so it can be carried out when the cooling water temperature is high.

DRYING-HEATING AND DEMISTING OPERATION

1. Press main power switch (1) of the air conditioner to turn the power ON.
2. Press fan switch (2) and set the air flow to the desired setting.
3. Press temperature control switch (3) and set to the desired temperature.
4. Press RECIRC/FRESH selector switch (4) to select FRESH.
5. Press air conditioner switch (5) to turn the air conditioner ON.

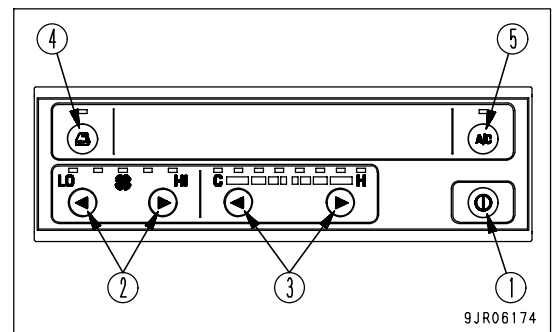

REMARK

When the outside temperature is below 0°C (32°F), the air conditioner (compressor) may not operate.

PRECAUTIONS WHEN USING

- To prevent any excessive load on the engine or compressor, use the air conditioner when the engine is running.
- If the machine is used in places where there is dust or bad smell, recirculate the air inside the cab when using the air conditioner.
- To prevent leakage of refrigerant in the air conditioner cooling circuit, operate the air conditioner for several minutes two or three times a month during the off-season. If the machine is left for a long period with the refrigerant leaking, rust will form inside the system and this will cause failure.
- To protect your health, do not make the inside of the cab too cool and do not let the cold air flow contact your skin directly for long periods.
Ventilate the cab from time to time.
- If the temperature inside the cab is high, open the door or window to let the hot air escape and let fresh air in before starting operation of the air conditioner.

PRECAUTIONS FOR INSPECTION AND MAINTENANCE

- Clean the air conditioner air filter and check the refrigerant. For details, see "CLEAN AIR CONDITIONER AIR FILTER (PAGE 4-27)" and "CHECK REFRIGERANT (GAS) LEVEL (PAGE 4-28)".
- To allow the air conditioner to show its full performance and provide a comfortable environment, have inspection and maintenance carried out periodically.
When adding refrigerant or carrying out other maintenance, special tools and instruments are needed, so ask your Komatsu distributor to carry out inspection and repair.

OPERATION MANUAL STORAGE

A pocket is provided at the rear of the operator's seat backrest for keeping the Operation and Maintenance Manual. Keep the Operation and Maintenance Manual in this pocket so that it can be read whenever necessary.

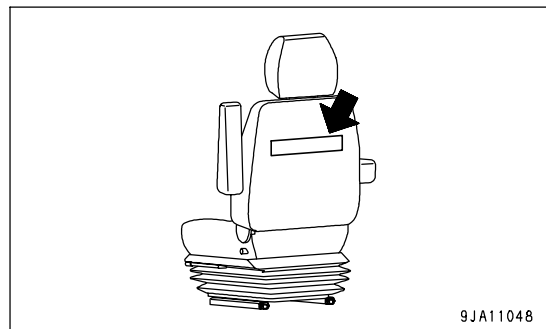

TOOL BOX

The tool box is provided above the tandem on the left side of the machine.

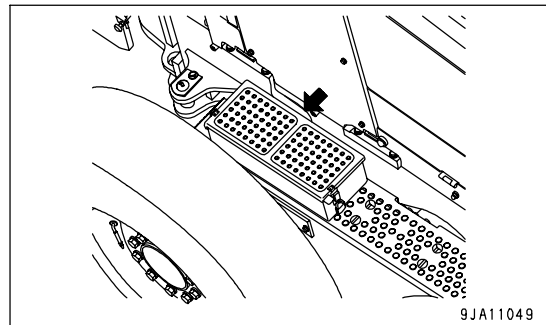

GREASE PUMP HOLDER

When opening the cover of the tool box, the compartment to stow the grease pump is found inside.

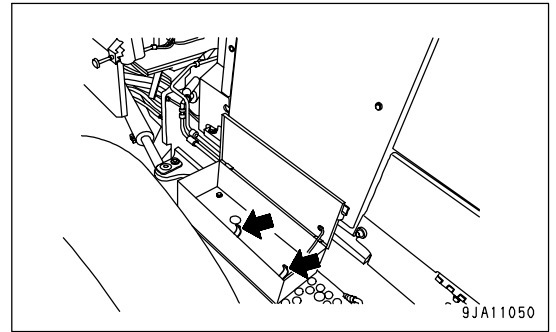

CUP HOLDER

This is on the left side of the operator's cab.

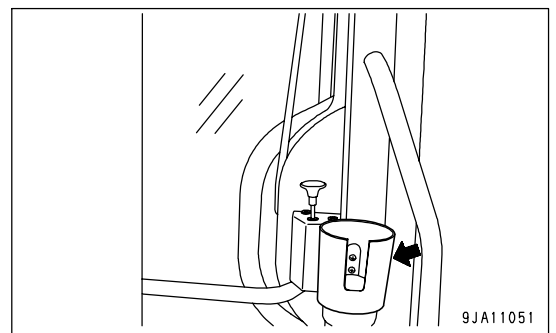

ASHTRAY

This is on the left side of the operator's cab.

Always extinguish your cigarette before putting it in the ashtray, then be sure to close the lid.

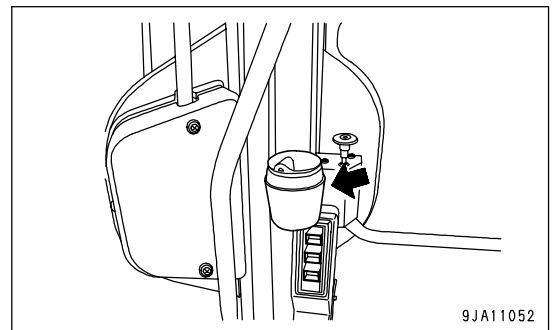

FIRE EXTINGUISHER

(If equipped)

A fire extinguisher is prepared on the right side in the operator's cab.

The directions are described on the nameplate affixed to it. Just in case of any urgent need, carefully read and understand them.



HANDLING MACHINES EQUIPPED WITH KOMTRAX

- KOMTRAX is a machine management system that uses wireless communications.
- A contract with your Komatsu distributor is necessary before the KOMTRAX system can be used. Any customers desiring to use the KOMTRAX system should consult their Komatsu distributor.
- The KOMTRAX equipment is a wireless device using radio waves, so it is necessary to obtain authorization and conform to the laws of the country or territory where the machine equipped with KOMTRAX is being used. Always contact your Komatsu distributor before selling or exporting any machine equipped with KOMTRAX.
- When selling or exporting the machine or at other times when your Komatsu distributor considers it necessary, it may be necessary for your Komatsu distributor to remove the KOMTRAX equipment or to carry out action to stop communications.
- If you do not obey the above precautions, neither Komatsu nor your Komatsu distributor can take any responsibility for any problem that is caused or for any loss that results.

BASIC PRECAUTIONS



WARNING

- Never disassemble, repair, modify, or move the communications terminal, antenna, or cables. This may cause failure or fire on the KOMTRAX equipment or the machine itself. (Your Komatsu distributor will carry out removal and installation of KOMTRAX.)
- Do not allow cables or cords to become caught; do not damage or pull cables or cords by force. Short circuits or disconnected wires may cause failure or fire on the KOMTRAX equipment or the machine itself.
- For anyone wearing a pacemaker, make sure that the communications antenna is at least 22 cm (8.7 in) from the pacemaker. The radio waves may have an adverse effect on the operation of the pacemaker.

NOTICE

- Even when the key in the starting switch of the KOMTRAX system is at the OFF position, a small amount of electric power is consumed. When putting the machine into long-term storage, take the action given in "LONG-TERM STORAGE (PAGE 3-176)".
- Please contact your Komatsu distributor before installing a top guard or other attachment that covers the cab roof.
- Be careful not to get water on the communications terminal or wiring.

REMARK

- The KOMTRAX system uses wireless communications, so it cannot be used inside tunnels, underground, inside buildings, or in mountain areas where radio waves cannot be received. Even when the machine is outside, it cannot be used in areas where the radio signal is weak or in areas outside the wireless communication service area.
- There is absolutely no need to inspect or operate the KOMTRAX communications terminal, but if any abnormality is found, please consult your Komatsu distributor.

OPERATION

CHECK BEFORE STARTING ENGINE

WALK-AROUND CHECK

Before starting the engine, look around and under the machine to check for loose nuts and bolts, or leakage of oil, fuel, or coolant, and check condition of the work equipment and hydraulic system. Also check for loose wiring and play, and accumulation of dust at places with high temperatures.



WARNING

Remove any flammable materials from around the battery, engine, muffler, turbocharger, or other high temperature engine parts. Leakage of fuel or oil will cause the machine to catch fire. Check carefully, be sure to repair any problem, or contact your Komatsu distributor.

Perform the following inspections and cleaning every day before starting engine for the day's work.

1. Check for damage, wear, play in work equipment, cylinders, linkage, hoses
Check for cracks, excessive wear, play in work equipment, cylinders, linkage, and hoses. If any problem is found, repair it.
2. Remove dirt and debris from around the engine, battery, and radiator.
Check for dirt accumulated around the engine and radiator. Also check for flammable material (dry leaves, twigs, etc.) around the battery, engine muffler, turbocharger, or other high temperature engine parts. If any dirt or flammable materials are found, remove them.
3. Check for coolant and oil leakage around the engine
Check for oil leakage from the engine and coolant leaks from the cooling system. If any problem is found, repair it.
4. Check for leakage from fuel line.
Check that there is no leakage of fuel or damage to the hoses and tubes. If any problem is found, carry out repairs.
5. Check for oil leakage of oil from transmission case, final drive case, tandem drive case, hydraulic tank, circle reverse gear case, hose, joints.
Check that there is no oil leakage. If any problem is found, repair the place where the oil is leaking.
6. Check for leakage of oil from brake line
Check that there is no leakage of oil. If any problem is found, repair the place where the oil is leaking.
7. Check for damaged or worn tires, wheels, and wheel hub bolts and nuts, check for loose wheel hub bolts and nuts.
Check for cracks or peeling of the tires and for cracks or wear to the wheels (side rim, rim base, lock ring). Tighten any loose wheel hub bolts or nuts. If any abnormality is found, repair or replace the part.
If any valve caps are missing, install new caps.
8. Check for problems in handrails, steps, loose bolts.
If any problem is found, repair it. Tighten any loose bolts.

9. Check for problem in gauges, monitor.

Check for problem in the gauges and monitor in the operator's cab. If any problem is found, replace the parts. Clean off any dirt from the surface.

10. Check for damaged mirror, reflector, loose mounting bolts

Check that there is no damage to the mirror or reflectors, and replace if there is any problem. Tighten any loose bolts.

Clean all dirt from the surface of the mirror and reflector.

11. Check for damage to the seat belt and mounting clamps.

! WARNING

Even if there appears to be no abnormality with the seat belt, replace it once every three years.

REMARK

The date of manufacture of the seat belt is marked on the belt at the place indicated by the arrow in the diagram on the right.

Check that there are no loose bolts on the equipment mounting the seat belt to the machine, and tighten if necessary.

Tightening torque: 27 to 34 Nm (2.8 to 3.5 kgm, 20 to 25 lbft)

If the belt is damaged or fluff is starting to form, or if there is any damage or deformation of the seat belt holders, replace the seat belt.

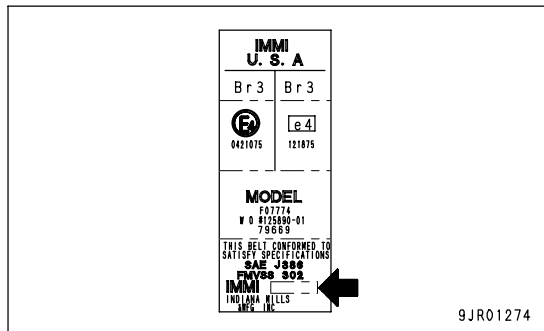
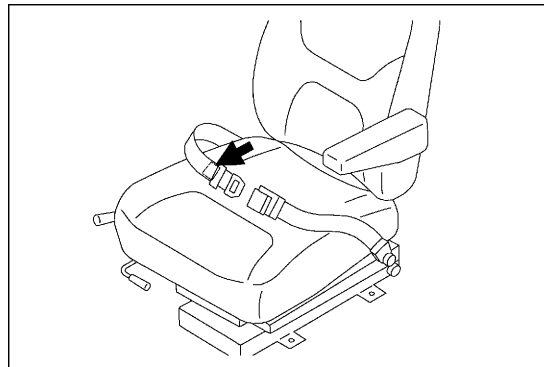

12. Is door lock normal?

Check that there is no damage to the cab door lock. Repair or replace if any problem is found.

13. Clean cab window

To ensure a good view during operations, always keep the cab windows clean.

Working on the frame, tire, or hood is very dangerous. Be sure to carry out the cleaning operation from the ground by using a handled mop, etc.

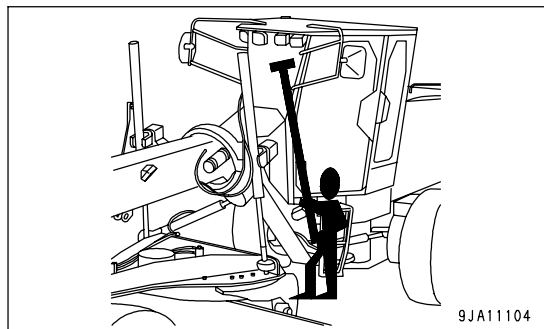

14. Inspect tires.

**WARNING**

If worn or damaged tires are used, they may burst and cause serious injury or death.

To ensure safety, do not use the following tires.

Wear:

- Tires with a tread grooves of less than 15% of that of a new tire
- Tires with extreme uneven wear or with stepped-type wear

Damage:

- Tires with damage that has reached the cords, or with cracks in the rubber
- Tires with cut or pulled cords
- Tires with peeled (separated) surface
- Tires with damaged bead
- Leaking or improperly repaired tubeless tires
- Deteriorated, deformed or abnormally damaged tires, which do not seem usable

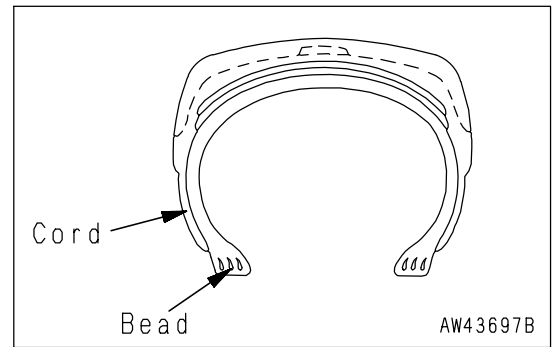

15. Inspect rims.

**WARNING**

Check the rims (wheels) and rings for deformation, corrosion and cracks.

In particular, check the side rings, lock rings and rim flanges thoroughly.

CHECK BEFORE STARTING

Be sure to check the items listed here before starting the engine for the day's work.

CHECK COOLANT LEVEL, ADD WATER

WARNING

- Do not open the radiator cap unless necessary. Wait for the engine to cool down before checking the coolant in the sub-tank.
- Immediately after the engine is stopped, the coolant is at a high temperature and the radiator is under high internal pressure. If the cap is removed to check the coolant level in this condition, there is a hazard of burns. Wait for the temperature to go down, then turn the cap slowly to release the pressure before removing it.

NOTICE

If the volume of coolant added is more than usual, check for possible water leakage.

Confirm that there is no oil in the coolant.

1. Confirm that the coolant in sub tank (1) is filled to a level between FULL and LOW. If the level is lower, open the cover, and fill Supercoolant (AF-NAC) of the same density as the Supercoolant (AF-NAC) in the radiator, through the water filler of sub tank (1), to a level between FULL and LOW.
2. After adding coolant, tighten the cap securely.

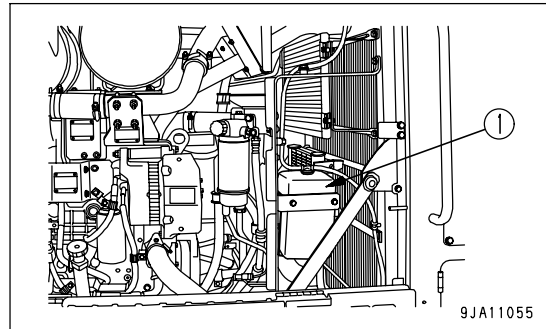

3. If sub-tank becomes empty, there is probably water leakage. After checking, repair any abnormality immediately. If no abnormality is found, check the level of the water in the radiator. If it is low, add Supercoolant (AF-NAC) of the same density as the Supercoolant in the radiator, then add Supercoolant to sub-tank.

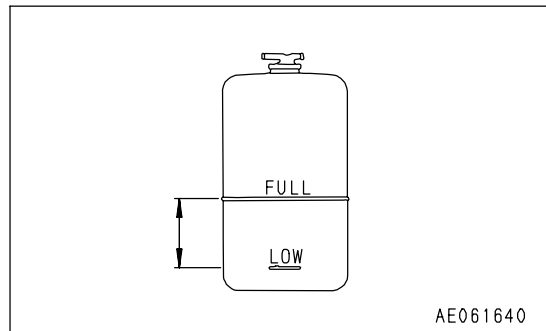

CHECK FUEL LEVEL, ADD FUEL

**WARNING**

- When adding fuel, never let the fuel overflow. This may cause a fire. If any fuel is spilled, wipe it up completely. If fuel is spilled on earth and sand, be sure to remove them together.
- Never bring flames near fuel because it is highly flammable and dangerous.
- Stop the engine before adding fuel. Do not enter the operator's cab when filling the tank with fuel.
- Do not leave your workplace when adding fuel.

NOTICE

If breather hole (1) in the cap is clogged, the pressure in the tank will drop and fuel will not flow. Clean the hole from time to time.

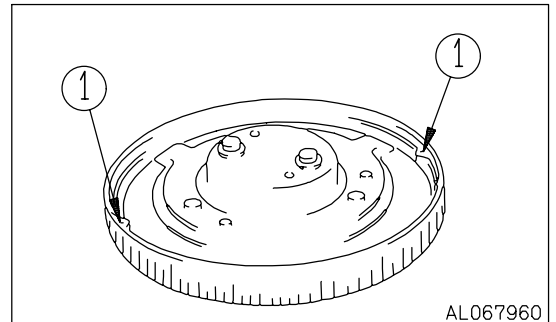

1. Turn the engine starting switch to the ON position and check the fuel level with fuel level gauge (G).
After checking, turn the switch back to the OFF position.

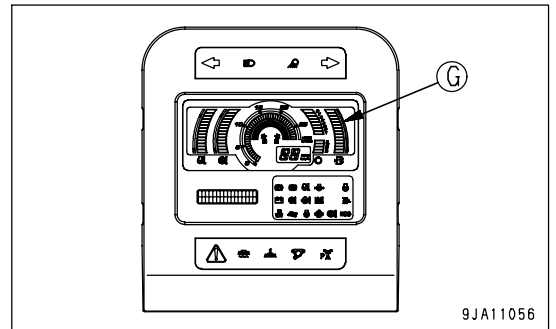

2. After completing work, fill the fuel tank through fuel filler port (F).
3. After adding fuel, tighten the cap securely.
Fuel tank capacity: 416 liters (109.91 US gal)

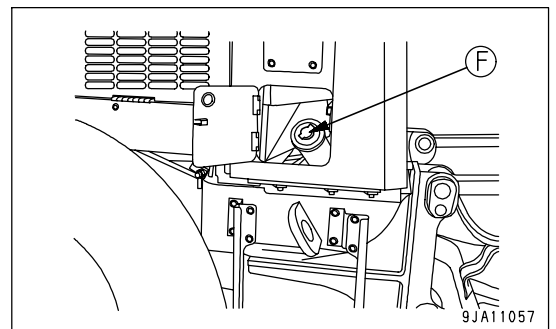

DRAIN WATER AND SEDIMENT IN FUEL TANK

Loosen fuel tank drain valve (1) and drain the sediment and water which are accumulated at the bottom, together with fuel to a container.

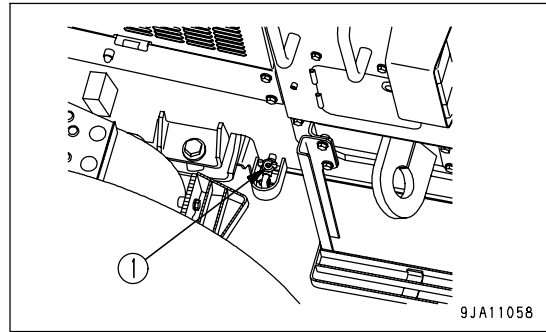

CHECK ENGINE OIL PAN LEVEL, ADD OIL

**WARNING**

Parts and oil are at high temperature immediately after the engine is stopped and may cause serious burns. Wait for the oil temperature to go down before performing this operation.

1. Open the engine side cover on the right side of the rear portion of the machine.
2. Remove dipstick (G), and wipe the oil off with a cloth.
3. Fully insert dipstick (G) into filler pipe, then remove it.
4. The oil level should be between the marks on dipstick (G).
If the oil level is below the mark, add engine oil through oil filler (F).

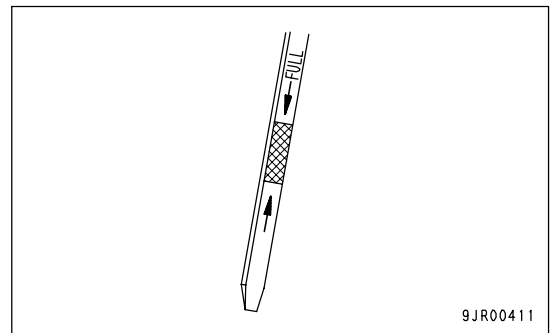
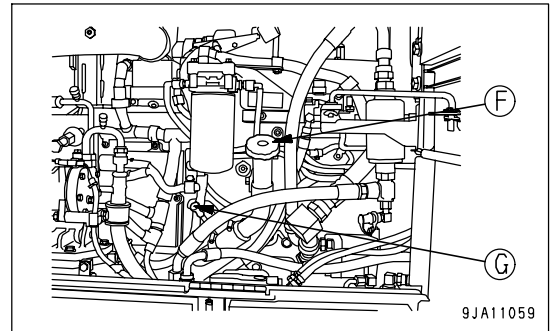

5. If the oil is above the H mark, open drain plug (P) at the rear right of the machine, drain the excess oil into a container, and check the oil level again.
6. If the oil level is correct, tighten the oil filler cap securely and close the engine side cover.

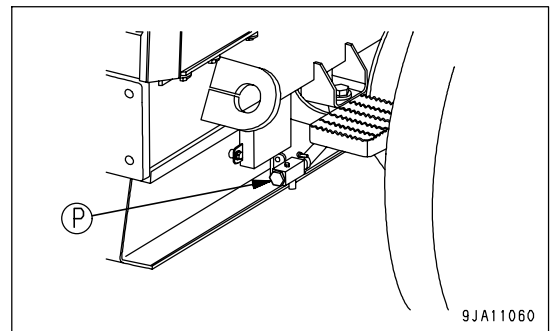
**REMARK**

- Wait for at least 15 minutes, after stopping the engine, before checking the oil level.
- If the machine is at an angle, make it horizontal before checking.

CHECK DUST INDICATOR

1. Check the position of yellow display panel (2) in the transparent portion of dust indicator (1).
2. If the yellow display panel reaches red line (3), clean the element. For details of the method of cleaning the element, see Section "CHECK, CLEAN AND REPLACE AIR CLEANER ELEMENT (PAGE 4-21)".
3. After inspecting, cleaning, or replacing, press the button of dust indicator (1) to return the yellow display panel to its original position.

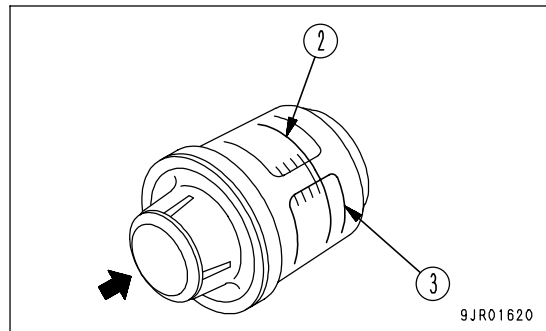
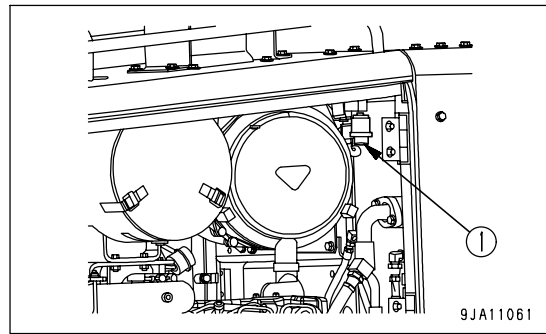
**CHECK AND ADJUST STEERING WHEEL**

Measure the steering wheel play only after starting the engine.

Standard: Less than 25 mm (1.0 in).

If the steering wheel play is out of the standard range, or if the steering wheel is waved, turned, or heavy to the abnormal extent, ask your Komatsu distributor for repairs.

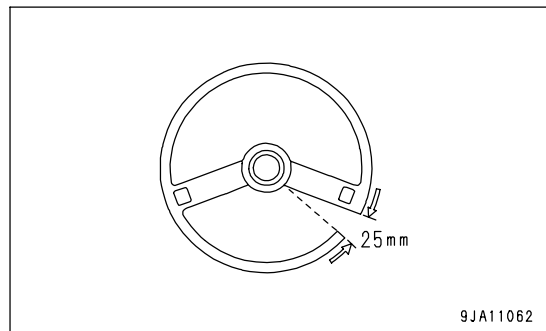

CHECK WATER SEPARATOR, DRAIN WATER

**WARNING**

- Each part of the engine is still highly heated immediately after the engine is stopped. Do not attempt to drain cooling water or remove the filter element cup.
- High pressure is generated inside the engine fuel piping, while the engine is running. Wait for more than 30 seconds after the engine stop for the engine to sufficiently cool down. Then start with draining cooling water or removing the filter element cup.
- Do not bring fire close.

1. Open the engine side cover on the left side of the machine.
The water separator (1) forms one unit with the fuel pre-filter, and is at the bottom.

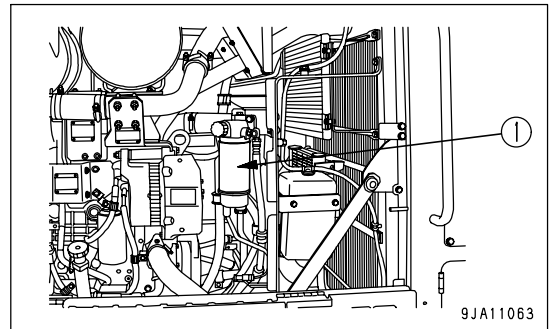

2. It is possible to judge the condition of water and sediment through transparent cap (3). If water or sediment is accumulated, set a container under drain hose (4) to collect the discharged water.
3. Loosen plug (2) and drain the water.
4. Tighten plug (2) as soon as fuel starts to be discharged from drain hose (4).
(Tightening torque: 0.2 - 0.45 Nm {0.02 - 0.046 kgm})

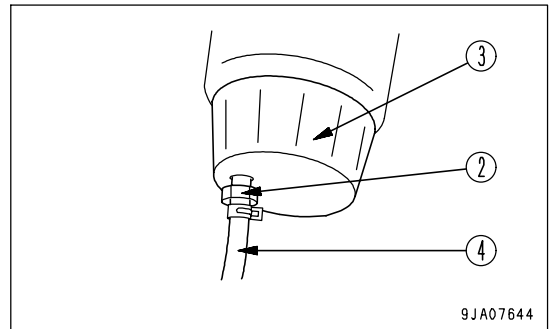
**REMARK**

If plug (2) is stiff, coat O-ring (5) of plug (2) with grease.

- 1) Set a fuel container under drain hose (4).
 - 2) Loosen plug (2), then drain all the sediment together with the fuel from drain hose (4).
 - 3) Check that nothing comes out from drain hose (4), then remove plug (2).
 - 4) Coat O-ring portion (5) with a suitable amount of grease. When doing this, be careful not to let the grease get on the drain valve water drain port (a) or the plug thread.
 - 5) Screw in plug (2) by hand until it contacts the bottom.
 - 6) Remove the fuel container.
- If transparent cap (3) is dirty and the contents cannot be easily seen, clean transparent cap (3) when replacing the filter.
 - When washing, if plug (2) is removed, coat the O-ring with grease, then tighten by hand until it contacts the bottom.

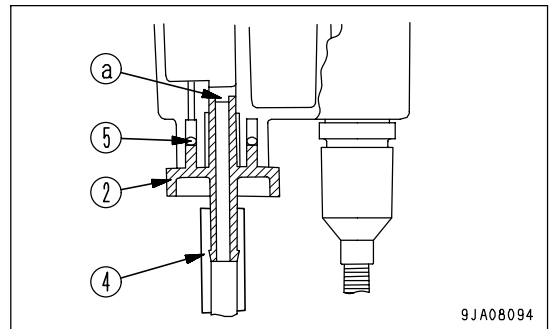

CHECK ELECTRIC WIRING



WARNING

- If the fuses frequently blow or if there are traces of short circuits in the electrical wiring, locate the cause and immediately perform repairs, or contact your Komatsu distributor for repairs.
- Keep the top surface of the battery clean and check the breather hole in the battery cap. If it is clogged with dirt or dust, wash the battery cap to clean the breather hole.

Check that there is no damage to the fuses; that fuses of the specified capacity are used; that there is no disconnection or trace of short-circuiting in the electric wiring and no damage to the covering. Check also that there is no loosened terminals. If any, tighten them.

Moreover, pay particular attention to the electric wiring when checking the battery, engine starting motor and alternator.

Be sure to check that there is no inflammable material accumulated around the battery. If any is found, remove immediately.

CHECK FLASHING OF LAMPS, CHECK FOR DIRT AND DAMAGE

CHECK INFLATION PRESSURE OF TIRES

Measure the inflation pressure with a tire pressure gauge, while the tires are cool, before starting work.

Check for damage or wear to the tires and the rims.

Check for loose wheel hub nuts (bolts).

The proper inflation pressure is shown below.

Tire size	Inflation pressure : kPa{kg/cm ² , PSI}
14.00-24-12PR	275 {2.75, 39.1}
14.00-24-14PR	300 {3.00, 42.6}
14.00R24TG☆	400 {4.00, 56.8}
17.5R25TG☆	300 {3.00, 42.6}

CHECK CONDITION OF WINDOW WASHER SPRAY

Operate the window washer and check that the washer fluid is sprayed out properly.

- If the fluid does not spray out properly, clean the washer nozzle with a safety pin or thin wire.
- If the condition is still not improved, please ask your Komatsu distributor to carry out inspection and repair.

CHECK WIPING EFFICIENCY OF WIPER

Operate the wiper and check that it wipes the window properly under each operating speed: Intermittent, low speed, high speed.

- Operate the window washer to make the glass wet when checking.
- If the wiping condition is poor, it is necessary to clean the surface of the glass or replace the rubber wiper blade.
- If the condition is still not improved, please ask your Komatsu distributor to carry out inspection and repair.

CHECK HORN

Operate the horn switch and check that the horn sounds.

If there is any abnormality, please ask your Komatsu distributor to carry out inspection and repair.

CHECK DEFROSTER FUNCTION

Operate the air conditioner and confirm that the air blows out from the blowout hole properly onto the front glass. If there is any abnormality, ask your Komatsu distributor to carry out inspections and repairs.

CHECK LOCKS

Check that all places can be locked properly.

(For details of the locations that can be locked, see "LOCKING (PAGE 3-167)".)

If any abnormality is found, please ask your Komatsu distributor to carry out inspection and repair.

OPENING AND CLOSING LOWER COVER

CAUTION

Do not travel or work with the lower cover open.
When the tandem swings, it may break the lower cover.

- After checking or servicing the inside of the engine compartment, do not close side panel (2) with lower cover (1) open.
(The lower cover is installed to the left and right sides.)
- If the machine travels or works with lower cover (1) open, tandem (3) may break the lower cover when it swings.

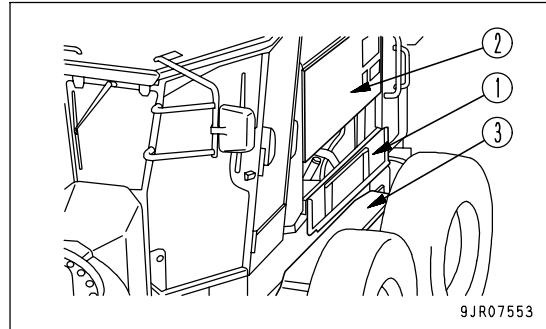

REMOVAL OF ARTICULATE LOCK PIN

WARNING

For general travel, maintenance, and transportation, always keep the articulate lock pin installed.

If the articulation is to be used during travel operations, remove articulate lock pin (1) and keep it in the place shown by the arrow.

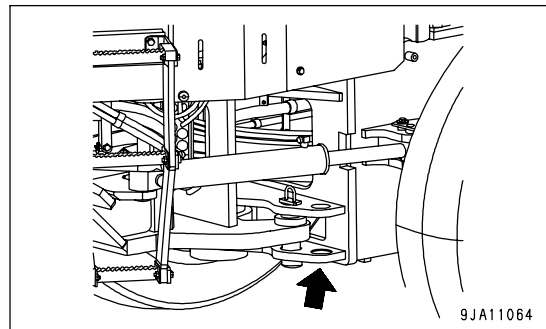

REMOVAL OF LEANING STOPPER

WARNING

If the machine travels with the leaning stopper fixed, it may be broken.

If leaning stopper (1) is inserted, remove it and keep it in the toolbox.

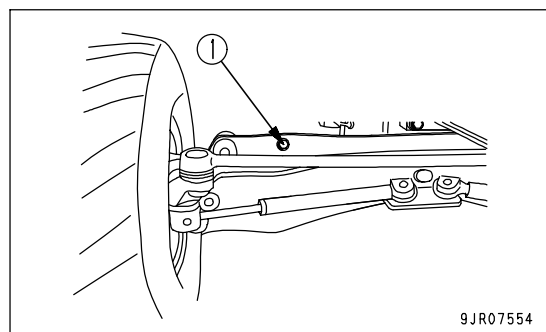

ADJUSTMENTS

ADJUST OPERATOR'S SEAT



WARNING

- Park the machine in a safe place and stop the engine when carrying out adjustment of the operator's seat.
- Adjust the seat position at the beginning of each shift or when operators change.
- Adjust the seat so that the brake pedal can be depressed all the way down with the operator's back against the backrest.

(A) Fore-and-aft adjustment

Pull lever (1) up, move the seat to the desired position, then release the lever.

Fore-and-aft adjustment: 110 mm (4.3 in) (11 stages)

(B) Adjusting reclining angle

Pull lever (2) up, set the seat back to a position where it is easy to carry out operations, then release the lever.

When doing this, keep your back pressed against the seat back. If your back is not against the seat back, the seat back may spring back suddenly.

(C) Adjusting seat tilt

• Front tilt

Push lever (3) down and adjust the angle of the front of seat.

- To raise the angle of the front of seat, keep the lever pushed down and apply your weight to the rear of seat.
- To lower the angle of the front of seat, keep the lever pushed down and apply your weight to the front of seat.

• Rear tilt

Pull lever (3) up and adjust the angle of the rear of the seat.

- To raise the rear of the seat, keep the lever pulled up and raise yourself slightly from the rear of the seat.
- To lower the rear of the seat, keep the lever pulled up and apply your weight to the rear of the seat.

Amount of tilt: Up 13°, down 13°

• Adjusting seat height

It is possible to raise or lower the seat by combining the front tilt and rear tilt.

Use the front (rear) tilt operation to set the seat to the desired height, then use the rear (front) tilt to make the seat horizontal.

Height adjustment: 60 mm (2.4 in)

(D) Adjusting armrest angle

Armrest (4) can be made to spring up by hand approx. 90°.

In addition, by turning the bottom (5) of the armrest by hand it is possible to make fine vertical adjustments of the armrest angle.

Armrest adjustment angle: 25°.

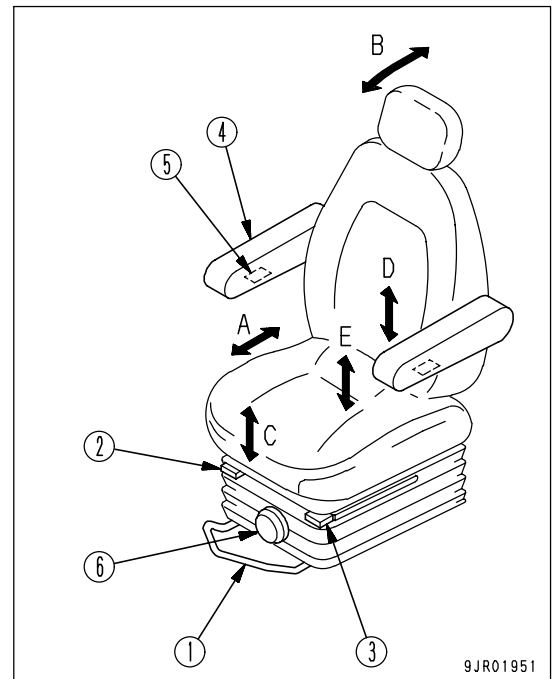

9JR01951

REMARK

Armrest (4) is designed so that it will automatically go up if the seat back is tipped forward without the armrest being raised.

(E) Adjusting suspension

To select the optimum suspension, turn knob (6) to adjust the dial for the suspension to the operator's weight as follows.

Turn **CLOCKWISE** to make **HARDER**

Turn **COUNTERCLOCKWISE** to make **SOFTER**

REMARK

To adjust to the optimum setting, turn knob (6) so that the indicator in the transparent portion inside the knob indicates the same as the operator's weight (kg).

ADJUST SEAT BELT**WARNING**

- Before fastening the seat belt, check that there is no problem in the securing brackets or belt. If there is any wear or damage, replace.
- Adjust and fasten the seat belt before operating the machine.
- Always use the seat belt when operating the machine.
- Do not use the seat belt with either half of the belt twisted.

FASTENING AND REMOVING BELT

Fasten the belt so that it is tight without being too tight.

1. Sit on the seat, depress the brake pedal fully, and adjust the seat so that your back is pressed against the backrest.
 2. Sit in the seat, pull the right side of the belt, then insert tongue (1) into buckle (2) until a click is heard.
 3. When removing the belt, press the red button in buckle (2) to free the belt.
- Fit the belt so that it follows your body and is not twisted.

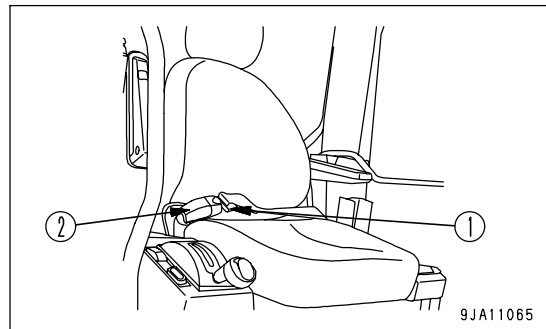

ADJUSTING POSITION OF STEERING CONSOLE, WORK EQUIPMENT CONTROL LEVERS**WARNING**

Do not carry out adjustments while traveling.

Depress the pedal (1). When the steering console is set to a desired position, release the pedal.

Adjust to a position that matches your physique and operating posture.

Steering wheel and gauges move in the same time.

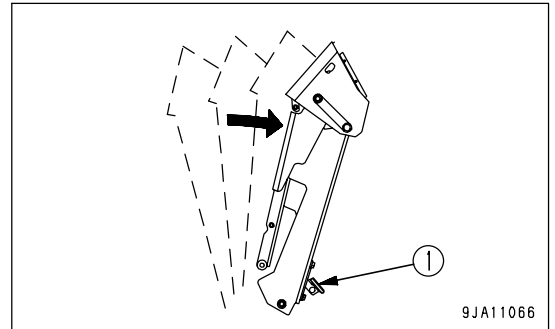
**ADJUSTING ANGLE OF STEERING WHEEL****WARNING**

Do not adjust the instrument panel when traveling.

Turn knob (1) to the left to release the lock, set the steering wheel to the desired position, tighten the knob, then fix the steering wheel.

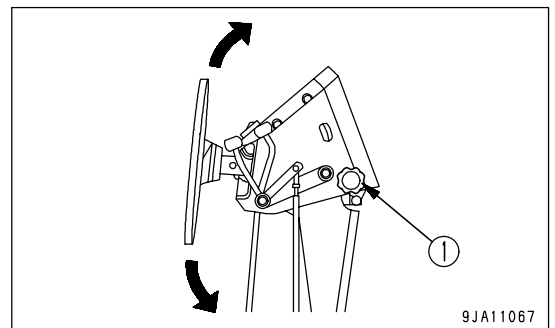

ADJUSTING MIRROR

! WARNING

- Be sure to adjust the mirrors before starting operations. If not adjusting them properly, you cannot secure the visibility and may be injured or may injure someone seriously.
- When adjusting the mirrors, keep your scaffolding by using a stool before starting the work.

Loosen mounting bolt (1) and nuts (2) of the mirror, then adjust the mirror to a position which gives the best view from the operator's seat.

When doing this, adjust so that is possible also to see part of the machine.

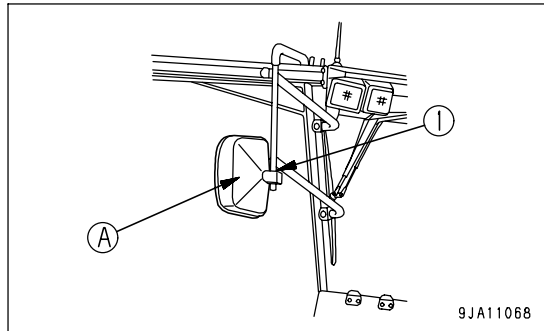

- Visible range
 Mirror (A): The hatched portion (A) and 1.5 m (4 ft 11 in) height from the ground can be seen.
 Mirror (B): The hatched portion (B) and 1.5 m (4 ft 11 in) height from the ground can be seen.

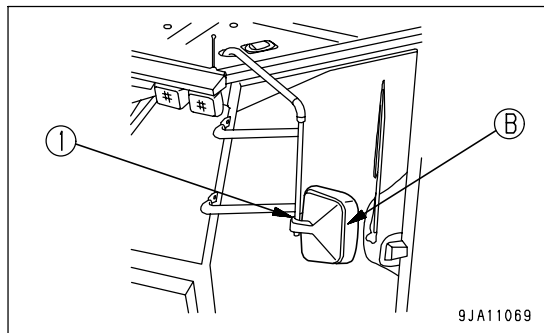

(H) 1 m (3 ft 3 in)
(I) 2 m (6 ft 7 in)

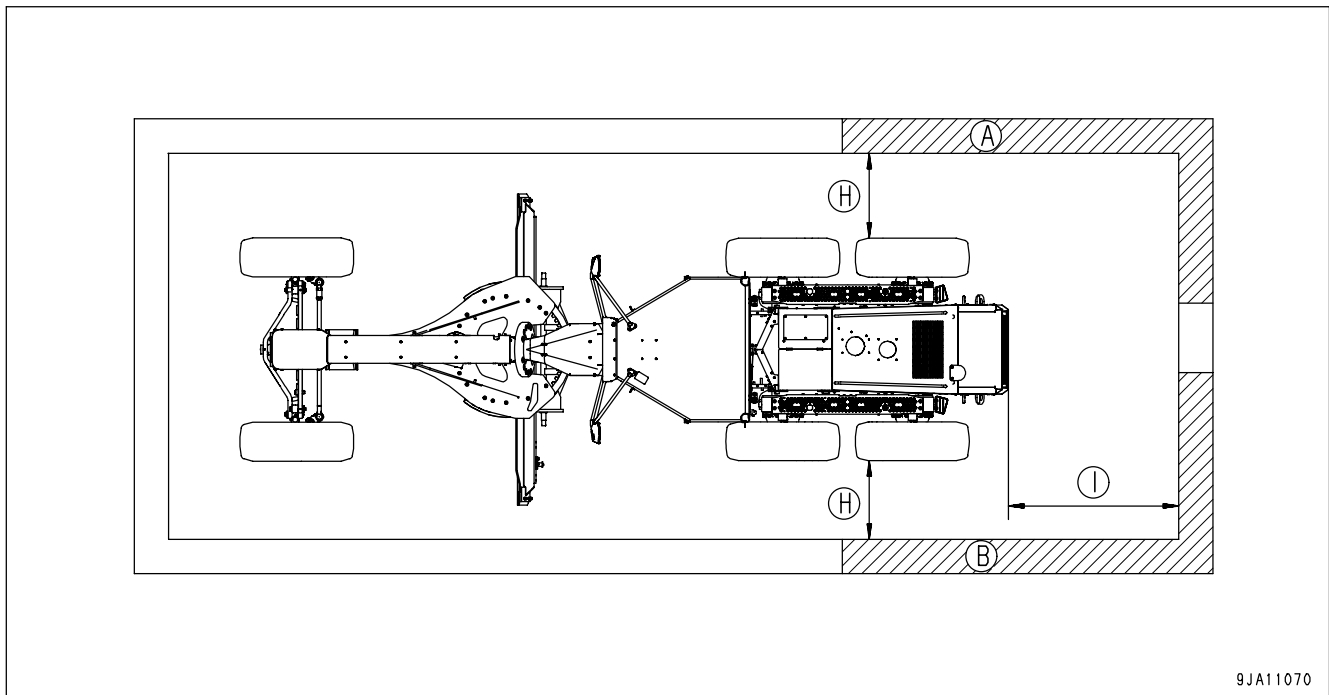

• Visible range

Mirror (C):

- The ground surface of 10 m (32 ft 10 in) width at 30 m (98 ft 5 in) distance to the rear of the machine can be seen.
- The position (a) (In 5 m (16 ft 5 in) width of ground surface at 30 m (98 ft 5 in) far from the rear of the machine) can be seen from the position (b) (at 1.5 m (4 ft 11 in) height and 0.75 m (2 ft 6 in) width of ground surface) at the rear of the machine.

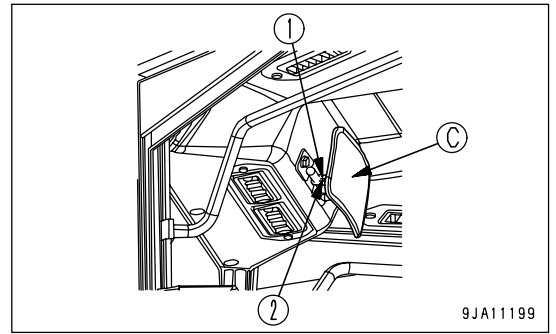

(J) 10 m (32 ft 10 in)

(K) 30 m (98 ft 5 in)

(L) 5 m (16 ft 5 in)

(M) 0.75 m (2 ft 6 in)

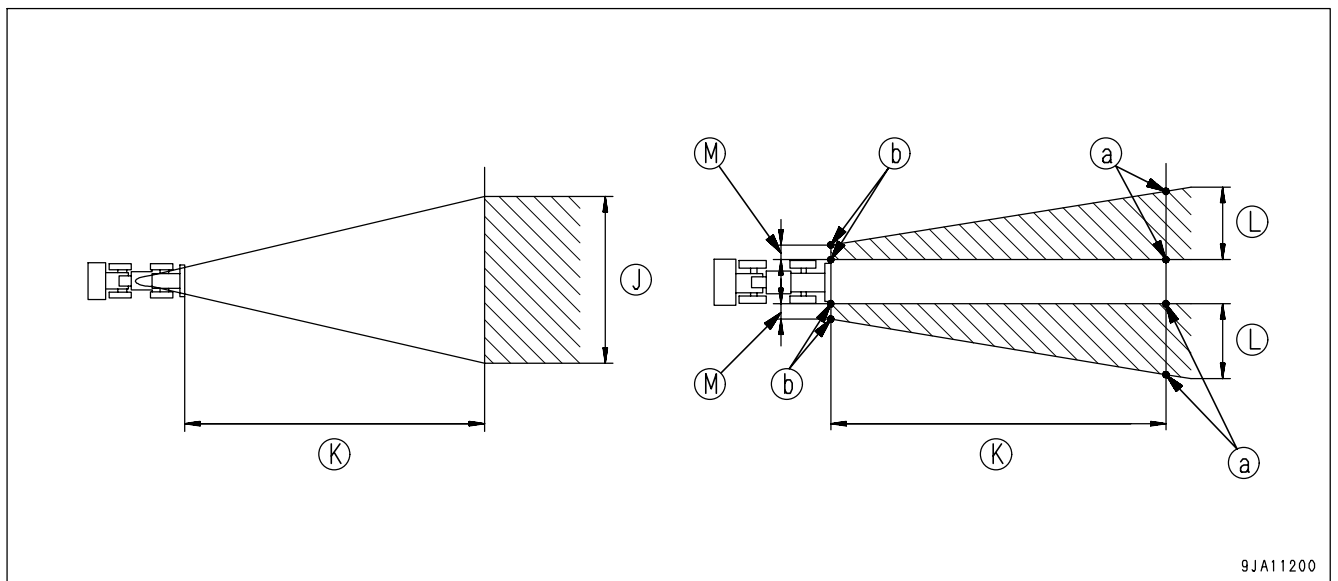

9JA11200

OPERATIONS, CHECKS BEFORE STARTING ENGINE

! WARNING

- When starting the engine, check that the gearshift lever is properly at the P (Parking) position.
If the control levers are touched by accident when the engine is started, the work equipment may move suddenly and cause a serious accident.
- When standing up from the operator's seat, always set the gearshift lever to the P (Parking) position, regardless of whether the engine is running or stopped.

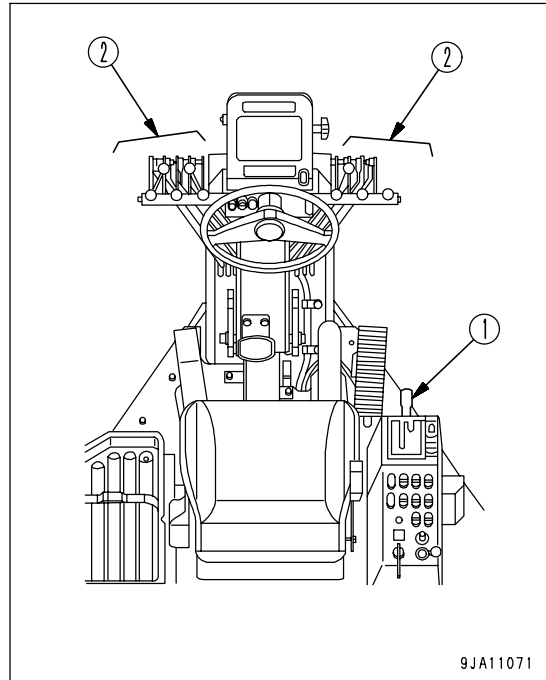

1. Check that gearshift lever (1) is at the P (Parking) position.
When starting the engine, if gearshift lever (1) is not at the P (Parking) position, the engine will not start.

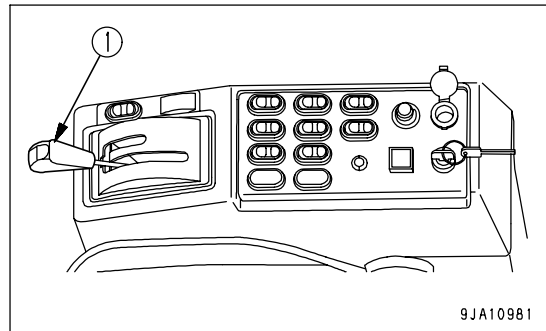

2. Check that work equipment control lever (2) is at the N (Holding) position.

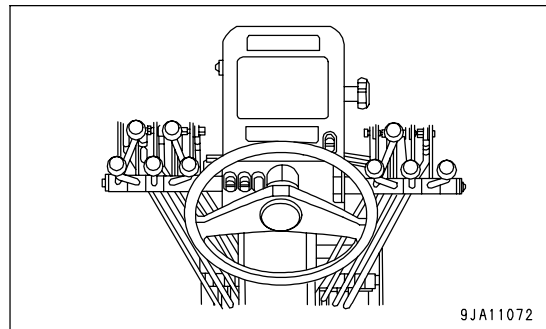

STARTING ENGINE

NORMAL STARTING

WARNING

- Sit down in the operator's seat before starting the engine.
- Do not attempt to start the engine by short-circuiting the engine starting circuit. Such an act may cause serious bodily injury or fire.
- Check that there are no persons or obstacles in the surrounding area, then sound the horn and start the engine.
- Exhaust gas is toxic. When starting the engine in confined spaces, be particularly careful to ensure good ventilation.

NOTICE

Do not keep the starting motor rotating continuously for more than 20 seconds.

If the engine will not start, wait for at least 2 minutes before trying to start the engine again.

Do not set the accelerator pedal to the full speed position when starting the engine.

1. Turn the key in starting switch (1) to the START position. The engine will start.

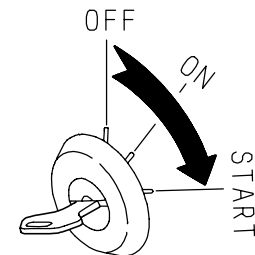
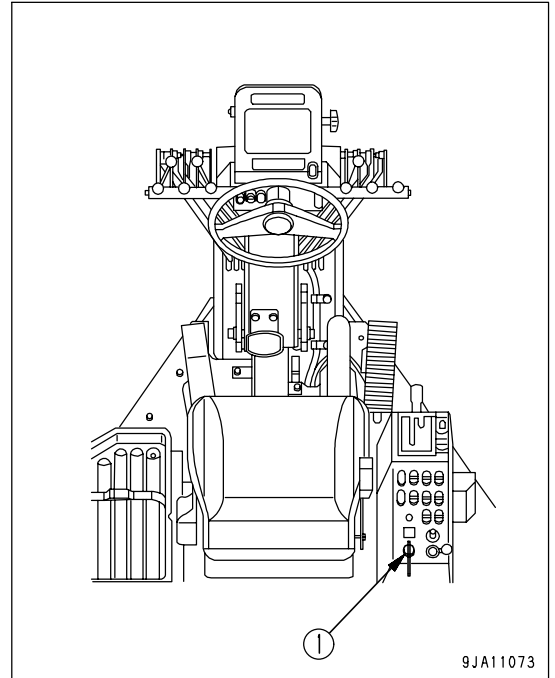

2. When the engine starts, release the key in starting switch (1). The key will return automatically to the ON position.

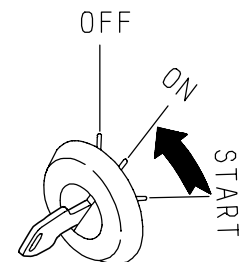

STARTING IN COLD WEATHER

! WARNING

- Start the engine only after sitting down in the operator's seat.
- Do not attempt to start the engine by short-circuiting the engine starting circuit. Such an act may cause a serious bodily injury or fire.
- Check that there are no persons or obstacles in the surrounding area, then sound the horn and start the engine.
- Never use starting aid fluids as they may cause explosions.
- Exhaust gas is toxic. When starting the engine in confined spaces, be particularly careful to ensure good ventilation.

NOTICE

Do not keep the starting motor rotating continuously for more than 20 seconds.

If the engine will not start, wait for at least 2 minutes before trying to start the engine again.

Do not set the accelerator pedal to the full speed position when starting the engine.

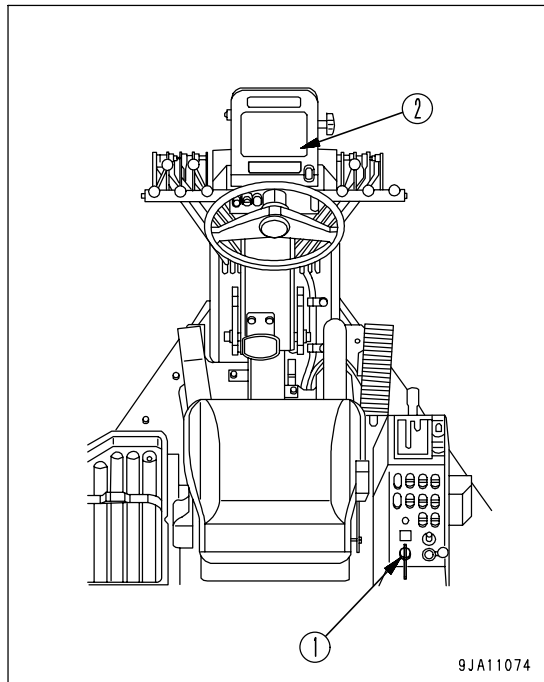

1. Turn the key in starting switch (1) to the ON position. Preheating will automatically start and preheating pilot lamp (2) will light up.

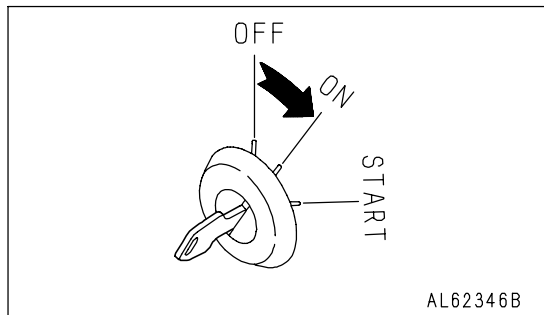

The time that the engine preheating pilot lamp stays lighted up depends on the ambient temperature as shown in the table below.

Ambient temperature	Lighting time
Above -4 °C	0 seconds
-4 °C to -15 °C	5 seconds to 30 seconds
Below -15 °C	30 seconds

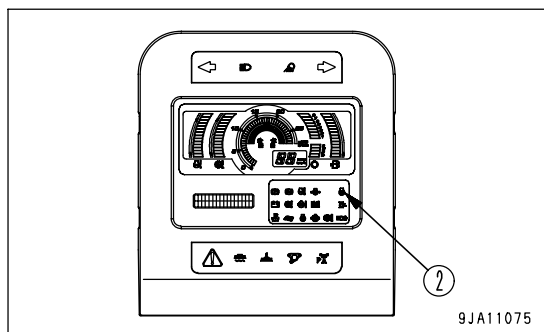

2. When the pre-heating is completed, the engine pre-heating pilot lamp will go out.
3. For manual preheat, see the items in "STARTING SWITCH (PAGE 3-36)".

4. Turn the key in starting switch (1) to the START position. The engine will start.

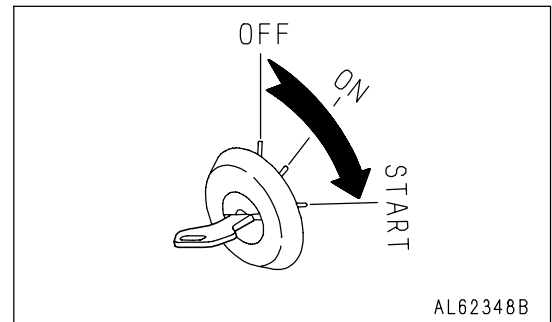

5. When the engine starts, release the key in starting switch (1). The key will return automatically to the ON position.

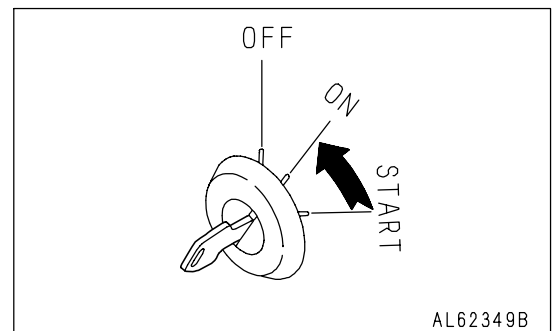

BREAKING-IN THE MACHINE



CAUTION

Your Komatsu machine has been thoroughly adjusted and tested before shipment. However, operating the machine under severe conditions at the beginning can adversely affect the performance and shorten the machine life.

Be sure to break-in the machine for the initial 100 hours (as indicated by the service meter).

During break-in operations, follow the precautions described in this manual.

NOTICE

Before operating the machine for the first time, check that there is coolant in the radiator. If the machine has been delivered without coolant in the radiator, run water through the system to flush the system thoroughly, then fill the radiator with coolant.

- Idle the engine for 5 minutes after starting it up.
- Avoid operation with heavy loads or at high speeds.
- Immediately after starting the engine, avoid sudden starts, sudden acceleration, unnecessary sudden stops, and sudden changes in direction.

OPERATIONS, CHECKS AFTER STARTING ENGINE

CHECK FOR EASE OF STARTING ENGINE, ABNORMAL NOISE

When starting the engine, check that the engine causes no abnormal noise and that it starts up easily and smoothly. Check also that there is no abnormal noise when the engine is idling or when the revolution rises slightly.

- When there is an abnormal noise at the engine startup and if that condition continues, the engine may be damaged. In that case, ask your Komatsu distributor to check the engine as soon as possible.

CHECK ENGINE AT LOW SPEED AND WHEN ACCELERATING

Check that there is no irregularity in the engine speed and that the engine does not suddenly stop when the machine is stopped during normal travel.

Check also that the engine accelerates smoothly when the accelerator pedal is depressed.

- Carry out the inspection in a safe place and check that there is no one in the surrounding area.
- If the condition at low speed or when accelerating is extremely poor and that condition continues, there is danger that the engine may be damaged, that the operating feeling may become strange, that the braking effect may deteriorate, or that an unexpected accident may happen, so please ask your Komatsu distributor to carry out repairs as soon as possible.

CHECK PARKING BRAKE

Check that the parking brake works properly.

If there is any abnormality in the operation of the parking brake or the brake does not provide the proper braking effect, please contact your Komatsu distributor for adjustment.

CHECK BRAKE PEDAL

Set to the machine on level ground with no obstacles in the surrounding area, then drive the machine slowly forward and in reverse and check the braking effect of the brakes.

If there is any abnormality in the operation of the brakes, please ask your Komatsu distributor to carry out adjustment.

CHECK TRAVEL OF BRAKE PEDAL

Depress the brake pedal fully and check the distance from the floor. Check that the pedal is not too close to the floor and that there is no abnormal feeling when operating the brake pedal.

If any abnormality is found, please ask your Komatsu distributor to carry out adjustments.

CHECK LOCATION OF ABNORMALITIES FROM PREVIOUS DAYS

Check the places where problems occurred when using the machine on previous days.

If any abnormality is found, please contact your Komatsu distributor for inspection and repair.

**WARNING**

- **Emergency stop**
If the operation is abnormal or any other trouble occurs, turn the key in the starting switch to the OFF position.
- **If the work equipment is operated without warming up the machine sufficiently, the response of the work equipment to the movement of the control lever will be slow. The work equipment may not move as the operator desires. Follow all warm-up procedures. Particularly in cold areas, make sure to warm up the machine properly.**

NORMAL OPERATION

After starting the engine, do not immediately start operations. First, perform the following operations and checks.

NOTICE

Do not accelerate the engine suddenly until the warming-up operation has been completed.

Do not run the engine at low idle or high idle continuously for more than 20 minutes.

If it is necessary to continue to run the engine at idle, apply a load from time to time or run the engine at a mid-range speed.

1. Always wait for the warming-up operation to be completed (until the engine idling speed is reduced from 1100 rpm to the low idling speed of 800 rpm).
2. After completing the warming-up operation, check that the gauges and caution lamps work properly.
If any problem is found, carry out maintenance or repair.
Run the engine under low load until engine water temperature gauge (1) enters the green range.
3. Check for abnormal exhaust gas color, noise, or vibration. If any problem is found, contact your Komatsu distributor.

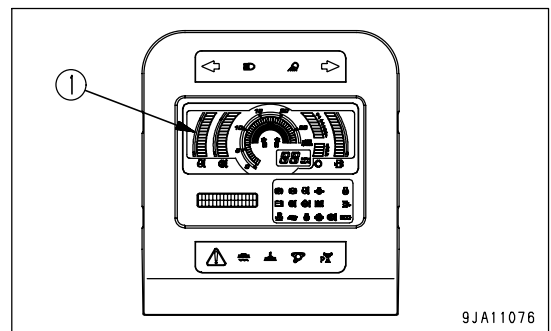

9JA11076

STOPPING ENGINE

NOTICE

- If the engine stops abruptly, service lives of the various parts of the engine threaten to shorten. Never stop it abruptly except in emergencies.
- In case of overheat of the engine, do not try to stop it abruptly but run it at medium speeds to cool down gradually, and then stop it.
- If the cooling fan does not rotate at the time of overheat, stop the engine.

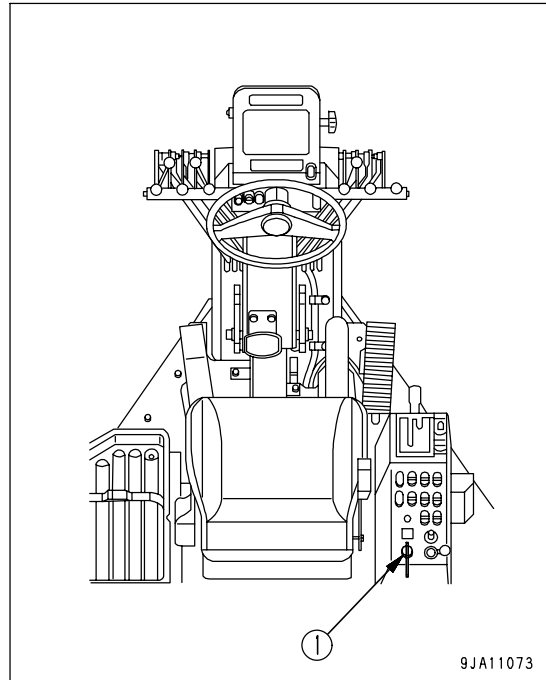

1. Run the engine at low idle for about 5 minutes to cool down gradually.
2. Turn the key of starting switch (1) to the OFF position to stop the engine.
3. Remove the key from starting switch (1).

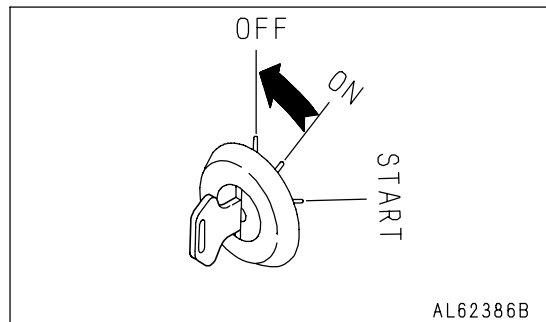

CHECK AFTER STOPPING ENGINE

1. Walk around the machine and check the work equipment, machine exterior, and undercarriage, also check for any leakage of oil or coolant. If any problems are found, repair them.
2. Fill the fuel tank.
3. Check the engine compartment for paper and debris. Clean out any paper and debris to avoid a fire hazard.
4. Remove any mud affixed to the undercarriage.

TRAVELING POSTURE FOR MACHINE



WARNING

- For general travel, always lock the front frame and rear frame with the articulate lock pin.
- Before moving any work equipment control lever, check the distance between the blade and tires.

NOTICE

Pay careful attention to the clearance between the blade and the front tire.

If articulation is carried out with the blade at the propulsion angle, the blade may cut the tire or bend the step.

During general travel, keep the front and rear ends of the blade evenly raised and positioned within the outer border of the machine as shown in the right figure.

Raise the blade to the height (A), at least 19 cm (7.5 in) above the ground.

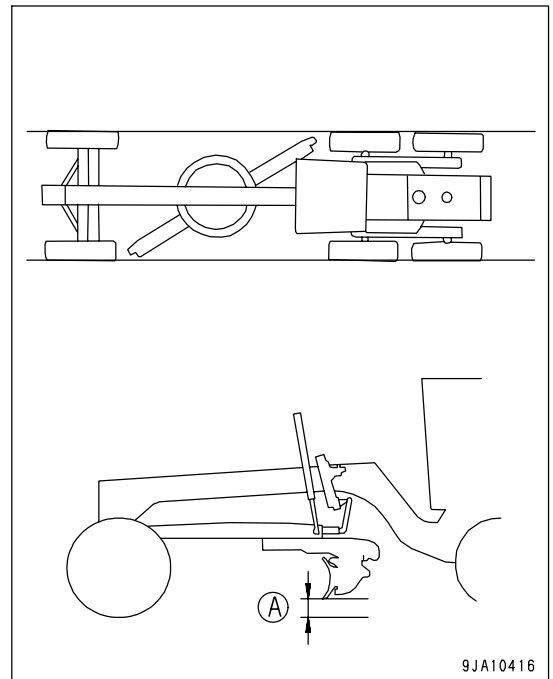

MOVING MACHINE OFF (FORWARD, REVERSE, SHIFTING GEAR), STOPPING

WARNING

- When moving off, check that the area around the machine is safe, and sound the horn before moving.
Clear all personnel from the machine and the area.
Use extreme care when reversing the machine. Note there is a blind spot behind the machine.
- Do not operate the machine when air pressure is abnormal.
- Before starting operations, check that the seat belt is properly installed.

NOTICE

Before starting the machine off, check that the brake oil pressure warning buzzer is not sounding.

CAUTION

Don't shift the gear while depressing the inching pedal.
2 or more second after shifting gear, depress the inching pedal from pressed position.

PREPARATIONS FOR MOVING OFF

WHEN SELECTING MANUAL MODE

1. Set the blade to the travel posture.
For traveling postures of the machine, see "TRAVELING POSTURE FOR MACHINE (PAGE 3-107)".
2. Depress the brake pedal (1), depress the inching pedal (2), and then set gear shift lever (3) to the 1st or 2nd speed.

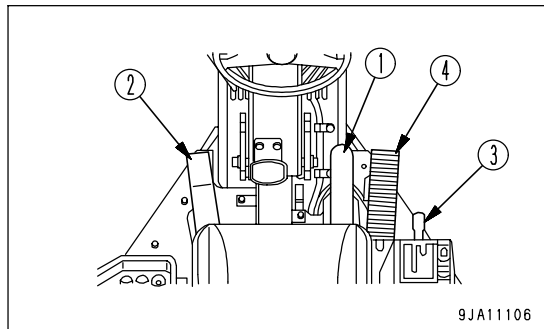

NOTICE

On slope, do not start the machine at higher gear speeds (3rd or higher).
Be sure to start at the 1st or 2nd gear speed on slope.

3. Always check that parking brake lamp (5) has gone out.

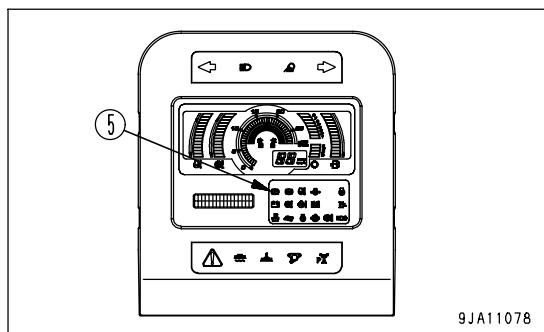

4. Return inching pedal (2) back gradually, while keeping brake pedal (1) depressed.
By returning inching pedal (2) back, the transmission starts to transmit the power.

NOTICE

In starting operations of the machine, provide an interval of at least 2 seconds between the operations of procedure 2. and procedure 4.

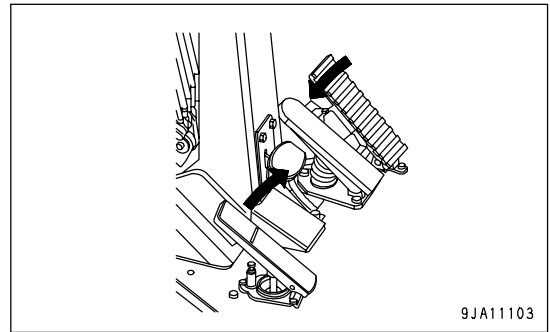

5. When the transmission starts to transmit the power, release brake pedal (1), return inching pedal (2) back, and then depress accelerator pedal (4). The machine starts.

NOTICE

If releasing brake pedal (1) on slope before the transmission starts to transmit the power, the machine may slip down.

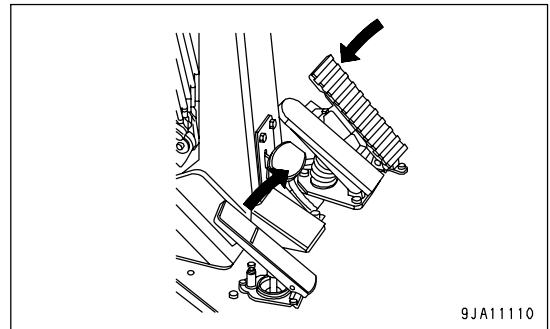

REMARK

Even if being in Manual mode, when the gear shift lever is set to the R3 or higher position, the automatic gear shift is selected and the machine starts at the R2 speed.

WHEN SELECTING TORQUE CONVERTER AUTO MODE

1. Set the blade to the travel posture.
2. Depress brake pedal (1) and set gear shift lever (2) to any of the 1st - 8th gear speeds.

REMARK

- If the gear shift lever is set to the F5 or higher position, the automatic gear shift is selected and the machine starts at the F4 speed.
- If the gear shift lever is set to the R3 or higher position, the automatic gear shift operates and the machine starts at the R2 speed.

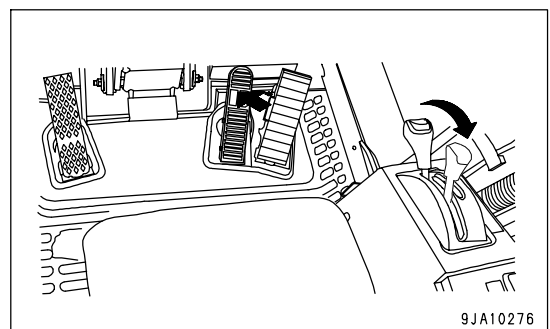
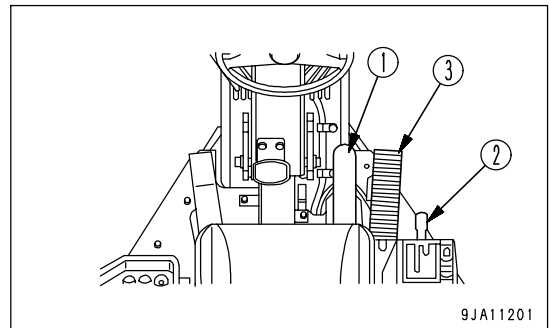

3. Always check that parking brake lamp (4) has gone out.

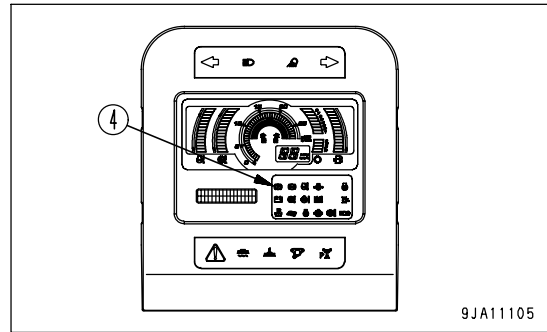

4. Return brake pedal (1) back, depress accelerator pedal (3) and starts off the machine.

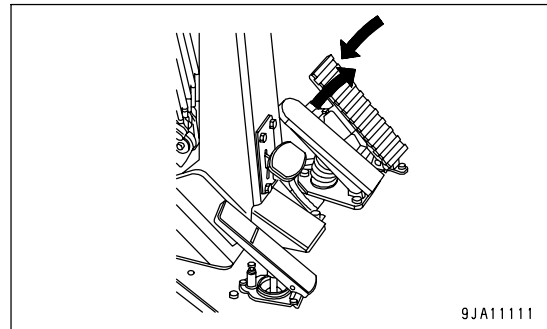

SHIFTING GEAR ON MACHINE

**WARNING**

- Avoid sudden gear shifts when traveling at high speeds. Before shifting down the gear, apply the brake to reduce the travel speed.
- Do not set the gear shift lever to the N (Neutral) position when traveling or going downhill. The braking force of the engine cannot be applied and there is danger of unexpected accidents. Be sure to travel by keeping the gear shift lever placed in any of the gear speed positions.

NOTICE

- When shifting gears, always shift one gear at a time.
- When operating gear shift lever (1), place it securely in each position.
- When moving gear shift lever (1) from N (NEUTRAL) to R (REVERSE) or F (FORWARD), release accelerator pedal (2) and operate the lever during low idling of the engine.
- Do not depress inching pedal (3) during gear shifts.

When shifting gear, do as follows.

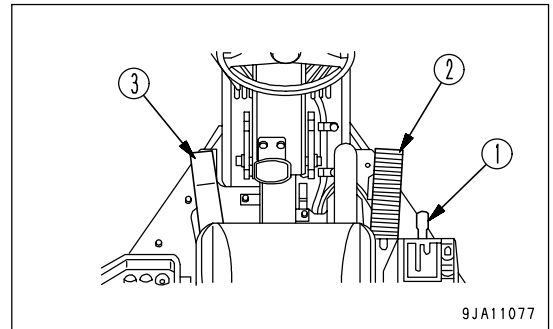
**INCREASE SPEED**

Loosen the depression of accelerator pedal (2) and set gear shift lever (1) up to the next gear speed.

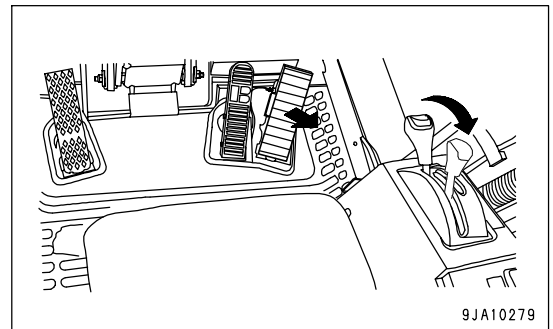
**REDUCING SPEED**

Release accelerator pedal (2) to reduce the engine speed and set gear shift lever (1) down to the next gear speed.

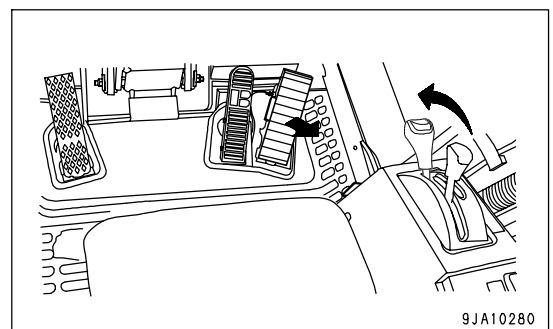
**REMARK**

An abrupt downshift operation (shifting down to the gear speed following the next one or farther at a time) probably actuates the function of preventing the engine from overrunning.

If this function starts, it is necessary to wait for the downshift to the desired gear speed through travel speed reduction by using the brake or naturally, because the desired gear speed is not obtained until the machine slows down to a certain travel speed.

**WARNING**

- When going downhill, shift down the transmission to use the engine brake.
- To prevent the engine from overrunning, the rotation range enabling downshifts is limited. Reduce the travel speed by depressing the brake pedal and, after the speed becomes within the range where downshifts are possible, carry out the downshift operation.

Gear speed	Travel speed enabling downshifts (km/h, (MPH))
F2 -> F1	4.5 (2.8)
F3 -> F2	6.5 (4.0)
F4 -> F3	9.0 (5.6)
F5 -> F4	13.0 (8.1)
F6 -> F5	20.0 (12.4)
F7 -> F6	29.0 (18.0)
F8 -> F7	39.5 (24.5)

SHIFTING BETWEEN FORWARD AND REVERSE

**WARNING**

- When shifting between forward and reverse, always check that it is safe to travel in the new direction. Use extreme care when reversing the machine. Note there is an blind spot behind the machine.
- Do not shift between forward and reverse when traveling at high speed.

When shifting between forward and reverse, always stop the machine first.

**CAUTION**

Don't shift the gear while depressing the inching pedal.

2 or more second after shifting gear, depress the inching pedal from pressed position.

WHEN SELECTING MANUAL MODE

1. Depress brake pedal (1) to reduce speed, then depress inching pedal (2) to stop the machine.

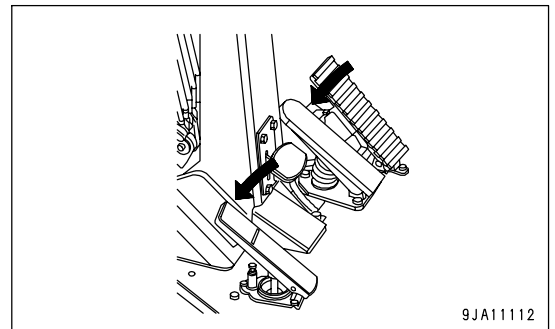
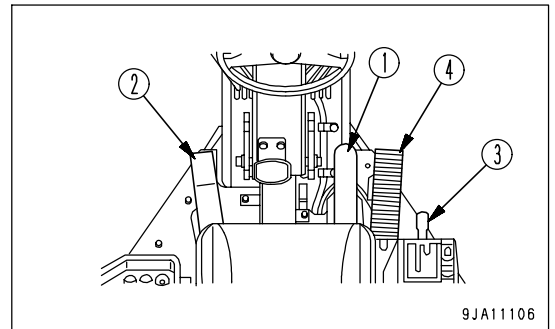

2. Shift gearshift lever (3) to F (FORWARD) or R (REVERSE) and set in 1st or 2nd speed.

NOTICE

On slope, do not start the machine at higher gear speeds (3rd or higher). Be sure to start at the 1st or 2nd gear speed on slope.

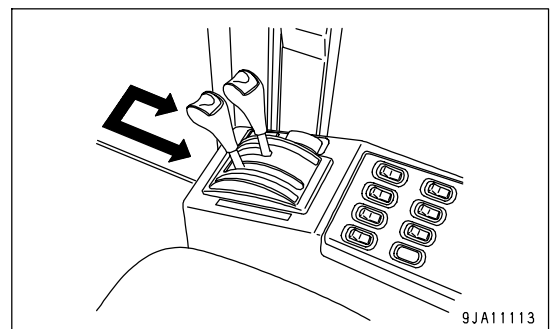

- 3. Return inching pedal (2) back gradually, while keeping brake pedal (1) depressed.
By returning inching pedal (2) back, the transmission starts to transmit the power.

NOTICE

In starting operations of the machine, provide an interval of at least 2 seconds between the operations of procedure 2. and procedure 3.

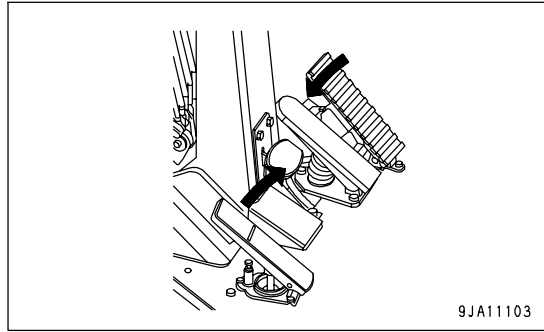

- 4. When the transmission starts to transmit the power, release brake pedal (1), return inching pedal (2) back, and then depress accelerator pedal (4). The machine starts.

NOTICE

If releasing brake pedal (1) on slope before the transmission starts to transmit the power, the machine may slip down.

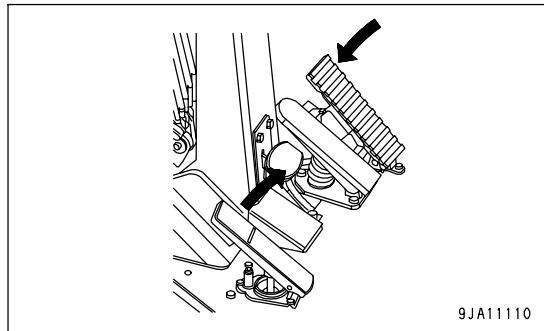

REMARK

- If carrying out a direction switching operation during travels, the gear speed probably shift down sequentially before the directional change, for the protection of the passenger and machine. This is not abnormal.
- Although, for safety, it is not possible to complete the direction change until the travel speed slows down to 4 km/h (2.5 MPH) or lower, it is not abnormal. If reducing the travel speed down to 4 km/h (2.5 MPH) or lower by using the brake during the direction switching operation, the direction changes automatically.

WHEN SELECTING TORQUE CONVERTER AUTO MODE

- 1. Depress brake pedal (1) to stop the machine.

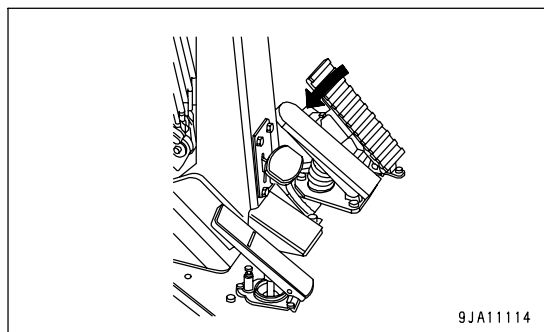
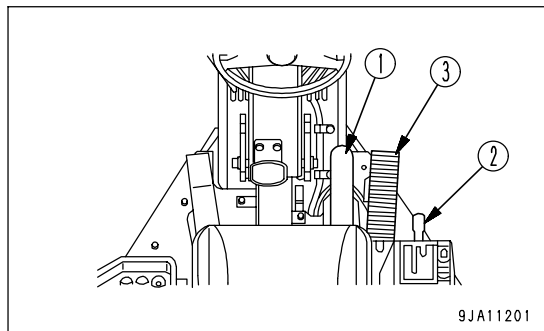

2. Switch over gear shift lever (2) to F (FORWARD) or R (REVERSE) and set it to the 1st or 2nd speed.

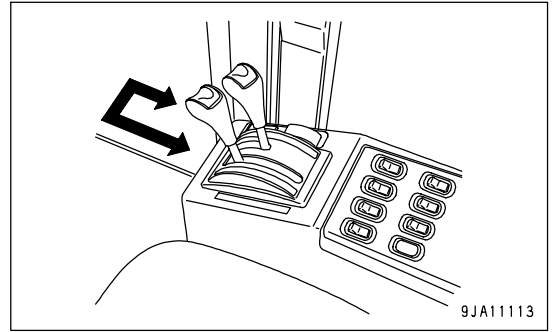

3. Return brake pedal (1) back and depress accelerator pedal (3).
The machine starts.

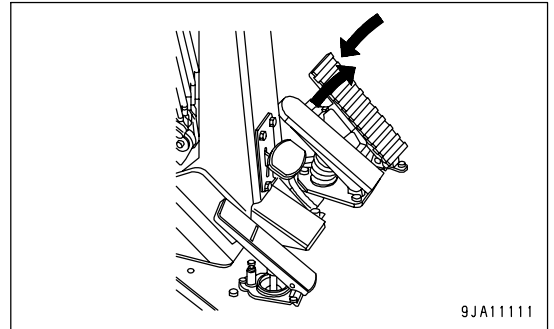
**REMARK**

- If carrying out a direction switching operation during travels, the gear speed probably shift down sequentially before the directional change, for the protection of the passenger and machine. This is not abnormal.
- Although, for safety, it is not possible to complete the direction change until the travel speed slows down to 4 km/h (2.5 MPH) or lower, it is not abnormal. If reducing the travel speed down to 4 km/h (2.5 MPH) or lower by using the brake during the direction switching operation, the direction changes automatically.

STOPPING MACHINE

**WARNING**

Avoid stopping suddenly. Give yourself ample room when stopping.

WHEN SELECTING MANUAL MODE

1. Release accelerator pedal (1).

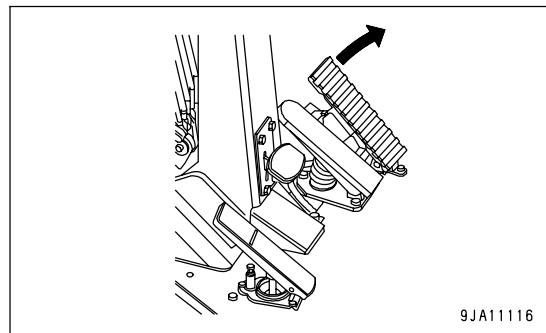
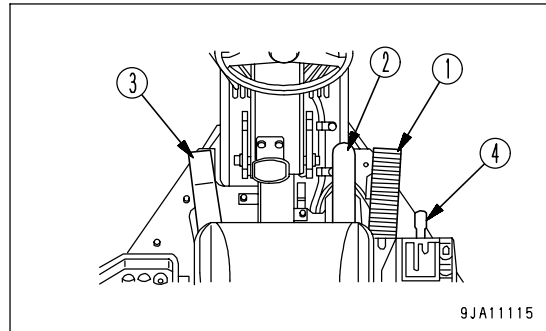

2. Depress brake pedal (2). Before the machine comes to a stop, depress inching pedal (3).

REMARK

As this model has the linked control function of torque converter with direct drive, the engine does not stop even if depressing the inching pedal belatedly or not depressing it at all.

However, as the lockup is automatically released to prevent the engine from stopping, the machine becomes in torque converter state.

After the machine starts and the engine and travel speeds increase, the machine automatically returns to lockup state.

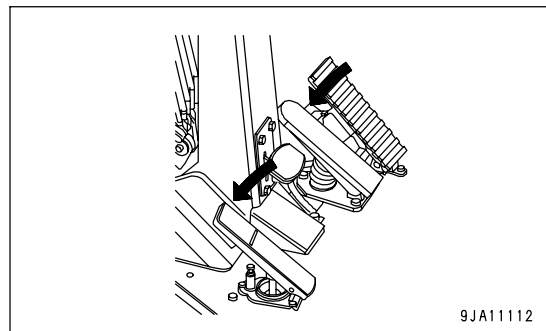

3. Set gear shift lever (4) to the P (PARKING) position while pressing its knob. The parking brake lamp lights up at the same time.

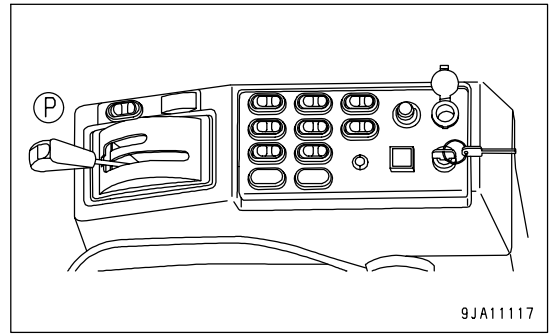

WHEN SELECTING TORQUE CONVERTER AUTO MODE

1. Release accelerator pedal (1).

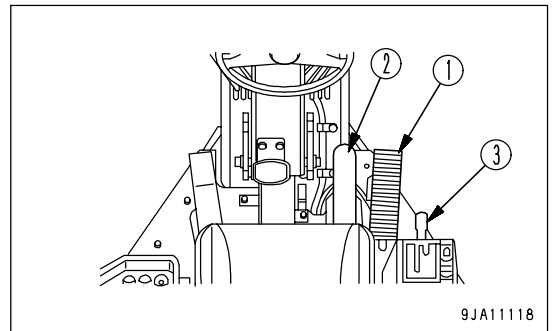

2. Depress brake pedal (2) and stop the machine.

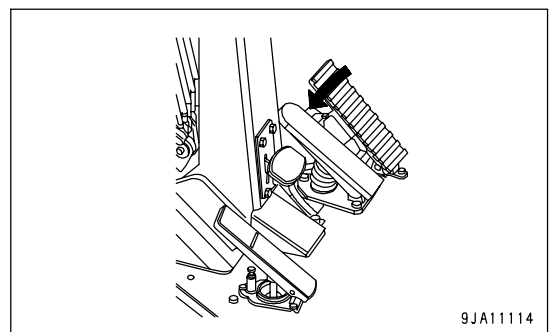
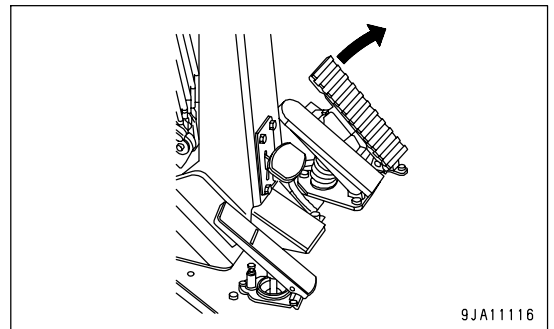

3. Set gear shift lever (3) to the P (PARKING) position while pressing its knob. The parking brake lamp lights up at the same time.

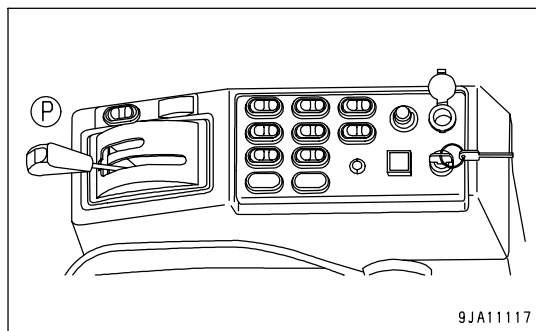

TURNING MACHINE

WARNING

- It is dangerous to turn the machine suddenly at high speed or to turn the machine on steep slopes.
- If the engine stops when the machine is traveling, the steering will become heavy, so never stop the engine.
This is particularly dangerous on slopes, so never allow the engine to stop while traveling on slopes under any circumstance.
If the engine stops, immediately apply the brake and stop the machine in a safe place.

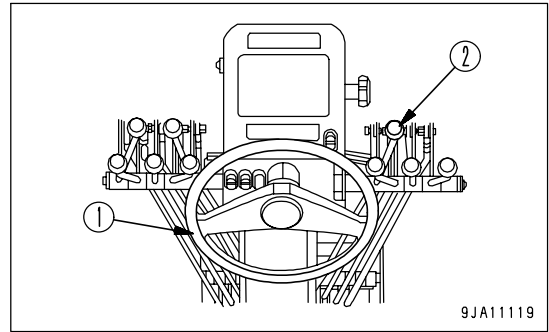

To turn the machine when traveling, turn steering wheel (1) in the direction of the turn.

LEANING OPERATION

When leaning control lever (2) is pushed forward (A), the front wheels lean to the left; when it is pulled back (C), the front wheels lean to the right.

When traveling forward and turning, lean the front wheels in the direction of the turn to reduce the turning radius.

When traveling in reverse and turning, lean the front wheels in the opposite direction to the turn to reduce the turning radius.

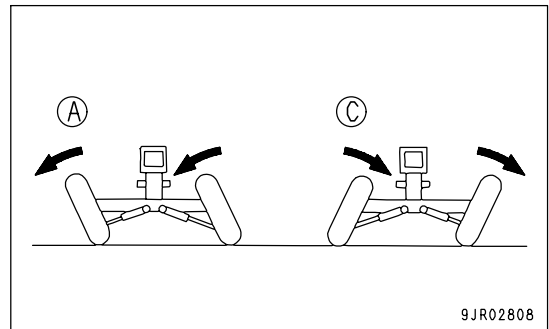
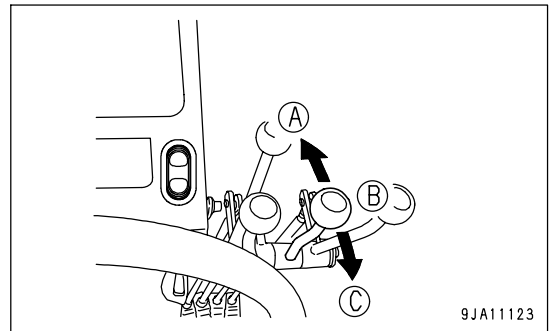

ARTICULATING OPERATION**WARNING**

Do not remove the lock pin for general travel.

NOTICE

When turning with the machine articulated, pay particular attention to the clearance between the blade end and the wheel.

Before carrying out articulation operations, remove the lock pin on the left side of the machine.

1. Stop the machine, remove pin (1), and insert it in the storage position (2).

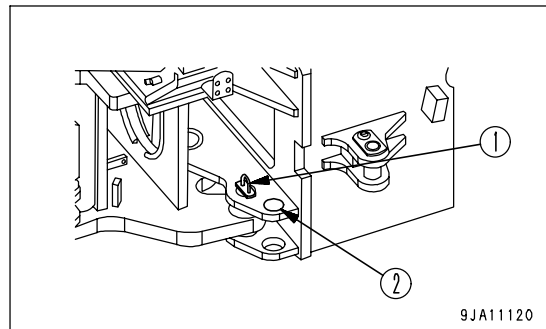

2. When articulation control lever (2) is pushed forward (A), the machine articulates to the left; when it is pulled back (C), the machine articulates to the right.

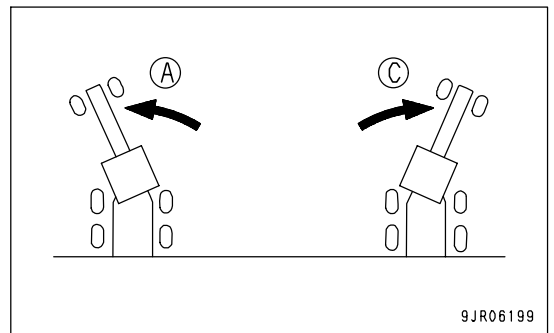
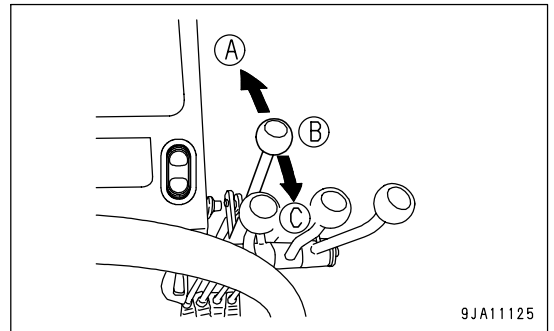
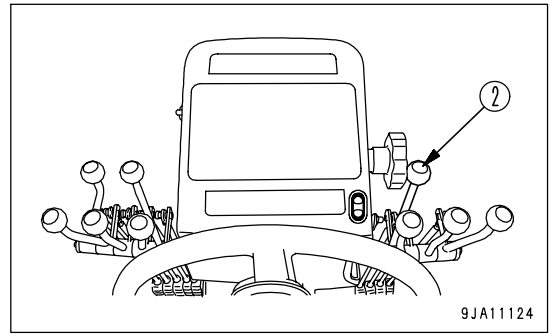

3. When not operating the articulation, set the front frame and rear frame straight, align the pin holes, and fix the front and rear frames in the original position with pin (1).

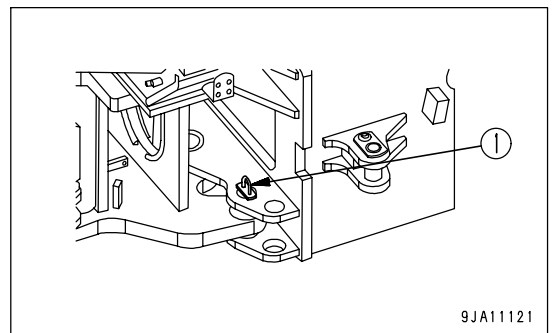

OPERATING WORK EQUIPMENT

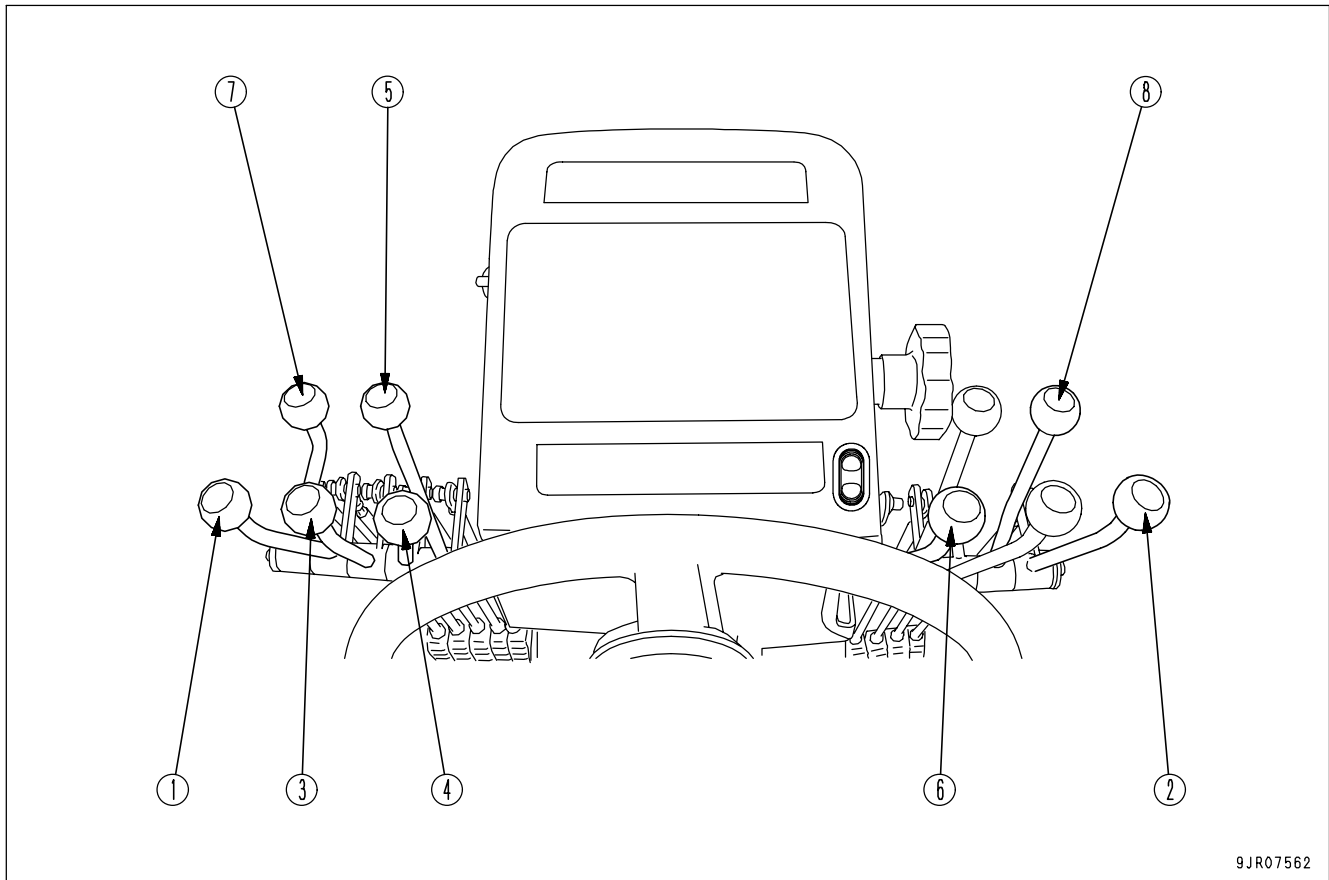

9JR07562

- (1) Left blade lift cylinder control lever
- (2) Right blade lift cylinder control lever
- (3) Blade side shift control lever
- (4) Blade rotation control lever
- (5) Power tilt control lever
- (6) Drawbar side shift control lever
- (7) Ripper/Scarifier control lever (if equipped)
- (8) Front attachment control lever (if equipped)

BLADE OPERATION

BLADE LIFT OPERATION

- When left blade lift cylinder control lever (1) is pushed forward (A), the left end of the blade goes down; when it is pulled back (C), the left end of the blade goes up.

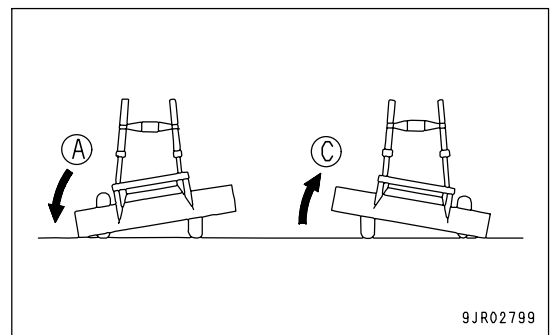
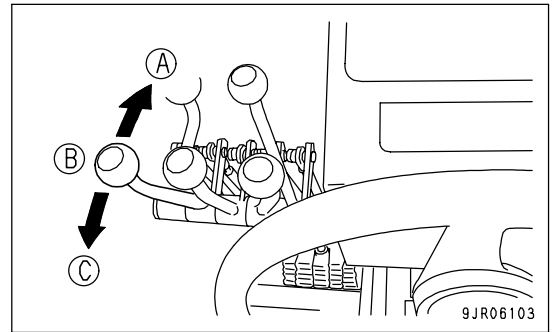

- When right blade lift cylinder control lever (2) is pushed forward (A), the right end of the blade goes down; when it is pulled back (C), the right end of the blade goes up.

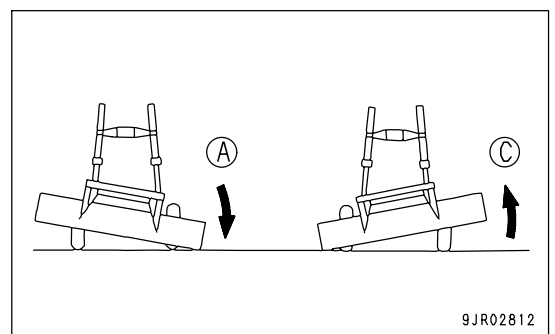
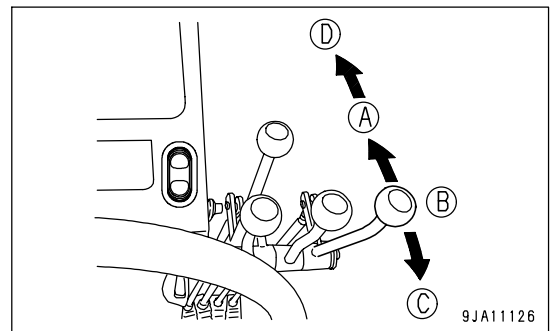

OPERATING BLADE SIDE SHIFT

When blade side shift control lever (3) is pushed forward (A), the blade shifts to the left; when it is pulled back (C), the blade shifts to the right.

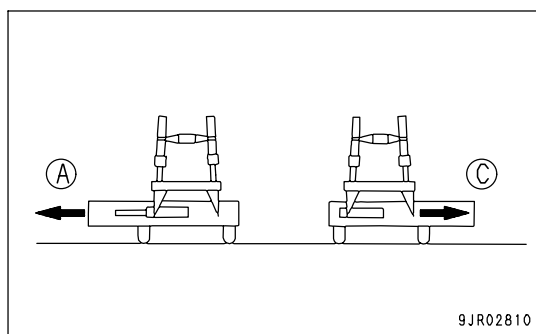
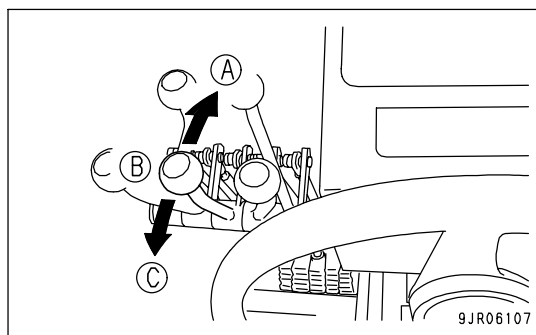

OPERATING BLADE ROTATION

When blade rotation control lever (4) is pushed forward (A), the blade rotates to the left; when it is pulled back (C), the blade rotates to the right.

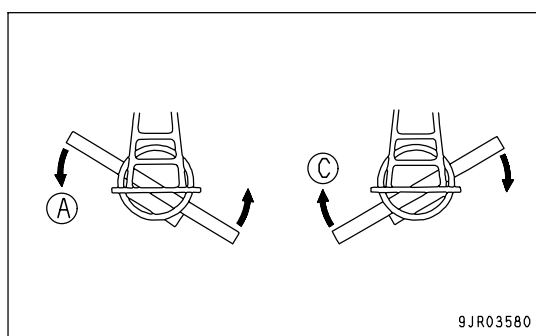
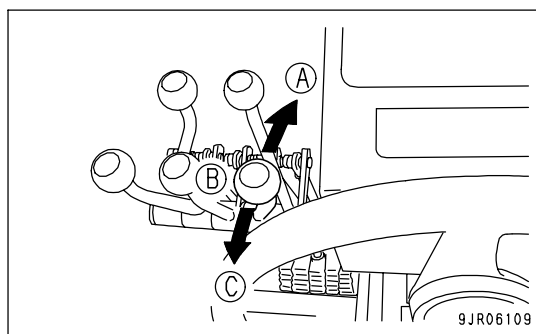

CHANGING BLADE CUTTING ANGLE

When power tilt control lever (5) is pushed forward (A), the cutting angle becomes larger; when it is pulled back (C), the cutting angle becomes smaller.

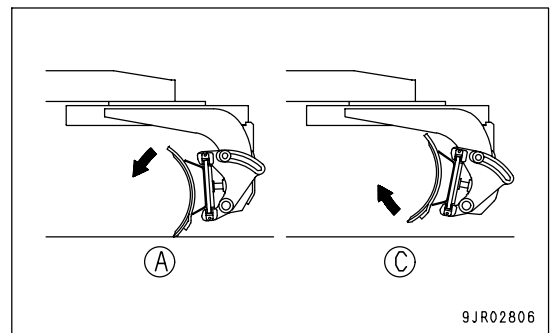
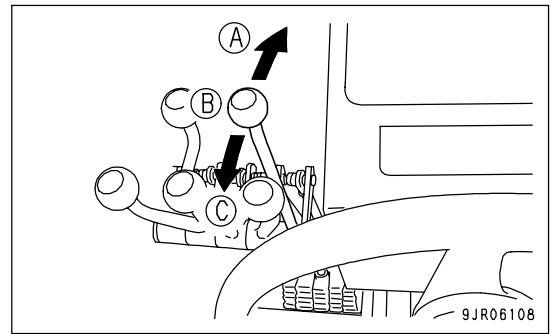

When cutting hard soil (D), make the cutting angle larger.
When cutting soft soil (E), make the cutting angle smaller.

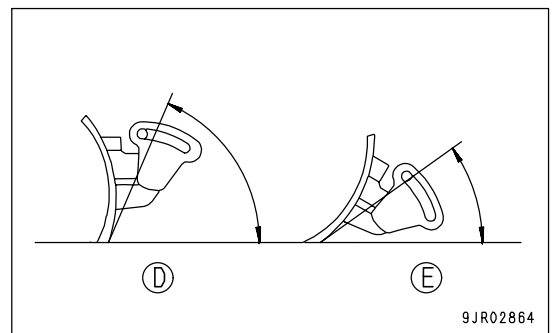

The distance between the cutting surface and the blade edge can be changed, so it is possible to carry out fine adjustment of the height of the cutting surface

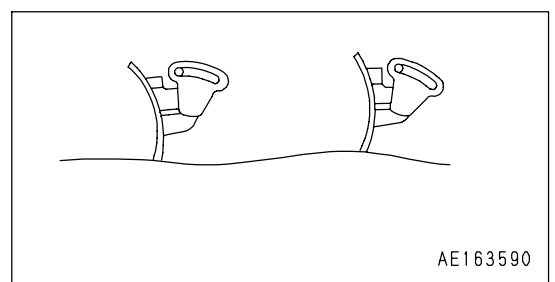

OPERATING DRAWBAR SIDE SHIFT

When drawbar side shift control lever (6) is pushed forward (A), the drawbar shifts to the left; when it is pulled back (C), the drawbar shifts to the right.

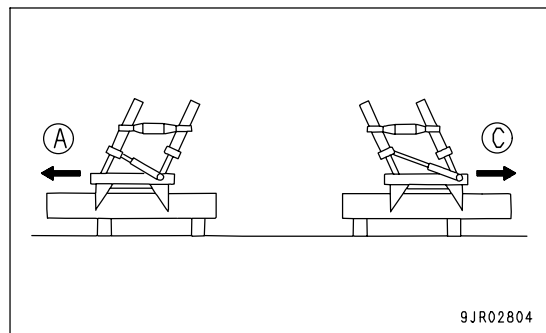
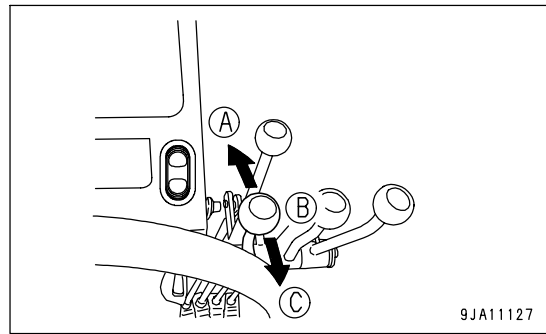

OPERATING RIPPER/SCARIFIER

When the machine is equipped with a ripper

When ripper/Scarifier control lever (7) is pushed forward (A), the ripper goes down; when it is pulled back (C), the ripper goes up.

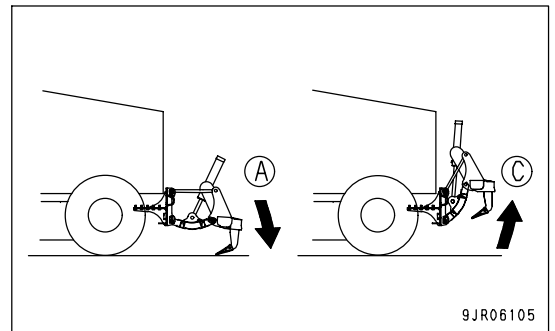
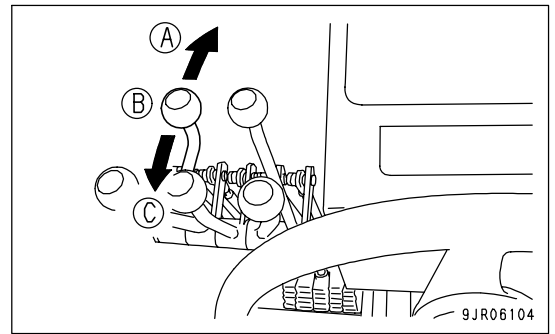

When the machine is equipped with a scarifier

When ripper/Scarifier control lever (7) is pushed forward (A), the scarifier goes down; when it is pulled back (C), the scarifier goes up.

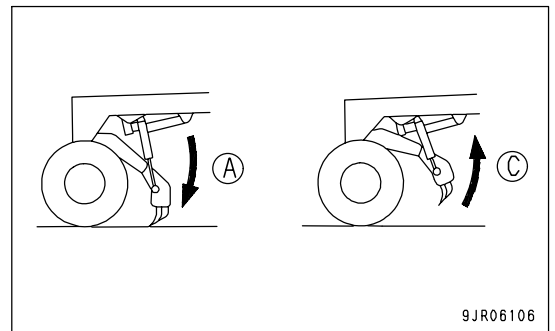

OPERATING FRONT ATTACHMENT

When the machine is equipped with a front blade

When front attachment control lever (8) is pushed forward (A), the front blade goes down; when it is pulled back (C), the front blade goes up.

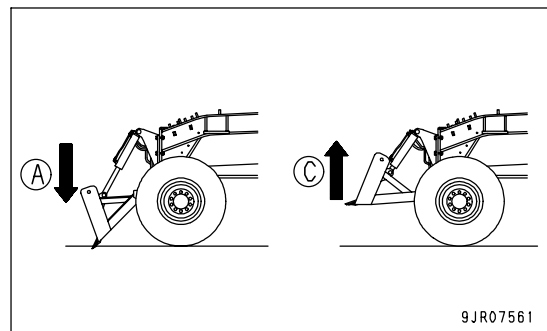
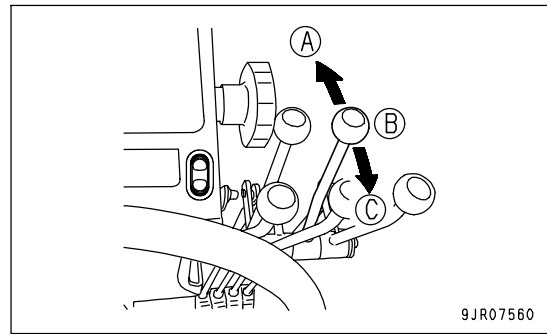

WORK WHICH CAN BE CARRIED OUT USING A MOTOR GRADER

LEVELING GROUND TO RIGHT

1. Operate the drawbar side shift and move the circle approx. 200 mm (7.9 in) to the left.

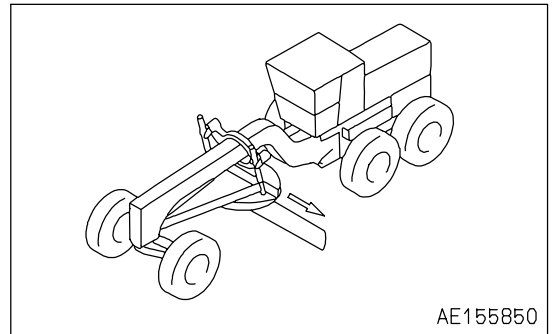

2. Set the blade so that the earth is discharged outside the rear left wheel.

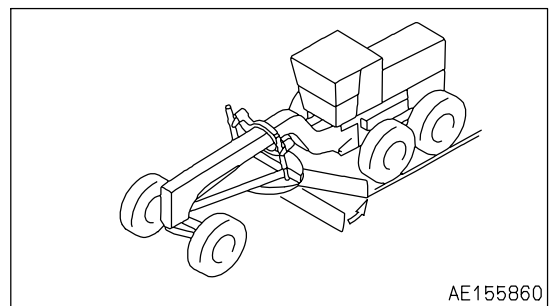

3. Operate the blade lift cylinder so that the blade is at the desired digging depth, then set it horizontal.

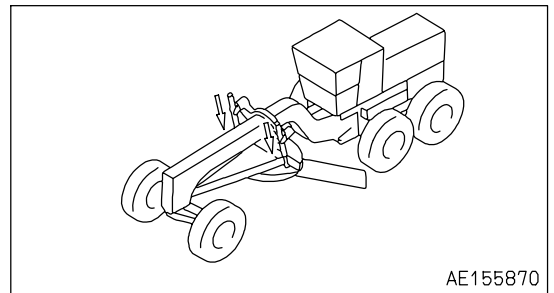

4. Lean the front wheels to the left.

REMARK

Leaning the wheels to the left prevents the machine from being pushed to the right by the load acting on the left side of the machine.

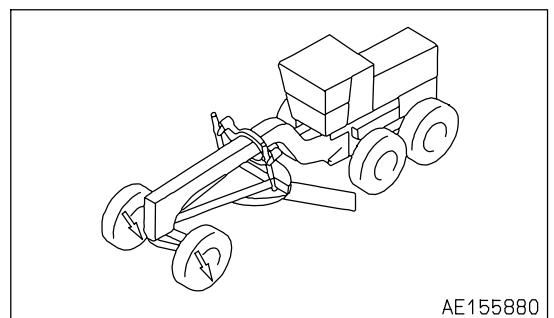

5. Rotate so that the blade is at the optimum position for the soil. (Be careful not to let the rear left wheel run over the windrow discharged from the blade.)

6. Operate the power tilt so that the top of the blade is slightly in front of the cutting edge, then start operation.
7. Discharge the soil to the side to prevent any excessive load from bearing on the machine.

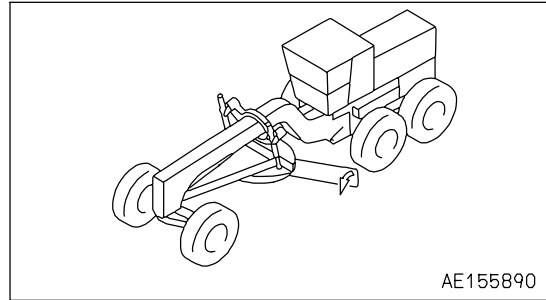

8. Spread fine crushed loose soil over the ground surface until it is level.

REMARK

- Generally speaking, carry out operations on flat ground with the frame straight to the blade. Articulate the frame to deal with the force in the side direction caused by the load on the blade.
- If the tires start to spin, turn the blade to a greater angle to reduce the digging width, thereby reducing the load on the machine.
- In leveling operations, discharge the soil outside the rear wheels. This makes it easier to steer with the rear wheels.

LEVELING GROUND TO LEFT

1. Operate the drawbar side shift and move the circle approx. 200 mm (7.9 in) to the right.

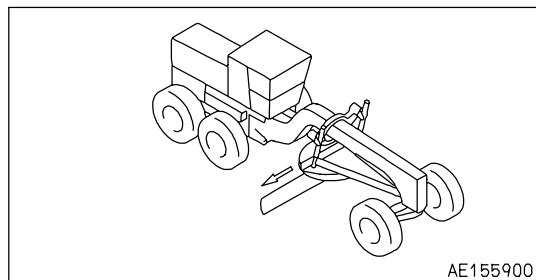

2. Set the blade so that the earth is discharged outside the rear right wheel.

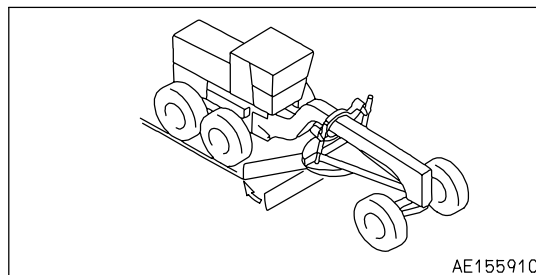

3. Operate the blade lift cylinder so that the blade is at the desired digging depth, then set it horizontal.

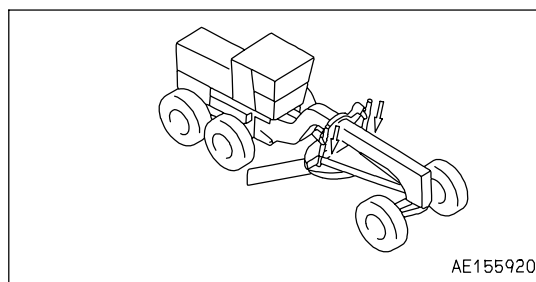

4. Lean the front wheels to the right.
5. Carry out the operation in the same way as when leveling to the right.

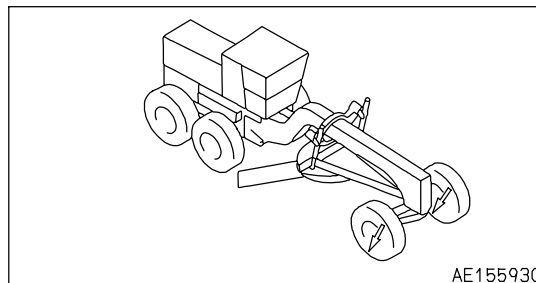

DIGGING RIGHT V-DITCHES

NOTICE

Set the frame straight. If the machine is articulated, the side of the tire will be pushed against the opposite slope face (back slope), and this will cause damage to the side face of the tire. In addition, mud will be pushed in between the tire and rim, and this will cause problems such as leakage of air and flat tires.

1. Rotate the blade and set at an angle so that the soil will be discharged on the inside of the rear left wheel.

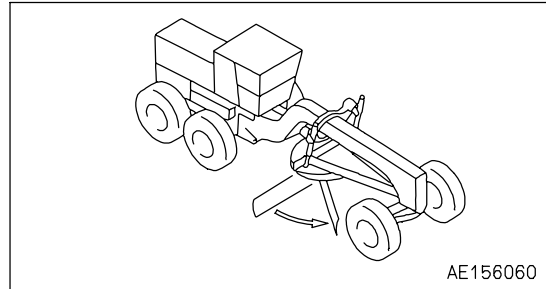

2. Set the right edge of the blade in line with the outside of the front right wheel.

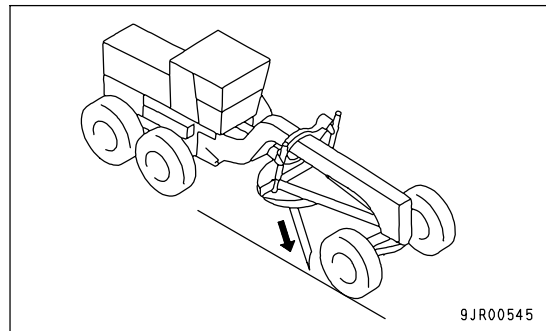

3. Operate the power tilt so that the top of the blade is slightly in front of the cutting edge.

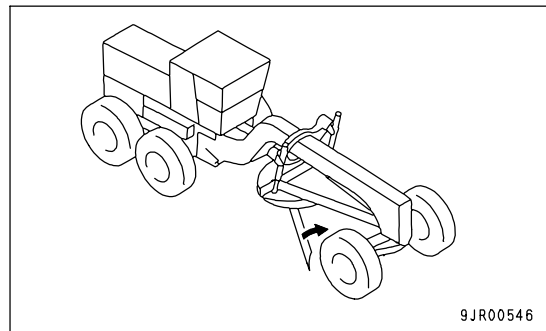

4. Operate the left blade lift cylinder and raise the left edge of the blade. (The right end of the blade determines the depth of the ditch. The left end of the blade determines the shape of the ditch.)

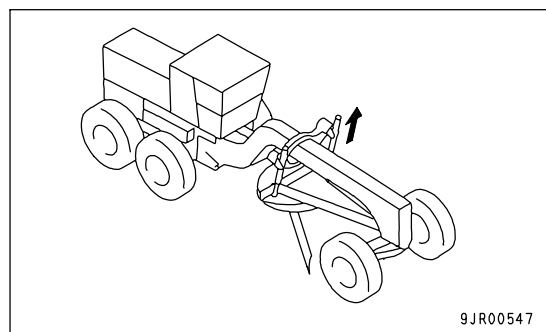

5. Lean the front tire to the left to prevent the tire from rubbing against the side face of the ditch.

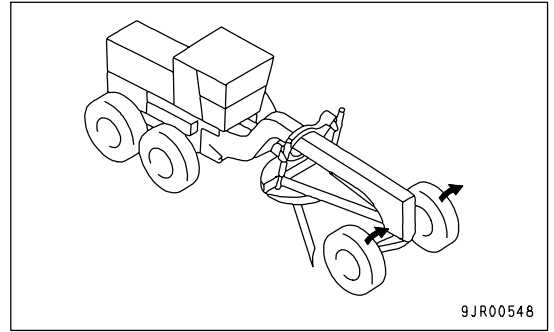

6. Operate the right blade lift cylinder and set the right end of the blade to a digging depth of 50 to 100 mm (2.0 to 3.9 in).
7. Operate the right blade lift cylinder while traveling to set the right edge of the blade to the desired digging depth.
8. Align the front right wheel with the bottom of the ditch and dig a ditch of the desired depth.
- First, dig to depth of 50 mm (2.0 in) to determine the line of the ditch.
 - The chassis is in an unstable position when digging ditches, so align the front and rear wheels with the bottom of the ditch when carrying out such operations.

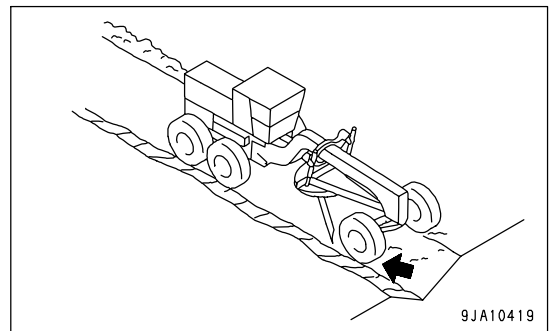

DIGGING LEFT V-DITCHES

NOTICE

Set the frame straight. If the machine is articulated, the side of the tire will be pushed against the opposite slope face (back slope), and this will cause damage to the side face of the tire. In addition, mud will be pushed in between the tire and rim, and this will cause problems such as leakage of air and flat tires.

1. Rotate the blade and set at an angle so that the soil will be discharged on the inside of the rear right wheel.

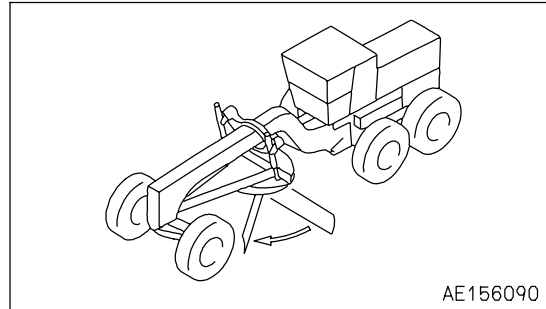

2. Set the left edge of the blade in line with the outside of the front left wheel.

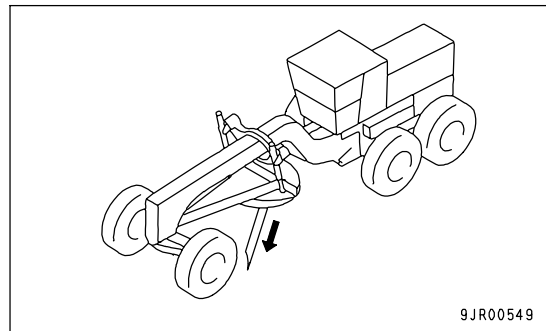

3. Operate the power tilt so that the top of the blade is slightly in front of the cutting edge.

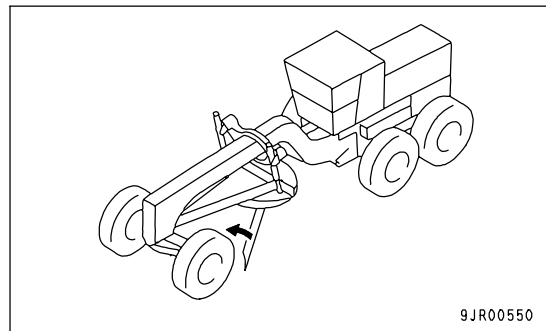

4. Operate the right blade lift cylinder and raise the right edge of the blade. (The left end of the blade determines the depth of the ditch. The right end of the blade determines the shape of the ditch.)

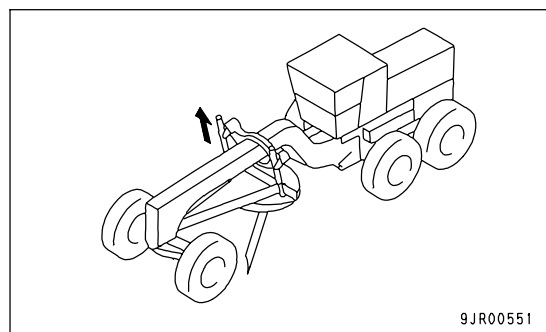

5. Lean the front tire to the right to prevent the tire from rubbing against the side face of the ditch.

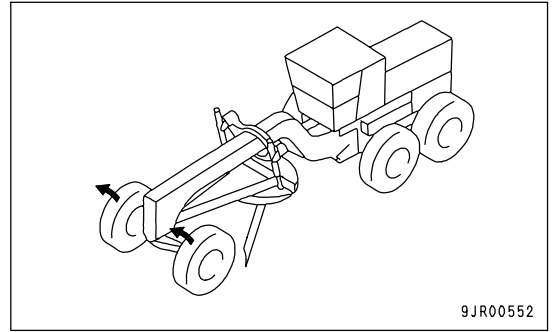

6. Operate the left blade lift cylinder and set the left end of the blade to a digging depth of 50 to 100 mm (2.0 to 3.9 in).
7. Operate the left blade lift cylinder while traveling to set the left end of the blade to the desired digging depth.
8. Align the front left wheel with the bottom of the ditch and dig a ditch of the desired depth.
- First, dig to depth of 50 mm (2.0 in) to determine the line of the ditch.
 - The chassis is in an unstable position when digging ditches, so align the front and rear wheels with the bottom of the ditch when carrying out such operations.

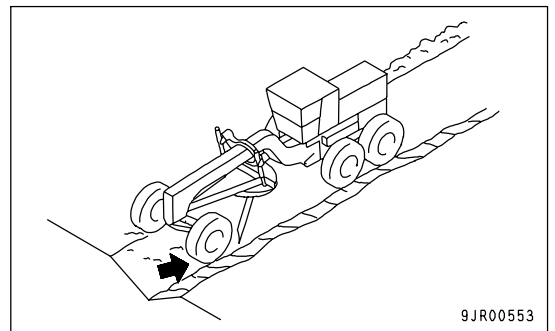

RIGHT DITCH FINISHING

1. Set the right side of the blade behind the front right wheel.

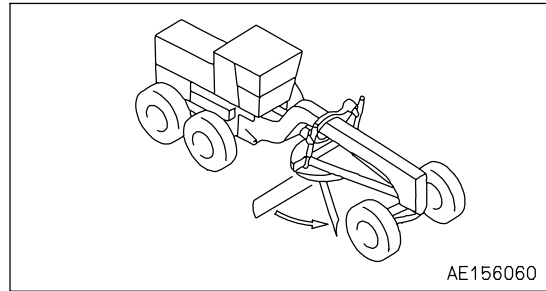

2. Operate the right blade lift cylinder and set the blade to the depth of the ditch.

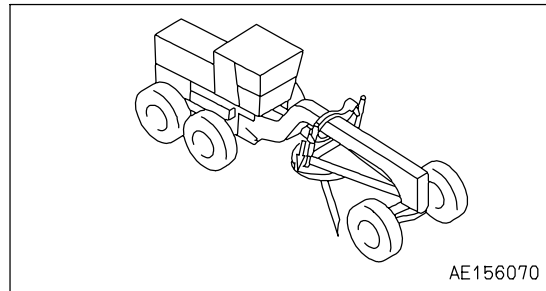

3. Be careful not to let the rear left wheel run over the window discharged from the blade.

Operate the blade lift cylinder and blade rotation to set the blade in position.

4. Lean the front wheels slightly to the left.

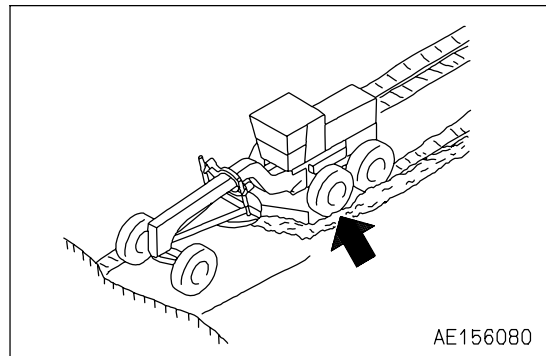

5. To push out the soil to the top of the slope face and the road shoulder, a separate pass is needed. Spread the soil, then carry out final finishing with the grader.

LEFT DITCH FINISHING

1. Set the left side of the blade behind the front left wheel.

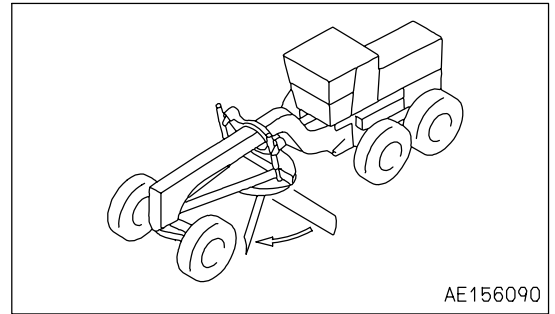

2. Operate the left blade lift cylinder and set the blade to the depth of the ditch.

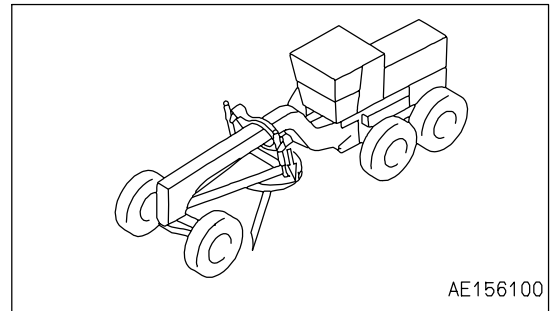

3. Be careful not to let the rear right wheel run over the windrow discharged from the blade.
Operate the blade lift cylinder and blade rotation to set the blade in position.
4. Lean the front wheels slightly to the right.

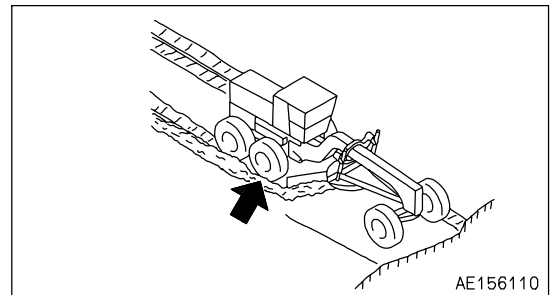

5. To push out the soil to the top of the slope face and the road shoulder, a separate pass is needed. Spread the soil, then carry out final finishing with the grader.

FINISHING RIGHT ROAD SHOULDER

1. Operate the drawbar shift cylinder to set the circle to the right end.

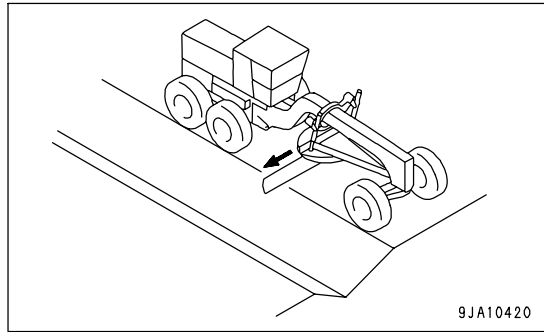

2. Set so that the right end of the blade is in line with the outside of the right tire. Set the blade so that the soil is discharged between the two wheels. (The soil can be moved more smoothly if the blade is at a small propulsion angle.)

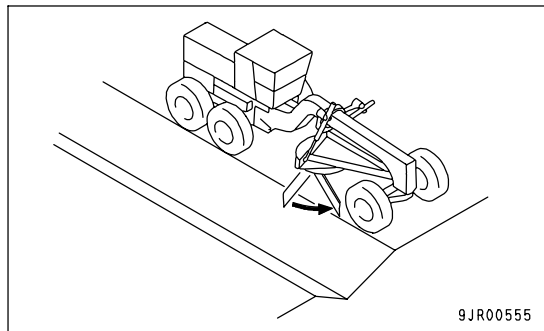

3. Align the center of the machine with the line of the soil discharged when digging the ditch.
4. Operate the left and right blade lift cylinders to keep the blade horizontal and at the desired digging depth.

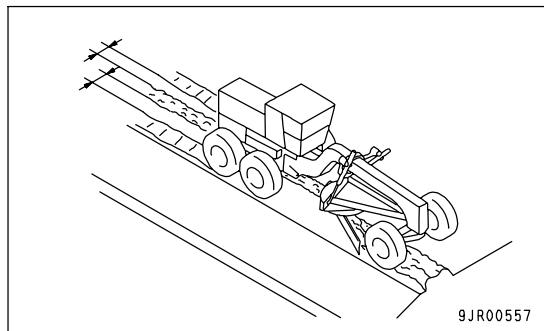

5. Lean the front wheels slightly to the left.

FINISHING LEFT ROAD SHOULDER

1. Operate the drawbar shift cylinder to set the circle to the left end.

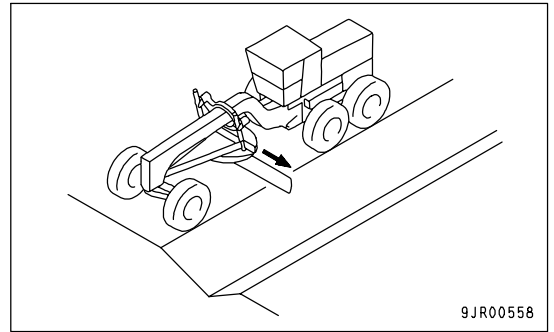

2. Set so that the left end of the blade is in line with the outside of the left tire. Set the blade so that the soil is discharged between the two wheels. (The soil can be moved more smoothly if the blade is at a small propulsion angle.)

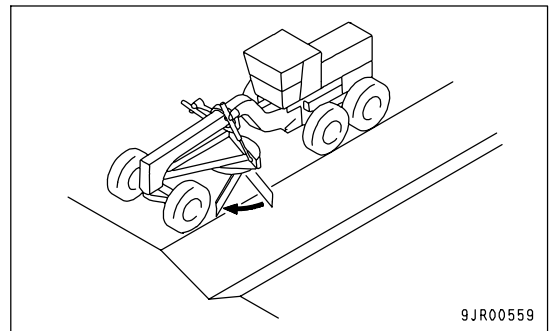

3. Align the center of the machine with the line of the soil discharged when digging the ditch.
4. Operate the left and right blade lift cylinders to keep the blade horizontal and at the desired digging depth.

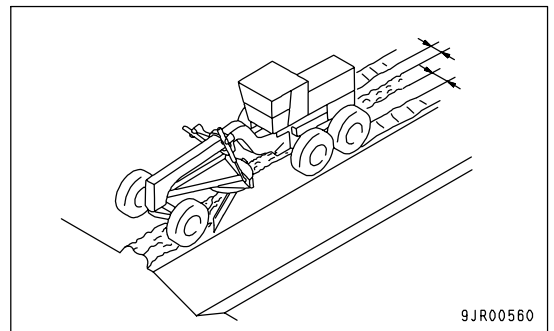

5. Lean the front wheels slightly to the right.

CONSTRUCTING ROAD - METHOD OF MAKING V-DITCH

The procedure shown in the diagrams is for one side of the road. Repeat the same operation on the opposite side of the road.

When carrying out Steps 4 and 7, articulate the frame.

1. Line of ditch: Light-duty digging

- Determine the line of the ditch along the measured points.
 Depth: approx. 50 mm (2.0 in)
 Travel speed: approx. 2 km/h (1.2 MPH)

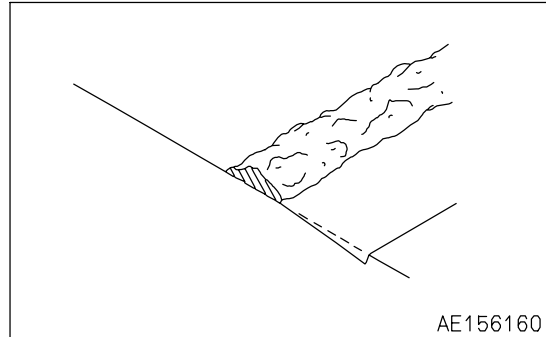

2. Second digging pass: Heavy-duty digging

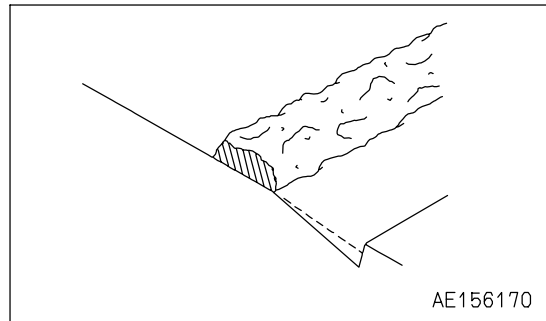

3. Third digging pass: Heavy-duty digging

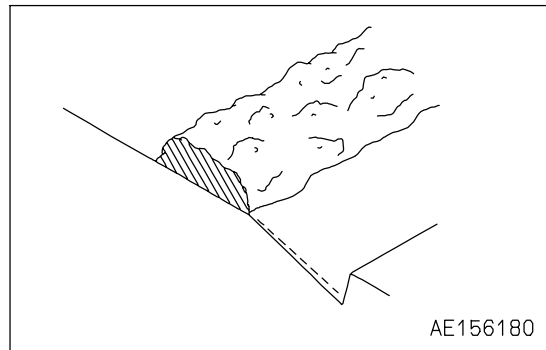

4. Finishing road shoulder

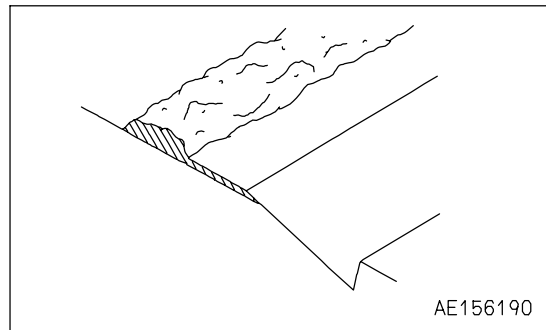

5. Leveling center

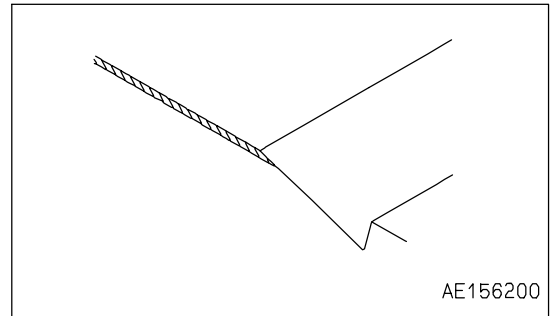

6. Fourth digging pass: Heavy-duty digging

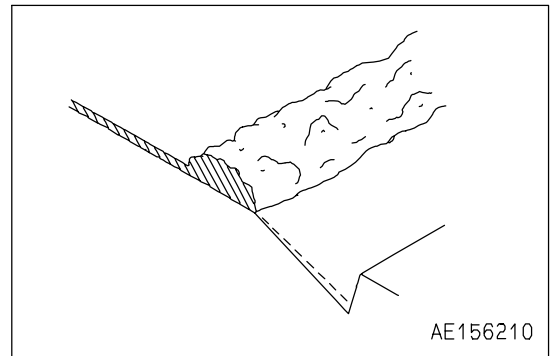

7. Finishing road shoulder

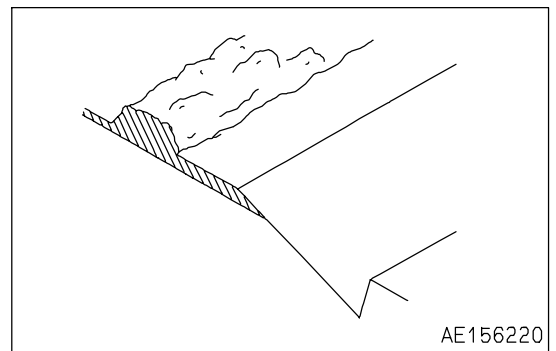

8. Spreading to center

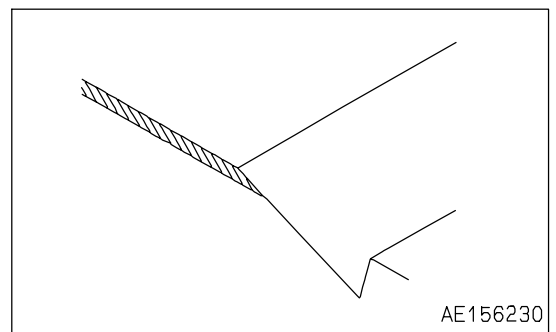

9. Slope face and bank
Use the bank cutting posture.

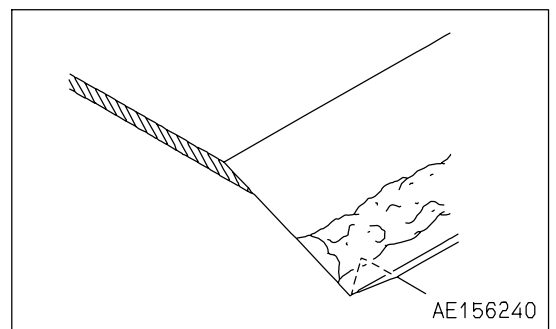

10. Finishing bottom of ditch

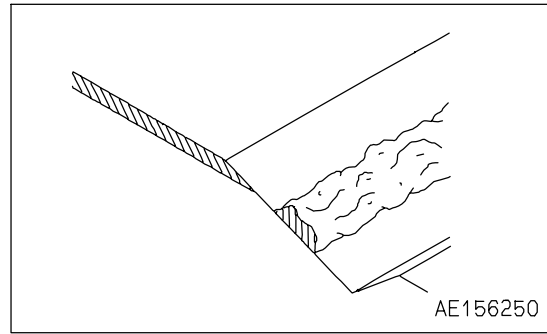

11. Ditch digging pass (finishing and shaping inside of the slope face)

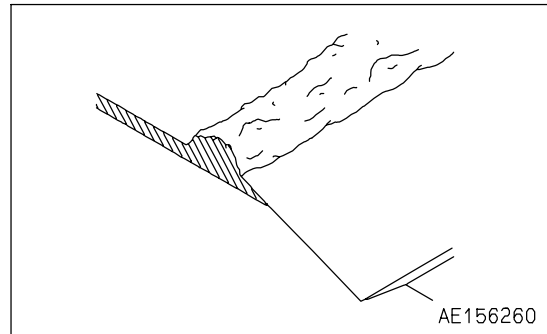

12. Finishing slope face

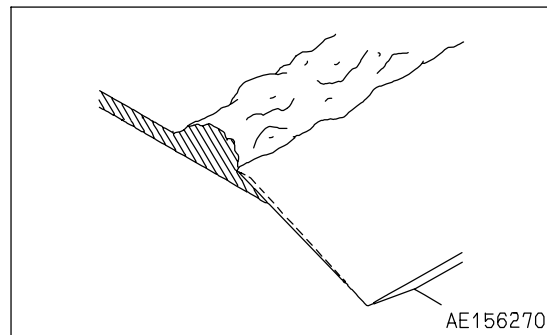

13. Finishing road shoulder

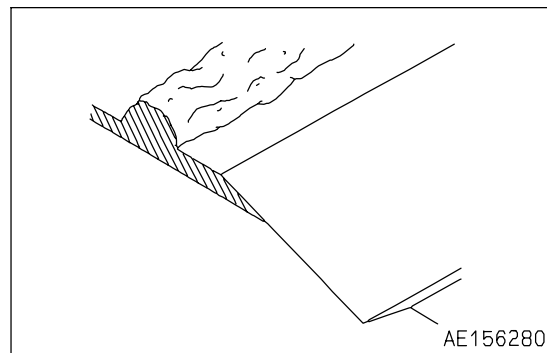

14. Leveling and finishing

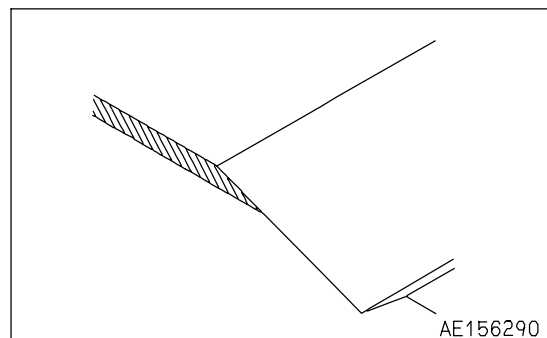

FLAT-BOTTOMED DITCH

If there is no V-groove, make a V-groove at depth (A) of the flat-bottomed ditch. The slope of the road shoulder must be flatter than usual.

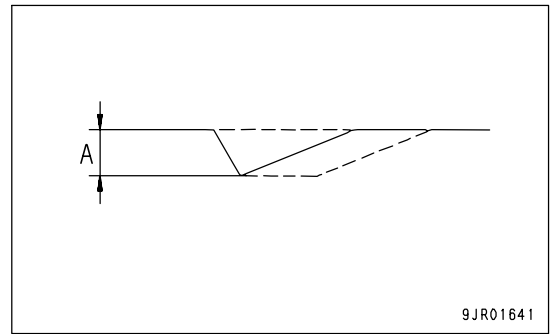

1. Operate the power tilt and angle the blade to the front.
2. Operate the drawbar shift cylinder and set the circle fully to the left of the machine.

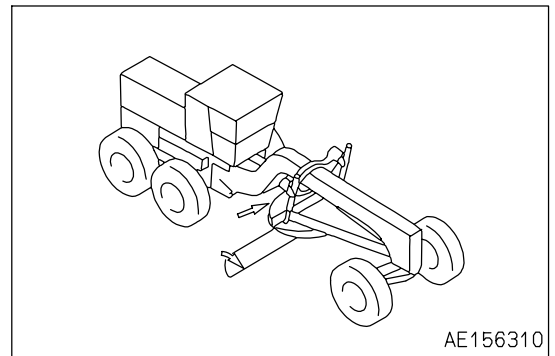

3. Place the front right tire in the bottom of the V-ditch.
4. Set the blade so that the right edge of the blade comes to the inside of the front right tire at the width of the flat-bottomed ditch.

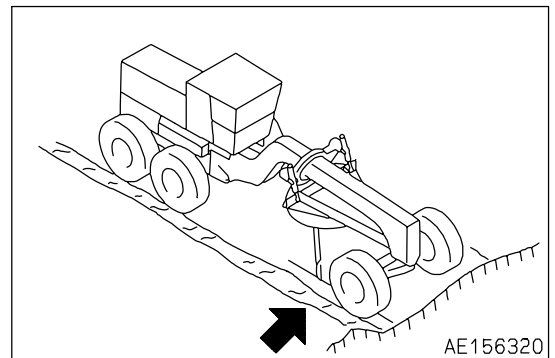

5. Operate the right blade lift cylinder to lower the right end of the blade, and set it to the digging depth.
6. Operate the left blade lift cylinder to raise the right end of the blade, and set it to the desired angle for the slope face of the road shoulder.

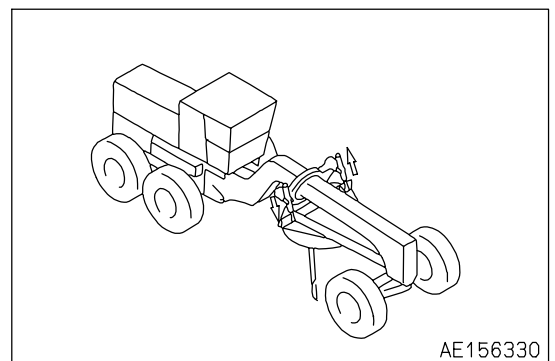

7. Lean the front wheels to the left. Dig the second V-groove (2) at the same depth or slightly deeper than the first V-groove (1).
8. Dig the flat bottom. Set the right blade lift cylinder to the desired depth.
9. Operate the left blade lift cylinder as required.

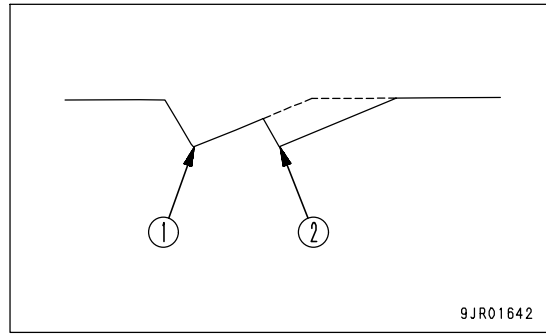

9JR01642

10. Set the front right tire at the bottom of the first V-ditch and start the operation.
11. Set the right edge of the blade at the bottom of the slope.

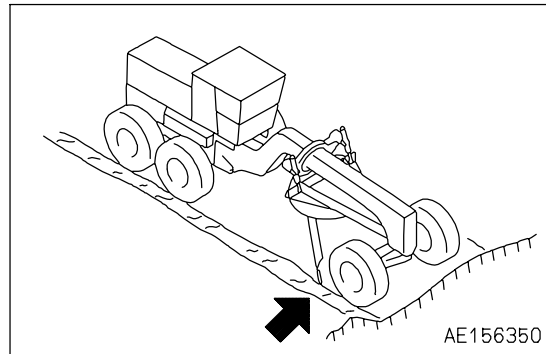

AE156350

12. Lower the right blade lift cylinder so that the tip of the blade is the set precision for the ditch.

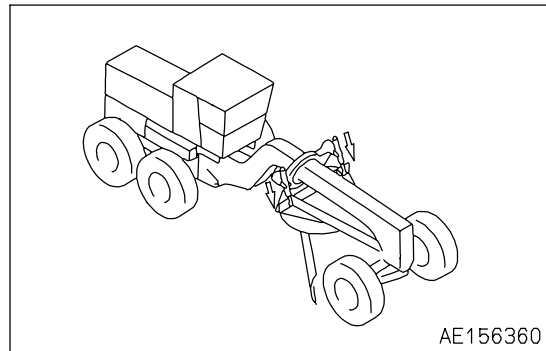

AE156360

13. Lower the left lift cylinder to the desired digging depth. Lean the front wheels to the left.

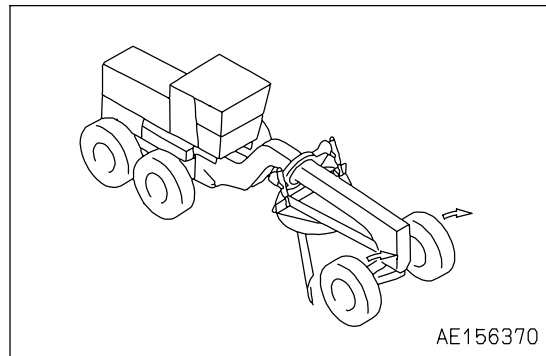

AE156370

14. Set the blade at an acute angle and push up the soil to the top of the ditch slope.
15. Spread the windrow and finish to the final precision.

CONSTRUCTING ROAD - METHOD FOR MAKING FLAT-BOTTOMED DITCH

The procedure shown in the diagrams is for one side of the road. Repeat the same operation on the opposite side of the road.

1. Make the slope face on the inside flat.

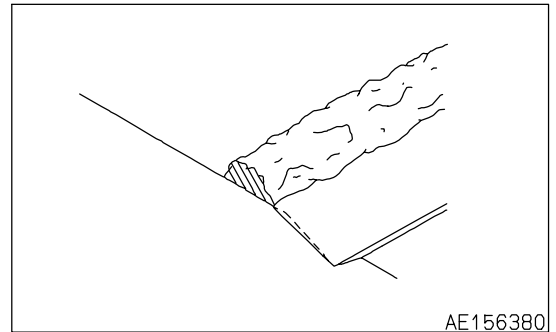

2. Dig the width and depth of the bottom of the ditch with the left ditching method.

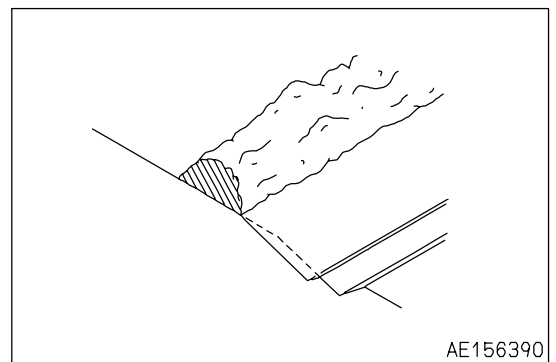

3. Finish the road shoulder.

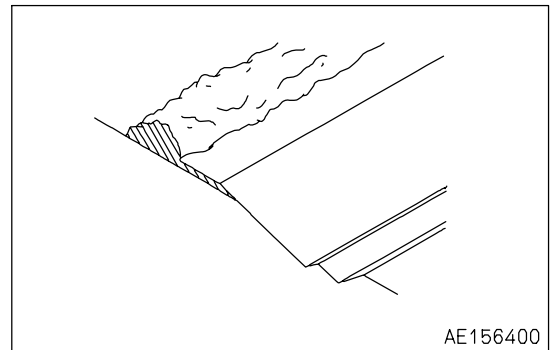

4. Spread the soil to the center.

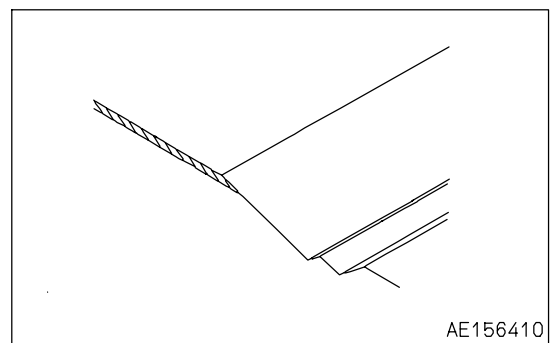

5. Finish the slope face on the bank.

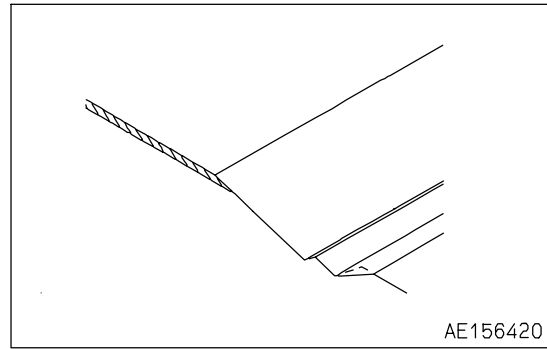

6. Make the bottom of the ditch flat.

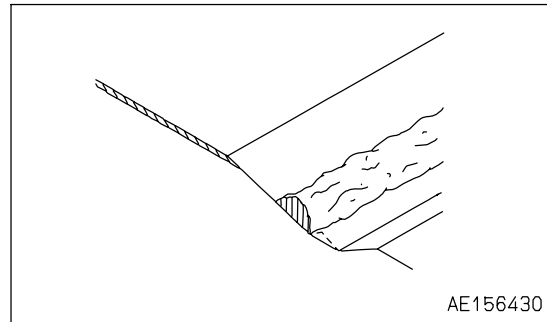

7. Finish the ditch.

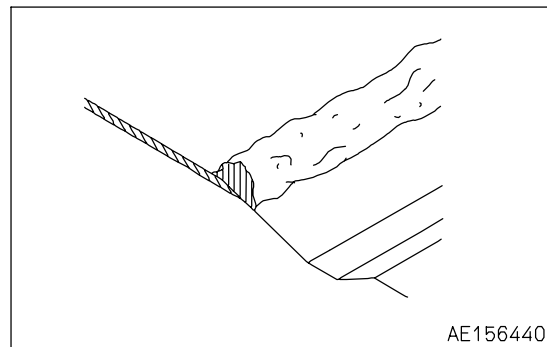

8. Finish the slope face on the inside.

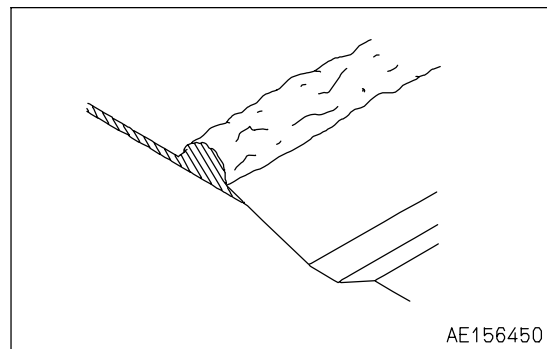

9. Finishing slope face

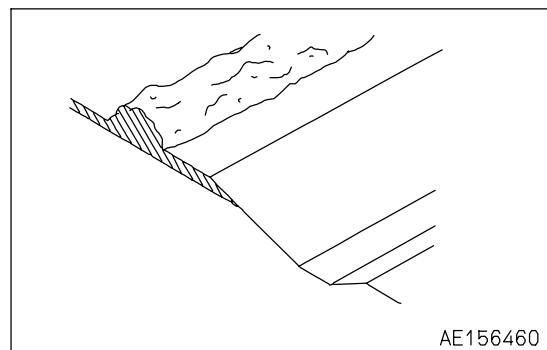

10. Leveling and finishing.

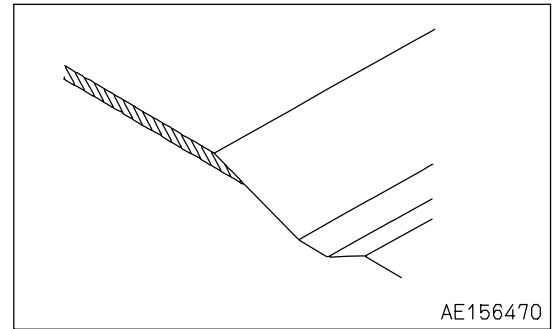
**FINISHING WITH GRADER FOR DITCHES WHERE WET ROAD SHOULDER IS LOOSE**

This method is used when avoiding hanging trees or protruding rocks which are obstacles when cleaning old ditches.

1. Articulate the machine so that the front wheels and blade remain in the ditch. Steer with the front wheels.
2. Keep the rear wheels on the road shoulder and be careful that the wheels do not slip on the soft weak soil of the ditch.

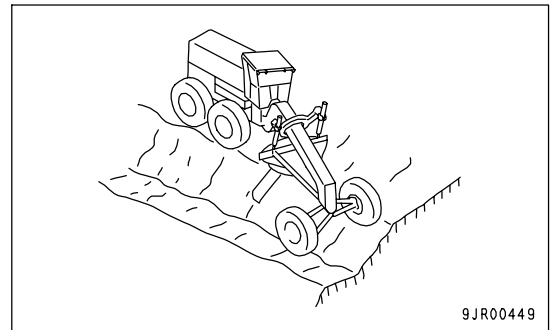
**LEVELING SLOPE FACE****WARNING**

- When operating on slopes where the machine may slip to the side, make sure that you understand the operation of the machine completely.
- Do not articulate the machine fully on steep slopes.
- On steep slopes, lower the engine speed and operate in 1st gear.
- When operating on slopes, use the accelerator to control the machine speed.

BANK CUTTING METHOD - RIGHT SIDE

WARNING

Lower the blade to the ground before removing the bank control lock pin.

1. The roadbed where the foundation is to be dug must be uniform.
2. If the soil is hard, angle the roadbed slightly towards the bank to prevent the machine from sliding to the side away from the bank.
3. Set to the bank cut posture. For details, see "BANK CUTTING POSTURE (RIGHT SIDE) (PAGE 3-158)".

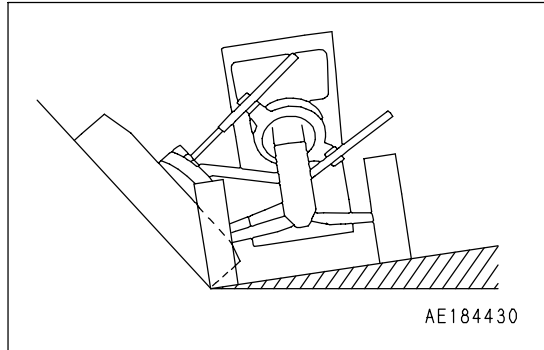

4. Rotate the circle and extend or retract the left and right blade lift cylinders to set to the bank slope face posture.
5. From the high bank position, rotate the blade so that the top of the blade is at the front. This sets it to the low bank posture, which is suited for scraping operations.

REMARK

If the top of the blade is rotated to the rear, the blade can be set to the reverse low bank posture, which makes it possible to cut the slope face while scraping up the soil.

To scrape up the soil smoothly, a shallow angle slope is needed. Rotate the blade until the bottom of the blade is close to the front tires. Be careful not to let the blade hit the tires.

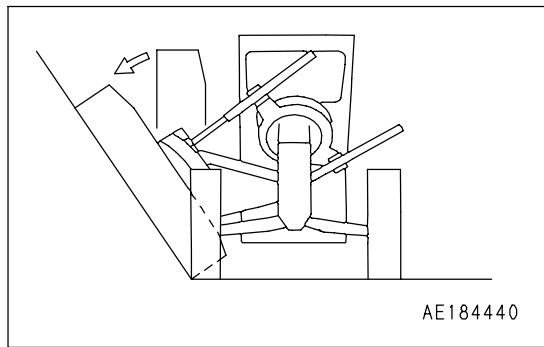

6. Extend the left blade lift cylinder, and set the tip of the left cutting edge of the blade in line with the outside of the rear wheels at the bottom of the slope face.
7. The rear right wheel must be in the V at the base of the slope face.

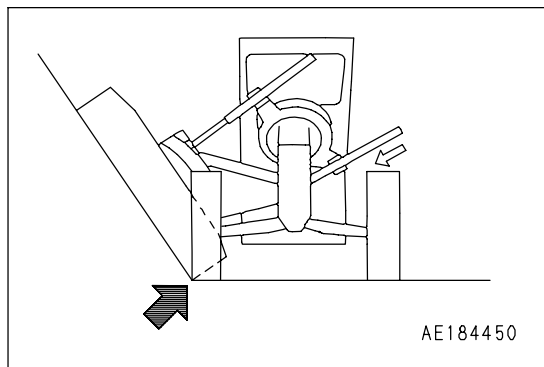

8. Extend the right blade lift cylinder and set the angle to the desired bank slope face.
9. Gradually progress with the cutting.

REMARK

The wheels should normally be almost perpendicular.

10. If the digging is comparatively heavy duty, angle the wheels towards the slope face.

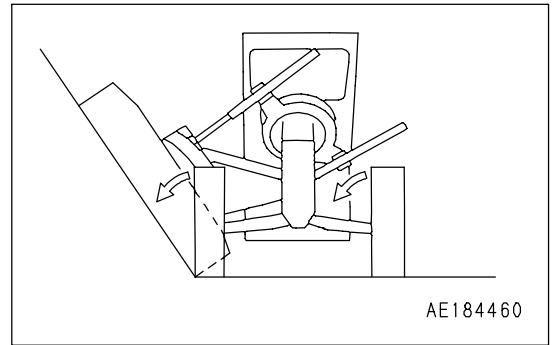

11. If the digging is comparatively light duty, angle the wheels away from the slope face.
Discharge the soil from the slope face to the outside of the rear wheels.

REMARK

The procedure in the diagram is for the right side. For the left side, set the blade in the opposite position.

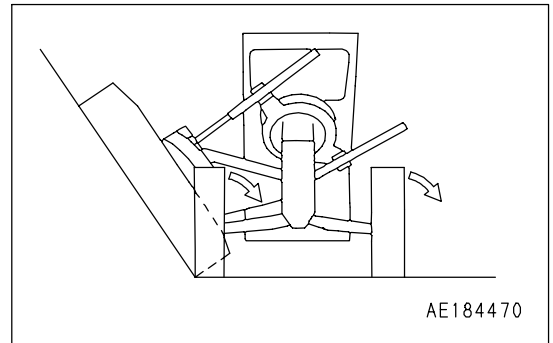

SHOULDER REACH METHOD - RIGHT SIDE

Set to the shoulder reach posture and carry out operations.

For details, see "SHOULDER REACH POSTURE (RIGHT SIDE) (PAGE 3-160)".

PRECAUTIONS WHEN OPERATION

PRECAUTIONS WHEN TRAVELING UPHILL OR DOWNHILL



WARNING

- Never shift gear or place the transmission in neutral when traveling on a slope. It is dangerous to do this, as the engine cannot be used to brake the machine. Always place the transmission in the appropriate speed range before starting to travel down a hill.
- To prevent overrun, always shift down one gear at time.



WARNING

- When going downhill, shift down the transmission to use the engine brake.
- To prevent the engine from overrunning, the rotation range enabling downshifts is limited. Reduce the travel speed by depressing the brake pedal and, after the speed becomes within the range where downshifts are possible, carry out the downshift operation.

Gear speed	Travel speed enabling downshifts (km/h, (MPH))
F2 -> F1	4.5 (2.8)
F3 -> F2	6.5 (4.0)
F4 -> F3	9.0 (5.6)
F5 -> F4	13.0 (8.1)
F6 -> F5	20.0 (12.4)
F7 -> F6	29.0 (18.0)
F8 -> F7	39.5 (24.5)

TRAVELING DOWNHILL

When traveling downhill, use the same speed range as when traveling uphill, and make full use of the braking force of the engine.

If the machine travel speed is still too fast, use the foot brake.

REMARK

If there is a risk of overrunning of the engine, the centralized warning lamp lights up and the short alarm sounds continuously, and the gear is possibly shifted up to the next speed at the same time. These are not abnormal.

As the travel speed slows down, the gear speed automatically returns to the speed set by the gear shift lever.

IF ENGINE STOPS



CAUTION

If the engine stops, the brake booster will not work, so the operating effort of the pedal will become heavier and the effect of the brake will become lower, even when the pedal is depressed with the same force.

If the engine stops on a slope, immediately depress the brake pedal fully to stop the machine, set the gearshift lever to the P (Parking) position, then start the engine again.

PRECAUTION FOR OPERATION

CAUTION

As this machine installes a torque converter with lockup clutch, the change-over between Manual mode and torque converter Auto mode is available by using the transmission mode selection switch.

However, as some operations possibly apply excessive loads to the lockup clutch and cause failures, observe the following cautions.

- When the torque converter is stalling in T/C auto mode, do not switch to Manual mode.
- Carry out laden moving (starting of the machine with its blade loaded) in Manual mode at F3 (the 3rd forward speed) or lower gear speed.
- Before making directional selections halfway on slope in Manual mode, be sure to stop the machine by applying the brake even when traveling at low speeds.
- Do not make gear shifts halfway on steep slope in Manual mode.

When entering a slope in Manual mode, select a gear speed suitable for the slope angle and then enter.

PERMITTED WATER DEPTH

When operating in water or swampy ground, do not go deeper than the permitted water depth (the distance to the bottom surface of the axle housing (1) and tandem drive (2)).

After completing operations, wash the machine and grease all parts that were under water.

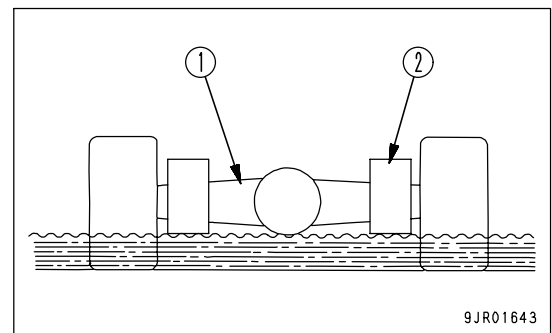

9JR01643

WHEN BRAKES DO NOT WORK

If the machine does not stop even when the brake pedal is depressed, set the gearshift lever to the P (Parking) position to apply the parking brake and stop the machine.

NOTICE

If the parking brake has been used as an emergency brake, please contact your Komatsu distributor to have the parking brake checked for any problem.

PRECAUTIONS WHEN USING ARTICULATED STEERING

When the articulation is used to steer the machine, the machine will turn sharply, so at high speed there is a danger that it will turn over. For this reason, only use the articulation at speeds of less than 10 km/h (6.2 MPH).

PRECAUTIONS WHEN TRAVELING ON ROADS

When traveling on roads (high speed travel), stop after traveling 80 km or 2 hours (whichever comes first), and rest for 30 minutes. For the next cycle, rest for one hour, and for the cycle after that, rest for 30 minutes. Repeat this double cycle until you reach the destination.

CAUTIONS IN OPERATION OF WORK EQUIPMENT

When operating the work equipment control lever, always pay careful attention to the movement of the work equipment and do not move it more than necessary as the work equipment or the hydraulic cylinder may hit and damage other parts.

When the work equipment is operated, special attention should be given to avoiding contact between the following parts.

- Blade and front wheel

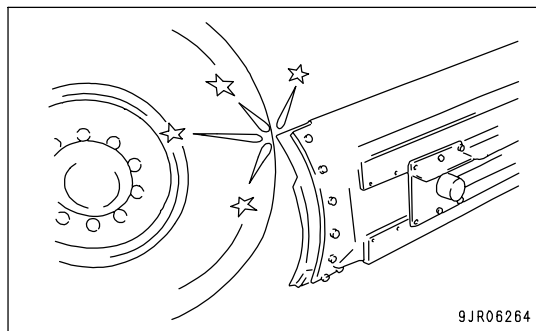

- Blade and step

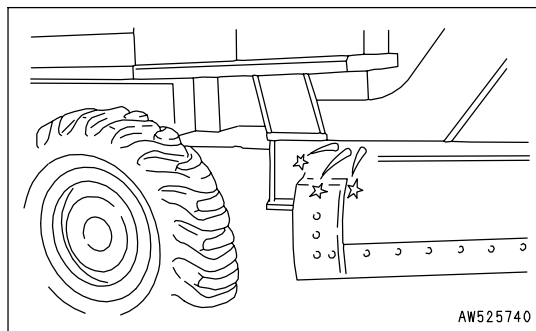

- Blade and frame
- Blade and operator's cab

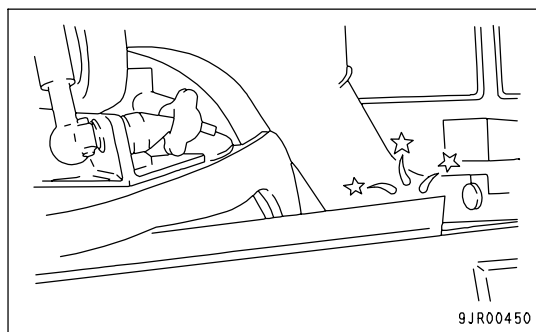

RIPPER OPERATIONS - WITH FRAME STRAIGHT



CAUTION

When using the ripper, set the frame straight.

For heavy-duty conditions, use 1 to 3 shanks.

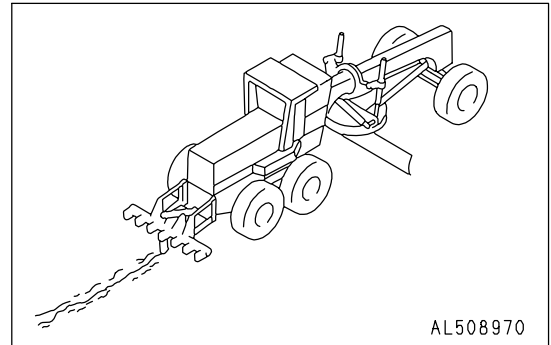

For general soil condition, use 3 to 5 shanks.

Keep the ripper at a depth where there is no tire slip and where the engine horsepower can be used to its full.

Travel in a straight line at approx. 2 to 4 km/h (1.2 to 2.5 MPH), and gradually insert the points into the ground.

On slopes, carry out ripping downhill to use the weight of the machine.

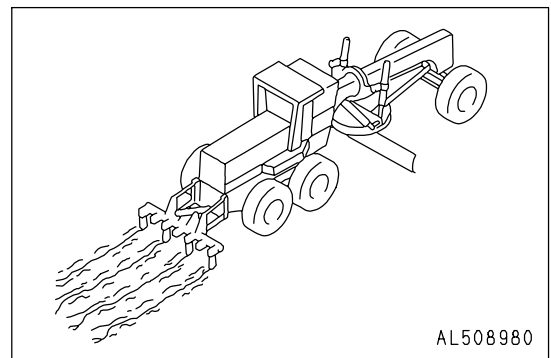

NOTICE

To prevent damage, raise the ripper from the ground before turning the machine.

Carry out cross ripping only when there is a special purpose.

When breaking up a paved surface, raise the ripper after digging up the ground the surface.

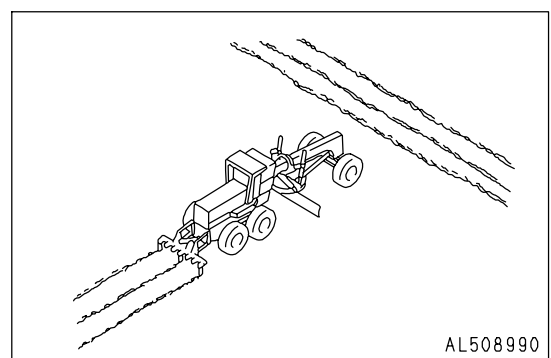

PRECAUTIONS WHEN INSTALLING FRONT BLADE



WARNING

Machine equipped with front blade has a blind spot in front of tire due to interruption by blade. Operate the machine carefully.

- Confirm that there are no person and other obstacles around the machine before starting.
- Sound the horn to warn the people around before starting.

-
- While traveling, keep the front blade at most raised position.
 - If the machine travels with front blade close to the ground, it may hit rocks in the ground and may be damaged.



CAUTION

Front blade is not equipped with safety device for heavy load.

If a heavy shock or excessive load is given to front blade, it may damage not only the front blade but also other parts of the machine.

When using front blade, take care about the followings.

- Use the front blade mainly for the leveling work.
- Do not scrape hard soil, compressed snow or ice, because it may damage the front blade or other parts of the machine.
- Even when scraping soft soil, avoid offset load work.
- Do not turn during operating front blade.

In case turning the machine is necessary due to avoidable reasons, raise the front blade to reduce the load, then operate the steering wheel.

ADJUSTING WORK EQUIPMENT POSTURE

Move the work equipment to the most suitable position for each operation and carry out operations efficiently.

BLADE PROTRUSION

The degree of protrusion is controlled by the control lever during operation. If further protrusion is needed, stop the grader for a while and change the installing position of the blade horizontal shifting cylinder piston rod, as follows.

1. Lower the blade to the ground.
2. Loosen the bolt holding the blade to the bracket at the tip of the cylinder rod, then remove the bolt and lock washer.
3. Retract or extend the cylinder and rod.
4. Align the bolt hole in the bracket with a hole in another place on the blade.
5. Install the lock washer and bolt, then tighten the bolt.
 - Protrusion to right: Position (1)
 - Protrusion to left: Position (2)
 - Standard position: Center

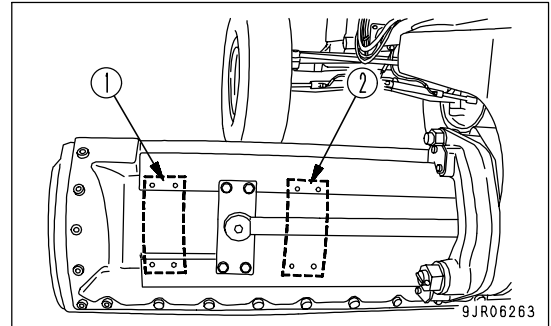

BLADE PROPULSION ANGLE

The angle between the blade and the center line of the machine body is called the blade propulsion angle.

Set the blade propulsion angle to about 60° for general cutting work, but set it narrower in the following situations.

- When the cutting resistance is high.
- When the soil is hard.
- When the soil accumulated in front of the blade does not flow smoothly.

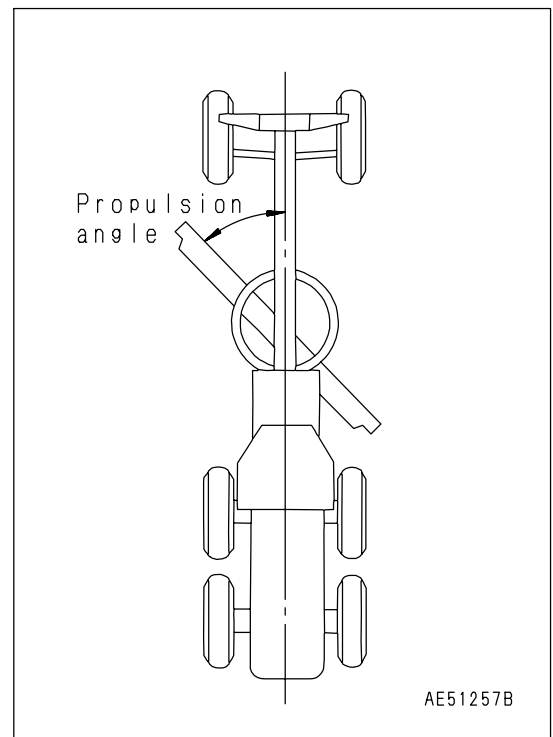

ADJUSTING BLADE CUTTING ANGLE

Generally, the operating efficiency is better if the blade cutting angle is large when cutting hard soil and small when cutting soft soil.

The blade cutting angle is installed to the power tilt blade, and it can be freely changed within the range below.

- Cutting angle
- Minimum: 32°
- Maximum: 81°

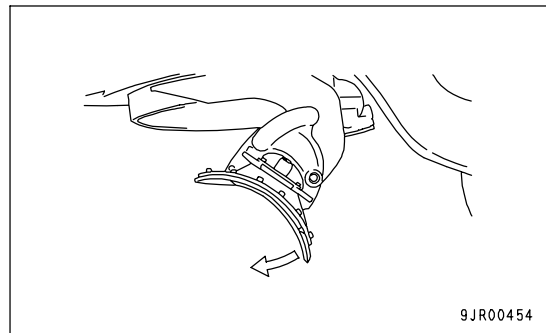
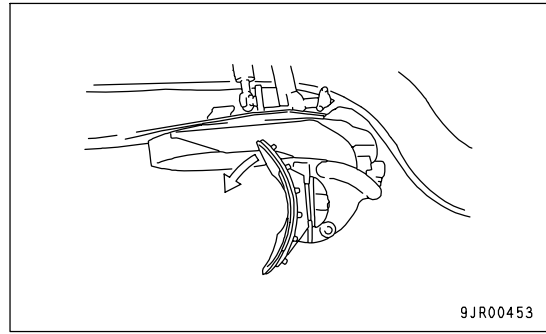

The power tilt blade can carry out normal blade operation, and also has the following advantages.

- It is possible to set to the optimum blade cutting angle to match the type of soil simply by operating one lever.

- (A): For hard soil
- (B): For soft soil

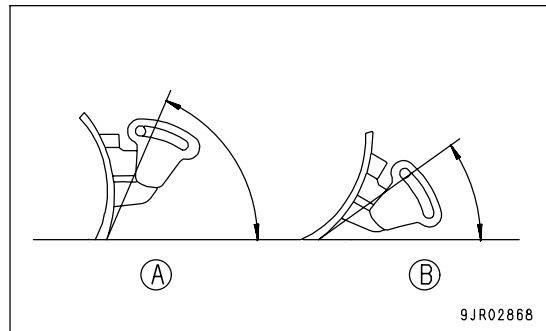

- It is possible to keep the cutting edge sharp for operations, so this blade can display its power when removing frozen ice during snow-clearing operations.

- (C): Frozen ice
- (D): Soft snow

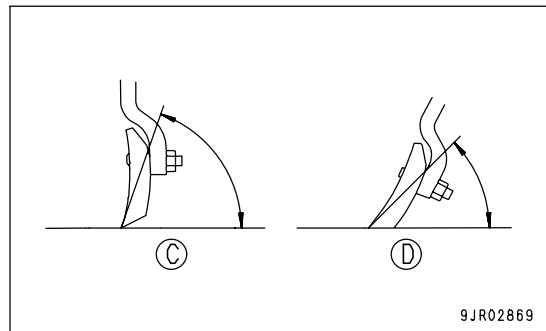

- It is possible to change the distance between the cutting edge and cutting surface, so fine adjustment can be made in the height of the cutting surface and cutting edge.

- When scooping up soil or snow with the low bank posture, the optimum blade cutting angle is selected, so work can be carried out efficiently.

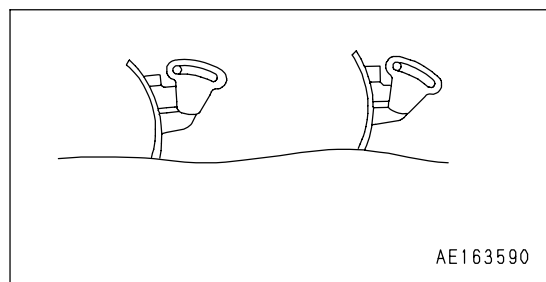

SAFETY DEVICE OF BLADE

A slip clutch is installed to the circle to prevent accidents when an abnormal impact load is applied to the end of the blade during work.

If any problem occurs in the slip clutch, the following problems may appear, so please contact your Komatsu distributor for repairs and adjustment.

Examples of failure

When operating the blade rotation control lever, the circle does not rotate.

- Even if the motor is running, the clutch is slipping and the circle does not rotate.
 - > As the clutch is likely to burn, adjustments are necessary.
- The hydraulic system is in relief state and the circle does not rotate.
 - > This is normal. However, if the slip torque is in maximum or excessively high, the clutch may be damaged.

BANK CUTTING POSTURE (RIGHT SIDE)

WARNING

Lower the blade to the ground before removing the bank control lock pin. Do not remove it at any other position. There is danger that it will rotate and the blade will fall.

NOTICE

- When shifting to the bank cut posture, be careful not to let the blade hit any other part of the machine.
- If the bank pin passes over the hole in the lifter guide, do not rotate the lifter any further. There is danger that the frame and bank pin case will come into contact and that the bank pin case will be broken.

1. Extend the blade and drawbar fully to the right, rotate the circle and set the end of the blade at the side of the front right wheel, then lower the blade so that it is lightly in contact with the ground.

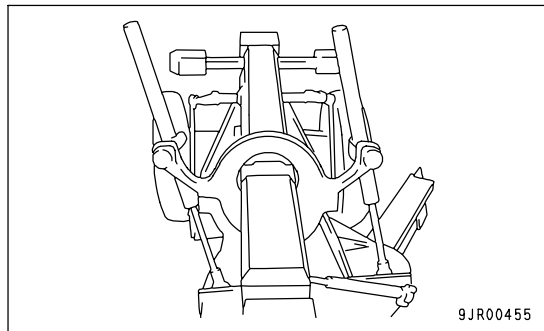

2. Push the bank control lock pin switch and remove lock pin (1). If lock pin (1) is held by lifter (2) and will not come out, operate the blade lift cylinder to make it possible to remove the pin.

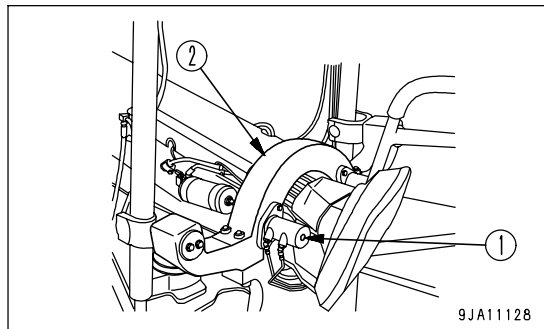

3. Check that indicator pin (3) at the rear of the lock pin has come out fully and that the lock pin has been removed, then extend the right blade lift cylinder and retract the left blade lift cylinder to rotate lifter (2) counterclockwise. Operate lifter (2) to the desired counter mark (A), then lock with lock pin (1). Check that the protrusion of indicator pin (3) has been removed and that the lock pin is completely locked.

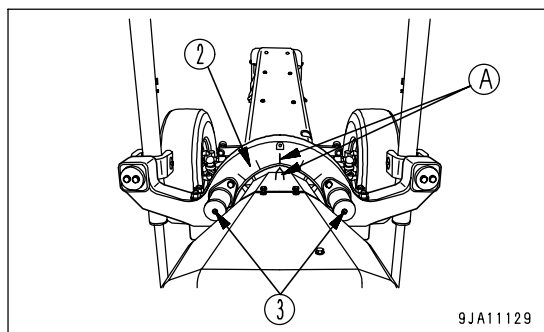

NOTICE

If the lock pin switch is kept pushed in the pin lock direction while the lifter is being rotated, there is danger that the bushing or lifter ring will be damaged. Rotate the lifter to the specified counter mark, then lock the lock pin.

- Retract the right lift cylinder and extend the left lift cylinder repeatedly, then raise the blade and rotate it to the right side of the machine to set the blade to the bank cut position.

When setting to the bank cut posture on the left side, use the same procedure as above, but in the opposite direction.

REMARK

To improve the banking performance, set the installation position of the piston rod of the blade side shift cylinder to the left position when carrying out the banking on right side, and to the right position when carrying out banking on the left side.

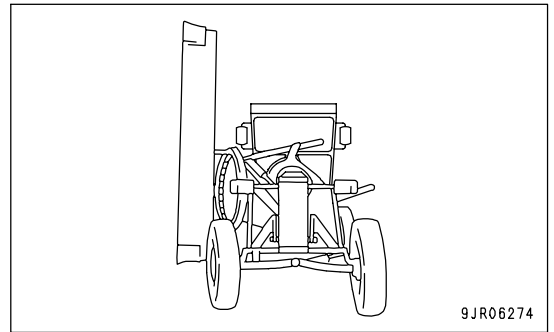

9JR06274

SHOULDER REACH POSTURE (RIGHT SIDE)

**WARNING**

Lower the blade to the ground before removing the bank control lock pin. Do not remove it at any other position. There is danger that it will rotate and the blade will fall.

NOTICE

- When shifting to the shoulder reach posture, be careful not to let the blade hit any other part of the machine.
- If the bank pin passes over the hole in the lifter guide, do not rotate the lifter any further. There is danger that the frame and bank pin case will come into contact and that the bank pin case will be broken.

1. Extend the blade and drawbar fully to the right, rotate the circle and set the end of the blade at the side of the front right wheel, then lower the blade so that it is lightly in contact with the ground.

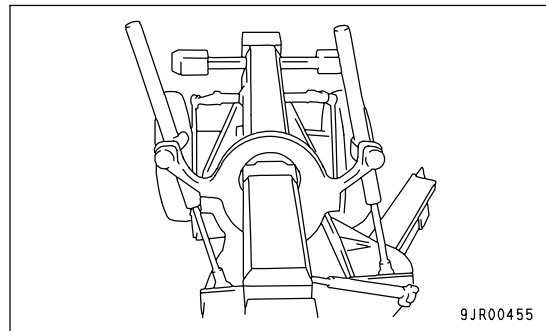

2. Push the bank control lock pin switch and remove lock pin (1). If lock pin (1) is held by lifter (2) and will not come out, operate the blade lift cylinder to make it possible to remove the pin.

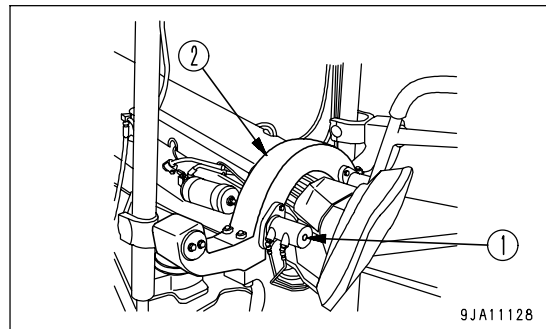

3. Check that indicator pin (3) at the rear of the lock pin has come out fully and that the lock pin has been removed, then extend the right blade lift cylinder and retract the left blade lift cylinder to rotate lifter (2) counterclockwise. Operate lifter (2) to the desired counter mark (A), then lock with lock pin (1). Check that the protrusion of indicator pin (3) has been removed and that the lock pin is completely locked.

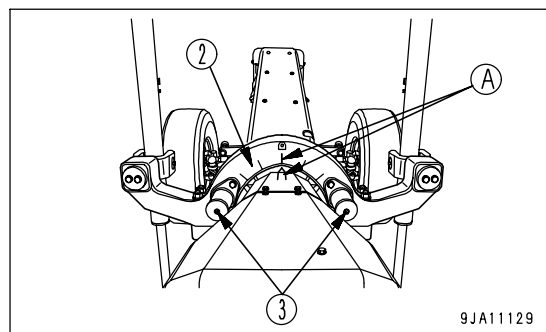

NOTICE

If the lock pin switch is kept pushed in the pin lock direction while the lifter is being rotated, there is danger that the bushing or lifter ring will be damaged. Rotate the lifter to the specified counter mark, then lock the lock pin.

4. Shift the blade to the side as shown in the diagram.
 - Shift the blade fully to the right.
 - Shift the drawbar fully to the right.
5. Rotate the circle and set to the desired position.

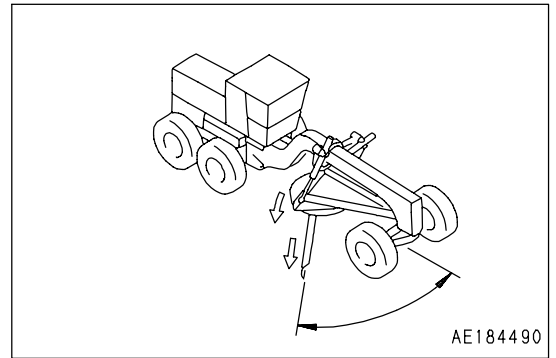

When setting to the shoulder reach posture on the left side, use the same procedure as above, but in the opposite direction.

REMARK

If it is desired to make the shoulder reach posture even larger, change the mounting position of the piston rod of the blade side shift cylinder.

For details, see "BLADE PROTRUSION (PAGE 3-155)".

ADJUSTING SCARIFIER

ADJUSTING CUTTING ANGLE

In general, on hard ground, the larger the cutting angle is, the more efficient the operation becomes.

Adjustment

Remove bolt (1), then move the position of the hole to the desired position.

The angle can be adjusted to 3 positions: 58°, 60°, 71°. 60° is the standard position.

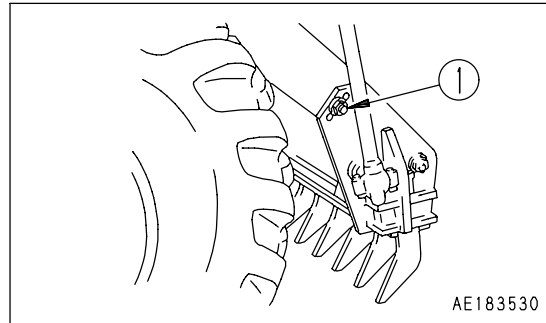

ADJUSTING DIGGING DEPTH

The digging depth can be adjusted as follows at 2 places to match the operation.

Adjusting with teeth

Remove the cotter pin, pull out wedge (1), then change the notch of tooth (2).

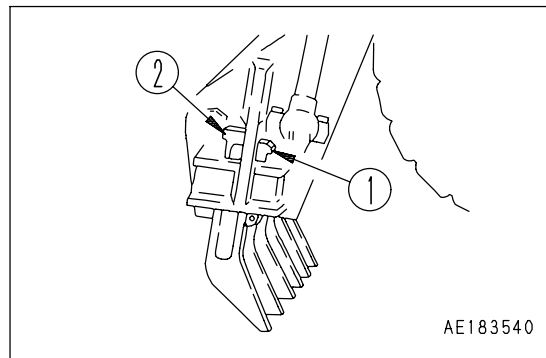

PRECAUTIONS WHEN HANDLING OR OPERATING SCARIFIER

- If the scarifier is fully raised and the blade is lowered to raise the body, the scarifier and drawbar will hit, and the drawbar will be damaged.
- If the blade is raised a few centimeters from the ground surface and rotated, the blade and scarifier will hit, and the blade will be damaged.
- If the blade is set within the machine width and the scarifier is lowered, the top of the blade and the scarifier will hit, and the top of the blade will be damaged.

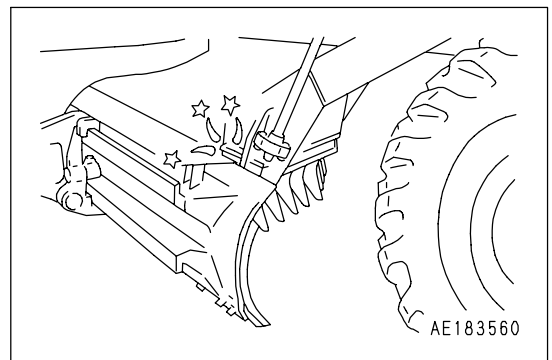
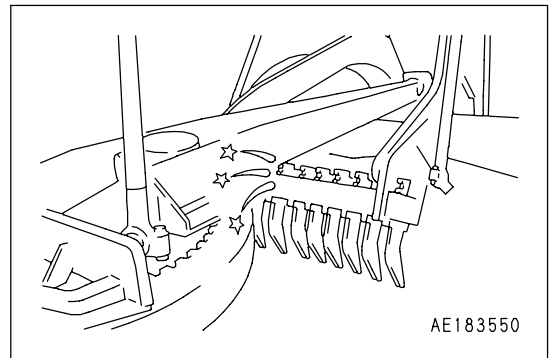

When carrying out bank cut operations, the scarifier is lowered to prevent the contact between the drawbar and the scarifier. At this time, be cautious as the scarifier possibly contacts and damages the tires, depending on the conditions of the scarifier and the irregularity of ground surfaces.

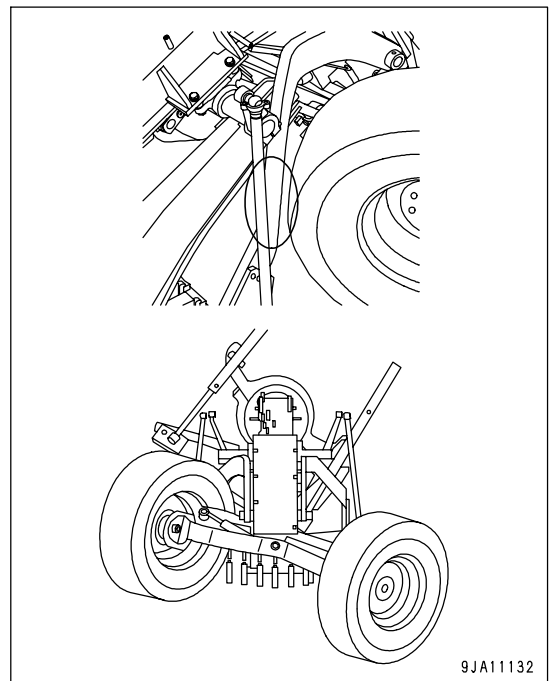

PARKING MACHINE

WARNING

- Avoid stopping suddenly. Leave an adequate margin when stopping. Avoid parking the machine on a slope.
- If the machine has to be parked on a slope, set it at right angles to the slope, put blocks under the tires and dig the blade into the ground surface to prevent the machine from moving.
- If the control levers are touched by mistake, the work equipment or machine may suddenly move and cause a serious accident. Before leaving the operator's seat, always set the gearshift lever to the P position.

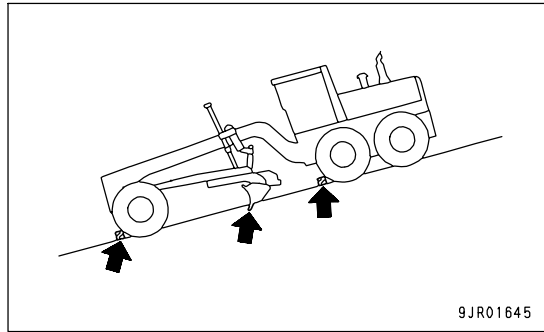

WHEN SELECTING MANUAL MODE

1. Release accelerator pedal (1).

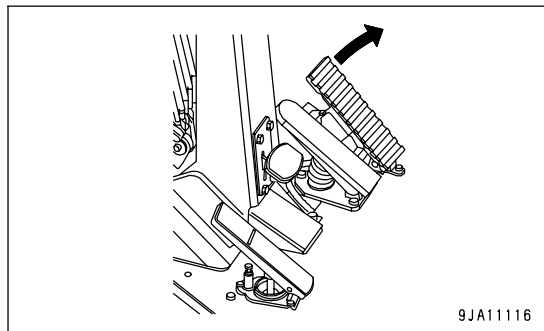
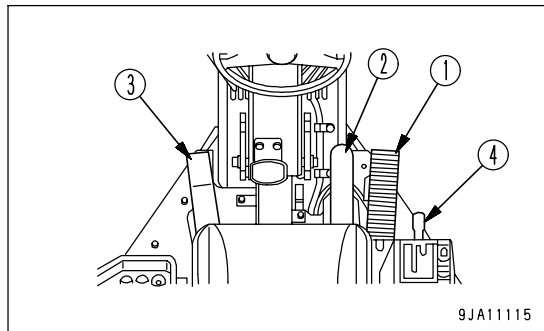

2. Depress brake pedal (2). Before the machine comes to a stop, depress inching pedal (3).

REMARK

As this model has the linked control function of torque converter with direct drive, the engine does not stop even if depressing the inching pedal belatedly or not depressing it at all.

However, as the lockup is automatically released to prevent the engine from stopping, the machine becomes in torque converter state.

After the machine starts and the engine and travel speeds increase, the machine automatically returns to lockup state.

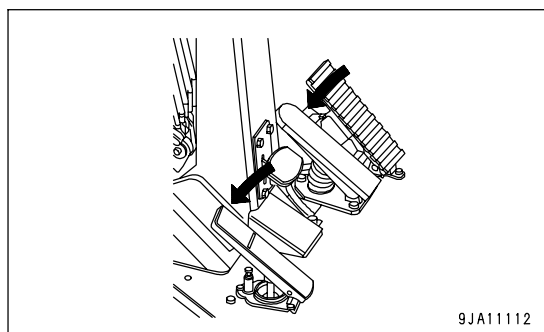

3. Set gear shift lever (4) to the P (PARKING) position while pressing its knob. The parking brake lamp lights up at the same time.

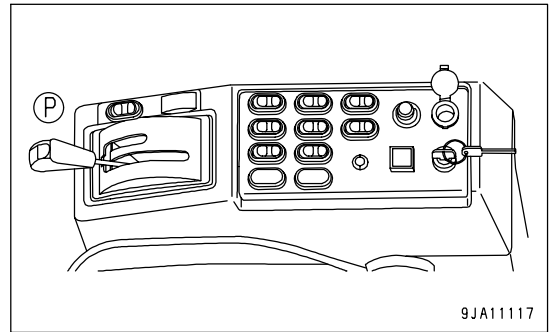

9JA11117

4. Operate the work equipment control lever, and lower the blade and the ripper (or the scarifier) to the ground.

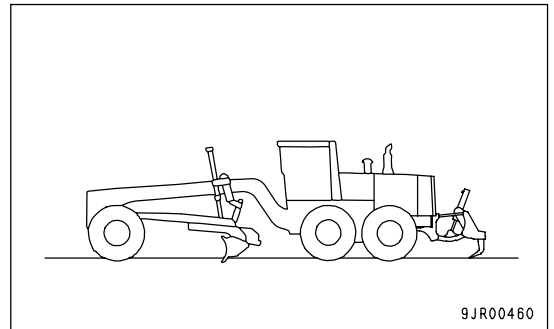

9JR00460

WHEN SELECTING TORQUE CONVERTER AUTO MODE

1. Release accelerator pedal (1).

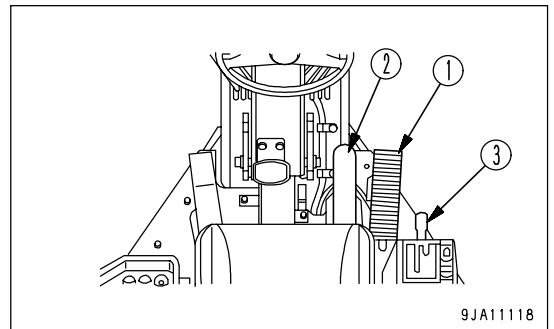

9JA11118

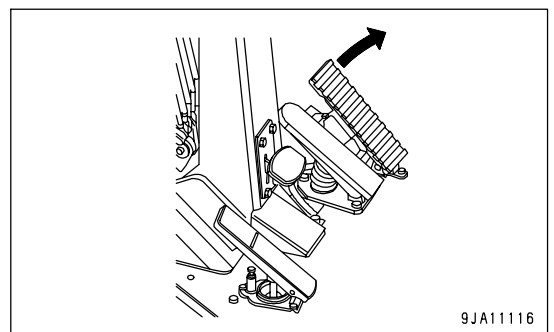

9JA11116

2. Depress brake pedal (2) and stop the machine.

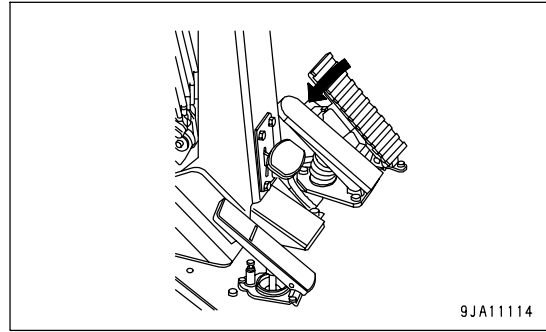

3. Set gear shift lever (3) to the P (PARKING) position while pressing its knob. The parking brake lamp lights up at the same time.

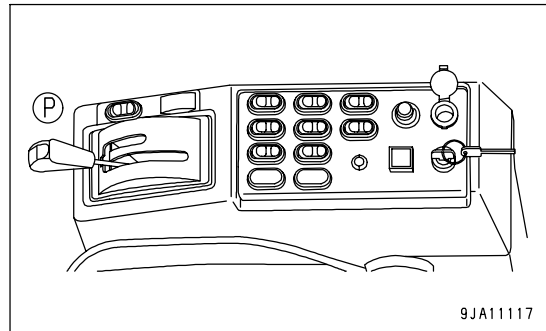

4. Operate the work equipment control lever, and lower the blade and the ripper (or the scarifier) to the ground.

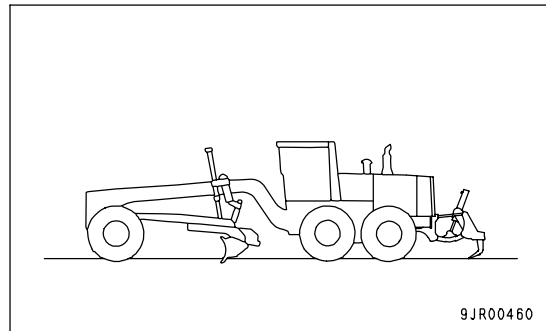

CHECKS AFTER COMPLETION OF OPERATION

Check the engine coolant temperature, engine oil pressure, and fuel level on the main panel.

In case the engine overheated, do not stop the engine suddenly, but run it at medium speeds to cool down before stopping it.

If the cooling fan does not rotate at the time of overheat, stop the engine immediately.

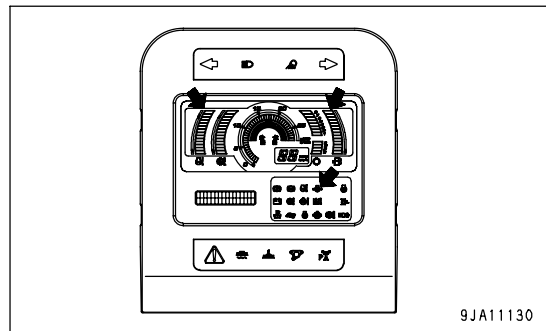

LOCKING

Always lock the following parts.

- (1) Cab door (left, right)
- (2) Engine side cover (left, right)
- (3) Battery cover
- (4) Fuel filler cap
- (5) Transmission oil filler cover (right side of the machine)
- (6) Tool box

REMARK

The starting switch key is used also for locks at (1) - (5) portions.

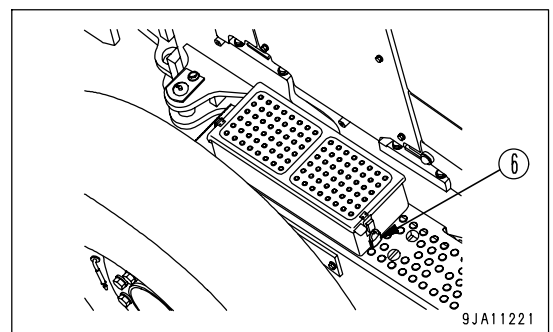
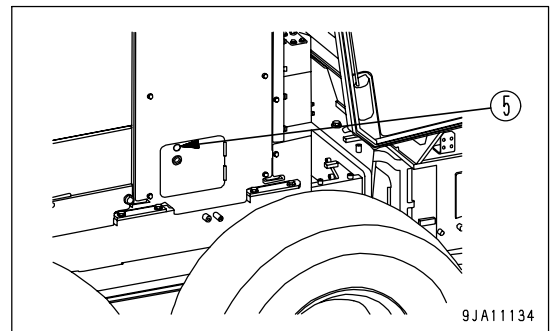
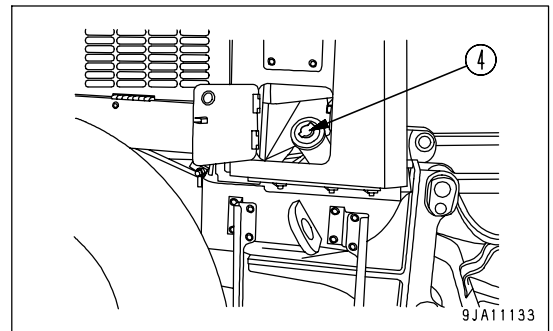
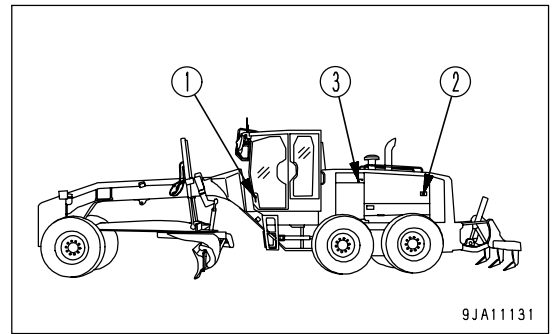

HANDLING THE TIRES

PRECAUTIONS WHEN HANDLING TIRES



WARNING

To ensure safety, the defective tires given below must be replaced with new tires.

- Tires where the bead wire has been cut, broken, or greatly deformed
- Excessively worn tires where more than 1/4 of the circumference of the carcass ply (excluding the breaker) is exposed
- Tires where damage to the carcass exceeds 1/3 of the tire width
- Tires where ply separation has occurred
- Tires where radial cracks extend to the carcass
- Tires where there is abnormal deterioration, deformation, and damage, and the tire cannot withstand use.

Please contact your Komatsu distributor when replacing the tires. It is dangerous to jack up the machine without taking due care.

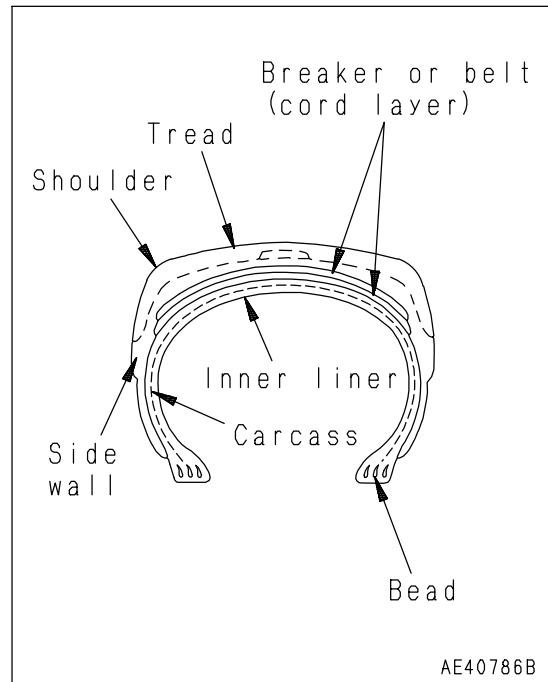

COMBINATION OF SNOW RADIAL TIRE AND CHAIN













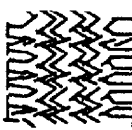
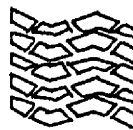
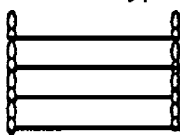
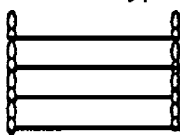

NOTICE

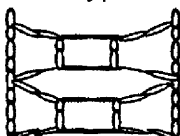
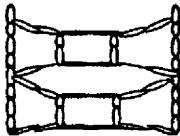
Traveling on asphalt or concrete roads with chains installed on snow radial tires possibly generates abnormal vibrations due to resonance, depending on the combination of tires and chains, it causes cracks and life shortening of various portions of the machine.

In addition, use the rims designated by Komatsu.

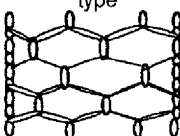
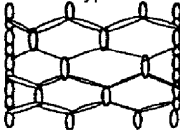
Do not use the combinations marked x in the following table.

Combination and usability of snow radial tires and chains

Patterns Tire chains	G lug	Block	Lug	Block
				
Ladder type 	 Can be used	 Cannot be used	 Cannot be used	 Cannot be used
H type 	 Can be used	 Can be used	 Can be used	 Can be used
Hexagonal pattern type 	 Can be used	 Can be used	 Can be used	 Can be used

TRANSPORTATION

When transporting the machine, observe all related laws and regulations, and be careful to assure safety.

STEPS FOR TRANSPORTATION

As a basic rule, always transport the machine on a trailer.

When selecting the trailer, see the weights and dimensions given in "SPECIFICATIONS (PAGE 5-2)".

Note that the specifications for the weights and dimensions for transportation differ according to the type of tires and type of blade.

LOADING, UNLOADING WORK



WARNING

- When loading or unloading the machine, run the engine at low speed, travel at low speed, and operate slowly.
- When loading or unloading the machine, stop the trailer on firm level ground.
In addition, keep well away from the road shoulder.
- Use ramps of ample width, length, thickness, and strength, and install them securely at an angle of less than 15°. When using an embankment, compact the fill soil thoroughly and make sure that the slope face does not collapse.
- Remove the mud stuck to the undercarriage to prevent the machine from slipping to the side on the ramps.
In addition, remove any water, snow, ice, grease, or oil from the ramps.
- Never change direction on the ramps. There is danger that the machine may tip over.
If it is necessary to change direction, return to the ground surface or the trailer platform, correct the direction, and start again.
- The position of the center of gravity of the machine will change suddenly at the connection of the ramp and trailer, and there is danger of the machine losing its balance. Always drive slowly over this point.

When loading or unloading, always use ramps or a platform and carry out the operations as follows.

1. Apply the brakes on the trailer securely and insert blocks under the tires to ensure that the trailer does not move.
Then fix the ramps in line with the centers of the trailer and the machine.
Be sure that the two sides are at the same height as one another.
Make the angle of the ramps a maximum of 15°. Set the distance between the ramps to match the center of the tires.
2. Set the machine in line with the ramps, then drive the machine slowly to load or unload it.
3. Load the machine correctly in the specified position on the trailer.

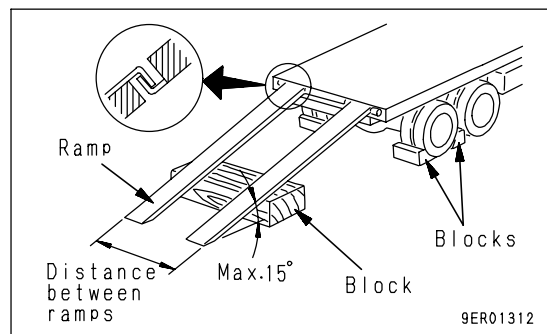

REMARK

- When loading or unloading the machine, rotate the blade from the travel posture, then raise it fully. This makes it easier to load or unload the machine.
- If the ripper teeth make it difficult to load the machine, remove the ripper teeth or install them so that they face the top inside. This makes loading easier.

PRECAUTIONS FOR LOADING

After placing the machine on the specified position of the trailer, secure it according to the following procedure.

1. Lower the work equipment slowly.
2. Set the gear shift lever at the P (parking) position.
3. Turn the starting switch to the OFF position, and stop the engine, then remove the key.
4. Lock the front frame and rear frame with the articulate lock pin.
5. Lock the front axle with the leaning stopper to prevent the front tires from falling down.
6. When transporting the machine, place wooden blocks underneath the front and rear tires to prevent the machine from moving about.
Also, hold it down with chain or rope.

REMARK

Round lifting hooks (1), hole in the frame under the operator's platform (2), and drawbar hole (3) can be used to hold the machine in position.

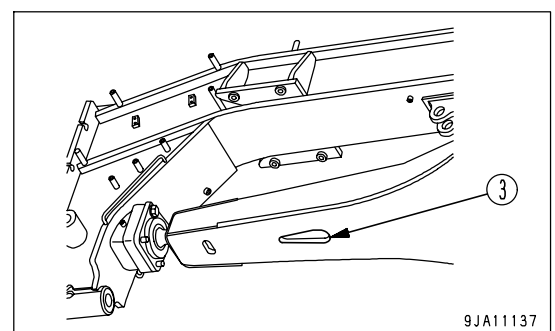
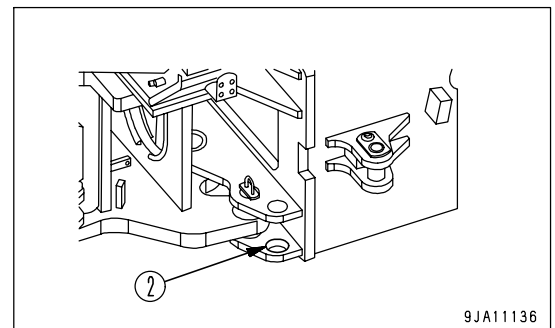
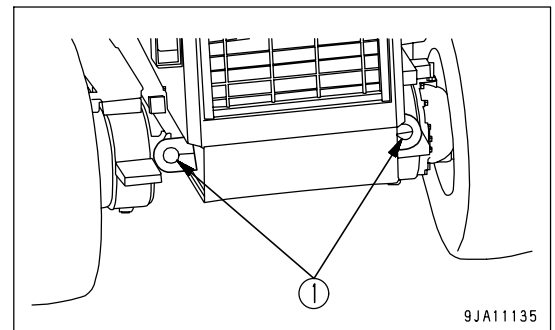

LIFTING MACHINE



WARNING

- The person using the crane to carry out lifting operations must be a qualified crane operator.
- Never carry out lifting operations if any person is on the lifted machine.
- Always use a wire rope that has ample strength for the weight of the lifted machine.
- Keep the machine horizontal when lifting it.
- When carrying out lifting operations, prevent the machine from moving unexpectedly by doing the followings:
Set the gear shift lever to the P (PARKING) position.
Lock by using the articulation lock pin.
- Never enter the area under or around the lifted machine.
- There is a risk of the machine losing its balance.

Therefore when lifting the machine, set it in the posture and use the lifting equipments shown in the following procedures.

NOTICE

This method of lifting applies to the standard specification machine.

The method of lifting differs according to the attachments and options installed.

For details of the procedure for machines that are not the standard specification, please consult your Komatsu distributor.

For weight, see "SPECIFICATIONS (PAGE 5-2)".

LIFTING PROCEDURE

Lifting position

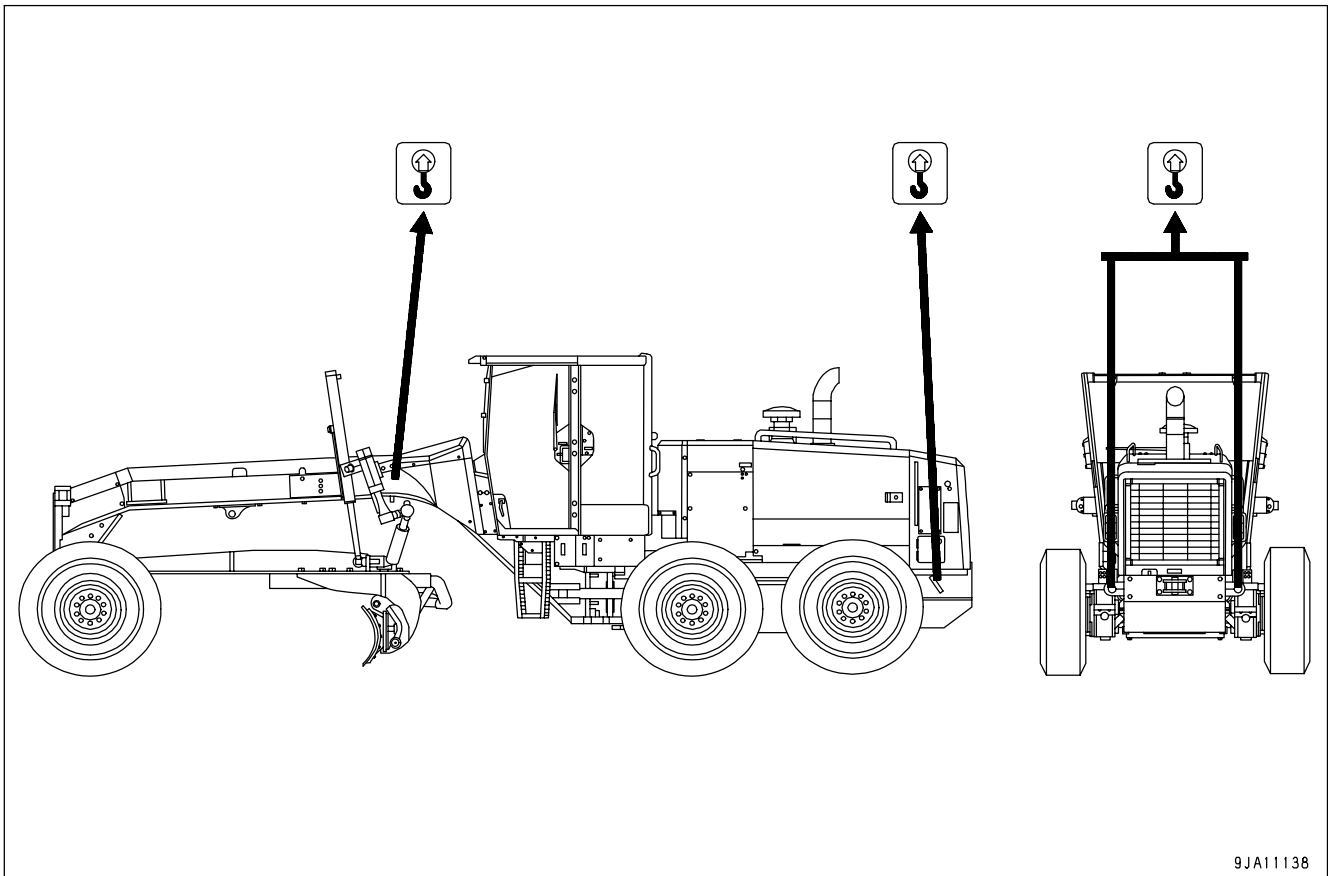

9JA11138

The machine can be lifted only if it has hook mark labels.

When lifting the machine, stop the machine on level ground and do as follows.

1. Start the engine, make sure that the machine is horizontal, then set the work equipment to the travel posture.

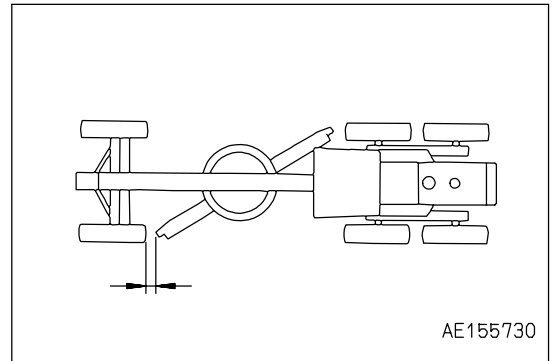

2. Stop the engine, confirm the safety around the operator's seat, and then lock by using the articulation lock pin to prevent the front frame and rear frame from articulating.

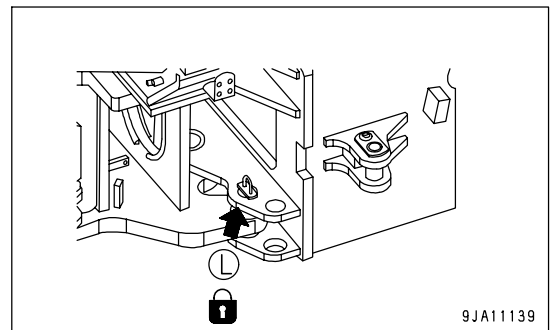

3. Use wire ropes and slings that match the weight of the machine, and wind the wire rope and fix it to the lifting points as shown in the figure.

NOTICE

- Use protectors, etc. so that the wire ropes will not be broken at sharp edges or narrow places.
- Use spreaders and bars having sufficient width so that they will not touch the machine.

4. Before lifting up the machine, set the slings and float the machine to 100 mm - 200 mm above the ground. Make sure that the wire ropes are not slack and the machine is kept horizontally, and then lift up the machine slowly.

COLD WEATHER OPERATION

PRECAUTIONS FOR LOW TEMPERATURE

If the temperature becomes low, it becomes difficult to start the engine, and the coolant may freeze, so do as follows.

FUEL AND LUBRICANTS

Change to oil with low viscosity for all components. For details of the specified viscosity, see "RECOMMENDED FUEL, COOLANT, AND LUBRICANT (PAGE 4-10)".

COOLANT



WARNING

- Antifreeze is toxic. Be careful not to get it into your eyes or on your skin. If it should get into your eyes or on your skin, wash it off with large amounts of fresh water and see a doctor at once.
- When changing the coolant or when handling coolant containing antifreeze that has been drained when repairing the radiator, please contact your Komatsu distributor or request a specialist company to carry out the operation. Antifreeze is toxic. Do not let it flow into drainage ditches or spray it onto the ground surface.

NOTICE

Please use Komatsu genuine supercoolant (AF-NAC) for the coolant. As a basic rule, we do not recommend the use of any coolant other than Komatsu genuine supercoolant.

The Supercoolant is already diluted with distilled water, so it is not flammable.

For details of the density of the Supercoolant and the interval for changing the coolant, see "CLEAN INSIDE OF COOLING SYSTEM (PAGE 4-18)".

BATTERY**WARNING**

- The battery generates flammable gas. Do not bring fire or sparks near the battery.
- Battery electrolyte is dangerous. If it gets in your eyes or on your skin, wash it off with a large amount of water and consult a doctor.
- Battery electrolyte dissolves paint. If it gets on the bodywork, wash it off immediately with water.
- If the battery electrolyte is frozen, do not charge the battery or start the engine with a different power source. There is danger that the battery may explode.
- Battery electrolyte is toxic. Do not let it flow into drainage ditches or spray it on to the ground surface.

When the ambient temperature drops, the capacity of the battery will also drop. If the battery charge ratio is low, the battery electrolyte may freeze. Maintain the battery charge as close as possible to 100%. Insulate it against cold temperature to ensure the machine can be started easily the next morning.

Measure the specific gravity and calculate the rate of charge from the following conversion table.

Charging Rate (%)	Electrolyte Temperature	20°C (68°F)	0°C (32°F)	-10°C (14°F)	-20°C (-4°F)
	100		1.28	1.29	1.30
90		1.26	1.27	1.28	1.29
80		1.24	1.25	1.26	1.27
75		1.23	1.24	1.25	1.26

When adding distilled water in cold weather, add it before starting operations in the morning to prevent the electrolyte from freezing.

CAUTIONS AFTER COMPLETION OF WORK

To prevent mud, water, or the undercarriage from freezing and making it impossible for the machine to move on the following morning, observe the following precautions.

- Mud and water on the machine body should be completely removed.
This is to prevent damage to the seal caused by mud or dirt getting inside the seal with drops of water.
- Park the machine on hard, dry ground.
If this is impossible, park the machine on wooden boards.
The boards help protect the tracks from being frozen in soil and the machine can start next morning.
- Open the drain valve and drain any water collected in the fuel system to prevent it from freezing.
- As the battery capacity drastically drops in low temperatures, cover or remove the battery from the machine, store the battery in a warm place, and install it the next morning.

AFTER COLD WEATHER

When the season changes and the weather becomes warmer, do as follows.

- Replace the fuel and oil for all parts with oil of the viscosity specified.
For details, see "RECOMMENDED FUEL, COOLANT, AND LUBRICANT (PAGE 4-10)".

LONG-TERM STORAGE

BEFORE STORAGE

When keeping in long-term storage (more than one month), store as follows.

- After every part is washed and dried, house the machine in a dry building. Never leave it outdoors.
In case it is indispensable to leave it outdoors, park the machine on the flat ground and cover it with canvas etc.
- Completely fill the fuel tank. This prevents moisture from collecting.
- Lubricate and change the oil before storage.
- Coat the exposed portion of the hydraulic cylinder piston rod with grease.
- Turn the battery disconnecter switch to the OFF position.
- Place gear shift levers at the P (parking) position.
- Fit a block under the center of the front wheel and the tandem case, jack up the tires from the ground, then put a block under the blade and lower it on top of the block.
- Lock the front axle with the leaning stopper to prevent the front tires from falling down.
- To prevent rust, fill with Komatsu genuine supercoolant (AF-NAC) to give a density of at least 30% for the engine coolant.

DURING STORAGE



WARNING

If it is necessary to perform the rust-prevention operation while the machine is indoors, open the doors and windows to improve ventilation and prevent gas poisoning.

- During storage, operate and move the machine for a short distance once a month so that a new film of oil will coat moving parts. At the same time, also charge the battery.
- When operating the work equipment, wipe off all the grease from the hydraulic cylinder rods.
- If the machine is equipped with an air conditioner, operate the air conditioner for 3 to 5 minutes once a month to lubricate all parts of the air conditioner compressor. Always run the engine at low idle when doing this. In addition, check the refrigerant level twice a year.

AFTER STORAGE

NOTICE

If the machine has been stored without carrying out the monthly rust-prevention operation, consult your Komatsu distributor before using it.

When using the machine after long-term storage, do as follows before using it.

- Wipe off the grease from the hydraulic cylinder rods.
- Add oil and grease to all places.
- When the machine is stored for a long period, moisture in the air will mix with the oil. Check the oil before and after starting the engine. If there is water in the oil, change all the oil.

TROUBLESHOOTING

AFTER RUNNING OUT OF FUEL



WARNING

When starting the engine again, check carefully that the area around the engine is safe before cranking the engine.

When starting the engine again after running out of fuel, fill with fuel, then bleed the air from the fuel system before starting the engine.

PROCEDURE FOR BLEEDING AIR

1. Fill the fuel tank with fuel.
2. Open up the engine side cover on the left side of the machine.
3. Loosen and pull out feed pump knob (2) and move it forward and backward.
 - The plug on the side surface of the fuel pre-filter head does not need to be removed.
 - Keep moving knob (1) until it becomes heavy.
4. After bleeding air, push in and tighten knob (1).

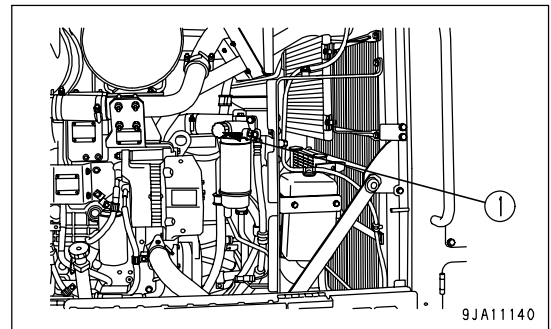

WHEN LEANING PIPING IS DAMAGED



WARNING

If the machine is driven with the leaning cylinder piston rod fluctuating or the front wheels leaning on one side because of damaged leaning piping, dangerously unstable steering and excessively worn tires will result. Repair the faulty leaning pipe quickly.

If the leaning piping is broken, call your Komatsu distributor for repair.

METHOD OF USING LEANING STOPPER

Fix the front axle and hole (1) in the leaning rod with the bolt in the tool box.

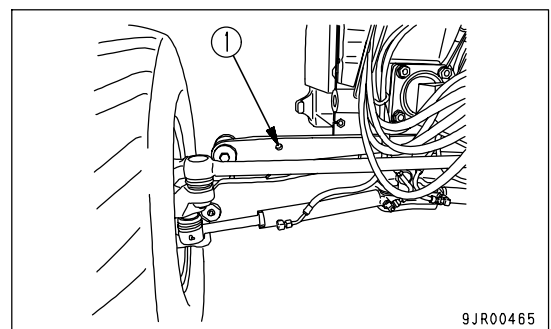

TOWING THE MACHINE



WARNING

- If any failure should occur in the brake system and the brakes will not work, then be extremely careful.
- If the machine is towed in the wrong way, there is the danger of an accident that could cause death or injury.
- Before releasing the brake, always put blocks under the wheels.
- Only use wire rope that has enough strength for the weight that it is being towed.
- Do not apply a load to the wire rope suddenly.

NOTICE

- Towing is for moving the machine to a place where inspection and maintenance can be carried out, and not for moving it long distances.
The machine must not be towed for long distances.
- For details of the procedure for towing a machine when it has broken down, please contact your Komatsu distributor.

WHEN ENGINE CAN BE USED

Always keep the engine running when towing the machine, so that the steering and braking can be used.

WHEN ENGINE CANNOT BE USED

- When towing a disabled machine the distance should be within 600 m (1968 ft) at a speed of 8 km/h (5.0 MPH) or less.
- If the distance is more than the above mentioned, or if more than one day has elapsed since the engine trouble, be sure to use a trailer for transportation.
- The parking brake is automatically applied. (A fixed time after the engine stops.)
It is necessary to release the parking brake, but the brake will then have no effect at all, so it is necessary to take special measures to ensure safety when moving the machine. This is particularly important on slopes.

NOTICE

If the machine is towed without the engine running, no lubrication oil will be supplied to the transmission. The gears and bearings are rotated, so this may cause them to be damaged.

- Tow the machine properly according to the instructions given below.
- The explanation given here is only to be used for a machine that has failed and is to be moved to a safe place for repairs. It must be moved a maximum of 600 m (1968 ft) and at a maximum speed of 8 km/h (5.0 MPH). This procedure is only for emergency purposes. If the machine must be moved a long distance, use a transporter.
- To protect the operator if the towrope or bar should break, install a protector plate to the machine being towed.
- If it is impossible to use the steering or brakes on the machine being towed, then do not have anyone sitting in the operator's seat.
- Before towing, check that the tow rope or bar are in good condition, and that they have ample strength for the towing operation. If the machine being towed may get stuck in mud or may have to be towed uphill, the tow rope or bar must be of a strength of at least 1.5 times greater than the weight of the machine being towed.
- Keep the angle of the towing line to the minimum. Operate the machine so that the angle does not become greater than 30° from the straight line.
- If the machine is moved suddenly, the towrope or bar will be subjected to an excessive load, and it may break. Start the machine gradually and travel at a constant speed.
- Normally, use a towing machine of about the same capacity as the machine being towed. The towing machine must have ample brake capacity, weight, and rimpull. Check that both machines can be controlled on slopes and on the tow road.

- When moving a failed machine on a downhill slope, a larger towing machine must be used to ensure ample control and braking power. Another method is to use a second towing machine at the rear of the failed machine. In this way, it is possible to prevent the failed machine from going out of control and turning over.
- It is impossible to determine the drawbar pull needed for various conditions. The minimum drawbar pull may be sufficient on horizontal, flat ground, but the maximum drawbar pull is needed on slopes or on rough roads.
- When towing a failed machine, please contact your Komatsu distributor.

METHOD OF RELEASING PARKING BRAKE



WARNING

- When releasing the parking brake, stop the machine on level ground and check that the surrounding area is safe. If it is necessary to release the brake on a slope in an emergency, block the tires before starting the operation.
- If the parking brake is released, the brake cannot be used, so check the safety carefully when moving the machine.

If the engine will not run for some reason, use the following methods to release the parking brake and tow the machine.

1. Turn to remove cover plug (2) of parking brake (1) on the front side of the final drive case.

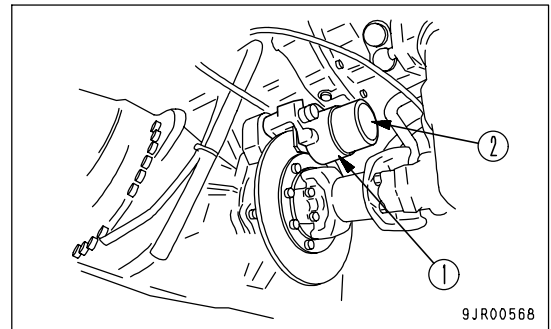

2. Loosen adjustment bolt (4) and locknut (3) inside the spring chamber until a clearance is formed between the disc and pad.
 - Lock nut (3): Width across flats; 20.8 mm (0.8 in)
 - Adjustment bolt (4): Width across flats of hexagonal socket; 8.1 mm (0.319 in)

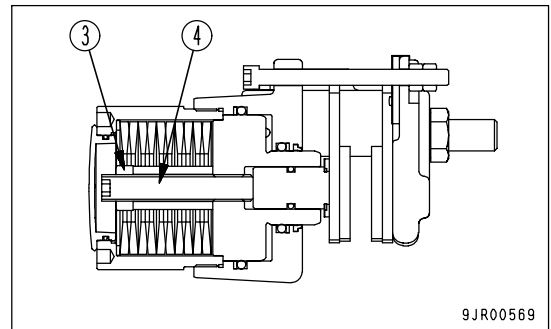

3. This will release parking brake (1).

NOTICE

After releasing the parking brake and moving the machine, it is necessary to adjust the parking brake again. Please contact your Komatsu distributor to have the parking brake adjusted.

IF BATTERY IS DISCHARGED



WARNING

- It is dangerous to charge a battery when installed on a machine. Make sure that it is removed before charging.
 - When checking or handling the battery, stop the engine and turn the starting switch key to the OFF position.
 - The battery generates hydrogen gas, so there is a hazard of explosion. Do not bring lighted cigarettes near the battery, or do anything that will cause sparks.
 - Battery electrolyte is dilute sulfuric acid, and it will attack your clothes and skin. If it gets on your clothes or on your skin, immediately wash it off with a large amount of water. If it gets in your eyes, wash it out with fresh water and consult a doctor.
 - When handling batteries, always wear safety glasses and rubber gloves.
 - When removing the battery, first disconnect the cable from the ground (normally the negative (-) terminal). When installing, install the positive (+) terminal first.
- If a tool touches the positive terminal and the chassis, there is danger that it will cause a spark, so be extremely careful.
- If the terminals are loose, there is danger that the defective contact may generate sparks that will cause an explosion.
 - When removing or installing the terminals, check which is the positive (+) terminal and which is the negative (-) terminal.

When removing, disconnect the cable from the ground terminal first.

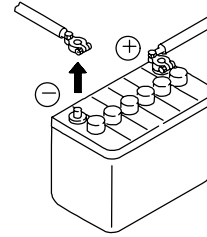

When installing, connect the cable to the positive (+) terminal first.

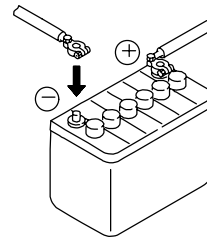

AW35946B

REMOVAL AND INSTALLATION OF BATTERY

- Before removing the battery, turn the battery disconnect switch to the OFF position.

(A): OFF

(B): ON

- Before removing the battery, remove the ground cable (normally connected to the negative (-) terminal).
If any tool touches between the positive terminal and the chassis, there is a hazard of sparks being generated.
- When installing the battery, connect the ground cable last.

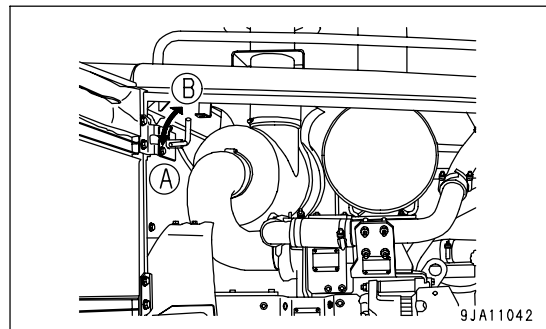

9JA11042

PRECAUTIONS WHEN CHARGING BATTERY

When charging the battery, if the battery is not handled correctly, there is danger that the battery may explode. Always follow the instructions in "IF BATTERY IS DISCHARGED (PAGE 3-180)" and the instruction manual accompanying the charger, and do as follows.

- Set the voltage of the charger to match the voltage of the battery to be charged. If the correct voltage is not selected, the charger may overheat and cause an explosion.
- Connect the positive (+) charger clip of the charger to the positive (+) terminal of the battery, then connect the negative (-) charger clip of the charger to the negative (-) terminal of the battery. Be sure to attach the clips securely.
- Set the charging current to 1/10 of the value of the rated battery capacity; when carrying out rapid charging, set it to less than the rated battery capacity.
If the charger current is too high, the electrolyte will leak or dry up, and this may cause the battery to catch fire and explode.
- If the battery electrolyte is frozen, do not charge the battery or start the engine with a different power source. There is a danger that this will ignite the battery electrolyte and cause the battery to explode.
- Do not use or charge the battery if the battery electrolyte level is below the LOWER LEVEL line. This may cause an explosion. Check the battery electrolyte level periodically and add distilled water to bring the electrolyte level to the UPPER LEVEL line.

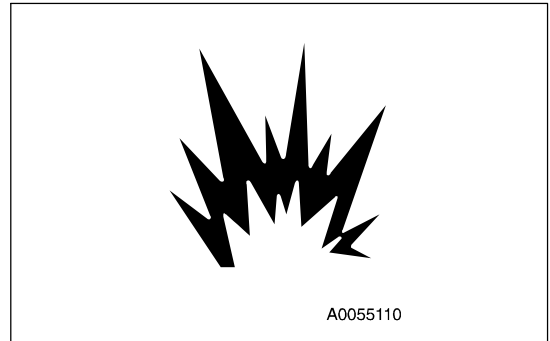

STARTING ENGINE WITH BOOSTER CABLE

When starting the engine with a booster cable, do as follows:

PRECAUTIONS WHEN CONNECTING AND DISCONNECTING BOOSTER CABLE



WARNING

- When connecting the cables, never contact the positive (+) and negative (-) terminals.
- When starting the engine with a booster cable, wear safety glasses and rubber gloves.
- Be careful not to let the normal machine and problem machine contact each other. This prevents sparks from generating near the battery which could ignite the hydrogen gas given off by the battery.
- Make sure that there is no mistake in the booster cable connections. The final connection is to the engine block of the problem machine, but sparks will be generated when this is done, so connect to a place as far as possible from the battery.
- When disconnecting the booster cable, take care not to bring the clips in contact with each other or with the machine body.

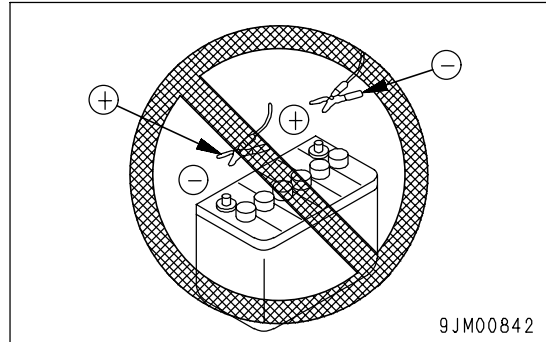

NOTICE

- The size of the booster cable and clip should be suitable for the battery size.
- The battery of the normal machine must be the same capacity as that of the engine to be started.
- Check the cables and clips for damage or corrosion.
- Make sure that the cables and clips are firmly connected.
- Check that the work equipment lock levers and parking brake levers of both machines are in the LOCK position.
- Check that each lever is in the NEUTRAL position.

CONNECTING THE BOOSTER CABLES

Keep the starting switch of the normal machine and problem machine in the OFF position.

Connect the booster cable as follows, in the order of the numbers marked in the diagram.

1. Connect one clip of booster cable (A) to the positive (+) terminal of the problem machine.
2. Connect the other clip of booster cable (A) to the positive (+) terminal of the normal machine.
3. Connect one clip of booster cable (B) to the negative (-) terminal of the normal machine.
4. Connect the other clip of booster cable (B) to the engine block of the problem machine.

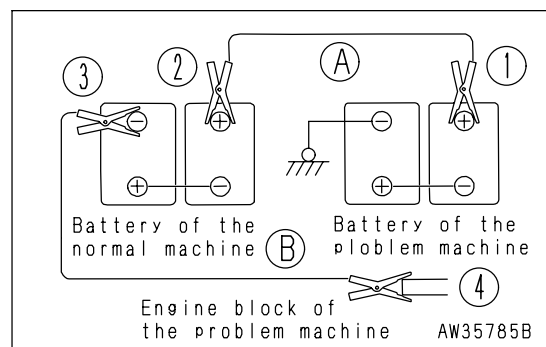

STARTING THE ENGINE



Check that the gearshift levers on both the normal machine and problem machine are at the P (Parking) position. Check also that all levers are at neutral.

1. Make sure the clips are firmly connected to the battery terminals.
2. Start engine of the normal machine and run it at high idle speed.
3. Turn the starting switch of the problem machine to the START position and start the engine.
If the engine doesn't start at first, try again after 2 minutes or so.

DISCONNECTING THE BOOSTER CABLES

After the engine has started, disconnect booster cables in the reverse order in which they were connected.

1. Remove one clip of booster cable (B) from the engine block of the problem machine.
2. Remove the other clip of booster cable (B) from the negative (-) terminal of the normal machine.
3. Remove one clip of booster cable (A) from the positive (+) terminal of the normal machine.
4. Remove the other clip of booster cable (A) from the positive (+) terminal of the problem machine.

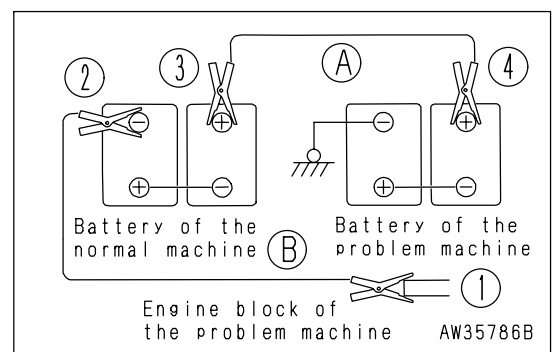

IF THE GEAR SHIFT LEVER OF THE TRANSMISSION HAS ANY TROUBLE

If the gear shift lever of the transmission has any trouble, operate the machine according to the following procedures.

1. Decelerate the machine with the brake and stop it on a safe place.
2. Set the gear shift lever to N (NEUTRAL) or P (PARKING).
3. In some trouble modes, the gear is not shifted even if the gear shift lever is operated.
In this case, perform the following procedure.

If the character display shows the failure code "DF10L4" of the action code "E03", operate the machine according to the following procedures.

- 1) Set the gear shift lever to the N (NEUTRAL) or P (PARKING) position and hold it in the position for at least 5 seconds.
- 2) By moving the gear shift lever to any of F5 to F8 or any of R1 to R4 after the shift indicator's lighting changes to its flashing, the machine travels at fixed gear speed of F2 or R2. Move the machine to a safe place.

The emergency escape function does not work in some cases depending on the trouble modes.

During operations of the restart mode, a flashing display appears on the shift indicator display of the machine monitor.

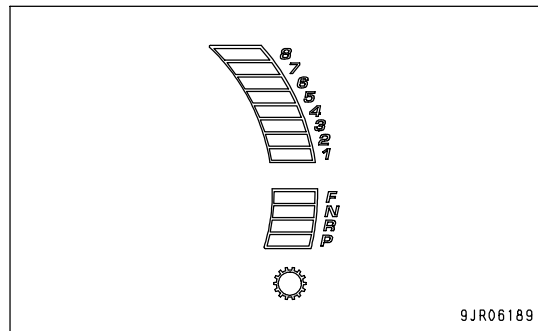

METHODS OF LOWERING WORK EQUIPMENTS AFTER THE ENGINE STOPS (RELEASE OF THE HYDRAULIC CIRCUIT PRESSURE FOR WORK EQUIPMENTS)

! WARNING

Check that the surrounding area is safe, then lower the work equipment.

Remove the cover using a step.

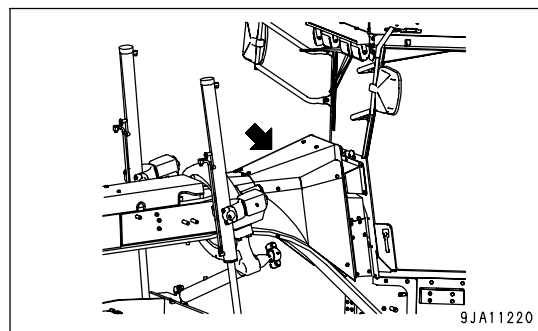

WHEN LOWERING THE BLADE

1. Slowly loosen the pressure releasing plug (1) in the control valve.
Width across flats of plug: 10 mm (0.4 in)

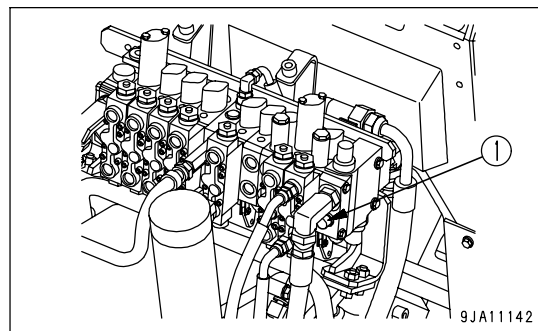

2. Lower the blade to the ground.
3. Tighten the pressure releasing plug (1).
Tightening torque: 19.6 to 24.5 Nm (2.0 to 2.5 kgm, 14.5 to 18.1 lbft)

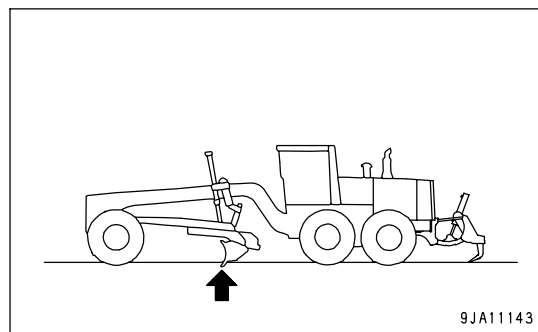

WHEN LOWERING THE RIPPER OR SCARIFIER

(If equipped)

1. Slowly loosen the pressure releasing plug (1) in the control valve.

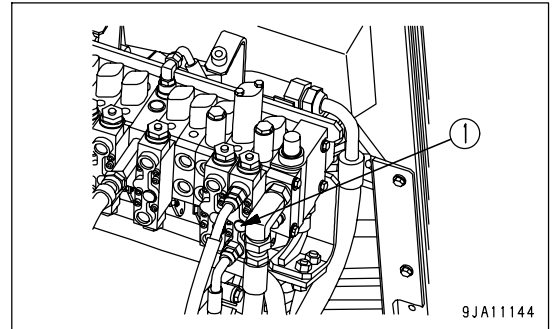

2. Lower the ripper or scarifier to the ground.
3. Tighten the pressure releasing plug (1).
Tightening torque: 19.6 to 24.5 Nm (2.0 to 2.5 kgm, 14.5 to 18.1 lbft)

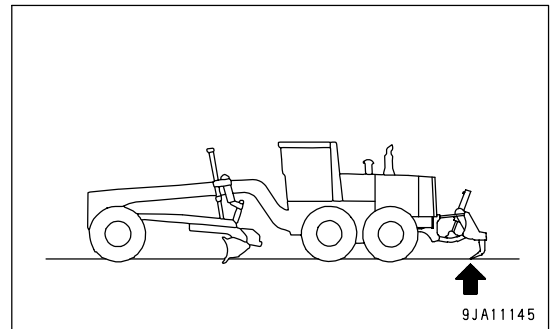
**WHEN LOWERING THE FRONT BLADE**

(If equipped)

1. Slowly loosen the pressure releasing plug (1) in the control valve.

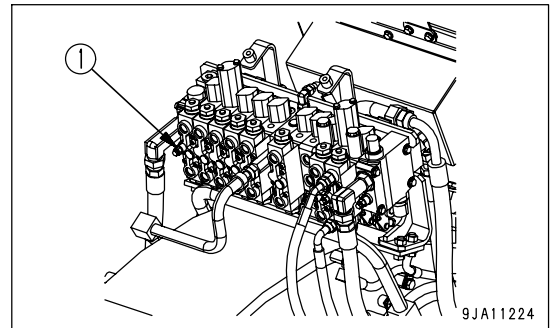

2. Lower the front blade to the ground.
3. Tighten the pressure releasing plug (1).
Tightening torque: 19.6 to 24.5 Nm (2.0 to 2.5 kgm, 14.5 to 18.1 lbft)

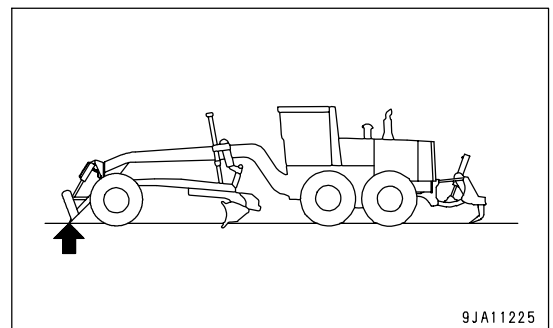

OTHER TROUBLE

ELECTRICAL SYSTEM

- (): Always contact your Komatsu distributor when dealing with these items.
- In cases of problems or causes which are not listed below, contact your Komatsu distributor for repairs.

Problem	Main causes	Remedy
Lamp does not glow brightly even when the engine runs at high speed	• Defective wiring	(• Check, repair loose terminals, disconnection)
Lamp flickers while engine is running		
Battery charge circuit caution lamp do not go out even when engine is running	• Defective monitor • Defective alternator • Defective wiring • Burnout of the slow blow fuse	(• Replace) (• Replace) (• Check, repair) (• Check, replace)
Abnormal noise is generated from alternator	• Defective alternator	(• Replace)
Starting motor does not turn when starting switch is turned to ON	• Defective wiring • Insufficient battery charge • Defective starting motor	(• Check, repair) • Charge (• Replace)
Pinion of starting motor keeps going in and out	• Insufficient battery charge	• Charge
Starting motor turns engine sluggishly	• Insufficient battery charge • Defective starting motor	• Charge (• Replace)
Starting motor disengages before engine starts	• Defective wiring • Insufficient battery charge	(• Check, repair) • Charge
Engine preheating pilot lamp does not go out	• Defective wiring • Defective monitor	(• Check, repair) (• Replace)
Battery charge circuit caution lamp does not light up while engine is stopped (with starting switch at ON position)	• Defective monitor • Defective wiring	(• Replace) (• Check, repair)
Outside of electrical intake air heater is not warm when touched by hand	• Defective wiring • Disconnection in electrical intake air heater • Defective operation of heater relay switch intake air heater	(• Check, repair) (• Replace) (• Replace heater relay switch)
Creaks come out from the accelerator pedal	• Running out of grease in the roller portion	• Greasing

CHASSIS

- (): Always contact your Komatsu distributor when dealing with these items.
- In cases of problems or causes which are not listed below, contact your Komatsu distributor for repairs.

Problem	Main causes	Remedy
Even when engine is running, machine does not move	<ul style="list-style-type: none"> • Gear shift lever is not in the proper position • Transmission oil pressure does not rise • Lack of oil in transmission case • Wear, scuffing of transmission pump • Leakage of oil from oil line • Clogged transmission filter element • Defective operation of transmission, control valve • Defective return of parking brake • Problem in transmission control 	<ul style="list-style-type: none"> • Set lever to the proper position (• Check, adjust) • Add oil to specified level. For details, see EVERY 250 HOURS SERVICE. (• Check, replace) (• Check, repair) • Clean, replace. For details, see EVERY 500 HOURS SERVICE. (• Check, repair) (• Check, repair) (• Check, repair)
Even when engine is run at full throttle, machine moves slowly, lacks power	<ul style="list-style-type: none"> • Lack of oil in transmission • Clogged transmission oil filter cartridge • Defective return of parking brake • Improper adjustment of engine 	<ul style="list-style-type: none"> • Add oil to specified level. For details, see EVERY 250 HOURS SERVICE. • Clean, replace. For details, see EVERY 1000 HOURS SERVICE. (• Check, repair) (• Check, repair)
More noise than usual is generated from power train	<ul style="list-style-type: none"> • Lack of oil in transmission case, tandem case 	<ul style="list-style-type: none"> • Add oil to specified level. For details, see EVERY 250 HOURS SERVICE.
Abnormal wear of front tires	<ul style="list-style-type: none"> • Incorrect adjustment of toe-in • Lack of inflation pressure 	<ul style="list-style-type: none"> • Adjust. For details, see EVERY 1000 HOURS SERVICE. • Check, adjust
Heat generated from front wheel hub	<ul style="list-style-type: none"> • Loose bearing preload adjustment nut for front wheel • Lack of grease 	<ul style="list-style-type: none"> (• Check, adjust [adjust bearing preload]) • Supply grease
Front wheels wobble when traveling	<ul style="list-style-type: none"> • Incorrect adjustment of toe-in, loose tie rod • Inflation pressure of left and right tires not same • Wheel not properly installed • Loose front wheel bearing mounting nut 	<ul style="list-style-type: none"> • Adjust. For details, see EVERY 1000 HOURS SERVICE. • Inflate tires to same air pressure • Install again. For details, see HANDLING TIRES. (• Adjust)
Steering wheel is heavy	<ul style="list-style-type: none"> • Defective Orbit-roll • Defective adjustment of priority valve • Lack of hydraulic oil 	<ul style="list-style-type: none"> (• Adjust) (• Check, repair) • Add oil to specified level.

Problem	Main causes	Remedy
Even when brake pedal is depressed, braking effect is poor	<ul style="list-style-type: none"> • Worn lining • Oil leakage in brake piping • Defective brake valve • Defective piston seal 	<ul style="list-style-type: none"> (• Check, repair) (• Check, repair) (• Check, repair) (• Replace)
Brake is dragging or always applied	<ul style="list-style-type: none"> • Clogging of the vent hole of the brake valve 	<ul style="list-style-type: none"> • Cleaning
Poor braking effect of parking brake	<ul style="list-style-type: none"> • Defective adjustment of brake • Oil on disc surface • Seized disc 	<ul style="list-style-type: none"> (• Adjust) (• Finish surface of disc with sandpaper) (• Finish surface of disc with sandpaper)
Blade moves up and down excessively during operation	<ul style="list-style-type: none"> • Play in lift cylinder ball joint • Excessive clearance between sliding surface of circle and drawbar • Worn blade rail guide bushing 	<ul style="list-style-type: none"> • Adjust shim. For details, see EVERY 250 HOURS SERVICE. • Adjust shim at circle guide connector. For details, see EVERY 500 HOURS SERVICE. • Replace guide bushing, shim Correct blade rail
Rotation of blade during operation is excessive	<ul style="list-style-type: none"> • Excessive clearance in circle in radial direction 	<ul style="list-style-type: none"> • Adjust position of guide connector. For details, see EVERY 500 HOURS SERVICE.
Work equipment does not move properly when work equipment control lever is operated	<ul style="list-style-type: none"> • Lack of oil 	<ul style="list-style-type: none"> • Add oil to specified level. For details, see EVERY 250 HOURS SERVICE.
Heat generated from parking brake disc	<ul style="list-style-type: none"> • Brake pad in contact with disc 	<ul style="list-style-type: none"> (• Adjust clearance)

ENGINE

- (): Always contact your Komatsu distributor when dealing with these items.
- In cases of problems or causes which are not listed below, contact your Komatsu distributor for repairs.

Problem	Main causes	Remedy
After warming-up operation, engine oil pressure monitor lights up even when engine speed is raised	<ul style="list-style-type: none"> • Oil level in engine oil pan is low (sucking in air) • Clogged oil filter cartridge • Leakage of oil due to damage, defective tightening of oil pipe, pipe join • Defective monitor • Defective oil pressure switch • Diluted with fuel, water • Defective pressure adjustment valve 	<ul style="list-style-type: none"> • Add oil to specified level For details, see CHECK BEFORE STARTING • Replace cartridge For details, see EVERY 500 HOURS SERVICE (• Check, repair) (• Replace) (• Replace) (• Check, repair) (• Check valve, replace spring)
Steam spurts out from top of radiator sub-tank (pressure valve)	<ul style="list-style-type: none"> • Coolant level is low. Leakage of coolant • Abnormality in the hydraulic circuit of the cooling fan • Dirt or scale accumulated in cooling system • Radiator fins clogged or bent 	<ul style="list-style-type: none"> • Check, add cooling water, repair cooling system For details, see WHEN REQUIRED (• Check, repair) • Change cooling water, clean cooling system For details, see WHEN REQUIRED • Clean or repair For details, see EVERY 500 HOURS SERVICE (• Replace thermostat) • Tighten cap or replace packing
Water temperature gauge is in top of red range	<ul style="list-style-type: none"> • Defective thermostat • Loose radiator filler cap (high altitude operations) • Defective water temperature gauge • Broken shroud or not installed • Defective pressure cap • Excessive load 	<ul style="list-style-type: none"> (• Replace) (• Check, repair, install) • Replace (• Check brake, check defective return of parking brake)
After warming-up operation, water temperature gauge does not work even when engine speed is raised	<ul style="list-style-type: none"> • Defective thermostat • Defective water temperature gauge 	<ul style="list-style-type: none"> (• Replace thermostat) (• Replace water temperature gauge)

Problem	Main causes	Remedy
Engine does not start when starting motor is turned	<ul style="list-style-type: none"> • Lack of fuel • Air in fuel system • Defective fuel supply pump or nozzle • Starting motor cranks engine sluggishly • Engine preheating pilot ramp does not light up • Defective compression • Defective valve clearance • Clogged fuel filter • Battery disconnect switch is OFF • Burnout of the fuse in the engine controller circuit 	<ul style="list-style-type: none"> • Add fuel. For details, see CHECK BEFORE STARTING (• Repair place where air is sucked in) (• Replace pump or nozzle) • See ELECTRICAL SYSTEM • See ELECTRICAL SYSTEM (• Adjust clearance) • Replace filter • Turn switch ON (• Check, repair wiring)
Exhaust gas is white or blue	<ul style="list-style-type: none"> • Too much oil in oil pan • Improper fuel 	<ul style="list-style-type: none"> • Reduce oil to specified level For details, see CHECK BEFORE STARTING • Change to specified fuel
Exhaust gas sometimes turns black	<ul style="list-style-type: none"> • Clogged air cleaner element • Defective injector • Defective compression • Defective turbocharger • Engine water temperature too low 	<ul style="list-style-type: none"> • Clean or replace. For details, see WHEN REQUIRED (• Replace injector) (• See "Defective compression" above) (• Wash or replace turbocharger) (• Check, replace thermostat)
Combustion noise occasionally makes breathing sound	<ul style="list-style-type: none"> • Defective nozzle • Defective fuel injection pump • Air in fuel line • Clogged fuel filter 	<ul style="list-style-type: none"> (• Replace nozzle) (• Replace pump) (• Repair location of air entry) • Replace fuel filter
Abnormal noise generated (fuel system or mechanical system)	<ul style="list-style-type: none"> • Low-grade fuel being used • Overheating • Damage inside muffler • Excessive valve clearance • Air in fuel line • Defective timing • Defective nozzle 	<ul style="list-style-type: none"> • Change to specified fuel • See "Engine water temperature gauge is in red range top" • Replace muffler (• Adjust clearance) • Bleed air (• Check, adjust) (• Repair, replace)
Engine does not stop	<ul style="list-style-type: none"> • Abnormality in controller power source system 	<ul style="list-style-type: none"> (• Check, repair wiring)

Problem	Main causes	Remedy
Does not reach rated speed when there is load	<ul style="list-style-type: none"> • Defective actuation of tachometer • Lack of fuel • Air in fuel line • Defective fuel supply pump, nozzle • Clogged fuel filter • Output of variable output selector signal not given • Oil level too high • Clogged air cleaner • Leakage of intake or exhaust from turbocharger • Use of poor quality fuel • Defective thermostat 	<ul style="list-style-type: none"> (• Check, replace) • Add fuel. See CHECK BEFORE STARTING (• Repair location of air entry) (• Replace) • Replace filter (• Replace transmission controller) • Adjust to correct level • Clean, replace (• Check, repair, replace) • Change fuel (• Replace)

FAILURE CODES

If any abnormality occurs, stop the machine in a safe place, set the gear shift lever to the P (Parking) position, then check the failure code and ask your Komatsu distributor to carry out repairs.

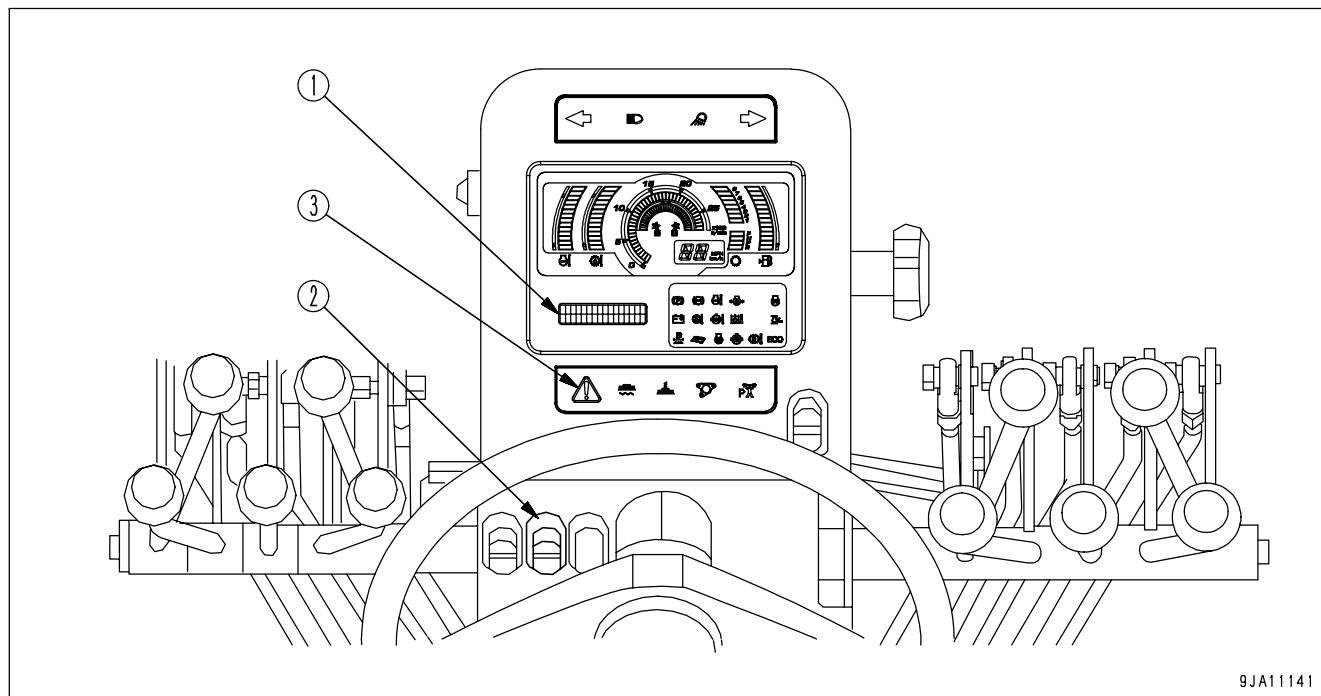

9JA11141

- (1) Character display
 (2) Machine monitor mode selector switch 2
 (3) Central caution lamp

When an abnormality display code appears on character display (1), take appropriate remedies based upon the following table.

REMARK

If different kinds of failures occur at the same time, their failure codes are arranged in the order of seriousness in the display.

The order of seriousness in this case is E03, E02 and E01, starting from the most serious one.

Action code	Character display (1)	Warning lamp	Alarm buzzer	Remedy
E01	Top line: Displays E01 Bottom line: Displays service meter	-	-	Failure in part of function, stops. When continuing operations, be extremely careful of location of failure. After completing operations, contact Komatsu distributor for repairs
E02	Top line: Displays E02 Bottom line: Displays service meter	Flashes	Sounds	Serious failure in part of function, stops. When continuing operations, be extremely careful of location of failure. After completing operations, contact Komatsu distributor for repairs
E03	Top line: Displays E03 Bottom line: Displays telephone number (If no telephone number is set, displays 0)	Flashes	Sounds	After moving to safe place, stop machine immediately. Contact Komatsu distributor for repairs

CONFIRMATION OF FAILURE CODE

1. When action code (A) is displayed, press the top (>) portion of machine monitor mode selector switch 2 (2) and check the failure code. Failure code (B) is displayed on character display (1).
2. Press the top (>) portion of machine monitor mode selector switch 2 (2) again. The service meter and odometer are displayed for several seconds, and then the screen returns to the action code screen.
If two or more failures are occurring, the next failure code is displayed.
3. Check the failure code, then contact your Komatsu distributor for repairs.

REMARK

- The failure code is the code displayed in the 6-digit area on the left side of the top line of character display (1).
- The code displayed on the right side of the failure code indicates the controller that detected the failure code.
MON: Machine monitor
TM: Transmission controller
ENG: Engine controller
- The bottom line of the character display shows the system where the failure is occurring.

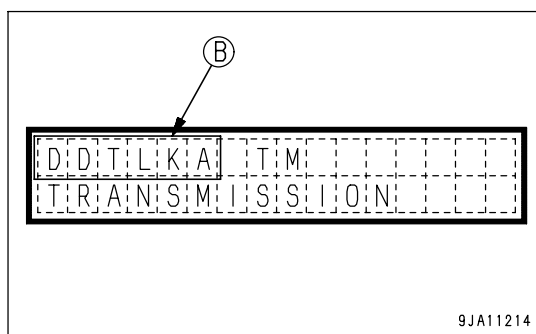
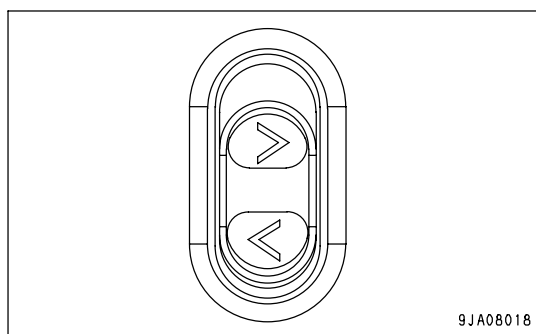
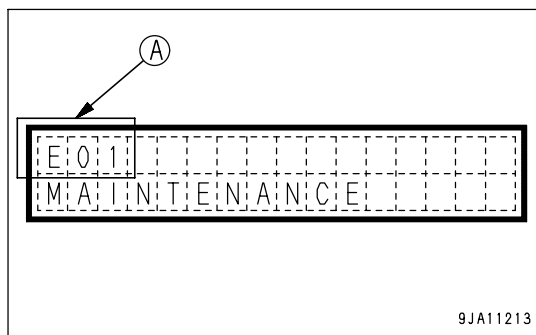

MAINTENANCE

WARNING

Please read and make sure that you understand the SAFETY section before reading this section.

GUIDES TO MAINTENANCE

Do not perform any inspection and maintenance operation that is not found in this manual.

Check service meter:

Check the service meter reading every day to see if the time has come for any necessary maintenance to be performed.

Komatsu genuine replacement parts:

Use Komatsu genuine parts specified in the Parts Book as replacement parts.

Komatsu genuine oils:

Use Komatsu genuine oils and grease. Choose oils and grease with proper viscosities specified for ambient temperature.

Always use clean washer fluid:

Use automobile window washer fluid, and be careful not to let any dirt get into it.

Clean oil and grease:

Use clean oil and grease. Also, keep the containers of the oil and grease clean. Keep foreign materials away from oil and grease.

Checking foreign material in drained oil:

After oil is changed or filters are replaced, check the old oil and filters for metal particles and foreign materials. If large quantity of metal particles or foreign materials are found, always report to the person in charge, and carry out suitable action.

Be careful of hot water and oil:

If your machine is equipped with a fuel strainer, do not remove it while fueling.

Welding instructions:

- Turn off the engine starting switch.
- Do not apply more than 200 V continuously.
- Connect grounding cable within 1 m (3.3 ft) of the area to be welded. If grounding cable is connected near instruments, connectors, etc., the instruments may malfunction.
- If a seal or bearing happens to come between the part being welded and grounding point, change the grounding point to avoid such parts.
- Do not use the area around the work equipment pins or the hydraulic cylinders as the grounding point.

Objects in your pockets:

- When opening inspection windows or the oil filler port of the tank to carry out inspection, be careful not to drop nuts, bolts, or tools inside the machine.
If such things are dropped inside the machine, it may cause damage and/or malfunction of the machine, and will lead to failure. If you drop anything inside the machine, always remove it immediately.
- Do not put unnecessary things in your pockets. Carry only things which are necessary for inspection.

Dusty worksites:

When working at dusty worksites, do as follows:

- Inspect the air cleaner clogging monitor frequently to see if the dust indicator is clogged.
Clean the air cleaner element at a shorter interval than specified.
- Clean the radiator core frequently to avoid clogging.
- Clean and replace the fuel filter frequently.
- Clean electrical components, especially the starting motor and alternator, to avoid accumulation of dust.
- When inspecting or changing the oil, move the machine to a place that is free of dust to prevent dirt from getting into the oil.

Avoid mixing oils:

If a different brand or grade of oil has to be added, drain the old oil and replace all the oil with the new brand or grade of oil. Never mix different brand or grade of oil.

Locking inspection covers:

Lock inspection cover securely into position with the lock bar. If inspection or maintenance is performed with inspection cover not locked in position, there is a danger that it may be suddenly blow shut by the wind and cause injury to the worker.

Bleeding air from hydraulic circuit:

When hydraulic equipment has been repaired or replaced, or the hydraulic piping has been removed and installed again, the air must be bled from the circuit.

Precautions when installing hydraulic hoses:

- When removing parts at locations where there are O-rings or gasket seals, clean the mounting surface, and replace with new parts.
When doing this, be careful not to forget to assemble the O-rings and gaskets.
- When installing the hoses, do not twist them or bend them sharply. If they are installed so, their service life will be shortened extremely and they may be damaged.

Checks after inspection and maintenance:

If you forget to perform the checks after inspection and maintenance, unexpected problems may occur, and this may lead to serious injury or property damage. Always do the following:

- Checks after operation (with engine stopped)
 - Have any inspection and maintenance points been forgotten?
 - Have all inspection and maintenance items been performed correctly?
 - Have any tools or parts been dropped inside the machine? It is particularly dangerous if parts are dropped inside the machine and get caught in the lever linkage mechanism.
 - Are there any leakage of coolant or oil? Have all nuts and bolts been tightened?
- Checks when operating engine
 - For details of the checks when operating the engine, see "TWO WORKERS FOR INSPECTION AND MAINTENANCE WHEN ENGINE IS RUNNING (PAGE 2-33)" and pay careful attention to safety.
 - Are the inspection and maintenance items working properly?
 - Is there any leakage of oil or fuel when the engine speed is raised?

OUTLINES OF SERVICE

- Always use Komatsu genuine parts for replacement parts, grease or oil.
- When changing the oil or adding oil, do not mix different types of oil. When changing the type of oil, drain all the old oil and fill completely with the new oil. Always replace the filter at the same time. (There is no problem if the small amount of oil remaining in the piping mixes with the new oil.)
- Unless otherwise specified, when the machine is shipped from the factory, it is filled with the oil and coolant listed in the table below.

Item	Type
Engine oil pan	Engine oil EO15W40-DH (Komatsu genuine parts)
Transmission case	Power train oil TO10 (Komatsu genuine parts)
Hydraulic system	
Final drive case	Power train oil TO30 (Komatsu genuine parts)
Tandem drive case	
Circle reverse gear case	Gear oil GO90 (Komatsu genuine parts)
Radiator	Supercoolant AF-NAC (Density:30% or above) (Komatsu genuine parts)

HANDLING OIL, FUEL, COOLANT, AND PERFORMING OIL CLINIC

OIL

- Oil is used in the engine and hydraulic equipment under extremely severe conditions (high temperature, high pressure), and deteriorates with use.
Always use oil that matches the grade and maximum and minimum ambient temperatures recommended in the Operation and Maintenance Manual. Even if the oil is not dirty, always change the oil at the specified interval.
- Oil corresponds to blood in the human body, always be careful when handling it to prevent any impurities (water, metal particles, dirt, etc.) from getting in.
The majority of problems with the machine are caused by the entry of such impurities.
Take particular care not to let any impurities get in when storing or adding oil.
- Never mix oils of different grades or brands.
- Always add the specified amount of oil.
Having too much oil or too little oil are both causes of problems.
- If the oil in the work equipment is not clear, there is probably water or air getting into the circuit. In such cases, please contact your Komatsu distributor.
- When changing the oil, always replace the related filters at the same time.
- We recommend you have an analysis made of the oil periodically to check the condition of the machine. For those who wish to use this service, please contact your Komatsu distributor.
- When using commercially available oil, it may be necessary to reduce the oil change interval.
We recommend that you use the Komatsu oil clinic to carry out a detailed checks of the characteristics of the oil.

FUEL

- To prevent the moisture in the air from condensing and forming water inside the fuel tank, always fill the fuel tank after completing the day's work.
- The fuel pump is a precision instrument, and if fuel containing water or dirt is used, it cannot work properly.
- Be extremely careful not to let impurities get in when storing or adding fuel.
- Always use fuel that matches the temperatures given in the Operation and Maintenance Manual.
 - If the fuel is used in temperatures lower than the specified temperature for use (particularly at temperatures of lower than -15°C), the properties of the fuel will make it congeal.
 - If the fuel is used in temperatures higher than the specified temperature for use, the viscosity will go down, and this may result in a drop in output or other problems.
- Before starting the engine, or when 10 minutes have passed after adding fuel, drain the sediment and water from the fuel tank.
- If the engine runs out of fuel, or if the filters have been replaced, it is necessary to bleed the air from the circuit.
- If there is any foreign material in the fuel tank, wash the tank and fuel system.

NOTICE

Use only diesel fuel.

The engine mounted on this machine employs electronic control and a high-pressure fuel injection device to obtain good fuel consumption and good exhaust gas characteristics. For this reason, it requires high precision for the parts and good lubrication. If kerosene or other fuel with low lubricating ability is used, there will be a big drop in durability.

COOLANT AND WATER FOR DILUTION

- The coolant has the important function of preventing corrosion as well as preventing freezing. Even in the areas where freezing is not an issue, the use of antifreeze coolant is essential. Komatsu machines are supplied with Komatsu Supercoolant (AF-NAC). Komatsu Supercoolant (AF-NAC) has excellent anticorrosion, antifreeze and cooling properties and can be used continuously for 2 years or 4000 hours. As a basic rule, we do not recommend the use of any coolant other than Komatsu genuine supercoolant (AF-NAC). If you use another coolant, it may cause serious problems, such as corrosion of the engine and aluminum parts of the cooling system.
- When using antifreeze, always observe the precautions given in the Operation and Maintenance Manual.
- The Supercoolant is already diluted with distilled water, so it is not flammable.
- With the Supercoolant (AF-NAC), the density used for the coolant differs according to the ambient temperature. For details of the coolant density, see "CLEAN INSIDE OF COOLING SYSTEM (PAGE 4-18)". Even in areas where it is not considered necessary to prevent freezing, always use Supercoolant (AF-NAC) with a density of over 30% in order to prevent corrosion of the cooling system. Supercoolant (AF-NAC) is diluted with distilled water that does not contain any ions or water-hardening substances. Never dilute the Supercoolant with ordinary water.
- If the engine overheats, wait for the engine to cool before adding coolant.
- If the coolant level is low, it will cause overheating, and will also cause problems with corrosion due to air entering the coolant.

GREASE

- Grease is used to prevent seizure and noises at the joints.
- This construction equipment is used under heavy-duty conditions. Always use the recommended grease and follow the change intervals and recommended ambient temperatures given in this Operation and Maintenance Manual.
- Grease fittings not listed in the inspection and maintenance section are grease fittings that are used at the time of overhaul, so there is no need to grease these points.
When using the machine after it has been in storage for a long time, carry out greasing if there is any stiffness or screeching.
- Always wipe off all of the old grease that is pushed out when greasing.
Be particularly careful to wipe off the old grease in places where sand or dirt sticking in the grease would cause wear of the rotating parts.

CARRYING OUT KOWA (Komatsu Oil Wear Analysis)

KOWA is a maintenance service that makes it possible to prevent machine failures and downtime. With KOWA, the oil is periodically sampled and analyzed. This enables early detection of wear of the machine drive parts and other problems.

We strongly recommend you to use this service. The oil analysis is carried out at actual cost, so the cost is low, and the results of the analysis are reported together with recommendations which will reduce repair costs and machine downtime.

KOWA ANALYSIS ITEMS

- Measurement of density of metal wear particles
This uses an ICP (Inductively Coupled Plasma) analyzer to measure the density of iron, copper, and other metal wear particles in the oil.

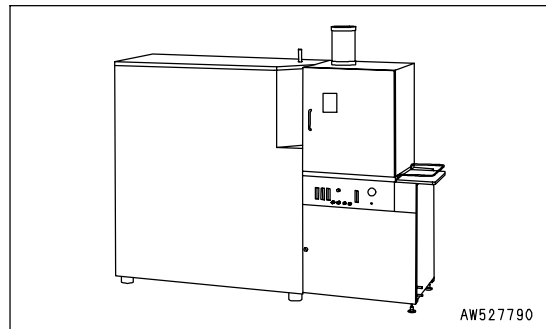

- Measurement of quantity of particles
This uses a PQI (Particle Quantifier Index) measurer to measure the quantity of iron particles of 5µm or more, enabling early detection of failures.

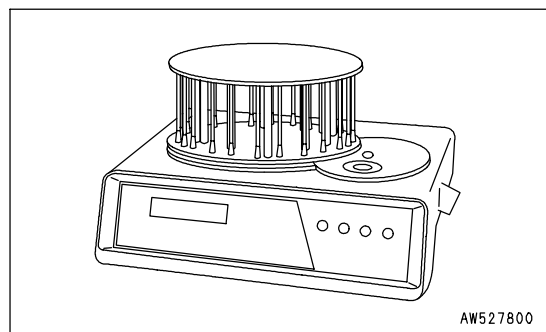

- Others
Measurements are made of items such as the ratio of water in the oil, density of the antifreeze coolant, ratio of fuel in the oil, and dynamic viscosity, enabling a highly precise diagnosis of the machine's health.

OIL SAMPLING

- Sampling interval
 - 250 hours: Engine
 - 500 hours: Other components
- Precautions when sampling
 - Make sure that the oil is well mixed before sampling.
 - Perform sampling at regular fixed intervals.
 - Do not perform sampling on rainy or windy days when water or dust can get into the oil.

For further details of KOWA, please contact your Komatsu distributor.

STORING OIL AND FUEL

- Keep indoors to prevent any water, dirt, or other impurities from getting in.
- When keeping drum cans for a long period, put the drum on its side so that the filler port of the drums is at the side to prevent moisture from being sucked in.
If drums have to be stored outside, cover them with a waterproof sheet or take other measures to protect them.
- To prevent any change in quality during long-term storage, be sure to use in the order of first in - first out (use the oldest oil or fuel first).

FILTERS

- Filters are extremely important safety parts. They prevent impurities in the fuel and air circuits from entering important equipment and causing problems.
Replace all filters periodically. For details, see the Operation and Maintenance Manual.
However, when working in severe conditions, replace the filters at shorter intervals according to the oil and fuel (sulfur content) being used.
- Never try to clean the filters (cartridge type) and use them again. Always replace with new filters.
- When replacing oil filters, check if any metal particles are attached to the old filter. If any metal particles are found, contact your Komatsu distributor.
- Do not open packs of spare filters until just before they are to be used.
- Always use Komatsu genuine filters.

RELATING TO ELECTRIC SYSTEM

- Before removing the battery, turn the battery disconnect switch to the OFF position.
- It is extremely dangerous if the electrical equipment becomes wet or the covering of the wiring is damaged. This will cause an electrical short circuit and may lead to malfunction of the machine. Do not wash the inside of the operator's cab with water. When washing the machine, be careful not to let water get into the electrical components.
- Service relating to the electric system is checking fan belt tension, checking damage or wear to the fan belt and checking battery fluid level.
- Never install any electric components other than those specified by Komatsu.
- External electro-magnetic interference may cause malfunction of the control system controller, before installing a radio receiver or other wireless equipment, contact your Komatsu distributor.
- When working at the seashore, carefully clean the electric system to prevent corrosion.
- When installing an operator's cab cooler or any other electrical equipment, connect it to an independent power source connector. The cables to supply power to the optional equipment must never be connected to the fuse, starting switch, or battery relay.

WEAR PARTS

Wear parts such as the filter element, air cleaner element, edge, etc. are to be replaced at the time of periodic maintenance or before their abrasion limits.

The wear parts should be changed correctly in order to use the machine economically.

For part change, Komatsu genuine parts of excellent quality should be used.

When ordering parts, please check the part number in the parts book.

WEAR PARTS LIST

The parts in parentheses are to be replaced at the same time.

Item	Part No.	Part Name	Q'ty	Replacement interval
Engine oil filter	6736-51-5142	Cartridge	1	EVERY 500 HOURS
Fuel prefilter	600-319-3601	Cartridge	1	
Fuel main filter	600-319-3750	Cartridge	1	EVERY 1000 HOURS
Transmission oil filter	714-07-28712	Cartridge	1	
Hydraulic filter	07063-51100 (07000-15195)	Element (O-ring)	1 (1)	
Air cleaner	600-185-5100	Element ass'y	1	-
Blade 3.7m t22 Blade with side edge	23B-70-31310	Edge	2	-
	or 232-70-12143			
	23B-70-31660	Side edge	2	
	or 23B-70-31271			
	(232-70-12550)	(Bolt)	(34)	
	(232-70-12480)	(Nut)	(34)	
	(01643-31645)	(Washer)	(34)	
232-70-31340	End bit (if equipped)	2		
(232-70-12560)	(Bolt)	(10)		
Blade 4.3m t25 Blade with side edge	23B-70-31460	Edge	2	-
	or 234-70-12193			
	23B-70-31660	Side edge	2	
	or 23B-70-31271			
	(232-70-12590)	(Bolt)	(38)	
	(232-70-12480)	(Nut)	(38)	
	(01643-31645)	(Washer)	(38)	
232-70-31340	End bit (if equipped)	2		
(232-70-12490)	(Bolt)	(10)		
Blade 3.7m t19 Blade without side edges but with end bits	232-70-12143	Edge	2	-
	232-70-52190	End bit	2	
	(232-70-12450)	(Bolt)	(28)	
	(232-70-12460)	(Bolt)	(4)	
	(232-70-12480)	(Nut)	(32)	
	(01643-31645)	(Washer)	(32)	

Blade 4.3m t19 Blade without side edges but with end bits	232-70-12143	Edge	2	-
	232-70-52190	End bit	2	
	(232-70-12450)	(Bolt)	(32)	
	(232-70-12460)	(Bolt)	(4)	
	(232-70-12480)	(Nut)	(36)	
	(01643-31645)	(Washer)	(36)	
Blade	23B-70-31331	Guide bushing	4	-
	23B-735-3320	Guide bushing	2	
Circle	23B-70-31680	Wear plate	6	-
	23B-70-51560	Guide	6	
Scarifier	232-71-51320	Tooth	11	-
Ripper	234-785-1121	Tooth	3	-
	(113-78-21170)	(Pin)	(3)	
Front blade	233-971-5120	Edge	2	-
	(232-70-12450)	(Bolt)	(14)	
	(232-70-12480)	(Nut)	(14)	
	(01643-31645)	(Washer)	(14)	

RECOMMENDED FUEL, COOLANT, AND LUBRICANT

- Komatsu genuine oils are adjusted to maintain the reliability and durability of Komatsu construction equipment and components.

In order to keep your machine in the best condition for long periods of time, it is essential to follow the instructions in this Operation and Maintenance Manual.

- Failure to follow these recommendations may result in shortened life or excess wear of the engine, power train, cooling system, and/or other components.
- Commercially available lubricant additives may be good for the machine, but they may also cause harm. Komatsu does not recommend any commercially available lubricant additive.
- Use the oil recommended according to the ambient temperature in the chart below.
- Specified capacity means the total amount of oil including the oil in the tank and the piping. Refill capacity means the amount of oil needed to refill the system during inspection and maintenance.
- When starting the engine in temperatures below 0°C (32°F), be sure to use the recommended multi-grade oil, even if the ambient temperature may become higher during the course of the day.
- If the machine is operated at a temperature below -20°C (-4°F), a separate device is needed, so consult your Komatsu distributor.
- When the fuel sulfur content is less than 0.5%, change the engine oil according to the period inspection table given in this Operation and Maintenance Manual.

If the fuel sulfur content is more than 0.5%, change the oil according to the following table.

Sulfur content (%)	Oil change interval
Less than 0.5	500 hours
0.5 - 1.0	250 hours
1.0 and up	Not recommendable (*)

* If these fuels are used, there is danger that serious trouble may occur because of early deterioration of the engine oil or early wear of the internal parts of the engine. If the local situation makes it necessary to use these fuels, always remember the following.

- 1) Be sure to check Total Basic Number (TBN) of oil frequently by TBN handy checker etc., and change oil based on the result.
- 2) Always be aware that oil change interval is extremely shorter than standard.
- 3) Be sure to carry out periodic engine inspection by distributor's expert since change interval of periodic replacement parts and overhaul interval are also shorter.

USE OF FUEL, COOLANT AND LUBRICANTS ACCORDING TO AMBIENT TEMPERATURE

Reservoir	Fluid Type	Ambient Temperature, degrees Celsius										Recommended Komatsu Fluids
		-22 -30	-4 -20	14 -10	32 0	50 10	68 20	86 30	104 40	122 °F 50 °C		
Engine oil pan	Engine oil	(Note.1)										Komatsu EOS0W30
		(Note.1)										Komatsu EOS5W40
		(Note.1)										Komatsu EO10W30-DH
		(Note.1)										Komatsu EO15W40-DH
		(Note.1)										Komatsu EO30-DH
Transmission case	Power train oil (Note.2)	(Note.1)										TO10
Hydraulic system	Power train oil	(Note.1)										TO10
Final drive case Tandem drive case	Power train oil	(Note.1)										TO30
Circle reverse gear case	Gear oil	(Note.1)										GO90
		(Note.1)										GO80
		(Note.1)										GO75
Grease fitting Work equipment	Hyper grease (Note.3)	(Note.1)										G2-T, G2-TE
	Lithium EP grease	(Note.1)										G2-LI
	Lubricants with molybdenum disulfide	(Note.1)										LM-G, LM-P
Cooling system	Supercoolant AF-NAC (Note.4)	(Note.1)										AF-NAC
Fuel tank	Diesel fuel	(Note.1)										ASTM Grade No.1-D S15 ASTM Grade No.1-D S500
		(Note.1)										ASTM Grade No.2-D S15 ASTM Grade No.2-D S500

• ASTM: American Society of Testing and Material

Capacity \ Reservoir		Engine oil pan	Transmission case	Tandem drive case	Final drive case
					Differential lock
Specified	Liters	25.4	60	57	17
	US gal	6.71	15.85	15.06	4.49
Refill	Liters	23.1	45	57	17
	US gal	6.10	11.89	15.06	4.49

Capacity \ Reservoir		Hydraulic system	Circle reverse gear case	Fuel tank	Cooling system
			Slip clutch type		
Specified	Liters	132	7	416	39.5
	US gal	34.87	1.85	107.8	10.44
Refill	Liters	69	7	-	39.5
	US gal	18.23	1.85	-	10.44

NOTICE

Always use diesel oil for the fuel.

To ensure good fuel consumption characteristics and exhaust gas characteristics, the engine mounted on this machine uses an electronically controlled high-pressure fuel injection device. This device requires high precision parts and lubrication, so if low viscosity fuel with low lubricating ability is used, the durability may drop markedly.

Note 1: HTHS (High-Temperature High-Shear Viscosity 150°C), specified by ASTM D4741 must be equal to or higher than 3.5 mPa-S. Komatsu EOS0W30 and EOS5W40 are the most suitable oils.

Note 2: Powertrain oil has different properties from engine oil. Be sure to use the recommended oils.

Note 3: Hyper grease (G2-T, G2-TE) has a high performance.

When it is necessary to improve the lubricating ability of the grease in order to prevent squeaking of pins and bushings, the use of G2-T or G2-TE is recommended.

Note 4: Supercoolant (AF-NAC)

1) Coolant has the important function of anticorrosion as well as antifreeze.

Even in the areas where freezing is not an issue, the use of antifreeze coolant is essential.

Komatsu machines are supplied with Komatsu Supercoolant AF-NAC. Komatsu Supercoolant AF-NAC has excellent anticorrosion, antifreeze and cooling properties and can be used continuously for 2 years or 4000 hours. Komatsu Supercoolant AF-NAC is strongly recommended wherever available.

2) For details of the Supercoolant AF-NAC density, see "CLEAN INSIDE OF COOLING SYSTEM (PAGE 4-18)". Supercoolant AF-NAC is supplied already diluted. In this case, add the pre-diluted fluid to keep the tank full. (Never dilute the Supercoolant with ordinary water.)

3) To maintain the anticorrosion properties of Supercoolant AF-NAC, always keep the density of Supercoolant between 30% and 68%.

RECOMMENDED BRANDS, RECOMMENDED QUALITY FOR PRODUCTS OTHER THAN KOMATSU GENUINE OIL

When using commercially available oils other than Komatsu genuine oil, consult your Komatsu distributor.

STANDARD TIGHTENING TORQUES FOR BOLTS AND NUTS

TORQUE LIST



If nuts, bolts, or other parts are not tightened to the specified torque, it will cause looseness or damage to the tightened parts, and this will cause failure of the machine or problems with operation.

Always pay careful attention when tightening parts.

Unless otherwise specified, tighten the metric nuts and bolts to the torque shown in the table below.

If it is necessary to replace any nut or bolt, always use a Komatsu genuine part of the same size as the part that was replaced.

Thread diameter of bolt (a)(mm)	Width across flats (b)(mm)	Tightening torque					
		Target value			Service limit		
		Nm	kgm	lbft	Nm	kgm	lbft
6	10	13.2	1.35	9.8	11.8-14.7	1.2-1.5	8.7-10.8
8	13	31	3.2	23.1	27-34	2.8-3.5	20.3-25.3
10	17	66	6.7	48.5	59-74	6.0-7.5	43.4-54.2
12	19	113	11.5	83.2	98-123	10.0-12.5	72.3-90.4
14	22	177	18	130.2	157-196	16.0-20.0	115.7-144.7
16	24	279	28.5	206.1	245-309	25.0-31.5	180.8-227.8
18	27	382	39	282.1	343-425	35.0-43.5	253.2-314.6
20	30	549	56	405.0	490-608	50.0-62.0	361.7-448.4
22	32	745	76	549.7	662-829	67.5-84.5	488.2-611.2
24	36	927	94.5	683.5	824-1030	84.0-105.0	607.6-759.5
27	41	1320	135.0	976.5	1180-1470	120.0-150.0	868.0-1085.0
30	46	1720	175.0	1265.8	1520-1910	155.0-195.0	1121.1-1410.4
33	50	2210	225.0	1627.4	1960-2450	200.0-250.0	1446.6-1808.3
36	55	2750	280.0	2025.2	2450-3040	250.0-310.0	1808.3-2242.2
39	60	3280	335.0	2423.1	2890-3630	295.0-370.0	2133.7-2676.2

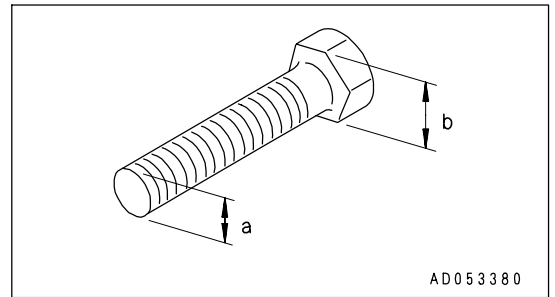

Apply the following table for Hydraulic Hose.

Nominal - No. of threads (a)	Width across flats (b) (mm)	Tightening torque					
		Target value			Permissible range		
		Nm	kgm	lbft	Nm	kgm	lbft
9/16 -18UNF	19	44	4.5	32.5	35 - 63	3.5 - 6.5	25.3 - 47.0
11/16 -16UN	22	74	7.5	54.2	54 - 93	5.5 - 9.5	39.8 - 68.7
13/16 -16UN	27	103	10.5	75.9	84 - 132	8.5 - 13.5	61.5 - 97.6
1 -14UNS	32	157	16.0	115.7	128 - 186	13.0 - 19.0	94.0 - 137.4
13/16 -12UN	36	216	22.0	159.1	177 - 245	18.0 - 25.0	130.2 - 180.8

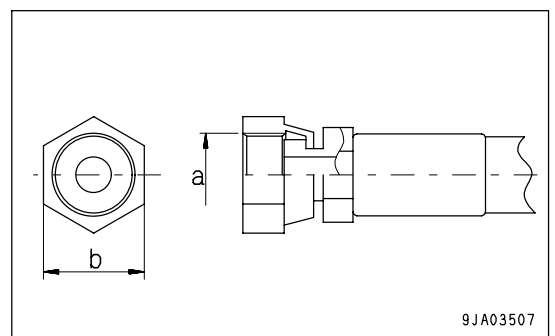

PERIODIC REPLACEMENT OF CRITICAL PARTS

To ensure safety at all times when operating or driving the machine, the user of the machine must always carry out periodic maintenance. In addition, to further improve safety, the parts in the safety-critical parts list on the next page must also be replaced at the specified interval. These parts are particularly closely connected to safety and fire prevention, so please contact your Komatsu distributor to have them replaced.

Material quality of these parts can change as time passes and they are likely to wear out or deteriorate. However, it is difficult to determine the extent of wear or deterioration at the time of periodic maintenance. Hence, it is required to replace them with new ones regardless of their condition after a certain period of usage. This is important to ensure that these parts maintain their full performance at all times.

Furthermore, should anything abnormal be found on any of these parts, replace it with a new one even if the periodic replacement time for the part has not yet arrived.

If any of the hose clamps show deterioration like deformation or cracking, replace the clamps at the same time as the hoses.

Also perform the checks with hydraulic hoses which need to be replaced periodically. Tighten all loose clamps and replace defective hoses, as required.

When replacing hoses, always replace O-rings, gaskets, and other such parts at the same time.

CRITICAL PARTS

No.	Safety critical parts for periodic replacement	Q'ty	Replacement interval
1	Fuel hose (fuel tank - fuel filter)	1	Every 2 years or every 4000 hours, whichever comes sooner
2	Fuel hose (fuel filter - engine)	1	
3	Fuel hose (engine - fuel tank)	1	
4	Rod packing, piston seals, of steering cylinder	4	
5	Dust seal for steering cylinder	2	
6	O-ring for steering cylinder	4	
7	Steering circuit rubber hose (steering pump - steering valve)	4	
8	Steering circuit rubber hose (steering cylinder - steering valve)	8	
9	Steering hose (steering valve - hydraulic tank)	3	
10	O-ring for steering valve	3	
11	O-ring, seals, of steering valve	2	
12	Dust seal for steering valve	1	
13	Leaning circuit rubber hose (right side of work equipment control valve - leaning cylinder)	4	
14	Packing, dust seals, piston seals, of leaning cylinder	4	
15	O-ring for leaning cylinder	2	
16	Brake circuit rubber hose (brake valve - accumulator)	2	
17	Brake circuit rubber hose (brake valve - slack adjuster)	2	
18	Brake circuit rubber hose (slack adjuster - brake)	4	
19	Brake hose (brake valve - hydraulic tank)	1	
20	Transmission hose	5	
21	Accumulator (for brake)	2	
22	Alarm	2	
23	Seat belt	1	

MAINTENANCE SCHEDULE CHART

MAINTENANCE SCHEDULE CHART

INITIAL 250 HOURS SERVICE (only after the first 250 hours)

Replace fuel main filter cartridge	4- 61
Change oil in transmission case, clean strainer	4- 63
Clean transmission breather	4- 64
Change oil in final drive case	4- 64
Clean final drive breather	4- 65
Change oil in circle reverse gear case	4- 71
Replace hydraulic tank filter element	4- 65
Change oil in hydraulic tank, clean strainer	4- 69
Change oil in tandem drive case	4- 72
Cheak engine valve clearance, adjust	4- 74

WHEN REQUIRED

Clean inside of cooling system	4- 21
Check, clean or replace air cleaner	4- 18
Drain water from fuel pre-filter	4- 25
Cheak electrical intake air heater	4- 26
Replace the cutting edges, reverse and replace end bit	4- 26
Check inching pedal	4- 27
Clean air conditioner air filter	4- 27
Check refrigerant (GAS) level	4- 28
Check tension of air conditioner compressor belt	4- 28
Clean air conditioner condenser	4- 29
Clean radiator fins and oil cooler fins	4- 30
Clean, inspect radiator fins, oil cooler fins, aftercooler fins, condenser fins	4- 34
Selection and inspection of tires	4- 36
Checking function of accumulator	4- 38

CHECK BEFORE STARTING

EVERY 50 HOURS SERVICE

Lubricating	4- 40
-------------------	-------

EVERY 250 HOURS SERVICE

Lubricating	4- 43
Check oil level in transmission case, add oil	4- 47
Check oil level in final drive case, add oil	4- 49
Check oil level in tandem drive case, add oil	4- 50
Check oil level in circle reverse gear case, add oil	4- 50
Check oil level in hydraulic tank, add oil	4- 51
Check level of battery electrolyte	4- 52
Check ball joint clearance, adjust	4- 54
Check and tighten wheel hub nut and hub bolt	4- 54
Checking wheel rim, lock ring and side ring for corrosion and wear	4- 54
Check parking brake	4- 54

EVERY 500 HOURS SERVICE

Change oil in engine oil pan, replace engine oil filter cartridge ----- 4- 55
 Replace fuel pre-filter cartridge ----- 4- 56
 Check circle guide clearance, adjust ----- 4- 58

EVERY 1000 HOURS SERVICE

Replace fuel main filter cartridge ----- 4- 61
 Replace transmission oil filter cartridge ----- 4- 62
 Change oil in transmission case, clean transmission case strainer ----- 4- 63
 Clean transmission breather ----- 4- 64
 Change oil in final drive case ----- 4- 64
 Clean final drive breather ----- 4- 65
 Replace hydraulic tank filter element ----- 4- 65
 Check looseness, play of ball joint at front of drawbar ----- 4- 66
 Check toe-in, adjust ----- 4- 66
 Check front wheel bearing play, adjust ----- 4- 67
 Check of engine air intake piping clamps for looseness ----- 4- 68

EVERY 2000 HOURS SERVICE

Change oil in hydraulic tank, clean strainer ----- 4- 69
 Change oil in circle reverse gear case ----- 4- 71
 Change oil in tandem drive case ----- 4- 72
 Check disc brake ----- 4- 73
 Check alternator, starting motor ----- 4- 74
 Check engine valve clearance, adjust ----- 4- 74
 Check vibration damper ----- 4- 74
 Check accumulator gas pressure ----- 4- 74
 Change grease in front wheel bearing ----- 4- 74

EVERY 4000 HOURS SERVICE

Check water pump ----- 4- 75
 Check actuation of compressor ----- 4- 75
 Check fan pulley ----- 4- 75
 Checking for looseness of high-pressure clamp, hardening of rubber ----- 4- 75
 Checking for missing fuel spray prevention cap, hardening of rubber ----- 4- 76
 Lubricating ----- 4- 76

EVERY 8000 HOURS SERVICE

Replace high-pressure piping clamp ----- 4- 77
 Replace fuel spray prevention cap ----- 4- 77

SERVICE PROCEDURE

INITIAL 250 HOURS SERVICE (only after the first 250 hours)

Carry out the following maintenance only after the first 250 hours of operation on new machines.

- REPLACE FUEL MAIN FILTER CARTRIDGE
- CHANGE OIL IN TRANSMISSION CASE, CLEAN STRAINER
- CLEAN TRANSMISSION BREATHER
- CHANGE OIL IN FINAL DRIVE CASE
- CLEAN FINAL DRIVE BREATHER
- CHANGE OIL IN CIRCLE REVERSE GEAR CASE
- REPLACE HYDRAULIC TANK FILTER ELEMENT
- CHANGE OIL IN HYDRAULIC TANK, CLEAN STRAINER
- CHANGE OIL IN TANDEM DRIVE CASE
- CHECK ENGINE VALVE CLEARANCE, ADJUST

For details of the method of replacing or maintaining, see the section on EVERY 250 HOURS, EVERY 500 HOURS, 1000 HOURS AND 2000 HOURS SERVICE.

WHEN REQUIRED

CLEAN INSIDE OF COOLING SYSTEM



WARNING

- Immediately after the engine is stopped, the coolant is at a high temperature and the radiator is under high internal pressure. If the cap is removed to drain the coolant in this condition, there is a danger of burns. Wait for the temperature to go down, then turn the cap slowly to release the pressure before removing it.
- The cleaning is carried out with the engine running. When standing up or leaving the operator's seat, set the gear shift lever to the P (Parking) position.
- For details of starting the engine, see "CHECK BEFORE STARTING ENGINE (PAGE 3-83)", "STARTING ENGINE (PAGE 3-101)" in the OPERATION section.
- Never enter the area behind the machine when the engine is running.

Stop the machine on level ground when cleaning or changing the coolant.

Clean the inside of the cooling system, change the coolant according to the table below.

Antifreeze coolant	Interval for cleaning inside of cooling system and changing antifreeze coolant
Komatsu supercoolant (AF-NAC)	Every two years or every 4000 hours whichever comes first

The coolant has the important function of preventing corrosion as well as preventing freezing.

Even in the areas where freezing is not an issue, the use of antifreeze coolant is essential.

Komatsu machines are supplied with Komatsu Supercoolant (AF-NAC). Komatsu Supercoolant (AF-NAC) has excellent anticorrosion, antifreeze and cooling properties and can be used continuously for 2 years or 4000 hours. As a basic rule, we do not recommend the use of any coolant other than Komatsu genuine supercoolant (AF-NAC). If you use another coolant, it may cause serious problems, such as corrosion of the engine and aluminum parts of the cooling system.

To maintain the anticorrosion properties of Supercoolant (AF-NAC), always keep the density of Supercoolant between 30% and 68%.

Supercoolant (AF-NAC) is already diluted with distilled water. When using coolant, investigate the lowest temperatures in the past and decide the density for the coolant from the coolant density table below.

When actually deciding the density for the coolant, set it for a temperature 10°C (18°F) below the actual temperature.

The coolant density varies according to the ambient temperature, but it must always be a minimum of 30%.

Coolant density table

Minimum Temp	°C	Above -10	-15	-20	-25	-30	-35	-40	-45	-50
	°F	Above 14	5	-4	-13	-22	-31	-40	-49	-58
Concentration (%)		30	36	41	46	50	54	58	61	64

WARNING

- Antifreeze is toxic. When open the drain valve, be careful not to get water containing antifreeze on you. If it gets in your eyes, flush your eyes with large amount of fresh water and see a doctor at once.
- When changing the coolant or draining the coolant from the radiator before carrying out repairs, ask a specialist company to handle any coolant containing antifreeze, or contact your Komatsu distributor. Antifreeze is toxic, so never pour it into drainage water ditches or drain it onto the ground surface.

The Supercoolant is already diluted with distilled water, so it is not flammable. (For details of the distilled water, see "COOLANT AND WATER FOR DILUTION (PAGE 4-5)". Check the density with a coolant tester.

Prepare a hose to use when filling with coolant.

- Prepare a container to catch drained coolant minimum 40 liters (10.57 US gal) capacity.

1. Stop the machine on level ground, then stop the engine.
2. Remove bolts (1) (2 pieces) to take cover (2) off.
3. Check that the cooling water temperature has gone down enough to make it possible to touch the radiator cap surface by hand, then turn radiator cap (3) slowly until it contacts the stopper to release the pressure.
4. Following this, push radiator cap (3), turn it until it contacts the stopper, then remove it.
5. Prepare a container to catch the coolant and open drain valve (4) at the left of the fuel tank to drain the coolant.
6. After draining the water, close drain valve (4) and fill with city water.
7. When the radiator is full, start the engine, and run it at low idle. Keep the engine running at low idle for 10 minutes until the coolant temperature reaches more than 90°C (194°F).
8. Stop the engine, open drain valve (4), and drain the water.
9. After draining the water, clean the cooling system with cleaning agent.
For the cleaning method, see the instructions for the cleaning agent.
10. Close drain valve (4).
11. Slowly fill the Supercoolant (AF-NAC) through the water filler up to the bottom of the filler port.
For details of the Supercoolant density, see the "COOLANT DENSITY TABLE".
12. To remove air in the coolant, run the engine for 5 minutes at low idle and for another 5 minutes at high idle.
(While running the engine, leave the water filler cap removed.)

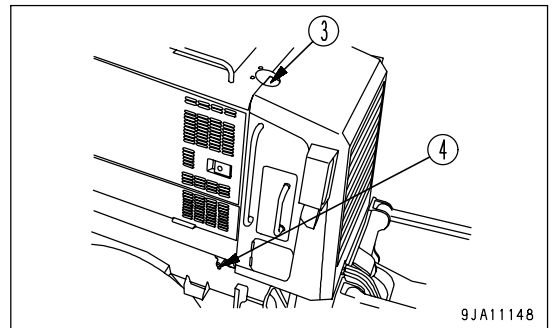
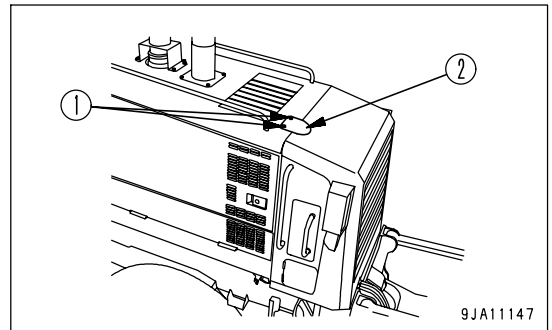

13. Drain the coolant from sub tank (5), wash the inside of the sub tank, then add water to between the FULL and LOW marks.
14. Stop the engine. About 3 minutes later, fill the Supercoolant (AF-NAC) almost up to the water filler, and tighten the cap. Check the coolant volume and, if short, add accordingly.

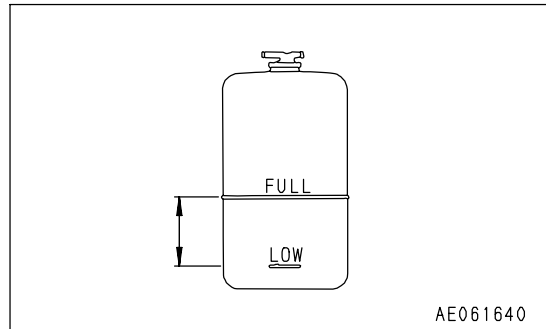
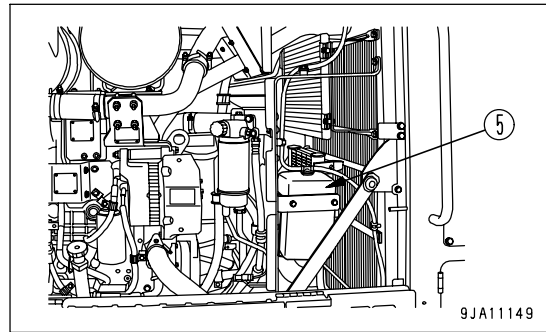

CHECK, CLEAN AND REPLACE AIR CLEANER ELEMENT

! WARNING

- If inspection, cleaning, or maintenance is carried out with the engine running, dirt will get into the engine and damage it. Always stop the engine before carrying out these operations.
- When using compressed air, there is danger that dirt may be blown around and cause serious injury. Always use protective glasses, dust mask, and other protective equipment.

CHECKING

1. Open the engine side cover on the right side of the machine.
2. If yellow display panel (2) in the transparent portion of dust indicator (1) reaches red line (3), clean the air cleaner element.

NOTICE

Do not clean the element before the yellow display panel of the dust indicator reaches the red line.

If the element is cleaned frequently before the yellow display panel of the dust indicator reaches the red line, the air cleaner will not be able to display its performance fully and the cleaning efficiency will also go down.

In addition, during the cleaning operation, more dirt stuck to the element will fall inside the inner element.

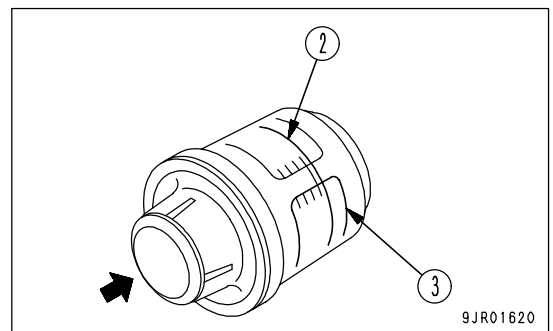
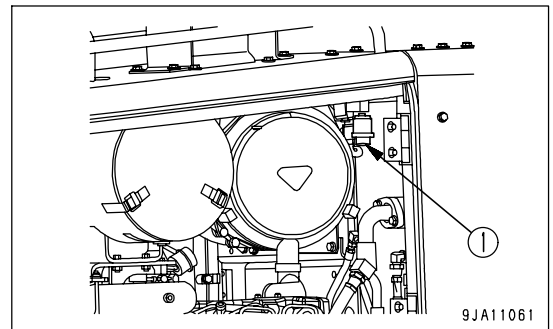

CLEANING OR REPLACING OUTER ELEMENT

1. Open the engine side cover on the right side of the machine.
2. Remove clips (3), then remove dust cup (4).

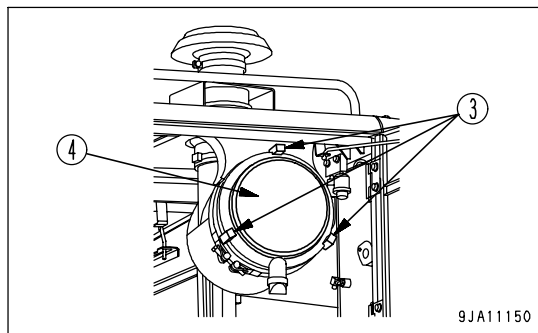

NOTICE

Never remove inner element (6). If it is removed, dust will enter and cause engine trouble.

3. Remove outer element (5).

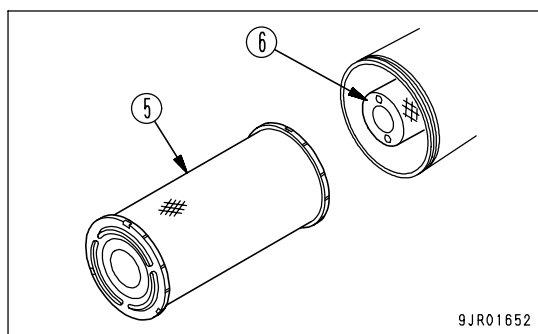

NOTICE

When cleaning the dust cup, do not remove evacuator valve (7).

4. Clean the inside of the air cleaner body and dust cup.

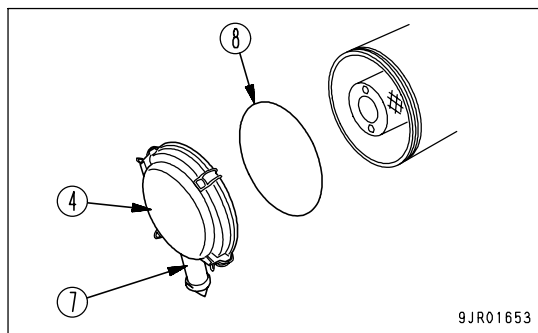

5. Blow dry compressed air (Max. 0.20 MPa (2 kg/cm², 28.4 PSI)) from the inside of the element along its folds. Then blow the compressed air from the outside along the folds, and again from the inside.

- 1) Replace the outer element if it has been cleaned 6 times repeatedly or used throughout a year. Replace the inner element at the same time.
- 2) If the yellow display panel of the dust indicator reaches the center of the scale (5 kPa) immediately after the outer element has been cleaned, replace both the inner and outer elements, even when the outer element has not been cleaned 6 times.

6. If small holes or thinner parts are found on the element when it is checked by shining a light through it after cleaning, replace the element.

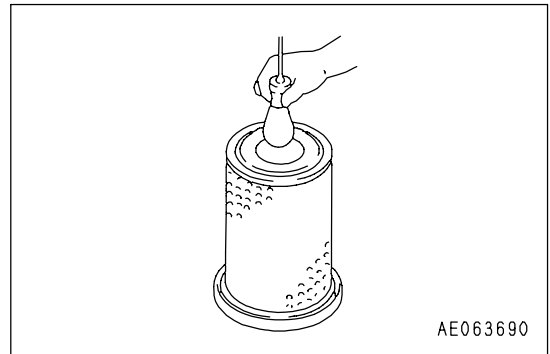
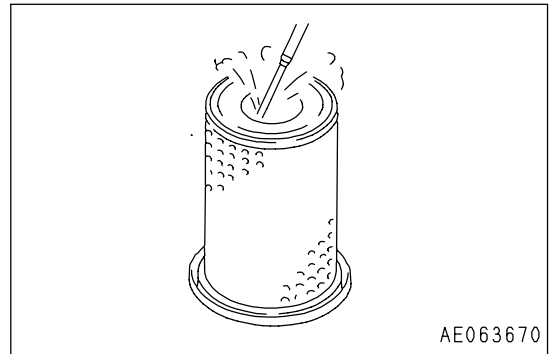

NOTICE

- When cleaning the element, do not hit it or beat it against something.
- Do not use an element whose folds or gasket or seal are damaged.
- If force is used when assembling, the clip or air cleaner body will be damaged, so push it in straight when installing it.
- Do not operate the machine with the inner element removed. This will damage the engine.

7. Set the cleaned outer element and install dust cup (4), then secure them with clips (3).

 **CAUTION**

If the inner and outer element have been replaced, always replace O-ring (8) with a new part.

8. Press the button on dust indicator (1) to return the yellow display panel to its original position.
9. Close the engine side cover on the right side of the machine.

REPLACING INNER ELEMENT

NOTICE

The inner element must not be used again even after its cleaning. When replacing the outer element, replace the inner element at the same time.

1. Open the engine side cover on the right side of the machine.
2. Remove clips (3), then remove dust cup (4).

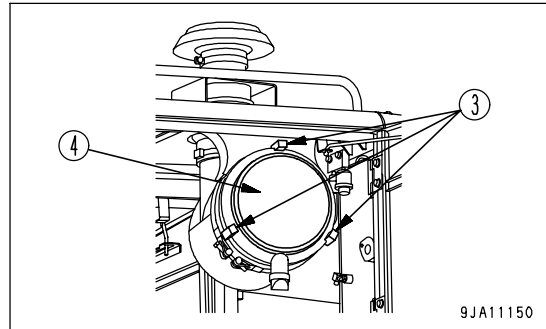

3. Remove outer element (5).
Do not remove inner element (6) at this time, however.

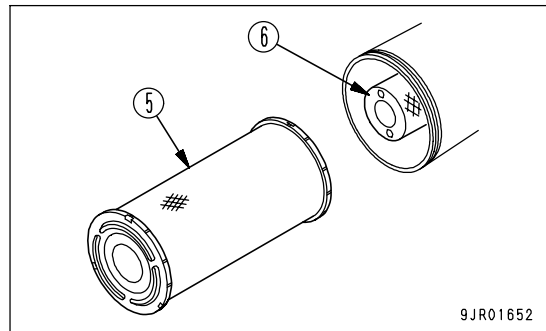

NOTICE

When cleaning the dust cup, do not remove evacuator valve (7).

4. Clean the inside of the air cleaner body and dust cup.

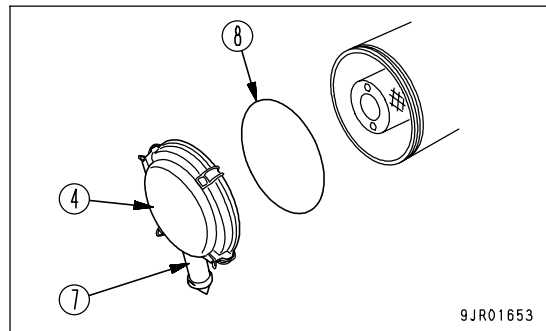

5. Remove inner element (6), then install a new inner element immediately.
6. Set new outer element (5) and install dust cup (4), then secure them with clips (3).

**CAUTION**

If the inner and outer element have been replaced, always replace O-ring (8) with a new part.

7. Press the button on dust indicator (1) to return the yellow display panel to its original position.
8. Close the engine side cover on the right side of the machine.

DRAIN WATER FROM FUEL PRE-FILTER

! WARNING

- After the engine is stopped, all parts are at high temperature, so do not drain the water or remove the element cup immediately after stopping the engine.
Wait for all parts to cool down before starting the operation.
- When the engine is running, the engine fuel line is under high-pressure. When draining the water or removing the element cup, wait for at least 30 seconds after stopping the engine to let the internal pressure go down.
- Do not bring any fire or flame close.

If water accumulates in the cup at the bottom of the fuel pre-filter, water separator monitor (1) on the machine monitor lights up. If the lamp lights up, drain the water from the fuel pre-filter as follows.

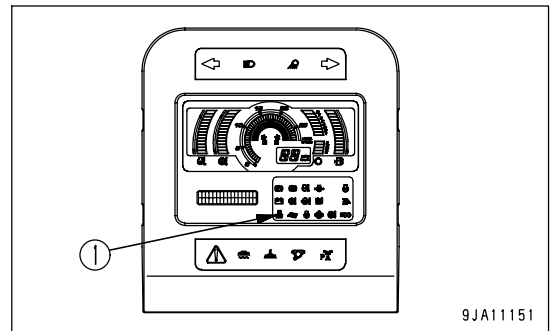

1. Open the engine side cover on the left side of the machine.
2. Prepare a container under the drain hose of fuel pre-filter (1) to catch the drained water.

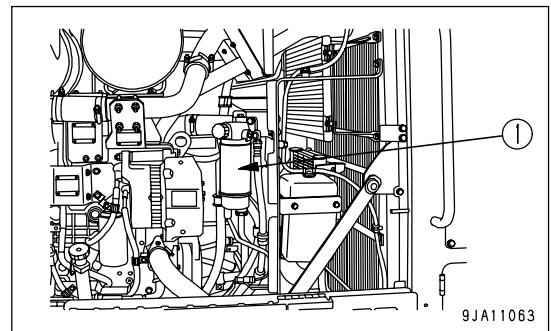

3. Loosen drain plug (2) at the bottom of the fuel pre-filter and drain the water.

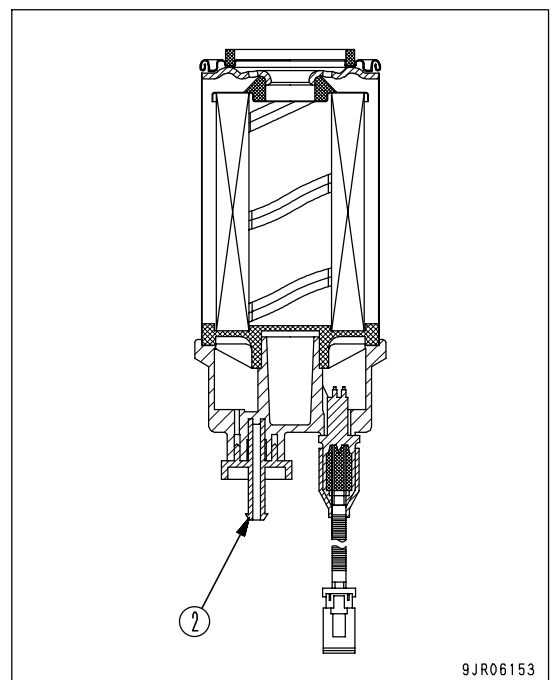

CHECK ELECTRICAL INTAKE AIR HEATER

Before the start of the cold season (once a year), contact your Komatsu distributor to have the electrical intake air heater repaired or checked for dirt or disconnections.

REPLACE THE CUTTING EDGES, REVERSE AND REPLACE END BIT



WARNING

Do not raise the blade unnecessarily high. Be sure not to put any part of your body underneath the blade when blocking it.

Replace the cutting edge before it wears to the end face of the blade.

Always replace the cutting edge and side edge when the distance from the blade holder is less than 10 mm (0.4 in).

If the mounting surface is worn, correct the mounting surface before replacing the cutting edge or side edge.

1. Lift the blade to a suitable height and put a block underneath the blade rail to prevent it from falling.
2. Remove bolts and nuts (1), then remove end bit and the cutting edge.
3. Clean the mounting face for cutting edge.
4. Install a new cutting edge to the blade.
5. If the cutting portion (outside) of the side edge is worn, reverse the side edges and install them on the opposite side, or replace the side edges.

Tightening torque of mounting nut : 260 ± 34.3 Nm
 $(26.5 \pm 3.5$ kgm ,
 191.7 ± 25.3 lbft)

6. After several hours of running, retighten the nuts.

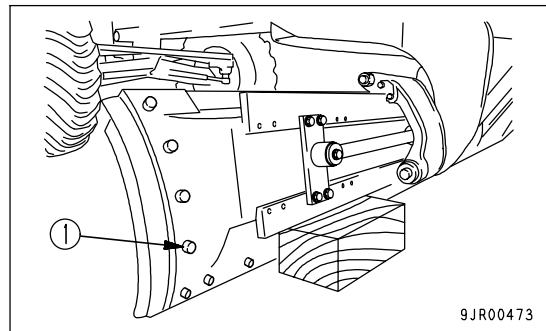

Replacement of cutting edge for front blade

(If equipped)

Replace the cutting edge with the same procedure as that of main blade.

Since front blade does not have a blade guide rail, put a block under the support of front blade before work.

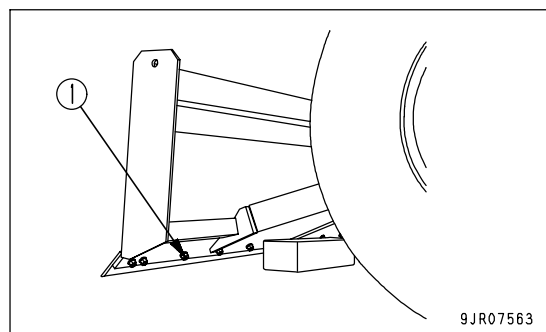

CHECK INCHING PEDAL

If any of the following problems have occurred, please contact your Komatsu distributor for inspection and adjustment.

- If the machine does not stop even the inching pedal is depressed.
- If the machine does not move or lacks power even the inching pedal is released.

CLEAN AIR CONDITIONER AIR FILTER

If the recirculation air filter at the suction port of the air conditioner unit or the fresh air filter at the external air suction port become clogged, the heating or cooling performance will drop, so clean the filter.

1. Remove the cover (1) at the bottom of the operator's compartment.
2. Pull out recirculation air filter (2) and clean it with a weak jet of compressed air.

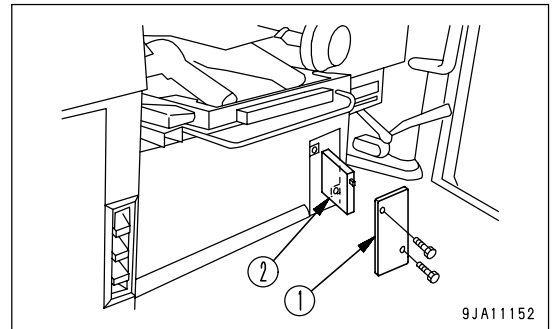

3. Remove cover (3) at the rear of the cab.
4. Remove fresh air filter (4).
5. Use a weak jet of compressed air to remove the dust stuck to the fresh air filter (4).

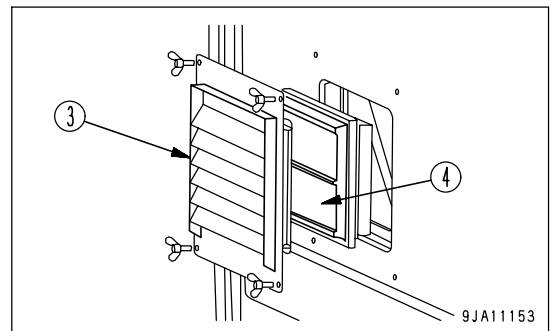

REMARK

The fresh air filter must face to a certain direction. Install it so that the thicker side faces indoors as shown in the right figure.

If there is oil on the filter, or if the filter is extremely dirty, wash it in a neutral agent. After rinsing it in water, dry it thoroughly before using it again.

Replace the filter with a new part every year. If the clogging of the filter cannot be removed by blowing with air or washing in water, replace the filter immediately.

CHECK REFRIGERANT (GAS) LEVEL



WARNING

If the refrigerant used in the air conditioner gets into your eyes or on your hands, it may cause loss of sight or frostbite. Do not touch the refrigerant. Never loosen any part of the refrigerant circuit.

Do not bring any flame close to any point where the refrigerant gas is leaking.

If the cooling effect is poor, the refrigerant (gas) level may be low. If this is the case, check the sight gauge of the receiver dryer under the right side of the cab.

REMARK

Run the engine at idle, and if bubbles appear in the sight glass when the air conditioner is set to cooling, the refrigerant level is low, so please contact your Komatsu distributor to have it refilled.

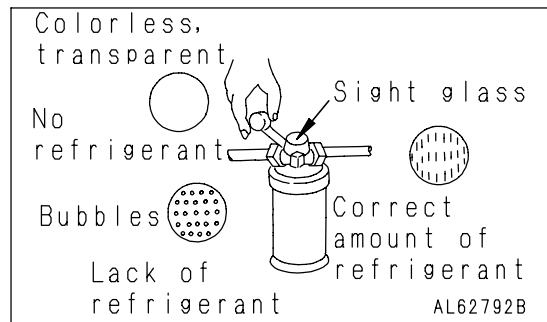

CHECK TENSION OF AIR CONDITIONER COMPRESSOR BELT

If the belt is loose, it will slip and it will become impossible to carry out cooling properly.

From time to time, check the belt tension. Press the belt at a point (A) midway between the drive pulley and compressor pulley and check that the deflection is 17 to 19 mm (0.67 to 0.75 in) (new belt: 15 to 16 mm (0.59 to 0.63 in)) when pushed with a finger force of approx. 98 N (10 kg).

When the belt is new, it is particularly likely to stretch at the initial stages, so it must be adjusted again after 2 to 3 days.

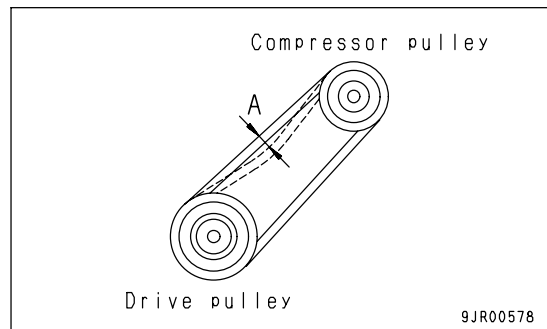

Check each pulley for damage, wear of the V-groove, and wear of the V-belt. Be particularly careful to check that the V-belt does not contact the bottom of the V-groove.

If the belt is stretched and there is no allowance for adjustment, or it is cut or cracked, replace it with a new belt.

When adjusting the V-belt, do not push the compressor directly with a bar; use a wrench.

CLEAN AIR CONDITIONER CONDENSER**WARNING**

- Do not wash the condenser with a steam cleaner. There is danger that the condenser could overheat.
- If high-pressure water hits your body directly or dirt is sent flying, there is danger of personal injury. Always wear protective glasses, dust mask, and other protective equipment.

If there is mud or dust on the air conditioner condenser, clean it with water.

If the water pressure is too high, the fins may get deformed. When washing with a high pressure washing machine, apply the water from a reasonable distance.

WASHING METHOD

Open the engine side cover and wash condenser (1) from the top of it with water.

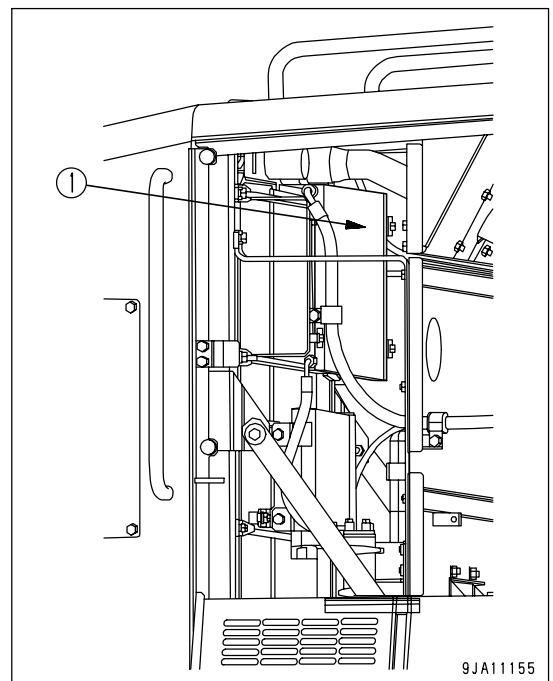

CLEAN RADIATOR FINS AND COOLER FINS



WARNING

If compressed air, pressurized water, or steam hits your body directly, or causes dirt to fly, it may lead to personal injury. Always wear safety glasses, dust mask, or other protective equipment.

Clean the radiator fins if any mud or dirt is stuck to the radiator.

CLEAN FINS BY ROTATING COOLING FAN IN REVERSE

NOTICE

When rotating the fan in reverse, be careful of flying dust, and be careful not to let any cloth get caught in the fan.

Dust may rise, so check that there is no one in the surrounding area when rotating the fan in reverse.

On jobsites where it is easy for dirt to stick to the radiator or cooler, turn cooling fan reverse rotation switch (1) ON to rotate the fan in reverse. This will blow off the dirt and dust stuck to the radiator or cooler, and can extend the cleaning interval.

1. Open engine side covers (1) on the right and left sides of the machine and fix them by using lock bars (2).
2. Open covers (3) on the right and left sides of the machine.

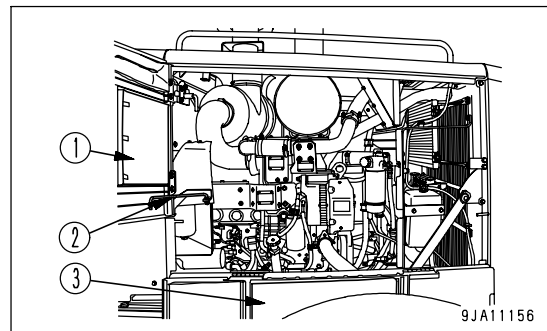
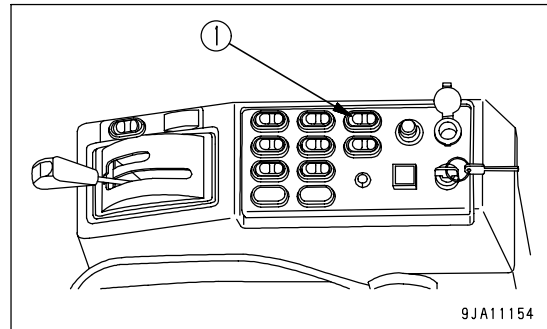

FAN REVERSING METHOD

NOTICE

- Never rotate the fan in reverse when carrying out the operation.
- Before operating the fan reverse rotation switch, run the engine at low idling.

1. Set the gear shift lever to the P (PARKING) position and apply the parking brake.
2. Run the engine at low idling.
3. Press position (A) of cooling fan reverse rotation switch (1).

REMARK

The cooling fan switches to the reverse rotation once pressing the cooling fan reverse rotation switch. As it is not necessary to continue to press, release the switch.

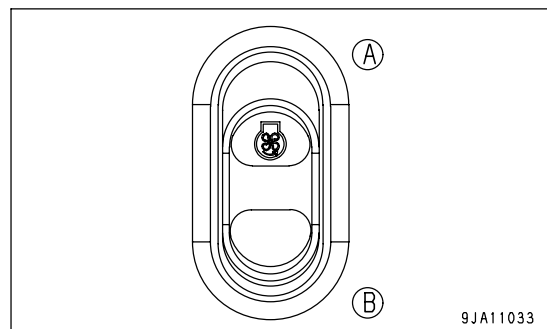

4. After the cooling fan reverse rotation pilot lamp on the machine monitor flashes, check that it lights up. The fan is set to rotate in reverse.

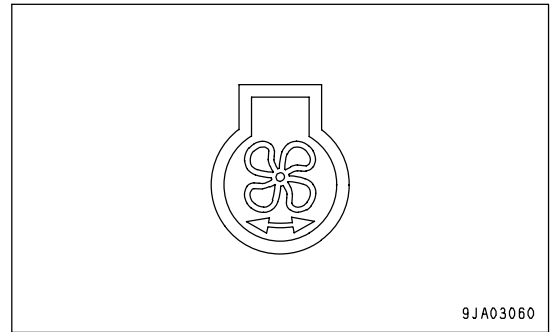

5. Run the engine at high idling.
 Select the time for running the engine at high idle as follows according to the condition of clogging.
 Normal clogging: 1 to 2 minutes
 Excessive clogging: 2 to 3 minutes
6. When the cleaning is completed, run the engine at low idling.
7. Press position (B) of cooling fan reverse rotation switch (1).

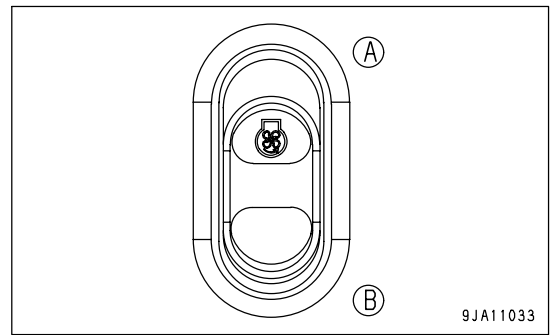

8. After the cooling fan reverse rotation pilot lamp on the machine monitor flashes, check that it goes out. The fan is set to rotate in the normal direction.

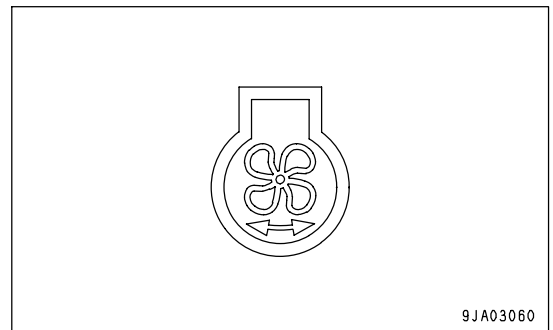

9. Run the engine at low idling for approx. 10 seconds.

NOTICE

In case of cleaning only by using the reverse rotation of the cooling fan, mud and dirt possibly remain. If switching the cooling fan rotation to the normal direction in this state, the mud and dirt probably stick fast again to the fin, etc. After reverse rotations of the cooling fan, stop the engine and clear the remaining mud and dirt off by using compressed air or a broom, etc. In addition, confirm that there is no flammable material around hot portions of the engine.

Major portions to check

(1) Center of the fin

(2) Surrounding area of the bracket

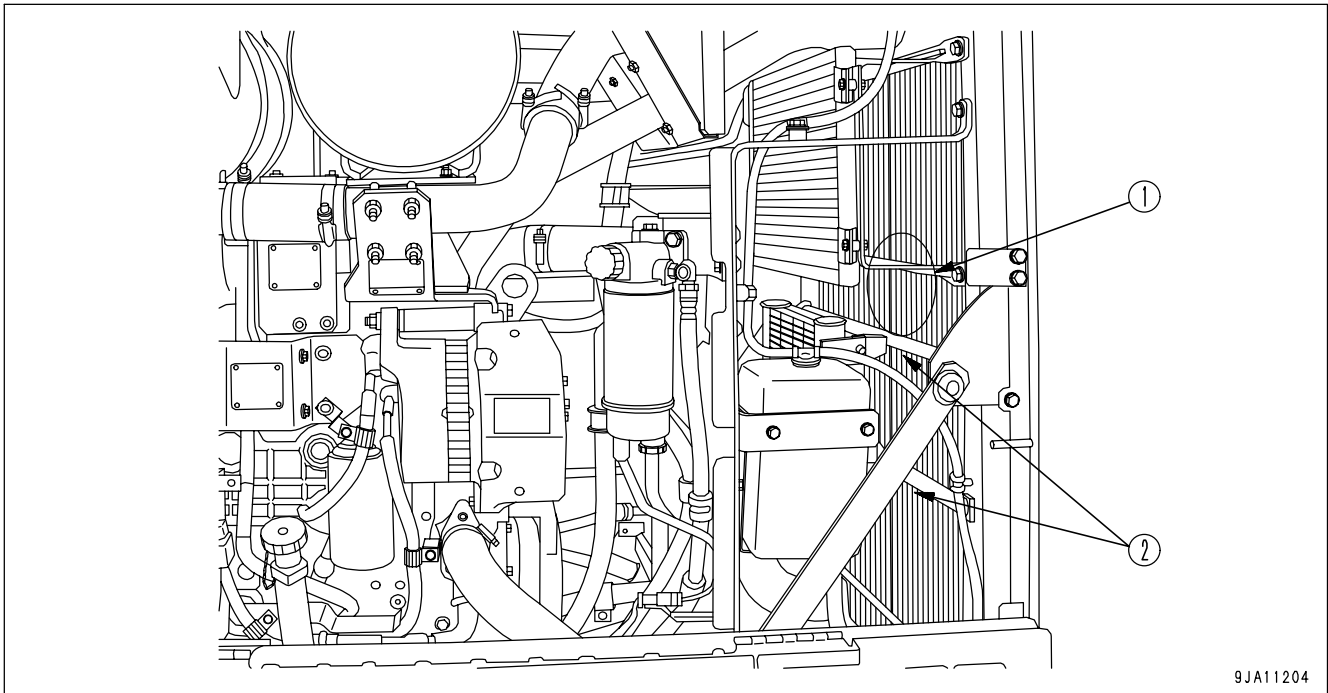

9JA11204

- (1) Lower part of the cooling room
- (2) Lower part of the engine room
- (3) Surrounding area of the turbo charger
- (4) Surrounding area of the exhaust manifold
- (5) Upper part of the engine hood

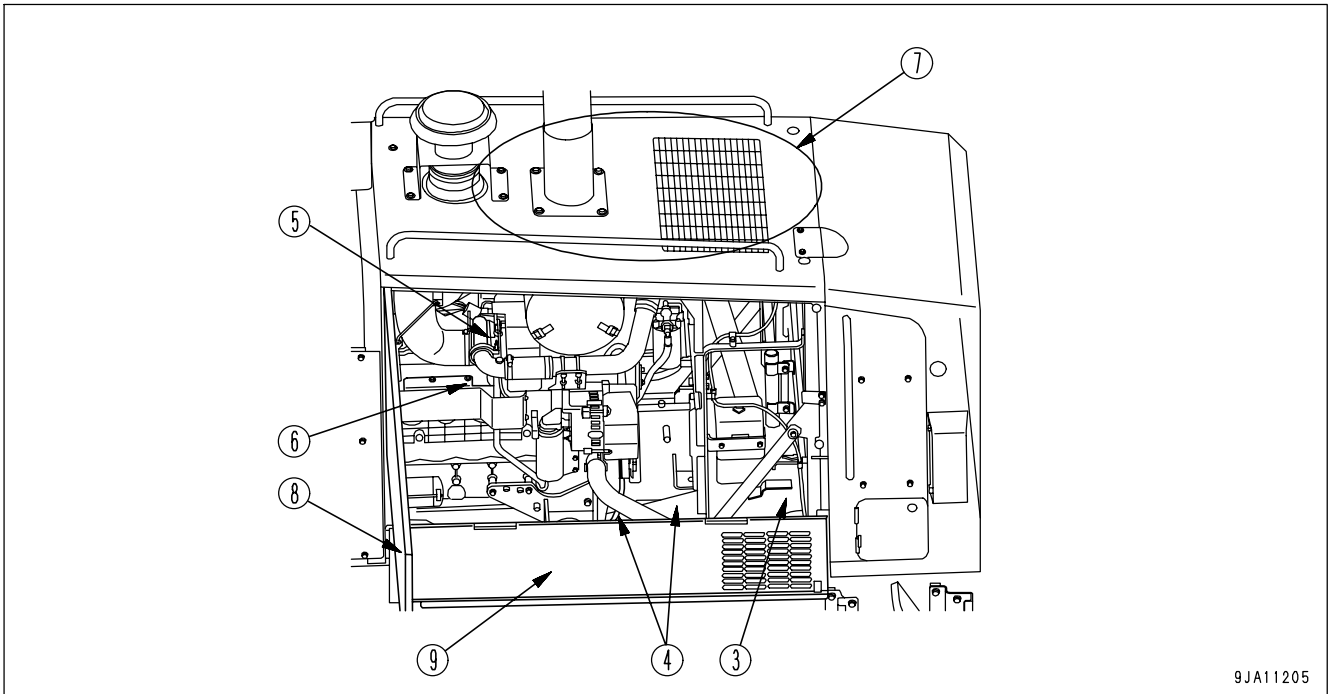

After cleaning, close engine side covers (8) and covers (9) on the right and left sides of the machine respectively. In addition, clear the flown dirt, etc. off from around the machine.

CLEAN, INSPECT RADIATOR FINS, OIL COOLER FINS, AFTERCOOLER FINS, CONDENSER FINS



WARNING

- If compressed air, pressurized water, or steam hits your body directly, or causes dirt to fly, it possibly leads to personal injury. Always wear safety glasses, dustproof mask and other protective equipments.
- When cleaning, use the maximum pressure of 0.2 MPa (2.0 kg/cm², 28.4 PSI) or less.
- Do not open the engine side cover when the engine is running. Before starting to clean, completely stop the engine.

NOTICE

To prevent damage to the fins, apply compressed air from an appropriate distance. Damaged fins may cause water leakage or overheating. In a dusty site, check the fins daily, irrespective of the maintenance interval.

1. Remove bolts (1) on the side surface of the hood to take panel (2) off.

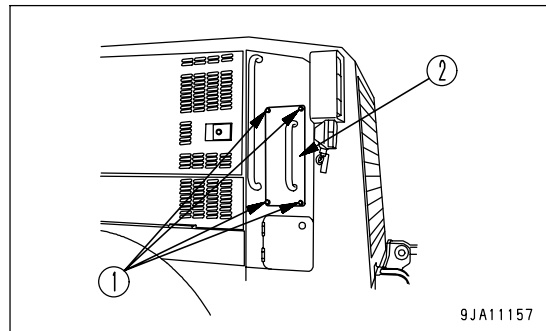

2. Remove bolts (3) on the side surface of the radiator shroud to take panel (4) off.
3. Check that there is no mud or dirt clogging the radiator fins, oil cooler fins, aftercooler fins, or condenser fins.

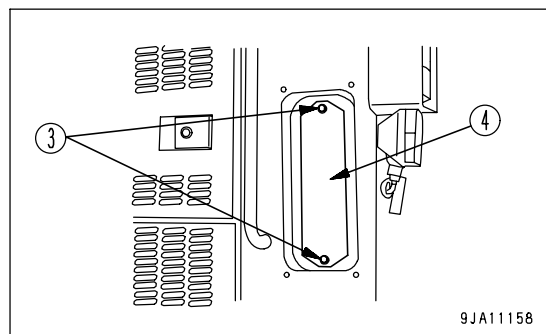

4. Clean the inside by inserting the steam injection nozzle through the clearances among the radiator, oil cooler, after-cooler (5), and air-conditioner condenser (6).

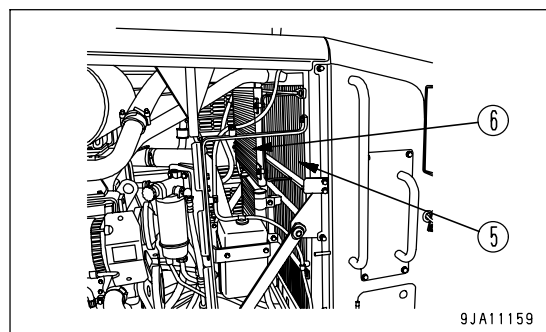

NOTICE

- When cleaning the fins, be careful not to bring nozzle (7) into contact with fins (8).
- When cleaning the fins, direct nozzle (7) at right angles to the radiator fins, oil cooler fins, aftercooler fins, and condenser fins.
- When using steam spray nozzle (7), fins (8) will be damaged if the nozzle is too close. Always keep the proper distance from the fins when cleaning.

Use the following conditions as a guideline when cleaning.

Spray pressure (A): Max. 0.20 MPa {2.0 kg/cm², 28.4 PSI}

Distance between nozzle and fin (B): Min. 100 mm (3.9 in)

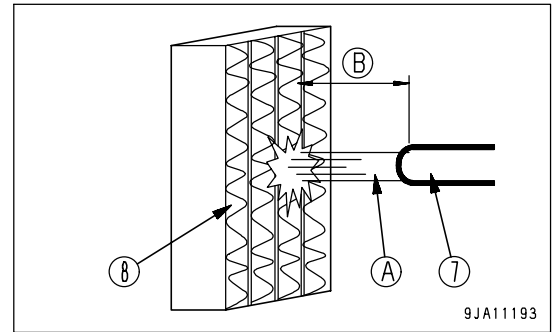

5. Check the rubber hose. Replace with a new one if the hose is found to have cracks or to be hardened by ageing. Further, check hose clamps for looseness.
6. Install panels (4) and (2), then tighten the bolts (3) and (1) to the specified tightening torque.

SELECTION AND INSPECTION OF TIRES

! WARNING

If a tire or a rim is handled improperly, the tire may burst or may be damaged and the rim may be broken and scattered, and that can cause serious injury or death.

- Since maintenance, disassembly, repair and assembly of the tires and rims require special equipment and skill, be sure to ask a tire repair shop to do the work.
- Do not heat or weld the rim to which the tire is installed. Do not make a fire near the tire.

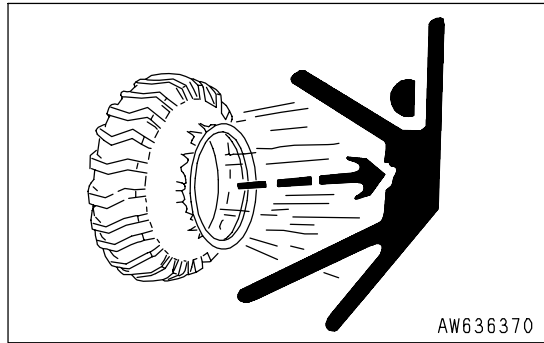

SELECTION OF TIRES

! WARNING

Select the tires according to the conditions of use and the weight of the attachments on the machine. Use only specified tires and inflate them to the specified pressure.

Select the tires according to the conditions of use and the weight of the attachments of the machine. Use the following table.

Since the travel speed indicated on the speedometer varies with the tire size, consult your Komatsu distributor when using optional tires.

	Tire size	Remarks
Standard tires	14.00-24-12PR	-
Optional tires	14.00-24-14PR	
	14.00R24TG☆	
	17.5R25TG☆	

CHECK OF INFLATION PRESSURE OF TIRES AND INFLATION OF THEM

! WARNING

When inflating a tire, check that no one will enter the working area. Use an air chuck which has a clip and which can be fixed to the air valve.

- While inflating the tire, check the inflation pressure occasionally so that it will not rise too high.
- If the rim is not fitted normally, it may be broken and scattered while the tire is inflated. To ensure safety, place a guard around the tire and do not work in front of the rim but work on the tread side of the tire.
- Abnormal drop of inflation pressure and abnormal fitting of the rim indicate trouble in the tire or rim. In this case, be sure to ask a tire repair shop to carry out repairs.
- Be sure to observe the specified inflation pressure.
- Do not adjust the inflation pressure of the tires just after high-speed travel or heavy-duty work.

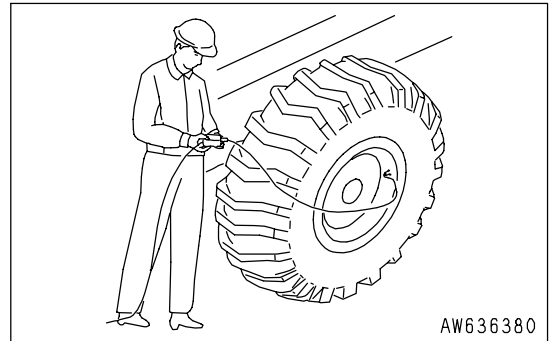

CHECK

Measure the inflation pressure with a tire pressure gauge, while the tires are cool, before starting work.

INFLATION OF TIRES

Adjust the inflation pressure properly.

When inflating a tire, use an air chuck which can be fixed to the air valve of the tire as shown in the figure. Do not work in front of the rim but work on the tread side of the tire.

The proper inflation pressure is shown below.

Tire size	Inflation pressure : kPa{kg/cm ² , PSI}
14.00-24-12PR	275 {2.75, 39.1}
14.00-24-14PR	300 {3.00, 42.6}
14.00R24TG ☆	400 {4.00, 56.8}
17.5R25TG ☆	300 {3.00, 42.6}

NOTICE

The optimum inflation pressure differs according to the type of work. For details, see "HANDLING THE TIRES (PAGE 3-168)".

CHECK FUNCTION OF ACCUMULATOR

For details of handling the accumulator, see Section "HANDLING ACCUMULATOR AND GAS SPRING (PAGE 2-38)".

ACCUMULATOR FOR BRAKE

When the brake pedal is depressed, the hydraulic spring effect of the accumulator actuates the brake smoothly.

If any change is felt in the smoothness of the brake operation during daily operations, the gas pressure in the accumulator has probably dropped.

Please contact your Komatsu distributor to have the accumulator inspected.

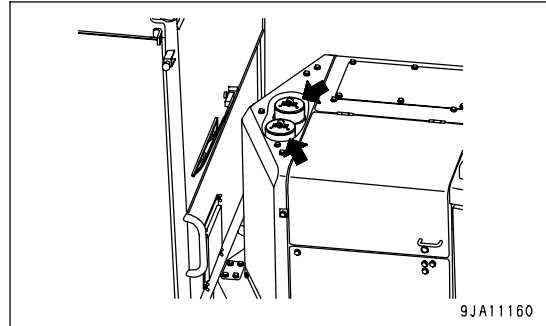

REMARK

- Even if there is any change in smoothness, there is no drop in brake performance including braking force.
- Replace the accumulator every 4000 hours or 2 years.

ACCUMULATOR FOR BLADE

(If equipped)

This accumulator buffers vertical vibration generated on the blade during road maintenance on rocky worksites, removal of compressed snow, or others by using hydraulic spring effects of accumulators.

If there is no change in vertical vibration transmitted from the blade between the times when the blade accumulator switch is ON and OFF, the gas pressure in the accumulator probably dropped.

Please contact your Komatsu distributor for inspections.

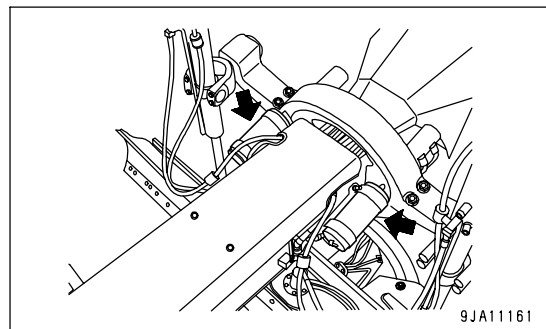

CHECK BEFORE STARTING

For details of the following items, see "CHECK BEFORE STARTING (PAGE 3-86)" in the OPERATION section.

- Check coolant level, add water
- Check fuel level, add fuel
- Drain water and sediment in fuel tank
- Check engine oil pan level, add oil
- Check dust indicator
- Check and adjust steering wheel
- Check water separator, drain water
- Check electric wiring
- Check flashing of lamps, check for dirt and damage
- Check inflation pressure of tire
- Check condition of window washer spray
- Check wiping efficiency of wiper
- Check horn
- Check defroster function
- Check locks

EVERY 50 HOURS SERVICE

LUBRICATING



WARNING

- Set the gear shift lever to the P (Parking) position and fix the front and rear frames by using the articulate lock pin.
- Lower the work equipment to the ground and stop the engine.
- Grease on flat ground.

- Apply grease to the grease fittings shown by arrows.
Sliding surface at top of circle, sliding surface on inside of circle,
face of circle gear teeth

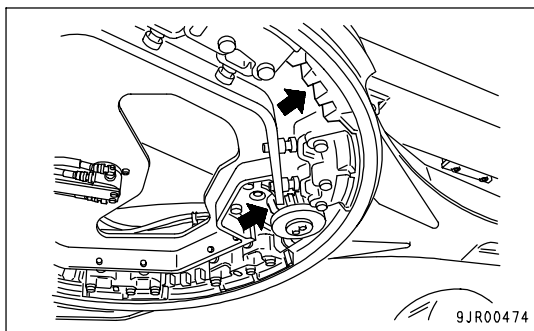

- Using a grease pump, pump in grease through the grease fittings shown by arrows.
 - After greasing, wipe off any old grease that was pushed out.
- Front axle center pin (2 places)

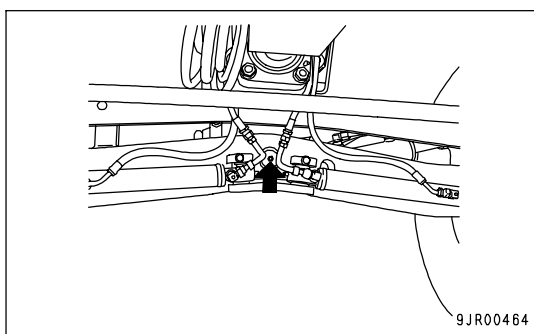
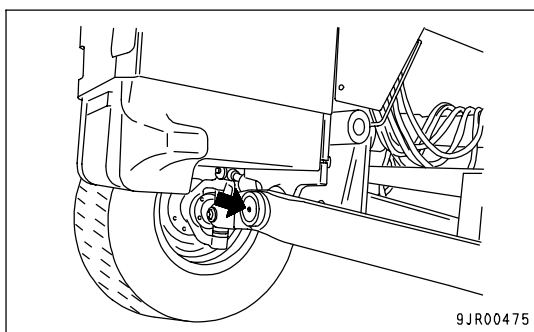

Steering linkage (6 places)

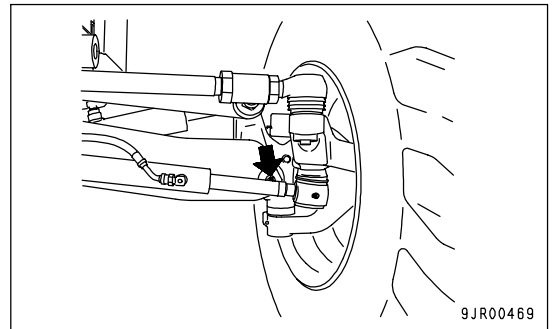
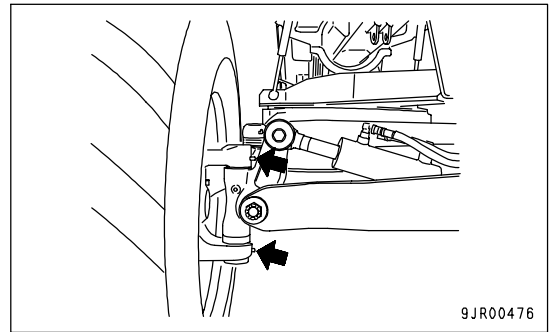

Steering cylinder pin (4 places)

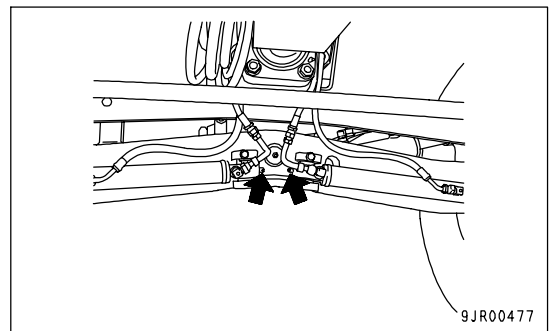

Tie rod (2 places)

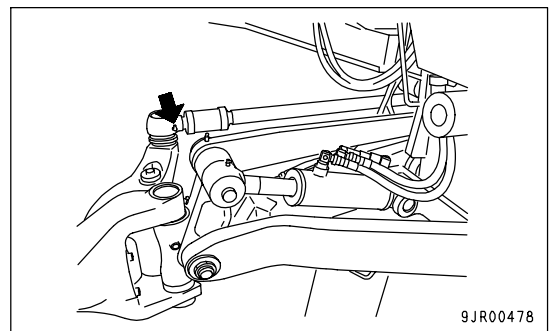

Leaning rod end (2 places)

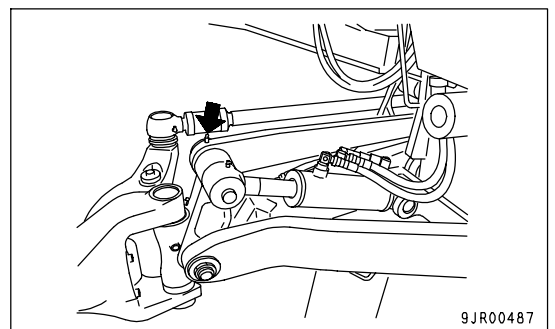

Leaning cylinder pin (2 places)

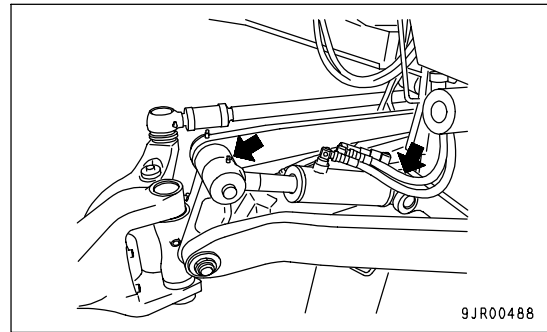

EVERY 250 HOURS SERVICE

Maintenance for every 50 hours service should be carried out at the same time.

LUBRICATING

 **WARNING**

- Set the gear shift lever to the P (Parking) position and fix the front and rear frames by using the articulate lock pin.
- Lower the work equipment to the ground and stop the engine.
- Grease on flat ground.

1. Using a grease pump, pump in grease through the grease fittings shown by arrows.
2. After greasing, wipe off any old grease that was pushed out.

Articulate pin (2 places)

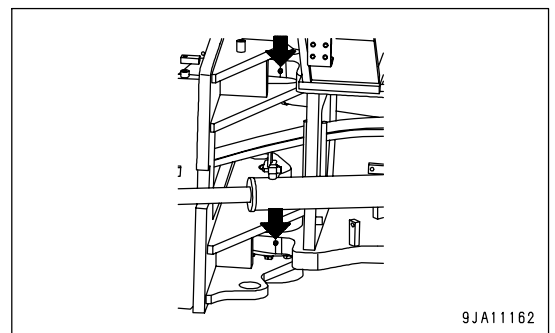

Articulate cylinder pin (4 places)

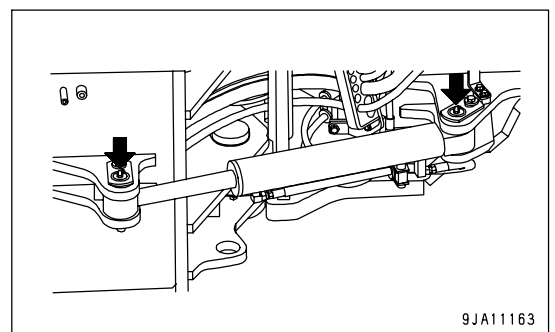

Blade lift cylinder yoke (6 places)

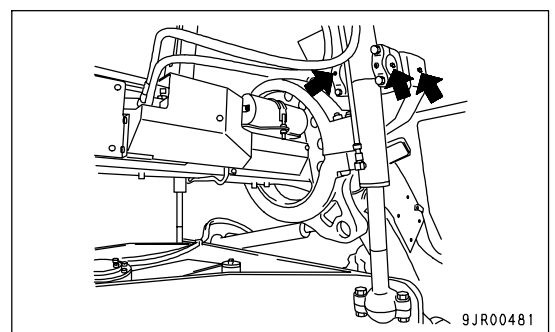

Blade lift cylinder ball joint (2 places)

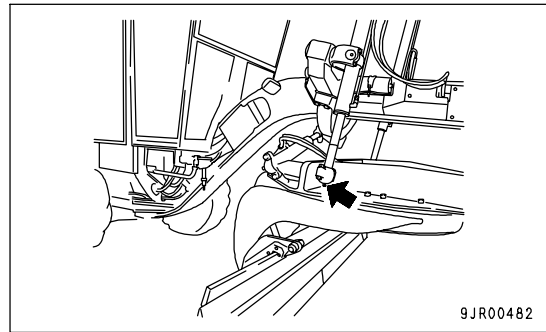

Drawbar ball joint (1 place)

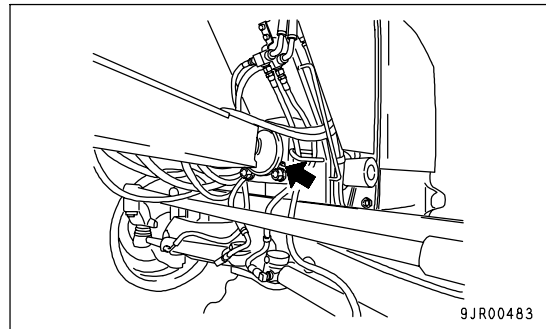

Drawbar side shift cylinder ball joint (2 places)

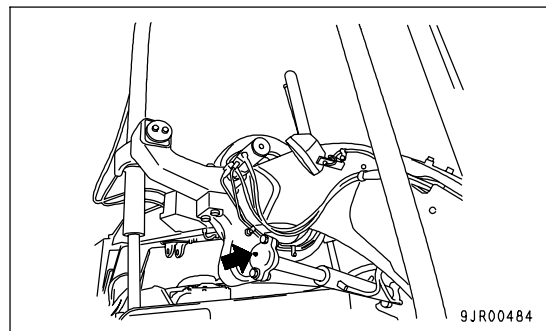

Adjuster bracket (2 places)

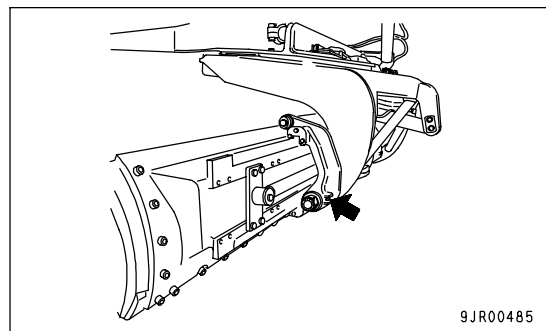

Power tilt cylinder pin (2 places)

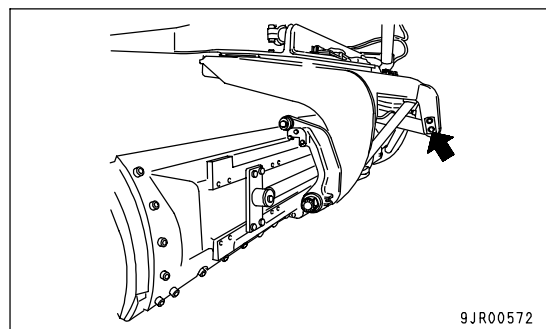

Lifter bracket (3 places)

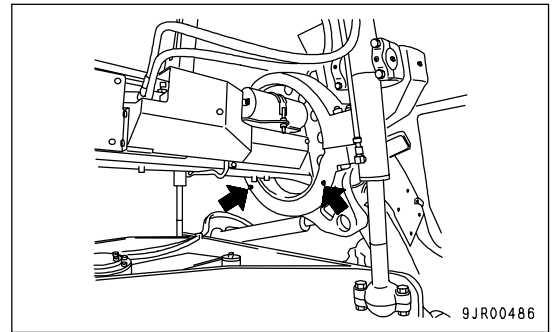

REMARK

When greasing the center of the lifter bracket (1 place), use a footstool or turn the lifter bracket fully to the left end for easier greasing.

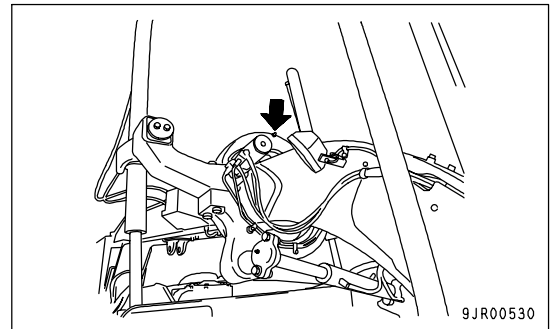

Ripper linkage pin (8 places)
(Machines equipped with ripper)

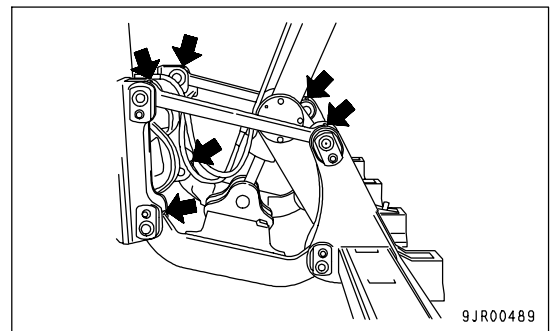

Ripper cylinder pin (3 places)
(Machines equipped with ripper)

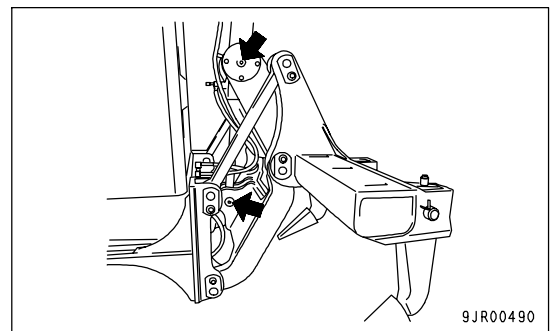

Scarifier shaft (2 places)
 (Machines equipped with scarifier)

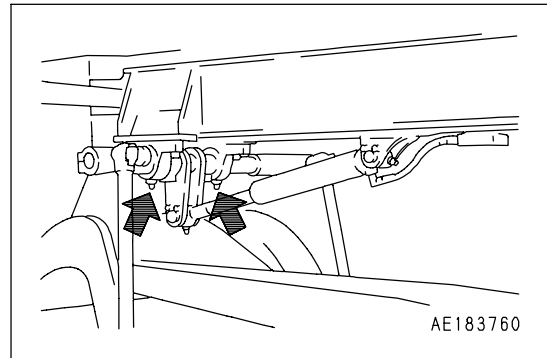

Scarifier ball joint (4 places)
 (Machines equipped with scarifier)

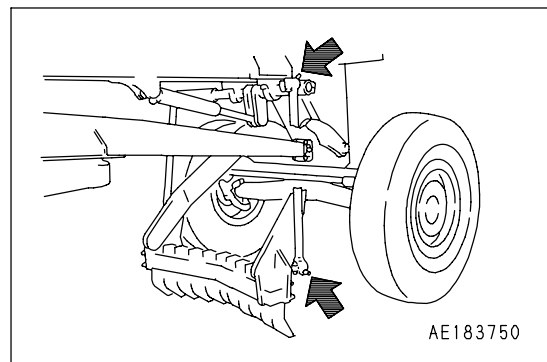

Scarifier cylinder pin (2 places)
 (Machines equipped with scarifier)

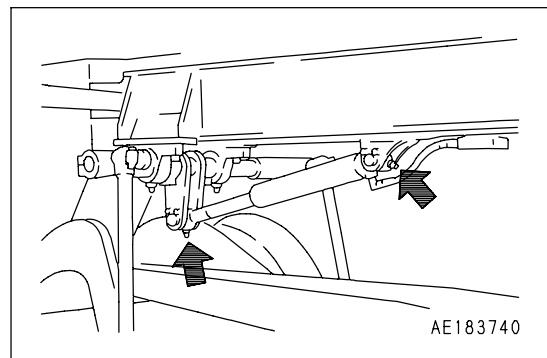

Front blade pin (4 places)
 (Machines equipped with front blade)
 (*: left and right, 1 place each)

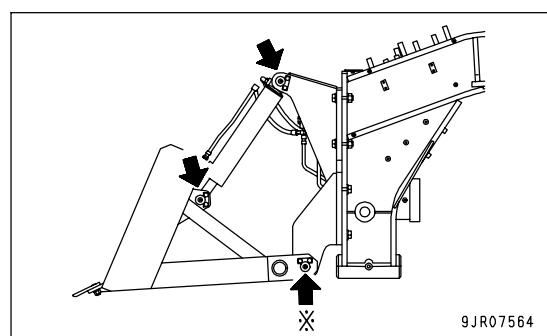

CHECK OIL LEVEL IN TRANSMISSION CASE, ADD OIL

! WARNING

- Parts and oil are still heated for some time after the engine stops. Start operations after the temperature drops.
- Before the check, set the gear shift lever to the P (PARKING) position to prevent the machine from moving and confirm that the respective levers are placed in the neutral position.

Carry out this procedure if there is any sign of oil on the transmission case, or if there is oil mixed with the cooling water.

1. Stop the engine.

NOTICE

Wait for at least 12 hours after stopping the engine before carrying out the inspection. If this is not done, there will be oil remaining at various places and it will be impossible to check the oil level correctly.

2. Remove cap of oil filler (F).
3. Take out the dipstick (G) and wipe off the oil with cloth.
4. Fully insert dipstick (G) into filler pipe, then remove it.
5. The oil level should be between the H and L marks on dipstick (G).
If the oil level is below the L mark, add oil through oil filler port (F).

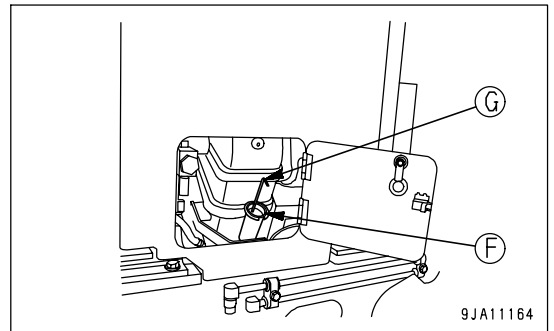

6. If the oil level is H line or above, remove drain plug (1), slowly loosen drain plug (2) to discharge the excess oil, and then check the oil level again.

Tightening torque

- drain plug (1): 59 to 78.5 Nm (6 to 8 kgm, 43.4 to 57.9 lbft)
- drain plug (2): 49 to 78.5 Nm (5 to 8 kgm, 36.2 to 57.9 lbft)

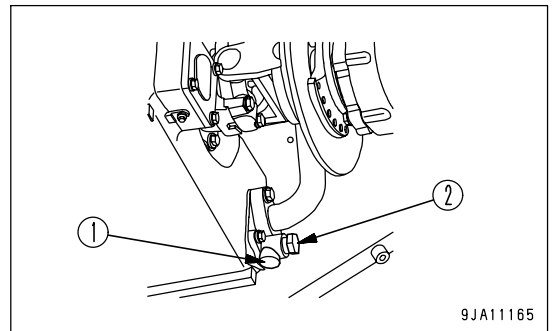

7. If the oil level is correct, insert dipstick (G) in the oil filler pipe, then install the oil filler cap.

On each surface of dipstick (G), the oil level for the time (A) when the engine is stopping (ENG STOP) or (B) when the engine is running at idle (ENG IDOLING) is stamped.

Use the stamps indicated in (A) for the engine stopped (ENG STOP).

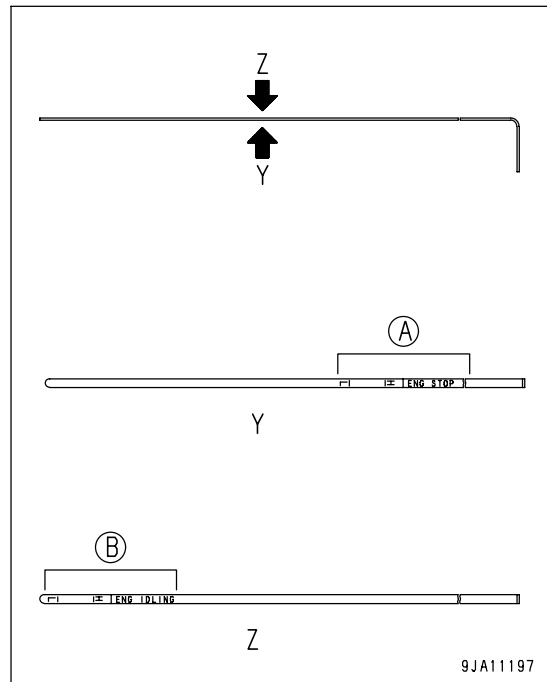

CHECK OIL LEVEL IN FINAL DRIVE CASE, ADD OIL

 **WARNING**

The parts and oil are at high temperature immediately after the engine is stopped, and may cause burns. Wait for the temperature to go down before starting the work.

1. Stop the engine, and leave it for 5 minutes.
2. Remove the oil filler cap, then take out dipstick (G), then wipe the oil off with a cloth.
3. Fully insert dipstick (G) into filler pipe, then remove it.
4. The oil level should be between the H and L marks on dipstick (G).
If the oil level is below the L mark, add oil through oil filler (F).

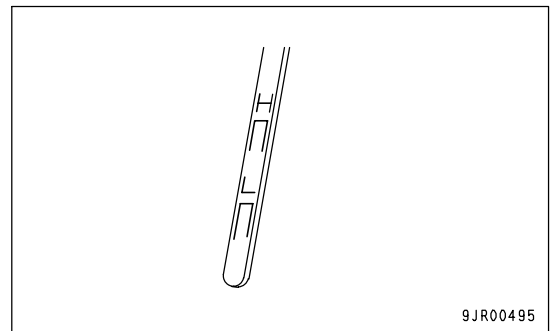
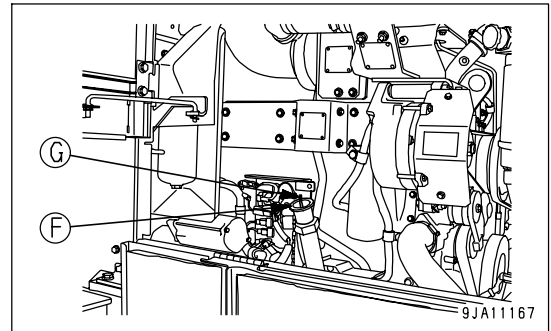

5. If the oil is above the H mark, drain the excess oil from drain plug (P), and check the oil level again.
6. If the oil level is correct, insert dipstick (G) in the oil filler pipe, then install the oil filler cap.

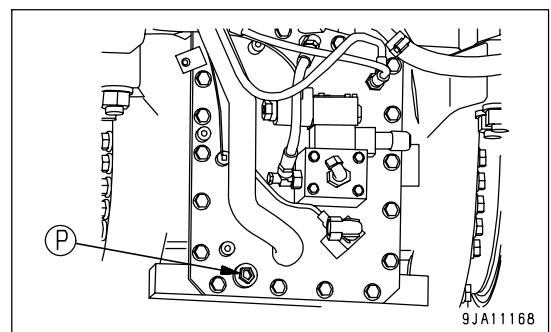

CHECK OIL LEVEL IN TANDEM DRIVE CASE, ADD OIL**! WARNING**

The parts and oil are at high temperature immediately after the engine is stopped, and may cause burns. Wait for the temperature to go down before starting the work.

1. Stop the engine and leave for at least 5 minutes.
2. Remove plug (G) and check that the oil level is near the bottom of the plug hole.
3. If the oil level is correct, install plug (G).
4. If the oil level is low, add oil through oil filler port (F).

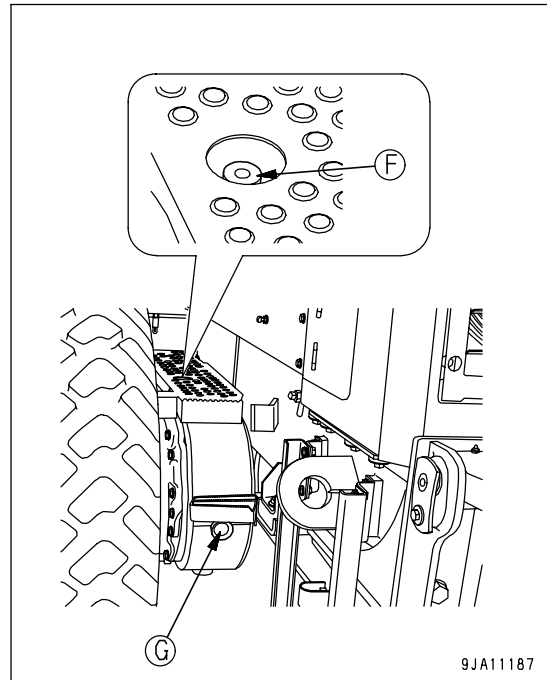
**CHECK OIL LEVEL IN CIRCLE REVERSE GEAR CASE, ADD OIL****! WARNING**

The parts and oil are at high temperature immediately after the engine is stopped, and may cause burns. Wait for the temperature to go down before starting the work.

1. Stop the engine and leave for at least 5 minutes.
2. Remove plug (G) and check that the oil leaks slowly.
3. If the oil level is low, add oil through oil filler port (F).
4. If the oil level is correct, install plug (G).

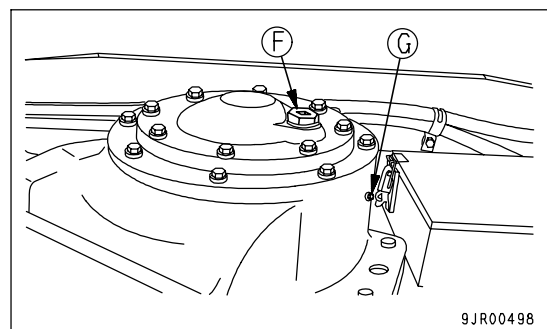
**NOTICE**

If the oil level is too high, the pressure inside the blade rotation gear case will become high when the oil temperature rises, and this will cause leakage of oil.

REMARK

There may be wear particles in the oil, but there is no problem using the oil as it is.

CHECK OIL LEVEL IN HYDRAULIC TANK, ADD OIL

! WARNING

- The parts and oil are at high temperature immediately after the engine is stopped, and may cause burns. Wait for the temperature to go down before starting the work.
- When removing the oil filler cap, turn it slowly to release the internal pressure, then remove it.

NOTICE

If oil has been added to above the window in the gauge, stop the engine, wait for the hydraulic oil to cool, then drain the excess oil from the drain plug. If the oil level is too high, it will damage the hydraulic circuit and cause the oil to spurt out.

1. Set the machine in position as follows to check the oil level.
 - Return the leaning of the front tires to the upright position and face the wheels straight to the front.
 - Set the front frame and rear frame facing straight (articulated angle = 0°). Install the articulate lock pin.
 - Return the blade sideshift to the center of the machine, set the blade at right angles to the chassis and lower it lightly to the ground.
 - To drain the oil from the accumulator on machines equipped with a blade accumulator, turn the blade accumulator switch ON and raise the blade to the maximum height. After doing this, turn the accumulator switch OFF and lower the blade to the ground.
2. Start the engine and run at low idle.
3. Check with sight gauge (G). The oil should be up to the window of gauge (G).

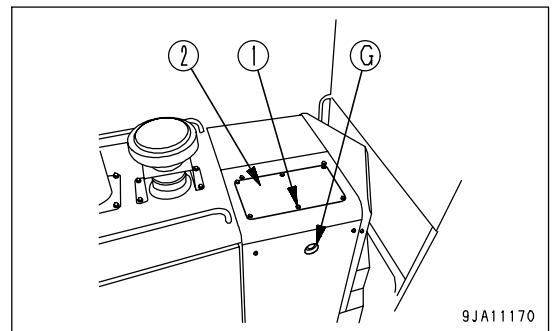

4. If the oil level is below the window of sight gauge (G), remove bolts (1) (6 pieces) and take cover (2) off. Then, add the oil through oil filler (F).

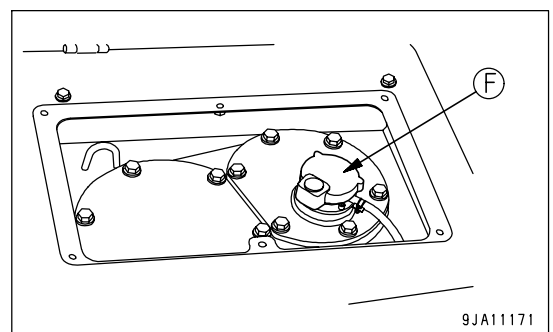

5. If the oil is above the window of the gauge, drain the excess oil from drain plug (P), then check the oil level again.

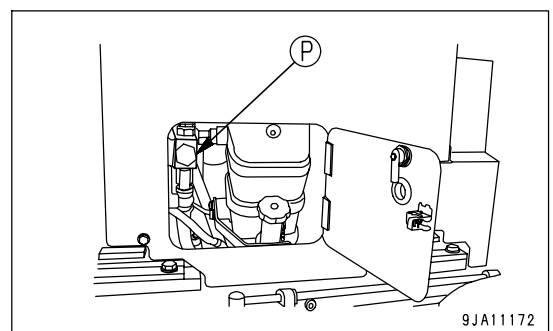

REMARK

Use the supplied hose to prevent oil from spraying out into the surrounding area.

6. If the oil level is appropriate, tighten the cap of oil filler (F) securely and remove the hose.

CHECK LEVEL OF BATTERY ELECTROLYTE

Perform this check before operating the machine.



WARNING

- Do not use the battery if the battery electrolyte level is below the LOWER LEVEL line. This will accelerate deterioration of the inside of the battery and reduce the service life of the battery. In addition, it may cause an explosion.
- The battery generates flammable gas and there is danger of explosion, do not bring fire or sparks near the battery.
- Battery electrolyte is dangerous. If it gets in your eyes or on your skin, wash it off with a large amount of water and consult a doctor.
- When adding distilled water to the battery, do not allow the battery electrolyte to go above the UPPER LEVEL line. If the electrolyte level is too high, it may leak and cause damage to the paint surface or corrode other parts.

NOTICE

When adding distilled water in cold weather, add it before starting operations in the morning to prevent the electrolyte from freezing.

Inspect the battery electrolyte level at least once a month and follow the basic safety procedures given below.

WHEN CHECKING ELECTROLYTE LEVEL FROM SIDE OF BATTERY

If it is possible to check the electrolyte level from the side of the battery, check as follows.

1. Use a wet cloth to clean the area around the electrolyte level lines and check that the electrolyte level is between the UPPER LEVEL (U.L.) and LOWER LEVEL (L.L.) lines.
If the battery is wiped with a dry cloth, static electricity may cause a fire or explosion.

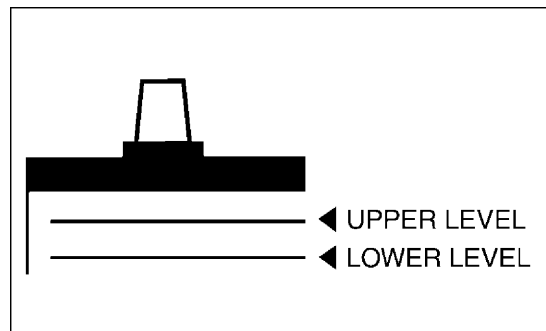

2. If the electrolyte level is below the midway point between the U.L. and L.L. lines, remove cap (1) and add distilled water to the U.L. line.
3. After adding distilled water, tighten cap (1) securely.

REMARK

If distilled water is added to above the U.L. line, use a syringe to lower the level to the U.L. line. Neutralize the removed fluid with baking soda (sodium bicarbonate), then flush it away with a large amount of water or consult your Komatsu distributor or battery maker.

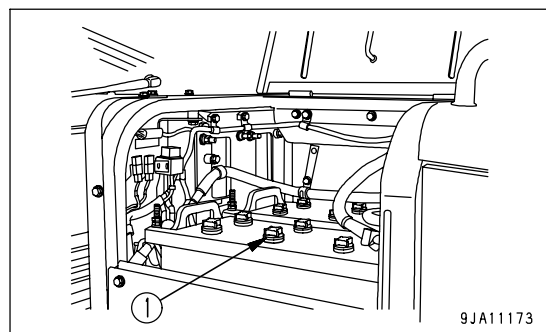

WHEN IT IS IMPOSSIBLE TO CHECK ELECTROLYTE LEVEL FROM SIDE OF BATTERY

If it is impossible to check the electrolyte level from the side of the battery, or there is no display of the UPPER LEVEL line on the side of the battery, check as follows.

1. Remove cap (1) at the top of the battery, look through the water filler port, and check the electrolyte surface. If the electrolyte does not reach the sleeve, add distilled water so that the level reaches the bottom of the sleeve (UPPER LEVEL line) without fail.

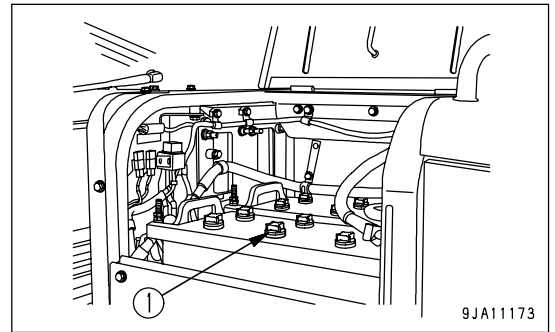

Use the diagram below for reference, and check if the electrolyte reaches the bottom of the sleeve.

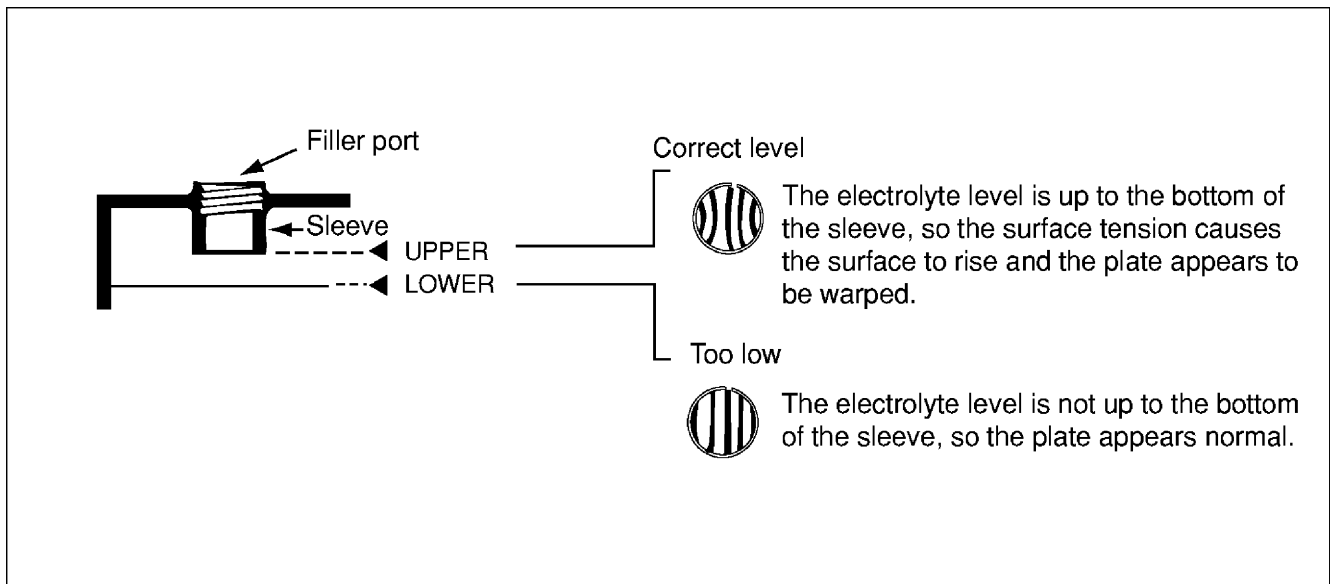

2. After adding distilled water, tighten cap (1) securely.

REMARK

If distilled water is added to above the bottom of the sleeve, use a syringe to lower the level to the bottom of the sleeve. Neutralize the removed fluid with baking soda (sodium bicarbonate), then flush it away with a large amount of water or consult your Komatsu distributor or battery maker.

WHEN IT IS POSSIBLE TO USE INDICATOR TO CHECK ELECTROLYTE LEVEL

If it is possible to use an indicator to check the electrolyte level, follow the instructions given.

CHECK BALL JOINT CLEARANCE, ADJUST

Check and adjust all locations with ball joints at the links of the work equipment.

Check for any play in the ball joint, and if the axial play is more than 1 mm (0.039 in), adjust as follows.

- Prepare a thickness gauge
 1. Remove all the shims from the ball joint.
 2. Tighten the caps with bolts (1) to make the same clearance on the left and right.
 3. Measure the clearance with a thickness gauge, then insert one shim more than this dimension, and tighten the cap.
 - Thickness of one shim : 0.2 mm (0.008 in),
 - 0.5 mm (0.020 in)

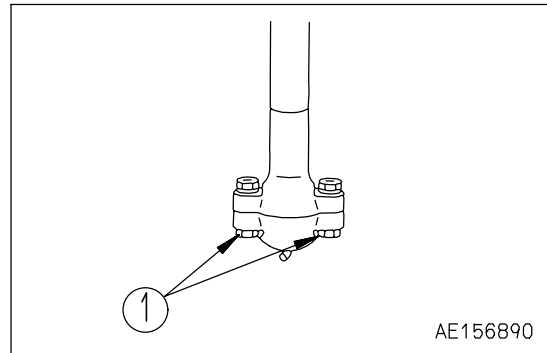

CHECK AND TIGHTEN WHEEL HUB NUT AND HUB BOLT

NOTICE

Loose wheel hub nuts and hub bolts (1) will result in shortened life of tires or other troubles.

1. Carefully check for loose bolts (1).
 - When checking for loose bolts (1), always turn the bolts (1) in the tightening direction to check.
 - Tightening torque: 610 to 765 Nm
(62.5 to 78.0 kgm , 452.1 to 564.2 lbf)
2. If a hub bolt is broken, replace all the hub bolts.

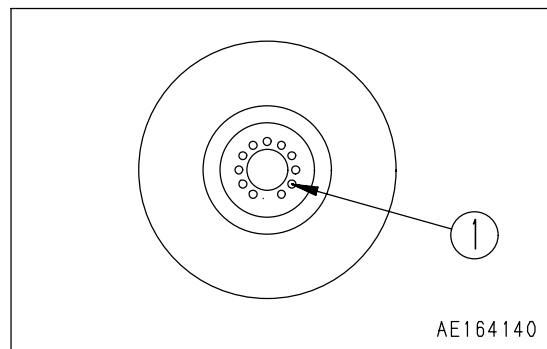

CHECKING WHEEL RIM, LOCK RING AND SIDE RING FOR CORROSION AND WEAR

If the wheel rim, lock ring and side ring are heavily corroded, ask the tire manufacturer or your Komatsu distributor for inspection.

CHECK PARKING BRAKE

1. Set the machine on a dry downhill slope, set the gearshift lever to the P (Parking) position, and check if the parking brake can hold the machine in position.
2. If any problem is found, please contact your Komatsu distributor.

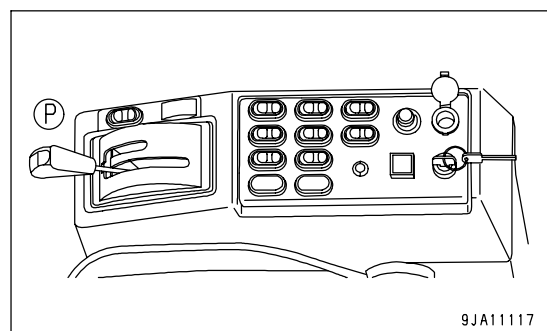

EVERY 500 HOURS SERVICE

Maintenance for every 50 and 250 hours service should be carried out at the same time.

CHANGE OIL IN ENGINE OIL PAN, REPLACE ENGINE OIL FILTER CARTRIDGE

! WARNING

- The parts and oil are at high temperature immediately after the engine is stopped, and may cause burns. Wait for the temperature to go down before starting the work.
- When removing the oil filler cap, turn it slowly to release the internal pressure, then remove it.

- Refill capacity: 23.1 liters (6.10 US gal)
- Prepare a filter wrench

1. Open oil filler (F).

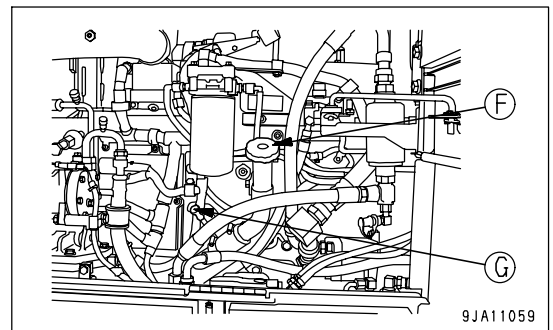

2. Set the container to catch the oil immediately under drain plug (P) on the rear right side of the machine.
3. Loosen drain plug (P), and drain the oil.
4. Check the drained oil, and if there are excessive metal particles or foreign material, please contact your Komatsu distributor.
5. Install drain plug (P).
Tightening torque: 118 to 162 Nm {12 to 16.5kgf-m, 86.8 to 119.3 lbft}

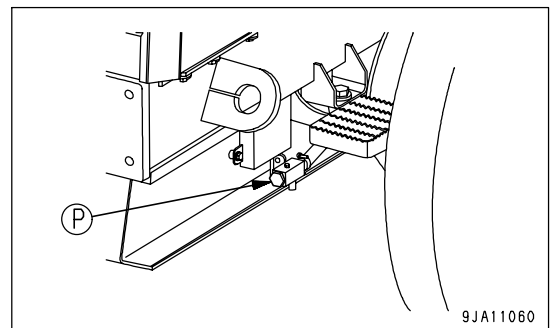

6. Using a filter wrench, turn filter cartridge (1) counterclockwise to remove it.
In particular, if this operation is carried out immediately after stopping the engine, a large amount of oil will come out, so wait for 10 minutes before starting the operation.
7. Clean the filter holder, coat the Sealing surface of a new filter cartridge with engine oil, then install it to the filter holder.
8. When installing, bring the seal surface into contact with the filter holder, then tighten a further approx. 3/4 turn of a turn.

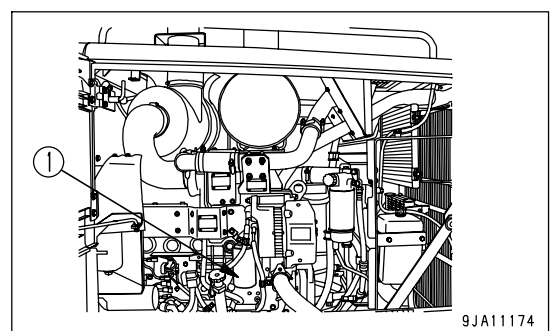

9. After replacing the filter cartridge, add engine oil through oil filler (F) until the oil level is between the marks on the dipstick (G).
10. Run the engine at idle for a short time, then stop the engine, and check that the oil level is between the marks on the dipstick. For details, see "CHECK ENGINE OIL PAN LEVEL, ADD OIL (PAGE 3-89)".

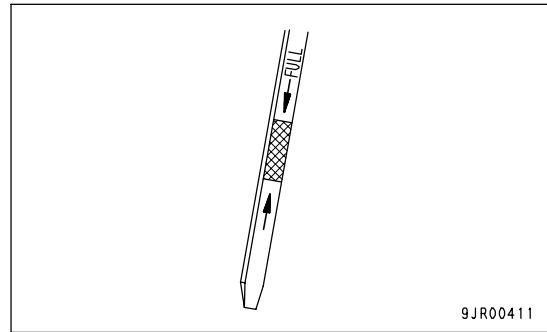

REPLACE FUEL PRE-FILTER CARTRIDGE

WARNING

- After the engine has been operated, all parts are at high temperature, so do not replace the filter immediately. Wait for all parts to cool down before starting the operation.
- High pressure is generated inside the engine fuel piping system when the engine is running. When replacing the filter, wait for at least 30 seconds after stopping the engine to let the internal pressure go down before replacing the filter.
- Do not bring any fire or flame close.

NOTICE

- Genuine Komatsu fuel filter cartridges use a special filter that has highly efficient filtering ability. When replacing the filter cartridge, always use a genuine Komatsu part.
 - The common rail fuel injection system used on this machine consists of more precise parts than the conventional injection pump and nozzle. If any part other than a genuine Komatsu filter cartridge is used, dust or dirt may get in and cause problems with the injection system. Always avoid using substitute parts.
 - When carrying out inspection or maintenance of the fuel system, pay more attention than normal to the entry of dirt. If dirt is stuck to any part, use fuel to wash it off completely.
- Container to catch the fuel
 - Prepare a filter wrench

1. Open the engine side cover on the left side of the machine.
2. The fuel pre-filter forms one unit with the water separator and is at the rear of the engine.
3. Remove connector (1) and clamp(2).
After removing the connector, cover the connector terminals with a vinyl bag or tape to protect them and prevent them from becoming dirty.
4. Set the container under the filter cartridge (3) to catch the drained oil.

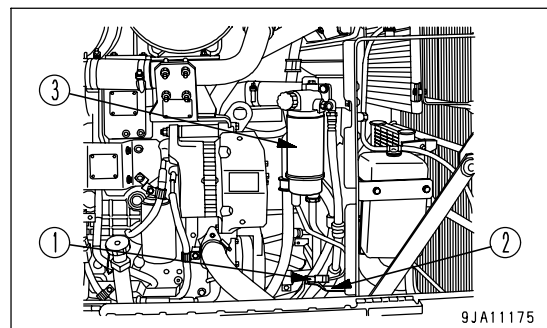

5. Remove hose (6) connected to drain plug (5).
6. Using a filter wrench, turn filter cartridge (3) counterclockwise to remove it.
7. After removing the cartridge, turn cup (4) of the water separator installed to the bottom of the cartridge counterclockwise. (This cup is used again. If it is damaged, replace it with a new part.)
8. Install cup (4) to the bottom of the new fuel pre-filter cartridge. When doing this, always replace the seal ring with a new part.
 - Tightening torque for cup: 10 Nm {1.0 kgm}
 When replacing the seal ring, coat the surface with clean fuel before installing it.
9. Check that drain plug (5) at the bottom of cup (4) of the fuel pre-filter is tightened securely.
 - Tightening torque: 0.2 to 0.45 Nm {0.02 to 0.046 kgm, 0.1 to 0.3 lbft}}
10. Clean the filter holder.

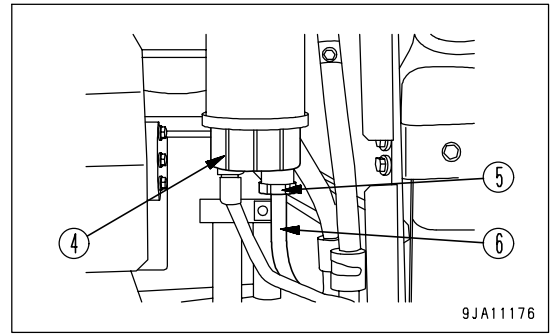

NOTICE

When filling the filter cartridge with fuel, carry out the filling operation with cap (A) fitted.

Cap (A) acts to prevent the entry of dirt or dust into the filter cartridge.

11. Fill the filter cartridge with clean fuel through the 8 small holes (B) in the new filter cartridge.
12. Coat thinly the packing surface of the filter cartridge with clean oil.

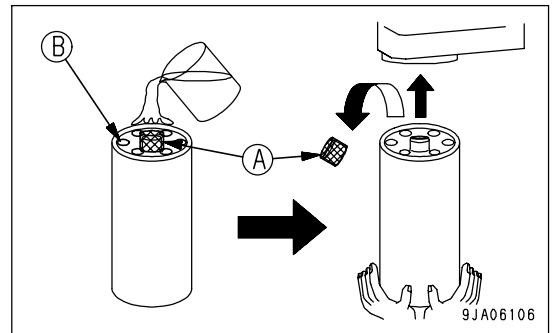

13. Remove filter cartridge cap (A) and install to the filter holder.
14. When installing, tighten until the packing surface contacts the seal surface of the filter holder, then tighten it 3/4 of a turn.
 - If the filter cartridge is tightened too far, the packing will be damaged and this will lead to leakage of fuel. If the filter cartridge is too loose, fuel will also leak from the packing, so always tighten the correct amount.
 - When tightening with a filter wrench, be extremely careful not to dent or damage the filter.
15. Connect removed connector (1), clamp (2) and hose (6).
16. When replacing the standard fuel filter cartridge (every 1000 hours), replace the cartridge and bleed the air. For details, see the items in "REPLACE FUEL MAIN FILTER CARTRIDGE (PAGE 4-61)".
17. Start the engine, check that there is no leakage of fuel from the filter seal surface or water separator mounting surface, then run for approx. 10 minutes at low idling.

PROCEDURE FOR BLEEDING AIR

1. Fill the fuel tank with fuel.
2. Open the engine side cover on the left side of the machine.
3. Loosen and pull out feed pump knob (1) and move it forward and backward.
 - The plug on the side surface of the fuel pre-filter head does not need to be removed.
 - Keep moving knob (1) until it becomes heavy.
4. After bleeding air, push in and tighten knob (1).

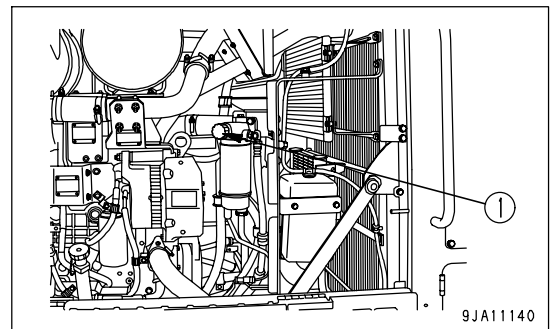

CHECK CIRCLE GUIDE CLEARANCE, ADJUST**WARNING**

- If there is no clearance between the root of the teeth (or the tip of the teeth) of the pinion gear of the circle rotator and the tip of the teeth (or the root of the teeth) of the circle gear after maintenance has been carried out, replace the guide.
- When raising the blade, do not raise it higher than necessary.

NOTICE

If the condition remains as below even after maintenance is carried out, replace the circle guide.

- When there is no clearance (R) between the circle and circle guide.
- When there is no clearance between the root of the teeth (or the tip of the teeth) of the pinion gear of the circle rotator and the tip of the teeth (or the root of the teeth) of the circle gear.
- Prepare the following:
 - Feeler gauge
- Shims (thickness: 1 mm (0.039 in), 0.5 mm (0.020 in); 2 types)

CHECKING

1. Raise the blade and use a feeler gauge to measure clearance (P) between the bottom face of the drawbar and the top face of the swing circle as shown in the diagram. The standard clearance is 1.5 ± 0.5 mm (0.059 ± 0.020 in).
2. Keep the blade raised and use a feeler gauge to measure clearance (Q) F (front), (Q) C (center), and (Q) R (rear) between the circle and circle guide as shown in the diagram when force is applied at the rear. Standard clearances (Q) F, (Q) C, and (Q) R are as follows.
(Q) F = 0 mm, (Q) C = 0.7 mm (0.028 in), (Q) R = 1.5 mm (0.059 in), or (Q) F = (Q) R = 1 mm (0.039 in)

ADJUSTING

Adjusting top and bottom position

1. Raise the blade, remove bolts (1), (5), and (9) for clearance (P), remove circle guides (2), (6), and (10), then adjust the shim thickness. (Shim thickness: 1 mm (0.039 in), 0.5 mm (0.020 in); 2 types)

Adjust the circle guide one place at a time.

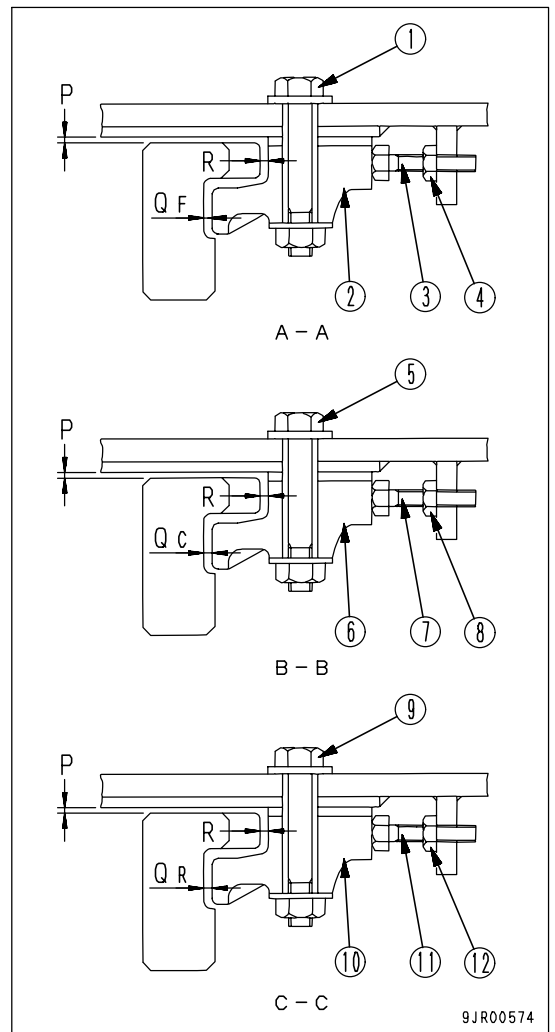
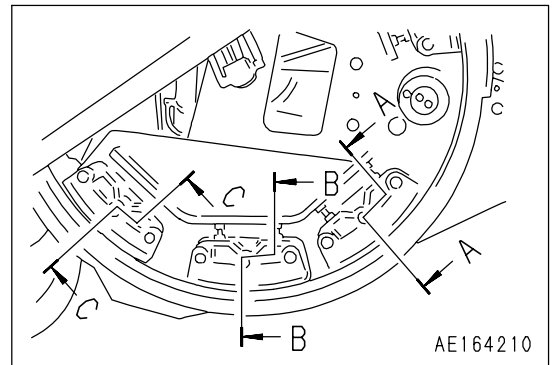

Adjusting front and rear position

2. Lower the blade lightly to the ground, loosen bolt (1), then loosen locknut (4), turn back bolt (3), push open circle guide (2), and make (Q) F = 0. (When doing this, push open the left and right bolts uniformly.)
3. Adjust circle (14) fore and aft so that the clearance (D) between the lower flange (13) of the circle rotator and the sliding surface of inner circumference of the circle is 20 - 22 mm (0.8 - 0.9 in). (15) Pinion gear

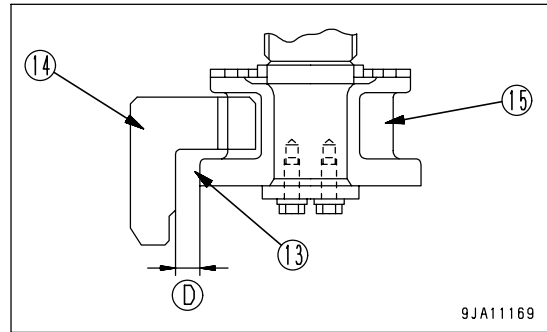

9JA11169

4. When (Q) F = 0, tighten locknut (4), then tighten bolt (1).

Adjusting left and right position

5. Loosen bolt (9), then loosen locknut (12), turn back bolt (11), push open circle guide (10), and make (Q) R = 0. (When doing this, push open the left and right bolts uniformly.)
6. Loosen bolt (5), then loosen locknut (8), turn back bolt (7), push open circle guide (6), and make (Q) C = 0. (When doing this, push open the left and right bolts uniformly.)
7. When (Q) R = 0, turn back bolt (11) half a turn, tighten locknut (12), return circle guide (10) until it contacts bolt (11), then tighten bolt (9).
8. The clearance between the tip of the teeth of the circle gear and the root of the teeth of the pinion gear should be 1.5 - 3.0 mm (0.059 - 0.118 in).
9. When (Q) C = 0, turn back bolt (7) 1/4 of a turn, tighten locknut (8), return circle guide (6) until it contacts bolt (7), then tighten bolt (5).
10. Check that it rotates 90° to the left and right at high bank.

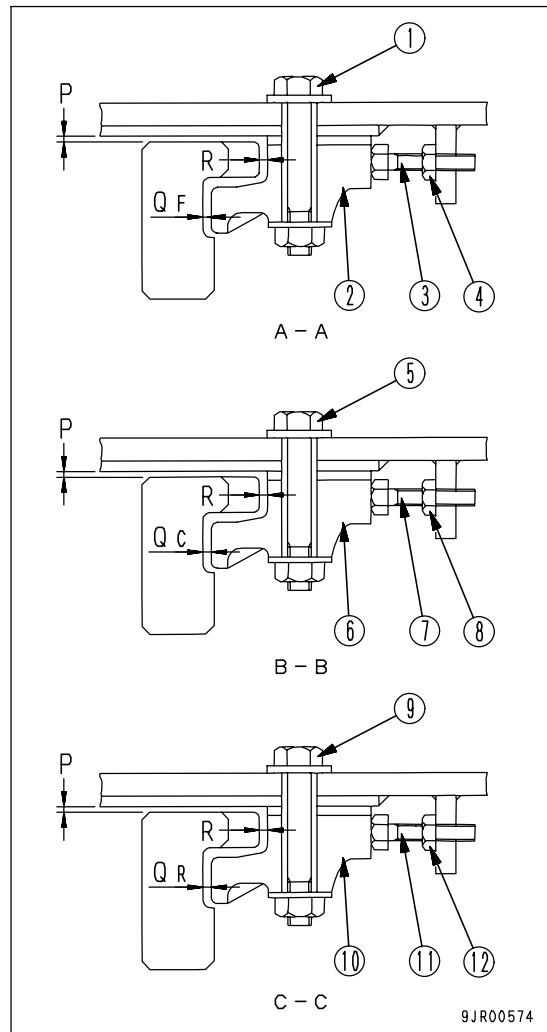

9JR00574

EVERY 1000 HOURS SERVICE

Maintenance for every 50, 250 and 500 hours should be carried out at the same time.

REPLACE FUEL MAIN FILTER CARTRIDGE

 **WARNING**

- After the engine has been operated, all parts are at high temperature, so do not replace the filter immediately. Wait for all parts to cool down before starting the operation.
- High pressure is generated inside the engine fuel piping system when the engine is running. When replacing the filter, wait for at least 30 seconds after stopping the engine to let the internal pressure go down before replacing the filter.
- Do not bring any fire or flame close.

NOTICE

- Genuine Komatsu fuel filter cartridges use a special filter that has highly efficient filtering ability. When replacing the filter cartridge, always use a genuine Komatsu part.
- The common rail fuel injection system used on this machine consists of more precise parts than the conventional injection pump and nozzle. If any part other than a genuine Komatsu filter cartridge is used, dust or dirt may get in and cause problems with the injection system. Always avoid using substitute parts.
- When carrying out inspection or maintenance of the fuel system, pay more attention than normal to the entry of dirt. If dirt is stuck to any part, use fuel to wash it off completely.

- Container to catch the fuel
- Prepare a filter wrench

1. Open the engine side cover on the right side of the machine.
2. Set the container to catch the fuel under the filter cartridge.
3. Using a filter wrench, turn filter cartridge (1) counterclockwise to remove it.
4. Clean the filter holder.

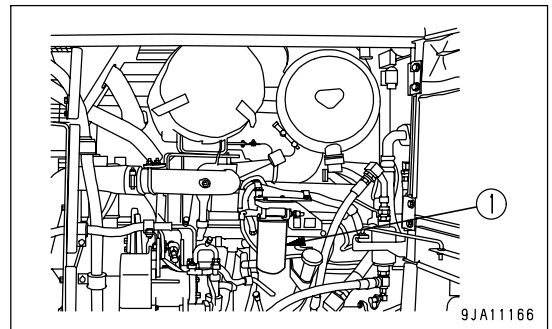

NOTICE

Do not fill the filter cartridge with fuel.

Cap (A) is installed to prevent dirt from entering the inside of the filter cartridge.

5. Coat the packing surface of the filter cartridge with oil.

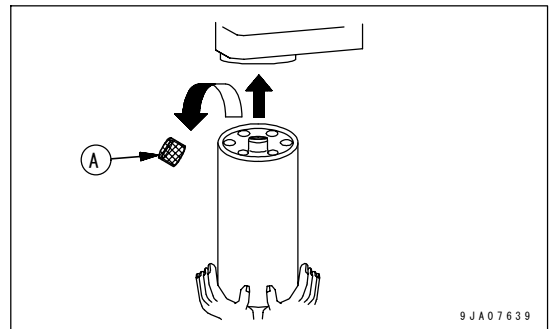

6. Remove filter cartridge cap (A) and install to the filter holder.

7. When installing, tighten until the packing surface contacts the seal surface of the filter holder, then tighten it 3/4 of a turn.
If the filter cartridge is tightened too far, the packing will be damaged and this will lead to leakage of fuel. If the filter cartridge is too loose, fuel will also leak from the packing, so always tighten the correct amount.
8. After completing replacement of filter cartridge (1), bleed the air from the system. For details, see "PROCEDURE FOR BLEEDING AIR (PAGE 4-62)".
9. After completing the air bleeding, start the engine and check that there is no leakage of fuel from the filter seal surface. If there is any leakage, check the tightening condition of the filter cartridge. If there is still fuel leakage, repeat Steps 1 - 3 to remove the filter cartridge, then check the packing surface for damage or embedded dirt. If any damage or embedded dirt is found, replace the cartridge with a new part and repeat Steps 4 - 8 to install it.

PROCEDURE FOR BLEEDING AIR

1. Fill the fuel tank with fuel.
2. Open the engine side cover on the left side of the machine.
3. Loosen and pull out feed pump knob (1) and move it forward and backward.
 - The plug on the side surface of the fuel pre-filter head does not need to be removed.
 - Keep moving knob (1) until it becomes heavy.
4. After bleeding air, push in and tighten knob (1).

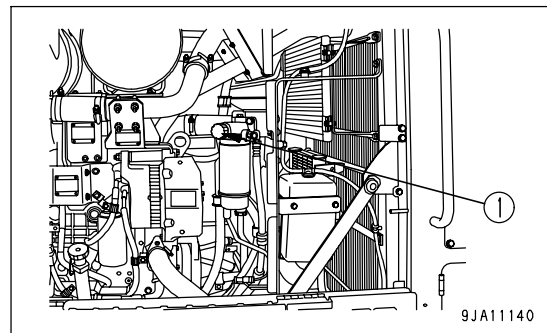

REPLACE TRANSMISSION OIL FILTER CARTRIDGE



WARNING

The parts and oil are at high temperature immediately after the engine is stopped, and may cause burns. Wait for the temperature to go down before starting the work.

- Prepare a ring wrench
1. Set the container under the filter cartridge to catch the drained oil.
 2. Using the ring wrench, turn filter cartridge (1) to the left to remove it.
 3. Clean the filter holder, coat the seal surface of the new filter cartridge thinly with clean engine oil, then install to the filter holder.

Tightening torque: 49 to 59 Nm (5 to 6 kgm, 36.2 to 43.4 lbf)

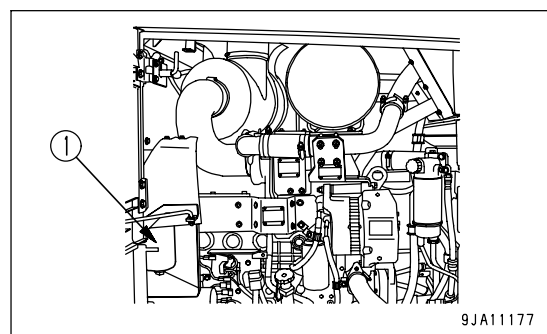

CHANGE OIL IN TRANSMISSION CASE, CLEAN STRAINER

! WARNING

The parts and oil are at high temperature immediately after the engine is stopped, and may cause burns. Wait for the temperature to go down before starting the work.

- Refill capacity: 45 liters (11.88 US gal)

1. Set a container under the transmission case to catch the oil.
2. Remove drain plug (1).
To prevent the oil from spurting out, gradually loosen drain plug (2).
3. After draining the oil, tighten drain plug (2) and install drain plug (1).

Tightening torque

- drain plug (1): 59 to 78.5 Nm (6 to 8 kgm, 43.4 to 57.9 lbft)
- drain plug (2): 49 to 78.5 Nm (5 to 8 kgm, 36.2 to 57.9 lbft)
- drain plug (3): 9.8 to 12.7 Nm (1.0 to 1.3 kgm, 7.2 to 9.4 lbft)

4. Remove drain plug (3) and drain the oil.
5. Remove bolt (4) to take cover (5) off, and take strainer (7) out to wash it.
6. Remove all the dirt stuck to the strainer (7), then wash it in clean diesel oil or flushing oil. If the strainer is damaged, replace it with a new part.
7. Install strainer (7) after washing it, replace O-ring (6) of cover (5) with a new one, install cover (5), and tighten bolt (4).

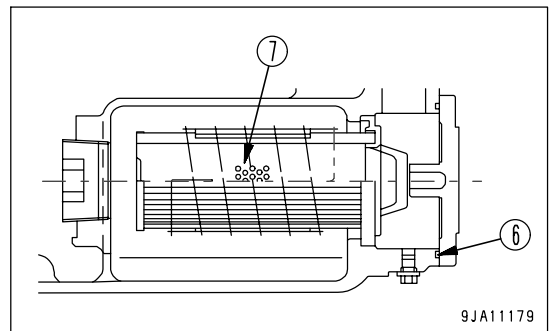
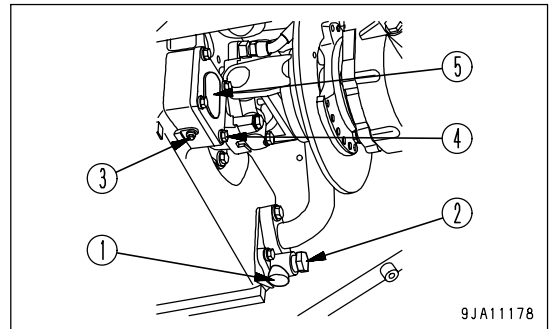

8. Pour in the specified amount of engine oil from oil filler (F).
9. After refilling, check that the oil is at the specified level. For details, see "CHECK OIL LEVEL IN TRANSMISSION CASE, ADD OIL (PAGE 4-47)".
10. Check that there is no leakage of oil from the transmission case or oil filter.

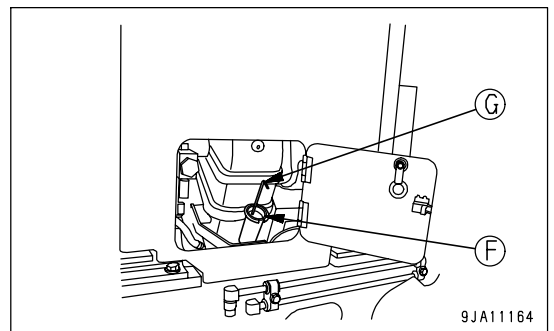

CLEAN TRANSMISSION BREATHER

1. Stop the engine and wait for the temperature at all parts to go down.
2. Remove all mud and dirt from around the breather.
3. Remove the breather and fit a cover to the breather mounting hole to prevent dirt from entering.
4. Soak the breather in flushing liquid and wash it.
5. Install the breather.

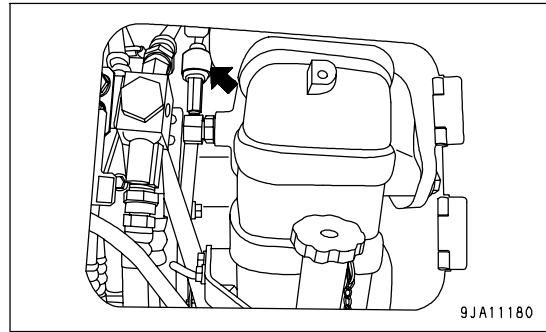

CHANGE OIL IN FINAL DRIVE CASE



WARNING

The parts and oil are at high temperature immediately after the engine is stopped, and may cause burns. Wait for the temperature to go down before starting the work.

- Refill capacity: 17 liters (4.49 US gal) (with differential lock)

1. Set a container under the final drive case to catch the oil.
2. To prevent getting oil on yourself, loosen drain plug (P) and drain the oil.
To prevent the oil from spurting out, loosen drain plug (P), then gradually remove it.
3. After draining the oil, install drain plug (P).
Tightening torque: 58.8 to 78.4 Nm
(6 to 8 kgm , 43.4 to 57.9 lbft)

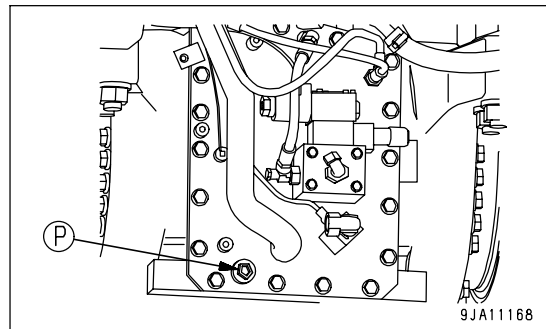

4. Pour in the specified amount of engine oil from oil filler (F).
5. After refilling, check that the oil is at the specified level. For details, see "CHECK OIL LEVEL IN FINAL DRIVE CASE, ADD OIL (PAGE 4-49)".
6. Check for oil leakage from the final drive case.

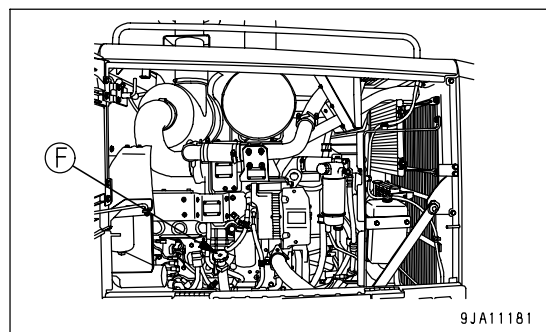

CLEAN FINAL DRIVE BREATHER

1. Stop the engine and wait for the temperature at all parts to go down.
2. Remove all mud and dirt from around the breather.
3. Remove the breather and fit a cover to the breather mounting hole to prevent dirt from entering.
4. Soak the breather in flushing liquid and wash it.
5. Install the breather.

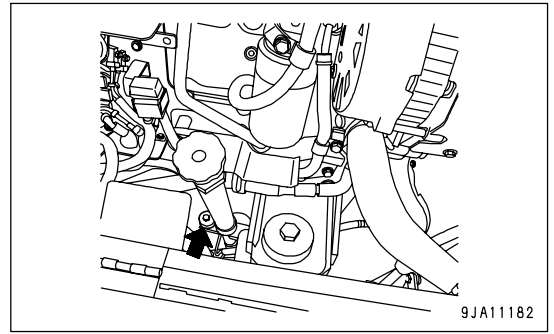

REPLACE HYDRAULIC TANK FILTER ELEMENT

! WARNING

The parts and oil are at high temperature immediately after the engine is stopped, and may cause burns. Wait for the temperature to go down before starting the work.

1. Remove bolt (1), then remove cover (2).
2. Remove bolts (3) to take cover (4) off.
3. Take out the element, clean the removed parts and the inside of the filter case, then install a new element.
4. Install cover (4) and bolt (3).
5. Install cover (2) and bolt (1).

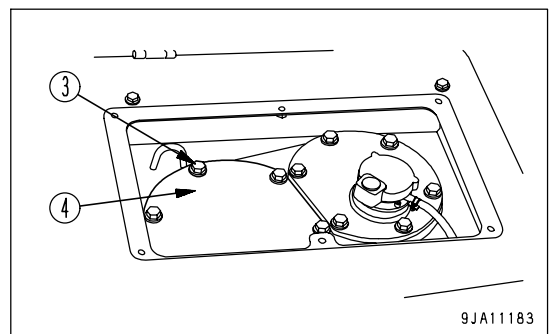
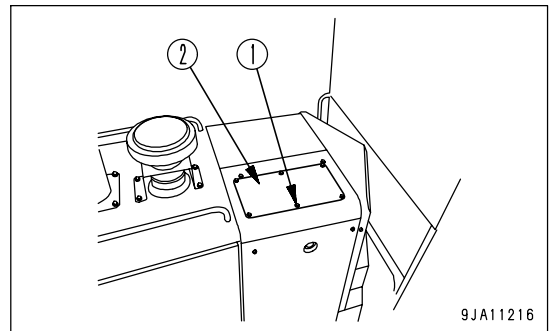

CHECK LOOSENESS, PLAY OF BALL JOINT AT FRONT OF DRAWBAR

Turn nut (1) at the mounting portion of the ball joint at the front of the drawbar to check if it is loose. If it is loose, tighten it.

Check for play of the ball joint, and if the play to the front and rear is more than 2 mm (0.079 in), remove a shim and adjust to 0.5 to 2 mm (0.020 to 0.079 in).

If it is tightened without any clearance, there is danger that the ball joint will break.

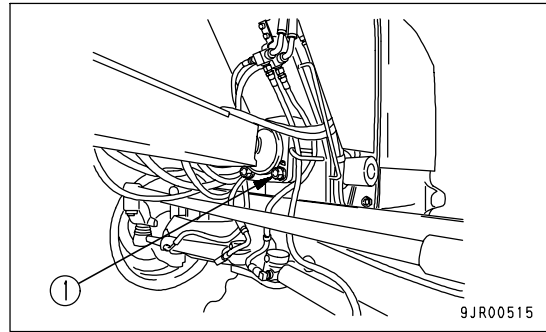

CHECK TOE-IN, ADJUST

HOW TO MEASURE TOE-IN:

Check toe-in and adjust it so that no side slip is caused. When no side slip tester is available, use the following procedure.

1. Park the grader on a level ground without steering and leaning the wheels.
Be sure to drive straight at least a few meters before parking.
2. Measure the height from the ground to the center of the front wheel axle.

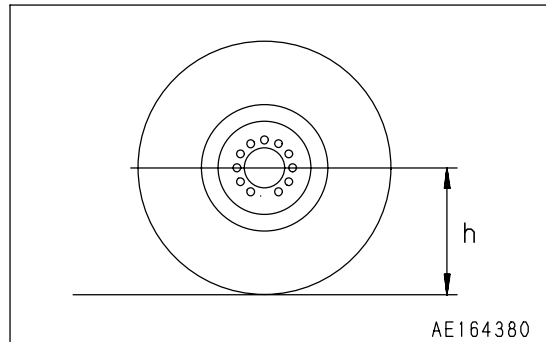

3. Mark the same dimension as measured in step 2 at about the center position of the tire width.
Use the same procedure to mark both the left and right tires.
4. Measure the distance between the two marks.
This distance is called "A".

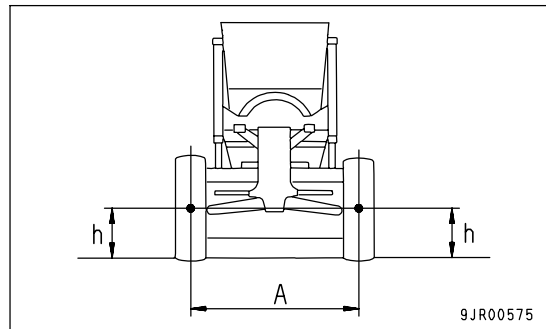

5. Next, drive the machine forward slowly to move the marks on the tire to the rear, and stop the machine when the marks come to the same position as the height from the ground to the center of the front axle.
Always travel forward when doing this.

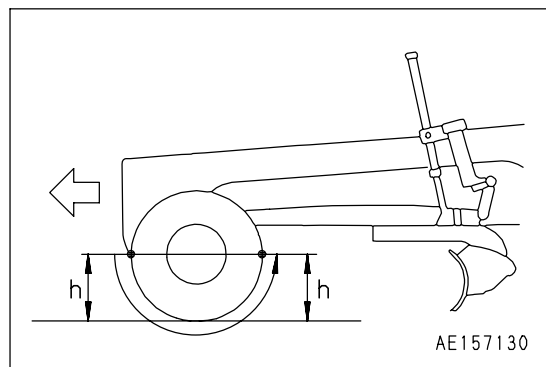

6. Measure the distance between the two marks.
This distance is called "B".
7. When toe-in (B - A) is adjusted to -5 ± 1 mm (-0.197 ± 0.039 in) of standard range, side slip is decreased to zero.
If any value other than the standard range is measured, adjust toe-in using the following procedure.

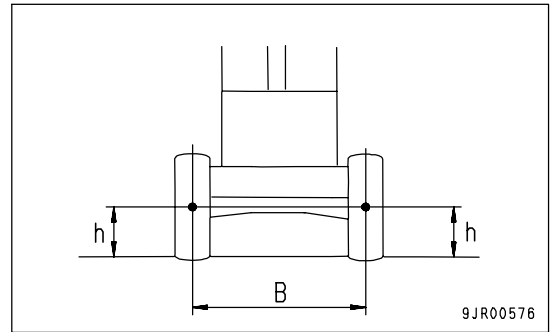

HOW TO ADJUST TOE-IN:

NOTICE

When adjusting, make sure that the front axle is horizontal and that the front wheels are not leaning.

1. Loosen tightening nut (1), fit a wrench to corner (2) of the tie rod, then turn the left and right tie rods as shown in the diagram on the right to adjust as follows.
To INCREASE toe-in, turn in DIRECTION OF ARROW
To DECREASE toe-in, turn in OPPOSITE DIRECTION
Amount of extension for 1/3 turn of left or right tie rod in direction of extension: 6 mm (0.236 in)
2. After adjusting, tighten tightening nut (1).

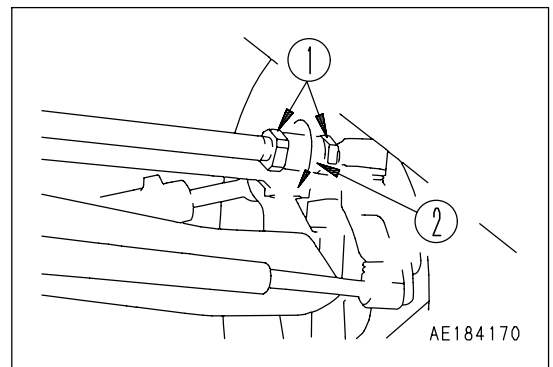

CHECK FRONT WHEEL BEARING PLAY, ADJUST

Please ask your Komatsu distributor to carry out this inspection and adjustment.

CHECK OF ENGINE AIR INTAKE PIPING CLAMPS FOR LOOSENESS

Check the clamps between the air cleaner, turbocharger, aftercooler, and engine for looseness. If any clamp is loosened, retighten it.

Tightening torque

- clamp (1): 10.0 to 11.0 Nm (102 to 112 kgm, 737.8 to 810.1 lbft)
- clamp (2): 8.3 to 9.3 Nm (85 to 95 kgm, 614.8 to 687.1 lbft)

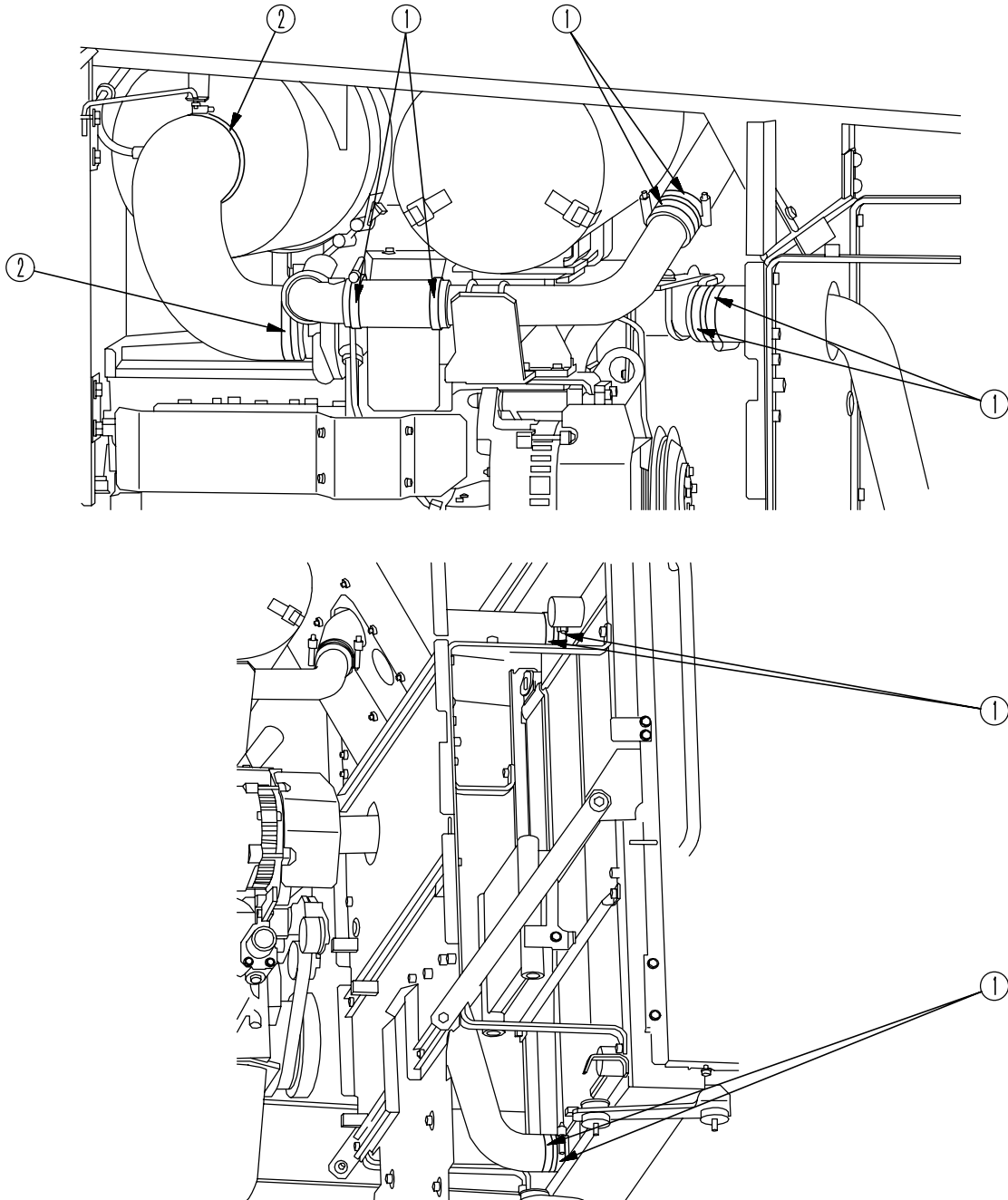

9JA11184

EVERY 2000 HOURS SERVICE

Maintenance for every 50, 250, 500 and 1000 hours service should be carried out at the same time.

CHANGE OIL IN HYDRAULIC TANK, CLEAN STRAINER



WARNING

- The parts and oil are at high temperature immediately after the engine is stopped, and may cause burns. Wait for the temperature to go down before starting the work.
- When removing the oil filler cap, turn it slowly to release the internal pressure, then remove it.

- Refill capacity: 45 liters (11.88 US gal)

1. Set the machine in position as follows to check the oil level.
 - Return the leaning of the front tires to the upright position and face the wheels straight to the front.
 - Set the front frame and rear frame facing straight (articulated angle = 0°). Install the articulate lock pin.
 - Return the blade sideshift to the center of the machine, set the blade at right angles to the chassis and lower it lightly to the ground.
2. Remove bolt (1), then remove cover (2).
3. Loosen oil filler port (F) slowly to completely release the air inside the hydraulic tank.
4. To return the oil inside the accumulator to the tank, stop the engine, then depress the brake approx. 20 times. For machines equipped with a blade accumulator, turn the accumulator "ON", then stop the engine, and operate the blade lift lever to release the pressure.

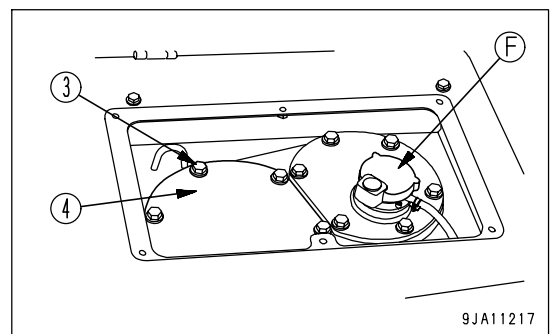
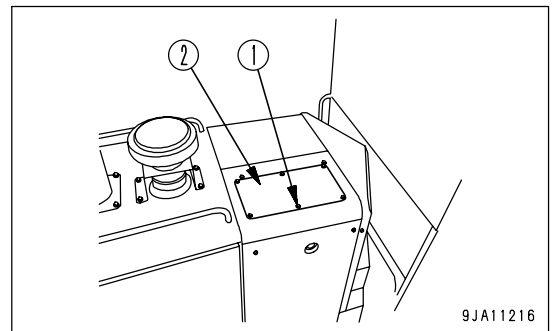

5. Put an oil container under drain plug (P) to catch the oil.
6. To prevent getting oil on yourself, remove drain plug (P) and drain the oil.
To prevent the oil from spurting out, gradually loosen drain plug (P).

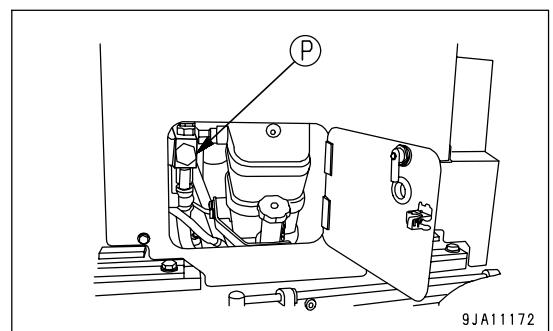

7. After draining the oil, remove bolts (3) (6 pieces) to take cover (4) off.

At this time, cover (4) possibly jumps out by the force of gas spring (5). While pushing down cover (4), remove bolts (3).

8. Pull up the top of rod (6), and remove spring (5) and strainer (7).

9. Remove any dirt stuck to strainer (7), then wash in clean diesel oil or flushing oil. If strainer (7) is broken, replace it with a new part.

10. Refit strainer (7) by inserting it into tank projecting part (8).

11. Assemble so that the protruding portion at the bottom of cover (4) holds spring (5) down, and then tighten with bolts (3).

12. Install drain plug (P).

Tightening torque: 118 to 162 Nm {12 to 16.5kgf·m, 86.8 to 119.3 lbft}

13. Pour in the specified amount of engine oil from oil filler (F).

14. After filling with oil, check that the oil is at the specified level. For details, see "CHECK OIL LEVEL IN HYDRAULIC TANK, ADD OIL (PAGE 4-51)".

15. Install oil filler (F).

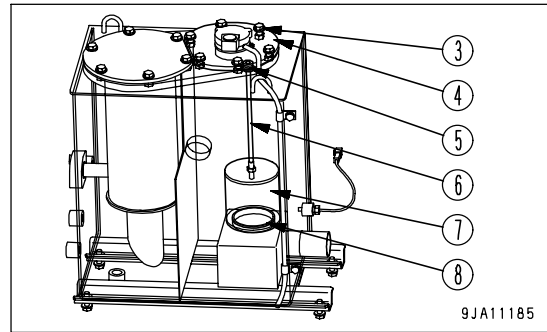

REMARK

Use the supplied hose to prevent oil from spraying out into the surrounding area.

16. If the oil level is correct, tighten the cap of oil filler (F), then remove the hose.

CHANGE OIL IN CIRCLE REVERSE GEAR CASE

! WARNING

The parts and oil are at high temperature immediately after the engine is stopped, and may cause burns. Wait for the temperature to go down before starting the work.

- Refill capacity: 7 liters (1.85 US gal) (Slip clutch type)

1. Set the container under drain plug (P) to catch the oil.
2. Remove drain plug (P) and drain the oil.
3. After draining the oil, clean drain plug (P) and install it again.

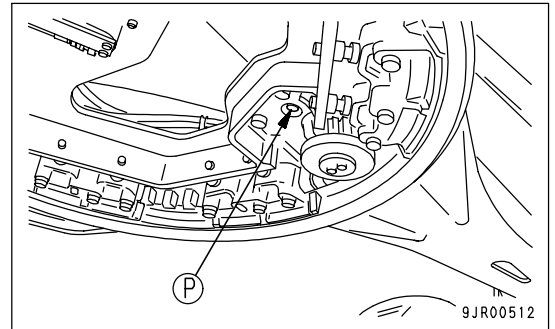

4. Remove oil filler plug (F) and add gear oil to the specified level.
5. After adding the oil, check that the oil is at the specified level.
For details, see "CHECK OIL LEVEL IN CIRCLE REVERSE GEAR CASE, ADD OIL (PAGE 4-50)"
6. Install oil filler plug (F).

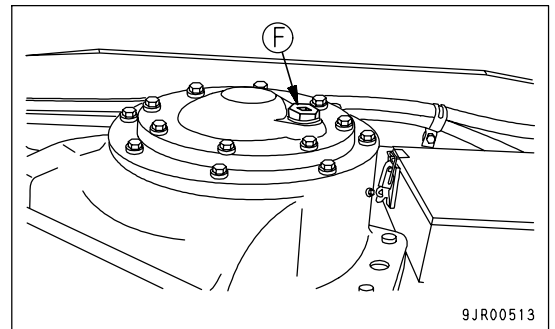

CHANGE OIL IN TANDEM DRIVE CASE**WARNING**

The parts and oil are at high temperature immediately after the engine is stopped, and may cause burns. Wait for the temperature to go down before starting the work.

- Refill capacity: Each 57 liters (15.06 US gal)
1. Put an oil container under drain plug (P) to catch the oil.
 2. Remove drain plug (P) and drain the oil.
 3. After draining the oil, clean drain plug (P) and install it again.
 4. Pour in the specified amount of engine oil from oil filler (F).
 5. After refilling the oil, check that the oil is at the specified level.
For details, see "CHECK OIL LEVEL IN TANDEM DRIVE CASE, ADD OIL (PAGE 4-50)".

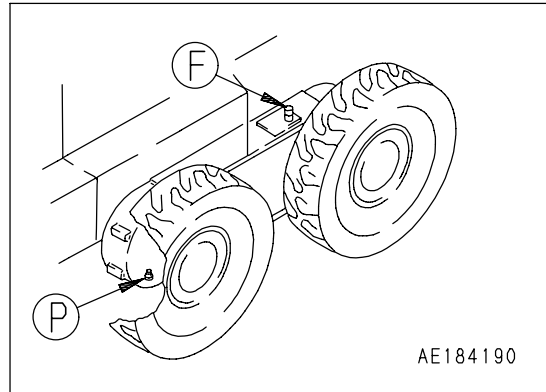

CHECK DISC BRAKE



WARNING

A small amount of oil will come out from the inspection plug hole, so do not look through the plug hole when the brake is applied.

PERIODICAL REPLACEMENT OF DISC BRAKE

Inspection: Every 12 months or 2000 hours.

Disassembly: If the disc brake has reached the wear limit or there is any problem in the brake system, judge if it is necessary to carry out disassembly or maintenance.

METHOD OF CHECKING BRAKE DISC WEAR

1. Remove cap (1) from the wear indicator.

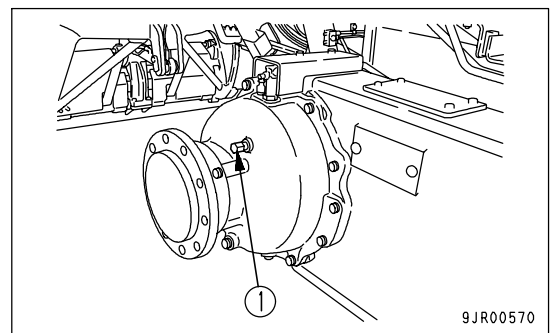

2. Depress the brake pedal and, leaving the brake applied, thrust down until the gauge (2) contacts piston (3).

3. Turn guide (4) until top surface (A) of guide (4) coincides with below-groove line (B) of gauge (2).

4. Tighten nut (5) to fix guide (4).

5. Install cap (1).

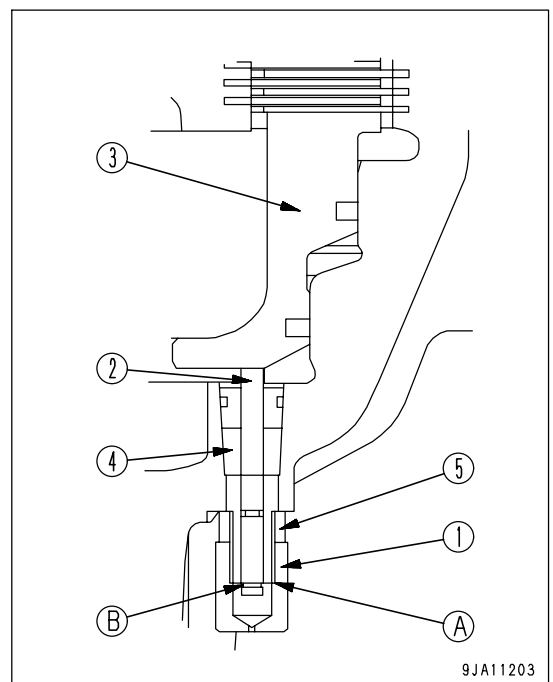

CHECK ALTERNATOR, STARTING MOTOR

The brushes may be worn or the bearing may have run out of grease, contact your Komatsu distributor for inspection and repairs.

If the engine is started frequently, have this inspection carried out every 1000 hours.

CHECK ENGINE VALVE CLEARANCE, ADJUST

As special tools is required for removing and adjusting the parts, you should request service from your Komatsu distributor.

CHECK VIBRATION DAMPER

Check that there are no cracks or peeling in the outside surface of the rubber.

If any cracks or peeling are found, contact your Komatsu distributor to have the parts replaced.

CHECK ACCUMULATOR GAS PRESSURE

Please contact your Komatsu distributor to have the gas pressure checked when making periodically replacement of safety parts or carrying out the legally required 2000 hour or every year service.

CHANGE GREASE IN FRONT WHEEL BEARING

Please contact your Komatsu distributor for inspection and adjustment.

EVERY 4000 HOURS SERVICE

Maintenance for every 50, 250, 500, 1000 and 2000 hours service should be carried out at the same time.

CHECK WATER PUMP

Check that there is no play in the pulley or any grease leakage, water leakage, or clogging of the drain hole. If any problem is found, contact your Komatsu distributor for disassembly and repair or replacement.

CHECK ACTUATION OF COMPRESSOR

Check the following items. If any problem is found, please ask your Komatsu distributor to carry out disassembly, repair, or replacement.

- Are the compressor and magnet clutch turned ON-OFF when the air conditioner switch is turned ON-OFF?
- Is any abnormal noise generated from the clutch or compressor body?

CHECK FAN PULLEY

Check that there is no play in the pulley or any grease leakage, water leakage, or clogging of the drain hole. If any problem is found, contact your Komatsu distributor for disassembly and repair or replacement.

CHECKING FOR LOOSENESS OF HIGH-PRESSURE CLAMP, HARDENING OF RUBBER

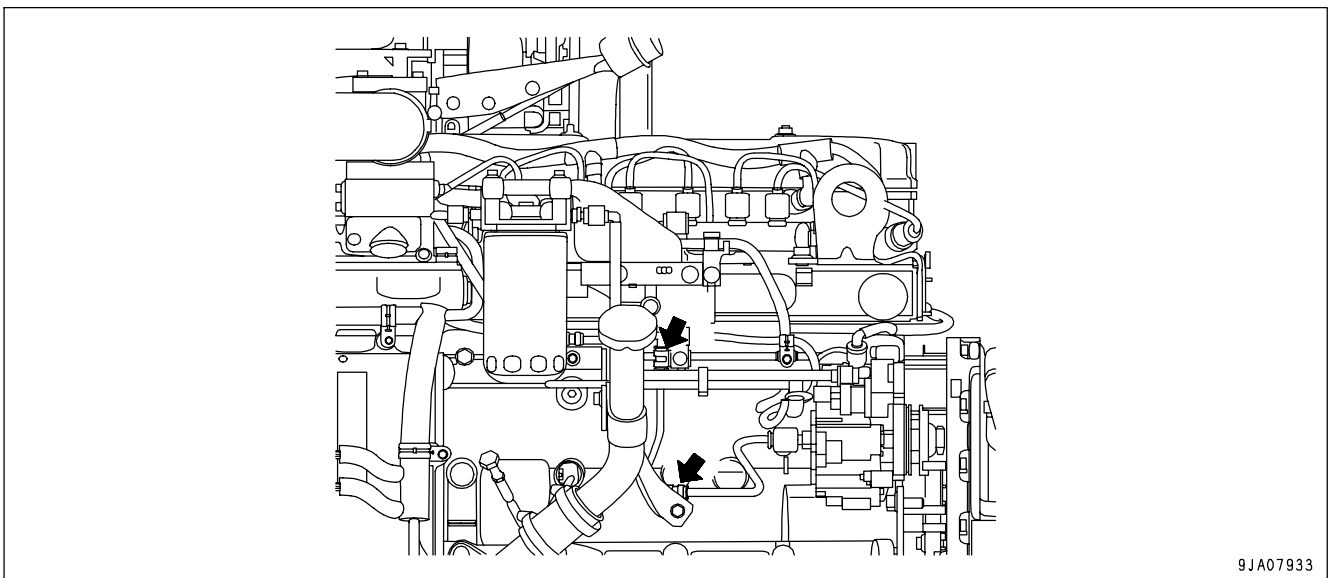

Check visually and touch by hand to check that there is no hardening of the rubber and no loose bolts of the mounting clamps (2 places) for the high-pressure piping between the supply pump and the common rail. If there are any problems, the parts must be replaced. In this case, please ask your Komatsu distributor to carry out replacement.

CHECKING FOR MISSING FUEL SPRAY PREVENTION CAP, HARDENING OF RUBBER

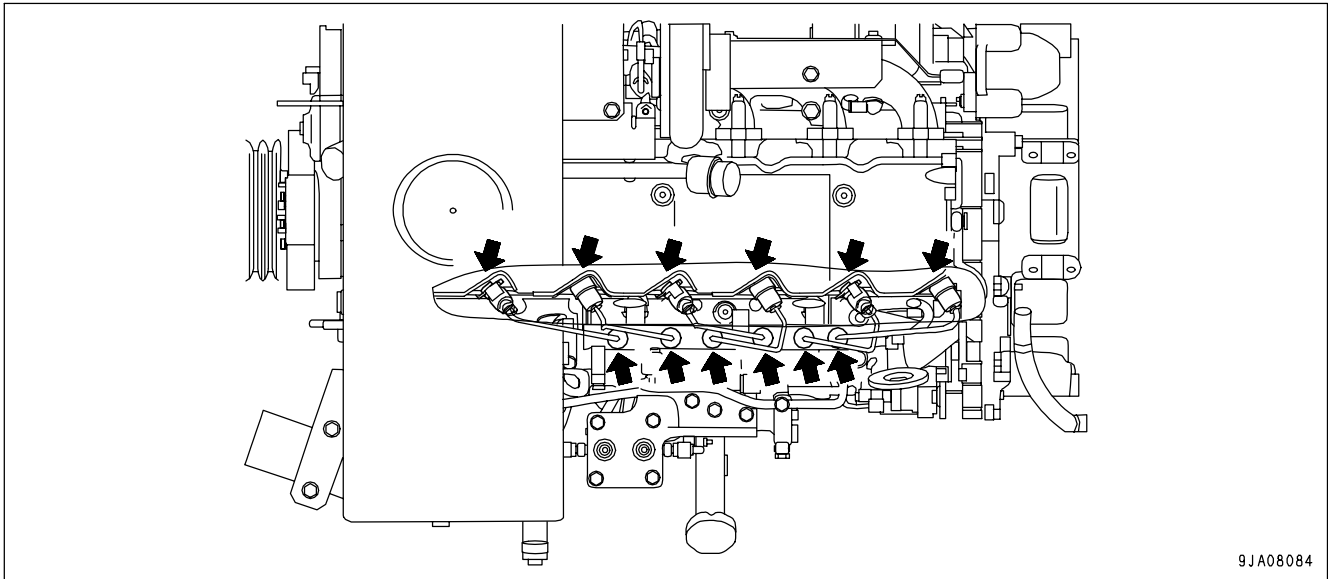

9JA08084

The fuel spray prevention caps (12 places) on the fuel injection piping and both ends of the high-pressure piping act to prevent the fuel from coming into contact with high-temperature parts of the engine and causing a fire if the fuel should leak or spray out. Check visually and touch by hand to check that there are no missing caps, loose bolts or hardening of the rubber. If there are any problems, the parts must be replaced. In this case, please ask your Komatsu distributor to carry out replacement.

LUBRICATING

! WARNING

- Set the gear shift lever to the P (Parking) position and fix the front and rear frames by using the articulate lock pin.
- Lower the work equipment to the ground and stop the engine.
- Grease on flat ground.

1. Using a grease pump, pump in grease through the grease fittings shown by arrows.
2. After greasing, wipe off any old grease that was pushed out.

Drive shaft (2 places)

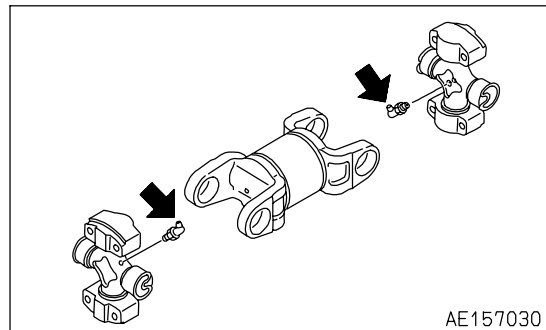

AE157030

EVERY 8000 HOURS SERVICE

Maintenance for every 50, 250, 500, 1000, 2000 and 4000 hours service should be carried out at the same time.

REPLACE HIGH-PRESSURE PIPING CLAMP

Ask your Komatsu distributor to carry out this work.

REPLACE FUEL SPRAY PREVENTION CAP

Ask your Komatsu distributor to carry out this work.

SPECIFICATIONS

SPECIFICATIONS

Item		Unit	GD655-5	
Operating weight (including operator 75 kg (165 lb))		kg (lb)	15,520 (34,222)	
Engine model		-	Komatsu SAA6D107E-1 diesel engine	
Flywheel horsepower		kW{HP}	107-134-149-163{143-179-200-218}	
A	Overall length	mm (ft in)	9,205 (30' 2")	
B	Overall height (Tail pipe)	mm (ft in)	2,995 (9' 10")	
C	Overall height (with low profile ROPS cab)	mm (ft in)	3,200 (10' 6")	
D	Overall width	mm (ft in)	2,485 (8' 2")	
Min. ground clearance		mm (ft in)	390 (1' 3")	
Min. turning radius		mm (ft in)	7,400 (24' 3")	
Travel speeds Travel speed at engine rated horsepower. Tire loaded radius : 0.61m (2 ft)	Forward	1st	km/h (MPH)	3.4 (2.1)
		2nd	km/h (MPH)	5.0 (3.1)
		3rd	km/h (MPH)	7.0 (4.3)
		4th	km/h (MPH)	10.2 (6.3)
		5th	km/h (MPH)	15.4 (9.6)
		6th	km/h (MPH)	22.3 (13.9)
		7th	km/h (MPH)	30.6 (19.0)
		8th	km/h (MPH)	44.3 (27.5)
	Reverse	1st	km/h (MPH)	4.5 (2.8)
		2nd	km/h (MPH)	9.2 (5.7)
		3rd	km/h (MPH)	20.3 (12.6)
		4th	km/h (MPH)	40.3 (25.0)

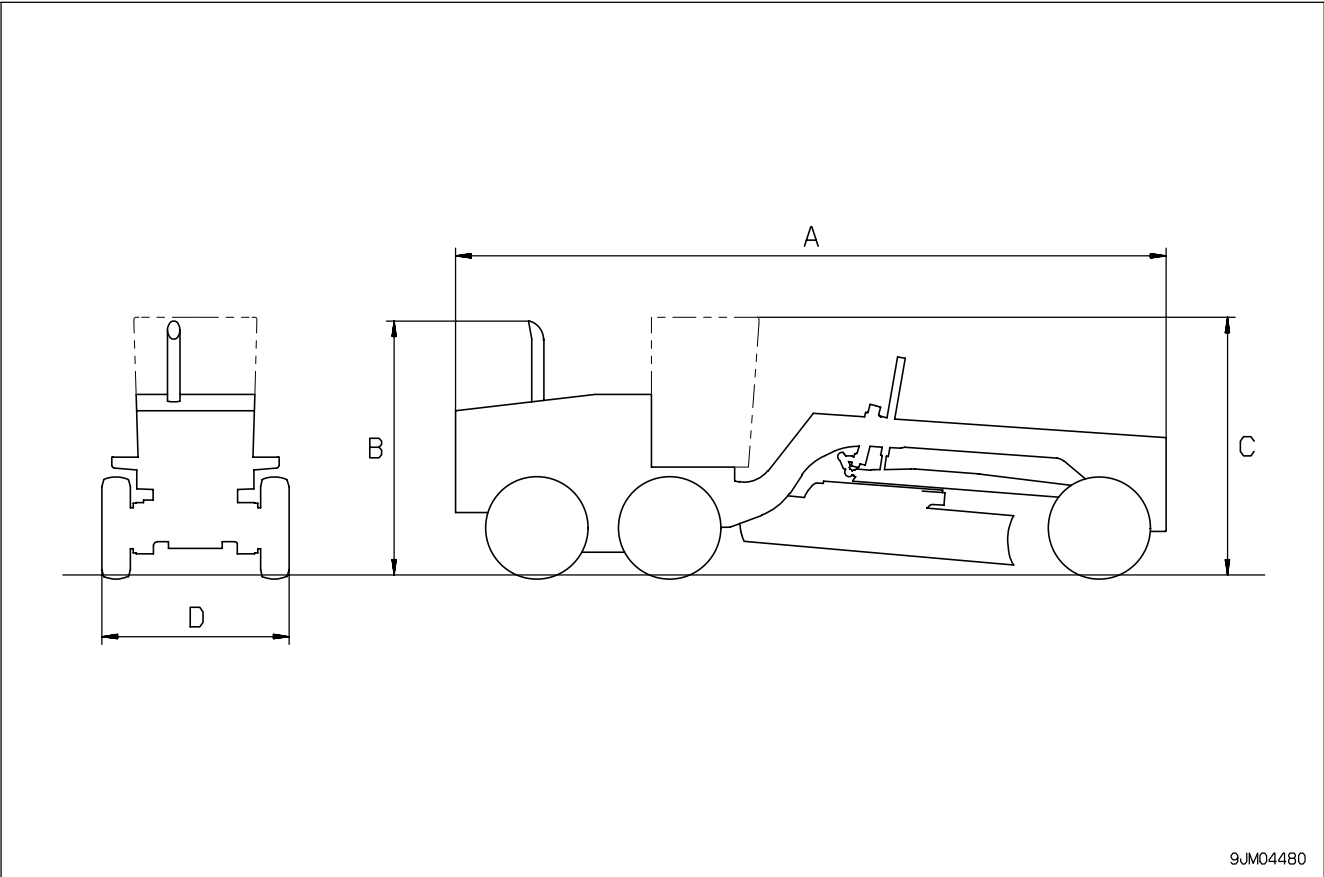

ATTACHMENTS, OPTIONS

WARNING

Please read and make sure that you understand the SAFETY section before reading this section.

HANDLING BLADE ACCUMULATOR

FEATURES OF BLADE ACCUMULATOR

IMPROVEMENT IN EASE OF SNOW-CLEARING OPERATION

- No need to operate blade
- No need to employ experienced operator (relief of condition)

SAFETY, PROTECTION

- Reduction in shock on road surfaces with many rocks or boulders (protection of operator and machine)
- Protection of buried structures (mounts and avoids protruding objects)

IMPROVEMENT IN STEERING ABILITY

- Improvement in steering when operating on curves
- Reduction in side slippage when operating on curves
- Ease of steering when using leaning
- Reduction in side slippage when using leaning

IMPROVEMENT IN EASE OF OPERATION

- Good pushing of blade
- Good avoidance by blade

METHOD OF OPERATING BLADE ACCUMULATOR

1. Lower the blade to the ground and stop the engine.

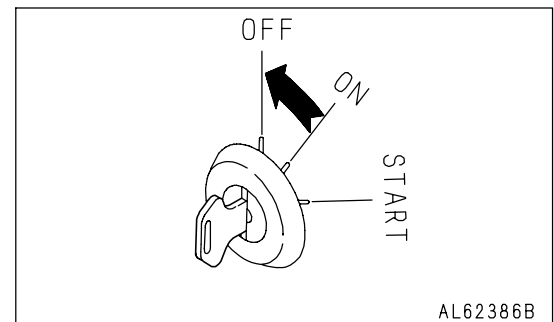
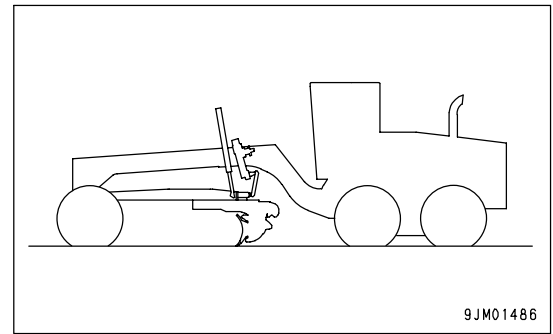

2. Turn the starting switch to ON position (electricity flows in the electrical circuit), then turn the accumulator switch ON.
3. Maintain the condition in Step 2, operate the left and right blade lift levers to the front and rear, and bleed the remaining pressure inside the accumulator and hydraulic circuit.
4. Turn the accumulator switch OFF, then start the engine.
5. Maintain the condition in Step 4, and extend the left and right blade lift cylinders approx. 50 mm (2.0 in). (When doing this, retaining pressure is generated at the bottom of the blade lift cylinders.)
6. Turn the accumulator switch ON and start the accumulator. The oil at the bottom end of the left and right blade lift cylinders will flow into the accumulator, the left and right blade cylinders will retract, and the front wheels will come into contact with the ground.

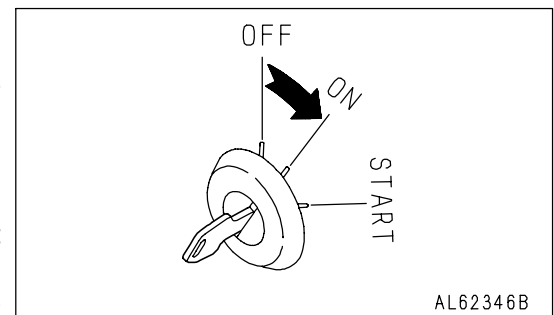

REMARK

- In the condition Step 6, the pressure is maintained at the bottom end of the blade lift cylinder so the blade pushes at a certain pressure.
- If operations are carried out in the condition in Step 6, the blade will be able to follow a rise or fall of approx. 50 mm (2.0 in) in the ground surface, so uniform accumulator operations can be carried out.
- In actual fact, by operating the blade lift cylinder lever in a suitable way, work is carried out within a certain up-down follow-up range with a small pushing pressure.
- Once the accumulator is set, there is no need to operate the blade lift cylinder when starting operations. If the operation is stopped and the switch is turned OFF, raise the blade and put the blade in contact with the ground again, then turn the switch ON to make it possible to set the accumulator to the same setting.

INDEX

<A>		PRECAUTIONS BEFORE STARTING	
ADJUSTING WORK EQUIPMENT		OPERATION -----	2- 13
POSTURE -----	3-155	PRECAUTIONS RELATED TO	
AIR CONDITIONER -----	3- 76	ATTACHMENTS AND OPTIONS -----	2- 19
AM/FM RADIO -----	3- 70	PRECAUTIONS RELATED TO	
ARTICULATE LOCK PIN -----	3- 63	PROTECTIVE STRUCTURES -----	2- 18
ASHTRAY -----	3- 81	PRECAUTIONS WHEN GETTING ON	
		OR OFF MACHINE -----	2- 16
		PRECAUTIONS WHEN RUNNING	
BACKUP ALARM -----	3- 69	ENGINE INSIDE BUILDING -----	2- 19
BEFORE READING THIS MANUAL -----	1- 2	PREPARATIONS FOR SAFE	
		OPERATION -----	2- 13
<C>		UNAUTHORIZED MODIFICATION -----	2- 19
CHECK AFTER STOPPING ENGINE -----	3-106	GENERAL VIEW -----	3- 2
CHECK BEFORE STARTING ENGINE -----	3- 83	GENERAL VIEW OF CONTROLS AND	
CHECKS AFTER COMPLETION OF		GAUGES -----	3- 3
OPERATION -----	3-166	GENERAL VIEW OF MACHINE -----	3- 2
COLD WEATHER OPERATION -----	3-174	GREASE PUMP HOLDER -----	3- 81
AFTER COLD WEATHER -----	3-175	GUIDES TO MAINTENANCE -----	4- 2
CAUTIONS AFTER COMPLETION OF			
WORK -----	3-175	<H>	
PRECAUTIONS FOR LOW		HANDLING BATTERY DISCONNECTOR	
TEMPERATURE -----	3-174	SWITCH -----	3- 67
COMBINATION OF SNOW RADIAL TIRE		HANDLING BLADE ACCUMULATOR -----	6- 2
AND CHAIN -----	3-169	HANDLING MACHINES EQUIPPED	
CONTROL LEVERS, PEDALS -----	3- 51	WITH KOMTRAX -----	3- 82
CRITICAL PARTS -----	4- 14	HANDLING OIL, FUEL, COOLANT, AND	
CUP HOLDER -----	3- 81	PERFORMING OIL CLINIC -----	4- 4
		HANDLING THE TIRES -----	3-168
<D>		<I>	
DUST INDICATOR -----	3- 63	INTENDED USE -----	1- 4
		DIRECTIONS OF MACHINE -----	1- 4
<E>		USE OF MACHINE -----	1- 4
ELECTRIC POWER TAKEOFF -----	3- 66	VISIBILITY FROM OPERATOR'S	
EXPLANATION OF COMPONENTS -----	3- 6	SEAT -----	1- 5
<F>		<L>	
FEATURES OF BLADE ACCUMULATOR --	6- 2	LOCATION OF PLATES, TABLE TO	
FIRE EXTINGUISHER -----	3- 81	ENTER SERIAL NO. AND	
FUSE BOX -----	3- 64	DISTRIBUTOR -----	1- 6
		EPA REGULATIONS, ENGINE	
<G>		NUMBER PLATE -----	1- 6
GENERAL PRECAUTIONS COMMON		PRODUCT IDENTIFICATION	
TO OPERATION AND MAINTENANCE ----	2- 13	NUMBER (PIN)/MACHINE SERIAL	
DO NOT GET CAUGHT IN WORK		NO. PLATE -----	1- 6
EQUIPMENT -----	2- 18	SERVICE METER POSITION -----	1- 7
FIRE PREVENTION -----	2- 15		

INDEX

IF THE GEAR SHIFT LEVER OF THE TRANSMISSION HAS ANY TROUBLE -----	3-183
METHODS OF LOWERING WORK EQUIPMENTS AFTER THE ENGINE STOPS (RELEASE OF THE HYDRAULIC CIRCUIT PRESSURE FOR WORK EQUIPMENTS) -----	3-184
OTHER TROUBLE -----	3-186
TOWING THE MACHINE -----	3-178
WHEN LEANING PIPING IS DAMAGED -----	3-177
TURNING MACHINE -----	3-119
 <W>	
WEAR PARTS -----	4- 8
WEAR PARTS LIST -----	4- 8
WORK WHICH CAN BE CARRIED OUT USING A MOTOR GRADER -----	3-129

GD655-5 MOTOR GRADER

Form No. TEN00368-01

©2010 KOMATSU
All Rights Reserved
Printed in Japan 04-10
