

Field Assembly Instruction

SEAW04280202

WA800-2

WHEEL LOADER

SERIAL NUMBERS **WA800-2 -10540** and up

This material is proprietary to Komatsu Dresser Company and is not to be reproduced, used, or disclosed except in accordance with written authorization from Komatsu Dresser Company.

It is our policy to improve our products whenever it is possible and practical to do so. We reserve the right to make changes or add improvements at any time without incurring any obligation to install such changes on products sold previously.

Due to this continuous program of research and development, periodic revisions may be made to this publication. It is recommended that customers contact their distributor for information on the latest revision.

CONTENTS

1. CHART OF SEPARATED UNITS	3
2. DIMENSIONS OF SEPARATED UNITS	3
3. ORDER FOR ASSEMBLY, FACILITIES TO USE, SCHEDULE FOR ASSEMBLY	4
4. WORK SPACE LAYOUT DIAGRAM	5
5. TOOLS AND EQUIPMENT TO USE	6
6. PARTS LIST FOR FIELD ASSEMBLY	14
7. PROCEDURE FOR FIELD ASSEMBLY	21
Assembly process No.	
A-1 Setting bare machine on supports	21
A-2 Assembly of rear axle	23
A-3 Assembly of front and rear drive shaft	27
A-4 Assembly of front axle	29
A-5 Assembly of fuel tank	33
A-6 Assembly of ladder (Left, Right)	41
A-7 Assembly of floor and cab assembly	42
A-8 Assembly of floor hand rail	52
A-9 Assembly of tire and wheel assembly	53
A-10 Assembly of battery box assembly	55
10A Assembly of counterweight assembly	60
A-11 Assembly of muffler pipe	61
A-12 Assembly of lift arm assembly	62
A-13 Assembly of front fender	66
A-14 Assembly of front lamp assembly	67
A-15 Assembly of ROPS canopy assembly	68
A-16 Assembly of bucket	70
M-1 Bleeding air from brake line	74
M-2 Greasing work equipment and chassis	75
M-3 Adjusting bucket positioner	76
M-4 Adjusting boom kick-out	77
M-5 Inspection of all parts	78
M-6 Procedure for starting engine	79
M-7 Procedure for bleeding air from piston pump	80
M-8 Procedure for bleeding air from work equipment hydraulic circuit	81
M-9 Charging air conditioner gas	82

APPENDIX

FIELD ASSEMBLY INSPECTION REPORT



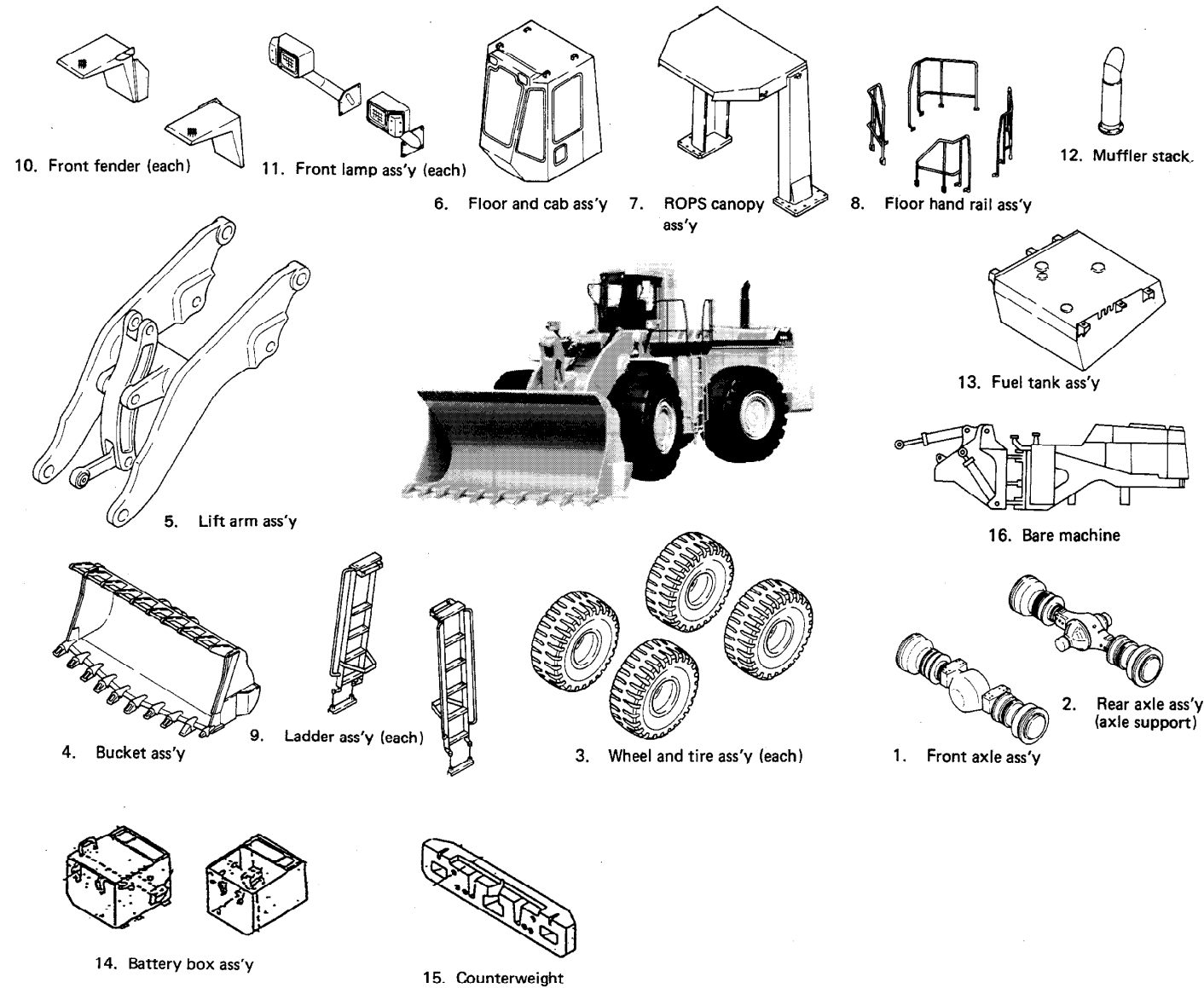





1. CHART OF SEPARATED UNITS

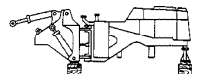
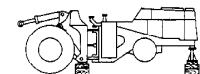
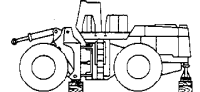
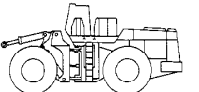
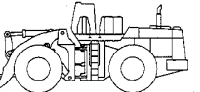

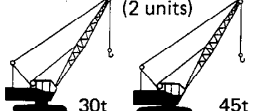
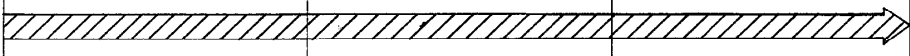
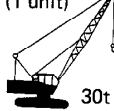
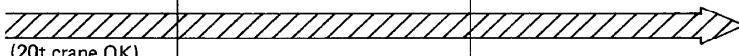
2. DIMENSIONS OF SEPARATED UNITS

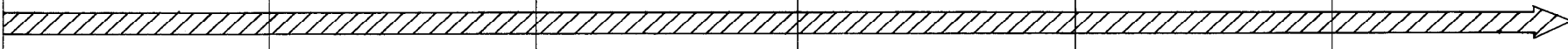
No.	Unit	Dimensions			
		Weight (kg)	Length (mm)	Width (mm)	Height (mm)
1	Front axle ass'y	8430	4340	1550	960
2	Rear axle ass'y (axle support)	8610 (300)	4340 (1354)	1700 (230)	960 (605)
3	Wheel and tire ass'y (each)	13900 (3475)	4800 (1200)	2720 (2720)	2720 (2720)
4	Bucket ass'y	9485	5030	2350	2430
5	Lift arm ass'y	11090	5200	1900	1460
6	Floor and cab ass'y	950	1515	1400	1950
7	ROPS canopy ass'y	1295	1633	2330	2197
8	Floor hand rail ass'y	20 20	1200 1400	1100 1200	350 350
9	Ladder ass'y (each)	100 (50)	2400	700	150
10	Front fender (each)	130 (65)	2000	700	900
11	Front lamp ass'y (each)	60 (30)	1100	550	180
12	Muffler stack (2 pcs)	50	1450	520	260
13	Fuel tank ass'y	790	2000	1900	850
14	Battery box ass'y	700	1800	1520	650
15	Counterweight	2500	350	3200	610
16	Bare machine	32570			
Total		90700			

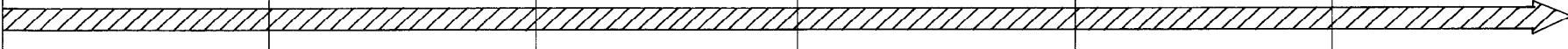
3. ORDER FOR ASSEMBLY, FACILITIES TO USE, SCHEDULE FOR ASSEMBLY

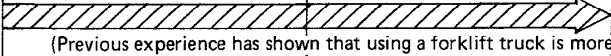
Day Time (hrs)	1st day								2nd day							3rd day													
	1	2	3	4	5	6	7	8	9	10	11	12	13	14	15	16	17	18	19	20	21	22	23						
Assembly unit	 1. Set chassis on supports	 1. Rear axle ass'y 2. Front axle ass'y (front wheel and tire ass'y) 3. Front, rear drive shaft	 1. Fuel tank ass'y 2. Ladder ass'y 3. Floor and cab ass'y 4. Floor handle ass'y 5. Wheel and tire ass'y (rear wheel and tire)	 1. Battery and counterweight ass'y ★ Bleed air from brake line ★ (Tighten wheel mounting nuts to specified torque)	 1. Muffler stack 2. Lift arm ass'y ★ Check oil, water levels; add oil and water ★ Start engine ★ Grease work equipment and chassis ★ Charge air conditioner with gas	 1. Front fender 2. Front lamp ass'y 3. ROPS canopy ass'y	 1. Bucket ass'y ★ Adjust bucket positioner, boom kick-out ★ Check all parts for oil leakage																						
Assembly Procedure No. Maintenance (adjustment) No.	A-1	A-2 – A-4	A-5 – A-9	A-10, 10A, M-1 (A-9)	A-11 – A-12 M-2 M-6 – M-9	A-13 – A-15	A-16 M-3 – M-5																						
Crane (hydraulic type with operator)	 (2 units) 30t 45t												 (1 unit) 30t (20t crane OK)																
Air compressor	37m ³ /min Komatsu EC35ZS or equivalent 																												
No. of workers	 5 persons																												
Forklift truck (operator included in number of workers above)	 2t	 (Previous experience has shown that using a forklift truck is more efficient, so we strongly recommend use of a forklift truck)																											
Remarks	Meeting before starting operation, unloading parts, start of assembly												Remove supports								Start engine								Completion of assembly

4. WORK SPACE LAYOUT DIAGRAM

(The larger the work space is, the easier it is to carry out operations. The area shown in the diagram below (25 m x 30 m) is the minimum size needed.)

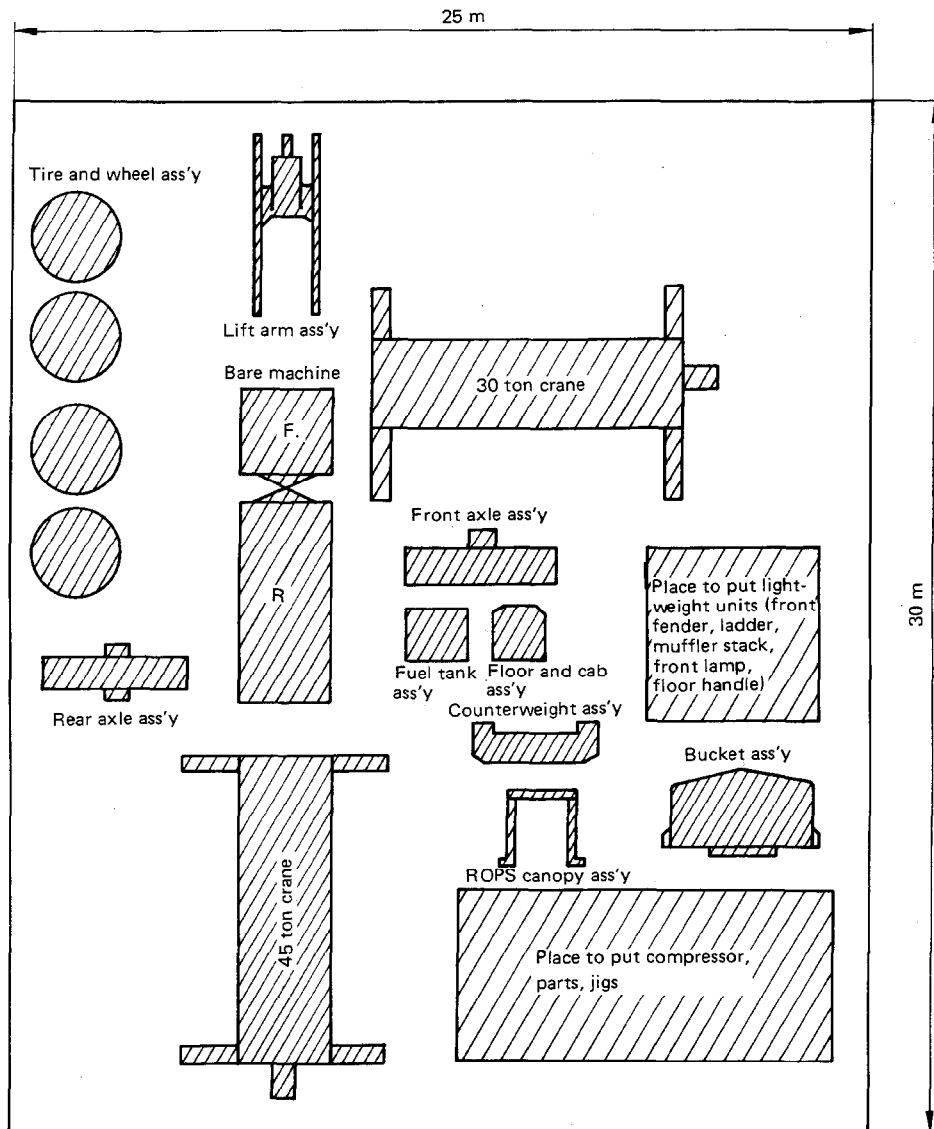

5. TOOLS AND EQUIPMENT TO USE

1. Tools required

No.	Name	Specification	Q'ty	Remarks
1	Set of common standard tools	Spanners, two-ended ring wrench, box wrench, cold chisel, screwdrivers, hammer, adjustable wrench, hexagon wrenches, etc.	2	
2	Power wrench	16 times	1	Front, rear axle mounts, ROPS canopy mount
3	Power wrench	4 times	1	Fuel tank mount
4	Socket	60 (Insertion angle; 38.1) x L: 84	1	For front, rear axle mount
5	Socket	36 (Insertion angle; 25.4) x L: 68	1	For rear axle support cover, tire, counterweight (lower)
6	Socket	46 (Insertion angle; 25.4) x L: 72	1	For fuel tank, counterweight
7	Socket	55 (Insertion angle; 38.1) x L: 82	1	ROPS mount
8	Socket	55 (Insertion angle; 25.4) x L: 82	1	ROPS mount
9	Extension bar	Insertion angle: 12.7 x L: 150	1	For fuel tank
10	Adapter	Insertion angle: 19 x 12.7 x L: 55	1	For fuel tank
11	Extenson bar	Insertion angle: 25.4 x L: 160	1	For tire, counterweight, ROPS canopy
12	Preset torque wrench (box type)	4 – 28 kgm	1	For power wrench
13	Interchangeable head type preset torque wrench	6 – 14 kgm	1	For connecting hoses and tubes
14	Interchangeable head type preset torque wrench	2 – 4.5 kgm	1	For connecting hoses and tubes
15	Interchangeable head type preset torque wrench	3 – 7 kgm	1	For connecting hoses and tubes
16	Heads (spanner type) for interchangeable head type preset	Width across flats: 27 (insertion hole: ϕ 15) Width across flats: 19 (insertion hole: ϕ 12) Width across flats: 22 (insertion hole: ϕ 12) Width across flats: 24 (insertion hole: ϕ 12)	One each	For connecting hoses and tubes
17	Preset torque wrench (box type)	20 – 140 kgm	1	For rear axle support cover, counterweight
18	Preset torque wrench (box type)	50 – 210 kgm	1	For counterweight
19	Preset torque wrench (box type)	6 – 42 kgm	1	For rear axle support cover
20	Impact wrench	Capacity: 1.5 – 7.5 kgm	1	
21	Impact wrench	Capacity: 5.5 – 31.5 kgm	1	

No.	Name	Specification	Q'ty	Remarks
22	Impact wrench	Capacity: 20.5 – 84.5 kgm	1	For tire, ROPS canopy
23	Adapter	Insertion angle: 19 x 25.4 x L: 71	1	For power wrench, torque wrench
24	Adapter	Insertion angle: 12.7 x 9.5 x L: 41	1	For power wrench, torque wrench
25	Large hammer	10 pounds	1	
26	Air grinder	–	1	
27	Bars	Large, medium, small	Two each	Hole adjustment, for moving heavy things
28	Bar	–	2	Hole adjustment
29	Grease gun (hand pump type)	Capacity: Approx. 300 cc	1	For oiling to pin
30	Oil container	Capacity: 1000 – 2000 cc	1	For bleeding air from brake line
31	Vinyl hose	I.D. ϕ 6.5 – ϕ 7.0 x L: 1000 – 1500	1	For bleeding air from brake line

2. Equipment required

No.	Name	Specification	Q'ty	Remarks
1	Truck crane	45 ton	1	
2	Truck crane	30 ton	1	
3	Forklift truck	2 ton	1	For unloading comparatively light components and parts, assembling fuel tank
4	Compressor	Capacity: 32ℓ	1	Impact wrench, bleeding air from brake
5	Roller for moving rear axle to side		1	See page 10, 4-6
6	Lever block	1 ton	3	For supporting cylinder, drive shaft
7	Stand (for worker)	4 steps (approx. 1.5 m)	3	For use during operation
8	Steel sheet	(t) 9 x 1219 x 2438	4	For positioning bare machine

No.	Equipment	Specification	Q'ty	Remarks
9	Steel sheet	(t)25 x 250 x 600	4	For positioning bare machine
10	Wooden blocks	400 x 400 x 900 200 x 400 x 800	14 4	For positioning bare machine
11	Air type grease gun	Capacity: 18ℓ	1	
12	Air compressor gas charger	Charge manifold, leak detector	1	If another gas charger is used, follow the instructions supplied with it.
13	Tester		1	

3. Lifting tools required

No.	Name	Specification	Q'ty	Remarks
1	Front frame lifting tool	2-point suspension (L=2250 chain diameter=φ20, sling hook=(SL))	1	See diagram below.
2	Rear frame lifting tool	Balanced 2-point suspension (Chain diameter=φ20, sling hook=(SL))	1	See diagram below.
3	Rear axle lifting tool	2-point suspension (L=5500 chain diameter=φ16, grab hook=(G))	1	See diagram below.
4	Nylon sling	50 x 2000	2	Axle support, cylinder sling
5	Front, rear axle lifting tool	Balanced 2-point suspension (Chain diameter=φ16, sling hook=(SL)) (Chain diameter=φ12.5, grab hook=(G))	1	See diagram below.
6	Nylon sling for drive shaft	50 x 5000	1	
7	Fuel tank lifting tool	2-point suspension (L=5000 chain diameter = φ6.3, sling hook=(SL))	2	See diagram below.
8	Floor and cab lifting tool	2-point suspension (L=2000, chain diameter=φ6.3, sling hook=(SL))	2	See diagram below.
9	Nylon sling	150 x 10000	1	Lifting tool for tire
10	Wire sling	Capacity: 15 ton L=2500 Capacity: 11 ton L=2000	2 1	Lifting tool for lift arm (lifting front) when removing blocks under chassis
11	Shackle	For 2 ton, 5 ton, 10 ton, 15 ton	Two each	

[Lifting tools]

1. Front frame lifting tool

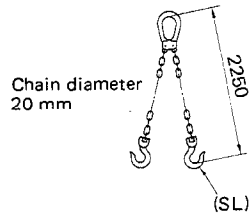

2. Rear frame lifting tool

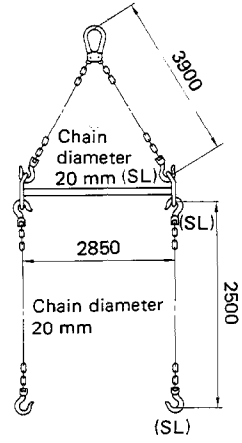

3. Rear axle lifting tool

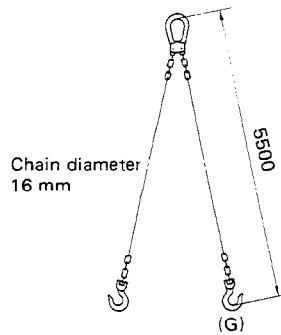

5. Front, rear axle lifting tool

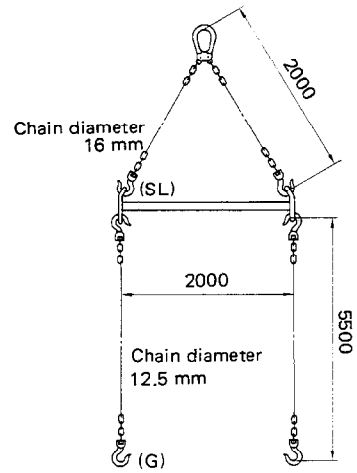

7.8. Fuel tank, floor and cab lifting tool

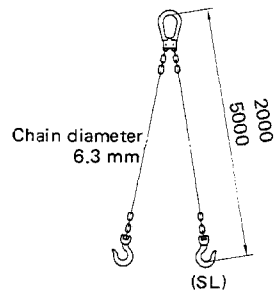

4. Oil, grease, fuel, paint, etc.

No.	Kind of fluid	Specification	Quantity
1	Oil Brake oil	SAE10W CD	10 ℓ
2	Molybdenum disulphide grease with high pressure additive	(KES LM-P, SAEJ310a NLGI: No. 1 or equivalent)	500 ml
3	Molybdenum disulphide lithium grease	(KES LM-G, SAEJ310a NLGI: No. 2 (or No. 1) or equivalent)	10 ℓ
4	Fuel	Diesel fuel	As necessary (Fuel tank: 1200 ℓ)
5	Paint for touching up	Komatsu yellow spray can Komatsu blue	3 cans 4 litre can
6	Air conditioner gas	Freon gas can (400 g)	1 can
7	Window washer solvent		2 cans

All the above items except No. 4 Fuel are shipped together with the machine.

(1) Others

Roller for moving rear axle to side

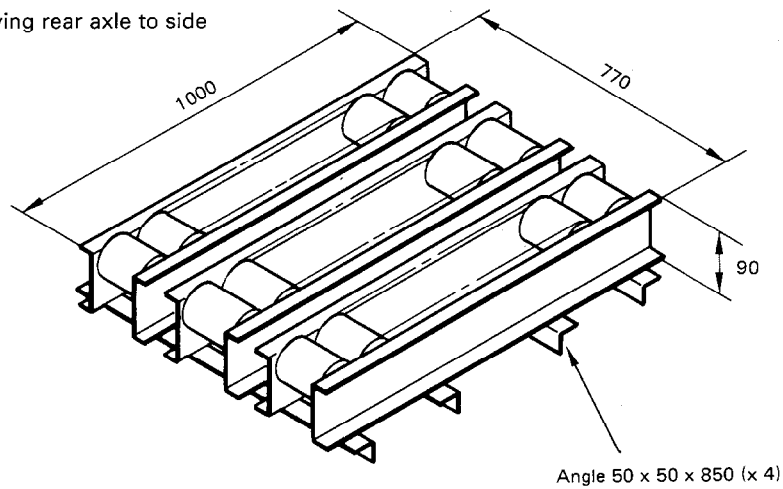

5. Protective wear

Work clothes, safety boots, helmet, thick gloves, goggles, raincoat

Local manufacturing diagram for lifting tool and roller

(1) Rear frame lifting tool

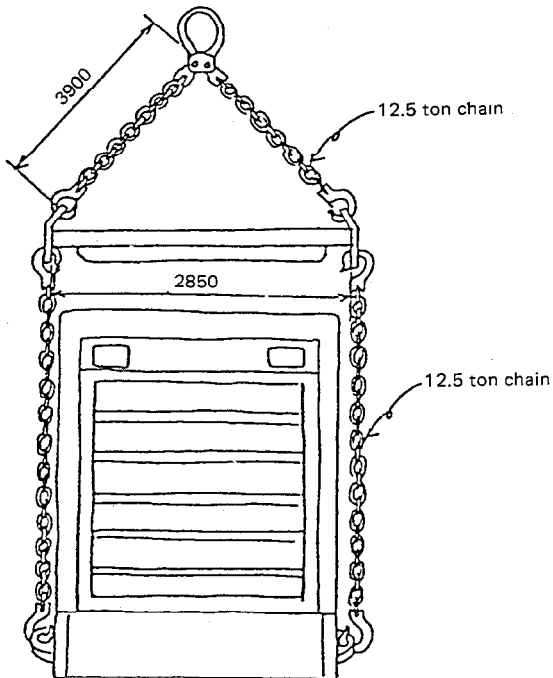

Note

- (1) There must be no burrs at the machined places.
- (2) Paint with Mansell system 2.5Y - 8/12 paint. (Yellow)

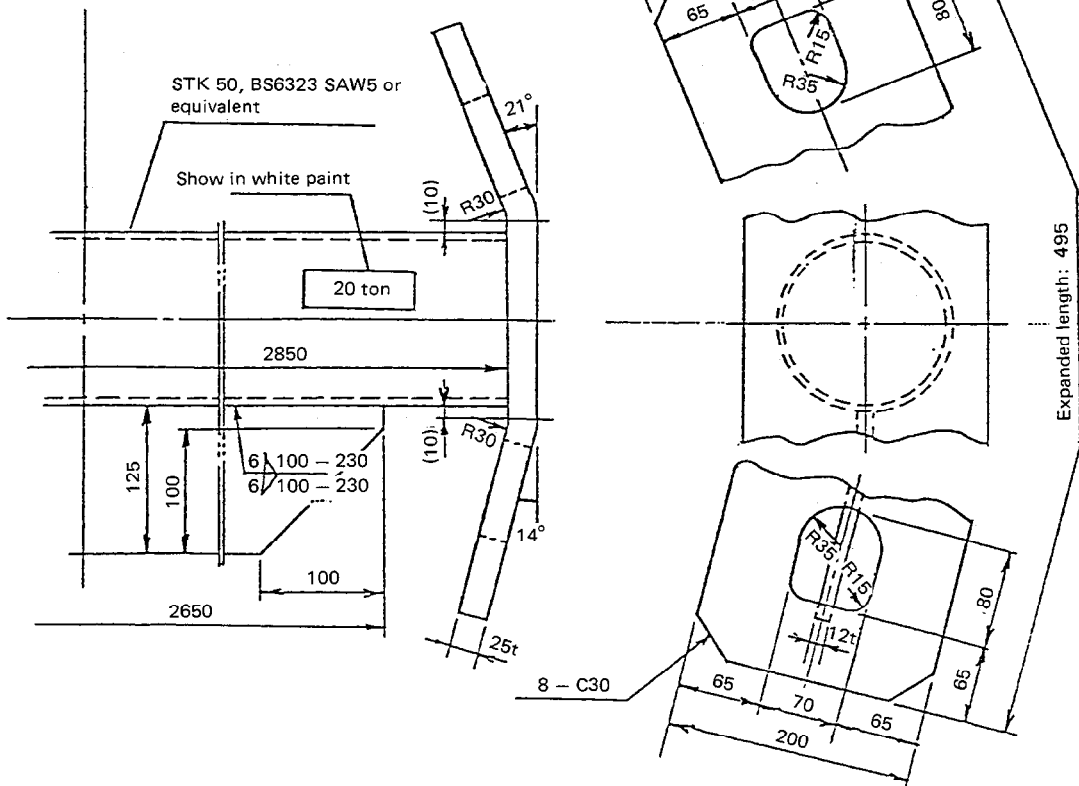

(2) Lifting tool for front, rear axle

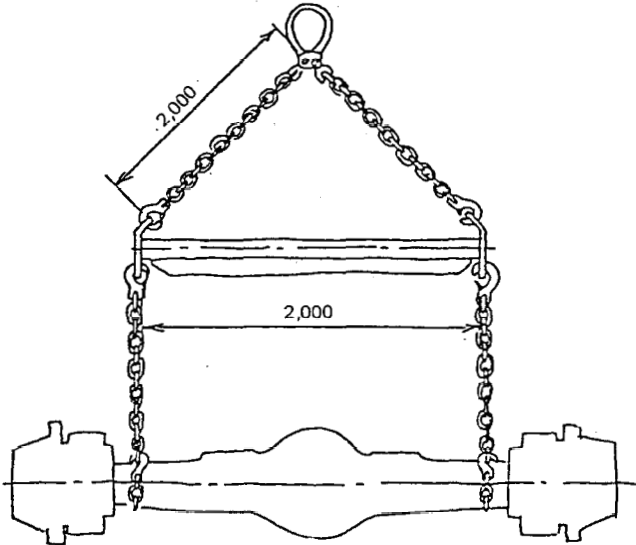

Note

- (1) After cutting, it is possible to finish the machined material with a grinder.
- (2) Paint with yellow paint.

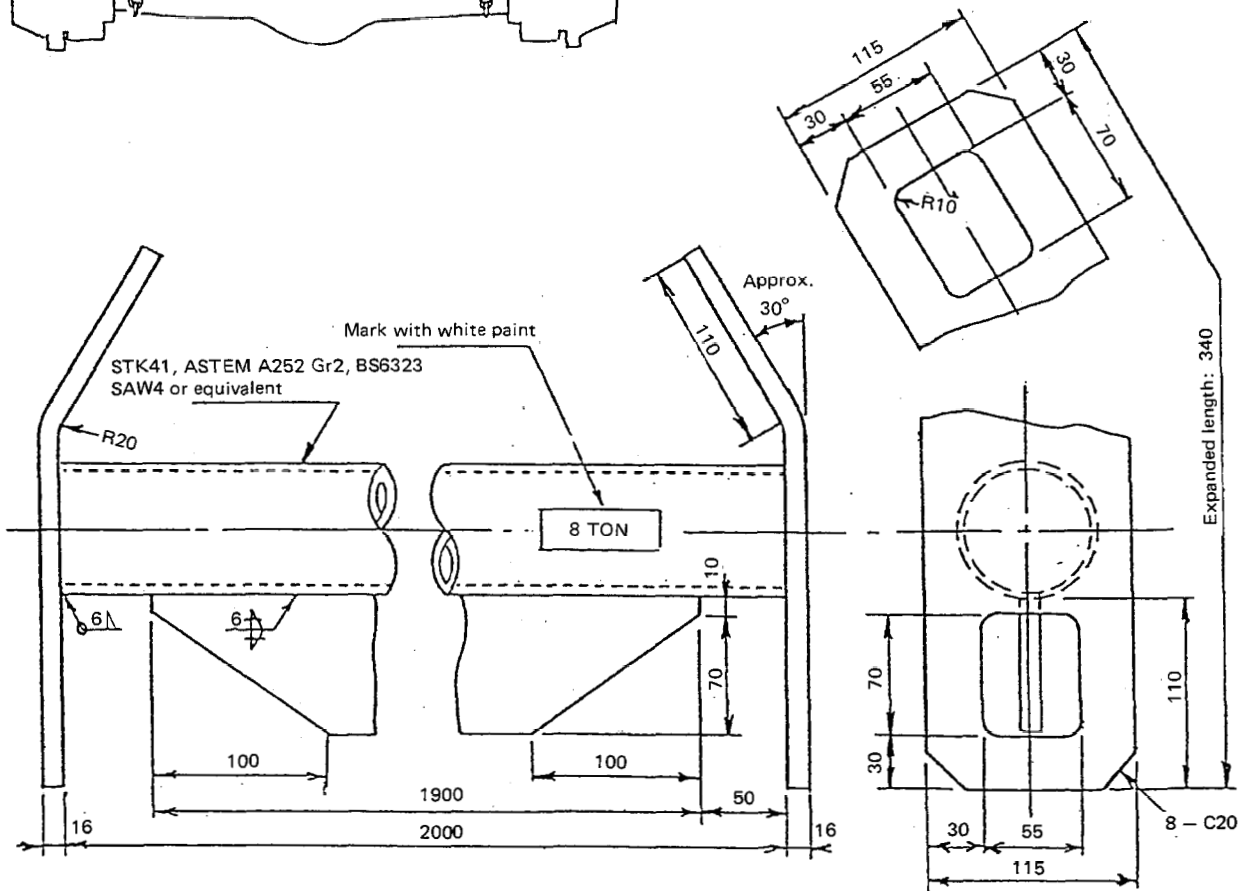

(3) Roller for moving rear axle to side

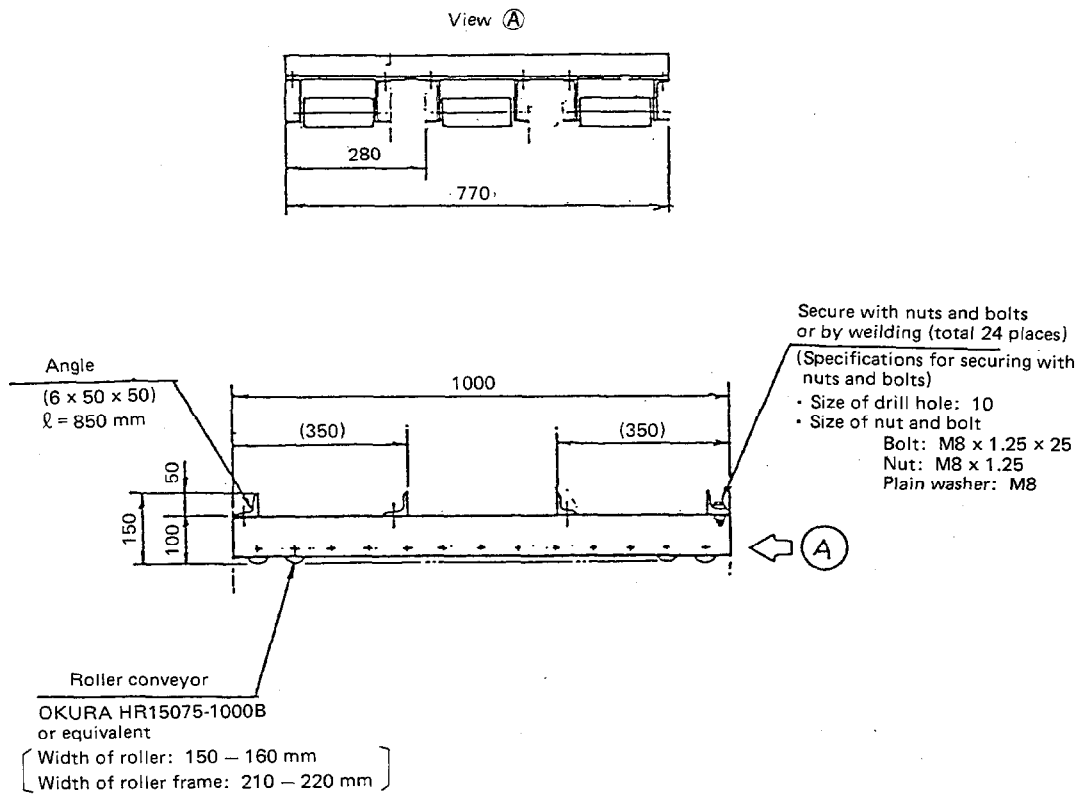

Note

- (1) Considering transportation and replacement of broken parts, it is a better idea to secure the angle and roller conveyor with nuts and bolts, as this will allow disassembly of the angle and roller conveyor.

6 PARTS LIST FOR FIELD ASSEMBLY

No.	Part No.	Part name	Q'ty	Assembly Process No.	Remarks
1. Rear axle assembly components					
1	427-46-12130	Bolt	4	A-2	Sent as individual parts
2	01643-33990	Washer	8	A-2	Sent as individual parts
3	01580-03931	Nut	4	A-2	Sent as individual parts
4	427-46-12170	Plate	1	A-2	Already temporarily installed to rear axle
5	01011-52420	Bolt	16	A-2	Already temporarily installed to rear axle
6	01643-32460	Washer	16	A-2	Already temporarily installed to rear axle
7	427-46-12161	Washer (thrust)	1	A-2	Already temporarily installed to rear axle
8	427-46-12180	Cover (thrust)	1	A-2	Sent as individual parts
9	01011-52400	Bolt	16	A-2	Already temporarily installed to rear frame
10	01643-32460	Washer	16	A-2	Already temporarily installed to rear frame
2. Drive shaft (front, rear) components					
1	427-20-12111	Drive shaft (rear)	1	A-3	Sent as individual part
2	427-20-13112	Drive shaft (front)	1	A-3	Temporarily installed to center support
3	01050-61895	Bolt	12	A-3	Already temporarily installed to axle and transmission yoke
3. Front axle assembly components					
1	427-46-11451	Bolt	16	A-4	Sent as individual parts
2	01643-33990	Washer	32	A-4	Sent as individual parts
3	01580-03931	Nut	16	A-4	Sent as individual parts
4. Fuel tank assembly components					
1	01011-63000	Bolt	6	A-5	Already temporarily installed to fuel tank mounting, support
2	01643-33080	Washer	6	A-5	Already temporarily installed to fuel tank mounting, support
3	416-855-1190	Shim	10	A-5	Sent as individual parts
4	08036-23014	Clamp (for securing radiator drain hose)	2	A-5	Temporarily installed to fuel tank
5	01010-51020	Bolt (for securing radiator drain hose)	2	A-5	Temporarily installed to fuel tank
6	01643-51032	Washer (for securing radiator drain hose)	2	A-5	Temporarily installed to fuel tank
9	08036-01814	Clip (for securing muffler drain hose)	5	A-5	Already temporarily installed to top of fuel tank
10	08036-02514	Clip (for mounting engine, blow-by hose)	8	A-5	Already temporarily installed to top of fuel tank
11	01435-01016	Bolt (for securing muffler drain hose)	5	A-5	Already temporarily installed to top of fuel tank
12	01010-51060	Bolt (for mounting engine, blow-by hose)	3	A-5	Already temporarily installed to top of fuel tank
13	01643-31032	Washer (for mounting engine, blow-by hose)	3	A-5	Already temporarily installed to top of fuel tank
14	07102-20319	Hose (return)	1	A-5	Already temporarily installed to top of fuel tank
15	07102-20428	Hose (suction)	1	A-5	Already temporarily installed to top of fuel tank

No.	Part No.	Part name	Q'ty	Assembly Process No.	Remarks
16	07102-20309	Hose (return)	1	A-5	Already temporarily installed to top of fuel tank
17	07102-20512	Hose (suction)	1	A-5	Already temporarily installed to top of fuel tank
18	427-04-11160	Tube (overflow)	1	A-5	Already temporarily installed to top of fuel tank
19	424-04-11120	Clip	2	A-5	Already temporarily installed to top of fuel tank
20	01010-51020	Bolt	2	A-5	Already temporarily installed to top of fuel tank
21	01643-31032	Washer	2	A-5	Already temporarily installed to top of fuel tank
22	07270-21045	Tube	1	A-5	Already temporarily installed to overflow tube
23	07280-01620	Clamp	1	A-5	Already temporarily installed to overflow tube
24	08036-01814	Clamp (fuel return, suction hoses)	2	A-5	Already temporarily installed to fuel hose at top of fuel tank
25	01435-01016	Bolt (fuel return, suction hoses)	1	A-5	Already temporarily installed to fuel hose at top of fuel tank
26	424-06-12790	Clamp (fuel return, suction hoses)	2	A-5	Already temporarily installed to fuel hose at top of fuel tank
27	01435-01025	Bolt (fuel return, suction hoses)	1	A-5	Already temporarily installed to fuel hose at top of fuel tank
28	08036-02514	Clip	2	A-5	Already temporarily installed to fuel hose
29	01010-51020	Bolt	1	A-5	Already temporarily installed to inside of rear frame
30	01643-31032	Washer	1	A-5	Already temporarily installed to inside of rear frame
31	424-06-12790	Clip	3	A-5	Already temporarily installed to fuel hose
32	01435-01016	Bolt	3	A-5	Already temporarily installed to inside of rear frame
33	08036-01814	Clip	2	A-5	Already temporarily installed to fuel hose
34	01435-01016	Bolt	2	A-5	Already temporarily installed to inside of rear frame
35	424-06-12790	Clip	1	A-5	Already temporarily installed to fuel hose
36	01435-01030	Bolt	2	A-5	Already temporarily installed to engine drain tube
37	01435-01030	Bolt	4	A-5	Already temporarily installed to radiator drain, oil cooler drain tube
5. Ladder assembly components					
1	01010-51635	Bolt	4	A-6	Already temporarily installed to hydraulic tank and air component box
2	01643-31645	Washer	4	A-6	Already temporarily installed to hydraulic tank and air component box
3	01010-51230	Bolt	4	A-6	Already temporarily installed to hydraulic tank and air component box
4	01643-31232	Washer	4	A-6	Already temporarily installed to hydraulic tank and air component box
6. Floor frame and cab assembly components					
1	425-54-13160	Cushion	8	A-7	Already temporarily installed to lower support
2	425-54-13170	Plate	8	A-7	Already temporarily installed to lower support
3	01011-51610	Bolt	4	A-7	Already temporarily installed to lower support
4	01643-31645	Washer	4	A-7	Already temporarily installed to lower support
5	421-40-11510	Locknut	4	A-7	Already temporarily installed to lower support
6	416-40-11150	Washer	4	A-7	Already temporarily installed to lower support

No.	Part No.	Part name	Q'ty	Assembly Process No.	Remarks
7	04050-11612	Cotter pin (for connecting throttle cable)	1	A-7	Already temporarily installed to yoke at tip of throttle cable
8	04205-10620	Pin (for connecting throttle cable)	1	A-7	Already temporarily installed to yoke at tip of throttle cable
9	08036-01214	Clip (for securing throttle cable cover)	1	A-7	Already temporarily installed to 427-54-13620 (cover)
10	01010-51020	Bolt (for securing throttle cable cover)	1	A-7	Already temporarily installed to 427-54-13620 (cover)
11	01643-31032	Washer (for securing throttle cable cover)	1	A-7	Already temporarily installed to 427-54-13620 (cover)
12	427-54-13620	Cover (for lower rear face of floor frame)	1	A-7	Sent as individual part
13	01435-01220	Bolt (for lower rear face of floor frame)	10	A-7	Already temporarily installed to floor frame
14	07281-00259	Clamp (for heater hot water hose)	2	A-7	Already temporarily installed to each IN and OUT hose
15	424-09-12550	Clip (for securing air conditioner drain hose)	5	A-7	Already temporarily installed to lower support and rear frame
16	01010-51020	Bolt (for securing air conditioner drain hose)	5	A-7	Already temporarily installed to lower support and rear frame
17	01643-31032	Washer (for securing air conditioner drain hose)	5	A-7	Already temporarily installed to lower support and rear frame
18	08036-01414	Clip (for wiring harness under floor frame)	3	A-7	Already temporarily installed to front wiring harness
19	01010-51020	Bolt (for wiring harness under floor frame)	3	A-7	Already temporarily installed to bottom of floor frame
20	01643-31032	Washer (for wiring harness under floor frame)	3	A-7	Already temporarily installed to bottom of floor frame
21	426-35-11250	Clip (for securing air component wiring harness)	2	A-7	Already installed to air component wiring harness
22	01010-51020	Bolt (for securing air component wiring harness)	2	A-7	Already temporarily installed to bottom of floor frame
23	01643-31032	Washer (for securing air component wiring harness)	2	A-7	Already temporarily installed to bottom of floor frame
26	01010-51020	Bolt (securing floor frame ground connection wire)	1	A-7	Already temporarily installed to lower support
27	01643-31032	Washer (securing floor frame ground connection wire)	1	A-7	Already temporarily installed to lower support
28	08035-03014	Clip (for securing front wiring harness)	1	A-7	Already temporarily installed to front wiring harness
29	01010-51020	Bolt (for securing front wiring harness)	1	A-7	Already temporarily installed to mounting bracket under floor frame
30	01643-31032	Washer (for securing front wiring harness)	1	A-7	Already temporarily installed to mounting bracket under floor frame
31	427-40-11210	Plate (Pitman arm)	1	A-7	Already temporarily installed to steering linkage rod
32	427-54-13530	Cover (floor frame front cover)	1	A-7	Sent as individual part
33	01435-01220	Bolt (floor frame front cover)	2	A-7	Already temporarily installed to floor frame
34	427-54-13510	Cover L.H. (floor frame lower side)	1	A-7	Sent as individual part
35	427-54-13520	Cover R.H. (floor frame lower side)	1	A-7	Sent as individual part
36	427-54-13270	Cover L.H. (floor frame lower side)	1	A-7	Sent as individual part
37	427-54-13280	Cover R.H. (floor frame lower side)	1	A-7	Sent as individual part
38	01435-01220	Bolt (floor frame lower side)	10	A-7	Already temporarily installed to floor frame
39	01435-01230	Bolt (floor frame lower side)	4	A-7	Already temporarily installed to floor frame
40	01435-01250	Bolt (floor frame lower side)	4	A-7	Already temporarily installed to floor frame
41	01584-01210	Nut (floor frame lower side)	2	A-7	Already temporarily installed to floor frame
7. Handrail components					
1	427-54-14110	Handrail (front L.H.)	1	A-8	Set as individual part

No.	Part No.	Part name	Q'ty	Assembly Process No.	Remarks
2	427-54-14120	Handrail (front R.H.)	1	A-8	Sent as individual part
3	427-54-14130	Handrail (rear L.H.)	1	A-8	Sent as individual part
4	427-54-14141	Handrail (rear R.H.)	1	A-8	Sent as individual part
5	01010-51230	Bolt	24	A-8	Already temporarily installed to left and right of floor
6	01643-31232	Washer	32	A-8	Already temporarily installed to left and right of floor
7	01010-51235	Bolt	8	A-8	Already temporarily installed to left and right of floor
8. Tire and wheel assembly components					
1	426-22-12930	Nut	212	A-4, A-9	Already temporarily installed to front and rear axles
2	01643-32460	Washer	212	A-4, A-9	Already temporarily installed to front and rear axles
9. Battery box assembly components					
1	01011-32450	Bolt	4	A-10	Already temporarily installed to rear frame mounting
2	01011-32470	Bolt	4	A-10	Already temporarily installed to rear frame mounting
3	01643-32460	Washer	8	A-10	Already temporarily installed to rear frame mounting
4	08038-00035	Cap	4	A-10	Already temporarily installed to battery cable (two each, left and right)
5	391-62-19240	Clip (for battery relay wiring harness)	1	A-10	Already temporarily installed to inside of right battery box
6	08035-03014	Clip (for battery relay wiring harness)	1	A-10	Already temporarily installed to inside of left battery box
7	01010-51020	Bolt (for battery relay wiring harness)	2	A-10	Already temporarily installed to left and right battery boxes
8	01643-31032	Bolt (for battery relay wiring harness)	2	A-10	Already temporarily installed to left and right battery boxes
9	426-35-11250	Clip (for securing rear wiring harness)	1	A-10	Already temporarily installed to left and right battery boxes
10	08036-01814	Clip (for securing rear wiring harness)	1	A-10	Already temporarily installed to left and right battery boxes
11	01010-51020	Bolt (for securing rear wiring harness)	2	A-10	Already temporarily installed to left and right battery boxes
12	01643-31032	Washer (for securing rear wiring harness)	2	A-10	Already temporarily installed to left and right battery boxes
13	427-06-12350	Wire (between left and right batteries)	1	A-10	Already temporarily installed to rear frame end
14	427-06-14570	Cover L.H.	1	A-10	Sent as individual part
15	427-06-14580	Cover R.H.	1	A-10	Sent as individual part
16	427-06-14540	Cover L.H.	1	A-10	Sent as individual part
17	427-06-14550	Cover R.H.	1	A-10	Sent as individual part
18	427-06-14560	Cover	2	A-10	Already temporarily installed to left and right battery boxes
19	427-06-14530	Cover	1	A-10	Sent as individual part
20	427-06-13132	Cover	1	A-10	Already temporarily installed to cover (427-06-14530)
21	427-06-13141	Cover	1	A-10	Already temporarily installed to cover (427-06-14530)
22	01435-01230	Bolt	6	A-10	Already temporarily installed to battery box and cover
23	01435-01025	Bolt	8	A-10	Already temporarily installed to battery box and cover
24	01435-01020	Bolt	8	A-10	Already temporarily installed to cover of left and right battery boxes

No.	Part No.	Part name	Q'ty	Assembly Process No.	Remarks
25	01010-52045	Bolt	4	A-10	Already temporarily installed to rear frame mounting
26	01643-32060	Washer	4	A-10	Already temporarily installed to rear frame mounting
27	01435-01225	Bolt	8	A-10	Already temporarily installed to cover (427-06-14530)
28	(620-3860-SC)	Step ass'y	1 each RH, LH	A-10	Sent as individual parts
29	01010-51225	Bolt	8	A-10	Already temporarily installed to left and right fuel tanks
30	01643-31232	Washer	8	A-10	Already temporarily installed to left and right fuel tanks
10. Counterweight components					
1	427-46-15121	Counterweight	1	A-10A	Sent as individual part
2	427-46-13120	Pin (drawbar)	1	A-10A	Sent as individual part (assembled to counterweight)
3	425-974-1160	Bolt (for mounting counterweight)	6	A-10A	Already temporarily installed to rear of rear frame
4	01643-33080	Washer (for mounting counterweight)	6	A-10A	Already temporarily installed to rear of rear frame
11. Lift arm assembly components					
1	427-70-11992	Pin (for pivot at front frame end)	2	A-12	Already temporarily installed to front frame pivot
2	427-70-11460	Shim (for pivot at front frame end)	4	A-12	Already temporarily installed to front frame pivot
3	01010-52450	Bolt (for pivot at front frame end)	2	A-12	Already temporarily installed to front frame pivot
4	427-70-11480	Washer (for pivot at front frame end)	2	A-12	Already temporarily installed to front frame pivot
5	427-70-11470	Shim (for pivot at front frame end)	2	A-12	Already temporarily installed to front frame pivot
6	427-70-11971	Pin (for connecting boom cylinder and rod)	2	A-12	Already temporarily installed to boom pivot
7	01010-52035	Bolt (for connecting boom cylinder and rod)	2	A-12	Already temporarily installed to boom pivot
8	427-70-11290	Washer (for connecting boom cylinder and rod)	2	A-12	Already temporarily installed to boom pivot
9	427-70-11941	Pin (for connecting bucket cylinder and rod)	1	A-12	Already temporarily installed to bellcrank
10	426-70-13270	Elbow	1	A-12	Already installed to pin (427-70-11941) for temporarily installing bellcrank
11	07217-50712	Elbow	4	A-12	Already installed to pin for temporarily installing front frame, boom pivot
12	07049-01620	Plug	15	A-12	Sent as individual parts
13	01010-52035	Bolt	1	A-12	Already temporarily installed to bellcrank pivot boss
14	427-70-11290	Washer	1	A-12	Already temporarily installed to bellcrank pivot boss
12. Muffler pipe components					
1	427-02-11121	Exhaust pipe	2	A-11	Sent as individual parts
2	427-02-11130	Plate	1	A-11	Already temporarily installed to top of center hood
3	01435-01230	Bolt	6	A-11	Already temporarily installed to top of center hood
4	01435-01250	Bolt	6	A-11	Already temporarily installed to top of center hood

No.	Part No.	Part name	Q'ty	Assembly Process No.	Remarks
13. Front lamp assembly components					
1	01435-01240	Bolt	8	A-14	Already temporarily installed to left and right of front frame
2	424-06-12720	Clip	2	A-14	Already temporarily installed to left and right of front frame
3	01010-51020	Bolt	2	A-14	Already temporarily installed to left and right of front frame
4	01643-31032	Washer	2	A-14	Already temporarily installed to left and right of front frame
14. Front fender components					
1	01010-51660	Bolt	6	A-13	Already temporarily installed to left and right of front frame
2	01643-31645	Washer	6	A-13	Already temporarily installed to left and right of front frame
3	427-54-13380	Bracket L.H.	1	A-13	Already temporarily installed to left and right of front frame
4	427-54-13410	Bracket R.H.	1	A-13	Already temporarily installed to left and right of front frame
5	01010-51230	Bolt	4	A-13	Already temporarily installed to left and right of front frame
6	01010-51245	Bolt	4	A-13	Already temporarily installed to left and right of front frame
7	01643-31232	Washer	4	A-13	Already temporarily installed to left and right of front frame
8	424-54-14220	Washer	4	A-13	Already temporarily installed to left and right of front frame
9	09415-05016	Cap	6	A-13	Already temporarily installed to left and right of front frame
10	427-54-13370	Fender L.H.	1	A-13	Sent as individual part
11	427-54-13380	Fender R.H.	1	A-13	Sent as individual part
12	01010-51230	Bolt	16	A-13	Sent as individual parts
13	01643-31232	Washer	4	A-13	Sent as individual parts
14	424-54-14220	Washer	12	A-13	Sent as individual parts
15. ROPS canopy assembly components					
1	01011-63650	Bolt	20	A-15	Already temporarily installed to rear frame ROPS support
2	01643-33690	Washer	20	A-15	Already temporarily installed to rear frame ROPS support
3	01435-01220	Bolt	4	A-15	Already temporarily installed to ROPS WELD
4	427-06-13180	Plate	2	A-15	Already temporarily installed to ROPS WELD
5	22W-06-12381	Working lamp ass'y	2	A-15	Already temporarily installed to ROPS WELD
6	425-70-13120	Clip	4	A-15	Already temporarily installed to ROPS WELD
7	01010-51020	Bolt	4	A-15	Already temporarily installed to ROPS WELD
8	01643-31032	Washer	4	A-15	Already temporarily installed to ROPS WELD
9	427-54-19111	ROPS WELD (with name plate)	1	A-15	Sent as individual part
16. Bucket assembly components					
1	427-809-1310	Bucket ass'y	1	A-16	Sent as individual part
2	(620-3930-SC)	Flange ass'y	6	A-16	Sent as individual parts

No.	Part No.	Part Name	Q'ty	Assembly Process No.	Remarks
3	(620-3890-SC)	Pin ass'y	3	A-16	Sent as individual parts
5	427-70-11260	Retainer	3	A-16	Sent as individual parts
6	01010-52070	Bolt	9	A-16	Sent as individual parts
7	01643-32060	Washer	9	A-16	Sent as individual parts
8	427-70-12530	O-ring	6	A-16	Sent as individual parts
9	427-70-11280	Shim t0.5	15	A-16	Sent as individual parts
10	427-70-11270	Shim t0.2	6	A-16	Sent as individual parts
12	425-70-11250	Cam	3	A-16	Sent as individual parts
13	01010-52455	Bolt	3	A-16	Sent as individual parts
14	01643-32460	Washer	6	A-16	Sent as individual parts
15	01580-12419	Nut	3	A-16	Sent as individual parts
17	427-70-11330	Shim t0.5	18	A-16	Sent as individual parts
18	427-70-11340	Shim t2.8	12	A-16	Sent as individual parts
19	01011-52025	Bolt	12	A-16	Sent as individual parts
20	01643-32060	Washer	24	A-16	Sent as individual parts
21	427-01-11150	Lock nut	12	A-16	Sent as individual parts

7. PROCEDURE FOR FIELD ASSEMBLY

Assembly Process No.

A-1 Setting bare machine on supports

Tools and facilities required

No.	Name (Parts No.)	Q'ty
1	Bar	2
2	30-ton crane	1
3	45-ton crane	1
4	Steel plate (t) 9 x 1219 x 2438	3
5	Steel plate (t) 25 x 250 x 600	-
6	Wooden block 400 x 400 x 900	14
7	Wooden block 200 x 400 x 800	4

Using a 30-ton or 45-ton crane, fix the hooks in the lifting eyes of the frame and raise the bare machine.

(Photo 1)

Front

kg 17 ton
Crane: 30 ton



2 point suspension
(See lifting tool table, No. 1)

Rear

kg 16 ton
Crane: 45 ton



Balanced lifting tool
(See lifting tool table, No. 2)

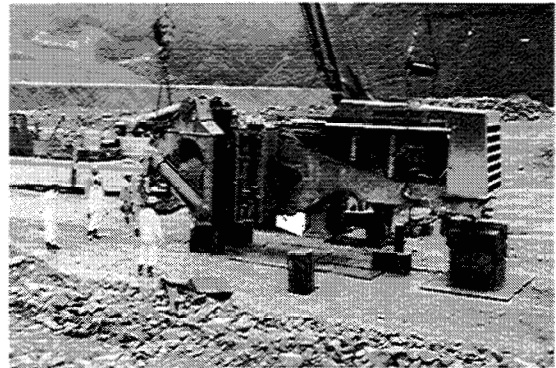

(Photo 1)

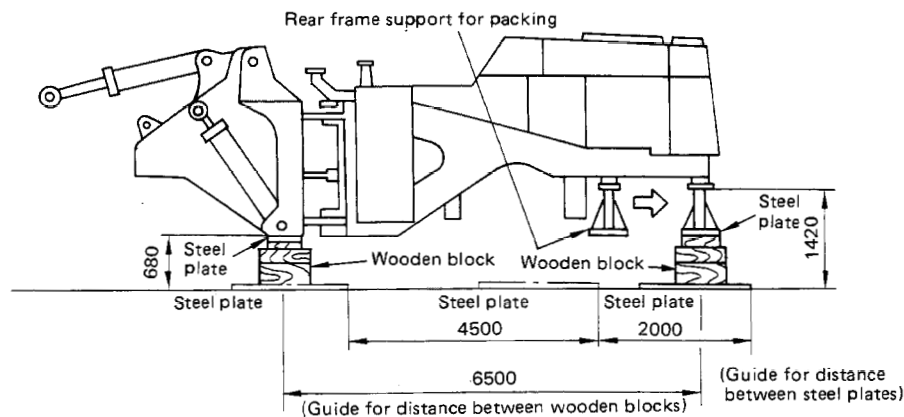
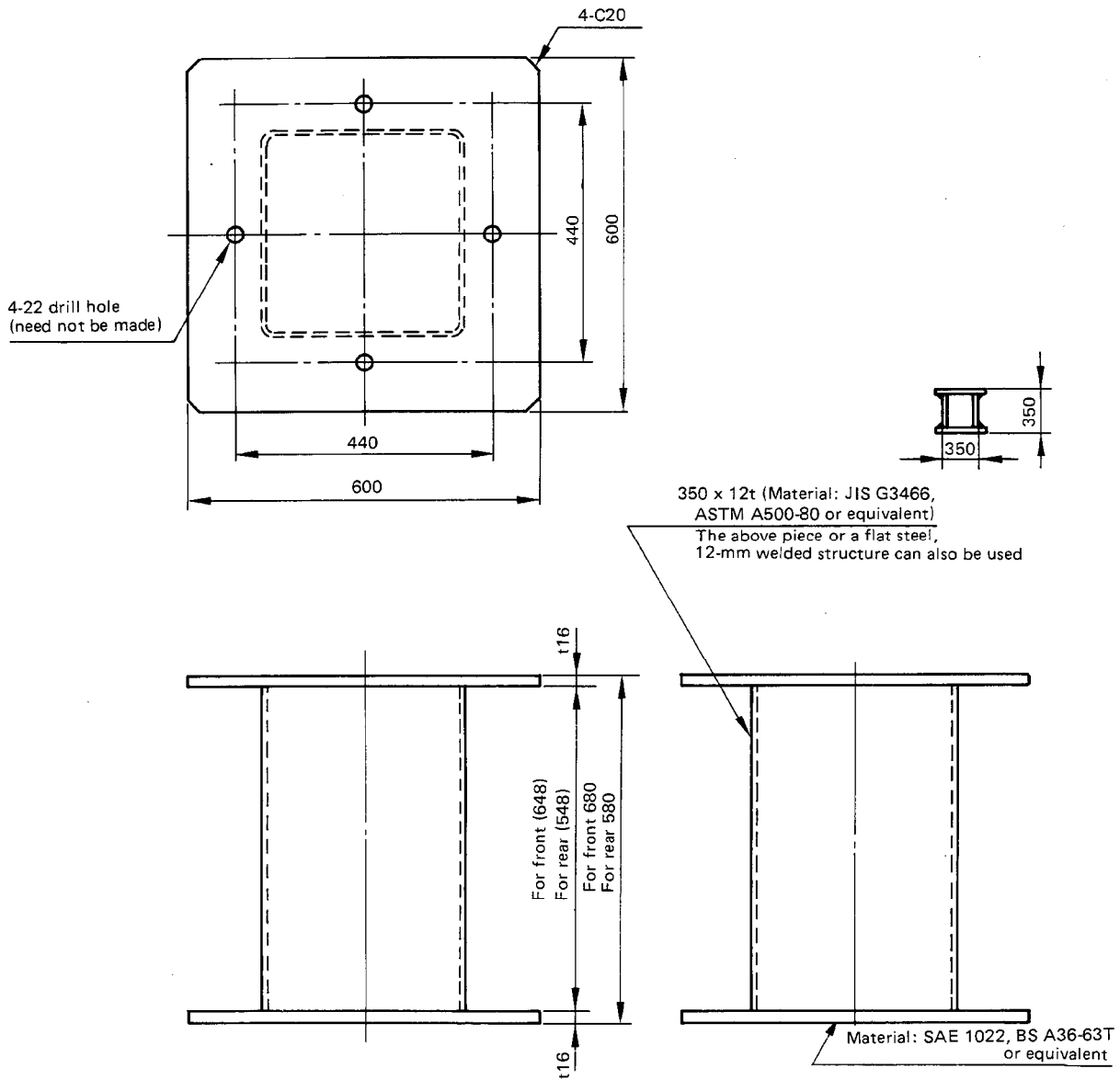

Fig. 1

Set the bare machine as shown in Fig. 1 above. (Raise from the ground the amount shown in the diagram so that the wheel and tire assemblies can be installed. When setting on an earth surface, put steel plates under the wooden blocks to prevent the bare machine from sinking into the ground or from tilting to one side. Use three steel sheets. (One sheet is for sliding the rear axle to the side.)

- ★ In particular, be sure to set on flat ground, and take every precaution to prevent the chassis from tilting to the left or right side.
(If the chassis is tilted, it is difficult to adjust the pin hole position when installing the lift arm)
- ★ If it is difficult to obtain wooden blocks locally, we recommend you to make the steel stand shown on the next page.

Steel stand drawing



Note 1: Unless otherwise indicated, weld the joints at 90° .

Quantity: For front 2
For rear 2

A-2 Assembly of rear axle

No.	Name (Parts No.)	Q'ty
1	Power wrench (x16) Torque wrench: 22 kgm	1
2	Socket 60 [□]	1
3	Socket 36 [□]	1
4	30-ton crane	1
5	Roller for moving to side	1

Assemble parts for rear axle

Mark	No.	Parts Name	Part No.	Q'ty
★	1	Bolt	427-46-12130	4
★	2	Washer	01643-33990	8
★	3	Nut	01580-03931	4
○	4	Bolt	01011-52420	16
○●	5	Washer	01643-32460	32
●	6	Bolt	01011-52400	16
○	7	Washer	427-46-12160	2
○	8	Plate	427-46-12170	1
★	9	Cover	427-46-12180	1

★: Sent as individual parts

○: Already temporarily installed to axle

●: Already temporarily installed to frame

1. Assemble the axle support assembly to the rear axle.

★ After installing the front axle support to the axle, fix to the axle with wire. (To prevent the support from coming out)

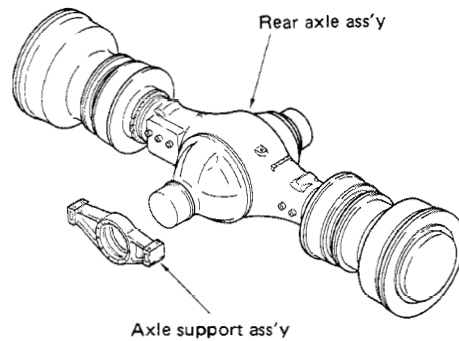

2. Assemble the rear axle and support assembly to the rear frame.

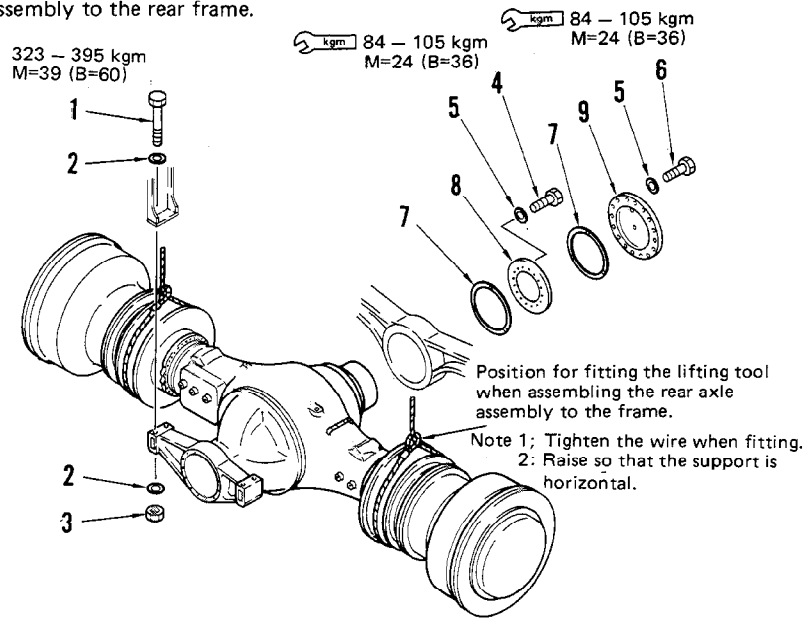

3. Connect the brake line hose to the slack adjuster.

kgm Connection: 6 - 10 kgm (B = 27):

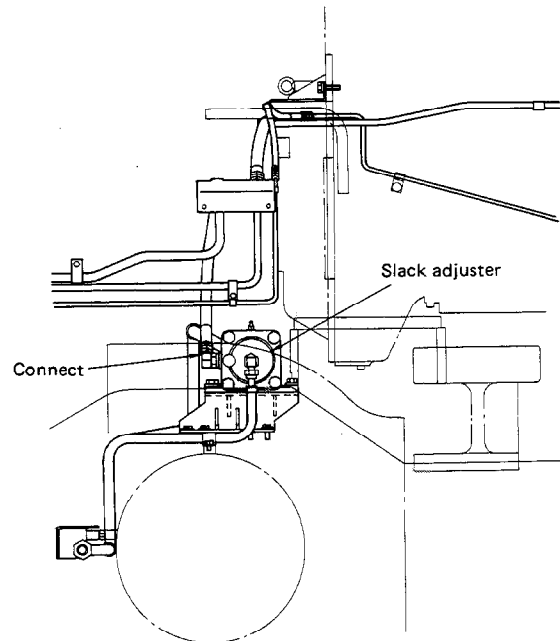

ASSEMBLY PROCEDURE

1. Cleaning inside of rear axle support, coating with grease.

Wipe the inside of the rear axle support clean with a cloth, then coat the inside face of the bushing with grease.

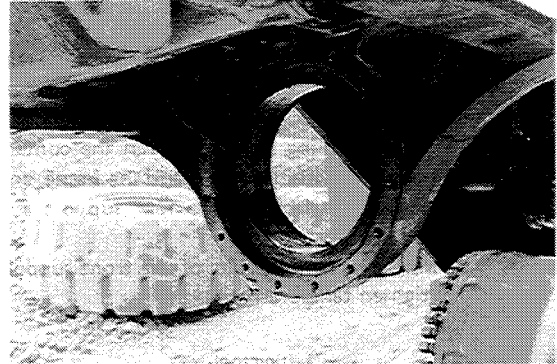

2. Setting on roller

Set the rear axle on top of the roller used to move it sideways (one end of the axle).

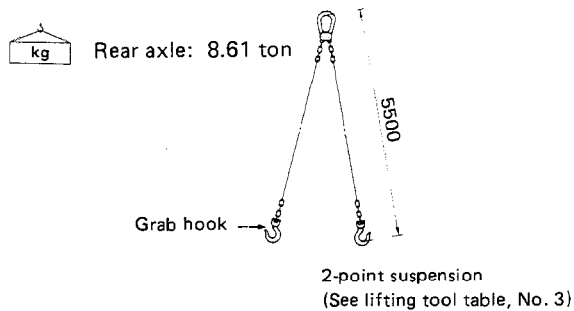

3. Assembly of front support

Clean the mount of the rear axle and inside surface of the front support, coat with grease, then assemble the front support to the rear axle.

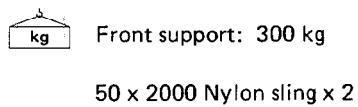

- ★ After installing the front axle support to the axle, fix it to the axle with wire. (To prevent the support from coming out)

4. Moving rear axle to side

Raise one end of the rear axle and move it to the side to center of the rear frame. (Move it to the side by pushing and using a crane.)

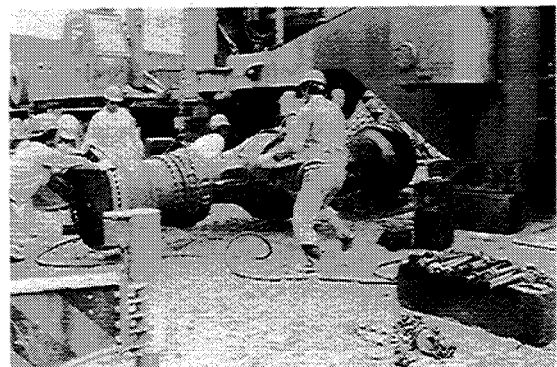

5. Assembly of rear axle

Change the position of the lifting tool, raise the rear axle, and insert the rear axle mount into the rear support.

- ★ Before assembling the axle, clean the contact surface of the front support and the frame, and the mating surface of the rear support and frame.
- Insert the mounting bolts of the front support and tighten temporarily.

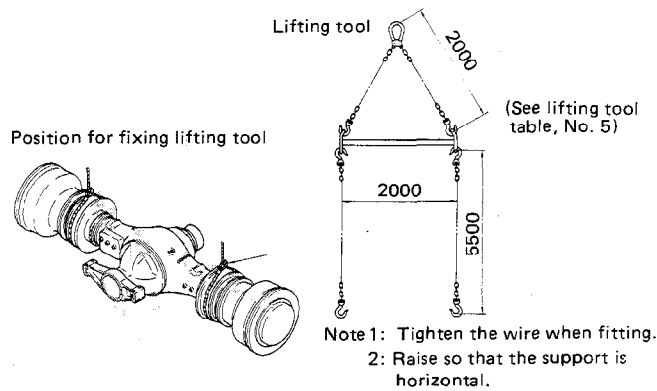
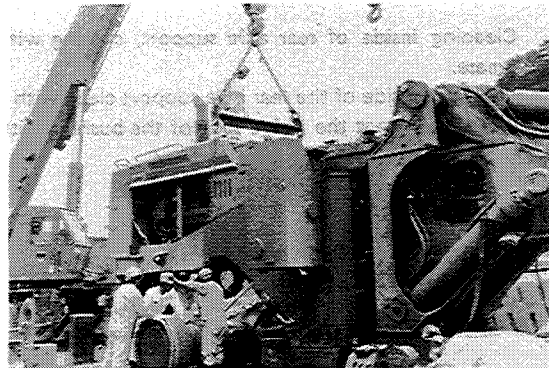

6. Assembly of thrust washer and cover

Assemble the thrust washer, plate, and cover to the rear of the rear support.

Coat the front and rear faces of the thrust washer with grease.

(Right photo: Photo with plate installed)

See the previous page for the tightening torque.

(Order for assembly of cover)

- (1) Use four workers to raise the cover, and install one bolt (diagram below).
- (2) Using the bolt as a fulcrum, turn the cover to set it in position, then assemble the other bolts.

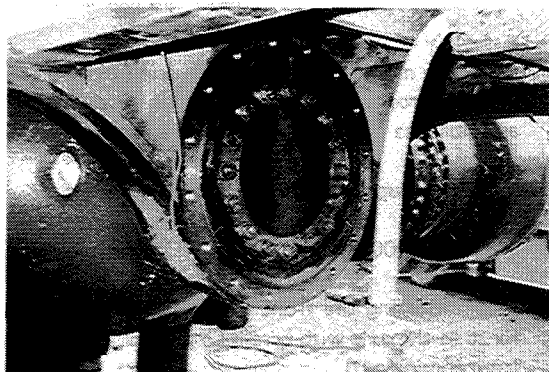
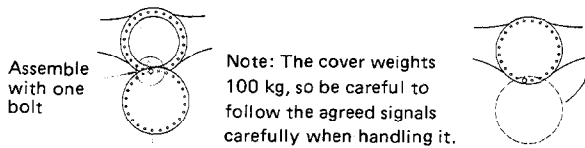

7. Tightening mounting bolts to specified torque

Using a power wrench (x16), tighten the mounting bolts of the front support to the specified torque.

- ★ See the previous page for the tightening torque.
- Connect the brake line hose to the slack adjuster. For details, see the previous page.

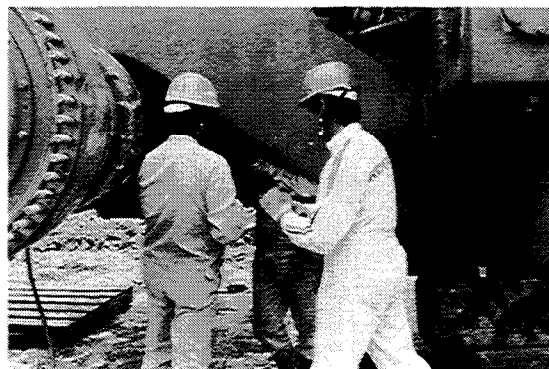

Assembly Process No.

A-3 Assembly of front and rear drive shaft

OUTLINE

Tools and facilities required

No.	Name (Parts No.)	Q'ty
1	Torque wrench (box type) (40 kgm)	1
2	30-ton crane	1
3	Lever block (1 ton)	1

Assembly parts for drive shaft

Mark	No.	Parts Name	Part No.	Q'ty
★	1	Rear drive shaft	427-20-12111	1
★	2	Front drive shaft	427-20-13111	1
○	3	Bolt	01050-61895	12

★: Sent as individual parts

○: Already temporarily installed to axle, transmission, and center yoke

1. Assembly of rear drive shaft

- ★ Before assembling the drive shaft, clean the mounting surface.
- ★ Assemble so that the grease nipples of the front and rear drive shafts face in the same direction at the grease nipple of the center shaft.

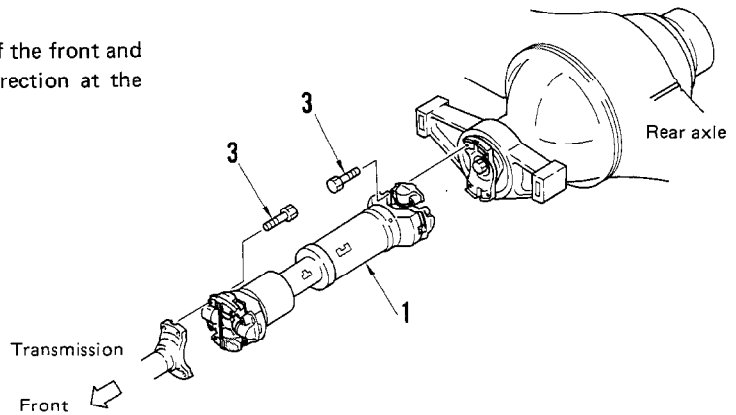

2. Assembly of front drive shaft

- ★ Assemble so that the grease nipples of the front and rear drive shafts face in the same direction as the grease nipple of the center shaft.

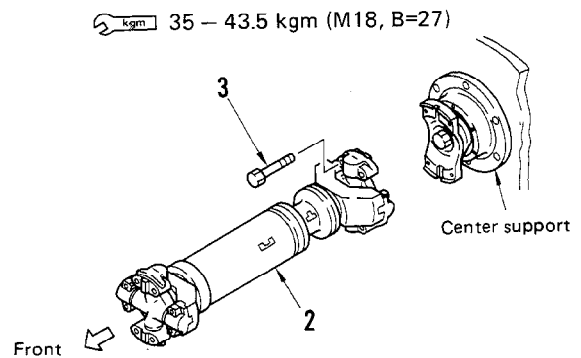

ASSEMBLY PROCEDURE

1. Adjusting position of rear drive shaft

Pass a long nylon sling (50 x 5000) through the center of the frame, raise with a crane from the top of the rear platform, adjust the position, and install.

- ★ See the previous page for the tightening torque of the bolts.
- ★ Be sure to give clear signals to the crane operator.

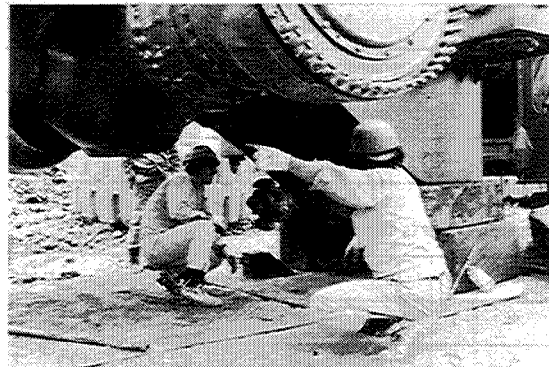

2. Supporting front drive shaft

Using a crane, raise from the top of the front frame, adjust the position, and assemble the center support end. After assembling, use a lever block and support the drive shaft with the lever block so that it faces slightly up (approx. 10°) from the level position.

- ★ See the previous page for the tightening torque of the bolts.
- ★ Be sure to give clear signals to the crane operator.

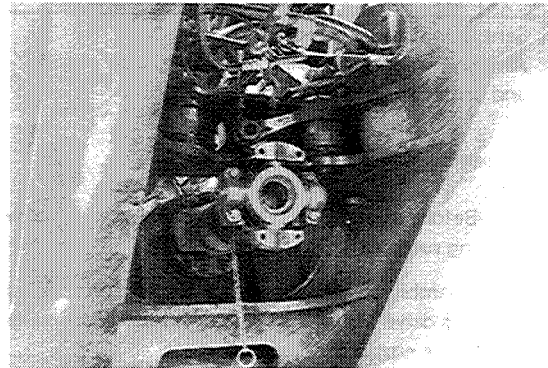

Assembly Process No.

No. A-4 Assembly of front axle

OUTLINE (installing of front axle)

Tools and facilities required

No.	Name (Parts No.)	Q'ty
1	Power wrench (x16 Torque wrench: 22 kgm)	1
2	Socket 60 [□]	1
3	Spanner type torque wrench (B=27) 8 kgm	1
4	Spanner type torque wrench (B=19) 2.5 kgm	1
5	Spanner type torque wrench (B=27) 39 kgm	1
6	30-ton crane	1

1. Assembly of front axle

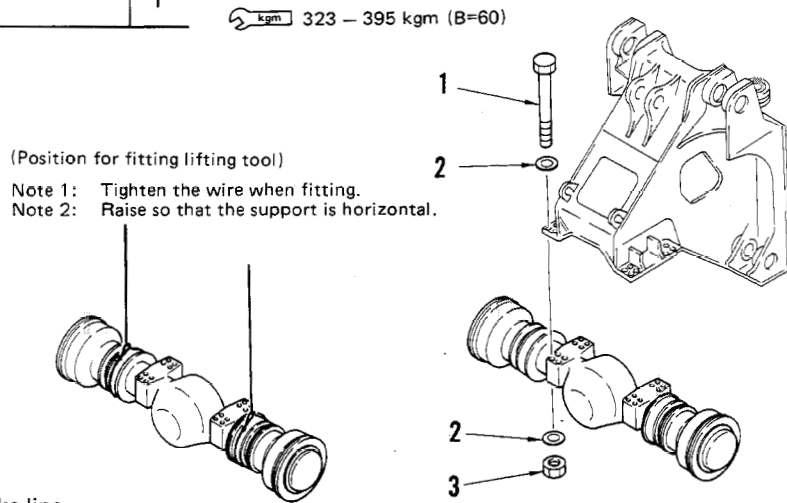

(2) Connecting brake and parking brake line

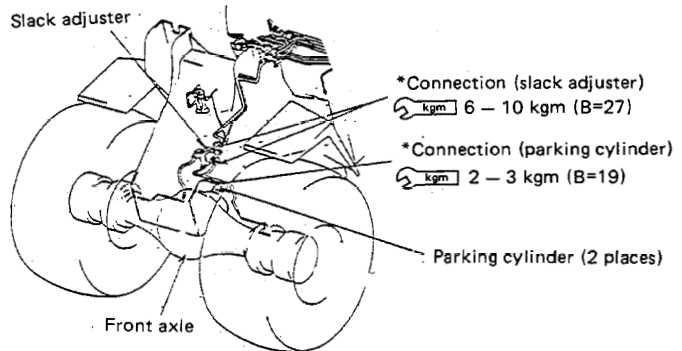

(3) Connecting drive shaft

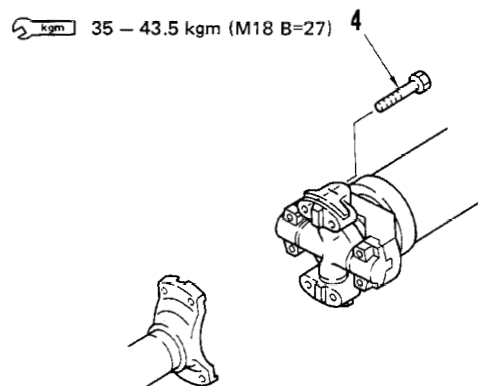

Assembly parts for front axle

Mark	No.	Parts Name	Part No.	Q'ty
★	1	Bolt	427-46-11451	16
★	2	Washer	01643-33990	32
★	3	Nut	01580-03931	16
○	4	Bolt	01050-61895	4

★: Sent as individual parts

○: Already temporarily installed to front axle

ASSEMBLY PROCEDURE

1. Assembly of front axle

- 1) Raise the front axle and install it to the front frame. Tighten the bolts temporarily.

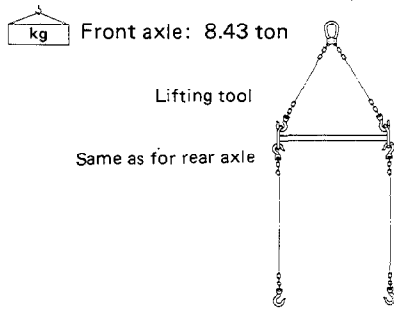

- 2) Using a power wrench (x16), tighten the mounting bolts to the specified torque.
 - ★ See the previous page for the tightening torque.
 - ★ Before assembling, clean the contact surface of the mount.
- 3) Connect the front drive shaft to the front axle yoke. (Adjust the position using a lever block.)
 - ★ See the previous page for the tightening torque.
- 4) Connect the slack adjuster and parking brake line hose.
 - ★ See the previous page for the tightening torque.

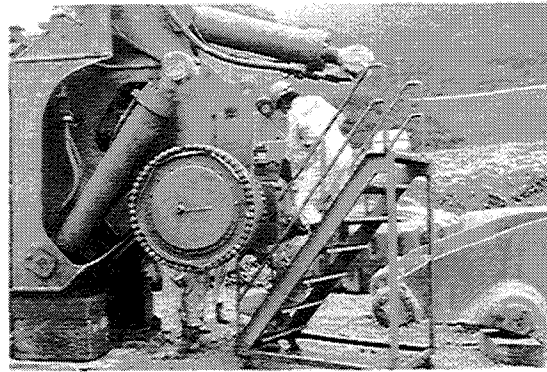

OUTLINE (installing of wheels)

Tools and facilities required

No.	Name (Parts No.)	Q'ty
1	Socket 36 [□]	1
2	Torque wrench: 95 kgm	1
3	Extension bar	1
4	30-ton crane	1
5	Nylon sling (150 x 10,000)	1

Assembly parts for front wheel and tire ass'y

Mark	No.	Parts Name	Part No.	Q'ty
○	1	Nut	426-22-12930	106
○	2	Washer	01643-32460	106

○: Already temporarily installed to front axle

Method for lifting tire



Tire and wheel assembly: 3.5 ton

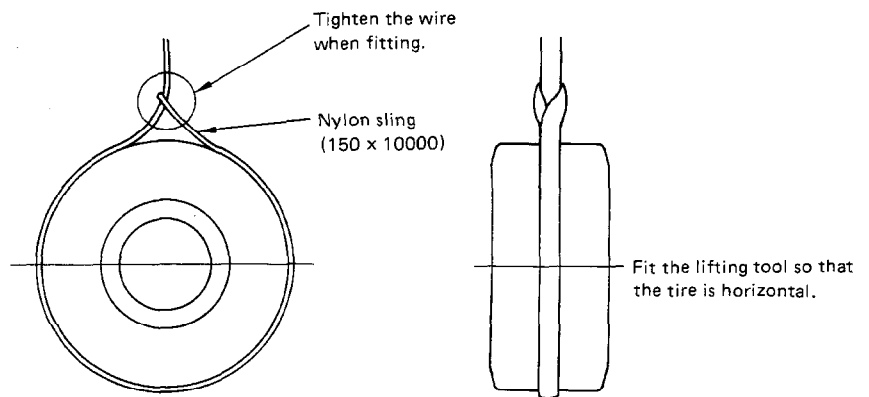
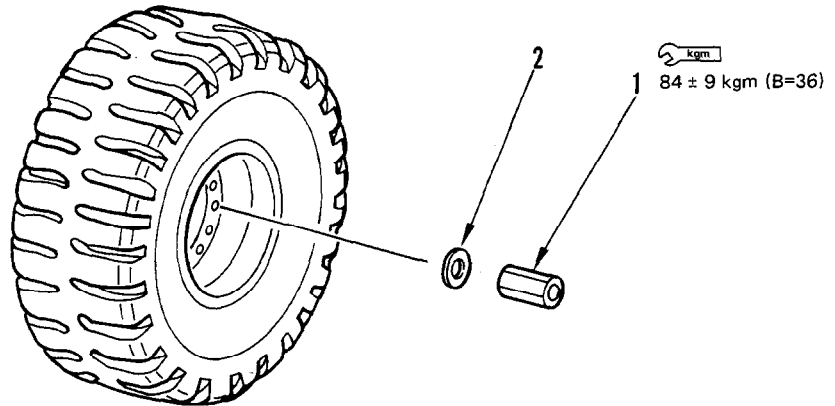

ASSEMBLY PROCEDURE

1. Assembly of tire

Raise the tire with a crane, set the tire on the axle, then assemble the nuts.



Tire and wheel assembly: 3.5 ton

Lifting tool: Nylon sling

- ★ The photograph shows the rear tire. Methods for lifting and assembly are the same for front and rear)
- ★ When positioning the tire and wheel assembly, be careful not to damage the tire inflation tube.



2. Temporary tightening of tire mounting nut

Temporarily tighten the tire mounting nut with an impact wrench.

- ★ The operation is carried out in a high position, and there are many nuts to tighten, so the operation is easier if a balancer is used to support the impact wrench.



3. Removing front support

Raise the front of the machine with a crane (45 ton), and remove the support.



Weight: 29 tons

Lifting tool: Wire sling (No. 6 type A Dia. 45 x 3000)

4. Using a torque wrench, tighten the tire mounting nuts to the specified torque.

- ★ See the previous page for the tightening torque.



Assembly Process No.

A-5 Assembly of fuel tank

OUTLINE

Tools and facilities required

No.	Name (Part No.)	Q'ty
1	Impact wrench	1
2	Power wrench (x 4)	1
3	Torque wrench (set: 24 kgm)	1
4	Extension	1
5	Socket 46 mm	1
6	30-ton crane	1

Assembly parts for fuel tank components

Mark	No.	Parts Name	Part No.	Q'ty
□	1	Bolt	01011-63000	6
□	2	Washer	01643-33080	6
★	3	Shim	416-855-1190	10

□: Already temporarily installed to fuel tank

★: Sent as individual parts

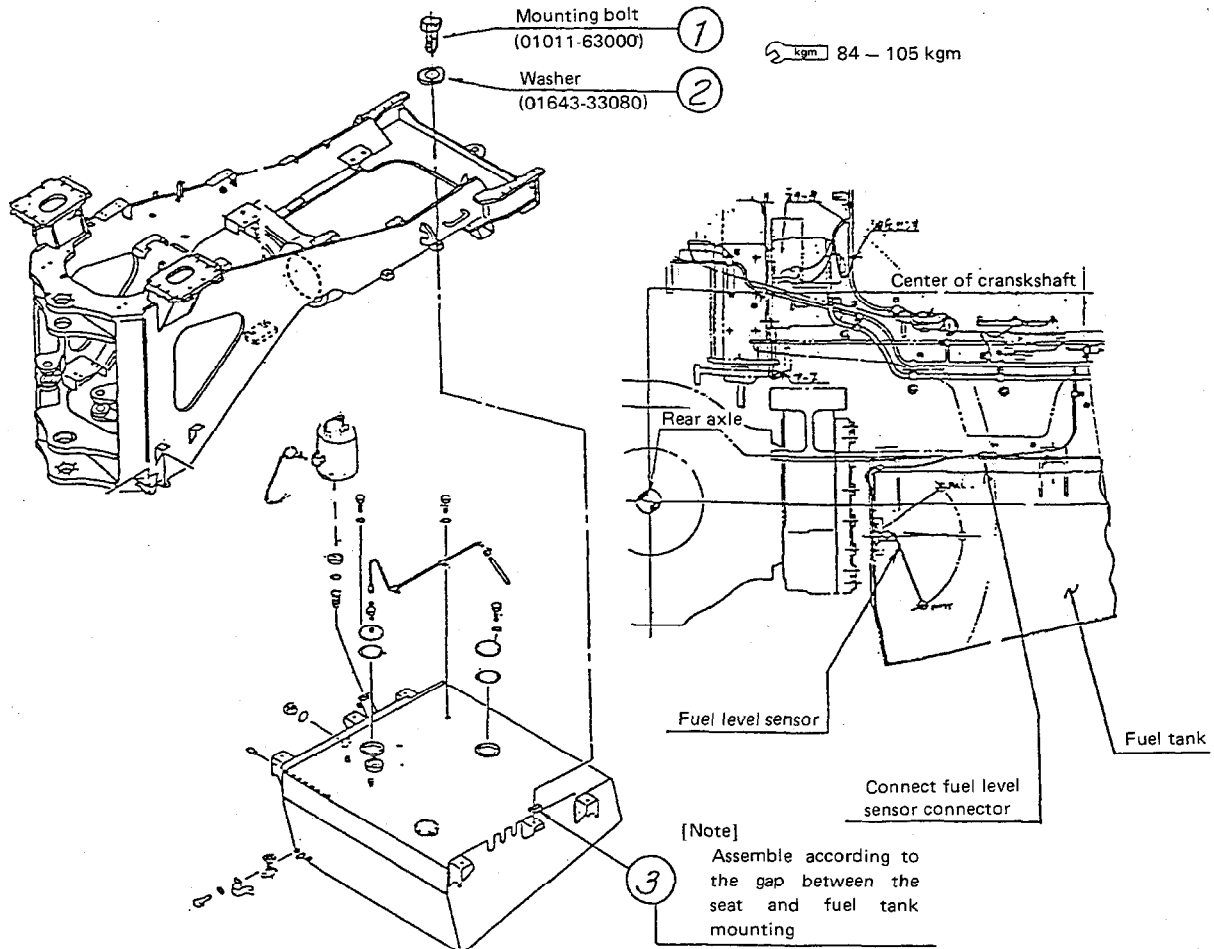

Tools and facilities required

No.	Name (Part No.)	Q'ty
1	Impact wrench	1
2	Socket 14 mm	1

Assembly parts for fuel tank components

Mark	No.	Parts Name	Part No.	Q'ty
□	36	Bolt	01435-01030	2
□	37	Bolt	01435-01030	4

□: Already temporarily installed to fuel tank

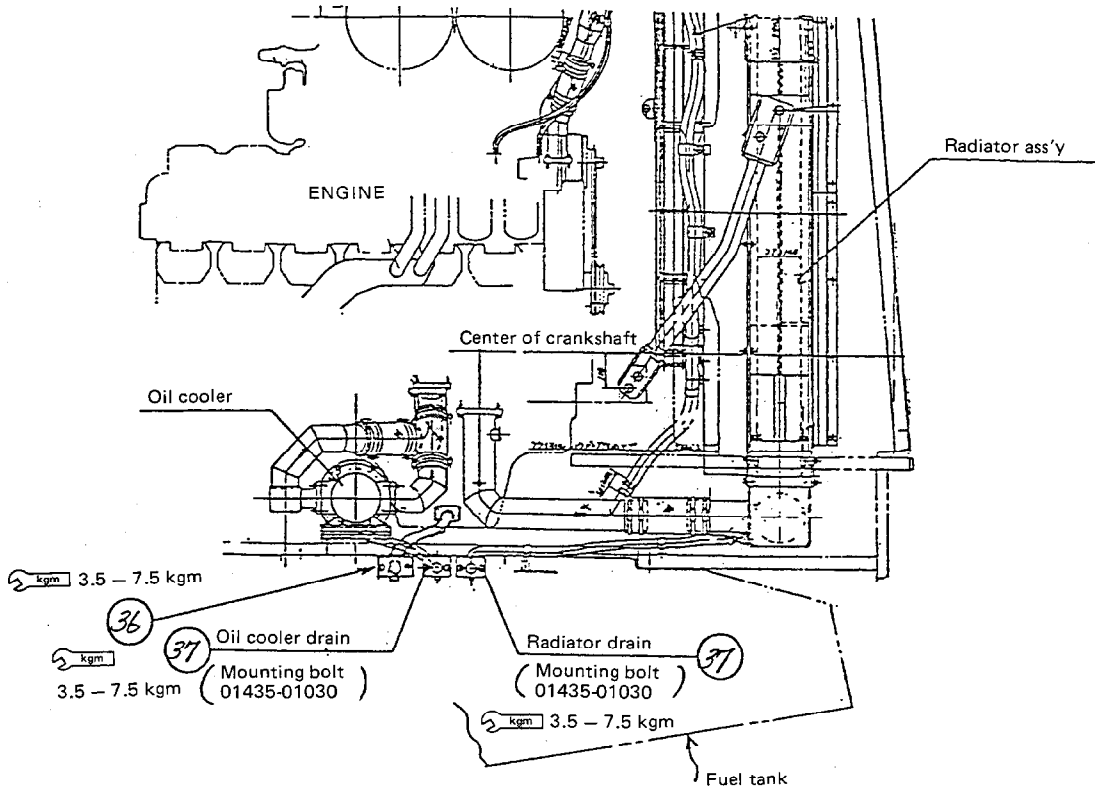

※ For the drain tube mounting bolts, remove the part temporarily installed to the fuel tank and use them.

Tools and facilities required

No.	Name (Part No.)	Q'ty
1	Impact wrench	1
2	Socket 14 mm	1
3	SP type torque wrench 24 x 500 kgcm	1
4	SP type torque wrench 27 x 800 kgcm	1

Assembly parts for securing fuel hoses

Mark	No.	Parts Name	Part No.	Q'ty
△	33	Clip (return)	08036-01814	2
▲	34	Bolt	01435-01016	2
△	35	Clip (suction)	424-06-12790	1

△: Temporarily installed to fuel hose
 ▲: Temporarily installed to rear frame



Tools and facilities required

No.	Name (Part No.)	Q'ty
1	Impact wrench	1
2	Socket 14 mm, 17 mm	1

Assembly parts for securing fuel hoses

Mark	No.	Parts Name	Part No.	Q'ty
△	28	Clip	08036-02514	1
▲	29	Bolt	01010-51020	1
▲	30	Washer	01643-31032	1
△	28	Clip	08036-02514	1
△	31	Clip	424-06-12790	2
▲	32	Bolt	01435-01016	2
△	31	Clip	424-06-12790	1
▲	32	Bolt	01435-01016	1

△: Temporarily installed to fuel hose

▲: Temporarily installed to rear frame

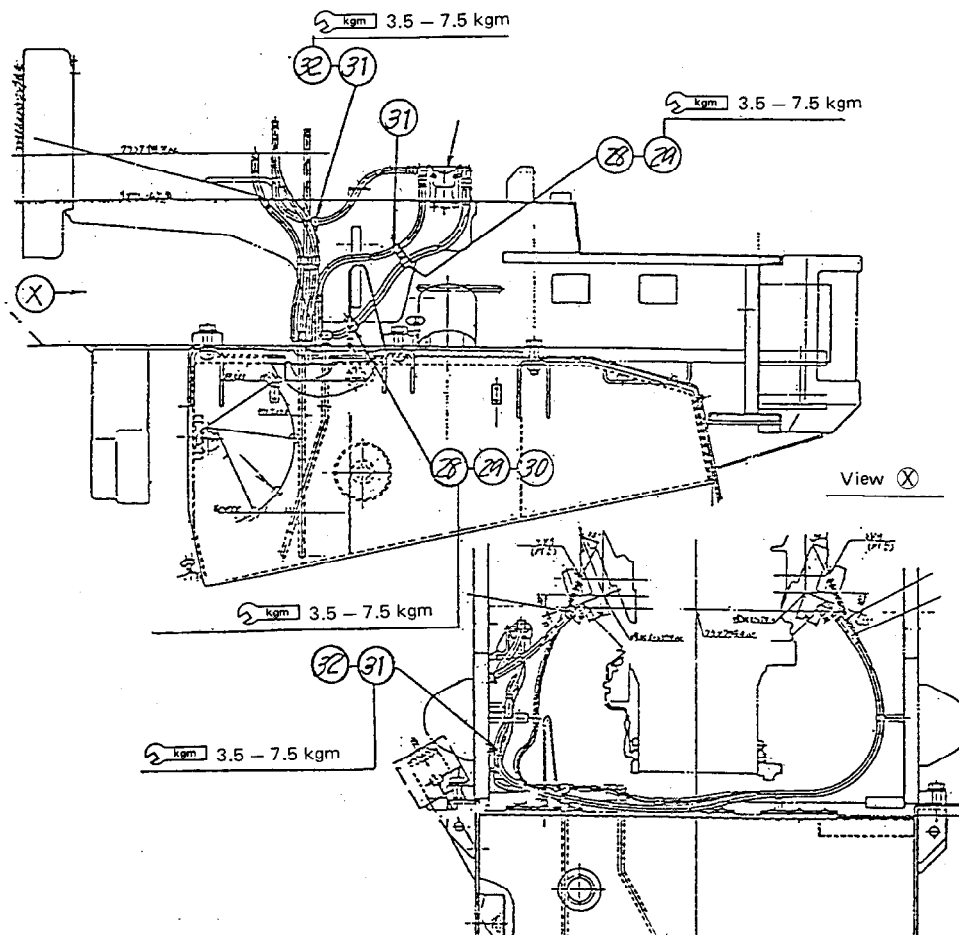

Tools and facilities required

No.	Name (Part No.)	Q'ty
1	Impact wrench	1
2	Socket 14 mm	1

Assembly parts for securing fuel hoses

Mark	No.	Part Name	Part No.	Q'ty
	24	Clamp	08036-01814	2
	25	Bolt	01435-01016	1
	26	Clamp	424-06-12780	2
	27	Bolt	01435-01025	1
	14	Hose (return)	07102-20319	1
	15	Hose (suction)	07102-20428	1
	16	Hose (return)	07102-20309	1
	17	Hose	07102-20512	1

No mark: Already temporarily installed to top of fuel tank

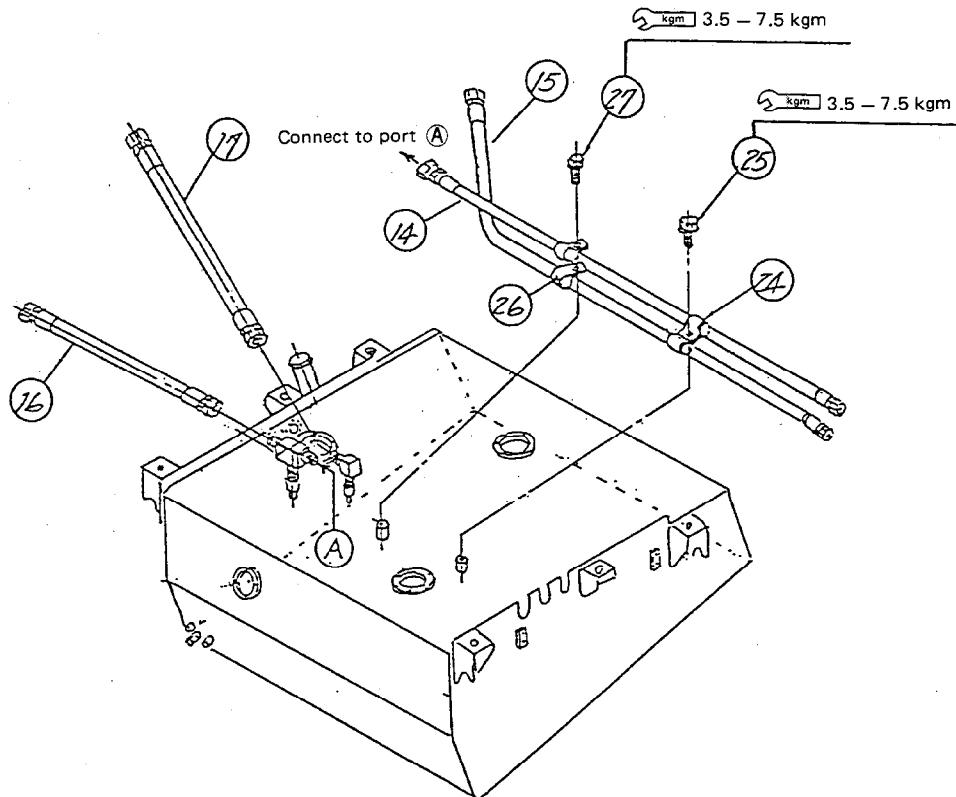

Tools and facilities required

No.	Name (Part No.)	Q'ty
1	Impact wrench	1
2	Socket 14 mm, 17 mm	1

Assembly parts for securing fuel hoses

Mark	No.	Part Name	Part No.	Q'ty
	9	Clip (muffler drain)	08036-01814	5
	10	Clip	08036-02514	8
	11	Bolt	01435-01016	5
	12	Bolt	01010-51016	3
	13	Washer	01643-31032	3

No mark: Already temporarily installed to top of fuel tank

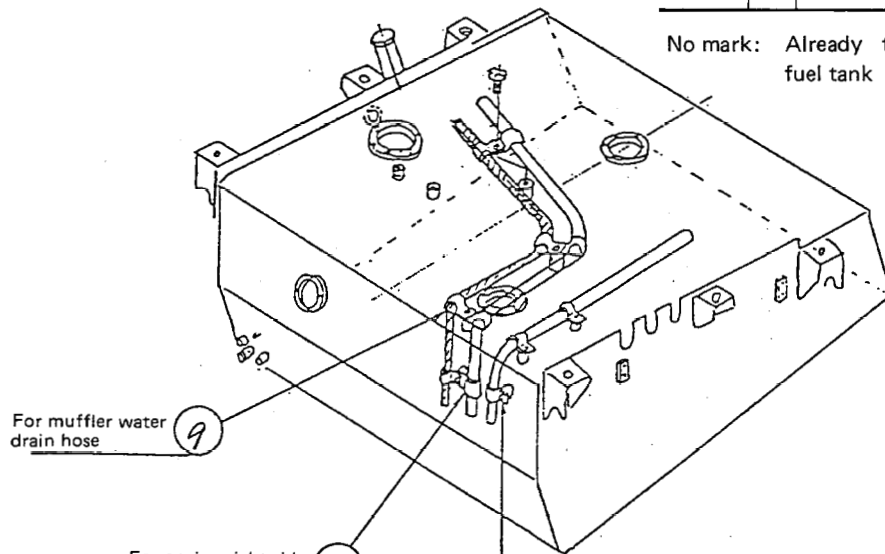

For muffler water drain hose (9)

For engine right side blow-by hose (x 5) (10)

(11) 3.5 - 7.5 kgm

For engine left side blow-by hose (x 4) (10)

(13) (12) 3.5 - 7.5 kgm

As seen from rear of engine

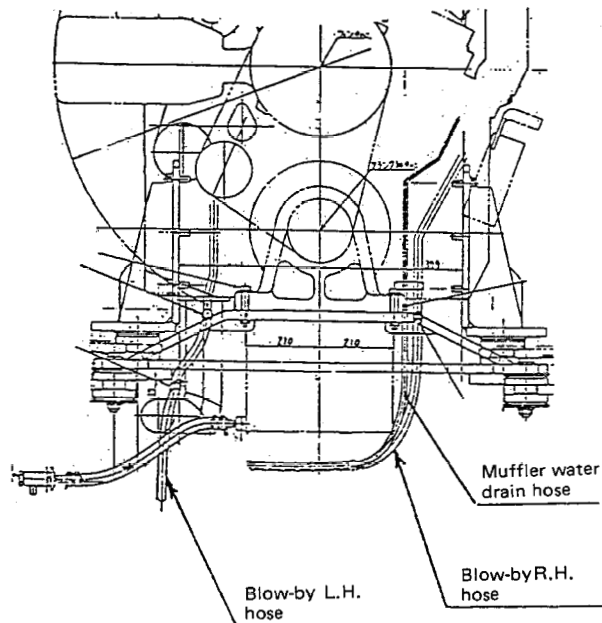

Tools and facilities required

No.	Name (Part No.)	Q'ty
1	Impact wrench	1
2	Socket 17 mm	1

Assembly parts for securing fuel hoses

Mark	No.	Part Name	Part No.	Q'ty
	18	Tube	427-04-11160	1
	19	Clip	424-04-11120	2
	20	Bolt	01010-51020	2
	21	Washer	01643-31032	2
	22	Tube	07270-21045	1
	23	Clamp	07280-01620	1
	4	Clamp	08036-23014	2
	5	Bolt	01010-51020	2
	6	Washer	01643-51032	2

No mark: Already temporarily installed to top of fuel tank

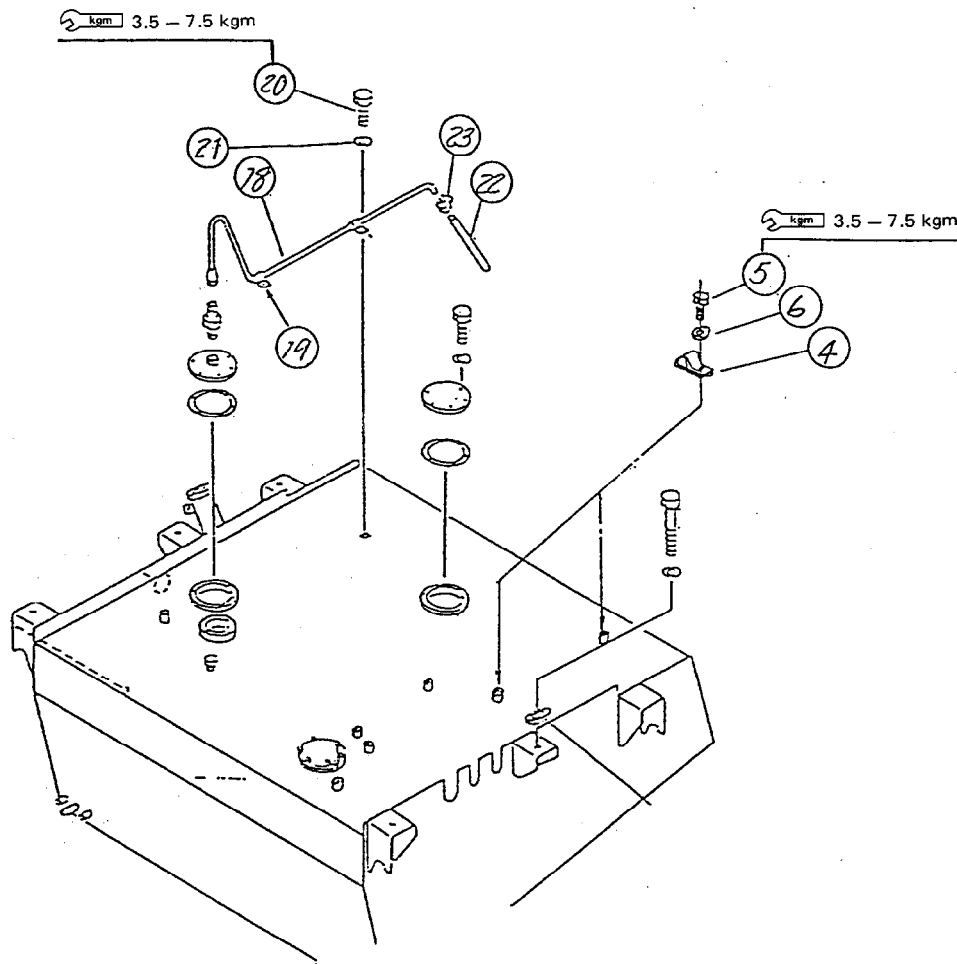

ASSEMBLY PROCEDURE

- Using a forklift truck, set the fuel tank assembly under the rear frame.



- Raise the fuel tank.

 Fuel tank: 700 kg

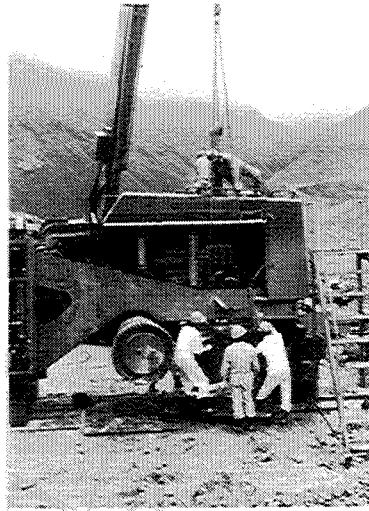
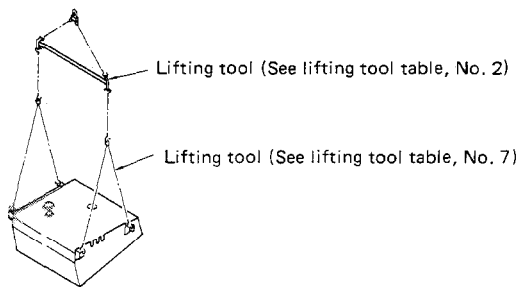

- ★ The fuel tank can be raised using the main winch and auxiliary winch of the crane. (When doing this, set the crane boom at right angles to the machine body)

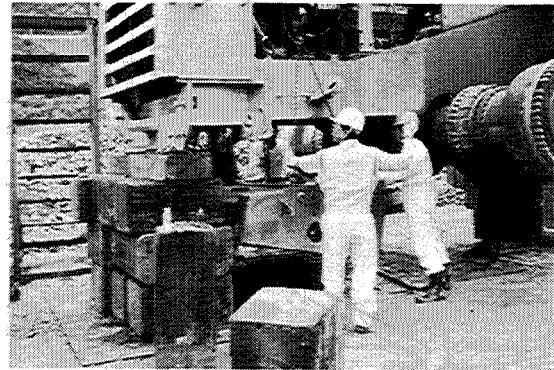
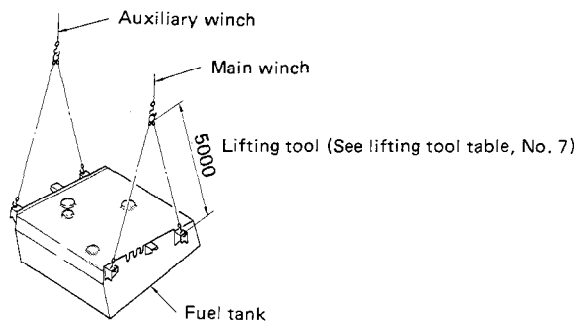

- Using a power wrench (4 x), tighten the mounting bolts to the specified torque.
 - ★ See the previous page for the tightening torque.
- Install the drain tubes of the engine, torque converter cooler, and radiator to the left side of the fuel tank. (See the previous page.)
- Connect the wiring harness of the fuel level sensor.
- Connect the fuel suction and return hoses.
- Connect the blowby, muffler, and cylinder block water drain hoses.
- Assemble the breather tube to the fuel tank. (See the previous page.)

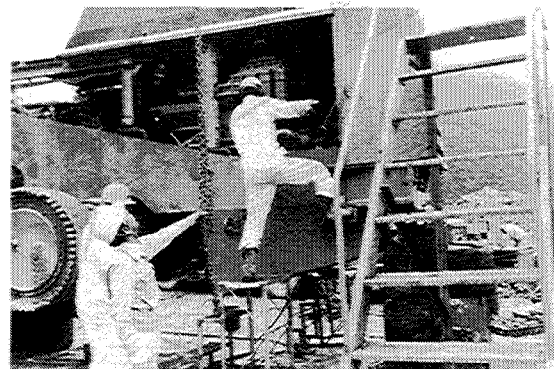

Assembly Process No.

A-6 Assembly of ladder (Left, Right)

Tools and facilities required

No.	Name (Parts No.)	Q'ty
1	30-ton crane	1

Assembly parts for ladder

Mark	No.	Parts Name	Part No.	Q'ty
■	1	Bolt	01010-51635	4
■	2	Washer	01643-31645	4
■	3	Bolt	01010-51230	4
■	4	Washer	01643-31232	4

■: Already temporarily installed to hydraulic tank and air component box

1. Assemble the ladder to the air component box (left) and hydraulic tank (right).

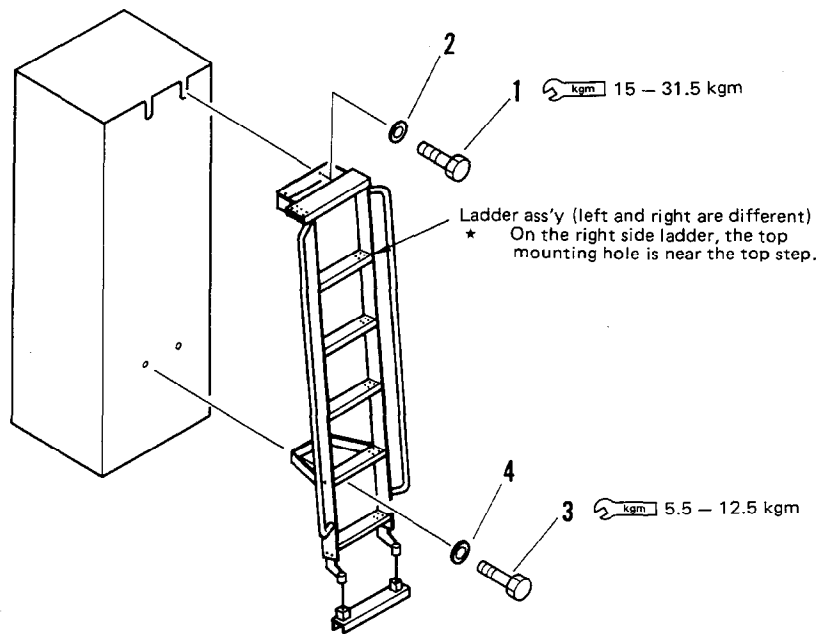

Assembly Process No.

A-7 Assembly of floor and cab assembly

OUTLINE

Tools and facilities required

No.	Name (Part No.)	Q'ty
1	1-ton 4-point lifting tool	1
2	Impact wrench	1
3	Socket 24 mm	1
4	Spanner	1
5	30 ton crane	1

Assembly parts for floor and cab components

Mark	No.	Part Name	Part No.	Q'ty
	1	Cushion	425-54-13160	8
	2	Plate	425-54-13170	8
	3	Bolt	01011-51610	4
	4	Washer	01643-31645	4
	5	Locknut	421-40-11510	4
	6	Washer	416-40-11150	4

No mark: Already temporarily installed to lower support

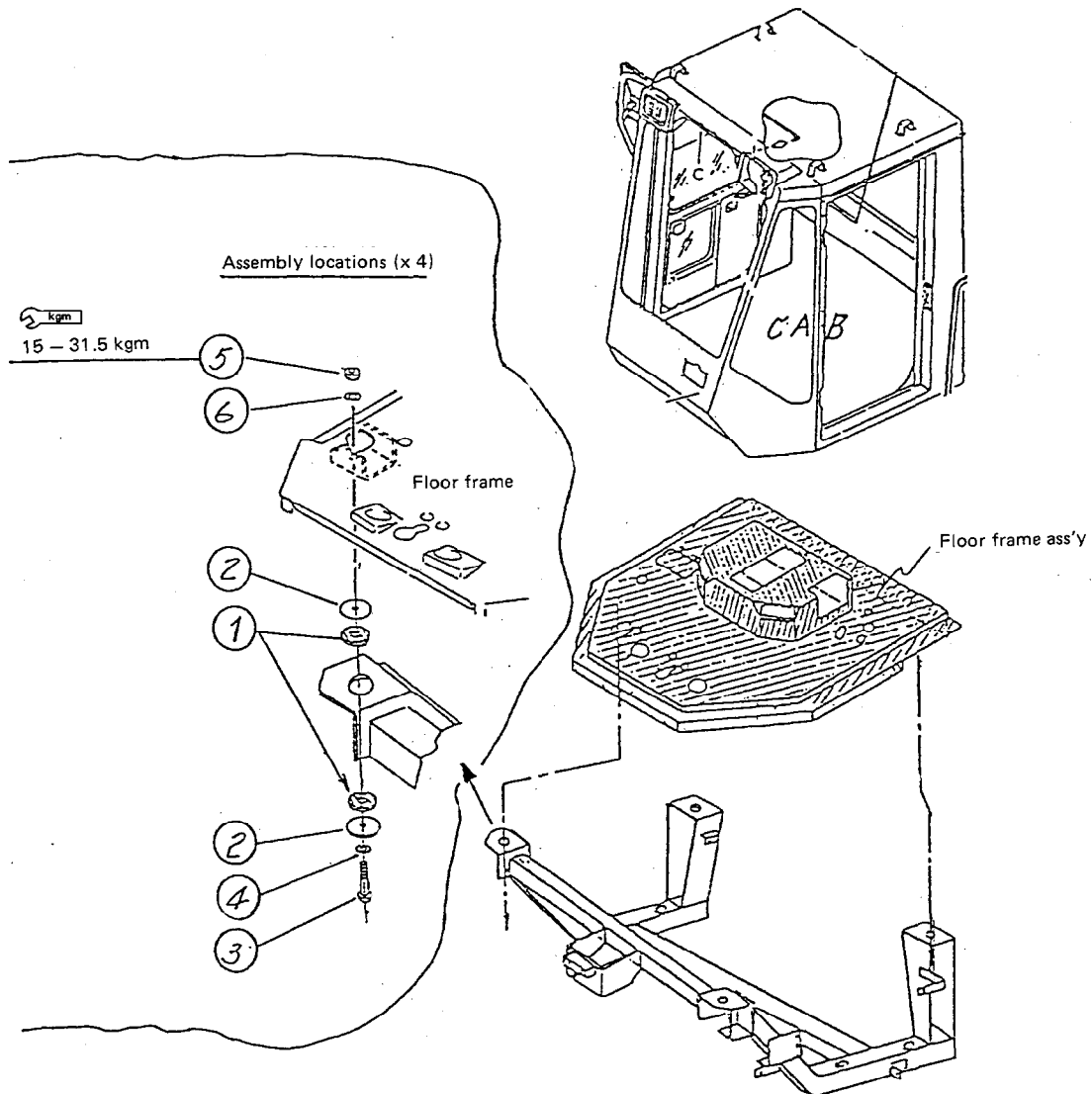

Tools and facilities required

No.	Name (Part No.)	Q'ty
1	Impact wrench	1
2	Socket 17 mm	1
3	Box driver 7 mm	1

Assembly parts for floor and cab component

Mark	No.	Part Name	Part No.	Q'ty
△	14	Clamp (for heater hot water hose)	07281-00259	2
□	15	Clip (for securing air conditioner drain hose)	424-09-12550	5
□	16	Bolt (for securing air conditioner drain hose)	01010-51020	5
□	17	Washer (for securing air conditioner drain hose)	01643-31032	5

- △: Already temporarily installed to each IN and OUT hose
- : Already temporarily installed to lower support and rear frame

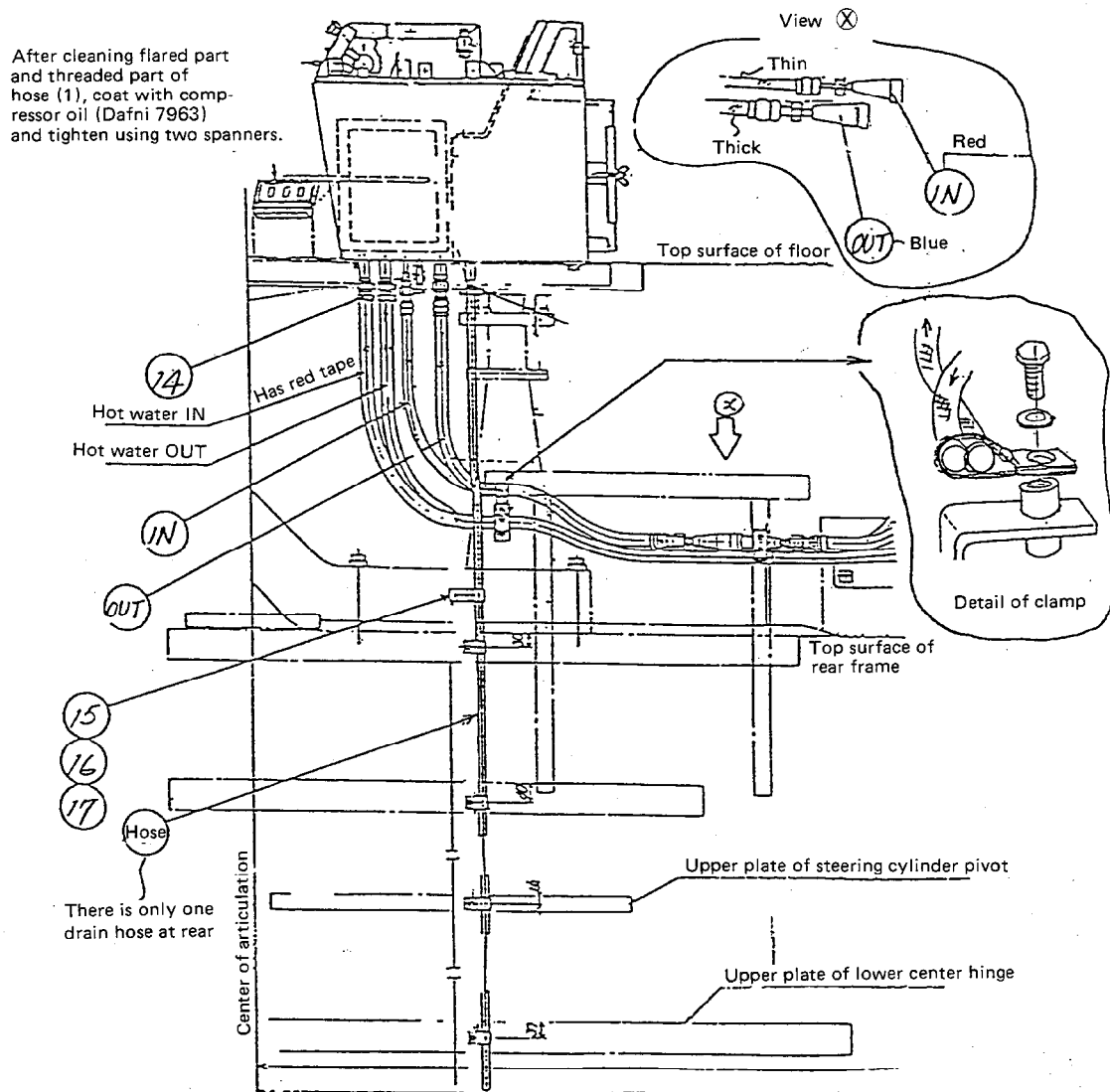

Tools and facilities required

No.	Name (Part No.)	Q'ty
1	SP type torque wrench 24 mm x 500 kgcm (1)	(1)
2	Impact wrench	1
3	Socket	1
4	Torque wrench 2800 QSP	1

Assembly parts for floor and cab component

Mark	No.	Part Name	Part No.	Q'ty
○	31	Plate (pitman arm)	427-40-11210	1

○: Already temporarily installed to steering linkage rod

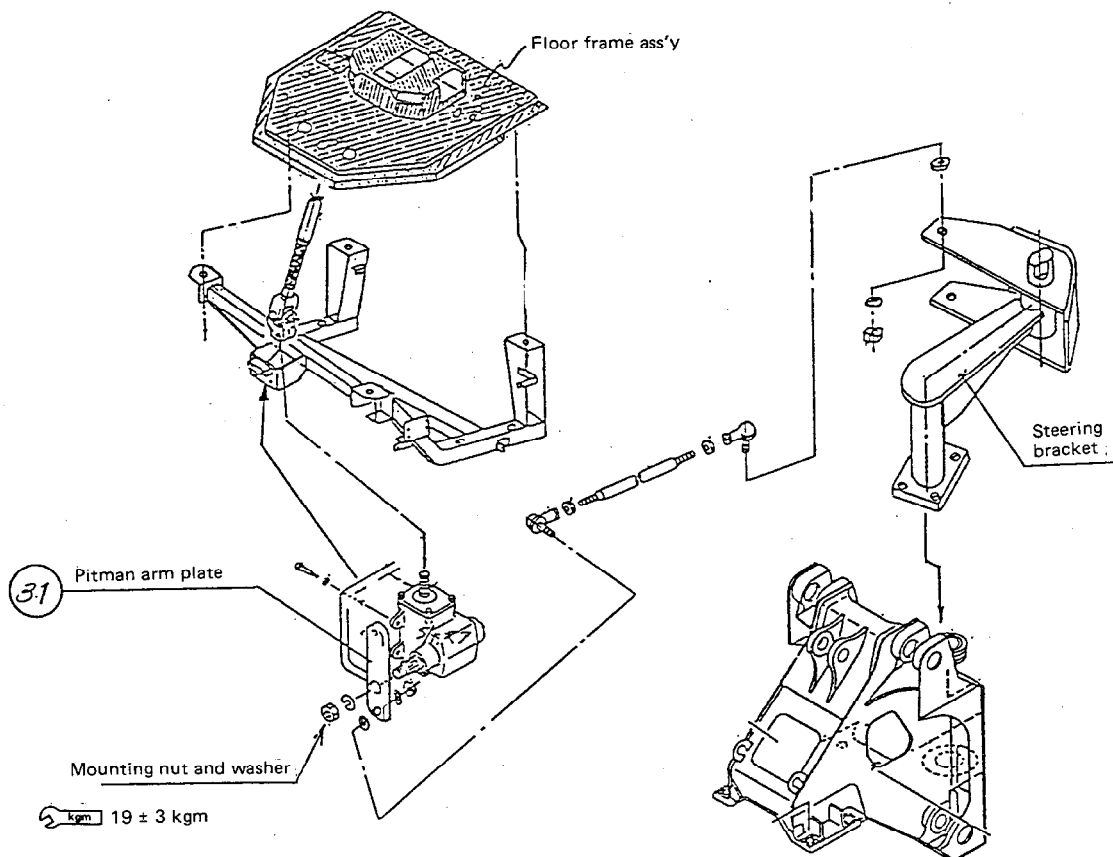
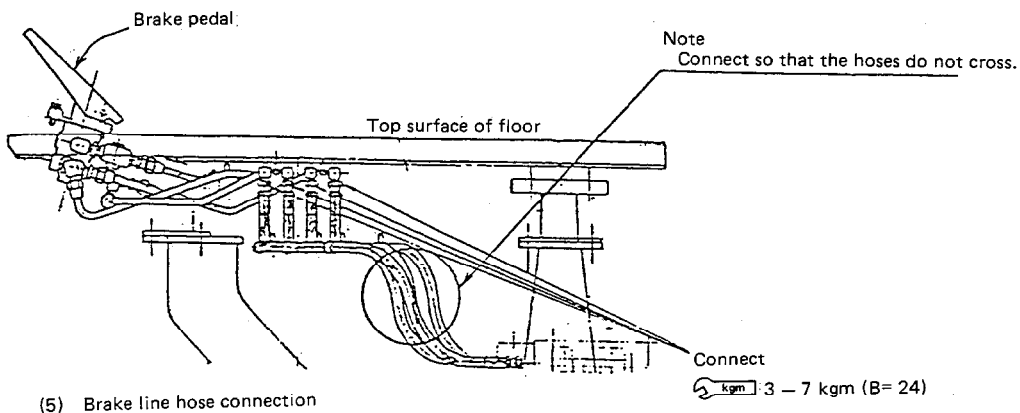

Tools and facilities required

No.	Name (Part No.)	Q'ty
1	Spanner type torque wrench 6 – 10 kgm	1
2	Spanner type torque wrench 3 – 7 kgm	1
3	30-ton crane	1

	PPC valve port	Main control valve port	Work equipment operation	Distinguishing mark on hose (color of taping)
Bucket	P4	PB1	TILT	RED
	P2	PA1	DUMP	BLUE
Lift	P3	PA2		YELLOW
	P1	PB2		GREEN

P1 – P4 →  5 ± 2 kgm (HEX 24)

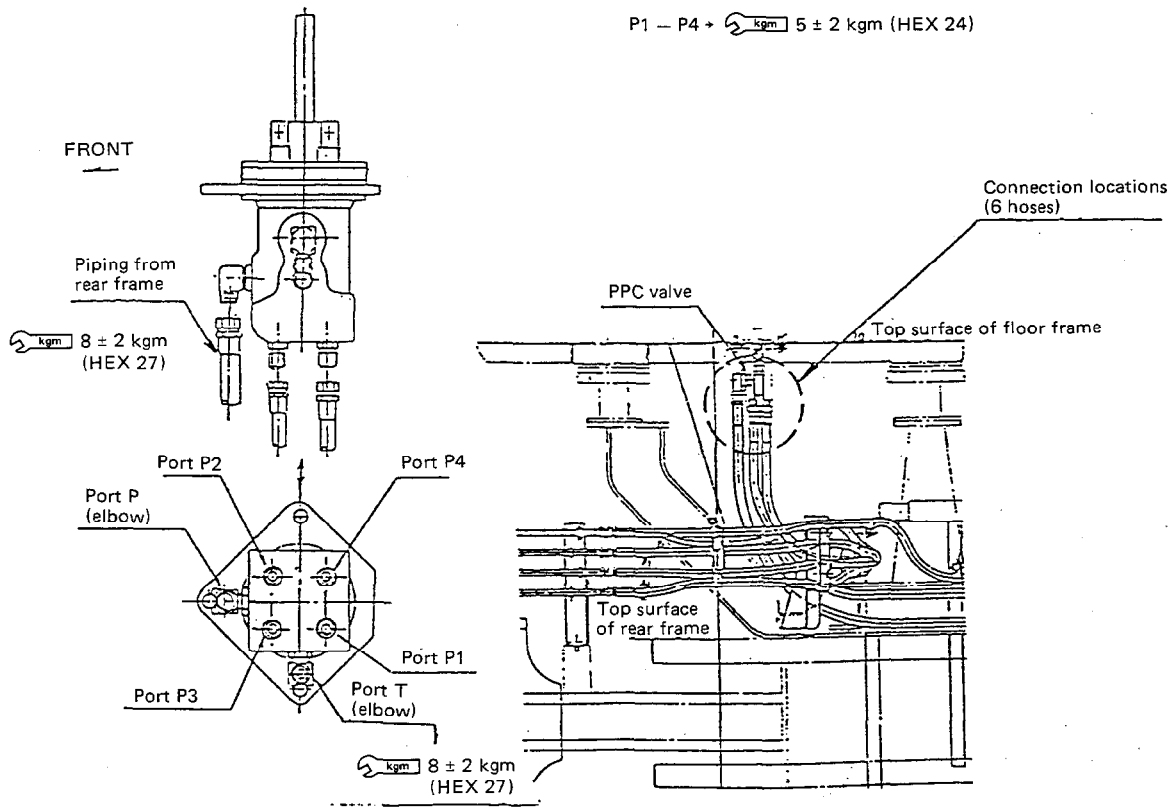

View as seen from bottom of valve

Assembly parts for securing fuel hoses

No.	Name (Part No.)	Q'ty
1	Impact wrench	1
2	Socket 17 mm	1

Assembly parts for securing wiring harnesses

Mark	No.	Part Name	Part No.	Q'ty
	26	Bolt (for securing floor frame ground connection wire)	01010-51020	1
	27	Washer (for securing floor frame ground connection wire)	01643-31032	1
●	28	Clip (for securing front wiring harness)	08035-03014	1
▲	29	Bolt (for securing front wiring harness)	01010-51020	1
▲	30	Washer (for securing front wiring harness)	01643-31032	1
●	18	Clip (for wiring harness under floor frame)	08036-01414	3
★	19	Bolt (for wiring harness under floor frame)	01010-51020	3
★	20	Washer (for wiring harness under floor frame)	01643-31032	3
■	21	Clip (for securing air component wiring harness)	426-35-11250	2
★	22	Bolt (for securing air component wiring harness)	01010-51020	2
★	23	Washer (for securing air component wiring harness)	01643-31032	2

No mark: Already temporarily installed to lower support.

- : Already temporarily installed to front wiring harness
- ▲: Already temporarily installed to floor frame lower mounting bracket
- ★: Already temporarily installed to bottom of floor frame
- : Already temporarily installed to air component wiring harness

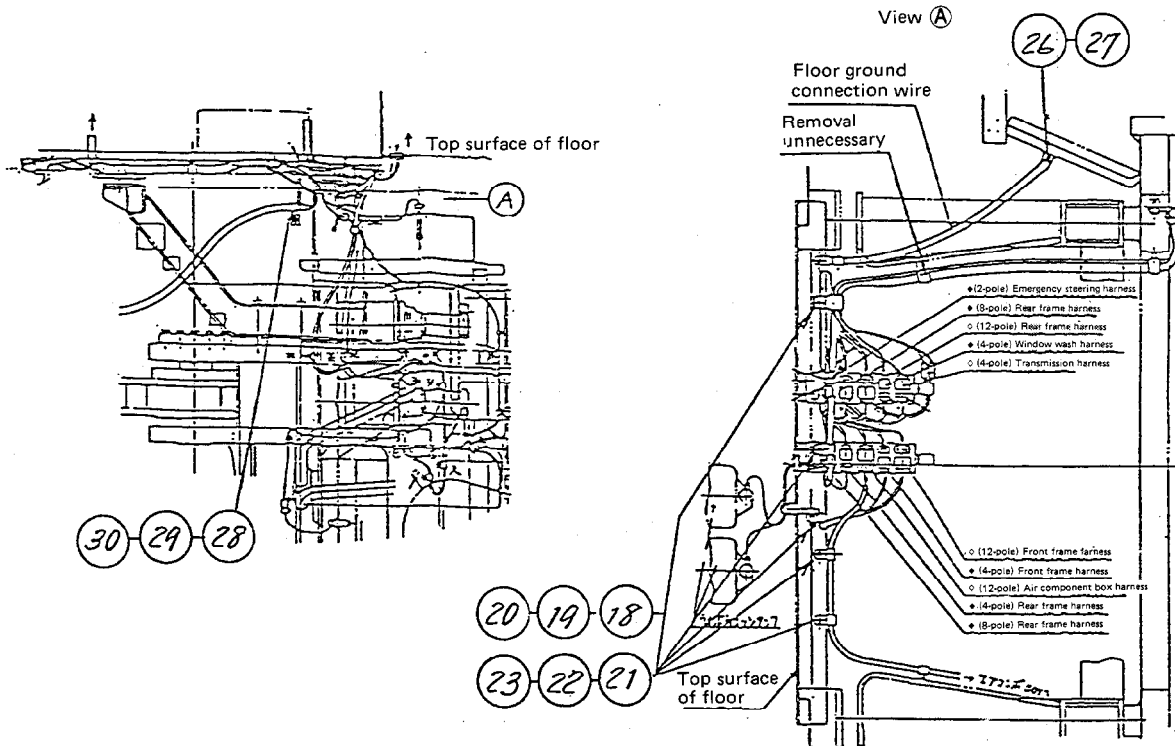

Tools and facilities required

No.	Name (Part No.)	Q'ty
1	Impact wrench	1
2	Socket 14 mm	1

Assembly parts for cover components

Mark	No.	Part Name	Part No.	Q'ty
☆	12	Cover (for lower rear face of floor frame)	427-54-13620	1
★	13	Bolt (for lower rear face of floor frame)	01435-01220	10

☆: Sent as individual part

★: Already temporarily installed to floor frame

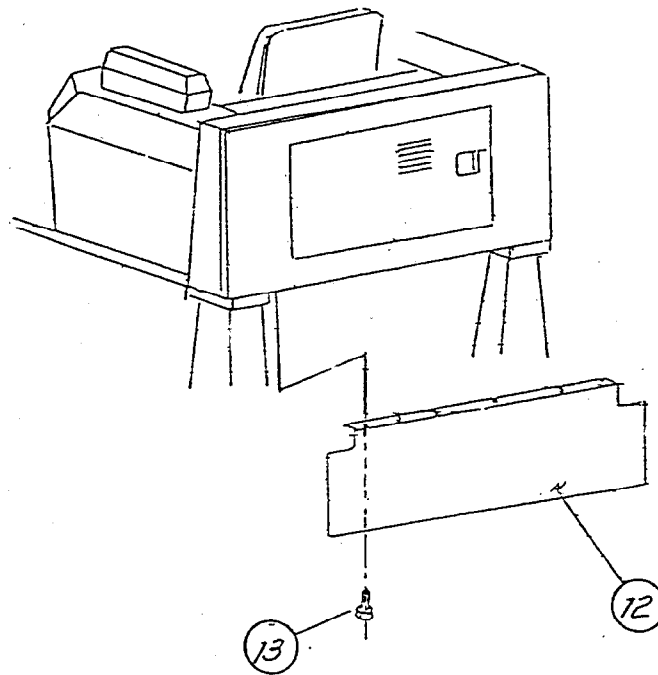

Tools and facilities required

No.	Name (Part No.)	Q'ty
1	Impact wrench	1
2	Socket, spanner 17 mm	1

Assembly parts for cover components

Mark	No.	Part Name	Part No.	Q'ty
☆	32	Cover (floor frame front cover)	427-54-13530	1
★	33	Bolt (floor frame front cover)	01435-01220	2
☆	34	Cover L.H. (floor frame lower side)	427-54-13510	1
☆	35	Cover R.H. (floor frame lower side)	427-54-13520	1
☆	36	Cover L.H. (floor frame lower side)	427-54-13270	1
☆	37	Cover R.H. (floor frame lower side)	427-54-13280	1
★	38	Bolt (floor frame lower side)	01435-01220	10
★	39	Bolt (floor frame lower side)	01435-01230	4
★	40	Bolt (floor frame lower side)	01435-01250	4
★	41	Nut (floor frame lower side)	01584-01210	2

☆: Sent as individual part

★: Already temporarily installed to floor frame

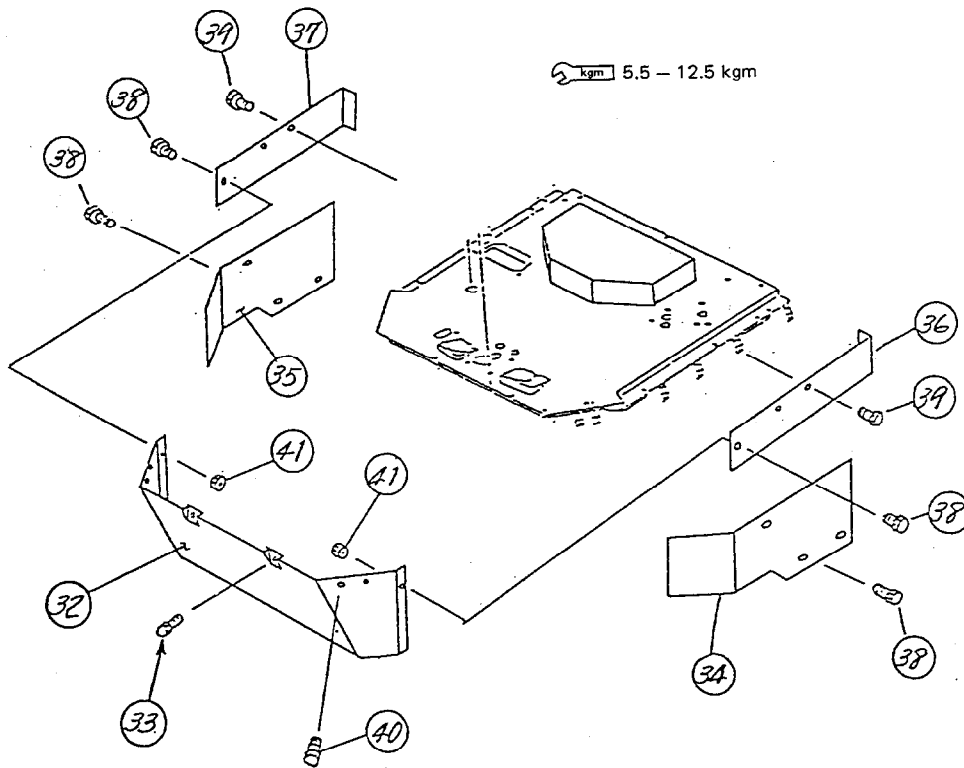

Tools and facilities required

No.	Name (Part No.)	Q'ty
1	Impact wrench	1
2	Socket 17 mm	1
3	Pliers	

Assembly parts for securing throttle cable

Mark	No.	Part Name	Part No.	Q'ty
○	7	Cotter pin (for connecting throttle cable)	04050-11612	1
○	8	Pin (for connecting throttle cable)	04205-10620	1
△	9	Clip (for securing throttle cable cover)	08036-01214	1
△	10	Bolt (for securing throttle cable cover)	01010-51020	1
△	11	Washer (for securing throttle cable cover)	01643-31032	1

○: Already temporarily installed to yoke at tip of throttle cable

△: Already temporarily installed to cover (427-54-13620)

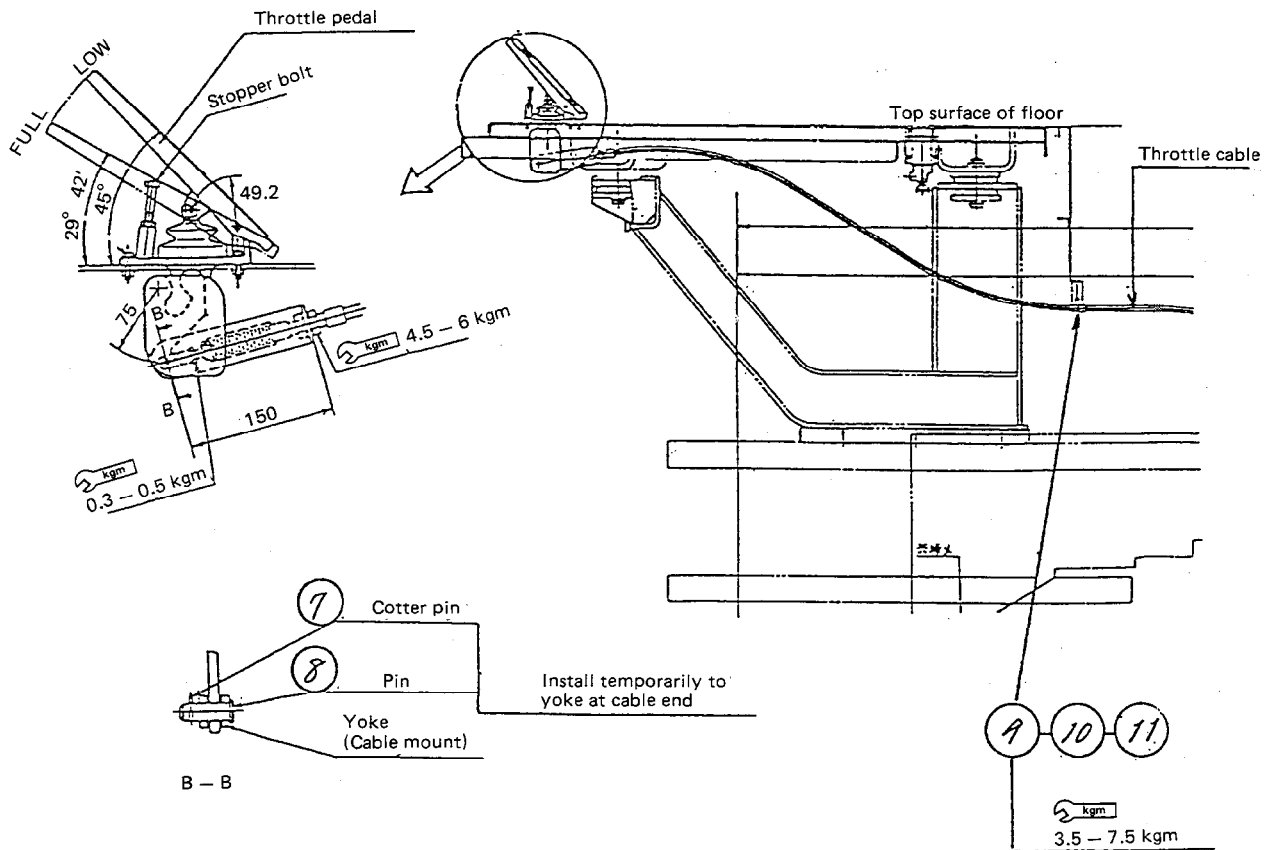

Opening of heater valve

Point of operation
To open valves (both IN and OUT)
of heater hot water line.

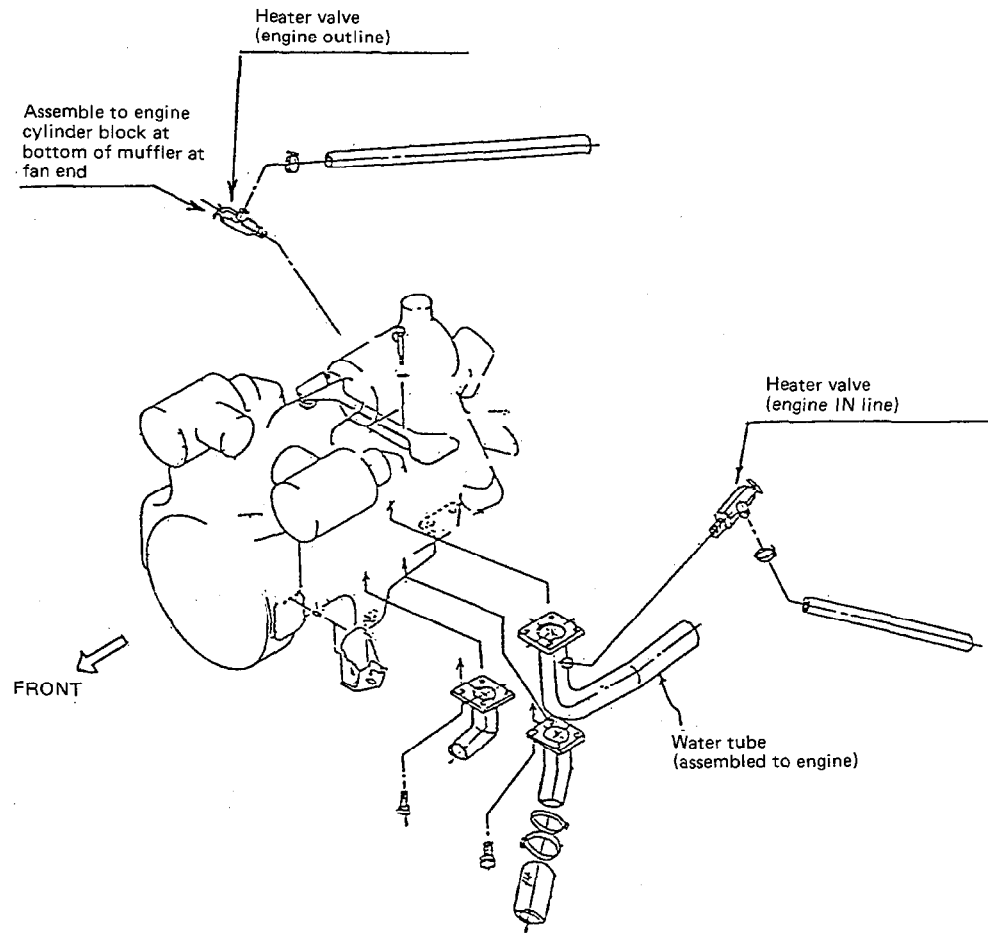

ASSEMBLY PROCEDURE

1. Raise the floor and cab assembly with a crane, and assemble it to the floor plate.

★ See the previous page for the tightening torque of the bolts.

 Floor and cab assembly: 950 kg
Lifting tool: 2-point suspension x 2
(See lifting tool table, No. 8)

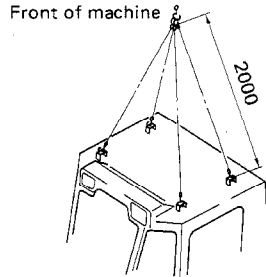

- ★ When assembling the floor and cab assembly, do not forget to insert the steering column joint into the steering gear box joint.

Insert the joint so that the steering wheel knob is in the position shown in the diagram below.

See the previous page.

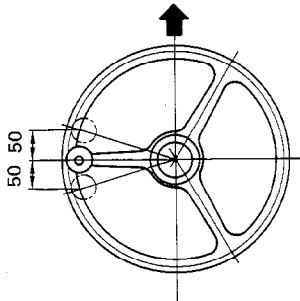

- ★ Before assembling, clean the contact surface of the mount.
2. Connect and clamp the heater hose, air conditioner hose, and air conditioner drain hose. See the previous page.
 3. Connect the hoses to the PCC valve. See the previous page.
 4. Connect and secure the wiring. See the previous page.
 5. Connect the brake line hose. See the previous page.
 6. Connect the steering column to the steering box. See the previous page.
 7. Assemble the cover under the floor. See the previous page.
 8. Connect the engine throttle cables (top right of torque converter and transmission), then secure with clips. See the previous page.

Assembly Process No.

A-8 Assembly of hand rail

Tools and facilities required

No.	Name (Part No.)	Q'ty
1	Impact wrench	1
2	Socket 19 mm	1
3	30 ton crane	1
4	Nylon lifting equipment	1

Assembly parts for handrail components

Mark	No.	Part Name	Part No.	Q'ty
	1	Handrail (front L.H.)	427-54-14110	1
	2	Handrail (front R.H.)	427-54-14120	1
	3	Handrail (rear L.H.)	427-54-14130	1
	4	Handrail (rear R.H.)	427-54-14141	1
○	5	Bolt	01010-51230	24
○	6	Washer	01643-31232	32
○	7	Bolt	01010-51235	8

No mark: Sent as individual part

○: Already temporarily installed to left and right of floor

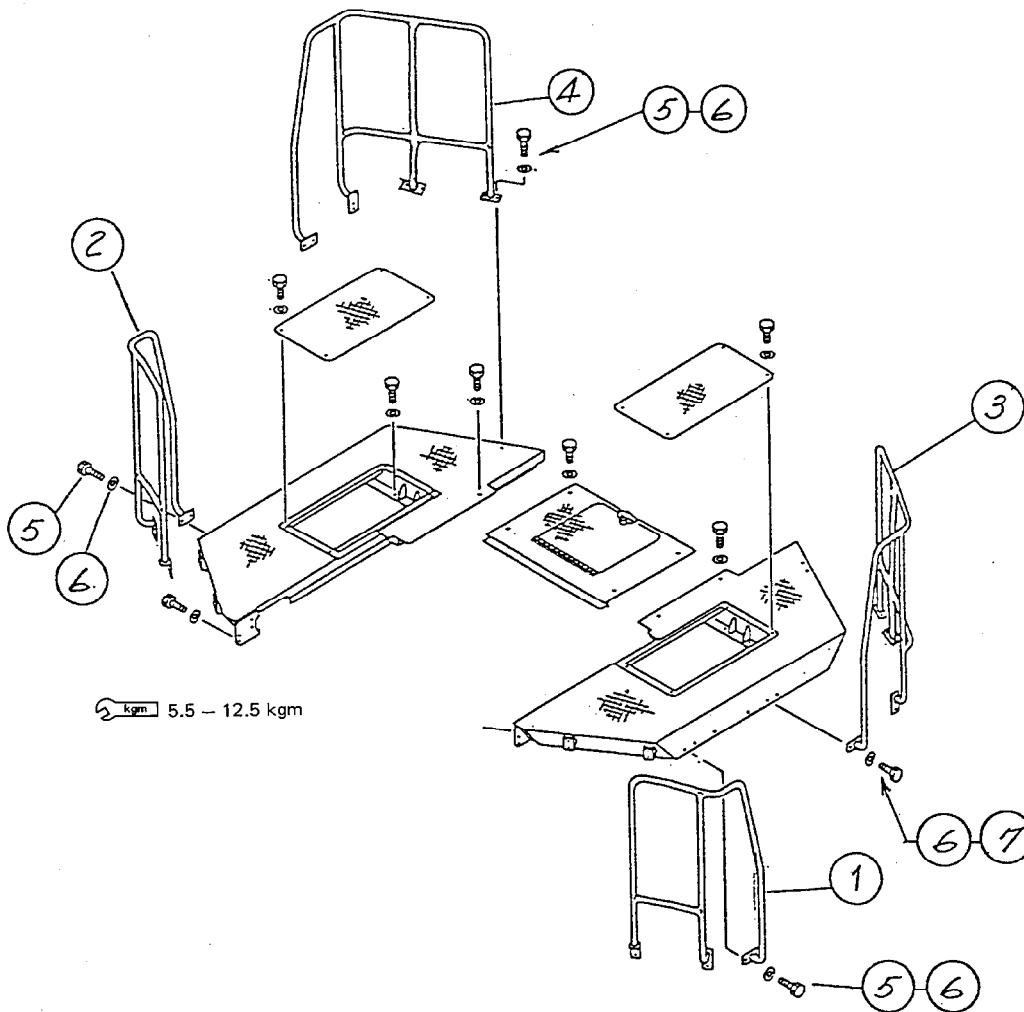

A-9 Assembly of tire and wheel assembly

OUTLINE

Tools and facilities required

No.	Name (Parts No.)	Q'ty
1	Socket 36 □	1
2	Torque wrench 95 kgm	1
3	Extension bar	1
4	30-ton crane	1
5	Nylon sling 150 x 10000	1

Assembly parts for rear wheel and tire ass'y

Mark	No.	Parts Name	Part No.	Q'ty
○	1	Nut	426-22-12930	106
○	2	Washer	01643-32460	106

○: Already temporarily installed to rear axle

Method for lifting tire

 Tire and wheel assembly: 3.5 ton

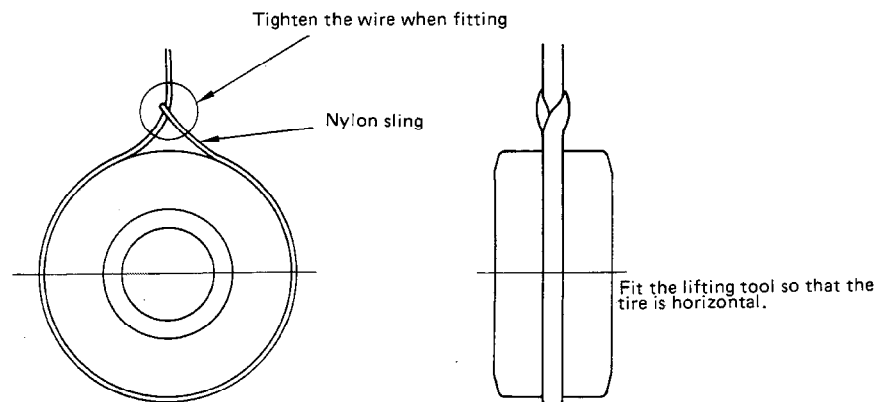
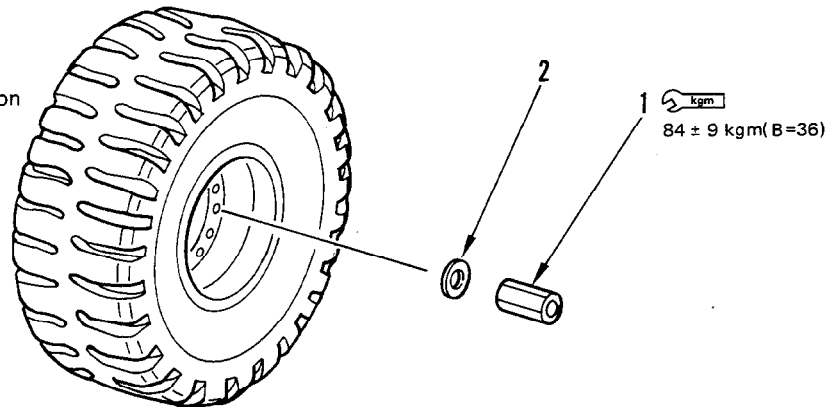

ASSEMBLY PROCEDURE

1. Assembly of tire

Raise the tire with a crane, set the tire on the axle, then assemble the nuts.



Tire and wheel assembly: 3.5 ton

Lifting tool: Nylon sling

- ★ When positioning the tire and wheel assembly, be careful not to damage the tire inflation tube.



2. Temporary tightening of tire mounting nut

Temporarily tighten the tire mounting nut with an impact wrench.

- ★ The operation is carried out in a high position, and there are many nuts to tighten, so the operation is easier if a balancer is used to support the impact wrench.



3. Removing rear support

Raise the rear of the machine with a crane (30 ton), and remove the support.



Weight: 19.5 ton

Lifting tool: Lifting tool for rear frame
(See lifting tool table, No. 2)

4. Using a torque wrench, tighten the tire mounting nuts to the specified torque.

- ★ See the previous page for the tightening torque.



Assembly Process No.

A-10 Assembly of battery box assembly

Tools and facilities required

No.	Name (Part No.)	Q'ty
1	Impact wrench	1
2	Socket, spanner 36 mm	1
3	Torque wrench 10000 QLE	1
4	30-ton crane or forklift truck (1 ton)	1
5	Nylon lifting equipment	1

Assembly parts for battery box components

Mark	No.	Part Name	Part No.	Q'ty
	1	Bolt	01011-32450	4
	2	Bolt	01011-32470	4
	3	Washer	01643-32460	8

No mark: Already temporarily installed to rear frame mounting

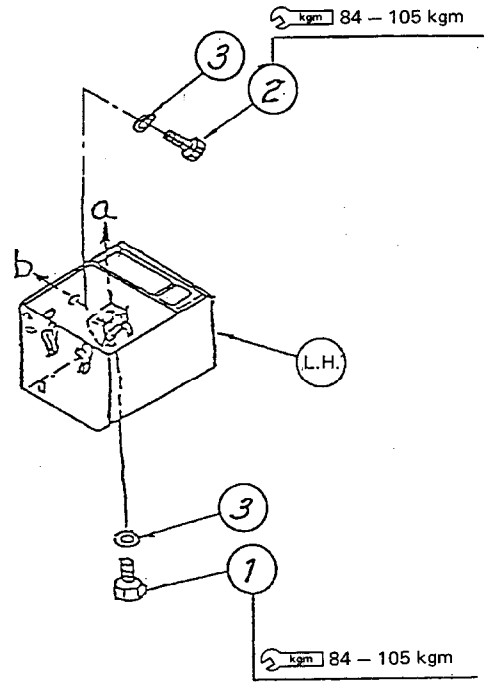
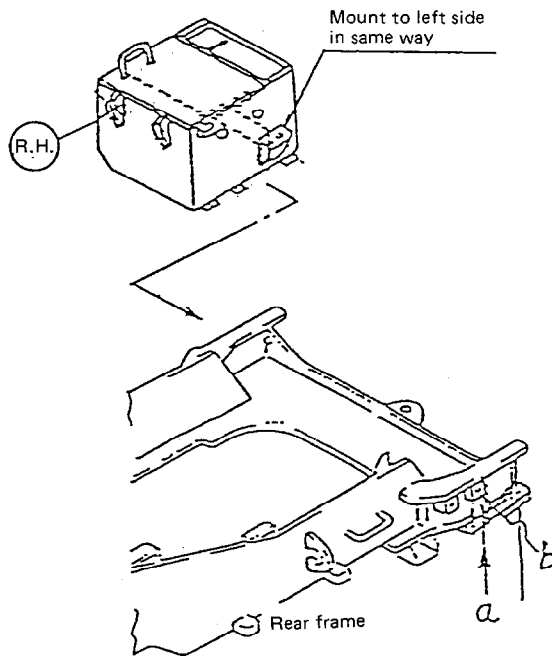

Tools and facilities required

No.	Name (Part No.)	Q'ty
1	Impact wrench	1
2	Socket 17 mm	1

Assembly parts securing wiring harnesses and wires

Mark	No.	Part Name	Part No.	Q'ty
□	4	Cap (2 each, left and right)	08038-00035	4
△	5	Clip (for battery relay wiring harness)	391-62-19240	1
○	6	Clip (for battery relay wiring harness)	08035-03014	1
	7	Bolt (for battery relay wiring harness)	01010-51020	2
	8	Bolt (for battery relay wiring harness)	01643-31032	2
	9	Clip (for securing rear wiring harness)	426-35-11250	1
	10	Clip (for securing rear wiring harness)	08036-01814	1
	11	Bolt (for securing wiring harness)	01010-51020	2
	12	Washer (for securing rear wiring harness)	01643-31032	1
●	13	Wire (between left and right batteries)	427-06-12350	1

- : Already temporarily installed to battery cable
- △: Already temporarily installed to inside of right battery box
- : Already temporarily installed to inside of left battery box
- : Already temporarily installed to rear frame end
- No mark: Already temporarily installed to left and right battery boxes

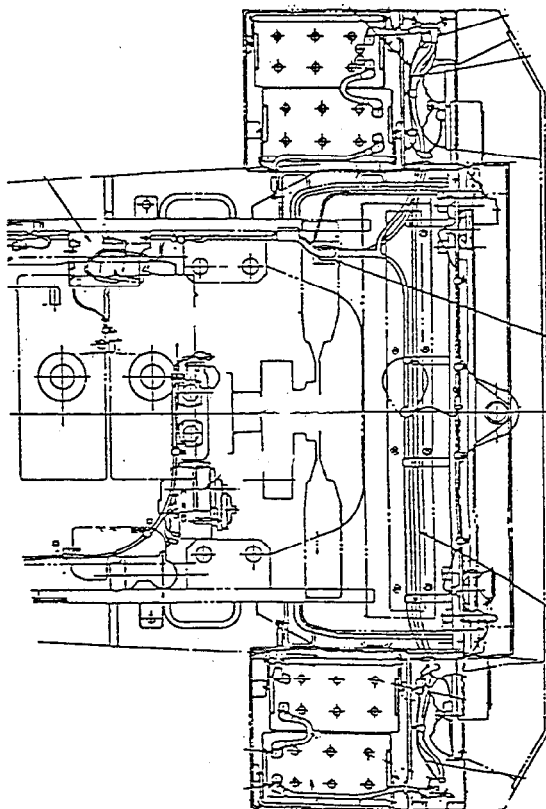

View of inside of left battery box as seen from front

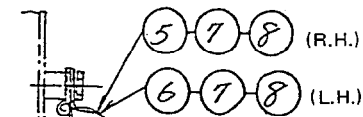
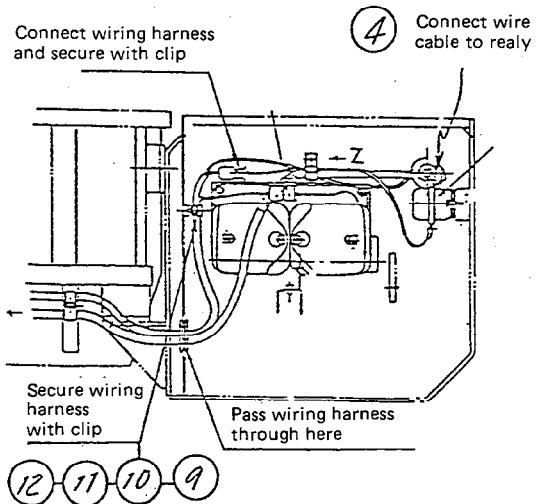

View Z

Tools and facilities required

No.	Name (Part No.)	Q'ty
1	Impact wrench	1
2	Socket 17 mm, 30 mm	1
3	Forklift truck (1 ton)	1

Assembly parts for cover components

Mark	No.	Part Name	Part No.	Q'ty
	14	Cover L.H.	427-06-14570	1
	15	Cover R.H.	427-06-14580	1
	16	Cover L.H.	427-06-14540	1
	17	Cover R.H.	427-06-14550	1
○	18	Cover	427-06-14560	2
	19	Cover	427-06-14530	1
△	20	Cover	427-06-13132	1
△	21	Cover	427-06-13141	1
□	22	Bolt	01435-01230	6
□	23	Bolt	01435-01025	8
●	24	Bolt	01435-01020	8
▲	25	Bolt	01010-52045	4
▲	26	Washer	01643-32060	4
△	27	Bolt	01435-01225	8

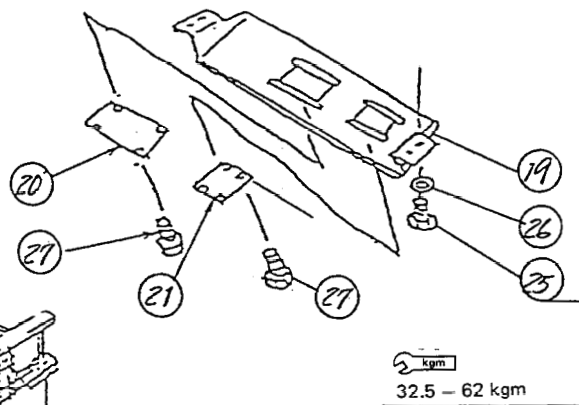
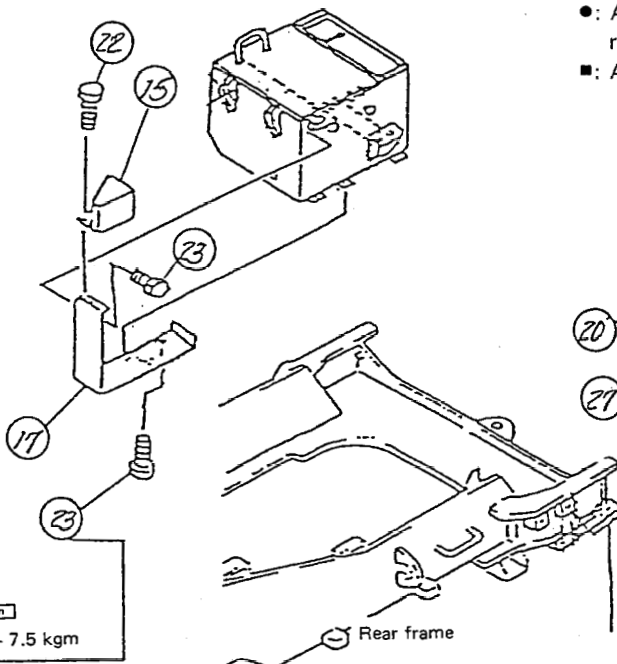
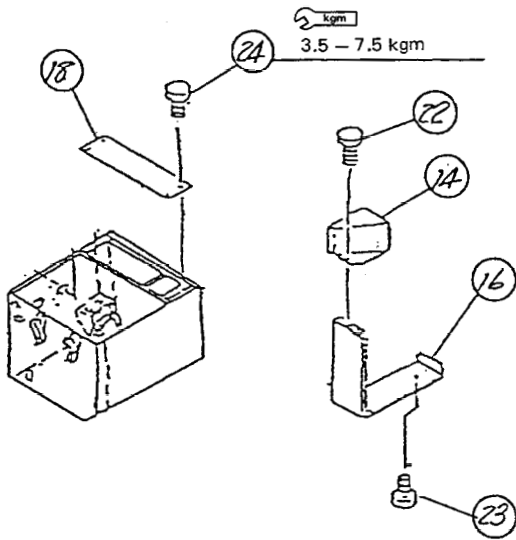

No mark: Sent as individual part

○: Already temporarily installed to left and right battery boxes

△: Already temporarily installed to cover (427-06-14530)

□: Already temporarily installed to battery box and cover

●: Already temporarily installed to cover for left and right battery boxes

■: Already temporarily installed to rear frame mounting

Assembly of step assembly

Tools and facilities required

No.	Name (Part No.)	Q'ty
1	Impact wrench	1
2	Socket, spanner 19 mm	1

Assembly parts for step components

Mark	No.	Part Name	Part No.	Q'ty
○	28	Step ass'y	(620-3860-SC)	1 each RH, LH
△	29	Bolt	01010-51225	8
△	30	Washer	01643-31232	8

○: Sent as individual part

△: Already temporarily installed to left and right fuel tanks

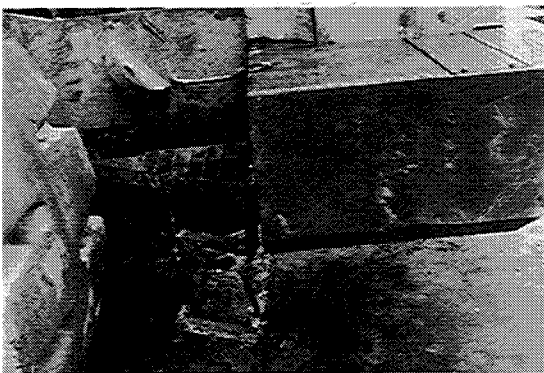
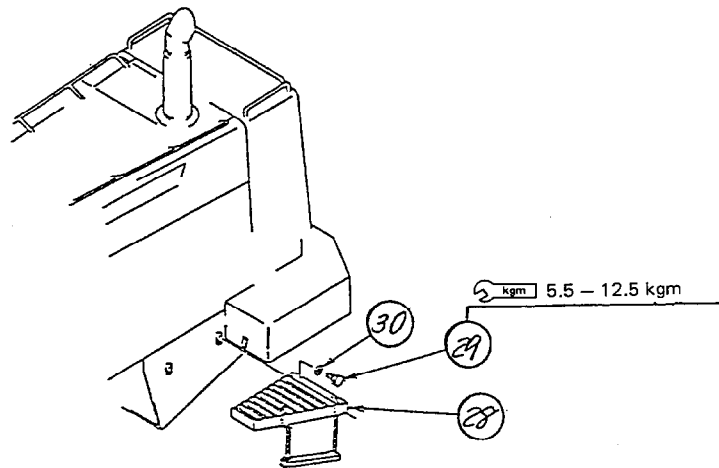

Assemble steps to fuel tank and counterweight

A-10A Assembly of counterweight assembly

Tools and facilities required

No.	Name (Part No.)	Q'ty
1	Torque wrench 21000 QLE	1
2	Socket 46 mm	1
3	Extension	1
4	Impact wrench (for M30)	1
5	30-ton crane	1

Assembly parts for counterweight components

Mark	No.	Part Name	Part No.	Q'ty
○	1	Counterweight	427-46-15121	1
△	2	Pin (drawbar)	427-46-13120	1
□	3	Bolt (for mounting counterweight)	425-974-1160	6
□	4	Washer (for mounting counterweight)	01643-33080	6

- : Sent as individual part
- △: Already temporarily installed to counterweight
- : Already temporarily installed to rear of rear frame

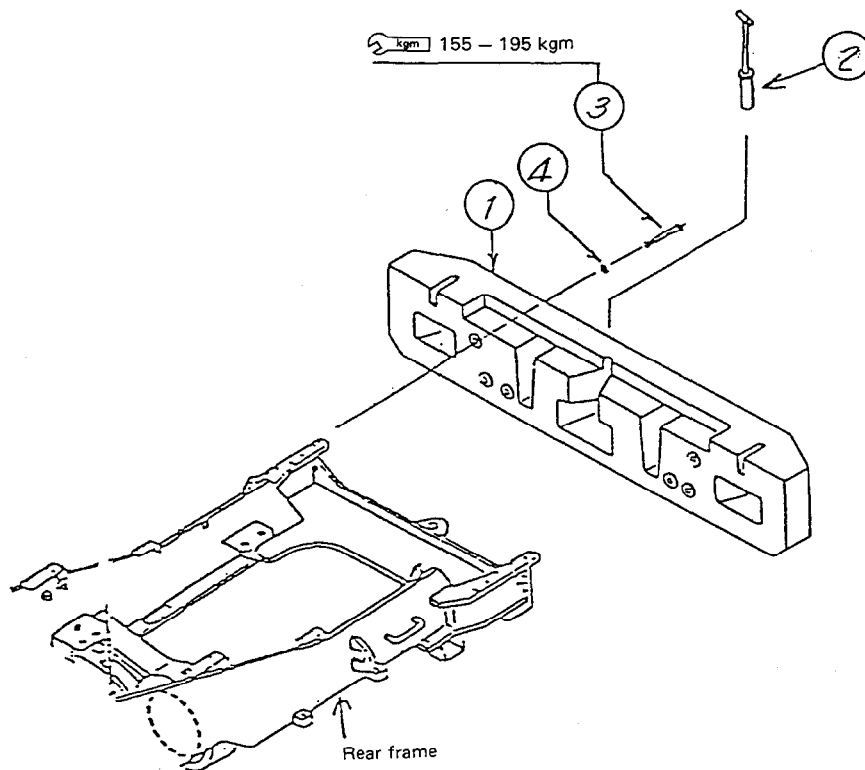

Assembly Process No. A-11 Assembly of muffler pipe

Tools and facilities required

No.	Name (Part No.)	Q'ty
1	Impact wrench	1
2	Socket 17 mm	1

Assembly parts for muffler pipe components

Mark	No.	Part Name	Part No.	Q'ty
○	1	Exhaust pipe	427-02-11121	2
△	2	Plate	427-02-11130	1
△	3	Bolt	01435-01230	6
△	4	Bolt	01435-01250	6

○: Sent as individual part

△: Already temporarily installed to top of center hood

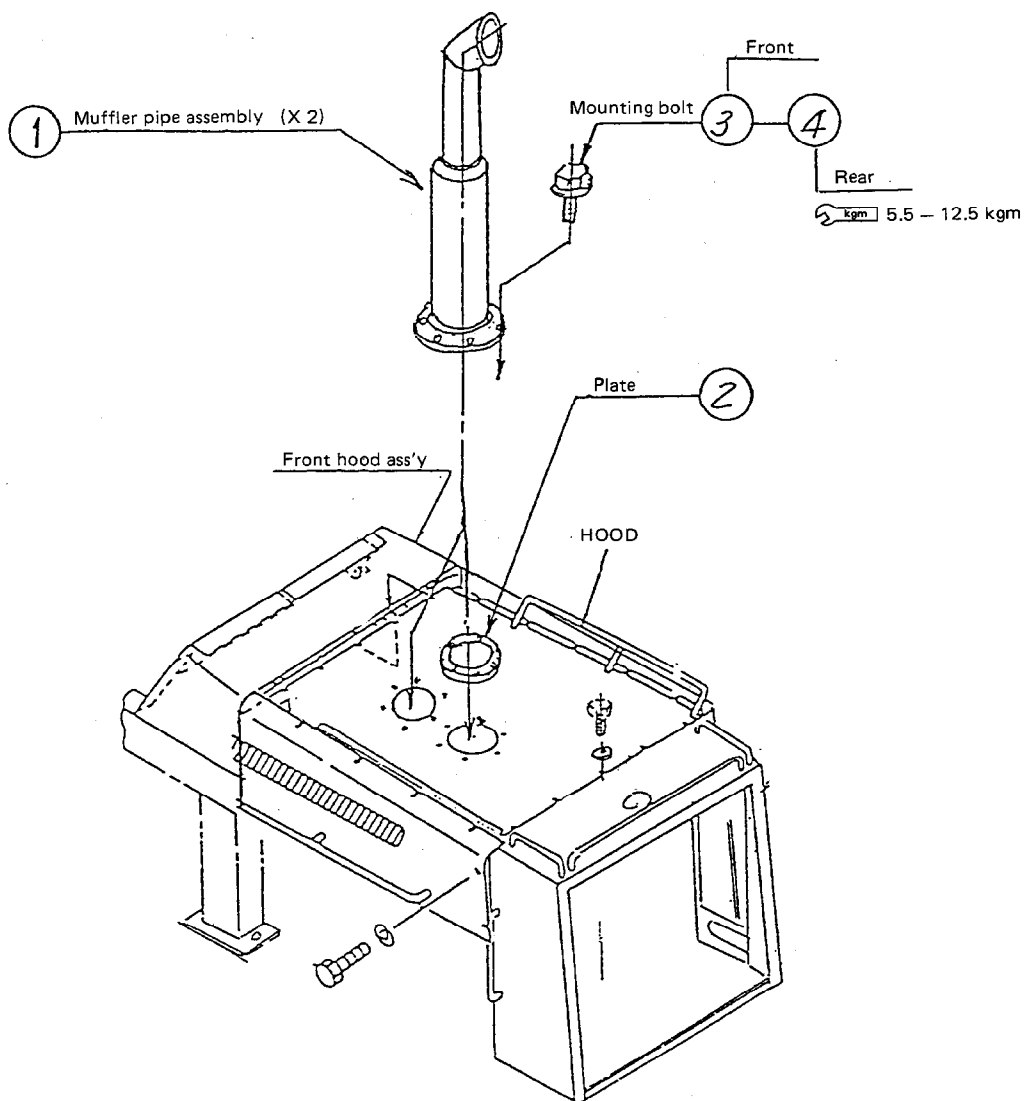

Assembly Process No.

A-12 Assembly of lift arm assembly

(1) Assembly of lift arm assembly

Tools and facilities required

No.	Name (Part No.)	Q'ty
1	Impact wrench	1
2	Socket 30 mm, 36 mm	1
3	Copper hammer	2
4	30-ton crane	1
5	40-ton crane	1
6	Lever block	3

Assembly parts for lift arm components

Mark	No.	Par Name	Part No.	Q'ty
○	1	Pin (for pivot at front frame end)	427-70-11992	2
○	2	Shim (for pivot at front frame end)	427-70-11460	4
○	3	Bolt (for pivot at front frame end)	01010-52450	2
○	4	Washer (for pivot at front frame end)	427-70-11480	2
○	5	Shim (for pivot at front frame end)	427-70-11470	2
△	6	Pin (for connecting boom cylinder and rod)	427-70-11971	2
△	7	Bolt (for connecting boom cylinder and rod)	01010-52035	2
△	8	Washer (for connecting boom cylinder and rod)	427-70-11290	2
	12	Plug	07049-01620	15
□	13	Bolt	01010-52035	1
□	14	Washer	427-70-11290	1
●	9	Pin	427-70-11941	1

○: Already temporarily installed to front frame pivot

△: Already temporarily installed to boom pivot

□: Already temporarily installed to bellcrank pivot

●: Already temporarily installed to bellcrank

No mark: Sent as individual part

Precautions

- (1) Before assembling the lift arm, start the engine. For details, see M-6 Procedure for starting engine.
- (2) When aligning the pin holes, never insert your fingers in the pin holes.

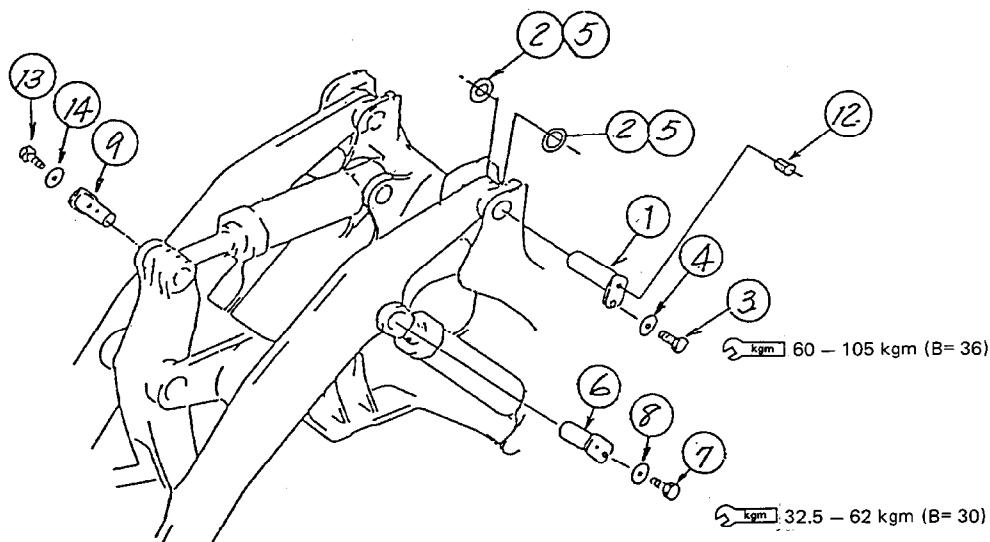

(2) Connection of remote grease tube

Tools and facilities required

No.	Name (Part No.)	Q'ty
1	Spanner	1
2	Torque wrench	

Assembly part for remote tube line components

Mark	No.	Part Name	Part No.	Q'ty
□	10	Elbow	426-70-13270	1
△	11	Elbow	07217-50712	4

○: Already installed to pin (427-70-11941) temporarily installing bellcrank

△: Already installed to pin temporarily installing front frame boom pivot

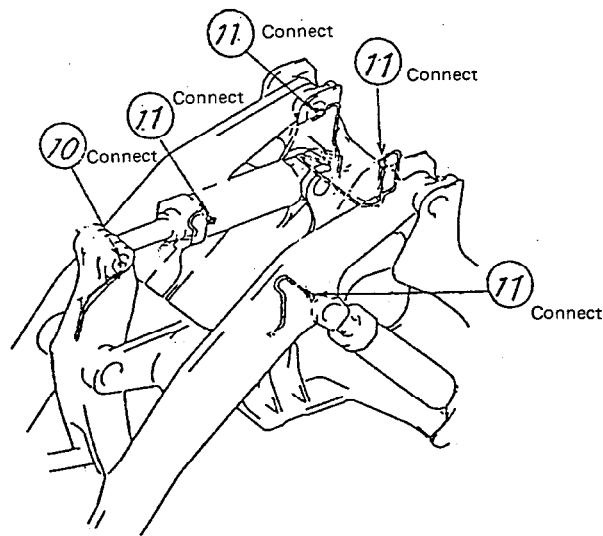

ASSEMBLY PROCEDURE

1. Holding dump, lift cylinders

Using the lever block, hold the dump and lift cylinders.

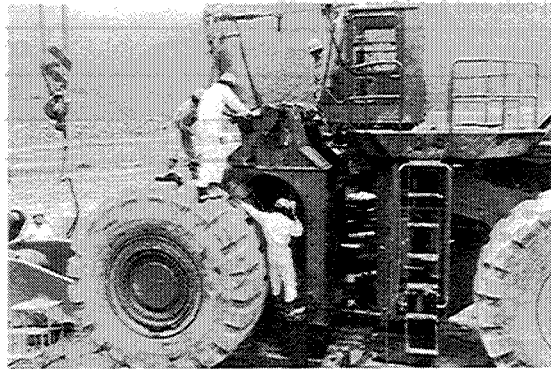
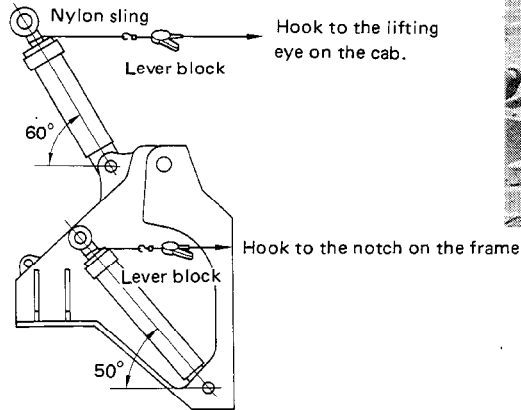

2. Inserting lift arm hinge pin

Raise the lift arm assembly with the crane, move above the front frame, set in position, and then insert the lift arm hinge pin.

 : 11 tons

Lifting tool: Wire sling $\phi 40 \times 1500$ (No. 6A)

- ★ When adjusting the position of the holes, be careful not to get your fingers caught!
- ★ Before inserting the pin, wipe the inside surface of the front frame and lift arm holes with a cloth, then coat the inside of the bushing in the lift arm hole with molybdenum disulphide paste LM-P.
- ★ Before inserting the pin, adjust with shims so that the clearance is less than 1.5 mm. Adjust so that the clearance is equal on the left and right sides.

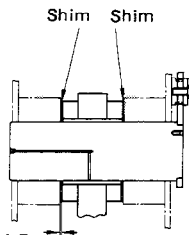

Clearance: Max. 1.5

- ★ When inserting the pin, coat the seal with grease, and be careful not to damage the seal.
- ★ When raising the lift arm, be careful not to hit and damage the pin at the lifting point.



3. Inserting lift cylinder head pin

After adjusting the position at the lift arm assembly end and lift cylinder end, insert the lift cylinder head pin.

- ★ Before inserting the pin, wipe the inside surface of the lift arm and lift cylinder holes with a cloth, then coat the inside of the bushing in the lift cylinder hole with molybdenum disulphide paste LM-P.
- ★ When inserting the pin, coat the seal with grease, and be careful not to damage the seal.



4. Inserting dump cylinder head pin

Using the crane, raise the dump cylinder head and adjust the position, then insert the dump cylinder head pin.

- ★ Start the engine, then raise the lift arm and adjust the position of the hole.
- ★ Before inserting the pin, wipe the inside surface of the bellcrank and dump cylinder holes with a cloth, then coat the inside of the bushing in the lift arm hole with molybdenum disulphide paste LM-P.
- ★ When inserting the pin, coat the seal with grease, and be careful not to damage the seal.
- ★ After assembling, fill with molybdenum disulphide lithium grease until grease comes out from the joint.



Assembly Process No.

A-13 Assembly of front fender

Tools and facilities required

No.	Name (Part No.)	Q'ty
1	Impact wrench	1
2	Socket 19 mm, 24 mm	1
3	Torque wrench	1
4	30-ton crane	1
5	Lifting wire	1

Assembly parts for fender components

Mark	No.	Part Name	Part No.	Q'ty
○	1	Bolt	01010-51660	6
○	2	Washer	01643-31645	6
○	3	Bracket L.H.	427-54-13380	1
○	4	Bracket R.H.	427-54-13410	1
○	5	Bolt	01010-51230	4
○	6	Bolt	01010-51245	4
○	7	Washer	01643-31232	4
○	8	Washer	424-54-14220	4
○	9	Cap	09415-05016	6
	10	Fender L.H.	427-54-13370	1
	11	Fender R.H.	427-54-13380	1
	12	Bolt	01010-51230	16
	13	Washer	01643-31232	4
	14	Washer	424-54-14220	12

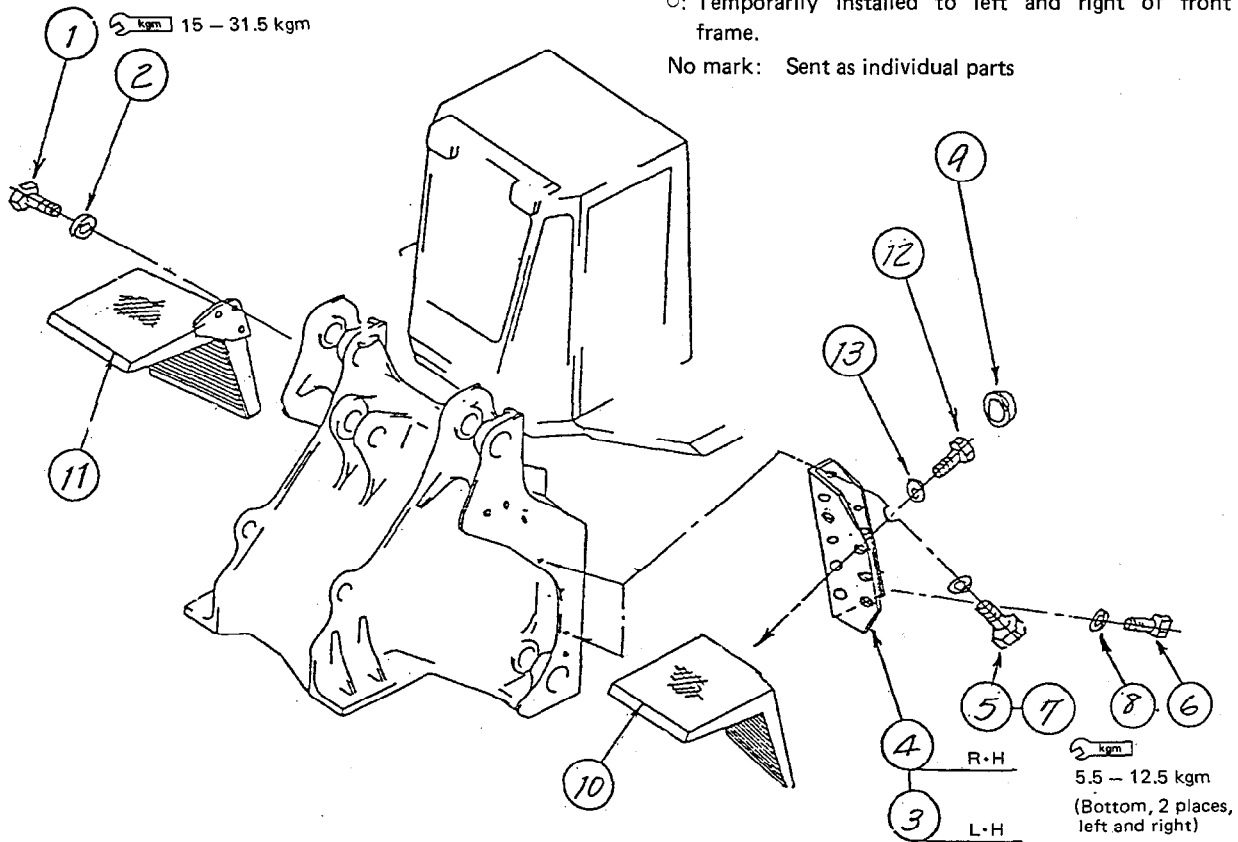

Assembly Process No.

A-14 Assembly of front lamp assembly

Tools and facilities required

No.	Name (Part No.)	Q'ty
1	Nylon lifting equipment	1
2	Impact wrench	1
3	Socket 17 mm	1
4	30-ton crane	1

Assembly parts for front lamp components

Mark	No.	Part Name	Part No.	Q'ty
	1	Bolt	01435-01240	8
	2	Clip	424-06-12720	2
	3	Bolt	01010-51020	2
	4	Washer	01643-31032	2

No mark: Already temporarily installed to left and right of front frame

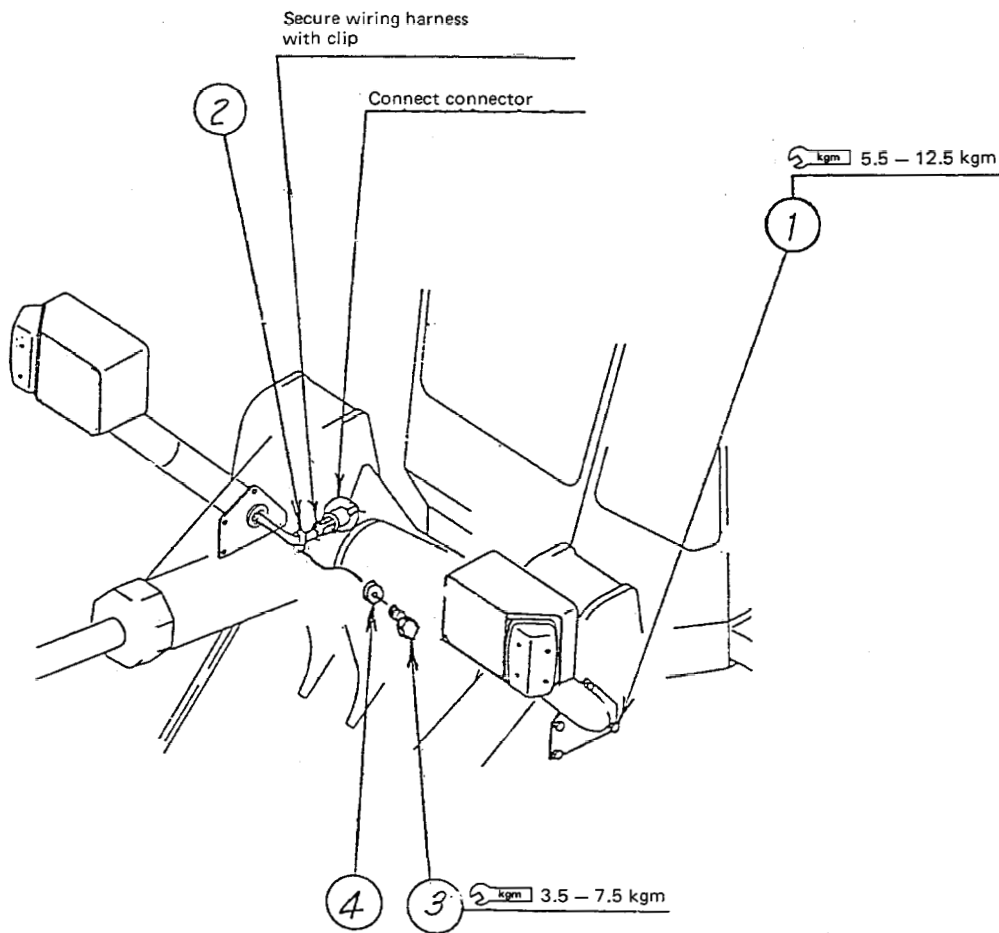

Assembly Process No.

A-15 Assembly of ROPS canopy assembly

Assembly parts for ROPS canopy components

Mark	No.	Part Name	Part No.	Q'ty
○	1	Bolt	01011-63650	20
○	2	Washer	01643-33690	20
△	3	Bolt	01435-01220	4
△	4	Plate	427-06-13180	2
△	5	Working lamp ass'y	22W-06-12381	2
△	6	Clip	425-70-13120	4

Mark	No.	Par Name	Part No.	Q'ty
△	7	Bolt	01010-51020	4
△	8	Washer	01643-31032	4
	9	ROPS WELD (with name plate)	427-54-19111	1

○: Already temporarily installed to rear frame ROPS support

△: Already temporarily installed to ROPS WELD

No mark: Sent as individual parts

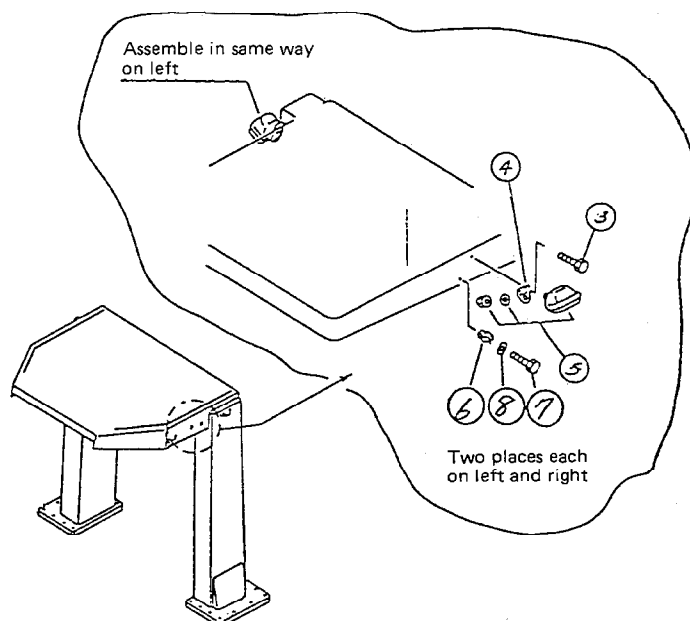
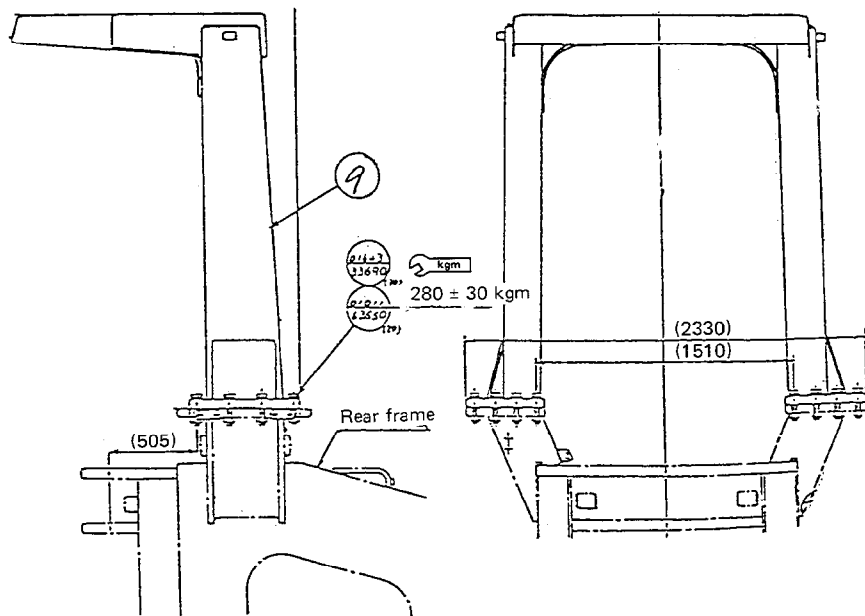

Tools and facilities for required

No.	Name (Parts No.)	Q'ty
1	Power wrench (x16) Torque wrench: 7.5 kgm	1
2	Socket 55 [□]	1
3	Extension bar	1
4	Torque wrench	1
5	Impact wrench	1
6	30-ton crane	1

1. Raising ROPS canopy assembly

Using a 30 or 45-ton crane, raise the ROPS canopy assembly and set in position on the mount.

 : 1.26 ton

Lifting tool: 2-point suspension (same as lifting tool for floor and cab ass'y)

- ★ Before assembling, clean the contact surface of the mount.

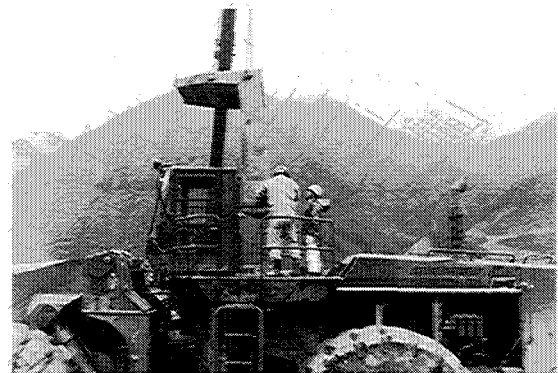

2. Temporarily tightening with impact wrench

Temporarily tighten with an impact wrench.

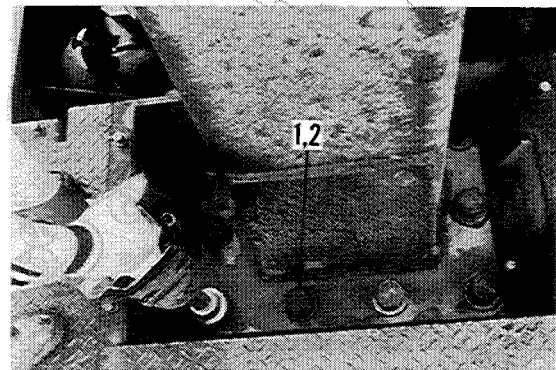

3. Tightening with power wrench and torque wrench

Tighten to the specified torque with the power wrench and torque wrench.

 Bolt: 280 ± 30 kgm

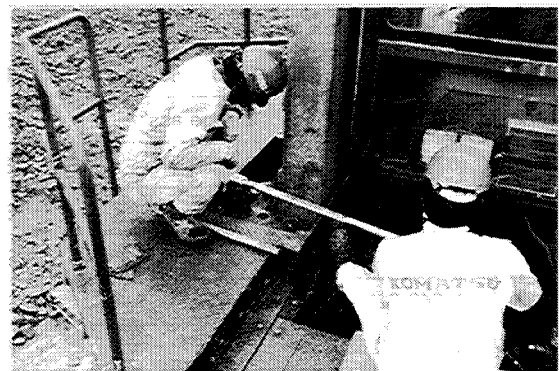

No. A-16 Assembly of bucket

OUTLINE

Tools and facilities required

No.	Name (Parts No.)	Q'ty
1	Torque wrench	1
2	30-ton crane	1
3	Grease gun	1

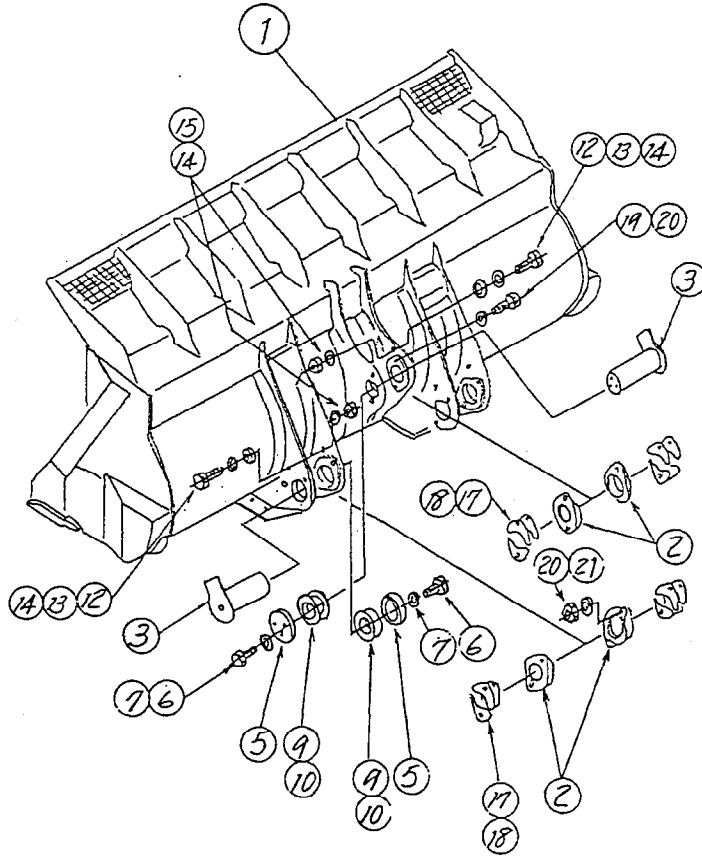

Boom pivot pin

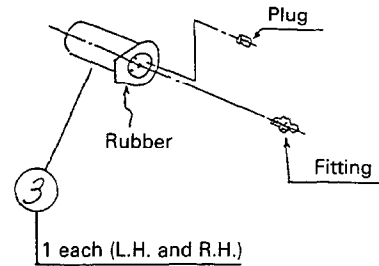

Bucket linkage pivot pin

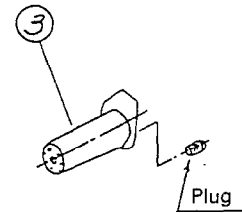

Parts sent as individual parts

No.	Part No.	Part Name	Q'ty
Bucket assembly mounting part			
1	427-809-1310	Bucket ass'y	1
2	(620-3930-SC)	Flange ass'y	6
3	(620-3890-SC)	Pin ass'y	3
5	427-70-11260	Retainer	3
6	01010-52070	Bolt	9
7	01643-32060	Washer	9
8	427-70-12530	O-ring	6
9	427-70-11280	Shim t0.5	15
10	427-70-11270	Shim t0.2	6

No.	Part No.	Part Name	Q'ty
12	425-70-11250	Cam	3
13	01010-52455	Bolt	3
14	01643-32460	Washer	6
15	01580-12419	Nut	3
17	427-70-11330	Shim t0.5	18
18	427-70-11340	Shim t2.8	12
19	01011-52025	Bolt	12
20	01643-32060	Washer	24
21	427-01-11150	Lock nut	12

ASSEMBLY PROCEDURE

- Using crane B, raise bucket (1) and set it in front of the machine.



Bucket: 8,600 kg

Lifting tool: Use the top part of the balance of the balance lifting tool for the rear axle.

- Remove the grease and paint from around the pin hole of bucket (1).
- Remove all the grease and paint from around the boom pivot and bucket link pivot pin holes.

- After temporarily assembling the pin in the boom pivot and bucket link pivot holes, use a guide to assemble flange assembly (2). When assembling the flange assembly, install dust prevention O-ring (8) also.

- ★ Check that the dust seal is assembled with the lip facing in the correct direction.
- ★ Check that the dust seal does not protrude from the end face of the flange.
- ★ Check that the O-ring is assembled to the flange.

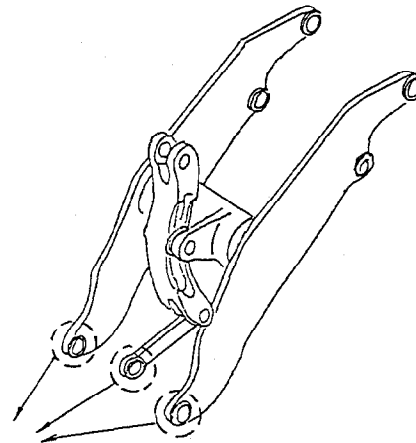
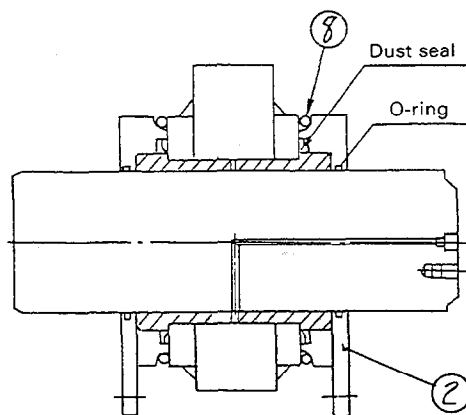
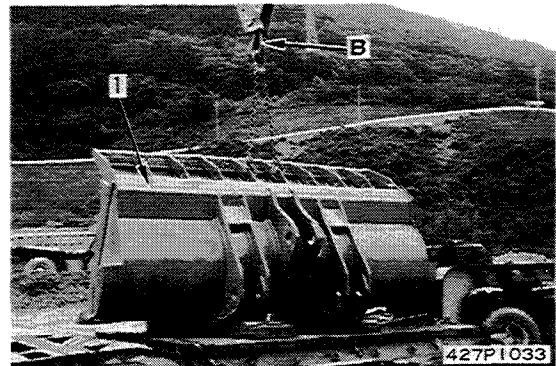

1) Using the pin as a guide, rotate the flange by hand to the left and right, and insert the lift arm and bucket link.

- ★ After inserting, rotate the flange 1 ~ 2 turns to settle the seal contact.
- ★ Pull out the flange approx. 5 mm from the lift arm and check that there is no abnormality in the dust seal.
- ★ Insert until the inside face of the flange contacts the end face of the bushing, then turn the mounting bolt holes of the flange approx. 25° to the rear of the lift arm.
- ★ Do not hit the flange with a hammer.
- ★ Carry out the same procedure for the other flanges.

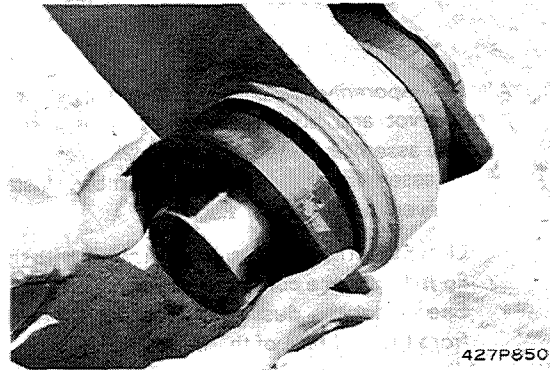
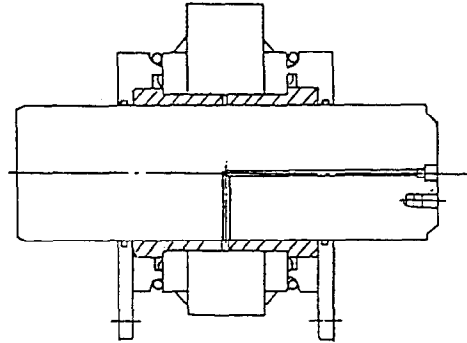

5. Insert the hinge pin in the boom and bucket.
(Raise the bucket with a crane to adjust the position of the hole.)

1) Bring the lift arm close to the bucket, align the position of the bucket mounting holes, then insert the pin.

- ★ When doing this, be careful not to hit the flange with the bucket.
- ★ Align the flange bolt hole and flange mounting hole of the bucket.

2) Push in flange (8) evenly towards lift arm boss, and measure clearance b. Select shims and assemble so that clearance is within standard value.

- ★ Clearance b: Max. 0.2 mm

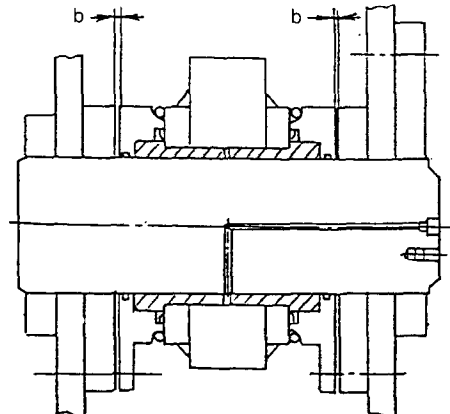
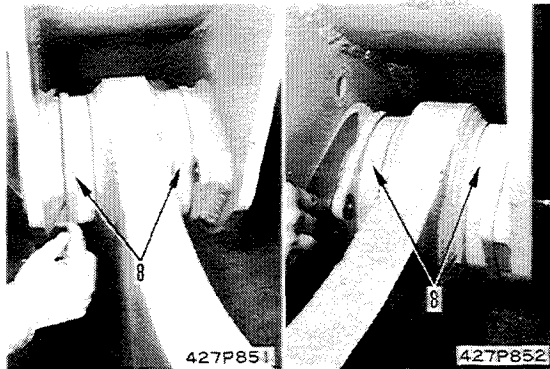

- Temporarily tighten bolt (3) so that cam (4) contacts mounting pin.

- ★ Tighten fully after installing retainer (7).

- Install retainer (7), and measure clearance C. Select shims and assemble so that clearance is within standard value.

- ★ Clearance c: Max. 0.2 mm

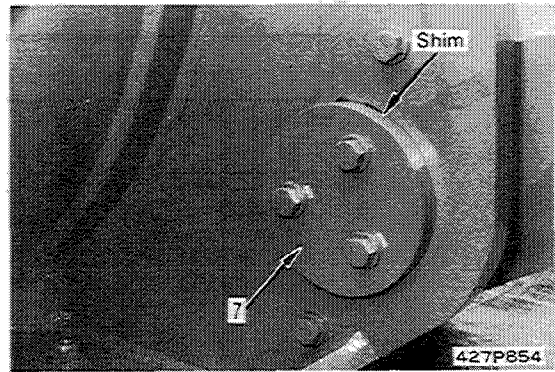
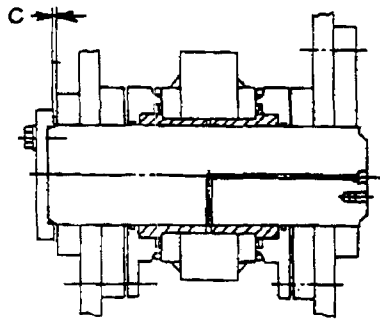
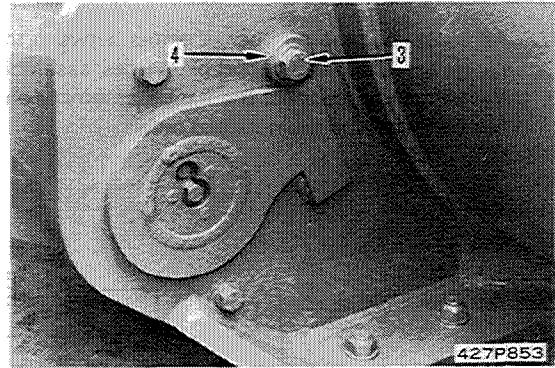

- Add one 0.2 mm shim to shim selected in Item 4), then assemble, and tighten mounting bolts of retainer (7).

 Mounting bolt: 84 — 105 kgm

- Select the number of shims so that the clearance between the flange assembly and bucket pivot boss is less than 0.5 mm. Then remove two 0.5 mm shims to make the clearance 1.5 mm at the places marked *.

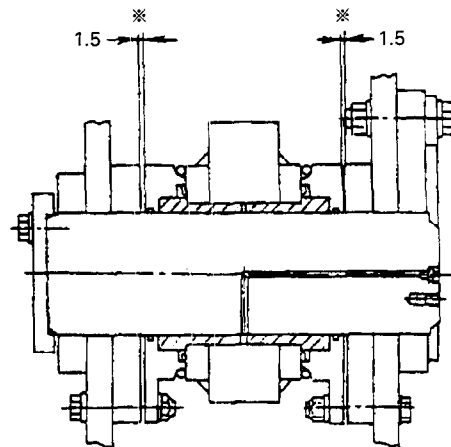

7. After deciding the number of shims between the flange assembly and bucket pivot boss, assemble the shims and connect the flange assembly and bucket pivot with the nuts and bolts.

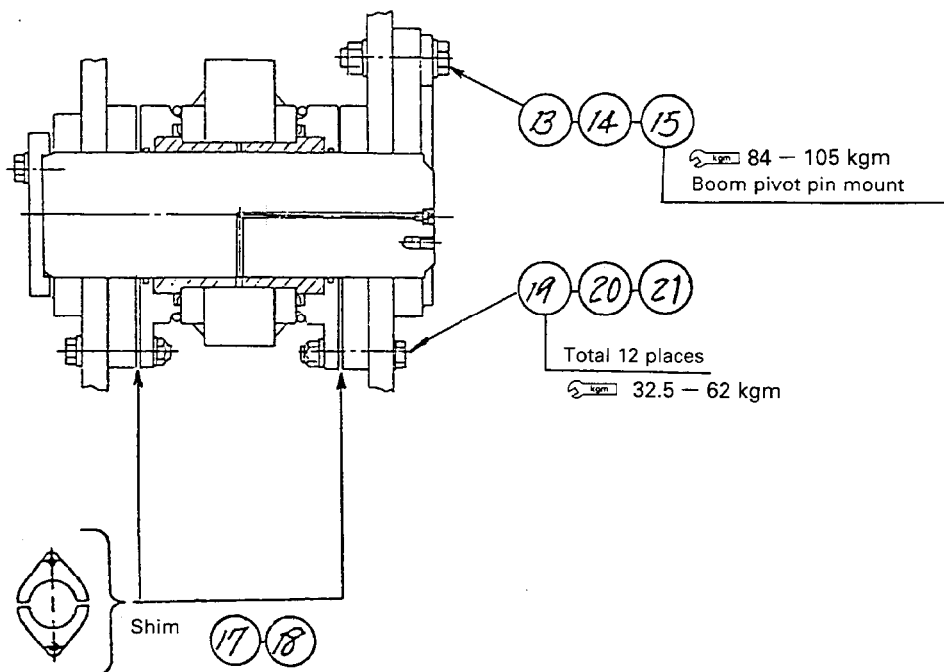

8. Raise bucket link (5), align pin hole, and insert pin.
 - ★ When doing this, be careful not to hit the flange against the bucket.
 - ★ Carry out the same procedure for the bucket pin.

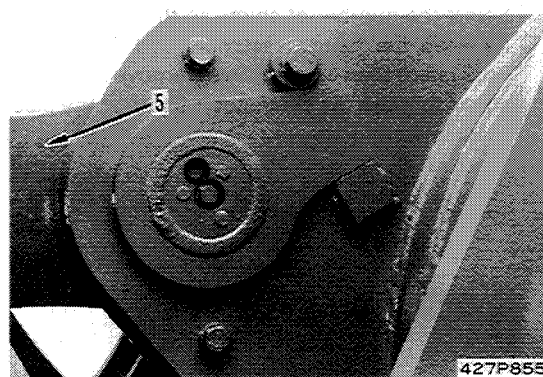

Structure of flange assembly

Note:

1. Press fit the lip of the dust seal as shown in the diagram below.
2. When press fitting the dust seal, coat the outside circumference with Loctite #262.

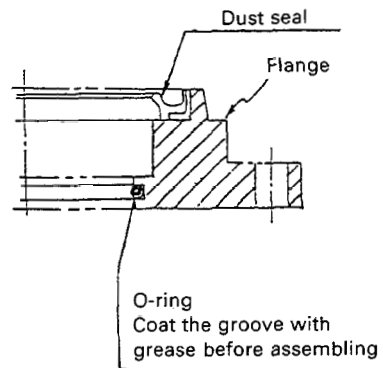
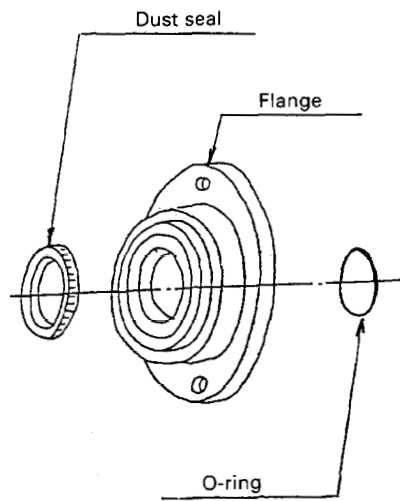

Assembly Process No.

M-1 Bleeding air from brake line

Tools and facilities required

No.	Name (Parts No.)	Q'ty
1	Compressor	1

1. Connect the compressor hose to the air coupler at the front inside the air component box, and charge with air.
2. Add oil to the brake oil tank at the top of the component box.

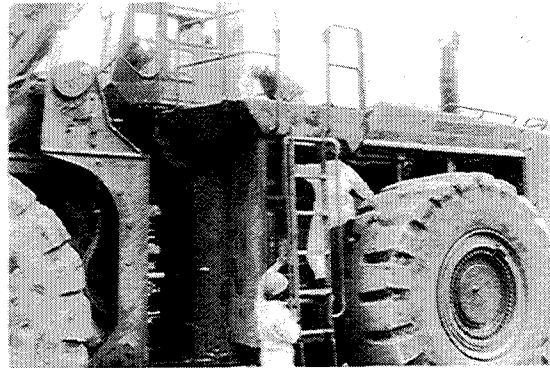

3. Remove the cap of the brake chamber bleeder screw, insert a vinyl hose into the screw, and put the other end into a container.

Insert vinyl hose here (bleeder screw)

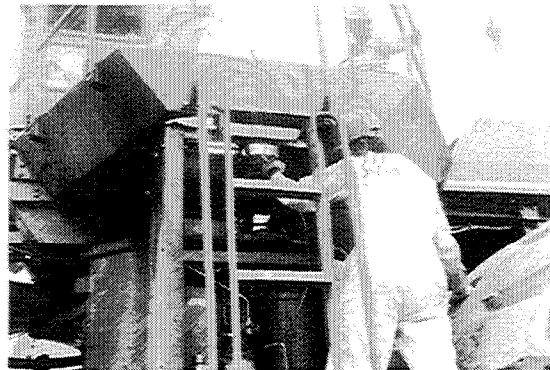
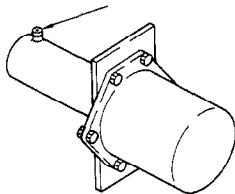

4. Depress the brake pedal, and loosen the bleeder screw to bleed the air. Tighten the bleeder screw first, then slowly release the brake pedal.

- ★ Carry out the operation with two workers. One worker depresses the brake pedal, and the other worker bleeds the air from the bleeder screw.
- ★ Keep adding brake oil.
- ★ Keep to the agreed signals, and be careful not to release the pedal while the bleeder screw is still loose.

5. Repeat this operation until no more bubbles come out with the liquid from the bleeder screw. When no more bubbles come out, depress the pedal fully and tighten the screw while the oil is flowing out.
 - ★ Repeat the same procedure to bleed the air from the four brake chambers.

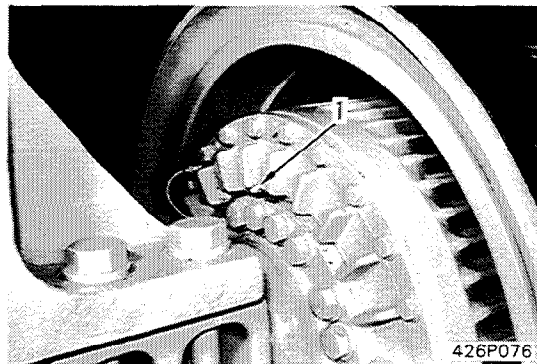

6. Remove the cap of the axle bleeder screw, insert a vinyl hose into the screw, and put the other end into a container.
7. Following the procedure for bleeding air from the brake chamber, bleed the air from the front axle and rear axle. (Total: 4 places)
8. Check the level of oil in the oil tank, and add oil if necessary.
9. After completing the bleeding of air, check that overstroke sensor rod (5) of brake chamber (4) has not come out. If it has come out, insert it to the end face of the brake chamber body.

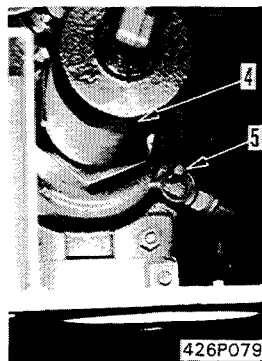

Assembly Process No.

M-2 Greasing work equipment and chassis

Tools and facilities required

No.	Name (Parts No.)	Q'ty
1	Grease gun (Air type)	1
2	Compressor	1

1. Coat the lift arm hinge, bucket cylinder head, and lift arm cylinder head with grease.
2. Grease the front and rear drive shafts.
3. Grease the rear axle support.

Assembly Process No.

M-3 Adjusting bucket positioner

1. Lower the bucket to the ground, set in a horizontal position, return the lever to the HOLD position, and stop the engine.
2. Fix plate (2) to the bucket cylinder bracket so that the center of switch (3) is in line with the corner of angle (1).
3. Remove cover (4) of the switch, and fix the switch so that the clearance between the plate and the sensor surface of the switch is 5 to 8 mm.
 - ★ Be careful of the torque when tightening the switch nut, and be careful not to damage the thread!
4. Start the engine and run at a midrange speed. Adjust so that the bucket operates at a level position, then install cover (4).

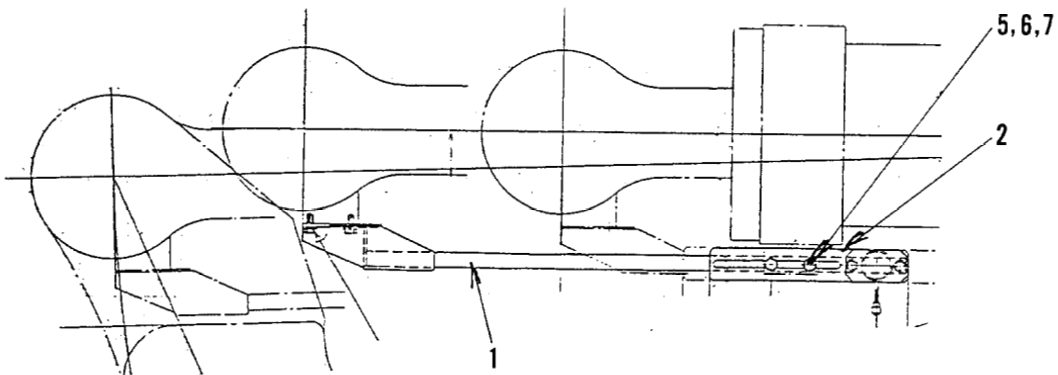
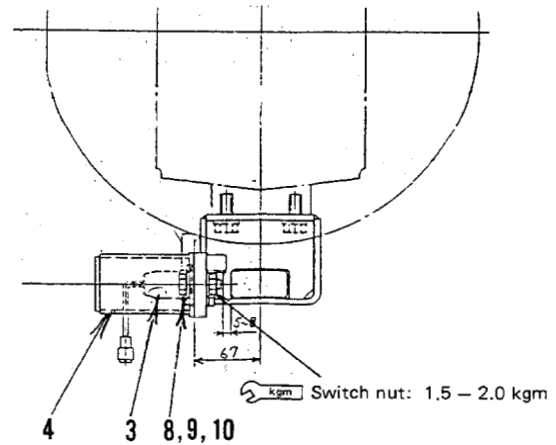



Part to assemble to body

Mark	No.	Parts Name	Part No.	Q'ty
	2	Plate	427-43-19230	1
	3	Switch	421-06-11164	1
	4	Cover	426-43-19110	1
	5	Bolt	01010-51245	2
	6	Nut	426-43-19160	2
	7	Washer	01643-31232	4
	8	Bolt	01010-51035	2
	9	Nut	426-43-19160	2
	10	Washer	01643-31232	4

M-4 Adjusting boom kick-out

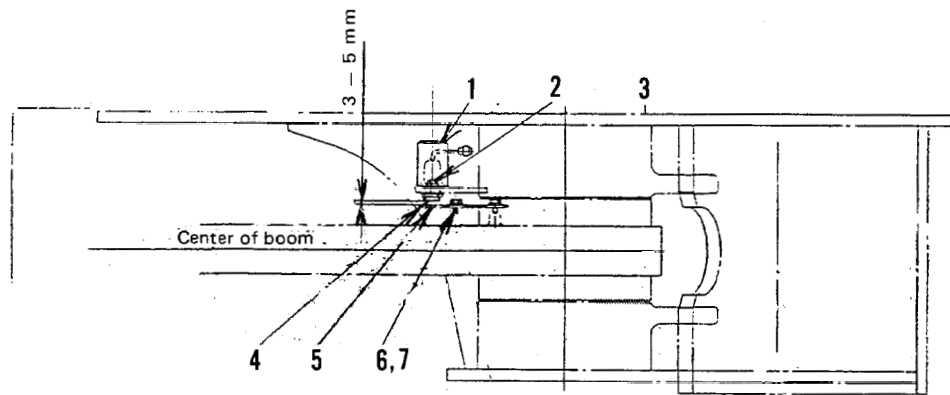
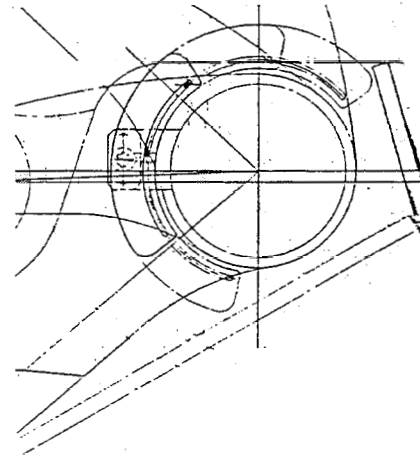
1. Raise the boom to near the maximum height, then mark the plate to show the position where the sensor of switch (4) is in line with the bottom edge of plate (5).
2. Lower the boom and stop the engine.
3. Fix the plate to the position marked.
4. Remove cover (1) of switch (4), and fix the switch so that the clearance between plate (5) and the sensor surface of the switch is 3 to 5 mm.
 - ★ Be careful of the torque when tightening the switch nut, and be careful not to damage the thread!
5. Start the engine and run at high idling. After actuating the kick-out, check that the bucket cylinder extends 2 to 5 mm when the boom is raised, then install cover (1).



 Mounting nut of switch (4): 1.5 – 2.0 kgm

Part to assemble to body

Mark	No.	Parts Name	Part No.	Q'ty
	1	Cover	426-43-19110	1
	2	Bolt	01010-51020	2
	3	Washer	01643-31032	2
	4	Switch	421-06-11164	1
	5	Plate	427-43-19120	1
	6	Bolt	01010-51020	2
	7	Washer	01643-31032	2

Assembly Process No.

M-5 Inspection of all parts

1. Inspect the assembled parts for interference, oil leakage, and air leakage.
2. Check the radiator water level, engine oil level, transmission oil level, hydraulic oil level, brake oil, and window washer fluid level.

M-6 Procedure for starting engine

1. **Check all oil and water levels, and add if necessary.**
 - Cooling water level
 - Engine oil pan oil level
 - Hydraulic tank oil level
 - Fuel level
 - ★ For details of the gauge positions and oil and water levels, see the Operation & Maintenance Manual.

2. **Bleed the air from the piston pump**

For details, see Procedure for Assembly Process No. M-7.

3. **Start the engine.**
 - 1) For details of starting the engine, see the Operation & Maintenance Manual.
 - ★ Check the method for stopping the engine.
 - 2) Run the engine for 10 minutes at low idling.
 - ★ When doing this, do not move the control levers.
 - ★ If there is any abnormality, such as oil leakage or abnormal noise, stop the engine immediately.
 - ★ For the procedure when starting machines that have been kept in long-term storage of six months or more, see page 79-1.

4. **Check after stopping the engine.**
 - ★ Check for any oil leakage.

5. **Bleed the air from the work equipment hydraulic circuit.**

For details, see Procedure for Assembly Process No. M-8.

★ When starting the engine of machines (completed machines or semi-completed machines) that have been kept in long-term storage of six months or more, carry out the following procedure.

1. Disconnect the Econoseal connector of the ENGINE STOP wiper motor installed inside the rear frame on the right side of the engine. (Disconnect from the engine wiring harness)
The connector in portion (A) in the diagram below.
2. Turn the engine starting key ON.
3. Turn the engine starting key to START and crank the starting motor for approx. 15 seconds.
 - ★ Carry out this procedure to circulate the lubricating oil through the whole engine.
 - ★ Turn the ENGINE STOP switch OFF to turn the fuel cut solenoid valve OFF and set the fuel injection pump to the NO INJECTION position.

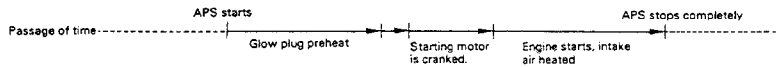

Starting switch	ON		START	ON
Preheater switch	OFF	ON	AUTO	
APS water temperature sensor	ON (Below 20°C)			OFF
Hold relay	OFF	ON		OFF
APS relay	OFF	ON		OFF
Glow plug	OFF	ON		OFF
Bimetal timer	ON		OFF	
Preheat monitor display	OUT	ON	OUT	
Fuel injection nozzle	No injection		Intermittent injection	No injection
Afterheating monitor display	OUT		Flashes	OUT

4. Reconnect the connector of the ENGINE STOP wiper motor removed in Step 1.

★ For the rest of the starting procedure, see the Operation and Maintenance Manual.

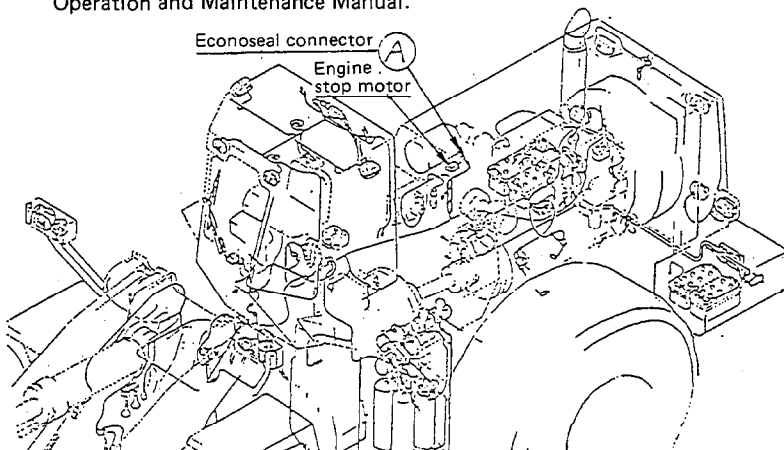

Assembly Process No.

M-7 Procedure for bleeding air from piston pump

Tools and facilities required

No.	Name (Parts No.)	Q'ty
1	Spanner (B=27)	1
2	Spanner (B=41)	1

★ Do not start the engine under any circumstances until the following operation is completed.

1. Loosen the plugs (★1 – ★3: 3 places in diagram at right) fitted above the tube at the suction side of the piston pump.
2. Loosen the holder (★4 in diagram at right) at the block end of the piston pump case drain hose.
3. Supply air from the outside from the air chuck.
★ If the air pressure rises too high, oil will spurt out from the plug or hose joint.
4. Adjust the pressurizing pressure of the hydraulic tank to 0.01 kg/cm² (adjustment point: (A) in diagram at right).
5. Open the pressurizing valve ((A) in diagram below), and pressurize the hydraulic tank.
6. Bleed the air until oil comes out from the plugs (★1 – ★3 in diagram below) and hose joint (★4 in diagram below), then tighten the plugs and hose joint.
7. Close the pressurizing valve ((A) in diagram at right).
8. Check the oil level, and add oil if necessary.
9. Remove the external air supply connected to the air chuck.

Hydraulic piping diagram

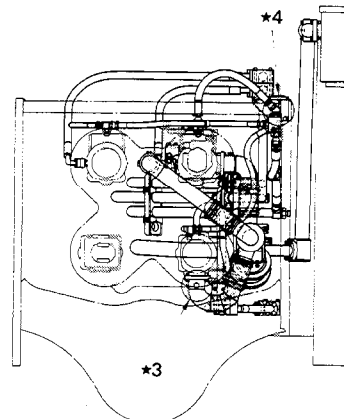
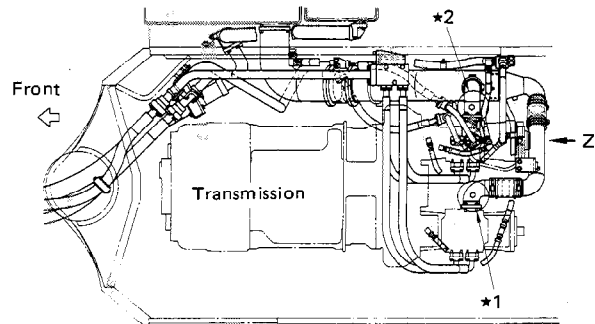

View Z

Air pressure piping diagram

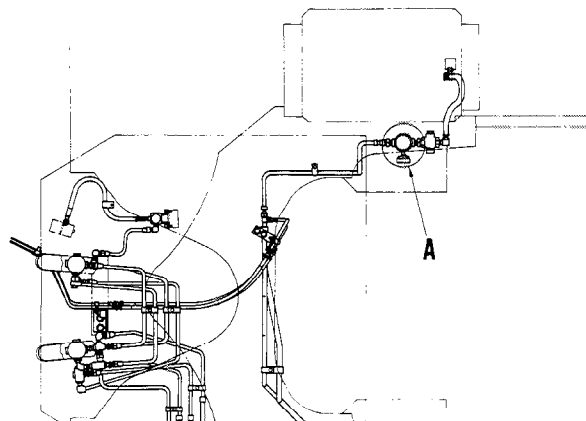

M-8 Procedure for bleeding air from work equipment hydraulic circuit

1. Bleeding air from cylinders

- 1) Run the engine at low idling and operate the cylinder to about 100 mm from the end of its stroke 3 – 4 times
- 2) Run the engine at midrange speed and operate the cylinder to about 100 mm from the end of its stroke 3 – 4 times
- 3) Run the engine at high idling and operate the cylinder to about 100 mm from the end of its stroke 3 – 4 times
- 4) Run the engine at low idling and operate the cylinder to relief at the end of its stroke 3 – 4 times
- 5) Run the engine at midrange speed and operate the cylinder to relief at the end of its stroke 3 – 4 times
- 6) Run the engine at high idling and operate the cylinder to relief at the end of its stroke 3 – 4 times

2. Bleeding air from the PPC circuit

- 1) Operate the bucket control lever to TILT and the boom control lever to FLOAT, and hold for about one minute after the cylinder reaches the end of its stroke.
- 2) Operate the bucket control lever to DUMP and the boom control lever to RAISE, and hold for about one minute after the cylinder reaches the end of its stroke.

M-9 Charging air conditioner gas

When assembling the WA800 according to the Procedure for Field Assembly, it is unnecessary to charge the air conditioner with gas. However, if inspection of the refrigerant level according to the procedure in the WA800 operation manual shows that the refrigerant level is too low, charge with gas as follows.

This procedure explains the method of gas charging using the gauge manifold. If another gas charging device is used, follow the instructions given in the operating manual for that charger.

EVACUATION

If air is left in the refrigerant cycle, it may cause problems such as rise in the high pressure, rusting of metal parts, and clogging of the expansion valve. For this reason, when the refrigerant cycle line is removed, the air inside the cycle must be completely removed. This operation is called evacuation.

Evacuation

1. Connect the charging hose to the gauge manifold.
2. Connect the evacuation pump to the gauge manifold with the charging hose.
3. Operate the evacuation pump until the low pressure gauge reading is over 700 mmHg, then continue evacuation for about 15 minutes.
4. Close the low pressure and high pressure valves.
5. Leave for 5 minutes, and check that there is no change in the gauge reading. If the gauge indicator returns to 0, tighten the piping and carry out the evacuation again.

Leak test

1. Remove the evacuation pump and connect the refrigerant can.
2. Push out the air inside the charging hose with the refrigerant.
3. Open the high pressure valve and charge the refrigerant until the low pressure gauge reads 1 kg/cm^2 .
4. Close the high pressure valve.
5. Using a tester, check for leakage of gas.

Precautions

- ★ Be careful not to ignite combustible substances such as gasoline.
 - ★ Be careful not to breathe in the burnt (poisonous) gas.
6. If there is any leakage, tighten the connections.
 7. Carry out the above evacuation procedure for at least 15 minutes.

Procedure for evacuation

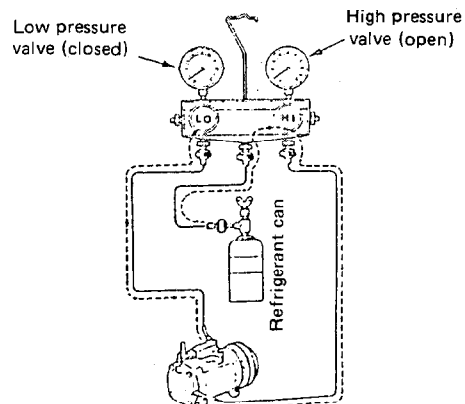
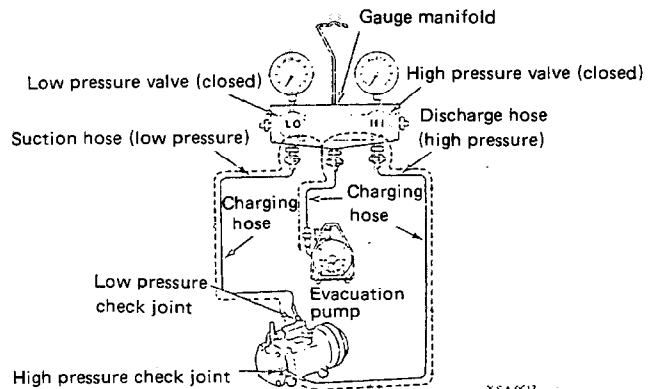
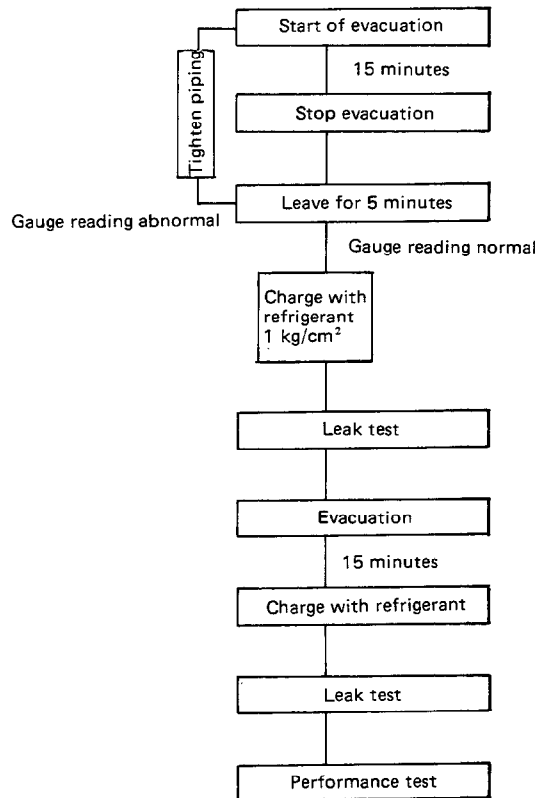

CHARGING WITH REFRIGERANT

Charging method

1. After evacuating, close the high pressure and low pressure valves. Then remove the evacuation pump and install the refrigerant can.
2. Push out the air inside the charging hose with the refrigerant.
3. Open the high pressure valve and charge the refrigerant.

Precautions

- ★ Do not open the low pressure valve.
 - ★ Do not start the engine (compressor).
4. When the charging speed drops, close the high pressure valve.
 5. Check that the high pressure valve is closed, then start the engine.
 6. Set the temperature control lever to COOL, and the fan switch to H. Open all the windows of the machine.
 7. Open the low pressure valve and the valve of the refrigerant can, and charge with refrigerant.

Precautions

- ★ Do not open the high pressure valve.
If the high pressure valve is opened, the high pressure gas will flow in the reverse direction and will break the refrigerant can, so never open the high pressure valve.
 - ★ Do not put the refrigerant can upside down.
8. Judge the amount which has been charged by using the performance graph.
 9. After charging with gas, close the low pressure valve and refrigerant can valve, then stop the engine.
 10. Remove the gauge manifold quickly.

When adding refrigerant, follow Steps 5 to 10.

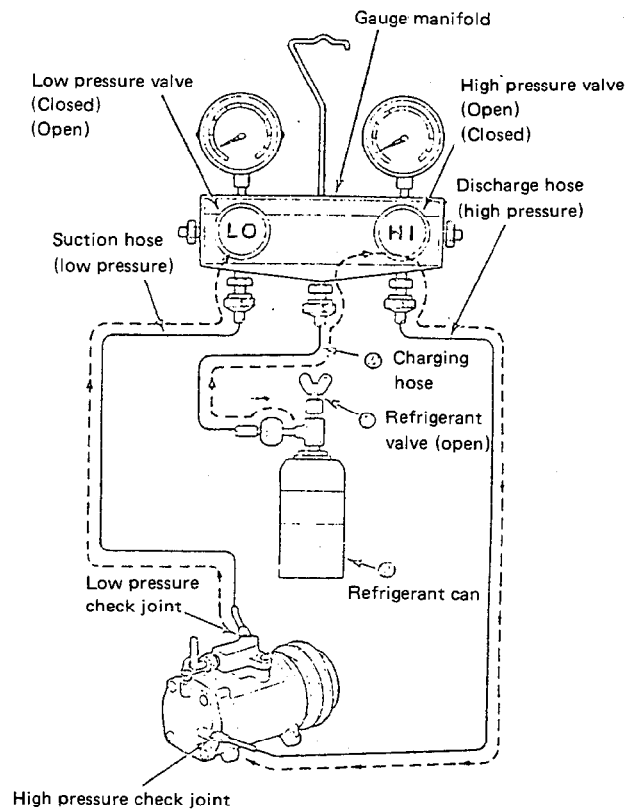

PERFORMANCE TEST

1. Set the gauge manifold in position.
2. Set a wet and dry thermometer to the suction port of the blower and a dry bulb thermometer to the air discharge port.
3. Set to the following measurement conditions.
 - Keep out of direct sunlight (shade)
 - Open the vent grill fully
 - Open all doors and windows
 - Set the temperature control lever to COOL
 - Set the fan switch to H
 - Set the engine speed to approx. 70% of the rated speed
 - No one on machine
4. After running for approx. 10 minutes under the measurement conditions, measure the temperature and pressure.
5. If the results measured at a humidity of 60 to 80% are within the parameters on the performance graph, the air conditioner is normal.

(Example)

Results

Intake temperature	(dry)	30°C	Humidity 60%
	(wet)	24°C	
Discharge temperature		15°C	
Discharge pressure		15.5 kg/cm ²	
Intake pressure		2.5 kg/cm ²	

Judgement

The air conditioner is normal

As shown in the above example, take the intake temperature on the horizontal axis as the standard, and read the discharge temperature, intake pressure, and discharge pressure on the vertical axis to compare the results of the measurement.

The performance graph shows the measurements taken at a humidity of 60 to 80%. If the humidity is below 60%, the readings tend to be lower; if the humidity is above 80%, the readings tend to be higher.

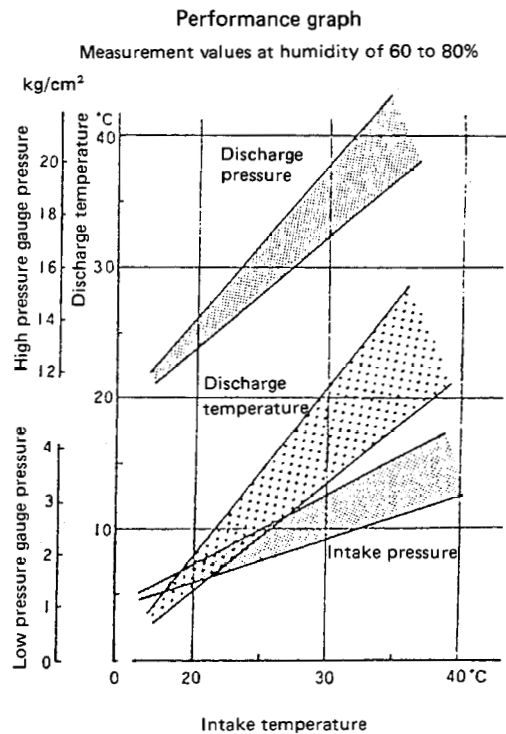

FIELD ASSEMBLY INSPECTION REPORT

After completion of assembling a machine, make inspections according to these check sheets for assuring machine performance and quality.

Model - Type WA800-2		Machine Serial No.	User Unit No.	Engine Model KOMATSU SA12V140	Engine Serial No.
Service Meter Reading	Date of Inspection		Attachment		
Location of Machine at Inspection			1		
			2		
			Manufacture		
Distributor's Name			Model		
			Serial No.		
Customer's Name		Address:		Signature:	Delivery Report No. attached
				Date:	

Inspector's Comments:

Inspector's Name:	KOMATSU USE ONLY: C. Sheet Receiving Date: _____ By _____ Remark:
Title	
Signature:	

Check Sheets filling instructions:

1. Use following indexes for entry of judgement

.....Normal

.....Correction made on abnormal point

.....Abnormal

.....Not applied

2. Enter actually measured values in parentheses, [_____] .

Notes:

- (1) Criteria are based on the standards when the machine is shipped out of the factory.

SUBMITTANCE OF THIS REPORT (AND CHECK SHEETS) TO KOMATSU IS ONE OF THE CONDITIONS OF WARRANTY VALIDATION, COPY FOR KOMATSU SHALL BE FORWARDED TO THE KOMATSU REGIONAL OFFICE TOGETHER WITH THE COPY OF DELIVERY SERVICE REPORT.

SEAW04280202

FIELD ASSEMBLY INSPECTION REPORT

After completion of assembling a machine, make inspections according to these check sheets for assuring machine performance and quality.

Model - Type WA800-2	Machine Serial No.	User Unit No.	Engine Model KOMATSU SA12V140	Engine Serial No.	
Service Meter Reading	Date of Inspection	Attachment			
Location of Machine at Inspection					
		1			2
		Manufacture			
		Model			
Distributor's Name		Serial No.			
Customer's Name	Address:		Signature:	Delivery Report No. attached	
		Date:			

Inspector's Comments:

Inspector's Name:	KOMATSU USE ONLY: C. Sheet Receiving Date: _____ By : _____ Remark:
Title	
Signature:	

Check Sheets filling instructions:

1. Use following indexes for entry of judgement

.....Normal

.....Correction made on abnormal point

.....Abnormal

.....Not applied







2. Enter actually measured values in parentheses, [].



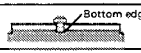



Notes:



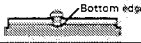







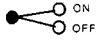



(1) Criteria are based on the standards when the machine is shipped out of the factory.















SUBMITTANCE OF THIS REPORT (AND CHECK SHEETS) TO KOMATSU IS ONE OF THE CONDITIONS OF WARRANTY VALIDATION, COPY FOR KOMATSU SHALL BE FORWARDED TO THE KOMATSU REGIONAL OFFICE TOGETHER WITH THE COPY OF DELIVERY SERVICE REPORT.



SEAW04280202



Category	No.	Item	Judgement procedure and standards	Measured value	Judgement	Repair checked	Details of repair
A. Specifications	1	Record serial number stamped on chassis	Stamped on right side of front frame	[]			
	2	Record engine serial No.	Stamped on right side of cylinder block (as seen from fan)	[]			
	3	Check specifications	Tires [— — PR, W/T, T/L, R, G, maker:]				
			Bucket [m ³ , w/teeth, w/o teeth, general-purpose bucket, spade nose bucket]				
			Others [(Option)]				
			[]				
	4	Paint color	Standard, specified color	[]			
5	Engine oil	SAE30, SAE10W	[]				
6	Antifreeze	Used or not, density	[°C]				
B. Oil, water levels, tire inflation pressure	1	Cooling water level	Above bottom edge of filler port 	[Top surface of core mm]			
	2	Engine oil level	H — L + 5, Wait for at least 15 minutes after stopping engine	[H ± mm]			
	3	Brake oil level	Top — middle of sight gauge	[O]			
	4	Hydraulic oil level	Top — middle of sight gauge	[O]			
	5	Transmission oil level	Within level of sight gauge (Engine stop)	[]			
	6	Axle oil level	Bottom of drain plug ± 10 mm	[]			
	7	Washer fluid	Tank at least 1/3 full	[]			
	8	Battery electrolyte level	Bottom of filler port — 10 mm above poles				
	9	Grease at all parts	All points must be greased				
	10	Tire inflation pressure	5.25 ^{+0.4} _{-0.2} kg/cm ²	[kg/cm ²]			
C. Starting	1	Operation, return of main switch	There must be no catching of the key; does ON, OFF work properly?				
	2	Operation of monitor panel self check	All modules must light up				
			All dashboard lamps must light up				
			Central warning lamp must light up				
			Alarm buzzer must sound				
	3	Operation of CHECK monitor	 Brake oil level: Does lamp light off?				
			 Engine oil level: Does lamp light off?				
 Cooling water level: Does lamp light off?							
4	Operation of PREHEAT switch (at AUTO position, does pilot lamp light up only when engine water temperature is approx. 13°C or below?)	Does preheating work with lever switch at ON? Does  (green) lamp light up? Does preheating work with lever switch at AUTO? Does  (green) lamp light up?					
5	Sounding of horn	Does horn sound properly? Is there any abnormal noise or vibration?					
6	Operation of shift lever neutral switch	Engine should start only when lever is at neutral position					
7	Operation of starting motor	There must be no abnormal noise or racing					

Category	No.	Item	Judgement procedure and standards	Measured value	Judgement	Repair checked	Details of repair
A. Specifications	1	Record serial number stamped on chassis	Stamped on right side of front frame	[]			
	2	Record engine serial No.	Stamped on right side of cylinder block (as seen from fan)	[]			
	3	Check specifications	Tires [— — PR, W/T, T/L, R, G, maker:]				
			Bucket [m ³ , w/teeth, w/o teeth, general-purpose bucket, spade nose bucket]				
			Others [(Option)]				
			[]				
	4	Paint color	Standard, specified color	[]			
5	Engine oil	SAE30, SAE10W	[]				
6	Antifreeze	Used or not, density	[°C]				
B. Oil, water levels, tire inflation pressure	1	Cooling water level	Above bottom edge of filler port 	[Top surface of core mm]			
	2	Engine oil level	H - L + 5, Wait for at least 15 minutes after stopping engine	[H ± mm]			
	3	Brake oil level	Top - middle of sight gauge	[○]			
	4	Hydraulic oil level	Top - middle of sight gauge	[○]			
	5	Transmission oil level	Within level of sight gauge (Engine stop)	[]			
	6	Axle oil level	Bottom of drain plug ± 10 mm	[]			
	7	Washer fluid	Tank at least 1/3 full	[]			
	8	Battery electrolyte level	Bottom of filler port - 10 mm above poles				
	9	Grease at all parts	All points must be greased				
	10	Tire inflation pressure	5.25 ^{+0.4} / _{-0.2} kg/cm ²	[kg/cm ²]			
C. Starting	1	Operation, return of main switch	There must be no catching of the key; does ON, OFF work properly?				
	2	Operation of monitor panel self check	All modules must light up				
			All dashboard lamps must light up				
			Central warning lamp must light up				
			Alarm buzzer must sound				
	3	Operation of CHECK monitor	 Brake oil level: Does lamp light off?				
			 Engine oil level: Does lamp light off?				
 Cooling water level: Does lamp light off?							
4	Operation of PREHEAT switch (at AUTO position, does pilot lamp light up only when engine water temperature is approx. 13°C or below?)	ON	Does preheating work with lever switch at ON?				
		AUTO	Does  (green) lamp light up?				
4		OFF	Does preheating work with lever switch at AUTO?				
			Does  (green) lamp light up?				
5	Sounding of horn	Does horn sound properly? Is there any abnormal noise or vibration?					
6	Operation of shift lever neutral switch	Engine should start only when lever is at neutral position					
7	Operation of starting motor	There must be no abnormal noise or racing					

Category	No.	Item	Adjustment procedure and standards	Measured value	Judge- ment	Repair checked	Details of repair
C. Starting	8	Engine starting	Should start within 10 seconds				
	9	Operation, indication of hourmeter	Pilot lamp should flash when engine is running. Counter reading [H]				
	10	Is there any abnormal lighting up of any caution pilot lamp?	When engine is stopped or when working				
	11	Check parking brake release 	Does (P) light up with lever switch ON? Machine must not start with shift lever at F or R with lever switch ON Buzzer and warning lamp should be actuated when shift lever is moved to F or R with lever switch ON With lever OFF and engine stopped, brake should be released by moving lever switch to ON and OFF				
D. Drive operation	• Travel operation Operating time: F1 – 5 min, F2 – 5 min, F3 – 5 min, R1 – 5 min, R2 – 5 min, R3 – 5 min. Total: 30 min						
	1	Does speedometer work properly?					
	2	 Does fuel gauge work properly?					
	3	 Does torque converter oil temperature gauge work properly?	Should be in green range				
	4	 Does water temperature gauge work properly?	Should be in green range				
	5	 Does air pressure gauge work properly?	Should be in green range				
	6	 Does charging caution lamp work properly?	Should flash when there is abnormality in charging circuit				
	7	 Does fuel level caution lamp work properly?	Should flash when fuel gauge enters red range				
	8	 Does transmission oil filter caution lamp work properly?	Should flash when transmission oil filter is clogged				
	9	Is there any abnormality in emergency caution lamp? (pilot, warning lamp, buzzer should be actuated when gauges are in red range)	 Failure in brake line  Engine oil pressure  Radiator water level  Air pressure  Engine water temperature  Torque converter oil temperature  Emergency steering actuated				
	10	Operation of air governor	Does load and unload work properly; is caution actuated at unload?				
	11	Is there any abnormal noise or vibration from engine, transmission, axle, etc.?					
	12	Is abnormal heat felt at axle or parking brake after travel?					
	13	Operation of dust indicator	There must be no showing of red piston.				

Category	No.	Item	Adjustment procedure and standards	Measured value	Judgment	Repair checked	Details of repair
C. Starting	8	Engine starting	Should start within 10 seconds				
	9	Operation, indication of hourmeter	Pilot lamp should flash when engine is running. Counter reading [H]				
	10	Is there any abnormal lighting up of any caution pilot lamp?	When engine is stopped or when working				
	11	Check parking brake release 	Does (P) light up with lever switch ON?				
			Machine must not start with shift lever at F or R with lever switch ON				
Buzzer and warning lamp should be actuated when shift lever is moved to F or R with lever switch ON							
		With lever OFF and engine stopped, brake should be released by moving lever switch to ON and OFF					
D. Drive operation		<ul style="list-style-type: none"> Travel operation Operating time: F1 – 5 min, F2 – 5 min, F3 – 5 min, R1 – 5 min, R2 – 5 min, R3 – 5 min. Total: 30 min 					
	1	Does speedometer work properly?					
	2	 Does fuel gauge work properly?					
	3	 Does torque converter oil temperature gauge work properly?	Should be in green range				
	4	 Does water temperature gauge work properly?	Should be in green range				
	5	 Does air pressure gauge work properly?	Should be in green range				
	6	 Does charging caution lamp work properly?	Should flash when there is abnormality in charging circuit				
	7	 Does fuel level caution lamp work properly?	Should flash when fuel gauge enters red range				
	8	 Does transmission oil filter caution lamp work properly?	Should flash when transmission oil filter is clogged				
	9	Is there any abnormality in emergency caution lamp? (pilot, warning lamp, buzzer should be actuated when gauges are in red range)	 Failure in brake line				
			 Engine oil pressure				
			 Radiator water level				
			 Air pressure				
			 Engine water temperature				
 Torque converter oil temperature							
		 Emergency steering actuated					
10	Operation of air governor	Does load and unload work properly; is caution actuated at unload?					
11	Is there any abnormal noise or vibration from engine, transmission, axle, etc.?						
12	Is abnormal heat felt at axle or parking brake after travel?						
13	Operation of dust indicator	There must be no showing of red piston.					

Category	No.	Item	Adjustment procedure and standards	Measured value	Judge- ment	Repair checked	Details of repair
E. Performance, function		<ul style="list-style-type: none"> ● Pressurizing test Operate the lift cylinder up and down, the bucket cylinder forward and back, and the steering cylinder to the left and right about 30 times each to the full stroke to pressurize. Depress the brake pedal on the left side and right side 30 times each (with the transmission cut-off switch at the ON position) V-shape loading 5 times (engine at full throttle, cylinder at full stroke)					
	1	Is abnormality shown by any lamp on the monitor panel?					
	2	Does engine low idling selector switch work properly?	Engine speed must change when switch is turned ON and OFF.				
	3	Is operating force of accelerator pedal correct?	Max. 7.0 kg	[kg]			
	4	Does accelerator pedal return properly?	It must return slowly without catching				
	5	Does emergency brake work properly?	Is it automatically released?				
	6	Does the brake pedal work properly?					
	7	Play, return of brake pedal	There must be no dragging				
	8	Does brake take effect properly?	Stopping distance when traveling at 20 km/h: less than 7.5 m	[m]			
	9	 Operation of transmission cut off switch	When lever switch is OFF, pilot lamp must be out, but transmission must not be cut				
	10	Operation of transmission cut-off					
	11	Is there any abnormality such as return time lag and shock after transmission is cut off?					
	12	Is operating force of shift lever correct?	0.3 – 0.9 kg	[kg]			
	13	Is operating force of range lever correct?	0.3 – 0.9 kg	[kg]			
	14	Does range lever 2nd speed stopper work properly?					
	15	Is there any mistaken operation of shift lever?	Operate F → N, R → N, F → R				
	16	Is there any mistaken operation of range lever?	Operate 1 ↔ 2 ↔ 3				
	17	Is there any abnormality such as transmission time lag or shock during starting or shifting gear?					
	18	Is operating force of lift lever correct?	Hold → Raise : Max. 3.5 kg Lower → Float : Max. 5.5 kg	[kg]			
	19	Does lift lever fit in notch properly?	FLOAT, LOWER, RAISE				
	20	Is operating force of bucket lever correct?	Max. 3.5 kg	[kg]			
	21	Does bucket lever fit in notch properly?	TILT				
	22	Operation of work equipment lever safety lock	Lock must not be deformed or come out of position when lever is operated				
	23	Adjustment of work equipment lever safety lock	Boom, bucket must not come down when lever is operated				
	24	Operation of accumulator	Boom, bucket must come down when engine is stopped and lever is operated				
	25	Adjustment of boom kick-out					
	26	Adjustment of bucket leveler					
	27	Is there any damage to lift cylinder rod?					
	28	Is there any damage to bucket cylinder?					
	29	Is operating force of steering wheel correct?	Less than 2 kg	[kg]			
	30	Is play of steering wheel correct?	50 – 90 mm	[mm]			
	31	Is amount of steering to left and right correct?	Clearance at articulate stopper at 1700 rpm: 45 – 50 mm	[Left: mm] [Right: mm]			
	32	Is position of steering wheel knob correct?	Left side ±50 mm 				
33	Abnormal noise, vibration, exhaust gas color, hunting of engine	Must be normal					





Category	No.	Item	Adjustment procedure and standards	Measured value	Judge- ment	Repair checked	Details of repair
E. Performance, function		<p>● Pressurizing test</p> <p>Operate the lift cylinder up and down, the bucket cylinder forward and back, and the steering cylinder to the left and right about 30 times each to the full stroke to pressurize.</p> <p>Depress the brake pedal on the left side and right side 30 times each (with the transmission cut-off switch at the ON position)</p> <p>V-shape loading 5 times (engine at full throttle, cylinder at full stroke)</p>					
	1	Is abnormality shown by any lamp on the monitor panel?					
	2	Does engine low idling selector switch work properly?	Engine speed must change when switch is turned ON and OFF.				
	3	Is operating force of accelerator pedal correct?	Max. 7.0 kg	[kg]			
	4	Does accelerator pedal return properly?	It must return slowly without catching				
	5	Does emergency brake work properly?	Is it automatically released?				
	6	Does the brake pedal work properly?					
	7	Play, return of brake pedal	There must be no dragging				
	8	Does brake take effect properly?	Stopping distance when traveling at 20 km/h: less than 7.5 m	[m]			
	9	 Operation of transmission cut off switch	When lever switch is OFF, pilot lamp must be out, but transmission must not be cut				
	10	Operation of transmission cut-off					
	11	Is there any abnormality such as return time lag and shock after transmission is cut off?					
	12	Is operating force of shift lever correct?	0.3 – 0.9 kg	[kg]			
	13	Is operating force of range lever correct?	0.3 – 0.9 kg	[kg]			
	14	Does range lever 2nd speed stopper work properly?					
	15	Is there any mistaken operation of shift lever?	Operate F → N, R → N, F → R				
	16	Is there any mistaken operation of range lever?	Operate 1 ↔ 2 ↔ 3				
	17	Is there any abnormality such as transmission time lag or shock during starting or shifting gear?					
	18	Is operating force of lift lever correct?	Hold → Raise : Max. 3.5 kg Hold → Lower : Max. 5.5 kg	[kg]			
	19	Does lift lever fit in notch properly?	FLOAT, LOWER, RAISE				
	20	Is operating force of bucket lever correct?	Max. 3.5 kg	[kg]			
	21	Does bucket lever fit in notch properly?	TILT				
	22	Operation of work equipment lever safety lock	Lock must not be deformed or come out of position when lever is operated				
	23	Adjustment of work equipment lever safety lock	Boom, bucket must not come down when lever is operated				
	24	Operation of accumulator	Boom, bucket must come down when engine is stopped and lever is operated				
	25	Adjustment of boom kick-out					
	26	Adjustment of bucket leveler					
	27	Is there any damage to lift cylinder rod?					
	28	Is there any damage to bucket cylinder?					
	29	Is operating force of steering wheel correct?	Less than 2 kg	[kg]			
	30	Is play of steering wheel correct?	50 – 90 mm	[mm]			
	31	Is amount of steering to left and right correct?	Clearance at articulate stopper at 1700 rpm: 45 – 50 mm	[Left: mm] [Right: mm]			
	32	Is position of steering wheel knob correct?	Left side ±50 mm 				
33	Abnormal noise, vibration, exhaust gas color, hunting of engine	Must be normal					





Category	No.	Item	Adjustment procedure and standards	Measured value	Judge- ment	Repair checked	Details of repair
E. Performance, function	34	Does engine stop?	Engine must not stop at stall position				
	35	Is rise in engine speed correct?	Must rise from low idling at each stall position				
	36	Operation of engine stop	Stop correctly when main switch is turned OFF				
	37	Operation of kick-down switch (F2 → F1)	Should shift down to F1 from F2				
	38	Does parking brake take effect properly?	Must hold machine on 1/5 grade slope				
	39	Does emergency steering work properly?	Can steering be operated on downhill slope with engine stopped				
	40	Is there any change in cooling water level, or oil in cooling water?					
	41	Is there any change in brake oil level?					
	42	During pressurizing, is there any abnormal noise or vibration from engine, transmission, axle, or work equipment?					
F. Others	1	Is there any tension in hoses or wiring harness when boom is raised?					
	2	Is there any interference in hoses or wiring harness when boom is raised?					
	3	Is there any interference when rear axle oscillates? (Check on both left and right sides)					
	4	Is there any interference when steering is turned? (Check on both left and right sides)					
G. Measuring basic performance	<ul style="list-style-type: none"> • Engine speed <p>Measurement conditions: Engine governor lever must contact governor stopper at full throttle. Cooling water temperature and torque converter oil temperature must be within operating range. Hydraulic oil temperature: $50 \pm 5^\circ\text{C}$</p>						
	1	Low idling speed	Selector switch OFF	$650 \begin{smallmatrix} +50 \\ -30 \end{smallmatrix}$ rpm	[rpm]		
			Selector switch ON	850 ± 50 rpm	[rpm]		
	2	High idling speed		2220 ± 50 rpm	[rpm]		
	3	Torque converter stall speed		2040 ± 50 rpm	[rpm]		
	4	Work equipment stall speed	Record measured value		[rpm]		
	5	Full stall speed	Record measured value		[rpm]		
	<ul style="list-style-type: none"> • Work equipment speed <p>Measurement conditions: Same as for engine speed above</p>						
	6	Boom raise speed	Unloaded:	$10.8 \begin{smallmatrix} +0.3 \\ -0.8 \end{smallmatrix}$	[sec]		
	7	Boom lower speed	Unloaded:	4.8 ± 0.5 sec	[sec]		
	8	Bucket tilt back speed (tilt with boom raised to maximum height)	Unloaded:	3.8 ± 0.3 sec	[sec]		
9	Bucket tilt forward speed (tilt with boom raised to maximum height)	Unloaded:	2.8 ± 0.3 sec	[sec]			
<ul style="list-style-type: none"> • Hydraulic drift of work equipment <p>Measurement conditions: Hydraulic oil temperature: $80 \pm 5^\circ\text{C}$ Set the bucket and boom horizontal when setting in the position to start measuring. Leave for 5 minutes, then start measuring.</p>							
10	Hydraulic drift of boom	Loaded, retraction of lift cylinder: Max. 130 mm/15 min		[mm/15 min]			
11	Hydraulic drift of bucket	Loaded, retraction of bucket cylinder: Max. 55.5 mm/15 min		[mm/15 min]			

Category	No.	Item	Adjustment procedure and standards	Measured value	Judge- ment	Repair checked	Details of repair
E. Performance, function	34	Does engine stop?	Engine must not stop at stall position				
	35	Is rise in engine speed correct?	Must rise from low idling at each stall position				
	36	Operation of engine stop	Stop correctly when main switch is turned OFF				
	37	Operation of kick-down switch (F2 → F1)	Should shift down to F1 from F2				
	38	Does parking brake take effect properly?	Must hold machine on 1/5 grade slope				
	39	Does emergency steering work properly?	Can steering be operated on downhill slope with engine stopped				
	40	Is there any change in cooling water level, or oil in cooling water?					
	41	Is there any change in brake oil level?					
	42	During pressurizing, is there any abnormal noise or vibration from engine, transmission, axle, or work equipment?					
F. Others	1	Is there any tension in hoses or wiring harness when boom is raised?					
	2	Is there any interference in hoses or wiring harness when boom is raised?					
	3	Is there any interference when rear axle oscillates? (Check on both left and right sides)					
	4	Is there any interference when steering is turned? (Check on both left and right sides)					
G. Measuring basic performance		<ul style="list-style-type: none"> • Engine speed <p>Measurement conditions: Engine governor lever must contact governor stopper at full throttle. Cooling water temperature and torque converter oil temperature must be within operating range. Hydraulic oil temperature: $50 \pm 5^\circ\text{C}$</p>					
	1	Low idling speed	Selector switch OFF 650^{+50}_{-30} rpm	[rpm]			
			Selector switch ON 850 ± 50 rpm	[rpm]			
	2	High idling speed	2220 ± 50 rpm	[rpm]			
	3	Torque converter stall speed	2040 ± 50 rpm	[rpm]			
	4	Work equipment stall speed	Record measured value	[rpm]			
	5	Full stall speed	Record measured value	[rpm]			
		<ul style="list-style-type: none"> • Work equipment speed <p>Measurement conditions: Same as for engine speed above</p>					
	6	Boom raise speed	Unloaded: $10.8^{+0.3}_{-0.8}$	[sec]			
	7	Boom lower speed	Unloaded: 4.8 ± 0.5 sec	[sec]			
	8	Bucket tilt back speed (tilt with boom raised to maximum height)	Unloaded: 3.8 ± 0.3 sec	[sec]			
9	Bucket tilt forward speed (tilt with boom raised to maximum height)	Unloaded: 2.8 ± 0.3 sec	[sec]				
	<ul style="list-style-type: none"> • Hydraulic drift of work equipment <p>Measurement conditions: Hydraulic oil temperature: $80 \pm 5^\circ\text{C}$ Set the bucket and boom horizontal when setting in the position to start measuring. Leave for 5 minutes, then start measuring.</p>						
10	Hydraulic drift of boom	Loaded, retraction of lift cylinder: Max. 130 mm/15 min	[mm/15 min]				
11	Hydraulic drift of bucket	Loaded, retraction of bucket cylinder: Max. 55.5 mm/15 min	[mm/15 min]				

Category	No.	Item	Adjustment procedure and standards	Measured value	Judge- ment	Repair checked	Details of repair
G. Measuring basic performance		• Steering speed Measurement conditions: Same as for engine speed above					
	12	Steering speed	Max. 3.2 sec with engine at full throttle	[Left: sec] [Right: sec]			
		• Air leakage					
	13	Drop in air pressure	Install air pressure gauge to air chuck, max. 1 kg/cm ² /30 min	[kg/cm ² /30 min]			
H. Lamps	1	Operation of lamp switches (headlamp, working lamp, hazard lamp)	No delay, looseness of knob				
	2	Lighting of parking lamps (front, rear, left, right)					
	3	Lighting of clearance lamps (left, right)					
	4	Lighting of tail lamps (left, right)					
	5	Lighting of monitor dashboard lamps (left, right)					
	6	Lighting of headlamps (left, right)					
	7	Lighting of working lamps	Lighting of pilot lamp				
	8	Lighting of brake lamps (left, right)					
	9	Lighting of backup lamp, sounding of backup buzzer					
	10	Operation of turn signal lamps (front left, right, top, bottom, rear left, right)	Flashing of pilot lamp				
	11	Operation of hazard lamps (front left, right, top, bottom, rear left, right)	Lighting of pilot lamp				
	12	Operation of radio	Is operation of all switches correct? Is there any abnormal sound?				
	13	Operation of car stereo	Is operation of all switches correct? Is there any abnormal sound?				
	14	Lighting of room lamp	Lights up when switch is ON and door (left, right) is opened				
	15	Operation of cigar lighter	Does it glow red hot, return automatically?				
	16	Operation of wiper (front, rear)	Is wiping range correct?				
	17	Operation of wiper washer liquid	Is direction of nozzle correct?				
	18	Operation of air conditioner	Operation of air conditioner switches (lamp lights up), operation of air flow switch (OFF, S, H, L)				
	19	Check air condition gas charge	There should be no bubbles in receiver sight gauge				
	20	Operation of air conditioner selector lever	Do COOL, HEAT move full stroke?				
	21	Operation of air conditioner RECIRC/FRESH selector lever	Does it move the full stroke?				
	22	Operation of air conditioner condenser fan					
I. Inspection of all parts	1	Is there any water leakage from engine water system (left, right)? (Radiator inlet and outlet hoses, radiator drain hose, radiator drain valve, radiator core, aeration hose, thermostat housing, water pump shaft seal, corrosion seal, contact surface of cylinder block water jacket cover, water manifold, torque converter cooler inlet and outlet hoses)					
	2	Is there any interference between the water piping and the sharp edge or movable parts?					

Category	No.	Item	Adjustment procedure and standards	Measured value	Judgment	Repair checked	Details of repair
G. Measuring basic performance		<ul style="list-style-type: none"> Steering speed Measurement conditions: Same as for engine speed above					
	12	Steering speed	Max. 3.2 sec with engine at full throttle	[Left: sec] [Right: sec]			
		<ul style="list-style-type: none"> Air leakage 					
	13	Drop in air pressure	Install air pressure gauge to air chuck, max. 1 kg/cm ² /30 min	[kg/cm ² /30 min]			
H. Lamps	1	Operation of lamp switches (headlamp, working lamp, hazard lamp)	No delay, looseness of knob				
	2	Lighting of parking lamps (front, rear, left, right)					
	3	Lighting of clearance lamps (left, right)					
	4	Lighting of tail lamps (left, right)					
	5	Lighting of monitor dashboard lamps (left, right)					
	6	Lighting of headlamps (left, right)					
	7	Lighting of working lamps	Lighting of pilot lamp				
	8	Lighting of brake lamps (left, right)					
	9	Lighting of backup lamp, sounding of backup buzzer					
	10	Operation of turn signal lamps (front left, right, top, bottom, rear left, right)	Flashing of pilot lamp				
	11	Operation of hazard lamps (front left, right, top, bottom, rear left, right)	Lighting of pilot lamp				
	12	Operation of radio	Is operation of all switches correct? Is there any abnormal sound?				
	13	Operation of car stereo	Is operation of all switches correct? Is there any abnormal sound?				
	14	Lighting of room lamp	Lights up when switch is ON and door (left, right) is opened				
	15	Operation of cigar lighter	Does it glow red hot, return automatically?				
	16	Operation of wiper (front, rear)	Is wiping range correct?				
	17	Operation of wiper washer liquid	Is direction of nozzle correct?				
	18	Operation of air conditioner	Operation of air conditioner switches (lamp lights up), operation of air flow switch (OFF, S, H, L)				
	19	Check air condition gas charge	There should be no bubbles in receiver sight gauge				
	20	Operation of air conditioner selector lever	Do COOL, HEAT move full stroke?				
	21	Operation of air conditioner RECIRC/FRESH selector lever	Does it move the full stroke?				
	22	Operation of air conditioner condenser fan					
I. Inspection of all parts	1	Is there any water leakage from engine water system (left, right)? (Radiator inlet and outlet hoses, radiator drain hose, radiator drain valve, radiator core, aeration hose, thermostat housing, water pump shaft seal, corrosion seal, contact surface of cylinder block water jacket cover, water manifold, torque converter cooler inlet and outlet hoses)					
	2	Is there any interference between the water piping and the sharp edge or movable parts?					

Category	No.	Item	Judge- ment	Repair checked	Details of repair
I. Inspection of all parts	3	Is there any fuel leakage from the engine fuel systems (left, right)? (Fuel tank inlet and outlet hoses, contact surface of fuel filter case, feed pump inlet and outlet tube joints, injection tube joints, nozzle mounts)			
	4	Is there any interference between the fuel system hoses and the sharp edge or movable parts?			
	5	Is there any oil leakage from the engine lubrication system (left, right)? (Contact surface of oil filter, dipstick tube mount, oil filler tube mount, contact surface of timing gear case, breather mount, contact surface of head cover, crankshaft seal, turbocharger lubrication tube, turbocharger seal, air compressor lubrication tube, contact surface of oil pan, engine oil drain hose, engine oil drain valve, engine oil cooler mount)			
	6	Is there any interference between the lubrication system hoses and the sharp edge or movable parts?			
	7	Is there any gas leakage from the engine exhaust system (left, right)? (Exhaust manifold mount, turbocharger mount, muffler, contact surface of head cover)			
	8	Is there any fuel leakage from the fuel tank? (Tank weld, contact surface of tank inspection cover, tank unit mount surface, tank drain valve)			
	9	Are the mounting bolts of the fuel tank loose or left untightened?			
	10	Is there any oil leakage from the torque converter piping? (Torque converter pump suction tube and hose joint, torque converter filter inlet and outlet hoses and tube joints, contact face of torque converter filter, torque converter cooler inlet and outlet hoses and tube joints)			
	11	Is there any interference between the torque converter piping hoses and the sharp edge or movable parts?			
	12	Is there any oil leakage from the torque converter or transmission? (Torque converter input shaft seal, contact surface of torque converter and transmission, contact surface of transmission transfer case, contact surface of transfer case front cover, transmission oil drain valve, transmission breather, transmission control valve mount, transmission control valve blind plug, transmission dipstick tube mount, transmission output shaft seal (front, rear))			
	13	Is there any oil leakage from the axles (front, rear)? (Differential shaft seal, contact surface of differential cage, differential carrier mount surface, differential drain plug, breather, contact surface of planetary gear cover, planetary gear oil filler plug, planetary gear drain plug, floating seal)			
	14	Are the mounting bolts of the axles (front, rear) loose or left untightened?			
	15	Are the mounting bolts of the axle supports loose or left untightened?			
	16	Are the mounting bolts of the tires and wheels loose or left untightened?			
	17	Is there any damage to the side walls of the tires?			
	18	Are the mounting bolts of the drive shaft loose or left untightened? (Front drive shaft, rear drive shaft)			
	19	Is there any oil leakage from the hydraulic tank? (Tank weld, contact surface of inspection cover (top, bottom, front), drain plug, sight gauge)			
	20	Is there any oil leakage from the hydraulic filter case? (Case weld, contact surface of inspection cover, contact surface of filter cover)			
	21	Is there any oil leakage from the hydraulic pumps (switch, loader, steering, torque converter, emergency steering)? (Pump mount, contact surface of case, contact surface of cover) <div style="display: flex; justify-content: space-around; align-items: center;"> <div style="text-align: center;"> <p>Switch</p>  </div> <div style="text-align: center;"> <p>Loader</p>  </div> </div> <div style="display: flex; justify-content: space-around; align-items: center; margin-top: 5px;"> <div style="text-align: center;"> <p>T/C</p>  </div> <div style="text-align: center;"> <p>Steering</p>  </div> </div> <p style="margin-top: 10px;">As seen from rear of machine</p> <ul style="list-style-type: none"> • The emergency steering pump is mounted to the front of the transfer case) 			

Category	No.	Item	Judge- ment	Repair checked	Details of repair	
I. Inspection of all parts	3	Is there any fuel leakage from the engine fuel systems (left, right)? (Fuel tank inlet and outlet hoses, contact surface of fuel filter case, feed pump inlet and outlet tube joints, injection tube joints, nozzle mounts)				
	4	Is there any interference between the fuel system hoses and the sharp edge or movable parts?				
	5	Is there any oil leakage from the engine lubrication system (left, right)? (Contact surface of oil filter, dipstick tube mount, oil filler tube mount, contact surface of timing gear case, breather mount, contact surface of head cover, crankshaft seal, turbocharger lubrication tube, turbocharger seal, air compressor lubrication tube, contact surface of oil pan, engine oil drain hose, engine oil drain valve, engine oil cooler mount)				
	6	Is there any interference between the lubrication system hoses and the sharp edge or movable parts?				
	7	Is there any gas leakage from the engine exhaust system (left, right)? (Exhaust manifold mount, turbocharger mount, muffler, contact surface of head cover)				
	8	Is there any fuel leakage from the fuel tank? (Tank weld, contact surface of tank inspection cover, tank unit mount surface, tank drain valve)				
	9	Are the mounting bolts of the fuel tank loose or left untightened?				
	10	Is there any oil leakage from the torque converter piping? (Torque converter pump suction tube and hose joint, torque converter filter inlet and outlet hoses and tube joints, contact face of torque converter filter, torque converter cooler inlet and outlet hoses and tube joints)				
	11	Is there any interference between the torque converter piping hoses and the sharp edge or movable parts?				
	12	Is there any oil leakage from the torque converter or transmission? (Torque converter input shaft seal, contact surface of torque converter and transmission, contact surface of transmission transfer case, contact surface of transfer case front cover, transmission oil drain valve, transmission breather, transmission control valve mount, transmission control valve blind plug, transmission dipstick tube mount, transmission output shaft seal (front, rear))				
	13	Is there any oil leakage from the axles (front, rear)? (Differential shaft seal, contact surface of differential cage, differential carrier mount surface, differential drain plug, breather, contact surface of planetary gear cover, planetary gear oil filler plug, planetary gear drain plug, floating seal)				
	14	Are the mounting bolts of the axles (front, rear) loose or left untightened?				
	15	Are the mounting bolts of the axle supports loose or left untightened?				
	16	Are the mounting bolts of the tires and wheels loose or left untightened?				
	17	Is there any damage to the side walls of the tires?				
	18	Are the mounting bolts of the drive shaft loose or left untightened? (Front drive shaft, rear drive shaft)				
	19	Is there any oil leakage from the hydraulic tank? (Tank weld, contact surface of inspection cover (top, bottom, front), drain plug, sight gauge)				
	20	Is there any oil leakage from the hydraulic filter case? (Case weld, contact surface of inspection cover, contact surface of filter cover)				
	21	Is there any oil leakage from the hydraulic pumps (switch, loader, steering, torque converter, emergency steering)? (Pump mount, contact surface of case, contact surface of cover)				
			<p>As seen from rear of machine</p> <p>Switch   Loader</p> <p>T/C   Steering</p> <p>● The emergency steering pump is mounted to the front of the transfer case)</p>			

Category	No.	Item	Judge- ment	Repair checked	Details of repair
Inspection of all parts	22	Is there any oil leakage from the main control valve (left, right)? (Relief valve, suction valve, unload valve, safety valve)			
	23	Is there any oil leakage from the steering valve? (Relief valve, safety valve, lever shaft seal)			
	24	Is there any oil leakage from the PPC valve?			
	25	Is there any oil leakage from the accumulator?			
	26	Is there any oil leakage from the PPC relief valve?			
	27	Is there any oil leakage from the diverter valve?			
	28	Is there any oil leakage from the boom cylinders (left, right)? (Shaft seal, head flange, tube weld)			
	29	Is there any oil leakage from the bucket cylinder? (Shaft seal, head flange, tube weld)			
	30	Is there any oil leakage from the steering cylinder? (Shaft seal, head flange, tube weld)			
	31	Is there any oil leakage from the hydraulic piping? (Piping joints, welds, plugs)			
	32	Is there any interference between the hydraulic piping and the sharp edge or movable parts?			
	33	Is there any oil leakage from the brake system? (Brake oil reservoir, master cylinder, slack adjusters (front, rear), piping joints)			
	34	Is there any interference between the brake piping and the sharp edge or movable parts?			
	35	Are the work equipment linkage lock pin bolt loose or left untightened? (Bucket – boom, bucket – bucket link, bucket link – bellcrank, bellcrank – bucket cylinder, bellcrank pivot, boom cylinder – boom, boom pivot)			
	36	Is there any oil leakage from the bucket mount (oilsealed type, 3 places)?			
	37	Are the mounting bolts of the counterweight loose or left untightened?			
	38	Is there any excessive difference in level between the counterweight and fuel tank? Difference: Max. 5 mm			
	39	Are the mounting bolts of the front fenders (left, right) loose or not tightened?			
	40	Are the mounting bolts of the front lamp support loose or left untightened?			
	41	Are the mounting bolts of the cab step loose or left untightened?			
	42	Is there any oil leakage from the engine throttle booster?			
	43	Is there any oil leakage from the engine throttle booster inlet and outlet hose joints?			
	44	Is there any interference between the engine throttle booster inlet and outlet hoses and the sharp edge or movable parts?			
	45	Is there any interference between the engine throttle cable and the sharp edge or movable parts?			
	46	Are any parts of the steering link loose or left untightened? (Pitman arm mounting nut, pitman arm stopper bolt locknuts, locknuts of all joints)			
	47	Is there any interference between the electric wiring and the sharp edge or movable parts?			
	48	Is electric wiring too tight?			
	49	Is there any looseness of electric wiring terminals; are any connectors disconnected? (Alternator, starting motor, sensors, battery, lamps, wipers)			

Category	No.	Item	Judge- ment	Repair checked	Details of repair
Inspection of all parts	22	Is there any oil leakage from the main control valve (left, right)? (Relief valve, suction valve, unload valve, safety valve)			
	23	Is there any oil leakage from the steering valve? (Relief valve, safety valve, lever shaft seal)			
	24	Is there any oil leakage from the PPC valve?			
	25	Is there any oil leakage from the accumulator?			
	26	Is there any oil leakage from the PPC relief valve?			
	27	Is there any oil leakage from the diverter valve?			
	28	Is there any oil leakage from the boom cylinders (left, right)? (Shaft seal, head flange, tube weld)			
	29	Is there any oil leakage from the bucket cylinder? (Shaft seal, head flange, tube weld)			
	30	Is there any oil leakage from the steering cylinder? (Shaft seal, head flange, tube weld)			
	31	Is there any oil leakage from the hydraulic piping? (Piping joints, welds, plugs)			
	32	Is there any interference between the hydraulic piping and the sharp edge or movable parts?			
	33	Is there any oil leakage from the brake system? (Brake oil reservoir, master cylinder, slack adjusters (front, rear), piping joints)			
	34	Is there any interference between the brake piping and the sharp edge or movable parts?			
	35	Are the work equipment linkage lock pin bolt loose or left untightened? (Bucket — boom, bucket — bucket link, bucket link — bellcrank, bellcrank — bucket cylinder, bellcrank pivot, boom cylinder — boom, boom pivot)			
	36	Is there any oil leakage from the bucket mount (oilsealed type, 3 places)?			
	37	Are the mounting bolts of the counterweight loose or left untightened?			
	38	Is there any excessive difference in level between the counterweight and fuel tank? Difference: Max. 5 mm			
	39	Are the mounting bolts of the front fenders (left, right) loose or not tightened?			
	40	Are the mounting bolts of the front lamp support loose or left untightened?			
	41	Are the mounting bolts of the cab step loose or left untightened?			
	42	Is there any oil leakage from the engine throttle booster?			
	43	Is there any oil leakage from the engine throttle booster inlet and outlet hose joints?			
	44	Is there any interference between the engine throttle booster inlet and outlet hoses and the sharp edge or movable parts?			
	45	Is there any interference between the engine throttle cable and the sharp edge or movable parts?			
	46	Are any parts of the steering link loose or left untightened? (Pitman arm mounting nut, pitman arm stopper bolt locknuts, locknuts of all joints)			
	47	Is there any interference between the electric wiring and the sharp edge or movable parts?			
	48	Is electric wiring too tight?			
	49	Is there any looseness of electric wiring terminals; are any connectors disconnected? (Alternator, starting motor, sensors, battery, lamps, wipers)			

Category	No.	Item	Judge- ment	Repair checked	Details of repair
I. Inspection of all parts	50	Are the mounting bolts of the cab loose or left untightened?			
	51	Is the operation of the operator's seat slide, tilt, vertical adjustment, weight adjustment, and seat back correct?			
	52	Is the operation of the steering wheel tilt and lock correct?			
	53	Is the operation of the cab door outer lock (key lock) and inner lock correct?			
	54	Is there any interference between the air conditioner hoses and the sharp edge or movable parts?			
	55	Is there any interference between the heater hoses and the sharp edge or movable parts?			
	56	Is there any peeling or damage to the paint at any place?			
	57	Have the caution plates come off the machine at any place?			

Category	No.	Item	Judge- ment	Repair checked	Details of repair
I. Inspection of all parts	50	Are the mounting bolts of the cab loose or left untightened?			
	51	Is the operation of the operator's seat slide, tilt, vertical adjustment, weight adjustment, and seat back correct?			
	52	Is the operation of the steering wheel tilt and lock correct?			
	53	Is the operation of the cab door outer lock (key lock) and inner lock correct?			
	54	Is there any interference between the air conditioner hoses and the sharp edge or movable parts?			
	55	Is there any interference between the heater hoses and the sharp edge or movable parts?			
	56	Is there any peeling or damage to the paint at any place?			
	57	Have the caution plates come off the machine at any place?			

Komatsu America International Company
 440 North Fairway Drive
 Vernon Hills, IL 60061-8112 U.S.A.
 Attn: Technical Publications
 Fax No. (847) 970-4186

PROPOSAL FOR MANUAL REVISION

FOR INTERNAL USE ONLY -- No. PMR

P R O P O S E R	NAME OF COMPANY:		LOCATION:	
			PHONE NO:	
	DEPARTMENT:		DATE:	
	NAME:			
MANUAL NAME:				
MANUAL NO:				
MACHINE MODEL: S/N IF APPLICABLE:				

PAGE NO:

PROBLEM:

Attach photo or sketch.
 If more space is needed, use another sheet.

FOR INTERNAL USE ONLY		
CORRECTIVE ACTION:		
