

# **JT1220 Tier 4i**

## **Parts Manual**

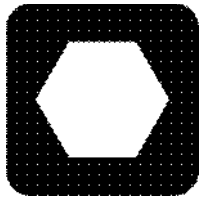

# ***Ditch Witch®***

## **JT1220**



### **Tier 4i**

ISSUE NO. 02PL-05/11

For Replacement Copy Order **P/N 053-1263**

This manual contains information concerning the following models:  
**JT1220 Tier 4i Directional Drilling System**

Copyright 2009, 2011 by The Charles Machine Works, Inc.

  **Ditch Witch**, Ditch Witch, CMW, AutoCrowd, Jet Trac, Roto Witch, Subsite, Fluid Miser, Power Pipe, Super Witch, Pierce Arrow, Zahn, The Underground, and The Underground Authority Worldwide are registered trademarks of The Charles Machine Works, Inc.

ID0238085



# FOREWORD

---

This manual contains illustrated parts lists to help you select quality ProTech<sup>®</sup> Replacement parts for your Ditch Witch<sup>®</sup> equipment. Using other replacement parts will lessen the productivity of your equipment.

- ◆ Part numbers enclosed in a box are no longer available from The Charles Machine Works, Inc. Your local Ditch Witch dealer may be able to locate the part for you.
- ◆ Footnotes provide more information to help you identify parts shown in the manual.
- ◆ Assembly instructions and Tech Bits articles referenced in footnotes are available through your local Ditch Witch dealer.
- ◆ Description and specifications in this book were current at publication. However, The Charles Machine Works, Inc. reserves the right to improve equipment, so this manual might not reflect the most current improvements.
- ◆ Instructions on recommended equipment use and maintenance are in the Operator's Manual that was shipped with your equipment.

## **Keep the following in mind when ordering ProTech replacement parts:**

- ◆ Specify parts you need by part number and description, not by illustration reference numbers.
- ◆ Have equipment model and serial number on hand to help ensure you get the right parts for your machine whether it's old or new.

**Thank you for buying and using Ditch Witch equipment and ProTech replacement parts.**



# WARRANTY

---

DW WARRANTY Policy  
July, 2005

## **POLICY 1: DITCH WITCH® EQUIPMENT AND REPLACEMENT PARTS LIMITED WARRANTY POLICY**

Subject to the limitation and exclusions herein, free replacement parts will be provided at any authorized Ditch Witch dealership for any Ditch Witch equipment or parts manufactured by The Charles Machine Works, Inc. (CMW) that fail due to a defect in material or workmanship within one (1) year of first commercial use (Exception: 2 years for all SK500 Attachments). Free labor will be provided at any authorized Ditch Witch dealership for installation of parts under this warranty during the first year following "initial commercial" use of the serial numbered Ditch Witch equipment on which it is installed. The customer is responsible for transporting their equipment to an authorized Ditch Witch dealership for all warranty work.

### **EXCLUSIONS FROM PRODUCT WARRANTY**

- All incidental or consequential damages.
- All defects, damages, or injuries caused by misuse, abuse, improper installation, alteration, neglect, or uses other than those for which products were intended.
- All defects, damages, or injuries caused by improper training, operation, or servicing of products in a manner inconsistent with manufacturer's recommendations.
- All engines and engine accessories (these are covered by original manufacturer's warranty).
- Tires, belts, and other parts which are subject to another manufacturer's warranty. (Such warranty will be available to purchaser.)
- ALL IMPLIED WARRANTIES NOT EXPRESSLY STATED HEREIN, INCLUDING ANY WARRANTY OF FITNESS FOR A PARTICULAR PURPOSE AND MERCHANTABILITY.

IF THE PRODUCTS ARE PURCHASED FOR COMMERCIAL PURPOSES, AS DEFINED BY THE UNIFORM COMMERCIAL CODE, THEN THERE ARE NO WARRANTIES WHICH EXTEND BEYOND THE FACE HEREOF AND THERE ARE NO IMPLIED WARRANTIES OF ANY KIND WHICH EXTEND TO A COMMERCIAL BUYER. ALL OTHER PROVISIONS OF THIS LIMITED WARRANTY APPLY INCLUDING THE DUTIES IMPOSED.

Ditch Witch products have been tested to deliver acceptable performance in most conditions. This does not imply they will deliver acceptable performance in all conditions. Therefore, to assure suitability, products should be operated under anticipated working conditions prior to purchase.

Defects will be determined by an inspection within thirty (30) days of the date of failure of the product or part by CMW or its authorized dealer. CMW will provide the location of its inspection facilities or its nearest authorized dealer upon inquiry. CMW reserves the right to supply remanufactured replacement parts under this warranty as it deems appropriate.

Extended warranties are available upon request from your local Ditch Witch dealer or CMW.

Some states do not allow exclusion or limitation of incidental or consequential damages, so the above limitation or exclusion may not apply. Further, some states do not allow exclusion of or limitation of how long an implied warranty lasts, so the above limitation may not apply. This limited warranty gives product owner specific legal rights and the product owner may also have other rights which vary from state to state.

For information regarding this limited warranty, contact CMW's Product Support Department, P.O. Box 66, Perry, OK 73077-0066, or contact your local Ditch Witch dealer.

# CONTENTS

---

## Decals

Decal Location - JT1220 Tier 4i.....	8
Decal Location - Pipe Box Loader .....	12

## Engine Components

Battery.....	40
Cooling System - Cooler Mounts.....	20
Cooling System - Fan Assembly .....	24
Cooling System - Radiator Plumbing.....	22
Electrical Mounting.....	34
Engine Mounts .....	18
Engine Oil System.....	30
Engine Service Parts.....	16
Engine Skid.....	38
Engine Throttle.....	26
Exhaust System .....	28
Front Fixed Hood .....	46
Front Hood Support .....	44
Front Opening Hood .....	48
Glow Plug Controls .....	36
Intake System .....	32
Rear Controls.....	42
Rear Fixed Hood.....	50
Rear Opening Hood.....	52

## Frame Components

Assisted Makeup - Begins w/.....	64
Carriage Spindle .....	58
Carriage .....	56
Frame Tilt.....	86
Front Idler Roller .....	80
Fuel Tank .....	74
Gearbox .....	78
Grease Cylinder .....	82
Ground Drive Tracks.....	76
Pipe Guide .....	68
Proximity Switches - Drill Pipe .....	90
Proximity Switches .....	88
Rotating Wrench - Begins w/ .....	70
Rotation Gear Box .....	62
Stabilizer .....	84
Stationary Wrench - Begins w/.....	72
Thrust Drive .....	60
Thrust Drive .....	66

## Operator's Station

Electrical Strike System .....	106
ESID Module & Gauge Panel.....	100
Ground Drive Control .....	108
Left Console.....	98
Operator Seat .....	96

Operator Station Floor .....	94
Right Console .....	104
Vandal Cover .....	102

## Hydraulics

Anchor Hydraulics.....	132
Auxiliary Hydraulics.....	136
Drilling Fluid Motor Hydraulics .....	140
Fan Drive Hydraulics .....	138
Filter And Reservoir Hydraulics .....	116
Frame Tilt Hydraulics.....	154
Front Thrust Hydraulics .....	126
Ground Drive Hydraulics.....	130
Hydraulic Cylinder (2.0" X 1.0") .....	160
Hydraulic Cylinder (3.0" X 1.5") .....	162
Hydraulic Cylinder (3.5" X 1.75") .....	164
Hydraulic Cylinder (3.5" X 1.75" X 2").....	166
Hydraulic Valve Parts.....	158
Hydraulic Oil Cooler Plumbing.....	118
Lubricator Hydraulics .....	134
P.O.R. Hydraulics .....	128
Pipe Box Shift Hydraulics .....	152
Pipe Grip Hydraulics .....	146
Pipe Lift Hydraulics .....	150
Pump Stack Mounting .....	112
Pump Stack Supply & Return .....	114
Pump/ Selector Hydraulics .....	122
Rotating Wrench Hydraulics .....	142
Rotation Hydraulics.....	120
Selector Hydraulics.....	124
Shuttle Hydraulics.....	148
Stabilizer Hydraulics .....	156
Stationary Wrench Hydraulics .....	144

## Anchor Systems

Anchor System - Begins w/.....	170
Anchor Valve/Lubricator Mount .....	172
Auto-Luber Assembly .....	180
Grease Pump .....	174
Lubricator Nozzle & Applicator.....	178
Lubricator Valve.....	176

## Fluid System

Drilling Fluid Plumbing .....	188
Drilling Fluid Pump Plumbing - Begins w/ .....	184
Drilling Fluid Pump.....	186
Drilling Fluid Transfer.....	190

Continued

# CONTENTS

---

## **Pipe Loader Systems**

Lifters .....	194
Pipe Box.....	206
Pipe Loader Valve/ Covers .....	202
Pivot Arm .....	204
Shuttle Guard.....	200
Shuttle Mount.....	198
Shuttle .....	196

## **Electrical**

<b>*See technical supplement for further electrical information .....</b>	<b>053-1350</b>
---	-----------------

## **Accessories**

Antifreeze Tank.....	212
Canopy.....	218
Pipe Box Loader.....	224
Softcab.....	220
T18B Tie Down Kit.....	222
Transport Pipe Box .....	226
Umbrella.....	214
Heated Greaser .....	216

## **Miscellaneous**

Bolt/Nut Torque Chart .....	230
Filters .....	234
Optional Kits .....	234
Parts Manual Change Request .....	235
Related Publications .....	234
Replacement O-Ring Chart.....	233
Warranty Registration .....	237

# DECALS

# DECAL LOCATION

## JT1220T4i

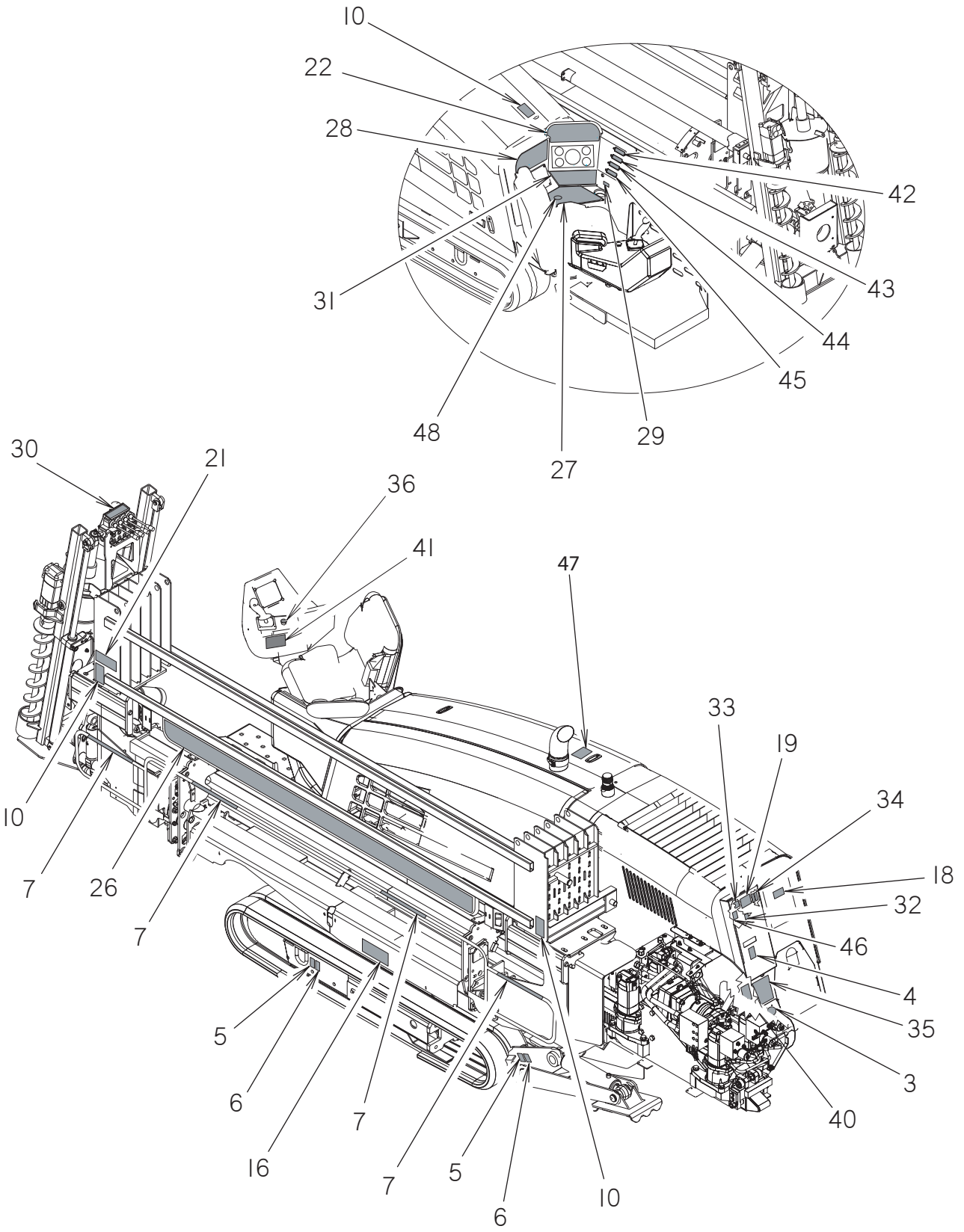

# DECAL LOCATION JT1220T4i

ELECTRIC  
BALL  
VALVE

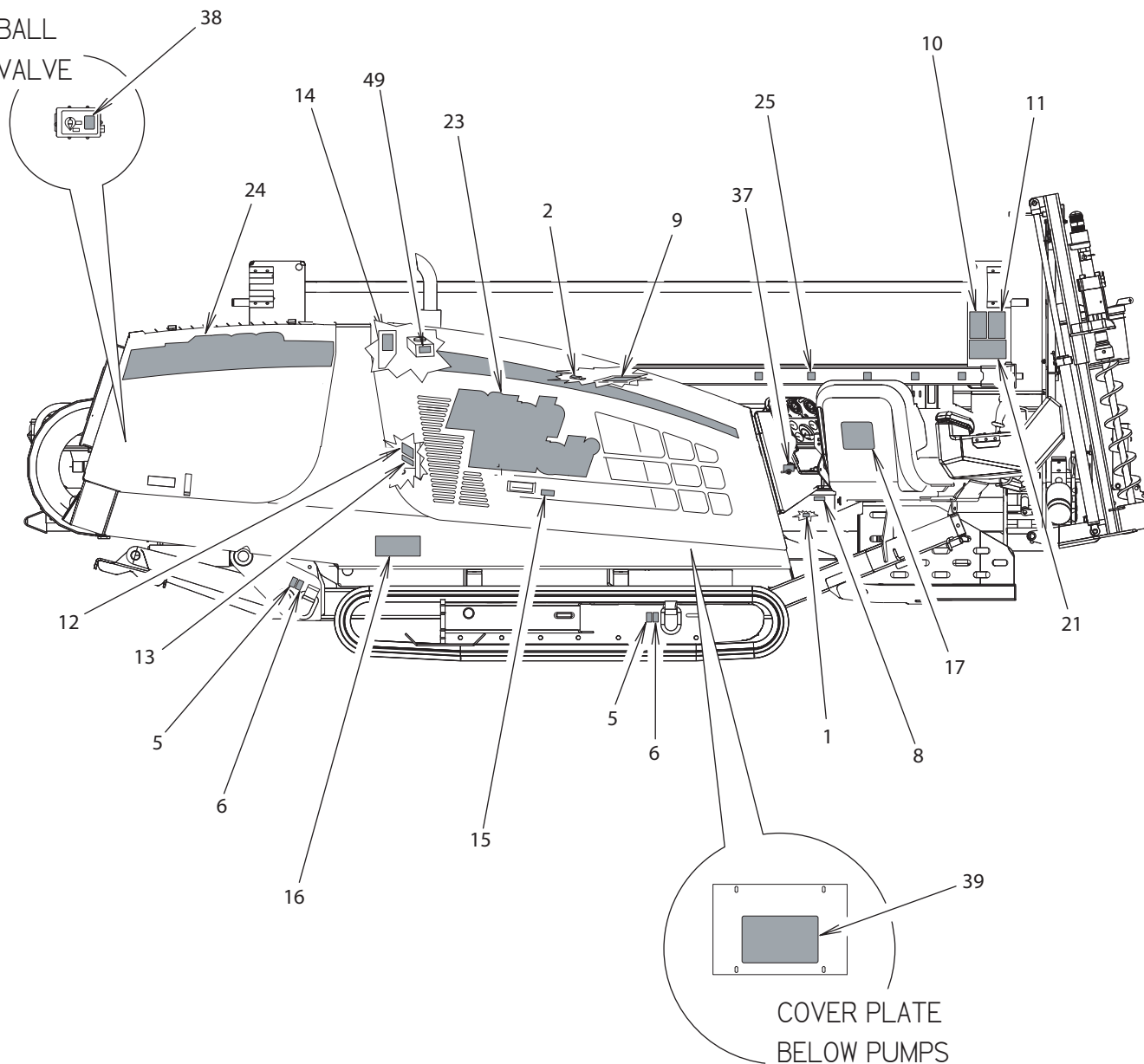

# DECAL LOCATION

## JT1220T4i

REF NO.	PART NUMBER	QTY	DESCRIPTION	REMARKS
	270-2400		DECAL KIT - JT1220T4i	
1	273-267	1	DITCH WITCH BATTERY	
2	270-2285	1	FAN SWITCH	
3	700-062	1	DIESEL FUEL CAP	
4	274-724	1	ONE CALL NOTIFICATION	
5	274-442	4	LIFT LOCATION	
6	274-318	4	TIE DOWN LOCATION	
7	275-230	4	DANGER STRIPE 1.75" x 18"	
8	275-203	1	BATTERY	
9	270-2286	1	RELAY DECAL	
10	275-184	4	WARNING MOVING PARTS	
11	273-278	1	DANGER WRENCH	
12	274-198	1	NOTICE OIL LEVEL	
13	275-120	1	RESERVOIR (THF)	
14	275-355	1	CAUTION HOT PARTS	
15	275-400	1	NOTICE OIL LEVEL	
16	274-049	2	DANGER ELECTROCUTION	
17	274-854	1	LOGO PLACARD	
18	275-048	1	IMPORTANT SAFETY RULES	
19	275-449	1	DITCH WITCH LOGO PLACARD	
20	274-291	1	SOUND POWER IO	SEE FOOT NOTE 1
21	275-197	2	DANGER ROTATING SHAFT	
22	273-407	1	GAUGE PANEL	
23	273-434	1	DITCH WITCH	
24	273-435	1	JT1220 W/ STRIPE	
25	273-444	1	PIPE BOX NUMBERS	
26	273-445	1	PIPE BOX STRIPE/MODEL ID	
27	700-067	1	CONTROL PANEL	
28	700-068	1	SWITCH PANEL	
29	700-069	1	IGNITION PANEL	
30	700-071	1	STAKE DRIVER	
31	700-092	1	SWITCH PANEL	
32	273-198	1	TRACKER CONTROL	
33	273-482	1	IGNITION SWITCH	
34	700-146	1	TRACK SWITCH	
35	700-147	1	FRAME TILT	
36	275-222	1	ENGINE STOP	
37	700-191	1	MASTER DISCONNECT SWITCH	
38	273-567	1	NOTICE NOT MANUAL SHUTOFF	
39	273-569	1	JT1220 TEST PORT LOCATIONS	
40	274-780	1	JET TRAC PATENT (S)	
41	700-245	1	RIGHT CONTROL	
42	270-2332	1	LED DISPLAY	
43	270-1405	1	LED DISPLAY	
44	270-1406	1	LED DISPLAY	
45	270-2333	1	LED DISPLAY	
46	273-061	1	START ASSIST	
47	273-459	1	WARNING EXPLOSION	
48	274-940	1	INDICATOR	
49	270-1504	1	NOTICE COMPLETE FILL	

### FOOTNOTES

1. NOT PART OF KIT.





# PIPE BOX LOADER DECAL LOCATION

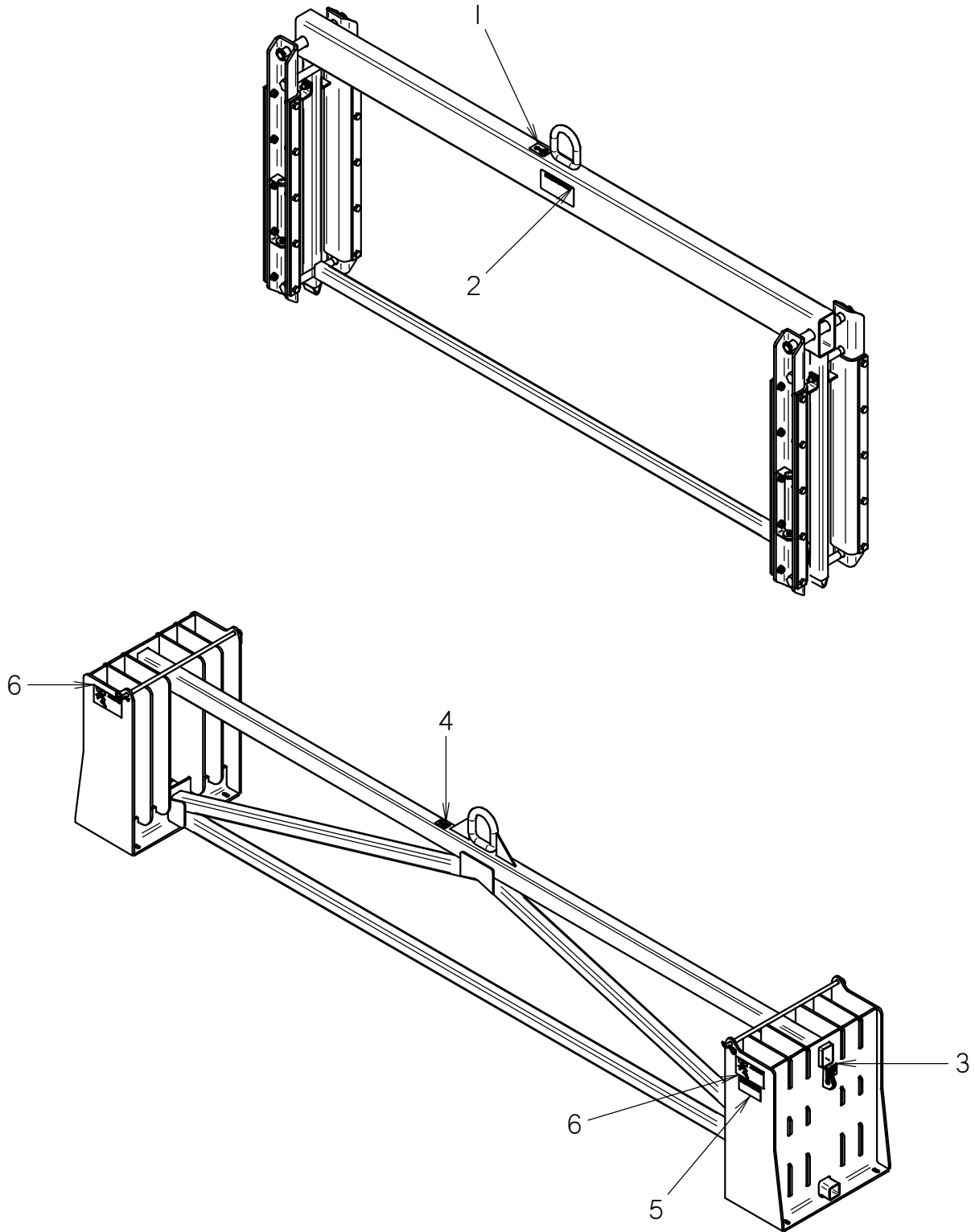

# PIPE BOX LOADER DECAL LOCATION

REF NO.	PART NUMBER	QTY	DESCRIPTION	REMARKS
1	274-442	1	LIFT LOCATION	
2	270-1018	1	PIPE BOX LOADER WEIGHT	
3	274-318	2	TIE DOWN LOCATION	OPPOSITE ENDS
4	274-442	1	LIFT LOCATION	
5	273-642	2	TRANSPORT BOX WEIGHT	JT2020 ONLY. 270-1016 USED ON JT1220, OPPOSITE CORNERS
6	275-326	4	WARNING, CRUSHING WEIGHT	OPPOSITE SIDES

NOT SHOWN:

FOOTNOTES:

NOTE:



# **ENGINE COMPONENTS**

# ENGINE SERVICE PARTS

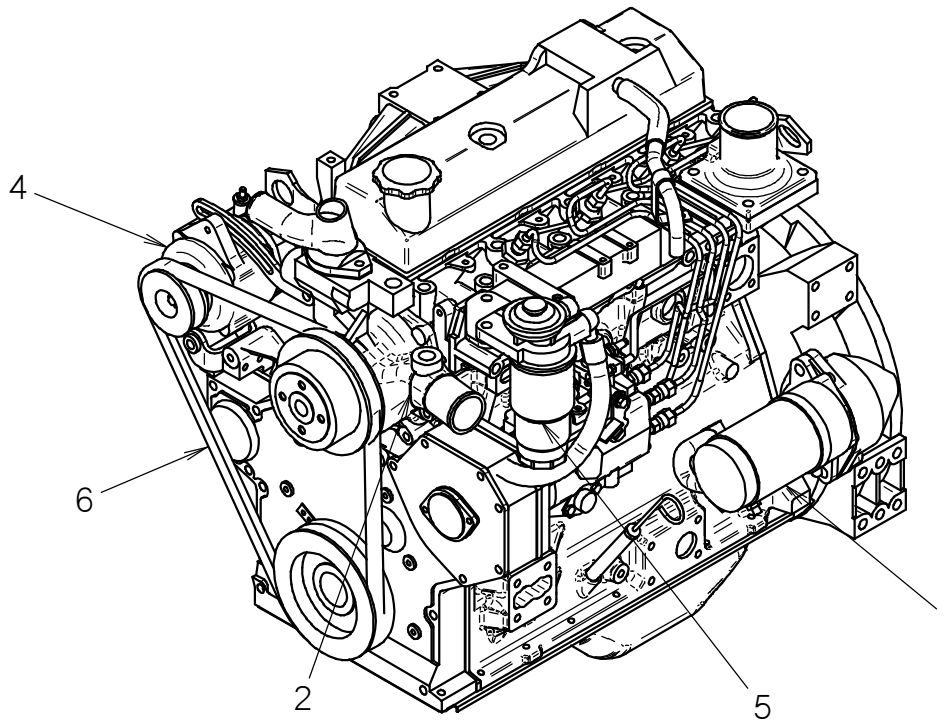
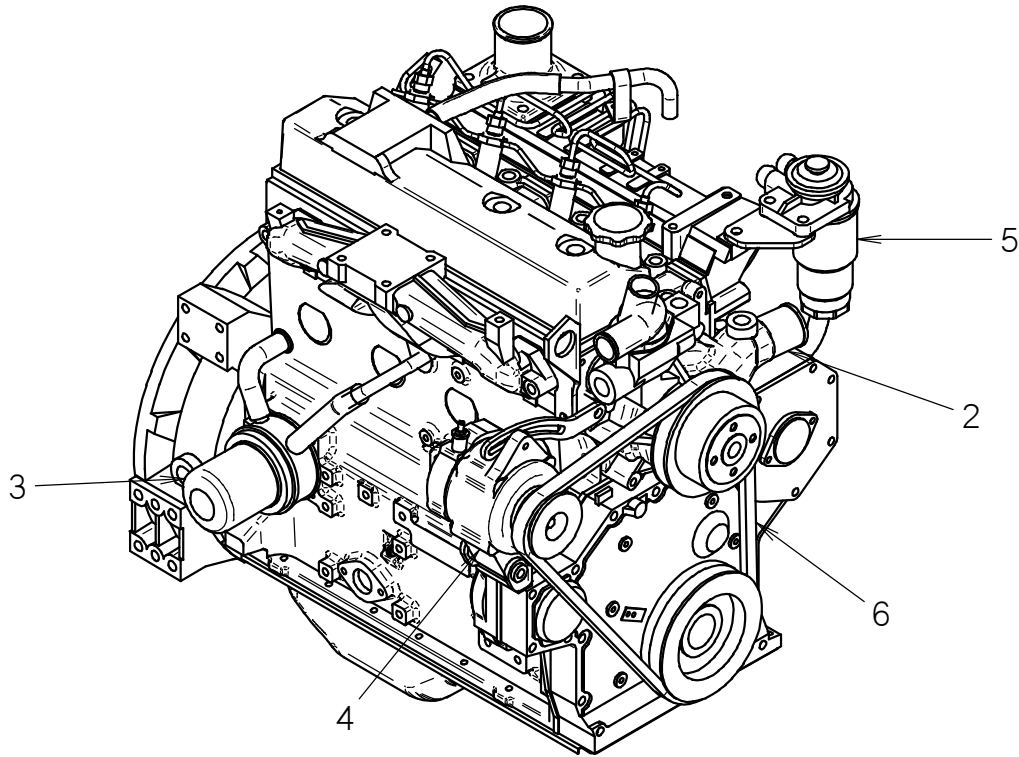

# ENGINE SERVICE PARTS

REF NO.	PART NUMBER	QTY	DESCRIPTION	REMARKS
	195-1320		ENGINE CUMMINS B3.3NA	
1	194-458	1	STARTING MOTOR	
2	194-459	1	WATER PUMP (CUMMINS B3.3)	
3	194-454	1	ENGINE OIL FILTER	
4	194-462	1	ALTERNATOR 12V/160A (B3.3)	
5	194-461	1	FUEL FILTER ELEMENT (B3.3)	
6	170-463	1	FAN BELT	

NOT SHOWN:

500-2084 FLUID LEVEL SENSOR

FOOTNOTES:

NOTE:

# ENGINE MOUNTS

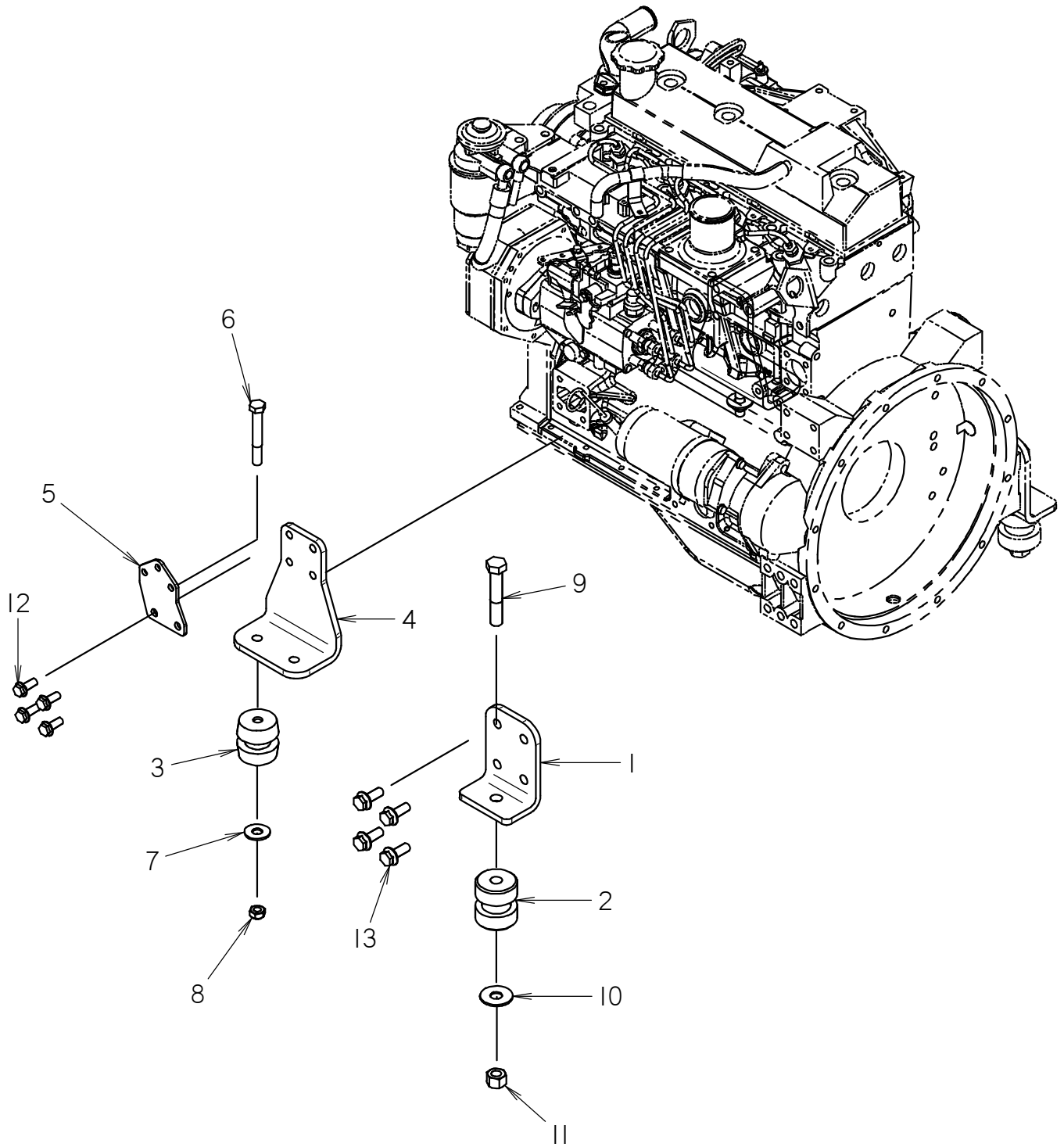

# ENGINE MOUNTS

REF NO.	PART NUMBER	QTY	DESCRIPTION	REMARKS
1	314-764	2	REAR ENGINE MOUNT	
2	116-217	2	SHOCK MOUNT (2-PIECE KIT)	
3	117-559	2	ISOLATOR	
4	300-5374	2	FRONT ENGINE MOUNT	
5	300-5404	1	BRACKET	
6	106-336	2	SCREW (M12-1.75 X 90MM)	
7	105-071	2	WASHER (1/2")	
8	106-685	2	LOCKNUT(M12-1.75,PRV TRQ,10.9)	
9	106-810	2	SCREW (M16-2.00 X 90MM, 10.9)	
10	105-359	2	WASHER (5/8)	
11	106-545	2	LOCKNUT (M16-2.0,PRV TRQ,10.9)	
12	106-724	8	FLG SCREW (M10-1.50 X 25MM)	USE LOCTITE 242 OR EQUIVALENT
13	106-469	8	FLG SCREW (M12-1.75 X 30MM)	USE LOCTITE 242 OR EQUIVALENT

NOT SHOWN:

FOOTNOTES:

NOTE:



# COOLING SYSTEM - COOLER MOUNTING

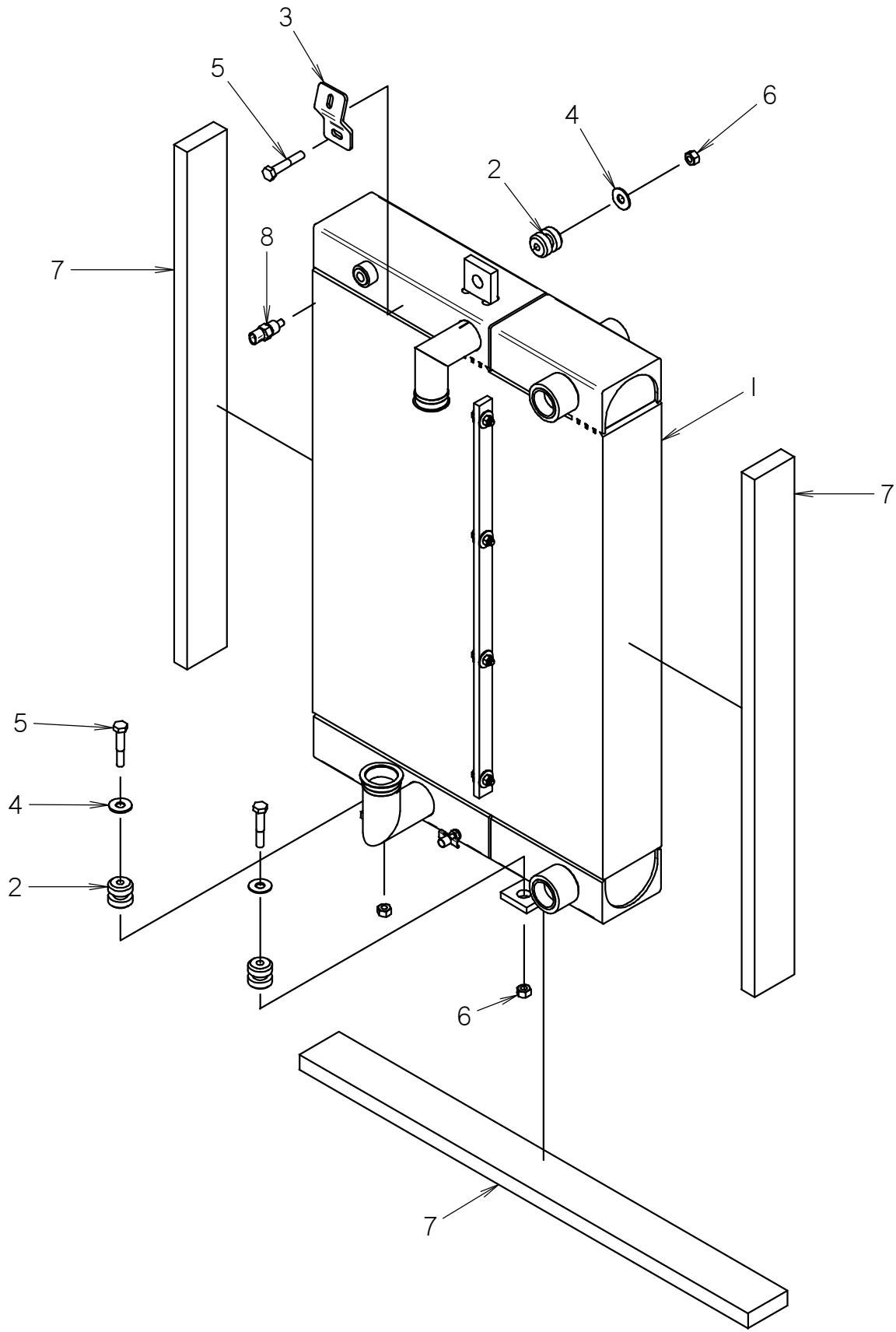

# COOLING SYSTEM - COOLER MOUNTING

REF NO.	PART NUMBER	QTY	DESCRIPTION	REMARKS
1	195-1359	1	COOLER	
2	116-128	3	SHOCK MOUNT	
3	300-5380	1	BRACKET	
4	105-059	3	WASHER (7/16")	
5	106-628	3	SCREW (M10-1.50 X 60MM)	
6	105-894	3	LOCKNUT(M10-1.50,PRV TRQ,10.9)	
7	118-168	3	SOUND INSULATION	
8	215-1434	1	COOLANT TEMP SENSOR	

NOT SHOWN:

FOOTNOTES:

NOTE:

# COOLING SYSTEM - RADIATOR PLUMBING

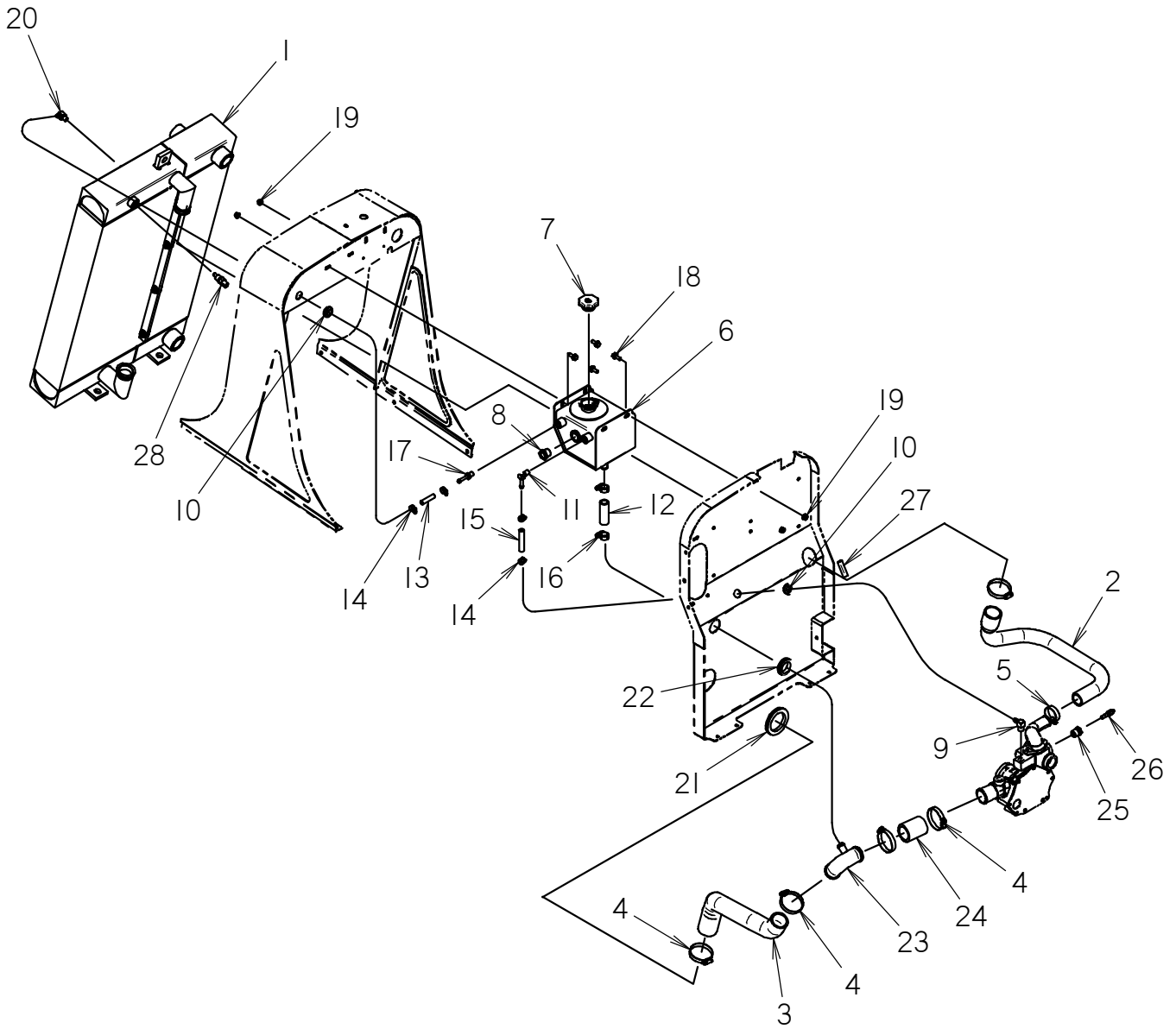

# COOLING SYSTEM - RADIATOR PLUMBING

REF NO.	PART NUMBER	QTY	DESCRIPTION	REMARKS
1	195-1359	1	COOLER	
2	195-1330	1	RADIATOR HOSE - UPPER	
3	195-1331	1	RADIATOR HOSE - LOWER	
4	110-134	5	WORM CLAMP (2.062" TO 2.750")	
5	110-133	1	WORM CLAMP (1-1/16" TO 1-15/16")	
6	300-5506	1	EXPANSION TANK	
7	111-084	1	RADIATOR CAP (16 PSI)	
8	110-549	1	SIGHT GAUGE (12N)	
9	153-871	1	S/O COUPLER (06N-06H90, BRS)	
10	115-069	2	GROMMET (3/4")	
11	155-288	1	S/O COUPLER (04N-06H90)	
12	116-751	19	BULK HOSE (3/4",SOLD PER FT)	USE 1 @ 19"
13	116-108	11	BULK HOSE (5/16", SOLD PER 1")	
14	110-249	4	WORM CLAMP (1/4" TO 5/8")	
15	116-881	15	BULK HOSE (3/8", SOLD PER FT)	
16	110-217	2	WORM CLAMP (7/16" TO 1")	
17	155-162	1	S/O COUPLER (04N-05H)	
18	106-162	4	FLG SCREW (M8-1.25 X 20MM, GD8)	
19	106-386	4	FLG LOCKNUT (M8-1.25)	
20	155-164	1	S/O COUPLER (04N-05H90)	USE 567 LOCTITE OR EQUIVALENT
21	105-1050	1	GROMMET (2-1/2")	
22	115-320	1	GROMMET (1-1/2")	
23	195-1448	1	S/O COUPLER (28H-28H90-12H)	
24	195-1452	3	BULK HOSE (1-3/4 ",SOLD PER 1")	USE 1 @ 3"
25	217-247	1	WATER TEMP ADAPTOR	
26	217-565	1	TEMPERATURE SENDER	
27	115-686	8	BULK EDGE (5/32",SOLD PER 1")	USE 1 @ 8"
28	215-1434	1	COOLANT TEMP SENSOR	

NOT SHOWN:

FOOTNOTES:

NOTE:

# COOLING SYSTEM - FAN ASSEMBLY

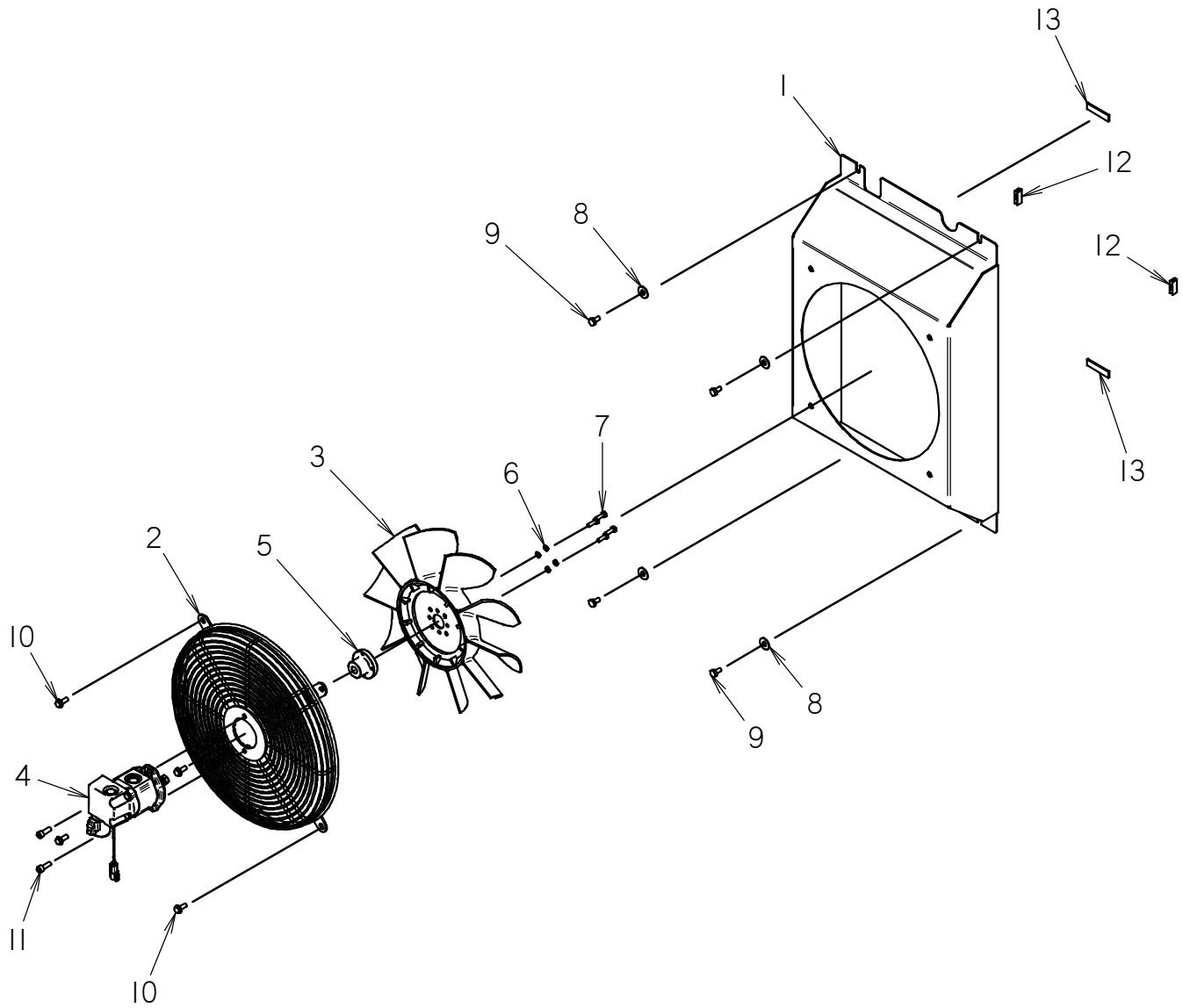



## ENGINE THROTTLE

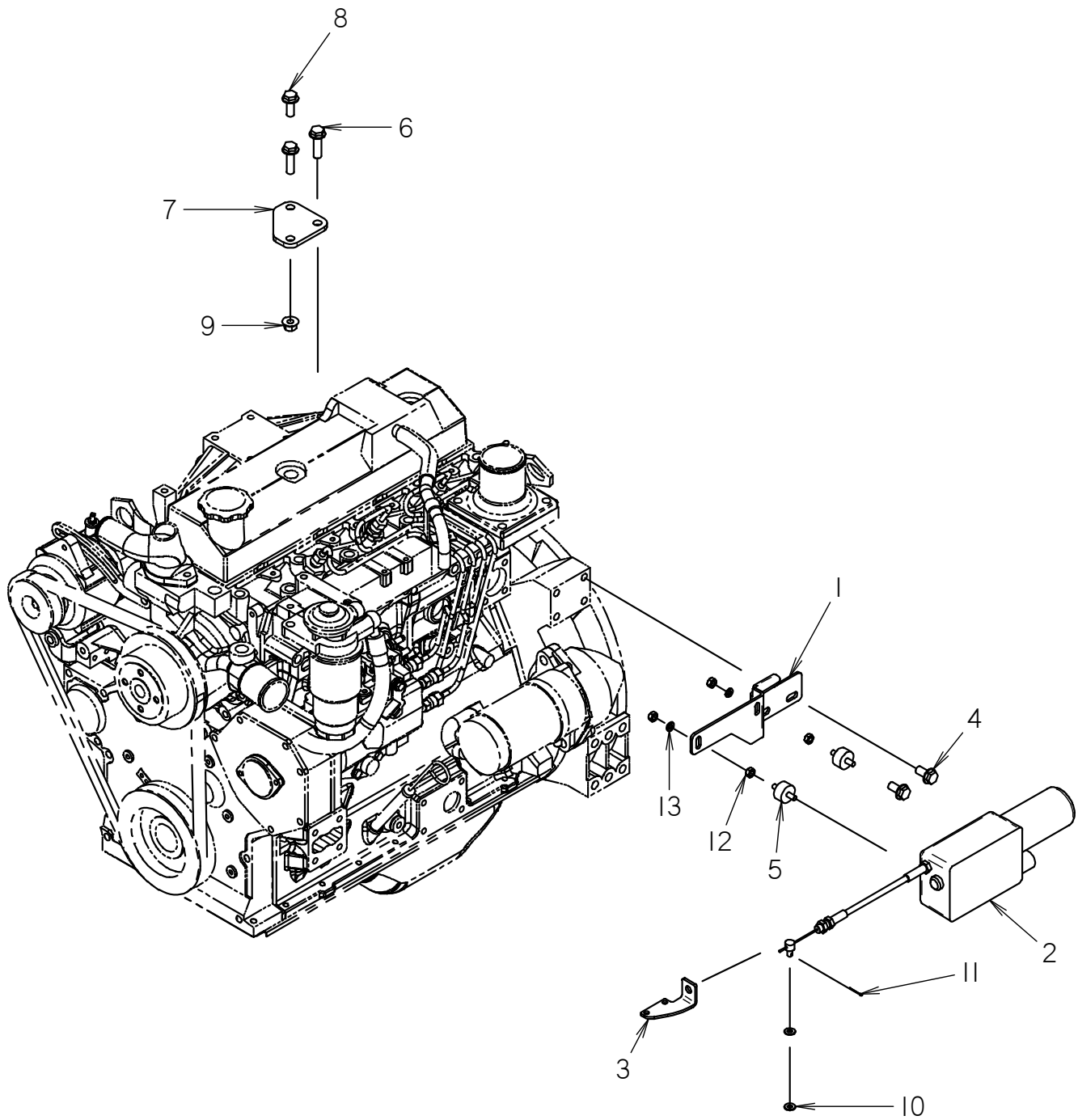

# ENGINE THROTTLE

REF NO.	PART NUMBER	QTY	DESCRIPTION	REMARKS
1	300-5765	1	MOUNT BRACKET	
2	213-116	1	LINEAR ACTUATOR	SEE FOOTNOTE 1
3	315-573	1	THROTTLE BRACKET	
4	106-382	2	FLG LK SCREW (M10-1.50 X 20MM)	USE LOCTITE 242 OR EQUIVALENT
5	300-5701	2	MOUNT, RUBBER STOCK	USE LOCTITE 242 OR EQUIVALENT
6	106-497	2	FLG SCREW (M10-1.50 X 35MM)	
7	300-7732	1	SPACER	
8	106-724	1	FLG SCREW (M10-1.50 X 25MM)	
9	106-387	1	FLG LOCKNUT (M10-1.50)	
10	105-284	2	WASHER (3/16")	
11	105-530	1	COTTER PIN (1/16" X 3/4")	
12	105-078	4	NUT (1/4-NC)	
13	105-079	2	LOCK WASHER (1/4)	

NOT SHOWN:

FOOTNOTES:

1. 196-366 CABLE, LINEAR ACTUATOR

NOTE:



## EXHAUST SYSTEM

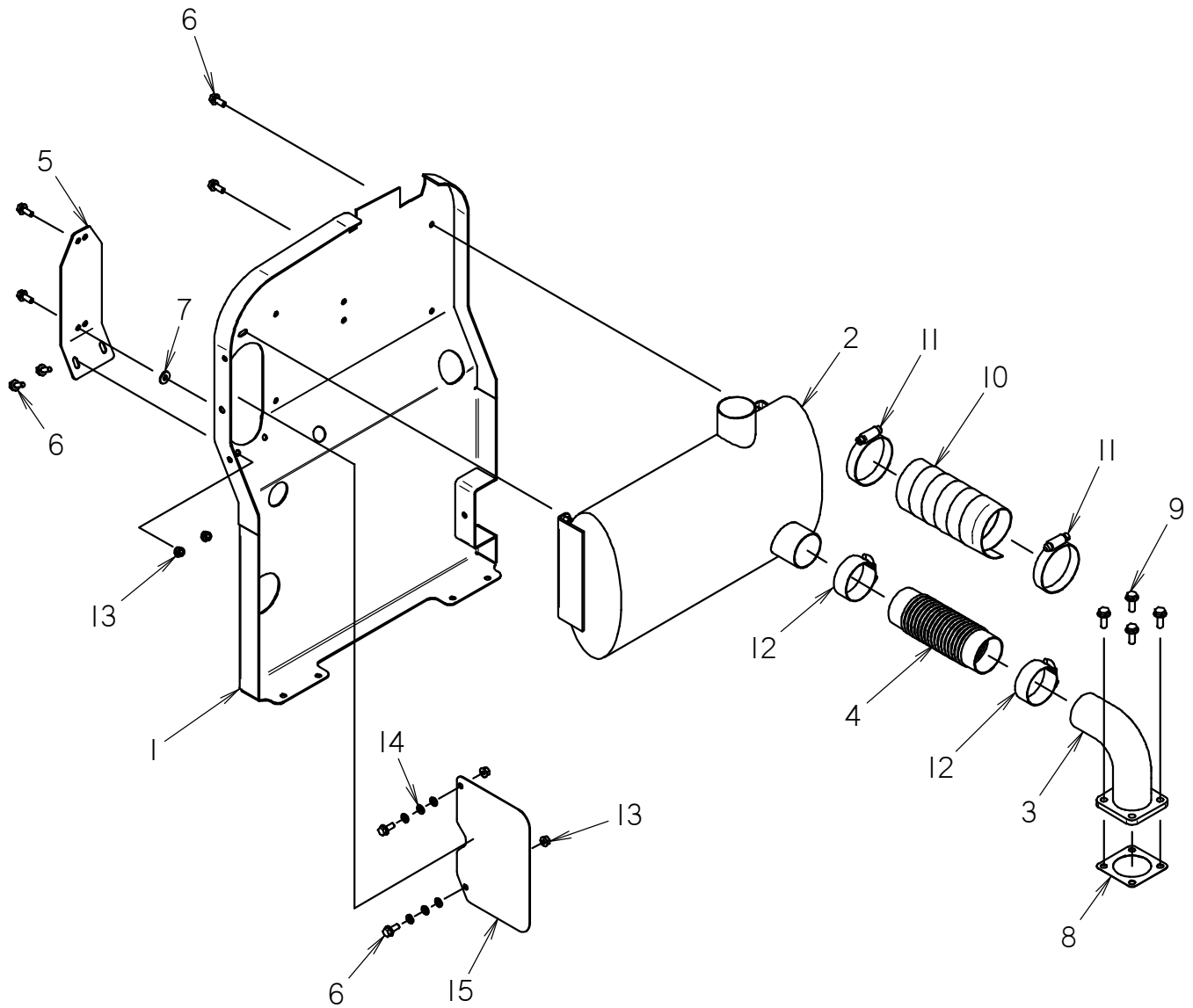

# EXHAUST SYSTEM

REF NO.	PART NUMBER	QTY	DESCRIPTION	REMARKS
1	300-5367	1	MID FIREWALL	
2	195-1360	1	MUFFLER	
3	195-1362	1	EXHAUST ELBOW	
4	195-1363	1	EXHAUST FLEX TUBE	
5	300-5400	1	COVER PLATE	
6	106-162	8	FLG SCREW (M8-1.25 X 20MM, GD8)	
7	105-117	1	WASHER (5/16")	
8	194-446	1	EXHAUST GASKET	
9	106-724	4	FLG SCREW (M10-1.50 X 25MM)	TORQUE TO 30 FT-LBS
10	115-834	1	EXHAUST WRAP (2", SOLD PER FT)	
11	110-311	2	WORM CLAMP (1-5/16" TO 3-1/4")	
12	105-1350	2	MUFFLER CLAMP (2.71")	
13	106-386	4	FLG LOCKNUT (M8-1.25)	
14	106-389	6	WASHER (M8)	
15	300-5751	1	PLATE	

NOT SHOWN:

FOOTNOTES:

NOTE:

# ENGINE OIL SYSTEM

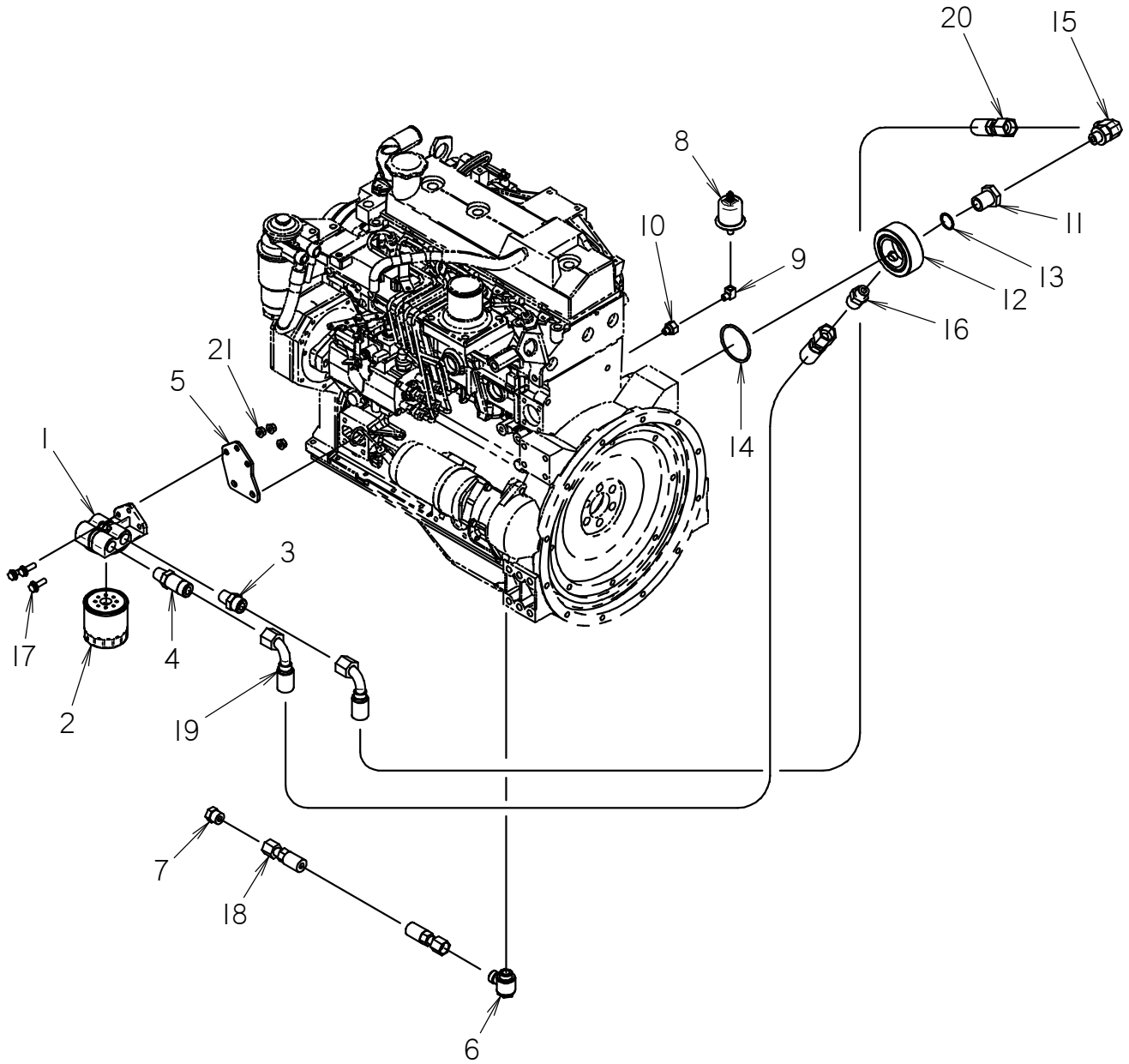

# ENGINE OIL SYSTEM

REF NO.	PART NUMBER	QTY	DESCRIPTION	REMARKS
1	194-514	1	REMOTE FILTER HEAD	
2	194-454	1	ENGINE OIL FILTER	
3	157-756	1	CONNECTOR (08N-100)	
4	150-2080	1	EXTENSION FITTING (08N-100)	
5	300-5404	1	BRACKET	
6	157-445	1	BANJO FITTING (M22)	
7	154-331	1	PLUG (080)	
8	215-1583	1	OIL PRESSURE SENDER (0-150 PSI)	BEGINS WITH S/N: CMWJ2020HA0001165, SEE FOOTNOTE 1 & 2
9	156-241	1	STREET ELBOW (02N-02NF90)	SEE FOOTNOTE 2
10	114-033	1	REDUCER (M10-1.00-02NF)	
11	158-109	1	FILTER MOUNT BOLT	
12	158-108	1	FILTER MOUNT FLANGE	
13	158-110	1	O-RING (-120 D90)	
14	157-020	1	O-RING (230 D90)	
15	154-323	1	CONNECTOR (08S-10090)	
16	154-391	1	CONNECTOR (08S-100)	
17	106-381	3	FLG LK SCREW (M8-1.25 X 25MM)	
18	154-711	1	HOSE (080FX-30"-3000)	
19	150-2915	1	HOSE (100FX90S-32"-250)	
20	150-2916	1	HOSE (100FX90S-36"-250)	
21	106-386	3	FLG LOCKNUT (M8-1.25)	

NOT SHOWN:

FOOTNOTES:

1. TO BE USED WITH 215-1582 OIL PRESSURE GAGE (0-150PSI). BEFORE S/N: CMWJ2020HA0001165 215-183 SENDER, OIL PRESSURE HD WAS USED WITH 215-1375 ANALOG OIL PRESSURE GAGE
2. USE LOCTITE 567 OR EQUIVALENT.

NOTE:

# INTAKE SYSTEM

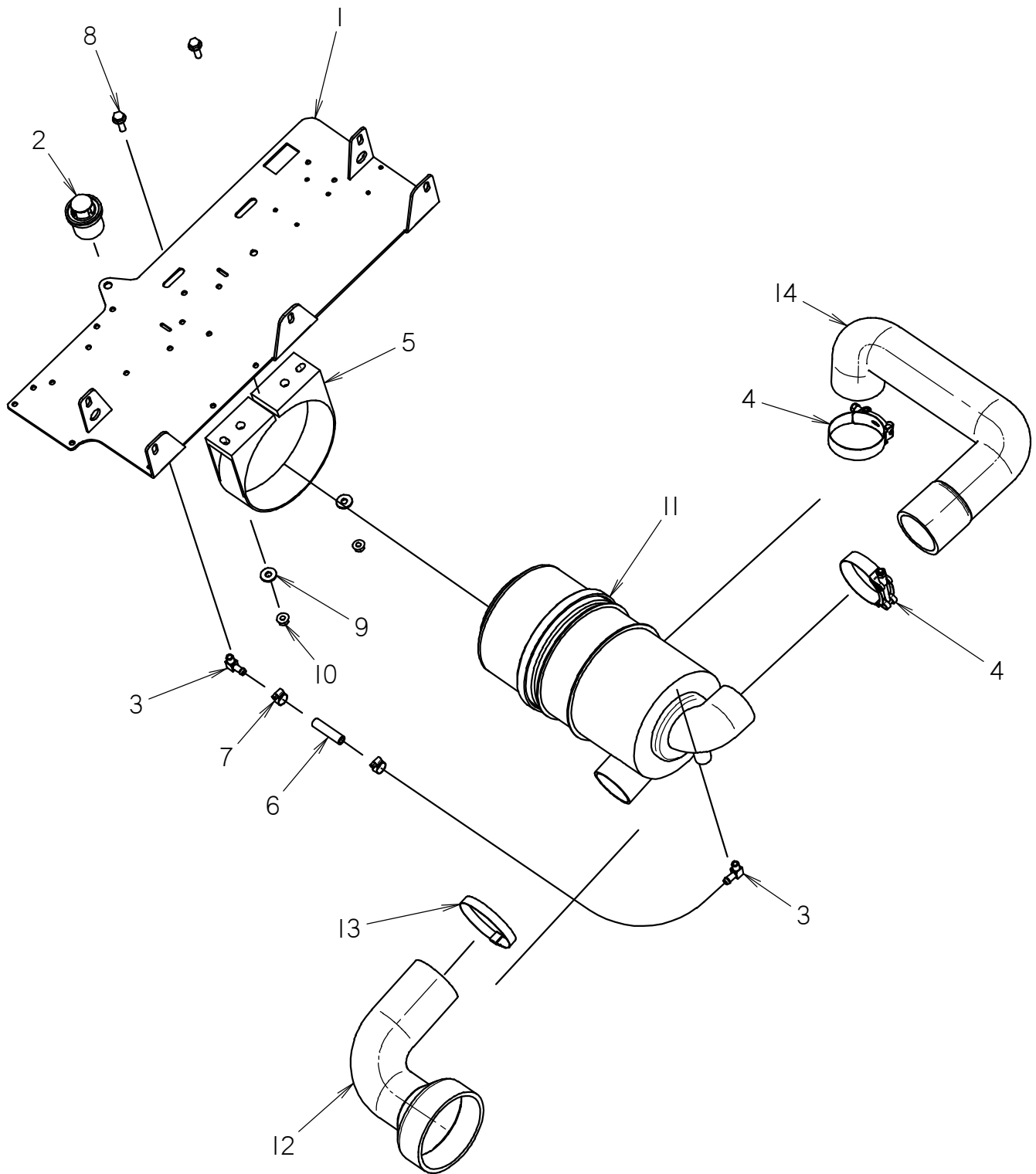

# INTAKE SYSTEM

REF NO.	PART NUMBER	QTY	DESCRIPTION	REMARKS
1	300-7238	1	CONTROLLER MOUNT	
2	195-1345	1	GRADUATED RESTRICTION INDICATOR (25"H2O)	
3	155-241	2	S/O COUPLER (02N-05H90)	
4	157-908	2	T-BOLT CLAMP (2.8125-3.187)	
5	149-165	1	MOUNTING CLAMP (6.79")	
6	116-108	15	BULK HOSE (5/16", SOLD PER 1")	
7	110-249	2	WORM CLAMP (1/4" TO 5/8")	
8	106-381	2	FLG LK SCREW (M8-1.25 X 25MM)	
9	105-117	2	WASHER (5/16")	
10	106-386	2	FLG LOCKNUT (M8-1.25)	
11	194-297	1	AIR FILTER	
12	195-1365	1	AIR INTAKE HOSE	
13	110-169	1	WORM CLAMP (2.812" TO 3.750")	
14	117-851	1	AIR INTAKE HOSE	

NOT SHOWN:

FOOTNOTES:

NOTE:

# ELECTRICAL MOUNTING

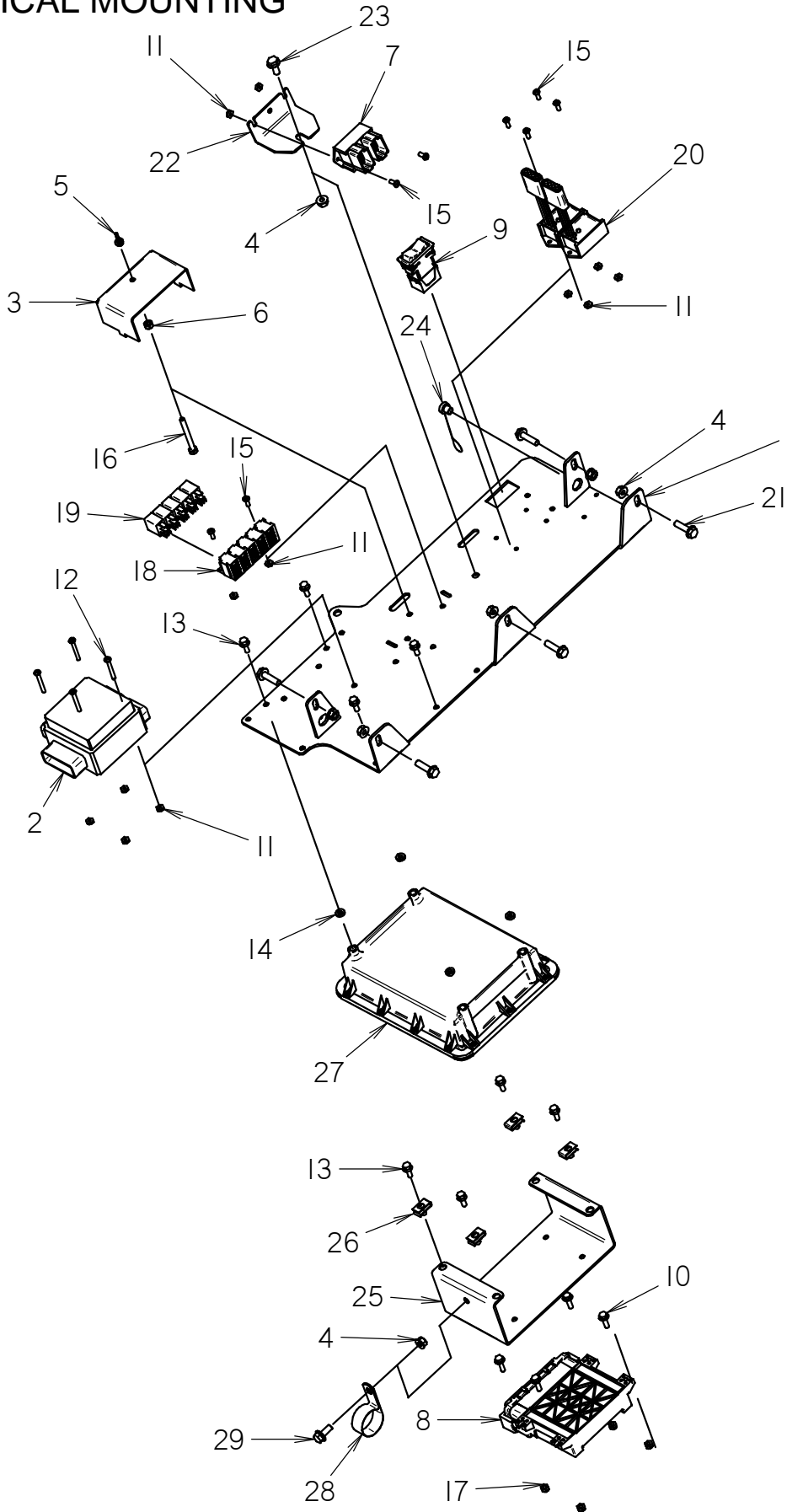

# ELECTRICAL MOUNTING

REF NO.	PART NUMBER	QTY	DESCRIPTION	REMARKS
1	300-7238	1	CONTROLLER MOUNT	
2	214-905	1	BUSSMAN V.E.C.	REPLACEMENT LID 500-1859
3	300-7593	1	COVER	
4	106-386	7	FLG LOCKNUT (M8-1.25)	
5	195-339	1	WING NUT (1/4-NC)	
6	105-078	1	NUT (1/4-NC)	
7	211-026	1	DIODE PACK (DEUTSCHI)	
8	220-1240	1	18-PIN CONTROLLER V3	SEE FOOTNOTE 1
9	217-907	1	ROCKER SWITCH (DPDT) ON-ON	
10	106-161	4	FLG SCREW (M6-1.00 X 20MM)	
11	106-048	12	LOCKNUT (#10-24)	
12	105-816	4	SCREW (#10-24 X1-1/2",PAN SLT)	
13	106-712	8	FLG SCREW (M6-1.00 X 16MM)	
14	155-751	4	WASHER (1/4", NEOPRENE)	
15	105-185	8	BOLT (#10-24 X 1/2", RD SLT)	
16	108-116	1	SCREW (1/4-NC X 2-1/2", GD5)	
17	106-237	4	LOCKNUT (M6-1.00,PRV TRQ,NLK)	
18	217-194	5	MICRO RELAY BASE	
19	217-710	5	MICRO RELAY (SPDT)	
20	217-184	2	DELAY TIMER (2-SECOND)	
21	106-163	5	FLG SCREW (M8-1.25 X 30MM)	
22	322-860	1	DIODE BRACKET	
23	106-991	1	FLG LK SCREW (M8-1.25 X 20MM)	
24	211-078	1	CONNECTOR CAP (TURCK RS-CC)	
25	300-5681	1	BRACKET	
26	106-574	4	CLIP NUT (M6-1.00)	
27	220-1023	1	JT CONTROLLER 2	
28	110-332	1	BOLT-ON CLAMP (1-5/8")	
29	106-162	1	FLG SCREW (M8-1.25 X 20MM, GD8)	

NOT SHOWN:

FOOTNOTES:

- BEGINS WITH S/N: CMW\_\_\_\_\_ FOR THE JT1220 AND S/N: CMW\_\_\_\_\_ FOR THE JT2020. OLDER UNITS CAN USE 220-1240 AS A REPLACEMENT FOR 220-1073.

NOTE:



# GLOW PLUG CONTROLS

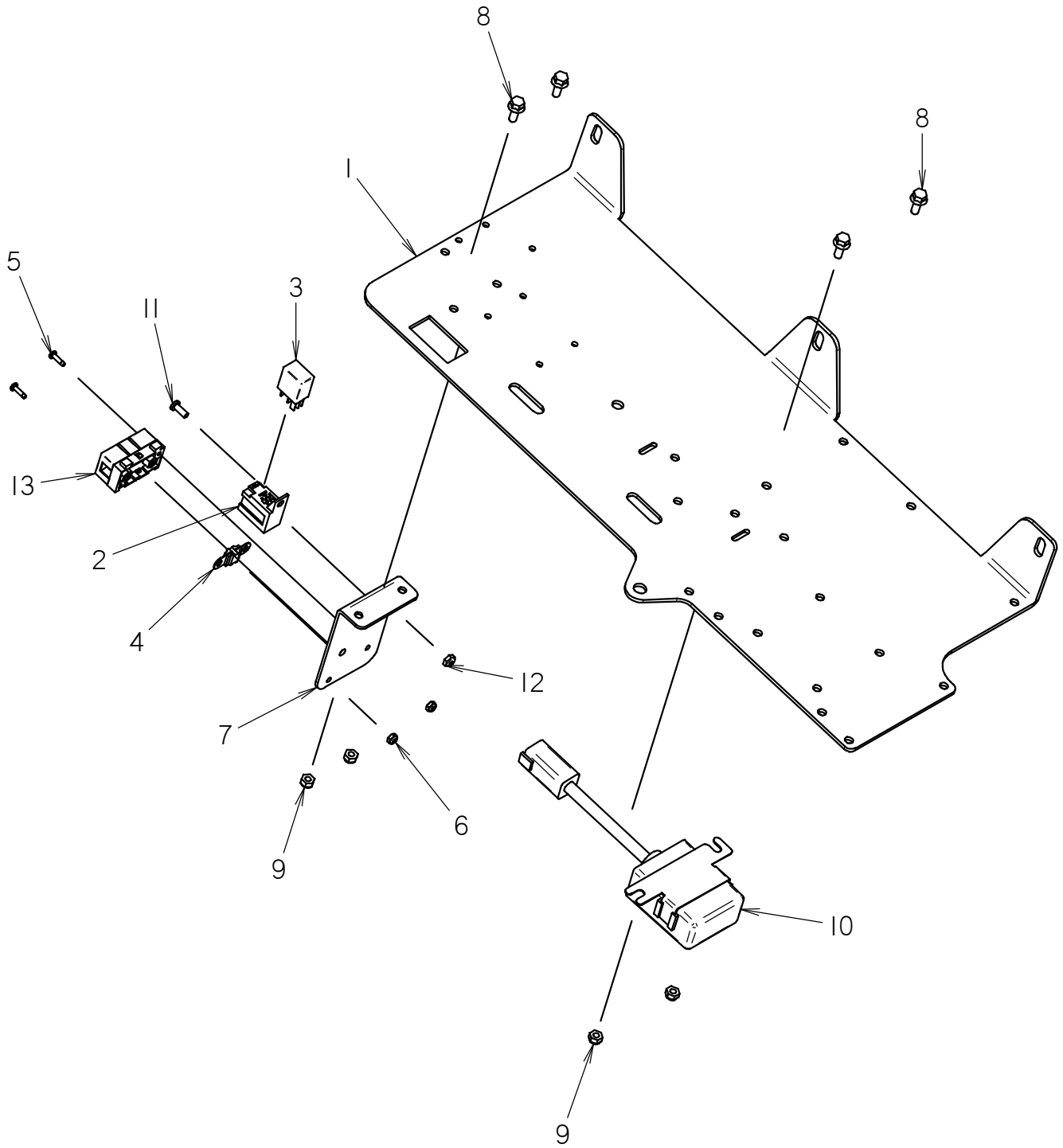

# GLOW PLUG CONTROLS

REF NO.	PART NUMBER	QTY	DESCRIPTION	REMARKS
1	300-7238	1	CONTROLLER MOUNT	
2	217-194	1	MICRO RELAY BASE	
3	217-710	1	MICRO RELAY (SPDT)	
4	211-317	1	BK/AMI 50 AMP FUSE	
5	105-189	2	SCREW (#6-32 X 1/2")	
6	107-859	2	NUT, LOCK, #6-32, NYLON INSERT	
7	300-8794	1	BRACKET	
8	106-712	4	FLG SCREW (M6-1.00 X 16MM)	
9	106-237	4	LOCKNUT (M6-1.00,PRV TRQ,NLK)	
10	195-1473	1	HEATER CONTROL MODULE	
11	105-185	1	BOLT (#10-24 X 1/2", RD SLT)	
12	106-048	1	LOCKNUT (#10-24)	
13	363-714	1	MODIFIED FUSE PANNEL ASSEMBLY	

NOT SHOWN:

FOOTNOTES:

NOTE:

# ENGINE SKID

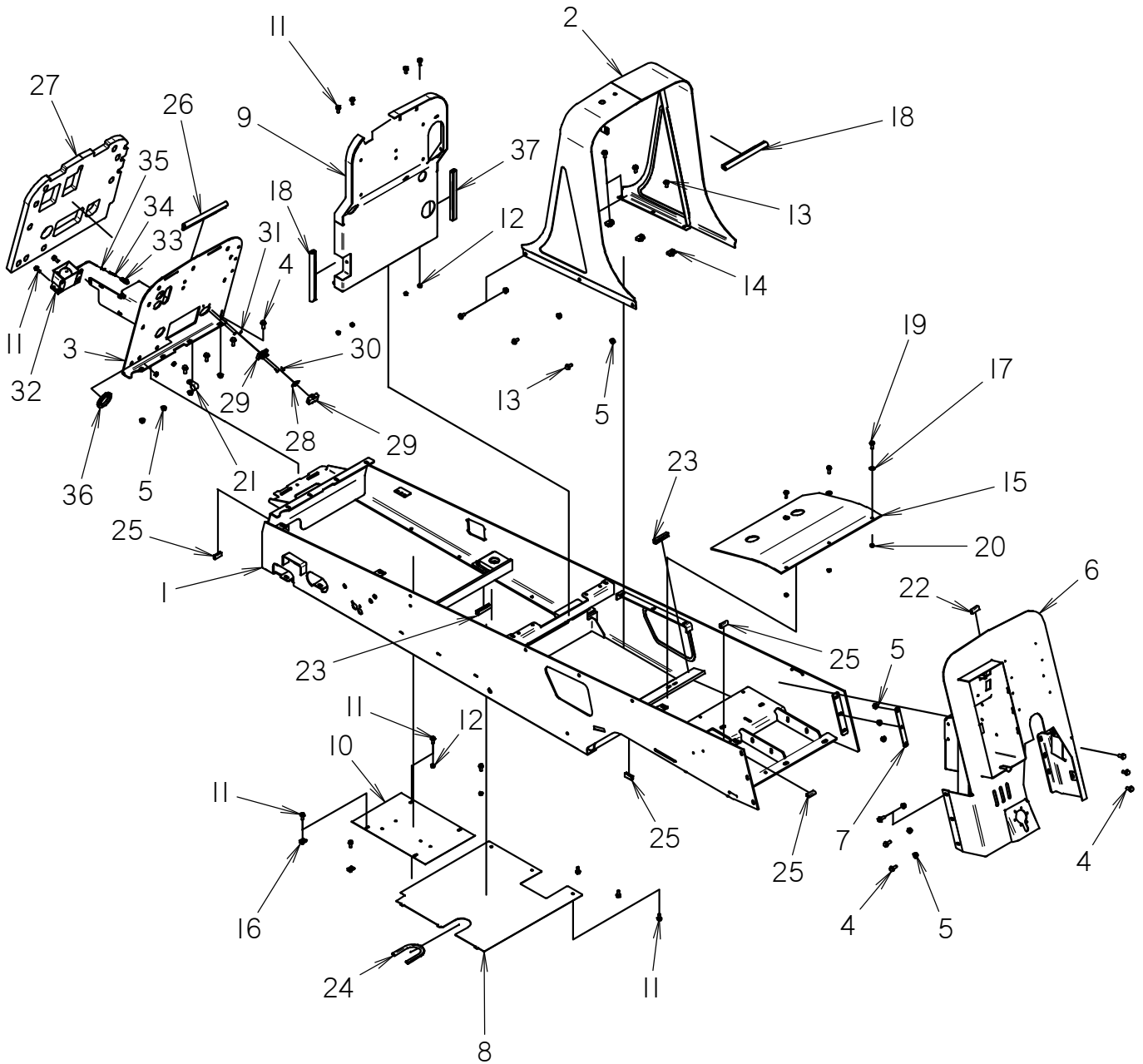

# ENGINE SKID

REF NO.	PART NUMBER	QTY	DESCRIPTION	REMARKS
1	300-4423	1	ENGINE SKID	
2	300-4434	1	CENTER MOUNT	
3	318-998	1	FRONT MOUNT	
4	106-724	10	FLG SCREW (M10-1.50 X 25MM)	
5	106-387	13	FLG LOCKNUT (M10-1.50)	
6	300-4441	1	BACK PLATE	
7	318-985	1	SPACER	
8	300-8452	1	FLOOR PLATE	
9	300-5367	1	MID FIREWALL	
10	320-405	1	COVER PLATE	
11	106-162	13	FLG SCREW (M8-1.25 X 20MM, GD8)	
12	106-386	8	FLG LOCKNUT (M8-1.25)	
13	106-382	6	FLG LK SCREW (M10-1.50 X 20MM)	
14	107-287	3	CLIP NUT (M10-1.50)	
15	362-1346	1	FLAP	
16	106-551	2	CLIP NUT (M8-1.25)	
17	105-117	3	WASHER (5/16")	
18	116-489	49	BULK EDGE (1/8",SOLD PER FT)	VARIOUS QUANTITIES AND LENGTHS
19	106-381	3	FLG LK SCREW (M8-1.25 X 25MM)	
20	107-096	3	LOCKNUT (M8-1.25, NLK)	
21	110-333	1	BOLT-ON CLAMP (1")	
22	116-421	69	BULK EDGE (1/8", SOLD PER FT)	1 @ 69"
23	116-259	17	BULK EDGE (1/2", SOLD PER FT)	VARIOUS QUANTITIES AND LENGTHS
24	115-686	11	BULK EDGE (5/32", SOLD PER 1")	1 @ 11"
25	115-704	52	BULK EDGE (1/4", SOLD PER 1")	VARIOUS QUANTITIES AND LENGTHS
26	116-978	61	BULK EDGE (1/4", SOLD PER FT)	1 @ 61"
27	118-165	1	SOUND INSULATION	
28	211-305	1	BK/AMI 125 AMP FUSE	
29	363-714	1	MODIFIED FUSE PANNEL ASSEMBLY	
30	105-189	2	SCREW (#6-32 X 1/2")	
31	105-215	2	NUT (#6-32)	
32	306-602	1	ALARM	
33	214-103	1	(2-WAY) MALE CONNECTOR	
34	214-104	2	PACKARD MALE TERMINAL	
35	157-645	2	WEATHER-PAC SEAL (2.80MM)	
36	115-686	5	BULK EDGE (5/32",SOLD PER 1")	1 @ 5"
37	117-978	77	BULK EDGE(3/16 W/ 1" BULBIFIT)	

NOT SHOWN:

FOOTNOTES:

NOTE:

# BATTERY

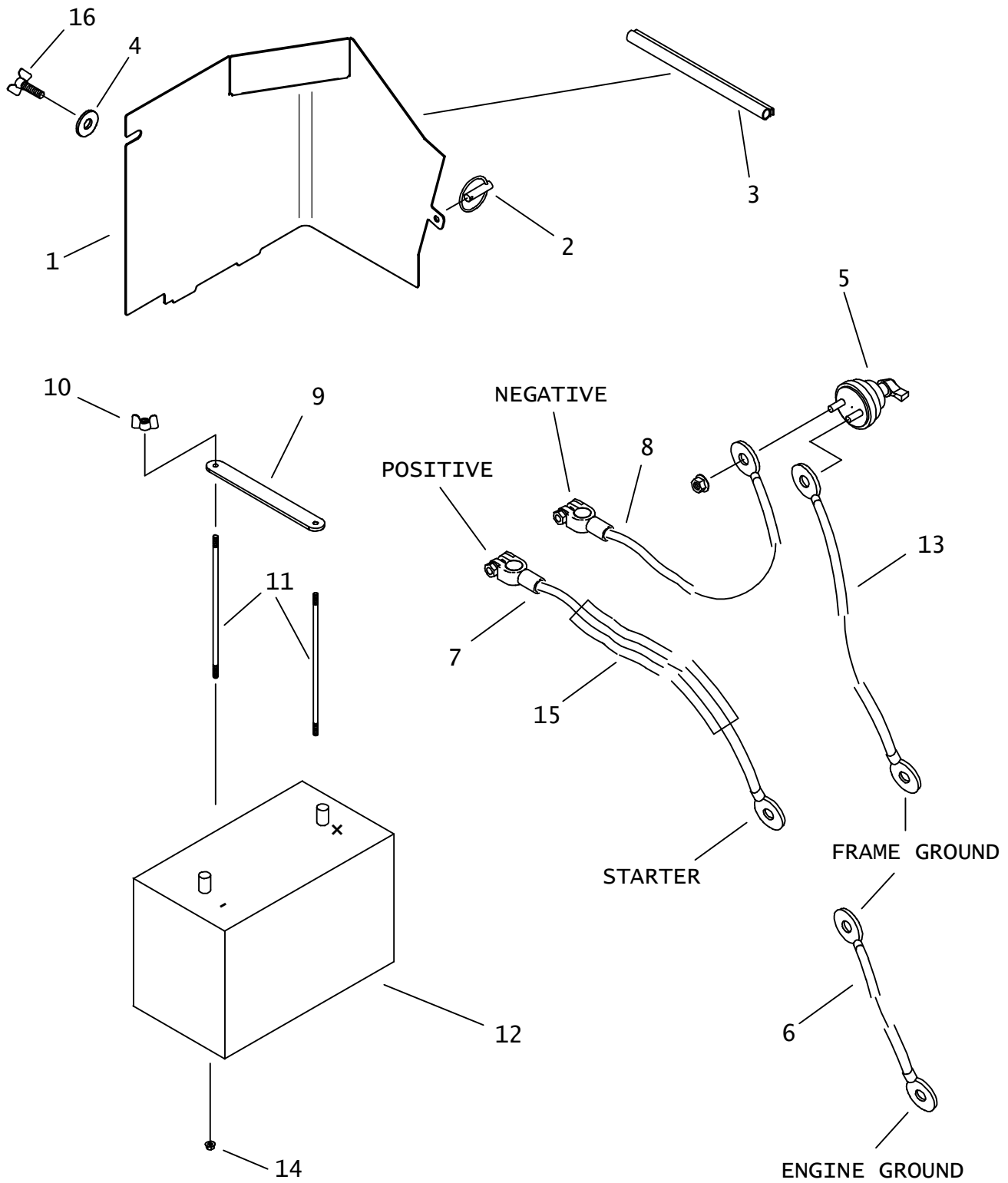

# BATTERY

REF NO.	PART NUMBER	QTY	DESCRIPTION	REMARKS
1.	300-5418	1	BATTERY COVER	
2.	110-737	1	PULL PIN (5/16" X 2")	
3.	116-421	AR	BULK EDGE (1/8",SOLD PER FT)	USE 1 @ 22"
4.	105-117	1	WASHER (5/16")	
5.	217-819	1	BATTERY DISCONNECT SWITCH	
6.	215-355	1	BAT CABLE (2/0 GA X 36", BLK)	
7.	213-159	1	BAT CABLE (2/0 GA X 63", RED)	
8.	215-337	1	BAT CABLE (2/0 GA X 19", BLK)	
9.	108-189	1	BATTERY HOLD DOWN	
10.	195-339	2	WINGNUT (1/4-NC)	
11.	356-491	2	TIE DOWN ROD (1/4-NC X 9.3")	
12.	215-262	1	BATTERY (12V, 925 AMP)	
13.	215-1562	1	BAT CABLE (2/0 GA X 28",BLACK)	
14.	105-832	2	FLG LOCKNUT (1/4-NC)	
15.	116-389	AR	BULK TUBING (3/4".SOLD PER FT)	INCLUDED WITH REF NO 7
16.	106-795	1	WING SCREW (M8-1.25 X 20MM)	

NOT SHOWN:

FOOTNOTES:

NOTE:

# REAR CONTROLS

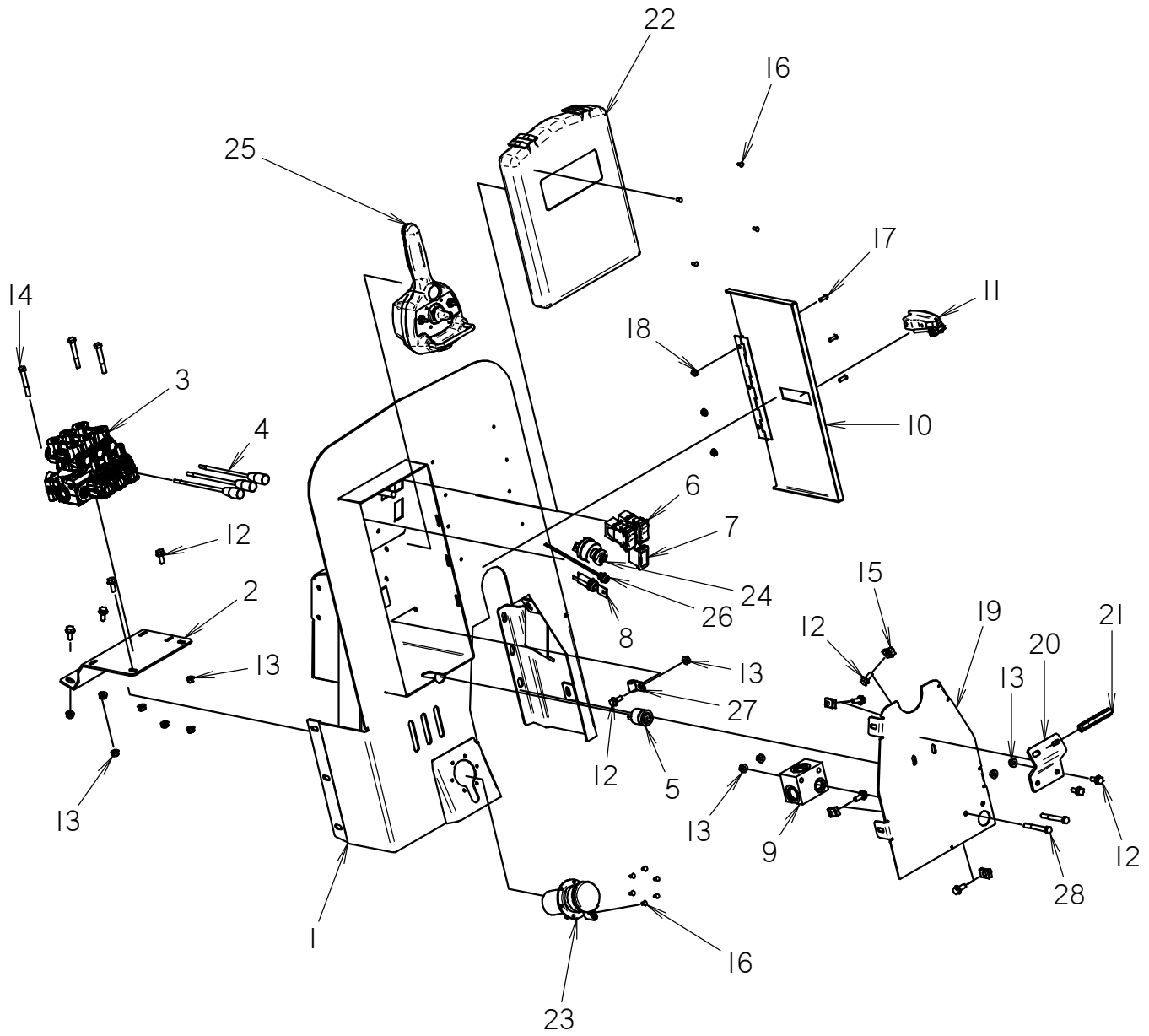

# REAR CONTROLS

REF NO.	PART NUMBER	QTY	DESCRIPTION	REMARKS
1	300-4441	1	BACK PLATE	
2	318-476	1	VALVE MOUNT	
3	157-240	1	SET UP VALVE	
4	365-426	3	LEVER (M8-1.25 X 200MM)	
5	306-603	1	AUDIO ALARM	
6	214-489	2	ROCKER SW (DPDT) (ON-OFF-ON)	
7	110-962	1	FILLER PLUG	
8	214-908	1	ON-OFF KEY SWITCH	
9	159-791	1	HYDRAULIC MANIFOLD BLOCK	
10	318-736	1	DOOR	
11	117-558	1	LATCH, ADJUST LEVER (LOCKING)	
12	106-162	11	FLG SCREW (M8-1.25 X 20MM, GD8)	
13	106-386	12	FLG LOCKNUT (M8-1.25)	
14	106-570	3	SCREW (M8-1.25 X 60MM)	
15	106-551	4	CLIP NUT (M8-1.25)	
16	110-560	10	POP RIVET (3/16" X 1/2", ALUM)	
17	107-193	3	SCREW (M6-1.00 X 16MM, BUT SOC)	
18	106-385	3	FLG LOCKNUT (M6-1.00)	
19	324-959	1	COVER PLATE	
20	322-614	1	CLAMP BRACKET	
21	195-972	1	U-BOLT CLAMP (1-3/4")	
22	318-588	1	MANUAL COMPARTMENT	
23	364-661	1	FILLER NECK	
24	214-852	1	IGNITION SWITCH	
25	214-589	1	GROUND DRIVE CONTROL	
26	214-563	1	RED LED (12V DC)	
27	110-126	1	BOLT-ON CLAMP (1/2")	
28	106-330	2	SCREW (M8-1.25 X 70MM)	

NOT SHOWN:

FOOTNOTES:

NOTE:



# FRONT HOOD SUPPORT

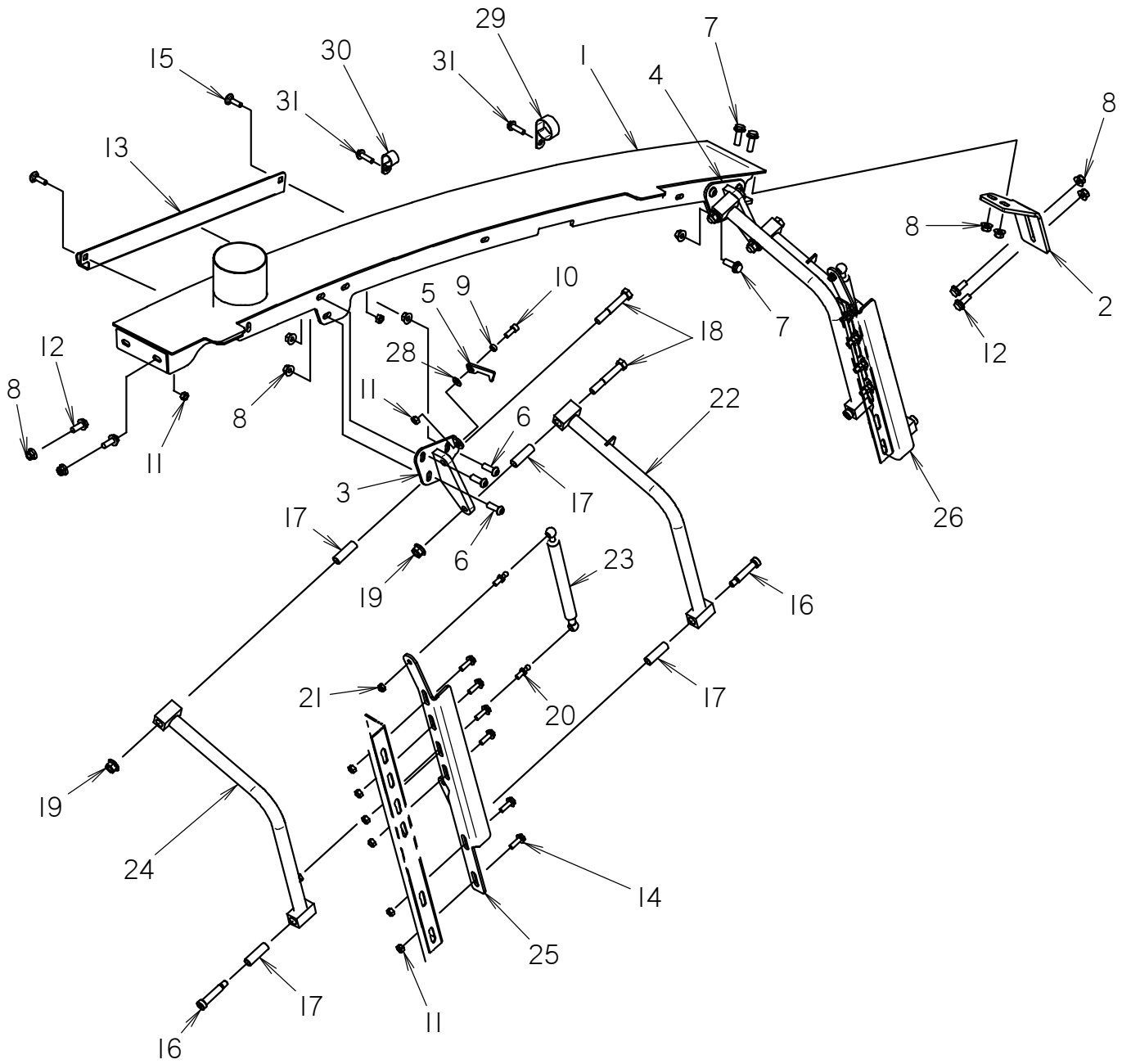

# FRONT HOOD SUPPORT

REF NO.	PART NUMBER	QTY	DESCRIPTION	REMARKS
1	300-7221	1	MID HOOD	
2	300-7230	1	FRONT MOUNT	
3	300-7233	1	REAR ARM MOUNT	
4	300-7236	1	FRONT ARM MOUNT	
5	300-7417	1	LATCH	
6	106-674	5	BOLT (M10-1.50 X 30MM,BUT SOC)	
7	106-383	3	FLG LK SCREW (M10-1.50 X 30MM)	
8	106-387	12	FLG LOCKNUT (M10-1.50)	
9	179-593	1	BUSHING	
10	105-842	1	SCREW (M8-1.25 X 20MM, SOC)	
11	106-561	13	LOCKNUT (M8-1.25,PRV TRQ,10.9)	
12	106-724	4	FLG SCREW (M10-1.50 X 25MM)	
13	300-5601	1	BRACKET	
14	106-381	10	FLG LK SCREW (M8-1.25 X 25MM)	
15	107-380	2	CARRIAGE BOLT(M8-1.25X30MM,BX)	
16	106-971	4	SHLD BLT (M12 X 50MM,M10-1.50)	
17	179-832	8	SLEEVE	
18	106-700	4	SCREW (M12-1.75 X 80MM)	
19	106-709	4	FLG LK NUT (M12-1.75)	
20	110-655	4	BALL SCREW (5/16-NC X 1/2")	
21	105-089	2	LOCKNUT (5/16-NC)	
22	319-706	2	ARM	
23	151-227	2	GAS STRUT	
24	319-707	2	ARM	
25	300-8533	1	HOOD BRACKET	
26	300-8531	1	HOOD BRACKET	
28	105-095	1	WASHER (1/4")	
29	110-332	1	BOLT-ON CLAMP (1-5/8")	
30	110-333	1	BOLT-ON CLAMP (1")	
31	106-163	2	FLG SCREW (M8-1.25 X 30MM)	

NOT SHOWN:

FOOTNOTES:

NOTE:

# FRONT FIXED HOOD

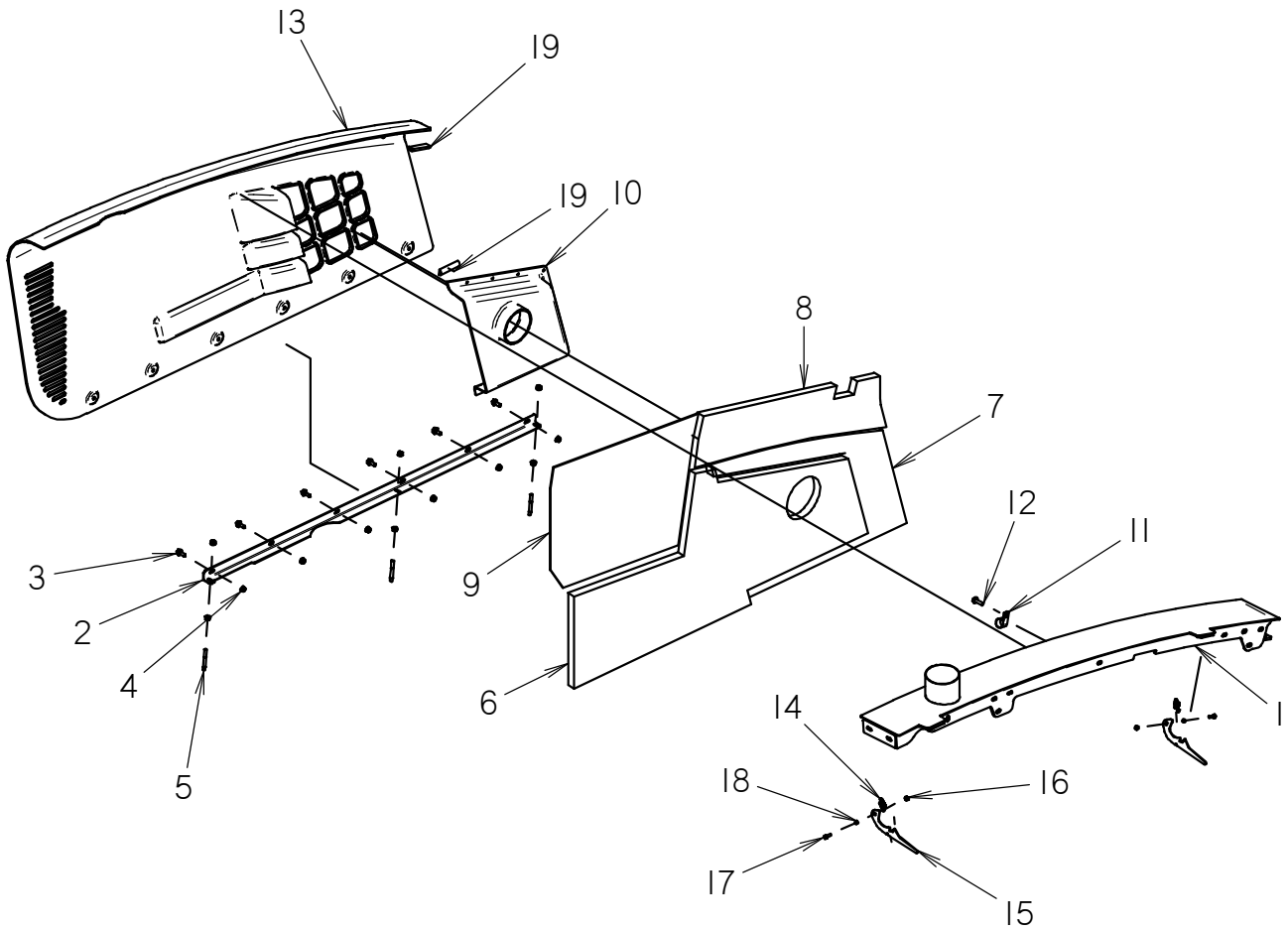

# FRONT FIXED HOOD

REF NO.	PART NUMBER	QTY	DESCRIPTION	REMARKS
1	300-7221	1	MID HOOD	
2	300-5556	1	BRACKET	
3	106-162	6	FLG SCREW (M8-1.25 X 20MM, GD8)	
4	106-386	12	FLG LOCKNUT (M8-1.25)	
5	108-112	3	STUD BOLT (M8-1.25 X 70MM)	
6	362-1297	1	SOUND INSULATION	
7	362-1296	1	SOUND INSULATION	
8	362-1298	1	SOUND INSULATION	
9	362-1303	1	THERMAL INSULATION	
10	362-1278	1	AIR BAFFLE	
11	110-333	1	BOLT-ON CLAMP (1")	
12	106-163	1	FLG SCREW (M8-1.25 X 30MM)	
13	362-1281	1	FRONT FIXED HOOD ASSY	SERVICE PART 191-504
14	115-619	2	EXTENSION SPRING	
15	300-7241	2	LATCH	
16	106-237	2	LOCKNUT (M6-1.00PRV TRQ,NLK)	
17	105-797	2	SCREW (M6-1.00 X 20MM, BX)	
18	300-8326	2	BUSHING	
19	118-183	167	BULK EDGE (SOLD BY FOOT)	VARIOUS LENGTHS AND QUANTITIES

NOT SHOWN:

FOOTNOTES:

NOTE:

# FRONT OPENING HOOD

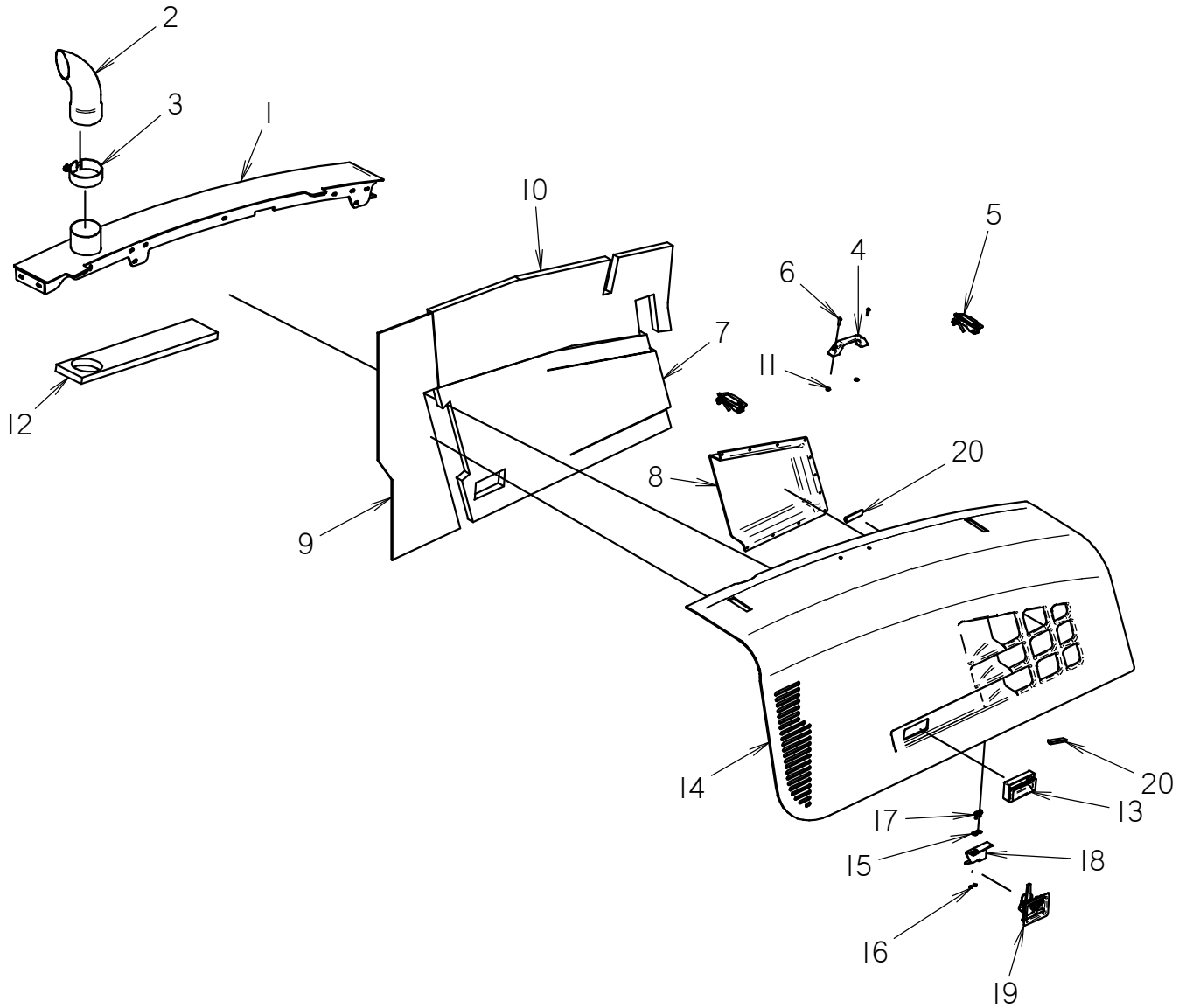

# FRONT OPENING HOOD

REF NO.	PART NUMBER	QTY	DESCRIPTION	REMARKS
1	300-7221	1	MID HOOD	
2	196-351	1	EXHAUST TUBE (4" X 12")	
3	194-027	1	MUFFLER CLAMP	
4	117-538	1	GRAB HANDLE	
5	117-558	2	LATCH, ADJUST LEVER (LOCKING)	
6	106-640	2	SCREW (M6-1.00 X 20MM,BUT SOC)	
7	362-1301	1	SOUND INSULATION	
8	362-1307	1	AIR BAFFLE	
9	362-1405	1	THERMAL INSULATION	
10	362-1300	1	SOUND INSULATION	
11	106-237	2	LOCKNUT (M6-1.00,PRV TRQ,NLK)	
12	362-1299	1	SOUND INSULATION	CUT AS REQUIRED TO FIT AROUND GUSSET
13	117-427	1	POCKET PULL HANDLE	
14	362-1283	1	FRONT HOOD ASSEMBLY	SEVICE PART 191-503
15	105-095	2	WASHER (1/4")	
16	106-048	2	LOCKNUT (#10-24)	
17	106-712	2	FLG SCREW (M6-1.00 X 16MM)	
18	300-8999	1	LOCK PLATE	
19	110-514	1	LOCKING LATCH (ADJUSTABLE)	
20	118-183	177	BULK EDGE (SOLD BY FOOT)	VARIOUS LENGTHS AND QUANTITIES

NOT SHOWN:

FOOTNOTES:

NOTE:

# REAR FIXED HOOD

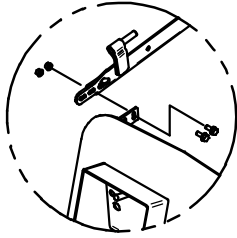

OLD STYLE

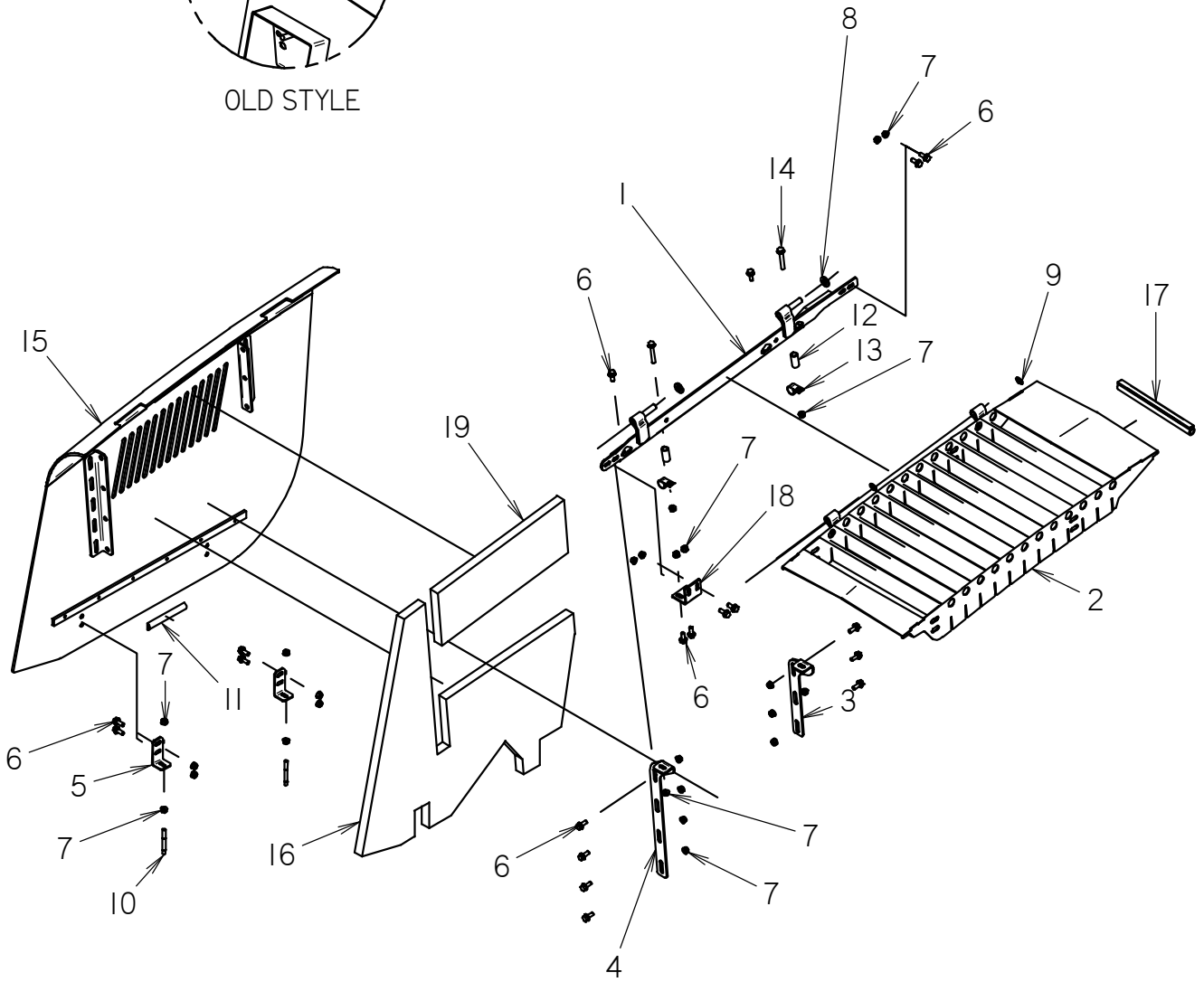

# REAR FIXED HOOD

REF NO.	PART NUMBER	QTY	DESCRIPTION	REMARKS
1	319-801	1	REAR HOOD SUPPORT	
2	300-5371	1	GRILLE	
3	300-5379	1	PANEL SUPPORT	
4	319-804	1	PANEL SUPPORT	
5	319-394	2	BRACKET	
6	106-162	19	FLG SCREW (M8-1.25 X 20MM, GD8)	
7	106-386	25	FLG LOCKNUT (M8-1.25)	
8	106-397	2	WASHER (M12, HARDENED)	
9	115-482	2	GRIP RING (.500")	
10	108-112	2	STUD BOLT (M8-1.25 X 70MM)	
11	118-183	92	BULK EDGE (SOLD BY FOOT)	
12	181-650	2	SPACER (1.395")	
13	110-373	2	BOLT-ON CLAMP (13/16")	
14	105-665	2	FLG SCREW (M8-1.25 X 55MM)	
15	362-1290	1	REAR FIXED HOOD ASSY	
16	362-1386	1	SOUND INSULATION	
17	116-489	16	BULK EDGE (1/8";SOLD PER FT)	
18	300-9448	1	REAR MOUNT BRACKET	
19	362-1445	1	SOUND INSULATION	

NOT SHOWN:

FOOTNOTES:

NOTE:



## REAR OPENING HOOD

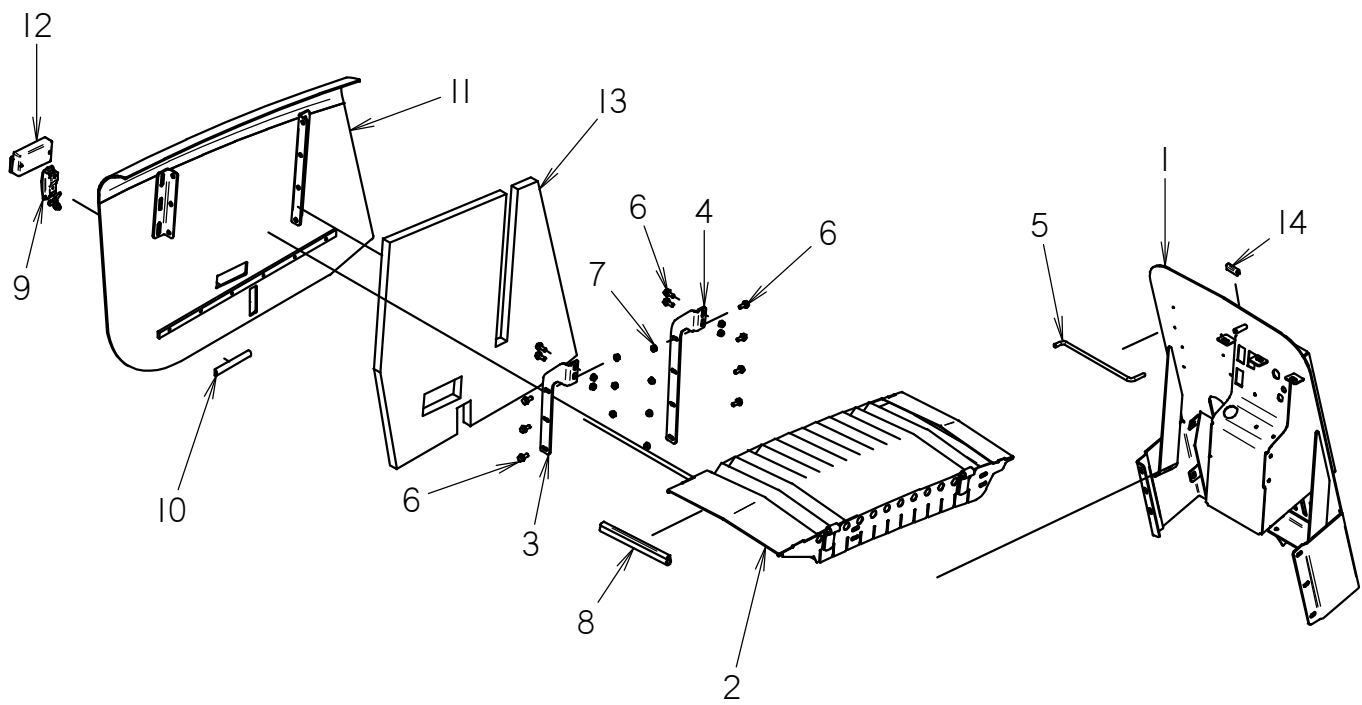

# REAR OPENING HOOD

REF NO.	PART NUMBER	QTY	DESCRIPTION	REMARKS
1	300-4441	1	BACK PLATE	
2	300-5371	1	GRILLE	
3	300-5378	1	HOOD BRACE	
4	319-799	1	HOOD BRACE	
5	179-583	1	PROP ROD	
6	106-162	11	FLG SCREW (M8-1.25 X 20MM, GD8)	
7	106-386	11	FLG LOCKNUT (M8-1.25)	
8	116-489	16	BULK EDGE (1/8",SOLD PER FT)	
9	117-558	1	LATCH, ADJUST LEVER (LOCKING)	
10	118-183	92	BULK EDGE (SOLD BY FOOT)	2 @ 46"
11	362-1291	1	REAR HOOD ASSY	
12	117-427	1	POCKET PULL HANDLE	
13	362-1387	1	SOUNDS INSULATION	
14	116-421	69	BULK EDGE (1/8", SOLD PER FT)	

NOT SHOWN:

FOOTNOTES:

NOTE:



# **FRAME COMPONENTS**

# CARRIAGE

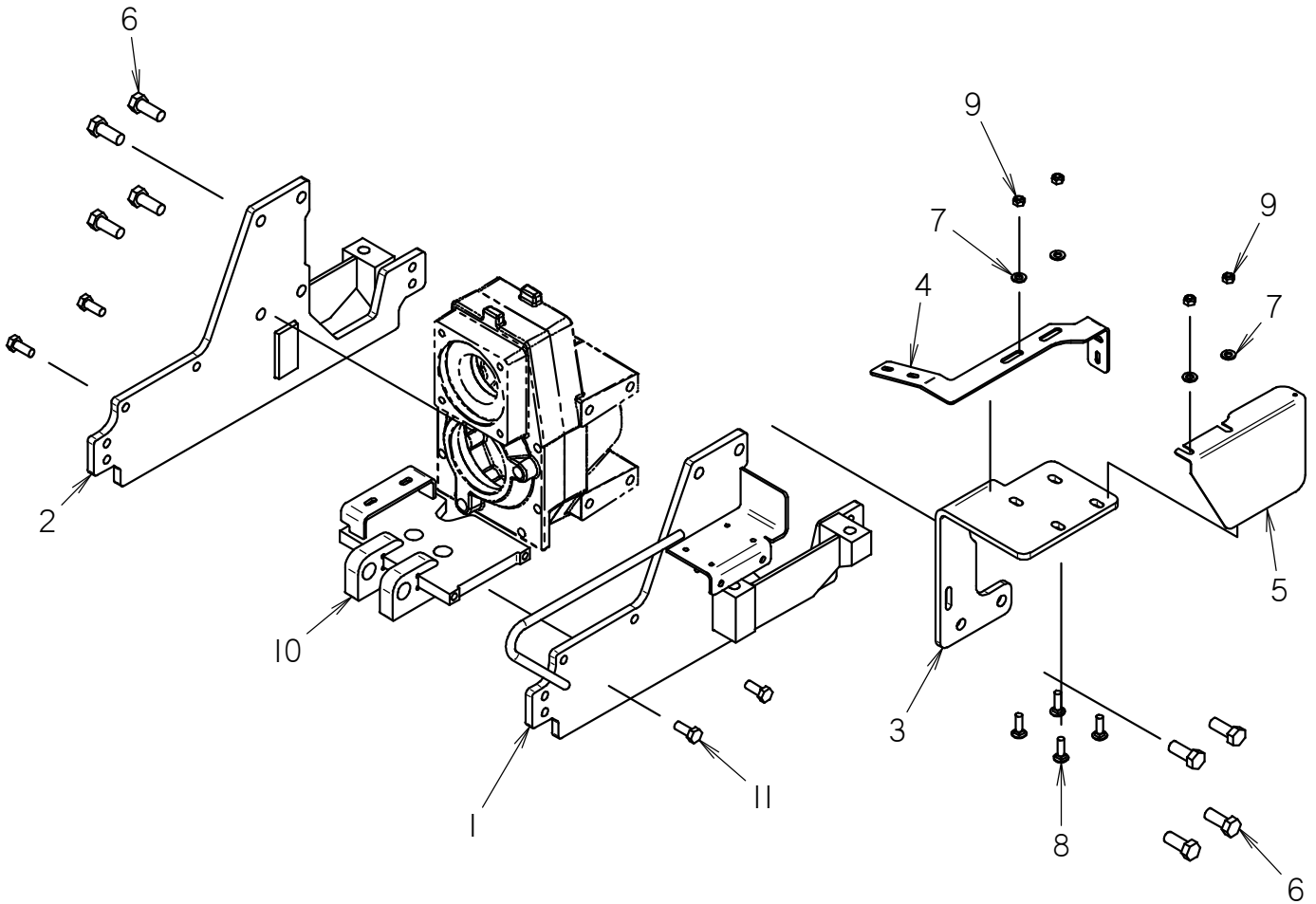

# CARRIAGE

REF NO.	PART NUMBER	QTY	DESCRIPTION	REMARKS
1	300-2816	1	RIGHT SIDE PLATE	
2	325-312	1	LEFT SIDE PLATE	
3	327-581	1	HOSE CARRIER MOUNT	
4	318-873	1	BRACKET, TOP	
5	327-618	1	SHIELD	
6	105-998	8	SCREW (M16-2.00 X 40MM)	TORQUE TO 140 FT LBS SEE FOOTNOTE 1
7	106-390	4	WASHER (M10)	
8	105-249	4	CARRIAGE BOLT(3/8-NC X 1-1/4")	
9	105-047	4	LOCKNUT (3/8-NC)	
10	318-353	1	REAR PLATE	
11	105-273	4	SCREW (M12-1.75 X 30MM)	TORQUE TO 55 FT LBS SEE FOOTNOTE 1

NOT SHOWN:

FOOTNOTES:

1. LOCTITE 242 OR EQUIV.

NOTE:

# CARRIAGE SPINDLE

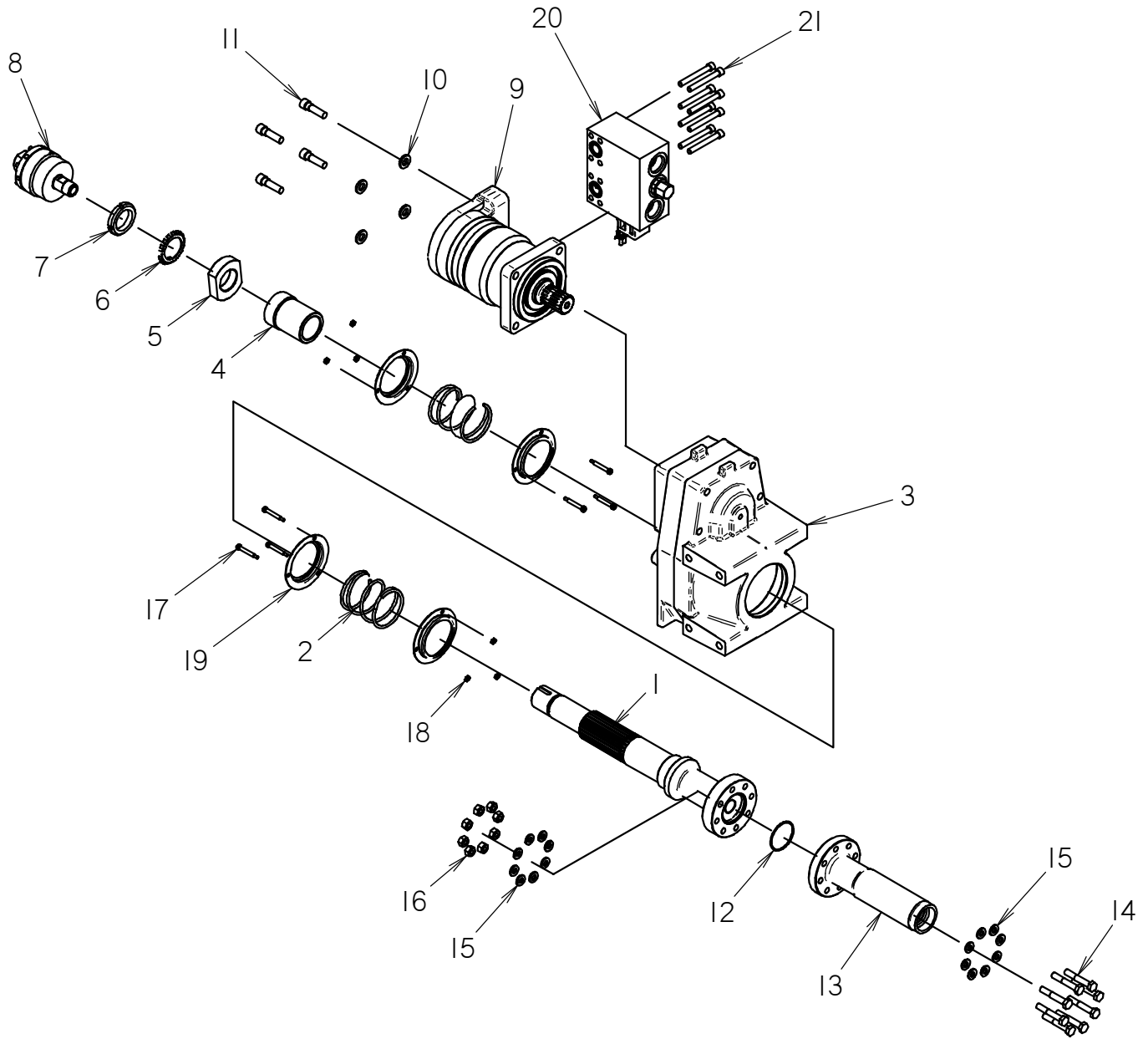

# CARRIAGE SPINDLE

REF NO.	PART NUMBER	QTY	DESCRIPTION	REMARKS
1	166-426	1	SLIDING OUTPUT SHAFT	APPLY 256-666 GREASE TO SPLINES
2	118-292	2	COMPRESSION SPRING	SEE FOOTNOTE 1
3	166-451	1	GEAR BOX	
4	177-034	1	SHAFT SPACER	
5	106-865	1	NUT	
6	185-074	1	TANG LOCK WASHER (1.792")	
7	185-067	1	THRUST LOCKNUT (1.767-NF-18)	
8	153-242	1	WATER SWIVEL (12N-12NF)	SEE FOOTNOTE 2
9	150-1026	1	ROTATION MOTOR	
10	106-397	4	WASHER (M12, HARDENED)	
11	106-707	4	SCREW (M12-1.75 X 45MM, SOC)	USE LOCTITE 242
12	157-019	1	O-RING (139 D90)	
13	400-604	1	SAVER SUB (1.47-4 F DS)	
14	106-642	8	SCREW (M10-1.50 X 65MM)	TORQUE TO 47 FT LBS
15	106-396	16	WASHER (M10, HARDENED)	
16	105-894	8	LOCKNUT (M10-1.50, PRV TRQ, 10.9)	
17	108-120	6	SHLD BLT (1/4" X 1-1/2", #10-24)	
18	106-048	6	LOCKNUT (#10-24)	
19	159-898	4	SPRING CAP	
20	159-577	1	RELIEF MANIFOLD	SERVICE PARTS INCLUDE: 150-1326 HYDRAULIC VALVE
21	105-857	8	BOLT (3/8-NC X 3", SOC, GD8)	

NOT SHOWN:

FOOTNOTES:

1. SUPERSEDES 117-921 COMPRESSION SPRING, 117-921 DOES NOT USE SPRING CAPS (REF 19)
2. INSTALL USING NICKLE THREAD SEALING TAPE (117-555) ON MALE THREADS, 191-248 SEAL KIT

NOTE:



# THRUST DRIVE

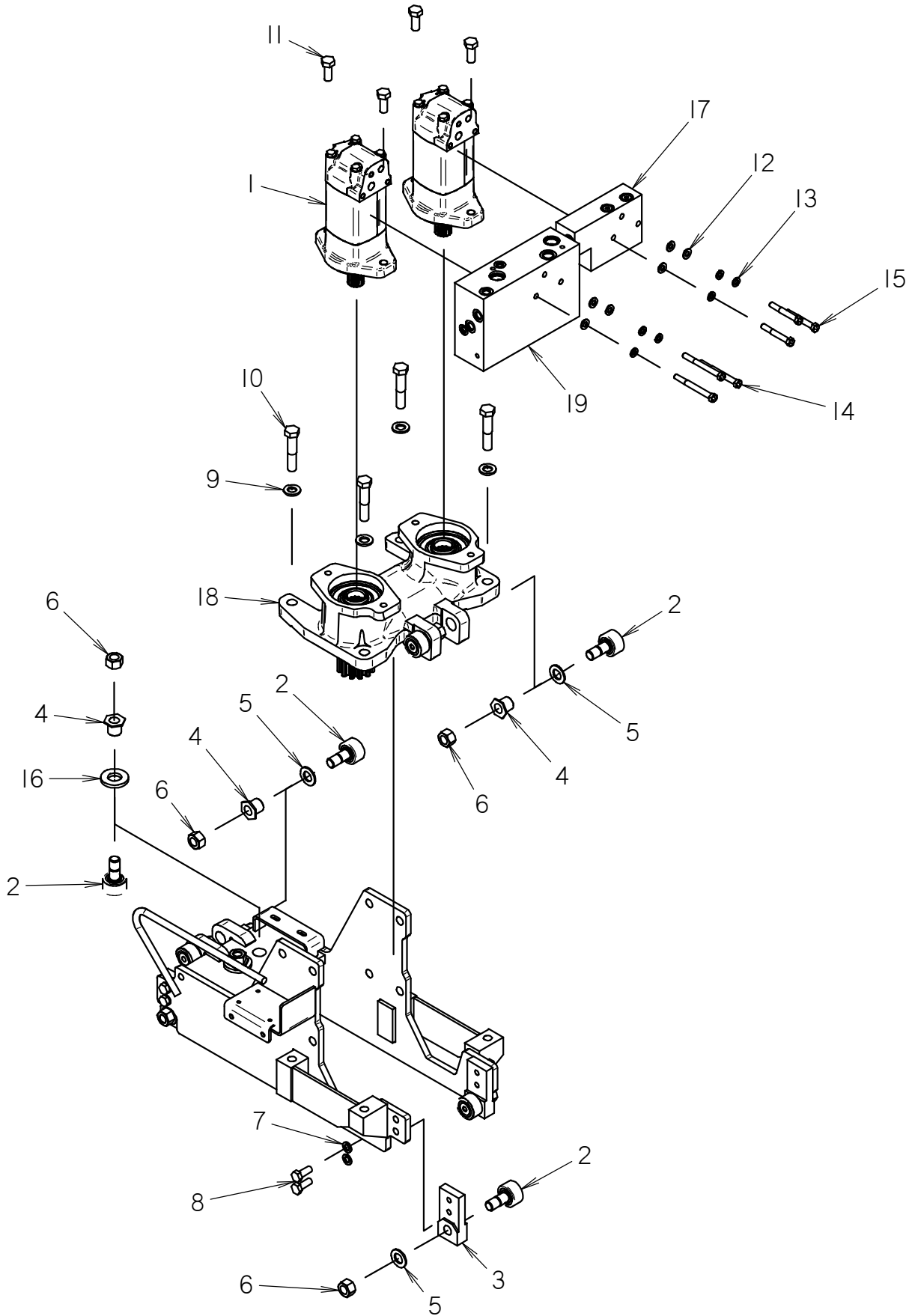

# THRUST DRIVE

REF NO.	PART NUMBER	QTY	DESCRIPTION	REMARKS
1	157-317	2	MOTOR	
2	141-730	10	RBC ROLLER	
3	318-344	4	LOWER ROLLER MOUNT	
4	179-704	6	ECCENTRIC BUSHING	
5	106-949	6	WASHER (3/4", HARDENED)	
6	105-388	10	NUT (3/4-NF)	
7	106-030	6	LOCK WASHER (M12)	TORQUE TO 62 FT LBS
8	105-273	8	SCREW (M12-1.75 X 30MM)	TORQUE TO 55 FT LBS, USE 242 LOCTITE
9	106-398	4	WASHER (M16, HARDENED)	
10	107-197	4	SCREW (M16-2.00 X 80MM, 10.9)	TORQUE TO 200 FT LBS, USE 242 LOCTITE
11	106-472	4	SCREW (M14-2.0 X 35MM)	
12	106-390	6	WASHER (M10)	TORQUE TO 88 FT LBS, USE 242 LOCTITE
13	105-072	6	LOCK WASHER (3/8")	
14	105-258	3	BOLT (3/8-NC X 3-3/4")	TORQUE TO 40 FT LBS, USE 242 LOCTITE
15	500-003	3	BOLT (3/8-NC X 2-3/4")	TORQUE TO 40 FT LBS, USE 242 LOCTITE
16	179-422	2	BOSS	
17	150-2050	1	MANIFOLD	SEE NOT SHOWN FOR SERVICE PARTS
18	166-448	1	THRUST DRIVE	
19	150-2049	1	MANIFOLD	SEE NOT SHOWN FOR SERVICE PARTS

**NOT SHOWN:**

500-1649	SOLENOID VALVE CARTRIDGE, 4W-2P, NC	USE ON 150-2050
500-1650	SOLENOID COIL	USE ON 150-2049 & 150-2050
500-1647	SOLENOID VALVE CARTRIDGE, 4W-2P	USE ON 150-2049
500-1727	HYD PILOT LOGIC CARTRIDGE, -10	USE ON 150-2049
500-1728	HYD PILOT LOGIC CARTRIDGE, -20	USE ON 150-2049

**FOOTNOTES:**

**NOTE:**

## ROTATION GEAR BOX

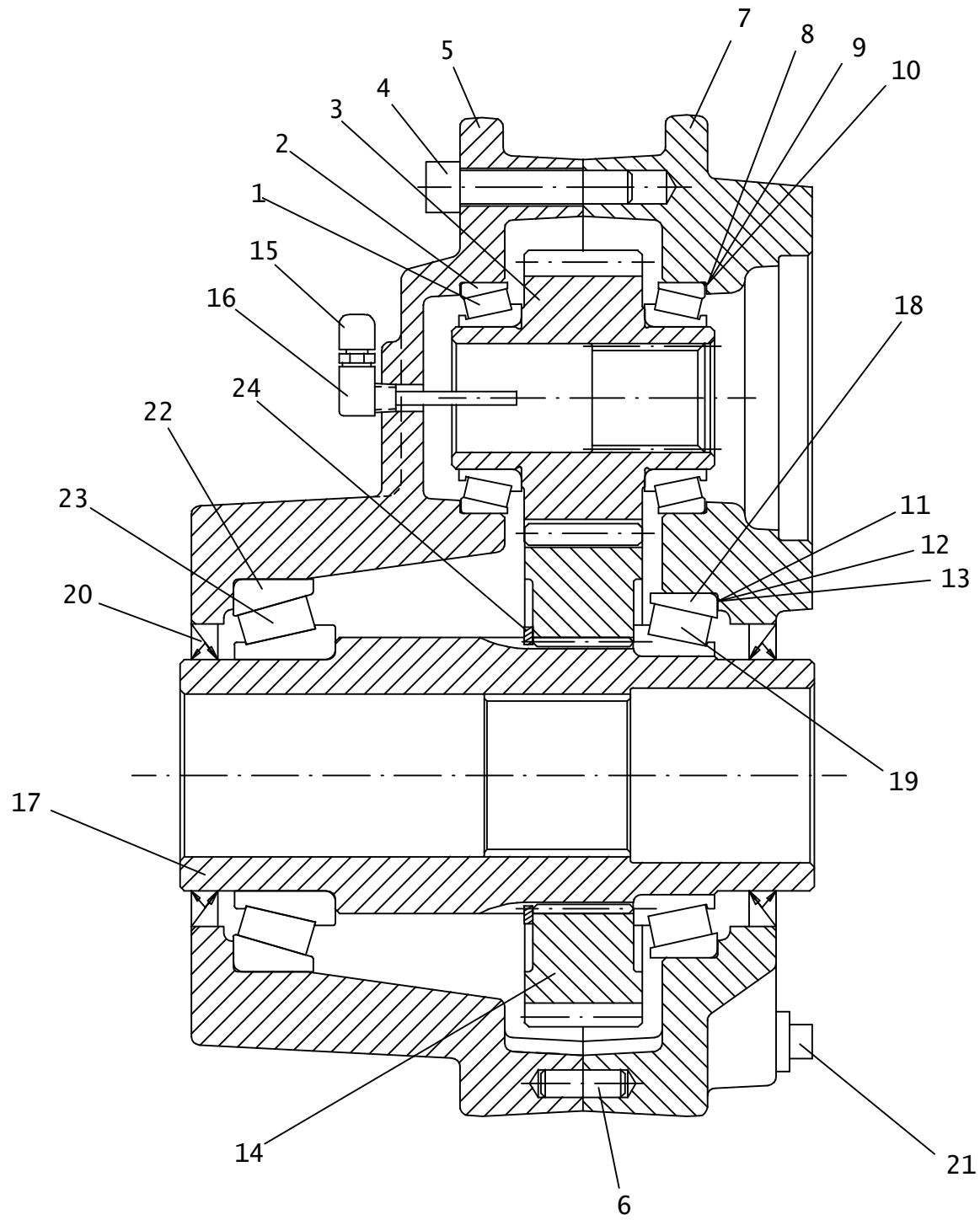

# ROTATION GEAR BOX

REF NO.	PART NUMBER	QTY	DESCRIPTION	REMARKS
	166-451		GEAR BOX (1.78:1 ROTATION)	INCL REF NO.'S 1 - 24
1.	126-100	2	TAPERED BEARING (2")	
2.	126-099	2	TAPERED RACE (3.25")	
3.	166-528	1	INPUT PINION	
4.	106-771	10	SCREW (M12-1.75 X 60MM, SOC)	
5.	162-027	1	GEARBOX HOUSING	
6.	106-866	2	DOWEL PIN (10MM X 30MM)	
7.	162-004	1	GEARBOX COVER	
8.	165-800	5	SHIM (.002")	
9.	165-801	5	SHIM (.003")	
10.	165-802	5	SHIM (.007")	
11.	165-829	5	SHIM (.002")	
12.	165-830	5	SHIM (.003")	
13.	165-828	5	SHIM (.007")	
14.	160-1102	1	OUTPUT GEAR	
15.	159-003	1	AIR VENT (02N)	
16.	514-123	1	PICKUP TUBE (02N-02NF90-2")	
17.	166-434	1	OUTPUT SHAFT	
18.	126-076	1	TAPERED RACE (5.118")	
19.	126-075	1	TAPERED BEARING (3.346")	
20.	155-869	2	INTERNAL SEAL (3.250")	
21.	115-211	2	PLUG (08N,SQ, MAG)	
22.	126-157	1	TAPERED RACE	
23.	126-156	1	TAPERED BEARING	
24.	115-896	1	EXTERNAL SNAP RING (3.875")	

NOT SHOWN:

FOOTNOTES:

NOTE:

# ASSISTED MAKE-UP

BEGINS WITH S/N CMWJ1220C60000122

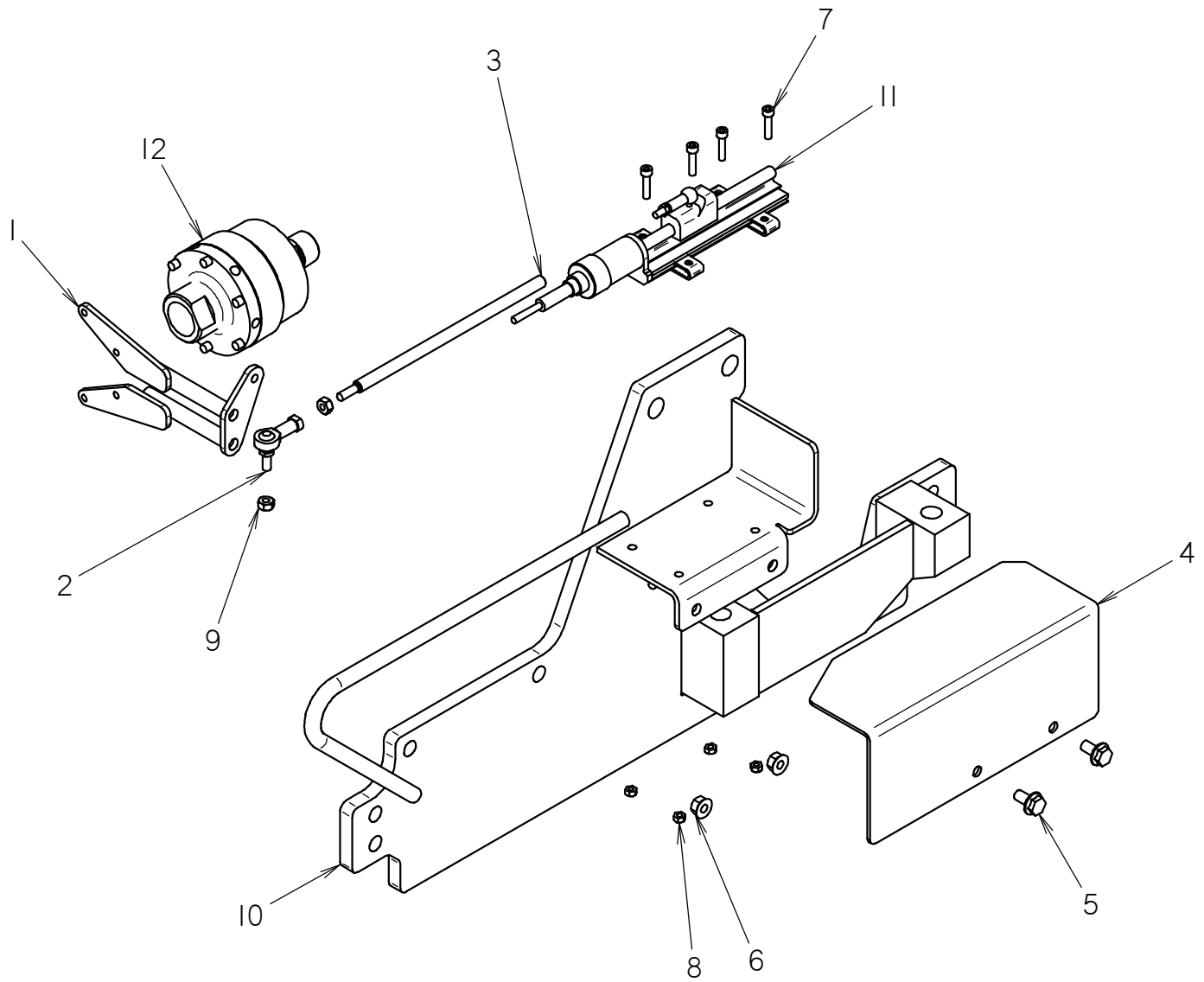

# ASSISTED MAKE-UP

BEGINS WITH S/N CMWJ1220C60000122

REF NO.	PART NUMBER	QTY	DESCRIPTION	REMARKS
1	300-2615	1	SLIDER	
2	110-774	1	BALL JOINT (1/4-NF)	
3	300-2620	1	SENSOR ROD	
4	300-2625	1	COVER	
5	106-380	2	FLG LK SCREW (M8-1.25 X 16MM)	
6	106-386	2	FLG LOCKNUT (M8-1.25)	
7	106-427	4	SCREW (M5-0.80 X 22MM, SOC)	
8	106-850	4	LOCKNUT (M5-0.80)	
9	105-152	2	NUT (1/4-NF)	
10	300-2816	1	RIGHT SIDE PLATE	
11	215-1002	1	POSITION SENSOR	
12	153-242	1	WATER SWIVEL (12N-12NF)	

NOT SHOWN:

FOOTNOTES:

NOTE:

# PINION DRIVE ASSEMBLY

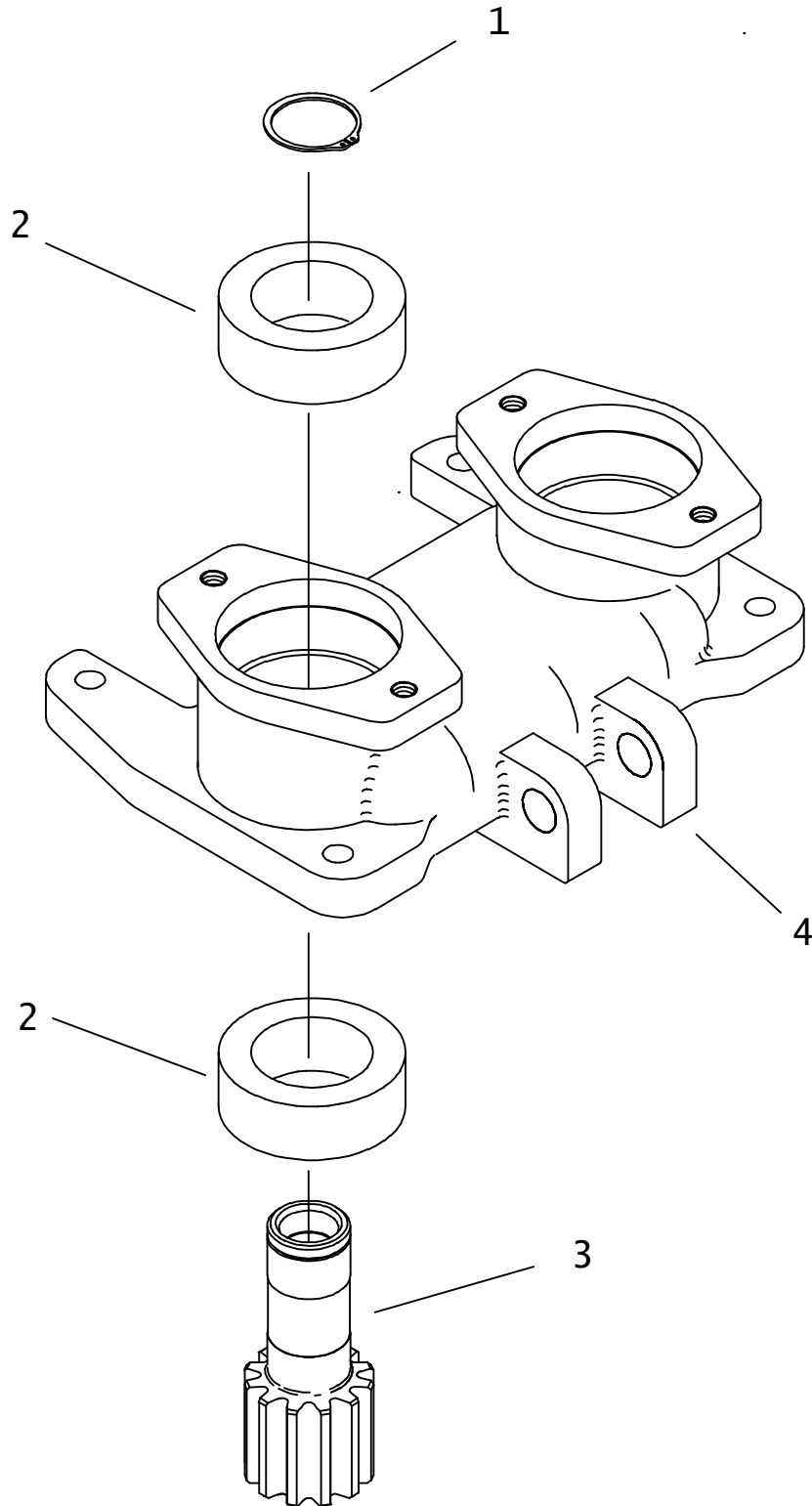

# PINION DRIVE ASSEMBLY

REF	PART				
NO.	NUMBER	QTY	DESCRIPTION		REMARKS
	166-448	-	PINION DRIVE		
1.	115-456	2	EXTERNAL SNAP RING		
2.	125-044	4	BALLBEARING (1.717")		
3.	160-1019	2	PINION		
4.	318-351	1	MOTOR PLATE		

NOT SHOWN:

FOOTNOTES:

NOTE:



## PIPE GUIDE

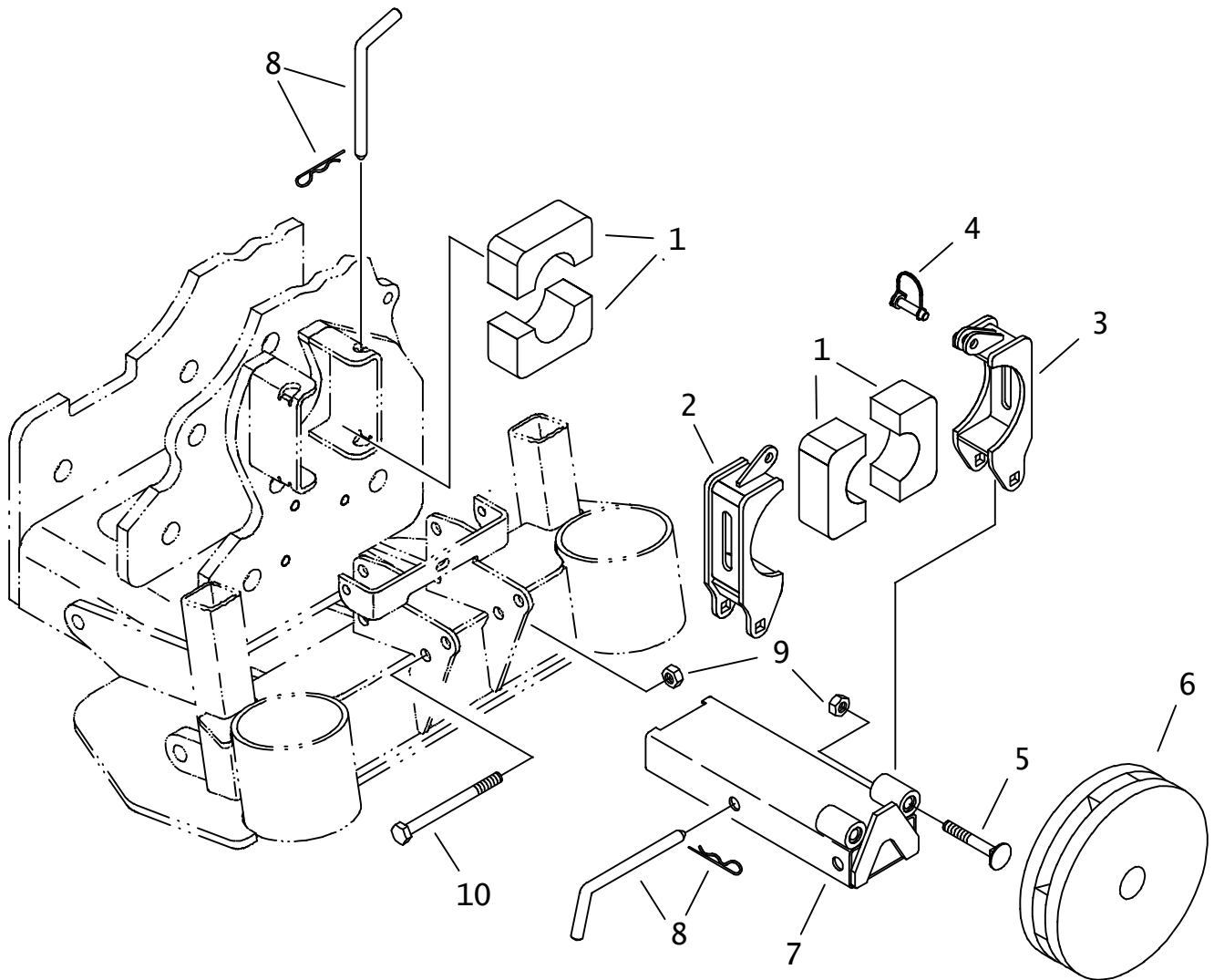

## PIPE GUIDE

REF NO.	PART NUMBER	QTY	DESCRIPTION	REMARKS
1.	362-1060	4	PIPE GUIDE	
2.	320-814	1	RIGHT PIPE GUIDE RETAINER	
3.	320-802	1	LEFT PIPE GUIDE RETAINER	
4.	110-368	1	SNAPPER PIN (3/8" X 1-1/2")	
5.	107-590	2	CARRIAGE BOLT (M12-1.75 X 80MM)	
6.	149-974	1	SPLIT ROD WIPER (1.5" ID)	
7.	318-863	1	PIPE GUIDE MOUNT	
8.	107-870	3	PULL PIN (.5" X 5")	
	110-033	-	HAIR CLIP PIN (1/8" X 1/2")	
9.	106-685	5	LOCKNUT(M12-1.75,PRV TRQ,10.9)	
10.	106-855	3	SCREW (M12-1.75 X 140MM)	

NOT SHOWN:

FOOTNOTES:

NOTE:

# ROTATING WRENCH

BEGINS WITH S/N:

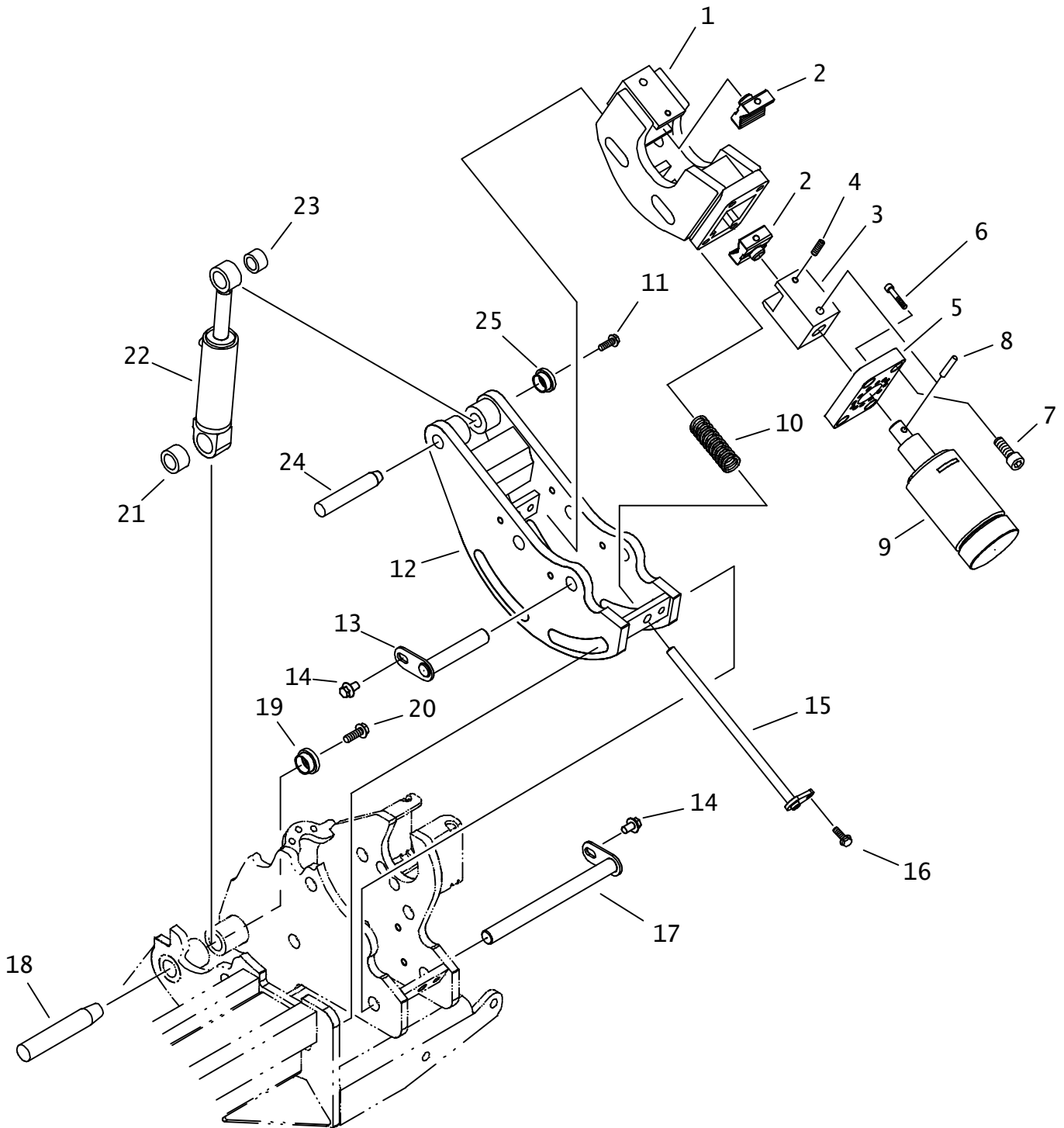

## ROTATING WRENCH BEGINS WITH S/N:

REF NO.	PART NUMBER	QTY	DESCRIPTION	REMARKS
1.	300-2509	1	REAR WRENCH	BEGINS WITH S/N: CMWJ1220K60000126
2.	357-222	2	JAW INSERT	
3.	357-225	1	JAW	
4.	106-529	2	SET SCREW (M10-1.50 X 10MM)	LOCTITE 242
5.	316-545	1	CYL HEAD PLATE	
6.	107-894	10	SCREW (M8-1.25 X 45MM, SOC)	LOCTITE 242
7.	107-884	4	SCREW (M16-2.00 X 45MM, SOC)	LOCTITE 242
8.	105-561	1	ROLL PIN (3/8" X 2-3/4")	
9.	151-213	1	CYL (3.5 X 1.75 X 2.0)	
10.	118-115	1	COMPRESSION SPRING	
11.	106-724	1	FLG SCREW (M10-1.50 X 25MM)	
12.	324-918	1	ROTATING WRENCH	
13.	318-511	2	WRENCH PIN - SHORT	
14.	105-1012	4	FLG LK SCREW (M12-1.75 X 20MM)	
15.	316-462	1	CENTERING PIN	
16.	106-383	1	FLG LK SCREW (M10-1.50 X 30MM)	
17.	318-512	2	WRENCH PIN - LONG	
18.	178-225	1	TAPERED PIN (31.7MM X 181.6MM)	
19.	181-982	1	TAPERED INSERT (1.25")	
20.	106-469	1	FLG SCREW (M12-1.75 X 30MM)	
21.	125-771	1	COMPOSITION BUSHING (1.25")	
22.	151-038	1	CYL (2.0 X 1.0 X 4.0)	
23.	125-770	1	COMPOSITION BUSHING (1")	
24.	179-987	1	TAPERED PIN (1" X 5.50")	
25.	181-981	1	TAPERED INSERT (1")	

NOT SHOWN:

FOOTNOTES:

NOTE:

# STATIONARY WRENCH

BEGIN WITH S/N:

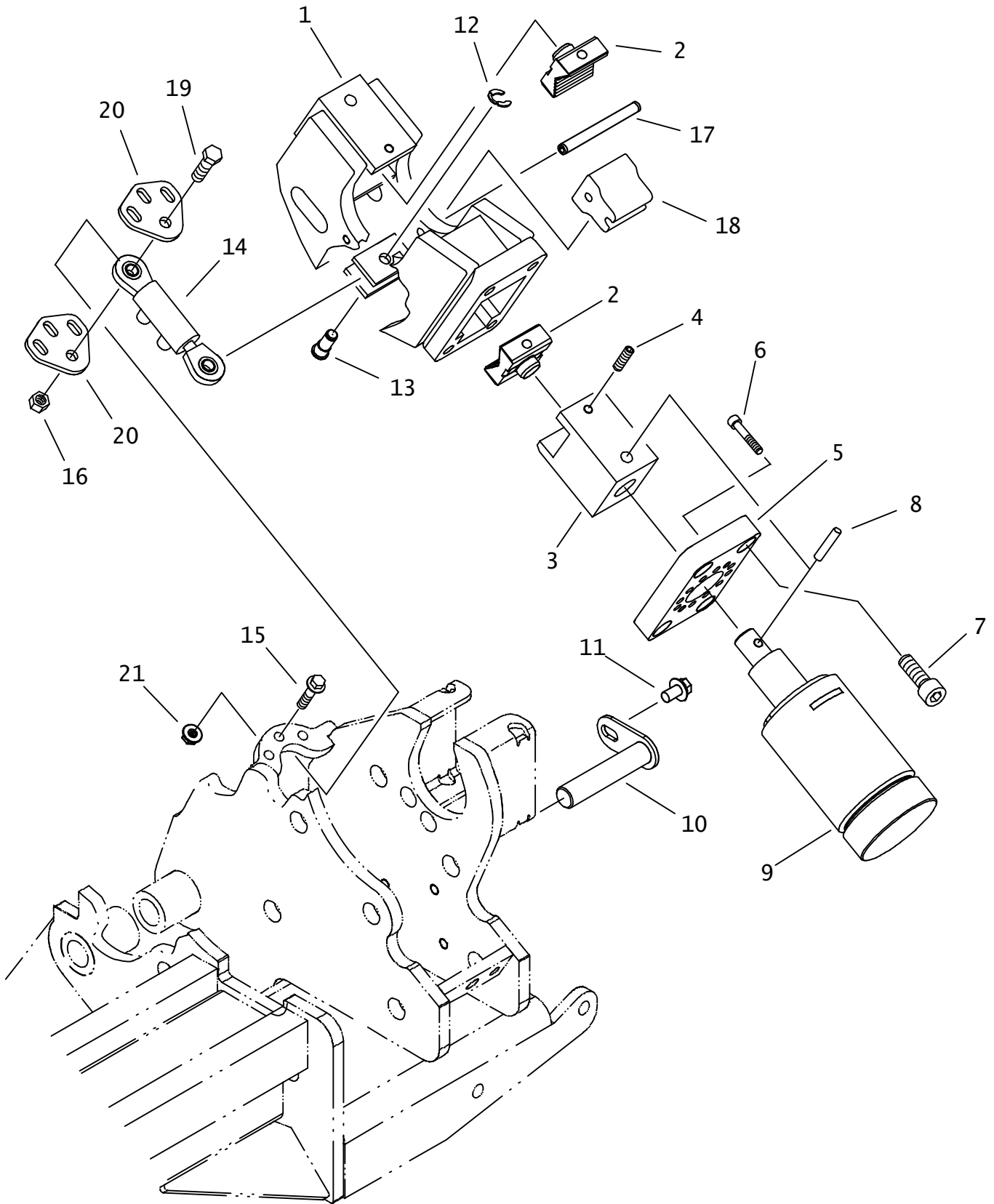

# STATIONARY WRENCH

BEGIN WITH S/N:

REF NO.	PART NUMBER	QTY	DESCRIPTION	REMARKS
1.	300-2510	1	FRONT WRENCH	BEGINS WITH S/N: CMWJI220K60000126
2.	357-222	2	JAW INSERT	
3.	357-225	1	JAW	
4.	106-529	2	SET SCREW (M10-1.50 X 10MM)	LOCTITE 242
5.	316-545	1	CYL HEAD PLATE	
6.	107-894	10	SCREW (M8-1.25 X 45MM, SOC)	LOCTITE 242
7.	107-884	4	SCREW (M16-2.00 X 45MM, SOC)	LOCTITE 242
8.	105-561	1	ROLL PIN (3/8" X 2-3/4")	
9.	151-213	1	CYL (3.5 X 1.75 X 2.0)	
10.	318-511	2	WRENCH PIN - SHORT	
11.	105-1012	2	FLG LK SCREW (M12-1.75 X 20MM)	
12.	115-506	1	KLIP RING (.500")	
13.	179-528	1	PIN	
14.	151-220	1	CYLINDER (1.0 X .50 X .90)	
15.	106-995	3	FLG LK SCREW (M10-1.50 X 45MM)	
16.	106-685	1	LOCKNUT(M12-1.75,PRV TRQ,10.9)	
17.	107-295	2	ROLL PIN (.375" X 3.750")	
18.	322-677	1	PIPE SUPPORT	
19.	106-477	1	SCREW (M12-1.75 X 45MM, 10.9)	
20.	323-061	2	MOUNT PLATE	
21.	106-387	3	FLG LOCKNUT (M10-1.50)	

NOT SHOWN:

FOOTNOTES:

NOTE:

# FUEL TANK

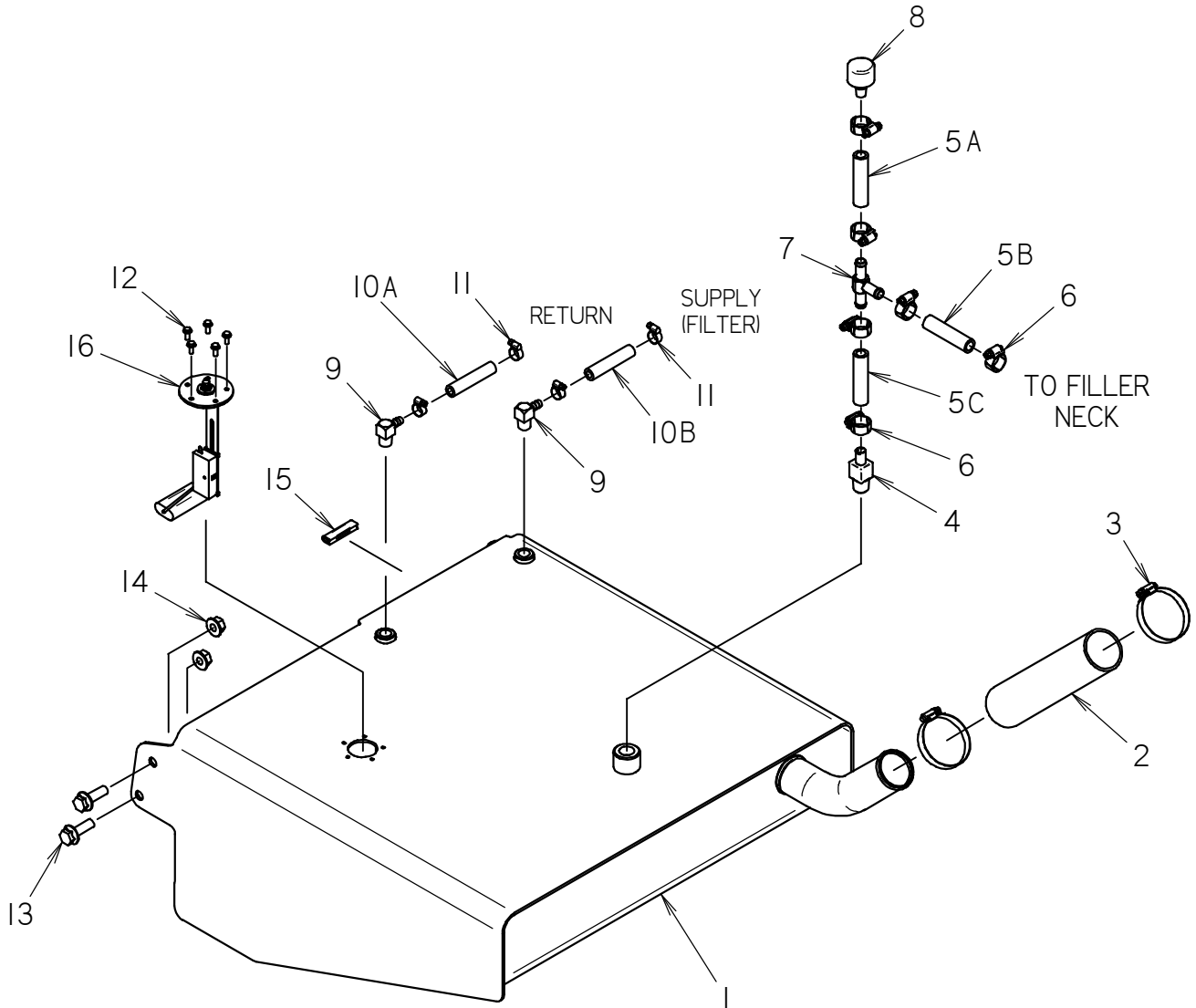

# FUEL TANK

REF NO.	PART NUMBER	QTY	DESCRIPTION	REMARKS
1	300-7774	1	FUEL TANK	
2	116-1003	10	BULK HOSE (2", SOLD PER IN)	USE 1 @ 10"
3	110-134	2	WORM CLAMP (2.062" TO 2.750")	
4	514-312	1	S/O COUPLER (08N-08H)	
5	116-322	27	BULK HOSE (1/2",SOLD PER 1')	USE 1 @ 2" (5A), 1 @ 22" (5B) & 1 @ 3" (5C)
6	110-217	6	WORM CLAMP (7/16" TO 1")	
7	156-729	1	S/O TEE (08H-08H-08H)	
8	111-021	1	BREATHER CAP (TANK)	
9	153-871	2	S/O COUPLER (06N-06H90, BRS)	
10	116-881	163	BULK HOSE (3/8", SOLD PER FT)	USE 1 @ 90" (10A) & 1 @ 73" (10B)
11	110-249	4	WORM CLAMP (1/4" TO 5/8")	
12	105-214	5	FLG SCREW (#10-24 X .5')	
13	106-632	2	FLG LK SCR (M12-1.75X35MM,SER)	
14	106-709	2	FLG LK NUT (M12-1.75)	
15	115-686	12	BULK EDGE (5/32",SOLD PER 1')	USE 1 @ 12"
16	217-568	1	FUEL SENDER	INCLUDES 165-704 GASKET

NOT SHOWN:

FOOTNOTES:

NOTE:



## GROUND DRIVE TRACKS

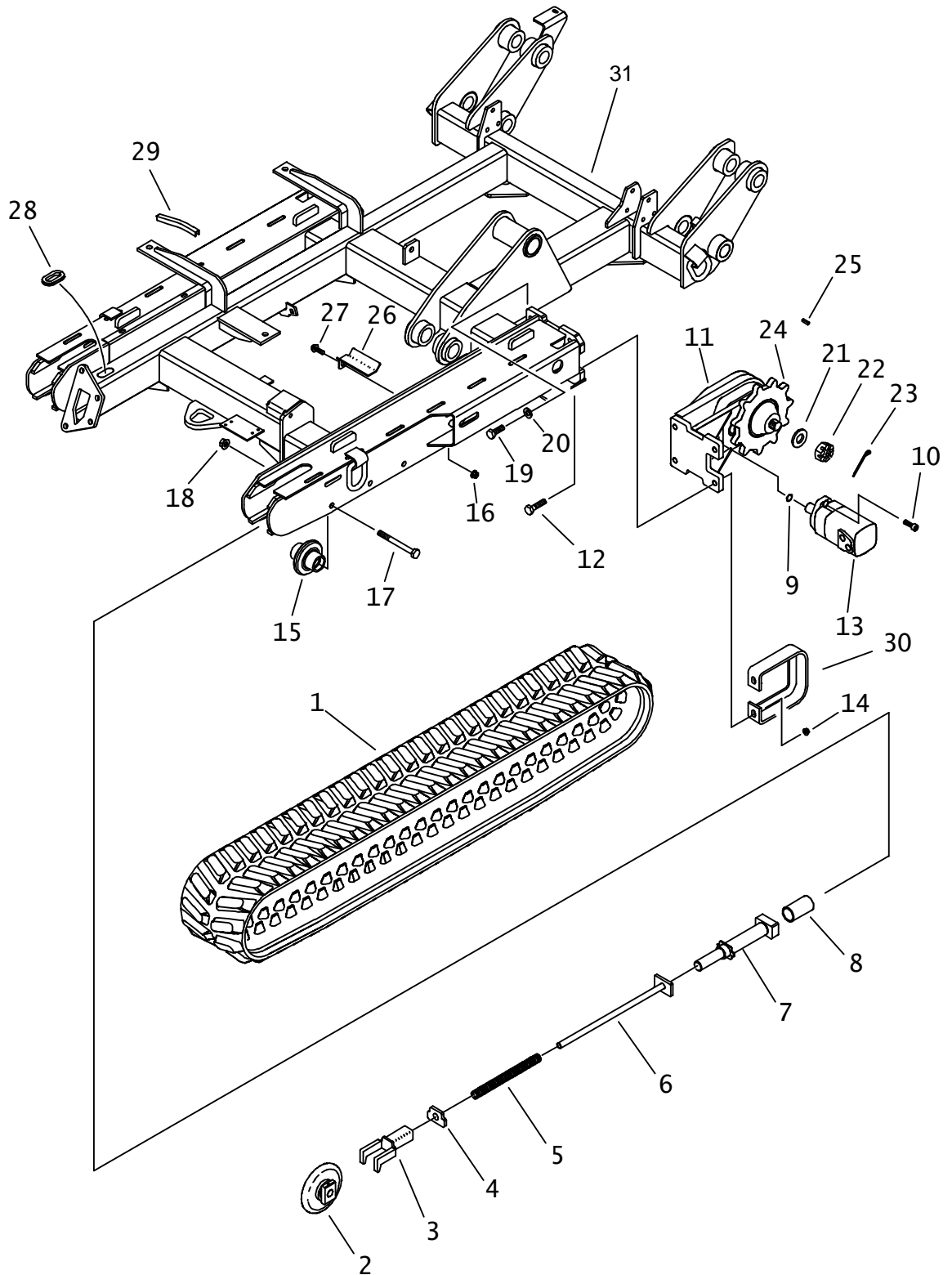

# GROUND DRIVE TRACKS

REF NO.	PART NUMBER	QTY	DESCRIPTION	REMARKS
1.	315-175	2	GROUND DRIVE TRACK	
2.	170-336	2	FRONT IDLER ROLLER	
3.	353-403	2	YOKE	
4.	353-482	2	SPRING PLATE	
5.	117-122	2	COMPRESSION SPRING	
6.	353-402	2	SPACER TUBE	
7.	151-161	2	GREASE CYLINDER	
8.	353-473	2	STOP TUBE	
9.	157-099	-	O-RING (O42 D70)	INCLUDED WITH 166-172
10.	106-204	4	BOLT (1/2-NC X 1-1/2", SOC)	TORQUE TO 100 FT-LB
11.	166-172	2	GEAR BOX (5.44:1)	GROUND DRIVE. Includes item 13
12.	106-341	4	SCREW (M16-2.00 X 70mm)	TORQUE TO 159 FT-LB
13.	155-581	-	HYD MOTOR	
	500-658		SEAL REPAIR KIT	
14.	106-355	4	FLG NUT (M16-2.00, 10.9)	
15.	170-335	14	IDLER ROLLER	
16.	106-709	2	FLG LOCKNUT (M12-1.75)	
17.	107-337	14	SCREW (M16-2.00 X 150mm, 10.9)	
18.	106-442	14	FLG LOCKNUT (M16-2.0, PRV TRQ)	
19.	106-340	4	SCREW (M16-2.00 x 50mm)	TORQUE TO 159 FT-LB
20.	106-392	4	WASHER (M16)	
21.	105-1352	2	WASHER (1.265)	
22.	105-917	2	CASTLE NUT (1-1/4-NF)	TORQUE TO 525-675 FT-LB
23.	105-501	2	COTTER PIN (.125" X 2.0")	
24.	174-008	2	SPROCKET (11T)	
	140-1084	2	SPROCKET (11T)	
25.	166-857	2	KEY (.437" X 1.950")	
26.	348-962	2	HOSE PROTECTOR	
27.	106-632	2	FLG LK SCREW (M12-1.75 X 35mm)	
28.	115-663	AR	GROMMET EDGE (1/4" X 12.7")	USE 6.35"
29.	116-259	AR	BULK EDGE (1/2", SOLD PER FT)	USE 7"
30.	324-456	2	TRACK SUPPORT	
31.	325-469	-	FRAME	

NOT SHOWN:

FOOTNOTES:

NOTE:

# GEARBOX GROUND DRIVE

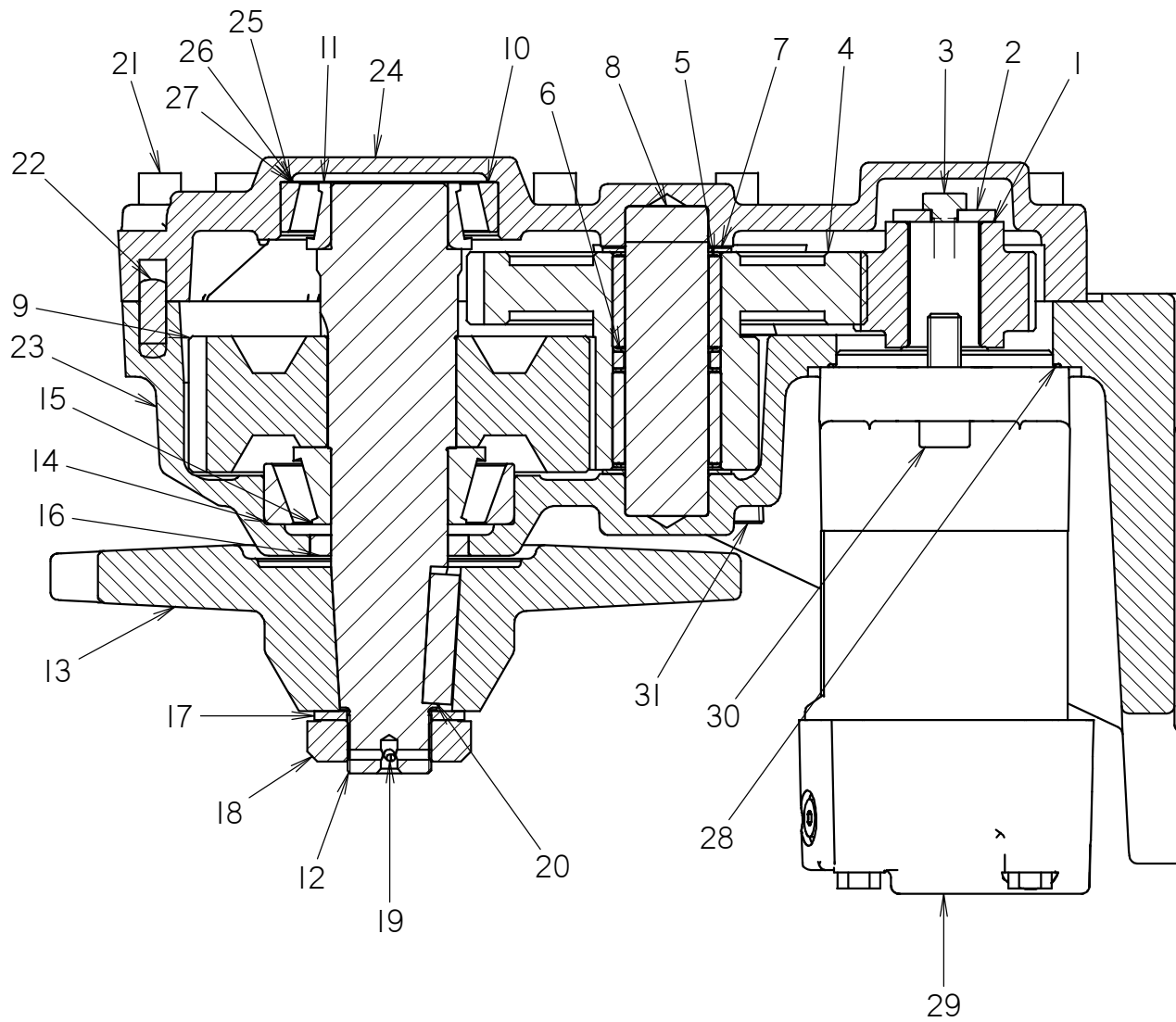

# GEARBOX GROUND DRIVE

REF NO.	PART NUMBER	QTY	DESCRIPTION	REMARKS
	166-172		GEARBOX (5.44:1)	INCLUDES REF. NO'S 1-12, 14-16, 21-31
1	168-052	1	INPUT PINION	
2	105-069	1	WASHER (4.06")	
3	105-024	1	LK BOLT (3/8-NC X 3/4", NLK)	TORQUE TO 45 FT-LBS
4	168-051	1	CLUSTER GEAR	
5	126-185	2	BEARING CAGE (1.50 WD)	
6	182-220	1	SPACER	
7	126-017	2	BEARING RACE (1.25")	
8	179-235	1	PIN	
9	168-053	1	OUTPUT GEAR	
10	125-270	1	TAPERED RACE (3.265")	
11	125-269	1	TAPERED BEARING (1.75")	
12	160-449	1	SHAFT	
13	140-1084	1	11 TOOTH SPROCKET	SUPERSEDES 174-008
14	125-326	1	TAPERED RACE (3.75")	
15	125-327	1	TAPERED BEARING (1.750")	
16	155-881	1	INTERNAL SEAL (1.750")	
17	105-1352	1	WASHER (1.265)	
18	105-917	1	CASTLE NUT (1-1/4-NF)	TORQUE TO 525-675 FT-LBS
19	105-501	1	COTTER PIN (1.25" X 2.0")	
20	166-857	1	KEY (.437" X 1.95")	
21	106-857	14	SCREW (M10-1.50 X 55MM, SOC)	TORQUE TO 45 FT-LBS
22	106-866	1	DOWEL PIN (M10 X 30MM)	
23	348-749	1	HOUSING (MACHINED)	
24	348-254	1	CAST COVER, MACHINED	
25	165-800	1	SHIM (.002")	AS REQUIRED
26	165-801	1	SHIM (.003")	AS REQUIRED
27	165-802	1	SHIM (.007")	AS REQUIRED
28	157-099	1	O-RING (O42 D70)	
29	155-581	1	HYD MOTOR	
30	106-204	2	BOLT (1/2 - NC X 1.50", SOC)	USE LOCTITE 271 OR EQUIVALENT, TORQUE TO 100 FT-LBS
31	115-025	4	PLUG (O8N, SQ FM, MAG)	

NOT SHOWN:

FOOTNOTES:

NOTE:

# FRONT IDLER

ENDS WITH S/N: CMWSK350P60000600  
ENDS WITH S/N: CMWSK650A60000427

ENDS WITH S/N: CMWSK500H60000254  
ENDS WITH S/N: CMWXT850C60000125

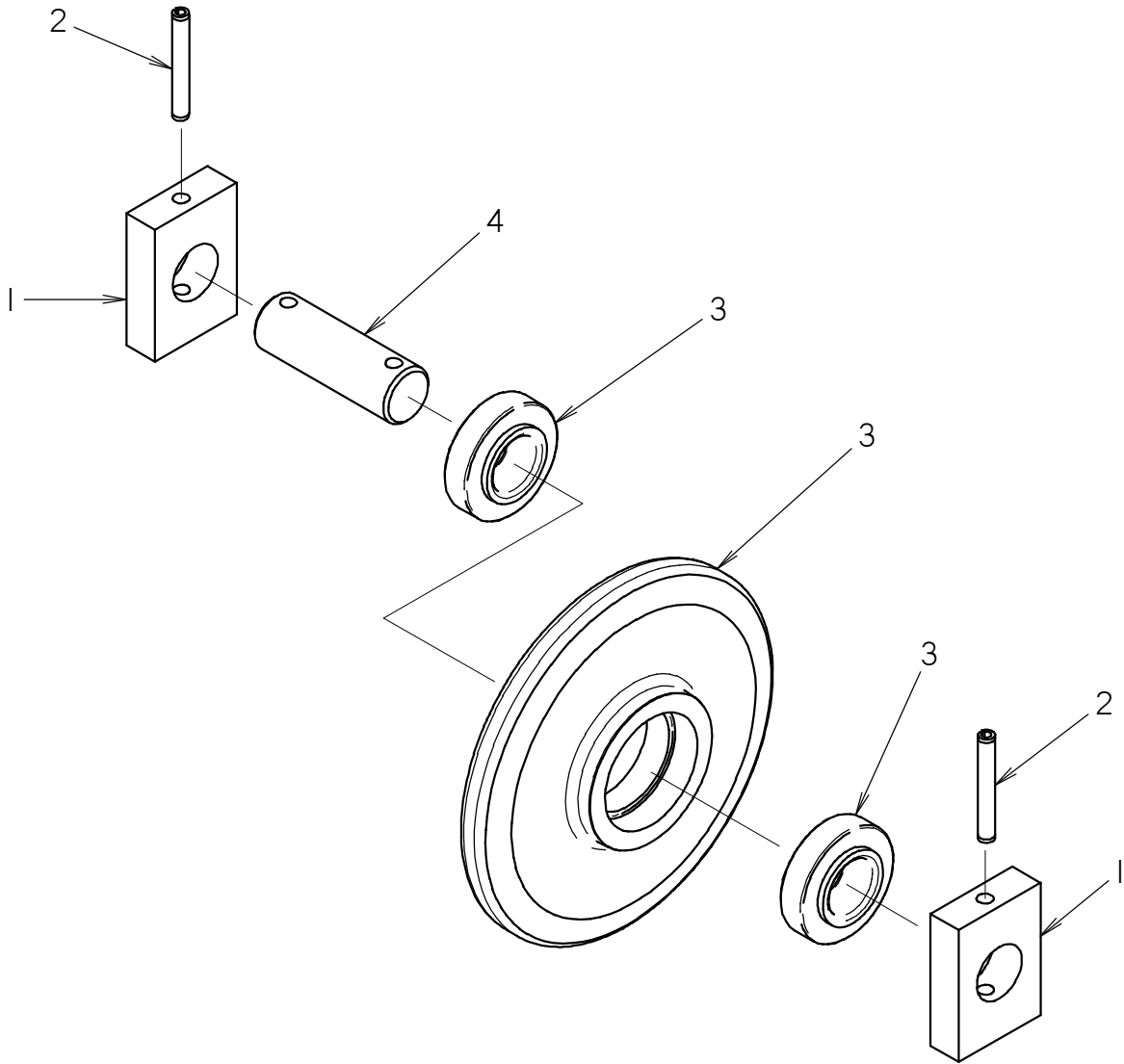

**FRONT IDLER**

ENDS WITH S/N: CMWSK350P60000600

ENDS WITH S/N: CMWSK500H60000254

ENDS WITH S/N: CMWSK650A60000427

ENDS WITH S/N: CMWXT850C60000125

REF PART

NO.	NUMBER	QTY	DESCRIPTION	REMARKS
	170-336	-	FRONT IDLER ROLLER	INCLUDES REF NO.'S 1-4
1	353-477	2	BLOCK, PUSH	
2	105-561	2	ROLL PIN (3/8" X 2-3/4")	
3	170-342	1	IDLER ROLLER SUB	SEE FOOTNOTE I
4	167-307	1	SHAFT, IDLER	

NOT SHOWN:

FOOTNOTES:

I. FOR REPLACEMENT BEARINGS, USE PART NUMBER 125-005.

NOTE:

# GREASE CYLINDER

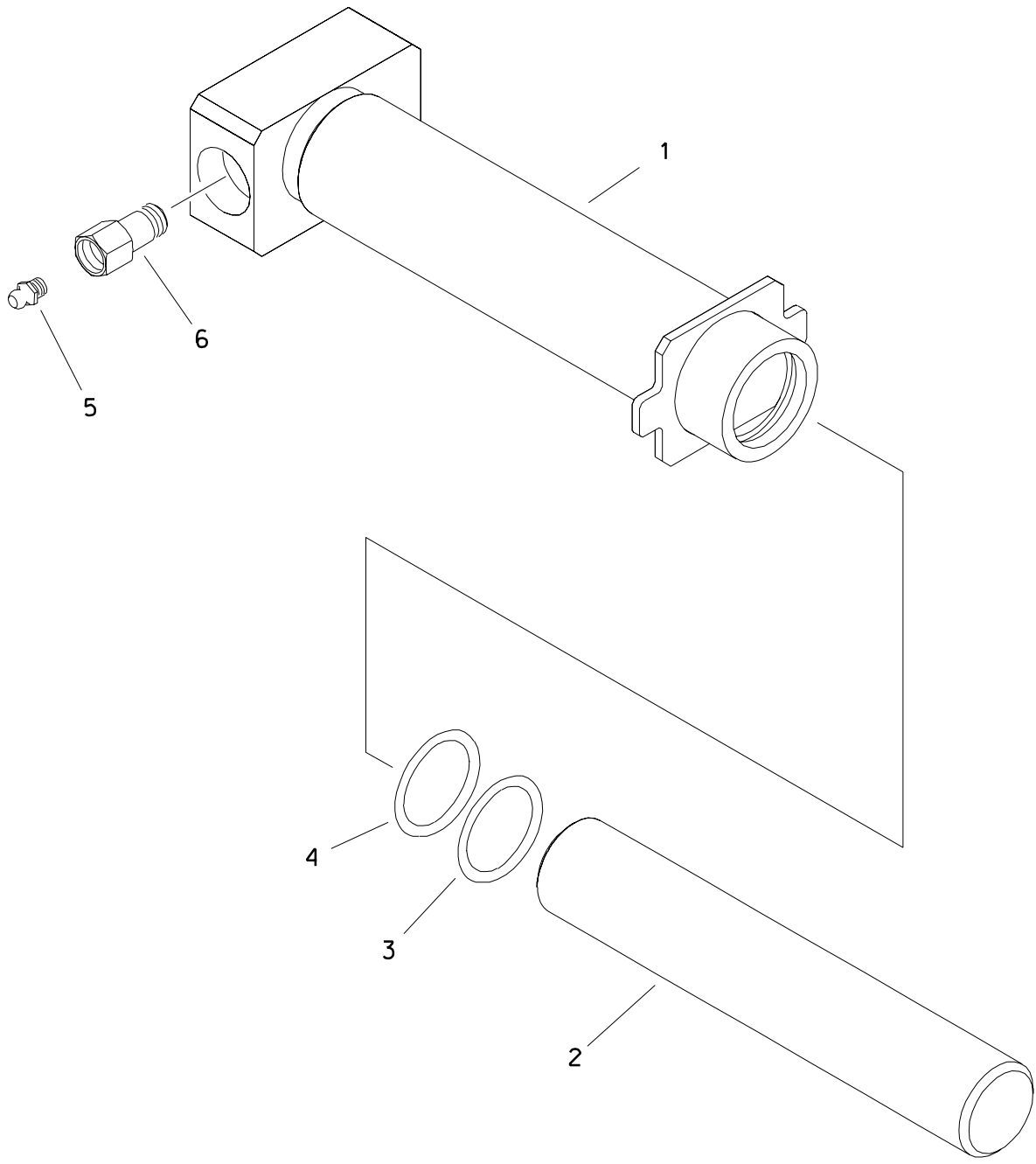

# GREASE CYLINDER

REF NO.	PART NUMBER	QTY	DESCRIPTION	REMARKS
	151-161		GREASE CYLINDER	INCL REF NO.'S 1 - 4
1.	353-404	1	GREASE CYLINDER	
2.	153-501	1	CYLINDER ROD	
3.	155-732	1	BACKUP RING (224 D90)	
4.	155-704	1	O-RING (224 D70)	
5.	115-019	1	ZERK (Q2N)	
6.	159-093	1	RELIEF VALVE (5/8-NF, Q2N)	

FOOTNOTES



## STABILIZER

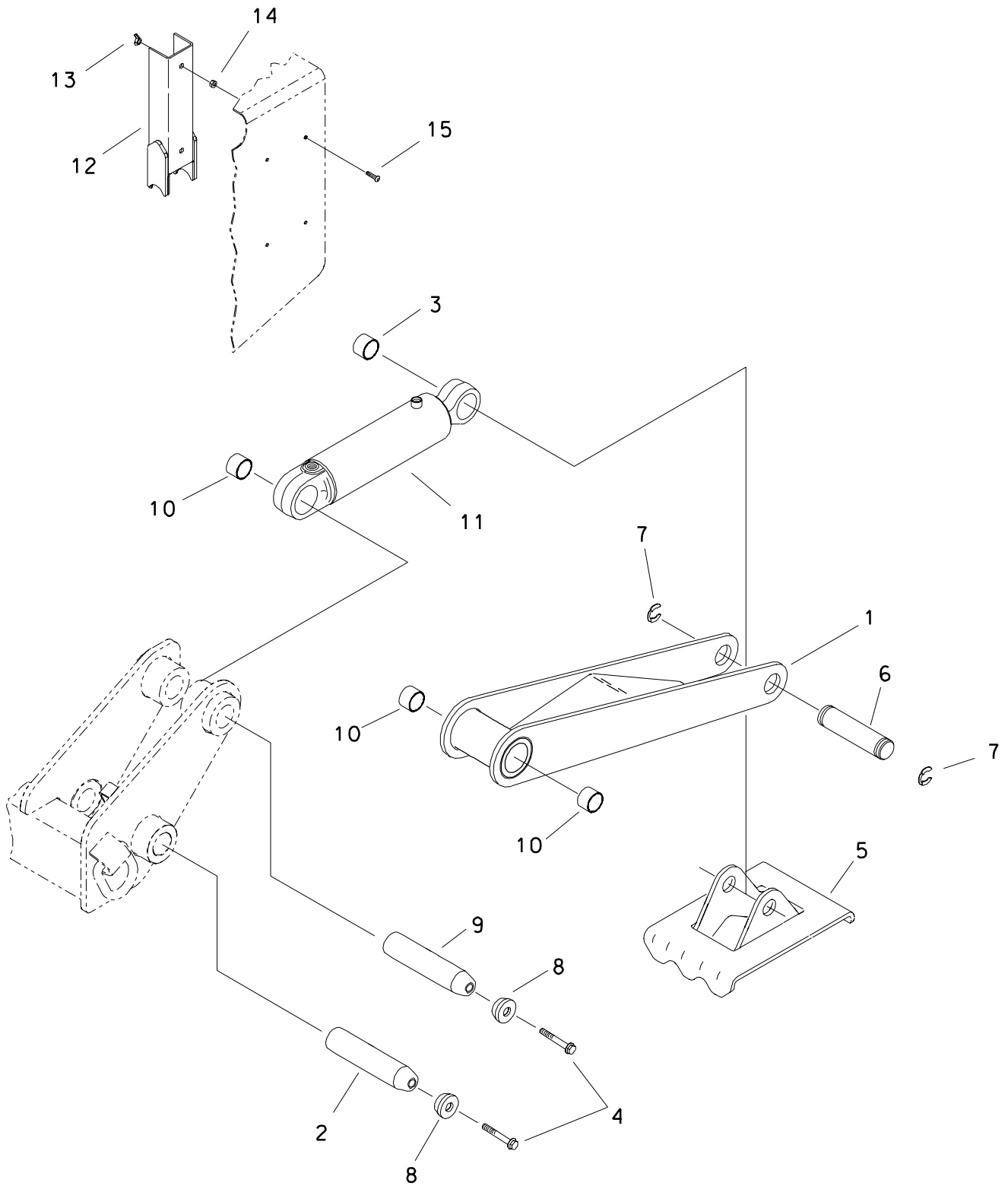

# STABILIZER

REF NO.	PART NUMBER	QTY	DESCRIPTION	REMARKS
1.	316-819	2	STABILIZER ARM	
2.	183-882	2	TAPERED PIN (44.4MM X 228.6MM)	
3.	178-884	2	TENSION BUSHING (1.5")	
4.	106-470	4	FLG SCREW (M16-2.00 X 40MM)	
5.	316-880	2	STABILIZER PAD	
6.	183-209	2	BARREL PIN	
7.	115-511	4	KLIP RING (1-1/2")	
8.	181-975	4	TAPERED INSERT (1.75")	
9.	179-242	2	TAPERED PIN (44.45MM X 196MM)	
10.	125-773	6	COMPOSITION BUSHING (1.75")	
11.	151-029	2	CYL (3" X 1.5" X 10")	
12.	323-706	2	CYLINDER LOCK	
13.	195-339	4	WING NUT (1/4-NC)	
14.	105-078	4	NUT (1/4-NC)	
15.	107-304	4	SCREW (1/4-NC X 1", BUT SOC)	

FOOTNOTES

# FRAME TILT

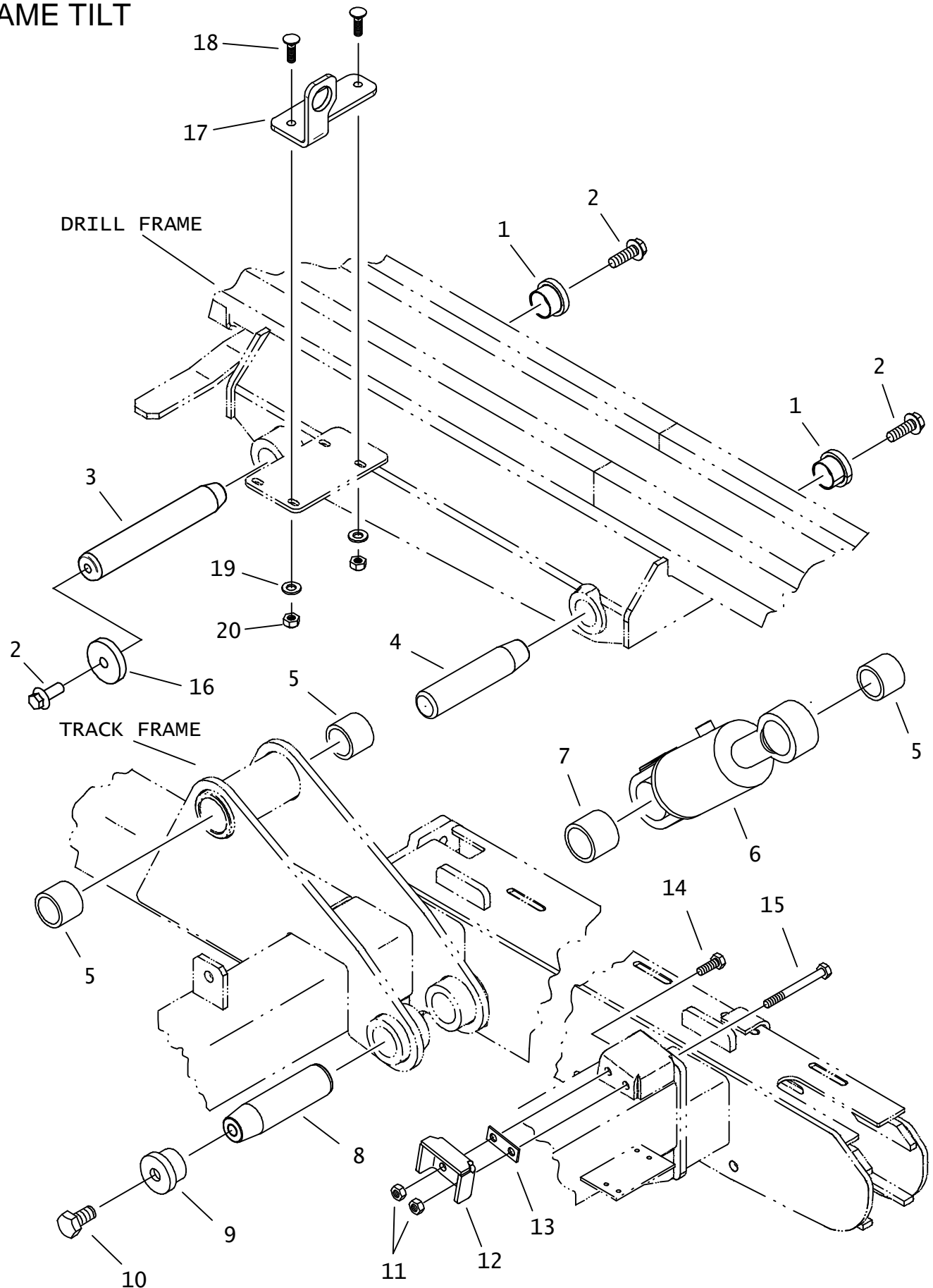

# FRAME TILT

REF NO.	PART NUMBER	QTY	DESCRIPTION	REMARKS
1.	181-975	2	TAPERED INSERT (1.75")	
2.	106-470	3	FLG SCREW (M16-2.0 X 40MM)	USE #242 LOCTITE OR EQUIVALENT
3.	179-503	1	TAPERED PIN (1.75" X 10.75")	
4.	183-768	1	TAPERED PIN (44.4MM X 205MM)	
5.	125-773	3	COMPOSITION BUSHING (1.75")	
6.	151-089	1	CYL (3.5 X 1.75 X 3.0)	
7.	125-754	1	COMPOSITION BUSHING (2")	
8.	183-919	1	TAPERED PIN (50.8MM X 190MM)	
9.	184-064	1	TAPERED INSERT (2")	
10.	106-344	1	SCREW (M20-2.5 X 40MM)	
11.	106-685	2	LOCKNUT(M12-1.75,PRV TRQ,10.9)	
12.	320-169	1	FRAME STOP	
13.	320-170	AR	SHIM PLATE	
14.	105-247	1	SCREW (M12-1.75 X 35MM)	
15.	106-579	1	SCREW (M12-1.75 X 120MM)	DO NOT USE
16.	107-660	1	WASHER	
17.	327-579	1	BULKHEAD BRACKET	
18.	105-249	2	CARRIAGE BOLT	
19.	106-390	2	WASHER (M10)	
20.	105-047	2	LOCK NUT	

NOT SHOWN:

FOOTNOTES:

NOTE:

# PROXIMITY SWITCHES

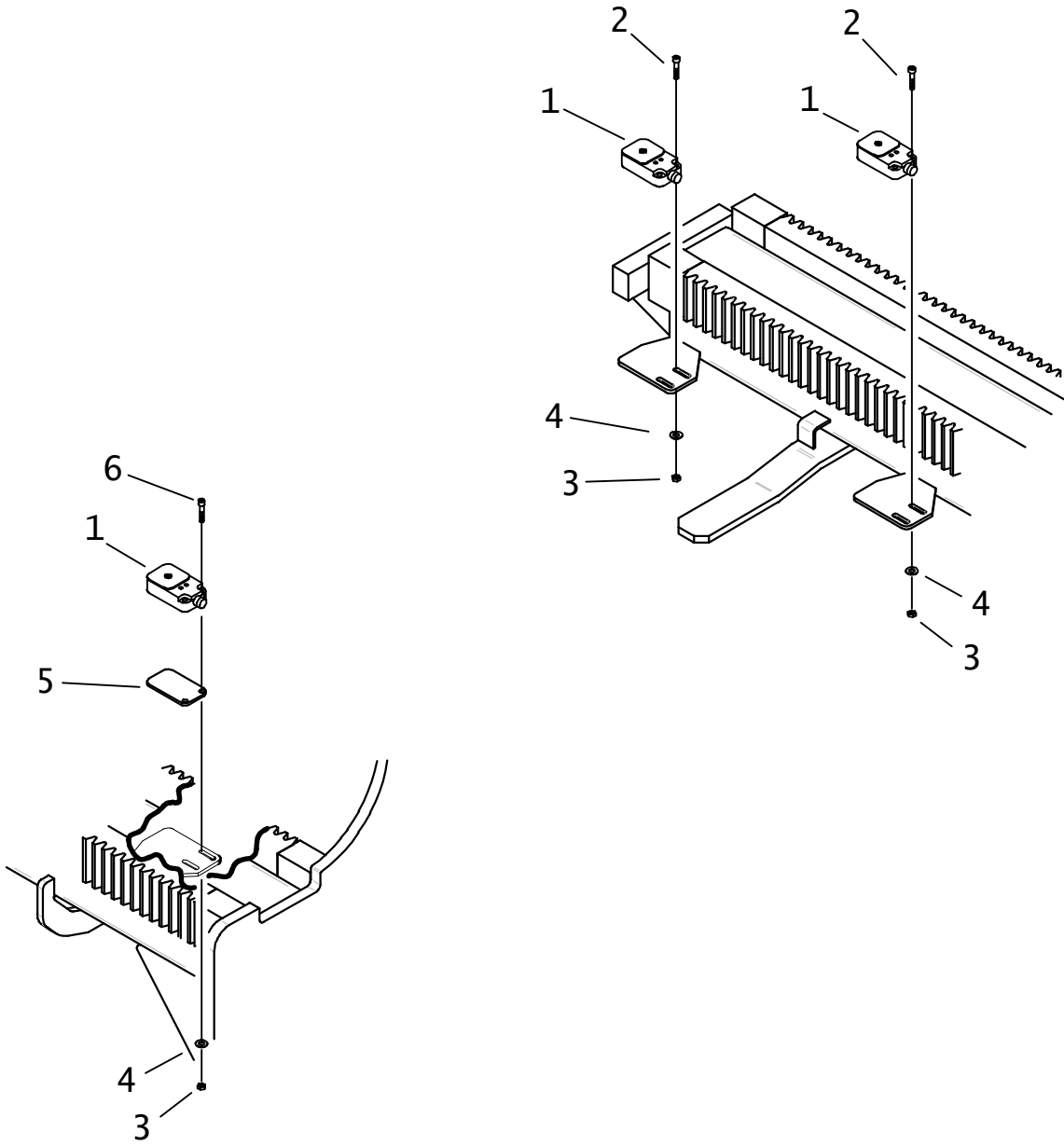

## PROXIMITY SWITCHES

REF NO.	PART NUMBER	QTY	DESCRIPTION	REMARKS
1.	215-1175	3	PROXIMITY SWITCH	
2.	106-426	4	SCREW (M5-0.80 X 25MM, SOC	
3.	106-850	6	LOCKNUT (M5-0.80)	
4.	105-284	6	WASHER (3/16")	
5.	107-451	1	SHIM	
6.	107-465	2	SCREW (M5-0.80 X 30MM, SOC	

NOT SHOWN:

FOOTNOTES:

NOTE:

# PROXIMITY SWITCHES DRILL PIPE

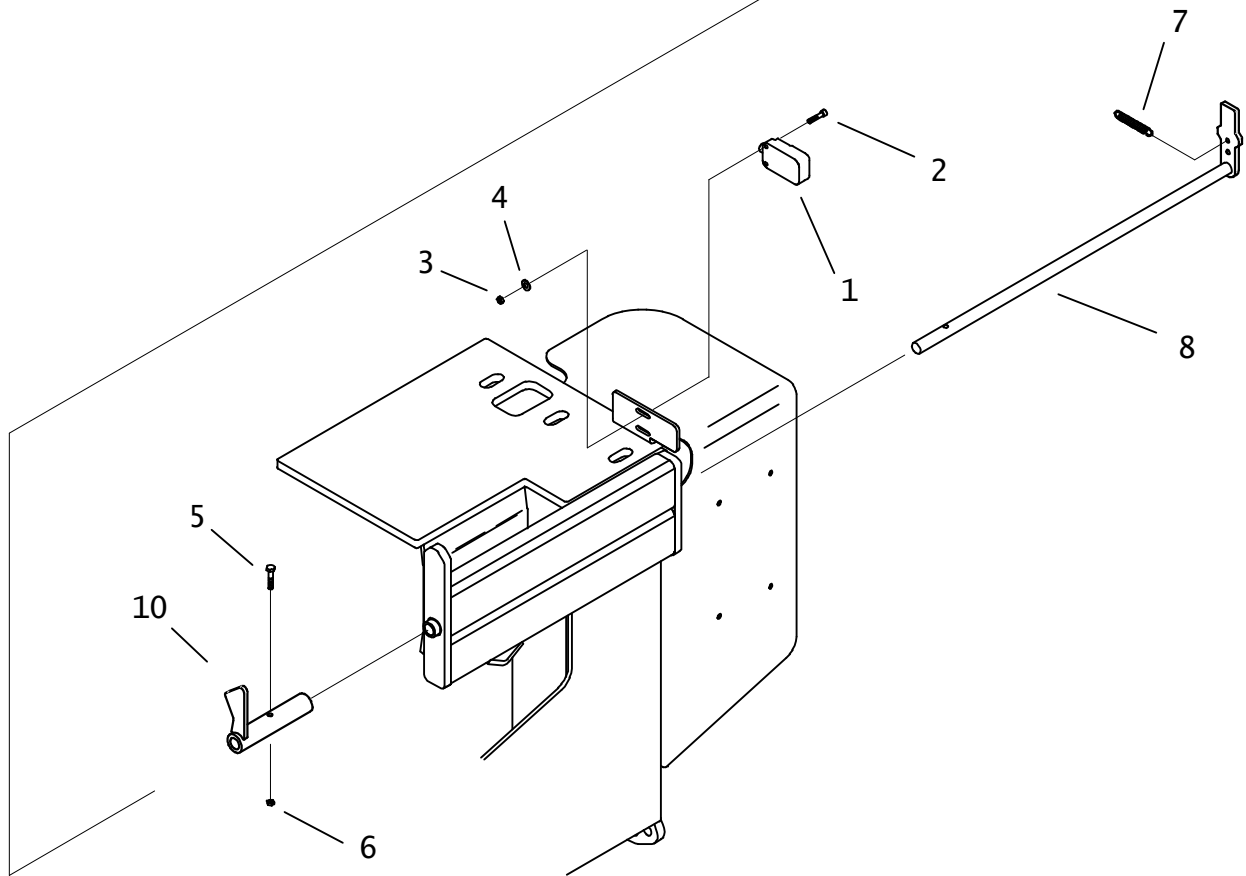
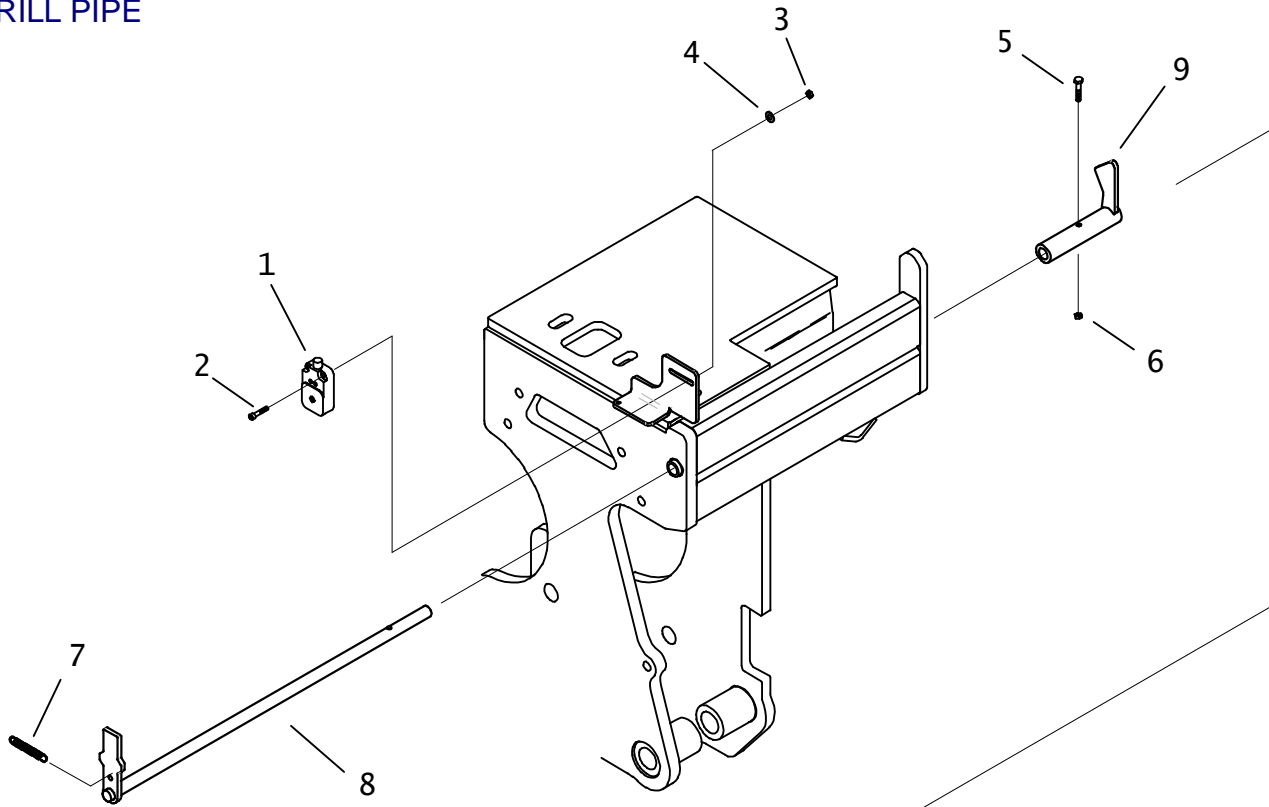

## PROXIMITY SWITCHES DRILL PIPE

REF NO.	PART NUMBER	QTY	DESCRIPTION	REMARKS
1.	215-1175	2	PROXIMITY SWITCH	
2.	106-426	4	SCREW (M5-0.80 X 25MM, SOC	
3.	106-850	4	LOCKNUT (M5-0.80)	
4.	105-284	4	WASHER (3/16")	
5.	105-818	2	BOLT (1/4-NC X 1-1/2)	
6.	105-085	2	LOCKNUT (1/4-NC)	
7.	115-601	2	EXTENSION SPRING (4.062")	
8.	300-1890	2	TARGET ARM	
9.	300-1889	1	FOLLOWER ARM, FRONT	
10.	300-1888	1	FOLLOWER ARM, REAR	

NOT SHOWN:

FOOTNOTES:

NOTE:





# **OPERATOR'S STATION**

## OPERATOR STATION FLOOR

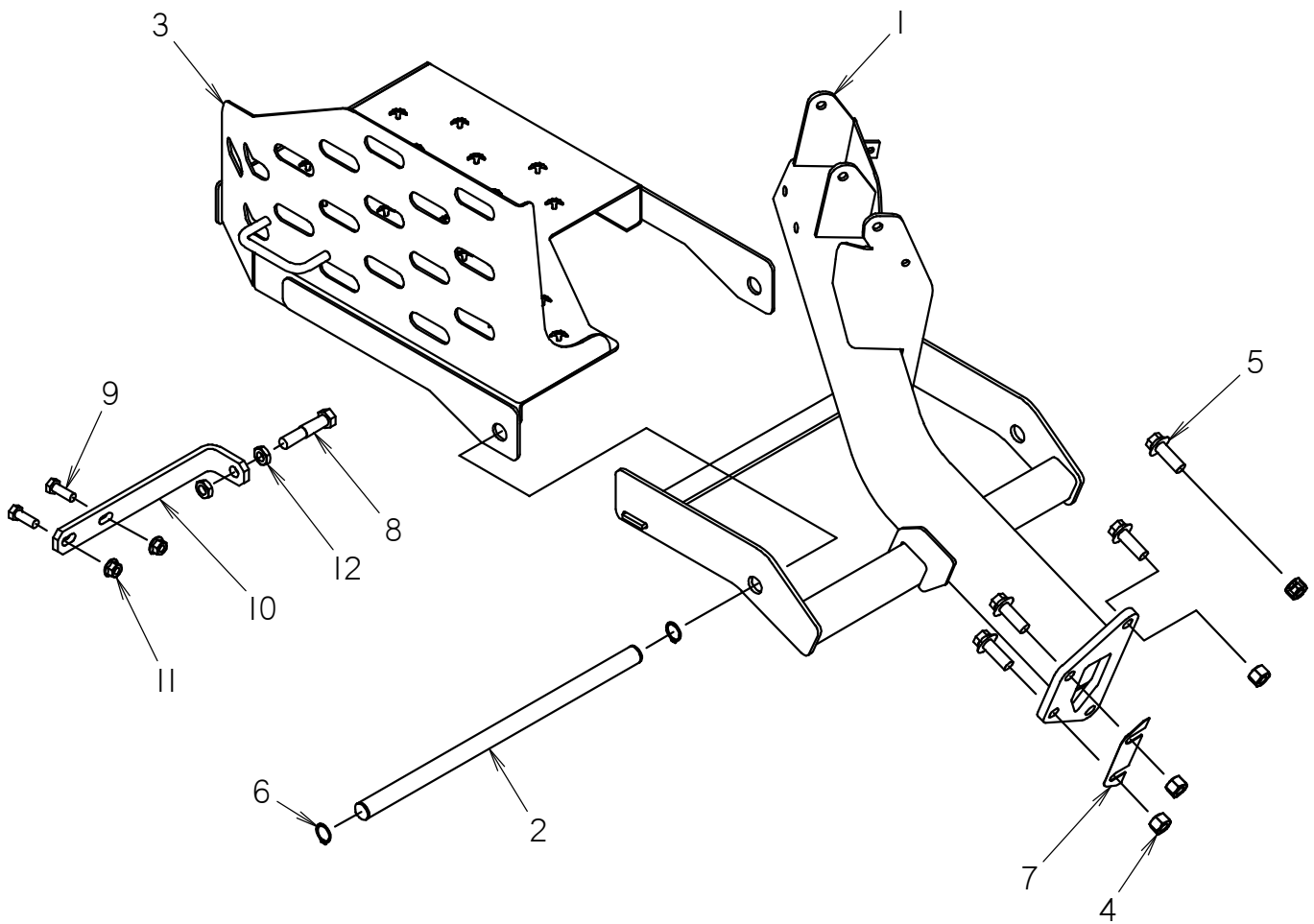

# OPERATOR STATION FLOOR

REF NO.	PART NUMBER	QTY	DESCRIPTION	REMARKS
1	300-5390	1	SEAT SUPPORT	
2	179-383	1	PIN, GROOVED	
3	300-5387	1	FLOOR	
4	106-545	4	LOCKNUT (M16-2.0,PRV TRQ,10.9)	
5	107-336	4	FLG SCREW (M16-2.00X45MM,10.9)	
6	115-484	2	EXTERNAL SNAP RING (1.000")	
7	119-008	1	SHIM	
8	107-197	1	SCREW (M16-2.00 X 80MM, 10.9)	
9	105-247	2	SCREW (M12-1.75 X 35MM)	
10	179-564	1	STOW BAR	
11	106-709	2	FLG LK NUT (M12-1.75)	
12	106-775	2	JAM NUT (M16-2.00)	

NOT SHOWN:

FOOTNOTES:

NOTE:

# OPERATOR SEAT

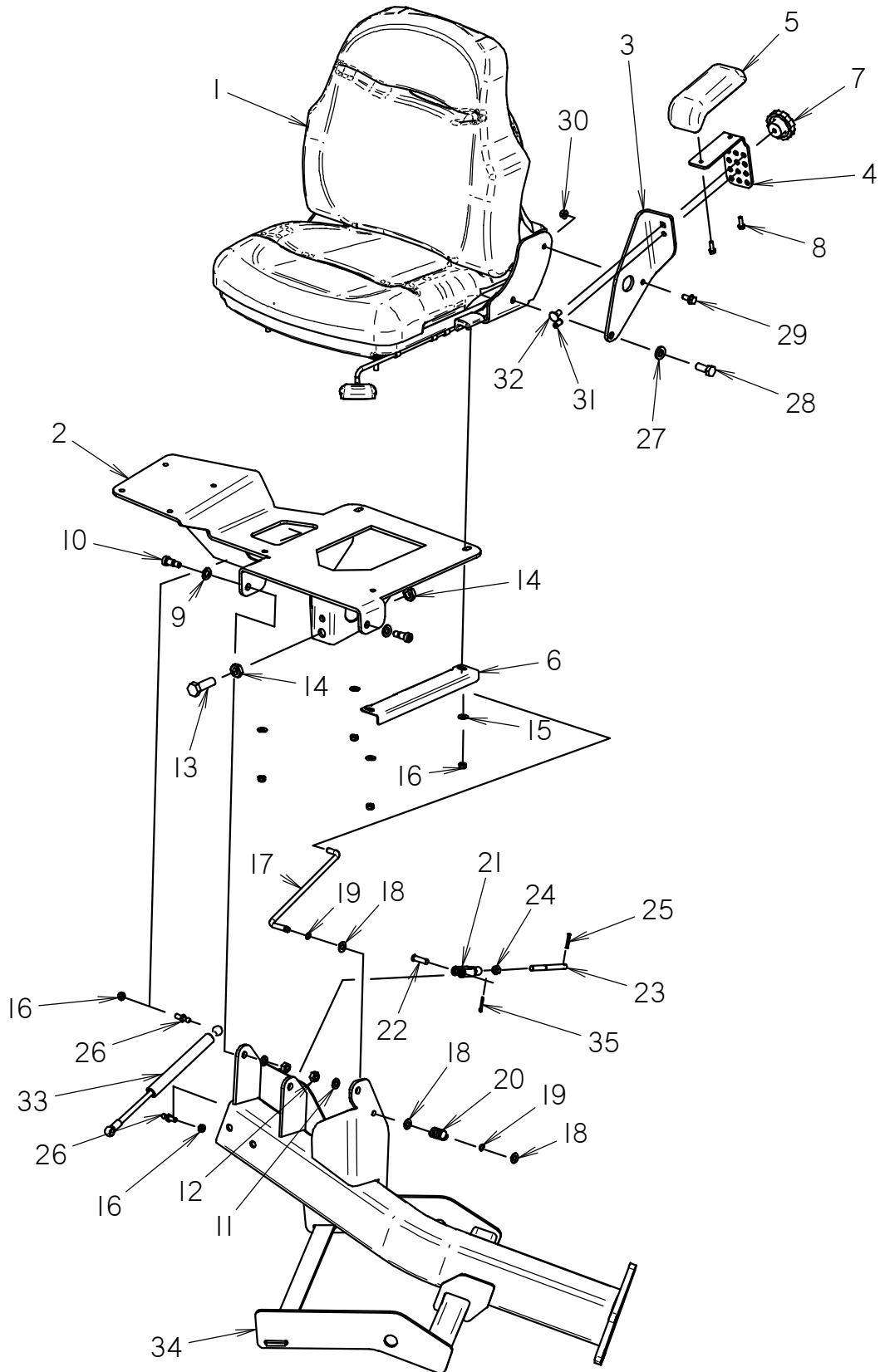

# OPERATOR SEAT

REF NO.	PART NUMBER	QTY	DESCRIPTION	REMARKS
1	117-631	1	SEAT ASSEMBLY	
2	300-5605	1	SEAT MOUNT	
3	324-426	1	ARMREST LOWER BRACKET	
4	318-611	1	UPPER ARM BRACKET	
5	117-314	1	ARM REST	
6	179-980	1	ROD GUIDE	
7	110-383	1	KNOB (3/8-NC, BLACK)	
8	106-159	2	FLG SCREW (1/4-NC X 3/4")	
9	106-391	2	WASHER (M12)	
10	107-802	2	SHLD BLT (M12 X 16MM,M10-1.50)	
11	106-390	2	WASHER (M10)	
12	105-894	2	LOCKNUT(M10-1.50,PRV TRQ,10.9)	
13	106-340	1	SCREW (M16-2.00 X 50MM)	
14	106-775	2	JAM NUT (M16-2.00)	
15	105-095	4	WASHER (1/4")	
16	105-089	6	LOCKNUT (5/16-NC)	
17	329-049	1	PROP BAR	
18	106-255	3	WASHER (.406")	
19	115-477	2	GRIP RING (.375")	
20	115-563	1	COMPRESSION SPRING	
21	110-027	1	CLEVIS (3/8-NF)	
22	110-053	1	CLEVIS PIN (3/8" X 1.078")	
23	179-782	1	STOP ROD	
24	105-093	1	NUT (3/8-NF)	
25	105-557	1	ROLL PIN (3/16" X 1-1/8")	
26	110-655	2	BALL SCREW (5/16-NC X 1/2")	
27	106-397	1	WASHER (M12, HARDENED)	
28	105-273	1	SCREW (M12-1.75 X 30MM)	
29	106-162	1	FLG SCREW (M8-1.25 X 20MM, GD8)	
30	106-386	1	FLG LOCKNUT (M8-1.25)	
31	108-174	1	ROLL PIN (3/8" X .750")	
32	107-702	1	CARRIAGE BOLT (3/8-NC X 3/4")	
33	105-694	1	STRUT (90 LB.)	
34	300-5390	1	SEAT SUPPORT	
35	105-523	1	COTTER PIN (.125" X .750")	

NOT SHOWN:

FOOTNOTES:

NOTE:

# LEFT CONSOLE

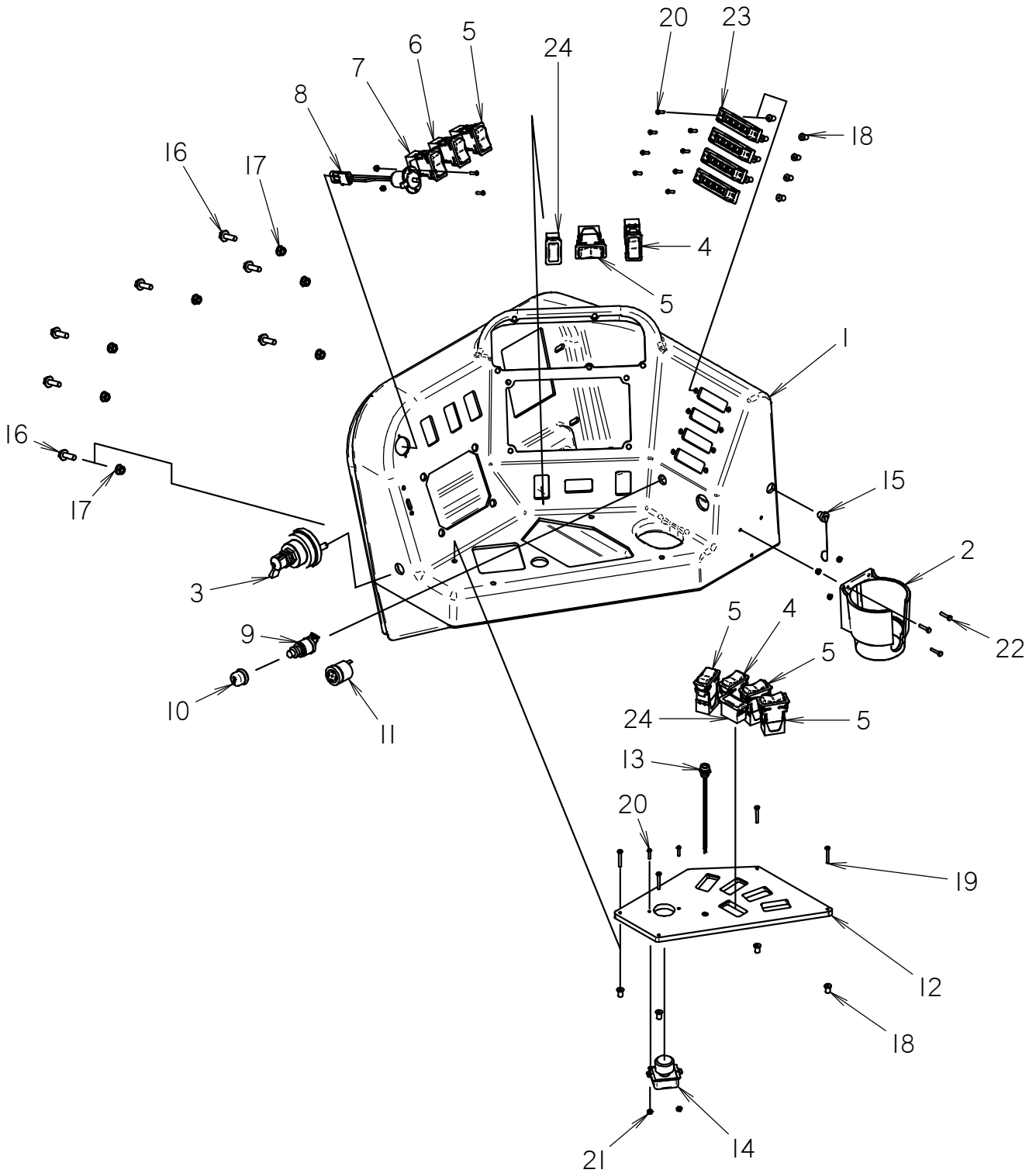

# LEFT CONSOLE

REF NO.	PART NUMBER	QTY	DESCRIPTION	REMARKS
1	362-1333	1	LEFT CONSOLE	
2	117-889	1	CUP HOLDER	
3	217-819	1	BATTERY DISCONNECT SWITCH	
4	217-907	2	ROCKER SWITCH (DPDT) ON-ON	
5	222-145	5	ROCKER SWITCH (DPDT) ON-ON-ION	
6	217-916	1	ROCKER SWITCH (DPDT) ON-OFF-ON	
7	217-908	1	ROCKER SWITCH (DPDT) ON-ON-ION	
8	214-301	1	ACCESSORY SOCKET	
9	306-607	1	HORN BUTTON	
10	306-608	1	BUTTON COVER	
11	306-603	1	AUDIO ALARM	
12	318-953	1	VALVE COVE PANEL	
13	214-563	1	RED LED (12V DC)	
14	214-566	1	POTENTIOMETER	
15	211-078	1	CONNECTOR CAP (TURCK RS-CC)	
16	106-381	7	FLG LK SCREW (M8-1.25 X 25MM)	
17	106-386	7	FLG LOCKNUT (M8-1.25)	
18	107-358	12	WELLNUT (M4-0.7 X 12.67MM LG)	
19	107-414	4	SCREW (M4-0.70 X 30MM,BUT SOC)	
20	107-580	12	SCREW (M4-0.70 X 16MM,BUT SOC)	
21	105-680	7	NUT (M4, W/LK WSHR)	
22	106-556	3	SCREW (M4-0.70 X 20MM)	
23	220-664	4	INDICATOR ASSEMBLY	
24	110-962	2	FILLER PLUG	

NOT SHOWN:

FOOTNOTES:

NOTE:



# ESID MODULE & GAUGE PANEL

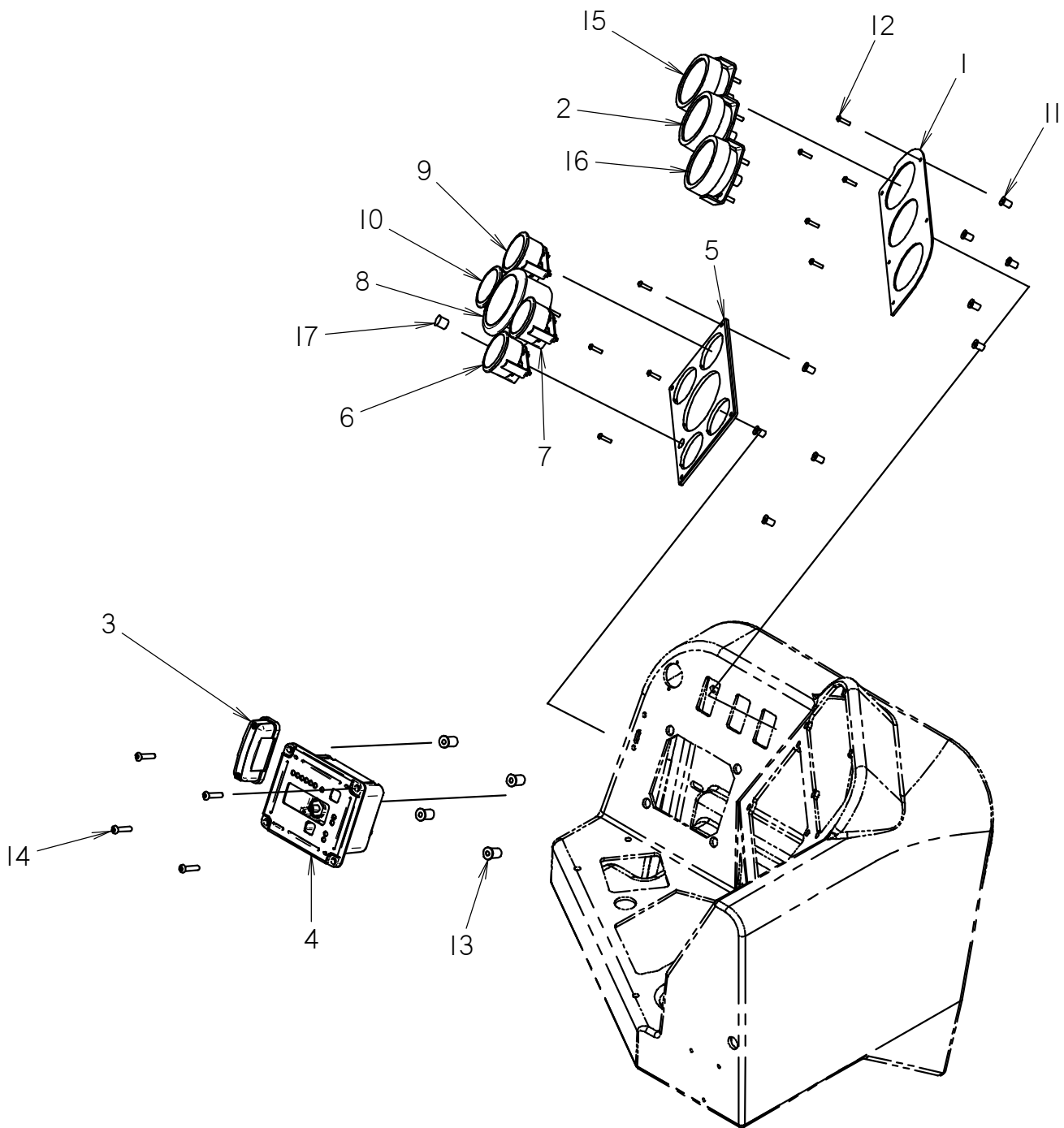

## ESID MODULE & GAUGE PANEL

REF NO.	PART NUMBER	QTY	DESCRIPTION	REMARKS
1	318-954	1	GAUGE PANEL	
2	217-294	1	PRESSURE GAUGE (3000 PSI)	USE 258-095 ON JT2020
3	217-275	1	CONSOLE LIGHT	
4	220-1222	1	ESID MODULE	
5	363-696	1	GAUGE CLUSTER PANEL	
6	215-1582	1	OIL PRESSURE GAUGE (0-150 PSI)	BEGINS WITH S/N: CMWJ2020HA0001165; SEE FOOTNOTE 1
7	215-1465	1	ANALOG WATER TEMP GAUGE	
8	215-1373	1	ANALOG TACH	
9	211-328	1	2.06" VOLTMETER GAUGE	
10	211-329	1	2.06" FUEL GAUGE	
11	107-358	9	WELLNUT (M4-0.7 X 12.67MM LG)	
12	107-580	9	SCREW (M4-0.70 X 16MM,BUT SOC)	
13	107-871	4	WELLNUT (M6-1.00 X 20.35MM LG)	
14	108-184	4	SCREW (M6-1.00 X 30MM, BUT SOC)	
15	150-1444	1	PRESSURE GAUGE (2000 PSI)	
16	258-045	1	PRESSURE GAUGE (4000 PSI)	USE 258-036 ON JT2020
17	362-1313	1	HOLE PLUG	

NOT SHOWN:

FOOTNOTES:

1. TO BE USED WITH 215-1583 OIL PRESSURE SENDER (0-150PSI). BEFORE S/N: CMWJ2020HA0001165 215-1375 ANALOG OIL PRESSURE GAUGE WAS USED WITH 215-183 SENDER, OIL PRESSURE HD

NOTE:

# VANDAL COVER

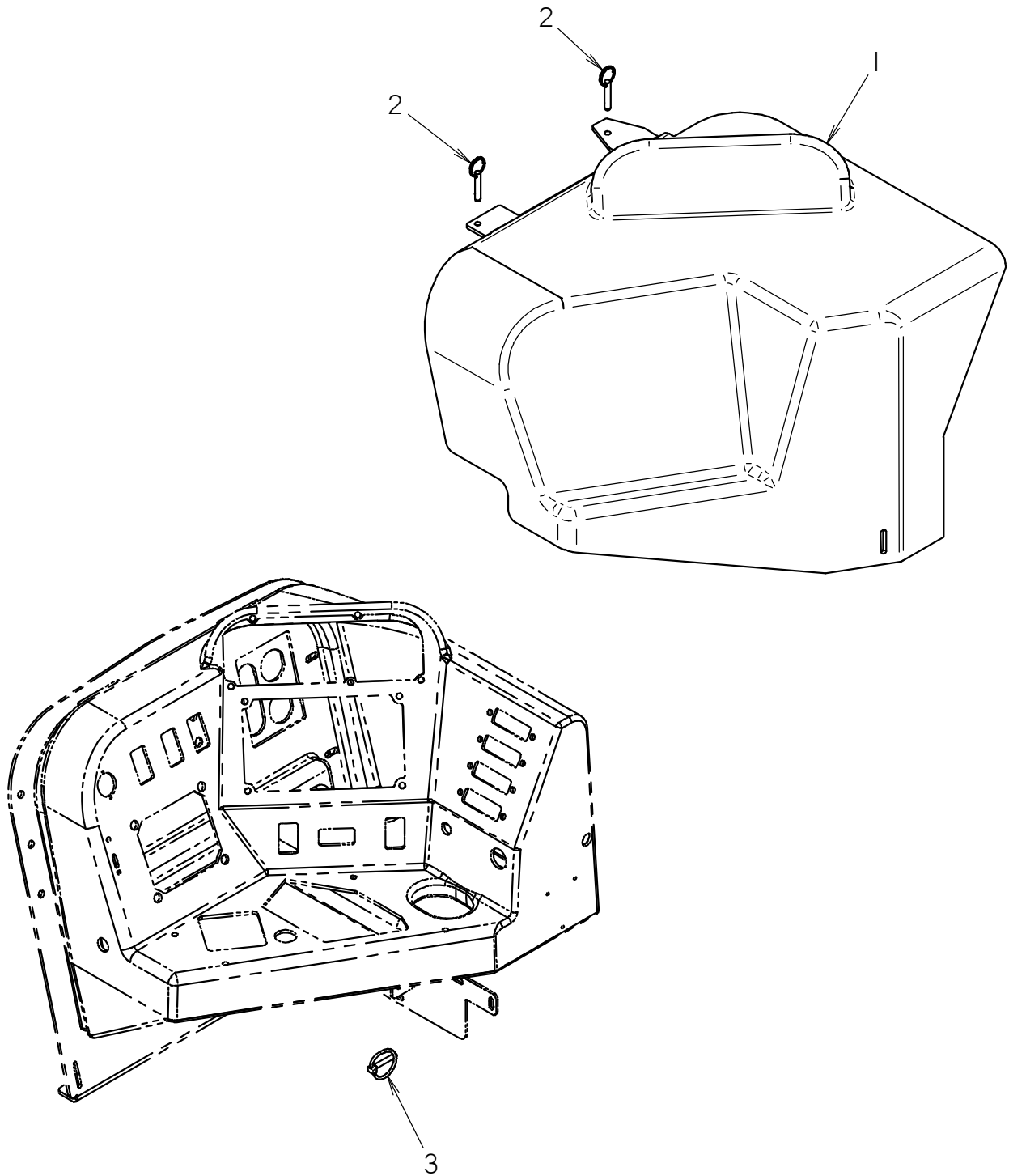

# VANDAL COVER

REF NO.	PART NUMBER	QTY	DESCRIPTION	REMARKS
1	362-999	1	VANDAL COVER	
2	110-737	2	PULL PIN (5/16" X 2")	
3	105-1428	1	LYNCH PIN (1/4 X 1-9/16)	

NOT SHOWN:

FOOTNOTES:

1. WHEN REMOVING VANDEL COVER, PLACE PINS IN MOUNT PLATE WELDED TO OUTSIDE FRAME RAIL OF ENGINE SKID, FOR SAFE STORAGE.

NOTE:

# RIGHT CONSOLE

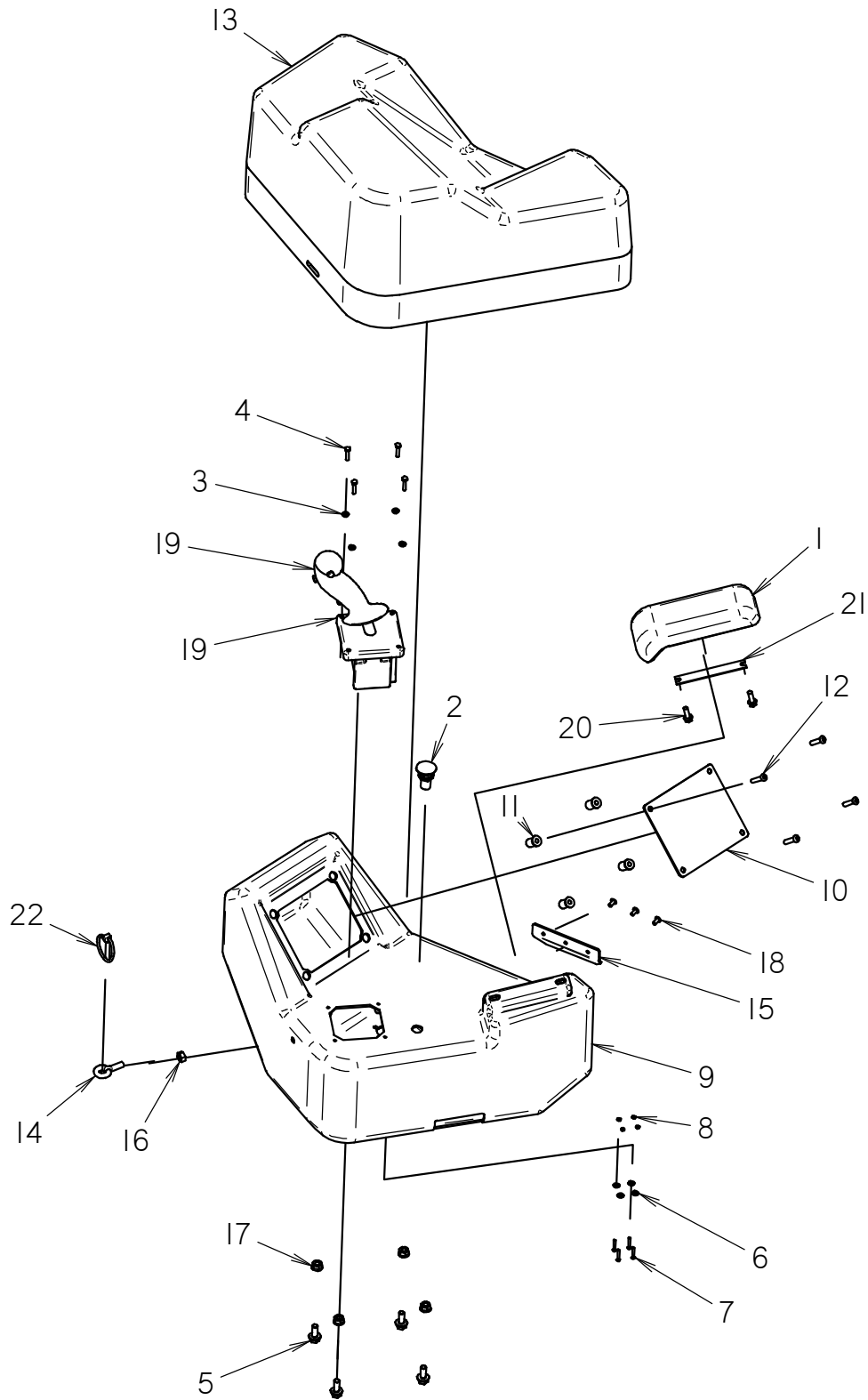

# RIGHT CONSOLE

REF NO.	PART NUMBER	QTY	DESCRIPTION	REMARKS
1	117-314	1	ARM REST	
2	217-206	1	BUTTON SWITCH (SPST)	
3	106-205	4	WASHER (1/9")	
4	106-556	4	SCREW (M4-0.70 X 20MM)	
5	106-162	4	FLG SCREW (M8-1.25 X 20MM, GD8)	
6	106-013	4	WASHER (3/16")	
7	107-269	4	SCREW (#4-40 X 3/4", PAN)	
8	105-662	4	NUT (#4-40)	
9	362-1331	1	RIGHT CONSOLE	
10	348-896	1	COVER PLATE	
11	107-871	4	WELLNUT (M6-1.00 X 20.35MM LG)	
12	108-184	4	SCREW (M6-1.00 X 30MM, BUT SOC)	
13	362-1336	1	WEATHER COVER	
14	107-570	1	EYE BOLT (M8-1.25 X 20MM)	
15	300-3589	1	BRACKET	
16	106-078	1	NUT (M8-1.25)	
17	106-386	4	FLG LOCKNUT (M8-1.25)	
18	110-560	3	POP RIVET (3/16" X 1/2", ALUM)	
19	215-1224	1	DUAL AXIS HALL EFFECT JOYSTICK	
20	106-159	2	FLG SCREW (1/4-NC X 3/4")	
21	300-6573	1	CLAMP PLATE	
22	105-1428	1	LYNCH PIN (1/4 X 1-9/16)	

## NOT SHOWN:

214-415 1 90D MODULE TO RIG CABLE

## FOOTNOTES:

## NOTE:

# ELECTRICAL STRIKE SYSTEM

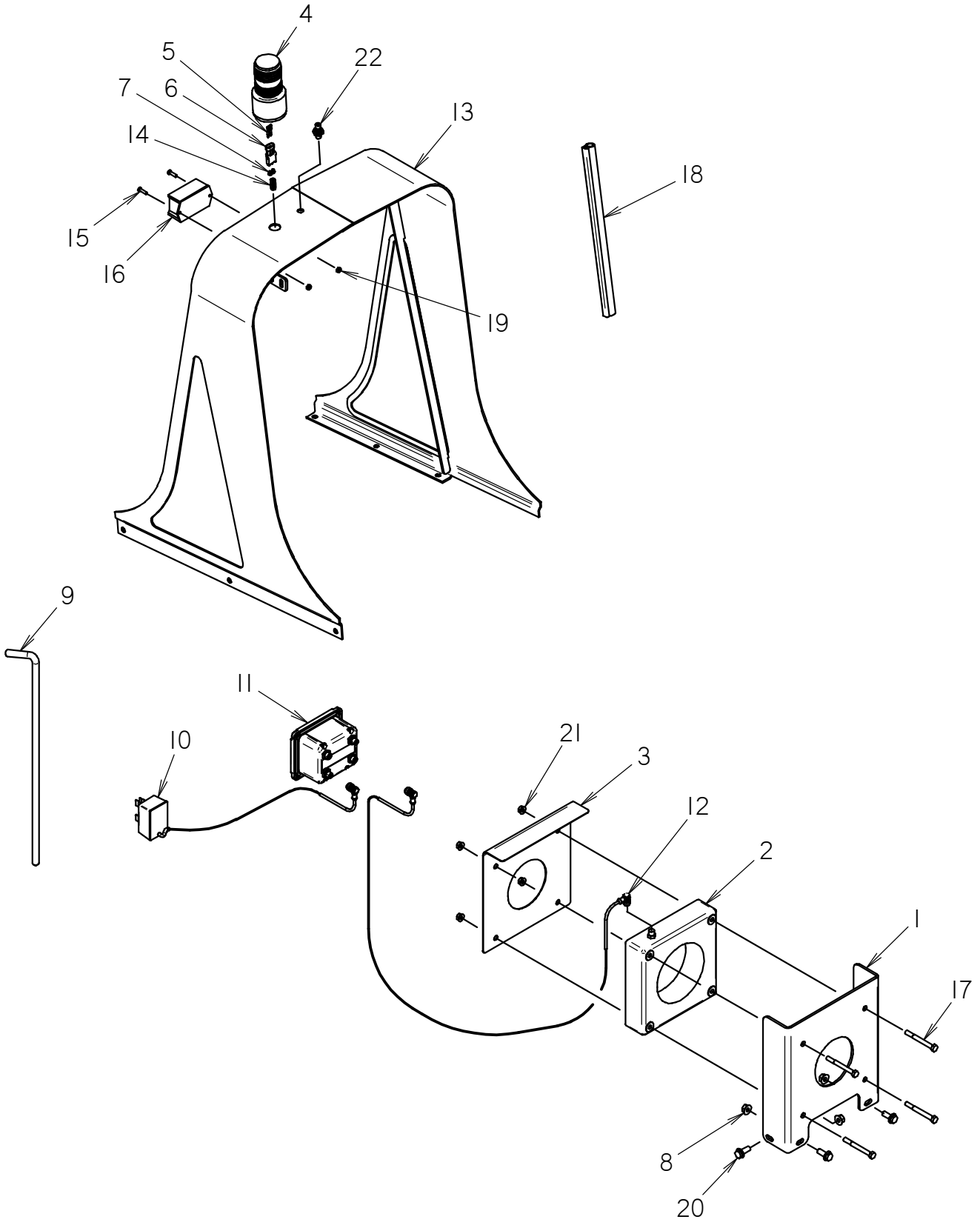

# ELECTRICAL STRIKE SYSTEM

REF NO.	PART NUMBER	QTY	DESCRIPTION	REMARKS
1	300-2131	1	TRANSFORMER COVER	BEGINS WITH S/N: CMWJ1220J60000130, & CMWJ2020E60000333
2	215-1081	1	CURRENT TRANSFORMER	BEGINS WITH S/N: CMWJ1220J60000130, & CMWJ2020E60000333
3	300-2168	1	COVER	BEGINS WITH S/N: CMWJ1220J60000130, & CMWJ2020E60000333
4	217-296	1	STROBE LIGHT (AMBER)	INCLUDES REF NO'S 5, 6 & 7
5	214-104	2	PACKARD MALE TERMINAL	
6	214-103	1	(2-WAY) MALE CONNECTOR	
7	157-645	2	WEATHER-PAC SEAL (2.80MM)	
8	106-266	4	FLG NUT (M10-1.50)	
9	215-799	1	VOLTAGE STAKE	
10	211-042	1	VOLTAGE LIMITER CABLE	
11	220-1222	1	ESID MODULE	
12	214-554	1	CURRENT COIL CABLE	
13	300-4434	1	CENTER MOUNT	
14	216-026	1	FLEX-GUARD (25")	USE 1 @ 13"
15	106-049	2	BOLT (#10-24 X 3/4", PLPS)	
16	220-1120	1	ENGINE SENSOR AMPLIFIER MODULE	
17	106-602	4	SCREW (M8-1.25 X 80MM)	
18	116-489	1	BULK EDGE (1/8",SOLD PER FT)	USE 1 @ 22"
19	106-048	2	LOCKNUT (#10-24)	
20	106-724	4	FLG SCREW (M10-1.50 X 25MM)	
21	106-386	4	FLG LOCKNUT (M8-1.25)	
22	211-055	1	ANTENNA BULKHEAD CONNECTOR	

NOT SHOWN:

318-993	1	TRANSFORMER COVER	ENDS WITH S/N: CMWJ1220V60000129, & CMWJ2020L60000331
211-083	1	CURRENT TRANSFORMER	ENDS WITH S/N: CMWJ1220V60000129, & CMWJ2020L60000331
309-758	1	COVER	ENDS WITH S/N: CMWJ1220V60000129, & CMWJ2020L60000331

FOOTNOTES:

NOTE:



# GROUND DRIVE CONTROL

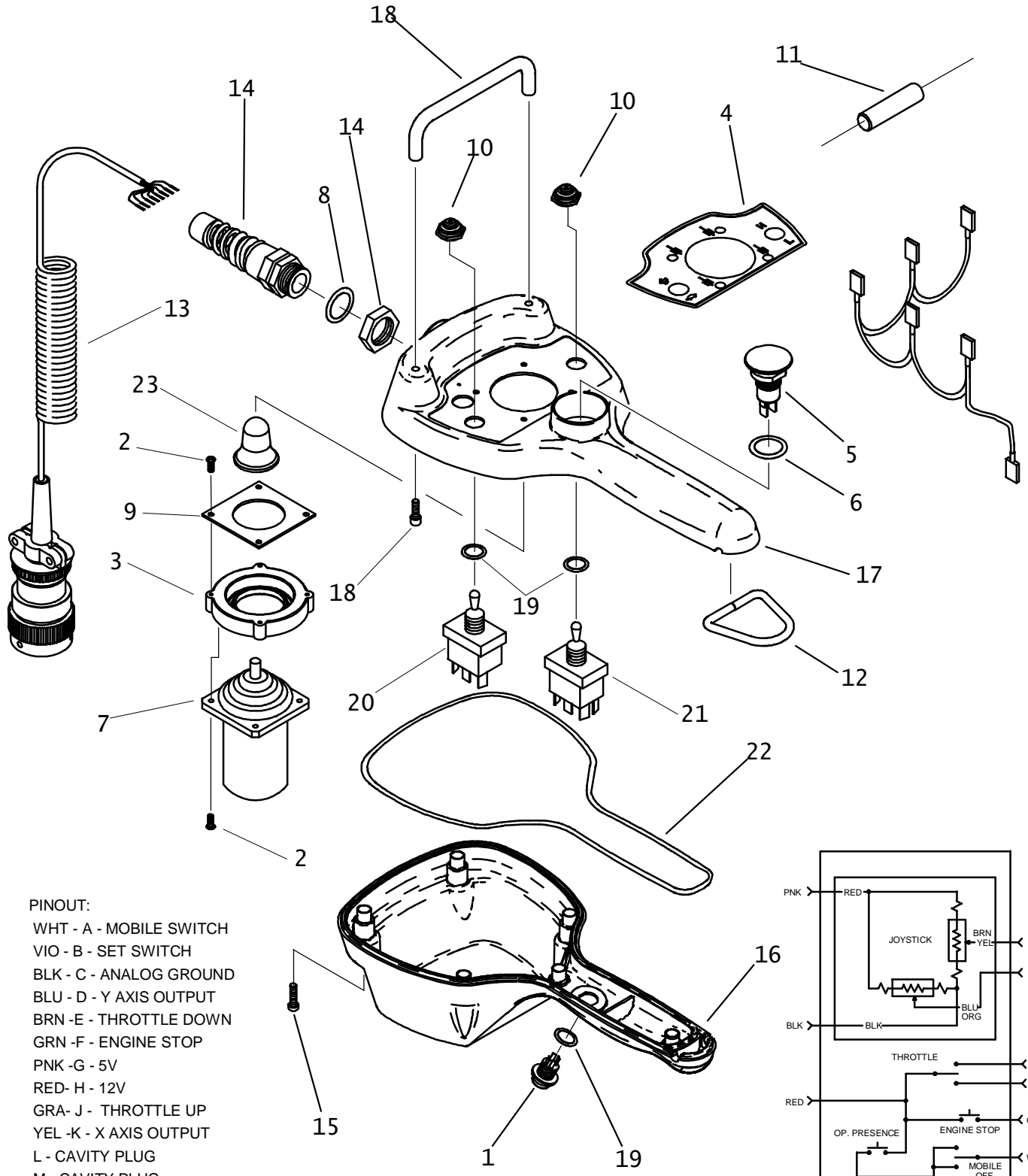

- PINOUT:**  
 WHT - A - MOBILE SWITCH  
 VIO - B - SET SWITCH  
 BLK - C - ANALOG GROUND  
 BLU - D - Y AXIS OUTPUT  
 BRN - E - THROTTLE DOWN  
 GRN - F - ENGINE STOP  
 PNK - G - 5V  
 RED- H - 12V  
 GRA- J - THROTTLE UP  
 YEL -K - X AXIS OUTPUT  
 L - CAVITY PLUG  
 M - CAVITY PLUG  
 N - CAVITY PLUG  
 P - CAVITY PLUG

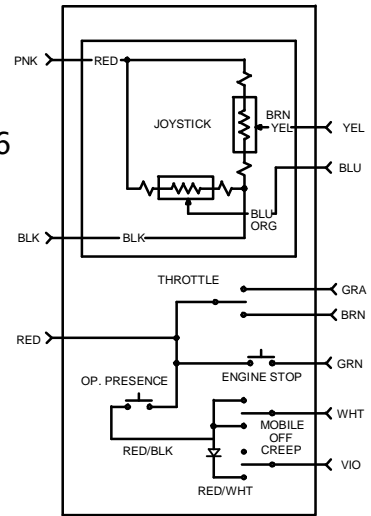

# GROUND DRIVE CONTROL

REF NO.	PART NUMBER	QTY	DESCRIPTION	REMARKS
	214-589		GROUND DRIVE CONTROL	
1.	214-614	1	PUSH BUTTON SWITCH (SPST) OFF-(ON)	
2.	106-820	8	SCREW, SELF TAPPING (3.0 X 12MM)	
3.	305-664	1	JOY STICK ADAPTER	
4.	274-998	1	DECAL	
5.	214-615	1	KILL SWITCH	
6.	157-040	1	O-RING (1-016 D90)	
7.	214-613	1	JOYSTICK ASSEMBLY	SEE FOOTNOTE 1
	215-1394	1	JOYSTICK ASSEMBLY	SEE FOOTNOTE 1
8.	157-017	1	O-RING (018 D90)	
9.	149-558	1	JOYSTICK GASKET	
10.	214-728	2	TOGGLE SWITCH HALF BOOT (SEAL)	
11.	215-1720	1	DIODE 1N5402	
12.	105-775	1	D-RING	
13.	211-020	1	COILED CORD-MALE	
14.	211-021	1	STRAIN RELIEF	
15.	106-876	6	SCREW	
16.	214-497	1	LOWER HOUSING	
17.	214-498	1	UPPER HOUSING	
18.	116-933	1	HANDLE	
	106-894	2	SCREW (#8-32 X 1" PLPS SS)	SEE FOOTNOTE 2
19.	157-039	2	O-RING (1-014 D90)	
20.	217-896	1	TOGGLE SWITCH	
21.	214-570	1	TOGGLE SWITCH (DPDT) ON-OFF-ON	
22.	116-549	AR	ROPE GASKET ( USE 27" )	
23.	116-932	1	JOYSTICK KNOB	

NOT SHOWN:

#### FOOTNOTES:

1. JOYSTICK SHOULD BE ORIENTED WITH LABEL POINTING TOWARDS CABLE END. (REV G)
1. JOYSTICK SHOULD BE ORIENTED WITH X+ ON LABEL POINTING TOWARDS CABLE END. (REV H)  
 Y-AXIS OUTPUT: 3.75V FORWARD 1.25V BACK  
 X-AXIS OUTPUT: 3.75V LEFT 1.25V RIGHT

2. APPLY THREAD LOCKING COMPOUND TO BOTH HANDLE SCREWS.

NOTE:



# HYDRAULICS

# PUMP STACK MOUNTING

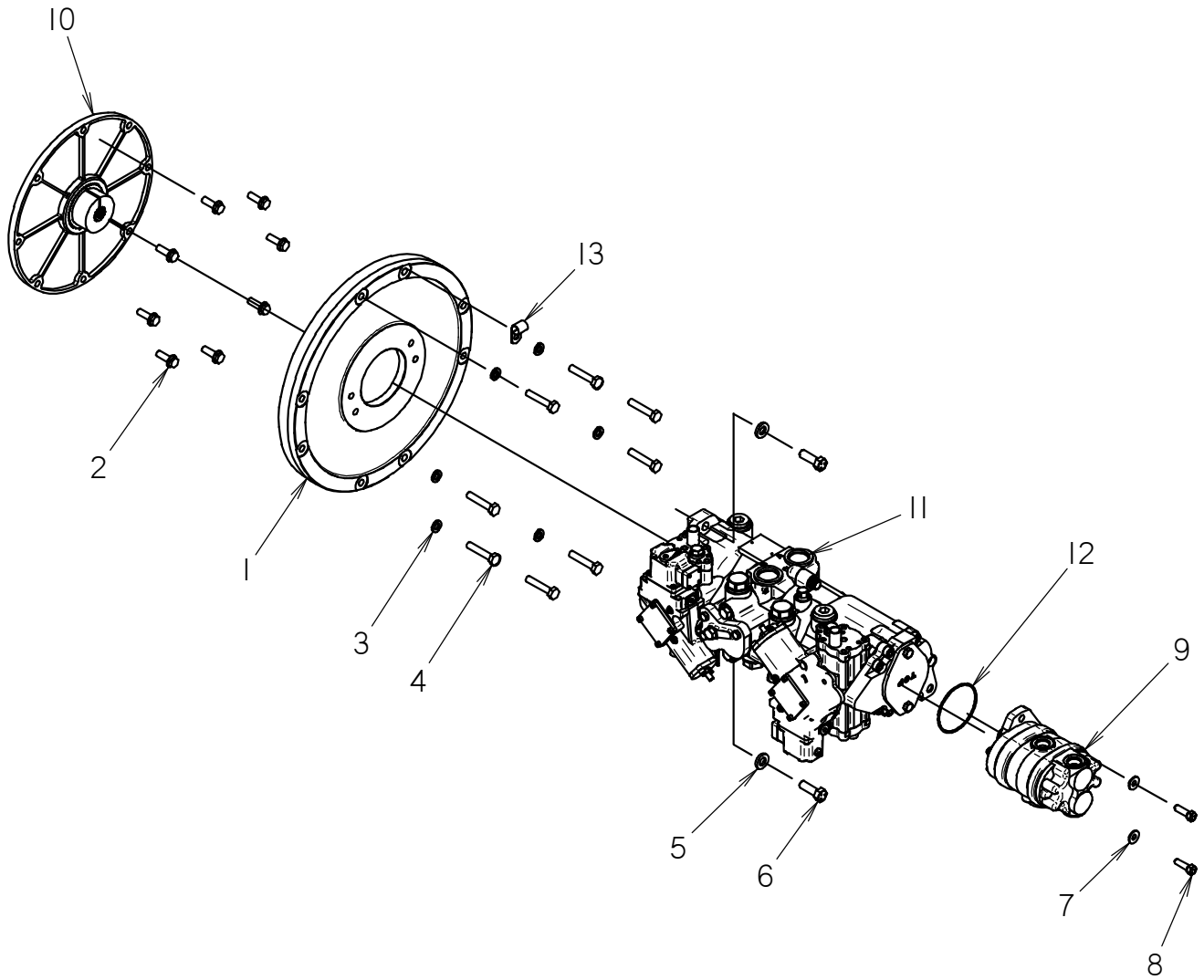

# PUMP STACK MOUNTING

REF NO.	PART NUMBER	QTY	DESCRIPTION	REMARKS
1	194-763	1	MOUNT PLATE	
2	106-383	8	FLG LK SCREW (M10-1.50 X 30MM)	USE LOCTITE 271 OR EQUIVALENT, TORQUE TO 33 FT-LBS
3	105-073	8	LOCK WASHER (7/16")	
4	105-839	8	SCREW (M10-1.50 X 55MM)	TORQUE TO 30 FT-LBS
5	106-397	2	WASHER (M12, HARDENED)	
6	105-062	2	BOLT (1/2-NC X 1-1/2", FER)	USE LOCTITE 242 OR EQUIVALENT
7	105-117	2	WASHER (5/16")	
8	105-052	2	BOLT (3/8-NC X 1-1/4")	USE LOCTITE 242 OR EQUIVALENT
9	157-860	1	DOUBLE GEAR PUMP	
10	194-704	1	FLYWHEEL COUPLING	TORQUE TO 50 FT-LBS
11	157-239	1	DUAL HYDROSTAT	
12	157-041	1	O-RING (152 D70)	
13	110-259	1	BOLT-ON CLAMP (625")	

NOT SHOWN:

FOOTNOTES:

NOTE:

# PUMP STACK SUPPLY & RETURN

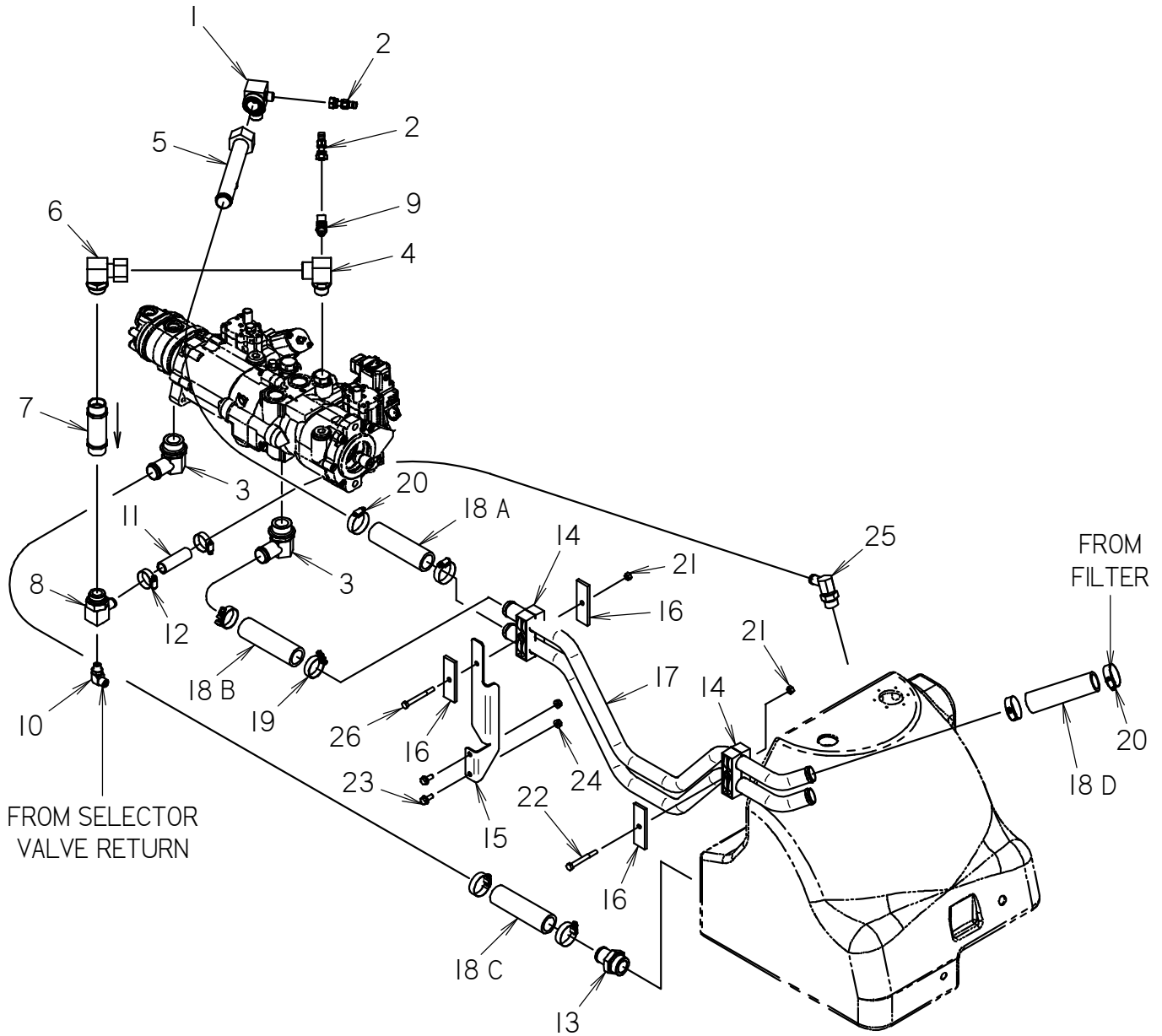

# PUMP STACK SUPPLY & RETURN

REF NO.	PART NUMBER	QTY	DESCRIPTION	REMARKS
1	157-768	1	CONNECTOR (I2S-200-060)	
2	159-157	2	QDC ADAPTER (Q2-060F)	
3	155-168	2	S/O COUPLER (20S-20H90)	
4	514-425	1	CONNECTOR (I2S-16090, 06SF)	
5	150-2205	1	HYD LINE	
6	153-908	1	UNION (I6S-160FX90)	
7	158-248	1	CHECK VALVE (I6SF-16SF,20 PSI)	
8	150-2700	1	CONNECTOR (I6S-12H90-06SF)	
9	154-224	1	CONNECTOR (O6S-06045)	
10	154-342	1	CONNECTOR (O6S-06090)	
11	116-636	40	BULK HOSE (3/4", SOLD PER FT)	
12	110-353	2	WORM CLAMP (3/4" TO 1-1/2")	
13	155-004	1	S/O COUPLER (20S-20H)	
14	110-274	2	BOLT-ON CLAMP (1-1/4",PER SET)	
15	300-5558	1	BRACKET	
16	300-5791	3	BACKUP PLATE	
17	150-2204	2	HYD LINE	
18	116-587	107	BULK HOSE (1-1/4",SOLD PER FT)	SEE FOOTNOTE I
19	149-342	2	T-BOLT CLAMP (1.687")	
20	110-133	6	WORM CLAMP(1-1/16"TO 1-15/16")	
21	106-561	2	LOCKNUT (M8-1.25,PRV TRQ,10.9)	
22	105-292	1	SCREW (M8-1.25 X 75MM)	
23	106-162	2	FLG SCREW (M8-1.25 X 20MM, GD8)	
24	106-386	2	FLG LOCKNUT (M8-1.25)	
25	155-174	1	S/O COUPLER (I2S-12H90)	
26	106-602	1	SCREW (M8-1.25 X 80MM)	

NOT SHOWN:

FOOTNOTES:

HOSE: A - 1 @ 28; B - 1 @ 12"; C - 1 @ 50; D - 1 @ 17"

NOTE:



# FILTER AND RESERVOIR HYDRAULICS

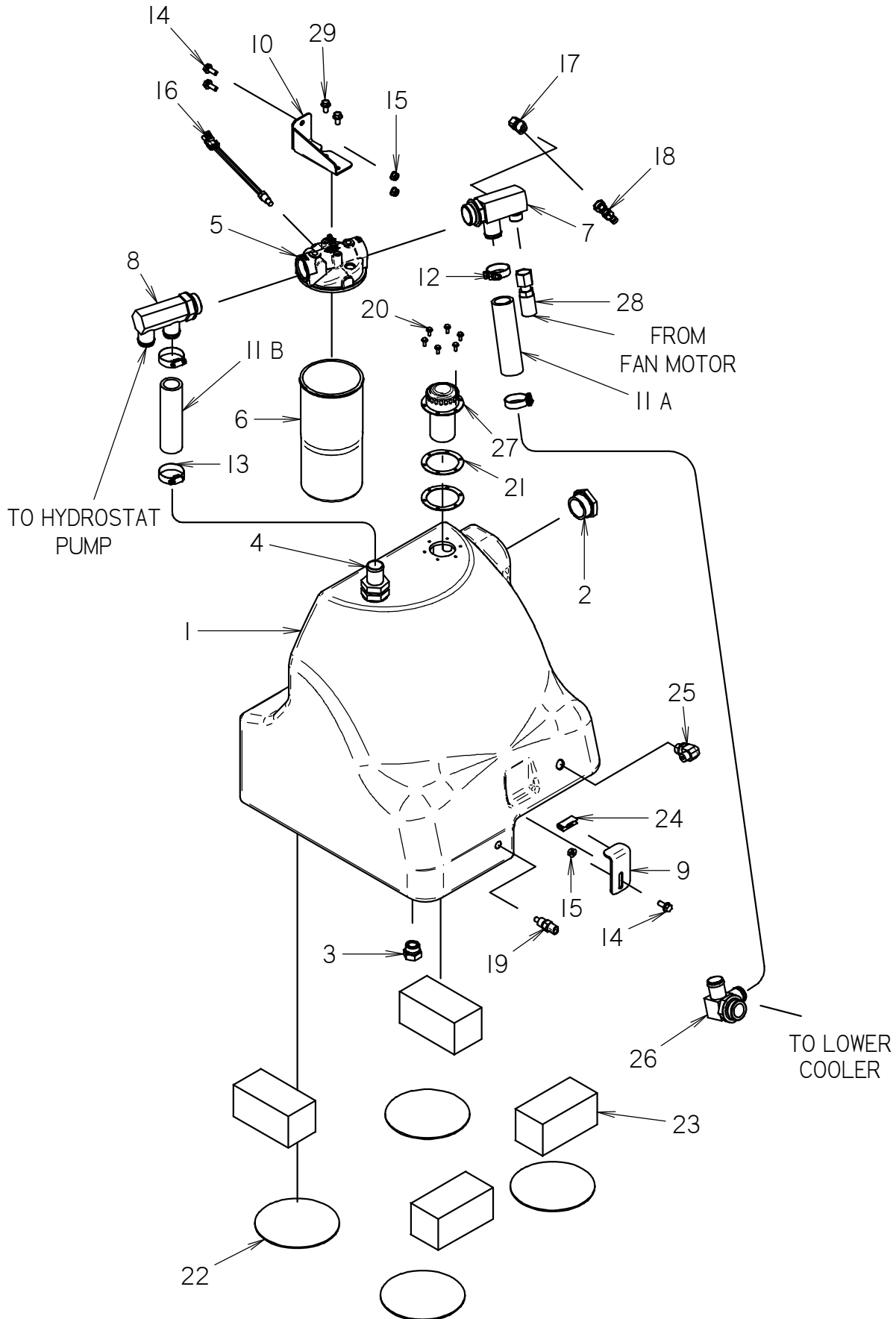

# FILTER AND RESERVOIR HYDRAULICS

REF NO.	PART NUMBER	QTY	DESCRIPTION	REMARKS
1	150-2088	1	HYDRAULIC TANK	
2	121-059	1	SIGHT GLASS (1-24)	
3	500-302	1	PLUG (1-12 S)	
4	150-2079	1	INLET FITTING (20S-20H)	
5	157-458	1	FILTER HEAD	
6	153-792	1	FILTER ELEMENT (10 MICRON)	
7	150-2728	1	CONNECTOR (20S-20H-100-06SF)	
8	150-2239	1	SPECIAL 90(20S-20H-20H)	
9	300-5375	1	BRACKET	
10	300-5377	1	MOUNT	
11	116-587	46	BULK HOSE (1-1/4",SOLD PER FT)	SEE FOOTNOTE 1
12	149-342	2	T-BOLT CLAMP (1.687")	
13	110-133	2	WORM CLAMP(1-1/16"TO 1-15/16")	
14	106-162	3	FLG SCREW (M8-1.25 X 20MM, GD8)	
15	106-386	3	FLG LOCKNUT (M8-1.25)	
16	214-854	1	TEMPERATURE SWITCH(1/4NPT,MALE)	
17	154-342	1	CONNECTOR (06S-06090)	
18	159-157	1	QDC ADAPTER (02-060F)	
19	215-1434	1	COOLANT TEMP SENSOR	
20	105-214	6	FLG SCREW (#10-24 X .5")	
21	165-626	2	FILLER NECK GASKET	
22	117-425	AR	LINER PAD (1/2" THK)	
23	362-1084	4	AIR BARRIER	
24	115-704	2	BULK EDGE (1/4", SOLD PER 1')	1 @ 2"
25	154-227	1	CONNECTOR (060-08S90)	
26	514-164	1	S/O BR TEE (20S-20H-20H)	
27	110-008	1	FILLER BREATHER ASSY.	
28	116-812	1	HOSE (100FX90S-71"-3000)	
29	501-325	2	FLG LK BOLT (5/16-NC X 5/8")	

NOT SHOWN:

FOOTNOTES:

HOSE A: 1 @ 34", HOSE B: 1 @ 12"

NOTE:

# HYDRAULIC OIL COOLER PLUMBING

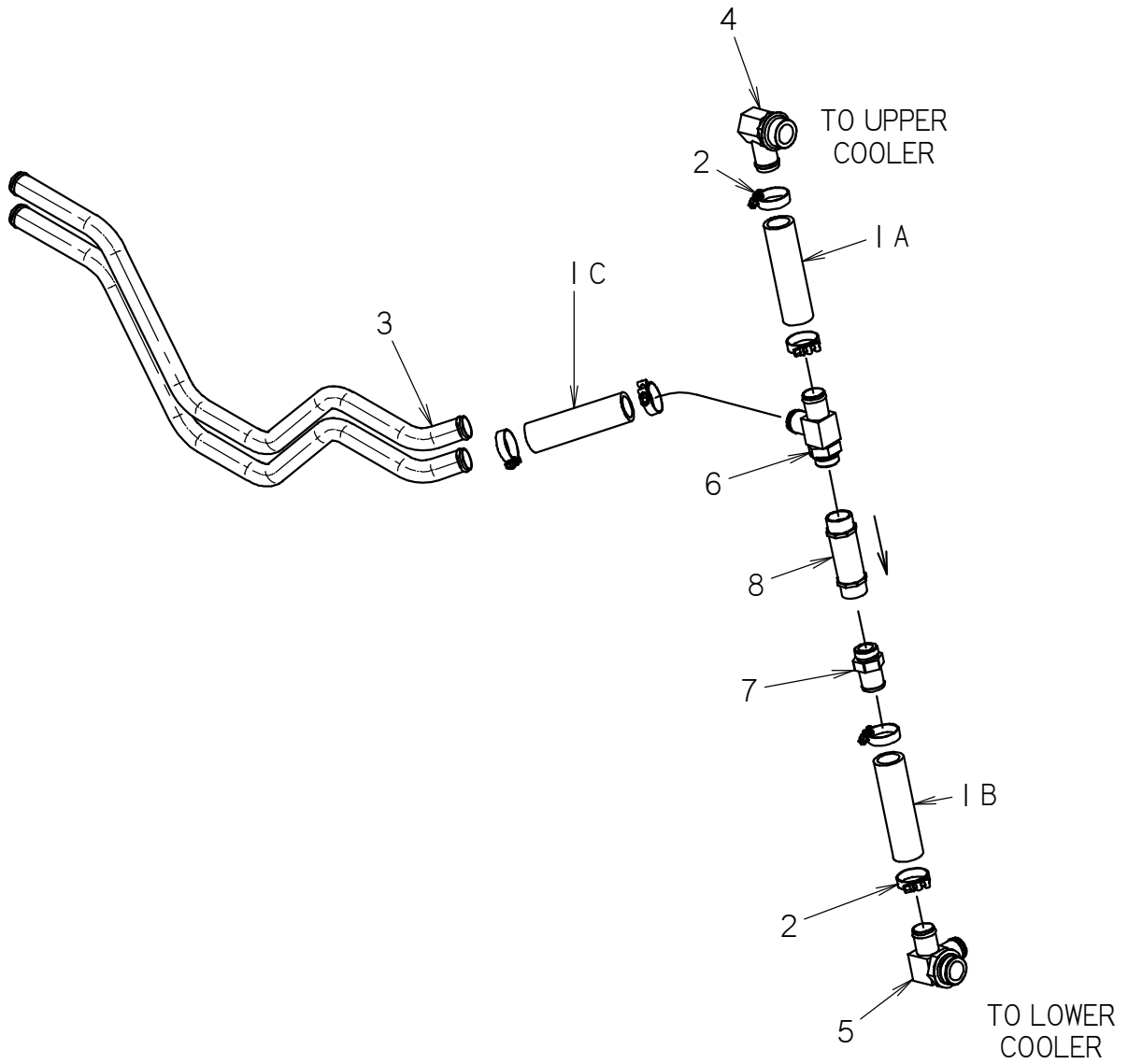

# HYDRAULIC OIL COOLER PLUMBING

REF NO.	PART NUMBER	QTY	DESCRIPTION	REMARKS
1	116-587	32	BULK HOSE (1-1/4",SOLD PER FT)	SEE FOOTNOTE 1
2	149-342	6	T-BOLT CLAMP (1.687")	
3	150-2204	2	HYD LINE	
4	155-168	1	S/O COUPLER (20S-20H90)	
5	514-164	1	S/O BR TEE (20S-20H-20H)	
6	150-2210	1	S/O RUN TEE (16S-20H-20H)	
7	155-047	1	S/O COUPLER (16S-20H)	
8	158-248	1	CHECK VALVE (16SF-16SF,20 PSI)	

NOT SHOWN:

FOOTNOTES:

1. HOSE A: 1 @ 17"; HOSE B: 1 @ 6", HOSE C: 1 @ 9"

NOTE:

## ROTATION HYDRAULICS

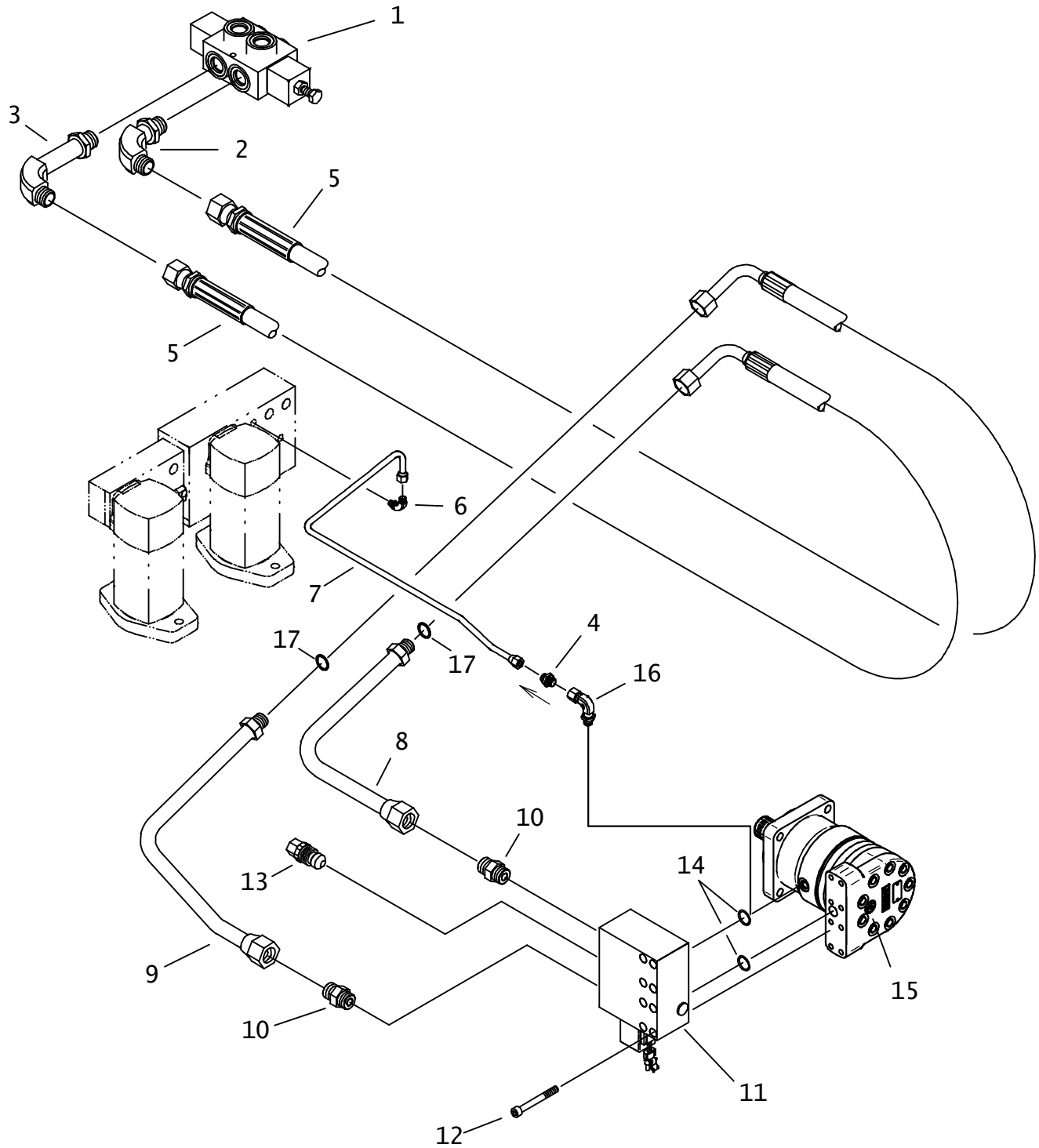

# ROTATION HYDRAULICS

REF NO.	PART NUMBER	QTY	DESCRIPTION	REMARKS
1.	159-912	-	HYD CONTROL VALVE	
	191-396	-	SEAL KIT	
	500-1942	-	SEAL WASHER	
2.	154-270	1	CONNECTOR (12S-12090)	
3.	154-338	1	CONNECTOR (12S-12090, XL)	
4.	159-750	1	FLOW CHECK VALVE(060-060)	
5.	157-368	2	HOSE (120FX90L-149"-5000)	
6.	514-049	1	CONNECTOR (04S-06090)	
7.	157-378	1	HYD LINE (-06)	
8.	157-887	1	HYD LINE (-16)	
9.	157-886	1	HYD LINE (-16)	
10.	154-281	2	CONNECTOR (16S-160)	
11.	159-577	1	RELIEF MANIFOLD	
	150-1326	1	HYDRAULIC VALVE	
12.	105-857	8	BOLT (3/8-NC X 3", SOC, GD8)	
13.	159-686	1	HYD RELIEF VALVE, ADJ	
	191-426	-	SEAL REPAIR KIT	
14.	155-737	-	O-RING (214 D70)	
15.	150-1026	-	ROTATION MOTOR	
	150-1041	-	SEAL KIT	
16.	154-343	1	UNION (06S-060FX90)	

NOT SHOWN:

FOOTNOTES:

NOTE:

# PUMP/ SELECTOR HYDRAULICS

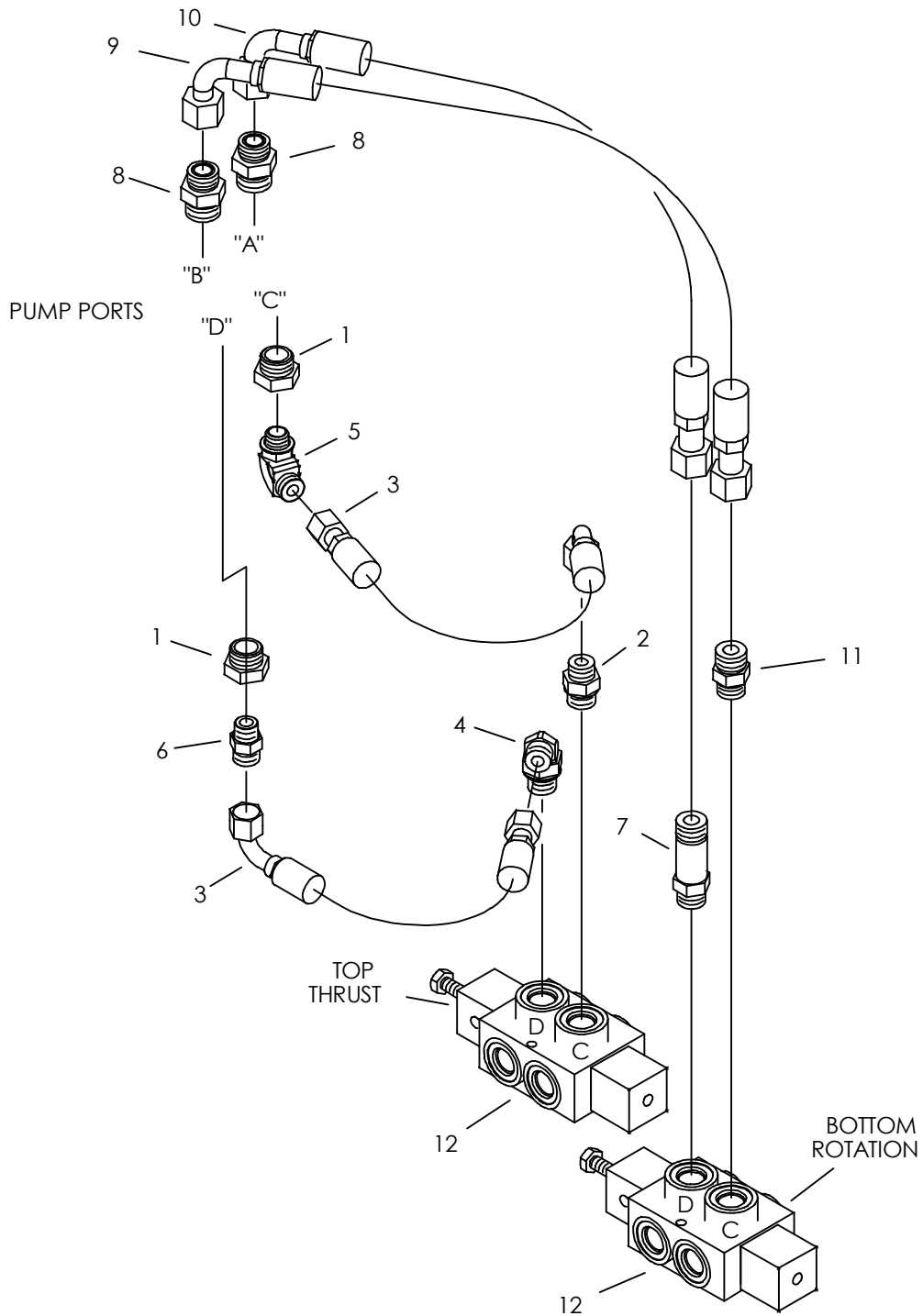

# PUMP/ SELECTOR HYDRAULICS

REF NO.	PART NUMBER	QTY	DESCRIPTION	REMARKS
1.	155-199	2	REDUCER (16S-10SF)	
2.	154-308	1	CONNECTOR (100-12S)	
3.	153-295	2	HOSE (100FX90S-18"-3000)	
4.	154-300	1	CONNECTOR (100-12S90)	
5.	154-298	1	CONNECTOR (10S-10090)	
6.	154-301	1	CONNECTOR (10S-100)	
7.	514-048	1	CONNECTOR (12S-120, LG)	
8.	154-367	2	CONNECTOR (120-16S)	
9.	153-077	1	HOSE (120FX90S-32"-5000)	
10.	153-076	1	HOSE (120FX90S-28"-5000)	
11.	154-269	1	CONNECTOR (12S-120)	
12.	159-912	-	HYD CONTROL VALVE	
	191-396	-	SEAL KIT	
	500-1942	-	SEAL WASHER	

NOT SHOWN:

FOOTNOTES:

NOTE:



# SELECTOR HYDRAULICS

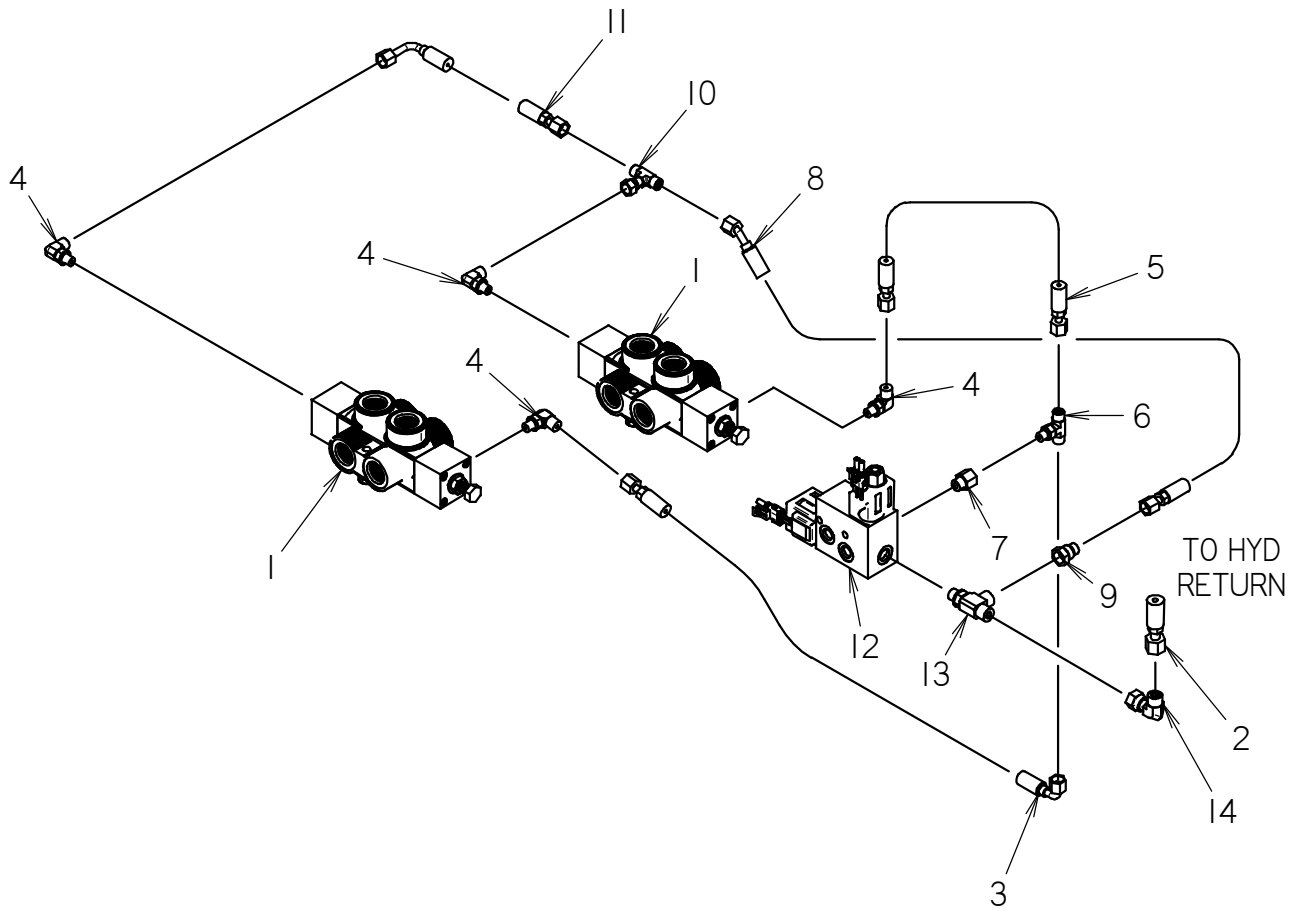

# SELECTOR HYDRAULICS

REF NO.	PART NUMBER	QTY	DESCRIPTION	REMARKS
1	159-912	2	HYD CONTROL VALVE	500-1942 SEAL WASHER
2	154-737	1	HOSE (060FX90-17"-3000)	
3	515-175	1	HOSE (040FX90-16-3000)	
4	154-252	4	CONNECTOR (04S-04090)	
5	154-825	1	HOSE (040FX-12"-3000)	
6	154-293	1	BRANCH TEE (04S-040-040)	
7	155-254	1	REDUCER (06S-04SF)	
8	515-331	1	HOSE (040FX45-22"-3000-AR)	
9	154-373	1	REDUCER (040-060F)	
10	154-379	1	UN BR TEE (040FX-040-040)	
11	159-889	1	HOSE (040FX90L8"-3000)	
12	157-776	1	MANIFOLD	SEE NOT SHOWN FOR SERVICE PARTS.
13	154-345	1	RUN TEE (06S-060-060)	
14	154-228	1	UNION (060-060FX90)	

NOT SHOWN:

516-089	SOLENOID VALVE WITH NUT	USED ON 4 WAY VALVE
500-1541	SOLENOID VALVE WITH NUT	USED ON 3 WAY VALVE
213-216	SOLENOID COIL WITH DIODE	USED ON 4 WAY VALVE
213-196	SOLENOID COIL WITH DIODE	USED ON 3 WAY VALVE

FOOTNOTES:

NOTE:

FRONT THRUST HYDRAULICS  
JT1220

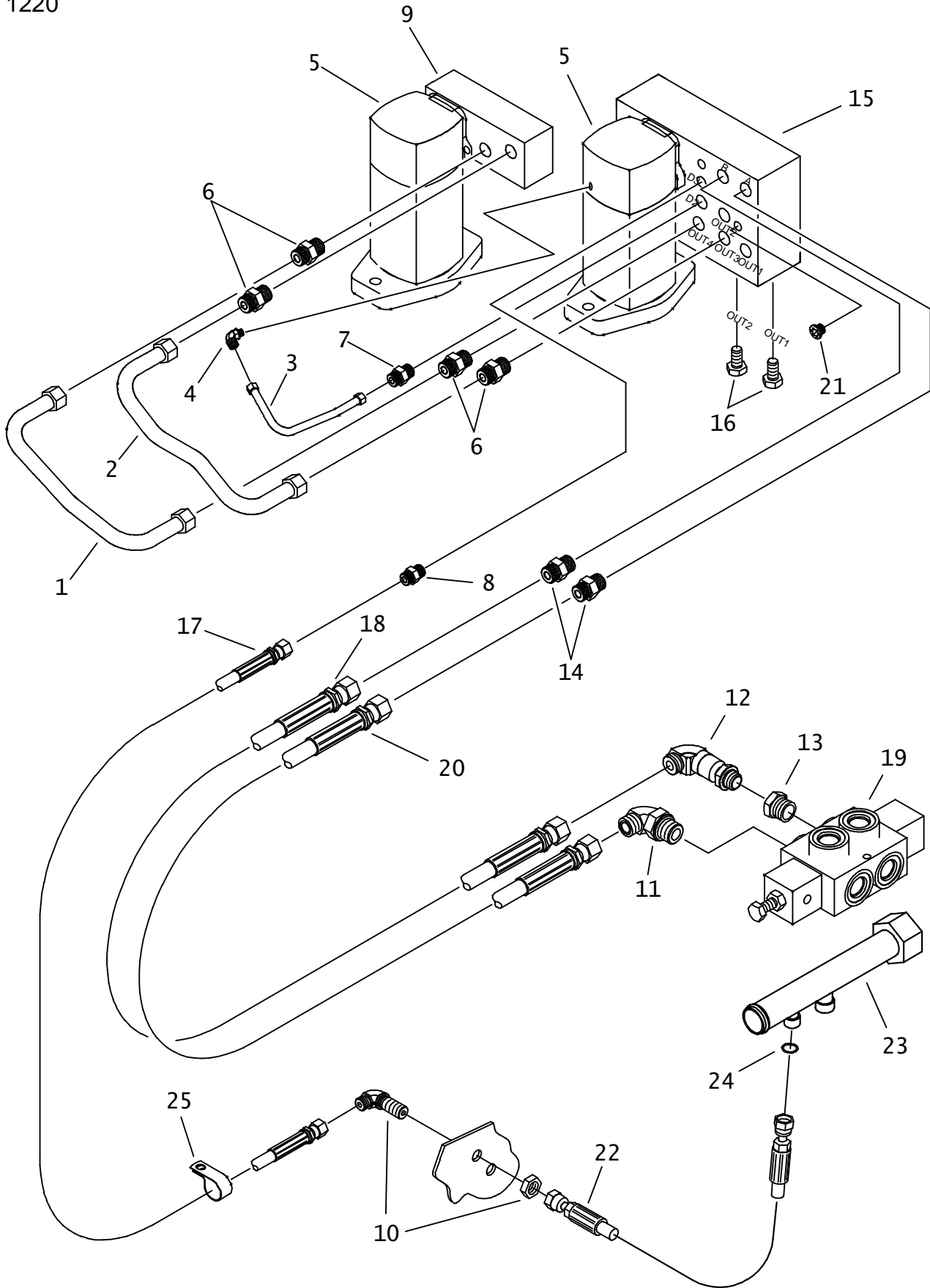

# FRONT THRUST HYDRAULICS

## JT1220

REF NO.	PART NUMBER	QTY	DESCRIPTION	REMARKS
1.	157-377	1	HYD LINE (-12)	
2.	157-376	1	HYD LINE (-12)	
3.	157-379	1	HYD LINE (-06)	
4.	514-049	1	CONNECTOR (04S-06090)	
5.	157-317	-	MOTOR	
	500-1269	-	SEAL REPAIR KIT	
6.	154-247	4	CONNECTOR (10S-120)	
7.	154-222	1	CONNECTOR (060-08S)	
8.	154-221	1	CONNECTOR (06S-060)	
9.	150-2050	-	MANIFOLD	
10.	154-229	1	BK CONNECTOR (060-06090BK)	
11.	154-300	1	CONNECTOR (100-12S90)	
12.	154-288	1	CONNECTOR (10S-10090, XL)	
13.	510-017	1	REDUCER (12S-10SF)	
14.	154-301	2	CONNECTOR (10S-100)	
15.	150-2049	-	MANIFOLD	
16.	154-381	2	PLUG (08S)	
17.	515-350	1	HOSE (060FX-133"-3000)	
18.	159-784	1	HOSE (100FX-141"-3000)	
19.	159-912	-	HYD CONTROL VALVE	
	191-396	-	SEAL KIT	
	500-1942	-	SEAL WASHER	
20.	157-967	1	HOSE (100FX-139"-3000)	
21.	154-383	1	PLUG (04S)	
22.	515-089	1	HOSE (060FX-15"-3000)	
23.	150-2205	1	HYD LINE	
24.	157-039	1	O-RING (014 D90)	
25.	110-333	1	BOLT-ON CLAMP (1")	

NOT SHOWN:

FOOTNOTES:

NOTE:

# P.O.R. HYDRAULICS

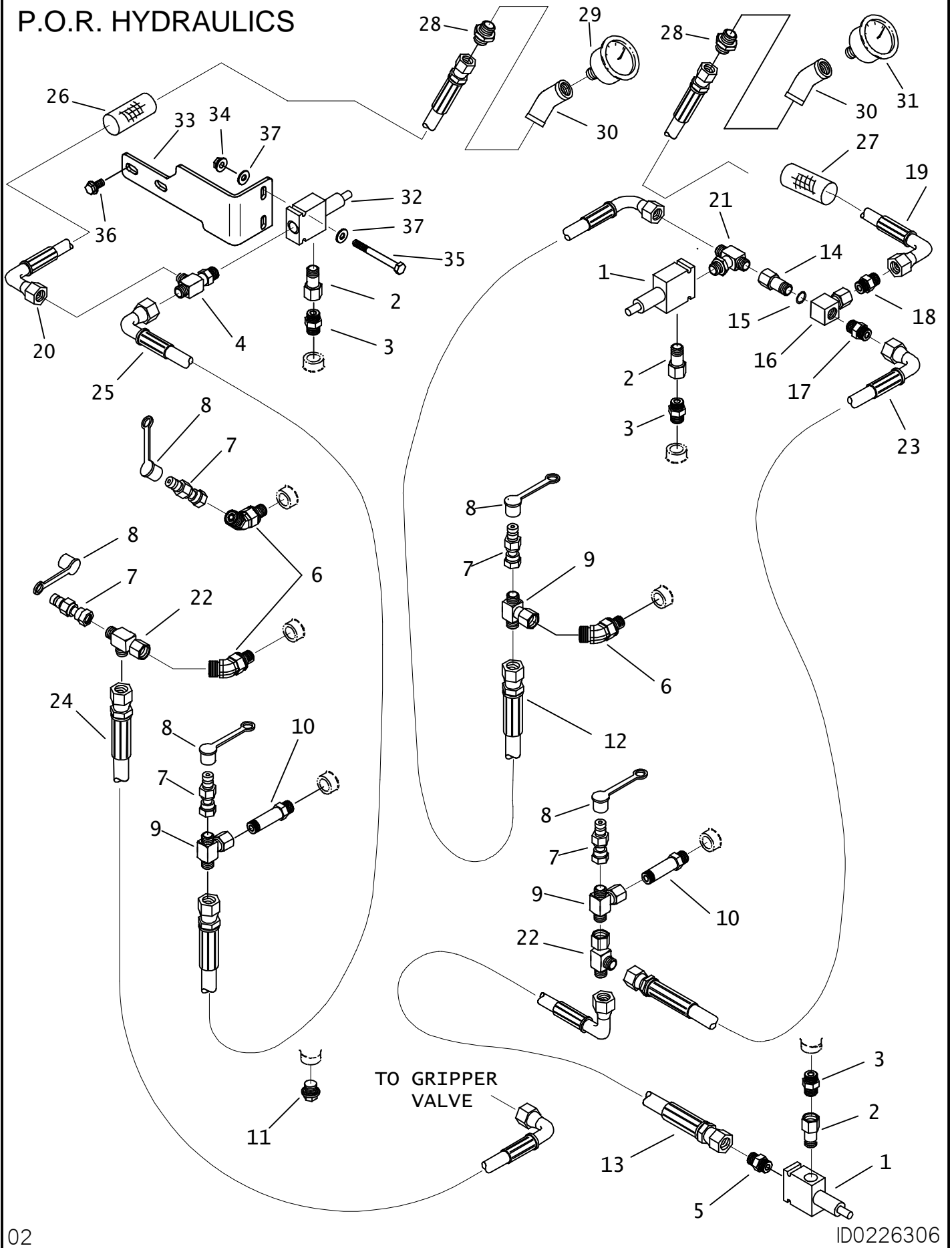

# P.O.R. HYDRAULICS

REF NO.	PART NUMBER	QTY	DESCRIPTION	REMARKS
1.	158-681	2	HYD RELIEF VALVE	
	500-756	-	SEAL REPAIR KIT	
2.	155-163	3	REDUCER (08S-06SF)	
3.	155-153	3	CONNECTOR (06S-06S)	
4.	159-744	1	TEE (08S-060-040, .060 ORF)	
5.	159-743	1	CONNECTOR (08S-060, ORF)	
6.	154-224	3	CONNECTOR (06S-060 45)	
7.	159-157	5	QDC ADAPTER (02-060FX)	
8.	159-148	-	DUST CAP ( 1 / 8")	
9.	154-348	3	UN BR TEE (060FX-060-060)	
10.	156-174	2	CONNECTOR (06S-060)	
11.	155-130	-	PLUG (06S)	
12.	157-822	1	HOSE (060FX90-30"-3000)	
13.	153-320	1	HOSE (060FX90L-17"-3000)	
14.	514-409	1	UNION (06J-060FX)	
15.	155-705	1	O-RING (906 D90)	
16.	158-600	1	HYD SHUTTLE VALVE	
17.	154-221	1	CONNECTOR (06S-060)	
18.	154-220	1	CONNECTOR (040-06S)	
19.	515-072	1	HOSE (040FX45-16"-3000)	
20.	154-991	1	HOSE (040FX90S-36"-5000)	
21.	159-745	1	TEE (08S-060-060, .060 ORF)	
22.	154-344	2	UN RUN TEE (060FX-060-060)	
23.	153-768	1	HOSE (060FX90S-18"-3000)	
24.	157-823	1	HOSE (060FX90S-26"-3000)	
25.	153-877	1	HOSE (060FX90M-26"-5500)	
26.	117-718	1	ABRASION SLEEVE (1" x 36")	
27.	117-194	1	ABRASION SLEEVE (1.00" x 16")	
28.	154-339	2	CONNECTOR (04N-040)	
29.	258-045	-	GAUGE (4000 PSI)	
30.	514-418	2	ELBOW (04NF-04NF45)	
31.	217-036	-	PRESSURE GAUGE (3000 PSI)	
32.	159-832	1	HYD RELIEF VALVE	
	500-756	-	SEAL REPAIR KIT	
33.	300-4616	1	P.O.R. SUPPORT BRACKET	
34.	106-385	2	FLG LOCKNUT (M6-1.00)	
35.	106-893	2	SCREW (M6-1.00 X 55MM)	
36.	106-382	2	FLANGE LOCK SCREW (M10-1.5 X 20MM)	
37.	105-095	4	WASHER (1/4")	

NOT SHOWN:

FOOTNOTES:

NOTE:

# GROUND DRIVE HYDRAULICS

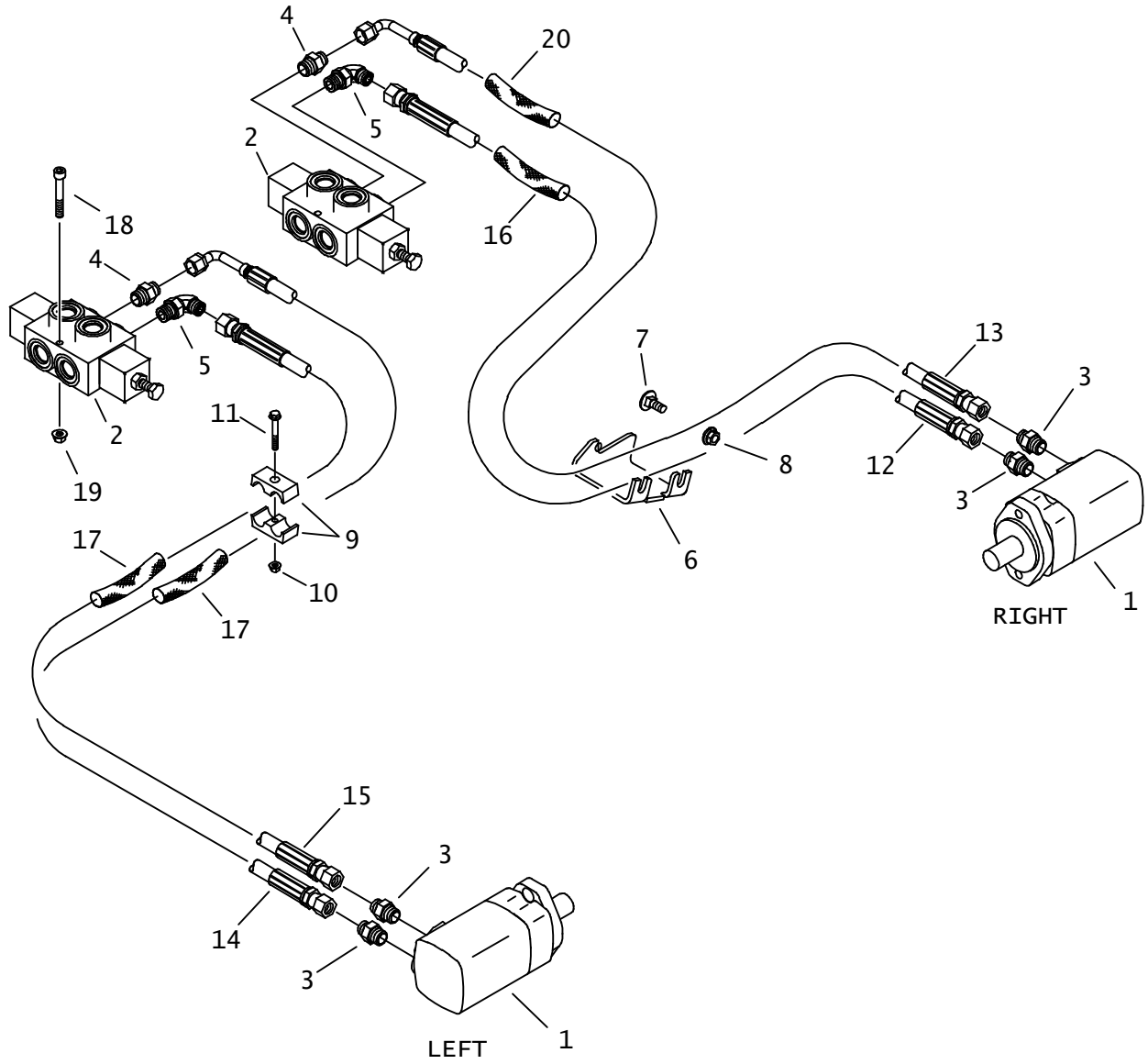

# GROUND DRIVE HYDRAULICS

REF NO.	PART NUMBER	QTY	DESCRIPTION	REMARKS
1.	155-581	-	HYD MOTOR	
	500-658	-	SEAL REPAIR KIT	
2.	159-912	2	HYD CONTROL VALVE	
	191-396	-	SEAL KIT	
	500-1942	-	SEAL WASHER	
3.	154-279	4	CONNECTOR (080-10S)	
4.	154-234	2	CONNECTOR (080-12S)	
5.	154-236	2	CONNECTOR (080-12S90)	
6.	318-411	1	HOSE PROTECTOR	
7.	107-683	2	CARRIAGE BOLT(M12-1.75 X 30MM)	
8.	106-709	2	FLG LK NUT (M12-1.75)	
9.	110-277	1	CLAMP (.875", SOLD AS SET)	
10.	106-561	1	LOCKNUT (M8-1.25,PRV TRQ,10.9)	
11.	107-194	1	FLG SCREW (M8-1.25 X 50MM)	
12.	154-677	1	HOSE (080FX-62"-3000)	
13.	515-194	1	HOSE (080FX90L-64"-3000)	
14.	157-902	1	HOSE (080FX90M-83"-3000)	
15.	157-903	1	HOSE (080FX-80"-3000)	
16.	117-980	1	ABRASION SLEEVE (1.25" X 64")	
17.	117-981	2	ABRASION SLEEVE (1.25" X 82")	
18.	106-725	4	SCREW (M10-1.50 X 65MM, SOC)	
19.	105-894	4	LOCKNUT (M10-1.50,PRV TRQ,10.9)	SEE FOOTNOTE 1
20.	117-391	1	ABRASION SLEEVE (1.25" X 66")	

NOT SHOWN:

FOOTNOTES:

I. TIGHTEN ONLY ENOUGH TO HOLD PARTS IN PLACE, DO NOT OVERTIGHTEN.

NOTE:



# ANCHOR HYDRAULICS

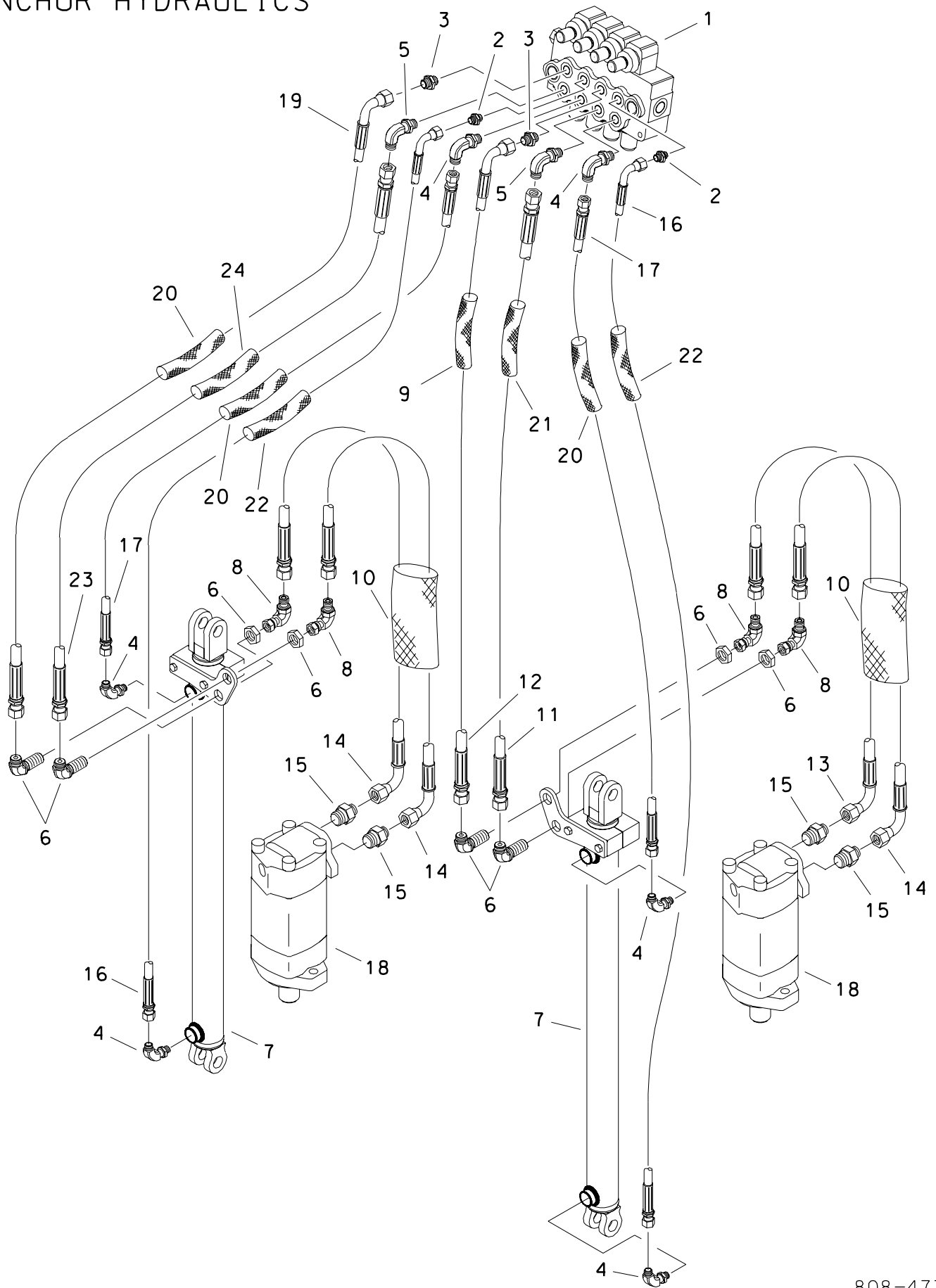

# ANCHOR HYDRAULICS

REF NO.	PART NUMBER	QTY	DESCRIPTION	REMARKS
1.	157-241	-	ANCHOR VALVE	
2.	154-220	2	CONNECTOR (040-06S)	
3.	154-221	2	CONNECTOR (06S-060)	
4.	154-226	6	CONNECTOR (040-06S90)	
5.	154-342	2	CONNECTOR (06S-06090)	
6.	154-229	4	BK CONNECTOR (060-06090BK)	
7.	151-214	-	HYD CYL	
8.	154-228	4	UNION (060-060FX90)	
9.	117-409	1	ABRASION SLEEVE (1.00" X 28")	
10.	117-679	2	ABRASION SLEEVE (1.59" X 32")	
11.	515-711	1	HOSE (060FX-25"-3000)	
12.	149-335	1	HOSE (060FX90M-26"-3000)	
13.	157-822	1	HOSE (060FX90-30"-3000)	
14.	515-707	3	HOSE (060FX90-32"-3000)	
15.	154-369	4	CONNECTOR (060-10S)	
16.	157-910	2	HOSE (040FX90M-53"-3000)	
17.	515-755	2	HOSE (040FX-25"-3000)	
18.	158-700	-	HYD MOTOR	
	500-658	-	SEAL REPAIR KIT	
19.	157-951	1	HOSE (060FX90M-25"-3000)	
20.	117-280	3	ABRASION SLEEVE (1.00" X 25")	
21.	117-684	1	ABRASION SLEEVE (1.00" X 26")	
22.	117-994	2	ABRASION SLEEVE (1.00" X 53")	
23.	157-936	1	HOSE (060FX-22"-3000)	
24.	117-611	1	ABRASION SLEEVE (1.00" X 22")	

FOOTNOTES

# LUBRICATOR HYDRAULICS

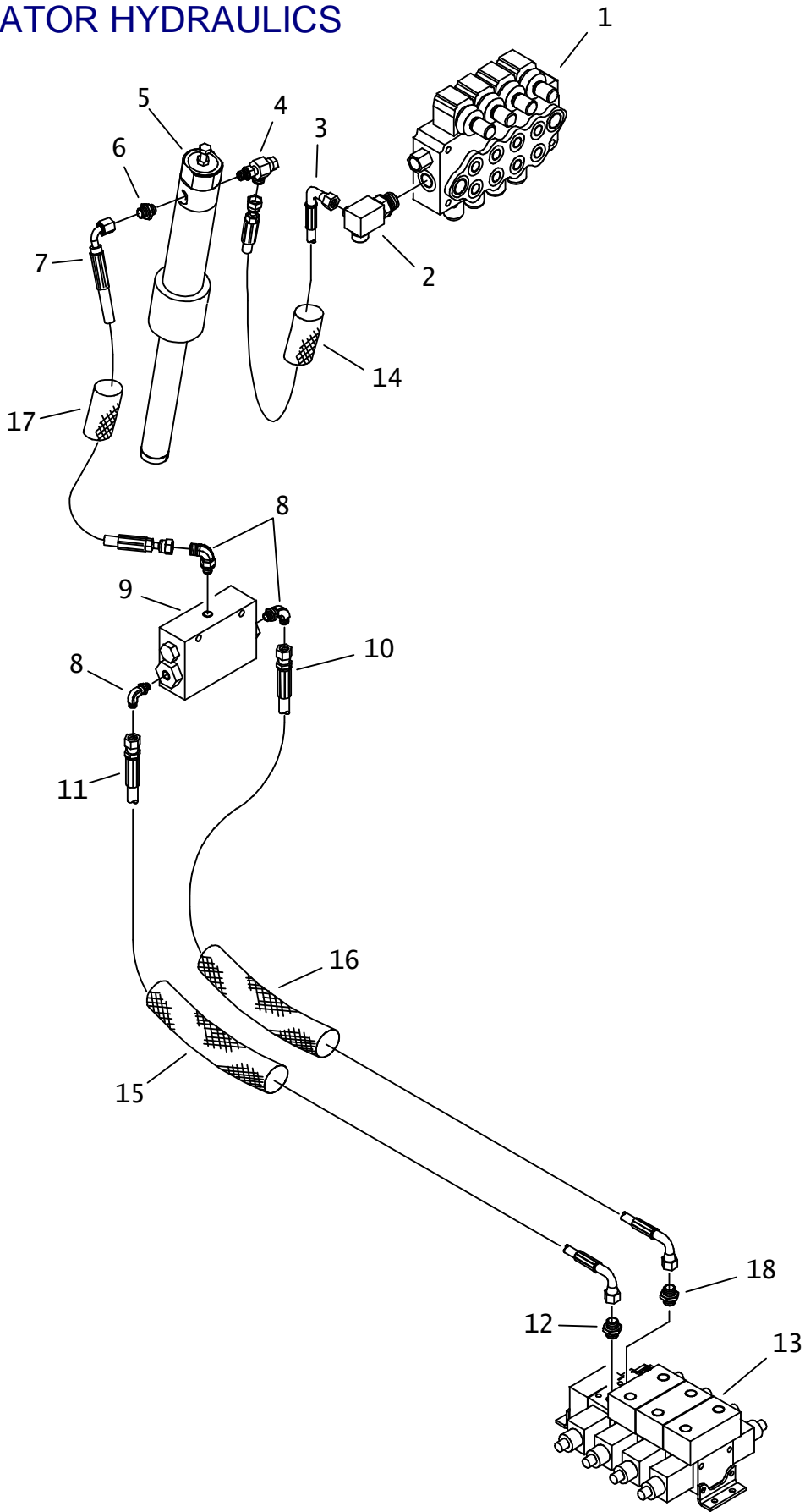

## LUBRICATOR HYDRAULICS

REF NO.	PART NUMBER	QTY	DESCRIPTION	REMARKS
1.	157-241	-	ANCHOR VALVE	
2.	157-433	1	CONNECTOR (10S-060-040)	
3.	515-175	1	HOSE (040FX90-16"-3000)	
4.	159-797	1	CONNECTOR (04S-04090, ORF/CHK)	
5.	350-398	-	GREASE PUMP PARTS	
6.	154-278	1	CONNECTOR (04S-040)	
7.	515-284	1	HOSE (040FX90-24"-3000)	
8.	154-252	3	CONNECTOR (04S-04090)	
9.	310-591	-	VALVE	
10.	515-277	1	HOSE (040FX90S-128"-3000)	
11.	154-916	1	HOSE (040FX90S-120"-3000)	
12.	154-220	1	CONNECTOR (040-06S)	
13.	157-778	-	HYDRAULIC VALVE	
14.	117-194	1	ABRASION SLEEVE (1.00" X 16")	
15.	117-986	1	ABRASION SLEEVE (1.00" X 120")	
16.	117-399	1	ABRASION SLEEVE (1.00" X 130")	
17.	117-989	1	ABRASION SLEEVE (1.00" X 24")	
18.	514-074	1	CONNECTOR (06S-040, ORF)	

NOT SHOWN:

FOOTNOTES:

NOTE:

# AUXILIARY HYDRAULICS

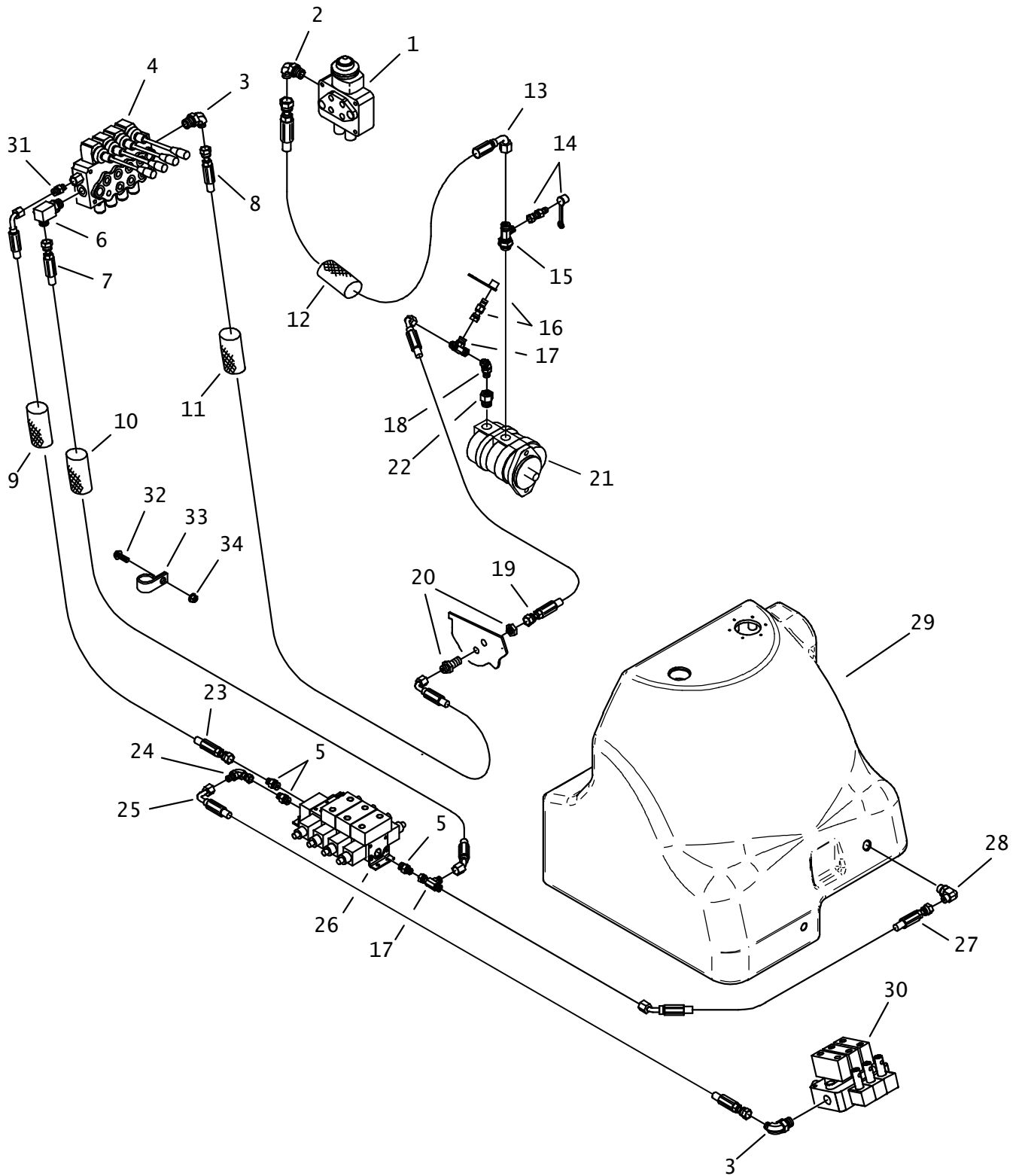

# AUXILIARY HYDRAULICS

REF NO.	PART NUMBER	QTY	DESCRIPTION	REMARKS
1.	153-988	-	VALVE, HYDRAULIC DIRECTIONAL	
2.	154-322	1	CONNECTOR (080-10S90)	
3.	154-421	2	CONNECTOR (060-10S90)	
4.	157-241	-	ANCHOR VALVE	
5.	154-221	3	CONNECTOR (06S-060)	
6.	157-433	-	CONNECTOR (10S-060-040)	
7.	157-964	1	HOSE (060FX45-158"-3000)	
8.	157-965	1	HOSE (060FX90S-154"-3000)	
9.	117-997	1	ABRASION SLEEVE (1.00" X 147")	
10.	117-998	1	ABRASION SLEEVE (1.00" X 158")	
11.	117-999	1	ABRASION SLEEVE (1.00" X 154")	
12.	117-388	1	ABRASION SLEEVE (1.25" X 42")	
13.	515-025	1	HOSE (080FX90-40"-3000)	
14.	159-156	1	QDC ADAPTER (02-040F)	
15.	154-473	1	RUN TEE (10S-080-040)	
16.	159-157	1	QDC ADAPTER (02-060F)	
17.	154-344	2	UN RUN TEE (060FX-060-060)	
18.	154-224	1	CONNECTOR (06S-06045)	
19.	155-486	1	HOSE (060FX90-31"-3000)	
20.	514-163	1	BK CONNECTOR (060-060BK)	
21.	157-860	-	DOUBLE GEAR PUMP	
	500-967		SEAL KIT	
22.	155-171	1	REDUCER (10S-06SF)	
23.	157-963	1	HOSE (060FX90S-146"-3000)	
24.	154-228	1	UNION (060-060FX90)	
25.	157-962	1	HOSE (060FX90M-78"-3000)	
26.	157-778	-	HYDRAULIC VALVE	
	502-102	-	100 PSI DUAL PO CHECK	
27.	159-721	1	HOSE (060FX45-52"-3000)	
28.	154-227	1	CONNECTOR (060-08S90)	
29.	150-2088	1	HYDRAULIC TANK	
30.	157-240	-	SET UP VALVE	
31.	154-222	1	CONNECTOR (060-08S)	
32.	105-271	1	SCREW (M10-1.5 X 40mm)	
33.	110-555	1	CLAMP (1-7/8")	
34.	106-387	1	FLG LOCKNUT (M10-1.50)	

NOT SHOWN:

FOOTNOTES:

NOTE:

# FAN DRIVE HYDRAULICS

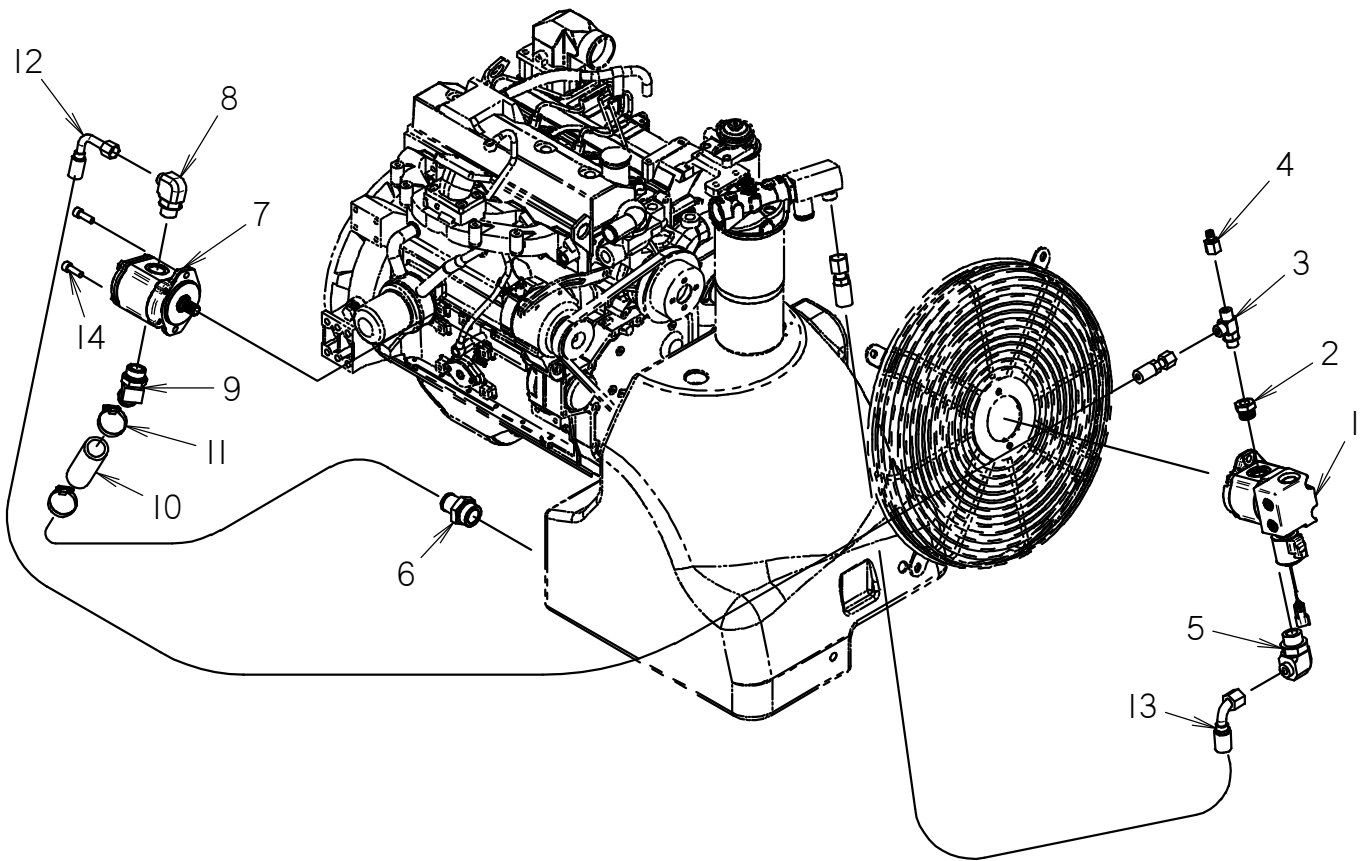

# FAN DRIVE HYDRAULICS

REF NO.	PART NUMBER	QTY	DESCRIPTION	REMARKS
1	150-2077	1	HYDRAULIC GEAR MOTOR	
2	153-770	1	REDUCER (12S-8SF)	
3	154-299	1	RUN TEE (08S-080-080)	
4	159-158	1	QDC ADAPTER (02-080FX)	
5	514-153	1	CONNECTOR (100-16S90)	
6	155-004	1	S/O COUPLER (20S-20H)	
7	150-2078	1	HYDRAULIC GEAR PUMP	
8	154-236	1	CONNECTOR (080-12S90)	
9	115-281	1	SO COUPLER (16S-20H45)	
10	116-587	27	BULK HOSE (1-1/4",SOLD PER FT)	
11	110-133	2	WORM CLAMP(1-1/16"TO 1-15/16")	
12	150-2757	1	HOSE (080FX90L-92"-3000)	
13	116-812	1	HOSE (100FX90S-71"-3000)	
14	106-755	2	SCREW (M10-1.50 X 30MM, SOC)	USE LOCTITE 242 OR EQUIVALENT.

NOT SHOWN:

FOOTNOTES:

NOTE:



# DRILLING FLUID HYDRAULICS

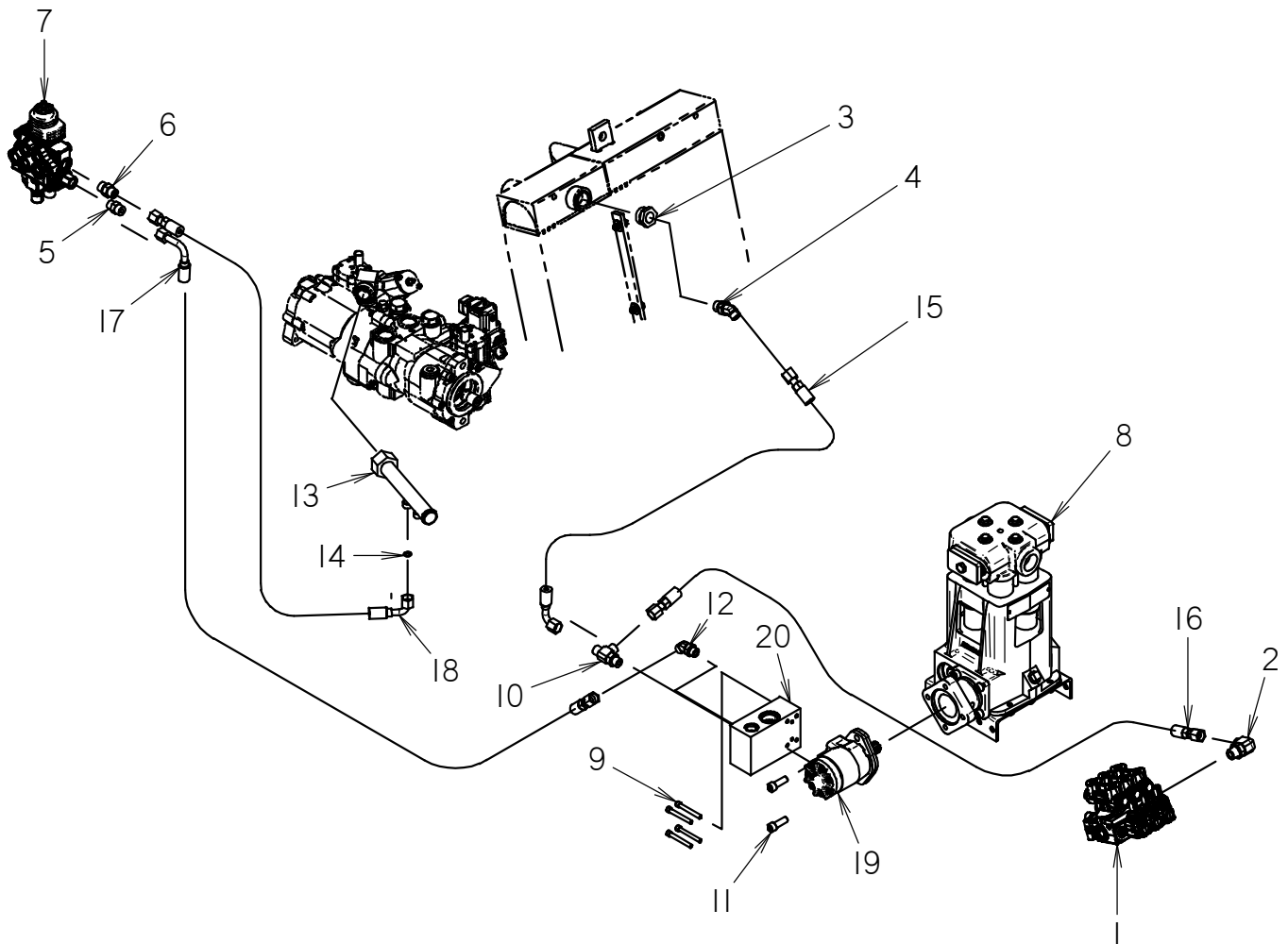

# DRILLING FLUID HYDRAULICS

REF NO.	PART NUMBER	QTY	DESCRIPTION	REMARKS
1	157-240	1	SET UP VALVE	
2	154-322	1	CONNECTOR (080-10S90)	
3	155-199	1	REDUCER (16S-10SF)	
4	154-264	1	CONNECTOR (080-10S45)	
5	154-233	1	CONNECTOR (08S-080)	
6	154-279	1	CONNECTOR (080-10S)	
7	153-988	1	VALVE, HYDRAULIC DIRECTIONAL	
8	157-267	1	DRILLING FLUID PUMP	
9	108-056	4	BOLT (5/16-NC X 2-1/2", SOC)	
10	154-299	1	RUN TEE (08S-080-080)	
11	106-204	2	BOLT (1/2 - NC X 1.50", SOC)	TORQUE TO 100 FT-LBS, USE LOCTITE 242 OR EQUIVALENT
12	154-284	1	CONNECTOR (08S-08045)	
13	150-2205	1	HYD LINE	
14	157-039	1	O-RING (014 D90)	
15	159-824	1	HOSE (080FX90S-38"-3000)	
16	154-720	1	HOSE (080FX-20"-3000)	
17	515-701	1	HOSE (080FX90S-122"-3000)	
18	150-2758	1	HOSE (080FX90S-28"-3000)	
19	157-773	1	HYDRAULIC MOTOR	
20	157-774	1	MANIFOLD	

NOT SHOWN:

FOOTNOTES:

NOTE:

# ROTATING WRENCH HYDRAULICS

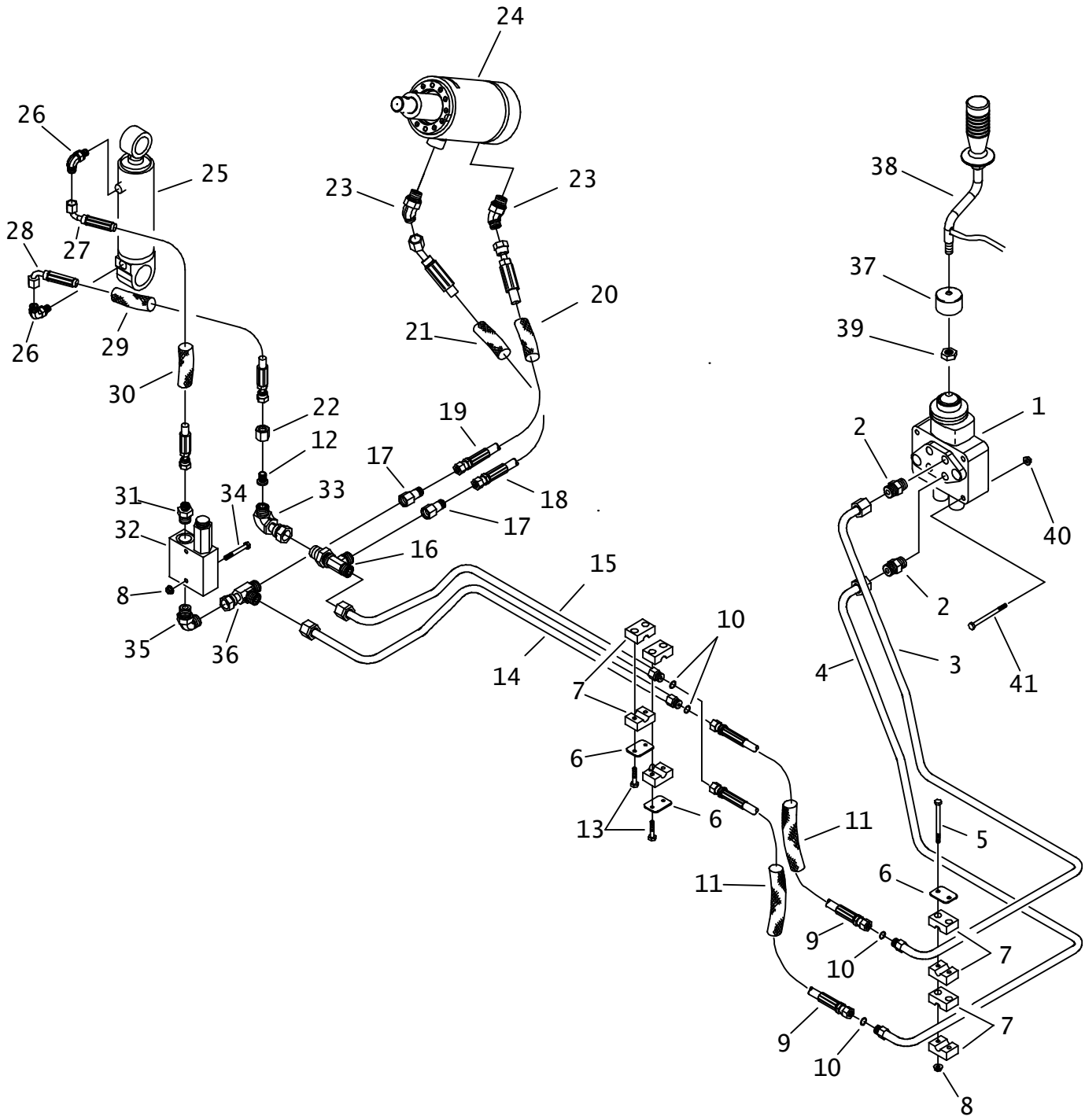

# ROTATING WRENCH HYDRAULICS

REF NO.	PART NUMBER	QTY	DESCRIPTION	REMARKS
1.	153-988	1	VALVE, HYDRAULIC DIRECTIONAL	
2.	154-233	2	CONNECTOR (08S-080)	
3.	150-2221	1	HYD LINE (-08)	
4.	150-2222	1	HYD LINE (-08)	
5.	105-843	2	SCREW (M6-1.00 X 80MM)	
6.	110-958	3	BACKUP PLATE	
7.	110-866	4	CLAMP SET (1/2")	
8.	106-385	4	FLG LOCKNUT (M6-1.00)	
9.	154-807	2	HOSE (060FX-24"-3000)	
10.	157-038	4	O-RING (012 D90)	
11.	117-280	2	ABRASION SLEEVE (1.00" X 25")	
12.	154-248	1	REDUCER STEM (040)	
13.	105-818	4	BOLT (1/4-NC X 1-1/2")	
14.	157-496	1	HYD LINE (-08)	
15.	157-497	1	HYD LINE (-08)	
16.	154-295	1	BK RUN TEE (080-080-080BK)	
17.	154-262	2	REDUCER (060-080F)	
18.	157-937	1	HOSE (060FX45-29"-3000)	
19.	159-846	1	HOSE (060FX-26"-3000)	
20.	117-684	1	ABRASION SLEEVE (1.00" X 26")	
21.	117-409	1	ABRASION SLEEVE (1.00" X 28")	
22.	154-272	1	REDUCER NUT (080F)	
23.	154-225	2	CONNECTOR (060-08S45)	
24.	151-213	-	CYL (4.0" X 2.0" X 2.0")	
25.	151-038	-	CYL (2.0 X 1.0 X 4.0)	
26.	154-252	2	CONNECTOR (04S-04090)	
27.	515-598	1	(040FX90-12"-3000)	
28.	515-599	1	(040FX90-13"-3000)	
29.	117-671	1	ABRASION SLEEVE (1.00" X 12")	
30.	117-278	1	ABRASION SLEEVE (1.00" X 14")	
31.	154-261	1	CONNECTOR (040-08S)	
32.	157-249	1	SEQUENCE VALVE	
33.	154-256	1	UNION (080-080FX90)	
34.	107-025	2	SCREW (M6-1.00 X 50MM)	
35.	154-235	1	CONNECTOR (08S-08090)	
36.	154-266	1	UNION RUN TEE (080FX-080-080)	
37.	111-077	1	VINYL CAP (1.625")	
38.	118-370	1	HANDLE	
39.	107-669	1	JAM NUT (M12-1.75)	
40.	106-386	3	FLG LOCKNUT (M8-1.25)	
41.	106-570	3	SCREW (M8-1.25 X 60MM)	

NOT SHOWN:

FOOTNOTES:

NOTE:

# STATIONARY WRENCH HYDRAULICS

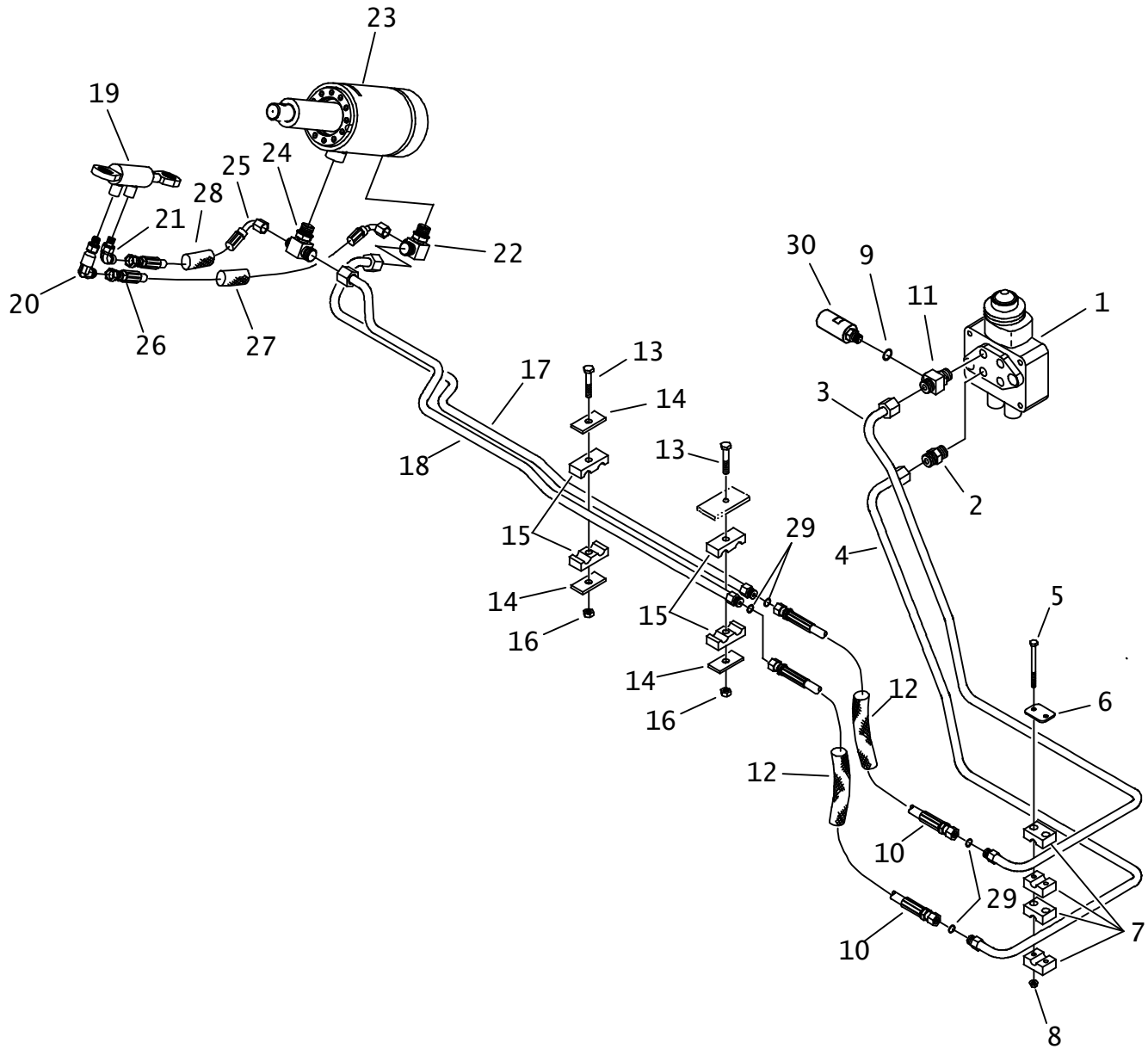

# STATIONARY WRENCH HYDRAULICS

REF NO.	PART NUMBER	QTY	DESCRIPTION	REMARKS
1.	153-988	-	VALVE, HYDRAULIC DIRECTIONAL	
2.	154-233	1	CONNECTOR (08S-080)	
3.	150-2223	1	HYD LINE (-08)	
4.	150-2224	1	HYD LINE (-08)	
5.	105-843	2	SCREW (M6-1.00 X 80MM)	
6.	110-958	1	BACKUP PLATE	
7.	110-866	2	CLAMP SET (1/2")	
8.	106-385	2	FLG LOCKNUT (M6-1.00)	
9.	155-705	1	O-RING (906 D90)	
10.	154-807	2	HOSE (060FX-24"-3000)	
11.	157-932	1	RUN TEE (08S-080-06SF)	
12.	117-280	2	ABRASION SLEEVE (1.00" X 25")	
13.	106-329	2	SCREW (M8-1.25 X 50MM)	
14.	305-256	3	BACKUP SPACER	
15.	110-270	4	BOLT-ON CLAMP (9/16", HALF)	
16.	107-096	2	LOCKNUT (M8-1.25, NLK)	
17.	157-494	1	HYD LINE (-08)	
18.	157-495	1	HYD LINE (-08)	
19.	151-220	-	CYLINDER (1.0 X .50 X .90)	
20.	154-474	1	CONNECTOR (04S-04090, XL)	
21.	154-252	1	CONNECTOR (04S-04090)	
22.	514-160	1	BRANCH TEE (08S-080-040)	
23.	151-213	-	CYL (4.0" X 2.0" X 2.0")	
24.	157-769	1	BRANCH TEE (08S-080-040)	
25.	153-364	1	HOSE (040FX90S-13"-3000)	
26.	154-857	1	HOSE (040FX90-19"-3000)	
27.	117-328	1	ABRASION SLEEVE (1.00" X 18")	
28.	117-671	1	ABRASION SLEEVE (1" X 12")	
29.	157-038	4	O-RING (012 D90)	
30.	215-1204	1	PRESSURE SWITCH (1850PSI)	

NOT SHOWN:

FOOTNOTES:

NOTE:

# PIPE GRIP HYDRAULICS

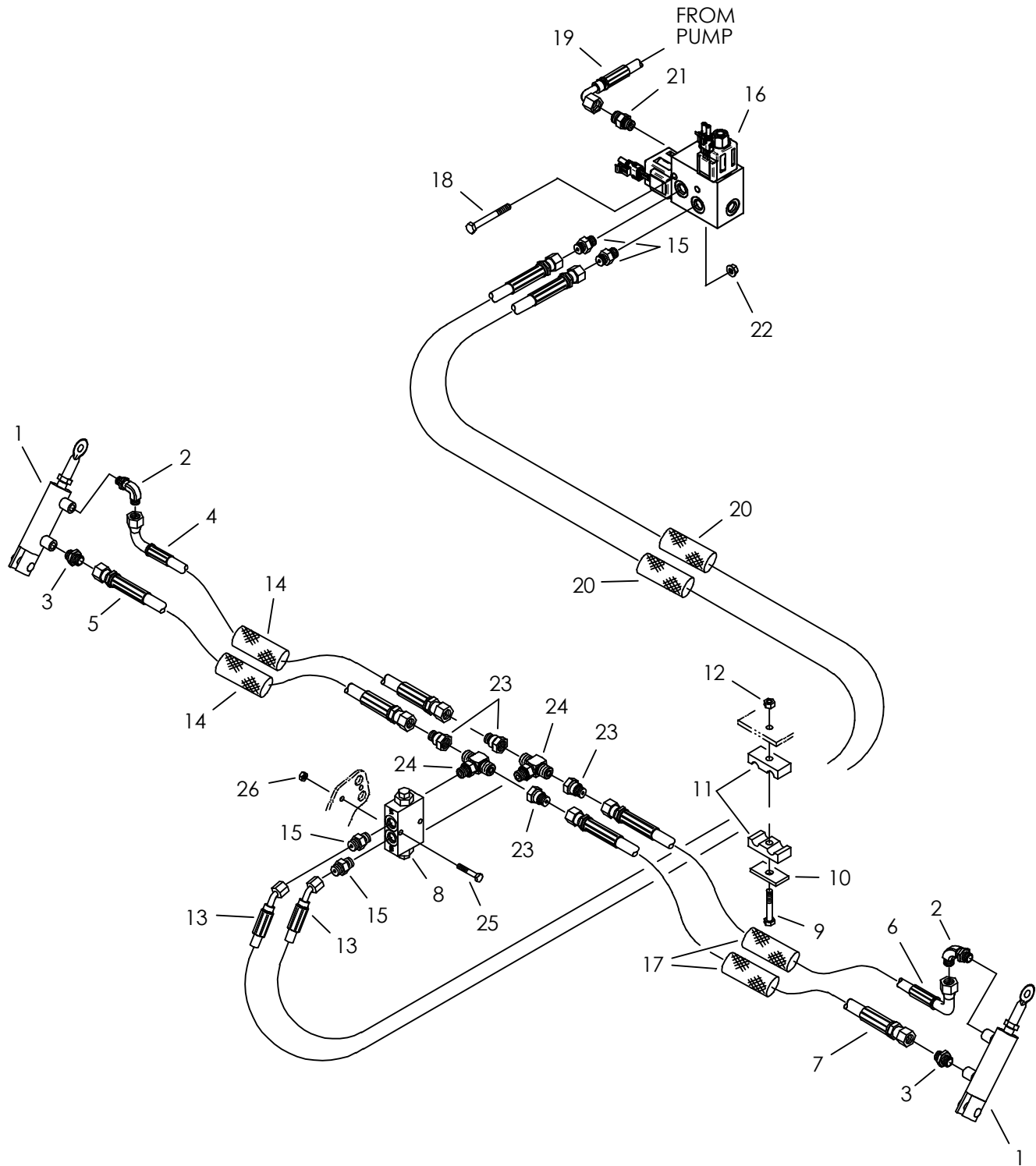

# PIPE GRIP HYDRAULICS

REF NO.	PART NUMBER	QTY	DESCRIPTION	REMARKS
1.	151-150	-	CYL (1.5" X .50" X 2")	
2.	154-252	2	CONNECTOR (04S-04090)	
3.	154-278	2	CONNECTOR (04S-040)	
4.	153-307	1	(040FX90S-38"-3000)	
5.	154-695	1	HOSE (040FX-38"-3000)	
6.	153-365	1	HOSE (040FX90S-34"-3000)	
7.	515-229	1	HOSE (040FX-34"-3000)	
8.	149-136	1	HYD LOCKOUT VALVE	
9.	106-329	1	SCREW (M8-1.25 X 50MM)	
10.	305-256	1	BACKUP SPACER	
11.	110-270	2	BOLT-ON CLAMP (9/16", HALF)	
12.	107-096	1	LOCKNUT (M8-1.25, NLK)	
13.	515-425	2	HOSE (040FX45-42"-3000)	
14.	117-717	2	ABRASION SLEEVE (1.00" X 40")	
15.	154-220	4	CONNECTOR (040-06S)	
16.	157-776	1	MANIFOLD	SEE NOT SHOWN FOR SERVICE PARTS.
17.	117-718	2	ABRASION SLEEVE (1" X 36")	
18.	106-330	2	SCREW (M8-1.25 X 70MM)	
19.	157-823	-	HOSE (060FX90S-26"-3000)	USE ON JT1220
	515-586	-	HOSE (060FX90S-21"-3000)	USE ON JT2020
20.	117-387	2	ABRASION SLEEVE (1.00" X 42")	
21.	154-221	1	CONNECTOR (06S-060)	
22.	106-386	2	FLG LOCKNUT (M8-1.25)	
23.	154-373	4	REDUCER (040-060F)	
24.	154-346	2	BRANCH TEE (06S-060-060)	
25.	105-818	2	BOLT (1/4-NC X 1-1/2")	
26.	105-085	2	LOCKNUT (1/4-NC)	

## NOT SHOWN:

516-089	SOLENOID VALVE WITH NUT	USED ON 4 WAY VALVE
500-1541	SOLENOID VALVE WITH NUT	USED ON 3 WAY VALVE
213-216	SOLENOID COIL WITH DIODE	USED ON 4 WAY VALVE
213-196	SOLENOID COIL WITH DIODE	USED ON 3 WAY VALVE

## FOOTNOTES:

## NOTE:



# SHUTTLE HYDRAULICS

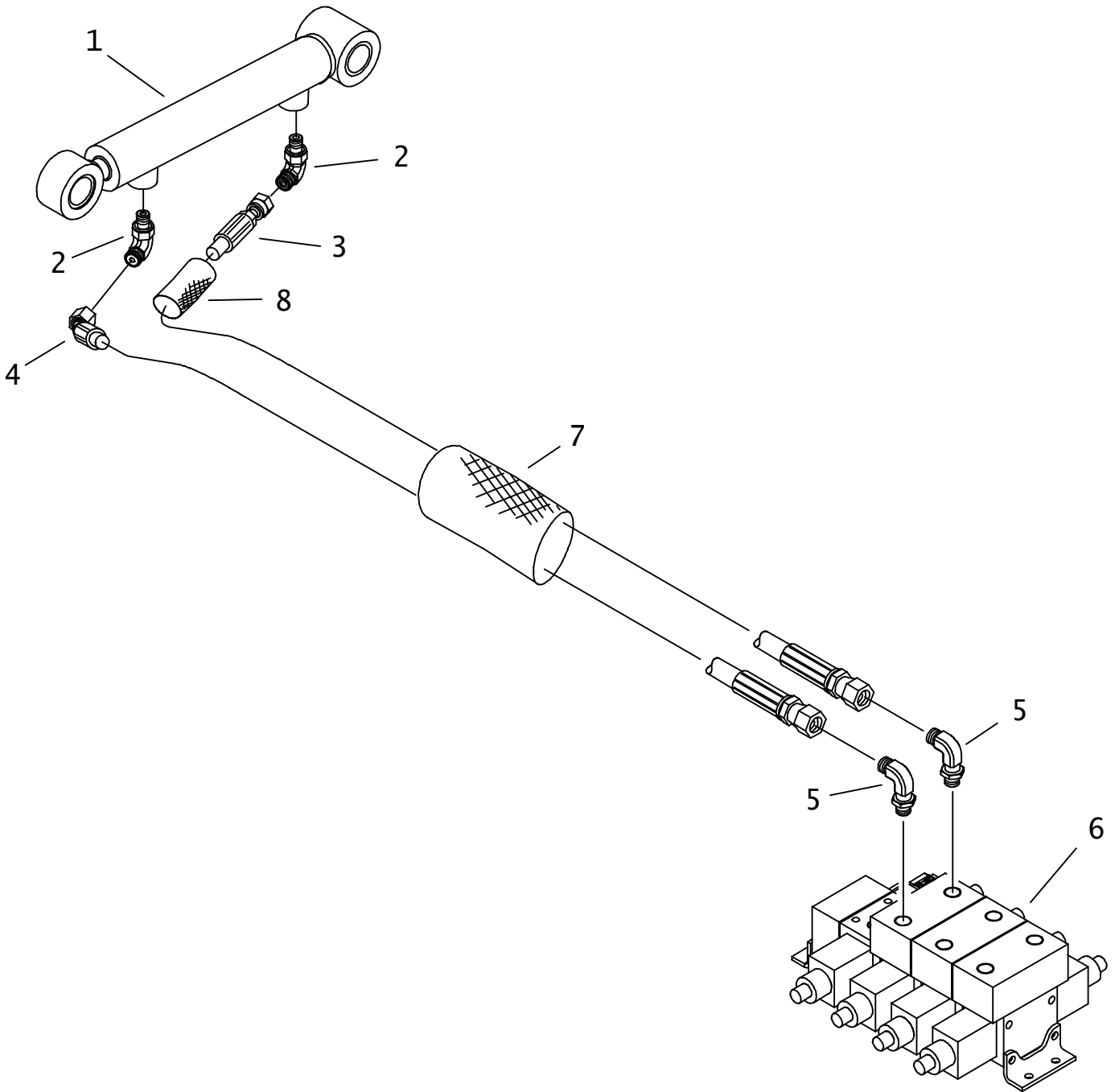

# SHUTTLE HYDRAULICS

REF NO.	PART NUMBER	QTY	DESCRIPTION	REMARKS
1.	151-230	-	CYL (1.25" X .75" X 6")	
2.	154-252	2	CONNECTOR (04S-04090)	
3.	515-054	1	HOSE (040FX-74"-3000)	
4.	515-120	1	HOSE (040FX45-67"-3000)	
5.	154-226	2	CONNECTOR (040-06S90)	
6.	157-778	-	HYDRAULIC VALVE	
7.	117-391	1	ABRASION SLEEVE (1.25" X 66")	
8.	117-670	1	ABRASION SLEEVE (1" X 10")	

NOT SHOWN:

FOOTNOTES:

NOTE:

# PIPE LIFT HYDRAULICS

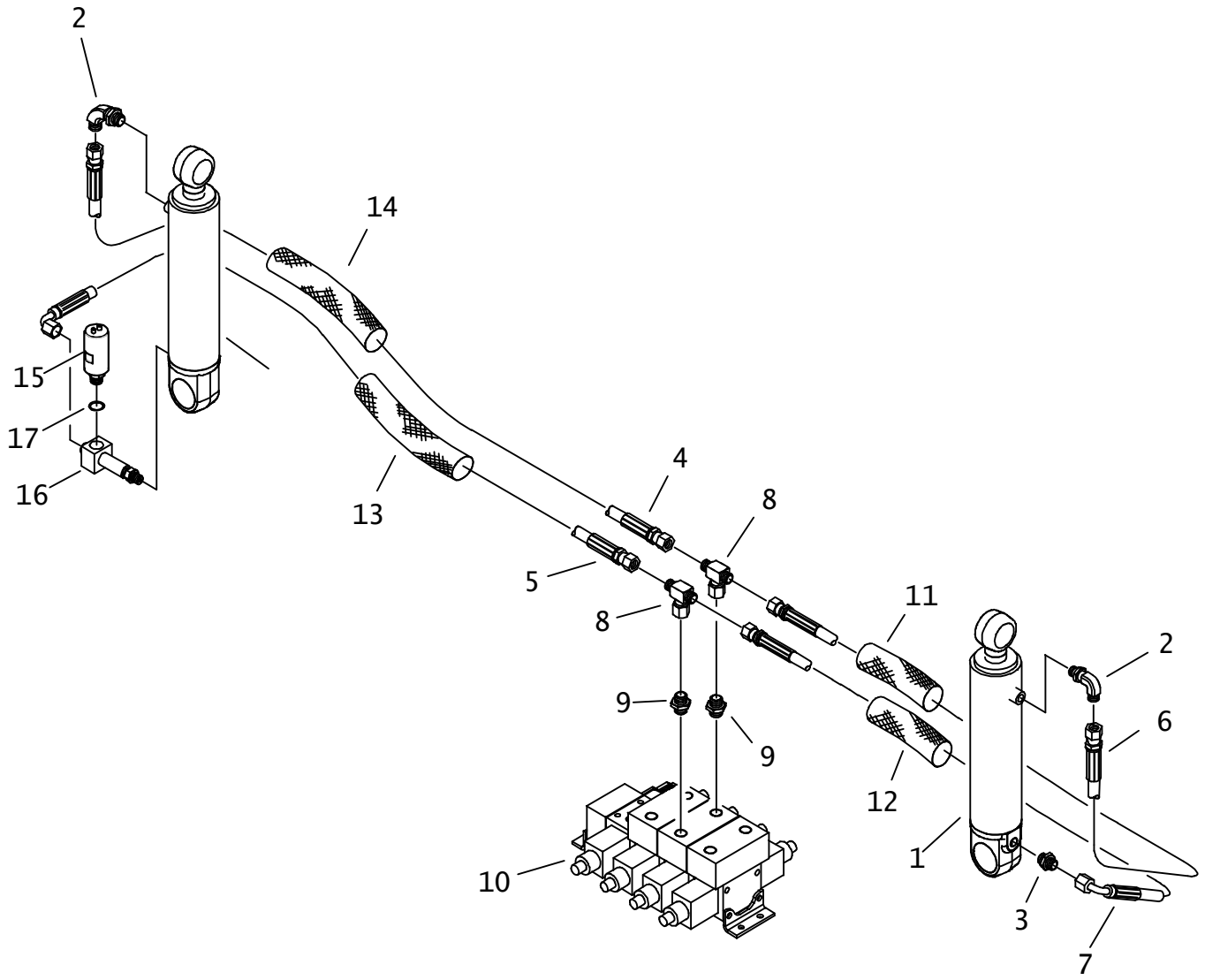

# PIPE LIFT HYDRAULICS

REF NO.	PART NUMBER	QTY	DESCRIPTION	REMARKS
1.	151-044	-	CYL (2.0 X 1.0 X 6.0)	
2.	154-252	2	CONNECTOR (04S-04090)	
3.	154-278	1	CONNECTOR (04S-040)	
4.	157-918	1	HOSE (040FX-88"-3000)	
5.	157-911	1	HOSE (040FX90S-85"-3000)	
6.	154-695	1	HOSE (040FX-38"-3000)	
7.	515-011	1	HOSE (040FX90-32"-3000)	
8.	154-379	2	UN BR TEE (040FX-040-040)	
9.	154-220	2	CONNECTOR (040-06S)	
10.	157-778	-	HYDRAULIC VALVE	
11.	117-717	1	ABRASION SLEEVE (1.00" X 40")	
12.	117-412	1	ABRASION SLEEVE (1.00" X 34")	
13.	117-398	1	ABRASION SLEEVE (1.00" X 86")	
14.	117-209	1	ABRASION SLEEVE (1.00" X 90")	
15.	215-1204	1	PRESSURE SWITCH (1850PSI)	
16.	157-933	1	RUN TEE (04S-040-06SF)	
17.	155-705	1	O-RING (906 D90)	

NOT SHOWN:

FOOTNOTES:

NOTE:

# PIPE BOX SHIFT HYDRAULICS

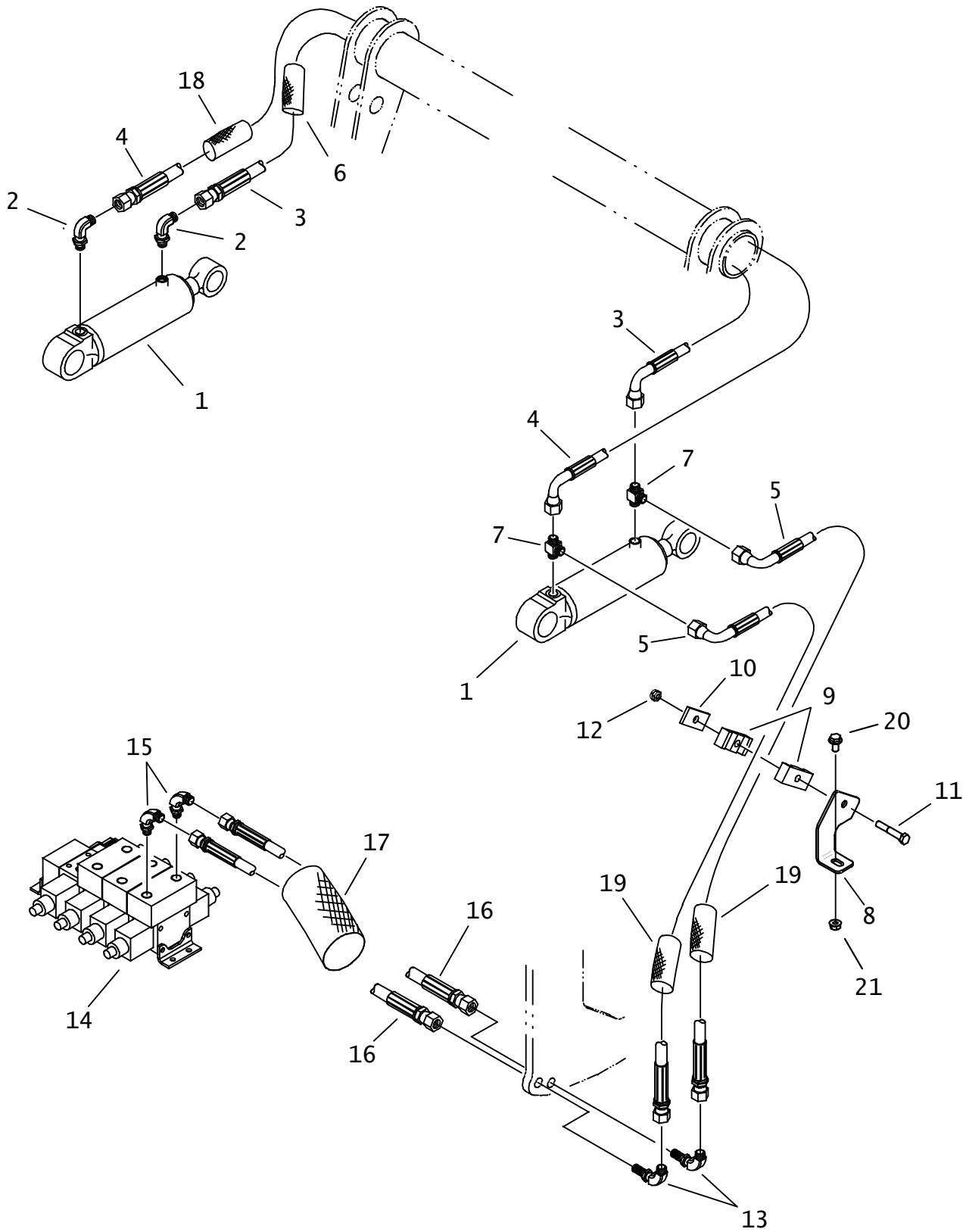

## PIPE BOX SHIFT HYDRAULICS

REF NO.	PART NUMBER	QTY	DESCRIPTION	REMARKS
1.	151-038	-	CYL (2.0 X 1.0 X 4.0)	
2.	154-252	2	CONNECTOR (04S-04090)	
3.	515-471	1	HOSE (040FX90-147"-3000)	
4.	153-283	1	HOSE (040FX90S-157"-3000)	
5.	515-447	2	HOSE (040FX90S-48"-3000)	
6.	117-997	1	ABRASION SLEEVE (1.00" X 147")	
7.	154-316	2	RUN TEE (04S-040-040)	
8.	327-670	1	CLAMP BRACKET	
	319-520	-	CLAMP BRACKET	NOT SHOWN. BRACKET ON CYLINDER SIDE OF HOSES
9.	110-270	2	BOLT-ON CLAMP (9/16", HALF)	
10.	305-256	1	BACKUP SPACER	
11.	106-329	1	SCREW (M8-1.25 X 50MM)	
12.	107-096	1	LOCKNUT (M8-1.25, NLK)	
13.	154-355	2	BK CONNECTOR (040-04090BK)	
14.	157-778	-	HYDRAULIC VALVE	
15.	154-226	2	CONNECTOR (040-06S90)	
16.	515-013	2	HOSE (040FX-42"-3000)	
17.	117-388	1	ABRASION SLEEVE (1.25" X 42")	
18.	117-998	1	ABRASION SLEEVE (1.00" X 158")	
19.	117-416	2	ABRASION SLEEVE (1.00" X 50")	
20.	106-380	1	FLG LK SCREW (M8-1.25 X 16MM)	
21.	106-386	1	FLG LOCKNUT (M8-1.25)	

FOOTNOTES

NOTE:

# FRAME TILT HYDRAULICS

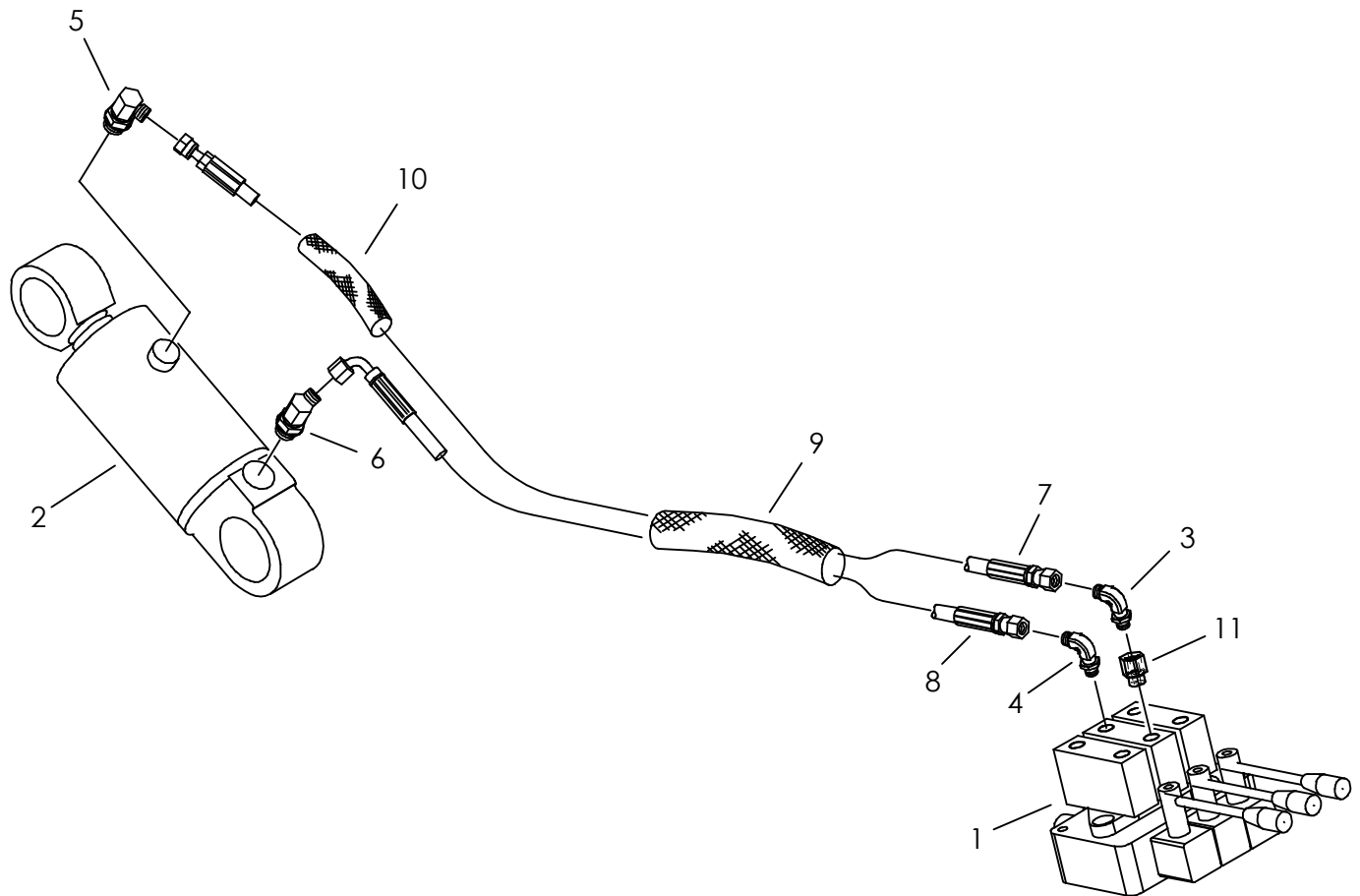

# FRAME TILT HYDRAULICS

REF NO.	PART NUMBER	QTY	DESCRIPTION	REMARKS
1.	157-240	-	SET UP VALVE	
2.	151-089	-	CYL (3.5 X 1.75 X 3.0)	
3.	154-364	1	CONNECTOR (040-06S90,ORF)	
4.	154-226	1	CONNECTOR (040-06S90)	
5.	154-276	1	CONNECTOR (040-08S90)	
6.	154-223	1	CONNECTOR (040-08S45)	
7.	154-725	1	HOSE (040FX-90"-3000)	
8.	515-075	1	HOSE (040FX90S-82"-3000)	
9.	117-556	1	ABRASION SLEEVE (1.25" X 80")	
10.	117-982	1	ABRASION SLEEVE (1" X 6")	
11.	159-931	1	CONNECTOR (06S-06SF)	

NOT SHOWN:

FOOTNOTES:

NOTE:



# STABILIZER HYDRAULICS

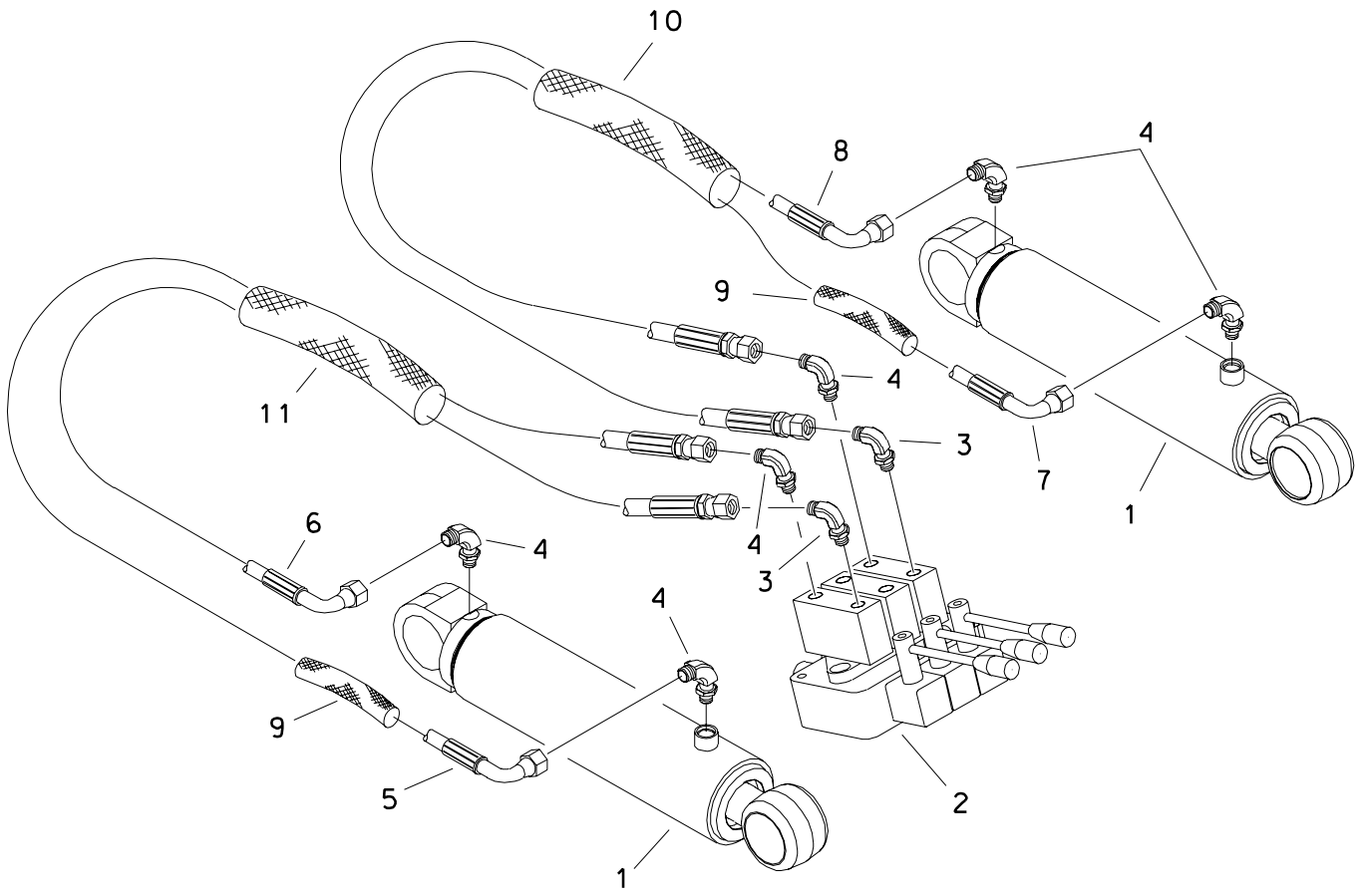

# STABILIZER HYDRAULICS

REF NO.	PART NUMBER	QTY	DESCRIPTION	REMARKS
1.	151-029	-	CYL (3.0 X 1.50 X 10.0)	
2.	157-240	-	SET UP VALVE	
3.	154-364	2	CONNECTOR (040-06S90,ORF)	
4.	154-226	6	CONNECTOR (040-06S90)	
5.	515-190	1	HOSE (040FX90S-88"-3000)	
6.	515-074	1	HOSE (040FX90S-77"-3000)	
7.	515-447	1	HOSE (040FX90S-48"-3000)	
8.	154-728	1	HOSE (040FX90S-36"-3000)	
9.	117-608	2	ABRASION SLEEVE (1.00" X 15")	
10.	117-323	1	ABRASION SLEEVE (1.25" X 37")	
11.	117-244	1	ABRASION SLEEVE (1.25" X 78")	

FOOTNOTES

# HYDRAULIC VALVE PARTS

157-778

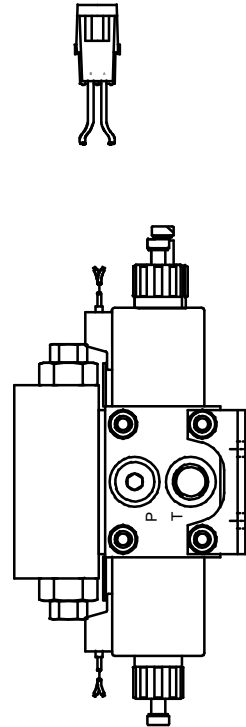
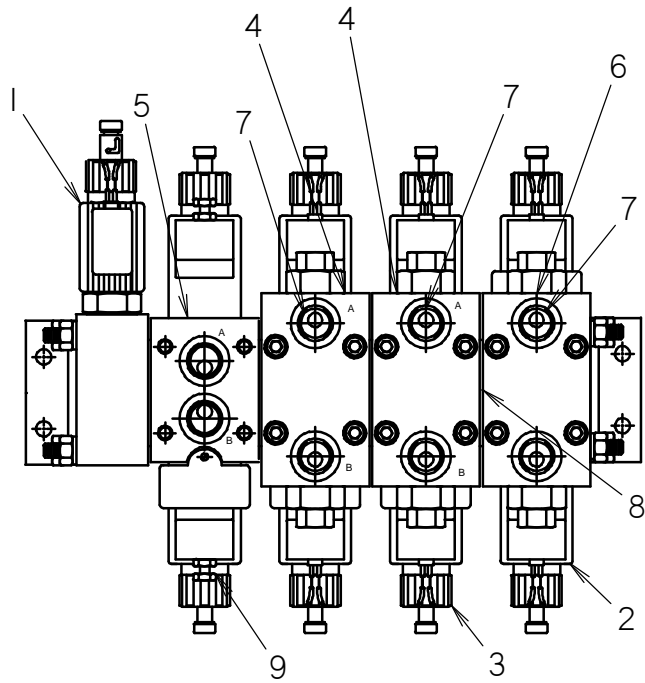

# HYDRAULIC VALVE PARTS

## 157-778

REF NO.	PART NUMBER	QTY	DESCRIPTION	REMARKS
1.	500-1034	1	UNLOADING INLET SUB ASSEMBLY	500-2112 - Cartridge only
2.	217-948	8	COIL, 12VDC	
3.	149-616	8	CAP NUT	
4.	500-1036	2	BV06 CONTROL VALVE SECTION	
5.	500-1037	1	BV06 CONTROL VALVE SECTION	
6.	500-1038	1	BV06 CONTROL VALVE SECTION	
7.	502-102	3	100 PSI DUAL PO CHECK	
8.	190-997	3	STACKING KIT	
9.	500-2004	4	BV06 CORE TUBE	

NOT SHOWN:

FOOTNOTES:

NOTE:

# HYDRAULIC CYLINDERS (2.0" X 1.0")

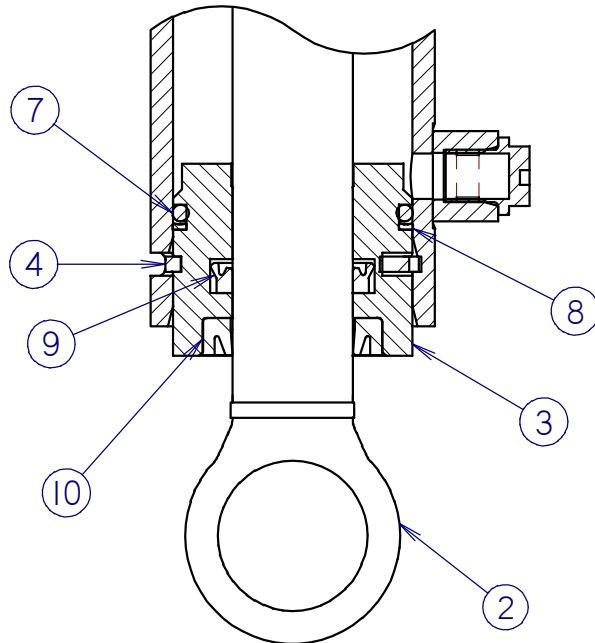
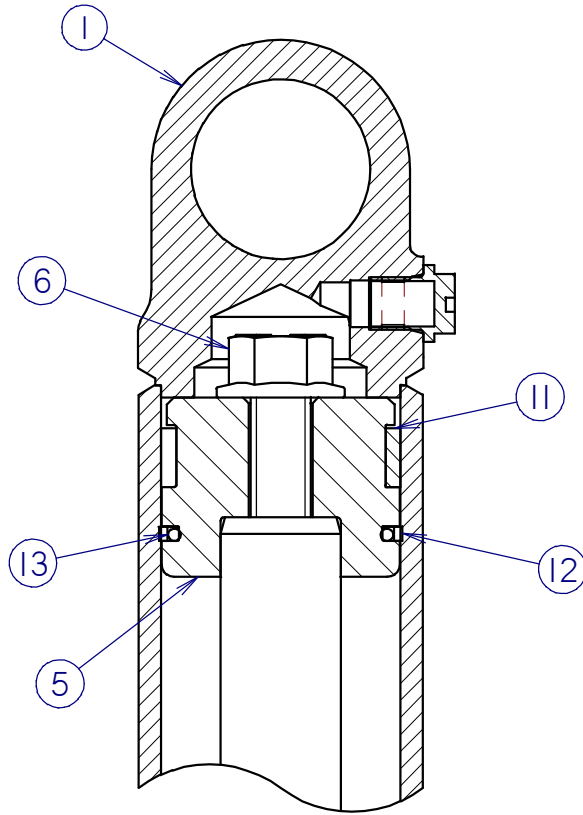

## HYDRAULIC CYLINDERS (2.0" X 1.0")

REF NO.	PART NUMBER	QTY	DESCRIPTION	REMARKS
	151-094	-	CYL (2.0 X 1.0 X 2.0)	SEE FOOTNOTES 1 & 2
1	152-029	1	CYLINDER BARREL (2.0 X 2.0)	
2	153-007	1	CYLINDER ROD (1.00 X 2.0)	
	149-667	-	CYL (2.0 X 1.0 X 2.5)	SEE FOOTNOTES 1 & 2
1	149-761	1	CYLINDER BARREL (2.0 X 2.5)	
2	149-728	1	CYLINDER ROD (1.00 X 2.5)	
	151-027	-	CYL (2.0 X 1.0 X 3.0)	SEE FOOTNOTES 1 & 2
1	150-282	1	CYLINDER BARREL (2.0 X 3.0)	
2	150-414	1	CYLINDER ROD (1.00 X 3.0)	
	151-038	-	CYL (2.0 X 1.0 X 4.0)	SEE FOOTNOTES 1 & 2
1	150-290	1	CYLINDER BARREL (2.0 X 4.0)	
2	150-421	1	CYLINDER ROD (1.00 X 4.0)	
	151-039	-	CYL (2.0 X 1.0 X 5.0)	SEE FOOTNOTES 1 & 2
1	150-291	1	CYLINDER BARREL (2.0 X 5.0)	
2	150-422	1	CYLINDER ROD (1.00 X 5.0)	
	151-044	-	CYL (2.0 X 1.0 X 6.0)	SEE FOOTNOTES 1 & 2
1	150-294	1	CYLINDER BARREL (2.0 X 6.0)	
2	150-424	1	CYLINDER ROD (1.00 X 6.0)	
	151-031	-	CYL (2.0 X 1.0 X 8.0)	SEE FOOTNOTES 1 & 2
1	150-285	1	CYLINDER BARREL (2.0 X 8.0)	
2	150-417	1	CYLINDER ROD (1.00 X 8.0)	
	151-076	-	CYL (2.0 X 1.0 X 10.0)	SEE FOOTNOTES 1 & 2
1	152-017	1	CYLINDER BARREL (2.0 X 10.0)	
2	150-444	1	CYLINDER ROD (1.00 X 10.0)	
	149-668	-	CYL (2.0 X 1.0 X 12.0)	SEE FOOTNOTES 1 & 2
1	150-286	1	CYLINDER BARREL (2.0 X 12.0)	
2	149-729	1	CYLINDER ROD (1.00 X 12.0)	
3	150-772	1	CYLINDER HEAD (2.0 X 1.00)	
4	150-778	1	LOCK RING (2.0)	
5	150-775	1	CYLINDER PISTON (2.0 X 1.00)	
6	106-096	1	FLG BOLT (1/2-NC X 1-3/4"GD8)	SEE FOOTNOTE 3
7	157-022	1	O-RING (224 D90)	
8	155-732	1	BACKUP RING (224 D90)	
9	157-540	1	U-SEAL (1.000")	
10	157-537	1	WIPER SEAL (1.000")	
11	125-774	1	WEAR RING	
12	157-534	1	BACKUP RING (131 D90)	
13	157-018	1	O-RING (131 D90)	

**NOT SHOWN:**

259-100	U-SEAL INSTALLER (1" - 1.499")
259-235	1.00 ROD WIPER TOOL
259-239	WIPER/SEAL INSTALLER (2")
259-241	PISTON INSTALLER (2")
259-188	CYL HEAD SPANNER - TWO PIN

**FOOTNOTES:**

- REF. #1 & #2 ARE SPECIFIC TO EACH CYLINDER, REF. #3 THRU #13 ARE COMMON FOR ALL THE ABOVE LISTED CYLINDERS
- SEAL REPAIR KIT P/N: 190-165
- APPLY LOCTITE 277 OR EQUIVALENT, TORQUE TO 90-100 FT-LBS

**NOTE:**

# HYDRAULIC CYLINDERS (3.0" X 1.5")

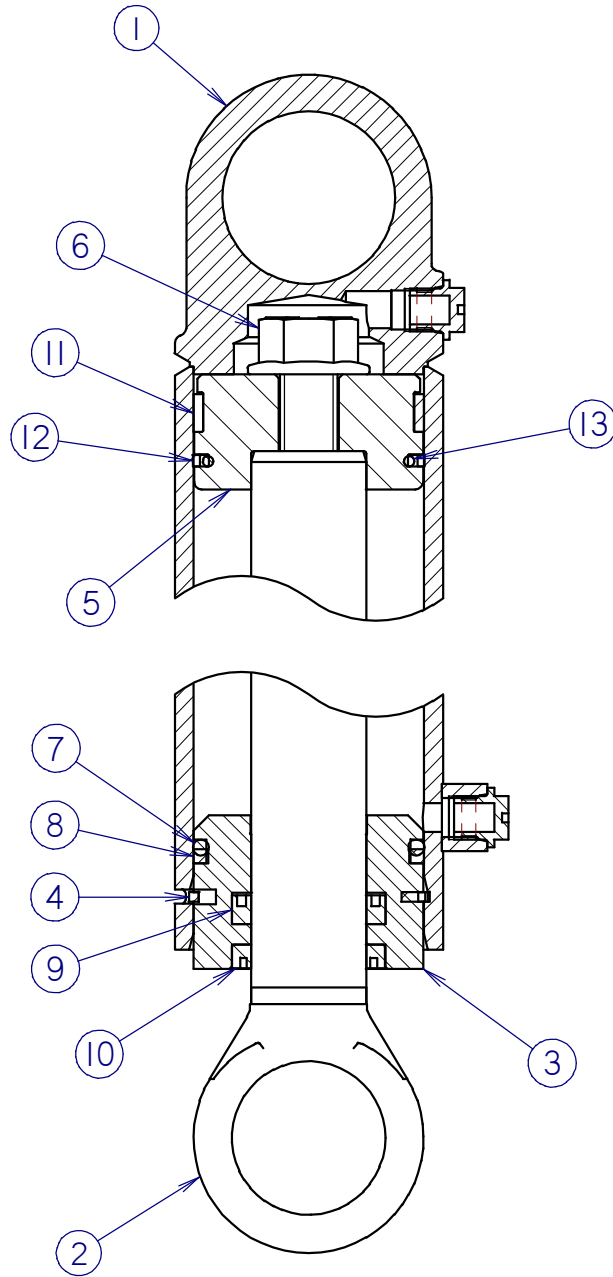

## HYDRAULIC CYLINDERS (3.0" X 1.5")

REF NO.	PART NUMBER	QTY	DESCRIPTION	REMARKS
	149-682	-	CYL (3.0 X 1.5 X 2.5)	SEE FOOTNOTES 1 & 2
1	149-804	1	CYLINDER BARREL (3.0 X 2.5)	
2	149-731	1	CYLINDER ROD (1.50 X 2.5)	
	151-049	-	CYL (3.0 X 1.5 X 3.0)	SEE FOOTNOTES 1 & 2
1	150-299	1	CYLINDER BARREL (3.0 X 3.0)	
2	150-431	1	CYLINDER ROD (1.50 X 3.0)	
	151-054	-	CYL (3.0 X 1.5 X 4.0)	SEE FOOTNOTES 1 & 2
1	152-004	1	CYLINDER BARREL (3.0 X 4.0)	
2	150-434	1	CYLINDER ROD (1.50 X 4.0)	
	151-179	-	CYL (3.0 X 1.5 X 5.0)	SEE FOOTNOTES 1 & 2
1	152-068	1	CYLINDER BARREL (3.0 X 5.0)	
2	153-038	1	CYLINDER ROD (1.50 X 5.0)	
	151-086	-	CYL (3.0 X 1.5 X 6.0)	SEE FOOTNOTES 1 & 2
1	152-008	1	CYLINDER BARREL (3.0 X 6.0)	
2	153-003	1	CYLINDER ROD (1.50 X 6.0)	
	151-136	-	CYL (3.0 X 1.5 X 8.0)	SEE FOOTNOTES 1 & 2
1	152-014	1	CYLINDER BARREL (3.0 X 8.0)	
2	153-027	1	CYLINDER ROD (1.50 X 8.0)	
	151-029	-	CYL (3.0 X 1.5 X 10.0)	SEE FOOTNOTES 1 & 2
1	150-284	1	CYLINDER BARREL (3.0 X 10.0)	
2	150-416	1	CYLINDER ROD (1.50 X 10.0)	
	151-043	-	CYL (3.0 X 1.5 X 12.0)	SEE FOOTNOTES 1 & 2
1	150-293	1	CYLINDER BARREL (3.0 X 12.0)	
2	150-426	1	CYLINDER ROD (1.50 X 12.0)	
	151-034	-	CYL (3.0 X 1.5 X 16.0)	SEE FOOTNOTES 1 & 2
1	150-288	1	CYLINDER BARREL (3.0 X 16.0)	
2	150-419	1	CYLINDER ROD (1.50 X 16.0)	
	151-117	-	CYL (3.0 X 1.5 X 20.0)	SEE FOOTNOTES 1 & 2
1	152-054	1	CYLINDER BARREL (3.0 X 20.0)	
2	150-669	1	CYLINDER ROD (1.50 X 20.0)	
3	150-774	1	CYLINDER HEAD (3.0 X 1.50)	
4	150-911	1	LOCK RING (3.0)	
5	150-777	1	CYLINDER PISTON (3.0 X 1.50)	
6	106-098	1	FLG BOLT (3/4-NC X 2", GD8)	SEE FOOTNOTE 3
7	155-734	1	O-RING (334 D90)	
8	155-733	1	BACKUP RING (334 D90)	
9	157-542	1	U-SEAL (1.500")	
10	157-539	1	WIPER SEAL (1.500")	
11	125-776	1	WEAR RING	
12	157-536	1	BACKUP RING (230 D90)	
13	157-020	1	O-RING (230 D90)	

**NOT SHOWN:**

259-040	U-SEAL INSTALLER (1.5" - UPI)
259-237	ROD WIPER INSTALLER (1.5")
259-065	PISTON SEAL INSTALLER (3")
259-066	PISTON INSTALLER (3")
259-188	CYL HEAD SPANNER - TWO PIN

**FOOTNOTES:**

- REF. #1 & #2 ARE SPECIFIC TO EACH CYLINDER, REF. #3 THRU #13 ARE COMMON FOR ALL THE ABOVE LISTED CYLINDERS.
- SEAL REPAIR KIT P/N: 190-167
- APPLY LOCTITE 277 OR EQUIVALENT, TORQUE TO 290-325 FT-LBS

**NOTE:**



## HYDRAULIC CYLINDERS (3.5" X 1.75")

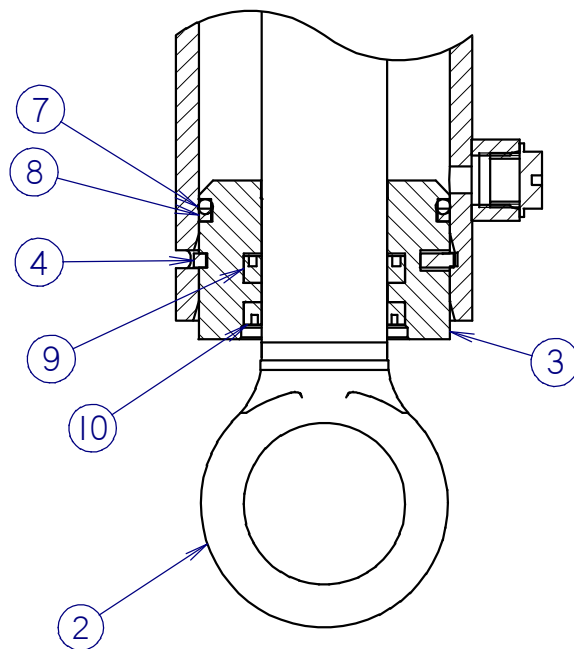
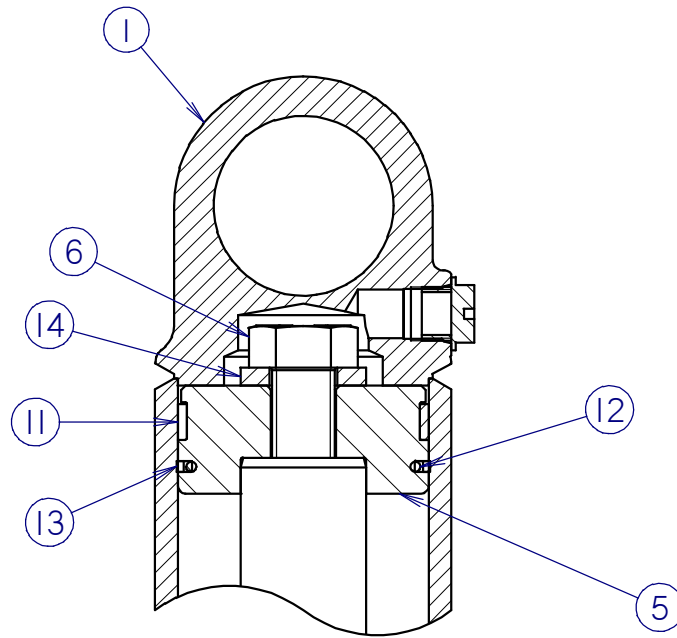

## HYDRAULIC CYLINDERS (3.5" X 1.75")

REF NO.	PART NUMBER	QTY	DESCRIPTION	REMARKS
	151-089	-	CYL (3.5 X 1.75 X 3.0)	SEE FOOTNOTES 1 & 2
1	152-025	1	CYLINDER BARREL (3.5 X 3.0)	
2	150-446	1	CYLINDER ROD (1.75 X 3.0)	
	151-112	-	CYL (3.5 X 1.75 X 4.0)	SEE FOOTNOTES 1 & 2
1	152-037	1	CYLINDER BARREL (3.5 X 4.0)	
2	153-015	1	CYLINDER ROD (1.75 X 4.0)	
	151-050	-	CYL (3.5 X 1.75 X 5.0)	SEE FOOTNOTES 1 & 2
1	150-300	1	CYLINDER BARREL (3.5 X 5.0)	
2	150-432	1	CYLINDER ROD (1.75 X 5.0)	
	151-046	-	CYL (3.5 X 1.75 X 6.0)	SEE FOOTNOTES 1 & 2
1	150-296	1	CYLINDER BARREL (3.5 X 6.0)	
2	150-428	1	CYLINDER ROD (1.75 X 6.0)	
	151-056	-	CYL (3.5 X 1.75 X 8.0)	SEE FOOTNOTES 1 & 2
1	152-006	1	CYLINDER BARREL (3.5 X 8.0)	
2	150-436	1	CYLINDER ROD (1.75 X 8.0)	
	149-689	-	CYL (3.5 X 1.75 X 10.0)	SEE FOOTNOTES 1 & 2
1	152-040	1	CYLINDER BARREL (3.5 X 10.0)	
2	149-732	1	CYLINDER ROD (1.75 X 10.0)	
	151-069	-	CYL (3.5 X 1.75 X 12.0)	SEE FOOTNOTES 1 & 2
1	150-297	1	CYLINDER BARREL (3.5 X 12.0)	
2	150-425	1	CYLINDER ROD (1.75 X 12.0)	
	149-799	-	CYL (3.5 X 1.75 X 16.0)	SEE FOOTNOTES 1 & 2
1	149-805	1	CYLINDER BARREL (3.5 X 16.0)	
2	153-004	1	CYLINDER ROD (1.75 X 16.0)	
	149-690	-	CYL (3.5 X 1.75 X 20.0)	SEE FOOTNOTES 1 & 2
1	149-765	1	CYLINDER BARREL (3.5 X 20.0)	
2	153-020	1	CYLINDER ROD (1.75 X 20.0)	
	149-691	-	CYL (3.5 X 1.75 X 24.0)	SEE FOOTNOTES 1 & 2
1	149-766	1	CYLINDER BARREL (3.5 X 24.0)	
2	149-733	1	CYLINDER ROD (1.75 X 24.0)	
3	150-761	1	CYLINDER HEAD (3.5 x 1.75)	
4	149-302	1	LOCK RING (3.5)	
5	149-301	1	CYLINDER PISTON (3.5 X 1.75)	
6	106-122	1	BOLT (7/8-NC X 2-1/4", GD8)	SEE FOOTNOTE 3
7	157-030	1	O-RING (338 D90)	
8	157-032	1	BACKUP RING (338 D90)	
9	157-550	1	U-SEAL (1.750")	
10	157-549	1	WIPER SEAL (1.750")	
11	125-784	1	WEAR RING	
12	157-031	1	O-RING (234 D90)	
13	157-554	1	BACKUP RING (234 D90)	
14	105-363	1	WASHER (7/8")	

**NOT SHOWN:**

259-040	U-SEAL INSTALLER (1.5" - UP)
259-238	WIPER INSTALLER (1.75")
259-244	PISTON SEAL INSTALLER (3.5")
259-245	PISTON INSTALLER (3.5")
259-188	CYL HEAD SPANNER - TWO PIN

**FOOTNOTES:**

- REF. #1 & #2 ARE SPECIFIC TO EACH CYLINDER, REF. #3 THRU #14 ARE COMMON FOR ALL THE ABOVE LISTED CYLINDERS.
- SEAL REPAIR KIT P/N: 190-174
- APPLY LOCTITE 277 OR EQUIVALENT, TORQUE TO 410-460 FT-LBS

**NOTE:**

# HYDRAULIC CYLINDER 3.5" X 1.75" X 2.0"

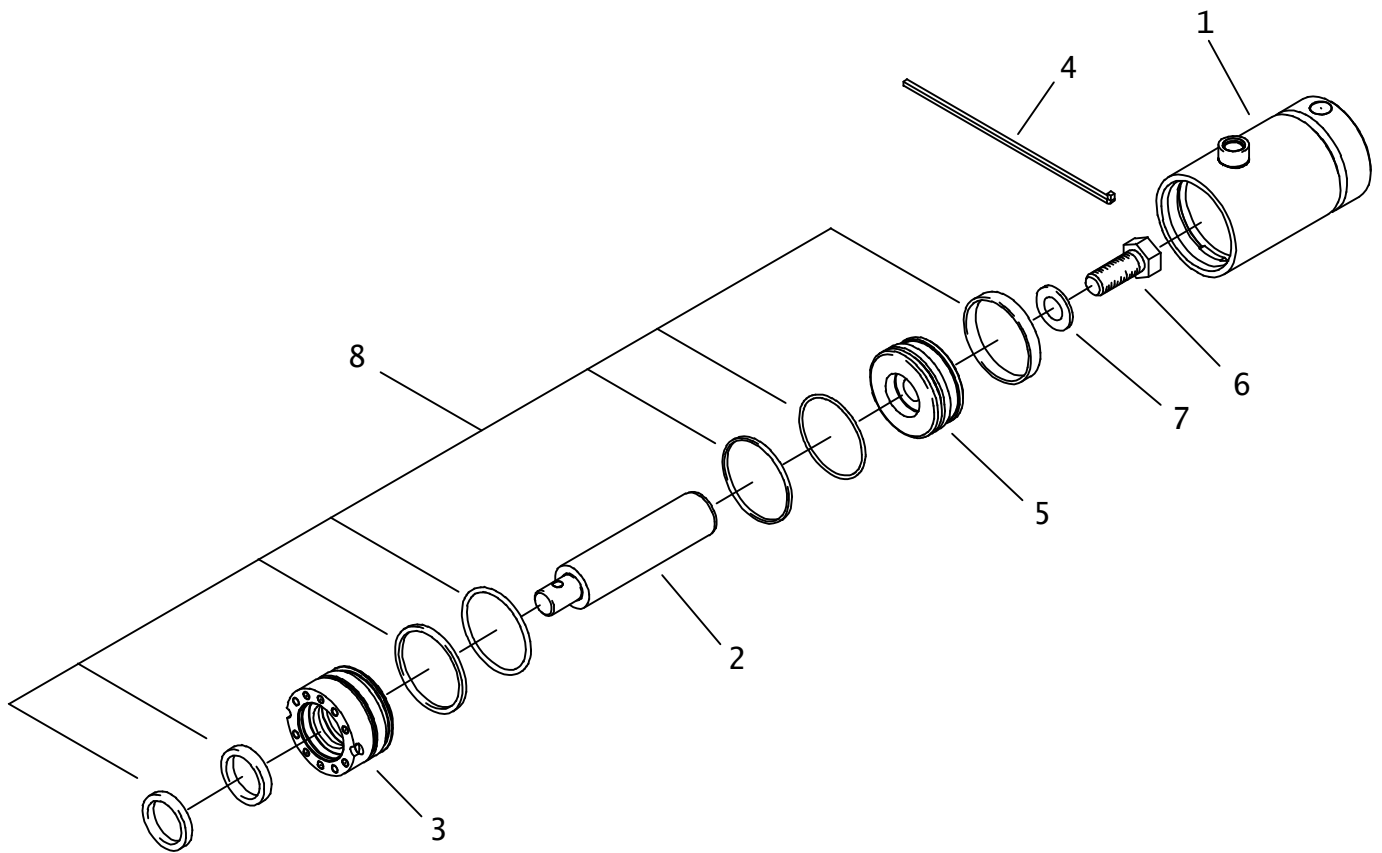

# HYDRAULIC CYLINDER

## 3.5" X 1.75" X 2.0"

REF NO.	PART NUMBER	QTY	DESCRIPTION	REMARKS
	151-213	-	CYL (3.5 X 1.75 X 2.0)	INCL REF NO.'S 1 THRU 15
1.	153-849	1	BARREL	
2.	153-845	1	CYL ROD	
3.	153-846	1	CYLINDER GLAND	
4.	149-302	1	LOCK RING (3.5")	
5.	149-301	1	CYL PISTON (3.5" X 1.75")	
6.	106-122	1	BOLT (7/8-NC X 2-1/4", GD8)	SEE FOOTNOTE 1
7.	105-363	1	WASHER (7/8")	
8.	190-174	1	SEAL REPAIR KIT	

NOT SHOWN:

FOOTNOTES:

- I. LUBRICATE WITH WD-40 OR EQUAL TORQUE TO 410-460 FT LBS (566-624 N.M.)

NOTE:



# **ANCHOR SYSTEMS**

# ANCHOR SYSTEM

BEGINS WITH S/N: CMWJ1220E60000136

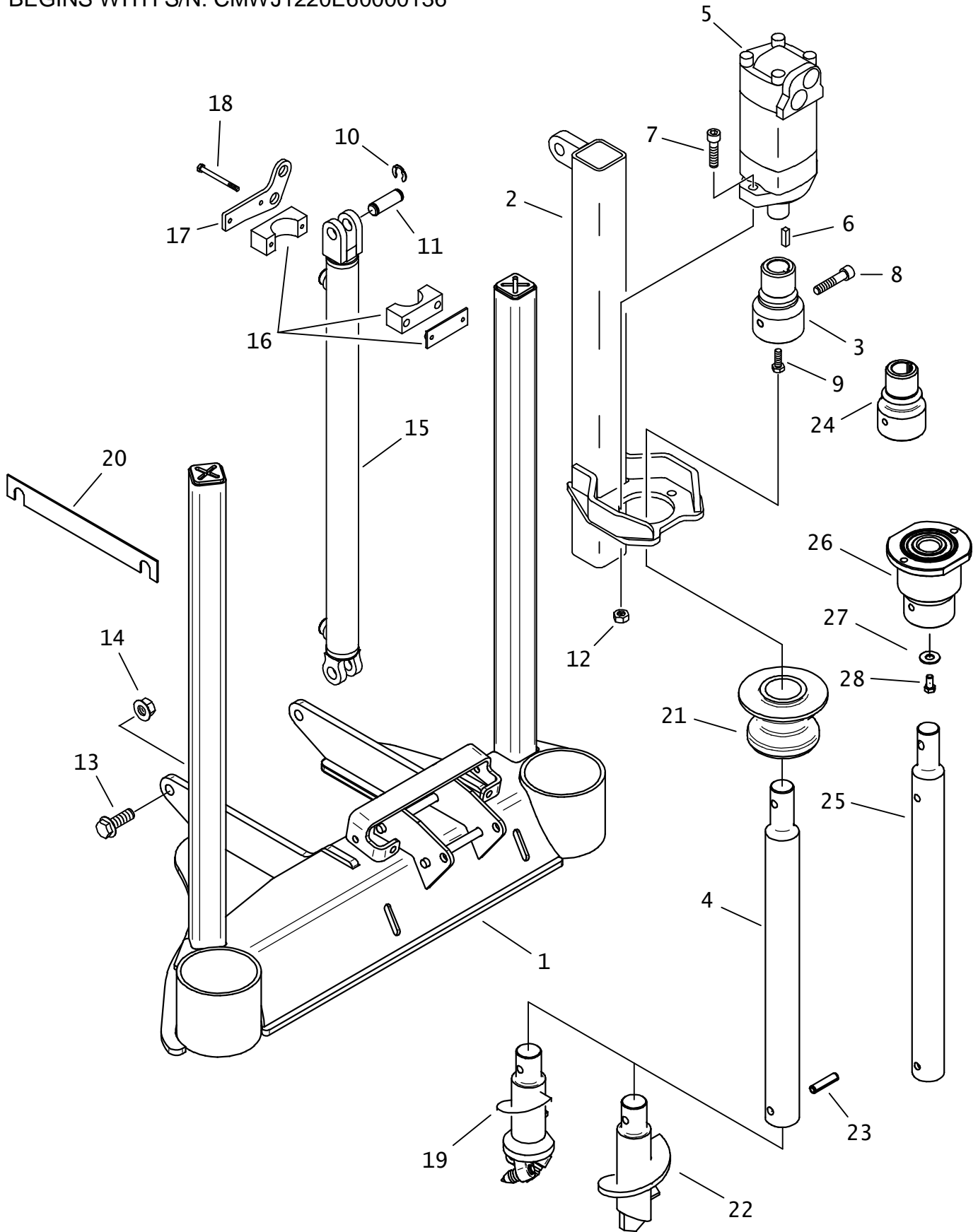

# ANCHOR SYSTEM

BEGINS WITH S/N: CMWJ1220E60000136

REF NO.	PART NUMBER	QTY	DESCRIPTION	REMARKS
1.	300-2951	1	ANCHOR FRAME	
2.	316-767	2	UPPER TUBE	
3.	<u>316-801</u>	2	ANCHOR DRIVER	SUPERSEDED WITH : 327-499; ITEM #24
4.	166-605	2	SHAFT (OLD STYLE)	SUPERSEDED WITH : 166-617; ITEM #25
5.	158-700	2	HYD MOTOR	INCL. REF #6
	500-658	-	SEAL REPAIR KIT	
	166-278	-	SHAFT ASSEMBLY	
6.	165-909	-	KEY (5/16" X 1-1/8")	
7.	106-707	4	SCREW (M12-1.75 X 45MM, SOC)	
8.	106-771	2	SCREW (M12-1.75 X 60MM, SOC)	
9.	105-156	2	BOLT (3/8-NC X 1-1/2")	NOT USED WITH 350-2174
10.	115-503	8	KLIP RING (.750")	
11.	179-736	4	PIN	
12.	106-685	4	LOCKNUT(M12-1.75,PRV TRQ,10.9)	NOT USED WITH 350-2174
13.	107-336	6	FLG SCREW (M16-2.00X45MM,10.9)	
14.	106-355	6	FLG NUT (M16-2.00, 10.9)	
15.	151-214	2	HYD CYL	
	500-1542	-	SEAL KIT	
16.	318-631	2	BOLT-ON CLAMP (1.88")	
17.	318-658	2	BULKHEAD BRACKET	
18.	107-196	4	BOLT (1/4-NC X 3")	
19.	327-457	-	ROCK ANCHOR	
	131-259	-	INSERT BIT - CARBIDE TIPPED	
20.	118-386	AR	SHIM	
21.	158-238	2	CENTERING CAP	
22.	327-460	-	AUGER (4")	
23.	107-331	2	ROLL PIN (M12 X 50MM)	
24.	<u>327-499</u>	2	ANCHOR DRIVER (NEW STYLE)	SUPERSEDED WITH: 350-2174; ITEM #26
25.	166-617	2	ANCHOR SHAFT	
26.	350-2174	2	ANCHOR DRIVE COUPLER	USED WITH 350-2174
27.	105-794	2	WASHER (M12)	USED WITH 350-2174
28.	105-825	2	FLG LK BOLT (3/8-NC X 3/4")	

NOT SHOWN:

FOOTNOTES:

NOTE:



# ANCHOR VALVE/LUBRICATOR MOUNT

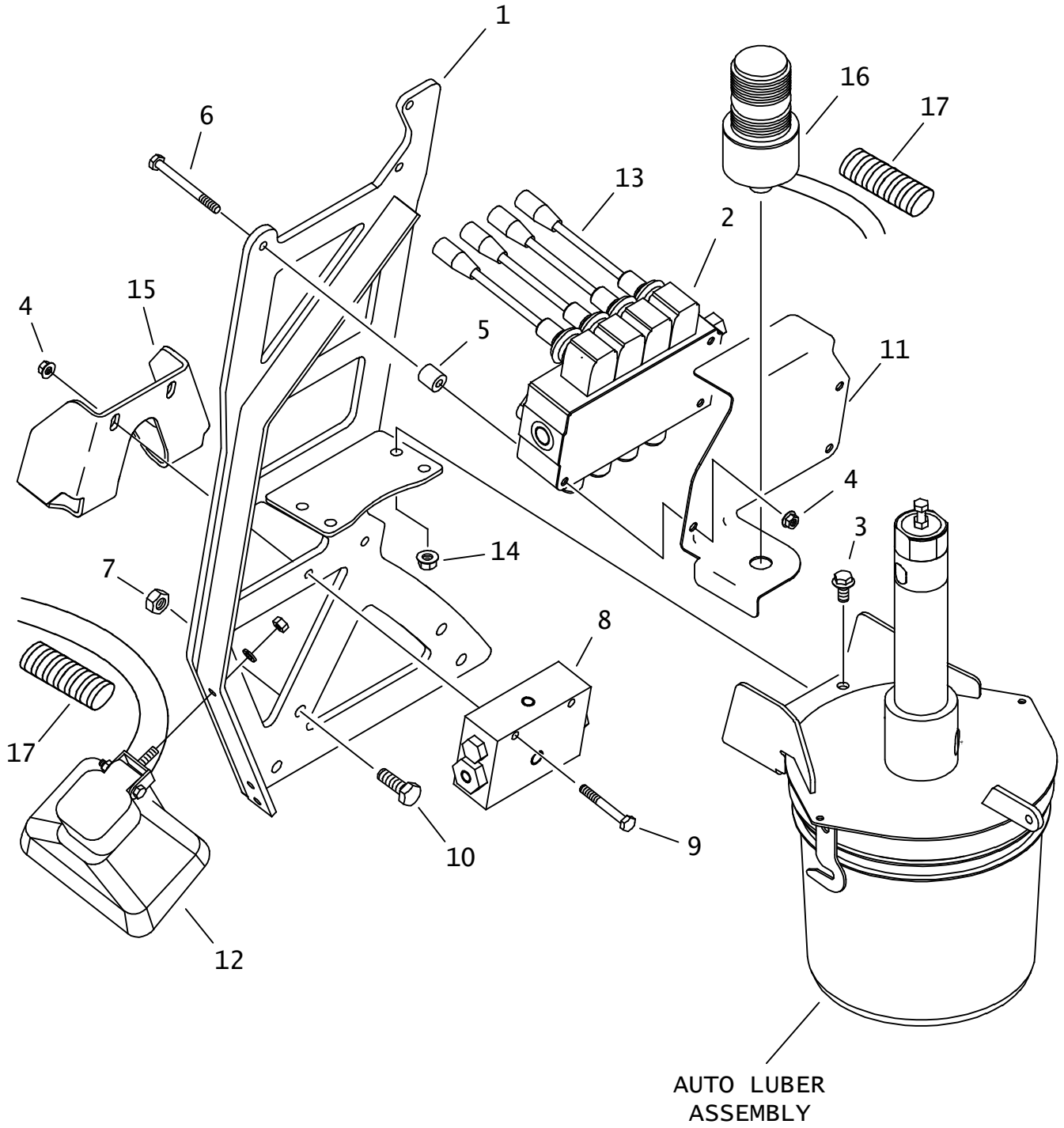

# ANCHOR VALVE/LUBRICATOR MOUNT

REF NO.	PART NUMBER	QTY	DESCRIPTION	REMARKS
1.	316-861	1	MOUNT	
2.	157-241	1	ANCHOR VALVE	
3.	106-382	4	FLG LK SCREW (M10-1.50 X 20MM)	
4.	106-386	5	FLG LOCKNUT (M8-1.25)	
5.	179-501	3	SPACER	
6.	107-078	3	SCREW (M8-1.25 X 90MM)	
7.	106-709	4	FLG LK NUT (M12-1.75)	
8.	310-591	1	VALVE	
9.	106-330	2	SCREW (M8-1.25 X 70MM)	
10.	106-333	4	SCREW (M12-1.75 X 40MM, 8.8)	
11.	319-330	1	LIGHT MOUNT	
12.	217-057	1	WORKING LIGHT - CLEAR	
	157-645	2	WEATHER-PAC SEAL (2.80MM)	
	214-103	1	(2-WAY) MALE CONNECTOR	
	214-104	2	PACKARD MALE TERMINAL	
13.	500-908	4	LEVER (M8-1.25, BLACK)	
14.	106-387	4	FLG LOCKNUT (M10-1.50)	
15.	323-513	1	BRACE	FOR USE ON JT1220
	325-281	1	BRACE	FOR USE ON JT2020
16.	217-297	1	STROBE LIGHT GREEN MED PROFILE	
	214-103	1	(2-WAY) MALE CONNECTOR	
	214-104	2	PACKARD MALE TERMINAL	
	157-645	2	WEATHER-PAC SEAL (2.80MM)	
17.	216-026	AR	FLEX-GUARD (.25")	SOLD PER IN. & USE 2 @ 15" EACH

NOT SHOWN:

FOOTNOTES:

NOTE:

# GREASE PUMP

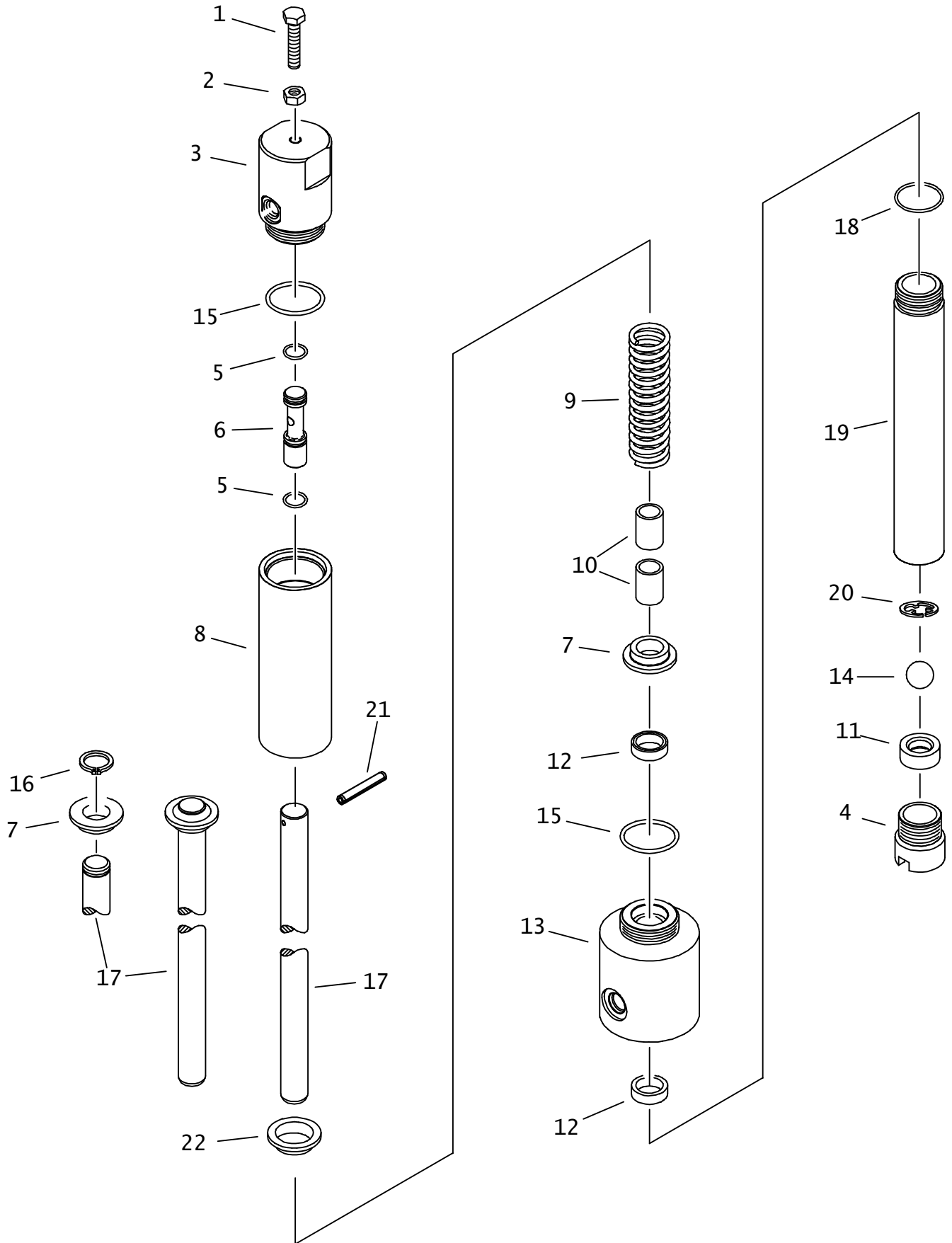

# GREASE PUMP

REF NO.	PART NUMBER	QTY	DESCRIPTION	REMARKS
	350-398		GREASE PUMP PARTS	INCL REF NO'S 1-20
1.	107-492	1	SCREW (M8-1.25 X 35MM,ALL THD)	
2.	106-078	1	NUT (M8-1.25)	
3.	350-686	1	CYLINDER CAP	
4.	350-692	1	INLET TUBE	
5.	157-049	2	O-RING (113 D70)	
6.	350-421	1	ADJUSTING SPOOL	
7.	350-671	1	ROD GUIDE	SEE FOOTNOTE 2
8.	350-682	1	BARREL	
9.	117-228	1	COMPRESSION SPRING	
10.	125-424	2	BRONZE BUSHING (.750")	
11.	350-691	1	VALVE SEAT	SEE FOOTNOTE 1
12.	117-227	2	SEAL (POLY PAK)	
13.	350-687	1	PUMP BODY	
14.	125-125	1	DETENT BALL (.750")	
15.	155-702	2	O-RING (920 D90)	
16.	<u>117-226</u>	-	EXTERNAL SNAP RING (.750")	SEE FOOTNOTE 2
	115-545	-	EXTERNAL SNAP RING (.75")	
17.	<u>350-689</u>	-	PLUNGER	SEE FOOTNOTE 2
	<u>308-603</u>	-	PLUNGER	SEE FOOTNOTE 3
	166-280	1	PLUNGER	
18.	155-748	1	O-RING (916 D90)	
19.	350-693	1	PUMP BARREL	
20.	301-0196	1	RETAINER CLIP	SEE FOOTNOTE 4
21.	105-525	1	ROLL PIN (3/16" X 1/4")	SEE FOOTNOTE 3
22.	178-467	1	ROD CAP	SEE FOOTNOTE 3

NOT SHOWN:

#### FOOTNOTES:

1. INSTALL WITH SMALLER BEVEL TOWARD INSIDE OF PUMP
2. 308-603 PLUNGER IS A DIRECT REPLACEMENT OF 350-689 PLUNGER, 117-226 RETAINER RING, AND AN ADDITIONAL 350-671 ROD GUIDE.
3. USE 166-280, 178-467 & 105-525 TO SUPERSEDE 308-603
4. RETAINER CLIP 301-0196 SUPERSEDES CLIP 105-653

NOTE:

# LUBRICATOR VALVE

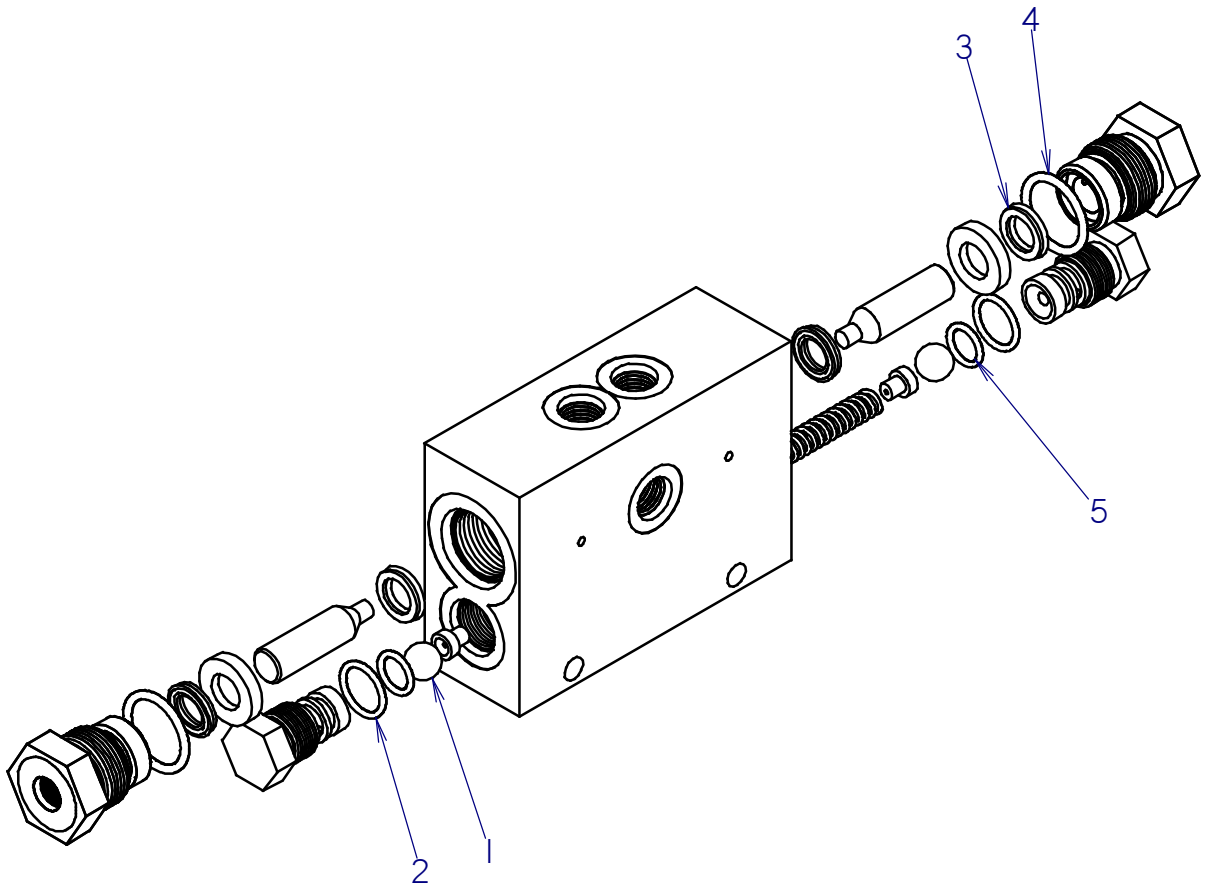

# LUBRICATOR VALVE

REF NO.	PART NUMBER	QTY	DESCRIPTION	REMARKS
	310-591	1	VALVE	
1	125-084	2	DETENT BALL (500)	
2	155-706	2	O-RING (908 D90)	
3	116-880	2	SEAL (POLY PAK)	
4	155-709	2	O-RING (912 D90)	
5	157-098	2	O-RING (111 D70)	

FOOTNOTES

NOTE:

# LUBRICATOR NOZZLE AND APPLICATOR

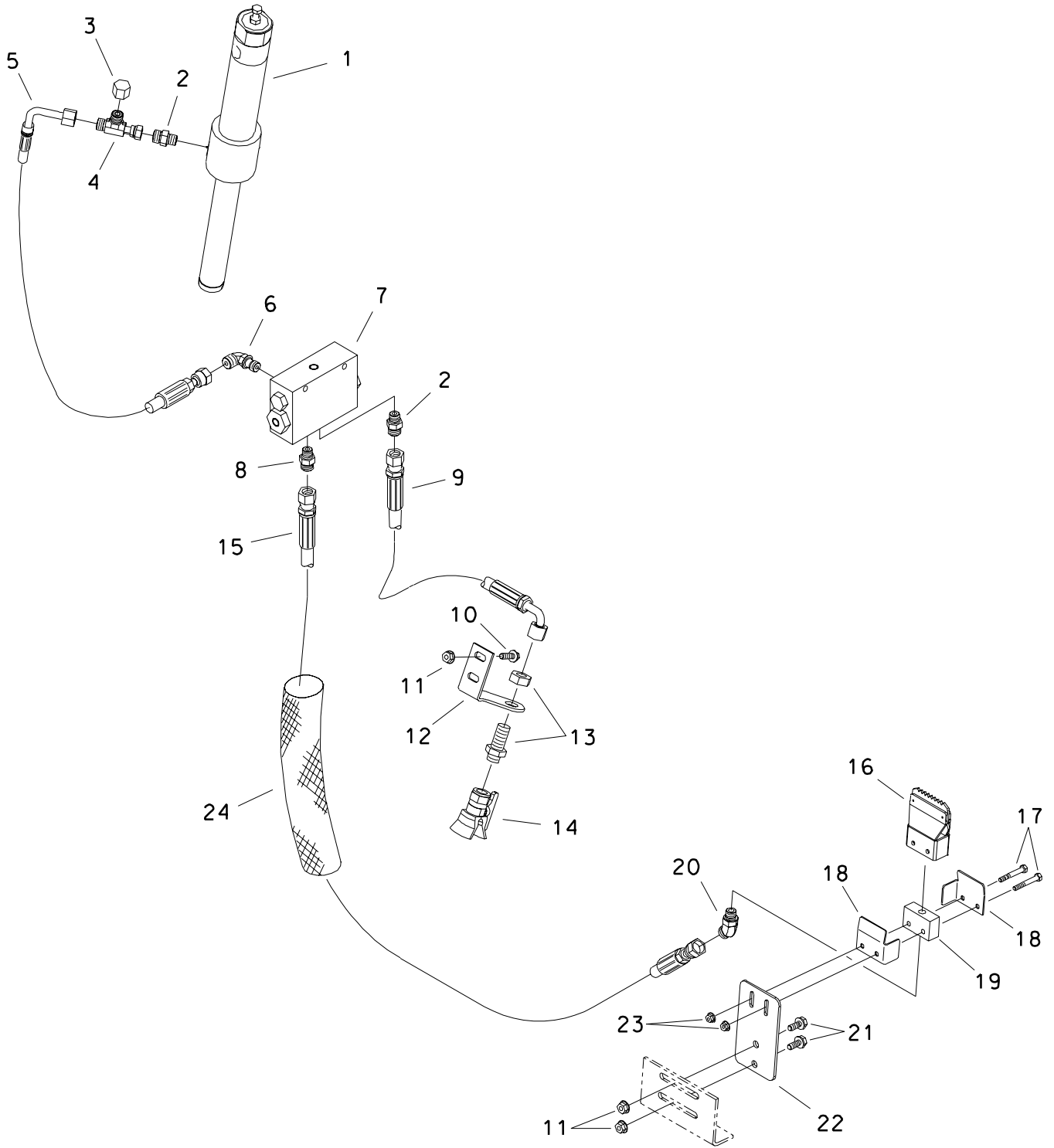

## LUBRICATOR NOZZLE AND APPLICATOR

REF NO.	PART NUMBER	QTY	DESCRIPTION	REMARKS
1.	350-398	-	GREASE PUMP PARTS	
2.	154-221	2	CONNECTOR (06S-060)	
3.	154-326	1	CAP (06DF)	
4.	154-344	1	UN RUN TEE (060FX-060-060)	
5.	157-928	1	HOSE (060FX90L-19"3000)	
6.	154-342	1	CONNECTOR (06S-06090)	
7.	310-591	-	VALVE	
8.	514-165	1	CONNECTOR (06S-060, DRF .078")	
9.	515-376	1	HOSE (060FX90-13"-3000)	
	153-585	-	HOSE (060FX-18"-3000, SPCL)	SEE FOOTNOTE 1
10.	106-381	2	FLG LK SCREW (M8-1.25 X 25MM)	
11.	106-386	4	FLG LOCKNUT (M8-1.25)	
12.	318-409	1	NOZZLE BRACKET	
13.	514-163	1	BK CONNECTOR (060-06DBK)	
14.	149-399	1	SPRAY NOZZLE (65)	
15.	157-929	1	HOSE (060FX-174"3000)	
16.	306-423	1	WIPER PARTS ASS'Y	
	116-937	1	APPLICATOR	
	107-394	4	WASHER (.375", ALUMINUM)	
	107-395	2	RIVET (.156 X .500) SEMI-TUBUL	
17.	106-093	2	SCREW (M6-1.00 X 45MM)	
18.	305-911	2	BRACKET, APPLICATOR	
19.	305-912	1	BASE, APPLICATOR	
20.	514-414	1	CONNECTOR (04S-06045)	
21.	106-162	2	FLG SCREW (M8-1.25 X 20MM)	
22.	316-954	1	APPLICATOR MOUNT PLATE	
23.	106-385	2	FLG LOCKNUT (M6-1.00)	
24.	117-987	1	ABRASION SLEEVE (1.00" X 174")	

## FOOTNOTES

1- HEATED HOSE, REQUIRES 154-228 UNION (060-060FX90)



# AUTO-LUBER ASSEMBLY

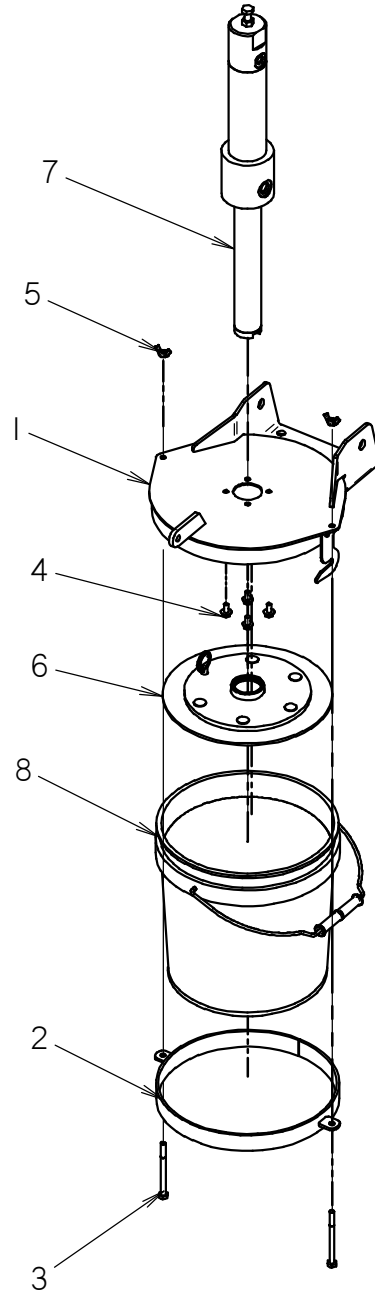

# AUTO-LUBER ASSEMBLY

REF NO.	PART NUMBER	QTY	DESCRIPTION	REMARKS
1	350-400	1	COVER WELDMENT	
2	350-399	1	BASE	
3	105-297	2	BOLT (1/4-NC X 3-1/4")	
4	106-378	4	FLG LK SCREW (M6-1.00 X 12MM)	
5	195-339	2	WING NUT (1/4-NC)	
6	350-1932	1	TOOL JOINT LUBE FOLLOWER	
7	350-398	1	GREASE PUMP PARTS	
8	259-858	1	TOOL JNT LUBE, STD SPRY 2 GAL	
	256-031	-	TOOL JNT LUBE, SUMR SPRY 2 GAL	

NOT SHOWN:

FOOTNOTES:

NOTE:



# **FLUID SYSTEMS**

# DRILLING FLUID PUMP PLUMBING

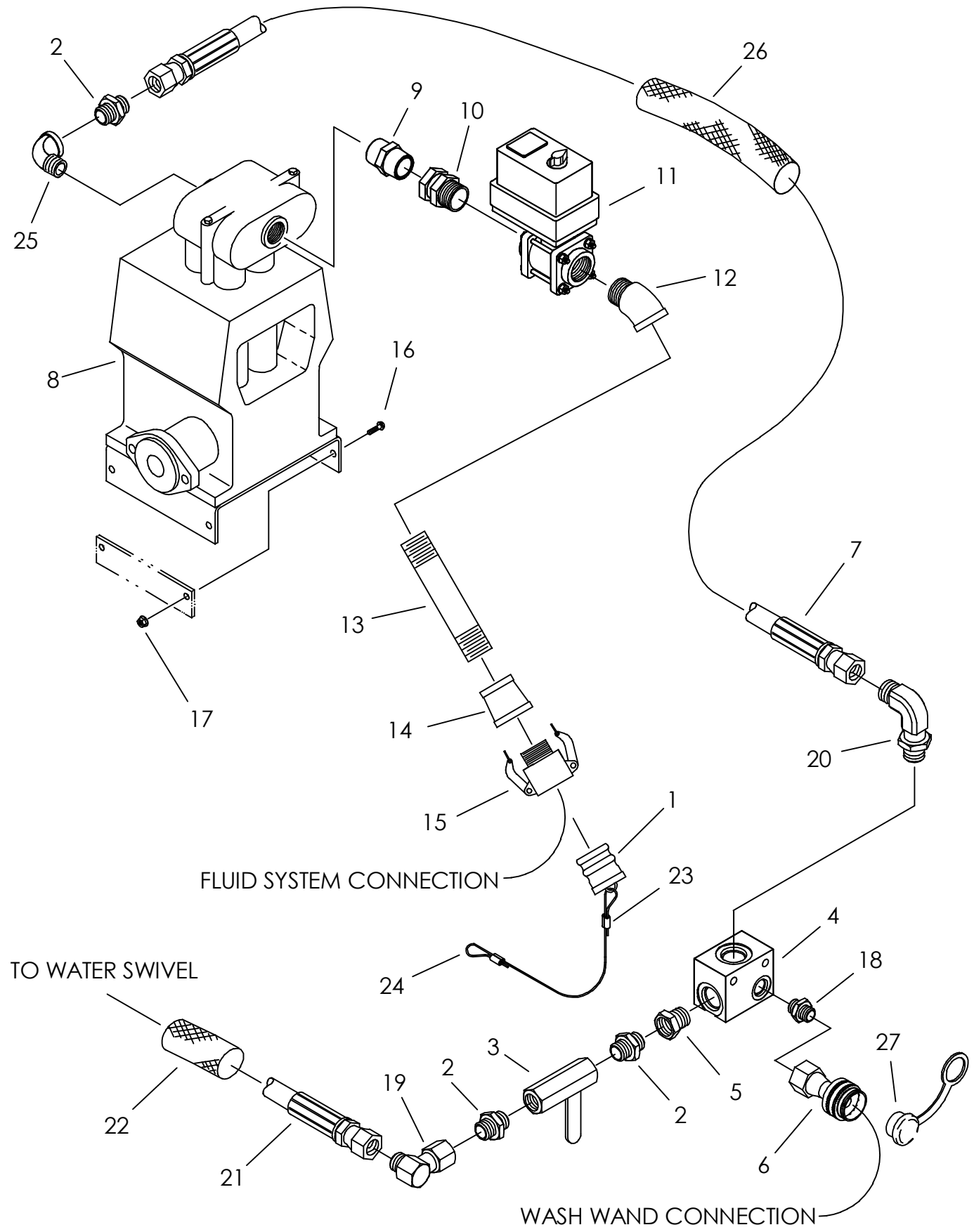

FLUID SYSTEM CONNECTION

TO WATER SWIVEL

WASH WAND CONNECTION

# DRILLING FLUID PUMP PLUMBING

REF NO.	PART NUMBER	QTY	DESCRIPTION	REMARKS
1.	110-630	1	DUST PLUG (1-1/2")	
2.	154-102	3	CONNECTOR (12N-12J)	
3.	120-073	1	SHUT OFF (12NF-12NF)	
4.	159-791	1	HYDRAULIC MANIFOLD BLOCK	
5.	154-144	1	UNION (12S-12JFX)	
6.	159-088	1	QDC BODY (08-08SF)	
	155-936	1	DUST PLUG (1/2" - 3/4")	
7.	159-579	1	HOSE (12JFX-30"-1500)	
8.	157-267	1	DRILLING FLUID PUMP	
9.	105-1558	1	PIPE NIPPLE -20 NPT	
10.	155-185	1	UNION (20NF-20N)	
11.	159-522	1	BALL VALVE, ELECTRIC (1-1/4")	SEE FOOTNOTE I
	190-1068	-	SEAT/O-RING REPAIR KIT	
	215-224	1	3 WAY WP MALE CONNECTOR	
	214-104	3	PACKARD MALE TERMINAL	
	157-645	3	WEATHER-PACK SEAL (2.80mm)	
	500-1337	1	1" FLANGE CLAMP	
	500-1339	1	EV MOTOR	
	500-1340	1	WEEP HOLE FILTER	
	159-575	1	STREET ELBOW (20N-20NF45)	
13.	150-2200	1	NIPPLE (20N-10")	
14.	514-124	1	SWAGE COLLAR (24NF-20NF,4.5")	
15.	159-500	1	FHC BODY (24-24N)	
16.	106-383	4	FLG LK SCREW (M10-1.50 X 30mm)	
17.	106-387	4	FLG LOCKNUT (M10-1.50)	
18.	154-466	1	CONNCOCTR (08S-08S)	
19.	154-026	1	UNION (12J-12JFX90)	
20.	154-014	1	CONNECTOR (12J-12S90)	
21.	154-617	-	HOSE (12JFX-95"-2250)	
22.	117-655	1	ABRASION SLEEVE (1.59" X 38")	
23.	350-275	2	ALUMINUM SLEEVE (1/16")	
24.	110-981	-	AR BULK CABLE (1/16",SOLD PER FT)	USE 12"
25.	115-120	1	STR ELB (12N-12NF90-2000PSI)	
26.	115-754	1	ABRASION SLEEVE (1.59" X 30")	
27.	155-936	1	DUST PLUG (1/2" - 3/4")	

NOT SHOWN:

FOOTNOTES:

I. ORDER P/N 500-1338 FOR BALL VALVE REPLACEMENT.

NOTE:

REFER TO O-RING CHART 800-301 FOR REPLACEMENT O-RINGS.

# DRILLING FLUID PUMP

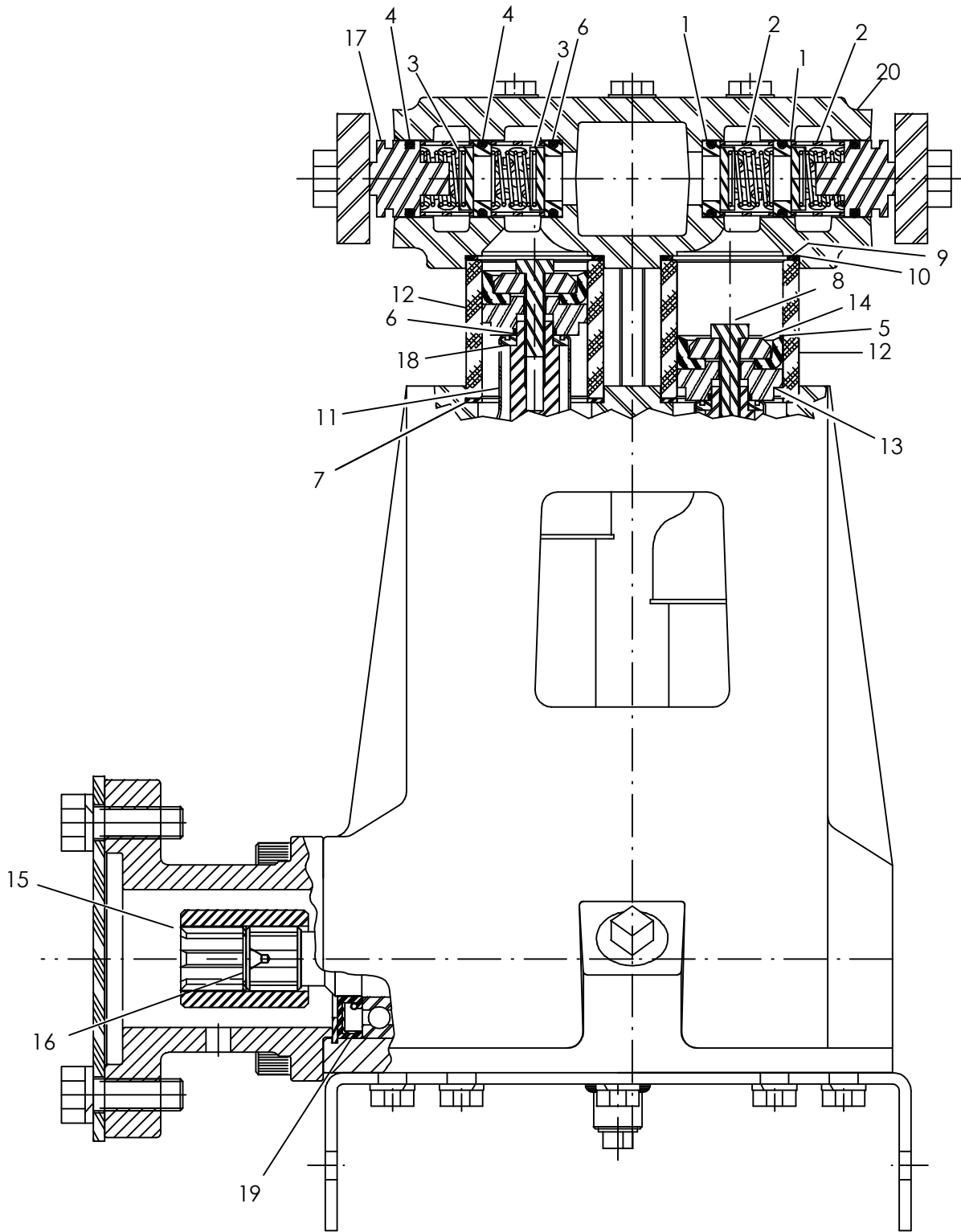

# DRILLING FLUID PUMP

REF NO.	PART NUMBER	QTY	DESCRIPTION	REMARKS
	157-267	1	DRILLING FLUID PUMP	
	197-115	-	REMANUFACTURED 157-267 PUMP	
	191-023	1	VALVE REPAIR KIT	INCLUDES REF NO'S 1-4
	191-034	1	PACKING REPAIR KIT	INCLUDES REF NO'S 5-10
1.	N/A	8	VALVE SEAT	
2.	N/A	8	CAGE	
3.	N/A	8	DISC AND SPRING	
4.	N/A	12	O-RING	
5.	N/A	4	CUP	
6.	N/A	4	O-RING	
7.	N/A	4	CYLINDER GASKET	
8.	N/A	4	HEX HD CAP SCREW (5/16-18 X 1 1/2" LG)	
9.	N/A	4	SEAL RING	
10.	157-159	4	O-RING (033 D90)	
11.	499-045	4	UMBRELLA SEAL	
12.	499-058	4	CERAMIC CYLINDER (1-3/8")	
13.	499-059	4	PACKING HOLDER	
14.	499-060	4	PACKING WASHER	
15.	499-066	1	COUPLER	PUMP TO DRIVE MOTOR
16.	499-067	1	RETAINING RING	USED ON EARLIER MODELS
	500-2012	1	SPRING PIN 3/32" X 1.5"	
17.	499-086	4	VALVE COVER	
18.	499-087	4	UMBRELLA WASHER	
19.	157-751	4	SEAL, CRANKSHAFT	
20.	499-825	1	FLUID CYLINDER	

NOT SHOWN:

FOOTNOTES:

NOTE:



# DRILLING FLUID PLUMBING

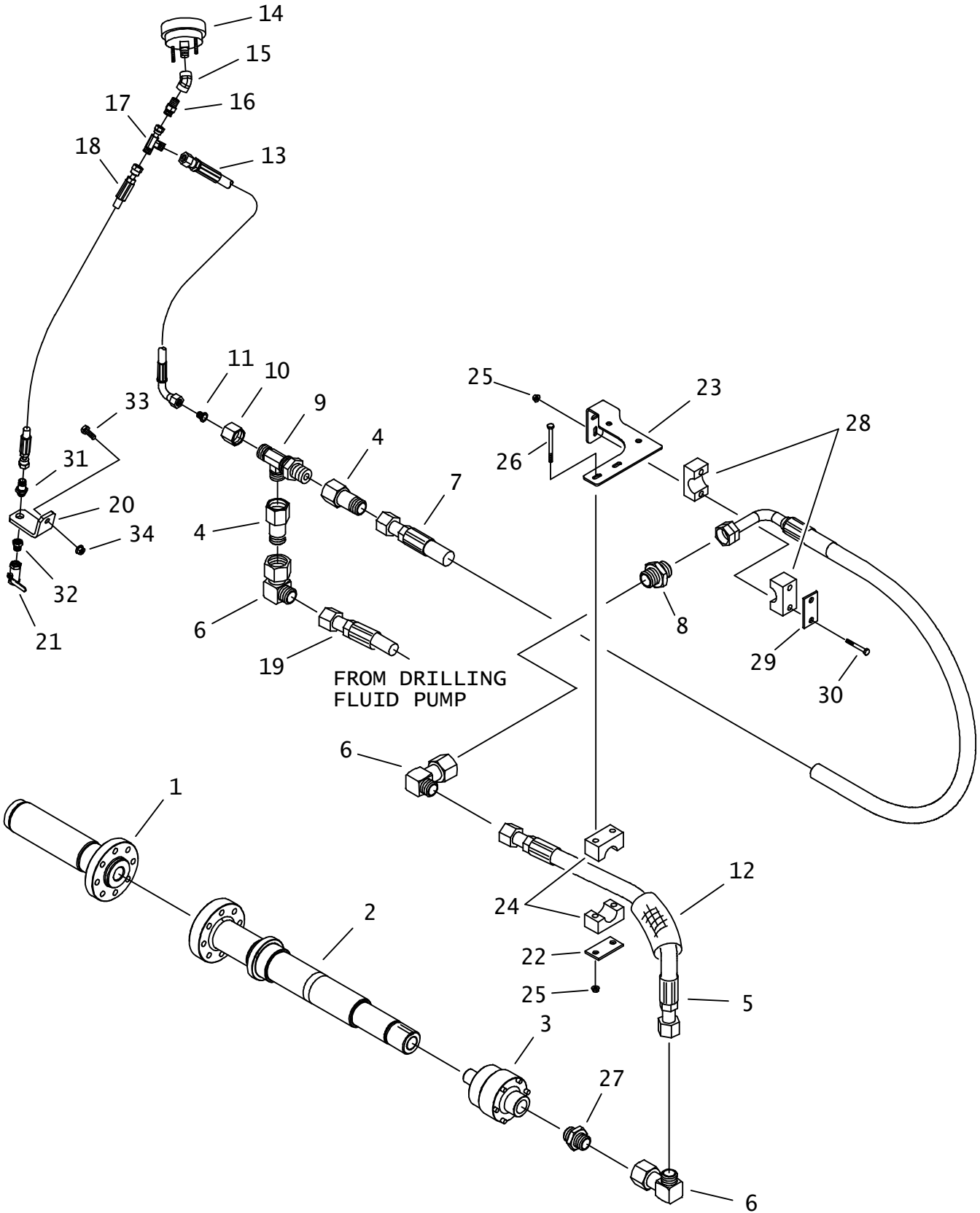

# DRILLING FLUID PLUMBING

REF NO.	PART NUMBER	QTY	DESCRIPTION	REMARKS
1.	400-604	-	SAVER SUB 1.73-4F DS	
2.	166-426	-	SLIDING OUTPUT SHAFT	
3.	153-242	-	WATER SWIVEL (12NF-12NF)	
	191-248		SEAL KIT	
4.	514-047	2	UNION (12J-120FX)	
5.	159-579	1	HOSE (12JFX-30"-1500)	
6.	154-026	3	UNION (12J-12JFX90)	
7.	157-969	1	HOSE (12JFX90L-119"-1500)	
8.	154-101	1	CONNECTOR (12J)	
9.	514-002	1	BK RUN TEE (120)	
10.	154-271	1	REDUCER NUT (120F)	
11.	154-282	1	REDUCER STEM (040)	
12.	115-754	1	ABRASION SLEEVE (1.59" X 30")	
13.	515-030	1	HOSE (040FX90S-64"-3000)	
<u>14.</u>	258-046	-	PRESSURE GAUGE (1500PSI)	
	150-1444	-	PRESSURE GAUGE (2000PSI)	
15.	514-418	1	ELBOW (04NF-04NF45)	
16.	154-339	1	CONNECTOR (04N-040)	
17.	154-265	1	UNION RUN TEE (040FX-040-040)	
18.	515-072	1	HOSE (040FX45-16"-3000)	
19.	154-617	1	HOSE (12JFX-95"-2250)	
20.	320-599	1	VALVE BRACKET	
21.	120-071	1	SHUT-OFF (04NF-04NF)	
22.	322-362	1	BACKUP SPACER	
23.	318-873	-	BRACKET, TOP	
24.	110-852	1	BOLT-ON CLAMP(1.25",SOLD PER SET)	
25.	105-832	4	FLG LOCKNUT (1/4-NC)	
26.	107-196	2	BOLT (1/4-NC X 3")	
27.	154-102	1	CONNECTOR (12N-12J)	
28.	110-411	1	BOLT-ON CLAMP (3/4", SET)	
29.	322-289	1	BACKUP (BOLT-ON)	
30.	105-106	2	BOLT (1/4-NC X 2")	
31.	153-238	1	BK CONNECTOR (040-06S)	
32.	153-264	1	REDUCER (04N-06SF)	
33.	106-381	1	FLG LK SCREW(M8-1.25 X 25mm)	
34.	106-386	1	FLG LOCKNUT (M8-1.25)	

NOT SHOWN:

FOOTNOTES:

NOTE:

## DRILLING FLUID TRANSFER

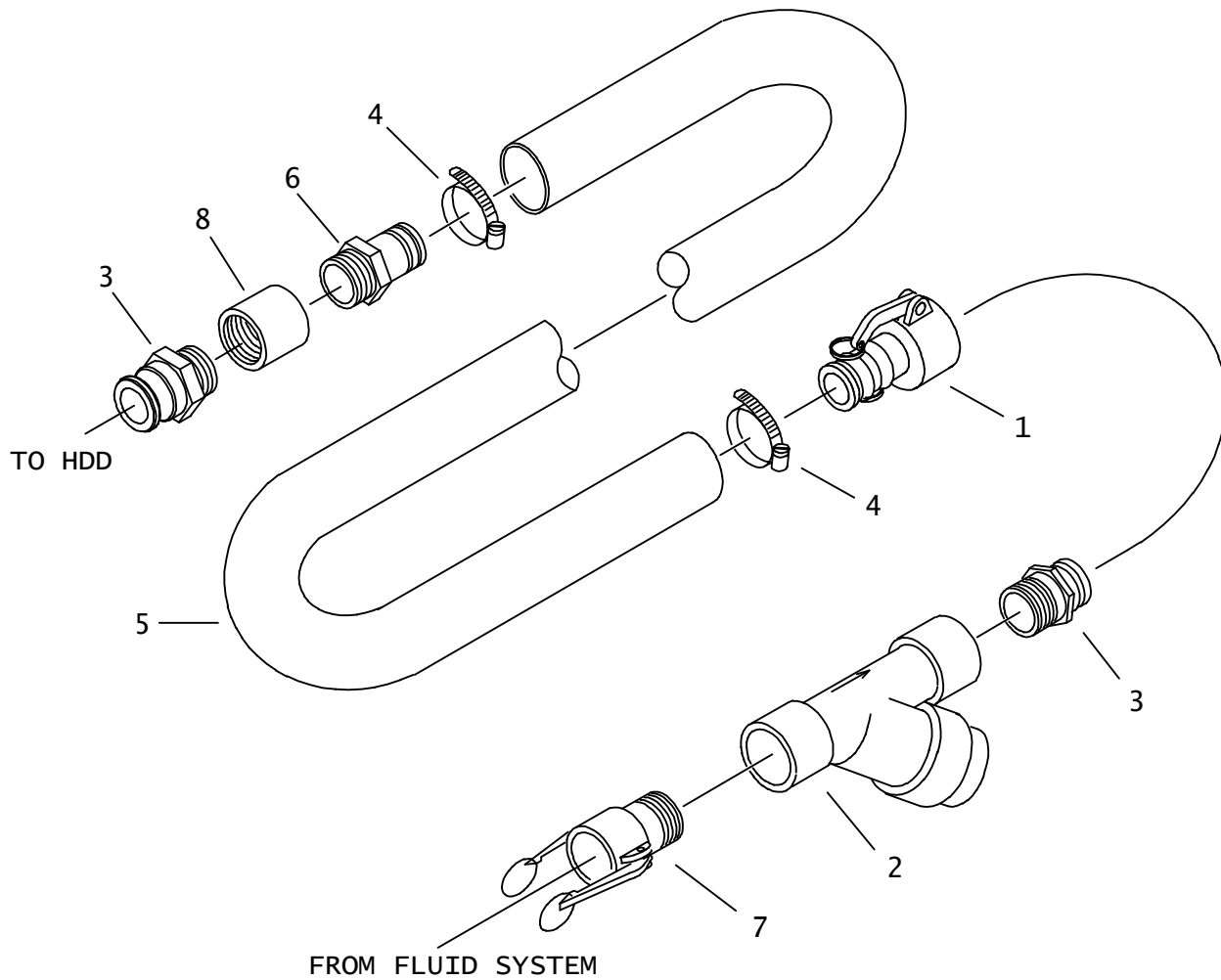

# DRILLING FLUID TRANSFER

REF NO.	PART NUMBER	QTY	DESCRIPTION	REMARKS
	159-587		TRANSFER HOSE ASSEMBLY	
				INCL REF NO'S 1, 3 (1), 4, 5, 6 & 8
1.	155-205	1	FHC BODY (20-24N)	
2.	159-476	1	Y-STRAINER (24NF)	
	159-503		SCREEN, Y-STRAINER (12 MESH)	
	500-2080		O-RING	USED ON Y STRAINER CAP
3.	155-204	2	FHC ADAPTER (24-24N)	
4.	110-250	2	WORM CLAMP (1," TO 2,,")	
5.	116-782	AR	BULK HOSE (1.50", SOLD PER 1")	USE 1 @ 300"
6.	155-188	1	S/O COUPLER (24N-24H)	
7.	159-500	1	FHC BODY (24-24N)	
8.	115-134	1	COLLAR (24NF)	

NOT SHOWN:

FOOTNOTES:

NOTE:



# **PIPE LOADER SYSTEMS**

## LIFTERS

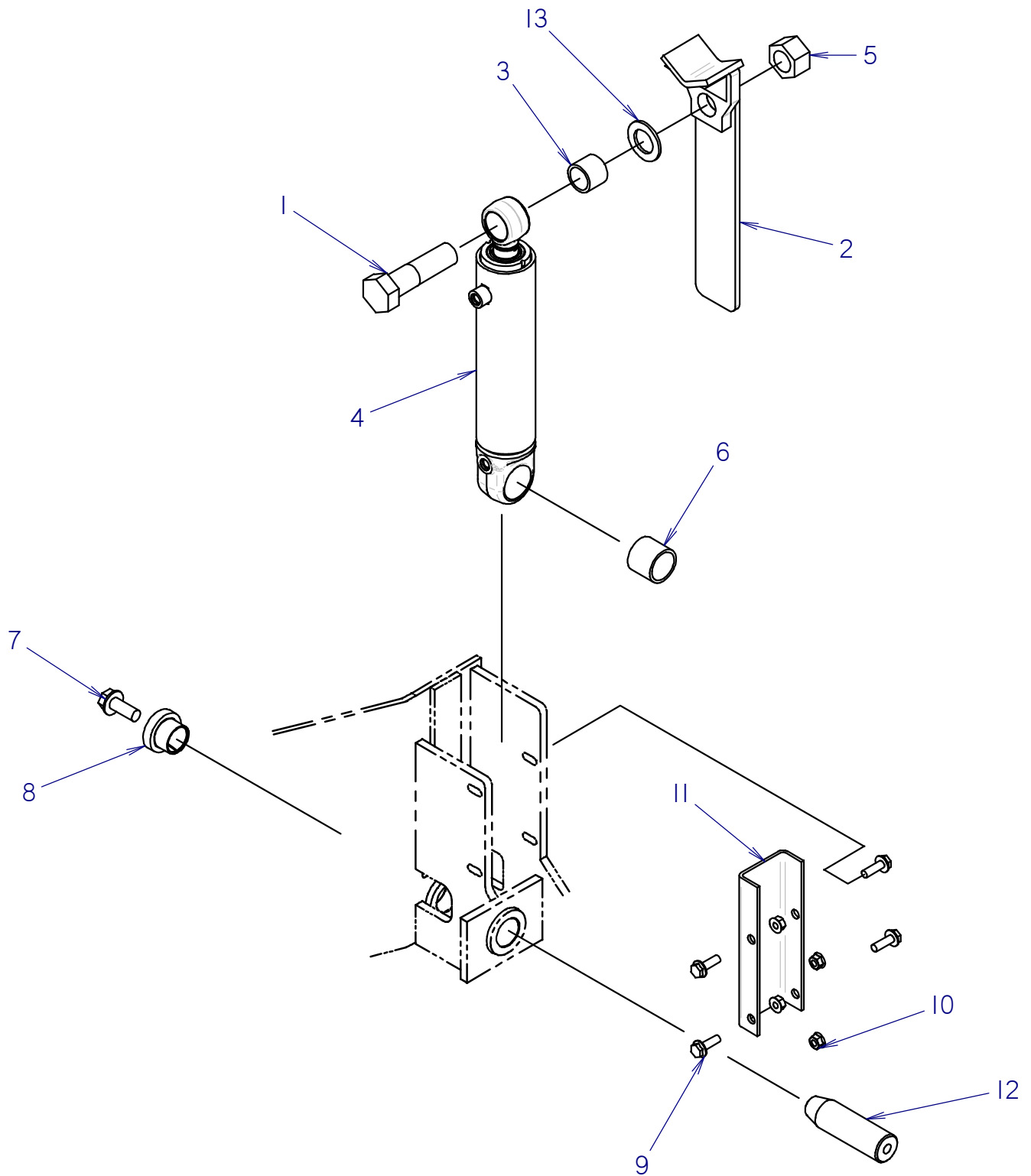

# LIFTERS

REF NO.	PART NUMBER	QTY	DESCRIPTION	REMARKS
1	106-664	1	SCREW (M24-3.00 X 90MM, 10.9)	
2	300-1061	1	LIFTER PLATE	USE ON JT2020 FOOTNOTE 1 (SEE FOOTNOTE 2 FOR JTI220)
3	125-770	1	COMPOSITION BUSHING (1.000")	
4	151-044	1	CYL (2.0 X 1.0 X 6.0)	
5	106-352	1	NUT (M24-3.00)	
6	125-771	1	COMPOSITION BUSHING (1.25")	
7	105-830	1	FLG LK BOLT (1/2-NC X 1-1/4")	
8	181-982	1	TAPERED INSERT (1.25")	
9	106-381	4	FLG LK SCREW (M8-1.25 X 25MM)	
10	106-386	4	FLG LOCKNUT (M8-1.25)	
11	324-482	1	CHANNEL	
12	178-394	1	TAPERED PIN (1.250" X 4.25")	
13	106-016	1	SPINDLE WASHER (1.062")	

NOT SHOWN:

FOOTNOTES:

1. 300-1061 | LIFTER PLATE, BEGINS WITH S/N: CMWJ2020H60000346 ; USE ON JT2220
2. 316-569 | LIFTER PLATE, BEGINS WITH S/N: CMWJ1220J60000130 ; USE ON JTI220

NOTE:



# SHUTTLE

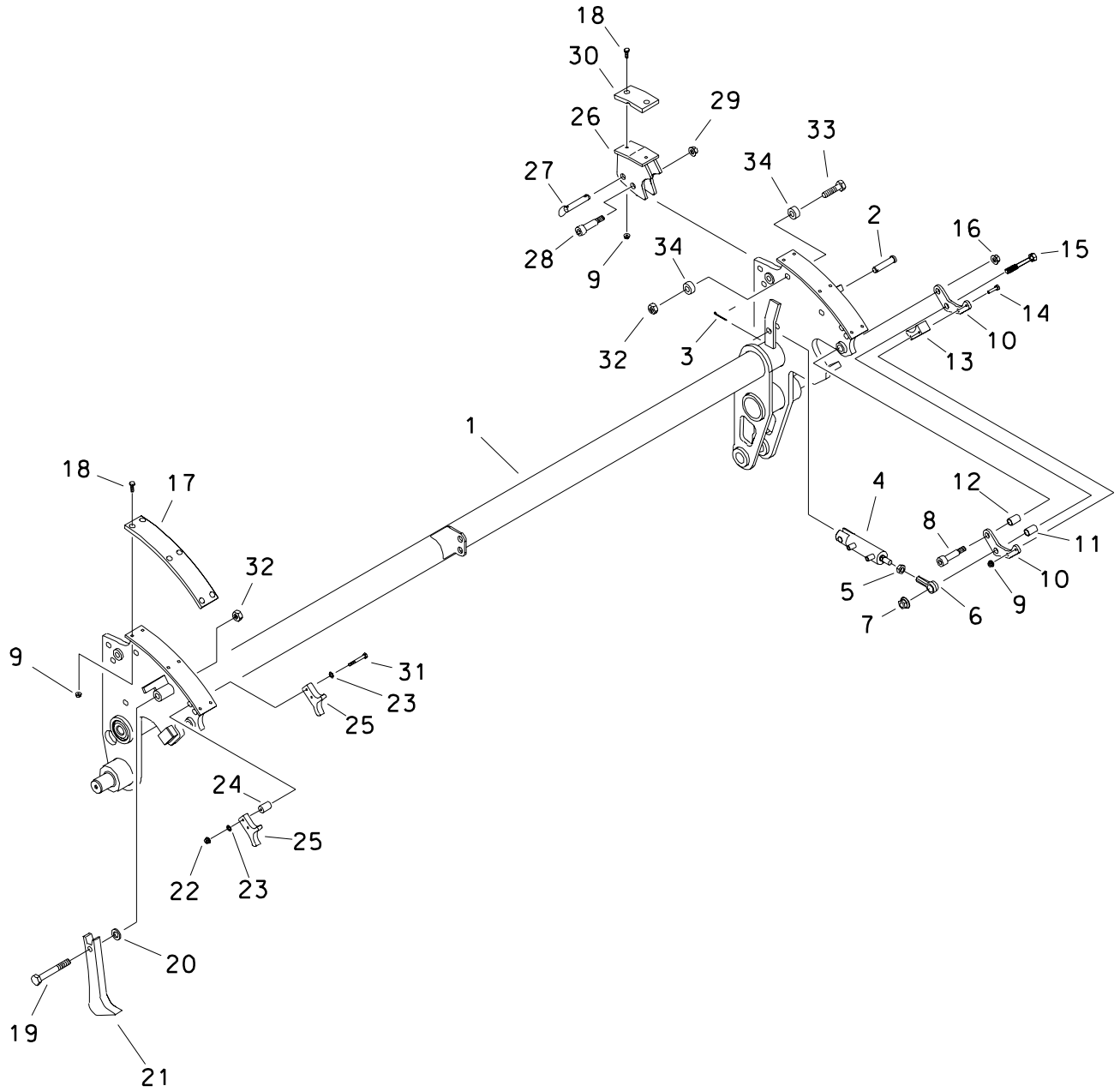

# SHUTTLE

REF NO.	PART NUMBER	QTY	DESCRIPTION	REMARKS
1.	316-508	1	SHUTTLE	
2.	108-057	2	CLEVIS PIN (1/2" X 2-1/4")	
3.	105-509	2	COTTER PIN (1/8" X 1")	
4.	151-150	2	CYL (1.5" X .50" X 2")	
5.	105-920	2	JAM NUT (7/16-NF)	
6.	110-983	2	ROD END (7/16" NF-20, FM)	
7.	106-758	2	LOCKNUT (M10-1.5)	
8.	106-132	2	SHLD BLT (1/2" X1-1/2", 3/8-NC)	
9.	106-385	20	FLG LOCKNUT (M6-1.00)	
10.	316-502	4	PLATE	
11.	179-387	2	GRIPPER SPACER	
12.	125-430	2	BRONZE BUSHING (.502")	
13.	315-740	2	SHUTTLE GRIPPER PAD	
14.	106-093	4	SCREW (M6-1.00 X 45MM)	
15.	106-142	2	SCREW (M10-1.50 X 65MM)	
16.	105-047	2	LOCKNUT (3/8-NC)	
17.	323-206	2	SHUTTLE WEAR PAD	
18.	106-640	16	SCREW (M6-1.00 X 20MM, BUT SOC)	
19.	106-584	2	SCREW (M12-1.75 X 100MM)	
20.	106-391	2	WASHER (M12)	
21.	316-495	2	CATCH ARM	
22.	106-237	4	LOCKNUT (M6-1.00, PRV TRQ, NLK)	
23.	106-388	8	WASHER (M6)	
24.	179-531	4	BUSHING	
25.	315-739	4	GRIPPER PAD	
26.	323-204	2	SWIVEL BODY	
27.	183-411	2	PULL PIN (1/2" X 2")	
28.	107-043	2	SHLD BLT (M12 X 35MM, M10-1.50)	
29.	105-894	2	LOCKNUT (M10-1.50, PRV TRQ, 10.9)	
30.	323-205	2	WEAR PAD	
31.	107-025	4	SCREW (M6-1.00 X 50MM)	
32.	106-685	4	LOCKNUT (M12-1.75, PRV TRQ, 10.9)	
33.	106-334	2	SCREW (M12-1.75 X 50MM)	
34.	179-831	4	BUSHING	

FOOTNOTES

# SHUTTLE MOUNT

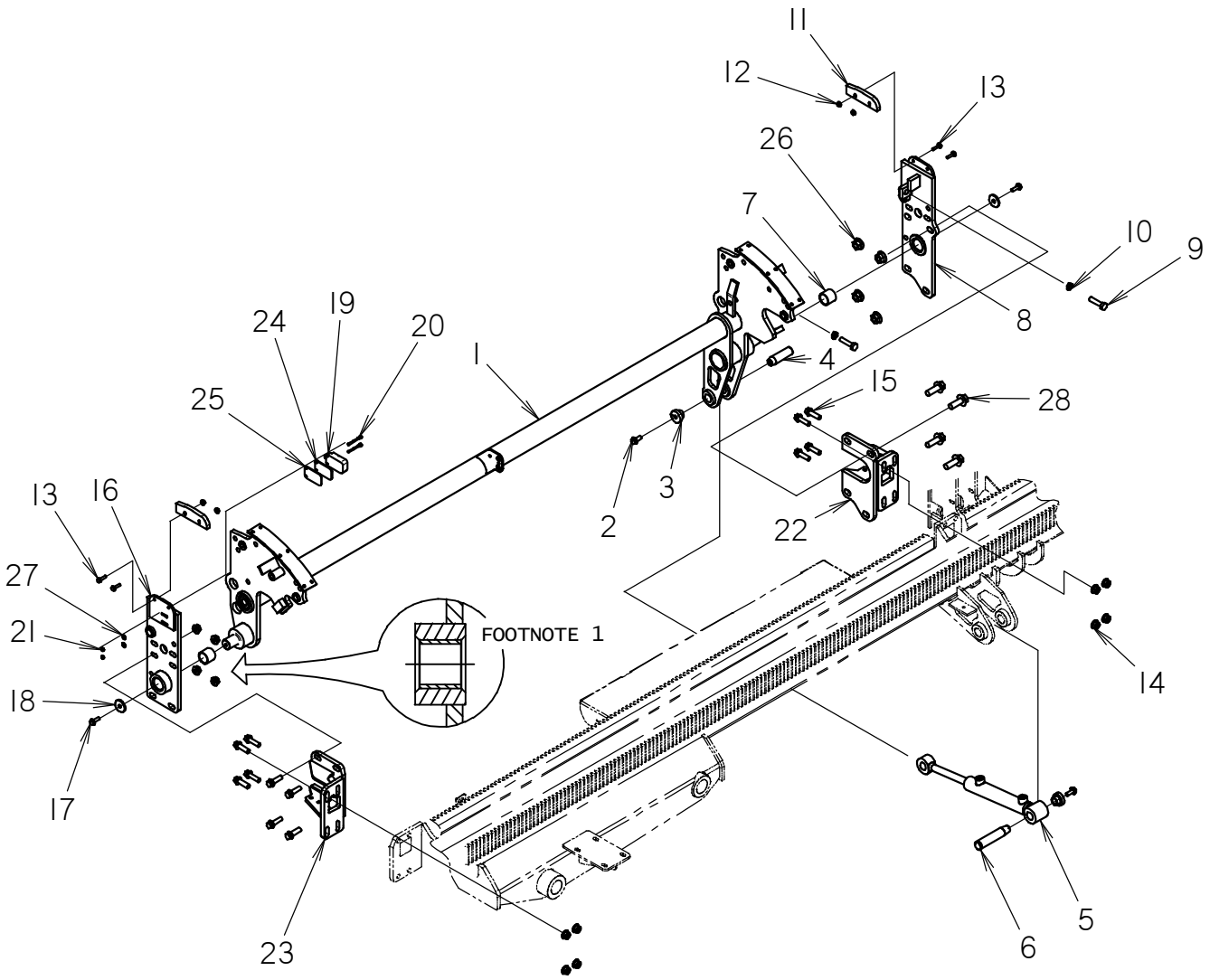

# SHUTTLE MOUNT

REF NO.	PART NUMBER	QTY	DESCRIPTION	REMARKS
1	316-508	1	SHUTTLE	
2	106-724	2	FLG SCREW (M10-1.50 X 25MM)	
3	181-981	2	TAPERED INSERT (1")	
4	183-820	1	TAPERED PIN (25.4MM X 86MM)	
5	151-230	1	CYL (1.25" X .75" X 6")	
6	183-764	1	25.4 X 126 TAPERED PIN	
7	125-771	2	COMPOSITION BUSHING (1.25")	
8	316-696	1	MOUNT PLATE	
9	106-334	2	SCREW (M12-1.75 X 50MM)	
10	107-669	2	JAM NUT (M12-1.75)	
11	119-004	2	CATCH ARM WARE PAD	
12	106-385	4	FLG LOCKNUT (M6-1.00)	
13	106-848	4	FLG SCREW (M6-1.00 X 25MM)	
14	106-709	12	FLG LK NUT (M12-1.75)	
15	107-565	12	FLG LK SCREW (M12-1.75 X 40MM)	
16	319-530	1	MOUNT PLATE	
17	106-381	2	FLG LK SCREW (M8-1.25 X 25MM)	
18	105-069	2	WASHER (.406")	
19	215-1175	1	PROXIMITY SWITCH	
20	108-091	2	SCREW (M5-0.80 X 50MM, SOC)	
21	106-850	2	LOCKNUT (M5-0.80)	
22	320-234	1	FRONT MOUNT BRACKET	
23	320-235	1	REAR MOUNT BRACKET	
24	107-451	1	SHIM (.135")	SEE FOOTNOTE 2
25	107-450	1	SHIM (.075")	SEE FOOTNOTE 2
26	106-355	4	FLG NUT (M16-2.00, 10.9)	
27	105-284	2	WASHER (3/16")	
28	107-336	4	FLG SCREW (M16-2.00X45MM,10.9)	

**NOT SHOWN:**

116-259

BULK EDGING (1/2" SOLD PER FT)

VARIOUS QUANTITIES & LENGTHS USED

**FOOTNOTES:**

1. ASSEMBLY BUSHING (REF 7) IN CENTER OF BOSS AS SHOWN
2. USE AS REQUIRED

**NOTE:**

## SHUTTLE GUARD

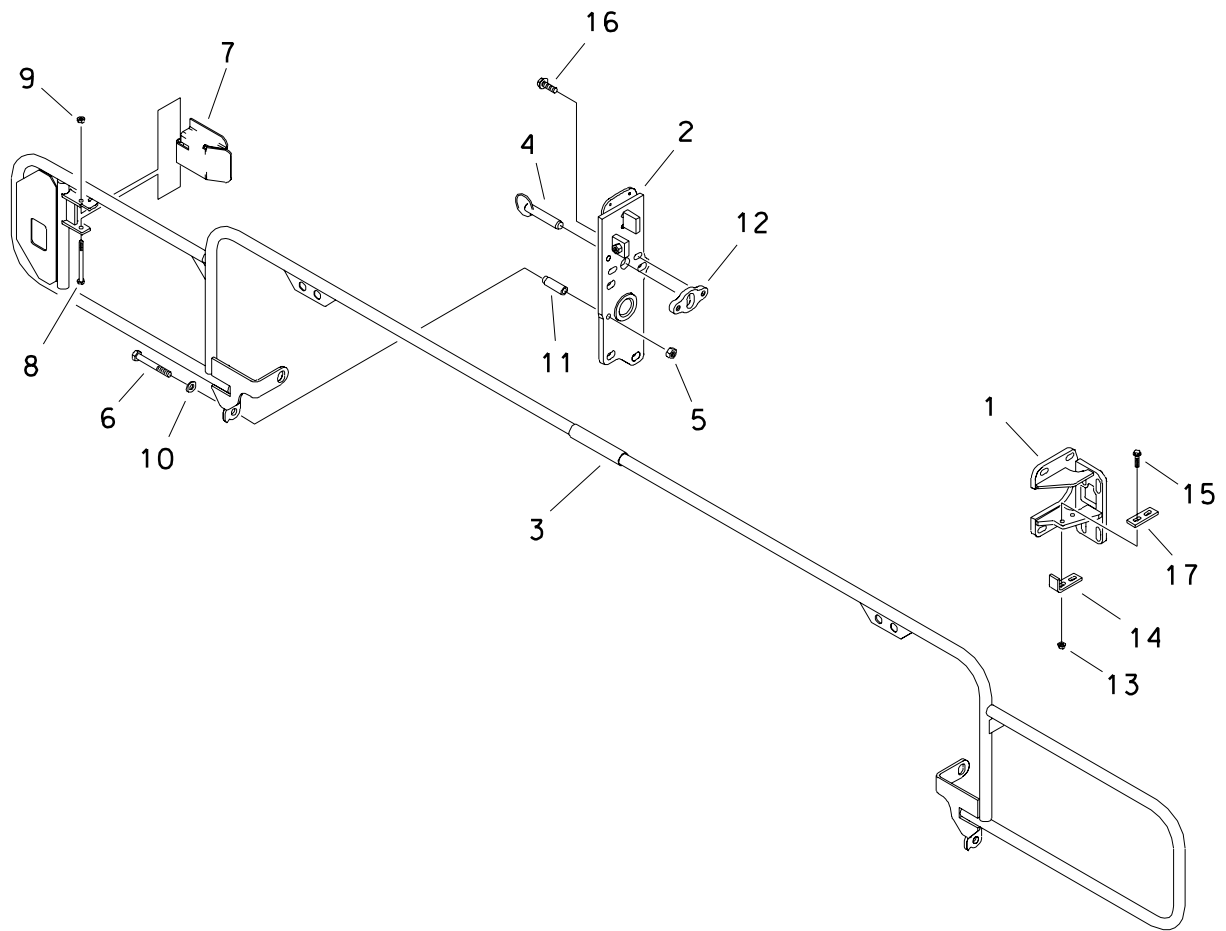

## SHUTTLE GUARD

REF NO.	PART NUMBER	QTY	DESCRIPTION	REMARKS
1.	320-235	-	REAR MOUNT BRACKET	
2.	316-696	-	MOUNT PLATE	
3.	319-823	1	SHUTTLE GUARD	
4.	107-877	2	PIN	
5.	106-089	2	NUT (M12-1.75, 10.9)	
6.	106-336	2	SCREW (M12-1.75 X 90MM)	
7.	319-832	1	PIPE STOP	
8.	107-078	1	SCREW (M8-1.25 X 90MM)	
9.	106-561	1	LOCKNUT (M8-1.25, PRV TRQ, 10.9)	
10.	106-391	2	WASHER (M12)	
11.	179-756	2	PIVOT TUBE	
12.	322-648	2	PIN PLATE	
13.	106-386	4	FLG LOCKNUT (M8-1.25)	
14.	322-498	2	STOP BRACKET	
15.	106-989	4	FLG LK SCREW (M8-1.25 X 35MM)	
16.	107-010	4	FLG LK SCREW (M12-1.75 X 30MM)	
17.	325-514	2	STOP BAR	

FOOTNOTES

## PIPE LOADER VALVE/COVERS

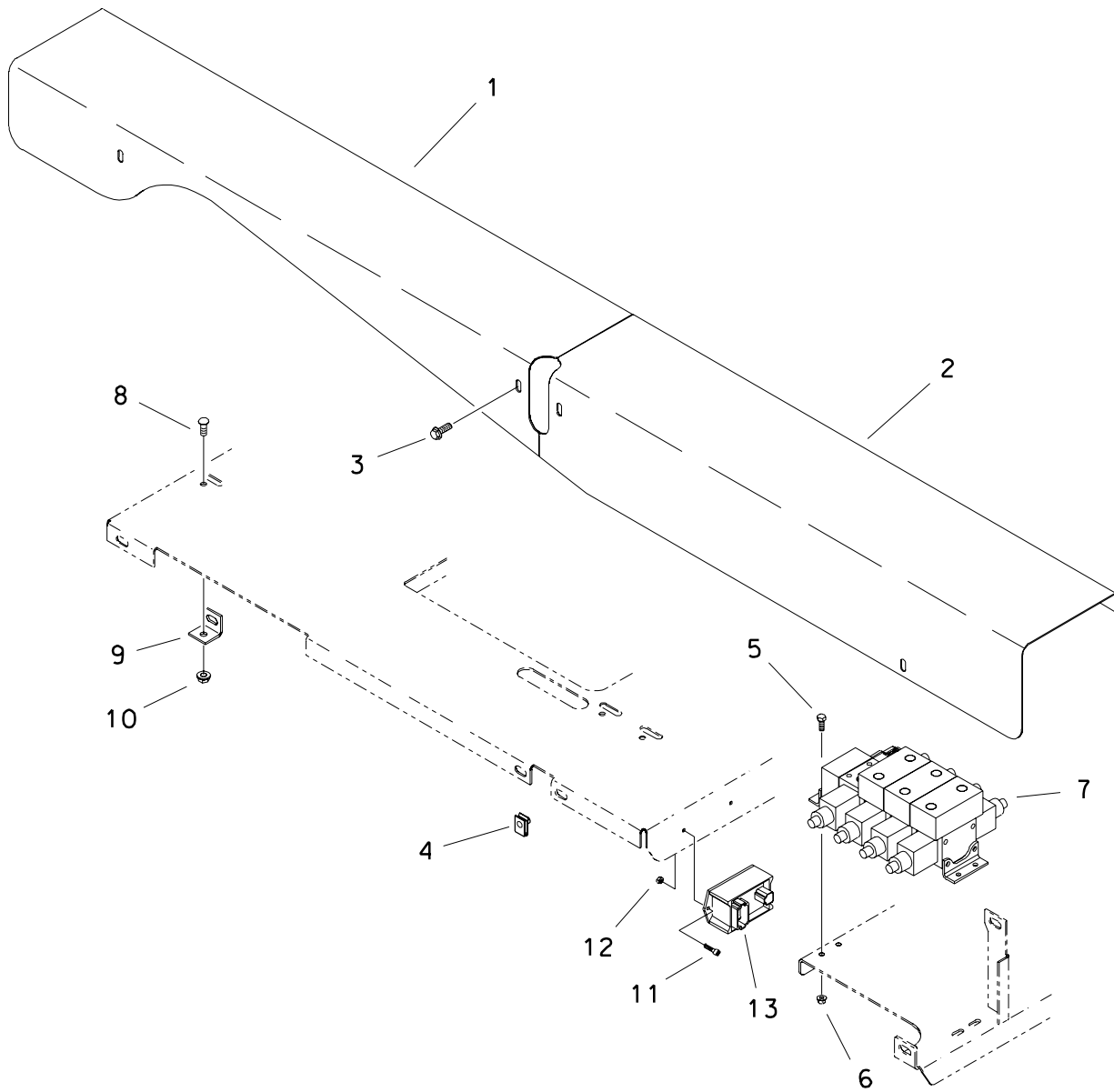

# PIPE LOADER VALVE/COVERS

REF NO.	PART NUMBER	QTY	DESCRIPTION	REMARKS
1.	319-506	1	FRONT COVER	
2.	319-507	1	REAR COVER	
3.	106-380	8	FLG SCREW(M8-1.25 X 16MM)	
4.	106-551	8	CLIP NUT (M8-1.25)	
5.	106-231	4	SCREW (M6-1.00 X 16MM)	
6.	106-385	4	FLG LOCKNUT (M6-1.00)	
7.	157-778	1	HYDRAULIC VALVE	
8.	107-032	3	SCREW (M8-1.25 X 20MM,BUT SOC)	
9.	320-656	3	CLIP NUT TAB	
10.	106-386	3	FLG LOCKNUT (M8-1.25)	
11.	106-049	2	BOLT (#10-24 X <sup>3</sup> / <sub>4</sub> " , PLPS)	
12.	106-048	2	LOCKNUT (#10-24)	
13.	211-025	1	IN-LINE DIODE PACK	

FOOTNOTES



## PIVOT ARM

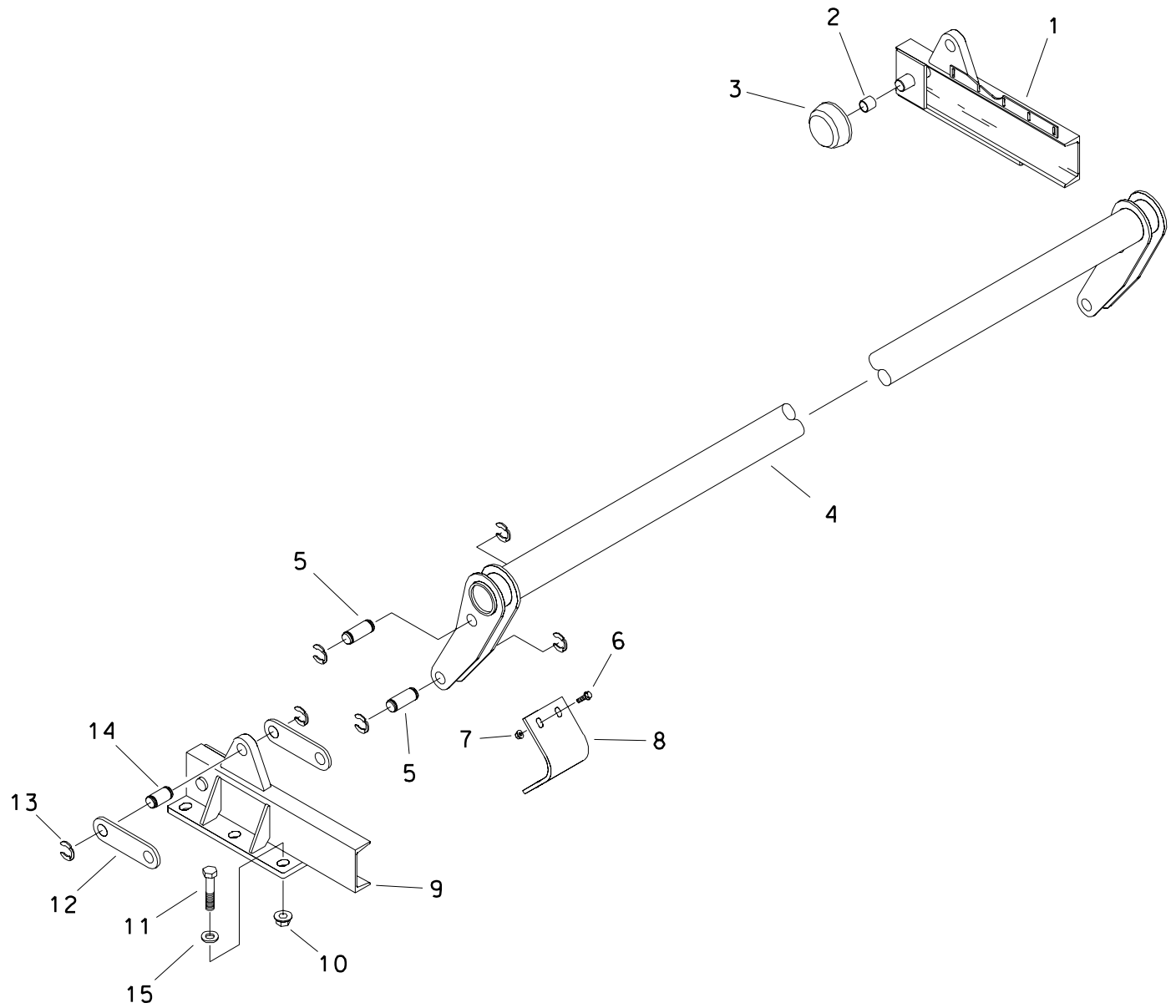

## PIVOT ARM

REF NO.	PART NUMBER	QTY	DESCRIPTION	REMARKS
1.	316-528	1	FRONT ROLLER GUIDE	
2.	125-770	2	COMPOSITION BUSHING (1")	
3.	184-084	2	CARRIAGE ROLLER	
4.	318-785	1	PIVOT ARM	
5.	179-451	4	TRAVERSE PIN	
6.	106-383	8	FLG LK SCREW (M10-1.50 X 30MM)	
7.	106-387	8	FLG LOCKNUT (M10-1.50)	
8.	318-678	2	PIVOT ARM BRACKET	
9.	316-529	1	REAR ROLLER GUIDE	
10.	106-355	6	FLG NUT (M16-2.00, 10.9)	
11.	106-616	6	SCREW (M16-2.00 X 55MM)	
12.	319-191	4	LINK	
13.	115-499	12	KLIP RING (1.000")	
14.	179-483	2	PIN	
15.	106-398	6	WASHER (M16, HARDENED)	

FOOTNOTES

## PIPE BOX

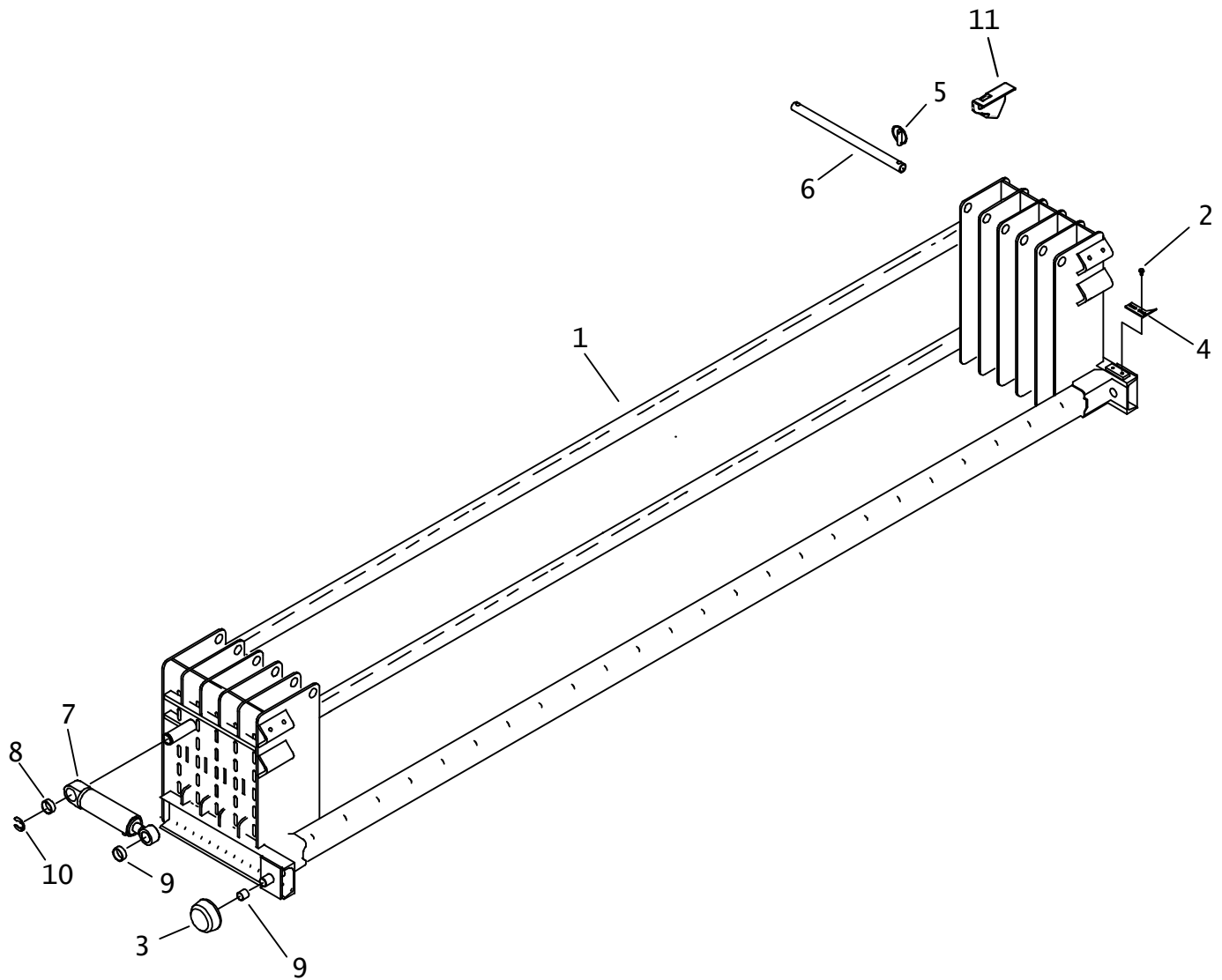

## PIPE BOX

REF NO.	PART NUMBER	QTY	DESCRIPTION	REMARKS
1.	316-530	1	PIPE BOX	
2.	106-224	2	FLG SCREW (M6-1.00 X 10MM)	
3.	184-084	2	CARRIAGE ROLLER	
4.	316-979	1	INDICATOR	
5.	110-228	4	LYNCH PIN (7/16" X 2")	
6.	107-882	2	PIN	
7.	151-038	2	CYL (2.0 X 1.0 X 4.0)	
8.	125-771	2	COMPOSITION BUSHING (1.25")	
9.	125-770	4	COMPOSITION BUSHING (1")	
10.	115-483	2	KLIP RING (1.250")	
11.	327-734	4	INDICATOR	

FOOTNOTES

NOTE:



# **ELECTRICAL**

**SEE TECHNICAL SUPPLEMENT FOR FURTHER  
ELECTRICAL INFORMATION**



# **ACCESSORIES**



# ANTIFREEZE TANK

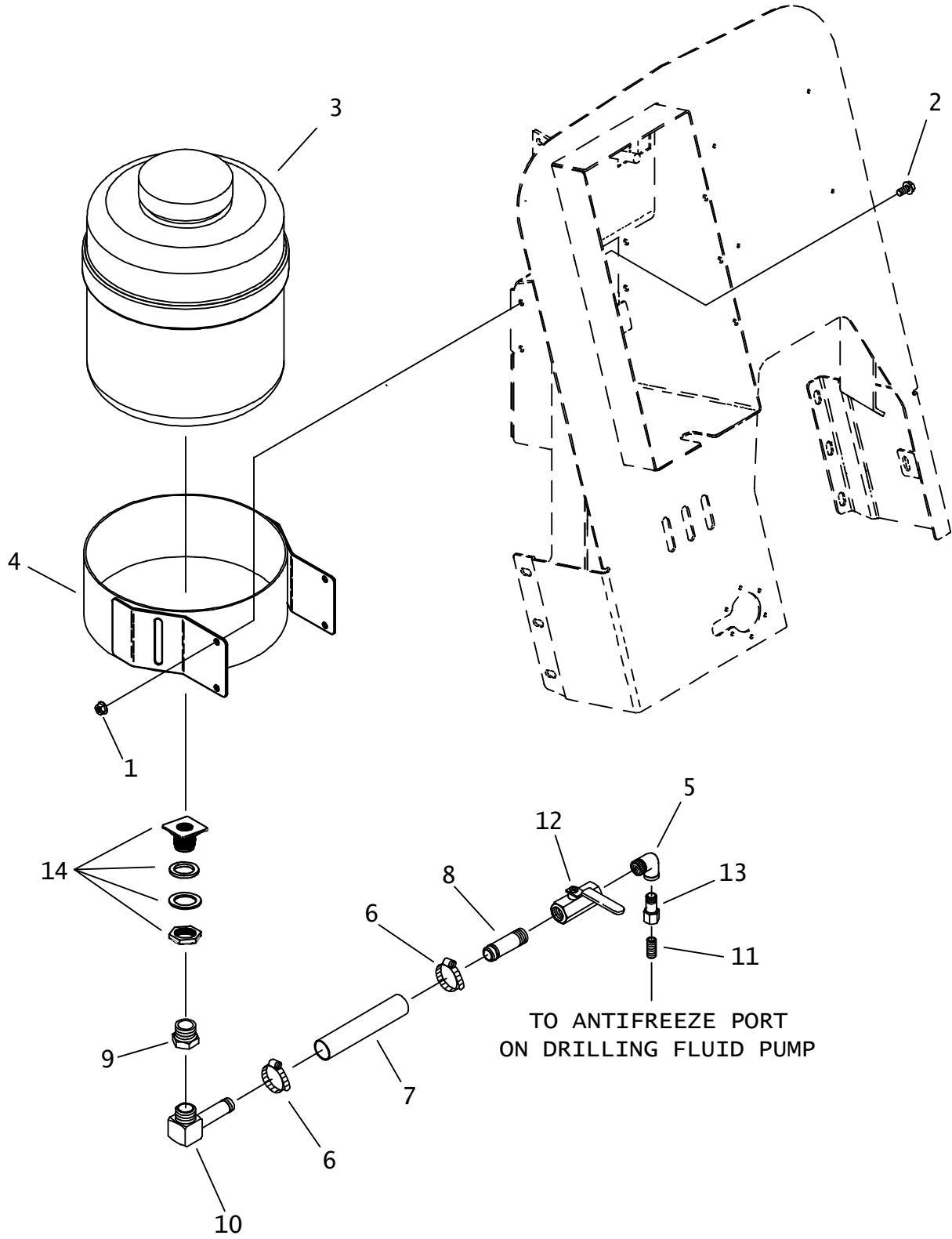

## ANTIFREEZE TANK

REF NO.	PART NUMBER	QTY	DESCRIPTION	REMARKS
	101-140		ANTIFREEZE TANK OPTION	INCL REF #1 THRU #14
1.	106-386	4	FLG LOCKNUT (M8-1.25)	
2.	106-380	4	FLG LK SCREW (M8-1.25 X 16MM)	
3.	364-325	1	ANTIFREEZE TANK (3 GAL)	SEE FOOTNOTE I
	110-707		TANK CAP (96NF)	
4.	315-125	1	TANK MOUNT	
5.	115-141	1	PIPE ELBOW (3/8NPT)	
6.	110-217	2	WORM CLAMP (7/16" TO 1")	
7.	116-881	AR	BULK HOSE (3/8", SOLD PER FT)	USE 1 @ 20"
8.	514-369	1	S/O COUPLER (06N-06H)	
9.	115-219	1	REDUCER (12N-06NF)	
10.	153-871	1	S/O COUPLER (06N-06H90, BRS)	
11.	115-129	1	ALL THREAD (04N) SCH 80	
12.	153-701	1	SHUT OFF (06NF-06NF)	
13.	115-106	1	REDUCER (06N-04NF)	
14.	500-1289	1	BK CONNECTOR (12NF,POLY)	

NOT SHOWN:

FOOTNOTES:

I. INCLUDES REFERENCE NO. 14

NOTE:

# UMBRELLA

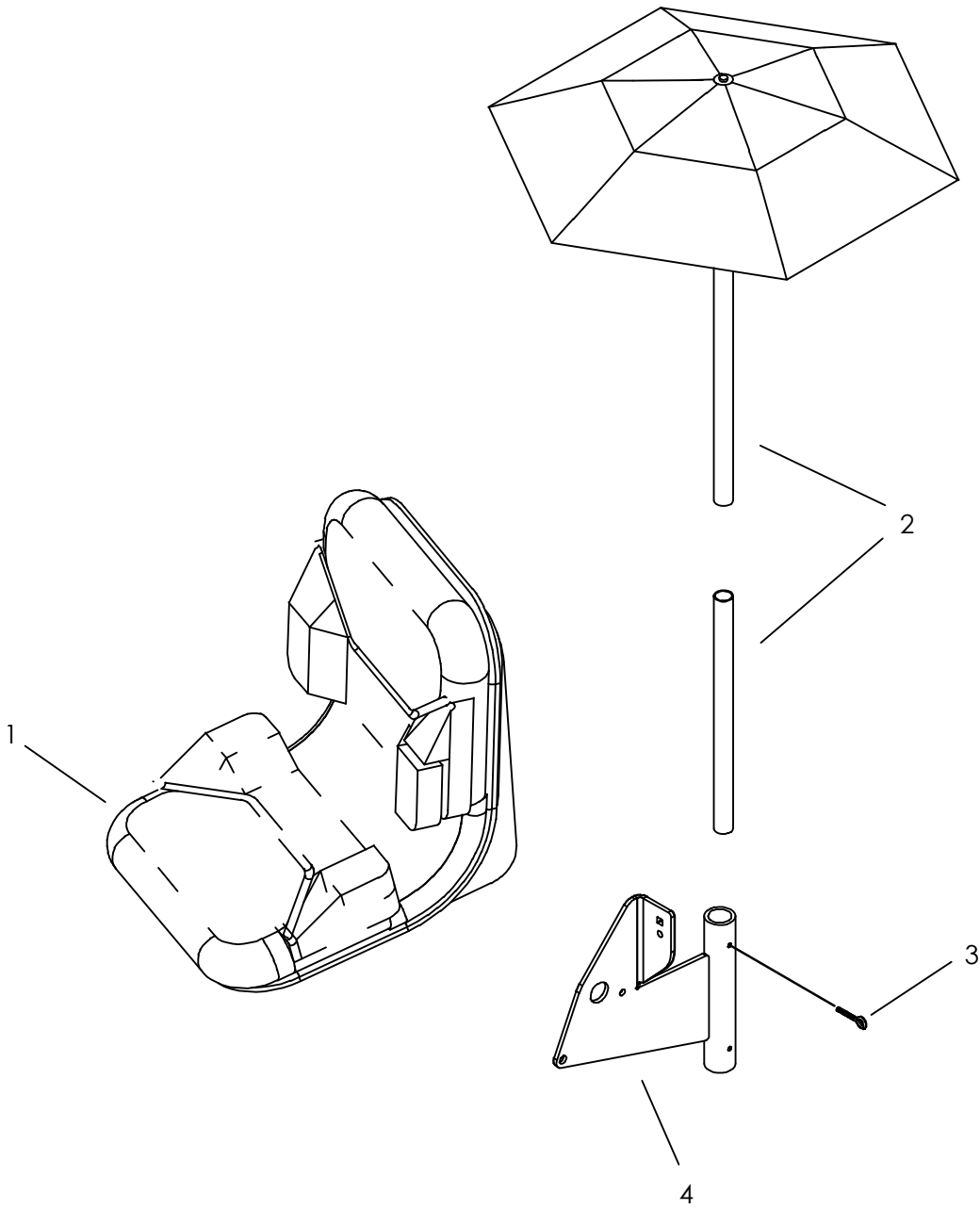

# UMBRELLA

REF NO.	PART NUMBER	QTY	DESCRIPTION	REMARKS
1.	117-631	-	SEAT	
2.	344-700	1	UMBRELLA	
	308-652	-	UMBRELLA POLE	
3.	105-204	2	EYE BOLT (1/4-NC X 1 1/2")	
4.	324-500	1	ARMREST	USE EXISTING HARWARE FOR MOUNTING (REF PARTS PAGE ID0039911)

NOT SHOWN:

FOOTNOTES:

UMBRELLA KIT (101-160) CONTAINS ITEMS 2, 3 AND 4.

NOTE:

# HEATED GREASER

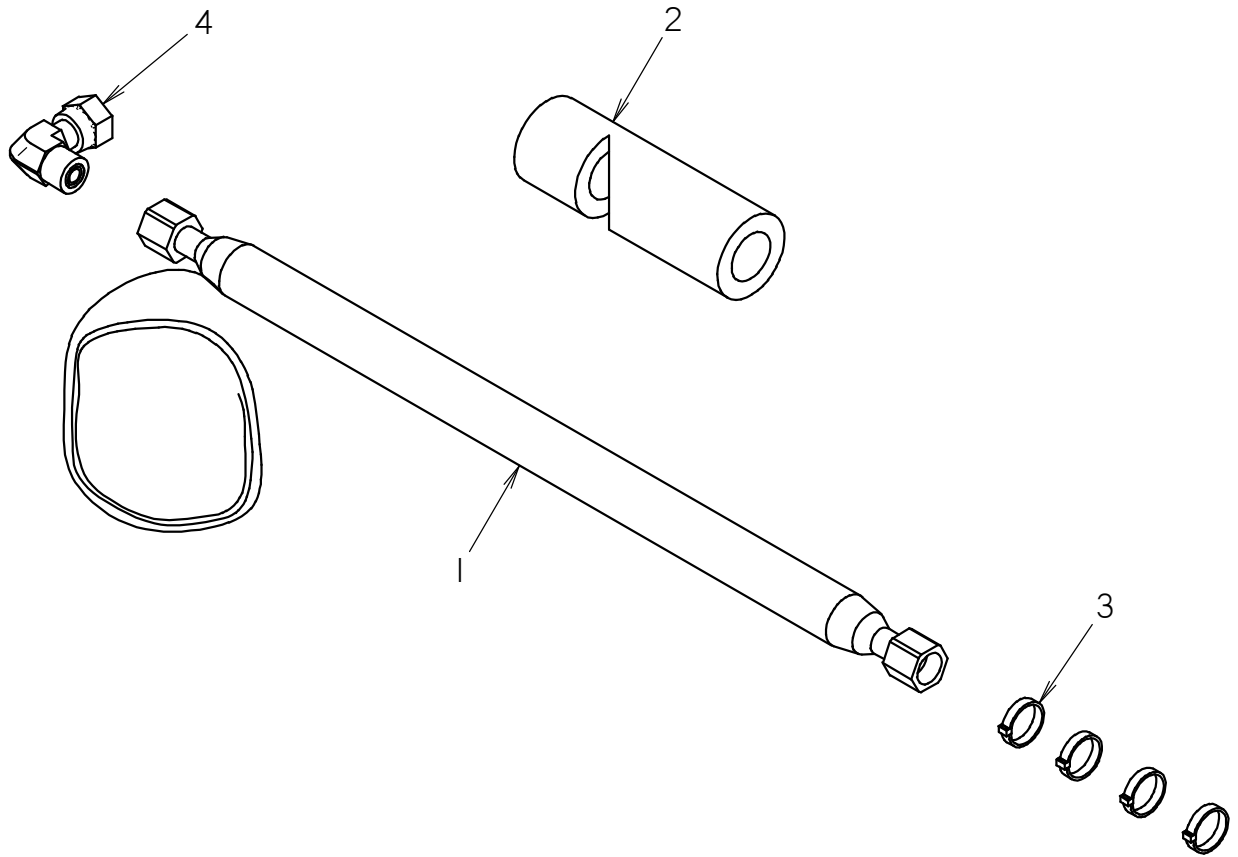

# HEATED GREASER

REF NO.	PART NUMBER	QTY	DESCRIPTION	REMARKS
	101-089		HEATED HOSE KIT	INCLUDES REF NO.'S 1-4
1	153-585	1	HOSE (060FX-18"-3000, SPCL)	
2	117-549	1	INSULATOR (1" ID X 5.00")	
3	110-030	4	CABLE TIE (1/16" TO 4")	
4	154-228	1	UNION (060-060FX90)	

NOT SHOWN:

FOOTNOTES:

NOTE:

## CANOPY

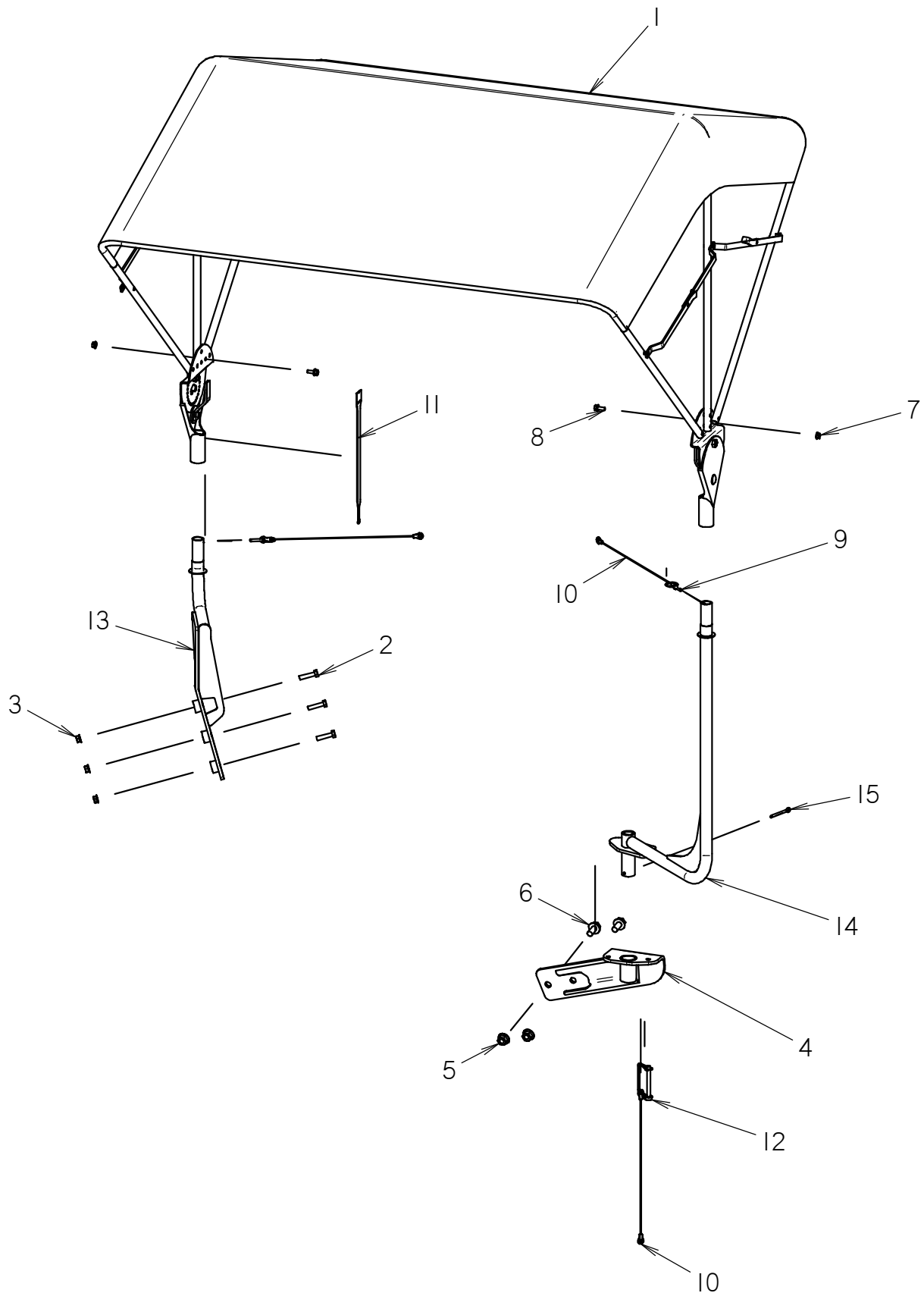

# CANOPY

REF NO.	PART NUMBER	QTY	DESCRIPTION	REMARKS
	190-1464		CANOPY KIT	INCLUDES REF #1 THRU #15
1	190-1286	1	CANOPY	
2	106-267	3	SCREW (M8-1.25 X 35MM)	
3	106-386	3	FLG LOCKNUT (M8-1.25)	
4	300-5729	1	PEDESTAL MOUNT	
5	106-709	2	FLG LK NUT (M12-1.75)	
6	106-806	2	FLG LK SCREW (M12-1.75 X 25MM)	
7	106-385	2	FLG LOCKNUT (M6-1.00)	
8	106-712	2	FLG SCREW (M6-1.00 X 16MM)	
9	110-284	2	PULL PIN (3/16" X 13/16")	
10	110-239	3	LANYARD CABLE (13.5")	
11	118-341	1	VELCRO STRAP	
12	110-032	1	SNAPPER PIN (5/16" X 2-1/2")	
13	324-515	1	CONSOLE MOUNT WELDMENT	
14	324-508	1	OUTER MOUNT	
15	105-502	1	COTTER PIN (3/16" X 2")	

NOT SHOWN:

FOOTNOTES:

NOTE:



## SOFTCAB

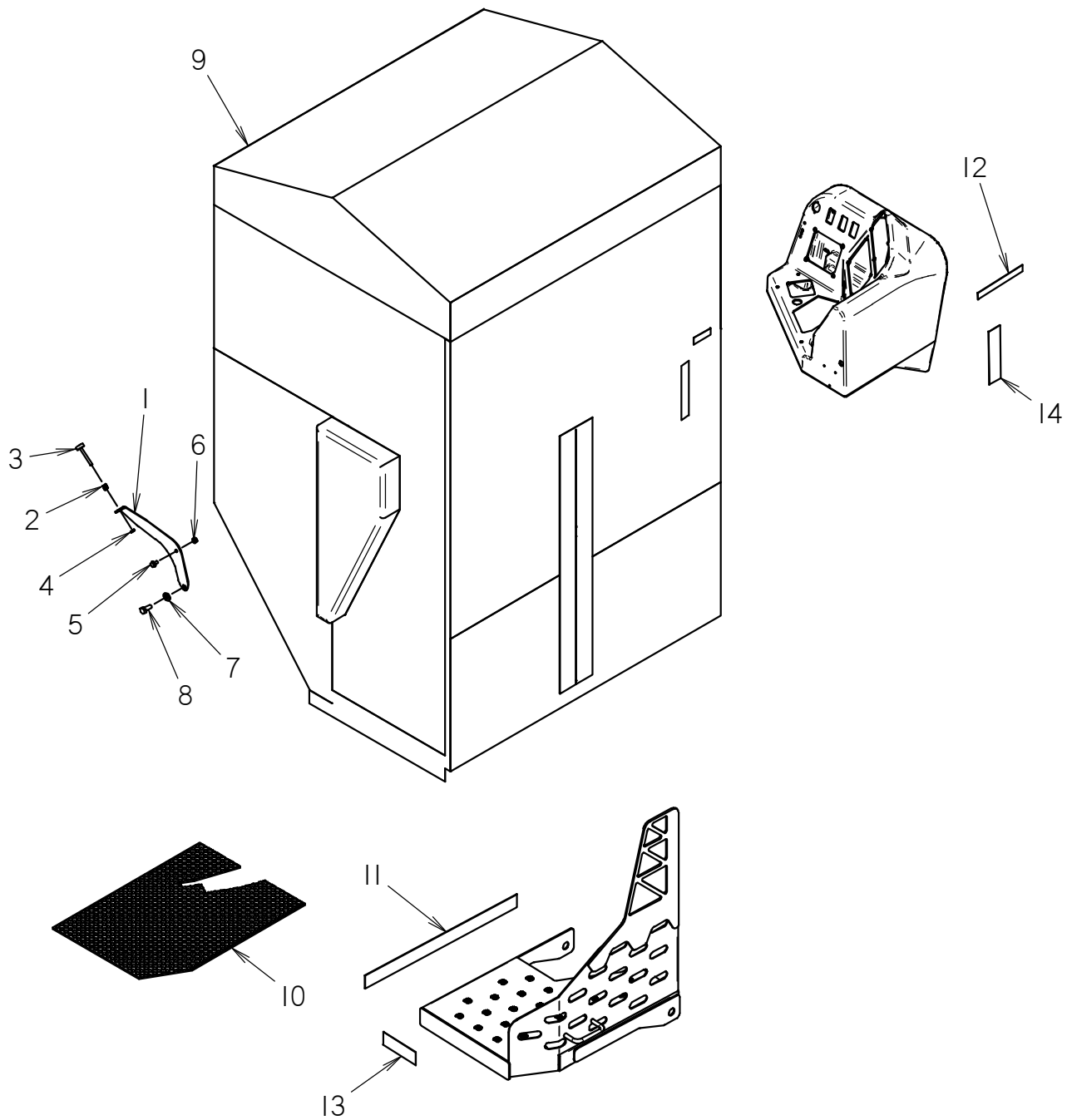

## SOFTCAB

REF NO.	PART NUMBER	QTY	DESCRIPTION	REMARKS
	190-1506		SOFTCAB KIT (JT1220/JT2020)	
1	327-358	1	SUPPORT PLATE	
2	106-038	1	NUTSERT 5/16	
3	118-337	1	BUMPER (2.5")	
4	106-252	1	JAM NUT (5/16-NC)	
5	106-380	1	FLG LK SCREW (M8-1.25 X 16MM)	
6	106-386	1	FLG LOCKNUT (M8-1.25)	
7	106-397	1	WASHER (M12, HARDENED)	
8	105-273	1	SCREW (M12-1.75 X 30MM)	
9	362-1454	1	SOFTCAB (JT1220T4/JT2020T3)	
10	362-1455	1	FLOOR MAT	
11	118-411	1	VELCRO STRIP (2" X 26")	
12	105-1472	1	VELCRO STRIP (1" X 8")	
13	105-1471	1	VELCRO STRIP (2" X 6")	
14	105-1470	1	VELCRO STRIP (2" X 8")	

NOT SHOWN:

FOOTNOTES:

NOTE:

# T18B TIE DOWN KIT

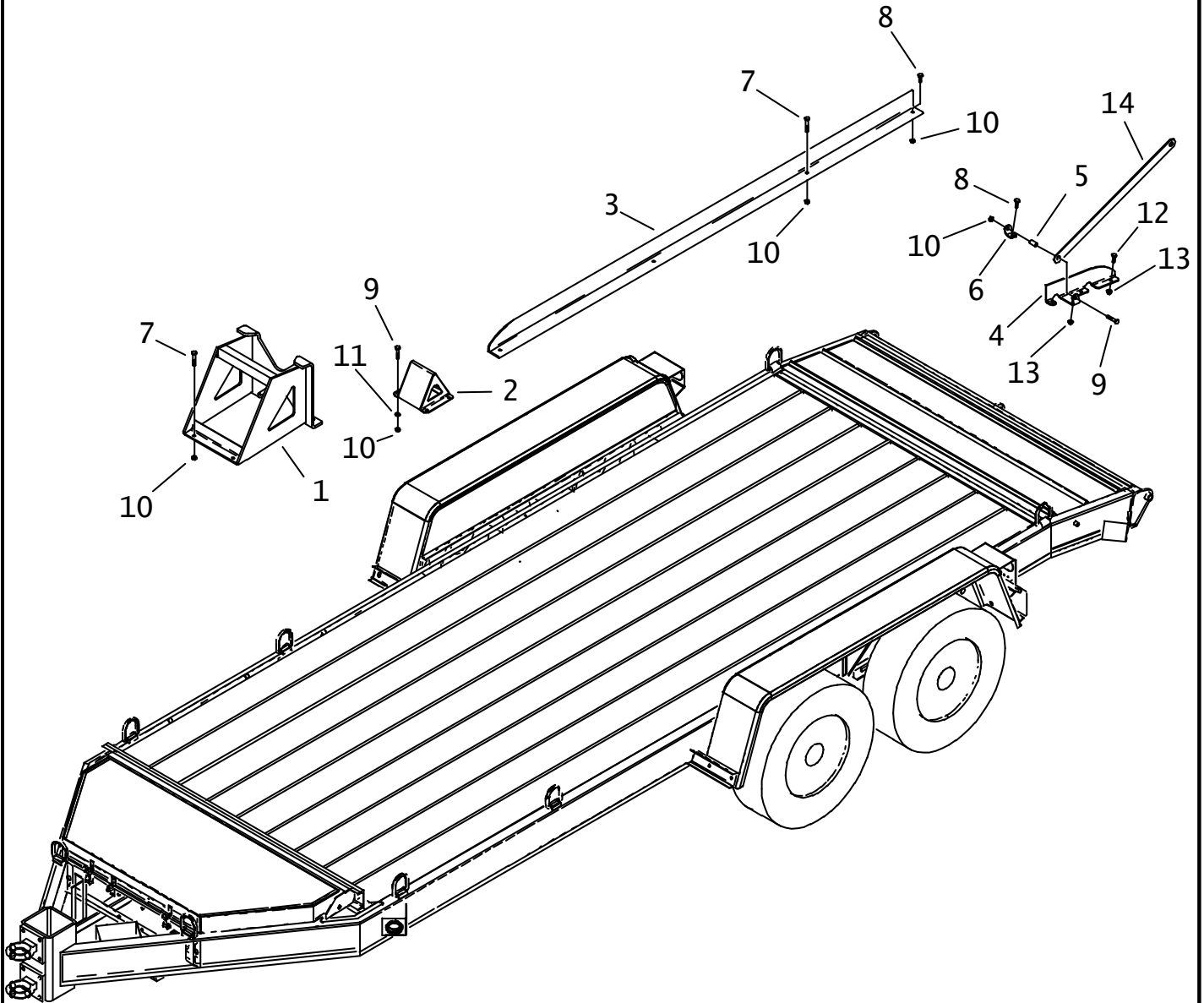

# T18B TIE DOWN KIT

REF NO.	PART NUMBER	QTY	DESCRIPTION	REMARKS
	104-065	-	T18B TIE DOWN KIT	SEE FOOTNOTE 1
1.	323-705	1	FRONT MOUNT	
2.	323-951	2	STOP	
3.	323-737	1	GUIDE RAIL	
4.	323-738	1	GUIDE PLATE	
5.	178-351	1	BUSHING	
6.	323-739	1	BRACKET	
7.	107-308	7	SCREW (M12-1.75 X 75MM)	
8.	106-333	2	SCREW (M12-1.75 X 40MM, 8.8)	
9.	107-507	9	SCREW (M12-1.75 X 65MM)	
10.	106-685	17	LOCKNUT(M12-1.75,PRV TRQ,10.9)	
11.	106-391	8	WASHER (M12)	
12.	105-273	3	SCREW (M12-1.75 X 30MM)	
13.	106-709	4	FLG LK NUT (M12-1.75)	
14.	308-917	-	STOW BAR ASSEMBLY	

NOT SHOWN:

324-465	1	RIGHT TIE DOWN ASSEMBLY
324-466	1	LEFT TIE DOWN ASSEMBLY

FOOTNOTES:

1. INCLUDES REF. NO.S 1 THRU 13, 051-384 INSTRUCTIONS, AND TIE DOWN ASSEMBLIES (NOT SHOWN)

NOTE:

# PIPE BOX LOADER

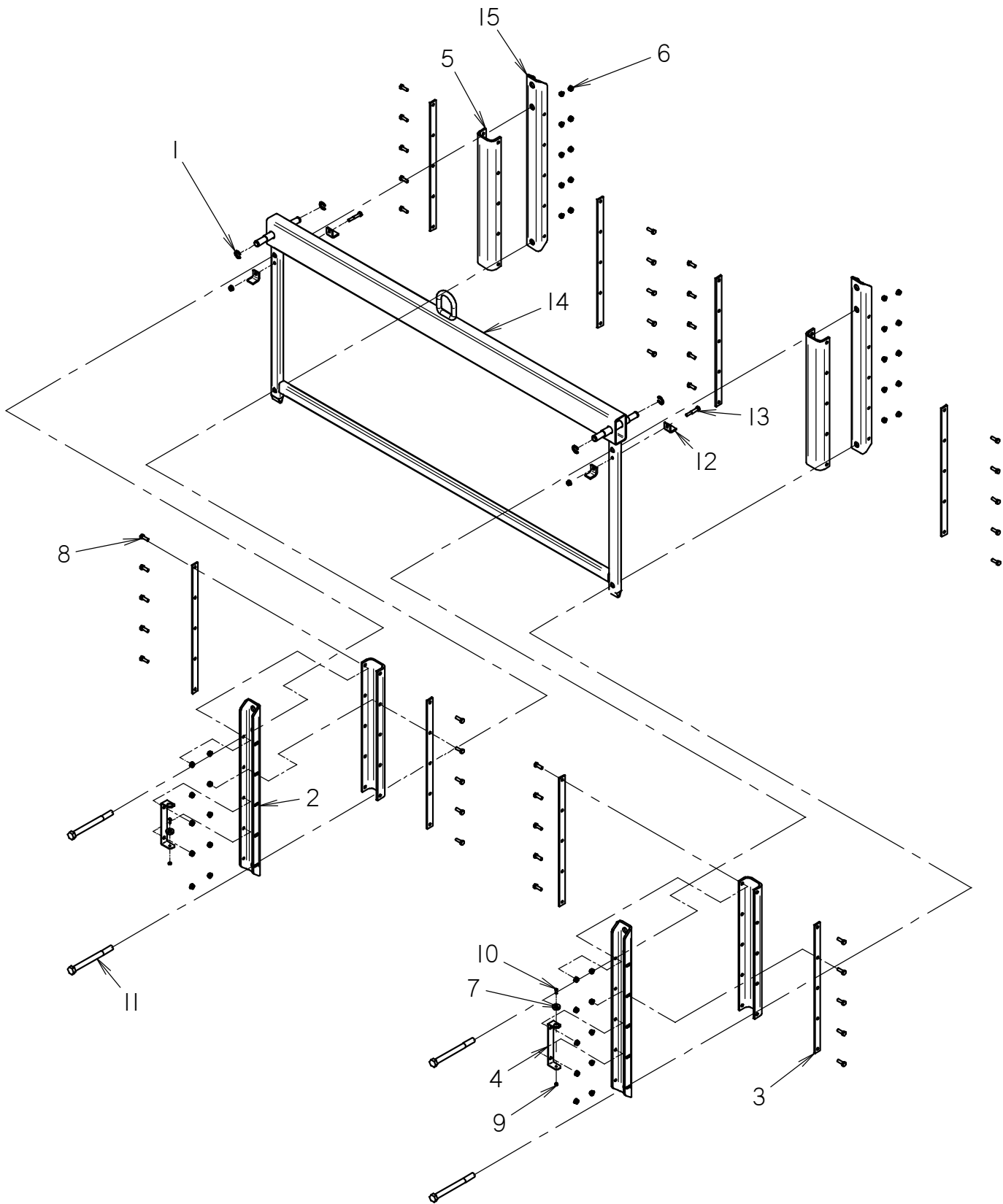

# PIPE BOX LOADER

REF NO.	PART NUMBER	QTY	DESCRIPTION	REMARKS
	101-167	-	PIPE BOX LOADER	INCLUDES REF NO.'S 1 THRU 15
1	115-503	4	KLIP RING (.750")	
2	325-857	2	CHANNEL	
3	118-380	8	CLAMP BAR	
4	177-090	2	STOW BAR	
5	325-856	4	RUBBER STRIP	SEE FOOTNOTE 1
6	106-386	42	FLG LOCKNUT (M8-1.25)	
7	108-182	2	MAGNET (25 MM)	
8	105-806	40	SCREW (M8-1.25 X 25MM)	
9	106-850	2	LOCKNUT (M5-0.80)	
10	108-183	2	SCREW (M5-0.8 X 16MM,CSK PLPS)	
11	106-612	4	SCREW (M6-2.00 X 180MM, 10.9)	
12	363-317	4	PROP BAR MOUNT TAB	USE WITH JT1220 ONLY
13	106-329	2	SCREW (M8-1.25 X 50MM)	USE WITH JT1220 ONLY
14	325-907	1	LIFT TUBE	
15	325-867	2	INSIDE CHANNEL	

NOT SHOWN:

FOOTNOTES:

1. APPLY 256-665 ADHESIVE TO FRONT FACE OF CHANNELS (REF. 2 & 15) BEFORE ASSEMBLING RUBBER STRIP (REF. 5)

NOTE:

## TRANSPORT PIPE BOX

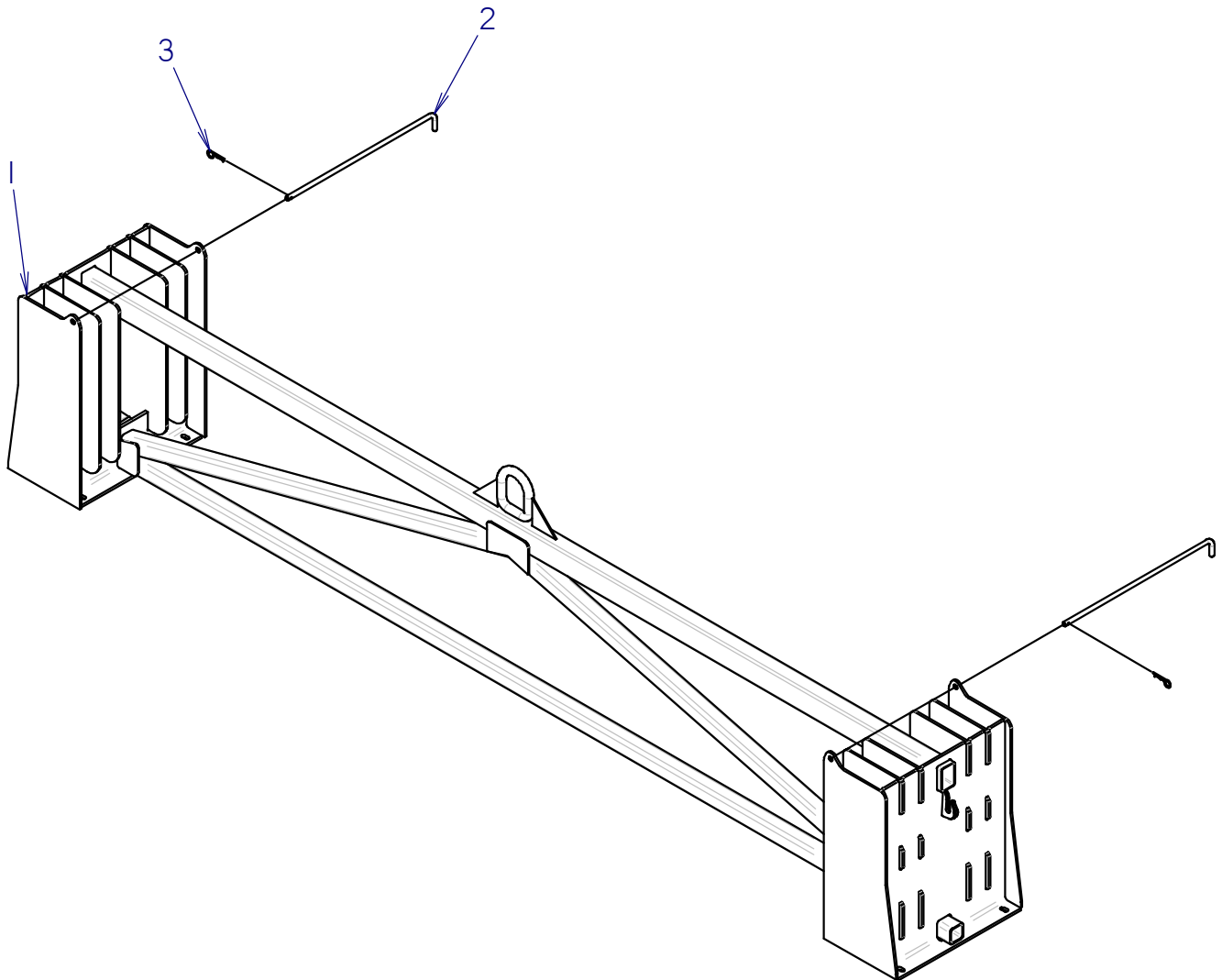

# TRANSPORT PIPE BOX

REF NO.	PART NUMBER	QTY	DESCRIPTION	REMARKS
	329-873	-	AUXILIARY PIPE BOX	INCLUDES REF NOS 1 THRU 3
1	329-857	1	TRANSPORT PIPE BOX	
2	177-028	2	TOP PIN	
3	110-033	2	HAIR CLIP PIN (1/8" X 1/2")	

NOT SHOWN:

FOOTNOTES:

NOTE:





# MISCELLANEOUS

# SAE Bolt and Nut Torque Value Chart

## Grade 5: UNC or UNF Thread

Size	Hex nut, or bolt tapped into hex nut, or d&t hole		Hex top deformed locknut		Flange nut, locknut, or bolt tapped into flange nut or d&t* hole	
	ft•lb	N•m	ft•lb	N•m	ft•lb	N•m
1/4	12	16	8	11	20	27
5/16	25	34	15	20	45	60
3/8	40	54	25	34	75	100
7/16	65	90	40	55	125	170
1/2	100	135	60	80	190	260
9/16	150	200	90	125	270	370
5/8	200	270	120	165	370	500
3/4	350	475	210	285	650	880
7/8	560	760	340	460	1250	1425
1	840	1140	500	680	1580	2145
1-1/8	1030	1400	320	840	1950	3645
1-1/4	1460	1980	880	1195	2760	3475

## Grade 8: UNC or UNF Thread

Size	Hex nut, or bolt tapped into hex nut, or d&t hole		Hex top deformed locknut		Flange nut, locknut, or bolt tapped into flange nut or d&t* hole	
	ft•lb	N•m	ft•lb	N•m	ft•lb	N•m
1/4	14	19	10	14	24	33
5/16	30	40	18	25	50	70
3/8	55	73	35	50	90	125
7/16	85	115	50	70	140	190
1/2	130	175	80	110	220	300
9/16	190	260	110	150	310	420
5/8	260	355	160	245	430	585
3/4	450	610	270	365	750	1015
7/8	730	990	440	600	1210	1640
1	1090	1480	650	880	1320	2465
1-1/8	1550	2100	930	1260	2580	3500
1-1/4	2180	2955	1310	1780	3640	4935

\*drilled and tapped

# Metric Bolt and Cap Screw Torque Values

Size	Class 4.8				Class 8.8 and 9.8				Class 10.9				Class 12.9			
	Lubricated		Dry		Lubricated		Dry		Lubricated		Dry		Lubricated		Dry	
	N•m	ft•lb	N•m	ft•lb	N•m	ft•lb	N•m	ft•lb	N•m	ft•lb	N•m	ft•lb	N•m	ft•lb	N•m	ft•lb
M6	4.8	3.5	6	4.5	9	6.5	11	8.5	13	9.5	17	12	15	11.5	19	14.5
M8	12	8.5	15	11	22	16	28	20	32	24	40	30	37	28	47	35
M10	23	17	29	21	43	32	55	40	63	47	80	60	75	55	95	70
M12	40	29	50	37	75	55	95	70	110	80	140	105	130	95	165	120
M14	63	47	80	60	120	88	150	110	175	130	225	165	205	150	260	190
M16	100	73	125	92	190	140	240	175	275	200	350	225	320	240	400	300
M18	135	100	175	125	260	195	330	250	375	275	475	350	440	325	560	410
M20	190	140	240	180	375	275	475	350	530	400	675	500	625	460	800	580
M22	260	190	330	250	510	375	650	475	725	540	925	675	850	625	1075	800
M24	330	250	425	310	650	475	825	600	925	675	1150	850	1075	800	1350	1000
M27	490	360	625	450	950	700	1200	875	1350	1000	1700	1250	1600	1150	2000	1500
M30	675	490	850	625	1600	950	1650	1200	1850	1350	2300	1700	2150	1600	2700	2000
M33	900	675	1150	850	1750	1300	2200	1650	2500	1850	3150	2350	2900	2150	3700	2750
M36	1150	850	1450	1075	2250	1650	2850	2100	3200	2350	4050	3000	3750	2750	4750	3500

Do not use these values if a different torque value or tightening procedure is given for specific application. Torque values listed are for general use only. Check tightness of fasteners periodically.

Shear bolts are designed to fail under predetermined loads. Always replace shear bolts with identical property class fasteners.

Fasteners should be replaced with the same or higher property class. If higher property class fasteners are used, these should only be tightened to strength of original.

Make sure fastener threads are clean and that the threads are properly started. This will prevent them from cross threading or galling when tightened.

Tighten plastic insert or crimped type steel locknuts to approximately 50% of dry torque indicated on chart. Apply torque to the nut - not the bolt head. Tighten toothed or serrated type locknuts to full torque value.

LUBRICATED means coated with lubricant. DRY means plain or zinc plated without any type of lubricant.

## Hydraulic Cylinder Bolt Torque Chart

Bolt Size (inch)	Bolt Part No.	Cylinder Repair Kit Part No.	Torque (ft•lb)	Torque (N•m)
1/2	106-096	190-165	90-100	120-135
5/8	106-097	190-166 & 190-169	180-200	245-270
3/4	106-098	190-167 & 190-170	290-325	395-440
7/8	106-122	190-172 & 190-174	410-640	550-625
1	106-145	190-175 & 190-189	630-700	855-950
1-1/8	106-146	190-177	770-850	1045-1170

As a general rule:

- 1/2-inch bolts are used in cylinders with 1-inch rods
- 5/8-inch bolts are used in cylinders with 1 1/4-inch rods
- 3/4-inch bolts are used in cylinders with 1 1/2-inch rods
- 7/8-inch bolts are used in cylinders with 1 3/4-inch rods
- 1-inch bolts are used in cylinders with 2-inch rods (one with 1 3/4-inch)
- 1-1/8-inch bolts are used in cylinders with 2-1/4-inch rods

**IMPORTANT:** Do not reuse cylinder piston bolts when rebuilding a hydraulic cylinder. Each cylinder repair kit contains a new bolt. Use it. Lubricate lightly and torque to value shown on chart.

# SAE & ORS Hydraulic Fitting Replacement O-Ring Chart

Fraction Size	Dash Size	SAE (Port Seal O-Ring)		ORS (Face Seal O-Ring)	
		Thread Size	O-Ring P/N	Thread Size	O-Ring P/N
1/16	1	NA	NA	NA	NA
1/8	2	5/16 - 24	NA	NA	NA
3/16	3	3/8 - 24	NA	NA	NA
1/4	4	7/16 - 20	155-760	9/16 - 18	157-037
5/16	5	1/2 - 20	NA	NA	NA
3/8	6	9/16 - 18	155-705	11/16 - 16	157-038
1/2	8	3/4 - 16	155-706	13/16 - 16	157-039
5/8	10	7/8 - 14	155-707	1 - 14	157-040
3/4	12	1-1/16 - 12	155-709	1-3/16 - 12	157-017
7/8	14	1-3/16 - 12	155-747	NA	NA
1	16	1-5/16 - 12	155-748	1-7/16 - 12	155-714
1-1/4	20	1-5/8 - 12	155-702	1-11/16 - 12	NA
1-1/2	24	1-7/8 - 12	157-001	2 - 12	NA
2	32	2-1/2 - 12	NA	NA	NA
2-1/2	40	3 - 12	NA	NA	NA
3	48	3-1/2 - 12	NA	NA	NA

Thread size indicates the diameter of the threaded area in fractions of an inch and number of threads per inch.

NA = not a current CMW part numbered o-ring, or dash size does not occur in current CMW applications

SAE = straight thread fitting that seals by sandwiching a hard o-ring between a shoulder on the male part and an angular surface at the mouth of the female port.

ORS = o-ring face seal; a type of fitting that seals by compressing a hard, captive o-ring between two flat parallel faces, one grooved for the o-ring and the other plain to act as the sealing surface

# JT1220 T4i

## Related Publications

Component	Ass'y	P/N
<b>Model:</b>		
JT1220 ..... Parts Manual .....		053-1263
JT1220 ..... Operators Manual .....		053-1383
JT1220 ..... Repair Guide (Service Manual) .....		N/A
JT1220 ..... Technical Supplement.....		053-1350
<b>Engine:</b>		
Cummins 60HP. .... Parts Manual – B3.3. ....	195-1320 .....	053-103
Cummins..... Operators Manual – B3.3. ....		055-069
Cummins... .. Repair Manual – B3.3.....		055-070

## Filters

<b>Engine:</b>		
Air Filter Parts Ass'y .....		194-297
Element (primary) .....		194-759
Element (secondary).....		194-758
Oil Filter Element (spin-on) – Cummins B3.3....		194-454
Fuel Filter Element (spin-on) – Cummins B3.3 .....		194-461
<b>Hydraulic:</b>		
Oil Filter Element (1-1/2-UNF, spin-on, Replacement) .....		153-792

## Optional Kits

O-ring Repair Kit - FLG, ORS & SAE (15 different O-rings) .....		190-051
O-ring Repair Kit - Field Service (46 different O-rings) .....		190-052



# Ditch Witch<sup>®</sup>

## Parts Manual Change Request

(Please print clearly)

Date: \_\_\_\_\_ Dealer No. (required): \_\_\_\_\_

Your Name: \_\_\_\_\_ Position: \_\_\_\_\_

Phone: \_\_\_\_\_ Fax: \_\_\_\_\_ E-mail: \_\_\_\_\_

### Publication Information:

Parts Manual No.: \_\_\_\_\_ - \_\_\_\_\_ Model: \_\_\_\_\_

Illustration Part No.: \_\_\_\_\_ Manual Page No.:

- |                        |          |
|------------------------|----------|
| 1. _____ - _____ ..... | 1. _____ |
| 2. _____ - _____ ..... | 2. _____ |
| 3. _____ - _____ ..... | 3. _____ |

### Nature of Change Request:

- Text
- Graphics
- Missing Information

Describe change requested (if possible, include copy of publication page with changes marked.):

---



---



---



---



---



---

**Please fax completed form to  
Parts Manual Department (580) 572-3525**

*Thank you for taking the time to submit this request. We will contact you if further information is needed to process your request.*





# **A Note To Ditch Witch Equipment Owners:**

If your equipment was purchased through a Ditch Witch dealer, there is no need to read further.

However, if you purchased from any other source, please fill out the form on the reverse side and return it to us.

This will enable you to receive updates on this equipment as well as information on new products of interest.

Thanks for using Ditch Witch equipment.

(Please Fold Along This Line And Seal At Bottom With Tape)



**NO POSTAGE  
NECESSARY  
IF MAILED  
IN THE  
UNITED STATES**

**BUSINESS REPLY MAIL**  
FIRST CLASS      PERMIT NO 23      PERRY OKLAHOMA

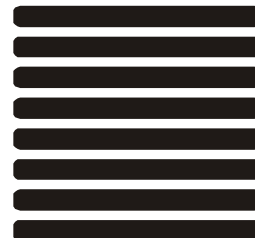

POSTAGE WILL BE PAID BY

**The Charles Machine Works, Inc.  
P.O. Box 66  
Perry, Oklahoma 73077-9989**



# Ditch Witch® Registration Card

Please Type or Print All Information

---

Purchaser's Company Name

---

Attention

---

Street Address or P.O. Box

---

City

County

---

State

Zip

Nation

---

(       )

Phone Number With Area Code

---

Model

Serial Number

---

Attachments/Accessories

Serial Numbers

---

Attachments/Accessories

Serial Numbers

---

Attachments/Accessories

Serial Numbers

---

Name of Ditch Witch Dealership

---

Your Signature