

# ***Ditch Witch***<sup>®</sup>

## **JT4020 Mach 1 All Terrain Tier 2**

ISSUE NO. 06PL-07/11

For Replacement Copy Order **P/N 053-137**

**This product is covered by one or more of the following patents:**

**US** B1 4,858,704; 4,953,638; 5,148,880; 5,242,026; 5,341,887; 5,490,569; 5,684,466; 5,713,423,  
5,794,719; 5,880,680; 5,941,322; 6,085,852; 6,109,371; 6,179,065; 6,216,803; 6,250,403;  
6,250,404; 6,290,606; 6,311,790; 6,411,094; 6,543,551; 6,550,547; 6,672,409; 6,739,413;  
6,776,246; 6,808,210; 6,827,158; RE37,450; RE37,923; RE37,975; RE38,418

**AU** 689,533; 706,544; 718,034, 755,862

**CA** 2,156,398

**FR** 674,093

**DE** 694 17 019; 695 29 634; 297 01 406

**EP** 0683845; 0674093; 0817901; 0846841

**GB** 2,209,239; 2,312,006; EP674,093; EP846,841

**JP** 3,458,247

**Other U.S. and foreign patents pending**

This manual contains information concerning the following models:  
**JT4020 Mach 1 All Terrain Tier 2 Directional Drilling System**

Copyright 2004, 2005, 2006, 2008, 2011 by The Charles Machine Works, Inc.

 **Ditch Witch**, Ditch Witch, CMW, AutoCrowd, Jet Trac, Roto Witch, Subsite, Fluid Miser, Power Pipe, Super Witch, Pierce Arrow, The Underground, The Underground Authority Worldwide, and Zahn are registered trademarks of The Charles Machine Works, Inc.

**ID0135017**



# FOREWORD

---

This manual contains illustrated parts lists to help you select quality ProTech<sup>®</sup> Replacement parts for your Ditch Witch<sup>®</sup> equipment. Using other replacement parts will lessen the productivity of your equipment.

- ◆ Part numbers enclosed in a box are no longer available from The Charles Machine Works, Inc. Your local Ditch Witch dealer may be able to locate the part for you.
- ◆ Footnotes provide more information to help you identify parts shown in the manual.
- ◆ Assembly instructions and Tech Bits articles referenced in footnotes are available through your local Ditch Witch dealer.
- ◆ Description and specifications in this book were current at publication. However, The Charles Machine Works, Inc. reserves the right to improve equipment, so this manual might not reflect the most current improvements.
- ◆ Instructions on recommended equipment use and maintenance are in the Operator's Manual that was shipped with your equipment.

## **Keep the following in mind when ordering ProTech replacement parts:**

- ◆ Specify parts you need by part number and description, not by illustration reference numbers.
- ◆ Have equipment model and serial number on hand to help ensure you get the right parts for your machine whether it's old or new.

**Thank you for buying and using Ditch Witch equipment and ProTech replacement parts.**

# WARRANTY

---

DW WARRANTY Policy  
July, 2005

## **POLICY 1: DITCH WITCH® EQUIPMENT AND REPLACEMENT PARTS LIMITED WARRANTY POLICY**

Subject to the limitation and exclusions herein, free replacement parts will be provided at any authorized Ditch Witch dealership for any Ditch Witch equipment or parts manufactured by The Charles Machine Works, Inc. (CMW) that fail due to a defect in material or workmanship within one (1) year of first commercial use (Exception: 2 years for all SK500 Attachments). Free labor will be provided at any authorized Ditch Witch dealership for installation of parts under this warranty during the first year following "initial commercial" use of the serial numbered Ditch Witch equipment on which it is installed. The customer is responsible for transporting their equipment to an authorized Ditch Witch dealership for all warranty work.

### **EXCLUSIONS FROM PRODUCT WARRANTY**

- All incidental or consequential damages.
- All defects, damages, or injuries caused by misuse, abuse, improper installation, alteration, neglect, or uses other than those for which products were intended.
- All defects, damages, or injuries caused by improper training, operation, or servicing of products in a manner inconsistent with manufacturer's recommendations.
- All engines and engine accessories (these are covered by original manufacturer's warranty).
- Tires, belts, and other parts which are subject to another manufacturer's warranty. (Such warranty will be available to purchaser.)
- ALL IMPLIED WARRANTIES NOT EXPRESSLY STATED HEREIN, INCLUDING ANY WARRANTY OF FITNESS FOR A PARTICULAR PURPOSE AND MERCHANTABILITY.

IF THE PRODUCTS ARE PURCHASED FOR COMMERCIAL PURPOSES, AS DEFINED BY THE UNIFORM COMMERCIAL CODE, THEN THERE ARE NO WARRANTIES WHICH EXTEND BEYOND THE FACE HEREOF AND THERE ARE NO IMPLIED WARRANTIES OF ANY KIND WHICH EXTEND TO A COMMERCIAL BUYER. ALL OTHER PROVISIONS OF THIS LIMITED WARRANTY APPLY INCLUDING THE DUTIES IMPOSED.

Ditch Witch products have been tested to deliver acceptable performance in most conditions. This does not imply they will deliver acceptable performance in all conditions. Therefore, to assure suitability, products should be operated under anticipated working conditions prior to purchase.

Defects will be determined by an inspection within thirty (30) days of the date of failure of the product or part by CMW or its authorized dealer. CMW will provide the location of its inspection facilities or its nearest authorized dealer upon inquiry. CMW reserves the right to supply remanufactured replacement parts under this warranty as it deems appropriate.

Extended warranties are available upon request from your local Ditch Witch dealer or CMW.

Some states do not allow exclusion or limitation of incidental or consequential damages, so the above limitation or exclusion may not apply. Further, some states do not allow exclusion of or limitation of how long an implied warranty lasts, so the above limitation may not apply. This limited warranty gives product owner specific legal rights and the product owner may also have other rights which vary from state to state.

For information regarding this limited warranty, contact CMW's Product Support Department, P.O. Box 66, Perry, OK 73077-0066, or contact your local Ditch Witch dealer.

# CONTENTS

---

## Decals

Decal Location - AT/JT42T2 .....	8
----------------------------------	---

## Engine Components

Air Filter System .....	30
Charge Air .....	36
Covers - Battery .....	46
Covers - Engine .....	40
Deareation .....	38
Engine .....	14
Engine Mount .....	20
Engine Oil Drain .....	28
Engine Skid .....	22
Engine Skid Edging .....	24
Fan & Shroud Assembly .....	18
Fan Drive .....	16
Gauge Panel .....	48
Radiator .....	32
Radiator Mount .....	34
Sound Insulation .....	44

## Operator's Station

Console .....	58
Console Gauges .....	62
Dual Axis Joystick .....	66
Left Console Relay Panel .....	60
Operator Station .....	52
Seat - Belts - Cover .....	56

## Track Frame & Main Frame

2-Post ROPS .....	82
Cylinder Grease .....	76
Drill Frame - Cover/Locks/Switches .....	84
Fuel Tank .....	80
Hose Retaining Clamp .....	86
Idler .....	72
Roller .....	74
Stabilizer - Rear .....	78
Track Group - Rubber .....	70

## Anchor Systems

Anchor .....	104
Anchor Drive - Left .....	100
Anchor Drive - Right .....	98
Anchor Valve/Cover Mount .....	92
Auger Anchor Base .....	90
Flange Hex Driver .....	102
Front Pipe Guide - JT4020AT .....	94
Front Pipe Guide - JT4020M1 .....	96

## Lubricator

Applicator .....	114
Auto-Luber .....	110
Grease Pump .....	112
Grease Pump Mounting .....	108
Selector Valve .....	116

## Drill Frame

Carriage - AT42M1/AT42T2 .....	124
Carriage - JT42M1/JT42T2 .....	126
Carriage Chain .....	128
Clamp Assembly .....	152
Grease Cylinder .....	156
Hose Track .....	150
Hydraulic Cylinder (4.5" x 2.25" x 2.75") .....	158
Pivot .....	120
Rotation Drive Gearbox - JT4020AT - Begins .....	140
Rotation Drive Gearbox - JT4020AT - Ends .....	136
Rotation Drive Gearbox - JT4020M1 .....	144
Rotation Drive Gearbox - JT42M1/JT42T2 .....	132
Spindle Drive Assembly .....	148
Thrust Drive .....	122
Thrust Idler .....	130
Wrench Pipe Guide .....	154

## Pipe Loader System

Gripper Cylinder .....	172
Guard Lock Pin .....	184
Pipe Box - AT Pipe .....	178
Pipe Box - JT Pipe .....	180
Pipe Loader Gripper .....	170
Pipe Loader Lifters .....	164
Pipe Loader Shuttle - Front .....	166
Pipe Loader Shuttle - Rear .....	168
Pipe Loader Shuttle Drive .....	162
Shuttle Guard .....	182
Shuttle Stop .....	174
Shuttle Stop Indicator .....	176

## Fluid System

Antifreeze Tank .....	204
Fluid Pump - Fluid - 70 GPM .....	196
Fluid Pump - Power .....	198
Fluid Pump - Power - L1122, L1622 .....	202
Mud Pump Plumbing - 70 GPM .....	188
Mud Pump Plumbing - 120 GPM .....	190
Mud Pump - Fluid - 120 GPM .....	194
Mud System Plumbing .....	192
Pump Mount .....	200
Wash Wand .....	206

## Hydraulics

2-Speed Track/Thrust .....	240
Anchor Motor Hydraulics - Left .....	292
Anchor Motor Hydraulics - Right .....	290
Anchor Supply Hydraulics .....	286
Anchor Valve Pressure & Return Hydraulics .....	288
Auxiliary Supply/Return Hydraulics .....	300
Auxiliary Valve .....	298
Cylinder (2" x 1" x 8") .....	320

**Continued**

# CONTENTS

---

## **Hydraulics Continued**

Cylinder (2" x 1.25" x 24") .....	320
Cylinder (3" x 1.75" x 8") .....	322
Cylinder (4" x 2" x 5") .....	324
Cylinder (4" x 2" x 10") .....	326
Cylinder Anchor Thrust - Left .....	294
Cylinder Anchor Thrust - Right .....	292
Fluid Check Supply Hydraulics .....	248
Fluid Motor Hydraulics .....	270
Frame Tilt Hydraulics .....	304
Greaser Hydraulics .....	314
Gripper Hydraulics .....	312
Hydraulic Reservoir .....	216
Inner Rotation Control Kit .....	262
Inner Rotation Hydraulics - AT .....	260
Inner Spindle Rotation Gauge - AT .....	228
Inner/Outer Spindle Drive Case .....	234
Load Sense Hydraulics - Begins .....	254
Load Sense Hydraulics - Ends .....	250
Load Sense Rear Hydraulics .....	258
Main Frame Bulkhead .....	220
Oil Cooler Hydraulics .....	210
Oil Cooler Return Hydraulics .....	212
Oil Return Hydraulics - Ends .....	214
Outer Rotation Hydraulics - Begins/Ends .....	232
Outer Rotation Hydraulics .....	230
Outer Spindle Drive Case - JT42M1/JT42T2 .....	236
Pipe Lifter Hydraulics - JT4020AT .....	310
Pipe Loader Supply & Return .....	306
Pipe Shuttle Hydraulics .....	308
Remote Filter .....	238
Rotation - Thrust/Mud Gauges .....	218
Rotation Gauge Valve - JT4020AT .....	224
Rotation Hydraulics .....	222
Rotation Test Ports (JT4020M1) .....	226
Seat Rotation Hydraulics .....	316
Shuttle Stop Hydraulics .....	302
Spindle Brake .....	242
Stabilizer Hydraulics .....	300
Thrust Drive Hydraulics .....	268
Thrust Hydraulics (JT4020AT) .....	266
Thrust/Track Drive Pump Hydraulics - Ends .....	264
Track Brake Hydraulics .....	246
Track Case Drain Hydraulics .....	274
Track Drive Hydraulics .....	272
Track Shift .....	244
Wrench Hydraulics - Front .....	278
Wrench Hydraulics - Rear .....	280
Wrench Hydraulics .....	276
Wrench Hydraulics - Rotate .....	282

## **Electrical**

Alarm/Strobe Light .....	336
Battery .....	332
Panel .....	334
Relay Panel .....	338
Right Console .....	330

## **Accessories**

Drilling Fluid Transfer .....	342
Fluid Mixing Accessories .....	344
Grounding Hardware .....	350
Heated Hose Kit .....	346
Tool Box .....	354
Vandal Covers .....	352
Working Light .....	348

## **Miscellaneous**

Bolt/Nut Torque Chart .....	358
Filters .....	362
Optional Kits .....	362
Parts Manual Change Request .....	363
Related Publications .....	362
Replacement O-Ring Chart .....	361
Warranty Registration .....	366

# DECALS

# DECAL LOCATION AT/JT42T2

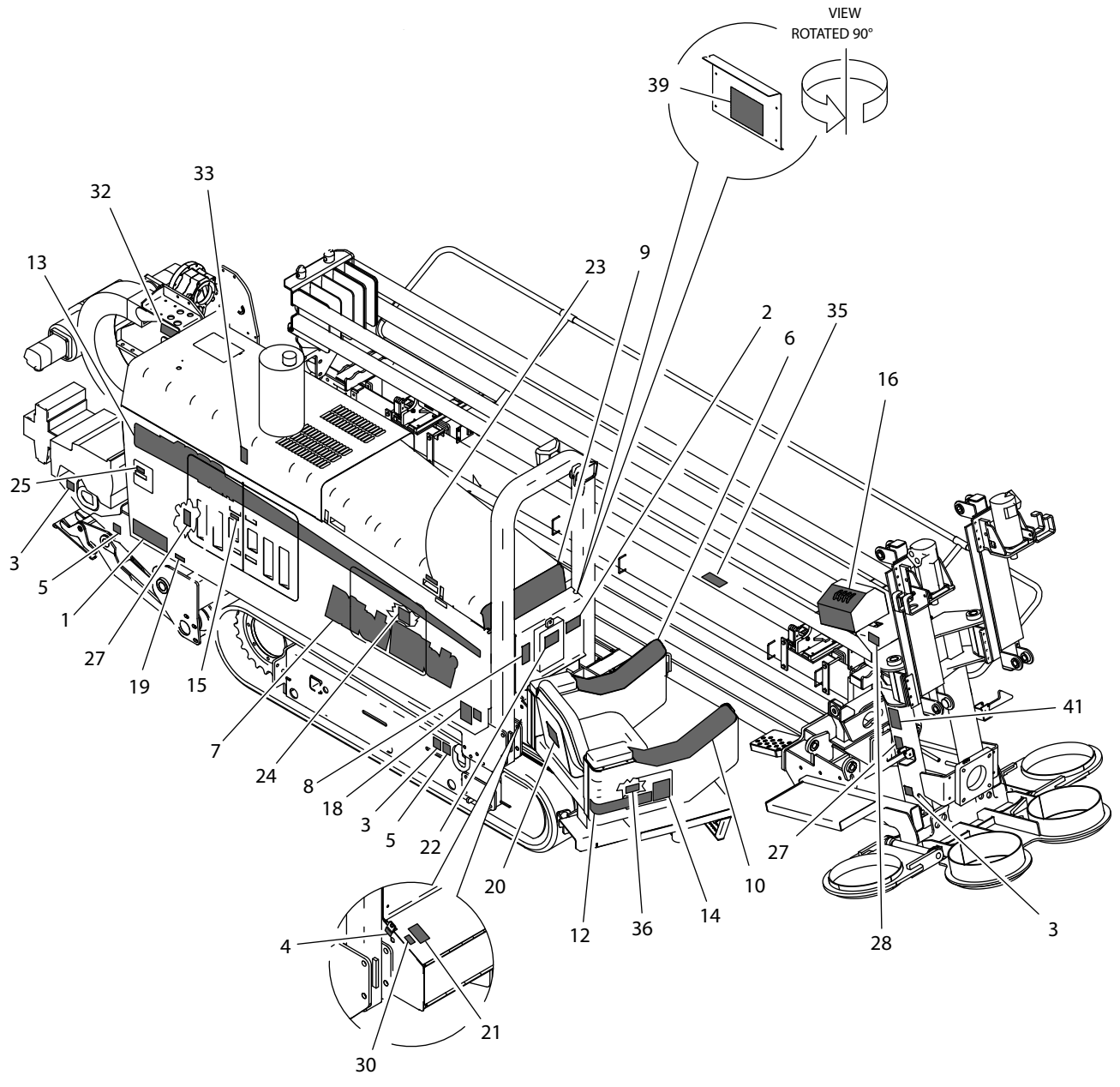



# DECAL LOCATION AT/JT42T2

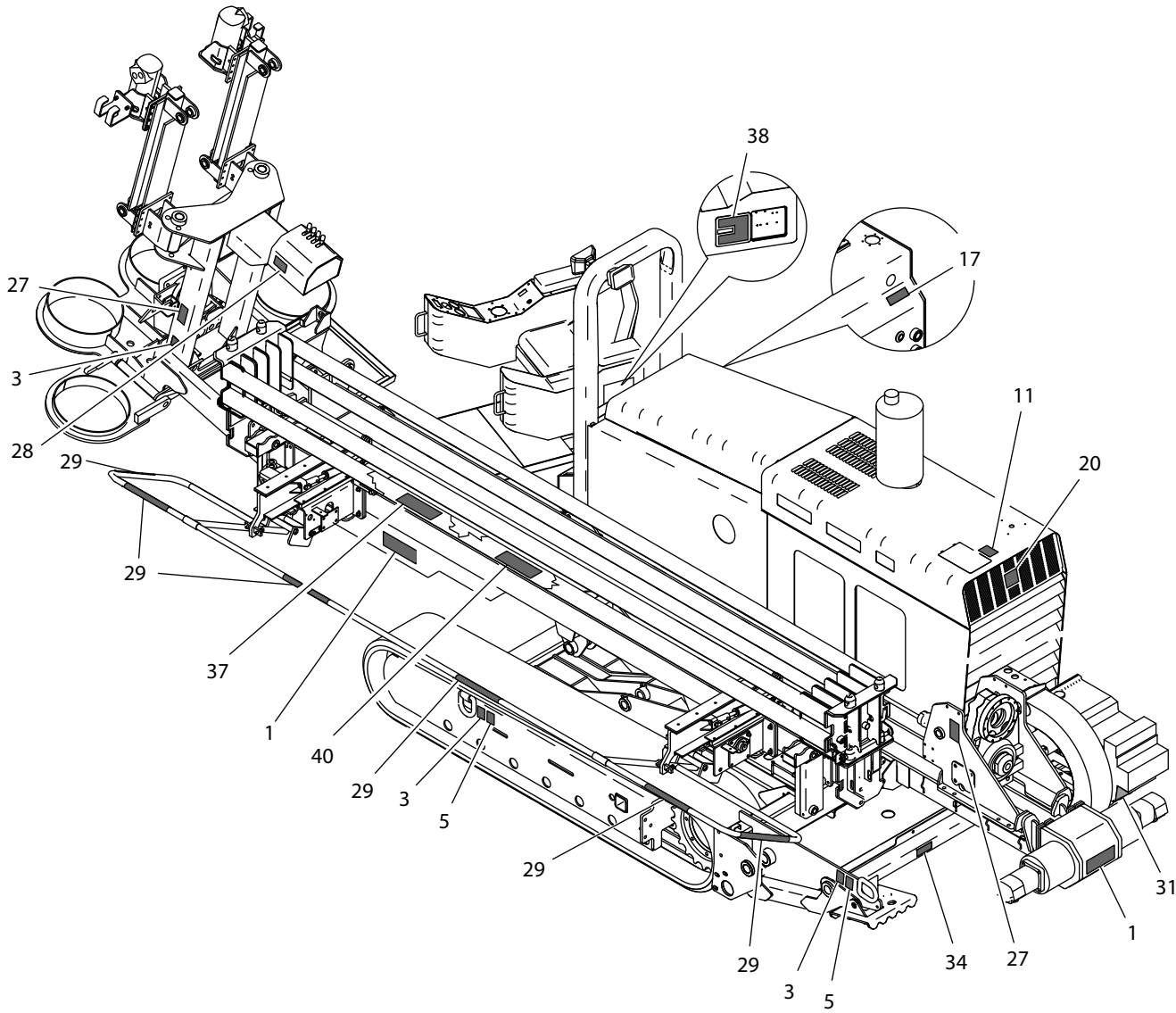

## DECAL LOCATION AT/JT42T2

REF NO.	PART NUMBER	QTY	DESCRIPTION	REMARKS
	275-943		DECAL KIT - AT42T2	
	275-942		DECAL KIT - JT42T2	
1.	274-049	2	DANGER ELECTROCUTION	
2.	274-050	1	WARNING JOBSITE HAZARD	
3.	274-318	6	TIE DOWN LOCATION	
4.	274-375	1	MASTER DISCONNECT SWITCH	
5.	274-442	4	LIFT LOCATION	
6.	700-060	1	JT40AT LEFT CONSOLE	
7.	273-539	1	DITCH WITCH LOGOTYPE	
8.	274-780	1	JET TRAC PATENT (S)	
9.	273-217	1	INSTRUMENT PANEL	SEE FOOTNOTE 2.
	700-070	1	JT4020 INSTRUMENT PANEL	SEE FOOTNOTE 1.
10.	700-232	1	IGNITION - JOYSTICK - GAUGE	
11.	273-452	1	NOTICE COOLANT	
12.	274-877	AR	GRAPHIC STRIPE	USE 24"
13.	273-540	1	JT4020 MODEL ID W/ STRIPE	SEE FOOTNOTE 2.
	273-595	1	JT4020AT MODEL-ID W/ STRIPE	SEE FOOTNOTE 1.
14.	275-307	1	DITCH WITCH EMBLEM	
15.	275-400	1	NOTICE OIL LEVEL	
16.	273-181	1	ANCHOR ROTATION-THRUST	
17.	274-198	1	NOTICE OIL LEVEL	
18.	273-016	1	SOUND POWER 11	SEE FOOTNOTE 3.
19.	275-497	1	OIL DRAIN I.D.	
20.	275-449	2	DITCH WITCH LOGO PLACARD	
21.	275-033	1	NOTICE ELECTRICAL SYSTEM	
22.	275-048	1	IMPORTANT SAFETY RULES	
23.	275-120	1	RESERVOIR (THF)	
24.	273-275	1	AT/JT INNER SPINDLE	SEE FOOTNOTE 1.
25.	275-148	1	FUEL TANK (DIESEL)	
26.	273-267	2	DITCH WITCH BATTERY	SEE FOOTNOTE 4.
27.	275-184	4	WARNING MOVING PARTS	
28.	275-197	2	DANGER ROTATING SHAFT	
29.	275-230	6	WARNING STRIPE (1.750" X 18")	
30.	275-203	1	BATTERY	
31.	700-061	1	WASH WAND	
32.	275-341	1	WARNING SLIDING PARTS	
33.	275-355	1	CAUTION HOT PARTS	
34.	275-372	1	IMPORTANT CYLINDER LOCK	
35.	273-227	1	SHUTTLE STOP INDICATOR	
36.	273-198	1	TRACKER CONTROL	
37.	273-233	1	FRONT WRENCH VALVE	
38.	273-597	1	LEFT RELAY PANEL	
39.	273-598	1	RELAY PANEL	
40.	273-384	1	PIPELOADER VALVE	
41.	273-278	1	DANGER WRENCH	

### FOOTNOTES

1. PART OF KIT NUMBER 275-943
2. PART OF KIT NUMBER 275-942
3. NOT PART OF KIT.
4. LOCATE DECAL ON BATTERY SO THAT DECAL IS VISIBLE WHEN VIEWING BATTERY.





# **ENGINE COMPONENTS**

# ENGINE

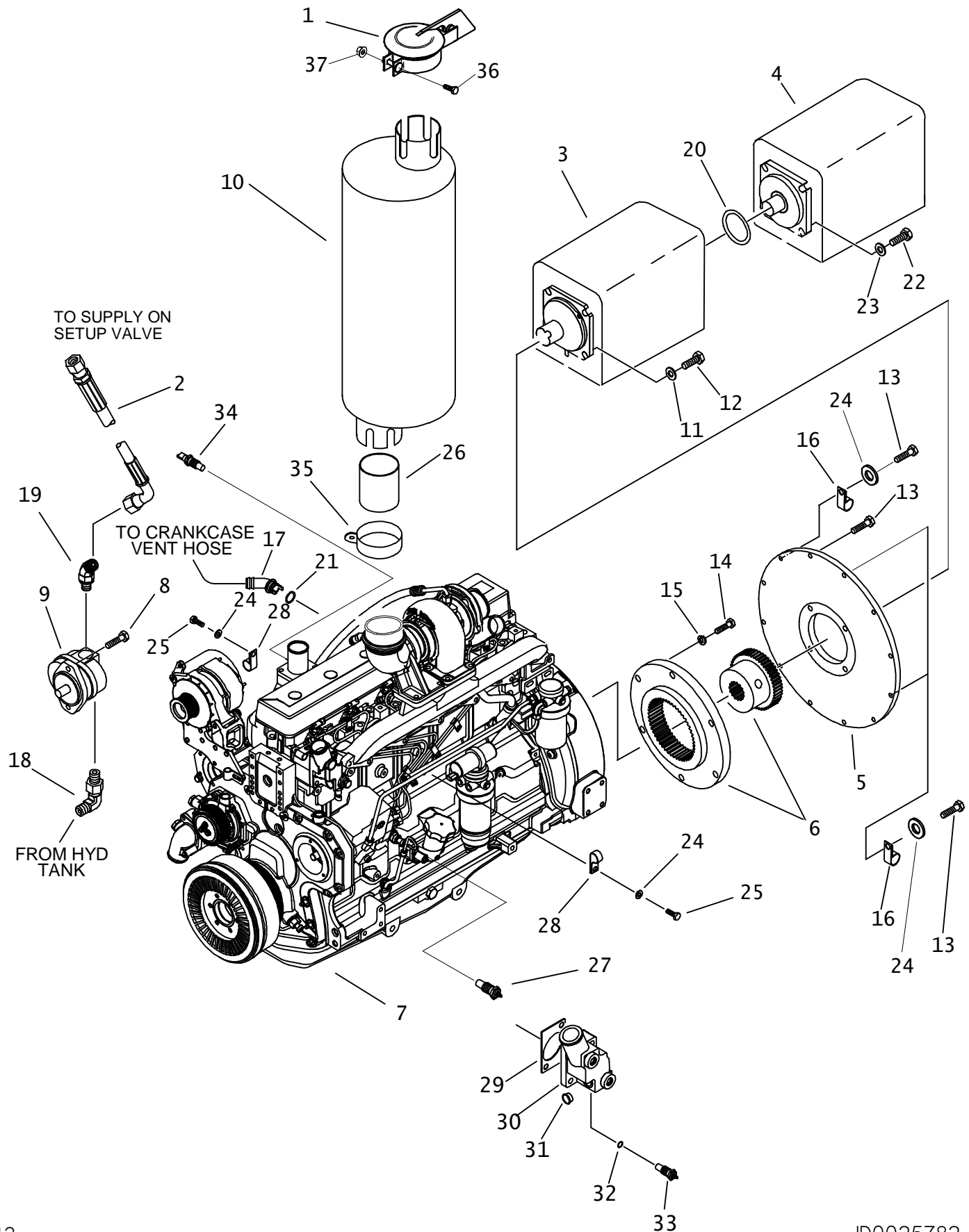

# ENGINE

REF NO.	PART NUMBER	QTY	DESCRIPTION	REMARKS
1.	157-864	1	RAIN CAP 4"	
2.	154-955	-	HOSE (080FX90-102"-3000)	
3.	153-340	1	HYDRAULIC PUMP	SEE FOOTNOTE 3
	149-939	1	FILTER ELEMENT	
4.	150-2180	1	HYDRAULIC PUMP LS	
	190-1371	-	PUMP SEAL KIT	
5.	336-051	1	FLY WHEEL HOUSING COVER	
6.	160-897	1	DRIVE COUPLING	SEE FOOTNOTE 1
7.	194-294	1	ENGINE, 6068HF275185JD	OBSOLETE
	194-823	-	THERMOSTAT	
	165-883	-	GASKET, THERMOSTAT	
	194-478	-	ENGINE OIL FILTER	
	194-464	-	FUEL FILTER ELEMENT	
	194-467	-	FINAL FUEL FILTER ELEMENT	
	217-451	-	ALTERNATOR (95 AMP)	
	211-022	-	STARTER	
	171-012	-	BELT	
	194-159	-	PUMP, ENGINE COOLANT	
	168-617	-	GASKET, WATER PUMP	
8.	106-079	2	SCREW (M10-1.50 X 30mm)	
9.	149-838	1	HYDRAULIC PUMP	SEE FOOTNOTE 2
	500-966	-	SEAL REPAIR KIT	
10.	194-456	1	MUFFLER	
11.	105-244	4	WASHER (1/2")	
12.	105-048	4	BOLT (1/2-NC X 1-1/2")	USE 242 LOCTITE
13.	106-383	12	FLG LK SCREW (M10-1.50 X 30mm)	USE 242 LOCTITE
14.	105-156	8	BOLT (3/8-NC X 1-1/2")	USE 242 LOCTITE, TORQUE TO 30 FT LBS
15.	105-072	8	LOCK WASHER (3/8")	
16.	110-333	3	BOLT-ON CLAMP (1")	
17.	153-161	-	ELBOW (-12H45, SPECIAL)	SERVICE PART FOR 194-294
18.	154-286	1	CONNECTOR (120-16S90)	
19.	154-264	1	CONNECTOR (080-10S45)	
20.	157-084	-	O-RING (159 D70)	
21.	157-050	-	O-RING (116 D70)	SERVICE PART FOR 194-294
22.	105-456	2	BOLT (5/8-NC X 1-3/4", GD8)	LOCTITE 242
23.	106-398	2	WASHER (M16, HARDENED)	
24.	106-390	3	WASHER (M10)	
25.	105-245	1	SCREW (M10-1.50 X 25MM)	
26.	179-686	1	SPACER	
27.	213-083	1	OIL PRESSURE SENSOR	

NOT SHOWN:

FOOTNOTES:

NOTE:

# ENGINE

REF NO.	PART NUMBER	QTY	DESCRIPTION	REMARKS
28.	110-259	2	BOLT-ON CLAMP (.625")	
29.	165-883	1	GASKET, THERMOSTAT	
30.	164-027	1	THERMOSTAT HOUSING	
31.	153-993	1	GASKET, THERMOSTAT TUBE	
32.	155-705	1	O-RING (906 D90)	
33.	213-081	1	COOLANT TEMPERATURE SENSOR	
34.	213-082	1	ENGINE HEAD TEMPERATURE SENSOR	
35.	194-027	1	MUFFLER CLAMP (4.143")	
36.	106-932	1	SCREW (M8-1.25 X 45MM)	
37.	107-096	1	LOCKNUT (M8-1.25, NLK)	

NOT SHOWN:

**FOOTNOTES:**

1. TORQUE CROSSBOLT TO 85-90 FT LB; MOUNT FLUSH WITH END OF SHAFT
2. RE-INSTALL GASKET FROM COVER PLATE.
3. ON THE BACK OF THE PUMP OF SOME EARLY MACHINES A DIFFERENT MOUNT PAD WAS USED. IF THE BOLT HOLDING THE PAD TO THE PUMP HAVE A WASHER UNDER THE BOLT HEAD USE O-RING 157-201 BETWEEN THE PUMPS.

**NOTE:**

REFER TO O-RING CHART (800-301) IN BACK OF THE BOOK FOR REPLACEMENT OF O-RINGS.





# FAN CLUTCH

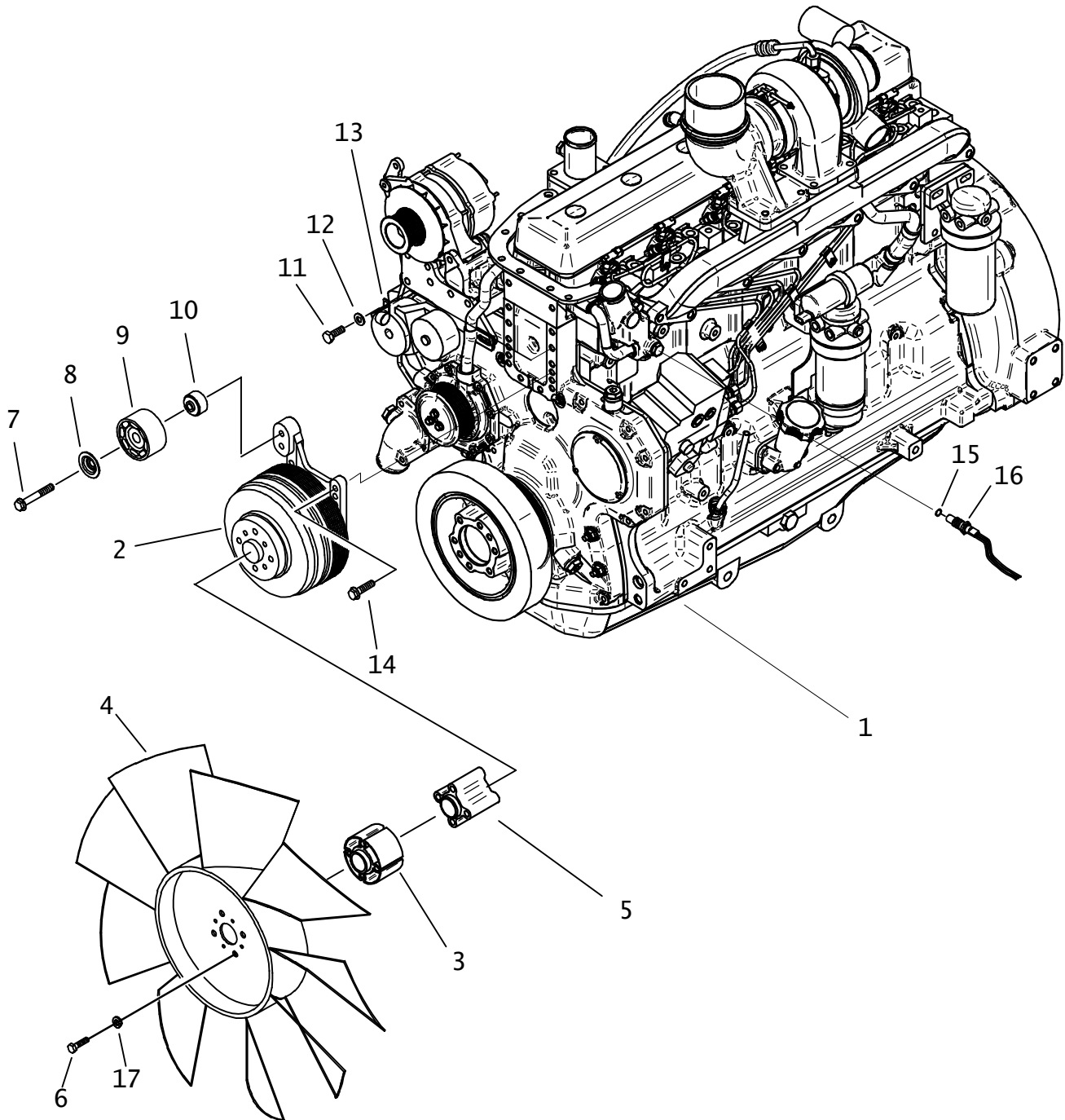

# FAN CLUTCH

REF NO.	PART NUMBER	QTY	DESCRIPTION	REMARKS
1.	194-294	-	ENGINE, 6068HF275185JD	OBSOLETE
2.	323-161	1	FAN DRIVE	
3.	184-404	1	COOLING FAN SPACER	
4.	194-134	1	FAN (26.0" OD, 2.50" BC)	
5.	184-190	1	FAN SPACER (SPACING 2.50)	
6.	106-473	4	SCREW (M8-1.25 X 130MM)	
7.	106-998	1	FLG LK SCREW (M10-1.50 X 70MM)	
8.	179-461	1	SLEEVE	
9.	170-372	1	IDLER PULLEY	
10.	179-462	1	SPACER	
11.	105-245	1	SCREW (M10-1.50 X 25MM)	
12.	106-390	1	WASHER (M10)	
13.	110-126	1	BOLT-ON CLAMP (1/2")	
14.	106-497	4	FLG SCREW (M10-1.50 X 35MM)	
15.	155-705	1	O-RING (906 D90)	
16.	214-895	1	TEMPERATURE SWITCH	
17.	105-091	4	LOCK WASHER (5/16")	

NOT SHOWN:

FOOTNOTES:

1. FAN MUST BE CENTERED IN DIAMETER OF RADIATOR SHROUD OPENING, INSTALL WITH NOTCHES TOWARD RADIATOR.
2. REMOVE O-RING FROM PLUG AND INSTALL ON WATER TEMPERATURE SENDER WHEN ASSEMBLING.

NOTE:

# ENGINE MOUNTS

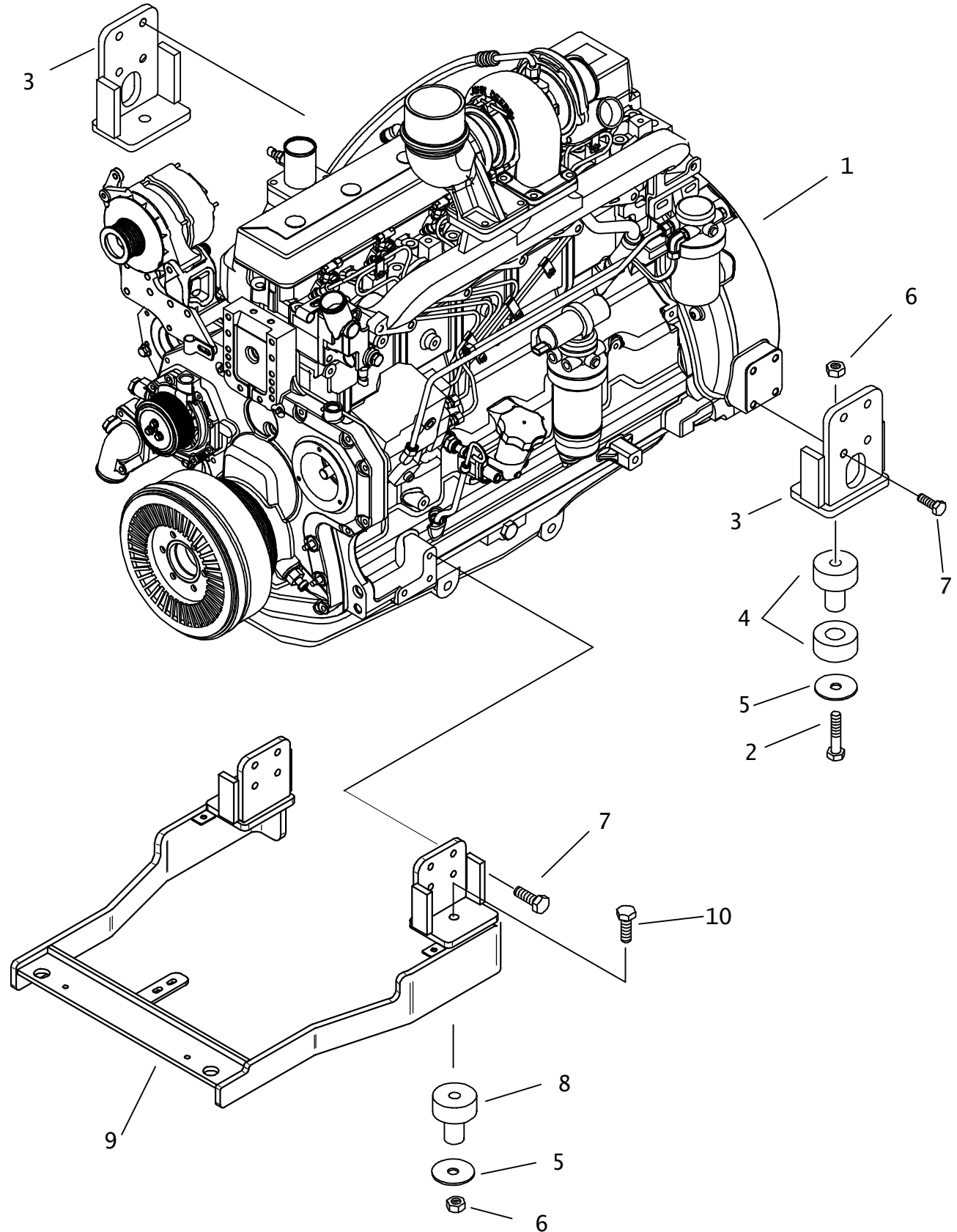

# ENGINE MOUNTS

REF NO.	PART NUMBER	QTY	DESCRIPTION	REMARKS
1.	194-294	-	ENGINE, 6068HF275185JD	OBSOLETE
2.	106-343	2	SCREW (M16-2.0 X 110mm)	
3.	354-325	2	REAR ENGINE MOUNT	
4.	116-127	2	SHOCK MOUNT	
5.	105-416	4	WASHER (5/8")	
6.	106-545	4	LOCKNUT (M16-2.00, PRV TRQ, 10.9)	
7.	105-247	14	SCREW (M12-1.75 X 35mm)	USE 242 LOCTITE
8.	116-726	2	SHOCK MOUNT	
9.	320-997	1	FRONT ENGINE MOUNT	
10.	106-342	2	SCREW (M16-2.0 X 90mm)	

NOT SHOWN:

FOOTNOTES:

NOTE:

# ENGINE SKID

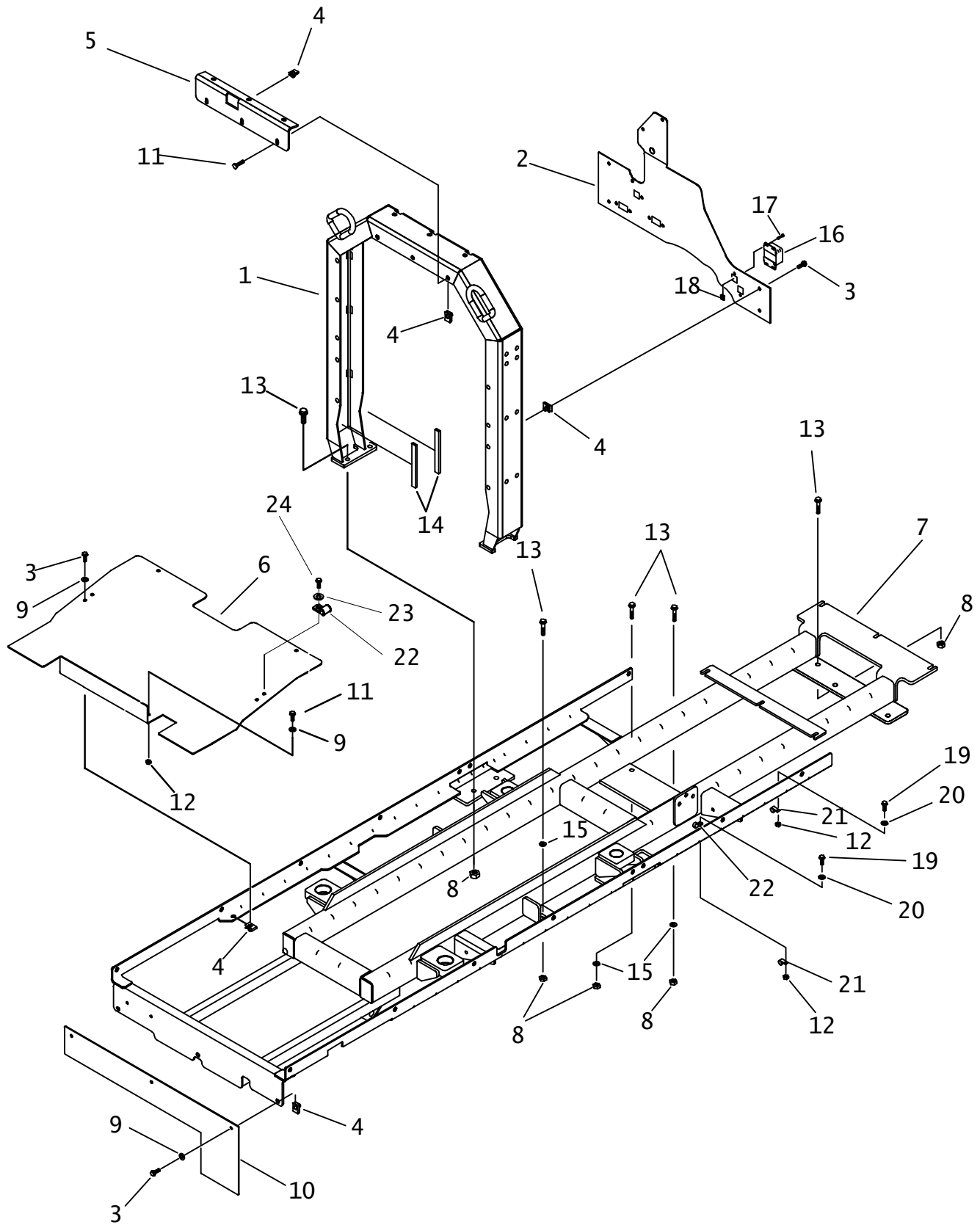

# ENGINE SKID

REF NO.	PART NUMBER	QTY	DESCRIPTION	REMARKS
1.	322-482	1	SKID LIFT	
2.	322-551	-	FIREWALL	
3.	106-991	11	FLG LK SCREW (M8-1.25 X 20mm)	
4.	106-551	50	CLIP NUT (M8-1.25)8.	
5.	323-620	1	HOOD SUPPORT	
6.	118-110	1	DEFLECTOR FLAP	
7.	320-849	1	ENGINE SKID	
8.	106-685	13	LOCKNUT (M12-1.75,PRV TRQ,10.9)	
9.	105-118	9	WASHER (3/8")	
10.	350-410	1	DEFLECTOR FLAP	
11.	106-381	5	FLG LK SCREW (M8-1.25 X 25mm)	
12.	106-561	4	LOCKNUT (M8-1.25, PRV TRQ, 10.9)	
13.	106-632	13	FLG LK SCR (M12-1.75 X 35MM,SER)	
14.	115-686	AR	BULK EDGE (5/32", SOLD PER 1")	USE 2 @ 5.0"
15.	106-391	4	WASHER (M12)	USED ON SLOTTED HOLES
16.	211-017	1	12V-5V VOLTAGE CONVERTOR	
17.	107-268	2	SCREW (M4-0.70 X 20MM, SOC)	
18.	107-516	2	CLIP NUT (M4-.7)	
19.	106-381	2	FLG LK SCREW (M8-1.25 X 25MM)	
20.	106-390	2	WASHER (M10)	
21.	110-333	3	BOLT-ON CLAMP (1")	
22.	110-126	2	BOLT-ON CLAMP (1/2")	
23.	105-117	1	WASHER (5/16")	
24.	106-992	1	FLG LK SCREW (M8-1.25 X 25MM)	

NOT SHOWN:

FOOTNOTES:

NOTE:

# ENGINE SKID EDGING

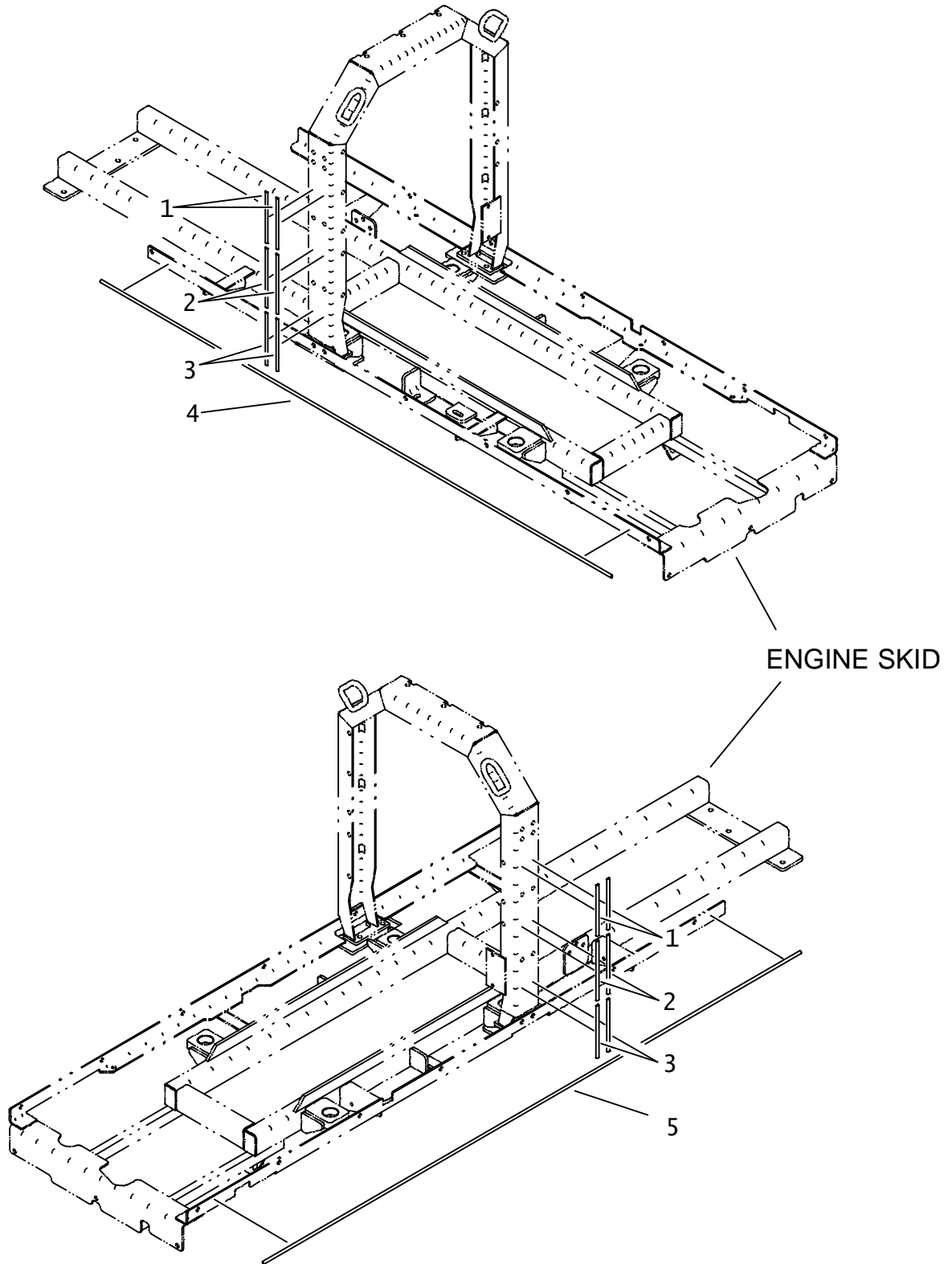



# ENGINE SKID EDGING

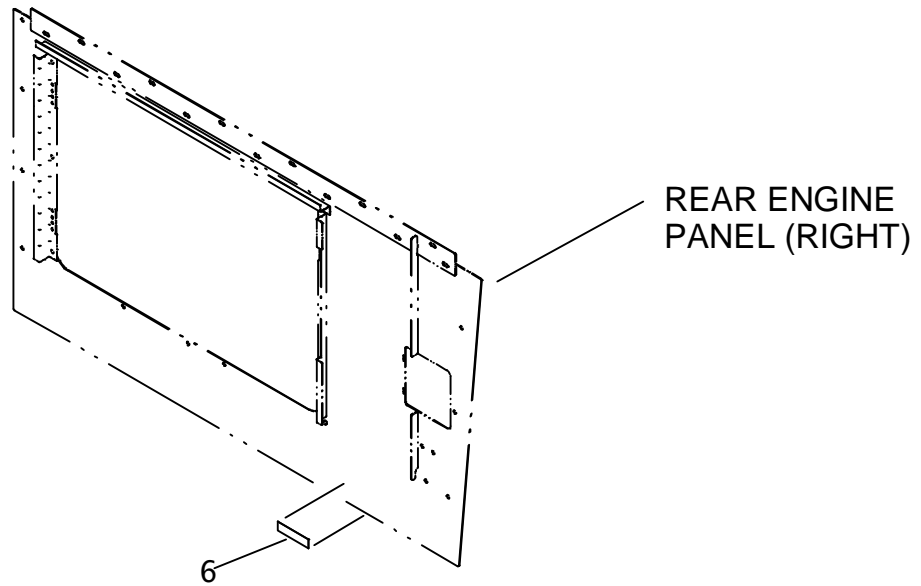
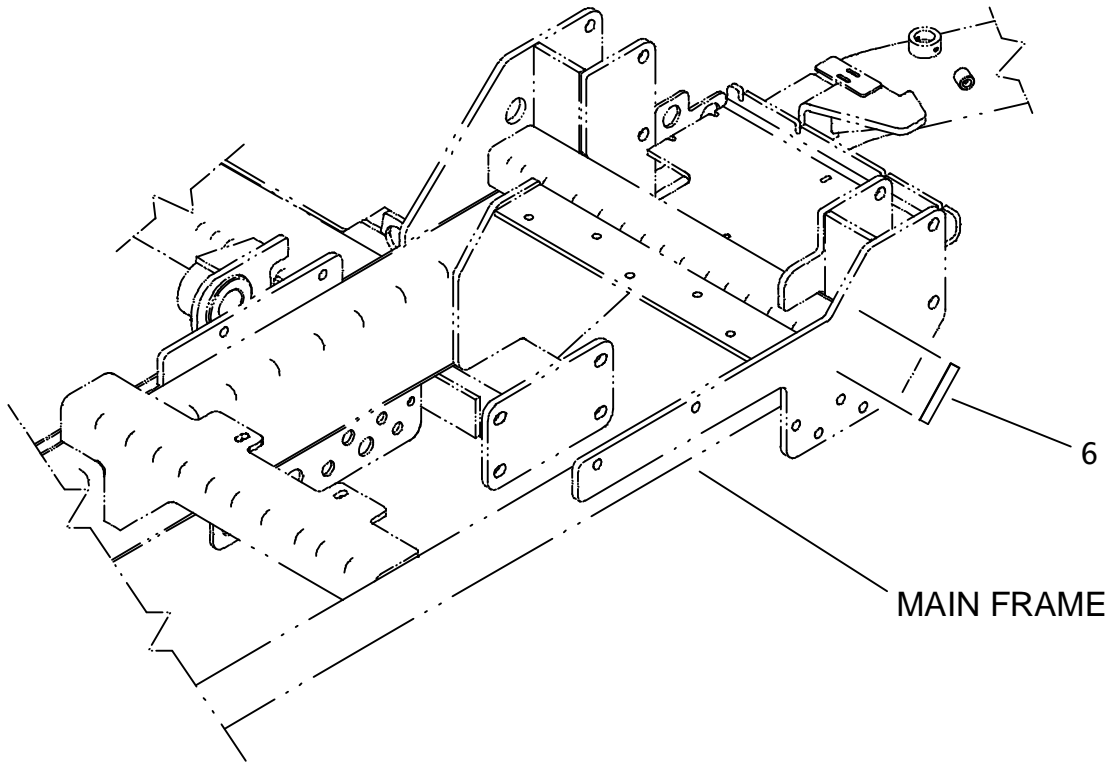

## ENGINE SKID EDGING

REF NO.	PART NUMBER	QTY	DESCRIPTION	REMARKS
1.	116-724	AR	BULK SEAL (3/32", SOLD PER 1')	USE 4 @ 7.2"
2.	116-724	AR	BULK SEAL (3/32", SOLD PER 1')	USE 4 @ 8.4"
3.	116-724	AR	BULK SEAL (3/32", SOLD PER 1')	USE 4 @ 7.4"
4.	116-724	AR	BULK SEAL (3/32", SOLD PER 1')	USE 1 @ 83.8"
5.	116-724	AR	BULK SEAL (3/32", SOLD PER 1')	USE 1 @ 88.2"
6.	391-322	AR	.040 X 1.0" UHMW-PE ADHES BACK	USE 8 @ 4"

NOT SHOWN:

FOOTNOTES:

NOTE:



## ENGINE OIL DRAIN

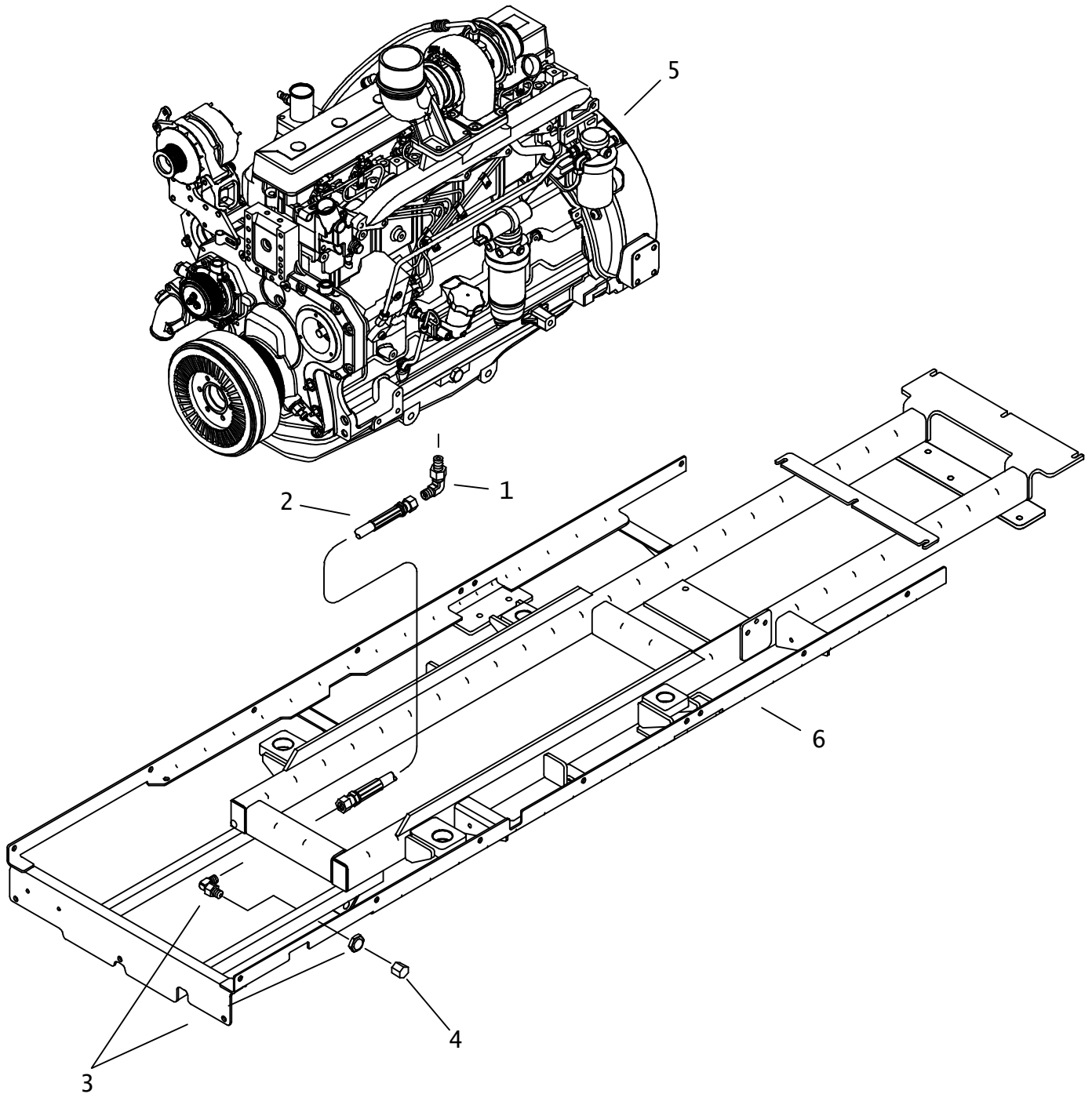

# ENGINE OIL DRAIN

REF NO.	PART NUMBER	QTY	DESCRIPTION	REMARKS
1.	154-467	1	CONNECTOR (M18-1.50-08J90)	
2.	154-576	1	HOSE (08JFX-22.5"-2000)	
3.	154-148	1	BK CONNECTOR (08J-08J90BK)	
4.	154-089	1	CAP (08JF)	
5.	194-294	-	ENGINE, 6068HF275185JD	OBSOLETE
6.	320-849	-	ENGINE SKID	

NOT SHOWN:

FOOTNOTES:

NOTE:

REFER TO O-RING CHART (800-301) IN BACK OF THE BOOK FOR REPLACEMENT OF O-RINGS.

# AIR FILTER SYSTEM

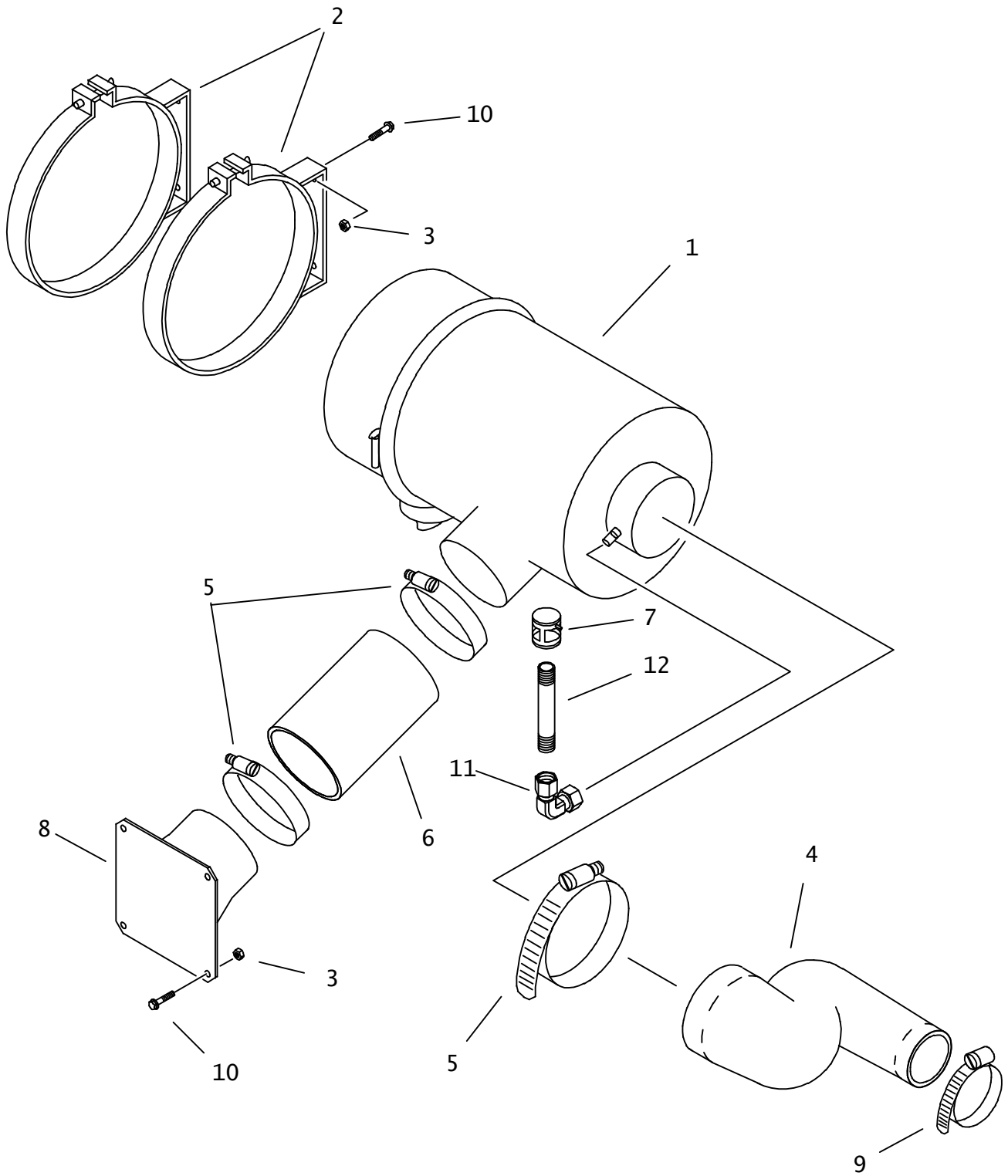

## AIR FILTER SYSTEM

REF NO.	PART NUMBER	QTY	DESCRIPTION	REMARKS
1.	194-599	1	ENGINE AIR CLEANER	
	194-600	1	AIR CLEANER ELEMENT	
2.	196-349	2	MOUNTING CLAMP (11.810")	
3.	106-561	8	LOCKNUT (M8-1.25, PRV TRQ, 10.9)	
4.	116-725	1	INTAKE HOSE (3" X 5")	
5.	110-391	3	WORM CLAMP (4-3/4" TO 5-5/8")	
6.	117-616	1	INTAKE HOSE (5" X 12")	
7.	194-788	1	RESTRICTION INDICATOR (25", H2O)	
8.	350-615	1	AIR INTAKE (5")	
9.	110-367	1	WORM CLAMP (3-1/4" TO 4-1/8")	
10.	106-162	8	FLG SCREW (M8-1.25 X 20MM)	
11.	156-228	1	ELBOW (02NF-02NF90)	
12.	115-188	1	NIPPLE (02N-4.250")	

FOOTNOTES

NOTE:

# RADIATOR

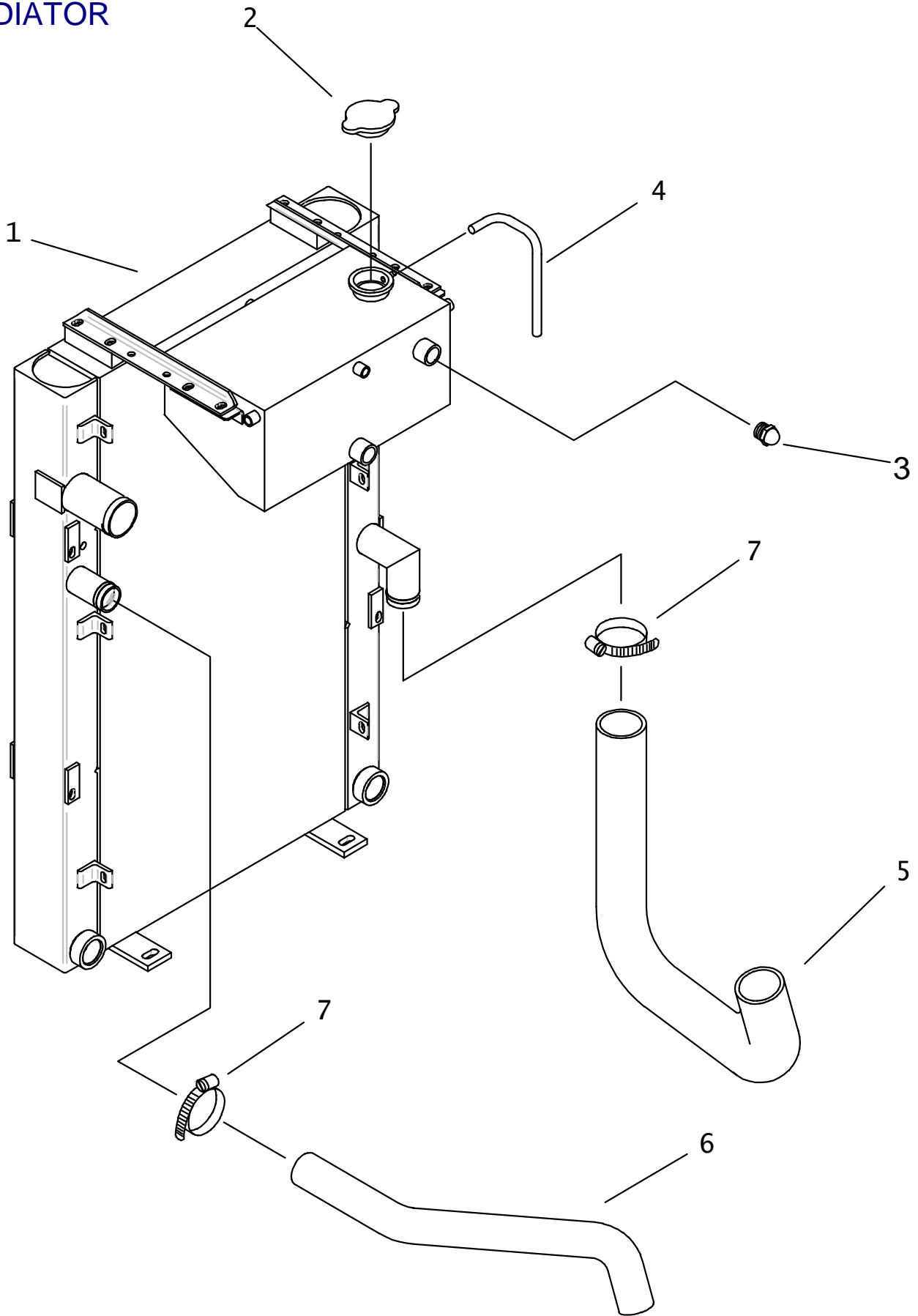



# RADIATOR

REF NO.	PART NUMBER	QTY	DESCRIPTION	REMARKS
1.	194-499	-	RADIATOR	
2.	111-084	-	RADIATOR CAP (16 PSI)	INCLUDED WITH RADIATOR
3.	110-549	-	SIGHT GAUGE (12N)	INCLUDED WITH RADIATOR
4.	116-108	AR	BULK HOSE (5/16", SOLD PER 1')	USE 1 @ 78" (OVERFLOW TUBE)
5.	118-090	1	LOWER COOLANT HOSE	
6.	118-089	1	UPPER COOLANT HOSE	
7.	110-134	1	WORM CLAMP (2.06" TO 2.75")	

NOT SHOWN:

FOOTNOTES:

NOTE:

# RADIATOR MOUNT

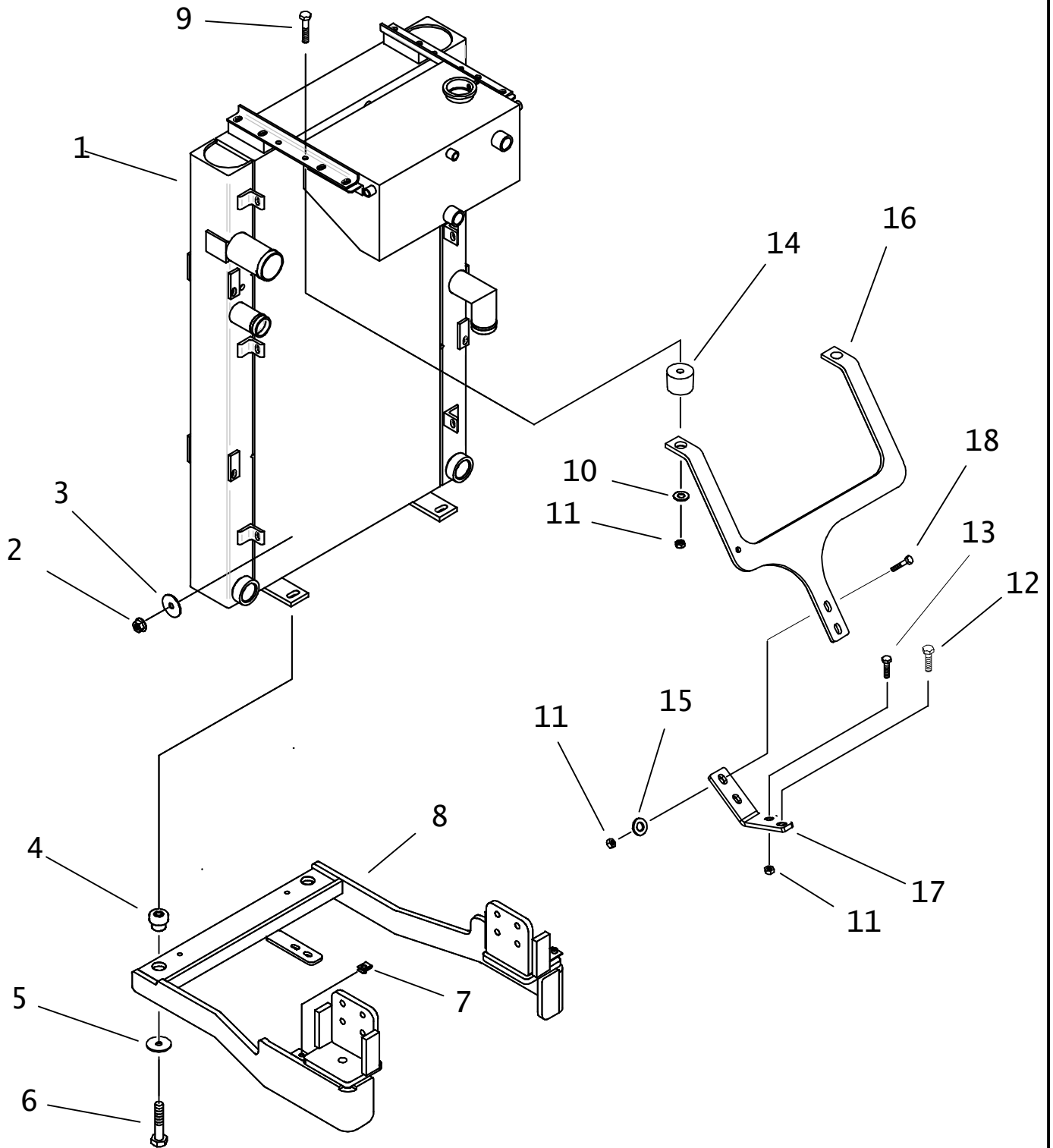

# RADIATOR MOUNT

REF NO.	PART NUMBER	QTY	DESCRIPTION	REMARKS
1.	194-499	1	RADIATOR	
2.	106-685	2	LOCKNUT(M12-1.75,PRV TRQ,10.9)	
3.	106-397	2	WASHER (M12, HARDENED)	
4.	317-032	2	GROMMET (1-1/8", T-MOUNT)	
5.	105-398	2	WASHER (1/2")	
6.	107-507	2	SCREW (M12-1.75 X 65MM)	
7.	106-551	8	CLIP NUT (M8-1.25)	
8.	320-997	1	FRONT ENGINE MOUNT	
9.	106-142	2	SCREW (M10-1.50 X 65MM)	
10.	106-622	2	WASHER (3/8")	
11.	105-894	10	LOCKNUT(M10-1.50,PRV TRQ,10.9)	
12.	107-004	1	FLG LK SCREW (M12-1.75 X 45MM)	
13.	106-383	1	FLG LK SCREW (M10-1.50 X 30MM)	
14.	117-906	2	SHOCK MOUNT (70D)	
15.	106-396	2	WASHER (M10, HARDENED)	
16.	322-547	1	TOP RADIATOR SUPPORT	
17.	323-349	1	BOTTOM RADIATOR SUPPORT	
18.	107-111	2	FLG SCREW (M10-1.50 X 35MM)	

## FOOTNOTES

(8) GALLONS JOHN DEERE PRE-MIXED 50-50 COOLANT

NOTE:

# SHROUD/CHARGE AIR

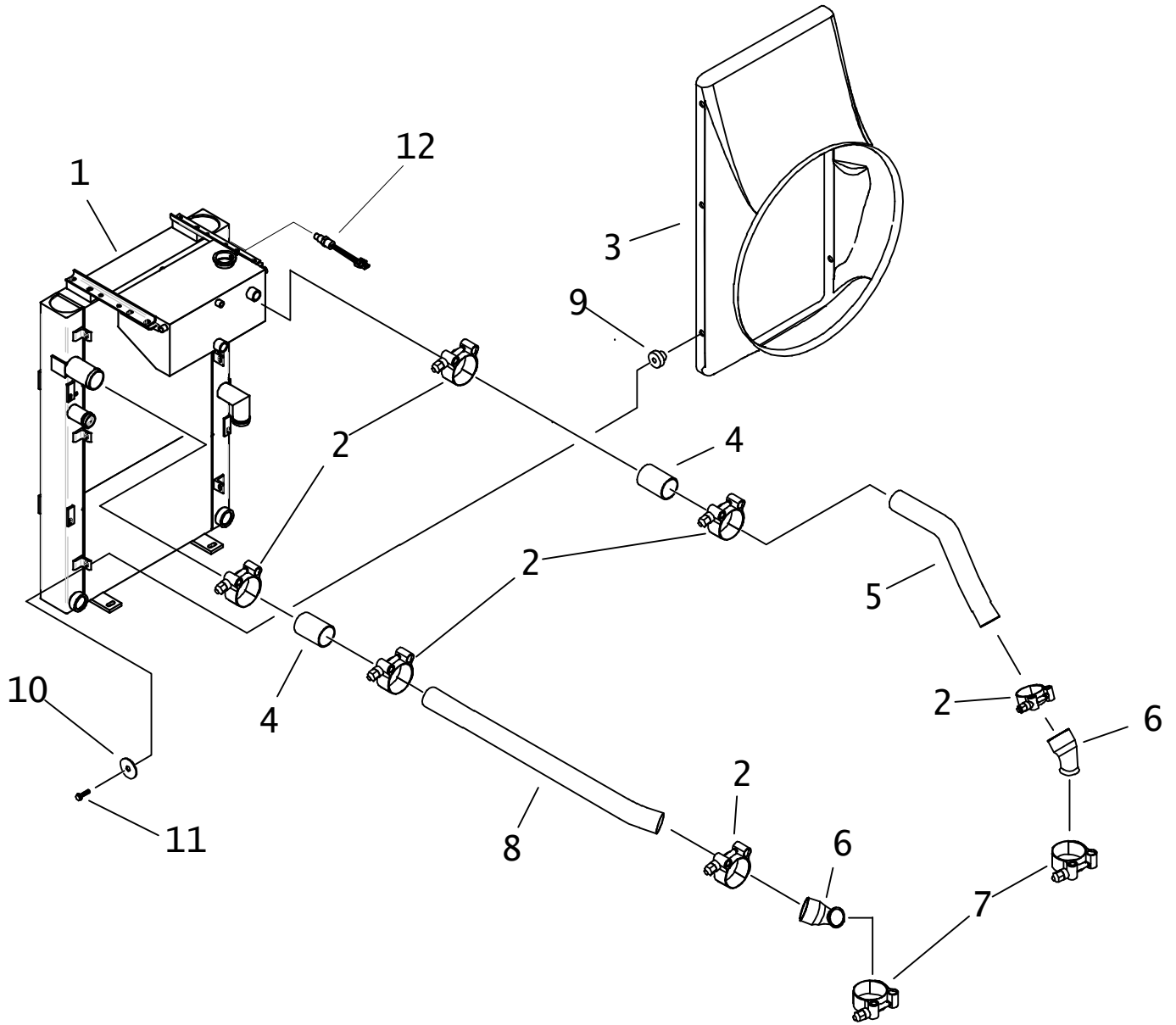

## SHROUD/CHARGE AIR

REF NO.	PART NUMBER	QTY	DESCRIPTION	REMARKS
1.	194-499	-	RADIATOR	
2.	111-135	6	T-BOLT CLAMP (2.750-3.062)	
3.	320-844	1	SHROUD	SEAL TO RADIATOR WITH CAULKING
4.	159-551	2	HUMP HOSE 2.5 STRAIGHT	
5.	157-325	1	CHARGE AIR COOLER EXIT TUBE	
6.	157-814	2	HOSE (32F-40F-45)	
7.	110-815	2	T-BOLT CLAMP(2.25" TO 2.56")	
8.	157-326	1	CHARGE AIR COOLER INLET TUBE	
9.	107-493	6	WELLNUT (3/8" -16)	
10.	105-118	6	WASHER (3/8")	
11.	105-874	6	FLG LK BOLT (3/8-NC X 1-1/2")	
12.	213-262	1	TEMPERATURE SWITCH	

### FOOTNOTES

1. LOOSEN BOLTS ON TURBOCHARGER AND ROTATE OUTLET TO ALIGN WITH CHARGE AIR COOLER INLET TUBE

NOTE:

# DEAERATION

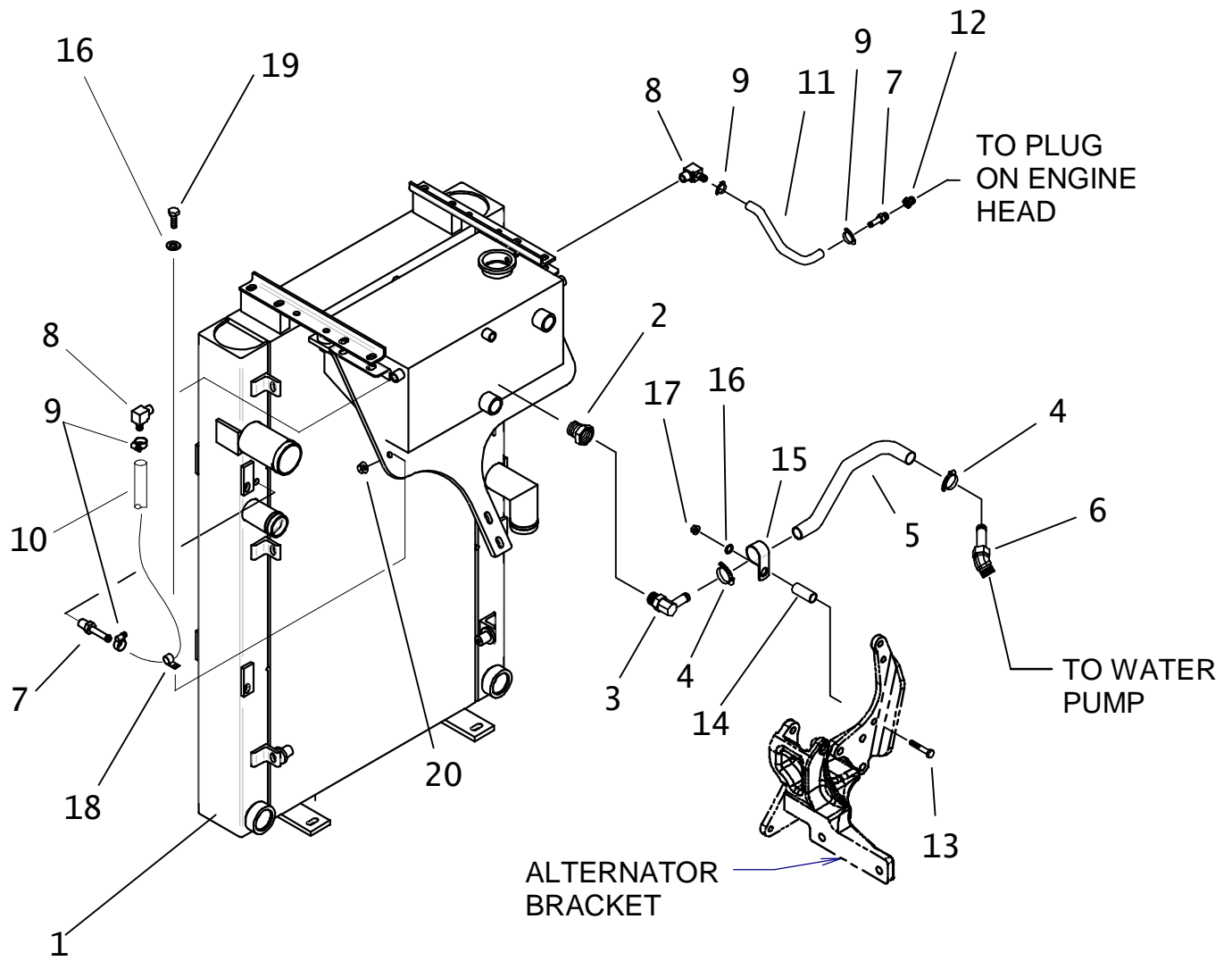

## DEAERATION

REF NO.	PART NUMBER	QTY	DESCRIPTION	REMARKS
1.	194-499	-	RADIATOR	
2.	155-202	1	REDUCER (12N-08NF)	USE 567 LOCTITE
3.	514-285	1	S/O COUPLER (08N-10H90)	USE 567 LOCTITE
4.	110-217	2	WORM CLAMP (7/16" TO 1")	
5.	116-750	AR	BULK HOSE (5/8",SOLD PER FT)	USE 1 @ 31"
6.	153-160	1	S/O COUPLER (18M-10H45)	
7.	155-162	2	S/O COUPLER (04N-05H)	USE 567 LOCTITE
8.	155-164	2	S/O COUPLER (04N-05H90)	USE 567 LOCTITE
9.	110-249	4	WORM CLAMP (1/4" TO 1")	
10.	116-108	AR	BULK HOSE (5/16", SOLD PER 1")	USE 1 @ 23"
11.	116-108	AR	BULK HOSE (5/16", SOLD PER 1")	USE 1 @ 49"
12.	115-286	1	REDUCER (08N-1/4-NF)	USE 567 LOCTITE
13.	106-570	1	SCREW (M8-1.25 X 60MM)	
14.	349-816	1	SPACER	
15.	110-333	1	BOLT-ON CLAMP (1")	
16.	106-390	2	WASHER (M10)	
17.	106-561	1	LOCKNUT (M8-1.25,PRV TRQ,10.9)	
18.	110-259	1	BOLT-ON CLAMP (.625")	
19.	106-724	1	FLG SCREW (M10-1.50 X 25MM)	
20.	106-387	1	FLG LOCKNUT (M10-1.50)	

FOOTNOTES

NOTE:

# FUEL LINES

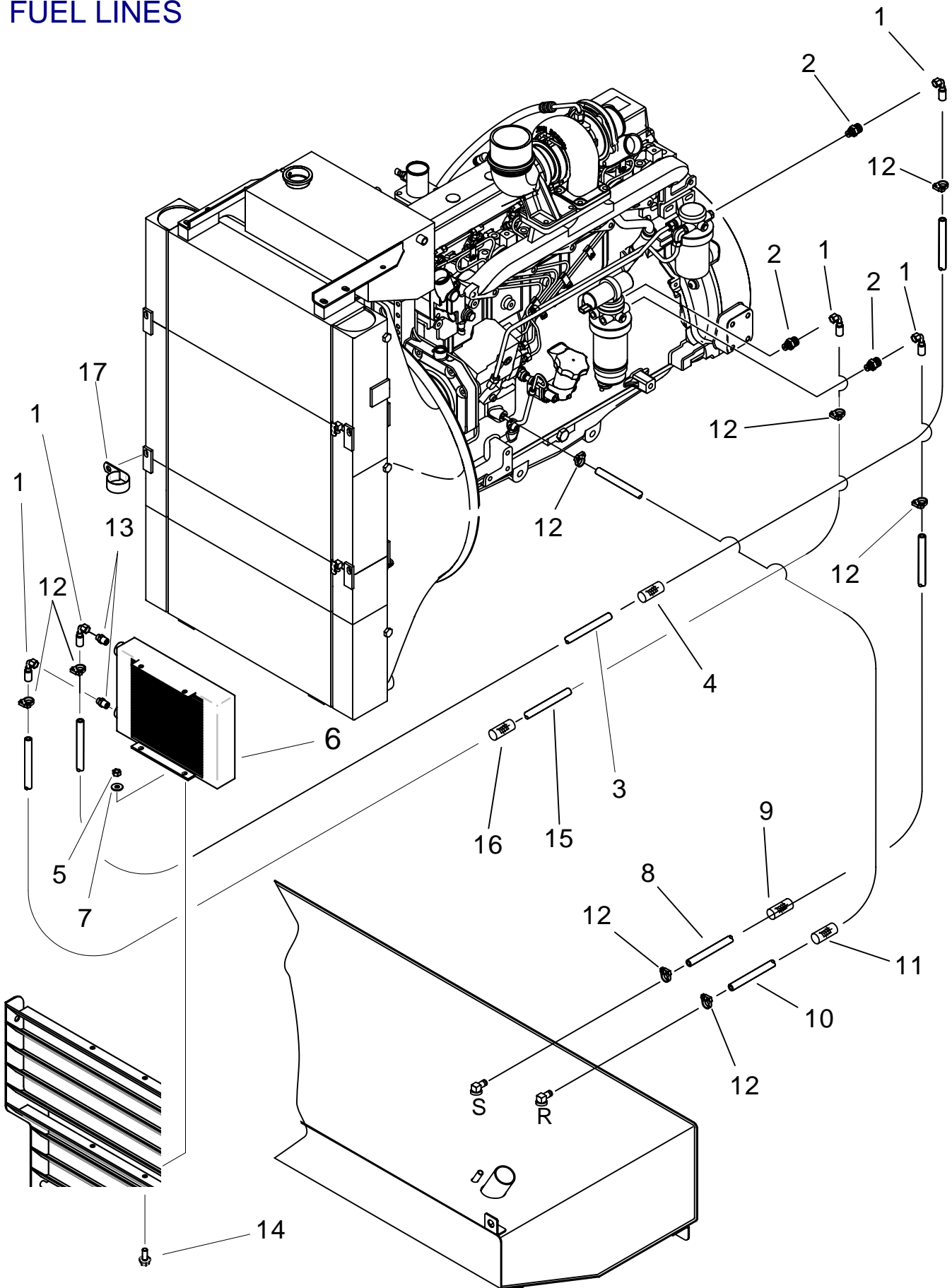



## FUEL LINES

REF NO.	PART NUMBER	QTY	DESCRIPTION	REMARKS
1.	159-763	5	STEM (06FFORX90S)	
2.	159-757	3	CONN (M12-1.5, 4MM X 06Q, 6.5MM)	
3.	116-881	AR	BULK HOSE (3/8", SOLD PER FT)	USE 1 @ 120"
4.	117-986	1	ABRASION SLEEVE (1.00" X 120")	
5.	106-561	4	LOCKNUT (M8-1.25, PRV TRQ, 10.9)	
6.	194-466	1	FUEL COOLER	
7.	105-117	4	WASHER (5/16")	
8.	116-881	AR	BULK HOSE (3/8", SOLD PER FT)	USE 1 @ 65"
9.	118-062	1	ABRASION SLEEVE (1.00" X 62")	
10.	116-881	AR	BULK HOSE (3/8", SOLD PER FT)	USE 1 @ 50"
11.	117-416	1	ABRASION SLEEVE (1.00" X 50")	
12.	118-344	8	SNAP-ON CLAMP (.593" TO .656")	
13.	153-858	2	FITTING (06Q-08N)	
14.	106-162	4	FLG SCREW (M8-1.25 X 20MM)	
15.	116-881	AR	BULK HOSE (3/8", SOLD PER FT)	USE 1 @ 102"
16.	117-867	1	ABRASION SLEEVE (1.00" X 100")	
17.	110-332	1	BOLT-ON CLAMP (1-5/8")	

NOT SHOWN:

FOOTNOTES:

NOTE:

# ENGINE COVERS

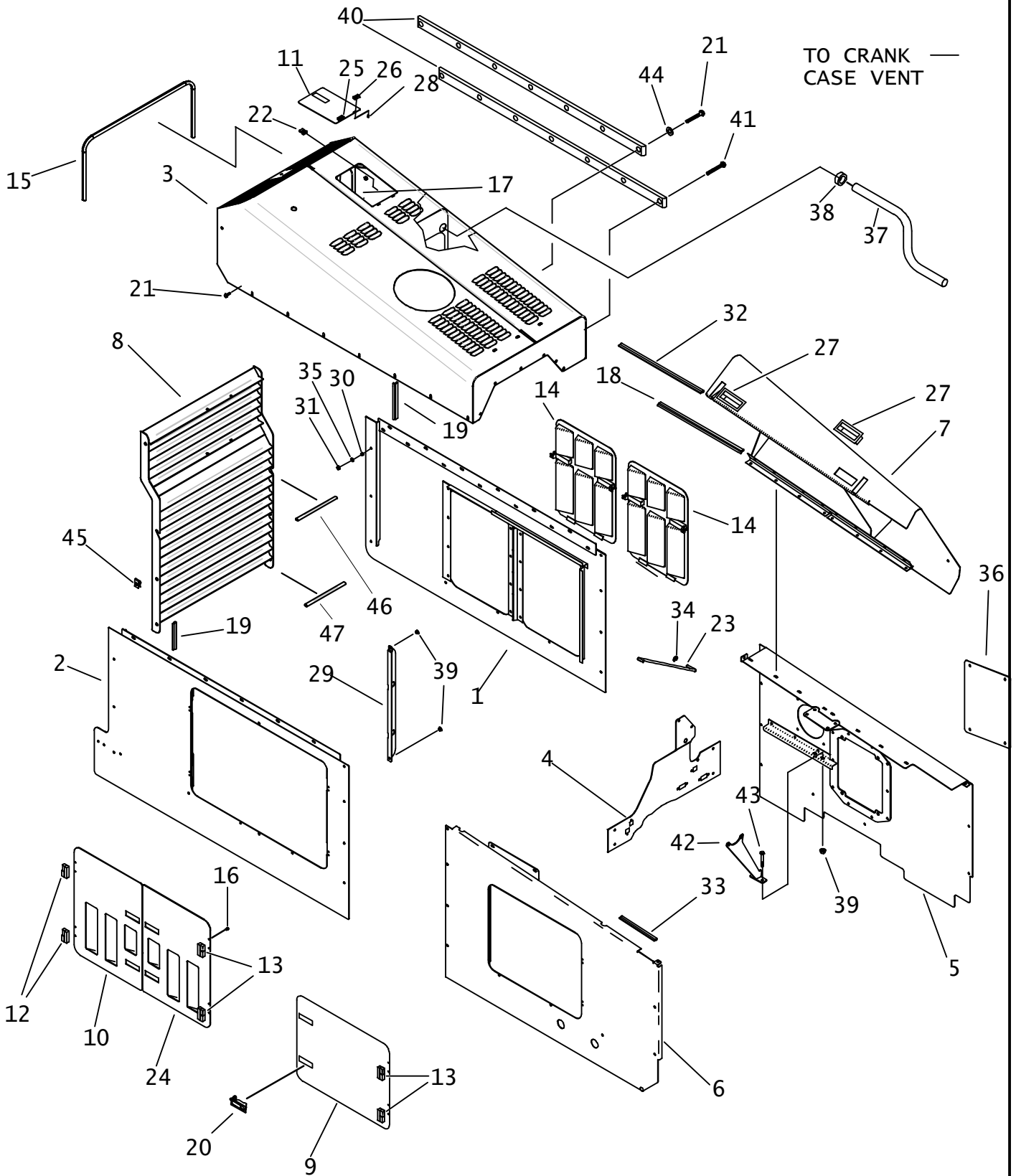

## ENGINE COVERS

REF NO.	PART NUMBER	QTY	DESCRIPTION	REMARKS
1.	320-847	1	REAR ENGINE PANEL (LEFT)	
2.	320-836	1	REAR ENGINE PANEL (RIGHT)	
3.	320-838	1	ENGINE PANEL (TOP)	
4.	322-551	1	FIRE WALL	
5.	310-452	1	FRONT ENGINE PANEL (LEFT)	
6.	310-448	1	FRONT ENGINE PANEL (RIGHT)	
7.	350-611	1	FRONT HOOD	
8.	320-837	1	GRILLE	
9.	354-579	1	DOOR PANEL	
10.	350-419	1	LEFT DOOR	
11.	354-875	1	DOOR PANEL	
12.	111-002	2	LIFT-OFF HINGE (OFF-SET)	
13.	105-617	4	LIFT-OFF HINGE (OFF-SET)	
14.	350-412	2	LEFT DOOR	
15.	116-489	AR	BULK EDGE (1/8",SOLD PER 1 FT)	USE 1 @ 55"
16.	106-228	24	SCREW (M5-.80 X 10mm)	
17.	116-489	AR	BULK EDGE (1/8",SOLD PER 1')	USE 1 @ 35.5"
18.	116-489	AR	BULK EDGE (1/8",SOLD PER 1')	USE 1 @ 31.5"
19.	116-489	AR	BULK EDGE (1/8",SOLD PER 1')	USE 2 @ 27.5"
20.	117-558	13	ADJUST LEVER LATCH (LOCKING)	
	214-961		KEY, PAIR (BASE CODE)	
	217-309		LOCK PLUG 4/LATCH (BASE CODE)	
21.	106-991	84	FLG LOCK SCREW (M8-1.25 X 20mm)	
22.	106-551	67	CLIP NUT (M8-1.25)	
23.	354-884	1	PROP BAR	
24.	350-420	1	RIGHT DOOR	
25.	111-051	1	HINGE	
26.	111-052	1	HINGE	
27.	110-989	2	POCKET PULL	
28.	105-650	16	SCREW (M4-.70 X 10mm)	
29.	350-745	1	BACKUP BAR	

FOOTNOTES

NOTE:

## ENGINE COVERS

REF NO.	PART NUMBER	QTY	DESCRIPTION	REMARKS
30.	184-870	2	SPACER	
31.	106-561	2	LOCKNUT (M8-1.25, PRV TRQ, 10.9)	
32.	115-686	AR	BULK EDGE (5/32",SOLD PER 1")	USE 1 @ 35.5"
33.	115-686	AR	BULK EDGE (5/32",SOLD PER 1")	USE 1 @ 8.0"
34.	115-477	1	GRIP RING (.375")	
35.	106-389	2	WASHER (M8)	
36.	308-718	1	DOOR	
37.	117-378	AR	BULK HOSE, L P (-12)(PER IN)	USE 1 @ 53.0", SEE FOOTNOTE 1
38.	115-033	1	GROMMET (1-1/4")	SEE FOOTNOTE 2
39.	106-386	4	FLG LOCKNUT (M8-1.25)	
40.	318-791	2	WEAR STRIP	
41.	106-992	7	FLG LK SCREW (M8-1.25 X 25MM)	
42.	318-481	-	SUPPORT	
43.	106-162	2	FLG SCREW(M8-1.25 X 20MM, GD8)	
44.	105-117	14	WASHER (5/16")	
45.	107-135	6	CLIP NUT (M8-1.25)	
46.	115-686	AR	BULK EDGE (5/32",SOLD PER 1")	USE 1 @ 4"
47.	115-686	AR	BULK EDGE (5/32",SOLD PER 1")	USE 1 @ 6"

### FOOTNOTES

1. INSTALL THROUGH HOLES IN TOP PANEL (309-236 REF#3) AFTER INSTALLING GROMMETS (115-033 REF#38).
2. INSTALL IN HOLES IN TOP PANEL (309-236 REF#3) BEFORE INSTALLING HOSE (117-378 REF#34).

NOTE:



# SOUND INSULATION ENGINE COVERS

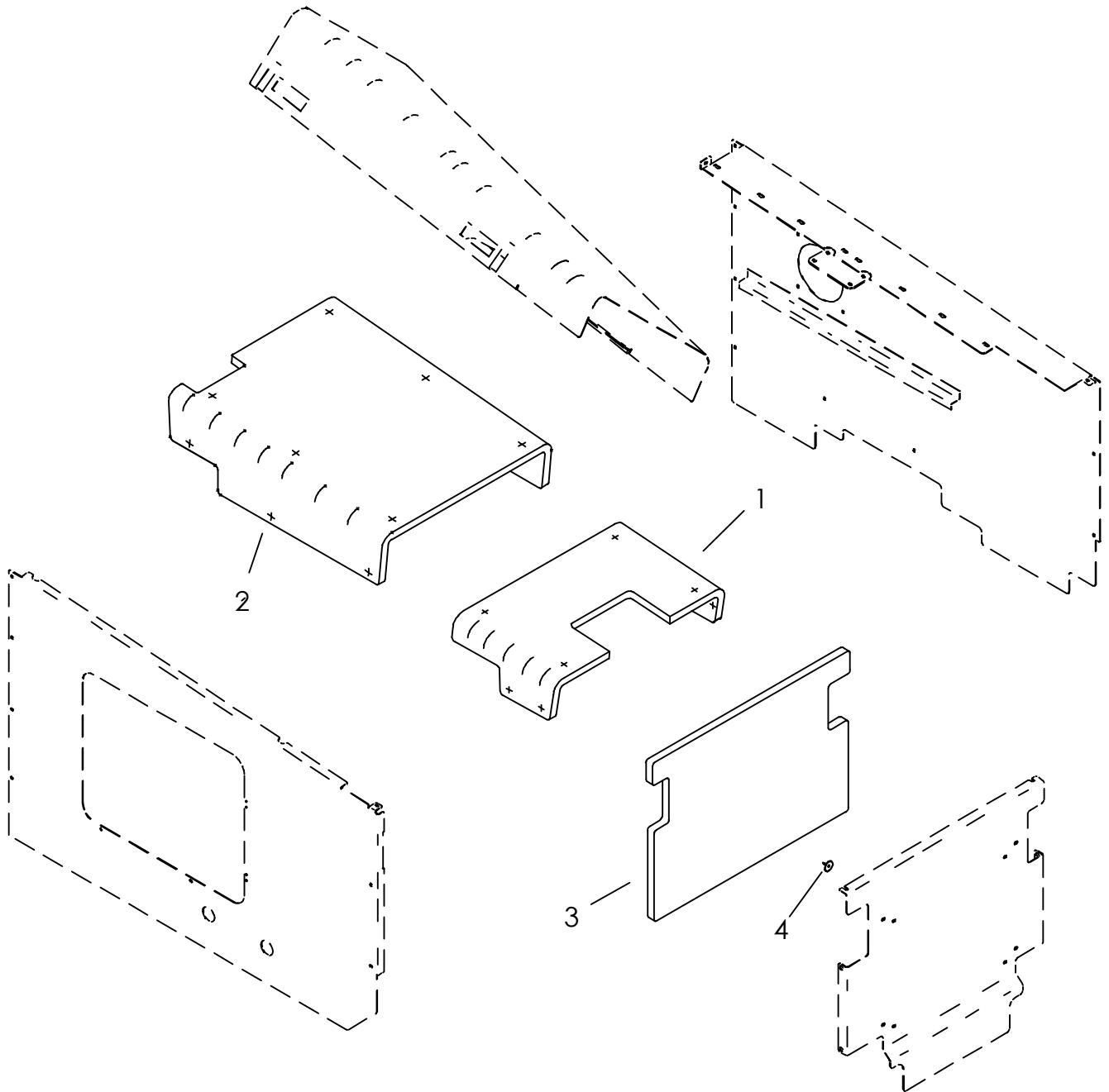

## SOUND INSULATION ENGINE COVERS

REF NO.	PART NUMBER	QTY	DESCRIPTION	REMARKS
1.	354-937	1	SOUND INSULATION (HOOD-FRONT)	SEE FOOTNOTE 1, 2
2.	354-938	1	SOUND INSULATION (HOOD-REAR)	SEE FOOTNOTE 1, 2
3.	354-939	1	SOUND INSULATION (BATTERY PANEL)	
4.	107-950	20	INSULATION STUD	SEE FOOTNOTE 2

NOT SHOWN:

FOOTNOTES:

1. FIBERGLASS MUST BE SCORED ALONG BEND LINE TO ACHIEVE ACCEPTABLE BEND RESULTS
2. "X" MARKS ON INSULATION INDICATE APPROX LOCATION OF INSULATION STUDS

NOTE:

# BATTERY COVERS

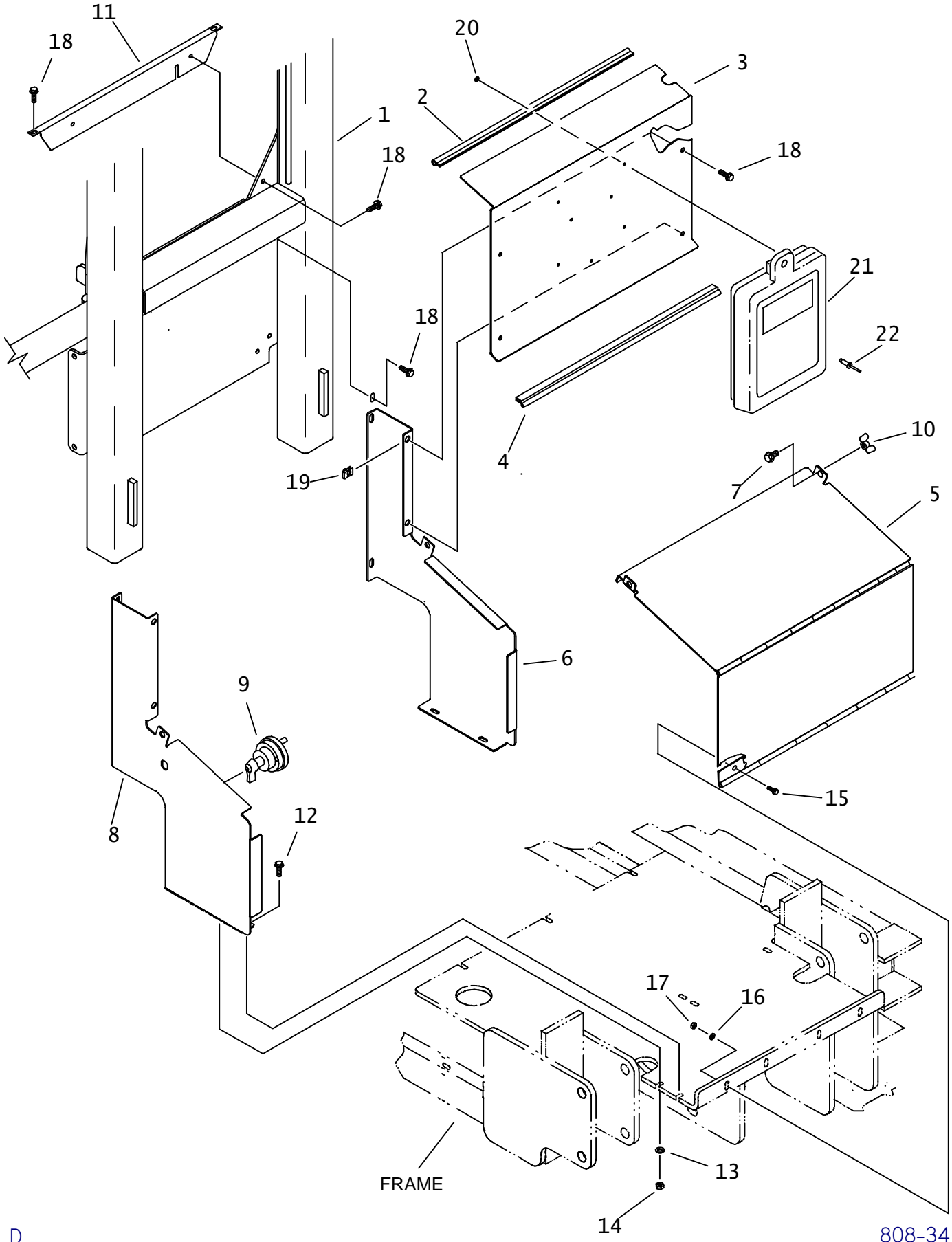

D

808-341



## BATTERY COVERS

REF NO.	PART NUMBER	QTY	DESCRIPTION	REMARKS
1.	309-190	-	2-POST ROPS	
2.	116-421	AR	BULK EDGE (1/8", SOLD PER 1')	USE 1 @ 21.5"
3.	354-467	1	RELAY BOARD COVER	BEFORE S/N
	320-998	-	RELAY COVER	
4.	116-489	AR	BULK EDGE (1/8", SOLD PER 1')	USE 1 @ 22"
5.	354-880	1	BATTERY COVER	BEFORE S/N
	320-999	-	BATTERY COVER	
6.	354-469	1	BATTERY SIDE PANEL (LEFT)	BEFORE S/N
	322-370	-	BATTERY SIDE PANEL (LEFT)	
7.	105-825	2	FLG LK BOLT (3/8-NC X 3/4")	
8.	354-468	1	BATTERY SIDE PANEL (RIGHT)	BEFORE S/N
	322-371	-	BATTERY SIDE PANEL (RIGHT)	
9.	217-819	-	BATTERY DISCONNECT SWITCH	
10.	105-180	2	WING NUT (3/8-NC)	
11.	309-189	1	COVER PLATE	
12.	106-381	4	FLG LK SCREW (M8-1.25 X 25MM)	
13.	105-117	4	WASHER (5/16")	
14.	106-561	4	LOCKNUT (M8-1.25, PRV TRQ, 10.9)	
15.	106-988	4	FLG LK SCREW (M6-1.00 X 20MM)	
16.	105-117	4	WASHER (5/16")	
17.	106-538	4	LOCKNUT (M6-1.00,PRV TRQ,10.9)	
18.	106-991	12	FLG LK SCREW (M8-1.25 X 20mm)	
19.	106-551	4	CLIP NUT (M8-1.25)	
20.	106-205	3	WASHER (.191")	
21.	318-588	1	MANUAL COMPARTMENT	
22.	110-560	4	POP RIVET (3/16" X 1/2", ALUM)	

FOOTNOTES

NOTE:

# GAUGE PANEL

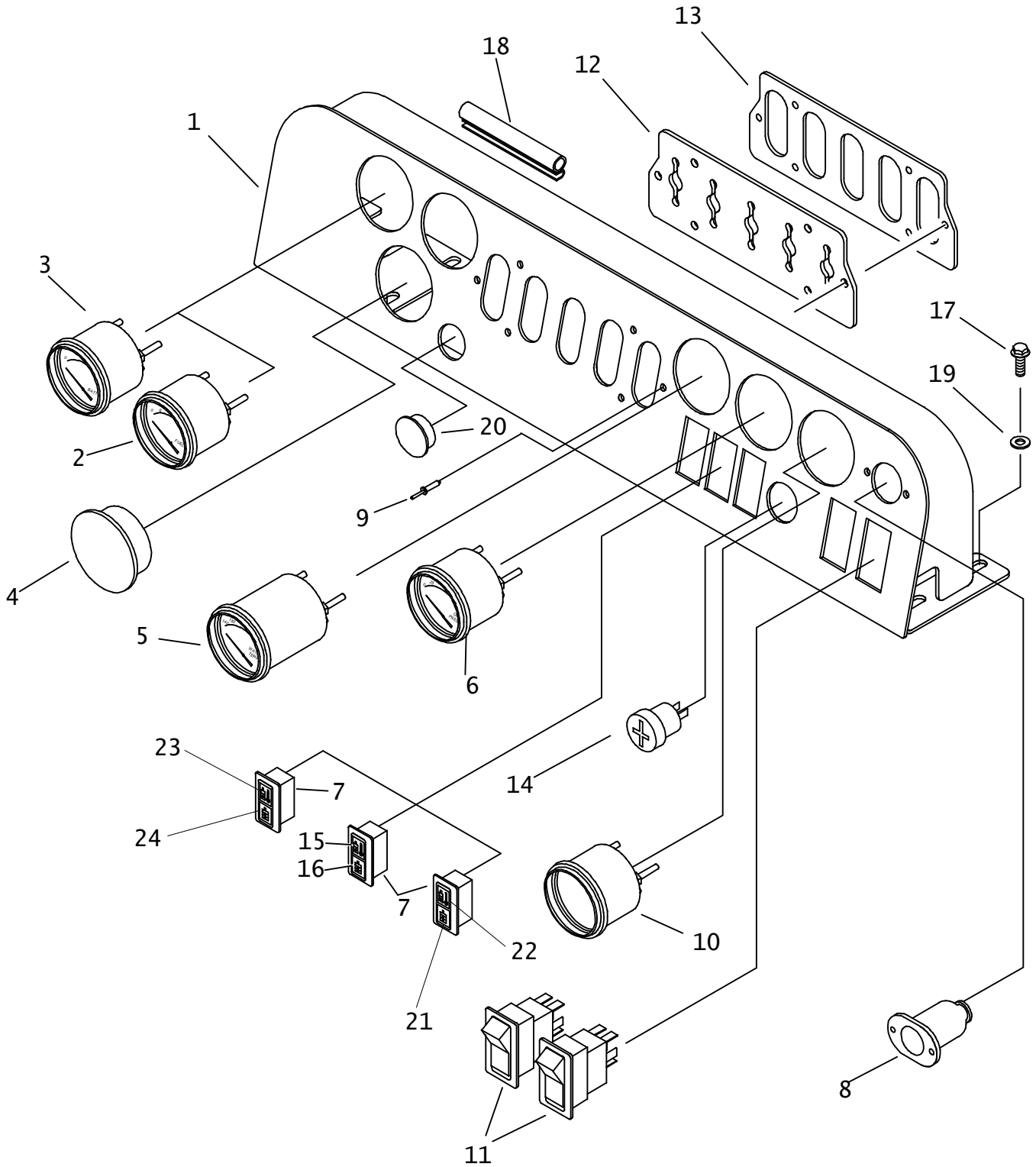

## GAUGE PANEL

REF NO.	PART NUMBER	QTY	DESCRIPTION	REMARKS
1.	308-337	1	INSTRUMENT PANEL	
2.	215-133	-	FUEL GAUGE	
	215-415		NITE-LIGHT KIT (12V DC)	
3.	215-129	-	VOLT METER	
	215-415		NITE-LIGHT KIT (12V DC)	
4.	111-067	1	EXPANSION PLUG (2.125")	
5.	258-077	-	WATER TEMPERATURE GAUGE	
	215-415		NITE-LIGHT KIT (12V DC)	
6.	258-076	-	OIL PRESSURE GAUGE	
	215-415		NITE-LIGHT KIT (12V DC)	
7.	217-020	3	PILOT LIGHT	ON-ON, SPDT
	217-046		BULB (12V DC)	
8.	214-301	-	ACCESSORY SOCKET	
9.	110-560	8	POP RIVET (3/16" X 1/2", ALUM)	
10.	211-275	-	DIAGNOSTIC GAUGE	
11.	217-907	-	ROCKER SWITCH (DPDT) ON-ON	
12.	117-383	1	CONTROL HANDLE SEAL	
13.	310-126	1	SEAL BACK-UP PANEL	
14.	306-603	-	AUDIO ALARM	
15.	217-027	-	INSERT (RED) HYD OIL HI TEMP	
16.	217-036	-	INSERT (YELLOW) HYD OIL PSI	
17.	106-987	4	FLG LOCK SCREW (M6-1.00 X 16mm)	
18.	116-489	AR	BULK EDGE (1/8", SOLD PER 1 FT)	USE 1 @ 32.5"
19.	106-076	4	WASHER (1/4")	
20.	111-112	1	PLUG (1.00)	
21.	217-028	1	INSERT (BLACK) BLANK	
22.	213-277	1	INSERT (YELLOW) PREHEAT	
23.	213-276	1	INSERT (YELLOW) ATTENTION	
24.	213-278	1	INSERT (RED) ENGINE FAULT	
NOT SHOWN:				
	106-574	5	CLIP NUT (M6-1.00)	ATTACH TO HYDRAULIC TANK

FOOTNOTES

NOTE:



# **OPERATOR'S STATION**

# OPERATOR STATION

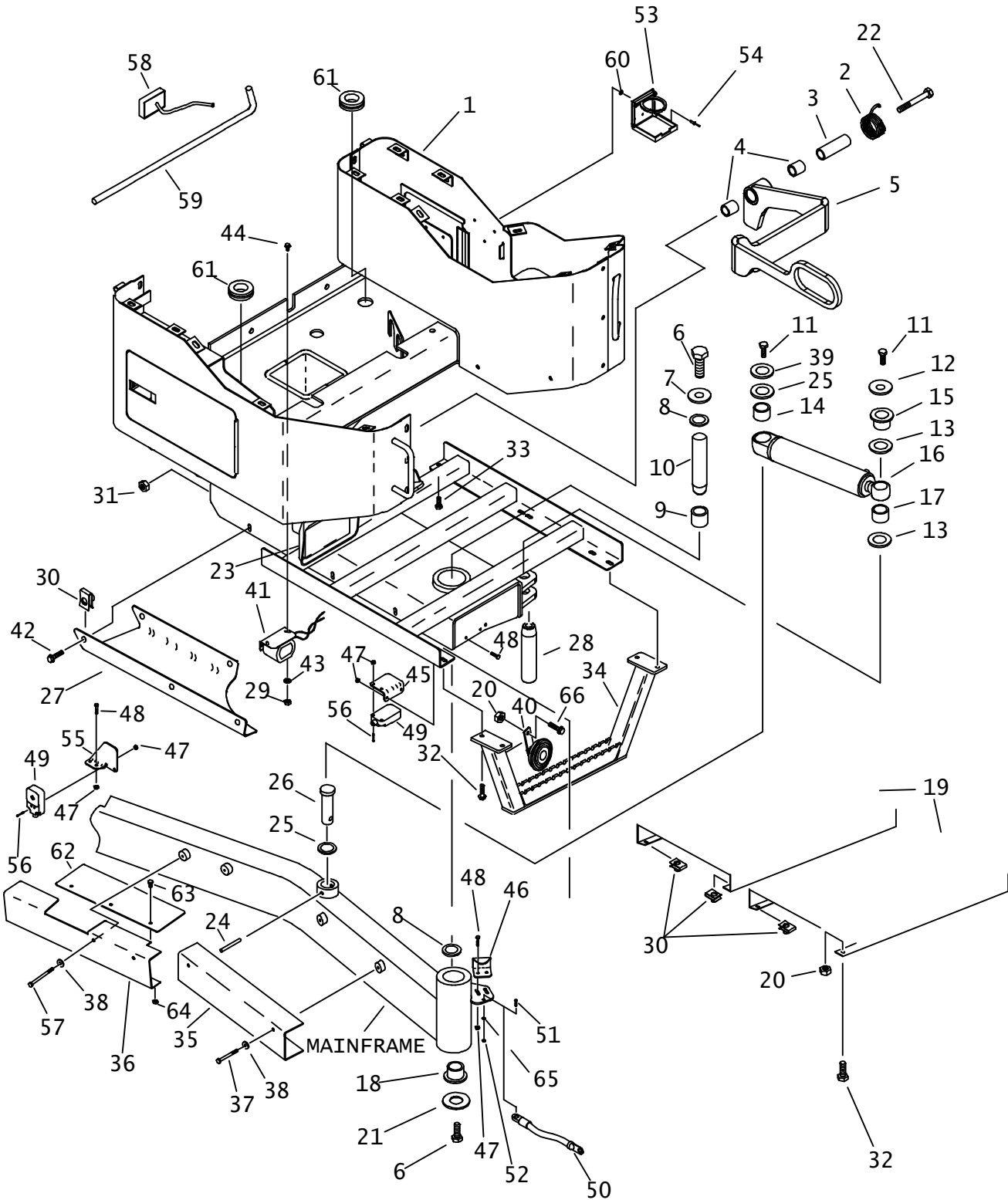

# OPERATOR STATION

REF NO.	PART NUMBER	QTY	DESCRIPTION	REMARKS
1.	313-733	1	OPERATOR FRAME	
2.	117-156	1	TORSION SPRING	
3.	354-454	1	HANDLE SPACER	
4.	125-813	2	COMPOSITION BUSHING (1")	
5.	319-499	1	HANDLE	
6.	106-345	2	SCREW (M20-2.50 X 50mm)	
7.	105-423	1	WASHER (3/4")	
8.	111-001	2	WASHER (M51.2)	
9.	125-754	1	COMPOSITION BUSHING (2")	
10.	179-226	1	TAPERED PIN (50.8mm X 272mm)	
11.	105-245	2	SCREW (M10-1.50 X 25mm)	
12.	106-396	1	WASHER (M10, HARDENED)	
13.	110-084	2	BRASS BUSHING (1-5/32")	
14.	125-771	1	COMPOSITION BUSHING (1.25")	
15.	181-981	1	TAPERED INSERT (1")	
16.	151-031	1	CYL (2" X 1" X 8")	
17.	125-770	1	COMPOSITION BUSHING (1")	
18.	184-064	1	TAPERED INSERT (2")	
19.	350-989	2	FLOOR TREADS	
20.	106-561	5	LOCKNUT (M8-1.25, PRV TRQ, 10.9)	
21.	106-399	1	WASHER (M20, HARDENED)	
22.	106-336	1	SCREW (M12-1.75 X 90mm)	
23.	217-007	1	WORKING LIGHT (CLEAR, RECT)	
24.	105-503	1	ROLL PIN (1/4" X 2")	
25.	110-093	2	MACHINERY BUSHING (1-1/4", 18GA)	
26.	179-225	1	PIN (31.75mm X 60mm)	
27.	350-988	1	CHANNEL COVER	
28.	183-767	1	TAPERED PIN (25.4mm X 60mm)	
29.	106-538	2	LOCKNUT (M6-1.00, PRV TRQ, 10.9)	
30.	106-551	11	CLIP NUT (M8-1.25)	
31.	106-685	1	LOCKNUT (M12-1.75, PRV TRQ, 10.9)	
32.	106-381	5	FLG LK SCREW (M8-1.25 X 25MM)	
33.	106-992	6	FLG LK SCREW (M8-1.25 X 25MM)	
34.	354-488	1	STEP	
35.	354-500	1	WIRE COVER	
36.	314-723	1	COVER	
37.	106-595	2	SCREW (M6-1.00 X 60mm)	
38.	106-388	4	WASHER (M6)	
39.	105-223	1	WASHER (3/8")	
40.	192-006	1	HIGH FREQUENCY HORN	
	192-005	1	HORN BRACKET	
	306-609	1	HIGH FREQUENCY HORN----- OBSOLETE	
41.	214-416	1	HORN (ELECTRIC)	
42.	106-991	5	FLG LK SCREW (M8-1.25 X 20MM)	

NOT SHOWN:

FOOTNOTES:

NOTE:

# OPERATOR STATION

REF NO.	PART NUMBER	QTY	DESCRIPTION	REMARKS
43.	106-389	2	WASHER (M8)	
44.	106-161	2	FLG SCREW (M6-1.00 X 20MM)	
45.	307-773	1	BRACKET, SWITCH	
46.	307-771	1	TARGET PLATE	
47.	106-850	10	LOCKNUT (M5-.80)	
48.	107-430	6	SCREW ( M5 X 14MM)	
49.	215-1175	2	PROXIMITY SWITCH	
50.	214-088	1	CABLE ASS'Y (6GA X 200 MM)	
51.	106-217	1	BOLT (1/4-NC X 1", SIL BRZ)	
52.	106-455	1	LOCKNUT (1/4-NC, SIL BRZ)	
53.	354-905	1	CUP HOLDER	
54.	110-560	3	POP RIVET (3/16" X 1/2", ALUM)	
55.	307-772	1	BRACKET, SWITCH	
56.	106-427	4	SCREW (M5-0.80 X 22MM, SOC)	
57.	106-945	2	SCREW (M6-1.00 X 100MM)	
58.	211-042	1	CURRENT TRANSFORMER	
59.	215-799	1	VOLTAGE STAKE	
60.	106-205	3	WASHER (.191")	
61.	115-355	2	GROMMET (1-3/8)	
62.	315-649	1	PLATE	
63.	106-234	3	SCREW (M6-1.00 X 12MM)	
64.	106-106	3	NUT (M6-1.00)	
65.	106-221	1	INT STAR WASHER (1/4", SIL BRZ)	
66.	106-162	1	FLG SCREW (M8-1.25 X 20MM)	

NOT SHOWN:

107-269	4	SCREW (#4-40 X 3/4", PAN)
106-277	4	NUT (#4-40, BRASS)
117-283	1	ABRASION SLEEVE (4.000" X 20")

FOOTNOTES:

NOTE:





## SEAT-BELT-COVER

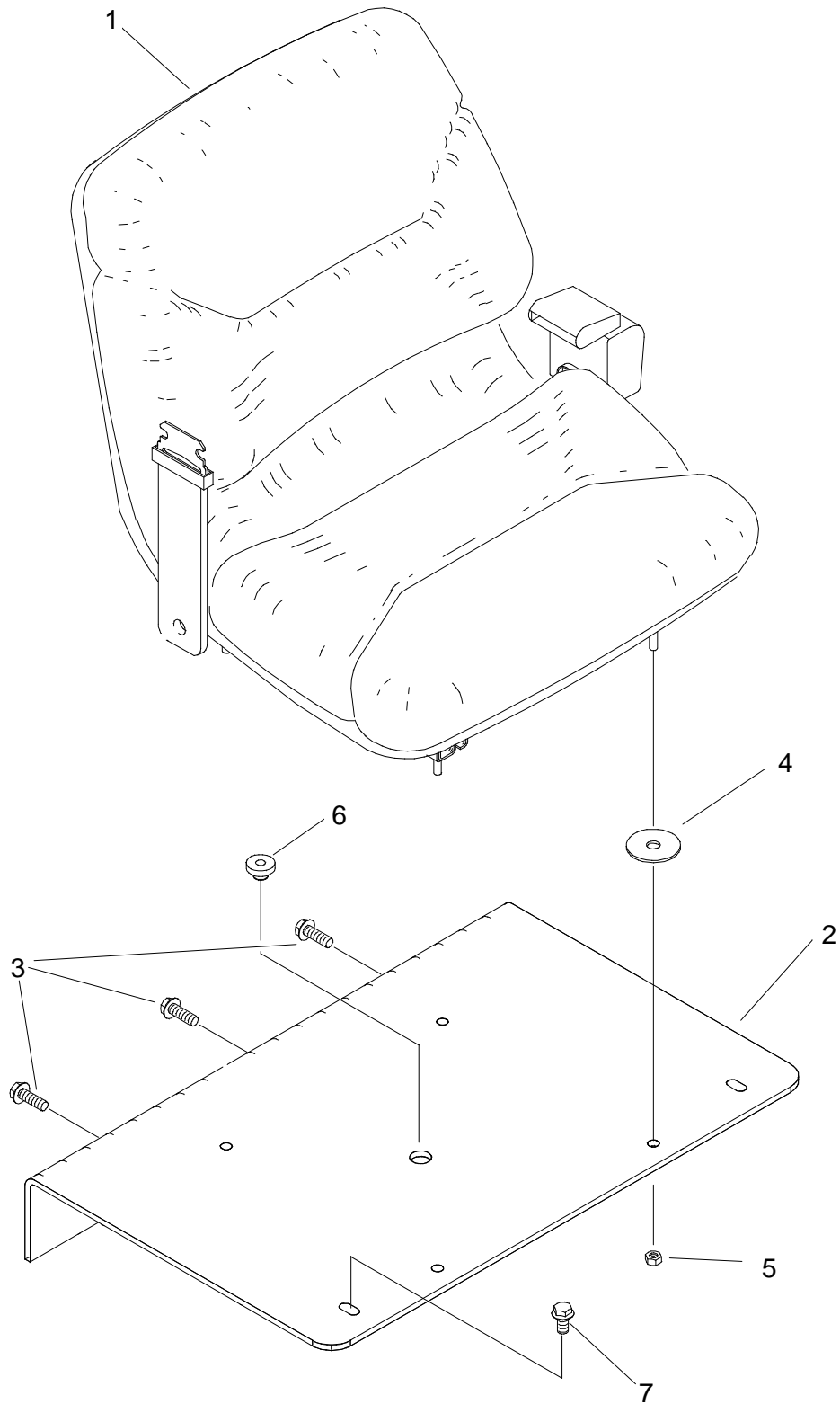

# SEAT-BELT-COVER

REF NO.	PART NUMBER	QTY	DESCRIPTION	REMARKS
1.	117-1000	1	SEAT ASS'Y W/ SEAT BELT	INCL SWITCH
	214-964	-	SEAT SWITCH W/ BOOT	
	214-965	-	SEAT SWITCH HARNESS	
2.	308-787	1	SEAT BASE	
3.	107-001	3	FLG LK SCREW (M10-1.50 X 25mm)	
4.	105-267	4	CUP WASHER (5/16")	
5.	106-561	4	LOCKNUT (M8-1.25,PRV TRQ,10.9)	
6.	116-203	1	GROMMET (9/16")	
7.	106-999	2	FLG LK SCREW (M10-1.50 X 20mm)	

NOT SHOWN:

FOOTNOTES:

NOTE:

## CONSOLE

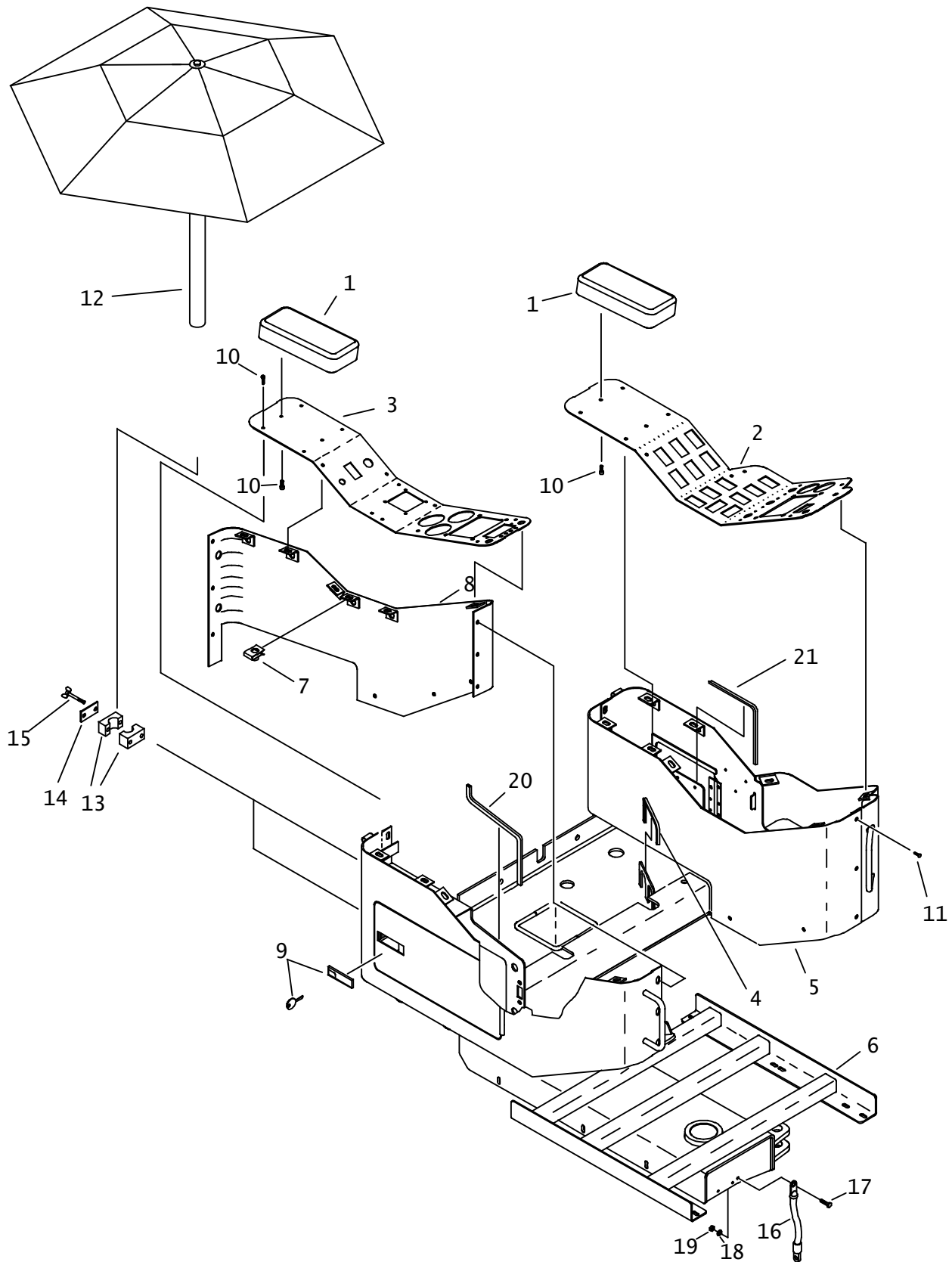

# CONSOLE

REF NO.	PART NUMBER	QTY	DESCRIPTION	REMARKS
1.	350-389	2	ARM REST PAD	
2.	313-729	1	LEFT CONSOLE COVER	
3.	211-011	1	RIGHT CONSOLE	
4.	116-789	AR	RUBBER EDGE TRIM 1/8" (12 GA)	USE 2 @ 10"
5.	350-749	1	LEFT CONSOLE	
6.	313-733	-	OPERATOR FRAME	
7.	106-574	37	CLIP NUT (M6-1.00)	
8.	308-790	1	RIGHT CONSOLE	
9.	117-558	2	ADJUST LEVER LATCH (LOCKING)	
	214-961		KEY, PAIR (BASE CODE)	
	217-309		LOCK PLUG 4/LATCH (BASE CODE)	
	<b>110-757</b>	2	LEVER LATCH (ADJUST LOCKING)	INCLUDES KEYS
	110-596	-	KEY (PAIR)	
10.	106-640	24	SCREW (M6-1.00 X 20mm, BUT SOC)	
11.	106-988	17	FLG LK SCREW (M6-1.00 X 20mm)	
12.	344-0001	1	UMBRELLA (6.5')	
	500-1962	-	POLE (16")	
13.	111-026	2	BOLT-ON CLAMP (1-1/4", PAIR)	
14.	322-362	2	BACKUP SPACER	
15.	105-621	4	WING BOLT (1/4-NC X 3")	
16.	214-088	-	CABLE ASS'Y (6GA X 200 MM)	
17.	106-217	1	BOLT (1/4-NC X 1", SIL BRZ)	
18.	106-221	1	INT STAR WASHER (1/4", SIL BRZ)	
19.	106-455	1	LOCKNUT (1/4-NC, SIL BRZ)	
20.	116-789	AR	RUBBER EDGE TRIM 1/8" (12 GA)	USE 1 @ 19"
21.	116-789	AR	RUBBER EDGE TRIM 1/8" (12 GA)	USE 1 @ 22"

NOT SHOWN:

FOOTNOTES:

NOTE:

# CONSOLE GAUGES

JT42T2 / AT42T2

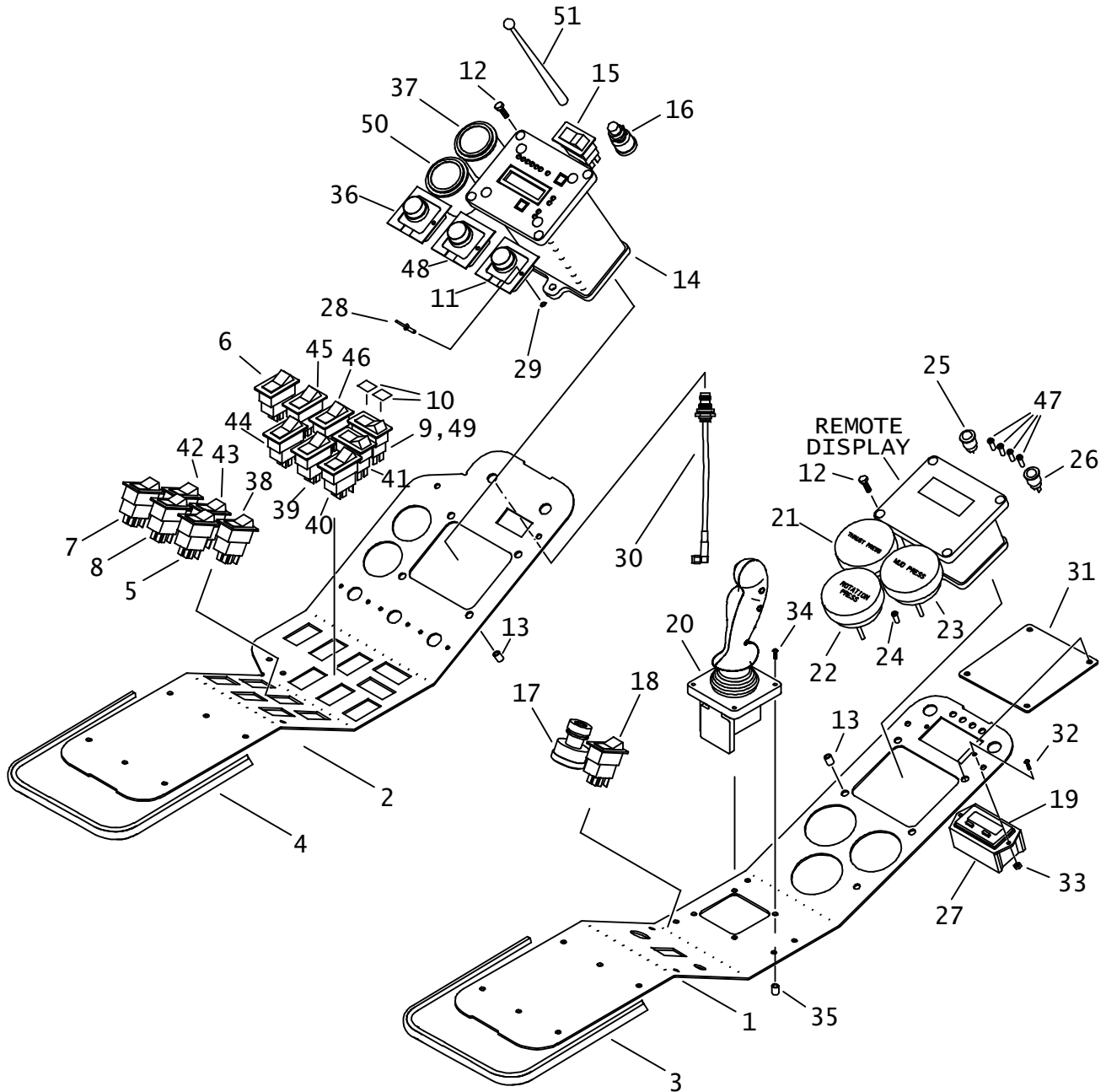

# CONSOLE GAUGES

## JT42T2 / AT42T2

REF NO.	PART NUMBER	QTY	DESCRIPTION	REMARKS
1.	211-011	-	RIGHT CONSOLE COVER	
2.	313-729	-	LEFT CONSOLE COVER	
3.	116-789	AR	RUBBER EDGE TRIM 1/8 " (12 GA)	USE 1 @ 86"
4.	116-789	AR	RUBBER EDGE TRIM 1/8 " (12 GA)	USE 1 @ 83"
5.	222-145	-	ROCKER SW DPDT (ON)-ON-(ON)	THROTTLE
6.	217-908	1	ROCKER SWITCH (DPDT) ON-ON-ON	INNER SPINDLE ON-OFF-(MAN), AT ONLY
	110-962	-	FILLER PLUG	JT ONLY
7.	217-912	-	ROCKER SWITCH (DPDT) ON-ON-ON	BORE/BACKREAM
8.	217-907	-	ROCKER SWITCH (DPDT) ON-ON	OUTER SPINDLE BRAKE
9.	217-923	-	ROCKER SW (DPDT) ON-OFF-ON	MOBILE/BORE
10.	217-156	2	DIFFUSION LENS (GREEN)	
11.	214-566	-	POTENTIOMETER	DRILL FLUID POT.
12.	106-640	8	SCREW (M6-1.00 X 20MM, BUT SOC)	
13.	105-630	8	NUTSERT(M6X1.0) .70-4.20THK	
14.	217-241	-	ESID MODULE	ELECTRICAL STRIKE SYSTEM
15.	217-911	-	ROCKER SWITCH (SPDT) ON-OFF-ON	SEAT ROTATE
16.	306-607	-	HORN BUTTON	HORN
	306-608	-	BUTTON COVER	
17.	214-852	1	IGNITION SWITCH	
	214-961	-	KEY, PAIR	
	214-962	-	SWITCH MOUNTING NUT	
18.	217-917	-	ROCKER SWTCH (DPDT) OFF-(ON)	ENGINE OVERRIDE
19.	319-412	1	FLOW METER WEATHER COVER	
20.	214-565	-	DUAL AXIS HALL EFFECT JOYSTICK	JOYSTICK
21.	258-063	-	GAUGE (4000 PSI)	THRUST PRESSURE GAUGE
22.	258-061	-	HYD PRESSURE GAUGE (6000 PSI)	INNER/OUTER ROTATION PRESSURE GAUGE
23.	258-062	-	PRESSURE GAUGE (1500PSI)	MUD PRESSURE GAUGE
24.	214-701	-	STATUS LIGHT	"MUD ON" LED
25.	214-563	-	RED LED 12V	DIAGNOSTIC LIGHT
26.	214-840	-	GREEN LED (12V DC)	CONTROL CYCLE LIGHT
27.	217-221	-	FLOW METER DISPLAY	MUD FLOW METER
28.	110-560	6	POP RIVET (3/16" X 1/2 ", ALUM)	
29.	106-205	6	WASHER (.191")	
30.	214-413	-	RIG RF CABLE 2130MM	
31.	348-896	1	COVER PLATE	COVER FOR HOLE WHEN REMOTE DISPLAY IS NOT INSTALLED.
32.	106-049	2	BOLT (#10-24 X 3/4 ", PLPS)	
33.	106-048	2	LOCKNUT (#10-24)	
34.	107-414	4	SCREW (M4-0.70 X 30MM, BUT SOC)	
35.	107-635	4	NUTSERT (M4 X 0.7)	
36.	211-089	-	4.5V-12.0V POTENTIOMETER	INNER SPINDLE POT., AT ONLY
37.	217-561	-	SPINDLE TACHOMETER (250 RPM)	OUTER SPINDLE TACH, AT ONLY
	111-067	-	EXPANSION PLUG (2.125")	JT ONLY
38.	214-489	-	ROCKER SW (DPDT) (ON)-OFF-(ON)	PIPE SHUTTLE
39.	217-907	-	ROCKER SWITCH (DPDT) ON-ON	REAR WRENCH

NOT SHOWN:

FOOTNOTES:

NOTE:

# CONSOLE GAUGES

## JT42T2 / AT42T2

REF NO.	PART NUMBER	QTY	DESCRIPTION	REMARKS
40.	217-907	-	ROCKER SWITCH (DPDT) ON-ON	FRONT WRENCH
41.	214-489	-	ROCKER SW (DPDT) (ON)-OFF-(ON)	LUBER
42.	214-489	-	ROCKER SW (DPDT) (ON)-OFF-(ON)	PIPE LIFT
43.	214-489	-	ROCKER SW (DPDT) (ON)-OFF-(ON)	PIPE GRIP
44.	214-489	-	ROCKER SW (DPDT) (ON)-OFF-(ON)	WRENCH ROTATE
45.	214-489	-	ROCKER SW (DPDT) (ON)-OFF-(ON)	INNER SPINDLE MANUAL CW/CCW, AT ONLY
	110-962	-	FILLER PLUG	JT ONLY
46.	214-489	-	ROCKER SW (DPDT) (ON)-OFF-(ON)	CRUISE CONTROL
47.	214-701	-	STATUS LIGHT	
48.	214-566	-	POTENTIOMETER	OUTER SPINDLE POT.
49.	217-925	-	ROCKER SWITCH (ACTUATOR)	
50.	211-099	-	SPINDLE TACHOMETER (250 RPM)	INNER SPINDLE TACH, AT ONLY
	111-067	-	EXPANSION PLUG (2.125")	JT ONLY
51.	221-177	-	ANTENNA UHF US-UK EXR450TN CEN	USA
	219-948	-	ANTENNA 420-450MHZ RT ANG TNC	INTERNATIONAL

NOT SHOWN:

FOOTNOTES:

NOTE:





# DUAL AXIS JOYSTICK

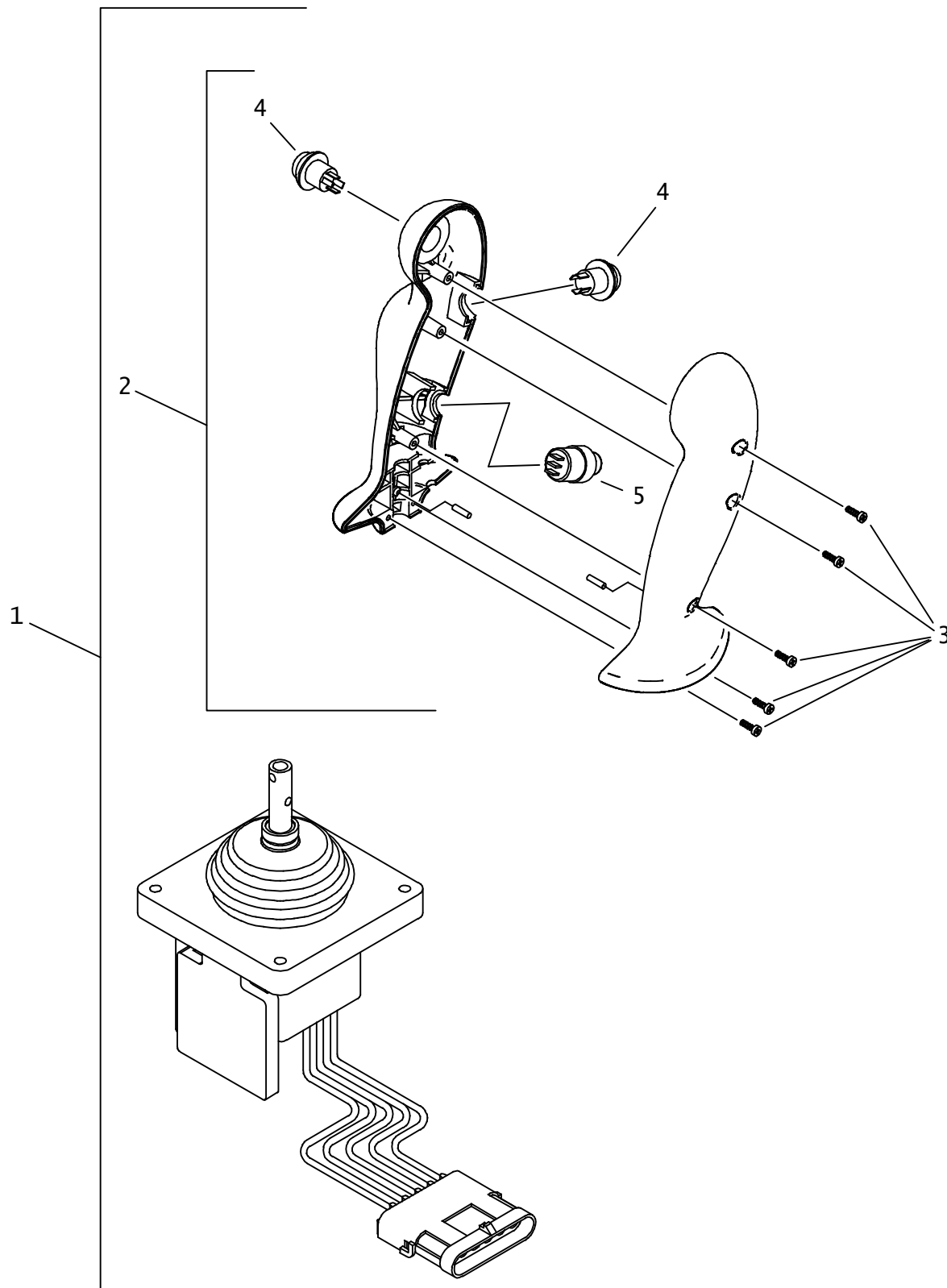

# DUAL AXIS JOYSTICK

REF	PART			
NO.	NUMBER	QTY	DESCRIPTION	REMARKS
1.	215-1224	-	DUAL AXIS JOYSTICK	
2.	500-1433	-	JOYSTICK HANDLE ASSEMBLY	INCLUDES REF No's 3,4,& 5
3.	107-410	-	SCREW (#2.5 X 8", PAN, PLASTIC)	
4.	214-614	-	PUSHBUTTON SW (SPST) OFF-(ON)	
5.	214-616	-	PUSHBUTTON SW (SPDT) ON-ON	

NOT SHOWN:

FOOTNOTES:

NOTE:



# **TRACK FRAME & MAIN FRAME**

# TRACK GROUP

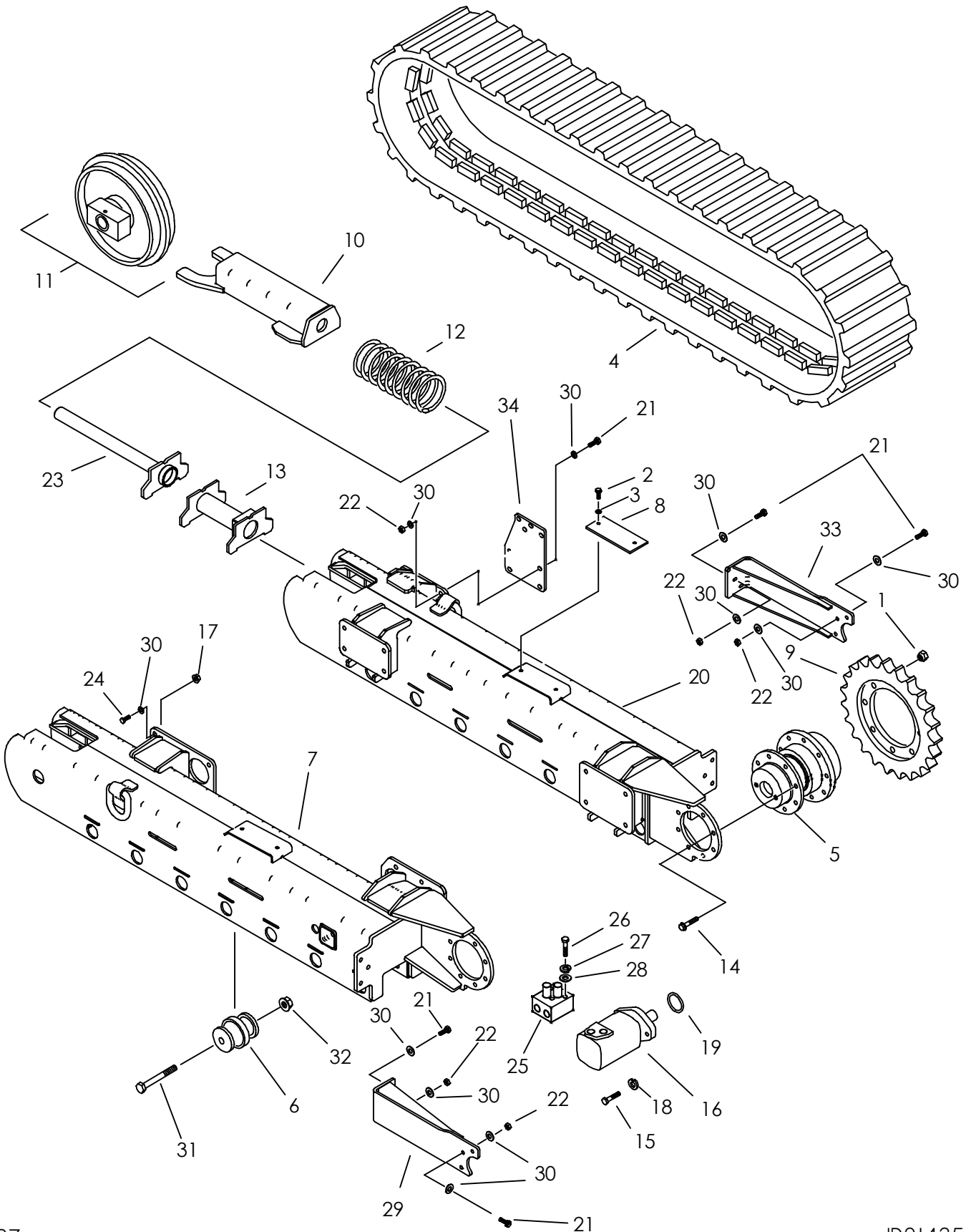

# TRACK GROUP

REF NO.	PART NUMBER	QTY	DESCRIPTION	REMARKS
1.	106-066	16	LUG NUT (5/8-NF)	
2.	107-010	4	FLG LOCK SCREW (M12-1.75 X 30mm)	
3.	106-397	4	WASHER (M12, HARDENED)	
4.	354-480	2	RUBBER TRACK (400MM,82P,72MM)	
5.	166-417	2	PLANETARY GEARBOX	TRACK PLANETARY, USE 500-2009 O-RING/GASKET KIT
	500-1755	-	INPUT SHAFT	
6.	354-861	14	ROLLER	
7.	350-757	1	LEFT ROLLER FRAME	
8.	349-314	2	SLIDE PAD	
9.	141-578	2	SPROCKET (20T)	
10.	354-517	2	YOKE	
11.	354-860	2	IDLER PARTS ASS'Y	
12.	117-164	2	COMPRESSION SPRING	COMPRESSED LENGTH 18" +0 -1/4" TO KEEP TRACKS TIGHT
13.	354-531	1	RIGHT GREASE CYLINDER	
	354-530	1	LEFT GREASE CYLINDER	
14.	105-970	16	FLG BOLT (5/8-NC X 2-1/2")	USE 242 LOCTITE
15.	107-773	4	SCREW (1/2-NC X 4.25", GD8)	USE 242 LOCTITE; TORQUE TO 130 FT LB
16.	153-592	1	HYDRAULIC MOTOR	RIGHT SIDE, USE SEAL KIT 500-752
	153-593	1	HYDRAULIC MOTOR	LEFT SIDE
17.	106-442	16	FLG LKNUT (M16-2.00, PRV TRQ, 10.9)	TORQUE SPECS.: SEE FOOTNOTE 1
18.	105-070	4	LOCK WASHER (.500")	
19.	155-768	2	O-RING (155 D70)	
20.	350-758	1	RIGHT ROLLER FRAME	
21.	106-616	20	SCREW (M16-2.00 X 55mm, 10.9)	
22.	106-545	27	LOCKNUT (M16-2.00,PRV TRQ, 10.9)	
23.	354-529	2	SPRING GUIDE	
24.	107-598	16	SCREW (M16 X 60MM 10.9)	
25.	153-767	2	COUNTERBALANCE MANIFOLD	
	158-020	2	HYDRAULIC VALVE	
26.	107-739	8	SCREW (3/8-NF X 5.25", GD 5)	
27.	105-072	8	LOCK WASHER (3/8")	
28.	106-390	8	WASHER (M10)	
29.	354-569	1	LEFT TRACK GUARD	
30.	106-398	56	WASHER (M16, HARDENED)	
31.	105-597	14	BOLT (1-NC X 7.50", GD8)	USE 242 LOCTITE
32.	105-919	14	FLG NUT (1-NC)	
33.	354-570	1	RIGHT TRACK GUARD	
34.	350-831	1	ROPS SUPPORT PLATE	

NOT SHOWN:

#### FOOTNOTES:

1. APPLY LOCTITE 242;TIGHTEN ALL TRACK-MAIN FRAME JOINT FASTENERS TO 150 FT LB AND FINAL TORQUE OF 225 FT LB AT NUT; OR INITIAL TORQUE TO 125 FT LB AND FINAL TORQUE TO 185 FT LB AT BOLT HEAD. DO NOT DRAW MATING SURFACES TOGETHER WITH A SINGLE NUT-BOLT COMBINATION.

NOTE:

## IDLER

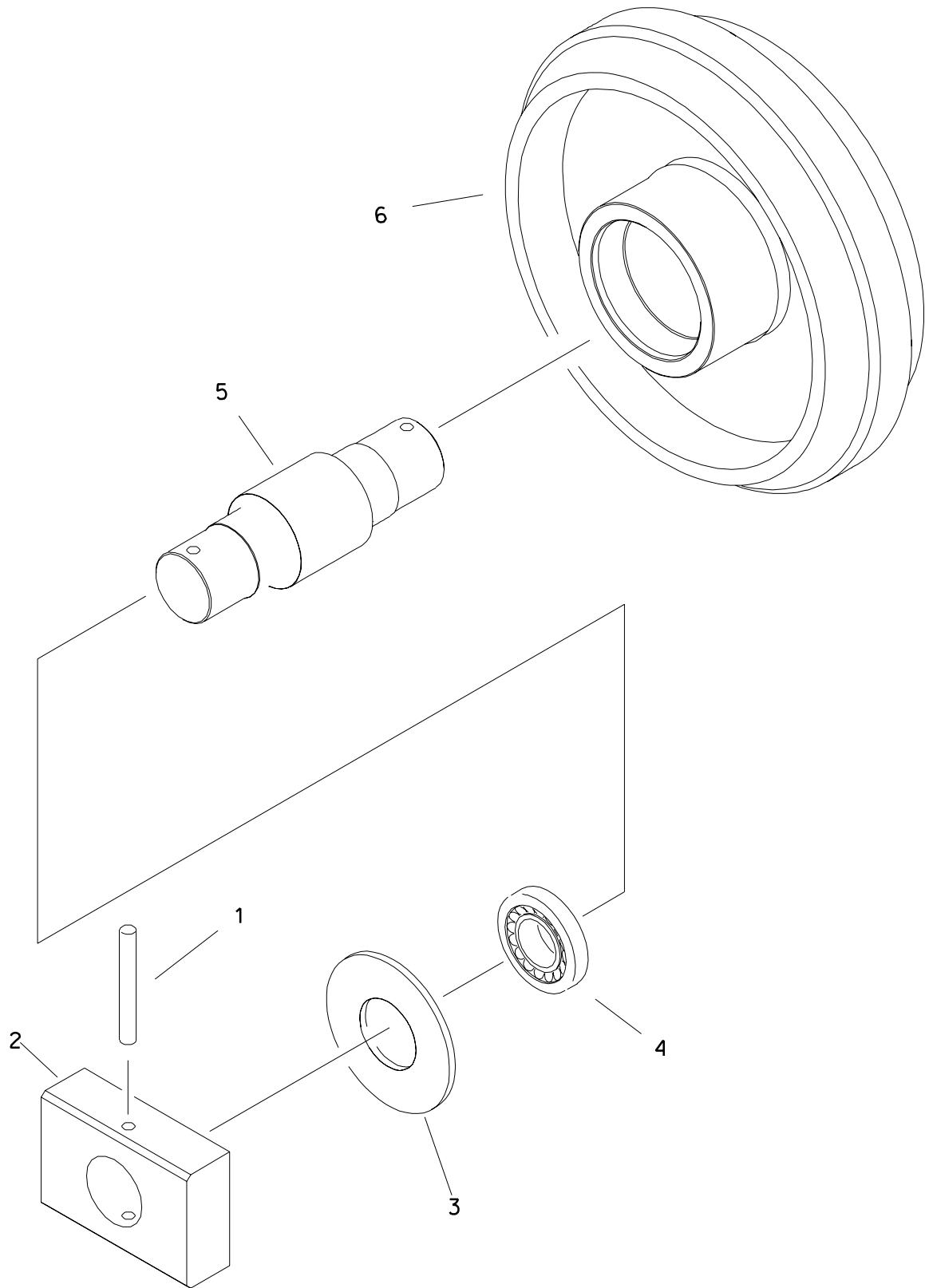



# IDLER

REF NO.	PART NUMBER	QTY	DESCRIPTION	REMARKS
	354-860		IDLER	INCL REF NO'S 1 - 6
1.	107-295	2	ROLL PIN (.375" X 3.75")	
2.	354-833	2	OUTER BLOCK	
3.	125-482	2	WASHER (2.283")	
4.	125-134	2	BALL BEARING (2.362")	PACK WITH GREASE
5.	354-827	1	IDLER SHAFT	
6.	350-515	1	IDLER	PACK INSIDE WITH GREASE

FOOTNOTES

## ROLLER

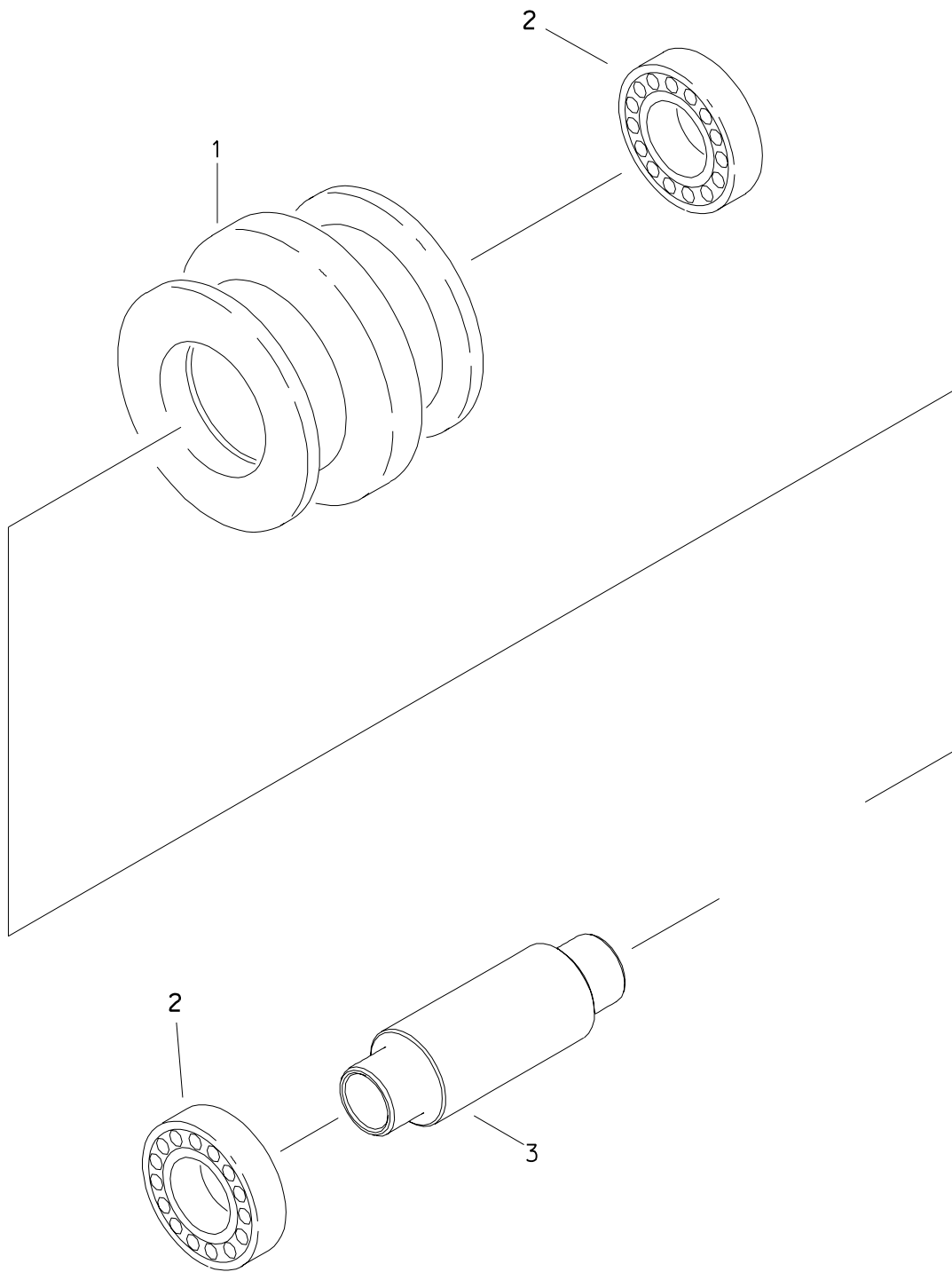

# ROLLER

REF NO.	PART NUMBER	QTY	DESCRIPTION	REMARKS
	354-861		ROLLER	INCL REF NO'S 1-3
1.	170-341	1	ROLLER SHELL	
2.	125-138	2	BALL BEARING (1.250")	
3.	167-336	1	SHAFT	

## FOOTNOTES

## GREASE CYLINDER

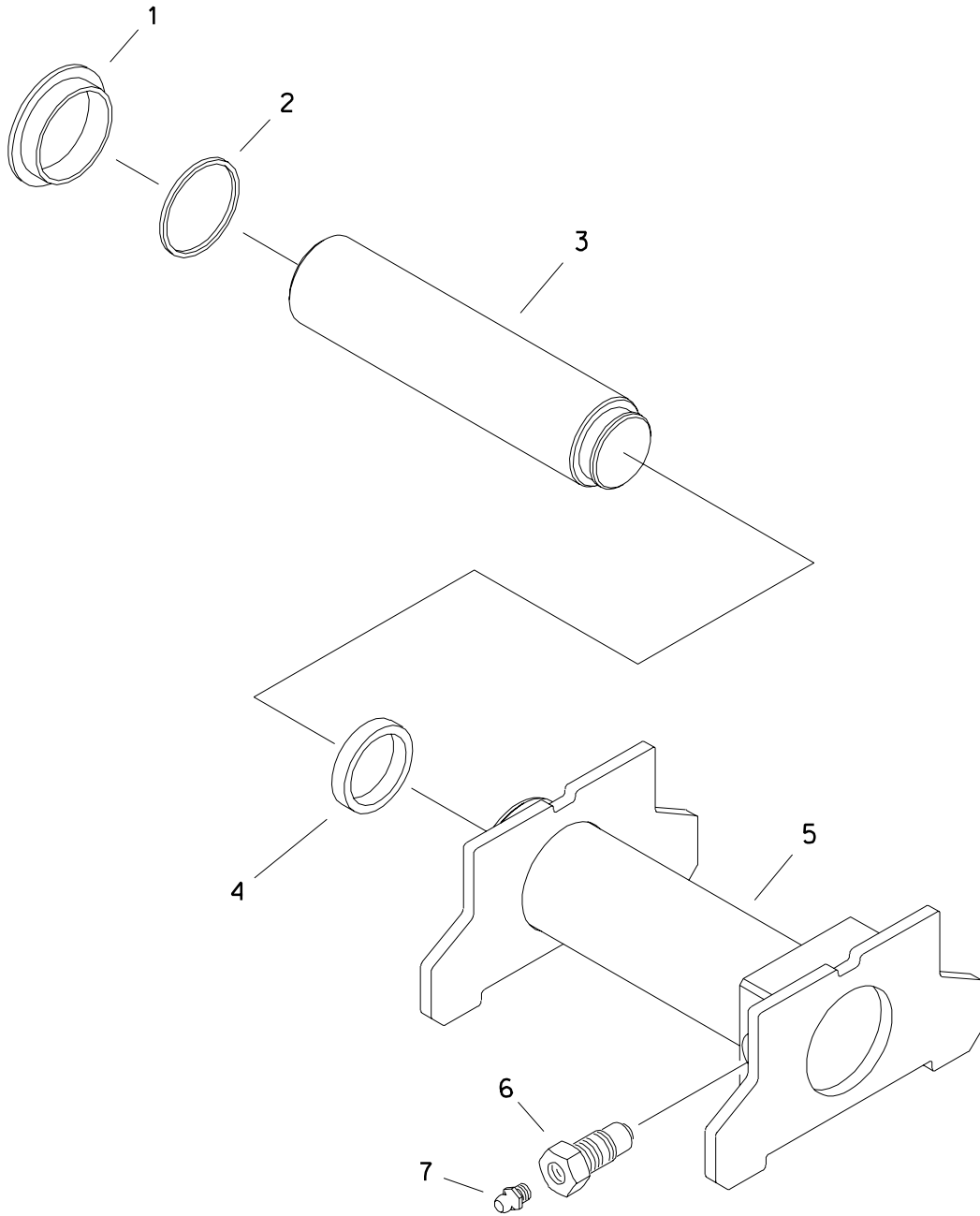

# GREASE CYLINDER

REF NO.	PART NUMBER	QTY	DESCRIPTION	REMARKS
	354-530	1	LEFT GREASE CYLINDER	INCL REF NO'S 1 THRU 7
	354-531	1	RIGHT GREASE CYLINDER	INCL REF NO'S 1 THRU 7
1.	157-562	1	RETAINER RING (2.625")	
2.	157-561	1	ROD WIPER (2.492")	
3.	150-682	1	GREASE CYLINDER ROD	
4.	157-560	1	PISTON SEAL (1.975")	
5.	151-184	1	RIGHT BARREL	
	151-183	1	LEFT BARREL	
6.	159-093	1	RELIEF VALVE (5/8-NF, 02N)	
7.	115-019	1	ZERK (02N)	

FOOTNOTES

## REAR STABILIZER

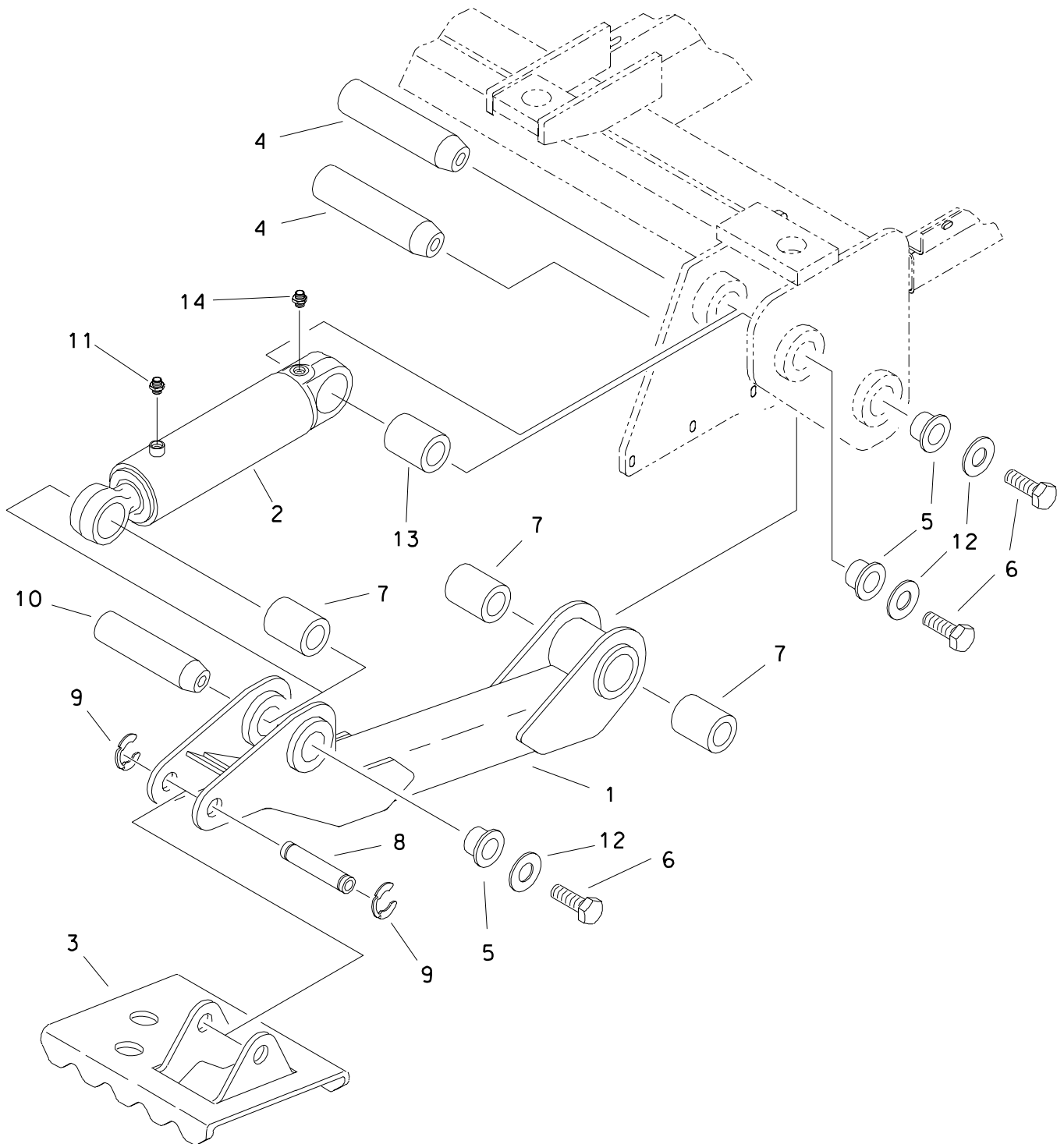

# REAR STABILIZER

REF NO.	PART NUMBER	QTY	DESCRIPTION	REMARKS
1.	350-508	1	RIGHT STABILIZER	
	354-537	1	LEFT STABILIZER	
2.	151-187	2	CYLINDER ASSEMBLY	4" X 2" X 10"
3.	350-850	1	RIGHT STABILIZER PAD	
	354-536	1	LEFT STABILIZER PAD	
4.	179-223	4	TAPERED PIN (50.8mm X 208mm)	
5.	184-064	6	TAPERED INSERT (2")	
6.	106-798	6	SCREW (M20-2.50 X 55mm, 10.9)	
7.	125-754	6	COMPOSITION BUSHING (2")	
8.	179-224	2	PAD PIN	
9.	115-483	4	KLIP RING (1.25")	
10.	183-832	2	TAPERED PIN (50.8MM X 135MM)	
11.	154-261	2	CONNECTOR (040-08S)	
12.	106-399	6	WASHER (M20, HARDENED)	
13.	125-844	2	COMPOSITION BUSHING (2")	
14.	154-374	2	CONNECTOR (040-08S, ORF)	

FOOTNOTES

NOTES

REFER TO O-RING CHART (800-301) IN BACK OF BOOK FOR REPLACEMENT OF O-RINGS.

# FUEL TANK

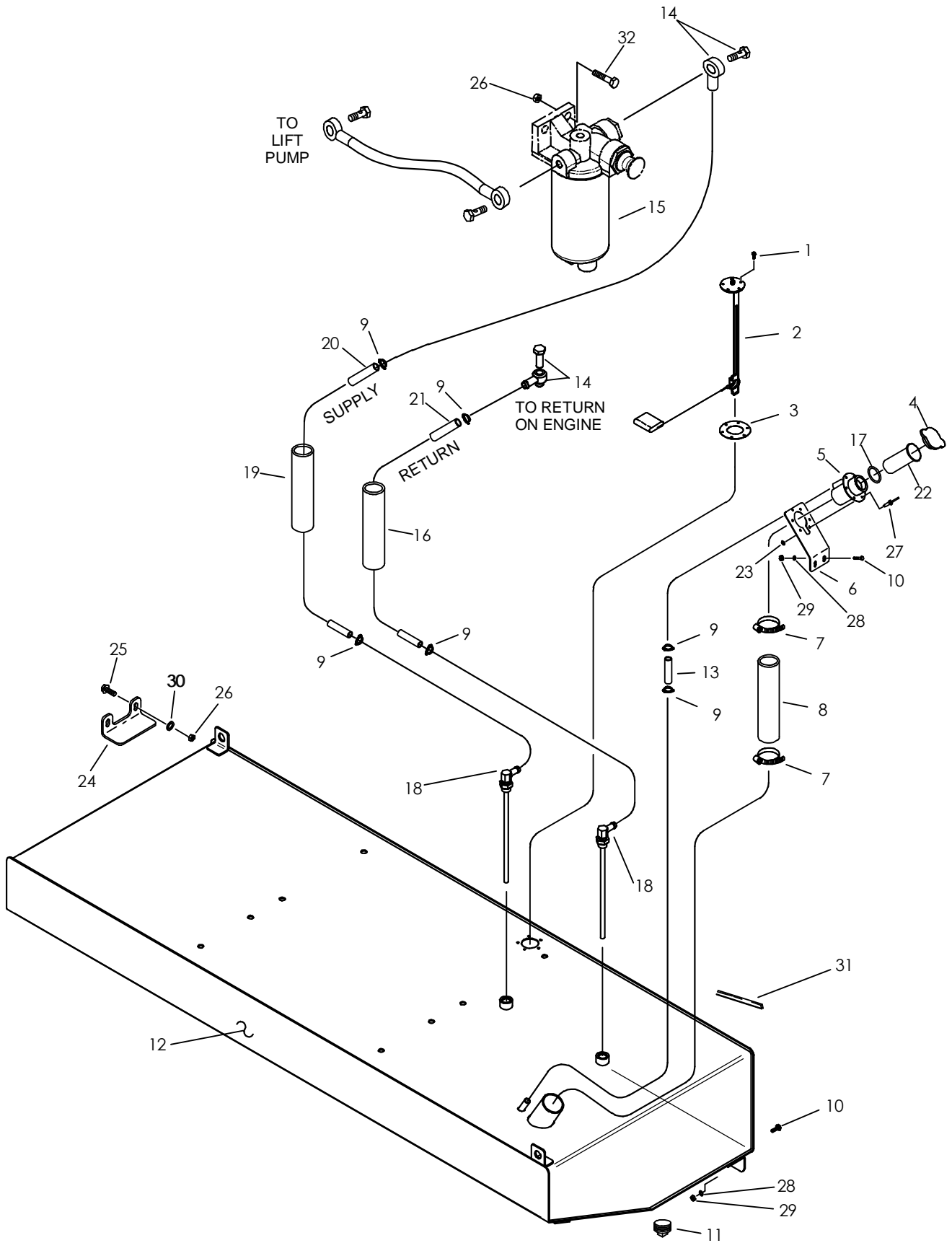



# FUEL TANK

REF NO.	PART NUMBER	QTY	DESCRIPTION	REMARKS
1.	105-214	5	FLG SCREW (#10-24 X 1/2")	
2.	217-568	1	FUEL SENDER	
3.	165-704	1	GASKET	
4.	110-010	1	FUEL CAP (1-1/2")	
5.	364-645	1	FILLER NECK	
6.	364-487	1	FUEL FILL BRACKET	
7.	110-134	2	WORM CLAMP (2-1/16" TO 2-3/4")	
8.	105-1110	1	FUEL HOSE (12-1/2")	
9.	110-217	4	WORM CLAMP (7/16" TO 1")	
10.	106-162	6	FLG SCREW (M8-1.25 X 20mm)	
11.	115-152	1	PLUG (12N, SQ, FM)	
12.	300-1949	1	FUEL TANK	
13.	116-322	AR	BULK HOSE (1/2", SOLD PER 1")	USE 1 @ 16"
14.	150-1231	2	S/O COUPLER (M12-1.5-08H90)	
15.	195-1035		PRIMARY FUEL FILTER	
	195-1036		SECONDARY FUEL FILTER	
16.	118-062	1	ABRASION SLEEVE (1.00" X 62")	
17.	155-708	1	O-RING (218-D70)	
18.	150-1229	2	PICKUP TUBE (08H90)	
19.	117-412	1	ABRASION SLEEVE (1.00" X 34")	
20.	116-322	AR	BULK HOSE (1/2", SOLD PER 1")	USE 1 @ 36"
21.	116-322	AR	BULK HOSE (1/2", SOLD PER 1")	USE 1 @ 63"
22.	364-663	1	FILLER NECK SCREEN	
23.	106-205	4	WASHER (.191")	INSTALL ON POP RIVET 110-253
24.	354-973	2	TANK CLAMP	
25.	106-632	4	FLG LK SCREW (M12-1.75 X 35mm, SER)	
26.	106-685	6	LOCKNUT (M12-1.75, PRV TRQ, 10.9)	
27.	110-253	4	POP RIVET (3/16" X 1/2")	
28.	105-117	6	WASHER 5/16")	
29.	106-561	6	LOCKNUT (M8-1.25, PRV TRQ, 10.9)	
30.	106-391	4	WASHER (M12)	
31.	116-789	AR	RUBBER EDGE TRIM (1/8", SOLD PER FT.)	USE 1 @ 15", SEE FOOTNOTE 1
32.	106-469	2	SCREW (M12-1.75 X 30mm)	

NOT SHOWN:

#### FOOTNOTES:

1. START EDGING 8" FROM END OF TANK AND USE LOCTITE 401.

NOTE:

# 2-POST ROPS

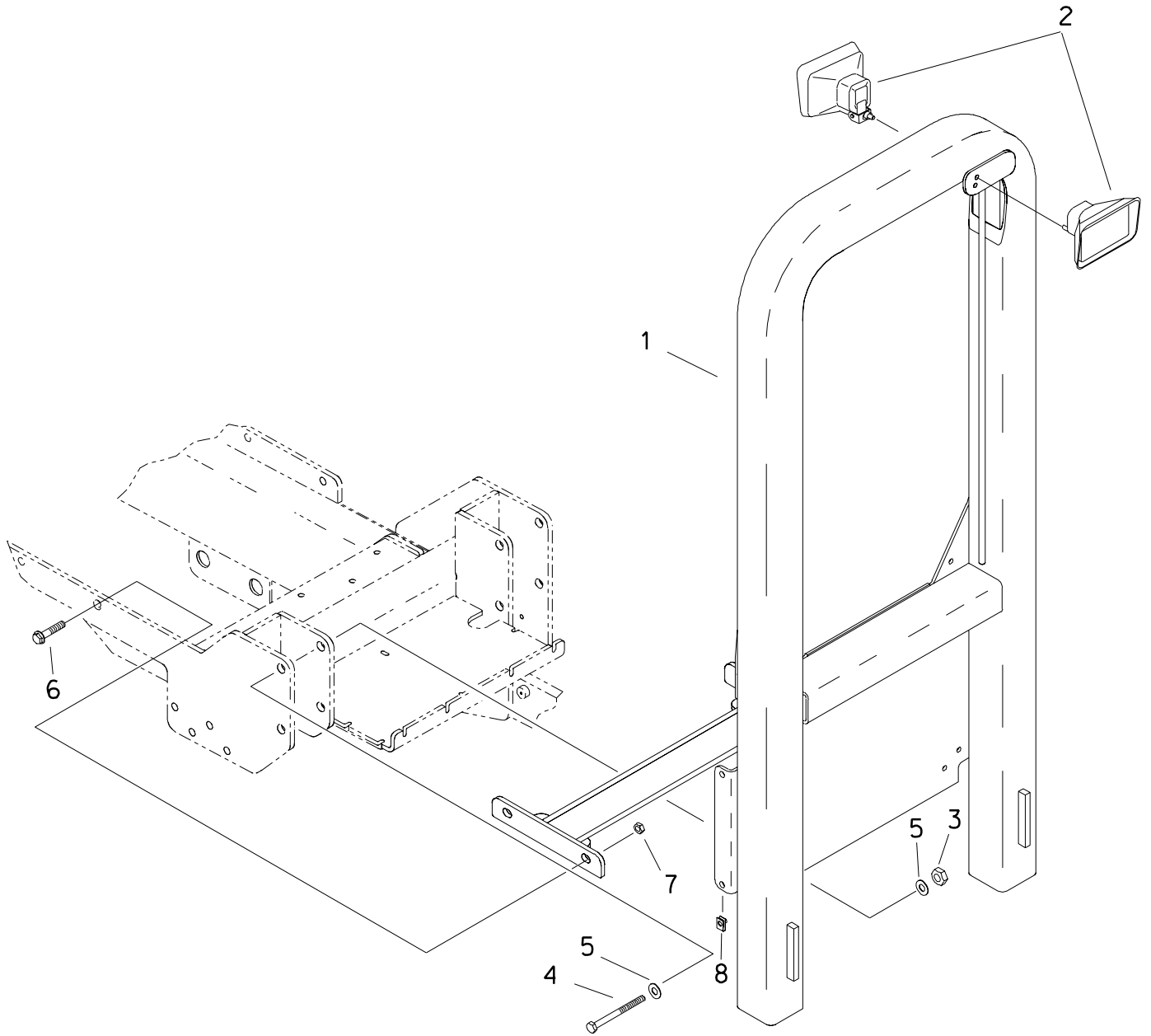

# 2-POST ROPS

REF NO.	PART NUMBER	QTY	DESCRIPTION	REMARKS
1.	309-190	1	2-POST ROPS	
2.	217-057	-	WORKING LIGHT - CLEAR	
	105-033	1	BOLT (5/16-NC X 2")	
	105-091	2	LOCK WASHER (5/16")	
	105-092	2	NUT (5/16-NC)	
3.	106-665	4	LOCKNUT (M20-2.50, 10.9)	
4.	106-373	4	SCREW (M20-2.5 X 160mm)	
5.	106-399	8	WASHER (M20, HARDENED)	
6.	106-470	4	FLG SCREW (M16-2.00 X 40mm)	
7.	106-545	4	LOCKNUT (M16-2.00, PRV TRQ, 10.9)	
8.	107-687	4	CLIP NUT M8-1.25, LONG, WIDE	

FOOTNOTES

# DRILLFRAME COVERS/LCKS/SWITCHES

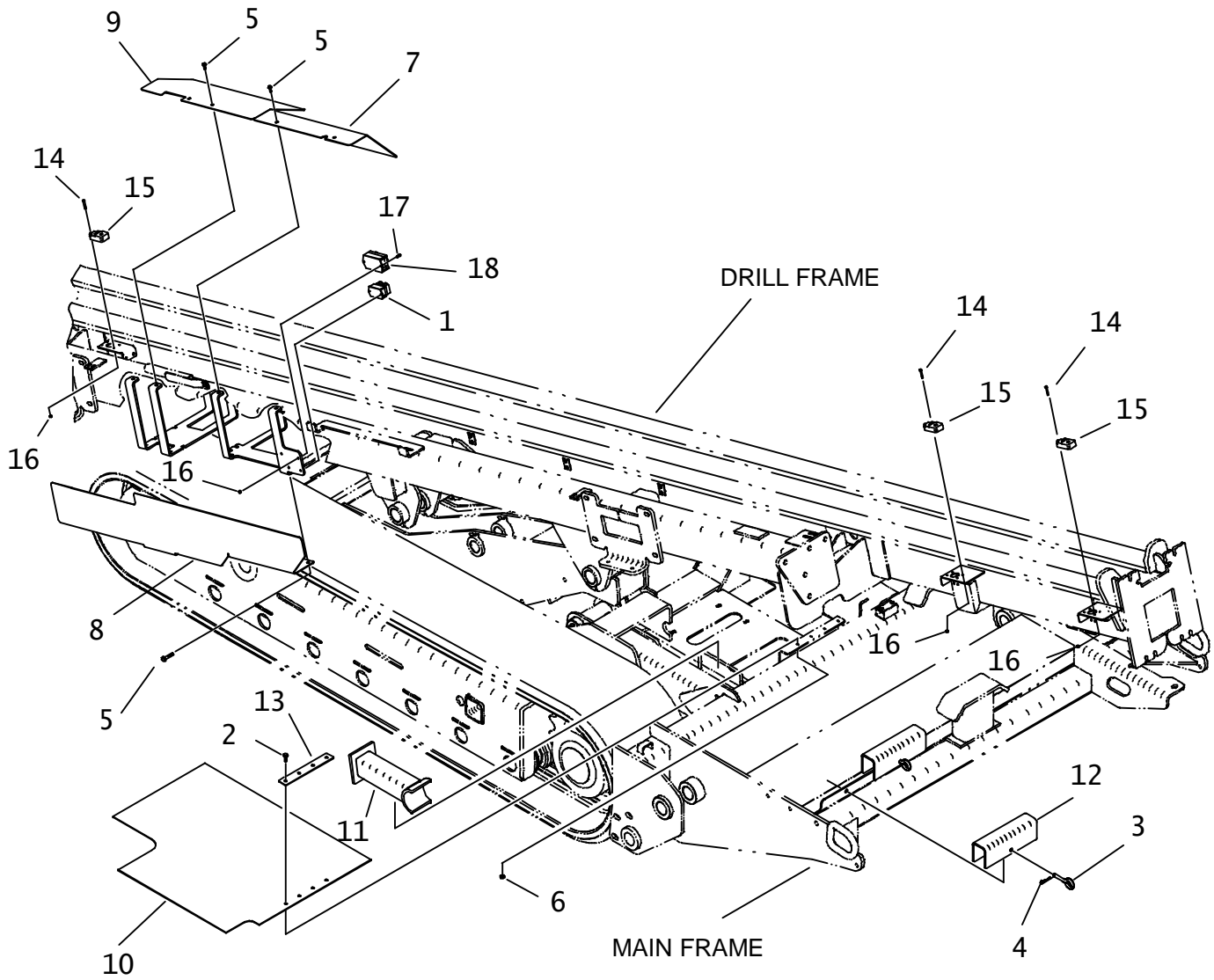

## DRILLFRAME COVERS/LCKS/SWITCHES

REF NO.	PART NUMBER	QTY	DESCRIPTION	REMARKS
1.	211-026	1	DIODE PACK (DEUTSCH)	
2.	106-162	4	FLG SCREW (M8-1.25 X 20MM)	
3.	110-034	2	EYE PIN (7/16" X 3")	
4.	110-033	2	HAIR CLIP PIN (1/8" X ")	
5.	106-991	8	FLG LK SCREW (M8-1.25 X 20MM)	
6.	106-561	4	LOCKNUT (M8-1.25, PRV TRQ, 10.9)	
7.	305-948	1	VALVE COVER	
8.	305-949	1	VALVE COVER	
9.	305-947	1	VALVE COVER	
10.	116-863	1	COVER FLAP	
11.	354-562	1	DRILL FRAME STIFF LEG	
12.	354-980	2	CYLINDER LOCK	
13.	350-514	1	CLAMP PLATE	
14.	107-465	6	SCREW (M5-0.80 X 30MM, SOC)	
15.	215-1175	3	PROXIMITY SWITCH	
16.	106-850	10	LOCKNUT (M5-0.80)	
17.	106-542	4	SCREW (M5-0.80X16MM, PAN PLPS)	
18.	211-025	-	IN-LINE DIODE PACK	

NOT SHOWN:

107-451 AR SHIM (.135")

213-103 AT/JT42M1 REAR STOP HARNESS

FOOTNOTES:

NOTE:

# HOSE RETAINING CLAMP

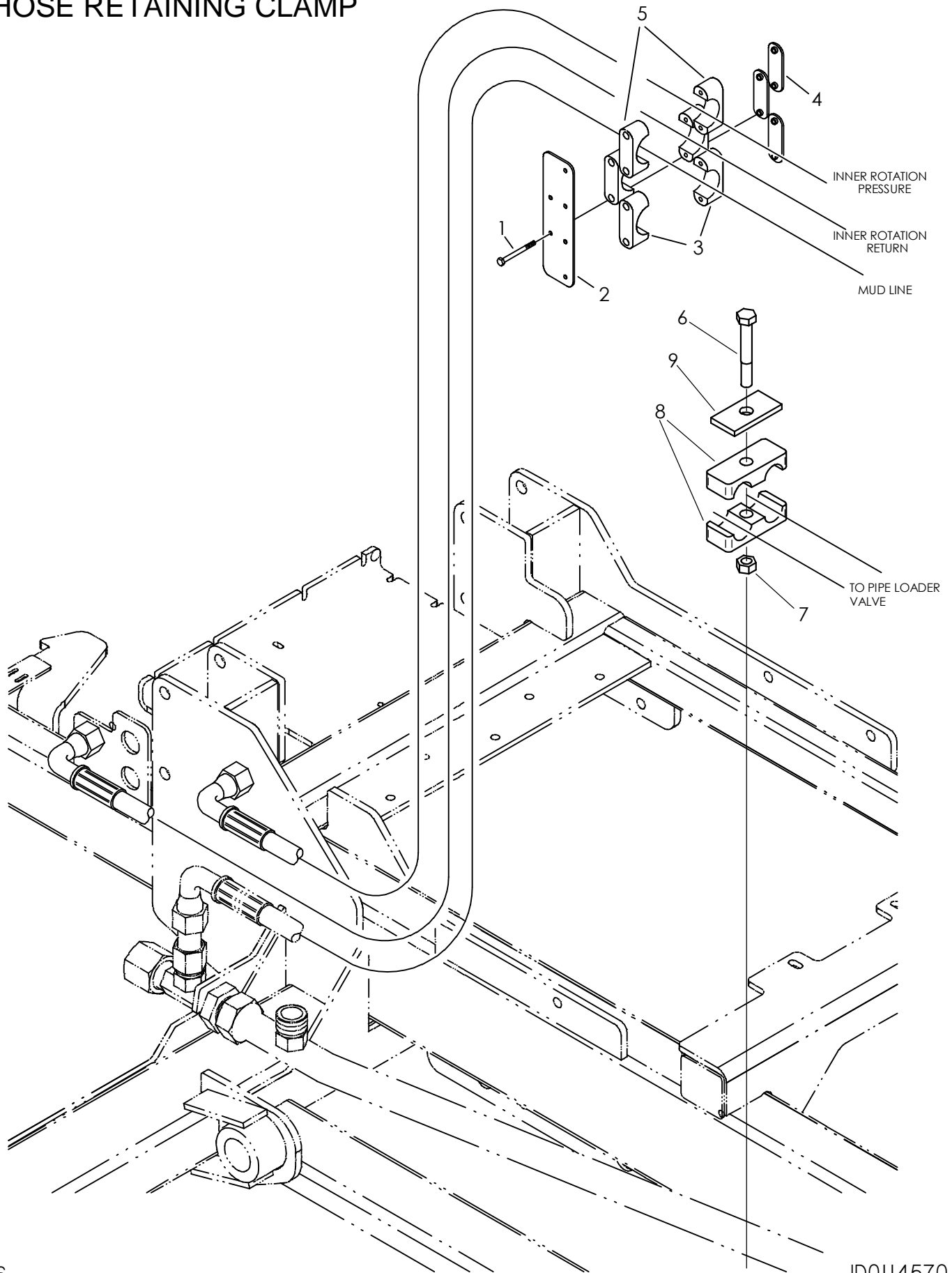

# HOSE RETAINING CLAMP

REF NO.	PART NUMBER	QTY	DESCRIPTION	REMARKS
1.	107-743	6	SCREW (1/4-NC X 2.75", GD 5)	
2.	314-794	1	PLATE	
3.	110-970	2	CLAMP (2.00")	
4.	110-972	3	WELD PLATE	
5.	111-010	1	BLT-ON CLAMP(1.750", SET)	
6.	106-570	1	SCREW (M8-1.25 X 60MM)	FOOTNOTE I
7.	106-561	1	LOCKNUT (M8-1.25 PRV TRQ, 10.9)	FOOTNOTE I
8.	110-195	2	BOLT-ON CLAMP (3/4", PER HALF)	FOOTNOTE I
9.	305-256	1	BACKUP SPACER	FOOTNOTE I

NOT SHOWN:

FOOTNOTES:

- I. USE WITH RACK & PINION UNITS ONLY

NOTE:





# **ANCHOR SYSTEMS**

# AUGER ANCHOR BASE

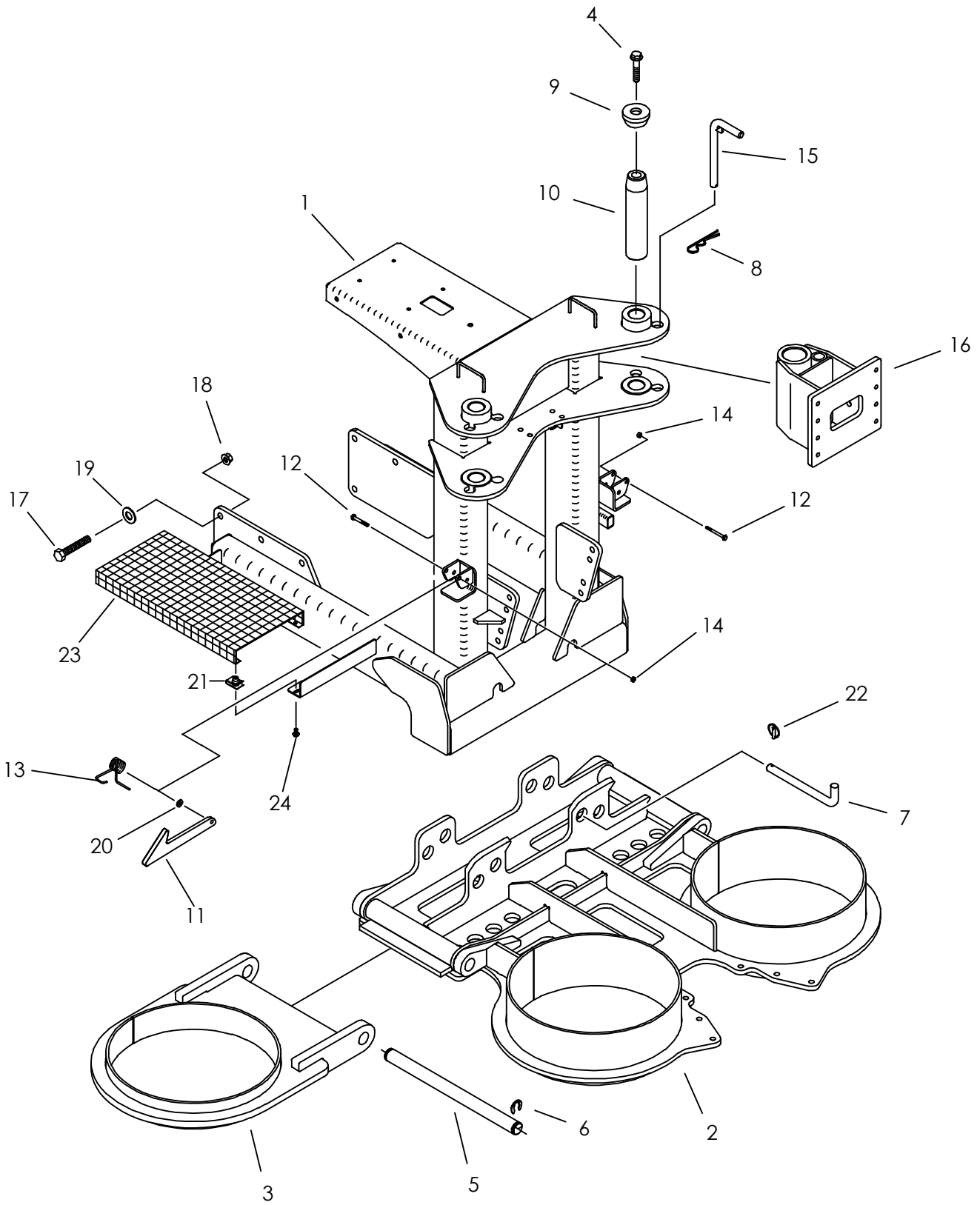

# AUGER ANCHOR BASE

REF NO.	PART NUMBER	QTY	DESCRIPTION	REMARKS
1.	310-362	-	ANCHOR ATTACHMENT FRAME	
	327-1059	-	ANCHOR ATTACHMENT FRAME	SEE FOOTNOTE I
2.	313-592	1	ANCHOR BASE	
3.	343-548	2	PIVOT	
4.	106-470	2	FLG SCREW (M16-2.00 X 40mm)	
5.	184-973	2	PIN	
6.	115-483	4	KLIP RING (1.25")	
7.	343-445	2	PIN (31.75MM X 262MM)	
8.	110-128	2	SPRING CLIP PIN (5/32" X 1")	
9.	181-975	2	TAPERED INSERT (1.75")	
10.	179-239	2	TAPERED PIN (44.4mm X 288mm)	
11.	350-371	2	LATCH	
12.	106-332	4	SCREW (M10-1.50 X 70mm)	
13.	115-580	2	TORSION SPRING	
14.	105-894	4	LOCKNUT (M10-1.50,PRV TRQ, 10.9)	
15.	350-516	2	PIN	
16.	309-209	2	ARM	
17.	106-798	8	SCREW (M20-2.50 X 55MM, 10.9)	USE LOC TITE 242
18.	106-356	8	FLG LOCKNUT (M20-2.50,10.9,PRV TRQ)	
19.	106-399	8	WASHER (M20, HARDENED)	
20.	105-884	6	WASHER (.531")	
21.	106-551	4	CLIP NUT (M8-1.25)	
22.	110-228	2	LYNCH PIN (7/16" X 2")	
23.	350-989	1	FLOOR TREADS	
24.	106-991	4	FLG LK SCREW (M8-1.25 X 20MM)	

NOT SHOWN:

FOOTNOTES:

I. USE ON 4020 WITH RACK AND PINION

NOTE:

# ANCHOR VALVE & COVER MOUNT

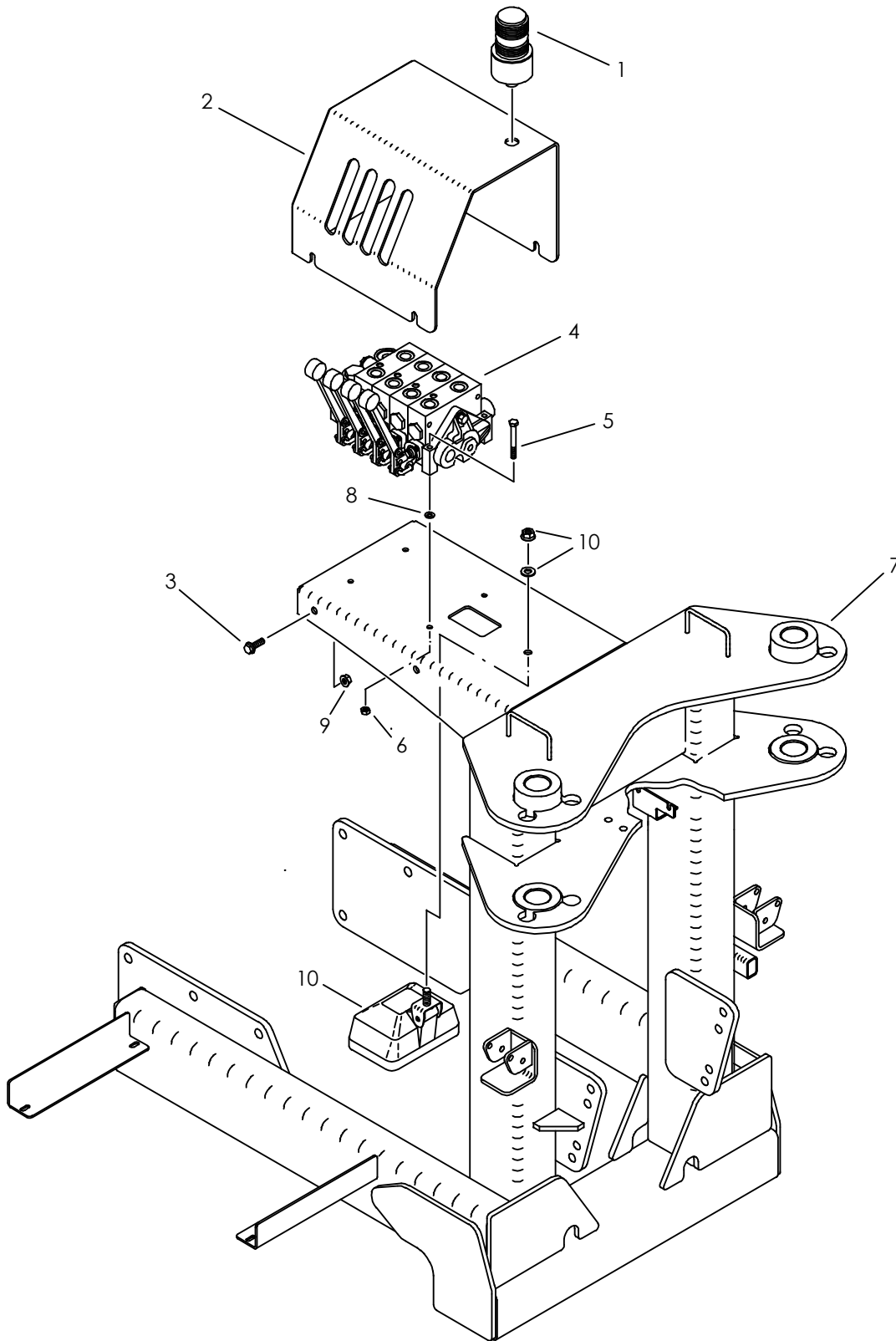

# ANCHOR VALVE & COVER MOUNT

REF NO.	PART NUMBER	QTY	DESCRIPTION	REMARKS
1.	214-697	-	STROBE LIGHT (12V, DC, GREEN)	INSTALL ELECTRICAL PLUG AFTER MOUNTING LIGHT
	217-297	-	STROBE LIGHT GREEN MED PROFILE	
	214-103	1	2-WAY MALE CONNECTOR	
	214-991	-	REPLACEMENT FLASH TUBE	
	217-303	-	REPLACEMENT LENS (GREEN)	
	157-645	2	WEATHER-PAC SEAL (2.80MM)	
	214-104	2	PACKARD MALE TERMINAL	
	217-301	-	BRUSH GUARD	
2.	309-254	1	VALVE COVER	
3.	106-383	4	FLG LK SCREW (M10-1.50 X 30MM)	
4.	149-952	-	HYD CONTROL VALVE (4-SPOOL)	
5.	106-330	3	SCREW (M8-1.25 X 70MM)	
6.	106-561	3	LOCKNUT (M8-1.25, PRV TRQ, 10.9)	
7.	310-362	-	ANCHOR ATTACHMENT FRAME	SEE FOOTNOTE I
	327-1059	-	ANCHOR ATTACHMENT FRAME	
8.	106-389	3	WASHER (M8)	
9.	106-387	4	FLG LOCKNUT (M10-1.50)	
10.	217-007	1	WORKING LIGHT (CLEAR, RECT)	

NOT SHOWN:

FOOTNOTES:

I. USE ON 4020 WITH RACK AND PINION.

NOTE:



# FRONT PIPE GUIDE. ALL TERRAIN ONLY

REF NO.	PART NUMBER	QTY	DESCRIPTION	REMARKS
1.	157-196	1	ROD WIPER	
2.	110-228	2	LYNCH PIN (7/16" X 2")	
3.	313-592	1	ANCHOR BASE	
4.	314-732	1	WIPER MOUNT	
5.	310-366	1	COVER	
6.	310-362	1	ANCHOR ATTACHMENT FRAME	
	327-1059	1	ANCHOR ATTACHMENT FRAME	SEE FOOTNOTE I
7.	319-747	1	GUIDE BEARING MOUNT	
8.	106-381	1	FLG LK SCREW (M8-1.25 X 25MM)	
9.	115-003	1	ZERK (1/4-NF, STR)	
10.	106-397	4	WASHER (M12, HARDENED)	
11.	106-602	4	SCREW (M8-1.25 X 80MM)	
12.	106-561	5	LOCKNUT (M8-1.25, PRV TRQ, 10.9)	
13.	105-117	8	WASHER (5/16")	
14.	107-307	4	BOLT (M12-1.75 X 45MM)	
15.	106-685	4	LOCKNUT (M12-1.75, PRV TRQ, 10.9)	
16.	211-084	1	CURRENT TRANSFORMER	
17.	314-359	2	GUIDE BLOCK (4.13)	
18.	314-387	1	BLOCK RETAINER	
19.	178-863	1	PIVOT PIN	
20.	115-503	2	KLIP RING (.750")	
21.	314-744	1	HOOK	
22.	350-400	-	COVER	

NOT SHOWN:

214-542	CURRENT COIL CABLE
211-042	VOLTAGE LIMITER
215-799	VOLTAGE STAKE

FOOTNOTES:

I. USE ON 4020 WITH RACK AND PINION. USE UPPER SET OF HOLES TO MOUNT 319-747.

NOTE:

# FRONT PIPE GUIDE

JT 4020 MACH 1 ONLY

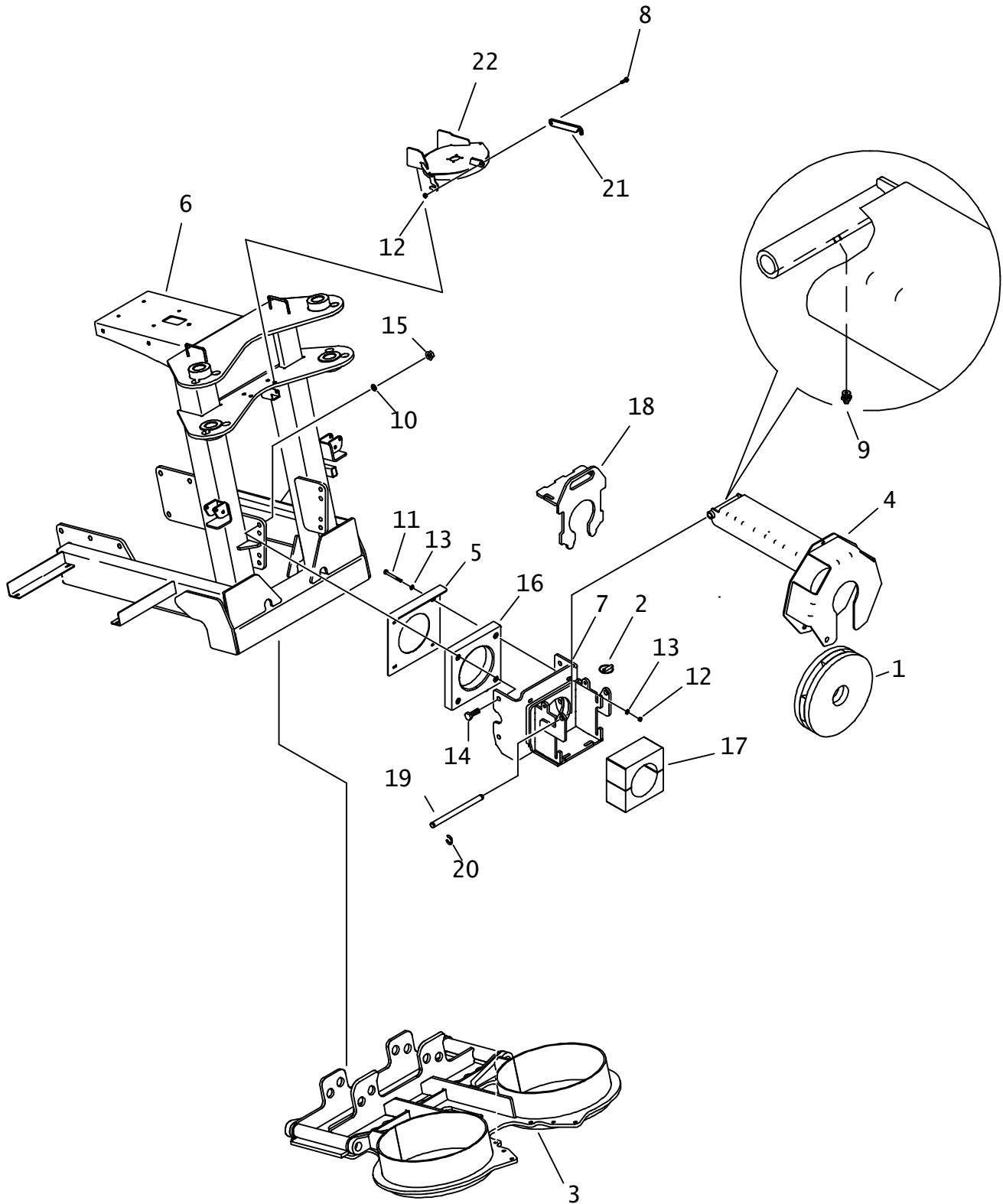



# FRONT PIPE GUIDE

## JT 4020 MACH 1 ONLY

REF NO.	PART NUMBER	QTY	DESCRIPTION	REMARKS
1.	117-627	1	ROD WIPER	
2.	110-228	2	LYNCH PIN (7/16" X 2")	
3.	313-592	1	ANCHOR BASE	
4.	314-732	1	WIPER MOUNT	
5.	310-366	1	COVER	
6.	310-362	1	ANCHOR ATTACHMENT FRAME	
	327-1059	1	ANCHOR ATTACHMENT FRAME	SEE FOOTNOTE I
7.	319-747	1	GUIDE BEARING MOUNT	
8.	106-381	1	FLG LK SCREW (M8-1.25 X 25MM)	
9.	115-003	1	ZERK (1/4-NF, STR)	
10.	106-397	4	WASHER (M12, HARDENED)	
11.	106-602	4	SCREW (M8-1.25 X 80MM)	
12.	106-561	5	LOCKNUT (M8-1.25, PRV TRQ, 10.9)	
13.	105-117	8	WASHER (5/16")	
14.	107-307	4	BOLT (M12-1.75 X 45MM)	
15.	106-685	4	LOCKNUT (M12-1.75, PRV TRQ, 10.9)	
16.	211-084	1	CURRENT TRANSFORMER	
17.	314-360	2	GUIDE BLOCK (3.50)	
18.	314-387	1	BLOCK RETAINER	
19.	178-863	1	PIVOT PIN	
20.	115-503	2	KLIP RING (.750")	
21.	314-744	1	HOOK	
22.	350-400	-	COVER	

## NOT SHOWN:

214-542	CURRENT COIL CABLE
211-042	VOLTAGE LIMITER
215-799	VOLTAGE STAKE

## FOOTNOTES:

USE ON 4020 WITH RACK AND PINION.

## NOTE:

# RIGHT AUGER ANCHOR DRIVE

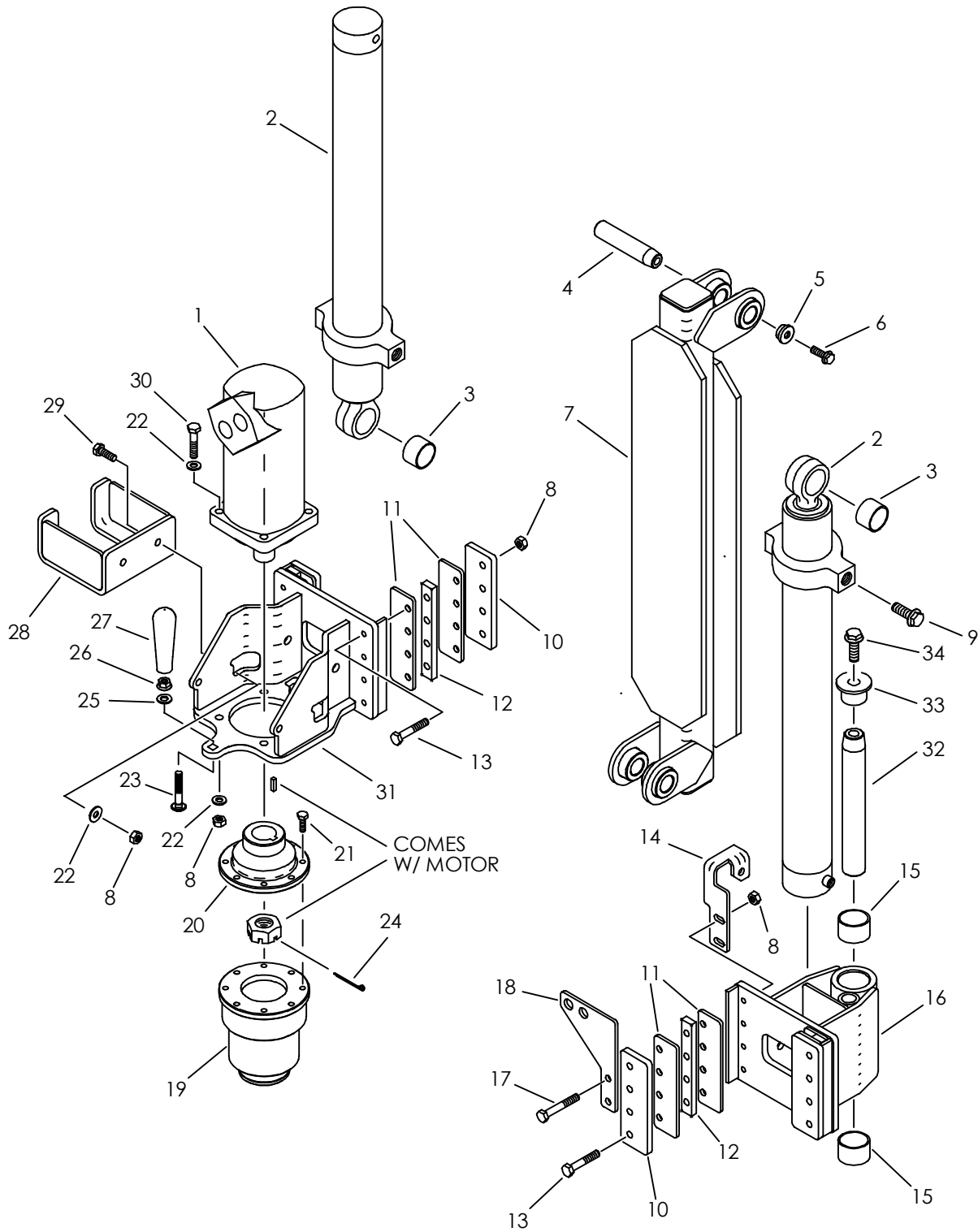

# RIGHT AUGER ANCHOR DRIVE

REF NO.	PART NUMBER	QTY	DESCRIPTION	REMARKS
1.	149-895	1	HYD MOTOR	
	500-390		SEAL REPAIR KIT - REAR	
	500-391		SEAL REPAIR KIT - SHAFT	
	502-177		SHAFT AND BEARING ASSY	
	107-792		BOLT (5/16"X 1-5/8", DBL HEX)	
	165-900		KEY (7/16" SQ X 1.250")	
	105-917		CASTLE NUT (1-1/4-NF)	SEE FOOTNOTE 1
	500-2123		FRONT RETAINER (ANCHOR MOTOR)	
2.	150-747	2	CYLINDER ASSEMBLY	
3.	125-771	2	COMPOSITION BUSHING (1.25")	
4.	183-765	2	TAPERED PIN (31.7MM X 110MM)	
5.	181-982	2	TAPERED INSERT (1.25")	
6.	106-469	2	FLG SCREW (M12-1.75 X 30MM)	USE LOCTITE 242
7.	359-799	1	MAST	
8.	106-685	23	LOCKNUT(M12-1.75,PRV TRQ,10.9)	
9.	106-471	4	FLG SCREW (M16-2.00 X 30MM)	USE LOCTITE 242
10.	309-194	4	CLAMP PLATE	
11.	309-195	8	GLIDE STRIP	
12.	309-203	4	CARRIAGE SPACER BAR	
13.	106-335	14	SCREW (M12-1.75 X 70MM)	
14.	309-205	1	BULKHEAD PLATE	
15.	125-773	2	COMPOSITION BUSHING (1.75")	
16.	309-209	1	ARM	
17.	106-700	2	SCREW (M12-1.75 X 80MM)	
18.	309-204	1	BULKHEAD PLATE	
19.	309-582	-	FLANGED HEX DRIVER	
20.	178-881	1	FLANGE	
21.	105-245	8	SCREW (M10-1.50 X 25MM)	USE LOCTITE 242
22.	106-397	9	WASHER (M12, HARDENED)	
23.	105-279	1	CARRIAGE BOLT (1/2-NC X 3")	
24.	105-501	1	COTTER PIN (1/8" X 2")	
25.	105-071	1	WASHER (1/2")	
26.	105-833	1	FLG LOCKNUT (1/2-NC)	
27.	110-531	1	HANDLE (1/2-NC, BLACK)	USE LOCTITE 242
28.	309-602	1	ANCHOR HANGER	
29.	106-333	2	SCREW (M12-1.75 X 40MM, 8.8)	
30.	106-594	4	SCREW (M12-1.75 X 60MM)	
31.	309-207	1	MOTOR MOUNT	
32.	179-239	1	TAPERED PIN (44.4MM X 288MM)	
33.	181-975	1	TAPERED INSERT (1.75")	
34.	106-470	1	FLG SCREW (M16-2.00 X 40MM)	USE LOCTITE 242

NOT SHOWN:

#### FOOTNOTES:

- I. TORQUE NUT TO 375 FT. LB. DRY OR 275 FT. LB. LUBED

NOTE:

# LEFT AUGER ANCHOR DRIVE

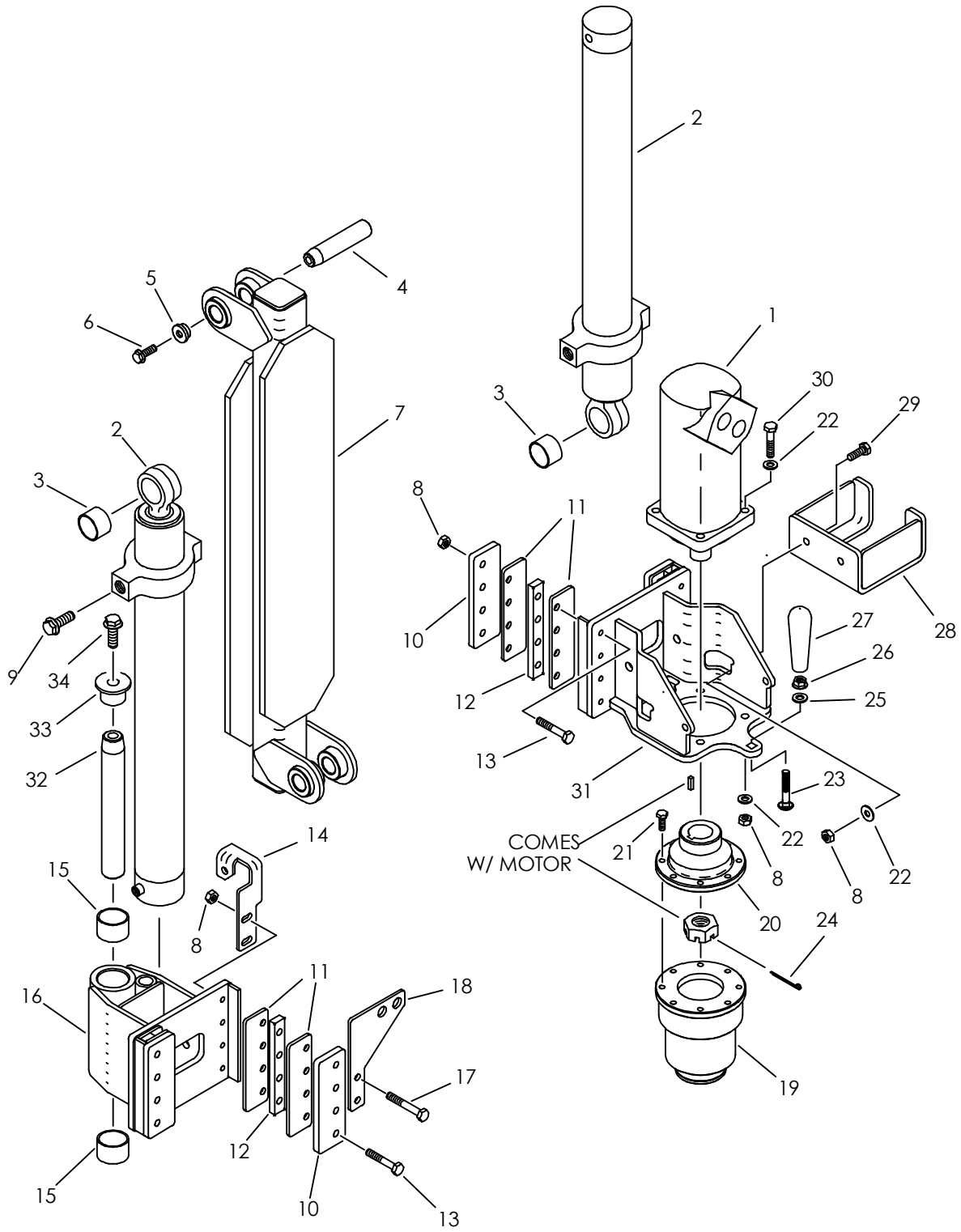

# LEFT AUGER ANCHOR DRIVE

REF NO.	PART NUMBER	QTY	DESCRIPTION	REMARKS
1.	149-895	1	HYD MOTOR	
	500-390		SEAL REPAIR KIT - REAR	
	500-391		SEAL REPAIR KIT - SHAFT	
	502-177		SHAFT AND BEARING ASS'Y	
	107-792		BOLT (5/16"X 1-5/8", DBL HEX)	
	165-900		KEY (7/16" SQ X 1.250")	
	105-917		CASTLE NUT (1-1/4-NF)	SEE FOOTNOTE 1
	500-2123		FRONT RETAINER (ANCHOR MOTOR)	
2.	150-747	2	CYLINDER ASSEMBLY	
3.	125-771	2	COMPOSITION BUSHING (1.25")	
4.	183-765	2	TAPERED PIN (31.7MM X 110MM)	
5.	181-982	2	TAPERED INSERT (1.25")	
6.	106-469	2	FLG SCREW (M12-1.75 X 30MM)	USE LOCTITE 242
7.	359-799	1	MAST	
8.	106-685	23	LOCKNUT(M12-1.75,PRV TRQ,10.9)	
9.	106-471	4	FLG SCREW (M16-2.00 X 30MM)	USE LOCTITE 242
10.	309-194	4	CLAMP PLATE	
11.	309-195	8	GLIDE STRIP	
12.	309-203	4	CARRIAGE SPACER BAR	
13.	106-335	14	SCREW (M12-1.75 X 70MM)	
14.	309-206	1	BULKHEAD PLATE	
15.	125-773	2	COMPOSITION BUSHING (1.75")	
16.	309-209	1	ARM	
17.	106-700	2	SCREW (M12-1.75 X 80MM)	
18.	309-204	1	BULKHEAD PLATE	
19.	309-582	-	FLANGED HEX DRIVER	
20.	178-881	1	FLANGE	
21.	105-245	8	SCREW (M10-1.50 X 25MM)	USE LOCTITE 242
22.	106-397	9	WASHER (M12, HARDENED)	
23.	105-279	1	CARRIAGE BOLT (1/2-NC X 3")	
24.	105-501	1	COTTER PIN (1/8" X 2")	
25.	105-071	1	WASHER (1/2")	
26.	105-833	1	FLG LOCKNUT (1/2-NC)	
27.	110-531	1	HANDLE (1/2-NC, BLACK)	USE LOCTITE 242
28.	309-602	1	ANCHOR HANGER	
29.	106-333	2	SCREW (M12-1.75 X 40MM, 8.8)	
30.	106-594	4	SCREW (M12-1.75 X 60MM)	
31.	309-207	1	MOTOR MOUNT	
32.	179-239	1	TAPERED PIN (44.4MM X 288MM)	
33.	181-975	1	TAPERED INSERT (1.75")	
34.	106-470	1	FLG SCREW (M16-2.00 X 40MM)	USE LOCTITE 242

NOT SHOWN:

#### FOOTNOTES:

1. TORQUE NUT TO 375 FT. LB. DRY OR 275 FT. LB. LUBED

NOTE:

# FLANGED HEX DRIVER ASS'Y

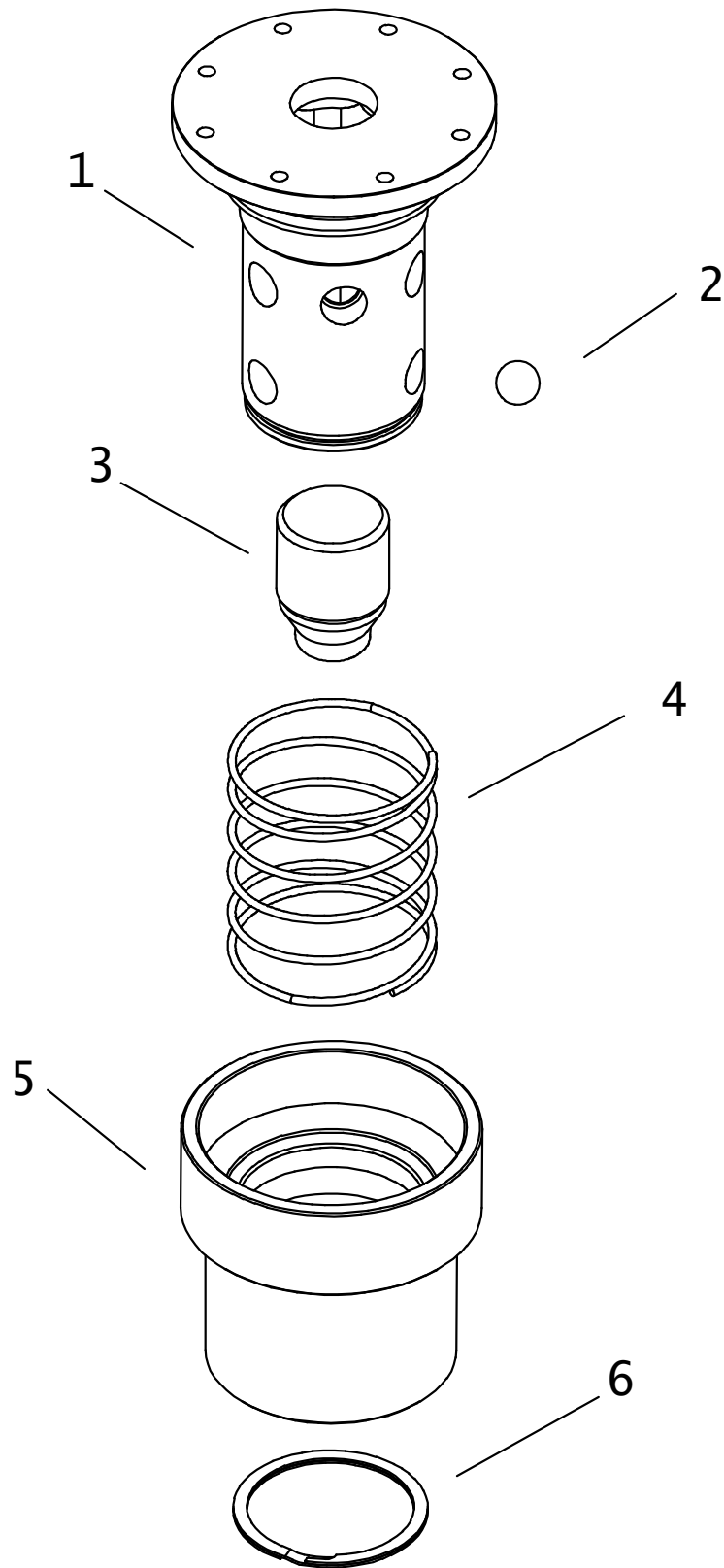

# FLANGED HEX DRIVER ASS'Y

REF NO.	PART NUMBER	QTY	DESCRIPTION	REMARKS
	309-582		FLANGED HEX DRIVER	INCLUDEDS REF NO. 1-6
1.	309-093	1	ANCHOR DRIVER	FOOTNOTE 2
2.	125-150	9	DETENT BALL (.875")	
3.	309-095	1	WEIGHT STOP	
4.	117-160	1	COMPRESSION RING	
5.	178-591	1	LOCK COLLAR	
6.	118-054	1	EXTERNAL SNAP RING	
	116-761	1	SPIRAL RETAINING RING	FOOTNOTE 1

NOT SHOWN:

FOOTNOTES:

1. USE WHEN INSTALLING UPDATED 309-093
2. UPDATED VERSION NECKED-DOWN FOR THICKER 116-761

NOTE:

# ANCHOR

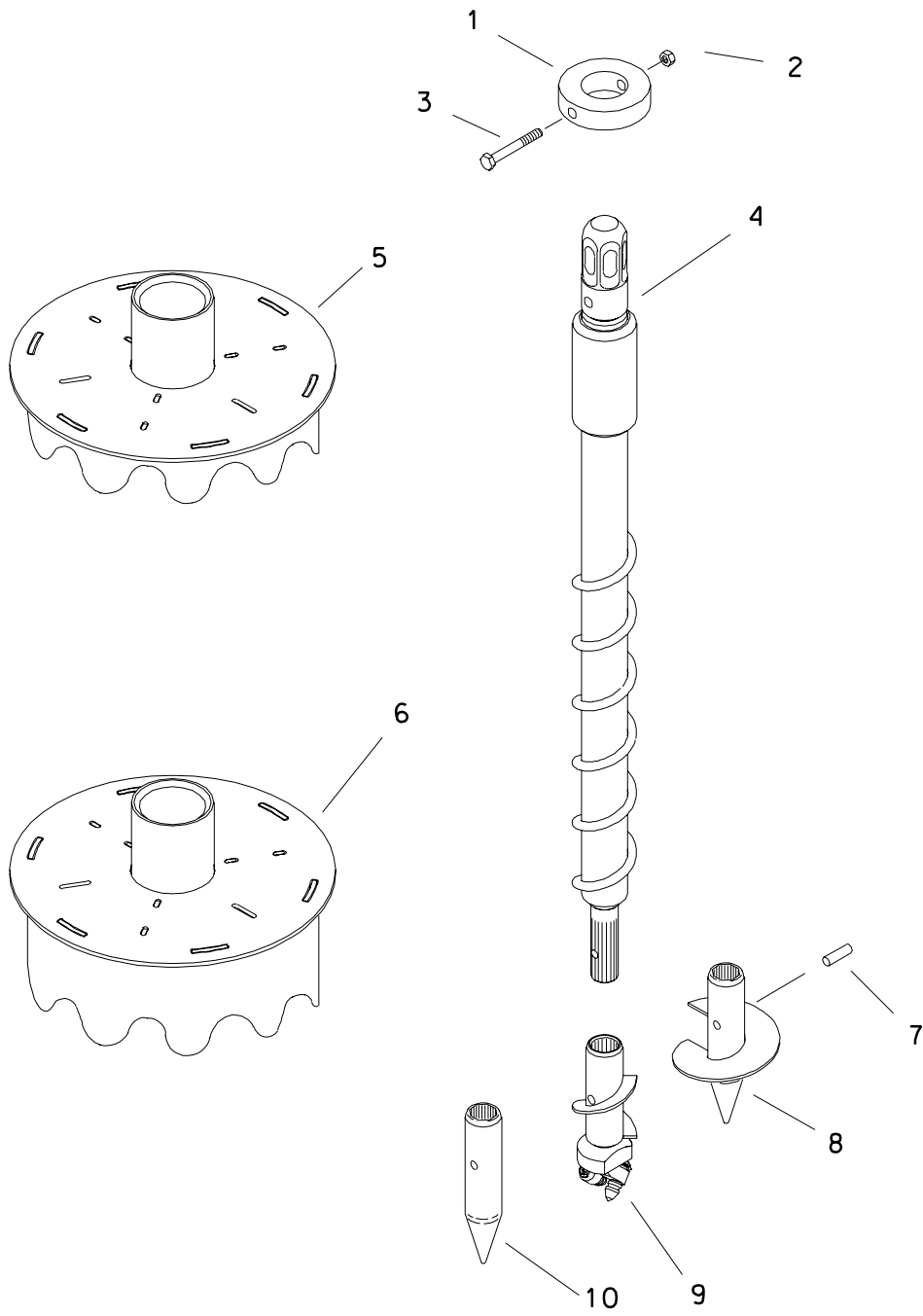



# ANCHOR

REF NO.	PART NUMBER	QTY	DESCRIPTION	REMARKS
	309-250	-	ANCHOR SHAFT	INCL REF NO'S 1-4
1.	178-513	1	COLLAR	
2.	106-685	1	LOCKNUT (M12-1.75, PRV TRQ, 10.9)	
3.	106-645	1	SCREW (M12-1.75 X 110MM, 10.9)	
4.	308-902	1	ANCHOR STAKE	
5.	309-750	1	CENTERING CAP	SHORT - USED IN SIDE POSITIONS
6.	308-903	1	CENTERING CAP	TALL - USED IN FRONT POSITIONS
7.	183-860	AR	ROLL PIN (1/2" X 1-7/8")	
8.	356-366	AR	AUGER (150MM)	
	356-365	AR	AUGER (225MM)	
	356-364	AR	AUGER (380MM)	
9.	369-438	AR	3.5" CAP ANCHOR BIT	ROCK BITS
	136-113	-	INSERT BIT - CARBIDE TIPPED	REPLACEMENT BIT FOR 369-438
	131-259	-	INSERT BIT - CARBIDE TIPPED	
	136-112	-	CLIP RETAINER	REPLACEMENT CLIP FOR 369-438
10.	357-330	AR	STAKE POINT	DIRT BITS

FOOTNOTES



# **LUBRICATOR SYSTEMS**

# GREASE PUMP MOUNTING

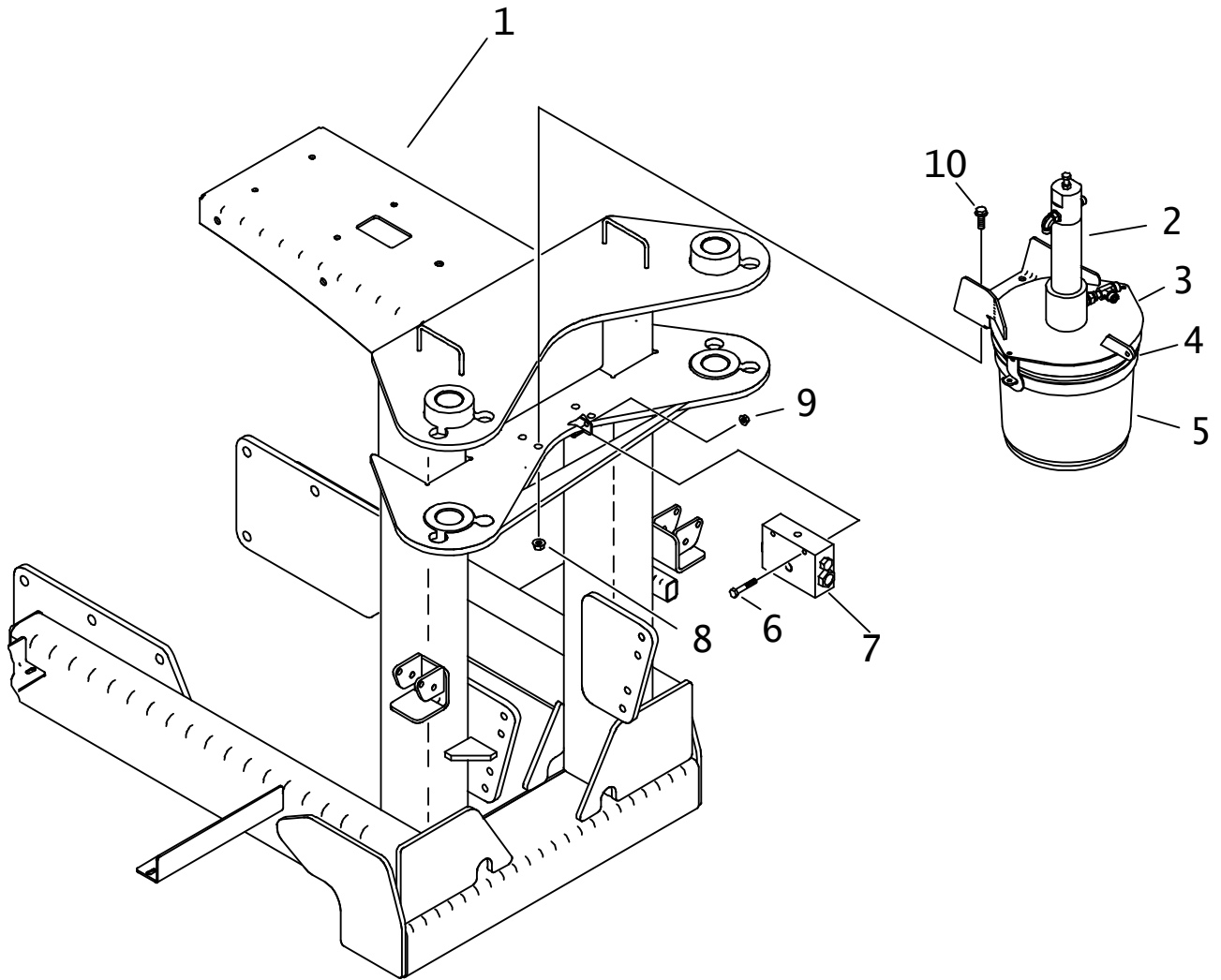

# GREASE PUMP MOUNTING

REF NO.	PART NUMBER	QTY	DESCRIPTION	REMARKS
1.	310-362	-	ANCHOR ATTACHMENT FRAME	
	327-1059	-	ANCHOR ATTACHMENT FRAME	SEE FOOTNOTE 1
2.	350-398	-	GREASE PUMP	
3.	350-400	-	COVER	
4.	350-399	-	BASE	
5.	259-858	-	TOOL JNT LUBE, STD SPRY 2 GAL	USE BELOW 80 DEG F MAX TEMP
	256-031	-	TOOL JNT LUBE, SUMR SPRY 2 GAL	USE ABOVE 50 DEG F MIN TEMP
6.	106-570	2	SCREW (M8-1.25 X 60MM)	
7.	310-591	1	VALVE ASS'Y	
8.	106-387	4	FLG LOCKNUT (M10-1.50)	
9.	106-386	2	FLG LOCKNUT (M8-1.25)	
10.	106-383	4	FLG LK SCREW (M10-1.50 X 30MM)	

NOT SHOWN:

FOOTNOTES:

USE ON 4020 WITH RACK AND PINION

NOTE:

# AUTO-LUBER ASSEMBLY

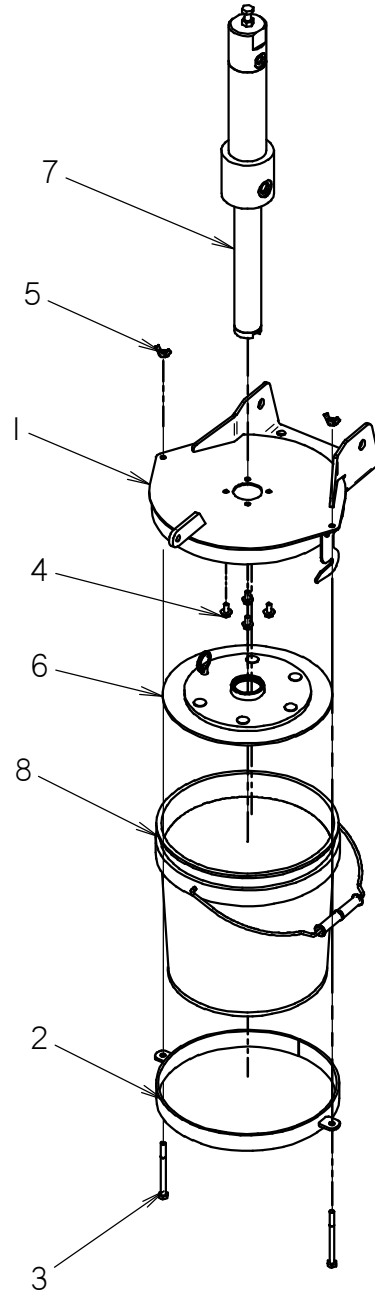

# AUTO-LUBER ASSEMBLY

REF NO.	PART NUMBER	QTY	DESCRIPTION	REMARKS
1	350-400	1	COVER WELDMENT	
2	350-399	1	BASE	
3	105-297	2	BOLT (1/4-NC X 3-1/4")	
4	106-378	4	FLG LK SCREW (M6-1.00 X 12MM)	
5	195-339	2	WING NUT (1/4-NC)	
6	350-1932	1	TOOL JOINT LUBE FOLLOWER	
7	350-398	1	GREASE PUMP PARTS	
8	259-858	1	TOOL JNT LUBE, STD SPRY 2 GAL	
	256-031	-	TOOL JNT LUBE, SUMR SPRY 2 GAL	

NOT SHOWN:

FOOTNOTES:

NOTE:

# GREASE PUMP

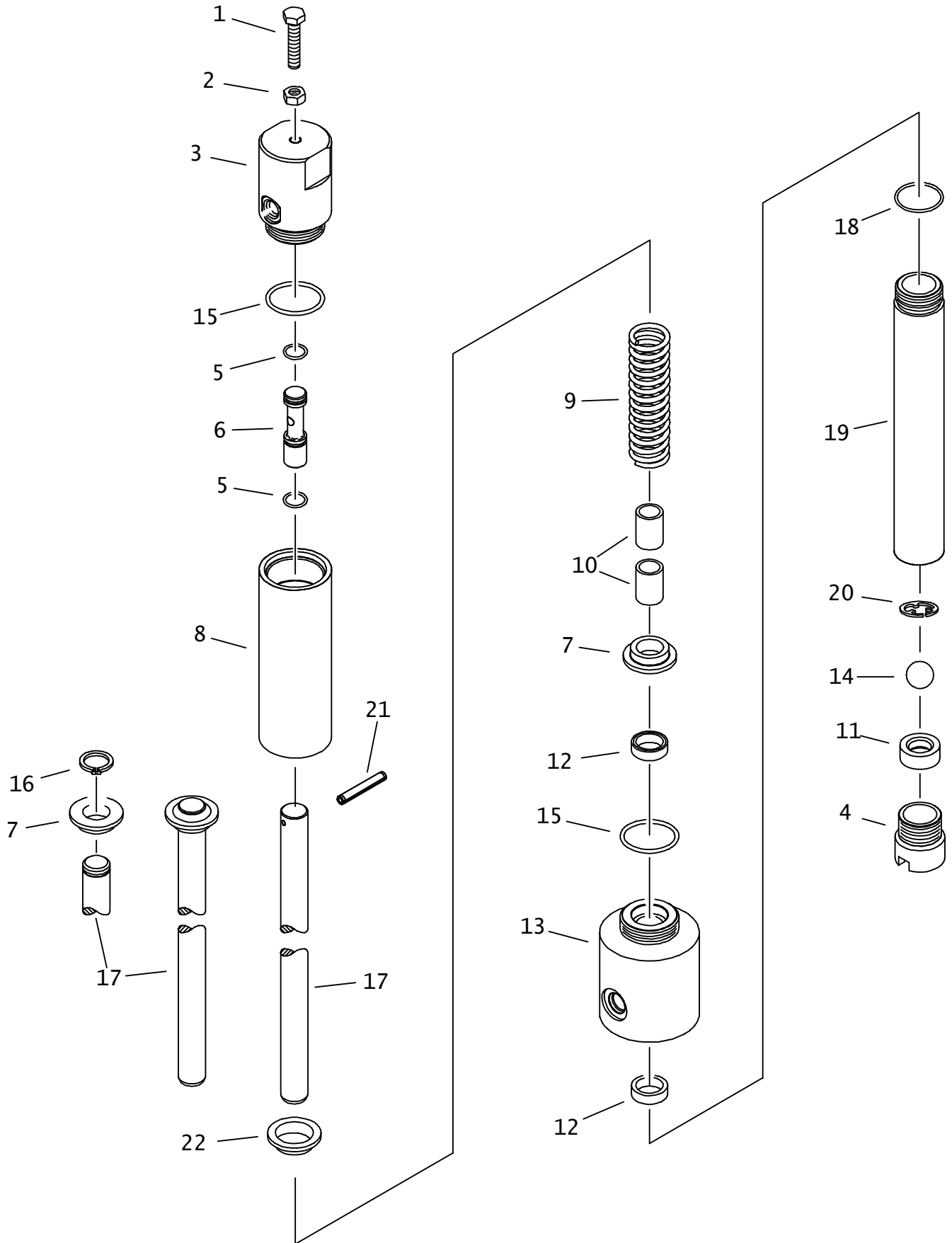



# GREASE PUMP

REF NO.	PART NUMBER	QTY	DESCRIPTION	REMARKS
	350-398		GREASE PUMP PARTS	INCL REF NO'S 1-20
1.	107-492	1	SCREW (M8-1.25 X 35MM,ALL THD)	
2.	106-078	1	NUT (M8-1.25)	
3.	350-686	1	CYLINDER CAP	
4.	350-692	1	INLET TUBE	
5.	157-049	2	O-RING (113 D70)	
6.	350-421	1	ADJUSTING SPOOL	
7.	350-671	1	ROD GUIDE	SEE FOOTNOTE 2
8.	350-682	1	BARREL	
9.	117-228	1	COMPRESSION SPRING	
10.	125-424	2	BRONZE BUSHING (.750")	
11.	350-691	1	VALVE SEAT	SEE FOOTNOTE 1
12.	117-227	2	SEAL (POLY PAK)	
13.	350-687	1	PUMP BODY	
14.	125-125	1	DETENT BALL (.750")	
15.	155-702	2	O-RING (920 D90)	
16.	<u>117-226</u>	-	EXTERNAL SNAP RING (.750")	SEE FOOTNOTE 2
	115-545	-	EXTERNAL SNAP RING (.75")	
17.	<u>350-689</u>	-	PLUNGER	SEE FOOTNOTE 2
	<u>308-603</u>	-	PLUNGER	SEE FOOTNOTE 3
	166-280	1	PLUNGER	
18.	155-748	1	O-RING (916 D90)	
19.	350-693	1	PUMP BARREL	
20.	301-0196	1	RETAINER CLIP	SEE FOOTNOTE 4
21.	105-525	1	ROLL PIN (3/16" X 1/4")	SEE FOOTNOTE 3
22.	178-467	1	ROD CAP	SEE FOOTNOTE 3

NOT SHOWN:

#### FOOTNOTES:

1. INSTALL WITH SMALLER BEVEL TOWARD INSIDE OF PUMP
2. 308-603 PLUNGER IS A DIRECT REPLACEMENT OF 350-689 PLUNGER, 117-226 RETAINER RING, AND AN ADDITIONAL 350-671 ROD GUIDE.
3. USE 166-280, 178-467 & 105-525 TO SUPERSEDE 308-603
4. RETAINER CLIP 301-0196 SUPERSEDES CLIP 105-653

NOTE:

# APPLICATOR

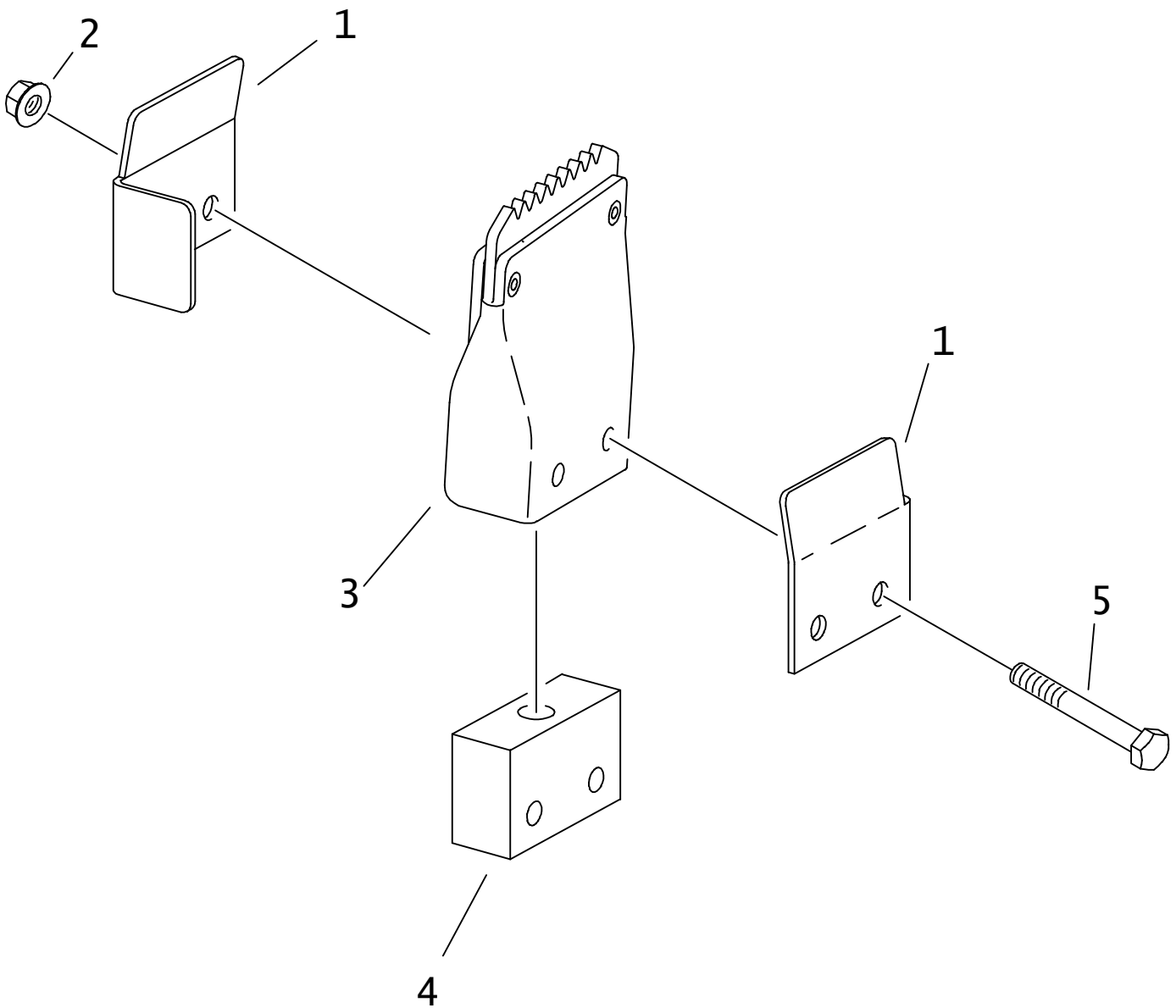

# APPLICATOR

REF NO.	PART NUMBER	QTY	DESCRIPTION	REMARKS
1.	305-911	2	BRACKET, APPLICATOR	
2.	106-385	2	FLG LOCKNUT (M6-1.00)	
3.	306-423	1	WIPER PARTS ASS'Y	
	116-937	1	APPLICATOR	
	107-394	4	WASHER (.375", ALUMINUM)	
	107-395	2	RIVET (.156 X .500) SEMI-TUBUL	
4.	305-912	1	BASE, APPLICATOR	
5.	106-093	2	SCREW (M6-1.00 X 45MM)	

NOT SHOWN:

FOOTNOTES:

NOTE:

# SELECTOR VALVE

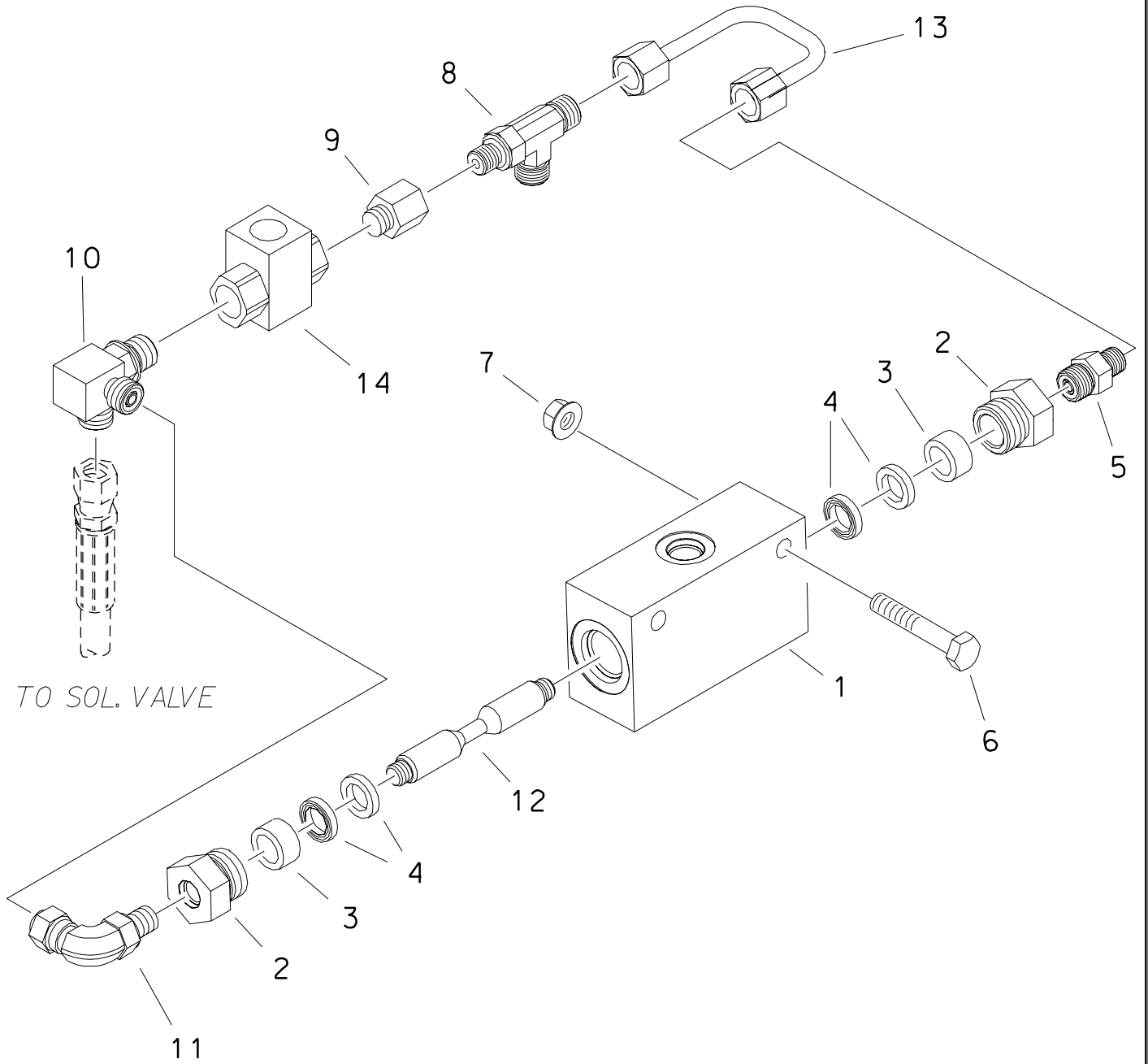

# SELECTOR VALVE

REF NO.	PART NUMBER	QTY	DESCRIPTION	REMARKS
	101-085		GREASER VALVE KIT	INCL. REF. 1-4 & 12
1.	343-291	1	VALVE BODY	
2.	149-152	2	REDUCER (10S-04SF)	
3.	343-292	2	SPACER	
4.	116-880	4	SEAL (POLY PAK)	
5.	154-278	1	CONNECTOR (04S-040)	
6.	106-329	2	SCREW (M8-1.25 X 50MM)	
7.	106-386	2	FLG LOCKNUT (M8-1.25)	
8.	154-316	1	RUN TEE (04S-040-040)	
9.	155-254	1	REDUCER (06S-04SF)	
10.	154-230	1	BRANCH TEE (06S-040-040)	
11.	514-257	1	UNION (04S-040F X90)	
12.	350-690	1	VALVE SPOOL	
13.	149-519	1	HYD LINE	
14.	158-600	1	HYD SHUTTLE VALVE	

FOOTNOTES

NOTE:

REFER TO O-RING CHART (800-301) IN BACK OF THE BOOK FOR REPLACEMENT OF O-RINGS.



# **DRILL FRAME**

# PIVOT

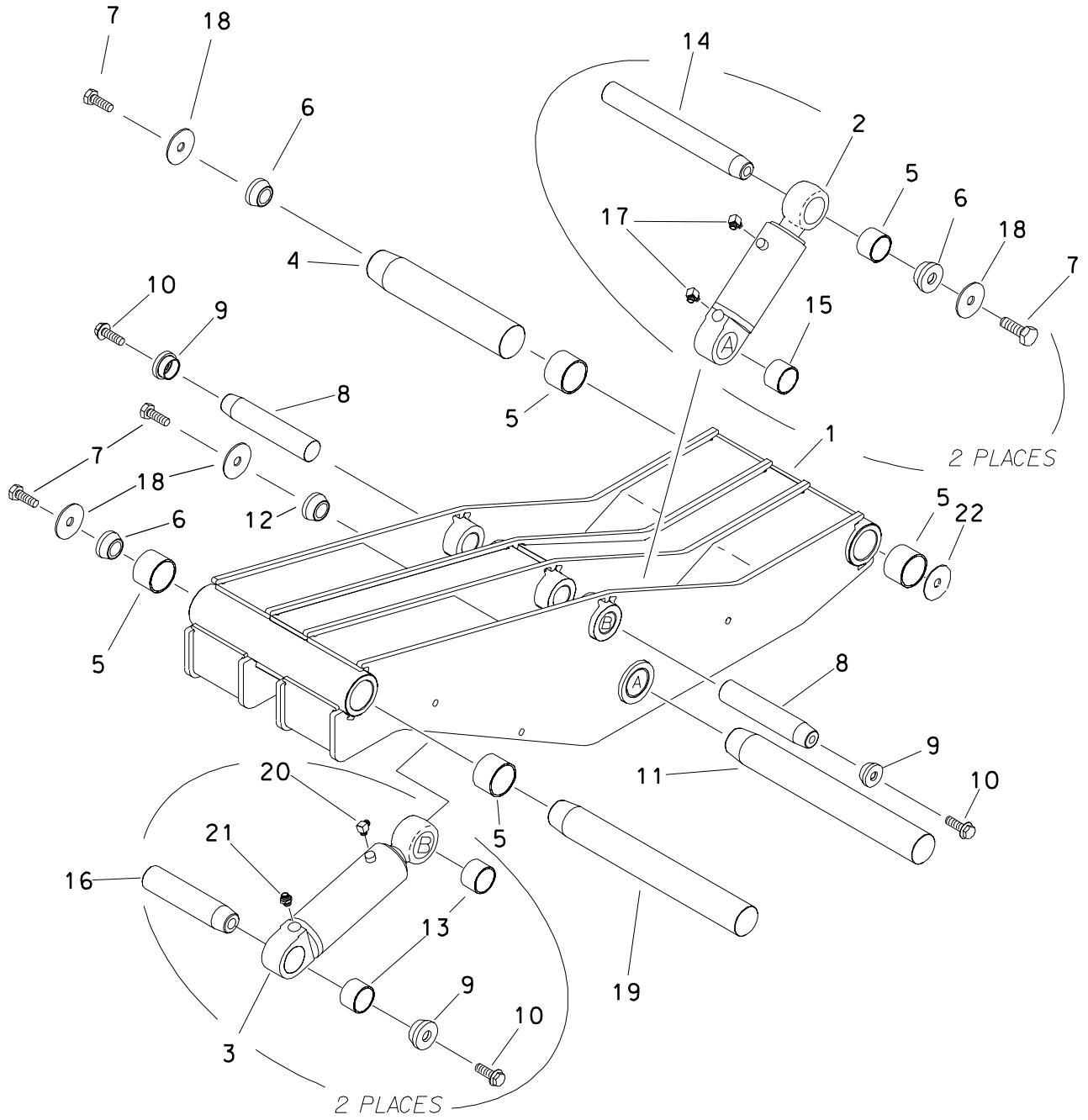



# PIVOT

REF NO.	PART NUMBER	QTY	DESCRIPTION	REMARKS
1.	350-724	1	PIVOT	
2.	151-066	2	CYL (4" X 2" X 5")	
3.	151-070	2	CYL (3" X 1.75" X 8")	
4.	179-220	1	TAPERED PIN (50.8mm X 585mm)	
5.	125-754	6	COMPOSITION BUSHING (2")	
6.	184-064	4	TAPERED INSERT (2.00")	
7.	106-798	5	SCREW (M20-2.50 X 55MM, 10.9)	
8.	183-768	2	TAPERED PIN (44.4mm X 205mm)	
9.	181-975	4	TAPERED INSERT (1.750")	
10.	106-470	4	FLG SCREW (M16-2.00 X 40mm)	
11.	179-221	1	TAPERED PIN (57.1mm X 425mm)	
12.	184-031	1	TAPERED INSERT (2.250")	
13.	125-773	4	COMPOSITION BUSHING (1.75")	
14.	179-077	2	TAPERED PIN (50.8mm X 170mm)	
15.	125-781	2	COMPOSITION BUSHING (2.259")	
16.	183-882	2	TAPERED PIN (44.4mm X 228.6mm)	
17.	154-276	4	CONNECTOR (040-08S90)	
18.	106-399	5	WASHER (M20, HARDENED)	
19.	179-248	1	2.0" X 22.04" PIN	
20.	154-226	2	CONNECTOR (040-06S90)	
21.	154-220	2	CONNECTOR (040-06S)	
22.	110-168	4	MACHINERY BUSHING (2.00")	

FOOTNOTES

NOTE  
REFER TO O-RING CHART (800-301) IN BACK OF THE BOOK FOR REPLACEMENT OF O-RINGS.

# THRUST DRIVE

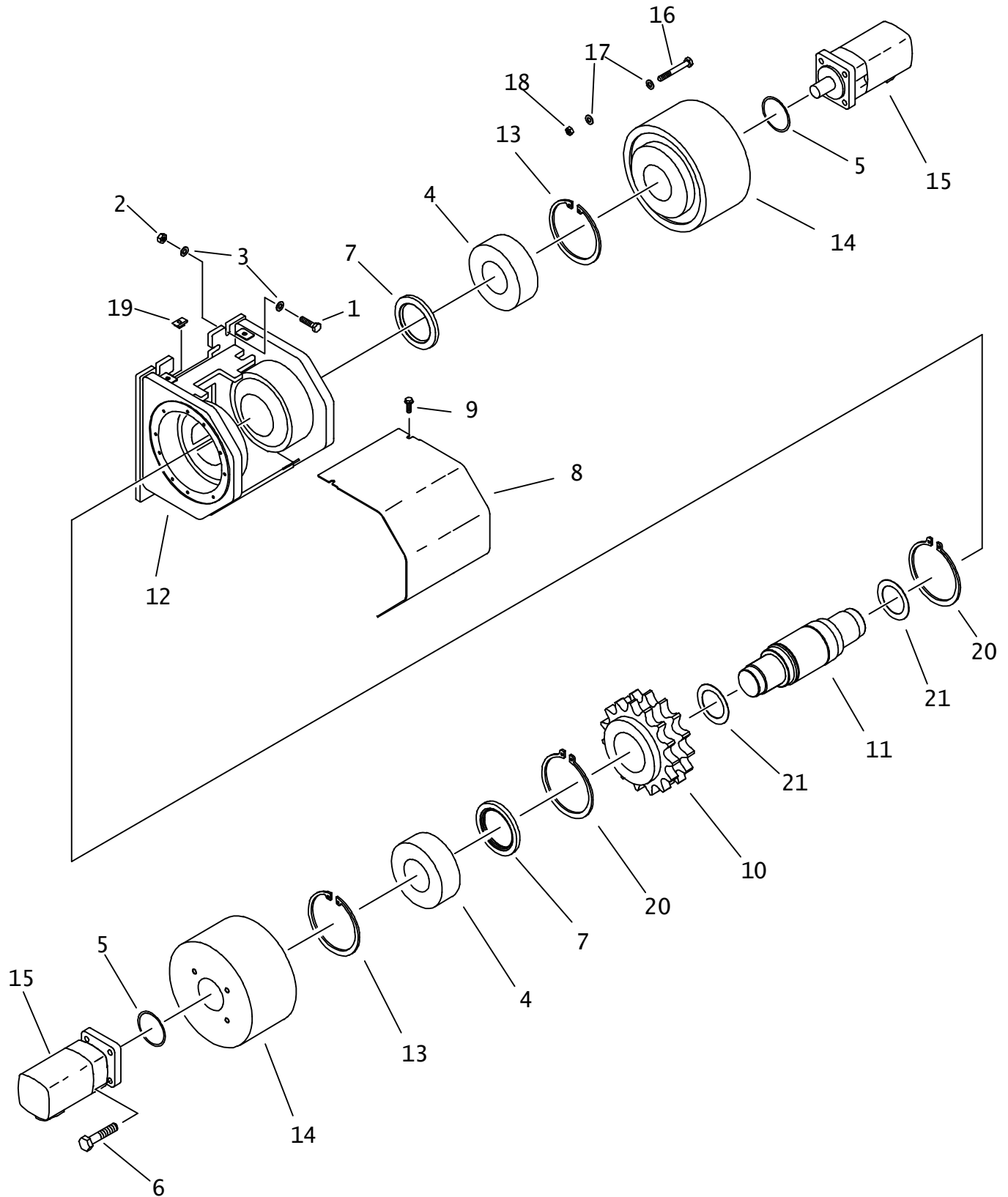

# THRUST DRIVE

REF NO.	PART NUMBER	QTY	DESCRIPTION	REMARKS
1.	106-334	8	SCREW (M12-1.75 X 50mm)	
2.	106-685	8	LOCKNUT (M12-1.75, PRV TRQ, 10.9)	
3.	106-397	16	WASHER (M12, HARDENED)	
4.	125-314	2	ROLLER BEARING (2.952")	
5.	157-084	2	O-RING (159 D70)	
6.	105-066	8	BOLT (1/2-NC X 1-3/4")	
7.	155-883	2	INTERNAL SEAL (3.750")	
8.	350-726	1	THRUST DRIVE COVER	
9.	106-991	4	FLG LK SCREW (M8-1.25 X 20MM)	
10.	174-028	1	SPROCKET, THRUST DRIVE, SPLINE	
11.	167-318	1	THRUST DRIVE SHAFT	
12.	350-725	1	THRUST DRIVE HOUSING	
13.	118-031	2	INTERNAL SNAP RING (6.250")	
14.	166-151	2	GEARBOX PLANETARY	SEE FOOTNOTE 1
	501-861		PRIMARY CARRIER (8")	
	501-862		SECONDARY CARRIER (8")	
	501-863		COVER	
	501-864		RING GEAR, 8"	OBSOLETE
	501-865		SUN GEAR, 8"	
15.	158-026	2	HYDRAULIC MOTOR (15 CU/IN)	
	500-1552		SEAL REPAIR KIT	
	500-1553		SHAFT AND BEARING KIT	
	500-711		SEAL REPAIR KIT - REAR	
	500-758		SEAL REPAIR KIT - SHAFT	
16.	105-808	24	BOLT (3/8-NC X 7")	TORQUE TO 40 FT-LB
17.	106-390	48	WASHER (M10)	
18.	105-047	24	LOCKNUT (3/8-NC)	
19.	106-551	4	CLIP NUT (M8-1.25)	
20.	118-044	2	EXTERNAL SNAP RING (4.250")	
21.	126-127	AR	THRUST WASHER RACE (1.750")	

NOT SHOWN:

FOOTNOTES:

1. APPLY A 3/16" MIN BEAD OF LOCTITE SUPERFLEX HIGH TEMP RTV (OR EQUIVALENT) ON BOTH SIDES OF EACH PLANETARY.

NOTE:

# CARRIAGE

AT42M1 & AT42T2 ONLY

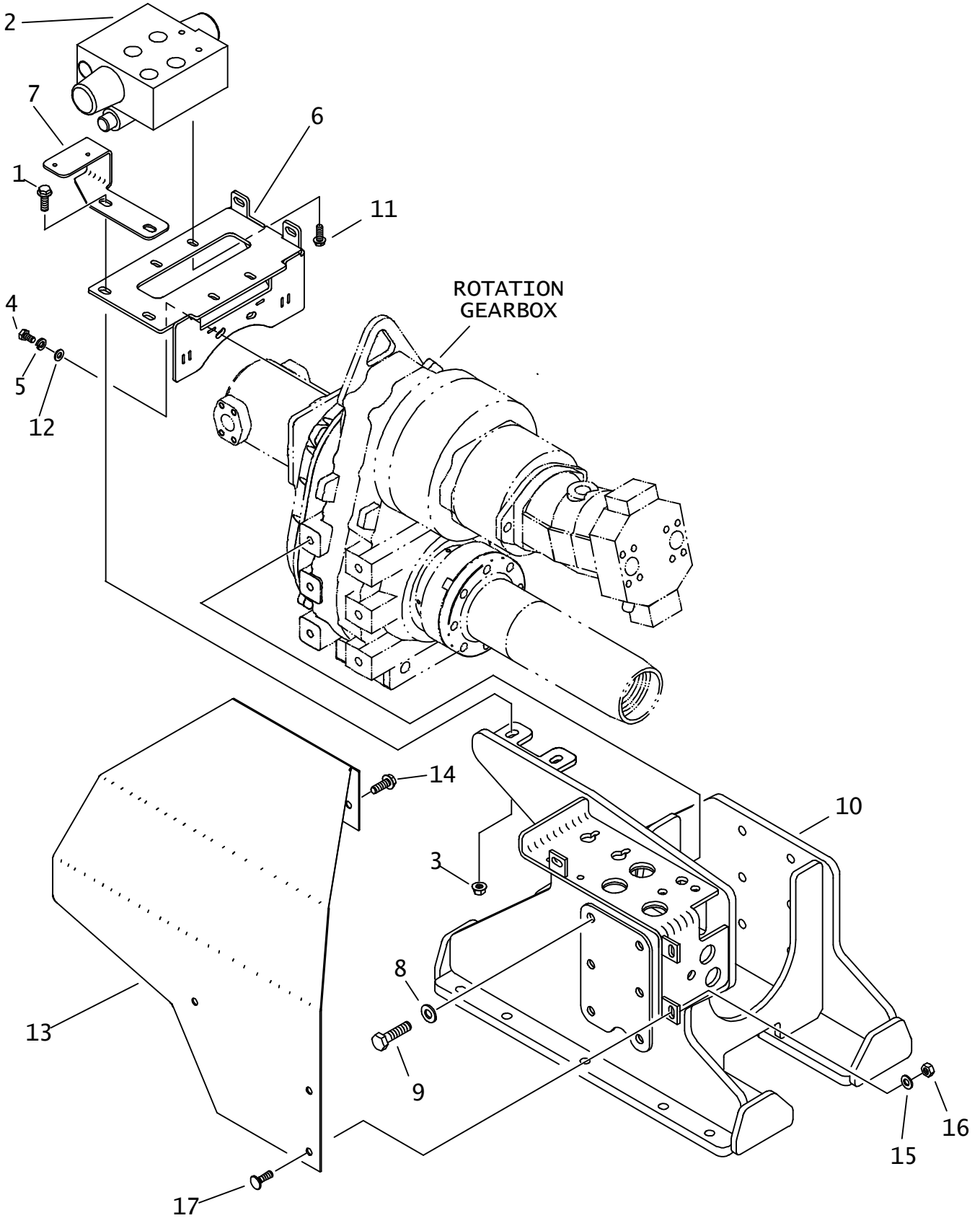

## CARRIAGE

### AT42M1 & AT42T2 ONLY

REF NO.	PART NUMBER	QTY	DESCRIPTION	REMARKS
1.	107-003	2	FLG LK SCREW (M12-1.75 X 35MM)	
2.	153-773	1	HYDRAULIC VALVE	
3.	106-354	2	FLANGE NUT (M12-1.75)	
4.	105-245	2	SCREW (M10-1.50 X 25MM)	
5.	106-090	2	LOCK WASHER (M10)	
6.	316-958	1	VALVE MOUNT PLATE	
7.	314-580	1	BRACKET	
8.	106-398	12	WASHER (M16, HARDENED)	
9.	106-666	12	SCREW (M16-2.00 X 65MM, 10.9)	USE 277 LOCTITE; TORQUE TO 225 FT LBS
10.	313-958	-	CARRIAGE	
11.	105-826	4	FLG LOCK BOLT (3/8-NC X 1")	USE 242 LOCTITE, AT ONLY
12.	106-390	2	WASHER (M10)	
13.	318-731	1	CARRIAGE COVER	
14.	106-469	2	FLG SCREW (M12-1.75 X 30MM)	
15.	106-391	5	WASHER (M12)	
16.	106-685	5	LOCKNUT(M12-1.75, PRV TRQ, 10.9)	
17.	107-683	3	CARRIAGE BOLT(M12-1.75 X 30MM)	

FOOTNOTES

NOTE:

# CARRIAGE

JT42M1 & JT42T2 ONLY

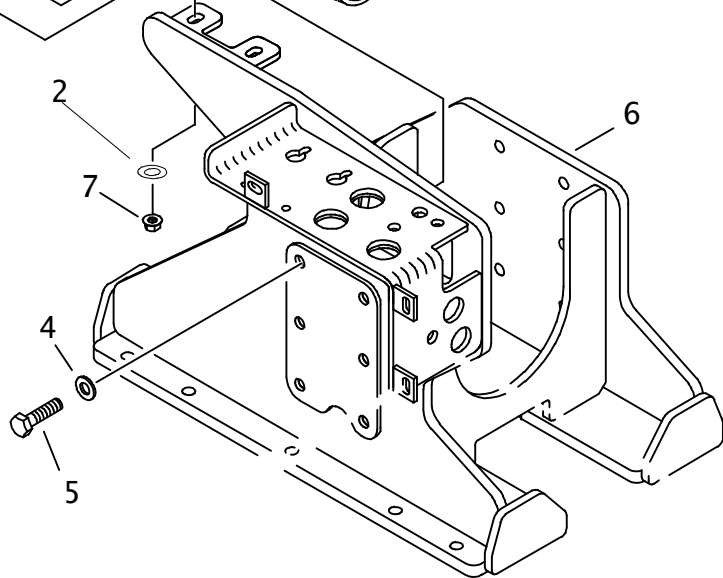
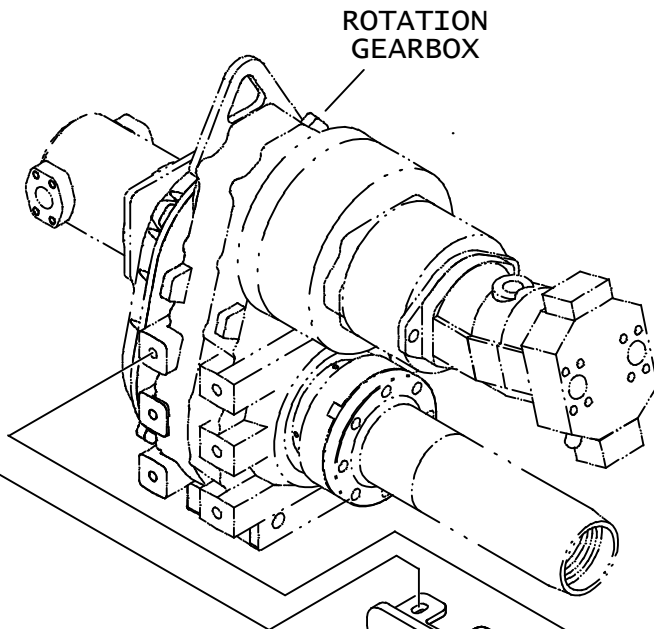
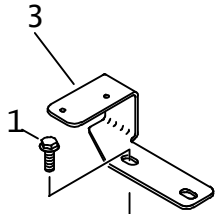

## CARRIAGE

### JT42M1 & JT42T2 ONLY

REF NO.	PART NUMBER	QTY	DESCRIPTION	REMARKS
1.	106-632	2	FLG LK SCR (M12-1.75X35MM,SER)	
2.	106-397	2	WASHER (M12, HARDENED)	
3.	314-580	1	BRACKET	
4.	106-398	12	WASHER (M16, HARDENED)	
5.	106-666	12	SCREW (M16-2.00 X 65MM, 10.9)	USE 277 LOCTITE; TORQUE TO 225 FT LBS
6.	313-958	-	CARRIAGE	
7.	106-685	2	LOCKNUT(M12-1.75,PRV TRQ,10.9)	

FOOTNOTES

NOTE:

# CARRIAGE CHAIN

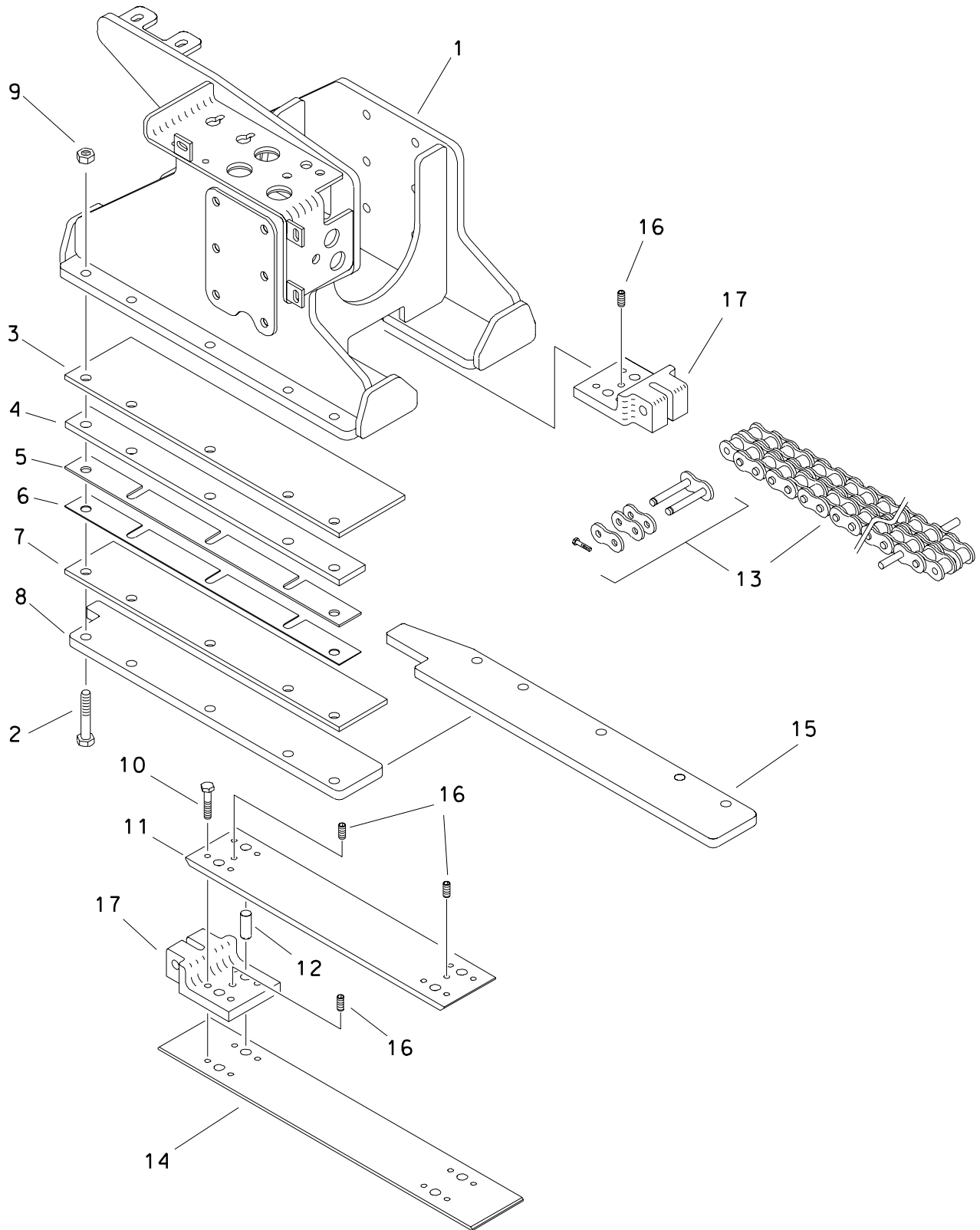



## CARRIAGE CHAIN

REF NO.	PART NUMBER	QTY	DESCRIPTION	REMARKS
1.	313-958	1	CARRIAGE	
2.	107-144	10	SCREW (M16-2.00 X 100MM)	
3.	315-403	2	TOP SLIDE BAR	
4.	315-404	2	THICK SLIDE SPACER	
5.	315-405	2	THIN SLIDE SPACER	
6.	116-997	2	SLIDE SHIM	
7.	315-406	2	BOTTOM SLIDE BAR	
8.	178-963	1	SLIDE BAR	RIGHT SIDE
9.	106-545	10	LOCKNUT (M16-2.0,PRV TRQ,10.9)	
10.	107-748	8	SCREW (M12-1.75 X 50MM, 10.9)	LOCTITE 242
11.	314-488	1	SLIDE BAR	
12.	107-881	4	DOWEL PIN .750 X 2.250	
13.	129-011	1	ROLLER CHAIN ASS'Y #140-2 303P	
	130-622	-	EXTENDED PIN (#140-2, .707")	
	130-624	-	CONNECTOR LINK (#140-2, .707")	
	129-020	1	ROLLER CHAIN #140-2 303P	SEE FOOTNOTE 1.
	179-601	-	EXTD PIN LINK #140-2, .701"	
	129-023	-	CONNECTOR LINK (#140-2, .701")	
14.	313-918	1	SLIDE BAR	
15.	318-976	1	SLIDE BAR	LEFT SIDE
16.	107-303	4	SET SCREW (M12-1.75 X 20MM)	
17.	314-484	1	CHAIN ANCHOR (#140-2, .707")	

## FOOTNOTES

1. ROLLER CHAIN ASSY (129-020) COMES WITH 2 CONNECTOR LINKS, AND 2 EXTENDED PINS.

# THRUST IDLER

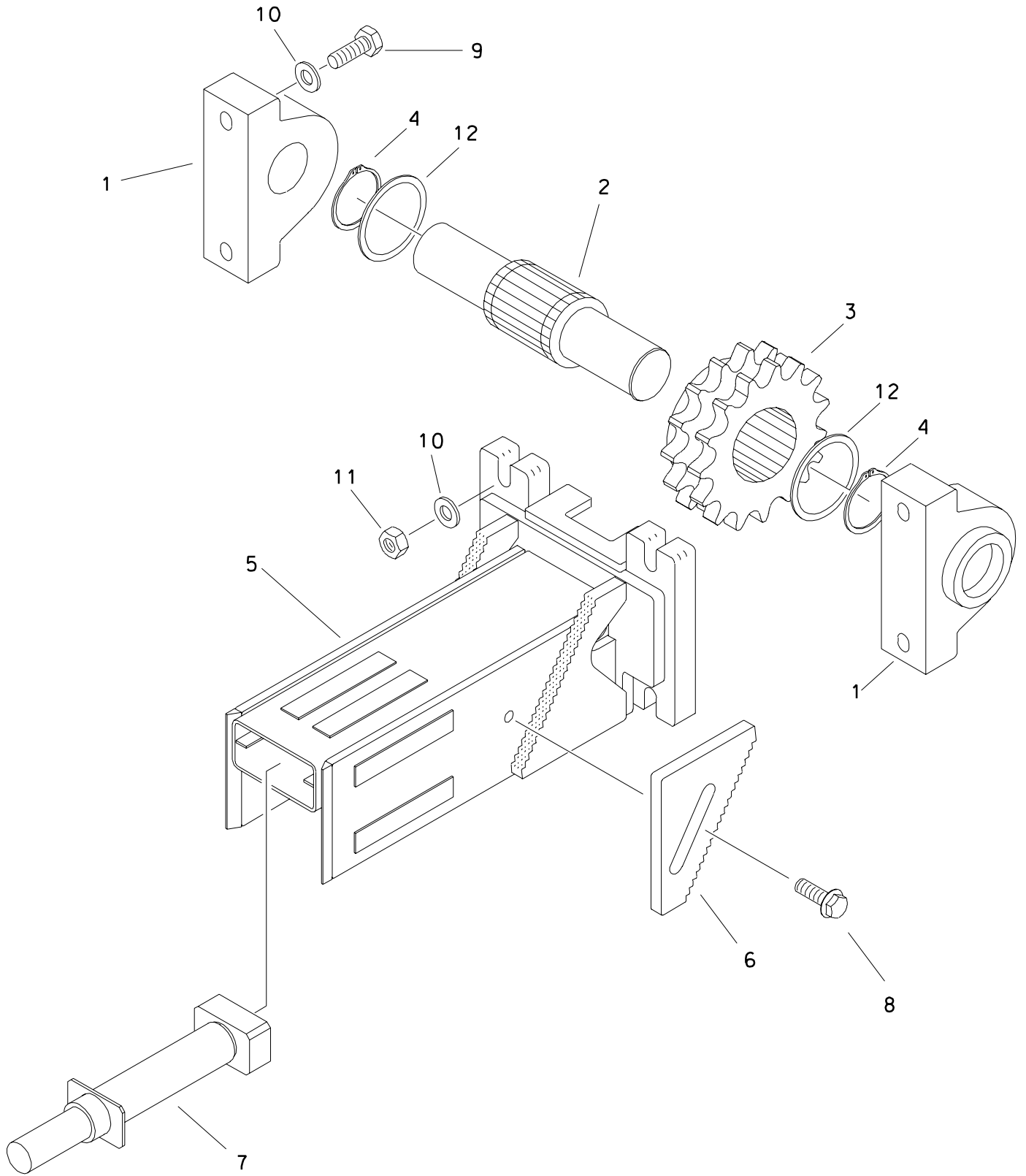

## THRUST IDLER

REF NO.	PART NUMBER	QTY	DESCRIPTION	REMARKS
1.	125-523	2	PILLOW BLOCK BEARING (2.930")	
	125-558	-	ADAPTER SLEEVE KIT (125-523)	
2.	166-473	1	IDLER SHAFT	BEGINS WITH SN 2W0295; SEE FOOTNOTE 2
	167-319	-	IDLER SHAFT	
	101-133	1	THRUST IDLER KIT	INCL. REF. NO.'S 2 - (166-473), 4 - (115-453) & REF. 12
3.	174-028	1	SPROCKET, THRUST DRIVE, SPLINE	SAME AS THRUST DRIVE
4.	118-044	2	EXTERNAL SNAP RING (4.250")	REQUIRED WITH SHAFT 167-319
	115-453	2	EXTERNAL SNAP RING (4")	BEGINS WITH SN 2W0295; SEE FOOTNOTE 2
5.	308-775	1	THRUST IDLER HOUSING	
6.	308-767	2	ADJUSTMENT PLATE	KEEP BOTH SIDES ON SAME NOTCH WHEN ADJUSTING
7.	151-165	1	GREASE CYLINDER	SEE FOOTNOTE 1
8.	106-470	2	FLG SCREW (M16-2.00 X 40mm)	
9.	106-633	4	BOLT (M20-2.50 X 130mm)	
10.	105-460	8	WASHER (13/16")	
11.	106-665	4	LOCKNUT (M20-2.50, 10.9)	
12.	179-489	2	INPUT SHIM 4.002 X 4.750 X .135	BEGINS WITH SN 2W0295; SEE FOOTNOTE 2

## FOOTNOTES

1. WHEN ADJUSTING, RELEASE PRESSURE AFTER POSITIONING ADJUSTMENT PLATES

2. WHEN REPLACING IDLER SHAFT (167-319),

ORDER 101-133 WHICH INCLUDES:

115-453 2 EXTERNAL SNAP RING

166-473 1 IDLER SHAFT

179-489 2 INPUT SHIM 4.002 X 4.750 X .135

# ROTATION GEARBOX

JT42M1 & JT42T2 ONLY

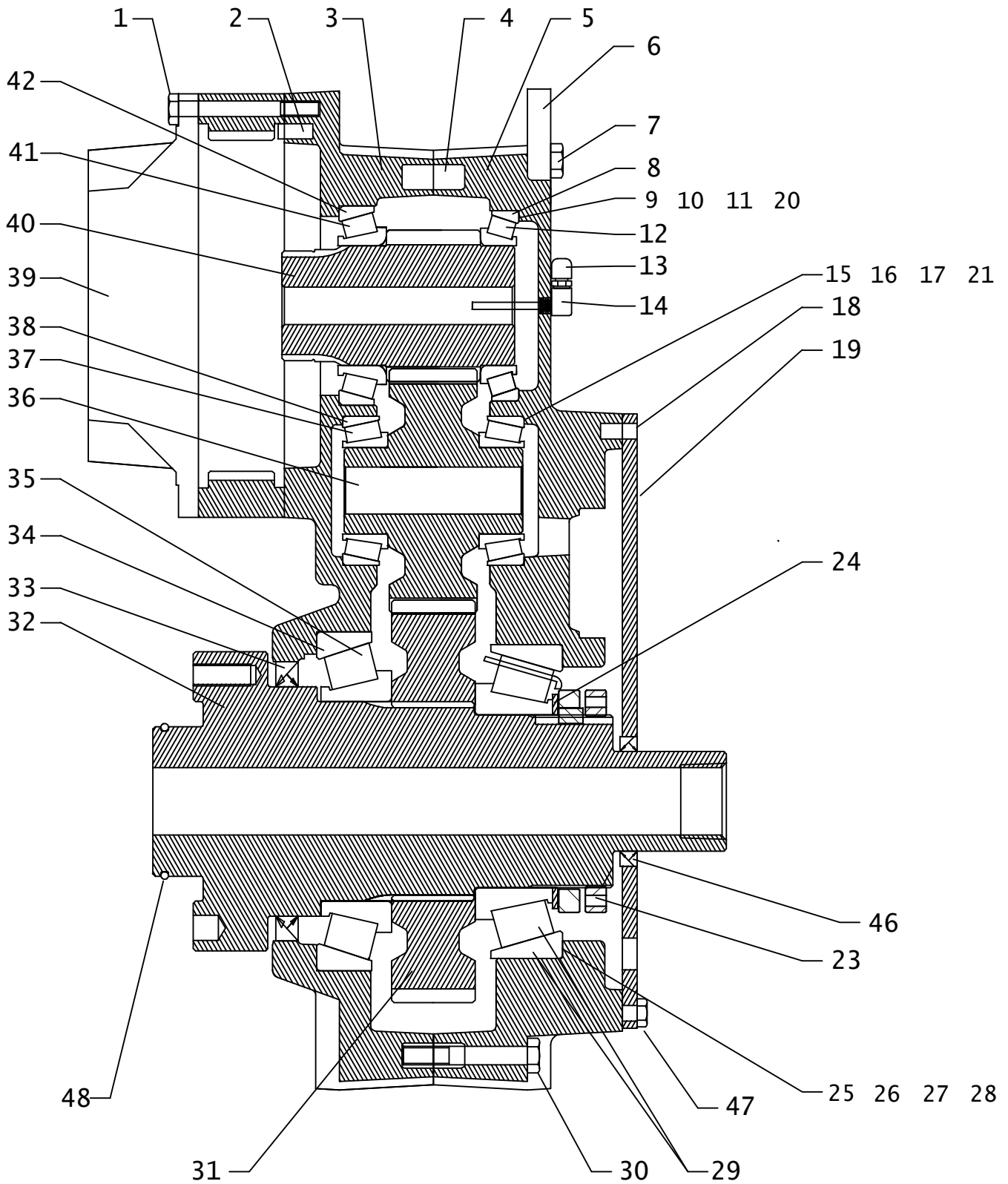

# ROTATION GEARBOX

JT42M1 & JT42T2 ONLY

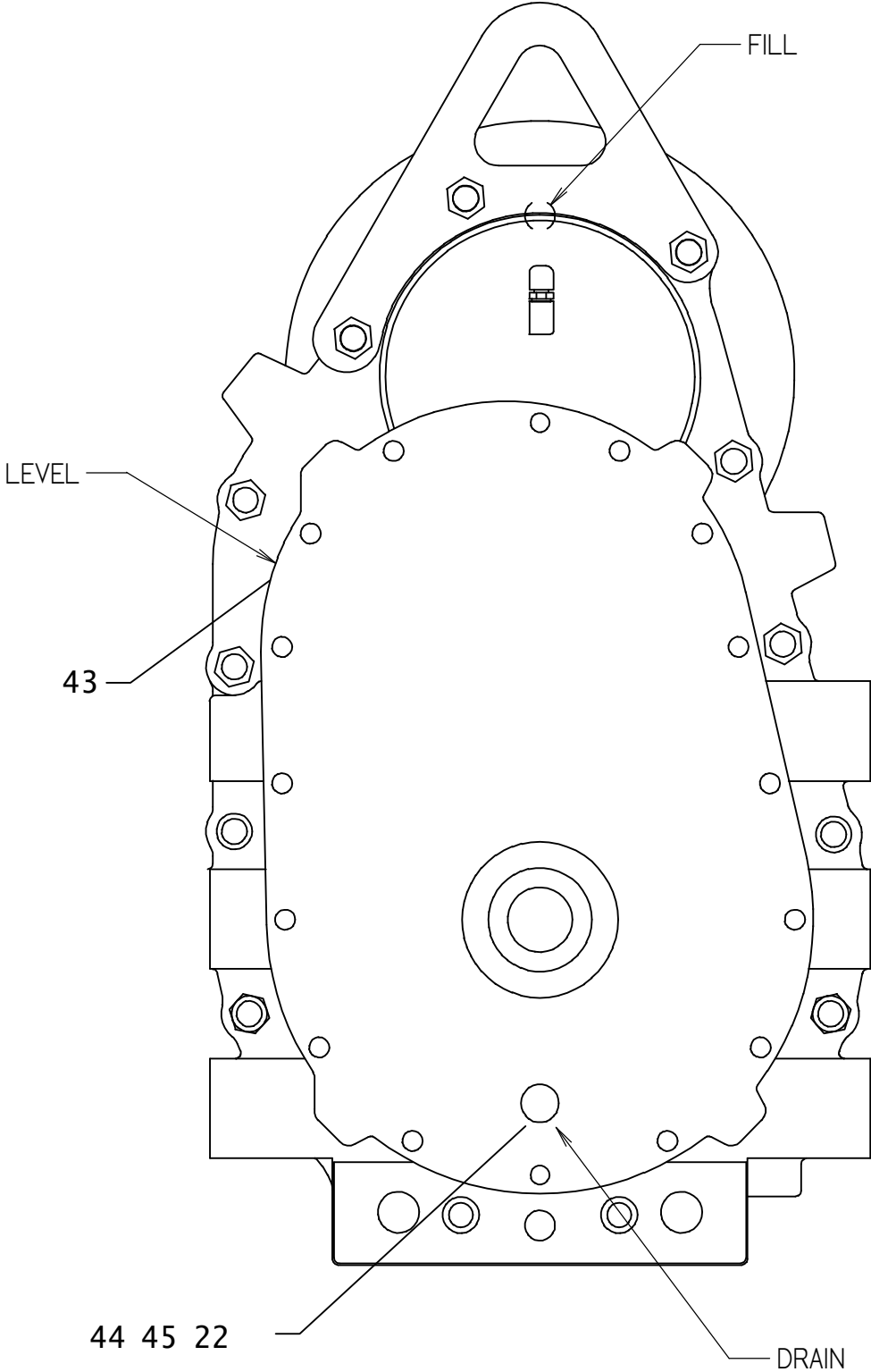

# ROTATION GEARBOX

## JT42M1 & JT42T2 ONLY

REF NO.	PART NUMBER	QTY	DESCRIPTION	REMARKS
	166-487	-	{JT} REBUILT ROTATION GEARBOX	
	166-489	-	{JT} ROTATION DRIVE GEARBOX	INCLUDES REF. #'S 1 - 49.
1.	105-179	12	BOLT (3/8-NC X 3-1/2")	TORQUE TO 40 FT LBS.
2.	105-534	3	DOWEL PIN (.375" X .875")	
3.	314-590	1	COVER CASTING (MACHINED)	
4.	500-818	2	DOWEL PIN (16MM X 40MM)	
5.	314-356	1	COVER CASTING (MACHINED)	
6.	313-947	-	LIFT BRACKET	
7.	106-336	-	SCREW (M12-1.75 X 90MM)	
8.	125-359	1	TAPERED RACE (4.781")	
9.	165-868	3	SHIM (.076MM)	
10.	165-869	3	SHIM (.051MM)	
11.	165-870	3	SHIM (.178MM)	
12.	125-360	1	TAPERED BEARING (3.000")	
13.	159-003	1	AIR VENT (02N)	
14.	514-123	1	PICKUP TUBE (02N-02NF90-2")	
15.	165-842	3	SHIM (.051MM)	
16.	165-843	3	SHIM (.076MM)	
17.	165-844	3	SHIM (.178MM)	
18.	106-866	2	DOWEL PIN (M10 X 30MM)	
19.	318-398	1	COVER	
20.	107-578	2	SHIM (.020")	
21.	107-577	2	SHIM (.020")	
22.	115-112	1	PLUG (08N, SQ)	
23.	<u>107-706</u>	1	NUT, SPANNER	
	190-1386	1	GEARBOX NUT	
	255-1006	-	MOLLY PASTE (SINGLE APPLICATION)	
24.	105-1313	1	HARDEND WASHER	
25.	165-810	3	SHIM (.002")	
26.	165-811	3	SHIM (.003")	
27.	165-812	3	SHIM (.007")	
28.	179-310	2	SHIM .020"	SEE FOOTNOTE 3
29.	125-1009	1	TAPERED BRNG/RACE (110MM)	
30.	106-117	10	SCREW (M12-1.75 X 80MM)	
31.	168-036	1	OUTPUT GEAR	
32.	166-389	1	SHAFT	
33.	153-615	1	INTERNAL SEAL (5.750" ID)	
34.	125-500	1	BEARING CUP	
35.	125-525	1	CONE	

NOT SHOWN:

FOOTNOTES:

NOTE:

## ROTATION GEARBOX JT42M1 & JT42T2 ONLY

REF NO.	PART NUMBER	QTY	DESCRIPTION	REMARKS
36.	168-035	1	IDLER GEAR	
37.	126-170	2	TAPERED BEARING (2.250")	
38.	126-171	2	TAPERED RACE (3.740")	
39.	166-152	1	ROTATION GEARBOX PLANETARY	SEE FOOTNOTE 1
40.	168-034	1	INPUT PINION	
41.	125-308	1	TAPERED BEARING (3.000")	
42.	125-309	1	TAPERED RACE (5.000")	
43.	115-025	1	PLUG (08N, SQ FM, MAG)	
44.	115-162	1	NIPPLE (08N-4")	
45.	115-155	1	COLLAR (08NF)	
46.	153-638	1	INTERNAL SEAL	
47.	106-755	14	SCREW (M10-1.50 X 30MM, SOC)	
48.	157-285	1	O-RING (238 D75 VITON)	

NOT SHOWN:

FOOTNOTES:

1. APPLY LOCTITE SUPERFLEX RED HIGH TEMP RTV OR EQUIVALENT - 3/16 DIA. MIN. BEAD.
2. THIS ITEM WILL COME IN GEARBOX. REMOVE AND INSTALL ITEMS 44,45,& 49.
3. 126-172 SUPERSEDED BY 125-1009. TIMKEN® 32222M WILL NOT WORK IN THIS APPLICATION.

NOTE:

**ROTATION GEARBOX**  
JT4020 ALL TERRAIN ONLY  
ENDS WITH S/N: CMWA40T3P70000017

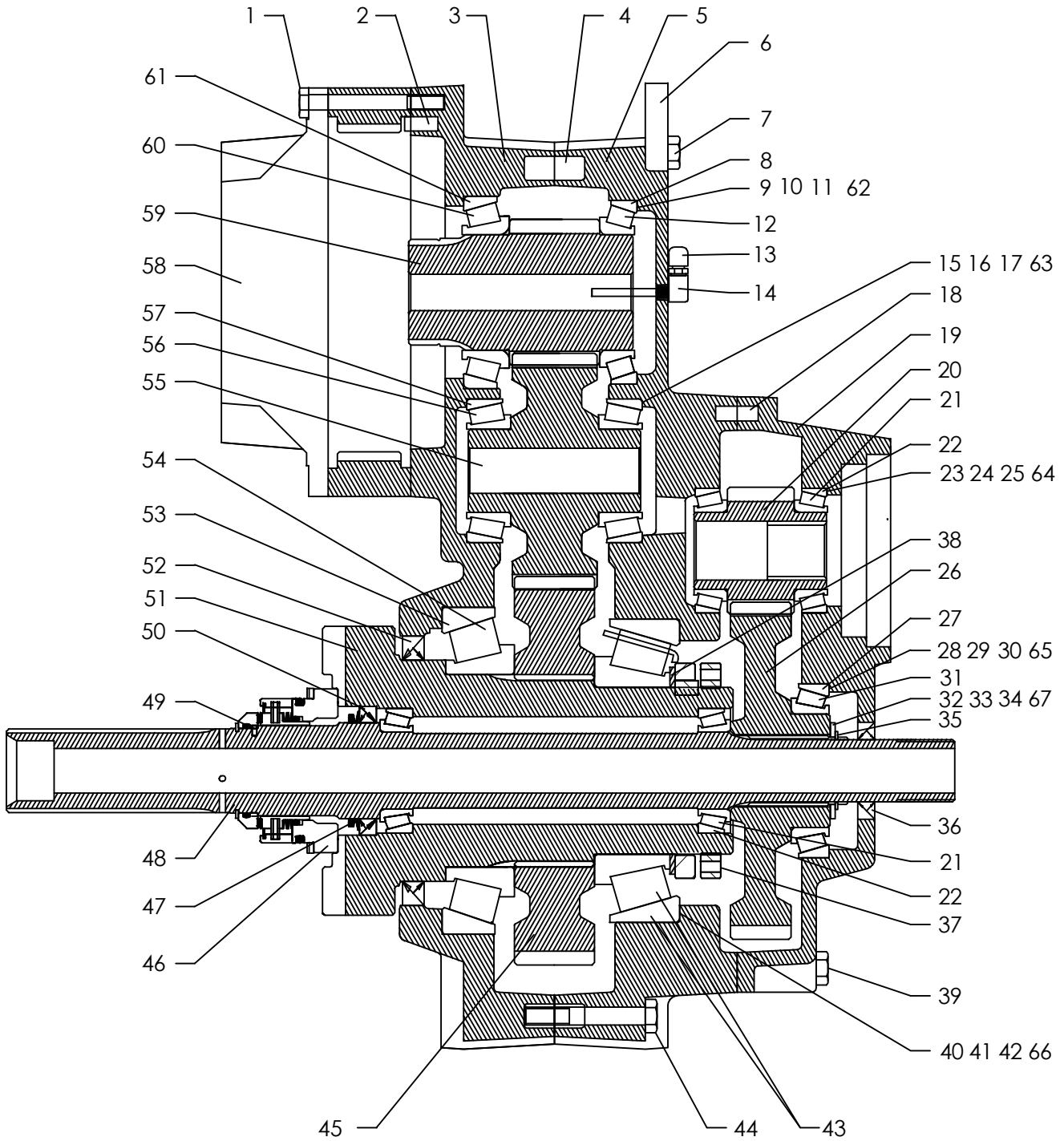



**ROTATION GEARBOX**  
JT4020 ALL TERRAIN ONLY  
ENDS WITH S/N: CMWA40T3P70000017

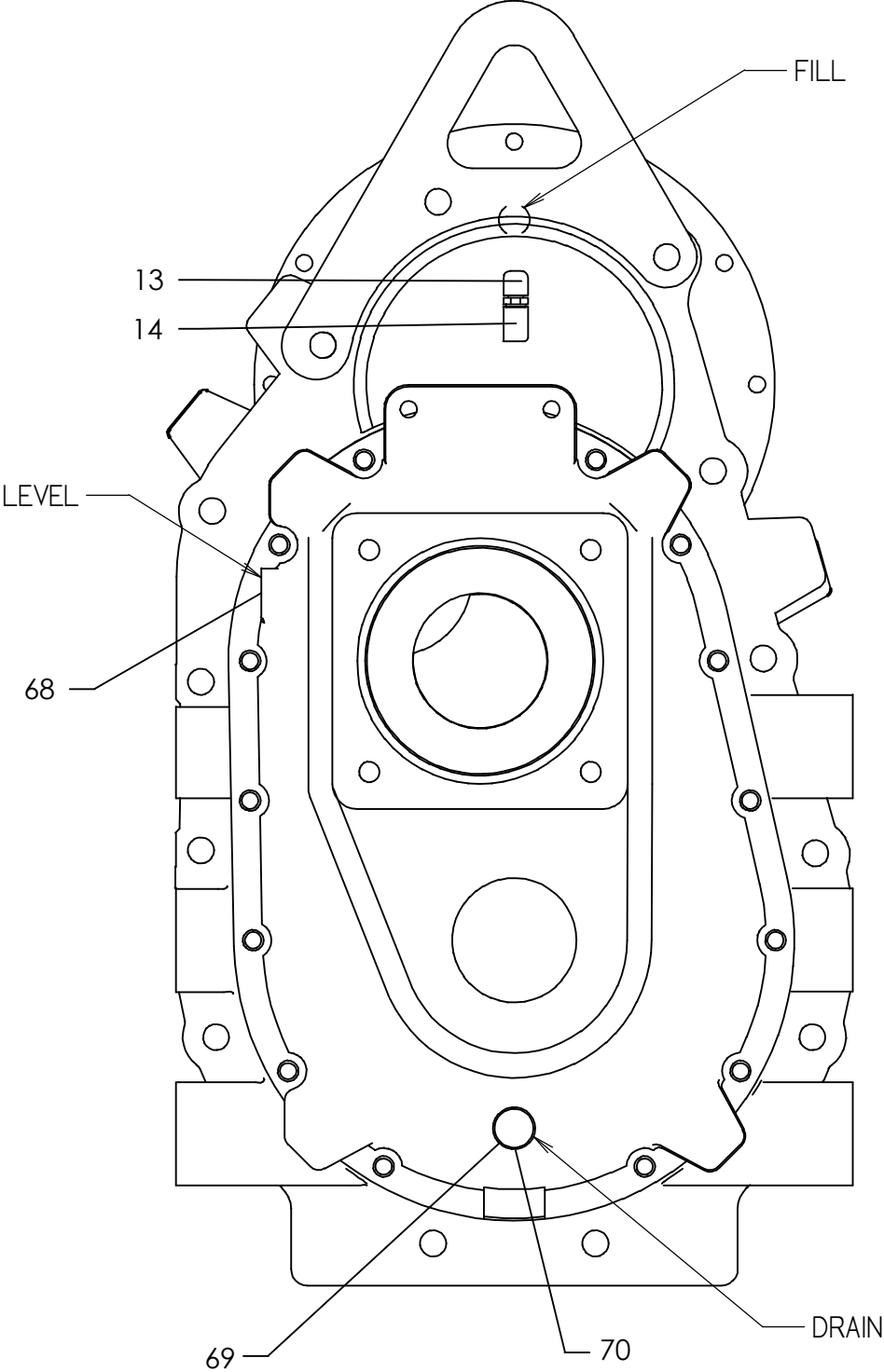

**ROTATION GEARBOX**  
**JT4020 ALL TERRAIN ONLY**  
**ENDS WITH S/N: CMWA40T3P70000017**

REF NO.	PART NUMBER	QTY	DESCRIPTION	REMARKS
	166-468	-	{AT} REBUILT GEARBOX	
	166-488	-	{AT} ROTATION DRIVE GEARBOX	NEW GEARBX, INCL REF. #'S 1-45,47,48,50-71.
1.	105-179	12	BOLT (3/8-NC X 3-1/2")	TORQUE TO 40 FT LBS. (54 N - M)
2.	105-534	3	DOWEL PIN (.375" X .875")	
3.	314-590	1	COVER CASTING (MACHINED)	
4.	500-818	2	DOWEL PIN (16MM X 40MM)	
5.	314-356	1	COVER CASTING (MACHINED)	
6.	313-947	-	LIFT BRACKET	
7.	106-336	-	SCREW (M12-1.75 X 90MM)	
8.	125-359	1	TAPERED RACE (4.781")	
9.	165-868	3	SHIM (.076MM)	
10.	165-869	3	SHIM (.051MM)	
11.	165-870	3	SHIM (.178MM)	
12.	125-360	1	TAPERED BEARING (3.000")	
13.	159-003	1	AIR VENT (02N)	
14.	514-123	1	PICKUP TUBE (02N-02NF90-2")	
15.	165-842	3	SHIM (.051MM)	
16.	165-843	3	SHIM (.076MM)	
17.	165-844	3	SHIM (.178MM)	
18.	106-866	2	DOWEL PIN (M10 X 30MM)	
19.	314-355	1	MOTOR COVER	
20.	166-402	1	INPUT PINION	
21.	126-100	4	TAPERED BEARING (2")	
22.	126-099	4	TAPERED RACE (3.25")	
23.	165-800	2	SHIM (.002")	
24.	165-801	2	SHIM (.003")	
25.	165-802	2	SHIM (.007")	
26.	166-403	1	GEAR	
27.	126-012	1	TAPERED RACE (4.527")	
28.	117-535	2	SHIM	
29.	117-536	2	SHIM	
30.	117-537	2	SHIM	
31.	126-013	1	TAPERED BEARING (2.952")	
32.	107-705	1	BEARING RACE (THRUST)	
33.	126-127	1	THRUST WASHER RACE (1.750")	
34.	117-534	1	SHIM	
35.	115-456	1	EXTERNAL SNAP RING (1.750")	

NOT SHOWN:

FOOTNOTES:

NOTE:

**ROTATION GEARBOX**  
**JT4020 ALL TERRAIN ONLY**  
**ENDS WITH S/N: CMWA40T3P70000017**

REF	PART				REMARKS
NO.	NUMBER	QTY	DESCRIPTION		
36.	153-616	1	INTERNAL SEAL (2.535")		
37.	107-706	1	NUT, SPANNER		
	190-1386	1	GEARBOX NUT		
	255-1006	-	MOLLY PASTE (SINGLE APPLICATION)		
38.	105-1313	1	HARDEND WASHER		
39.	106-755	14	SCREW (M10-1.50 X 30MM, SOC)		
40.	165-810	3	SHIM (.002")		
41.	165-811	3	SHIM (.003")		
42.	165-812	3	SHIM (.007")		
43.	125-1009	1	TAPERED BRNG/RACE (110MM)		SEE FOOTNOTE 2
44.	106-117	10	SCREW (M12-1.75 X 80MM)		
45.	168-036	1	OUTPUT GEAR		
46.	191-278	1	SEAL KIT		INCLUDES REF. 49
	157-285	-	O-RING (238 D75 VITON)		
47.	153-614	1	SEAL, V-RING		
48.	166-387	1	SHAFT		
49.	107-803	1	PIN .125 X .25		
50.	155-801	1	INTERNAL SEAL (2.500")		
51.	166-388	1	SHAFT		
52.	153-615	1	INTERNAL SEAL (5.750" ID)		
53.	125-500	1	BEARING CUP		
54.	125-525	1	CONE		
55.	168-035	1	IDLER GEAR		
56.	126-170	2	TAPERED BEARING (2.250")		
57.	126-171	2	TAPERED RACE (3.740")		
58.	166-152	1	ROTATION GEARBOX PLANETARY		SEE FOOTNOTE 1
59.	168-034	1	INPUT PINION		
60.	125-308	1	TAPERED BEARING (3.000")		
61.	125-309	1	TAPERED RACE (5.000")		
62.	107-578	2	SHIM (.020")		
63.	107-577	2	SHIM (.020")		
64.	107-575	2	SHIM (.020")		
65.	179-309	2	SHIM .020"		
66.	179-310	2	SHIM .020"		
67.	110-054	1	MACHINE BUSHING (1-3/4", 14GA)		
68.	115-025	1	PLUG (08N, SQ FM, MAG)		
69.	115-161	1	NIPPLE (08N, 3-1/2")		
70.	514-106	-	CAP (08NF)		

NOT SHOWN:

FOOTNOTES:

1. APPLY LOCTITE SUPERFLEX RED HIGH TEMP RTV OR EQUIVALENT - 3/16 DIA. MIN. BEAD.
2. 126-172 SUPERSEDED BY 125-1009. TIMKEN® 32222M WILL NOT WORK IN THIS APPLICATION.

NOTE:

# ROTATION GEARBOX

JT4020 ALL TERRAIN ONLY  
BEGINS WITH S/N: CMWA40T3K70000018

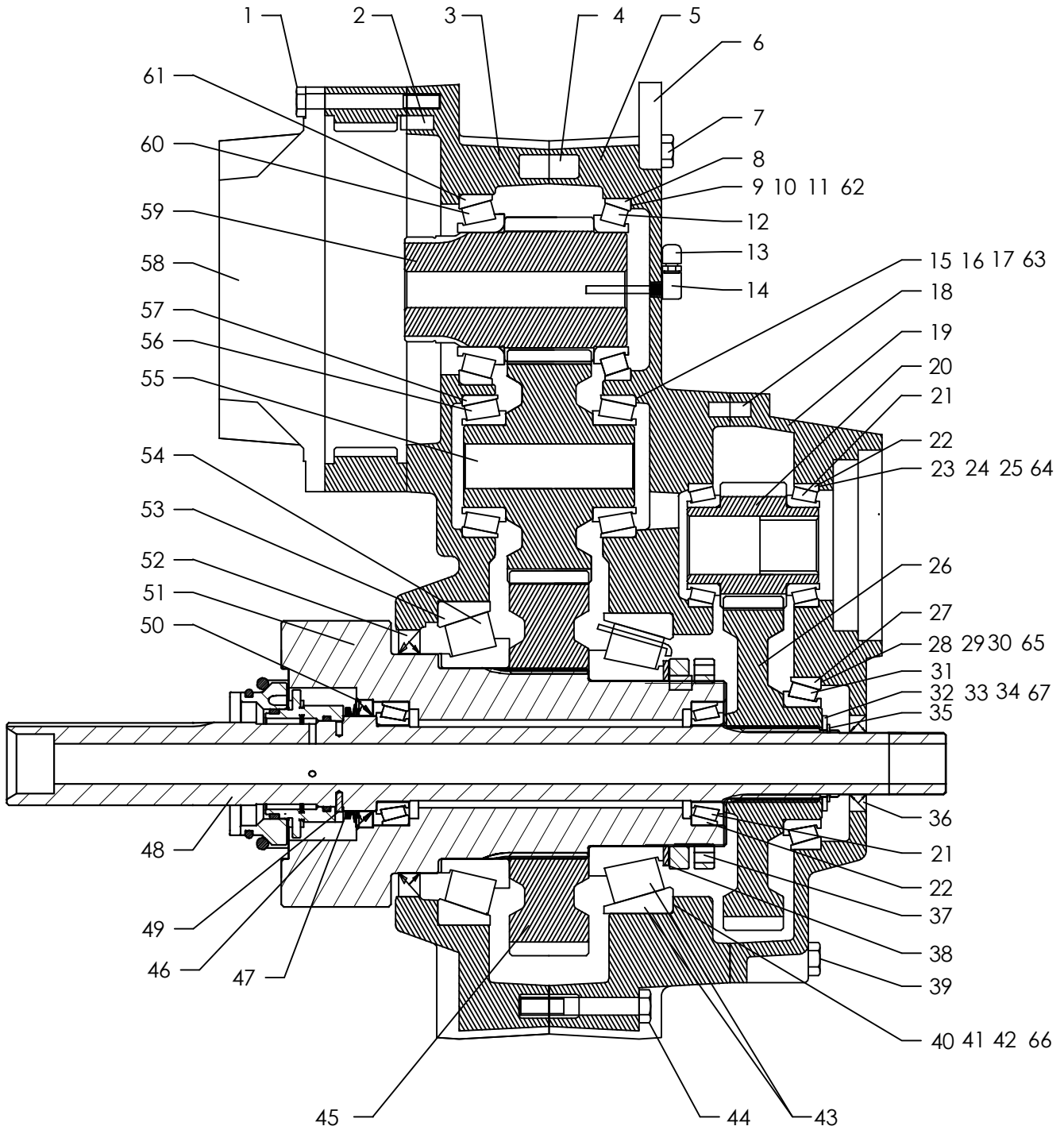

**ROTATION GEARBOX**  
JT4020 ALL TERRAIN ONLY  
BEGINS WITH S/N: CMWA40T3K70000018

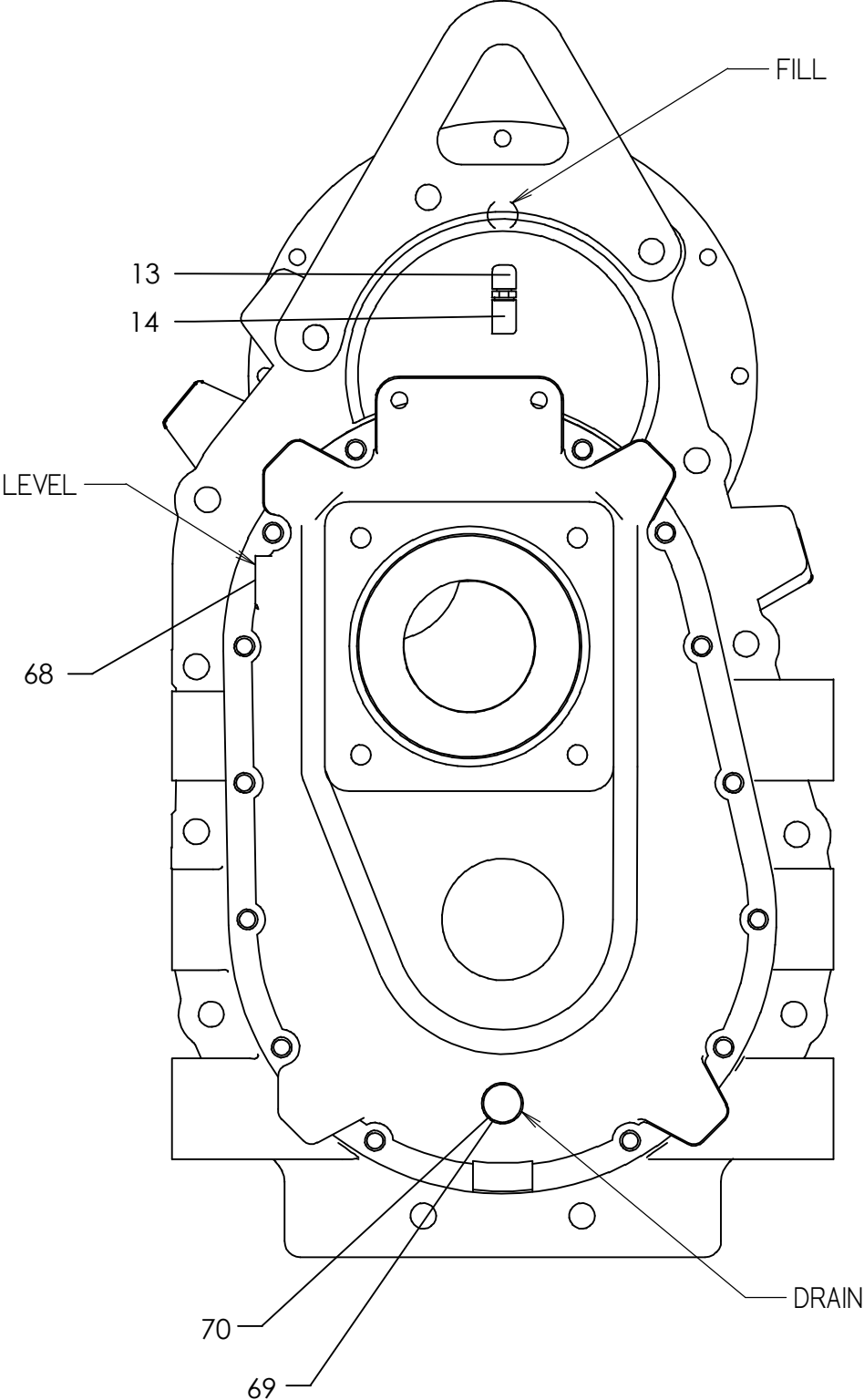

**ROTATION GEARBOX**  
**JT4020 ALL TERRAIN ONLY**  
**BEGINS WITH S/N: CMWA40T3K70000018**

REF NO.	PART NUMBER	QTY	DESCRIPTION	REMARKS
	166-468	-	{AT} REBUILT GEARBOX	
	166-488	-	{AT} ROTATION DRIVE GEARBOX	NEW GEARBX, INCL REF. #'S 1-45,47,48,50-71.
1.	105-179	12	BOLT (3/8-NC X 3-1/2")	TORQUE TO 40 FT LBS. (54 N - M)
2.	105-534	3	DOWEL PIN (.375" X .875")	
3.	314-590	1	COVER CASTING (MACHINED)	
4.	500-818	2	DOWEL PIN (16MM X 40MM)	
5.	314-356	1	COVER CASTING (MACHINED)	
6.	313-947	-	LIFT BRACKET	
7.	106-336	-	SCREW (M12-1.75 X 90MM)	
8.	125-359	1	TAPERED RACE (4.781")	
9.	165-868	3	SHIM (.076MM)	
10.	165-869	3	SHIM (.051MM)	
11.	165-870	3	SHIM (.178MM)	
12.	125-360	1	TAPERED BEARING (3.000")	
13.	159-003	1	AIR VENT (02N)	
14.	514-123	1	PICKUP TUBE (02N-02NF90-2")	
15.	165-842	3	SHIM (.051MM)	
16.	165-843	3	SHIM (.076MM)	
17.	165-844	3	SHIM (.178MM)	
18.	106-866	2	DOWEL PIN (M10 X 30MM)	
19.	314-355	1	MOTOR COVER	
20.	166-402	1	INPUT PINION	
21.	126-100	4	TAPERED BEARING (2")	
22.	126-099	4	TAPERED RACE (3.25")	
23.	165-800	2	SHIM (.002")	
24.	165-801	2	SHIM (.003")	
25.	165-802	2	SHIM (.007")	
26.	166-403	1	GEAR	
27.	126-012	1	TAPERED RACE (4.527")	
28.	117-535	2	SHIM	
29.	117-536	2	SHIM	
30.	117-537	2	SHIM	
31.	126-013	1	TAPERED BEARING (2.952")	
32.	107-705	1	BEARING RACE (THRUST)	
33.	126-127	1	THRUST WASHER RACE (1.750")	
34.	117-534	1	SHIM	
35.	115-456	1	EXTERNAL SNAP RING (1.750")	

NOT SHOWN:

FOOTNOTES:

NOTE:

**ROTATION GEARBOX**  
**JT4020 ALL TERRAIN ONLY**  
**BEGINS WITH S/N: CMWA40T3K70000018**

REF NO.	PART NUMBER	QTY	DESCRIPTION	REMARKS
36.	153-616	1	INTERNAL SEAL (2.535")	
37.	107-706	1	NUT, SPANNER	OBSOLETE
	190-1386	1	GEARBOX NUT	
	255-1006	-	MOLLY PASTE (SINGLE APPLICATION)	
38.	105-1313	1	HARDENED WASHER	
39.	106-755	14	SCREW (M10-1.50 X 30MM, SOC)	
40.	165-810	3	SHIM (.002")	
41.	165-811	3	SHIM (.003")	
42.	165-812	3	SHIM (.007")	
43.	125-1009	1	TAPERED BRNG/RACE (110MM)	SEE FOOTNOTE 2
44.	106-117	10	SCREW (M12-1.75 X 80MM)	
45.	168-036	1	OUTPUT GEAR	
46.	190-1163	1	SEAL KIT	INCLUDES REF. 49
47.	153-614	1	SEAL, V-RING	
48.	166-491	1	SHAFT	
49.	105-1539	1	PIN, GROOVED (5/32" X 1/2")	
50.	155-801	1	INTERNAL SEAL (2.500")	
51.	166-492	1	SHAFT	
52.	153-615	1	INTERNAL SEAL (5.750" ID)	
53.	125-500	1	BEARING CUP	
54.	125-525	1	CONE	
55.	168-035	1	IDLER GEAR	
56.	126-170	2	TAPERED BEARING (2.250")	
57.	126-171	2	TAPERED RACE (3.740")	
58.	166-152	1	ROTATION GEARBOX PLANETARY	SEE FOOTNOTE 1
59.	168-034	1	INPUT PINION	
60.	125-308	1	TAPERED BEARING (3.000")	
61.	125-309	1	TAPERED RACE (5.000")	
62.	107-578	2	SHIM (.020")	
63.	107-577	2	SHIM (.020")	
64.	107-575	2	SHIM (.020")	
65.	179-309	2	SHIM .020"	
66.	179-310	2	SHIM .020"	
67.	110-054	1	MACHINE BUSHING (1-3/4", 14GA)	
68.	115-025	1	PLUG (08N, SQ FM, MAG)	
69.	115-161	1	NIPPLE (08N, 3-1/2")	
70.	514-106	-	CAP (08NF)	

NOT SHOWN:

FOOTNOTES:

1. APPLY LOCTITE SUPERFLEX RED HIGH TEMP RTV OR EQUIVALENT - 3/16 DIA. MIN. BEAD.
2. 126-172 SUPERSEDED BY 125-1009. TIMKEN® 32222M WILL NOT WORK IN THIS APPLICATION.

NOTE:

# ROTATION GEARBOX JT4020 MACH 1 ONLY

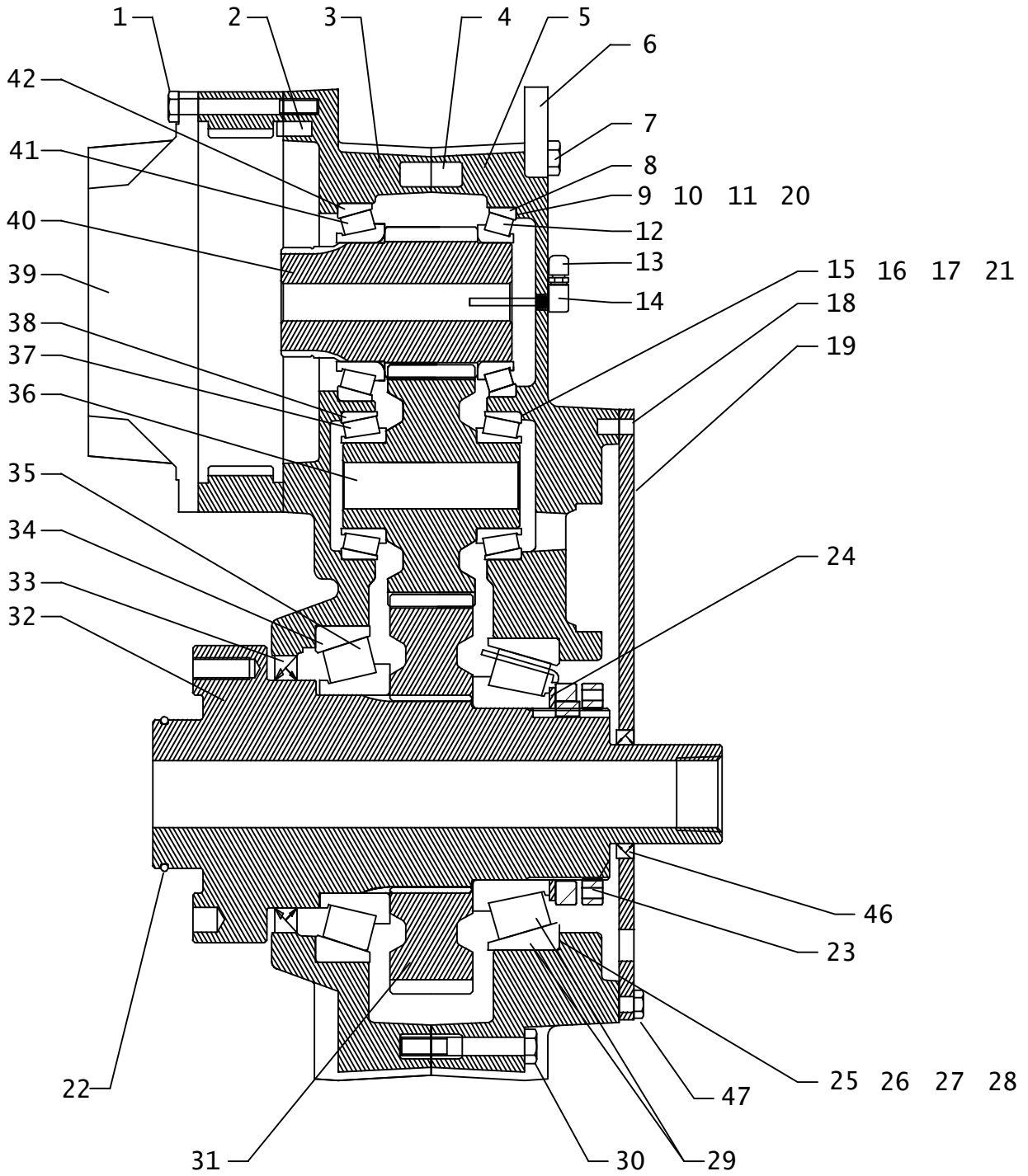



# ROTATION GEARBOX

JT4020 MACH 1 ONLY

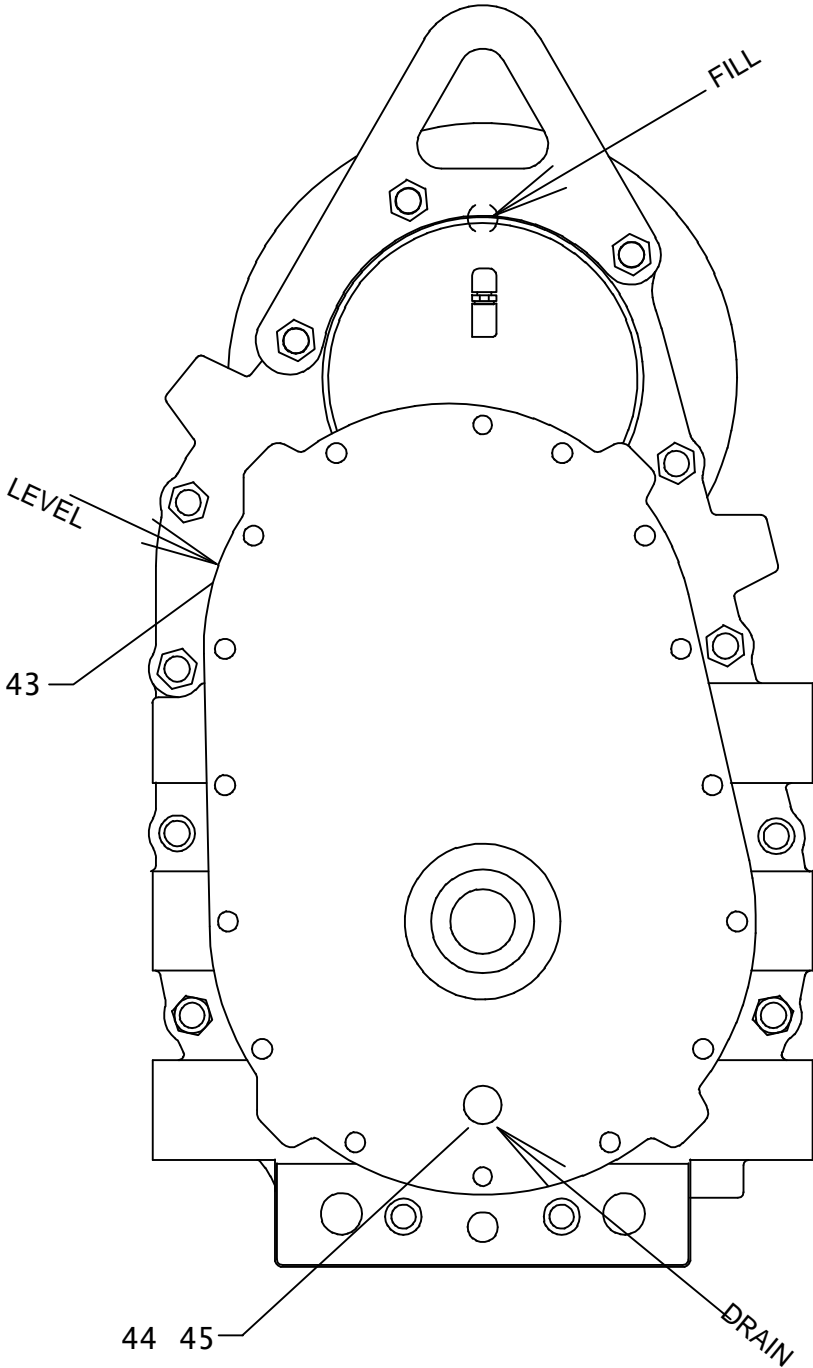

# ROTATION GEARBOX

## JT4020 MACH 1 ONLY

REF NO.	PART NUMBER	QTY	DESCRIPTION	REMARKS
	166-487	-	{JT} REBUILT ROTATION GEARBOX	
	166-489	-	{JT} ROTATION DRIVE GEARBOX	INCLUDES REF. #'S 1 - 48.
1.	105-179	12	BOLT (3/8-NC X 3-1/2")	TORQUE TO 40 FT LBS.
2.	105-534	3	DOWEL PIN (.375" X .875")	
3.	314-590	1	COVER CASTING (MACHINED)	
4.	500-818	2	DOWEL PIN (16MM X 40MM)	
5.	314-356	1	COVER CASTING (MACHINED)	
6.	313-947	-	LIFT BRACKET	
7.	106-336	-	SCREW (M12-1.75 X 90MM)	
8.	125-359	1	TAPERED RACE (4.781")	
9.	165-868	3	SHIM (.076MM)	
10.	165-869	3	SHIM (.051MM)	
11.	165-870	3	SHIM (.178MM)	
12.	125-360	1	TAPERED BEARING (3.000")	
13.	159-003	1	AIR VENT (02N)	
14.	514-123	1	PICKUP TUBE (02N-02NF90-2")	
15.	165-842	3	SHIM (.051MM)	
16.	165-843	3	SHIM (.076MM)	
17.	165-844	3	SHIM (.178MM)	
18.	106-866	2	DOWEL PIN (M10 X 30MM)	
19.	318-398	1	COVER	
20.	107-578	2	SHIM (.020")	
21.	107-577	2	SHIM (.020")	
22.	157-285	1	O-RING (238 D75 VITON)	
23.	<u>107-706</u>	1	NUT, SPANNER	
	190-1386	1	GEARBOX NUT	
	255-1006	-	MOLLY PASTE (SINGLE APPLICATION)	
24.	105-1313	1	HARDEND WASHER	
25.	165-810	3	SHIM (.002")	
26.	165-811	3	SHIM (.003")	
27.	165-812	3	SHIM (.007")	
28.	179-310	2	SHIM .020"	
29.	125-1009	1	TAPERED BRNG/RACE (110 mm)	SEE FOOTNOTE 2
30.	106-117	10	SCREW (M12-1.75 X 80MM)	
31.	168-036	1	OUTPUT GEAR	
32.	166-389	1	SHAFT	
33.	153-615	1	INTERNAL SEAL (5.750" ID)	
34.	125-500	1	BEARING CUP	

NOT SHOWN:

FOOTNOTES:

NOTE:

# ROTATION GEARBOX

## JT4020 MACH 1 ONLY

REF NO.	PART NUMBER	QTY	DESCRIPTION	REMARKS
35.	125-525	1	CONE	
36.	168-035	1	IDLER GEAR	
37.	126-170	2	TAPERED BEARING (2.250")	
38.	126-171	2	TAPERED RACE (3.740")	
39.	166-152	1	ROTATION GEARBOX PLANETARY	SEE FOOTNOTE 1
40.	168-034	1	INPUT PINION	
41.	125-308	1	TAPERED BEARING (3.000")	
42.	125-309	1	TAPERED RACE (5.000")	
43.	115-025	1	PLUG (08N, SQ FM, MAG)	
44.	115-161	1	NIPPLE (08N, 3-1/2")	
45.	514-106	-	CAP (08NF)	
46.	153-638	1	INTERNAL SEAL	
47.	106-755	14	SCREW (M10-1.50 X 30MM, SOC)	

NOT SHOWN:

FOOTNOTES:

1. APPLY LOCTITE SUPERFLEX RED HIGH TEMP RTV OR EQUIVALENT - 3/16 DIA. MIN. BEAD.
2. I26-172 SUPERSEDED BY I25-1009. TIMKEN® 32222M WILL NOT WORK IN THIS APPLICATION.

NOTE:

# SPINDLE DRIVE

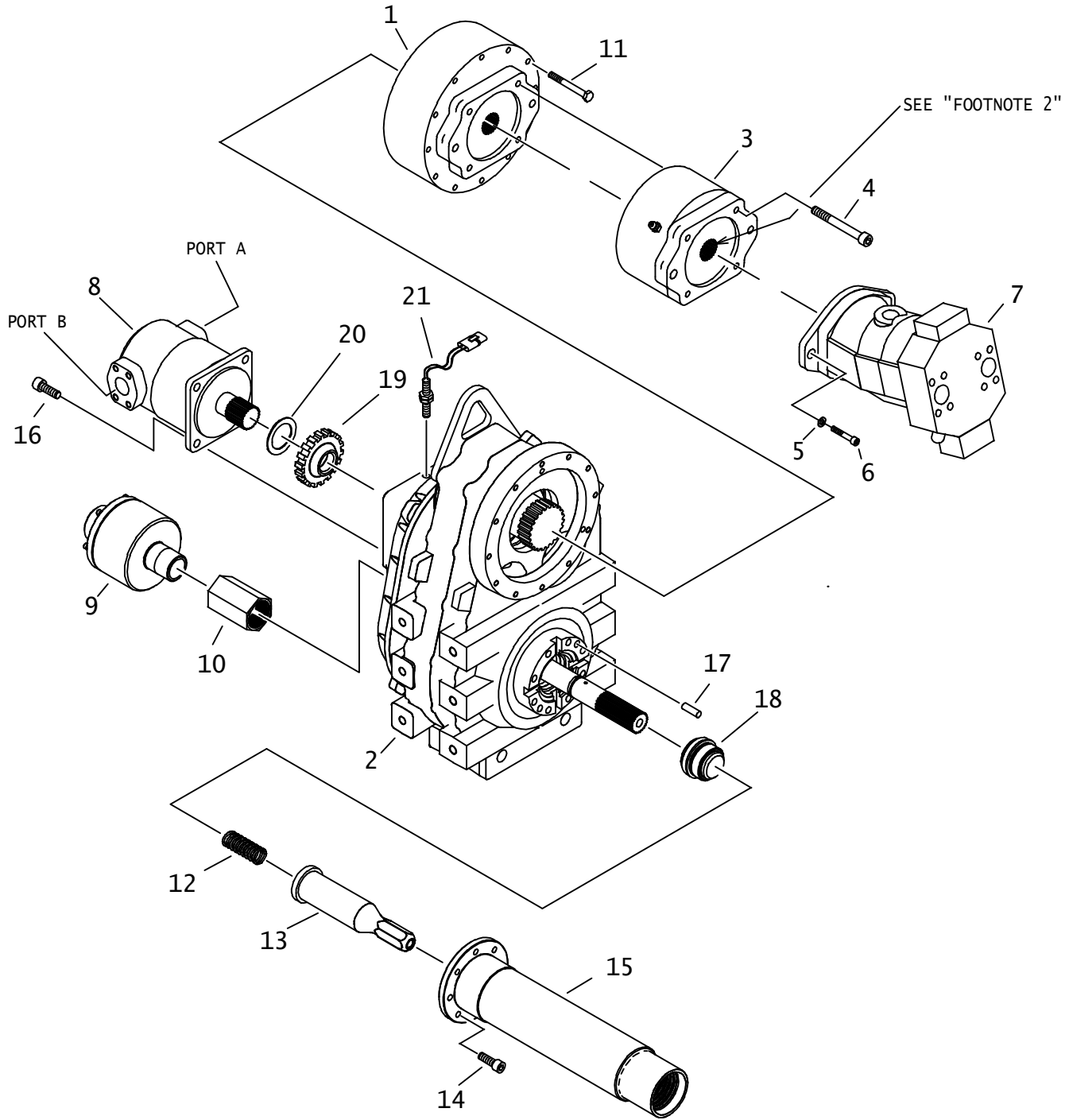

# SPINDLE DRIVE

REF NO.	PART NUMBER	QTY	DESCRIPTION	REMARKS
	166-396	-	{AT} ROTATION DRIVE	AT ONLY, INCLUDES REF. #'S 1-8, & 11-21
	166-482	-	{JT} ROTATION DRIVE	JT ONLY, INCLUDES REF. #'S 1-7,11,14,15, & 17.
1.	166-152	-	ROTATION GEARBOX PLANETARY	
2.	166-488	-	{AT} ROTATION DRIVE GEARBOX	
	166-489	-	{JT} ROTATION DRIVE GEARBOX	
3.	160-1099	1	MODULAR BRAKE	APPLY ANTISIEZE AS INDICATED IN FOOTNOTE 2
	163-212	-	BLEEDER SCREW, DISC BRAKE	
	500-1283	-	OIL SEAL	
	191-169	-	STACK SERVICE KIT	
	191-167	-	GASKET KIT	
	191-168	-	BEARING KIT	
	191-166	-	O-RING KIT	
4.	107-495	4	BLT (1/2-NC X 4.50", SOC GD 8)	USE 242 LOCTITE; TORQUE TO 90 FT LBS
5.	106-398	2	WASHER (M16, HARDENED)	
6.	105-997	2	BOLT (5/8-NC X 1-3/4", SOC)	USE 242 LOCTITE; TORQUE TO 175 FT LBS
7.	158-059	1	HYD MOTOR	AT ONLY
	153-244	-	HYD MOTOR	JT ONLY
	214-886	-	SOLENOID COIL	
	502-172	-	HALL SPEED SENSOR	AT ONLY
8.	153-612	1	HYDRAULIC MOTOR	USE RED SILICON, AT ONLY
	191-263	AR	SEAL REPAIR KIT	
9.	153-208	1	WATER SWIVEL (24N-24NF)	SEE FOOTNOTE 5
10.	153-684	1	SPEC BUSHING (-26-24NF)	USE 567 LOCTITE, AT ONLY
11.	105-179	-	BOLT (3/8-NC X 3-1/2")	TORQUE TO 40 FT LBS
12.	117-541	1	SPRING	AT ONLY
13.	316-841	1	HEX	AT ONLY
14.	106-244	8	SCREW (M16-2.00 X 60MM, SOC)	USE 242 LOCTITE; TORQUE TO 225 FT LBS
15.	400-651	1	SAVER SUB	AT PIPE: SEE FOOTNOTE 3
	400-1135	1	SAVER SUB 3.25-4F SS	
	401-265	1	SAVER SUB ASSEMBLY SS 3.25-4F	SEE FOOTNOTE 4
	400-1133	1	SAVER SUB SS 3.25-4F	
	400-957	-	SAVER SUB ASSEMBLY 2.59-4F DS	JT PIPE
	400-1134	1	SAVER SUB 2.59-4F DS	
16.	105-282	4	BOLT (1/2-NC X 1-1/4", SOC)	USE 242 LOCTITE; TORQUE TO 90 FT LBS, AT ONLY
17.	500-818	2	DOWEL PIN (16MM X 40MM)	
18.	191-278	-	SEAL KIT	AT ONLY: SEE FOOTNOTE 3
	190-1163	-	SEAL KIT	SEE FOOTNOTE 4
19.	166-432	1	SPEED SENSOR RING	AT ONLY
20.	110-220	AR	MACH BUSHING (1-1/2", 14GA)	AT ONLY
21.	215-1472	1	PROXIMITY SWITCH 12MM WP	AT ONLY & REFER TO F/N 1 & F/N 6

NOT SHOWN:

#### FOOTNOTES:

1. INSTALL PROXIMITY SWITCH (REF. 21) TWO TURNS OUT FROM CONTACT WITH SPEED SENSOR RING (REF. 20).
2. APPLY ANTISIEZE TO INTERIOR OF SHAFT COUPLER ON THE BRAKE SECTION (REF. 4) WHERE THE ROTATION MOTOR (REF. 8) MOUNTS BEFORE ASSEMBLY.
3. ENDS WITH S/N: CMWA40T3P70000017
4. BEGINS WITH S/N: CMWA40T3K70000018
5. INSTALL USING NICKLE THREAD SEALING TAPE (117-555) ON MALE THREADS.
6. PROXIMITY SWITCH 215-1472 SUPERCEDES PROXIMITY SWITCH 214-913.

NOTE:

# HOSE TRACK

ENDS WITH S/N: CMWA40T3PB0000138  
CMWJ40T3CB0000136

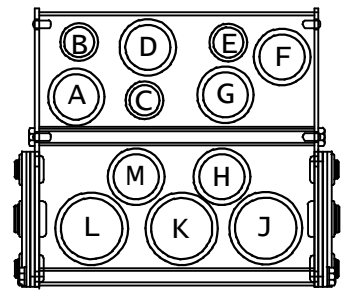
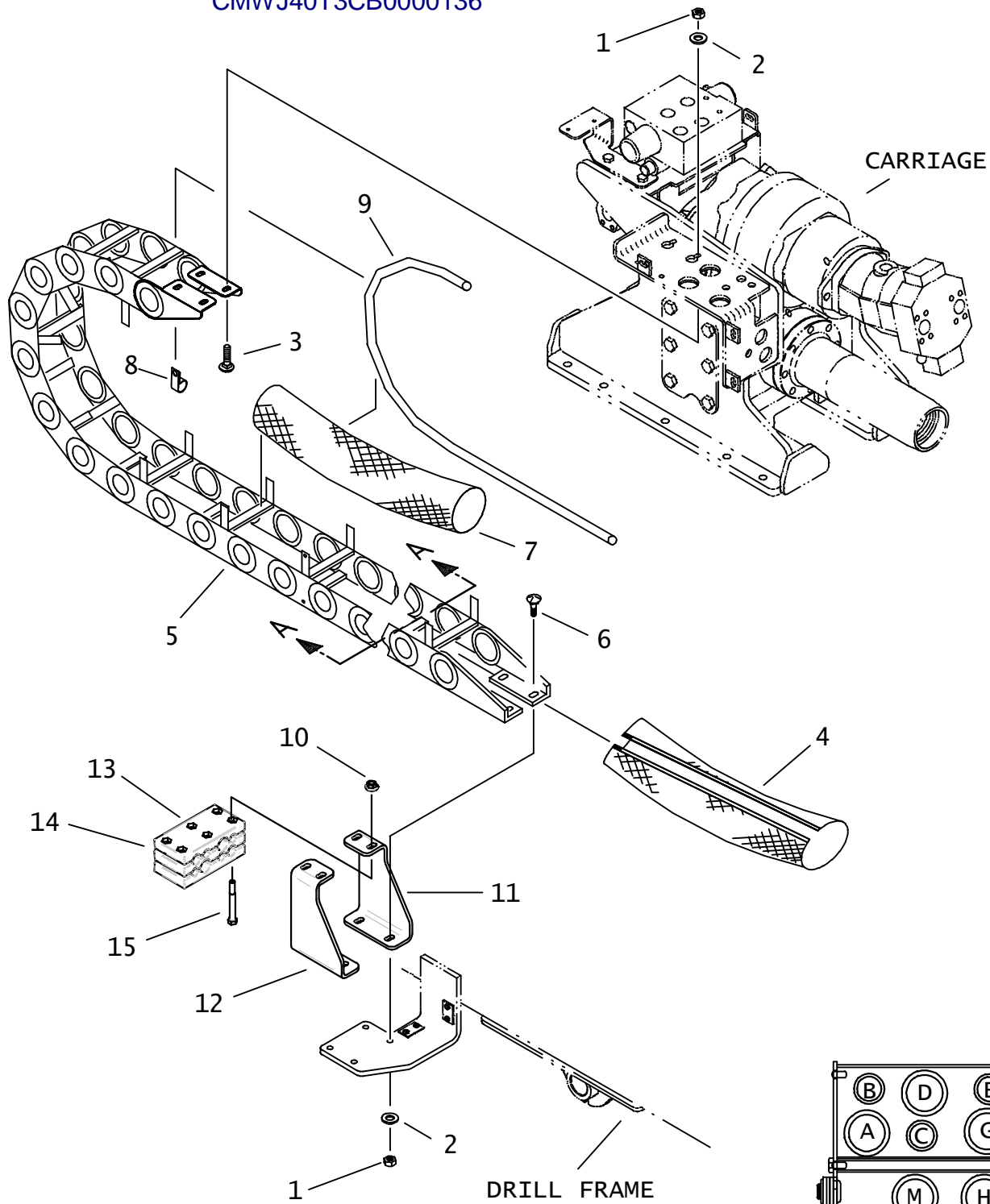

VIEW A-A  
SEE NOT SHOWN

# HOSE TRACK

ENDS WITH S/N: CMWA40T3PB0000138  
CMWJ40T3CB0000136

REF NO.	PART NUMBER	QTY	DESCRIPTION	REMARKS
1.	105-047	8	LOCKNUT (3/8-NC)	
2.	105-117	6	WASHER (5/16")	
3.	105-600	4	CARRIAGE BOLT (3/8-NC X 1")	
4.	150-1787	-	HOSE BAG FOR 150-1750	4020 WITH RACK AND PINION ONLY
	117-919	-	HOSE BAG W/ELECT HARN PCK	USED ON 117-881 ONLY.
	117-991	-	HOSE BAG	
5.	150-1750	1	HOSE TRACK 4020 R&P	4020 WITH RACK AND PINION ONLY
	117-969	1	HOSE CARRIER	INCLUDES REF NO. 4 & 8.
	499-606	-	REPAIR SECTION, 4-LINK	SEE FOOTNOTE 1. FOR 117-969 AND 150-1750.
	499-604	-	BAR KIT	SEE FOOTNOTE 2. FOR 117-969 AND 150-1750.
	499-605	-	HARDWARE KIT	SEE FOOTNOTE 3. FOR 117-969 AND 150-1750.
	499-607	-	EXTENDER KIT	SEE FOOTNOTE 4. FOR 117-969 AND 150-1750.
	499-608	-	EASY OUT BAR KIT	SEE FOOTNOTE 6. FOR 117-969 AND 150-1750.
	499-567	-	MOUNTING BRACKET KIT	SEE FOOTNOTE 5.
	117-881	1	HOSE CARRIER	OBSOLETE
	499-563	-	REPAIR SECTION, 4-LINK	SEE FOOTNOTE 1. FOR 117-881 ONLY.
	499-564	-	BAR KIT	SEE FOOTNOTE 2. FOR 117-881 ONLY.
	499-565	-	HARDWARE KIT	SEE FOOTNOTE 3. FOR 117-881 ONLY.
	499-566	-	EXTENDER KIT	SEE FOOTNOTE 4. FOR 117-881 ONLY.
	499-568	-	EASY OUT BAR KIT	SEE FOOTNOTE 6. FOR 117-881 ONLY.
6.	107-566	4	CARRIAGE BOLT (3/8-NC X 1.50")	
7.	117-995	1	ABRASION SLEEVE (2.07" X 156")	SEE FOOTNOTE 7.
8.	110-333	1	BOLT-ON CLAMP (1")	SEE FOOTNOTE 7.
9.	117-378	1	BULK HOSE, LOW PRESSURE (-12)	USE 147.0". SEE FOOTNOTE 7.
10.	105-814	6	FLG LOCKNUT (3/8-NC)	
11.	300-8896	1	LEFT MOUNT BRACKET	
12.	300-8895	1	RIGHT MOUNT BRACKET	
13.	362-1408	2	CAP PLATE	
14.	362-1407	1	CENTER PLATE	
15.	105-081	6	BOLT (3/8-NC X 3-1/4")	

#### NOT SHOWN:

150-1701	A	HOSE (060FX-280"-3000)	
150-1700	B	HOSE (040FX45-282"-3000)	
150-1980	C	HOSE (040FX-282"-3000)	
150-1979	D	HOSE (080FX-289"-3000)	
150-1700	E	HOSE (040FX45-282"-3000)	AT ONLY
150-1709	F	HOSE(060FX45-302"-3000)	
215-1358	G	HOSE TRACK HARNESS	
150-1702	H	HOSE (160FX90S-299"-6000)	
150-1705	J	HOSE(200FX90L-300"-3000)	
150-1708	K	HOSE(200FX90S-283"-3000)	
150-1704	L	HOSE(200FX90S-287"-3000,SPEC)	
150-1702	M	HOSE (160FX90S-299"-6000)	

#### FOOTNOTES:

- 4-LINK REPAIR SECTION SUPPLIED ASSEMBLED WITH 8X LINK PINS AND SNAP RINGS SHIPPED LOOSE
- KIT CONTENTS: 8X ALUMINUM FLAT BARS, 32X 10-24 UNC SCREWS
- KIT CONTENTS: 8X LINK PINS, 8X LINK PIN SNAP RINGS
- KIT CONTENTS: 8X WINDOW EXTENDERS, 8X 1/4-20 UNC SCREWS AND NUTS
- KIT CONTENTS: 2X RIGHT AND LEFT MOUNTING BRACKETS, 8X LINK PINS, 8X LINK PIN SNAP RINGS
- KIT CONTENTS: 10X EASY-OUT BAR
- NOT USED ON 4020 WITH RACK AND PINION.

#### NOTE:

# CLAMP ASSEMBLY AT42M1

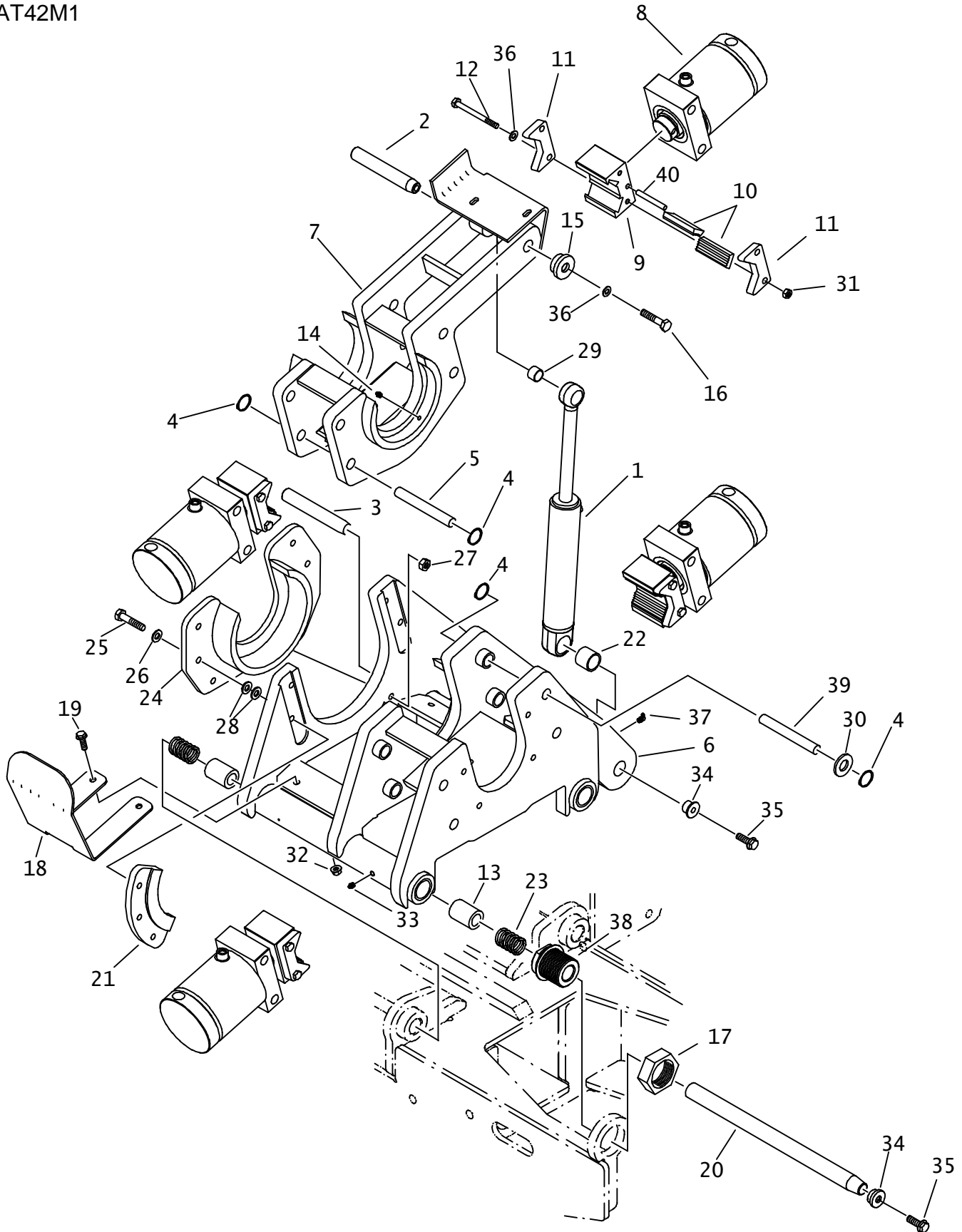



# CLAMP ASSEMBLY

## AT42M1

REF NO.	PART NUMBER	QTY	DESCRIPTION	REMARKS
1.	151-031	1	CYL (2" X 1" X 8")	
2.	184-789	1	TAPERED PIN (25.4MM X 158.7MM)	
3.	178-075	1	TAPERED PIN (31.7MM X 240MM)	
4.	118-053	16	EXTERNAL SNAP RING (.875")	
5.	105-1133	4	PIN	APPLY ANTI-SEIZE TO PIN
6.	313-716	1	STATIONARY CLAMP	
7.	313-717	1	ROTATION CLAMP	
8.	151-212	4	CYL (4.50" X 2.25" X 2.75")	
9.	314-747	4	JAW BLOCK	
10.	350-446	8	GRIPPER INSERT	AT PIPE
	320-155	-	GRIPPER INSERT	JT PIPE
11.	313-881	8	PLATE	
12.	105-022	8	BOLT (3/8-NC X 4")	
13.	178-456	4	BUSHING 1.26ID X 1.75OD X 1.75	
14.	115-003	8	ZERK (1/4-NF, STR)	
15.	181-981	1	TAPERED INSERT (1")	
16.	105-245	1	SCREW (M10-1.50 X 25MM)	
17.	105-695	2	NUT (2 3/8-16 UNJ)	LOCTITE 242
18.	310-114	1	PLATE	
19.	106-383	2	FLG LK SCREW (M10-1.50 X 30MM)	
20.	178-906	2	TAPERED PIN (1.250" X 25.310")	
21.	314-363	2	BACKUP PLATE	
22.	125-771	1	COMPOSITION BUSHING (1.25")	
23.	117-297	4	COMPRESSION SPRING	
24.	313-715	1	RETAINER	
25.	106-659	7	SCREW (M12-1.75 X 55MM)	LOCTITE 242
26.	106-397	7	WASHER (M12, HARDENED)	
27.	106-685	1	LOCKNUT(M12-1.75, PRV TRQ, 10.9)	
28.	110-096	14	MACHINERY BUSHING (1/2")	
29.	125-770	1	COMPOSITION BUSHING (1")	
30.	105-318	AR	WASHER (7/8")	INSTALL WASHERS SO THAT SLACK IS REMOVED
31.	105-047	8	LOCKNUT (3/8-NC)	LOCTITE 242
32.	106-387	2	FLG LOCKNUT (M10-1.50)	
33.	115-001	1	ZERK (02N)	
34.	181-982	3	TAPERED INSERT (1.25")	
35.	106-469	3	FLG SCREW (M12-1.75 X 30MM)	
36.	106-396	8	WASHER (M10, HARDENED)	
37.	115-004	1	ZERK (02N45)	
38.	178-283	2	BOSS	
39.	105-1134	4	PIN	APPLY ANTI-SEIZE TO PIN
40.	107-777	4	SPIRAL SPRING PIN (.375" X 3.00")	

NOT SHOWN:

FOOTNOTES:

NOTE:

# WRENCH PIPE GUIDE

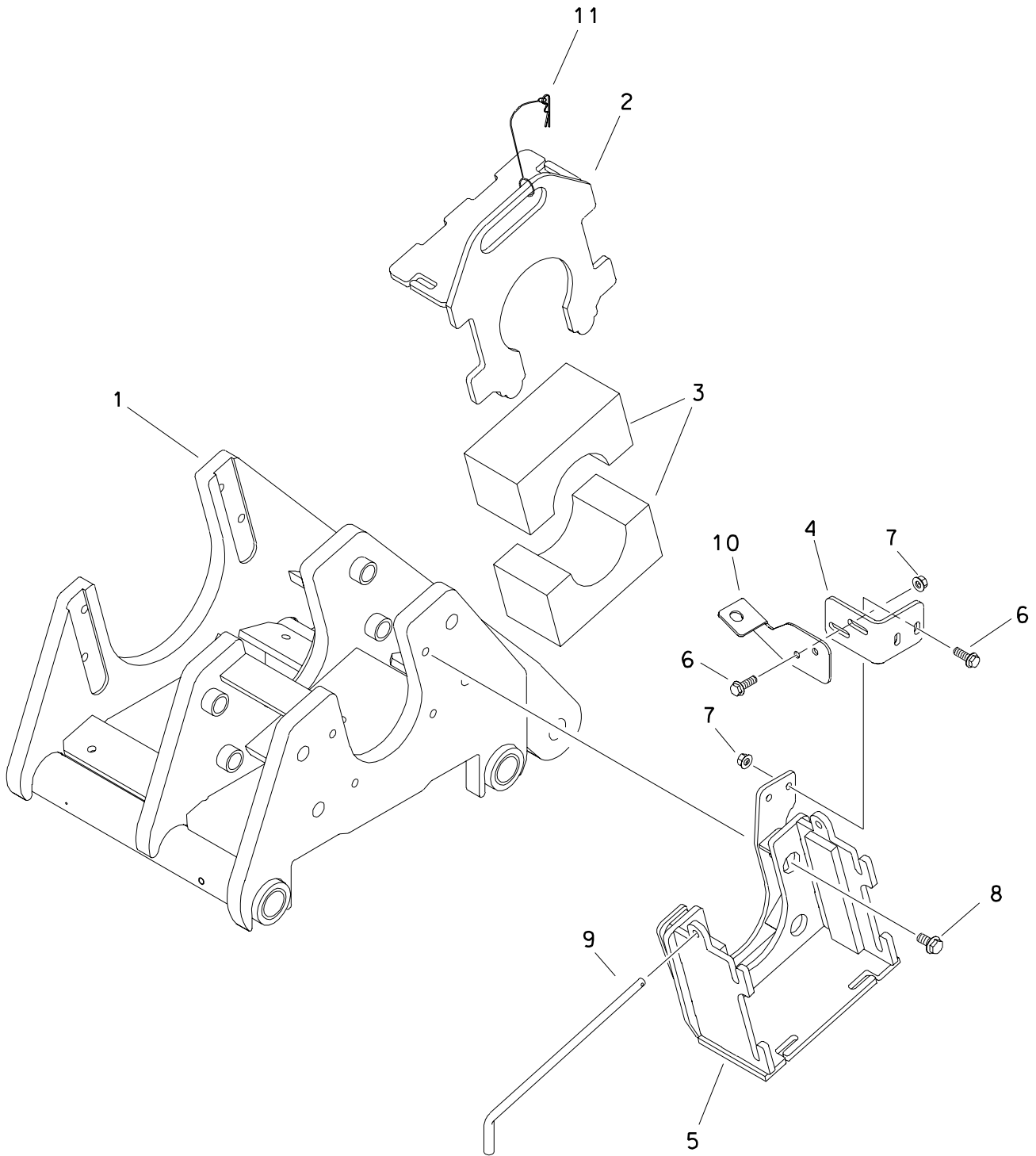

# WRENCH PIPE GUIDE

REF NO.	PART NUMBER	QTY	DESCRIPTION	REMARKS
1.	313-716	-	STATIONARY CLAMP	
2.	313-761	1	BLOCK RETAINER	
3.	314-359	2	GUIDE BLOCK (4.13)	AT PIPE
	314-360	2	GUIDE BLOCK (3.50)	JT PIPE
4.	316-742	1	BRACKET, SPRAY	
5.	313-760	1	WRENCH GUIDE FRAME	
6.	106-724	4	FLG SCREW (M10-1.50 X 25MM)	
7.	106-387	4	FLG LOCKNUT (M10-1.50)	
8.	106-806	4	FLG LK SCREW (M12-1.75 X 25MM)	
9.	346-061	1	PIN	
10.	318-854	1	BRACKET, SPRAY	
11.	110-410	1	SAFETY CLIP & LANYARD	

FOOTNOTES

# GREASE CYLINDER

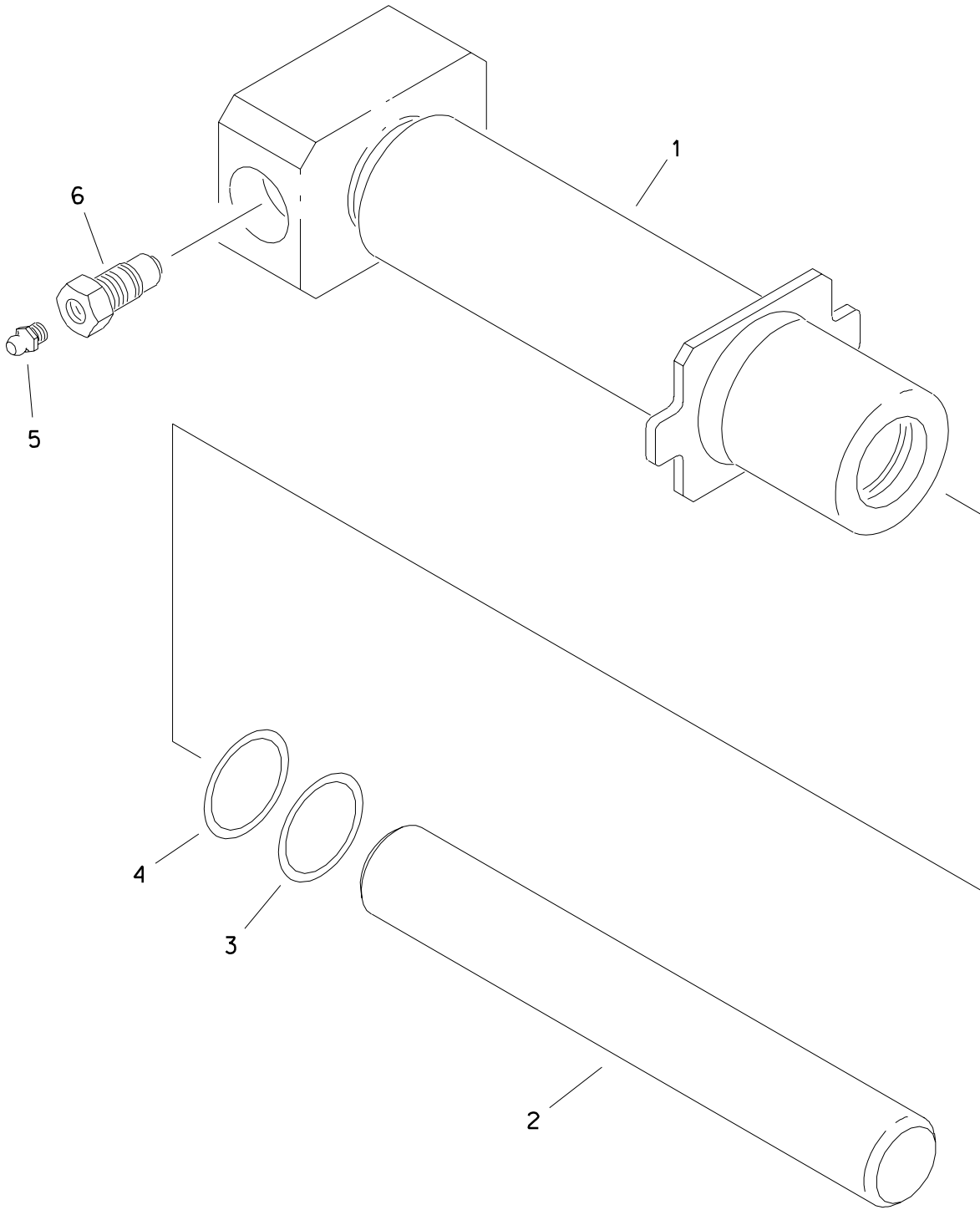

# GREASE CYLINDER

REF NO.	PART NUMBER	QTY	DESCRIPTION	REMARKS
	151-165		GREASE CYLINDER	INCL REF NO'S 1 - 6
1.	353-404	1	GREASE CYLINDER	
2.	153-534	1	GREASE CYLINDER ROD	
3.	155-732	1	BACKUP RING (224 D90)	
4.	155-704	1	O-RING (224 D70)	
5.	115-019	1	ZERK (Q2N)	
6.	159-093	1	RELIEF VALVE (5/8-NF, Q2N)	

FOOTNOTES

# HYDRAULIC CYLINDER (4.50" X 2.25" X 2.75")

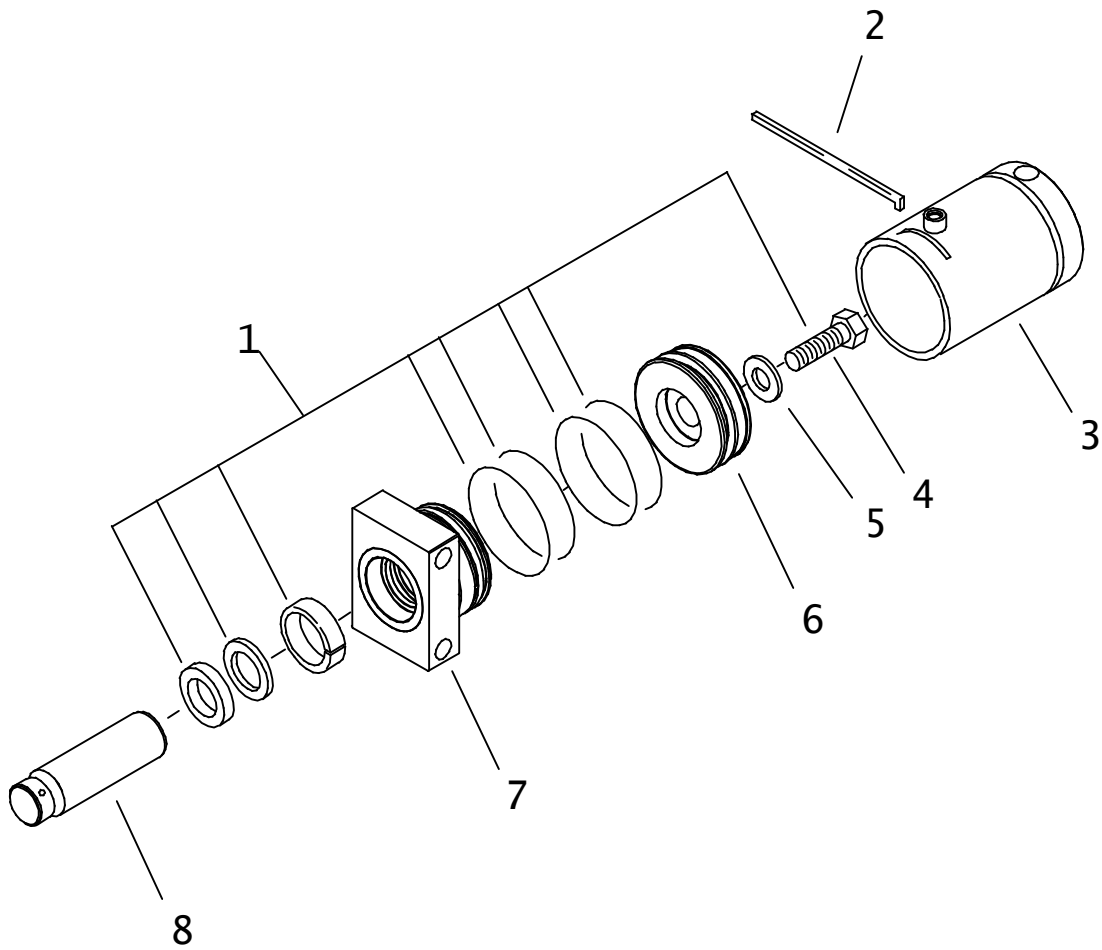

## HYDRAULIC CYLINDER (4.50" X 2.25" X 2.75")

REF NO.	PART NUMBER	QTY	DESCRIPTION	REMARKS
	151-212		CYLINDER ASSEMBLY	INCLUDES REF NO'S 2 THRU 8
1.	190-900	1	SEAL REPAIR KIT	
2.	150-711	1	LOCK RING	
3.	152-073	1	4.5 X 2.75 BARREL	
4.	106-146	1	BOLT (1-1/8-NC X 2-1/2", GD8)	SEE FOOTNOTE 1
5.	106-147	1	WASHER (1-1/8")	
6.	149-168	1	4.5 X 2.25 PISTON	SEE FOOTNOTE 2
7.	151-207	1	GLAND	
8.	153-753	1	CYLINDER ROD	

NOT SHOWN  
259-040 U-SEAL INSTALLER (1.500" - UP)

### FOOTNOTES

1. USE LOCTITE 271 OR 277. TORQUE TO 770-850 FT-LBS (1045-1150 NM).
2. UNITIZED PISTON INCLUDES WEAR RINGS, SQUARE LOADER RING & PISTON SEAL.

NOTE:





# **PIPE LOADER SYSTEMS**

# PIPE LOADER SHUTTLE DRIVE

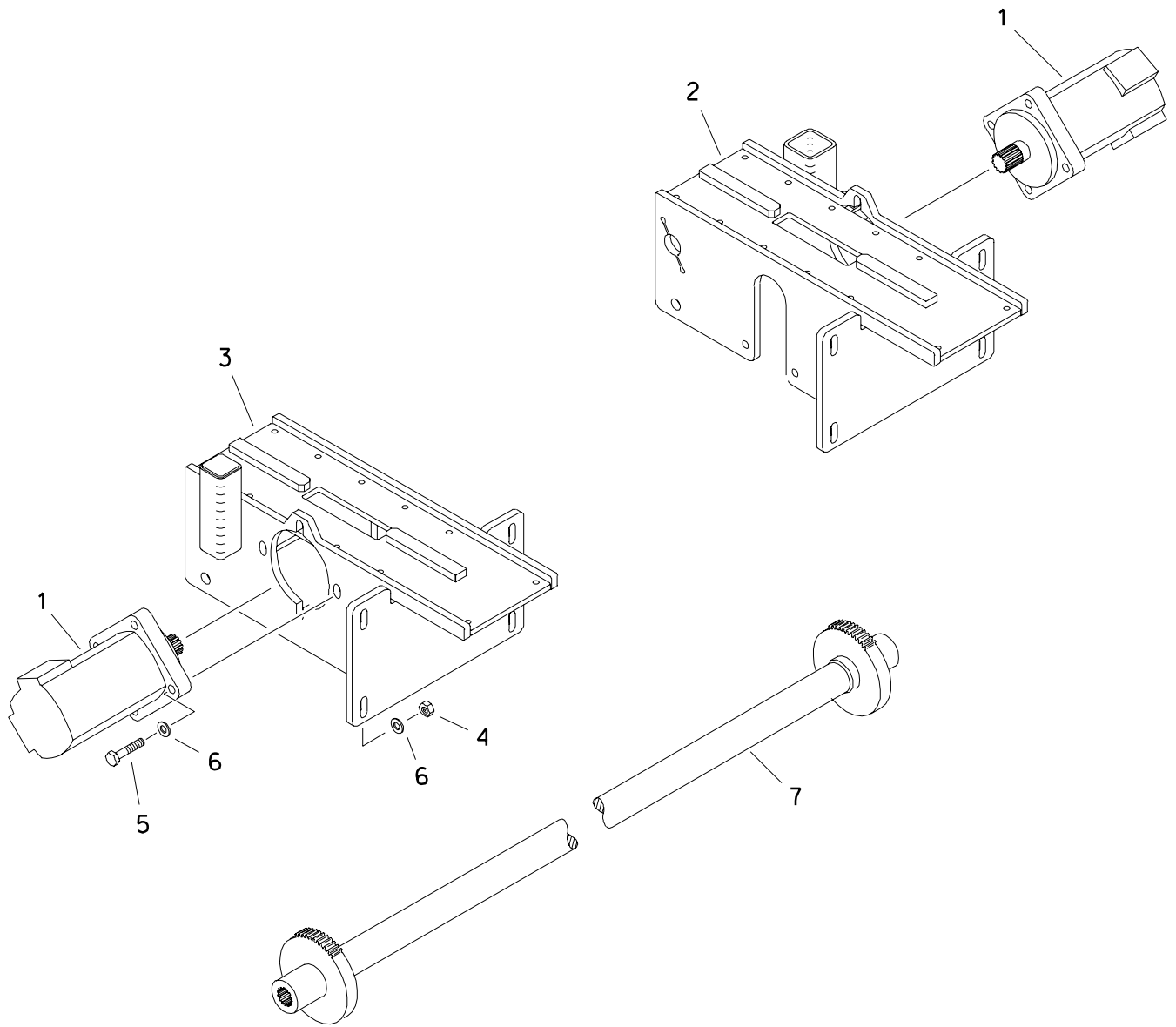

# PIPE LOADER SHUTTLE DRIVE

REF NO.	PART NUMBER	QTY	DESCRIPTION	REMARKS
1.	158-026	2	HYDRAULIC MOTOR (15 CU/IN)	
2.	307-591	-	FRONT SHUTTLE SUPPORT	
3.	307-592	-	REAR SHUTTLE SUPPORT	
4.	106-685	8	LOCKNUT (M12-1.75, PRV TRQ, 10.9)	
5.	106-594	8	SCREW (M12-1.75 X 60MM)	
6.	106-397	16	WASHER (M12, HARDENED)	
7.	313-969	1	PINION SHAFT	

FOOTNOTES

# PIPE LOADER LIFTERS

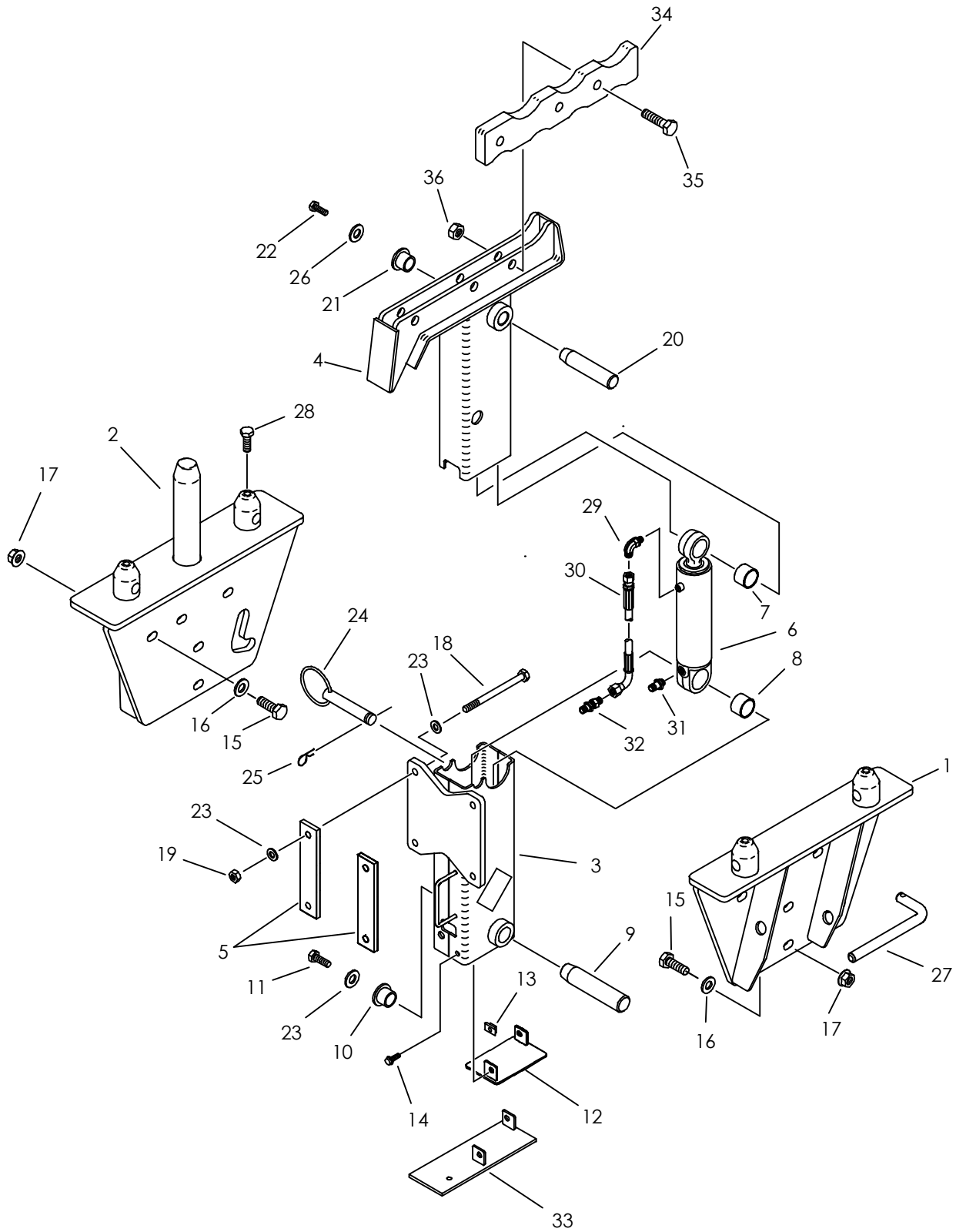

# PIPE LOADER LIFTERS

REF NO.	PART NUMBER	QTY	DESCRIPTION	REMARKS
1.	313-792	1	FRONT BOX SUPPORT	
2.	313-791	1	REAR BOX SUPPORT	
3.	313-783	2	LIFTER OUTER TUBE	
4.	313-805	2	PIPE LIFTER	
	327-1069	2	PIPE LIFTER	SEE FOOTNOTE 2
5.	354-338	4	MOUNT PLATE	
6.	151-031	2	CYL (2.0" X 1.00" X 8.000")	
7.	125-770	2	COMPOSITION BUSHING (1")	
8.	125-771	2	COMPOSITION BUSHING (1.25")	
9.	183-863	2	TAPERED PIN (31.7MM X 128MM)	
10.	181-982	2	TAPERED INSERT (1.25")	
11.	105-273	2	SCREW (M12-1.75 X 30mm)	
12.	356-297	1	STABILIZER CAP	REAR LIFTER
13.	106-551	4	CLIP NUT (M8-1.25)	
14.	106-991	4	FLG LK SCREW (M8-1.25 X 20mm)	
15.	106-340	10	SCREW (M16-2.00 X 50mm)	
16.	106-398	10	WASHER (M16, HARDENED)	
17.	106-442	10	FLG LOCKNUT (M16-2.00, PRV TRQ)	
18.	106-620	8	SCREW (M12-1.75 X 150mm)	
19.	106-685	8	LOCKNUT (M12-1.75, PRV TRQ, 10.9)	
20.	179-024	2	TAPERED PIN (25.4MM X 117MM)	
21.	181-981	2	TAPERED INSERT (1.00")	
22.	105-245	2	SCREW (M10-1.50 X 25mm)	
23.	106-397	18	WASHER (M12, HARDENED)	
24.	180-559	2	PULL PIN (1" X 4.625")	
25.	110-128	2	SPRING CLIP PIN (5/32" X 1")	
26.	106-396	2	WASHER (M10, HARDENED)	
27.	178-446	2	PIPE ROTATION PIN	JT ONLY
28.	106-477	4	SCREW (M12-1.75 X 45MM, 10.9)	
29.	154-252	-	CONNECTOR (04S-04090)	
30.	515-179	-	HOSE (040FX90-11"-3000)	
31.	154-403	-	CONNECTOR (04S-040, XL)	
32.	154-275	-	BK CONNECTOR (040-040BK)	
33.	306-741	1	CAP	FRONT LIFTER
34.	313-782	2	PIPE LIFTER INSERT	SEE FOOTNOTE 1
	300-7416	2	PIPE LIFTER INSERT	SEE FOOTNOTE 1 & 2
35.	106-341	6	SCREW (M16-2.00 X 70MM)	
36.	106-545	6	LOCKNUT (M16-2.0, PRV TRQ, 10.9)	

NOT SHOWN:

#### FOOTNOTES:

1. PIPE LIFTER INSERT IS REVERSABLE. SIDE W/ 3 NOTCHES IS FOR THE AT, SIDE W/ 4 NOTCHES IS FOR JT.
2. USE ON 4020 WITH RACK AND PINION.

NOTE:

# FRONT PIPE LOADER SHUTTLE

JT42 T3, AT42 T3

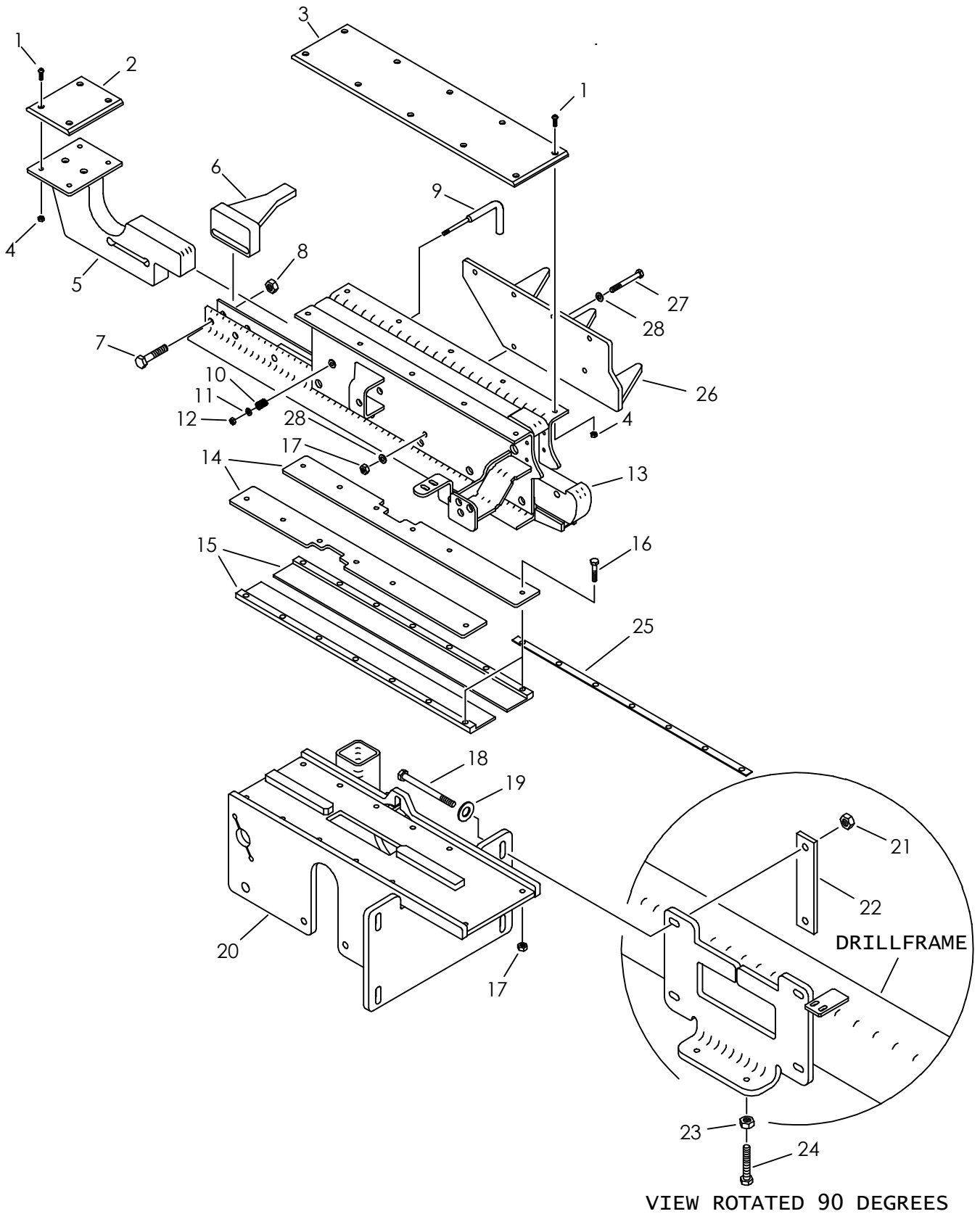

# FRONT PIPE LOADER SHUTTLE

## JT42 T3, AT42 T3

REF NO.	PART NUMBER	QTY	DESCRIPTION	REMARKS
1.	106-640	14	SCREW (M6-1.00 X 20MM,BUT SOC)	
2.	307-623	1	PIPE SLIDE BEARING	
3.	315-112	1	PIPE SLIDE BEARING	
4.	106-237	14	LOCKNUT (M6-1.00,PRV TRQ,NLK)	
5.	313-685	1	SINGLE PIPE LOADER	
6.	307-594	1	SHUTTLE STOP	
7.	106-659	2	SCREW (M12-1.75 X 55MM)	
8.	106-685	2	LOCKNUT(M12-1.75,PRV TRQ,10.9)	
9.	178-414	1	SHOULDER PIN	
10.	117-116	1	COMPRESSION SPRING	
11.	105-095	1	WASHER (1/4")	
12.	105-085	1	LOCKNUT (1/4-NC)	
13.	313-683	1	FRONT SHUTTLE	
14.	307-605	2	PLATE	
15.	307-621	2	SHUTTLE SLIDE BEARING	
16.	106-328	12	SCREW (M8-1.25 X 40MM)	
17.	106-561	17	LOCKNUT (M8-1.25,PRV TRQ,10.9)	
18.	107-213	4	SCREW (M12-1.75 X 160MM)	
19.	106-397	4	WASHER (M12, HARDENED)	
20.	307-591	1	FRONT SHUTTLE SUPPORT	
	327-1063	1	FRONT SHUTTLE SUPPORT	SEE FOOTNOTE I
21.	106-685	4	LOCKNUT(M12-1.75,PRV TRQ,10.9)	
22.	354-338	2	MOUNT PLATE	
23.	106-089	2	NUT (M12-1.75, 10.9)	
24.	107-701	2	SCREW (M12-1.75 X 100MM)	
	105-1079	2	SCREW (M12-1.75 X 140MM)	SEE FOOTNOTE I
25.	117-539	AR	SHIM	USE ONLY IF PLASTIC IS TOO THIN
26.	313-701	1	AT ROW SELECT	
	313-702	1	JT ROW SELECT	
27.	105-292	5	SCREW (M8-1.25 X 75MM)	
28.	106-395	10	WASHER (M8, HARDENED)	

NOT SHOWN:

#### FOOTNOTES:

I. USE ON 4020 WITH RACK AND PINION

NOTE:

# REAR PIPE LOADER SHUTTLE AT42M1

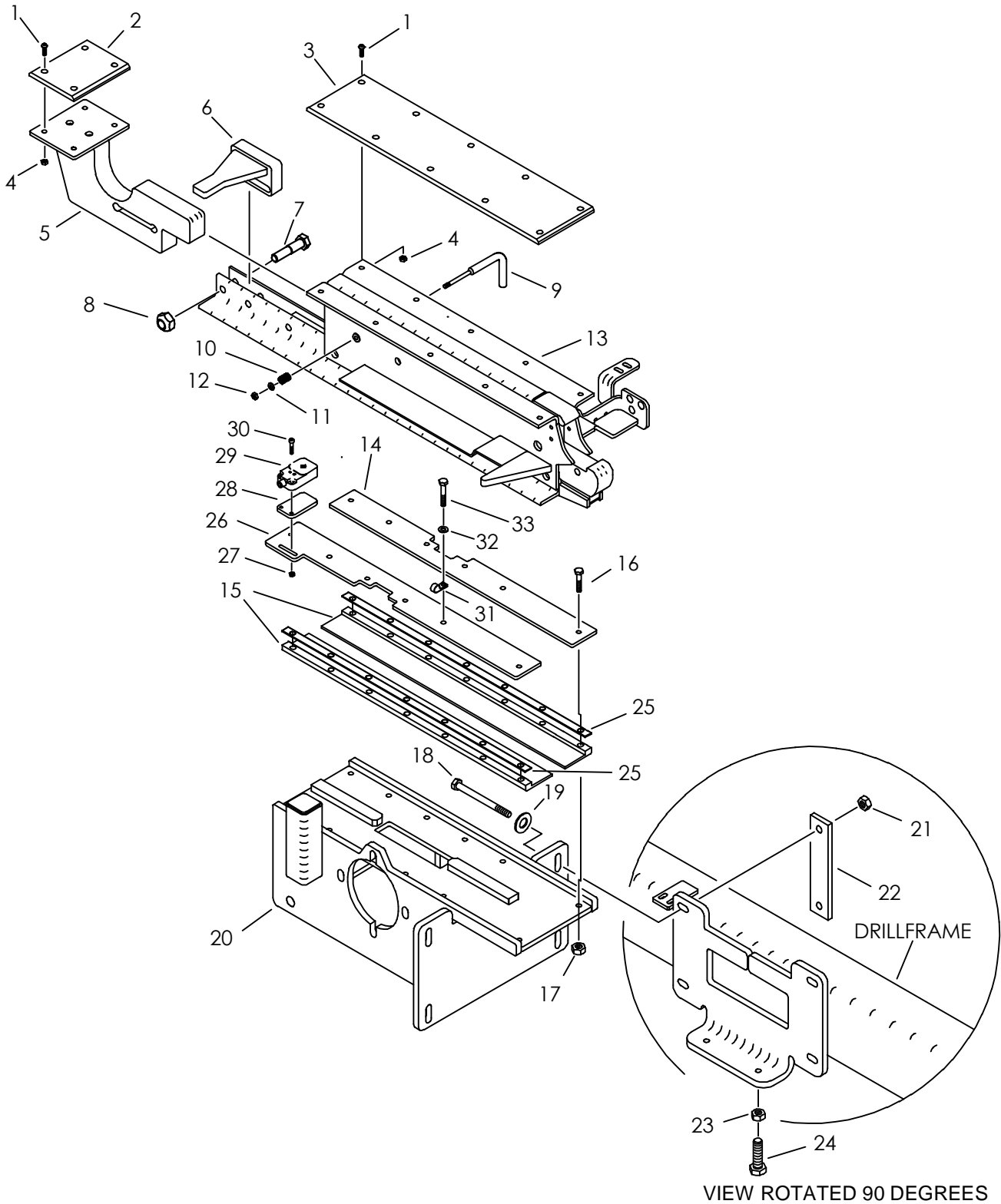



# REAR PIPE LOADER SHUTTLE

## AT42M1

REF NO.	PART NUMBER	QTY	DESCRIPTION	REMARKS
1.	106-640	14	SCREW (M6-1.00 X 20MM,BUT SOC)	
2.	307-623	1	PIPE SLIDE BEARING	
3.	315-112	1	PIPE SLIDE BEARING	
4.	106-237	14	LOCKNUT (M6-1.00,PRV TRQ,NLK)	
5.	313-685	1	SINGLE PIPE LOADER	
6.	307-594	1	SHUTTLE STOP	
7.	106-659	2	SCREW (M12-1.75 X 55MM)	
8.	106-685	2	LOCKNUT(M12-1.75,PRV TRQ,10.9)	
9.	178-414	1	SHOULDER PIN	
10.	117-116	1	COMPRESSION SPRING	
11.	105-095	1	WASHER (1/4")	
12.	105-085	1	LOCKNUT (1/4-NC)	
13.	313-684	1	REAR SHUTTLE	
14.	307-605	1	PLATE	
15.	307-621	2	SHUTTLE SLIDE BEARING	
16.	106-328	11	SCREW (M8-1.25 X 40MM)	
17.	106-561	12	LOCKNUT (M8-1.25,PRV TRQ,10.9)	
18.	107-213	4	SCREW (M12-1.75 X 160MM)	
19.	106-397	4	WASHER (M12, HARDENED)	
20.	307-592	1	REAR SHUTTLE SUPPORT	
	327-1064	1	REAR SHUTTLE SUPPORT	SEE FOOTNOTE I
21.	106-685	4	LOCKNUT(M12-1.75,PRV TRQ,10.9)	
22.	354-338	2	MOUNT PLATE	
23.	106-089	2	NUT (M12-1.75, 10.9)	
24.	107-701	2	SCREW (M12-1.75 X 100MM)	
	105-1079	2	SCREW (M12-1.75 X 140MM)	SEE FOOTNOTE I
25.	117-539	AR	SHIM	USE ONLY IF PLASTIC IS TOO THIN
26.	307-947	1	PLATE	
27.	106-850	2	LOCKNUT (M5-0.80)	
28.	107-451	AR	SHIM (.135")	USE ONLY IF GAP IS TOO LARGE
29.	215-1175	-	PROXIMITY SENSOR	
30.	107-465	2	SCREW (M5-0.80 X 30MM, SOC)	
31.	110-259	1	BOLT-ON CLAMP (.625")	
32.	106-389	1	WASHER (M8)	
33.	106-932	1	SCREW (M8-1.25 X 45MM)	

NOT SHOWN:

#### FOOTNOTES:

I. USE ON 4020 WITH RACK AND PINION

NOTE:

# PIPE LOADER GRIPPER

JT42 T3, AT42 T3

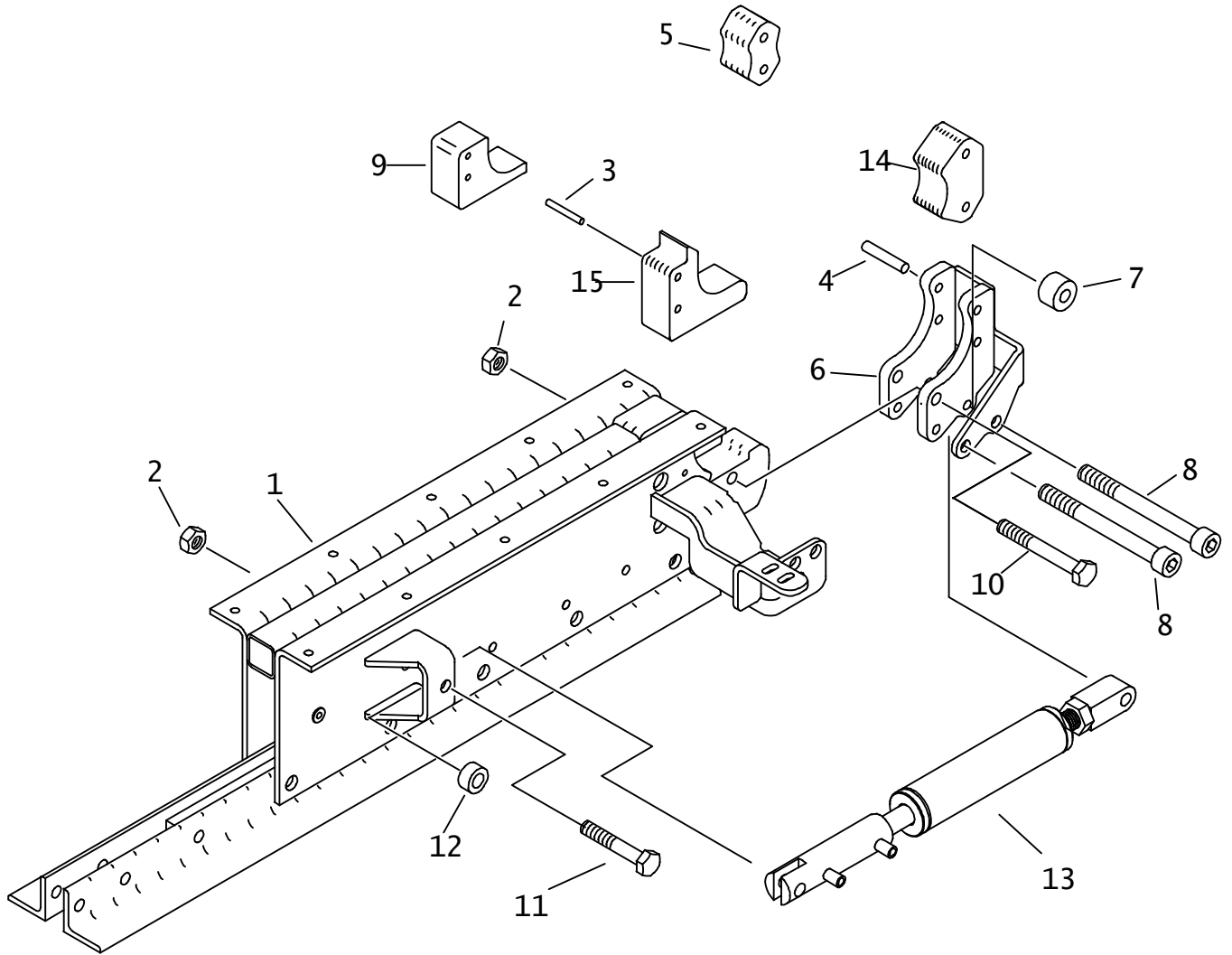

# PIPE LOADER GRIPPER

## JT42 T3, AT42 T3

REF NO.	PART NUMBER	QTY	DESCRIPTION	REMARKS
1.	313-683	1	FRONT SHUTTLE	
	313-684	1	REAR SHUTTLE	
2.	105-065	4	LOCK NUT (1/2-NC)	
3.	105-503	4	ROLL PIN (1/4" X 2")	
4.	105-555	4	ROLL PIN (3/8" X 2-1/2")	
5.	313-705	2	GRIPPER PAD	USE WITH AT PIPE
6.	313-686	1	FRONT GRIPPER	
	313-687	1	REAR GRIPPER	
7.	307-614	2	ROLLER	
8.	107-613	4	SHLD BLT M12 X 40MM, M10-1.50,SP	LOCTITE 277
9.	313-704	2	SHUTTLE PAD	USE WITH AT PIPE
10.	105-300	2	BOLT (1/2-NC X 3-1/4")	
11.	105-472	2	BOLT (1/2-NC X 5")	
12.	354-354	2	SPACER	
13.	191-161	2	GRIPPER CYLINDER	
14.	319-369	2	GRIPPER PAD	USE WITH JT PIPE
15.	319-368	2	SHUTTLE PAD	USE WITH JT PIPE

NOT SHOWN:

FOOTNOTES:

NOTE:

## GRIPPER CYLINDER

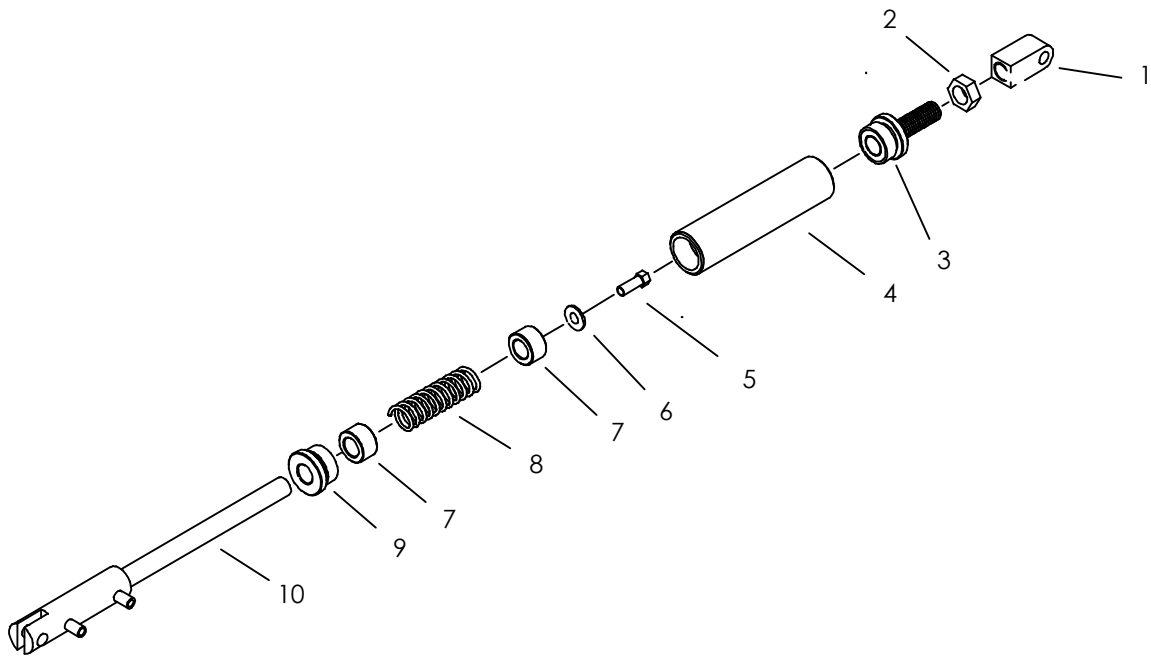

# GRIPPER CYLINDER

REF NO.	PART NUMBER	QTY	DESCRIPTION	REMARKS
	191-161		GRIPPER CYLINDER	
1.	354-357	1	ROD END	
2.	105-310	1	JAM NUT (3/4-NC)	
3.	354-323	1	PLUNGER	
4.	354-355	1	TUBE	
5.	105-031	1	BOLT (3/8-NC X 1")	LOCKTITE 242
6.	105-118	1	WASHER (3/8")	
7.	354-356	2	SPRING GUIDE	
8.	117-180	1	COMPRESSION SPRING	
9.	354-432	1	CAP	
10.	150-731	1	CYL ASS'Y	USE HIGH TEMP PHILLIP GREASE ON ROD

NOT SHOWN:

FOOTNOTES:

NOTE:

## SHUTTLE STOP

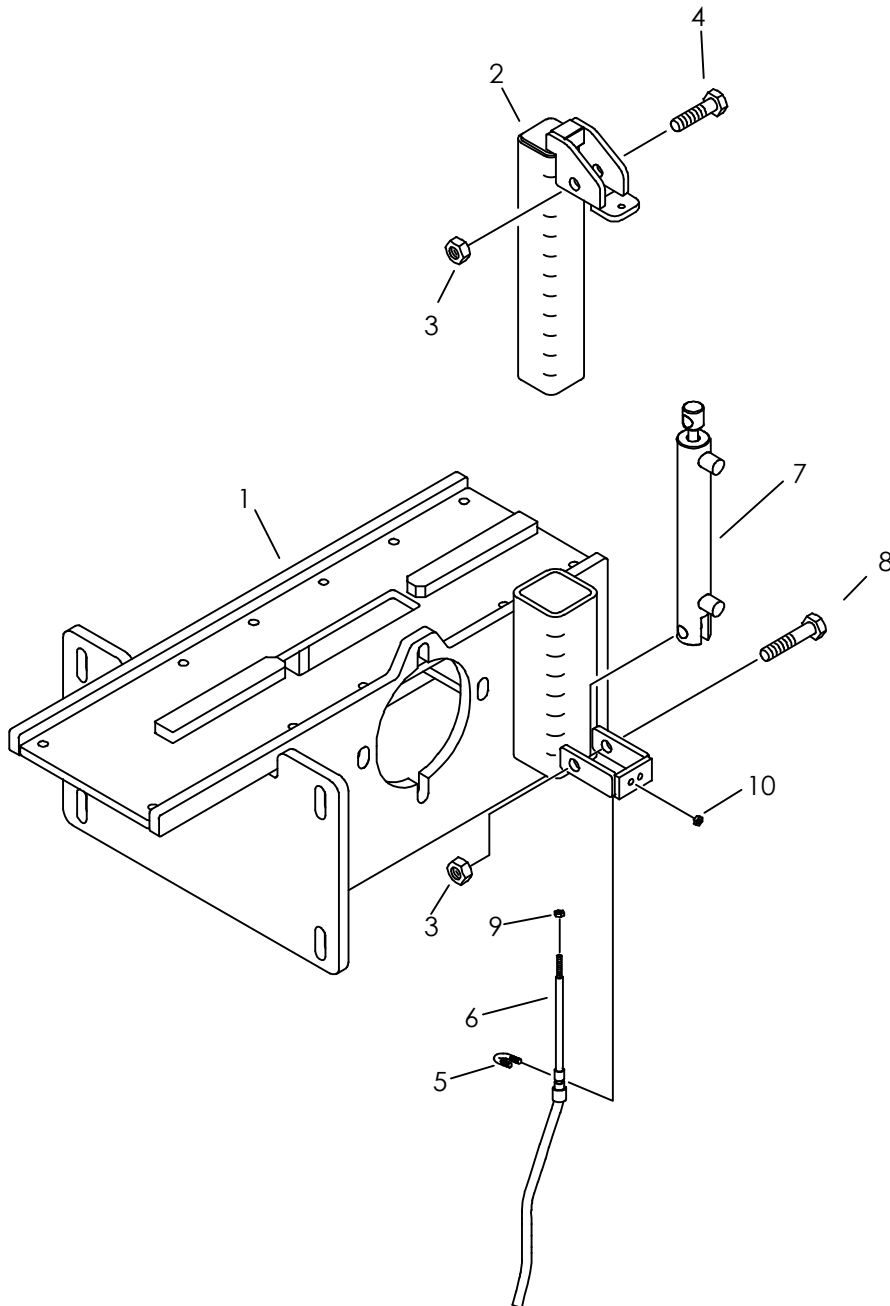

# SHUTTLE STOP

REF NO.	PART NUMBER	QTY	DESCRIPTION	REMARKS
1.	327-1063	-	FRONT SHUTTLE SUPPORT	SEE FOOTNOTE 1
2.	308-344	1	STOP TUBE WELDMENT	
3.	105-065	2	LOCKNUT (1/2-NC)	
4.	105-002	1	BOLT (1/2-NC X 2-1/4")	
5.	106-630	1	U-BOLT (#10-24 X 5/16")	
6.	196-286	1	CONTROL CABLE	
7.	150-727	1	CYL (1.0" X .500" X 4.0")	
8.	105-067	1	BOLT (1/2-NC X 2-3/4")	
9.	106-138	2	NUT (M5-0.80)	
10.	105-186	2	NUT (#10-24)	

NOT SHOWN:

FOOTNOTES:

1. USE ON 4020 WITH RACK & PINION

NOTE:

# SHUTTLE STOP INDICATOR

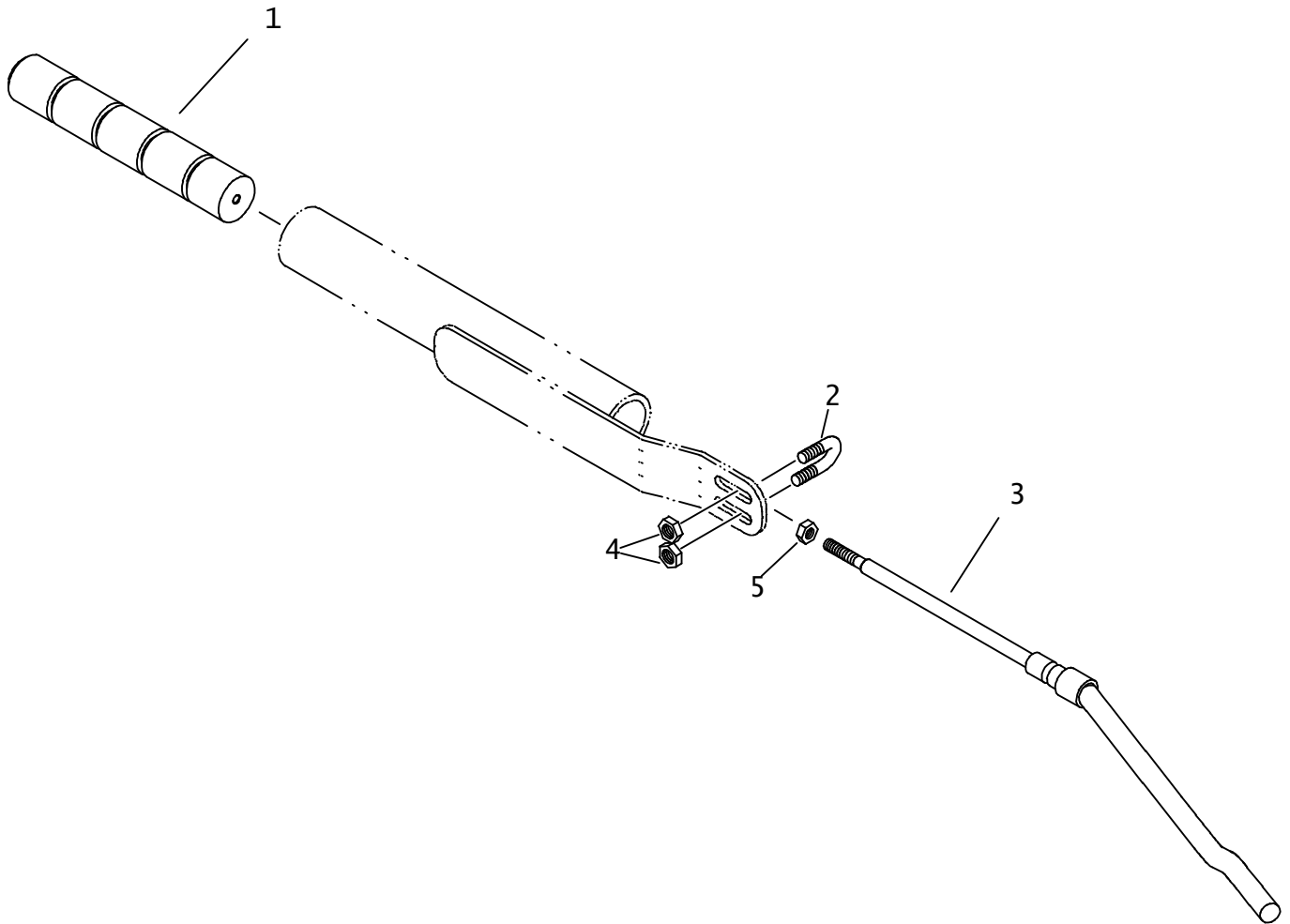



# SHUTTLE STOP INDICATOR

REF	PART			
NO.	NUMBER	QTY	DESCRIPTION	REMARKS
1.	258-032	1	ROW SELECT INDICATOR	
2.	106-630	1	U-BOLT (#10-24 X 5/16")	
3.	196-286	-	CONTROL CABLE	
4.	105-186	2	NUT (#10-24)	
5.	106-138	1	NUT (M5-0.80)	

NOT SHOWN:

FOOTNOTES:

NOTE:

# PIPE BOX AT42T2 PIPE

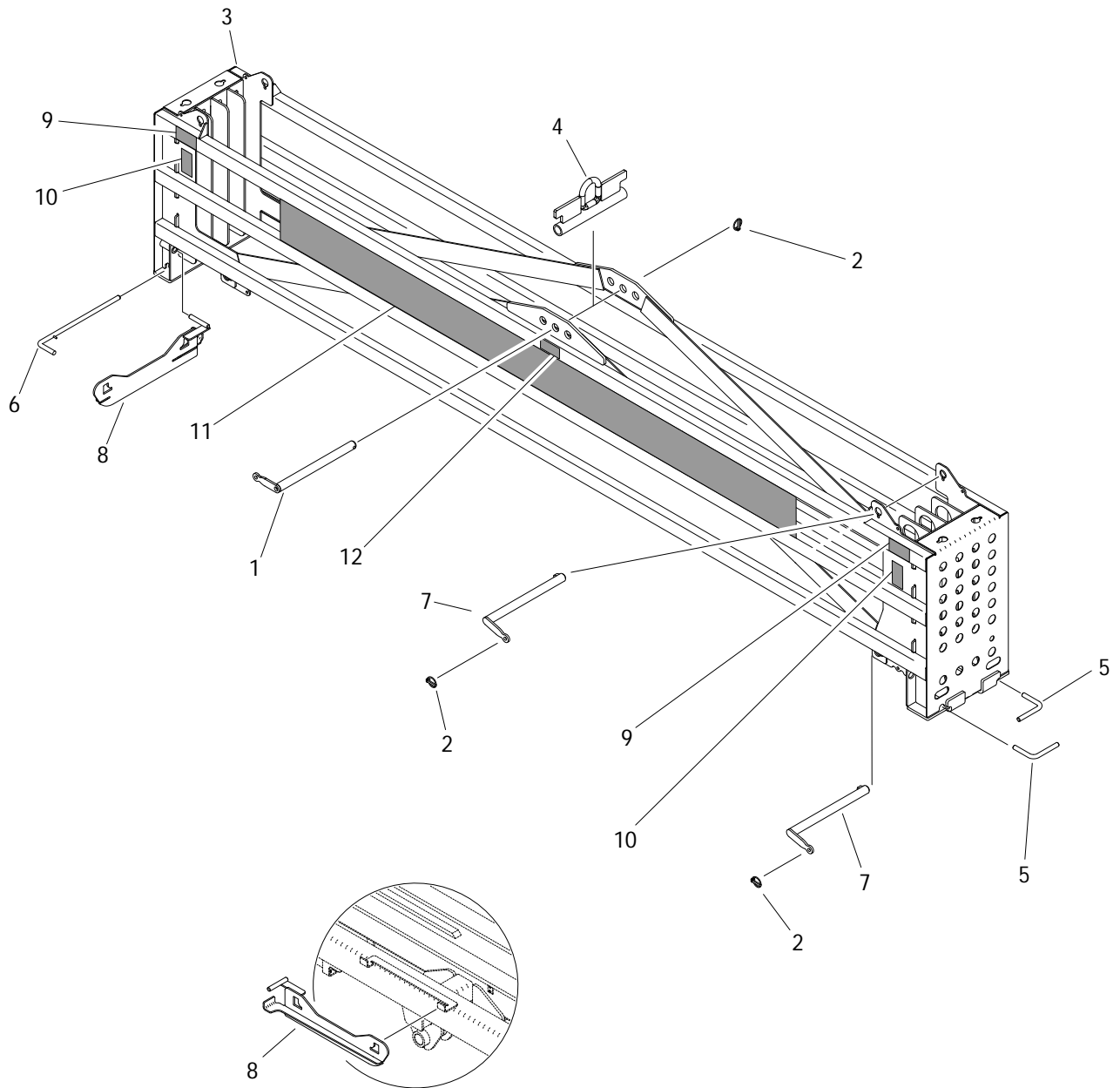
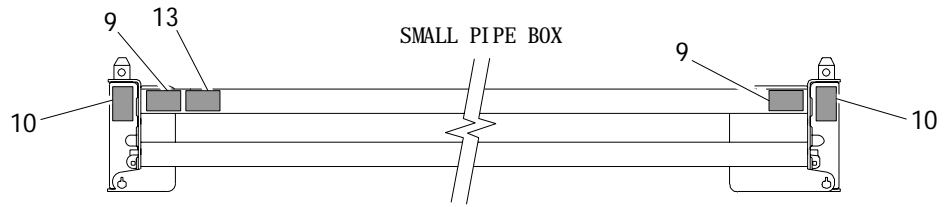

# PIPE BOX

## AT42T2 PIPE

REF NO.	PART NUMBER	QTY	DESCRIPTION	REMARKS
	315-982		LARGE PIPE BOX ASS'Y	PARTS ASSEMBLY, INCLUDES ITEMS 1-12
	315-981		SMALL PIPE BOX PARTS ASS'Y	PARTS ASSEMBLY, INCLUDES ITEMS 1-10 & #13.
1.	308-084	1	LIFT PIN	
2.	110-228	5	LYNCH PIN (7/16"X2")	
3.	313-939	1	AT4020 PIPE BOX (TALL)	PART OF 315-982
	313-955	1	AT4020 PIPE BOX (SHORT)	PART OF 315-981
4.	314-574	1	LIFT PIN BLOCK	
5.	178-445	2	REAR PIN	
6.	308-091	1	FRONT PIN	
7.	308-086	4	SUPPORT PIN	
8.	308-868	1	SINGLE PIPE GUIDE	
9.	275-326	4	WARNING CRUSHING WEIGHT	USE 701-326 IN ALL FOREIGN KITS
10.	275-184	4	WARNING MOVING PARTS	USE 701-184 IN ALL FOREIGN KITS
11.	273-596	1	JT4020AT PIPE BOX MODEL-ID	
12.	273-373	1	LG PIPE BOX WEIGHTS	PART OF 315-982
13.	273-372	1	SM PIPE BOX WEIGHTS	PART OF 315-981

FOOTNOTES

# PIPE BOX JT42T2 PIPE

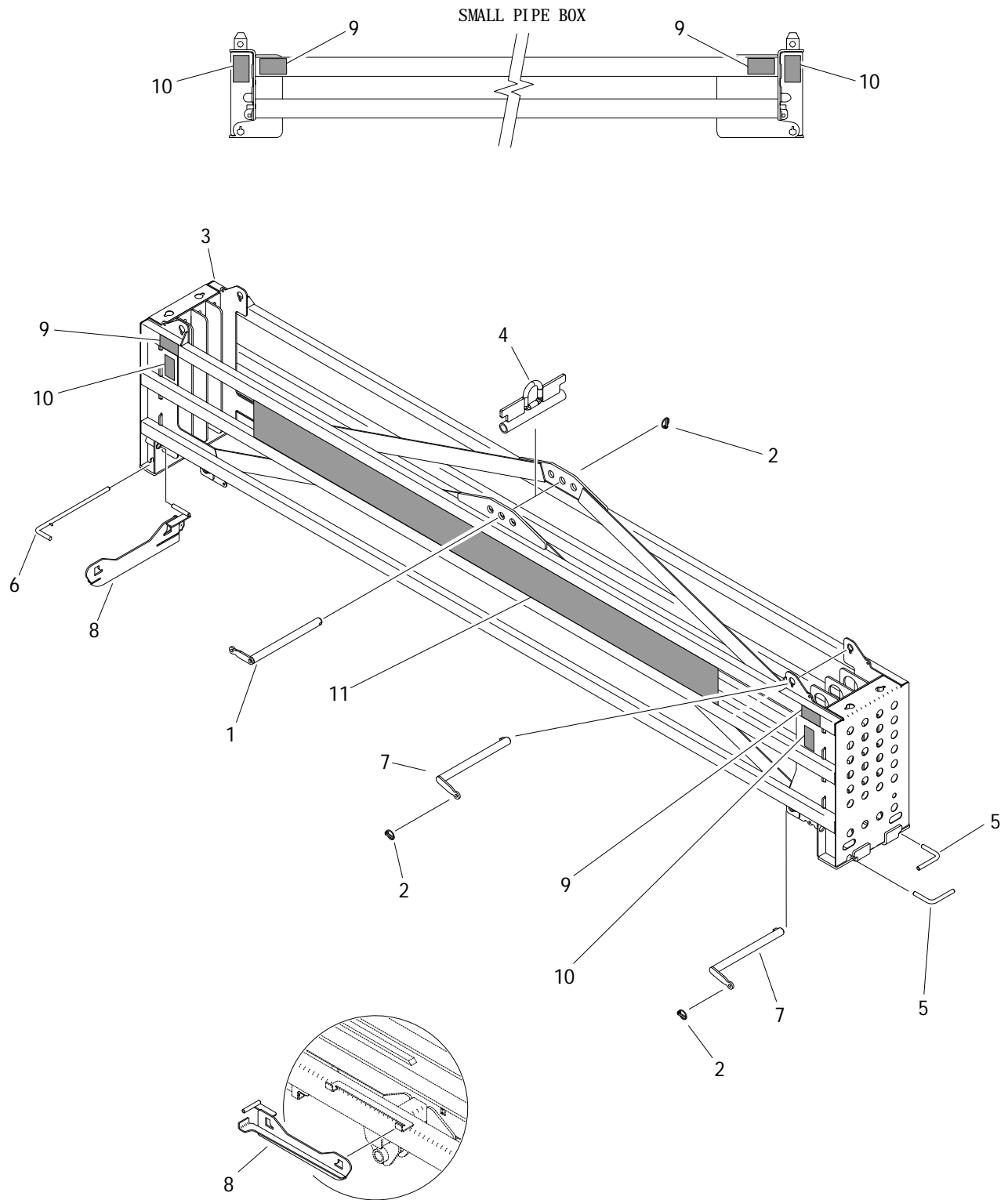

# PIPE BOX

## JT42T2 PIPE

REF NO.	PART NUMBER	QTY	DESCRIPTION	REMARKS
	310-361		LARGE PIPE BOX	PARTS ASSEMBLY, INCLUDES ITEMS 1-11
	309-912		SMALL PIPE BOX	PARTS ASSEMBLY, INCLUDES ITEMS 1-10
1.	308-084	1	LIFT PIN	
2.	110-228	5	LYNCH PIN (7/16"X2")	
3.	308-082	1	PIPE BOX	PART OF 310-361
	309-709	1	PIPE BOX	PART OF 309-912
4.	308-083	1	LIFT PIN BLOCK	
5.	178-445	2	REAR PIN	
6.	308-091	1	FRONT PIN	
7.	308-086	4	SUPPORT PIN	
8.	308-868	1	SINGLE PIPE GUIDE	
9.	275-326	4	WARNING CRUSHING WEIGHT	USE 701-326 IN ALL FOREIGN KITS
10.	275-184	4	WARNING MOVING PARTS	USE 701-184 IN ALL FOREIGN KITS
11.	273-538	1	MODEL ID W/ LOGOTYPE	

FOOTNOTES

# SHUTTLE GUARD

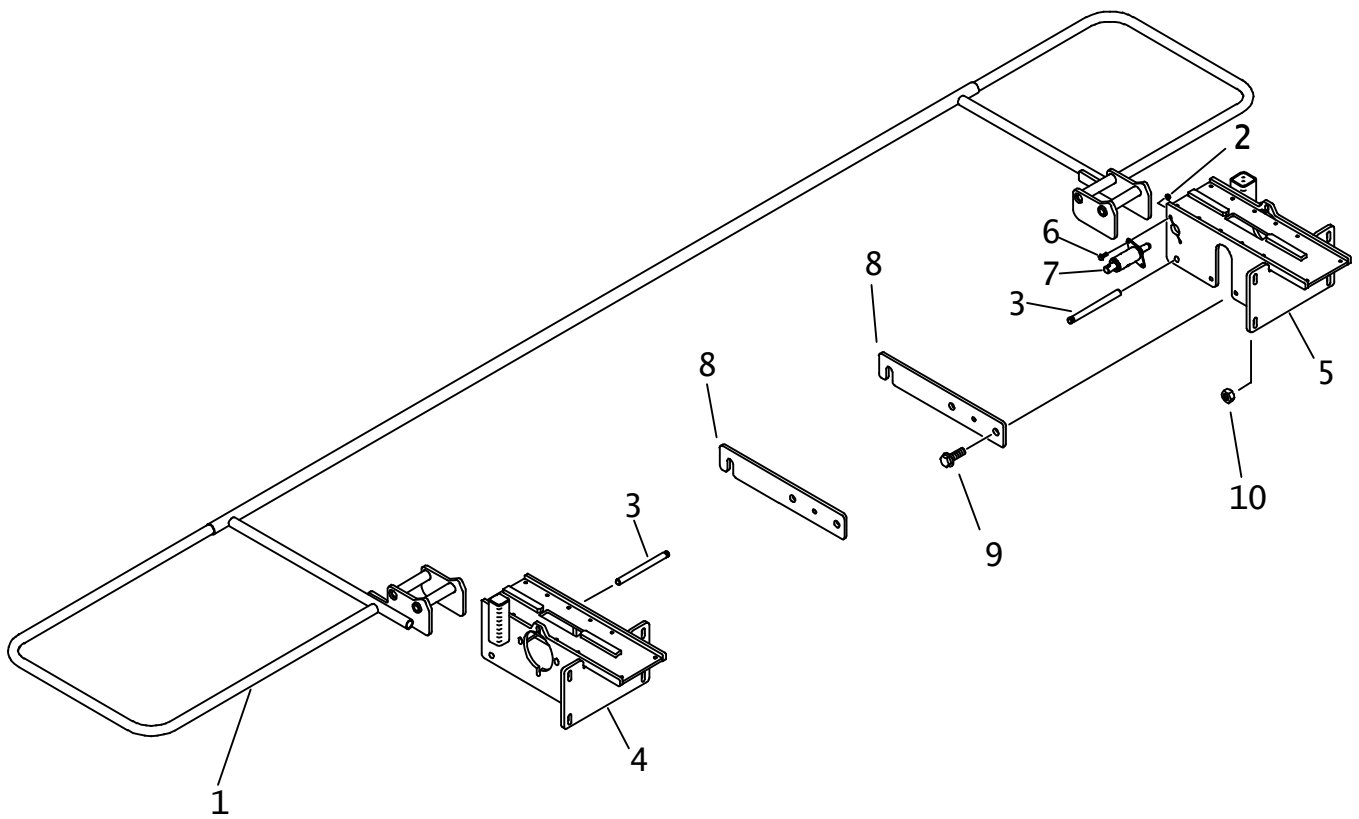

# SHUTTLE GUARD

REF NO.	PART NUMBER	QTY	DESCRIPTION	REMARKS
1.	313-968	1	SHUTTLE GUARD	
2.	106-561	2	LOCKNUT (M8-1.25,PRV TRQ,10.9)	
3.	178-415	2	PIN	
4.	307-592	-	REAR SHUTTLE SUPPORT	
	327-1064	-	REAR SHUTTLE SUPPORT	SEE FOOTNOTE I
5.	307-591	-	FRONT SHUTTLE SUPPORT	
	327-1063	-	FRONT SHUTTLE SUPPORT	SEE FOOTNOTE I
6.	106-992	2	FLG LK SCREW (M8-1.25 X 25MM)	
7.	354-571	1	GUARD LOCK PIN	
8.	307-619	2	PIN RETAINER	
9.	106-632	4	FLG LK SCR (M12-1.75X35MM,SER)	
10.	106-685	4	LOCKNUT(M12-1.75,PRV TRQ,10.9)	

NOT SHOWN:

FOOTNOTES:

USE ON 4020 WITH RACK AND PINION

NOTE:

# GUARD LOCK PIN

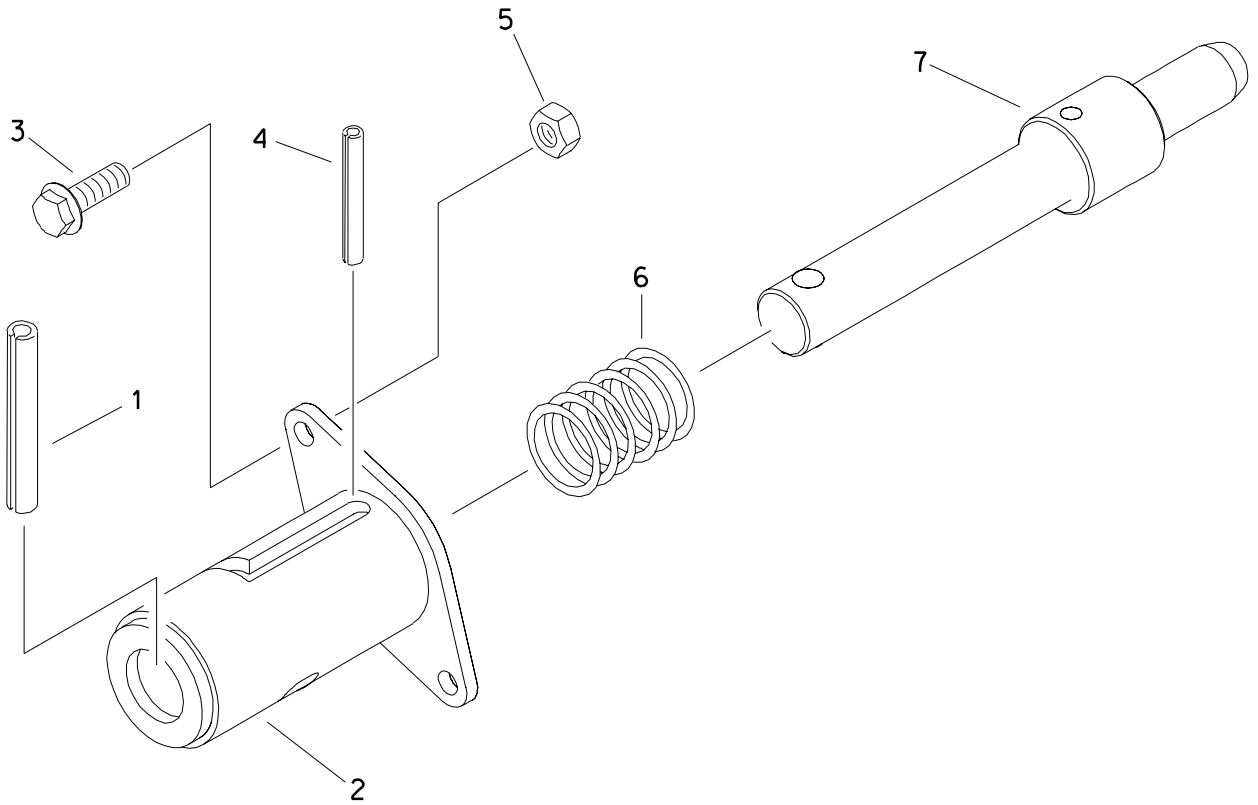



# GUARD LOCK PIN

REF NO.	PART NUMBER	QTY	DESCRIPTION	REMARKS
	354-571		GUARD LOCK PIN	INCL REF NO.'S 1 THRU 7
1.	105-561	1	ROLL PIN (3/8" X 2-3/4")	
2.	354-566	1	PIN HOUSING	
3.	106-992	2	FLG LK SCREW (M8-1.25 X 25mm)	
4.	105-503	1	ROLL PIN (1/4" X 2")	
5.	106-561	2	LOCKNUT (M8-1.25, PRV TRQ, 10.9)	
6.	115-560	1	COMPRESSION SPRING	
7.	178-095	1	LOCKOUT PIN	

FOOTNOTES



# **FLUID SYSTEMS**

# FLUID PUMP PLUMBING 70 GPM

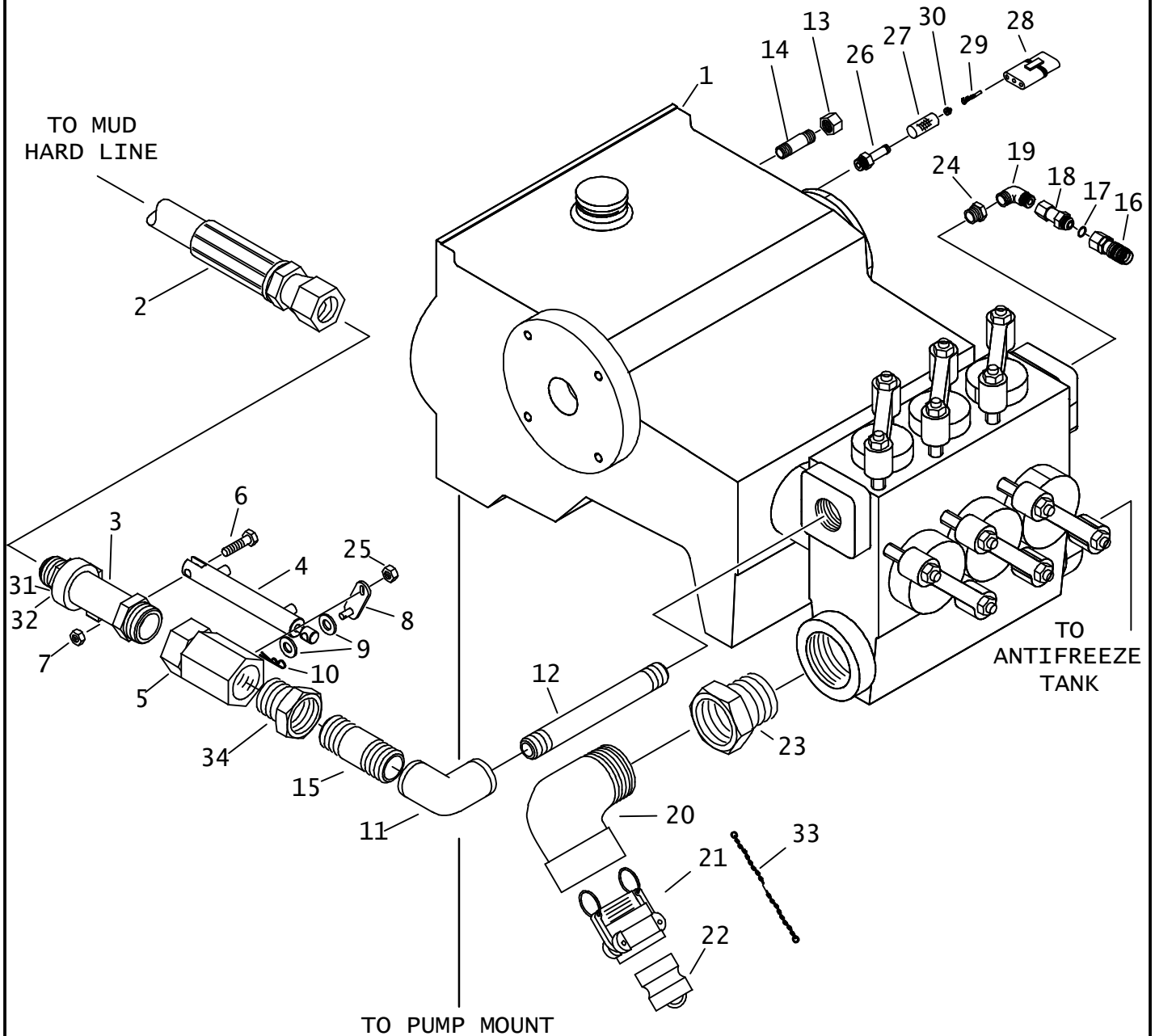

# FLUID PUMP PLUMBING

## 70 GPM

REF NO.	PART NUMBER	QTY	DESCRIPTION	REMARKS
1.	158-434	1	FLUID PUMP	
2.	157-419	1	HOSE (24JFX-240FX-32"-1250)	
3.	149-646	1	CYLINDER MOUNT (32N-24J)	
4.	151-211	1	CYL (1.25" X .50" X 4.00")	
5.	149-076	1	SHUT-OFF (32NF-32NF)	
	191-069	-	BALL VALVE REPAIR KIT	
6.	106-334	1	SCREW (M12-1.75 X 50MM)	
7.	106-685	1	LOCKNUT(M12-1.75,PRV TRQ,10.9)	
8.	306-388	1	VALVE ARM	
9.	106-391	2	WASHER (M12)	
10.	105-512	1	COTTER PIN (3/32" Xf")	
11.	515-679	1	ELBOW (20NF-20NF90)	
12.	157-418	1	NIPPLE (20N-8")	
13.	514-106	1	CAP (08NF)	
14.	115-161	1	NIPPLE (08N, 3-1/2")	
15.	115-207	1	NIPPLE (20N-2")	
16.	159-088	1	QDC BODY (08-08SF)	
17.	155-706	1	O-RING (908 D90)	
18.	156-732	1	CONNECTOR (08J-08O)	
19.	154-490	1	CONNECTOR (12N-08090)	
20.	114-004	1	STREET ELBOW (32N-32NF90)	
21.	159-485	1	FHC BODY (32-32N)	
22.	149-120	1	DUST PLUG (32 FHC)	
23.	114-024	1	REDUCER (40N-32NF)	
24.	155-208	1	REDUCER (20N-12NF)	
25.	106-018	1	JAM NUT (3/8-NF)	
26.	216-047	1	SPEED PICKUP	
27.	216-026	1	FLEX-GUARD (.250")	
28.	215-224	1	3-WAY WP MALE CONNECTOR	
29.	214-104	3	PACKARD MALE TERMINAL	
30.	157-645	3	WEATHER-PAC SEAL (2.80MM)	
31.	178-969	AR	SHIM (.062)	REFER TO SERVICE BULLETIN 052-596 FOR INSTALLATION
32.	178-970	AR	SHIM (.100)	REFER TO SERVICE BULLETIN 052-596 FOR INSTALLATION
33.	313-759	1	LANYARD	
34.	515-678	1	REDUCER (32N-20NF)	

NOT SHOWN:

FOOTNOTES:

NOTE:

1. REFER TO O-RING CHART (800-301) IN BACK OF THE BOOK FOR REPLACEMENT OF O-RINGS.

# MUD PUMP PLUMBING 120 GPM

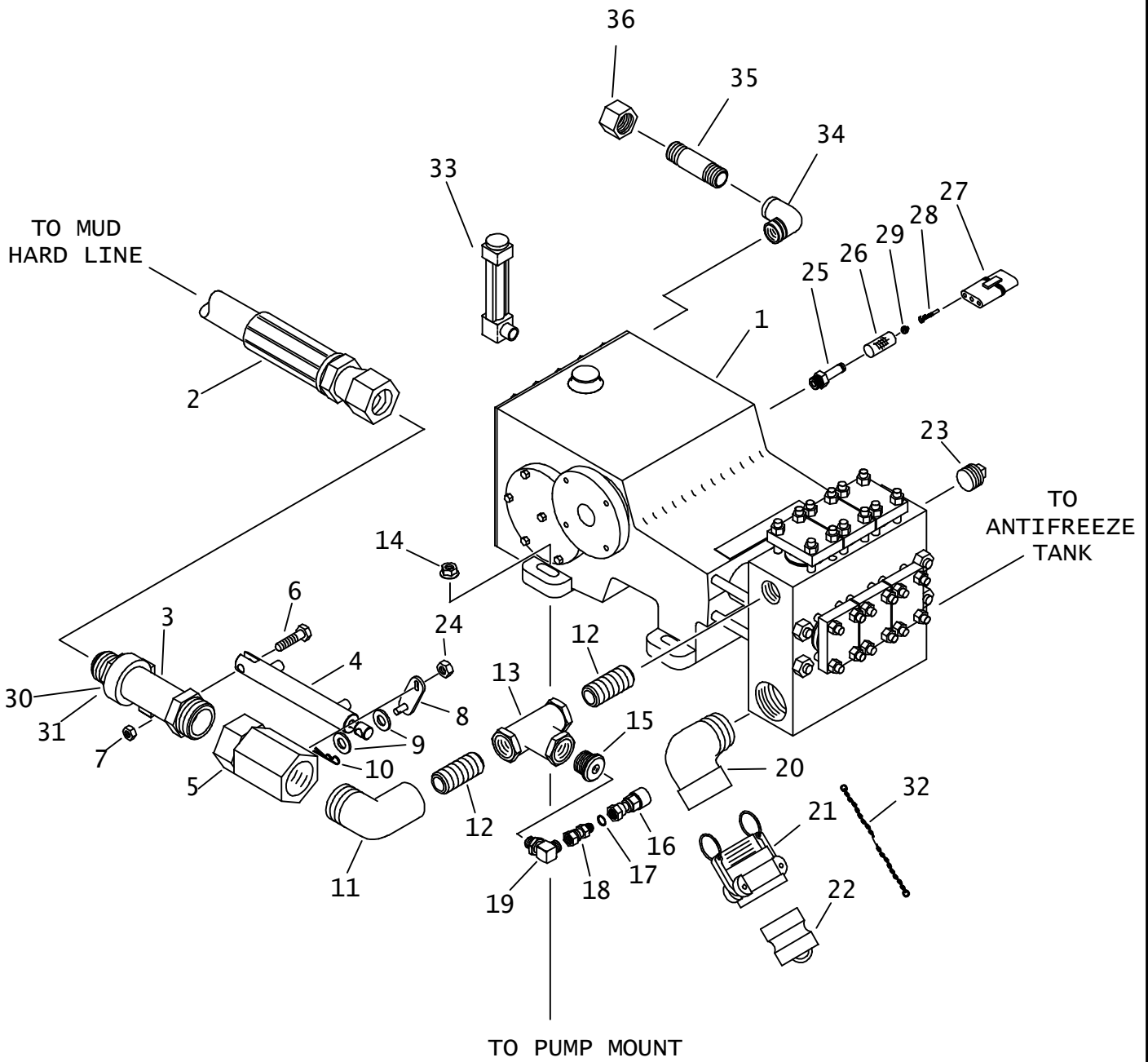

# MUD PUMP PLUMBING

## 120 GPM

REF NO.	PART NUMBER	QTY	DESCRIPTION	REMARKS
1.	149-396	1	MUD PUMP	INCLUDES REF NO. 45
2.	153-390	1	HOSE (24JFX-240FX-38"-1250)	
3.	149-646	1	CYLINDER MOUNT (32N-24J)	
4.	151-211	1	CYL (1.25" X .50" X 4.00")	
5.	149-1001	1	SHUT-OFF (32NF-32NF)	
	191-069	-	BALL VALVE REPAIR KIT	
6.	106-334	1	SCREW (M12-1.75 X 50MM)	
7.	106-685	1	LOCKNUT(M12-1.75,PRV TRQ,10.9)	
8.	306-388	1	VALVE ARM	
9.	106-391	2	WASHER (M12)	
10.	105-512	1	COTTER PIN (3/32" xf")	
11.	115-052	1	ELBOW (32N-32NF90)	
12.	515-680	2	NIPPLE (32N-2")	
13.	153-344	1	TEE (32NF-32NF-32NF)3000PSI	
14.	106-442	4	FLG LOCKNUT (M16-2.00,PRV TRQ)	
15.	115-064	1	REDUCER (32N-12NF)	
16.	159-088	1	QDC BODY (08-08SF)	
17.	155-706	1	O-RING (908 D90)	
18.	156-732	1	CONNECTOR (08J-080)	
19.	154-490	1	CONNECTOR (12N-08090)	
20.	114-017	1	STREET ELBOW (48N-48NF90)	
21.	514-386	1	FHC BODY (3-1/2" FHC X 3"NPT)	
22.	153-255	1	FHC PLUG (-56)	
23.	156-938	1	PLUG (32N)	
24.	106-018	1	JAM NUT (3/8-NF)	
25.	216-047	1	SPEED PICKUP	
26.	216-026	1	FLEX-GUARD (.250")	
27.	215-224	1	3-WAY WP MALE CONNECTOR	
28.	214-104	3	PACKARD MALE TERMINAL	
29.	157-645	3	WEATHER-PAC SEAL (2.80MM)	
30.	178-969	AR	SHIM (.062)	REFER TO SERVICE BULLETIN 052-596 FOR INSTALLATION
31.	178-970	AR	SHIM (.100)	REFER TO SERVICE BULLETIN 052-596 FOR INSTALLATION
32.	313-759	1	LANYARD	
33.	499-557	1	SIGHTGLASS	
34.	115-115	1	STREET ELBOW (08N-08NF90)	
35.	115-164	1	NIPPLE (08N-2")	
36.	514-106	1	CAP (08NF)	

NOT SHOWN:

FOOTNOTES:

NOTE:

1. REFER TO O-RING CHART (800-301) IN BACK OF THE BOOK FOR REPLACEMENT OF O-RINGS.

# MUD SYSTEM PLUMBING

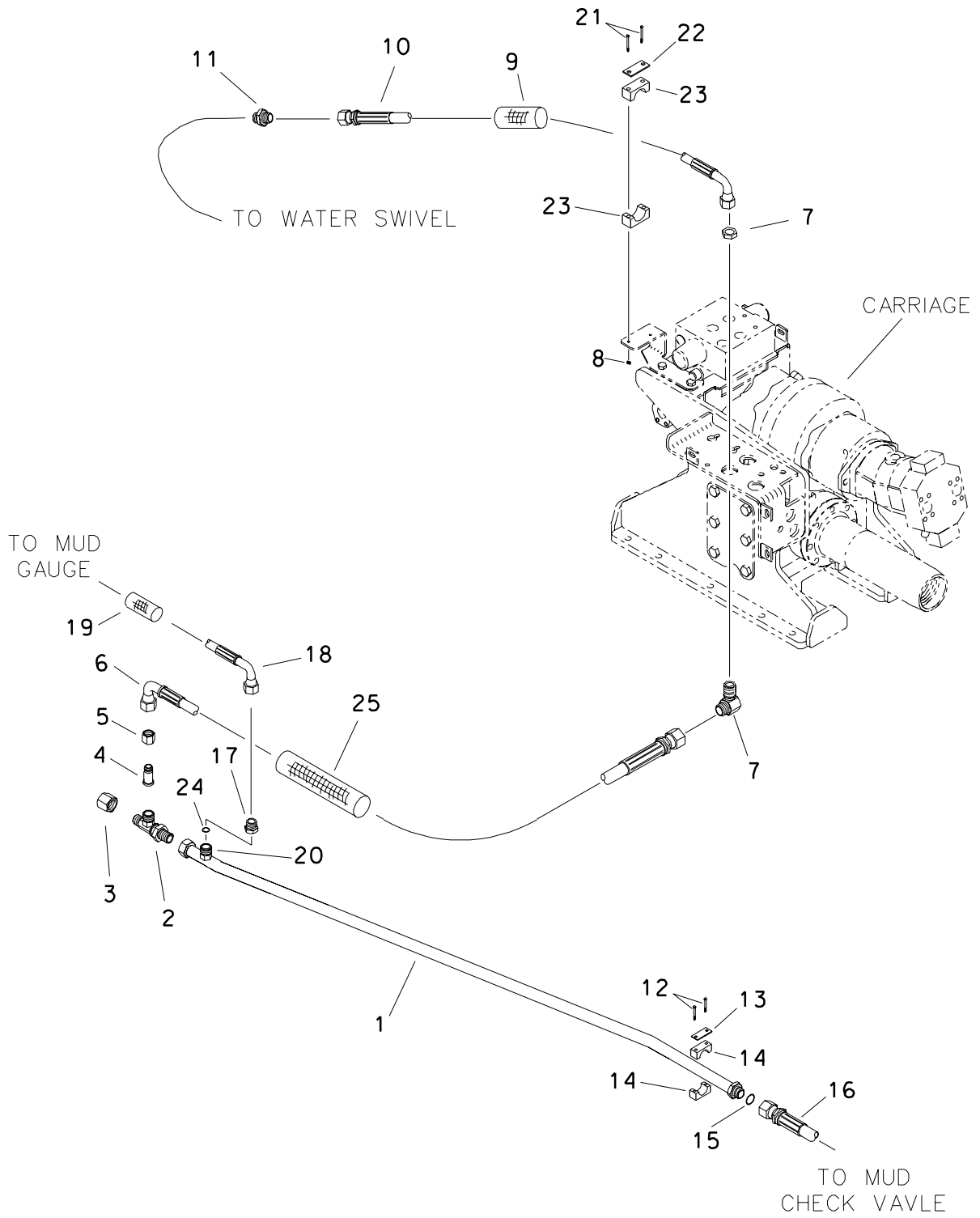



# MUD SYSTEM PLUMBING

REF NO.	PART NUMBER	QTY	DESCRIPTION	REMARKS
1.	156-892	1	HYDRAULIC LINE (-24)	
2.	514-413	1	BK RUN TEE (240-240-240BK)	
3.	149-083	1	CAP (24DF)	
4.	149-086	1	REDUCER NUT (24DF)	
5.	149-085	1	REDUCER STEM (200)	
6.	153-745	1	HOSE (200FX90S-213"-3000)	
7.	153-679	1	SP CONNECTOR (200-20090BK)	
8.	106-237	2	LOCKNUT (M6-1.00,PRV TRQ,NLK)	
9.	117-568	1	ABRASION SLEEVE (2.38" X 66")	
10.	153-433	1	HOSE (200FX90L-66"-3000)	
11.	153-392	1	CONNECTOR (-24N-200)	
12.	105-224	2	BOLT (1/4-NC X 2-1/2")	
13.	322-362	1	BACKUP SPACER	
14.	111-008	1	BOLT-ON CLAMP (1-1/2", SET)	
15.	157-130	1	O-RING (029 D90)	
16.	153-390	-	HOSE (24JFX-240FX-38"-1250)	120 GPM
	157-419	-	HOSE (24JFX-240FX-32"-1250)	70 GPM
17.	154-373	1	REDUCER (040-060F)	
18.	515-137	1	HOSE (040FX90-90"-3000)	
19.	117-209	1	ABRASION SLEEVE (1.00" X 90")	
20.	157-038	1	O-RING (012 D90)	
21.	107-151	2	SCREW (M6-1.00 X 85MM)	
22.	110-973	1	COVER PLATE	
23.	110-970	1	CLAMP (2.00") PAIR	
24.	157-038	1	O-RING (012 D90)	
25.	117-705	1	ABRASION SLEEVE (2.38" X 78")	

FOOTNOTES

# FLUID PUMP (FLUID END) 120 GPM

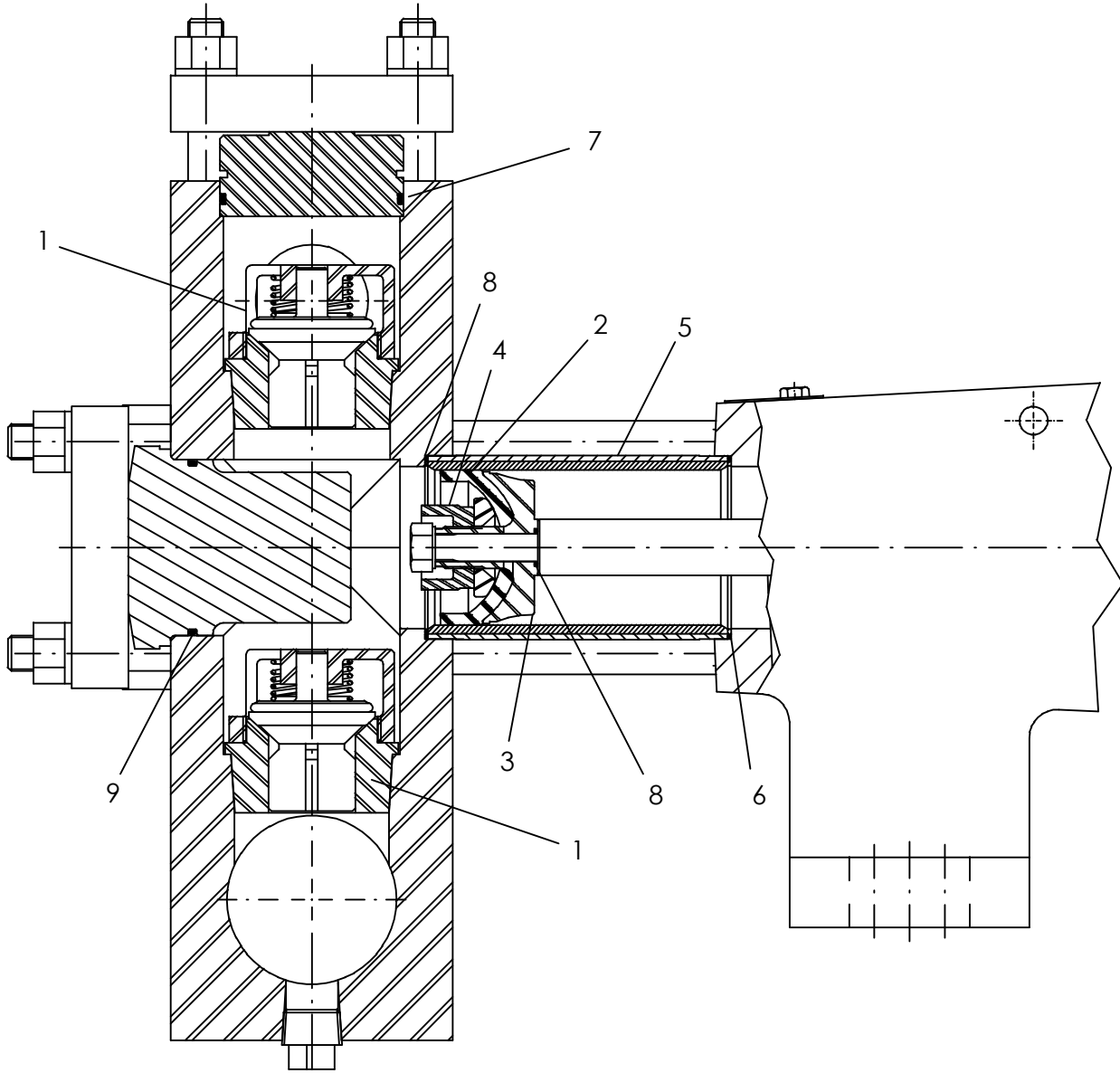

# FLUID PUMP (FLUID END)

## 120 GPM

REF NO.	PART NUMBER	QTY	DESCRIPTION	REMARKS
1.	191-054	1	VALVE REPAIR KIT	INCLUDES PARTS FOR ALL VALVES IN PUMP. SEE FOOTNOTE 1.
2.	191-1008	1	PACKING REPAIR KIT	
3.	499-041	3	CUP HOLDER	
4.	499-039	3	PLUNGER NUT	
5.	499-089	3	CYL (2.750")	
6.	499-042	3	CYLINDER GASKET	
7.	157-191	3	O-RING (233 D90)	
8.	157-202	3	O-RING (042 D70)	
9.	157-031	3	O-RING (234 D90)	

NOT SHOWN:

**FOOTNOTES:**

KIT INCLUDES ALL PARTS, O-RINGS, GASKETS AND PLUNGER NUTS TO REBUILD ALL CYLINDERS.

NOTE:

# FLUID PUMP (FLUID END) 70 GPM

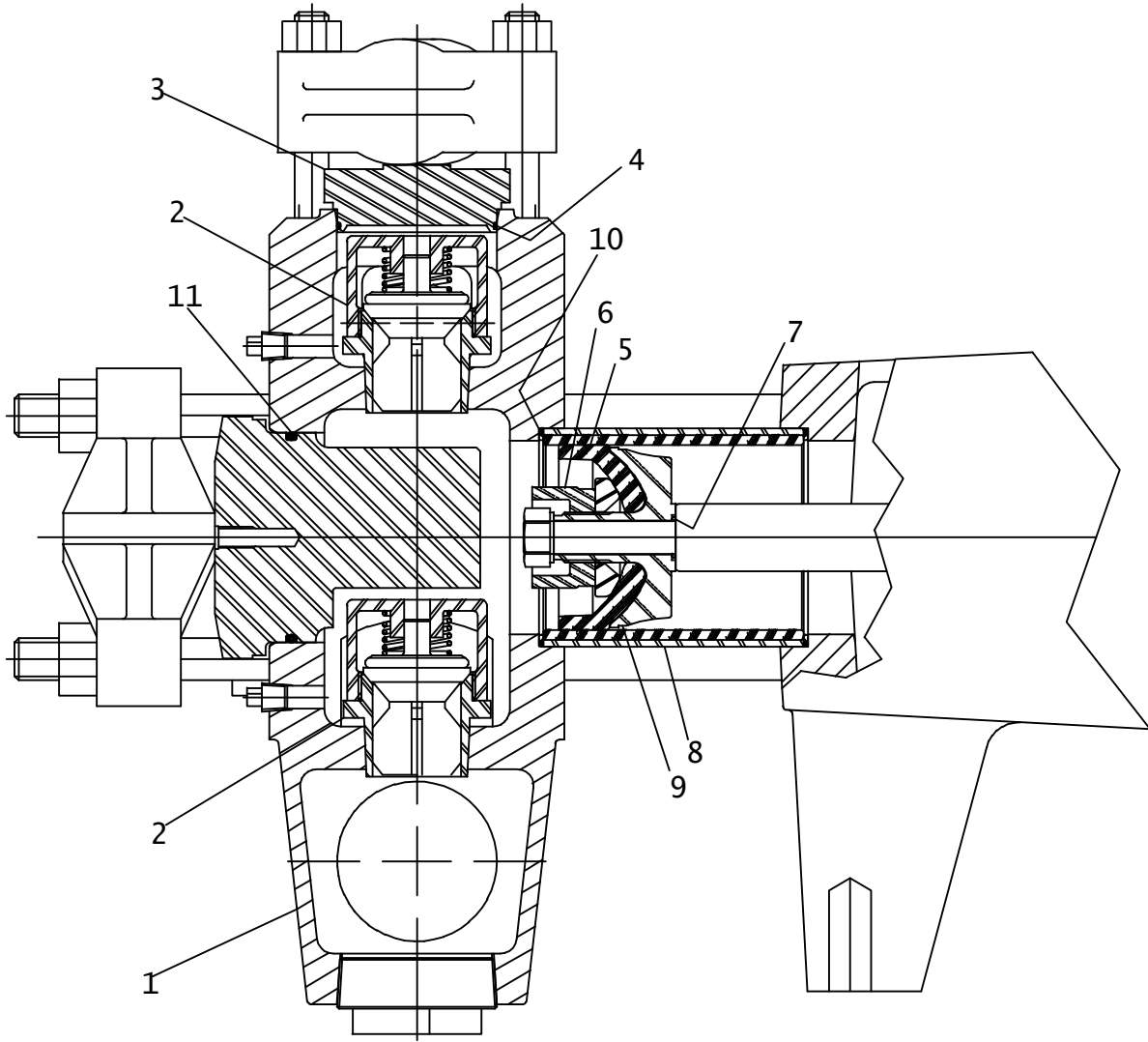

# FLUID PUMP (FLUID END)

## 70 GPM

REF NO.	PART NUMBER	QTY	DESCRIPTION	REMARKS
	158-434		FLUID PUMP	INCL REF NO'S 1 - 11
	197-062		REBUILT 158-434 MUD PUMP	INCL REF NO'S 1 - 11
	158-017		MUD PUMP	
	190-783		L1122 A/R VALVE SERVICE KIT	INCL REF NO'S 2, 4 & 11
1.	499-035	1	FLUID CYLINDER	
2.	499-036	6	VALVE	
3.	499-037	3	VALVE COVER	
4.	157-190	3	O-RING (139 D90)	
5.	191-1008	1	PACKING REPAIR KIT	SEE FOOTNOTE 1
6.	499-039	3	PLUNGER NUT	
7.	155-778	3	O-RING (014 D70, VITON)	
8.	499-040	3	CYLINDER (2-3/4")	
9.	499-041	3	CUP HOLDER	
10.	499-042	6	CYLINDER GASKET	
11.	157-191	3	O-RING (233 D90)	

NOT SHOWN:

FOOTNOTES:

KIT INCLUDES ALL PARTS, O-RINGS, GASKETS AND PLUNGER NUTS TO REBUILD ALL CYLINDERS

NOTE:

# FLUID PUMP (POWER END)

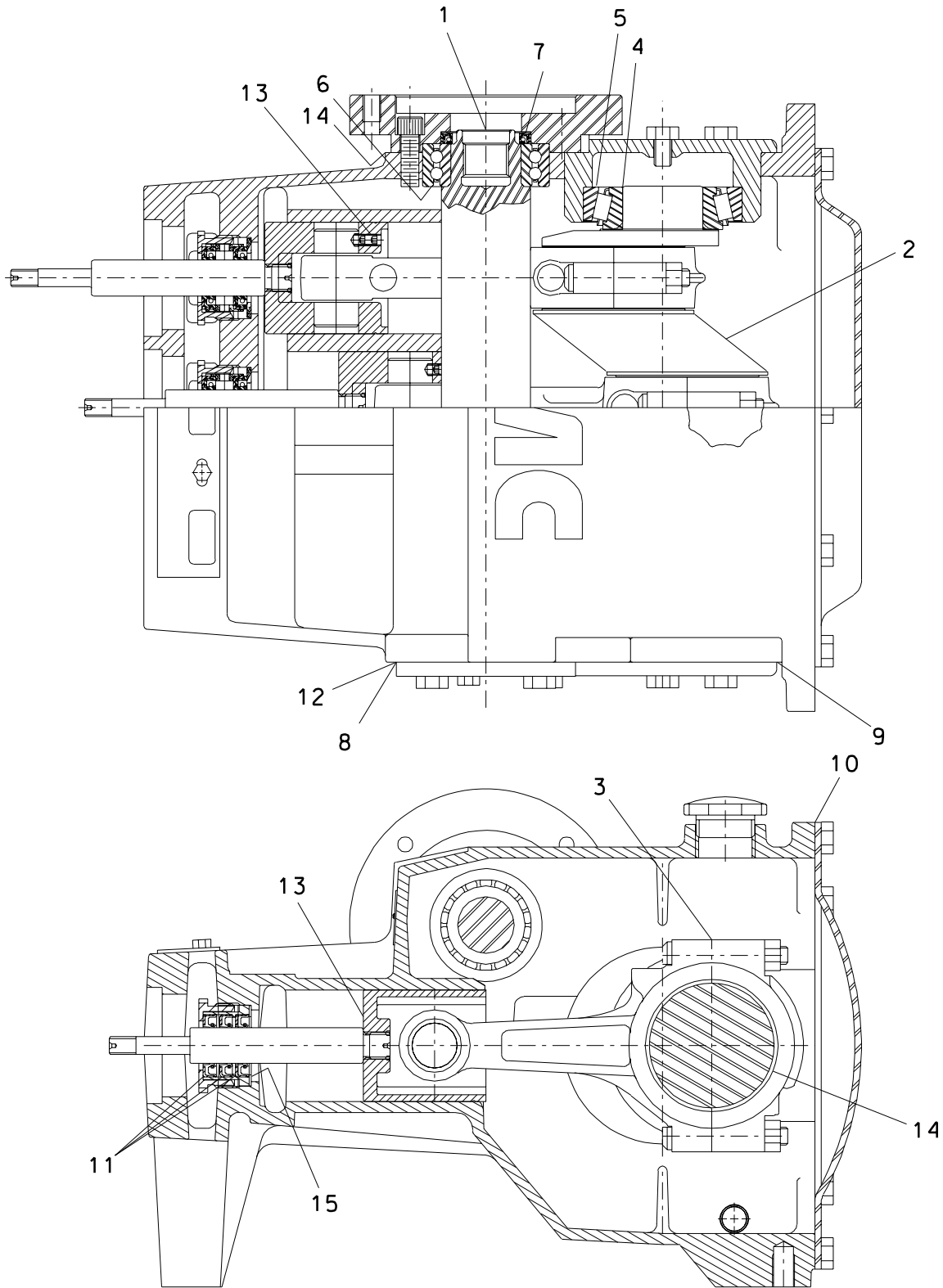

# FLUID PUMP (POWER END)

REF NO.	PART NUMBER	QTY	DESCRIPTION	REMARKS
	158-434		FLUID PUMP	INCL REF NO'S 1 - 15
	197-062		REBUILT 158-434 FLUID PUMP	
	158-017		FLUID PUMP	INCL REF NO'S 1 - 15
1.	499-075	1	PINION SHAFT	
2.	499-076	1	ECCENTRIC GEAR	
3.	499-077	3	CONNECTING ROD	
4.	126-192	2	TAPERED BEARING (2.250")	
5.	126-193	2	TAPERED RACE (4.437")	
6.	125-144	2	BALL BEARING (1.968")	
7.	157-738	1	OIL SEAL, PINION SHAFT	
8.	165-884	2	GASKET, PINION CAP	
9.	165-885	2	GASKET, BEARING CAP	
10.	165-886	1	GASKET, BACKCOVER	
11.	157-739		INTERNAL SEAL (1.125")	
12.	165-887	6	SHIM	
13.	499-078	3	CROSSHEAD	
14.	126-194	6	ROD BEARING (PAIR)	
15.	165-888	3	SEAL HOLDER - GASKET	

FOOTNOTES

# PUMP MOUNT

70GPM & 120GPM FLUID PUMPS

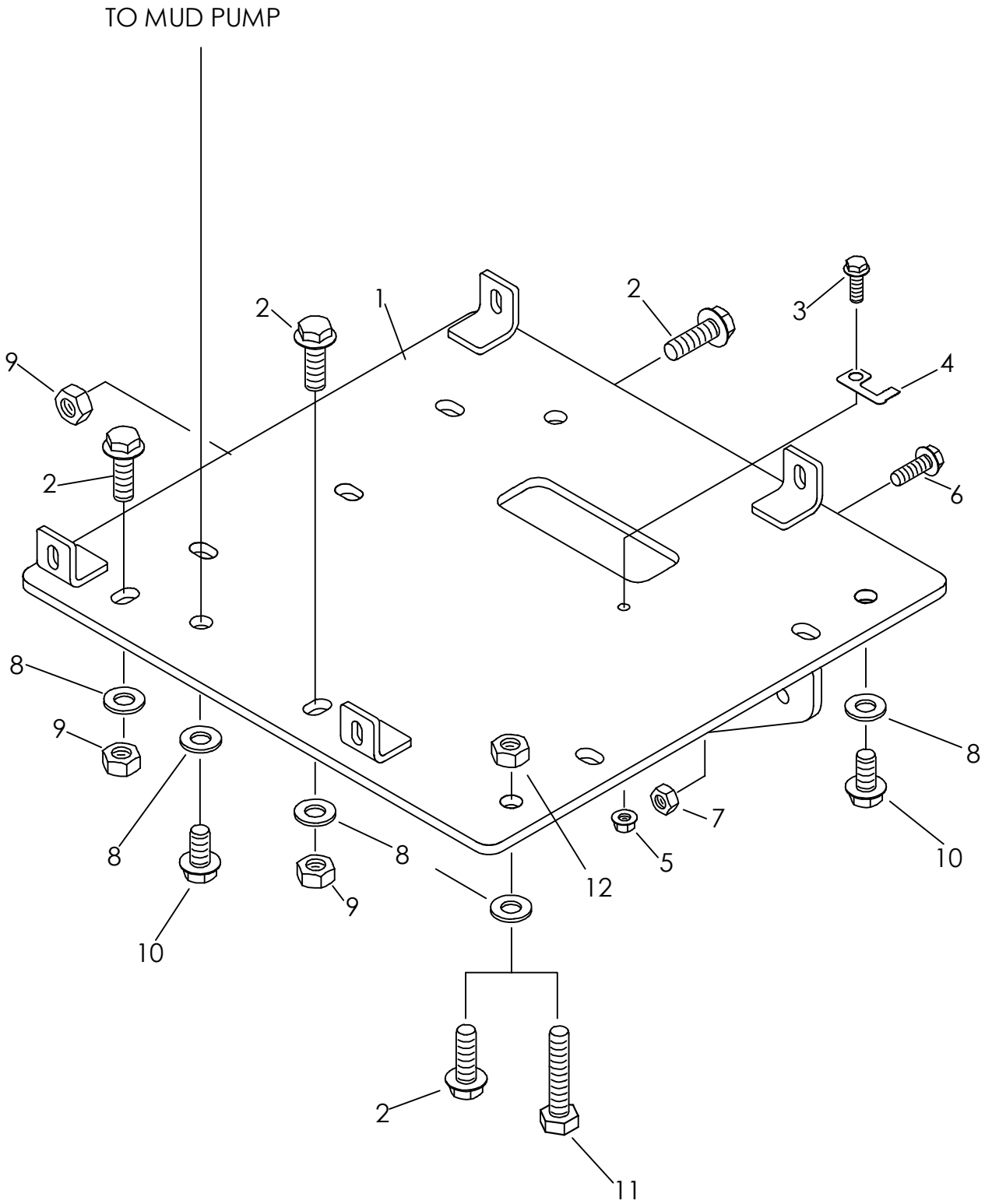



## PUMP MOUNT

### 70GPM & 120GPM FLUID PUMPS

REF NO.	PART NUMBER	QTY	DESCRIPTION	REMARKS
1.	319-544	1	PUMP MOUNT	USED WITH 70 GPM & 120 GPM PUMPS
2.	106-470	AR	FLG SCREW (M16-2.00 X 40MM)	USE 4 W/70 GPM & 3 W/120 GPM PUMPS
3.	106-381	1	FLG LK SCREW (M8-1.25 X 25MM)	USED WITH 70 GPM & 120 GPM PUMPS
4.	211-041	1	CONNECTOR CLIP	USED WITH 70 GPM & 120 GPM PUMPS
5.	106-386	1	FLG LOCKNUT (M8-1.25)	USED WITH 70 GPM & 120 GPM PUMPS
6.	106-632	1	FLG LK SCR (M12-1.75X35MM,SER)	USED WITH 70 GPM & 120 GPM PUMPS
7.	106-685	1	LOCKNUT(M12-1.75,PRV TRQ,10.9)	USED WITH 70 GPM & 120 GPM PUMPS
8.	106-398	8	WASHER (M16, HARDENED)	USED WITH 70 GPM PUMP
	105-398	6	WASHER (1/2")	USED WITH 120 GPM PUMP
9.	106-545	3	LOCKNUT (M16-2.0,PRV TRQ,10.9)	USED WITH 70 GPM & 120 GPM PUMPS
10.	105-400	5	BOLT (5/8-NC X 1-1/4")	USED WITH 70 GPM PUMP
	106-341	3	SCREW (M16-2.0 X 70MM)	USED WITH 120 GPM PUMP
11.	108-100	1	SCREW (M16-2 X 80MM, 10.9)	USED WITH 120 GPM PUMP
12.	106-545	1	LOCKNUT (M16-2.0,PRV TRQ,10.9)	USED WITH 70 GPM PUMP

NOT SHOWN:

FOOTNOTES:

NOTE:

# FLUID PUMP (POWER END)

L1122, L1622

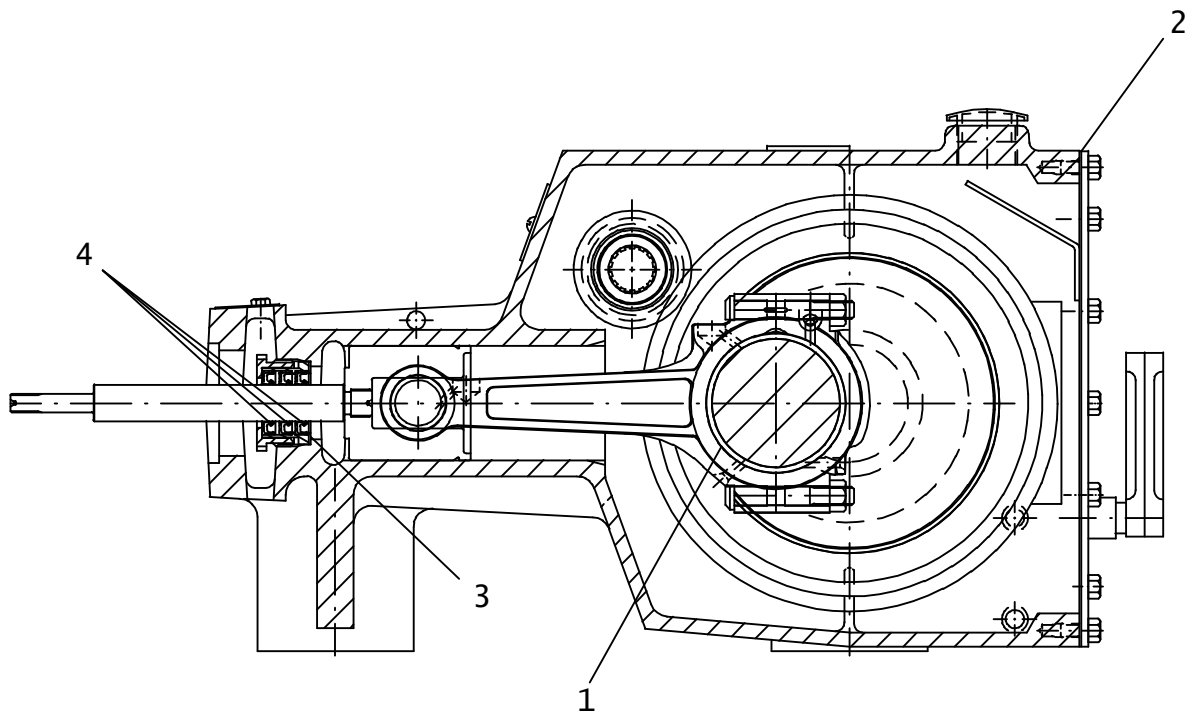
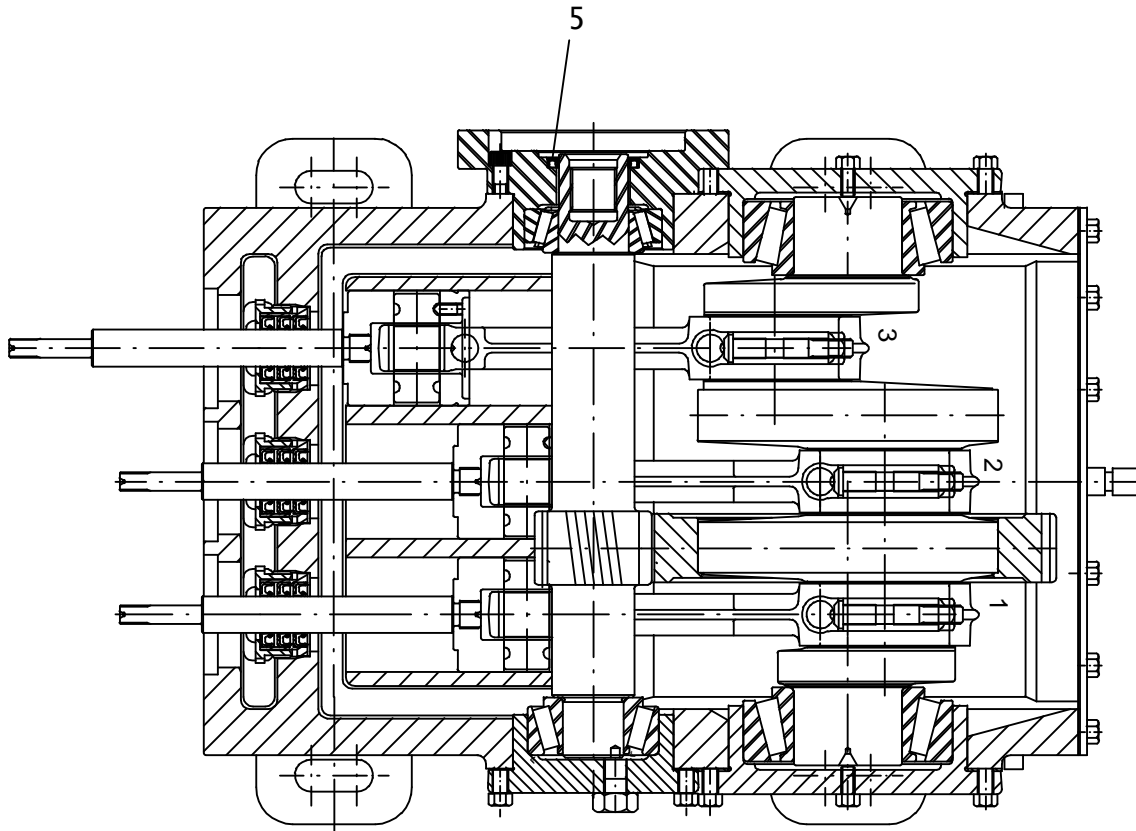

## FLUID PUMP (POWER END)

L1122, L1622

REF NO.	PART NUMBER	QTY	DESCRIPTION	REMARKS
1.	126-194	3	ROD BEARING (PAIR)	CONNECTING ROD USE 3 PAIR PER PUMP
2.	165-896	1	BACK COVER GASKET	
3.	165-888	3	SEAL HOLDER GASKET	
4.	157-739	9	INTERNAL SEAL	PLUNGER ROD
5.	157-742	1	INTERNAL SEAL	ADAPTER

NOT SHOWN:

FOOTNOTES:

NOTE:

# ANTIFREEZE TANK

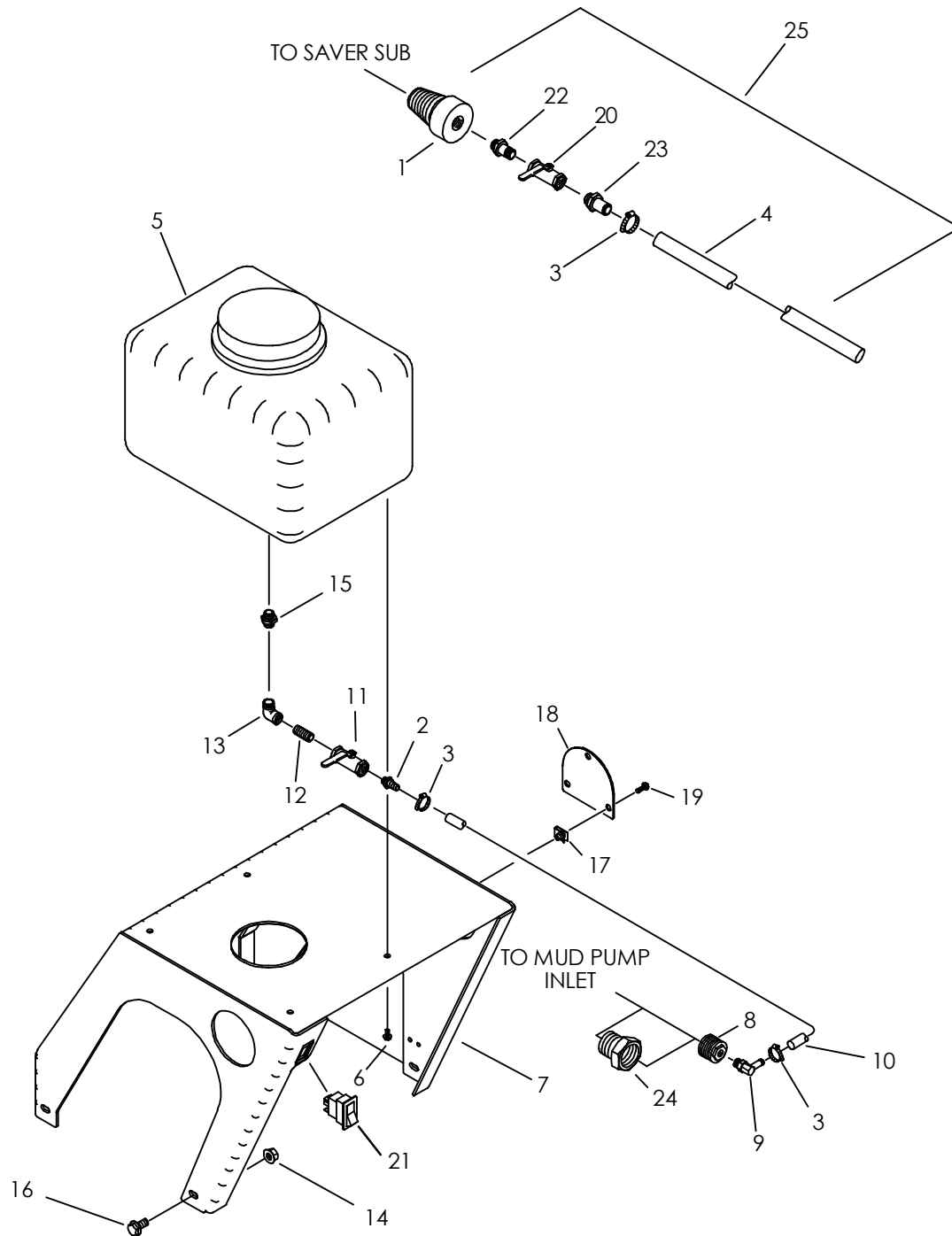

## ANTIFREEZE TANK

REF NO.	PART NUMBER	QTY	DESCRIPTION	REMARKS
1.	211-097	1	ADAPTER	USE WITH AT PIPE (OD = 4.125")
	194-244	1	ADAPTER	USE WITH JTMI PIPE (OD = 3.50")
2.	155-136	1	S/O COUPLER (16N-16H)	
3.	110-353	3	WORM CLAMP (3/4" TO 1-1/2")	
4.	116-897	AR	BULK TUBING (1", SOLD PER 1')	USE 1 @ 72"
5.	364-515	1	WATER TANK (8 GAL)	
	190-053	-	POLY-PATCH TANK REPAIR KIT	
	110-707		TANK CAP (96NF)	
6.	105-836	4	FLG LOCK BOLT (1/4-NC X 1/2")	
7.	319-546	1	TANK MOUNT	
8.	115-085	1	REDUCER (32N-16NF)	SEE FOOTNOTE 1
	153-335	1	REDUCER BUSHING (48N-16NF)	SEE FOOTNOTE 2
9.	155-137	1	S/O COUPLER (16N-16H90)	
10.	116-460	AR	BULK HOSE (1", SOLD PER 1')	USE 1 @ 20" FOR 70 GPM PUMP
	116-460	AR	BULK HOSE (1", SOLD PER 1')	USE 1 @ 22" FOR 70 GPM PUMP
11.	514-318	1	SHUT-OFF (16NF-16NF)	ROTATE HANDLE TO SIDE, POINTED DOWN.
12.	114-011	1	ALL THREAD (16N)	
13.	115-440	1	STREET ELBOW (16N-16NF90)	
14.	106-387	4	FLG LOCKNUT (M10-1.50)	
15.	514-400	1	BK CONN (16NF-16NFBK, NYL)	
16.	106-164	4	FLG LK SCREW (M10-1.50 X 30MM)	
17.	106-551	3	CLIP NUT (M8-1.25)	
18.	310-694	1	COVER	
19.	106-991	3	FLG LK SCREW (M8-1.25 X 20MM)	
20.	120-074	1	SHUT-OFF VALVE (16S-16S)	
21.	217-907	1	ROCKER SWITCH (DPDT) ON-ON	
22.	514-121	1	CONNECTOR (16N-16S)	
23.	514-088	1	S/O COUPLER (16S-16H)	
24.	114-024	1	REDUCER (40N-32NF)	SEE FOOTNOTE 1
25.	101-134	1	ANTI-FREEZE RECLAIMER	USE W/ AT PIPE; INCLUDES REF. #S 1, 3, 4, 20, 22, 23
	101-137	1	ANTI-FREEZE RECLAIMER	USE W/ JT PIPE; INCLUDES REF. #S 1, 3, 4, 20, 22, 23

### NOT SHOWN:

153-255 FHC PLUG (-56)

USE TO PLUG FHC FEMALE INLET ON MUD PUMP.

### FOOTNOTES:

1. USED WITH I58-434 (70 GPM MUD PUMP)
2. USED WITH I49-396 (120 GPM MUD PUMP)

### NOTE:

REFER TO O-RING CHART (800-301) IN BACK OF THE BOOK FOR REPLACEMENT OF O-RINGS.

## WASH WAND

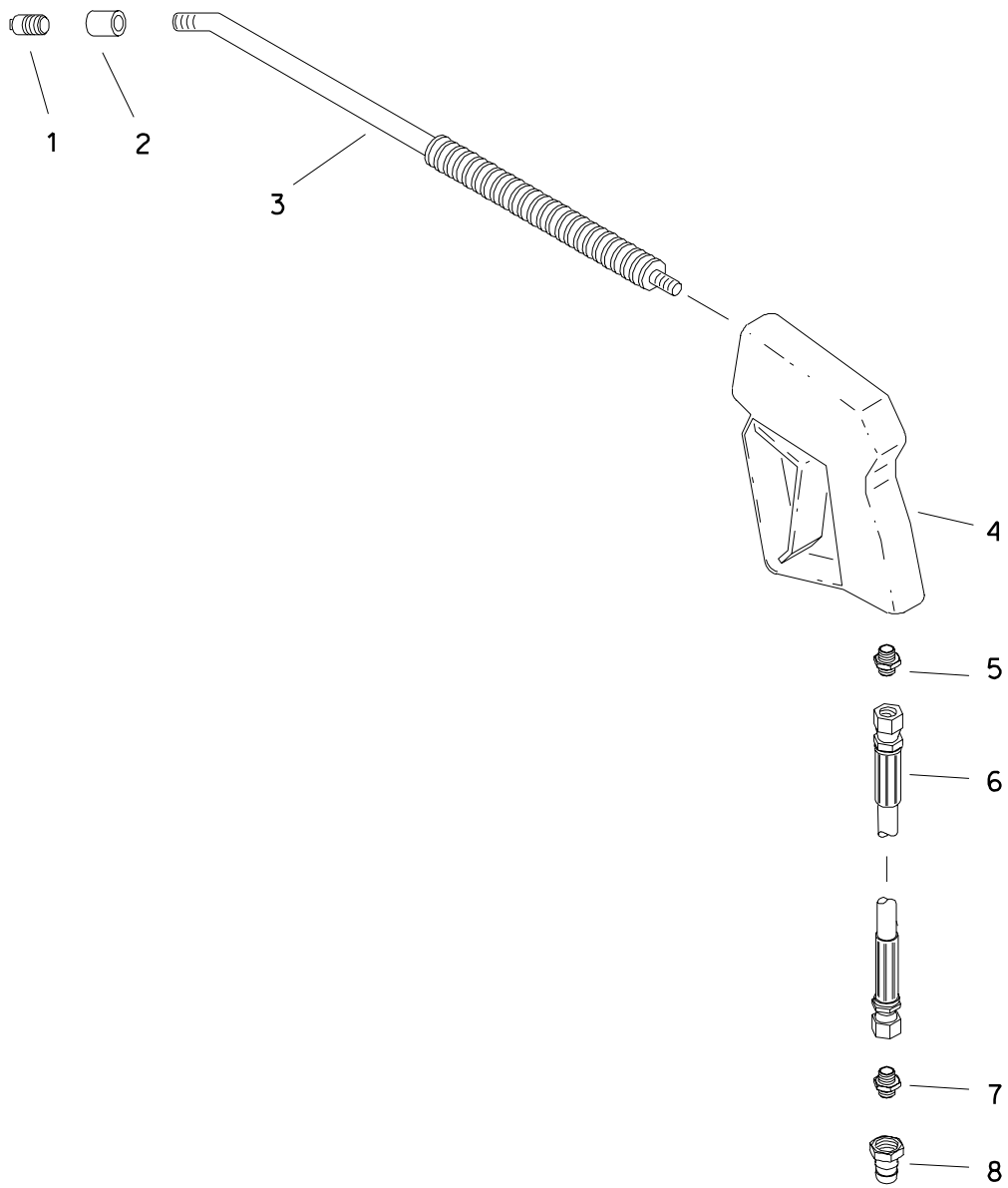

# WASH WAND

REF NO.	PART NUMBER	QTY	DESCRIPTION	REMARKS
1.	155-242	1	NOZZLE (04N, ORF .047", TC)	
2.	115-170	1	COLLAR (04NF)	
3.	259-353	1	WASH WAND (04N-36")	
4.	259-197	1	SPRAY GUN	
	190-179		SEAL REPAIR KIT	RHINO INDUSTRIES (190-938 CHAPPELL SUPPLY)
5.	514-141	1	CONNECTOR (06N-080)	
6.	154-753	1	HOSE (08OFX-600"-3000)	
7.	154-233	1	CONNECTOR (08S-080)	
8.	159-089	1	QDC ADAPTER (08-08SF)	
	190-186		SEAL REPAIR KIT	

FOOTNOTES

NOTE  
REFER TO O-RING CHART (800-301) IN BACK OF THE BOOK FOR REPLACEMENT OF O-RINGS.





# HYDRAULICS

# OIL COOLER HYDRAULICS

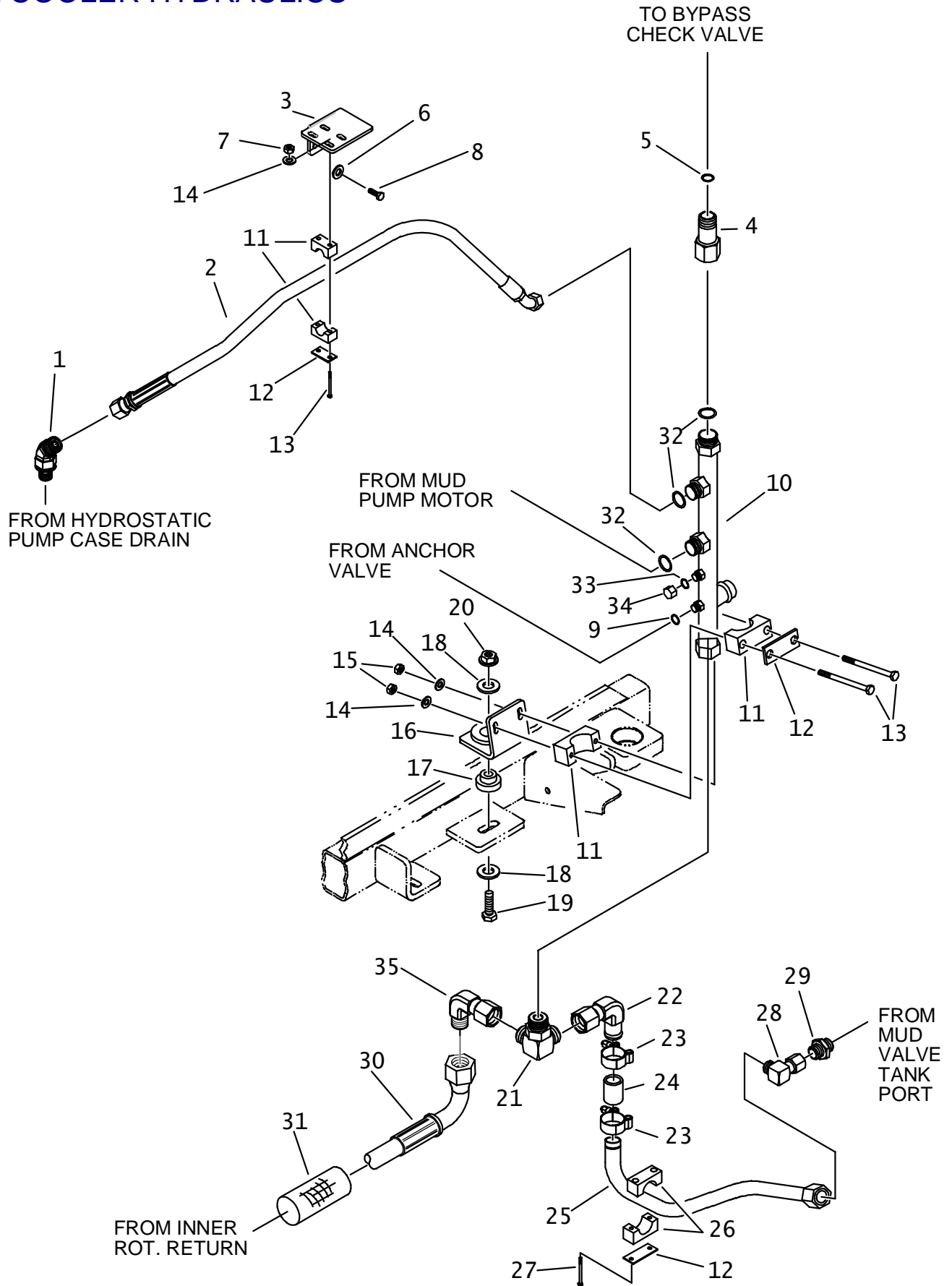

## OIL COOLER HYDRAULICS

REF NO.	PART NUMBER	QTY	DESCRIPTION	REMARKS
1.	154-371	1	CONNECTOR (12S-16045)	
2.	159-756	1	HOSE (160FX45-38"-200)	CASE DRAIN
3.	354-464	1	TOP REAR COOLANT BRACKET	
4.	510-014	1	UNION (16J-160FX)	
5.	155-748	1	O-RING (916 D90)	
6.	106-396	2	WASHER (M10, HARDENED)	
7.	105-085	2	LOCKNUT (1/4-NC)	
8.	105-245	2	SCREW (M10-1.50 X 25MM)	
9.	157-040	1	O-RING (014 D90)	
10.	153-389	1	COOLER BY-PASS	
11.	111-008	2	BOLT-ON CLAMP (1-1/2", SET)	
12.	322-362	3	BACKUP SPACER	
13.	107-283	4	BOLT (1/4-NC X 3")	
14.	106-076	4	WASHER (1/4")	
15.	105-085	3	LOCKNUT (1/4-NC)	
16.	318-387	1	MOUNT	
17.	116-498	1	SHOCK MOUNT	
18.	105-884	2	WASHER (.531")	
19.	105-229	1	BOLT (1/2-NC X 2")	
20.	105-833	1	FLG LOCKNUT (1/2-NC)	
21.	157-261	1	SPECIAL TEE (16S-200-200)	
22.	157-260	1	ELBOW (20H-200FX90, SPECIAL)	
23.	111-028	2	T-BOLT CLAMP (1.75"-2.00")	
24.	117-896	1	BULK HOSE (1-1/4",SOLD PER 1")	USE 1 @ 8.50"
25.	157-251	1	HYD LINE (20)	VALVE DRAIN
26.	110-852	1	BLT-ON CLP(1.25",SOLD PER SET)	
27.	105-224	2	BOLT (1/4-NC X 2-1/2")	
28.	514-422	1	CONNECTOR (200-200FX90)	
29.	514-094	1	CONNECTOR (16S-200)	
30.	153-751	1	HOSE (200FX90S-88"-3000)	SEE FOOTNOTE 1, AT ONLY
	514-177	-	CAP (200F)	JT ONLY
31.	117-567	1	ABRASION SLEEVE (2.38" X 86")	
32.	155-714	3	O-RING (021 D90)	
33.	157-039	1	O-RING (014 D90)	
34.	154-327	1	CAP (080F)	
35.	514-422	1	CONNECTOR (200-200FX90)	SEE FOOTNOTE 1, AT ONLY

NOT SHOWN:

FOOTNOTES:

- HOSE AND ELBOW REPLACED BY 514-177 CAP FOR JT MACH 1

NOTE:

REFER TO O-RING CHART (800-301) IN BACK OF THE BOOK FOR REPLACEMENT OF O-RINGS.

# OIL COOLER HYDRAULICS

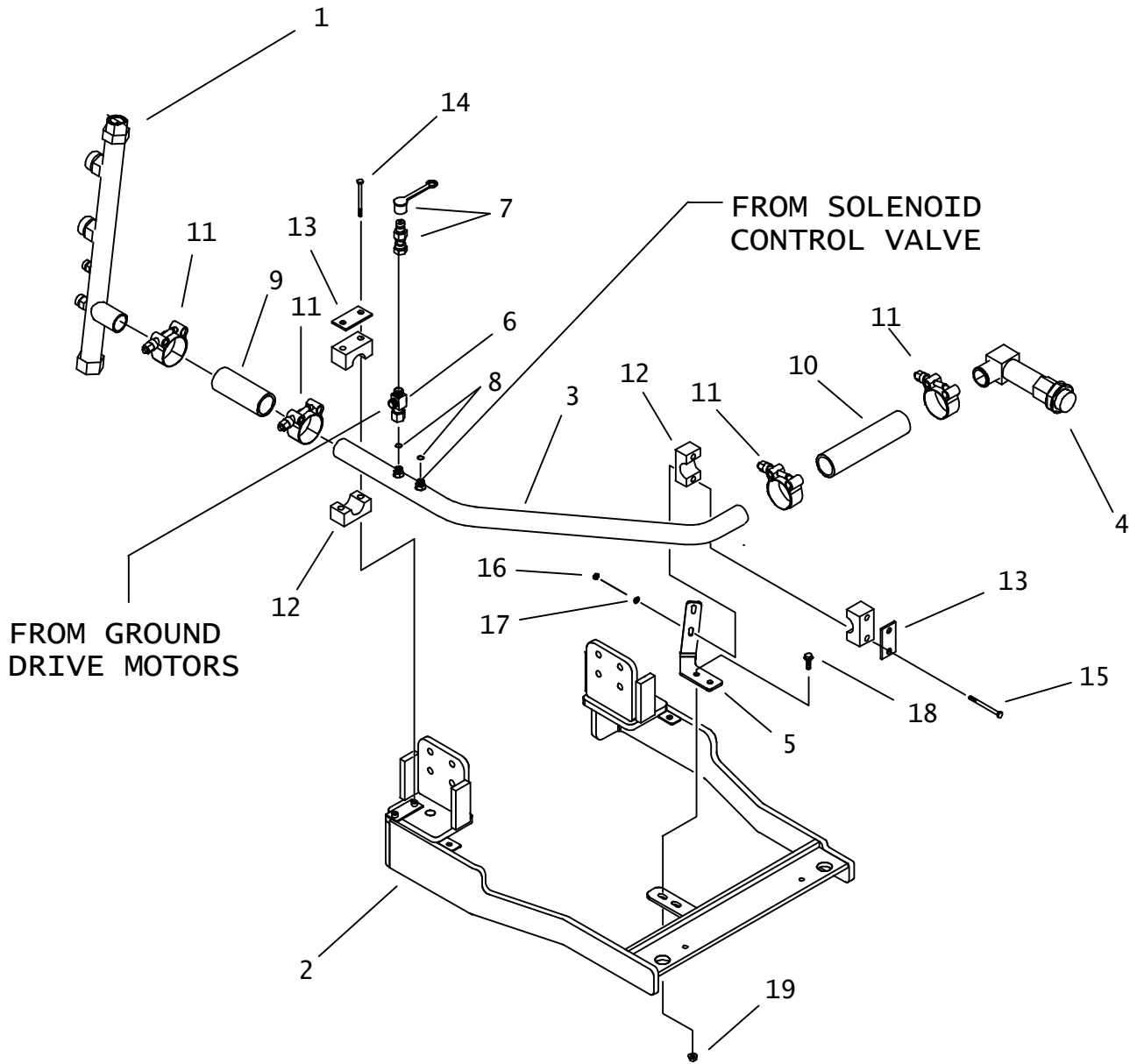

## OIL COOLER HYDRAULICS

REF NO.	PART NUMBER	QTY	DESCRIPTION	REMARKS
1.	153-389	-	COOLER BY-PASS	
2.	320-997	-	FRONT ENGINE MOUNT	
3.	157-328	-	COOLER SUPPLY TUBE	
4.	153-994	1	SPECIAL ELBOW (20S-24H, XL)	
5.	323-362	1	BRACKET	
6.	154-265	1	UNION RUN TEE (040FX-040-040)	
7.	159-156	1	QDC ADAPTER (02-040F)	
8.	157-037	2	O-RING (011 D90)	
9.	117-897	1	BULK HOSE (1-1/2", SOLD PER 1")	USE 1 @ 4.75"
10.	117-897	1	BULK HOSE (1-1/2", SOLD PER 1")	USE 1 @ 8.0"
11.	318-890	4	T-BLT CLP BRIDG 1.875 - 2.188	
12.	111-008	2	BOLT-ON CLAMP (1-1/2", SET)	
13.	322-362	2	BACKUP SPACER	
14.	105-224	2	BOLT (1/4-NC X 2-1/2")	
15.	107-283	2	BOLT (1/4-NC X 3")	
16.	105-085	2	LOCKNUT (1/4-NC)	
17.	106-076	2	WASHER (1/4")	
18.	106-724	2	FLG SCREW (M10-1.50 X 25MM)	
19.	106-387	2	FLG LOCKNUT (M10-1.50)	

FOOTNOTES

NOTE:

# OIL RETURN HYDRAULICS

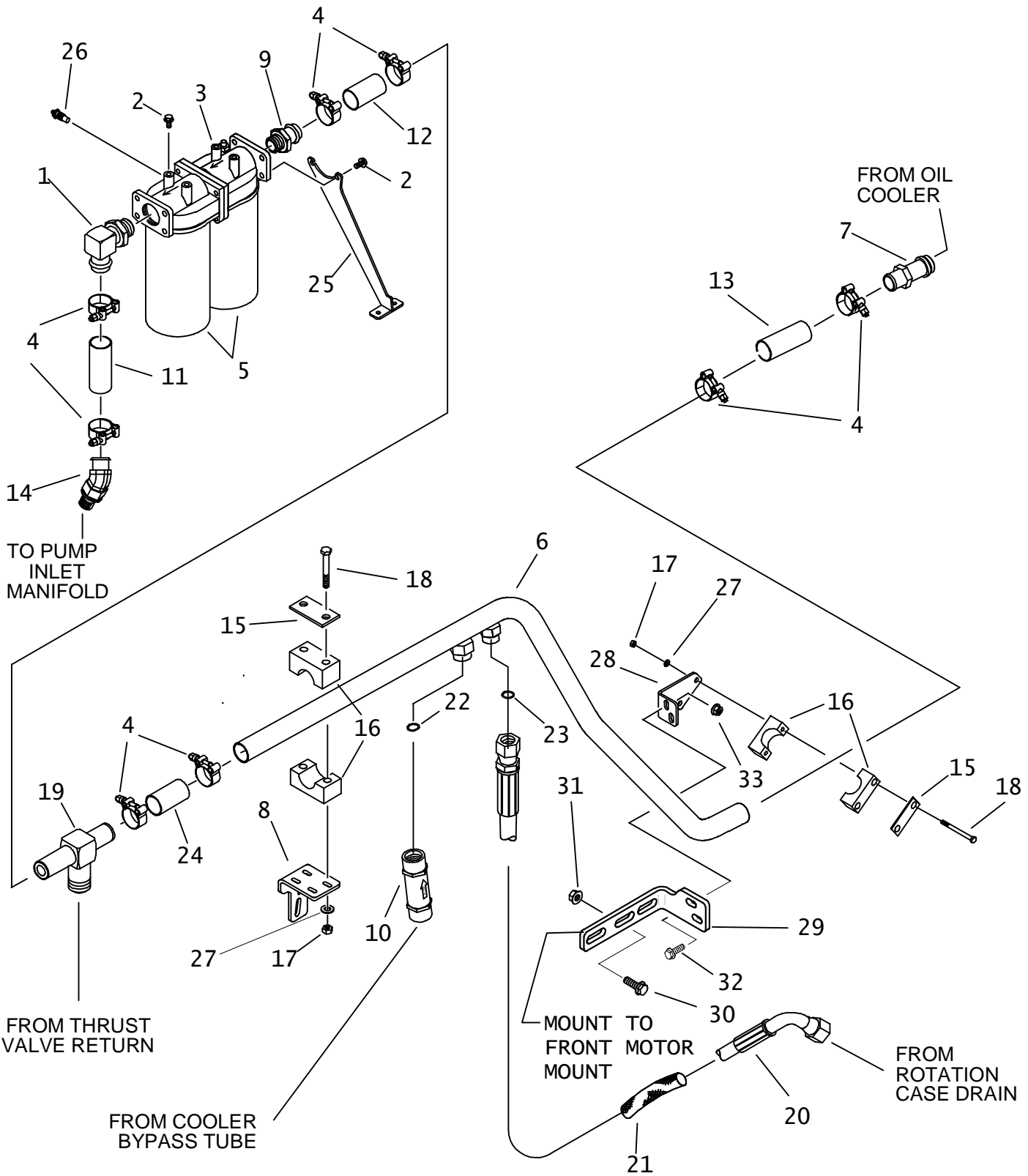

## OIL RETURN HYDRAULICS

REF NO.	PART NUMBER	QTY	DESCRIPTION	REMARKS
1.	514-135	1	S/O COUPLER (24S-24H90)	
2.	105-825	6	FLG LK BOLT (3/8-NC Xf")	
3.	157-766	1	FILTER HEAD (20SF-20SF)	
4.	318-890	8	T-BLT CLP BRIDG 1.875 - 2.188	
5.	157-486	2	FILTER ELEMENT (10 MICRON)	
6.	157-327	1	COOLER RETURN TUBE	
7.	157-453	1	S/O COUPLER (20S-24H, LONG)	COOLER RETURN
8.	354-464	-	TOP REAR COOLANT BRACKET	
9.	514-138	1	S/O COUPLER (24S-24H)	
10.	153-436	1	FLOW CHECK (16SF-16SF)	FLOW ARROW ON CHECK VALVE MUST POINT UPWARD
11.	117-897	AR	BULK HOSE (1-1/2",SOLD PER 1")	USE 1 @ 10.0"
12.	117-897	AR	BULK HOSE (1-1/2", SOLD PER 1')	USE 1 @ 5.50"
13.	117-897	AR	BULK HOSE (1-1/2",SOLD PER 1")	USE 1 @ 9.00"
14.	153-370	1	S/O COUPLER (24S-24H45)	
15.	322-362	2	BACKUP SPACER	
16.	111-008	2	BOLT-ON CLAMP (1-1/2", SET)	
17.	105-085	4	LOCKNUT (1/4-NC)	
18.	107-283	4	BOLT (1/4-NC X 3")	
19.	514-441	1	S/O BR TEE (160-24H-24H)	
20.	155-470	1	HOSE (12OFX90M-90"-3000)	
21.	115-924	1	ABRASION SLEEVE (1.59" X 88")	
22.	155-748	1	O-RING (916 D90)	
23.	157-017	1	O-RING (018 D90)	
24.	117-897	AR	BULK HOSE (1-1/2",SOLD PER 1")	USE 1 @ 9.0"
25.	318-481	1	SUPPORT	
26.	217-765	1	INDICATOR SWITCH	
27.	106-076	6	WASHER (1/4")	
28.	323-359	1	BRACKET	
29.	323-360	1	BRACKET	
30.	107-565	2	FLG LK SCREW (M12-1.75 X 40MM)	
31.	106-709	1	FLG LK NUT (M12-1.75)	
32.	106-724	2	FLG SCREW (M10-1.50 X 25MM)	
33.	106-387	2	FLG LOCKNUT (M10-1.50)	

### FOOTNOTES

### NOTE:

NOTE  
REFER TO O-RING CHART (800-301) IN BACK OF THE BOOK FOR REPLACEMENT OF O-RINGS.

## HYDRAULIC RESERVOIR

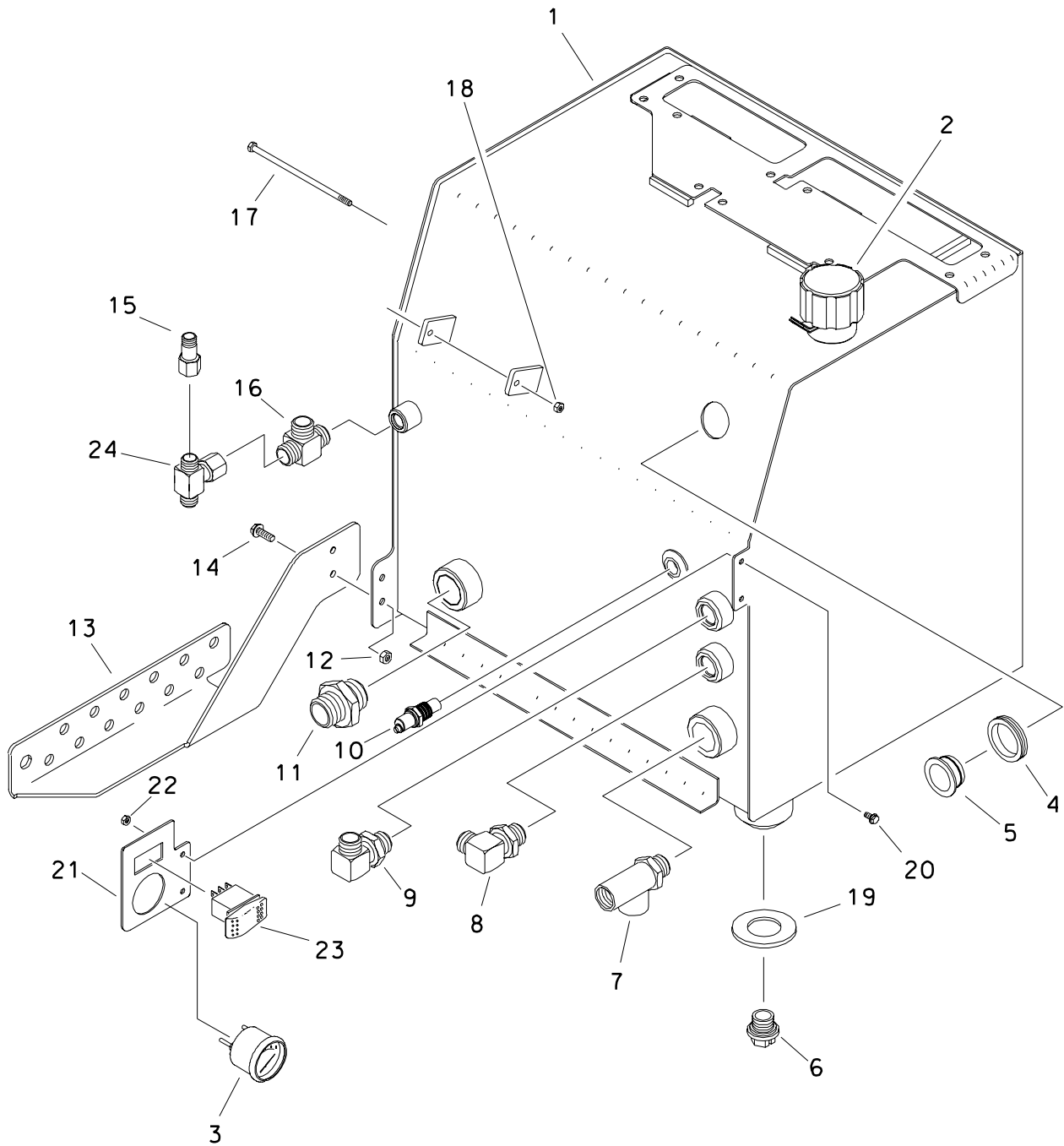



## HYDRAULIC RESERVOIR

REF NO.	PART NUMBER	QTY	DESCRIPTION	REMARKS
1.	350-614	1	HYDRAULIC RESERVOIR	
2.	153-766	1	LOCKING CAP (VENTED)	USE PERMATEx AVIATION GASKET SEALER
3.	215-128	-	HOUR METER	AT ONLY
4.	115-320	1	GROMMET (1-1/2")	
5.	116-218	1	SIGHT GLASS (2")	INCL REFLECTOR, SEE FOOTNOTE 1
	360-849	-	REFLECTOR	
6.	149-398	1	DRAIN PLUG (1-UNF, .375 ORF)	
7.	153-899	1	RUN TEE (20S-16SF-16SF)	
8.	154-377	1	CONNECTOR (12S-16090)	
9.	154-286	1	CONNECTOR (120-16S90)	
10.	214-819	1	TEMPERATURE SWITCH	USE 567 LOCTITE
11.	155-148	1	S/O COUPLER (20S-24H)	
12.	106-561	2	LOCKNUT (M8-1.25, PRV TRQ, 10.9)	
13.	354-466	1	BULKHEAD PLATE	
14.	106-162	2	FLG SCREW (M8-1.25 X 20MM)	
15.	154-262	-	REDUCER (060-080F)	
16.	154-299	-	RUN TEE (08S-080-080)	
17.	106-061	1	BOLT (1/4-NC X 6-1/2")	
18.	105-085	1	LOCKNUT (1/4-NC)	
19.	149-829	1	1" SEAL WASHER	
20.	106-986	2	FLG LK SCREW (M6-1.00 X 12MM)	AT ONLY
21.	313-873	1	GAUGE PANEL	AT ONLY
22.	106-106	2	NUT (M6-1.00)	AT ONLY
23.	217-912	-	ROCKER SWITCH (DPDT) ON-ON-ON	AT ONLY
24.	154-257	1	UN BR TEE (080FX-080-080)	

## FOOTNOTES

1. REFER TO SPECIAL TOOL DIAGRAM 052-524, FOR INSTALLATION.

## NOTE:

REFER TO O-RING CHART (800-301) IN BACK OF THE BOOK FOR REPLACEMENT OF O-RINGS.

# ROTATION, THRUST AND MUD GAUGES

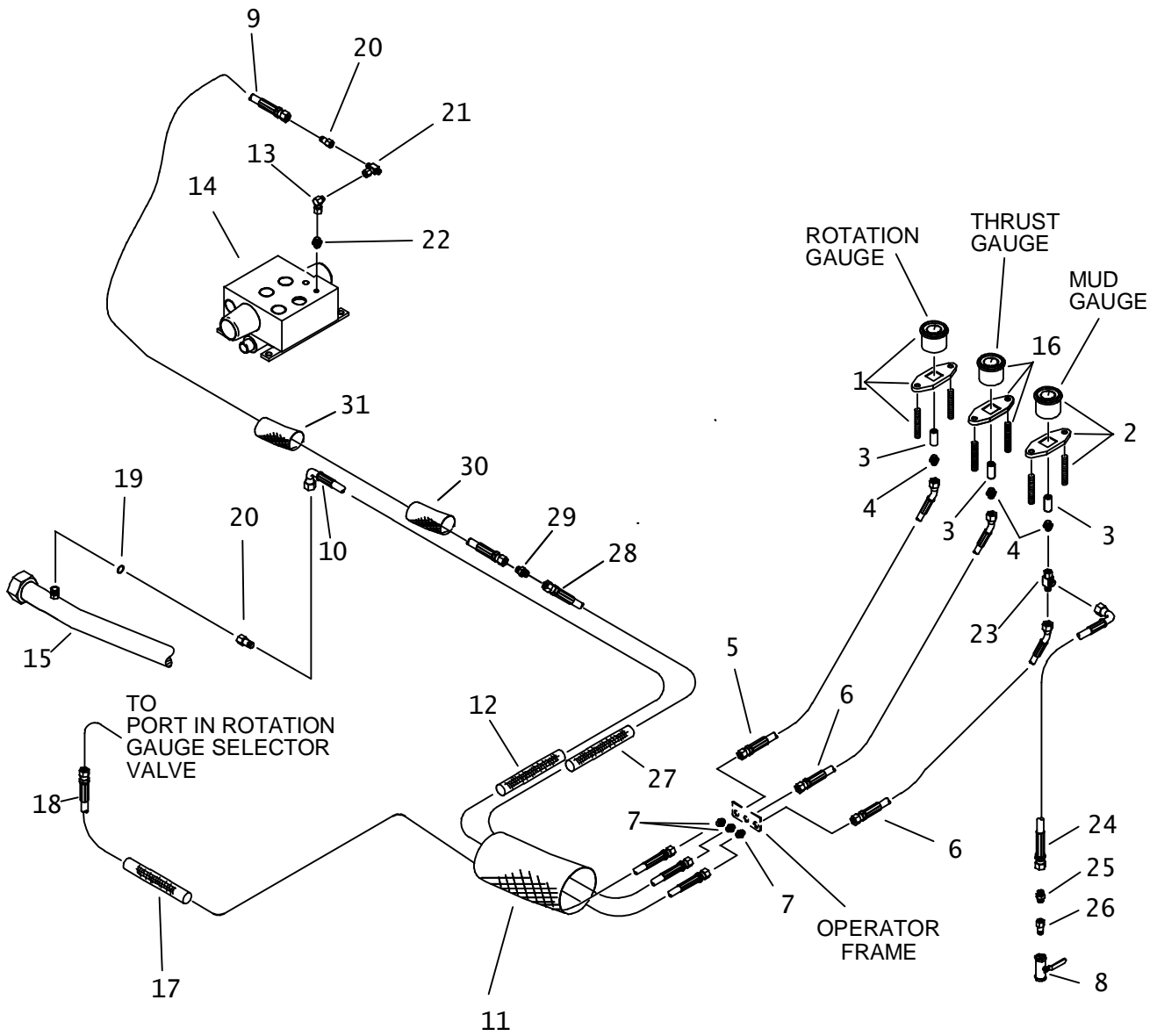

# ROTATION, THRUST AND MUD GAUGES

REF NO.	PART NUMBER	QTY	DESCRIPTION	REMARKS
1.	258-061	1	HYD PRESSURE GAUGE (6000 PSI)	
2.	150-1964	1	PRESSURE GAUGE (2000PSI)	
3.	514-408	3	COLLAR (04NF)	
4.	154-339	3	CONNECTOR (04N-040)	
5.	515-646	1	HOSE (040FX45-62"-10000)	
6.	515-283	2	HOSE (040FX45-62"-3000)	
7.	154-275	3	BK CONNECTOR (040-040BK)	
8.	120-071	1	SHUT-OFF (04NF-04NF)	
9.	515-161	1	HOSE (040FX-160"-3000)	
	150-1980	1	HOSE (040FX-282"-3000)	USE ON 4020 WITH RACK AND PINION. SEE FOOTNOTE 4
10.	515-137	1	HOSE (040FX90-90"-3000)	
11.	117-283	1	ABRASION SLEEVE (4.000" X 20")	
12.	117-209	1	ABRASION SLEEVE (1.00" X 90")	
13.	154-228	-	UNION (060-060FX90)	
14.	157-440	-	THRUST VALVE (ELECTRIC)	SEE FOOTNOTE 2
	150-1458	-	THRUST VALVE (ELECTRIC)	SEE FOOTNOTE 3
	500-1290	-	THRUST VALVE COIL	
15.	156-892	-	HYDRAULIC LINE (-24)	
16.	258-063	1	GAUGE (4000 PSI)	
17.	117-792	1	ABRASION SLEEVE (1.00" X 115")	
18.	153-730	1	HOSE (040FX-116"-6000)	SEE FOOTNOTE 1
19.	157-038	1	O-RING (012 D90)	
20.	154-373	2	REDUCER (040-060F)	
21.	154-348	-	UNION BRANCH TEE (060FX-060-060)	
22.	154-411	-	CONNECTOR (04S-060)	
23.	154-265	1	UNION RUN TEE (040FX-040-040)	
24.	515-179	1	HOSE (040FX90-11"-3000)	
25.	153-238	1	BK CONNECTOR (040-06S)	
26.	153-264	1	REDUCER (04N-06SF)	
27.	117-400	1	ABRASION SLEEVE (1.00" X 72")	
28.	515-330	1	HOSE (040FX45-76"-3000-AR)	
29.	154-275	1	BK CONNECTOR (040 -040BK)	
30.	117-612	1	ABRASION SLEEVE (1.00" X 46")	
31.	117-1019	1	ABRASION SLEEVE (1.25" X 234")	

## FOOTNOTES:

- HOSE CONNECTS TO PUMP FOR JT4020 MACH 1
- ENDS WITH S/N: CMWJ42T2J60000023; CMWA42T2E60000029; CMWA40T3P60000002; CMWJ40T3T60000001
- BEGINS WITH S/N: CMWA40T3K60000003; CMWJ40T3P60000002
- CONNECTS AT MAIN FRAME BULKHEAD

## NOTE:

REFER TO O-RING CHART (800-301) IN BACK OF THE BOOK FOR REPLACEMENT OF O-RINGS.

**MAIN FRAME BULKHEADS**  
 ENDS WITH S/N CMWA40T3C70000014  
 ENDS WITH S/N CMWJ40T3L70000025

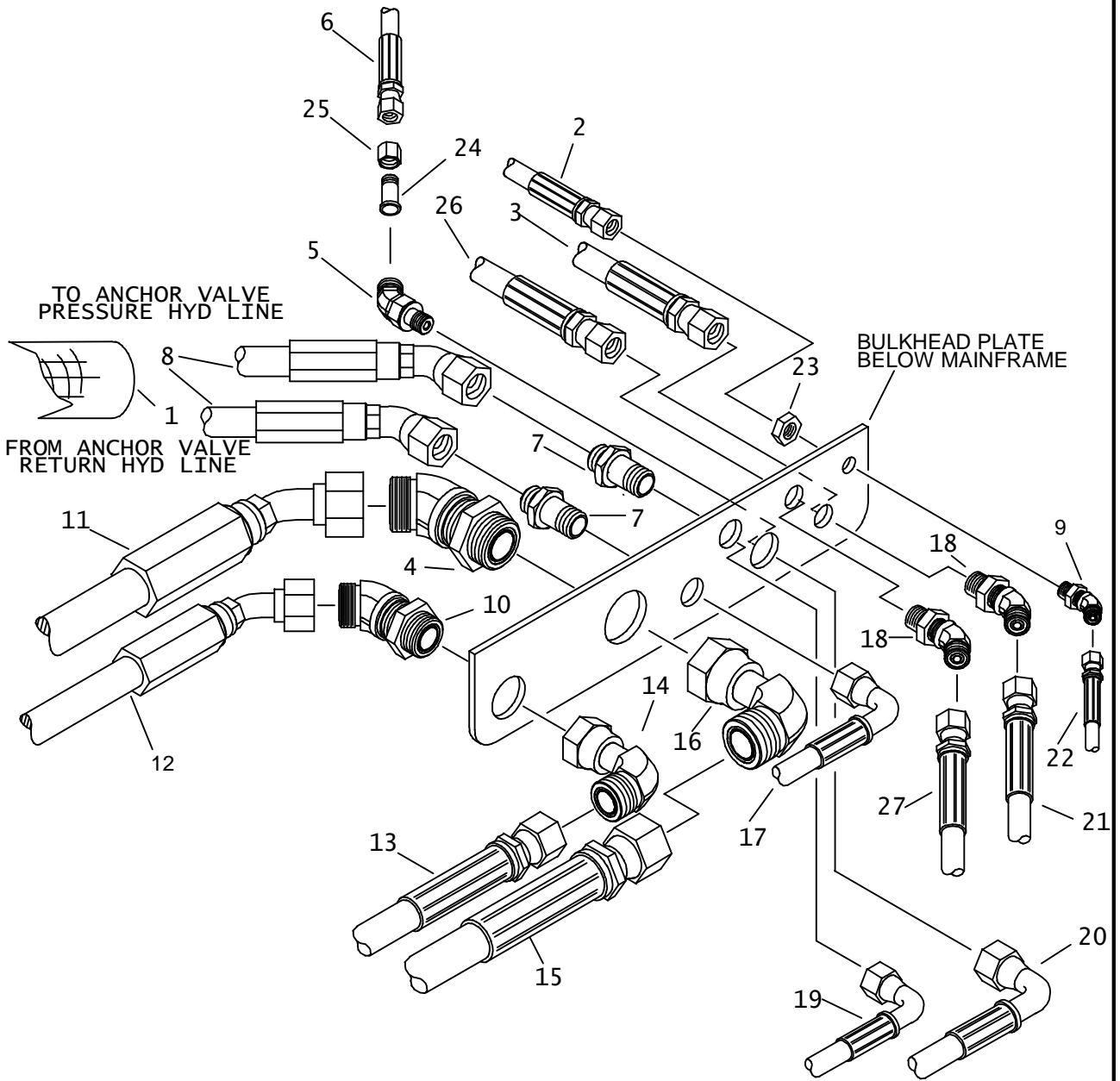

# MAINFRAME BULKHEADS

## ENDS WITH S/N CMWA40T3C70000014

## ENDS WITH S/N CMWJ40T3L70000025

REF NO.	PART NUMBER	QTY	DESCRIPTION	REMARKS
1.	115-899	1	ABRASION SLEEVE (2.54" X 54")	
2.	154-651	-	HOSE (040FX-66"-3000)	TO HARD LINE TO SERIES PARALLEL VALVE
3.	515-141	-	HOSE (080FX90-82"-3000)	TO PIPE LOADER VALVE
4.	153-395	1	BK CONNECTOR (200-20045)	
5.	154-448	1	BK CONNECTOR (120-12045BK)	
6.	515-750	-	HOSE (060FX-210"-3000)	FROM ROTATION MOTOR CASE DRAIN
7.	154-309	2	BK CONNECTOR (100-100BK)	
8.	515-671	-	HOSE (100FX45-52"-3000)	SEE GRAPHICS
9.	154-285	1	BK CONNECTOR (040-04045BK)	
10.	514-242	1	BK CONNECTOR (160-16045BK)	
11.	157-499	-	HOSE (200FX-47"-3000, SPECIAL)	TO THRUST VALVE, SUPPLY
12.	515-655	-	HOSE (160FX90-47"-3000)	FROM THRUST VALVE, RETURN
13.	154-815	-	HOSE (160FX-48"-4000)	TO RETURN LINE (BEFORE FILTERS)
14.	154-290	1	UNION (160-160FX90)	
15.	157-754	-	HOSE (200FX45-27"-3000, SPEC)	FROM LOAD SENSE PUMP
16.	514-422	1	CONNECTOR (200-200FX90)	
17.	515-690	-	HOSE (100FX90L-58"-3000)	TO COOLER TUBE
18.	154-393	2	BK CONNECTOR (080-08045BK)	
19.	515-454	-	HOSE (100FX90L-20"-3000)	FROM LOAD SENSE PUMP
20.	155-470	-	HOSE (120FX90M-90"-3000)	TO UPPER COOLER TUBE
21.	515-140	-	HOSE (080FX90-56"-3000)	FROM HYDRAULIC CONTROL VALVE ON HYD TANK
22.	154-692	-	HOSE (040FX-54"-3000)	FROM THRUST SHIFT SOLENOID VALVE
23.	105-431	1	JAM NUT (9/16-NF)	
24.	154-459	1	REDUCER STEM (060)	
25.	154-271	1	REDUCER NUT (120F)	
26.	515-741	1	HOSE (080FX90S-112"-3000)	FROM DRAIN ON LOADER VALVE
27.	154-739	1	HOSE (080FX-32"-3000)	

NOT SHOWN:

FOOTNOTES:

NOTE:

REFER TO O-RING CHART (800-301) IN BACK OF THE BOOK FOR REPLACEMENT OF O-RINGS.

# ROTATION HYDRAULICS

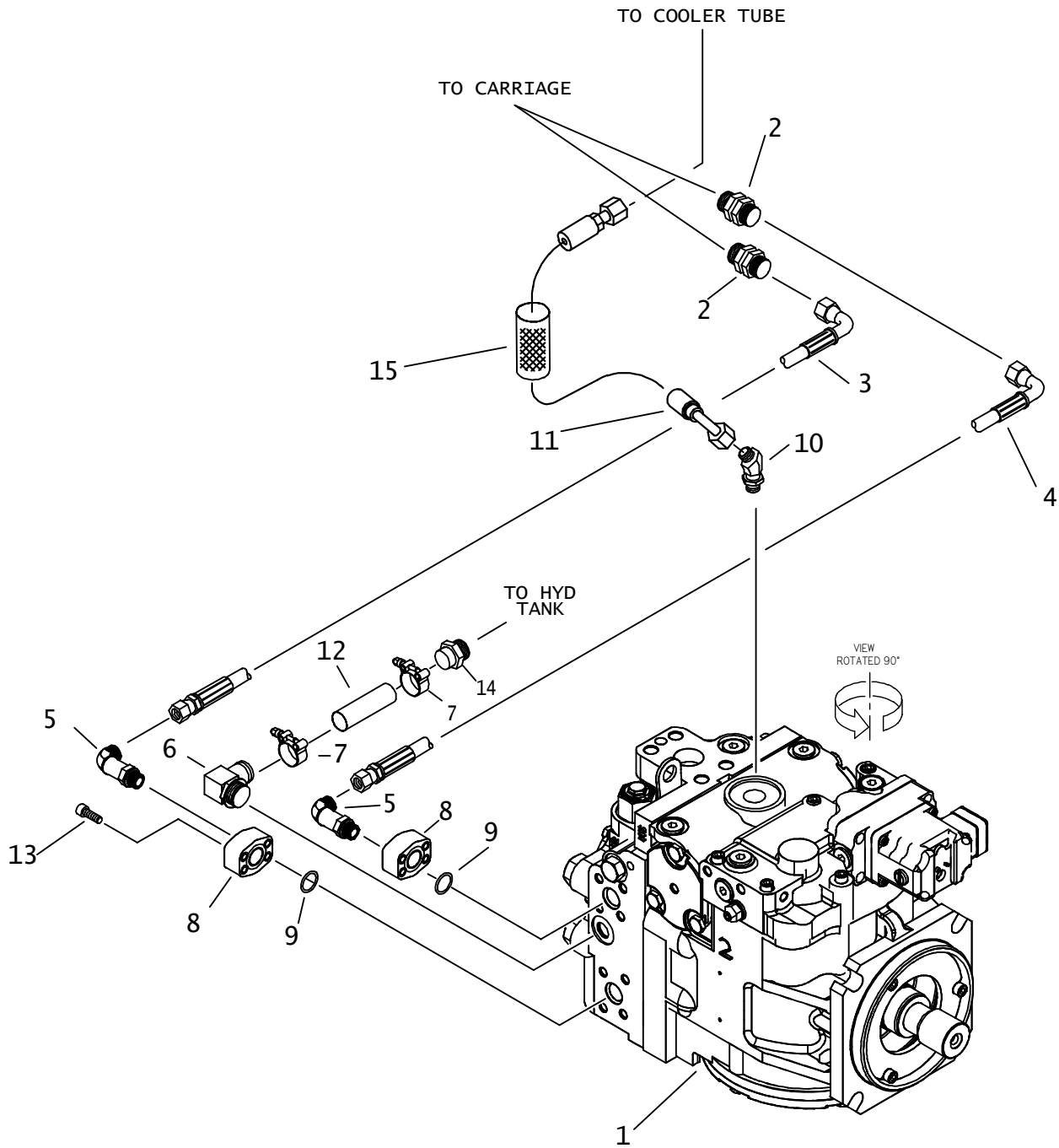

# ROTATION HYDRAULICS

REF NO.	PART NUMBER	QTY	DESCRIPTION	REMARKS
1.	153-340	-	HYDRAULIC PUMP	SEAL KIT 190-764
2.	154-389	2	BK CONNECTOR (160-160BK)	
3.	515-666	1	HOSE (160FX90-52"-6000)	
4.	154-763	1	HOSE (160FX90S-54"-6000)	
5.	154-289	2	CONNECTOR (16S-16090, XL)	
6.	155-176	1	S/O COUPLER (20H-24S90)	
7.	111-028	2	T-BOLT CLAMP (1.75"-2.00")	
8.	514-245	2	HEAD FLANGE (16HFL-16SF)	
9.	157-029	2	O-RING (219 D90)	
10.	154-371	1	CONNECTOR (12S-16045)	
11.	156-177	1	HOSE (160FX45-38"-200)	CASE DRAIN
12.	116-588	AR	BULK HOSE (1-1/2", SOLD PER FT)	USE 1 @ 18.5"
13.	105-918	8	BOLT (7/16-NC X 1-1/2", SOC)	
14.	155-148	-	S/O COUPLER (20S-24H)	
15.	117-654	1	ABRASION SLEEVE (1.75" X 38")	

NOT SHOWN:

FOOTNOTES:

NOTE:

REFER TO O-RING CHART (800-301) IN BACK OF THE BOOK FOR REPLACEMENT OF O-RINGS.

# STATION GAUGE VALVE

JT4020 ALL TERRAIN ONLY

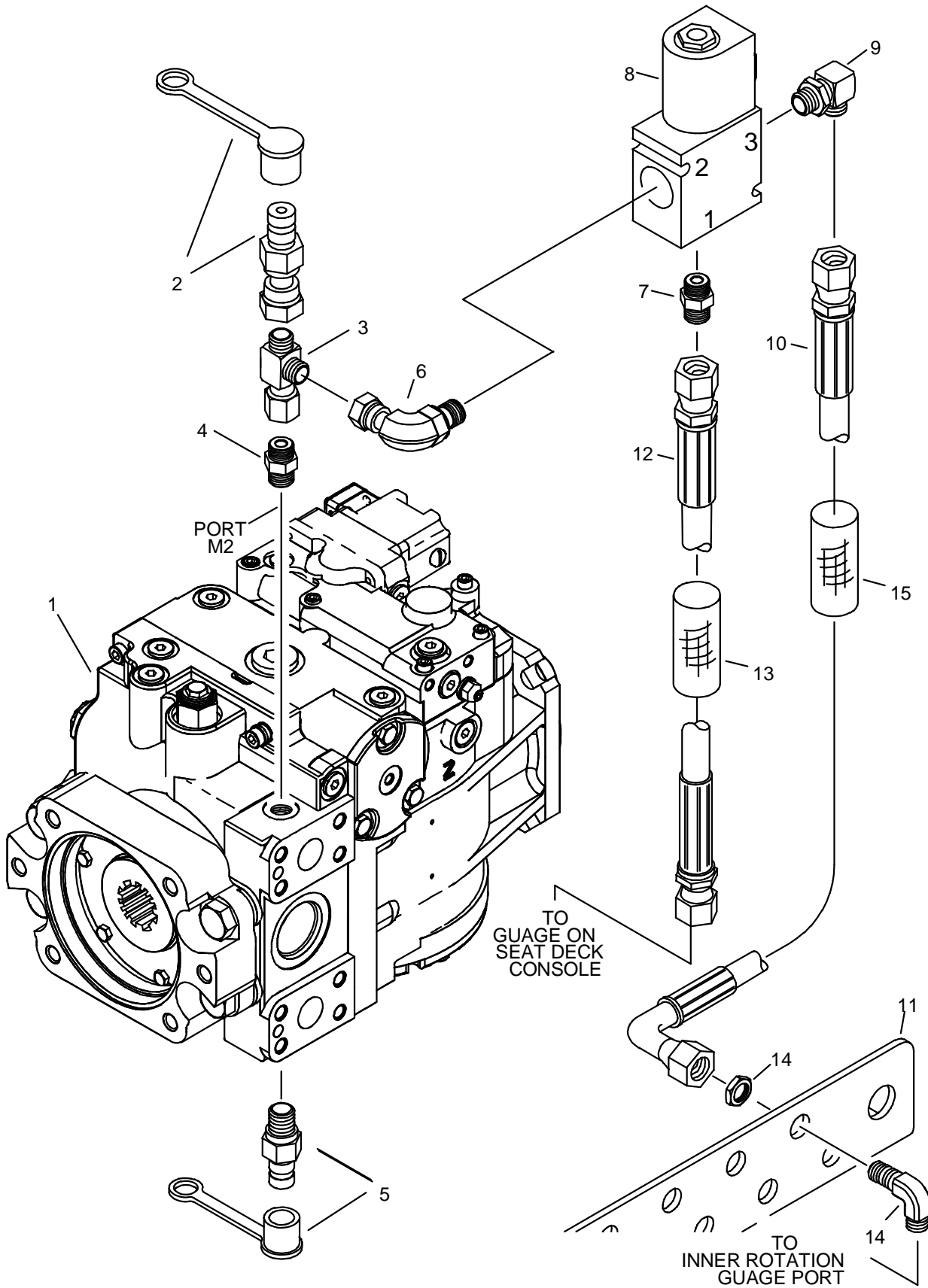



# STATION GAUGE VALVE

## JT4020 ALL TERRAIN ONLY

REF NO.	PART NUMBER	QTY	DESCRIPTION	REMARKS
1.	153-340	-	HYDRAULIC PUMP	
2.	159-157	1	QDC ADAPTER (02-060F)	
	159-148	-	DUST CAP (1/8")	
3.	154-344	1	UN RUN TEE (060FX-060-060)	
4.	154-221	1	CONNECTOR (06S-060)	
5.	159-147	1	QDC ADAPTER (02-06S)	
	159-148	-	DUST CAP (1/8")	
6.	154-343	1	UNION (06S-060FX90)	
7.	154-220	1	CONNECTOR (040-06S)	
8.	153-771	1	HYDRAULIC VALVE	
9.	154-226	1	CONNECTOR (040-06S90)	
10.	515-437	1	HOSE (040FX90-21"-3000)	
11.	354-466	-	BULKHEAD PLATE	
12.	153-730	-	HOSE (040FX-116"-6000)	
13.	117-792	-	ABRASION SLEEVE (1.00" X 115")	
14.	154-355	1	BK CONNECTOR (040-04090BK)	
15.	117-566	1	ABRASION SLEEVE (1.25" X 11")	

NOT SHOWN:

FOOTNOTES:

NOTE:

REFER TO O-RING CHART (800-301) IN BACK OF THE BOOK FOR REPLACEMENT OF O-RINGS.

# ROTATION TEST PORTS

JT4020 MACH 1 ONLY

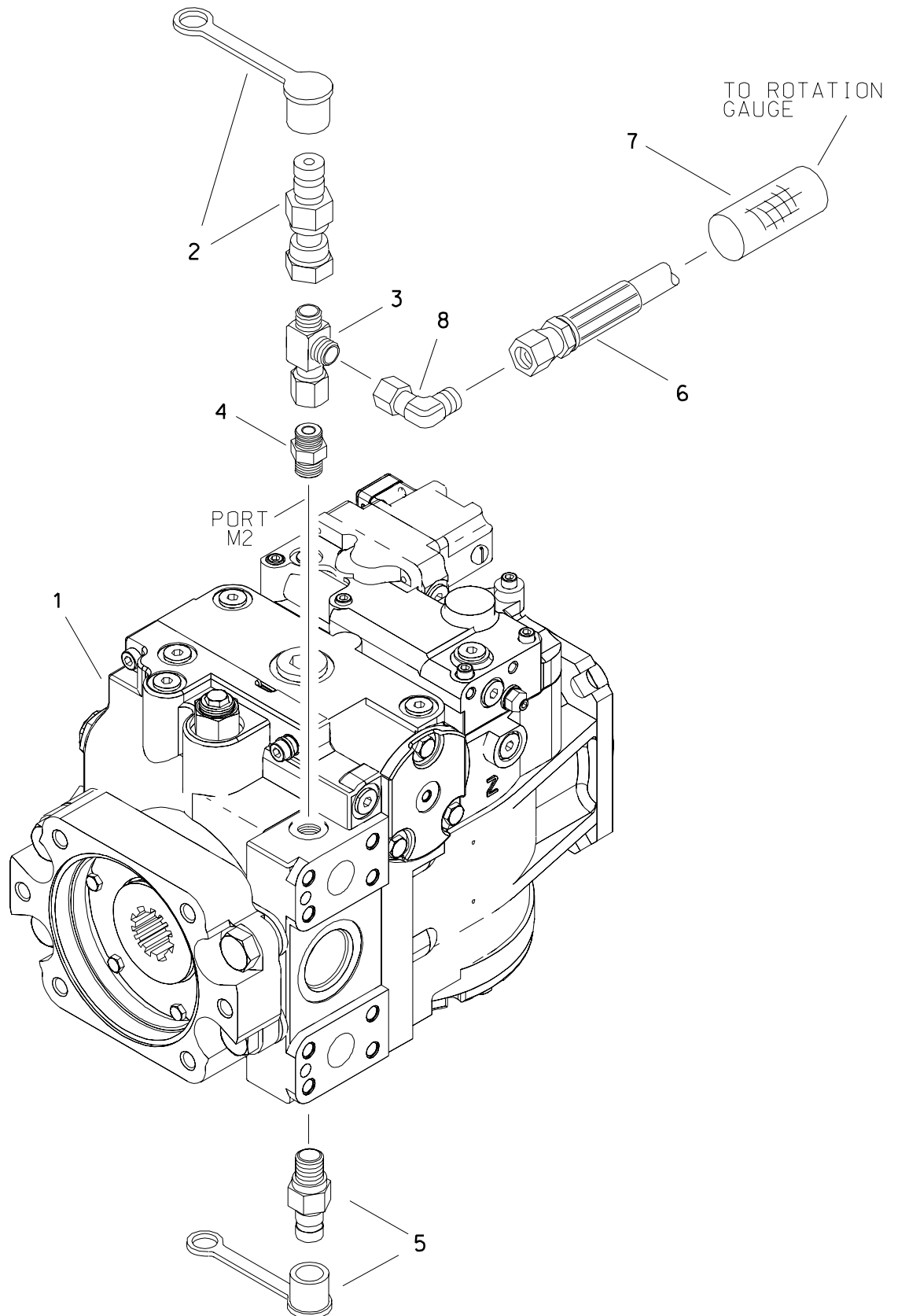

# ROTATION TEST PORTS

## JT4020 MACH 1 ONLY

REF NO.	PART NUMBER	QTY	DESCRIPTION	REMARKS
1.	153-340	1	HYDRAULIC PUMP	
2.	159-156	1	QDC ADAPTER (02-040F)	
	159-148	-	DUST CAP (1/8")	
3.	154-265	1	UN RUN TEE (040FX-040-040)	
4.	154-220	1	CONNECTOR (040-06S)	
5.	159-147	1	QDC ADAPTER (02-06S)	
	159-148	-	DUST CAP (1/8")	
6.	153-730	1	HOSE (040FX-116"-6000)	
7.	117-792	1	ABRASION SLEEVE (1.00" X 115")	
8.	154-255	1	UNION (040-040FX90)	

### FOOTNOTES

REFER TO O-RING CHART (800-301) IN BACK OF THE BOOK FOR REPLACEMENT OF O-RINGS.

# INNER SPINDLE ROTATION GAUGE

JT4020 ALL TERRAIN ONLY

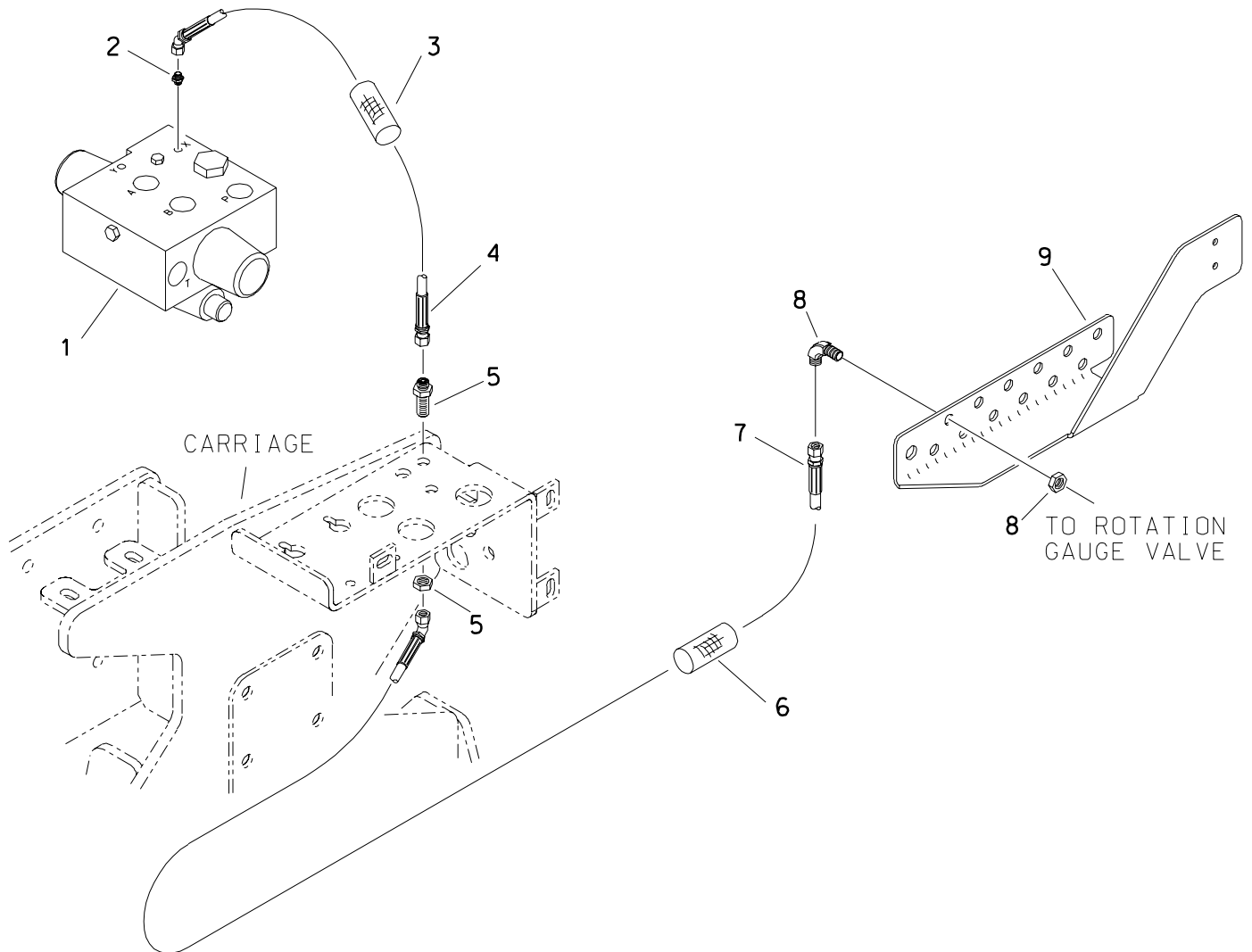

# INNER SPINDLE ROTATION GAUGE JT4020 ALL TERRAIN ONLY

REF NO.	PART NUMBER	QTY	DESCRIPTION	REMARKS
1.	153-773	-	HYDRAULIC VALVE	
2.	154-278	1	CONNECTOR (04S-040)	
3.	117-409	1	ABRASION SLEEVE (1.00" X 28")	
4.	153-073	1	HOSE (040FX45-28"-3000)	
5.	154-275	1	BK CONNECTOR (040-040BK)	
6.	117-693	1	ABRASION SLEEVE (1.00" X 60")	
7.	153-748	1	HOSE (040FX45-212"-3000)	
8.	154-355	-	BK CONNECTOR (040-04090BK)	
9.	354-466	-	BULKHEAD PLATE	

FOOTNOTES

# OUTER ROTATION HYDRAULICS

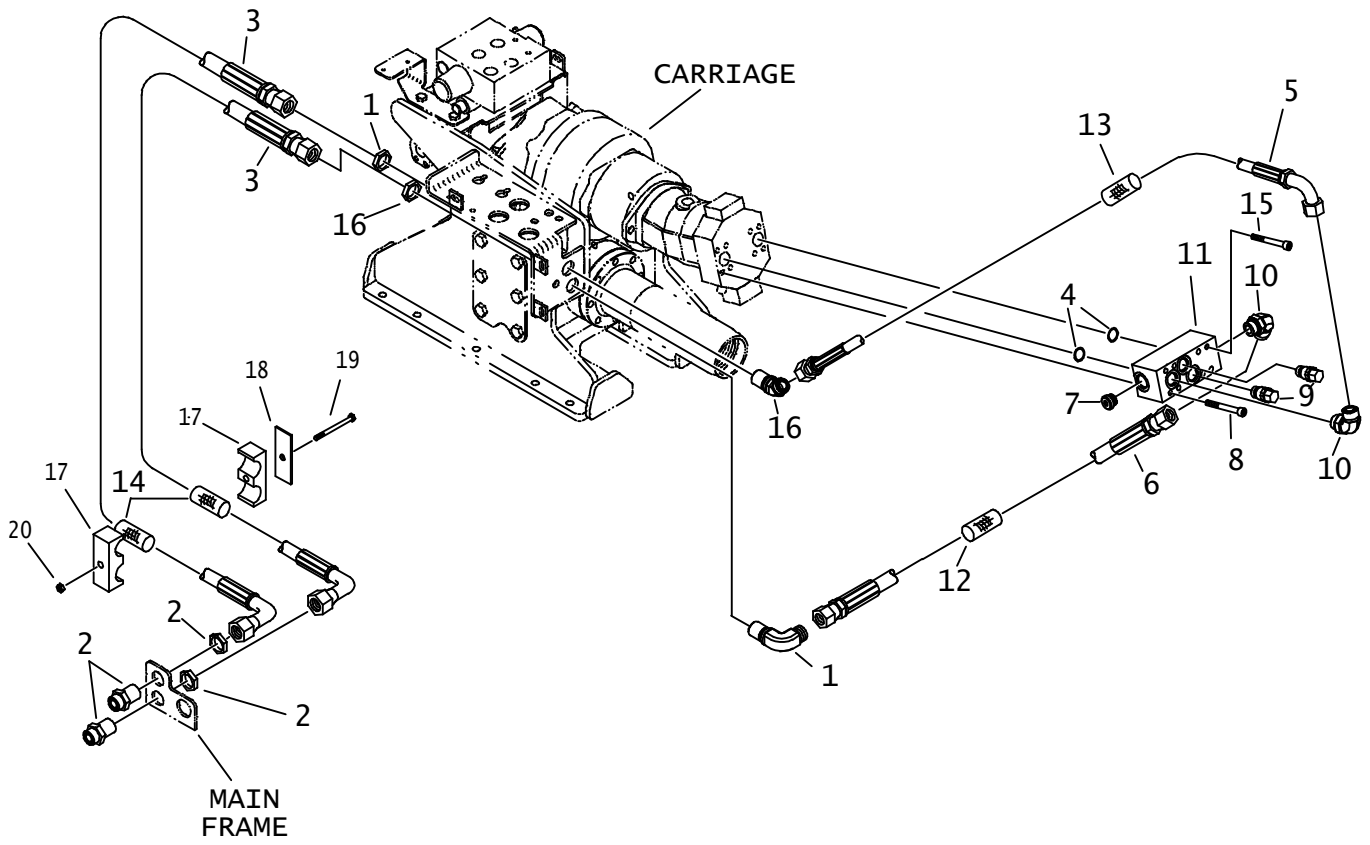

# OUTER ROTATION HYDRAULICS

REF NO.	PART NUMBER	QTY	DESCRIPTION	REMARKS
1.	154-419	1	BK CONNECTOR (160-16090BK)	
2.	154-389	3	BK CONNECTOR (160-160BK)	
3.	153-744	2	HOSE (160FX90S-229"-6000)	
	150-1702	2	HOSE (160FX90S-299"-6000)	SEE FOOTNOTE 2
4.	157-029	2	O-RING (219 D90)	
5.	157-364	1	HOSE (160FX90S-18.75"-6000)	
6.	153-743	1	HOSE (160FX-24"-6000)	
7.	155-184	1	PLUG (16S)	
8.	107-806	4	SCR (7/16-NC X 3.50, SOC, GD8)	USE LOCTITE 242, TORQUE TO 85 FT LB
9.	149-566	2	HYDRAULIC VALVE	SEE FOOTNOTE 1
	191-031	-	SEAL REPAIR KIT	
10.	154-287	2	CONNECTOR (16S-16090)	
11.	157-363	1	CARTRIDGE MANIFOLD	
12.	117-675	1	ABRASION SLEEVE (1.75" X 24")	
13.	117-564	1	ABRASION SLEEVE (1.75" X 15")	
14.	117-292	2	ABRASION SLEEVE (2.07" X 70")	
15.	107-535	4	SCR (7/16-NC X 3.75, SOC, GD8)	USE LOCTITE 242; TORQUE TO 85 FT LBS
16.	514-242	1	BK CONNECTOR (160-16045BK)	
17.	110-359	1	BOLT-ON CLAMP (1-1/2", SET)	
18.	315-623	1	BACKUP SPACER	
19.	107-078	1	SCREW (M8-1.25 X 90MM)	
20.	106-561	1	LOCKNUT (M8-1.25, PRV TRQ, 10.9)	

NOT SHOWN:

#### FOOTNOTES:

- TORQUE TO 80-90 FT LBS; TIGHTEN ONLY AT BASE DEEP SOCKET
- USE ON 4020 WITH RACK AND PINION

#### NOTE:

- \* REFER TO O-RING CHART (800-301) IN BACK OF THE BOOK FOR REPLACEMENT OF O-RINGS.
- \* SEE PARTS PAGE ID0203288 FOR S/N BEGINING WITH CMWJ40T3E80000063 & ENDING WITH S/N CMWJ40T3E80000082

# OUTER ROTATION HYDRAULICS

BEGINS WITH S/N: CMWJ40T3E80000063

ENDS WITH S/N: CMWJ40T3T80000082

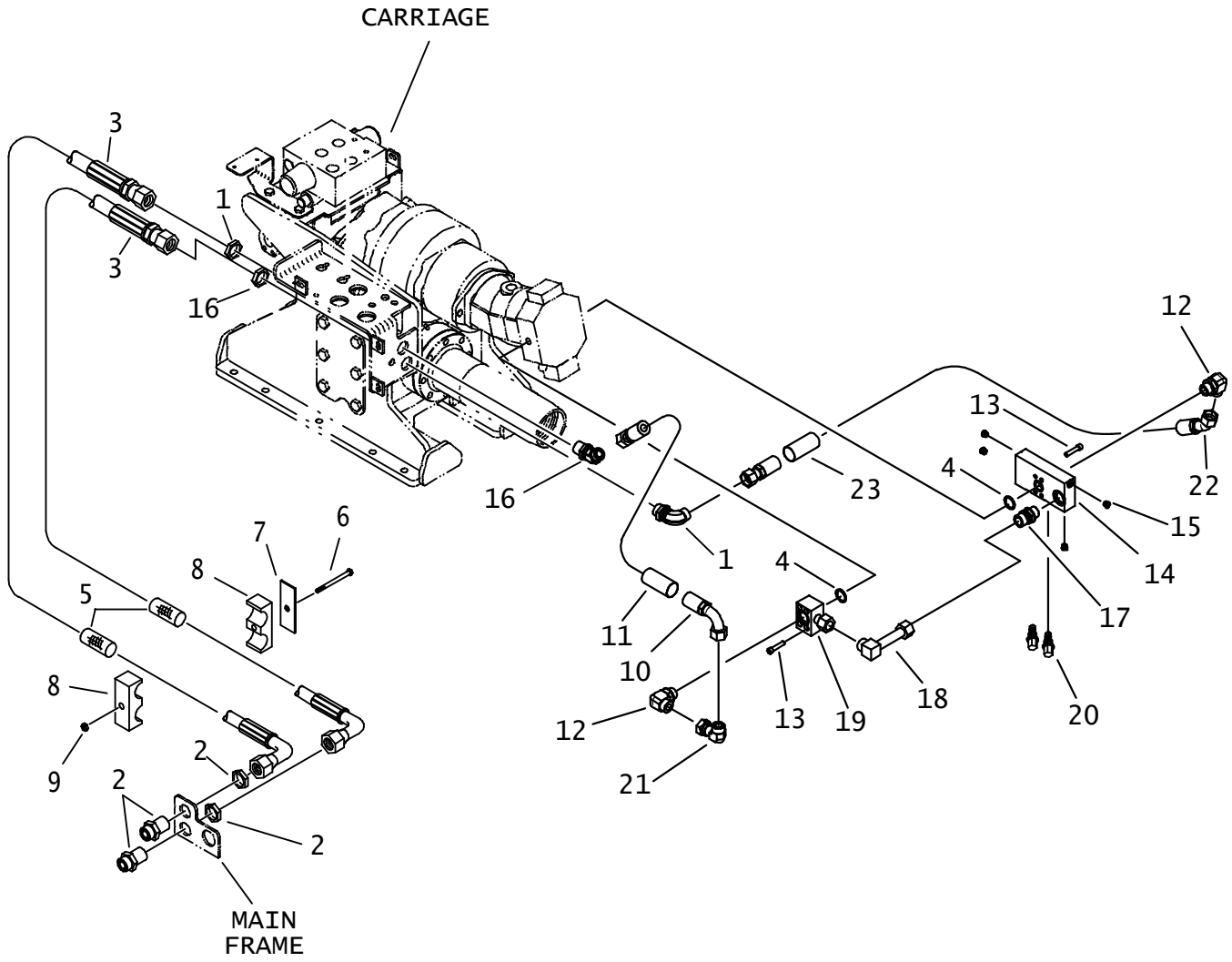



# OUTER ROTATION HYDRAULICS

BEGINS WITH S/N: CMWJ40T3E80000063

ENDS WITH S/N: CMWJ40T3T80000082

REF NO.	PART NUMBER	QTY	DESCRIPTION	REMARKS
1.	154-419	1	BK CONNECTOR (160-16090BK)	
2.	154-389	3	BK CONNECTOR (160-160BK)	
3.	150-1702	2	HOSE (160FX90S-299"-6000)	
4.	157-029	2	O-RING (219 D90)	
5.	117-292	2	ABRASION SLEEVE (2.07" X 70")	
6.	107-078	1	SCREW (M8-1.25 X 90MM)	
7.	315-623	1	BACKUP SPACER	
8.	110-359	1	BOLT-ON CLAMP (1-1/2", SET)	
9.	106-561	1	LOCKNUT (M8-1.25, PRV TRQ, 10.9)	
10.	150-2142	1	HOSE (160FX90-14"-6000)	
11.	117-564	1	ABRASION SLEEVE (1.75" X 15")	
12.	154-287	2	CONNECTOR (16S-16090)	
13.	106-804	8	SCREW (7/16-NC X 2", SOC, GR8)	USE LOCTITE 242 TORQUE TO 85 FT LBS
14.	149-589	1	CARTRIDGE MANIFOLD	
15.	154-384	4	PLUG (06S)	
16.	514-242	1	BK CONNECTOR (160-16045BK)	
17.	149-377	1	HYDRAULIC ADAPTER, SPECIAL	
18.	149-425	1	UNION (160-16090, SPECIAL)	
19.	149-376	1	ADAPTER MANIFOLD	
20.	149-566	2	HYDRAULIC VALVE	TORQUE TO 80-90 FT. LBS, TIGHTEN ONLY AT BASE WITH DEEP SOCKET
21.	154-290	1	UNION (160-160FX90)	
22.	150-2143	1	HOSE (160FX45-19"-6000)	
23.	117-794	1	ABRASION SLEEVE (1.75" X 18")	

NOT SHOWN:

FOOTNOTES:

NOTE:

REFER TO O-RING CHART (800-301) IN BACK OF THE BOOK FOR REPLACEMENT OF O-RINGS.

**INNER/OUTER SPINDLE DRIVE CASE DRAIN**  
 ENDS WITH S/N CMWA40T3C7000014

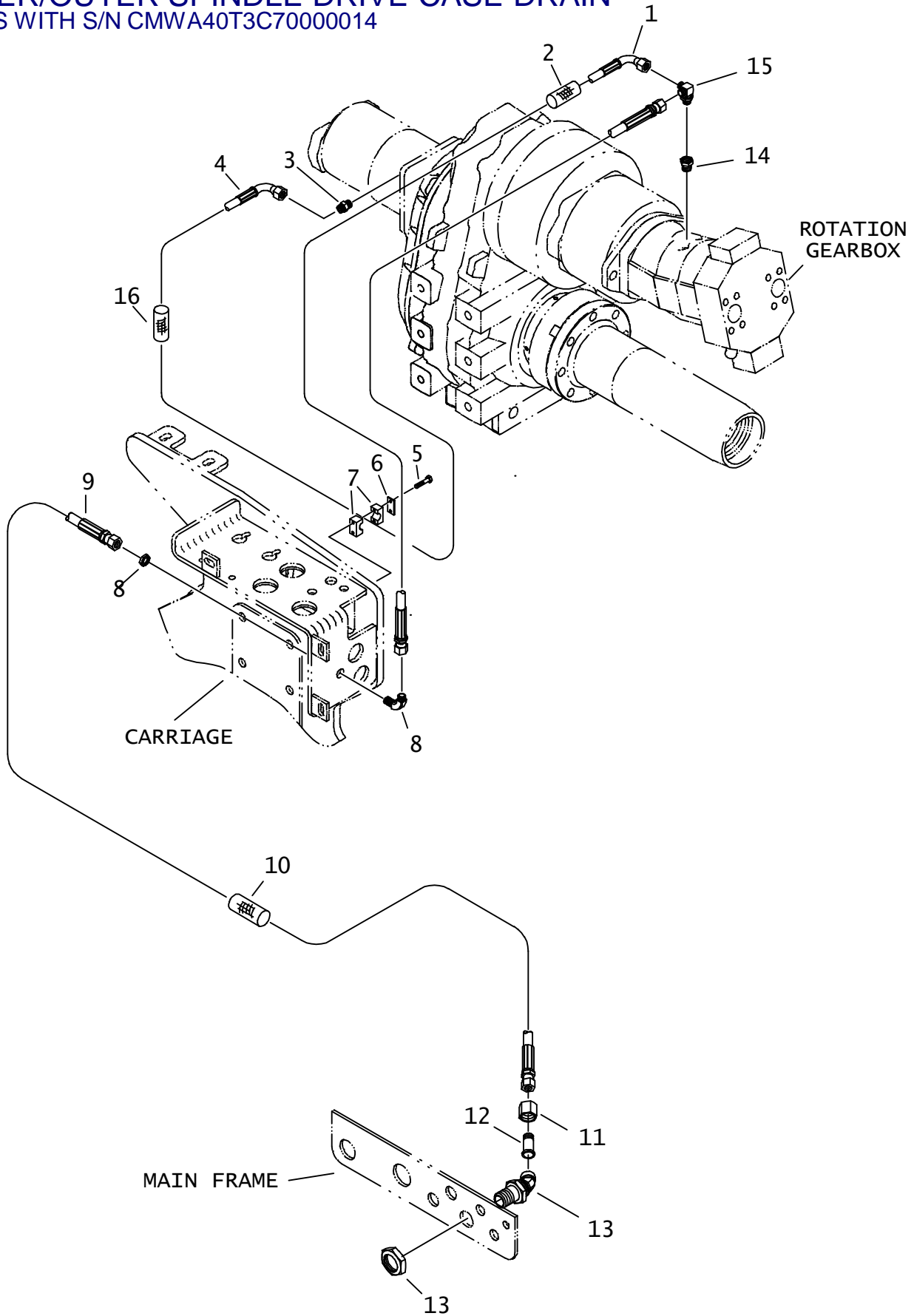

## INNER/OUTER SPINDLE DRIVE CASE DRAIN ENDS WITH S/N CMWA40T3C70000014

REF NO.	PART NUMBER	QTY	DESCRIPTION	REMARKS
1.	153-768	1	HOSE (060FX90S-18"-3000)	
2.	117-328	1	ABRASION SLEEVE (1.00" X 18")	
3.	156-174	1	CONNECTOR (06S-060)	AT ONLY
4.	153-769	1	HOSE (060FX90L-33"-3000)	AT ONLY
5.	105-818	2	BOLT (1/4-NC X 1-1/2")	AT ONLY
6.	322-289	1	BACKUP (BOLT-ON)	AT ONLY
7.	110-411	1	BOLT-ON CLAMP (3/4", SET)	AT ONLY
8.	154-229	1	BK CONNECTOR (060-06090BK)	
9.	515-750	1	HOSE (060FX-210"-3000)	
10.	117-416	1	ABRASION SLEEVE (1.00" X 50")	
11.	154-271	1	REDUCER NUT (120F)	
12.	154-459	1	REDUCER STEM (060)	
13.	154-448	1	BK CONNECTOR (120-12045BK)	
14.	153-770	1	REDUCER (12S-08SF)	
15.	514-051	1	BRANCH TEE (08S-060-060)	AT ONLY
	157-381	-	CONNECTOR (08S-06090S)	JT ONLY
16.	117-411	1	ABRASION SLEEVE (1.00" X 32")	AT ONLY

NOT SHOWN:

FOOTNOTES:

NOTE:

# OUTER SPINDLE DRIVE CASE DRAIN

ENDS WITH S/N CMWJ40T3L7000025

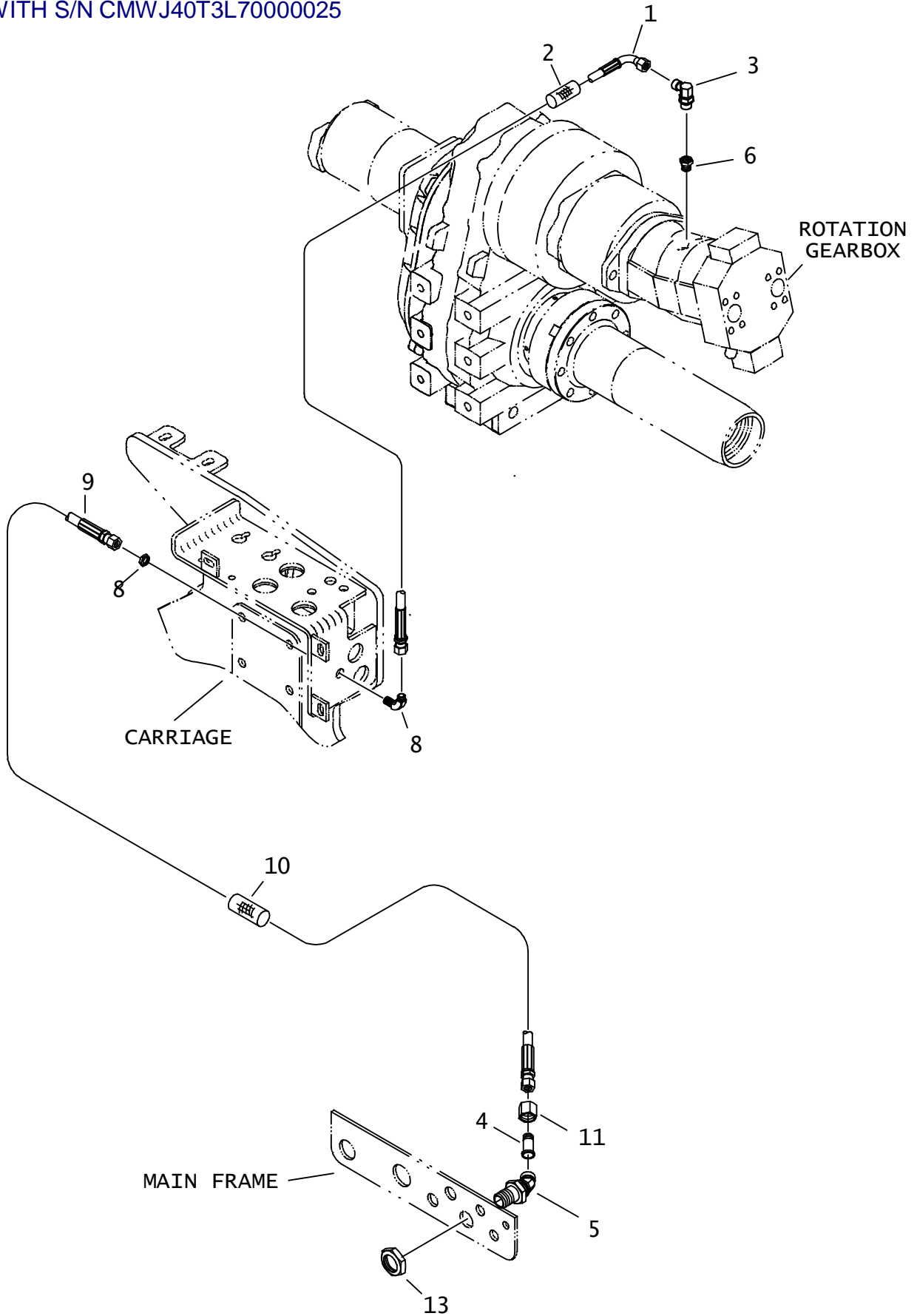

## OUTER SPINDLE DRIVE CASE DRAIN

### ENDS WITH S/N CMWJ40T3L70000025

REF NO.	PART NUMBER	QTY	DESCRIPTION	REMARKS
1.	153-768	1	HOSE (060FX90S-18"-3000)	
2.	117-328	1	ABRASION SLEEVE (1.00" X 18")	
3.	157-381	1	CONNECTOR (08S-06090S)	
4.	154-459	1	REDUCER STEM (060)	
5.	154-448	1	BK CONNECTOR (120-12045BK)	
6.	153-770	1	REDUCER (12S-08SF)	
8.	154-229	1	BK CONNECTOR (060-06090BK)	
9.	515-750	1	HOSE (060FX-210"-3000)	
10.	117-416	1	ABRASION SLEEVE (1.00" X 50")	
11.	154-271	1	REDUCER NUT (120F)	

NOT SHOWN:

FOOTNOTES:

NOTE:

# REMOTE FILTER

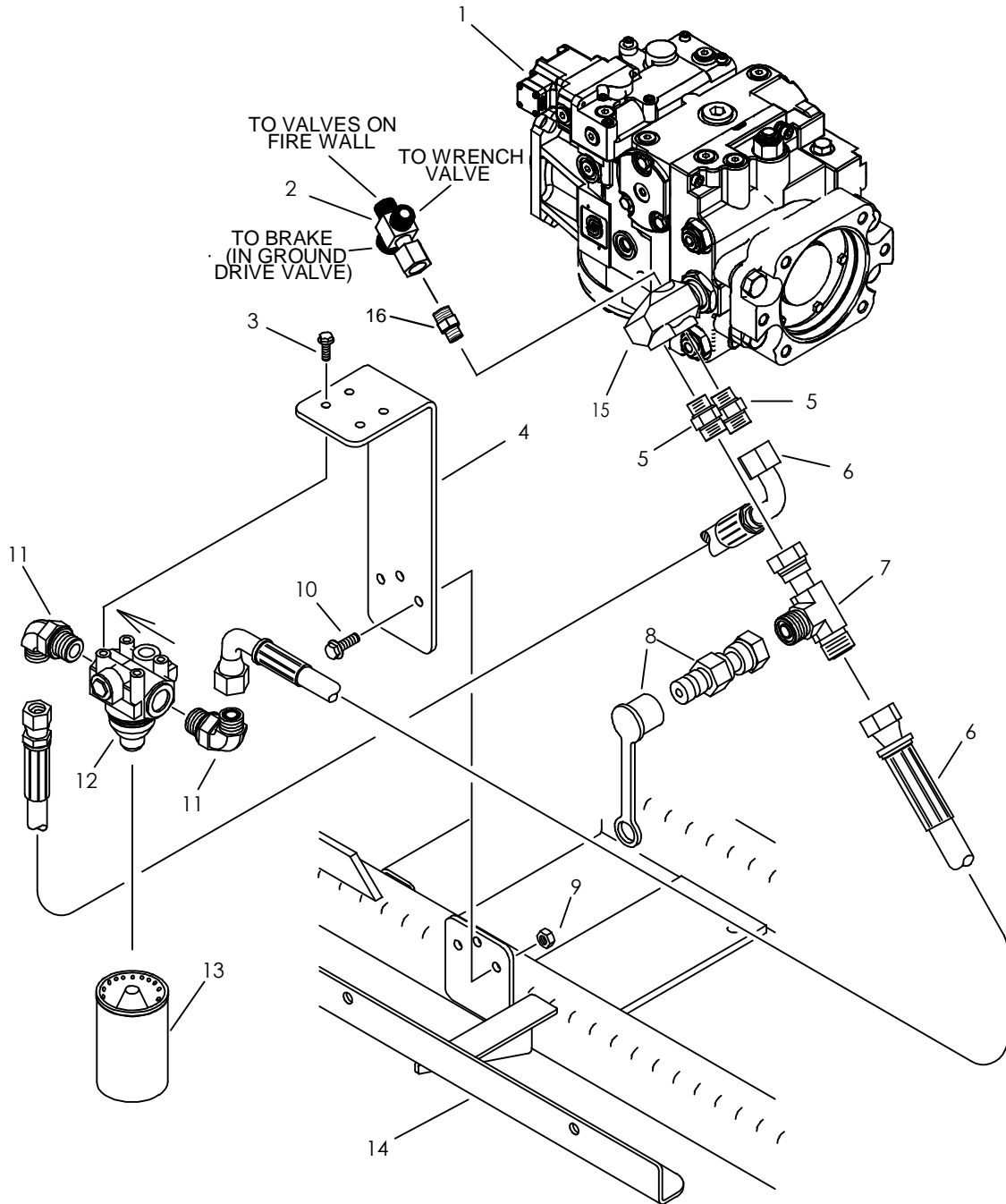

## REMOTE FILTER

REF NO.	PART NUMBER	QTY	DESCRIPTION	REMARKS
1.	153-340	-	HYDRAULIC PUMP	INCLUDES ITEM 15
2.	150-1097	1	CROSS (F060-060-080-060)	
3.	105-823	4	FLG LK BOLT (5/16-NC X 3/4")	
4.	310-571	1	CHARGE FILTER BRACKET	
5.	154-301	2	CONNECTOR (10S-100)	
6.	153-268	2	HOSE (100FX90S-24"-1500)	
7.	154-488	1	UN RUN TEE (100FX-100-100)	
8.	159-159	1	QDC ADAPTER (02-100FX)	
	159-148	-	DUST CAP (1/8")	
9.	105-894	3	LOCKNUT(M10-1.50, PRV TRQ, 10.9)	
10.	106-724	3	FLG SCREW (M10-1.50 X 25MM)	
11.	154-300	2	CONNECTOR (100-12S90)	
12.	153-050	1	FILTER HEAD (12 SF)	
13.	149-939	1	FILTER	
14.	354-597	-	ENGINE SKID	
15.	149-845	-	REMOTE FILTRATION KIT (75/100)	PART OF ITEM 1, INCLUDES O-RING
16.	154-221	-	CONNECTOR (06S-060)	

NOT SHOWN:

FOOTNOTES:

NOTE:

REFER TO O-RING CHART (800-301) IN BACK OF THE BOOK FOR REPLACEMENT OF O-RINGS.

# 2 SPEED TRACK AND THRUST

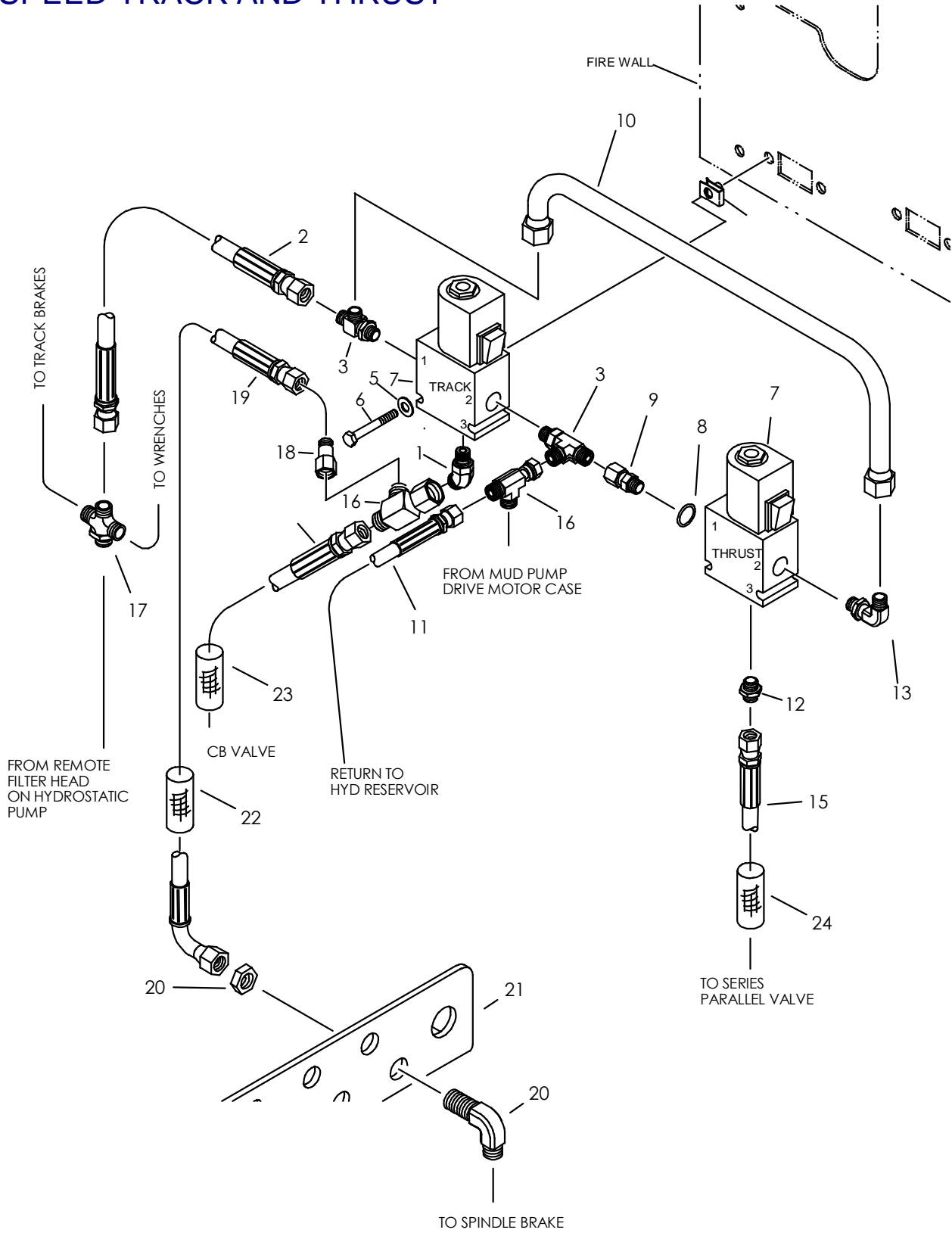



## 2 SPEED TRACK AND THRUST

REF NO.	PART NUMBER	QTY	DESCRIPTION	REMARKS
1.	154-224	1	CONNECTOR (06S-06045)	
2.	154-832	1	HOSE (060FX-23"-3000)	
3.	154-345	2	RUN TEE (06S-060-060)	
4.	106-574	4	CLIP NUT (M6-1.00)	
5.	106-076	4	WASHER (1/4")	
6.	107-025	4	SCREW (M6-1.0 X 50mm)	
7.	158-627	2	SOLENOID VALVE	
	500-756	1	SEAL REPAIR KIT	
	217-770	1	SOLENOID COIL	
	158-636	1	SOLENOID VALVE CARTRIDGE	
8.	155-705	1	O-RING (906 D90)	
9.	514-409	1	UNION (06J-060FX)	
10.	156-295	1	HYD LINE (-6)	
11.	515-221	1	HOSE (060FX90S-28"-3000)	
12.	154-220	1	CONNECTOR (040-06S)	
13.	154-342	1	CONNECTOR (06S-06090)	
14.	154-806	1	HOSE (060FX-54"-3000)	
15.	154-692	1	HOSE (040FX-54"-3000)	
16.	154-344	2	UN RUN TEE (060FX-060-060)	
17.	149-847	-	CROSS (06S-060-060-080)	
18.	154-373	1	REDUCER (040-060F)	
19.	154-727	1	HOSE (040FX90-30"-3000)	
20.	154-355	1	BK CONNECTOR (040-04090BK)	
21.	354-466	1	BULKHEAD PLATE	
22.	117-396	1	ABRASION SLEEVE (1.25" X 28")	
23.	117-395	1	ABRASION SLEEVE (1.25" X 50")	
24.	117-714	1	ABRASION SLEEVE (1.00" X 54")	

NOT SHOWN:

FOOTNOTES:

NOTE:

REFER TO O-RING CHART (800-301) IN BACK OF THE BOOK FOR REPLACEMENT OF O-RINGS.

# SPINDLE BRAKE

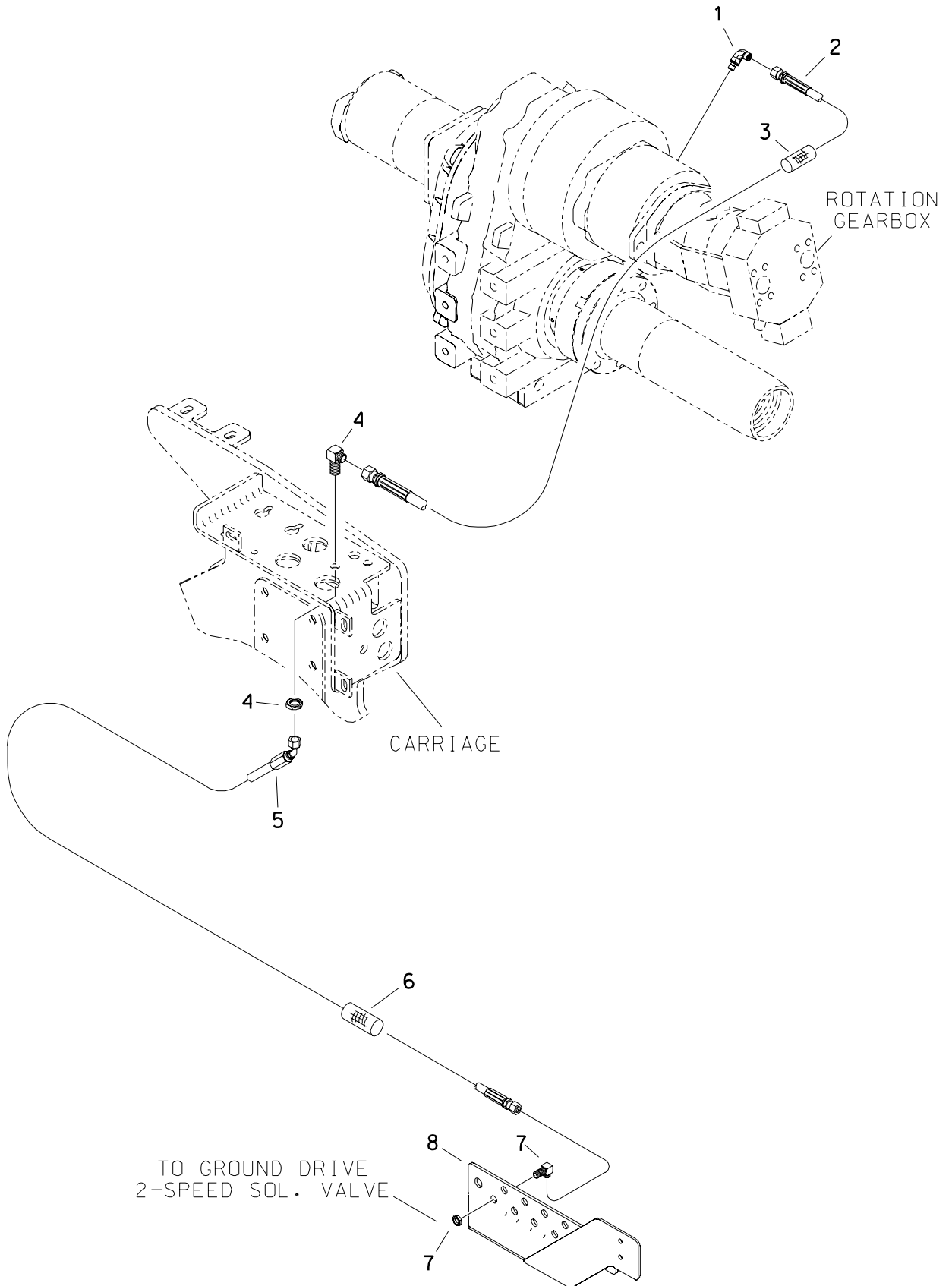

# SPINDLE BRAKE

REF NO.	PART NUMBER	QTY	DESCRIPTION	REMARKS
1.	154-252	1	CONNECTOR (04S-04090)	
2.	515-543	1	HOSE (040FX-21"-3000)	
3.	117-607	1	ABRASION SLEEVE (1.00" X 21")	
4.	154-355	1	BK CONNECTOR (040-04090BK)	
5.	153-748	1	HOSE (040FX45-212"-3000)	
6.	117-693	1	ABRASION SLEEVE (1.00" X 60")	
7.	154-355	1	BK CONNECTOR (040-04090BK)	
8.	354-466	-	BULKHEAD PLATE	

## FOOTNOTES

# TRACK SHIFT

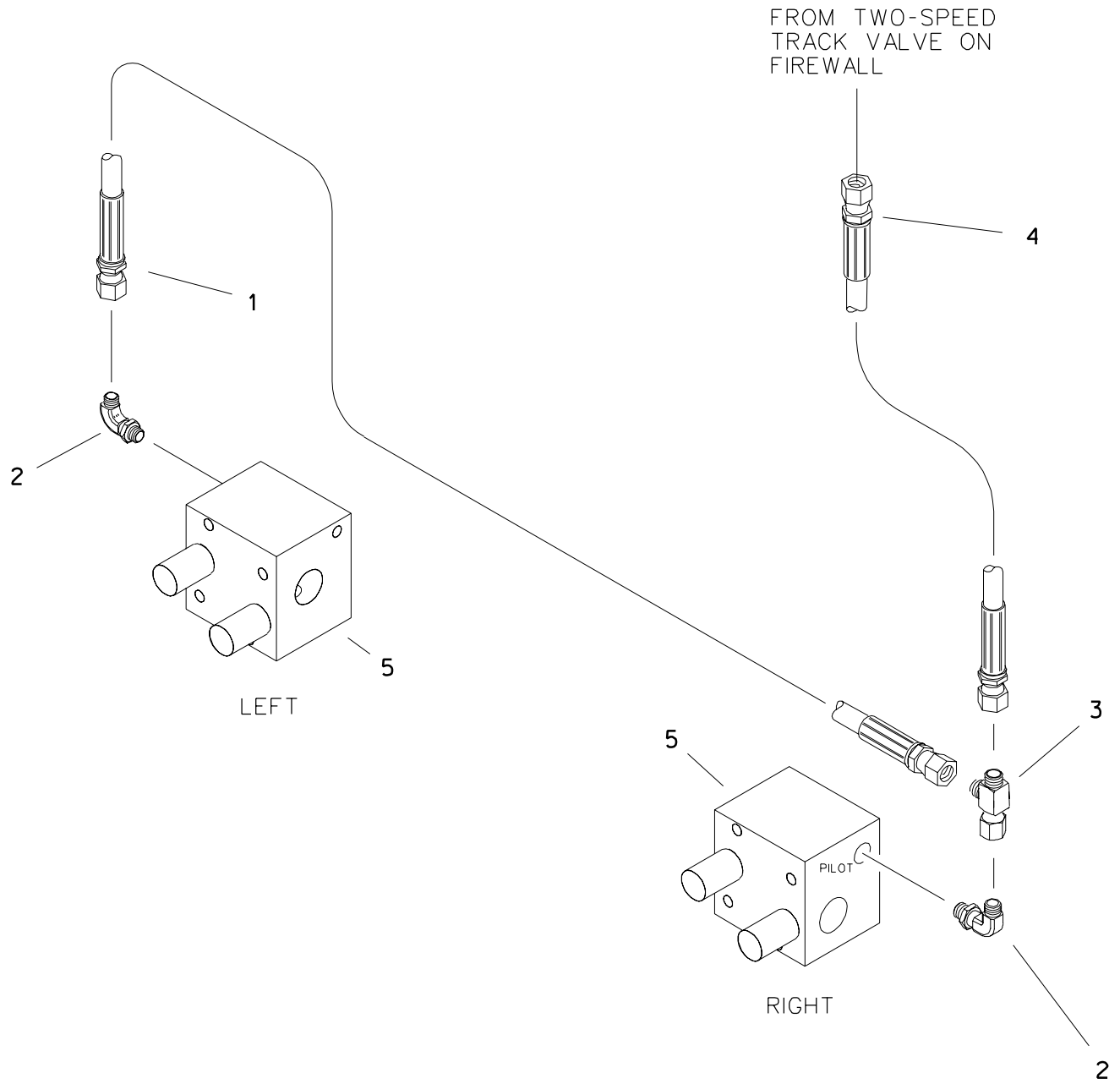

# TRACK SHIFT

REF NO.	PART NUMBER	QTY	DESCRIPTION	REMARKS
1.	154-797	1	HOSE (060FX-48"-3000)	
2.	514-049	2	CONNECTOR (04S-06090)	
3.	154-344	1	UNION RUN TEE (060FX-060-060)	
4.	154-806	1	HOSE (060FX-54"-3000)	
5.	153-767	-	COUNTERBALANCE MANIFOLD	SERVICE CARTRIDGE

### FOOTNOTES

### NOTE

REFER TO O-RING CHART (800-301) IN BACK OF THE BOOK FOR REPLACEMENT OF O-RINGS.

## TRACK BRAKE

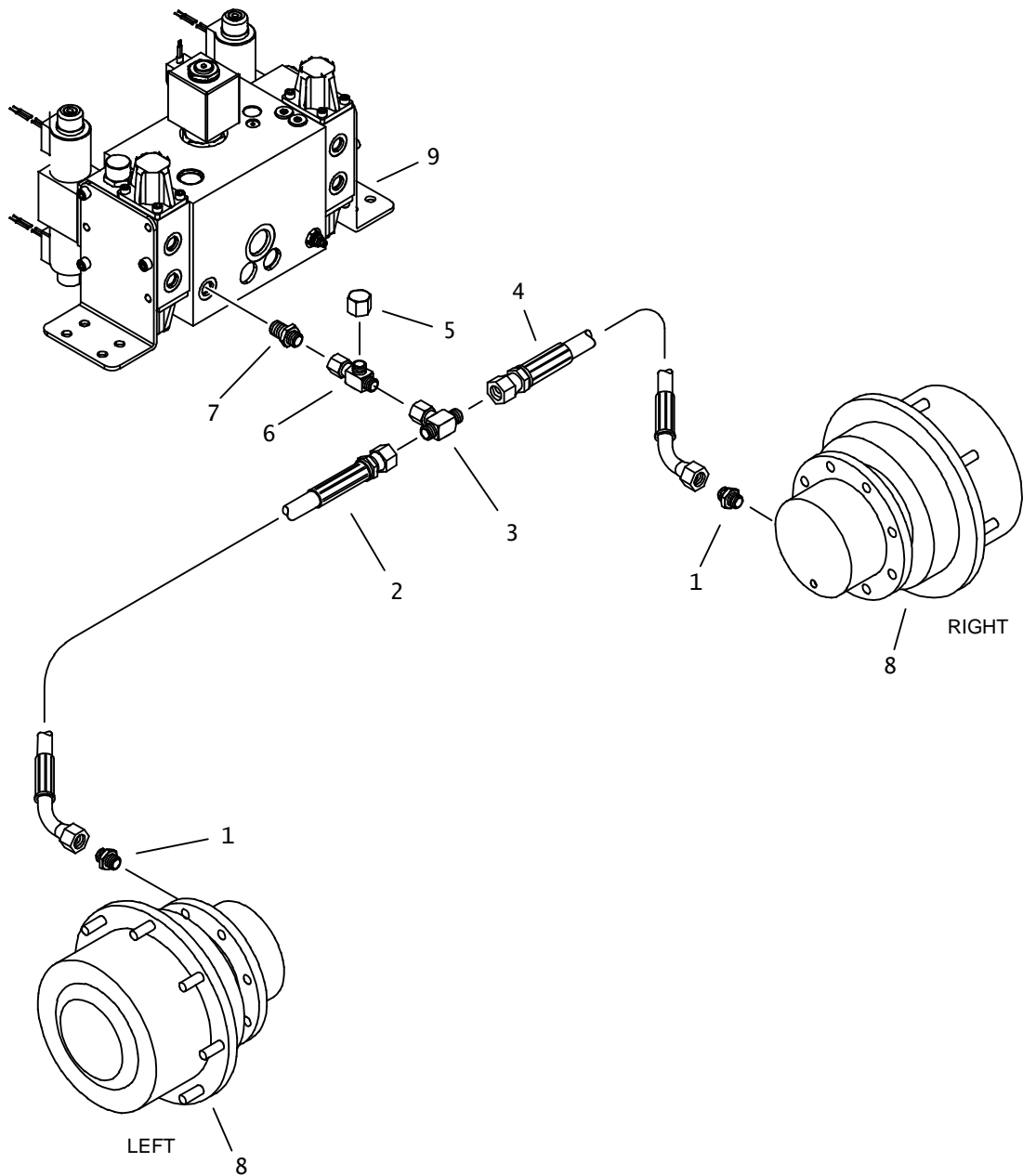

# TRACK BRAKE

## REF PART

NO.	NUMBER	QTY	DESCRIPTION	REMARKS
1.	154-411	2	CONNECTOR (04S-060)	
2.	515-188	1	HOSE (060FX90S-23"-3000)	
3.	154-348	1	UNION BR TEE (060FX-060-060)	
4.	154-738	1	HOSE (060FX90-34"-3000)	
5.	154-326	1	CAP (060F)	
6.	154-344	1	UNION RUN TEE (060FX-060-060)	
7.	154-221	1	CONNECTOR (06S-060)	
8.	166-285	2	PLANETARY GEARBOX	
	157-613	-	INTERNAL SEAL	
	500-2029	-	RETAINER RING, INTERNAL	
9.	153-639	-	HYD CONTROL VALVE	SEE FOOTNOTE 1

NOT SHOWN:

## FOOTNOTES:

153-639 IS SUPERSEDED BY 150-1815

## NOTE:

REFER TO O-RING CHART (800-301) IN BACK OF THE BOOK FOR REPLACEMENT OF O-RINGS.

# FLUID CHECK SUPPLY HYDRAULICS

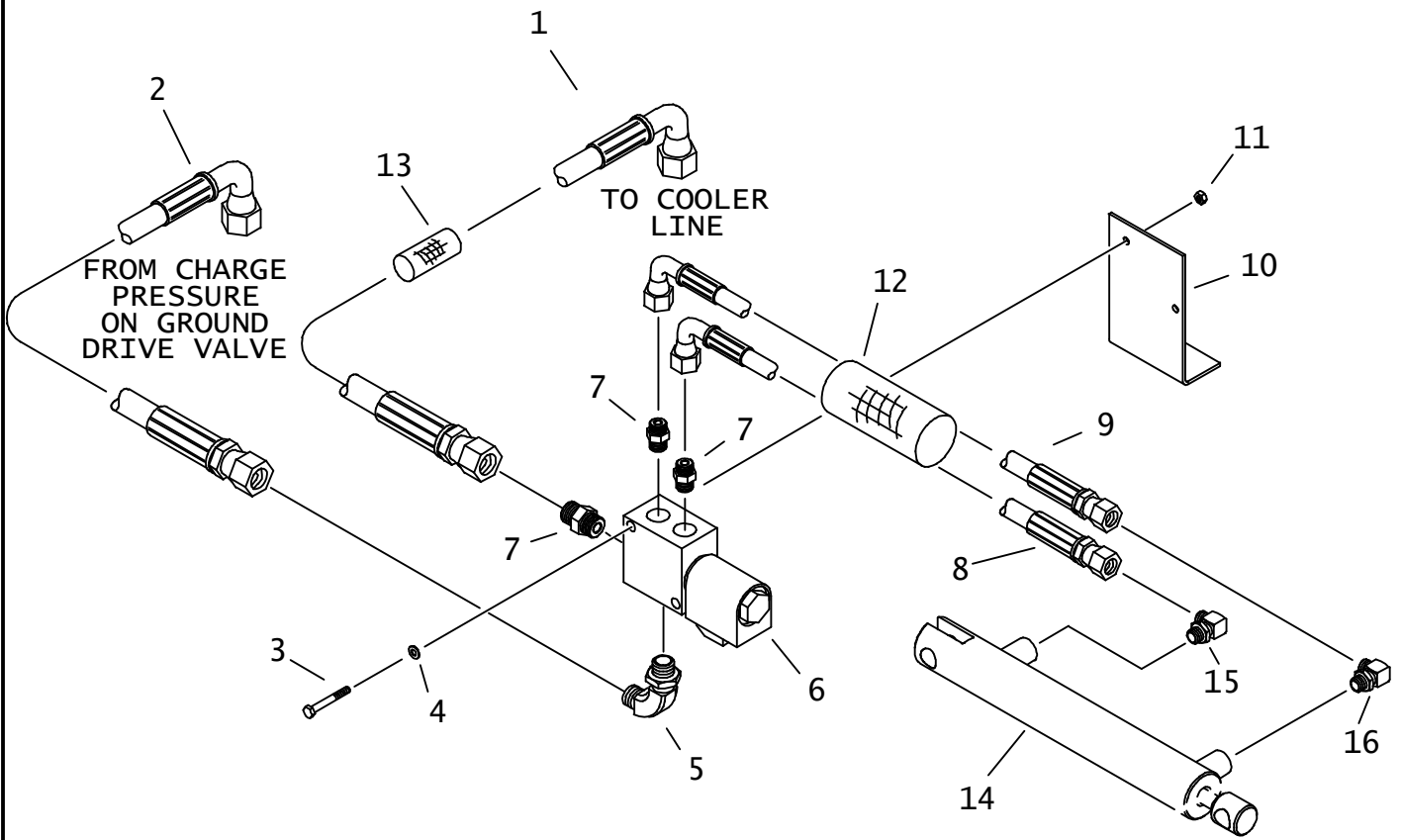



## FLUID CHECK SUPPLY HYDRAULICS

REF NO.	PART NUMBER	QTY	DESCRIPTION	REMARKS
1.	515-696	1	HOSE (040FX90M-58"-3000)	
2.	515-583	1	HOSE (060FX90-12"-3000)	
3.	107-025	2	SCREW (M6-1.00 X 50MM)	
4.	105-095	2	WASHER (1/4")	
5.	154-342	1	CONNECTOR (06S-06090)	
6.	149-550	1	SOLENOID CONTROL VALVE	
	214-491	1	COIL (12V)	
7.	154-220	3	CONNECTOR (040-06S)	
8.	515-074	1	HOSE (040FX90-77"-3000)	
9.	154-982	1	HOSE (040FX90S-80"-3000)	
10.	310-637	1	VALVE BRACKET	
11.	106-538	1	LOCKNUT (M6-1.00, PRV TRQ, 10.9)	
12.	115-963	1	ABRASION SLEEVE (1.59" X 75")	
13.	117-326	1	ABRASION SLEEVE (1.00" X 58")	
14.	150-727	-	CYL (1.0" X .500" X 4.0")	
15.	154-401	1	CONNECTOR (04S-04090, ORF)	
16.	154-252	1	CONNECTOR (04S-04090)	

NOT SHOWN:

FOOTNOTES:

NOTE:

REFER TO O-RING CHART (800-301) IN BACK OF THE BOOK FOR REPLACEMENT OF O-RINGS

# LOAD SENSE HYDRAULICS

ENDS WITH S/N CMWJ40T3P70000019

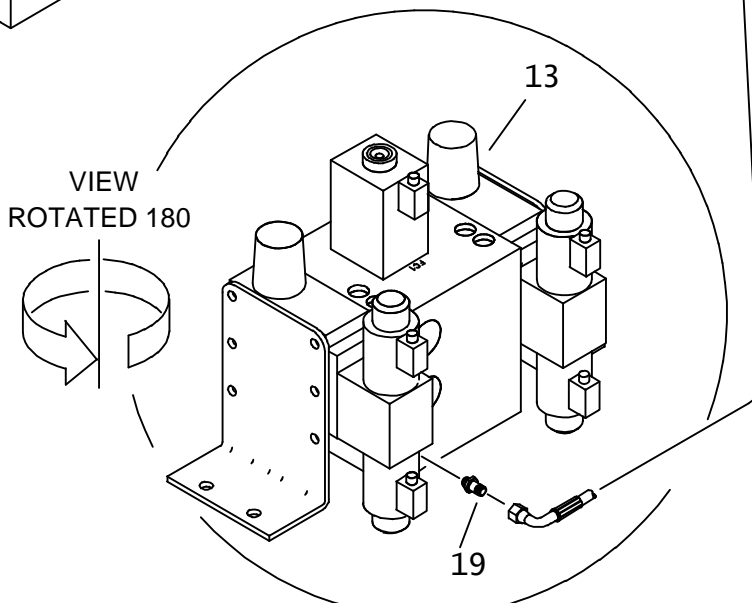
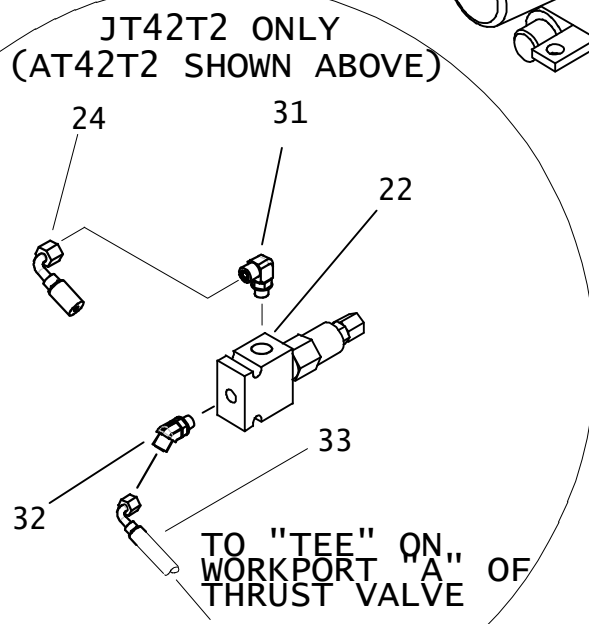
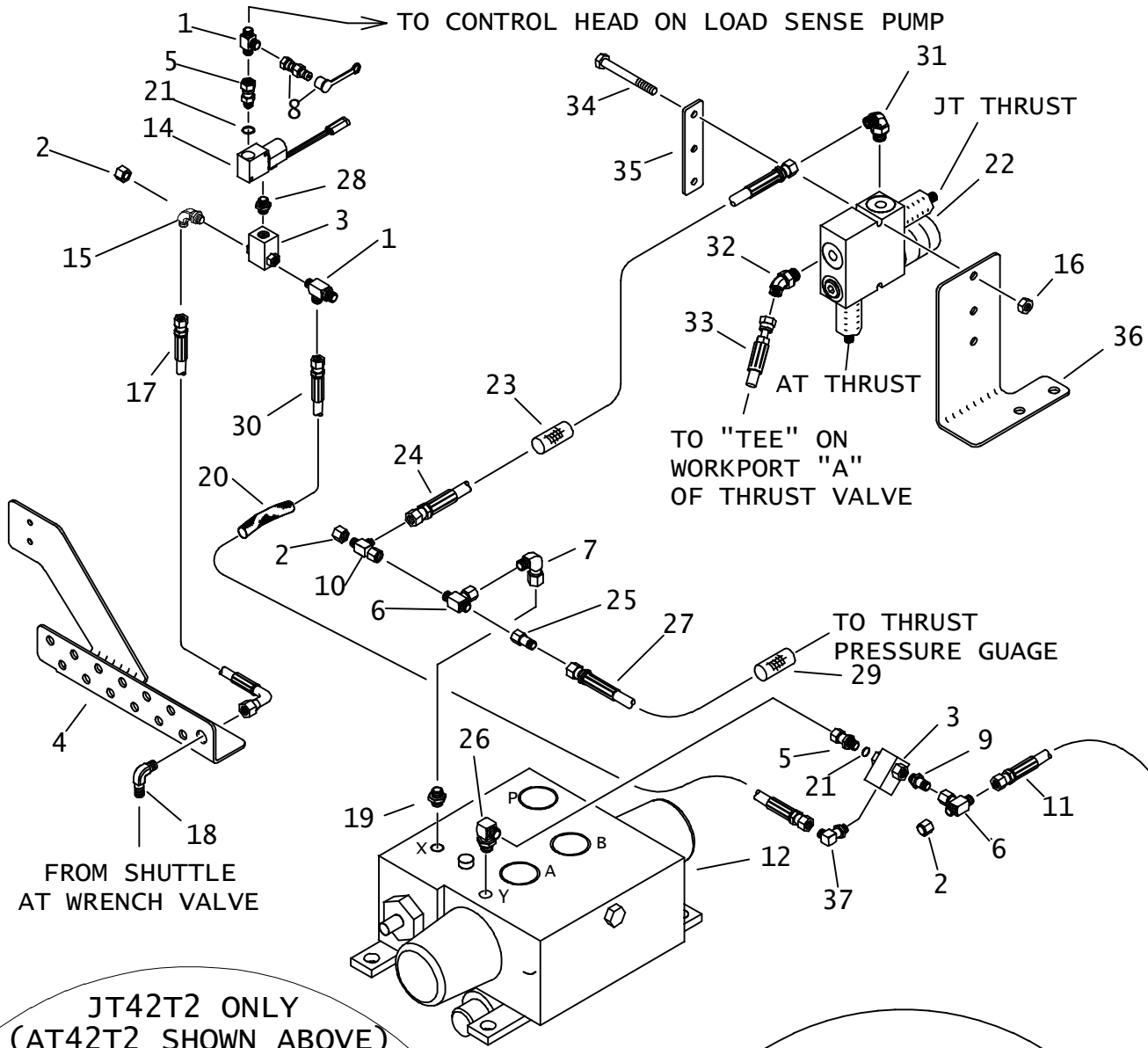

## LOAD SENSE HYDRAULICS

### ENDS WITH S/N CMWJ40T3P70000019

REF NO.	PART NUMBER	QTY	DESCRIPTION	REMARKS
1.	154-345	2	RUN TEE (06S-060-060)	
2.	154-326	3	CAP (060F)	
3.	158-600	2	HYD SHUTTLE VALVE	NOT SERVICABLE PER SUPPLIER
4.	354-466	-	BULKHEAD PLATE	
5.	514-409	2	UNION (06J-060FX)	
6.	154-348	2	UNION BR TEE (060FX-060-060)	
7.	154-228	1	CONNECTOR (060-060FX90)	
8.	159-157	1	QDC ADAPTER (02-060F)	
	159-148	-	DUST CAP (1/8")	
9.	154-221	1	CONNECTOR (06S-060)	
10.	154-344	1	UNION RUN TEE (060FX-060-060)	
11.	149-559	1	HOSE (060FX90M-20"-3000)	
12.	157-440	-	THRUST VALVE (ELECTRIC)	SEE FOOTNOTE 4
	150-1458	-	THRUST VALVE (ELECTRIC)	SEE FOOTNOTE 5
	500-1290	-	THRUST VALVE COIL	
13.	153-639	-	HYD CONTROL VALVE	SEE FOOTNOTE 6
	217-897		SOLENOID COIL (LARGE)	
	214-434		SOLENOID COIL (SMALL)	
	149-565		3-WAY CARTRIDGE VALVE	
	150-1525		PROPORTIONAL VALVE	
	150-2032		PRESSURE COMPENSATOR VALVE	
	150-2033		SEAL KIT	
14.	158-661	1	HYD CONTROL VALVE	
	500-757	-	SEAL REPAIR KIT	
	214-491	-	COIL, 12V	
15.	154-342	1	CONNECTOR (06S-06090)	
16.	106-237	2	LOCKNUT (M6-1.00, PRV TRQ, NLK)	
17.	154-738	1	HOSE (060FX90-34"-3000)	
18.	154-229	1	BK CONNECTOR (060-06090BK)	
19.	154-411	2	CONNECTOR (04S-060)	
20.	117-702	1	ABRASION SLEEVE (1.00" X 68")	
21.	155-705	2	O-RING (906 D90)	
22.	153-328	1	HYDRAULIC VALVE	SEE FOOTNOTE 3, AT ONLY
	516-121	1	VALVE	JT ONLY
	155-074	-	PLUG (08S, SOC, FM)	SEE FOOTNOTE 2
23.	117-411	1	ABRASION SLEEVE (1.00" X 32")	
24.	153-305	1	HOSE (060FX-31"-3000)	AT ONLY
	515-188	1	HOSE (060FX90S-23"-3000)	JT ONLY
25.	154-373	1	REDUCER (040-060F)	

NOT SHOWN:

#### FOOTNOTES:

- VALVE MOUNT BRACKET BOLTS DOWN TO FRAME ALONG WITH GROUND DRIVE VALVE BRACKET HARDWARE.
- TORQUE FACTORY PLUG (NO O-RING) TO 24 LB-FT.  
TORQUE SERVICE PLUG (WITH O-RING) TO 72 LB-FT.
- THE PLUG THAT COMES INSTALLED IN THE VALVE MAY HAVE TO BE MOVED TO THE "A" PORT.
- ENDS WITH S/N: CMWJ42T2J60000023; CMWA42T2E60000029; CMWA40T3P60000002; CMWJ40T3T60000001.
- BEGINS WITH S/N: CMWA40T3K60000003; CMWJ40T3P60000002.
- 153-639 HYD CONTROL VALVE IS SUPERSEDED BY 150-1815 HYD CONTROL VALVE.

NOTE:

## LOAD SENSE HYDRAULICS

### ENDS WITH S/N CMWJ40T3P70000019

REF NO.	PART NUMBER	QTY	DESCRIPTION	REMARKS
26.	514-049	1	CONNECTOR (04S-06090)	
27.	515-161	1	HOSE (040FX-160"-3000)	
28.	155-153	1	CONNECTOR (06S-06S)	
29.	117-759	1	ABRASION SLEEVE (1.00" X 160")	
30.	154-808	1	HOSE (060FX-74"-3000)	
31.	154-227	1	CONNECTOR (060-08S90)	AT ONLY
	154-342	1	CONNECTOR (06S-06090)	JT ONLY
32.	154-225	1	CONNECTOR (060-08S45)	AT ONLY
	154-224	1	CONNECTOR (06S-06045)	JT ONLY
33.	515-538	1	HOSE (060FX90S-15"-3000)	NOTE HOSE ORIENTATION DIFFERENCE BETWEEN AT & JT
34.	106-893	2	SCREW (M6-1.00 X 55MM)	
35.	310-400	1	BACKUP PLATE	
36.	314-459	1	PLATE	SEE FOOTNOTE 1
37.	157-420	1	CONN (06S-06090,ORF .028)	

NOT SHOWN:

FOOTNOTES:

NOTE:



# LOAD SENSE HYDRAULICS

BEGINS WITH S/N CMWJ40T3P70000020

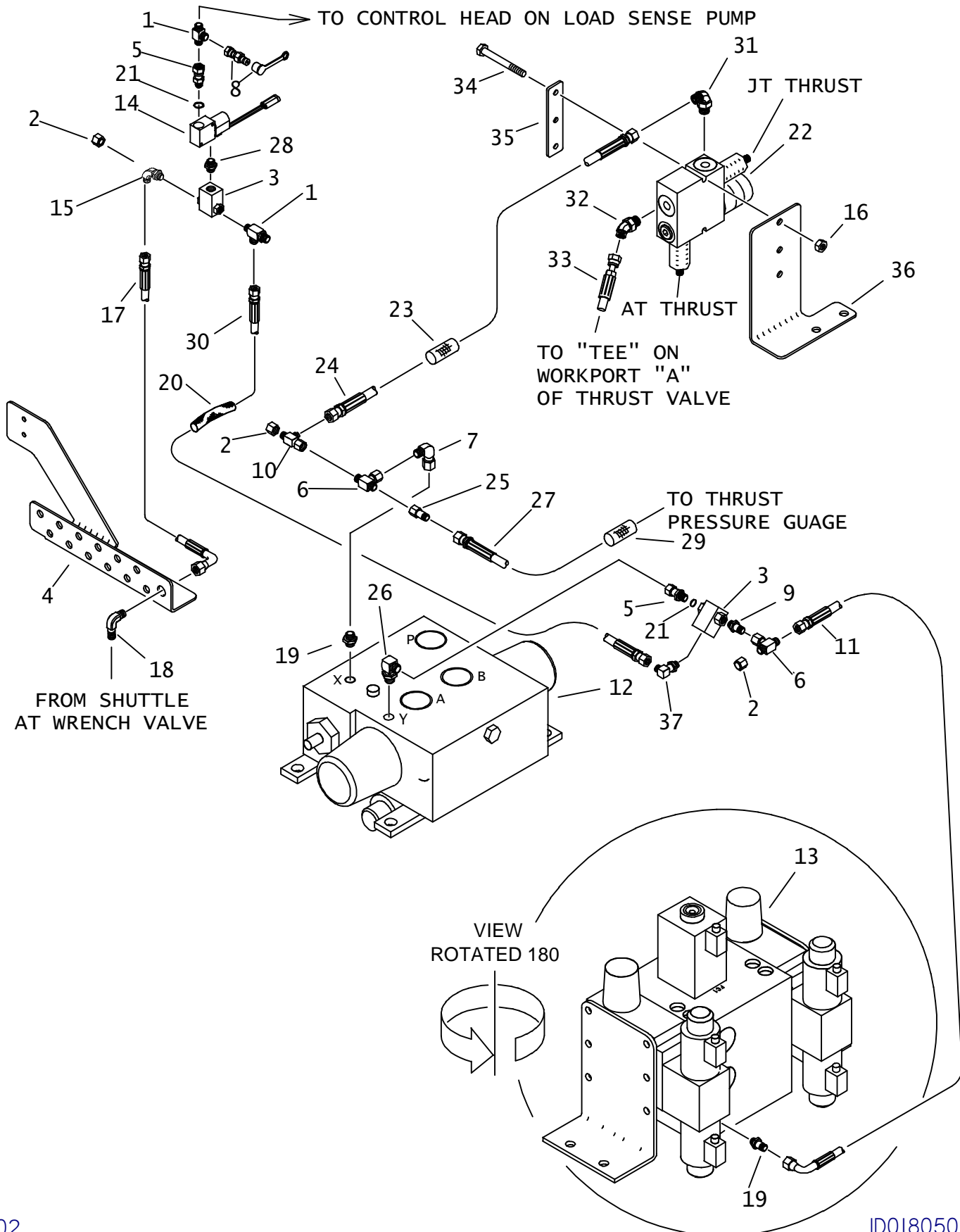

## LOAD SENSE HYDRAULICS

BEGINS WITH S/N CMWJ40T3P70000020

REF NO.	PART NUMBER	QTY	DESCRIPTION	REMARKS
1.	154-345	2	RUN TEE (06S-060-060)	
2.	154-326	3	CAP (060F)	
3.	158-600	2	HYD SHUTTLE VALVE	NOT SERVICABLE PER SUPPLIER
4.	354-466	-	BULKHEAD PLATE	
5.	514-409	2	UNION (06J-060FX)	
6.	154-348	2	UNION BR TEE (060FX-060-060)	
7.	154-228	1	CONNECTOR (060-060FX90)	
8.	159-157	1	QDC ADAPTER (02-060F)	
	159-148	-	DUST CAP (1/8")	
9.	154-221	1	CONNECTOR (06S-060)	
10.	154-344	1	UNION RUN TEE (060FX-060-060)	
11.	149-559	1	HOSE (060FX90M-20"-3000)	
12.	157-440	-	THRUST VALVE (ELECTRIC)	SEE FOOTNOTE 3
	150-1458	-	THRUST VALVE (ELECTRIC)	SEE FOOTNOTE 4
	500-1290	-	THRUST VALVE COIL	
13.	153-639	-	HYD CONTROL VALVE	SEE FOOTNOTE 5
	217-897		SOLENOID COIL (LARGE)	
	214-434		SOLENOID COIL (SMALL)	
	149-565		3-WAY CARTRIDGE VALVE	
	150-1525		PROPORTIONAL VALVE	
	150-2032		PRESSURE COMPENSATOR VALVE	
	150-2033		SEAL KIT	
14.	158-661	1	HYD CONTROL VALVE	
	500-757	-	SEAL REPAIR KIT	
	214-491	-	COIL, 12V	
15.	154-342	1	CONNECTOR (06S-06090)	
16.	106-237	2	LOCKNUT (M6-1.00, PRV TRQ, NLK)	
17.	154-738	1	HOSE (060FX90-34"-3000)	
18.	154-229	1	BK CONNECTOR (060-06090BK)	
19.	154-411	2	CONNECTOR (04S-060)	
20.	117-702	1	ABRASION SLEEVE (1.00" X 68")	
21.	155-705	2	O-RING (906 D90)	
22.	153-328	1	HYDRAULIC VALVE	SEE FOOTNOTE 2
23.	117-411	1	ABRASION SLEEVE (1.00" X 32")	
24.	153-305	1	HOSE (060FX-31"-3000)	
25.	154-373	1	REDUCER (040-060F)	

NOT SHOWN:

FOOTNOTES:

1. VALVE MOUNT BRACKET BOLTS DOWN TO FRAME ALONG WITH GROUND DRIVE VALVE BRACKET HARDWARE.
2. AT THRUST RELIEF ADJUSTMENT MUST BE SCREWED IN COMPLETELY FOR JT MACHINES TO OPERATE PROPERLY.
3. ENDS WITH S/N: CMWJ42T2J60000023; CMWA42T2E60000029; CMWA40T3P60000002; CMWJ40T3T60000001.
4. BEGINS WITH S/N: CMWA40T3K60000003; CMWJ40T3P60000002.
5. 153-639 HYD CONTROL VALVE IS SUPERSEDED BY 150-1815 HYD CONTROL VALVE.

NOTE:

# LOAD SENSE HYDRAULICS

BEGINS WITH S/N CMWJ40T3P70000020

REF NO.	PART NUMBER	QTY	DESCRIPTION	REMARKS
26.	514-049	1	CONNECTOR (04S-06090)	
27.	515-161	1	HOSE (040FX-160"-3000)	
28.	155-153	1	CONNECTOR (06S-06S)	
29.	117-759	1	ABRASION SLEEVE (1.00" X 160")	
30.	154-808	1	HOSE (060FX-74"-3000)	
31.	154-227	1	CONNECTOR (060-08S90)	
32.	154-225	1	CONNECTOR (060-08S45)	
33.	515-538	1	HOSE (060FX90S-15"-3000)	
34.	106-893	2	SCREW (M6-1.00 X 55MM)	
35.	310-400	1	BACKUP PLATE	
36.	314-459	1	PLATE	SEE FOOTNOTE 1
37.	157-420	1	CONN (06S-06090,ORF .028)	

NOT SHOWN:

FOOTNOTES:

NOTE:





# LOAD SENSE REAR HYDRAULICS

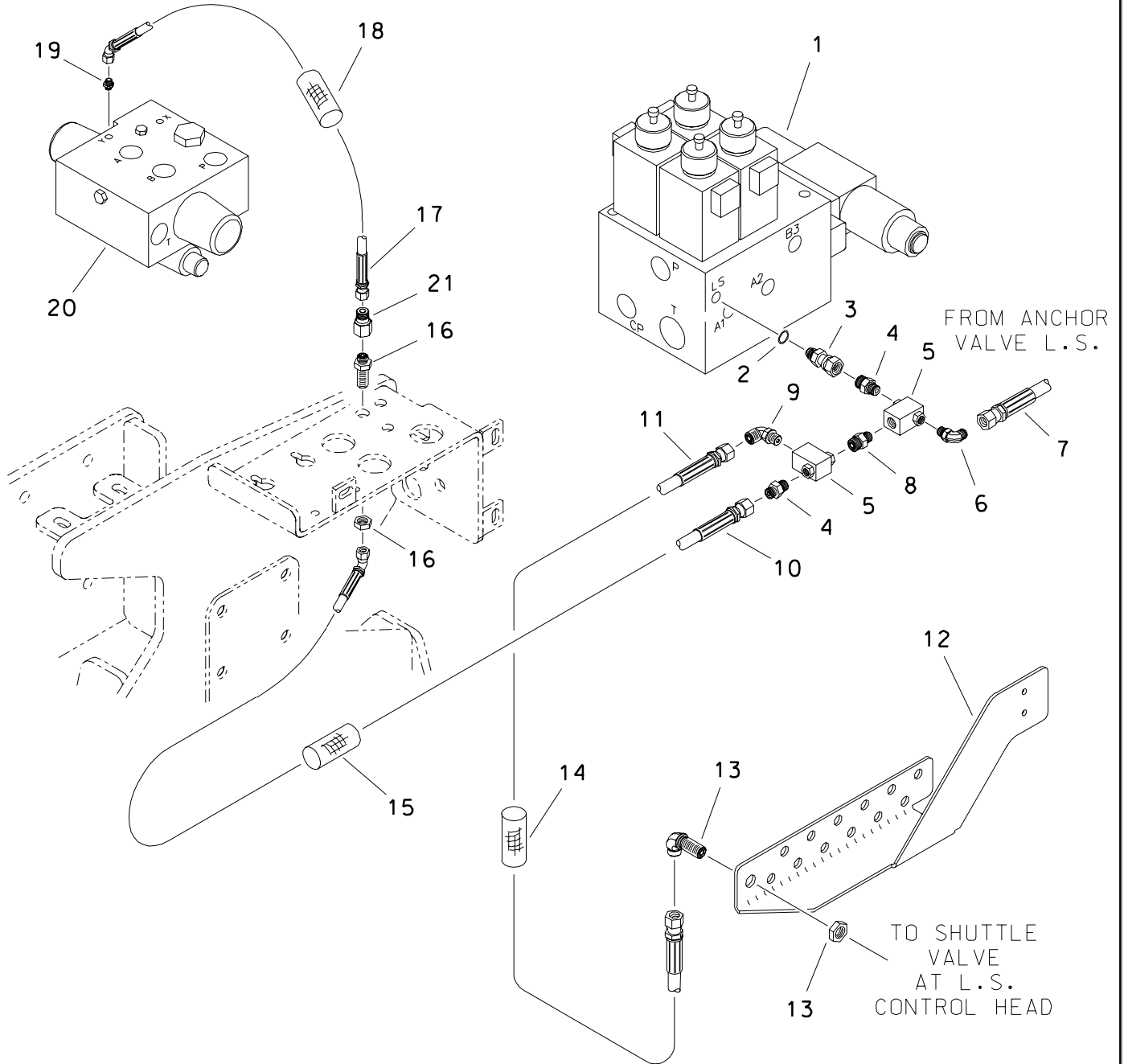

## LOAD SENSE REAR HYDRAULICS

REF NO.	PART NUMBER	QTY	DESCRIPTION	REMARKS
1.	153-410	-	HYDRAULIC VALVE	
2.	155-705	1	O-RING (906 D90)	
3.	514-409	1	UNION (06J-06DFX)	
4.	154-221	2	CONNECTOR (06S-060)	SEE FOOTNOTE 1
5.	158-600	2	HYD SHUTTLE VALVE	ONE ONLY FOR JT
6.	154-342	1	CONNECTOR (06S-06090)	
7.	515-410	-	HOSE (06DFX45-118"-3000)	
8.	155-153	1	CONNECTOR (06S-06S)	AT ONLY
9.	157-420	1	CONN (06S-06090, ORF .028)	AT ONLY
10.	157-288	1	HOSE (06DFX45-238"-3000)	AT ONLY
11.	154-816	1	HOSE (06DFX-120"-3000)	
12.	354-466	-	BULKHEAD PLATE	
13.	154-229	-	BK CONNECTOR (060-06090BK)	
14.	117-212	1	ABRASION SLEEVE (1.25" X 118")	
15.	117-400	1	ABRASION SLEEVE (1.00" X 72")	AT ONLY
16.	514-163	1	BK CONNECTOR (060-060BK)	AT ONLY
17.	153-073	1	HOSE (04DFX45-28"-3000)	AT ONLY
18.	117-409	1	ABRASION SLEEVE (1.00" X 28")	AT ONLY
19.	157-286	1	CONNECTOR (04S-040, ORF .028)	AT ONLY
20.	153-773	-	HYDRAULIC VALVE	AT ONLY
21.	154-373	1	REDUCER (040-060F)	AT ONLY

## FOOTNOTES

1. REPLACED BY 510-015 1X FOR JT4020 MACH 1

## NOTES

REFER TO O-RING CHART (800-301) ON BACK OF THE BOOK FOR REPLACEMENT OF O-RINGS.

# INNER ROTATION HYDRAULICS

JT4020 ALL TERRAIN ONLY

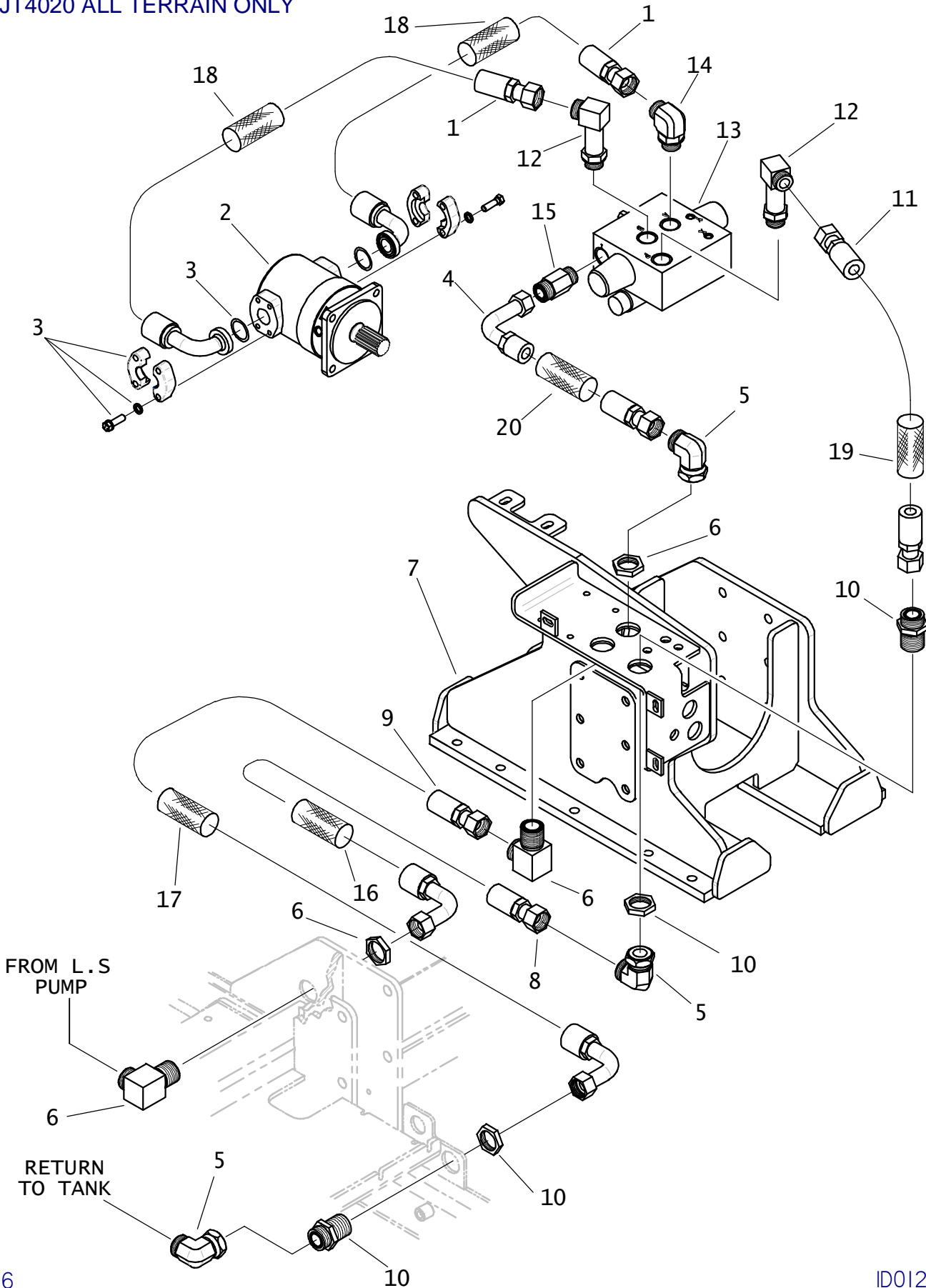

## INNER ROTATION HYDRAULICS

### JT4020 ALL TERRAIN ONLY

REF NO.	PART NUMBER	QTY	DESCRIPTION	REMARKS
1.	153-663	2	HOSE (160FX-20FL90S-36.5-3000)	USE 1 @ 74"
2.	153-612	-	HYDRAULIC MOTOR	
	191-263	-	SEAL REPAIR KIT	
3.	159-036	2	SPLIT FLANGE (20F, SET)	
4.	153-665	1	HOSE (160FX90L-200FX-15"-3000)	
5.	514-422	3	CONNECTOR (200-200FX90)	
6.	153-679	2	SP CONNECTOR (200-20090BK)	
7.	313-958	-	CARRIAGE	
8.	157-752	1	HOSE (200FX90S-217"-3000,SPEC)	
9.	153-746	1	HOSE (200F90L-230"-3000)	
10.	514-096	2	BK CONNECTOR (200-200BK)	
11.	153-664	1	HOSE (160FX-200FX45-20.5-3000)	
12.	154-289	2	CONNECTOR (16S-16090,XL)	
13.	153-773	-	HYDRAULIC VALVE	
14.	154-287	1	CONNECTOR (16S-16090)	
15.	154-398	1	CONNECTOR (16S-160,XLG)	
16.	115-894	1	ABRASION SLEEVE (2.38" X 60")	
17.	117-705	1	ABRASION SLEEVE (2.38" X 78")	
18.	115-731	2	ABRASION SLEEVE (2.38" X 34")	
19.	117-565	1	ABRASION SLEEVE (1.75" X 19")	
20.	117-564	1	ABRASION SLEEVE (1.75" X 15")	

NOT SHOWN:

FOOTNOTES:

NOTE:

## INNER ROTATION CONTROL KIT

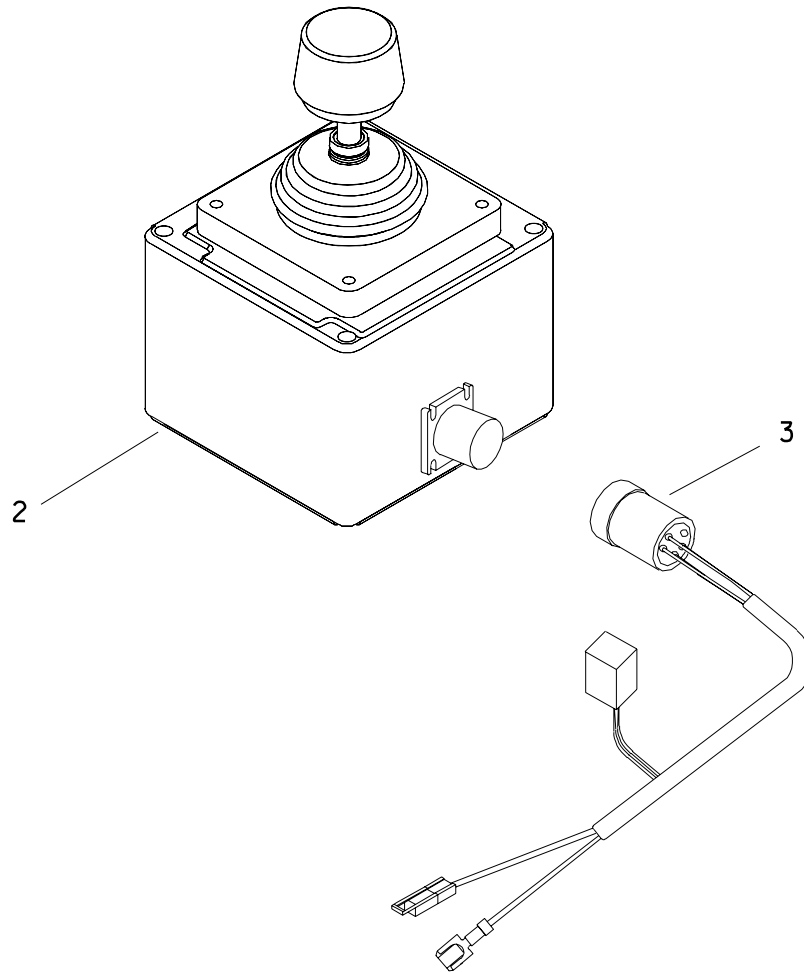

# INNER ROTATION CONTROL KIT

REF NO.	PART NUMBER	QTY	DESCRIPTION	REMARKS
	101-155	-	INNER ROTATION CONTROL KIT	CONTAINS REF NO. 1-3
1.	051-346	1	INNER ROT JOYSTICK KIT INSTR	NOT SHOWN
2.	101-156	1	SPINDLE CONTROL BOX	
3.	213-099	1	INNER ROTATION HARNESS	
	217-710	-	MICRO RELAY (SPDT)	NOT SHOWN

FOOTNOTES

# THRUST/TRACK DRIVE PUMP HYDRAULICS

ENDS WITH S/N CMWA40T3C70000014

ENDS WITH S/N CMWJ40T3L70000025

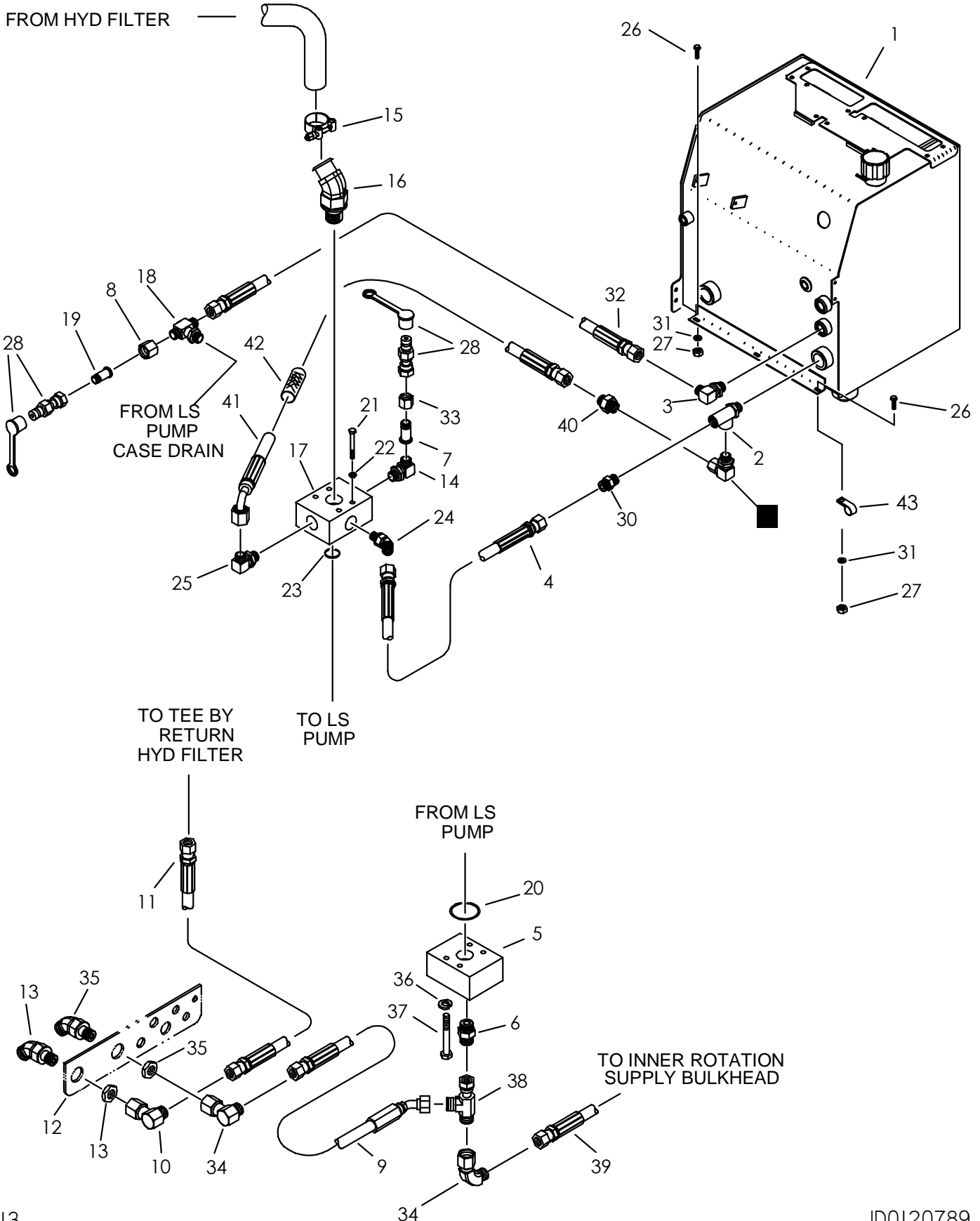



# THRUST/TRACK DRIVE PUMP HYDRAULICS

ENDS WITH S/N CMWA40T3C70000014

ENDS WITH S/N CMWJ40T3L70000025

REF NO.	PART NUMBER	QTY	DESCRIPTION	REMARKS
1.	350-614	-	HYDRAULIC RESERVOIR	
2.	153-899	1	RUN TEE (20S-16SF-16SF)	
3.	154-377	1	CONNECTOR (12S-16090)	
4.	157-498	1	HOSE (160FX-22"-212)	
5.	153-393	1	MANIFOLD BLOCK	
6.	514-097	1	CONNECTOR (20S-200)	
7.	154-249	1	REDUCER STEM (080)	
8.	154-340	1	REDUCER NUT (160F)	
9.	157-754	1	HOSE (200FX45-27"-3000, SPEC)	
10.	154-290	1	UNION (160-160FX90)	
11.	154-815	1	HOSE (160FX-48"-4000)	
12.	350-740	-	BULKHEAD PLATE	
13.	514-242	1	BK CONNECTOR (160-16045BK)	
14.	514-010	1	CONNECTOR (120-20S90)	
15.	318-890	-	T-BLT CLP BRIDG 1.875-2.188	
16.	153-370	-	S/O COUPLER (24S-24H45)	
17.	153-892	1	PUMP INLET MANIFOLD	
18.	154-347	1	BRANCH TEE (16S-160-160)	
19.	154-341	1	REDUCER STEM (080)	
20.	157-128	1	O-RING (225 D90)	
21.	105-110	4	BOLT (1/2-NC X 4-1/2")	
22.	105-070	4	LOCK WASHER (.500")	
23.	157-015	1	O-RING (232 D70)	
24.	154-371	1	CONNECTOR (12S-16045)	
25.	514-196	1	CONNECTOR (160-20S90)	
26.	106-381	6	FLG LK SCREW (M8-1.25 X 25MM)	
27.	106-561	6	LOCKNUT (M8-1.25, PRV TRQ, 10.9)	
28.	159-158	2	QDC ADAPTER (02-080FX)	
	159-148		DUST CAP (1/8")	
29.	153-908	1	UNION (16S-160FX90)	
30.	153-903	1	CHECK VALVE	
31.	105-118	6	WASHER (3/8")	
32.	157-755	1	HOSE (160FX-20"-212)	
33.	154-271	1	REDUCER NUT (120F)	
34.	514-422	2	CONNECTOR (200-200FX90)	AT ONLY
	514-177	-	CAP (200F)	JT ONLY
35.	153-395	1	BK CONNECTOR (200-20045)	
36.	105-385	4	LOCK WASHER (5/8")	
37.	105-943	4	BOLT (5/8-NC X 2-3/4")	
38.	514-142	1	UN RUN TEE (200FX-200-200)	
39.	157-753	1	HOSE (200FX-26"-3000, SPEC)	AT ONLY
40.	153-904	1	CHECK VALVE	
41.	153-938	1	HOSE (160FX90S-30"-200)	
42.	117-296	1	ABRASION SLEEVE (2.07" X 30")	
43.	110-333	1	BOLT-ON CLAMP (1")	

NOT SHOWN:

FOOTNOTES:

NOTE:

1. REFER TO O-RING CHART (800-301) IN BACK OF THE BOOK FOR REPLACEMENT OF O-RINGS.

# THRUST HYDRAULICS

## JT4020 ALL TERRAIN

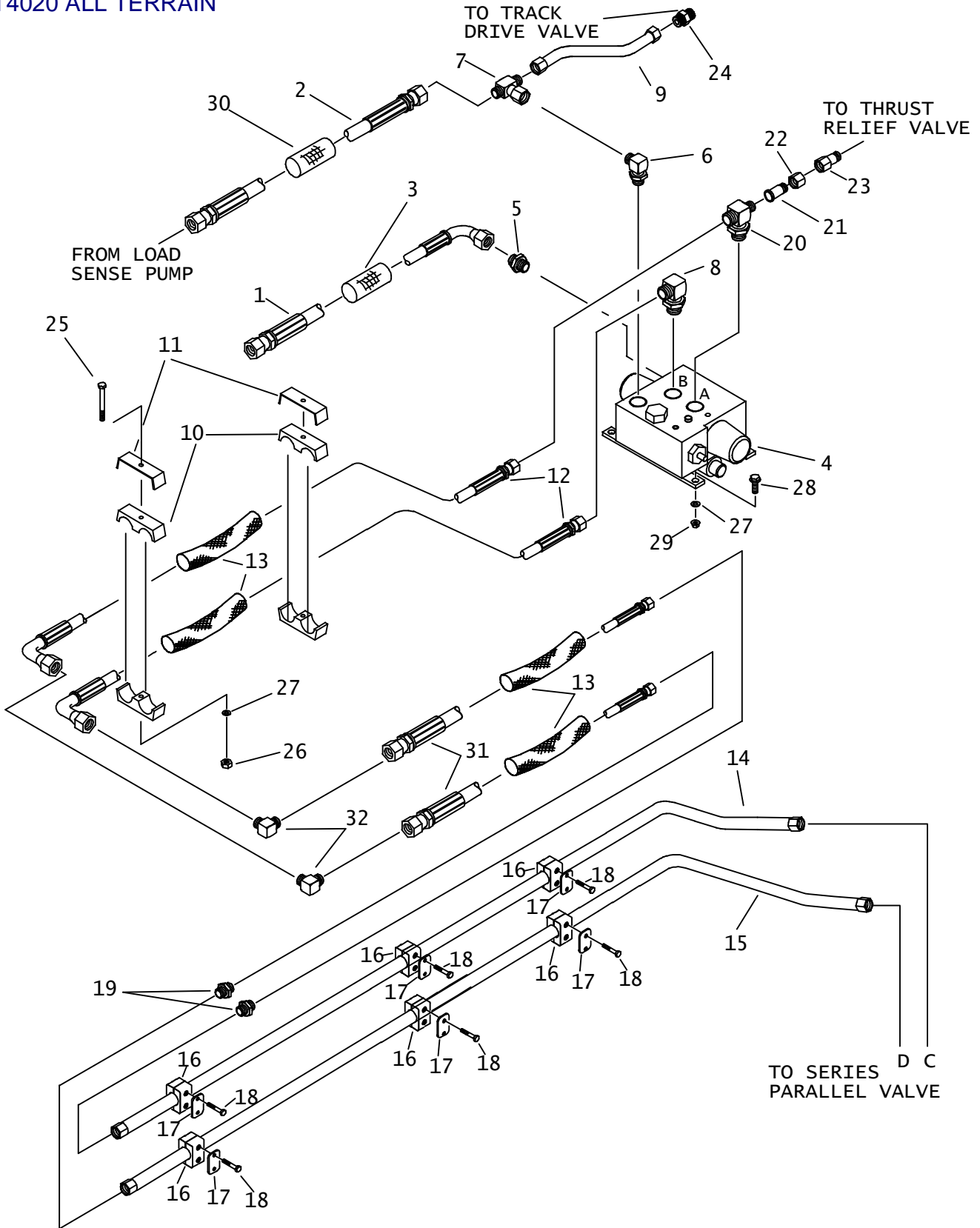

# THRUST HYDRAULICS

## JT4020 ALL TERRAIN

REF PART NO.	NUMBER	QTY	DESCRIPTION	REMARKS
1.	515-655	1	HOSE (160FX90-47"-3000)	
2.	157-499	1	HOSE (200FX-47"-3000, SPECIAL)	
3.	115-715	1	ABRASION SLEEVE (2.07" X 42")	
4.	157-440	-	THRUST VALVE (ELECTRIC)	SEE FOOTNOTE 1
	150-1458	-	THRUST VALVE (ELECTRIC)	SEE FOOTNOTE 2
	500-1290	-	THRUST VALVE COIL	
5.	154-398	1	CONNECTOR (16S-160, XLG)	
6.	154-287	1	CONNECTOR (16S-16090)	
7.	153-391	1	TEE (-200-160-160FX)	
8.	154-289	1	CONNECTOR (16S-16090, XL)	
9.	156-896	1	HYD LINE (160FX-4.7")	
10.	110-359	2	BOLT-ON CLAMP (1-1/2", SET)	
11.	315-623	2	BACKUP SPACER	
12.	515-656	2	HOSE (160FX90-55"-3000)	
	149-045	1	HYD LINE (-16)	
	149-046	1	HYD LINE (-16)	
13.	117-289	4	ABRASION SLEEVE (2.07" X 55")	
14.	149-296	1	HYD LINE (-16)	
15.	149-295	1	HYD LINE (-16)	
16.	110-573	6	BOLT-ON CLAMP (1", PER SET)	
17.	322-289	6	BACKUP (BOLT-ON)	
18.	105-818	12	BOLT (1/4-NC X 1-1/2")	
19.	154-439	2	CONNECTOR (160-160)	
20.	154-347	1	BRANCH TEE (16S-160-160)	
21.	154-341	1	REDUCER STEM (080)	
22.	154-340	1	REDUCER NUT (160F)	
23.	154-262	1	REDUCER (060-080F)	
24.	154-281	1	CONNECTOR (16S-160)	
25.	106-602	2	SCREW (M8-1.25 X 80MM)	
26.	106-561	2	LOCKNUT (M8-1.25, PRV TRQ, 10.9)	
27.	106-396	10	WASHER (M10, HARDENED)	
28.	106-079	8	SCREW (M10-1.50 X 30MM)	
29.	105-894	8	LOCKNUT (M10-1.50, PRV TRQ, 10.9)	
30.	117-668	1	ABRASION SLEEVE (2.38" X 42")	
31.	157-845	2	HOSE (160FX-53.5"-3000)	
32.	514-009	2	CONNECTOR (160-16090)	

NOT SHOWN:

#### FOOTNOTES:

1. ENDS WITH S/N: CMWJ42T2J60000023; CMWA42T2E60000029; CMWA40T3P60000002; CMWJ40T3T60000001
2. BEGINS WITH S/N: CMWA40T3K60000003; CMWJ40T3P60000002

#### NOTE:

REFER TO O-RING CHART (800-301) IN BACK OF THE BOOK FOR THE REPLACEMENT OF O-RINGS.

## THRUST DRIVE HYDRAULICS

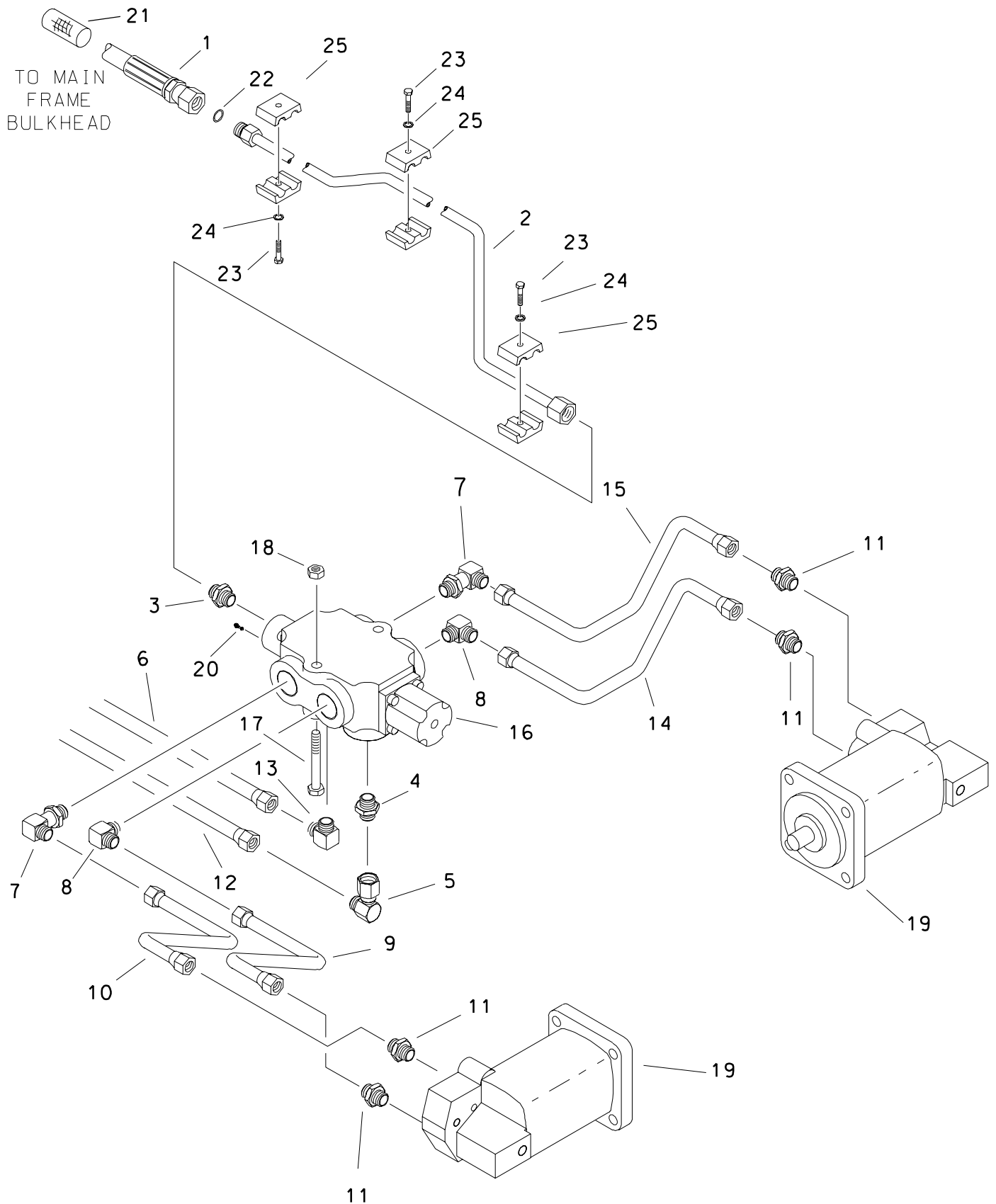

## THRUST DRIVE HYDRAULICS

REF NO.	PART NUMBER	QTY	DESCRIPTION	REMARKS
1.	154-651	1	HOSE (040FX-66"-3000)	
2.	153-040	1	HYD LINE	
3.	154-411	1	CONNECTOR (04S-060)	
4.	154-281	1	CONNECTOR (16S-160)	
5.	154-290	1	UNION (160-160FX90)	
6.	149-296	-	HYD LINE (-16)	
7.	154-338	2	CONNECTOR (12S-12090, XL)	
8.	154-270	2	CONNECTOR (12S-12090)	
9.	156-886	1	HYD LINE (-12)	
10.	156-885	1	HYD LINE (-12)	
11.	154-269	4	CONNECTOR (12S-120)	
12.	149-295	-	HYD LINE (-16)	
13.	154-287	1	CONNECTOR (16S-16090)	
14.	156-884	1	HYD LINE (-12)	
15.	156-883	1	HYD LINE (-12)	
16.	149-343	1	HYDRAULIC CONTROL VALVE	
	190-863		SEAL REPAIR KIT	
	500-698	-	END CAP	NOT DRILLED/TAPPED
	310-800	-	END CAP	DRILLED/TAPPED
17.	106-570	2	SCREW (M8-1.25 X 60mm)	
18.	106-561	2	LOCKNUT (M8-1.25, PRV TRQ, 10.9)	
19.	158-026	2	HYD MOTOR (15 CU/IN)	
20.	163-101	1	BLEEDER VALVE	
21.	117-613	1	ABRASION SLEEVE (1.00" X 64")	
22.	157-037	1	O-RING (011 D90)	
23.	105-197	3	BOLT (1/4-NC X 1")	
24.	105-117	3	WASHER (5/16")	
25.	110-998	3	CLAMP HALVES (3/8") PAIR	

## FOOTNOTES

NOTE  
REFER TO O-RING CHART (800-301) IN BACK OF THE BOOK FOR REPLACEMENT OF O-RINGS.

# FLUID MOTOR HYDRAULICS

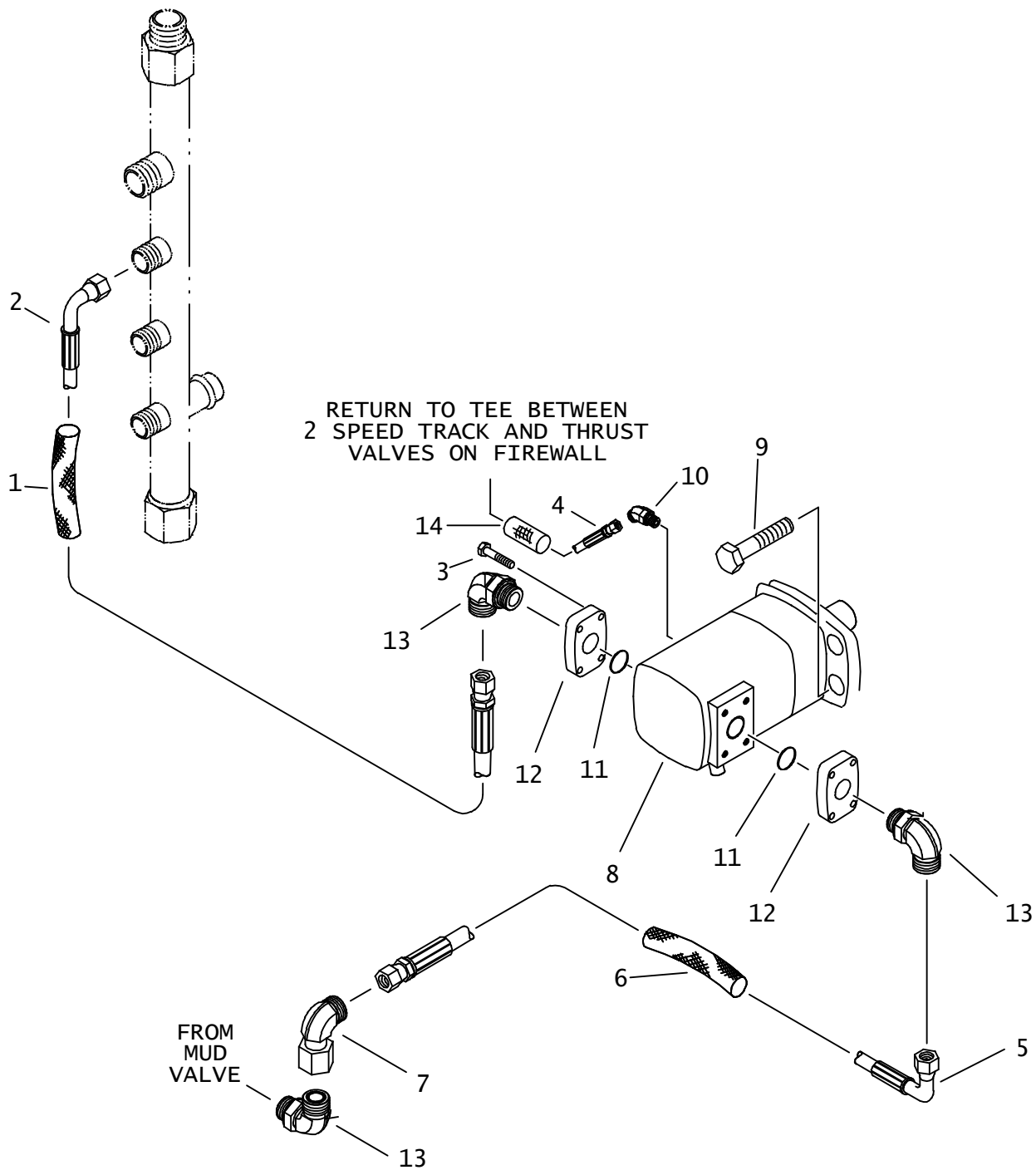

# FLUID MOTOR HYDRAULICS

REF NO.	PART NUMBER	QTY	DESCRIPTION	REMARKS
1.	117-097	1	ABRASION SLEEVE (2.07" X 80")	
2.	157-284	1	HOSE (160FX90S-84"-3000)	
3.	105-918	8	BOLT (7/16-NC X 1-1/2", SOC)	
4.	154-789	1	HOSE (060FX-102"-3000)	
5.	153-432	1	HOSE (160FX90S-64"-3000)	
6.	117-179	1	ABRASION SLEEVE (2.07" X 62")	
7.	154-290	1	UNION (160-160FX90)	
8.	149-395	1	HYDRAULIC MOTOR	SEE FOOTNOTE 2
	158-013	1	HYDRAULIC MOTOR	SEE FOOTNOTE 1
	500-1532	AR	SEAL REPAIR KIT	
9.	105-282	4	BOLT (1/2-NC X 1-1/4", SOC)	
10.	154-224	1	CONNECTOR (06S-06045)	
11.	157-078	2	O-RING (222 D90)	
12.	149-084	2	HEAD FLANGE (20FL-16SF)	
13.	154-287	3	CONNECTOR (16S-16090)	
14.	117-213	1	ABRASION SLEEVE (1.00" X 96")	

NOT SHOWN:

FOOTNOTES:

1. USED WITH 158-434 (70 GPM MUD PUMP)
2. USED WITH 149-396 (120 GPM MUD PUMP)

NOTE

REFER TO O-RING CHART (800-301) IN BACK OF THE BOOK FOR REPLACEMENT OF O-RINGS.

NOTE:

# TRACK DRIVE HYDRAULICS

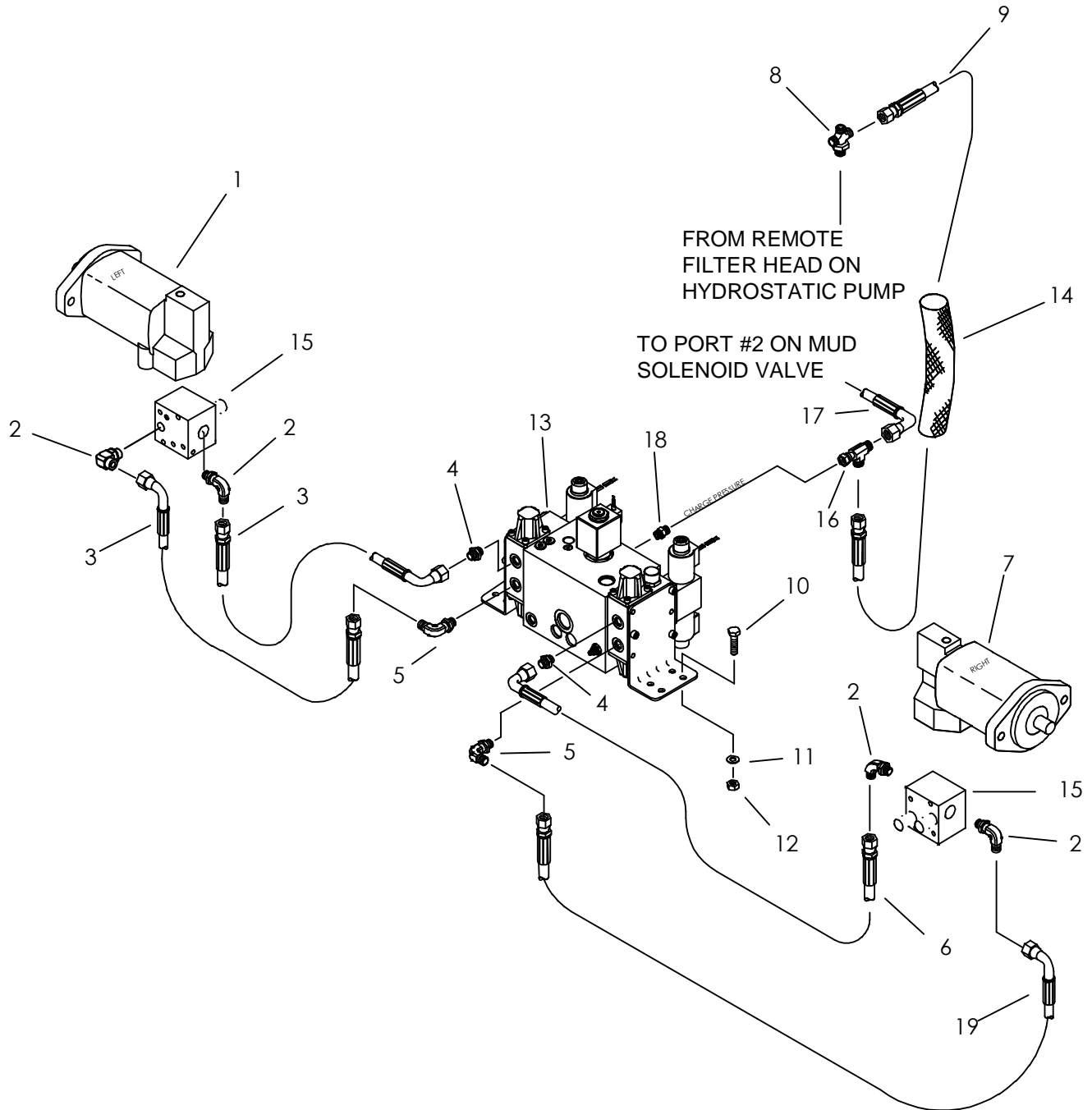



# TRACK DRIVE HYDRAULICS

REF NO.	PART NUMBER	QTY	DESCRIPTION	REMARKS
1.	153-593	1	HYDRAULIC MOTOR	LEFT TRACK
2.	154-270	4	CONNECTOR (12S-12090)	
3.	153-758	2	HOSE (120FX90S-14"-3000)	
4.	154-247	2	CONNECTOR (10S-120)	
5.	154-273	2	CONNECTOR (10S-12090)	
6.	153-759	1	HOSE (120FX90M-16"-3000)	
7.	153-592	1	HYDRAULIC MOTOR	RIGHT TRACK, USE SEAL KIT 500-752
8.	149-847	-	CROSS (06S-060-060-080)	
9.	154-757	1	HOSE (060FX-86"-3000)	
10.	106-079	4	SCREW (M10-1.50 X 30mm)	
11.	106-396	4	WASHER (M10, HARDENED)	
12.	105-894	4	LOCKNUT (M10-1.50, PRV TRQ, 10.9)	
13.	153-639	1	HYD CONTROL VALVE	SEE FOOTNOTE 1
14.	117-398	1	ABRASION SLEEVE (1.00" X 86")	
15.	153-767	2	COUNTERBALANCE MANIFOLD	
16.	154-344	1	UN RUN TEE (060FX-060-060)	
17.	515-583	-	HOSE (060FX90-12"-3000)	
18.	156-174	1	CONNECTOR (06S-060)	BACK PORT (NOT SHOWN)
19.	153-928	1	HOSE (120FX90L-16"-3000)	

NOT SHOWN:

FOOTNOTES:

1. 153-639 HYD CONTROL VALVE IS SUPERSEDED BY 150-1815 HYDRAULIC CONTROL VALVE

NOTE:

REFER TO O-RING CHART (800-301) IN BACK OF THE BOOK FOR REPLACEMENT OF O-RINGS.

## TRACK CASE DRAIN HYDRAULICS

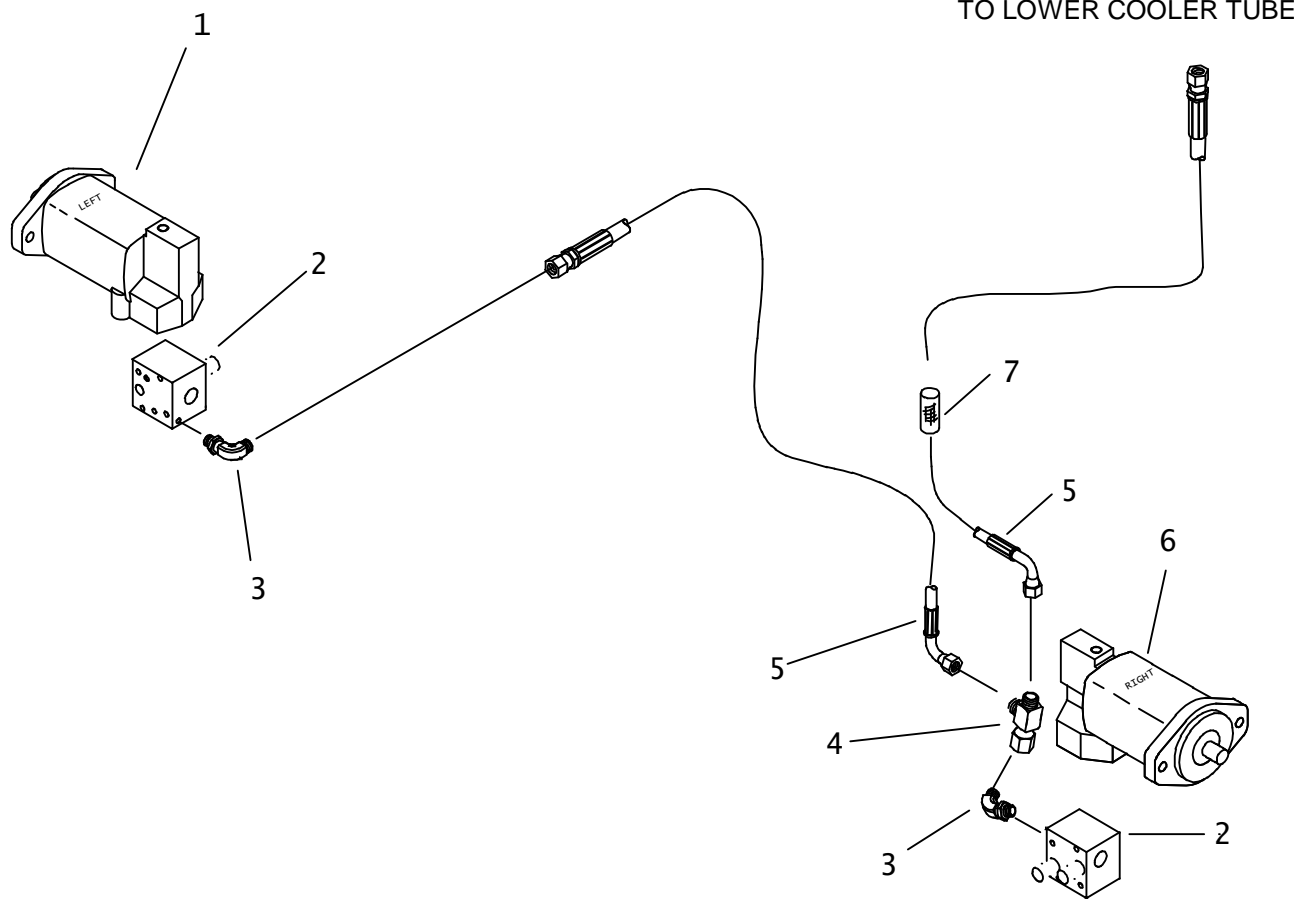

# TRACK CASE DRAIN HYDRAULICS

REF NO.	PART NUMBER	QTY	DESCRIPTION	REMARKS
1.	153-593	-	HYDRAULIC MOTOR	
2.	153-767	-	COUNTERBALANCE MANIFOLD	
3.	154-252	2	CONNECTOR (04S-04090)	
4.	154-265	1	UN RUN TEE (040FX-040-040)	
5.	154-728	2	HOSE (040FX90-36"-3000)	
6.	153-592	-	HYDRAULIC MOTOR	USE SEAL KIT 500-752
7.	117-718	1	ABRASION SLEEVE (1.00" X 36")	

NOT SHOWN:

FOOTNOTES:

NOTE:

REFER TO O-RING CHART (800-301) IN BACK OF THE BOOK FOR REPLACEMENT OF O-RINGS.



# WRENCH HYDRAULICS

REF NO.	PART NUMBER	QTY	DESCRIPTION	REMARKS
1.	153-410	1	HYDRAULIC VALVE	
	499-309	-	SOLENOID	
	499-311	-	SOLENOID CARTRIDGE	
	499-312	-	SOLENOID COIL	
	501-872	-	SHUTTLE VALVE	
	499-313	-	CHECK VALVE	
	191-103	-	SEAL REPAIR KIT	
	191-104	-	SEAL REPAIR KIT	
	500-703	-	SEAL REPAIR KIT	
2.	154-797	-	HOSE (060FX-48"-3000)	
3.	154-227	2	CONNECTOR (060-08S90)	
4.	154-884	-	HOSE (080FX90-60"-3000)	
5.	515-214	-	HOSE (080FX45-80"-3000)	
6.	154-235	3	CONNECTOR (08S-08090)	
7.	154-269	2	CONNECTOR (12S-120)	
8.	154-367	1	CONNECTOR (120-16S)	
9.	154-996	-	HOSE (060FX-58"-3000)	
10.	149-572	1	CONNECTOR (08S-08090-06SF)	
11.	215-1227	1	PRESSURE SWITCH (500PSI)	
12.	515-410	-	HOSE (060FX45-118"-3000)	
13.	154-342	-	CONNECTOR (06S-06090)	
14.	514-409	1	UNION (06J-060FX)	
15.	154-221	-	CONNECTOR (06S-060)	AT ONLY
	510-015	-	ADAPTER (06S-060, ORF)	JT ONLY, INSTALL IN LOCATION 22.
16.	158-600	-	HYD SHUTTLE VALVE	
17.	154-816	-	HOSE (060FX-120"-3000)	
18.	107-420	3	SCREW (M10-1.50 X 140MM)	
19.	106-390	3	WASHER (M10)	
20.	105-894	3	LOCKNUT(M10-1.50,PRV TRQ,10.9)	
21.	155-705	2	O-RING (906 D90)	
22.	155-153	-	CONNECTOR (06S-06S)	AT ONLY
23.	157-420	-	CONN (06S-06090,ORF .028)	AT ONLY
24.	157-288	-	HOSE (060FX45-234"-3000)	AT ONLY

NOT SHOWN:

FOOTNOTES:

NOTE:

REFER TO O-RING CHART (800-301) IN BACK OF THE BOOK FOR REPLACEMENT OF O-RINGS.

# FRONT WRENCH HYDRAULICS

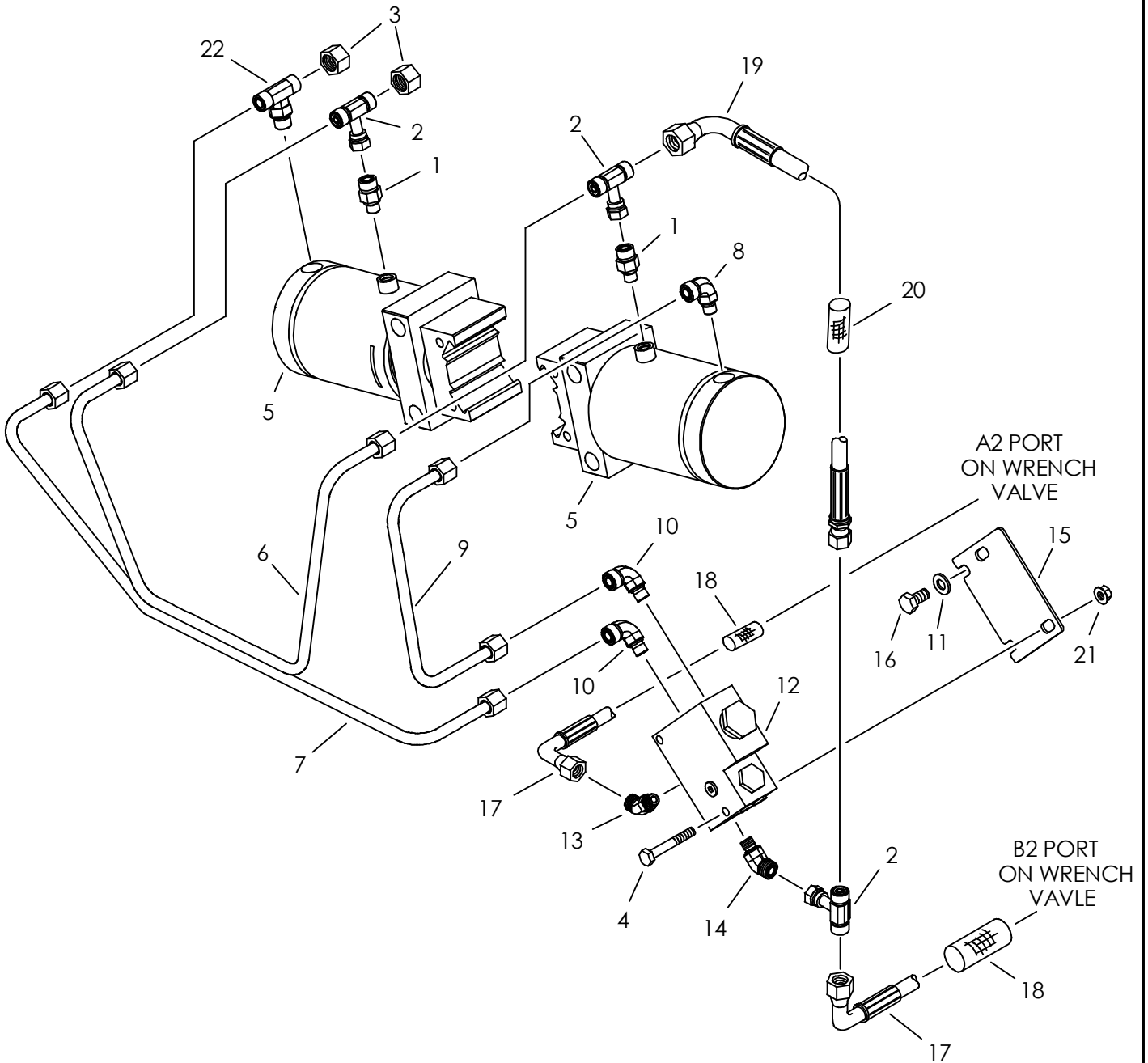

# FRONT WRENCH HYDRAULICS

REF NO.	PART NUMBER	QTY	DESCRIPTION	REMARKS
1.	154-246	2	CONNECTOR (06S-080)	
2.	154-257	3	UN BR TEE (080FX-080-080)	
3.	154-327	2	CAP (080F)	
4.	106-142	2	SCREW (M10-1.50 X 65MM)	
5.	151-212	2	CYLINDER ASSEMBLY	4.50" X 2.25" X 2.75"
6.	153-649	1	HYD LINE	
7.	153-650	1	HYDRAULIC LINE (08)	
8.	154-253	1	CONNECTOR (06S-08090)	
9.	153-647	1	HYDRAULIC LINE (-08)	
10.	154-235	2	CONNECTOR (08S-08090)	
11.	106-397	2	WASHER (M12, HARDENED)	
12.	149-791	1	HYDRAULIC CONTROL VALVE	USE SERVICE PARTS: 500-2041 SEAL KIT & 500-2042 SEAL
13.	154-264	1	CONNECTOR (080-10S45)	
14.	154-283	1	CONNECTOR (06S-08045)	
15.	310-911	1	PLATE	
16.	107-521	2	SCREW (M12-1.75 X 20MM)	
17.	154-884	2	HOSE (080FX90-60"-3000)	
18.	117-392	2	ABRASION SLEEVE (1.25" X 60")	
19.	154-750	1	HOSE (080FX90-28"-3000)	
20.	117-396	1	ABRASION SLEEVE (1.25" X 28")	
21.	107-661	2	FLG LKNUT (M10-1.50, PRV TRQ)	
22.	153-728	1	TEE (06S-080-080)	

NOT SHOWN:

FOOTNOTES:

NOTE:

REFER TO O-RING CHART (800-301) IN BACK OF THE BOOK FOR REPLACEMENT OF O-RINGS.

# REAR WRENCH HYDRAULICS

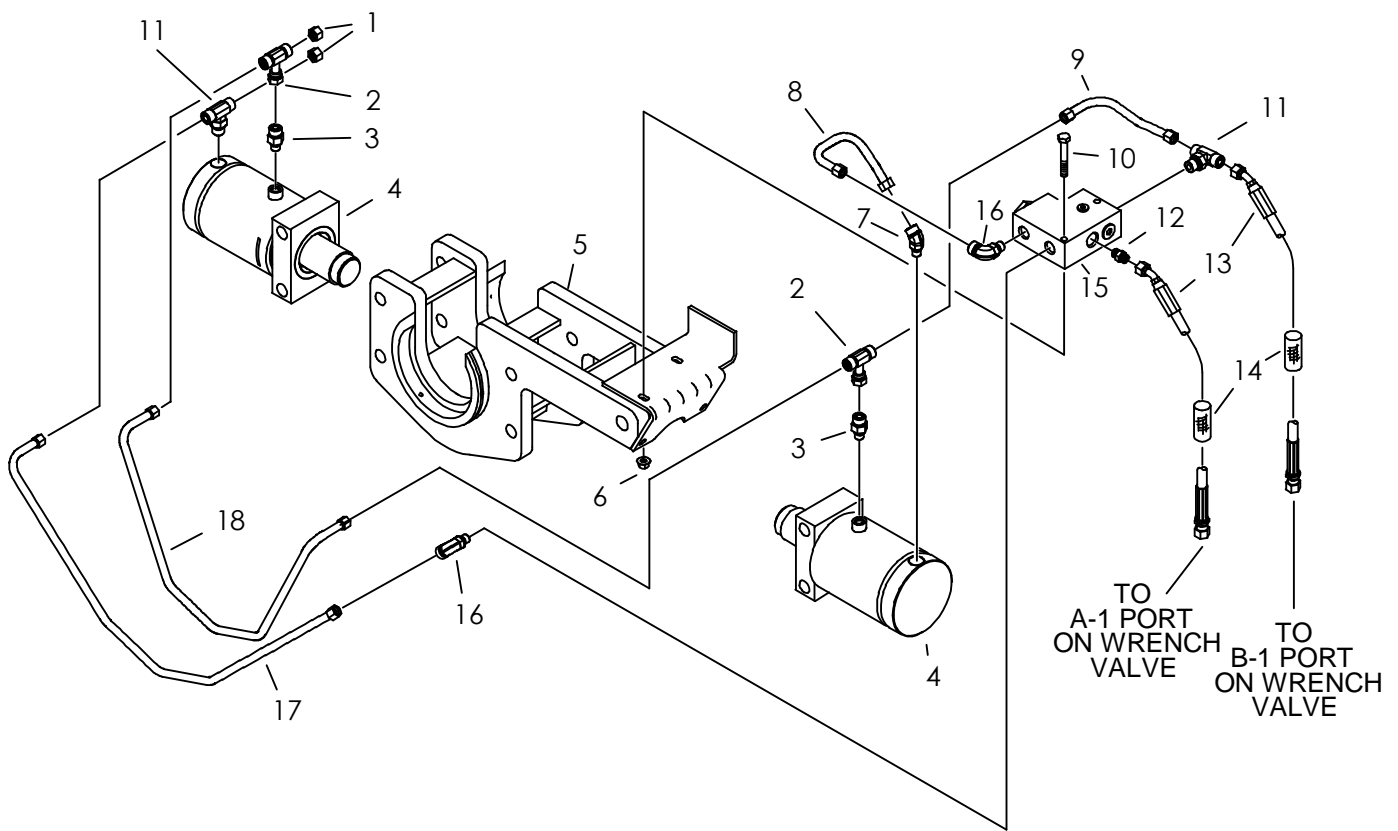



# REAR WRENCH HYDRAULICS

REF NO.	PART NUMBER	QTY	DESCRIPTION	REMARKS
1.	154-327	2	CAP (080F)	
2.	154-257	2	UN BR TEE (080FX-080-080)	
3.	154-246	2	CONNECTOR (06S-080)	
4.	151-212	-	CYLINDER ASSEMBLY	
5.	313-717	-	ROTATION CLAMP	
6.	107-661	2	FLG LKNUT (M10-1.50, PRV TRQ)	
7.	154-283	1	CONNECTOR (06S-08045)	
8.	153-726	1	HYDRAULIC LINE (-08)	
9.	153-648	1	HYDRAULIC LINE (-08)	
10.	106-332	2	SCREW (M10-1.50 X 70MM)	
11.	153-728	2	TEE (06S-080-080)	
12.	154-279	1	CONNECTOR (080-10S)	
13.	515-214	2	HOSE (080FX45-80"-3000)	
14.	117-556	2	ABRASION SLEEVE (1.25" X 80")	
15.	149-791	1	HYDRAULIC CONTROL VALVE	USE SERVICE PARTS: 500-2041 SEAL KIT & 500-2042 SEAL
16.	154-235	2	CONNECTOR (08S-08090)	
17.	153-651	1	HYDRAULIC LINE (-08)	
18.	153-652	1	HYDRAULIC LINE (-08)	

NOT SHOWN:

FOOTNOTES:

NOTE:

REFER TO O-RING CHART (800-301) IN BACK OF THE BOOK FOR REPLACEMENT OF O-RINGS.

# WRENCH ROTATE HYDRAULICS

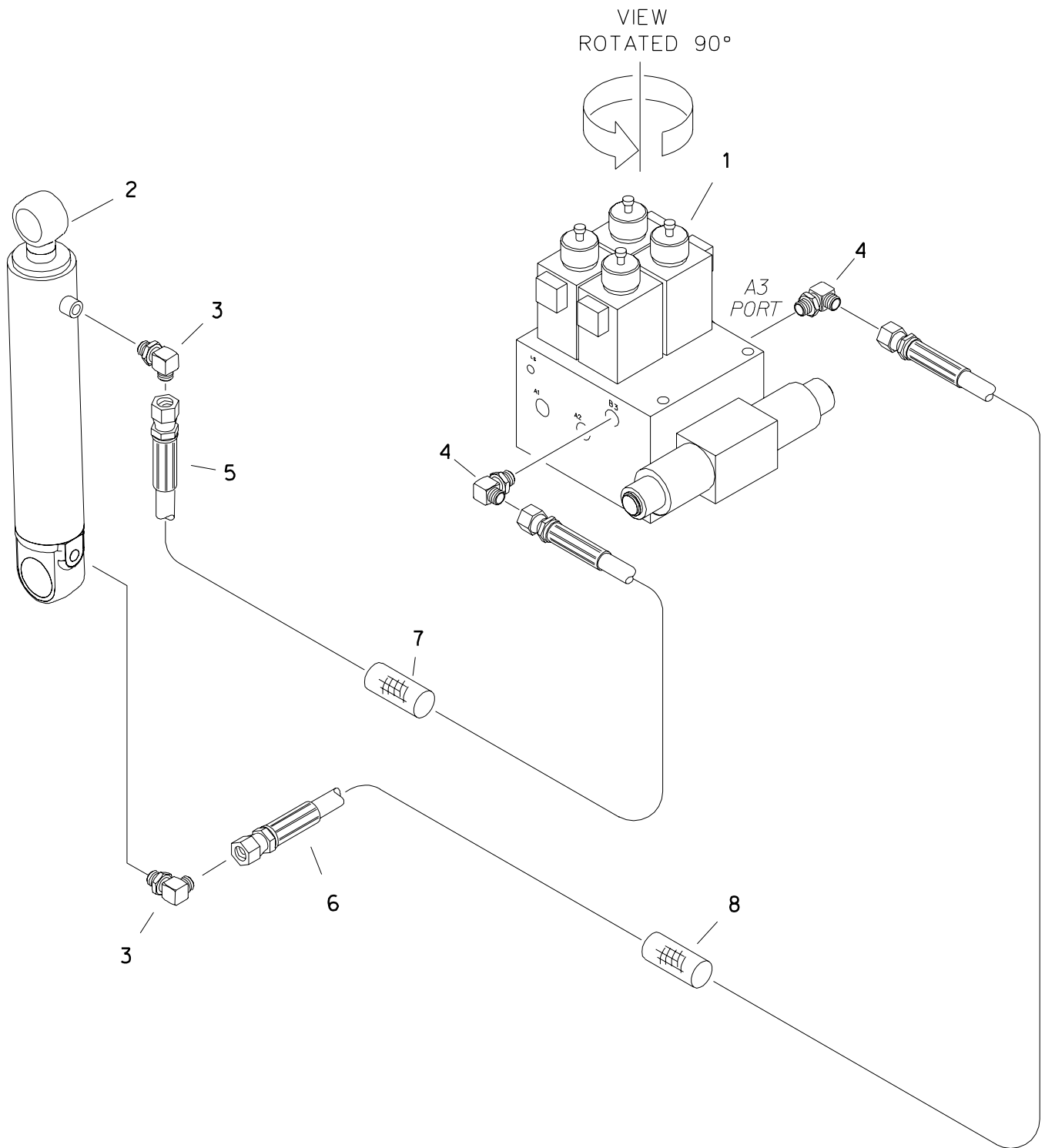

# WRENCH ROTATE HYDRAULICS

REF NO.	PART NUMBER	QTY	DESCRIPTION	REMARKS
1.	153-410	-	HYDRAULIC VALVE	
2.	151-031	-	CYL (2.0" X 1.0" X 8.0")	
3.	514-049	2	CONNECTOR (04S-06090)	
4.	154-227	-	CONNECTOR (060-08S90)	
5.	154-996	1	HOSE (060FX-58"-3000)	
6.	154-797	1	HOSE (060FX-48"-3000)	
7.	117-326	1	ABRASION SLEEVE (1.00" X 58")	
8.	117-416	1	ABRASION SLEEVE (1.00" X 50")	

FOOTNOTES

NOTES

REFER TO O-RING CHART (800-301) IN BACK OF THE BOOK FOR REPLACEMENT OF O-RINGS.

# ANCHOR SUPPLY HYDRAULICS

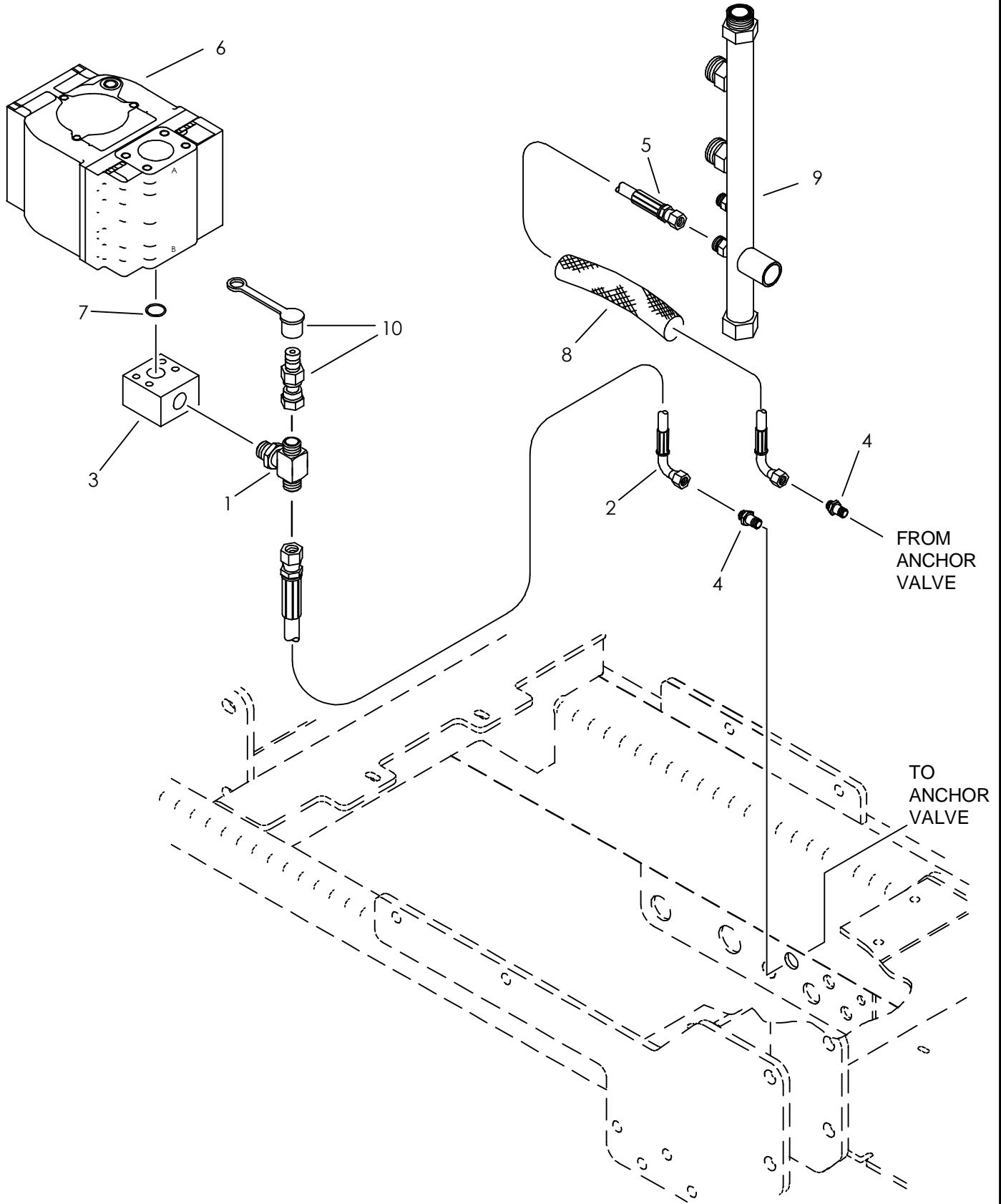

# ANCHOR SUPPLY HYDRAULICS

REF NO.	PART NUMBER	QTY	DESCRIPTION	REMARKS
1.	154-318	1	BRANCH TEE (10S-100-100)	
2.	515-454	1	HOSE (100FX90L-20"-3000)	
3.	153-393	1	MANIFOLD BLOCK	
4.	154-309	2	BK CONNECTOR (100-100BK)	
5.	515-690	1	HOSE (100FX90L-58"-3000)	
6.	150-2180	-	HYDRAULIC PUMP LS	
	190-1371	-	PUMP SEAL KIT	
7.	157-128	-	O-RING (225 D90)	
8.	115-903	1	ABRASION SLEEVE (1.59" x 50")	
9.	153-389	-	COOLER BY-PASS	
10.	159-159	1	QDC ADAPTER (02-100FX)	
	159-148	1	DUST CAP (1/8")	

NOT SHOWN:

FOOTNOTES:

NOTE:

REFER TO O-RING CHART (800-301) IN BACK OF THE BOOK FOR REPLACEMENT OF O-RINGS.

# ANCHOR VALE PRESSURE & RETURN HYDRAULICS

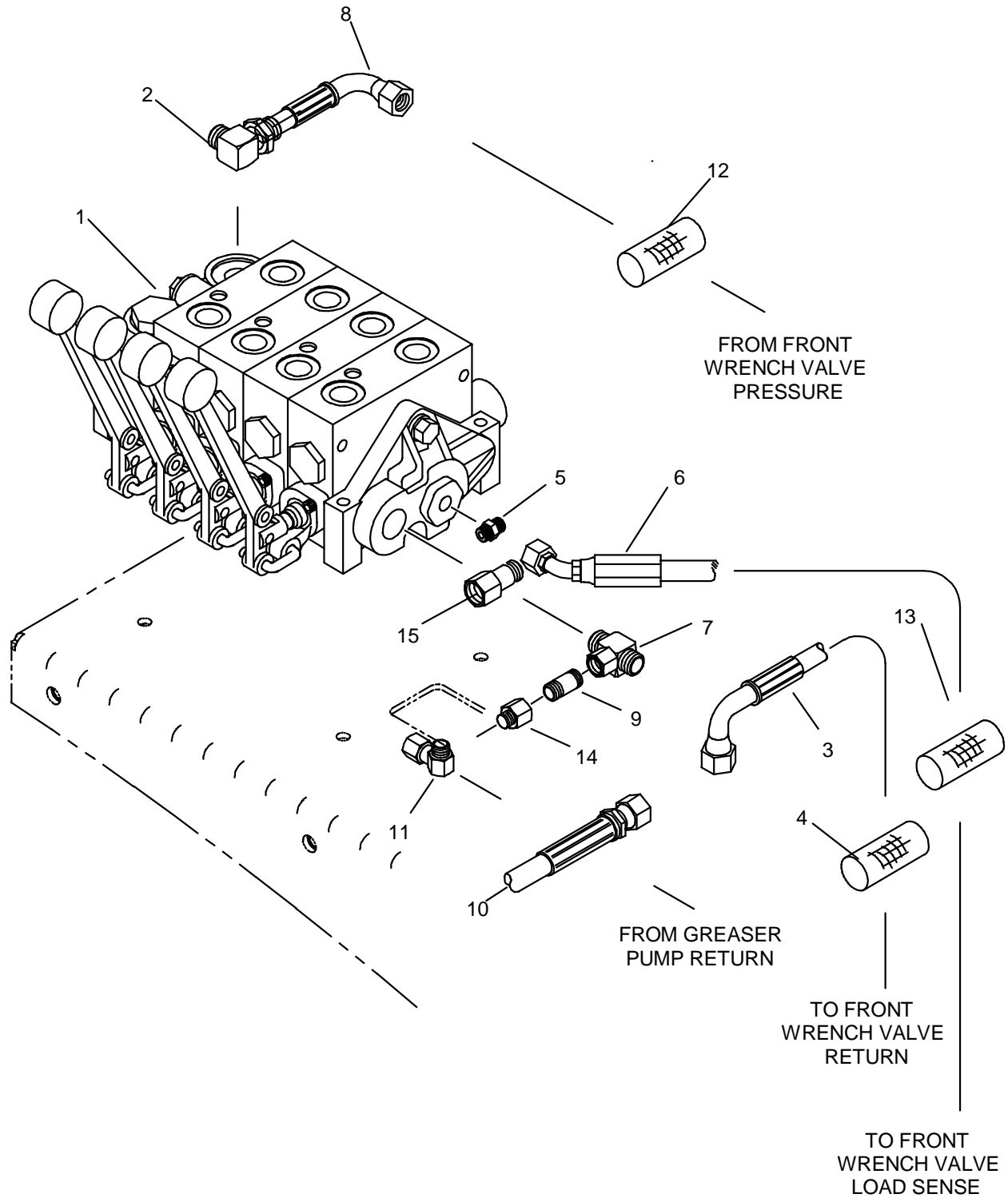

## ANCHOR VALE PRESSURE & RETURN HYDRAULICS

REF NO.	PART NUMBER	QTY	DESCRIPTION	REMARKS
1.	158-064	1	HYD CONTROL VALVE (4-SPOOL)	
2.	154-300	1	CONNECTOR (100-12S90)	
3.	515-670	1	HOSE (100FX90-85"-3000)	
4.	115-817	1	ABRASION SLEEVE (1.59" X 84")	
5.	154-411	1	CONNECTOR (04S-060)	
6.	515-410	1	HOSE (060FX45-118"-3000)	
7.	154-458	1	UNION RUN TEE (06SFS-10S-100)	
8.	515-618	1	HOSE (100FX90-95"-3000)	
9.	159-381	1	CHECK VALVE (06S-060)	
10.	149-827	1	HOSE (040FX90S-24"-3000)	
11.	154-255	1	UNION (040-040FX90)	
12.	116-787	1	ABRASION SLEEVE (1.59" X 95")	
13.	117-212	1	ABRASION SLEEVE (1.25" X 118")	
14.	154-373	1	REDUCER (040-060F)	
15.	510-017	1	REDUCER (12S-10SF)	

NOT SHOWN:

FOOTNOTES:

NOTE:

REFER TO O-RING CHART (800-301) IN BACK OF THE BOOK FOR REPLACEMENT OF O-RINGS.

# RIGHT ANCHOR MOTOR HYDRAULICS

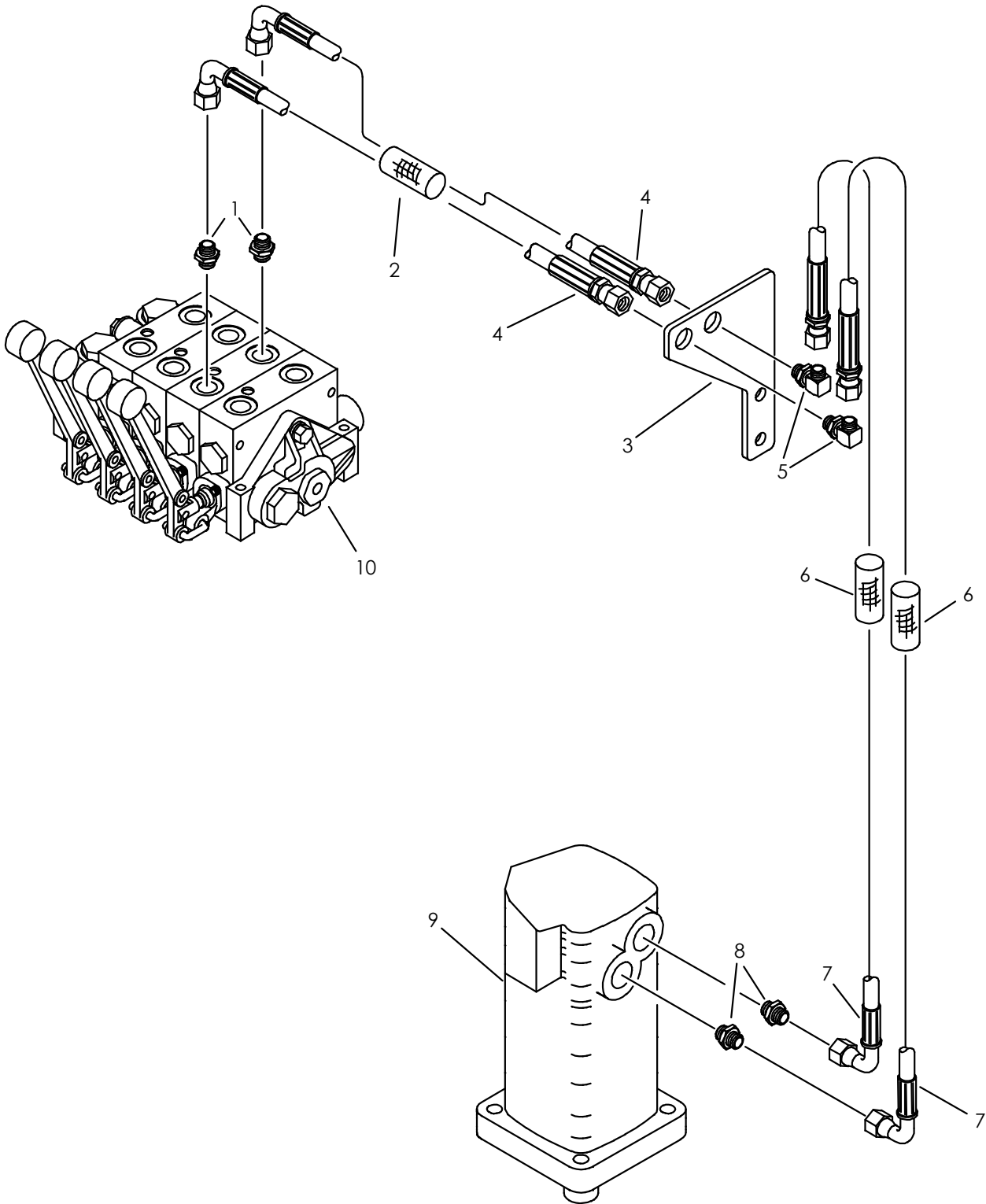



## RIGHT ANCHOR MOTOR HYDRAULICS

REF NO.	PART NUMBER	QTY	DESCRIPTION	REMARKS
1.	154-233	2	CONNECTOR (08S-080)	
2.	117-455	1	ABRASION SLEEVE (2.07" X 38")	
3.	309-204	1	BULKHEAD PLATE	
4.	515-025	2	HOSE (080FX90-40"-3000)	
5.	154-396	2	BK CONNECTOR (080-08090BK)	
6.	117-324	2	ABRASION SLEEVE (1.25" X 48")	
7.	154-716	2	HOSE (080FX90-48"-3000)	
8.	154-307	2	CONNECTOR (16S-080)	
9.	149-895	-	HYD MOTOR	
	500-390		SEAL REPAIR KIT - REAR	
	500-391		SEAL REPAIR KIT - SHAFT	
	502-177		SHAFT AND BEARING ASS'Y	
	500-2123		FRONT RETAINER (ANCHOR MOTOR)	
10.	158-064	-	HYD CONTROL VALVE (4-SPOOL)	

NOT SHOWN:

FOOTNOTES:

NOTE:

REFER TO O-RING CHART (800-301) IN BACK OF THE BOOK FOR REPLACEMENT OF O-RINGS

# LEFT ANCHOR MOTOR HYDRAULICS

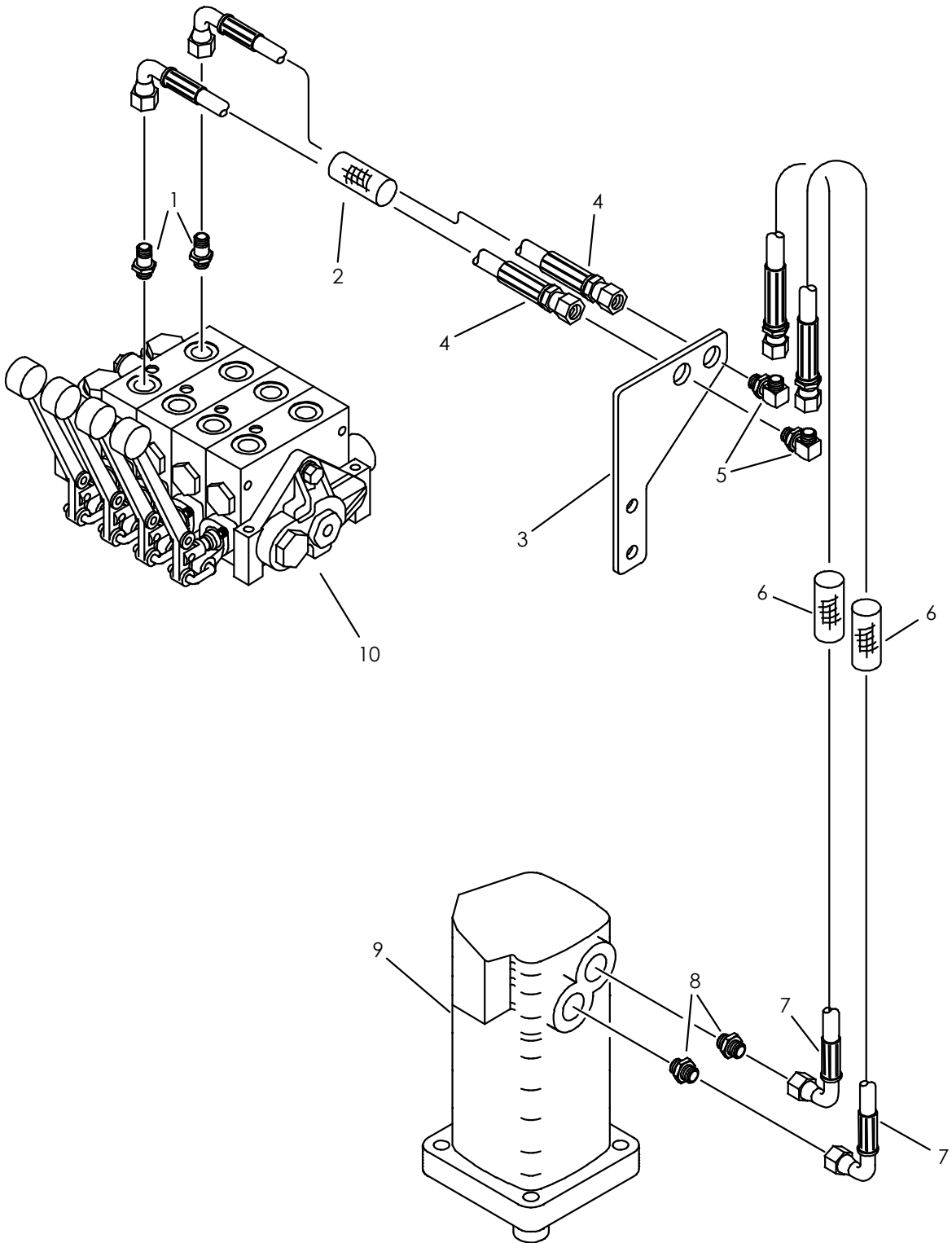

## LEFT ANCHOR MOTOR HYDRAULICS

REF NO.	PART NUMBER	QTY	DESCRIPTION	REMARKS
1.	154-438	2	CONNECTOR (08S-080, LG)	
2.	117-293	1	ABRASION SLEEVE (2.07" X 46")	
3.	309-204	1	BULKHEAD PLATE	
4.	154-716	2	HOSE (080FX90-48"-3000)	
5.	154-396	2	BK CONNECTOR (080-08090BK)	
6.	117-324	2	ABRASION SLEEVE (1.25" X 48")	
7.	154-716	2	HOSE (080FX90-48"-3000)	
8.	154-307	2	CONNECTOR (16S-080)	
9.	149-895	-	HYD MOTOR	
	500-390	-	SEAL REPAIR KIT - REAR	
	500-391	-	SEAL REPAIR KIT - SHAFT	
	502-177	-	SHAFT AND BEARING	
10.	158-064	-	HYD CONTROL VALVE (4-SPOOL)	

NOT SHOWN:

FOOTNOTES:

NOTE:

REFER TO O-RING CHART (800-301) IN BACK OF THE BOOK FOR REPLACEMENT OF O-RINGS.

# RIGHT ANCHOR THRUST CYLINDER

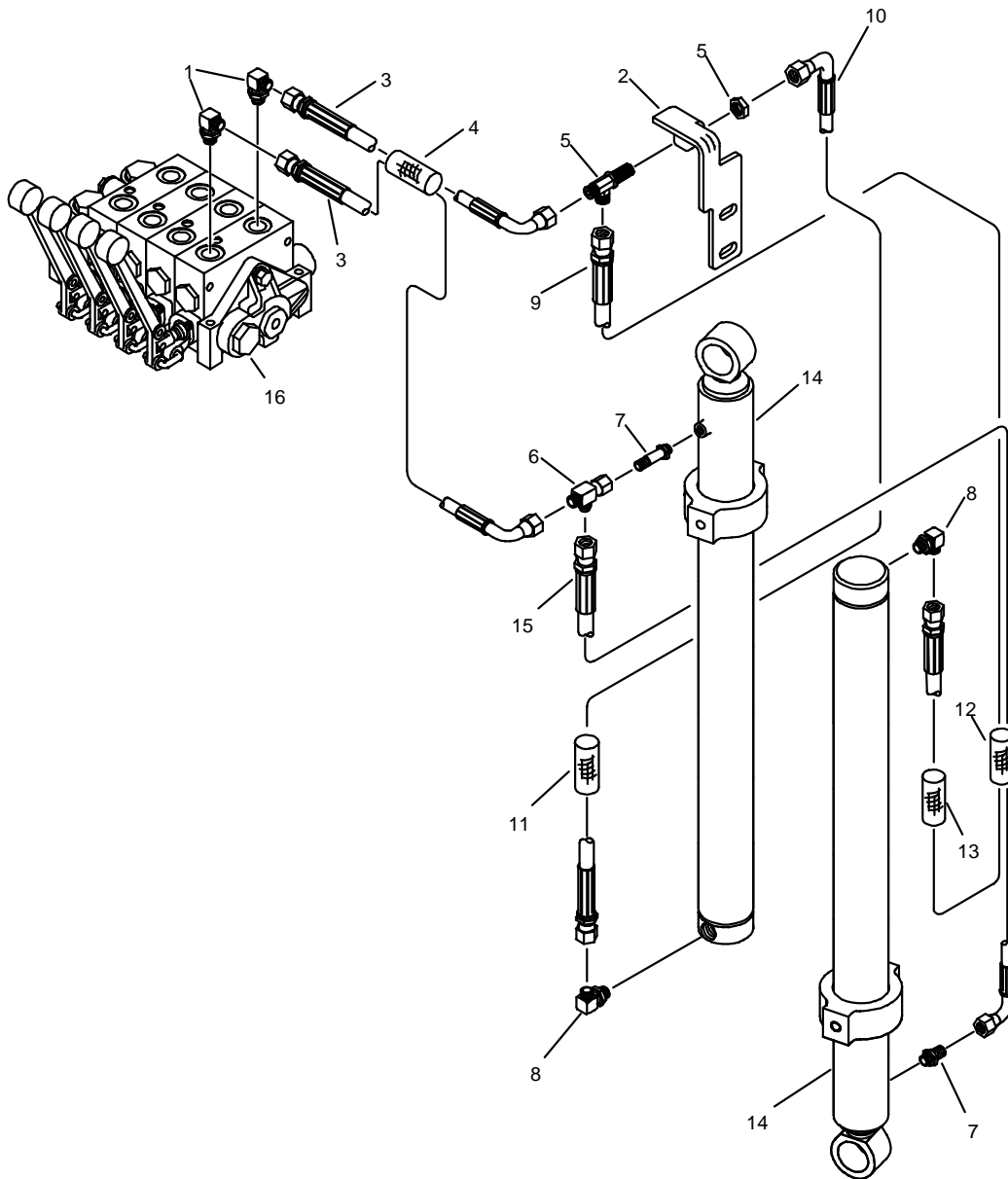

## RIGHT ANCHOR THRUST CYLINDER

REF NO.	PART NUMBER	QTY	DESCRIPTION	REMARKS
1.	154-276	2	CONNECTOR (040-08S90)	
2.	309-205	1	BULKHEAD PLATE	
3.	154-728	2	HOSE (040FX90-36"-3000)	
4.	117-655	1	ABRASION SLEEVE (1.59" X 38")	
5.	154-424	1	BK RUN TEE (040-040-040BK)	
6.	154-265	1	UNION RUN TEE (040FX-040-040)	
7.	154-403	2	CONNECTOR (04S-040, XL)	
8.	154-252	2	CONNECTOR (04S-04090)	
9.	515-054	1	HOSE (040FX-74"-3000)	
10.	515-683	1	HOSE (040FX90-28"-3000)	
11.	117-684	1	ABRASION SLEEVE (1.00" X 26")	
12.	117-657	1	ABRASION SLEEVE (1.59" X 54")	
13.	117-676	1	ABRASION SLEEVE (1.00" X 30")	
14.	150-747	2	CYLINDER ASSEMBLY	
15.	515-682	1	HOSE (040FX90M-48"-3000)	
16.	158-064	-	HYD CONTROL VALVE (4-SPOOL)	

NOT SHOWN:

FOOTNOTES:

NOTE:

REFER TO O-RING CHART (800-301) IN BACK OF THE BOOK FOR REPLACEMENT OF O-RINGS.

# LEFT ANCHOR THRUST CYLINDER

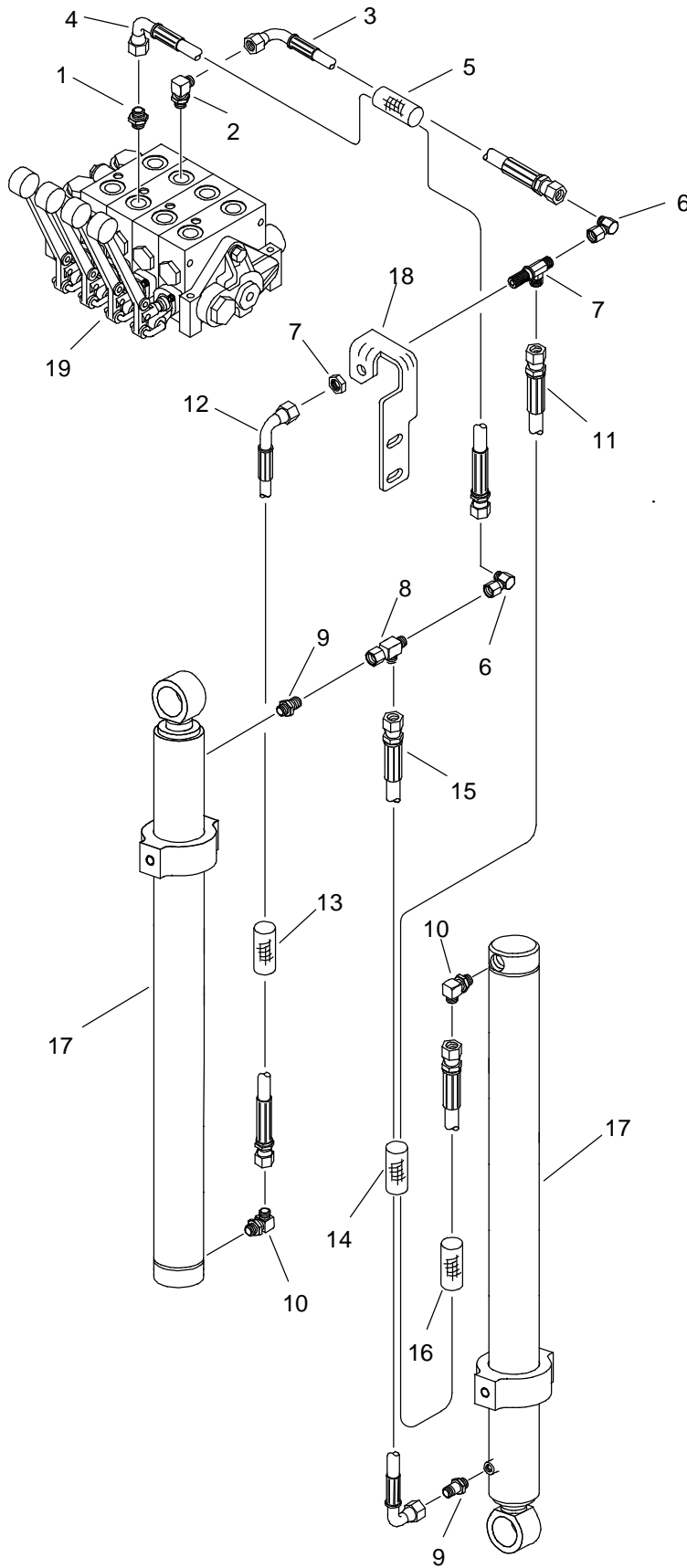

# LEFT ANCHOR THRUST CYLINDER

REF NO.	PART NUMBER	QTY	DESCRIPTION	REMARKS
1.	154-261	1	CONNECTOR (040-08S)	
2.	154-276	1	CONNECTOR (040-08S90)	
3.	515-593	1	HOSE (040FX90-38"-3000)	
4.	515-012	1	HOSE (040FX90-42"-3000)	
5.	115-737	1	ABRASION SLEEVE (1.59" X 40")	
6.	154-255	2	UNION (040-040FX90)	
7.	154-424	1	BK RUN TEE (040-040-040BK)	
8.	154-265	1	UNION RUN TEE (040FX-040-040)	
9.	154-403	2	CONNECTOR (04S-040, XL)	
10.	154-252	2	CONNECTOR (04S-04090)	
11.	515-054	1	HOSE (040FX-74"-3000)	
12.	515-683	1	HOSE (040FX90-28"-3000)	
13.	117-684	1	ABRASION SLEEVE (1.00" X 26")	
14.	117-657	1	ABRASION SLEEVE (1.59" X 54")	
15.	515-682	1	HOSE (040FX90M-48"-3000)	
16.	117-676	1	ABRASION SLEEVE (1.00" X 30")	
17.	150-747	2	CYLINDER ASSEMBLY	
18.	309-206	1	BULKHEAD PLATE	
19.	158-064	-	HYD CONTROL VALVE (4-SPOOL)	

NOT SHOWN:

FOOTNOTES:

NOTE:

REFER TO O-RING CHART (800-301) IN BACK OF THE BOOK FOR REPLACEMENT OF O-RINGS.

## AUXILIARY VALVE

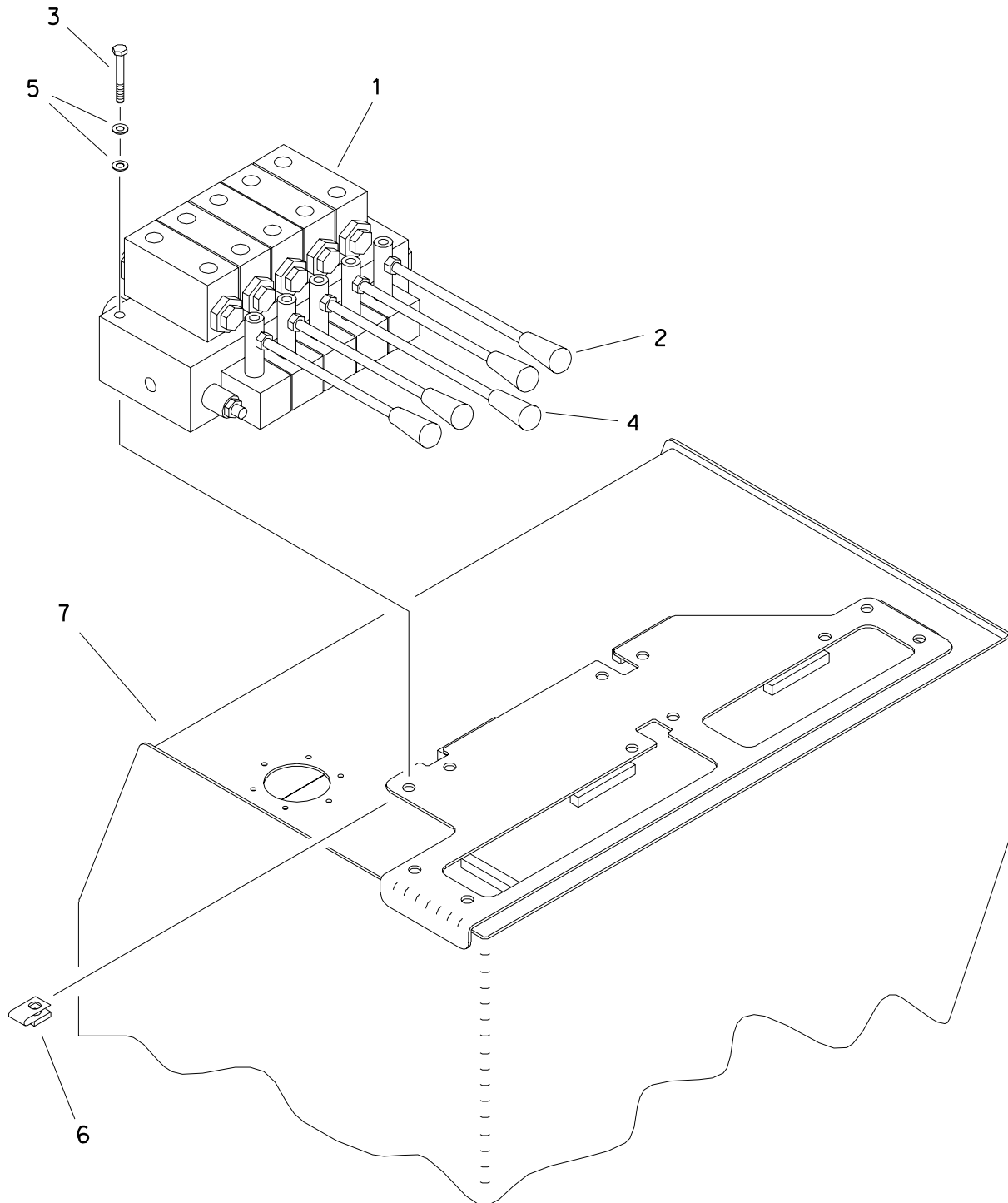



## AUXILIARY VALVE

REF NO.	PART NUMBER	QTY	DESCRIPTION	REMARKS
1.	149-882	-	HYD CONTROL VALVE (5-SPOOL)	
2.	365-426	4	LEVER (M8-1.25 X 200MM)	
3.	106-595	3	SCREW (M6-1.00 X 60MM)	
4.	500-502	1	CONTROL VALVE HANDLE	
5.	106-076	6	WASHER (1/4")	
6.	106-574	3	CLIP NUT (M6-1.00)	
7.	350-614	-	HYD RESERVOIR	

FOOTNOTES

# AUXILIARY SUPPLY & RETURN HYDRAULICS

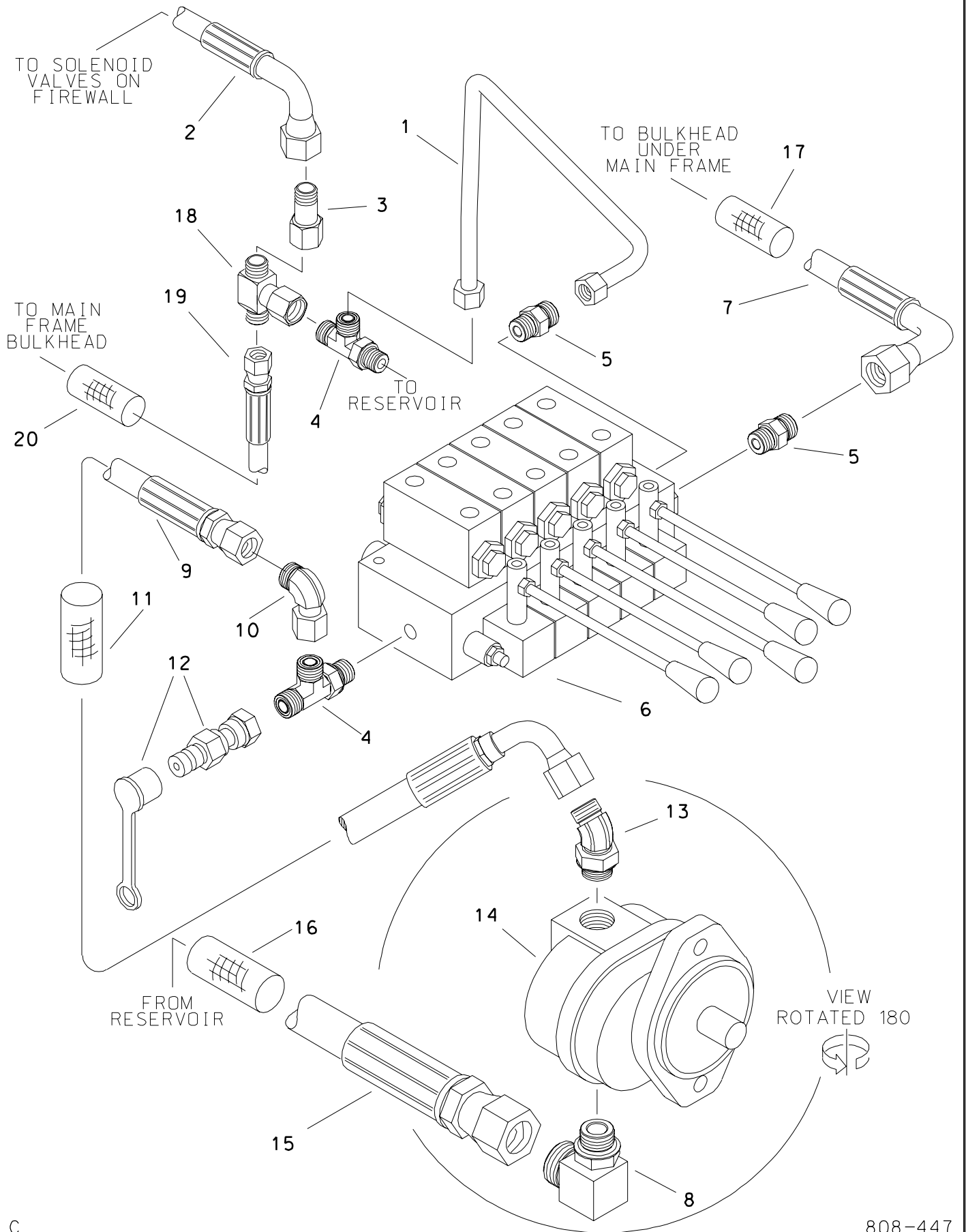

## AUXILIARY SUPPLY &amp; RETURN HYDRAULICS

REF NO.	PART NUMBER	QTY	DESCRIPTION	REMARKS
1.	153-106	1	HYD LINE	
2.	515-221	-	HOSE (060FX90S-28"-3000)	
3.	154-262	1	REDUCER (060-080F)	
4.	154-299	2	RUN TEE (08S-080-080)	
5.	154-233	2	CONNECTOR (08S-080)	
6.	149-882	-	HYD CONTROL VALVE (5-SPDOL)	
7.	515-140	1	HOSE (080FX90-56"-3000)	
8.	154-286	1	CONNECTOR (120-16S90)	
9.	154-955	1	HOSE (080FX90-102"-3000)	
10.	154-256	1	UNION (080-080FX90)	
11.	115-902	1	ABRASION SLEEVE (1.59" X 100")	
12.	159-158	1	QDC ADAPTER (02-080FX)	
	159-148	-	DUST CAP (1/8")	
13.	154-264	1	CONNECTOR (080-10S45)	
14.	149-838	1	HYDRAULIC PUMP	
15.	154-862	1	HOSE (120FX-80"-2250)	
16.	115-817	1	ABRASION SLEEVE (1.59" X 84")	
17.	117-655	1	ABRASION SLEEVE (1.59" X 38")	
18.	154-257	1	UN BR TEE (080FX-080-080)	
19.	154-739	1	HOSE (080FX-32"-3000)	
20.	117-396	1	ABRASION SLEEVE (1.25" X 28")	

## NOTES:

REFER TO O-RING CHART (800-301) IN BACK OF THE BOOK FOR REPLACEMENT OF O-RINGS.

# STABILIZER HYDRAULICS

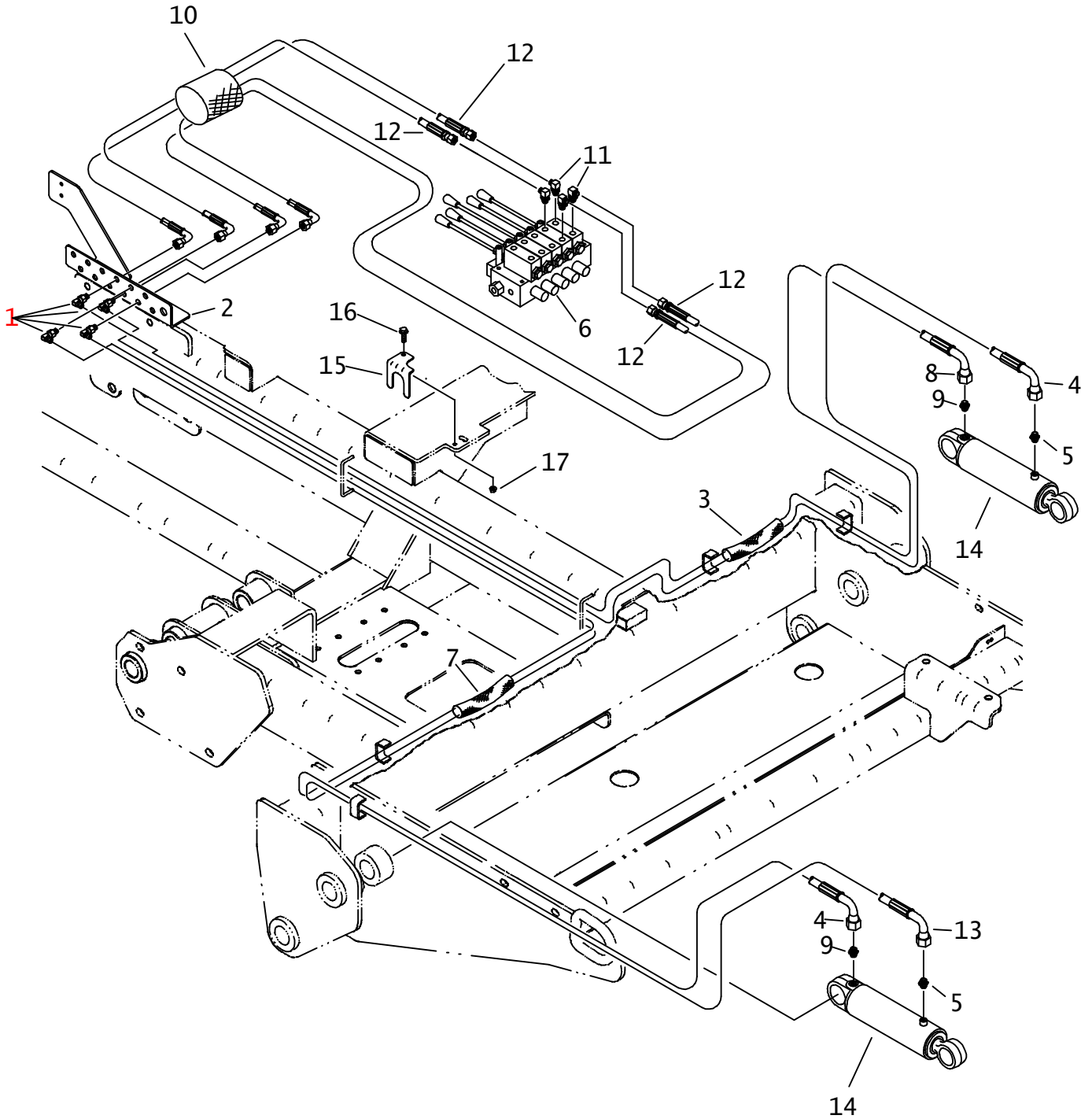

## STABILIZER HYDRAULICS

REF NO.	PART NUMBER	QTY	DESCRIPTION	REMARKS
1.	154-355	4	BK CONNECTOR (040-04090BK)	
2.	354-466	-	BULKHEAD PLATE	
3.	116-633	1	ABRASION SLEEVE (1.59" X 115")	
4.	515-277	2	HOSE (040FX90S-128"-3000)	
5.	154-261	2	CONNECTOR (040-08S)	
6.	149-882	1	HYD CONTROL VALVE (5-SPOOL)	
7.	116-632	1	ABRASION SLEEVE (1.59" X 130")	
8.	515-239	1	HOSE (040FX90S-116"-3000)	
9.	154-374	1	CONNECTOR (040-08S, ORF)	
10.	117-789	-	HOSE BAG (4" X 36")	
11.	154-226	4	CONNECTOR (040-06S90)	
12.	515-439	4	HOSE (040FX90S-50"-3000)	
13.	515-146	1	HOSE (040FX90S-140"-3000)	
14.	151-187	2	CYLINDER ASSEMBLY	4" X 2" X 10"
15.	309-549	1	BRACKET	
16.	106-381	1	FLG LK SCREW (M8-1.25 X 25MM)	
17.	106-386	1	FLG LOCKNUT (M8-1.25)	

NOT SHOWN:

FOOTNOTES:

NOTE:

REFER TO O-RING CAHRT (800-301) IN BACK OF THE BOOK FOR REPLACEMENT OF O-RINGS.

# SHUTTLE STOP HYDRAULICS

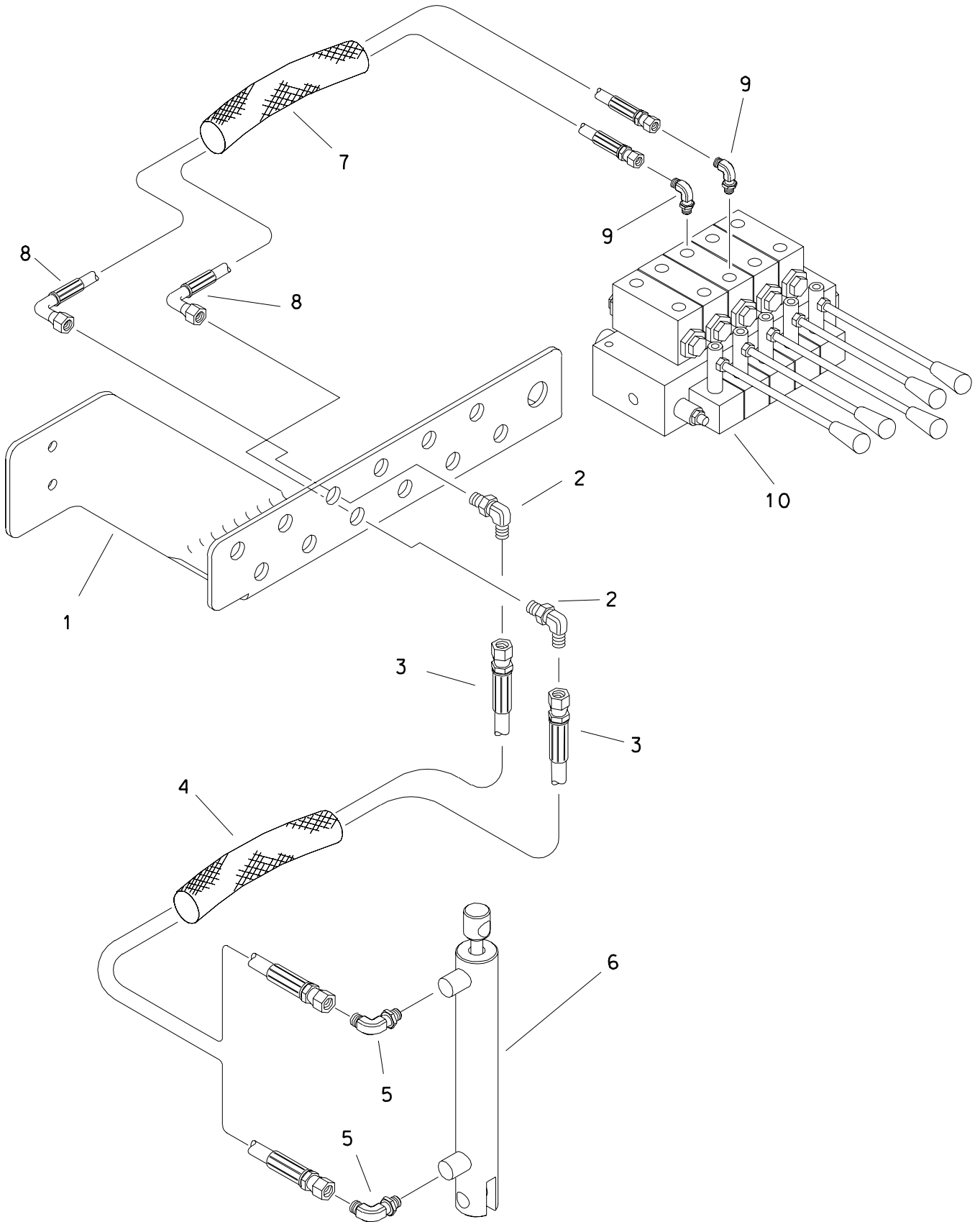

# SHUTTLE STOP HYDRAULICS

REF NO.	PART NUMBER	QTY	DESCRIPTION	REMARKS
1.	354-466	1	BULKHEAD PLATE	
2.	154-355	2	BK CONNECTOR (040-04090BK)	
3.	515-161	2	HOSE (040FX-160"-3000)	
4.	117-741	1	ABRASION SLEEVE (1.59" X 145")	
5.	154-401	2	CONNECTOR (04S-04090, ORF)	
6.	150-727	1	CYL (1.0" X .500" X 4.0")	
7.	117-789	-	HOSE BAG (4.000" X 36")	
8.	515-447	2	HOSE (040FX90S-48"-3000)	
9.	154-226	2	CONNECTOR (040-06S90)	
10.	149-882	-	HYD CONTROL VALVE (5-SPool)	

FOOTNOTES

NOTE

REFER TO O-RING CHART (800-301) IN BACK OF THE BOOK FOR THE REPLACEMENT OF O-RINGS.

# FRAME TILT HYDRAULICS

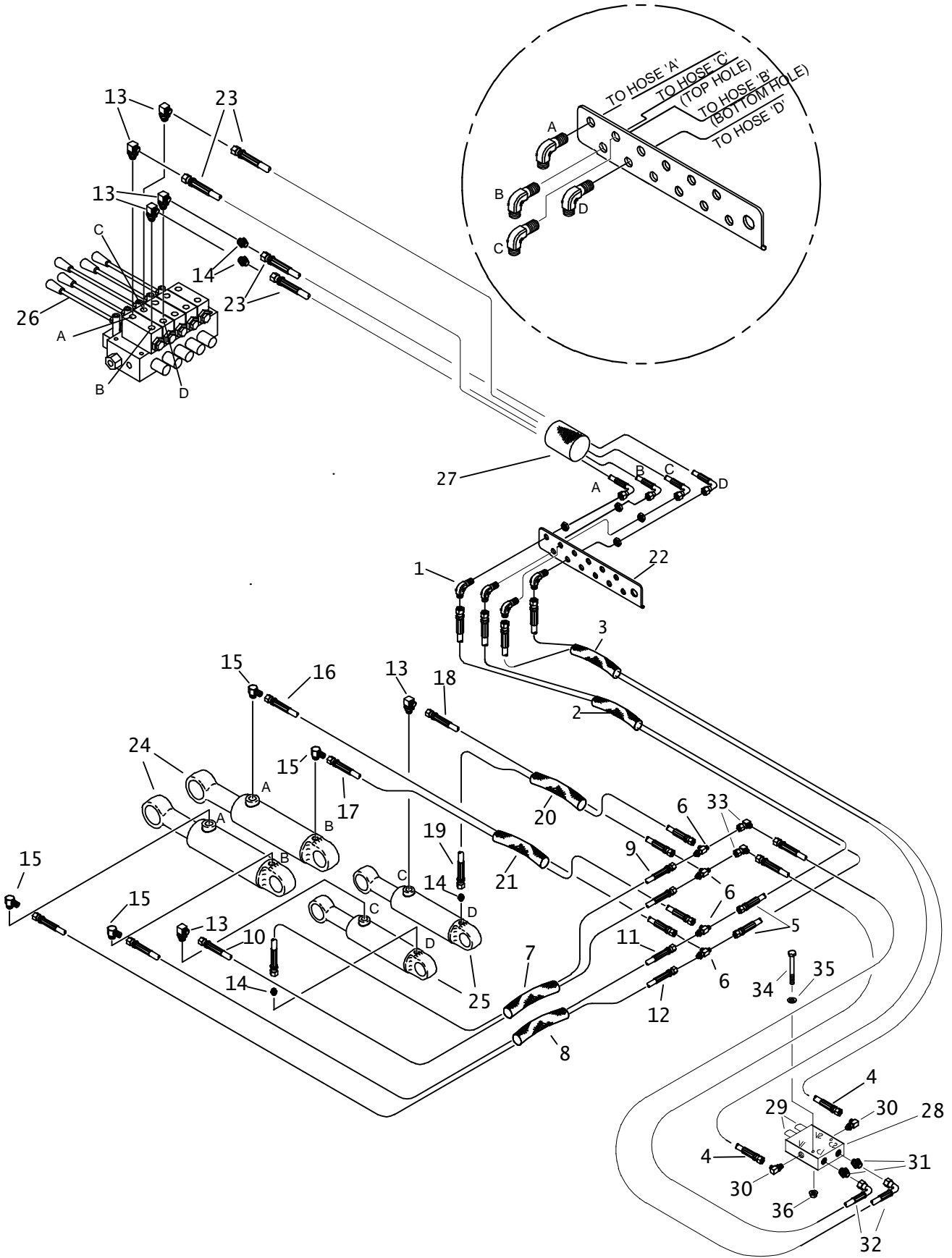



# FRAME TILT HYDRAULICS

REF NO.	PART NUMBER	QTY	DESCRIPTION	REMARKS
1.	154-355	4	BK CONNECTOR (040-04090BK)	
2.	117-603	1	ABRASION SLEEVE (1.59" X 62")	
3.	117-656	1	ABRASION SLEEVE (1.59" X 45")	
4.	515-424	2	HOSE (040FX-56"-3000)	
5.	154-681	2	HOSE (040FX-62"-3000)	
6.	154-424	4	BK RUN TEE (040-040-040BK)	
7.	115-777	1	ABRASION SLEEVE (1.59" X 15")	
8.	117-679	1	ABRASION SLEEVE (1.59" X 32")	
9.	154-672	1	HOSE (040FX-15"-3000)	
10.	515-735	1	HOSE (040FX-22"-3000)	
11.	154-668	1	HOSE (040FX-32"-3000)	
12.	154-653	1	HOSE (040FX-40"-3000)	
13.	154-226	6	CONNECTOR (040-06S90)	
14.	154-220	2	CONNECTOR (040-06S)	
15.	154-276	4	CONNECTOR (040-08S90)	
16.	154-911	1	HOSE (040FX-36"-3000AR)	
17.	515-509	1	HOSE (040FX-28"-3000)	
18.	155-484	1	HOSE (040FX-16"-3000)	
19.	154-719	1	HOSE (040FX-10"-3000)	
20.	115-776	1	ABRASION SLEEVE (1.59" X 7")	
21.	117-708	1	ABRASION SLEEVE (1.59" X 28")	
22.	354-466	-	BULKHEAD PLATE	
23.	515-447	4	HOSE (040FX90S-48"-3000)	
24.	151-066	2	CYL (4.0 X 2.0 X 5.0)	
25.	151-070	2	CYL (3.0" X 1.75" X 8.000")	
26.	149-882	-	HYD CONTROL VALVE (5-SPOOL)	
27.	117-789	1	HOSE BAG (4.000" X 36")	ALL HOSES FROM VALVE (149-882) GO INTO HOSE BAG.
28.	502-184	1	VALVE BLOCK	SEE FOOTNOTE 1
29.	500-478	2	COUNTERBALANCE CARTRIDGE KIT	SEE FOOTNOTE 1 & 2
30.	154-226	2	CONNECTOR (040-06S90)	SEE FOOTNOTE 1
31.	154-220	2	CONNECTOR (040-06S)	SEE FOOTNOTE 1
32.	154-726	2	HOSE (040FX90-15"-3000)	SEE FOOTNOTE 1
33.	154-255	2	UNION (040-040FX90)	SEE FOOTNOTE 1
34.	106-570	1	SCREW (M8-1.25 X 60MM)	SEE FOOTNOTE 1
35.	105-117	1	WASHER (5/16")	SEE FOOTNOTE 1
36.	106-386	1	FLG LOCKNUT (M8-1.25)	SEE FOOTNOTE 1

NOT SHOWN:

#### FOOTNOTES:

1. USE ON 4020 WITH RACK AND PINION
2. TURN ADJUSTMENT SCREW COMPLETELY OUT

#### NOTE:

REFER TO O-RING CHART (800-301) IN BACK OF THE BOOK FOR REPLACEMENT OF O-RINGS.

# PIPE LOADER SUPPLY & RETURN

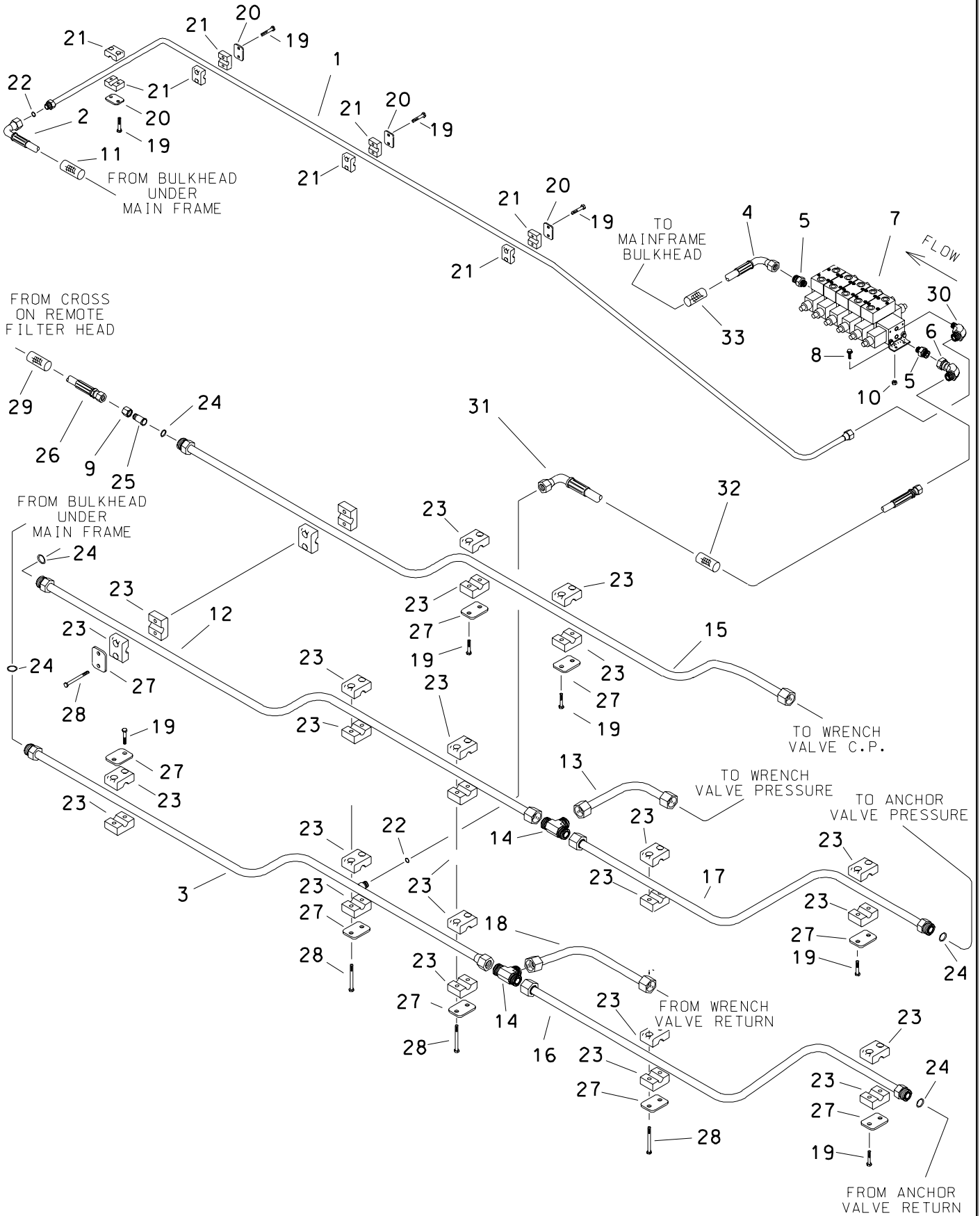

# PIPE LOADER SUPPLY & RETURN

REF NO.	PART NUMBER	QTY	DESCRIPTION	REMARKS
1.	149-449	1	HYD LINE	
2.	515-141	1	HOSE (080FX90-82"-3000)	
3.	149-447	1	HYD LINE	
4.	515-741	1	HOSE (080FX90S-112"-3000)	
5.	154-246	2	CONNECTOR (06S-080)	
6.	154-256	1	UNION (080-080FX90)	
7.	157-764	1	HYDRAULIC VALVE	
8.	106-379	4	FLG LK SCREW (M6-1.00 X 20MM)	
9.	154-310	1	REDUCER NUT (100F)	
10.	106-385	4	FLG LOCKNUT (M6-1.00)	
11.	117-390	1	ABRASION SLEEVE (1.25" X 85")	
12.	149-446	1	HYD LINE	
13.	149-476	1	HYD LINE	
14.	154-455	2	TEE (120)	
15.	149-448	1	HYD LINE	
16.	149-444	1	HYD LINE	
17.	149-445	1	HYD LINE	
18.	149-477	1	HYD LINE	
19.	105-818	18	BOLT (1/4-NC X 1-1/2")	
20.	110-958	4	BACKUP PLATE	
21.	110-866	4	CLAMP (1/2")	
22.	157-039	2	O-RING (014 D90)	
23.	110-411	13	BOLT-ON CLAMP (3/4", SET)	
24.	157-040	5	O-RING (016 D90)	
25.	154-312	1	REDUCER STEM (080)	
26.	154-877	1	HOSE (080FX90-90"-3000)	
27.	322-289	9	BACKUP (BOLT-ON)	
28.	107-743	8	SCREW (1/4-NC X 2.75, GD 5)	
29.	116-787	1	ABRASION SLEEVE (1.59" X 95")	
30.	154-253	1	CONNECTOR (06S-08090)	
31.	154-740	1	HOSE (080FX90S-26"-3000)	
32.	117-337	1	ABRASION SLEEVE (1.25" X 25")	
33.	117-389	1	ABRASION SLEEVE (1.25" X 104")	

## FOOTNOTES

## NOTES

REFER TO O-RING CHART (800-301) IN BACK OF THE BOOK FOR REPLACEMENT OF O-RINGS.

# PIPE SHUTTLE HYDRAULICS

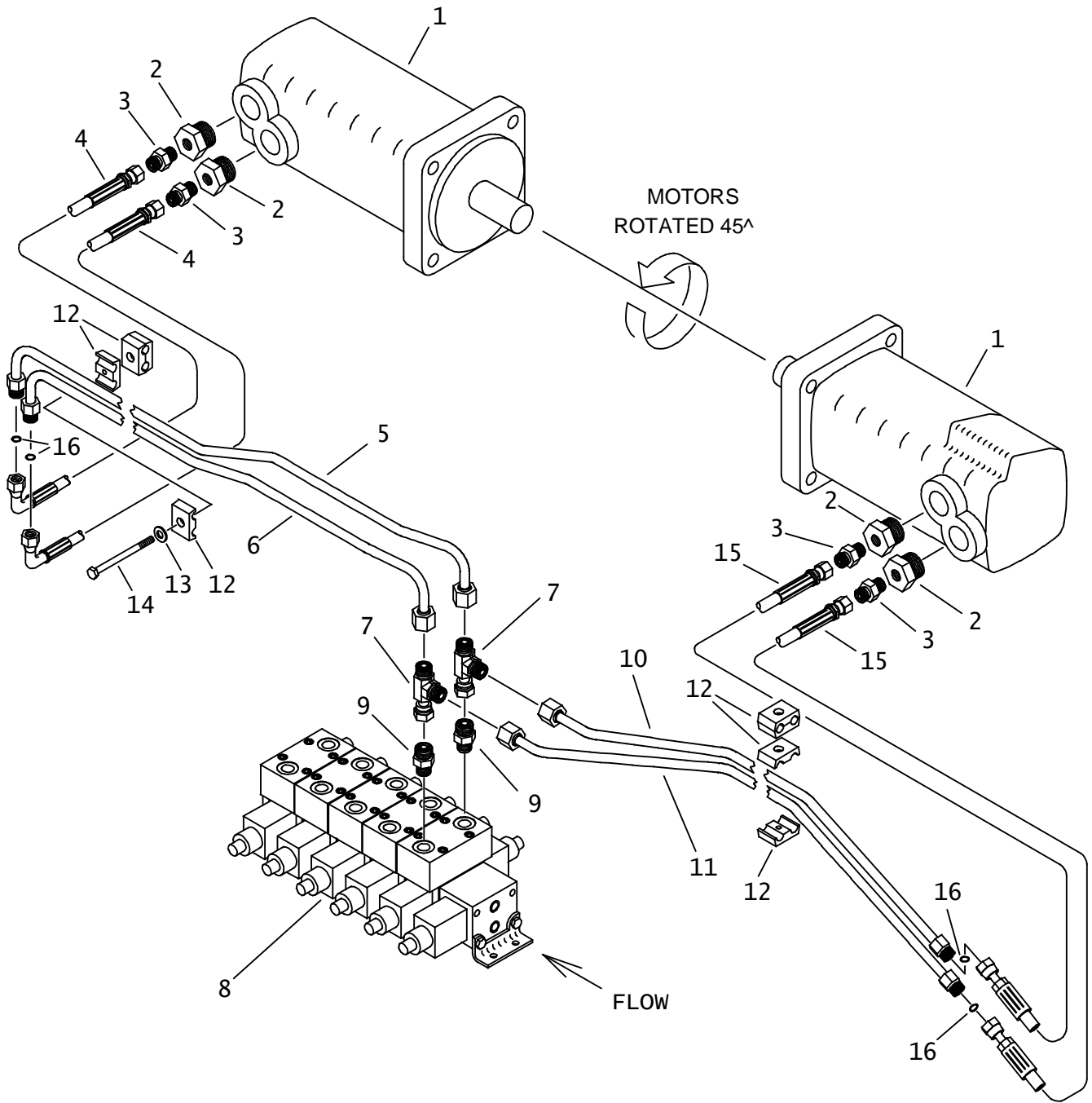

## PIPE SHUTTLE HYDRAULICS

REF NO.	PART NUMBER	QTY	DESCRIPTION	REMARKS
1.	158-026	-	HYDRAULIC MOTOR (15 CU/IN)	
	500-1552	-	SEAL REPAIR KIT	
	500-1553	-	SHAFT AND BEARING KIT	
	500-711	-	SEAL REPAIR KIT-REAR	
	500-758	-	SEAL REPAIR KIT-SHAFT	
2.	155-129	4	REDUCER (12S-06SF)	
3.	154-220	4	CONNECTOR (040-06S)	
4.	515-175	2	HOSE (040FX90-16"-3000)	
5.	153-673	1	HYD LINE	TOP
6.	153-674	1	HYD LINE	BOTTOM
7.	154-344	2	UN RUN TEE (060FX-060-060)	
8.	157-764	-	HYDRAULIC VALVE	
9.	154-221	2	CONNECTOR (06S-060)	
10.	149-426	1	HYD LINE	
11.	149-959	1	HYD LINE	
12.	110-998	8	CLAMP HALVES (3/8") PAIR	
13.	105-117	5	WASHER (5/16")	
14.	105-297	5	BOLT (1/4-NC X 3-1/4")	
15.	154-800	2	HOSE (040FX-18"-3000)	SEE FOOTNOTE 1
16.	157-037	4	O-RING (011 D90)	

NOT SHOWN:

FOOTNOTES:

- I. ON MACHINES PRIOR TO RACK AND PINION, USE 155-484 TO REPLACE THIS HOSE

NOTE:

# PIPE LIFTER HYDRAULICS

JT4020 ALL TERRAIN ONLY

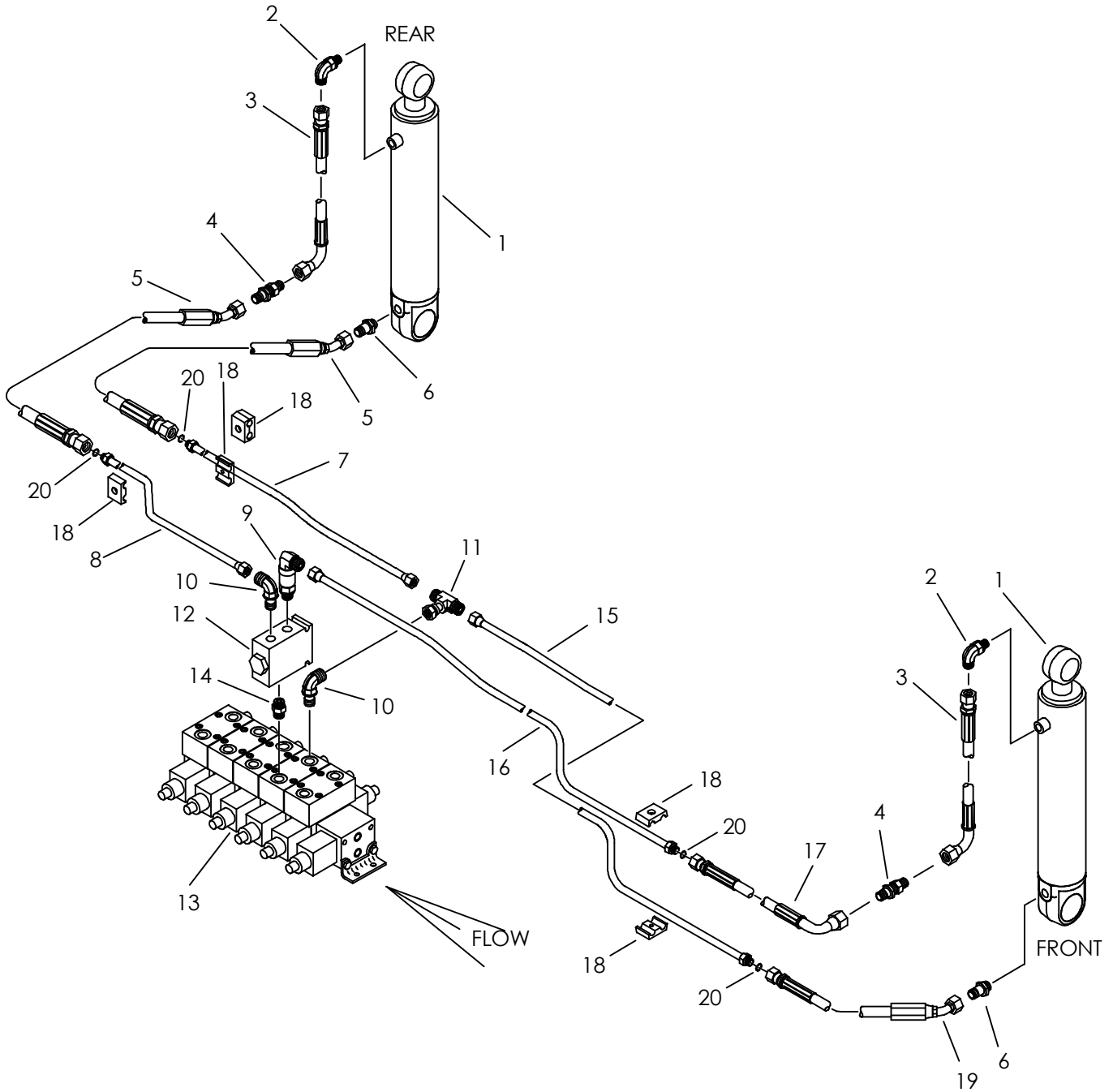

# PIPE LIFTER HYDRAULICS

## JT4020 ALL TERRAIN ONLY

REF NO.	PART NUMBER	QTY	DESCRIPTION	REMARKS
1.	151-031	2	CYL (2.0" X 1.0" X 8.0")	
2.	154-252	2	CONNECTOR (04S-04090)	
3.	515-179	2	HOSE (040FX90-11"-3000)	
4.	154-275	2	BK CONNECTOR (040-040BK)	
5.	515-072	2	HOSE (040FX45-16"-3000)	
6.	154-403	2	CONNECTOR (04S-040, XL)	
7.	153-669	1	HYD LINE	TOP
8.	153-670	1	HYD LINE	BOTTOM
9.	154-471	1	CONNECTOR (060-06S90,LG)	
10.	154-342	2	CONNECTOR (06S-06090)	
11.	154-348	1	UN BR TEE (060FX-060-060)	
12.	516-087	1	FLOW DIVIDER	
13.	157-764	1	HYDRAULIC VALVE	
14.	155-153	1	CONNECTOR (06S-06S)	
15.	149-439	1	HYD LINE	
16.	149-440	1	HYD LINE	
17.	515-175	1	HOSE (040FX90-16"-3000)	
18.	110-998	7	CLAMP HALVES (3/8") PAIR	
19.	154-934	1	HOSE (040FX45-18"-3000)	
20.	157-037	4	O-RING (011 D90)	

NOT SHOWN:

FOOTNOTES:

NOTE:

## GRIPPER HYDRAULICS

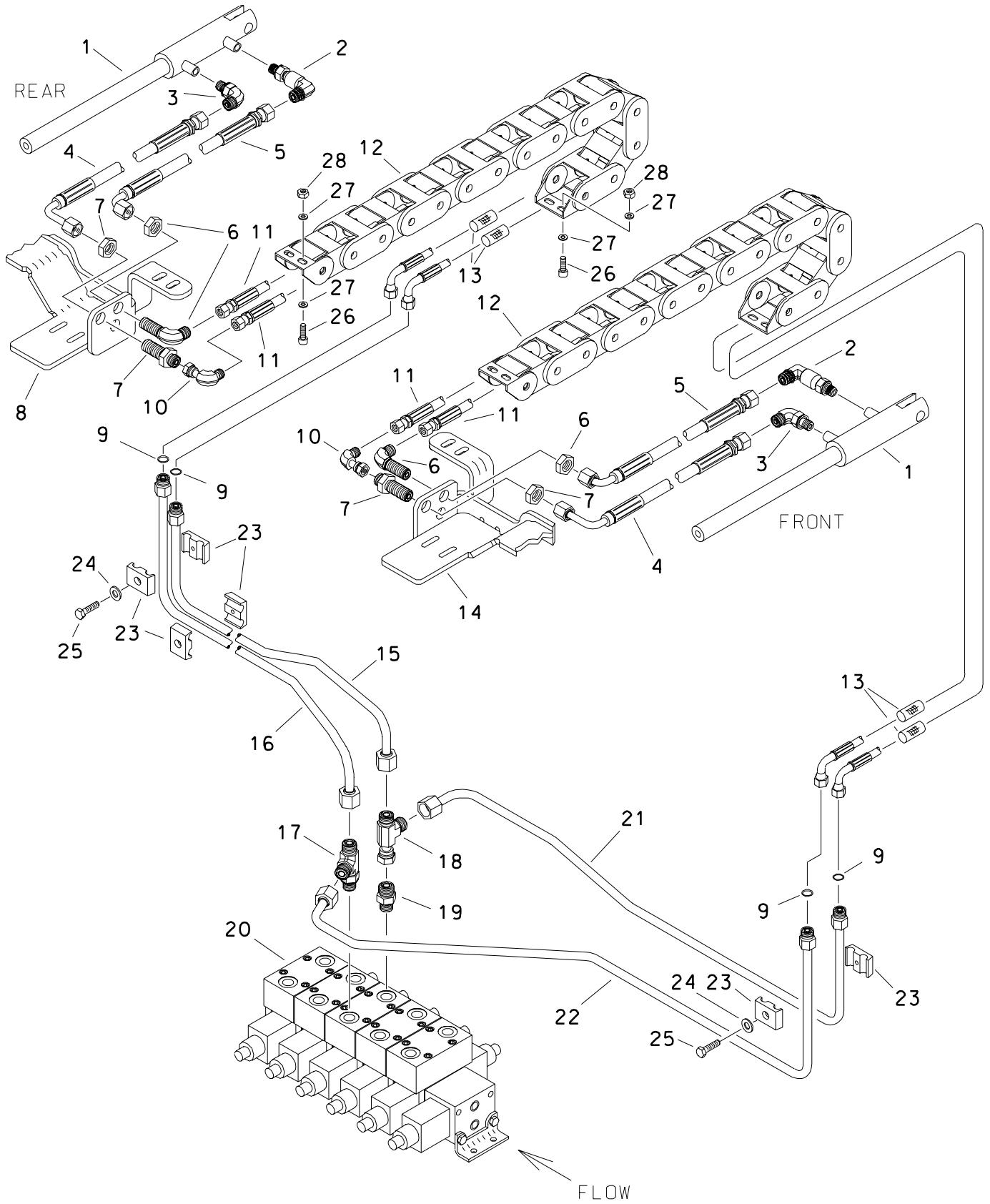



## GRIPPER HYDRAULICS

REF NO.	PART NUMBER	QTY	DESCRIPTION	REMARKS
1.	150-731	2	CYL ASS'Y	
2.	154-474	2	CONNECTOR (04S-04090,XL)	
3.	154-252	2	CONNECTOR (04S-04090)	
4.	157-362	2	HOSE (040FX90L-11"-3000)	
5.	515-598	2	HOSE (040FX90-12"-3000)	
6.	154-355	2	BK CONNECTOR (040-04090BK)	
7.	154-275	2	BK CONNECTOR (040-040BK)	
8.	313-684	-	REAR SHUTTLE	
9.	157-037	4	O-RING (011 D90)	
10.	154-255	2	UNION (040-040FX90)	
11.	153-365	4	HOSE (040FX90S-34"-3000)	
12.	306-746	2	HOSE TRACK	
13.	117-397	4	ABRASION SLEEVE (1.25" X 35")	
14.	313-683	-	FRONT SHUTTLE	
15.	153-671	1	HYD LINE	TOP
16.	153-672	1	HYD LINE	BOTTOM
17.	153-667	1	SPECIAL TEE (06S,ORF-060-060)	
18.	154-344	1	UN RUN TEE (060FX-060-060)	
19.	156-067	1	CONNECTOR (06S-060, ORF .031")	
20.	157-764	-	HYDRAULIC VALVE	
21.	149-427	1	HYD LINE	TOP
22.	149-428	1	HYD LINE	BOTTOM
23.	110-998	6	CLAMP HALVES (3/8") PAIR	
24.	105-117	2	WASHER (5/16")	
25.	105-197	2	BOLT (1/4-NC X 1")	
26.	106-640	8	SCREW (M6-1.00 X 20MM, BUT SOC)	
27.	105-284	16	WASHER (3/16")	
28.	106-237	8	LOCKNUT (M6-1.00,PRV TRQ,NLK)	

FOOTNOTES

# GREASER HYDRAULICS

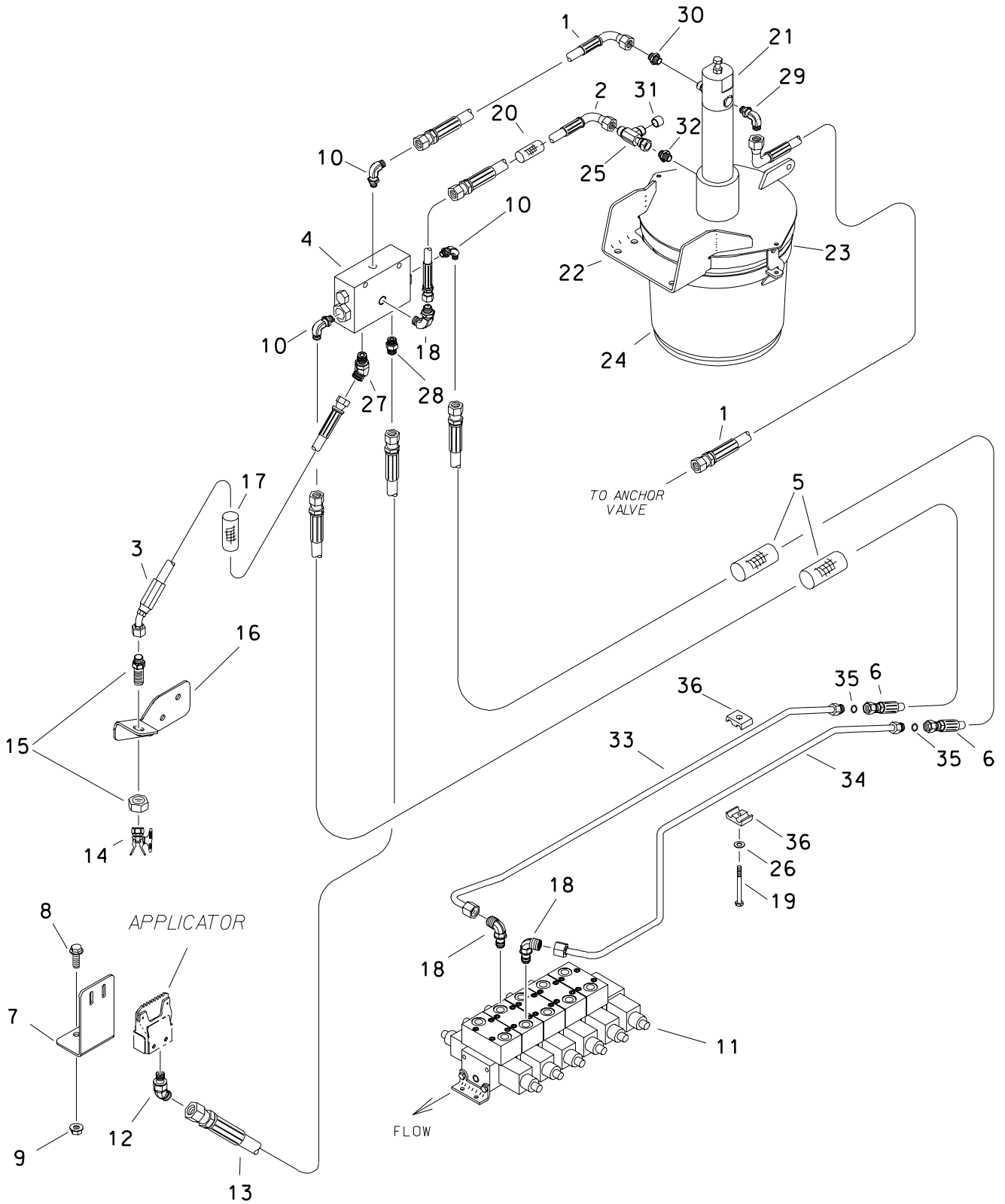

## GREASER HYDRAULICS

REF NO.	PART NUMBER	QTY	DESCRIPTION	REMARKS
1.	149-827	2	HOSE (040FX90S-24"-3000)	
2.	153-320	1	HOSE (060FX90L-17"-3000)	
3.	149-825	1	HOSE (060FX90L-28"-3000)	
4.	310-591	1	VALVE ASS'Y	SEE FOOTNOTE 3
5.	117-211	2	ABRASION SLEEVE (1.25" X 90")	
6.	154-724	2	HOSE (040FX-82"-3000)	
7.	318-607	1	BRACKET, WIPEP	SEE FOOTNOTE 4
8.	106-724	2	FLG SCREW (M10-1.50 X 25MM)	
9.	106-387	2	FLG LOCKNUT (M10-1.50)	
10.	154-252	3	CONNECTOR (04S-04090)	
11.	157-764	-	HYDRAULIC VALVE	SEE FOOTNOTE 3
12.	514-414	1	CONNECTOR (04S-06045)	
13.	153-424	1	HOSE (060FX-236"-3000)	
14.	401-155	1	SPRAY NOZZLE	
-	191-258	1	SPRAY NOZZLE HANDLE KIT	
-	153-096	1	CAP GASKET, NYLON	
15.	514-163	1	BK CONNECTOR (060-060BK)	
16.	318-854	-	BRACKET, SPRAY	
17.	117-684	1	ABRASION SLEEVE (1.00" X 26")	
18.	154-342	3	CONNECTOR (06S-06090)	
19.	105-297	1	BOLT (1/4-NC X 3-1/4")	
20.	117-194	1	ABRASION SLEEVE (1.00" X 16")	
21.	350-398	-	GREASE PUMP	
22.	350-400	-	COVER	
23.	350-399	-	BASE	
24.	259-858	-	TOOL JNT LUBE, STD SPRY 2 GAL	
-	256-031	-	TOOL JNT LUBE, SUMR SPRY 2 GAL	
25.	154-344	1	UN RUN TEE (060FX-060-060)	
26.	105-117	1	WASHER (5/16")	
27.	154-224	1	CONNECTOR (06S-06045)	SEE FOOTNOTE 1
28.	514-165	1	CONNECTOR (06S-060, DRF .078")	SEE FOOTNOTE 2
29.	154-401	1	CONNECTOR (04S-04090, DRF)	
30.	154-278	1	CONNECTOR (04S-040)	
31.	154-326	1	CAP (060F)	
32.	154-221	1	CONNECTOR (06S-060)	
33.	149-956	1	HYD LINE	
34.	149-957	1	HYD LINE	
35.	157-037	2	O-RING (011 D90)	
36.	110-998	1	CLAMP HALVES (3/8") PAIR	

## FOOTNOTES

1. TO SPRAY NOZZEL.
2. TO REAR APPLICATOR.
3. FOR PARTS BREAKDOWN OF SELECTOR VALVE & APPLICATOR, SEE SPECIFIC PARTS PAGES.
4. USE SCREWS WITH APPLICATOR TO ATTACH TO BRACKET.

## NOTE

REFER TO O-RING CHART (800-301) ON BACK OF THE BOOK FOR REPLACEMENT OF O-RINGS.

## SEAT ROTATION HYDRAULICS

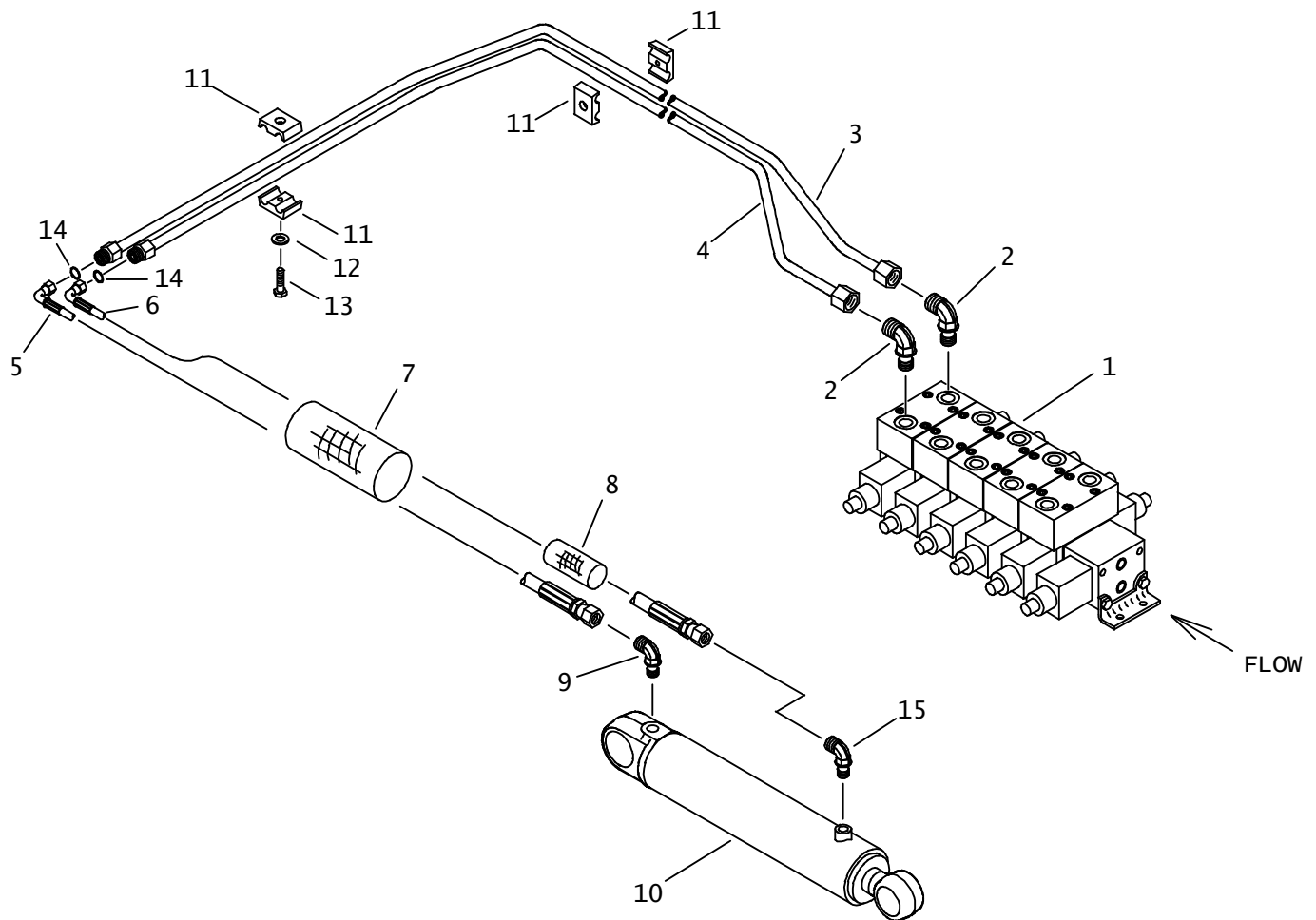

# SEAT ROTATION HYDRAULICS

REF NO.	PART NUMBER	QTY	DESCRIPTION	REMARKS
1.	157-764	-	HYDRAULIC VALVE	
2.	154-342	2	CONNECTOR (06S-06090)	
3.	149-450	1	HYD LINE	TOP
4.	149-451	1	HYD LINE	BOTTOM
5.	515-203	1	HOSE (040FX90-135"-3000)	
6.	515-146	1	HOSE (040FX90S-140"-3000)	
7.	117-619	1	ABRASION SLEEVE (1.59" X 135")	
8.	117-671	1	ABRASION SLEEVE (1.00" X 12")	
9.	154-401	1	CONNECTOR (04S-04090, ORF)	
10.	151-031	1	CYL (2.0" X 1.0" X 8.0")	
11.	110-998	5	CLAMP HALVES (3/8") PAIR	
12.	105-117	1	WASHER (5/16")	
13.	105-197	1	BOLT (1/4-NC X 1")	
14.	157-037	2	O-RING (011 D90)	
15.	154-252	1	CONNECTOR (04S-04090)	

NOT SHOWN:

FOOTNOTES:

NOTE:

REFER TO O-RING CHART (800-301) IN BACK OF THE BOOK FOR REPLACEMENT OF O-RINGS.

# HYDRAULIC CYLINDER (2.0" X 1.00" X 8.0")

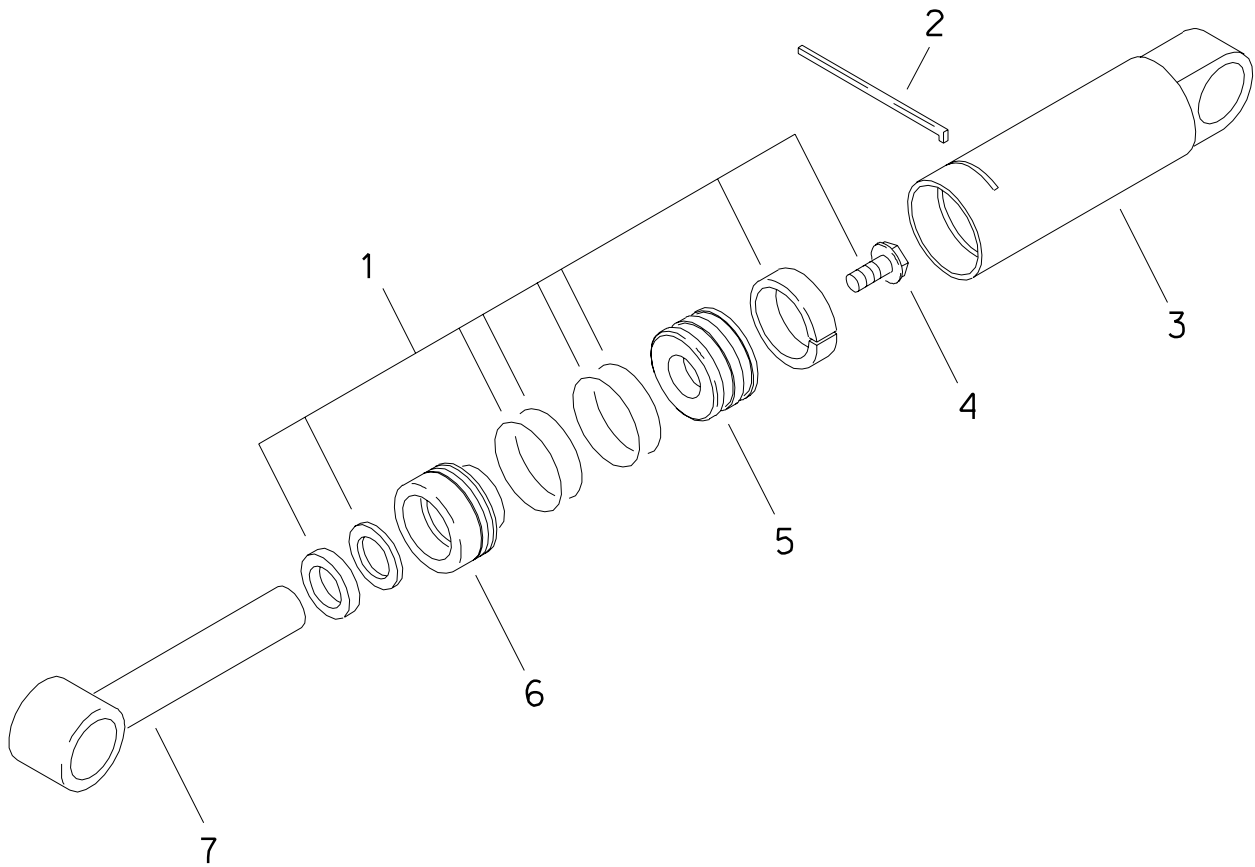

# HYDRAULIC CYLINDER (2.0" X 1.00" X 8.0")

REF NO.	PART NUMBER	QTY	DESCRIPTION	REMARKS
	151-031		CYL (2.0" X 1.0" X 8.0")	INCL. REF. NO.'S 1 THRU 7
1.	190-165	1	SEAL REPAIR KIT (2" X 1")	
2.	150-778	1	LOCK RING (2")	
3.	150-285	1	CYLINDER BARREL (2")	
4.	106-096	1	FLG BOLT (1/2-NC X 1-3/4", GD8)	SEE FOOTNOTE 1
5.	150-775	1	CYLINDER PISTON (2.0" X 1.0")	
6.	150-772	1	CYLINDER HEAD (2" X 1")	
7.	150-417	1	CYLINDER ROD	

NOT SHOWN:

	259-100		U-SEAL INSTALLER (1" - 1.499")	
	259-235		1.00 ROD WIPER TOOL	
	259-239		WIPER/SEAL INSTALLER (2")	
	259-241		PISTON INSTALLER (2")	
	259-188		CYL HEAD SPANNER - TWO PIN	

FOOTNOTES  
 1 - TORQUE TO 90-100 FT-LBS (120-135 N.M).

# HYDRAULIC CYLINDER

2.0" X 1.25" X 24.0"

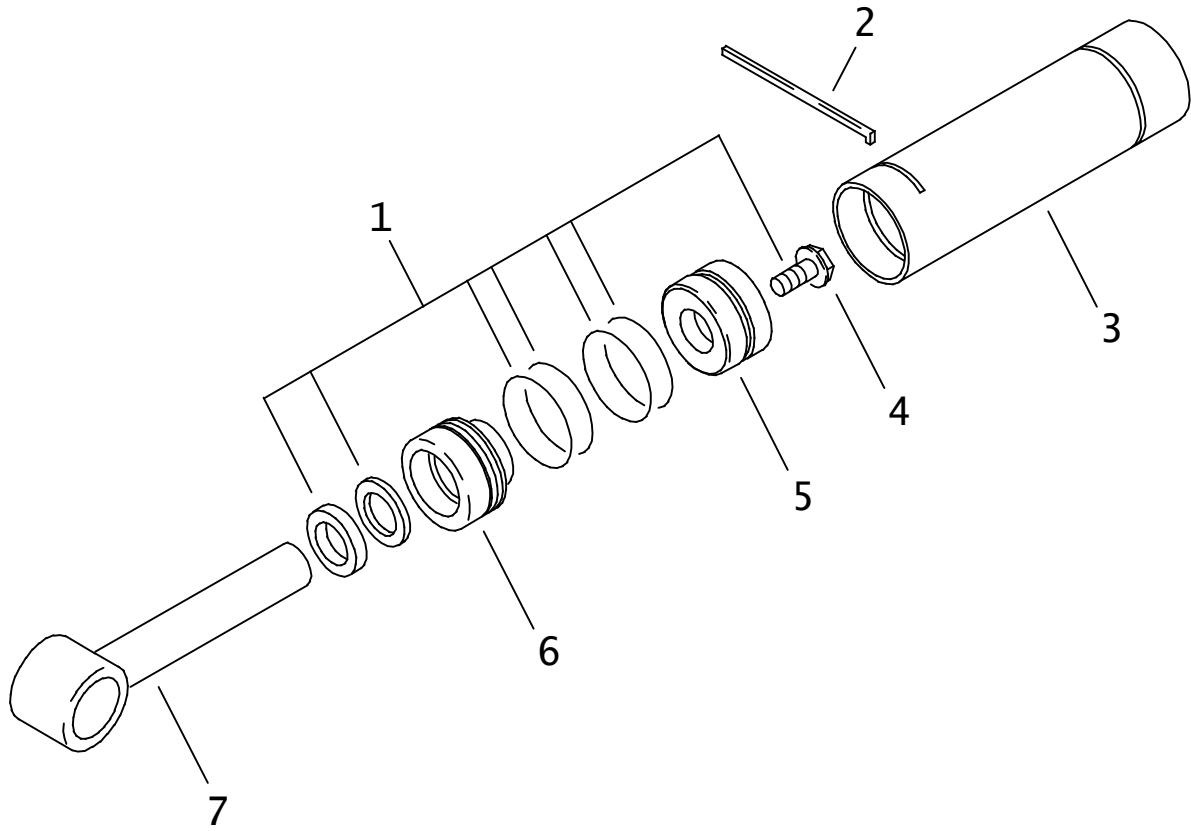



# HYDRAULIC CYLINDER

## 2.0" X 1.25" X 24.0"

REF NO.	PART NUMBER	QTY	DESCRIPTION	REMARKS
	150-747		CYL (2" X 1.25" X 24")	INCLUDE REF NO:S 1 THRU 7
1.	190-169	1	SEAL REPAIR KIT (2.0" X 1.25")	INCLUDES REF NO:S 4 & 5
2.	150-778	1	LOCK RING (2")	
3.	151-170	1	CYLINDER BARREL	
4.	106-097	1	FLG BOLT (5/8-NC X 1-3/4", GD8)	SEE FOOTNOTE I
5.	150-771	1	CYLINDER PISTON (2.0" X 1.25")	INCLUDES MOLDED-ON WEAR RING
6.	150-770	1	CYLINDER HEAD (2.0" X 1.25")	
7.	150-679	1	CYLINDER ROD (1.25")	

### NOT SHOWN:

259-100	U-SEAL INSTALLER (1"-1.499")
259-236	WIPER INSTALLER (1.250")
259-239	WIPER/SEAL INSTALLER (2")
259-241	PISTON INSTALLER (2")
259-188	CYL HEAD SPANNER - TWO PIN

### FOOTNOTES

I. APPLY LOCTITE 271 OR 277. TORQUE TO 180-200 FT-LBS (245-270 N.M)

### NOTE:

# HYDRAULIC CYLINDER

3" X 1.75" X 8"

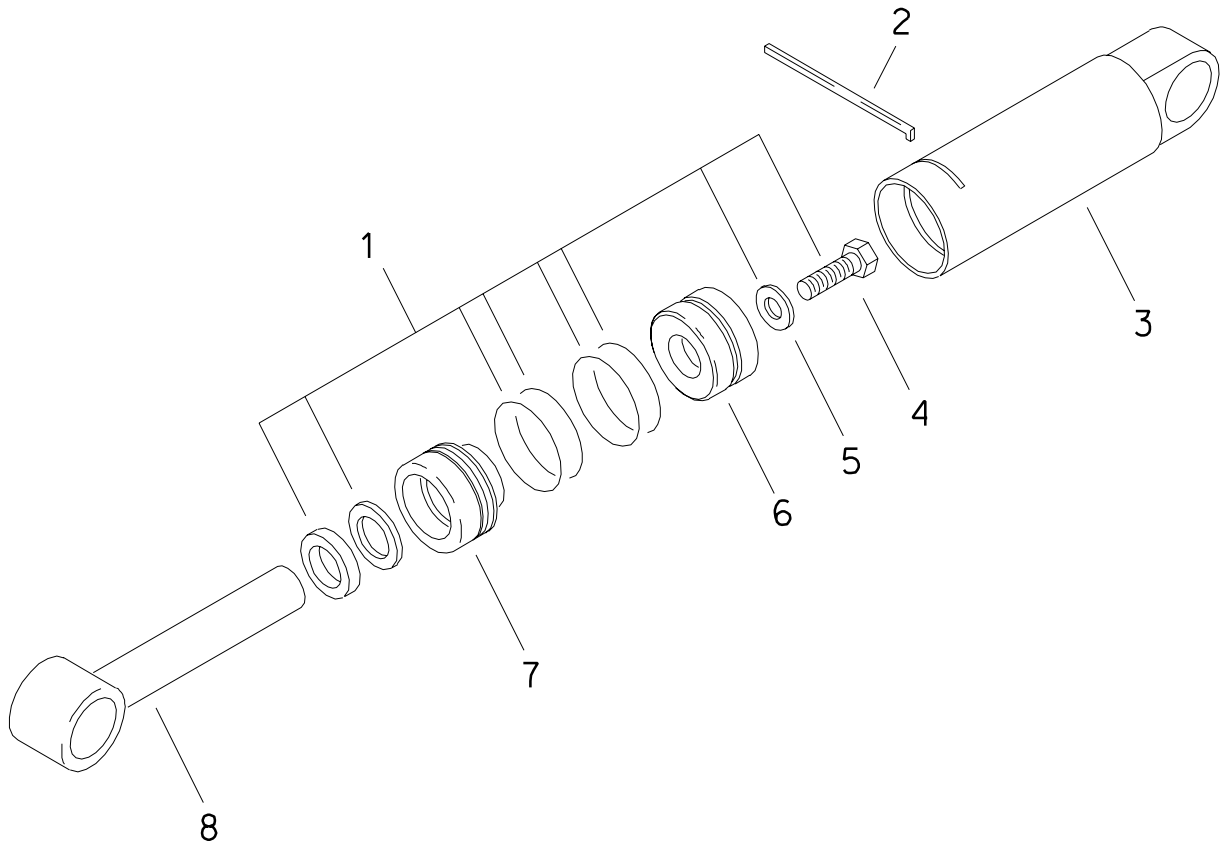

## HYDRAULIC CYLINDER

3" X 1.75" X 8"

REF NO.	PART NUMBER	QTY	DESCRIPTION	REMARKS
	151-070		CYL (3.0" X 1.75" X 8.0")	INCL REF NO.'S 1 THRU 7
1.	190-172	1	SEAL REPAIR KIT (3.0" X 1.75")	INCL REF NO.'S 4 THRU 5
2.	150-911	1	LOCK RING (3")	
3.	152-014	1	CYLINDER BARREL (3")	
4.	106-122	1	BOLT (7/8-NC X 2-1/4", GD8)	SEE FOOTNOTE 1
5.	105-363	1	WASHER (7/8")	
6.	150-765	1	CYLINDER PISTON (3" X 1.75")	INCL MOLDED-ON WEAR RING
7.	150-763	1	CYLINDER HEAD (3" X 1.75")	
8.	150-436	1	CYLINDER ROD (1.75")	

## NOT SHOWN:

259-040 U-SEAL INSTALLER (1.5" - UP)  
 259-238 WIPER INSTALLER (1.75")  
 259-065 PISTON SEAL INSTALLER (3")  
 259-066 PISTON INSTALLER (3")  
 259-188 CYL HEAD SPANNER - TWO PIN

## FOOTNOTES

1. CLEAN & DRY THREADS. APPLY RED LOCTITE (RC 271 OR RC 272). TORQUE TO 410-460 FT-LBS (560-625 N.M.)

# HYDRAULIC CYLINDERS (4.0" X 2.0")

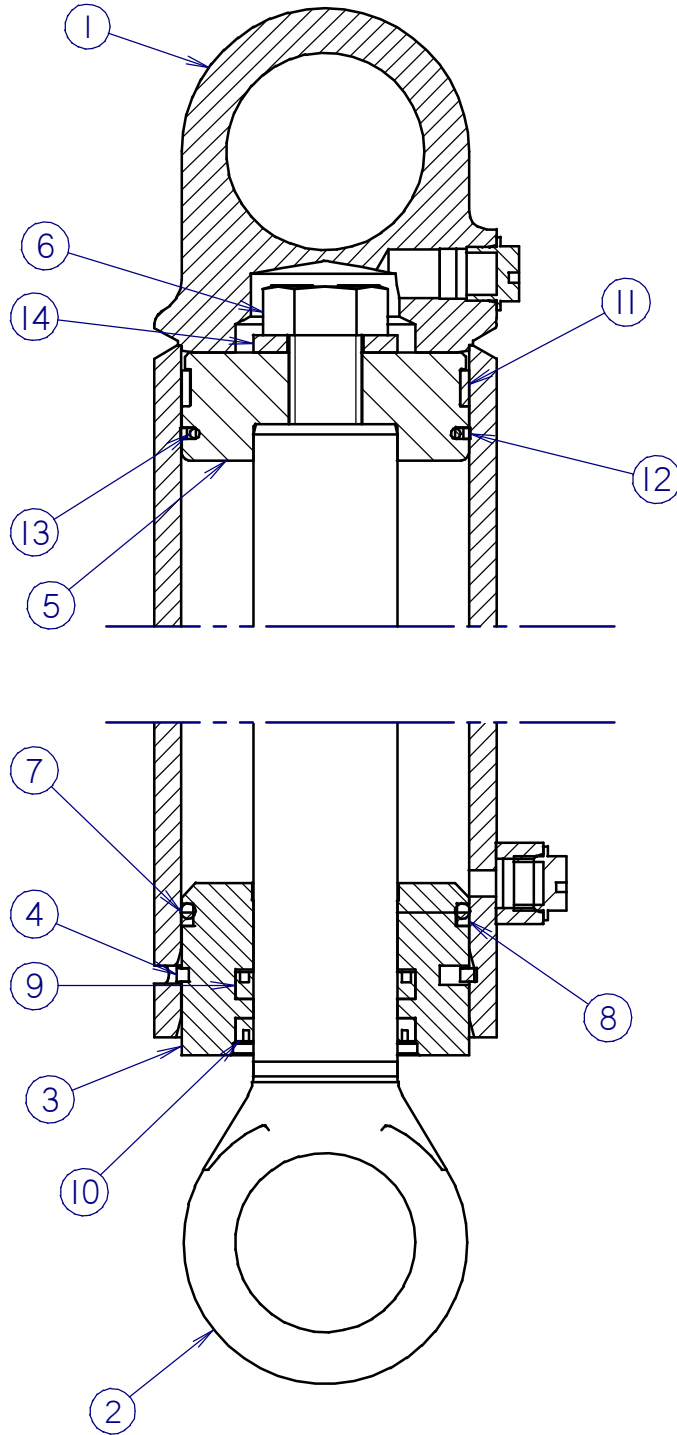

## HYDRAULIC CYLINDERS (4.0" X 2.0")

REF NO.	PART NUMBER	QTY	DESCRIPTION	REMARKS
	149-698	-	CYL (4.0 X 2.0 X 4.0)	SEE FOOTNOTES 1 & 2
1	149-768	1	CYLINDER BARREL (4.0 X 4.0)	
2	153-021	1	CYLINDER ROD (2.00 X 4.0)	
	151-066	-	CYL (4.0 X 2.0 X 5.0)	SEE FOOTNOTES 1 & 2
1	152-012	1	CYLINDER BARREL (4.0 X 5.0)	
2	150-440	1	CYLINDER ROD (2.00 X 5.0)	
	149-699	-	CYL (4.0 X 2.0 X 6.0)	SEE FOOTNOTES 1 & 2
1	152-062	1	CYLINDER BARREL (4.0 X 6.0)	
2	149-735	1	CYLINDER ROD (2.00 X 6.0)	
	149-700	-	CYL (4.0 X 2.0 X 8.0)	SEE FOOTNOTES 1 & 2
1	152-030	1	CYLINDER BARREL (4.0 X 8.0)	
2	149-736	1	CYLINDER ROD (2.00 X 8.0)	
	149-701	-	CYL (4.0 X 2.0 X 10.0)	SEE FOOTNOTES 1 & 2
1	149-769	1	CYLINDER BARREL (4.0 X 10.0)	
2	153-016	1	CYLINDER ROD (2.00 X 10.0)	
	151-088	-	CYL (4.0 X 2.0 X 12.0)	SEE FOOTNOTES 1 & 2
1	150-298	1	CYLINDER BARREL (4.0 X 12.0)	
2	150-429	1	CYLINDER ROD (2.00 X 12.0)	
	149-702	-	CYL (4.0 X 2.0 X 16.0)	SEE FOOTNOTES 1 & 2
1	152-007	1	CYLINDER BARREL (4.0 X 16.0)	
2	149-737	1	CYLINDER ROD (2.00 X 16.0)	
	149-703	-	CYL (4.0 X 2.0 X 20.0)	SEE FOOTNOTES 1 & 2
1	149-770	1	CYLINDER BARREL (4.0 X 20.0)	
2	149-738	1	CYLINDER ROD (2.00 X 20.0)	
	149-704	-	CYL (4.0 X 2.0 X 24.0)	SEE FOOTNOTES 1 & 2
1	152-063	1	CYLINDER BARREL (4.0 X 24.0)	
2	149-739	1	CYLINDER ROD (2.00 X 24.0)	
3	149-006	1	CYLINDER HEAD (4.0 X 2.00)	
4	149-303	1	LOCK RING (4.0)	
5	149-307	1	CYLINDER PISTON (4.0 X 2.00)	
6	106-145	1	BOLT (1-NC X 2-1/4", GD8)	SEE FOOTNOTE 3
7	157-035	1	O-RING (342 D90)	
8	157-036	1	BACKUP RING (342 D90)	
9	157-559	1	U-SEAL (2.000")	
10	157-558	1	WIPER SEAL (2.000")	
11	125-793	1	WEAR RING	
12	157-570	1	BACKUP RING (238 D90)	
13	157-044	1	O-RING (238 D90)	
14	106-144	1	WASHER (1")	

### FOOTNOTES

- REF. #1 & #2 ARE SPECIFIC TO EACH CYLINDER, REF. #3 THRU #14 ARE COMMON FOR ALL THE ABOVE LISTED CYLINDERS.
- SEAL REPAIR KIT P/N: 190-189
- APPLY LOCTITE 277 OR EQUIVALENT, TORQUE TO 630-700 FT-LBS

### NOT SHOWN:

- 259-040 U-SEAL INSTALLER (1.5" - UPI)
- 259-239 WIPER/SEAL INSTALLER (2")
- 259-246 PISTON SEAL INSTALLER (4")
- 259-247 PISTON INSTALLER (4")
- 259-188 CYL HEAD SPANNER - TWO PIN

# HYDRAULIC CYLINDER (4.0" X 2.00" X 10.0")

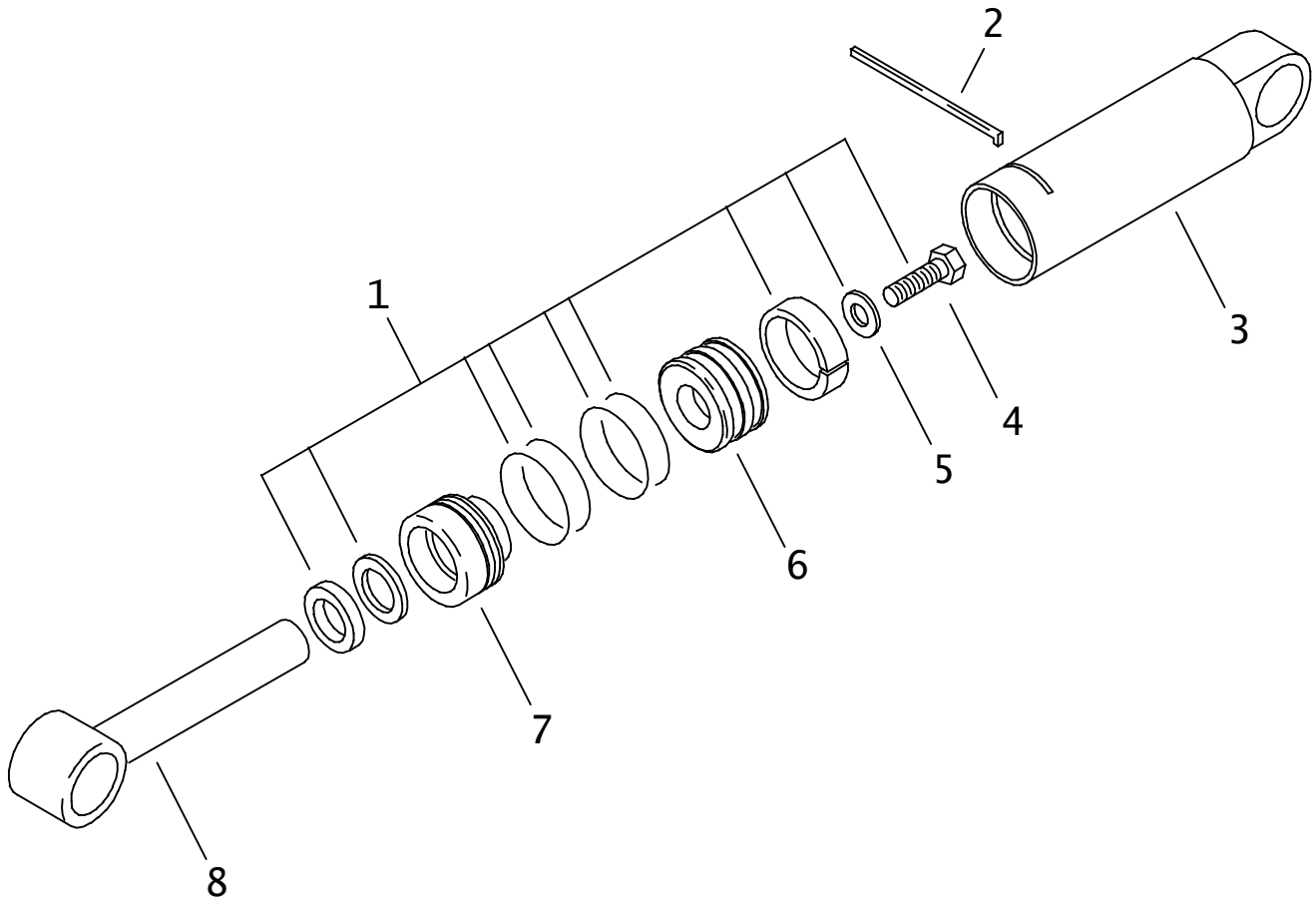

## HYDRAULIC CYLINDER (4.0" X 2.00" X 10.0")

REF NO.	PART NUMBER	QTY	DESCRIPTION	REMARKS
	151-187		CYLINDER ASSEMBLY	INCLUDES REF NO'S 1 THRU 7
1.	190-189	1	SEAL REPAIR KIT (4.0" X 2.0")	INCLUDES REF. NO'S 4 & 5
2.	149-303	1	LOCK RING (4")	
3.	152-071	1	CYLINDER BARREL	
4.	106-145	1	BOLT (1-NC X 2-1/4", GD8)	SEE FOOTNOTE 1
5.	106-144	1	WASHER (1")	
6.	149-307	1	CYLINDER PISTON (4" X 2")	
7.	149-006	1	CYLINDER HEAD (4" X 2")	
8.	153-016	1	CYLINDER ROD	

### NOT SHOWN:

259-040	U-SEAL INSTALLER (1.500"-UP)
259-239	WIPER/SEAL INSTALLER (2")
259-246	PISTON SEAL INSTALLER (4")
259-247	PISTON INSTALLER (4")
259-188	CYL HEAD SPANNER - TWO PIN

### FOOTNOTES

1 APPLY LOCTITE 271 OR 277. TORQUE TO 630-700 FT-LBS (855-950 NM)

### NOTE:





# **ELECTRICAL**

## RIGHT CONSOLE

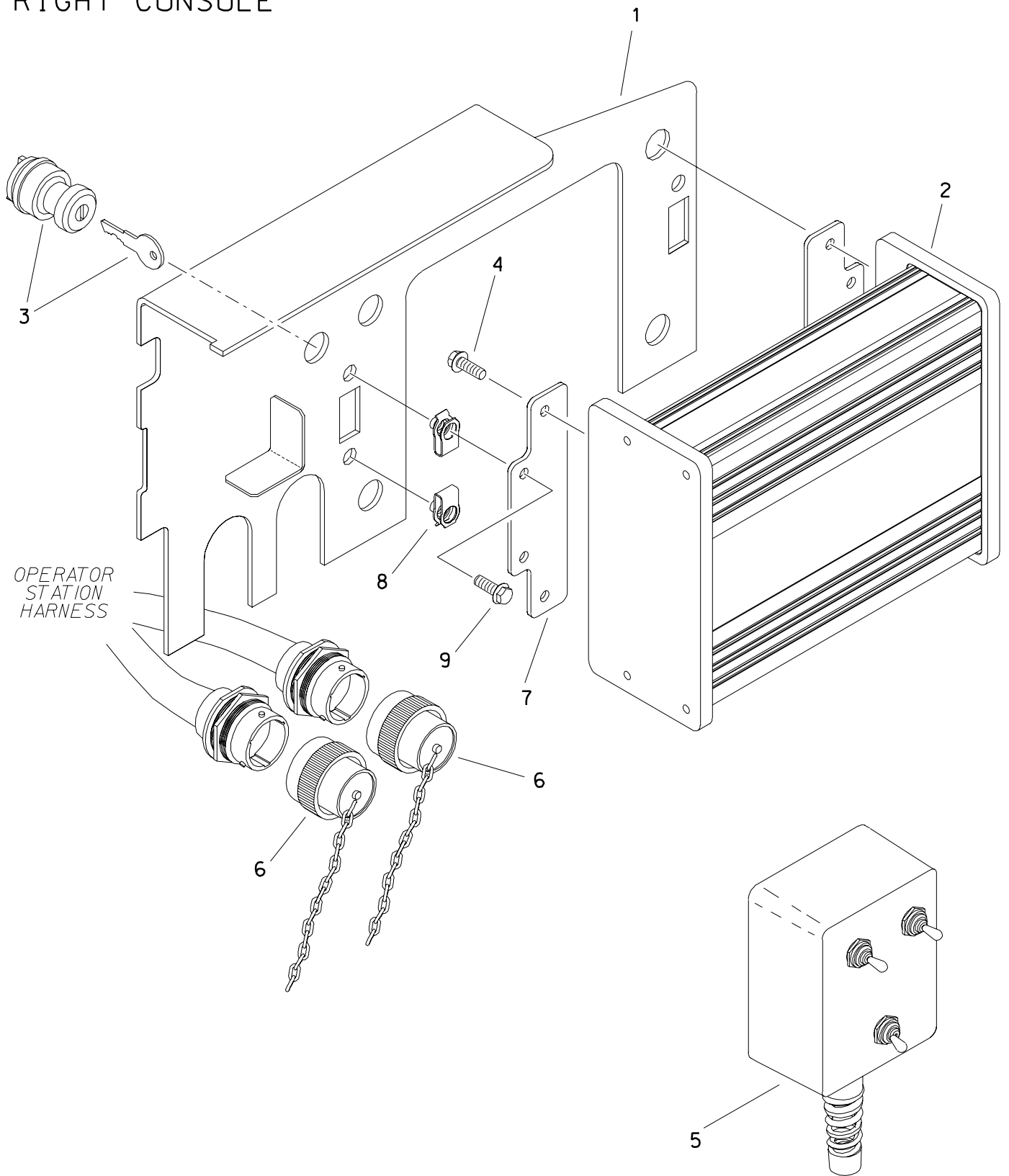

# RIGHT CONSOLE

REF NO.	PART NUMBER	QTY	DESCRIPTION	REMARKS
1.	313-733	-	OPERATOR FRAME	
2.	216-059	-	CONTROL MODULE	
3.	217-248	-	OFF-ON KEY SWITCH	
	214-908	-	ON-OFF KEY SWITCH	
4.	106-378	4	FLG LK SCREW (M6-1.00 X 12MM)	
5.	214-648	1	OVERRIDE CONTROL BOX	
6.	214-812	2	PROTECTIVE CAP	
7.	316-791	2	MOUNTING BRACKET	
8.	106-574	3	CLIP NUT (M6-1.00)	
9.	106-988	3	FLG LK SCREW (M6-1.00 X 20MM)	

## FOOTNOTES



# BATTERY

REF NO.	PART NUMBER	QTY	DESCRIPTION	REMARKS
1.	215-262	2	BATTERY (12V, 925 AMP)	
2.	116-717	2	BATTERY PAD	
3.	347-857	1	DUAL BATTERY STRAP	
4.	106-154	6	FLG LOCKNUT (1/4-NF)	
5.	361-484	2	BRAKE ROD	
6.	105-044	1	JAM NUT (1/2-NC)	
7.	105-070	1	LOCK WASHER (1/2").	
8.	217-819	1	BAT DISCONNECT SWITCH	
9.	215-314	1	BAT CABLE (1/0 GA X 22", BLK)	
10.	106-381	1	FLG LK SCREW (M8-1.25 X 25MM)	
11.	106-561	1	LOCKNUT (M8-1.25,PRV TRQ,10.9)	
12.	215-337	1	BAT CABLE (2/0 GA X 19", BLK)	
13.	106-076	2	WASHER (1/4")	
14.	213-290	1	BAT CABLE (1/0 GA X 7.5", BLK)	
15.	213-291	1	BAT CABLE (1/0 GA X 7.5", RED)	
16.	213-292	1	BAT CABLE (2/0 GA X 82", RED)	

FOOTNOTES

NOTE:

# PANEL

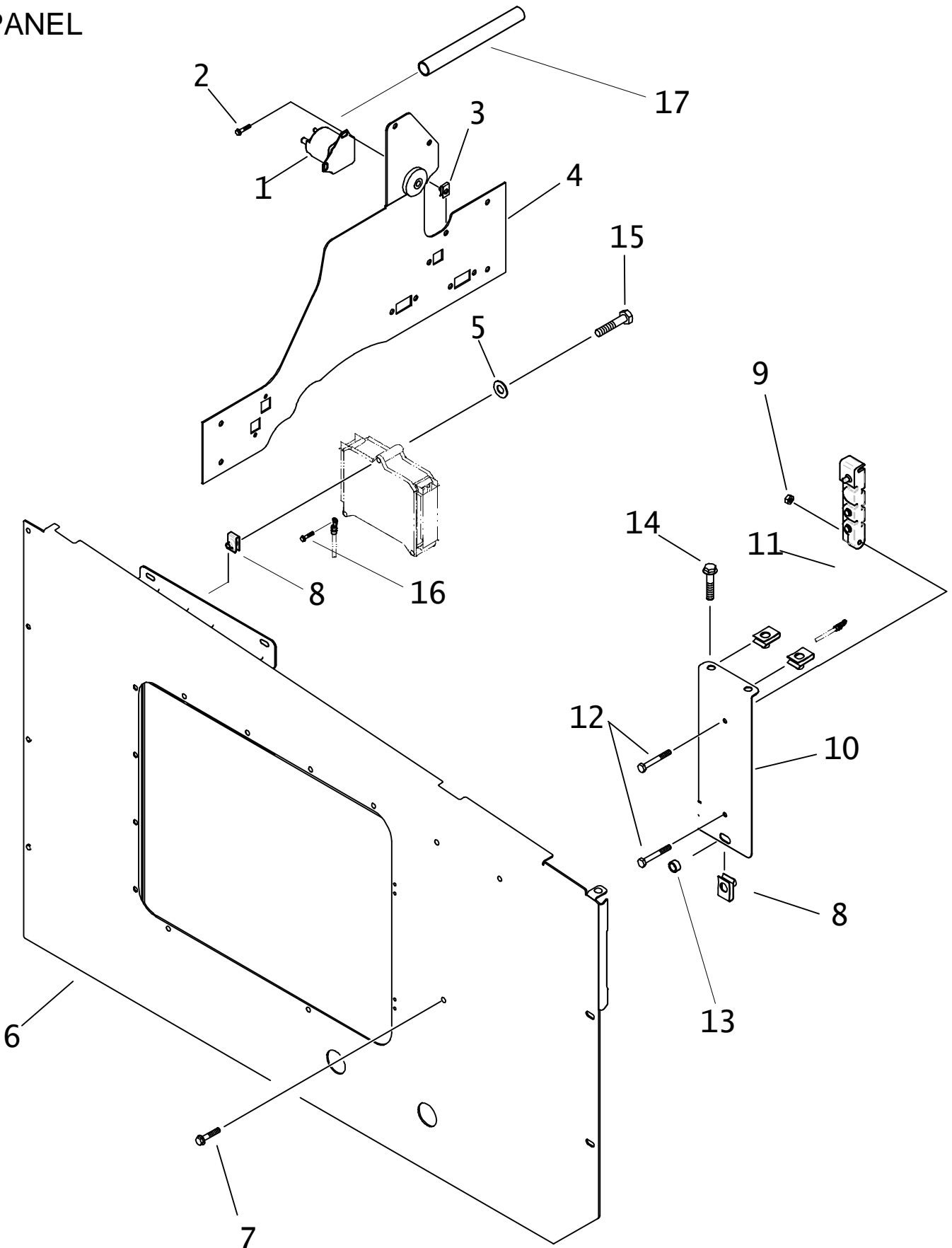

# PANEL

REF NO.	PART NUMBER	QTY	DESCRIPTION	REMARKS
1.	214-979	1	PREHEAT SOLENOID	
2.	106-986	2	FLG LK SCREW (M6-1.00 X 12MM)	
3.	106-574	2	CLIP NUT (M6-1.00)	
4.	322-551	1	FIREWALL	
5.	106-389	3	WASHER (M8)	
6.	310-448	1	FRONT ENGINE PANEL (RIGHT)	
7.	106-989	1	FLG LK SCREW (M8-1.25 X 35MM)	
8.	106-551	6	CLIP NUT (M8-1.25)	
9.	106-106	2	NUT (M6-1.00)	
10.	320-996	1	J-BOX MOUNT	
11.	213-061	1	CAN MULTIPORT MODULE	
12.	107-025	2	SCREW (M6-1.00 X 50MM)	
13.	184-870	1	SPACER	
14.	106-991	2	FLG LK SCREW (M8-1.25 X 20MM)	
15.	107-872	3	SCREW (M8-1.25 X 65MM)	
16.	105-214	1	FLG SCREW (#10-24 X 1/2")	
17.	118-258	1	ABRASION SLEEVE (.750" X 12")	

NOT SHOWN:

FOOTNOTES:

NOTE:

# ALARM AND STROBE LIGHT ELECTRICAL STRIKE SYSTEM

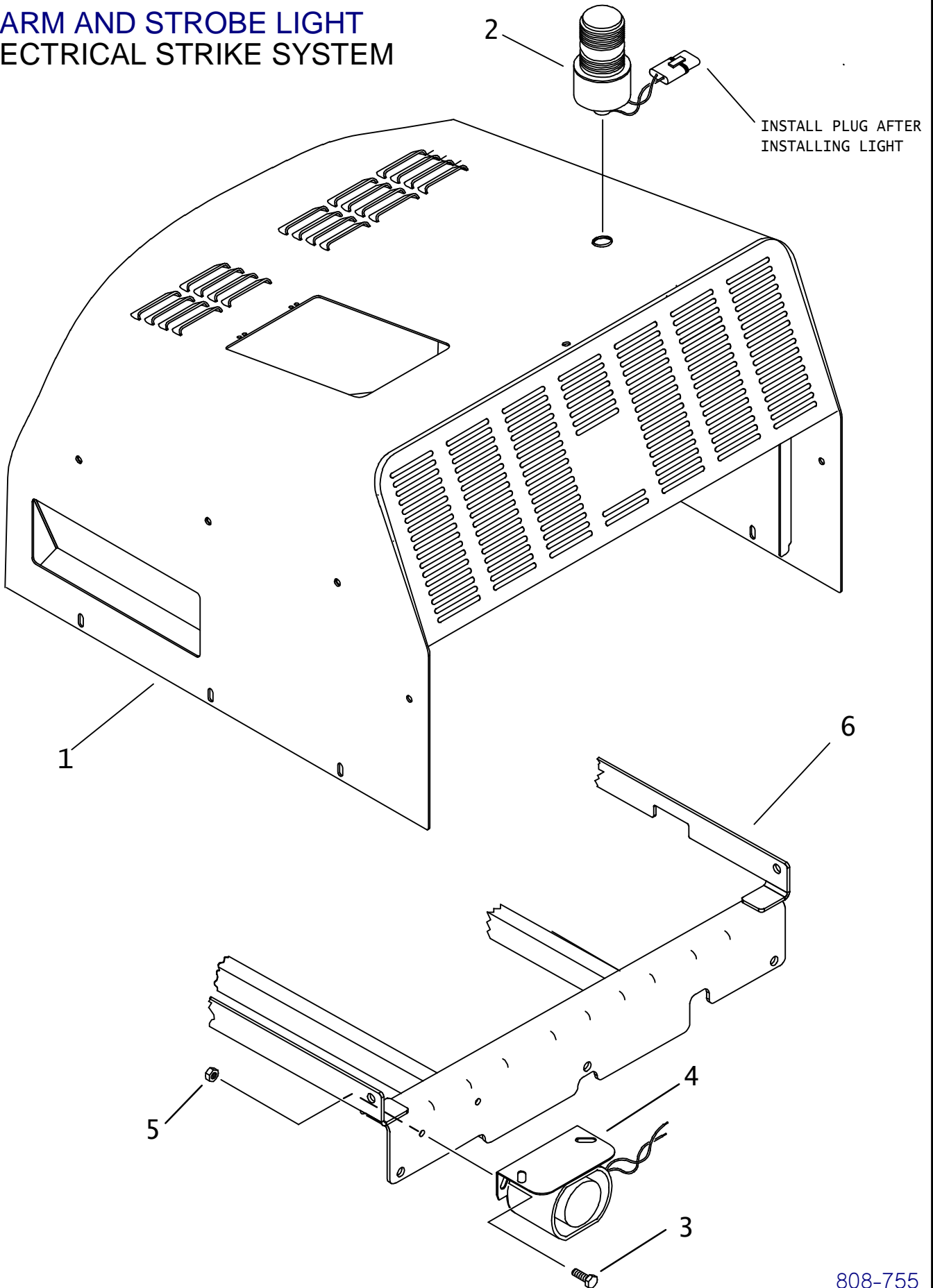



## ALARM AND STROBE LIGHT ELECTRICAL STRIKE SYSTEM

REF NO.	PART NUMBER	QTY	DESCRIPTION	REMARKS
1.	320-838	-	ENGINE PANEL (TOP)	
2.	217-296	1	STROBE LIGHT AMBER MED PROFILE	
3.	106-162	2	FLG SCREW(M8-1.25 X 20MM, GD8)	
4.	306-602	1	BACKUP ALARM	
5.	106-561	2	LOCKNUT (M8-1.25, PRV TRQ, 10.9)	
6.	320-849	-	ENGINE SKID	

FOOTNOTES

NOTE:

# RELAY PANEL

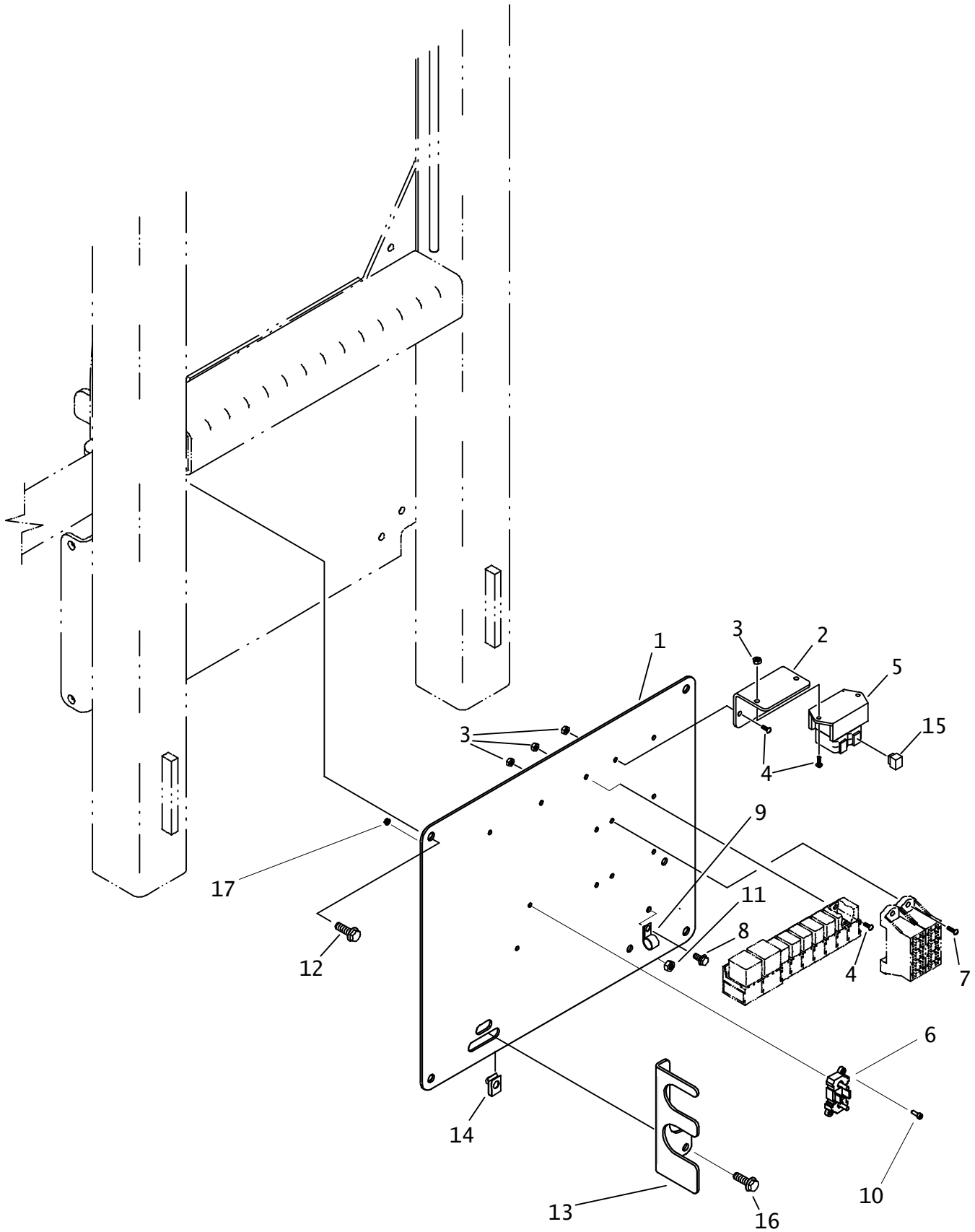

## RELAY PANEL

REF NO.	PART NUMBER	QTY	DESCRIPTION	REMARKS
1.	324-997	1	RELAY PANEL	
2.	310-981	1	BRACKET	
3.	106-048	13	LOCKNUT (#10-24)	
4.	105-185	7	BOLT (#10-24 X 1/2", RD SLT)	
5.	211-026	1	DIODE PACK (DEUTSCH)	
6.	211-306	1	FB/HVAMI FUSE HOLDER	SUPERSEDED BY 363-714
	211-305	1	BK/AMI 125 AMP FUSE	
7.	106-049	6	BOLT (#10-24 X 3/4", PLPS)	
8.	106-378	1	FLG LK SCREW (M6-1.00 X 12MM)	
9.	110-333	1	BOLT-ON CLAMP (1")	
10.	106-715	2	SCREW (M4-0.70 X 12MM, SOC)	
11.	106-237	1	LOCKNUT (M6-1.00,PRV TRQ,NLK)	
12.	106-991	5	FLG LK SCREW (M8-1.25 X 20MM)	
13.	324-996	1	HARNESS BRACKET	
14.	106-551	1	CLIP NUT (M8-1.25)	
15.	214-781	1	12 WAY PLUG	
16.	107-095	1	FLG SCREW (M8-1.25 X 16MM)	
17.	105-680	2	NUT (M4, W/LK WSHR)	

NOT SHOWN:

FOOTNOTES:

NOTE:



# **ACCESSORIES**

# DRILLING FLUID TRANSFER

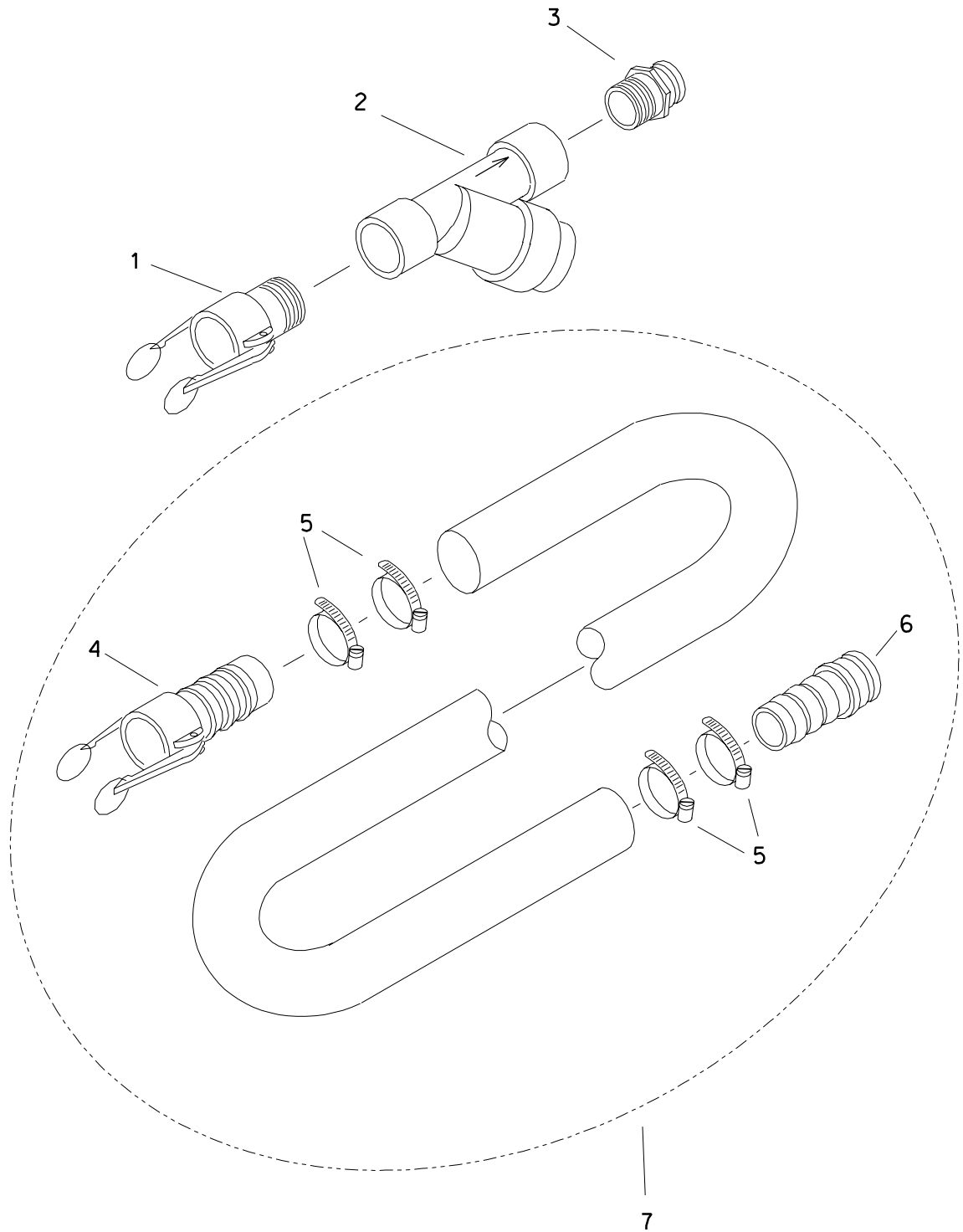

# DRILLING FLUID TRANSFER

REF NO.	PART NUMBER	QTY	DESCRIPTION	REMARKS
	153-371		Y-STRAINER PARTS ASS'Y	INCL REF NO'S 1 - 3
1.	514-386	1	FHC BODY (3-1/2" FHC X 3"NPT)	
2.	159-439	1	Y-STRAINER (48NF)	
	159-490	-	STRAINER (4" X 9")	
	165-895	-	O-RING (END CAP)	
	111-083	-	END CAP	
	308-651	-	END CAP CLAMP	
3.	155-263	1	FHC ADAPTER (56-48N)	
4.	155-264	-	FHC BODY (56-48H)	USE TO REPAIR 153-358
5.	110-367	-	WORM CLAMP (3.250" TO 4.125")	USE TO REPAIR 153-358
6.	153-341	-	FHC ADAPTER (56-48H)	USE TO REPAIR 153-358
7.	153-358	-	TRANSFER HOSE (3" FHC, 50')	USE REF NO'S 4 - 6 TO REPAIR

FOOTNOTES

# FLUID MIXING ACCESSORIES

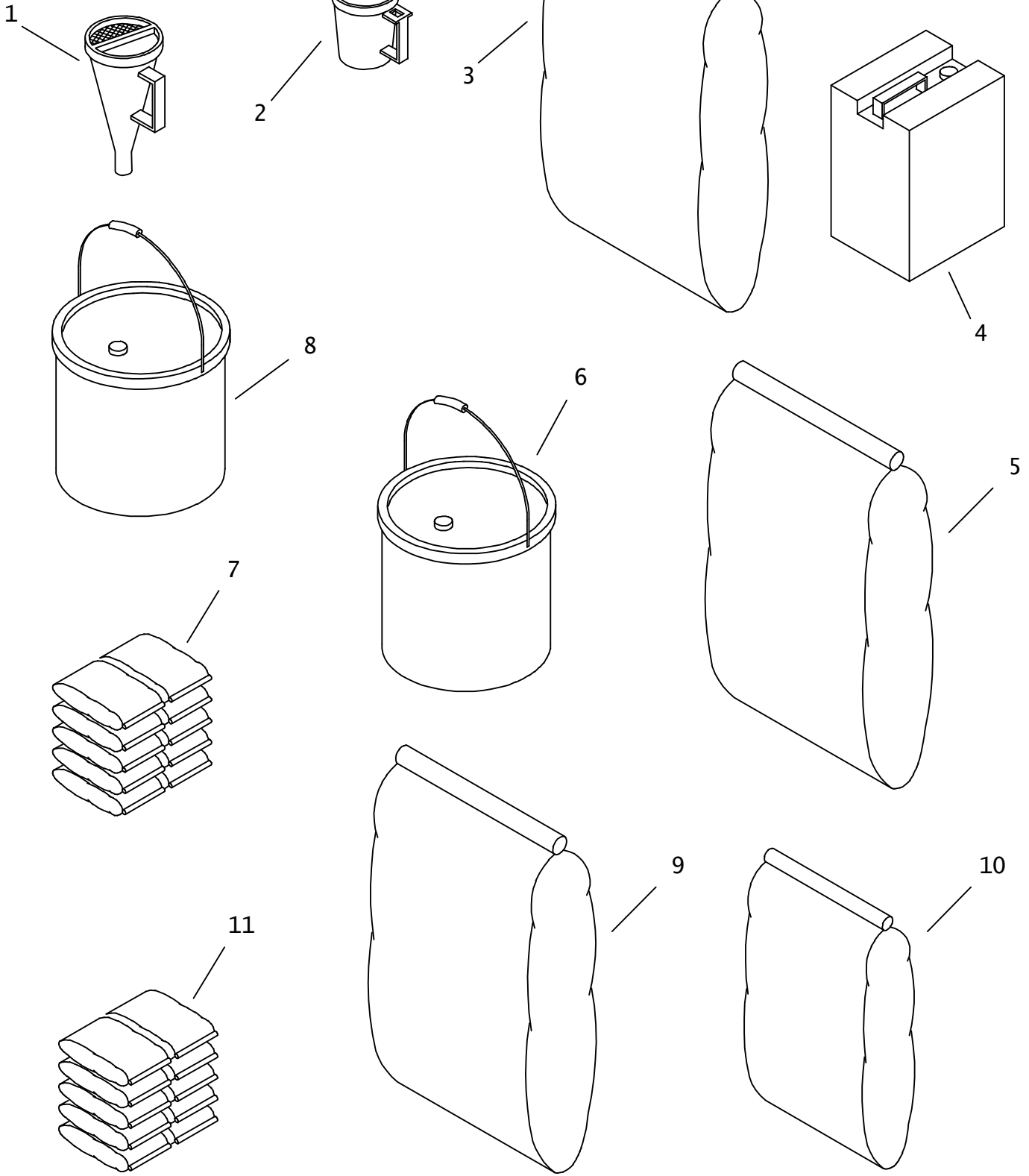



## FLUID MIXING ACCESSORIES

REF NO.	PART NUMBER	QTY	DESCRIPTION	REMARKS
1.	259-195	1	VISCOSITY FUNNEL	
2.	259-196	1	VISCOSITY CUP	
3.	259-804	AR	BENTONITE, QUIK-GEL (50 LB)	
4.	259-805	AR	LIQUID POLYMER, EZ-MUD (5 GAL)	
5.	259-807	AR	BENTONITE, BORE-GEL (50 LB)	
6.	259-808	AR	VISCOSIFIER, LIQUI-TROL (5 GAL)	
7.	259-809	AR	POWDER POLYMER, QUIK-TROL (20 LB)	
8.	259-810	AR	WET AGENT, CON-DET (5 GAL)	
9.	259-821	AR	'PAC-R' FILTRATION CONTROL	
10.	259-822	AR	'BARAZAN D+' VISCOSIFIER	
11.	259-832	AR	'NO SAG' (20# BOX/10-2#BAGS)	

NOT SHOWN:

191-158	1	DRILLING FLUID TEST KIT
259-487	1	SHEAROMETER

FOOTNOTES:

NOTE:

# HEATED HOSE KIT

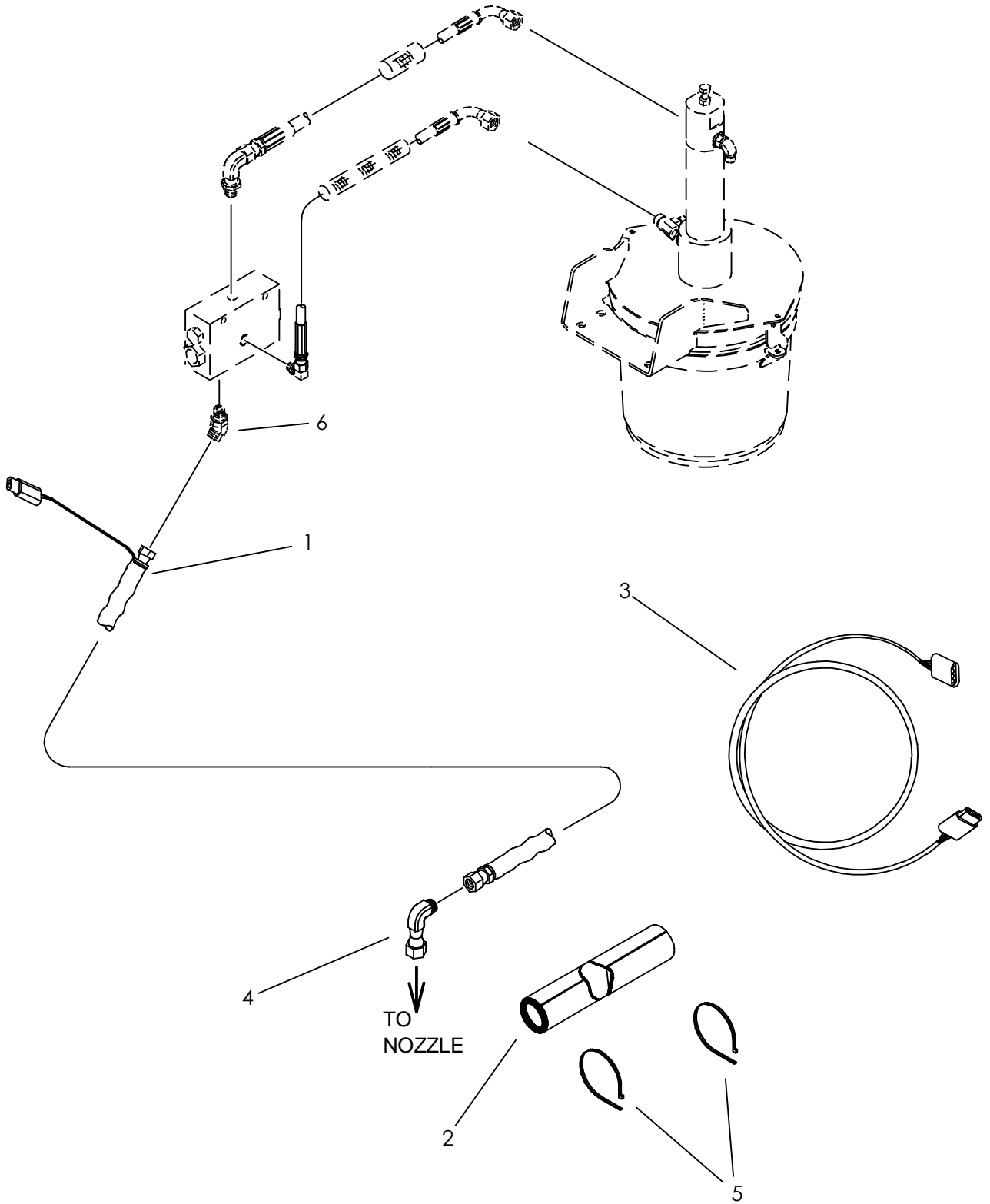

# HEATED HOSE KIT

REF NO.	PART NUMBER	QTY	DESCRIPTION	REMARKS
	101-088		JT27M1 HEATED HOSE KIT	USE REF.'S 1, 2, 3, & 5
	101-089		HEATED HOSE KIT	USE REF.'S 1, 2, 4, & 5
1.	153-585	1	HOSE (060FX-18"-3000,SPCL)	
2.	117-549	1	INSULATOR (1" ID X 5.00")	
3.	214-843	1	GREASER JUMPER HARNESS	USED ON JT2720 MACH 1 ONLY
4.	154-228	1	UNION (060-060FX90)	USED ON JT1720 MACH 1 & JT4020 MACH 1 ONLY
5.	110-030	4	CABLE TIE (1/16" TO 4")	
6.	154-224	1	CONNECTOR (06S-06045)	

NOT SHOWN:

FOOTNOTES:

NOTE:

REFERE TO INSTALLATION INSTRUCTION 051-291.

# WORKING LIGHT

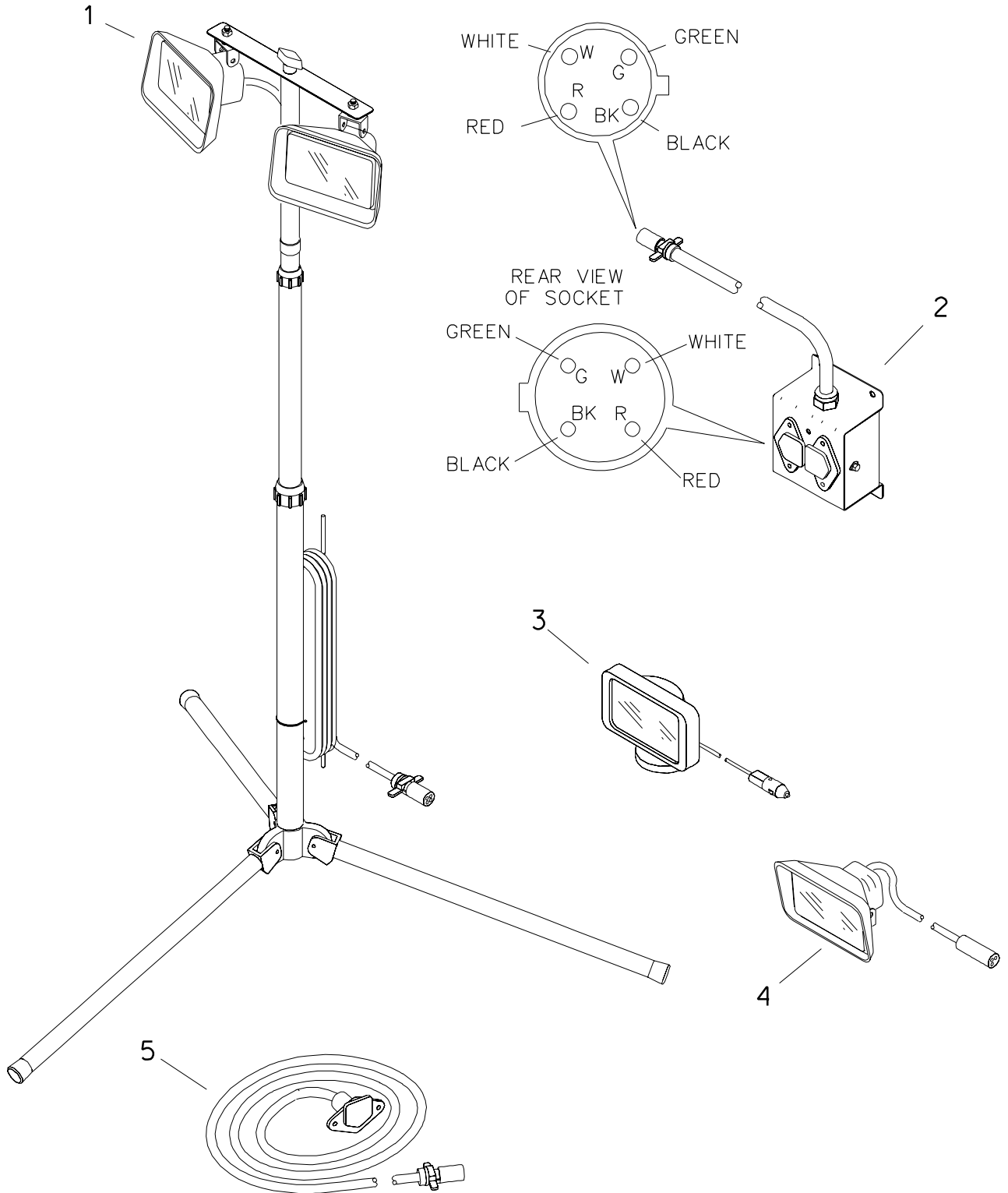

## WORKING LIGHT

REF NO.	PART NUMBER	QTY	DESCRIPTION	REMARKS
1.	190-663	1	WORKING LIGHT CONVERSION KIT	INCL TRIPOD
	217-084	-	TRIPOD	
	217-094	1	DUAL LIGHT CABLE	
	217-080	2	WORKING LAMP (12V DC)	RECTANGULAR, MULTI-PURPOSE
	214-228	2	LIQUID-TIGHT FITTING	
	106-176	2	CONDUIT LOCKNUT (Ø8N)	
	110-373	1	BOLT-ON CLAMP (13/16")	
	106-162	1	FLG SCREW (M8-1.25 X 20mm)	
	106-386	1	FLG LOCKNUT (M8-1.25)	
	347-832	1	BRACKET (LIGHT KIT)	
	110-030	1	CABLE TIE (1/16" TO 4")	
	110-259	1	BOLT-ON CLAMP (.625")	
2.	190-664	1	LIGHT BOX KIT	
	347-833	1	LIGHT JUNCTION BOX	
	347-836	1	BACK PLATE	
	214-229	1	LIGHT HARNESS	JUNCTION BOX
	217-040	3	CONNECTOR (4-WAY, FM)	
	217-039	1	INDICATOR LIGHT (RED)	
	106-379	10	FLG LK SCREW (M6-1.00 X 20mm)	
	106-106	6	NUT (M6-1.00)	
	106-754	4	WELD NUT (M10-1.50)	
3.	217-098	1	WORK LAMP {12V DC, MAGNETIC}	
4.	190-665	1	LIGHT KIT (SINGLE)	
	217-080	1	WORKING LAMP (12V DC)	RECTANGULAR, MULTI-PURPOSE
	217-092	1	SINGLE LIGHT CABLE	
	214-228	1	LIQUID-TIGHT FITTING	
	106-176	1	CONDUIT LOCKNUT (Ø8N)	
5.	217-096	1	EXTENSION CABLE (30M {100'})	

FOOTNOTES

## GROUNDING HARDWARE

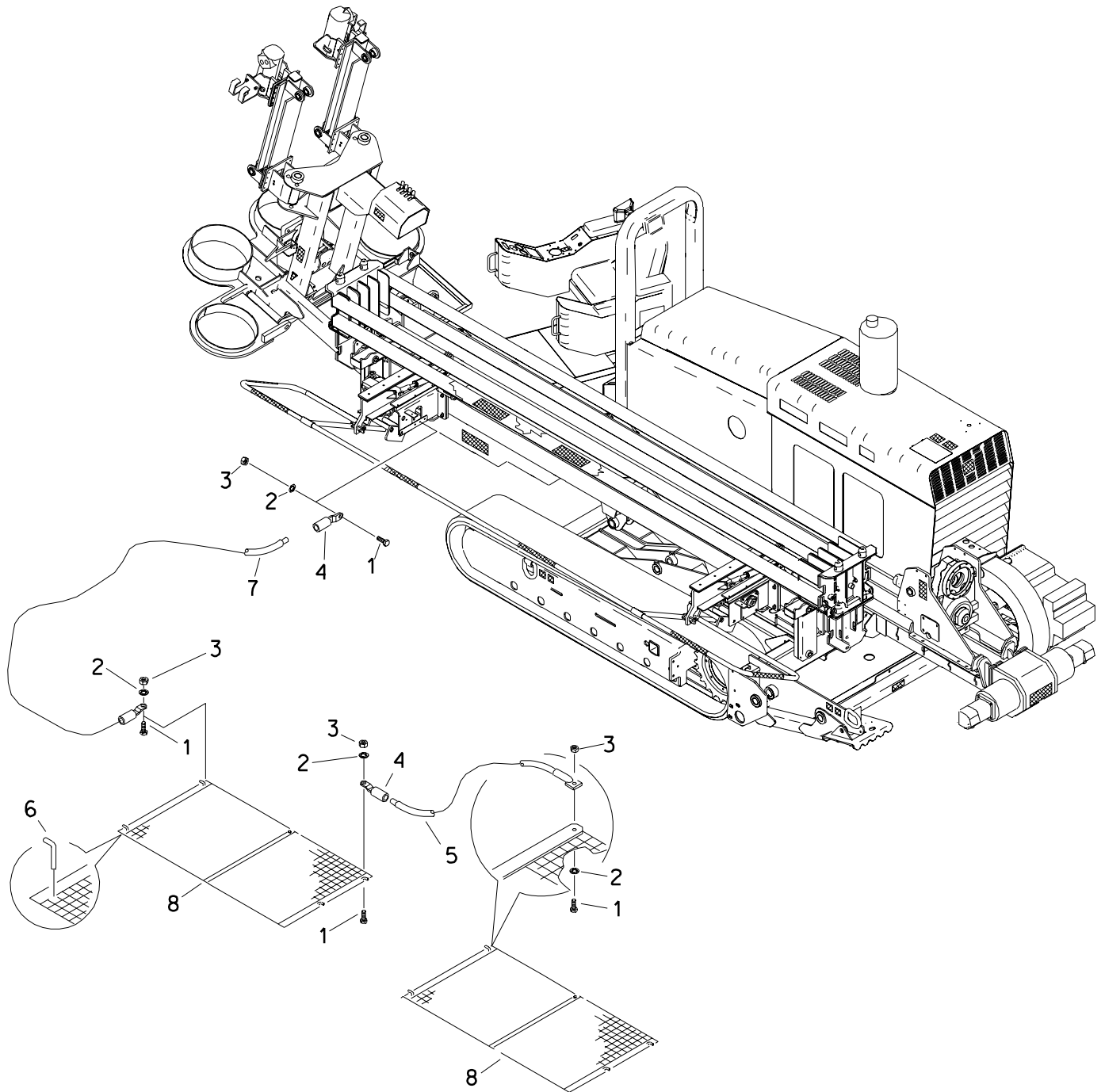

# GROUNDING HARDWARE

REF NO.	PART NUMBER	QTY	DESCRIPTION	REMARKS
	100-074	-	STRIKE MAT KIT	INCL REF NO'S 1-8
1.	106-217	4	BOLT (1/4-NC X 1", SIL BRZ)	
2.	106-221	4	INT STAR WASHER (1/4", SIL BRZ)	
3.	106-455	4	LOCKNUT (1/4-NC, SIL BRZ)	
4.	215-771	2	GROUND RECEPTACLE (.3125" FM)	
5.	215-827	1	GROUND CABLE (6 GA X 6' M-EYE)	
6.	183-658	8	MAT STAKE	
7.	215-790	1	GROUND CABLE (6GA X 20' M-EYE)	
8.	215-824	2	GRID (6')	

FOOTNOTES

# VANDAL COVERS

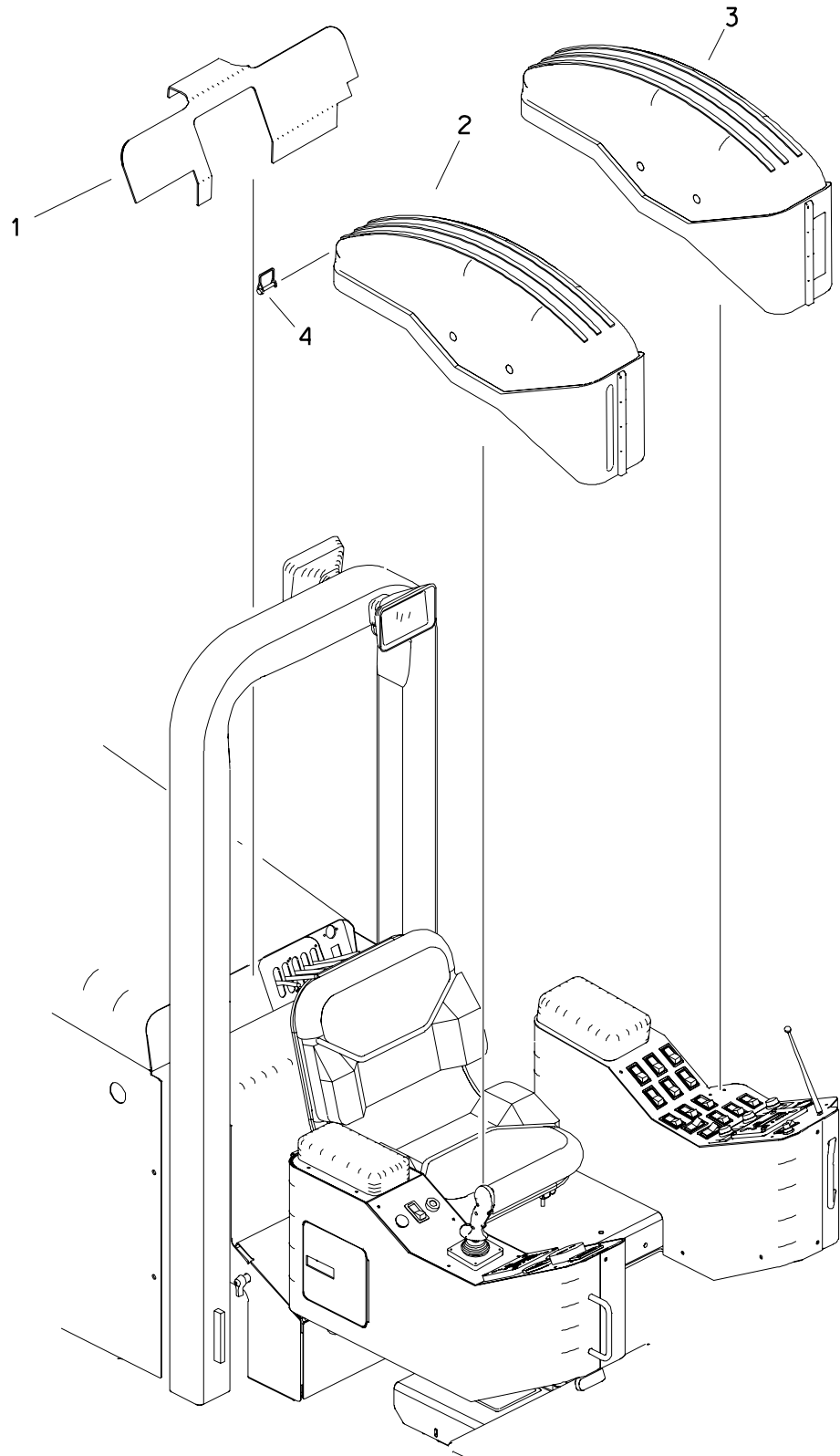



# VANDAL COVERS

REF NO.	PART NUMBER	QTY	DESCRIPTION	REMARKS
	N/A		VANDAL KIT	
1.	310-961	1	GAUGE VANDAL COVER	
2.	310-960	1	RIGHT SIDE VANDAL COVER	
3.	315-790	1	LEFT SIDE VANDAL COVER	
4.	110-032	2	SNAPPER PIN (5/16" X 2-1/2")	

FOOTNOTES

## TOOL BOX

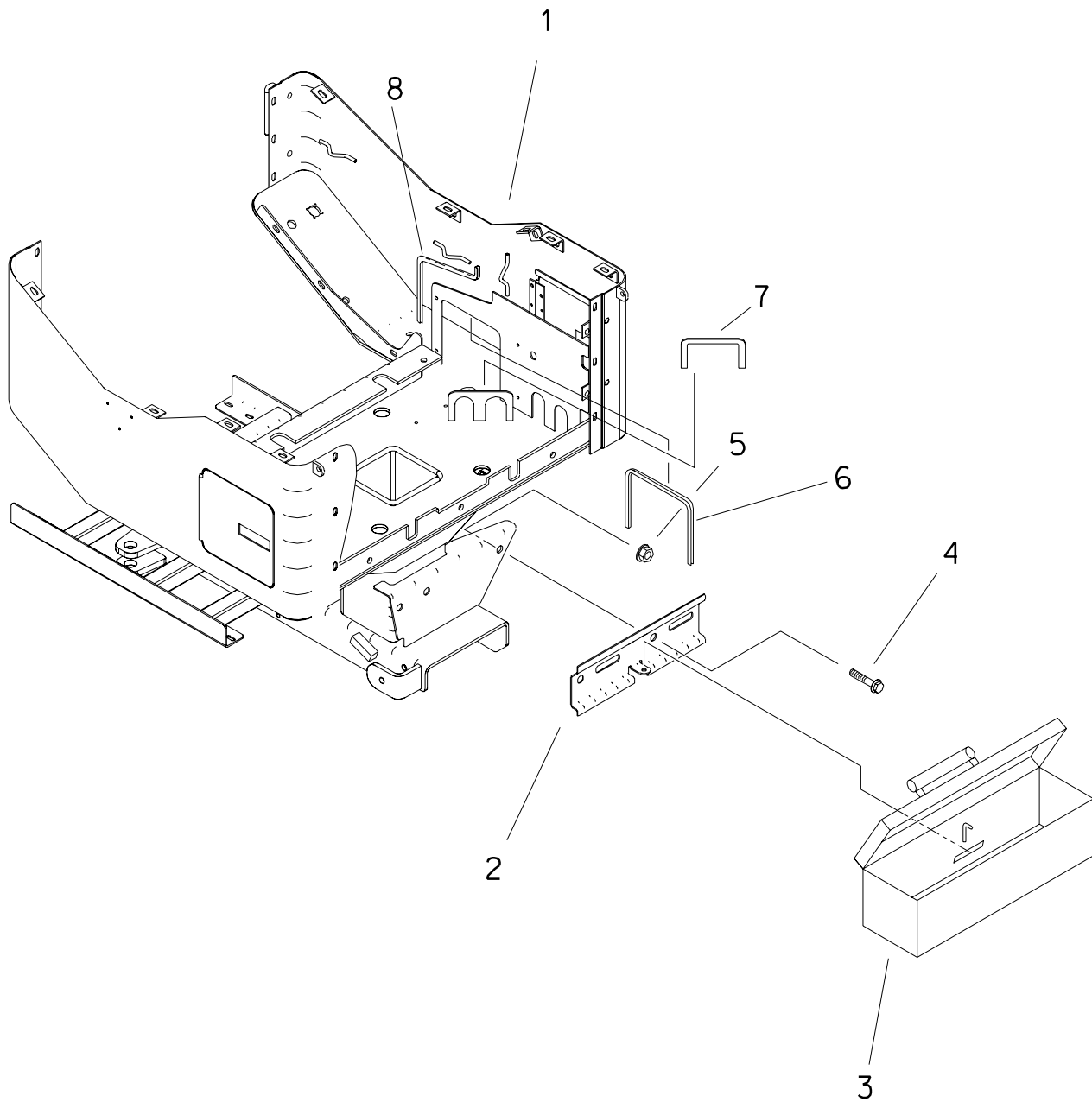

# TOOL BOX

REF NO.	PART NUMBER	QTY	DESCRIPTION	REMARKS
1.	308-794	-	OPERATOR FRAME	
	313-778	-	PLATE	SEE FOOTNOTE 1.
2.	313-777	1	BRACKET	
3.	313-776	1	TOOL BOX	
4.	106-471	2	FLG SCREW (M16-2.00 X 30MM)	
5.	106-442	2	FLG LOCKNUT (M16-2.00,PRV TRQ)	
6.	116-789	AR	RUBBER EDGE TRIM 1/8" (FT)	USE 1 AT 18"
7.	116-789	AR	RUBBER EDGE TRIM 1/8" (FT)	USE 2 AT 10"
8.	116-789	AR	RUBBER EDGE TRIM 1/8" (FT)	USE 1 AT 19"

## FOOTNOTES

1. EARLY MACHINES WILL REQUIRE THIS PART TO BE WELDED TO OPERATOR CONSOLE.



# MISCELLANEOUS

# SAE Bolt and Nut Torque Value Chart

## Grade 5: UNC or UNF Thread

Size	Hex nut, or bolt tapped into hex nut, or d&t hole		Hex top deformed locknut		Flange nut, locknut, or bolt tapped into flange nut or d&t* hole	
	ft•lb	N•m	ft•lb	N•m	ft•lb	N•m
1/4	12	16	8	11	20	27
5/16	25	34	15	20	45	60
3/8	40	54	25	34	75	100
7/16	65	90	40	55	125	170
1/2	100	135	60	80	190	260
9/16	150	200	90	125	270	370
5/8	200	270	120	165	370	500
3/4	350	475	210	285	650	880
7/8	560	760	340	460	1250	1425
1	840	1140	500	680	1580	2145
1-1/8	1030	1400	320	840	1950	3645
1-1/4	1460	1980	880	1195	2760	3475

## Grade 8: UNC or UNF Thread

Size	Hex nut, or bolt tapped into hex nut, or d&t hole		Hex top deformed locknut		Flange nut, locknut, or bolt tapped into flange nut or d&t* hole	
	ft•lb	N•m	ft•lb	N•m	ft•lb	N•m
1/4	14	19	10	14	24	33
5/16	30	40	18	25	50	70
3/8	55	73	35	50	90	125
7/16	85	115	50	70	140	190
1/2	130	175	80	110	220	300
9/16	190	260	110	150	310	420
5/8	260	355	160	245	430	585
3/4	450	610	270	365	750	1015
7/8	730	990	440	600	1210	1640
1	1090	1480	650	880	1320	2465
1-1/8	1550	2100	930	1260	2580	3500
1-1/4	2180	2955	1310	1780	3640	4935

\*drilled and tapped

# Metric Bolt and Cap Screw Torque Values

Size	Class 4.8				Class 8.8 and 9.8				Class 10.9				Class 12.9			
	Lubricated		Dry		Lubricated		Dry		Lubricated		Dry		Lubricated		Dry	
	N•m	ft•lb	N•m	ft•lb	N•m	ft•lb	N•m	ft•lb	N•m	ft•lb	N•m	ft•lb	N•m	ft•lb	N•m	ft•lb
M6	4.8	3.5	6	4.5	9	6.5	11	8.5	13	9.5	17	12	15	11.5	19	14.5
M8	12	8.5	15	11	22	16	28	20	32	24	40	30	37	28	47	35
M10	23	17	29	21	43	32	55	40	63	47	80	60	75	55	95	70
M12	40	29	50	37	75	55	95	70	110	80	140	105	130	95	165	120
M14	63	47	80	60	120	88	150	110	175	130	225	165	205	150	260	190
M16	100	73	125	92	190	140	240	175	275	200	350	225	320	240	400	300
M18	135	100	175	125	260	195	330	250	375	275	475	350	440	325	560	410
M20	190	140	240	180	375	275	475	350	530	400	675	500	625	460	800	580
M22	260	190	330	250	510	375	650	475	725	540	925	675	850	625	1075	800
M24	330	250	425	310	650	475	825	600	925	675	1150	850	1075	800	1350	1000
M27	490	360	625	450	950	700	1200	875	1350	1000	1700	1250	1600	1150	2000	1500
M30	675	490	850	625	1600	950	1650	1200	1850	1350	2300	1700	2150	1600	2700	2000
M33	900	675	1150	850	1750	1300	2200	1650	2500	1850	3150	2350	2900	2150	3700	2750
M36	1150	850	1450	1075	2250	1650	2850	2100	3200	2350	4050	3000	3750	2750	4750	3500

Do not use these values if a different torque value or tightening procedure is given for specific application. Torque values listed are for general use only. Check tightness of fasteners periodically.

Shear bolts are designed to fail under predetermined loads. Always replace shear bolts with identical property class fasteners.

Fasteners should be replaced with the same or higher property class. If higher property class fasteners are used, these should only be tightened to strength of original.

Make sure fastener threads are clean and that the threads are properly started. This will prevent them from cross threading or galling when tightened.

Tighten plastic insert or crimped type steel locknuts to approximately 50% of dry torque indicated on chart. Apply torque to the nut - not the bolt head. Tighten toothed or serrated type locknuts to full torque value.

LUBRICATED means coated with lubricant. DRY means plain or zinc plated without any type of lubricant.

## Hydraulic Cylinder Bolt Torque Chart

Bolt Size (inch)	Bolt Part No.	Cylinder Repair Kit Part No.	Torque (ft•lb)	Torque (N•m)
1/2	106-096	190-165	90-100	120-135
5/8	106-097	190-166 & 190-169	180-200	245-270
3/4	106-098	190-167 & 190-170	290-325	395-440
7/8	106-122	190-172 & 190-174	410-640	550-625
1	106-145	190-175 & 190-189	630-700	855-950
1-1/8	106-146	190-177	770-850	1045-1170

As a general rule:

- 1/2-inch bolts are used in cylinders with 1-inch rods
- 5/8-inch bolts are used in cylinders with 1 1/4-inch rods
- 3/4-inch bolts are used in cylinders with 1 1/2-inch rods
- 7/8-inch bolts are used in cylinders with 1 3/4-inch rods
- 1-inch bolts are used in cylinders with 2-inch rods (one with 1 3/4-inch)
- 1-1/8-inch bolts are used in cylinders with 2-1/4-inch rods

**IMPORTANT:** Do not reuse cylinder piston bolts when rebuilding a hydraulic cylinder. Each cylinder repair kit contains a new bolt. Use it. Lubricate lightly and torque to value shown on chart.



# SAE & ORS Hydraulic Fitting Replacement O-Ring Chart

Fraction Size	Dash Size	SAE (Port Seal O-Ring)		ORS (Face Seal O-Ring)	
		Thread Size	O-Ring P/N	Thread Size	O-Ring P/N
1/16	1	NA	NA	NA	NA
1/8	2	5/16 - 24	NA	NA	NA
3/16	3	3/8 - 24	NA	NA	NA
1/4	4	7/16 - 20	155-760	9/16 - 18	157-037
5/16	5	1/2 - 20	NA	NA	NA
3/8	6	9/16 - 18	155-705	11/16 - 16	157-038
1/2	8	3/4 - 16	155-706	13/16 - 16	157-039
5/8	10	7/8 - 14	155-707	1 - 14	157-040
3/4	12	1-1/16 - 12	155-709	1-3/16 - 12	157-017
7/8	14	1-3/16 - 12	155-747	NA	NA
1	16	1-5/16 - 12	155-748	1-7/16 - 12	155-714
1-1/4	20	1-5/8 - 12	155-702	1-11/16 - 12	NA
1-1/2	24	1-7/8 - 12	157-001	2 - 12	NA
2	32	2-1/2 - 12	NA	NA	NA
2-1/2	40	3 - 12	NA	NA	NA
3	48	3-1/2 - 12	NA	NA	NA

Thread size indicates the diameter of the threaded area in fractions of an inch and number of threads per inch.

NA = not a current CMW part numbered o-ring, or dash size does not occur in current CMW applications

SAE = straight thread fitting that seals by sandwiching a hard o-ring between a shoulder on the male part and an angular surface at the mouth of the female port.

ORS = o-ring face seal; a type of fitting that seals by compressing a hard, captive o-ring between two flat parallel faces, one grooved for the o-ring and the other plain to act as the sealing surface

# AT/JT4020 T2

## Related Publications

Component	Ass'y	P/N
<b>Model:</b>		
JT4020 T2/AT4020 T2.....	Parts Manual .....	053-137
JT4020 T2/AT4020 T2.....	Operators Manual .....	054-082
JT4020 T2/AT4020 T2 .....	Repair Guide (Service Manual) .....	N/A
JT4020 T2/AT4020 T2.....	Technical Supplement .....	053-148
<b>Engine:</b>		
John Deere .....	Operators Manual – 6068HF275 .....	194-294 ..... 054-087

## Filters

<b>Engine:</b>		
Air Filter Parts Ass'y .....		194-599
Element (primary) .....		194-600
Oil Filter Element (spin-on) .....		194-478
Fuel Filter Primary Element.....		194-492
Fuel Filter Secondary Element.....		194-467
Fuel Strainer (04H) In Fuel Tank.....		194-457
<b>Hydraulic:</b>		
Oil Filter Element ( _ - / _ -UNF, spin-on) – Charge Remote .....		149-939
Element ( _ - / _ -UNF, spin-on, Micron 10, Replacement) - Return .....		157-486

## Optional Kits

O-ring Repair Kit - FLG, ORS & SAE (15 different O-rings) .....	190-051
O-ring Repair Kit - Field Service (46 different O-rings) .....	190-052



# Ditch Witch®

## Parts Manual Change Request

(Please print clearly)

Date: \_\_\_\_\_ Dealer No. (required): \_\_\_\_\_

Your Name: \_\_\_\_\_ Position: \_\_\_\_\_

Phone: \_\_\_\_\_ Fax: \_\_\_\_\_ E-mail: \_\_\_\_\_

### Publication Information:

Parts Manual No.: \_\_\_\_\_ - \_\_\_\_\_ Model: \_\_\_\_\_

Illustration Part No.:	Manual Page No.:
1. _____ - _____ .....	1. _____
2. _____ - _____ .....	2. _____
3. _____ - _____ .....	3. _____

Nature of Change Request:

- Text
- Graphics
- Missing Information

Describe change requested (if possible, include copy of publication page with changes marked.):

---



---



---



---



---



---

**Please fax completed form to  
Parts Manual Department (580) 572-3525**

*Thank you for taking the time to submit this request. We will contact you if further information is needed to process your request.*



**A Note To  
Ditch Witch  
Equipment Owners:**

If your equipment was purchased through a Ditch Witch dealer, there is no need to read further.

However, if you purchased from any other source, please fill out the form on the reverse side and return it to us.

This will enable you to receive updates on this equipment as well as information on new products of interest.

Thanks for using Ditch Witch equipment.

(Please Fold Along This Line And Seal At Bottom With Tape)



**NO POSTAGE  
NECESSARY  
IF MAILED  
IN THE  
UNITED STATES**

**BUSINESS REPLY MAIL**  
FIRST CLASS      PERMIT NO 23      PERRY OKLAHOMA

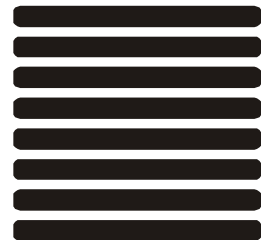

POSTAGE WILL BE PAID BY

**The Charles Machine Works, Inc.  
P.O. Box 66  
Perry, Oklahoma 73077-9989**



# Ditch Witch® Registration Card

Please Type or Print All Information

---

Purchaser's Company Name

---

Attention

---

Street Address or P.O. Box

---

City

County

---

State

Zip

Nation

(      )

---

Phone Number With Area Code

---

Model

Serial Number

---

Attachments/Accessories

Serial Numbers

---

Attachments/Accessories

Serial Numbers

---

Attachments/Accessories

Serial Numbers

---

Name of Ditch Witch Dealership

---

Your Signature