



Bedienungsanleitung für MAN-Industrie-Gasmotoren
Operating Instructions for MAN Industrial Gas Engines
Instructions de service pour moteurs industriels à gaz MAN

E 2842 LE 302
E 2842 LE 312

Operating Instructions –
MAN Industrial Gas Engines



Dear Customer,

these Operating Instructions are intended to familiarize you with your new MAN Industrial Gas Engine and how it operates.

This manual is supplemented by the publication “Fuels, Lubricants and Coolants for MAN Gas Engines”.



Note:

Both publications apply to the engine and must always be kept to hand in its vicinity in the engine room.

Comply in full with instructions relating to operation, prevention of accidents and environmental protection.

MAN Gas Engines are developed and manufactured in line with the latest state of the art. However, trouble-free operation and high performance can only be achieved if the specified maintenance intervals are observed and only approved fuels, lubricants and coolants are used.



Note:

Only use fuel, coolants and lubricants in accordance with MAN's regulations otherwise the manufacturer's warranty will not apply!

For basic information on the fuels see the publication “Fuels, Lubricants and Coolants for MAN Gas Engines”.

You can find the approved products in the internet under:

<http://www.man-mn.com/> → Products & Solutions → E-Business

It is imperative and in your own interest to entrust your MAN Local Service Centre with the removal of any disturbances and with the performance of checking, setting, and repair work.

Yours faithfully,
MAN Nutzfahrzeuge Aktiengesellschaft
Werk Nürnberg

Subject to change to keep abreast with technological progress.

© 2005 MAN Nutzfahrzeuge Aktiengesellschaft
No parts of this publication may be reproduced or translated without prior written permission of MAN. MAN explicitly reserves all rights according to copyright law.

Important instructions which concern technical safety and protection of persons are emphasised as shown below.

**Danger:**

This refers to working and operating procedures which must be complied with in order to rule out the risk to persons.

**Caution:**

This refers to working and operating procedures which must be complied with in order to prevent damage to or destruction of material.

**Note:**

Explanations useful for understanding the working or operating procedure to be performed.

Fitting flat seals / gaskets

Flat seals / gaskets are often inserted with sealing agents or adhesives to make fitting them easier or to achieve better sealing. Flat seals may slip in operation due to the “sewing-machine” effect, in particular if they are used between parts with different rates of linear expansion under heat (e.g. aluminium and cast iron), and leaks may then occur.

Example:

the cap of the front crankshaft seal. If a sealing agent or an adhesive is used here the flat seal will move inwards in the course of time as a result of the different expansion rates of the materials. Oil will be lost, for which the shaft seal may be thought to be responsible.

Flat seals / gaskets can be fitted properly only if the following points are observed:

- Use only genuine MAN seals / gaskets
- The sealing faces must be undamaged and clean
- Do not use any sealing agent or adhesive – as an aid to fitting the seals a little grease can be used if necessary so that the seal will stick to the part to be fitted
- Tighten bolts evenly to the specified torque

	Page
Preface	51
Instructions	52
Declaration	54
Nameplates	55
Safety regulations	56
Commissioning and operation	62
Engine views	62
First commissioning	66
Cooling system	66
Commissioning	70
Starting	71
Operation monitoring system	72
Shutting down	72
Gas system	73
Maintenance and care	74
Lubrication system	74
Cooling system	77
Temporary decommissioning of engines	79
Technical data	80
Maintenance plan for operation with natural gas	84
Maintenance plan for operation with biological gas for 60% CH₄, 40% CO₂	87
Index	94

Declaration

In accordance with Article 4, paragraph 2, in conjunction with Appendix II, section B, of Directive 89/392/EEC, version 93/44/EEC

MAN Nutzfahrzeuge Aktiengesellschaft,

hereby declares that the engine described below is destined for installation in a machine as defined in the EC directive on machines.

Engine model:

Design:

For data see original declaration

Engine number:

If required this declaration is enclosed with the delivery note.

Rating / speed:



Note:

The manufacturer of the complete ready-to-use machine in which this engine is to be installed must take the further action necessary in the context of indirect safety-related engineering and provision of instructions to ensure that the ready-to-use machine complies with the requirements of the EC directive on machines. The engine must not be put into operation until the complete machine satisfies the conditions laid down in the EC directive on machines 89/392/EEC, most recently amended by 93/44/EEC, or the latest amendment of said directive.

MAN Nutzfahrzeuge Aktiengesellschaft

Vogelweiherstraße 33

D-90441 Nürnberg

Nameplates



In all your correspondence please always quote engine model, serial number and job number (Order number).

For this reason it is advisable to read off the data from the engine type plates before putting the engine into operation and to enter them in the appropriate spaces.

The engine type plates are on the crankcase.

Model

delivered on

installed on

Engine serial number

Order number

MAN Nutzfahrzeuge Aktiengesellschaft
 Typ
 Motor-Nr. / Engine No. NI/II

MAN Nutzfahrzeuge Aktiengesellschaft
 Werk Nurnberg Germany
GAS ENGINE

Bauj. Year	Typ	Model	Motor-Nr.	Serial No	
<input type="text"/>	<input type="text"/>	<input type="text"/>	<input type="text"/>	<input type="text"/>	
Werk-Nr.	Job No	Leistung kW	Rating kW	Drehz. 1/min	Speed rpm
<input type="text"/>	<input type="text"/>	<input type="text"/>	<input type="text"/>	<input type="text"/>	<input type="text"/>
Temp.°C	Leistg. PS	Rating BHP	Aufstellhöhe m uNN Altitude m		
<input type="text"/>	<input type="text"/>	<input type="text"/>	<input type="text"/>		
LGK. Temp. Water		<input type="text"/>			
<input type="text"/>		<input type="text"/>			

-0243

General notes

Day-to-day use of power engines and the service products (fuels, lubricants, coolants) necessary for running them presents no problems if the persons occupied with their operation, maintenance and care are given suitable training and think as they work.

This summary is a compilation of the most important regulations. These are broken down into main sections which contain the information necessary for preventing injury to persons, damage to property and pollution. In addition to these regulations those dictated by the type of engine and its site are to be observed also.

Important:

If despite all precautionary measures an accident occurs, in particular from contact with acids, scalding from hot oil or coolants, splashing antifreeze in the eyes etc. ***consult a doctor immediately.***

1. Regulations designed to prevent accidents with injury to persons

During commissioning, starting and operation

- Before putting the engine into operation for the first time, read the operating instructions carefully and familiarize yourself with the “critical” points. If you are unsure, ask your MAN representative.
- For reasons of safety we recommend you attach a notice to the door of the engine room prohibiting the access of unauthorized persons and that you draw the attention of the operating personal to the fact that they are responsible for the safety of persons who enter the engine room.
- The engine must be started and operated only by authorized personnel. Ensure that the engine cannot be started by unauthorized persons.
- When the engine is running, do not get too close to the rotating parts. Wear close-fitting clothing.
- The applicable regulations for gas installations must be complied with.
- Switch on the ventilation system in the engine compartment before first starting up the engine.



- Do not touch hot engine with bare hands:
Risk of burns.



- Exhaust gases are toxic. Comply with the regulations for the installation of MAN gas engines intended for operation in closed spaces. Ensure that there is adequate ventilation and air extraction.
- Keep vicinity of engine, ladders and stairways free of oil and grease. Accidents caused by slipping can have serious consequences.

During maintenance and care

- Change the oil when the engine is warm from operation.

Caution:

There is a risk of burns and scalding. Don't touch oil drain screws or the oil filter with your bare hands.



- Take into account the amount of oil in the sump. Use a vessel of sufficient size to ensure that the oil will not overflow.
- Open the coolant circuit only when the engine has cooled down. If opening while the engine is still warm is unavoidable, comply with the instructions in the chapter entitled "Maintenance and Care".
- Neither tighten up nor open pipes and hoses (lube oil circuit, coolant circuit and any additional hydraulic oil circuit) during the operation. The fluids which flow out can cause injury.
- When using compressed air, e.g. for cleaning the radiator, wear goggles.
- Keep service products (anti-freeze) only in containers which can not be confused with drinks containers.
- Comply with the manufacturer's instructions when handling batteries.
Caution:
Accumulator acid is toxic and caustic. Battery gases are explosive.





2. Regulations designed to prevent damage to engine and premature wear

The engine may be operated only within the framework of the performance figures given by the manufacturer. Detailed information on this can be found in the sales literature.

If faults occur, find the cause immediately and have it eliminated in order to prevent more serious damage. If necessary inform MAN's customer service.

Use only genuine MAN spare parts. MAN does not accept any responsibility for damage resulting from the installation of parts from other companies or for installation by unauthorised persons.

In addition to the above, note the following points:

- Never let the engine run when dry, i.e. without lube oil or coolant.
- When starting do not use any additional starting aids.
- Use only MAN-approved service products (gas, engine oil, antifreeze and anti-corrosion agent). Pay attention to cleanliness.
- Have the engine maintained at the specified intervals.
- Do not switch off the engine immediately when it is warm, but let it run without load for about 5 minutes so that temperature equalization can take place.
- Never put cold coolant into an overheated engine. See "Maintenance and care".
- ***Do not add so much engine oil that the oil level rises above the max marking on the dipstick. Do not exceed the maximum permissible tilt of the engine.***
Serious damage to the engine may result if these instructions are not adhered to.
- Always make sure that the control and monitoring equipment (e.g. for oil pressure, coolant and exhaust gas temperature) function perfectly.

3. Regulations designed to prevent pollution

Engine oil and filter elements / cartridges

- Take old oil only to an old oil collection point.
- Take strict precautions to ensure that no oil gets into the drains or the ground.

Caution:

The drinking water supply could be contaminated.

- Filter elements are classed as dangerous waste and must be treated as such.

Coolant

- Treat undiluted anti-corrosion agent and / or anti-freeze as dangerous waste.
- When disposing of spent coolant comply with the regulations of the relevant local authorities.

4. Notes on safety in handling used engine oil *

Prolonged or repeated contact between the skin and any kind of engine oil decreases the skin. Drying, irritation or inflammation of the skin may therefore occur. Used engine oil also contains dangerous substances which have caused skin cancer in animal experiments. If the basic rules of hygiene and health and safety at work are observed, health risks are not to the expected as a result of handling used engine oil.

Health precautions:

- Avoid prolonged or repeated skin contact with used engine oil.
- Protect your skin by means of suitable agents (creams etc.) or wear protective gloves.
- Clean skin which has been in contact with engine oil.
 - Wash thoroughly with soap and water. A nailbrush is an effective aid.
 - Certain products make it easier to clean your hands.
 - Do not use petrol, Diesel fuel, gas oil, thinners or solvents as washing agents.
- After washing apply a fatty skin cream to the skin.
- Change oil-soaked clothing and shoes.
- Do not put oily rags into your pockets.

Ensure that used engine oil is disposed of properly
– Engine oil can endanger the water supply –

For this reason do not let engine oil get into the ground, waterways, the drains or the sewers. Violations are punishable.

Collect and dispose of used engine oil carefully. For information on collection points please contact the seller, the supplier or the local authorities.

* Adapted from “Notes on handling used engine oil”.

5. Safety instructions for dealing with gaseous fuels

Gaseous fuels consist mainly of methane, propane and butane and of traces of higher hydrocarbons and of inert components such as carbon dioxide and nitrogen.

- Smoking and playing with fire is prohibited.
- Leakage in the gas supply system causes a risk of explosion and must be immediately eliminated.
- Fire extinguishers and other extinguishing equipment must be within easy reach.
- Don't store any flammable material in the engine compartment.



Behaviour in the event of escaping gas

- Close the cut-off cock of the gas supply.
- Switch off the main switch of the electrical system.
- Block off the area at risk. Instruct unauthorised persons to leave the area at risk.
- In the event of escaping gas inform those responsible immediately and arrange for repair.

Behaviour in the event of fire

- Call the fire brigade.
- Help injured people immediately.
- In the event of a pure gas fire the escaping gas flame must not be extinguished. If appropriate cool the burning object.
Burning gas = controlled gas!
- Stop the flames spreading to surrounding areas.
- If the flames spread to the surrounding area fight the flames with fire extinguishers.

Engine views E 2842 LE 302

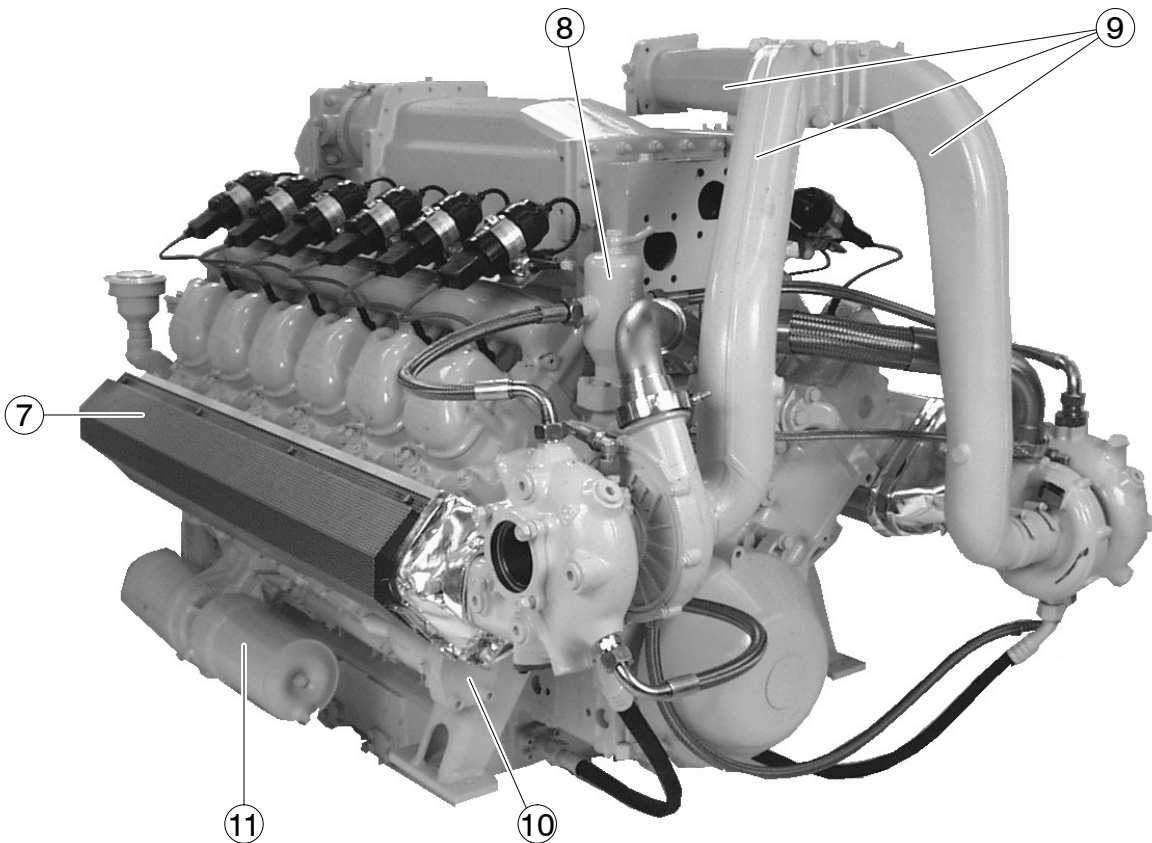
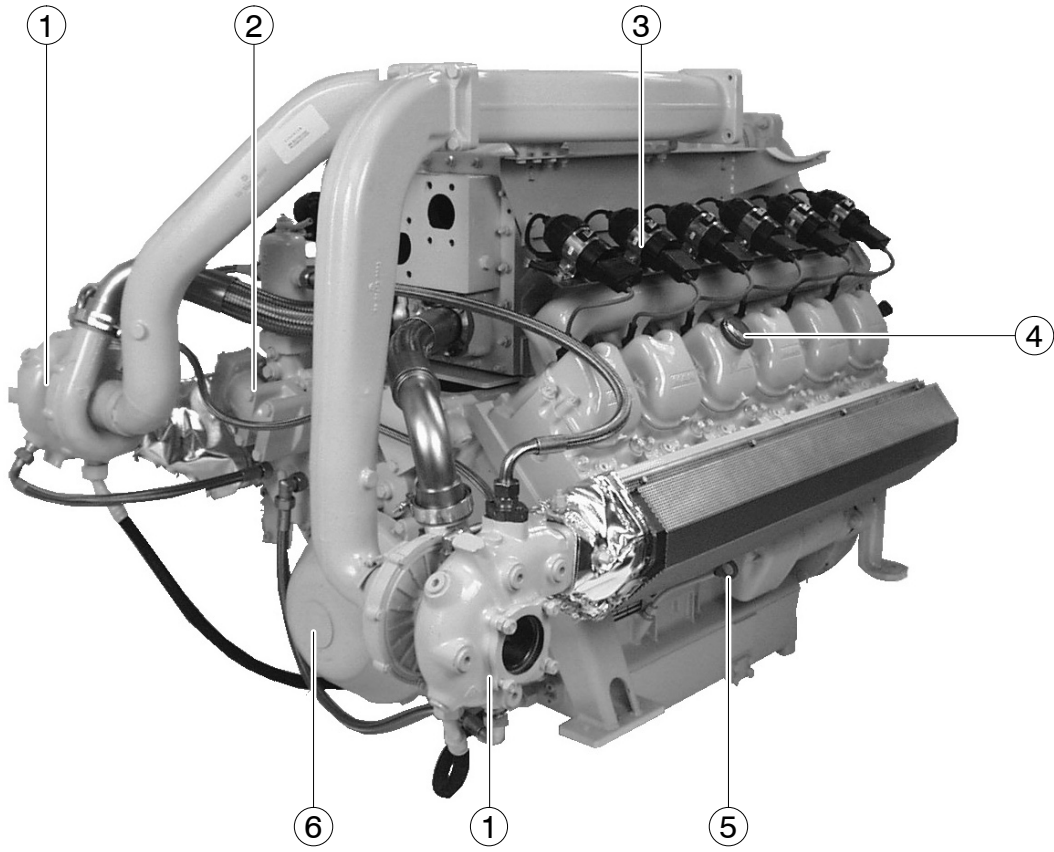

- ① Turbocharger
- ② Coolant outlet
- ③ Ignition coils
- ④ Oil filler neck
- ⑤ Oil dipstick
- ⑥ Protective cover for crankshaft / vibration damper
- ⑦ Exhaust manifold with Heat Protection Plate
- ⑧ Breather housing for coolant
- ⑨ Intake manifold
- ⑩ Coolant inlet
- ⑪ Oil filter

**Note:**

The gas line, consisting of a ball valve, gas filter, solenoid valves, gas pressure regulator, gas mixer and air filter, is not part of MAN's extent of delivery.

Engine views E 2842 LE 312

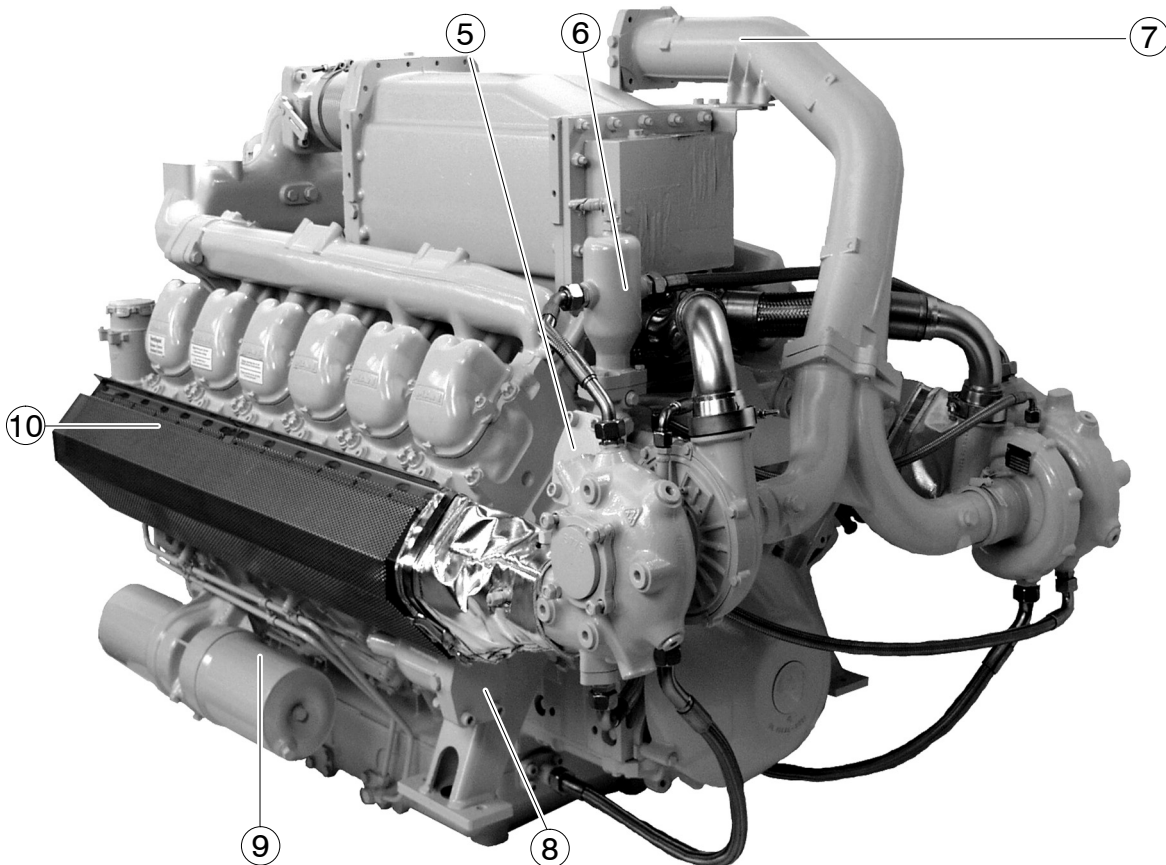
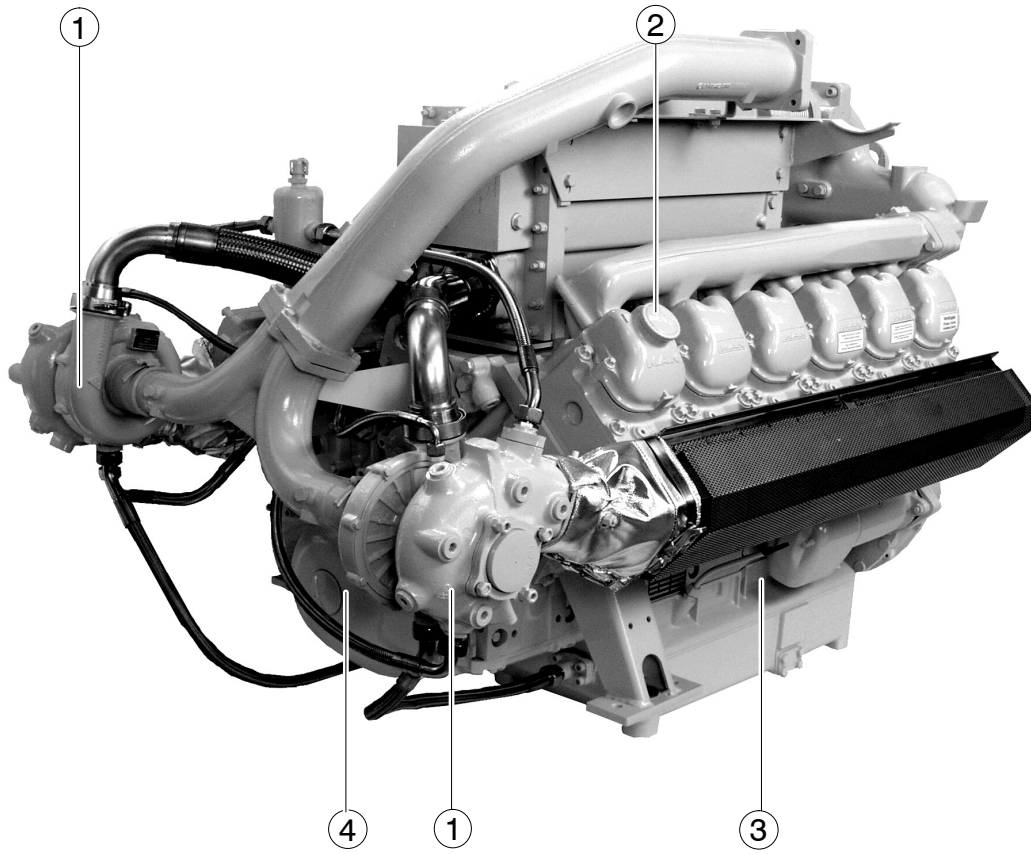

- ① Turbocharger
- ② Oil filler neck
- ③ Oil dipstick
- ④ Protective cover for crankshaft / vibration damper
- ⑤ Coolant outlet
- ⑥ Breather housing for coolant
- ⑦ Intake manifold
- ⑧ Coolant inlet
- ⑨ Oil filter
- ⑩ Exhaust manifold with Heat Protection Plate



Note:

The gas line, consisting of a ball valve, gas filter, solenoid valves, gas pressure regulator, gas mixer and air filter, is not part of MAN's extent of delivery.

First commissioning

When putting a new or overhauled engine into operation for the first time pay attention to the “Installation Instructions for MAN Industrial Gas Engines” without fail.

It is recommended that new or overhauled engines should not be operated at a load higher than about 75% maximum load during the first 5 hours of operation. After this the engine should be slowly brought up to the specified maximum power.

**Caution:**

Use only approved fuels, lubricants etc. (see brochure “Fuels, lubricants etc.”). Otherwise the manufacturer’s warranty will become null and void.

Cooling system

**Danger:**

Draining hot coolant involves a risk of scalding.

Fill the cooling system of the engine with a mixture of drinkable tap water and antifreeze agent on the ethylene glycole basis or anti-corrosion agent. The coolant must be filled up in accordance with the filling instructions of the co-generation plant manufacturer.

For suitable protective agents see the approved fuels, coolants and lubricants in accordance with MAN 324 and MAN 248.

Diagram of cooling system with diaphragm expansion vessel

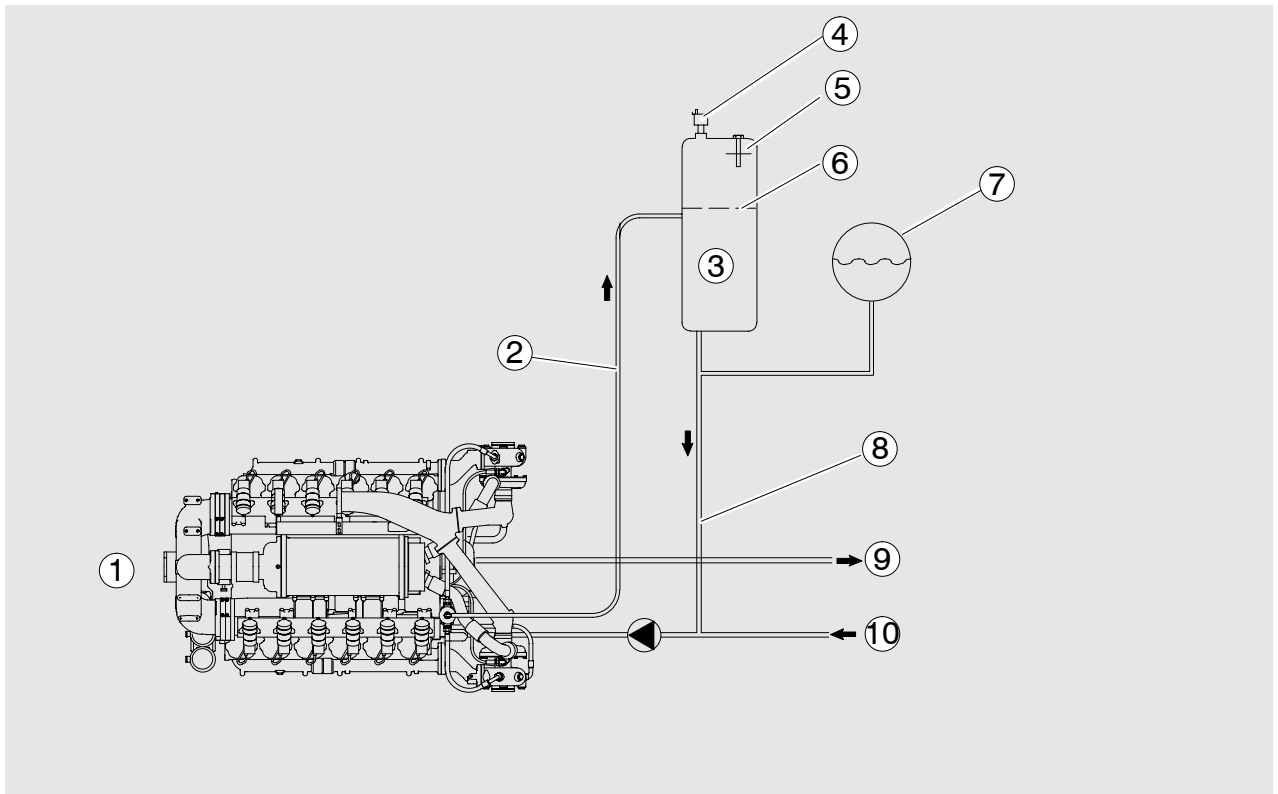

- | | |
|---|---|
| ① Engine | ⑥ Plate with 5x10 mm bore |
| ② Bleeder line \varnothing 10 mm,
flow rate 7 l/min to max. 10 l/min | ⑦ Diaphragm expansion vessel (0,6 bar) |
| ③ Bleeder reservoir | ⑧ Connection line to the intake side
of the coolant pump \varnothing 25 mm |
| ④ Automatic breather valve | ⑨ Coolant inlet |
| ⑤ Sensor for liquid level | ⑩ Coolant outlet |

- Overpressure safety valve 3,5 bar
Operating pressure: min. 0,6 bar
max. 3,0 bar
- Observe the filling regulations of the manufacturer of the cogeneration power unit
- For coolant filling quantity, see “Technical data”
- Fill up the cooling system with the filler device, keeping the breathers open until the coolant emerges bubble-free
- Close breathers and increase pressure to a value which is approx. 0,2–0,4 bar above the pre-pressure of the expansion vessel
- Start up system. Let it cool down after trail operation (i.e. after it reaches the operating temperature)
- When the cooling temperature has fallen to below 50°C, increase the system pressure to 0,5 bar above the pre-pressure of the expansion vessel via the filler device

Diagram of cooling system with expansion tank

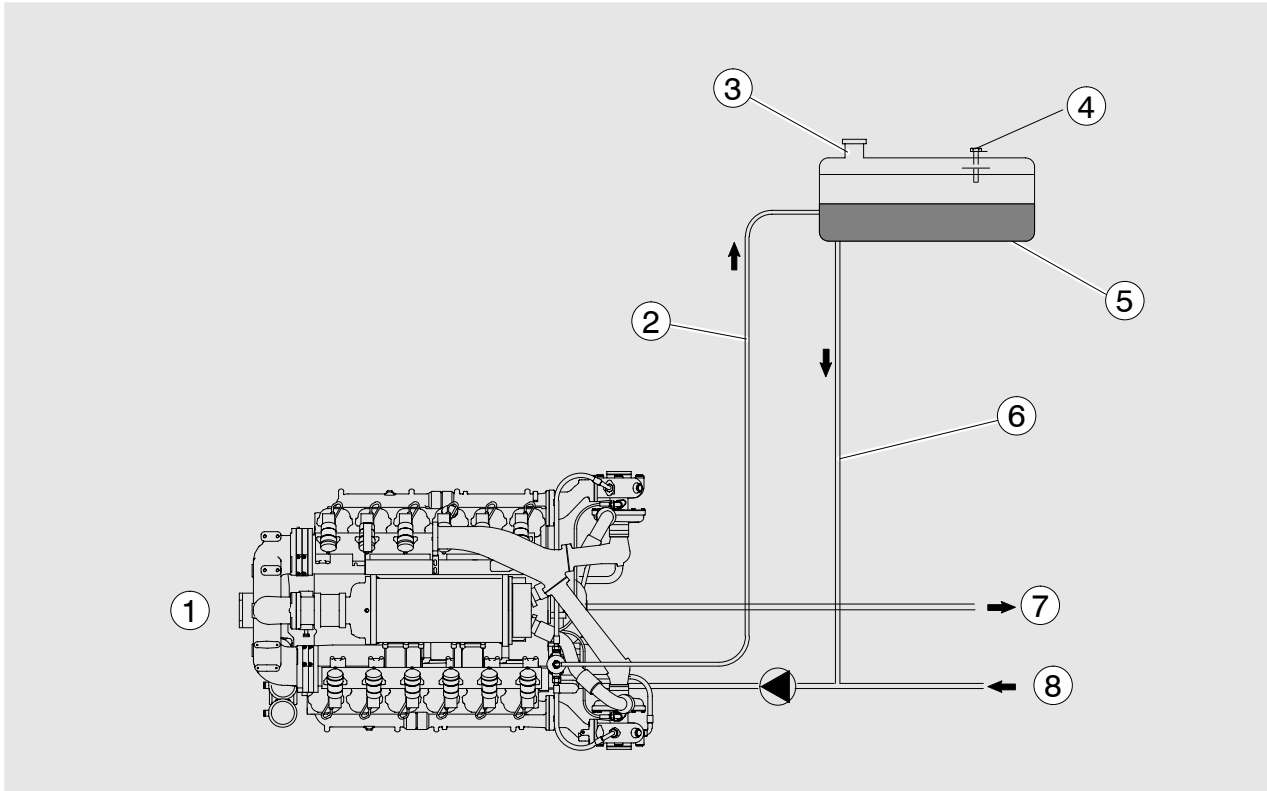

- | | |
|---|---|
| ① Engine | ④ Expansion tank |
| ② Bleeder line \varnothing 10 mm,
flow rate 7 l/min to max. 10 l/min | ⑤ Connection line to the intake side
of the coolant pump \varnothing 25 mm |
| ③ Filler cap with
over- / underpressure | ⑥ Coolant inlet |
| | ⑦ Coolant outlet |
- Valve: 0,6 / -0,08 bar
 - Observe the filling regulations of the manufacturer of the cogeneration power unit
 - For coolant filling quantity, see "Technical data"

Coolant must be added at the filler neck only.

- Remove cap (large cap)
- Slowly pour in coolant
- Close expansion tank
- Let the engine run approx. 15 minutes at rated speed
- Switch off engine, turn the cap with the safety valve carefully to first catch – let off pressure – then carefully open and if necessary top up coolant
- Do not put cold coolant into an engine which is warm from operation. Ensure that the ratio of water to anti-freeze is correct
- With the engine is next put into operation (with the engine cold) check the coolant level and top up is necessary
- Repeat this procedure until no more coolant can be added

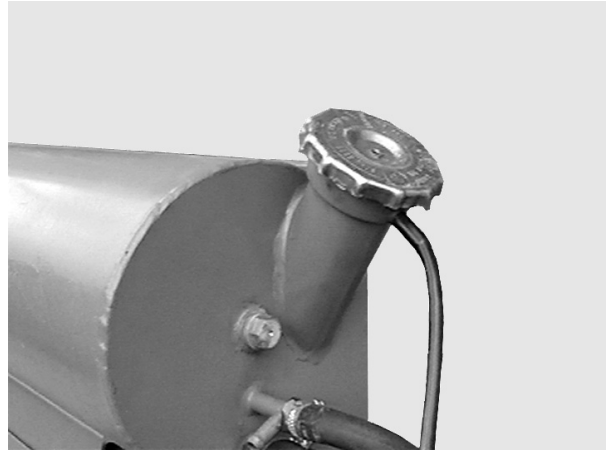

Filling with engine oil



Caution:

Do not add so much engine oil that the oil level rises above the max. marking on the dipstick. Overfilling will result in damage to the engine.

The engines are as a rule supplied without oil.

Pour oil into engine via filler neck, see page 75.

For the quantity required see “Technical Data”.

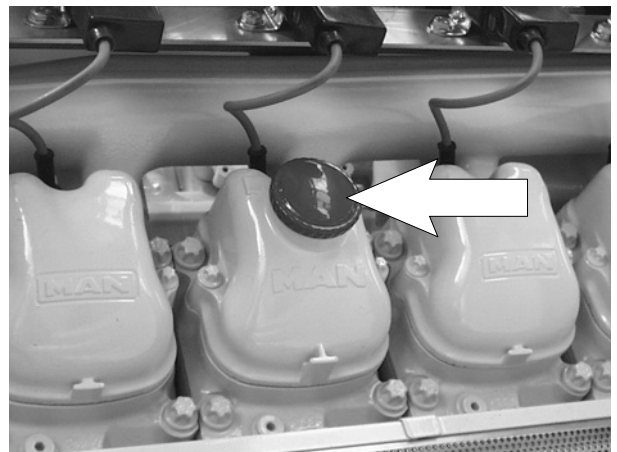

Commissioning

Before daily starting the engine, check fuel level, coolant level and engine oil level and replenish, if necessary.

**Caution:**

Use only approved fuels, lubricants etc. (see brochure "Fuels, lubricants etc."). Otherwise the manufacturer's warranty will become null and void.

Checking oil level

Check engine oil level only approx. 20 minutes after the unit has been switched off.

- Pull out dipstick (arrow)
- wipe it with a clean, lintfree cloth
- and push it in again up to the stop
- Pull out dipstick again

The oil level should be between the two notches in the dipstick and must never fall below the lower notch. Top up oil as necessary.

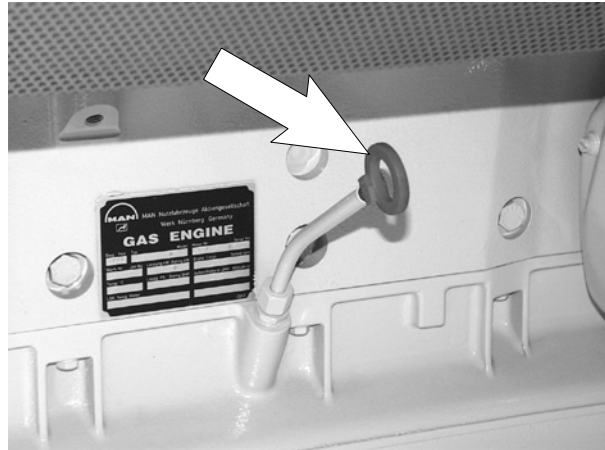
**Caution:**

Do not add so much engine oil that the oil level rises above the max. marking on the dipstick. Overfilling will result in damage to the engine.

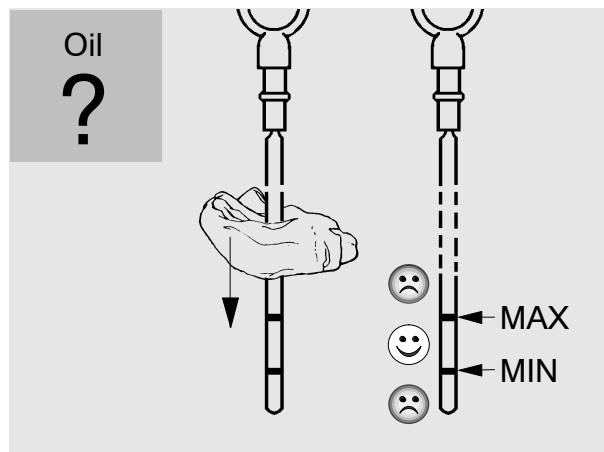

Ensure utmost cleanliness when handling fuels, lubricants and coolants.

Starting

**Danger:**

Before starting make sure that no-one is in the engine's danger area.

IC 900 ignition system is used for MAN's E 2842 LE 302 / E 2842 LE312 gas engine. The electronic ignition system is a high-voltage capacitor ignition system with microprocessor control based on crankshaft revolutions. The ignition system must be parameterised before it is started up. For further information please refer to the operating instructions for the ignition system and the guide to installation.

Switch on coolant pump before the start.

Switch the starter on and let it run for at least 3 seconds to ensure an adequate flow of air.

Following the flow of air the ignition and the gas line are released (generally automatically).

When the rated speed has been reached the system can be put under load. The load applied is increased from 0 to 100% over a period of 3 minutes. The thermal load on the engine block is thus minimised.

The oil pressure gauge must show the lubricating oil pressure. If this is not the case switch the engine off immediately.

Operation monitoring system

**Caution:**

If faults occur, find their cause immediately and have them eliminated in order to prevent more serious damage! If necessary consult MAN's customer service.

The oil pressure and coolant temperature are constantly monitored during operation.

The engine is automatically immobilised if the values fall short of or exceed the limits.

Shutting down

The load application is reduced by means of a ramp regulation from 100 to 0% over a period of at least 3 minutes. The thermal load on the engine block is thus minimised.

- Switch off the release of the gas line
- The engine slows down
- Switch off the ignition and control after approx. 5 seconds

**Note:**

The coolant pump continues to run for about 5 minutes after the engine has stopped. The thermal load on the engine block is thus minimised.

**Danger:**

The gas supply must always be switched off before the ignition so that no traces of unburned gas can pass into the exhaust gas line.

- In the event of damage to the engine cut-off never switch off with the ignition
- Close the main cut-off cock
- Don't switch off the ignition until the engine is stationary

Ensure that the engine cannot be started by unauthorized persons.

Gas system

**Note:**

The gas tract is not included in MAN's extent of delivery. The starting up, operation, monitoring of the operational safety, servicing and care of the gas system must be carried out in accordance with the manufacturer's instructions.

Adjustment when starting up

When the engine is first started up a suitable fuel / air mixture for the gas type used must be set. Any deviations from this will impair the power output, the engine efficiency and the exhaust gas emissions.

The requirements relating to gas quality can be found in the "MAN Data Sheet – Minimum Gas Quality Requirement for MAN Gas Engines".

The operating pressure for natural gas must be at least 20 mbar.
The gas pressure should remain as constant as possible within this range.

To achieve a correct gas / air mixture the inlet air in the engine chamber must be at a temperature between 15 and 30°C.

The gas must not contain any condensate when it enters the gas mixer.

Faults

We urgently recommend that malfunction is repaired in an authorised specialist workshop.

Air filter

The maximum pressure difference downstream and upstream of the filter must not be in excess of 35 mbar (350 mm head of water).

The filter element must therefore be exchanged in good time in accordance with the service instructions.

Gas filter

The gas filter must strain out particles $> 30 \mu\text{m}$.

Lubrication system

Ensure utmost cleanliness when handling fuels, lubricants and coolants.

**Caution:**

Use only approved fuels, lubricants etc. (see brochure “Fuels, lubricants etc.”). Otherwise the manufacturer’s warranty will become null and void.

Engine oil change

**Danger:**

The oil is hot- risk of scalding. Do not touch the oil drain plug with bare fingers.
The oil damages the environment. Handle it with care!

With the engine at operating temperature, remove the oil drain plugs (arrows) on the oil sump and the oil filter bowl (arrows) and allow the old oil to drain off completely.

Use a vessel of sufficient size to ensure that the oil does not overflow.

Refit the oil drain plugs with new gaskets.

**Note:**

Change the oil filter elements every time the engine oil is changed.

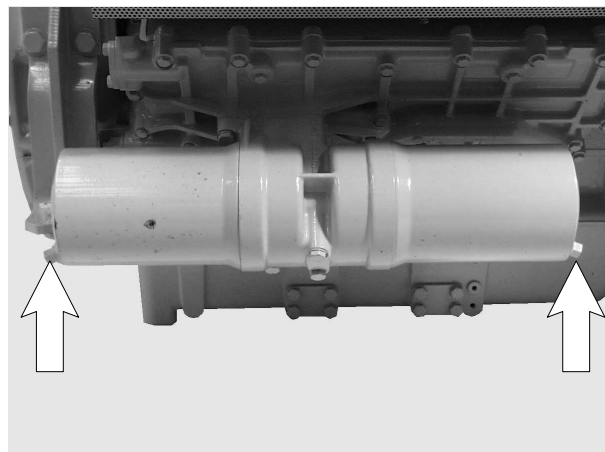
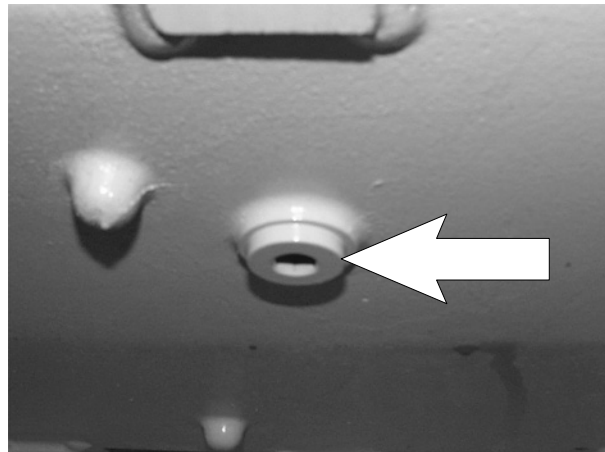

Refilling with oil



Caution:

Do not add so much engine oil that the oil level rises above the max. marking on the dipstick. Overfilling will result in damage to the engine.

Refill with fresh engine oil at the oil filler neck (arrow).

After filling start the engine and let it run for a few minutes at low speed.



Caution:

If no oil pressure builds up after approx. 10 seconds switch off the engine immediately.

Check oil pressure and check for leaks. Then shut down the engine. After about 20 minutes, check the oil level.

- Pull out dipstick (arrow)
- wipe it with a clean, lintfree cloth
- and push it in again up to the stop
- Pull out dipstick again

The oil level should be between the two notches in the dipstick and must never fall below the lower notch. Top up oil as necessary.

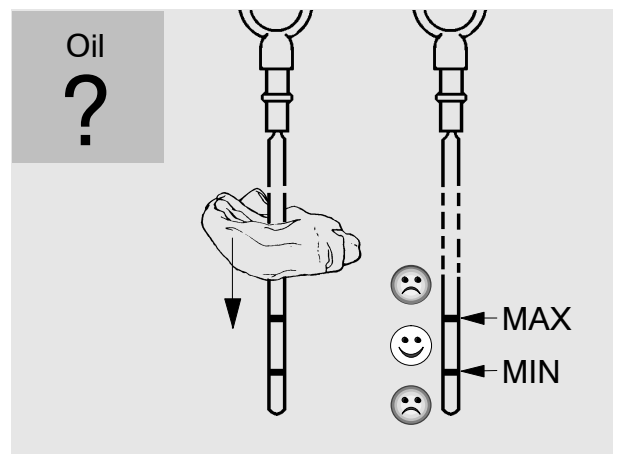
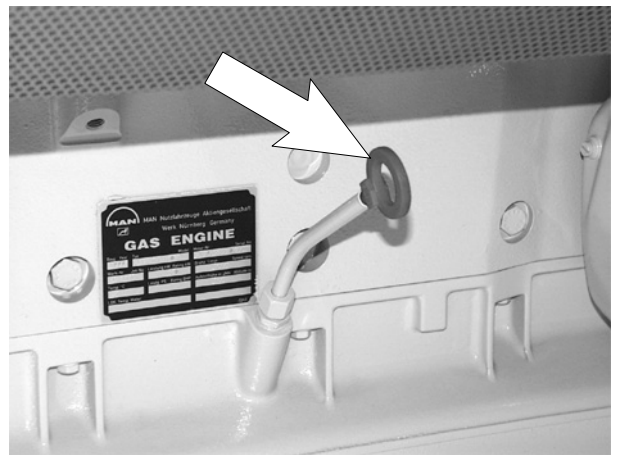
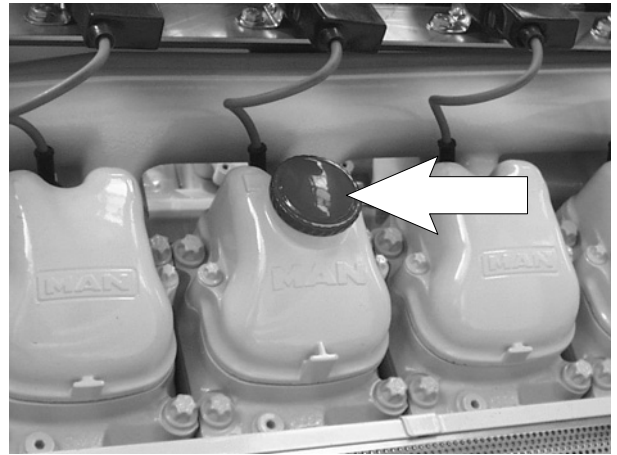

Changing oil filter

However, oil filter cartridges must be changed at every oil change.



Caution:

Used oil and oil filters are classed as dangerous waste. Observe safety regulations to prevent damage to the environment.

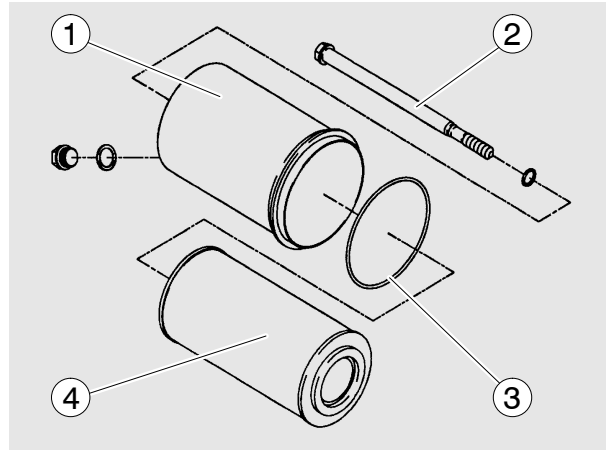

Renewal of filter cartridges



Danger:

Oil filter can and oil filter are filled with hot oil.
Risk of burns and scalds.

- Take off the filter housing ① after removing the mounting bolt ②.
- Renew filter cartridge ④. Thoroughly clean all other parts in cleaning fluid
- Mount the filter housing ① with new round sealing ③.



Note:

To prevent the sealing ring ③ twisting hold the filter housing ① firmly when tightening up the mounting bolt ②.

Cooling system



Danger:

Draining hot coolant involves a risk of scalding.

For a suitable protective agent see “Approved fuels, coolants and lubricants in accordance with MAN 324 and 248”.

Draining the cooling system



Caution:

Drain coolant into a suitable container and dispose of it in accordance with regulations.

Drain coolant as follows when cooling system has **cooled down**:

- Provide a large enough reservoir underneath
- Briefly open cap (large cap) on the filler neck of the expansion tank to equalise the pressure and close again
- Remove the drain plug on the crank-case ② and oil cooler housing ①
- Then remove cap
- Coolant runs into the reservoir
- Filling / bleeding the cooling system

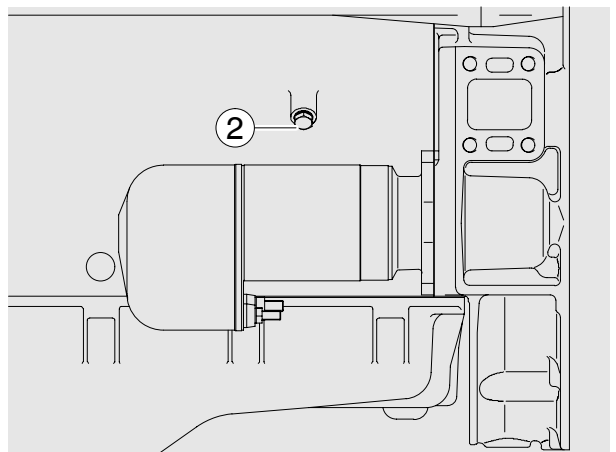
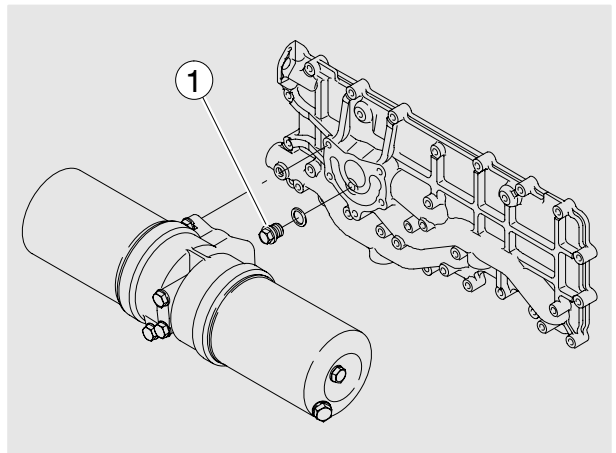
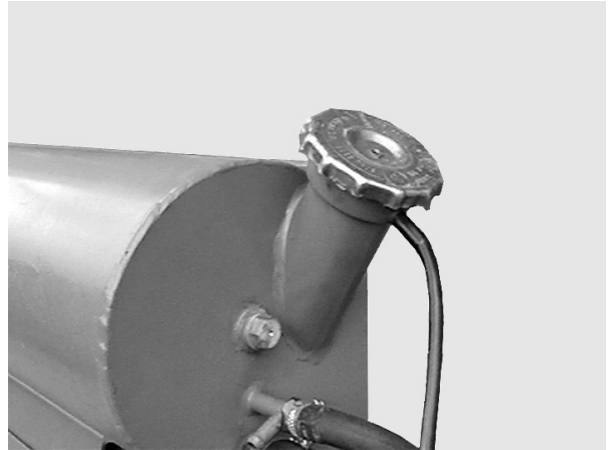

Fill / bleed the cooling system (only when engine has cooled down)

Fill the cooling system of the engine with a mixture of drinkable tap water and anti-freeze agent on ethylene glycole basis or anti-corrosion agent.

**Caution:**

Use only approved fuels, lubricants etc. (see brochure “Fuels, lubricants etc.”). Otherwise the manufacturer’s warranty will become null and void.

Coolant may be filled up **only in via the filler neck** (large cap) of the expansion tank

- Remove cap (large cap)
- Slowly pour in coolant
- Close expansion tank
- Let the engine run approx. 15 minutes at rated speed
- Switch off engine, turn the cap with the safety valve carefully to first catch – let off pressure – then carefully open and if necessary top up coolant
- Do not put cold coolant into an engine which is warm from operation. Ensure that the ratio of water to anti-freeze is correct
- With the engine is next put into operation (with the engine cold) check the coolant level and top up is necessary
- Repeat this procedure until no more coolant can be added



Cooling system with diaphragm expansion vessel

- After filling the cooling system let the electric coolant pump run for about 15 minutes and bleed the cooling system.
- Watch the pressure in the cooling system and check the coolant level.

**Danger:**

If in exceptional cases the cooling circuit has to be opened when the engine is warm, observe the safety instructions of the manufacturer of the cogeneration power unit.

Temporary decommissioning of engines

Temporary anti-corrosion protection according to MAN works norm M 3069 is required for engines which are to be put out of service for fairly long periods.

The works norm can be obtained from our After-Sales Service department Nuremberg works.



Technical data

Model	E 2842 LE 302	
Design	V-form, 90°	
Cycle	4-stroke Otto engine charged with intercooling	
Number of cylinders	12	
Bore	128 mm	
Stroke	142 mm	
Swept volume	21930 cm ³	
Compression ratio	10 : 1	
Rating		
< TA Luft	336 kW at 1500 rpm 359 kW at 1800 rpm	
TA-Luft / 2	320 kW at 1500 rpm	
<p>The power data applies to operation with natural gas with a calorific value of 36350 kJ/m³, and a methane number > 80. In the event of a higher calorific value the engine adjustment is to be corrected so that the specified engine output is not exceeded. In the event of lower calorific values the output will be reduced accordingly. To achieve the rated output the engine must be re-adjusted.</p>		
Firing order	1-12-5-8-3-10-6-7-2-11-4-9	
Valve clearance (cold engine)		
Intake	0.60 mm	
Exhaust	0.60 mm	
Valve timing		
Intake opens	12° before TDC	
Intake closes	48° after BDC	
Exhaust opens	61° before BDC	
Exhaust closes	11° after TDC	
Ignition timing	TA-Luft	TA-Luft 2
1500 rpm	16° before TDC	13° before TDC
1800 rpm	18° before TDC	16° before TDC

Technical data



Engine lubrication	Force feed	
Oil pressure during operation (depending on oil temperature, oil viscosity class and engine rpm)	must be monitored by oil pressure monitors gauges	
Oil filter	Full-flow filter with 2 paper filter cartridges.	
Oil capacity in oil sump (litres)	min.	max.
semi-flat	22 l	30 l
deep	40 l	90 l
Oil change quantity (with filter)		
semi-flat	33 l	
deep	93 l	
Engine cooling system	Liquid cooling	
Coolant temperature	80 / 88°C Engine inlet / outlet	
Coolant filling quantity	in engine approx. 23 l	
Electrical equipment		
Starter	24 V; 6.5 kW	
Ignition system	High-voltage capacitor ignition system; 24 V	



Technical data

Model	E 2842 LE 312	
Design	V-form, 90°	
Cycle	4-stroke Otto engine charged with intercooling	
Number of cylinders	12	
Bore	128 mm	
Stroke	142 mm	
Swept volume	21930 cm ³	
Compression ratio	11 : 1	
Rating		
< TA Luft	400 kW at 1500 rpm 420 kW at 1800 rpm	
TA-Luft / 2	380 kW at 1500 rpm 400 kW at 1800 rpm	
<p>The power data applies to operation with natural gas with a calorific value of 36350 kJ/m³, and a methane number > 80. In the event of a higher calorific value the engine adjustment is to be corrected so that the specified engine output is not exceeded. In the event of lower calorific values the output will be reduced accordingly. To achieve the rated output the engine must be re-adjusted.</p>		
Firing order	1-12-5-8-3-10-6-7-2-11-4-9	
Valve clearance (cold engine)		
Intake	0.60 mm	
Exhaust	0.60 mm	
Valve timing		
Intake opens	12° before TDC	
Intake closes	48° after BDC	
Exhaust opens	61° before BDC	
Exhaust closes	11° after TDC	
Ignition timing	TA-Luft	TA-Luft 2
1500 rpm	16° before TDC	13° before TDC
1800 rpm	18° before TDC	16° before TDC

Technical data



Engine lubrication	Force feed	
Oil pressure during operation (depending on oil temperature, oil viscosity class and engine rpm)	must be monitored by oil pressure monitors gauges	
Oil filter	Full-flow filter with 2 paper filter cartridges.	
Oil capacity in oil sump (litres)	min.	max.
semi-flat	22 l	30 l
deep	40 l	90 l
Oil change quantity (with filter)		
semi-flat	33 l	
deep	93 l	
Engine cooling system	Liquid cooling	
Coolant temperature	80 / 88°C Engine inlet / outlet	
Coolant filling quantity	in engine approx. 23 l	
Electrical equipment		
Starter	24 V; 6.5 kW	
Ignition system	High-voltage capacitor ignition system; 24 V	



Maintenance plan for operation with natural gas E 2842 LE 312

Interval by hours of operation at 1500 rpm 1)	Maintenance service						Service completed Stamp / signature
	E1	E2	E3	R1	R2	R3	
20–50 or after commissioning and R2, R3	x						
900		x 2)					
1800		x	x				
2700		x					
3600		x	x				
4500		x					
5400		x	x				
6300		x					
7200		x	x				
8100		x					
9000		x	x				
9900		x					
10800		x	x				
11700		x					
12600		x	x				
13500		x					
14400		x	x				
15000				x			
15300		x					
16200		x	x				
17100		x					
18000		x	x				
18900		x					
19800		x	x				
20700		x					
21600		x	x				
22500		x					
23400		x	x				
24300		x					
25000					x		
25200		x	x				
26100		x					

- 1) The service intervals may depend on the operating conditions and the gas quality.
For the extent of work to be done see page 86.
- 2) After 900 hours of operation the cylinder head bolts must be retightened.

Maintenance plan for operation with natural gas

E 2842 LE 312



Interval by hours of operation at 1500 rpm ¹⁾	Maintenance service						Service completed Stamp / signature
	E1	E2	E3	R1	R2	R3	
27000		x	x				
27900		x					
28800		x	x				
29700		x					
30000				x			
30600		x	x				
31500		x					
32400		x	x				
33300		x					
34200		x	x				
35100		x					
36000		x	x				
36900		x					
37800		x	x				
38700		x					
39600		x	x				
40500		x					
41400		x	x				
42300		x					
43200		x	x				
44100		x					
45000		x	x	x			
45900		x					
46800		x	x				
47700		x					
48600		x	x				
49500		x					
50000					x	x	
50400		x	x				



Maintenance plan for operation with natural gas E 2842 LE 312

E1	<ul style="list-style-type: none">● Check for leaks● Check screw connections● Change engine oil / oil analysis*)● Change oil filter *)● Record operating data● Check starting procedure● Set / check butterfly valve● Clean gas filter● Clean or change pulse pickup● Check coolant concentration● Check ignition point● Check coolant circuit / system pressure● Measure crankcase pressure● Measure exhaust back pressure● Clean or change mixture cooler● Check emissions and lambda	E3	<ul style="list-style-type: none">● Change sparkplugs● Measure compression● Set / check butterfly valve● Clean gas filter● Clean or change pulse pickup● Check coolant concentration● Check /change oil trap● Check ignition point● Check coolant circuit / system pressure● Measure crankcase pressure● Measure exhaust back pressure● Clean or change mixture cooler● Check emissions and lambda● Check /calibrate sensors
E2	<ul style="list-style-type: none">● Check for leaks● Check screw connections● Change engine oil / oil analysis*)● Change oil filter *)● Record operating data● Check sparkplugs● Check starting procedure● Check intake vacuum● Check valve clearance, adjust if necessary	R1	<ul style="list-style-type: none">● Change coolant● Change turbocharger● Measure crankshaft axial play
		R2	<ul style="list-style-type: none">● Change cylinder liners● Change conrods● Change piston rings● Change cylinder heads● Change pistons
		R3	<ul style="list-style-type: none">● Overhaul engine generally

*) The engine oil change intervals must be determined on the basis of regular oil analyses depending on the conditions of operation and the engine oil used in accordance with MAN works standard M 3271-2.

- The oil analysis must be carried out after the first 600 hours of operation

**Maintenance plan for operation with biological gas
for 60% CH₄, 40% CO₂ – E 2842 LE 312**



Interval by hours of operation at 1500 rpm ¹⁾	Maintenance service						Service completed Stamp / signature
	E1	E2	E3	R1	R2	R3	
20–50 or after commissioning and R2, R3	x						
400		x ²⁾					
800		x					
1200		x					
1600		x	x				
2000		x					
2400		x					
2800		x					
3200		x	x				
3600		x					
4000		x					
4400		x					
4800		x	x				
5200		x					
5600		x					
6000		x					
6400		x	x				
6800		x					
7200		x					
7600		x					
8000		x	x				
8400		x					
8800		x					
9200		x					
9600		x	x				
10000		x					
10400		x					
10800		x					
11200		x	x				
11600		x					
12000		x					
12400		x					

1) The service intervals may depend on the operating conditions and the gas quality.
For the extent of work to be done see page 92.

2) After 400 hours of operation the cylinder head bolts must be retightened.



**Maintenance plan for operation with biological gas
for 60% CH₄, 40% CO₂ – E 2842 LE 312**

Interval by hours of operation at 1500 rpm 1)	Maintenance service						Service completed Stamp / signature
	E1	E2	E3	R1	R2	R3	
12800		x	x				
13200		x					
13600		x					
14000		x					
14400		x	x				
14800		x					
15000				x			
15200		x					
15600		x					
16000		x	x				
16400		x					
16800		x					
17200		x					
17600		x	x				
18000		x					
18400		x					
18800		x					
19200		x	x				
19600		x					
20000		x					
20400		x					
20800		x	x				
21200		x					
21600		x					
22000		x					
22400		x	x				
22800		x					
23200		x					
23600		x					
24000		x	x				
24400		x					
24800		x					
25200		x					
25600		x	x				
26000		x					
26400		x					
26800		x					
27200		x	x				

**Maintenance plan for operation with biological gas
for 60% CH₄, 40% CO₂ – E 2842 LE 312**



Interval by hours of operation at 1500 rpm ¹⁾	Maintenance service						Service completed Stamp / signature
	E1	E2	E3	R1	R2	R3	
27600		x					
28000		x					
28400		x					
28800		x	x				
29200		x					
29600		x					
30000		x		x	x		
30400		x	x				
30800		x					
31200		x					
31600		x					
32000		x	x				
32400		x					
32800		x					
33200		x					
33600		x	x				
34000		x					
34400		x					
34800		x					
35200		x	x				
35600		x					
36000		x					
36400		x					
36800		x	x				
37200		x					
37600		x					
38000		x					
38400		x	x				
38800		x					
39200		x					
39600		x					
40000		x	x				
40400		x					
40800		x					
41200		x					
41600		x	x				
42000		x					
42400		x					



**Maintenance plan for operation with biological gas
for 60% CH₄, 40% CO₂ – E 2842 LE 312**

Interval by hours of operation at 1500 rpm 1)	Maintenance service						Service completed Stamp / signature
	E1	E2	E3	R1	R2	R3	
42800		x					
43200		x	x				
43600		x					
44000		x					
44400		x					
44800		x	x				
45000				x			
45200		x					
45600		x					
46000		x					
46400		x	x				
46800		x					
47200		x					
47600		x					
48000		x	x				
48400		x					
48800		x					
49200		x					
49600		x	x				
50000		x					
50400		x					
50800		x					
51200		x	x				
51600		x					
52000		x					
52400		x					
52800		x	x				
53200		x					
53600		x					
54000		x					
54400		x	x				
54800		x					
55200		x					
55600		x					
56000		x	x				
56400		x					
56800		x					
57200		x					

**Maintenance plan for operation with biological gas
for 60% CH₄, 40% CO₂ – E 2842 LE 312**



Interval by hours of operation at 1500 rpm ¹⁾	Maintenance service						Service completed Stamp / signature
	E1	E2	E3	R1	R2	R3	
57600		x	x				
58000		x					
58400		x					
58800		x					
59200		x	x				
59600		x					
60000		x		x	x	x	
60400		x					
60800		x	x				



Maintenance plan for operation with biological gas for 60% CH₄, 40% CO₂ – E 2842 LE 312

E1	<ul style="list-style-type: none">● Check for leaks● Check screw connections● Change engine oil / oil analysis*)● Change oil filter *)● Record operating data● Check starting procedure● Set / check butterfly valve● Clean gas filter● Clean or change pulse pickup● Check coolant concentration● Check ignition point● Check coolant circuit / system pressure● Measure crankcase pressure● Measure exhaust back pressure● Check emissions and lambda	E3	<ul style="list-style-type: none">● Check valve clearance, adjust if necessary● Change sparkplugs● Measure compression● Set / check butterfly valve● Clean gas filter● Clean or change pulse pickup● Check coolant concentration● Check /change oil trap● Check ignition point● Check coolant circuit / system pressure● Measure crankcase pressure● Measure exhaust back pressure● Clean or change mixture cooler● Check emissions and lambda● Check /calibrate sensors
E2	<ul style="list-style-type: none">● Check for leaks● Check screw connections● Change engine oil / oil analysis*)● Change oil filter *)● Record operating data● Check sparkplugs● Check starting procedure● Check intake vacuum	R1	<ul style="list-style-type: none">● Change coolant● Change turbocharger● Measure crankshaft axial play
		R2	<ul style="list-style-type: none">● Change cylinder liners● Change conrods● Change piston rings● Change cylinder heads● Change pistons
		R3	<ul style="list-style-type: none">● Overhaul engine generally

*) The engine oil change intervals must be determined in accordance with MAN works standard M 3271-2 on the basis of regular oil analyses depending on the conditions of operation and the engine oil used.

- The oil analysis must be carried out after the first 200 hours of operation
- If the gas composition fluctuates regular oil analyses must be carried out
- If the engine runs on biological gas it must be fitted with the 90 l oil pan



A series of horizontal dotted lines for writing notes.

A		
Air filter	73
C		
Changing oil filter	76
Checking oil level	70
Commissioning	70
Commissioning and operation	62–73
Cooling system	66 , 77–78
D		
Declaration	54
Draining the cooling system	77
E		
Engine oil change	74
Engine views	62
F		
Fill / bleed the cooling system	78
Filling with engine oil	69
First commissioning	66–69
G		
Gas filter	73
Gas system	73
General notes	56–62
I		
Instructions	52
L		
Lubrication system	74–76
M		
Maintenance and care	74–79
Maintenance plan		
Operation with biological gas	87
Operation with natural gas	84
N		
Nameplates	55
O		
Operation monitoring system	72
R		
Refilling with oil	75
S		
Safety regulations		
Dealing with gaseous fuels	61
Handling used engine oil	60
Preventing accidents with injury to persons	..	56
Preventing damage to engine and premature wear	58
Preventing environmental damage	59
Shutting down	72
Starting	71
T		
Technical data	80–83
Temporary decommissioning	79



MAN Nutzfahrzeuge AG
Geschäftseinheit Motoren
Vogelweiherstraße 33
D-90441 Nürnberg

Ein Unternehmen der MAN Gruppe

Printed in Germany

51.99493-8420