



Operating Instructions for MAN Industrial Diesel Engines
Bedienungsanleitung für MAN-Industriedieselmotoren
Instrucciones de servicio para motores Diesel industriales MAN
Instruction de service pour moteurs Diesel industriels MAN
Norme di servizio per Motori Diesel industriali MAN

D 2866 LE 201 / 202 / 203 / 211

Operating Instructions –
MAN Industrial Diesel Engines





Dear Customer,

these Operating Instructions are intended to familiarize you with your new MAN Diesel engine and how it operates.

This manual is supplemented by the publication “Fuels, Lubricants and Coolants for MAN Diesel Engines” and the “Service record book”.



Note:

All three publications belong to the engine and must always be kept ready to hand near the engine in the engine room.

Comply in full with instructions relating to operation, prevention of accidents and environmental protection.

MAN Diesel engines are developed and manufactured in line with the latest state of the art. However, trouble-free operation and high performance can only be achieved if the specified maintenance intervals are observed and only approved fuels, lubricants and coolants are used.

It is imperative and in your own interest to entrust your MAN Local Service Centre with the removal of any disturbances and with the performance of checking, setting, and repair work.

Yours faithfully,
MAN Nutzfahrzeuge Aktiengesellschaft
Werk Nürnberg

Subject to change to keep abreast with technological progress.

© 2004 MAN Nutzfahrzeuge Aktiengesellschaft
No parts of this publication may be reproduced or translated without prior written permission of MAN. MAN explicitly reserves all rights according to copyright law.

Important instructions which concern technical safety and protection of persons are emphasised as shown below.

**Danger:**

This refers to working and operating procedures which must be complied with in order to rule out the risk to persons.

**Caution:**

This refers to working and operating procedures which must be complied with in order to prevent damage to or destruction of material.

**Note:**

Explanations useful for understanding the working or operating procedure to be performed.

Fitting flat seals / gaskets

Flat seals / gaskets are often inserted with sealing agents or adhesives to make fitting them easier or to achieve better sealing. Flat seals may slip in operation due to the “sewing-machine” effect, in particular if they are used between parts with different rates of linear expansion under heat (e.g. aluminium and cast iron), and leaks may then occur.

Example:

the cap of the front crankshaft seal. If a sealing agent or an adhesive is used here the flat seal will move inwards in the course of time as a result of the different expansion rates of the materials. Oil will be lost, for which the shaft seal may be thought to be responsible.

Flat seals / gaskets can be fitted properly only if the following points are observed:

- Use only genuine MAN seals / gaskets
- The sealing faces must be undamaged and clean
- Do not use any sealing agent or adhesive – as an aid to fitting the seals a little grease can be used if necessary so that the seal will stick to the part to be fitted
- Tighten bolts evenly to the specified torque

Preface	5
Instructions	6
Declaration	8
Nameplates	9
Safety regulations	10
Commissioning and operation	14
Engine views	14
First commissioning	16
Commissioning	17
Starting	18
Operation monitoring system	19
Shutting down	19
Maintenance and care	20
Lubrication system	20
Fuel system	23
Cooling system	26
Air filter	28
Checking V-belts	32
Turbocharger	34
Intercooler	34
Starter motor	34
Alternator	35
Temporary decommissioning of engines	35
Technical data	36
Troubleshooting table	38
Index	40

Declaration

In accordance with Article 4, paragraph 2, in conjunction with Appendix II, section B, of Directive 89/392/EEC, version 93/44/EEC

MAN Nutzfahrzeuge Aktiengesellschaft,

hereby declares that the engine described below is destined for installation in a machine as defined in the EC directive on machines.

Engine model:

Design:

For data see original declaration

Engine number:

If required this declaration is enclosed with the delivery note.

Rating / speed:



Note:

The manufacturer of the complete ready-to-use machine in which this engine is to be installed must take the further action necessary in the context of indirect safety-related engineering and provision of instructions to ensure that the ready-to-use machine complies with the requirements of the EC directive on machines. The engine must not be put into operation until the complete machine satisfies the conditions laid down in the EC directive on machines 89/392/EEC, most recently amended by 93/44/EEC, or the latest amendment of said directive.

MAN Nutzfahrzeuge Aktiengesellschaft

Vogelweiherstraße 33

D-90441 Nürnberg

Nameplates



In all your correspondence please always quote engine model, serial number and job number (Order number).

For this reason it is advisable to read off the data from the engine type plates before putting the engine into operation and to enter them in the appropriate spaces.

The engine type plates are on the crankcase.

Model

delivered on

installed on

Engine serial number

Order number

MAN Nutzfahrzeuge Aktiengesellschaft
 Typ
 Motor-Nr. / Engine No. NI/II

		MAN Nutzfahrzeuge Aktiengesellschaft			
		Werk Nürnberg Germany			
DIESEL ENGINE					
Bauj. Year	Typ	Model	Motor-Nr.	Serial No	
<input type="text"/>	<input type="text"/>	<input type="text"/>	<input type="text"/>	<input type="text"/>	
Werk-Nr.	Job No	Leistung kW	Rating kW	Drehz. 1/min	Speed rpm
<input type="text"/>	<input type="text"/>	<input type="text"/>	<input type="text"/>	<input type="text"/>	<input type="text"/>
Temp.°C	Leistg. PS	Rating BHP	Aufstellhöhe m uNN Altitude m		
<input type="text"/>	<input type="text"/>	<input type="text"/>	<input type="text"/>		
-0219					

General notes

Handling diesel engines and the necessary resources is no problem when the personnel commissioned with operation and maintenance are trained accordingly and use their common sense.

This summary is a compilation of the most important regulations. These are broken down into main sections which contain the information necessary for preventing injury to persons, damage to property and pollution. In addition to these regulations those dictated by the type of engine and its site are to be observed also.

Important:

If, despite all precautions, an accident occurs, in particular through contact with caustic acids, fuel penetrating the skin, scalding from hot oil, anti-freeze being splashed in the eyes etc., **consult a doctor immediately.**

1. Regulations designed to prevent accidents with injury to persons

During commissioning, starting and operation

- Before putting the engine into operation for the first time, read the operating instructions carefully and familiarize yourself with the “critical” points. If you are unsure, ask your MAN representative.
- For reasons of safety we recommend you attach a notice to the door of the engine room prohibiting the access of unauthorized persons and that you draw the attention of the operating personal to the fact that they are responsible for the safety of persons who enter the engine room.
- The engine must be started and operated only by authorized personnel. Ensure that the engine cannot be started by unauthorized persons.
- When the engine is running, do not get too close to the rotating parts. Wear close-fitting clothing.
- Do not touch the engine with bare hands when it is warm from operation – risk of burns.
- Exhaust gases are toxic. Comply with the instructions for the installation of MAN Diesel engines which are to be operated in enclosed spaces. Ensure that there is adequate ventilation and air extraction.
- Keep vicinity of engine, ladders and stairways free of oil and grease. Accidents caused by slipping can have serious consequences.



During maintenance and care

- Always carry out maintenance work when the engine is switched off. If the engine has to be maintained while it is running, e.g. changing the elements of change-over filters, remember that there is a risk of scalding. Do not get too close to rotating parts.
- Change the oil when the engines is warm from operation.
Caution:
There is a risk of burns and scalding. Do not touch oil drain plugs or oil filters with bare hands.
- Take into account the amount of oil in the sump. Use a vessel of sufficient size to ensure that the oil will not overflow.
- Open the coolant circuit only when the engine has cooled down. If opening while the engine is still warm is unavoidable, comply with the instructions in the chapter entitled "Maintenance and Care".
- Neither tighten up nor open pipes and hoses (lube oil circuit, coolant circuit and any additional hydraulic oil circuit) during the operation. The fluids which flow out can cause injury.
- Fuel is inflammable. Do not smoke or use naked lights in its vicinity. The tank must be filled only when the engine is switched off.
- When using compressed air, e.g. for cleaning the radiator, wear goggles.
- Keep service products (anti-freeze) only in containers which can not be confused with drinks containers.
- Comply with the manufacturer's instructions when handling batteries.
Caution:
Accumulator acid is toxic and caustic. Battery gases are explosive.



2. Regulations designed to prevent damage to engine and premature wear

Do not demand more from the engine than it is able to supply in its intended application. Detailed information on this can be found in the sales literature. The injection pump must not be adjusted without prior written permission of MAN Nürnberg.



Safety regulations

If faults occur, find the cause immediately and have it eliminated in order to prevent more serious damage.

Use only genuine MAN spare parts. MAN will accept no responsibility for damage resulting from the installation of other parts which are supposedly “just as good”.

In addition to the above, note the following points:

- Never let the engine run when dry, i.e. without lube oil or coolant.
- When starting do not use any additional starting aids (e.g. injection with starting pilot).
- Use only MAN-approved service products (fuel, engine oil, anti-freeze and anti-corrosion agent). Pay attention to cleanliness. The Diesel fuel must be free of water. See “Maintenance and care”.
- Have the engine maintained at the specified intervals.
- Do not switch off the engine immediately when it is warm, but let it run without load for about 5 minutes so that temperature equalization can take place.
- Never put cold coolant into an overheated engine. See “Maintenance and care”.
- ***Do not add so much engine oil that the oil level rises above the max. marking on the dipstick. Do not exceed the maximum permissible tilt of the engine.***
Serious damage to the engine may result if these instructions are not adhered to.
- Always ensure that the testing and monitoring equipment (for battery charge, oil pressure, coolant temperature) function satisfactorily.
- It is advisable to switch off the engine if an alarm of any kind is displayed in the engine monitoring and diagnostic system. If this is not possible for any reason, the engine should be run no faster than 1200 rpm until the fault is remedied.
- Comply with instructions for operation of the alternator. See “Maintenance and care”.
- Do not let the seawater pump run dry. If there is a risk of frost, drain the pump when the engine is switched off.

3. Regulations designed to prevent pollution

Engine oil and filter elements / cartridges, fuel / fuel filter

- Take old oil only to an old oil collection point.

- Take strict precautions to ensure that no oil or Diesel fuel gets into the drains or the ground.

Caution:

The drinking water supply could be contaminated.

- Filter elements are classed as dangerous waste and must be treated as such.

Coolant

- Treat undiluted anti-corrosion agent and / or anti-freeze as dangerous waste.
- When disposing of spent coolant comply with the regulations of the relevant local authorities.

4. Notes on safety in handling used engine oil *

Prolonged or repeated contact between the skin and any kind of engine oil decreases the skin. Drying, irritation or inflammation of the skin may therefore occur. Used engine oil also contains dangerous substances which have caused skin cancer in animal experiments. If the basic rules of hygiene and health and safety at work are observed, health risks are not to the expected as a result of handling used engine oil.

Health precautions:

- Avoid prolonged or repeated skin contact with used engine oil.
- Protect your skin by means of suitable agents (creams etc.) or wear protective gloves.
- Clean skin which has been in contact with engine oil.
 - Wash thoroughly with soap and water. A nailbrush is an effective aid.
 - Certain products make it easier to clean your hands.
 - Do not use petrol, Diesel fuel, gas oil, thinners or solvents as washing agents.
- After washing apply a fatty skin cream to the skin.
- Change oil-soaked clothing and shoes.
- Do not put oily rags into your pockets.

**Ensure that used engine oil is disposed of properly
– Engine oil can endanger the water supply –**

For this reason do not let engine oil get into the ground, waterways, the drains or the sewers. Violations are punishable.

Collect and dispose of used engine oil carefully. For information on collection points please contact the seller, the supplier or the local authorities.

* Adapted from "Notes on handling used engine oil".

Engine views D 2866 LE 201

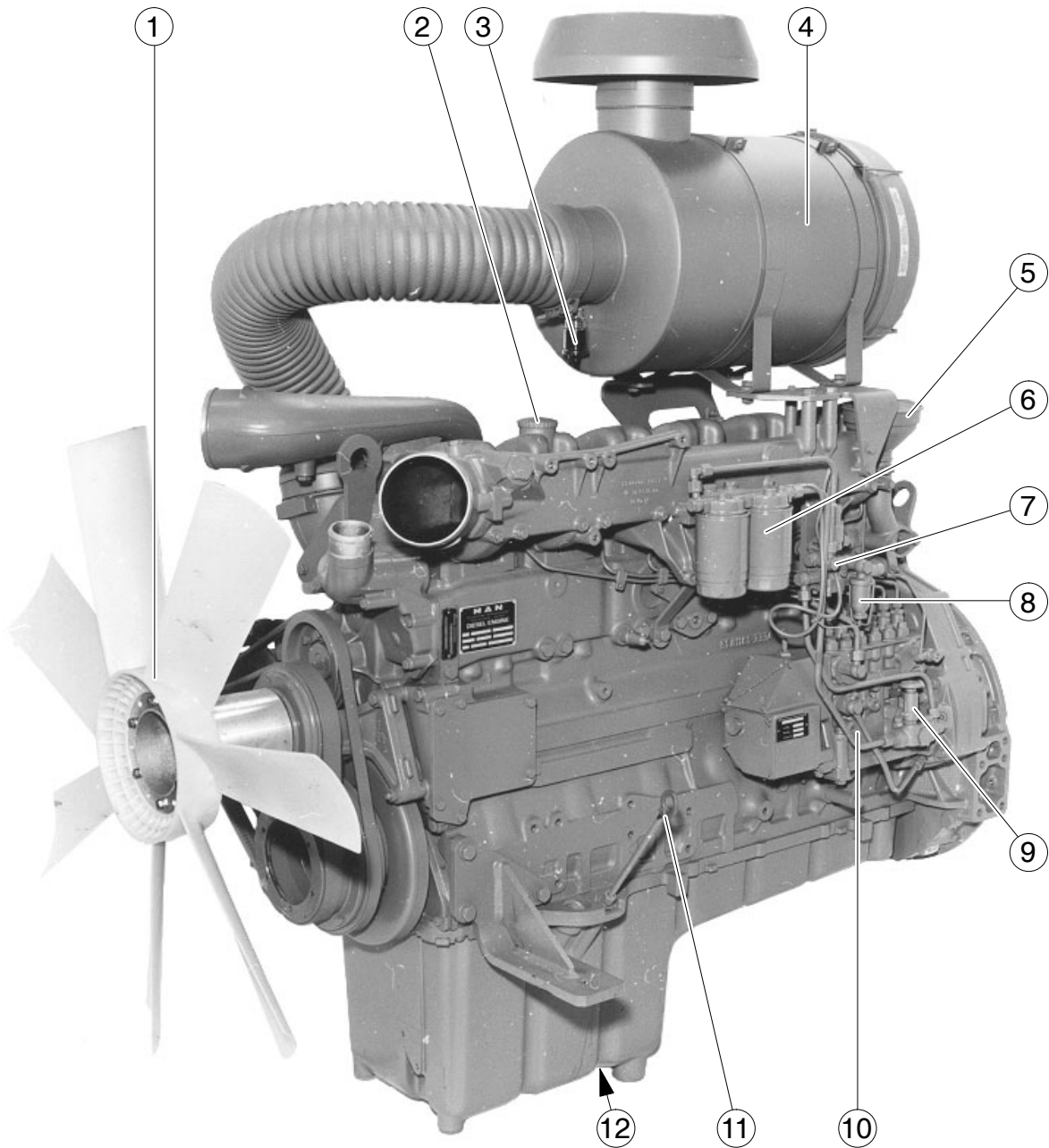

- | | |
|----------------------------------|-------------------------------------|
| ① Fan | ⑦ Electro-hydraulic shut-off (EHAB) |
| ② Oil filler neck | ⑧ Fuel strainer |
| ③ Air filter contamination gauge | ⑨ Fuel lift pump |
| ④ Air Cleaner | ⑩ Injection pump |
| ⑤ Crankcase breather | ⑪ Oil dipstick |
| ⑥ Fuel filter | ⑫ Oil drain plug |

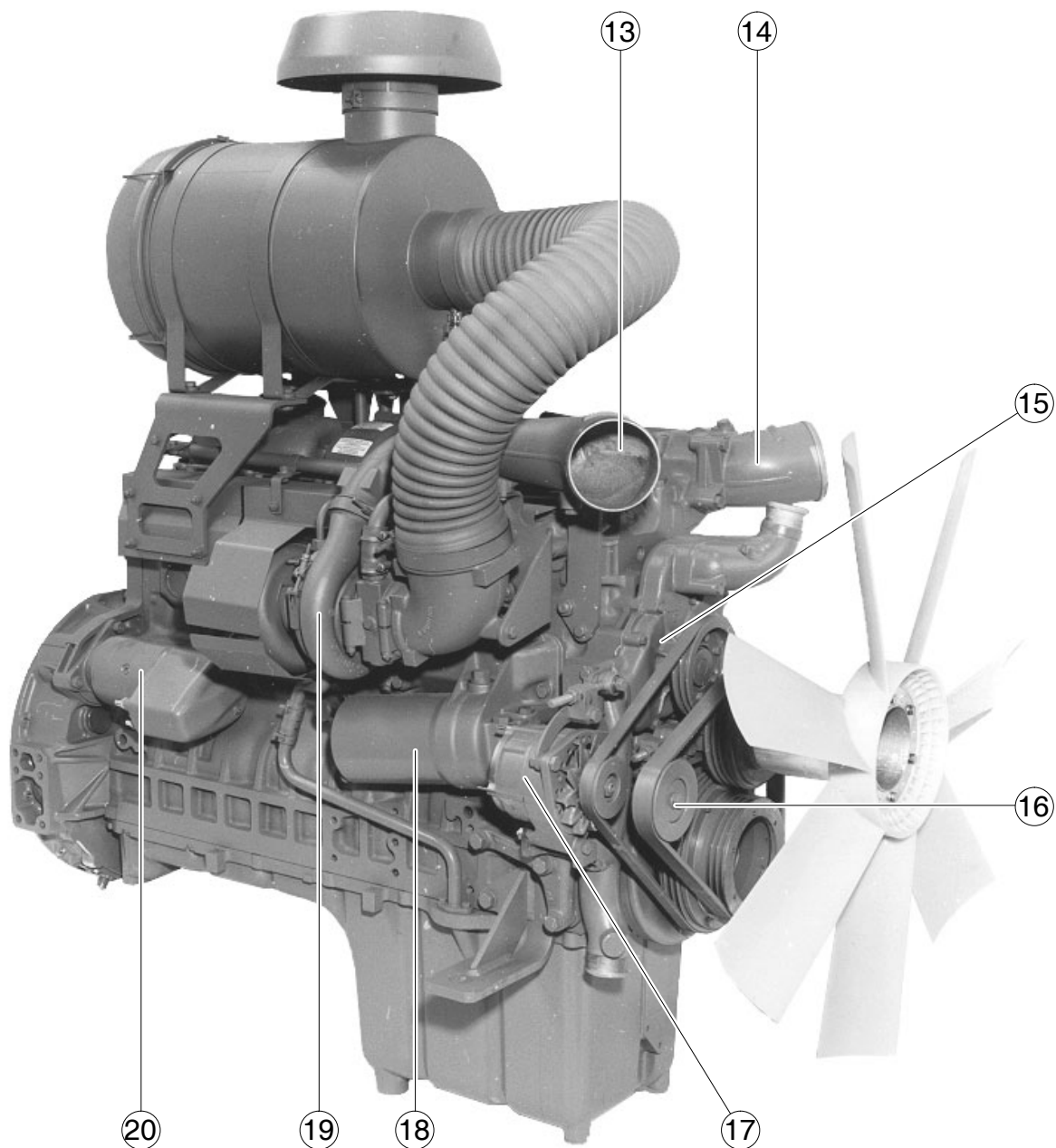

⑬ Combustion air pipe to intercooler

⑭ Combustion air pipe from intercooler

⑮ Water pump

⑯ Tensioning pulley

⑰ Alternator

⑱ Oil filter

⑲ Turbocharger

⑳ Starter motor

First commissioning

At the time of initial commissioning of a new or overhauled engine make sure to have observed the “Technical Information for the installation of MAN Diesel engines”.

It is recommended that new or overhauled engines should not be operated at a load higher than about 75% maximum load during the first few hours of operation. Initial run-in should be at varying speeds. After this initial run-in, the engine should be brought up to full output gradually.

**Note:**

Use only approved fuels, lubricants etc. (see brochure “Fuels, lubricants etc.”). Otherwise the manufacturer’s warranty will become null and void.

Filling with fuel

**Caution:**

Fill the tank only when the engine is switched off. Pay attention to cleanliness. Do not spill fuel. Use only approved fuels (see “Fuels, Lubricants etc.”).

Filling-in of coolant

Fill the cooling system of the engine with a mixture of drinkable tap water and anti-freeze agent on ethylene glycole basis or anti-corrosion agent. See Publication “Fuels, Lubricants and Coolants for MAN Diesel Engines”.

- Pour in coolant slowly via expansion tank, see page 26
- For coolant filling quantity, see “Technical data“

Filling with engine oil

**Caution:**

Do not add so much engine oil that the oil level rises above the max. marking on the dipstick. Overfilling will result in damage to the engine.

The engines are as a rule supplied without oil. Pour oil into engine via filler neck, see page 21. For the quantity required see “Technical Data”.

Commissioning

Before daily starting the engine, check fuel level, coolant level and engine oil level and replenish, if necessary.



Note:

Use only approved fuels, lubricants etc. (see brochure “Fuels, lubricants etc.”). Otherwise the manufacturer’s warranty will become null and void.

Checking oil level

Check the oil level when the engine is horizontal, but only if at least 20 minutes have passed since the machine was switched off.

- Pull out dipstick
- wipe it with a clean, lintfree cloth
- and push it in again up to the stop
- Pull out dipstick again

The oil level should be between the two notches in the dipstick and must never fall below the lower notch. Top up oil as necessary.



Caution:

Do not add so much engine oil that the oil level rises above the max. marking on the dipstick. Overfilling will result in damage to the engine.

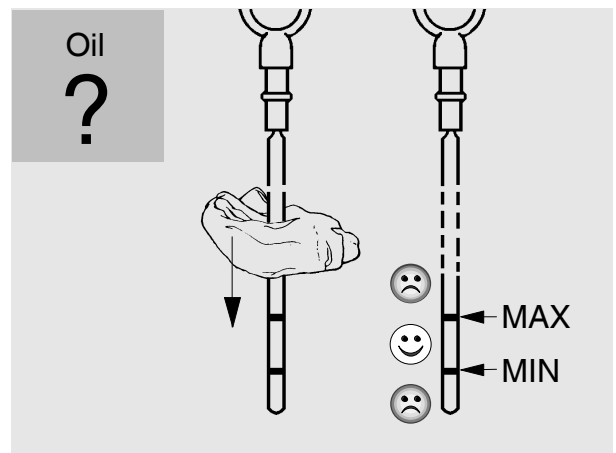

Ensure utmost cleanliness when handling fuels, lubricants and coolants.

Starting

**Danger:**

Before starting make sure that no-one is in the engine's danger area.

**Caution:**

When starting do not use any additional starting aids (e.g. injection with starting pilot).

- Ensure that no load is on the engine before starting it, eg switch off load, disengage clutch, put gearbox into neutral etc.

With engines without starting aid or at temperatures above 5–10°C or when engine without flame starter is already hot:

- Insert starter key in starting lock
- Press starter button until engine starts

With engines with starting aid (flame starter), at temperatures around 0°C and below:

- Insert starter key in starting lock
- Switch on flame starter; signal lamp "Preheating" is on
- Signal lamp "Preheating" is flashing; press starter button until engine starts

**Caution:**

- When engine starts, release starter button immediately
- If engine does not start, actuate starter for about 10 seconds, wait for 30 seconds and then attempt to start engine again and so on

With engine with automatic starting (eg standby power units) it is indispensable that none of the moving parts be accessible. Warning signs "Unit starts automatically" are to be attached to the engine. Regulation on this which may apply locally are to be satisfied.

When engine is running, lube oil pressure must build up at the oil pressure gauge. If not switch off engine immediately.

Avoid running the cold engine for any length of time since in any internal combustion engine this is liable to cause increased wear due to corrosion. Prolonged idling is harmful to the environment.

Operation monitoring system

**Caution:**

Do not overload the engine. Do not exceed the maximum permissible engine tilt. If faults occur, find their cause immediately and have them eliminated in order to prevent more serious damage!

During operation the oil pressure in the engine lubrication system must be monitored. If the monitoring devices register a drop in the lube oil pressure, switch off the engine immediately.

Shutting down

Do not switch off engine immediately operation at high loads, but let it idle for about 5 minutes to achieve a temperature equalisation.

Then switch off engine manually via the stop lever at the injection pump or via the stop device provided (shutdown solenoid, electric speed governor etc.)

**Danger:**

Ensure that the engine can not be started by unauthorized persons.

Lubrication system

Ensure utmost cleanliness when handling fuels, lubricants and coolants.

**Note:**

Use only approved fuels, lubricants etc. (see brochure "Fuels, lubricants etc."). Otherwise the manufacturer's warranty will become null and void.

Engine oil change

**Danger:**

The oil is hot- risk of scalding. Do not touch the oil drain plug with bare fingers. Oil is an environmental hazard. Handle it with care!

With the engine at operating temperature, remove the oil drain plugs on the oil sump and the oil filter bowl and allow the old oil to drain off completely.

Use a vessel of sufficient size to ensure that the oil does not overflow.

As the oil drain plug is often not accessible, a manually operated vane pump may be attached to the engine for draining the oil.

Pump the old oil out of the sump while the engine is still warm. Remove oil drain plugs in oil filter bowl and let old oil drain out of oil filters.

Refit the oil drain plugs with new gaskets.

**Note:**

Change the oil filter elements every time the engine oil is changed

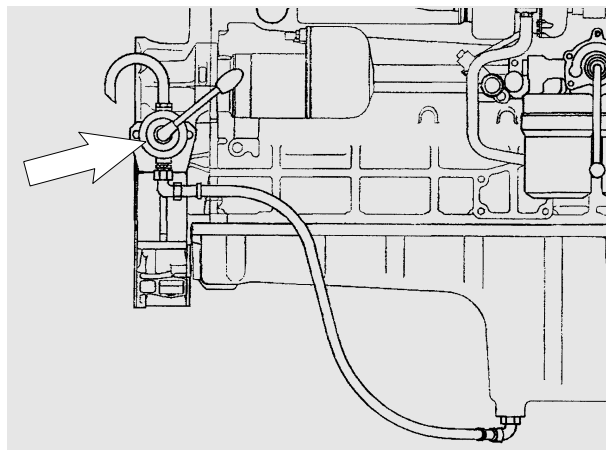
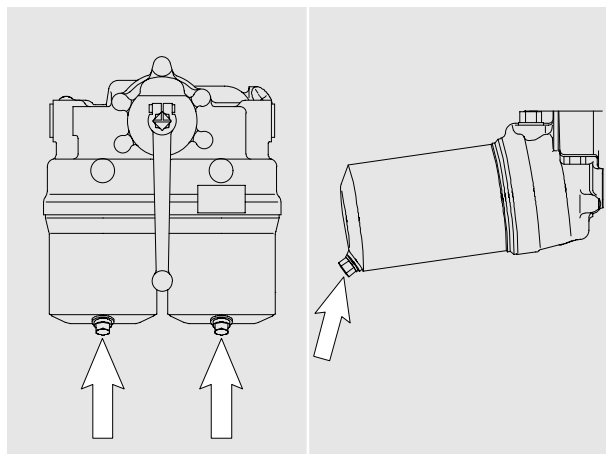
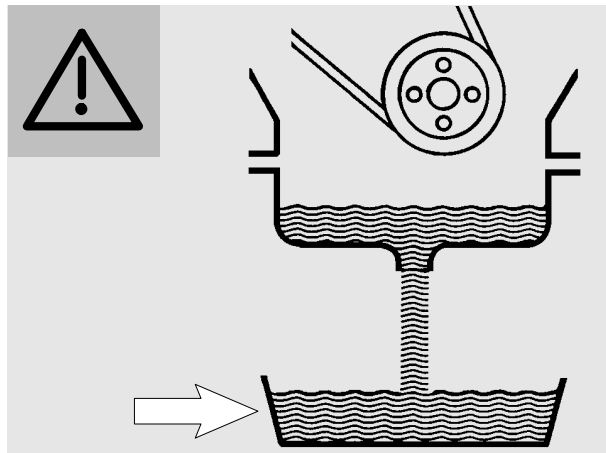

Refilling with oil



Caution:

Do not add so much engine oil that the oil level rises above the max. marking on the dipstick. Overfilling will result in damage to the engine.

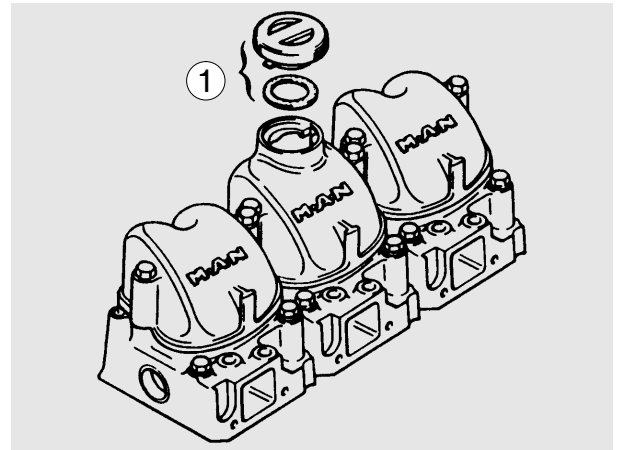

Refill with fresh engine oil at the oil filler neck ①.

After filling start the engine and let it run for a few minutes at low speed.



Caution:

If no oil pressure builds up after approx. 10 seconds switch off the engine immediately.

Check oil pressure and check that there is no oil leakage.

Then shut down the engine. After about 20 minutes, check the oil level.

- Pull out dipstick
- wipe it with a clean, lintfree cloth
- and push it in again up to the stop
- Pull out dipstick again

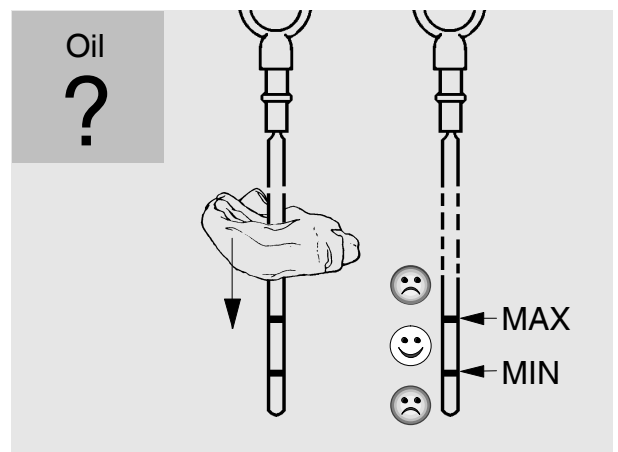

The oil level should be between the two notches in the dipstick and must never fall below the lower notch. Top up oil as necessary.

Changing oil filter

A changeover-type oil filter, the filter elements of which can be replaced even during operation, can be fitted on request.

However, oil filter cartridges must be changed at every oil change.

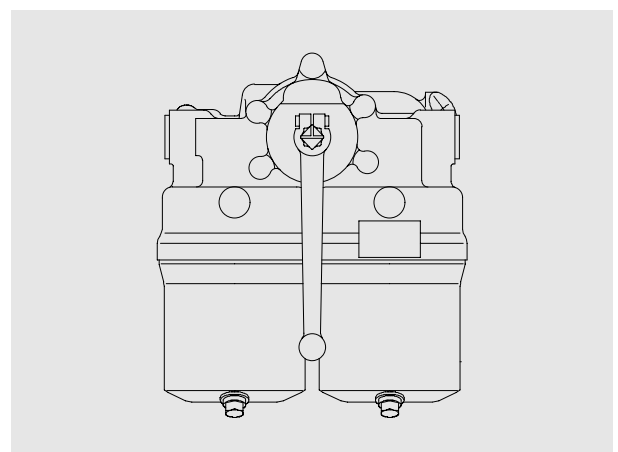

During continuous operation position the selector lever that both filter halves are in operation.

Observe positions of selector lever!



Caution:

Do not leave selector lever in any intermediate position because this would be liable to interfere with oil supply. If in doubt stop engine to change oil filter.

Renewal of filter cartridges

- Allow the filter content to run off along drain plugs ①. Hold a suitable vessel under hole



Danger:

The oil is hot and under pressure when the drain plug is opened. Risk of burns and scalds.

- After releasing the clamping bolts ③ remove filter bowls ②
- Renew filter cartridges ④. Thoroughly clean all other parts in cleaning fluid (do not allow cleaning fluid to enter the oil circuit)
- Use new gaskets ⑤ for reassembly of filter bowls



Note:

To prevent the seal ⑤ from twisting hold the filter bowl ② firmly when tightening the tensioning screw ③.



Caution:

Used oil filters are classed as dangerous waste and must be disposed of accordingly.

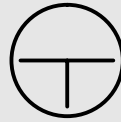

Continuous operation
(both filter halves
in operation)



Right-hand filter
cut out



Left-hand filter
cut out

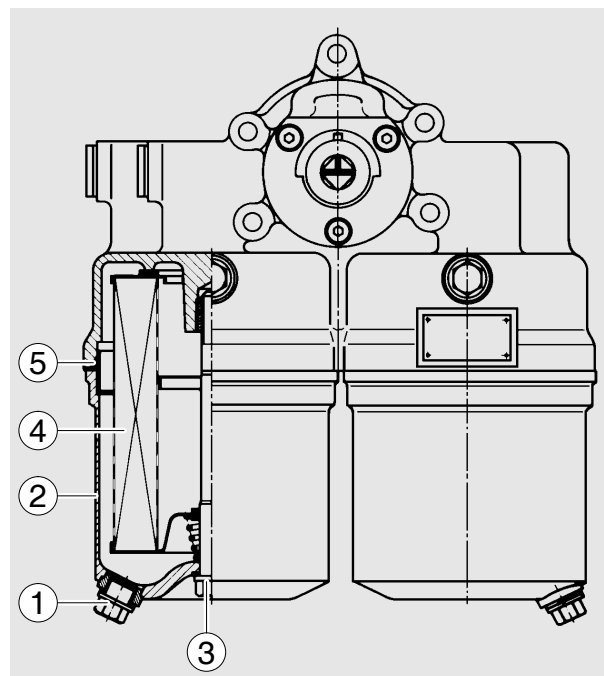
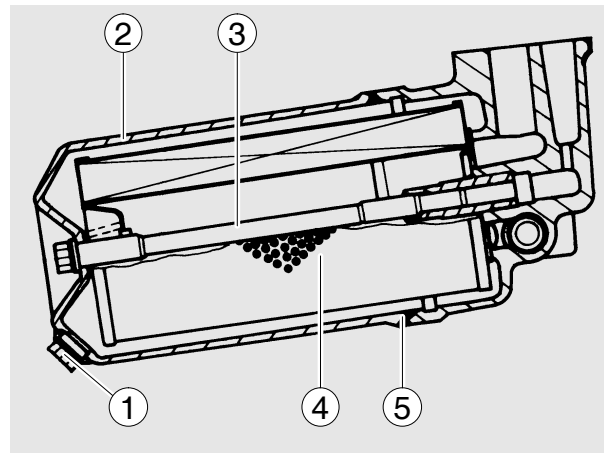

Fuel system

Fuel

If Diesel fuel which contains moisture is used the injection system and the cylinder liners / pistons will be damaged. This can be prevented to some extent by filling the tank as soon as the engine is switched off while the fuel tank is still warm (formation of condensation is prevented). Drain moisture from storage tanks regularly. Installation of a water trap upstream of the fuel filter is also advisable. Do not use any additives to improve flow properties in winter.

Injection pump

No alterations must be made to the injection pump. If the lead seal is damaged the warranty on the engine will become null and void.

Faults

We urgently recommend that you have faults in the injection pump rectified only in an authorised specialist workshop.

Cleaning fuel pre-cleaner

Strip the fuel pre-cleaner ①:

- Unscrew knurled nut of pre-cleaner
- Swing out retaining arm and take out filter housing ③ with strainer filter ②
- Wash out filter housing and strainer filter in clean Diesel fuel and blow dry with compressed air
- Re-assemble in reverse order

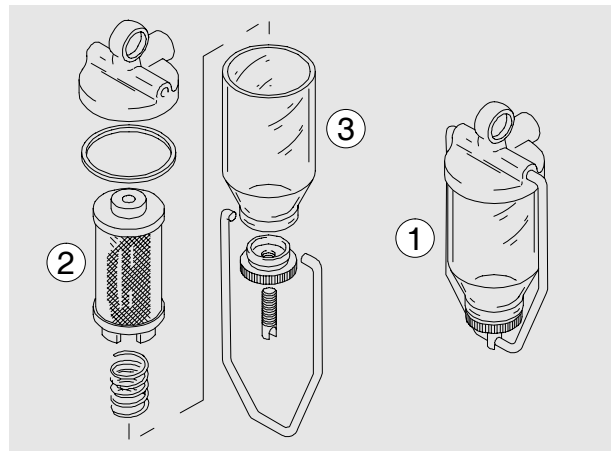

- Actuate tappet of hand primer until overflow valve of injection pump is heard to open
- Screw in the tappet of the hand pump again and tighten it
- Start engine
- Check fuel pre-cleaner for leaks

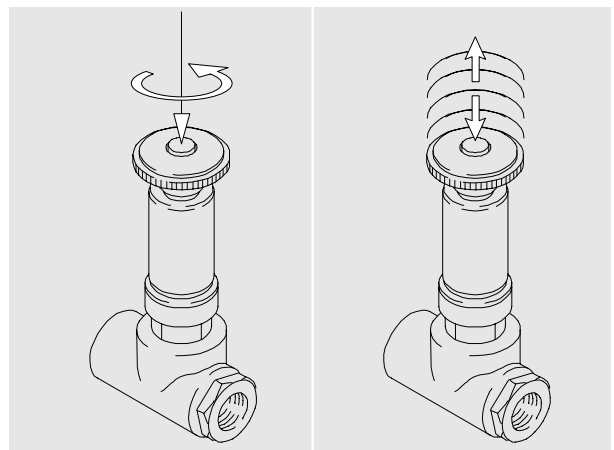

Parallel fuel filter

(Single and parallel box-type filter)

Changing fuel filter

Only when engine is switched off

- Loosen filter with tape wrench and remove it
- Wet seal on new filter with fuel
- Screw on filter by hand
- After this, bleed the fuel system
- Check filter for leaks

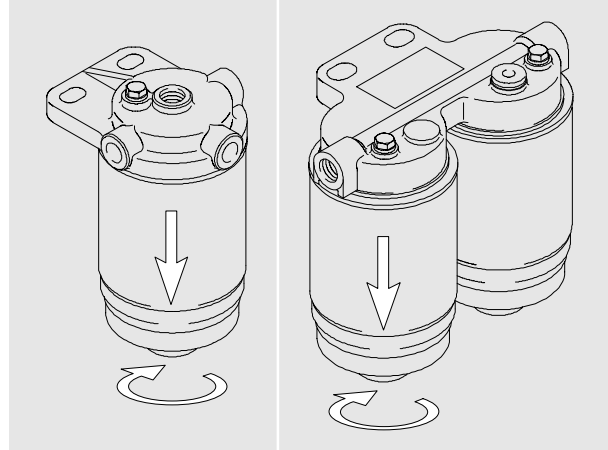

Caution:

Used fuel filters are classed as dangerous waste and must be disposed of accordingly.

Change-over fuel filter

Where the changeover-type filter is installed, the servicing procedure is for the filter side requiring to be shut off with the engine running. During continuous operation, the selector lever should be placed in a position where both filter halves are in operation.



Caution:

Do not leave selector lever in any intermediate position because this would be liable to interfere with fuel supply. If in doubt stop the engine to change the fuel filter.

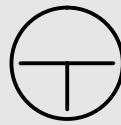

Continuous operation
(both filter halves
in operation)



Right-hand filter
cut out



Left-hand filter
cut out

Changing fuel filter

- Loosen filter with tape wrench and remove it
- Wet seal on new filter with fuel
- Screw on filter by hand
- After this, bleed the fuel system
- Check filter for leaks



Caution:

Used fuel filters are classed as dangerous waste and must be disposed of accordingly.

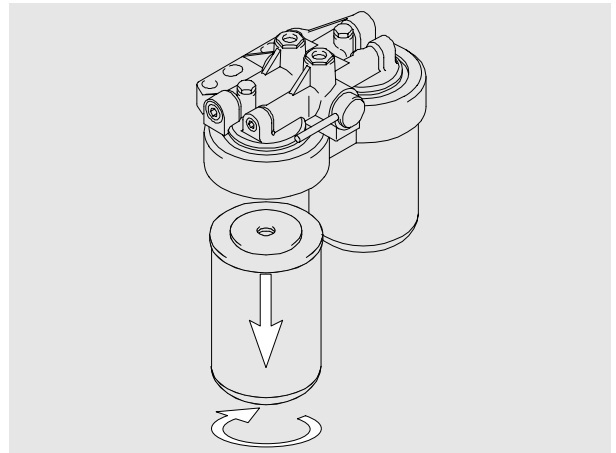

Bleeding the fuel system



Note:

To bleed the fuel system switch on the “ignition” so that the EHAB will be open.
The single box-type filter has only one bleed screw.

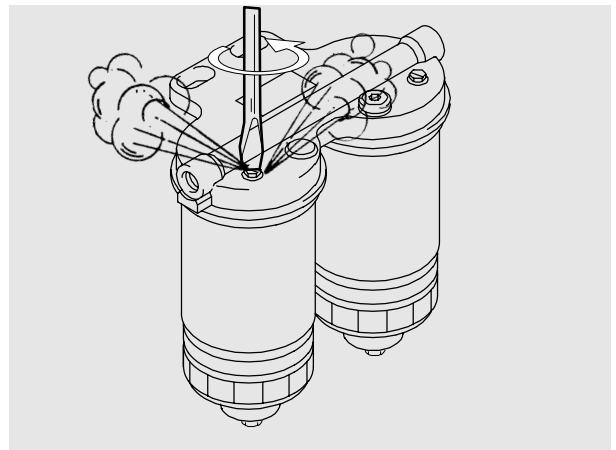

An arrow on the filter head indicates the direction of fuel flow.

- Unscrew bleed screw of first filter in direction of flow by one or two turns
- Actuate tappet of hand primer until fuel emerges without bubbles
- Screw in the tappet of the hand pump again and tighten it
- Close bleed screw again
- Repeat this procedure at the second bleed screw
- Check filter for leaks

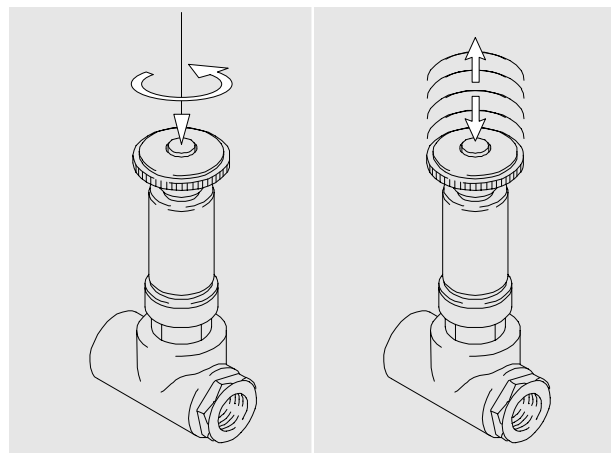

Cooling system

 **Danger:**
Draining hot coolant involves a risk of scalding.

Draining the cooling system

 **Caution:**
Drain coolant into a suitable container and dispose of it in accordance with regulations.

Drain coolant as follows, but only **when the engine has cooled down**:

- Briefly open cap (large cap) on the filler neck of the expansion tank for pressure compensation
- Remove drain plugs from crankcase, and expansion tank
- Then remove cap
- Drain coolant into a container of adequate size
- Refit screw plugs
- Fill / bleed the cooling system

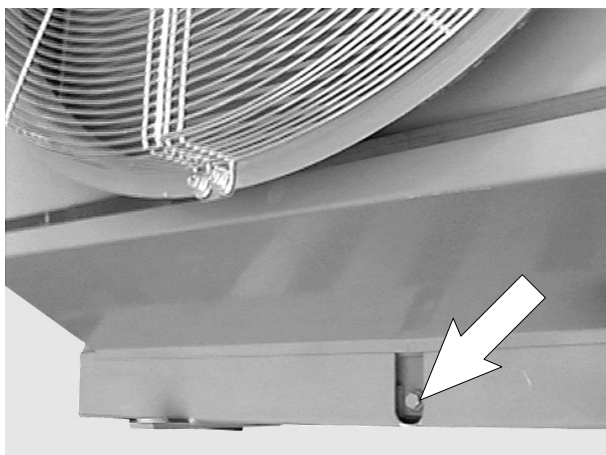
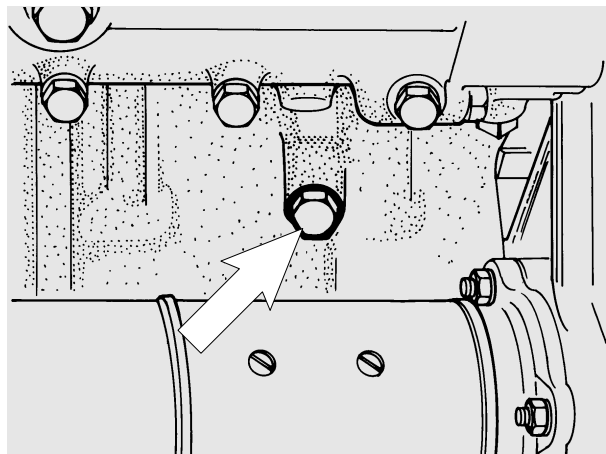
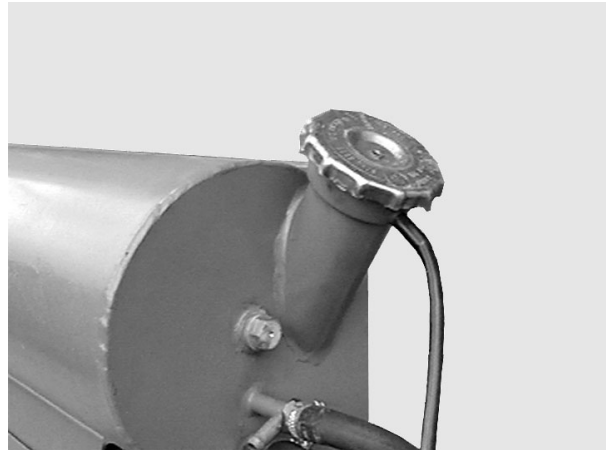

Fill / bleed the cooling system (only when engine has cooled down)

Fill the cooling system of the engine with a mixture of drinkable tap water and anti-freeze agent on ethylene glycole basis or anti-corrosion agent.

See Publication “Fuels, Lubricants and Coolants for MAN Diesel Engines”.

Coolant must be added at the filler neck only.

Do not put cold coolant into an engine which is warm from operation.

Ensure that the ratio of water to anti-freeze is correct.

- Remove cap
- Fill in the coolant slowly
- Refit end cover
- Run the engine briefly and then check coolant level once more



Danger:

If, in an **exceptional** case, the coolant level has to be checked in an engine that has reached operating temperature, first carefully turn the cap with safety valve to the first stop, let off pressure, then open carefully.

Air filter

Fitted: Duralite air filter



Note:

Do not service or wash out the filter.

The filter must be changed after every 200 hours of operation.

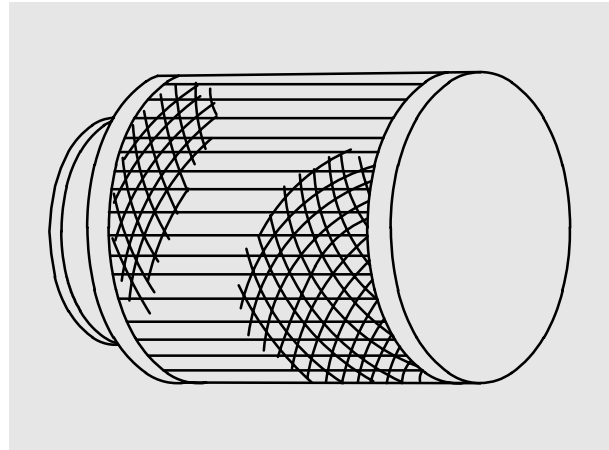

Fitted: Piclon air filter

- ① Connection for contamination gauge
- ② Filter housing
- ③ Retainer
- ④ Filter cartridge
- ⑤ Hex nut
- ⑥ Lid
- ⑦ Dust collector

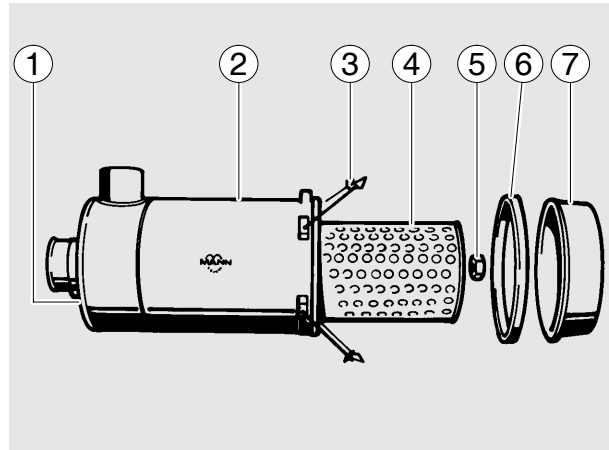

Service only when engine is switched off.

Dust collector

The dust collector must be emptied at regular intervals. The collector should never be more than half full of dust.

When the two retainers have been folded up the dust collector can be taken off. Remove the lid of the dust collector and empty the collector.

Ensure that the lid and the collector are reassembled correctly. A lug on the collector fits into a recess in the edge of the lid. If the filter is installed horizontally note the “oben” (“top”) marking on the filter bowl.



Contamination gauge

- ① Red display cylinder
- ② Return knob

In the window a red field appears which grows in size as the contamination increases.

If the red field is fully visible in the window, the air filter is contaminated and must be cleaned or changed.

When the filter has been changed pull the return knob. The red field then disappears.

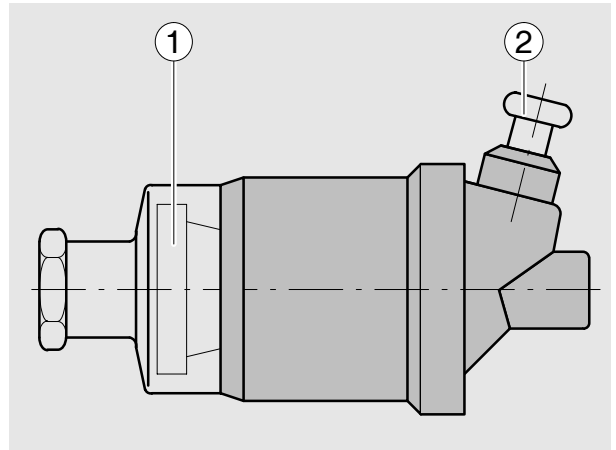

Display: filter service is due

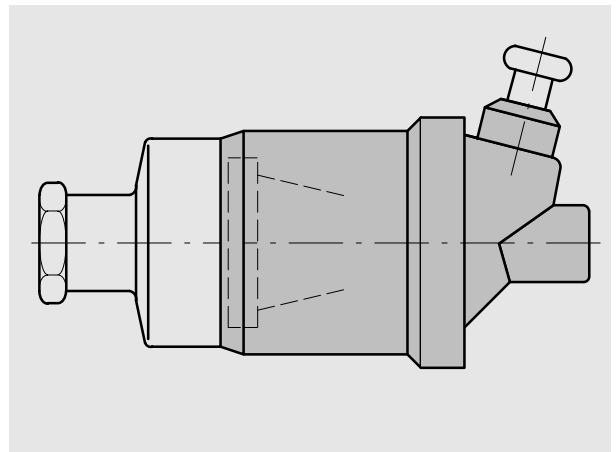

Display: filter is ready for operation

Changing the filter cartridge



Caution:

No dust must get to the clear air end.

Remove the hex nut, take out the contaminated cartridge and fit a new one.

Clean the filter housing with a damp cloth, especially at the sealing face for the cartridge.

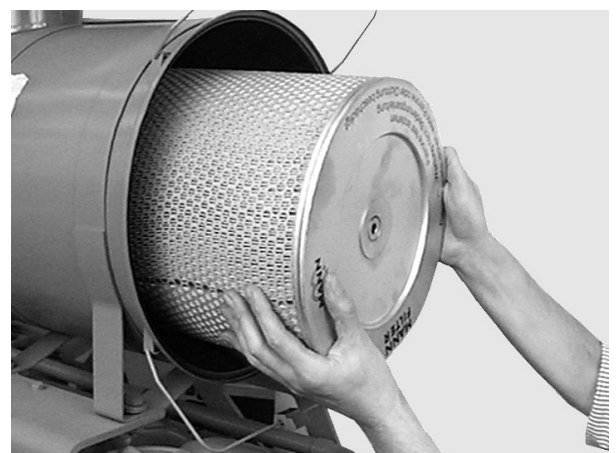

Caution:

The engine must not be run without a main cartridge.

Cleaning the cartridge

**Caution:**

The filter cartridge should normally be changed. Clean it only in emergencies (e.g. when no replacement is available).

Blowing out (wear goggles)

To do this fit a pipe to the compressed air gun. The end of the pipe should be bent by approx. 90°. The pipe must be long enough to reach the bottom of the cartridge.

Blow the cartridge out from the inside with dry compressed air (max. 5 bar) by moving the pipe up and down inside the cartridge until no more dust is released.

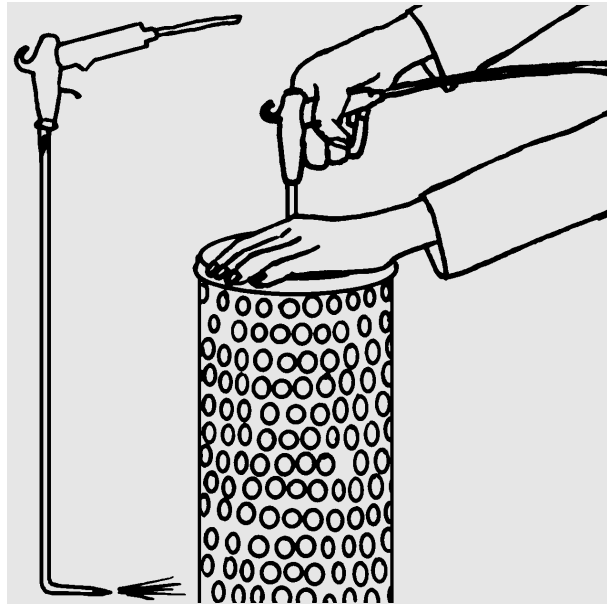

Checking the cartridge

When a cartridge has been cleaned it must be examined for damage before it is refitted, e.g. damage to the paper bag and rubber seals. Check also for compression of or dents in the metal jacket.

Tears and holes in the paper bag can be found by shining a torch into the bag.

On no account re-use damaged cartridges. If in doubt fit a new cartridge.

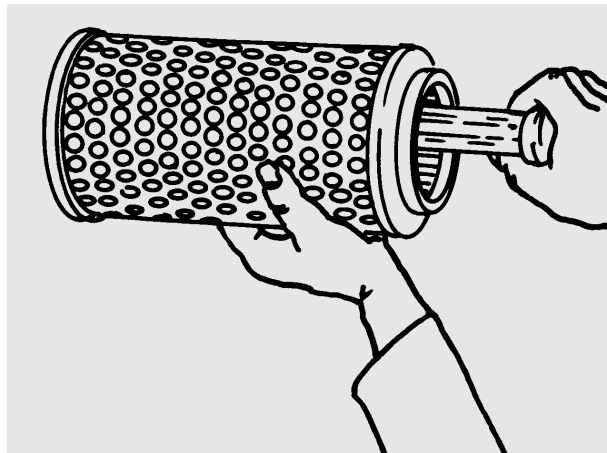

Safety cartridge

When the main cartridge is being serviced the safety cartridge remains in the filter housing. The engine must not be run without the main cartridge.

Safety cartridges must be neither cleaned nor re-used.

Safety cartridges must be changed:

- at the latest after being in use for two years
- if, after the main cartridge has been serviced (changed), the contamination gauge responds again immediately
- if the main cartridge is defective

When the main cartridge has been removed the safety cartridge is accessible and can be removed also.

Remove the hex nut.

Pull out the safety cartridge.

Insert a new safety cartridge. Refit and tighten the hex nut.



Checking V-belts

Checking condition

- Check V-belts for cracks, oil, overheating and wear
- Change damaged V-belts

Checking tension

Use V-belt tension tester to check V-belt tension.

- Lower indicator arm ① into the scale
- Apply tester to belt at a point midway between two pulleys so that edge of contact surface ② is flush with the V-belt
- Slowly depress pad ③ until the spring can be heard to disengage. This will cause the indicator to move upwards

If pressure is maintained after the spring has disengaged a false reading will be obtained!

Reading of tension

- Read of the tensioning force of the belt at the point where the top surface of the indicator arm ① intersects with the scale
- Before taking readings make ensure that the indicator arm remains in its position

If the value measured deviates from the setting value specified, the V-belt tension must be corrected.

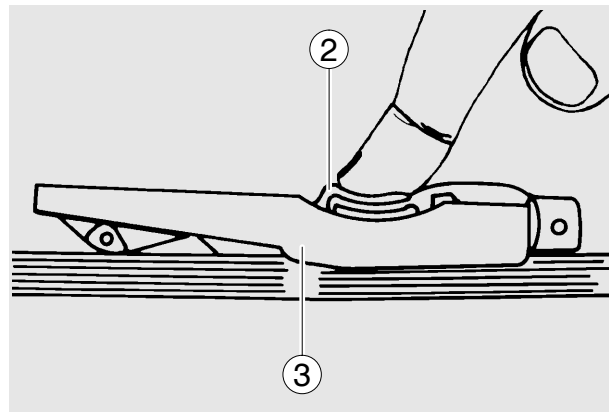
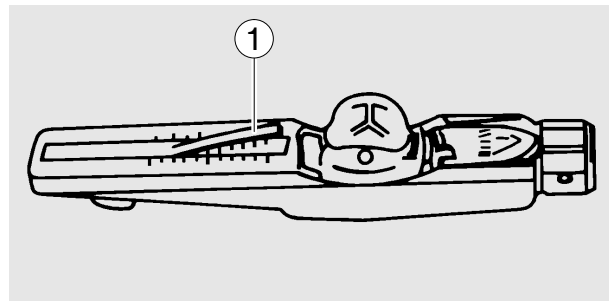
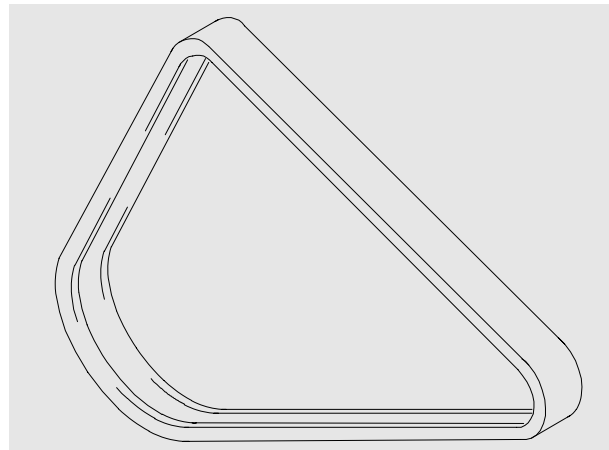

Drive belt width	Tensioning forces according to the kg graduation on the tester		
	New installation		When servicing after long running time
	Installation	After 10 min. running time	
2/3VX	90–100	70–80	60

Tensioning and changing V-belt

Water pump – Alternator

- Remove fixing bolts ①
- Remove lock-nut ②
- Adjust nut ③ until V-belts have correct tensions
- Retighten lock-nut and fixing bolts

To replace the V-belts loosen lock-nut and swing alternator inwards.

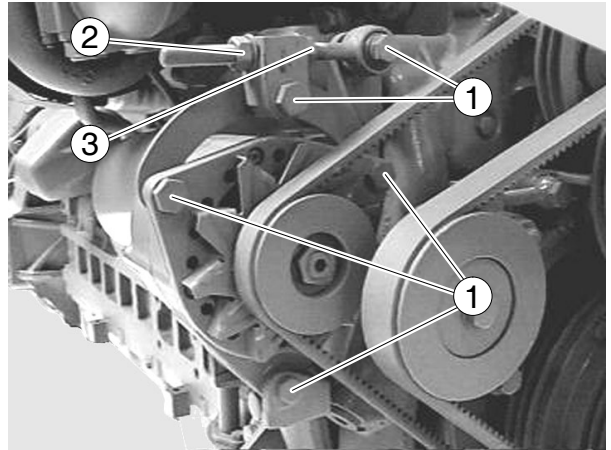

Fan – Tensioning pulley

- Remove fixing bolts ①
- Remove lock-nut ②
- Adjust nut ③ until V-belts have correct tensions
- Retighten lock-nut and fixing bolts

To change the V-belts turn the adjusting nut back and swing the tension pulley inwards.

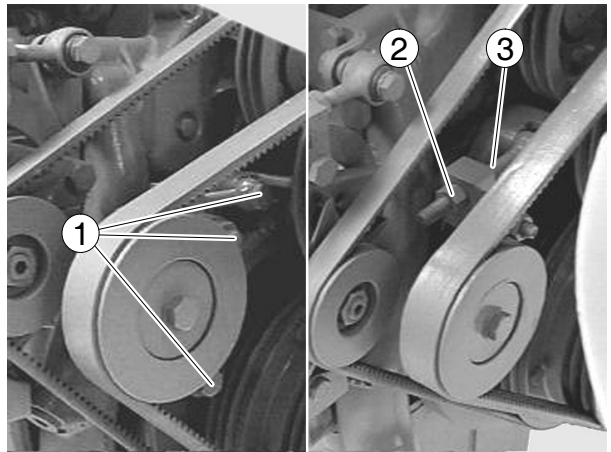

Turbocharger

At every engine oil change check the oil pipes for leaks and constrictions.

Furthermore, a regular check should be kept on charge air and exhaust gas pipes. Any leakages should be attended to at once because they are liable to cause overheating of the engine.

Intercooler

If the coolant output is to be retained as far as possible, the intercooler must be cleaned at certain intervals.

Starter motor

Check that the electric cables are properly fastened and that contacts and plug connections are secure.

In engines fitted with electronic speed pickups at the gear ring (eg electronic speed governor and EDC), the speed pickup are to be cleaned too and metal chips that may adhere are to be removed.

**Caution:**

Always disconnect the battery earth cable before starting work on the electrical system. Connect up the earth cable last, as there is otherwise a risk of short-circuits.

Alternator

The alternator is maintenance-free.

Nevertheless, it must be protected against dust and, above all, against moisture.

In order to avoid damage to the alternator, observe the following instructions:

While the engine is running

- Do not de-energize the main battery switch!
- Do not disconnect the battery or pole terminals or the cables!
- If, during operation, the battery charge lamp suddenly lights up, stop the engine immediately and remedy the fault in the electrical system!
- Do not run the engine unless the battery charge control is in satisfactory order!
- Do not short-circuit the connections of the alternator with those of the regulator or said connections with ground, not even by briefly bringing the connections into contact!
- Do not operate the alternator without battery connection!

Temporary decommissioning of engines

Temporary anti-corrosion protection according to MAN works norm M 3069 is required for engines which are to be put out of service for fairly long periods.

The works norm can be obtained from our After-Sales Service department, Nuremberg works.



Technical data

Model	D 2866 LE 201 / 202 / 203 / 211
Design	in-line vertical
Cycle	4-stroke Diesel with turbocharger and intercooler
Combustion system	Direct injection
Turbocharging	Turbocharger with intercooler
Number of cylinders	6
Bore	128 mm
Stroke	155 mm
Swept volume	11 967 cm ³
Compression ratio	15.5 : 1
Rating	see engine nameplate
Firing order	1-5-3-6-2-4
Valve clearance (cold engine)	
Intake	0.50 mm
Exhaust	0.50 mm
Valve timing	
Intake opens	23° before TDC
Intake closes	12° after BDC
Exhaust opens	60° before BDC
Exhaust closes	30° after TDC
Fuel system	
Injection	In-line pump, with flange fastening
Governor	Electronic speed governor (GAC)
Injectors	six-hole nozzles
Opening pressure of injector	
New nozzle holder:	340+10 bar
Used nozzle holder:	320+10 bar

Start of delivery $\pm 1^\circ$ crank angle before TDC (Speed constant = without timing adjustment)		
	with optimised consumption	with optimised NO _x
D 2866 LE 201		
1500 1/min, constant	16°	8°
1800 1/min, constant	16°	12°
D 2866 LE 202		
1500 1/min, constant	16°	8°
1800 1/min, constant	16°	10°
D 2866 LE 203		
1500 1/min, constant	16°	11°
1800 1/min, constant	17°	14°
D 2866 LE 211		
1500 1/min, constant	16°	9°
1800 1/min, constant	16°	12°
Engine lubrication	Force feed	
Oil capacity in oil sump (litres)	min.	max.
deep	24 l	30 l
deep, on-board unit	14 l	18 l
shallow	16 l	20 l
Oil change quantity (with filter)		
deep	33 l	
deep, on-board unit	21 l	
shallow	23 l	
Oil pressure during operation (depending on oil temperature, oil viscosity class and engine rpm)	must be monitored by oil pressure monitors / gauges	
Oil filter	Full-flow filter with paper filter elements	
Engine cooling system	Liquid cooling	
Coolant temperature	80–90°C, temporarily 95°C allowed	
Electrical equipment		
Starter	24 V; 5.4 kW	
Alternator	28 V; 35 or 55 A	



Troubleshooting table

Fault										
Engine does not start, or starts only with difficulty										
Engine starts but does not reach full speed or stalls										
Engine idles out of true when warm, misfiring										
Engine speed fluctuates during operation										
Power output unsatisfactory										
Coolant temperature too high, coolant being lost										
Lube oil pressure too low										
Lube oil pressure too high										
Black smoke accompanied by loss of power										
Blue smoke										
White smoke										
Knocking in the engine										
Engine "too loud"										
Reason										
•										Fuel tank empty
•										Fuel cock closed
•	•	•	•					•		Air in fuel system
•	•	•	•					•		Fuel pre-filter / pre-cleaner clogged
•										Condensation in fuel
•	•		•				•			Air filter clogged
•										Electric circuit interrupted
•										Batteries flat
•										Starter / solenoid switch defective
•	•						•	•	•	Start of delivery not correct / incorrectly set
•										Injection nozzles clogged
•										Internal damage to engine (piston seized, possibly caused by water in fuel)
	•		•					•		Fuel quality not in accordance with specifications or fueled severely contaminated
		•								Lower idling speed set too low
•	•							•	•	Valve clearance incorrect
		•								Injection nozzles of injection pipes leaking
			•							Too little fuel in tank
			•							Rev. counter defective
			•				•	•		Injection nozzles defective or carbonized
				•						Engine being asked to do more than it has to
				•						Fuel supply faulty, fuel too warm
							•			Oil level in sump too high
				•						Incorrect rated speed setting
					•					Coolant level too low
					•					Air in coolant circuit

Troubleshooting table



Fault										
Engine does not start, or starts only with difficulty										
Engine starts but does not reach full speed or stalls										
Engine idles out of true when warm, misfiring										
Engine speed fluctuates during operation										
Power output unsatisfactory										
Coolant temperature too high, coolant being lost										
Lube oil pressure too low										
Lube oil pressure too high										
Black smoke accompanied by loss of power										
Blue smoke										
White smoke										
Knocking in the engine										
Engine "too loud"										
Reason										
									●	Radiator very dirty
									●	Tension of water-pump V-belts incorrect (slip)
									●	Cap with working valves on expansion tank / radiator defective or leaking
									●	Temperature gauge defective
									●	Coolant pipes leaking, blocked or twisted
									●	Oil level in sump too low
									●	Engine temperature too high
									●	Oil filter clogged
									● ●	Oil pressure gauge defective
									● ●	Selected oil viscosity not suitable for ambient temperature (oil too thin)
									●	Oil in sump too thin (mixed with condensation or fuel)
									●	Engine cold
									● ●	Engine, coolant or intake air still too cold
									●	Lube oil getting into combustion chamber (piston worn, piston rings worn or broken)
									●	Overpressure in crankcase (crankcase breather clogged)
									●	long operation under a low load
									●	Coolant getting into combustion chamber (cylinder head / gasket leaking)
									●	Engine operating temperature incorrect
									●	Intake or exhaust pipe leaking

A		
Air filter	28–31	
Alternator	35	
B		
Bleeding the fuel system	25	
C		
Changing oil filter	21	
Checking oil level	17	
Checking V-belts	32–33	
Cleaning fuel pre-cleaner	23	
Commissioning	17	
Commissioning and operation	14–19	
Cooling system	26–27	
D		
Declaration	8	
Draining the cooling system	26	
E		
Engine oil change	20	
Engine views	14	
F		
Fill / bleed the cooling system	27	
Filling with engine oil	16	
Filling with fuel	16	
Filling-in of coolant	16	
First commissioning	16	
Fuel filters	24	
Changing fuel filter	24, 25	
Fuel system	23–25	
I		
Injection pump	23	
Instructions	6	
Intercooler	34	
L		
Lubrication system	20–22	
M		
Maintenance and care	20–35	
N		
Nameplates	9	
O		
Operation monitoring system	19	
R		
Refilling with oil	21	
S		
Safety regulations	10–13	
Handling used engine oil	13	
Preventing accidents with injury to persons	10	
Preventing damage to engine and premature wear	11	
Preventing environmental damage	12	
Shutting down	19	
Starter motor	34	
Starting	18–19	
T		
Technical data	36–37	
Temporary decommissioning	35	
Troubleshooting table	38–39	
Turbocharger	34	



MAN Nutzfahrzeuge AG
Geschäftseinheit Motoren
Vogelweiherstraße 33
D-90441 Nürnberg

Ein Unternehmen der MAN Gruppe

Printed in Germany

51.99493-8471