

ENGINE HARNESS WIRING DIAGRAM

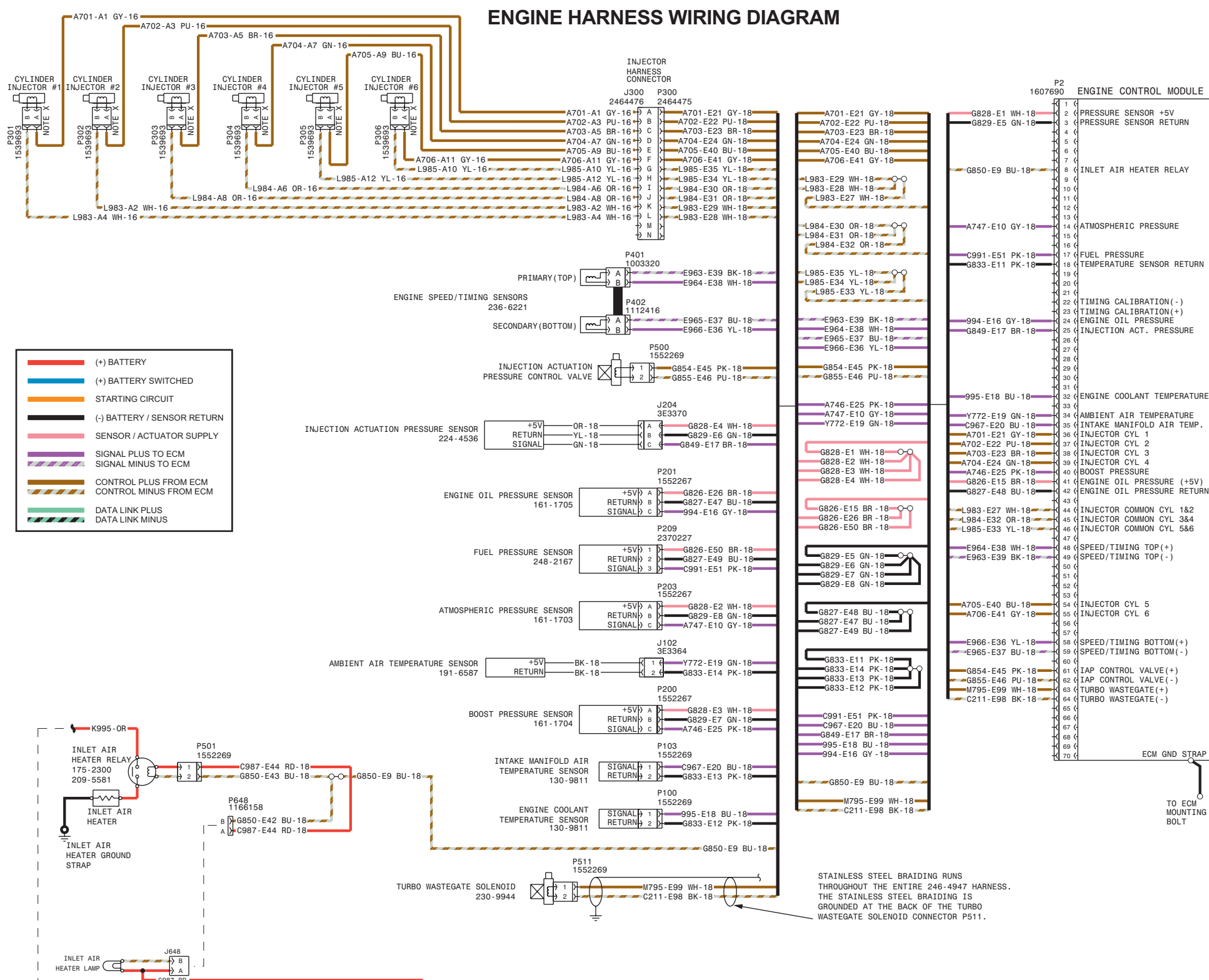

TYPICAL VEHICLE HARNESS WIRING DIAGRAM

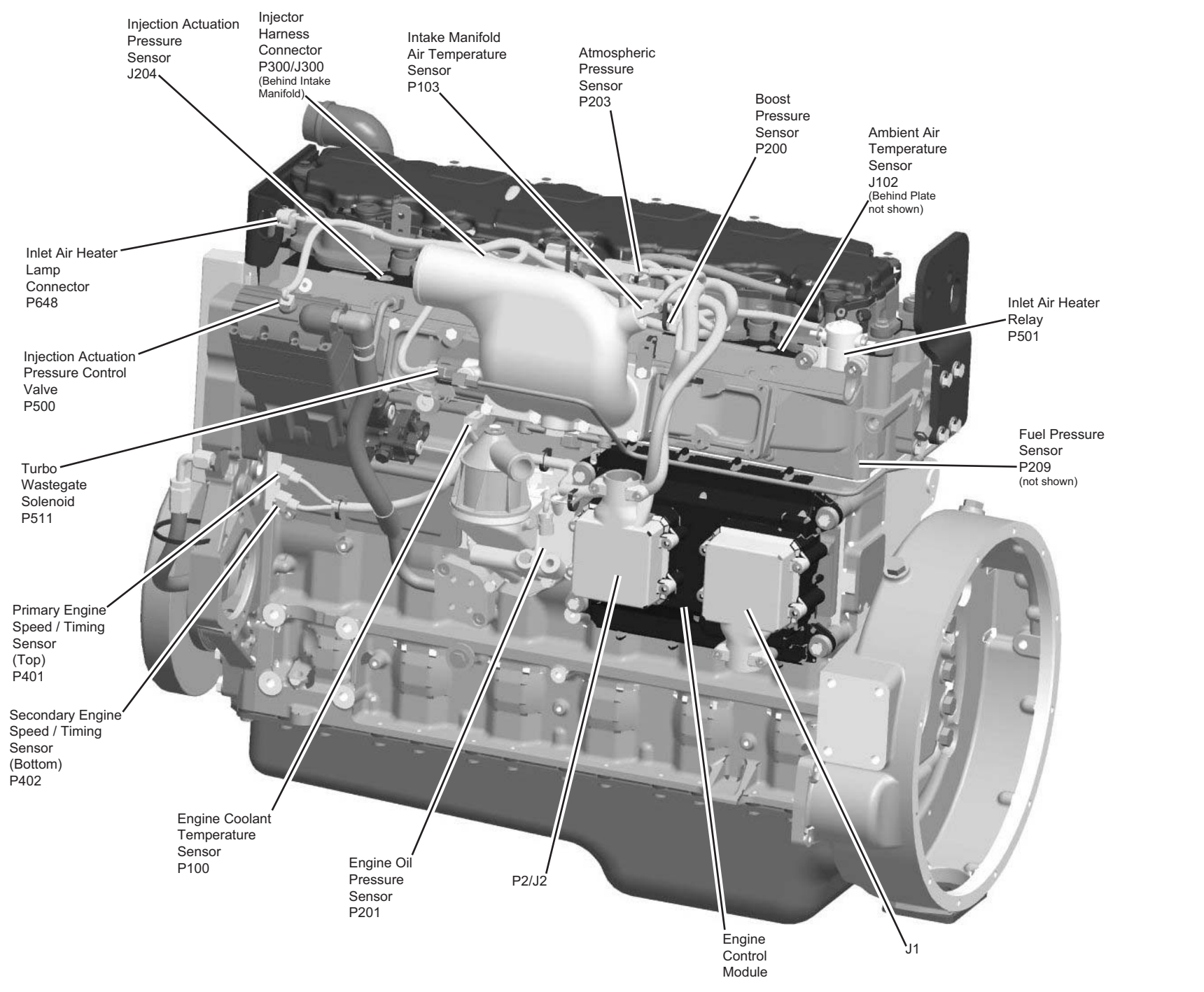
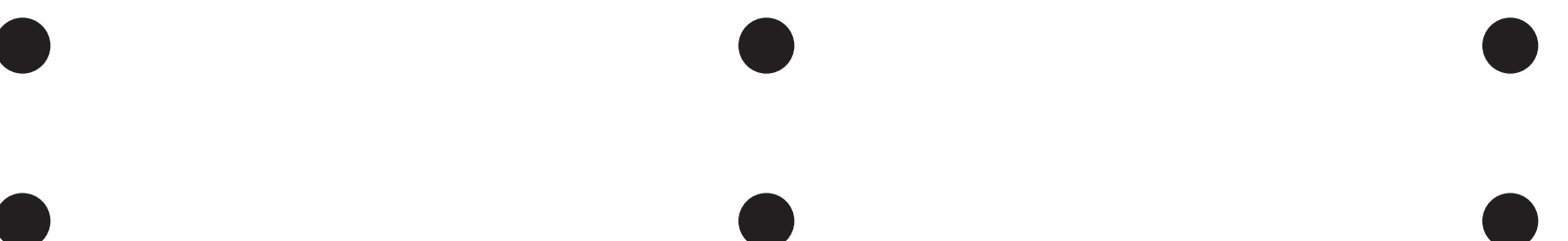
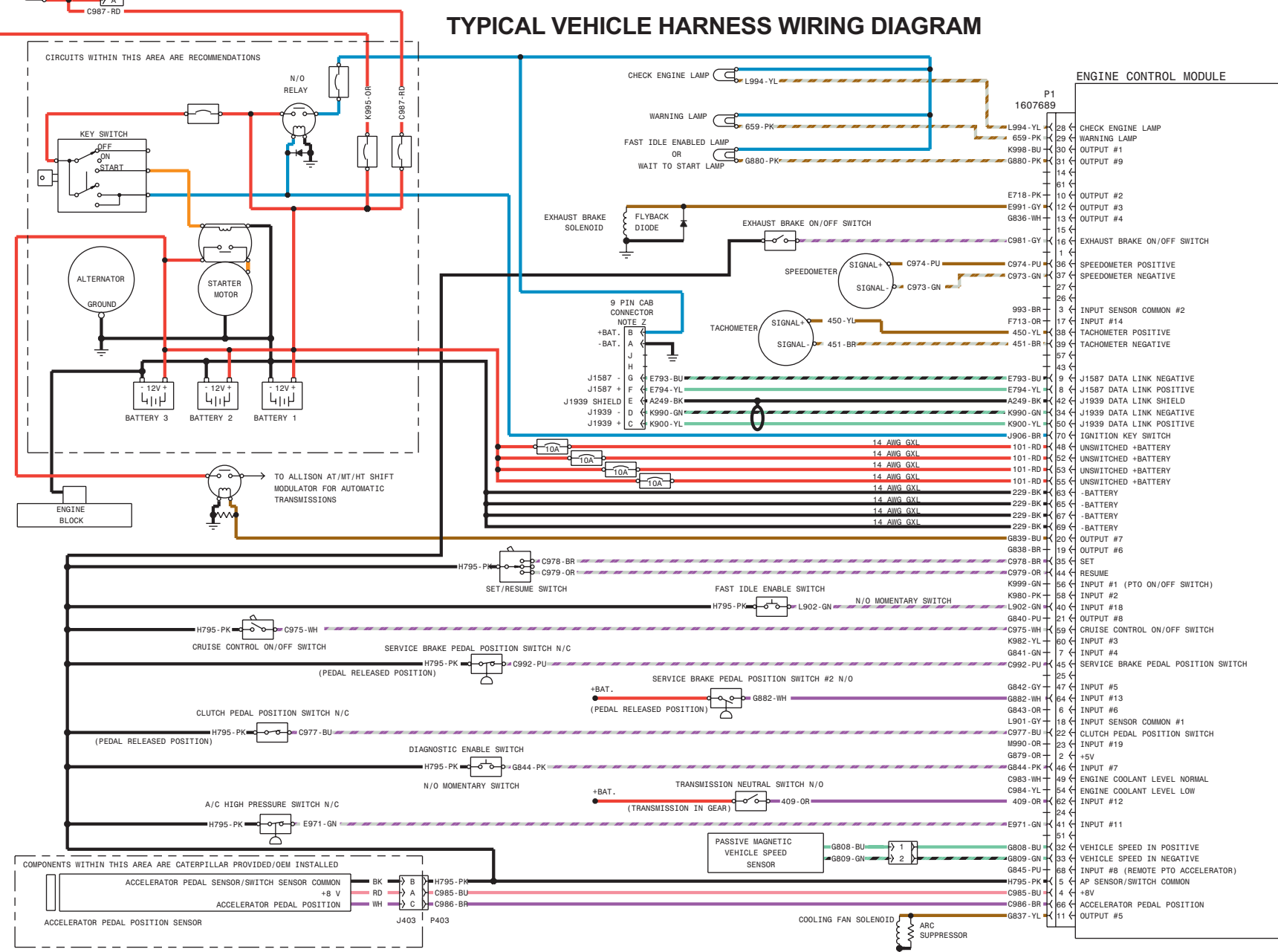

Connector and Splice Locations for Harness 246-4947

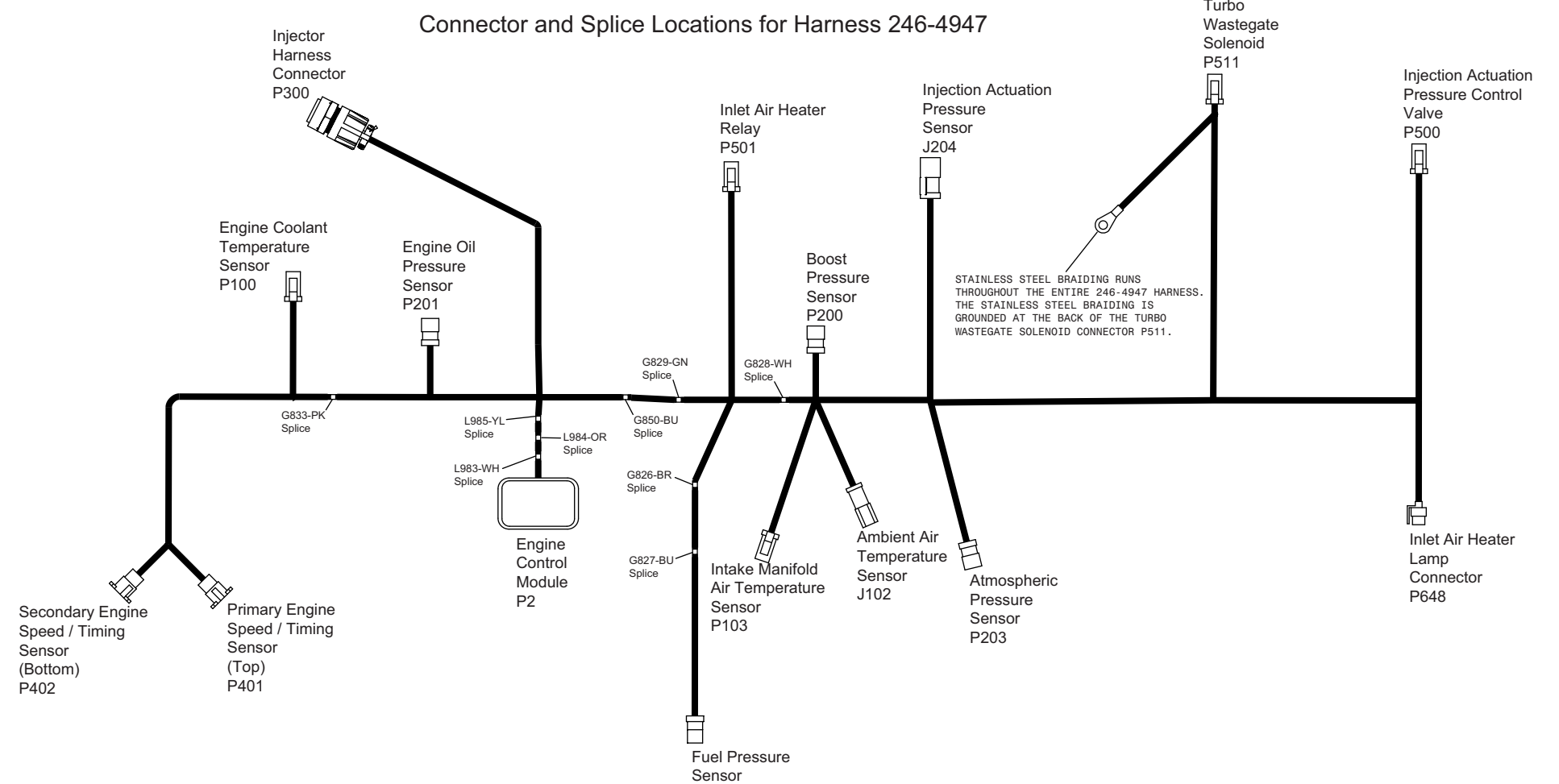

THIS SCHEMATIC IS FOR THE C7 TRUCK ENGINE (S/N: FML & FMM)

IDENT	HARNESS	CHG
E	246-4947	04 (J2 / ENGINE)
A	246-4948	01 (INJECTOR)

NOTE X: USE KIT 156-7106 WHEN REPLACING CONNECTOR 153-9693. REFER TO REHS1809 FOR REPAIR AND INSTALLATION DETAILS.
 NOTE Z: THE CONNECTOR ON THIS SCHEMATIC IS BLACK AND CONNECTS DIRECTLY TO SERVICE TOOL CABLE 157-4829. THE DIAGNOSTIC CONNECTOR NOT SHOWN HAS -BATTERY ON PIN (A) AND -BATTERY ON PIN (B). THIS CONNECTOR IS GRAY AND CONNECTS TO SERVICE TOOL CABLE 159-4166.

Related Electrical Service Manuals

Title	Form Number
Electrical Troubleshooting Guide	SEN9808
Systems Operation / Testing and Adjusting	SEN9812