

SECTION 5 STEERING SYSTEM

Group 1	Structure and Function	5-1
Group 2	Operational Checks and Troubleshooting	5-17
Group 3	Tests and Adjustments	5-25
Group 4	Disassembly and Assembly	5-33

SECTION 5 STEERING SYSTEM

GROUP 1 STRUCTURE AND FUNCTION

1. OUTLINE

The steering system of this machine consists of a variable displacement piston pump supplying a load sensing steering system and a closed center loader system.

This system offers faster response from the priority valve of flow amplifier and the pump. Also it offers advantages in connection with cold start up and improvements in system stability.

The components of the steering system are :

- Steering pump
- Flow amplifier
- Steering unit
- Steering cylinders

The flow amplifier contains a directional valve, an amplification stage, a priority valve, a pilot pressure relief valve and shock and suction valve.

The steering pump draws hydraulic oil from the hydraulic tank.

Outlet flow from the pump flows to the priority valve of flow amplifier. The priority valve of flow amplifier preferentially supplies flow, on demand, to the steering unit. When the machine is steered, the steering unit routes flow to the steering cylinders to articulate the machine.

When the machine is not being steered, or if pump flow is greater than steering flow, the priority valve supplies flow to the loader system.

That is, output flow from the steering pump enters into the main control valve for the operation of the attachment.

2. HYDRAULIC CIRCUIT

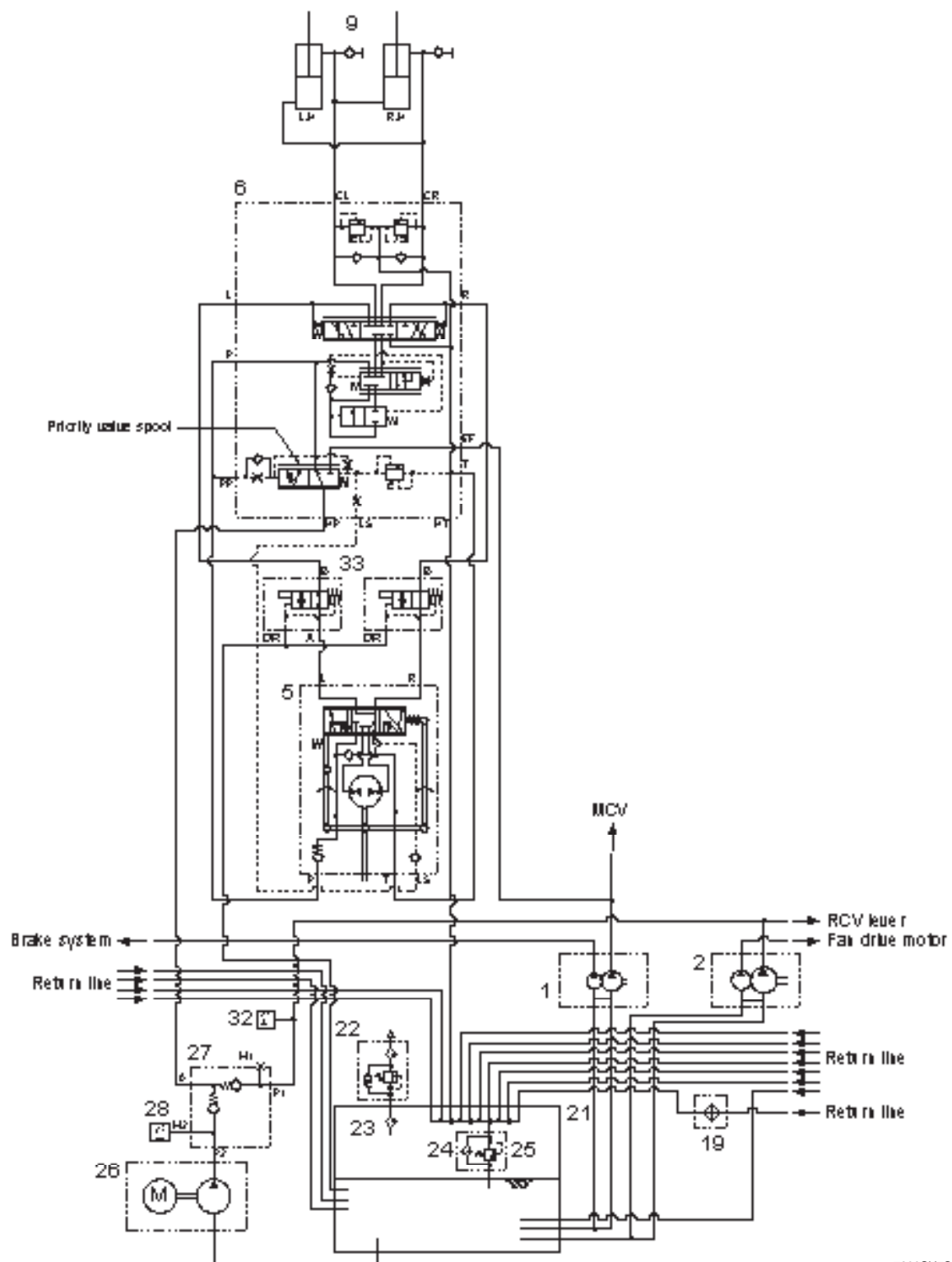

7809SU5SE01

- | | | | | | |
|---|---------------------|----|----------------|----|----------------------------|
| 2 | Steering & fan pump | 19 | Oil cooler | 25 | Bypass valve |
| 5 | Steering unit | 21 | Hydraulic tank | 26 | Motor pump (option) |
| 6 | Flow amplifier | 22 | Air breather | 27 | Check valve block (option) |
| 9 | Steering cylinder | 23 | Strainer | 28 | Pressure sensor (option) |
| | | 24 | Return filter | 32 | Pressure sensor |

1) NEUTRAL

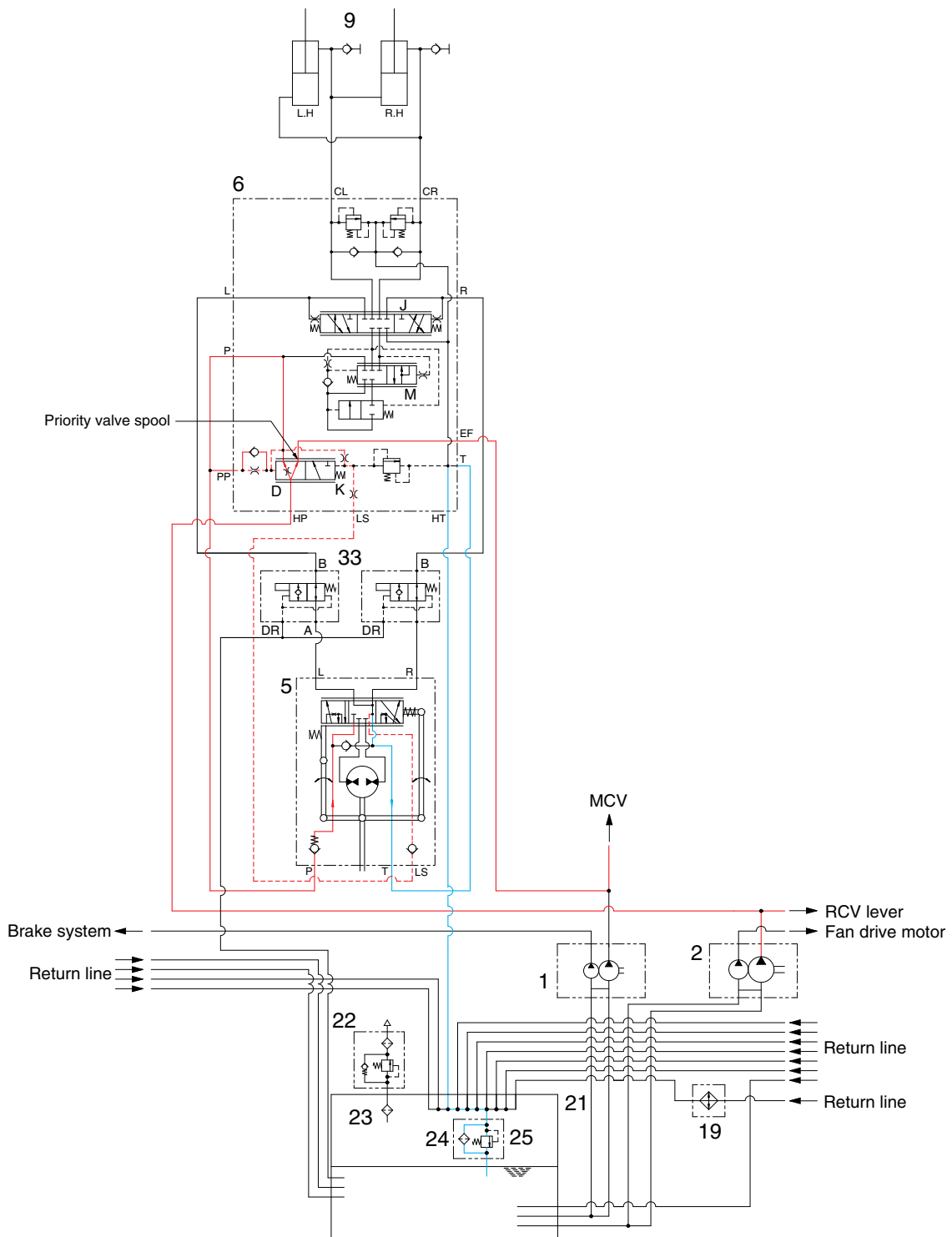

7809SU5SE02

- The steering wheel is not being operated so control spool (G) does not move.
- The oil from the steering pump enters port HP of the priority valve of flow amplifier and the inlet pressure oil moves the spool (D) to the right.
- Almost all of pump flow goes to the loader system (main control valve) through the EF port and partly flows into the hydraulic tank (21) through the control spool (G). This small flow is useful to prevent the thermal shock problem of the steering unit (5).

3) RIGHT TURN

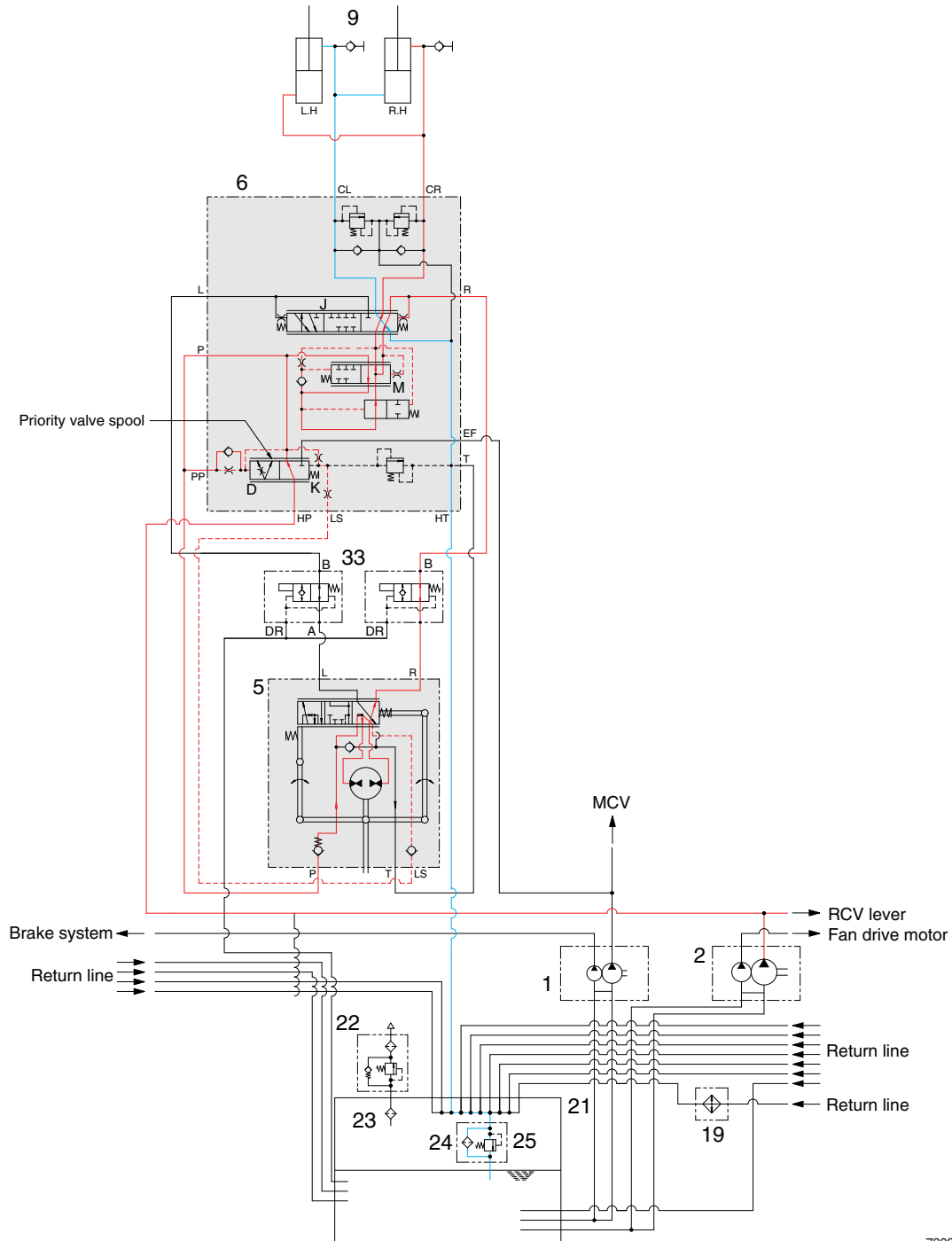

7809SU5SE04

- When the steering wheel is turned to the right, the spool (G) within steering unit (5) connected with steering column shaft is pushed to the right direction.
- The oil discharged from the pump flows into HP port of flow amplifier (6).
- The delivered oil passes through the main orifice of steering unit (5), through the priority valve spool (D) of flow amplifier (6). The position of priority spool (D) is determined when the pressure difference between front and rear of main orifice is balanced with control spring (K) force.
- The oil supplied through the directional spool (J) from the steering unit (5) is combined with the direct oil from the priority valve spool (D) in the amplifier spool (M). The amplified oil flows into the small chamber of the right steering cylinder and large chamber of the left steering cylinder respectively.
- Oil returned from left and right cylinder returns to hydraulic tank through directional spool (J) of flow amplifier (6).
- When the above operation is completed, the machine turns to the right.

3. STEERING PUMP (+FAN PUMP)

1) STRUCTURE (1/2)

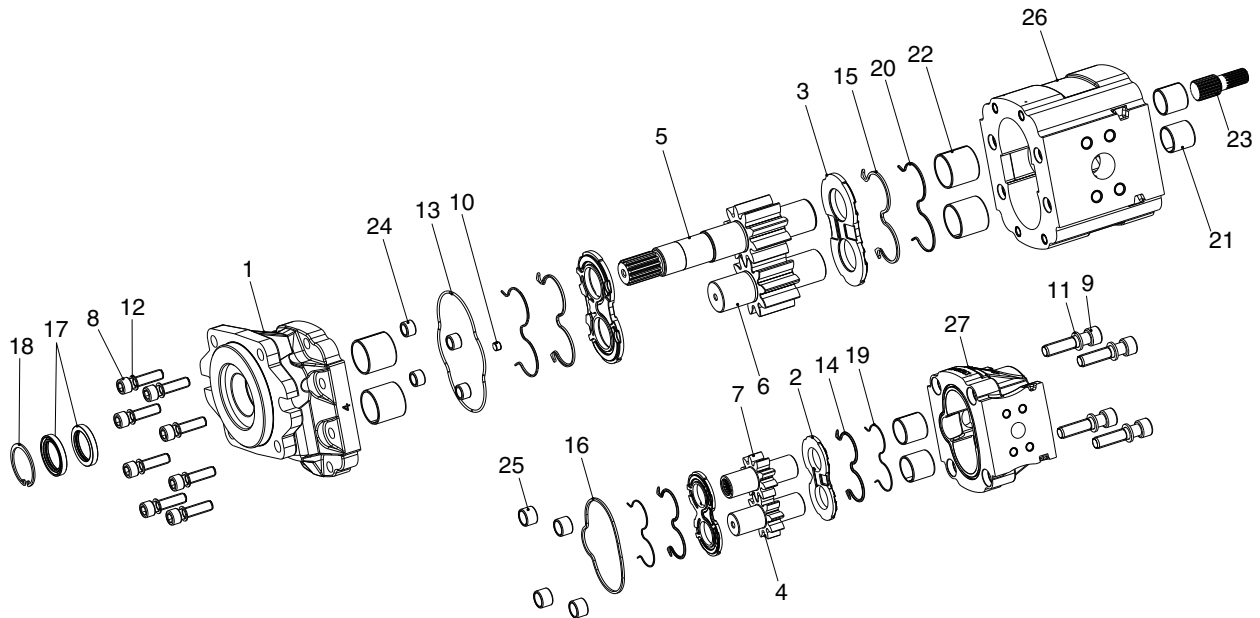

7809SU6WE10

- | | | | | | |
|---|--------------|----|-------------|----|---------------|
| 1 | Front cover | 10 | Screw | 19 | Antiextrusion |
| 2 | Thrust plate | 11 | Washer | 20 | Back up ring |
| 3 | Thrust plate | 12 | Washer | 21 | Bearing |
| 4 | Driven gear | 13 | O-ring seal | 22 | Bearing |
| 5 | Drive shaft | 14 | Seal | 23 | Spline hub |
| 6 | Driven gear | 15 | Seal | 24 | Bushing |
| 7 | Drive shaft | 16 | Seal | 25 | Bushing |
| 8 | Screw | 17 | Shaft seal | 26 | Housing |
| 9 | Screw | 18 | Ring | 27 | Housing |

4. FLOW AMPLIFIER

1) STRUCTURE

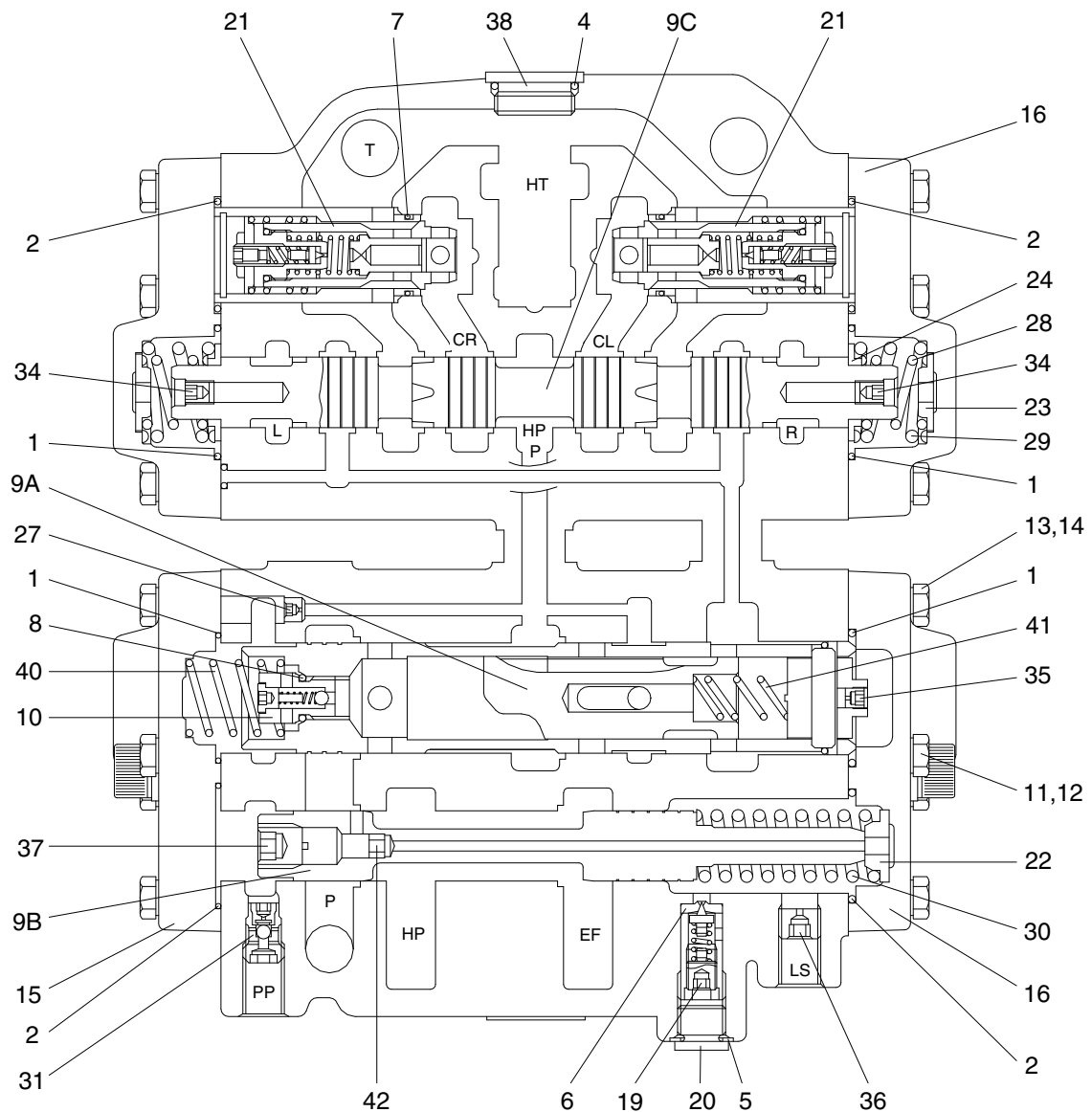

(770-7) 5-6

1	O-ring	12	Spring washer	28	Spring
2	O-ring	13	Screw	29	Spring
4	O-ring	14	Spring washer	30	Spring
5	Washer	15	End cover	31	Throttle check valve
6	Washer	16	End cover	34	Orifice
7	O-ring	19	Relief valve	35	Orifice
8	O-ring	20	Plug	36	Orifice
9A	Amplifier valve	21	Shock, suction valve	37	Plug
9B	Priority valve	22	Spring seat	38	Plug
9C	Directional valve	23	Spring seat	40	Spring
10	Check valve	24	Spring guide	41	Spring
11	Screw	27	Orifice	42	Orifice

2) OPERATION

(1) Introduction

The flow amplifier contain a directional valve, an amplification stage, a priority valve, a pilot pressure relief valve and shock and suction valves.

The flow amplifier amplifies the oil flow from the steering unit cylinder ports L or R by an amplification factor of 8. The amplified oil flow is directed from the flow amplifier ports CL or CR to the steering cylinder. The amplified flow is proportional to the rate of the steering wheel rotation.

If the oil flow from the pump fails, the flow amplifier cuts off the amplification.

(2) Priority valve

The priority valve is used in load sensing systems where the same pump supplies oil to both steering system and working hydraulics.

The steering system always has first priority.

The pressure on the LS connection is almost zero during measuring (steering unit in neutral position).

(3) Shock valves

The shock valves protect the flow amplifier against shock from external forces on the steering cylinders. The shock valves in flow amplifier limit the maximum pressure drop from CL to HT and from CR to HT.

(4) HP-HT ports characteristic

The pilot pressure relief valve protects the steering unit against excess pressure. The pilot pressure relief valve together with the priority valve limit the maximum steering pressure HP-HT.

(5) Neutral

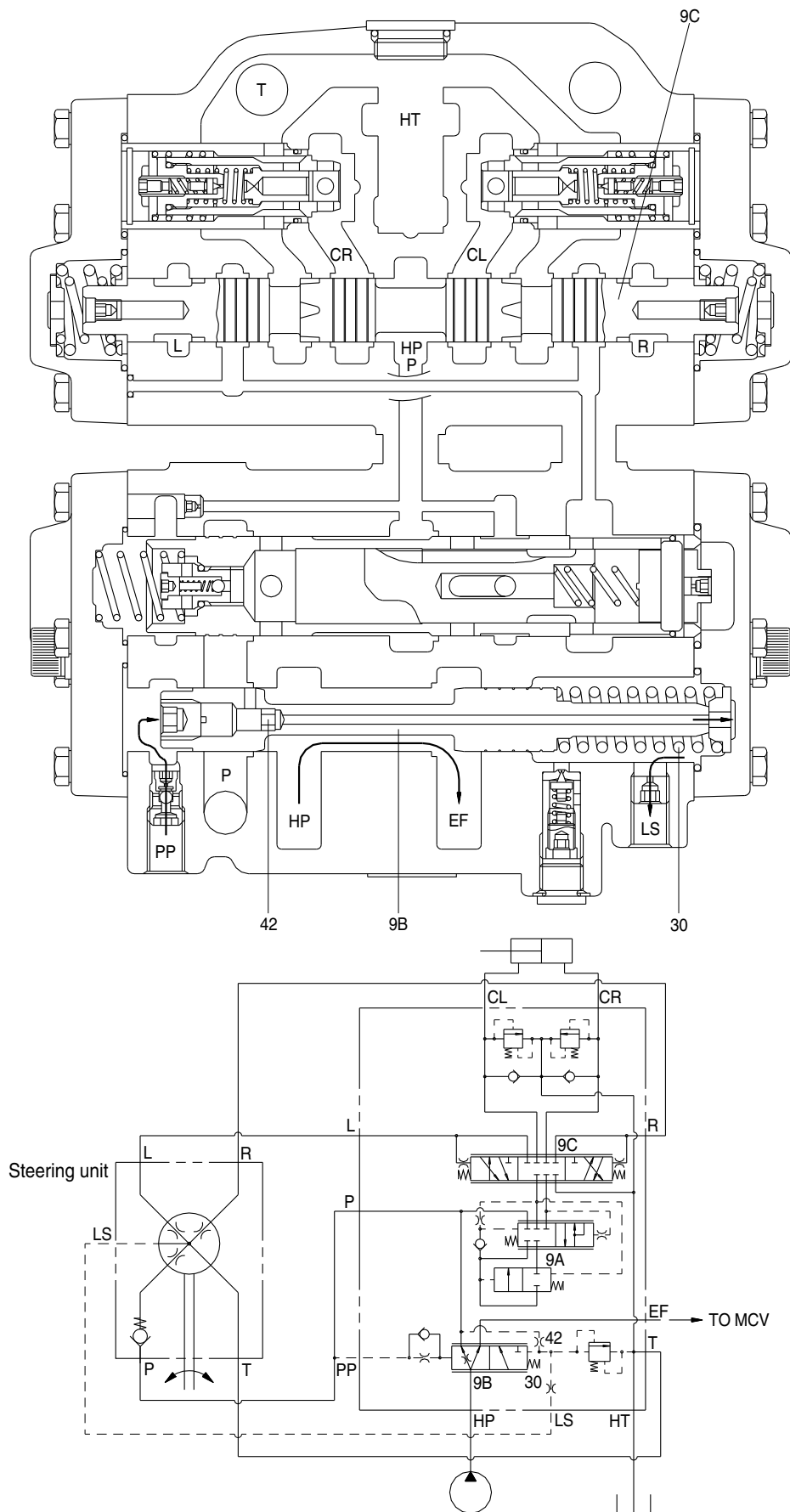

In neutral position, the oil passes from the pump across the integrated priority valve (9B) in the flow amplifier for discharge through the EF port. With the steering unit in neutral, flow through it is blocked and all flow through the priority valve (9B) in flow amplifier is directed out the EF port to the loader control valve.

With the engine off, the priority valve spool (9B) is pushed to the left by the spring (30). The passage to the EF port is blocked while the passage to the P port is open.

When the machine is first started, all pump flow is routed to the steering unit which blocks the flow. With the flow blocked, the pressure increases.

Steering inlet pressure is supplied through the dynamic orifice (42) in the spool. This causes the priority valve spool (9B) to shift to the right against the spring (30) and open the EF port.

As long as the steering unit is in neutral, just enough pressure is maintained at the steering unit to keep the priority valve spool (9B) shifted to the right.

The operating pressure in the loader system has no effect on the operation of the priority valve (9B) of flow amplifier. With the loader actuated in relief, the priority valve (9B) will not shift until the machine is steered.

Flow through the priority valve spool (9B) passes from the P port through the orifice (42) and into the LS port. It flows through the steering unit LS passage which is routed to return when the steering unit is in neutral. This provides a warm-up circuit for the steering unit to prevent binding of the steering unit due to oil temperature extremes.

In neutral position, also the directional valve (9C) is in its center position.

This means that knock and impacts from the cylinder are not transmitted to the steering unit.

The flow amplifier is thus of the non-reaction type.

(6) Mid-turn

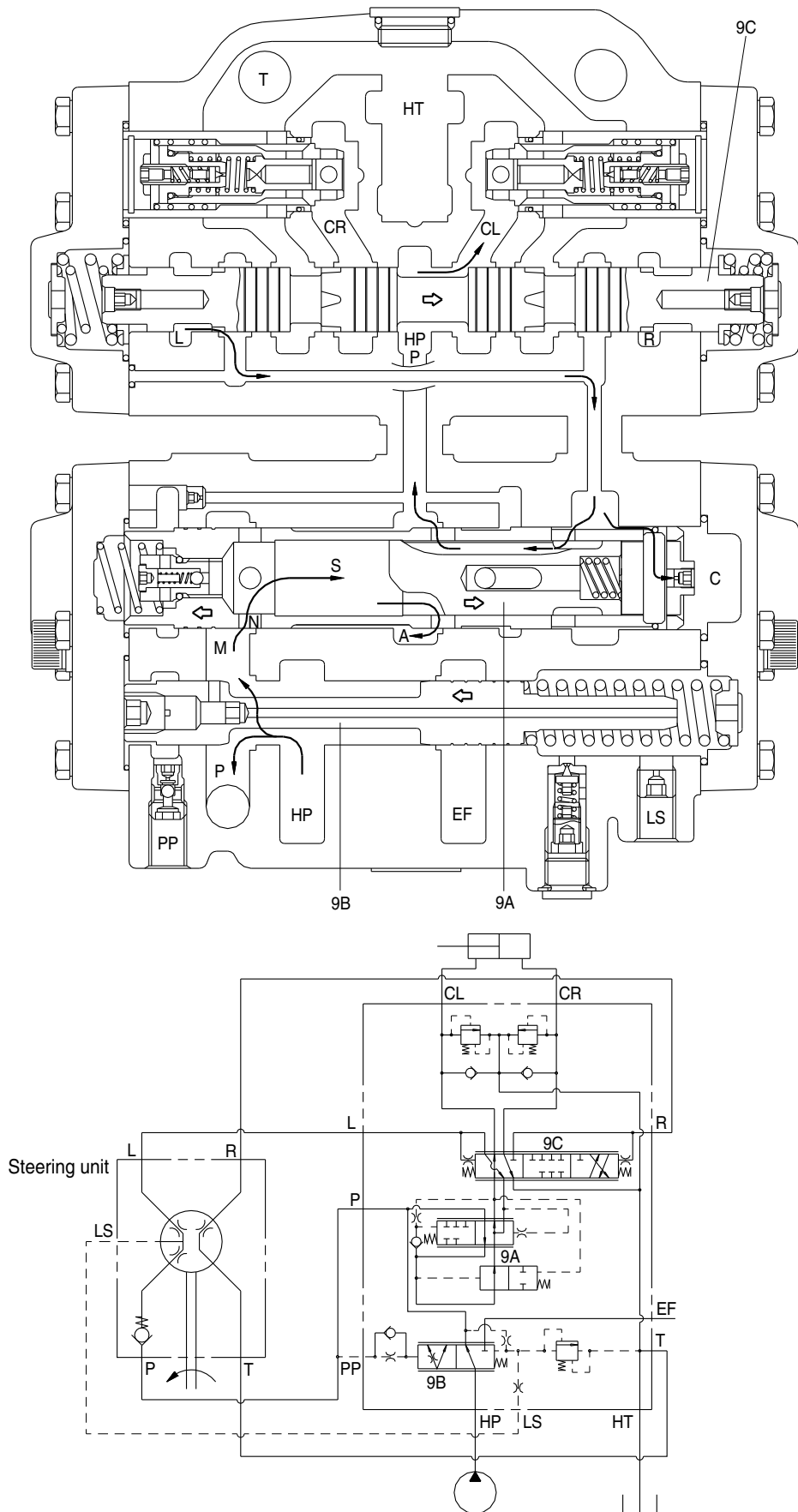

If the steering wheel is turned to the left, a LS signal is passed to the priority valve (9B). The priority valve (9B) is reversed so that more oil is passed across the P port to the steering unit for discharge through the L port of the flow amplifier.

The directional valve (9C) is reversed through the pressure being transmitted across the boring in the spool whereby the spool is moved the right.

The opening shall allow connection between the pilot flow and the pressure control/amplifier valve (9A).

The pilot pressure from the orifice in chamber C moves the valve to the left and passage for the pilot flow therefore is possible out of hole F.

The main flow passes from the priority valve (9B) to the circular channel M. As the amplifier spool is moved to the left, the passage will now be open across the holes N to the chamber S.

The spool goes to a position so that the pressure in chamber S equals the pressure in chamber C.

The passage is now open for the main flow through the priority valve (9B) across the holes A.

The main flow and pilot flow merge and is passed across the directional valve (9C) to the steering cylinder through CL port.

The return oil passes across the directional valve (9C) to the hydraulic tank.

(7) Full turn

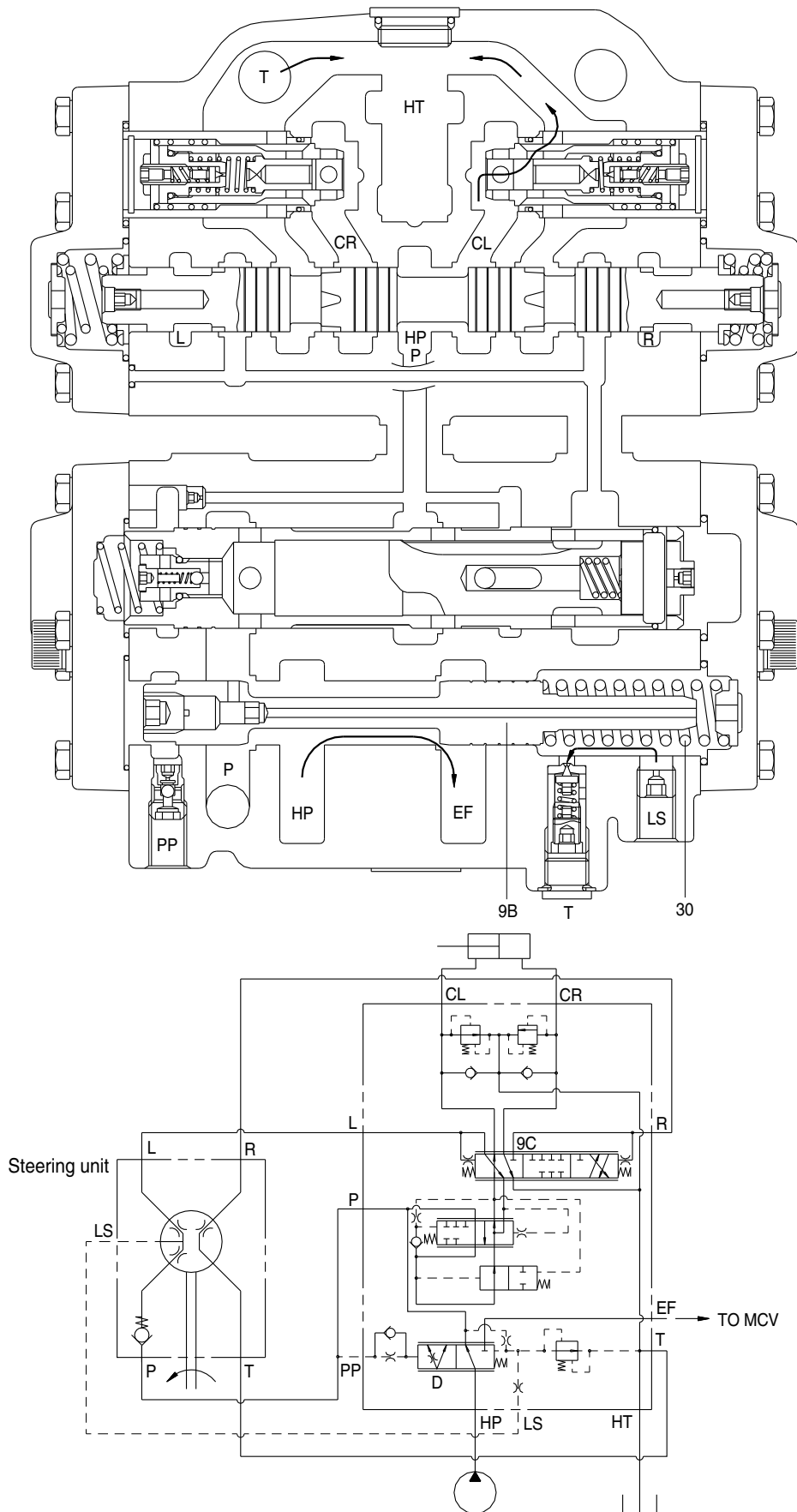

7707A5SE102

When the machine is steered to a full turn, the frames bottom against the steering stops. To limit steering system pressure, a relief system is built into the priority valve assembly (9B).

When the frames bottom is stopped, the pressure in the steering cylinders increases. This pressure is sensed at the LS port. When the pressure in the LS port increases enough to push priority valve spool (9B) off its seat, oil in the load sensing circuit flows to return through the T port. Load sensing pressure is limited to the pressure setting of the relief valve.

Pressure to the steering unit (pilot pressure), which is sensed at the left end of the priority valve spool (9B) in flow amplifier, continues to increase until it can move the spool to the right against the load sensing pressure plus spring (30) force. At this time, all oil flows out of the EF port to the loader control valve.

If the loader attachment is being operated while steering, the loader function will slow until the machine reaches the steering stops. At that time, the loader cycle speed will increase until the machine is steered again.

5. STEERING UNIT

1) STRUCTURE

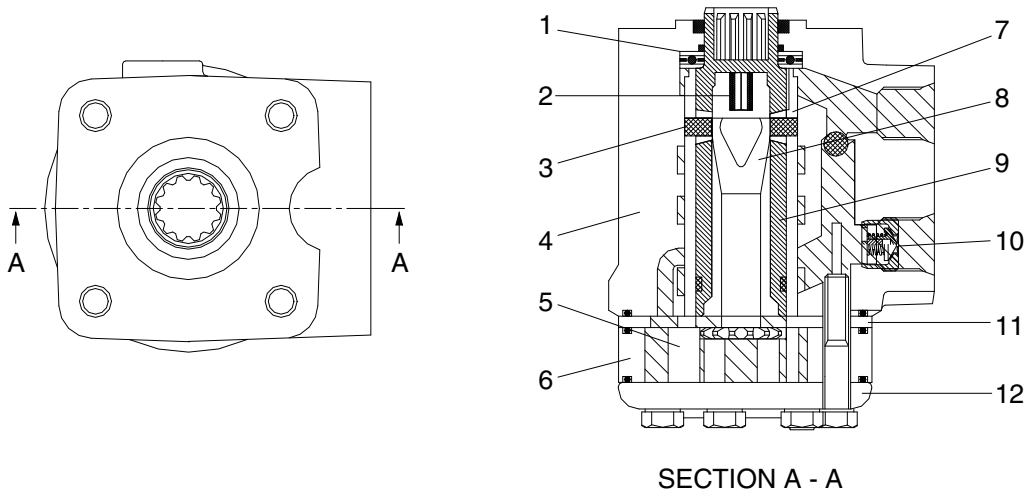

7607SE17

1	Bearing	5	Gear wheel	9	Spool
2	Neutral position spring	6	Gear rim	10	Check valve
3	Cross pin	7	Sleeve	11	Distributor plate
4	Housing	8	Cardan shaft	12	End cover

2) OPERATION

The steering unit consists of a rotary valve and a rotary meter.

Via a steering column the steering unit is connected to the steering wheel of the machine.

When the steering wheel is turned, oil is directed from the steering system pump via the rotary valve (spool and sleeve) and rotary meter (gear wheel set) to the cylinder ports L or R, depending on the direction of turn. The rotary meter meters the oil flow to the steering cylinder in proportion to the angular rotation of the steering wheel.

Spool (9) is connected directly to the drive shaft of steering wheel. It is connected to sleeve (7) by cross pin (3) (not in contact with the spool when the steering wheel is at neutral) and neutral position spring (2).

Cardan shaft(8) is meshed at the top with cross pin (3) and forms one unit with sleeve (7).

At the same time, it is meshed with gear rim (5) of the gerotor set by spline.

There are four ports in valve body. They are connected to the pump circuit, tank circuit, and the head, and left and right steering cylinder. In addition, the pump port and tank port are connected inside the body by the check valve. Therefore, if there is any failure in the pump of engine, oil can be sucked in directly from the tank through the check valve.

6. STEERING CYLINDER

1) STRUCTURE

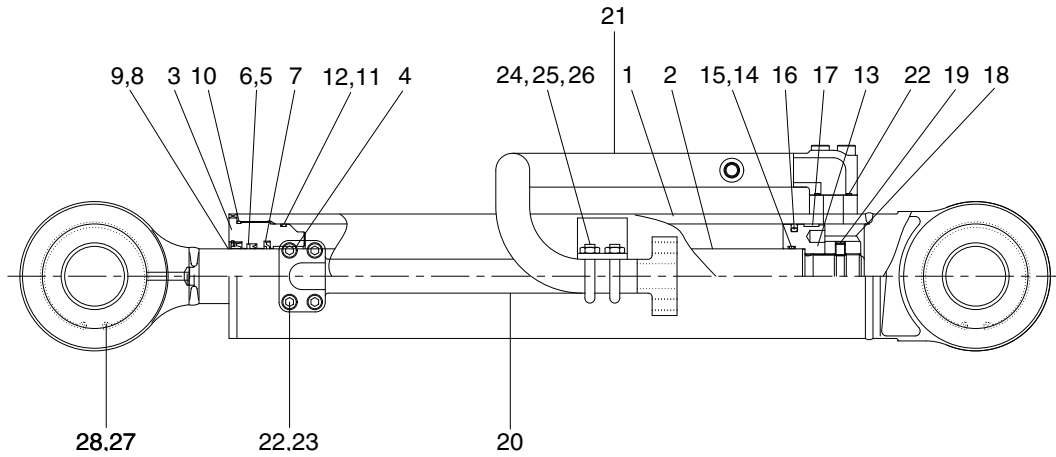

7809SU5SE05

1	Tube assembly	11	O-ring	21	Pipe assy
2	Rod assy	12	Back-up ring	22	O-ring
3	Gland	13	Piston	23	Hexagon bolt
4	Du bushing	14	O-ring	24	U-bolt
5	Rod seal	15	Back-up ring	25	Hexagon nut
6	Back-up ring	16	Piston seal	26	Spring washer
7	Buffer ring	17	Wear ring	27	Spherical bearing
8	Dust wiper	18	Piston nut	28	Retaining ring
9	Retaining ring	19	Set screw		
10	O-ring	20	Pipe assy		

2) OPERATION

This machine use to cross connected cylinder for steering operation.

The steering cylinder use a gland (3) to remove piston and sealed seals. Dust wiper (8) located on the in side of the rod cover protects cylinder inner parts from dust. The piston (13) is fastened to the rod (2).

The piston uses a single wear ring (17) with a piston seal (16) to seal between the piston and tube. The gland seals against the tube with two O-rings. The rod is sealed against the gland with a rod seal (5).