



## Rear Rail to Lower Quarter Extension







## Parts List

Quantity	Part Number	Description	Image / Notes
1	1091423-S0-A (LH) 1091424-S0-A (RH)	Rear Rail to Lower Quarter Extension	
12 rivets needed; order 20 rivets	1063943-00-A	● Structural Bulb Rivet, 6.5 mm	All rivets come in packages of 10; order all rivets in multiples of 10.
1	—	Structural Adhesive	<b>⚠ WARNING:</b> Use only Tesla-approved structural adhesive; refer to <a href="#">BR-15-92-008</a> , "Approved Structural Adhesive and Urethane Sealants" for a list of current approved structural adhesives.  Refer to <a href="#">BR-17-92-002</a> , "Obtaining Adhesives, Coolant, and Other Chemicals" for information on how to obtain approved structural adhesive.
1	—	Seam Sealer	Source locally; not available from Tesla.

These part numbers were current at the time of publication. Use the revisions listed or later, unless otherwise specified in the [Parts Manual](#).



## Repair Information

Repair Information	Warnings and Cautions	Special Tools
<p>This procedure is for the left-hand component; the procedure is identical for the right-hand component.</p>	<p> <b>WARNING:</b> Wear the appropriate personal protective equipment (PPE) when performing this procedure.</p> <p> <b>CAUTION:</b> This procedure involves only aluminum components. Use the appropriate tools to avoid cross-contamination.</p>	<p>No special tools are required to perform this procedure.</p>



## Prerequisites

Remove the [Trunk Floor Extension](#).





## Removal

1 Remove the original component.

A Use a drill with a spot weld bit to drill out the factory spot welds.  
▲ Factory Spot Weld (x9)



**NOTE:** Factory spot weld locations shown are approximate. Exact spot weld locations and number vary from vehicle to vehicle.



**NOTE:** Some components have been removed from the diagram for clarity.

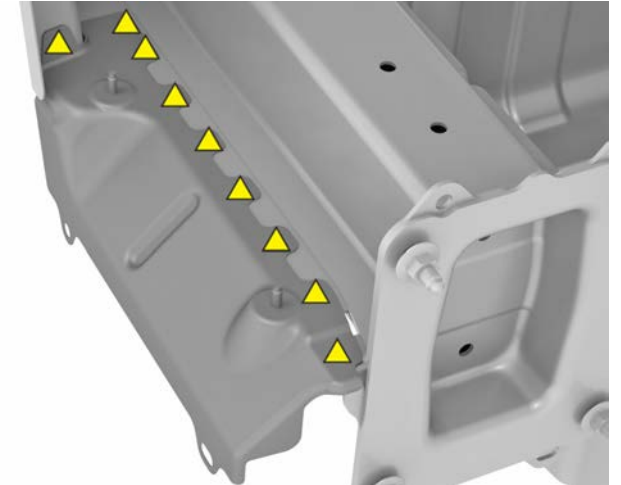



## Removal

1 Remove the original component (continued).

**B** Use a heat gun to heat the adhesive joints, and then use a hammer and chisel to remove the original component.



**WARNING:** Do not heat the adhesive joints above 100°C (212°F). Heating the adhesive joints above 100°C (212°F) can weaken the aluminum and compromise vehicle crash integrity.



**WARNING:** Do not heat any adhesive joints of components that are not being removed. Heating adhesive joints weakens the adhesive bond and could compromise vehicle crash integrity.





## Removal

- 1 Remove the original component (continued).
  - B Use a heat gun to heat the adhesive joints, and then use a hammer and chisel to remove the original component (continued).





## Removal

2

Use a disc sander with a medium-abrasive surface conditioning disc to remove any remaining materials from the bond paths. Use a belt sander with a medium-abrasive belt for any areas that cannot be reached with a disc sander. Vacuum any adhesive dust.



**WARNING:** Remove the epoxy adhesive in a well-ventilated area. Wear suitable personal protective equipment.



**WARNING:** Use only sanding wheels and belts that are 80 grit or finer on aluminum components. Using sanding wheels or belts that are coarser than 80 grit can cause fractures in the aluminum.



**CAUTION:** Beware of cross-contamination. Do not use the same equipment to remove epoxy from aluminum and steel. Cross-contamination might result in galvanic corrosion.







## Replacement

- 1 Prepare for installation.
  - A Put the new component into position and clamp it into place.





## Replacement

1 Prepare for installation (continued).

B Mark the fastener locations on the new component.

● Structural Bulb Rivet, 6.5 mm (x9)



**NOTE:** Some components have been removed from the diagram for clarity.

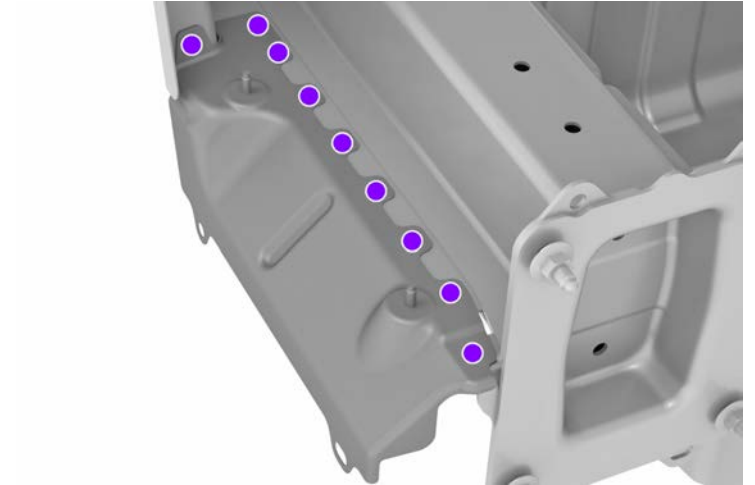



## Replacement

1 Prepare for installation (continued).

C Use a drill with a 6.8 mm (17/64 in) bit to drill holes for structural bulb rivets.



**NOTE:** Install a grip screw after drilling each hole to keep the panel aligned while drilling the remaining holes.





## Replacement

- 1 Prepare for installation (continued).
  - D Mark the bond path areas on the new component. These areas will be prepared for bonding in a later step.



- E Remove the new component.





## Replacement

2 Prepare the surfaces.

A

Use a disc sander with a medium-abrasive surface conditioning disc to remove the e-coat on the new component in the bond path areas. Use a belt sander with a medium-abrasive belt for any areas that cannot be reached with a disc sander.



**WARNING:** Remove the e-coat in a well-ventilated area. Wear suitable personal protective equipment.



**WARNING:** Use only sanding wheels and belts that are 80 grit or finer on aluminum components. Using sanding wheels or belts that are coarser than 80 grit can cause fractures in the aluminum.



**CAUTION:** Within two hours of removing the e-coat or paint, cover the abraded aluminum areas in the bond path with a thin primer layer of structural adhesive. If the abraded aluminum areas are not primed within two hours, they must be abraded again to remove any oxidation.





## Replacement

2 Prepare the surfaces (continued).

**B** Clean all the bond paths on the new component or components and on the vehicle with isopropyl alcohol (IPA).



**WARNING:** Wipe off the remaining isopropyl alcohol with a clean, dry towel immediately after application. Do not let the remaining isopropyl alcohol air dry. Allowing the remaining isopropyl alcohol to air dry can compromise the adhesive bond.



3 Apply structural adhesive.

**A** Spread a thin coating of structural adhesive as a primer layer on the bond paths on the vehicle and the new component.



**NOTE:** Assembly must be performed while the primer layer is still wet. The drying time of the adhesive varies depending on temperature and humidity.





## Replacement

**3** Apply structural adhesive (continued).

**B** While the primer layer is still wet, apply a bead of structural adhesive on top of the primer layer on the new component.



**4** Install the new component.

**A** Put the new component into position.





## Replacement

4 Install the new component (continued).

B Insert the structural bulb rivets.

● Structural Bulb Rivet, 6.5 mm (x9)



**NOTE:** Some components have been removed for clarity.

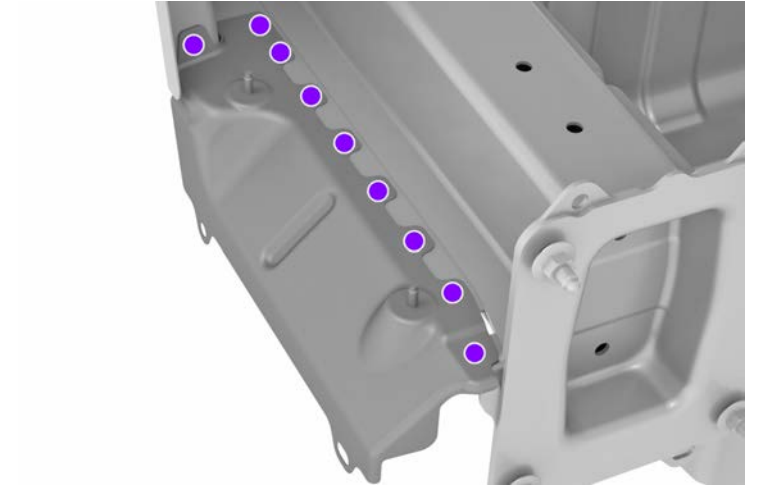





## Replacement

- 4 Install the new component (continued).
- C Install a clamp in the area that is not secured with fasteners.
- D Install the structural bulb rivets.





## Replacement

**4** Install the new component (continued).

**E** Wipe off any excess adhesive.

**F** Bake the structural adhesive so that the bonded panels reach a temperature of 60°C–80°C (140°F–176°F) for at least 30 minutes to achieve full strength.



**WARNING:** Do not allow the High Voltage Battery to reach a temperature above 74°C (165°F). Heating the High Voltage Battery above 74°C (165°F) for an extended period could result in injury to personnel and/or damage to the battery.

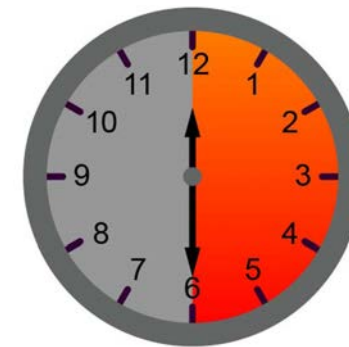

00:30:00+

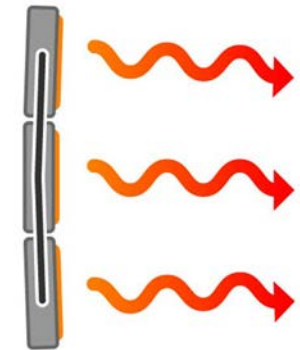

60°C–80°C



## Replacement

5 Seal the seams in the factory locations, and as necessary.

6 Install the new [Trunk Floor Extension](#).

