

# Engine

<b>MODEL</b>	<b>IVECO NEF S4D104E</b>
<b>TYPE</b>	<b>TURBO</b>
<b>NET HORSEPOWER</b>	<b>99 HP / 2200 rpm</b>
<b>TORQUE</b>	<b>398 Nm / 1400 rpm</b>
<b>DISPLACEMENT</b>	<b>4,485 l</b>
<b>COMPRESSION RATIO</b>	<b>17,5 : 1 bar</b>

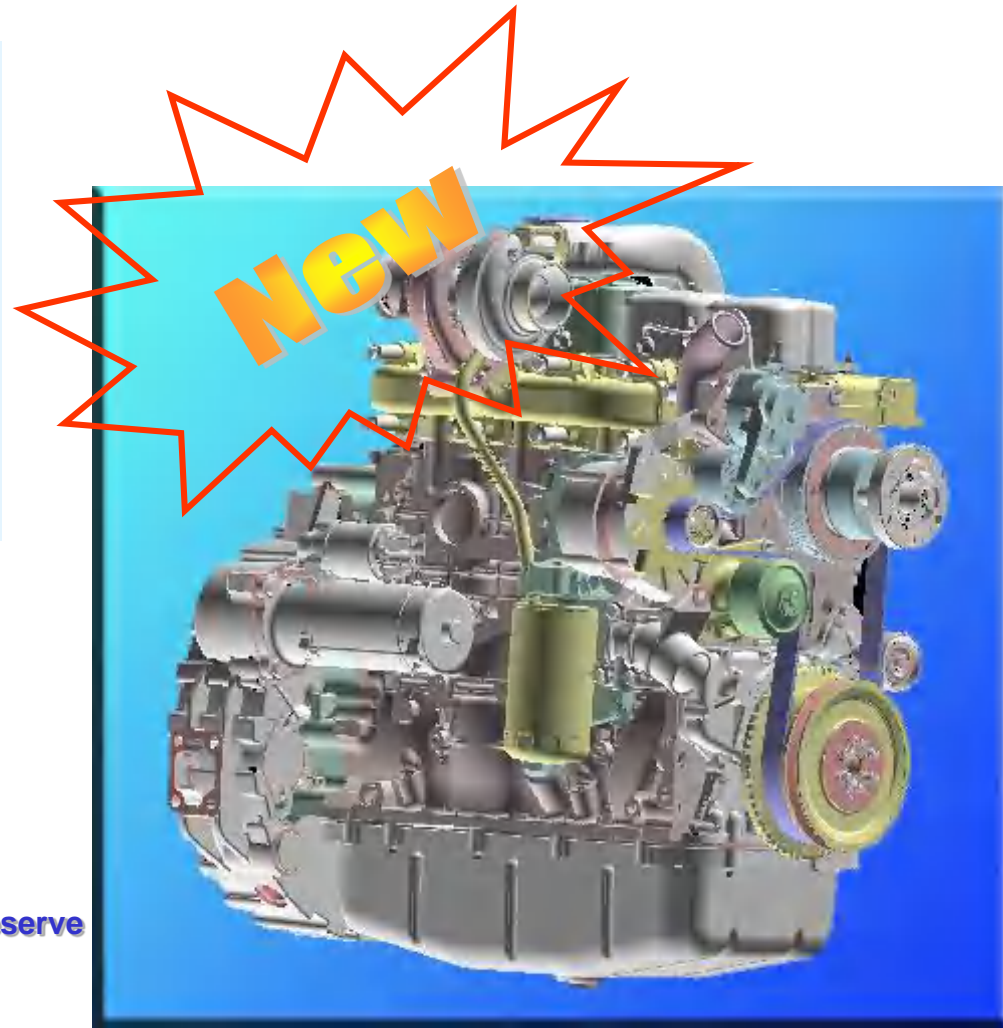

- **Very clean engine**
- **In compliance with following homologations: 97/68 CE Stage 2 and EPA Tier 2**
  - **High displacement (4,5 litres) to guarantee reserve of torque, power and low utilisation**
  - **Reduced specific fuel consumption**
  - **Reduced noise level**

**STAGE 2 normative:  
WB93/97R-5 Gas emissions**

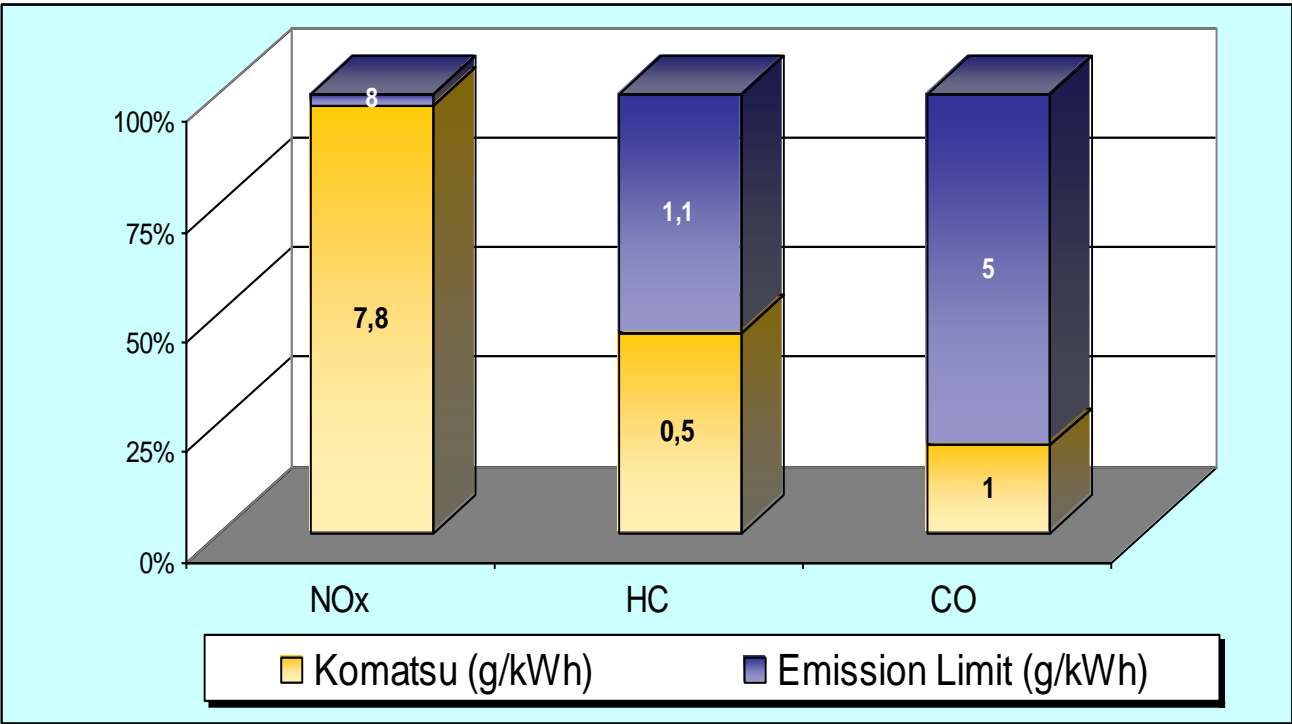

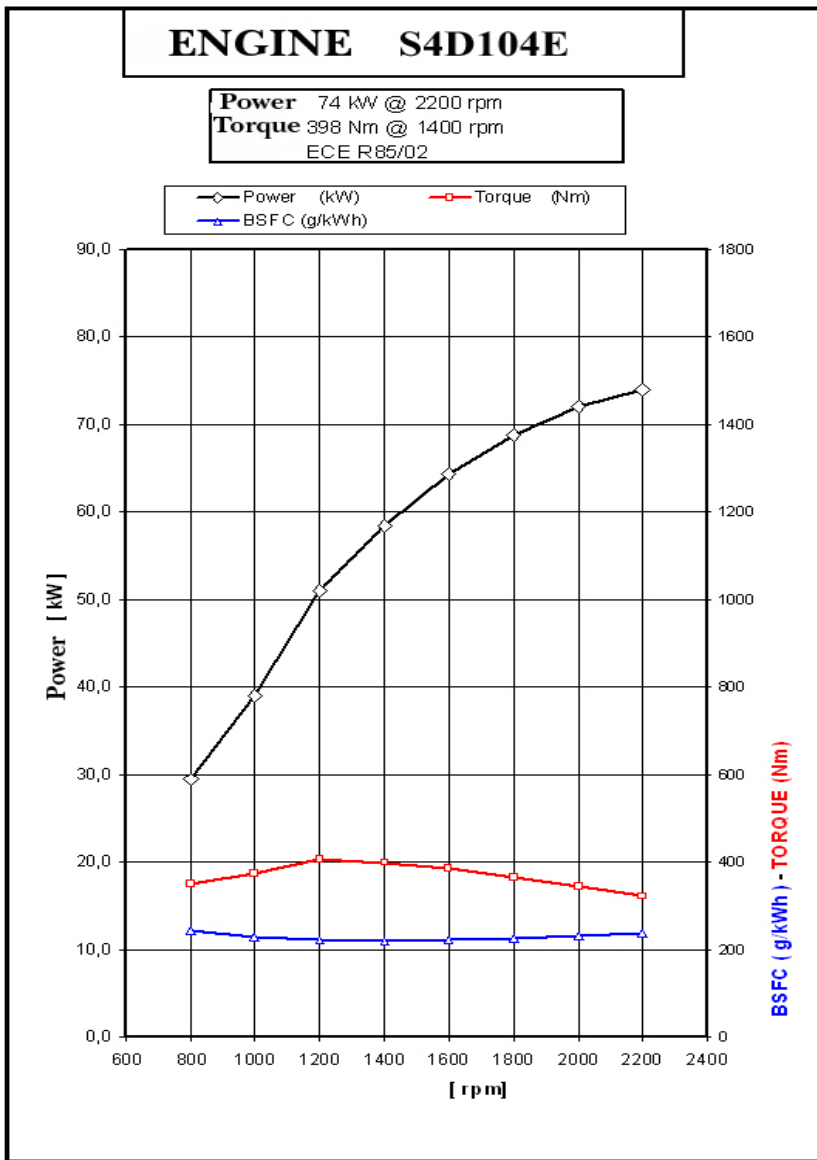

Customer Service Department

**COOLING SYSTEM**

The engine cooling system, closed circuit forced circulation type, generally incorporates the following components:

- Expansion tank; placement, shape and dimensions are subject to change according to the engine's equipment.
- Radiator, which has the duty to dissipate the heat subtracted to the engine by the cooling liquid. Also this component will have specific peculiarities based on the equipment developed, both for what concerns the placement and the dimensions.
- Visc pusher fan, having the duty to increase the heat dissipating power of the radiator. This component as well will be specifically equipped based on the engine's development.

- Heat exchanger to cool the lubrication oil: even this component is part of the engine's specific equipment.
- Centrifugal water pump, placed in the front part of the engine block.
- Thermostat regulating the circulation of the cooling liquid.
- The circuit may eventually be extended to the compressor, if this is included in the equipment.

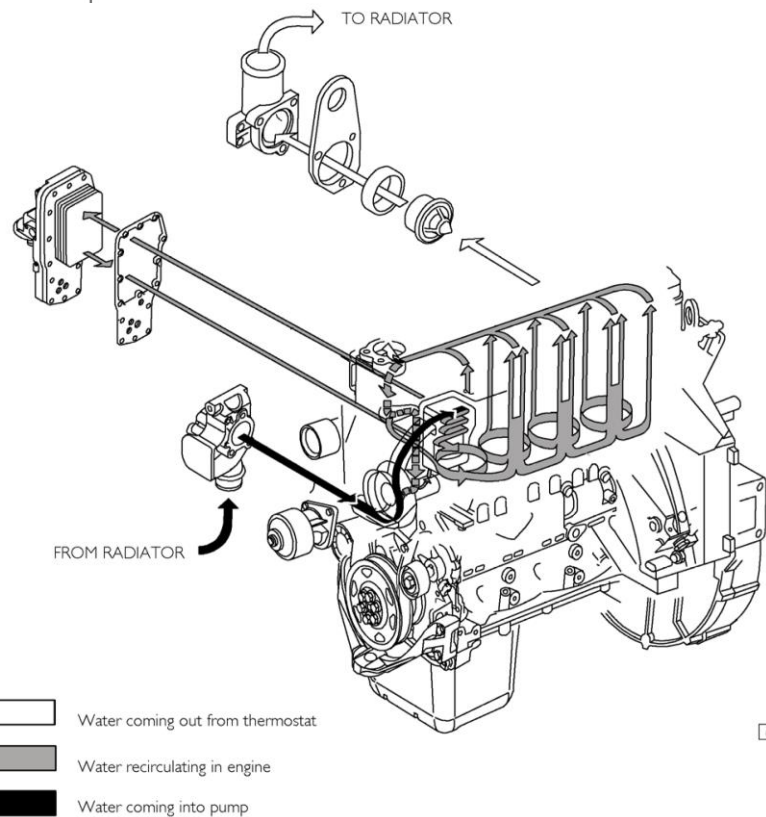

COOLING SYSTEM LAYOUT (4 cyl. engines)

**LUBRICATION**

Lubrication by forced circulation is achieved through oil rotary expansion pump (4), placed in the front part of the basement, driven by the straight-tooth gear splined to the shaft's bar hold.

From the pan, the lubrication oil flows to the driving shaft, to the camshaft and to the valve drive.

Lubrication involves the heat exchanger (2,3) as well, the supercharged (through pipe 1) and the eventual compressor for any eventual compressed air system.

All these components may often vary according to the specific duty.

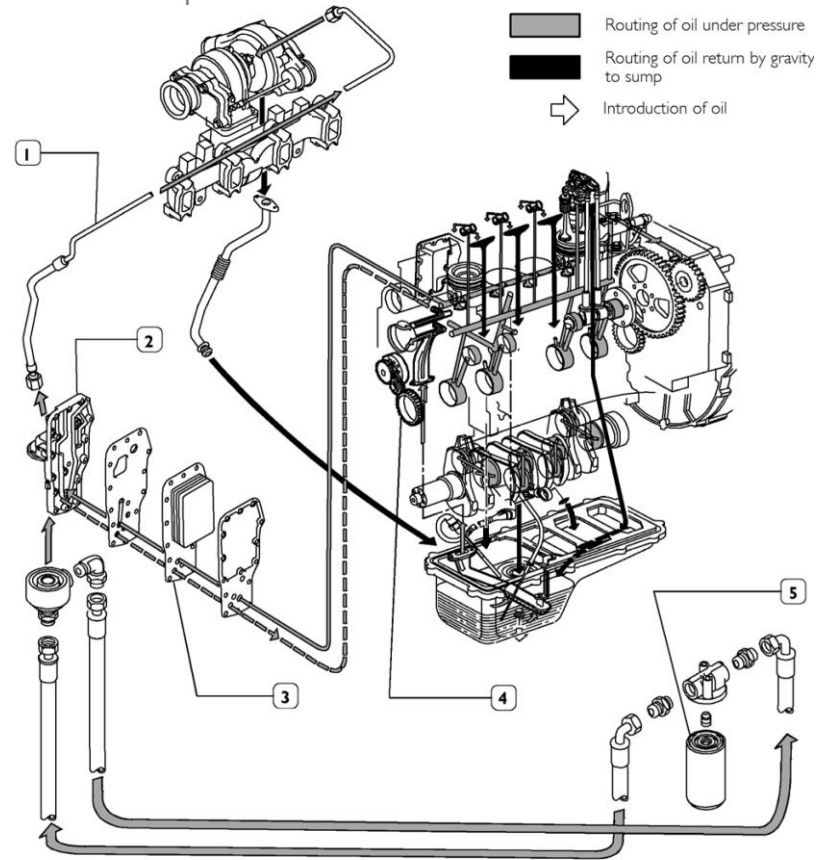

LUBRICATION SYSTEM LAYOUT (4 cyl. engines)

- 1. Lubrication oil pipe to supercharger - 2. Heat exchanger body - 3. Heat exchanger - 4. Oil rotary expansion pump - 5. Oil filter

**Injection pump**

The pump is rotary type, and it is driven by a gear coupled with the camshaft gear.

**(S)4D104E - 1** *Cut views*

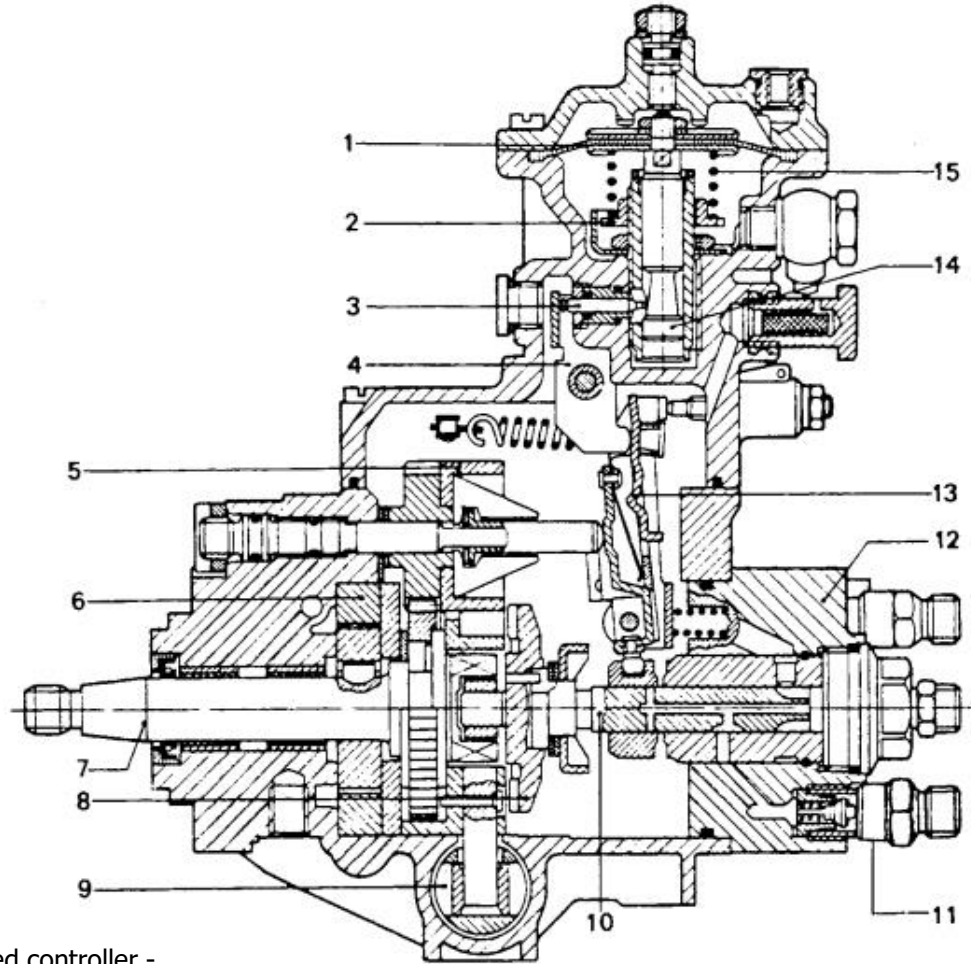

**Longitudinal section of injection pump**

- 1. Membrane - 2. Adjusting hub nut - 3. Feeler - 4. Control lever - 5. Speed controller -
- 6. Booster pump - 7. Driving shaft - 8. Cam disk - 9. Injection adjuster -
- 10. Distributor piston - 11. Feed connection piece - 12. Hydraulic head -
- 13. Control plate - 14. Control rod - 15. Counterspring.

### 1 Supply step

The distributor piston (6) is placed in the b.d.c. and the slide valve (8) shuts the bore for the fuel cut-off (7). The fuel is fed into the compression chamber via feed pipe (1) that is kept open by the solenoid valve (2).

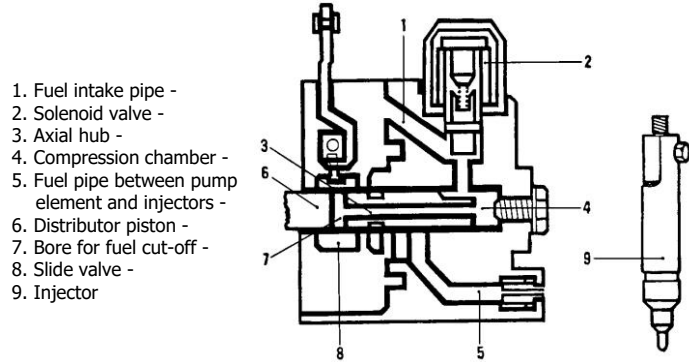

1. Fuel intake pipe -
2. Solenoid valve -
3. Axial hub -
4. Compression chamber -
5. Fuel pipe between pump element and injectors -
6. Distributor piston -
7. Bore for fuel cut-off -
8. Slide valve -
9. Injector

### 2 Feed step

The distributor piston (5) is lifted under influence of the cam disk to the T.D.C. and rotates at the same time around its own axis. By means of these two movements the fuel intake pipe (1) is closed and the fuel in the compression chamber (2) is simultaneously compressed. The inner pipe (3) of the distributor piston is connected to pipe (4) and makes the fuel feed to the injectors (6) possible.

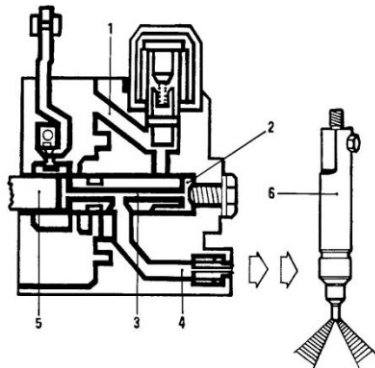

1. Fuel intake pipe -
2. Compression chamber -
3. Inner pipe of distributor piston -
4. Fuel pipe between pump element and injectors -
5. Distributor piston -
6. Injectors

### 3 Feed end

The distributor piston (6) opens the high-pressure chamber by means of pipe (4) during its lift to the T.D.C., by means of this a pressure compensation between inner chamber of the distributor piston, feed pipe to the injection valves and inner chamber of the pump housing takes place.

As the pressure subsequently is too low to operate the injection valve, the fuel is cut-off.

1. Fuel intake pipe -
2. Compression chamber -
3. Feed pipe -
4. Pipe for fuel cut-off -
5. Slide valve -
6. Distributor piston.

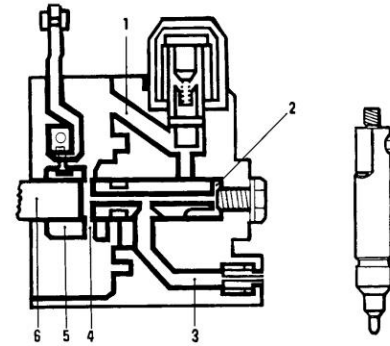

### 4 Stopping of engine

The engine is stopped by means of disconnecting the starter contact. The solenoid valve current (4) is interrupted. By means of the spring (3) the solenoid valve presses the moveable valve pin (2) to the stop, and thus the fuel intake pipe (1) is interrupted.

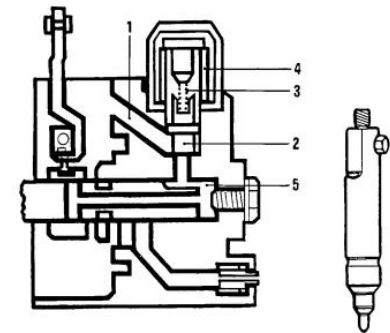

1. Fuel intake pipe -
2. Moveable valve pin -
3. Spring -
4. Solenoid valve -
5. Compression chamber.



## L.D.A. Mode of operation

The LDA device adjusts the fuel throughput independent of the air pressure in the suction manifold. This air pressure acts upon the membrane (1) which is rigidly connected to the controller pin (4). The lower part of the controller pin (4) is provided with a conical mounting (5) with a feeler pin (6). By means of the axial displacement of the controller pin (4) the feeler pin (6) is also displaced and acts upon the stop lever (7). The stop lever rotates on its own axis (8) and acts upon the controller disk in such a way that the fuel throughput is adjusted to the air quantity fed into the cylinders.

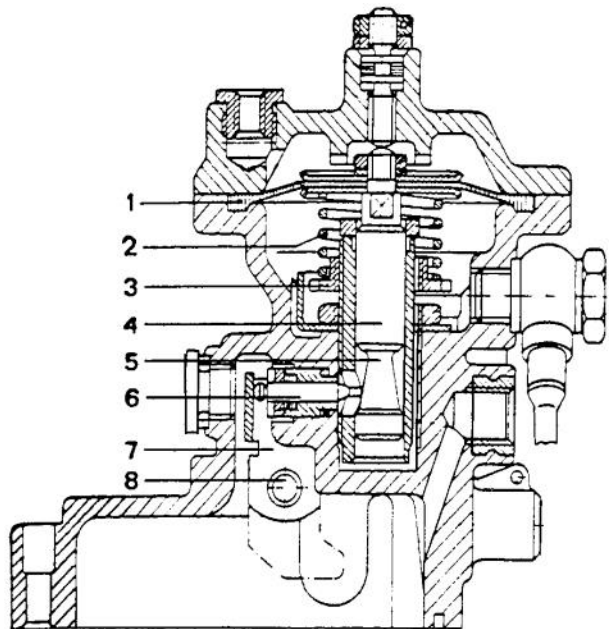

## Starting

If the solenoid valve (6) is supplied with current, fuel is fed into the compression chamber (7); in this case the governor weights of the governor collar (5) are closed, and the leaf spring (2) presses the lifter (1) and the slider (4) into the additional feed position.

Thus the whole lift of the pump element is used for the feed to the injection valve.

1. Starter lifter -
2. Leaf spring -
4. Slider -
5. Governor collar -
6. Solenoid valve -
7. Compression chamber.

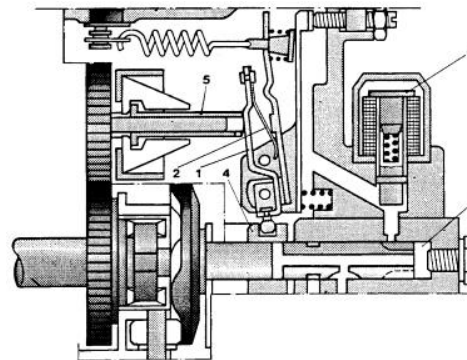

## Starting device disconnected

After starting of the engine the governor collar (5) moves axially as a result of the centrifugal force caused by the expansion of the governor weights (7), and causes the starter lifter (1) to contact the tension lever (3) and squeezes the leaf spring (2). Under these conditions the slider (4) is moved to idling position.

1. Starter lever -
2. Leaf spring -
3. Tension lever -
4. Slider -
5. Governor collar -
6. Solenoid valve -
7. Ground.

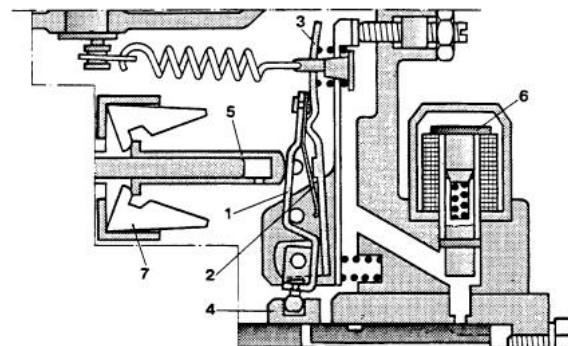

**Description**

The load-dependent adjustment of the start of delivery (LFB) enables a "smoother" engine operation (reduced in noise). The LFB device is realised by means of the following changes:

- Governor collar with an additional bore to the anti pump bore.
- Controller shaft with an oblong hole and two cross holes
- Pump housing with a hole that is closed from outside by means of a ball and that is connected to the feed chamber.

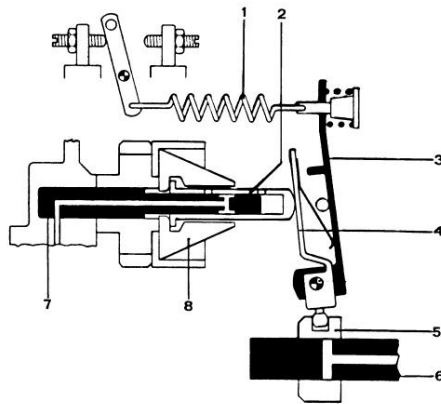

- 1. Control spring -
- 2. Governor collar -
- 3. Tension lever -
- 4. Starter lever -
- 5. Slider -
- 6. Distributor piston -
- 7. Control shaft -
- 8. Governor weights.

Design of the controller with feed-dependent adjustment of the start of delivery

**Mode of operation**

Independent of the position of the outer accelerator pedal the fuel feed is reduced, if the governor collar (4) is displaced by the governor weights of the controller by means of the centrifugal force in case of an increase of the speed.

For a smoother engine operation and a reduced fuel feed the start of delivery must be reduced. As the injection adjustment device in the rotary piston pump is a hydraulic device, the pressure increase must be reduced in order to obtain a decreasing start of delivery: this is obtained by means of the LFB device.

If the governor collar (4) that runs on the controller shaft (2) connects the bore (3) to the hub (6) and the bore (7), a part of the diesel fuel under pressure is fed via the pipe (1 and 5) into the feed chamber. This fuel causes a reduced pressure increase in the pump and a reduced start of delivery.

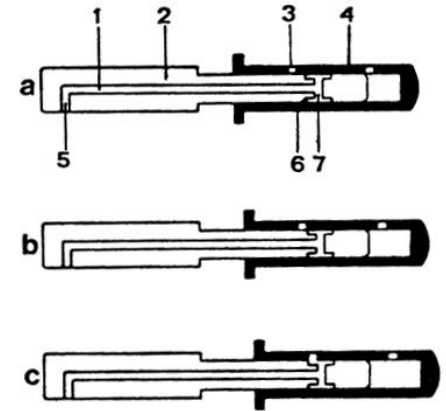

- a. Collar in idling position -
- b. Collar in movement -
- c. Collar in adjustment condition, inner pressure loss -
- 1. Oblong hole in controller shaft -
- 2. Controller shaft -
- 3. Cross hole governor collar -
- 4. Governor collar -
- 5. Cross hole controller shaft -
- 6. Edge from controller centre -
- 7. Cross hole controller shaft..

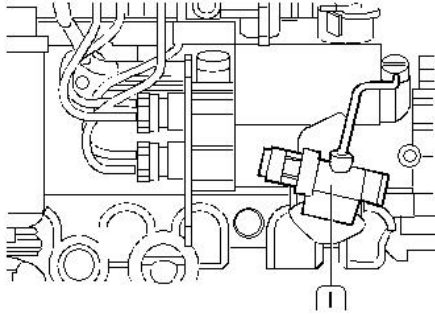

The KKSB device allows to set the required cold start injection advance.

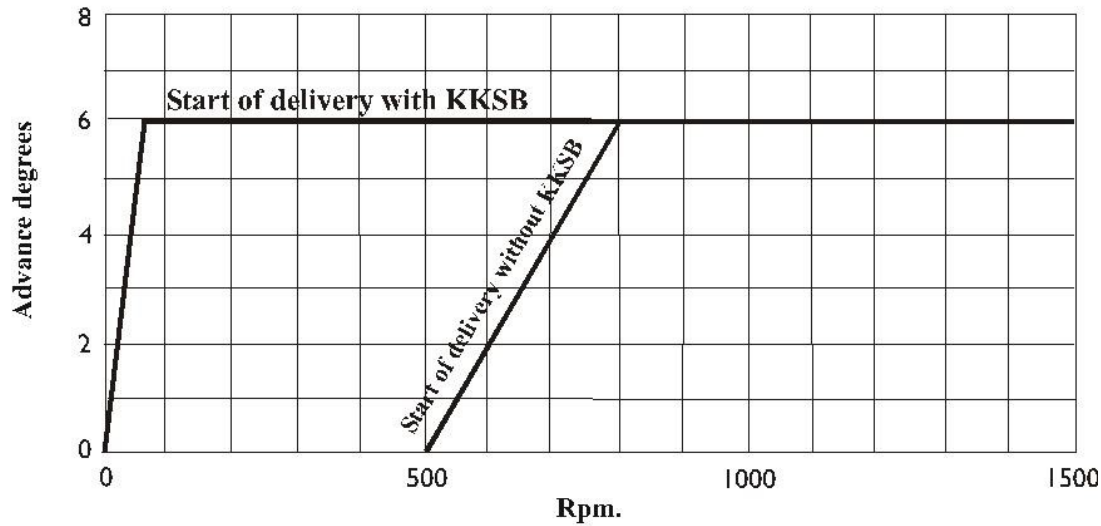

Customer Service Department

**FIP REMOVAL Please refer to IVECO shop manual page 35**

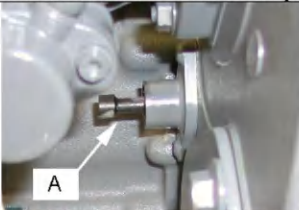
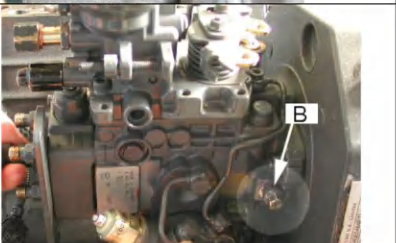
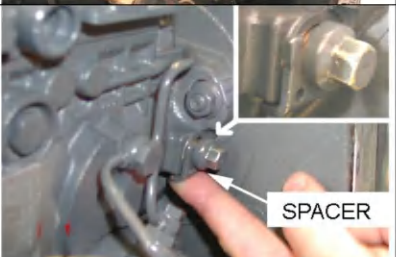
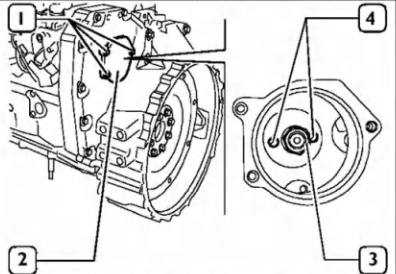
1.01		<ol style="list-style-type: none"> <li>1. Remove the rocker arm covers related to cyl N° 1 (fan pulley side) N° 4 (flywheel side)</li> <li>2. Move the flywheel until the cyl N°1 is on the top dead point with cyl N°4 valves in balance.</li> <li>3. In this position please insert flywheel locking pin "A" fig 1.01</li> </ol>
1.02		<ol style="list-style-type: none"> <li>4. Remove screw "B" (fig 1.02).</li> </ol>
1.03		<ol style="list-style-type: none"> <li>5. Remove the SPACER (fig 1.03)</li> </ol>
1.04	<ol style="list-style-type: none"> <li>6. Screw up bolt "B" (fig. 1.02) and fix it (in this moment we are locking the pump shaft.)</li> </ol>	
1.05		<ol style="list-style-type: none"> <li>7. Remove the cover</li> </ol>
1.06	<ol style="list-style-type: none"> <li>8. Remove the FIP shaft locking nut.</li> <li>9. Remove the FIP case locking nuts.</li> <li>10. Remove FIP</li> </ol>	

**FIP INSTALLATION (Please refer to IVECO shop manual page 20 fig 41)**

2.01	<ol style="list-style-type: none"> <li>11. Make sure that the distribution gears are correctly assembled; that the flywheel locking pin is still inserted and reverse the removal procedure (installing the FIP be sure that fixing slots are centred related to their own nuts). Lock the FIP drive gear nut.</li> </ol>
------	---

**IN ORDER TO VERIFY THE CORRECT INJECTION TIMING**

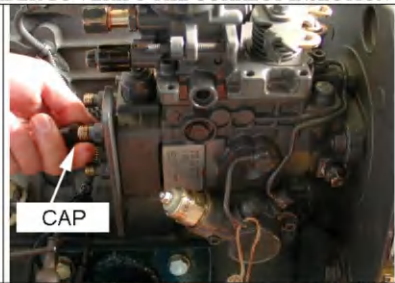
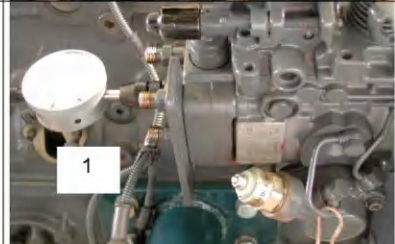
3.01		<ol style="list-style-type: none"> <li>12. Remove the FIP shaft locking screw (fig 1.02)</li> <li>13. Remove the cap in fig 3.01</li> </ol>
3.02		<ol style="list-style-type: none"> <li>14. Install the dial gauge "1" (fig 3.02) with 2 mm pre load.</li> <li>15. Remove the flywheel locking pin "A" fig 1.01</li> </ol>
3.03	<ol style="list-style-type: none"> <li>16. Force the fly wheel to turn clock wise, and check the dead point (stop point) of the dial gauge indicator.</li> <li>17. Re set the dial gauge to zero.</li> <li>18. While pushing the flywheel locking pin, force the fly wheel to rotate anti clock wise until the locking pin locks the flywheel again.</li> <li>19. Remove the FIP case nuts and rotate it in order to read on the dial gauge the following values (mm): <ul style="list-style-type: none"> <li>• Natural Aspirated Engine: 1.35±0.05</li> <li>• Turbo Engine: 1.0±0.05</li> </ul> </li> </ol>	
3.04	<ol style="list-style-type: none"> <li>20. Repeat the procedure from step 3.02 until the values read on the gauge are the once reported.</li> <li>21. Lock again the FIP case nuts.</li> </ol>	

**FIP timing resetting**

(this procedure must be performed any time the FIP shaft locking screw has not been used (or forgotten) during the removal or after any FIP repair.)

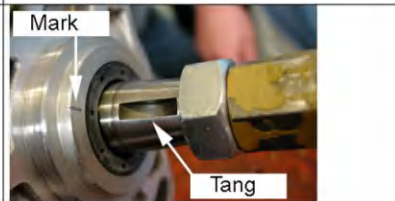
4.01	<ol style="list-style-type: none"> <li>22. After the FIP removal fix it on a bench.</li> </ol>	
4.02		<ol style="list-style-type: none"> <li>23. Make sure that the FIP shaft is free to rotate, removing the screw "B" as in item 1.02.</li> <li>24. Look anywhere in the FIP flange the specific mark (shown in fig 4.02).</li> <li>25. Rotate the FIP shaft in order to match the mark with the tang.</li> <li>26. Lock the screw "B"</li> <li>27. Follow the FIP installation procedure.</li> </ol>

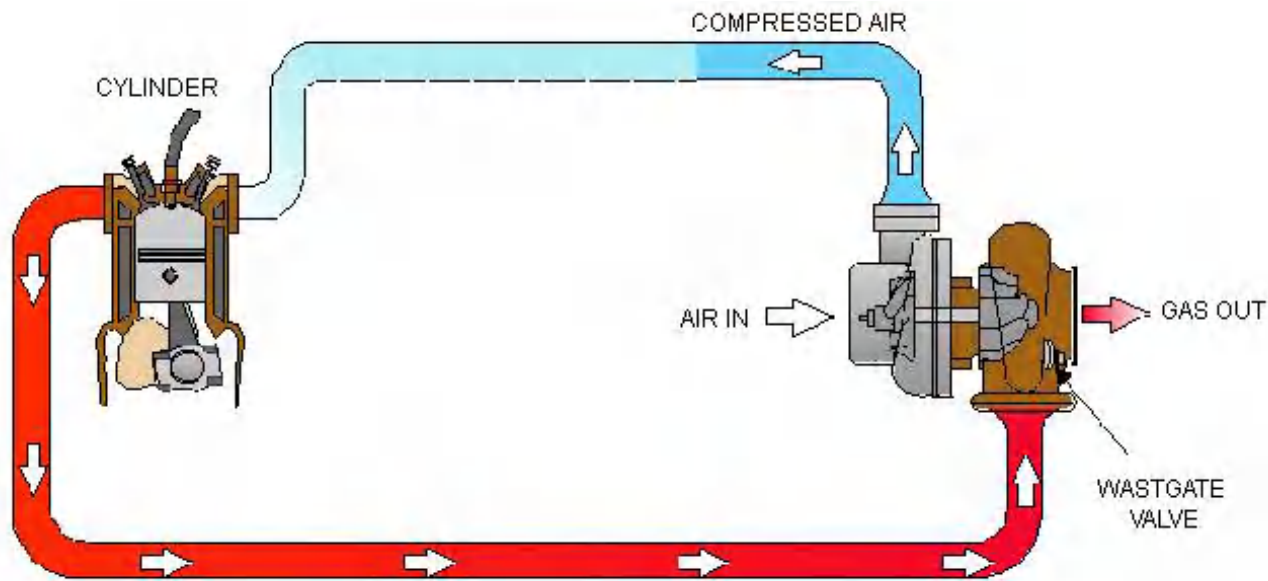
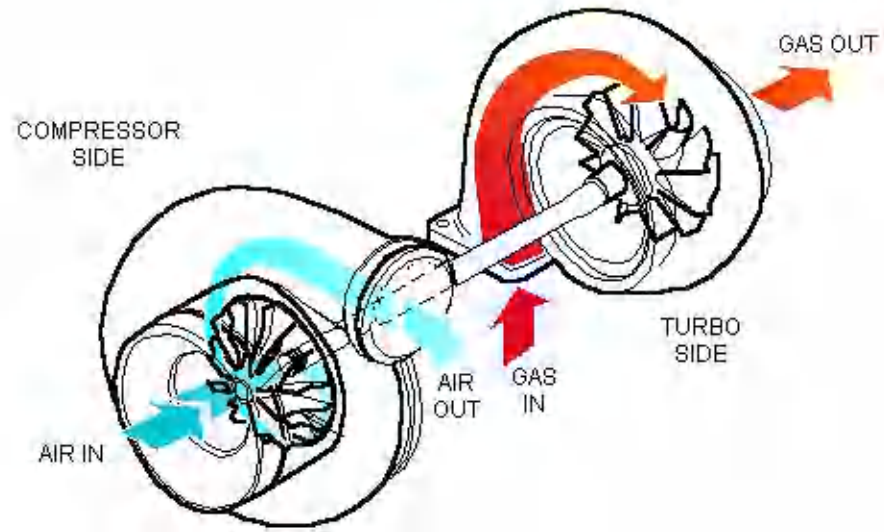

Customer Service Department

Ring kit (+0,40 mm)

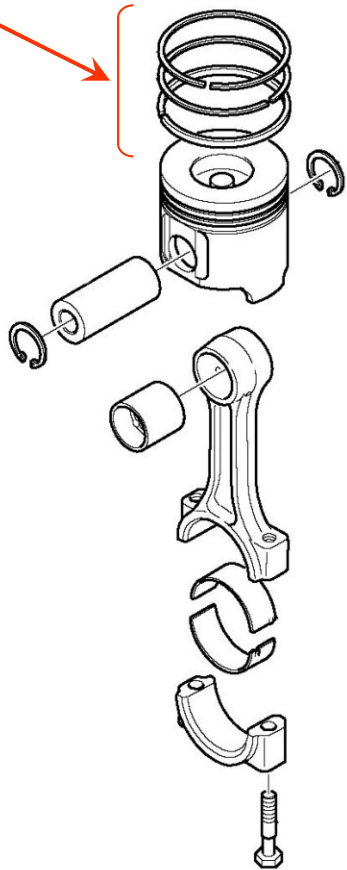

Piston assy (+0,40 mm)

Bearing (-0,25 mm)  
Bearing (-0,50 mm)

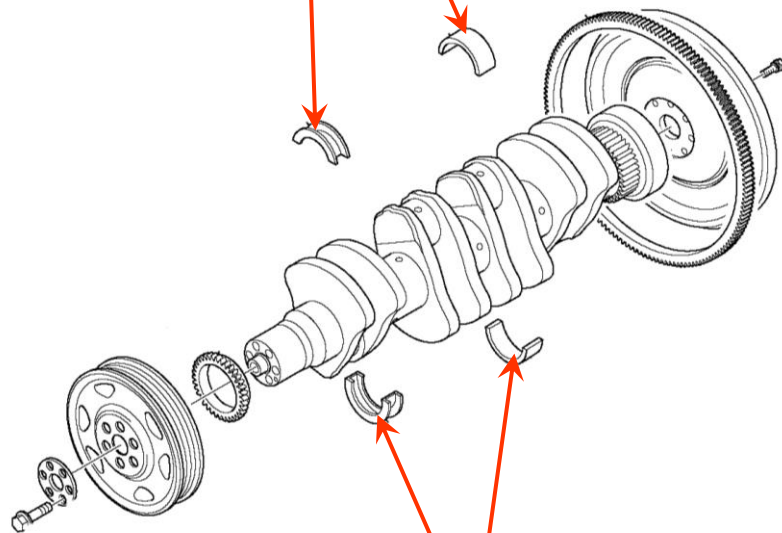

Bearing (-0,25 mm)  
Bearing (-0,50 mm)

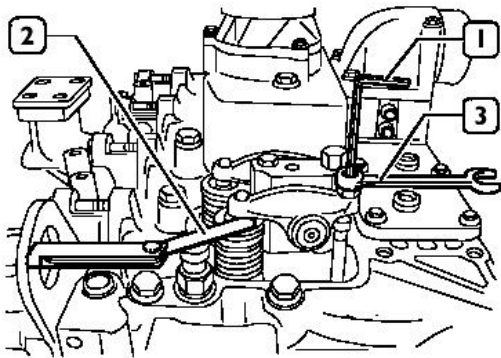

Adjust the slack between rocker arms and valves using socket wrench (1), point wrench (3) and feeler gauge (2).

Correct working slack is:

- suction valves  $0.30 \pm 0.05$  mm
- exhaust valves  $0.55 \pm 0.05$  mm.



In order carry out a quicker adjustment of the working slack between rocker arms and valves, proceed as following:

Rotate the engine drive shaft, balance the valves of cylinder 1 and adjust the valves identified by star symbol, as indicated in the following table:

Cylinder n	1	2	3	4
Suction	*	-	-	-
Exhaust	*	*	*	-

Rotate the engine drive shaft of 360 deg., balance the valves of cylinder 4 and adjust the valves identified by star symbol, as indicated in the following table:

Cylinder n°	1	2	3	4
Suction	-	*	*	*
Exhaust	-	-	-	*

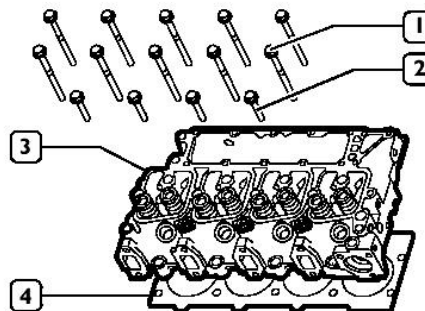

- Place the head (3) over the block and insert screws (1) and (2).



If the valves have been removed from the head, it is necessary to assemble them before assembling the head itself on the engine block.

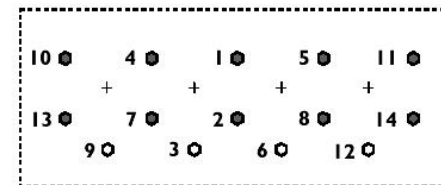

- Lubricate cylinder head bolts and install to head.
- Bolts must be torqued using stitching pattern starting with the centre bolts and moving out. Bolts to be torqued in stages: all bolts torqued to snug torque, then 90 degrees rotation for all bolts. Then a further 90 degrees for the M12 x 140 and M12 x 180.

M12 x 70	50 Nm + 90 deg's
M12 x 140	40 Nm + 180 deg's
M12 x 180	70 Nm + 180 deg's

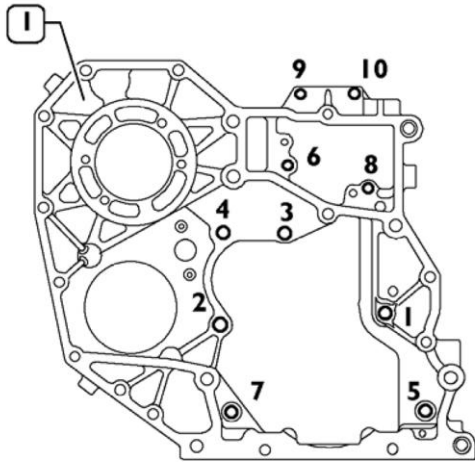

DIAGRAM SHOWING SCREW TIGHTENING TO FIX REAR GEARBOX

- Reassemble to box (1) to the engine block.
- Tighten the fixing screws in the same position as found out during disassembly and fix the screws to the locking couples listed here below, following the order as shown in the picture.

Screws M12	65 ÷ 89 Nm
Screws M8	20 ÷ 28 Nm
Screws M10	42 ÷ 52 Nm

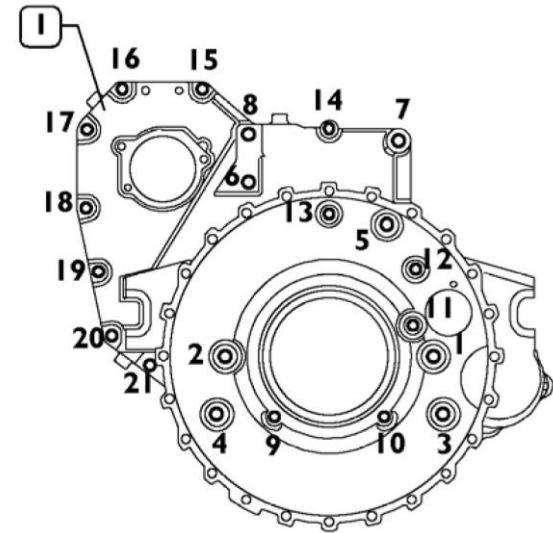

DIAGRAM SHOWING SCREW TIGHTENING TO FIX FLYWHEEL COVER BOX.

- Reassemble the box (1) to the engine block, tighten the fixing screws in the same position as found out during disassembly and fix the screws to the locking couples listed here below, following the order as shown in the picture.

Screws M12	75 ÷ 95 Nm
Screws M10	44 ÷ 53 Nm



Before assembly, always check that the threads of the ports and of the screws have no evidence of tear and wear nor dirt.



Exhaust manifold

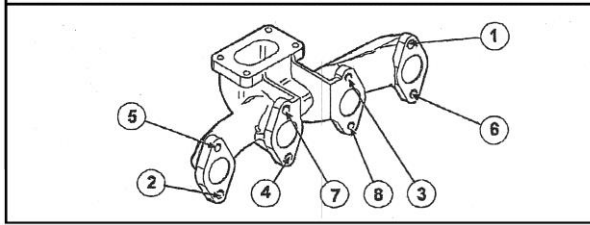

Turbo compressor:

- first step: 4-3-1-2
- second step: 1-4-2-3

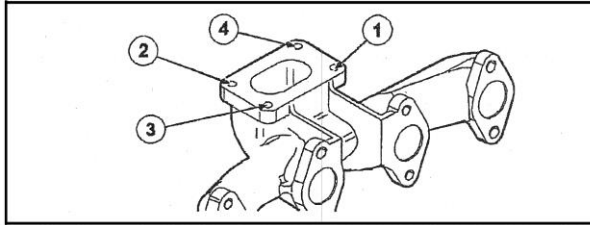

Oil pan:

- first step: from 1 to 16
- second step: from 17 to 32

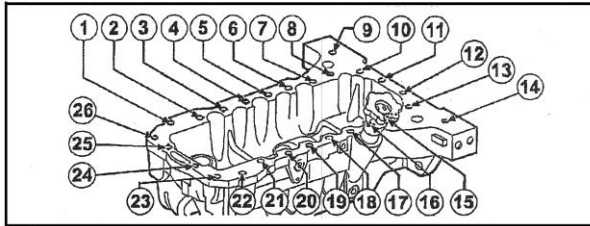

Heat exchanger

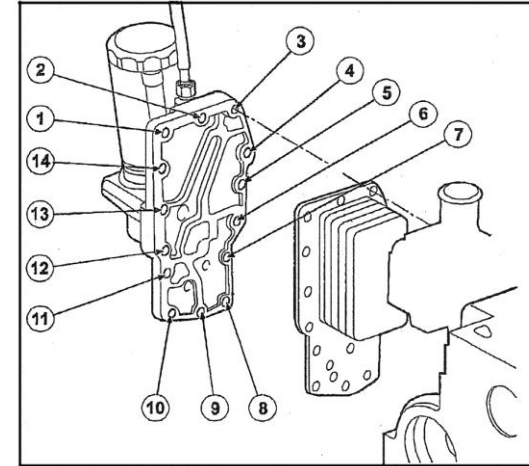

COMPONENT	TORQUE	
	Nm	kgm
Cooling Nozzles (M8x1.25x10)	15 ± 3	1.5 ± 0.3
Main bearing cap	1st stage	50 ± 6
	2nd stage	80 ± 6
	3rd stage	90° ± 5°
Rear gear housing assembly (M8x1.25x40) (M8x1.25x25) (M10x1.5)	24 ± 4	2.4 ± 0.4
	24 ± 4	2.4 ± 0.4
	49 ± 5	4.9 ± 0.5
Oil pump (M8x1.25x30)	8 ± 1	0.8 ± 0.1
Front cover assembly (M8x1.25x45) (M8x1.25x30)	24 ± 4	2.4 ± 0.4
	24 ± 4	2.4 ± 0.4
Connecting rod bolts (M11x1.25)	1st stage	30 ± 3
	2nd stage	60 ± 5
	3rd stage	60° ± 5°
Ladder frame assembly (M10x1.25x25)	43 ± 5	4.3 ± 0.5
Oil rifle plugs (M10x1) (M14x1.5)	6 ± 1	0.6 ± 0.1
	11 ± 2	1.1 ± 0.2
Assemble oil suction tube (M8x1.25x20)	24 ± 4	2.4 ± 0.4
Oil pan assembly (M8x1.25x25) (M18x1.50)	24 ± 4	2.4 ± 0.4
	60 ± 9	6.0 ± 0.9
Set timing pin	5 ± 1	0.5 ± 0.1
Fuel pump assembly	M8 screw	24 ± 4
	M6 screw	10 ± 1
	M6 nut	10 ± 1
M10x1.5 flange head nuts	pre-torque	10 - 15
		50 - 55
Fuel pump gear (drive gear nut)	Snug torque	15 - 20
	Final torque	85 - 90
Timing pin cap of fuel pump	30 - 35	3.0 - 3.5
Rocker assys (M8)	24 ± 4	2.4 ± 0.4
Cylinder head bolts (M12x70) (M12x140) (M12x180)	50 + 90°	5.0 + 90°
	40 + 180°	4.0 + 180°
	70 + 180°	7.0 + 180°
Assy rocker covers (M8x1.25x25)	24 ± 4	2.4 ± 0.4
Intake manifold (M8x1.25)	24 ± 4	2.4 ± 0.4
Assy air intake connection (M8x1.25)	24 ± 4	2.4 ± 0.4
Oil bypass valve into lube filter head (M22x1.5x10)	80 ± 8	8.0 ± 0.8
Plug (M12x1.5x12)	10 ± 1	1.0 ± 0.1
Exhaust manifold (M10x1.5x65)	43 ± 6	4.3 ± 0.6
Water pump (M8x1.25x25)	24 ± 4	2.4 ± 0.4
Water outlet connection (M8x1.25x35) (M8x1.25x70)	24 ± 4	2.4 ± 0.4
	24 ± 4	2.4 ± 0.4
Fan support (M10x1.5x20)	33 ± 5	3.3 ± 0.5
Fan pulley (M6) (M10)	10 ± 2	1.0 ± 0.2
	43 ± 6	4.3 ± 0.6

COMPONENT	TORQUE	
	Nm	kgm
Rear lifting bracket (M12x1.75x30)	77 ± 12	7.7 ± 1.2
Crankshaft pulley (M12x1.75x10.9)	110 ± 5	11.0 ± 0.5
Flywheel housing (M12x120) (M12x80) (M10x80) (M10x40)	85 ± 10	8.5 ± 1.0
	85 ± 10	8.5 ± 1.0
	49 ± 5	4.9 ± 0.5
	49 ± 5	4.9 ± 0.5
Flywheel housing (M12x1.25)	1st stage	30 ± 4
	2nd stage	60° ± 5°
Assy rear cover plate to flywheel housing (M8x1.25x16)	24 ± 4	2.4 ± 0.4
Fuel injectors	60 ± 5	6.0 ± 0.5
Fuel lift pump	24 ± 4	2.4 ± 0.4
Turbocharger to exhaust manifold (M10)	43 ± 6	4.3 ± 0.6
Oil feed to oil filter head	24 ± 4	2.4 ± 0.4
Oil feed to turbocharger (M12x1.5)	35 ± 5	3.5 ± 0.5
Oil drain (M8x1.25x16)	24 ± 4	2.4 ± 0.4
Alternator to alternator support (M8x1.25x30)	24 ± 4	2.4 ± 0.4
Alternator to water inlet conn. assy (M8x1.25x30)	24 ± 4	2.4 ± 0.4
Lower alternator mounting (M10x1.25x25)	24 ± 4	2.4 ± 0.4
Alternator upper pivot to support (M10)	49 ± 5	4.9 ± 0.5
Alternator mounting hardware (M12x1.75x120)	43 ± 6	4.3 ± 0.6
Alternator wiring (M6x1.0 nut)	10 ± 2	1.0 ± 0.2
Starter motor to gear case (M10)	49 ± 5	4.9 ± 0.5

Customer Service Department



ANOMALY	POSSIBLE CAUSE	REMEDY
The engine does not start	Battery flat or faulty.	Check and recharge battery. Replace battery if necessary.
	Connections to battery terminals corroded or loose.	Clean, examine and tighten the nuts on the battery terminals. Replace the cable terminals and the nuts if excessively corroded.
	Incorrect timing of injection pump.	Check and correctly time the injection pump.
	Deposits or water in the fuel tank.	Disconnect the hoses and clean them using a jet of compressed air. Dismantle and clean the injection pump. Remove water from tank and refuel.
	No fuel in tank.	Refuel.
	No power supply.	Overhaul or replace the fuel or transfer pump.
	Air bubbles in the fuel lines or injection pump.	Check the hoses to ensure that air is in fact present and also check the fuel pump. Eliminate the air from the injection pump by unscrewing the cap and working the fuel pump by hand.
Faulty starter motor.	Repair or replace the starter motor.	

ANOMALY	POSSIBLE CAUSE	REMEDY
The engine does not start at low temperatures	Fuel system clogged with paraffin crystals forming due to the use of unsuitable fuel.	Replace the fuel with fuel suitable for use at low temperatures. Replace the fuel filters.
	K.K.S.B. device for cold spark advance control operating incorrectly.	Check or replace the injection pump.
The engine cuts out.	Idle rpm too low.	Adjust with adjustment screw.
	Irregular flow of injection pump.	Adjust flow.
	Impurities or water in the fuel lines.	Disconnect the hoses and clean them using a jet of compressed air. Dismantle and clean the injection pump. Remove water from fuel tank and refuel.
	Clogged fuel filter.	Dismantle and replace if necessary.
	Presence of air in the fuel and injection system.	Check that the hoses are not cracked or the unions loose. Replace worn parts, remove the air from the hoses and deaerate the injection pump and fuel filter by unscrewing the caps and working the primer pump by hand.
	Broken injection pump controls.	Replace the faulty parts.
	Abnormal clearance between camshaft cams and tappets.	Adjust clearance by replacing shims.
Burnt, corroded or chalky valves.	Replace the valves, rectify or replace the cylinder head seatings.	

ANOMALY	POSSIBLE CAUSE	REMEDY
The engine overheats	Faulty water pump.	Check the unit and replace if necessary. Replace the gasket.
	Malfunctioning thermostat.	Replace the thermostat.
	Fouling in coolant openings in the cylinder head and cylinder groups.	Wash following the standards specified for the type of descaling product used.
	Water pump drive belt slack.	Check and adjust the tightness of the belt.
	Coolant level too low.	Top-up radiator with coolant.
	Incorrect engine timing.	Check timing and tune correctly.
	Incorrect calibration of injection pump.	Correct the delivery rate of the pump on a bench so that the injection is at the specified rate.
	Dry air cleaner blocked.	Clean the air filter or replace if necessary.
Engine operation is irregular and lacks power	Incorrect timing of injection pump.	Check timing and correctly set pump.
	K.K.S.B. automatic cold advance device malfunctioning.	Check or replace injection pump.
	Excessive piston wear.	Check or replace injection pump.
	Incorrect calibration of speed regulator.	Check and correctly calibrate the regulator.

ANOMALY	POSSIBLE CAUSE	REMEDY
Engine operation is irregular and lacks power	Partial blockage of nozzles or faulty operation of injectors.	Clean the nozzles of the atomisers using the appropriate tools and completely overhaul the injectors.
	Impurities or water in the fuel and injection system.	Carefully clean the system and refuel.
	Incorrect play between camshaft cams and tappets.	Check and correct play
	Faulty turbocharger.	Replace complete unit.
	Air cleaner blocked.	Clean or replace air cleaner.
	Faulty operation of L.D.A. device	Check that the diaphragm is not perforated, that the counter spring is suitable and that it has the correct loading (check on test bench). Check that there is adequate air pressure inside the intake manifold in relation to the engine rpm under full-load conditions.
	Tie rods between accelerator pedal and regulation lever incorrectly adjusted.	Adjust the tie-rods so that the command lever can be moved to the full delivery position.
Engine running with abnormal knocking	Faulty operation of injectors.	Replace all injectors.
	Fuel lines blocked.	Dismantle the hoses, clean them and replace those that are seriously dented.
	Incorrect set-up of injection pump.	Correct the set-up of the pump so that injection occurs at the specified angle.

ANOMALY	POSSIBLE CAUSE	REMEDY
Engine running with abnormal knocking	Knocking of crankshaft causing excessive play on one or more main or rod bearings or excessive play on shoulders.	Rectify the pins of the crankshaft and install smaller bearings. Replace the thrust half-rings.
	Crankshaft unbalanced.	Check alignment of crankshaft.
	Loosening of screws securing flywheel.	Replace the loosened screws and tighten all the screws to the specified torque.
	Misalignment of rods.	Replace the rods.
	Noise from piston journals due to excessive play of piston hubs and in the rod bushing.	Replace the piston journal and/or the piston and rod bushing.
	Loose bushings in the rod seatings.	Replace with new bushings.
The engine smokes abnormally. Black or dark grey smoke.	Excessive maximum pump output.	Disconnect the pump and adjust delivery in accordance with the data given in the calibration table.
	K.K.S.B. device out of calibration or malfunctioning.	Check operation by a tester and adjust correctly as described in the manual.
	There is an excessive delay on the injection pump.	Correct the set-up.

ANOMALY	POSSIBLE CAUSE	REMEDY
The engine smokes abnormally. Black or dark grey smoke.	The injection pump has an excessive advance.	Correct the set-up.
	The holes in the atomisers (or some of them) are partially or entirely blocked.	Replace the injectors with a series of new injectors or clean and rectify the original ones using suitable equipment.
	Air cleaner blocked or deteriorated.	Clean or replace the filter element.
	Loss of compression in the engine due to: stuck or worn flexible rings; worn cylinder liners; valves deteriorated or badly adjusted.	Overhaul the engine or limit the interventions to the relative parts.
	Unsuitable injectors, different types of injectors or incorrectly calibrated.	Replace or calibrate the injectors.
	Injection hoses with an unsuitable internal diameter, end of hoses pinched due to repeated blocking.	Check conditions of the end or unions and where necessary replace the hoses.
Blue, grey-blue, grey smoke tending to white.	Excessive delay in injection pump.	Correct the set-up of the pump.
	K.K.S.B. automatic cold advance device malfunctioning.	Check or replace injection pump.
	Faulty injector.	Replace the injector.
	Leaking of oil from the piston rings caused by glued or worn rings or wearing of cylinder liner walls.	Overhaul the engine.
	Engine oil passing through the intake guides-valves following wearing of guides or valve stems.	Recondition the cylinder head.
	Engine too cold (thermostat blocked or inefficient).	Replace the thermostat.