

DETROIT DIESEL



TECHNICIAN GUIDE



**SERIES 4000 COMMON RAIL
FUEL SYSTEM**

ATTENTION

This bulletin is a guideline for qualified personnel. The information contained in this bulletin may not be complete and is subject to change without notice.

WORK SAFELY



CAUTION:

The service procedures recommended by Detroit Diesel Corporation and described in this Technicians Guide are effective methods of performing service and repairs. Some of these procedures require the use of tools specially designed for this purpose.

Accordingly, anyone who intends to use a replacement part, service procedure or tool which is not recommended by Detroit Diesel Corporation must first determine that neither their safety nor the safe operation of the engine will be jeopardized by the replacement part, service procedure or tool selected.

This Technician's Guide contains various work procedures that must be carefully observed in order to reduce the risk of personal injury during service or repair or the possibility that improper service or repair may damage the engine or render it unsafe. It is also important to understand that these work

procedures are not exhaustive, because it is impossible for Detroit Diesel Corporation to warn of all the possible hazardous consequences that might result from failure to follow these instructions.

A service technician can be severely injured if caught in the pulleys, belts or rotating parts of an engine that is accidentally started. To avoid personal injury, take this precaution before starting to work on an engine:

Disconnect the battery from the starting system by removing one or both of the battery cables (disconnect negative [ground] cable first). With the electrical circuit disrupted, accidental contact with the starter button will not produce an engine start.

Follow all lockout procedures as required.

SAFETY PRECAUTIONS TO OBSERVE WHEN WORKING ON THE ENGINE

1. Consider the hazards of the job and wear protective gear such as safety glasses, safety shoes, hard hats, hearing protection, etc. to provide adequate protection.
 2. When using a lifting device, make sure the lifting device is fastened securely. Be sure the item to be lifted does not exceed the capacity of the lifting device.
 3. Always use caution when using power tools.
 4. When using compressed air to clean a component, such as flushing a radiator or cleaning an air cleaner element, use a safe amount of air. Too much air can rupture or in some other way damage a component and create a hazardous situation that can lead to personal injury. Always wear adequate eye protection (safety glasses, safety face shield) when working with compressed air.
 5. To avoid possible personal injury when working with chemicals, steam and/or hot water, wear adequate protective clothing (face shield, rubber apron, gloves, boots, etc.) work in a well ventilated area, and exercise caution.
 6. Avoid the use of carbon tetrachloride, carbon dissolved, methylene, chloride, perchloroethylene and trichloroethylene as cleaning agents because of harmful vapors they release. Use 1.1.1 – trichlorethane.
- However, while less toxic than other chlorinated solvents, use it with caution. Be sure the work area is adequately ventilated and wear protective gloves, goggles or face shield and an apron. Follow chemical manufacturer's use and safety recommendations.
- Mineral spirits or mineral spirits based solvents are highly flammable. They must be stored and used in "No Smoking" areas away from sparks and open flames.
7. Do not weld on or near the diesel fuel tank until it has been thoroughly emptied and ventilated. Possible explosion could result if this precaution is not taken.
 8. Failure to inspect parts thoroughly before installation, failure to install the proper parts or failure to install parts properly can result in component or engine mal-function and/or damage and may also result in personal injury.
 9. When working on an engine that is running, accidental contact with the hot exhaust manifolds or turbochargers can cause severe burns. Avoid making contact across the two terminals of a battery, which can result in severe arcing.
 10. Turbocharger air inlet shields should be used if operation of the turbocharger is necessary without normal piping, to avoid injury.

Series 4000 Fuel System Technician Guide

Table of Contents

	<u>Page</u>
INTRODUCTION	1
SAFETY	1
DESCRIPTION OF FUEL SYSTEM	3
COMMON RAIL FUEL SYSTEM OPERATION	5
DETROIT DIESEL ELECTRONIC CONTROL (DDECIV)	9
COMPONENT REVIEW (INDEX)	15
• HIGH-PRESSURE FUEL PUMP	17
• LOW-PRESSURE DELIVERY FUEL PUMP	25
• ELECTRONIC UNIT INJECTOR	31
• FUEL RAILS AND LINES	37
• FLOW LIMITER VALVES	53
• C&I FUEL JUNCTION BLOCK AND SECONDARY FILTERS	57
• MARINE SECONDARY FUEL FILTERS	61
• ECM COLD PLATE (S)	63
• FUEL LEAK MONITOR SYSTEM (MARINE)	65
• DDEC SENSORS	67
FUEL SYSTEM PLUMBING REQUIREMENTS	68
DAVCO FUEL PRO FILTERS	70
FUEL SYSTEM PRIMING PROCEDURE	72
FUEL SYSTEM TROUBLE SHOOTING	74
TORQUE SPECIFICATIONS FOR FUEL SYSTEM COMPONENTS	78
SERVICE PUBLICATIONS	80
NOTES	

Series 4000 Fuel System Technician Guide

INTRODUCTION

The purpose of a properly designed fuel system is to provide clean fuel, free from air, water or dirt, and to deliver fuel to the engine at correct amounts for good combustion to provide optimum power, fuel economy and emissions compliance.

A unique feature of the Series 4000 is the common rail fuel injection system. This system relies on a single high-pressure fuel pump that provides a continuous supply of fuel, at injection pressure, to all of the injectors at all times. This common rail fuel system does not require cam driven unit injectors or injection pumps with separate cam driven plungers to make fuel pressure for each injector. The unit injectors in the Series 4000 common rail fuel system do not make fuel pressure. DDECIV Electronics alone control injector timing, the amount of fuel and atomization of fuel being supplied from the high-pressure rails. The Common Rail Fuel System provides the Series 4000 with the most advanced fuel system technology available today.

The Common Rail Fuel System consists of many unusual components not found in other diesel fuel systems. Therefore, the Fuel System Technician Guide is intended to help better understand the Common Rail Fuel System operation and components as well as provide failure analysis to properly maintain this unique system for maximum performance.

This manual is applicable to all engine sizes and product applications of the Series 4000 and is intended to be expanded upon, as additional information becomes available. It is also a good place for the technician to add helpful notes on the fuel system for future reference.

SAFETY

Safety is always our first concern. To guard against safety mishaps while working on the common rail fuel system, there are a couple of areas of caution to be noted:

The common rail fuel system operates at pressures up to 19.6 KPSI (19,000 PSI). Fuel at this pressure can be very hazardous causing bodily injury or fire if proper repair procedures are not followed. Fuel under high pressure creates a very fine spray, which can penetrate the skin or cut! Appropriate safety equipment should be worn to prevent injury. **NEVER ATTEMPT REPAIRS OF HIGH-PRESSURE FUEL LEAKS WHILE AN ENGINE IS IN OPERATION!**

Under certain conditions the high-pressure fuel lines from the high-pressure fuel rail to the injectors can become heated from combustion gases. Care should be taken to prevent the possibility of burns from excessive contact with these fuel lines.

Description of Fuel System

Common Rail Fuel System - A Bank

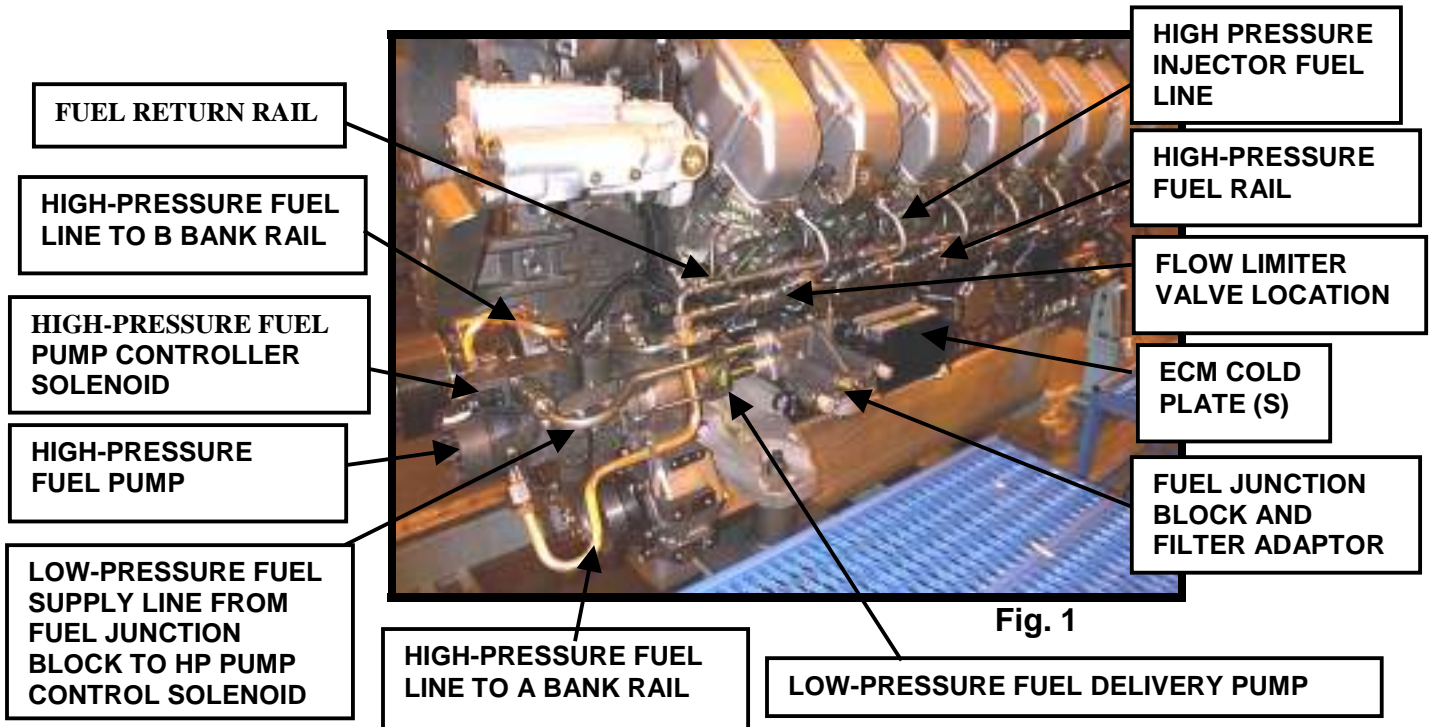

Fuel Delivery System - A Bank

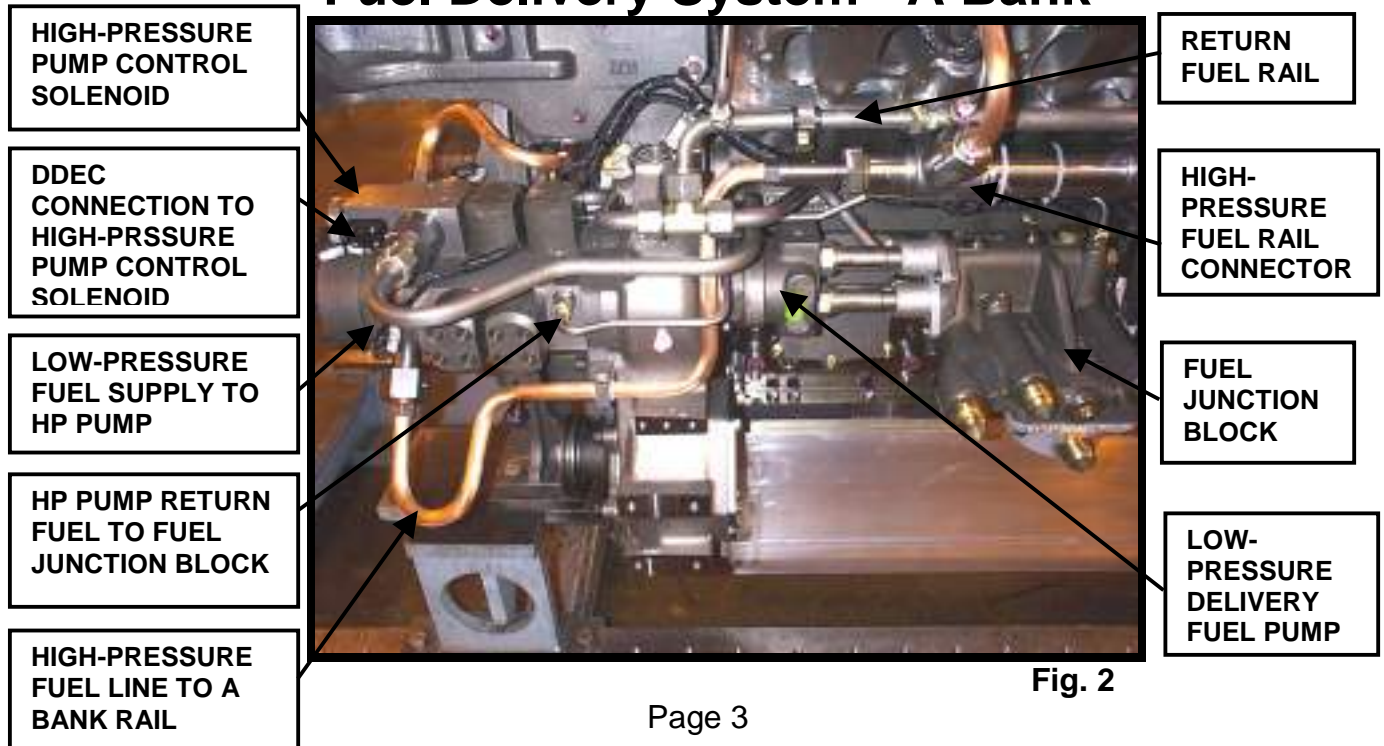

Description of Fuel System

High-pressure Rail - A Bank

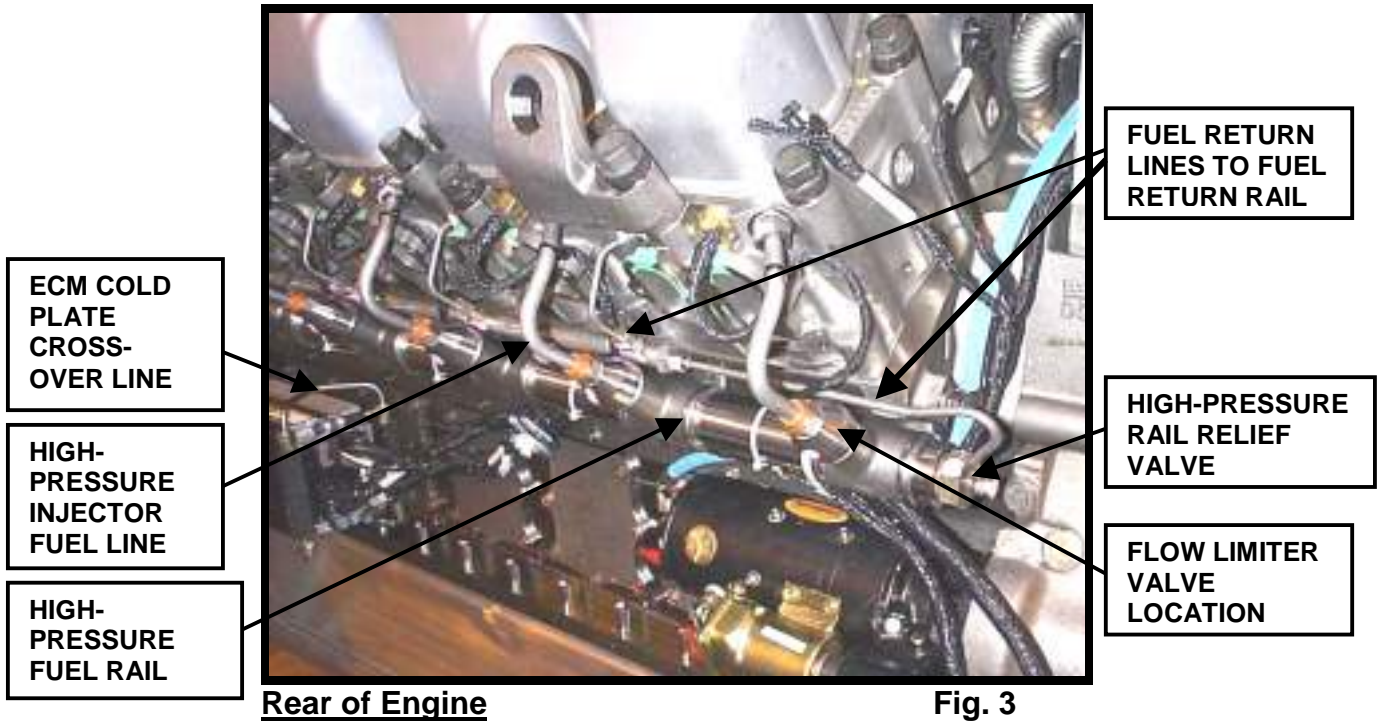

High-pressure Rail B Bank

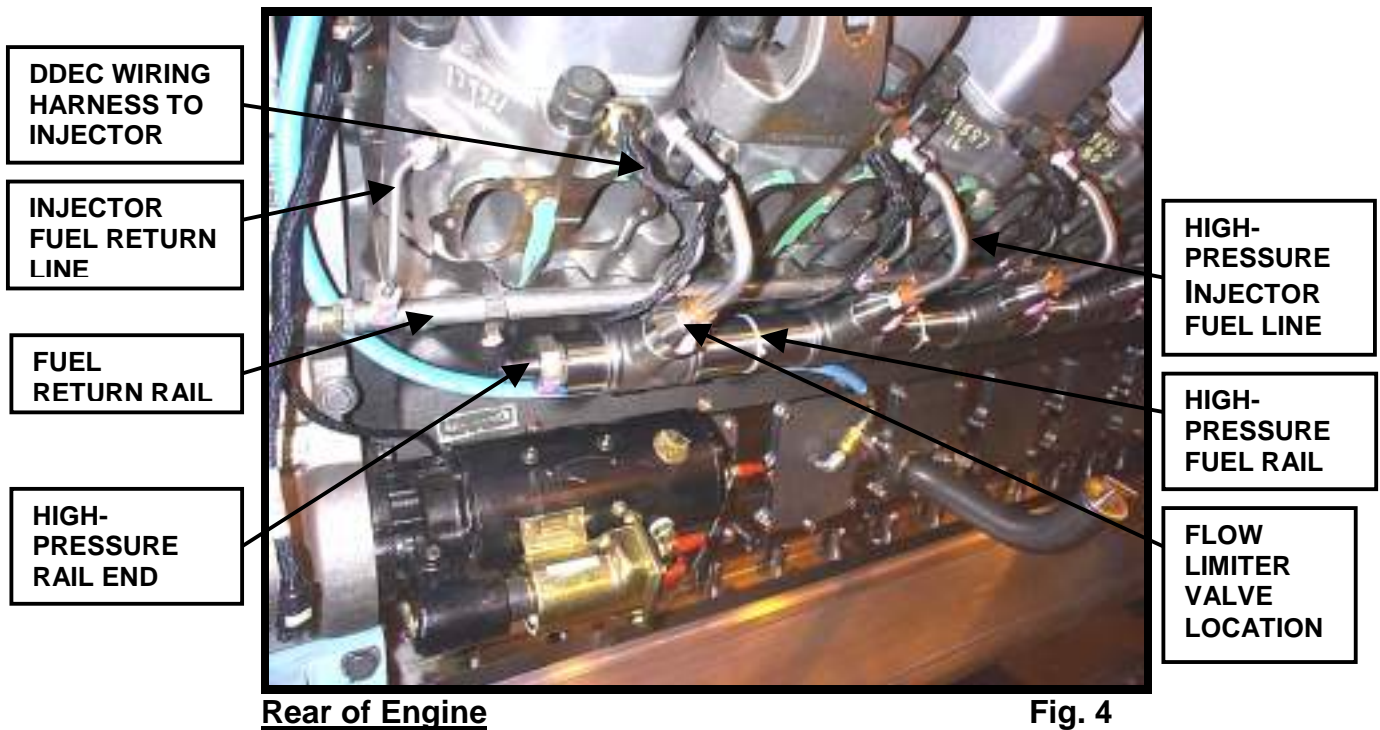

Common Rail Fuel System Operation

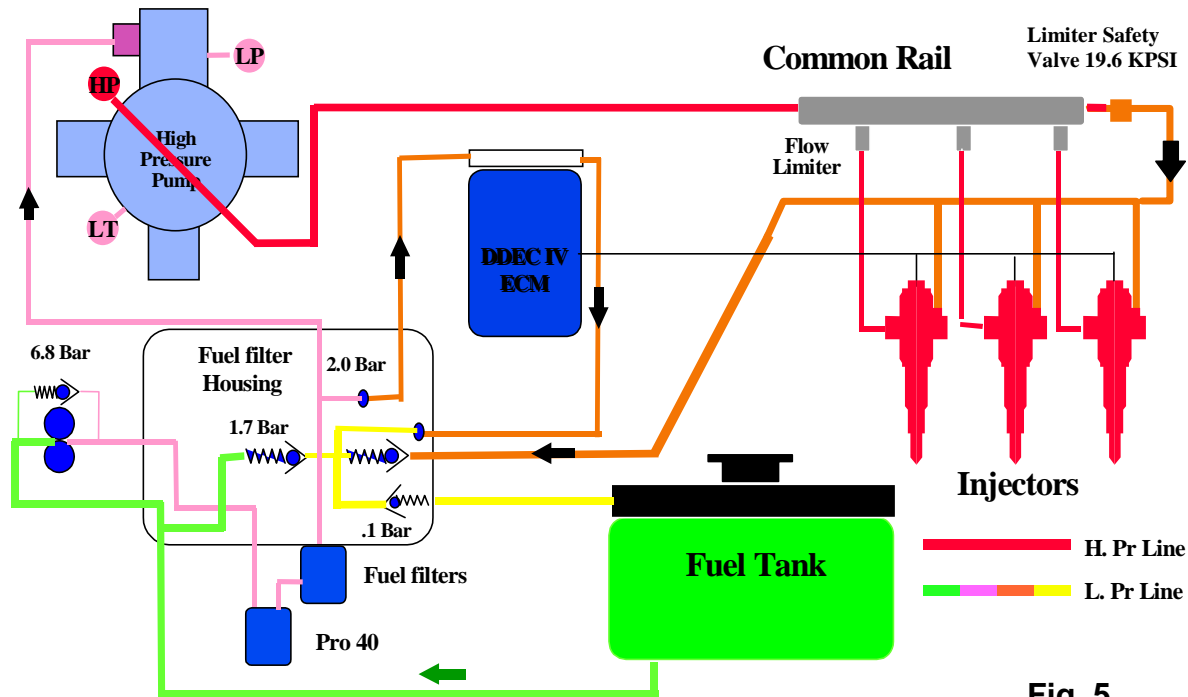

Fig. 5

The Common Rail Fuel System used on the Series 4000 is a two-stage fuel distribution system. Gear driven fuel pumps maintain constant fuel supply pressure. This pressure is supplied to the common rails then to all injectors. Constant high-pressure is available regardless of crankshaft position or engine speed.

The first stage is the fuel transfer side which brings fuel from the fuel tank, through the filters, and provides low-pressure fuel supply of 65 PSI at idle to 85 PSI at full load to the second stage high pressure system. Additionally, low-pressure fuel is sent to the ECM Cold Plates to protect the ECM's from excessive heat (Refer to page 63). An OEM supplied fuel cooler should be incorporated in the fuel system to assist the cooling function for the ECM's. Additionally, low-pressure fuel is used for cooling and lubrication in the high-pressure fuel pump. However, unlike other fuel systems, fuel temperature has no effects on engine power or performance due to the extremely high fuel operating pressure, which prevents the fuel from boiling and vaporizing.

The high-pressure system receives the low-pressure fuel at the control regulator and further pressurizes it in the high-pressure pump from (8.3 KPSI at idle to 17.4 KPSI) for non-low flow injectors and (7.25KPSI at idle to 13.1KPSI) for low flow injectors at maximum load conditions to the high-pressure rails. (Refer to page 17). Fuel pressure at Full No-Load averages about 11.4 KPSI. A 19.6 KPSI safety-relief valve on the A-bank rail protects the fuel system components from damage due to excessive pressure.

Common Rail Fuel System Operation

High-pressure fuel as received at each injector provides lubrication and cooling of the injectors while awaiting the DDECIV signal from the ECM's to the injector solenoid to start the injection event. Approximately 90% of the fuel received at the injectors is injected into the engine cylinder for combustion, while 10% of the fuel is returned to the fuel tank under full load conditions.

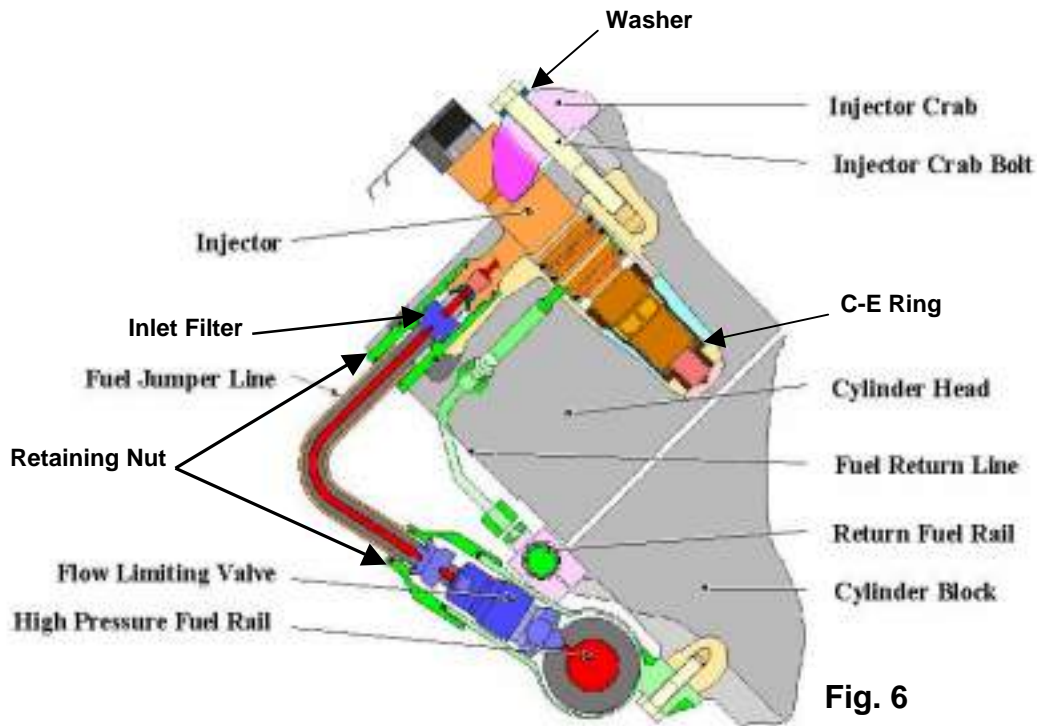

CROSS SECTION VIEW OF FUEL SYSTEM AT CYLINDER HEAD

The high-pressure fuel rails provide continuous pressure at all times to all injectors within the engine. The high-pressure fuel rail at each cylinder location is a port, which is fitted with a flow-limiter valve. High-pressure fuel passes from the stainless steel high-pressure rails through flow limiter valves to the injectors. The flow limiter valves operate by sensing fuel flow differential, which can shut off the flow of fuel to prevent excessive over fueling of a cylinder in the event of a faulty injector (Refer to page 53).

All of the joints from the high-pressure rail to the flow limiter valves to the injectors are conical shaped metal-to-metal sealing (Refer to page 37).

Common Rail Fuel System Operation

The high-pressure fuel line to the injectors is double walled with an air gap between the stainless steel inner tube and the outer copper protective tube (Refer to page 44). This air gap is also a vent from the injector providing early warning of poor injector C-E Ring sealing. The injector has a vent hole drilled in the body from below the lower O-ring land out through the injector arm to the high-pressure line joint surface, which aligns with the air gap in the high-pressure fuel line (Refer to page 31).

The injector is retained in the cylinder head hole tube by the injector hold down clamp and retaining bolt. The clamp load provided by this hold down crab and bolt works with the C-E Ring located at the injector nozzle to provide a compression seal with the injector hole tube inner surface. The high-pressure injector fuel line fittings are held in position to the tube by retaining nuts on each end (Refer to page 44). These retaining nuts have reverse threads, which requires a special tool for installation.

At the inlet of the injector, recessed in the arm, is an inlet filter screen. This screen is a safety element intended to trap foreign material, which could find its way to the injector. The injector assembly has three O-ring seals between the injector body and the cylinder head to control the flow of the return fuel from the injector into the cylinder head return passage (Refer to page 31). Unused fuel from the injector exits the injector through the passage between the second and third O-ring land into the return port in the cylinder head. The return fuel then passes through the external return fuel line from the cylinder head to the return fuel rail back to the fuel tank.

Cylinder Head View

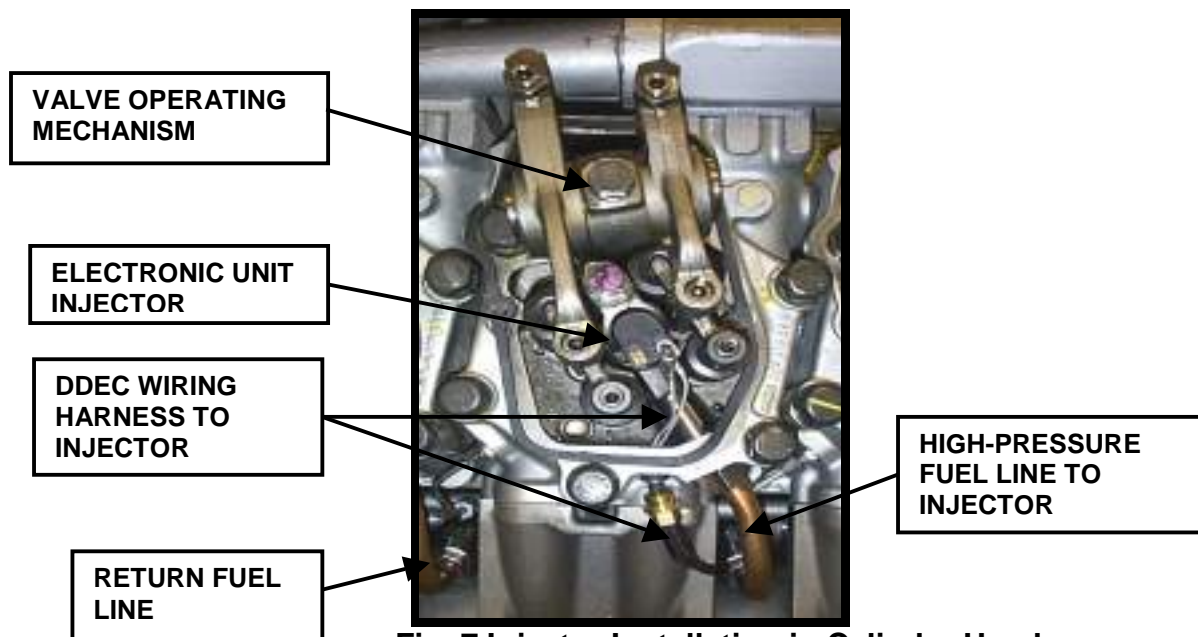

Fig. 7 Injector Installation in Cylinder Head

Detroit Diesel Electronic Controls

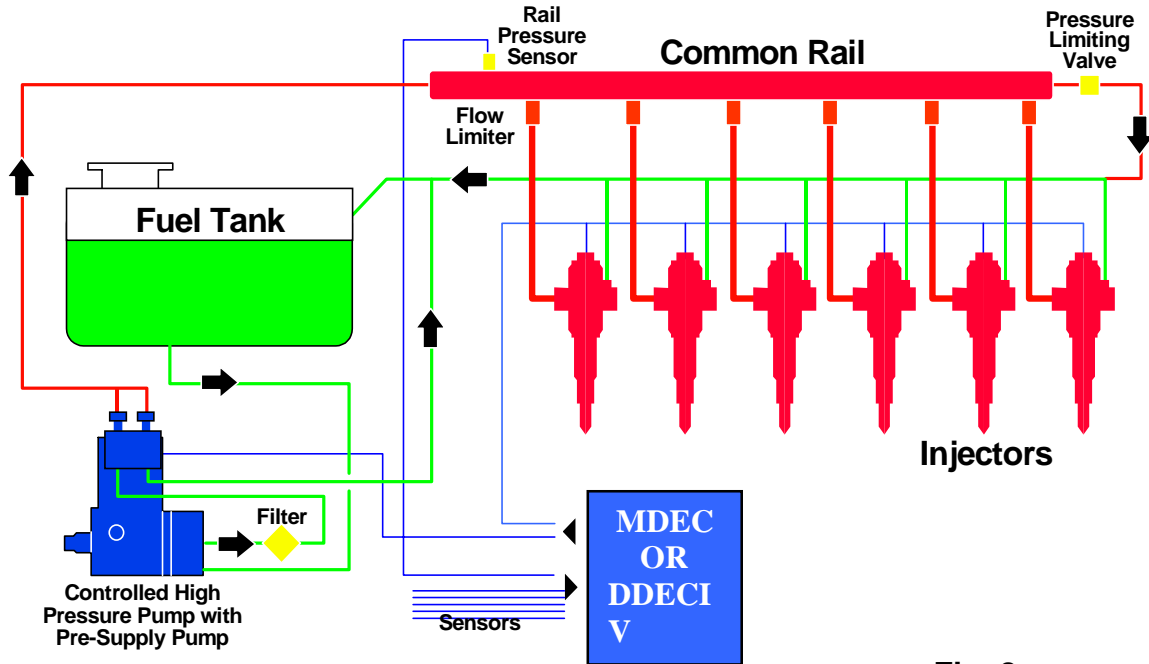

Fig. 8

DDECIV electronics control the beginning of injection or timing of the event and the duration of the injection event, which determines the amount of fuel being injected. Timing of the injection event is totally a function of DDECIV and not that of the camshaft lobe profile as in other fuel systems.

DDECIV sends a signal to the injector solenoid to inject fuel into the cylinders. To provide this control, DDECIV electronics utilize state of the art microprocessors to gather information from the engine and its operating environment to be used in determining the optimum schedule of fuel injection. Part of the information gathered is from the fuel system itself. DDECIV receives feedback for the injector solenoids as to their performance in the form of Response Times as seen in the DDEC printout shown in Fig. 9.

RESPONSE TIMES		
INJECTOR	A1	0.82ms
INJECTOR	A5	0.82ms
INJECTOR	A3	0.82ms
INJECTOR	A6	0.83ms
INJECTOR	A2	0.82ms
INJECTOR	A4	0.84ms
INJECTOR	B2	0.83ms
INJECTOR	B4	0.83ms
INJECTOR	B1	0.83ms
INJECTOR	B5	0.84ms
INJECTOR	B3	0.82ms
INJECTOR	B6	0.83ms

Fig. 9 Injector Response Times Printout.

Detroit Diesel Electronic Controls

The Common Rail Fuel System consists of several sensors used to evaluate its own performance. These sensors are; high fuel pressure, low fuel pressure and fuel temperature, which are located on the high-pressure fuel pump as shown in Fig. 10.

The low fuel pressure sensor provides information on the availability of low-pressure fuel being supplied to the high-pressure pump. The high fuel pressure sensor provides information on the fuel pressure within the high-pressure rails available for injection. The fuel temperature sensor provides information on the temperature of the fuel being supplied to protect the ECM's and high-pressure fuel pump.

HIGH-PRESSURE FUEL PUMP

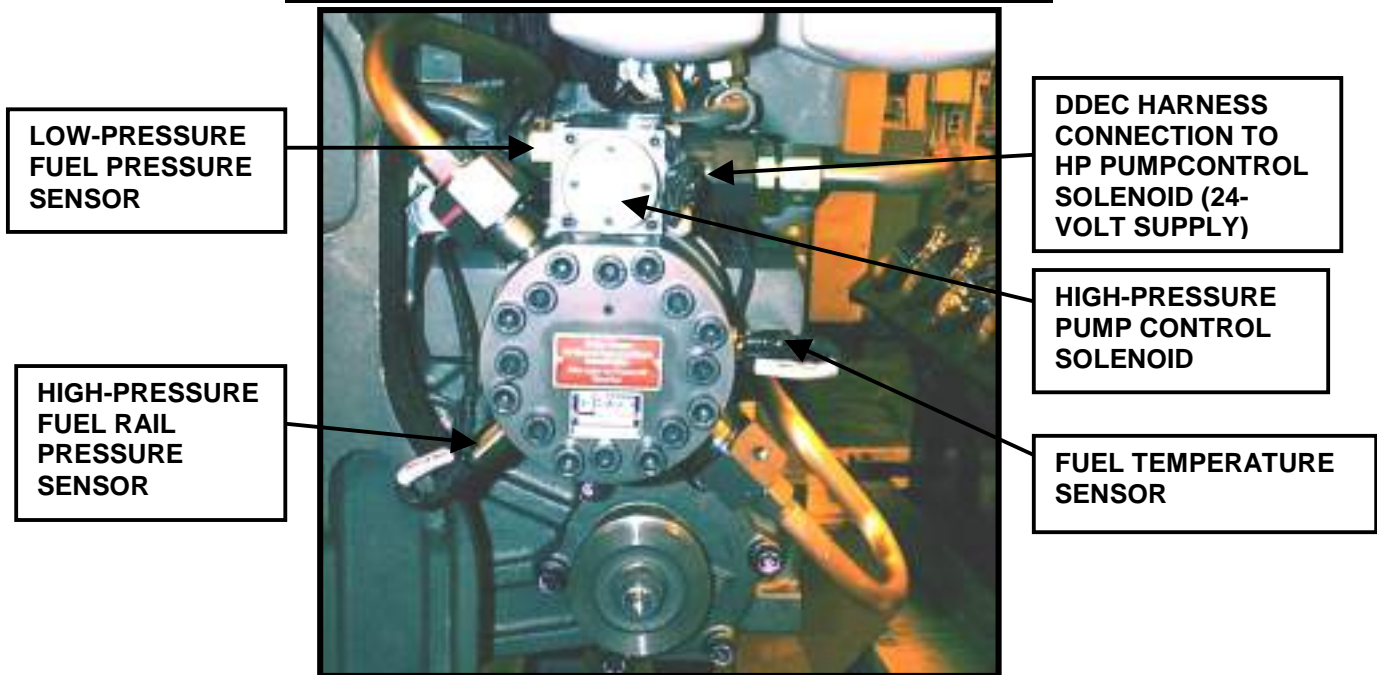

Fig. 10 High-pressure Pump Sensor Locations.

The high-pressure fuel pump receives low-pressure fuel from the fuel delivery pump and controls the high-pressure fuel output with the control solenoid, which receives input from the Master ECM and provides feedback information to the Master ECM. This input and output can be read with a DDR as PWM3 and Injection Pump Usage (Refer to Fig. 11).

The normal PWM3 operating range is 8-52%. Injection pump usage operates between 2% and 98% range. The normal injection pump usage at 100% engine load is in the 45-65% range at 1900 RPM. The control solenoid operates on 24 Volts DC with a fuse located in the OEM supplied power circuit.

Detroit Diesel Electronic Controls

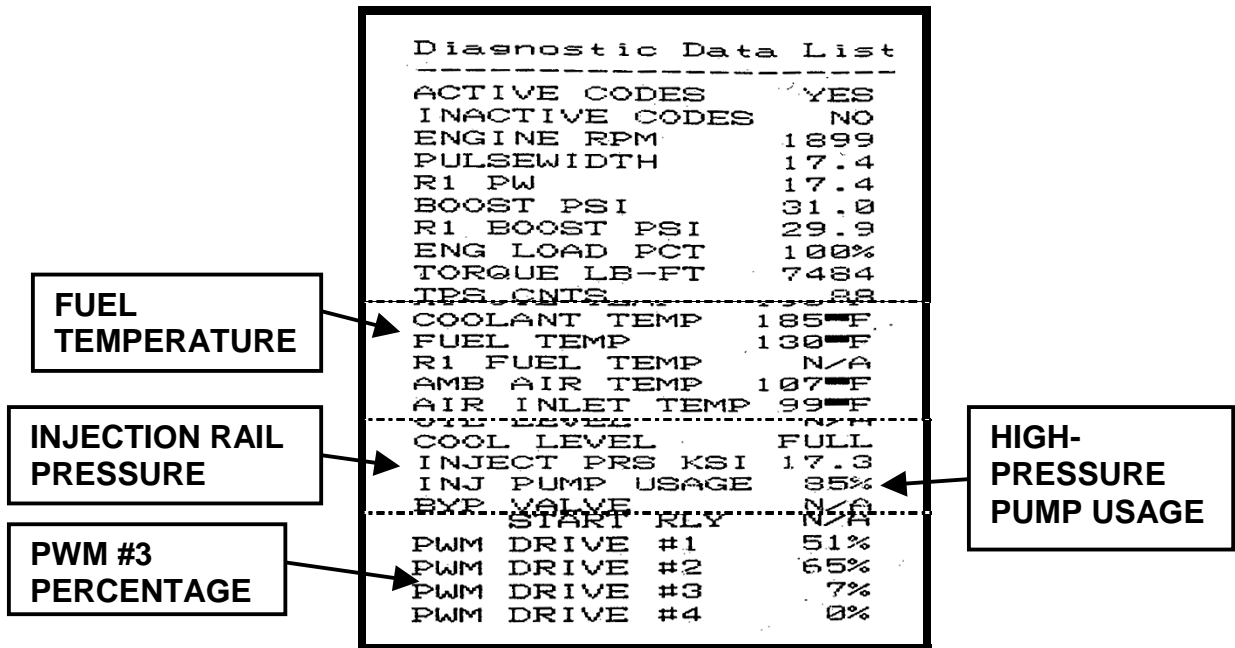

Fig. 11 Diagnostic Data List Printout.

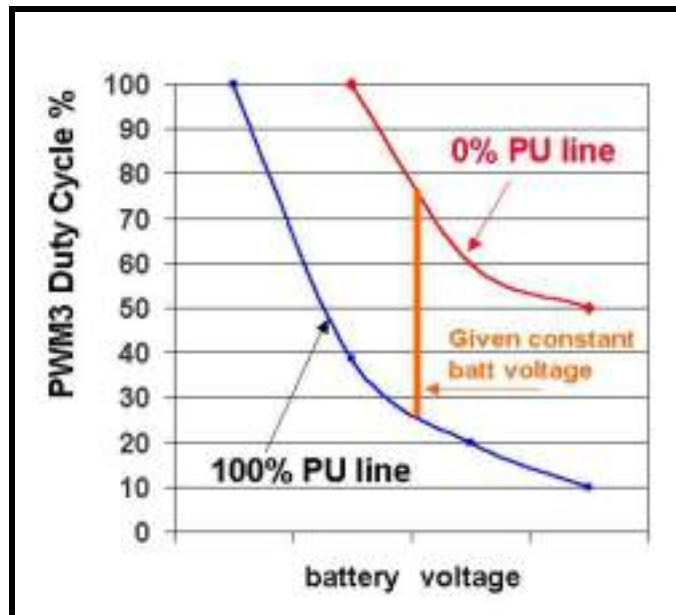

Fig. 12 Relationship Between High-pressure Pump % (Percent) Usage and PWM3.

Detroit Diesel Electronic Controls

ELECTRONIC PILOT INJECTION (EPI)

Normal fuel injection has long ignition delays resulting in large quantities of fuel to be injected before the beginning of combustion. With large amounts of fuel at the beginning of combustion, there is a high rate of cylinder pressure rise, white smoke from unburned fuel and excessive combustion noise.

DDEC controlled Electronic Pilot Injection (EPI) provides a small quantity of fuel injection in advance of the normal injection beginning the combustion process. This is followed by the main quantity of fuel injection to complete combustion. EPI is a form of indirect injection reducing the ignition delay period thereby reducing the rate of pressure rise effectively reducing the unburned fuel and cylinder knock during startup.

Significant reduction in fuel consumption, peak cylinder pressure, rate of pressure rise and emissions are all achieved with EPI.

HALF ENGINE IDLE

The half engine idle feature controlled by DDEC enables the engine to maintain higher cylinder temperature during idle to light load operating conditions. Half engine idle is activated depending on the percent of load, air intake temperature and engine coolant temperature. Half engine operation may occur up to 1900-rpm engine speed.

Half engine operation differs with the 12V4000 from the 16V4000 models on the 12V, only the master ECM fires the "A" bank cylinders; with the 16V, both ECM's control (4) cylinders each for either bank randomly.

Detroit Diesel Electronic Controls

16V4000 Half Engine Operating Zones

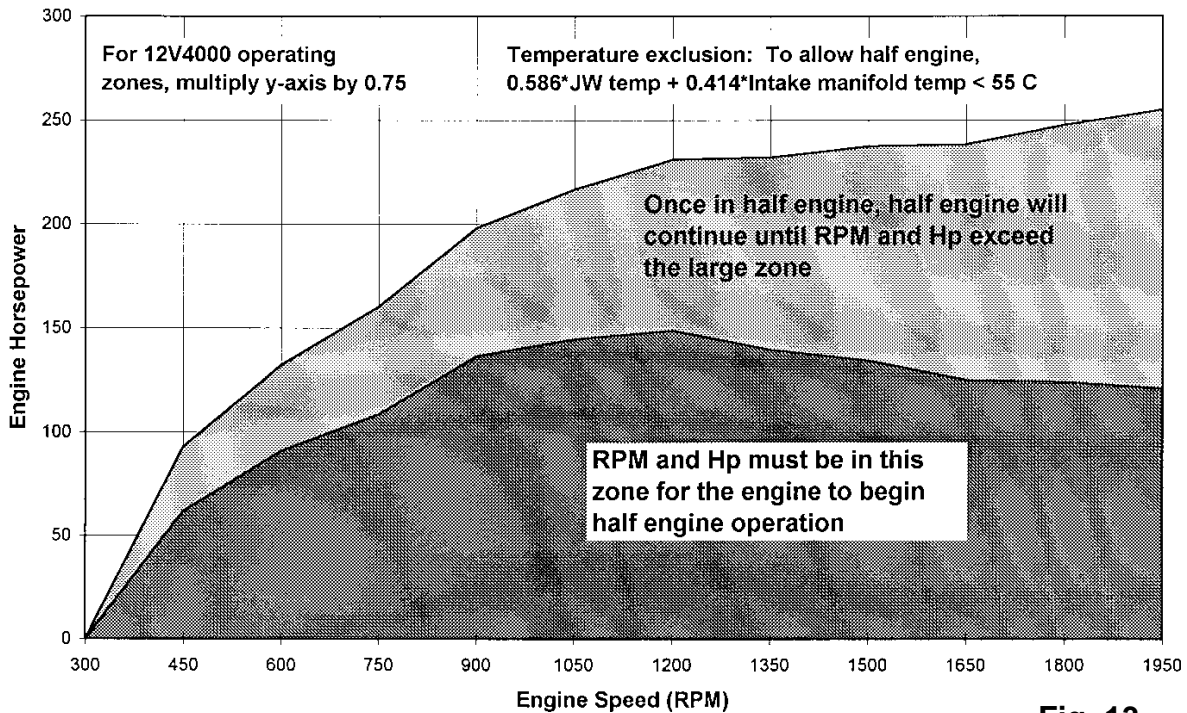

Fig. 13

Series 4000 Low Pressure Fuel Limits

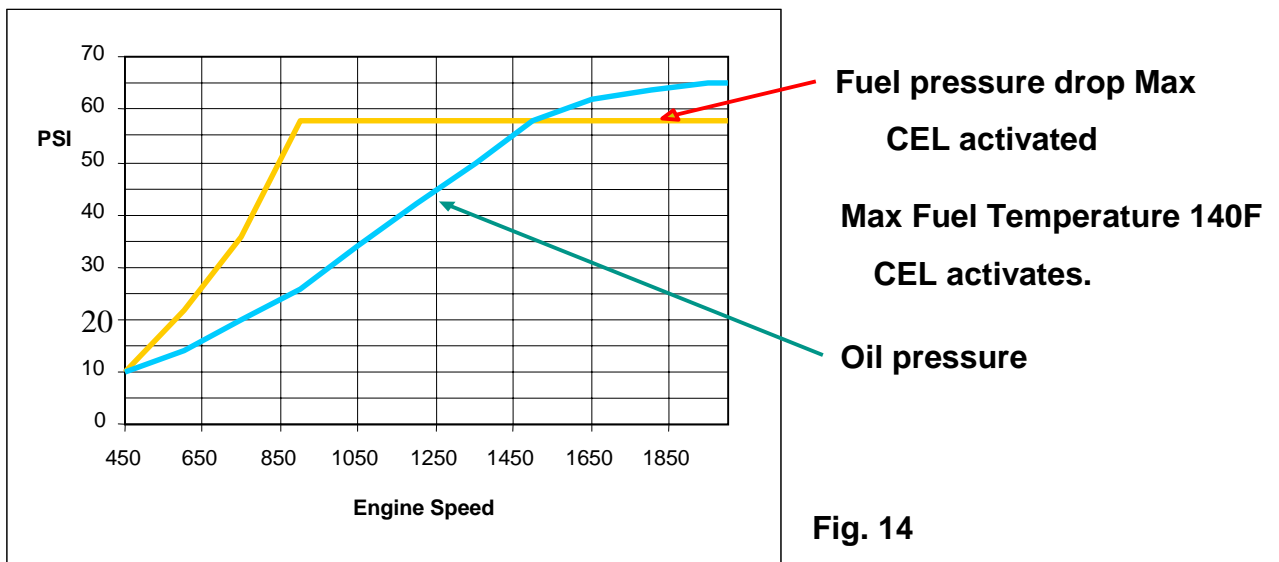

Fig. 14

COMPONENT REVIEW INDEX

	<u>Page</u>
• HIGH-PRESSURE FUEL PUMP	17
• LOW-PRESSURE FUEL DELIVERY PUMP	25
• ELECTRONIC UNIT INJECTOR	31
• FUEL RAILS AND LINES	37
• FLOW LIMITER VALVES	53
• C&I FUEL JUNCTION BLOCK AND SECONDARY FUEL FILTERS	57
• MARINE SECONDARY FUEL FILTERS	61
• ECM COLD PLATE (S)	63
• FUEL LEAK MONITOR SYSTEM (MARINE)	65
• DDEC SENSORS	67

HIGH-PRESSURE FUEL PUMP

The high-pressure fuel pump is mounted on the front side of the gear case and is driven by the A-bank idler gear. The high-pressure pump utilizes a break away driven gear, which disengages itself in the event of a pump failure to prevent engine gear train damage.

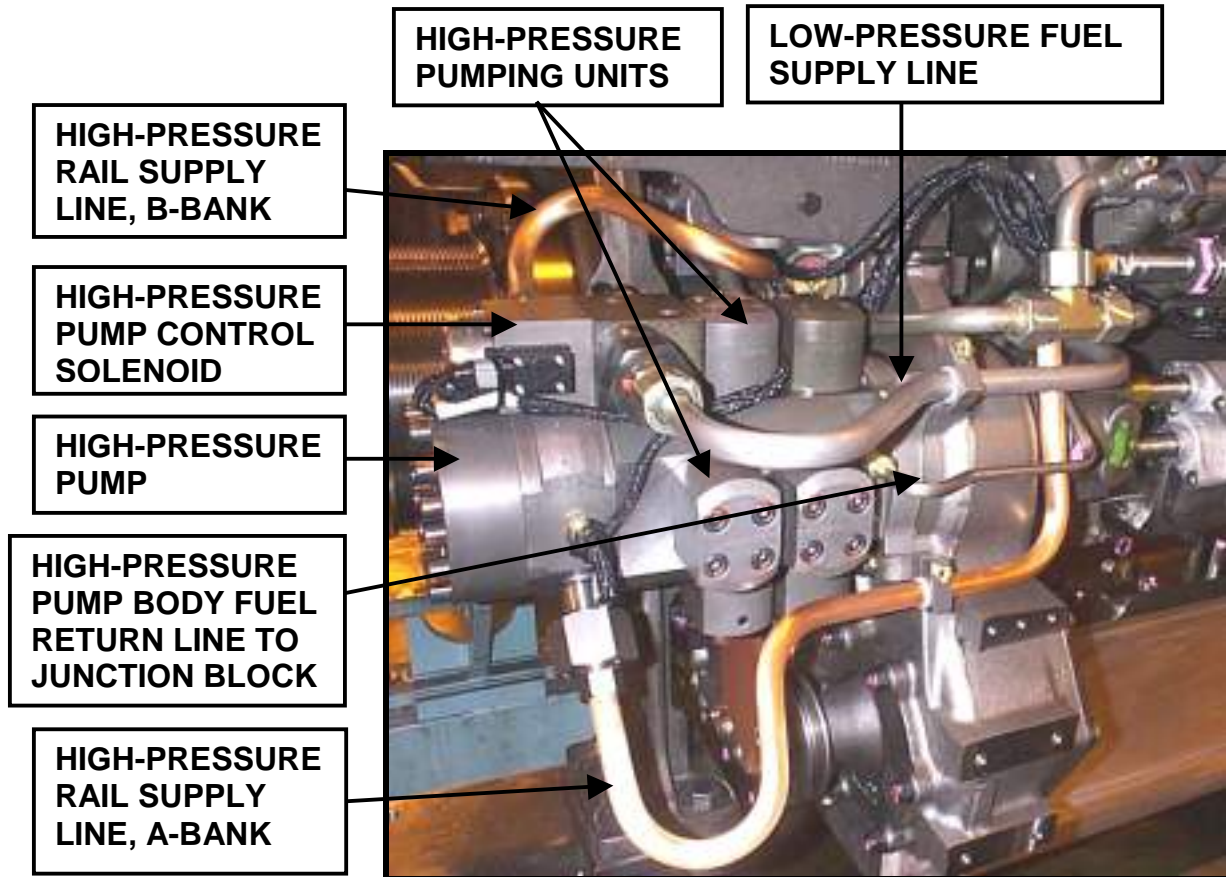

Fig. 15 High-pressure Fuel Pump Installation.

The high-pressure pump receives filtered low-pressure fuel from the fuel delivery pump at the control solenoid. The high-pressure pump control solenoid meters the amount of fuel entry to the high-pressure pump body and pumping units. The control solenoid is 24 volt operated to close against spring pressure in the open direction. (See Page 23).

Part of the fuel received by the high-pressure pump passes to the pump crankcase where it provides lubrication and cooling to the pump camshaft bearings and ceramic rings. The lubrication and cooling fuel exits the high-pressure pump body by a fuel return line to the fuel junction block (See Fig. 15).

HIGH-PRESSURE FUEL PUMP

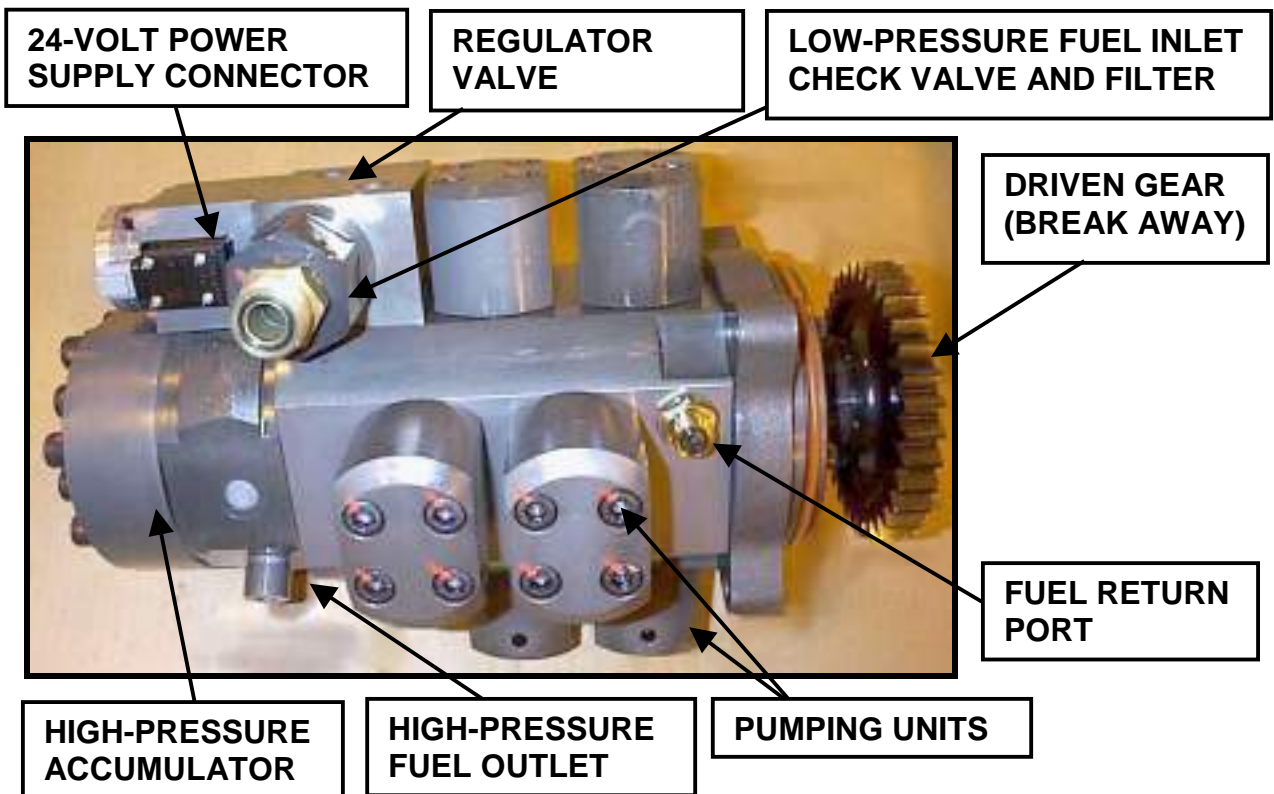
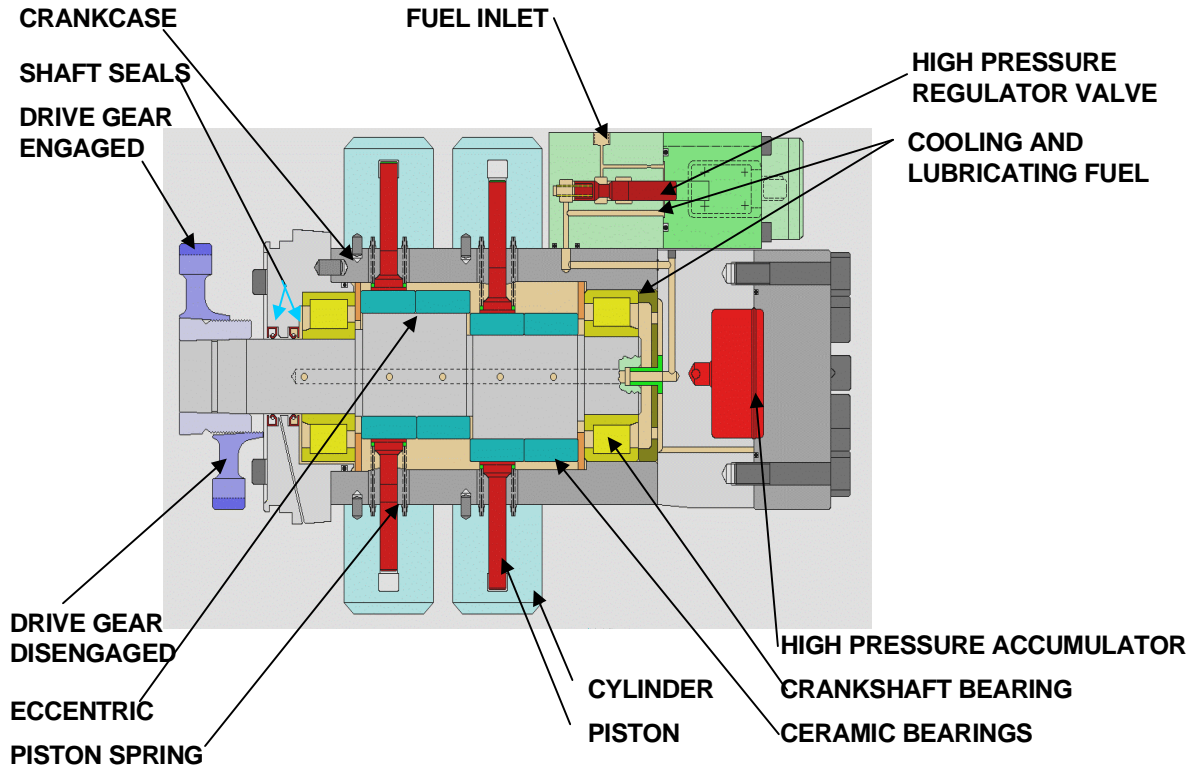

Fig. 16 High-pressure Fuel Pump Assembly

The majority of the fuel entering the high-pressure pump is directed to high pressure pumping units for pressurization to the required operating pressure. There are eight pumping units shown in Figure 16, which are operated by the eccentric camshaft rings and controlled by inlet and outlet check valves. Fuel enters the pumping unit through the inlet check valve, pressurized by the piston to the high operating pressure, then exits through the outlet check valve to the accumulator. There are two high-pressure outlet ports for transferring the pressurized fuel to both the A-bank and B-bank high-pressure rails.

HIGH-PRESSURE FUEL PUMP



SIDE CUT AWAY VIEW (Fig. 17)

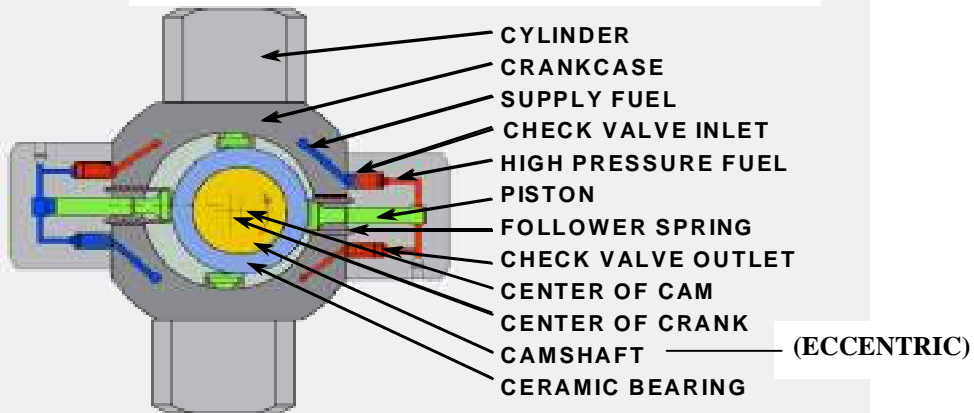

END CUT AWAY VIEW (Fig. 18)

INSPECTION AND ANALYSIS HIGH-PRESSURE FUEL PUMP



Fig. 19 Normal Gear Position



Fig. 20 Disengaged Gear Position

CONDITION: High-pressure pump seized, drive gear disengaged.

CAUSE: High-pressure fuel pump bearing failure. Low-pressure fuel flow restriction, which starved the high-pressure pump causing a lack of lubrication or cooling condition.

RECOMMENDATION: Replace High-pressure pump assembly and follow fuel system cleaning procedure in Maintenance Section. Evaluate fuel system for source of low-pressure fuel flow restriction.

REUSE: Do Not Reuse!

NOTICE: Do not disassemble the high-pressure fuel pump for any reason! If the pump fails to rotate, replace the pump assembly. All high-pressure fuel pumps are to be returned intact as Reliabilt® cores.

INSPECTION AND ANALYSIS HIGH-PRESSURE FUEL PUMP



Fig. 21 High-pressure Fuel Pump Leak at Weep hole.

CONDITION: High-pressure pump leak at weep hole. A damp area at the pump weep hole is acceptable for service. Continuous dripping at the weep hole would define a leak and require servicing.

CAUTION: Presence of excessive amount of diesel fuel could present a safety hazard and should be addressed immediately.

CAUSE: Pump drive shaft pump body seal leaking. Fuel system contaminants can contribute to this cause. Excessive fuel temperature or dry operation of the pump may also result in seal damage.

RECOMMENDATION: Replace High-pressure pump assembly. Evaluate fuel condition and condition of equipment fuel system for contributing factors. Review events of dry operation and priming procedures being used.

REUSE: Do Not Reuse!

NOTICE: Do not disassemble the high-pressure fuel pump for any reason! All high-pressure fuel pumps are to be returned intact as Reliabilt® cores.

HIGH-PRESSURE FUEL PUMP REGULATOR VALVE ASSEMBLY

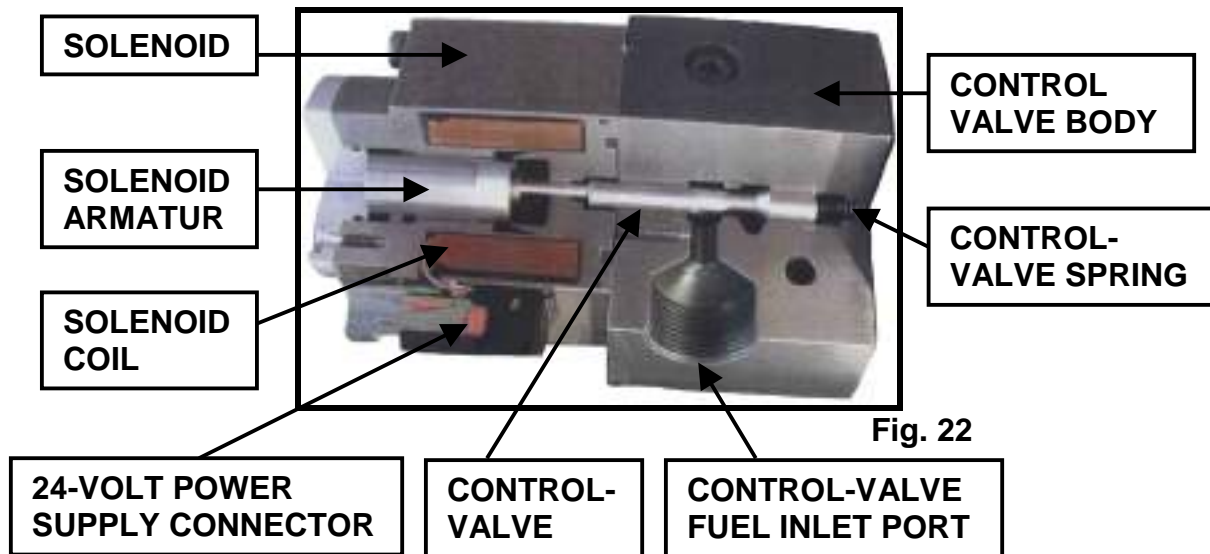

Low-pressure fuel is received at the control-valve fuel inlet port. The control valve plunger is spring actuated in the full fuel position when 24-volt power supply is not present at the solenoid. Depending on the supply voltage received, the solenoid armature acts against the control valve plunger and spring to move to the desired fuel inlet flow rate past the control valve determined by DDEC.

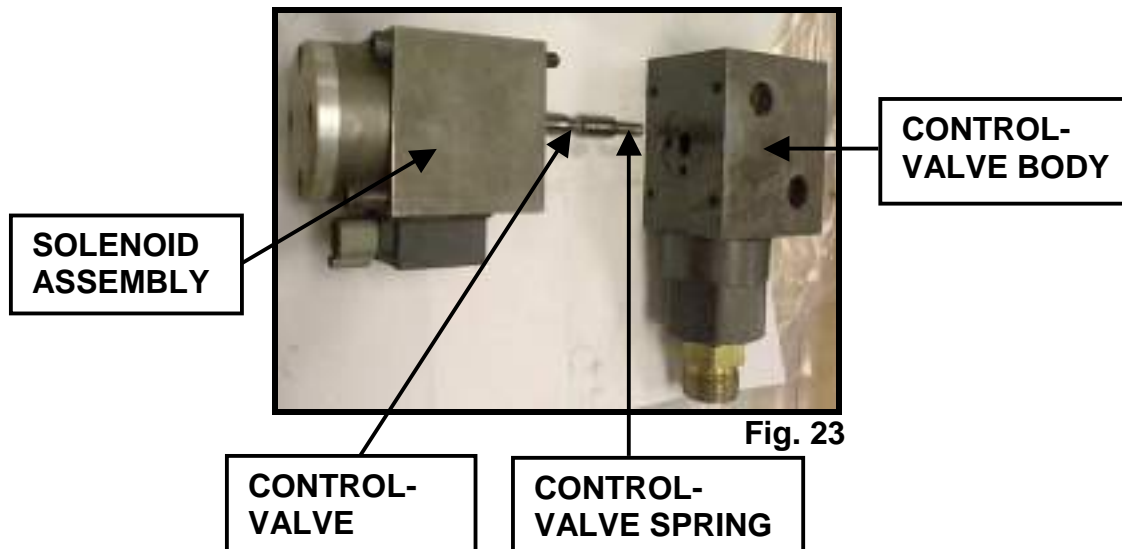

The regulator valve assembly is made up of the solenoid assembly and the control-valve body assembly, which includes the control valve plunger and control valve spring. Only the solenoid assembly is serviced separately from the complete regulator valve assembly.

LOW-PRESSURE FUEL DELIVERY PUMP

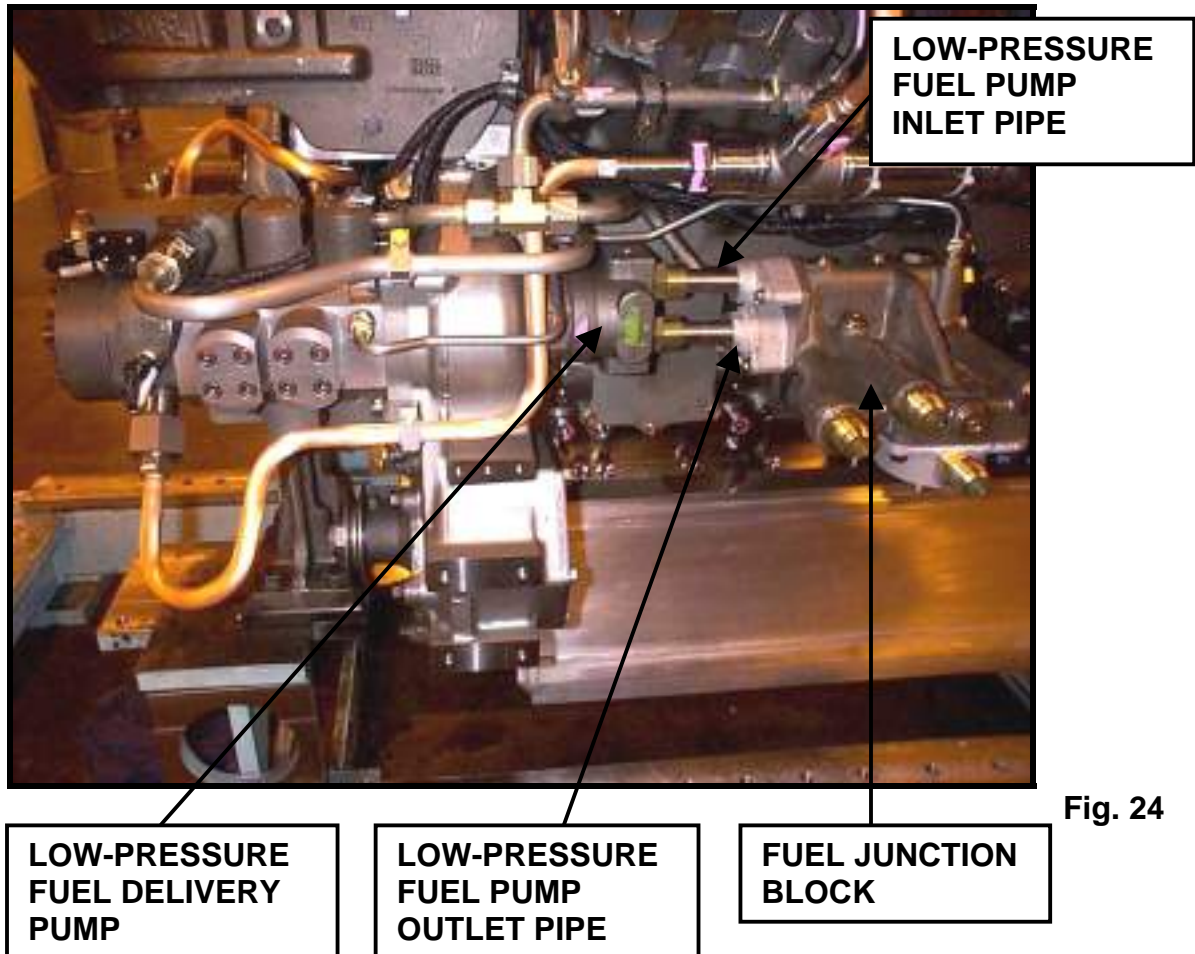

Fig. 24

The low-pressure fuel delivery pump receives fuel from the fuel junction block through the low-pressure pump inlet pipe. The fuel is then pressurized by the low-pressure fuel delivery pump to a normal operating pressure range of 64 PSI to 85 PSI at rated speed. The pressurized fuel is then sent to the fuel junction block via the low-pressure fuel pump outlet pipe. The fuel junction block directs the low-pressure fuel through the primary and secondary fuel filter to the supply line providing low-pressure fuel to the high-pressure fuel pump regulator valve assembly inlet port.

LOW-PRESSURE FUEL DELIVERY PUMP

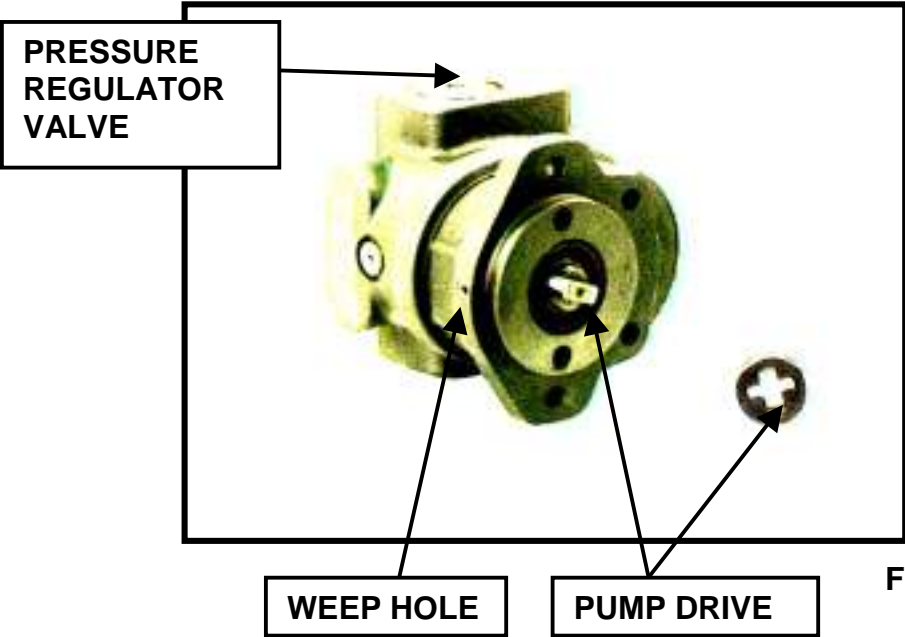

Fig. 25

The low-pressure fuel delivery pump is mounted on the backside of the gear case housing and is gear driven from the rear of the A-bank idler gear behind the high-pressure pump drive. The delivery pump is a gear type mechanical pump utilizing a drive gear with shaft and a driven gear in a two-piece housing (Fig. 26). Pressurized fuel is regulated by a pressure regulator valve and spring mounted in the pump cover (Fig. 25). The maximum pressure is regulated to 105-PSI output. The body and cover of the fuel pump contain support bearings for the drive and driven gears (Fig. 27).

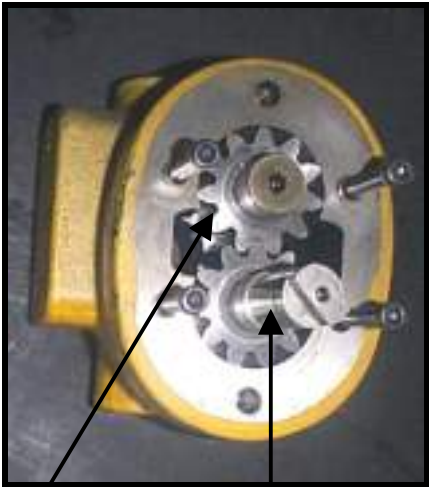

Fig. 26



Fig. 27

DRIVEN GEAR DRIVE GEAR

PUMP COVER SUPPORT BEARINGS

LOW-PRESSURE FUEL DELIVERY PUMP

There are two seals on the drive gear shaft (Fig. 28). The inner seal is used to retain fuel in the pump from leaking past the drive shaft into the engine. The outer seal prevents engine oil from entering the fuel system through the fuel pump. There is a small weep hole located in the pump body to allow for drainage and early warning should either seal begin to leak (Refer to Fig. 25).



Fig. 28

SHAFT SEAL

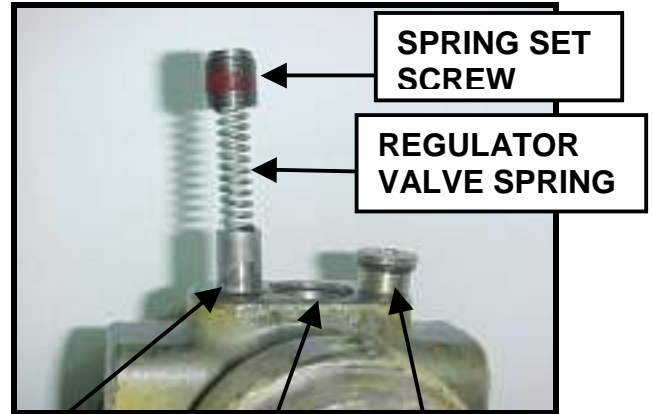

Fig. 29

SPRING SET
SCREW

REGULATOR
VALVE SPRING

REGULATOR
VALVE

REGULATOR
VALVE BORE

PLUG

INSPECTION AND ANALYSIS

LOW-PRESSURE FUEL PUMP



Fig. 30 Low-pressure fuel leak at weep hole.

CONDITION: Low-pressure pump leak at weep hole. A damp area at the pump weep hole is acceptable for service. Continuous dripping at the weep hole would define a leak and require servicing.

CAUTION: Presence of excessive amount of diesel fuel could present a safety hazard and should be addressed immediately.

CAUSE: Pump drive shaft pump body seal leaking. Fuel system contaminants can contribute to this cause. Excessive fuel temperature or dry operation of the pump may also result in seal damage.

RECOMMENDATION: Replace Low-pressure pump assembly. Evaluate fuel condition and condition of equipment fuel system for contributing factors. Review events of dry operation and priming procedures being used.

REUSE: Do Not Reuse!

NOTICE: Do not disassemble the Low-pressure fuel pump for any reason!
If the pump fails to rotate, replace the pump assembly. All Low-pressure fuel pumps are to be returned intact as Reliabilt® cores.

ELECTRONIC UNIT INJECTOR

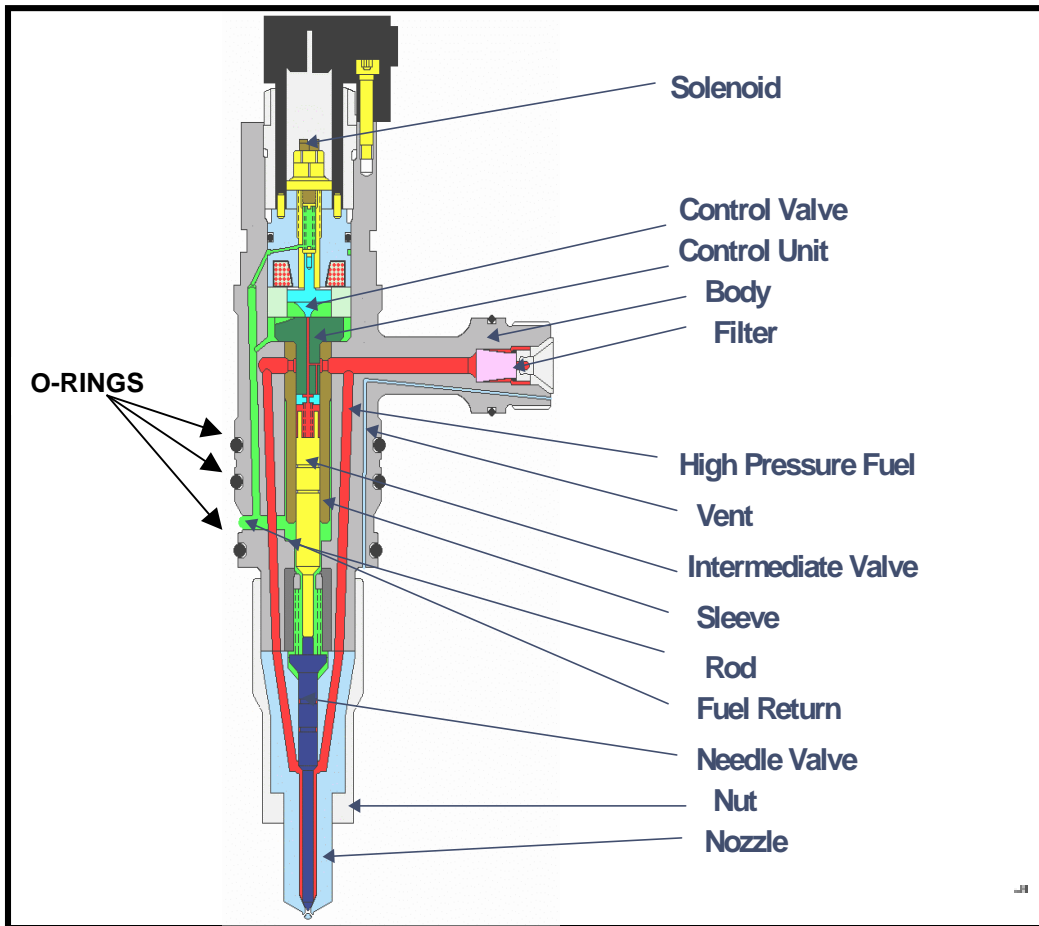

Fig. 31 Injector Assembly (Cutaway)

The Electronic Unit Injector delivers the fuel input into each cylinder. The unit injector receives high-pressure fuel continuously from the high-pressure rails. The unit injector does not need to make pressure, therefore, there is no camshaft driven mechanism requiring adjustment or tune-up. The amount of fuel and timing is controlled by DDECIV.

DDECIV controls the fuel flow in the injector by sending a signal to the injector solenoid. The control valve is spring loaded in the closed position and opens when the solenoid is energized. Each injector has its own calibration code, which is factory determined and stamped on the injector identification plate (Fig. 32 and Fig. 33). The calibration code can be any number from 00 to 99 (Fig. 34). The calibration code is entered into DDECIV with the DDR reader or DDDL, so that DDECIV can balance each injector for uniform fuel output and performance.

ELECTRONIC UNIT INJECTOR

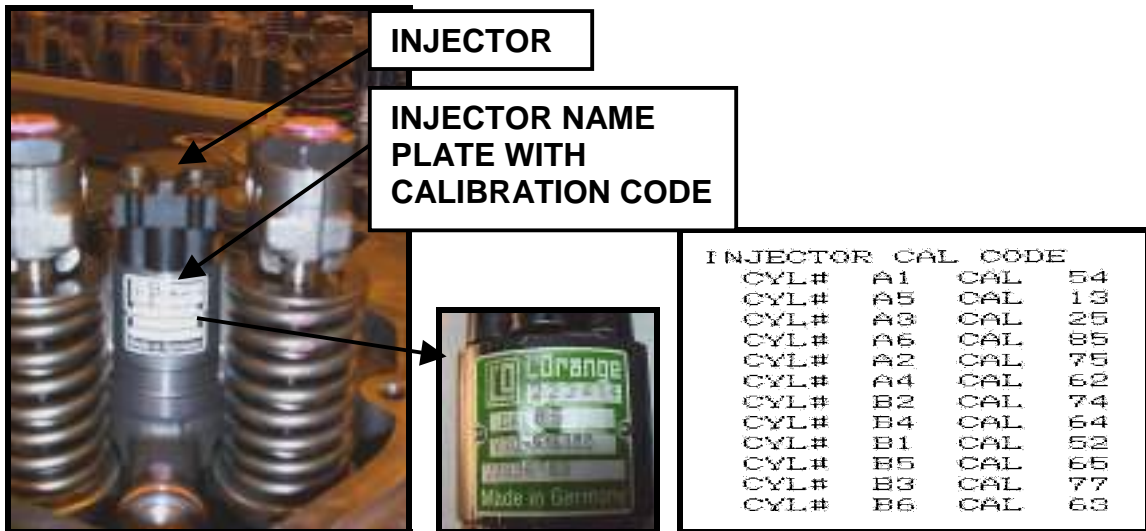

Fig. 32

Fig 33

Fig. 34

The energized solenoid lifts the control valve, which hydraulically permits the rod to rise and the needle to lift from its seat. This action allows fuel to flow from the injector tip into the combustion chamber. To end fueling the solenoid is de-energized, allowing the control valve to fall against the control unit, which causes hydraulic pressure to build above the rod forcing it and the needle downward until the needle closes against its seat.

About 10% of the fuel, which entered the unit injector is used for lubrication and cooling, exits the injector through the fuel return port. The fuel return port is located between the second and third o-ring lands on the injector body (Fig. 35). The return fuel exits the injector from the fuel return port to a port in the cylinder head to the return fuel line to the return manifold.

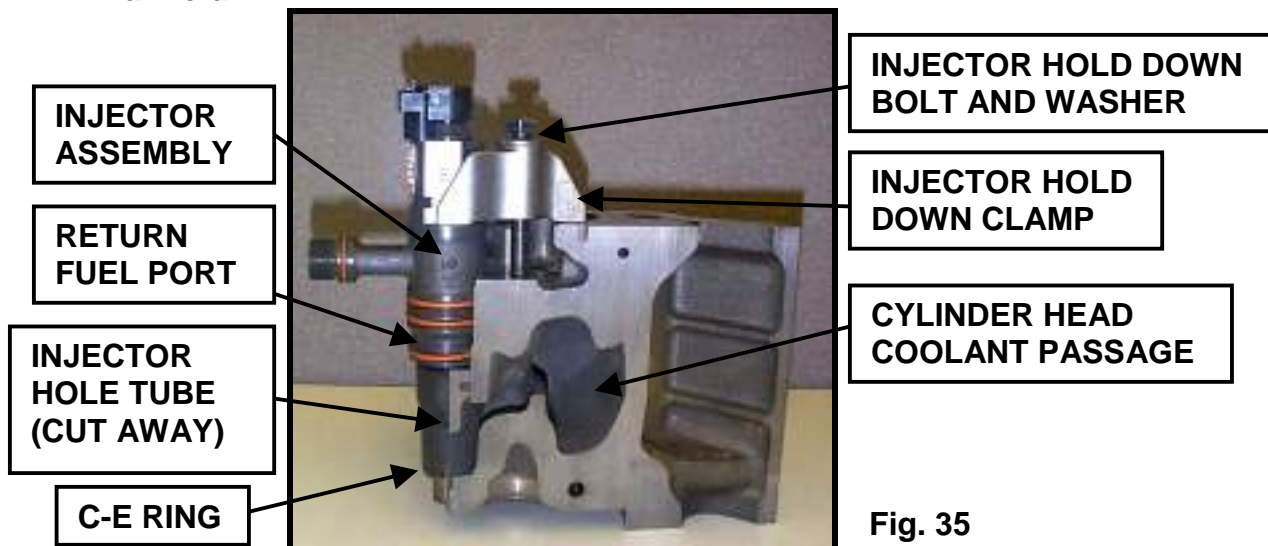

Fig. 35

INSPECTION AND ANALYSIS ELECTRONIC UNIT INJECTOR



Fig. 36 NEW

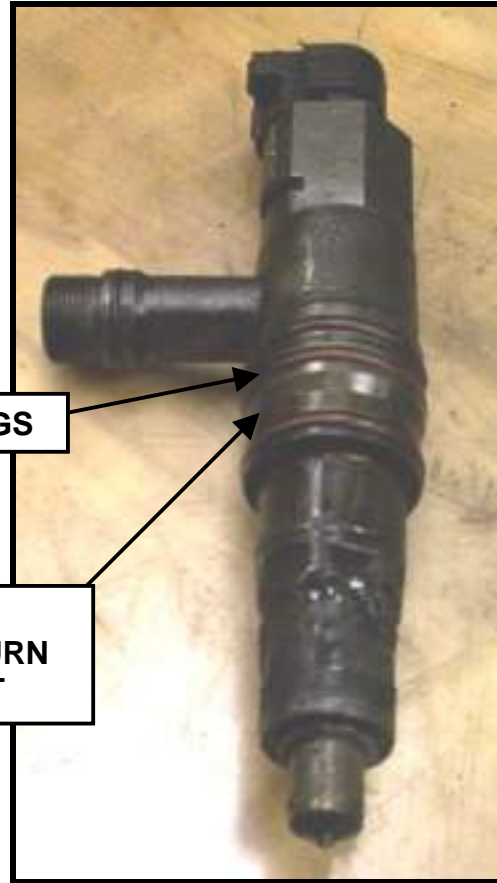

Fig. 37 HEAVY CARBONED FROM
FAILED C-E RING

CONDITION: Injector damaged from compression and carbon. O-ring damage can occur from combustion heat, which could result in return fuel leaking past the o-rings into the engine oil or compression entering the return fuel.

CAUSE: Leaking C-E Ring. May be defective C-E Ring or a loose or broken hold down bolt.

RECOMMENDATION: Inspect injector hole tube for damage. Replace Injector Assembly with new C-E Ring and o-rings. Insure proper hold down bolt torque is used.

REUSE: Do Not Reuse!

INSPECTION AND ANALYSIS

INJECTOR C-E RING



Fig. 38 NORMAL

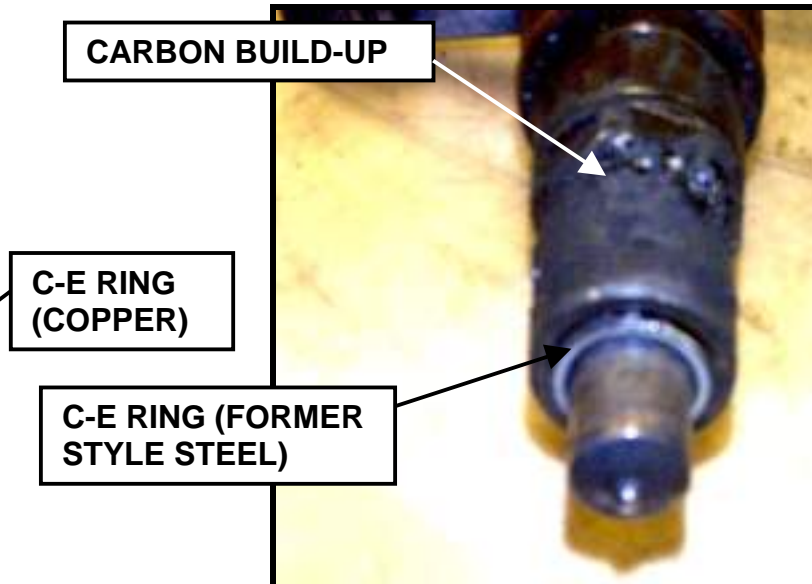

Fig. 39 (FORMER STYLE TWO PIECE)
LEAKING COMBUSTION

CONDITION: C-E Ring leaking combustion causing carbon build-up on injector body and injector hole tube. Carbon will also in injector vent passage and high-pressure fuel line. Injector O-rings may be burnt and damaged. Injector hole tube may also be damaged from combustion gases.

CAUSE: Improper hold-down clamp bolt torque or missing washer on hold-down bolt or defective C-E Ring.

RECOMMENDATION: Replace Injector assembly, C-E Ring and O-rings. Inspect hold-down bolt and clamp. Replace if needed. Replace Injector hole tube.

REUSE: If carbon is present in high-pressure fuel line, do not reuse injector or high pressure fuel line. Replace both as the vent passage is plugged with carbon.

INSPECTION AND ANALYSIS CYLINDER HEAD FUEL INJECTOR TUBE

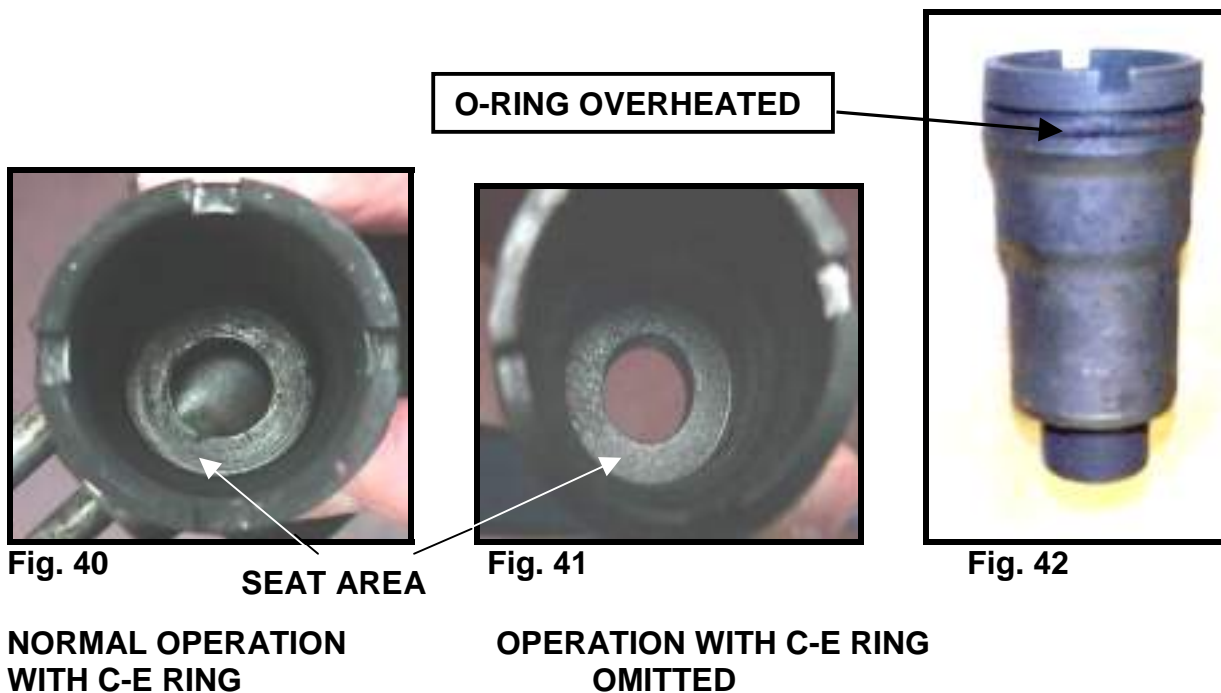

CONDITION: Combustion leaking into injector tube area causing carbon Build-up in the tube and coolant leak from overheated injector tube o-ring.

CAUSE: C-E Ring was omitted during injector installation.

RECOMMENDATION: Inspect for signs of erosion inside tube area at seat area. Severe carbon buildup will require the replacement of the tube and o-rings. Clean thoroughly, insure C-E Ring seat area is flat and free of carbon.

REUSE: Replace injector tube if C-E ring has failed. Insure new C-E Rings are used when injector is installed.

INSPECTION AND ANALYSIS

FUEL INJECTOR HOLD-DOWN CLAMP & BOLT

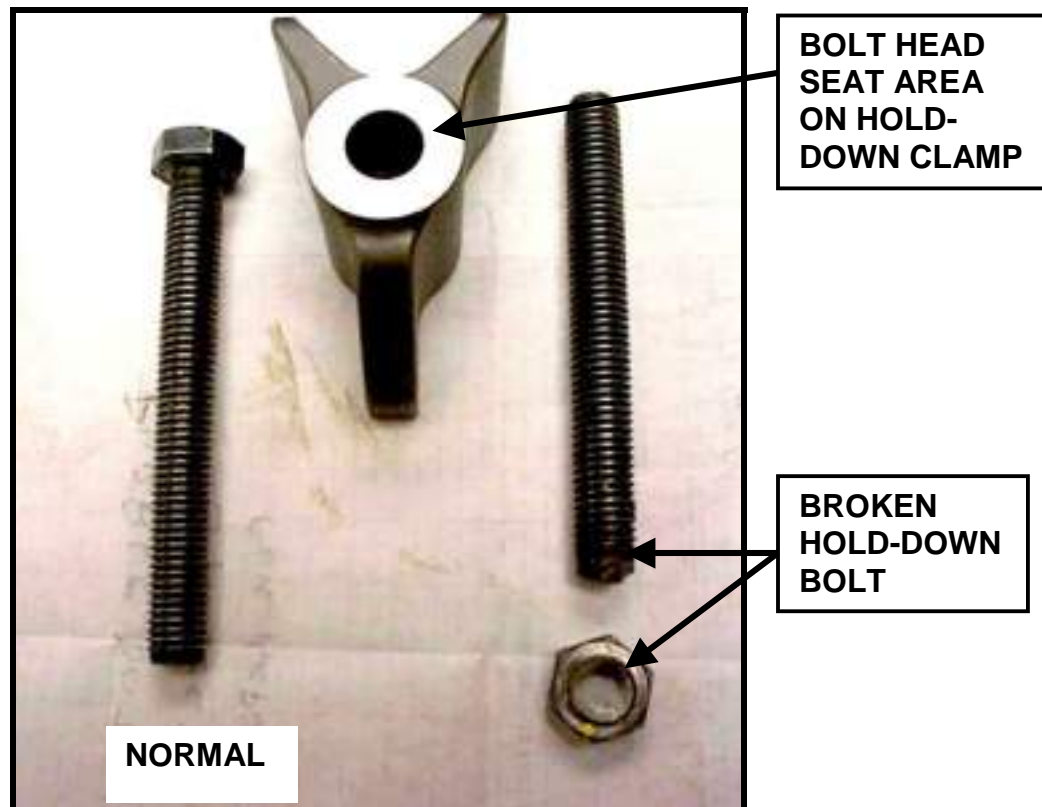

Fig. 43 Injector Hold-down Bolt Failure

CONDITION: Broken hold-down bolt.

CAUSE: Excessive torque during installation.

RECOMMENDATION: Replace bolt and add new hardened washer. Follow proper torque specifications shown in the Torque Specifications section.

REUSE: Do not reuse! Inspect hold-down clamp bolt head seat area for signs of fretting. If fretting is present, replace bolt even if bolt is not broken. Fretting is a sign of the bolt working from possible being stretched, which could result in a broken bolt and loss of clamp load on the injector. Replace the hold-down clamp if it is severely fretted.

FUEL RAILS AND LINES



Fig. 44 Common Rail Fuel System

The rails of the Common Rail Fuel System include the high-pressure and the low-pressure return rails. The high-pressure rails are of stainless steel construction with port locations for each fuel limiter valve seat (Fig. 45). The front of the high-pressure rails has fittings to accept a high-pressure fuel line. The rear of the high-pressure rail is fitted with a safety relief valve assembly on the A-bank or a plug assembly on the B-bank. The safety relief valve spills pressure at 19.6 KPSI to the A-bank return rail. The two low-pressure return rails accept the injector return fuel from each cylinder head.

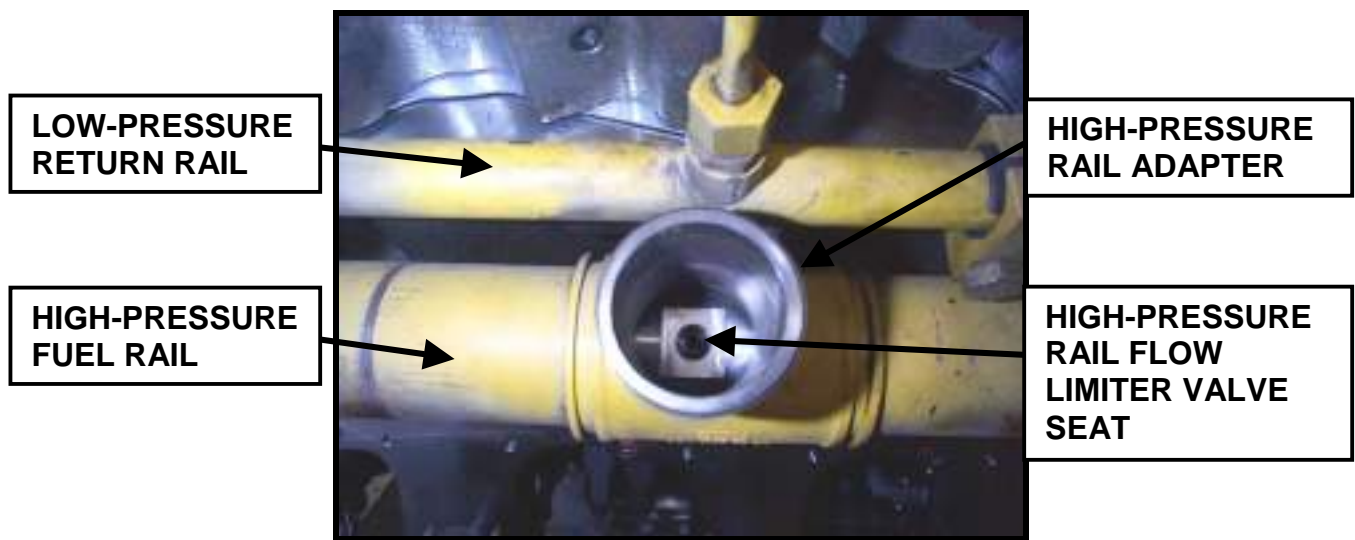

Fig. 45 View of High-pressure Rail Limiter Valve Seat.

INSPECTION AND ANALYSIS HIGH-PRESSURE RAILS



Fig. 46



Fig. 47



Fig. 48
USED AND CORRODED



Fig. 49
CLEANED FOR REUSE

LIMITER
VALVE SEAT
AREA

CONDITION: Externally Corroded and Dirty.

CAUSE: Normal Operation.

RECOMMENDATION: Completely disassemble and clean. Sand rails so rail connector can be easily removed. Inspect seating areas for fuel limiter valves and repair if needed. Follow repair procedures found in the maintenance section.

REUSE: Reuse if all sealing surfaces are in good condition.

INSPECTION AND ANALYSIS HIGH-PRESSURE RAIL CONNECTOR



Fig. 50 NEW



Fig. 51 USED, CORRODED

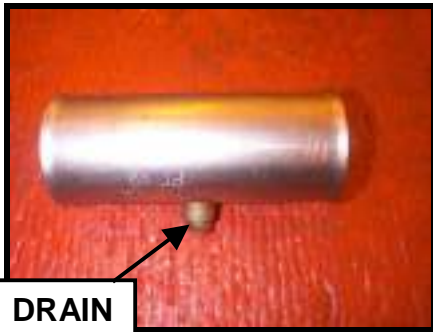

DRAIN

Fig. 52 Protective Sleeve
(Marine & Hydro Frac Only!)



CONNECTOR
THREADS
DAMAGED
DURING ENGINE
DISASSEMBLY

Fig. 53

CONDITION: Corroded and Dirty. Damage from improper protection during engine disassembly.

CAUSE: Normal Operation. Damaged threads are from not using protective caps when the fuel lines are removed.

RECOMMENDATION: Clean and inspect for cracks or damaged high-pressure fuel line connector threads.

REUSE: Reuse if no damage is found. Do not attempt repair of connector threads!

INSPECTION AND ANALYSIS HIGH-PRESSURE RAIL RELIEF VALVE AND PLUG

Fig. 54 High-pressure Rail Plug



High Pressure Rail Relief Valve



Note: Do not disassemble Pressure Relief Valve!
Fig. 55



For Reference only!
Fig. 56

CONDITION: Leaking fuel past seating surfaces.

CAUSE: Debris or cracks present on seating surfaces.

RECOMMENDATION: Inspect for damage to seating surfaces or presence of debris.

DO NOT DISASSEMBLE THE PRESSURE RELIEF VALVE, AS IT CANNOT BE READJUSTED WITHOUT SPECIAL TOOLS!

REUSE: Reuse unless found damaged or cracked.

HIGH PRESSURE FUEL LINE

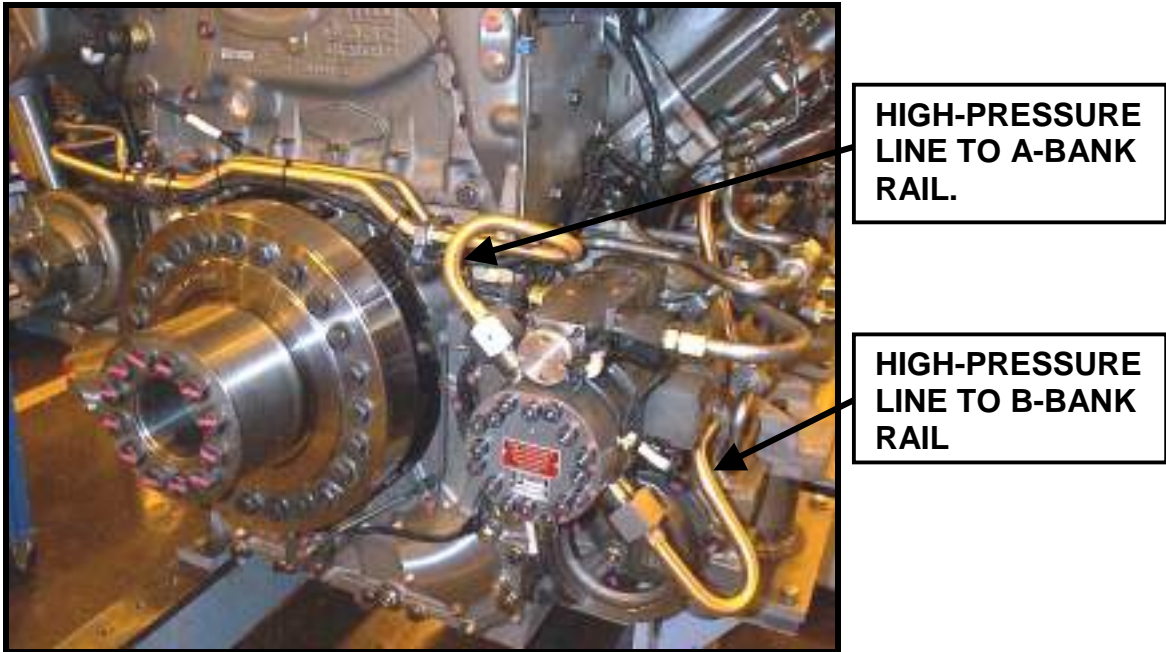
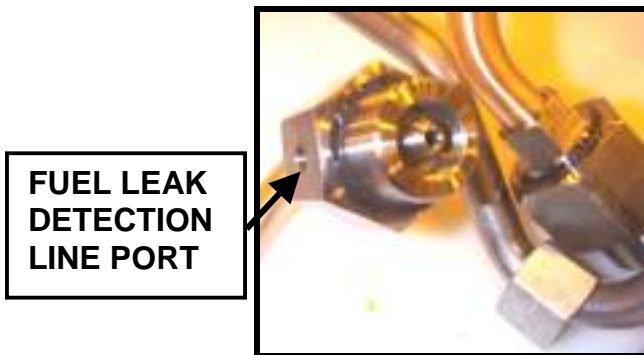

Fig. 57 High-pressure Fuel Line System



FUEL LEAK
DETECTION
LINE PORT

Fig.58 High-pressure line connector



Fig. 59 High-pressure line from rails to injectors

All the high-pressure fuel lines are designed to carry the fluctuating high-pressures of this system by utilizing a unique double walled construction. This double walled construction consists of a stainless steel inner wall with a copper protective outer wall forming an air vent passage between them.

Care should be taken at anytime the high-pressure fuel line is removed from an injector as breaking the torque on the outer retaining nuts will also loosen the inner retaining nuts and could cause improper seating if not properly retorqued before re-installation. Care must be taken to protect these sealing surfaces at any time the high-pressure lines or flow-Limiter valves are removed as damage to these sealing surfaces can result in a high-pressure fuel leaks.

HIGH PRESSURE FUEL LINE

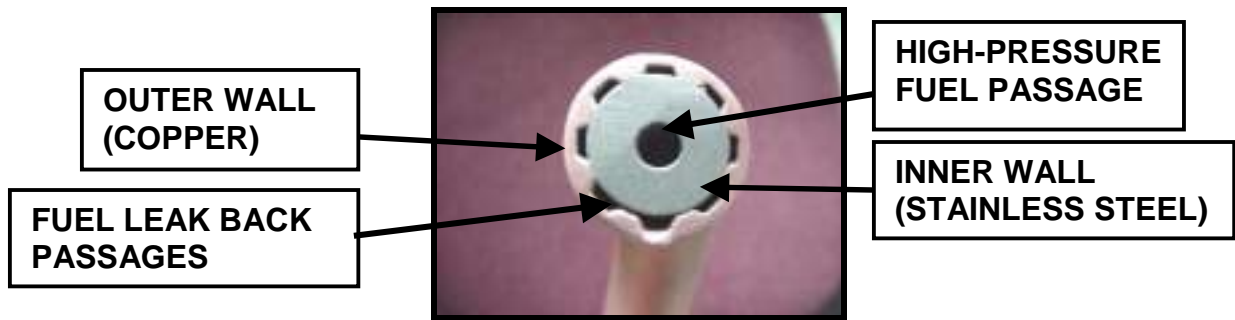

Fig. 60 High-pressure fuel line construction (cross-section view).

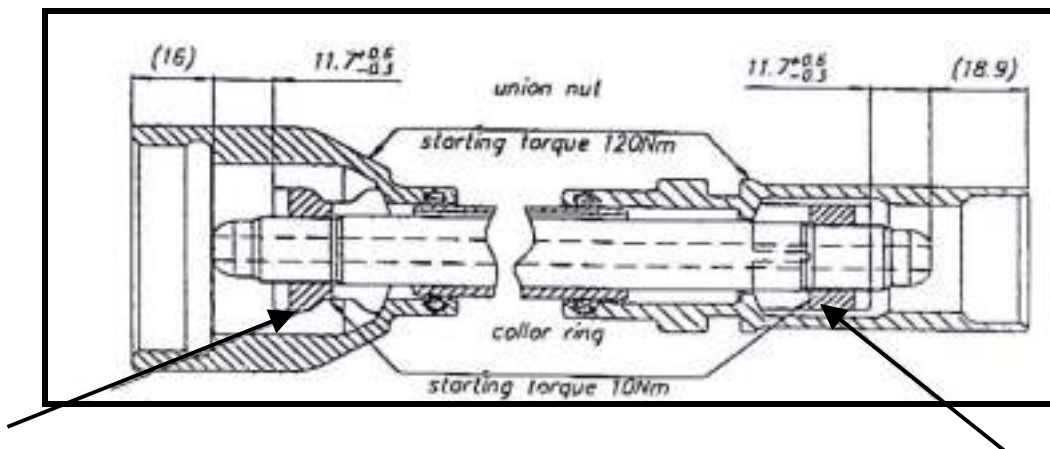

Fig. 61 High-pressure fuel line construction (cutaway).

Check the counterclockwise turning collar ring after loosening of the union nut by screwing completely backwards to the end of the tread and torquing to 10Nm using DDC special tool J-45252.

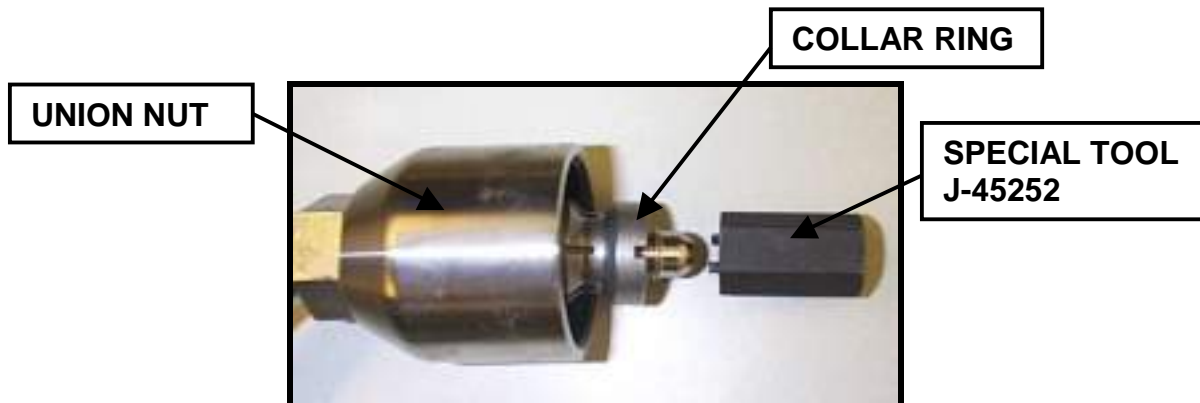

Fig. 62 High-pressure fuel line collar ring adjustment.

INSPECTION AND ANALYSIS

HIGH-PRESSURE FUEL LINES PUMP TO RAILS



Fig. 63 High-pressure Fuel Leak at the Connector.

CONDITION: Fuel line leaking at high-pressure fuel line connector from high-pressure fuel pump to high-pressure fuel rail.

CAUSE: Debris, crack or damaged seat or improper adjustment of internal collar ring at either connector on the ends of fuel line causing an improper stack-up condition.

RECOMMENDATION:

Inspect for debris presence in connection, clean as required.
Check internal collar ring for proper adjustment and torque, correct.
Inspect all seat surfaces for damage or fretting, replace fuel line if found.

REUSE: Reuse unless sealing surfaces are found damaged.

INSPECTION AND ANALYSIS HIGH-PRESSURE FUEL LINES INJECTOR TO RAILS



Fig.64 High-pressure Fuel Leak at the High-pressure Rail.



Fig. 65

CONDITION: Fuel line leaking at high-pressure fuel line from injector to high-pressure fuel rail.

CAUSE: Debris (carbon) or damaged seat connections at three possible locations (Fuel line to injector, Fuel line to fuel limiter valve, limiter valve to fuel rail) or improper adjustment of internal collar ring at either connector on the ends of fuel line causing an improper stack-up condition.

RECOMMENDATION:

Inspect for debris (carbon) presence in connection, clean as required.
Check internal collar ring for proper adjustment and torque, correct.
Inspect all seat surfaces for damage or fretting, replace fuel line if found.

REUSE: Reuse unless sealing surfaces are found damaged.

INSPECTION AND ANALYSIS

HIGH PRESSURE FUEL LINE TO INJECTORS



Fig. 66



Fig. 67

CARBON BUILD UP
BETWEEN THE INNER
AND OUTER TUBE



Fig. 68 NORMAL



Fig. 69 OVERHEATED & CARBONED FROM
LEAKING C-E RING

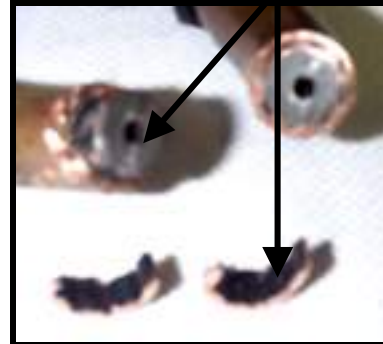

Fig. 70

CONDITION: Fuel Line overheated and carbon filled between inner and outer tube. Refer to cut away to see carbon build up between tubes.

CAUSE: Leaking or omitted Injector C-E Ring, improper hold down bolt torque or defective C-E Ring.

RECOMMENDATION: Replace High Pressure Fuel Line, Injector and C-E Ring. Under normal conditions, Clean, inspect sealing areas for damage, replace o-rings, and tighten internal nuts before reuse.

REUSE: Do Not Reuse! Cleaning is not possible.

RETURN RAILS AND LINES



Fig.71 Low-pressure Fuel Rails

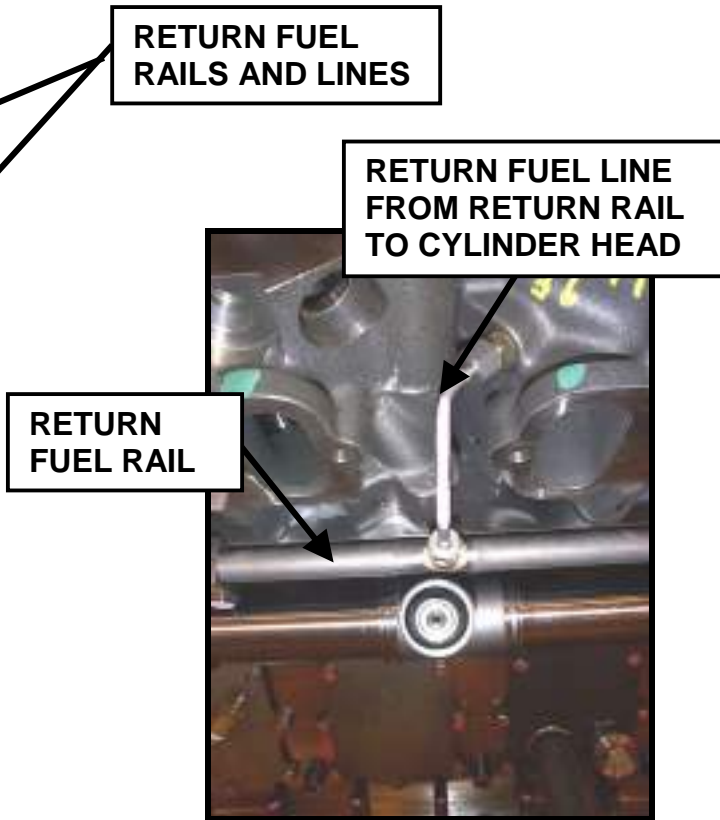

Fig. 72 Low-pressure Injector Fuel Return Line

The return fuel rails are located on each bank of the Series 4000 attached to the cylinder block above the high-pressure rails. The return fuel rails provide a common collection of all returned fuel from the injectors and the A-bank high-pressure rail relief valve. (See Fig. 73) The return fuel rails are constructed of steel with O-ring seals at each connection point. The return fuel lines from each cylinder head have a flair type metal to metal joint at the return fuel rail fittings.



Fig. 73 High-pressure Fuel Rail Pressure Regulator Return Fuel Line.

INSPECTION AND ANALYSIS

RETURN FUEL LINES

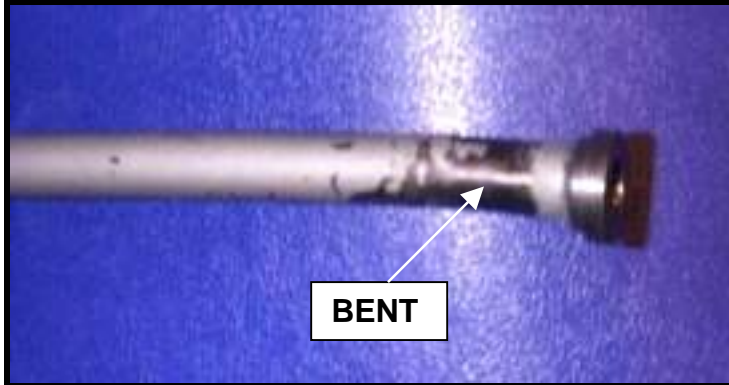

Fig. 74



Fig. 75



Fig. 76

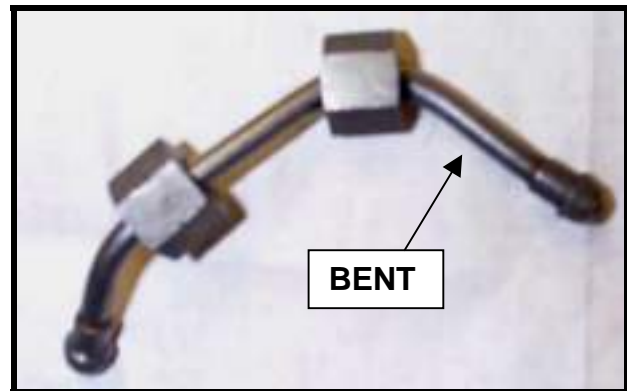

Fig. 77

CONDITION: Bent, cracked or damaged return fuel lines.

CAUSE: Improper installation, lack of proper support or mishandling after removal.

RECOMMENDATION: Inspect return fuel lines for signs of external damage such as impact, electrical shorts or fretting. Bent or cracked fuel lines are indications of being forced into position or over tightened during installation. Sealing surfaces of the return fuel lines should be inspected for nicks, scratches or cracks. Proper care should be taken in handling and storing to prevent damage. Replace any found damaged.

REUSE: DO NOT REUSE!

FLOW- LIMITER VALVE

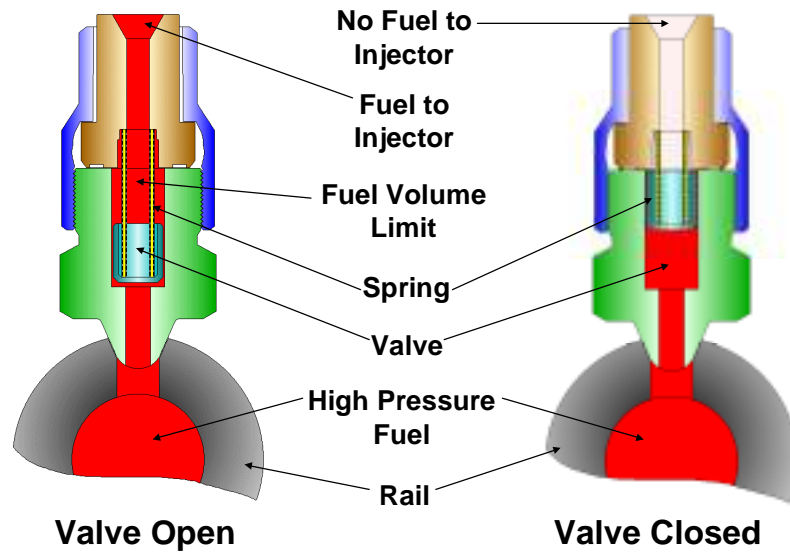

Fig. 78

There are flow-limiter valves for each injector to prevent over fueling of the cylinder should something happen to an injector. The flow-limiter valves are located on each bank between the injector high-pressure fuel lines and the high-pressure fuel rail. These valves sense fuel flow and will shut off the flow of fuel to the injector if the flow rate exceeds the spring tension of the flow-limiter valve. This is normally 1.5 times the normal injector fueling rate.



Fig. 79 FLOW-LIMITER VALVE DISASSEMBLED

The flow limiter valves consist of spring and a valve, which floats in the fuel flow until the flow exceeds that of the spring, thereby causing the valve to close on the seat of the body. The fuel inlet from the high-pressure rail is tapered to accept the cone shaped nozzle of the flow-limiter valve. The outlet of the flow-limiter valve also is cone shaped to accept the injector high-pressure fuel line. The conditions of this cone shaped sealing areas are very important in the prevention of fuel leaks. Anytime the injector high-pressure lines are removed; care should be taken to protect all the sealing surfaces of the flow-limiter valve, high-pressure rail and the injector high-pressure fuel line.

INSPECTION AND ANALYSIS FLOW-LIMITER VALVE



Fig. 80

NORMAL



Fig. 81

**OVERHEATED & CAR-
BONED FROM LEAKING
C-E RING**



Fig. 82

CORRODED FROM WATER

CONDITION: Overheated or corroded.

CAUSE: Overheated from leaking C-E Ring or corroded from exposure to water.

RECOMMENDATION: Normal condition, Inspect sealing surfaces for damage. Overheated or corroded conditions replace flow-limiter valve assembly.

REUSE: Reuse normal condition only! Replace if damaged sealing surfaces.

C&I FUEL JUNCTION BLOCK AND SECONDARY FUEL FILTERS

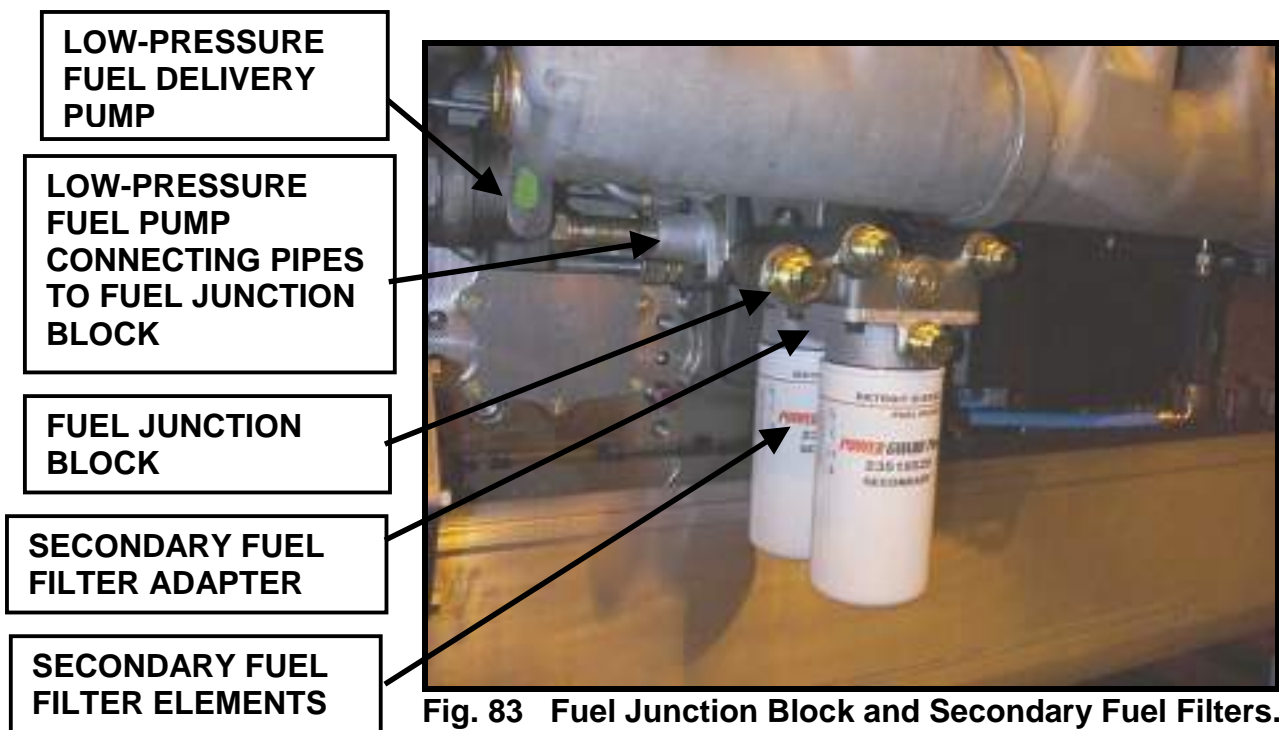

The fuel junction block receives unfiltered fuel from the equipment fuel tank and controls the direction of flow to the low-pressure fuel pump, filters and ECM cold plate(s). The fuel junction block also accepts the return fuel from the high-pressure pump. There are three check valves located in the fuel junction block to aid in directing the fuel flow. See the fuel flow diagram in Fig. 86.

Attached to the bottom of the fuel junction block is the secondary fuel filter adapter, which accepts two spin-on 5-micron cartridge type fuel filters. Refer to Fig. 87 or exploded view of the fuel junction block and secondary fuel filter adapter assembly.

FUEL JUNCTION BLOCK

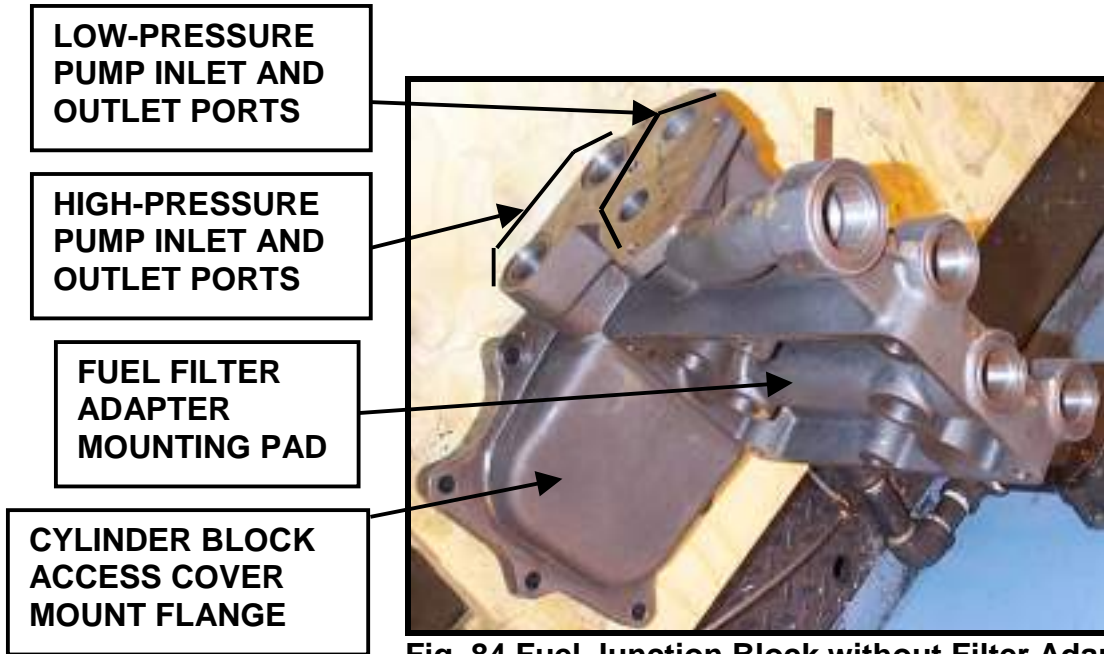

Fig. 84 Fuel Junction Block without Filter Adapter.

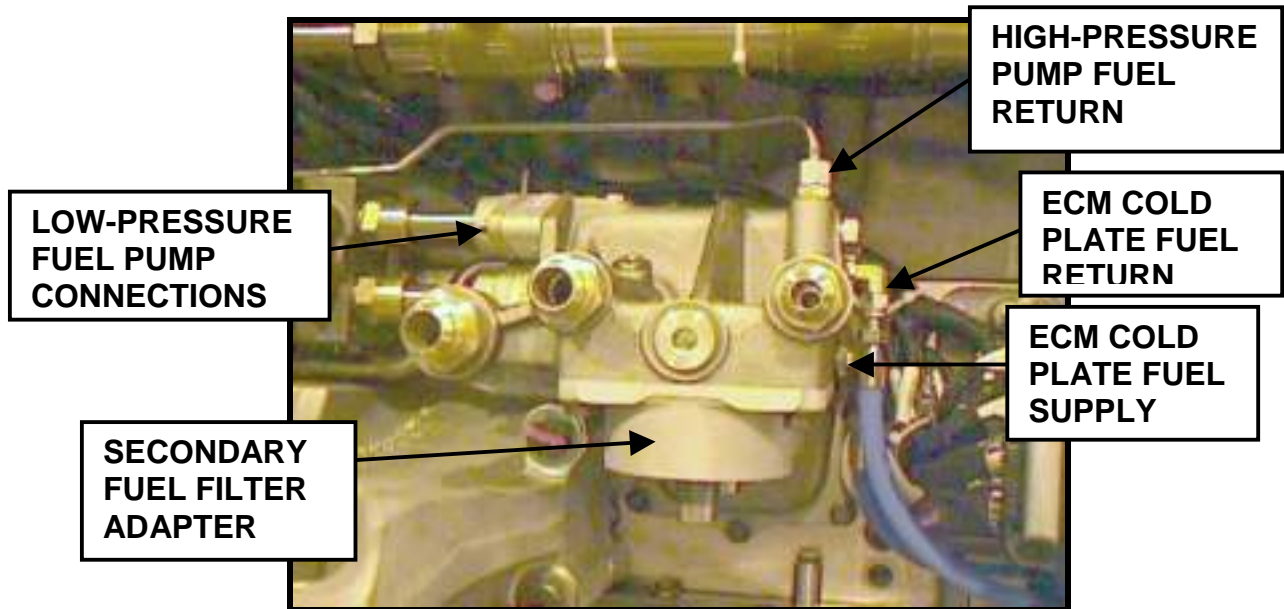

Fig. 85 Fuel Junction Block Engine Fuel Line Connections.

FUEL JUNCTION BLOCK

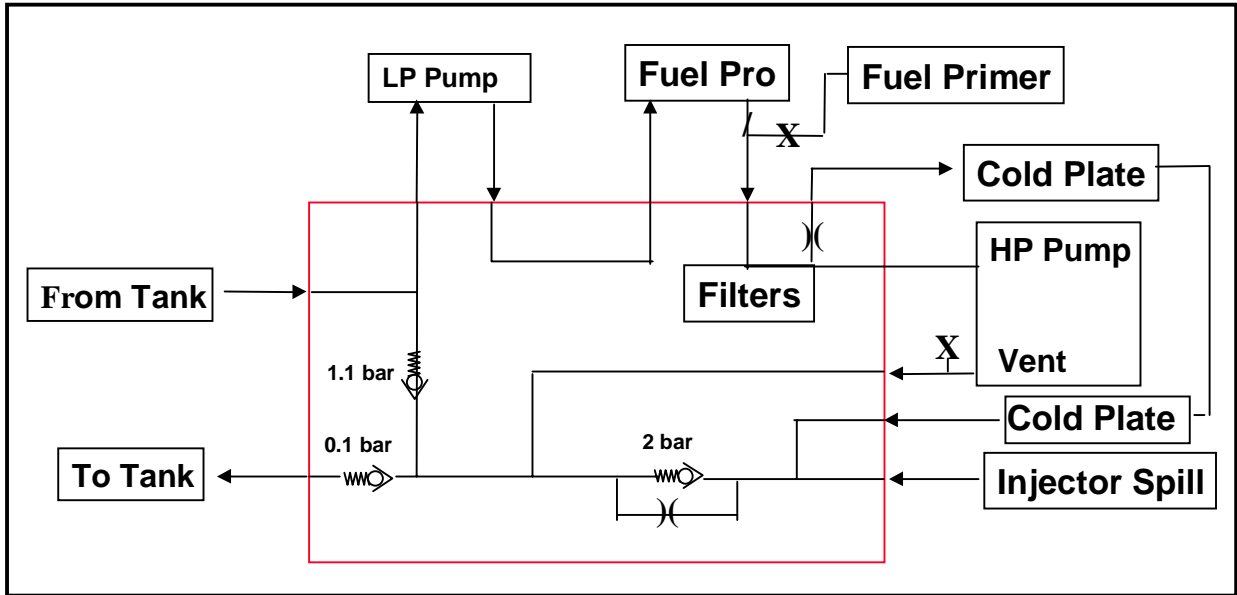

Fig. 86 Fuel Junction Block Fuel Flow Schematic (C&I).
(Note: Refer to Fuel System Plumbing for other applications.)

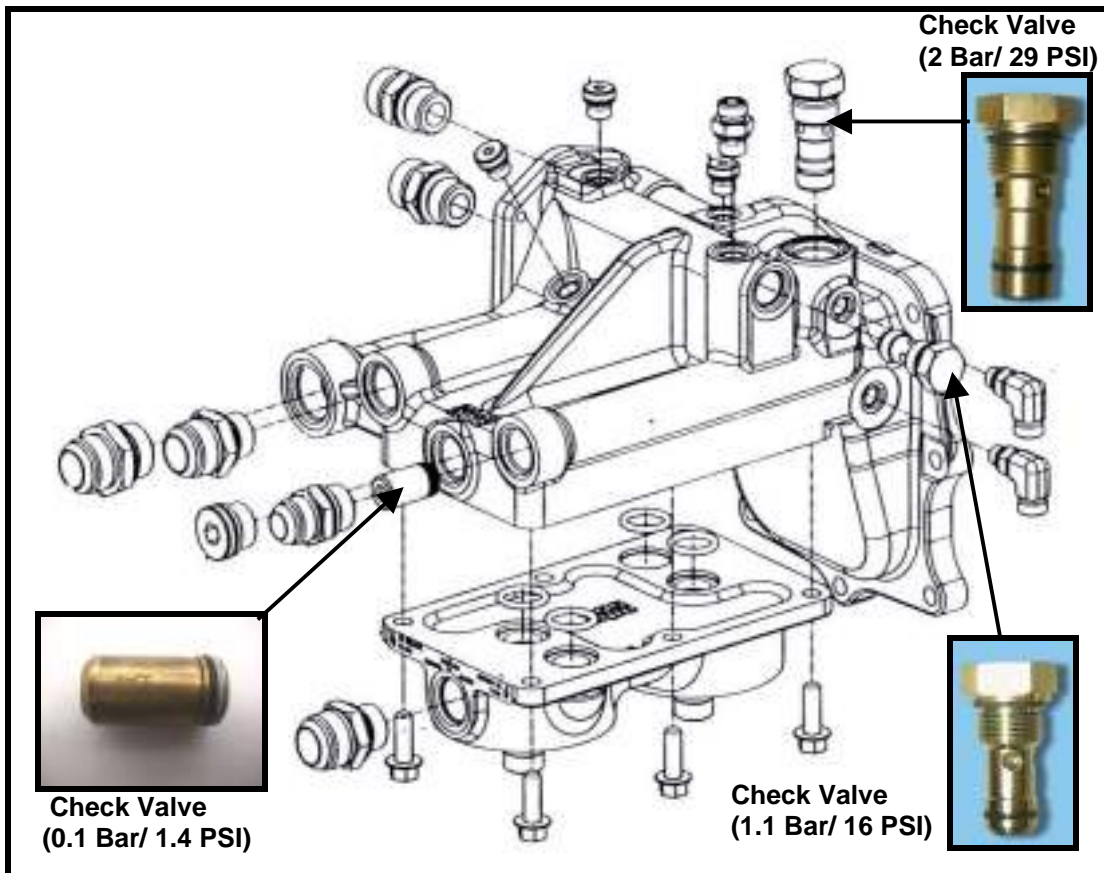

Fig. 87 Fuel Junction Block Assembly with Check Valve Locations

MARINE SECONDARY FUEL FILTERS

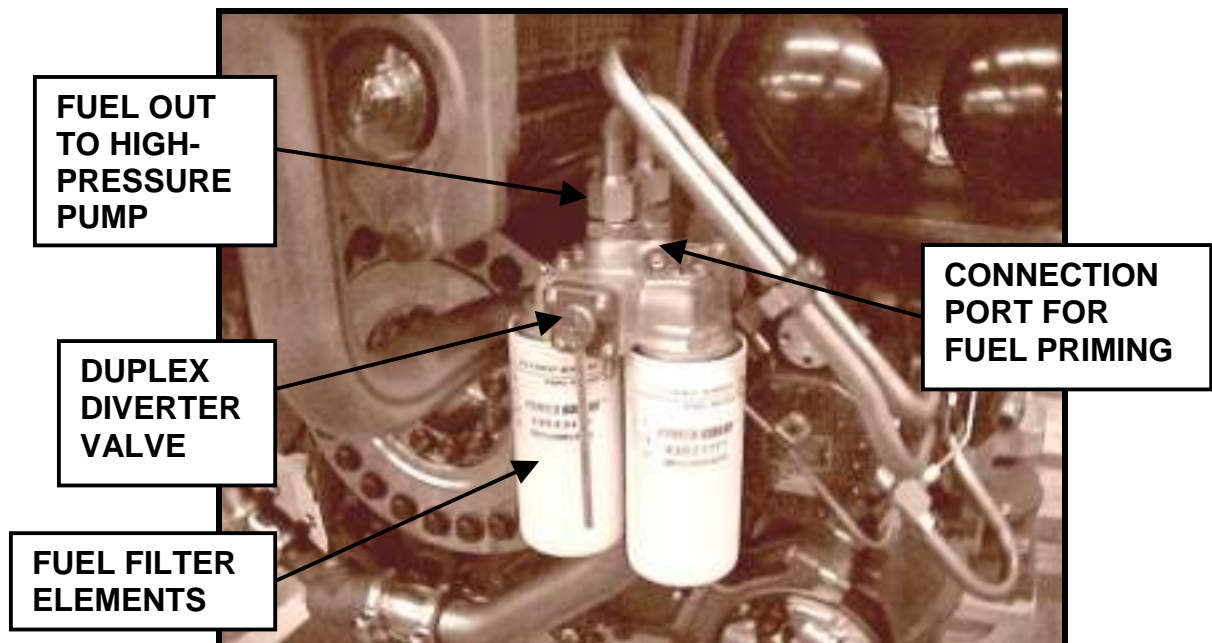

Fig. 88 Marine Secondary Fuel Filter Installation.

Marine engine applications utilize a different secondary fuel filter installation than found on the C&I models. The marine secondary fuel filter is located on the front of the engine mounted on a support bracket. The marine secondary fuel filter incorporates a duplex diverter valve and a port to connect a fuel line to a fuel priming pump. The duplex diverter valve permits switching filters for servicing of the fuel filters during engine operation.

ECM COLD PLATE (S)

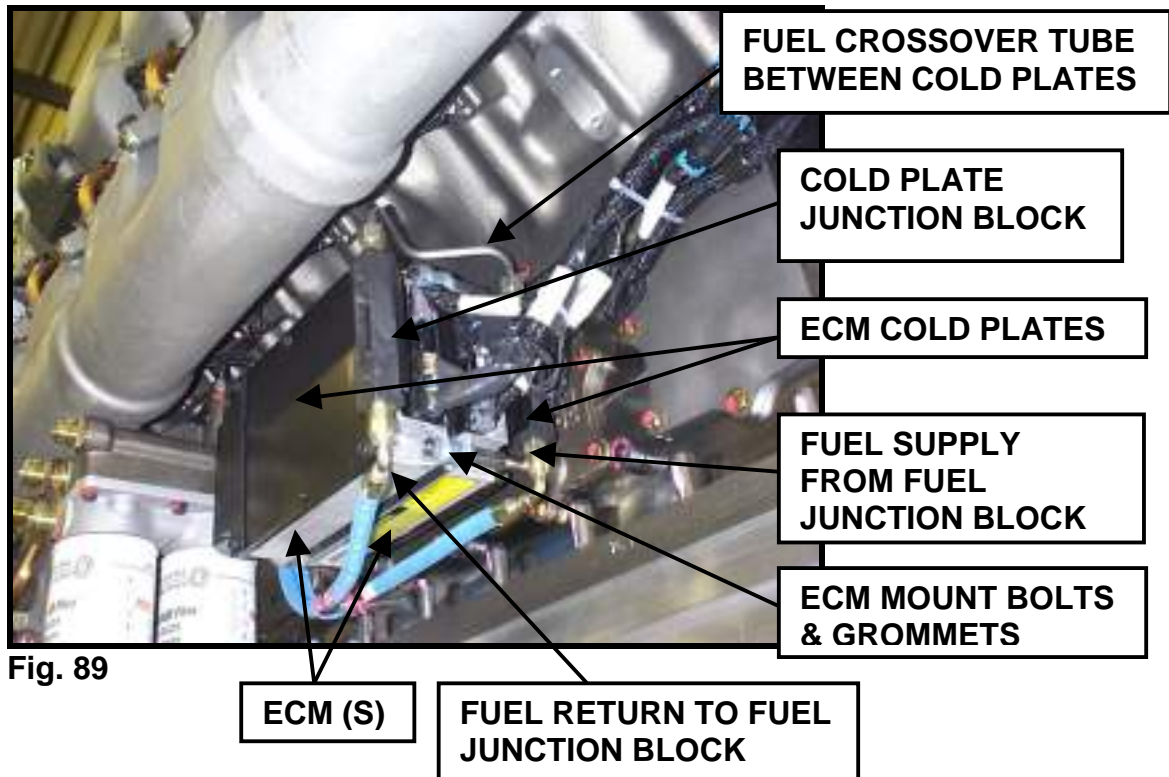

Fig. 89

The ECM cold plate(s) provide protective cooling to the ECM(s) to remove heat generated within the ECM(s). Also the ECM cold plate(s) act as a thermal barrier to protect the ECM(s) from external heat sources.

The ECM(s) and cold plate(s) are located on the "A" bank of the cylinder block between the intake manifold and the oil pan bolt rail. For an 8V4000, a single ECM is mounted between the ECM cold plate and the cylinder block cover plate. The 12V4000 and 16V4000 both have two ECM's sandwiched between two ECM cold plates connected by a fuel crossover tube, which are then mounted to cylinder block cover plate.

The ECM cold plate(s) are made up of two aluminum plates assembled with directional baffles to allow fuel flow between them. At one end is a junction block made of 30% reinforced polyester, molded around brass fittings to receive the fuel inlet and outlet fittings (refer to Fig. 91). The ECM cold plate(s) receive cooling filtered low-pressure inlet fuel from the fuel junction block. On dual ECM configurations, fuel passes through the inner ECM cold plate first and then transfers via the fuel crossover tube to the outer ECM cold plate before returning back to the fuel junction block. The return fuel is then returned back to the equipment fuel tank.

ECM COLD PLATE (S)

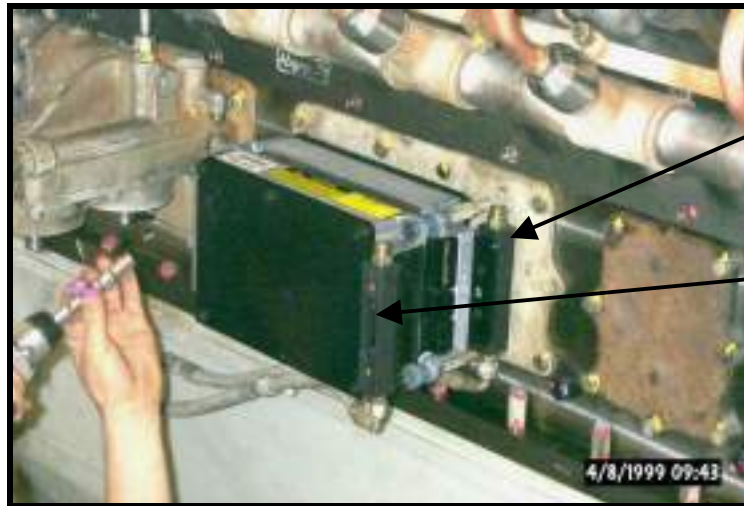

RECEIVER ECM
COLD PLATE
JUNCTION BLOCK

MASTER ECM
COLD PLATE
JUNCTION BLOCK

Fig. 90 Cold Plates Mounted on ECM's

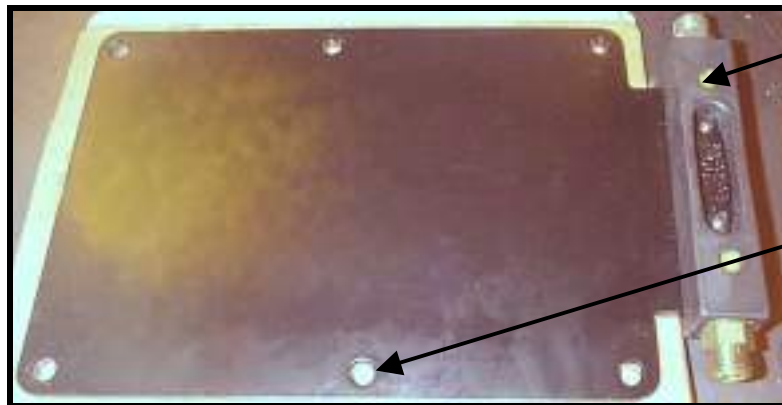

COLD PLATE
JUNCTION
BLOCK

COLD PLATE
MOUNT SCREW
LOCATIONS TO
ECM

Fig. 91 Cold Plate Assembly

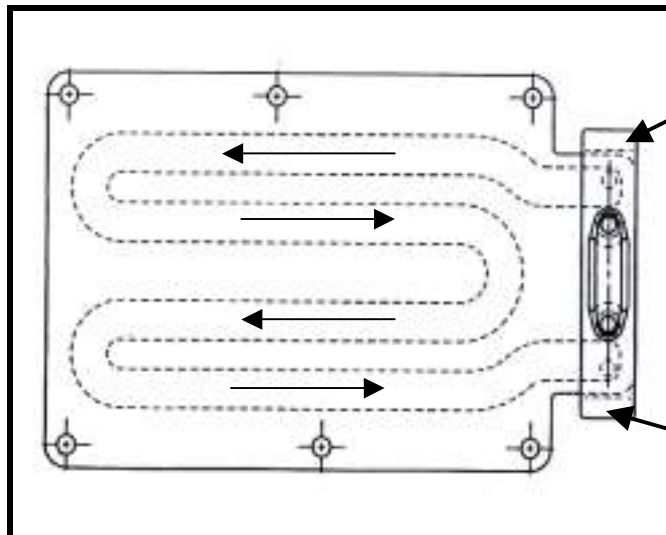

COLD PLATE
JUNCTION BLOCK
INLET PORT

COLD PLATE
JUNCTION BLOCK
OUTLET PORT

Fig. 92 Cold Plate Fuel Flow

FUEL LEAK MONITOR SYSTEM (MARINE)



Fig. 93 Marine Fuel System (MDEC Controls)

Marine applications have a high-pressure line leak monitoring system installed to detect the occurrence of high-pressure fuel leaking at the high-pressure fuel pump connectors (“A” and “B” bank). The leak monitor sensor is connected to the electronic controls of the engine (MDEC or DDEC) and will provide an alarm if a leak is detected. Two types of leak monitor junction blocks are used depending on the electronic controls and fuel coolers used on the engine. (Fig. 94 and Fig. 95)

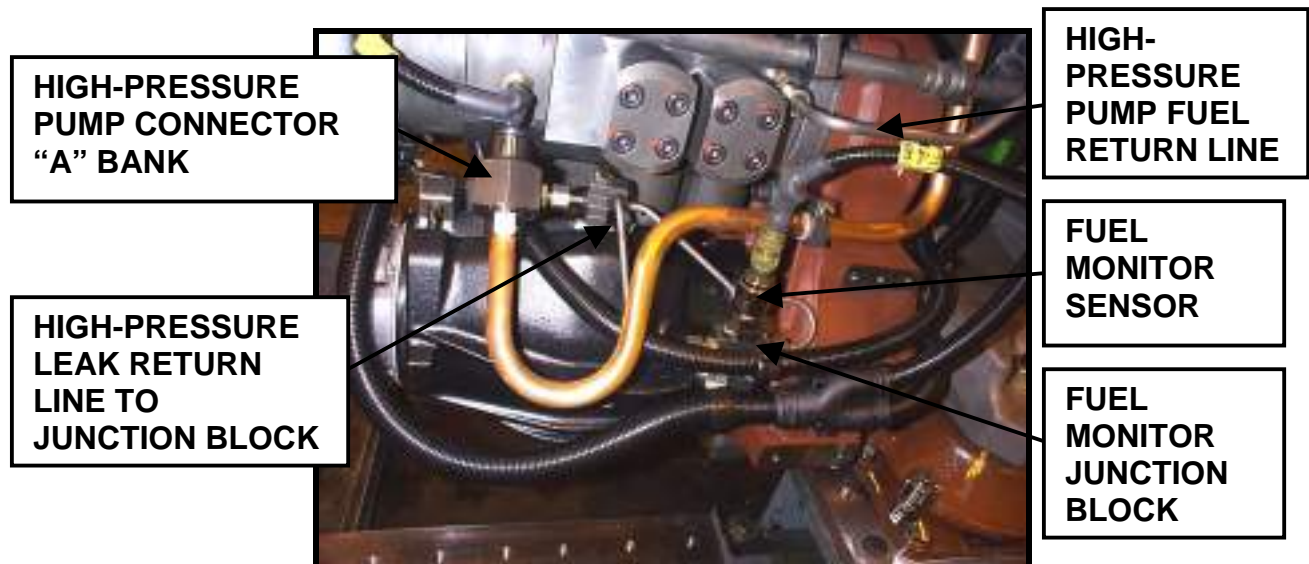

Fig. 94 Fuel Leak Monitor System (MDEC Controls)

FUEL LEAK MONITOR SYSTEM (MARINE)

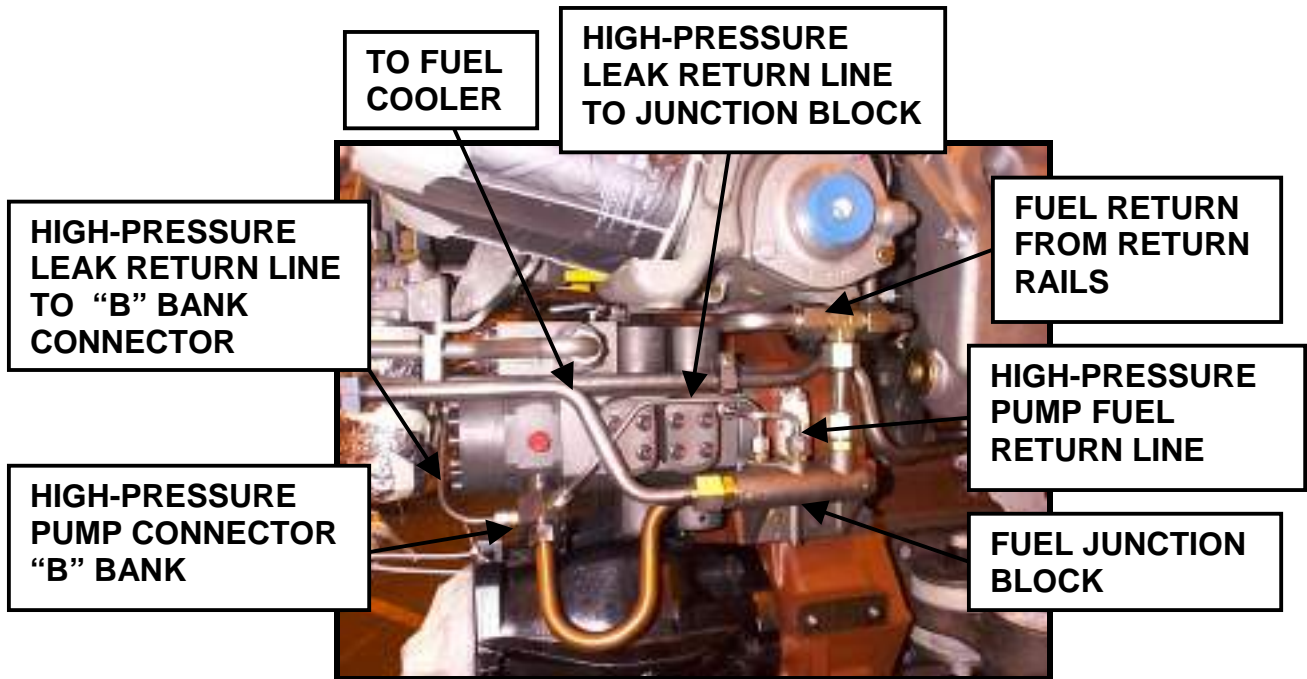

Fig. 95 Fuel Leak Monitor System (DDEC Controls)

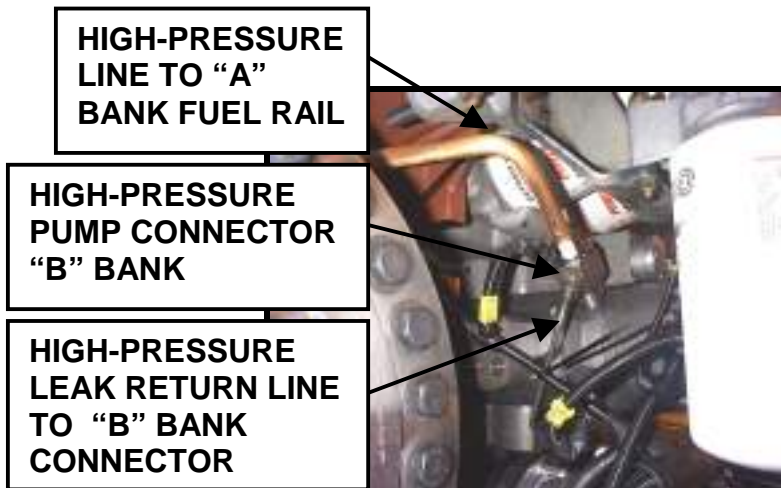

Fig. 96 Fuel Leak Monitor Return Line "A" Bank (Both MDEC or DDEC Controls)

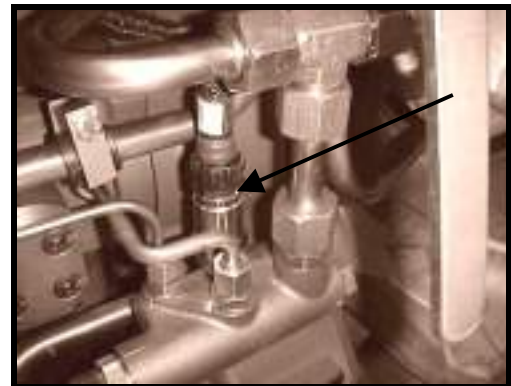

Fig. 97 Fuel Leak Monitor Sensor in junction block

DDEC SENSORS

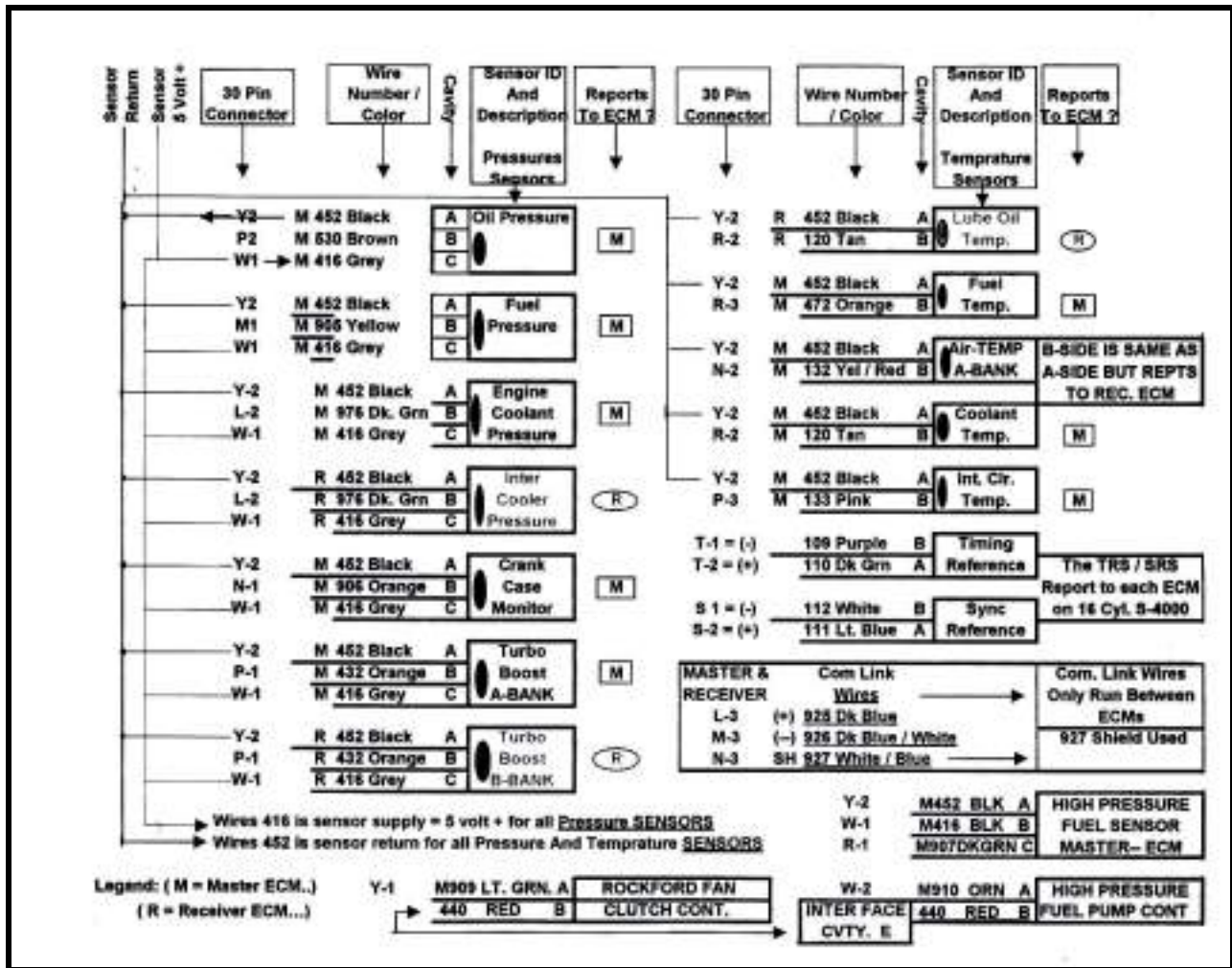

Fig. 98 DDEC Sensor and Wire Identification Chart.

The common rail fuel system for the Series 4000 contains three sensors, the high-pressure fuel pressure sensor (See Fig. 99), low-pressure fuel pressure sensor (See Fig. 101) and a fuel temperature sensor (See Fig. 100). Refer to the Detroit Diesel Electronic Controls section Fig. 10 for sensor locations. Additionally, a leak monitor sensor utilized for marine applications (See Fig. 102).

DDEC SENSORS

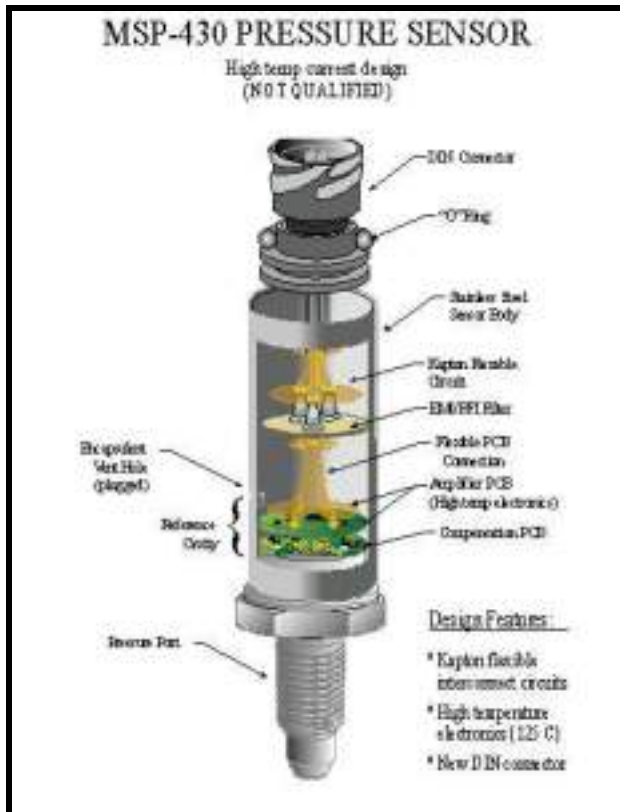

Fig. 99 High-pressure Fuel Sensor (Cutaway View)



Fig. 100 Fuel Temperature Sensor

The fuel temperature sensor is not located in the fuel inlet, but instead in the high-pressure pump it self. Therefore, the fuel temperature will assist in warning of impending pump failures.

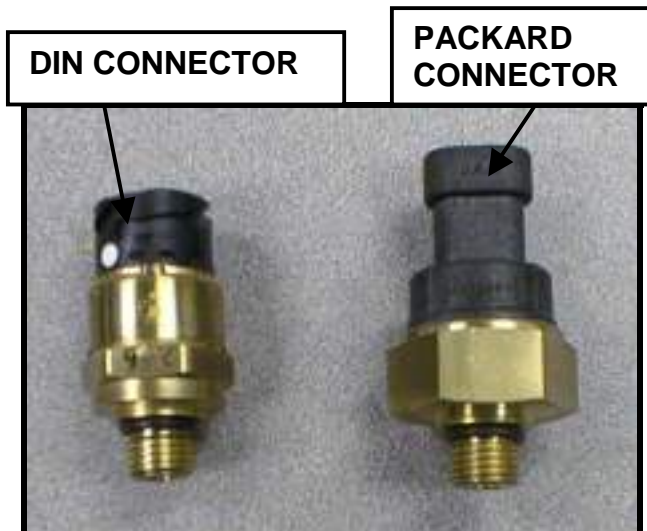

Fig. 101 Low-pressure Fuel Sensors



Fig. 102 Leak Monitor Sensor

FUEL SYSTEM PLUMBING REQUIREMENTS

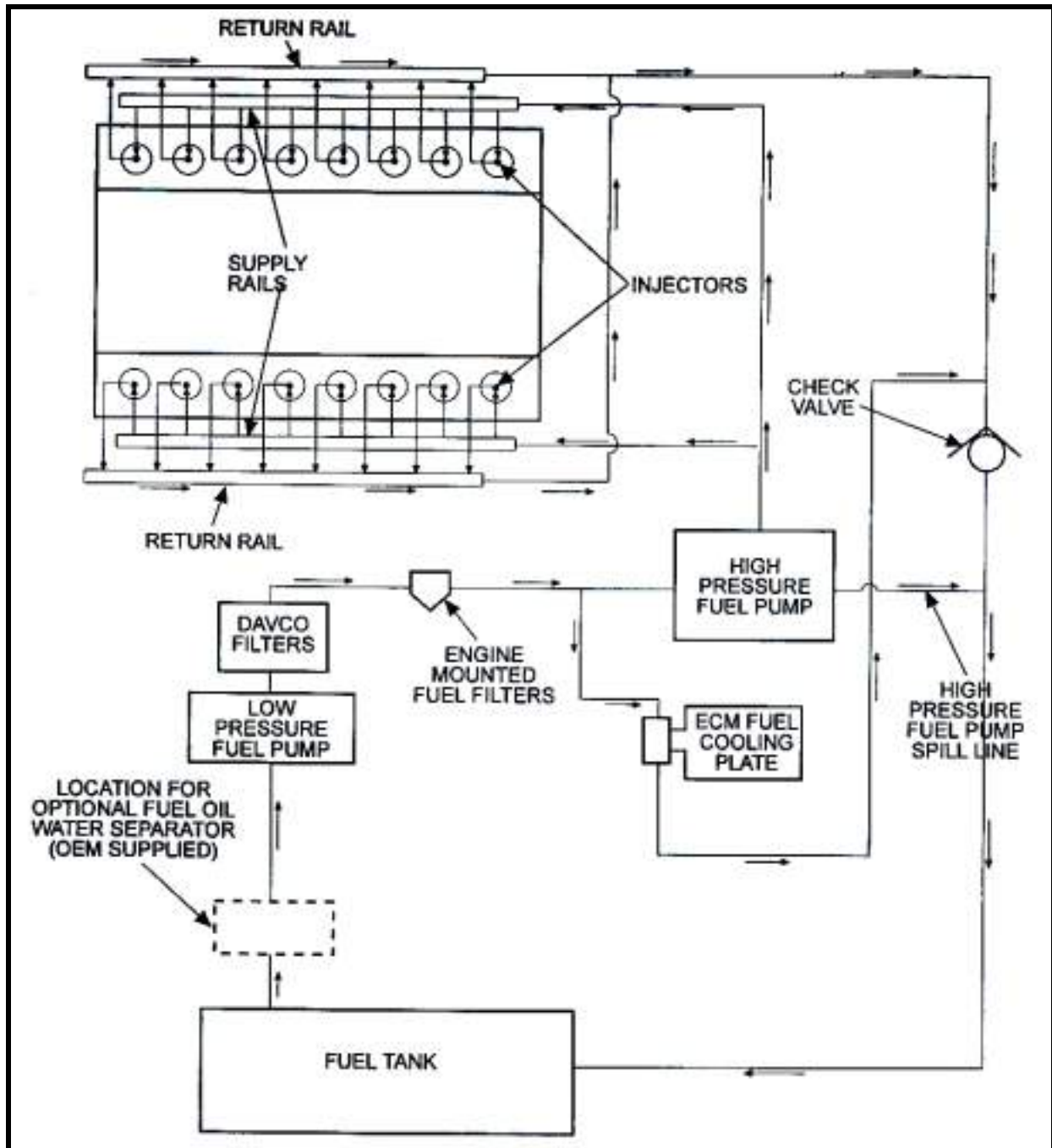

Fig. 103 Fuel System Plumbing Schematic

Care should be taken not to exceed the maximum fuel pump suction limits of 6 in. Hg (0.2 bar) for a clean system or 12 in. Hg (0.4 bar) for a dirty system. The maximum restriction for the fuel return line to the fuel tank is 15 in. Hg (0.5 bar).

FUEL SYSTEM PLUMBING REQUIREMENTS

Fuel coolers are installed on engines to reduce the temperature of the fuel being returned from the engine to the fuel tank. Such a cooler can be installed in the fuel system between the fuel junction block and the fuel tank. Fuel coolers are effective and can lower fuel tank temperatures by as much as 20° F (11°C).

Fuel coolers are required for construction and industrial applications where ambient air temperatures exceed 95°F (35.0°C). Excessive fuel temperature can adversely affect the high-pressure fuel pump and ECM's. The maximum allowable fuel inlet temperature is 140°F (60°C). DDEC activates a check engine light at 179.6°F (82°C).

Fuel supply hoses must be SAE number 16 (25mm I.D.) or larger. The fuel return hoses must be SAE number 12 (18mm I.D.) or larger. Route hoses at least 12 in. away from all exhaust components and do not route against sharp edges or in an area where the hose may rub or vibrate against vehicle parts.

DAVCO FUEL FILTERS

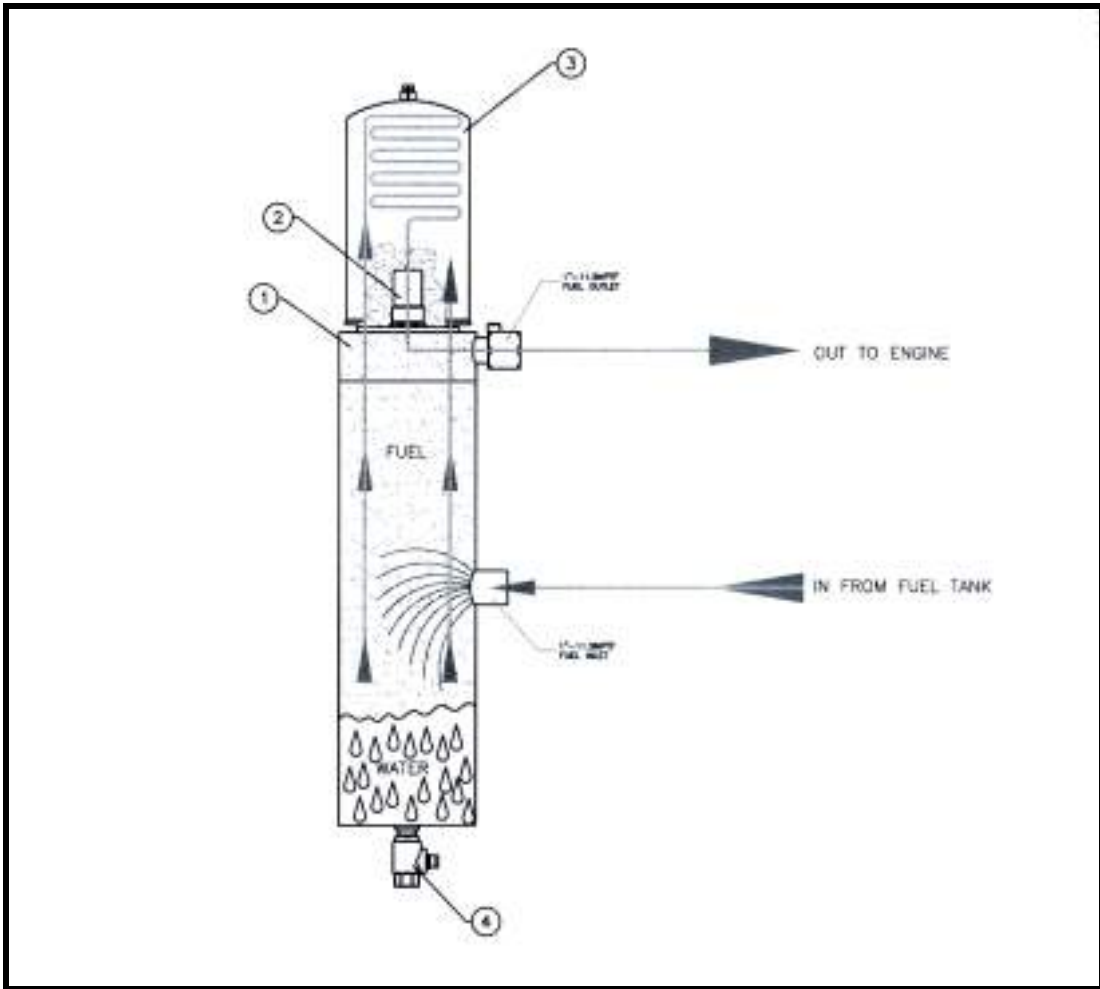

Fig. 104 Fuel Pro 40 Fuel/Water Separator with Filter

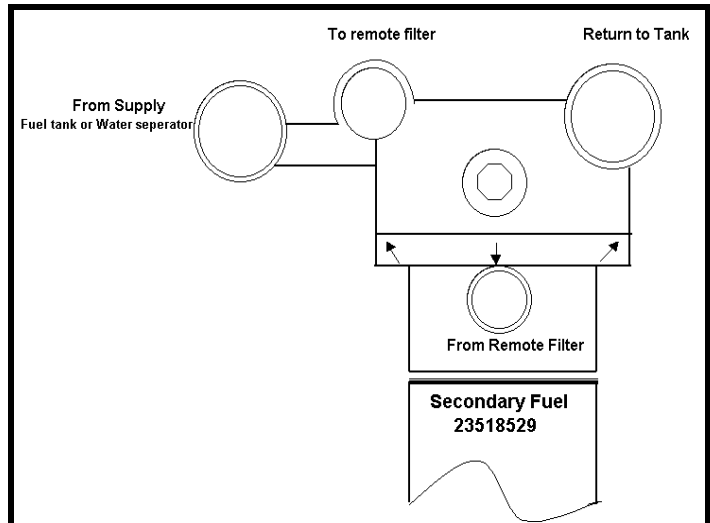
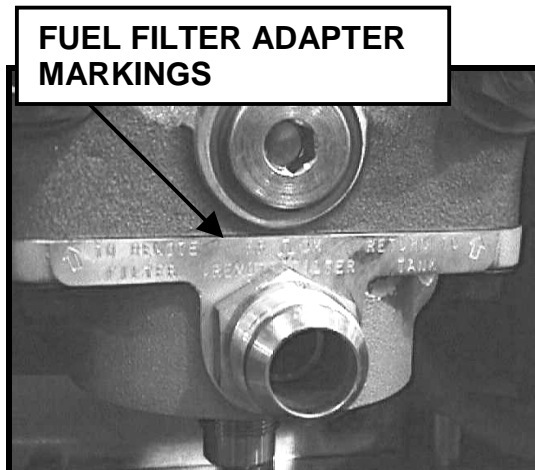

Fig. 105 C&I Fuel Junction Block Off-engine Fuel Line Connection Identification

DAVCO FUEL FILTERS

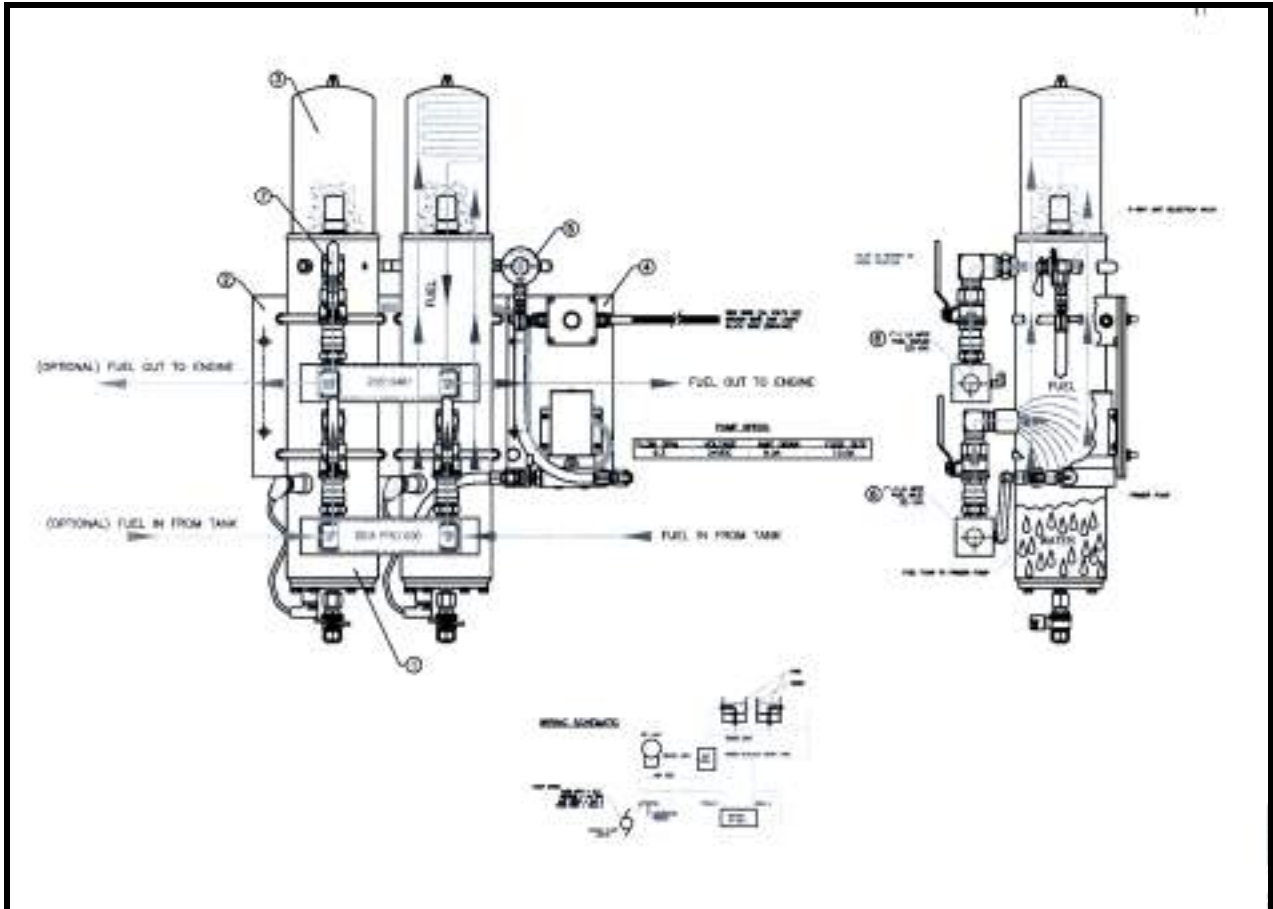

Fig. 105 Marine Sea Pro 600 Fuel/Water Separator with Filter

FUEL SYSTEM PRIMING PROCEDURE

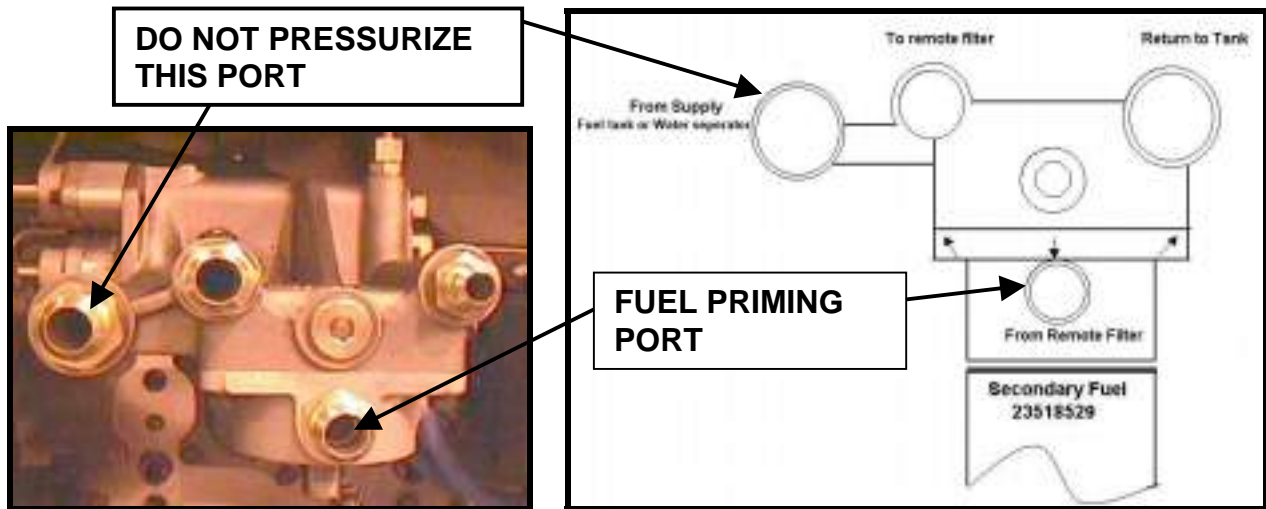

Fig. 106 Fuel Junction Block Fuel Priming Port Location

PRIMING PROCEDURE

1. Open the vehicle fuel supply and return valves, if applicable.
2. Connect an external pressurized fuel supply (0.5 to 2.0 bar pressure) to the priming port shown in Fig. .

NOTICE: Do not skip step 3. Do not try to bleed air at another location. Severe damage to the high-pressure fuel pump will occur if it is not full of fuel at engine start-up.



Fig. 107 Fuel System Vent Valve

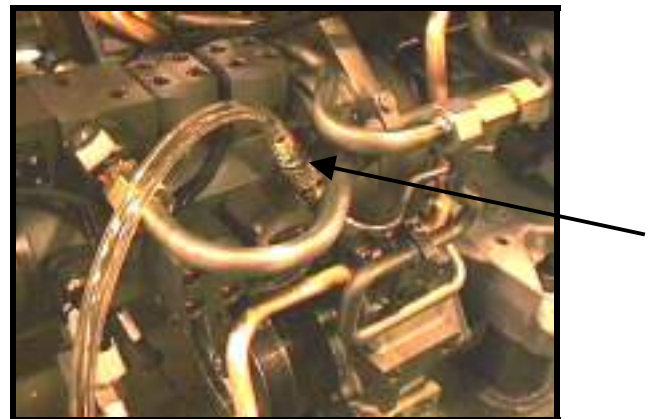

Fig. 108 Vent Valve with Quick Coupling and Hose Connected

FUEL SYSTEM PRIMING PROCEDURE

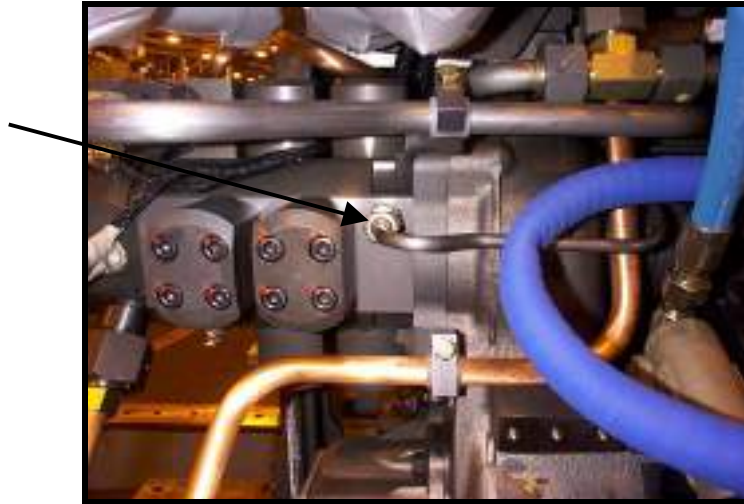

Fig. 109 High-pressure Pump Fuel Return Line Fitting

- 3. Connect a hose with quick disconnect coupling P/N PD 243 to the vent valve located on the body of the high-pressure fuel pump. (See Fig.107 and Fig.108) Place the open end of the hose in a container to catch fuel discharge. On older units, loosen the fitting of the return fuel line on the high-pressure fuel pump to allow air to bleed out of the pump crankcase. (See Fig.109) When fuel flows without air bubbles present, disconnect the quick coupling or tighten the return line fitting.**
- 4. Disconnect the priming fuel supply.**
- 5. Crank the engine in 20-second intervals, up to four times.**
- 6. If the engine did not start, repeat the steps beginning with step 2.**
- 7. After three attempts and the engine still did not start, loosen the high-pressure fuel lines from the injectors at cylinder locations A1 and B1, at the high-pressure fuel rails. Repeat the steps beginning with step 2.**
- 8. Tighten the high-pressure line at cylinder A1 and B1 at the high-pressure fuel rail connectors. Torque to 100 Nm + 10 Nm (74 lb. ft + 7.4 lb. ft).**

FUEL SYSTEM TROUBLE SHOOTING

To help determine the root cause of the fuel system problem, A complete DDEC data list or DDDL should be taken at the following three steady state points:

1. Idle, while the code is active
2. Full power, rated speed
3. Rated speed, no load

The data list must contain the following parameters:

- Engine S/N
- 6N4D
- Injection control pressure
- Fuel rail pump utilization
- Fuel delivery pressure
- Engine RPM
- Fuel temperature
- Percent engine load
- Battery voltage
- PWM3 output

The high-pressure fuel pump is directly affected by the availability of low-pressure fuel being supplied. The lack of sufficient low-pressure fuel supply will result in the control solenoid PWM3 demand signal being raised above normal range and the pump usage exceeding 97 percent. Excessive high-pressure pump usage above 97 percent will cause a PWM3 DDEC Code above normal range and eventual failure of the high-pressure pump.

Hard Starting

Probable Causes	Check	Corrective Action
No fuel supply	Fuel supply	Replenish
Bad seat at the high-pressure rail relief valve	High-pressure rail relief valve	Clean or replace as needed

Engine Fires Erratically After Starting

Probable Causes	Check	Corrective Action
Fuel system is not vented	Does engine fire steady after short period	Open system vent
Fuel injector faulty	Injector wiring, unit injector solenoid, ECM's	Replace injector, wiring harness or ECM's as required

FUEL SYSTEM TROUBLE SHOOTING

Engine Does Not Reach Full-Load Speed

Probable Causes	Check	Corrective Action
Fuel Injectors faulty	Injectors, wiring harness, ECM's	Replace as needed
High-pressure fuel pump insufficient pressure	Check fuel supply Check battery voltage to controller	Replenish Correct cause for low battery voltage

Engine Speed Not Steady

Probable Causes	Check	Corrective Action
Fuel Injectors faulty	Injectors, wiring harness, ECM's	Replace as needed
High-pressure fuel pump controller faulty	Check battery voltage to controller	Correct cause for low battery voltage Replace controller
Excessive fuel inlet restriction	Plugged fuel filters Incorrectly plumbed remote fuel filters	Replace filters Correct remote fuel filter plumbing

Code 63, PWM 3 Above Normal Range

Probable Causes	Check	Corrective Action
No battery voltage on 440 circuit to high-pressure pump controller	Available battery voltage Wiring harness and connectors	Replace batteries Repair or replace wiring harness or connectors
Short in ECM	DDEC Codes	Replace ECM
Controller faulty		Replace controller
Restricted or low fuel supply	Fuel Supply Fuel Filters and lines for obstruction	Replenish Replace filters Repair fuel lines
High-pressure pump	If low-pressure fuel supply OK, disconnect 24-Volt power supply	Injection pressure does not change, replace high-pressure pump

FUEL SYSTEM TROUBLE SHOOTING

Code 63, PWM 3 Below Normal Range

Probable Causes	Check	Corrective Action
440 Not on it's own battery post	Wiring harness	Repair wiring harness or connectors
Controller faulty		Replace controller

Fuel Leaks at Injector

Probable Causes	Check	Corrective Action
Fuel in oil	Injector O-rings	Replace O-rings
Injector O-ring Leaking	C-E ring leaking	Replace C-E ring and O-rings.
Loose fuel line	Fuel line torque	Retorque
Fuel line connector internal nut adjustment	Connector internal nut torque	Retorque

Fuel Leaks at Fuel Rail

Probable Causes	Check	Corrective Action
Fuel line connector internal nut adjustment	Connector internal nut torque	Retorque
Limiter valve seat at high-pressure fuel rail	Limiter valve seat	Repair seat or replace high-pressure fuel rail

Fuel Pressure Too High

Probable Causes	Check	Corrective Action
High-pressure fuel sensor faulty	DDEC code DDEC fuel pressure reading	Replace sensor
High-pressure fuel pump controller faulty	Check battery voltage to controller	Low battery voltage Replace controller

FUEL SYSTEM TROUBLE SHOOTING

High-pressure Fuel Pump Leaking at Weep Hole

Probable Causes	Check	Corrective Action
High-pressure pump leaking fuel	Fuel temperature	Correct cause of high fuel temperature
	Contaminated fuel	Clean fuel system and replace contaminated fuel
High-pressure pump leaking oil	High-pressure pump crankcase seal	Replace high-pressure pump
	Crankcase pressure	Correct cause of high crankcase pressure
	High-pressure pump drive seal	Replace high-pressure pump

Low Fuel Pressure

Probable Causes	Check	Corrective Action
Fuel level too low	Fuel Supply	Replenish
Fuel supply blocked	Shut off valve in system	Open
Fuel line leaking	Seals and torque of fittings	Seal, replace if needed Tighten fittings
Fuel filter plugged	Secondary and remote filters	Replace filters
Fuel delivery pump faulty	Fuel delivery pump and drive	Replace as needed
High-pressure fuel pressure sensor faulty	DDEC codes	Replace
High-pressure fuel pump controller faulty	Check battery voltage to controller	Correct cause for low battery voltage
High-pressure rail relief valve leaking	Fuel return from relief valve	Clean or replace relief valve as needed
High-pressure fuel pump generating insufficient pressure	DDEC fuel pressure reading	Replace high-pressure pump

TORQUE SPECIFICATIONS FOR FUEL SYSTEM COMPONENTS

<u>DESCRIPTION</u>	<u>SIZE</u>	<u>CAT.</u>	<u>USAGE DESCRIPTION</u>	<u>TORQUE (Nm)</u>
BOLT	M3	A	INJECTOR TERMINAL	1.4 - 2.0
<i>BOLT, CLASS 10.9 (P/N 5249902101)</i>	<i>M12</i>	<i>A</i>	<i>INJECTOR HOLD DOWN CLAMP</i>	<i>115 - 125</i>
METAL TO METAL CONE SEAL	M14 X 1.5	A	HIGH PRESSURE FUEL SENSOR	30 - 40
METAL TO METAL CONE SEAL	M16 X 1.5	A	LOW PRESSURE FUEL RAIL END CAP	30 - 33
FUEL LINE	M24 X 1.5	C	NUT, HP FUEL LINES (REFERENCE CATEGORY F)*	100 - 110*
FUEL LINE	M40 X 1.5	C	NUT, HP FUEL LINES (REFERENCE CATEGORY F)*	100 - 110*
FUEL LINE	M42 X 1.5	A	FUEL RAIL NUT	550 - 605
FUEL LINE		C	NUT, HP FUEL LINES (HP PUMP TO RAILS) (REFERENCE CATEGORY F)*	100-110
SENSOR	M18 X 1.5	A	FUEL MONITOR – MARINE	25 – 28

CATEGORY (CAT.) DESCRIPTIONS

- A - LOAD WITHIN DESIGN CAPABILITY.
PROCESS VERIFICATION CONTROLLED BY CORRECT TOOLING.
VERIFICATION - TO MINIMUM TORQUE VALUE.
- C - LOAD REQUIRED SENSITIVE TO BOTH LOW & HIGH VALUES.
PROCESS CONTROLLED BY SPECIAL TORQUE EQUIPMENT OR
PROCESS
VERIFICATION - TO GIVEN RANGE OF TORQUE VALUES.
- F - JOINT SENSITIVE TO TORQUE SEQUENCE. SEE ENGINE BUILD
INSTRUCTIONS.

**NOTE: TORQUE SPECIFICATION DOES NOT APPLY TO HOT ENGINES.
RECHECK OF TORQUE AT ROOM TEMPERATURE TO BE NOT LESS THAN 90
PERCENT OF MINIMUM ASSEMBLY VALUE.**

SERVICE INFORMATION

TECHNICAL SERVICE LETTERS

- **NO.: 01 TS – 28 May 1, 2001**
Addition of an Injector Hold-down Bolt Washer with Revised Torque
- **NO.: 00 TS – 24 June 6, 2000**
Injector Response Time (IRT) Long Codes

SERVICE INFORMATION BULLETINS

- **1-4000-99 February 1999**
Injector Seal Installation Improvement
- **5-4000-99 August 1999**
Fuel System Cleaning After High-pressure Pump Failure
- **6-4000-99 October 1999**
New Floating Style Fuel Tubes Replace Brazed Fuel Tubes
- **3-4000-00 January 2000**
Release of Low-pressure Fuel Tube Support
- **9-4000-00 March 2000**
Model Year 2000 Emissions Requirements
- **20-4000-00 December 2000**
Improved Injector C-E Ring Released
- **9-4000-01 May 2001**
Improved Low-pressure Fuel Plumbing System

MTU SERVICE INFORMATION BULLETINS

- **4000-99/0028**
HP Fuel Lines, Tightening of Thrust Rings after Disassembly

18SP INSTALLATION INSTRUCTIONS

- **18SP503**
Installation of DIN Common Rail Fuel Pressure Sensor



NO.: 01 TS - 28
May 1, 2001

TO: All Detroit Diesel Distributors - Worldwide

FROM: S-4000 Technical Service Department

ATTN: General Service Manager

SUBJECT: Addition of an Injector Hold-down Bolt Washer with Revised Torque

To improve the injector clamp retention, Detroit Diesel released for production a hardened injector hold-down bolt washer P/N 23509483 effective with Series 4000 engine serial numbers (12V) 5262000340 and (16V) 5272000713.



Fig. 1) Cut-away showing injector installation with hardened washer installed.

Additionally, the torque for the injector hold-down bolt has been revised from 100-110 N-m to 115- 125 N-m (85-92 ft-lbs.).

At any time injectors are serviced, include the new hardened washer and revised torque specification during re-installation of the injector.

With these changes and the use of the most current C-E ring (P/N 23540260), the need to retorque the injector hold-down bolts during the 50-Hour Inspection is no longer required.

Floyd Pemberton
S-4000 Technical Service Department





00 TS-24

June 6, 2000

TO: All Detroit Diesel Distributors - Worldwide

FROM: S-4000 Technical Service Department

ATTN: General Service Manager

SUBJECT: Injector Response Time (IRT) Long Codes

Applications: All Construction, Industrial and Generator Applications.

Injector Response Time (IRT) long codes have a greater tendency for occurrence in certain cylinders as a result of increased electrical resistance being detected. This resistance can occur in the OEM power harness, injector harnesses or in the injector solenoids themselves.

To reduce the possibility of Injector Response Time long codes; Detroit Diesel has released the following improvements:

1. Engine Power Harness - 3rd receiver ground wire.

All applications have pin S of the 16-pin power harness connector populated with a 12 AWG-ground wire, which runs back to battery ground (just like the other #150 ground wires). All three have pin S labeled as wire 954.

To further help with response time problems and noisy injector operation, a third ground wire can be installed for the receiver power harness.

Use one of the spare wires in the engine power harness to run 150 R #3 from pin B on the 5 pin receiver power harness connector to pin S on the 16 pin Duetsch connector. This will equalize the power harness resistance for both ECM's and provide additional protection against IRT codes on the receiver ECM.

Additionally, LeTourneau and Unit Rig installations will have pin S unused and plugged. These two OEMs would need to modify the harnesses for a 3rd 150 R wire. Units in the field would have to have an additional #12 AWG-wire installed on the OEM side of the Duetsch power connector back to battery ground.

For Generator applications without the 16 pin power harness connector, an additional #12 AWG-wire will need to be installed from the pin B of the 5 pin receiver power harness connector back to battery ground.

Repower installations should be rewired to take advantage of the additional ground. All repowers must have the correct size wire on the power harness.

2. New equal resistance injector harnesses have been released in March (Refer to Service Information Bulletin 11-4000-00).

(12V- A bank) P/N 23540167, (12V- B bank) P/N 23540166

(16V- A bank) P/N 23540165, (16V- B bank) P/N 23540164

3. Updating former injectors to low flow style injectors P/N 23526589 and re-calibrating the ECM's (Reference Service Information Bulletin 9-4000-00), will reduce the DDEC sensitivity to Injector Response Times.

AUTHOR: Floyd Pemberton

AUTHOR'S TITLE: S-4000 Technical Service Department

DETROIT DIESEL



MTU/DDC Series 4000™ Service Information

NUMBER: 1-4000-99 S.M. REF.: Information Only ENGINE: 4000 DATE: February 1999

SUBJECT:INJECTOR SEAL INSTALLATION IMPROVEMENT

INTRODUCTION

The fuel injector CE-ring assembly on Series 4000™ engines **must** be installed in the correct position to provide reliable service.

DETAILS AND REASON

The current fuel injector CE-ring assembly 5240160419 replaces former CE-ring seal 0000160119. This CE-ring assembly **must** be mounted on the fuel injector with the flat side placed towards the spray tip nut. Correct positioning of the injector CE-ring assembly insures proper sealing of the fuel injector into the cylinder head, preventing oil leakage past the fuel injector into the cylinder bore. To aid installation of the CE-ring assembly, apply a small amount of grease to the injector body.

ADDITIONAL SERVICE INFORMATION

Additional service information will be available in the Detroit Diesel ~~SEM~~ which is currently in process. This manual will include the injector information.

6SE4000,

DETROIT DIESEL
CORPORATION



13400 Outer Drive, West / Detroit, Michigan 48239-4001
Telephone: 313-592-5000
www.detroitdiesel.com

Detroit Diesel®, Detroit Diesel and Spinning Arrows Design® are registered trademarks of Detroit Diesel Corporation. Series 4000™ is a trademark of Detroit Diesel Corporation.

© Copyright 1999 Detroit Diesel Corporation. All rights reserved. Printed in U.S.A.

DETROIT DIESEL



MTU/DDC Series 4000™ Service Information

NUMBER: 5-4000-99 S.M. REF.: Information Only ENGINE: 4000 DATE: August 1999

SUBJECT: FUEL SYSTEM CLEANING AFTER HIGH-PRESSURE PUMP FAILURE

INTRODUCTION

Detroit Diesel has released a cleaning procedure for the U. S.-manufactured Series 4000™ engine fuel system to be completed after a high-pressure fuel pump has failed. This condition requires that the entire fuel system be thoroughly cleaned of ceramic particles to prevent further damage to the fuel system components.

DETAILS AND REASON

Detroit Diesel has released a cleaning procedure for the U. S.-manufactured Series 4000 engine high-pressure fuel system in the event a high-pressure fuel pump fails. Should the idler gear be disengaged from the pump shaft, this would indicate that the ceramic bearing has failed. If a bearing fails, the shaft of the high-pressure pump will seize and will not rotate. If this condition is experienced, the following cleaning procedure **must** be performed to prevent further damage to the fuel system components.

NOTICE:

Failure to clean the fuel system of ALL ceramic particles will result in the contamination failure of the fuel system components.



CAUTION:

To avoid personal injury when low drying, wear adequate eye protection (safety glasses or face plate) and do not exceed 276 kPa (40 psi) air pressure.

Cleaning Procedure: High-Pressure System

1. Remove the high-pressure fuel pump assembly from the engine.
2. Remove all high-pressure fuel lines from the high-pressure pump to the fuel rails and from the rails to the fuel injectors. Flush all lines with clean solvent or diesel fuel and blow clean with shop air.
3. With the injectors still installed in the cylinder heads, inspect the high-pressure inlet for debris build-up at the inlet filter; if debris is evident, replace the injectors.
4. Remove, disassemble and clean all fuel flow limiter valves.
5. Remove the regulator from the "A" bank high-pressure fuel rail and the plug from the end of the "B" rail.

Clean both high-pressure fuel rails with clean solvent or diesel fuel and blow clean with shop air. Disassemble and clean the “A” bank rail pressure regulator. See Figure 1.

6. Reassemble following the service manual procedures and torque specifications.

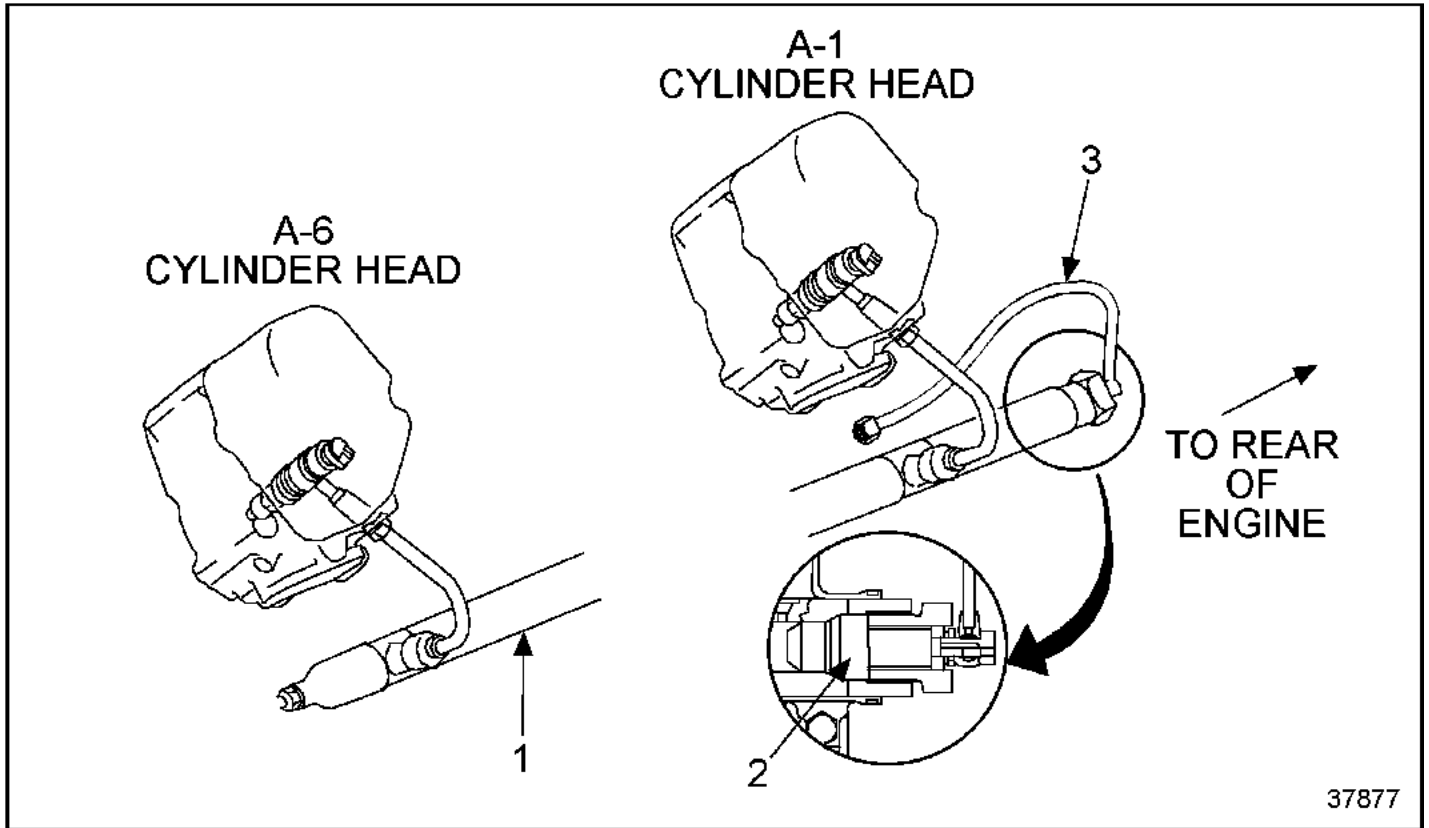

1. High Pressure Fuel Rail

2. Pressure Regulator

3. Fuel Line

Figure 1 'A' Bank Fuel Rail

Cleaning Procedure: Low-Pressure System

1. Replace the low-pressure fuel transfer pump.
2. Remove the secondary fuel filter and fuel junction block assembly. Remove all filters, plugs and regulators from the junction block. Flush and blow out all passages.
3. Inspect for cleanliness, as this is the critical area for particle build-up.
4. Reassemble following service manual procedures and torque specifications.

ADDITIONAL SERVICE INFORMATION

Additional service information is available in the Detroit Diesel **SOME**

NOTE:

Service manuals are available from authorized Detroit Diesel distributors.

DETROIT DIESEL
CORPORATION



13400 Outer Drive, West / Detroit, Michigan 48239-4001
Telephone: 313-592-5000
www.detroitdiesel.com

Detroit Diesel®, Detroit Diesel with Spinning Arrows Design® are registered trademarks of Detroit Diesel Corporation. Series 4000™ is a trademark of Detroit Diesel Corporation.
© Copyright 1999 Detroit Diesel Corporation. All rights reserved. Printed in U.S.A.



NUMBER: 6-4000-99 S.M. REF.: Information Only ENGINE: 4000 DATE: October 1999

SUBJECT: NEW FLOATING STYLE FUEL TUBES REPLACE BRAZED FUEL TUBES

INTRODUCTION

Improved floating style fuel tubes have replaced the former brazed tubes between the low pressure fuel pump and the fuel junction block on all U.S.-manufactured Series 4000™ engines. This change took effect with unit serial numbers 5242000020 (8V engines), 5262000199 (12V engines), and 5272000443 (16V engines).

DETAILS AND REASON

The former rigid, brazed tubes connecting the low pressure fuel pump with the fuel junction block have been replaced by floating tubes with O-ring seals at both ends. The former brazed tubes had O-ring seals at the fuel junction block only. See Figure 1.

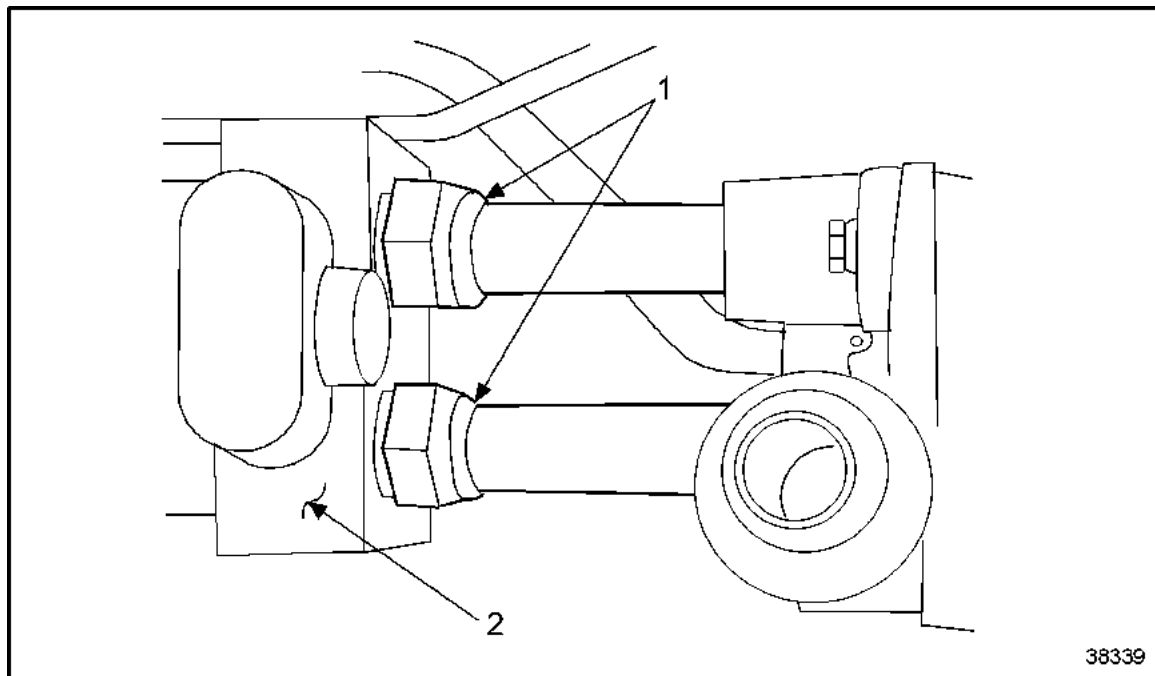

1. Brazed Joint

2. Fuel Pump

Figure 1 Former Rigid Fuel Tubes

See Figure 2 for the current floating tube design.

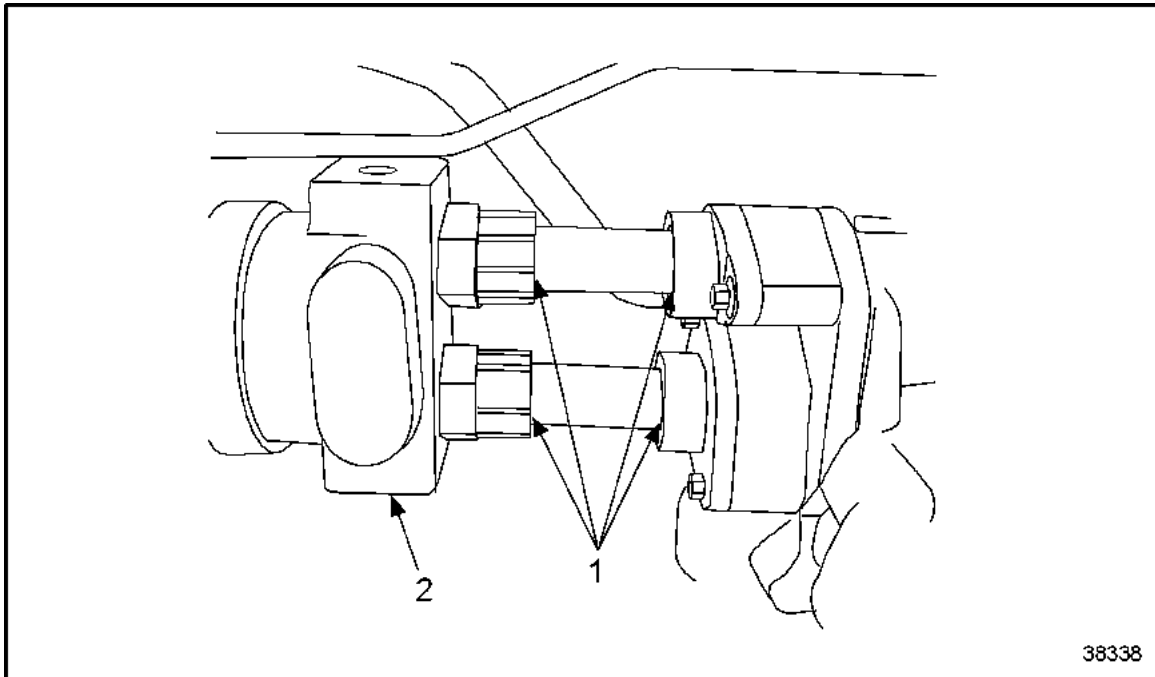

1. O-Ring Joint

2. Fuel Pump

Figure 2 Current Floating Fuel Tubes

See Figure 3 for location of floating tube components and part numbers .

Listed in Table 1 are the former and current part numbers.

Item No.	Former Part No.	Current Part No.	Qty. on 8V Engine	Qty. on 12V, 16V Engines	Description
1	5244760001	5240920016	2	2	Tube
2	5244710021	5240910189	2	2	Flange
3	11509512	11500720	4	-	Bolt
3	11509512	11505269	-	4	Bolt
4	-	5240910053	2	2	Spacer
5	-	5240910089	2	2	Fitting
6	-	700429037002	4	4	O-Ring
7	-	700429024001	8	8	O-Ring

Table 1 Fuel Tube Parts List

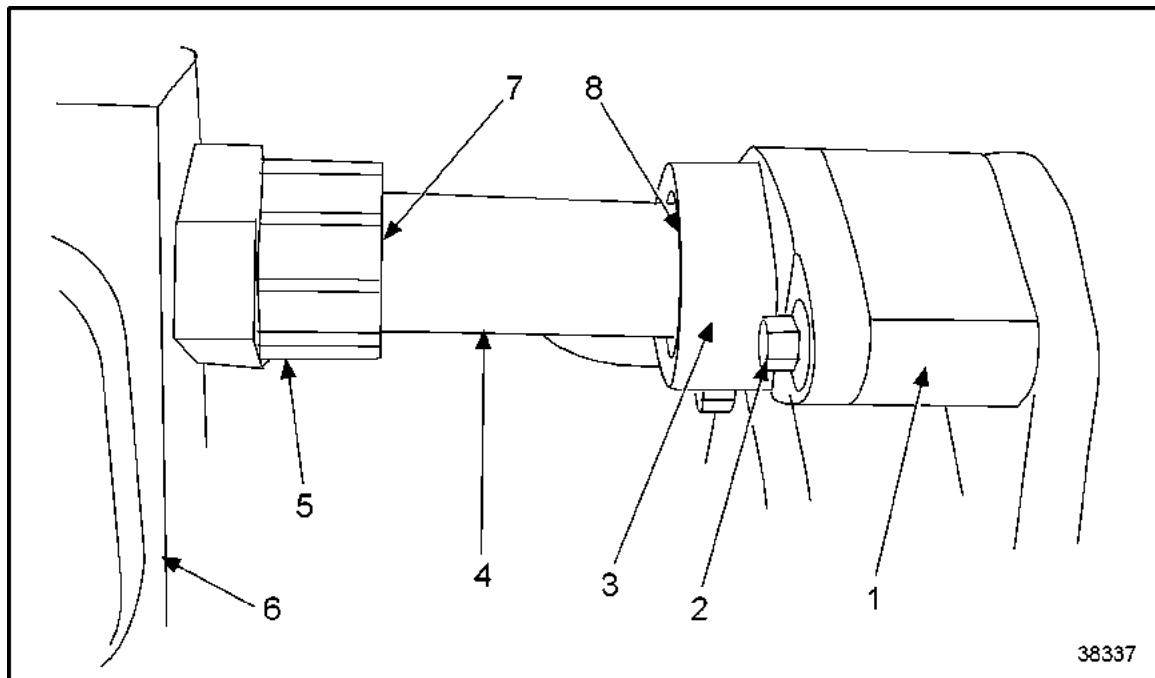

- 1. Spacer
- 2. Bolt
- 3. Flange
- 4. Tube
- 5. Fitting
- 6. Fuel Pump
- 7. O-Ring, Tube-to-Fitting
- 8. O-Ring, Tube-to-Flange

Figure 3 Location of Floating Fuel Tube Components

INTERCHANGEABILITY AND SERVICE

To ensure interchangeability, all current parts *must* be used together when the former parts are replaced. The former tube and flange will no longer be serviced.

NOTE:

Detroit Diesel recommends replacing the former rigid brazed fuel tubes with the floating tube components when the normal W4 or W5 inspections are performed. These inspections are covered in the *Series 4000 Service Manual*.

ADDITIONAL SERVICE INFORMATION

Additional service information is available in the *Series 4000 Service Manual*, 6SE4000. The next revision to this manual will include the revised information.

NOTE:

Service manuals are available from authorized Detroit Diesel distributors.

DETROIT DIESEL
CORPORATION



13400 West Outer Drive, Detroit, MI 48239-4001
Telephone: 313-592-5000
FAX: 313-592-7288

DETROIT DIESEL



MTU/DDC Series 4000™ Service Information

NUMBER: 3-4000-00 **S.M. REF.:** Information Only **ENGINE:** 4000 **DATE:** January 2000

SUBJECT: RELEASE OF LOW-PRESSURE FUEL TUBE SUPPORT

INTRODUCTION

Detroit Diesel has released a support bracket for the low-pressure fuel tube on U.S.-manufactured Detroit Diesel Series 4000™ engines. This change went into effect with serial numbers 5262000219 (12V) and 5272000507 (16V).

DETAILS AND REASON

To prevent possible vibration-induced damage to the low pressure fuel tube, Detroit Diesel has released a support bracket that mounts between the fuel junction block and high-pressure fuel pump. The bracket requires five additional parts for proper installation, which will eliminate possible fatigue fractures in the tube. The component part numbers are listed in Table 1.

Description	Part Number	Quantity
Bolt, M8 x 55mm	000931008227	1
Clip	700325022100	2
Grommet	5249970081	1
Bracket	5801533240	1
Spacer, 15mm	8332030053	1
Bolt, M12 x 45mm	11500945	1

Table 1 Component Parts List

INTERCHANGEABILITY

To install the low-pressure fuel tube support bracket, remove one (1) bolt (M12 x 40mm) from the high-pressure pump mounting at the one o'clock position (discard bolt). Install the grommet around the low-pressure fuel tube at the location where the two clips will be placed around the tube. See Figure 1.

Place clips on the top and bottom of the grommet facing each other and then, using the bolt (M8 x 55mm) and spacer, secure it with the L-shaped bracket to the top of the high-pressure pump mount. Torque bolt to 21N·m to 24 N·m (16 lb·ft to 18 lb·ft). Attach the other end of the L-shaped bracket to the high-pressure fuel pump mounting bolt hole (where the M12 bolt was previously removed) and secure with bolt (M12 x 45mm). Torque to 100 N·m to 110 N·m (74 lb·ft to 81 lb·ft).

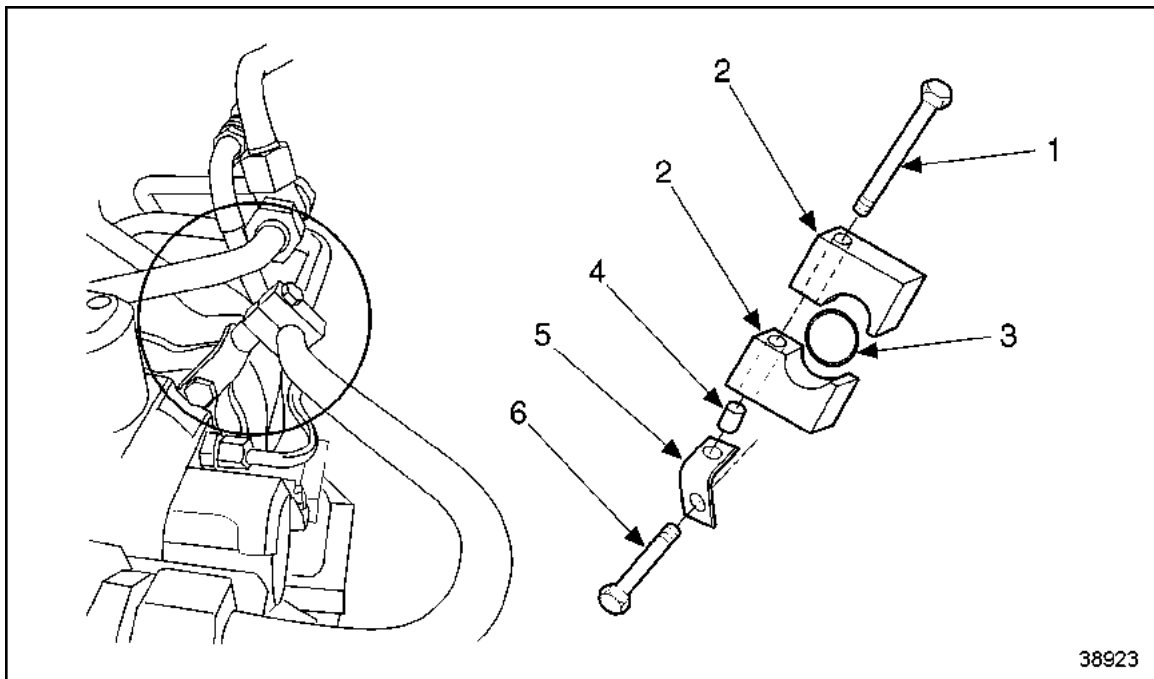

1. Bolt M8 x 55

2. Clip

3. Grommet

4. Spacer

5. Bracket

6. Bolt M12 x 45mm

Figure 1 Component Parts

ADDITIONAL SERVICE INFORMATION

Additional service information is available in the Detroit Diesel *Series 4000 Service Manual*, 6SE4011. The next revision to this manual will include the revised information.

NOTE:

Service manuals are available from authorized Detroit Diesel distributors. If this bulletin was obtained from the Internet, service manual page(s) are available by returning to the screen "SIB Index", selecting attachment pages, and printing the page(s).

DETROIT DIESEL
CORPORATION



13400 Outer Drive, West / Detroit, Michigan 48239-4001
Telephone: 313-592-5000
www.detroitdiesel.com

DETROIT DIESEL



MTU/DDC Series 4000™ Service Information

NUMBER: 9-4000-00 REV. S.M. REF.: Information Only ENGINE: 4000 DATE: March 2000

REVISION: Revision bar indicates change. Please discard bulletin 9-4000-00 dated February 2000.

SUBJECT: MODEL YEAR 2000 EMISSIONS REQUIREMENTS

INTRODUCTION

Effective December 13, 1999, Detroit Diesel introduced products that meet model year 2000 emission standards for all U.S.-manufactured Series 4000™ engines used in construction and industrial applications. To accomplish compliance with model year 2000 engine emission standards, new DDEC® base calibrations and new injectors were released for production. This has required the engine model numbering changes listed in Table 1.

Former Engine Model Numbers	Current Engine Model Numbers	Application
T1237K11	T1237K33	Construction/Industrial
T1237K16	T1237K36	Generator
T1237K73	T1237K39	Hydrofrac
T1637K73	T1637K39	Hydrofrac
T1637K11	T1637K33	Construction/Industrial
T1637K16	T1637K36	Generator

Table 1 Series 4000 Engine Model Numbers

DETAILS AND REASON

Detroit Diesel has released new DDEC base calibrations and new injectors to meet the requirements of model year 2000 engine emission standards. The new DDEC base calibrations are : 6N4D-501, 502, 503, 505, 506, and 507. The former non-certified DDEC base calibrations were 6N4D 402, 403, 404, 462, 463, and 464. The new DDEC base calibrations were added to the DDC® mainframe, effective December 13, 1999.

The new DDEC base calibrations are matched to the new injectors P/N E23526589 released for model year 2000 engine emission certification. The former non-certified DDEC base calibrations **can only be used** with the following former production injectors: P/N23526170; 0010100351; 0010100251; 0000107951; or 0000107851.

The model year 2000 emission-certified engines have special stickers P/N 23540085 placed on both the front A and B bank rocker covers and on the ECM cold plate to indicate that the engine has the new certified injectors installed. See Figure 1.

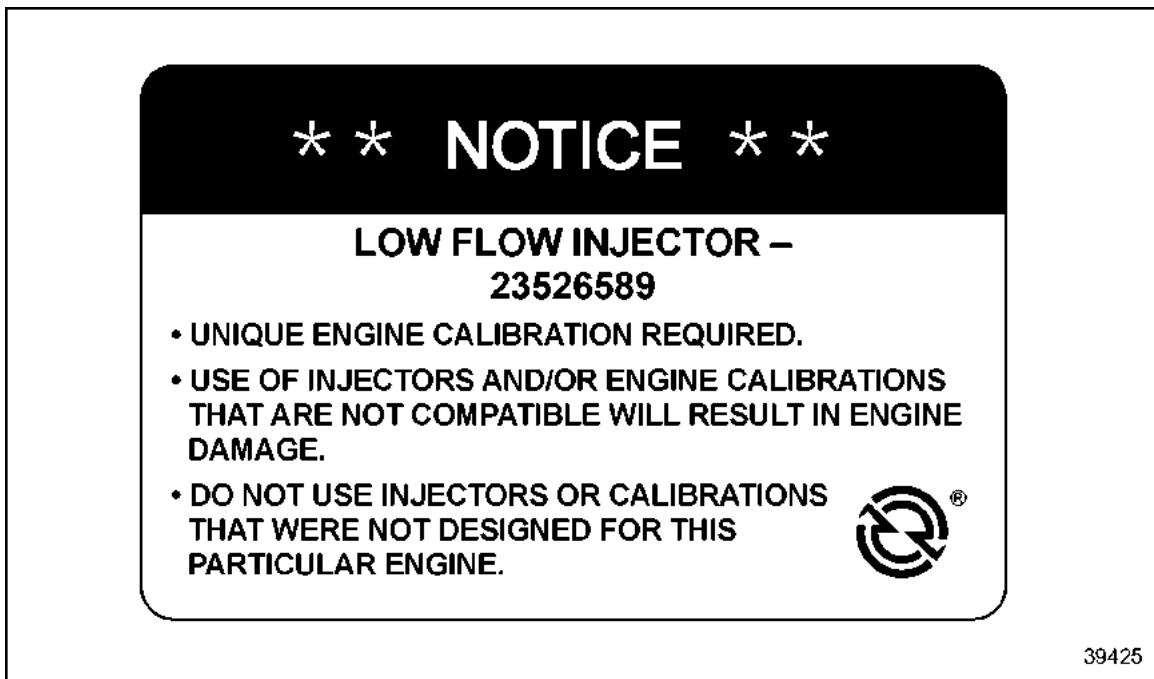

Figure 1 Rocker Cover/ECM Sticker

For service replacement, the new sticker is packaged with each certified injector. This sticker must be placed on the engine, as mentioned above, of any unit being updated in the field to prevent injector mixing or the incorrect DDEC base calibration from being inadvertently used with the new injectors. For calibration upgrades, see 6N4M groups listed in Table 2.

Model #	Certified	Injector	Rating 6N4M	Cal. 6N4D	No. Cyl.	Rated Power bhp@rpm	Other Rating Allowed	Notes
T1637K73	No	6589	1294	533	16V	3000@1950		Hydrofrac Only
T1637K11	No	6589	1095	523	16V	2700@1900	2500,2300@1900	
T1637K11	No	6589	1095	527	16V	2700@1900	2500,2700SL @1900	High Altitude
T1637K11	No	6589	1085	524	16V	2500@1900	2300@1900	
T1637K11	No	6589	1085	528	16V	2500@1900	2500SL@1900	High Altitude
T1637K11	No	6589	1103	525	16V	2300@1900		
T1637K11	No	6589	1103	526	16V	2146@1900		Excavator,1600kW
T1637K11	No	6589	1999	464	16V	2100@1900		Loader
T1637K11	No	6589	1998	463	16V	2000@1900		Loader
T1637K11	No	6589	1997	462	16V	1800@1900		Loader
T1637K16	No	6589	1151	529	16V	2935@1800	2670,2000@1800	60Hz Standby,Prime, Continuous;
T1637K16	No	6589	1220	530	16V	2600@1500	2360,1945@1500	50Hz Standby,Prime, Continuous
T1637K16	No	6589	1220	530	16V	2600@1500	2360,1945@1500	50Hz Standby,Prime, Continuous;
T1637K16	No	6589	1235	531	16V	2550@1800	2320@1800	60Hz Standby,Prime
T1637K16	No	6589	1235	531	16V	2550@1800	2320@1800	60Hz Standby,Prime;
T1637K16	No	6589	1236	532	16V	2260@1500	2055@1500	50Hz Standby, Prime
T1637K16	No	6589	1236	532	16V	2260@1500	2055@1500	50Hz Standby, Prime;
T1237K16	No	6589	1149	518	12V	2200@1800	2000,1500@1800	60Hz Standby,Prime, Continuous
T1237K16	No	6589	1149	518	12V	2200@1800	2000,1500@1800	60Hz Standby,Prime, Continuous;
T1237K16	No	6589	1237	519	12V	1965@1500	1785,1470@1500	50Hz Standby,Prime, Continuous

Model #	Certified	Injector	Rating 6N4M	Cal. 6N4D	No. Cyl.	Rated Power bhp@rpm	Other Rating Allowed	Notes
T1237K16	No	6589	1237	519	12V	1965@1500	1785,1470@1500	50Hz Standby,Prime, Continuous;
T1237K16	No	6589	1238	520	12V	1850@1800	1680@1800	60Hz Standby,Prime
T1237K16	No	6589	1238	520	12V	1850@1800	1680@1800	60Hz Standby,Prime;
T1237K16	No	6589	1239	521	12V	1615@1500	1440@1500	50Hz Standby, Prime
T1237K16	No	6589	1239	521	12V	1615@1500	1440@1500	50Hz Standby, Prime;

Table 2 6N4M Calibration Upgrade Chart

INTERCHANGEABILITY

Both the non-certified and certified DDEC base calibrations will be maintained on the DDC® mainframe for service. Mixing the incorrect DDEC base calibration with the wrong type of injector **must not be done**. Only the former non-certified DDEC base calibration should be used with the former P/N E23526170 injector. If updating to either the new DDEC base calibration or new emission-certified injector is required, both the injector and base calibration must be changed together in complete sets.

Notice
Mixing new certified injectors with former non-certified injectors or DDEC base calibration will result in loss of power. Utilizing non-certified injectors with the new certified DDEC base calibration will result in excessive cylinder pressures which could cause internal engine damage.

ADDITIONAL SERVICE INFORMATION

Additional service information is available in the Detroit Diesel *Series 4000 Service Manual*, 6SE4011.

NOTE:

Service manuals are available from authorized Detroit Diesel distributors.

DETROIT DIESEL
CORPORATION



13400 Outer Drive, West / Detroit, Michigan 48239-4001
Telephone: 313-592-5000
www.detroitdiesel.com



MTU/DDC Series 4000™ Service Information

NUMBER: 20-4000-00 S.M. REF.: Information Only ENGINE: 4000 DATE: December 2000

SUBJECT: IMPROVED INJECTOR C-E RING RELEASED

INTRODUCTION

Detroit Diesel has released an improved injector C-E ring for all Series 4000™ engines. This change took effect in production with unit serial numbers 5242000024 (8V), 5262000500 (12V), and 5272000874 (16V).

DETAILS AND REASON

To reduce the possibility of compression leaks past the injector, Detroit Diesel has replaced the former C-E ring (P/N 5240160419) that incorporated location tabs on the inner diameter of the C-E ring, with an improved C-E ring (P/N 23540260) without the locating tabs. See Figure 1.

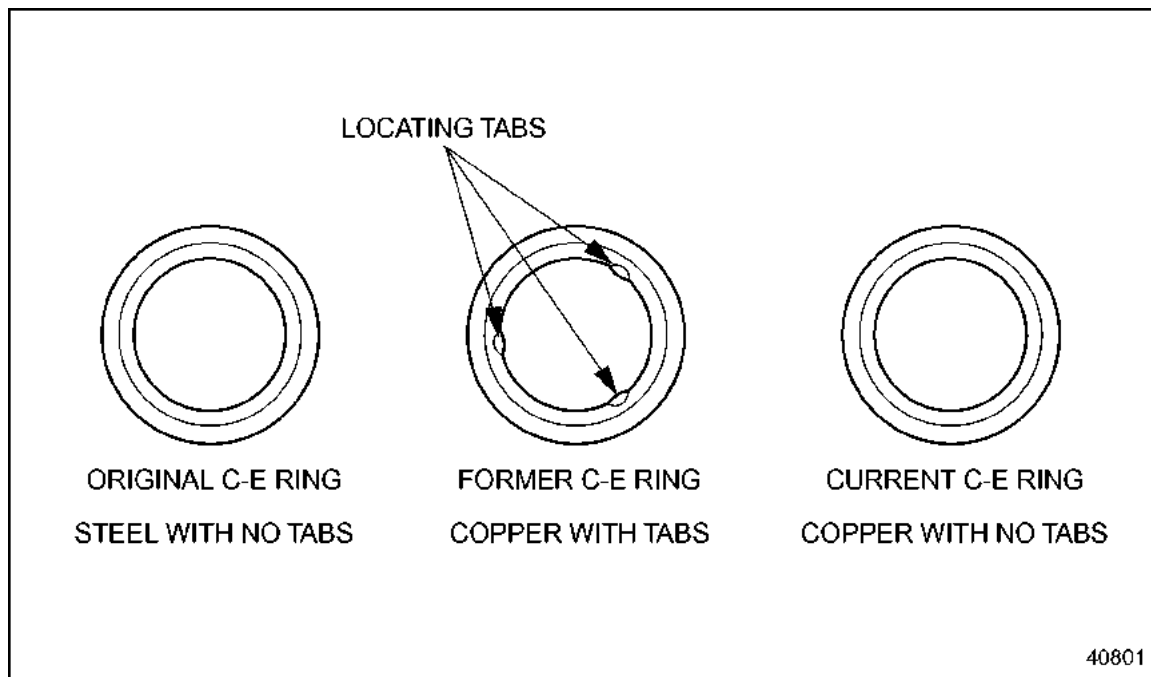

Figure 1 Current and Former C-E Rings

INTERCHANGEABILITY AND SERVICE

The former and current C-E rings are completely interchangeable within an engine, but only the current C-E ring (P/N 23540260) will be serviced.

NOTE:

When installing the current C-E ring, a small amount of heavy lubricating grease will need to be applied to the C-E ring mating surface of the injector. This will help retain the C-E ring to the injector while the injector is installed into the injector hole tube of the cylinder head. The locating tabs on the former C-E ring retained the ring to the injector during installation.

ADDITIONAL SERVICE INFORMATION

Additional service information is available in the Detroit Diesel *Series 4000 Service Manual* 6SE4011, dated October 1999.

NOTE:

Service manuals are available from authorized Detroit Diesel distributors.

DETROIT DIESEL
CORPORATION



13400 Outer Drive, West / Detroit, Michigan 48239-4001
Telephone: 313-592-5000
www.detroitdiesel.com

DETROIT DIESEL



MTU/DDC Series 4000™ Service Information

NUMBER: 9-4000-01 **S.M. REF.:** Information Only **ENGINE:** 4000 **DATE:** May 2001

SUBJECT: IMPROVED LOW-PRESSURE FUEL PLUMBING SYSTEM

INTRODUCTION

Detroit Diesel has released an improved low-pressure fuel plumbing system for all Series 4000™ engines used in construction, industrial and generator applications. This improvement took place in production with engine serial numbers 5262000565 (12V) and 5272000959 (16V).

DETAILS AND REASON

Detroit Diesel has released an improved low-pressure fuel plumbing system to provide improved sealing at the connections and to provide the ability to vent the fuel system of trapped air during the fuel priming procedure.

The improved low-pressure fuel plumbing now incorporates fuel line connector fittings utilizing an O-ring seal versus the former flared metal-to-metal type sealing. See Figure 1. To be compatible with this change, all new low-pressure fuel lines and support brackets were also released.

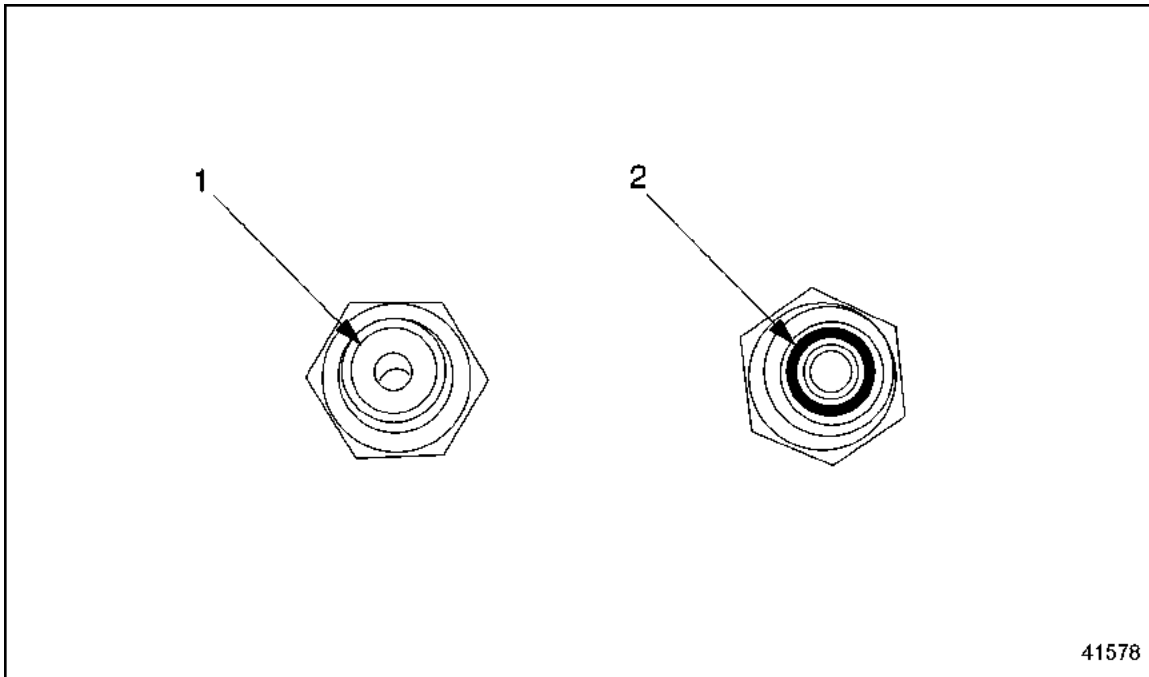

1. Former Flared Seat

2. Improved O-ring Seal

Figure 1 Improved Low-pressure Fuel Line Fitting

Additionally, a new vent valve has been installed in the fuel return line tee-fitting on the body of the high-pressure pump. See Figure 2. This vent valve is a quick disconnect coupling and hose to facilitate air venting during the fuel system priming process. See Figure 3 and see Figure 4.

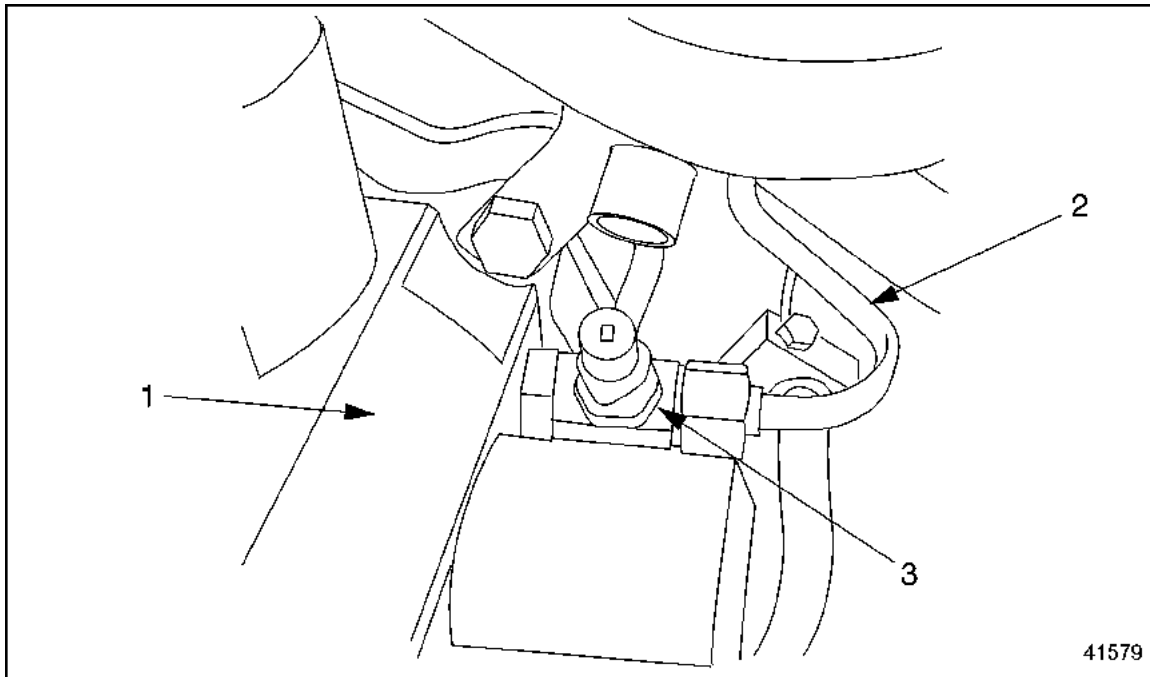

1. High-pressure Fuel Pump

3. Vent Valve

2. Fuel Return Line

Figure 2 Fuel System Vent Valve

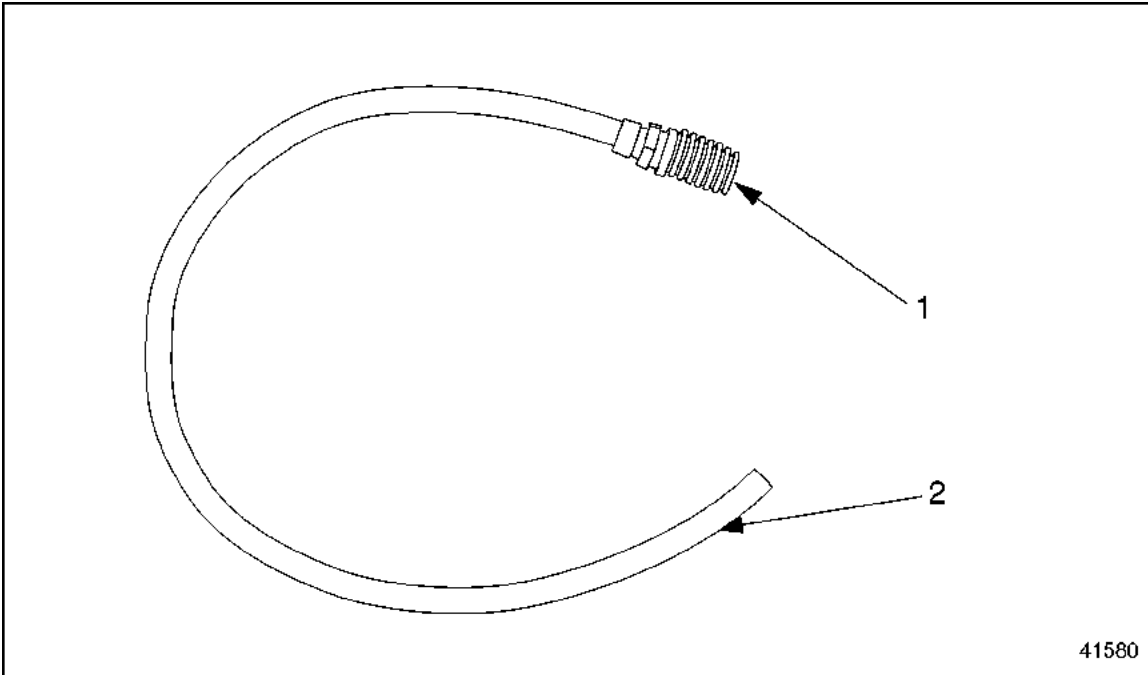

1. Quick Disconnect Coupling, P/N PD243

2. Hose

Figure 3 Fuel System Vent Valve Coupling and Hose

The quick disconnect coupling P/N PD243 is available from Parker Hannifin Corp. Parker Hannifin can be located on the Internet at <http://www.parker.com> A locally available hose is attached to permit capture of any fuel that escapes during the process of bleeding the fuel system.

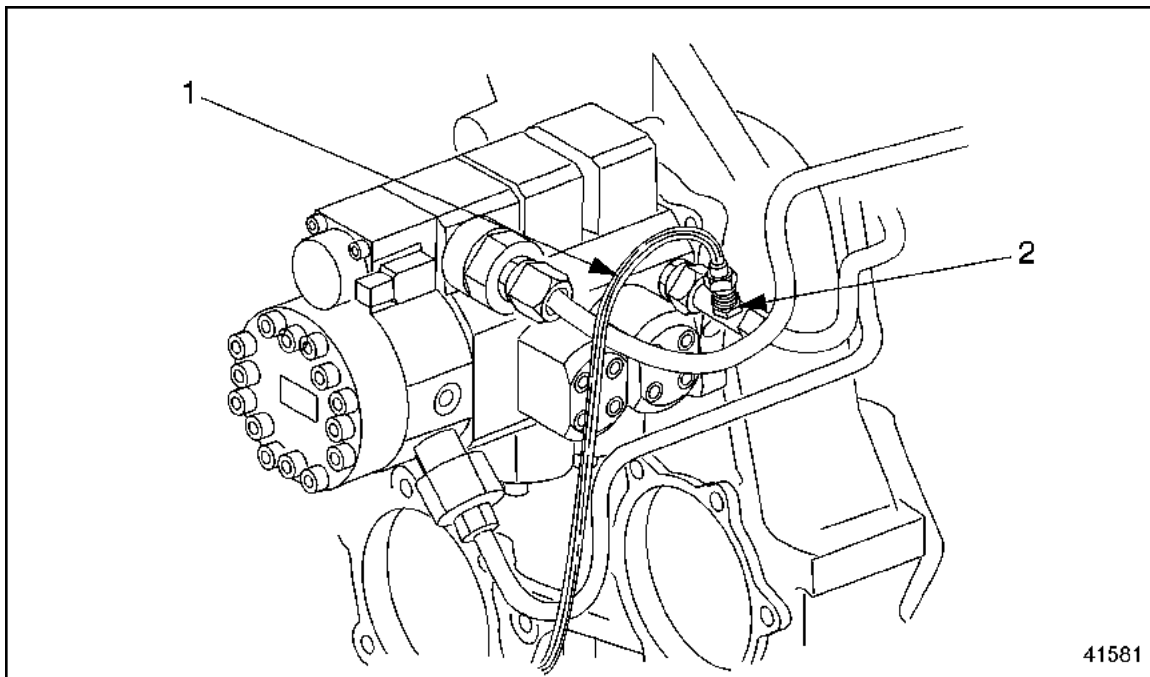

1. Quick Disconnect Coupling with Hose

2. Vent Valve

Figure 4 Fuel System Vent Valve with Coupling and Hose Connected

See Figure 5 for the complete low-pressure fuel system.

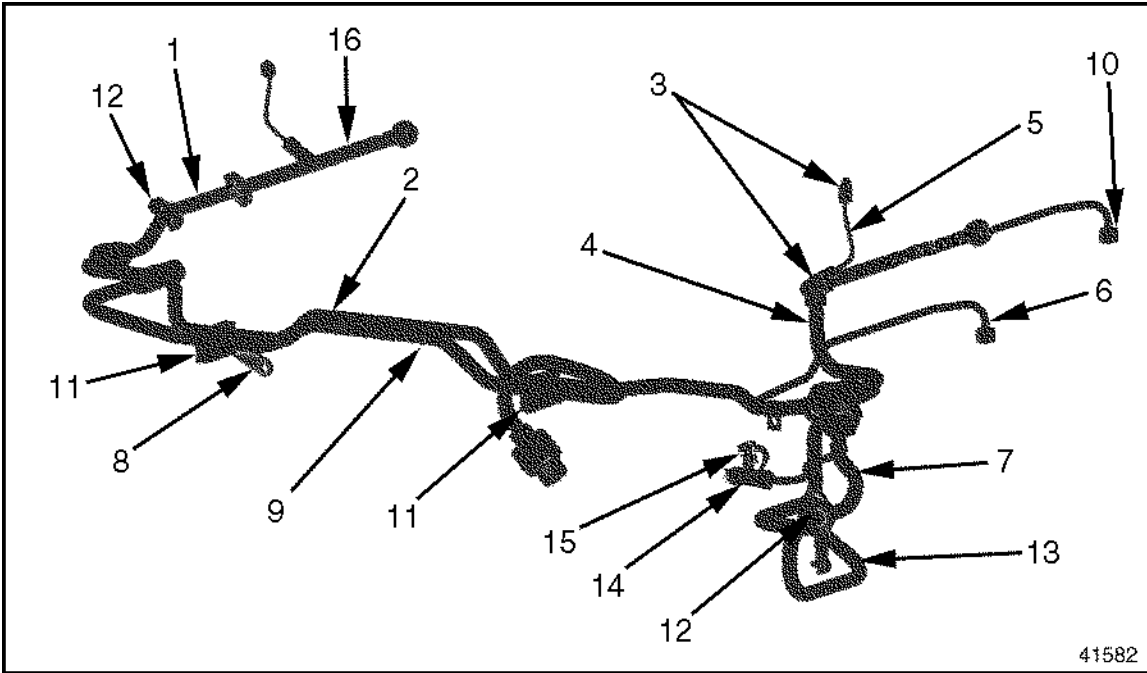

Listed in Table 1 are the service parts.

Figure 5 Low-pressure Fuel System

	DESCRIPTION	12V QTY	16V QTY	CURRENT P/N	FORMER P/N
1	Tube Asm, Fuel Return Manifold (B Bank)	1	1	23540104	5240901076
2	Tube Asm, Fuel Return Manifold Rt	1	1	23540106	5240901176
3	Fitting, M12-1.5	24	32	23540102	915006004002
4	Tube Asm, Fuel Return Manifold Lt	1	1	23540105	5240901276
5	Tube Asm, Fuel Return Manifold	12	16	23540103	5240702832
6	Tube Asm, HP Pump Vent ORFS (884.5 x 10)	1	1	23540111	5244760301
7	Tube Asm to Junction Block	1	1	23540107	5240901376
8	Bracket B Bank Gearcase Fuel Line	1	1	23540108	5240781141
9	Tube Asm Dbl Wall Fuel HP Pump to RB Rail	1	1	23540110	5260900776
10	Tube Asm Safety v/v Fuel Return Rail	1	1	23540810	5240704232
11	Clamp Half Tube, 1/1 D9-22, S4000	2	2	23540127	
12	Clamp Half Tube, 1/1 D11-22, S4000	18	22	23540132	23540132
13	Bracket Fuel Return to Junction Block	1	1	23540109	
14	Fitting Tee M16-1.5 x ISO 6149-2 to 11/16	1	1	23540112	
15	Vent Valve	1	1	23540113	
16	Return Fuel Rail	2	2	5260700238	5240700538

Table 1 Parts List

INTERCHANGEABILITY

The former and current low-pressure fuel lines and fittings are not separately interchangeable.

ADDITIONAL SERVICE INFORMATION

Additional service information is available in the Detroit Diesel *Series 4000 Service Manual*, dated October 1999. The next revision to this manual will include the revised information.

NOTE:

Service manuals are available from authorized Detroit Diesel distributors.

DETROIT DIESEL
CORPORATION



13400 Outer Drive, West / Detroit, Michigan 48239-4001
Telephone: 313-592-5000
www.detroitdiesel.com

BR 4000

Kraftstoffhochdruckleitung, Anzug der Druckringe nach Demontage

HP Fuel Lines, Tightening of Thrust Rings after Disassembly

Tubazione carburante AP, serraggio anelli di spinta dopo lo smontaggio

Conduite de combustible HP, serrage des anneaux de pression après montage

BR 4000

Kraftstoffhochdruckleitung, Anzug der Druckringe nach Demontage

Mitteilungsgrund

Bei der Demontage von Kraftstoffhochdruckleitungen an Motoren der oben genannten Baureihe kommt es vor, daß sich die Druckringe (A) an den Leitungsenden lösen. Um Kraftstoffleckagen zu vermeiden, müssen die Druckringe unbedingt vor der erneuten Montage wieder angezogen werden (**Linksgewinde**). Das Anziehdrehmoment beträgt: 10Nm.

Um die Nuten der Druckringe nicht zu beschädigen steht zwischenzeitlich ein Spezialwerkzeug (Sachnr. F3 0379 005) zur Verfügung.

Hinweis: Der Anziehdrehmoment für die Montage der Kraftstoffhochdruckleitungen (Überwurfmutter) (B) beträgt: 100Nm + 10Nm.

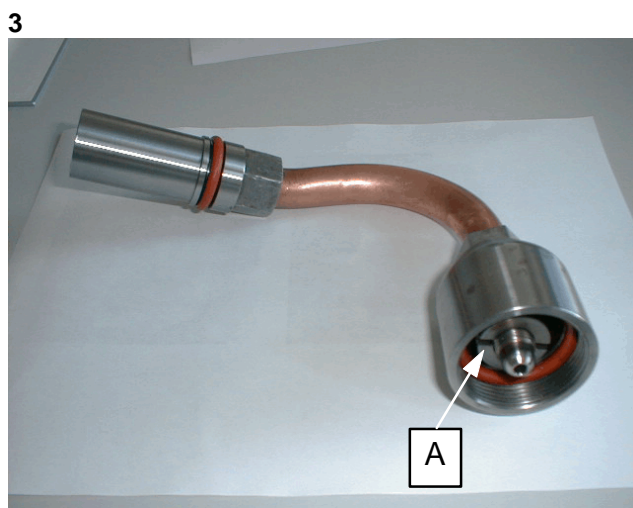
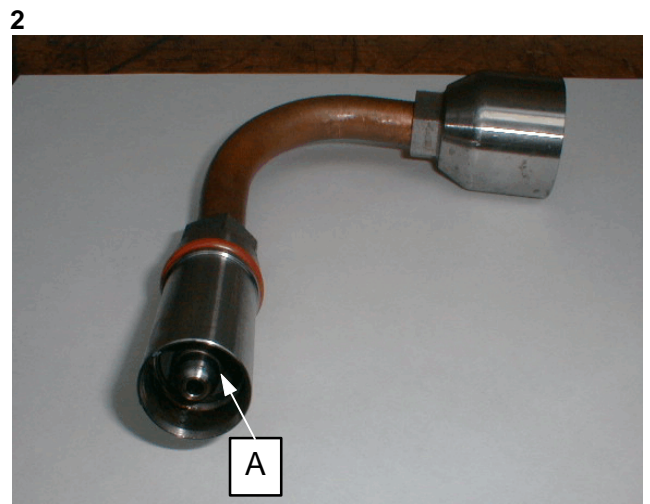
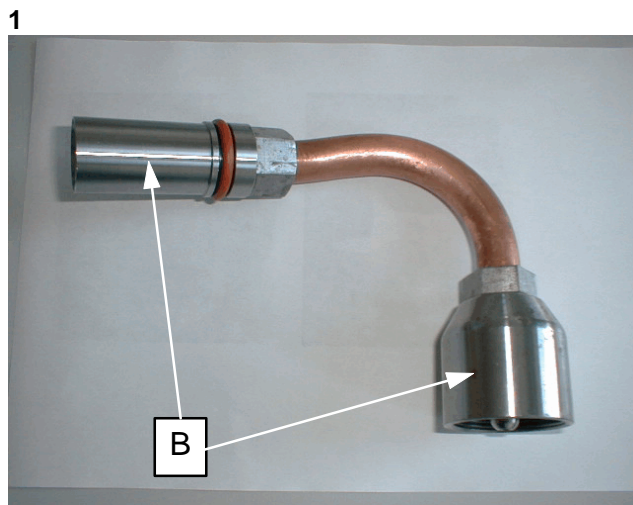

Series 4000 Engines

HP Fuel Lines, Tightening of Thrust Rings after Disassembly

Reason for Information

During disassembly of the HP fuel lines on the above engines, the thrust rings (A) at the ends of the fuel lines may become loose.

To avoid fuel leaks, it is essential that the thrust rings be retightened (**left-hand thread**) to 10 Nm before reassembly.

In the meantime, a special tool (**Part No. F3 0379 005**) is now available to eliminate the risk of damage to the thrust ring grooves.

Note: The tightening torque for the HP fuel line union nuts (B) during assembly is 100Nm + 10Nm.

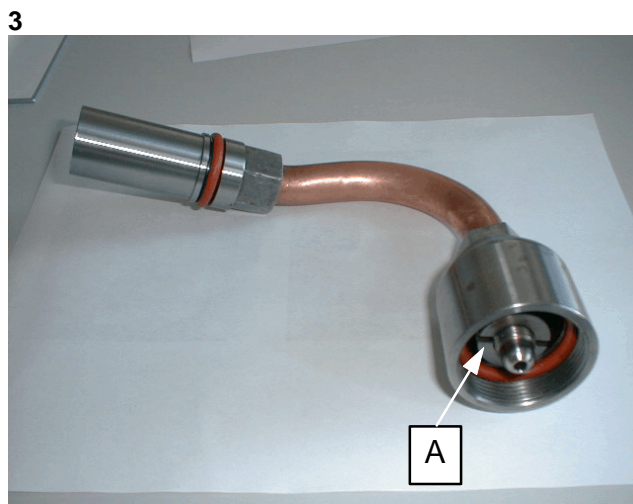
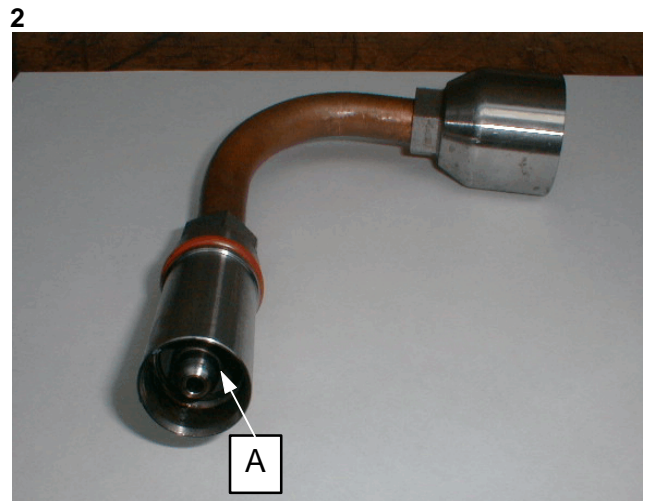
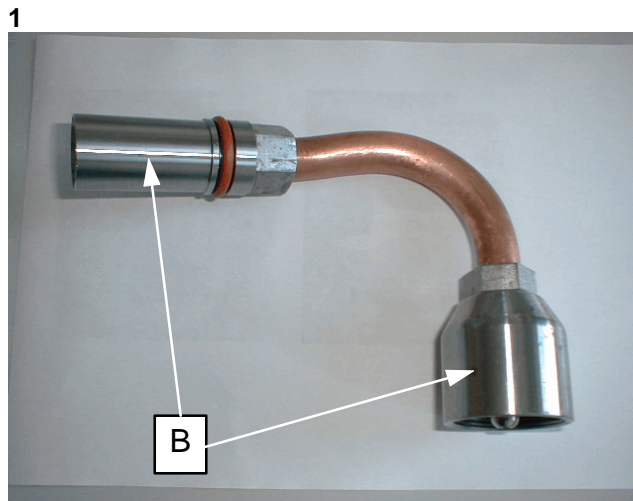

Serie 4000

Tubazione carburante AP, serraggio anelli di spinta dopo lo smontaggio

Motivo dell'informazione

In occasione dello smontaggio di tubazioni carburante AP sui motori della serie in oggetto può succedere che si allentino gli anelli di spinta (A) alle estremità delle tubazioni. Allo scopo di evitare perdite di carburante, prima del rimontaggio gli anelli di spinta verranno assolutamente serrati di nuovo (filettatura sinistrorsa). La coppia di serraggio è di: 10 Nm.

Per non danneggiare le scanalature degli anelli di spinta, possiamo mettere a disposizione nel frattempo un attrezzo speciale (n. di prodotto F3 0379 005).

Nota: La coppia di serraggio per il montaggio delle tubazioni AP (dadi a risvolto) (B) è di : 100 Nm + 10 Nm.

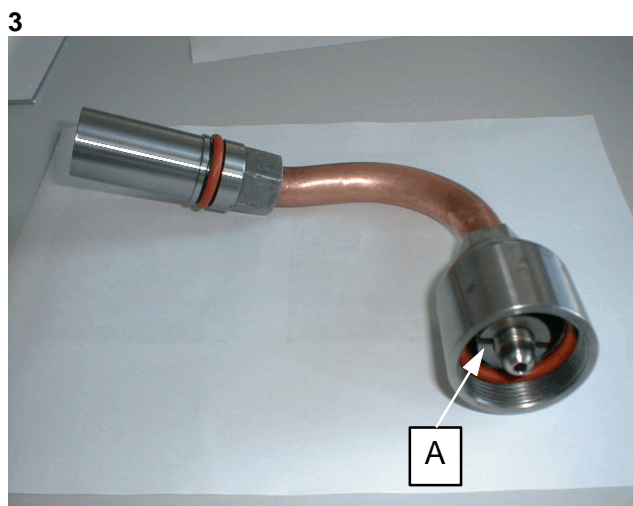
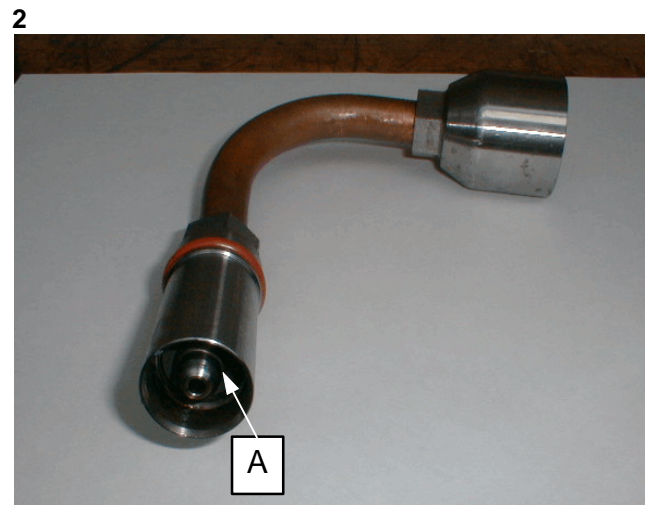
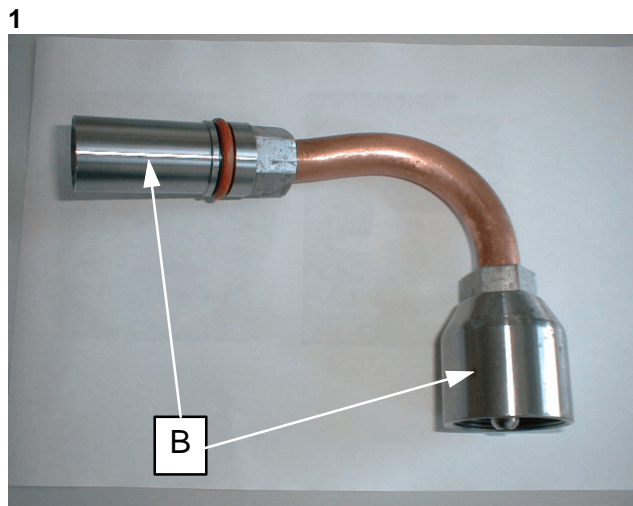

Série 4000

Ensemble 70

Conduite de combustible HP, serrage des anneaux de pression après montage

Raison de l'information

Lors du désassemblage de conduites de combustible HP sur les moteurs de la série susréféréncée il peut arriver que les anneaux de pression (A) aux extrémités des conduites se détachent. Afin d'éviter des fuites il faut absolument les resserrer avant l'assemblage (filetage à gauche). Le couple de serrage est de 10 Nm.

Il existe entre-temps un outillage spécial permettant d'éviter un endommagement des rainures des anneaux de pression (N° F3 0379 005).

Remarque: Le couple de serrage des conduites de combustible HP (écrous-raccords) (B) s'élève à 100 Nm + 10Nm.

1

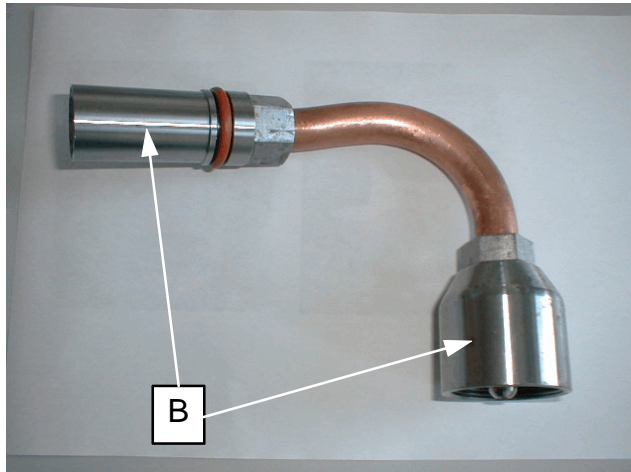

2

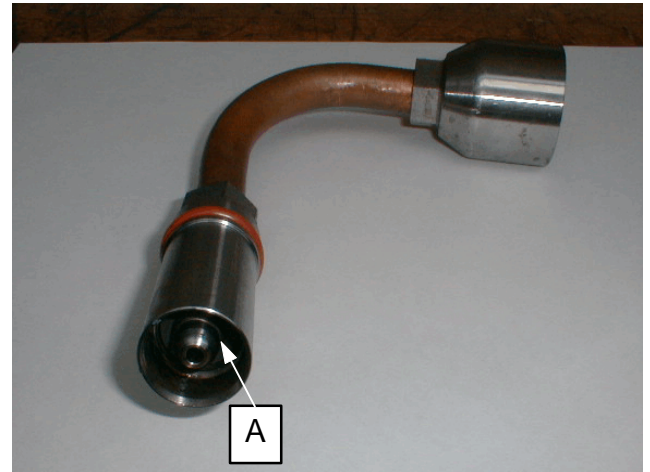

3

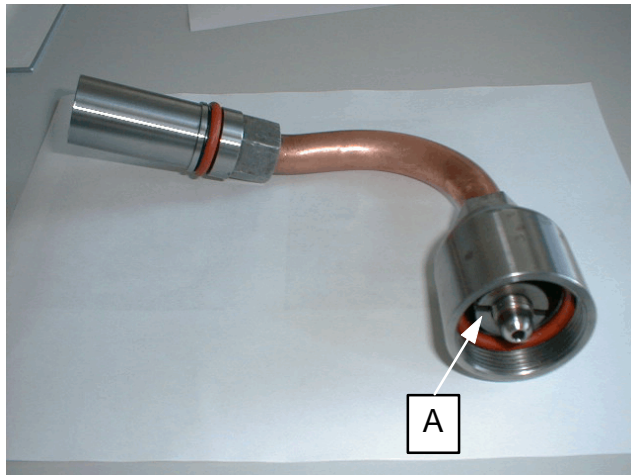

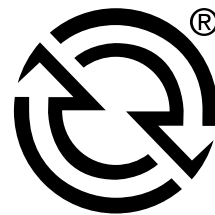

Installation Instructions

18SP503—Installation of DIN Common Rail Fuel Pressure Sensor

Introduction

A new common rail fuel pressure sensor has been developed for Series 4000™ engine applications.

NOTE:

This sensor is *not* intended for use on Series 50®, Series 60®, or Series 2000™ engines.

This sensor has an improved, more durable connector made to German DIN* standards. The new sensor also will improve reliability. The improved sensor

connector is designed to withstand higher levels of vibration and dust, dirt, and moisture intrusion.

In order to mate the sensor to existing engine harnesses, a special DIN harness adaptor is used. The old connector must be removed from the engine harness and the DIN adaptor must be spliced in its place.

The part numbers of the sensor and adaptor included in the service kit and their applications are listed in Table 1.

DIN Service Kit Part No.	DIN Sensor Part No.	Application	Used to Replace Sensor Part No.	Harness Adaptor Part No.
23527976	23526036 or 23540503	S4000 Common Rail Fuel Pressure	0035351331	23525849

Table 1 - Replacement Sensor/Adaptor Part Numbers

Installation Instructions

Install the improved sensor on the engine as follows:

	CAUTION:
<p>To avoid personal injury from accidental engine startup, disconnect battery power to the engine starter before working on the sensor wiring system.</p>	

1. With the engine at ambient temperature and cool to the touch, disconnect the engine harness.
2. After noting which wire goes to which cavity on the harness connector, remove the connector for the sensor being replaced by cutting the wires.
3. Remove the former sensor from the engine and install the improved sensor in its place.
4. Listed in Table 2 are the colors of the wires on the harness adaptor and the colors of the engine harness wires they must be connected with.

Wire Color					
Harness Adaptor	Engine Harness	Old Connector Cavity	New Connector Cavity	Wire #	Description
Black	Black	A		4	452 ground
Green	Dark Green	B		2	907 signal
Red	Gray	C		1	416 supply

Table 2 - Crankcase Pressure Sensor Connections

* Deutsches Institut für Normung or "German Standards Institute"

5. Strip the end of each wire from the harness and splice it to the appropriate harness adaptor wire listed in Table 2. Solder or crimp the splice.

NOTE:

Solder splicing is *preferred*, but crimp splices are acceptable.

6. Cover each wire splice with heat shrink tubing, preferably the self-adhesive type, so that no bare wire is exposed.

7. Cover all 3 spliced wires with an overall heat shrink tube. This tube should overlap the braided covering on the adapter end and on the harness end.

NOTE:

Do not cover the entire adapter with heat shrink tube. The heat shrink should end 3-1/2 inches from the back of the connector to allow the sensor to vent through the braided covering. See Figure 1.

8. Connect the harness adaptor to the new sensor, reconnect battery power, start the engine, and check for proper sensor operation.

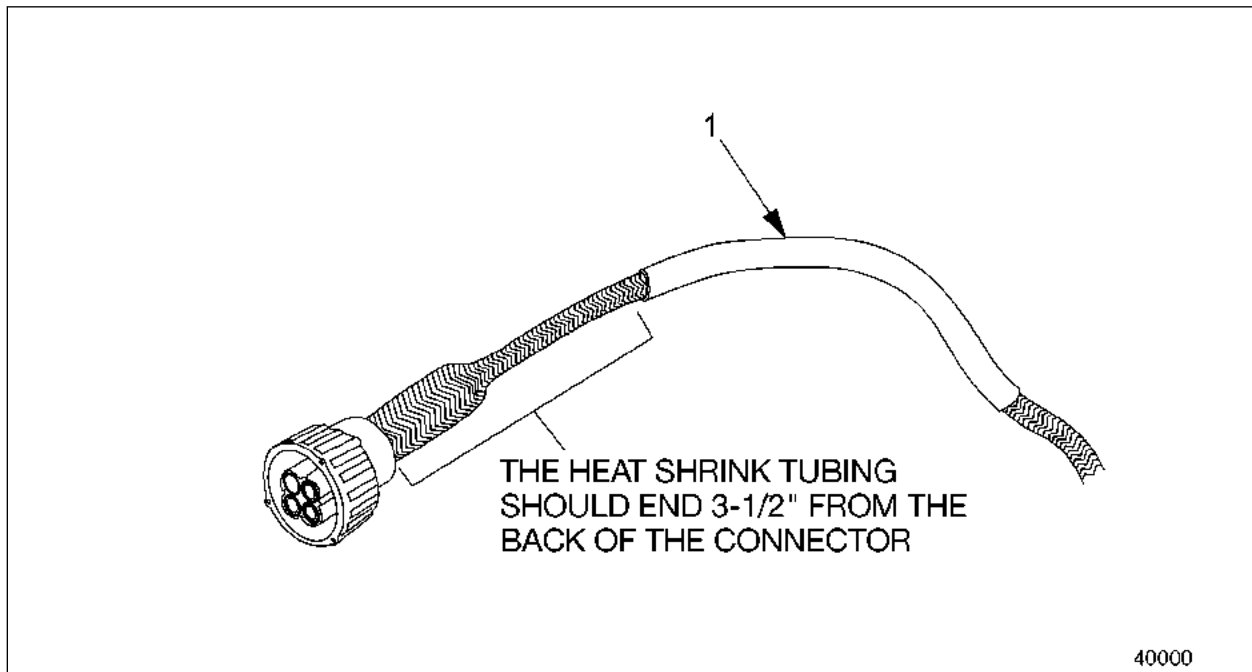

1. Heat Shrink Tubing

Figure 1. Location of Heat Shrink Tubing

DETROIT DIESEL



13400 Outer Drive, West, Detroit, Michigan 48239-4001
Telephone: 313-592-5000
www.detroitdiesel.com

18SP503 Page 2 of 2

NOTES

NOTES

NOTES

All information subject to change without notice.

7SE375 0106 Copyright © 2001 DETROIT DIESEL CORPORATION
A DAIMLER CHRYSLER Company