

SECTION 2 STRUCTURE AND FUNCTION

Group 1 Pump Device	2-1
Group 2 Main Control Valve	2-22
Group 3 Swing Device	2-58
Group 4 Travel Device	2-69
Group 5 RCV Lever	2-83
Group 6 RCV Pedal	2-90

SECTION 2 STRUCTURE AND FUNCTION

GROUP 1 PUMP DEVICE

1. STRUCTURE

The pump device consists of main pump, regulator and gear pump.

1) OUTLINE (1/2) - WITHOUT PTO TYPE

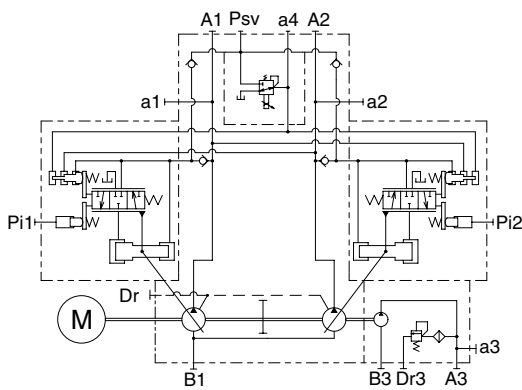
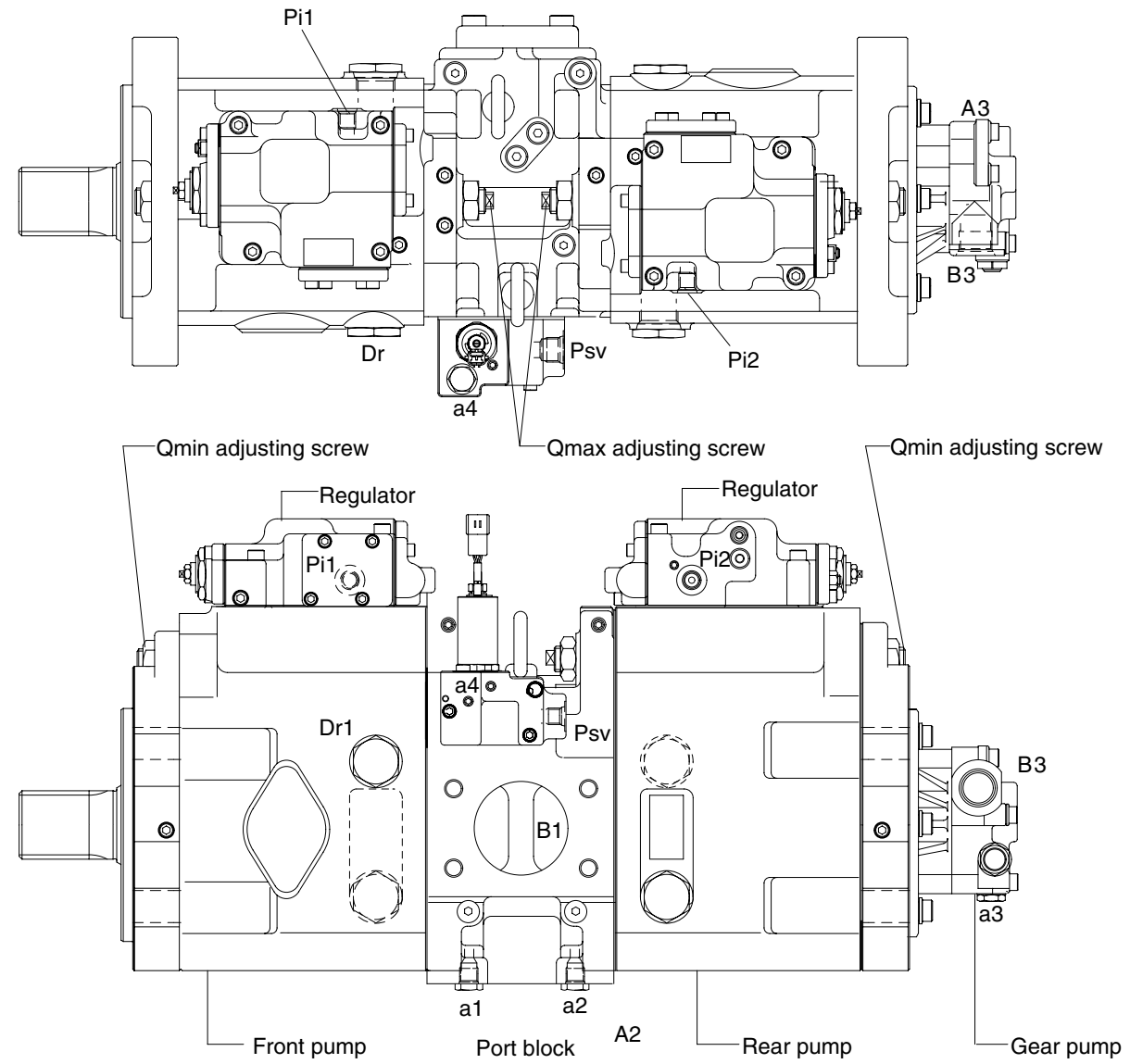

Port	Port name	Port size
A1, 2	Delivery port	SAE6000 psi 1"
B1	Suction port	SAE2500 psi 3"
Dr	Drain port	PF 3/4 - 23
Pi1, i2	Pilot port	PF 1/4 - 15
Psv	Servo assist port	PF 1/4 - 15
a1, 2, 4	Gauge port	PF 1/4 - 15
a3	Gauge port	PF 1/4 - 14
A3	Gear pump delivery port	PF 1/2 - 19
B3	Gear pump suction port	PF 3/4 - 20.5
Dr3	Gear pump drain port	PF 3/8 - 15

300S2MP01

2) OUTLINE (2/2) - WITH PTO TYPE

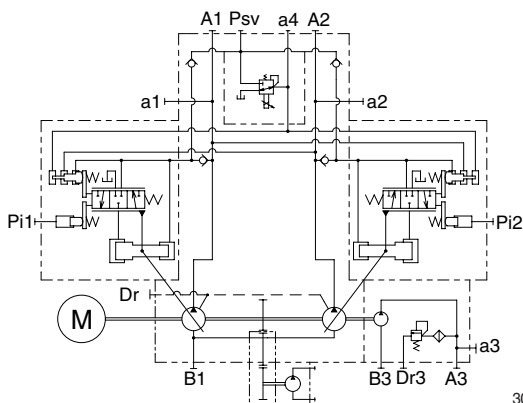
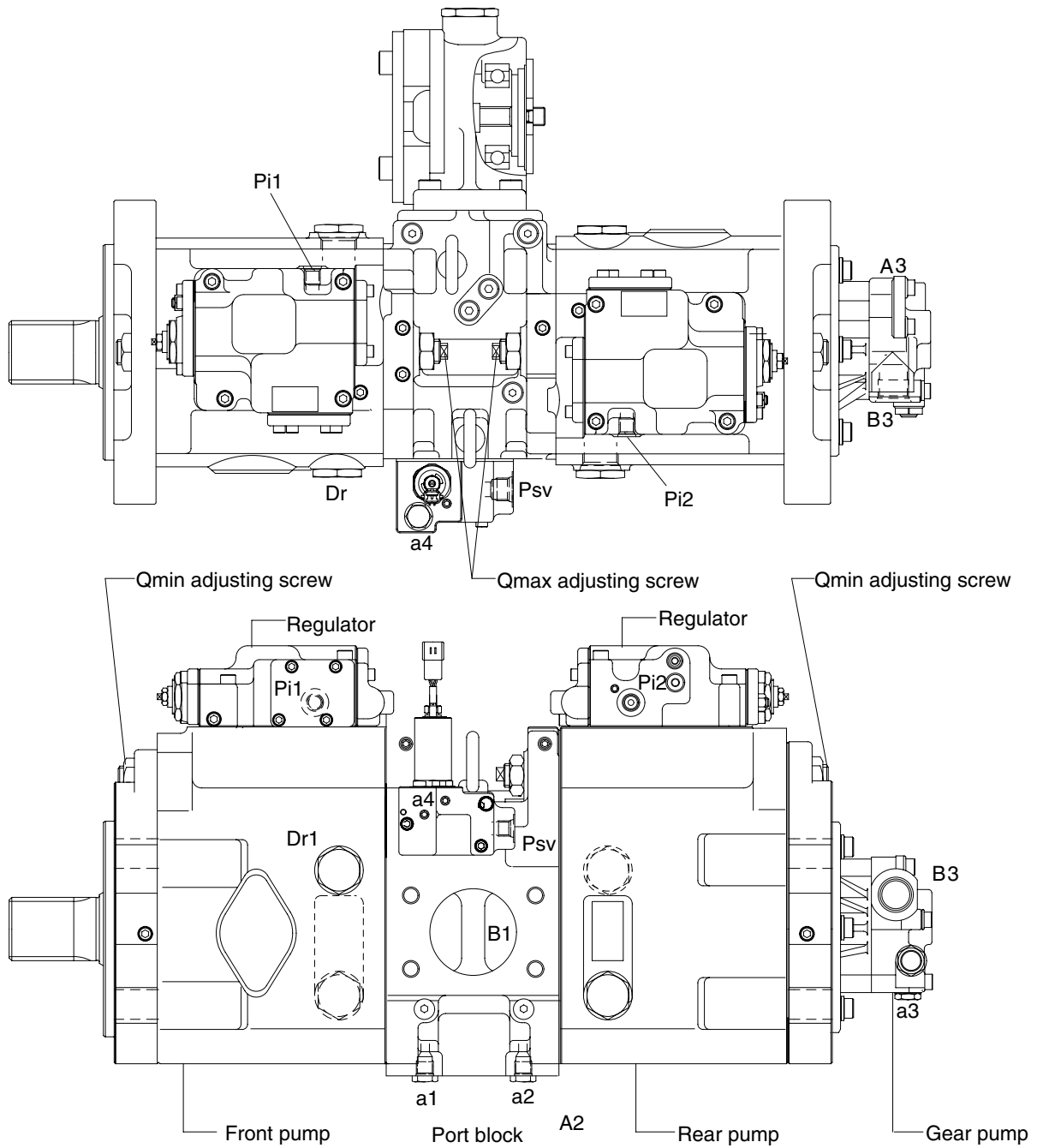

300S2MP02

Port	Port name	Port size
A1, 2	Delivery port	SAE6000 psi 1"
B1	Suction port	SAE2500 psi 3"
Dr	Drain port	PF 3/4 - 23
Pi1, i2	Pilot port	PF 1/4 - 15
Psv	Servo assist port	PF 1/4 - 15
a1, 2, 4	Gauge port	PF 1/4 - 15
a3	Gauge port	PF 1/4 - 14
A3	Gear pump delivery port	PF 1/2 - 19
B3	Gear pump suction port	PF 3/4 - 20.5
Dr3	Gear pump drain port	PF 3/8 - 15

2) MAIN PUMP (1/3)

The main pump consists of two piston pumps (front & rear) and valve block.

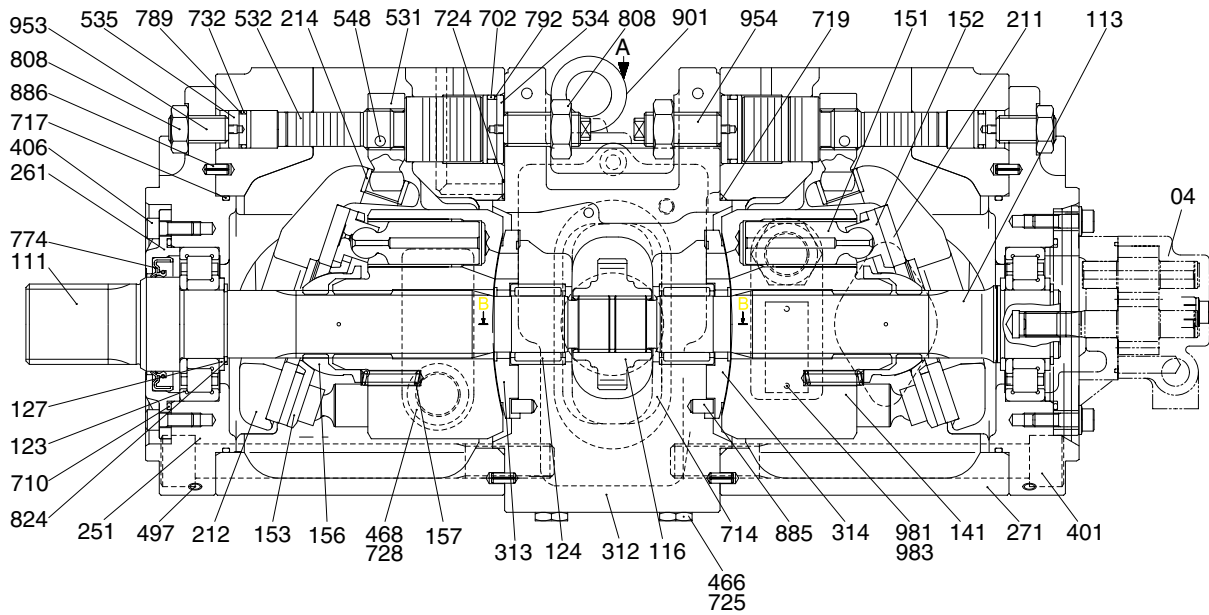

300S2MP03

04	Gear pump	313	Valve plate (R)	717	O-ring
111	Drive shaft (F)	314	Valve plate (L)	719	O-ring
113	Drive shaft (R)	401	Hexagon socket bolt	723	O-ring
114	1st gear	406	Hexagon socket bolt	724	Square ring
123	Roller bearing	465	ROH plug	725	O-ring
124	Needle bearing	466	VP plug	728	O-ring
127	Bearing spacer	468	VP plug	732	O-ring
141	Cylinder block	497	MH plug	774	Oil seal
151	Piston	531	Tilting pin	789	Back up ring
152	Shoe	532	Servo piston	792	Back up ring
153	Set plate	534	Stopper (L)	806	Hexagon head nut
156	Spherical bushing	535	Stopper (S)	808	Hexagon head nut
157	Cylinder spring	541	Seat	824	Snap ring
211	Shoe plate	543	Stopper 1	885	Valve plate pin
212	Swash plate	544	Stopper 2	886	Spring pin
214	Tilting bushing	545	Steel ball	901	Eye bolt
251	Swash plate support	548	Feedback pin	953	Set screw
261	Seal cover (F)	702	O-ring	954	Set screw
271	Pump casing	710	O-ring		
312	Valve block	714	O-ring		

MAIN PUMP (2/3)

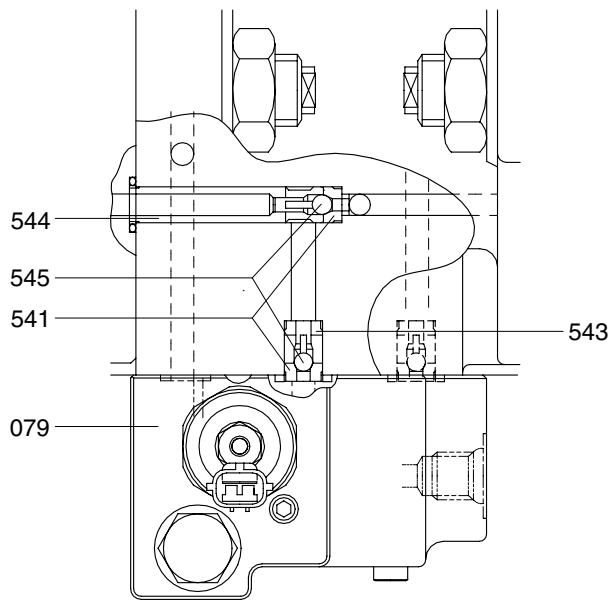

VIEW A

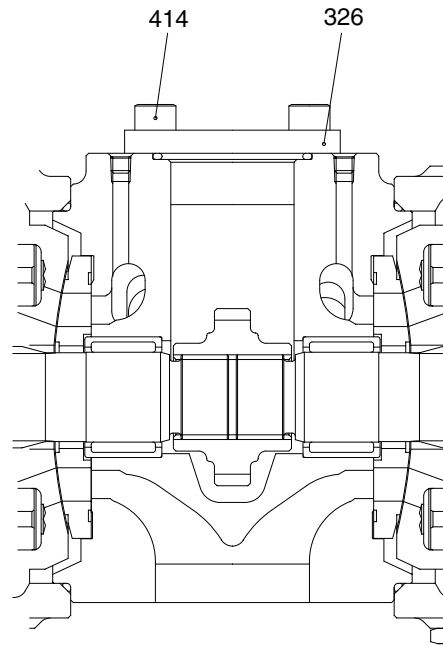

VIEW B-B

300S2MP04

- | | | |
|---------------------------------|---------------|----------------|
| 079 Proportional reducing valve | 541 Seat | 544 Stopper 2 |
| 326 Cover | 543 Stopper 1 | 545 Steel ball |
| 414 Hexagon socket bolt | | |

MAIN PUMP (3/3, WITH PTO TYPE)

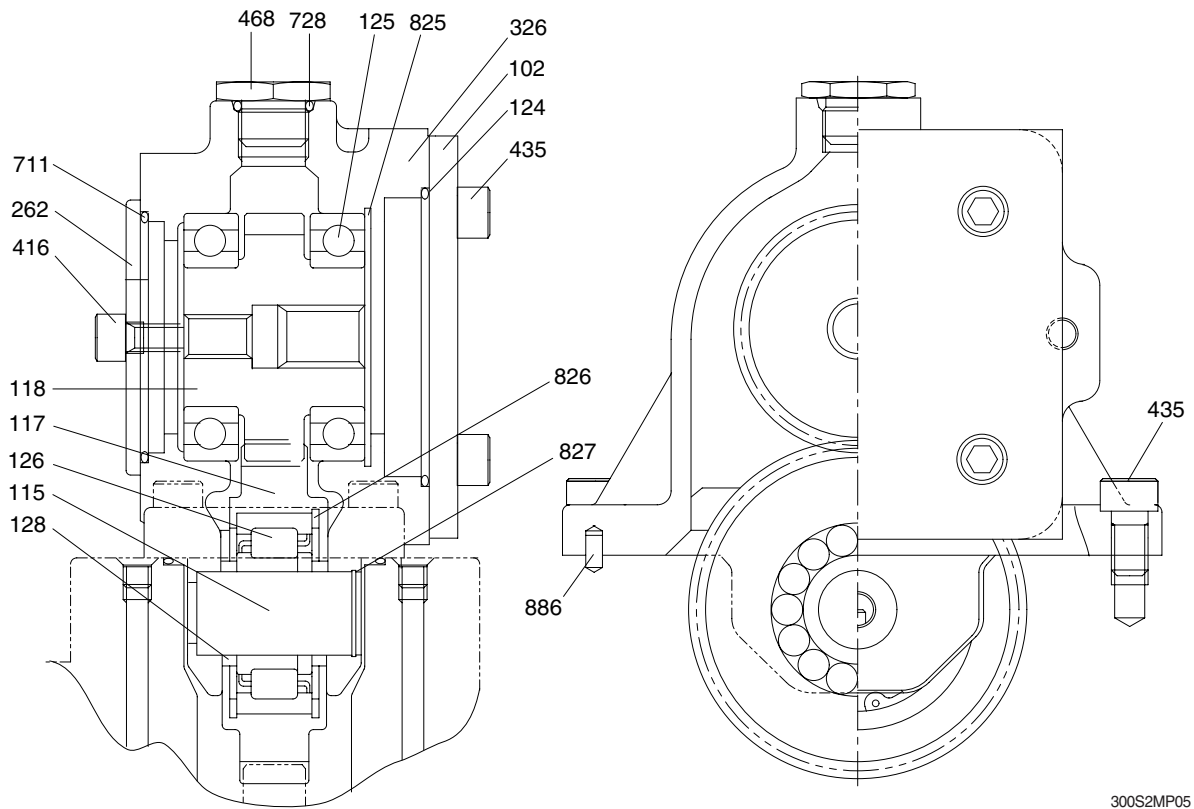

300S2MP05

- | | | | | | |
|-----|----------------|-----|------------------|-----|---------------|
| 102 | Cover | 262 | Cover | 724 | O-ring |
| 115 | Idler shaft | 326 | Gear case | 728 | O-ring |
| 117 | 2nd gear | 414 | Hex socket screw | 825 | Retainer ring |
| 118 | 3rd gear | 435 | Hex socket screw | 826 | Retainer ring |
| 125 | Ball bearing | 468 | Plug | 885 | Spring pin |
| 126 | Roller bearing | 711 | O-ring | 886 | Pin |
| 128 | Bearing spacer | | | | |

2) REGULATOR (1/2)

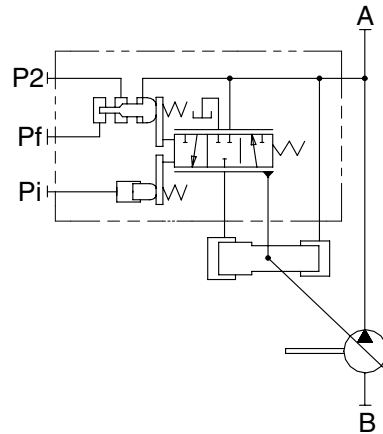
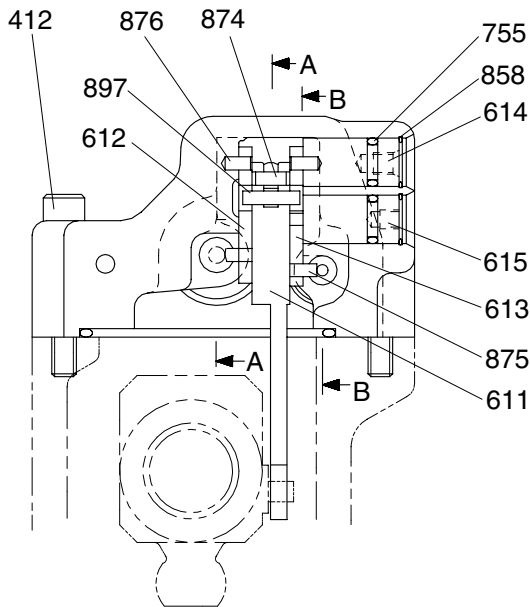

Port	Port name	Port size
A	Delivery port	SAE 6000 PSI 1"
B	Suction port	SAE 2500 PSI 3"
Pi	Pilot port	PF 1/4-15
Pf	Power shift pressure	-
P2	Companion delivery pressure	-

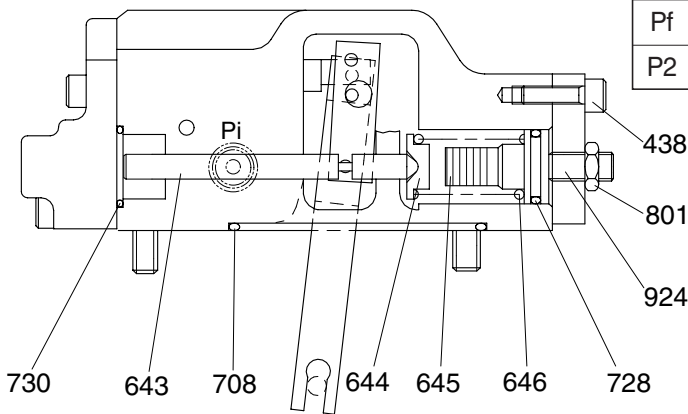

SECTION B-B

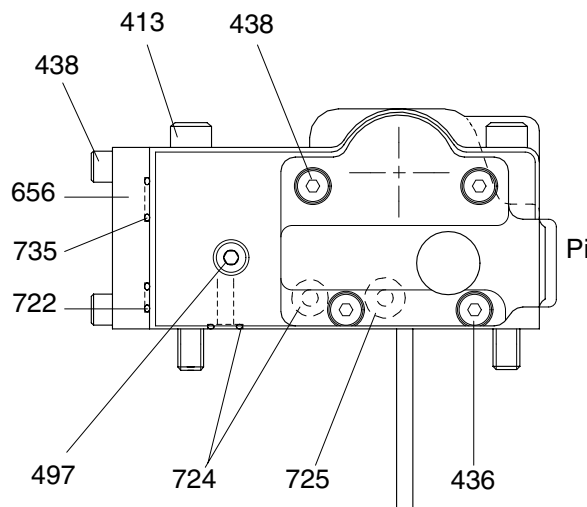

VIEW C

- 412 Hexagon socket screw
- 413 Hexagon socket screw
- 436 Hexagon socket screw
- 438 Hexagon socket screw
- 497 Plug
- 611 Feed back lever
- 612 Lever (1)
- 613 Lever (2)
- 614 Fulcrum plug
- 615 Adjust plug
- 643 Pilot piston
- 644 Spring seat (Q)
- 645 Adjust stem (Q)
- 646 Pilot spring
- 656 Block cover
- 708 O-ring
- 722 O-ring
- 724 O-ring
- 725 O-ring
- 728 O-ring
- 730 O-ring
- 735 O-ring
- 755 O-ring
- 801 Nut
- 858 Snap ring
- 874 Pin
- 875 Pin
- 876 Pin
- 897 Pin
- 924 Set screw

300S2MP06

REGULATOR (2/2)

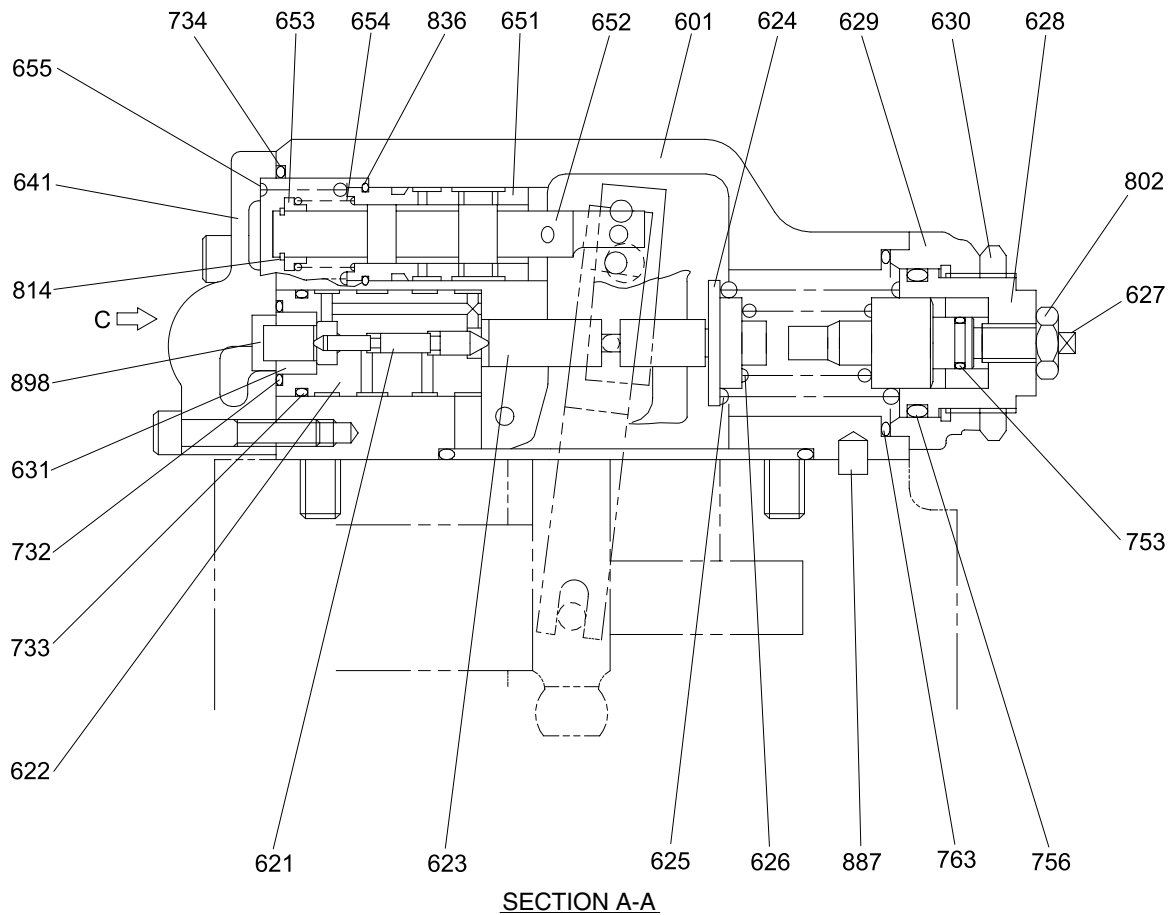

300S2MP07

- | | | |
|------------------------|-------------------|---------------|
| 601 Casing | 630 Lock nut | 734 O-ring |
| 621 Compensator piston | 631 Sleeve, pf | 753 O-ring |
| 622 Piston case | 641 Pilot cover | 756 O-ring |
| 623 Compensator rod | 651 Sleeve | 763 O-ring |
| 624 Spring seat (C) | 652 Spool | 802 Nut |
| 625 Outer spring | 653 Spring seat | 814 Snap ring |
| 626 Inner spring | 654 Return spring | 836 Snap ring |
| 627 Adjust stem (C) | 655 Set spring | 887 Pin |
| 628 Adjust screw (C) | 732 O-ring | 898 Pin |
| 629 Cover (C) | 733 O-ring | |

3) GEAR PUMP

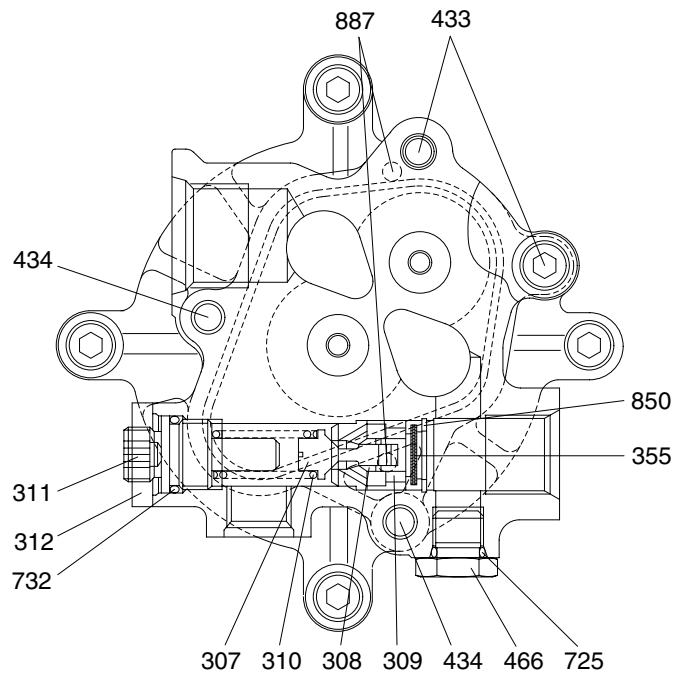
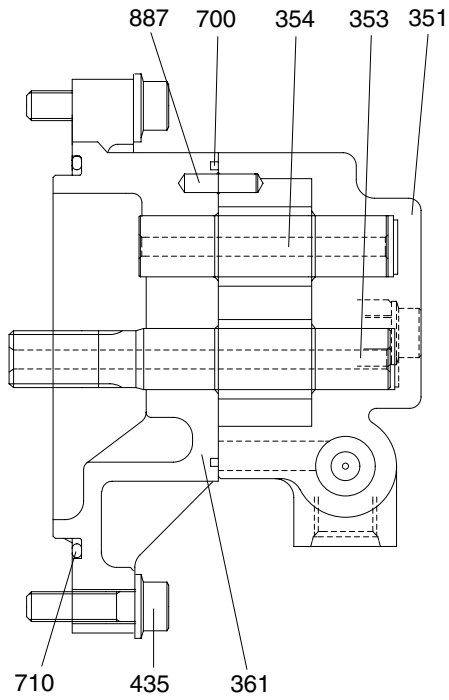

300S2MP08

- 307 Poppet
- 308 Seat
- 309 Ring
- 310 Spring
- 311 Screw
- 312 Lock nut
- 351 Gear case

- 353 Drive gear
- 354 Driven gear
- 355 Filter
- 361 Front case
- 433 Flange socket
- 434 Flange socket
- 435 Flange socket

- 466 Plug
- 700 Ring
- 710 O-ring
- 725 O-ring
- 732 O-ring
- 850 Snap ring
- 887 Pin

2. FUNCTION

1) MAIN PUMP

The pumps may be classified roughly into the rotary group performing a rotary motion and working as the major part of the whole pump function: the swash plate group that varies the delivery rates: and the valve cover group that changes over oil suction and discharge.

(1) Rotary group

The rotary group consists of drive shaft (F)(111), cylinder block (141), piston shoes (151,152), set plate (153), spherical bush (156), and cylinder spring (157). The drive shaft is supported by bearing (123,124) at its both ends.

The shoe is caulked to the piston to form a spherical coupling. It has a pocket to relieve thrust force generated by loading pressure and to take hydraulic balance so that it slides lightly over the shoe plate (211). The sub group composed by a piston and a shoe is pressed against the shoe plate by the action of the cylinder spring via a retainer and a spherical bush. Similarly, the cylinder block is pressed against valve plate (313) by the action of the cylinder spring.

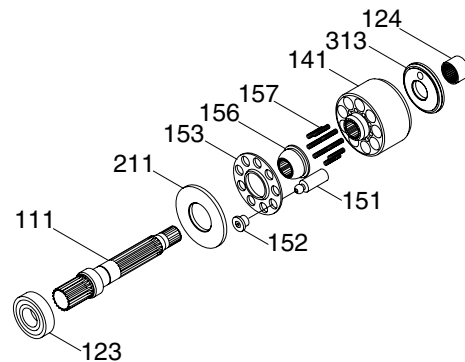

(2) Swash plate group

The swash plate group consists of swash plate (212), shoe plate (211), swash plate support (251), tilting bush (214), tilting pin (531) and servo piston (532).

The swash plate is a cylindrical part formed on the opposite side of the sliding surface of the shoe and is supported by the swash support.

If the servo piston moves to the right and left as hydraulic force controlled by the regulator is admitted to hydraulic chamber located on both sides of the servo piston, the swash plate slides over the swash plate support via the spherical part of the tilting pin to change the tilting angle (α)

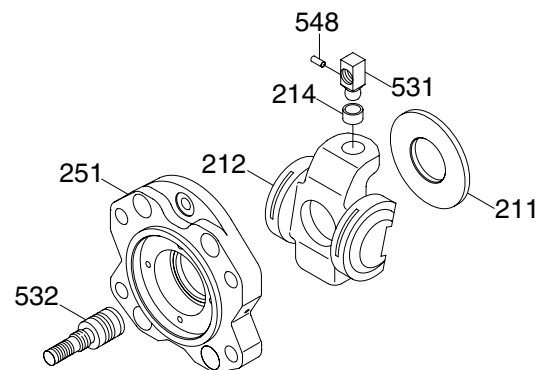

29092MP07

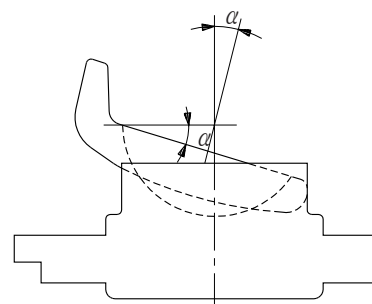

2-7

(3) Valve block group

The valve block group consists of valve block (312), valve plate (313) and valve plate pin (885).

The valve plate having two melon-shaped ports is fixed to the valve block and feeds and collects oil to and from the cylinder block.

The oil changed over by the valve plate is connected to an external pipeline by way of the valve block.

Now, if the drive shaft is driven by a prime mover (electric motor, engine, etc), it rotates the cylinder block via a spline linkage at the same time. If the swash plate is tilted as in Fig (previous page) the pistons arranged in the cylinder block make a reciprocating motion with respect to the cylinder block, while they revolve with the cylinder block.

If you pay attention to a single piston, it performs a motion away from the valve plate (oil sucking process) within 180 degrees, and makes a motion towards the valve plate (or oil discharging process) in the rest of 180 degrees. When the swash plate has a tilting angle of zero, the piston makes no stroke and discharges no oil.

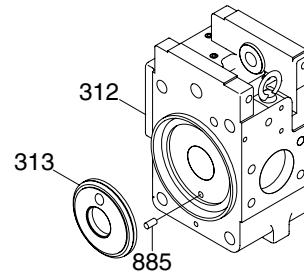

29092MP08

2) REGULATOR

Regulator consists of the negative flow control, total horse power control and power shift control function.

(1) Negative flow control

By changing the pilot pressure P_i , the pump tilting angle (delivery flow) is regulated arbitrarily, as shown in the figure.

This regulator is of the negative flow control in which the delivery flow Q decreases as the pilot pressure P_i rises.

With this mechanism, when the pilot pressure corresponding to the flow required for the work is commanded, the pump discharges the required flow only, and so it does not consume the power uselessly.

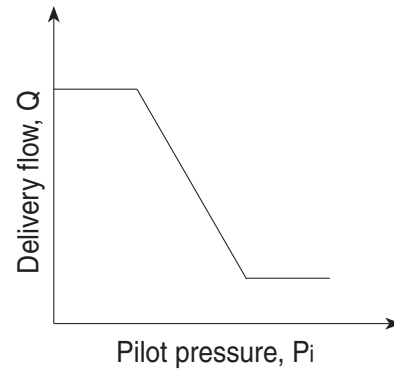

① Flow reducing function

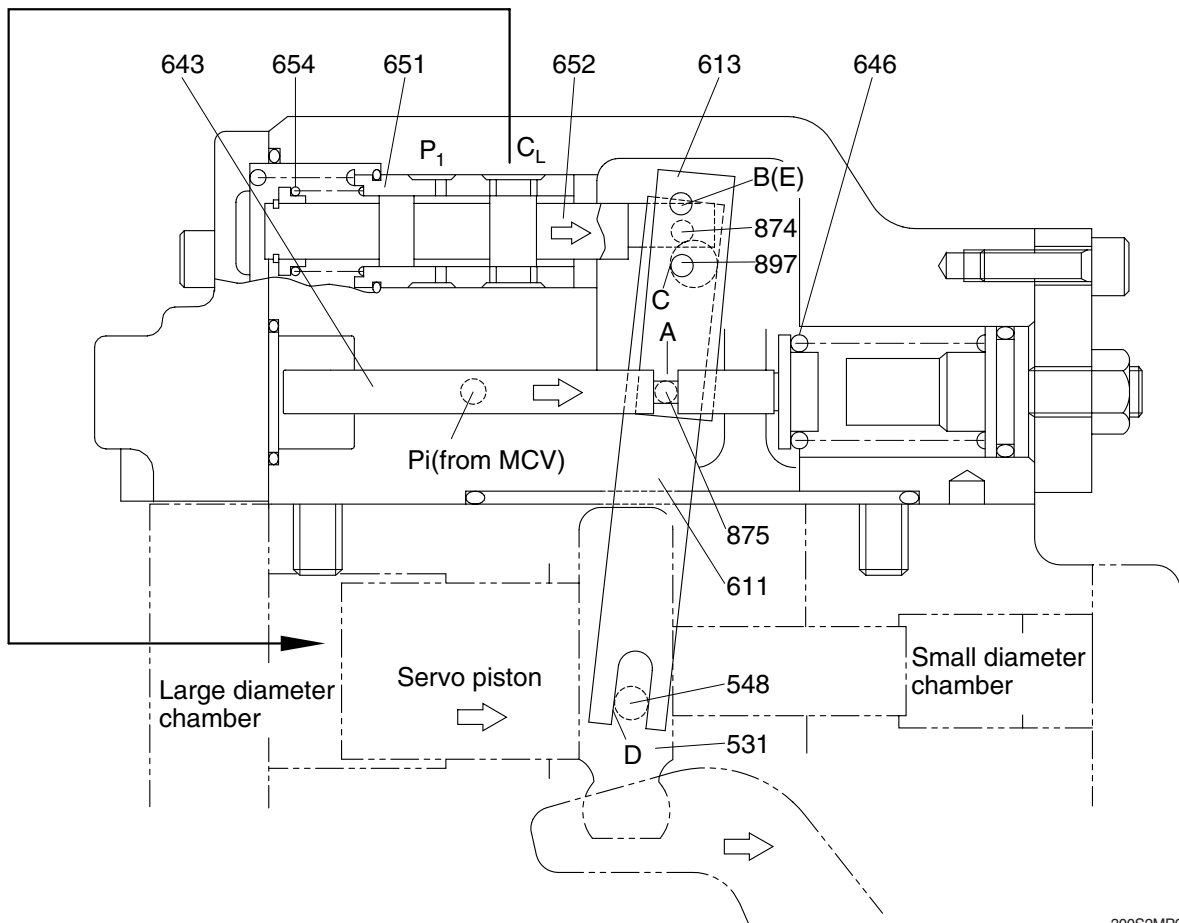

300S2MP09

As the pilot pressure P_i rises, the pilot piston (643) moves to the right to a position where the force of the pilot spring (646) balances with the hydraulic force.

The groove (A) in the pilot piston is fitted with the pin (875) that is fixed to lever 2 (613). Therefore, when the pilot piston moves, lever 2 rotates around the fulcrum of point B [Fixed by the fulcrum plug (614) and pin (875)]. Since the large hole section (C) of lever 2 contains a protruding pin (897) fixed to the feedback lever (611), the pin (897) moves to the right as lever 2 rotates. Since the opposing-flat section (D) of the feedback lever is fitted with the pin (548) fixed by the tilting pin (531) that swings the swash plate, the feedback lever rotates around the fulcrum of point D, as the pin (897) moves.

Since the feedback lever is connected with the spool (652) via the pin (874), the spool moves to the right.

The movement of the spool causes the delivery pressure P_1 to connect to port CL through the spool and to be admitted to the large diameter section of the servo piston. The delivery pressure P_1 that is constantly admitted to the small diameter section of the servo piston moves the servo piston to the right due to the area difference, resulting in decrease of the tilting angle.

When the servo piston moves to the right, point D also moves to the right. The spool is fitted with the return spring (654) and is tensioned to the left at all times, and so the pin (897) is pressed against the large hole section (C) of lever 2.

Therefore, as point D moves, the feedback lever rotates around the fulcrum of point C, and the spool is shifted to the left. This causes the opening between the sleeve (651) and spool (652) to close slowly, and the servo piston comes to a complete stop when it closes completely.

② Flow increasing function

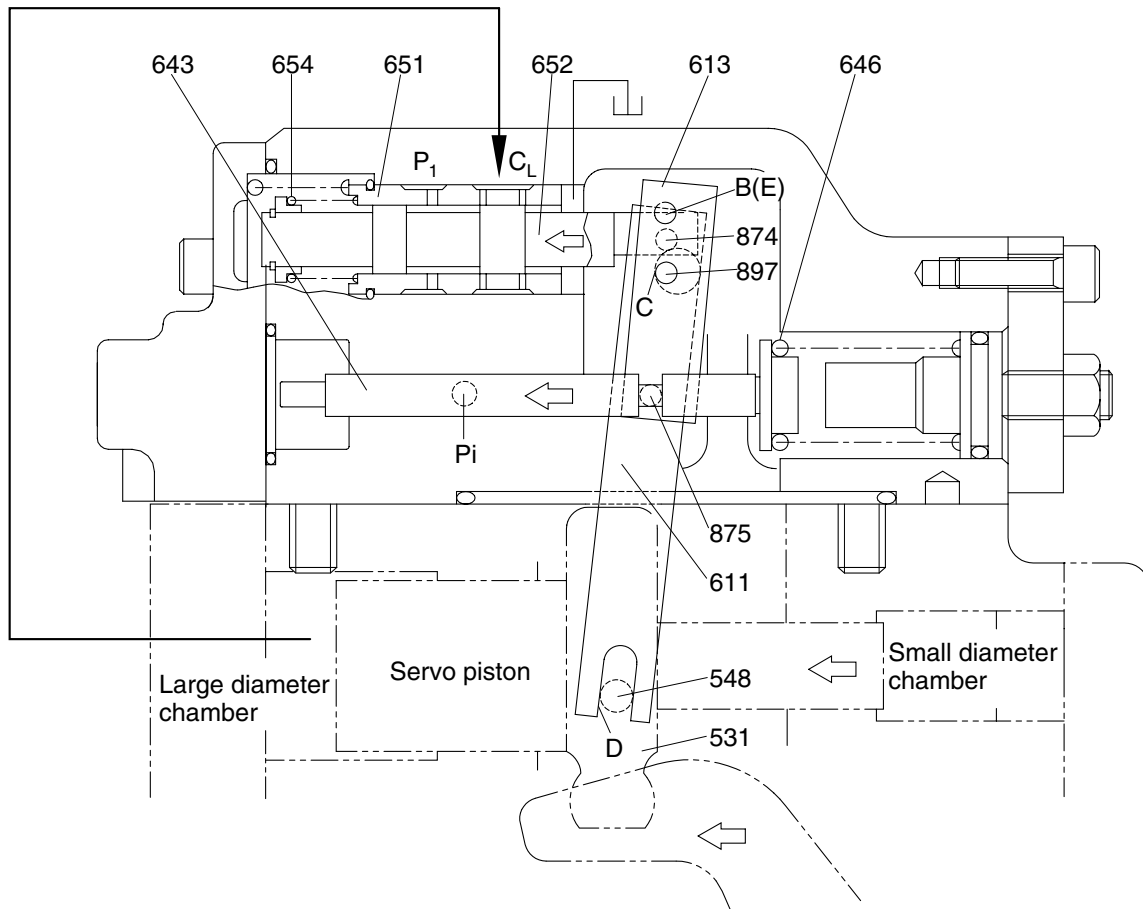

300S2MP10

As the pilot pressure P_i decreases, the pilot piston (643) moves to the left by the action of the pilot spring (646) and causes lever 2 (613) to rotate around the fulcrum of point B. Since the pin (897) is pressed against the large hole section (C) of lever 2 by the action of the return spring (654) via the spool (652), pin (874), and feedback lever (611), the feedback lever rotates around the fulcrum of point D as lever 2 rotates, and shifts the spool to the left. Port CL opens a way to the tank port as the spool moves. This deprives the large diameter section of the servo piston of pressure, and shifts the servo piston to the left by the discharge pressure P_1 in the small diameter section, resulting in an increase in the flow rate.

As the servo piston moves, point D also moves to the left, the feedback lever rotates around the fulcrum of point C, and the spool moves to the right till the opening between the spool and sleeve is closed.

③ **Adjustment of flow control characteristic**

The flow control characteristic can be adjusted with the adjusting screw.

Adjust it by loosening the hexagon nut (801) and by tightening (or loosening) the hexagonal socket head screw (924).

Tightening the screw shifts the control chart to the right as shown in the figure.

※ **Adjusting values are shown in table.**

Speed	Adjustment of flow control characteristic		
	Tightening amount of adjusting screw (924)	Flow control starting pressure change amount	Flow change amount
(min ⁻¹)	(Turn)	(kgf/cm ²)	(l /min)
1800	+1/4	+1.5	+10.9

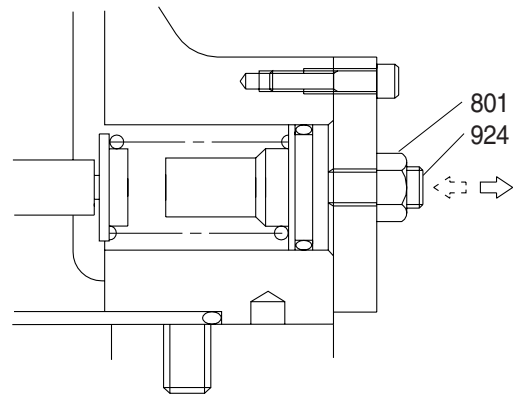

2-12

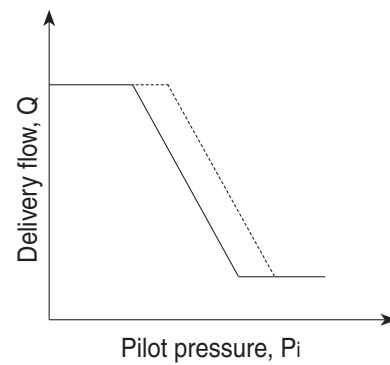

(2) Total horsepower control

The regulator decreases the pump tilting angle (delivery flow) automatically to limit the input torque within a certain value with a rise in the delivery pressure P1 of the self pump and the delivery pressure P2 of the companion pump.

(The input horsepower is constant when the speed is constant.)

Since the regulator is of the simultaneous total horsepower type that operates by the sum of load pressures of the two pumps in the tandem double-pump system, the prime mover is automatically prevented from being overloaded, irrespective of the load condition of the two pumps, when horsepower control is under way.

Since this regulator is of the simultaneous total horsepower type, it controls the tilting angles (displacement volumes) of the two pumps to the same value as represented by the following equation :

$$\begin{aligned} T_{in} &= P1 \times q / 2 \pi + P2 \times q / 2 \pi \\ &= (P1+P2) \times q / 2 \pi \end{aligned}$$

The horsepower control function is the same as the flow control function and is summarized in the following. (for detailed behaviors of respective parts, refer to the section of flow control).

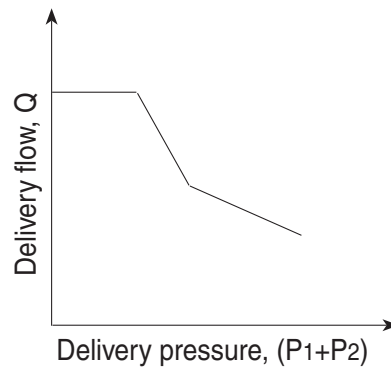

① Overload preventive function

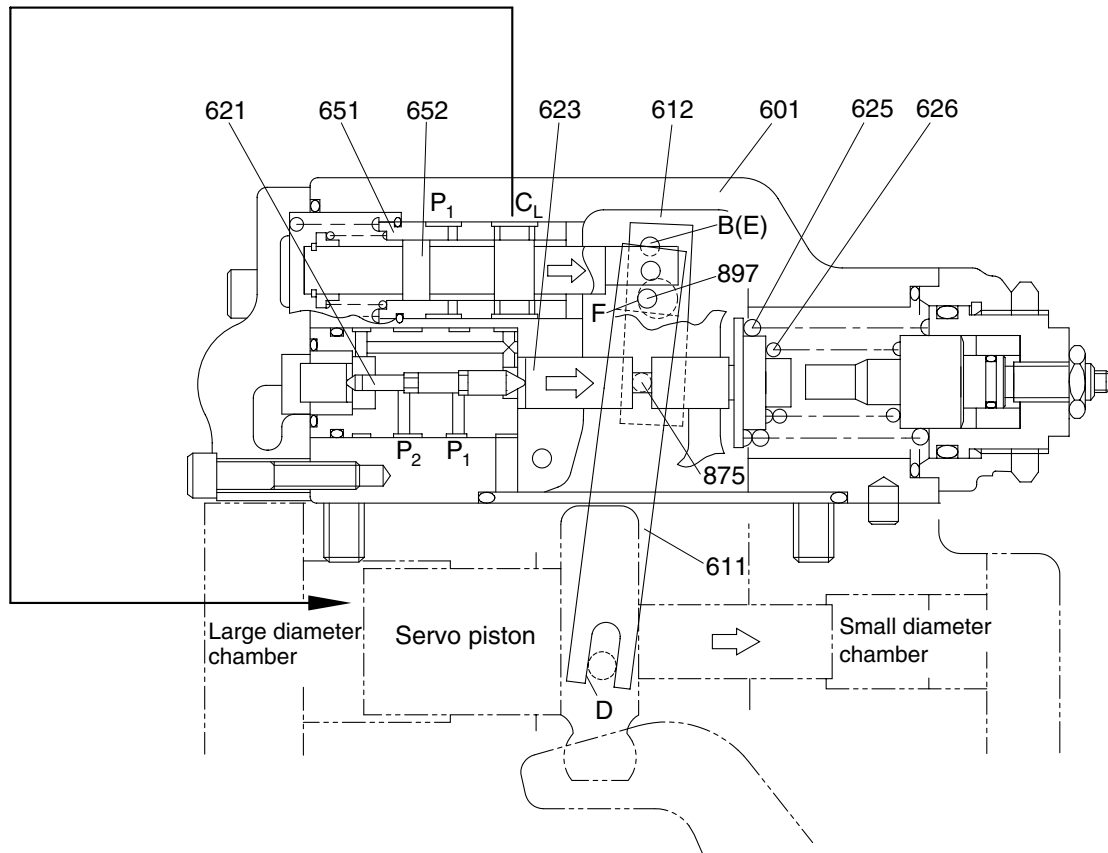

300S2MP11

When the self pump delivery pressure P_1 or the companion pump delivery pressure P_2 rises, it acts on the stepped part of the compensating piston (621). It presses the compensating rod (623) to the right till the force of the outer spring (625) and inner spring (626) balances with the hydraulic force. The movement of the compensating rod is transmitted to lever 1 (612) via pin (875).

Lever 1 rotates around the pin (875) (E) fixed to the casing (601).

Since the large hole section (F) of lever 1 contains a protruding pin (897) fixed to the feedback lever (611), the feedback lever rotates around the fulcrum of point D as lever 1 rotates, and then the spool (652) is shifted to the right. As the spool moves, the delivery pressure P_1 is admitted to the large diameter section of the servo piston via port CL, causes the servo piston move to the right, reduces the pump delivery, flow rate, and prevents the prime mover from being overloaded. The movement of the servo piston is transmitted to the feedback lever via point D. Then the feedback lever rotates around the fulcrum of point F and the spool is shifted to the left. The spool moves till the opening between the spool (652) and sleeve (651) is closed.

② Flow reset function

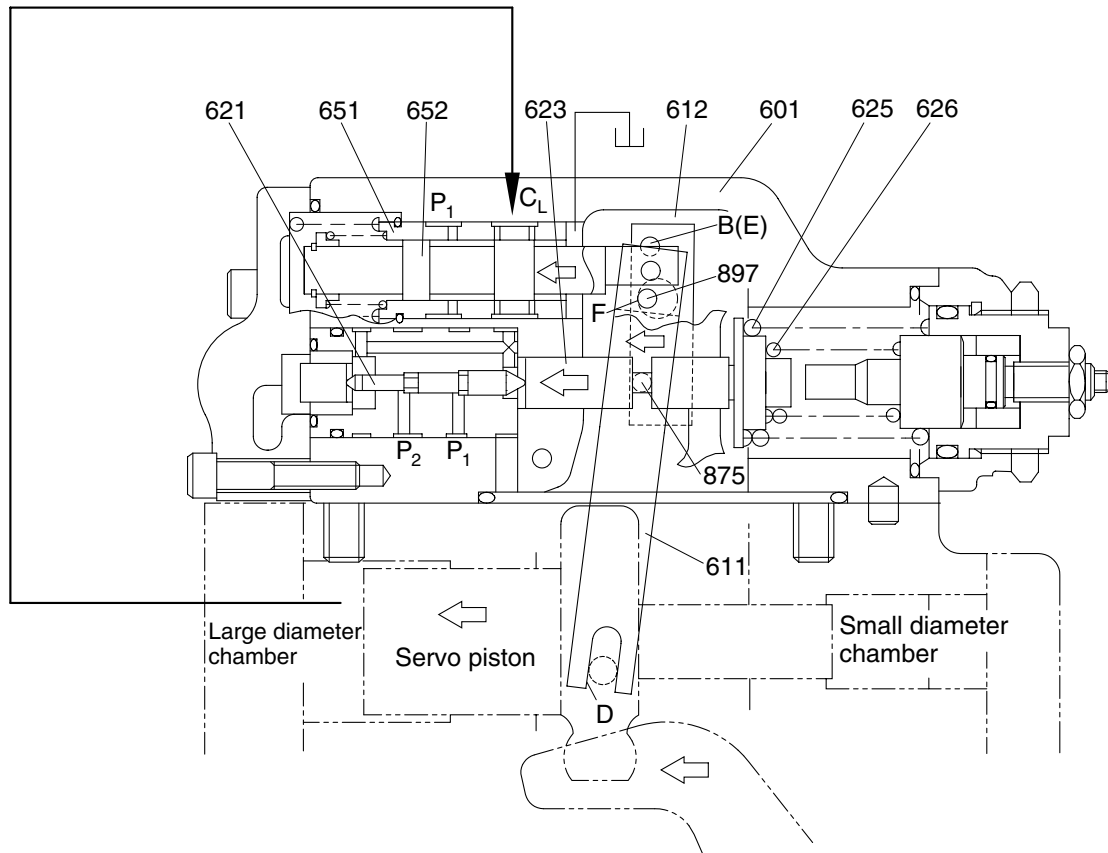

300S2MP12

As the self pump delivery pressure P_1 or the companion pump delivery pressure P_2 decreases, the compensating rod (623) is pushed back by the action of the springs (625 & 626) to rotate lever 1 (612) around point E. Rotating of lever 1 (612) causes the feedback lever (611) to rotate around the fulcrum of point D and then the spool (652) to move to the left. As a result, port CL opens a way to the tank port.

This causes the servo piston to move to the left and the pump's delivery rate to increase.

The movement of the servo piston is transmitted to the spool by the action of the feedback mechanism to move it till the opening between the spool and sleeve is closed.

③ **Low tilting angle (low flow) command preferential function**

As mentioned above, flow control and horsepower control tilting angle commands are transmitted to the feedback lever and spool via the large-hole sections (C & F) of levers 1 and 2. However, since sections C and F have the pins (Ø4) protruding from the large hole (Ø8), only the lever lessening the tilting angle contacts the pin (897); the hole (Ø8) in the lever of a larger tilting angle command is freed without contacting the pin (897). Such a mechanical selection method permits preference of the lower tilting angle command of the flow control and horsepower control.

④ **Adjustment of input horsepower**

Since the regulator is of total cumulative horsepower type, adjust the adjusting screws of both the front and rear pumps, when changing the horsepower set values. The pressure change values by adjustment are based on two pumps pressurized at the same time, and the values will be doubled when only one pump is loaded.

a. **Adjustment of outer spring**

Adjust it by loosening the hexagon nut (630) and by tightening (or loosening) the adjusting screw C (628). Tightening the screw shifts the control chart to the right and increases the input horsepower as shown in the figure. Since turning the adjusting screw C by N turns changes the setting of the inner spring (626), return the adjusting screw QI (627) by $N \times A$ turns at first. ($A=1.59$)

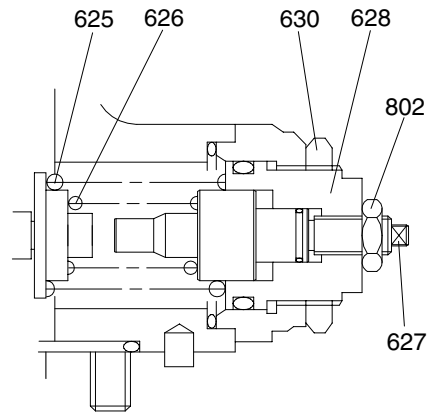

※ **Adjusting values are shown in table.**

Speed	Adjustment of outer spring		
	Tightening amount of adjusting screw (C) (628)	Compensating control starting pressure change amount	Input torque change amount
(min ⁻¹)	(Turn)	(kgf/cm ²)	(kgf · m)
1800	+1/4	+17.5	+6.1

8007A2MP03

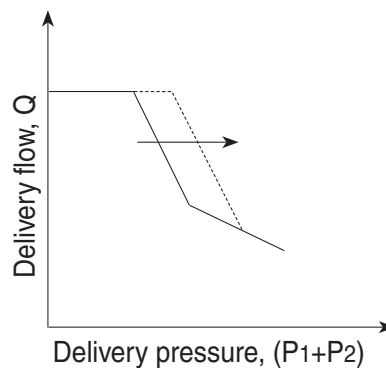

b. Adjustment of inner spring

Adjust it by loosening the hexagon nut (802) and by tightening (or loosening) the adjusting screw QI (627).

Tightening the screw increases the flow and then the input horsepower as shown in the figure.

※ Adjusting valves are shown in table.

Speed	Adjustment of inner spring		
	Tightening amount of adjusting screw (QI) (627)	Flow change amount	Input torque change amount
(min ⁻¹)	(Turn)	(kgf/cm ²)	(kgf · m)
1800	+1/4	+16.7	+6.6

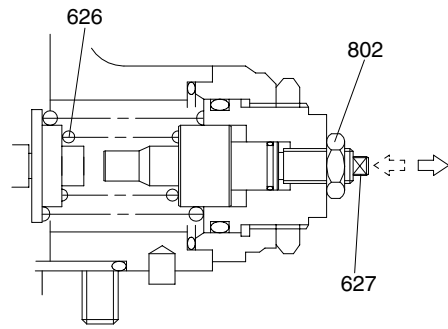

8007A2MP04

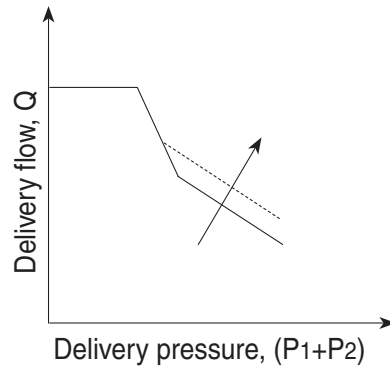

(3) Power shift control

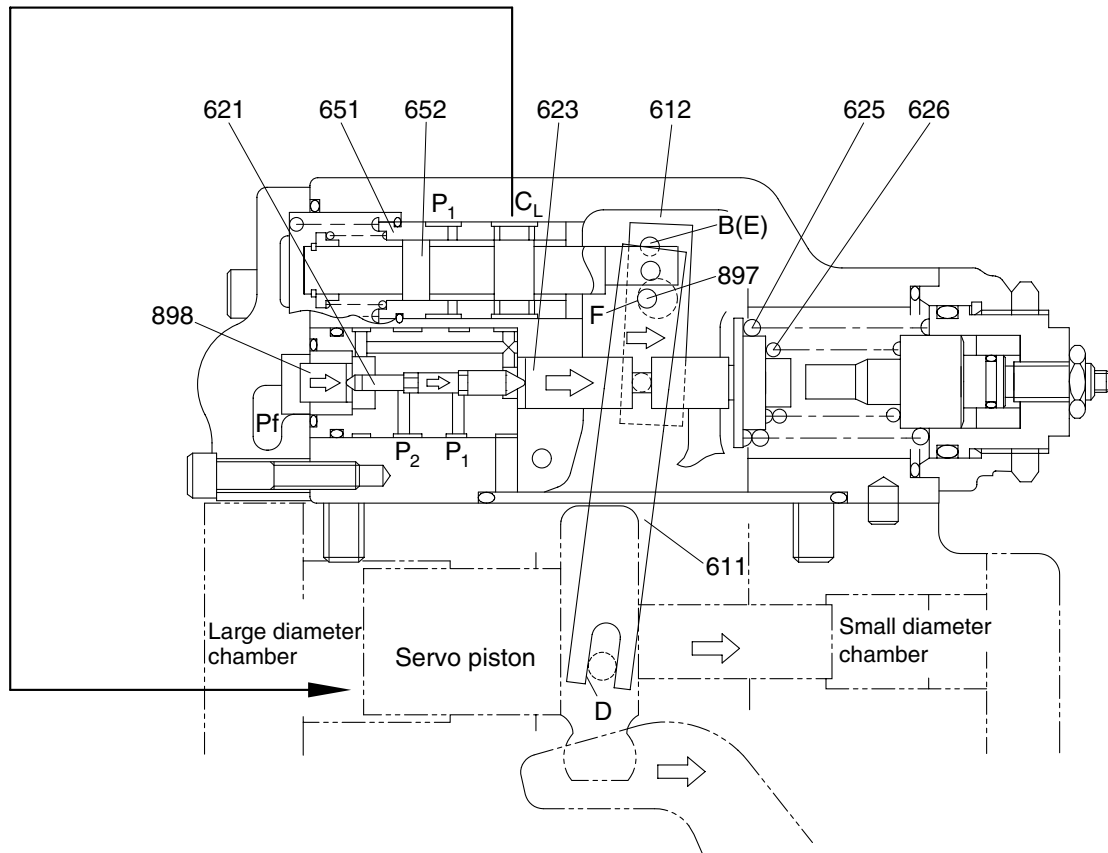

300S2MP13

The set horsepower valve is shifted by varying the command current level of the proportional pressure reducing valve attached to the pump. Only one proportional pressure reducing valve is provided.

However, the secondary pressure P_f (power shift pressure) is admitted to the horsepower control section of each pump regulator through the pump's internal path to shift it to the same set horsepower level.

This function permits arbitrary setting of the pump output power, thereby providing the optimum power level according to the operating condition.

The power shift pressure P_f controls the set horsepower of the pump to a desired level, as shown in the figure.

As the power shift pressure P_f rises, the compensating rod (623) moves to the right via the pin (898) and compensating piston (621).

This decreases the pump tilting angle and then the set horsepower in the same way as explained in the overload preventive function of the horsepower control. On the contrary, the set horsepower rises as the power shift pressure P_f falls.

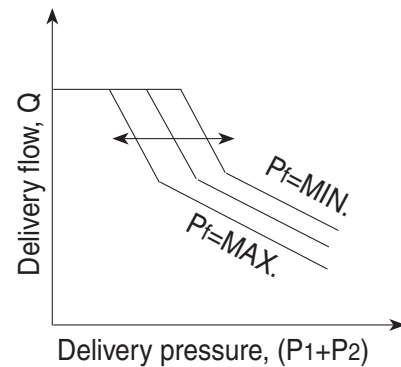

(4) Adjustment of maximum and minimum flows

① Adjustment of maximum flow

Adjust it by loosening the hexagon nut (808) and by tightening (or loosening) the set screw (954).

The maximum flow only is adjusted without changing other control characteristics.

Speed (min ⁻¹)	Adjustment of max flow	
	Tightening amount of adjusting screw (954) (Turn)	Flow change amount (ℓ/min)
1800	+1/4	-6.9

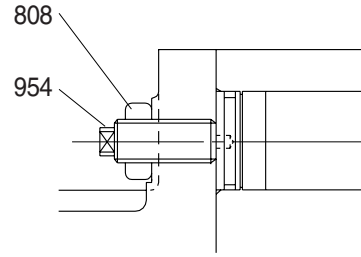

2-19(1)

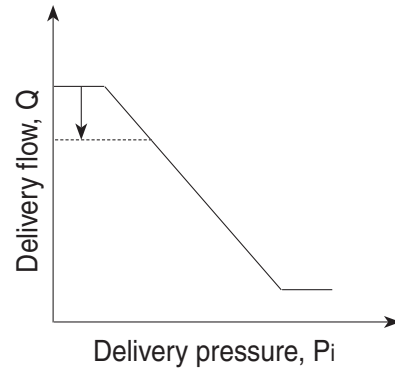

② Adjustment of minimum flow

Adjust it by loosening the hexagon nut (808) and by tightening (or loosening) the hexagonal socket head set screw (953). Similarly to the adjustment of the maximum flow, other characteristics are not changed.

However, remember that, if tightened too much, the required horsepower during the maximum delivery pressure (or during relieving) may increase.

Speed (min ⁻¹)	Adjustment of min flow	
	Tightening amount of adjusting screw (953) (Turn)	Flow change amount (ℓ/min)
1800	+1/4	+6.9

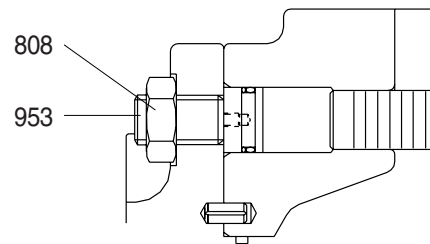

2-19(2)

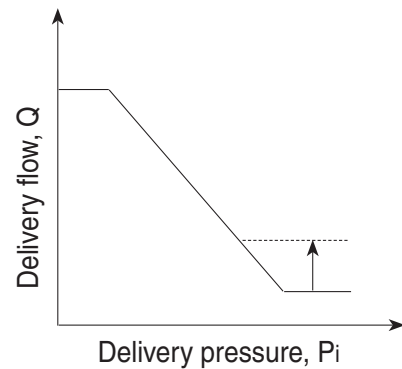

GROUP 2 MAIN CONTROL VALVE

1. STRUCTURE (1/8)

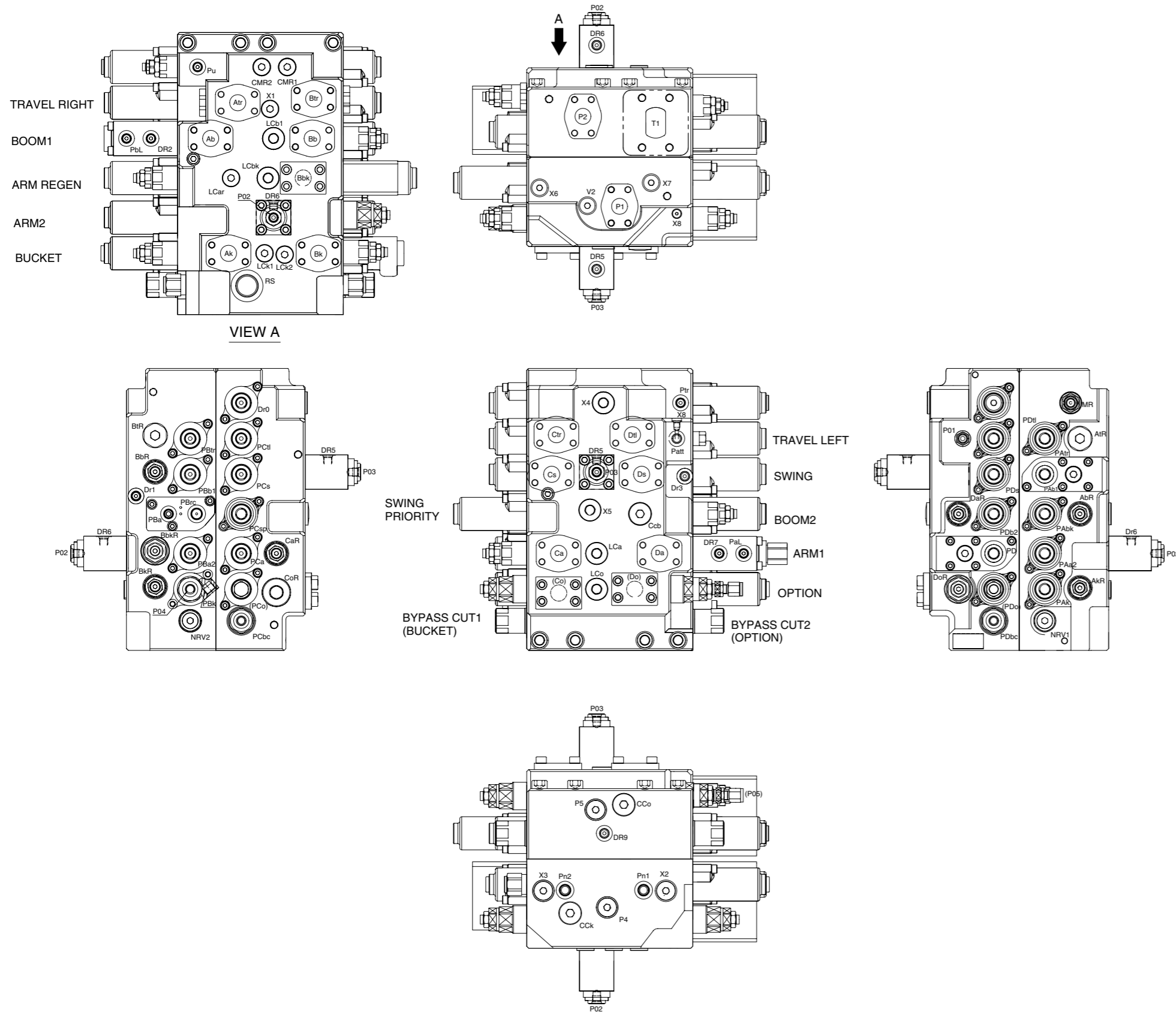

Mark	Port name	Port size	Tightening torque
Rs	Make up for swing motor	PF1	20~25 kgf · m (145~180 lbf · ft)
Patt PbL PCbc (PDbc) P01 P02 P03 P04 (P05) PaL Ptr Pu DR1 DR2 DR3 DR4 DR5 DR7 DR9	Auto idle signal-attachment Lock valve pilot port (boom) Bucket in confluence pilot port Option confluence pilot port Pilot signal port Pilot signal port Swing logic pilot port Bucket parallel orifice pilot port Option B confluence pilot port Lock valve pilot port (arm) Auto idle signal-travel Power boost Drain port Drain port Drain port Drain port Drain port Drain port Drain port	PF1/4	3.5~4.0 kgf · m (25.3~28.9 lbf · ft)
(P4) (P5)	- -	PF1/2	10~12 kgf · m (72.3~86.8 lbf · ft)
PATr PBtr PCtl PDtl PAB1 PDb2 PBb1 PCs PDS PBA PBA2 PCsp PABk PBrc PCa PDA PAA2 PAk PBk PCo PDo Pn1 Pn2 V2	Travel pilot port-RH (FW) Travel pilot port-RH (BW) Travel pilot port-LH (BW) Travel pilot port-LH (FW) Boom up pilot port Boom up confluence pilot port Boom down pilot port Swing pilot port (LH) Swing pilot port (RH) Arm in regen-cut signal selector port Arm in confluence pilot port Swing priority pilot port Option A pilot port (breaker) Arm in regeneration cut port Arm in pilot port Arm out pilot port Arm out confluence pilot port Bucket in pilot port Bucket out pilot port Option B pilot port Option B pilot port Negative control signal port (A2 port side) Negative control signal port (A1 port side) Carry-over port	PF3/8	7~8 kgf · m (50.6~57.8 lbf · ft)
Atr Btr Ctl Dtl Ab Bb Cs Ds Bbk Ca Da Ak Bk (Co) (Do) P1 P2	Travel motor port-LH (FW) Travel motor port-LH (BW) Travel motor port-RH (BW) Travel motor port-RH (FW) Boom up port Boom down port Swing motor port (LH) Swing motor port (RH) Option A port (breaker) Arm in port Arm out port Bucket in port Bucket out port Option B port Option B port Pump port (A2 side) Pump port (A1 side)	M10	5.0~6.5 kgf · m (36.2~47.0 lbf · ft)
T1	Return port	M12	8.0~11.0 kgf · m (57.9~79.6 lbf · ft)

300S2MC01

STRUCTURE (2/8)

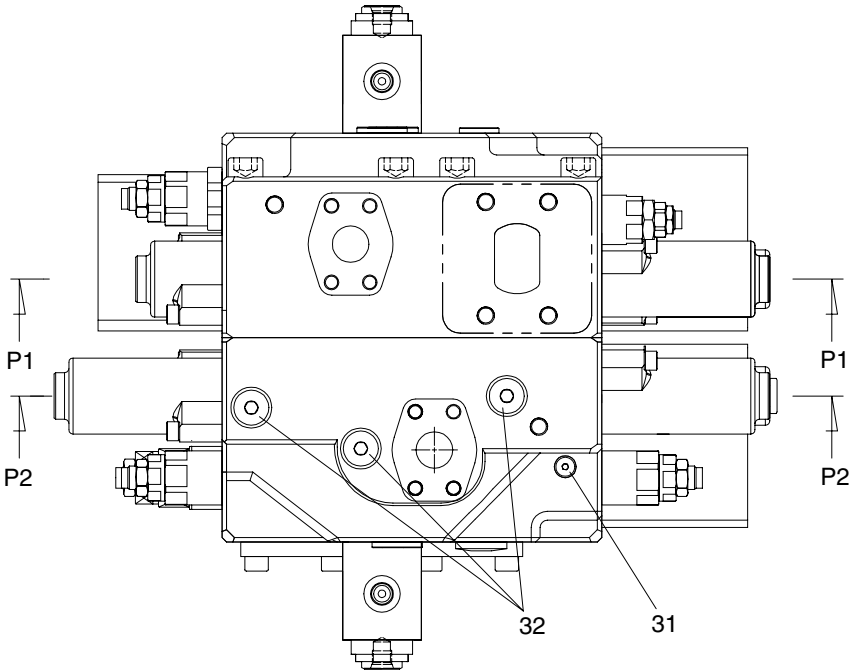

TOP VIEW

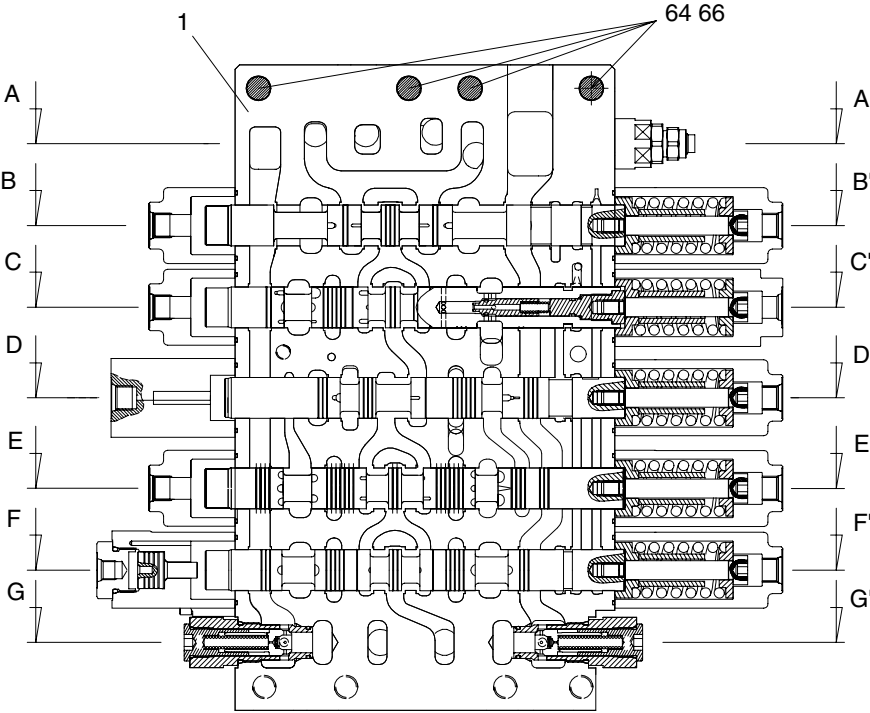

- 1 Housing P1
- 31 Plug
- 32 Plug
- 64 Hex socket head bolt
- 66 Spring washer

P1 BLOCK SPOOL SECTION

220S2MC02

STRUCTURE (3/8)

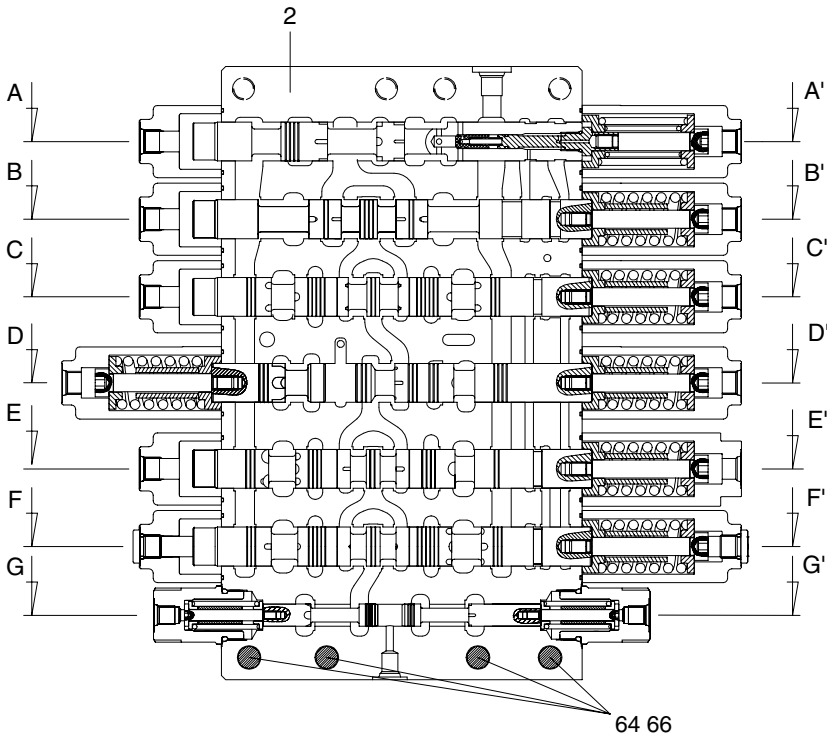

P2 BLOCK SPOOL SECTION

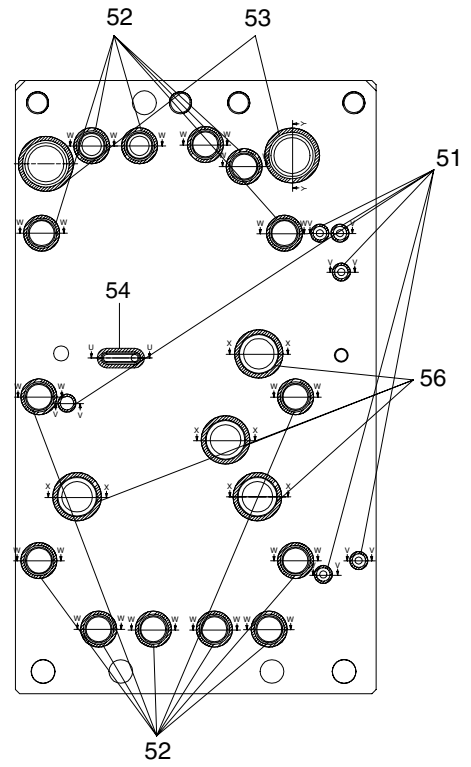

CONTACT FACE

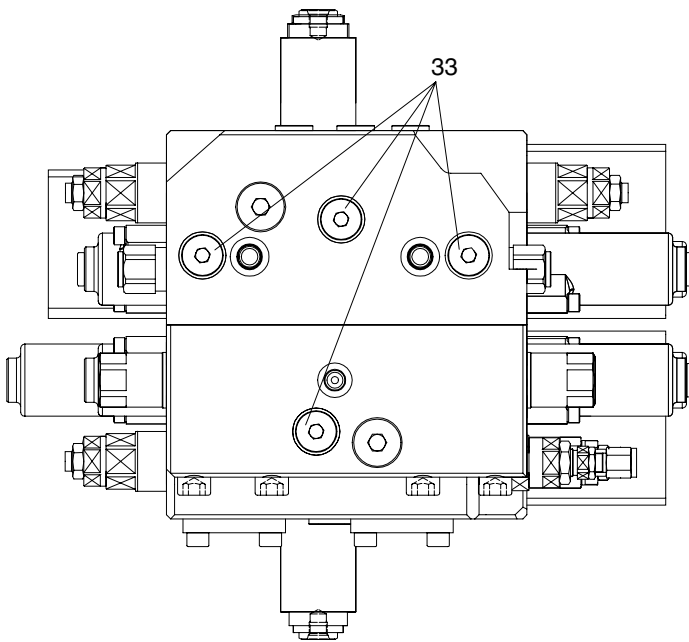

BOTTOM VIEW

- 2 Housing 2
- 33 Plug
- 51 O-ring
- 52 O-ring
- 53 O-ring
- 54 O-ring
- 56 O-ring
- 64 Hex socket head bolt
- 66 Spring washer

300S2MC03

STRUCTURE (4/8)

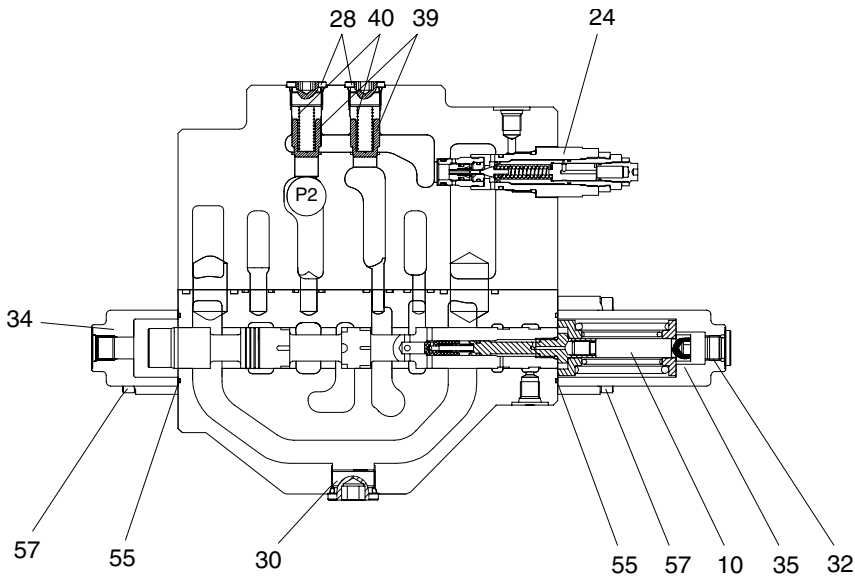

- 10 Travel straight spool kit
- 24 Main relief valve
- 28 Plug
- 30 Plug
- 32 Plug
- 34 Pilot cover A
- 35 Pilot cover B
- 39 Check valve poppet 2
- 40 Check valve spring 2
- 55 O-ring
- 57 Hex socket head bolt

A-A' (STRAIGHT TRAVEL AND SUPPLY)

220S2MC04

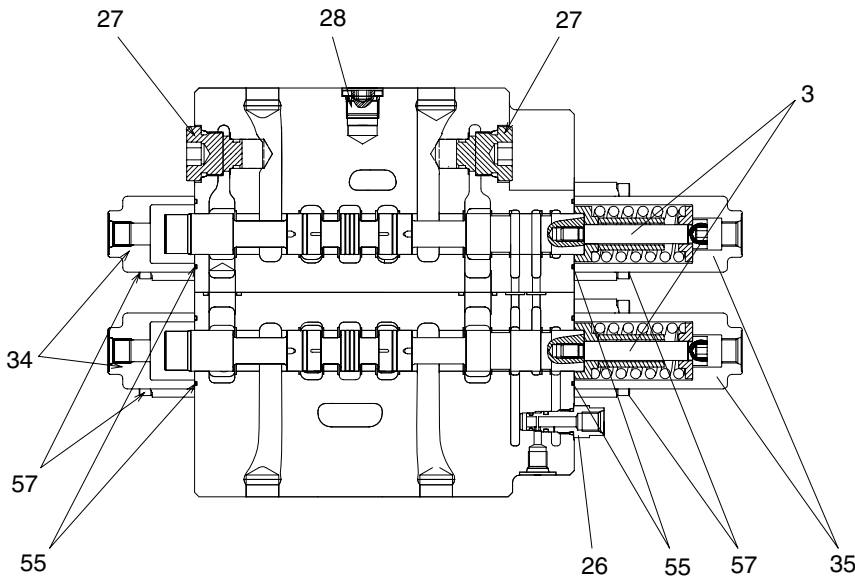

- 3 Travel spool kit
- 26 Orifice signal plug
- 27 ORV plug
- 28 Plug
- 34 Pilot cover A
- 35 Pilot cover B
- 55 O-ring
- 57 Hex socket head bolt

B-B' (TRAVEL RIGHT AND LEFT)

220S2MC05

STRUCTURE (5/8)

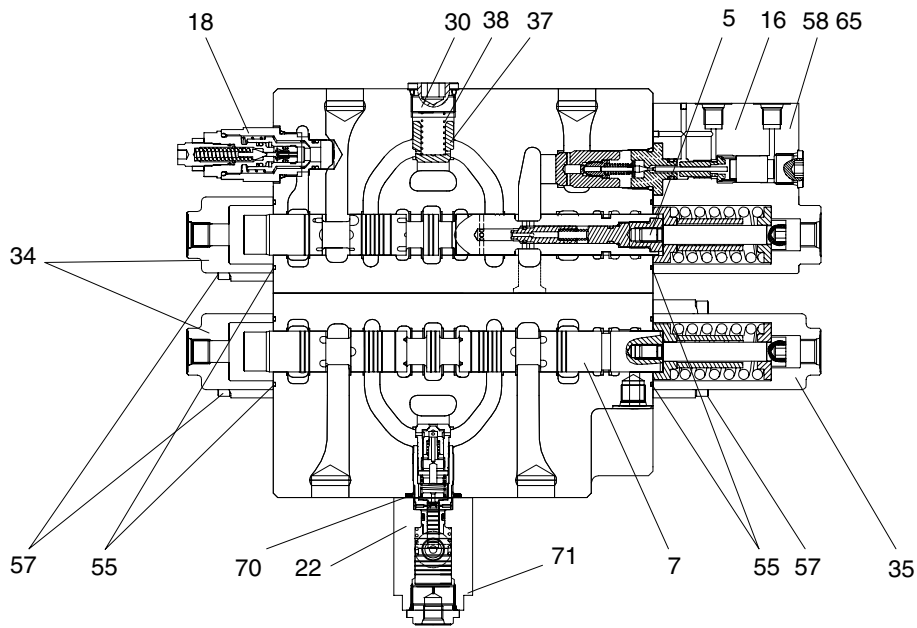

C-C' (SWING AND BOOM1)

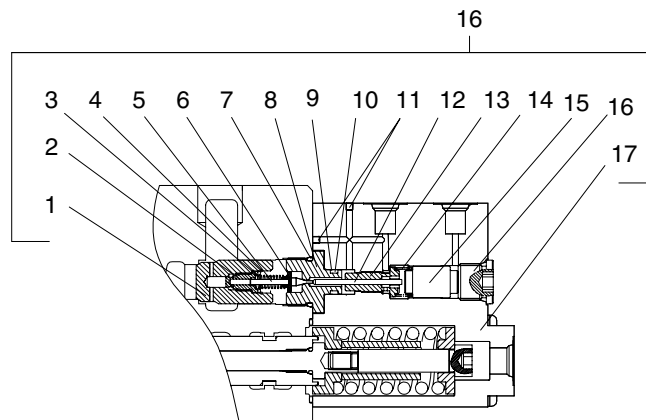

HOLDING VALVE

300S2MC06

- | | | |
|-----------------------|--------------------------|-------------------------|
| 5 Boom 1 spool kit | 16-9 Back up ring | 30 Plug |
| 7 Swing spool kit | 16-10 O-ring | 34 Pilot cover A |
| 16 Holding valve assy | 16-11 Plug | 35 Pilot cover B |
| 16-1 Main poppet | 16-12 Pilot piston | 37 Check valve poppet 1 |
| 16-2 Restrictor | 16-13 Piston guide | 38 Check valve spring 1 |
| 16-3 Pilot spring | 16-14 Spring | 55 O-ring |
| 16-4 C-ring | 16-15 Main piston | 57 Hex socket head bolt |
| 16-5 Pilot poppet | 16-16 Plug | 58 Hex socket head bolt |
| 16-6 Poppet guide | 16-17 Block | 65 Spring washer |
| 16-7 O-ring | 18 Overload relief valve | 70 O-ring |
| 16-8 Poppet seat | 22 Swing logic valve | 71 Hex socket head bolt |

STRUCTURE (6/8)

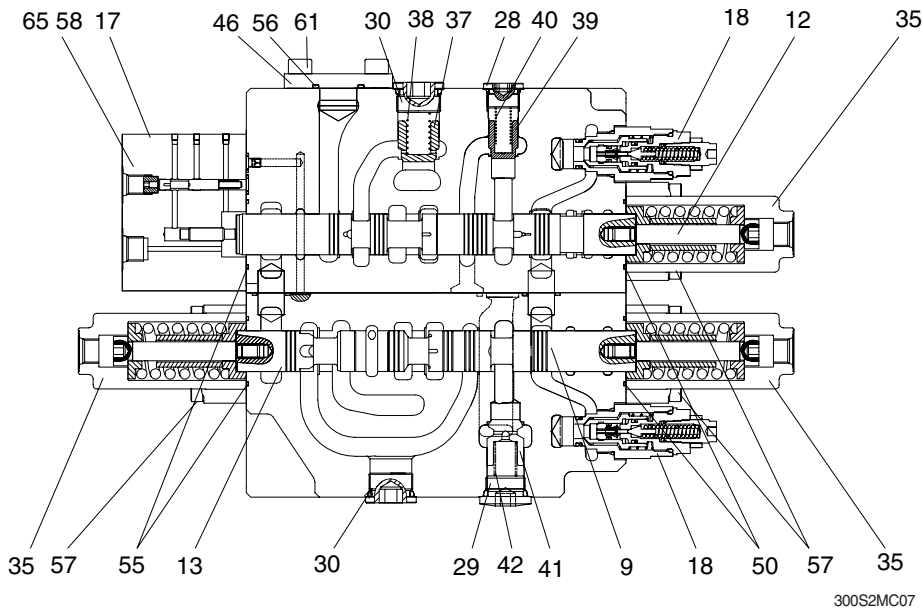

D-D' (SWING PRI, BOOM 2 & ARM REGEN)

- 9 Boom 2 spool kit
- 12 Arm regen spool kit
- 13 Swing priority spool kit
- 17 Regen valve
- 18 Overload relief valve
- 28 Plug
- 29 Plug
- 30 Plug
- 35 Pilot cover B
- 37 Check valve poppet 1
- 38 Check valve spring 1
- 39 Check valve poppet 2
- 40 Check valve spring 2
- 41 Check valve poppet 3
- 42 Check valve spring 3
- 46 Flange
- 50 Gasket 3
- 55 O-ring
- 56 O-ring
- 57 Hex socket head bolt
- 58 Hex socket head bolt
- 61 Hex socket head bolt
- 65 Spring washer

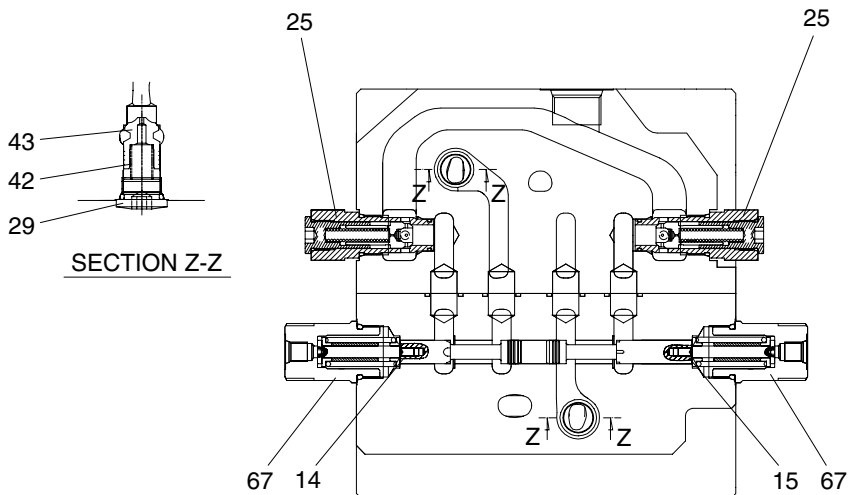

G-G' (BYPASS CUT & NEGATIVE CONTROL)

- 14 Bypass cut 1 spool kit (bucket)
- 15 Bypass cut 1 spool kit (option)
- 25 Negacon valve
- 29 Plug
- 42 Check valve spring 3
- 43 Check valve poppet 4
- 67 BC plug

STRUCTURE (7/8)

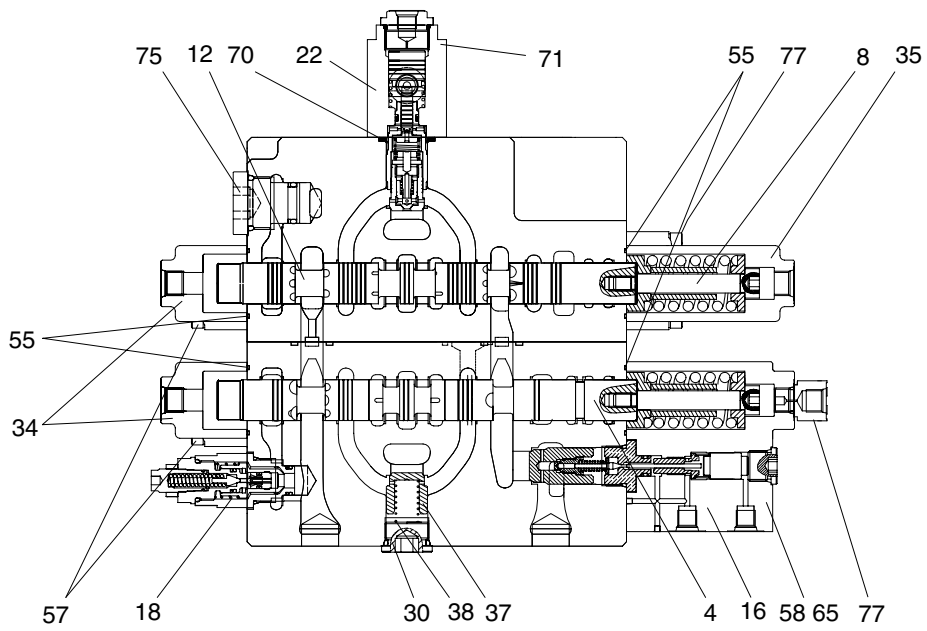

E-E' (ARM 1 & ARM 2)

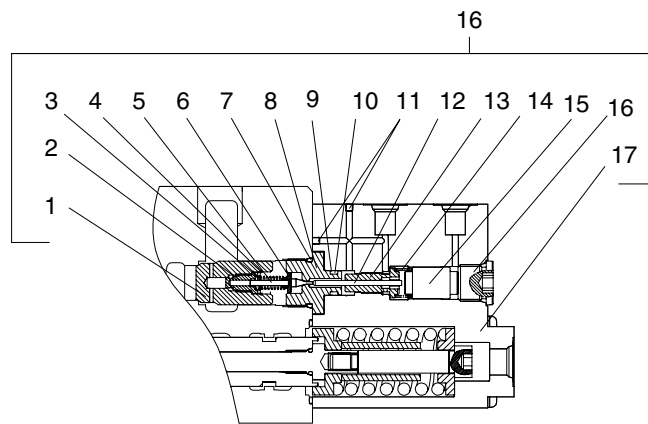

HOLDING VALVE

300S2MC09

- | | | | | | |
|------|---------------------|-------|-----------------------|----|----------------------|
| 4 | Arm 1 spool kit | 16-9 | Back up ring | 34 | Pilot cover A |
| 8 | Arm 2 spool kit | 16-10 | O-ring | 35 | Pilot cover B |
| 12 | Arm regen spool kit | 16-11 | Plug | 37 | Check valve poppet 1 |
| 16 | Holding valve assy | 16-12 | Pilot piston | 38 | Check valve spring 1 |
| 16-1 | Main poppet | 16-13 | Piston guide | 55 | O-ring |
| 16-2 | Restrictor | 16-14 | Spring | 57 | Hex socket head bolt |
| 16-3 | Pilot spring | 16-15 | Main piston | 58 | Hex socket head bolt |
| 16-4 | C-ring | 16-16 | Plug | 65 | Spring washer |
| 16-5 | Pilot poppet | 16-17 | Block | 70 | O-ring |
| 16-6 | Poppet guide | 18 | Overload relief valve | 71 | Hex socket head bolt |
| 16-7 | O-ring | 22 | Swing logic valve | 75 | Plug |
| 16-8 | Poppet seat | 30 | Plug | 77 | Orifice plug |

STRUCTURE (8/8)

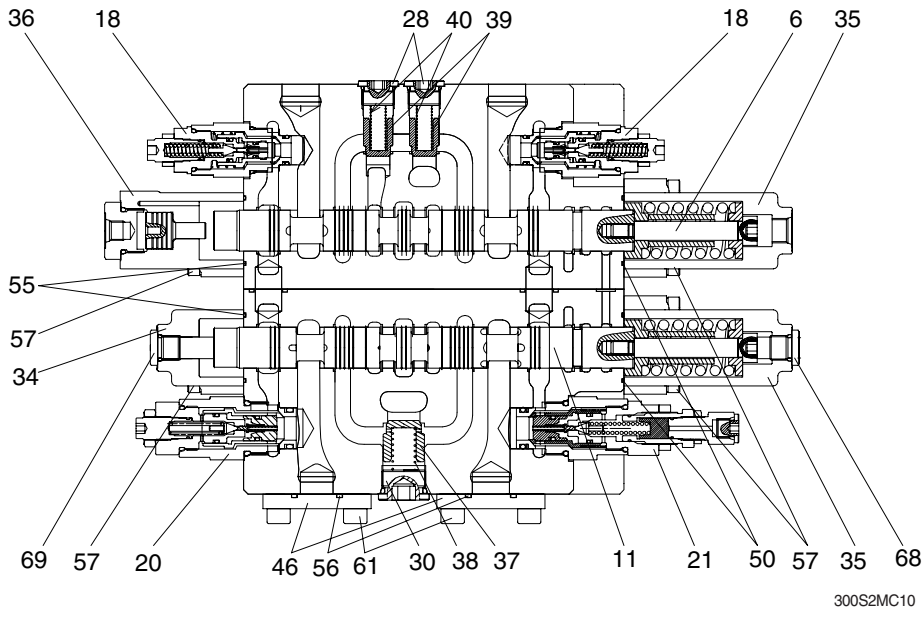

F-F' (OPTION & BUCKET)

- 6 Bucket spool kit
- 11 Option spool kit
- 18 Overload relief valve
- 20 Overload relief valve
- 21 Overload relief valve
- 28 Plug
- 30 Plug
- 34 Pilot cover A
- 35 Pilot cover B
- 36 Pilot cover (stroke limit)
- 37 Check valve poppet 1
- 38 Check valve spring 1
- 39 Check valve poppet 2
- 40 Check valve spring 2
- 46 Flange
- 50 Gasket 3
- 55 O-ring
- 56 O-ring
- 57 Hex socket head bolt
- 61 Hex socket head bolt
- 68 Plug kit 1
- 69 Plug kit 2

2. HYDRAULIC CIRCUIT

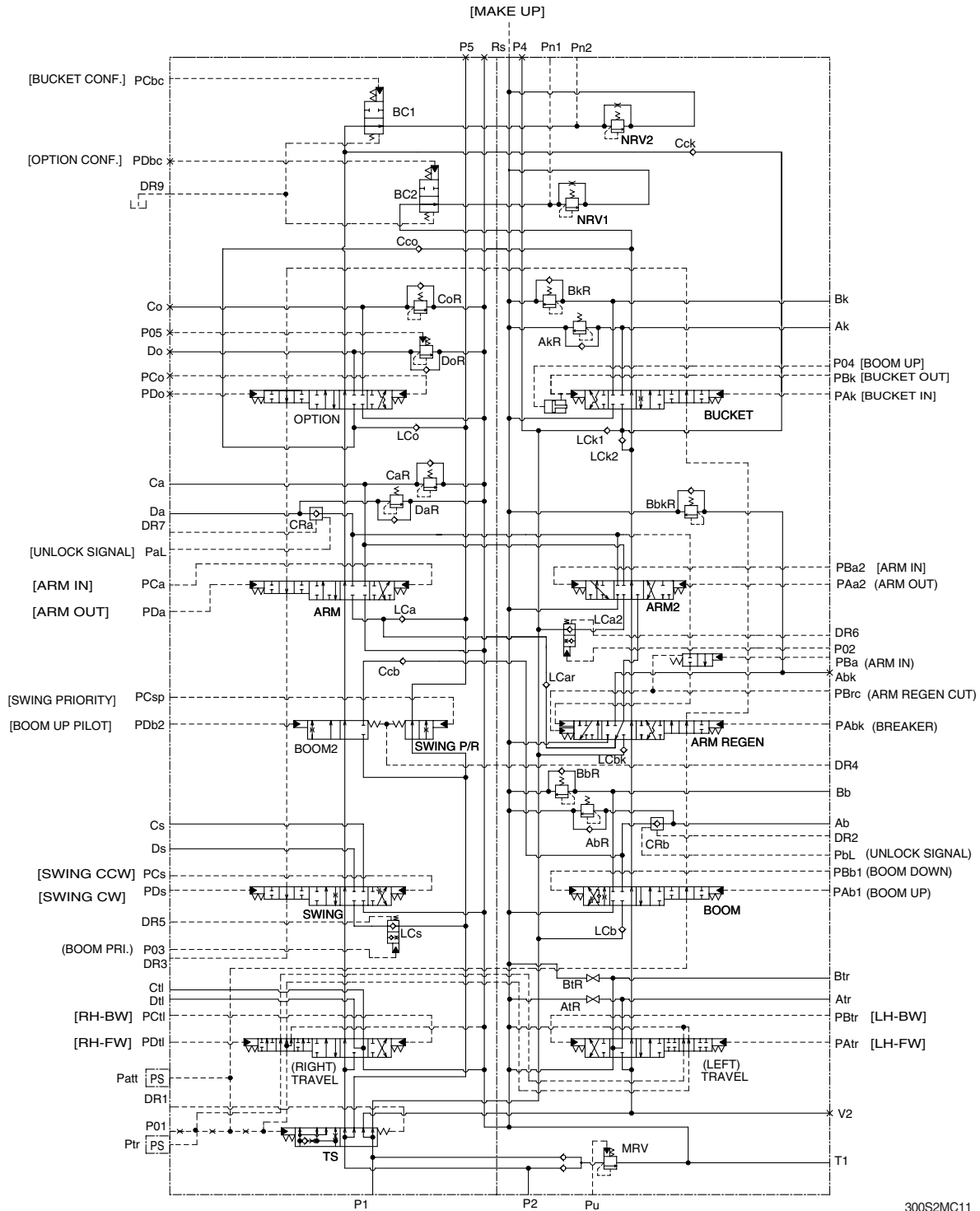

3. FUNCTION

1) CONTROL IN NEUTRAL POSITION

(1) P1 housing side

The pressurized oil discharged from hydraulic pump flows into the main control valve through the inlet port P1 and pass the land of the straight travel spool into the P1 bypass passage and P1 parallel passage.

When the straight travel spool is neutral, the P1 side bypass passage is not cut-off and the pressurized oil is directed to the tank port T1 through the bypass passage of spools (travel right -> boom 1 -> arm regeneration -> arm 2 -> bucket), the negative control valve of P1 and tank passage.

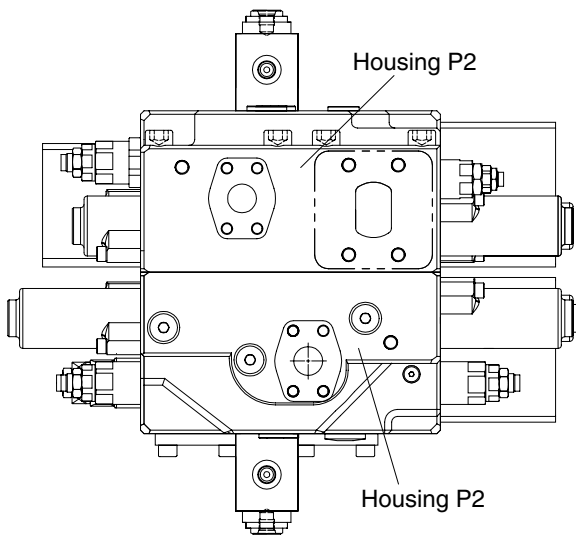

TOP VIEW

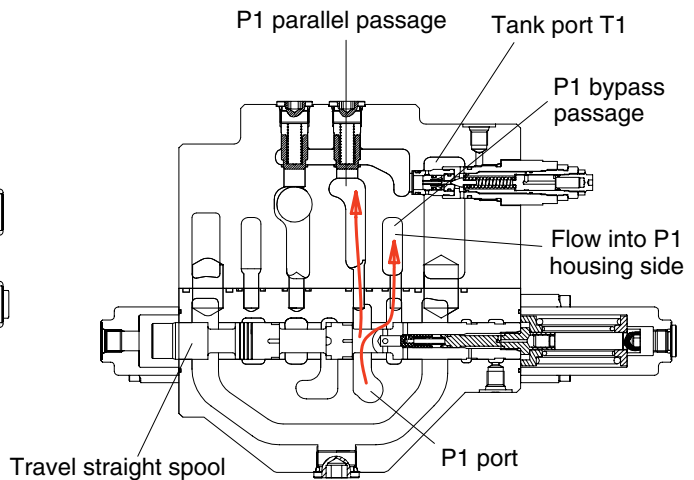

A-A' (STRAIGHT TRAVEL AND SUPPLY)

220S2MC13

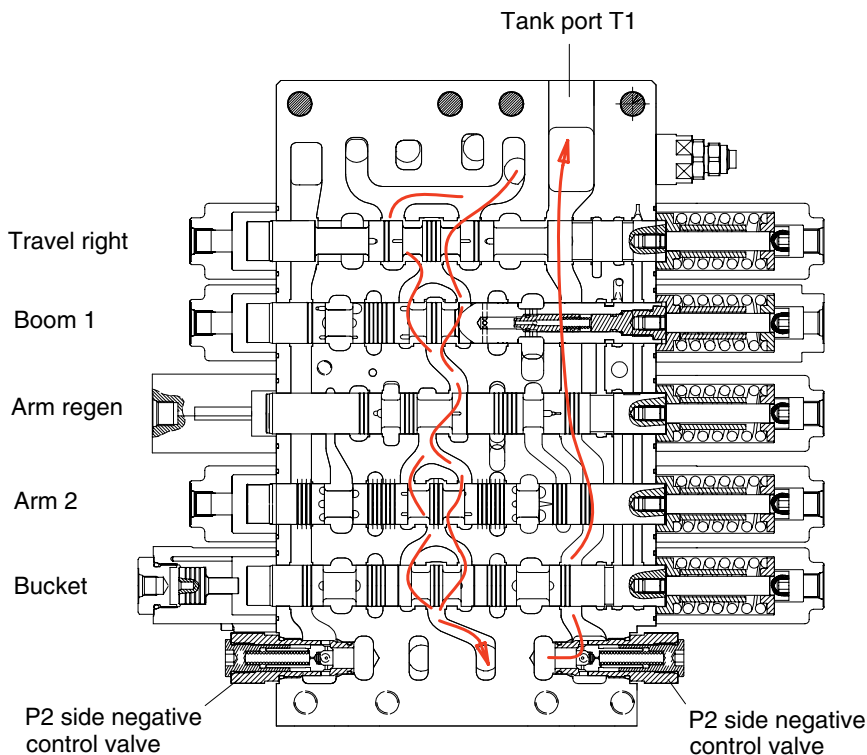

P1 BLOCK SPOOL SECTION

220S2MC14

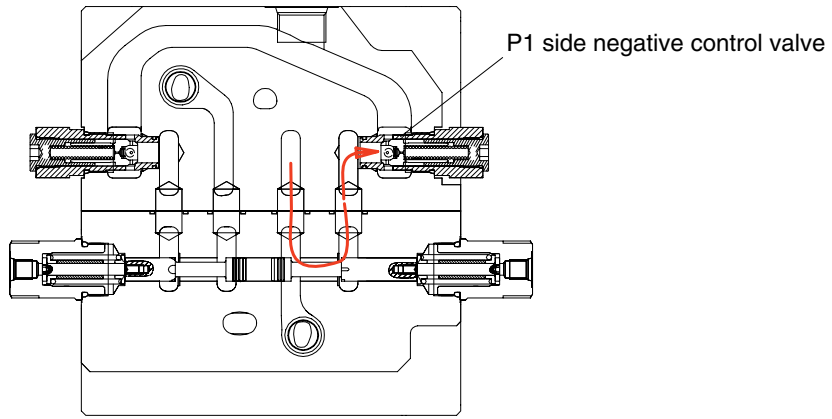

G-G' (BYPASS CUT & NEGATIVE CONTROL)

220S2MC15

(2) P2 housing side

The pressurized oil discharged from hydraulic pump flows into the main control valve through the inlet port P2 and pass the land of the straight travel spool into the P2 bypass passage and P2 parallel passage.

When the straight travel spool is neutral, the P2 side bypass passage is not cut-off and the pressurized oil is directed to the tank port T1 through the bypass passage of spools (travel left -> swing -> boom 2 and swing priority -> arm 1 -> option), the negative control valve of P2 and tank passage.

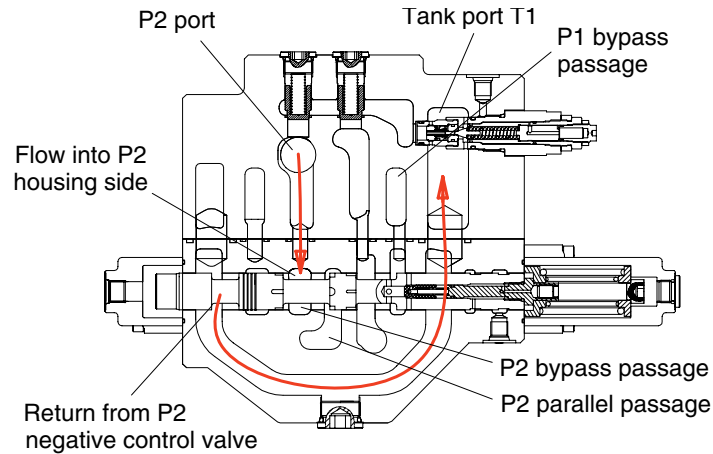

A-A' (STRAIGHT TRAVEL AND SUPPLY)

220S2MC16

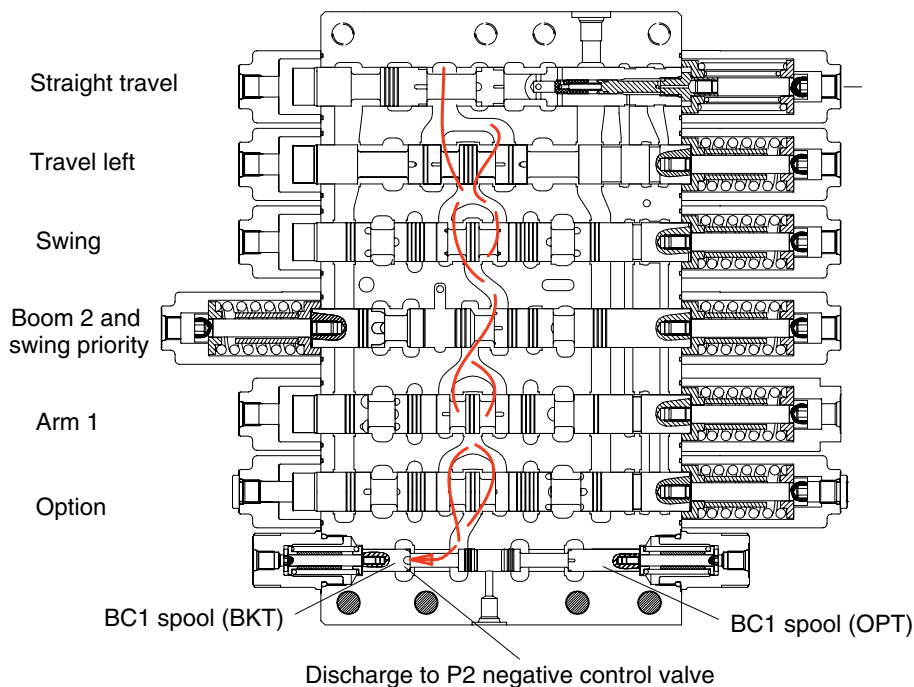

P2 BLOCK SPOOL SECTION

220S2MC17

2) TRAVEL OPERATION

(1) Travel forward operation

During the travel forward operation, the pilot secondary pressure from the remote control valve is supplied to the spring side of pilot port and it shifts travel spools to the left direction.

The pressurized oil from the pump flows into the bypass passage of the travel spools through the land of the straight travel spool.

When the travel spools are shifted and the bypass passage is shut-off. The pressurized oil flowed into bypass passage is supplied to the travel motors through opened port Atr and Dtl.

On the other hand, the return oil from the travel motors flows into main control valve inside through the port Btr and Ctl and return to the tank passage.

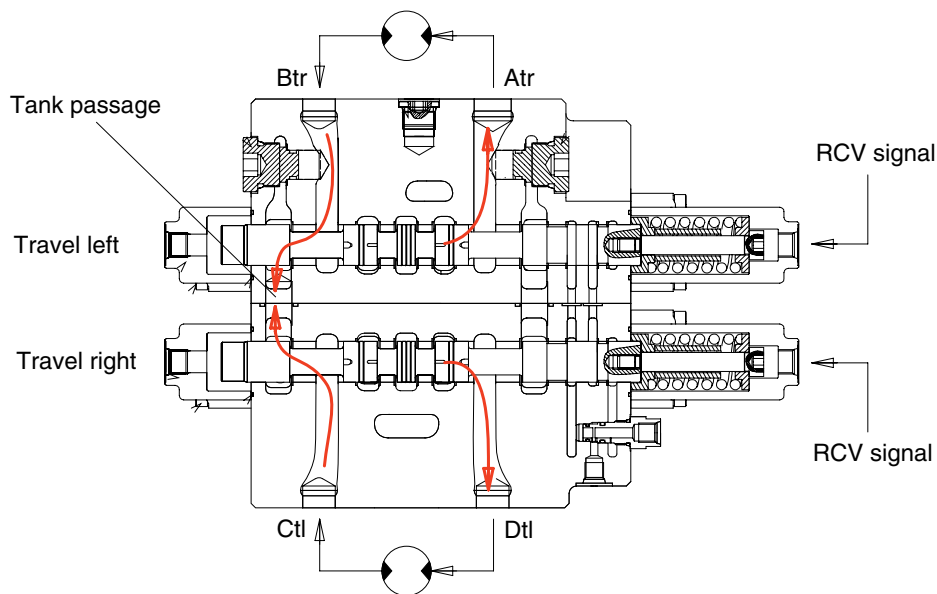

B-B' (TRAVEL RIGHT AND LEFT)

220S2MC18

(2) Travel backward operation

During the travel backward operation, the pilot secondary pressure from the remote control valve is supplied to the against pilot port of the spring side and it shifts travel spools to the right direction.

The pressurized oil from the pump flows into the bypass passage of the travel spools through the land of the straight travel spool.

When the travel spools are shifted and the bypass passage is shut-off. The pressurized oil flowed into bypass passage is supplied to the travel motors through opened port Btr and Ctl.

On the other hand, the return oil from the travel motors flows into main control valve inside through the port Atr and Dtl and return to the tank passage.

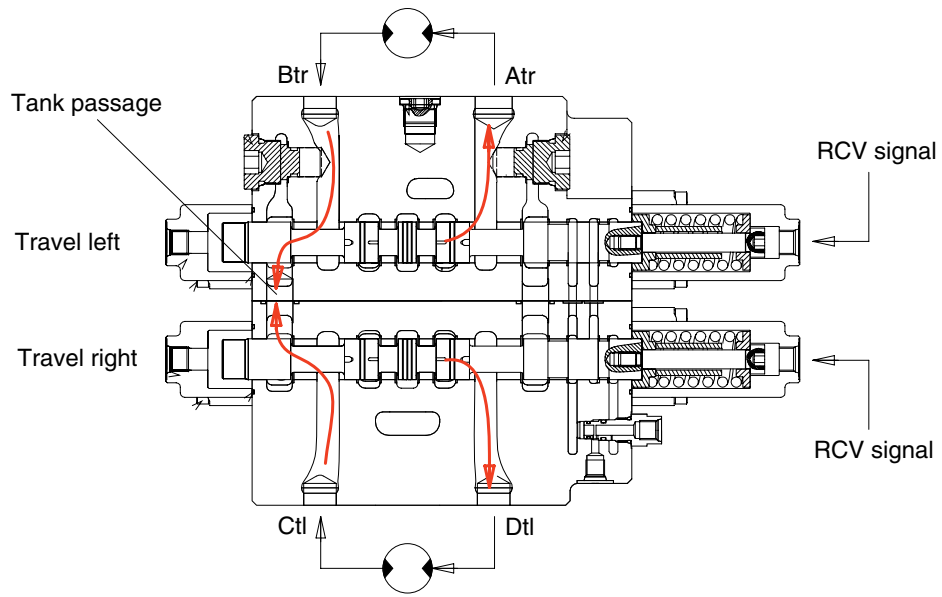

B-B' (TRAVEL RIGHT AND LEFT)

220S2MC19

(3) Travel straight function

This function keeps straight travel in case of simultaneous operation of other actuators (boom, arm, bucket, swing etc) during a straight travel.

In normal conditions, travel straight spool keeps neutral conditions, the pressurized oil of the P1 and P2 pumps is supplied to each passage independently.

When the attachment spool is operated under the travel operation of both sides, the pilot pressure is supplied to the spring side port of the travel straight spool and then the travel straight spool is shifted to the left direction.

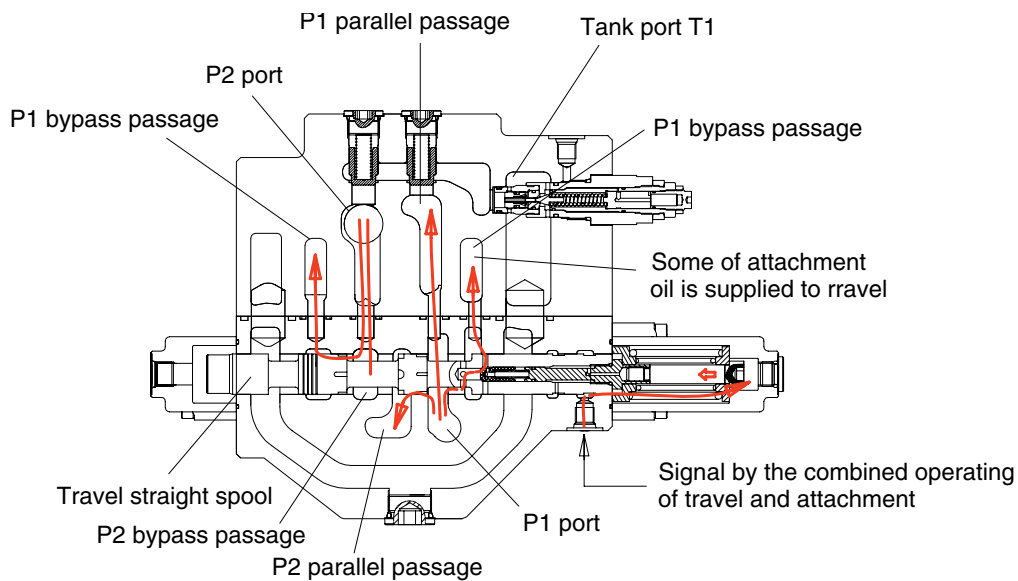

A-A' (STRAIGHT TRAVEL AND SUPPLY)

220S2MC20

After changeover of the travel straight spool, the pressurized oil discharged from the P1 pump is connected with P2 port oil and is supplied to the attachment line through both parallel passage of the P1 and P2.

Also, some of the pressurized oil open the check valve of the spool inside through side of the travel straight spool and is connected with the bypass passage of the P2 side.

On the other hand, the pressurized oil discharged from the P2 pump is connected with P1 port oil and is supplied to the travel line through both parallel passage of the P1 and P2.

Accordingly the attachment spool is operated under the travel operation of both sides, the pressurized oil discharged from P2 pump is mainly supplied to left and right travel line and the pressurized oil discharged from P1 pump is mainly supplied to attachment line.

As a result, simultaneous operation of both travel spools and attachment is not influenced to the travel operation of the both sides and the machine keeps straight travel.

3) BOOM OPERATION

(1) Boom up operation

During the boom up operation, the pilot secondary pressure from the RCV is supplied to the port of the spring side and shifts the boom 1 spool to the left direction. The P1 bypass passage is shut off by the movement of the boom 1 spool and the pressurized oil from P2 port is entered P1 parallel passage and then passes through the load check valve, bridge passage and boom holding valve then flows into the head side of the boom cylinder via Ab port. (In this case, the boom holding valve is free flow condition)

At the same time, the pilot secondary pressure from RCV is supplied to the port of the spring side of boom 2 and shifts the boom 2 spool. The bypass passage is shut off by the movement of the boom 2 spool and the pressurized oil from P2 port entered boom summation passage via the P2 parallel passage, notch of the boom 2 spool, the check valve.

The oil from boom 2 spool combined with the boom 1 spool oil and is supplied Ab port.

At the same time, the return oil from rod side of the boom cylinders flows the boom 1 spool through the Bb port and return to the hydraulic oil tank through the tank passage.

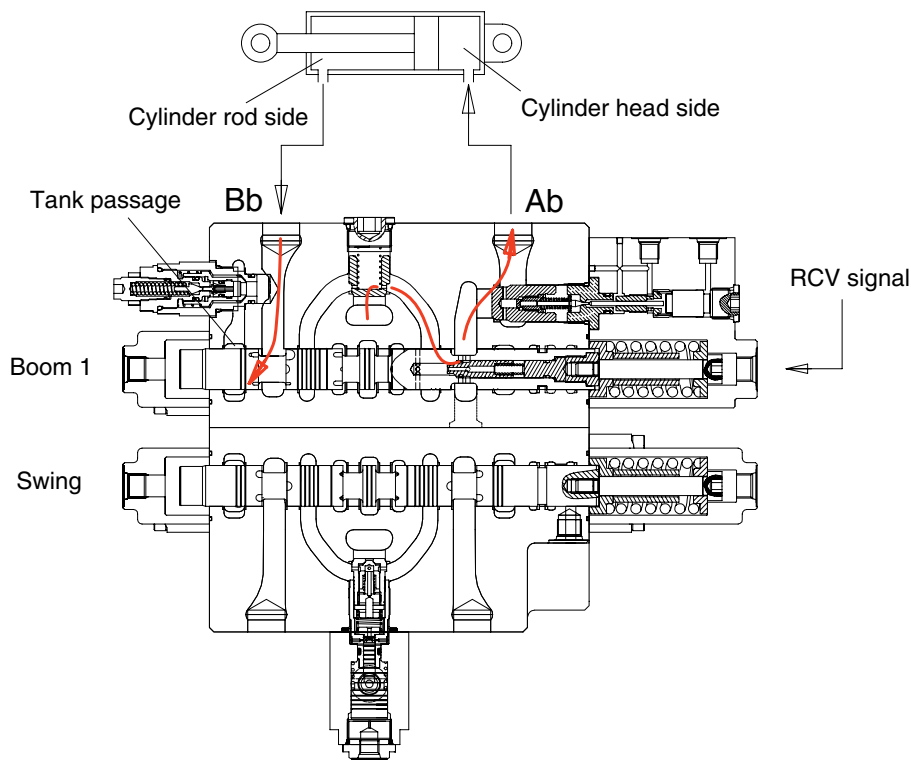

C-C' (SWING AND BOOM1)

220S2MC21

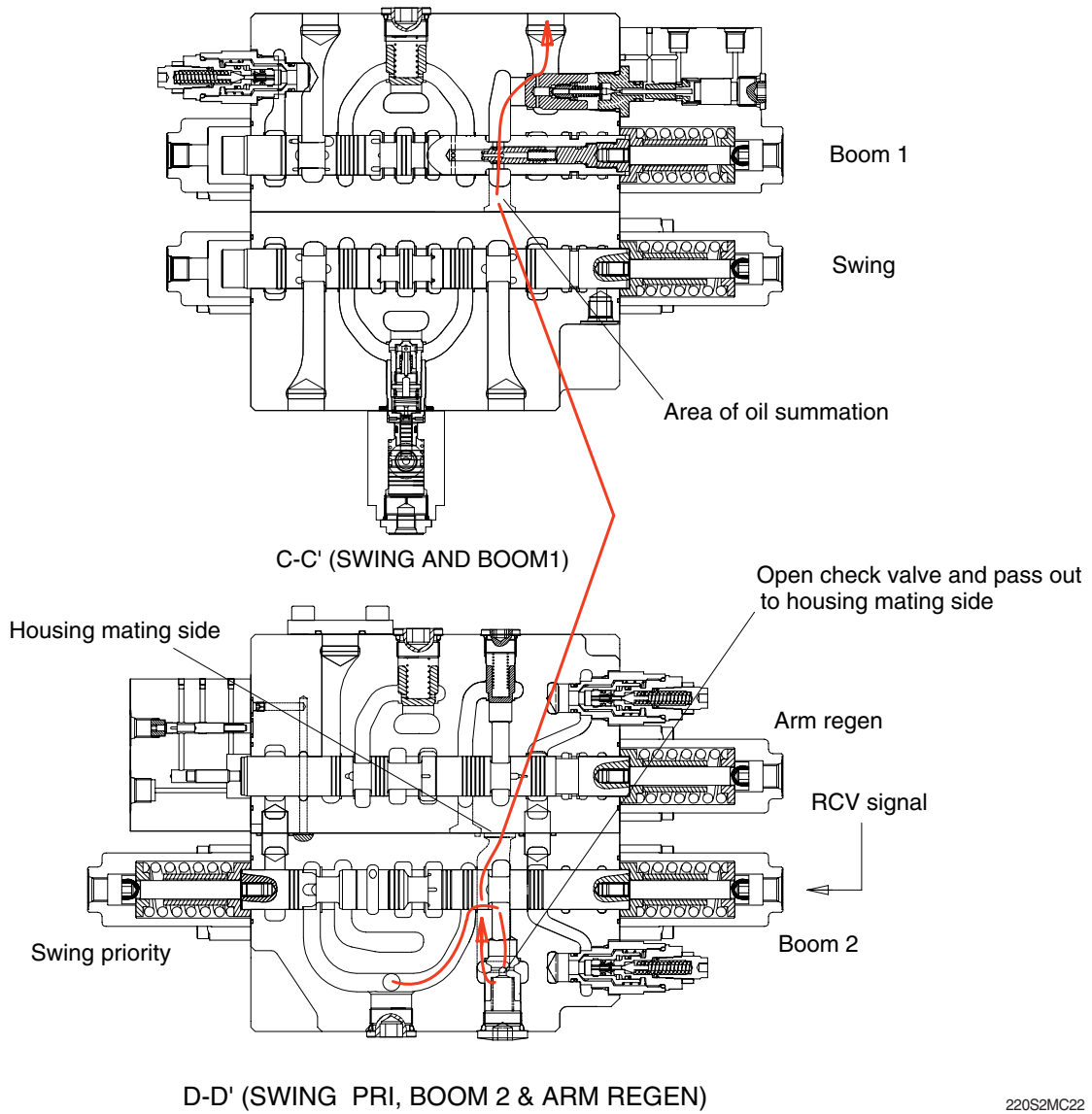

220S2MC22

(2) Boom down operation

During the boom down operation, the pilot secondary pressure from the RCV is supplied to the against port of the spring side and shifts the boom 1 spool to the right direction. The P1 bypass passage is shut off by the movement of the boom 1 spool and the pressurized oil from P1 port is entered P1 parallel passage and then passes through the load check valve and bridge passage then flows into the rod side of the boom cylinder via Bb port.

At the same time, the return oil from head side of the boom cylinders flows the boom 1 spool through the Ab port and the boom holding valve and return to the hydraulic oil tank through the tank passage.

At this time, some of the return oil from the boom head side passes to the connected passage of the boom 1 spool inside and flows into the P1 parallel passage. (Boom spool inside regeneration function). At this time, the boom holding valve is open status and the operation principles are described following page.

During the boom down operation, the flow is not combined.

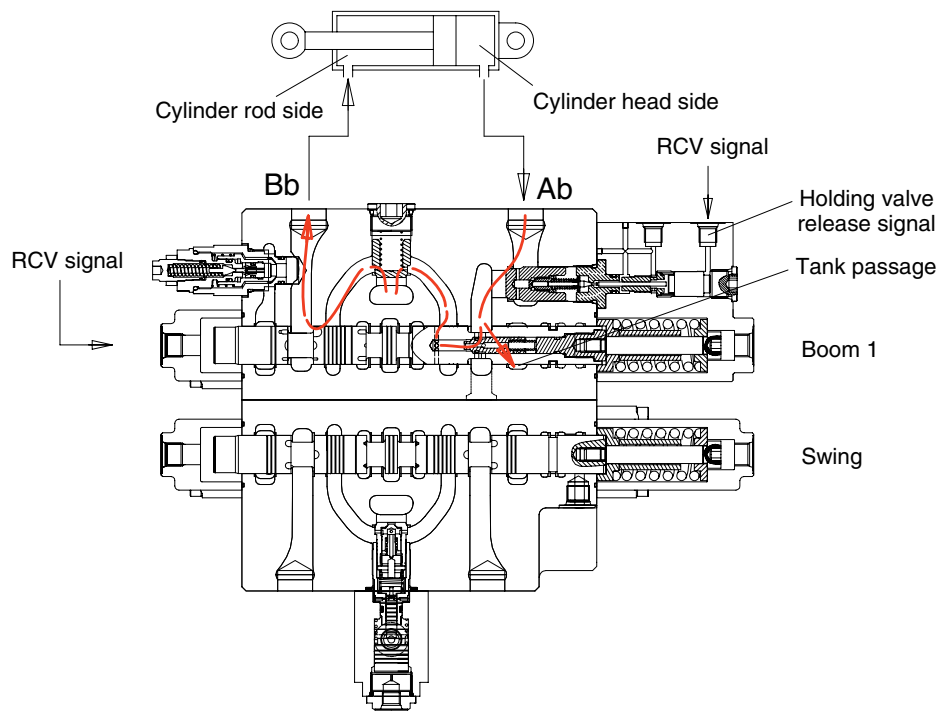

C-C' (SWING AND BOOM1)

220S2MC23

4) HOLDING VALVE OPERATION

(1) Holding operation

At neutral condition, the pilot piston chamber is connected to drain port through the pilot port.

And the main piston is seated by the spring B.

Also, the pressurized oil from the actuator entered to inside of the holding valve through the periphery hole of the main poppet, crevice of the main poppet and the restrictor and the periphery hole of the restrictor.

Then, this pressured oil pushed the pilot poppet to the poppet seat and the main poppet to the seat of body.

So the pressurized oil from the holding side of the actuator is not escaped and the actuator is not moved.

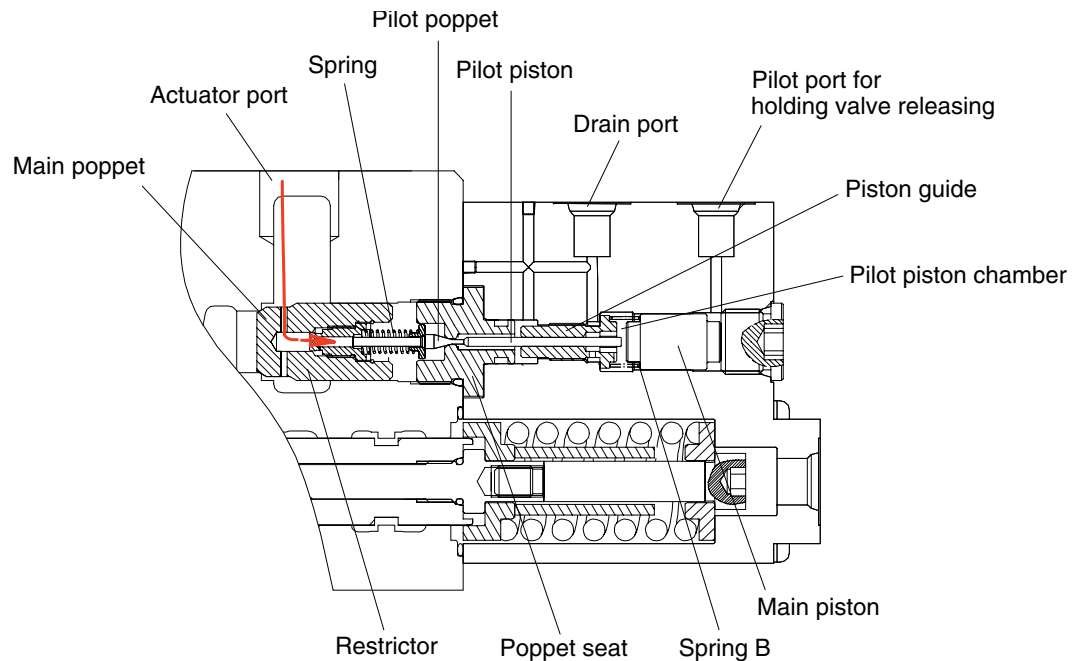

HOLDING VALVE BLOCK SECTION

220S2MC24

(2) Releasing holding operation

The pilot pressure is supplied to the pilot port for releasing holding valve and shifts the main piston to the left direction against the spring B and shifts the pilot poppet to the left direction through the pilot piston and open the passage for the drain.

At same time, the return oil from actuator returns to the drain port through the periphery hole of main poppet, crevice of the main poppet and the restrictor, the periphery hole of the restrictor, inside of holding valve, crevice of the pilot poppet and the drain passage of the holding valve.

After above operation, pressure of inside of holding valve is decreased and the main poppet is opened by the return oil of the actuator and the return oil from actuator returns to the tank passage through the notch of spool.

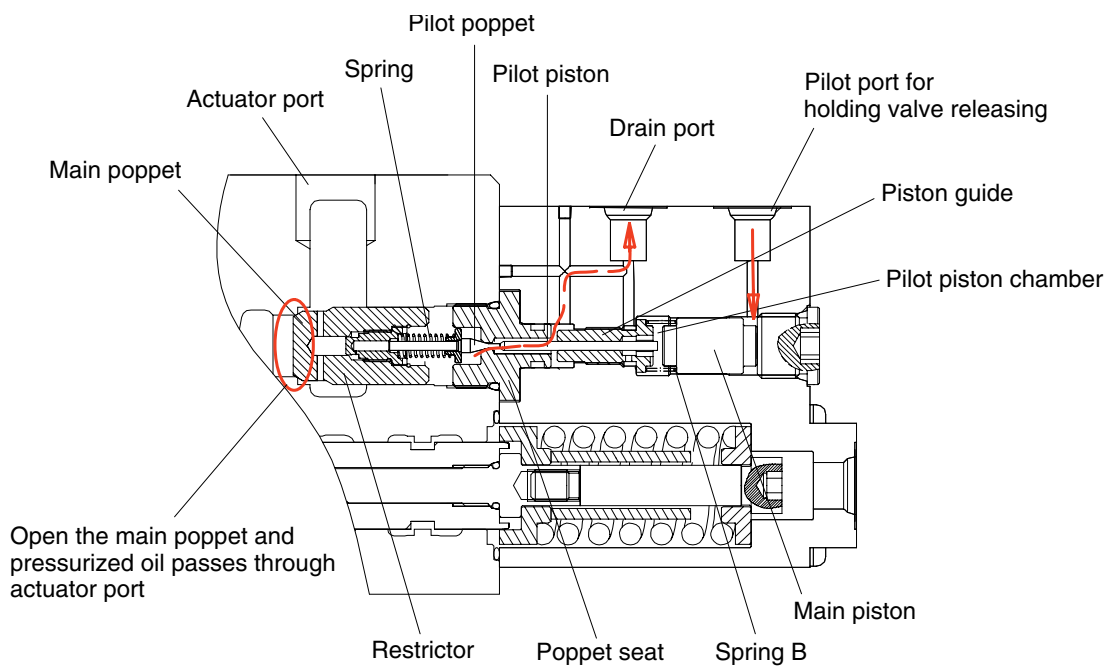

HOLDING VALVE BLOCK SECTION

220S2MC25

5) BUCKET OPERATION

(1) Bucket in operation

① Bucket operation only

During the bucket in operation, the pilot secondary pressure from the RCV is supplied to port of the spring side and shifts the bucket spool to the left direction.

The P1 bypass passage is shut off by the movement of the bucket spool and the pressurized oil from P1 port entered P1 parallel passage and is directed to the Ak port through the check valve 2. At the same time, the pressurized oil from P1 bypass passage is directed to the AK port through the check valve 1.

The return oil from the rod side of the bucket cylinder (Bk port) returns to the hydraulic oil tank through the tank passage.

② Combined operation

When combined operation of the bucket and other actuators, mostly same as above operation but the fluid from P1 bypass passage is empty by the upstream operation such as the arm or boom operation.

So only the fluid from P1 parallel passage is supplied to the Ak port.

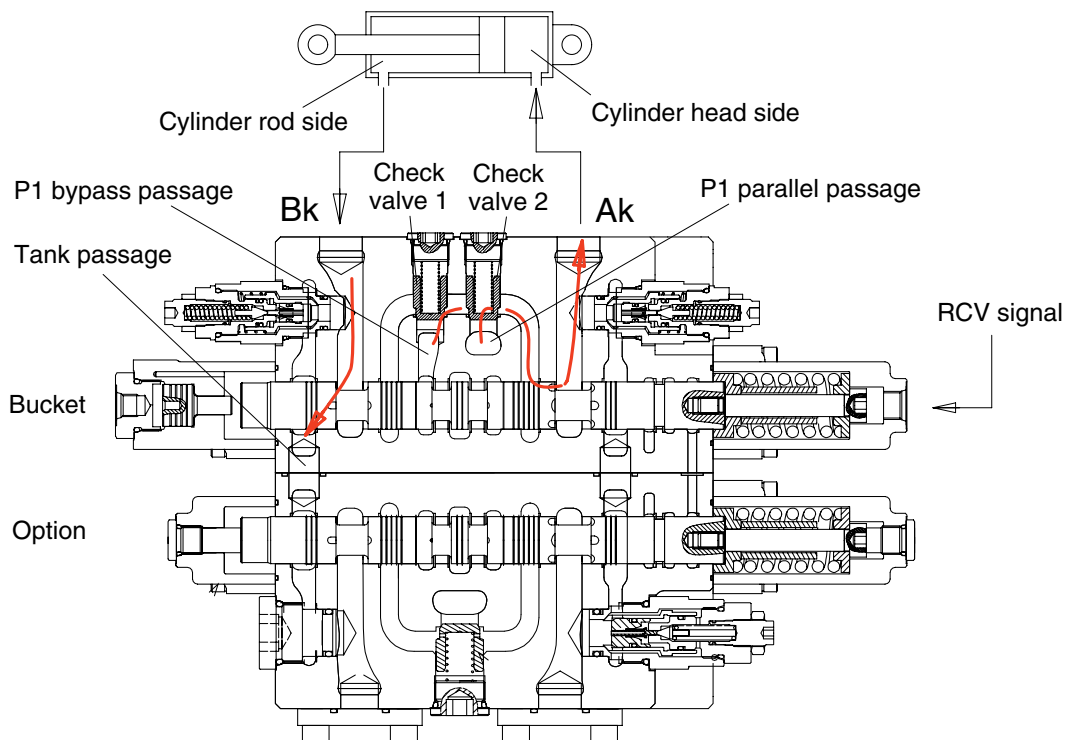

F-F' (OPTION AND BUCKET)

220S2MC26

(2) Bucket slow operation (incase bucket in)

This function is used to speed up of the boom or arm by reducing the bucket speed when the bucket operation with boom or arm operation simultaneously.

The bucket slow pilot pressure is supplied the pilot port of the BC1 spool and the piston is shifted to the right and then the bucket spool stroke is limited and the oil passage from P1 to the bucket cylinder is reduced and the oil flow of the bucket spool is reduced.

Bucket flow summation function, bypass cut-off 1 spool

During the bucket in operation, the pilot secondary pressure from the RCV is supplied to port of the spring side and shifts the BC1 (bucket) spool to the right direction.

The P2 parallel passage is shut off by the movement of the BC1 spool and the pressurized oil from P2 port opens the check poppet and combined with the flow of the bucket spool.

(Only bucket in operation)

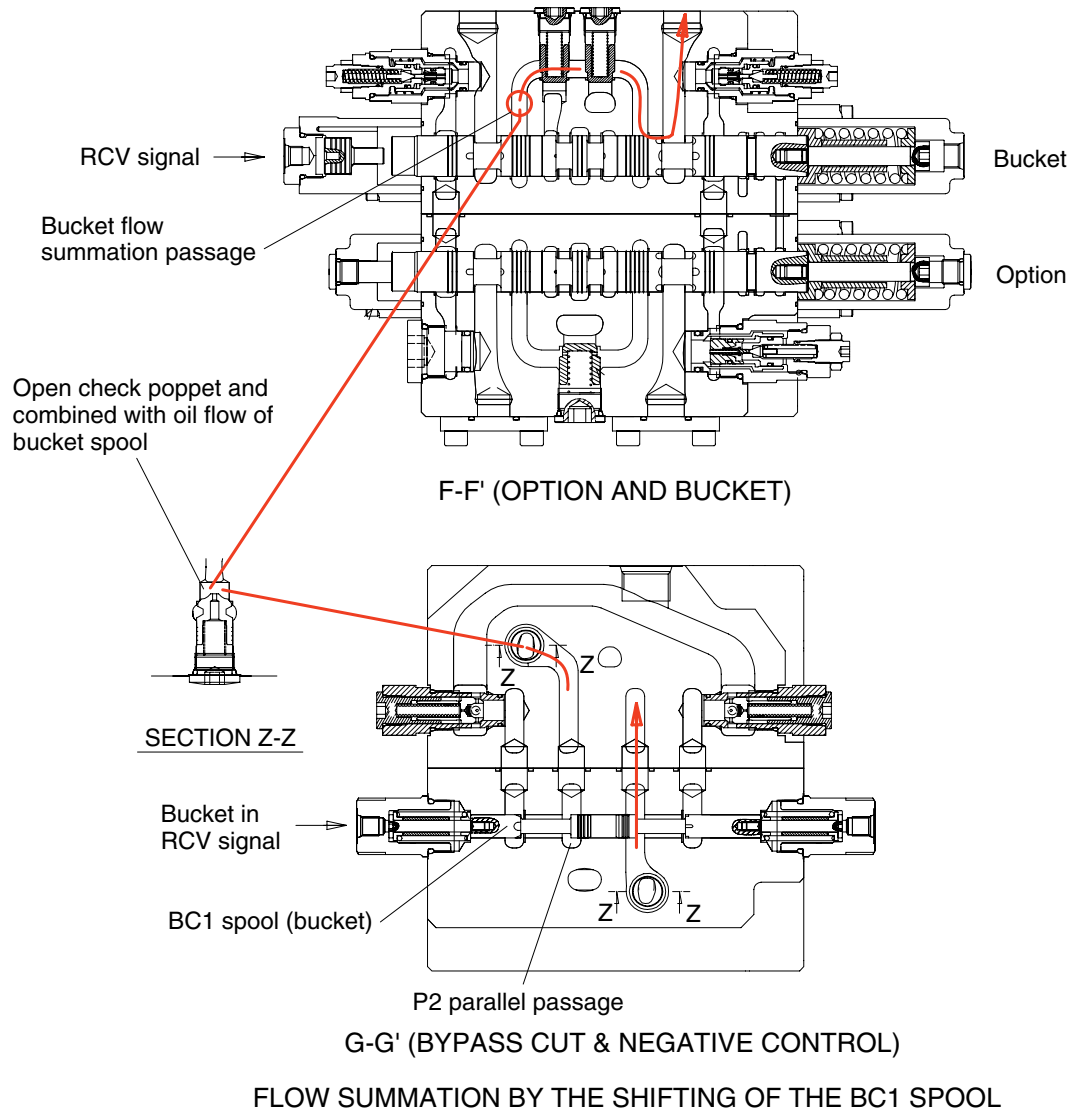

220S2MC27

(3) Bucket out operation

① Bucket operation only

During the bucket out operation, the pilot secondary pressure from the RCV is supplied to against port of the spring side and shifts the bucket spool to the right direction.

The P1 bypass passage is shut off by the movement of the bucket spool and the pressurized oil from P1 port entered P1 parallel passage and is directed to the Bk port through the check valve 2.

At the same time, the pressurized oil from P1 bypass passage is directed to the Bk port through the check valve 1.

The return oil from the head side of the bucket cylinder (Ak port) returns to the hydraulic oil tank through the tank passage.

② Combined operation

When combined operation of the bucket and other actuators, exactly same as above operation.

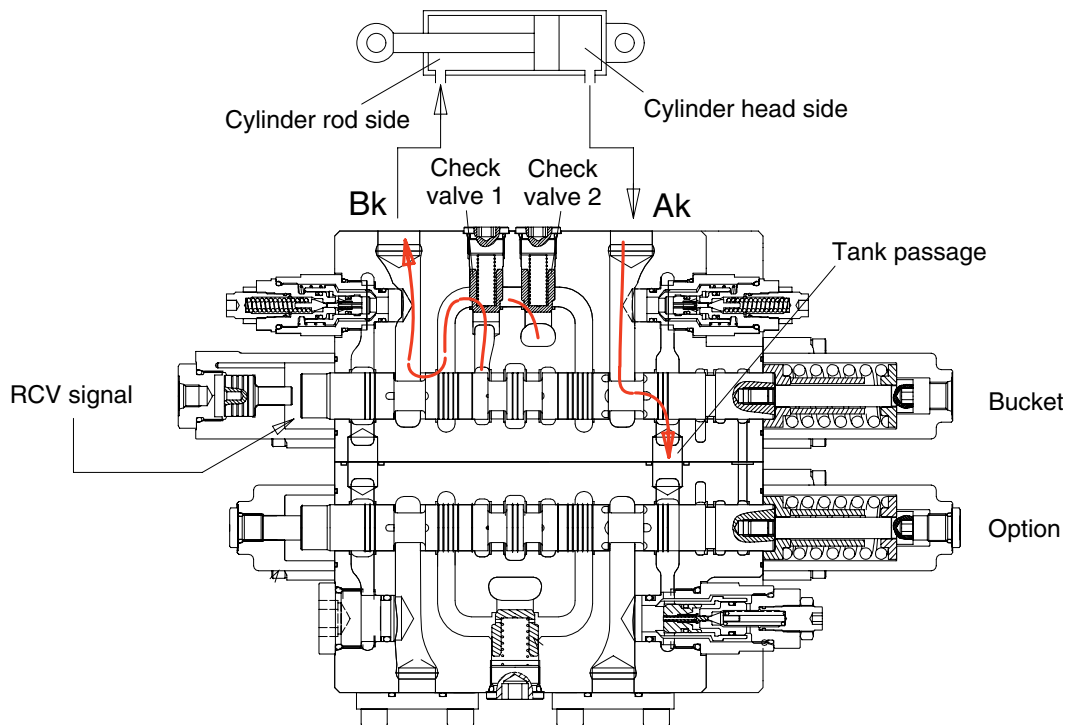

F-F' (OPTION AND BUCKET)

220S2MC28

6) SWING OPERATION

(1) Swing left and right operation

During the swing left operation, the pilot secondary pressure from the RCV is supplied to the port of the spring side and shifts the swing spool in left direction. The P2 bypass passage is shut off by the movement of the swing spool and the pressurized oil from P2 port flows into the P2 parallel passage and open the load check valve and is supplied to swing motor through the Ds port.

As the result, the return oil from the swing motor flows into the main control inside through Cs port and returns to the hydraulic oil tank through the swing spool and the tank passage.

In case of swing right operation, the operation is similar to swing left operation but the pilot secondary pressure from the RCV is supplied to the port of the spring opposite side.

Accordingly, the pressurized oil from P2 parallel passage flows into swing motor through the Cs port and returns to the hydraulic oil tank through the Ds port and the tank passage.

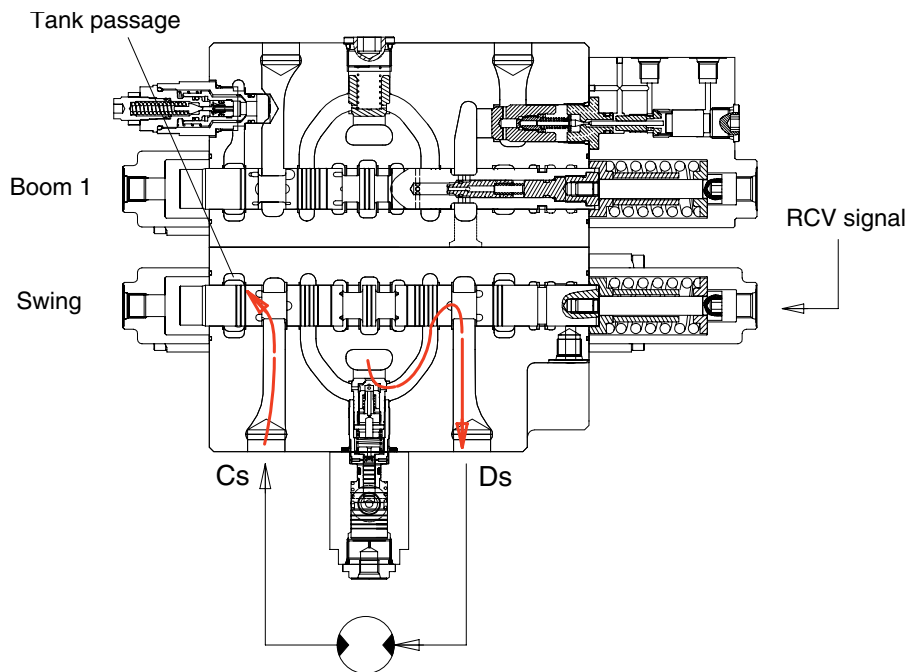

C-C' (SWING AND BOOM1)

220S2MC29

(2) Boom priority function

This function is used to speed up of the boom by reducing the swing speed when the swing operation with boom operation simultaneously.

The boom priority signal is supplied the pilot port and the poppet of the swing logic valve is closed and then the pressurized oil from P2 port is reduced by the oil leaking through the orifice.

As a result, the swing speed is slowed.

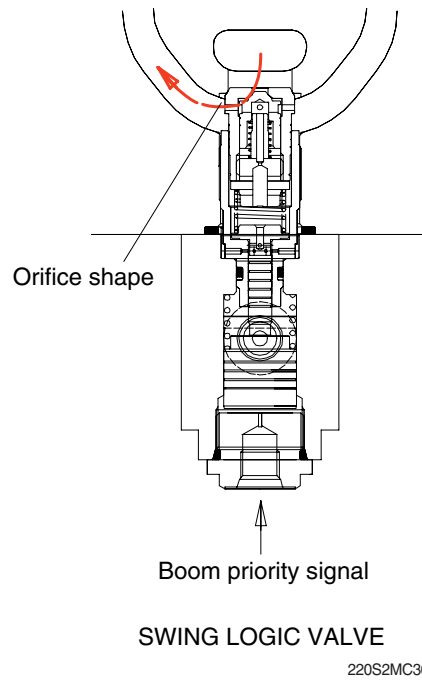

7) ARM OPERATION

(1) Arm in operation

During the arm in operation, the pilot secondary pressure from the RCV is supplied to the port of the spring opposite side and shifts the arm 1 spool in the right direction.

The P2 bypass passage is shut off by the movement of the arm 1 spool and the pressurized oil from the P2 port flows into the arm cylinder head side through P2 parallel passage, the load check valve, bridge passage and the Ca port.

At the same time, the pilot secondary pressure from the RCV is supplied to the port of spring opposite side and shifts the arm 2 spool in the right direction. The P2 bypass passage is shut off by the movement of the arm 2 spool and the pressurized oil from the P1 port flows into the arm summation passage through P1 parallel passage, the check valve and the notch of the arm 2 spool.

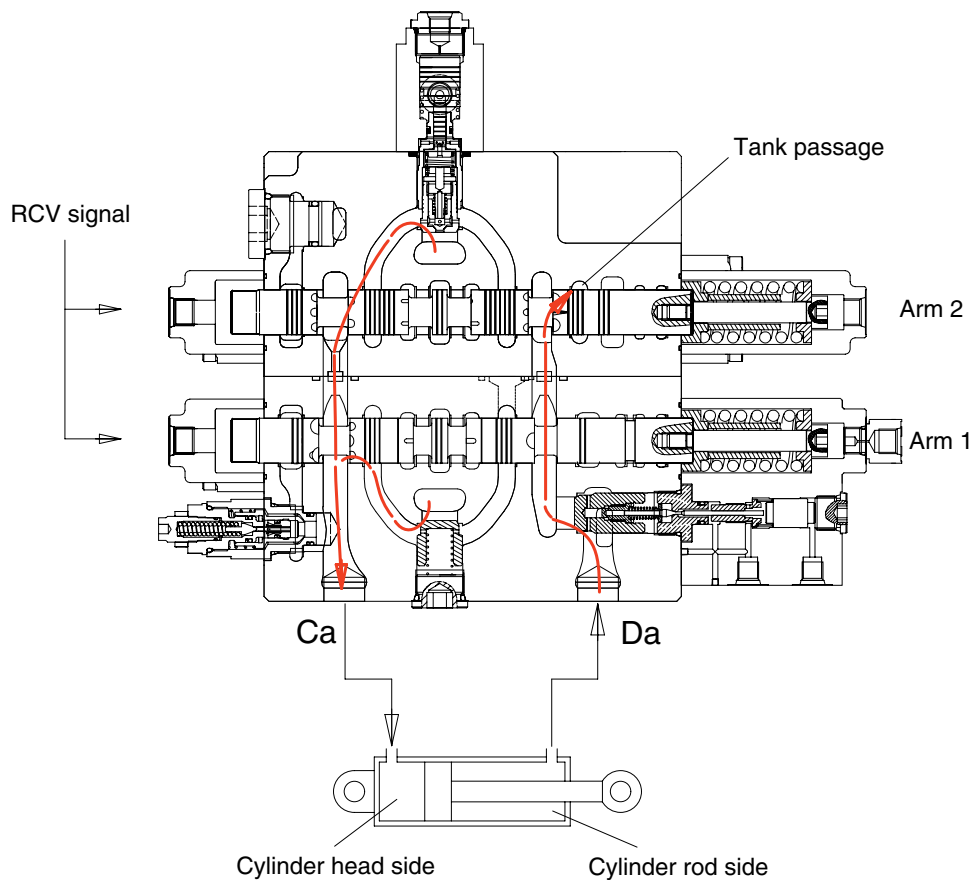

E-E' (ARM 1 AND ARM 2)

300S2MC31

ARM REGENERATION

The return oil from the arm cylinder rod side passes the arm holding valve (open condition) through the Da port and the notch of the arm 1 and arm 2, and swing priority spool. And some of the oil return to the tank passage through the notch of the arm regeneration spool and most of the oil is supplied to the head side of the arm cylinder through internal summation passage.

This is called the arm regeneration function.

The amount of regeneration fluid is changed by movement of the arm regeneration spool. A few fluids of the oil that is supplied to the head side of the arm cylinder passes the selector spool (in this case, the selector spool is opened by the arm in pilot pressure) built in the arm regeneration block through internal passage and is pushed the piston C.

The amount of the regeneration oil from the rod side of the arm cylinder to the tank passage is increased by the movement of the piston C and the arm regeneration spool to the right direction and the arm regeneration flow is decreased as much increased oil.

The pressure of the arm cylinder head increases, then, the arm regeneration flow decreases.

Furthermore, the arm regeneration cut-off pressure is supplied to the port of the spring opposite side and the arm regeneration spool is moved to the right direction fully. The flow from the arm cylinder rod to the tank passage is maximum condition.

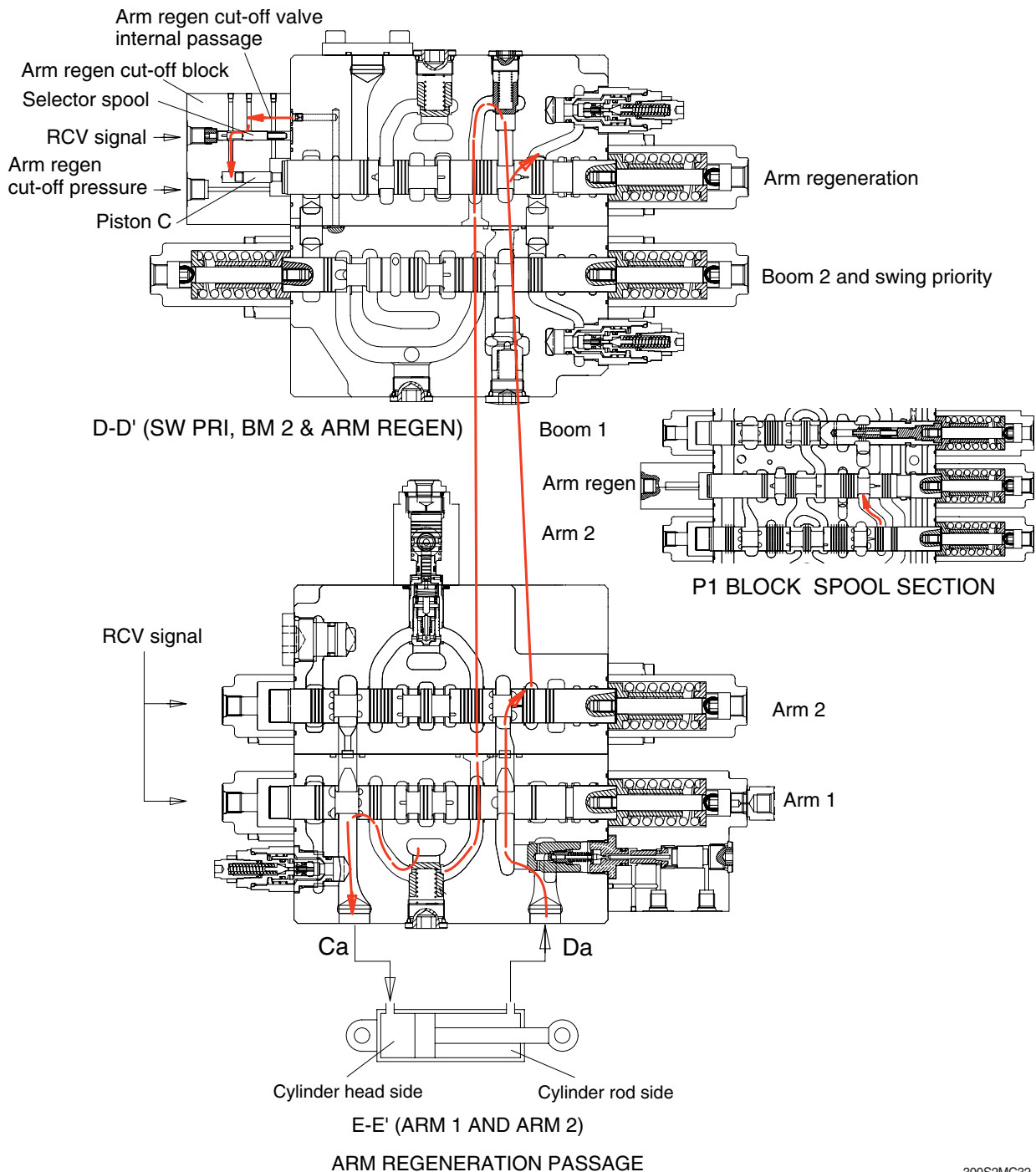

(2) Arm out operation

During arm out operation, the pilot secondary pressure from the RCV is supplied to the port of the spring side and shifts the arm 1 spool to the left direction.

The bypass passage is shut off by the movement of the arm 1 spool and the pressurized oil from the P2 port flows into arm 1 spool through the P2 parallel passage. Then it enters into the arm cylinder rod side through the load check, bridge passage, arm holding valve (oped status) and the port Da.

Also, the pilot secondary pressure from the RCV is supplied to the port of the spring side and shifts the arm 2 spool to the left direction.

The bypass passage is shut off by the movement of the arm 2 spool and the pressurized oil from the P2 port through the P2 parallel passage. Then it combined with the flow of the arm 1 passage through P1 parallel passage, the check valve, bridge passage, the notch of the arm 1 and the arm holding valve (open status).

On the other hand, the return flow from the arm cylinder head side returns to the hydraulic tank through the port Ca, the notch of the arm 1 spool and tank passage.

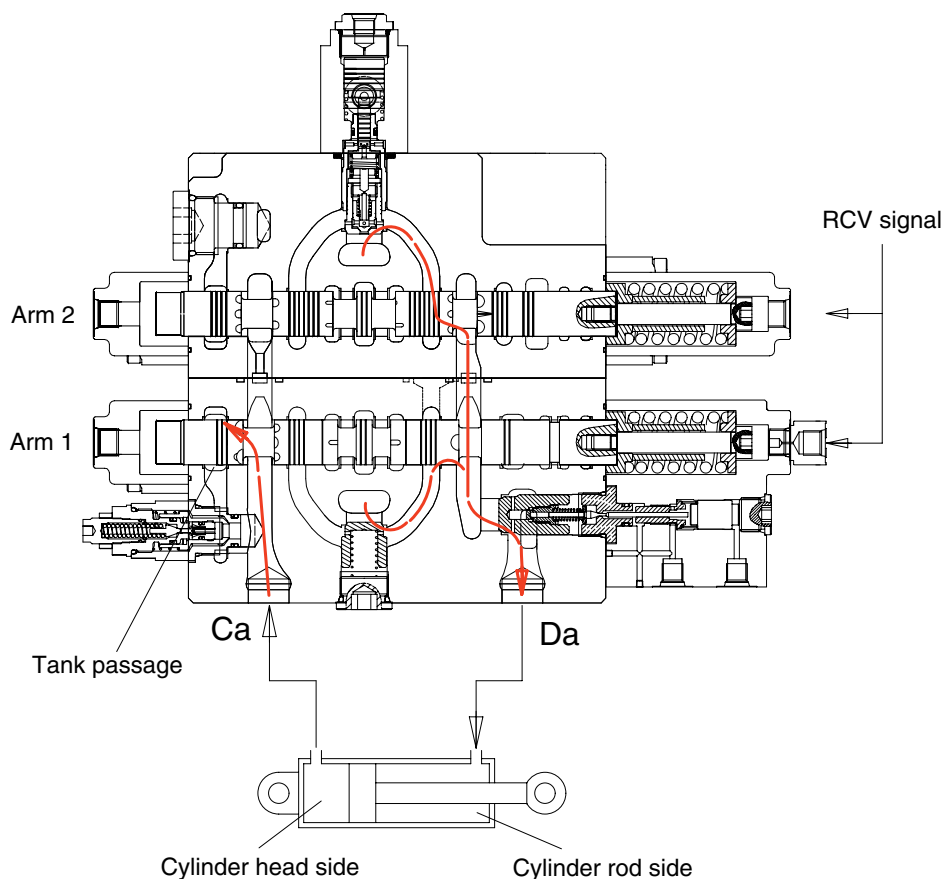

E-E' (ARM 1 AND ARM 2)

300S2MC33

8) OPERATION OF SWING PRIORITY SPOOL

During swing priority operation, the pilot secondary pressure is supplied to the port of the spring side of the swing priority spool and shift swing priority spool to the right direction.

The pressurized oil from the P2 port flows into the P2 parallel passage through the notch of the swing priority spool.

When the swing priority spool is neutral condition, the passage is same as normal condition. But due to shifting of the swing priority spool, the orifice is formed between the notch of the swing priority spool and the land of the block housing and then the fluid to the swing side more than the downstream of the swing spool such as the arm 1 and option spool.

As a result, the flow is supplied to the swing operation most preferential.

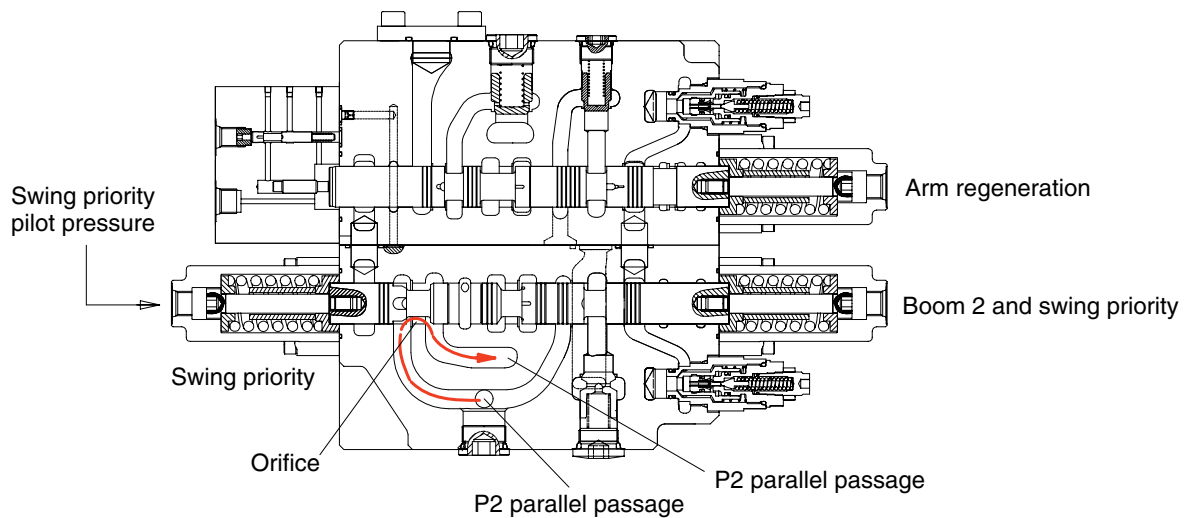

D-D' (SWING PRI, BOOM 2 & ARM REGENERATION)

220S2MC34

9) OPERATION OF OPTION SPOOL

(1) 1-way operation

- ※ The pilot pressure is supplied to the port of the spring side and shifts spool to the left direction. The pilot secondary pressure from the RCV is supplied to the port of the spring opposite side of the option spool, the P2 bypass passage is shut off by the movement of the option spool and the pressurized oil from the P2 port flows into the actuator through the P2 parallel passage, the check valve, bridge passage and the Do port.

(2) 2-way operation

- ※ Shifts spool to the left and right direction.
 - When the spool shifts to the left, same as 1-way operation.
 - When the spool shifts to the right, the pressurized oil from the P2 port flows into the actuator through the P2 parallel passage, the check valve, bridge passage and the Co port.

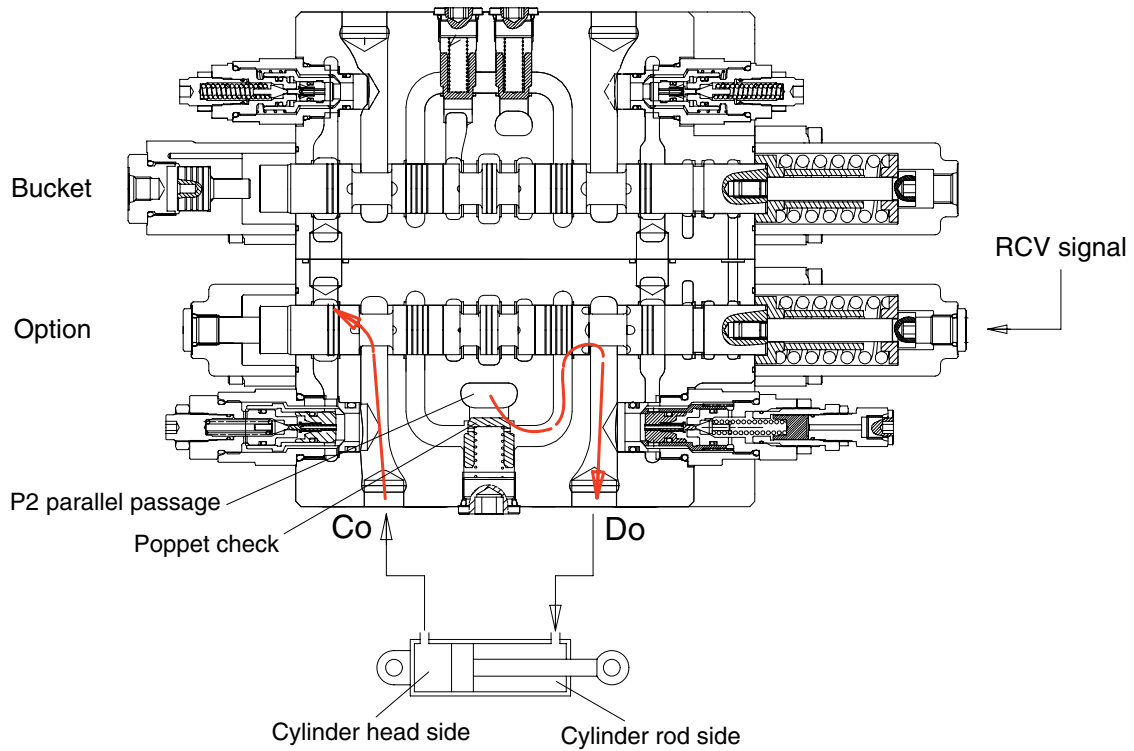

F-F' (OPTION AND BUCKET)

300S2MC35

Option flow summation function, bypass cut-off 2 spool

During the 2-way option operation, the pilot secondary pressure from the RCV is supplied to port of the spring side and shifts the BC2 (option) spool.

The P1 parallel passage is shut off by the movement of the BC2 spool and the pressurized oil from P1 port opens the check poppet and combined with flow of the option spool.

(Only bucket in operation)

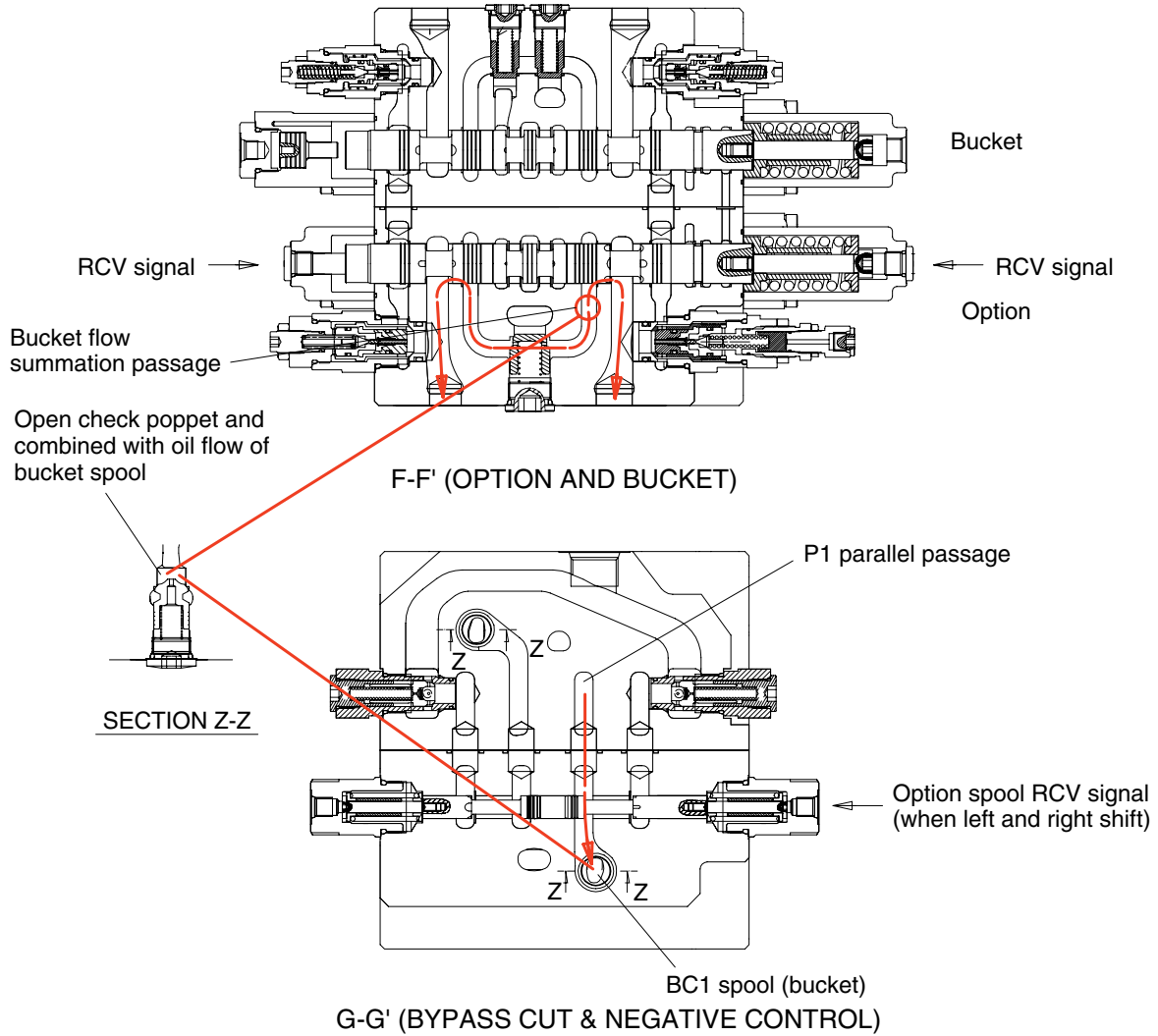

FLOW SUMMATION BY THE SHIFTING OF THE BC2 SPOOL

300S2MC36

10) OPERATION OF NEGATIVE CONTROL VALVE

When no function is being actuated on P1 side, the hydraulic fluid from the P2 port, flows into the tank passage through the P1 bypass passage and the orifice of the negative control valve.

The negative control pressure caused by this operation is transferred to the regulator of the piston pump through the Pn1 port.

This pressure controls the swash plate angle of the pump to the minimum and minimize the flow of the P1 side.

When one or more spools are shifted, the P1 bypass passage is shut-off and the flow is almost zero.

Accordingly, the negative control pressure that is supplied to the pump through Pn1 port is lowered and the swash plate angle becomes maximum and the flow of the P1 side becomes maximum.

On the other hand, the negative control pressure is increased and high than the setting pressure of the spring, the negative control valve is opened and the flow passes to the hydraulic tank and functions as a relief valve.

The operation of the negative control valve of the P2 side is same as that of the P1 side.

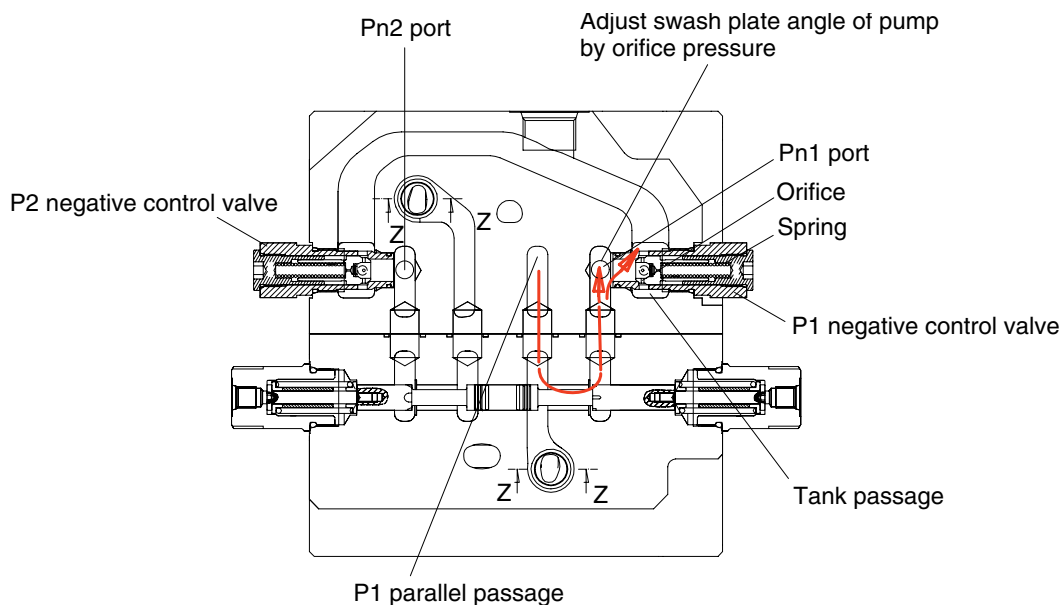

OPERATION OF NEGATIVE CONTROL VALVE

220S2MC37

11) OPERATION OF MAIN RELIEF VALVE

(1) Neutral

The pressurized oil passes through the internal passage of the piston A, fitted in the main poppet and the orifice A and is filled up in the chamber A of the inside and seats the main poppet against socket and socket against the housing securely.

(2) When operation (relief)

- ① When the pressurized oil flowed in the chamber A through the orifice becomes equal to the set pressure of the spring, the hydraulic oil apply to the main poppet through the piston and pushes open the pilot poppet and flows to tank passage through the piston A internal passage, orifice A, chamber A, periphery orifice B and the hole E.

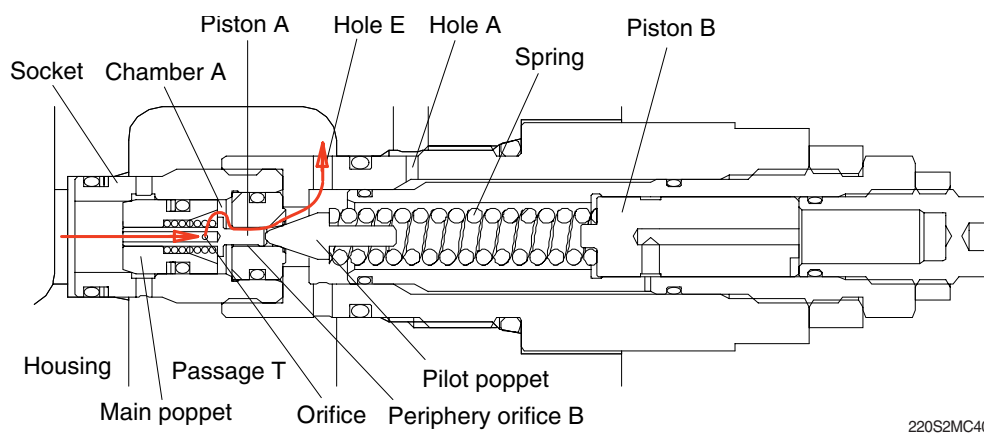

220S2MC40

OPERATION 1 OF MAIN RELIEF VALVE

- ② The pressure in chamber A is lowered by moving of the pilot poppet and the main poppet is opened. As a result, the pressurized oil flows out to the tank passage through the hole of the socket side.

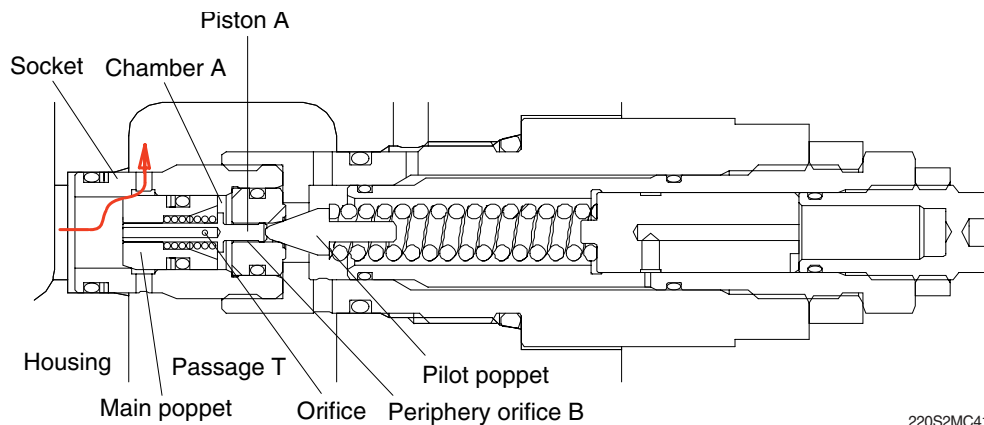

220S2MC41

OPERATION 2 OF MAIN RELIEF VALVE

(3) When retraction (return)

On the other hand, the pressure of the pressurized oil becomes lower than set pressure of the spring, the main poppet is seated by spring force. Then the pressure of the chamber A becomes equal to the pressure of the P port and the main poppet is seated to the seat of the socket. The valve returns to the initial condition.

Power boost function

During power boost operation, the pilot pressure for the power boost enters inside of the piston B through the hole A, the crevice passage and the side hole of the piston B.

It pushes the piston to the left direction and the set pressure of the spring is increased.

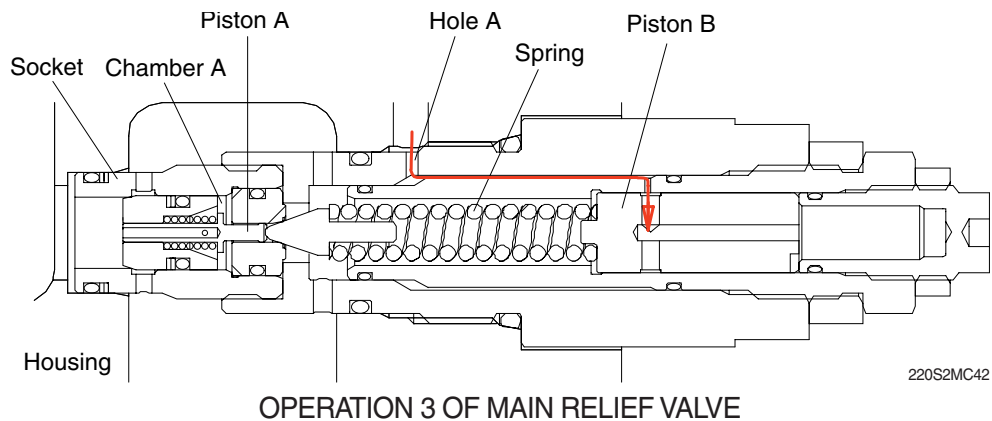

12) OPERATION OF PORT RELIEF VALVE

(1) Function as relief valve

- ① The pressurized oil passes through the internal passage of the piston A, fitted in the main poppet and the orifice A and is filled up in the chamber A of the inside and seats the main poppet against socket and socket against the housing securely.

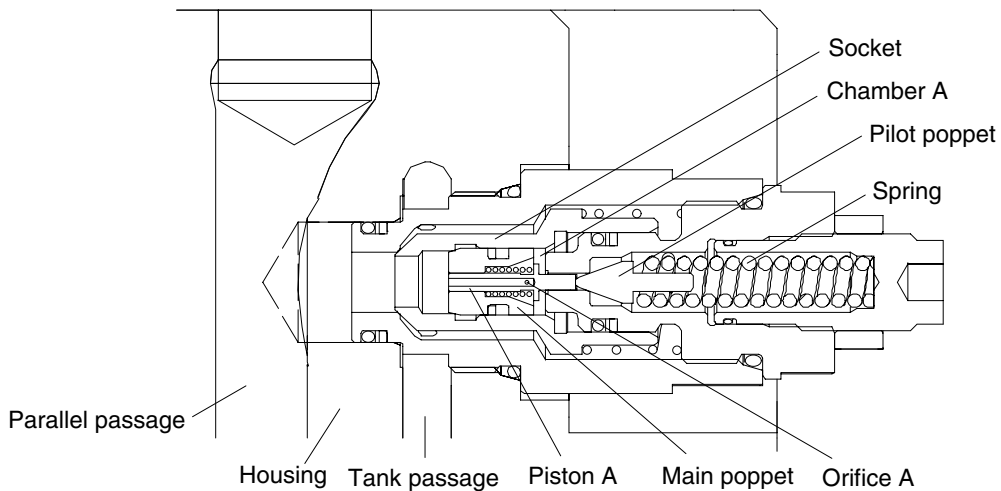

PORT RELIEF VALVE

220S2MC43

- ② When the pressurized oil from the actuators becomes equal to the set pressure of the spring, the hydraulic oil apply to the pilot poppet and pushes the pilot poppet to the right direction and flows to tank passage through the piston A internal passage, orifice A, chamber A, periphery orifice B and the hole E.

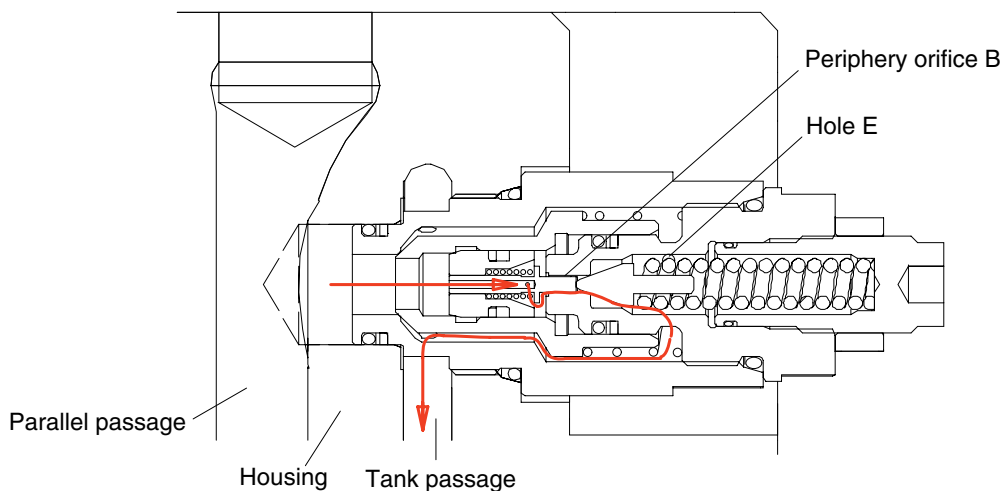

OPERATION 1 OF PORT RELIEF VALVE

220S2MC44

- ③ The pressure in chamber A is lowered by moving of the pilot poppet and the main poppet is opened. As a result, the pressurized oil from the actuator port flows out to the tank passage through the hole of the socket side.

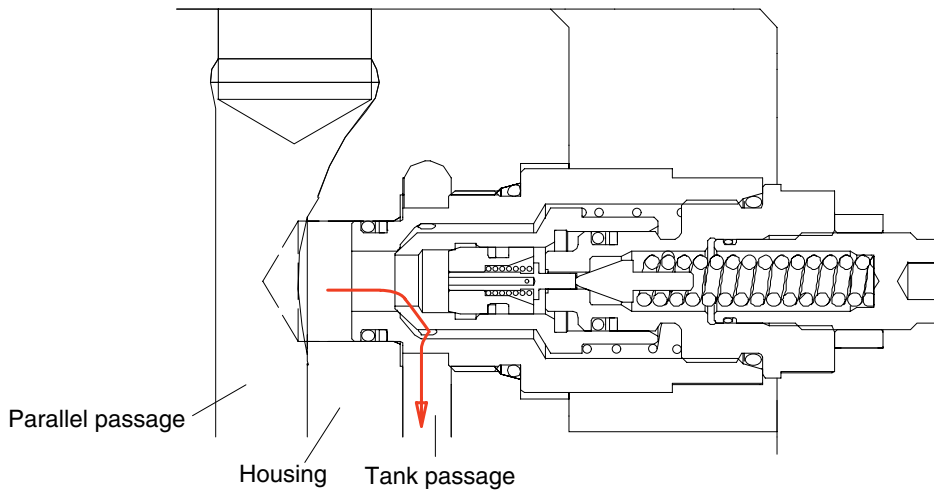

OPERATION 2 OF PORT RELIEF VALVE

220S2MC45

- ④ On the other hand, the pressure of the actuator becomes lower than set pressure of the spring, the pilot poppet is seated by spring force. Then the pressure of the chamber A becomes equal to the pressure of the actuator port and the main poppet is seated to the seat of the socket. The valve returns to the initial condition.

Make up function

When negative pressure exists at the actuator port, the oil is supplied through tank passage. When the pressure at tank passage becomes higher than that of at the actuator port, it pushed the socket moves in the right direction. Then, the gap between the housing and socket is opened and pressurized oil from the tank passage flows into parallel passage side.

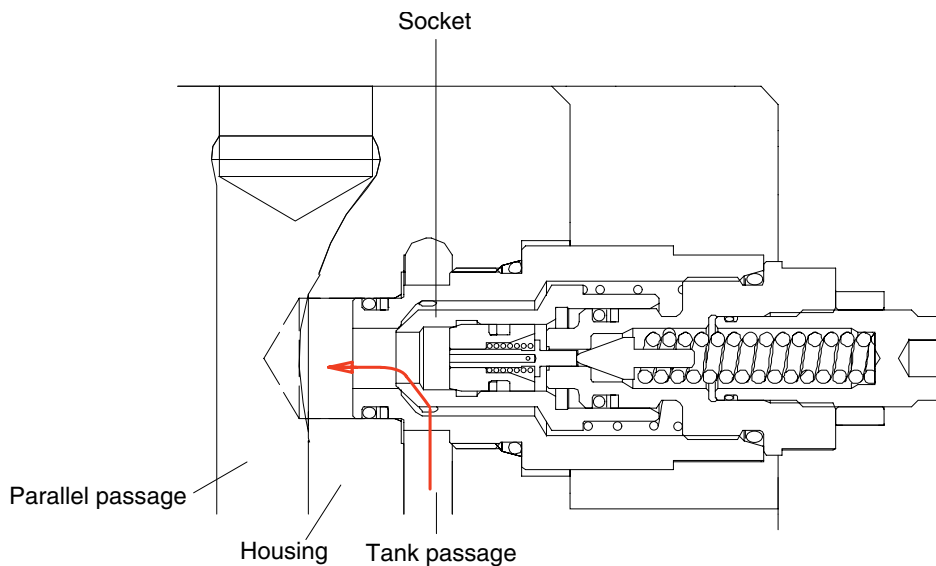

MAKE UP FUNCTION OF PORT RELIEF VALVE

220S2MC46

GROUP 3 SWING DEVICE

1. STRUCTURE

Swing device consists swing motor, swing reduction gear.

Swing motor include mechanical parking valve, relief valve, make up valve and time delay valve.

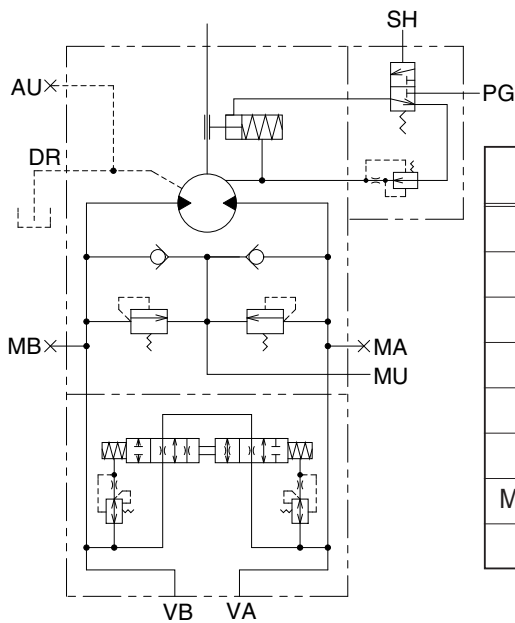
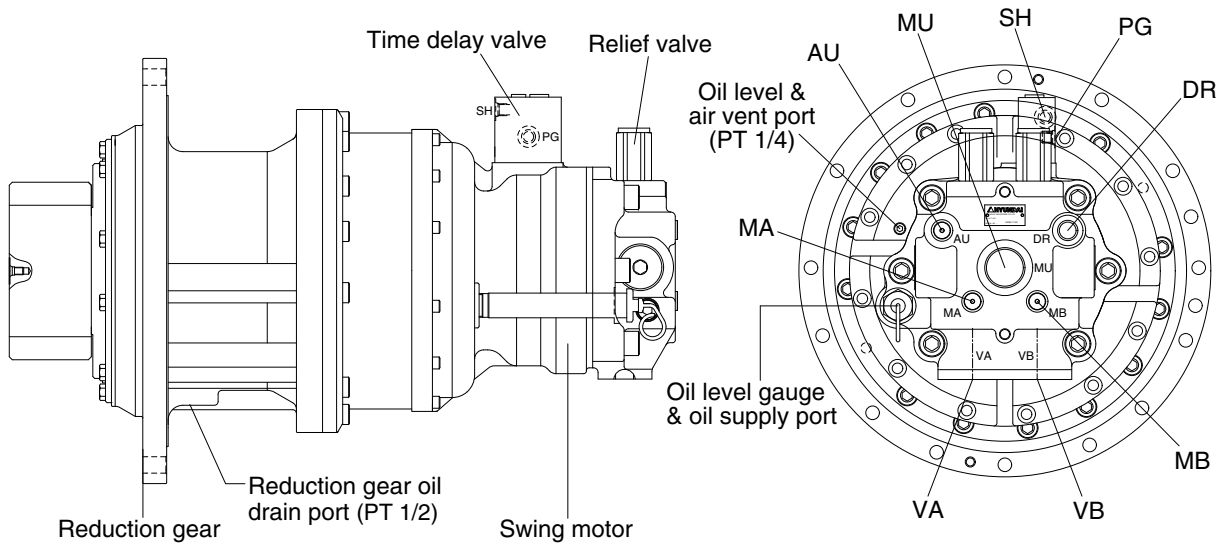

Hydraulic circuit

Port	Port name	Port size
VA	Main port	Ø 20
VB	Main port	Ø 20
DR	Drain port	PF 1/2
MU	Make up port	PF 1 1/4
PG	Brake release stand by port	PF 1/4
SH	Brake release pilot port	PF 1/4
MA, MB	Gauge port	PF 1/4
AU	Air vent port	PF 1/4

300L2SM01

1) SWING MOTOR

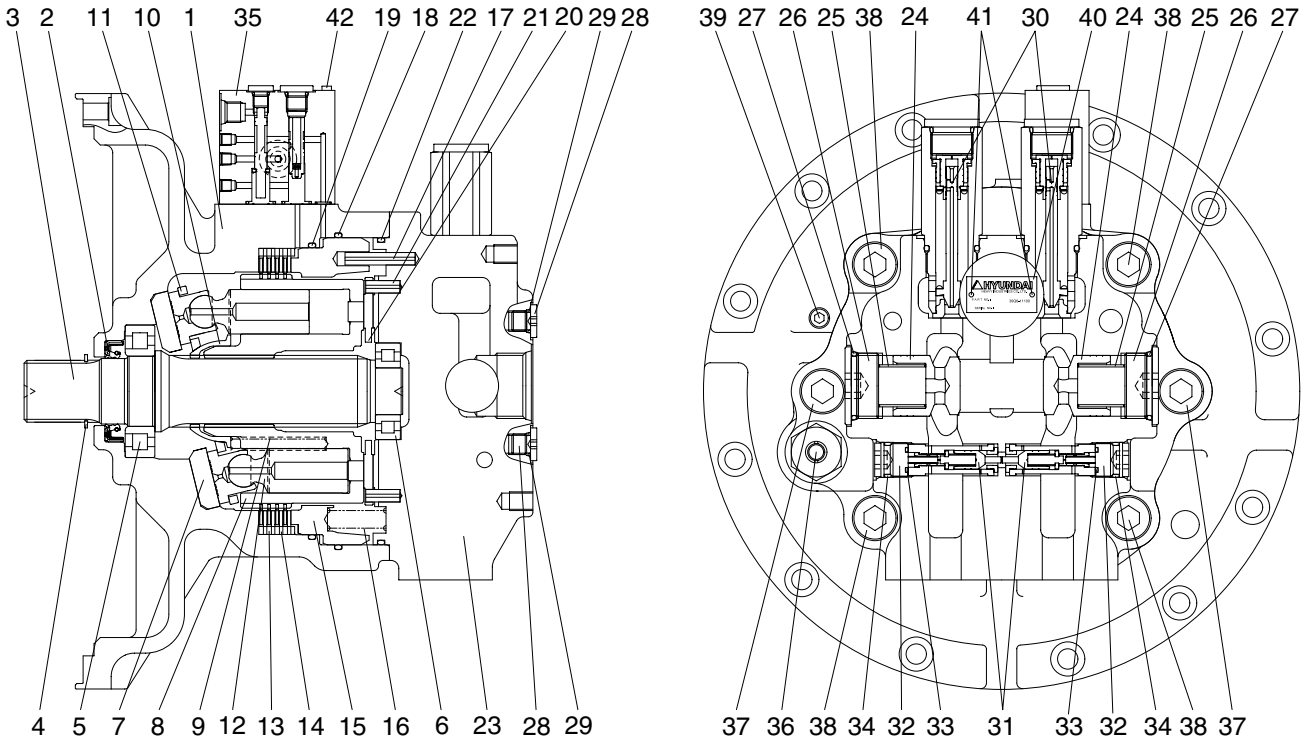

300L2SM02

- | | | |
|-------------------|-------------------|----------------------------|
| 1 Casing | 15 Parking piston | 29 O-ring |
| 2 Oil seal | 16 Brake spring | 30 Relief valve assy |
| 3 Shaft | 17 Spring pin | 31 Reactionless valve assy |
| 4 Snap ring | 18 O-ring | 32 Plug |
| 5 Roller bearing | 19 O-ring | 33 O-ring |
| 6 Needle bearing | 20 Valve plate | 34 O-ring |
| 7 Swash plate | 21 Spring pin | 35 Time delay valve assy |
| 8 Cylinder block | 22 O-ring | 36 Level gauge |
| 9 Spring | 23 Valve casing | 37 Socket bolt |
| 10 Ball guide | 24 Check valve | 38 Socket bolt |
| 11 Retainer plate | 25 Spring | 39 Plug |
| 12 Piston assy | 26 Plug | 40 Name plate |
| 13 Friction plate | 27 O-ring | 41 Rivet |
| 14 Separate plate | 28 Plug | 42 Socket bolt |

2) REDUCTION GEAR

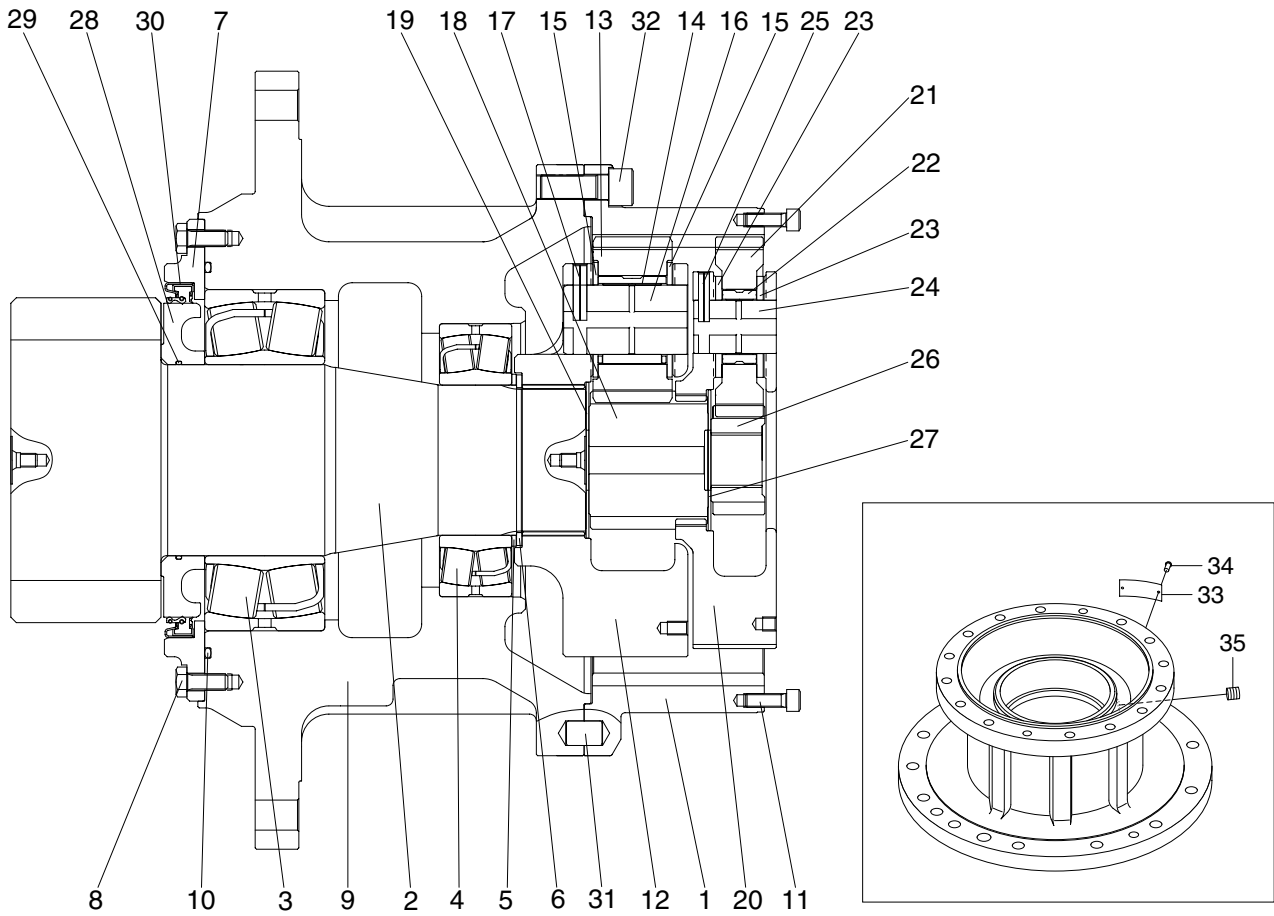

300L2SM03

- | | | | | | |
|----|----------------------|----|------------------|----|----------------------|
| 1 | Ring gear | 13 | Planetary gear 2 | 25 | Spring pin 1 |
| 2 | Drive shaft | 14 | Needle bearing 2 | 26 | Sun gear 1 |
| 3 | Bearing | 15 | Thrust washer 2 | 27 | Thrust plate 1 |
| 4 | Bearing | 16 | Carrier pin 2 | 28 | Sleeve |
| 5 | Thrust plate | 17 | Spring pin 2 | 29 | O-ring |
| 6 | Snap ring | 18 | Sun gear 2 | 30 | Oil seal |
| 7 | Cover | 19 | Thrust plate 2 | 31 | Parallel pin |
| 8 | Hex head bolt | 20 | Carrier 1 | 32 | Hex socket head bolt |
| 9 | Casing | 21 | Planetary gear 1 | 33 | Name plate |
| 10 | O-ring | 22 | Needle bearing 1 | 34 | Rivet |
| 11 | Hex socket head bolt | 23 | Thrust washer 1 | 35 | Plug |
| 12 | Carrier 2 | 24 | Carrier pin 1 | | |

2. PRINCIPLE OF DRIVING

2.1 Generating the turning force

The high hydraulic supplied from a hydraulic pump flows into a cylinder block (8) through valve casing of motor (1), and valve plate (20).

The high hydraulic is built as flowing on one side of Y-Y line connected by the upper and lower sides of piston (12).

The high hydraulic can generate the force, $F1=P \times A$ (P : supplied pressure, A : water pressure area), like following pictures, working on a piston.

This force, $F1$, is divided as $N1$ thrust partial pressure and $W1$ radial partial pressure, in case of the plate of a tilt angle, α .

$W1$ generates torque, $T=W1 \times R1$, for Y-Y line connected by the upper and lower sides of the piston as following pictures.

The sum of torque ($\sum W1 \times R1$), generated from each piston (4~5 pieces) on the side of a high hydraulic, generates the turning force.

This torque transfers the turning force to a cylinder (8) through a piston; because a cylinder is combined with a turning axis and spline, a turning axis rotates and a turning force is sent.

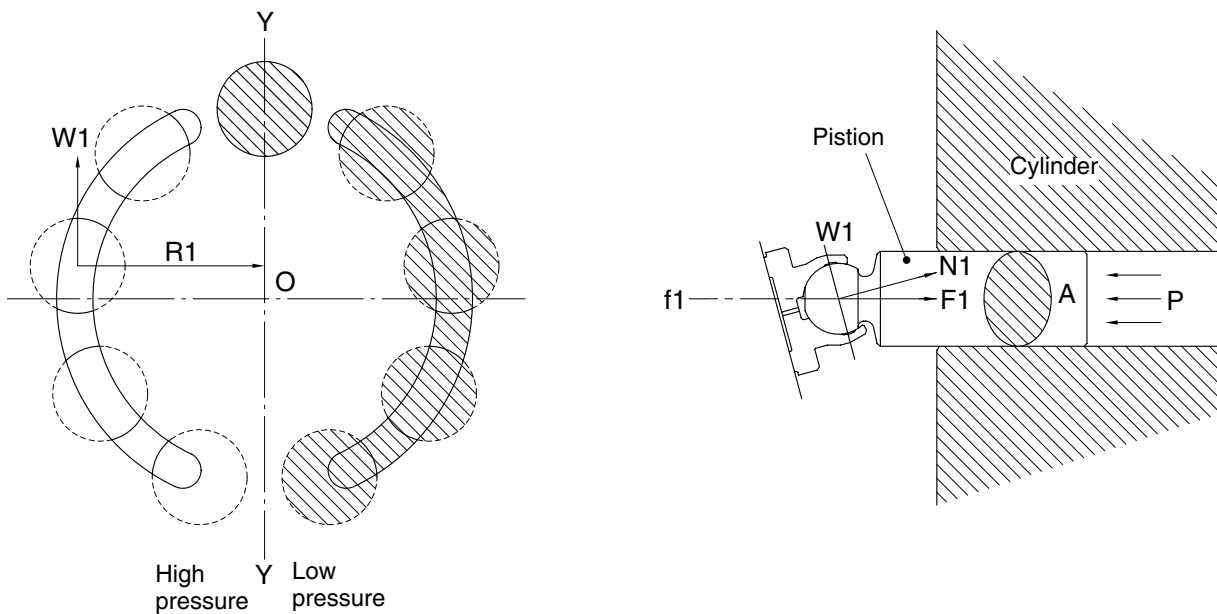

21078TM05

2) MAKE UP VALVE

In the system using this type of motor, there is no counter balance functioning valve and there happens the case of revolution exceeding hydraulic supply of motor. To prevent the cavitation caused by insufficient oil flow there is a make up valve to fill up the oil insufficiency.

A make up valve is provided immediately before the port leading to the hydraulic oil tank to secure feed pressure required when the hydraulic motor makes a pumping action. The boost pressure acts on the hydraulic motor's feed port via the make up valve.

Pressurized oil into the port B, the motor rotate counterclockwise.

If the plunger of MCV moves neutral position, the oil in the motor is drain via left relief valve, the drain oil run into motor via right make up valve, which prevent the cavitation of motor.

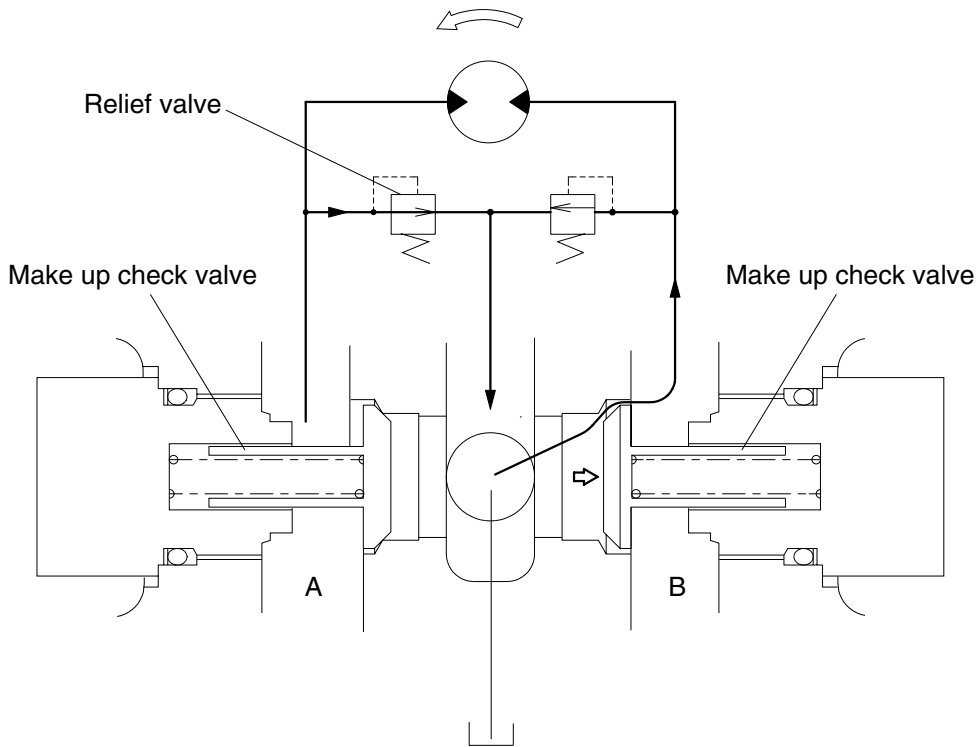

21092SM04

3) RELIEF VALVE

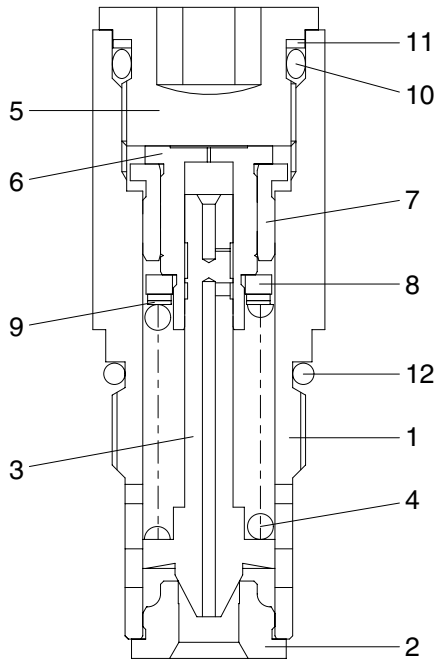

- 1 Body
- 2 Seat
- 3 Plunger
- 4 Spring
- 5 Adjusting screw
- 6 Piston
- 7 Bushing
- 8 Spring seat
- 9 Shim
- 10 O-ring
- 11 Back up ring
- 12 O-ring

14007A2SM05

(1) Construction of relief valve

The valve casing contains two cartridge type relief valves that stop the regular and reverse rotations of the hydraulic motor. The relief valves relieve high pressure at start or at stop of swing motion and can control the relief pressure in two steps, high and low, in order to insure smooth operation.

(2) Function of relief valve

Figure illustrates how the pressure acting on the relief valve is related to its rising process. Here is given the function, referring to the figure following page.

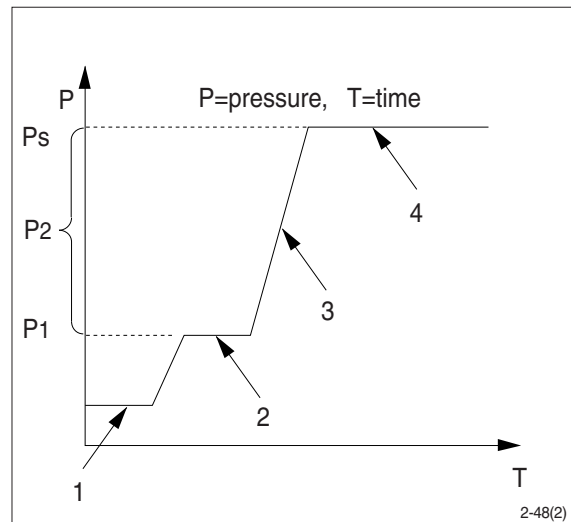

- ① Ports (P,R) at tank pressure.

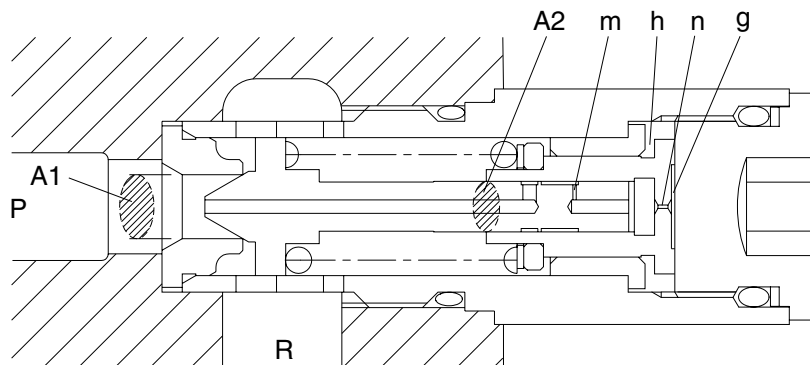

14007A2SM06

- ② When hydraulic oil pressure ($P \times A_1$) reaches the preset force (F_{SP}) of spring (4), the plunger (3) moves to the right as shown.

$$P_1 \times A_1 = F_{SP} + P_g \times A_2$$

$$P_1 = \frac{F_{SP} + P_g \times A_2}{A_1}$$

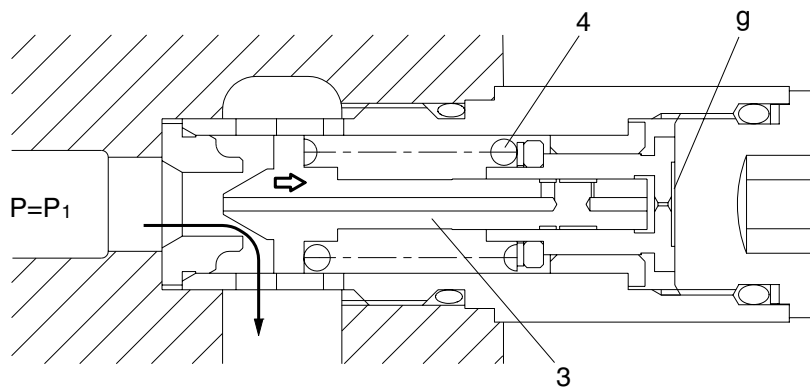

14007A2SM07

- ③ The oil flow chamber g via orifice m and n. When the pressure of chamber g reaches the preset force (F_{SP}) of spring (4), the piston (6) moves left and stop the piston (6) hits the bottom of bushing (7).

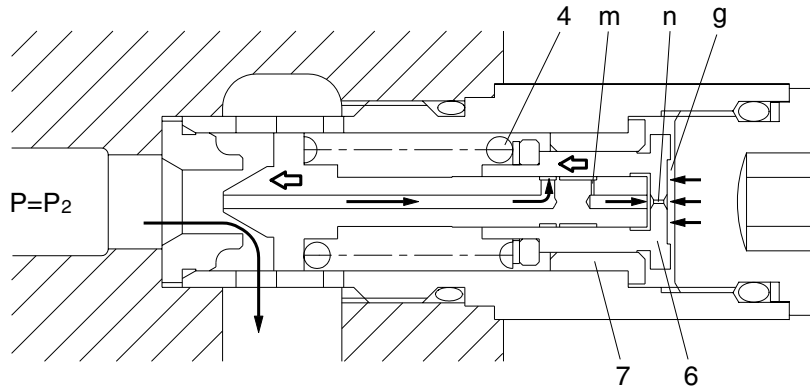

14007A2SM08

- ④ When piston (6) hits the bottom of bushing (7), it stops moving to the left any further. As the result, the pressure in chamber (g) equals (P_s).

$$P_s \times A_1 = F_{sp} + P_s \times A_2$$

$$P_s = \frac{F_{sp}}{A_1 - A_2}$$

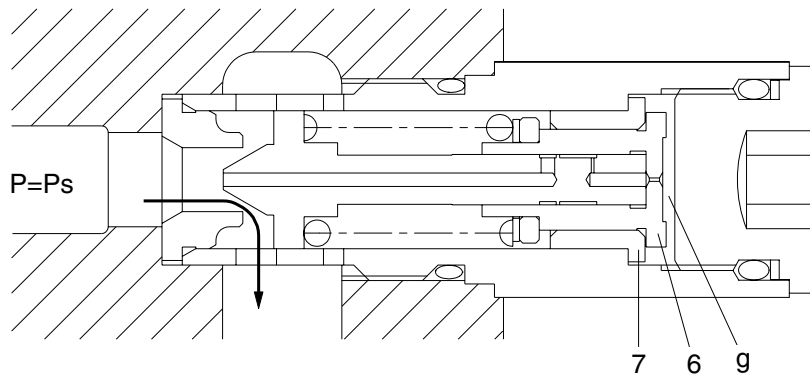

14007A2SM09

4) BRAKE SYSTEM

(1) Control valve swing brake system

This is the brake system to stop the swing motion of the excavator during operation.

In this system, the hydraulic circuit is throttled by the swing control valve, and the resistance created by this throttling works as a brake force to slow down the swing motion.

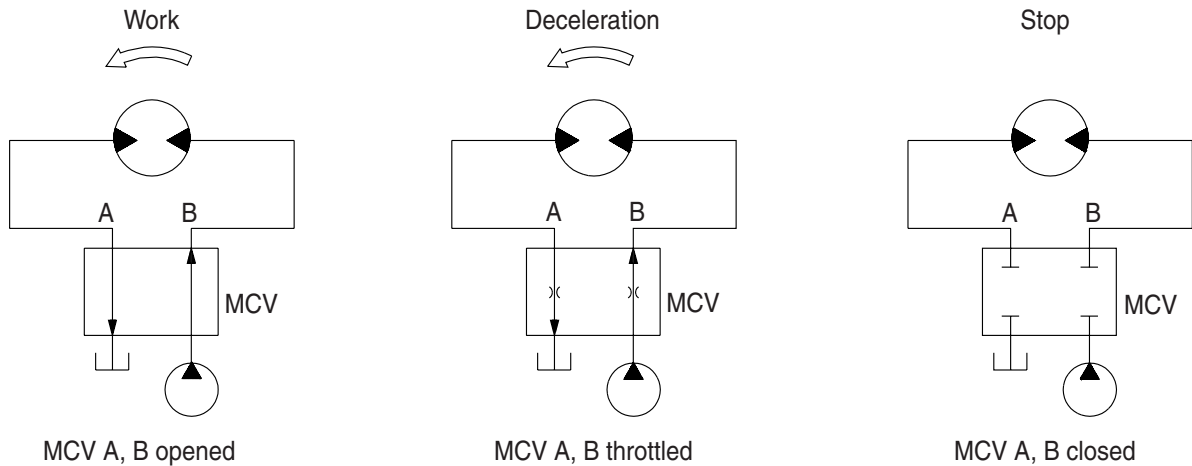

2-48(1)

(2) Mechanical swing parking brake system

This is function as a parking brake only when all of the RCV lever (except swing, arm in) are not operated.

① Brake assembly

Circumferential rotation of separate plate (16) is constrained by the groove located at housing (1). When housing is pressed down by brake spring (20) through friction plate (15), separate plate (16) and brake piston (17), friction force occurs there.

Cylinder block (10) is constrained by this friction force and brake acts, while brake releases when hydraulic force exceeds spring force.

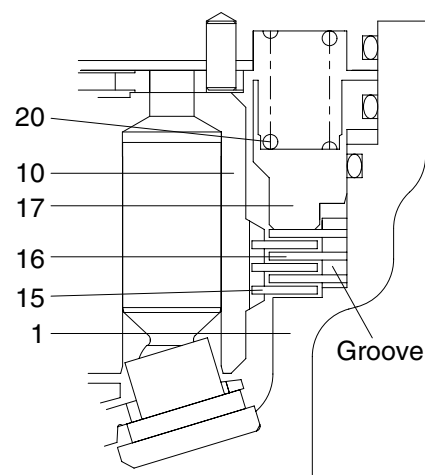

21092SM15

1	Housing	16	Separate plate
10	Cylinder block	17	Brake piston
15	Friction plate	20	Spring

② Operating principle

a. When the RCV lever (1) is set to the swing or arm in operating position, the pilot oil go to SH of the time delay valve (35).

This pressure moves spool (5) to the leftward against the force of the spring(8), so pilot pump charged oil (P3) goes to the chamber G through port PG.

This pressure is applied to move the piston (17) to the upward against the force of the spring (20). Thus, it releases the brake force.

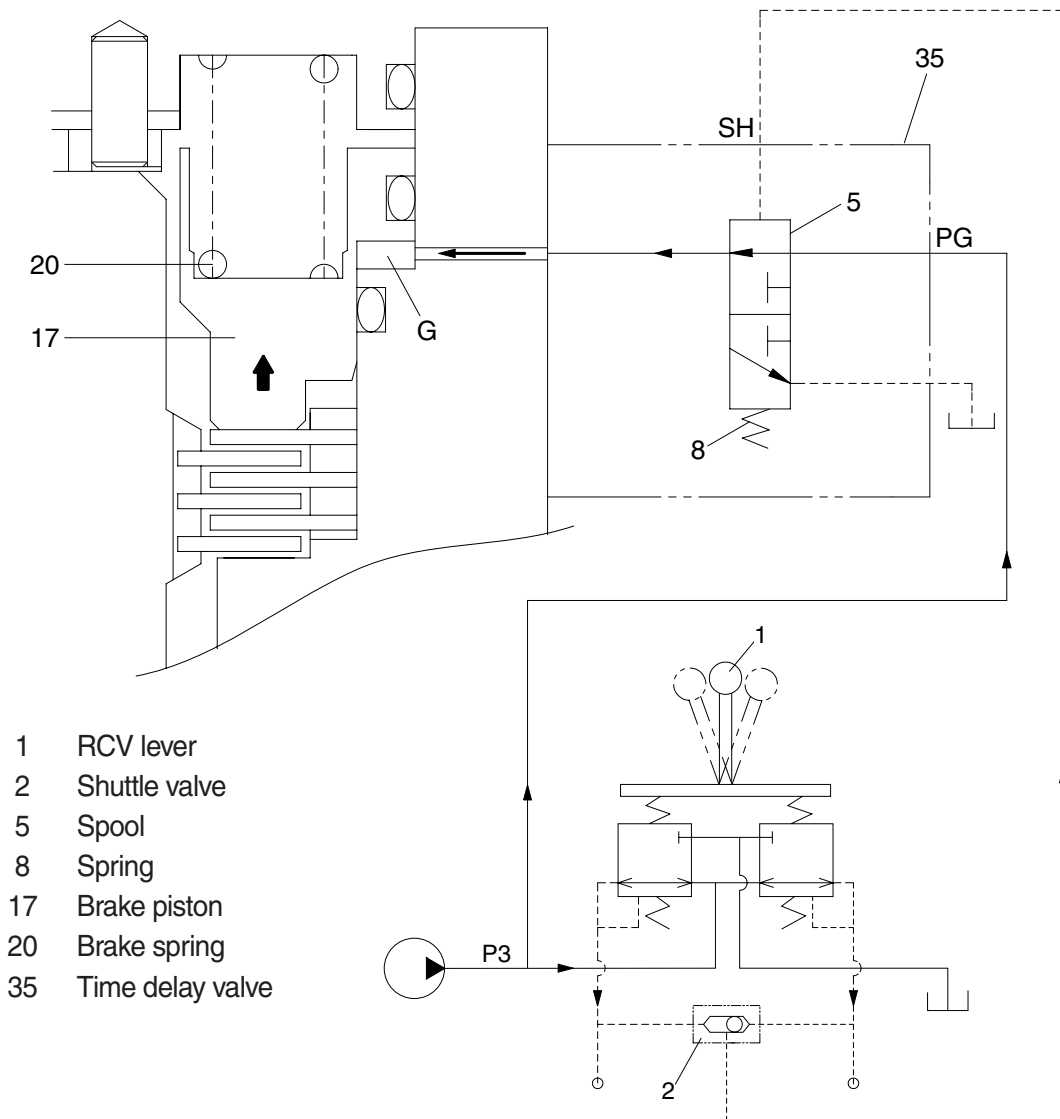

300L2SM04

- b. When all of the RCV lever (1) are set the neutral position, the spool (5) returns to the top. Then, the brake piston (17) is moved lower by spring force and the return oil from the chamber G flows back to tank port. At this time, the brake works.

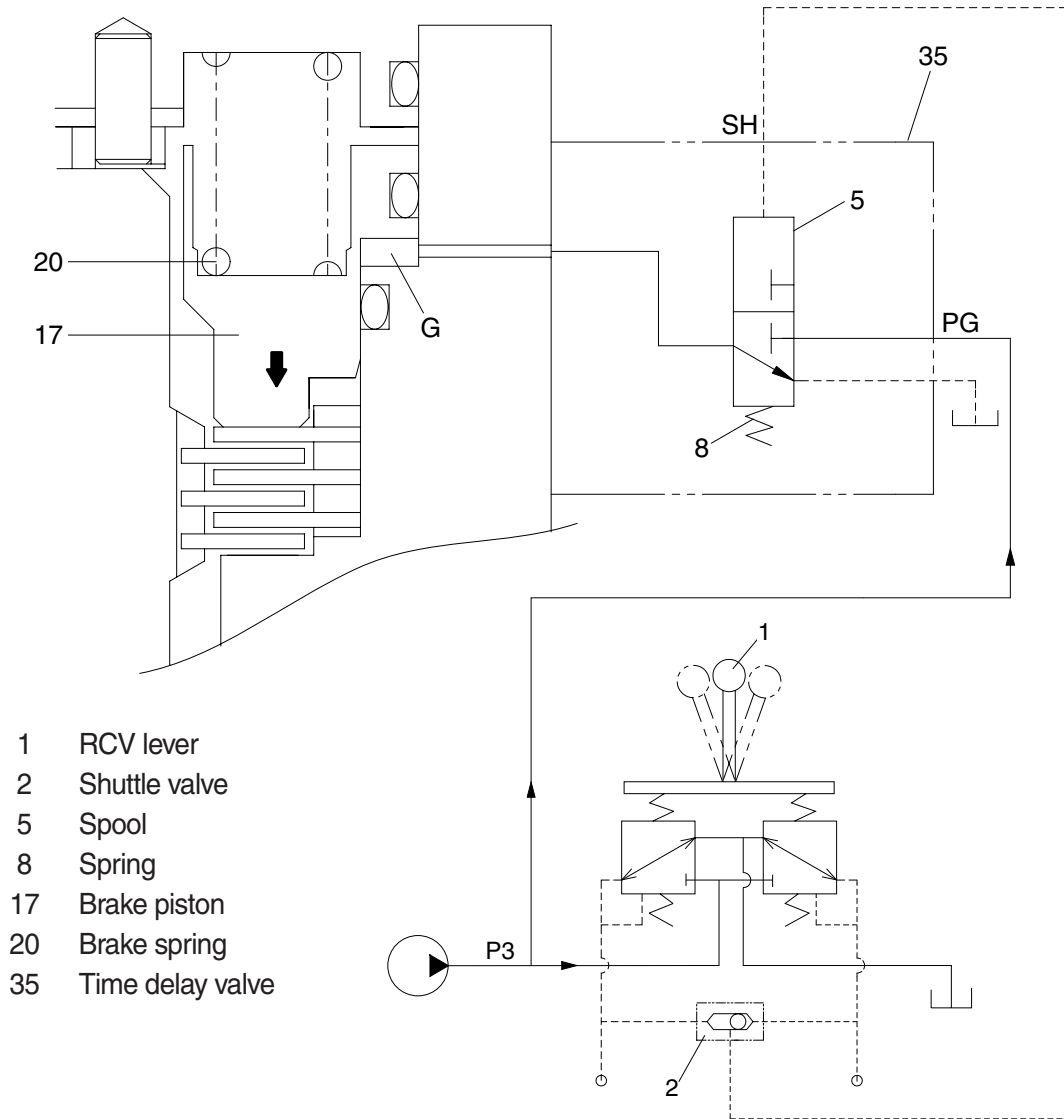

300L2SM05

GROUP 4 TRAVEL DEVICE (TYPE 1 & 2)

1. CONSTRUCTION

Travel device consists travel motor and gear box.

Travel motor includes brake valve, parking brake and high/low speed changeover mechanism.

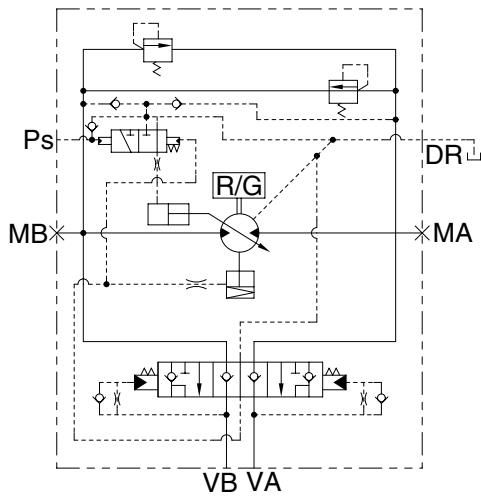
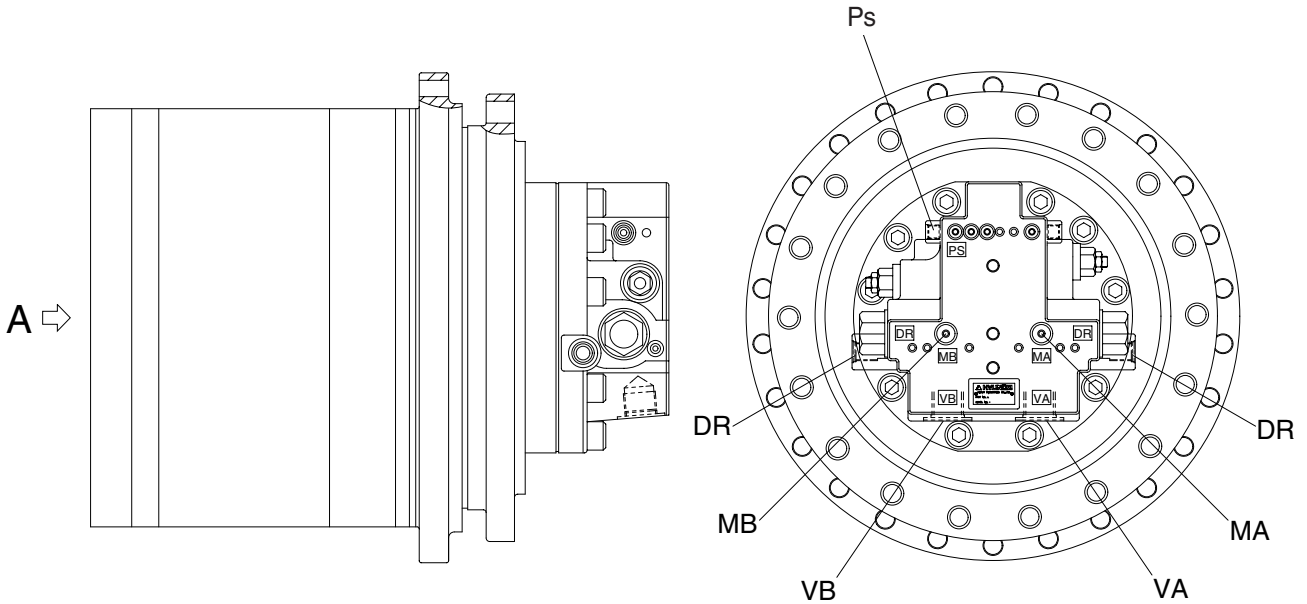

HYDRAULIC CIRCUIT

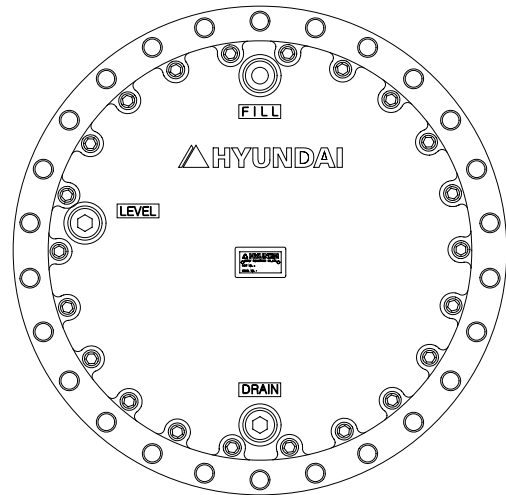

VIEW A

300L2TM01

Port	Port name	Port size
VA, VB	Valve port	PF 1
Ps	Pilot port	PF 1/4
DR	Drain port	PF 1/2
MA, MB	Gauge port	PF 1/4

2. SPECIFICATION

1) TRAVEL MOTOR

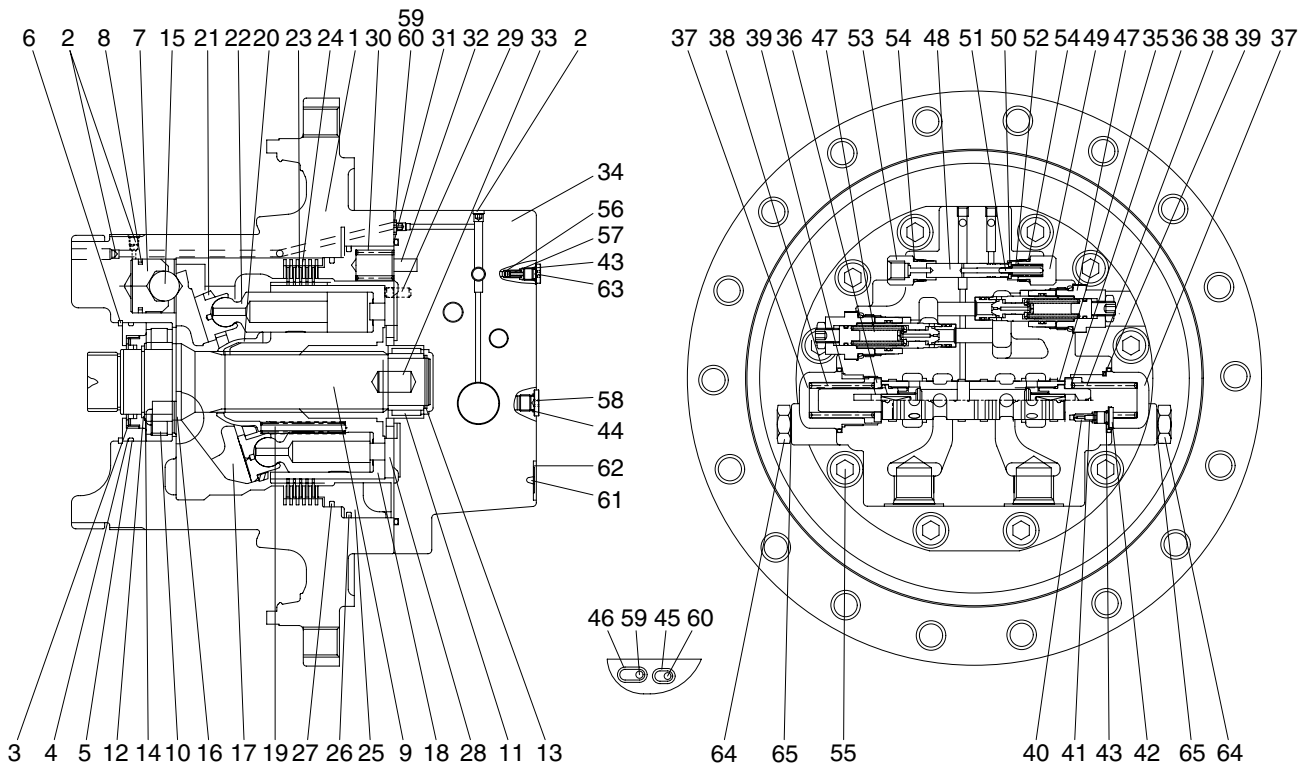

300L2TM02

1	Casing	23	Friction plate	45	O-ring
2	Plug	24	Separate plate	46	O-ring
3	Oil seal	25	Parking piston	47	Relief valve assy
4	Thrust block	26	D-ring	48	Spool
5	O-ring	27	D-ring	49	Plug
6	Snap ring	28	Valve plate	50	Spring seat
7	Piston	29	Parallel pin	51	Parallel pin
8	Piston seal	30	Spring	52	Spring
9	Shaft	31	O-ring	53	Connector
10	Cylinder roller bearing	32	Spring pin	54	O-ring
11	Needle bearing	33	Parallel pin	55	Hexagon socket head bolt
12	Snap ring	34	Rear cover	56	Check valve
13	Snap ring	35	Main spool assy	57	Spring
14	Thrust plate	36	Spring seat	58	Plug
15	Steel ball	37	Plug	59	Restrictor
16	Pivot	38	Spring	60	Restrictor
17	Swash plate	39	O-ring	61	Name plate
18	Cylinder block	40	Restrictor	62	Rivet
19	Spring	41	Spring	63	Plug
20	Ball guide	42	Plug	64	Plug
21	Retainer plate	43	O-ring	65	O-ring
22	Piston assy	44	O-ring		

2) TRAVEL REDUCTION GEAR

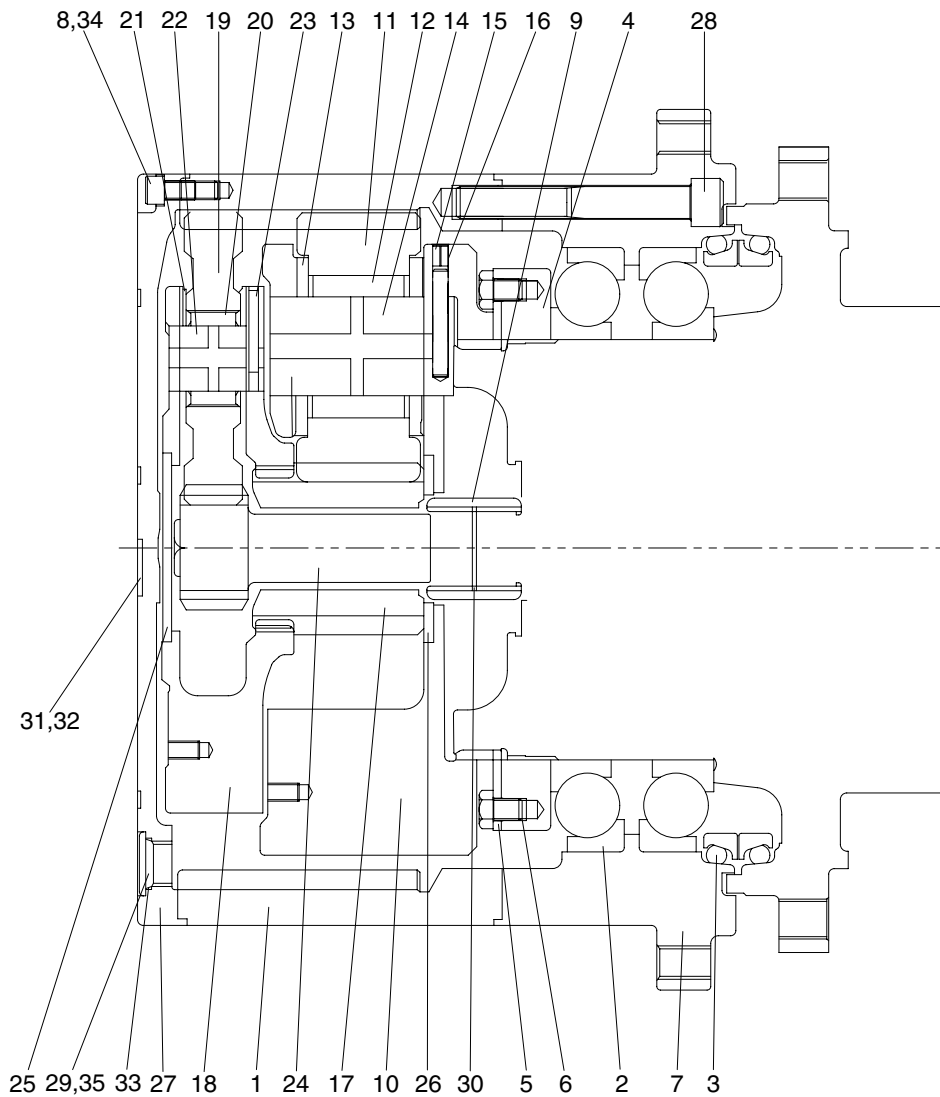

300S2TM03

1	Gear ring	13	Thrust washer 2	25	Thrust plate
2	Ball bearing	14	Carrier pin 2	26	Thrust plate
3	Floating seal assy	15	Spring pin 2	27	Cover
4	Nut ring	16	Solid pin 2	28	Hexagon socket head bolt
5	Lock plate	17	Sun gear 2	29	Plug
6	Hexagon socket head bolt	18	Carrier 1	30	Snap ring
7	Housing	19	Planetary gear 1	31	Name plate
8	Hexagon socket head bolt	20	Needle bearing 1	32	Rivet
9	Coupling	21	Thrust washer 1	33	O-ring
10	Carrier 2	22	Carrier pin 1	34	Rubber cap
11	Planetary gear 2	23	Spring pin 1	35	Rubber cap
12	Needle bearing 2	24	Sun gear 1		

3. OPERATION

1) MOTOR

High pressure oil delivered from hydraulic pump is led to inlet port that is provided in the brake valve portion and, through the rear cover (34) and valve plate (28), led to cylinder block (18). The oil flow and direction of shaft rotation are indicated in table.

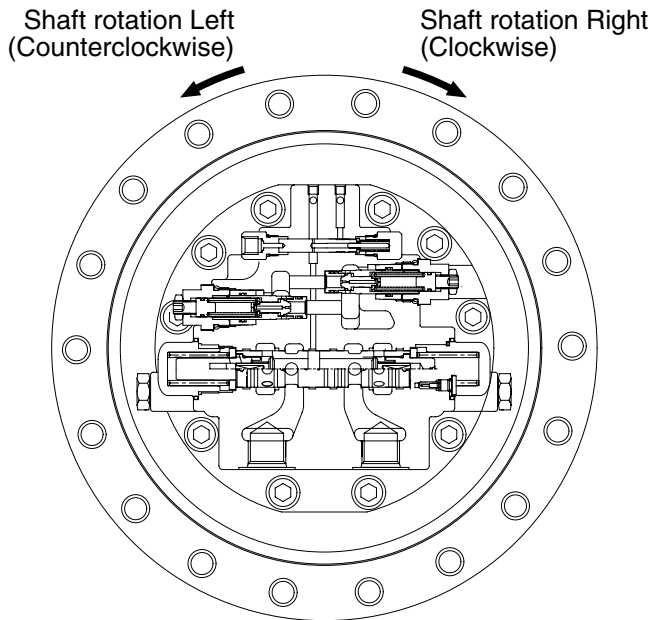

Inlet port	Outlet port	Direction of shaft rotation (viewing from rear cover)
VB	VA	Right (clockwise)
VA	VB	Left (counterclockwise)

300L2TM04

As shown in below figure, high pressure oil is supplied to the pistons which are on one side of the line Y-Y that connects upper and lower dead points and produces force F1.

$$F1 = P \times A \quad (P : \text{pressure, } A : \text{area of piston section})$$

The swash plate (17) with inclined angle of α divides this force F1 into thrust force F2 and radial force F31-34.

This radial force is applied to axis Y-Y as turning force and generate drive torque of T.

$$T = r_1 \cdot F31 + r_2 \cdot F32 + r_3 \cdot F33 + r_4 \cdot F34$$

This drive torque is transmitted via cylinder block (18) to driving shaft (9).

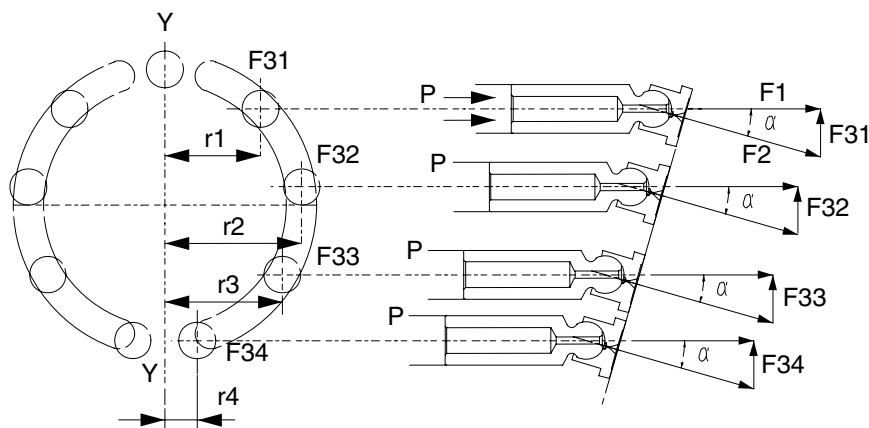

29092TM07

2) PARKING BRAKE

Parking brake is released when high pressure oil selected by the brake valve portion that is connected directly to the rear cover (34), is applied to the parking piston (25).

Otherwise the braking torque is always applied.

This braking torque is generated by the friction between the separated plates (24), inserted into the casing (1), and friction plates (23), coupled to cylinder block (18) by the outer splines.

When no pressure is activated on the parking piston (25), it is pushed by the brake springs (30) and it pushes friction plates (23) and separated plates (24) towards casing (1) and generates the friction force which brakes the rotation of cylinder block (18) and hence the shaft (9).

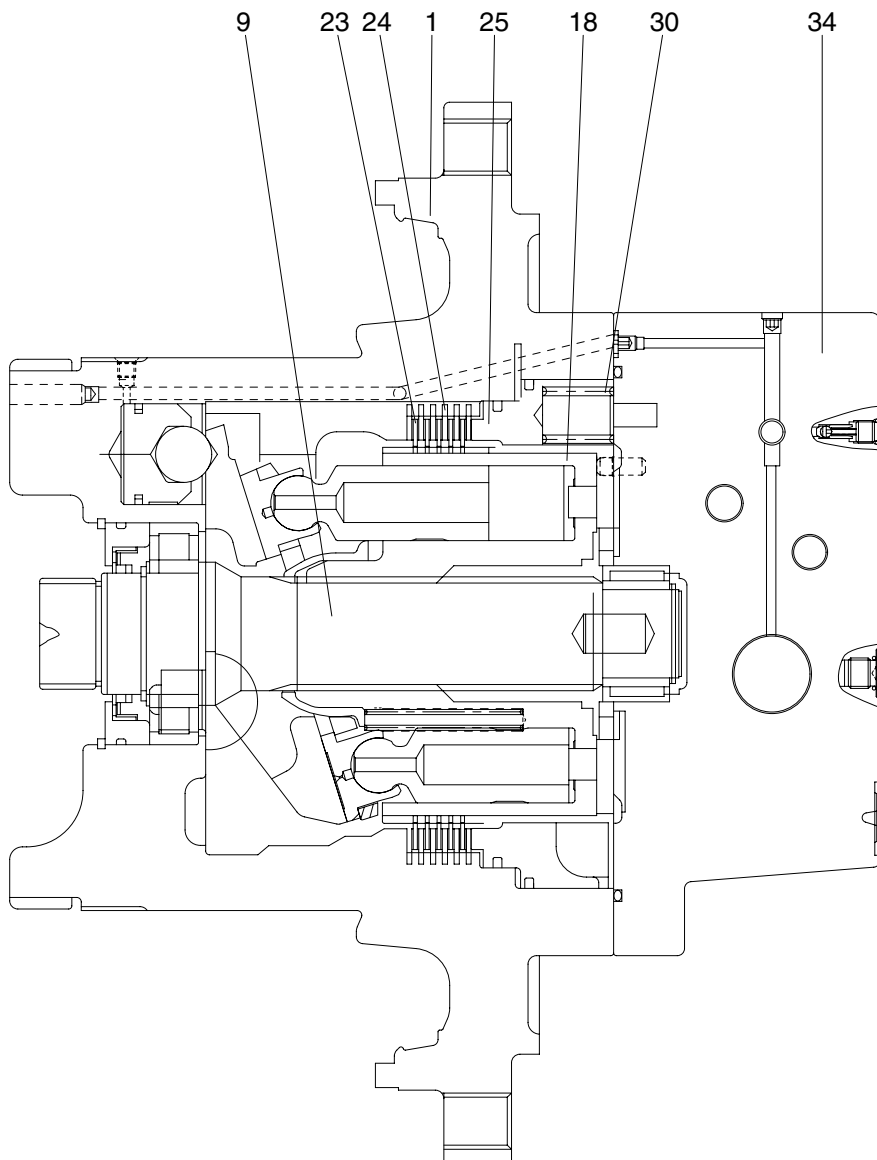

2609A2TM05

3) CAPACITY CONTROL MECHANISM

Figure typically shows the capacity control mechanism.

When high speed pilot line is charged with the pressure P_A that overcome the spring (52), the spring (52) is compressed and spool (48) shifts to the right to connect the port P and port C.

Then, the highest pressure is selected by the check valve (56) from inlet and outlet pressure of the motor and high speed pilot line pressure and pushes shifter piston (7). As a result, swash plate (17) turns around the line L which connect the two pivots (16) as shown by dotted lines. The turn stops at the stopper (1-1) of casing and swash plate (17) keeps the position.

In this case, the piston stroke become shorter and motor capacity become smaller and motor rotates faster, around 1.60 times, by the same volume of oil.

When no pressure is in the high speed pilot line P_A , spool (35) is pushed back by the spring (52) and pressure that pressed the shifter piston (7) is released to the hydraulic tank through restrictor (60).

Here, nine pistons are there and they equally spaced on the swash plate (17). The force that summed up those of pistons comes to almost the center of the swash plate (17) as shown. Since the pivots (16) are off-set by S from the center, the rotating force of product S and the force moves swash plate (17) to the former position and the speed returns to low.

When the power demand exceeds the engine power, such as in steep slope climbing or turning at high speed mode, the system step down to the low speed automatically. The mechanism is that: pump pressure is led to the port P_B and this pressure activate on pin (51). When the pressure at P_B exceeds predetermined value, spool (48) returns to the left by the counter-pressure against pin (51) and the pressure on the shifter piston (7) through port C is released to the tank and the motor comes to low speed.

When P_B goes down, the spool (48) moves to the right and the speed become high.

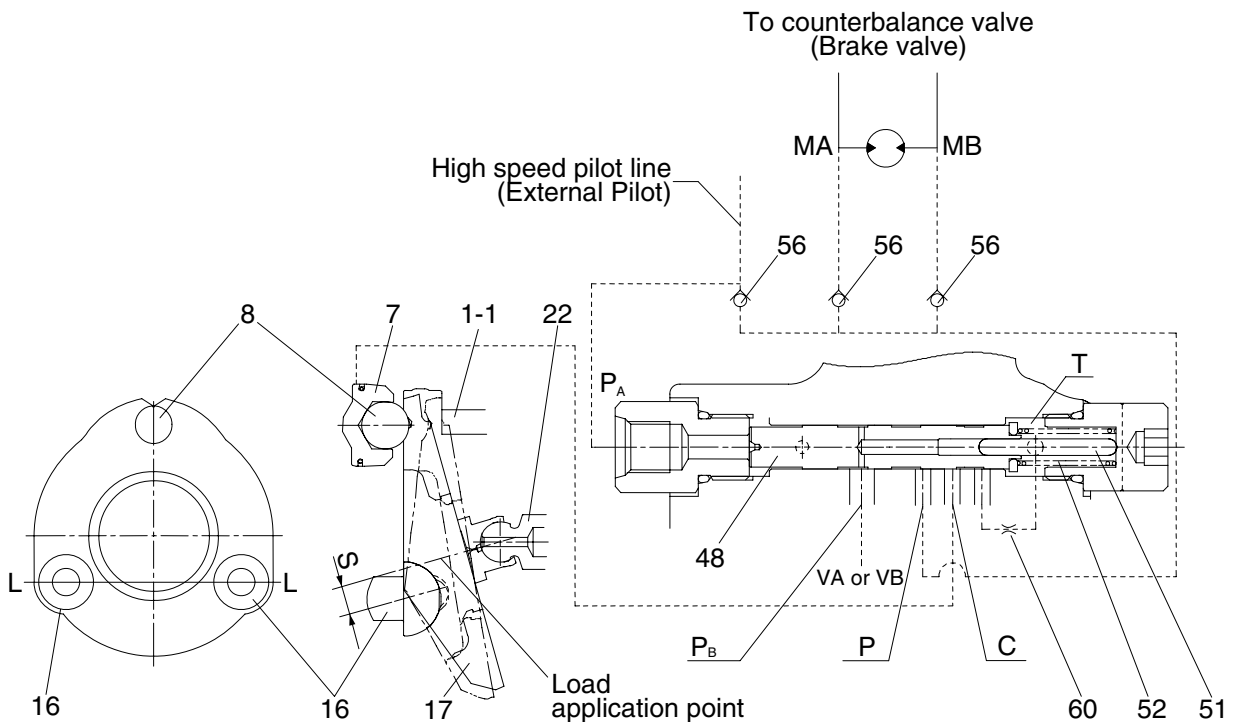

2609A2TM06

4) OVERLOAD RELIEF VALVE

(1) Structure

This valve is screwed in the motor rear cover (34) and consists of : plug (47-1) that is screwed and fixed in the rear cover (34), poppet (47-10) and supports the poppet seat (47-11), spring (47-4) that is operating relief valve setting pressure and supports the spring seat (47-5), that is inserted in the sleeve (47-6), screw (47-14) that is adjust the spring force, nut (47-15) that fix screw (47-14), piston (47-7) that reduce the shock.

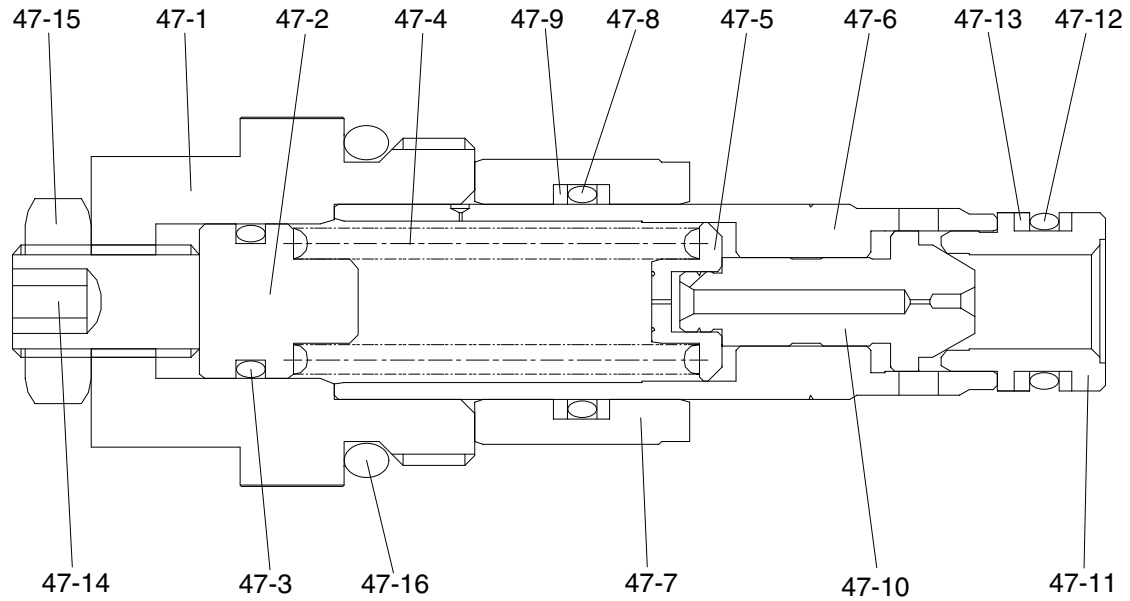

2609A2TM07

47-1 Plug	47-7 Piston	47-12 O-ring
47-2 Guide	47-8 O-ring	47-13 Back-up ring
47-3 O-ring	47-9 Back-up ring	47-14 Socket screw
47-4 Spring	47-10 Poppet	47-15 Hexagon nut
47-5 Spring seat	47-11 Poppet seat	47-16 O-ring
47-6 Sleeve		

(2) Operation

Two pieces of overload valves are located at cross-over position in the counterbalance circuit of brake valve and have the following functions:

- ① When hydraulic motor starts, keep the driving pressure below predetermined value and while accelerating, bypasses surplus oil to return line.
- ② When stopping the motor, keep the brake pressure, that develops on the outlet side of motor, under the predetermined value to stop the inertial force.
- ③ To accelerate sharply while starting, and to mitigate the braking shock while stopping. For these purposes, the developed pressure is kept comparatively low for a short period, then keep the line pressure as normal value. While the pressure is low, meshing of reduction gears, crawler and sprocket etc. can be smoothly done and the shock are absorbed.

When starting, "A" port pressure of overload valve increases, this pressure is applied to the effective diameter of poppet (47-10) which seats on the poppet seat (47-11) and, at the same time, is delivered, via small hole, to the spring seat (47-5) located inside the sleeve (47-6) and the seat bore pressure increases up to "A" port pressure. The poppet (47-10) opposes to spring (47-4) by the force of the pressure exerted on the area difference between poppet seat's effective diameter and spring seat bore and keep the predetermined pressure.

When hydraulically braking, the piston (47-7) is at the left position by the driving pressure, and when "A" port pressure increases, the pressure is applied also to the piston (47-7) through the small hole in the poppet (47-10) and piston (47-7) moves rightward until it touches the stopper in rear cover. In this while, the poppet (47-10) maintains "A" port pressure at comparatively low against the spring (47-4) force and exhaust oil to "B" port side. After the piston reached to the plug, the valve acts the same as at starting.

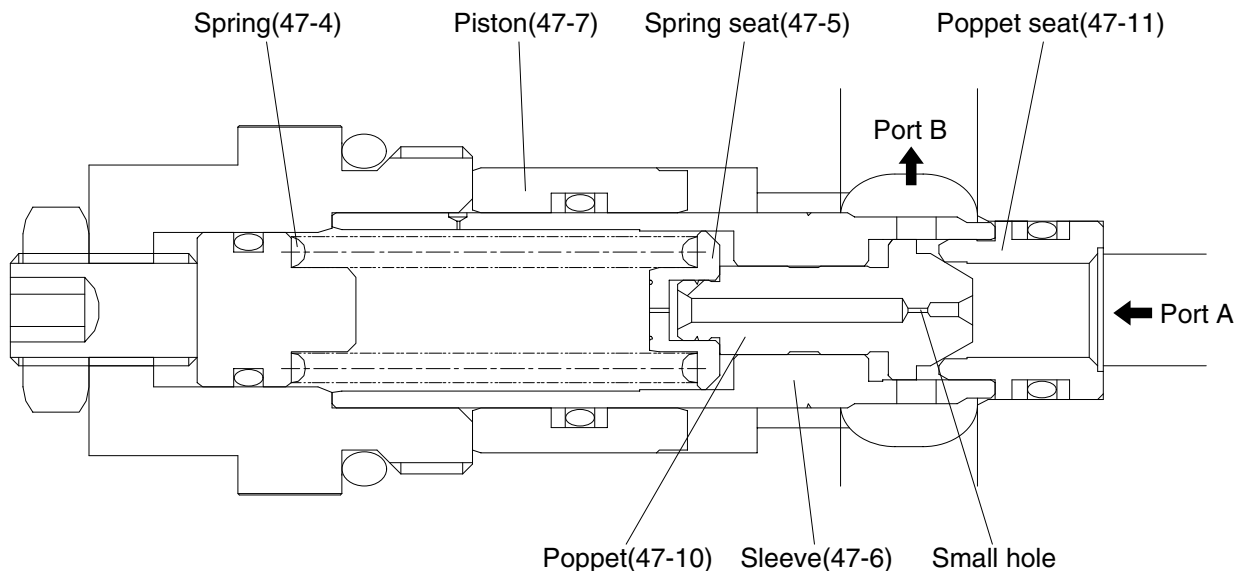

2609A2TM08

5) BRAKE VALVE

(1) Structure

The brake valve portion mainly consists of the following parts:

① Spool

By shifting the spool (35), the discharged oil from hydraulic motor is automatically shut off or restricted according to the condition and give the effect of holding, accelerating, stopping and counterbalance operations.

(See page 2-74, (2) Operation)

② Check valve (built in the spool)

This valve is located in the oil supplying passage to hydraulic motor, and at the same time functions to lock oil displacement. Therefore, this valve serves as not only a suction valve but also a holding valve for hydraulic motor.

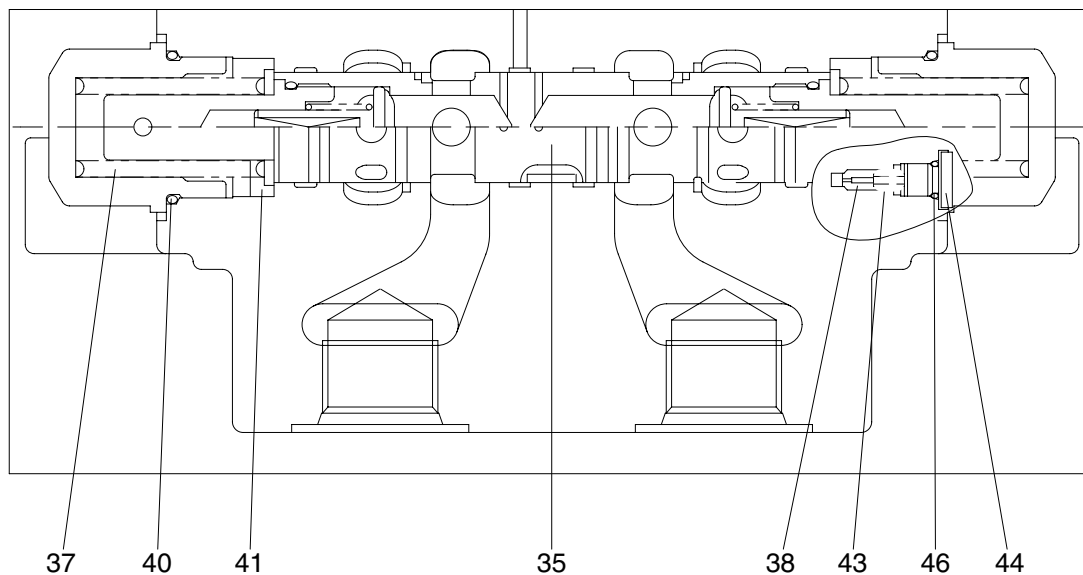

2609A2TM09

35	Main spool	40	O-ring	44	O-ring
37	Spring	41	Spring seat	46	Plug
38	Restrictor	43	Restrictor spring		

(2) Operation

① Holding operation

When the control valve is at neutral position, VA and VB ports are connected to the tank, and the spring (38) located on both spool ends holds the spool (35) at central position.

Therefore, the passages from VA to MA and VB to MB are closed, which result in closing MA and MB ports connected to hydraulic motor.

Since the passage to parking brake is connected to the tank line, the brake cylinder pressure is equal to the tank pressure and the brake is applied by the springs. Thus, the rotation of the motor is mechanically prevented.

If external torque is exerted on the motor shaft, the motor would not rotate as usual by this negative parking brake.

In case the brake should be released for some reason, pressure is built on MA or MB port. But, due to oil leakage inside hydraulic motor or so, high-pressure oil escapes from the closed circuit and motor rotates a bit. So, the cavitation tends to occur in the lower pressure side of the closed circuit. Then, the check valve, built in the spool (35), operates to avoid the cavitation and opens the passage from VA to MA or from VB to MB. Then the oil equivalent to the leakage is sucked from the tank line to the closed circuit.

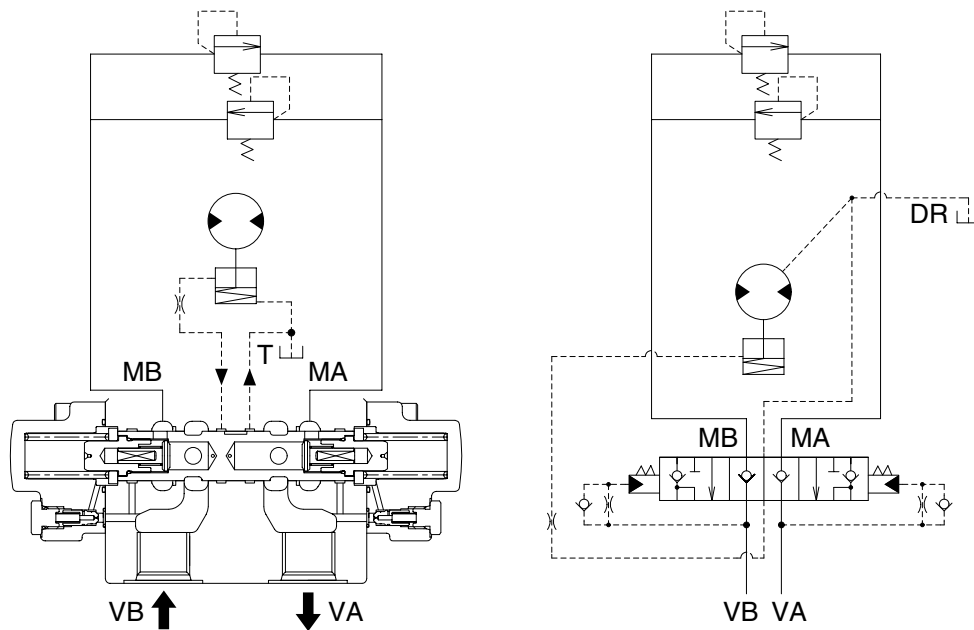

25092TM29

② Accelerating operation

When VA and VB ports are connected respectively to pump and tank by operating the control valve, hydraulic oil from pump is forwarded through VA port to push open the check valve provided inside spool (35), and oil flows to motor via MA port to rotate the motor.

Therefore, the pressure increases and negative brake is released by the pressure supplied from pump. At the same time, the pressure of pilot chamber increases to push and move the spool (35) leftwards, overcoming the spring (38) force. Thus, the return line from MB to VB opens to rotate the motor.

In case inertia load is too big to start rotation, accelerating pressure reaches the set pressure of relief valve and high pressure oil is being relieved while the motor gains the rotational speed.

As the rotational speed goes up, the relieved volume decreases, and finally the motor rotates at a fixed speed.

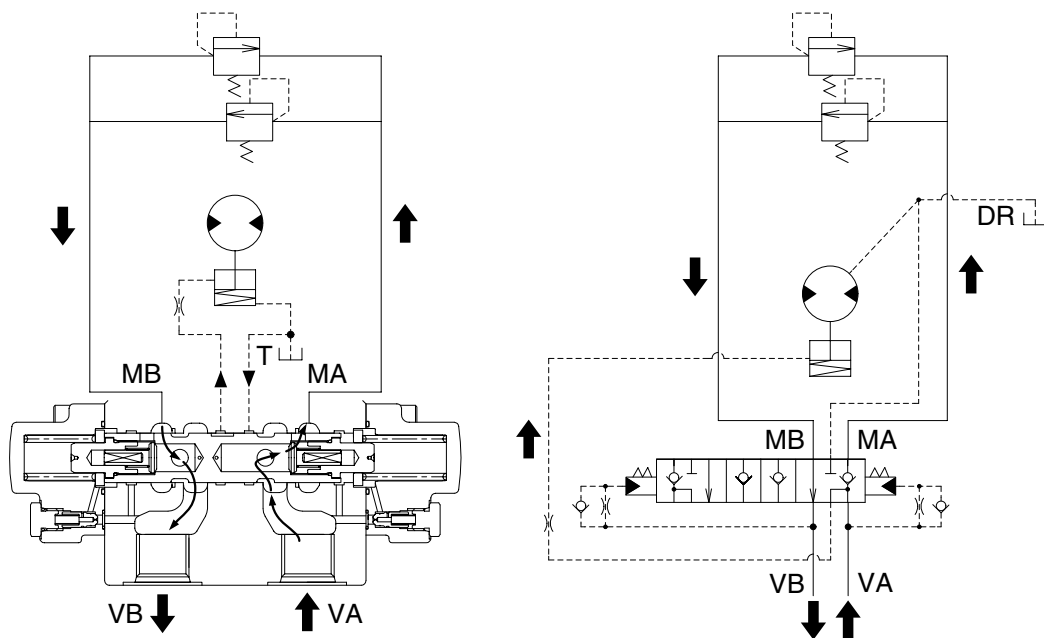

25092TM30

③ Stopping operation

Returning the control valve to neutral position while running the motor, the oil supply is cut off and VA and VB ports are connected to the tank line. Then the pressure of the pilot chamber located on both spool ends become equal, and the spool (35) returns to the neutral position by spring (38) force. Thus, the passage from MA to VA is closed.

Owing to the inertia force of the load, the hydraulic motor tends to continue the rotation. Here, the motor functions as a pump and forwards the oil to MB port but the passage is blocked and MB port pressure increases. Then the relief valve opens to relieve the pressure and rotational speed decelerates and at last the motor stops.

Negative brake release pressure is gradually lowered due to the restrictor and finally the brake works and the motor is mechanically stopped.

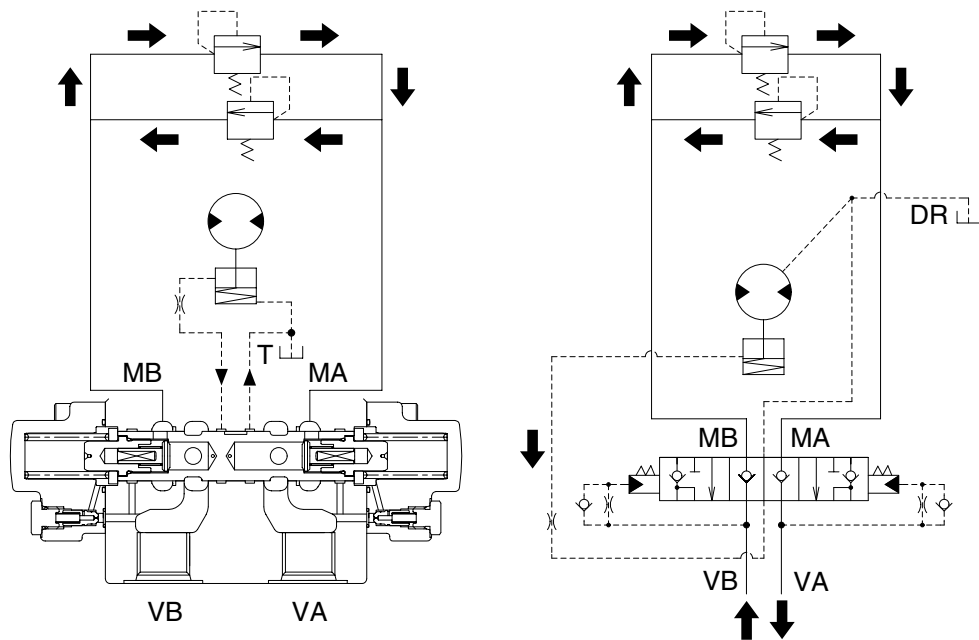

25092TM31

④ Counterbalance operation

Counterbalance operation is required to decelerate slowly the hydraulic motor while absorbing inertia force.

In case the hydraulic oil is gradually decreased from pump to VB port, the drive shaft of hydraulic motor tends to rotate faster than that matched to the volume of oil supply.

Consequently, the pilot chamber pressure on MB to VB side decreases and the spring (38) force moves the spool (35) leftwards towards neutral position.

Therefore, the area of passage from MA to VA becomes smaller and the pressure on MA side rises due to increased resistance in the passage and the motor receives hydraulic braking effect.

If the motor rotates slower than that matched to the volume of supplied oil, the pilot chamber pressure on VB port increases, and spool (35) moves rightwards to enlarge the area of passage from MA to VA. Therefore the braking effect becomes smaller and the rotational speed of motor is controlled to correspond to the volume of supplied oil.

In order to give stable counterbalance operation, the restrictors (40) are set in the pilot chamber to damp the spool (35) movement.

The parking brake is released during pressure adjusting action of the spool (35).

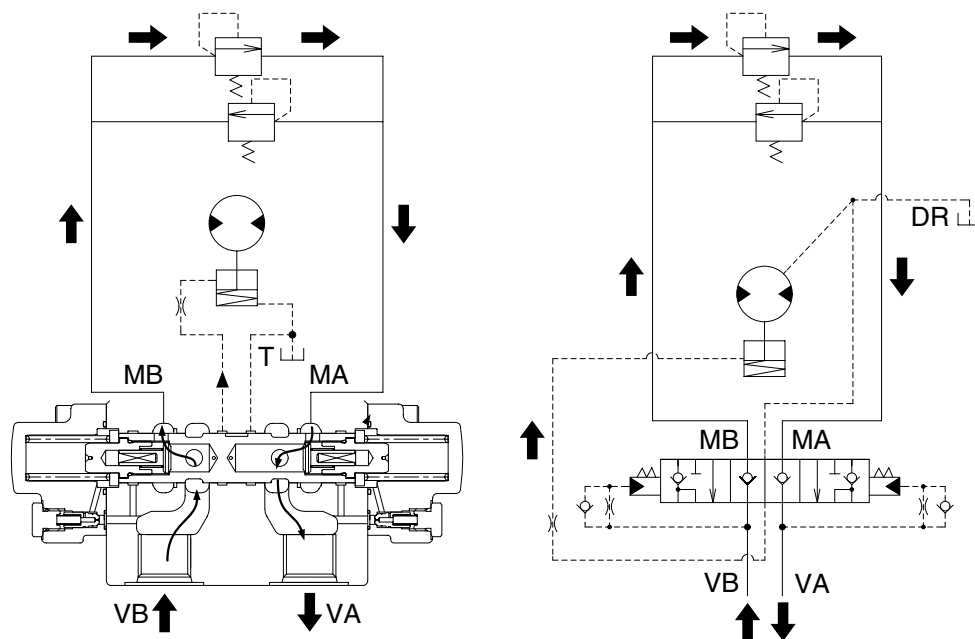

25092TM32

6) REDUCTION GEAR

Reduction unit slows down the rotating speed of motor and converts motor torque to strong rotating force.

This reduction unit utilizes two stages, planetary reduction system.

Planetary reduction system consists of sun gear, planetary gears, (planetary) carriers, and ring gear.

When the sun gear (s) is driven through input shaft, planetary pinions (b), rotating on their center, also move, meshing with fixed ring gear (a), around sun gear (s).

This movement is transferred to carrier (k) and deliver the torque.

This mechanism is called planetary gear mechanism.

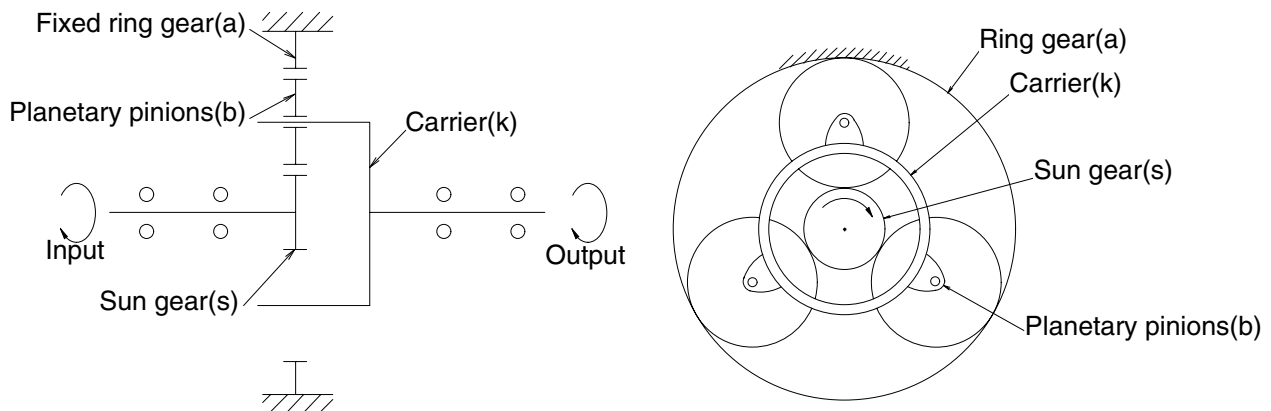

29072TM10

29072TM11

When the sun gear **S1** is driven by input shaft, planetary action occurs among gears **S1**, **a** and **b** and revolution of gear **b** transfers the rotation of carrier **K1** to second sun gear **S2**, and also evokes planetary action between gear **S2**, **a** and **d**.

This time, because carrier **K2** is fixed to frame, gear **d** drives ring gear **a** and then ring gear **a** rotates to drive sprocket.

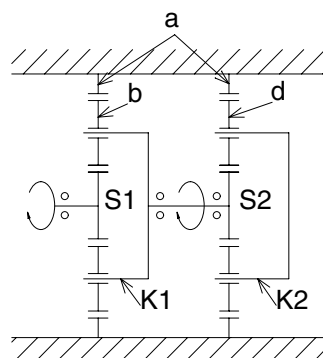

29072TM12

GROUP 5 RCV LEVER

1. STRUCTURE

The casing has the oil inlet port P (primary pressure) and the oil outlet port T (tank). In addition the secondary pressure is taken out through ports 1, 2, 3 and 4 provided at the bottom face.

※ Refer to the parts manual for the types of the RCV lever.

1) TYPE M1, M3, M5

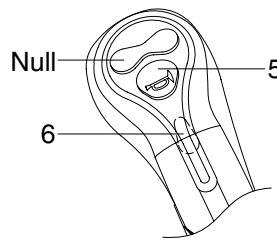
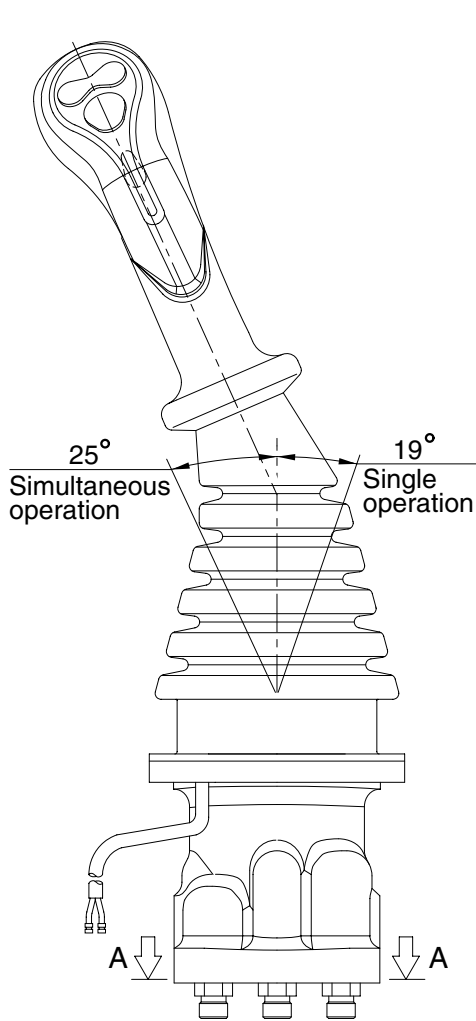

TYPE M1, M3

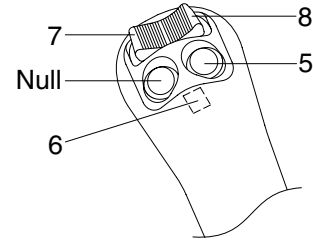

TYPE M5

Switches

Type	No.	LH	RH
M1, M3	5	One touch decel	Horn
	6	Power boost	Breaker
M5	5	One touch decel	Horn
	6	Power boost	Null
	7	CCW rotation	Close
	8	CW rotation	Open

※ Number 7 and 8 : Option attachment

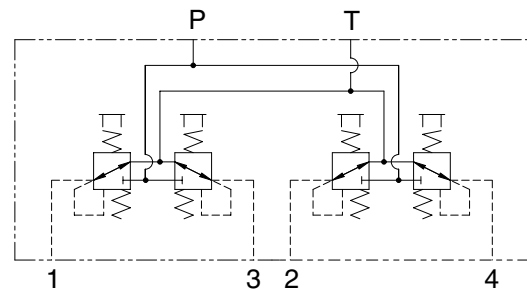

Hydraulic circuit

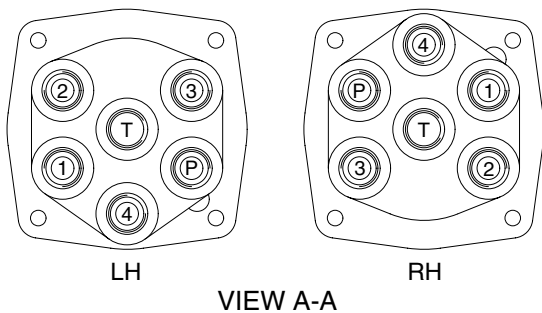

Pilot ports

Port	LH	RH	Port size
P	Pilot oil inlet port	Pilot oil inlet port	PF 3/8
T	Pilot oil return port	Pilot oil return port	
1	Left swing port	Bucket out port	
2	Arm out port	Boom up port	
3	Right swing port	Bucket in port	
4	Arm in port	Boom down port	

300L2RL01

2) TYPE M2, M4, M6

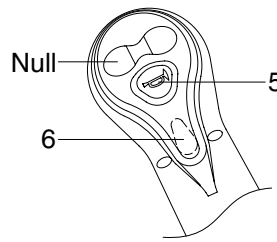
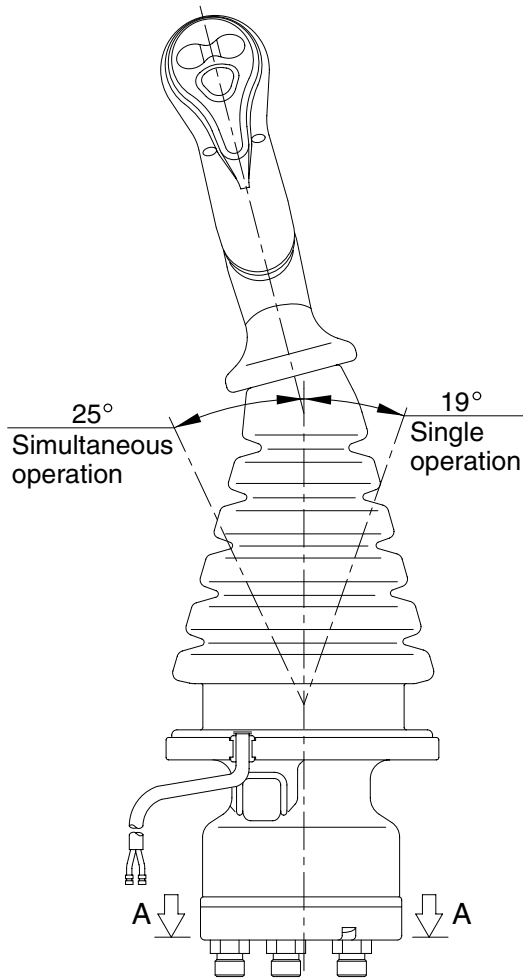

TYPE M2, M4

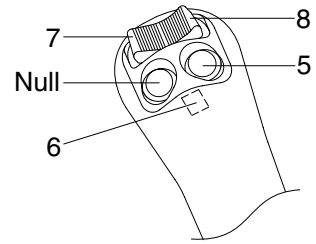

TYPE M6

Switches

Type	No.	LH	RH
M2, M4	5	One touch decel	Horn
	6	Power boost	Breaker
M6	5	One touch decel	Horn
	6	Power boost	Null
	7	CCW rotation	Close
	8	CW rotation	Open

※ Number 7 and 8 : Option attachment

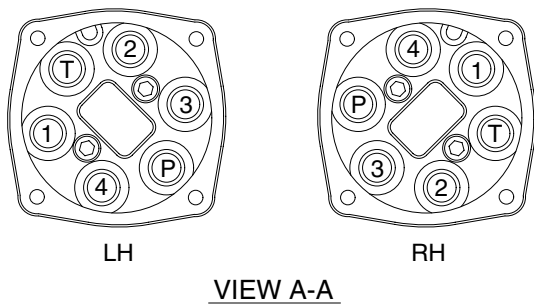
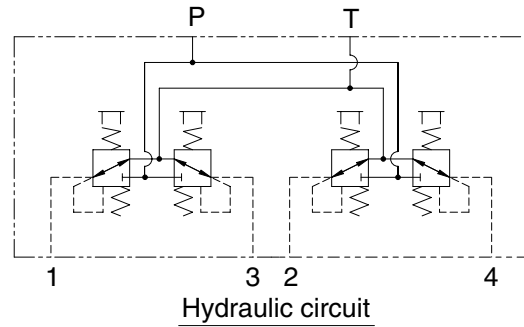

Pilot ports

Port	LH	RH	Port size
P	Pilot oil inlet port	Pilot oil inlet port	PF 3/8
T	Pilot oil return port	Pilot oil return port	
1	Left swing port	Bucket out port	
2	Arm out port	Boom up port	
3	Right swing port	Bucket in port	
4	Arm in port	Boom down port	

300L2RL05

3) CROSS SECTION

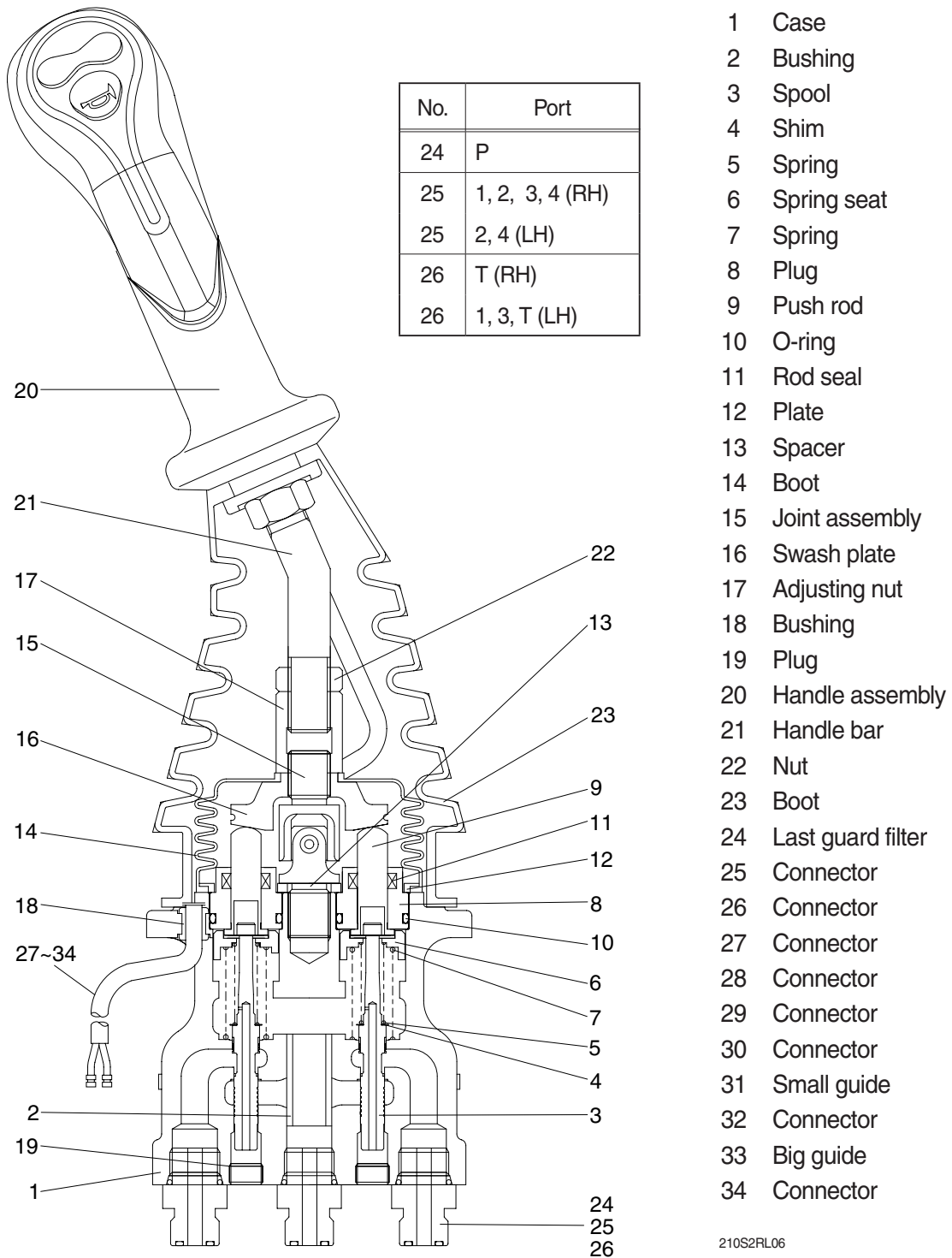

Item numbers are based on the type M1.

The construction of the pilot valve is shown in the attached cross section drawing. The casing has vertical holes in which reducing valves are assembled.

The pressure reducing section is composed of the spool (3), spring (5) for setting secondary pressure, return spring (7), spring seat (6) and shim (4). The spring for setting the secondary pressure has been generally so preset that the secondary pressure is 5 to 20.5 kgf/cm² (depending on the type). The spool is pushed against the push rod (9) by the return spring.

When the push rod is pushed down by tilting the handle, the spring seat comes down simultaneously and changes setting of the secondary pressure spring.

2. FUNCTIONS

1) FUNDAMENTAL FUNCTIONS

The pilot valve is a valve that controls the spool stroke, direction, etc of a main control valve. This function is carried out by providing the spring at one end of the main control valve spool and applying the output pressure (secondary pressure) of the pilot valve to the other end.

For this function to be carried out satisfactorily, the pilot valve is composed of the following elements.

- (1) Inlet port (P) where oil is supplied from hydraulic pump.
- (2) Output ports (1, 2, 3 & 4) to apply pressure supplied from inlet port to ends of control valve spools.
- (3) Tank port (T) necessary to control the above output pressure.
- (4) Spool to connect output port to inlet port or tank port.
- (5) Mechanical means to control output pressure, including springs that work on the above spools.

2) FUNCTIONS OF MAJOR SECTIONS

Item numbers are based on the type M1.

The functions of the spool (3) are to receive the supply oil pressure from the hydraulic pump at its port P, and to change over oil paths to determine whether the pressure oil of port P is led to output ports 1, 2, 3 & 4 or the output port pressure oil to tank port T.

The spring (5) works on this spool to determine the output pressure.

The change the deflection of this spring, the push rod (9) is inserted and can slide in the plug (8).

For the purpose of changing the displacement of the push rod through the swash plate (16) and adjusting nut (17) are provided the handle assy (20) that can be tilted in any direction around the fulcrum of the universal joint (15) center.

The spring (7) works on the case (1) and spring seat (6) and tries to return the push rod (9) to the zero-displacement position irrespective of the output pressure, securing its resetting to the center position.

This also has the effect of a reaction spring to give appropriate control feeling to the operator.

3) OPERATION

The operation of the pilot valve will be described on the basis of the hydraulic circuit diagram shown below and the attached operation explanation drawing.

The diagram shown below is the typical application example of the pilot valve.

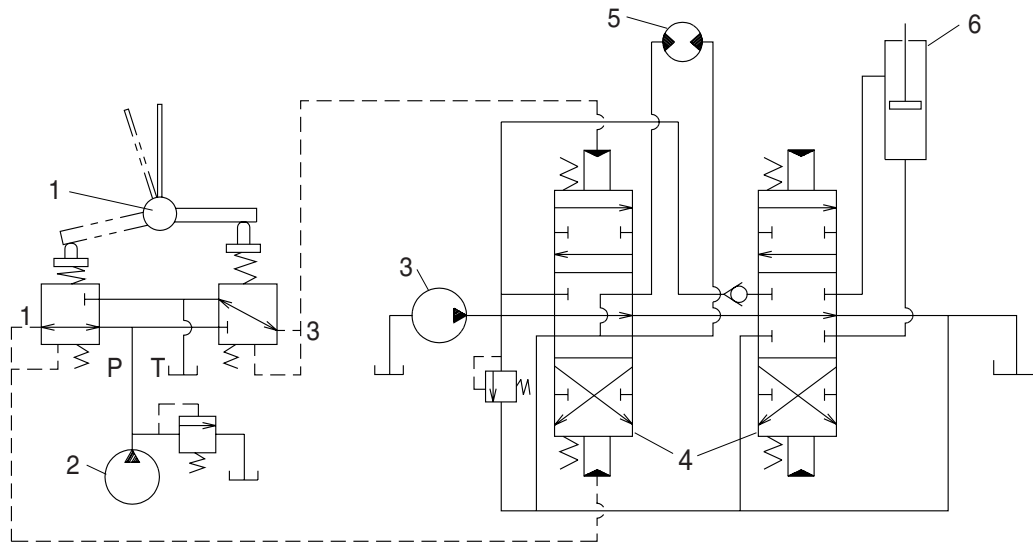

2-70

1 Pilot valve
2 Pilot pump

3 Main pump
4 Main control valve

5 Hydraulic motor
6 Hydraulic cylinder

(1) Case where handle is in neutral position

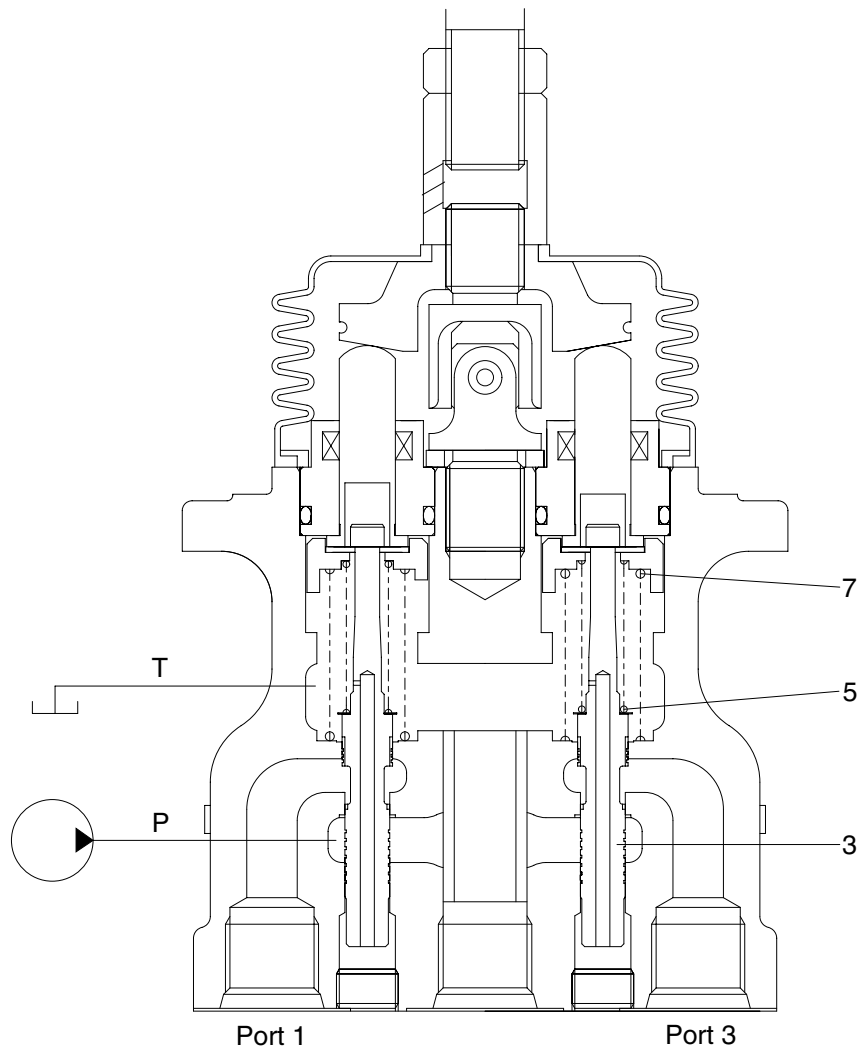

300L2RL03

The force of the spring (5) that determines the output pressure of the pilot valve is not applied to the spool (3). Therefore, the spool is pushed up by the spring (7) to the position of port (1, 3) in the operation explanation drawing. Then, since the output port is connected to tank port T only, the output port pressure becomes equal to tank pressure.

(2) Case where handle is tilted

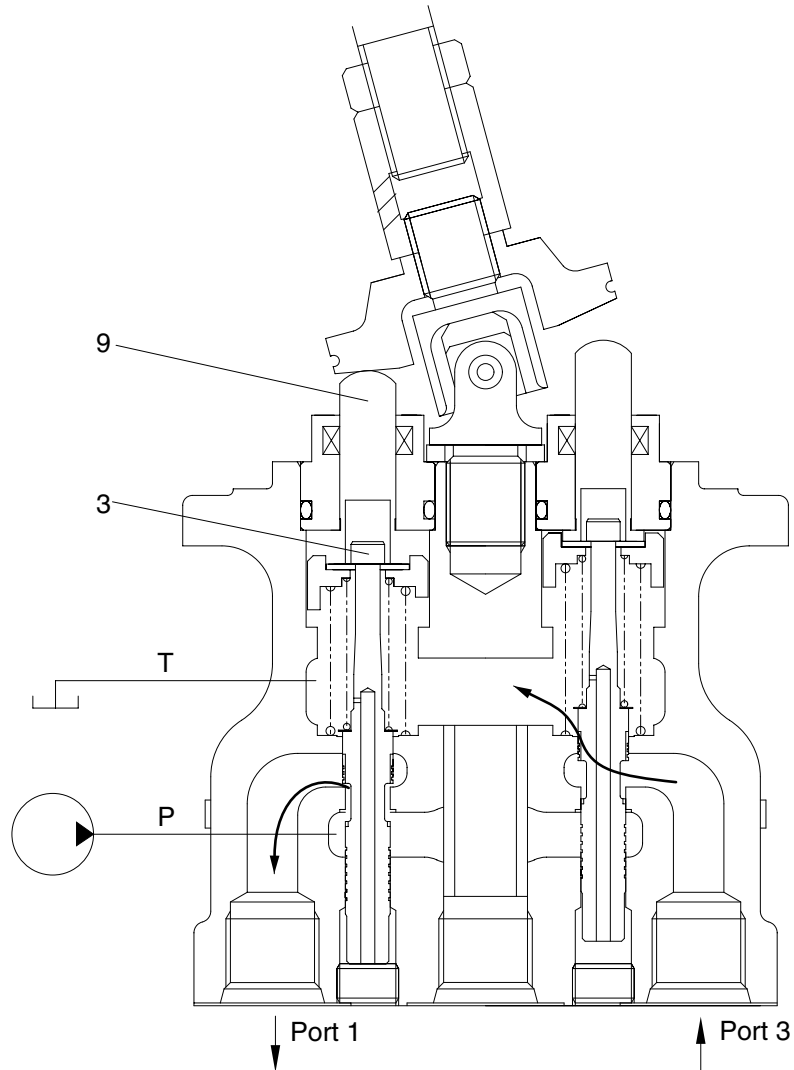

300L2RL04

When the push rod (9) is stroked, the spool (3) moves downwards.

Then port P is connected with port (1) and the oil supplied from the pilot pump flows through port (1) to generate the pressure.

When the pressure at port (1) increases to the value corresponding to the spring force set by tilting the handle, the hydraulic pressure force balances with the spring force. If the pressure at port (1) increases higher than the set pressure, port P is disconnected from port (1) and port T is connected with port (1). If it decreases lower than the set pressure, port P is connected with port (1) and port T is disconnected from port 1.

In this manner the secondary pressure is kept at the constant value.

Besides, in some type, when the handle is tilted more than a certain angle, the upper end of the spool contacts with the inside bottom of the push rod and the output pressure is left to be connected with port P.

GROUP 6 RCV PEDAL

1. STRUCTURE

The casing (spacer) has the oil inlet port P (primary pressure), and the oil outlet port T (tank). In addition the secondary pressure is taken out through ports 1, 2, 3 and 4 provided at the bottom face.

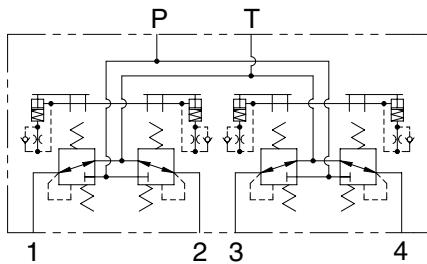
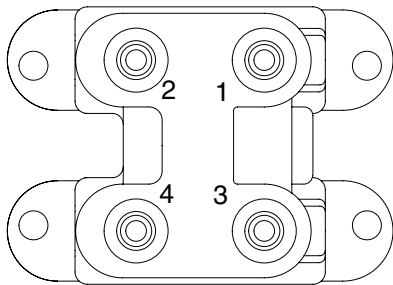
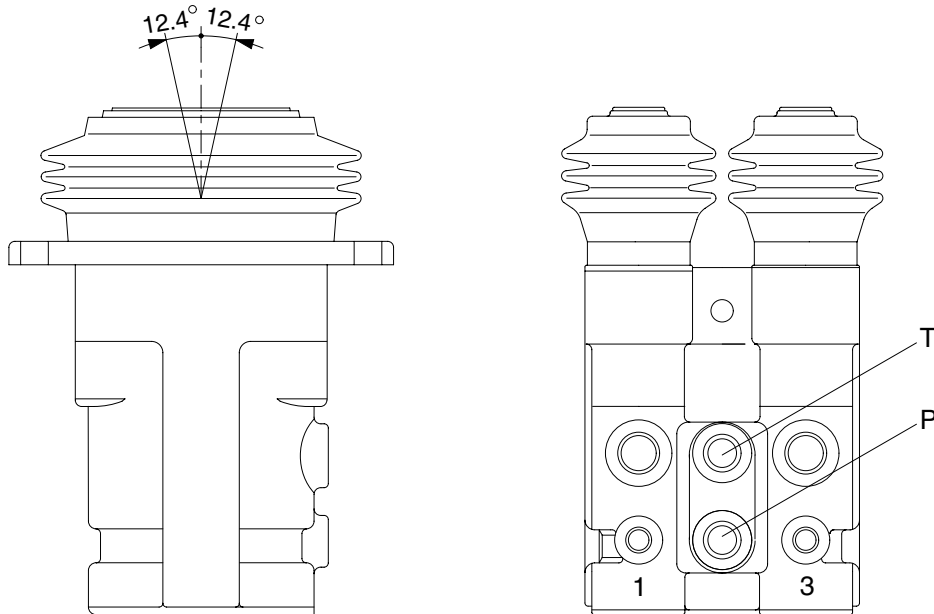

Hydraulic circuit

Port	Port	Port size
P	Pilot oil inlet port	PF 1/4
T	Pilot oil return port	
1	Travel (LH, Forward)	
2	Travel (LH, Backward)	
3	Travel (RH, Forward)	
4	Travel (RH, Backward)	

130ZF2RP01

CROSS SECTION

The construction of the RCV pedal is shown in the below drawing. The casing has vertical holes in which reducing valves are assembled.

The pressure reducing section is composed of the spool (7), spring (5) for setting secondary pressure, return spring (9), stopper (8), and spring seat (6). The spring for setting the secondary pressure has been generally so preset that the secondary pressure is 6.3 ± 1 to 24.9 ± 1.5 kgf/cm² (depending on the type). The spool is pushed against the push rod (13) by the return spring.

When the push rod is pushed down by tilting pedal, the spring seat comes down simultaneously and changes setting of the secondary pressure spring.

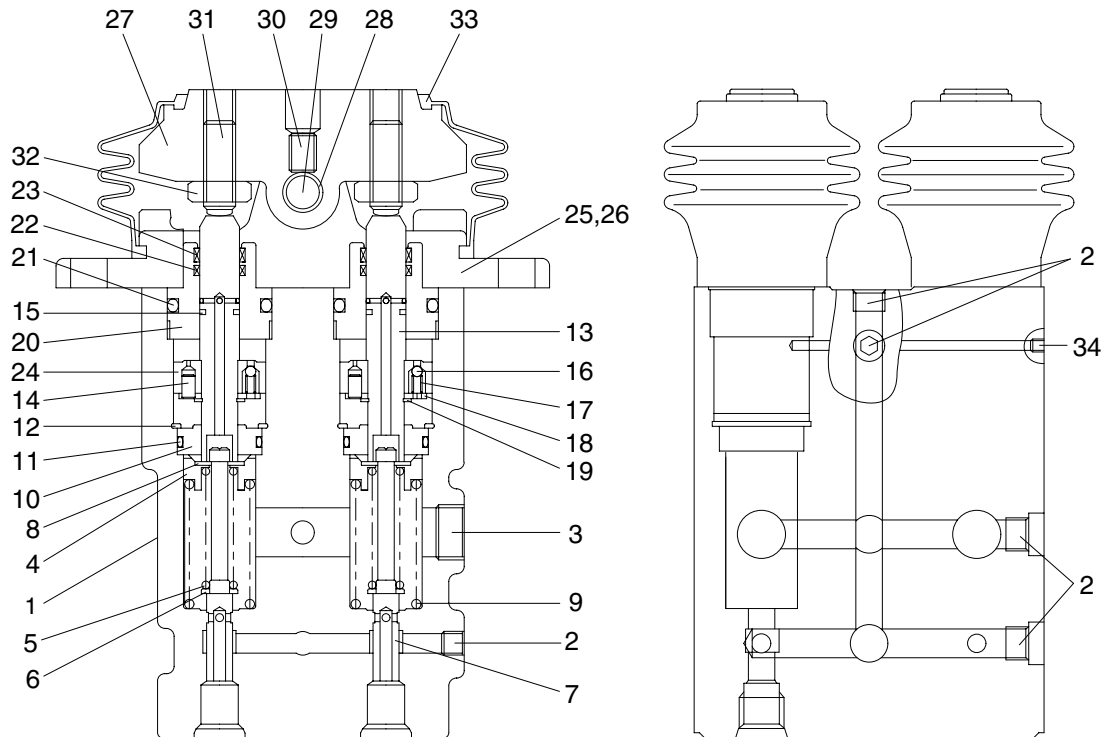

1	Body	13	Push rod	25	Cover
2	Plug	14	Spring pin	26	Wrench bolt
3	Plug	15	Seal	27	Cam
4	Spring seat	16	Steel ball	28	Bushing
5	Spring	17	Spring	29	Cam shaft
6	Spring seat	18	Plate	30	Set screw
7	Spool	19	Snap ring	31	Set screw
8	Stopper	20	Plug	32	Hex nut
9	Spring	21	O-ring	33	Bellows
10	Rod guide	22	Rod seal	34	Expand
11	O-ring	23	Dust seal	35	Name plate
12	Snap ring	24	Piston		

130ZF2RP02

2. FUNCTION

1) FUNDAMENTAL FUNCTIONS

The pilot valve is a valve controls the spool stroke, direction, etc of a main control valve. This function is carried out by providing the spring at one end of the main control valve spool and applying the output pressure (secondary pressure) of the pilot valve to the other end.

For this function to be carried out satisfactorily, the pilot valve is composed of the following elements.

- (1) Inlet port (P) where oil is supplied from hydraulic pump.
- (2) Output port (1, 2, 3 & 4) to apply pressure supplied from inlet port to ends of control valve spools.
- (3) Tank port (T) necessary to control the above output pressure.
- (4) Spool to connect output port to inlet port tank port.
- (5) Mechanical means to control output pressure, including springs that work on the above spools.

2) FUNCTIONS OF MAJOR SECTIONS

The functions of the spool (7) are to receive the supply oil pressure from the hydraulic pump at its port P, and to change over oil paths to determine whether the pressure oil of port P is led to output ports 1, 2, 3 & 4 or the output spool to determine the output pressure.

The spring (5) works on this spool to determine the output pressure.

The change the deflection of this spring, the push rod (13) is inserted and can slide in the plug (20). For the purpose of changing th displacement of the push rod through the cam (27) and adjusting nut (32) are provided the pedal that can be tilted in any direction around the fulcrum of the cam (27) center.

The spring (9) works on the body (1) and spring seat (6) and tries to return the push rod (13) to the zero-displacement position irrespective of the output pressure, securing its resetting to the center position.

This also has the effect of a reaction spring to give appropriate control feeling to the operator.

3) OPERATION

The operation of the pilot valve will be described on the basis of the hydraulic circuit diagram shown below and the attached operation explanation drawing.

The diagram shown below is the typical application example of the pilot valve.

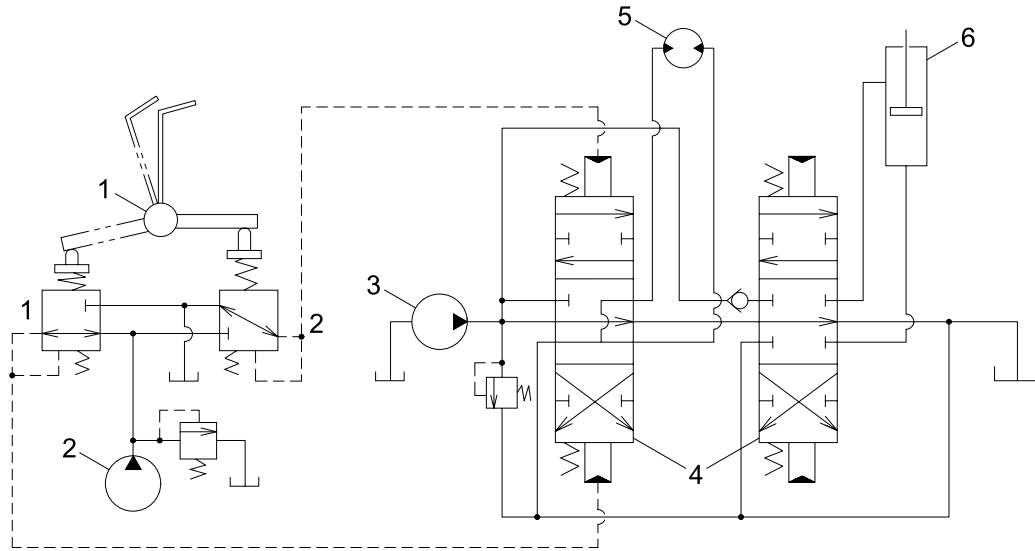

36072SF01

- 1 Pilot valve
- 2 Pilot pump

- 3 Main pump
- 4 Main control valve

- 5 Hydraulic motor
- 6 Hydraulic cylinder

(1) Case where pedal is in neutral position

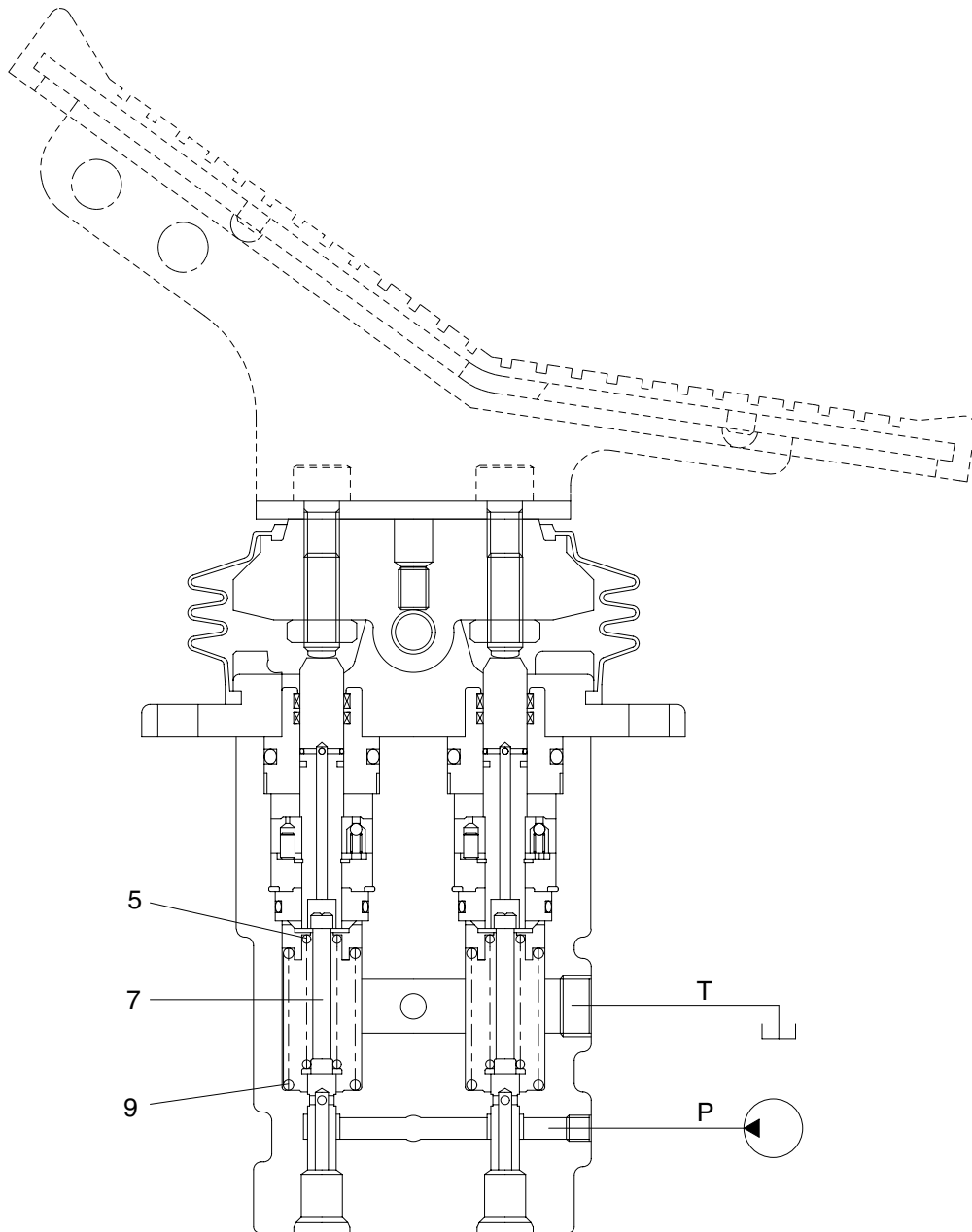

130ZF2RP03

The force of the spring (5) that determines the output pressure of the pilot valve is not applied to the spool (7). Therefore, the spool is pushed up by the spring (9) to the position of 1 and port 2. Then, since the output port is connected to tank port T only, the output port pressure becomes equal to tank pressure.

(2) Case where pedal is tilted

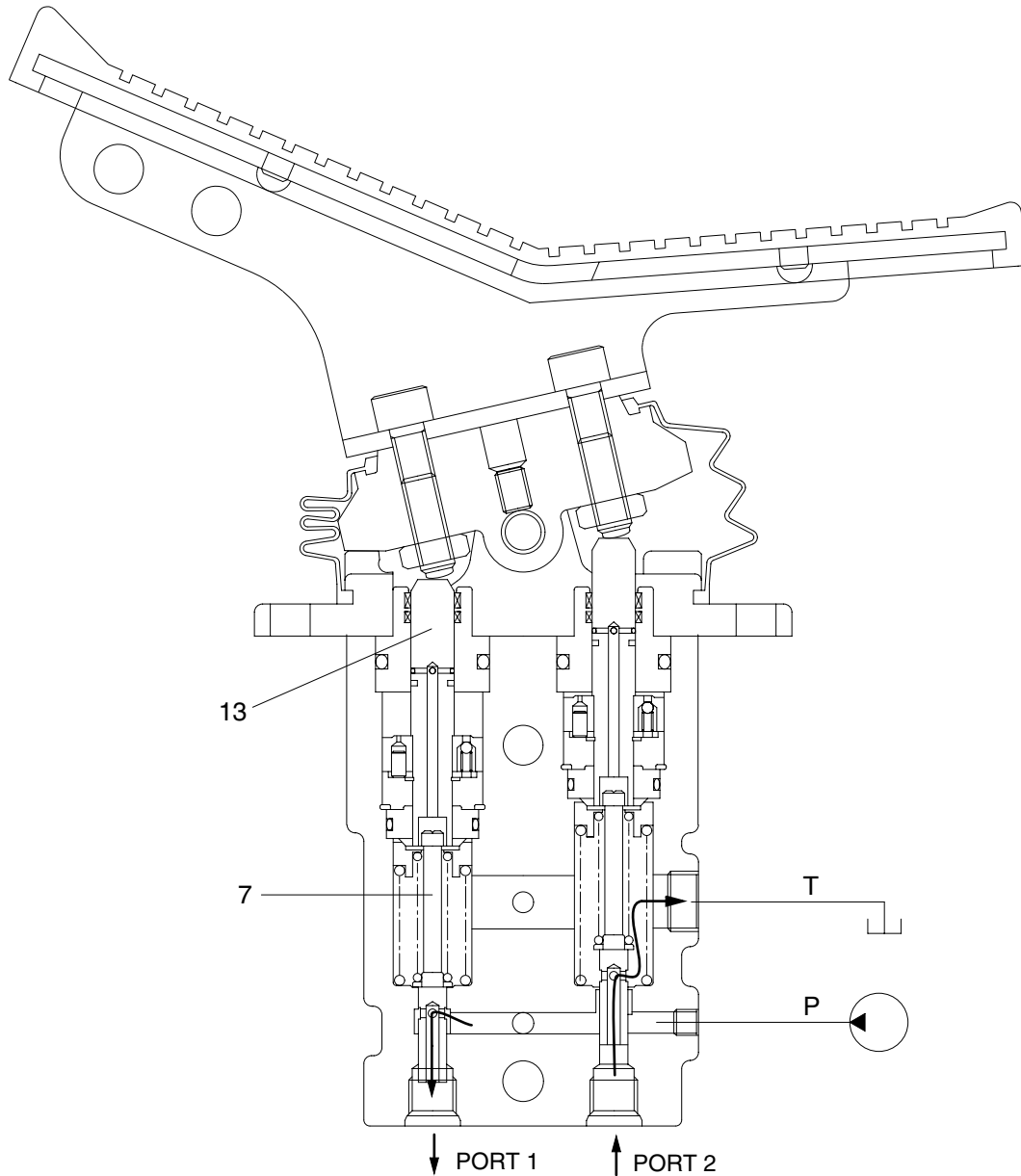

220F2RP04

When the push rod (13) is stroked, the spool (7) moves downwards.

Then port P is connected with port 1, and the oil supplied from the pilot pump flows through port 1 to generate the pressure.

When the pressure at port 1 increases to the value corresponding to the spring force set by tilting the handle, the hydraulic pressure force balances with the spring force. If the pressure at port 1 increases higher than the set pressure, port P is disconnected from port 1 and port T is connected with port 1. If it decreases lower than the set pressure, port P is connected with port 1 and port T is disconnected from port 1.

In this manner the secondary pressure is kept at the constant value.

Besides, in some type, when the handle is tilted more than a certain angle, the upper end of the spool contacts with inside bottom of the push rod and the output pressure is left to be connected with port P.