

FOREWORD

This manual covers the service procedures of the TOYOTA FORKLIFT 7FGU/7FDU35 ~ 80 series and 7FGCU35 ~ 70 series. Please use this manual for providing quick, correct servicing of the corresponding forklift models.

This manual deals with the above models as of December 2000. Please understand that disagreement can take place between the descriptions in the manual and actual vehicles due to change in design and specifications. Any change or modifications thereafter will be informed by Toyota Industrial Equipment Parts & Service News.

For the service procedures of the mounted engine, read the repair manuals listed below as reference together with this manual.

(Reference)

Repair manuals related to this manual are as follows:

TOYOTA GM6-262 ENGINE
REPAIR MANUAL (No. C4630)

TOYOTA GM6-262 ENGINE
REPAIR MANUAL Supplement (No. CU668)

TOYOTA 11Z, 12Z, 13Z, 14Z ENGINE
REPAIR MANUAL (No. C4615-2)

TOYOTA 15Z ENGINE
REPAIR MANUAL (No. CE673)

Three Way Catalytic System
REPAIR MANUAL (No. CU643-2)

LPG DEVICE (for GM6-262 engine)
REPAIR MANUAL (No. CU667)

TOYOTA INDUSTRIAL EQUIPMENT 7FGU/7FDU35-80 OPS
REPAIR MANUAL (No. CU041)

TOYOTA INDUSTRIAL EQUIPMENT
PARTS & SERVICE NEWS (No. GE-7008)

TOYOTA Material Handling Company

A Division of TOYOTA INDUSTRIES CORPORATION

SECTION INDEX

NAME	SECTION
GENERAL	0
ENGINE	1
TORQUE CONVERTER & TRANSMISSION	2
PROPELLER SHAFT	3
DIFFERENTIAL	4
FRONT AXLE	5
REAR AXLE	6
STEERING	7
BRAKE	8
BODY	9
MATERIAL HANDLING SYSTEM	10
MAST	11
CYLINDER	12
OIL PUMP	13
OIL CONTROL VALVE	14
SAS	15
APPENDIX	16

GENERAL

Page

0

EXTERIOR VIEWS	0-2
VEHICLE MODEL (~ 2007.12)	0-3
VEHICLE MODEL (2008.1 ~)	0-3A
FRAME NUMBER (~ 2007.12)	0-4
FRAME NUMBER (2008.1 ~)	0-4A
HOW TO USE THIS MANUAL	0-5
EXPLANATION METHOD	0-5
TERMINOLOGY	0-6
ABBREVIATIONS	0-6
OPERATIONAL TIPS	0-7
HOISTING THE VEHICLE	0-7
ATTENTIVE POINTS ON SAS	0-8
CIRCUIT TESTER	0-9
STANDARD BOLT & NUT TIGHTENING	
TORQUE	0-11
BOLT STRENGTH TYPE IDENTIFICATION METHOD	0-11
TIGHTENING TORQUE TABLE	0-12
PRECOAT BOLTS	0-13
HIGH PRESSURE HOSE FITTING	
TIGHTENING TORQUE	0-13
WIRE ROPE SUSPENSION ANGLE LIST	0-14
SAFE LOAD FOR EACH WIRE ROPE	
SUSPENSION ANGLE	0-14
COMPONENTS WEIGHT (~ 2007.12)	0-15
COMPONENTS WEIGHT (2008.1 ~)	0-15A
RECOMMENDED LUBRICANT	
QUANTITY & TYPES (~ 2007.12)	0-16
RECOMMENDED LUBRICANT	
QUANTITY & TYPES (2008.1 ~)	0-16A
LUBRICATION CHART	0-17
PERIODIC MAINTENANCE	0-20
PERIODIC REPLACEMENT OF PARTS AND	
LUBRICANTS	0-26

EXTERIOR VIEWS

Pneumatic tire model

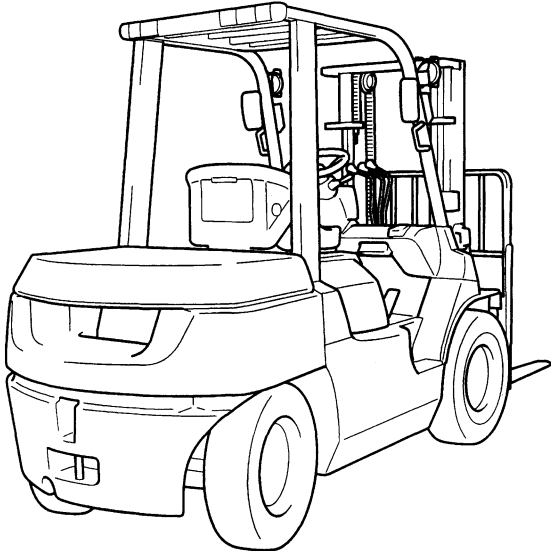
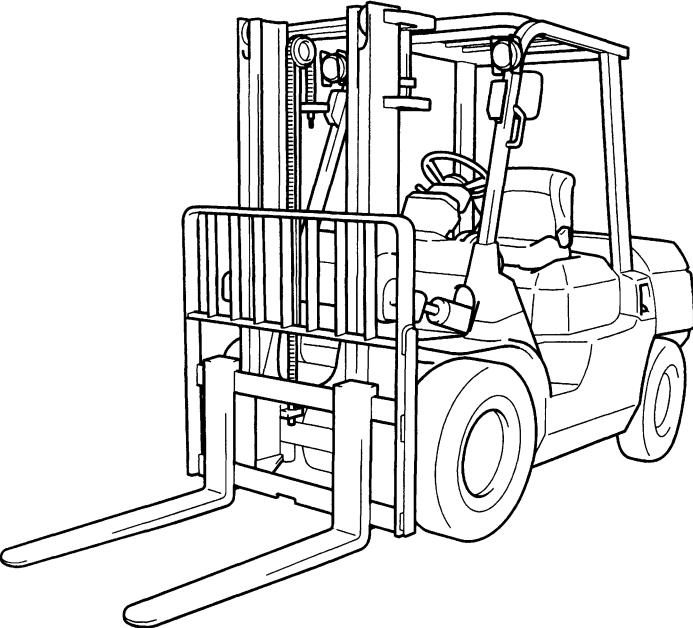

Cushion tire model

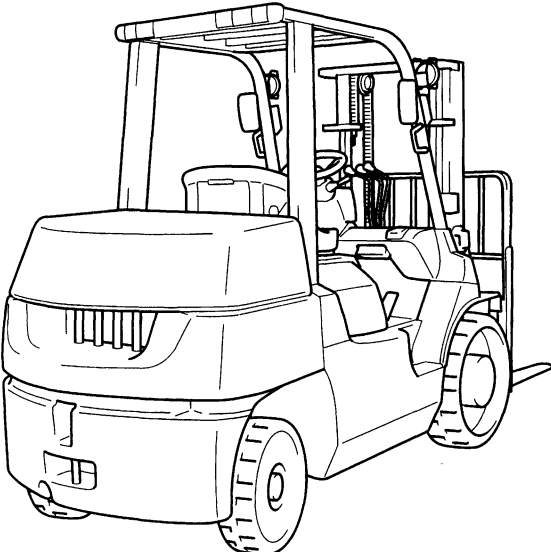
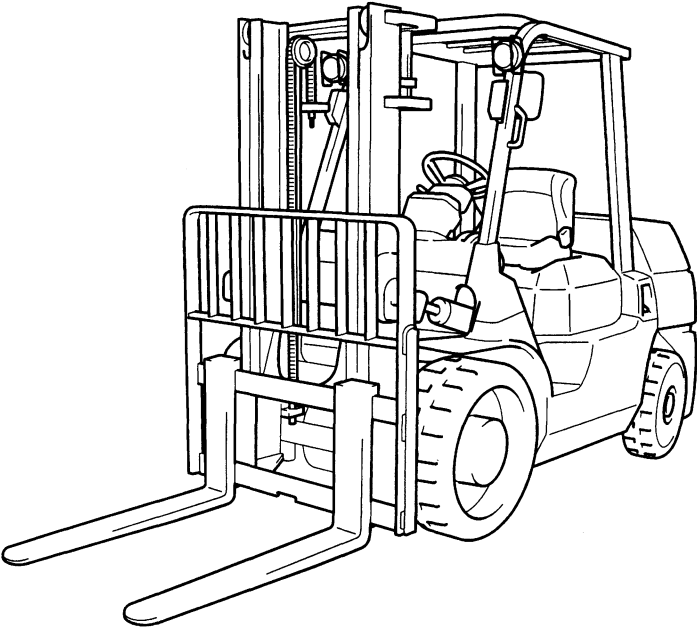

VEHICLE MODEL (~ 2007.12)

Pneumatic Tire Models (Pn)

Classification		Load Capacity	Vehicle Model	Transmission Type	Engine	
Series	Model					
Pn3.5 ton series	Pn35	8000 lbs	7FGU35	T/C	G4 (GM6-262)	Gasoline
			7FDU35	T/C	13Z	Diesel
	Pn40	9000 lbs	7FGKU40	T/C	G4 (GM6-262)	Gasoline
			7FDKU40	T/C	13Z	Diesel
Pn4.5 ton series	Pn45	10000 lbs	7FGU45	T/C	G4 (GM6-262)	Gasoline
			7FDU45	T/C	13Z	Diesel
	Pn50	11000 lbs	7FGAU50	T/C	G4 (GM6-262)	Gasoline
			7FDAU50	T/C	13Z	Diesel
Pn6.0 ton series	Pn60	13500 lbs	7FGU60	T/C	G4 (GM6-262)	Gasoline
			7FDU60	T/C	13Z	Diesel
	Pn70	15500 lbs	7FGU70	T/C	G4 (GM6-262)	Gasoline
			7FDU70	T/C	13Z	Diesel
	Pn80	17500 lbs	7FGU80	T/C	G4 (GM6-262)	Gasoline
			7FDU80	T/C	13Z	Diesel

Cushion Tire Models (Cu)

Classification		Load Capacity	Vehicle Model	Transmission Type	Engine	
Series	Model					
Cu3.5 ton series	Cu35	8000 lbs	7FGCU35	T/C	G4 (GM6-262)	Gasoline
	Cu45	10000 lbs	7FGCU45	T/C	G4 (GM6-262)	Gasoline
Cu5.5 ton series	Cu55	12000 lbs	7FGCU55	T/C	G4 (GM6-262)	Gasoline
	Cu60	13500 lbs	7FGCU60	T/C	G4 (GM6-262)	Gasoline
	Cu70	15500 lbs	7FGCU70	T/C	G4 (GM6-262)	Gasoline

Note:

The G4 engine is the same as the GM6-262 engine except for the nomenclature.

VEHICLE MODEL (2008.1 ~)

Pneumatic Tire Models (Pn)

Classification		Load Capacity	Vehicle Model	Transmission Type	Engine	
Series	Model					
Pn3.5 ton series	Pn35	8000 lbs	7FGU35	T/C	G4 (GM6-262)	Gasoline
			7FDU35	T/C	15Z	Diesel
	Pn40	9000 lbs	7FGKU40	T/C	G4 (GM6-262)	Gasoline
			7FDKU40	T/C	15Z	Diesel
Pn4.5 ton series	Pn45	10000 lbs	7FGU45	T/C	G4 (GM6-262)	Gasoline
			7FDU45	T/C	15Z	Diesel
	Pn50	11000 lbs	7FGAU50	T/C	G4 (GM6-262)	Gasoline
			7FDAU50	T/C	15Z	Diesel
Pn6.0 ton series	Pn60	13500 lbs	7FGU60	T/C	G4 (GM6-262)	Gasoline
			7FDU60	T/C	15Z	Diesel
	Pn70	15500 lbs	7FGU70	T/C	G4 (GM6-262)	Gasoline
			7FDU70	T/C	15Z	Diesel
	Pn80	17500 lbs	7FGU80	T/C	G4 (GM6-262)	Gasoline
			7FDU80	T/C	15Z	Diesel

Cushion Tire Models (Cu)

Classification		Load Capacity	Vehicle Model	Transmission Type	Engine	
Series	Model					
Cu3.5 ton series	Cu35	8000 lbs	7FGCU35	T/C	G4 (GM6-262)	Gasoline
	Cu45	10000 lbs	7FGCU45	T/C	G4 (GM6-262)	Gasoline
Cu5.5 ton series	Cu55	12000 lbs	7FGCU55	T/C	G4 (GM6-262)	Gasoline
	Cu60	13500 lbs	7FGCU60	T/C	G4 (GM6-262)	Gasoline
	Cu70	15500 lbs	7FGCU70	T/C	G4 (GM6-262)	Gasoline

Note:

The G4 engine is the same as the GM6-262 engine except for the nomenclature.

FRAME NUMBER (~ 2007.12)

Frame No. Punching Position

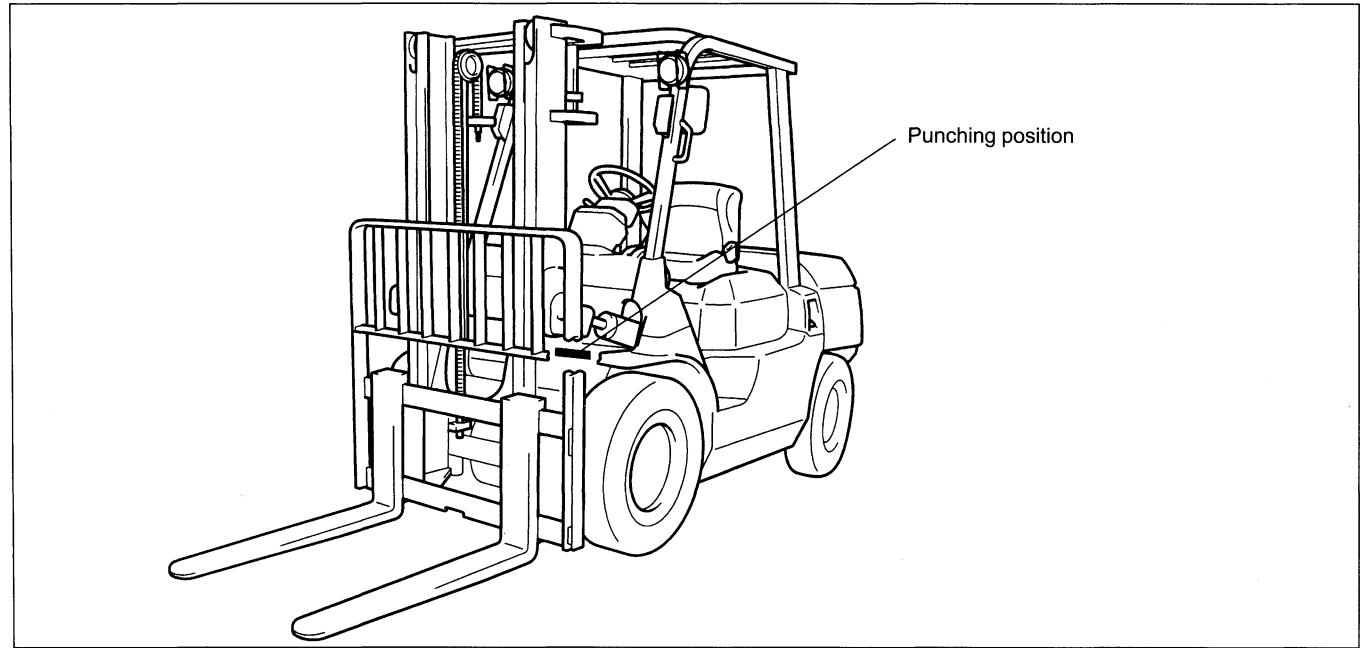

0

	Series	Engine	Vehicle model	Punching format
Pneumatic tire	3.5 ton series	G4 (GM6-262)	7FGU35	7FGKU40 - 60011
			7FGKU40	
		13Z	7FDU35	7FDKU40 - 60011
			7FDKU40	
	4.5 ton series	G4 (GM6-262)	7FGU45	7FGAU50 - 60011
			7FGAU50	
		13Z	7FDU45	7FDAU50 - 60011
			7FDAU50	
	6.0 ton series	G4 (GM6-262)	7FGU60	7FGU80 - 60011
			7FGU70	
7FGU80				
13Z		7FDU60	7FDU80 - 60011	
		7FDU70		
		7FDU80		
Cushion tire	3.5 ton series	G4 (GM6-262)	7FGCU35	7FGCU45 - 60011 * 7FGCU45 © 60011
			7FGCU45	
	5.5 ton series	G4 (GM6-262)	7FGCU55	7FGCU70 - 60011
			7FGCU60	
			7FGCU70	
			7FGCU70	

*: EEC spec.

FRAME NUMBER (2008.1 ~)

Frame No. Punching Position

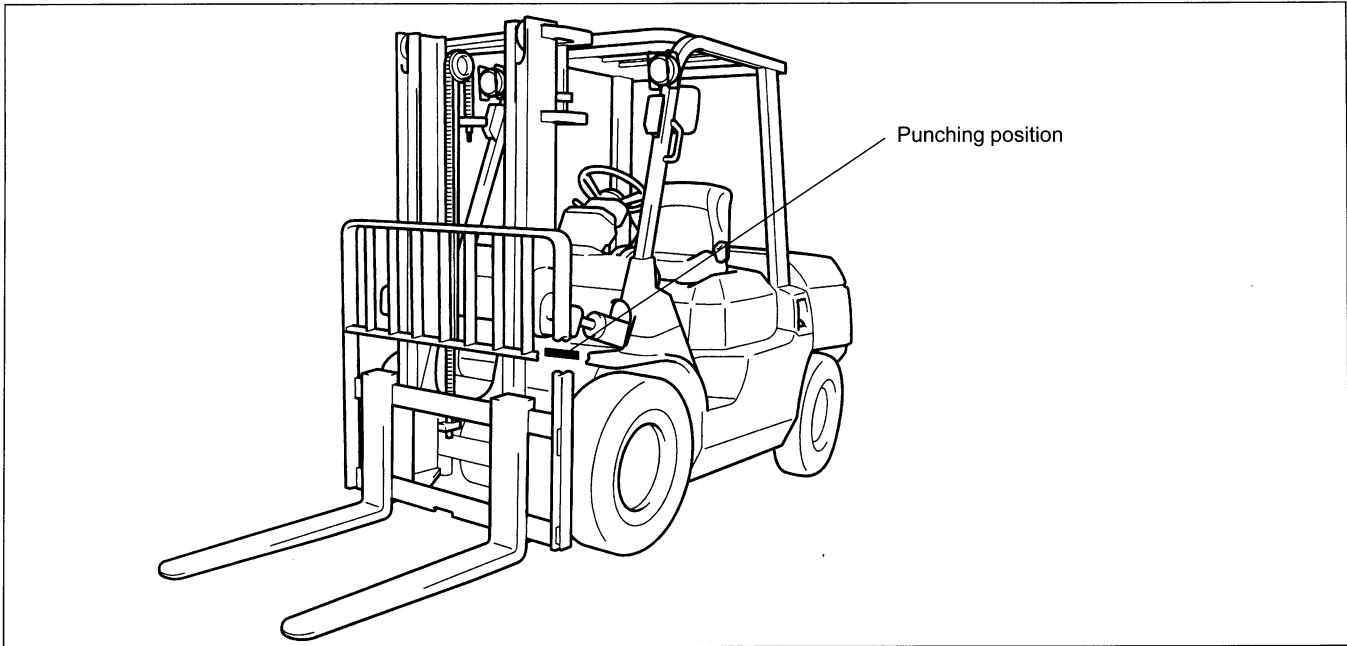

	Series	Engine	Vehicle model	Punching format
Pneumatic tire	3.5 ton series	G4 (GM6-262)	7FGU35	7FGKU40 - 70011
			7FGKU40	
		15Z	7FDU35	A7FDKU40 - 70011
			7FDKU40	
	4.5 ton series	G4 (GM6-262)	7FGU45	7FGAU50 - 70011
			7FGAU50	
		15Z	7FDU45	A7FDAU50 - 70011
			7FDAU50	
	6.0 ton series	G4 (GM6-262)	7FGU60	7FGU80 - 70011
			7FGU70	
			7FGU80	
		15Z	7FDU60	A7FDU80 - 70011
7FDU70				
7FDU80				
Cushion tire	3.5 ton series	G4 (GM6-262)	7FGCU35	7FGCU45 - 70011 * 7FGCU45 © 70011
			7FGCU45	
	5.5 ton series	G4 (GM6-262)	7FGCU55	7FGCU70 - 70011 * 7FGCU70 © 70011
			7FGCU60	
			7FGCU70	
			7FGCU70	

*: EEC spec.

HOW TO USE THIS MANUAL

EXPLANATION METHOD

1. Operation procedure

(1) The operation procedure is described in either pattern A or pattern B below.

Pattern A: Explanation of each operation step with illustration.

Pattern B: Explanation of operation procedure by indicating step numbers in one illustration, followed by explanation of cautions and notes summarized as point operations.

Example of description in pattern B

DISASSEMBLY·INSPECTION·REASSEMBLY Tightening torque unit T = N·m (kgf·cm) [ft·lbf]

- Step Nos. are partially sometimes omitted in illustrations.
- When a part requiring tightening torque instruction is not indicated in the illustration, the part name is described in the illustration frame.

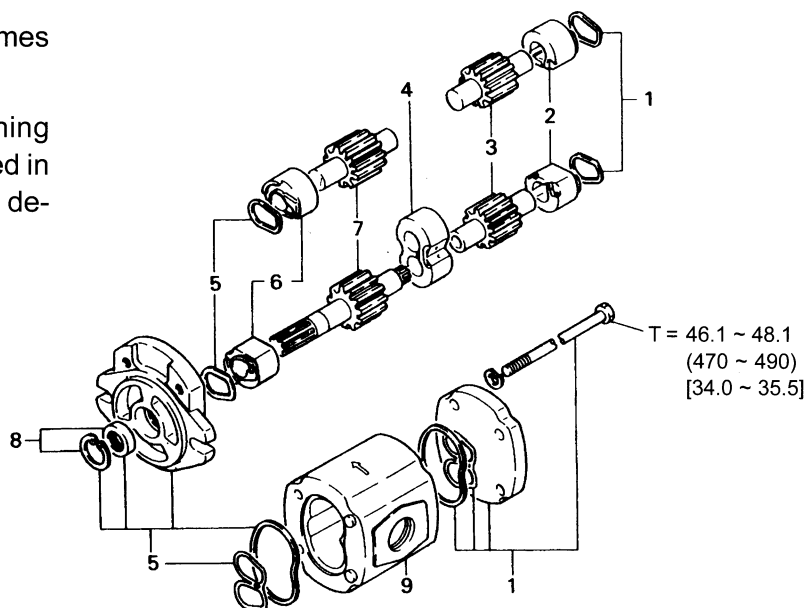

Disassembly Procedure

- 1 Remove the cover. **[Point 1]**
- 2 Remove the bushing **[Point 2]** ← Operation explained later
- 3 Remove the gear.

Point Operations Explanation of key point for operation with an illustration

[Point 1]

Disassembly: Put a match mark when removing the pump cover.

[Point 2]

Inspection: Measure the bushing inside diameter.

Limit: 19.12 mm (0.7528 in)

2. How to read components figures

- (1) The components figure uses the illustration in the parts catalog for the vehicle model. Please refer to the catalog for checking the part name.
The number at the right shoulder of each components figure indicates the Fig. number in the parts catalog.

(Example)

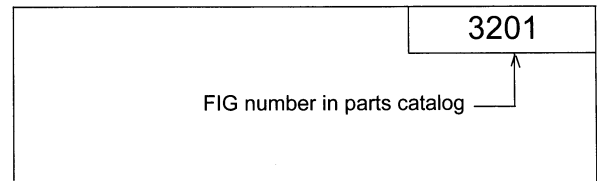

3. Matters omitted in this manual

- (1) This manual omits description of the following jobs, but perform them in actual operation:
- ① Cleaning and washing of removed parts as required
 - ② Visual inspection (partially described)

TERMINOLOGY

Caution:

Important matters of which negligence may cause hazards on human body. Be sure to observe them.

Note:

Important items of which negligence may cause breakage or breakdown, or matters in operation procedure requiring special attention.

Standard: Values showing allowable range in inspection and adjustment.

Limit: Maximum or minimum allowable value in inspection or adjustment.

ABBREVIATIONS

Abbreviation (code)	Meaning	Abbreviation (code)	Meaning
ASSY	Assembly	SAE	Society of Automotive Engineers (USA)
Cu	Cushion tire models	SAS	System of active stability
LH	Left hand	SST	Special service tool
LLC	Long life coolant	STD	Standard
M/T	Manual transmission	T =	Tightening torque
NMR	No-load maximum speed	T/C	Torque converter & transmission
OPT	Option	○ ○ T	Number of teeth (○ ○)
O/S	Oversize	U/S	Undersize
Pn	Pneumatic tire models	W/	With
PS	Power steering	L/	Less
RH	Right hand		

OPERATIONAL TIPS

1. Safe operation

- (1) After jacking up, always support with wooden blocks or rigid stands.
- (2) When hoisting the vehicle or its heavy component, use wire rope(s) with a sufficient reserve in load capacity.
- (3) Always disconnect the battery terminal before the inspection or servicing of electrical parts.

2. Tactful operation

- (1) Prepare the mechanic tools, necessary measuring instruments (circuit tester, megger, oil pressure gauge, etc.) and SSTs before starting operation.
- (2) Before disconnecting wiring, always check the cable color and wiring state.
- (3) When overhauling functional parts, complicated portions or related mechanisms, arrange the parts neatly to prevent confusion.
- (4) When disassembling and inspecting such a precision part as the control valve, use clean tools and operate in a clean location.
- (5) Follow the described procedures for disassembly, inspection and reassembly.
- (6) Replace gaskets, packings and O-rings with new ones each time they are disassembled.
- (7) Use genuine Toyota parts for replacement.
- (8) Use specified bolts and nuts. Observe the specified tightening torque at the time of reassembly. Tighten to the center of the specified tightening torque range.
If no tightening torque is specified, tighten the bolt or nut according to the standard tightening torque table.

3. Grasping the trouble state

When a trouble occurs, do not attempt immediate disassembly or replacement but first check if the trouble requires disassembly or replacement for remedying.

4. Disposal of waste fluid, etc.

When draining waste fluid from the vehicle, receive it in a container.

If any oil, fuel, coolant, oil filter, battery or other harmful substance is directly discharged or scrapped without permission, it will either adversely affect human health or destroy the environment. Always sort waste fluids, etc. and treat them properly by requesting disposal by specialized companies.

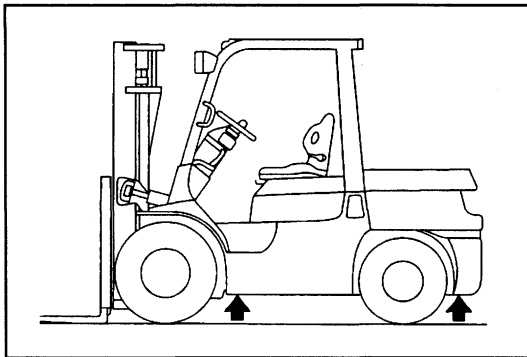

5. Jack up points

Front side:

Jack up at the bottom surface of the frame.

Rear side:

Jack up at the under the counterweight.

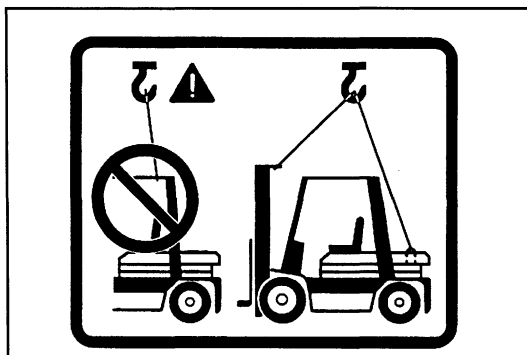

HOISTING THE VEHICLE

When hoisting the vehicle, sling with wire rope(s) at the mast hook holes and the counterweight hook holes.

ATTENTIVE POINTS ON SAS

1. Reference should be made to separate manual "New Model Feature 7FG(C)U/7FDU35-80 Pub. No.PU017" for the explanations of SAS functions and operations.
2. Read Section 15 SAS "Precautions for Repair" on Page 15-8 in this repair manual in advance.
3. Whenever the repair or replacement is performed to the place where relative to SAS function, re-setting procedure by which the SAS regain proper function must be performed. (See Page 15-23)
4. The warning on the SAS caution label must be confirmed when the modification or change is such as to change the original specification.
If improper, change the label. (See Page 15-11)
5. Care should always be exercised for safety operation whenever you operate the truck.
Make distinction between the SAS featured trucks and those of none, because the control features are different.
6. The SAS oil control valves comprise many precision valves. Since dirty or contaminated hydraulic oil will adversely affect the functions of these valves, always wash the parts clean at the time of installation after disassembly or for replacement of hydraulic parts (valves, piping, etc.). Periodic replacement of the hydraulic oil is very important.
7. Since this vehicle uses high-precision electronic devices, modification of electrical parts may cause faults. Always use genuine Toyota parts when replacing or installing electrical parts (auxiliary equipment, optional parts, etc.).

CIRCUIT TESTER

Circuit testers are available in both the analog and digital types. They should be used selectively according to the purpose of measurement.

Analog type: This type is convenient for observing movement during operation, but the measured value should only be used for reference or rough judgement.

Digital type: Fairly accurate reading is possible, but it is difficult to observe the variation or movement.

1. Difference in measurement results with the digital type and analog type

* The result may be different between measurements with the analog type and digital type.

Always use a circuit tester according to its operation manual.

Cautions when the polarities are different between the analog type and digital type are described below.

(1) Analog circuit tester

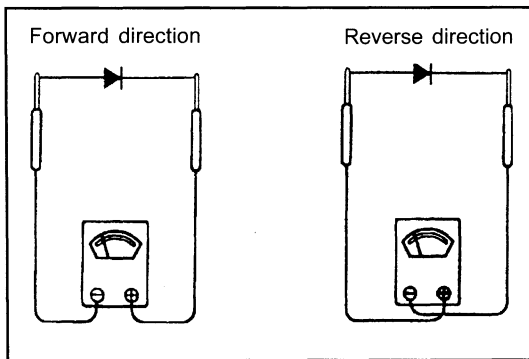

Measurement result example

Tester range: $k\Omega$ range

	Analog type
Forward	Continuity exists
	11 $k\Omega$
Reverse	No continuity
	∞

(2) Digital circuit tester

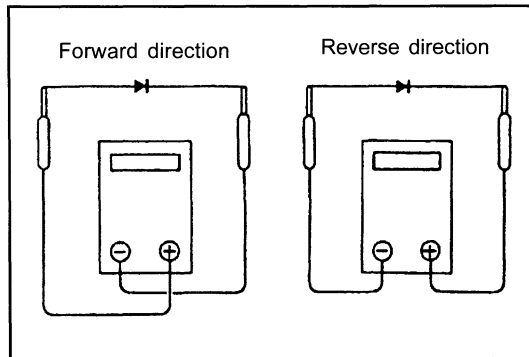

Measurement result example

Tester range: $M\Omega$ range

	Digital type
Forward	No continuity
	1
Reverse	Continuity exists
	2 $M\Omega$

2. Difference in result of measurement with circuit tester

The circuit tester power supply voltage depends on the tester type. 1.5 V, 3.0 V or 6.0 V is used.

The resistance of a semiconductor such as a diode varies with the circuit tester power supply voltage.

The diode characteristics are shown in the figure below.

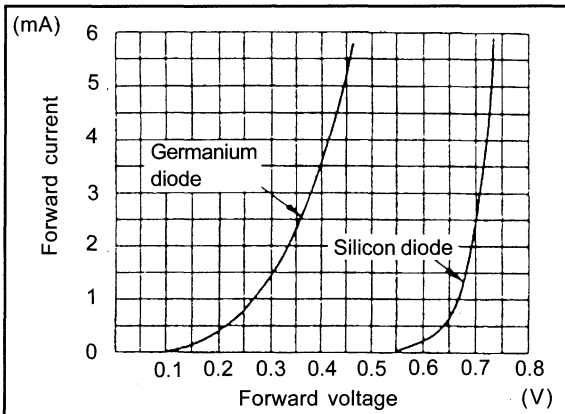

The resistance values of the same semiconductor measured with two types of circuit testers having different power supply voltages are different.

This manual describes the results of measurement with a circuit tester whose power supply voltage is 3.0 V.

3. Difference in measurement result by measurement range (analog type)

In the analog type circuit tester, changing the measurement range switches over the internal circuit to vary the circuit resistance. Even when the same diode is measured, the measurement result varies with the measurement range.

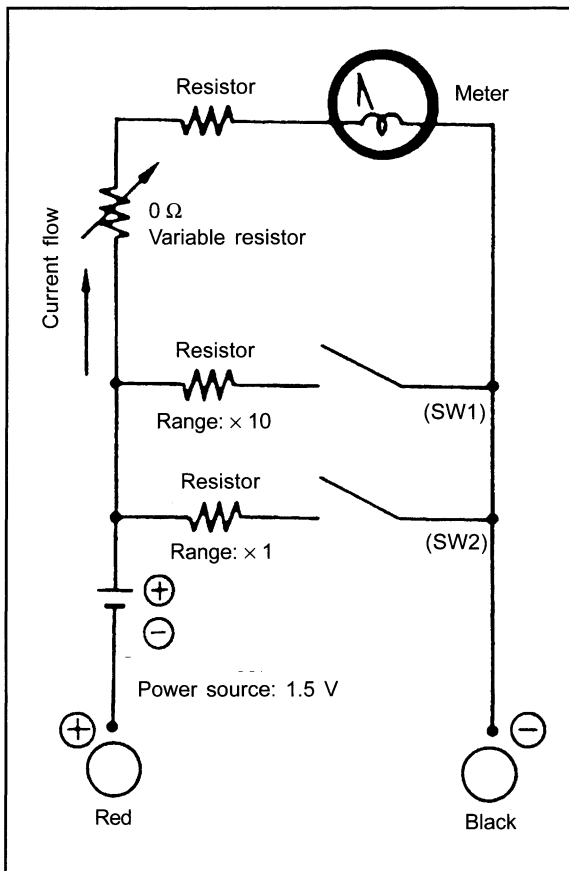

Always use the range described in the repair manual for measurement.









STANDARD BOLT & NUT TIGHTENING TORQUE

Standard bolt and tightening torques are not indicated.
Judge the standard tightening torque as shown below.

1. Find out the type of the bolt from the list below and then find the bolt tightening torque from the table.
2. The nut tightening torque can be judged from the mating bolt type.

BOLT STRENGTH TYPE IDENTIFICATION METHOD

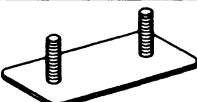
IDENTIFICATION BY BOLT SHAPE

	Shape and class	Class
Hexagon head bolt	 Bolt head No.	4 = 4T 5 = 5T 6 = 6T 7 = 7T 8 = 8T
	 No mark	4T
Hexagon flange bolt	 No mark	4T
Hexagon head bolt	 Two protruding lines	5T
Hexagon flange bolt	 Two protruding lines	6T
Hexagon head bolt	 Three protruding lines	7T
Hexagon head bolt	 Four protruding lines	8T
Welded bolt		4T
Stud bolt	 No mark	4T
	 Grooved	6T

IDENTIFICATION BY PART NO.

Hexagon head bolt

Parts No.
91611-40625

Length (mm)
 Diameter (mm)
 Class

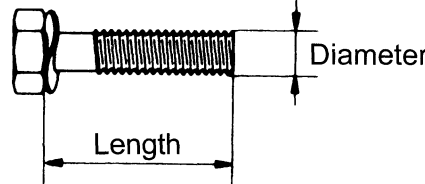

Diameter

Length

Stud bolt

Part No.
92132-40614

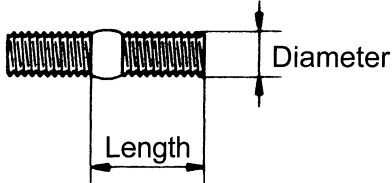

Length (mm)
 Diameter (mm)
 Class



Diameter

Length

TIGHTENING TORQUE TABLE

Class	Diameter mm	Pitch mm	Specified torque					
			Hexagon head bolt 			Hexagon flange bolt 		
			N·m	kgf-cm	ft-lbf	N·m	kgf-cm	ft-lbf
4T	6	1.0	5.4	55	48 in-lbf	5.9	60	52 in-lbf
	8	1.25	13	130	9	14	145	10
	10	1.25	25	260	19	28	290	21
	12	1.25	47	480	35	53	540	39
	14	1.5	75	760	55	83	850	61
	16	1.5	113	1150	83	—	—	—
5T	6	1.0	6.4	65	56 in-lbf	7.5	75	65 in-lbf
	8	1.25	16	160	12	18	175	13
	10	1.25	32	330	24	36	360	26
	12	1.25	59	600	43	65	670	48
	14	1.5	91	930	67	100	1050	76
	16	1.5	137	1400	101	157	1600	116
6T	6	1.0	7.8	80	69 in-lbf	8.8	90	78 in-lbf
	8	1.25	19	195	14	21	215	16
	10	1.25	38	400	29	43	440	32
	12	1.25	72	730	53	79	810	59
	14	1.5	110	1100	80	123	1250	90
	16	1.5	170	1750	127	191	1950	141
7T	6	1.0	11	110	8	12	120	9
	8	1.25	25	260	19	28	290	21
	10	1.25	52	530	38	58	590	43
	12	1.25	95	970	70	103	1050	76
	14	1.5	147	1500	108	167	1700	123
	16	1.5	226	2300	166	—	—	—
8T	6	1.0	12	125	9	14	145	9
	8	1.25	29	300	22	32	330	24
	10	1.25	61	620	45	68	690	50
	12	1.25	108	1100	80	123	1250	90
	14	1.5	172	1750	127	196	2000	145
	16	1.5	265	2700	195	299	3050	221

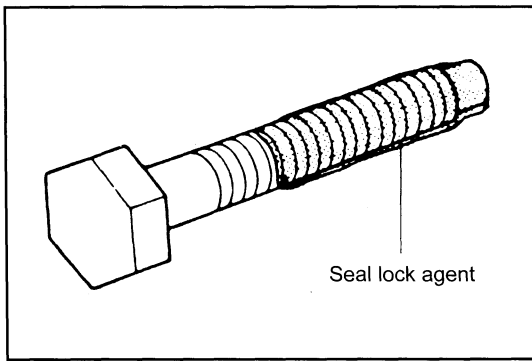

PRECOAT BOLTS

(Bolts with seal lock agent coating on threads)

1. Do not use the precoat bolt as it is in either of the following cases:
 - (a) After it is removed.
 - (b) When the precoat bolt is moved (loosened or tightened) by tightness check, etc.

Note:

For torque check, use the lower limit of the allowable tightening torque range. If the bolt moves, re-tighten it according to the steps below.

2. Method for reuse of precoat bolts
 - (1) Wash the bolt and threaded hole. (The threaded hole must be washed even for replacement of the bolt.)
 - (2) Perfectly dry the washed parts by air blowing.
 - (3) Coat the specified seal lock agent to the threaded portion of the bolt.

HIGH PRESSURE HOSE FITTING TIGHTENING TORQUE

1. When connecting a high pressure hose, wipe the hose fitting and mating nipple contact surfaces with clean cloth to remove foreign matters and dirt. Also check no dent or other damage on the contact surfaces before installation.
2. When connecting a high pressure hose, hold the hose to align the fitting with the nipple and tighten the fitting.
3. The maximum tightening torque must not exceed twice the standard tightening torque.

Nominal diameter of screw	Standard tightening torque N·m (kgf·cm) [ft·lbf]		Hose inside diameter mm (in)
	Standard	Tightening range	
7/16 — 20UNF	25 (250) [18.1]	24 ~ 26 (240 ~ 270) [17.4 ~ 19.5]	6 (0.24)
9/16 — 18UNF	49 (500) [36.2]	47 ~ 52 (480 ~ 530) [34.7 ~ 38.3]	9 (0.35)
3/4 — 16UNF	59 (600) [43.4]	56 ~ 62 (570 ~ 630) [41.2 ~ 45.6]	12 (0.47)
7/8 — 14UNF	59 (600) [43.4]	56 ~ 62 (570 ~ 630) [41.2 ~ 45.6]	12 (0.47), 15 (0.59)
1-1/16 — 12UNF	118 (1200) [86.8]	112 ~ 123 (1140 ~ 1250) [82.5 ~ 90.4]	19 (0.75)
1-5/16 — 12UNF	137 (1400) [101.3]	130 ~ 144 (1330 ~ 1470) [96.2 ~ 106.4]	25 (0.98)
PF1/4	25 (250) [18.1]	24 ~ 26 (240 ~ 270) [17.4 ~ 19.5]	6 (0.24)
PF3/8	49 (500) [36.2]	47 ~ 52 (480 ~ 530) [34.7 ~ 38.3]	9 (0.35)
PF1/2	59 (600) [43.4]	56 ~ 62 (570 ~ 630) [41.2 ~ 45.6]	12 (0.47)
PF3/4	118 (1200) [86.8]	112 ~ 123 (1140 ~ 1250) [82.5 ~ 90.4]	19 (0.75)
PF1	137 (1400) [101.3]	130 ~ 144 (1330 ~ 1470) [96.2 ~ 106.4]	25 (0.98)

WIRE ROPE SUSPENSION ANGLE LIST

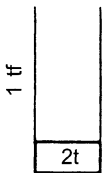
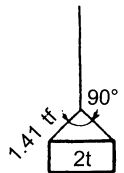
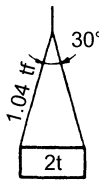
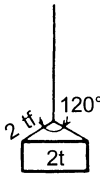
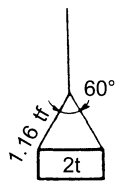
Lifting angle	Tension	Compression	Suspension method	Lifting angle	Tension	Compression	Suspension method
0°	1.00 time	0 time		90°	1.41 time	1.00 time	
30°	1.04 time	0.27 time		120°	2.00 time	1.73 time	
60°	1.16 time	0.58 time					

SAFE LOAD FOR EACH WIRE ROPE SUSPENSION ANGLE

Unit: N (tf) [lbf]

Rope diameter	Cutting load	Single-rope suspension	Two-rope suspension					Four-rope suspension			
		0°	0°	30°	60°	90°	0°	30°	60°	90°	
6 mm (0.24 in)	21380 (2.18) [4807]	3040 (0.31) [683.6]	6080 (0.62) [1367]	5880 (0.6) [1323]	5200 (0.53) [1169]	4310 (0.44) [970]	12160 (1.24) [2734]	11770 (1.2) [2646]	10400 (1.06) [2337]	8630 (0.88) [1940]	
8 mm (0.32 in)	31480 (3.21) [7078]	4410 (0.45) [992.3]	8830 (0.9) [1985]	8530 (0.87) [1918]	7650 (0.78) [1720]	6280 (0.64) [1411]	17650 (1.8) [3969]	17060 (1.74) [3937]	15300 (1.56) [3440]	12550 (1.28) [2322]	
10 mm (0.4 in)	49230 (5.02) [11.69]	6960 (0.71) [1565.6]	14020 (1.43) [3153]	13440 (1.37) [3021]	11770 (1.2) [2646]	9810 (1.0) [2205]	27460 (2.8) [6174]	26480 (2.7) [5954]	23540 (2.4) [5292]	19610 (2.0) [4410]	
12.5 mm (0.5 in)	76880 (7.84) [17387]	10980 (1.12) [2469.5]	21570 (2.2) [4851]	21280 (2.1) [4631]	18630 (1.9) [4190]	14710 (1.5) [3308]	43150 (4.4) [9702]	41190 (4.2) [9261]	37270 (3.8) [8379]	29420 (3.0) [6615]	
14 mm (0.56 in)	96400 (9.83) [21675]	13730 (1.4) [3087]	27460 (2.8) [6174]	26480 (2.7) [5954]	23540 (2.4) [5292]	18630 (1.9) [4190]	54920 (5.6) [12348]	52960 (5.4) [11907]	47070 (4.8) [10584]	37270 (3.8) [8379]	

COMPONENTS WEIGHT (~ 2007.12)

Component		Weight kg (lb)
Engine	G4 (GM6-262)	185 (408)
	13Z	325 (717)
Torque converter & transmission	Pn35~50, Cu35~70 model	150 (331)
	Pn60 ~ 80 model	170 (375)
Counter weight	Pn35 model	Approx. 2230 (4920)
	Pn40 model	Approx. 2630 (5800)
	Pn45 model	Approx. 2880 (6350)
	Pn50 model	Approx. 3130 (6950)
	Pn60 model	Approx. 3430 (7565)
	Pn70 model	Approx. 4110 (9065)
	Pn80 model	Approx. 4790 (10565)
	Cu35 model	Approx. 2370 (5225)
	Cu45 model	Approx. 3120 (6880)
	Cu55 model	Approx. 3500 (7720)
	Cu60 model	Approx. 3920 (8645)
	Cu70 model	Approx. 4570 (10080)
V mast ASSY L/backrest and fork (with lift cylinder, max. lifting height: 3000 mm (118 in))	Pn35-40 model	Approx. 890 (1960)
	Pn45 model	Approx. 1140 (2510)
	Pn50 model	Approx. 1270 (2800)
	Pn60-70 model	Approx. 1340 (2950)
	Pn80 model	Approx. 1340 (2950)
	Cu35 model	Approx. 890 (1960)
	Cu45 model	Approx. 950 (2090)
	Cu55 model	Approx. 1270 (2800)
	Cu60-70 model	Approx. 1340 (2950)

COMPONENTS WEIGHT (2008.1 ~)

Component		Weight	kg (lb)	
Engine	G4 (GM6-262)		185 (408)	
	15Z		304 (670)	
Torque converter & transmission	Pn35 ~ 50, Cu35 ~ 70 model		150 (331)	
	Pn60 ~ 80 model		170 (375)	
Counter weight	Pn35 model	GM6-262	Approx. 2230 (4920)	
		15Z	Approx. 2265 (4995)	
	Pn40 model	GM6-262	Approx. 2630 (5800)	
		15Z	Approx. 2665 (5880)	
	Pn45 model	GM6-262	Approx. 2880 (6530)	
		15Z	Approx. 2930 (6460)	
	Pn50 model	GM6-262	Approx. 3130 (6950)	
		15Z	Approx. 3180 (7015)	
	Pn60 model	GM6-262	Approx. 3430 (7565)	
		15Z	Approx. 3480 (7675)	
	Pn70 model	GM6-262	Approx. 4110 (9065)	
		15Z	Approx. 4135 (9120)	
	Pn80 model	GM6-262	Approx. 4790 (10565)	
		15Z	Approx. 4825 (10640)	
		Cu35 model		Approx. 2370 (5225)
		Cu45 model		Approx. 3120 (6880)
		Cu55 model		Approx. 3500 (7720)
		Cu60 model		Approx. 3920 (8645)
	Cu70 model		Approx. 4570 (10080)	
V mast ASSY L/backrest and fork (with lift cylinder, max. lifting height: 3000 mm (118 in.))	Pn35-40 model		Approx. 890 (1960)	
	Pn45 model		Approx. 1140 (2510)	
	Pn50 model		Approx. 1270 (2800)	
	Pn60-70 model		Approx. 1340 (2950)	
	Pn80 model		Approx. 1340 (2950)	
	Cu35 model		Approx. 890 (1960)	
	Cu45 model		Approx. 950 (2090)	
	Cu55 model		Approx. 1270 (2800)	
	Cu60-70 model		Approx. 1340 (2950)	

RECOMMENDED LUBRICANT QUANTITY & TYPES (~ 2007.12)

Description		Application	Quantity ℓ (US gal)	Classification	Type
Engine	Gasoline	G4 (GM6-262)	4.2 (1.11)	API SH, SJ	Motor oil SAE30 (SAE20 in cold area) SAE20W-40 (SAE10W-30 in cold area)
	Diesel	13Z	12.5 (3.30)	API CE, CF	Diesel engine oil SAE30 (SAE20 in cold area) SAE10W-30
Transmission		T/C	12.0 (3.17)	ATF	GM Dexron® II
Differential	Pn35~50 models	9.0 (2.38)	API GL-4, GL-5	Hypoid gear oil SAE85W-90	
	Pn60~80 models	10.0 (2.64)			
	Cu35~70 models	7.0 (1.85)			
Planetary gear	Pn60~80 models	See page 5-21 (One side : 1.5 (0.40))	↑	↑	
	Cu35~70 models	See page 5-21			
Hydraulic oil (V mast, max. lifting height 3000mm (118in))	Pn35~80, Cu55~70 models	69 (18.2)	SO VG32	Hydraulic oil	
	Cu35~45 models	38 (10.0)			
Fuel tank	Pn35~40, Cu55~70 models	105 (27.7)	—	—	
	Pn45~80 models	120 (31.7)			
	Cu35~45 models	48 (12.7)			
Chassis parts	All models	Proper quantity	—	<ul style="list-style-type: none"> • MP grease • Molybdenum disulfide grease 	
Coolant (excluding reservoir tank)	G4 (GM6-262)	13.0 (3.46)	LLC	<ul style="list-style-type: none"> • LLC 30-50% mixture (for winter or all-season) • Coolant with rust-inhibitor (for spring, summer and autumn) 	
	13Z	13.0 (3.46)			
Coolant (Reservoir Tank)	All models	0.6 (0.16) (at Full level)	↑	↑	

RECOMMENDED LUBRICANT QUANTITY & TYPES (2008.1 ~)

Description		Application	Quantity ℓ (US gal)	Classification	Type
Engine	Gasoline	G4 (GM6-262)	4.2 (1.11)	API SH, SJ	Motor oil SAE30 (SAE20 in cold area) SAE20W-40 (SAE10W-30 in cold area)
	Diesel	15Z	14.5 (3.83)	API CE, CF	Diesel engine oil SAE30 (SAE20 in cold area) SAE10W-30
Transmission		T/C	12.0 (3.17)	ATF	GM Dexron® II
Differential	Pn35~50 models		9.0 (2.38)	API GL-4, GL-5	Hypoid gear oil SAE85W-90
	Pn60~80 models		10.0 (2.64)		
	Cu35~70 models		7.0 (1.85)		
Planetary gear	Pn60~80 models		See page 5-21 (One side : 1.5 (0.40))	↑	↑
	Cu35~70 models		See page 5-21		
Hydraulic oil (V mast, max. lifting height 3000mm (118in))	Pn35~80, Cu55~70 models		69 (18.2)	SO VG32	Hydraulic oil
	Cu35-45 models		38 (10.0)		
Fuel tank	Pn35-40, Cu55~70 models		105 (27.7)	—	—
	Pn45~80 models		120 (31.7)		
	Cu35-45 models		48 (12.7)		
Chassis parts	All models	Proper quantity	—	—	<ul style="list-style-type: none"> • MP grease • Molybdenum disulfide grease
Coolant (excluding reservoir tank)	G4 (GM6-262)	13.0 (3.46)	LLC	<ul style="list-style-type: none"> • LLC 30-50% mixture (for winter or all-season) • Coolant with rust-inhibitor (for spring, summer and autumn) 	
	15Z	14.0 (3.70)			
Coolant (Reservoir Tank)	All models	0.6 (0.16) (at Full level)	↑	↑	

LUBRICATION CHART

Pneumatic Tire Model (Pn35~50)

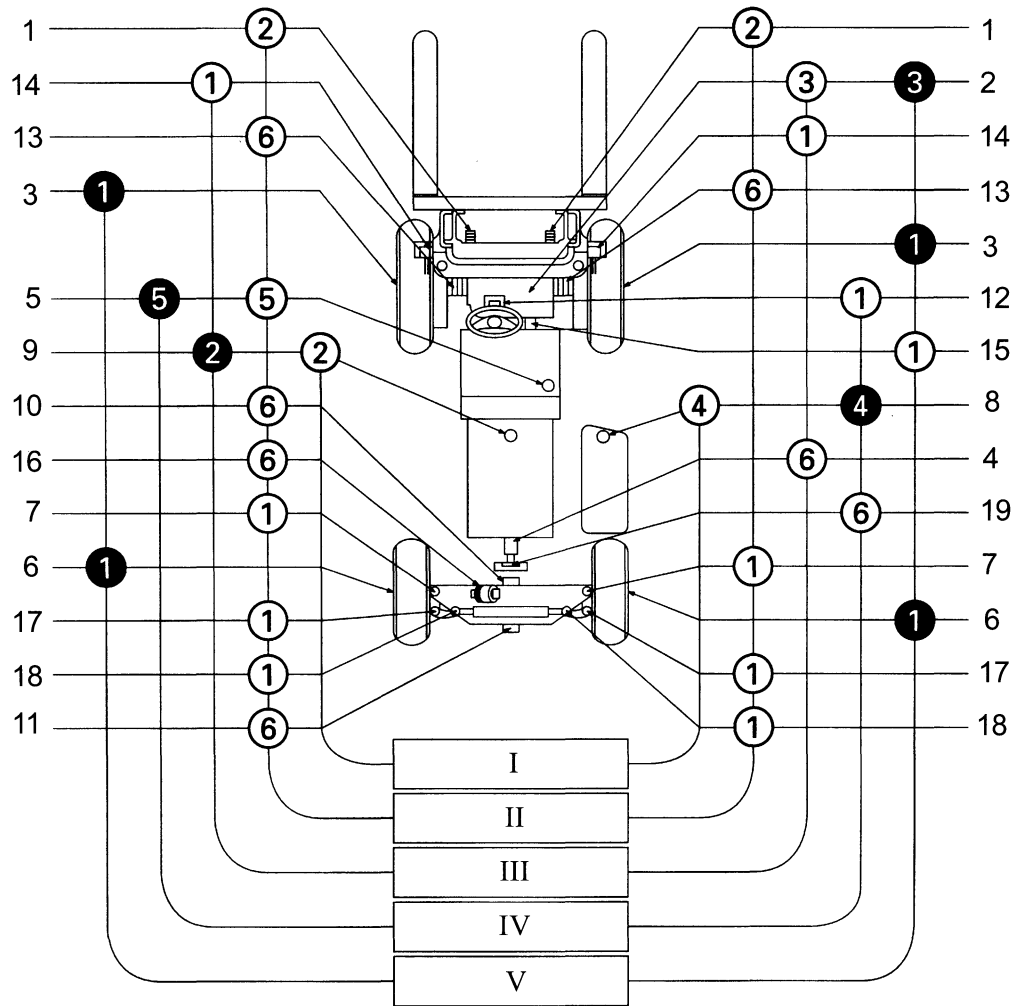

- Inspection
- Replacement
- ① MP grease
- ② Engine oil
- ③ Hypoid gear oil
- ④ Hydraulic oil
- ⑤ Automatic transmission fluid
- ⑥ Molybdenum disulfide grease

- I. Inspect every 8 hours (daily)
- II. Inspect every 40 hours (weekly)
- III. Inspect every 250 hours (6 weeks)
- IV. Inspect every 1000 hours (6 monthly)
- V. Inspect every 2000 hours (annual)

- | | |
|-----------------------------|------------------------------------|
| 1 Chain | 11 Rear axle beam rear pin |
| 2 Differential | 12 Tilt steering locking mechanism |
| 3 Front wheel bearing | 13 Mast support bushing |
| 4 Oil pump drive shaft | 14 Tilt cylinder front pin |
| 5 Torque converter case | 15 Propeller shaft |
| 6 Rear wheel bearing | 16 Swing lock cylinder lower pin |
| 7 Steering knuckle king pin | 17 Tie rod end pin |
| 8 Oil tank | 18 Rear axle cylinder end pin |
| 9 Engine crank case | 19 Oil pump spline shaft |
| 10 Rear axle beam front pin | |

Pneumatic Tire Model (Pn60~80)

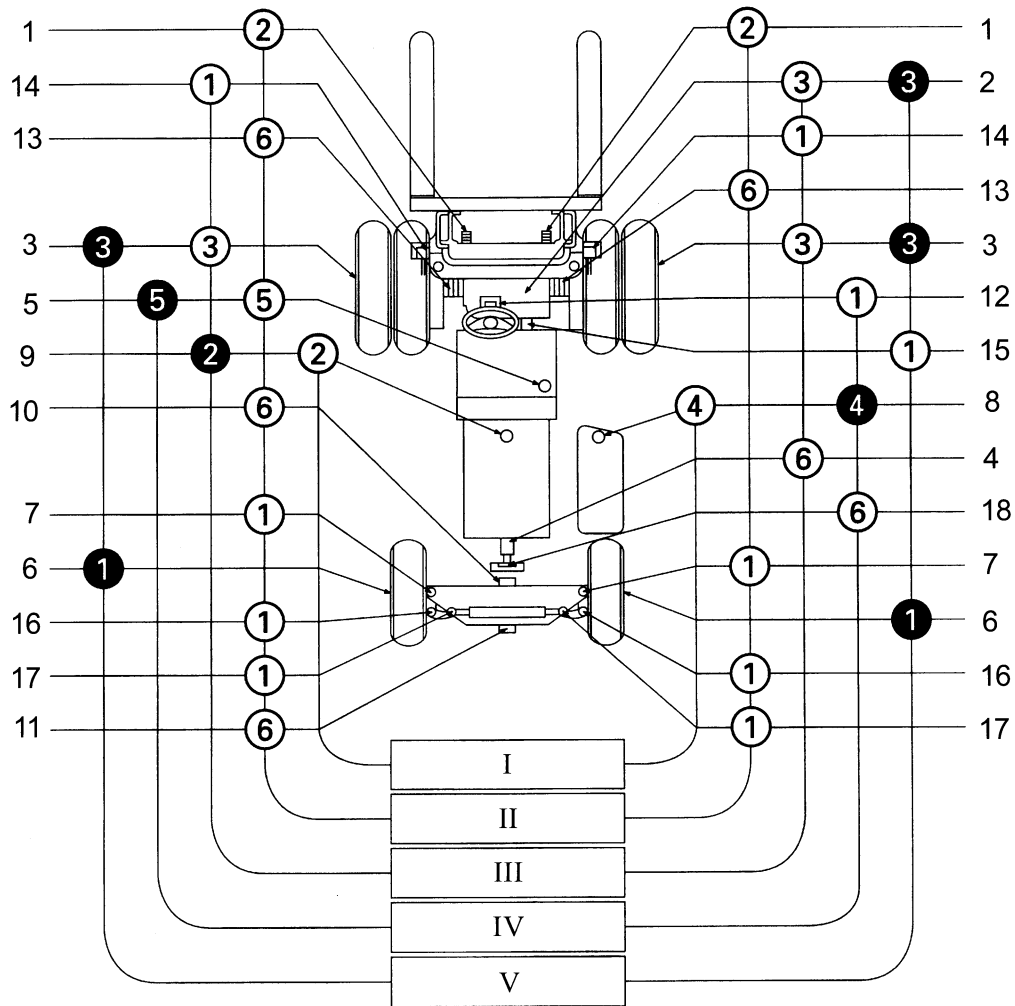

- Inspection
- Replacement
- ① MP grease
- ② Engine oil
- ③ Hypoid gear oil
- ④ Hydraulic oil
- ⑤ Automatic transmission fluid
- ⑥ Molybdenum disulfide grease

- I. Inspect every 8 hours (daily)
- II. Inspect every 40 hours (weekly)
- III. Inspect every 250 hours (6 weeks)
- IV. Inspect every 1000 hours (6 monthly)
- V. Inspect every 2000 hours (annual)

- | | |
|-----------------------------|------------------------------------|
| 1 Chain | 11 Rear axle beam rear pin |
| 2 Differential | 12 Tilt steering locking mechanism |
| 3 Planetary gear | 13 Mast support bushing |
| 4 Oil pump drive shaft | 14 Tilt cylinder front pin |
| 5 Torque converter case | 15 Propeller shaft |
| 6 Rear wheel bearing | 16 Tie rod end pin |
| 7 Steering knuckle king pin | 17 Rear axle cylinder end pin |
| 8 Oil tank | 18 Oil pump spline shaft |
| 9 Engine crank case | |
| 10 Rear axle beam front pin | |

Cushion Tire Model

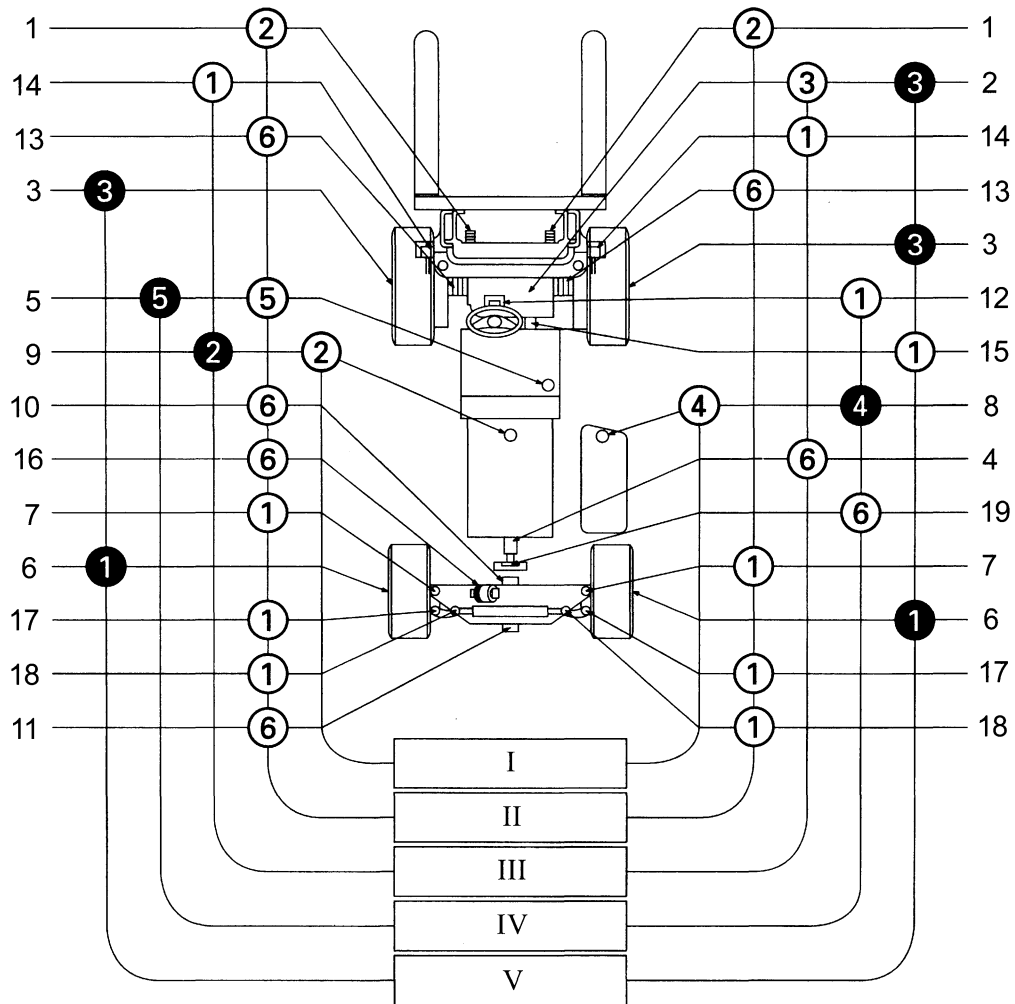

- Inspection
- Replacement
- ① MP grease
- ② Engine oil
- ③ Hypoid gear oil
- ④ Hydraulic oil
- ⑤ Automatic transmission fluid
- ⑥ Molybdenum disulfide grease

- I. Inspect every 8 hours (daily)
- II. Inspect every 40 hours (weekly)
- III. Inspect every 250 hours (6 weeks)
- IV. Inspect every 1000 hours (6 monthly)
- V. Inspect every 2000 hours (annual)

- | | |
|-----------------------------|------------------------------------|
| 1 Chain | 11 Rear axle beam rear pin |
| 2 Differential | 12 Tilt steering locking mechanism |
| 3 Planetary gear | 13 Mast support bushing |
| 4 Oil pump drive shaft | 14 Tilt cylinder front pin |
| 5 Torque converter case | 15 Propeller shaft |
| 6 Rear wheel bearing | 16 Swing lock cylinder lower pin |
| 7 Steering knuckle king pin | 17 Tie rod end pin |
| 8 Oil tank | 18 Rear axle cylinder end pin |
| 9 Engine crank case | 19 Oil pump spline shaft |
| 10 Rear axle beam front pin | |

PERIODIC MAINTENANCE

INSPECTION METHOD

I : Inspection. Repair or replacement if required.
 M : Measurement. Repair or adjustment if required.
 T : Retightening C : Cleaning L : Lubrication
 * : For new vehicle *1 : Flaw detector

Item		Inspection Period			
		Every 6 weeks	Every 3 months	Every 6 months	Every 12 months
		Every 250 hours	Every 500 hours	Every 1000 hours	Every 2000 hours
ENGINE					
Main body	Proper starting and abnormal noise	I	←	←	←
	Rotating condition at idling	M	←	←	←
	Rotating condition during acceleration	M	←	←	←
	Exhaust gas condition	I	←	←	←
	Air cleaner element	C	←	←	←
	Valve clearance	M*			M
	Compression				M
	Cylinder head bolt loosening				T
	Muffler rubber mount				I
PCV system	Clogging and damage in PCV valve and piping	I	←	←	←
Governor	No-load maximum rpm	M	←	←	←
Lubrication system	Oil leak	I	←	←	←
	Oil level	I	←	←	←
	Clogging and dirt of oil filter	I	←	←	←
Fuel system	Fuel leak	I	←	←	←
	Operation of carburetor link mechanism	I	←	←	←
	Dirt and clogging of fuel filter and element	I	←	←	←
	Injection timing			M	←
	Injection nozzle injection pressure and spray status				M
	Draining of sedimenter			I	←
Cooling system	Coolant level in radiator and leak	I	←	←	←
	Rubber hose degradation	I	←	←	←
	Radiator cap condition	I	←	←	←
	Fan belt tension, looseness and damage	I	←	←	←
	Radiator rubber mount				I

Item		Inspection Period	Every 6 weeks	Every 3 months	Every 6 months	Every 12 months
			Every 250 hours	Every 500 hours	Every 1000 hours	Every 2000 hours
POWER TRANSMISSION SYSTEM						
Differential	Leak	I	←	←	←	←
	Oil level	I	←	←	←	←
	Bolt loosening					T
Planetary gear	Leak	I	←	←	←	←
	Oil level	I	←	←	←	←
	Bolt loosening					T
Torque converter & transmission	Leak	I	←	←	←	←
	Fluid level	I	←	←	←	←
	Operating mechanism function and looseness	I	←	←	←	←
	Control valve and clutch functions	I	←	←	←	←
	Inching valve function	I	←	←	←	←
	Stall and hydraulic pressure measurement				M	←
Propeller shaft and axle shaft	Loose joint		T	←	←	←
	Looseness at spline connections					I
	Looseness of universal joint					I
	Twisting and cracks of axle shaft					I
DRIVE SYSTEM						
Wheels	Tire inflation pressure	M	←	←	←	←
	Tire cuts, damage and uneven wearing	I	←	←	←	←
	Loose rim and hub nuts	T	←	←	←	←
	Tire groove depth	M	←	←	←	←
	Metal chips, pebbles and other foreign matter trapped in tire grooves	I	←	←	←	←
	Rim, side bearing and disc wheel damage	I	←	←	←	←
	Abnormal sound and looseness of front wheel bearing	I	←	←	←	←
	Abnormal sound and looseness of rear wheel bearing	I	←	←	←	←

Item		Inspection Period	Every 6 weeks	Every 3 months	Every 6 months	Every 12 months
			Every 250 hours	Every 500 hours	Every 1000 hours	Every 2000 hours
Front axle	Cracks, damage and deformation of housing					I
Rear axle	Cracks, damage and deformation of beam					I
	Looseness of axle beam in vehicle longitudinal direction	M*				M
STEERING SYSTEM						
Steering wheel	Play and looseness	I	←	←	←	←
	Function	I	←	←	←	←
Steering valve	Oil leak	I	←	←	←	←
	Looseness of mounting	T	←	←	←	←
Power Steering	Oil leak	I	←	←	←	←
	Mounting and linkage looseness	I	←	←	←	←
	Damage of power steering hose					I
Knuckle	King pin looseness	I	←	←	←	←
	Cracks and deformation					I
BRAKING SYSTEM						
Brake pedal	Play and reserve	M	←	←	←	←
	Braking effect	I	←	←	←	←
Parking brake	Operating force	I	←	←	←	←
	Braking effect	I	←	←	←	←
	Rod and cable looseness and damage	I	←	←	←	←
Brake pipe	Leak, damage and mounting condition	I	←	←	←	←
Brake booster and wheel cylinder	Function, wear, damage, leak and mounting looseness					I

Item		Inspection Period			
		Every 6 weeks	Every 3 months	Every 6 months	Every 12 months
		Every 250 hours	Every 500 hours	Every 1000 hours	Every 2000 hours
Brake drum and brake shoe	Clearance between drum and lining	M	←	←	←
	Wear of shoe sliding portion and lining				I
	Drum wear and damage				I
	Shoe operating condition				I
	Anchor pin rusting				I
	Return spring fatigue				M
	Automatic adjuster function				I
Backing plate	Deformation, cracks and damage				I
	Loose mounting				T
MATERIAL HANDLING SYSTEM					
Forks	Abnormality of fork and stopper pin	I	←	←	←
	Misalignment between left and right fork fingers	I	←	←	←
	Cracks at fork root and welded part				I ¹
Mast and lift bracket	Deformation and damage of each part and crack at welded part	I	←	←	←
	Mast and lift bracket looseness	I	←	←	←
	Wear and damage of mast support bushing				I
	Wear, damage and rotating condition of rollers	I	←	←	←
	Wear and damage of roller pins				I
	Wear and damage of mast trip	I	←	←	←
Chain and chain wheel	Tension, deformation and damage of chain	I	←	←	←
	Chain lubrication	I	←	←	←
	Elongation of chain				I
	Abnormality of chain anchor bolt	I	←	←	←
	Wear, damage and rotating condition of chain wheel	I	←	←	←
Various attachments	Abnormality and mounting condition of each part	I	←	←	←
HYDRAULIC SYSTEM					
Cylinder	Loosening and damage of cylinder mounting	T	←	←	←
	Deformation and damage of rod, rod screw and rod end	I	←	←	←
	Cylinder operation	I	←	←	←

Item		Inspection Period			
		Every 6 weeks	Every 3 months	Every 6 months	Every 12 months
		Every 250 hours	Every 500 hours	Every 1000 hours	Every 2000 hours
Cylinder	Natural drop and natural forward tilt (hydraulic drift)	M	←	←	←
	Oil leak and damage	I	←	←	←
	Wear and damage of pin and pin support	I	←	←	←
	Lifting speed	M	←	←	←
	Uneven movement	I	←	←	←
Oil pump	Oil leak and abnormal sound	I	←	←	←
Hydraulic oil tank	Oil level and contamination	I	←	←	←
	Tank and oil strainer			C	←
	Oil leak	I	←	←	←
Control lever	Loose linkage	I	←	←	←
	Operation	I	←	←	←
Oil control valve	Oil leak	I	←	←	←
	Relief pressure measurement				M
	Relief valve and tilt lock valve functions	I	←	←	←
Hydraulic piping	Oil leak	I	←	←	←
	Deformation and damage	I	←	←	←
	Loose joint	T	←	←	←
ELECTRICAL SYSTEM					
Ignition timing	Cracks on distributor cap	I	←	←	←
	Distributor side terminal burning	I	←	←	←
	Distributor cap center piece wear and damage	I	←	←	←
	State of spark plug (carbon, soot)				I
	Plug cord internal discontinuity				I
	Ignition timing			M	←
Starting motor	Pinion gear meshing status	I	←	←	←
Charger	Charging function	I	←	←	←
Battery	Battery fluid level	I	←	←	←
	Battery fluid specific gravity			M	←
Electrical wiring	Damage of wiring harness	I	←	←	←
	Fuses	I	←	←	←

Item		Inspection Period			
		Every 6 weeks	Every 3 months	Every 6 months	Every 12 months
		Every 250 hours	Every 500 hours	Every 1000 hours	Every 2000 hours
Preheater	Open-circuit in intake heater			I	←
Engine stop- ping system	Diesel engine key stop device function	I	←	←	←
SAFETY DEVICES, ETC.					
Head guard	Cracks at welded portion	I	←	←	←
	Deformation and damage	I	←	←	←
Back-rest	Loosening of mounting	T	←	←	←
	Deformation, crack and damage	I	←	←	←
Lighting system	Function and mounting condition	I	←	←	←
Horn	Function and mounting condition	I	←	←	←
Direction indicator	Function and mounting condition	I	←	←	←
Instruments	Functions	I	←	←	←
Backup buzzer	Function and mounting condition	I	←	←	←
Rear-view mirror	Dirt, damage	I	←	←	←
	Rear reflection status	I	←	←	←
Seat	Loosening and damage of mounting	I	←	←	←
	Seatbelt damage and function	I	←	←	←
Body	Damage and cracks of frame, cross members, etc.				I
	Bolt looseness				T
SAS	Functions	I	←	←	←
	Loosening and damage at sensor mounting portion	I	←	←	←
	Damage, deformation, oil leakage and loosening of the mounting of functional parts	I	←	←	←
	Loosening and damage of wire harnesses	I	←	←	←
	Lock cylinder accumulator performance				I
	Rusting and corrosion of load sensor				I
Others	Grease up	L	←	←	←

Add : 2006.12 ~ (for GM6-262 engine model)

Item		Inspection Period			
		Every 6 weeks	Every 3 months	Every 6 months	Every 12 months
		Every 250 hours	Every 500 hours	Every 1000 hours	Every 2000 hours
ENGINE					
Accelerator potentiometer	Function				
Fuel system	Air induction leaks				
	Vacuum leaks				
	EPR coolant leaks				
	Shut-off valve leaks and closing				
Cooling system	Radiator core	C	←	←	←
Exhaust system	Exhaust manifold leaks				
	Exhaust pipe leaks				
	Catalyst mechanical damage				
	HEGO sensor connector and wires burns, cuts or damage				
ELECTRICAL SYSTEM					
Ignition coil	Secondary ignition coil tower			C	←
Spark plug wire	Cuts, abrasions or hardening				
Battery	Battery case for leaks or damage				←
	Battery cable for damage corrosion or contamination				←
Electrical	Cuts, abrasions or corrosion				
Connector	Retainer locks				←
SAFETY DEVICES, ETC.					
Accessory drive belts	Cracks, breaks, splits or glazing				←

PERIODIC REPLACEMENT OF PARTS AND LUBRICANTS

● : Replacement

Item	Interval	Every 6 weeks	Every 3 months	Every 6 months	Every 12 months
		Every 250 hours	Every 500 hours	Every 1000 hours	Every 2000 hours
Engine oil		●	←	←	←
Engine oil filter		● *1	●	←	←
Engine coolant (every 2 years for LLC)			●	←	←
Fuel filter				●	←
Torque converter oil				●	←
Torque converter oil filter				●	←
Differential oil					●
Planetary gear oil					●
Hydraulic oil				●	←
Hydraulic oil filter		● *1		●	←
Wheel bearing grease					●
Spark plugs					● *6
Air cleaner element					●
Cups and seals for brake booster and wheel cylinders					●
Power steering hoses					● *2
Power steering rubbers parts					● *2
Hydraulic hoses					● *2
Fuel hoses					● *2
Torque converter rubber hoses					● *2
Chains					● *3
SAS Swing lock cylinder					● *5

*1: for new vehicle *2: Every 2 years *3: Every 3 years *5: Every 10000 hours

*6: Every 3 years or every 2500 hours

Replacement shall be made upon arrival of the operation hours or months, whichever is earlier.

ENGINE

	Page		Page
ENGINE EXTERIOR VIEWS	1-2	BATTERY	
MAJOR SPECIFICATIONS	1-3	SPARK PLUG (G4 (GM6-262))	1-25
ENGINE PERFORMANCE		COMPONENTS	1-25
CURVES	1-5	SPECIFICATIONS	1-25
ENGINE ASSY	1-6	BATTERY	1-26
REMOVAL·INSTALLATION	1-6	SPARK PLUG (G4 (GM6-262)).....	1-27
AIR BLEEDING FROM FUEL		V BELT TENSION ADJUSTMENT	1-28
SYSTEM (DIESEL VEHICLE).....	1-9	ACCELERATOR PEDAL	1-29
ENGINE SPEED INSPECTION AND		COMPONENTS	1-29
ADJUSTMENT	1-9	INSPECTION·ADJUSTMENT	1-30
G4 (GM6-262) ENGINE	1-9	ACCELERATOR PEDAL SWITCH	
13Z·15Z ENGINE	1-13	INSPECTION AND ADJUSTMENT	
AIR CLEANER	1-14	(EEC SPEC.) (~2005.9).....	1-30
SPECIFICATIONS	1-14	ELECTRONIC GOVERNOR	1-32
COMPONENTS	1-14	COMPONENTS	1-32
AIR CLEANER CLEANING·		PRECAUTIONS FOR REPAIR	1-33
INSPECTION	1-15	OUTLINE OF REPAIR PROCEDURE...	1-33
CLOGGING WARNING SYSTEM		BASIC INSPECTION	1-34
INSPECTION	1-16	FINAL INSPECTION	1-34
RADIATOR.....	1-16	SELF-DIAGNOSIS	1-35
COMPONENTS	1-16	DIAGNOSTIC CODE LIST	1-36
SPECIFICATIONS	1-17	SYSTEM CIRCUIT.....	1-37
COOLANT CAPACITY AND		FUNCTIONAL PARTS INSPECTION ...	1-37
ANTIFREEZE TABLE	1-17	SENSOR AND SWITCH	
FAN DRIVE	1-18	ADJUSTMENT	1-40
REMOVAL·INSTALLATION	1-18	TROUBLESHOOTING	1-44
DISASSEMBLY·INSPECTION·		EZ PEDAL (OPT)	1-53
REASSEMBLY	1-20	COMPONENTS	1-53
MUFFLER & EXHAUST PIPE	1-23	DISASSEMBLY·INSPECTION·	
COMPONENTS	1-23	REASSEMBLY	1-54
REMOVAL·INSTALLATION	1-24	ADJUSTMENT	1-56

ENGINE EXTERIOR VIEWS

G4 (GM6-262) Engine

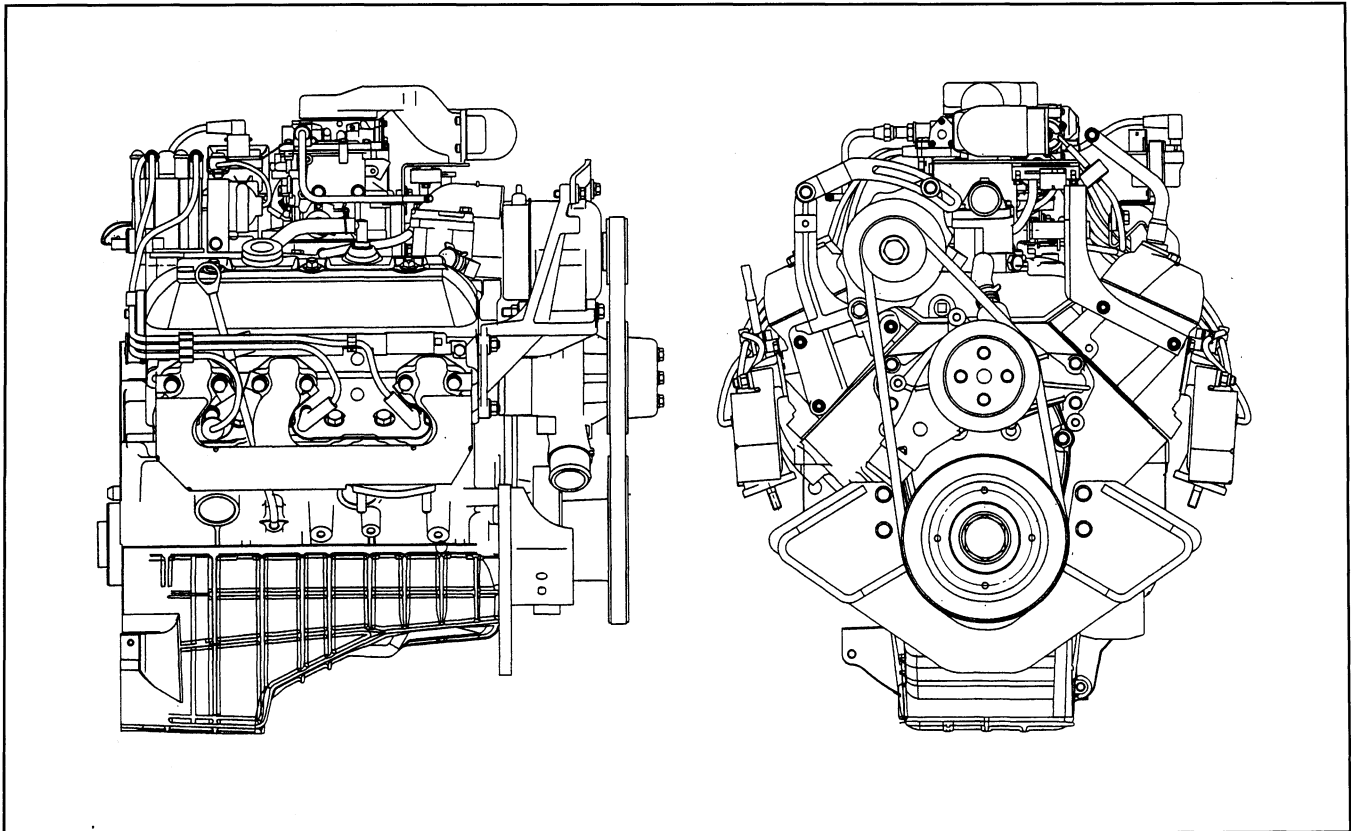

13Z Engine (~ 2007.12)

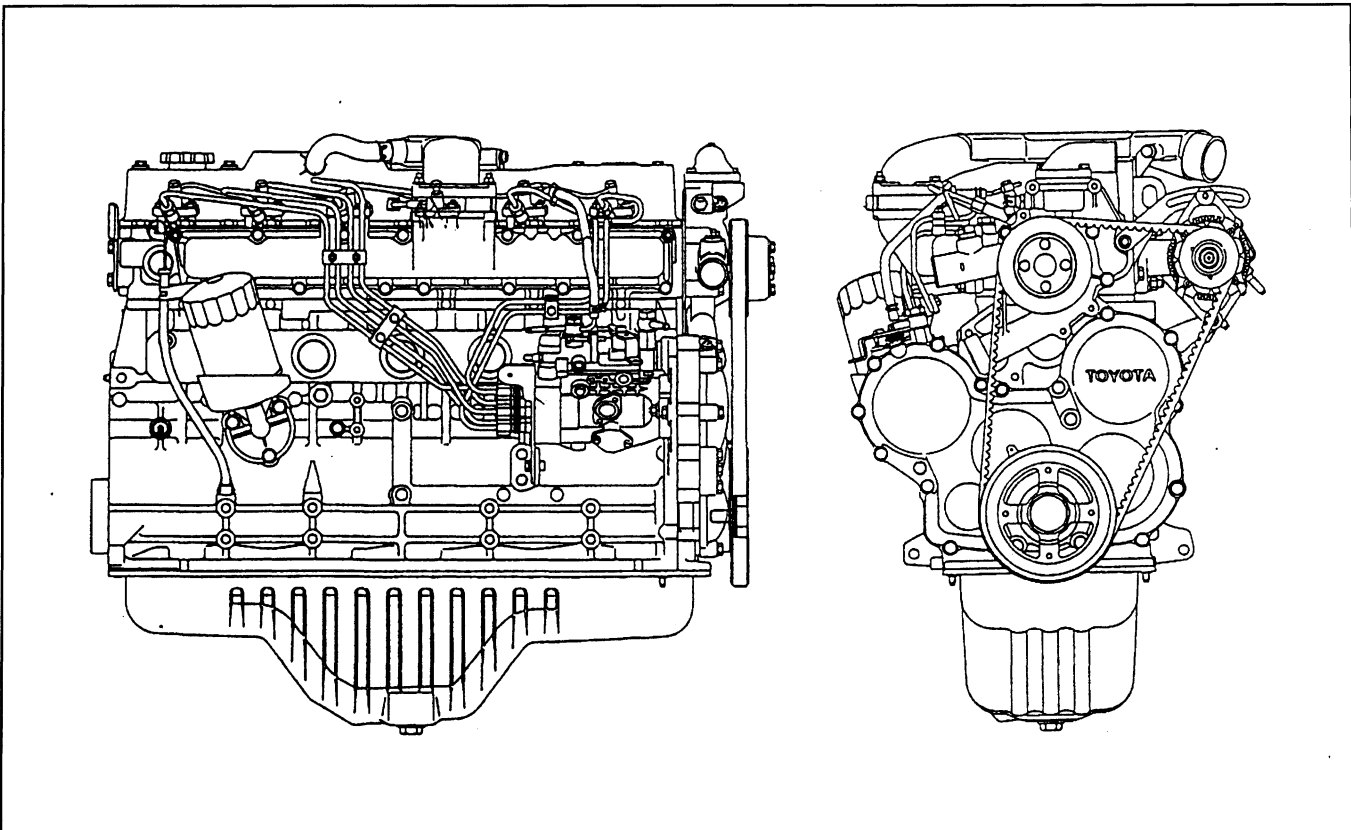

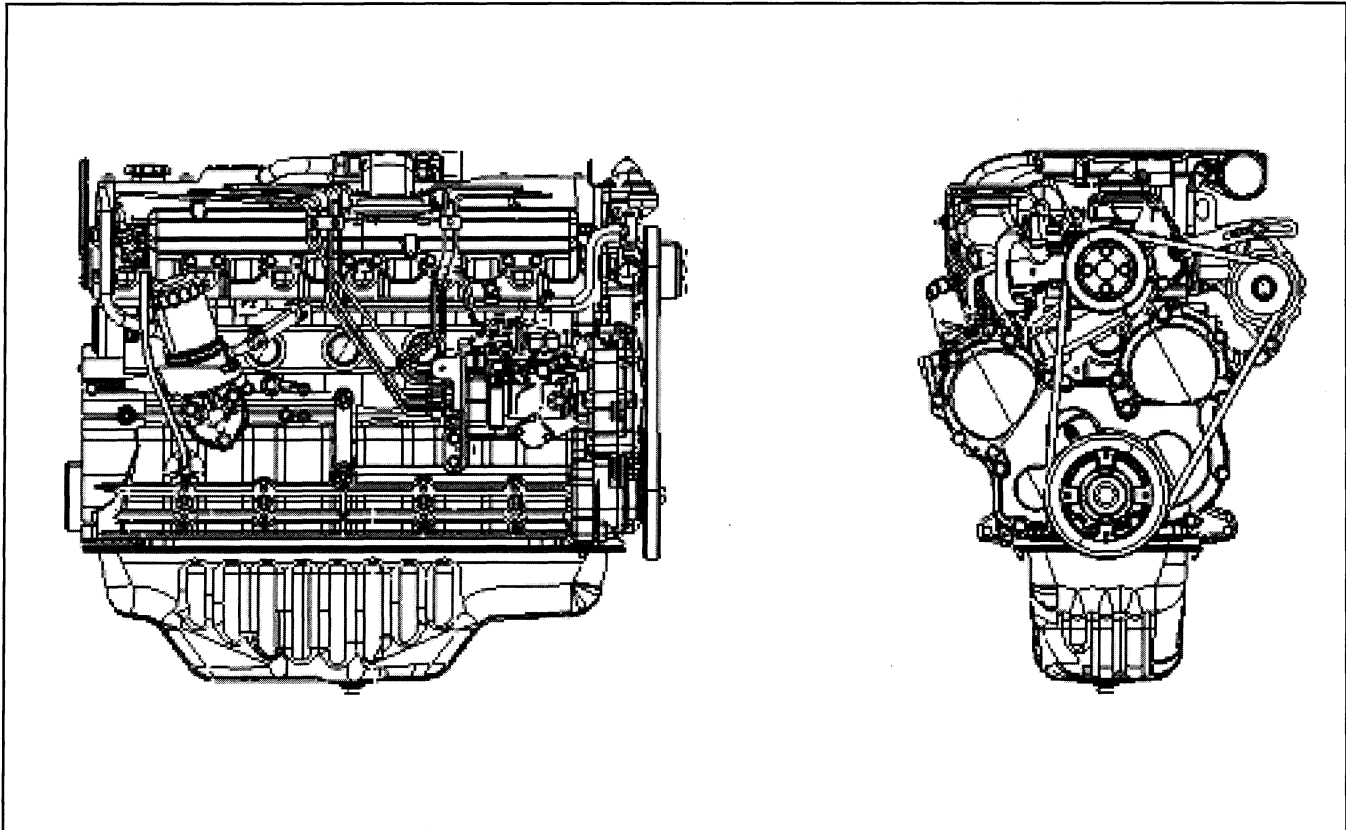

MAJOR SPECIFICATIONS

GM (GM6-262) Engine (~ 2006.12)

		Gasoline	Gasoline/LPG	LPG
Engine type		Gasoline 4-cycle		
Number of cylinders and arrangement		V-type 6 cylinders, vertical		
Combustion chamber type		Wedge type		
Valve mechanism		OHV, chain-driven		
Bore × stroke	mm (in)	101.60 × 88.39 (4.0 × 3.480)		
Total displacement	cm ³ (in ³)	4300 (262)		
Compression ratio		9.2		
Maximum power kW (PS)/rpm (~ 2003.12)	NMR 2350 rpm *1 (Pn35 ~ 50, Cu35-45 model)	67/2350 (91/2350)	61/2350 (83/2350)	61/2150 (83/2150)
	NMR 2600 rpm (Pn60 ~ 80, Cu55 ~ 70 model)	71/2600 (96/2600)	64/2600 (87/2600)	64/2400 (87/2400)
Maximum power kW (PS)/rpm (2004.1 ~ 2006.12)	NMR 2350 rpm *1 (Pn35 ~ 50, Cu35-45 model)	63/2350 (86/2350)	60/2350 (82/2350)	59/2150 (80/2150)
	NMR 2600 rpm (Pn60 ~ 80, Cu55 ~ 70 model)	66/2600 (90/2600)	62/2600 (84/2600)	60/2400 (82/2400)
Maximum torque	N·m (kgf-m)/rpm	294/1200 (30/1200)	284/1200 (29/1200)	284/1200 (29/1200)
Minimum specific fuel consumption	g/kW-h (g/PS-h)/rpm	258/1800 (190/1800)	249/1400 (183/1400)	250/1400 (184/1400)
Governor system		Electronic governor	Electronic governor	Air governor (Electronic governor *2)
Service weight	kg (lb)	185 (408)		
No-load maximum rpm		rpm		
		See page 1-9.		

Note:

*1: LPG exclusive is NMR 2400 rpm.

*2: Governor system for LPG exclusive Pn50 ~ 80, Cu70 models is used electronic governor.
(Maximum power spec. is same as LPG convertible.)

GM (GM6-262) Engine (2006.12 ~)

		Gasoline	Gasoline/LPG	LPG
Engine type		Gasoline 4-cycle		
Number of cylinders and arrangement		V-type 6 cylinders, vertical		
Combustion chamber type		Wedge type		
Valve mechanism		OHV, chain-driven		
Bore × stroke	mm (in)	101.60 × 88.39 (4.0 × 3.480)		
Total displacement	cm ³ (in ³)	4300 (262)		
Compression ratio		9.2		
Maximum power kW (PS)/rpm	NMR 2350 rpm (Pn35 ~ 50, Cu35·45 model)	63/2350 (84/2350)	←	62/2350 (83/2350)
	NMR 2600 rpm (Pn60 ~ 80, Cu55 ~ 70 model)	66/2600 (88/2600)	←	65/2600 (87/2600)
Maximum torque	N·m (kgf·m)/rpm	266/1600 (27/1600)	282/1200 (28.7/1200)	281/1200 (28.6/1200)
Governor system		Electronic throttle control	←	←
Service weight	kg (lb)	185 (408)		

13Z Engine (~ 2007.12)

Engine type		Diesel 4-cycle	
Number of cylinders and arrangement		In-line 6 cylinders, vertical	
Combustion chamber type		Direct injection type	
Valve mechanism		OHV, gear-driven	
Bore × stroke		mm (in)	98.0 × 102.0 (3.858 × 4.016)
Total displacement		cm ³ (in ³)	4616 (281)
Compression ratio		~ 2003.12: 18.5	2003.12 ~ : 18.9
Maximum power kW (PS)/rpm	NMR 2400 rpm (Pn35 ~ 50 model)	~ 2003.12: 62 (85) / 2200	2003.12 ~ : 57 (78) / 2200
	NMR 2600 rpm (Pn60 ~ 80 model)	~ 2003.12: 66 (90) / 2400	2003.12 ~ : 59 (80) / 2300
Maximum torque		N·m (kgf·m)/rpm	~ 2003.12: 284 (29) / 1600 2003.12 ~ : 265 (27.0) / 2000
Minimum specific fuel consumption		g/kW·h (g/PS·h)/rpm	218 (160) / 1000
Service weight		kg (lb)	325 (717)
No-load maximum rpm		rpm	Pn35 ~ 50 model: 2400 Pn60 ~ 80 model: 2600

15Z Engine (2008.1 ~)

Number of cylinders and mounting		In-line 6 · Vertically mounted	
Combustion chamber shape		Swirl chamber type	
Valve mechanism		OHV · Gear driven	
Displacement		cm ³ (in. ³)	5204 (318)
Bore × stroke		mm (in.)	98.0 × 115.0 (3.9 × 4.5)
Compression ratio		21.5	
Maximum power kW (PS)/rpm	NMR 2400 rpm (7FDU35 ~ 7FDAU50)	60 (82) / 2200	
	NMR 2600 rpm (7FDU60 ~ 7FDA80)	63 (86) / 2400	
Maximum torque		N·m (kgf·m)/rpm	280 (28.6) / 1800
Maximum specific fuel consumption		g/kW·h (g/PS·h)/rpm	240 (177) / 1000
Engine weight (oil included)		kg (lb)	304 (670)
Non-load maximum rpm		rpm	7FDU35 ~ 7FDAU50: 2400 7FDU60 ~ 7FDA80: 2600
Fuel		Diesel	

ENGINE PERFORMANCE CURVES

G4 (GM6-262) Engine (~ 2003.12)

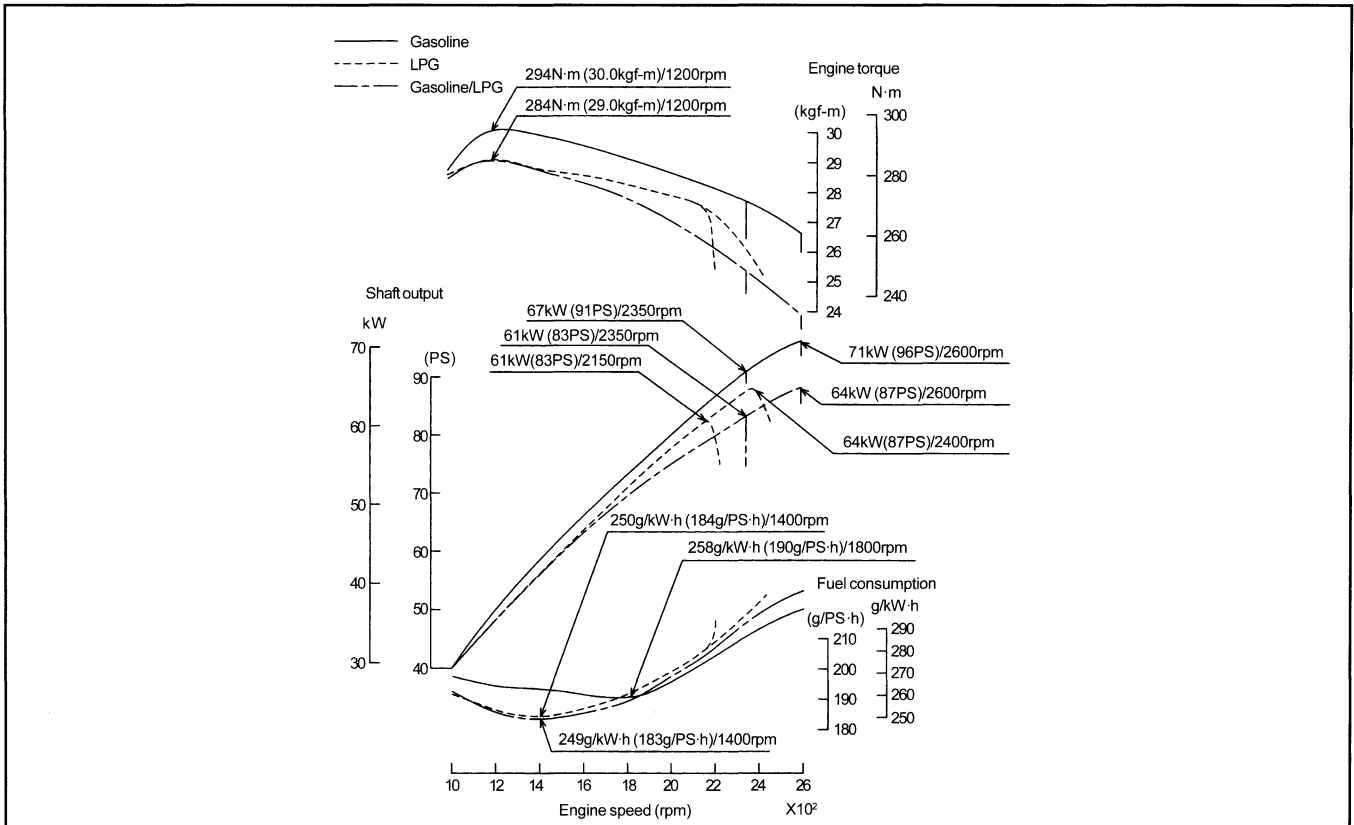

13Z Engine (~ 2003.12)

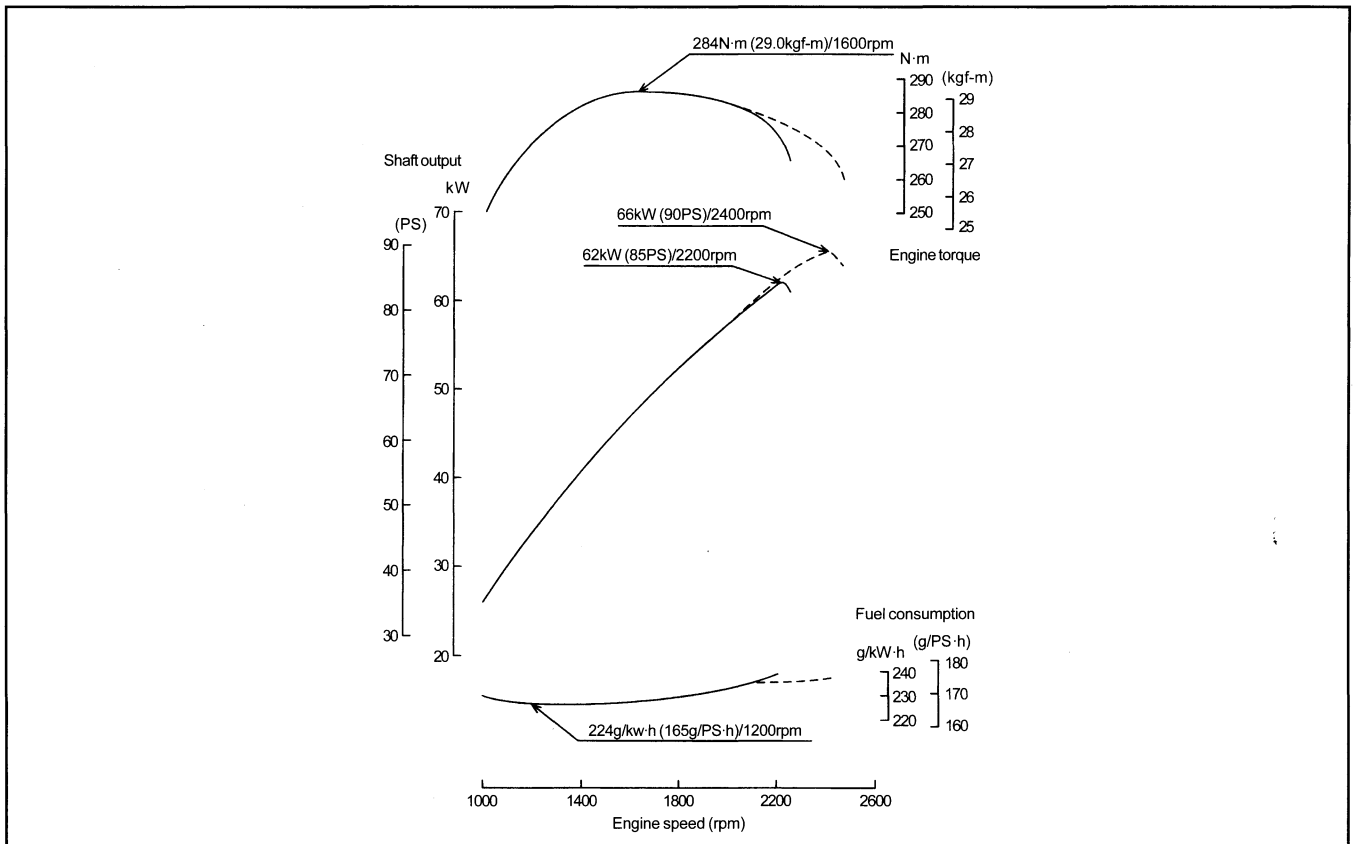

GM (GM6-262) Engine (2004.1 ~ 2006.12)

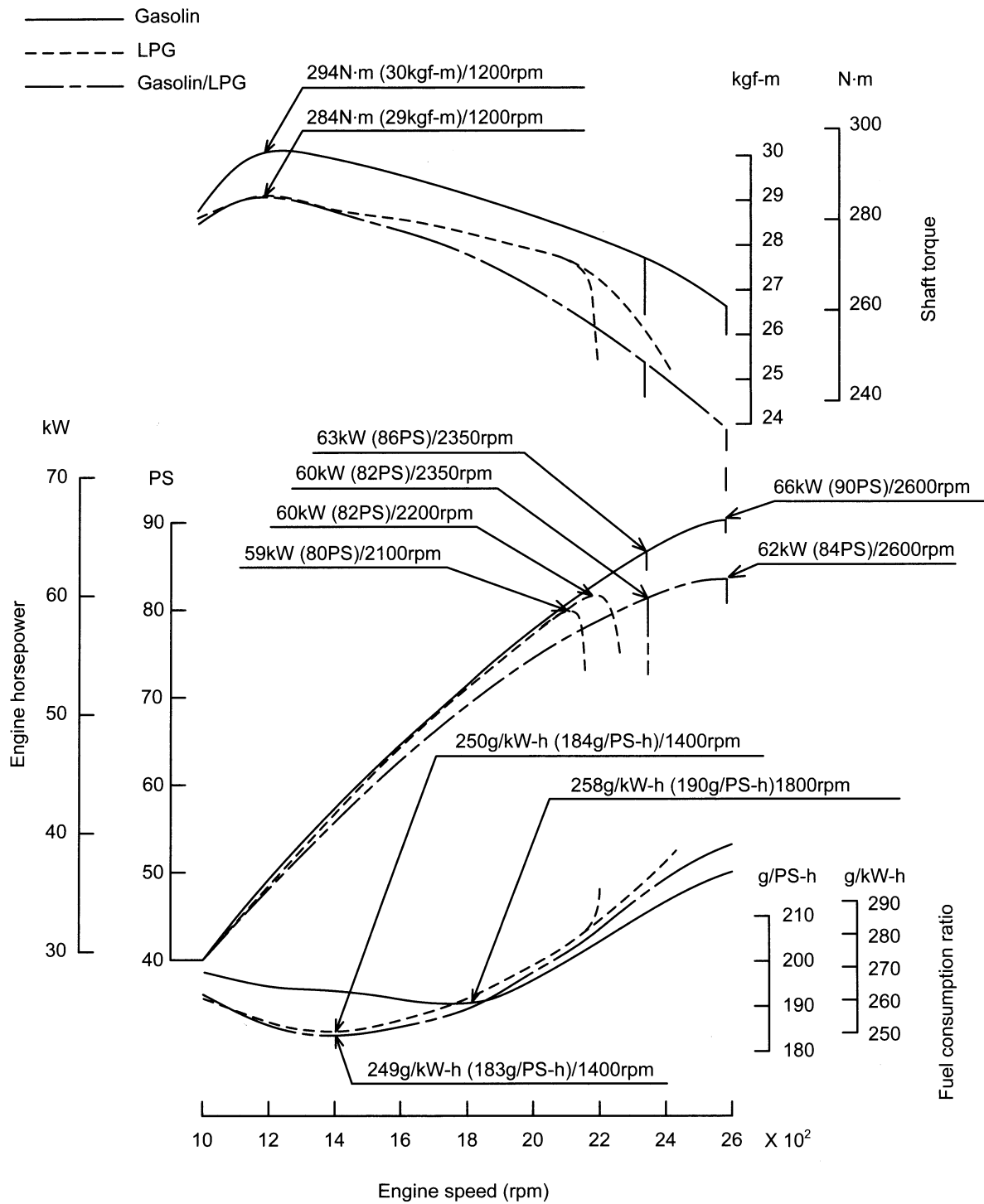

13Z Engine (2003.12 ~ 2007.12)

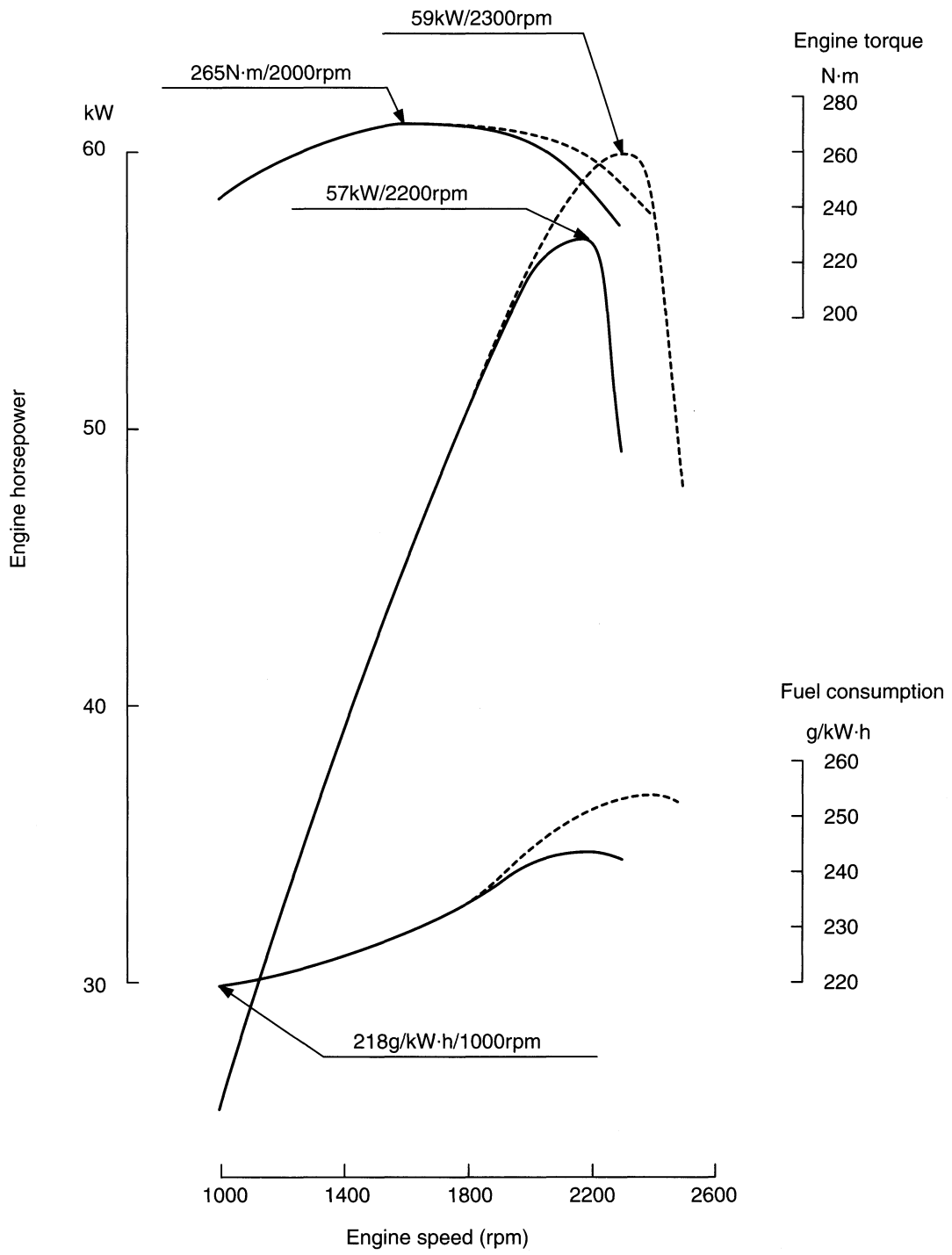

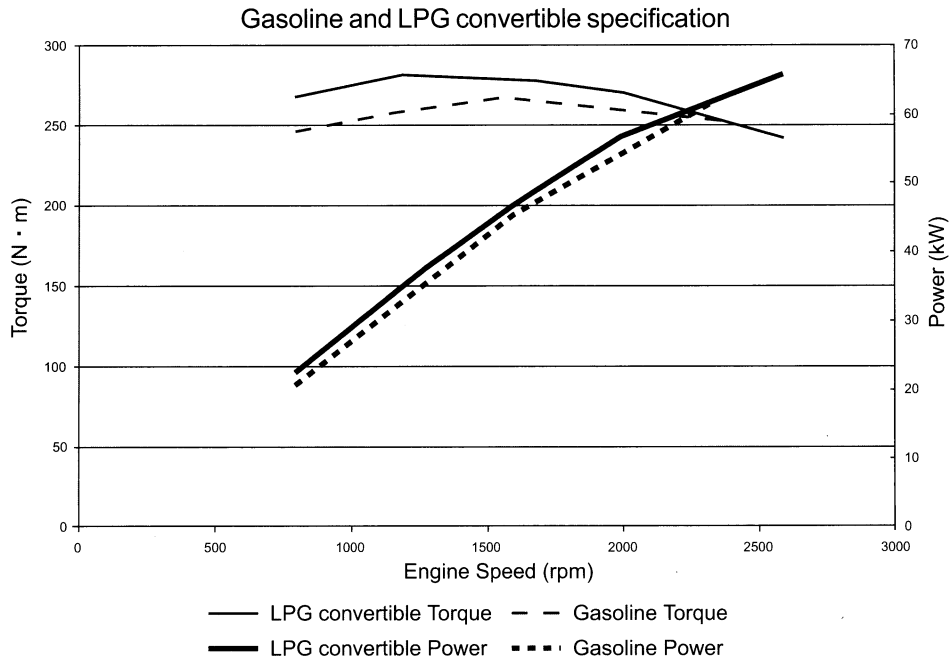

Dual Fuel's gasoline has the same performance as Gasoline exclusive only

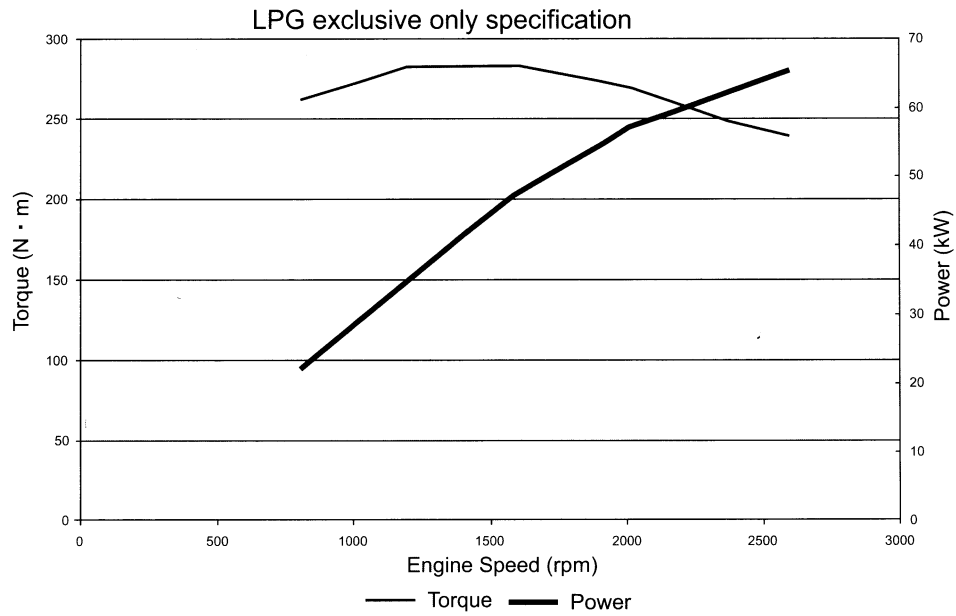

15Z Engine: 7FDU35 ~ 50 (2008.1 ~)

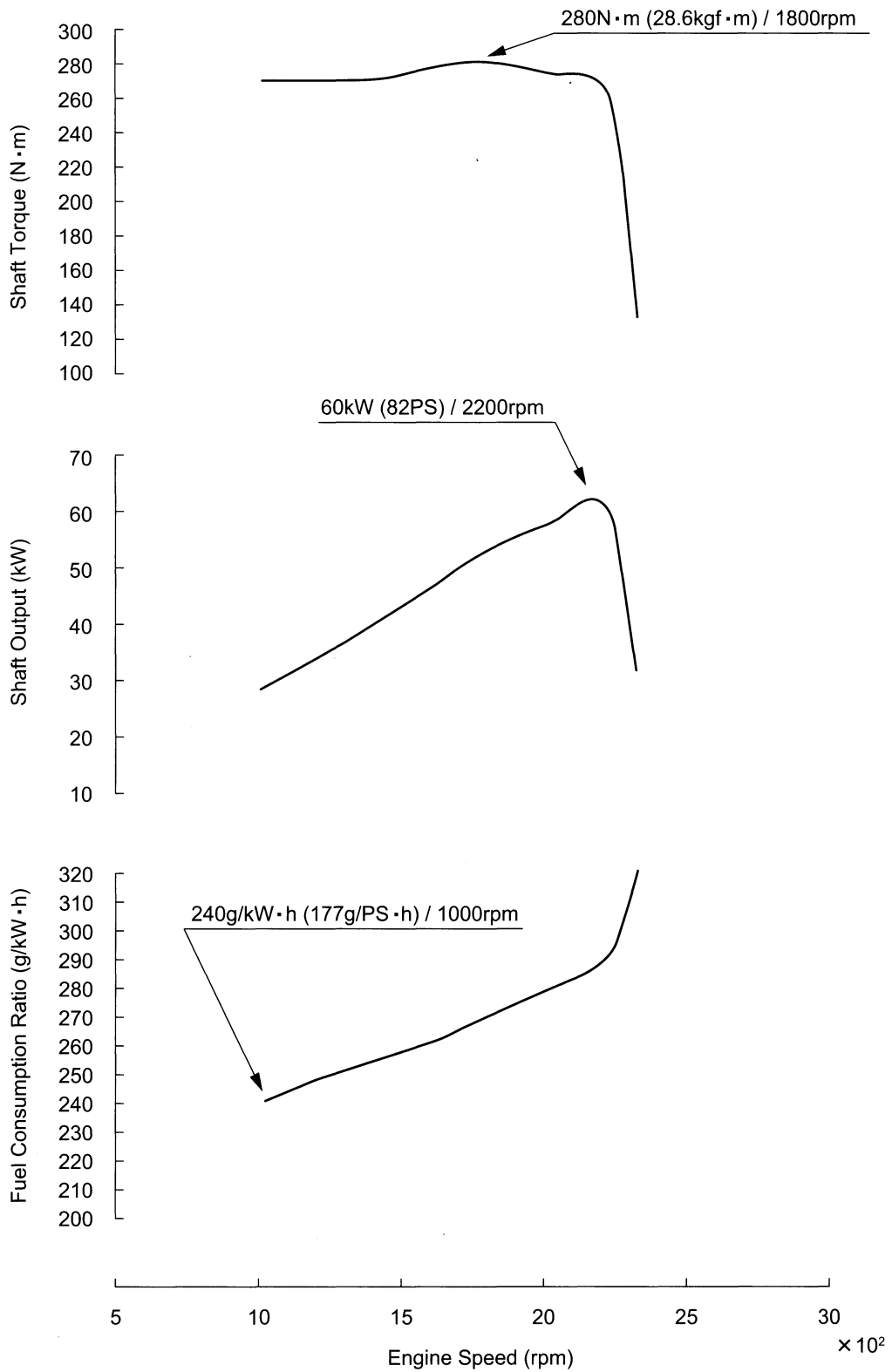

15Z Engine: 7FDU60 ~ 80 (2008.1 ~)

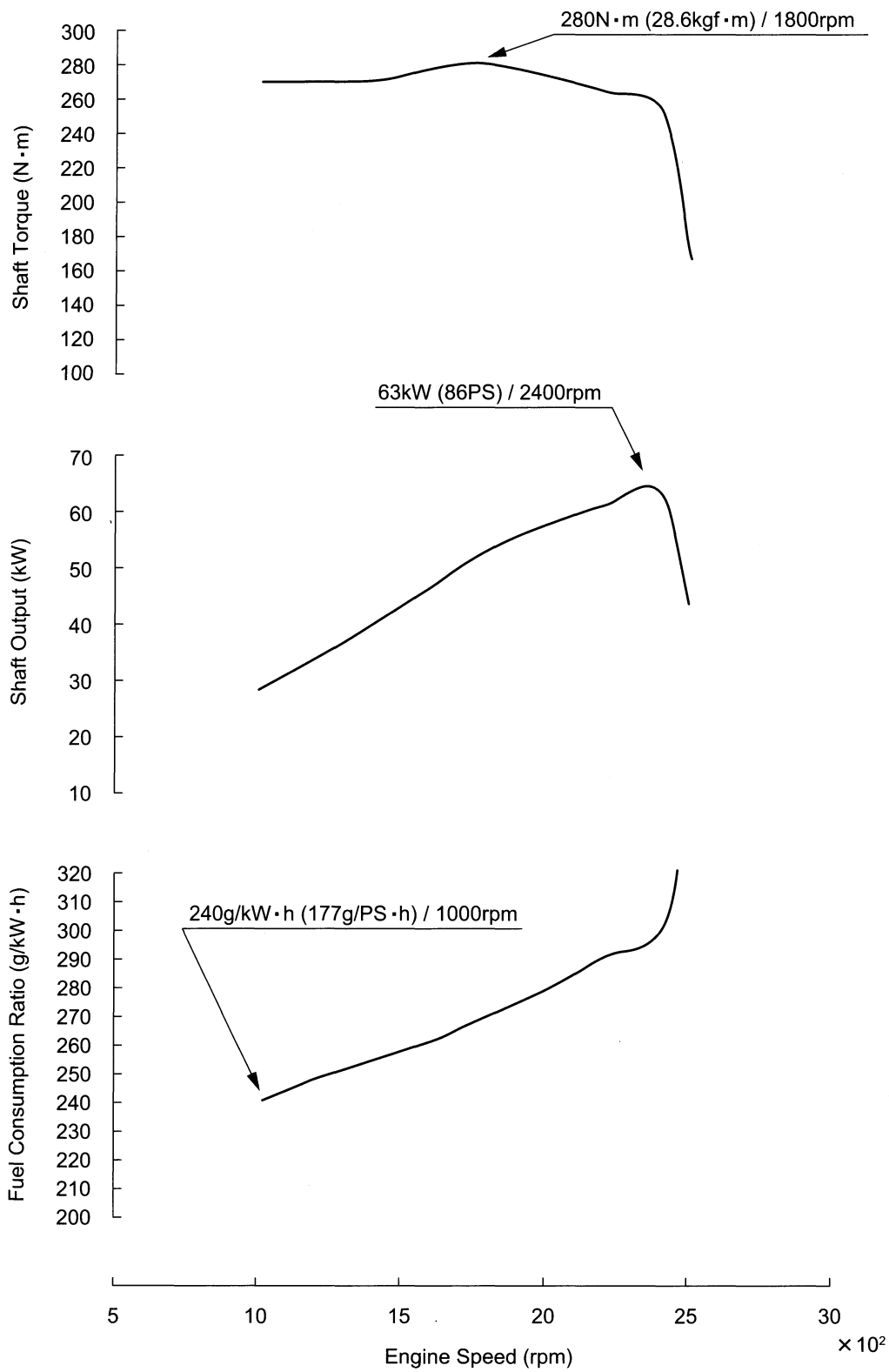

ENGINE ASSY

REMOVAL·INSTALLATION

T = N·m (kgf·cm) [ft·lbf]

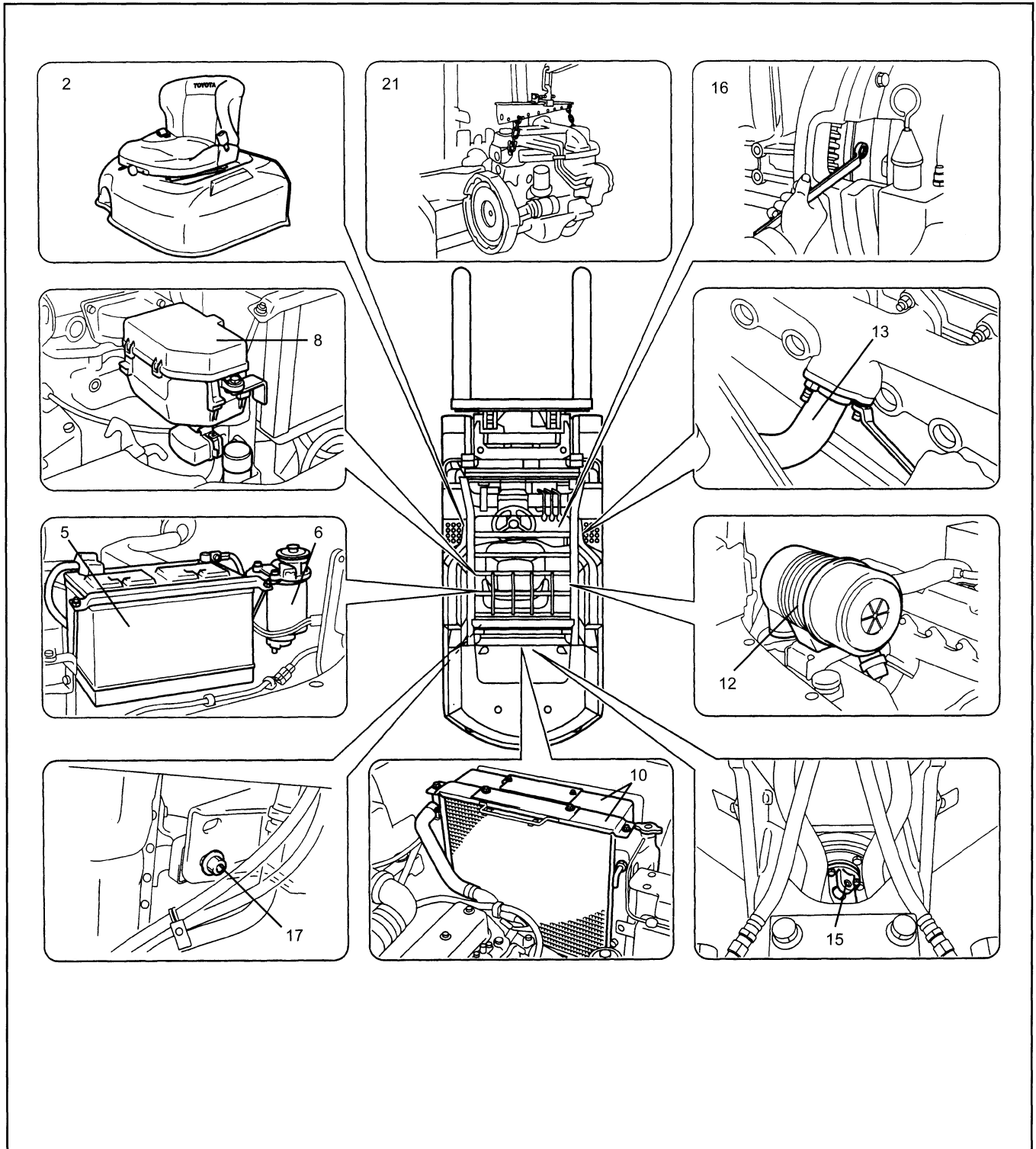

Engine mounting nut	T = 53.9 ~ 99.0 (550 ~ 1010) [39.8 ~ 73.1]
End plate set bolt	T = 49A.0 ~ 78.0 (500 ~ 800) [36.2 ~ 57.9]
Flywheel set bolt	G4 (GM6-262) : T = 98.07 ~ 156.9 (1000 ~ 1600) [72.35 ~ 115.8] 13Z-15Z : T = 98.07 ~ 156.9 (1000 ~ 1600) [72.35 ~ 115.8]
Flexible plate set bolt	T = 14.7 ~ 21.6 (150 ~ 220) [10.9 ~ 15.9]

Removal Procedure

- 1 Remove the radiator cover.
- 2 Remove the engine hood.
- 3 Remove the toe board.
- 4 Drain coolant.
- 5 Remove the battery and battery tray.
- 6 13Z-15Z engine vehicle:
Disconnect the accelerator wire and fuel hose.
Free the sedimenter bracket by removing the set bolts.
- 7 G4 (GM6-262) engine vehicle: Disconnect the fuel hose.
- 8 Remove the relay block and electrical parts plate set bolt to free them.
- 9 Disconnect the connectors and wiring harness clamps around the engine.
- 10 13Z-15Z engine vehicle:
Disconnect the torque converter cooler hose and hydraulic oil cooler hose.
Remove the radiator and fan shroud.
- 11 G4 (GM6-262) engine vehicle: Disconnect the radiator hose.
- 12 Remove the air cleaner.
- 13 Disconnect the exhaust pipe.
- 14 Disconnect the starting motor wiring.
- 15 Remove the oil pump drive shaft ASSY. (see page 13-12)
- 16 Remove the flexible plate set bolts. **[Point 1]**
- 17 Remove the engine mounting nuts.
- 18 Slightly hoist the engine ASSY. **[Point 2]**
- 19 Support the torque converter housing with wooden blocks.
- 20 Separate the torque converter housing and engine ASSY. **[Point 3]**
- 21 Remove the engine ASSY W/flywheel and torque converter end plate.
- 22 Remove the flywheel.
- 23 Remove the torque converter end plate and starting motor.

Installation Procedure

The installation procedure is the reverse of the removal procedure.

Note:

- **Bleed air from the fuel system after installation of the engine ASSY. (for diesel vehicle) (see page 1-9.)**
- **Apply thread tightener (08833-76002-71 (08833-00080)) on the flywheel set bolt, and tighten it.**

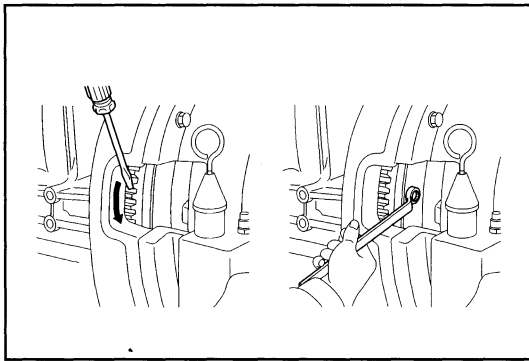

Point Operations

[Point 1]

Removal-Installation:

Remove the flexible plate set bolts while turning the flywheel with a screwdriver.

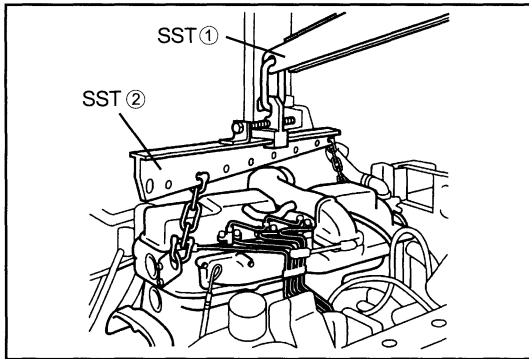

[Point 2]

Removal-Installation:

SST 09010-20111-71 --- ①

09010-23320-71 --- ②

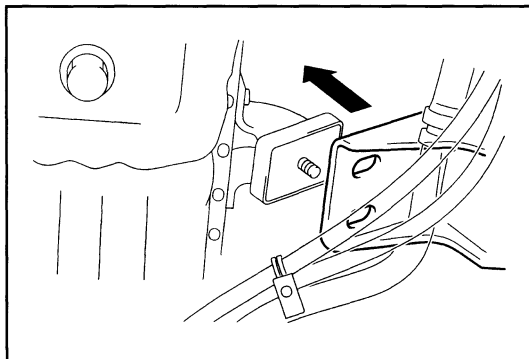

Removal:

Tentatively hoist up until the mounting bolt completely comes out from the hole in the frame.

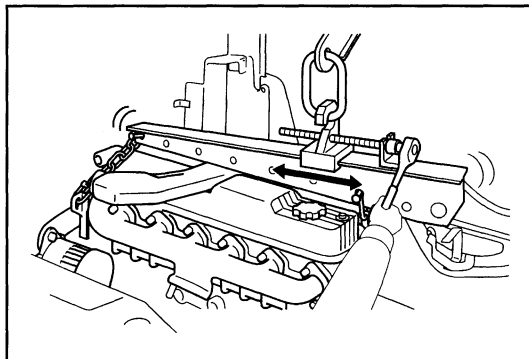

[Point 3]

Removal:

Use a straight-edge screwdriver for separation. If the fitting is too tight, change the SST hook position and adjust the engine angle for easier separation.

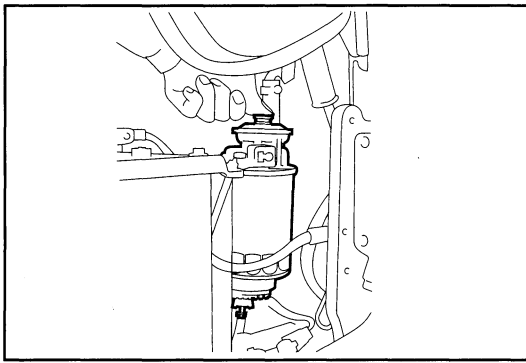

AIR BLEEDING FROM FUEL SYSTEM (DIESEL VEHICLE)

1. Operate the hand pump of the fuel filter until the pump operating force becomes heavy.

ENGINE SPEED INSPECTION AND ADJUSTMENT

Note:

Warm up the engine, set the vehicle to the following conditions, and conduct inspection and adjustment.

Coolant temperature: 80°C (176°F) or more, engine oil temperature: 70°C (158°F) or more

G4 (GM6-262) ENGINE

Note: (2004.1 ~)

For GM6-262 engine speed adjustment, refer to "Three Way Catalytic System" in the repair manual supplement issued in January 2004 (Pub. No.CU643-2).

Standard

Model	Gasoline engine or Gasoline/LPG engine model			LPG engine model			
	Pn35 ~ 45 Cu35 ~ 45	Pn50	Pn60 ~ 80 Cu55 ~ 70	Pn35 ~ 45 Cu35 ~ 45	Pn50 Cu35-45 (VSCS*)	Cu55 ~ 60	Pn60 ~ 80 Cu70 Cu55 ~ 70 (VSCS*)
	Electronic governor system			Air governor system	Electronic governor system	Air governor system	Electronic governor system
Idle speed rpm	750 ⁺⁵⁰ ₋₀	850 ⁺⁵⁰ ₋₀	800 ± 30	850 ± 25	850 ⁺⁵⁰ ₋₀	850 ± 25	800 ± 30
Idle-up speed rpm	No idle-up speed			1000 ± 25	No idle-up speed	1000 ± 25	No idle-up speed
No-load maximum speed rpm	2350 ± 30	2350 ± 30	2600 ± 30	2400 ± 50	2350 ± 30	2600 ± 50	2600 ± 30
Loaded maximum speed (speed down at tilt relief) rpm	/			250 or less	/	350 or less	/

*: Vehicle Speed Control system spec.

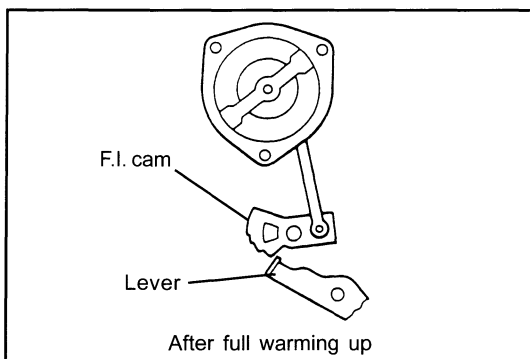

IDLE SPEED INSPECTION-ADJUSTMENT <Electronic Governor System>

Note: The idling speed is electronically controlled.

1. Check the lever is not on the F.I. (First Idle) cam. If the lever is on the cam, depress the accelerator pedal for racing engine, and check the lever position again. If the lever still stays on the F.I. cam, the engine warm up is insufficient.

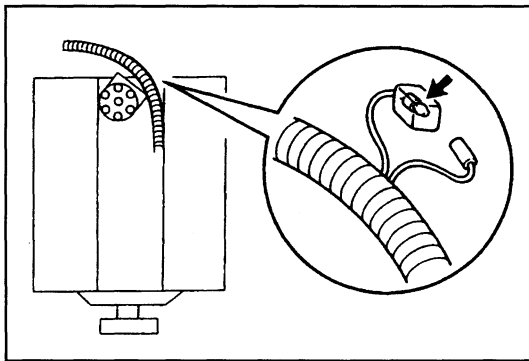

2. Install a tachometer.
 - (1) Disconnect the inspection connector and connect the tachometer measurement cord to the male side.
 - (2) Disconnect the vacuum hose.

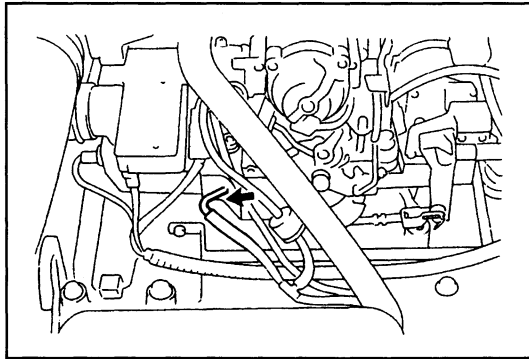

3. Idle speed inspection and adjustment
 - (1) Measure the idle speed.

Standard: See page 1-9.

Adjust the mixture adjusting screw so that the negative pressure then is stabilized at the highest level.

Note: When the idling speed is high, check if the idle adjusting screw is pushing the lever. If so, loosen the screw.

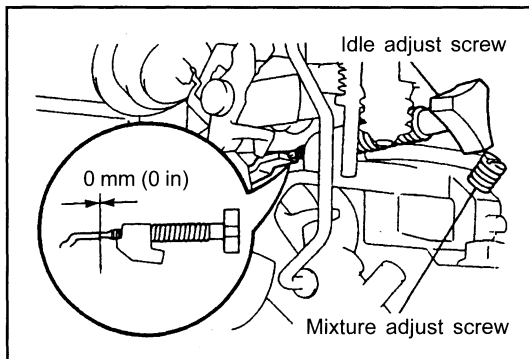

- (2) Check and adjust the clearance between the idle adjusting screw and lever.

Standard: 0 mm (0 in)

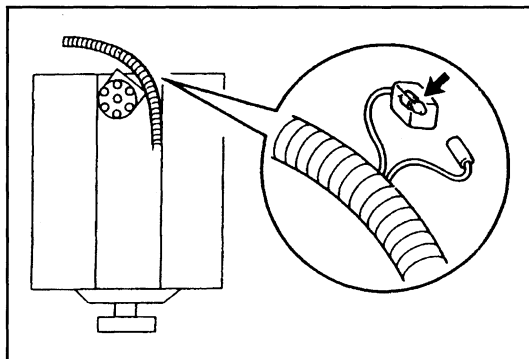

<Air Governor System>

1. Install a tachometer.
2. Check the idling speed.

Standard: See page 1-9.

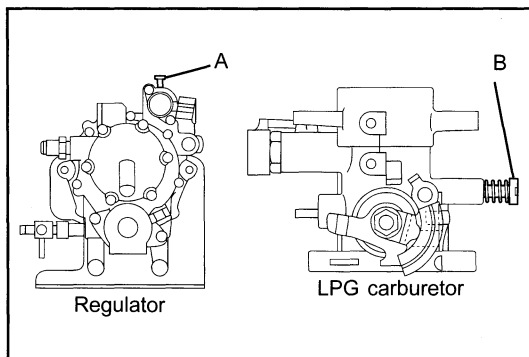

3. If the measured value is out of the specified range, make adjustment according to the following procedure:
 - (1) Make adjustment by turning the adjusting screw B. (If less than the standard, turn the adjusting screw A counterclockwise beforehand.)
 - (2) Slowly turn the adjusting screw A clockwise or counterclockwise until the maximum speed is obtained.
 - (3) Determine the positions of adjusting screw B by repeating steps (1) and (2) until the value obtained in step (2) satisfies the standard.
 - (4) Slowly turn the adjusting screw A clockwise from (3) to the position where the speed begins to drop, and then turn it 45 degrees counterclockwise.

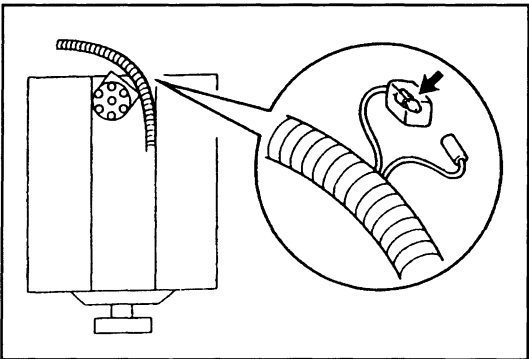
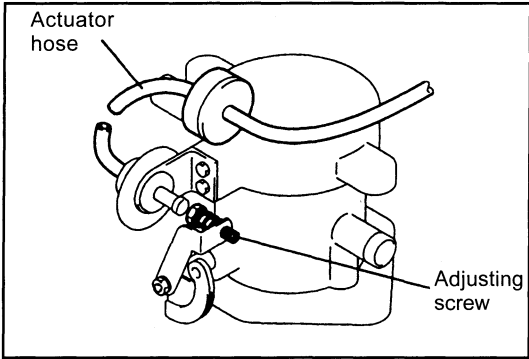
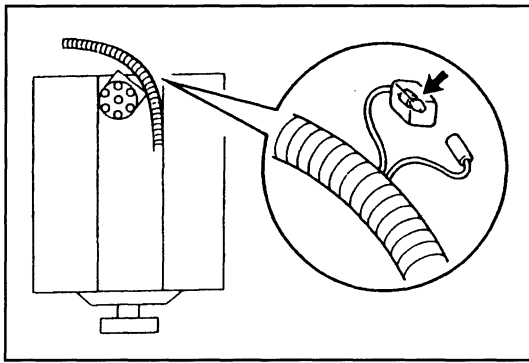

IDLE UP INSPECTION·ADJUSTMENT

<Air Governor System>

1. Install a tachometer.
2. Check the idle-up speed.
 - (1) Start the engine. Disconnect the vacuum hose from the idle-up actuator and measure the speed.

Standard: See page 1-9.

- (2) If the standard is not satisfied, make adjustment by turning the adjusting screw.

Note: Turn the adjusting screw clockwise to increase speed.

- (3) After adjustment, connect the vacuum hose.

NO-LOAD MAXIMUM SPEED INSPECTION·ADJUSTMENT

<Electronic Governor System>

Note: The maximum speed is controlled electronically.

1. Install a tachometer.
2. Inspect the no-load maximum speed when the accelerator pedal is fully depressed.

Standard: See page 1-9.

Since adjustment is impossible, refer to the troubleshooting section when the standard is not satisfied.

<Air Governor System>

1. Install a tachometer.
2. Inspect and adjust the no-load maximum speed.
 - (1) Measure the speed when the accelerator pedal is fully depressed.

Standard: See page 1-9.

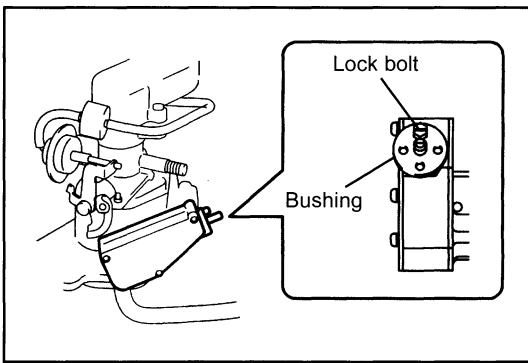

- (2) If the standard is not satisfied, adjust the speed. Remove the air governor bushing lock bolt. Turn the air governor bushing while fixing the adjusting screw to adjust the speed.
- (3) Install the air governor bushing lock bolt.

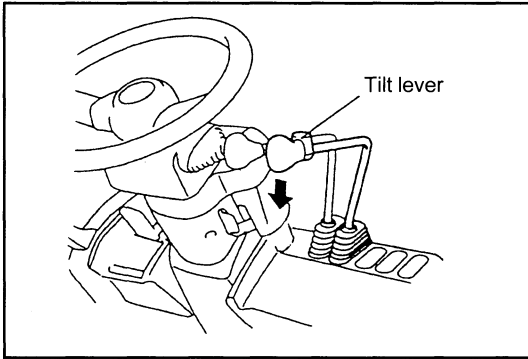

LOADED MAXIMUM SPEED MEASUREMENT

Note: In the electronic governor system, the maximum speed is controlled electronically.

<Air Governor System>

1. Operate the tilt lever fully backward with the engine running at the maximum speed, and measure the decrease in speed (relief down) upon full relief.

Standard: See page 1-9.

2. If the standard is not satisfied, turn the adjusting screw for adjustment.

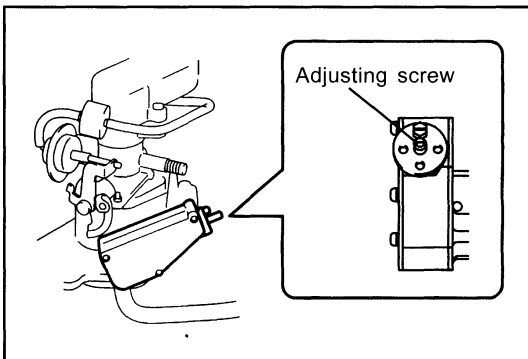

13Z-15Z ENGINE

Idling Speed Inspection·Adjustment

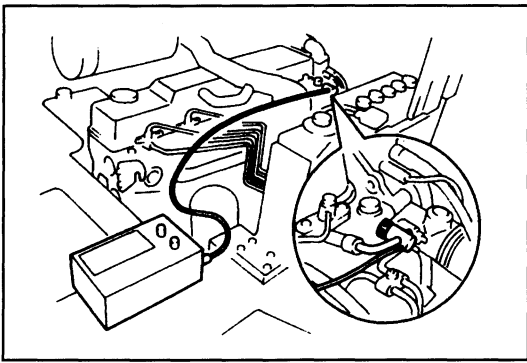

1. Install the engine tachometer.

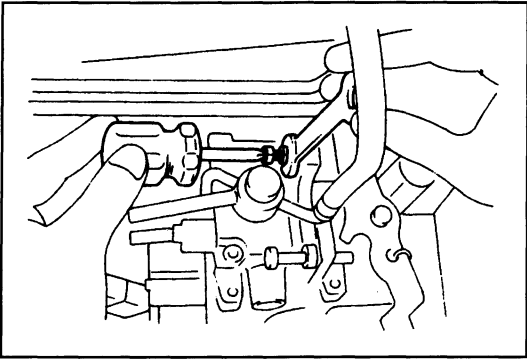

2. Inspect the idling speed.

Standard: 750 ± 25 rpm

3. Adjust the idling speed.
 - (1) Loosen the lock nut and make adjustment by means of the idle adjusting screw.

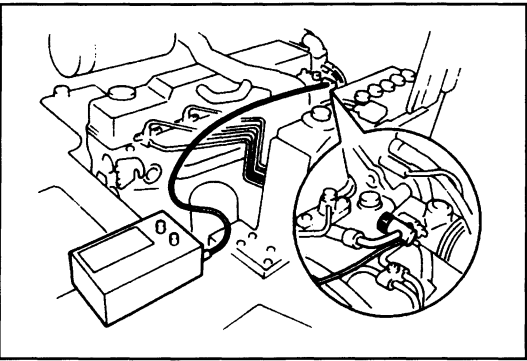

No-load Maximum Speed Inspection·Adjustment

1. Install the engine tachometer.
 - (1) Fully depress the accelerator pedal and inspect the no-load maximum speed.

Standard:

Pn35 ~ 50 model 2400 ± 50 rpm

Pn60 ~ 80 model 2600 ± 50 rpm

3. Adjust the no-load maximum speed.
 - (1) Remove the seal.
 - (2) Make adjustment by means of the maximum speed adjusting screw.

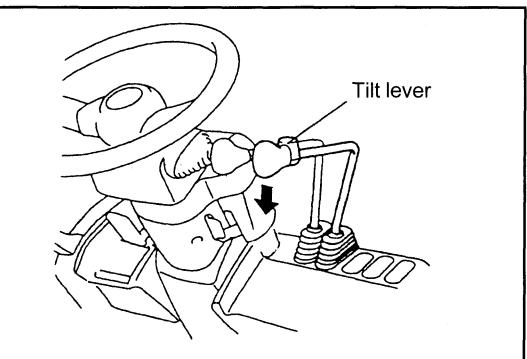
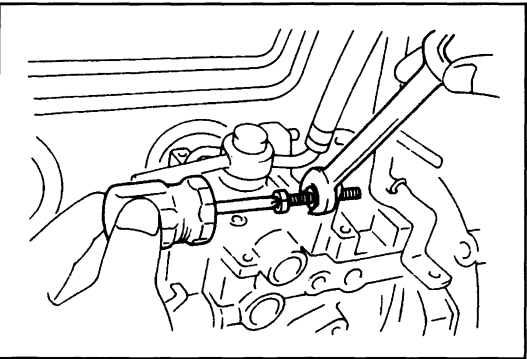

4. Inspect the relief speed.
 - (1) Operate the tilt lever fully backward with the engine running at the maximum speed, and measure the decrease in speed (relief down) upon full relief.

Standard:

13Z (~ 2007.12) :

Pn35 ~ 50 model 200 rpm or less

Pn60 ~ 80 model 300 rpm or less

15Z (2008.1 ~) :

Pn35 ~ 50 model 200 rpm or less

Pn60 ~ 80 model 600 rpm or less

5. Seal the engine with wire after adjustment.

AIR CLEANER

SPECIFICATIONS

		Single (STD)
Type		Cyclone type
Size		8-inch
Intake type		Fresh air introduction type
Filtering area	cm ² (in ²)	32400 (5022)
Others		With evacuator valve

COMPONENTS

1703

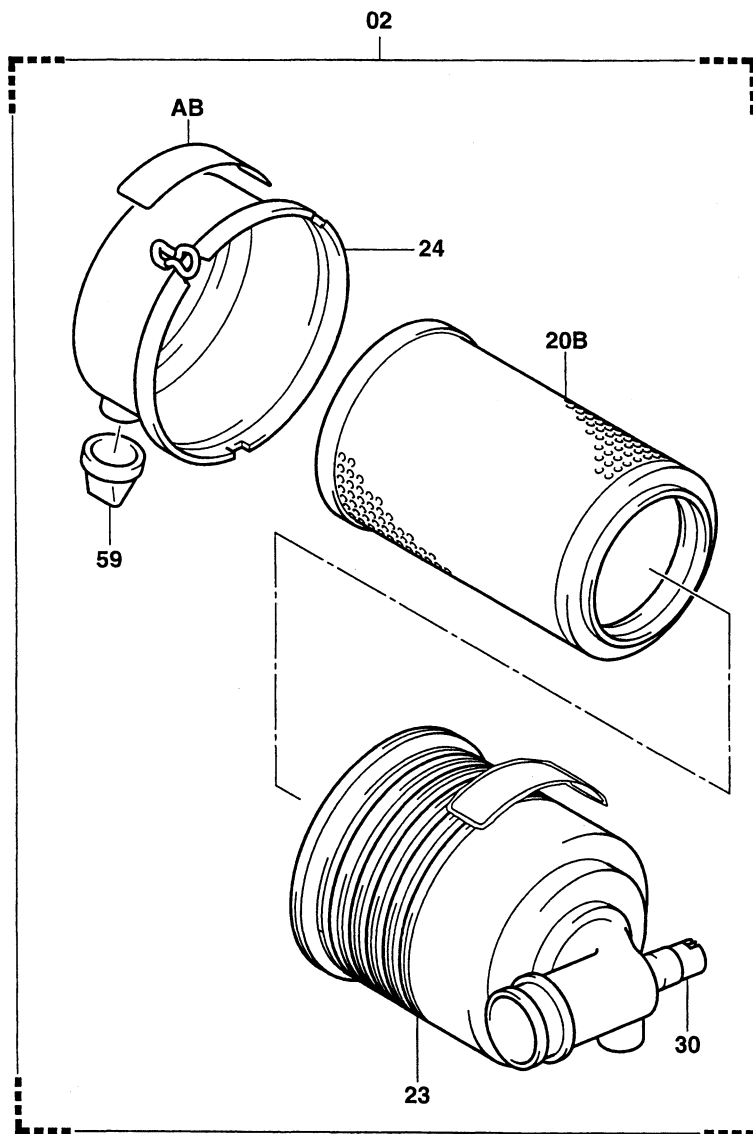

1703-436A

AIR CLEANER CLEANING-INSPECTION

1. Open the engine hood.
2. Remove the element.

Note:

In case of the double element type (OPT), do not remove the inner element for other than replacement.

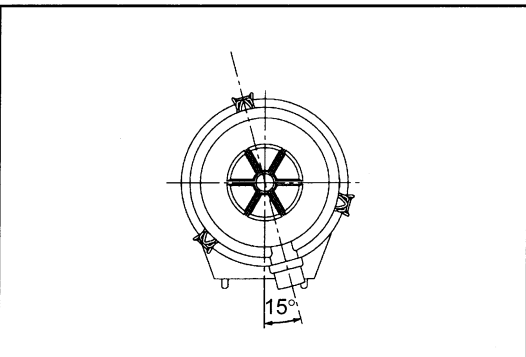
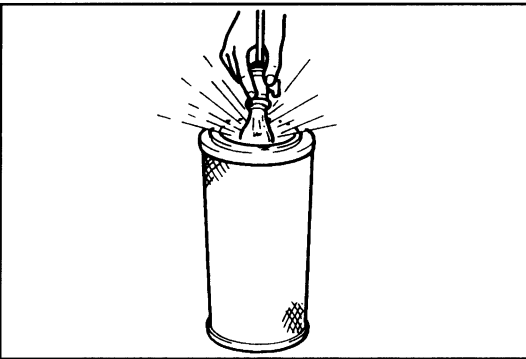
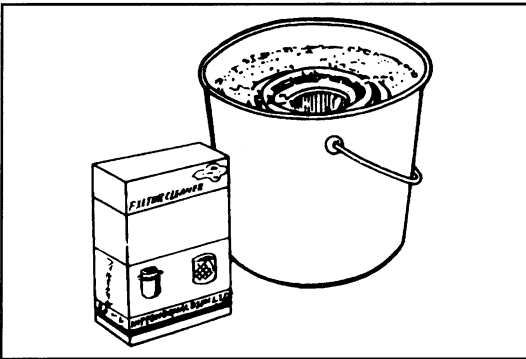
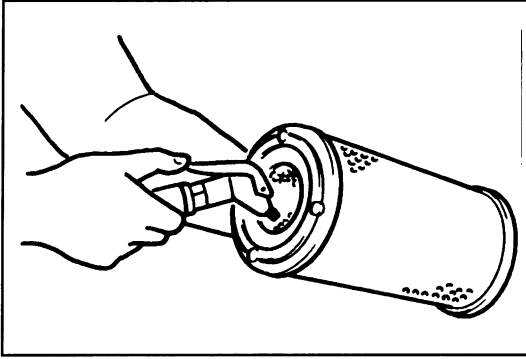
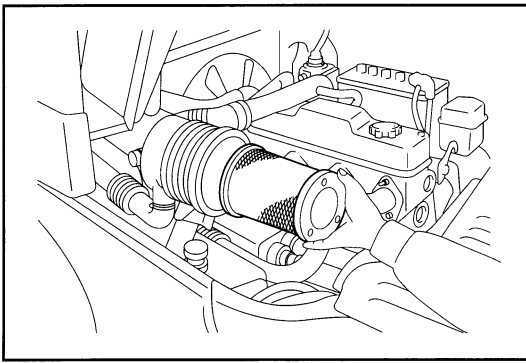

3. Clean the element.
 - (1) For ordinary cleaning, blow with compressed air [690 kPa (7kgf/cm²) [100 psi] or less] vertically along the pleats from the inside of the element.
If heavily contaminated, washing is possible.
 - (2) Element washing method
Dissolve neutral detergent in tepid water (approx. 40°C (104°F)) and immerse the element in it for about 30 minutes. Then, rinse the element well with clear water. [Water pressure: 275 kPa (2.8 kgf/cm²) [40 psi] or less]
After washing, naturally dry the element or dry the element with a dryer (cold air).

Note:

- Do not damage the element during washing.
- Never use compressed air or hot air for drying.

4. Clean the evacuator valve (dust discharge valve).
 - (1) Hold the tip end of the evacuator valve and discharge dust and dirt from the inside of the valve.
5. Inspect the element.
 - (1) After cleaning, place an electric bulb in the element to inspect any damage in the element. If any pinhole, tear or damage is found, replace it with a new element.
6. Element replacement
Replace the element after it is washed six times or generally at intervals of 12 months.
7. Install the element.
 - (1) Install the evacuator valve in the illustrated direction.

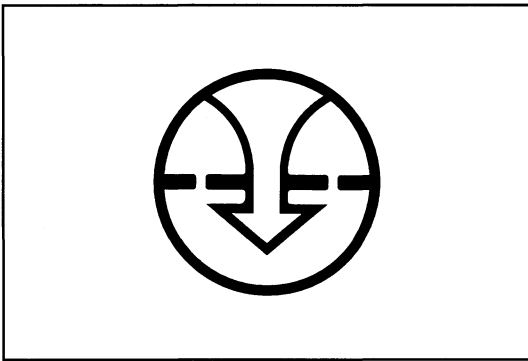

CLOGGING WARNING SYSTEM INSPECTION

1. Warning lamp inspection
 - (1) See that the air cleaner warning lamp comes on when the ignition switch is turned ON and goes out when the engine starts.
2. Individual inspection
 - (1) Use a mity vac to apply a negative pressure to the vacuum switch, and inspect conduction.

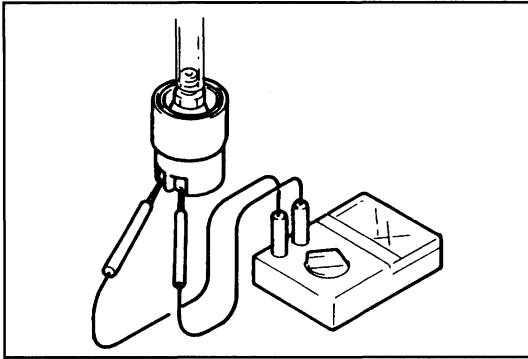

Standard

7473 ± 569 Pa (762 ± 58 mm H₂O)
 (56.0 ± 4.3 mmHg) [30.00 ± 2.28 in H₂O]
 [2.205 ± 0.169 in Hg]: Conduction

RADIATOR COMPONENTS

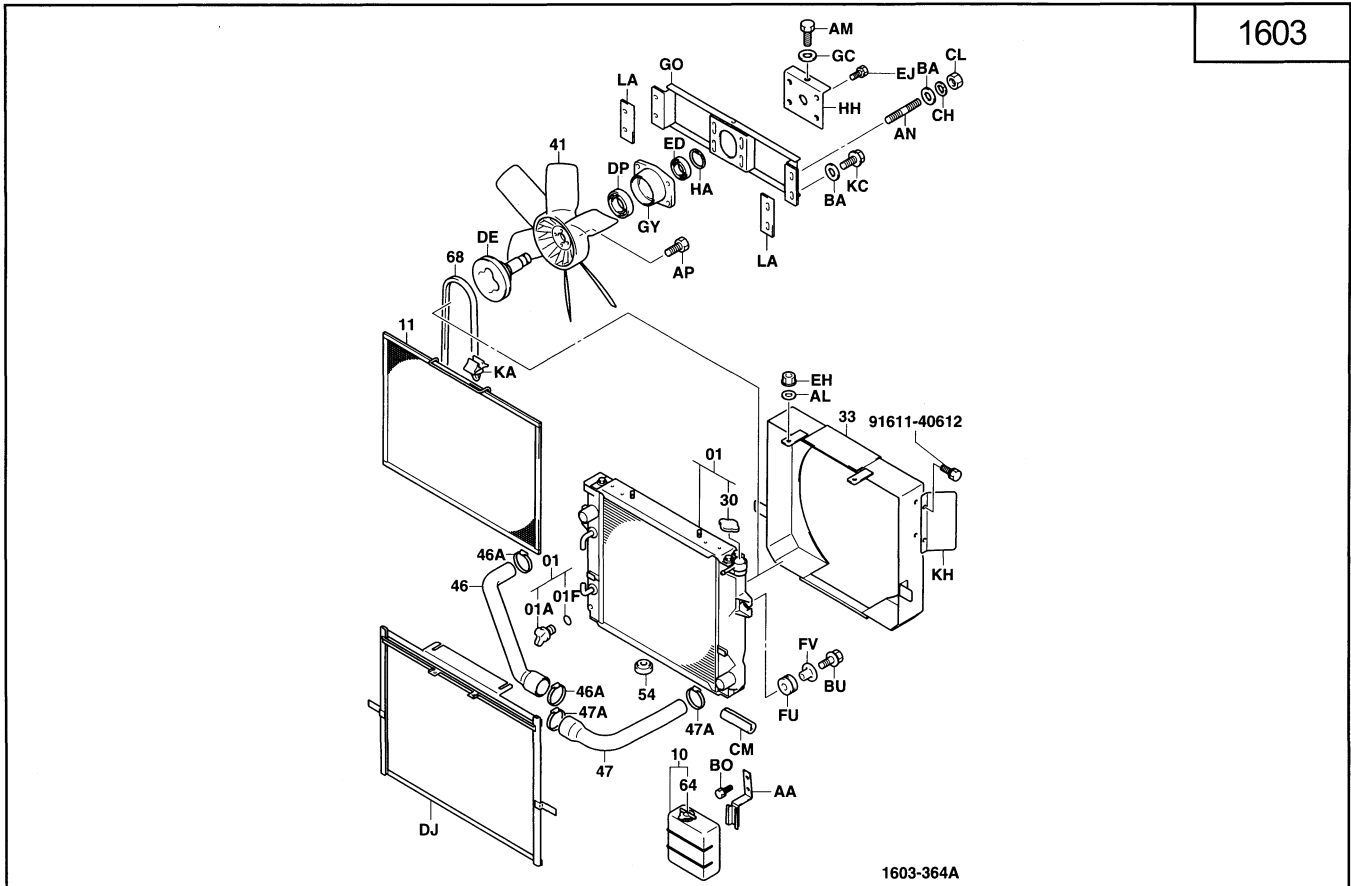

SPECIFICATIONS

Type	Crossflow	
Fin type	Corrugated fin	
Coolant capacity (in radiator)	See the table below	
Cap opening pressure	kPa (kgf/cm ²) [psi]	88 ± 14.7 (0.9 ± 0.15) [13 ± 2.1]
Others	Built in torque converter cooler Built in hydraulic oil cooler (Pn35 ~ 50 (13Z) model: OPT, Others: STD)	

COOLANT CAPACITY AND ANTIFREEZE TABLE ~ 2007.12

Unit: ℓ (US gal)

	Radiator capacity	Total amount of coolant	LLC mixing ratio at 30 % (to - 15°C (5°F))	LLC mixing ratio at 50 % (to - 35°C (- 31°F))	Antirust mixing at 5%
13Z: Pn35 ~ 50 model	2.9 (0.77)	13.0 (3.43)	3.9 (1.03)	6.5 (1.72)	0.7 (0.18)
Others	2.6 (0.69)	↑	↑	↑	↑

2008.1 ~

	Radiator capacity	Total amount of coolant	LLC mixing ratio at 30 % (to - 15°C (5°F))	LLC mixing ratio at 50 % (to - 35°C (- 31°F))	Antirust mixing at 5%
GM engine model	2.6 (0.69)	13.0 (3.43)	3.9 (1.03)	6.5 (1.72)	0.7 (0.18)
15Z engine model	3.7 (0.98)	14.0 (3.70)	4.2 (1.11)	7.0 (1.85)	0.7 (0.18)

Note:

- The total amount of coolant does not include the capacity of the reservoir tank.
- Reservoir tank capacity: 0.6ℓ (0.16 US gal) (at FULL mark position)

FAN DRIVE

REMOVAL-INSTALLATION

Note:

For the removal and installation of the pulley on the oil pump side, see the Oil Pump Removal-Installation section (on page 13-6).

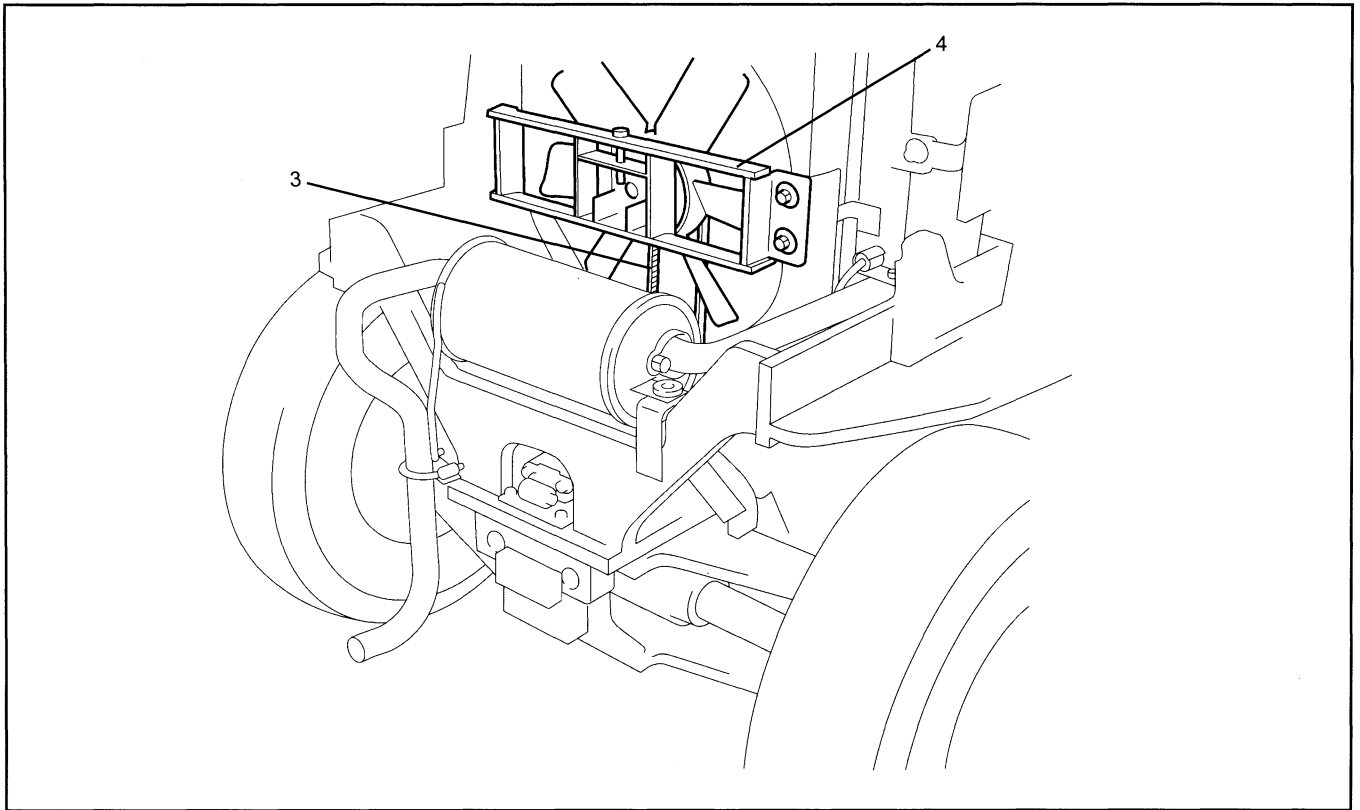

Removal Procedure

- 1 Remove the radiator cover.
- 2 Remove the counterweight. (See page 0-15 for the weight of the counterweight.)
- 3 Remove the fan belt. **[Point 1]**
- 4 Remove the fan support ASSY. **[Point 2]**

Installation Procedure

The installation procedure is the reverse of the removal procedure.

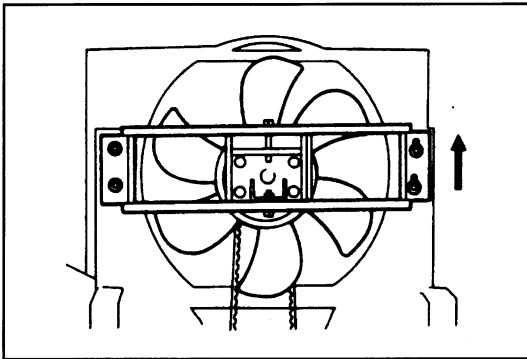
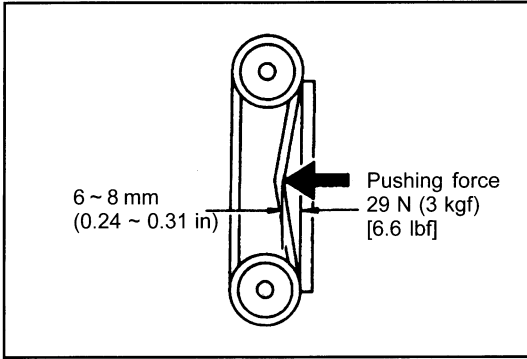
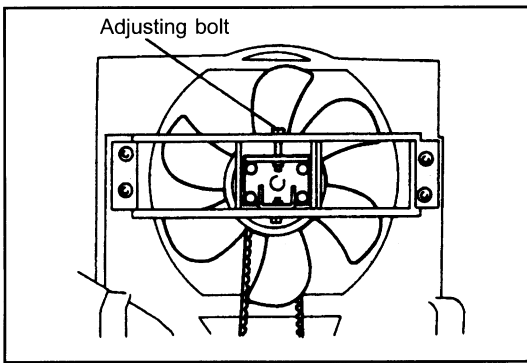

Point Operations

[Point 1]

Installation:

Fan belt tension adjustment

1. Adjust the fan belt tension to the standard level by turning the adjusting bolt.

Standard:

6 ~ 8 mm (0.24 ~ 0.31 in)

[Flexure upon pushing with a force of 29 N
(3 kgf) (6.6 lbf)]

2. Tighten the pulley set bolt.
3. After running the engine for several seconds, inspect the fan belt tension again.

[Point 2]

Installation:

Set the fan belt on the pulley, and tighten the set bolt while pulling the plate upward.

DISASSEMBLY·INSPECTION·REASSEMBLY

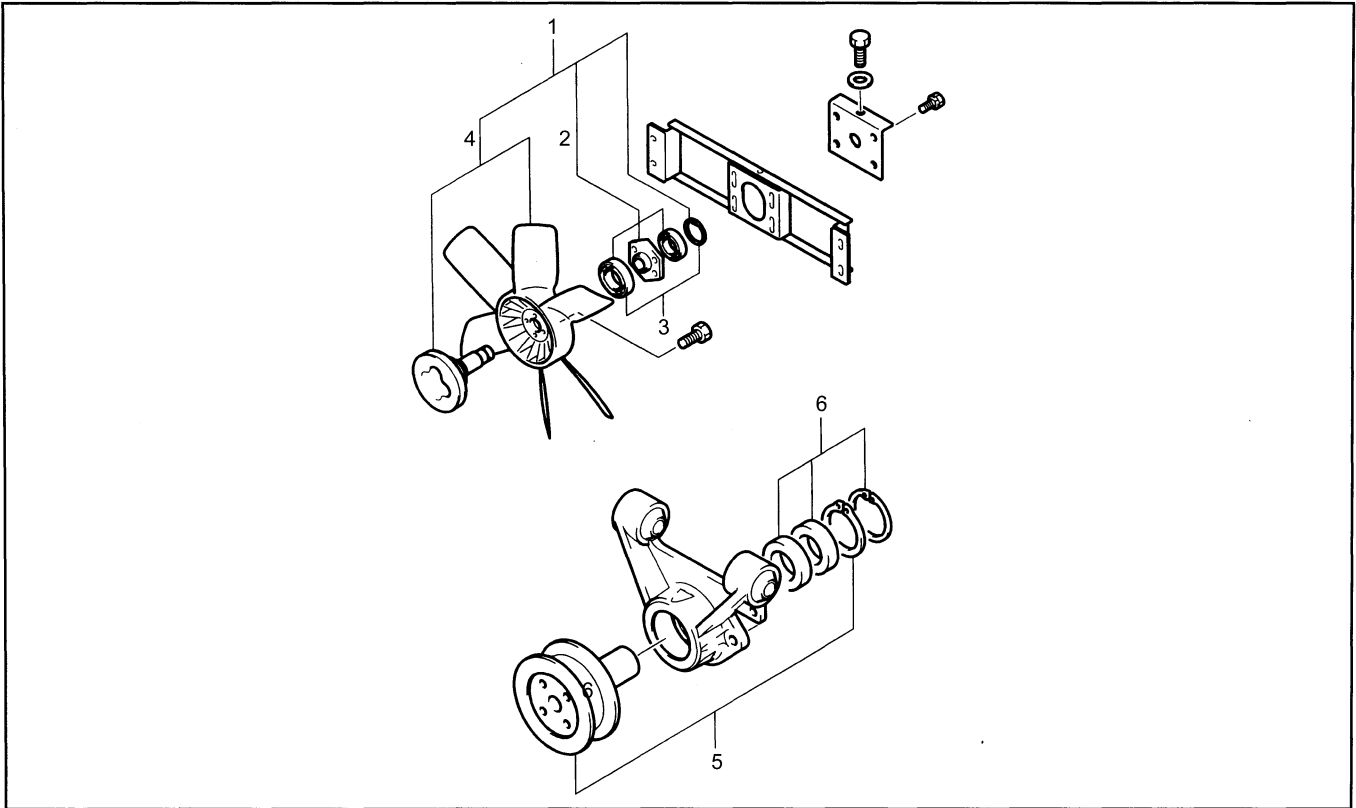

Disassembly Procedure

Fan side

- 1 Remove the fan and bearing housing from the fan support.
- 2 Remove the bearing housing. **[Point 1]**
- 3 Remove the bearing. **[Point 2]**
- 4 Remove the fan and pulley.

Oil pump side

- 5 Remove the pulley. **[Point 3]**
- 6 Remove the bearing. **[Point 4]**

Reassembly Procedure

The reassembly procedure is the reverse of the disassembly procedure.

Point Operations

[Point 1]

Disassembly:

Bearing housing removal

1. Remove the snap ring.
2. Use the SST and remove the bearing housing.
SST 09950-76014-71
(SST 09950-40011)

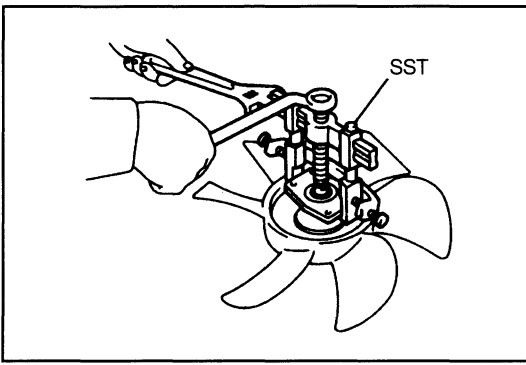

Reassembly:

Bearing housing installation

1. Use the SST and install the bearing housing.
SST 09623-76001-71
(SST 09623-30011)
2. Install the snap ring.

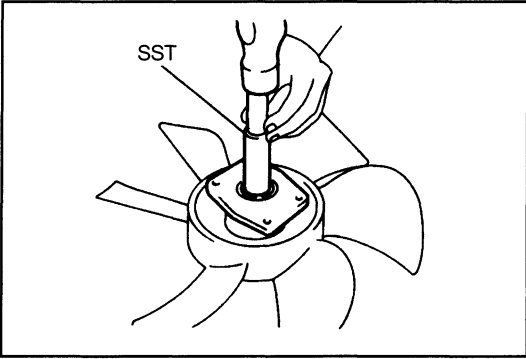

[Point 2]

Disassembly:

Use the SST and remove the bearing on the fan side.

SST 09950-76014-71
(SST 09950-40011)

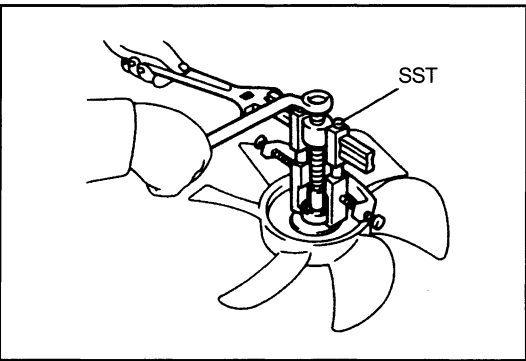

Reassembly:

Use the SST and install the bearing on the fan side.

SST 09623-76001-71
(SST 09623-30011)

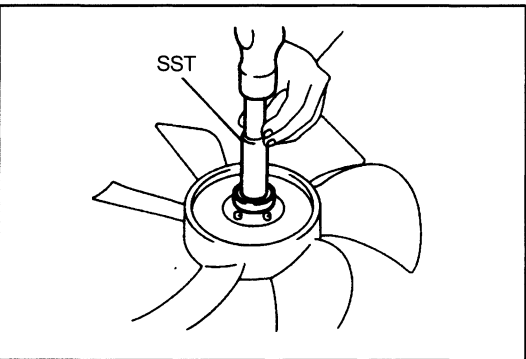

Disassembly:

Use the SST and remove the bearing on the housing side.

SST 09623-76001-71
(SST 09623-30011)

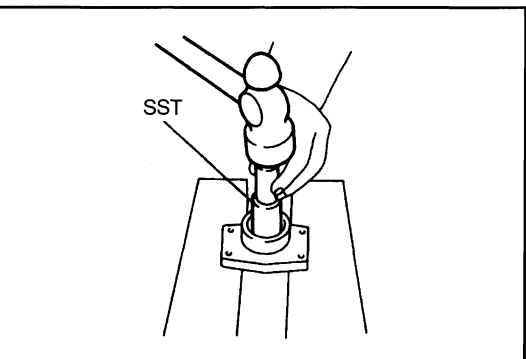

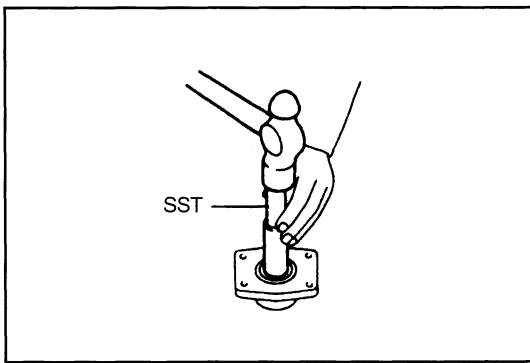

Reassembly:
 Use the SST and install the bearing on the fan side.
 SST 09623-30011

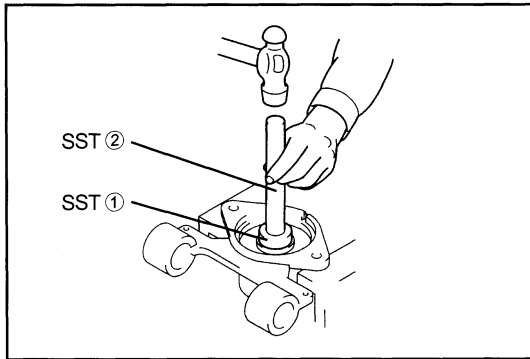

[Point 3]
 Disassembly:
 Pulley removal

1. Remove the snapping.
2. Use the SSTs to remove the pulley.
 SST 09950-76018-71 --- ①
 (SST 09950-60010)
 SST 09950-76020-71 --- ②
 (SST 09950-70010)

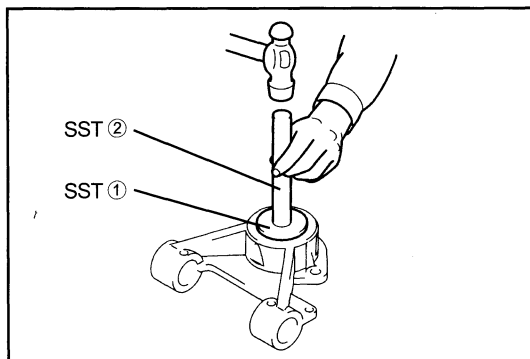

[Point 4]
 Disassembly:
 Bearing removal

1. Remove the snap ring.
2. Use the SST and remove the bearing.
 SST 09950-76018-71 --- ①
 (SST 09950-60010)
 SST 09950-76020-71 --- ②
 (SST 09950-70010)

Reassembly:
 Bearing installation

1. Use the SST and install the bearing.
 SST 09950-76018-71 --- ①
 (SST 09950-60010)
 SST 09950-76020-71 --- ②
 (SST 09950-70010)
2. Install the snap ring.

MUFFLER & EXHAUST PIPE

COMPONENTS

G4 (GM6-262) Engine
(~ 2003.12)

1702

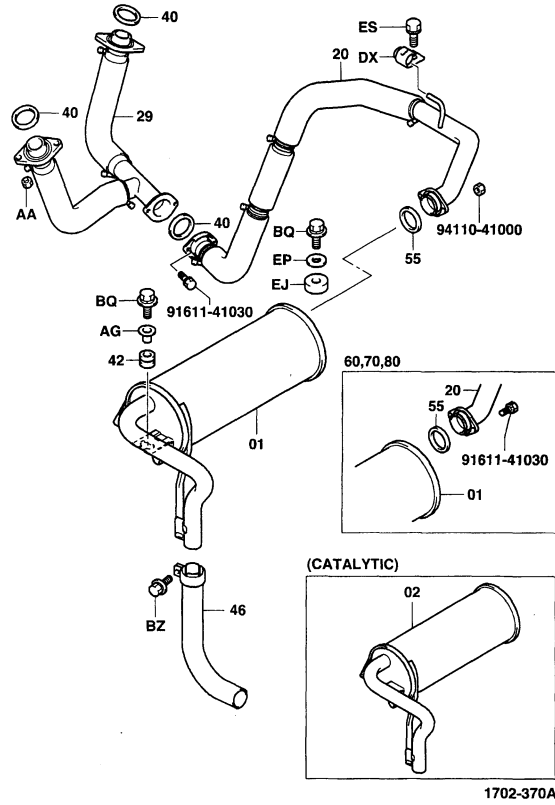

13Z-15Z Engine

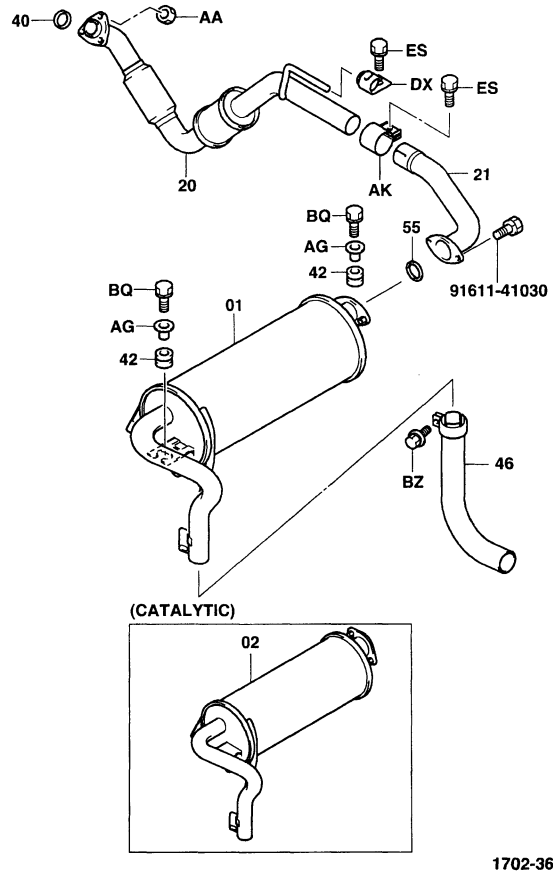

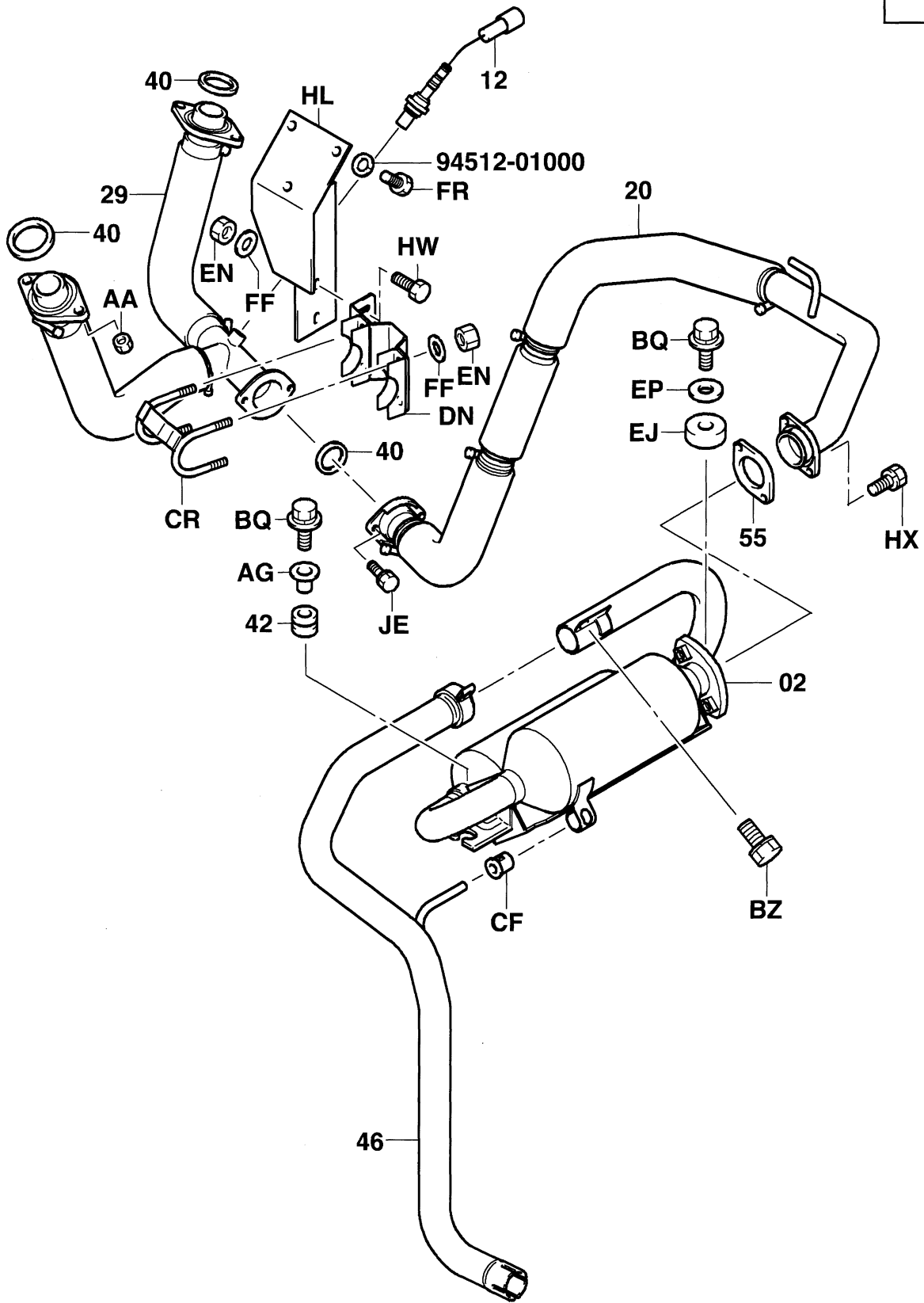

GM6-262 Engine (2003.9 ~)

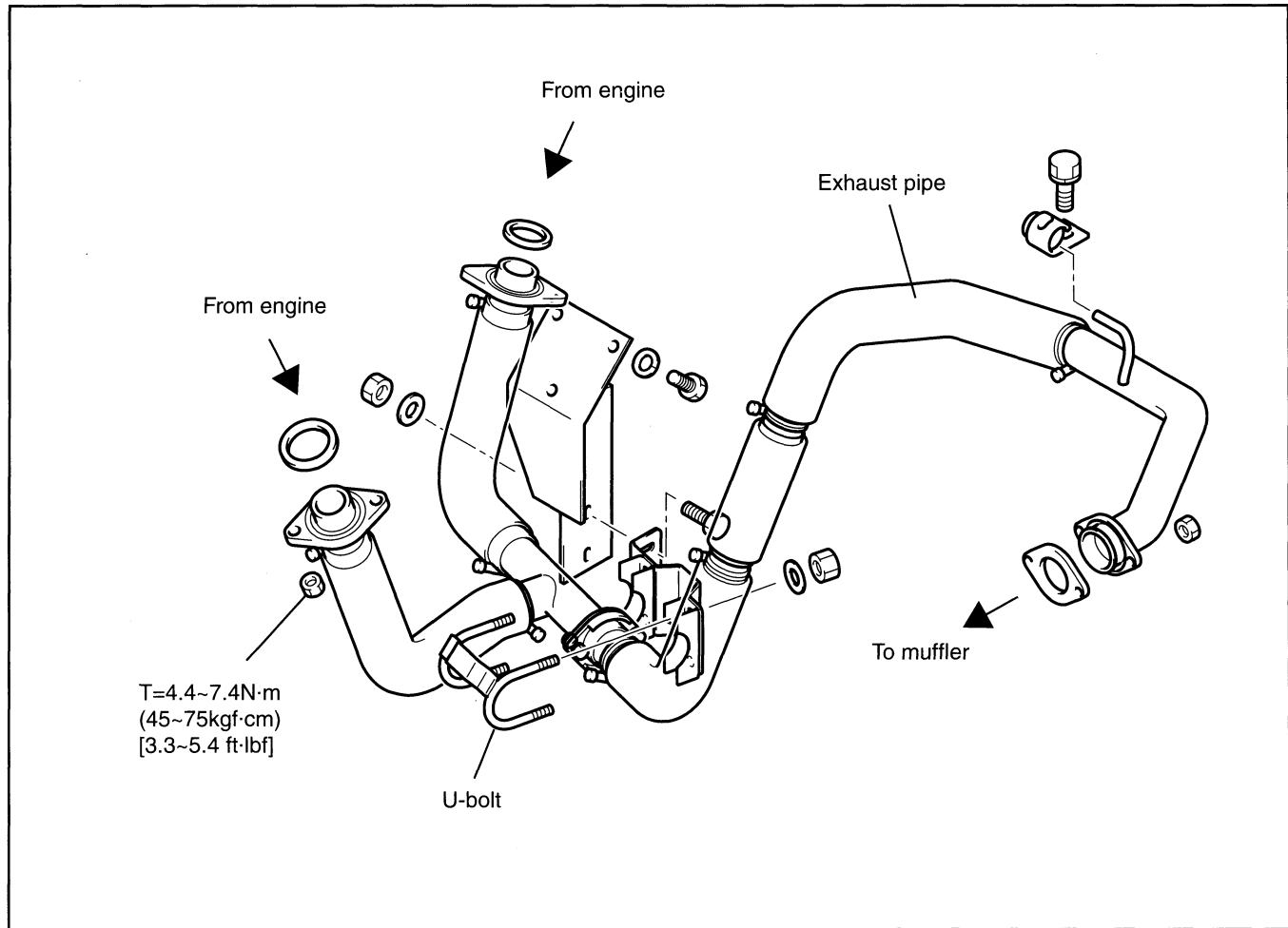

REMOVAL-INSTALLATION

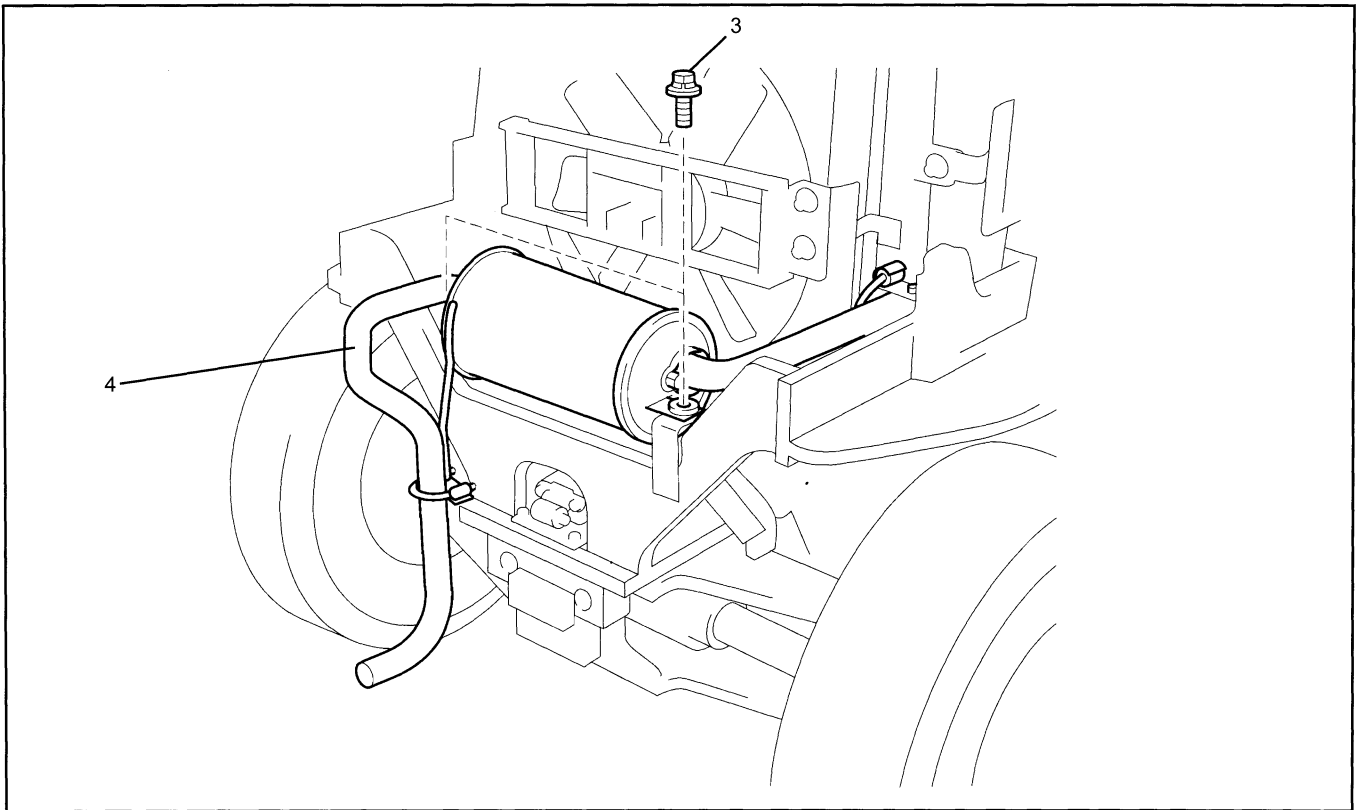

Removal Procedure

- 1 Remove the radiator cover.
- 2 Remove the counterweight. (See page 0-15 for the weight of the counterweight.)
- 3 Remove the muffer set bolts.
- 4 Remove the muffer by disconnection from the exhaust pipe.

Installation Procedure

The installation procedure is the reverse of the removal procedure.

**Thank you very much
for your reading.**

Please Click Here

**Then Get More
Information.**