

i02228217

Exhaust Manifold - Remove and Install

SMCS Code: 1059-010

Removal Procedure

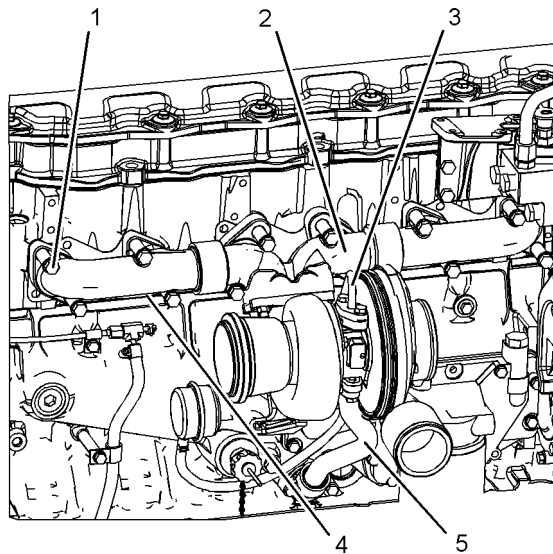

Illustration 24

g01124147

1. Disconnect tube assembly (3) and tube assembly (5).
2. Attach a suitable lifting device to exhaust manifold (2) and the turbocharger. The weight of exhaust manifold (2) and the turbocharger is approximately 40 kg (88 lb).
3. Remove bolts (1) and locks (4).
4. Remove exhaust manifold (2), the turbocharger, and the gaskets from the cylinder head assembly.

Installation Procedure

Table 10

Required Tools			
Tool	Part Number	Part Description	Qty
A	2P-2333	High Temperature Sealer	1
B	5P-3931	Anti-Seize Compound	1

NOTICE

Excessive use of sealant can cause damage to components.

To avoid component damage use only the amount of sealant necessary for the application.

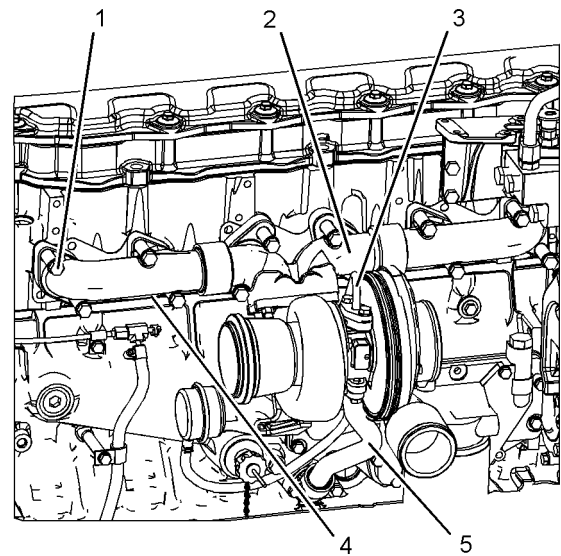

Illustration 25

g01124147

1. Apply Tooling (A) to the outside diameter of the male ends of exhaust manifold (2). Assemble exhaust manifold (2) and remove the excess sealer from the joints.
2. Apply Tooling (B) to the threads of bolts (1). Attach a suitable lifting device to exhaust manifold (2) and the turbocharger. The weight of exhaust manifold (2) and the turbocharger is approximately 40 kg (88 lb). Position the gaskets, exhaust manifold (2), and the turbocharger on the cylinder head assembly. Install locks (4) and bolts (1).
3. Connect tube assembly (3) and tube assembly (5).

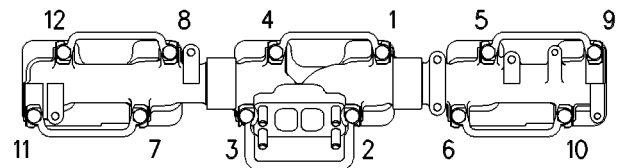

Illustration 26

g00617739

4. Tighten Bolt (1) through Bolt (12) in a numerical sequence.

Tighten bolts to the following torque. 4 ± 1 N·m
(35 ± 9 lb in)

5. Tighten Bolt (1) through Bolt (12) in a numerical sequence.

Tighten bolts to the following torque. .. 45 ± 5 N·m
(33 ± 4 lb ft)

6. Bend the locking tab over the flat of each bolt head.

Note: Prior to starting or running the engine, allow the sealant in the exhaust manifold joints to air dry for 24 hours.

i02228257

Air Inlet Heater Solenoid - Remove and Install

SMCS Code: 1090-010-OD

Removal Procedure

⚠ WARNING

Disconnect batteries before performance of any service work.

1. Disconnect the battery. Refer to Operation and Maintenance Manual, "Battery or Battery Cable - Disconnect".

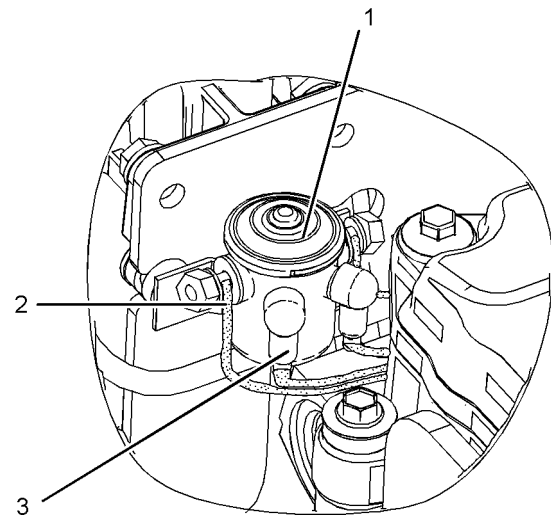

Illustration 27

g01124203

2. Disconnect harness assemblies (2) and harness assemblies (3).
3. Remove solenoid (1).

Installation Procedure

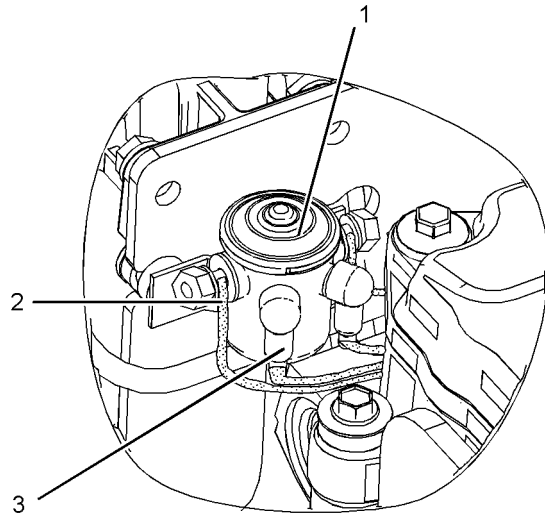

Illustration 28

g01124203

1. Position solenoid (1) on the engine.
2. Connect harness assemblies (2) and harness assemblies (3).
3. Connect the battery. Refer to Operation and Maintenance Manual, "Battery or Battery Cable - Disconnect".

i02228289

Inlet and Exhaust Valves - Remove and Install

SMCS Code: 1105-010

Removal Procedure

Table 11

Required Tools			
Tool	Part Number	Part Description	Qty
A	5S-1330	Valve Spring Compressor	1

Start By:

- a. Remove the cylinder head assembly. Refer to Disassembly and Assembly, "Cylinder Head - Remove".

NOTICE

Keep all parts clean from contaminants.

Contaminants may cause rapid wear and shortened component life.

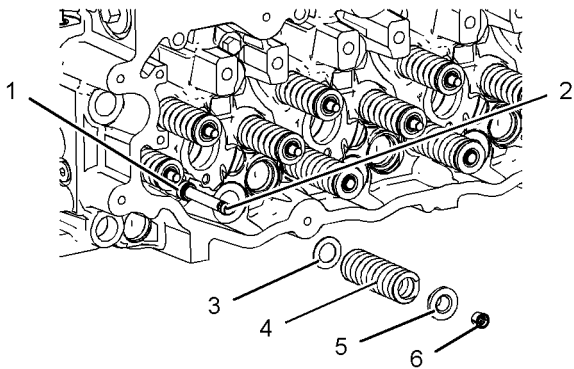

Illustration 29

g01127720

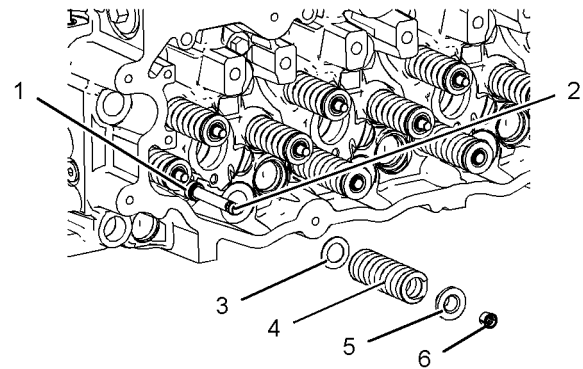

Illustration 30

g01127720

⚠ WARNING

The valve spring keepers can be thrown from the valve when the valve spring compressor is released. Ensure that the valve spring keepers are properly installed on the valve stem. To help prevent personal injury, keep away from the front of the valve spring keepers and valve springs during the installation of the valves.

Note: The following components of the exhaust valves are different from the components of the inlet valves: spring retainer (5), valve spring (4), and valve (2).

1. Use Tooling (A) to compress valve spring (4). Remove retainer locks (6).
2. Remove Tooling (A). Remove spring retainer (5), valve spring (4), and washer (3).
3. Remove valve seal (1) and valve (2).

Installation Procedure

Table 12

Required Tools			
Tool	Part Number	Part Description	Qty
A	5S-1330	Valve Spring Compressor	1

NOTICE

Keep all parts clean from contaminants.

Contaminants may cause rapid wear and shortened component life.

⚠ WARNING

Improper assembly of parts that are spring loaded can cause bodily injury.

To prevent possible injury, follow the established assembly procedure and wear protective equipment.

1. Lubricate valve (2) with clean engine oil. Install valve (2) in the cylinder head assembly. Install new valve seal (1) against the valve guide.
2. Place the following items on the valve stem: washer (3), valve spring (4), and spring retainer (5).

Note: A small amount of grease can be used to hold the retainer locks in position during installation.

3. Use Tooling (A) to compress valve spring (4). Install retainer locks (6).

End By:

- a. Install the cylinder head assembly. Refer to Disassembly and Assembly, "Cylinder Head - Install".

i02228414

Inlet and Exhaust Valve Guides - Remove and Install

SMCS Code: 1104-010

Removal Procedure

Table 13

Required Tools			
Tool	Part Number	Part Description	Qty
A	1U-7793	Valve Guide Driver	1
B	9U-6895	Valve Guide Driver	1

Start By:

- Remove the inlet and exhaust valves. Refer to Disassembly and Assembly, "Inlet and Exhaust Valves - Remove and Install".

NOTICE

Keep all parts clean from contaminants.

Contaminants may cause rapid wear and shortened component life.

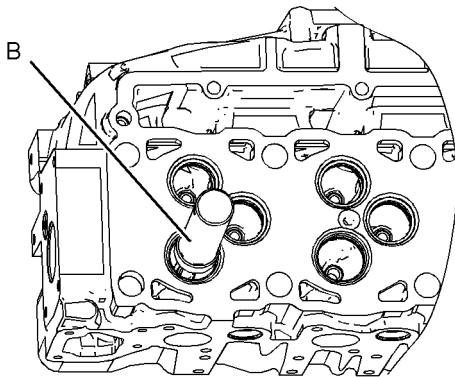

Illustration 31

g01124395

- Use Tooling (A) to remove the inlet valve guides from the cylinder head assembly. Use Tooling (B) to remove the exhaust valve guides from the cylinder head assembly.

Installation Procedure

Table 14

Required Tools			
Tool	Part Number	Part Description	Qty
A	1U-7793	Valve Guide Driver	1
B	9U-6895	Valve Guide Driver	1
C	1U-7792	Guide Collar	1
D	149-4008	Guide Collar	1

NOTICE

Keep all parts clean from contaminants.

Contaminants may cause rapid wear and shortened component life.

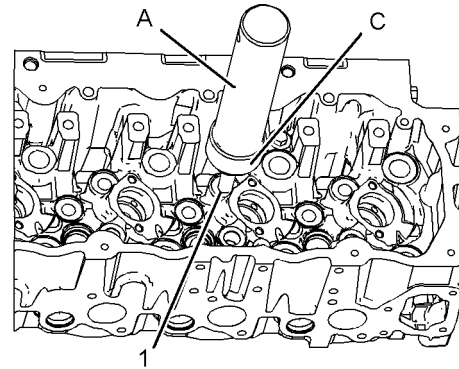

Illustration 32

g01124397

Note: Position the valve guides and tap on the top of the valve guides. This is done in order to start the valve guides into the cylinder head assembly.

- Use Tooling (A) and Tooling (C) to install inlet valve guides (1). Install inlet valve guides (1) until the protrusion is 23.0 ± 0.50 mm (0.90 ± 0.020 inch) above the cylinder head assembly.
- Use Tooling (B) and Tooling (D) to install the exhaust valve guides. Install the exhaust valve guides until the protrusion is 17.8 ± 0.50 mm (0.70 ± 0.020 inch) above the cylinder head assembly.

End By:

- Install the inlet and exhaust valves. Refer to Disassembly and Assembly, "Inlet and Exhaust Valves - Remove and Install".

i02954230

Inlet and Exhaust Valve Seat Inserts - Remove and Install

SMCS Code: 1103-010

Removal Procedure

Table 15

Required Tools			
Tool	Part Number	Part Description	Qty
A ⁽¹⁾	6V - 4194	Valve Seat Extractor ⁽²⁾	1
	165 - 5647	Valve Seat Extractor ⁽³⁾	1
	6V - 4804	Handle	1
	6V - 4192	Shaft	1
	6V - 4199	Lifting Bracket	1

- (1) Part of the 166 - 7441 Valve Seat Extractor Tool Group
- (2) Use for removal of the exhaust valve seats
- (3) Use for removal of the inlet valve seats

Start By:

- a. Remove the inlet and exhaust valves. Refer to Disassembly and Assembly, "Inlet and Exhaust Valves - Remove and Install".

NOTICE

Keep all parts clean from contaminants.

Contaminants may cause rapid wear and shortened component life.

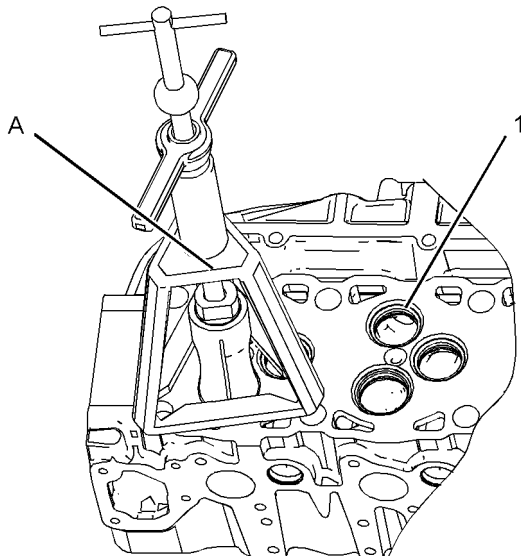

Illustration 33

g01124436

1. Use Tooling (A) to remove valve seat inserts (1).

Installation Procedure

Table 16

Required Tools			
Tool	Part Number	Part Description	Qty
B	149 - 6115	Installer	1
	133 - 9306	Valve Guide	1

NOTICE

Keep all parts clean from contaminants.

Contaminants may cause rapid wear and shortened component life.

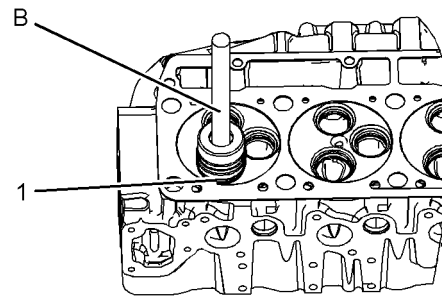

Illustration 34

g01475612

1. Lower the temperature of new valve seat inserts (1).
2. Use Tooling (B) and a suitable press to install the new valve seat inserts in the cylinder head.

Note: Do not machine the prefinished valve seat inserts in order to correct the valve stem projection. An excessive valve stem projection indicates that the valve seat insert is not seated or material was not cleaned from the bottom of the counterbore.

End By:

- a. Install the inlet valves and exhaust valves. Refer to Disassembly and Assembly, "Inlet and Exhaust Valves - Remove and Install".

i02519791

Engine Oil Filter Base and Oil Cooler - Remove

SMCS Code: 1306-011; 1378-012

Removal Procedure

Table 17

Required Tools			
Tool	Part Number	Part Description	Qty
A	185-3630	Strap Wrench Assembly	1

NOTICE

Care must be taken to ensure that fluids are contained during performance of inspection, maintenance, testing, adjusting and repair of the product. Be prepared to collect the fluid with suitable containers before opening any compartment or disassembling any component containing fluids.

Refer to Special Publication, NENG2500, "Caterpillar Tools and Shop Products Guide" for tools and supplies suitable to collect and contain fluids on Caterpillar products.

Dispose of all fluids according to local regulations and mandates.

1. Drain the coolant system. Refer to Operation and Maintenance Manual, "Refill Capacities and Recommendations".

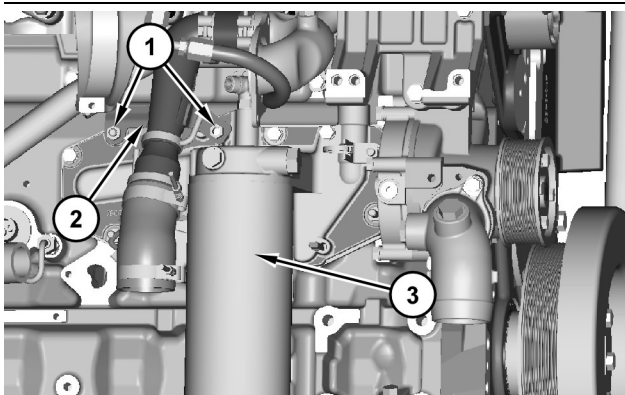

Illustration 35

g01261004

2. Remove nuts (1). Remove bracket (2) and the hose assembly. Use Tooling (A) and remove oil filter (3).

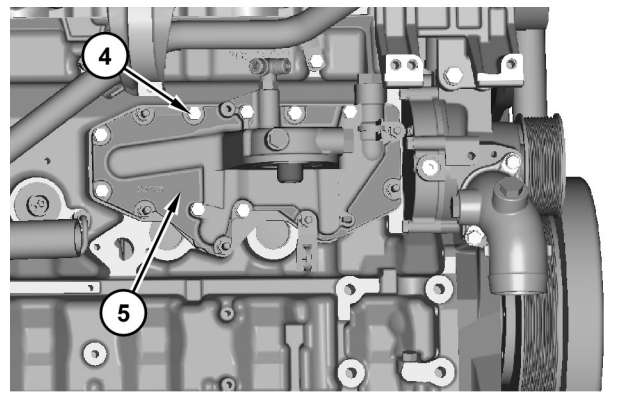

Illustration 36

g01261010

3. Remove bolts (4). Remove engine oil filter base (5) and the gasket.

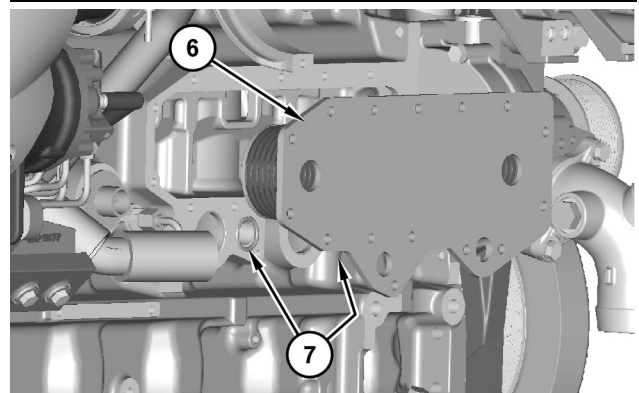

Illustration 37

g01261014

4. Remove oil cooler (6) and the gasket. Remove O-ring seals (7).

i02229026

Engine Oil Filter Base - Disassemble

SMCS Code: 1306-015

Disassembly Procedure

Start By:

- a. Remove the engine oil filter base and the oil cooler. Refer to Disassembly and Assembly, "Engine Oil Filter Base and Oil Cooler - Remove".

NOTICE

Keep all parts clean from contaminants.

Contaminants may cause rapid wear and shortened component life.

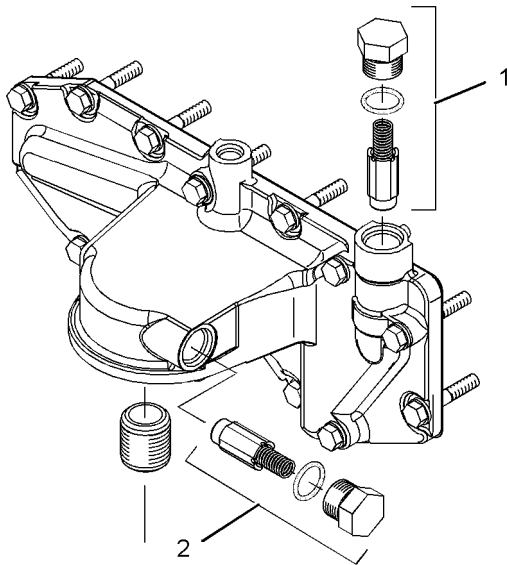

Illustration 38

g01124604

⚠ WARNING

Personal injury can result from being struck by parts propelled by a released spring force.

Make sure to wear all necessary protective equipment.

Follow the recommended procedure and use all recommended tooling to release the spring force.

- (1) Oil cooler bypass valve
- (2) Oil filter bypass valve

i02229174

Engine Oil Filter Base - Assemble

SMCS Code: 1306-016

Assembly Procedure

NOTICE

Keep all parts clean from contaminants.

Contaminants may cause rapid wear and shortened component life.

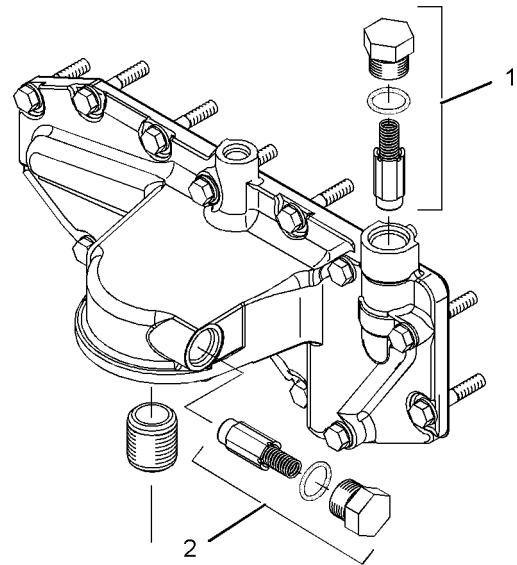

Illustration 39

g01124604

⚠ WARNING

Improper assembly of parts that are spring loaded can cause bodily injury.

To prevent possible injury, follow the established assembly procedure and wear protective equipment.

- (1) Oil cooler bypass valve
- (2) Oil filter bypass valve

End By:

- a. Install the engine oil filter base and the oil cooler. Refer to Disassembly and Assembly, "Engine Oil Filter Base and Oil Cooler - Install".

i02519800

Engine Oil Filter Base and Oil Cooler - Install

SMCS Code: 1306-012; 1378-012

Installation Procedure

Table 18

Required Tools			
Tool	Part Number	Part Description	Qty
A	185-3630	Strap Wrench Assembly	1

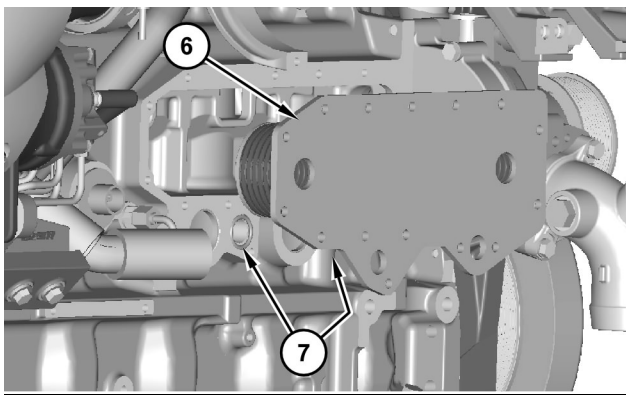

Illustration 40

g01261018

Note: Check O-ring seals for wear or for damage. If necessary, replace the O-ring seals.

1. Install O-ring seals (7). Install oil cooler (6) and the gasket.

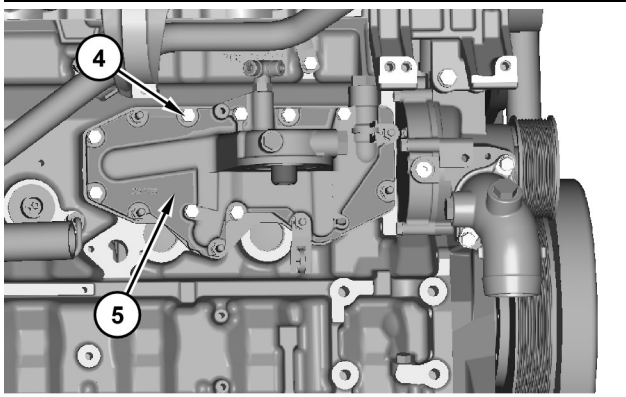

Illustration 41

g01261019

2. Install the gasket and engine oil filter base (5). Install bolts (4).

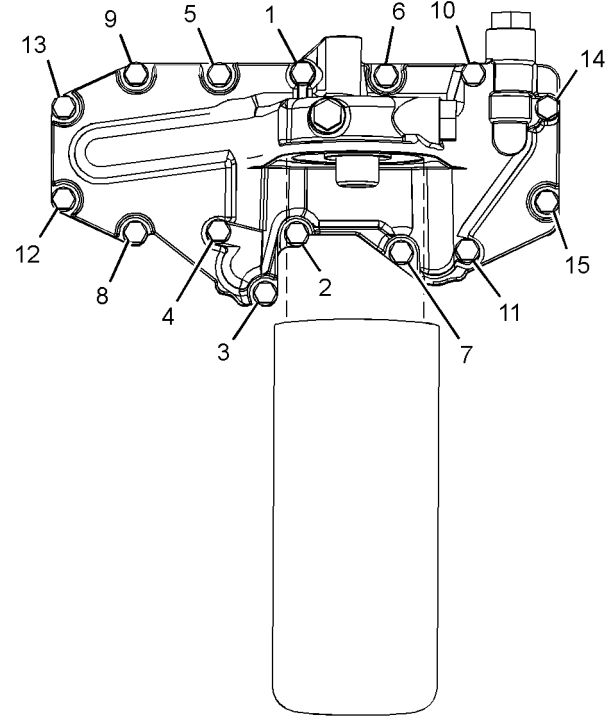

Illustration 42

g01261020

3. Tighten bolts (4) in a numerical sequence to a torque of 15 N·m (11 lb ft). Tighten bolts (4) in a numerical sequence to a torque of 28 N·m (21 lb ft).

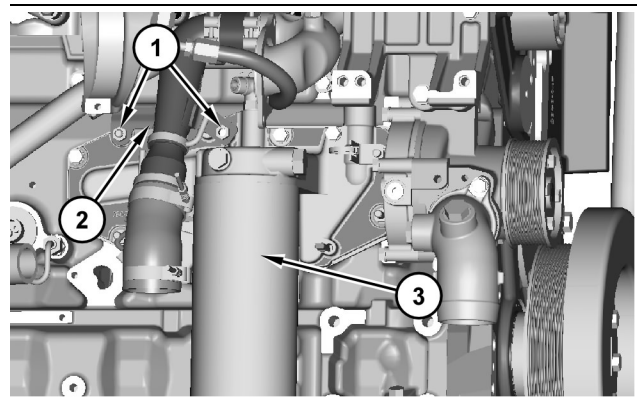

Illustration 43

g01261022

4. Install oil filter (3) with Tooling (A). Install the hose assembly and bracket (2). Install nuts (1).
5. Fill the coolant system. Refer to Operation and Maintenance Manual, "Refill Capacities and Recommendations".

i02229240

i02229280

Engine Oil Pump - Remove

SMCS Code: 1304-011

Removal Procedure

Start By:

- a. Remove the engine oil pan. Refer to Disassembly and Assembly, "Engine Oil Pan - Remove and Install".

NOTICE

Keep all parts clean from contaminants.

Contaminants may cause rapid wear and shortened component life.

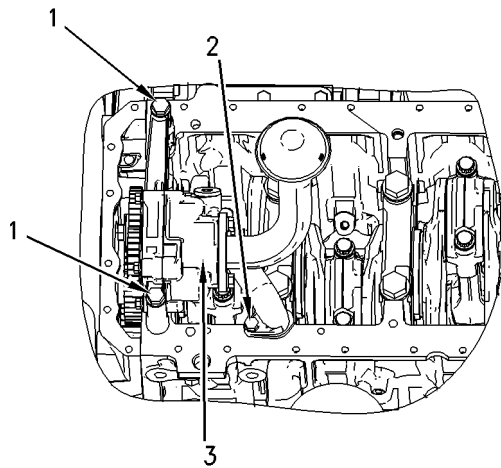

Illustration 44

g00987795

1. Remove bolts (1) and bolt (2).
2. Remove engine oil pump (3).
3. Remove the O-ring seals.

Engine Oil Pump - Disassemble

SMCS Code: 1304-015

Disassembly Procedure

Table 19

Required Tools			
Tool	Part Number	Part Description	Qty
A	8B-7554	Bearing Cup Puller Gp	1
B	1P-0510	Driver Gp	1

Start By:

- a. Remove the engine oil pump. Refer to Disassembly and Assembly, "Engine Oil Pump - Remove".

NOTICE

Keep all parts clean from contaminants.

Contaminants may cause rapid wear and shortened component life.

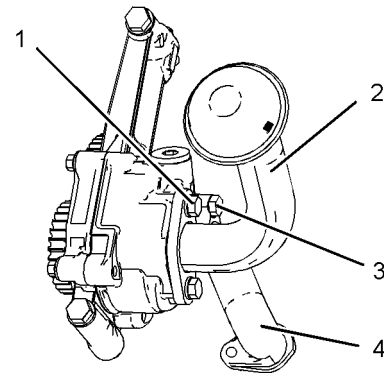

Illustration 45

g01127669

1. Remove bolts (1), oil pickup tube (2), and the gasket from the engine oil pump. Remove bolt (3) and outlet elbow (4) from the engine oil pump.

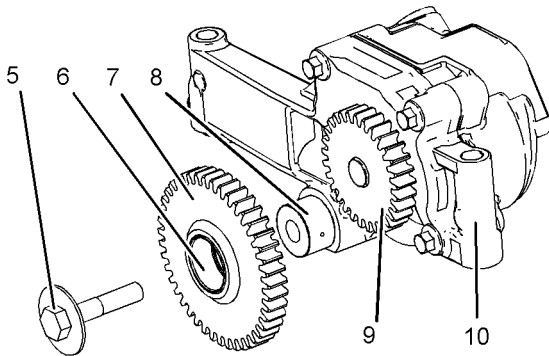

Illustration 46

g01127673

2. Remove bolt (5).
3. Remove idler gear (7) from shaft (8).
4. Use Tooling (B) and remove bearing (6) from idler gear (7).
5. Use Tooling (A) to remove drive gear (9) from engine oil pump (10).

i02229316

Engine Oil Pump - Assemble

SMCS Code: 1304-016

Assembly Procedure

Table 20

Required Tools			
Tool	Part Number	Part Description	Qty
B	1P-0510	Driver Gp	1

NOTICE

Keep all parts clean from contaminants.

Contaminants may cause rapid wear and shortened component life.

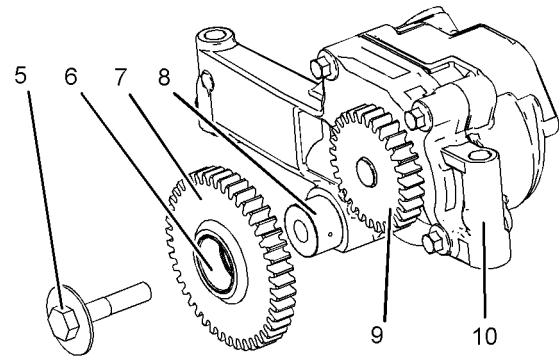

Illustration 47

g01127673

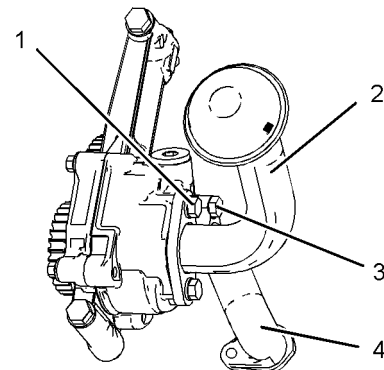

Illustration 48

g01127669

1. Use Tooling (B) and press drive gear (9) on the shaft assembly until drive gear (9) is flush with the end of the shaft assembly.
2. Install bearing (6) in idler gear (7). Install bearing (6) so the distance between the hub bolt face of idler gear and bearing (6) is 0.75 ± 0.25 mm (0.030 ± 0.010 inch).
3. Install idler gear (7) on shaft (8). Install bolt (5). Tighten bolt (5) to a torque of 70 ± 15 N·m (52 ± 11 lb ft).
4. Position the gasket and oil pickup tube (2) onto engine oil pump (10). Install bolts (1).
5. Position the O-ring seal and outlet elbow (4) onto engine oil pump (10). Install bolt (3).

End By:

- a. Install the engine oil pump. Refer to Disassembly and Assembly, "Engine Oil Pump - Install".

i02229347

Engine Oil Pump - Install

SMCS Code: 1304-012

Installation Procedure

NOTICE

Keep all parts clean from contaminants.

Contaminants may cause rapid wear and shortened component life.

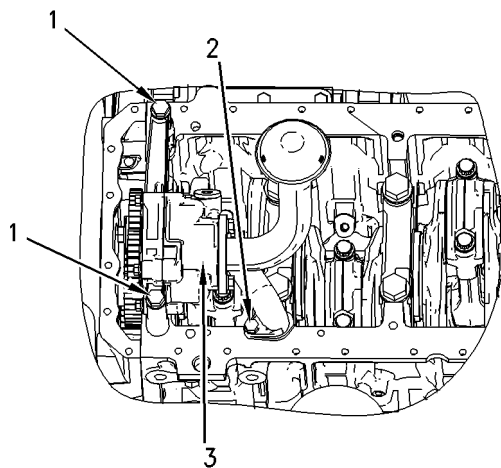

Illustration 49

g00987795

1. Install the O-ring seals. Position engine oil pump (3) on the cylinder block.
2. Install bolts (1) and bolt (2).

End By:

- a. Install the engine oil pan. Refer to Disassembly and Assembly, "Engine Oil Pan - Remove and Install".

i02229479

Water Pump - Remove

SMCS Code: 1361-011

Removal Procedure

Start By:

- a. Remove the alternator. Refer to Disassembly and Assembly, "Alternator - Remove and Install".

NOTICE

Keep all parts clean from contaminants.

Contaminants may cause rapid wear and shortened component life.

NOTICE

Care must be taken to ensure that fluids are contained during performance of inspection, maintenance, testing, adjusting and repair of the product. Be prepared to collect the fluid with suitable containers before opening any compartment or disassembling any component containing fluids.

Refer to Special Publication, NENG2500, "Caterpillar Tools and Shop Products Guide" for tools and supplies suitable to collect and contain fluids on Caterpillar products.

Dispose of all fluids according to local regulations and mandates.

1. Drain the coolant system. Refer to Operation and Maintenance Manual, "Refill Capacities and Recommendations".

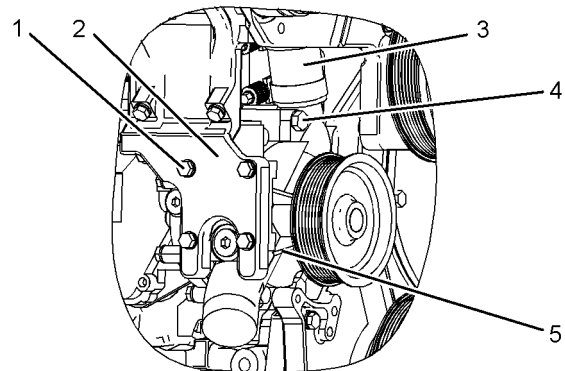

Illustration 50

g01124776

2. Remove bolts (1). Remove support bracket (2).
3. Disconnect hose (3).
4. Remove bolts (4). Remove water pump (5).