

How to read this Parts Catalog.

1. Parts mentioned in Parts Catalog may not necessarily be standard equipping parts
2. Parts change may be made without prior notice.
3. Form of this Parts Catalog.

Y00F2161 29. FUEL INJECTION PUMP(W/BOOST)				(A)=4JH-DT (D)=4JH-DTZA (B)=4JH-DTZ (E)=4JH-DTZ (C)=4JH-DTZP (F)=
REF.	LEV.	PARTS NO.	DESCRIPTION	(A) (B) (C) (D) (E) (F) I R K
1	1	729595-51390	FUEL INJECTION PUMP	1 1 1 1 1
1-1	1	729595-51391	FUEL INJECTION PUMP	1 1 1 1 1
		(A=E00185) (B=E00200)		
3	2	26022-060162	SCREW M 6X 16	9 9 9 9 9
1 3-1	2	26022-060162	SCREW M 6X 16	4 4 4 4 4 K
		(A=E00156) (B=E00156) (C=E00156) (D=E00156) (E=E00156)		
4	2	129470-51040	CAMSHFT	1 1 1 1 1
5	2	122710-51050	BEARING,ROLLER	2 2 2 2 2
6	2	129470-50160	RETAINER	1 1 1 1 1

Remarks	
(1)	BOOST COMPEMSATOR TYPE. OPTIONAL PART. TO E/#00155 (4JH-DT,4JH-DTZ)

① Ref. No.

The Ref. No. in the list may not be accord with the Ref. No. on illustration.

(Ex.) Illustration No.

List head No.

1

1

(Befor change)



1

1-1

(After change)

When interchangeable symbol N, R, and K, illustrations for new parts are sometimes omitted.

② Lev.(Level)

Indication and Meaning of Level

Level Hereunder is given the relation among the number of number (1,2,3) the level and the nominal parent-child relationship.

1 ----- Parent parts (Assembly parts)

2 ----- Child parts included in " 1 " (Semi-Assembly parts, component parts of Assembly parts.)

3 ----- Child parts included in " 2 ", Grand-child parts in terms of " 1 ".

(Component parts of Semi- Assembly parts.)

Note) A parts of non- sale parts are illustrated but not listed.

③ Change Mark

Change Mark "1" is given to the part for which a design change was made at this time.

The design change was not shown in the last published Parts Catalog.

④ Interchangeability Mark

In the case where a part change took place, one of the following interchangeability marks is indicated for that part.

Symbol	Interchangeability	Contents note
N	Old New	New Part is interchangeable for Old Part but not interchangeable conversely.
Q	Old New	New Part is not interchangeable for Old Part but interchangeable conversely.
R	Old New	New Part is interchangeable for Old Part and vice versa.
S	Old New	New Part is not interchangeable for Old Part and vice versa.
W		Part newly added.
Z		Part discontinued.
F		Not interchangeable single part but interchangeable by set of the related parts.
K		Changed only in quantity used.

⑤ Effective Machine No.

When a part is changed, Effective Machine No. of a Model for which the part is applicable is indication in each column of (A)- (F).

Product Symbol	Product No.	Product Symbol	Product No.
C	Clutch No. Compressor No.	M	Machine No.
D	Drive No.	T	Tractor No.
E	Engine No.	Note1) ※	Date

Note1) Date may follow the symbol in some cases. (Ex.) ※ 1996.01

Note2) As far as engine models shown by "XXX" are concerned, the modification of the parts could not be predicted or the engine models themselves could not be identified.

Note3) (A=E/#00185) means that the design change on the part has been effective for the model at the column (A) (in this case, for 4JH-DT) on and from E/# (Engine Serial Number) 00185.

⑥ Remarks Mark

Figures or alphabets (Symbols) are entered in the remark column.

The comments (remarks) on the pertinent parts are indicated in the lower part of the list by the same symbols as those stated above.

P R E F A C E

1. This parts catalog carries Yanmar crawler back - hoe VI050.

2. Parts catalog history

	Parts catalog No.	Published	Remarks
1st edition	000Y00K 2910	Nov., 1994	Abolish old edition
1st revised	000Y00K 2911	Jul., 1996	Abolish old edition
2nd revised	000Y00K 2912	Jan., 1998	

3. Model name

SECTION	Column	Model name	Manufactured	M/#
I (Vehicle)	(A)	VI050 C(R)	1993/ 7 ~1997/ 6	00501~01504
	(B)	VI050 P(R)		
II (Engine)	(A)	4TNE88L - RBV	1993/ 7 ~1997/ 5	00376~15607

(Note) C:cabin, P:canopy, R:rubber crawler, JP:Japan, EP:Europe,
EX:export except Europe

4. Your understanding is asking that this parts catalog is not a technical data manual setting forth as servicing procedures, This parts catalog is using simplified illustration. Be sure to use Yanmar Genuine Parts in your maintenance servicing of Yanmar products. Be careful not to use the simple parts available in the market ; otherwise their use in repairing causes such as an early breakage, for instance.

SPECIFICATIONS

Name			YANMAR CRAWLER BACKHOE	
Model			VI050 - PR	VI050 - CR
Engine	Model		4TNE88L - RBV	
	Bore × Stroke		88 × 90	
Dimensions	Transport length	mm	5300	
	Transport width	mm	2000	
	Transport height	mm	2455	2500
Std. bucket capacity		m ³	0.09 ~ 0.16 (0.14)	
Std. bucket width(Outside)		mm	700	
Max. digging depth		mm	3600	
Max. cutting height		mm	5900	5500
Max. dump height		mm	4250	3900
Max. reach at ground level		mm	5800	
Min. swing radius		mm	2000(Swing 1700)	2100(Swing 1800)
Boom swing angle		degree	Left 70 & Right 70	
Max. digging force(Std. bucket)		kgf	3300	
Travel speed(High/Low)		km/h	4.5 / 2.3	
Gradability		degree	30	
Average ground pressure		kgf/cm ²	0.28	0.29
Track shoe width(Std.)		mm	400	
Blade	Width × height	mm	2000 × 420	
	Capacity	m ³	0.35	
Machine mass		kg	4600	4720

1 [本機塗装色]
[PAINTED COLOR LIST]

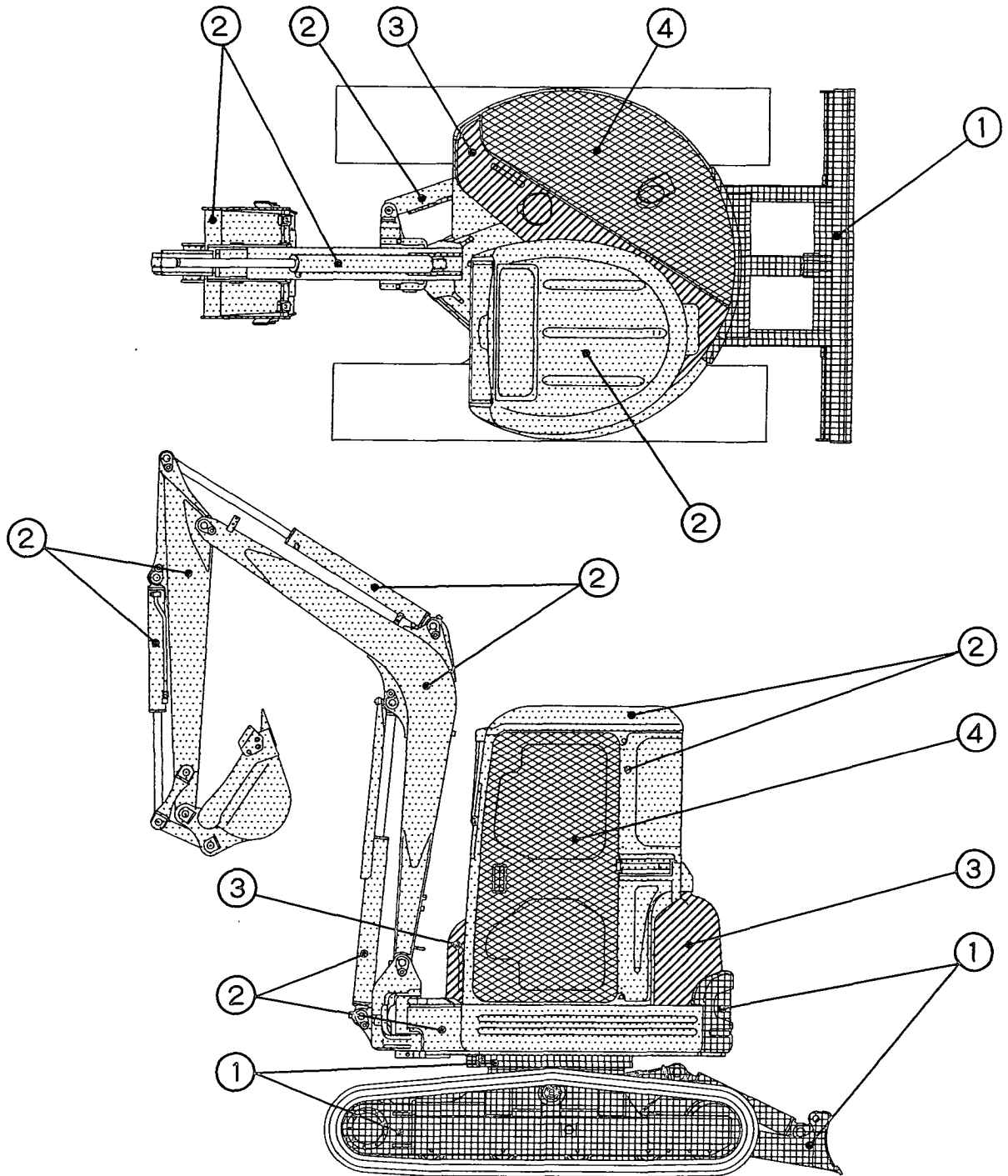

部所 PART	表示 DESC RIPTION	塗装色 マンセル記号	PAINTED COLOR MUNSEL No.	色区分 COLOR CODE
①		ヤンマーオーシャングリーン 7.62BG6.3/8.09	YANMAR OCEAN GREEN 7.62BG6.3/8.09	98
②		ヤンマーピーコックグリーン 3.8BG5.31/9.15	YANMAR PEAR COCK GREEN 3.8BG5.31/9.15	97
③		ヤンマーシトラスグリーン 4.84GY8.42/6.99	YANMAR CITROUS GREEN 4.84GY8.42/6.99	96
④		ヤンマーダークオリーブグレー 5.39Y2.92/0.78	YANMAR DARK OLIVE GREY 5.39Y2.92/0.78	72

2 [塗料部品番号] [PAINT PART No.]

部所 PART	塗装色 PAINTED COLOR	塗料部品番号 PAINT No.		
		16ℓ缶 16ℓCAN	4ℓ缶 4ℓCAN	スプレー SPRAY
①	ヤンマーオーシャングリーン YANMAR OCEAN GREEN	981101-09598	977620-40980	977620-30981
②	ヤンマーピーコックグリーン YANMAR PEAR COCK GREEN	981101-09597	977620-40970	977620-30971
③	ヤンマーシトラスグリーン YANMAR CITROUS GREEN	981101-09599	977620-40990	977620-30991
④	ヤンマーダークオリーブグレー YANMAR DARK OLIVE GREY	-----	977620-40720	TOR-90460003

3 [塗装色部品の表現] [EXPRESSION OF PAINTED PARTS]

部品番号 PART NO.	部品名 PART NAME	塗装色 PAINTED COLOR
172165-81103-4	ブームCMP (グリーン) (97) BOOM CMP (GREEN) (97)	ヤンマーピーコックグリーン YANMAR PEAR COCK GREEN

(注) 部品名末尾の () 内は塗装色を示す。
(NOTE) () AT THE END OF PART NAME SHOWS PAINT COLOR.

4 [主要部品の塗装色] [COLOR OF MAIN PARTS]

部所 PART	塗装色 PAINTED COLOR	主な部品 MAIN PARTS
①	ヤンマーオーシャングリーン YANMAR OCEAN GREEN	下部走行体 ブレード カウンターウエイト スイングシリンダ ブレードシリンダ UNDER TRAVELING BODY BLADE COUNTER WEIGHT SWING CYLINDER BLADE CYLINDER
②	ヤンマーピーコックグリーン YANMAR PEARCOCK GREEN	ターニングフレーム ブーム アーム キャビン本体 バケツ フロントカバー TURNING FRAME BOOM ARM CABIN BUCKET FRONT COVER
③	ヤンマーシトラスグリーン YANMAR CITROUS GREEN	ボンネット BONNET
④	ヤンマーダークオリーブグレー YANMAR DARK OLIVE GREY	ステップ、キャビンドア レバー類 インパネ ペダルカバー エンジン廻り STEP, CABIN DOOR LEVER INSTRUMENT PANEL PEDAL COVER ENGINE RELATED PART

絵目次 (1) 主要部品 PICTURESQUE INDEX (1) . . . MAIN PARTS

鏡板 . . . FIG. 1~5
 LABEL
 工具 . . . FIG. 6
 TOOL
 安全鏡板 . . . FIG. 92, 93
 SAFETY LABEL
 P.T.Oキット . . . FIG. 94
 P.T.O KIT

コンプレッサー&Vプーリー (クーラー仕様) . . . FIG. 11
 COMPRESSOR & V PULLEY (COOLER SPEC.)
 ラジエータ&オイルクーラ . . . FIG. 12
 RADIATOR & OIL COOLER
 燃料タンク&燃料パイプ . . . FIG. 15
 FUEL TANK & FUEL PIPE
 作動油タンク . . . FIG. 64
 HYD. OIL TANK

カバー (クーラー仕様) . . . FIG. 14
 COVER (COOLER SPEC.)
 ラジオカセット . . . FIG. 23, 24
 RADIO CASSETTE
 フレームカバー . . . FIG. 34
 FRAME COVER
 シート&シートマウント . . . FIG. 35
 SEAT & SEAT MOUNT
 ステップ . . . FIG. 36
 STEP
 ボンネット . . . FIG. 37
 BONNET
 ダクト . . . FIG. 38
 DUCT
 キャビン . . . FIG. 39~41
 CABIN
 キャビンドア . . . FIG. 42
 CABIN DOOR
 キャノピ&キャノピフレーム . . . FIG. 43
 CANOPY & CANOPY FRAME

吸気パイプ&排気パイプ . . . FIG. 7
 SUC. PIPE & EXH. PIPE
 エンジンマウント . . . FIG. 10
 ENGINE MOUNT
 バッテリー . . . FIG. 16
 BATTERY
 電気部品 . . . FIG. 17~20
 ELECTRIC PART
 ヒータ&デフロスタ . . . FIG. 22
 HEATER & DEFROSTER
 油圧ポンプ&油圧手 . . . FIG. 44, 45
 HYD. OIL PUMP & JOINT

ブーム&ブームブラケット . . . FIG. 86
 BOOM & BOOM BRACKET

ワークランプ . . . FIG. 21
 WORK LAMP

アームシリンダ . . . FIG. 48
 ARM CYLINDER

ブームシリンダ . . . FIG. 46, 47
 BOOM CYLINDER

スイングシリンダ . . . FIG. 50, 51
 SWING CYLINDER

ローラ&アジャスト . . . FIG. 25
 ROLLER & ADJUST
 クローラ . . . FIG. 26
 CRAWLER

走行モータ . . . FIG. 53
 TRAVEL MOTOR

ブレードシリンダ . . . FIG. 52
 BLADE CYLINDER
 ブレード . . . FIG. 91
 BLADE

アクセル . . . FIG. 8, 9
 ACCELERATOR
 操縦装置 . . . FIG. 27~32
 CONTROL EQUIP.
 リモコンバルブ . . . FIG. 59
 REMOTE CONTROL VALVE

バケットシリンダ . . . FIG. 49
 BUCKET CYLINDER
 アーム&バケットリンク . . . FIG. 87
 ARM & BUCKET LINK
 バケット . . . FIG. 88~90
 BUCKET

パイピング (クーラー仕様) . . . FIG. 13
 PIPING (COOLER SPEC.)
 ローハイバルブ (旧形) . . . FIG. 62
 LOW-HIGH VALVE (PREVIOUS)
 油圧配管 . . . FIG. 65~77
 HYD. OIL PIPING
 コントロール配管 . . . FIG. 78~83
 CONTROL PIPING
 潤滑グリース . . . FIG. 85
 GREASING

フレーム&旋回ベアリング . . . FIG. 33
 FRAME & TURNING BEARING
 旋回モータ . . . FIG. 54, 55
 TURNING MOTOR
 スイベルジョイント . . . FIG. 56
 SWIVEL JOINT
 コントロールバルブ . . . FIG. 57, 58
 CONTROL VALVE
 ロータリバルブ (4ウェイマルチチェンジ) . . . FIG. 61
 ROTARY VALVE (4-WAY MULTI CHANGE)
 2ウェイバルブ (2ウェイマルチチェンジ) . . . FIG. 60
 2-WAY VALVE (2-WAY MULTI CHANGE)
 P.T.Oバルブ . . . FIG. 63
 P.T.O. VALVE

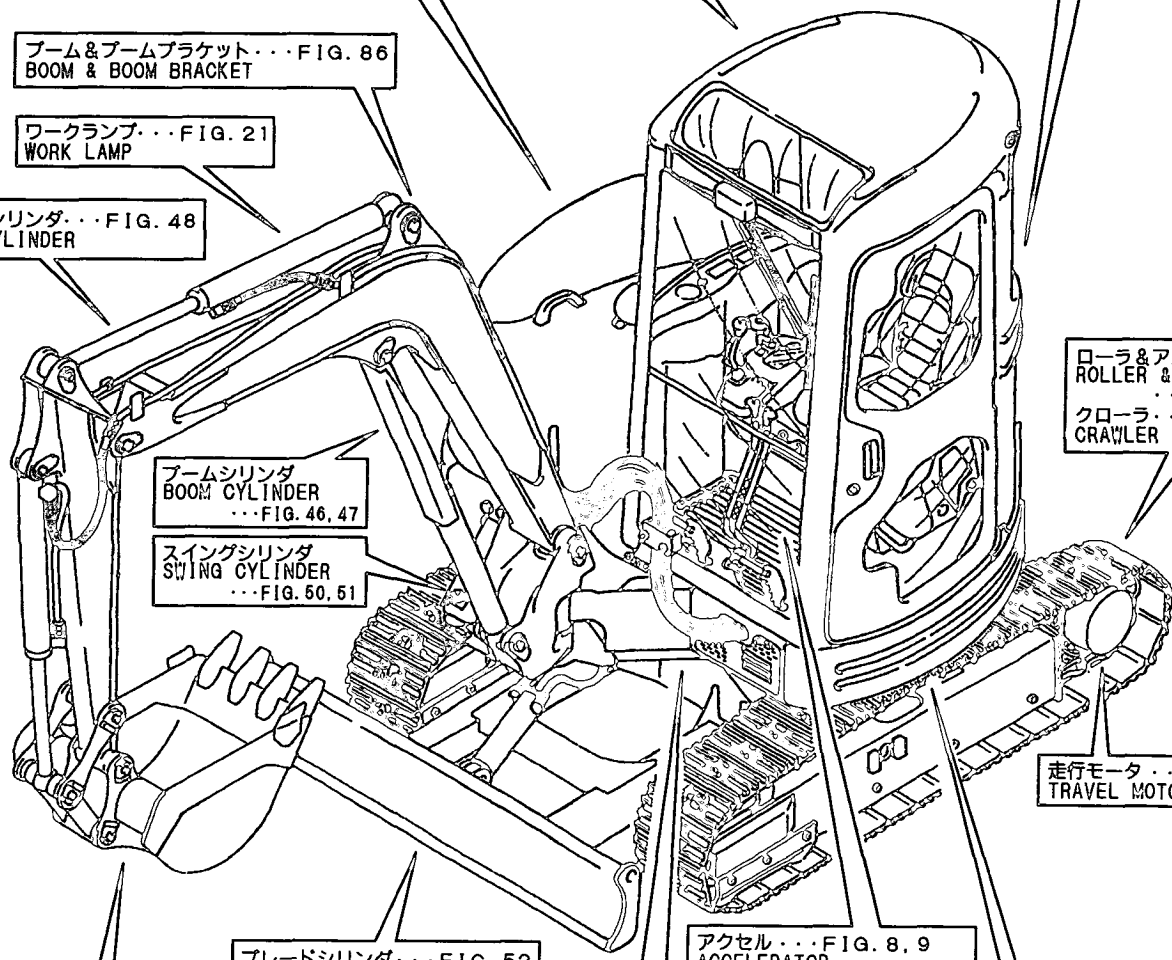

絵目次 (2) 油圧関係 PICTURESQUE INDEX (2) . . . HYDRAULIC SECTION

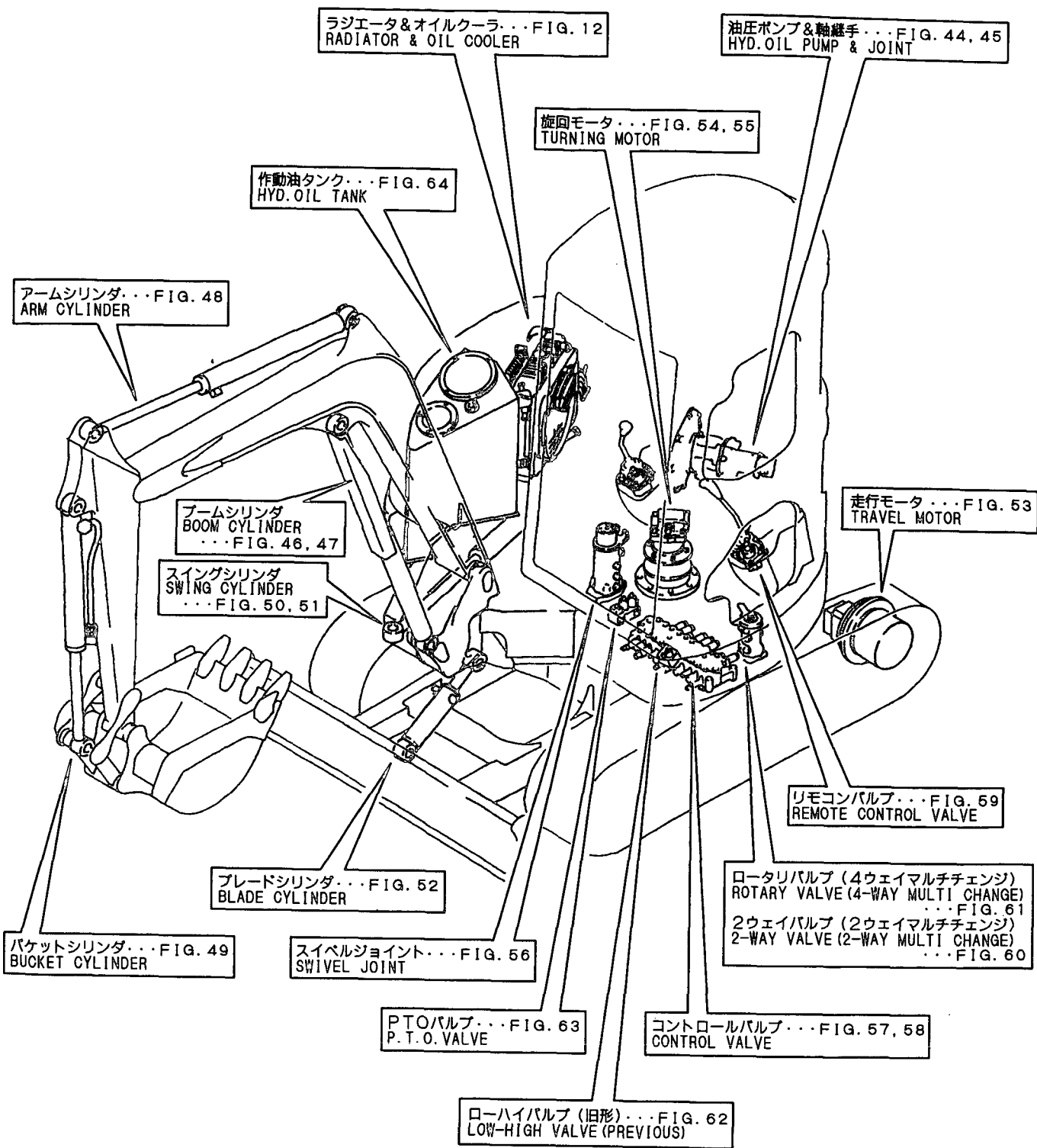

絵目次 (3) 項目別
PICTURESQUE INDEX (3) FIGURE

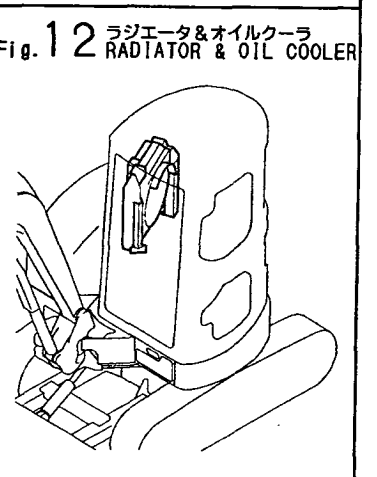
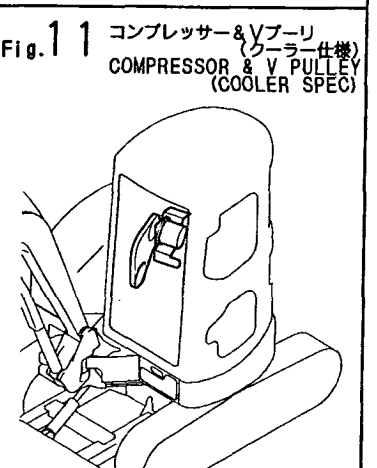
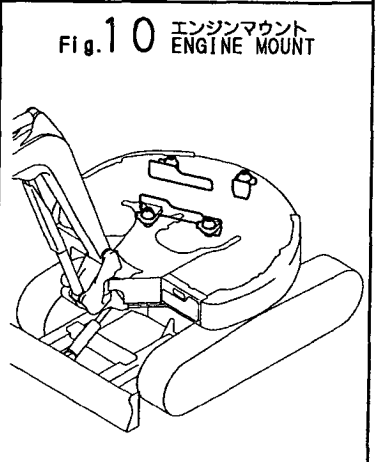
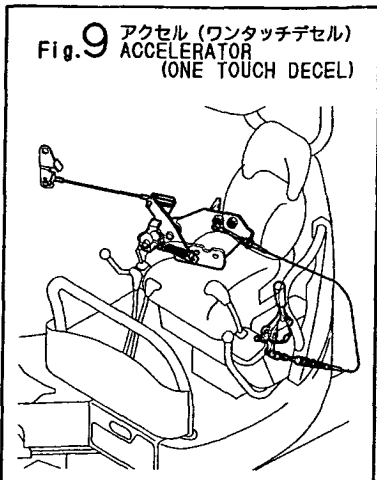
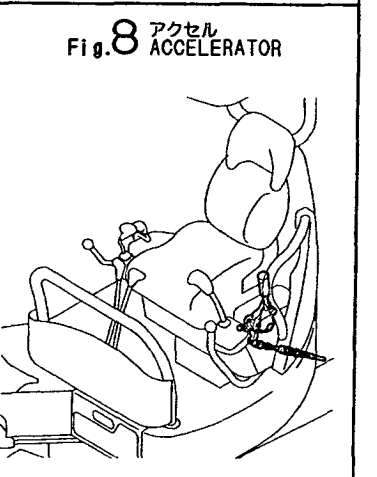
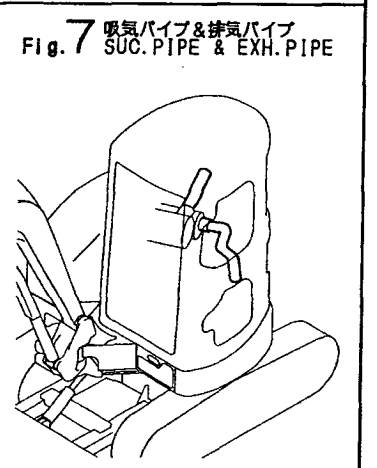
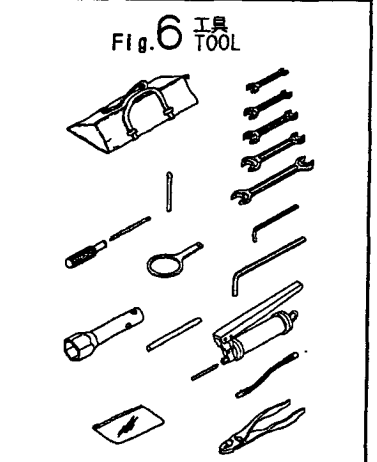
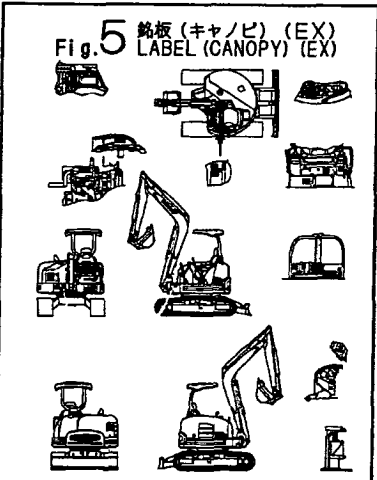
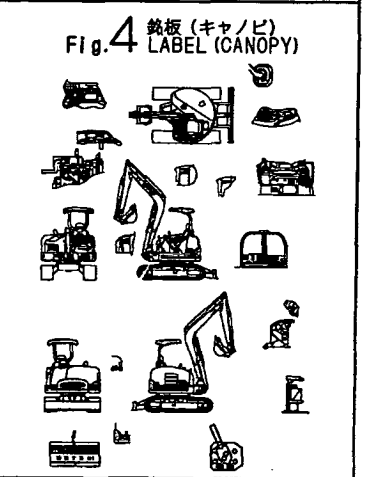
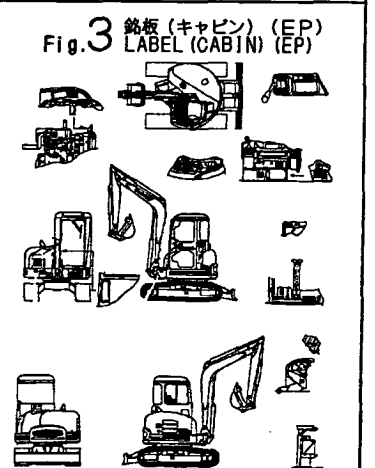
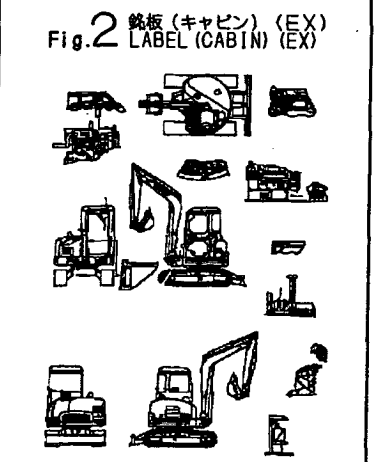
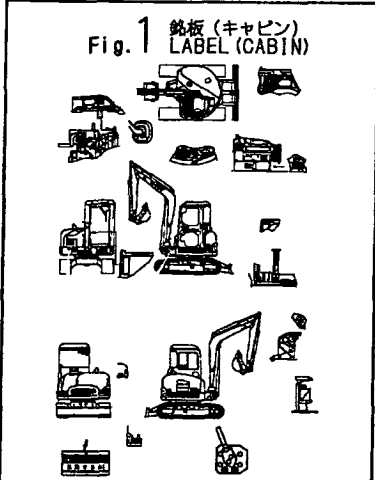

絵目次 (3) 項目別
PICTURESQUE INDEX (3) FIGURE

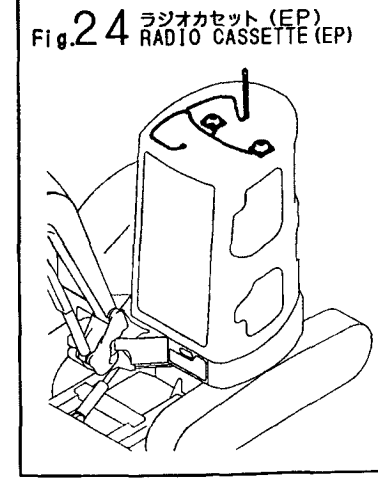
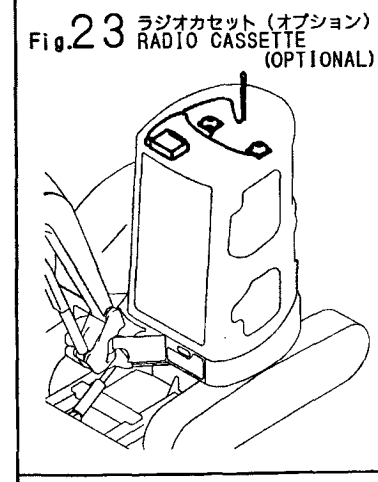
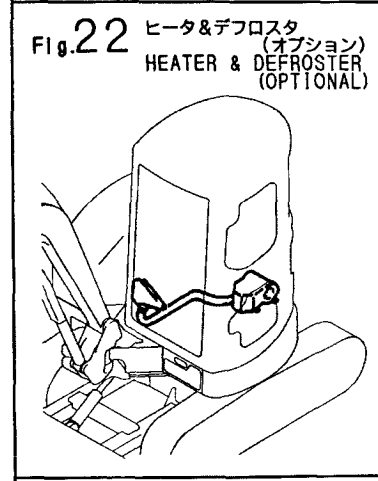
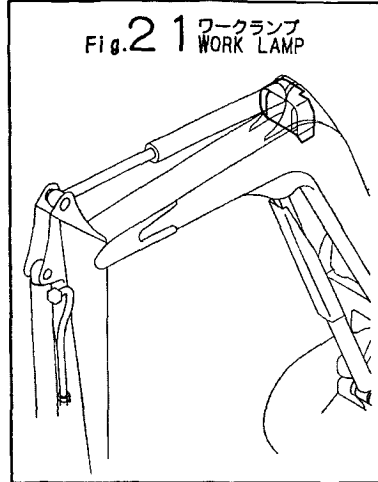
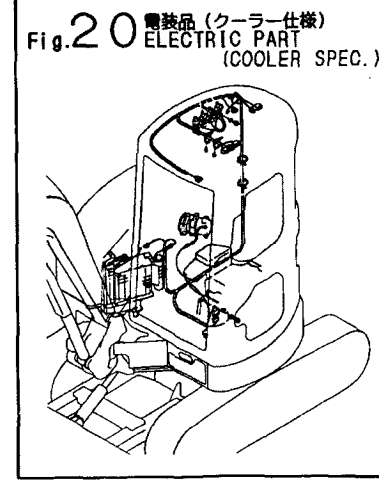
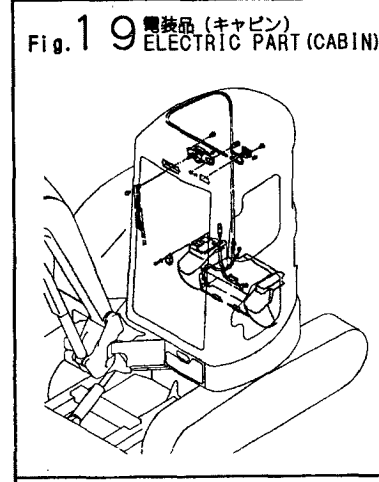
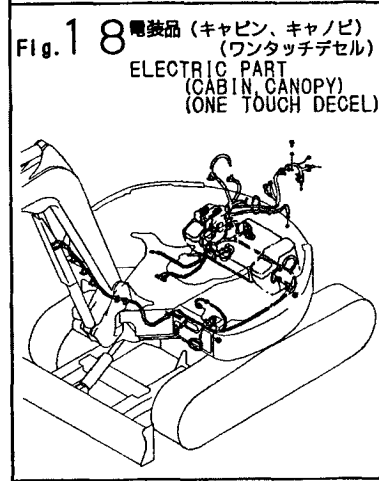
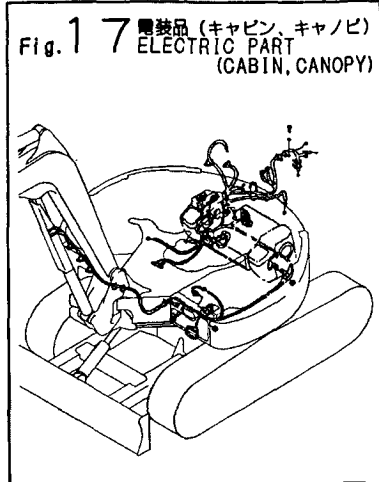
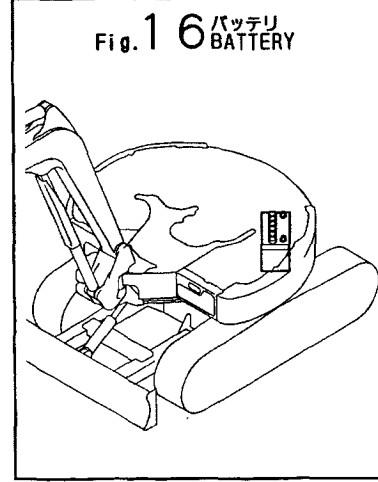
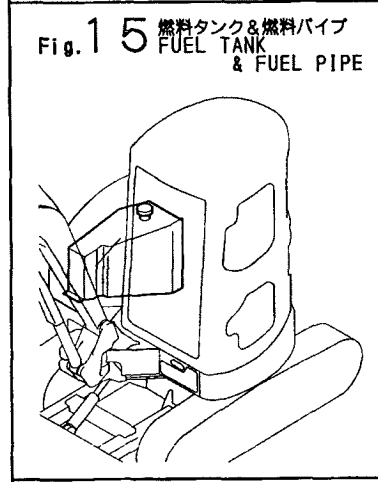
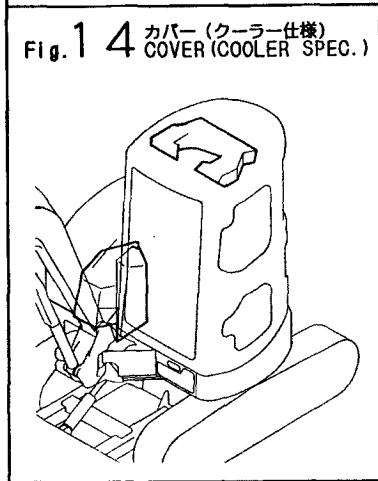
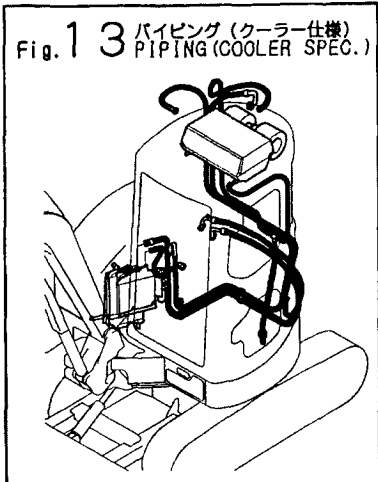

絵目次 (3) 項目別
PICTURESQUE INDEX (3) FIGURE

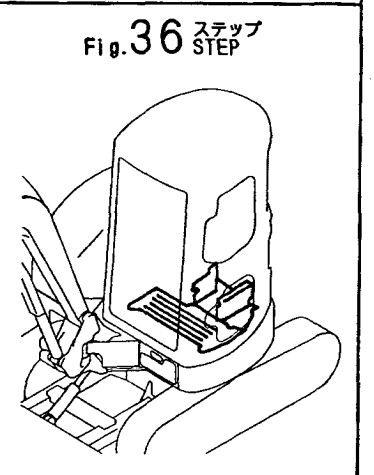
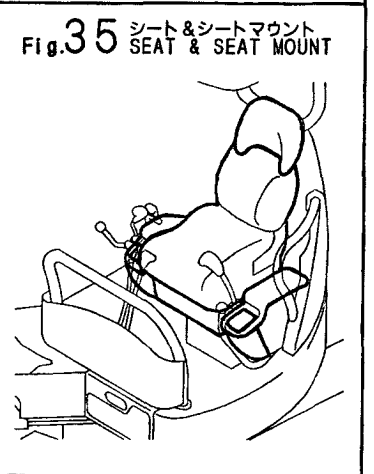
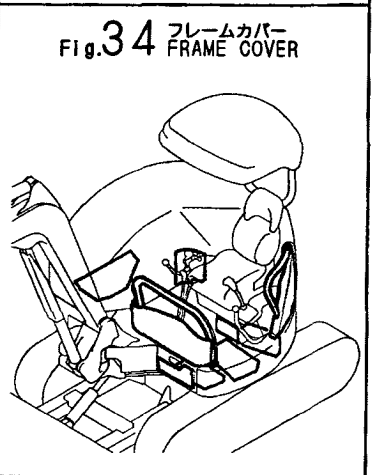
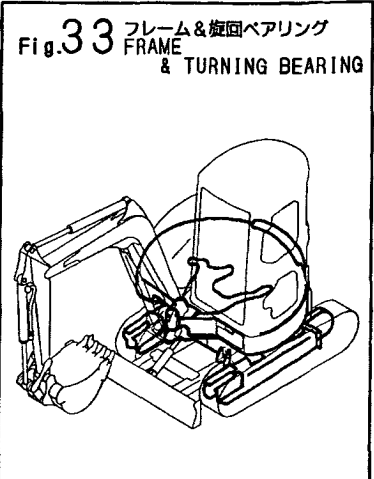
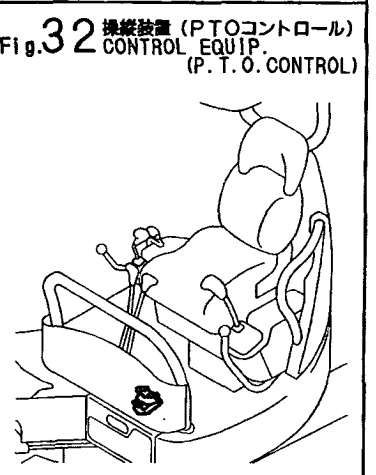
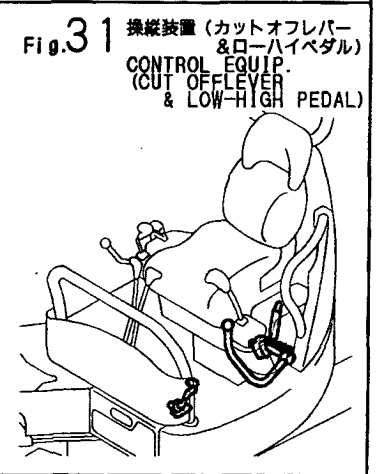
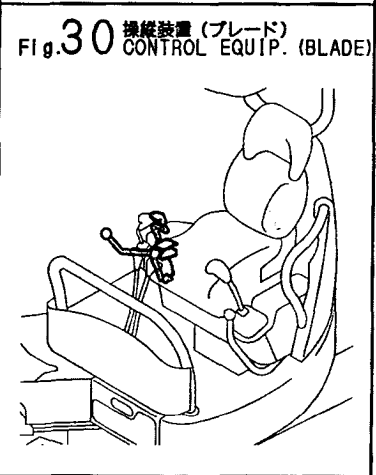
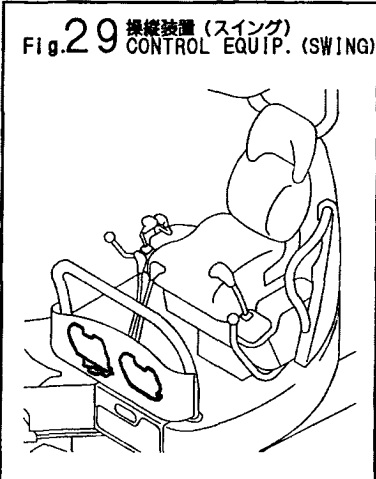
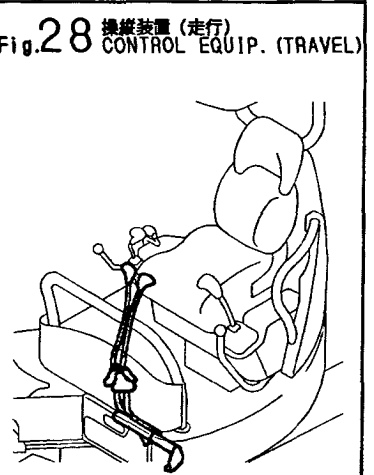
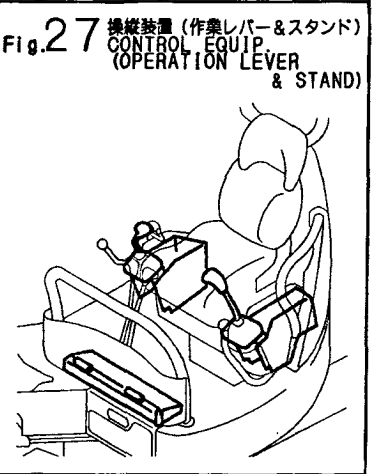
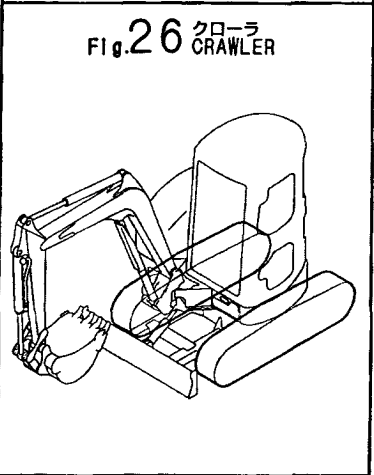
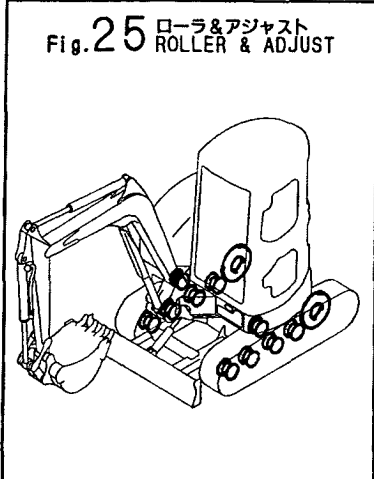

絵目次 (3) 項目別
PICTURESQUE INDEX (3) FIGURE

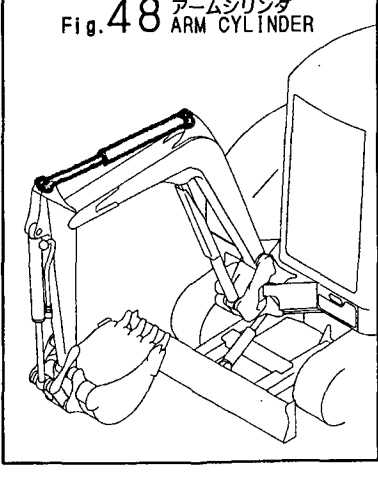
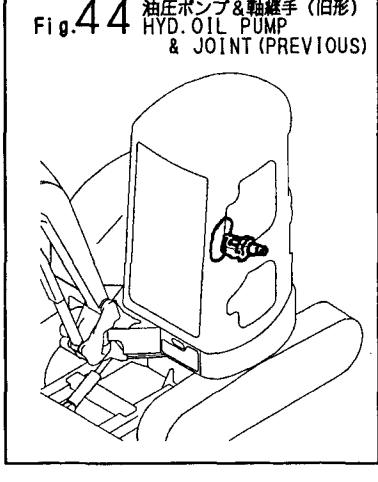
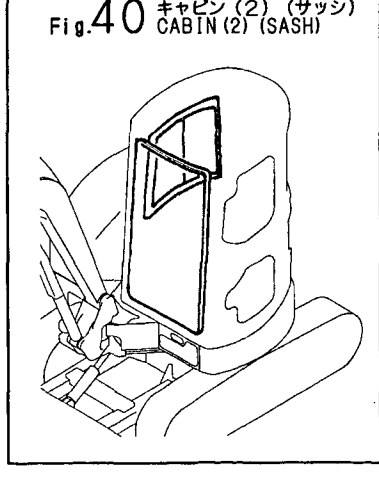
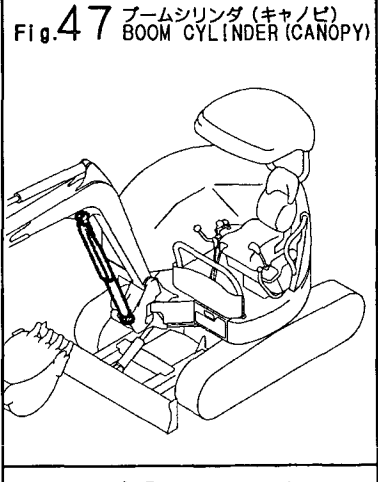
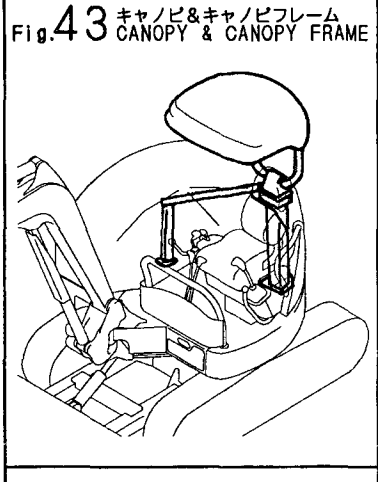
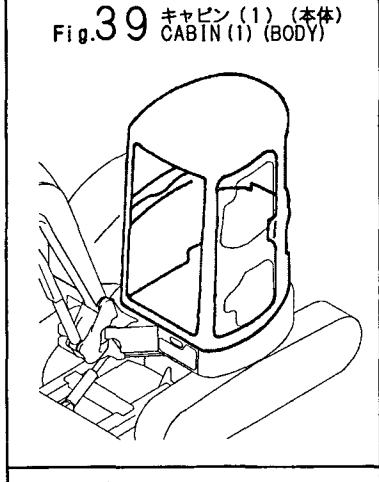
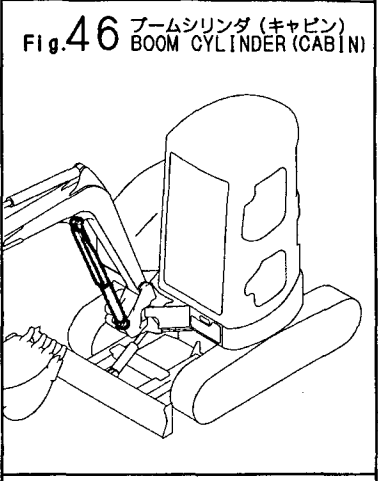
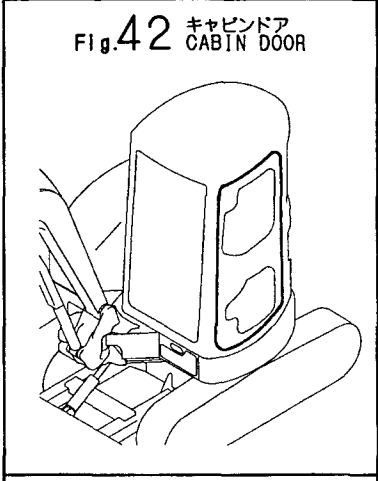
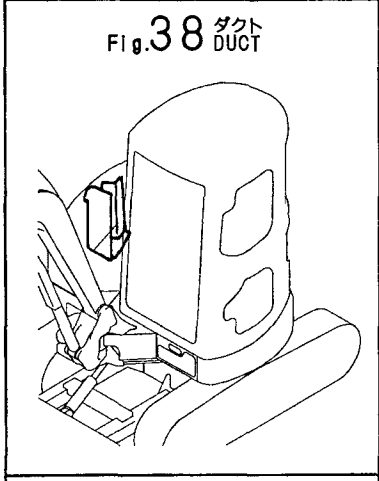
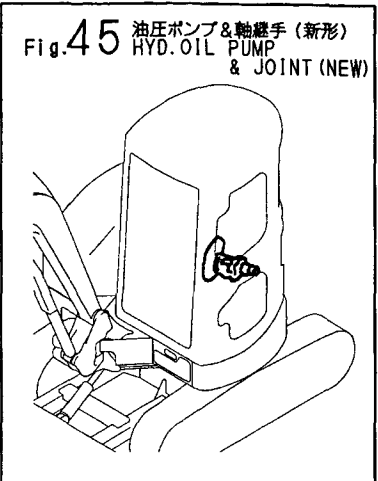
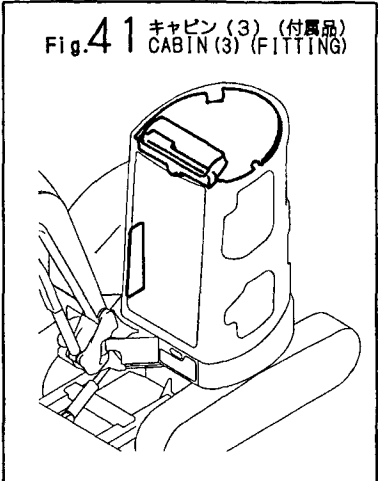
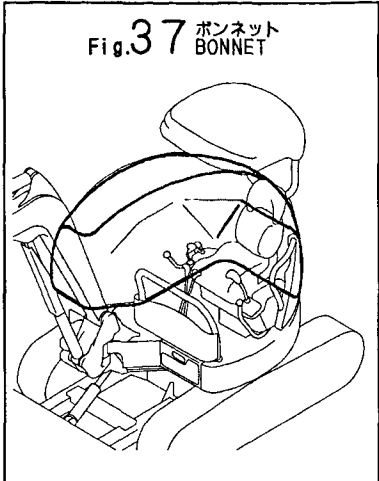

絵目次 (3) 項目別
PICTURESQUE INDEX (3) FIGURE

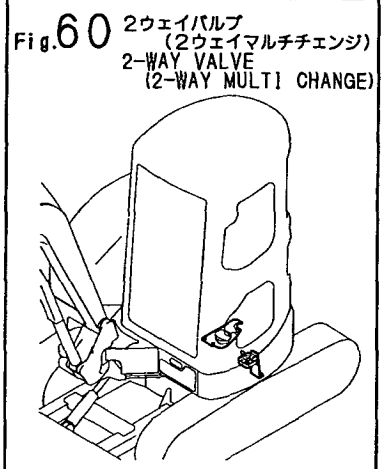
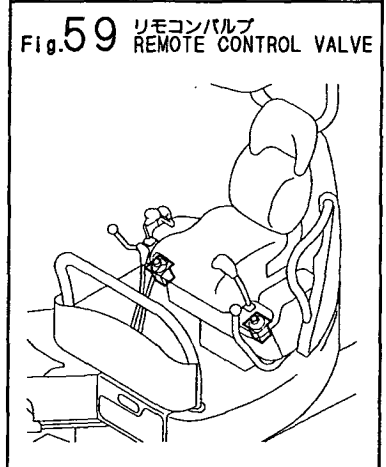
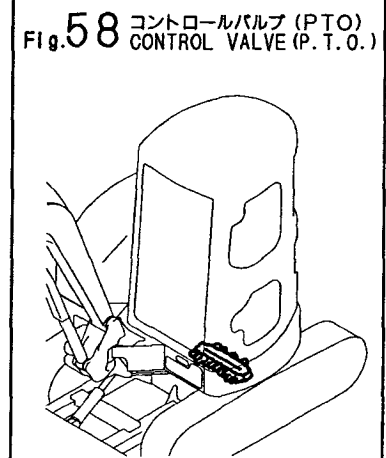
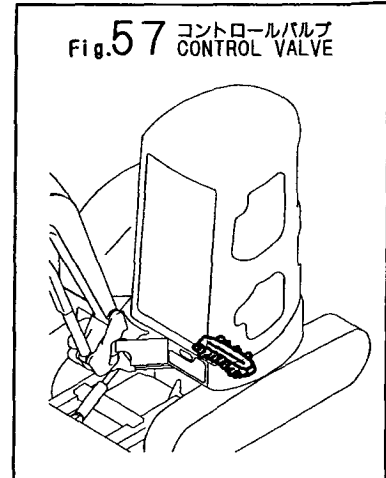
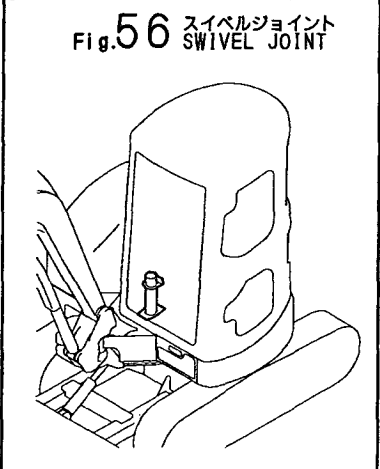
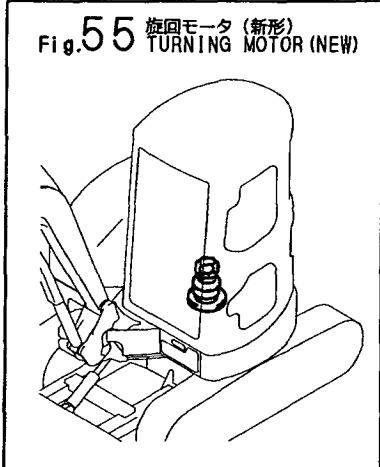
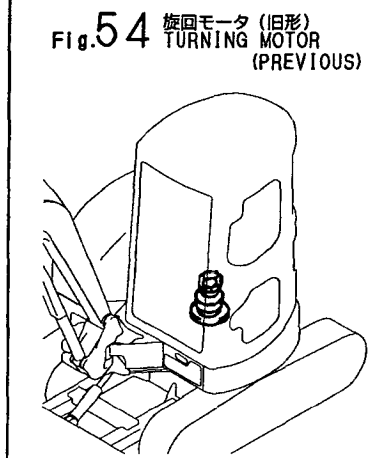
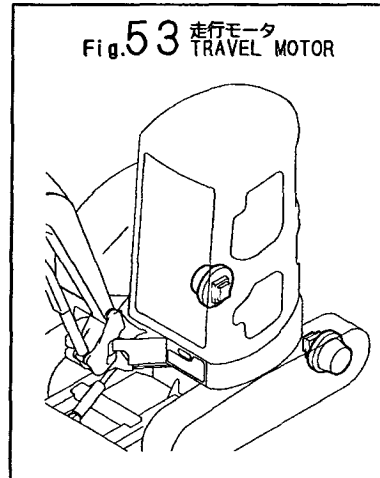
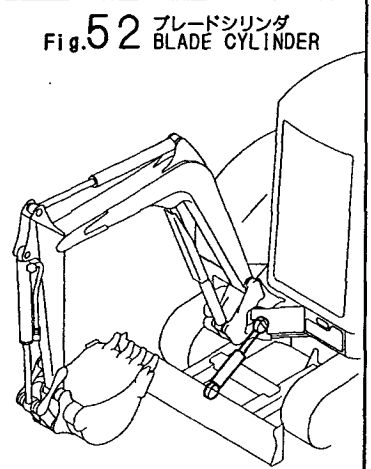
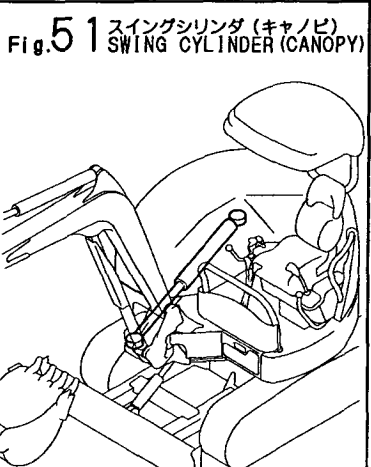
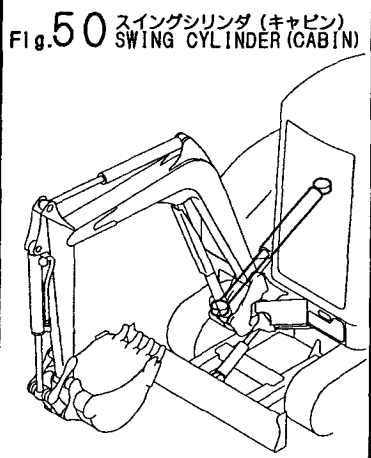
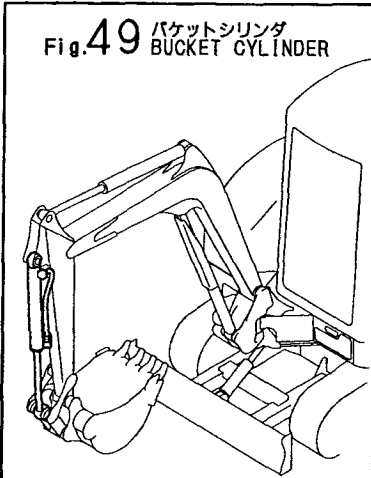

絵目次 (3) 項目別 PICTURESQUE INDEX (3) FIGURE

Fig.61 ロータリバルブ
(4ウェイマルチチェンジ)
ROTARY VALVE
(4-WAY MULTI CHANGE)

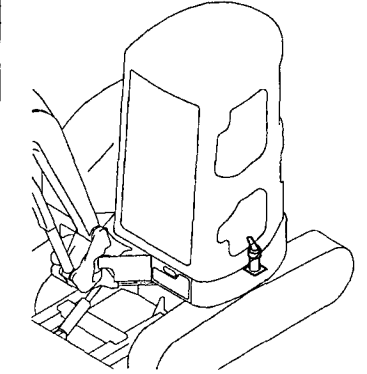

Fig.62 ローハイバルブ (旧形)
LOW-HIGH VALVE
(PREVIOUS)

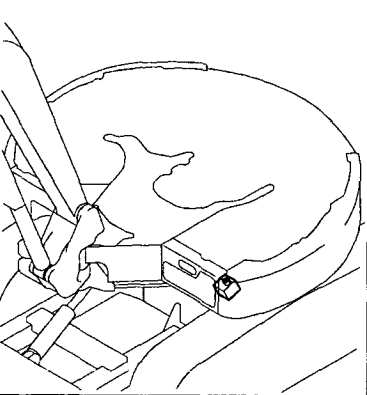

Fig.63 P.T.Oバルブ
P.T.O VALVE

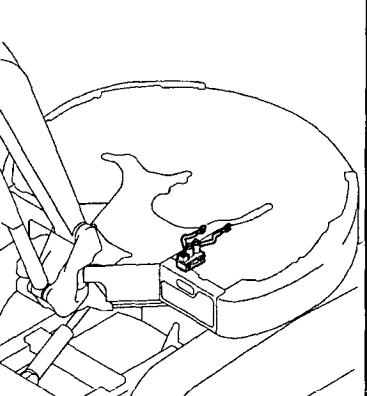

Fig.64 作動油タンク
HYD.OIL TANK

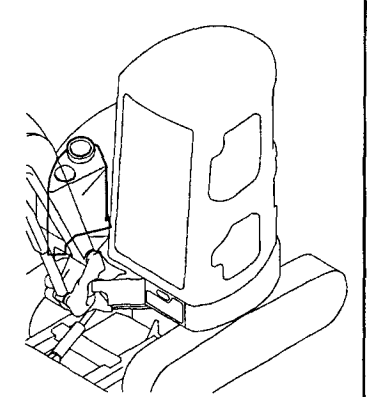

Fig.65 油圧配管 (タンク~ポンプ
~バルブ) (旧形)
HYD.OIL PIPING
(TANK ~ PUMP
~ VALVE) (PREVIOUS)

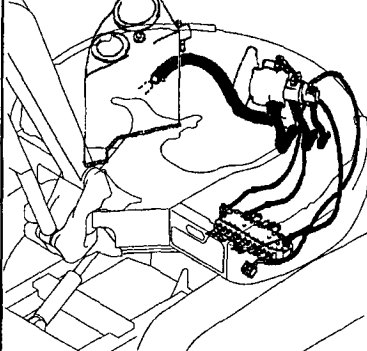

Fig.66 油圧配管 (タンク~ポンプ
~バルブ) (新形)
HYD.OIL PIPING (TANK
~ PUMP ~ VALVE) (NEW)

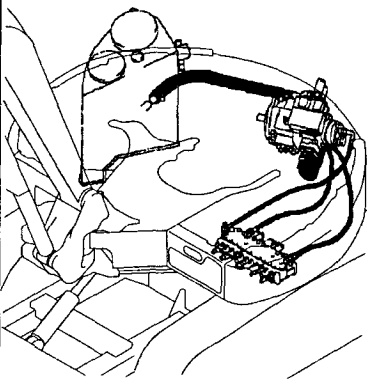

Fig.67 油圧配管
(バルブ~モータ、ブーム)
HYD.OIL PIPING
(VALVE ~ MOTOR, BOOM)

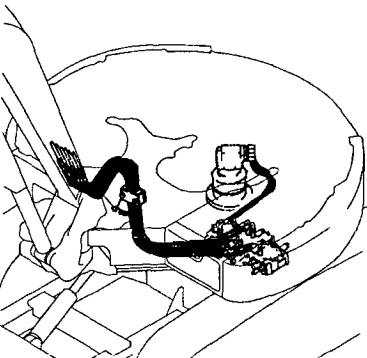

Fig.68 油圧配管 (バルブ
~スィベル、スイング)
HYD.OIL PIPING (VALVE
~ SWIVEL, SWING)

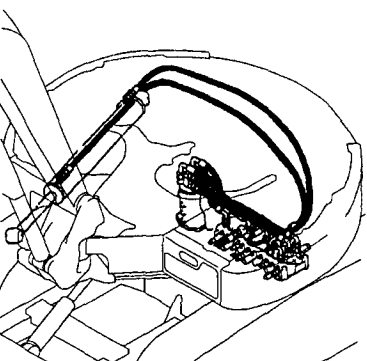

Fig.69 油圧配管 (リターン) (旧形)
HYD.OIL PIPING
(RETURN) (PREVIOUS)

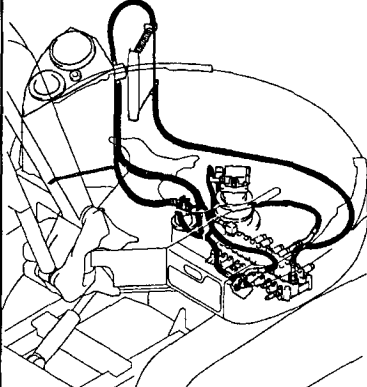

Fig.70 油圧配管 (リターン) (旧形)
HYD.OIL PIPING (RETURN)
(PREVIOUS)

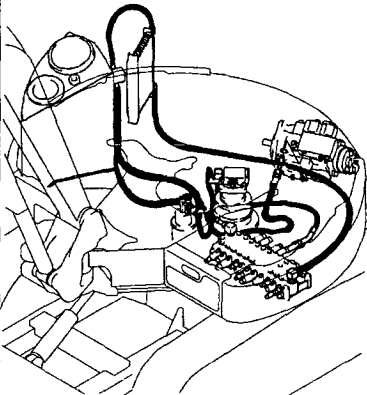

Fig.71 油圧配管 (リターン) (新形)
HYD.OIL PIPING (RETURN)
(NEW)

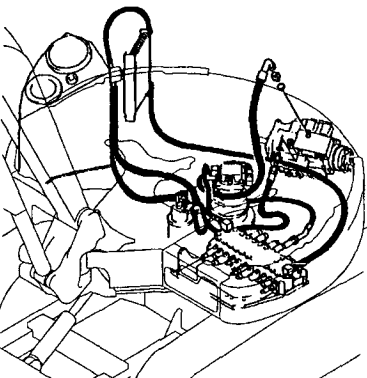
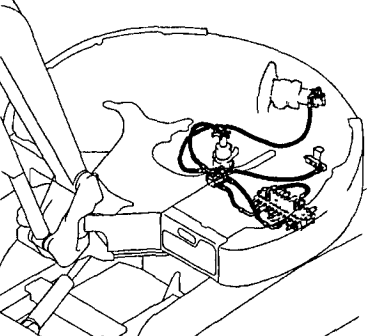

Fig.72 油圧配管 (PTOバルブ、
フレーム) (旧形)
HYD.OIL PIPING (P.T.O. VALVE, FRAME)
(PREVIOUS)



絵目次 (3) 項目別
PICTURESQUE INDEX (3) FIGURE

Fig.73 油圧配管 (PTOバルブ、フレーム) (旧形)
HYD. OIL PIPING (P. T. O. VALVE, FRAME) (PREVIOUS)

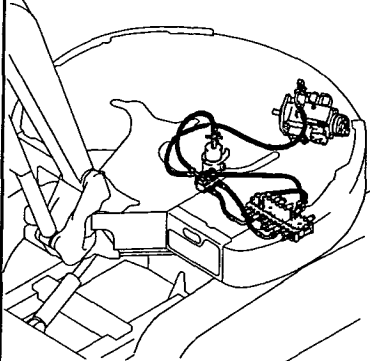

Fig.74 油圧配管 (PTOバルブ、フレーム) (新形)
HYD. OIL PIPING (P. T. O. VALVE, FRAME) (NEW)

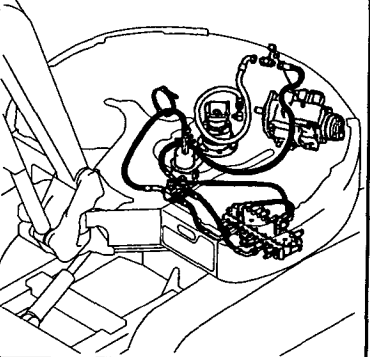

Fig.75 油圧配管 (走行)
HYD. OIL PIPING (TRAVEL)

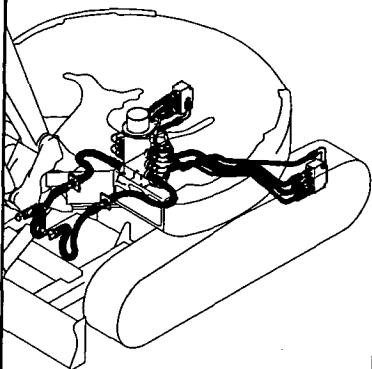

Fig.76 油圧配管 (ブーム)
HYD. OIL PIPING (BOOM)

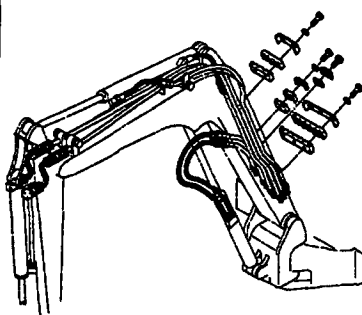

Fig.77 油圧配管 (PTOバルブ、ブーム)
HYD. OIL PIPING (P. T. O. VALVE, BOOM)

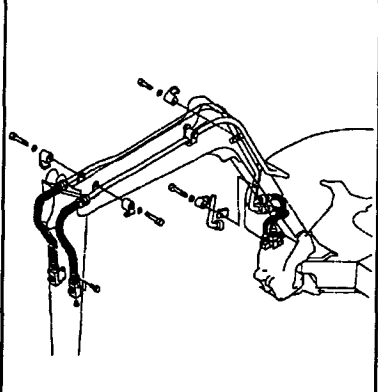

Fig.78 コントロール配管 (ダイレクト) (旧形)
CONTROL PIPING (DIRECT) (PREVIOUS)

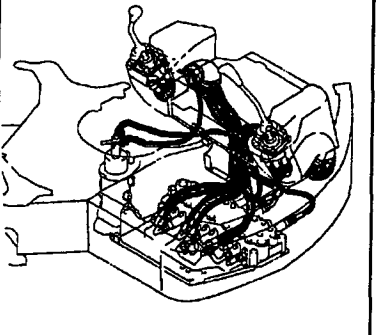

Fig.79 コントロール配管 (ダイレクト) (新形)
CONTROL PIPING (DIRECT) (NEW)

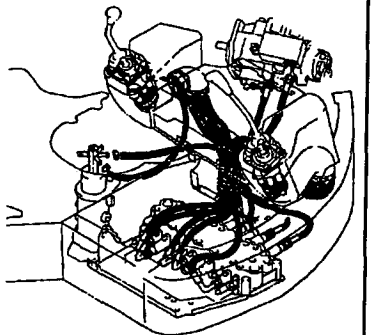

Fig.80 コントロール配管 (2ウェイバルブ ~コントロールバルブ ~リモコンバルブ)
CONTROL PIPING (2-WAY VALVE ~ CONTROL VALVE ~ REMO.-CON. VALVE)

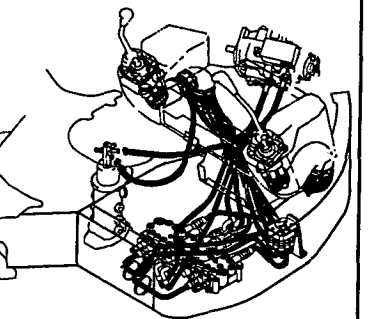

Fig.81 コントロール配管 (リモコンバルブ ~ロータリバルブ) (旧形)
CONTROL PIPING (REMOTE CONTROL VALVE ~ ROTARY VALVE) (PREVIOUS)

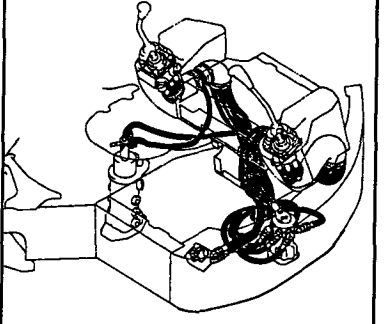

Fig.82 コントロール配管 (リモコンバルブ ~ロータリバルブ) (新形)
CONTROL PIPING (REMOTE CONTROL VALVE ~ ROTARY VALVE) (NEW)

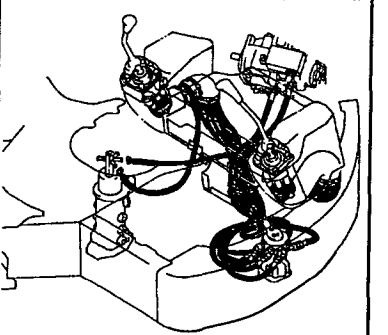

Fig.83 コントロール配管 (ロータリバルブ ~コントロールバルブ) (旧形)
CONTROL PIPING (ROTARY VALVE ~ CONTROL VALVE) (PREVIOUS)

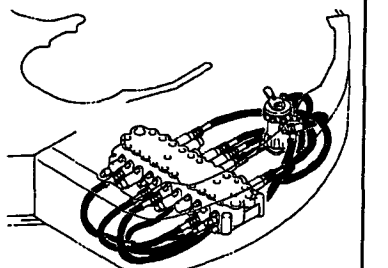
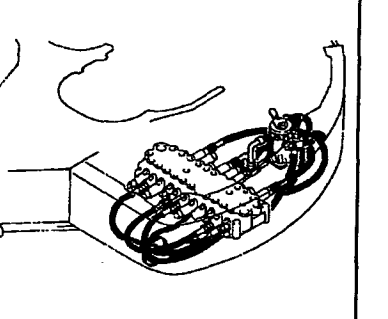

Fig.84 コントロール配管 (ロータリバルブ ~コントロールバルブ) (新形)
CONTROL PIPING (ROTARY VALVE ~ CONTROL VALVE) (NEW)



絵目次 (3) 項目別
PICTURESQUE INDEX (3) FIGURE

Fig.85 速隔グリーシング
GREASING

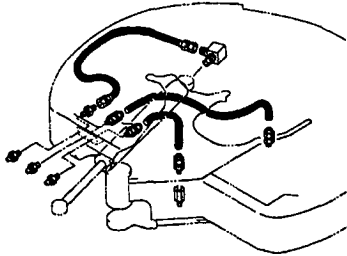

Fig.89 バケットSタイプ
(アタッチメント)
BUCKET S TYPE
(ATTACHMENT)

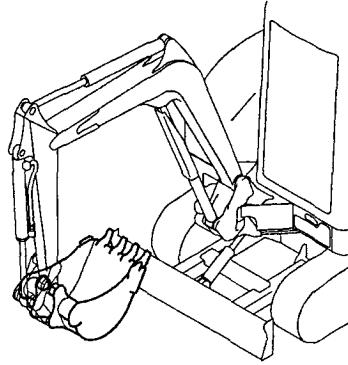

Fig.93 安全銘板 (EP)
SAFETY LABEL (EP)

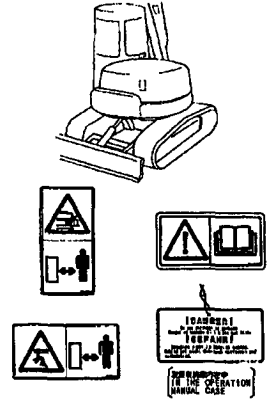

Fig.86 ブーム&ブームブラケット
BOOM & BOOM BRACKET

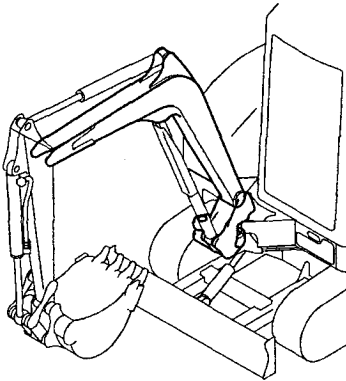

Fig.90 バケット (アタッチメント)
BUCKET (ATTACHMENT)

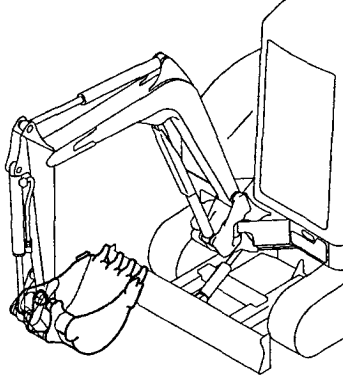

Fig.94 P.T.O.キット
P.T.O. KIT

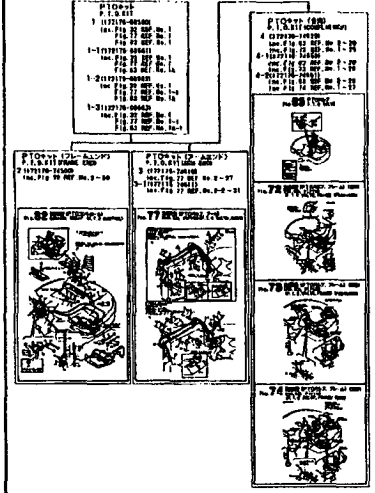

Fig.87 アーム&バケットリンク
ARM & BUCKET LINK

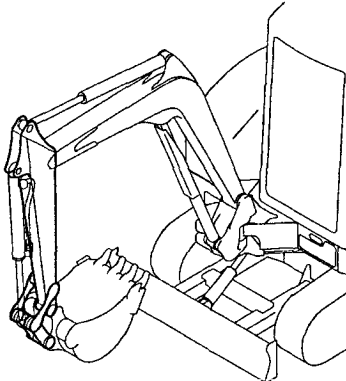

Fig.91 ブレード
BLADE

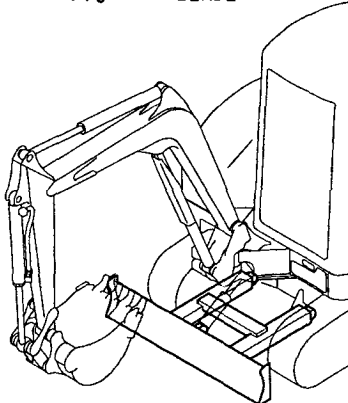

Fig.88 バケットSタイプ
BUCKET S TYPE

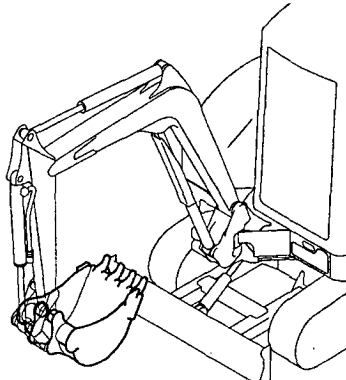
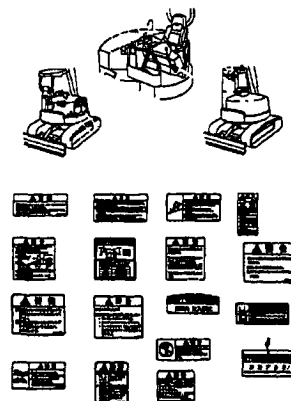
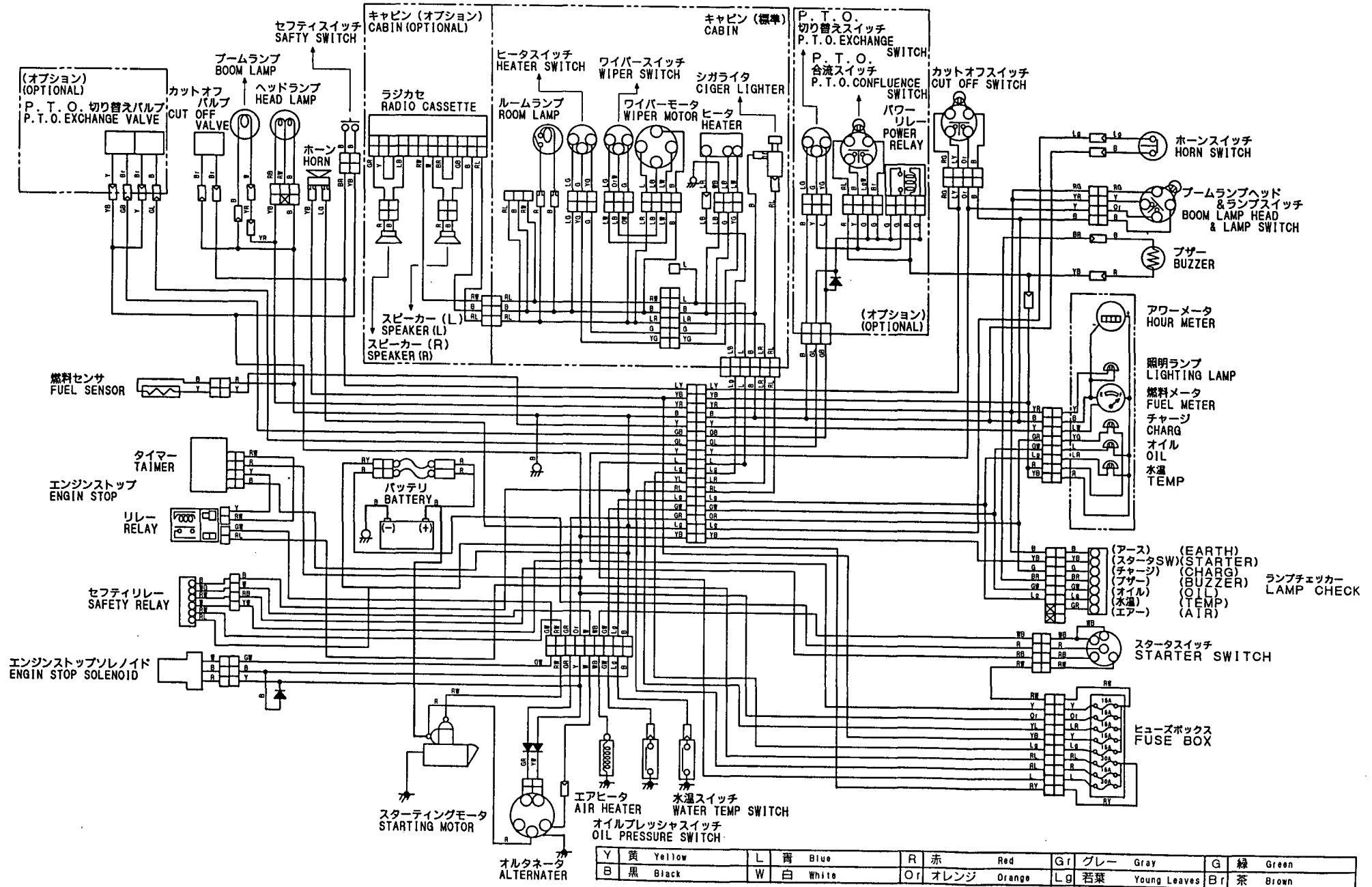

Fig.92 安全銘板 (JP)
SAFETY LABEL (JP)



配線図 (1)
WIRING DIAGRAM (1) 初号機~M/#00869



配線図 (2)
WIRING DIAGRAM (2)

https://truckmanualshub.com/
M/#00870~M/#00964

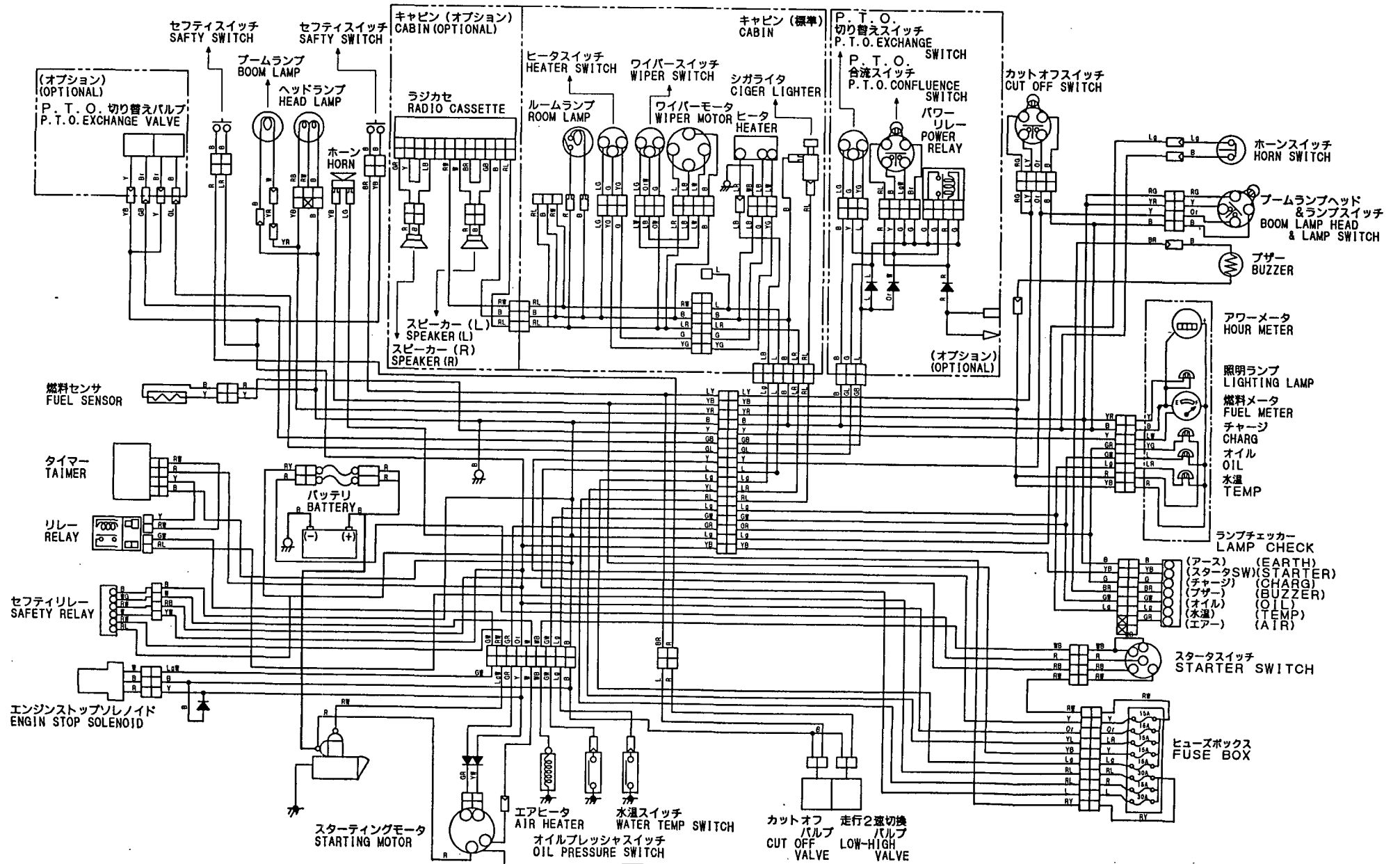

Y	黄 Yellow	L	青 Blue	R	赤 Red	Gr	グレー Gray	G	緑 Green
B	黒 Black	W	白 White	Or	オレンジ Orange	Lg	若葉 Young Leaves	Br	茶 Brown

配線図 (3)
WIRING DIAGRAM (3) M/#00965~M/#01008

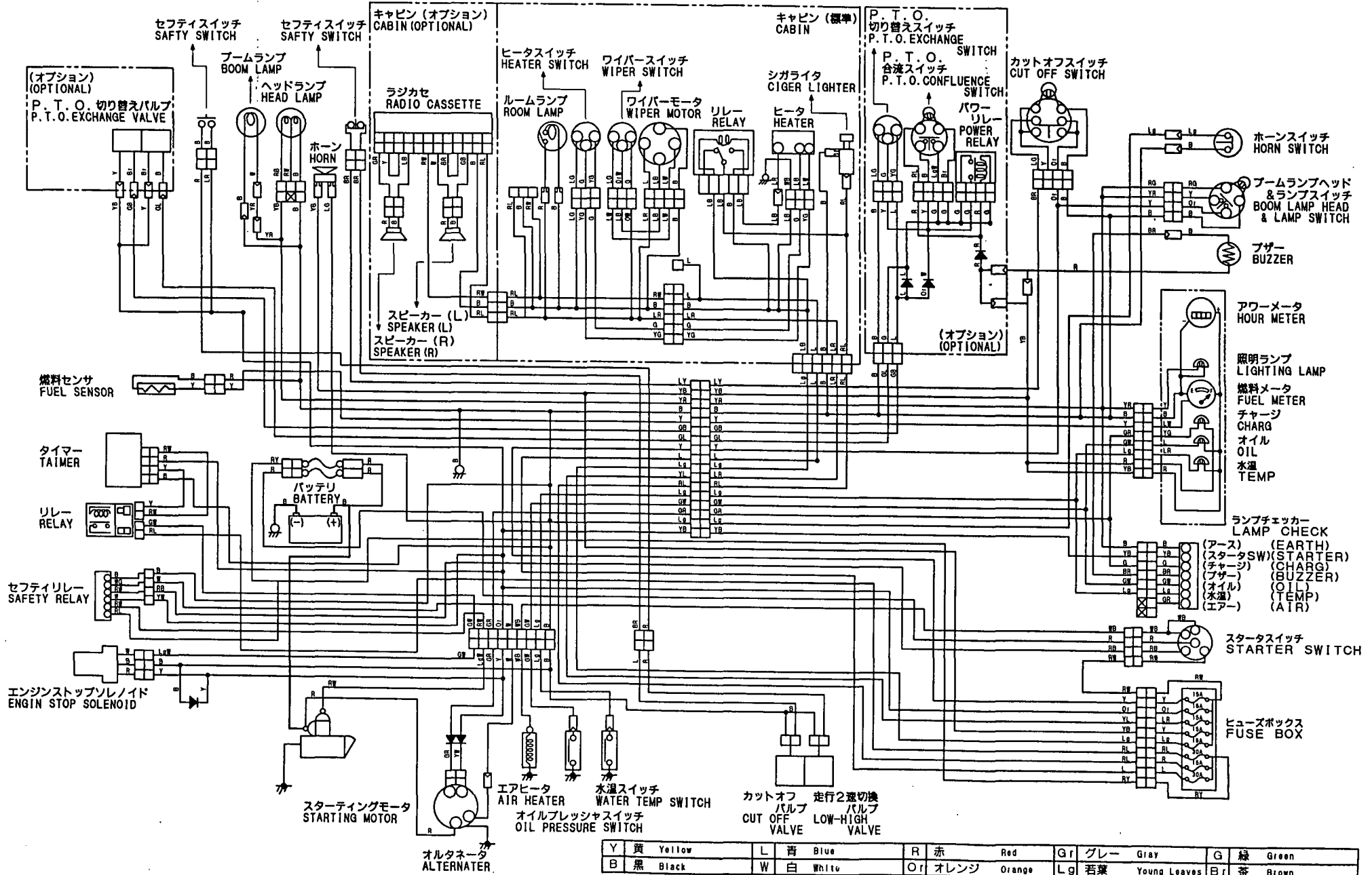

配線図 (4)
WIRING DIAGRAM (4)

https://truckmanualshub.com/
M/#01009~

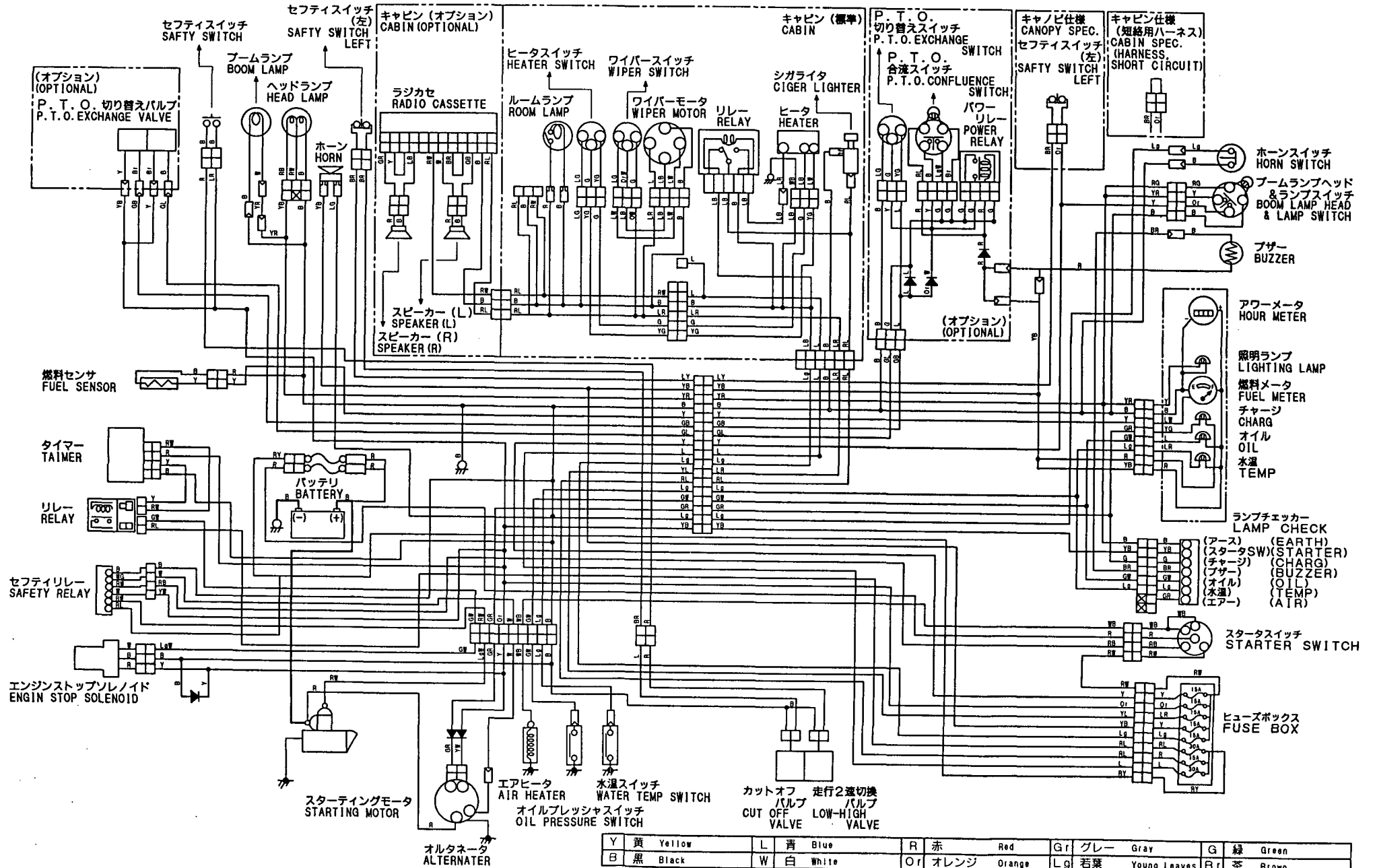

Y	黄 Yellow	L	青 Blue	R	赤 Red	Gr	グレー Gray	G	緑 Green
B	黒 Black	W	白 White	Or	オレンジ Orange	Lg	若葉 Young Leaves	Br	茶 Brown

1,1,,772176-03110,, "LABEL SET (CABIN)",1,,,,,,,,,,,,,
1-1,1,,772176-03111,, "LABEL SET (CABIN)",1,,,,,,N,,,,M/#00963,,,,,,
2,2,,172176-03110,, "LABEL, SPECIFICATION",1,,,,,,,,,,,,,
3,2,,172176-03120,, "LABEL,FEED WATER",1,,,,,,,,,,,,,
4,2,,172164-03130,, "LABEL,GREASE FEED",1,,,,,,,,,,,,,
5,2,,172176-03150,, "LABEL (VIO50",2,,,,,,,,,,,,,
5-1,2,,172176-03151,, "LABEL (VIO50",2,,,,,,N,,,,M/#00620,,,,,,
6,2,,172519-03150,, "LABEL, ACCEL",1,,,,,,,,,,,,,
7,2,,172141-03170,, "LABEL, RESTART",1,,,,,,,,,,,,,
8,2,,172164-03170,, "REAR EMBLEM",1,,,,,,,,,,,,,
8-1,2,,172164-03171,, "EMBLEM, REAR",1,,,,,,R,,,,M/#01358,,,,,,
9,2,,172164-03180,, "MARK,NO.1",1,,,,,,,,,,,,,
10,2,,172165-03261,, "LABEL, BOOM",1,,,,,,,,,,,,,
11,2,,172164-03190,, "LABEL, TURN.",1,,,,,,,,,,,,,
11-1,2,,172164-03560,, LABEL,1,,,,,,N,,,,M/#00963,,,,,,
12,2,,172141-03201,, "LABEL,ENGINE ROOM(C)",1,,,,,,,,,,,,,
12-1,2,,172141-03202,, "LABEL,CAUTION",1,,,,,,N,,,,M/#00963,,,,,,
13,2,,172147-03210,, LABEL,1,,,,,,,,,,,,,
14,2,,172165-03220,, "LABEL, GREASE",1,,,,,,,,,,,,,
15,2,,172519-03290,, "LABEL, ENG.COVER",1,,,,,,,,,,,,,
15-1,2,,172519-04180,, "LABEL,WARNING",1,,,,,,N,,,,M/#00963,,,,,,
16,2,,172137-03301,, "LABEL, TURNING LOCK",1,,,,,,Z,,,,M/#01328,,,,,,
17,2,,172142-03301,, LABEL,1,,,,,,,,,,,,,
17-1,2,,172142-03302,, "LABEL,CAUTION",1,,,,,,N,,,,M/#00963,,,,,,
18,2,,172155-03310,, "LABEL, OILING",1,,,,,,,,,,,,,
19,2,,172141-03360,, "LABEL, START SWITCH",1,,,,,,,,,,,,,
20,2,,172165-03610,, "LABEL A",1,,,,,,,,,,,,,
20-1,2,,172964-03610,, "LABEL A",1,,,,,,N,,,,M/#00963,,,,,,
21,2,,172165-03620,, "LABEL B",1,,,,,,,,,,,,,
21-1,2,,172164-03500,, LABEL,1,,,,,,N,,,,M/#00963,,,,,,
22,2,,172165-03660,, "LABEL, BATTERY",1,,,,,,,,,,,,,
22-1,2,,172165-03661,, "LABEL,DANGER",1,,,,,,N,,,,M/#00963,,,,,,
23,2,,121470-44540,, "LABEL, SUB-TANK",1,,,,,,,,,,,,,
24,2,,933112-52400,, "LABEL, FUEL",1,,,,,,,,,,,,,
24-1,2,,172183-03250,, LABEL,1,,,,,,N,,,,M/#00963,,,,,,
25,2,,172162-03180,, "LABEL,HEATER SWITCH",1,,,,,,Z,,,,M/#00852,,,,,,
26,2,,172162-03190,, "LABEL,WIPER SWITCH",1,,,,,,Z,,,,M/#00852,,,,,,
27,2,,172164-03200,, "LABEL,BRAND",1,,,,,,,,,,,,,
28,2,,172164-03210,, "LABEL, CAB.",1,,,,,,,,,,,,,
29,2,,172165-03460,, "LABEL, PATERN A",1,,,,,,,,,,,,,
30,2,,172183-03280,, "LABEL, LOCK",1,,,,,,,,,,,,,
31,2,,172164-03510,, LABEL,1,,,,,,W,,,,M/#00963,,,,,,
32,2,,172164-03520,, "LABEL,DANGER",1,,,,,,W,,,,M/#00963,,,,,,
33,2,,172164-03540,, LABEL,1,,,,,,W,,,,M/#00963,,,,,,
34,2,,172964-03370,, LABEL,1,,,,,,W,,,,M/#00963,,,,,,
35,2,,172964-03390,, "LABEL,WARNING",1,,,,,,W,,,,M/#00963,,,,,,
36,2,,172964-03480,, LABEL,1,,,,,,W,,,,M/#00963,,,,,,
36-1,2,,172964-03481,, LABEL,1,,,,,,N,,,,M/#00993,,,,,,
37,2,,172519-04290,, "LABEL,WARNING",1,,,,,,W,,,,M/#00963,,,,,,
38,2,,172519-04300,, LABEL,1,,,,,,W,,,,M/#00963,,,,,,
39,2,,172162-03240,, "LABEL,WIPER",1,,,,,,W,,,,M/#00926,,,,,,
39-1,2,,172162-03241,, LABEL,1,,,,,,N,,,,M/#00963,,,,,,
39-2,2,,172162-03241,, LABEL,1,,,,,,Z,,,,M/#01245,,,,,,
40,2,,172164-03530,, "LABEL,WARNING",1,,,,,,W,,,,M/#00963,,,,,,
41,2,,172173-03250,, LABEL,1,,,,,,W,,,,M/#01090,,,,,,
41A,2,,172164-03350,, "LABEL,LIFTING",1,,,,,,W,,,,M/#01302,,,,,,
42,1,,172165-03240,, LABEL,1,,,,,,2,,,,,
43,1,,172165-03230,, "LABEL, P.T.O.",1,,,,,,1,,,,,
43-1,1,,172165-03231,, "LABEL, P.T.O.",1,,,,,,N,1,,M/#00852,,,,,,
44,1,,172168-03401,, LABEL,1,,,,,,W,M,,M/#01014,,,,,,
45,1,,172168-03410,, LABEL,1,,,,,,W,3,,M/#01014,,,,,,
46,1,,172165-03471,, LABEL,1,,,,,,W,5,,M/#01014,,,,,,
47,1,,172175-03550,, LABEL(2-WAY,1,,,,,,4,,,,,

48,1,,172173-03560,, "LABEL (YANMAR",1,,,,,4,,,,,
49,1,,172173-03570,, "LABEL (KOMATSU",1,,,,,4,,,,,
50,1,,172165-03212,, "LABEL, PTO SELECT",1,,,,,W,1,,M/#00852,,,,,
51,1,,172165-03280,, "LABEL, PTO SWITCH",1,,,,,W,1,, "M/#FRPM 1",,,,,
52,1,,172151-03050,, LABEL,1,,,,,3,,,,,

1,1,,772176-03170,, "LABEL SET (C EX",1,,,,,,,,,,,,,
2,2,,172176-03340,, "LABEL,SPECIFICATION",1,,,,,,,,,,,,,
3,2,,172176-03320,, "LABEL,FEED WATER(E",1,,,,,,,,,,,,,
4,2,,172176-03330,, "LABEL,GREASE FEED(E",1,,,,,,,,,,,,,
5,2,,172176-03151,, "LABEL (VIO50",2,,,,,,,,,,,,,
6,2,,172519-03150,, "LABEL, ACCEL",1,,,,,,,,,,,,,
7,2,,172141-03440,, LABEL,1,,,,,,,,,,,,,
8,2,,172164-03170,, "REAR EMBLEM",1,,,,,,,,,,,,,
8-1,2,,172164-03171,, "EMBLEM, REAR",1,,,,,,R,,,M/#01358,,,,,,
9,2,,172164-03180,, "MARK,NO.1",1,,,,,,,,,,,,,
10,2,,172165-03261,, "LABEL, BOOM",1,,,,,,,,,,,,,
11,2,,172171-03780,, LABEL,1,,,,,,,,,,,,,
12,2,,172171-03800,, LABEL,1,,,,,,,,,,,,,
13,2,,172147-03210,, LABEL,1,,,,,,,,,,,,,
14,2,,172171-03510,, "LABEL, GREASE",1,,,,,,,,,,,,,
15,2,,172171-03810,, LABEL,1,,,,,,,,,,,,,
16,2,,172137-03301,, "LABEL, TURNING LOCK",1,,,,,,Z,,,M/#01328,,,,,,
17,2,,172171-03720,, LABEL,1,,,,,,,,,,,,,
18,2,,172155-03790,, LABEL,1,,,,,,,,,,,,,
19,2,,172141-03360,, "LABEL, START SWITCH",1,,,,,,,,,,,,,
20,2,,172165-03460,, "LABEL, PATERN A",1,,,,,,,,,,,,,
21,2,,172171-03700,, LABEL,1,,,,,,,,,,,,,
22,2,,172171-03770,, LABEL,1,,,,,,,,,,,,,
23,2,,124764-44810,, "LABEL, SUB-TANK",1,,,,,,,,,,,,,
24,2,,172183-03450,, "LABEL,FUEL",1,,,,,,,,,,,,,
25,2,,172183-03280,, "LABEL, LOCK",1,,,,,,,,,,,,,
26,2,,172171-03790,, "LABEL, RADIATOR",1,,,,,,,,,,,,,
27,2,,172164-03210,, "LABEL, CAB.",1,,,,,,,,,,,,,
28,2,,172171-03760,, LABEL,1,,,,,,,,,,,,,
29,2,,172171-03750,, LABEL,2,,,,,,,,,,,,,
30,2,,172171-03740,, LABEL,1,,,,,,,,,,,,,
31,2,,172164-03200,, "LABEL,BRAND",1,,,,,,,,,,,,,
32,2,,172125-03950,, "LABEL, AIR CLEANER",1,,,,,,,,,,,,,
33,2,,172171-03710,, LABEL,1,,,,,,,,,,,,,
33A,2,,172171-03400,, PLATE,1,,,,,,W,,,M/#01245,,,,,,
34,1,,172165-03231,, "LABEL, P.T.O.",1,,,,,,1,,,,,,
35,1,,172165-03212,, "LABEL, PTO SELECT",1,,,,,,1,,,,,,
36,1,,172165-03280,, "LABEL, PTO SWITCH",1,,,,,,1,,,,,,
37,1,,172141-03501,, "LABEL(ADJUST CRAWLER",1,,,,,,2,,,,,,

Fig. 2 銘板 (キャビン) (EX) LABEL (CABIN) (EX)

見出しNo. 1は、見出しNo. 2から33Aを含みます。
1 inc. 2 ~ 33A

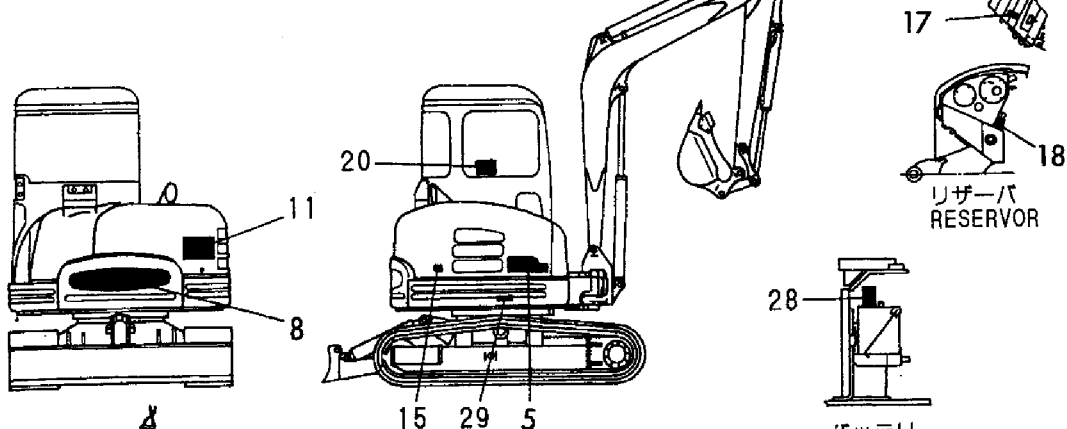
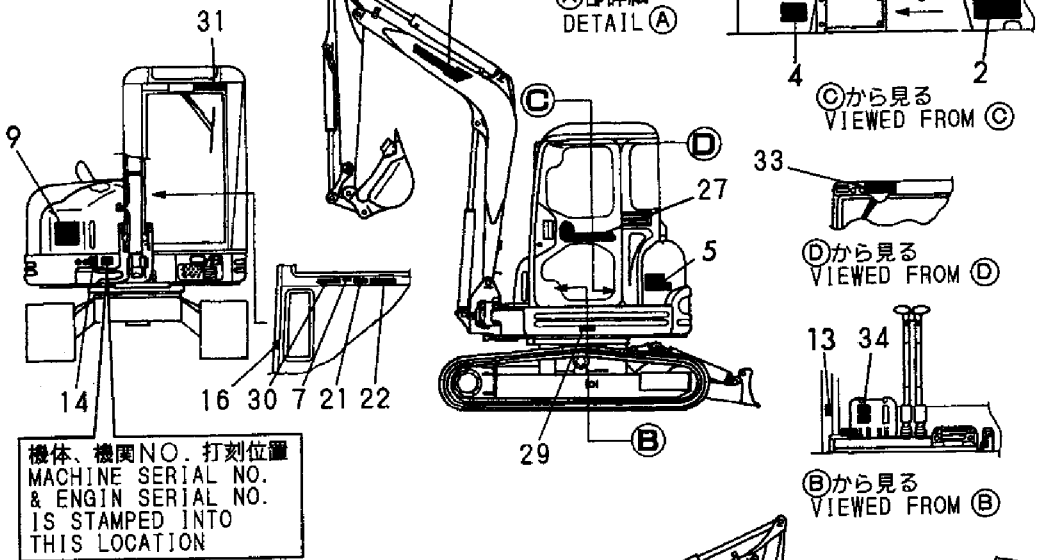
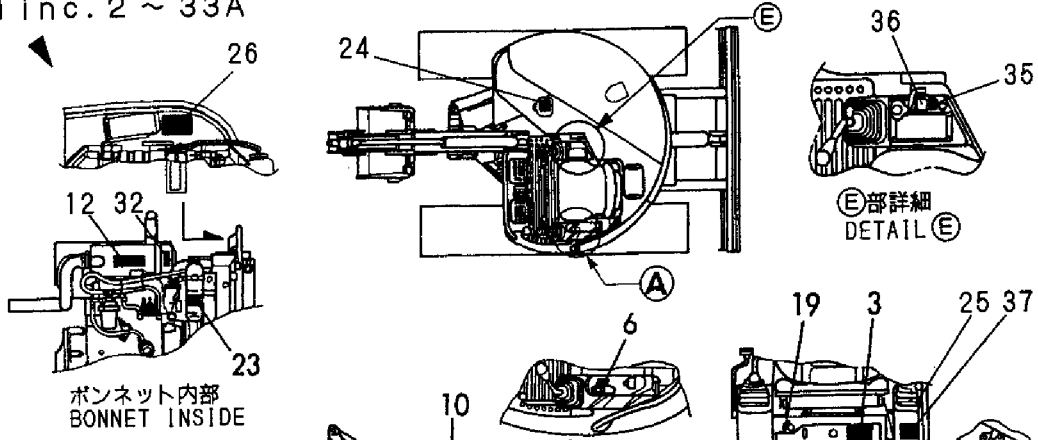

取説収納庫内在中
IN THE OPERATION
MANUAL CASE

1,1,,772176-03200,, "LABEL SET (AY",1,,,,,,,,,,,,,,,,,,,,,
2,2,,172176-03210,, "LABEL, SPECIFICATION",1,,,,,,,,,,,,,,,,,,,,,
3,2,,172176-03220,, "LABEL, FEED WATER",1,,,,,,,,,,,,,,,,,,,,,
3-1,2,,172176-03221,, LABEL,1,,,,,,S,,,,M/#10402,,,,,,,,,,,,,
4,2,,172176-03230,, "LABEL, GREASE FEED",1,,,,,,,,,,,,,,,,,,,,,
5,2,,172176-03151,, "LABEL (VIO50",2,,,,,,,,,,,,,,,,,,,,,
6,2,,172519-03150,, "LABEL, ACCEL",1,,,,,,,,,,,,,,,,,,,,,
7,2,,172143-03180,, LABEL,1,,,,,,,,,,,,,,,,,,,,,
8,2,,172164-03170,, "REAR EMBLEM",1,,,,,,,,,,,,,,,,,,,,,
8-1,2,,172164-03171,, "EMBLEM, REAR",1,,,,,,R,,,,M/#01358,,,,,,,,,,,,,
9,2,,172164-03180,, "MARK,NO.1",1,,,,,,,,,,,,,,,,,,,,,
10,2,,172165-03261,, "LABEL, BOOM",2,,,,,,,,,,,,,,,,,,,,,
10-1,2,,172142-03451,, "LABEL, BOOM",2,,,,,,S,,,,M/#01402,,,,,,,,,,,,,
11,2,,172147-03210,, LABEL,1,,,,,,,,,,,,,,,,,,,,,
12,2,,172165-03440,, "LABEL, GREASE",1,,,,,,,,,,,,,,,,,,,,,
13,2,,172143-03240,, LABEL,1,,,,,,Z,,,,M/#01402,,,,,,,,,,,,,
14,2,,172137-03301,, "LABEL, TURNING LOCK",1,,,,,,Z,,,,M/#01328,,,,,,,,,,,,,
15,2,,172142-03280,, LABEL,1,,,,,,Z,,,,M/#10402,,,,,,,,,,,,,
16,2,,933112-45300,, "LABEL, DANGER (A)",1,,,,,,Z,,,,M/#10402,,,,,,,,,,,,,
17,2,,933112-50700,, "LABEL, OIL FEED",1,,,,,,,,,,,,,,,,,,,,,
17-1,2,,172187-03550,, "LABEL,OILING(F,G)",1,,,,,,S,,,,M/#10402,,,,,,,,,,,,,
18,2,,172141-03360,, "LABEL, START SWITCH",1,,,,,,,,,,,,,,,,,,,,,
19,2,,933112-55700,, "LABEL, SUB-TANK",1,,,,,,,,,,,,,,,,,,,,,
20,2,,933112-52500,, "LABEL, FUEL",1,,,,,,,,,,,,,,,,,,,,,
20-1,2,,172187-03560,, "LABEL,FUEL(F,G)",1,,,,,,S,,,,M/#10402,,,,,,,,,,,,,
21,2,,172164-03200,, "LABEL,BRAND",1,,,,,,,,,,,,,,,,,,,,,
22,2,,172164-03210,, "LABEL, CAB.",1,,,,,,,,,,,,,,,,,,,,,
23,2,,172165-03460,, "LABEL, PATERN A",1,,,,,,,,,,,,,,,,,,,,,
24,2,,172183-03280,, "LABEL, LOCK",1,,,,,,,,,,,,,,,,,,,,,
25,2,,172174-03690,, "LABEL,RADIATOR",1,,,,,,M,,,,,,,,,,,,,
26,2,,172174-03620,, LABEL,1,,,,,,M,,,,,,,,,,,,,
27,2,,172143-03250,, "LABEL,ADJUST CRAWLER",1,,,,,,,,,,,,,,,,,,,,,
28,2,,172165-03231,, "LABEL, P.T.O.",1,,,,,,,,,,,,,,,,,,,,,
29,2,,172165-03212,, "LABEL, PTO SELECT",1,,,,,,,,,,,,,,,,,,,,,
30,2,,172165-03280,, "LABEL, PTO SWITCH",1,,,,,,,,,,,,,,,,,,,,,
31,2,,172174-03660,, "LABEL,CABLE",1,,,,,,M,,,,,,,,,,,,,
32,2,,172164-03720,, LABEL,1,,,,,,W,,,,M/#01398,,,,,,,,,,,,,
33,2,,172164-03730,, LABEL,1,,,,,,W,,,,M/#01398,,,,,,,,,,,,,
34,2,,172171-03420,, "CAUTION PLATE ASSY",1,,,,,,W,,,,M/#01277,,,,,,,,,,,,,
35,1,,172187-03600,, LABEL,1,,,,,,,,,,,,,,,,,,,,,
36,1,,172187-03610,, LABEL,1,,,,,,,,,,,,,,,,,,,,,
37,1,,172187-03620,, LABEL,2,,,,,,,,,,,,,,,,,,,,,

Fig. 3 銘板 (キャビン) (EP) LABEL (CABIN) (EP)

見出しNo. 1は、見出しNo. 2から34を含みます。
1 inc. 2 ~ 34

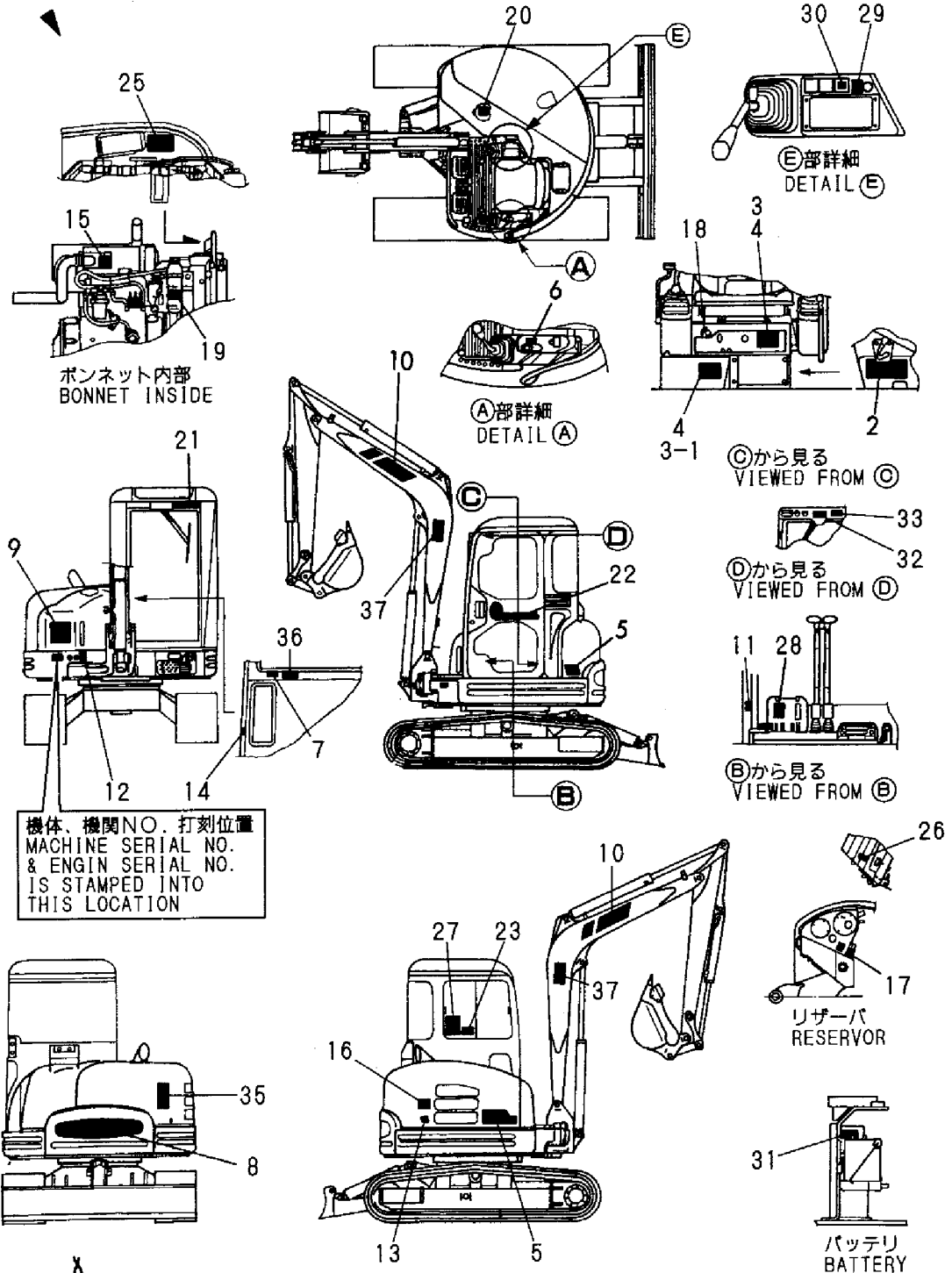

! DANGER !
Do not attempt to modify.
Always in position of 1's not use while
! GEFAHR !
Werkzeug in 1's nicht annehmen.
Nicht bei 1's Fall, Druck, Explosion und
Verletzung.

34

1,1,,772176-03100,, "LABEL SET (CANOPY)",,1,,,,,,,,,,,,,,,,,,,,,
1-1,1,,772176-03101,, "LABEL SET (CANOPY)",,1,,,,,N,,,,,M/#00963,,,,,,
2,2,,172176-03110,, "LABEL, SPECIFICATION",,1,,,,,,,,,,,,,,,,,,,,,
3,2,,172176-03120,, "LABEL,FEED WATER",,1,,,,,,,,,,,,,,,,,,,,,
4,2,,172164-03130,, "LABEL,GREASE FEED",,1,,,,,,,,,,,,,,,,,,,,,
5,2,,172176-03150,, "LABEL (VIO50",,2,,,,,,,,,,,,,,,,,,,,,
5-1,2,,172176-03151,, "LABEL (VIO50",,2,,,,,N,,,,,M/#00620,,,,,,
6,2,,172519-03150,, "LABEL, ACCEL",,1,,,,,,,,,,,,,,,,,,,,,
7,2,,172141-03170,, "LABEL, RESTART",,1,,,,,,,,,,,,,,,,,,,,,
8,2,,172164-03170,, "REAR EMBLEM",,1,,,,,,,,,,,,,,,,,,,,,
8-1,2,,172164-03171,, "EMBLEM, REAR",,1,,,,,R,,,,,M/#01358,,,,,,
9,2,,172164-03180,, "MARK,NO.1",,1,,,,,,,,,,,,,,,,,,,,,
10,2,,172165-03261,, "LABEL, BOOM",,1,,,,,,,,,,,,,,,,,,,,,
11,2,,172164-03190,, "LABEL, TURN.",,1,,,,,,,,,,,,,,,,,,,,,
11-1,2,,172164-03560,, LABEL,,1,,,,,N,,,,,M/#00963,,,,,,
12,2,,172141-03201,, "LABEL,ENGINE ROOM(C)",,1,,,,,,,,,,,,,,,,,,,,,
12-1,2,,172141-03202,, "LABEL,CAUTION",,1,,,,,N,,,,,M/#00963,,,,,,
13,2,,172147-03210,, LABEL,,1,,,,,,,,,,,,,,,,,,,,,
14,2,,172165-03220,, "LABEL, GREASE",,1,,,,,,,,,,,,,,,,,,,,,
15,2,,172519-03290,, "LABEL, ENG.COVER",,1,,,,,,,,,,,,,,,,,,,,,
15-1,2,,172519-04180,, "LABEL,WARNING",,1,,,,,N,,,,,M/#00963,,,,,,
16,2,,172137-03301,, "LABEL, TURNING LOCK",,1,,,,,Z,,,,,M/#01328,,,,,,
17,2,,172142-03301,, LABEL,,1,,,,,,,,,,,,,,,,,,,,,
17-1,2,,172142-03302,, "LABEL,CAUTION",,1,,,,,N,,,,,M/#00963,,,,,,
18,2,,172155-03310,, "LABEL, OILING",,1,,,,,,,,,,,,,,,,,,,,,
19,2,,172141-03360,, "LABEL, START SWITCH",,1,,,,,,,,,,,,,,,,,,,,,
20,2,,172165-03610,, "LABEL A",,1,,,,,,,,,,,,,,,,,,,,,
20-1,2,,172964-03610,, "LABEL A",,1,,,,,N,,,,,M/#00963,,,,,,
21,2,,172165-03620,, "LABEL B",,1,,,,,,,,,,,,,,,,,,,,,
21-1,2,,172164-03500,, LABEL,,1,,,,,N,,,,,M/#00963,,,,,,
22,2,,172165-03660,, "LABEL, BATTERY",,1,,,,,,,,,,,,,,,,,,,,,
22-1,2,,172165-03661,, "LABEL,DANGER",,1,,,,,N,,,,,M/#00963,,,,,,
23,2,,121470-44540,, "LABEL, SUB-TANK",,1,,,,,,,,,,,,,,,,,,,,,
24,2,,933112-52400,, "LABEL, FUEL",,1,,,,,,,,,,,,,,,,,,,,,
24-1,2,,172183-03250,, LABEL,,1,,,,,N,,,,,M/#00963,,,,,,
25,2,,172164-03140,, "LABEL,FRONT",,1,,,,,,,,,,,,,,,,,,,,,
26,2,,172151-03540,, "LABEL,PATTERN A",,1,,,,,,,,,,,,,,,,,,,,,
27,2,,172183-03280,, "LABEL, LOCK",,1,,,,,,,,,,,,,,,,,,,,,
27-1,2,,172183-03280,, "LABEL, LOCK",,2,,,,,K,,,,,M/#01014,,,,,,
28,2,,172164-03510,, LABEL,,1,,,,,W,,,,,M/#00963,,,,,,
29,2,,172164-03520,, "LABEL,DANGER",,1,,,,,W,,,,,M/#00963,,,,,,
30,2,,172164-03540,, LABEL,,1,,,,,W,,,,,M/#00963,,,,,,
31,2,,172964-03370,, LABEL,,1,,,,,W,,,,,M/#00963,,,,,,
32,2,,172964-03390,, "LABEL,WARNING",,1,,,,,W,,,,,M/#00963,,,,,,
33,2,,172964-03480,, LABEL,,1,,,,,W,,,,,M/#00963,,,,,,
33-1,2,,172964-03481,, LABEL,,1,,,,,N,,,,,*1995.07,,,,,,
34,2,,172519-04290,, "LABEL,WARNING",,1,,,,,W,,,,,M/#00963,,,,,,
35,2,,172519-04300,, LABEL,,1,,,,,W,,,,,M/#00963,,,,,,
36,2,,172173-03250,, LABEL,,1,,,,,W,,,,,M/#01090,,,,,,
36A,2,,172164-03350,, "LABEL,LIFTING",,1,,,,,W,,,,,M/#01302,,,,,,
37,1,,172165-03240,, LABEL,,1,,,,,2,,,,,,,,,,,,,
38,1,,172165-03230,, "LABEL, P.T.O.",,1,,,,,1,,,,,,,,,,,,,
38-1,1,,172165-03231,, "LABEL, P.T.O.",,1,,,,,N,1,,,,,M/#00852,,,,,,
39,1,,172168-03401,, LABEL,,1,,,,,W,3,,,,,M/#01074,,,,,,
40,1,,172168-03410,, LABEL,,1,,,,,W,M,,,,,M/#01074,,,,,,
41,1,,172165-03550,, LABEL,,1,,,,,W,5,,,,,"FROM 1ST",,,,,,
42,1,,172173-03550,, "LABEL (2-WAY",,1,,,,,4,,,,,,,,,,,,,
43,1,,172173-03560,, "LABEL (YANMAR",,1,,,,,4,,,,,,,,,,,,,
44,1,,172173-03570,, "LABEL (KOMATSU",,1,,,,,4,,,,,,,,,,,,,
45,1,,172165-03212,, "LABEL, PTO SELECT",,1,,,,,W,1,,,,,M/#00852,,,,,,
46,1,,172165-03280,, "LABEL, PTO SWITCH",,1,,,,,W,1,,,,,M/#FRPM 1",,,,,,
48,1,,172151-03050,, LABEL,,1,,,,,3,,,,,,,,,,,,,

Fig. 4 銘板 (キャノピー) (JP) LABEL (CANOPY) (JP)

見出しNo. 1-1は、見出しNo. 2から36Aを含みます。
1-1 inc. 2 ~ 36A

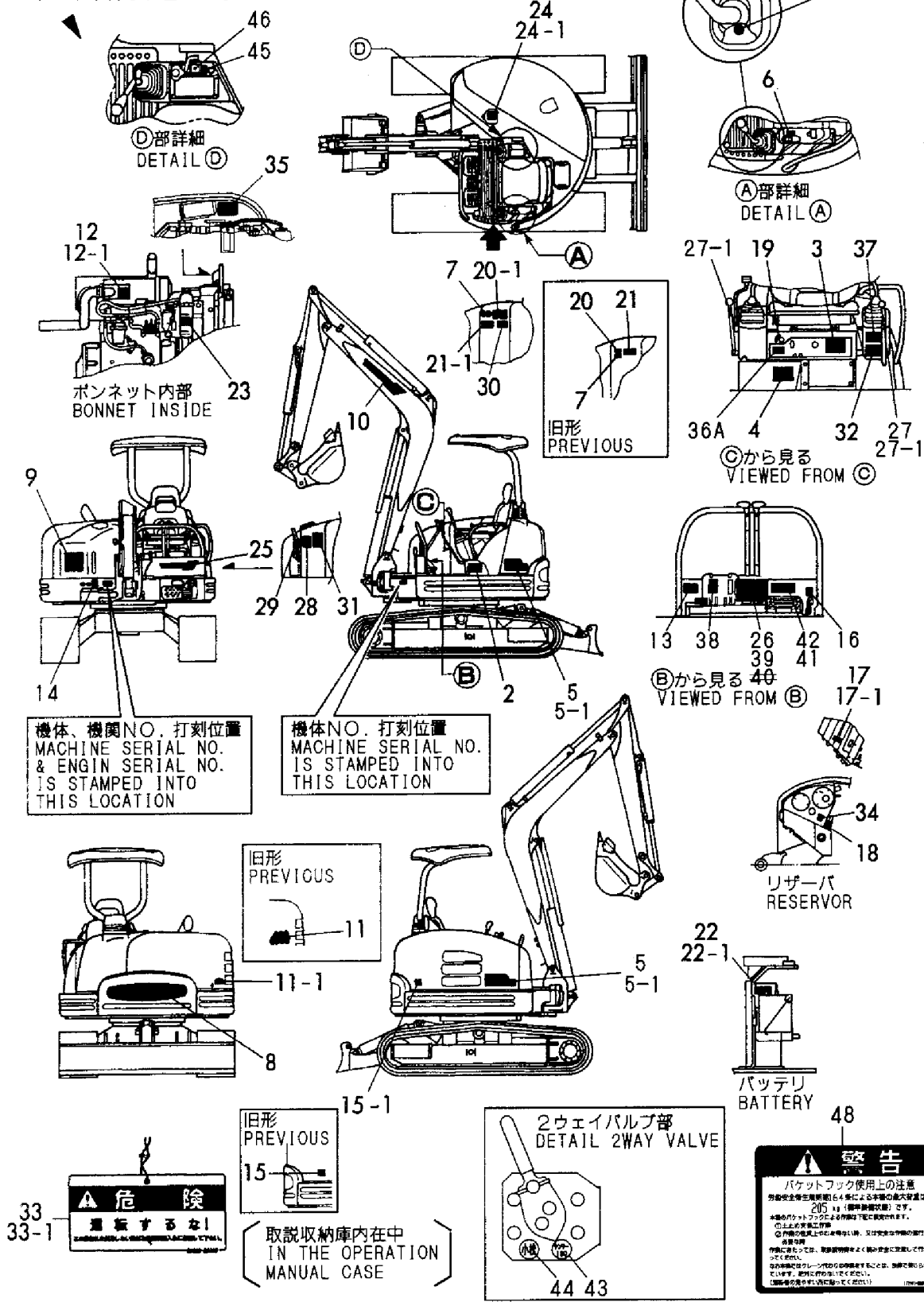

33-1 **危険**
運転するな!

取説収納庫内在中
IN THE OPERATION
MANUAL CASE

警告
バケットフック使用上の注意
労働安全衛生規則第64条による半端の最大荷重は、
205kg (標準最大荷重) です。
本機のバケットフックは205kgの荷重で設計されています。
①土上の突貫工事
②作業の場地上に作業をしない時、又は安全な作業の場地上に
作業しない時
作業にあたっては、取説を十分よく読み安全に作業して作
業してください。
この取説はクレーン作りの取説ではありません。誤用してはな
りません。誤用は危険に繋がります。
取説の取扱いをよく読んでください。

1,1,,772176-03180,, "LABEL SET (P EX",,1,,,,,,,,,,,,,
2,2,,172176-03340,, "LABEL,SPECIFICATION",,1,,,,,,,,,,,,,
3,2,,172176-03320,, "LABEL,FEED WATER(E",,1,,,,,,,,,,,,,
4,2,,172176-03330,, "LABEL,GREASE FEED(E",,1,,,,,,,,,,,,,
5,2,,172176-03151,, "LABEL (VIO50",,2,,,,,,,,,,,,,
6,2,,172519-03150,, "LABEL, ACCEL",,1,,,,,,,,,,,,,
7,2,,172141-03440,, LABEL,,1,,,,,,,,,,,,,
8,2,,172164-03170,, "REAR EMBLEM",,1,,,,,,,,,,,,,
8-1,2,,172164-03171,, "EMBLEM, REAR",,1,,,,,R,,,,,M/#01358,,,,,
9,2,,172164-03180,, "MARK,NO.1",,1,,,,,,,,,,,,,
10,2,,172165-03261,, "LABEL, BOOM",,1,,,,,,,,,,,,,
11,2,,172171-03780,, LABEL,,1,,,,,,,,,,,,,
12,2,,172171-03800,, LABEL,,1,,,,,,,,,,,,,
13,2,,172147-03210,, LABEL,,1,,,,,,,,,,,,,
14,2,,172171-03510,, "LABEL, GREASE",,1,,,,,,,,,,,,,
15,2,,172171-03810,, LABEL,,1,,,,,,,,,,,,,
16,2,,172137-03301,, "LABEL, TURNING LOCK",,1,,,,,Z,,,,,M/#01328,,,,,
17,2,,172171-03720,, LABEL,,1,,,,,,,,,,,,,
18,2,,172155-03790,, LABEL,,1,,,,,,,,,,,,,
19,2,,172141-03360,, "LABEL, START SWITCH",,1,,,,,,,,,,,,,
20,2,,172151-03540,, "LABEL,PATTERN A",,1,,,,,,,,,,,,,
21,2,,172171-03700,, LABEL,,1,,,,,,,,,,,,,
22,2,,172171-03770,, LABEL,,1,,,,,,,,,,,,,
23,2,,124764-44810,, "LABEL, SUB-TANK",,1,,,,,,,,,,,,,
24,2,,172183-03450,, "LABEL,FUEL",,1,,,,,,,,,,,,,
25,2,,172164-03140,, "LABEL,FRONT",,1,,,,,,,,,,,,,
26,2,,172171-03790,, "LABEL, RADIATOR",,1,,,,,,,,,,,,,
27,2,,172171-03760,, LABEL,,1,,,,,,,,,,,,,
28,2,,172183-03280,, "LABEL, LOCK",,2,,,,,,,,,,,,,
29,2,,172125-03950,, "LABEL, AIR CLEANER",,1,,,,,,,,,,,,,
30,2,,172171-03710,, LABEL,,1,,,,,,,,,,,,,
31,2,,172171-03740,, LABEL,,1,,,,,,,,,,,,,
32,2,,172171-03750,, LABEL,,2,,,,,,,,,,,,,
32A,2,,172171-03400,, PLATE,,1,,,,,W,,,,,M/#01245,,,,,
33,1,,172165-03231,, "LABEL, P.T.O.",,1,,,,,1,,,,,,,,,,,,,
34,1,,172165-03212,, "LABEL, PTO SELECT",,1,,,,,1,,,,,,,,,,,,,
35,1,,172165-03280,, "LABEL, PTO SWITCH",,1,,,,,1,,,,,,,,,,,,,
36,1,,172141-03501,, "LABEL(ADJUST CRAWLER",,1,,,,,2,,,,,,,,,,,,,

Fig. 5 銘板 (キャノピ) (EX) LABEL (CANOPY) (EX)

見出しNo. 1は、見出しNo. 2から32Aを含みます。
1 inc. 2 ~ 32A

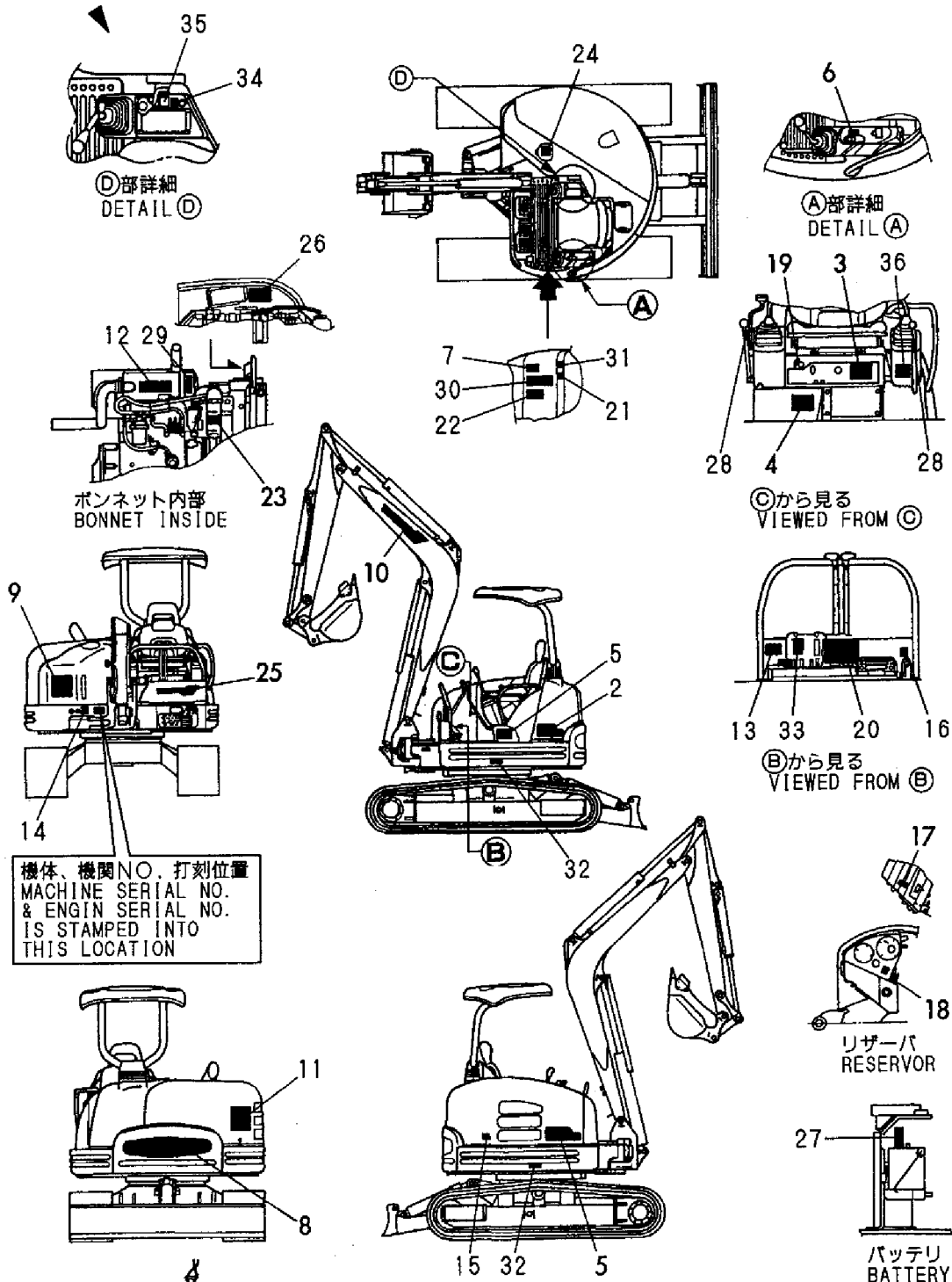

機体、機関NO. 打刻位置
MACHINE SERIAL NO.
& ENGIN SERIAL NO.
IS STAMPED INTO
THIS LOCATION

32A



取説収納庫内在中
IN THE OPERATION
MANUAL CASE

1,1,,772176-05100,, "TOOL SET",1,1,,,,,,,,,,,,,
2,2,,933110-90000,, "BAG, TOOL",1,1,,,,,,,,,,,,,
3,2,,172112-38111,, "PIN, COTTER",2,2,,,,,,,,,,,,,
4,2,,104200-92350,, "DRIVER, SCREW",1,1,,,,,,,,,,,,,
5,2,,119640-92750,, "WRENCH, FILTER",1,1,,,,,,,,,,,,,
6,2,,172122-05100,, NOZZLE,1,1,,,,,,,,,,,,,
6-1,2,,172122-05101,, NOZZLE,1,1,,,,,N,,,M/#00965,,M/#00965,,,,,,
7,2,,28110-080100,, "WRENCH 8X10",1,1,,,,,,,,,,,,,
8,2,,28110-120140,, "WRENCH 12X14",2,2,,,,,,,,,,,,,
9,2,,28110-170190,, "WRENCH 17X19",1,1,,,,,,,,,,,,,
10,2,,28110-220240,, "WRENCH 22X24",1,1,,,,,,,,,,,,,
11,2,,28110-270300,, "WRENCH 27X30",1,1,,,,,,,,,,,,,
12,2,,28150-140000,, "BAR WRENCH 14",1,1,,,,,,,,,,,,,
13,2,,28150-080000,, "BAR WRENCH 8",1,1,,,,,,,,,,,,,
14,2,,28227-271400,, "BOX WRENCH 27X140",1,1,,,,,,,,,,,,,
15,2,,28230-120250,, "TURNING HANDLE",1,1,,,,,,,,,,,,,
16,2,,933110-09700,, "HOSE, GREASE",1,1,,,,,,,,,,,,,
16-1,2,,933110-09701,, "HOSE, GREASE",1,1,,,,,N,,,M/#00965,,M/#00965,,,,,,
17,2,,933110-09800,, "GUN 800, GREASE",1,1,,,,,,,,,,,,,
17-1,2,,933110-09801,, "GUN 800, GREASE",1,1,,,,,N,,,M/#00965,,M/#00965,,,,,,
18,2,,933171-00470,, "PLIERS 200",1,1,,,,,,,,,,,,,
21,1,,172176-07330,, "BAG, MANUAL",1,1,,,,,W,,,M/#00960,,M/#00960,,,,,,

Fig. 6 工具 TOOL

見出しNo. 1は、見出しNo. 2から18を含みます。
1 inc. 2 ~ 18

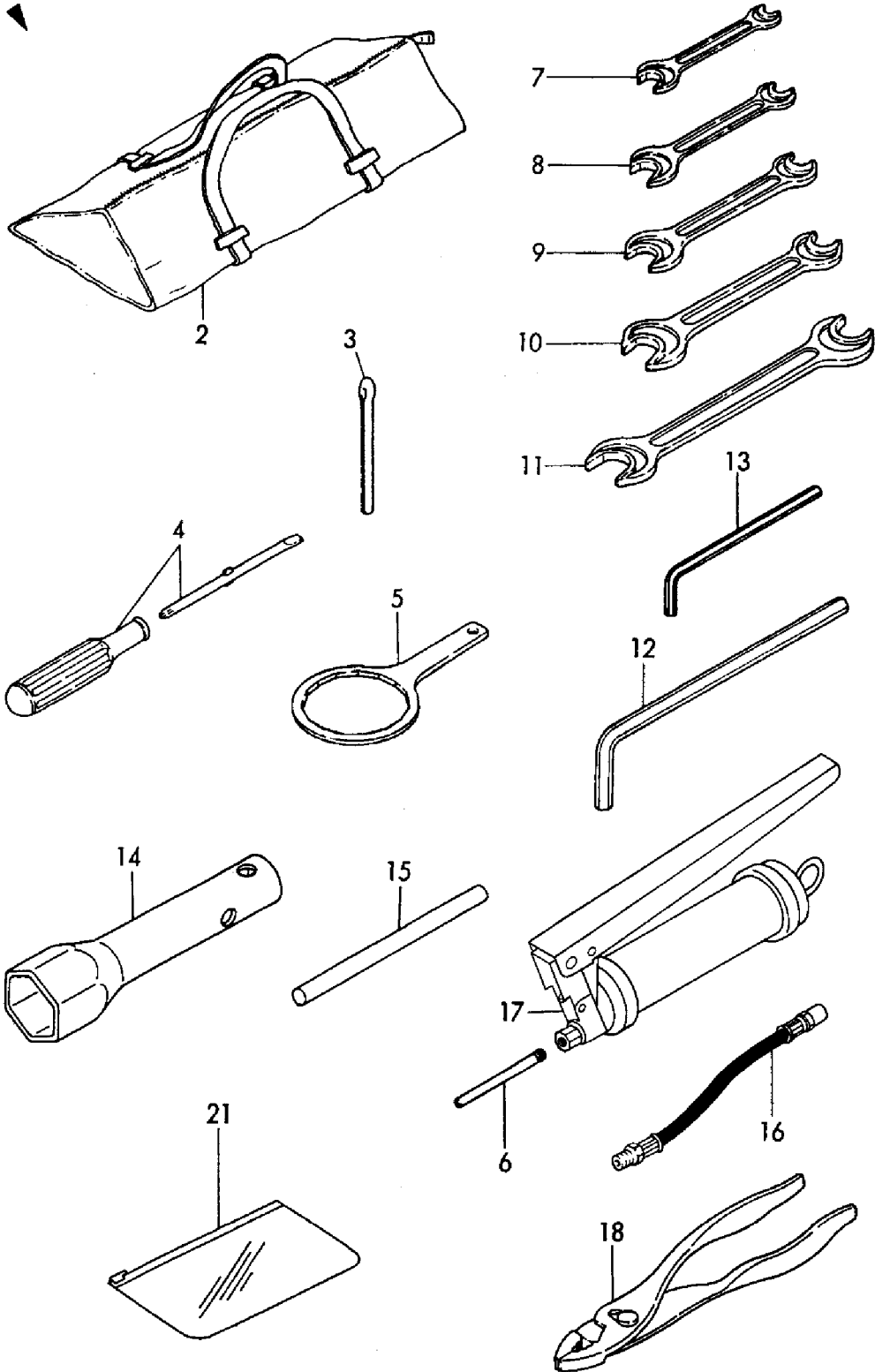

1,1,,172164-11300,, "PIPE, EXHAUST",1,1,,,,,Z,,,M/#00965,,M/#00965,,,,,
2,1,,121120-13580,,CLAMP,1,1,,,,,,,,,,,,,
3,1,,26106-100652,, "BOLT M10X 65 PLATED",1,1,,,,,,,,,,,,,
4,1,,26706-100002,, "NUT M10",1,1,,,,,,,,,,,,,
5,1,,23000-070000,, "CLAMP 70",2,2,,,,,,,,,,,,,
6,1,,172164-11400,, "HOSE, AIR CLEANER",1,1,,,,,,,,,,,,,
7,1,,172164-11290,, "PIPE, EXH.",1,1,,,,,W,,,M/#00965,,M/#00965,,,,,
9,2,,172164-11310,,MAT,1,1,,,,,W,,,M/#00965,,M/#00965,,,,,

Fig. 7 吸気パイプ&排気パイプ
SUC. PIPE & EXH. PIPE

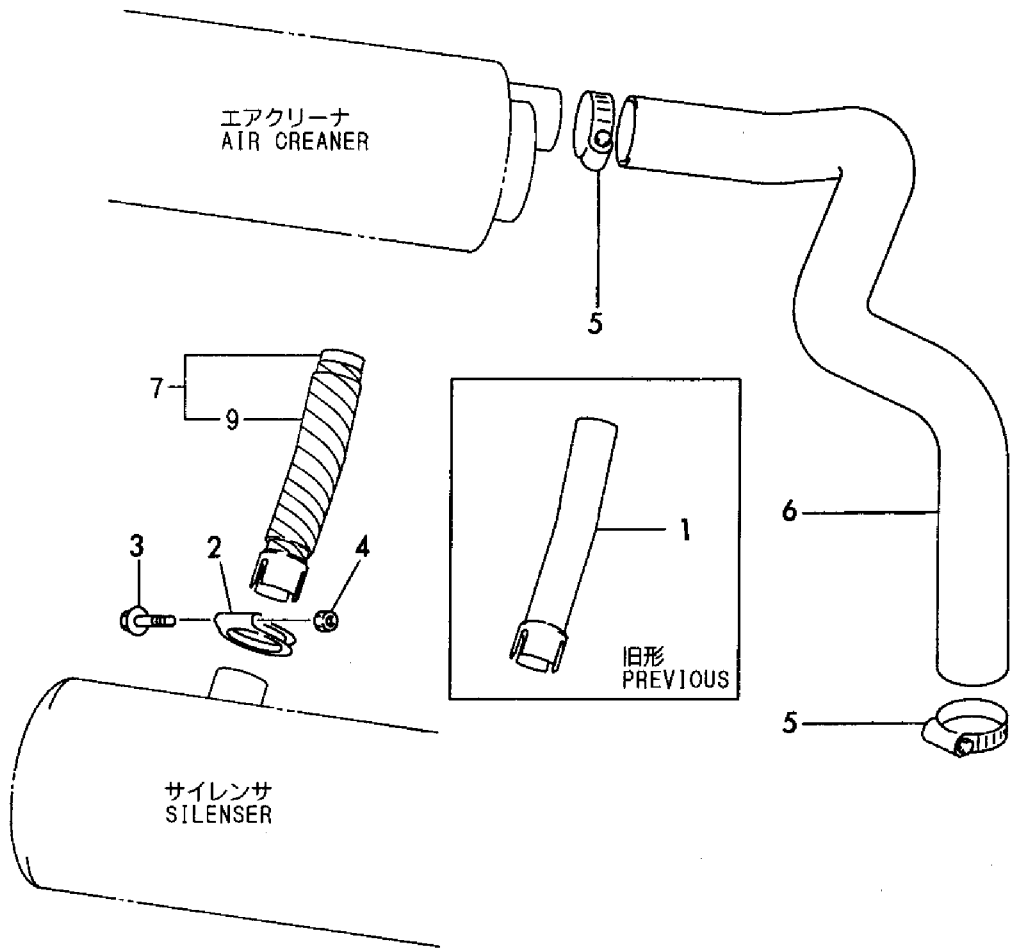

1,1,,172165-12100,, "LEVER ASSY, ACCEL.",1,1,,,,,,,,,,,,,
1A,2,,172165-12140,,GRIP(RED,1,1,,,,,W,,,M/#01180,,M/#01180,,,,,,
2,1,,172147-12100,,SUPPORT,1,1,,,,,,,,,,,,,
3,1,,172170-12110,,CABLE,1,1,,,,,,,,,,,,,
4,1,,172137-12270,, "JOINT, CABLE",1,1,,,,,,,,,,,,,
5,1,,172113-12521,, "PIN, CABLE",1,1,,,,,,,,,,,,,
6,1,,1C6281-52310,, "PIN 6,COME-OFF SNAP",2,2,,,,,,,,,,,,,
7,1,,1A1040-56900,, "PIN 6X 17",1,1,,,,,,,,,,,,,
8,1,,22137-060000,, "WASHER 6, POLISHED",2,2,,,,,,,,,,,,,
9,1,,22217-080000,, "SPRING WASHER 8",2,2,,,,,,,,,,,,,
10,1,,26116-080202,, "BOLT M 8X 20 PLATED",2,2,,,,,,,,,,,,,
11,1,,26013-100252,, "BOLT W/WASHER M10X25",2,2,,,,,,,,,,,,,

Fig. 8 アクセル
ACCELERATOR

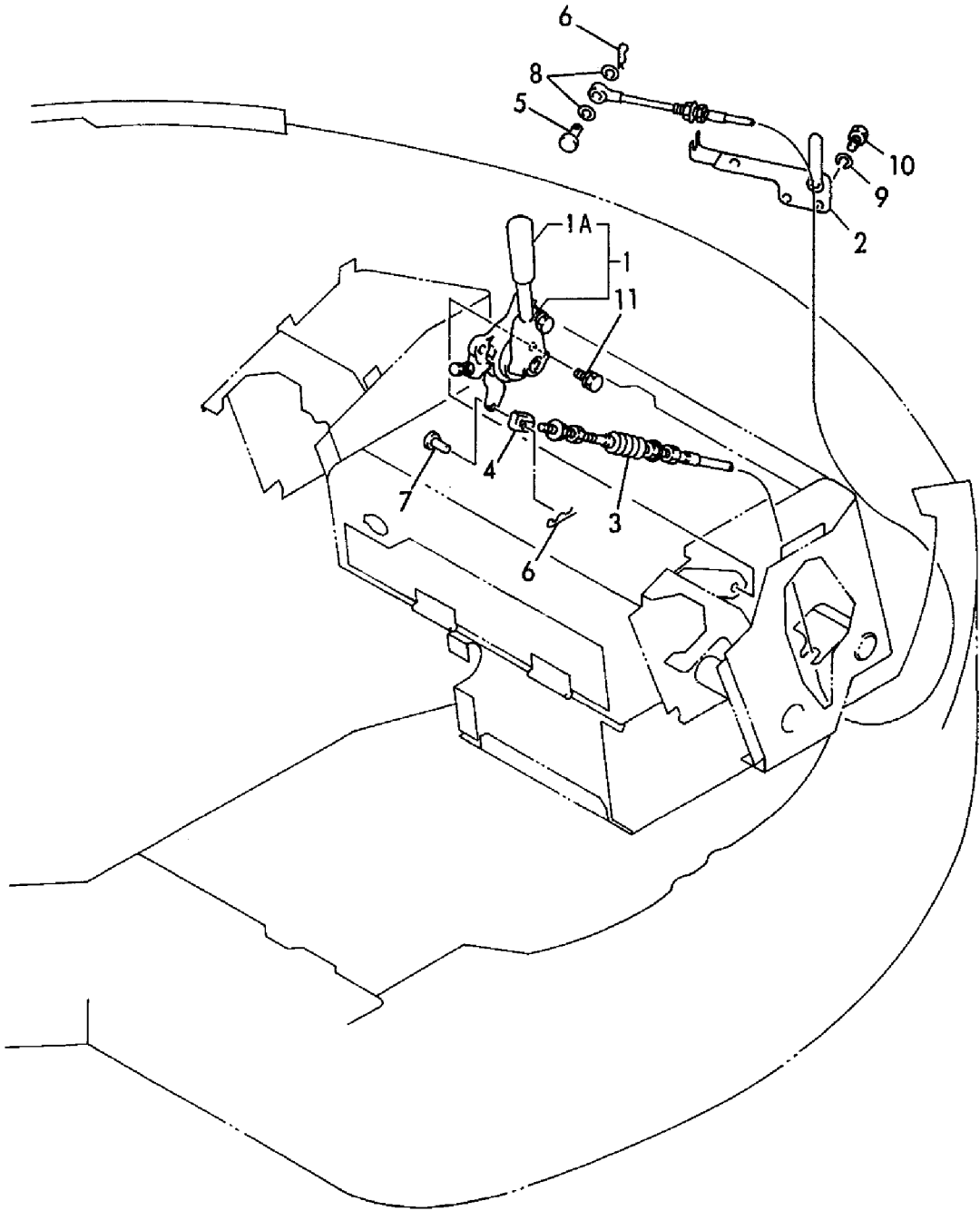

1,1,,172176-08200,, "DECELERATE(P) KIT",,1,,,,,1,,,,,
2,1,,172176-08210,, "DECELERATE(C) KIT",1,,,,,1,,,,,
2-1,1,,172176-08200,, "DECELERATE(P) KIT",1,,,,,N,1,,M/#01505,,,,,
3,2,,172164-12110,, "BASE CMP",1,1,,,,,
4,3,,24550-014200,, "BUSH 14X20",1,1,,,,,
5,2,,172176-14600,, STAY,1,1,,,,,
6,2,,172176-12110,, CABLE(ACCELERATOR200,1,1,,,,,
7,2,,172190-12130,, "CABLE(ACCELERATOR OD",1,1,,,,,
8,2,,172164-12160,, "LINK B CMP",1,1,,,,,
10,3,,24550-014200,, "BUSH 14X20",1,1,,,,,
11,2,,172164-12200,, "SHAFT CMP",1,1,,,,,
12,2,,172175-12230,, "LINK A",1,1,,,,,
13,2,,933166-17730,, "WASHER 10.5X30",1,1,,,,,
14,2,,172175-12350,, "SPRING, RETURN",1,1,,,,,
15,2,,172175-12370,, PLATE,1,1,,,,,
16,2,,172113-12521,, "PIN, CABLE",1,1,,,,,
17,2,,1C6281-52310,, "PIN 6,COME-OFF SNAP",6,6,,,,,
18,2,,1A1040-56900,, "PIN 6X 17",1,1,,,,,
19,2,,1A3809-56915,, "PIN 6X 20",1,1,,,,,
20,2,,119620-66820,, JOINT,1,1,,,,,
21,2,,22137-060000,, "WASHER 6, POLISHED",7,7,,,,,
22,2,,22217-100000,, "SPRING WASHER 10",1,1,,,,,
23,2,,22351-040025,, "PIN 4X25,SPRING",1,1,,,,,
24,2,,24311-000210,, "O-RING 1A P-21.0",4,4,,,,,
25,2,,26013-080252,, "BOLT M 8X 25",2,2,,,,,
26,2,,26013-100252,, "BOLT W/WASHER M10X25",2,2,,,,,
27,2,,26116-100162,, "BOLT M10X 16 PLATED",1,1,,,,,
28,2,,26716-060002,, "NUT 6",1,1,,,,,
29,1,,172137-12270,, "JOINT, CABLE",1,1,,,,,
30,1,,172165-12100,, "LEVER ASSY, ACCEL.",1,1,,,,,
31,2,,172165-12140,, GRIP(RED,1,1,,,,,

Fig. 9 アクセル (ワンタッチデセル)
ACCELERATOR (ONE TOUCH DECEL)

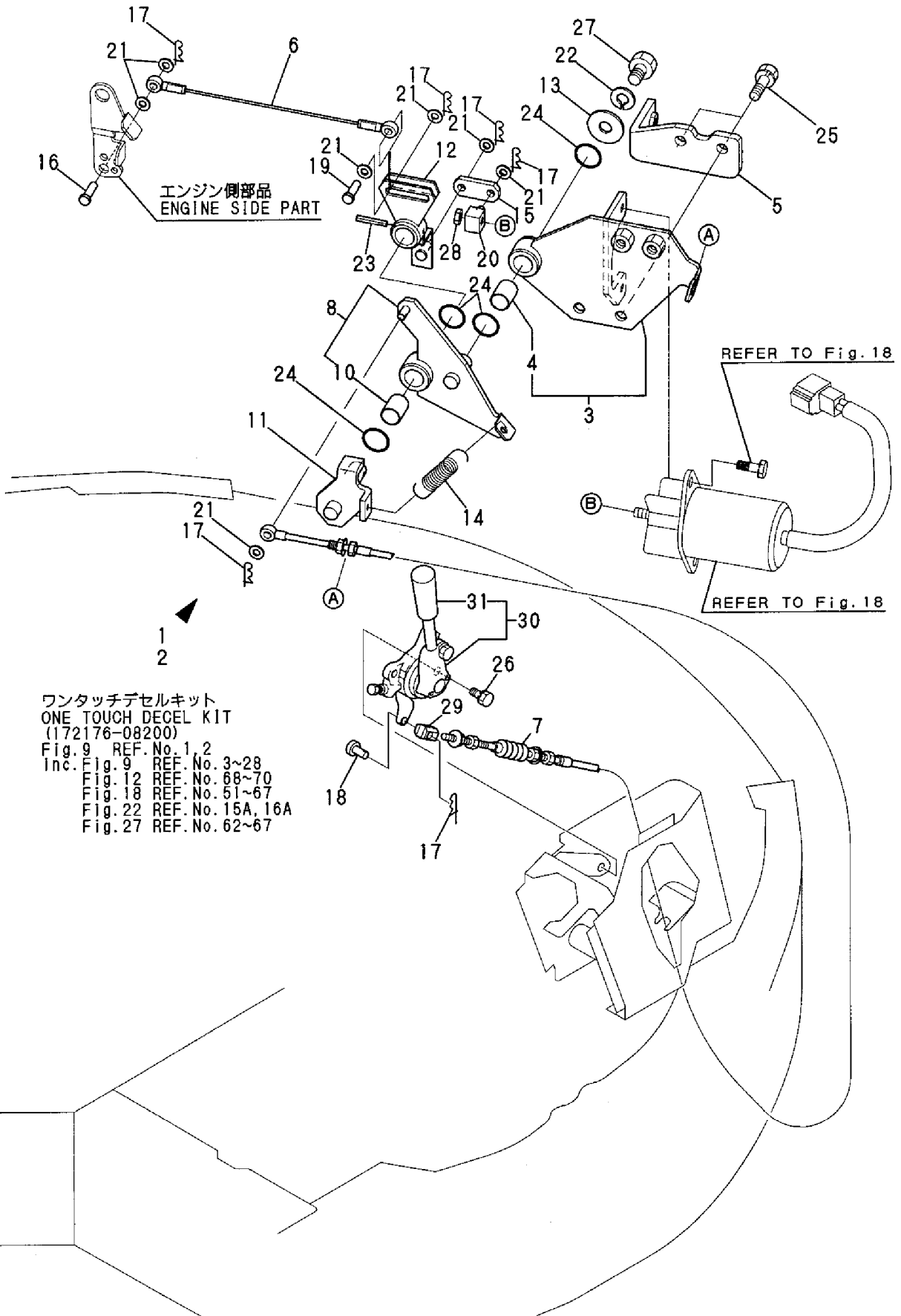

ワンタッチデセルキット
ONE TOUCH DECEL KIT
(172176-08200)
Fig. 9 REF. No. 1, 2
Inc. Fig. 9 REF. No. 3~28
Fig. 12 REF. No. 66~70
Fig. 18 REF. No. 51~67
Fig. 22 REF. No. 15A, 16A
Fig. 27 REF. No. 62~67

1,1,,172165-13130,, "BRACKET RF CMP",2,2,,,,,,,,,,,,,
2,1,,172165-13160,, "BRACKET LR ASSY",1,1,,,,,,,,,,,,,
3,1,,172162-13170,, WASHER,2,2,,,,,,,,,,,,,
4,1,,172162-13190,, "BOLT M16X150",4,4,,,,,,,,,,,,,
5,1,,172165-13191,, "BRACKET RR CMP",1,1,,,,,,,,,,,,,
6,1,,172162-13200,, "BOLT M10X30",12,12,,,,,,,,,,,,,
7,1,,172165-13240,, STOPPER,2,2,,,,,,,,,,,,,
7-1,1,,172165-13241,, "STOPPER ASSY",2,2,,,,,R,,,M/#00832,,M/#00832,,,,,,
8,1,,172165-13270,, MOUNT.ENGINE,8,8,,,,,,,,,,,,,
9,1,,26076-120352,, "BOLT M12X 35",8,8,,,,,,,,,,,,,
10,1,,172137-46040,, "SEAT, SPRING",12,12,,,,,,,,,,,,,
11,1,,22217-100000,, "SPRING WASHER 10",12,12,,,,,,,,,,,,,
12,1,,22217-120000,, "SPRING WASHER",8,8,,,,,,,,,,,,,
13,1,,22217-160000,, "SPRING WASHER 16",4,4,,,,,,,,,,,,,
14,1,,172165-13220,, WASHER,8,8,,,,,,,,,,,,,
15,1,,172162-13200,, "BOLT M10X30",10,,,,,,1,,,,,,,,,
16,1,,172165-13610,, "BOLT M10X 40",2,,,,,,1,,,,,,,,

1,1,,172176-08100,, "COOLER KIT",1,,,,,,,,,1,,,,,,,,,
2,2,,194630-15520,, "COLLAR 9.2X13.8X11",1,,,,,,,,,1,,,,,,,,,
3,2,,124240-01883,, "GASKET, (NON-ASB.)",1,,,,,,,,,Z,,M/#00504,,,,,,,,,
4,2,,172176-18100,, "BRACKET ASSY",1,,,,,,,,,1,,,,,,,,,
5,2,,172176-18150,, "BRACKET ASSY",1,,,,,,,,,1,,,,,,,,,
6,2,,172176-18200,, "V-BELT",1,,,,,,,,,1,,,,,,,,,
7,2,,172176-18300,, "PULLEY",1,,,,,,,,,Z,,M/#00504,,,,,,,,,
8,2,,172165-18630,, "ADJUSTER ASSY",1,,,,,,,,,1,,,,,,,,,
9,2,,129430-42330,, "BEARING,BALL",2,,,,,,,,,Z,,M/#00504,,,,,,,,,
10,2,,129430-42352,, "V-PULLEY",1,,,,,,,,,Z,,M/#00504,,,,,,,,,
11,2,,22137-080000,, "WASHER 8, POLISHED",1,,,,,,,,,1,,,,,,,,,
12,2,,22190-080002,, "SEAL WASHER 8S",4,,,,,,,,,1,,,,,,,,,
13,2,,22217-060000,, "SPRING WASHER 6",1,,,,,,,,,1,,,,,,,,,
14,2,,22217-080000,, "SPRING WASHER 8",1,,,,,,,,,1,,,,,,,,,
14-1,2,,22217-080000,, "SPRING WASHER 8",2,,,,,,,,,K,,M/#00504,,,,,,,,,
15,2,,26716-060002,, "NUT 6",2,,,,,,,,,1,,,,,,,,,
16,2,,26716-080002,, "NUT M 8",1,,,,,,,,,1,,,,,,,,,
16-1,2,,26716-080002,, "NUT M 8",2,,,,,,,,,K,,M/#00504,,,,,,,,,
17,2,,26106-080202,, "BOLT M 8X 20 PLATED",4,,,,,,,,,1,,,,,,,,,
18,2,,172162-18020,, "COMPRESSOR",1,,,,,,,,,1,,,,,,,,,
19,2,,172164-18261,, "COVER ASSY, PULLEY",1,,,,,,,,,1,,,,,,,,,
20,2,,172164-18350,, "BRACKET ASSY",1,,,,,,,,,1,,,,,,,,,
21,2,,172165-18751,, "PLATE",1,,,,,,,,,1,,,,,,,,,
22,2,,22217-080000,, "SPRING WASHER 8",2,,,,,,,,,1,,,,,,,,,
23,2,,26013-080252,, "BOLT M 8X 25",4,,,,,,,,,1,,,,,,,,,
24,2,,26106-080552,, "BOLT M 8X 55 PLATED",1,,,,,,,,,1,,,,,,,,,
25,2,,26106-080552,, "BOLT M 8X 55 PLATED",2,,,,,,,,,1,,,,,,,,,
26,2,,26116-080202,, "BOLT M 8X 20 PLATED",2,,,,,,,,,1,,,,,,,,,
27,2,,172165-13610,, "BOLT M10X 40",1,,,,,,,,,1,,,,,,,,,
28,2,,124240-01871,, "COVER, HO-P",1,,,,,,,,,Z,,M/#00504,,,,,,,,,
29,2,,106100-44650,, "PULLEY, TENSION",1,,,,,,,,,W,,M/#00504,,,,,,,,,
30,2,,106100-44960,, "CAP",1,,,,,,,,,W,,M/#00504,,,,,,,,,
31,2,,129430-42349,, "V-PULLEY ASSY",1,,,,,,,,,W,,M/#00504,,,,,,,,,
32,3,,129430-42310,, "BALL BEARING",1,,,,,,,,,W,,M/#00504,,,,,,,,,
33,3,,129430-42352,, "V-PULLEY",1,,,,,,,,,W,,M/#00504,,,,,,,,,
34,3,,129430-42369,, "V-PULLEY",1,,,,,,,,,W,,M/#00504,,,,,,,,,

Fig. 11 コンプレッサー&Vプーリ (クーラー仕様)
 COMPRESSOR & V PULLEY (COOLER SPEC.)

クーラーキット
 COOLER KIT
 (172176-08100)
 Fig. 11 REF. No. 1
 1 inc.

Fig. 11	REF. No.	2~34
Fig. 12	REF. No.	~10
Fig. 13	REF. No.	~62
Fig. 14	REF. No.	~49
Fig. 20	REF. No.	~11
Fig. 34	REF. No.	1, 2
Fig. 36	REF. No.	1
Fig. 37	REF. No.	~5
Fig. 38	REF. No.	~5
Fig. 39	REF. No.	18B, 23, 24, 53~55
Fig. 41	REF. No.	16B, 22B, 23B, 34

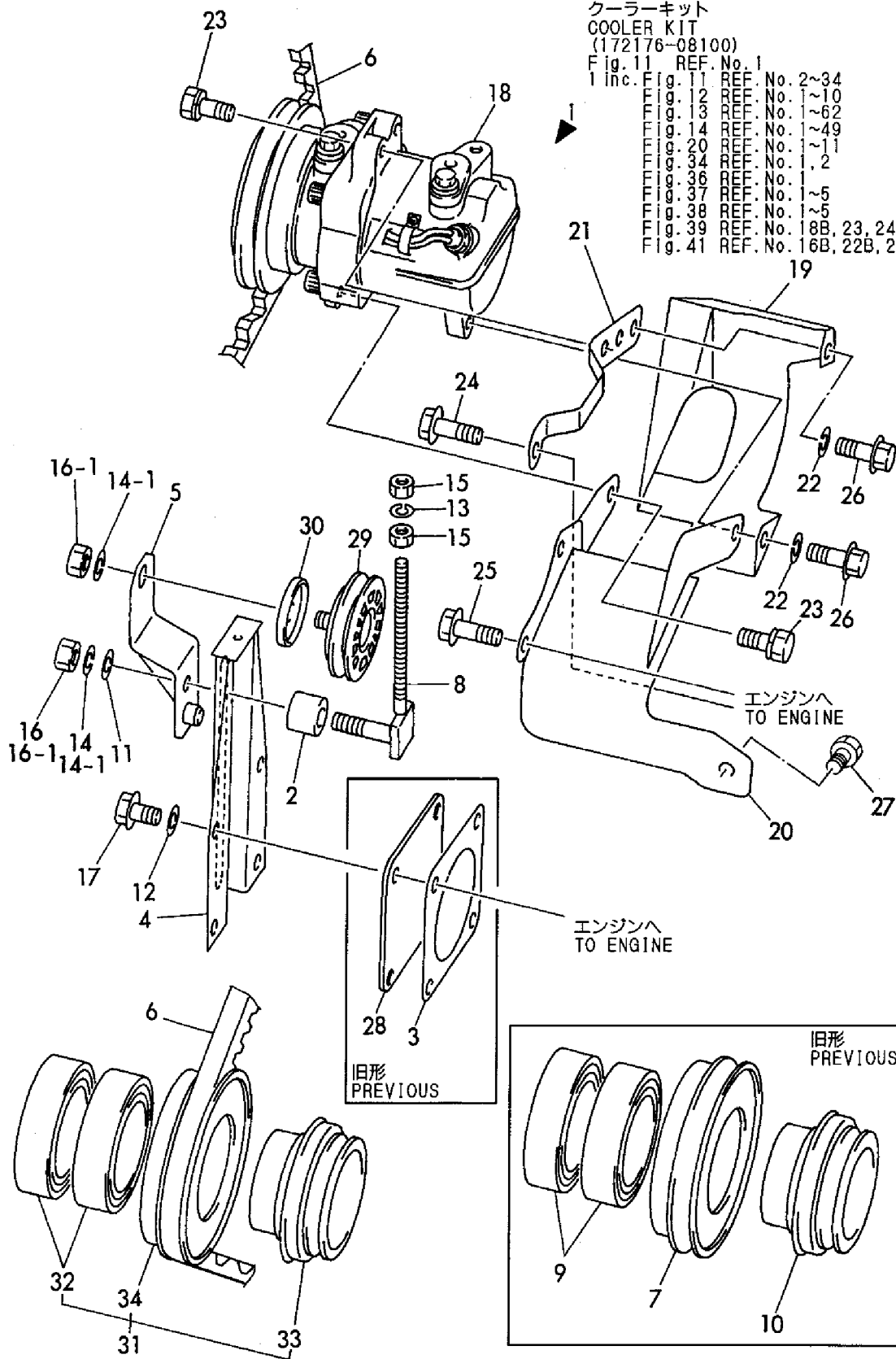

1,2,,172164-13240,,HOSE,1,,,,,1,,,,,
2,2,,172122-13400,, "CLAMP,RADIATOR HOSE",1,,,,,1,,,,,
3,2,,194250-51660,, "BAND 250",2,,,,,1,,,,,
4,2,,22217-080000,, "SPRING WASHER 8",1,,,,,1,,,,,
5,2,,26116-080162,, "BOLT 8X16",1,,,,,1,,,,,
6,2,,172176-13200,, "NET, WIRE",1,,,,,1,,,,,
6-1,2,,172176-13201,, "NET, WIRE",1,,,,,N,1,,M/#00965,,,,,
7,2,,22137-080000,, "WASHER 8, POLISHED",4,,,,,1,,,,,
8,2,,22217-080000,, "SPRING WASHER 8",2,,,,,1,,,,,
9,2,,26116-080202,, "BOLT M 8X 20 PLATED",2,,,,,1,,,,,
10,2,,26716-080002,, "NUT M 8",2,,,,,1,,,,,
11,1,,172164-13600,, "MOUNT L",1,1,,,,,
12,1,,172164-13630,, "MOUNT R",1,1,,,,,
13,1,,172164-13670,, "BRACKET(C), COOLER",1,1,,,,,
14,1,,172164-13691,, PLATE,1,1,,,,,
15,1,,172725-16380,, "GROMMET 15X20",1,1,,,,,
16,1,,129430-44500,, RADIATOR,1,1,,,,,
17,2,,124450-44590,, "CAP, RADIATOR",1,1,,,,,
19,2,,129430-44660,, SHROUD,1,1,,,,,
20,2,,124450-44800,, "LABEL, RADIATOR",1,1,,,,,
21,2,,26014-060122,, "BOLT M 6X 12",4,4,,,,,
22,1,,171064-44510,, "SUB-TANK ASSY",1,1,,,,,
23,2,,171064-44520,, "BODY, SUB-TANK",1,1,,,,,
24,2,,121450-44531,, CAP,1,1,,,,,
25,2,,124450-44560,, CLAMP,1,1,,,,,
26,2,,121470-44581,, GASKET,1,1,,,,,
27,2,,23065-070225,, "HOSE 7X 225",1,1,,,,,
28,1,,124450-44550,, "CLAMP, SUB-TANK",1,1,,,,,
29,1,,129403-44592,, "NET,WIRE",1,1,,,,,
30,1,,121256-44600,, "BRACKET, SUB-TANK",1,1,,,,,
31,1,,26716-080002,, "NUT M 8",3,3,,,,,
32,1,,121450-49110,, "COCK ASSY, 3-WAY",1,1,,,,,
34,2,,121250-49121,, PLUG,1,1,,,,,
35,2,,24311-000160,, "O-RING 1A P-16.0",1,1,,,,,
36,1,,124766-59050,, "CLAMP 12",2,2,,,,,
37,1,,124766-59050,, "CLAMP 12",4,4,,,,,
38,1,,22137-080000,, "WASHER 8, POLISHED",6,6,,,,,
39,1,,22137-080000,, "WASHER 8, POLISHED",4,4,,,,,
40,1,,22137-080000,, "WASHER 8, POLISHED",4,4,,,,,Z,,,M/#01104,,M/#01104,,,,,
41,1,,22217-080000,, "SPRING WASHER 8",3,3,,,,,
42,1,,22217-080000,, "SPRING WASHER 8",2,2,,,,,Z,,,M/#00767,,M/#00767,,,,,
43,1,,22217-080000,, "SPRING WASHER 8",2,2,,,,,
44,1,,22217-080000,, "SPRING WASHER 8",16,16,,,,,
44-1,1,,22217-080000,, "SPRING WASHER 8",12,12,,,,,K,,,M/#01104,,M/#01104,,,,,
45,1,,22217-080000,, "SPRING WASHER 8",4,4,,,,,
46,1,,23010-038000,, "CLAMP 38",4,4,,,,,
47,1,,26013-080162,, "BOLT W/WASHER M8X16",4,4,,,,,
48,1,,26013-100252,, "BOLT W/WASHER M10X25",4,4,,,,,
49,1,,26051-080002,, "NUT M 8",8,8,,,,,
50,1,,26116-080202,, "BOLT M 8X 20 PLATED",16,16,,,,,
50-1,1,,26116-080202,, "BOLT M 8X 20
PLATED",12,12,,,,,K,,,M/#01104,,M/#01104,,,,,
51,1,,26116-080202,, "BOLT M 8X 20 PLATED",2,2,,,,,
52,1,,26116-080202,, "BOLT M 8X 20 PLATED",3,3,,,,,
53,1,,26116-080202,, "BOLT M 8X 20 PLATED",4,4,,,,,
54,1,,26557-080202,, "SCREW M 8X 20",2,2,,,,,
54-1,1,,26022-080162,, "SCREW M 8X 16",2,2,,,,,N,,,M/#00767,,M/#00767,,,,,
55,1,,933168-55770,, "BAND 146",1,1,,,,,
56,1,,172165-74900,, "COOLER,OIL",1,1,,,,,
56-1,1,,172165-74901,, "OIL COOLER",1,1,,,,,F,3,,M/#01104,,M/#01104,,,,,
57,1,,172176-13500,, "HOSE, WATER DRAIN",1,1,,,,,
57-1,1,,1E6451-77620,, "PIPE,FUEL",1,1,,,,,N,,,M/#00643,,M/#00643,,,,,
58,1,,172116-13410,, "HOSE(B), WATER DRAIN",2,2,,,,,

58-1,1,,172116-13410,, "HOSE(B), WATER
DRAIN",1,1,,,,,K,,,M/#00643,,M/#00643,,,,,
59,1,,172164-13430,, "BRACKET E",1,1,,,,,
60,1,,172164-13450,, "BRACKET F",1,1,,,,,
61,1,,172164-13520,, "RUBBER, SEAL",1,1,,,,,
62,1,,172734-14620,, "PIPE L=300, FUEL",1,1,,,,,W,,,M/#00643,,M/#00643,,,,,
63,1,,172164-13200,, "HOSE A",1,1,,,,,
63-1,1,,172164-13201,, "HOSE A",1,1,,,,,S,,,M/#01104,,M/#01104,,,,,
64,1,,172164-13210,, "HOSE B",1,1,,,,,
65,1,,172122-13310,, "MOUNT, RADIATOR",4,4,,,,,
66,1,,172164-13340,, "BRACKET A",1,1,,,,,
67,1,,172164-13370,, "BRACKET B",1,1,,,,,
68,1,,172126-16540,, "CLAMP 10X70",1,1,,,,,2,,,,,
69,1,,22217-100000,, "SPRING WASHER 10",1,1,,,,,2,,,,,
70,1,,26116-100162,, "BOLT M10X 16 PLATED",1,1,,,,,2,,,,,

Fig. 12 ラジエータ&オイルクーラ RADIATOR & OIL COOLER

見出しNo. 16は、見出しNo. (16) から21を含みます。
16 inc. (16) ~ 21

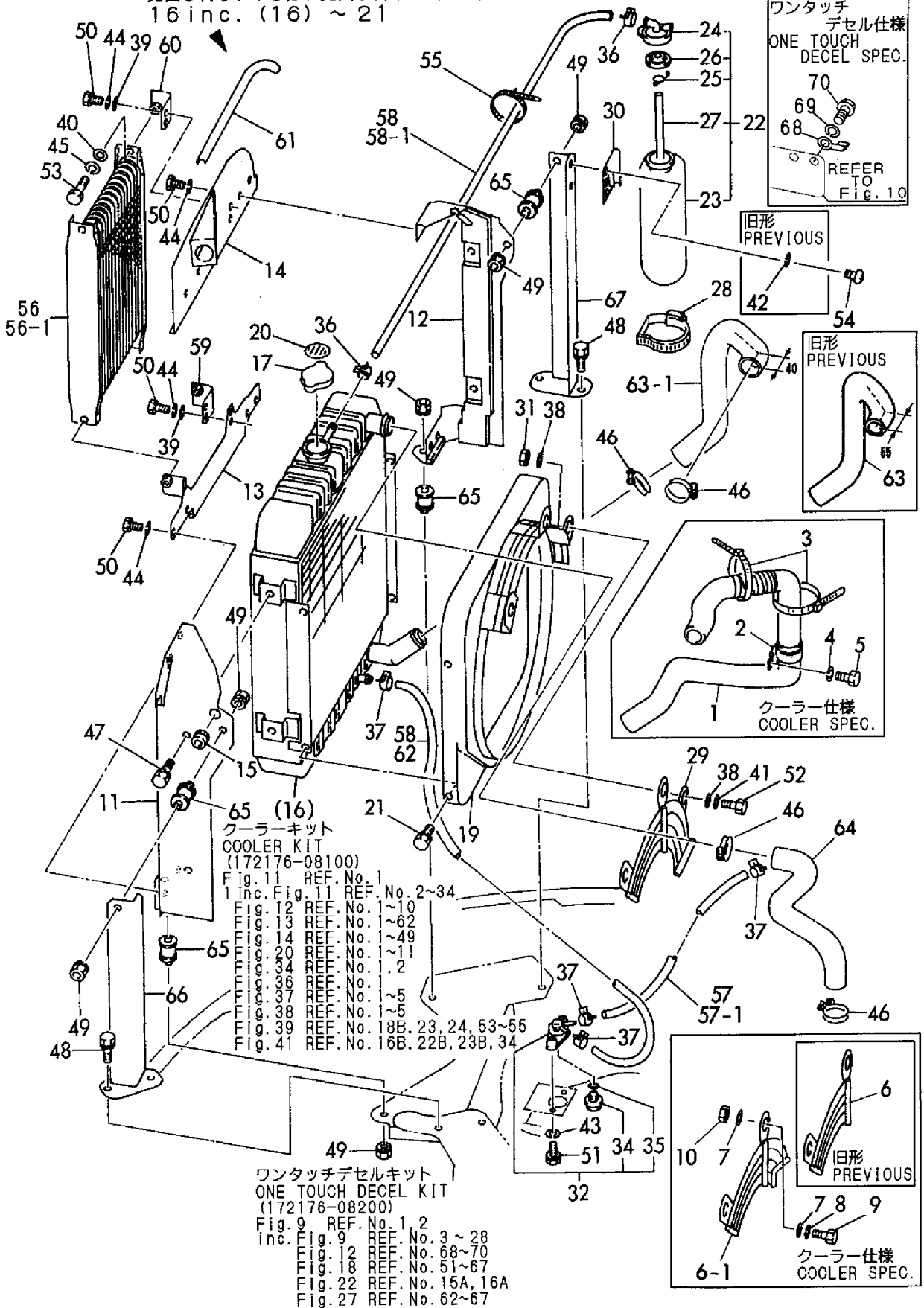

1,2,,194145-04810,, "WASHER 10",4,,,,,,,,,,,,,,,,,,,,,
2,2,,172126-11510,, "BAND 300",2,,,,,,,,,,,,,,,,,,,,,
3,2,,172122-13310,, "MOUNT, RADIATOR",4,,,,,,,,,,,,,,,,,,,,,
4,2,,172183-13480,, "RUBBER, SEAL",1,,,,,,,,,,,,,,,,,,,,,
5,2,,172164-18000,, "COOLER (A) ASSY",1,,,,,,,,,,,,,,,,,,,,,
6,3,,172162-18040,, BRACKET,1,,,,,,,,,,,,,,,,,,,,,
7,3,,172162-18070,, "PLUG, DRAIN",2,,,,,,,,,,,,,,,,,,,,,
8,3,,172164-18080,, MOTOR,1,,,,,,,,,,,,,,,,,,,,,
9,3,,172165-18080,, CONNECTOR,1,,,,,,,,,,,,,,,,,,,,,
10,3,,172164-18700,, HOSE,1,,,,,,,,,,,,,,,,,,,,,
11,3,,172164-18710,, HOSE,1,,,,,,,,,,,,,,,,,,,,,
12,3,,172164-18720,, HOSE,1,,,,,,,,,,,,,,,,,,,,,
13,3,,172164-18730,, TUBE,1,,,,,,,,,,,,,,,,,,,,,
14,3,,172164-18740,, HOSE,1,,,,,,,,,,,,,,,,,,,,,
15,3,,172164-18780,, CONDENSER,1,,,,,,,,,,,,,,,,,,,,,
16,3,,172164-18790,, FAN,1,,,,,,,,,,,,,,,,,,,,,
17,3,,172164-18800,, CLIP,1,,,,,,,,,,,,,,,,,,,,,
18,3,,172164-18810,, CLIP,1,,,,,,,,,,,,,,,,,,,,,
19,3,,172164-18820,, GROMMET,1,,,,,,,,,,,,,,,,,,,,,
20,3,,1E8080-79430,, "SWITCH ASSY, CONTROL",1,,,,,,,,,,,,,,,,,,,,,
21,3,,1E8080-79450,, "KNOB, FAN",1,,,,,,,,,,,,,,,,,,,,,
22,3,,933169-22940,, "SPACER, RESERVOIR",1,,,,,,,,,,,,,,,,,,,,,
22-1,3,,933171-17770,, "SHIM SET",1,,,,,N,,,,M/#01398,,,,,
23,3,,198325-87110,, DRYER,1,,,,,,,,,,,,,,,,,,,,,
24,3,,198325-87200,, "CASE, LOWER",1,,,,,,,,,,,,,,,,,,,,,
25,3,,197830-87910,, GRILLE,2,,,,,,,,,,,,,,,,,,,,,
26,3,,197821-88380,, INSULATOR,1,,,,,,,,,,,,,,,,,,,,,
27,3,,197830-88611,, GRILLE,2,,,,,,,,,,,,,,,,,,,,,
28,3,,1E8080-79470,, "NUT 4, JN",3,,,,,,,,,,,,,,,,,,,,,
29,2,,172164-18400,, "COVER ASSY",1,,,,,,,,,,,,,,,,,,,,,
30,2,,172164-18530,, "BRACKET ASSY",1,,,,,,,,,,,,,,,,,,,,,
31,2,,172164-18750,, "HOSE, DRAIN",1,,,,,,,,,,,,,,,,,,,,,
32,2,,172164-18760,, "HOSE, DRAIN",1,,,,,,,,,,,,,,,,,,,,,
33,2,,172164-18770,, "HOSE, DRAIN",1,,,,,,,,,,,,,,,,,,,,,
34,2,,172164-18850,, GROMMET,1,,,,,,,,,,,,,,,,,,,,,
35,2,,172164-18860,, "GUIDE ASSY, HOSE",2,,,,,,,,,,,,,,,,,,,,,
36,2,,172164-19190,, PLATE,1,,,,,,,,,,,,,,,,,,,,,
37,2,,172164-19200,, RUBBER,1,,,,,,,,,,,,,,,,,,,,,
38,2,,172164-19230,, EV,2,,,,,,,,,,,,,,,,,,,,,
39,2,,172164-19240,, SPONGE,1,,,,,,,,,,,,,,,,,,,,,
40,2,,1A1380-59480,, "CLAMP A, SM. & DYN. CORD",2,,,,,,,,,,,,,,,,,,,,,
41,2,,172137-62970,, "GROMMET 16",2,,,,,,,,,,,,,,,,,,,,,
42,2,,172164-66640,, "RUBBER, SEAL 400",1,,,,,,,,,,,,,,,,,,,,,
43,2,,22137-060000,, "WASHER 6, POLISHED",4,,,,,,,,,,,,,,,,,,,,,
44,2,,22137-060000,, "WASHER 6, POLISHED",2,,,,,,,,,,,,,,,,,,,,,
45,2,,22137-080000,, "WASHER 8, POLISHED",2,,,,,,,,,,,,,,,,,,,,,
46,2,,22157-100000,, "WASHER 10",2,,,,,,,,,,,,,,,,,,,,,
47,2,,22217-060000,, "SPRING WASHER 6",4,,,,,,,,,,,,,,,,,,,,,
48,2,,22217-080000,, "SPRING WASHER 8",8,,,,,,,,,,,,,,,,,,,,,
49,2,,22869-400160,, SCREW,12,,,,,,,,,,,,,,,,,,,,,
50,2,,26013-060162,, "BOLT M 6X 16",2,,,,,,,,,,,,,,,,,,,,,
51,2,,26013-060252,, "BOLT M 6X 25",2,,,,,,,,,,,,,,,,,,,,,
52,2,,26013-080162,, "BOLT W/WASHER M8X16",2,,,,,,,,,,,,,,,,,,,,,
53,2,,26013-080202,, "BOLT W/WASHER M8X20",2,,,,,,,,,,,,,,,,,,,,,
54,2,,26013-080252,, "BOLT M 8X 25",2,,,,,,,,,,,,,,,,,,,,,
55,2,,26013-100252,, "BOLT W/WASHER M10X25",2,,,,,,,,,,,,,,,,,,,,,
56,2,,26013-100302,, "BOLT M10X 30",4,,,,,,,,,,,,,,,,,,,,,
57,2,,26023-050122,, "SCREW M 5X 12",3,,,,,,,,,,,,,,,,,,,,,
58,2,,26116-060602,, "BOLT M 6X 60 PLATED",4,,,,,,,,,,,,,,,,,,,,,
59,2,,26367-050002,, "NUT M 5",1,,,,,,,,,,,,,,,,,,,,,
60,2,,26716-080002,, "NUT M 8",8,,,,,,,,,,,,,,,,,,,,,
61,2,,933166-16110,, "GROMMET 30X9.5",1,,,,,,,,,,,,,,,,,,,,,
62,2,,172164-18100,, "MOUNT ASSY",1,,,,,,,,,,,,,,,,,,,,,

Fig. 13 パイピング (クーラー仕様) PIPING (COOLER SPEC.)

見出しNo. 5は、見出しNo. 6から
28を含みます。
5 inc. 6 ~ 28

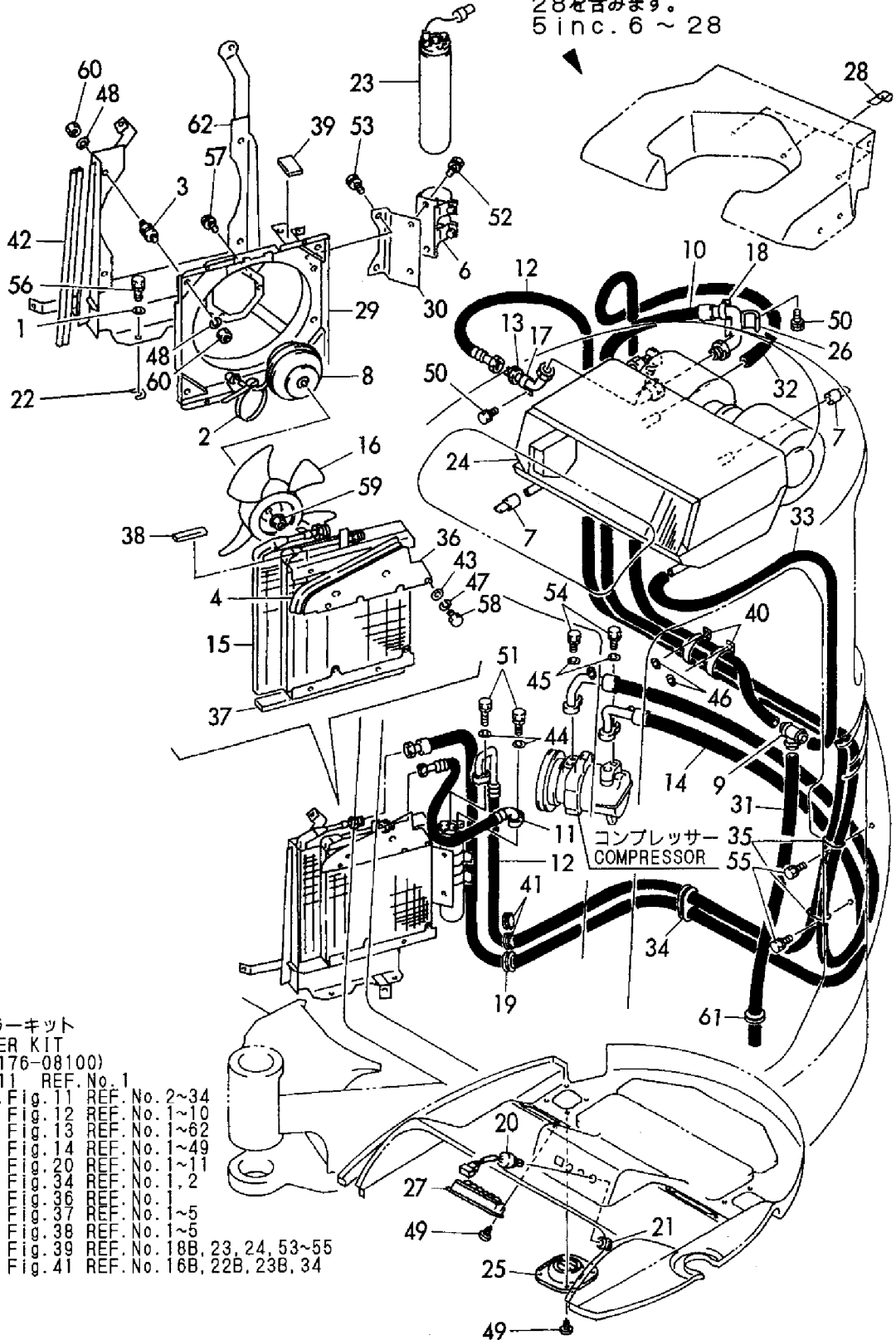

クーラーキット
COOLER KIT
(172176-08100)

Fig.	REF. No.	No.
Fig. 11	REF. No. 1	No. 2~34
Fig. 12	REF. No. 1	No. 1~10
Fig. 13	REF. No. 1	No. 1~62
Fig. 14	REF. No. 1	No. 1~49
Fig. 20	REF. No. 1	No. 1~11
Fig. 34	REF. No. 1	No. 1, 2
Fig. 36	REF. No. 1	No. 1~5
Fig. 37	REF. No. 1	No. 1~5
Fig. 38	REF. No. 1	No. 1~5
Fig. 39	REF. No. 18B	23, 24, 53~55
Fig. 41	REF. No. 16B	22B, 23B, 34

1,2,,172122-13310,, "MOUNT, RADIATOR",3,,,,,,,,,,,,,
2,2,,172176-17870,, MOUNT,2,,,,,,,,,,,,,
3,2,,172164-18300,, "COVER ASSY",1,,,,,,,,,,,,,
4,2,,172164-18550,, "BRACKET ASSY",1,,,,,,,,,,,,,
5,2,,172164-18650,, PLATE,1,,,,,,,,,,,,,
6,2,,172164-18830,, MOUNT,2,,,,,,,,,,,,,
7,2,,172164-18900,, DUCT,1,,,,,,,,,,,,,
8,2,,172164-18910,, PLATE,1,,,,,,,,,,,,,
9,2,,172164-18920,, FILTER,1,,,,,,,,,,,,,
10,2,,172164-18960,, "PANEL ASSY",1,,,,,,,,,,,,,
11,2,,172164-19100,, "SWITCH W/LAMP",1,,,,,,,,,,,,,
12,2,,172164-19110,, PLATE,2,,,,,,,,,,,,,
13,2,,172164-19130,, "BOLT M10X 25",4,,,,,,,,,,,,,
14,2,,172164-19150,, BRACKET,1,,,,,,,,,,,,,
15,2,,172164-19170,, "PLATE ASSY",2,,,,,,,,,,,,,
16,2,,172164-19210,, "RUBBER SEAL",1,,,,,,,,,,,,,
17,2,,172164-19220,, "RUBBER SEAL",1,,,,,,,,,,,,,
18,2,,172164-19260,, SEAL,1,,,,,,,,,,,,,
19,2,,172164-19270,, SEAL,1,,,,,,,,,,,,,
20,2,,172164-19300,, "COVER ASSY",1,,,,,,,,,,,,,
21,2,,194167-61650,, "NUT 5008",4,,,,,,,,,,,,,
22,2,,194940-61790,, "SCRFW 5X16",5,,,,,,,,,,,,,
23,2,,194940-61790,, "SCRFW 5X16",4,,,,,,,,,,,,,
24,2,,172151-62240,, GROMMET,1,,,,,,,,,,,,,
25,2,,172519-63240,, "BOLT 8X 16",2,,,,,,,,,,,,,
26,2,,172164-65640,, "WASHER 32X11X2.3",4,,,,,,,,,,,,,
27,2,,172164-65710,, "RUBBER, SEAL B",2,,,,,,,,,,,,,
28,2,,172165-66980,, "BOLT M 8X 25",3,,,,,,,,,,,,,
29,2,,172176-68200,, WASHER,2,,,,,,,,,,,,,
30,2,,1E8385-79310,, "WASHER 8",3,,,,,,,,,,,,,
31,2,,22157-080000,, "WASHER 8",4,,,,,,,,,,,,,
32,2,,22217-080000,, "SPRING WASHER 8",1,,,,,,,,,,,,,
33,2,,22217-080000,, "SPRING WASHER 8",5,,,,,,,,,,,,,
34,2,,26013-080202,, "BOLT W/WASHER M8X20",4,,,,,,,,,,,,,
35,2,,26013-080202,, "BOLT W/WASHER M8X20",4,,,,,,,,,,,,,
36,2,,26013-080202,, "BOLT W/WASHER M8X20",6,,,,,,,,,,,,,
37,2,,26013-080252,, "BOLT M 8X 25",2,,,,,,,,,,,,,
38,2,,26589-060162,, "SCREW M6,BINDING",2,,,,,,,,,,,,,
39,2,,26716-080002,, "NUT M 8",1,,,,,,,,,,,,,
40,2,,26716-080002,, "NUT M 8",5,,,,,,,,,,,,,
41,2,,22137-050000,, "WASHER 5, POLISHED",4,,,,,,,,,,,,,
42,2,,172164-03300,, "LABEL, CONTROL PANEL",1,,,,,,,,,,,,,
43,2,,172162-03510,, "LABEL, CAUTION",1,,,,,,,,,,,,,
45,2,,22137-080000,, "WASHER 8, POLISHED",1,,,,,,,,,,,,,
46,2,,172164-66150,, "SPONGE, RUBBER",1,,,,,,,,,,,,,
47,2,,22217-050000,, "SPRING WASHER 5",4,,,,,,,,,,,,,
48,2,,26116-050162,, "BOLT M 5X 16 PLATED",4,,,,,,,,,,,,,
49,2,,933152-09280,, "BAND 170",1,,,,,W,,,,M/#01486,,,,,

Fig. 14 カバー (クーラー仕様)
COVER (COOLER SPEC.)

クーラーキット

COOLER KIT

(172176-08100)

Fig. 11 REF. No. 1

1 inc. Fig. 11 REF. No. 2~34

Fig. 12 REF. No. 1~10

Fig. 13 REF. No. 1~62

Fig. 14 REF. No. 1~49

Fig. 20 REF. No. 1~11

Fig. 34 REF. No. 1, 2

Fig. 36 REF. No. 1

Fig. 37 REF. No. 1~5

Fig. 38 REF. No. 1~5

Fig. 39 REF. No. 18B, 23, 24, 53~55

Fig. 41 REF. No. 16B, 22B, 23B, 34

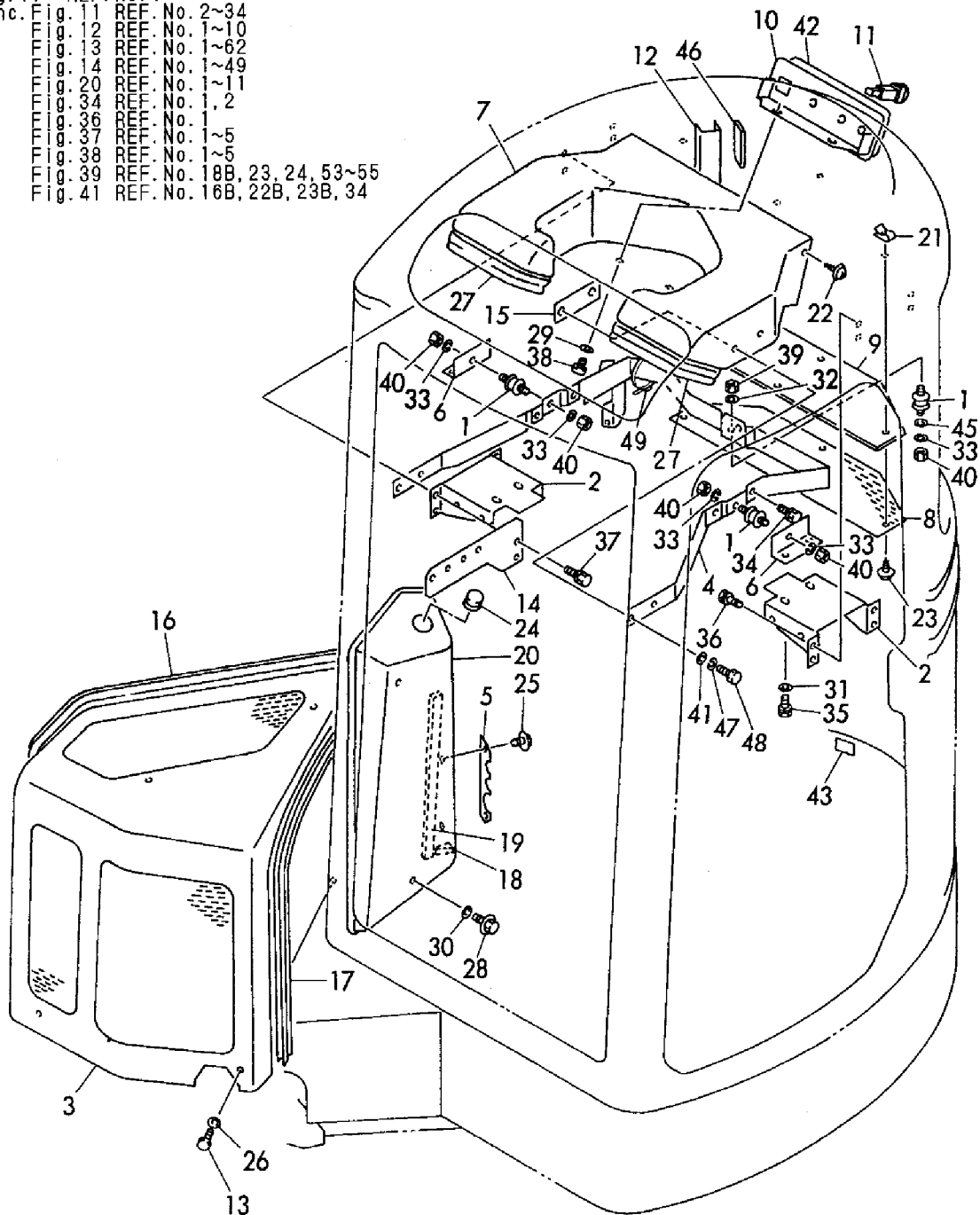

1,1,,772164-14100,, "TANK ASSY, FUEL",1,1,,,,,,,,,,,,,,,,,,,,,
2,2,,104200-11920,, COCK,1,1,,,,,,,,,,,,,,,,,,,,,
4,2,,172164-14170,, "GAUGE, FUEL",1,1,,,,,,,,,,,,,,,,,,,,,
4-1,2,,172164-14171,, HOSE,2,2,,,,,N,,,M/#00731,,M/#00731,,,,,,
5,2,,172162-14180,, "GAUGE UNIT,FUEL",1,1,,,,,,,,,,,,,,,,,,,,,
6,2,,172162-14200,, GASKET,1,1,,,,,,,,,,,,,,,,,,,,,
7,2,,172141-14260,, FLOAT,1,1,,,,,,,,,,,,,,,,,,,,,
8,2,,172122-14300,, "CAP, FUEL TANK",1,1,,,,,,,,,,,,,,,,,,,,,
8-1,2,,172122-14301,, "CAP, FUEL TANK",1,1,,,,,N,,,M/#01277,,M/#01277,,,,,,
9,3,,105430-55070,, GASKET,1,1,,,,,,,,,,,,,,,,,,,,,
9-1,3,,172122-14350,, GASKET,1,1,,,,,S,,,M/#01277,,M/#01277,,,,,,
10,2,,101504-55101,, "STRAINER,FUEL INLET",1,1,,,,,,,,,,,,,,,,,,,,,
10-1,2,,172183-14250,, "FILTER (FUEL",1,1,,,,,N,,,M/#01104,,M/#01104,,,,,,
11,2,,22217-050000,, "SPRING WASHER 5",5,5,,,,,,,,,,,,,,,,,,,,,
12,2,,23010-014000,, "CLAMP 14",2,2,,,,,,,,,,,,,,,,,,,,,
13,2,,26557-050122,, "SCREW M 5X 12",5,5,,,,,,,,,,,,,,,,,,,,,
14,1,,22137-140000,, "WASHER 14,POLISHED",4,4,,,,,,,,,,,,,,,,,,,,,
15,1,,22217-140000,, "SPRING WASHER 14",4,4,,,,,,,,,,,,,,,,,,,,,
16,1,,23080-013000,, "CLAMP 13,HOSE",1,1,,,,,,,,,,,,,,,,,,,,,
17,1,,26116-140352,, "BOLT M14X 35 PLATED",4,4,,,,,,,,,,,,,,,,,,,,,
18,1,,172171-14300,, W-CLAMP,3,3,,,,,,,,,,,,,,,,,,,,,
18-1,1,,172171-14300,, W-CLAMP,2,2,,,,,K,,,M/#01111,,M/#01111,,,,,,
19,1,,172116-14620,, "PIPE,FUEL",1,1,,,,,,,,,,,,,,,,,,,,,
20,1,,172164-14620,, "HOSE 1200",1,1,,,,,,,,,,,,,,,,,,,,,
21,1,,172176-14620,, "HOSE 1360",1,1,,,,,,,,,,,,,,,,,,,,,
22,1,,129335-55700,, "SEPARATOR, WATER",1,1,,,,,,,,,,,,,,,,,,,,,
23,2,,104200-55321,, "VALVE, TAPER",1,1,,,,,,,,,,,,,,,,,,,,,
24,2,,104200-55330,, "SPRING, TAPER VALVE",1,1,,,,,,,,,,,,,,,,,,,,,
25,2,,104200-55341,, "HANDLE, COCK",1,1,,,,,,,,,,,,,,,,,,,,,
26,2,,124064-55510,, "BOWL, FUEL STRAINER",1,1,,,,,,,,,,,,,,,,,,,,,
27,2,,102103-55520,, O-RING,1,1,,,,,,,,,,,,,,,,,,,,,
28,2,,110250-55610,, "RING, RETAINING",1,1,,,,,,,,,,,,,,,,,,,,,
29,2,,121257-55720,, "SPRING, SCREEN",1,1,,,,,,,,,,,,,,,,,,,,,
30,2,,121257-55731,, FLOAT,1,1,,,,,,,,,,,,,,,,,,,,,
32,2,,101720-55750,, "PLUG 6",2,2,,,,,,,,,,,,,,,,,,,,,
33,2,,104200-55750,, "SCREW M 4",1,1,,,,,,,,,,,,,,,,,,,,,
34,2,,171081-55910,, SCREEN,1,1,,,,,,,,,,,,,,,,,,,,,
35,2,,23418-060000,, "GASKET 6, NYLON",2,2,,,,,,,,,,,,,,,,,,,,,
36,2,,24311-240100,, "O-RING 1A P-10A",1,1,,,,,,,,,,,,,,,,,,,,,
37,1,,124766-59050,, "CLAMP 12",6,6,,,,,,,,,,,,,,,,,,,,,
38,1,,22217-080000,, "SPRING WASHER 8",1,1,,,,,,,,,,,,,,,,,,,,,
39,1,,26116-080702,, "BOLT M 8X 70 PLATED",1,1,,,,,,,,,,,,,,,,,,,,,
40,1,,933110-00301,, "KEY ASSY",1,1,,,,,,,,,,,,,,,,,,,,,
41,1,,933152-09280,, "BAND 170",1,1,,,,,W,,,M/#01111,,M/#01111,,,,,,

Fig. 15 燃料タンク&燃料パイプ FUEL TANK & FUEL PIPE

見出しNo. 1は、見出しNo. (1) から13を含みます。
1 inc. (1) ~ 13

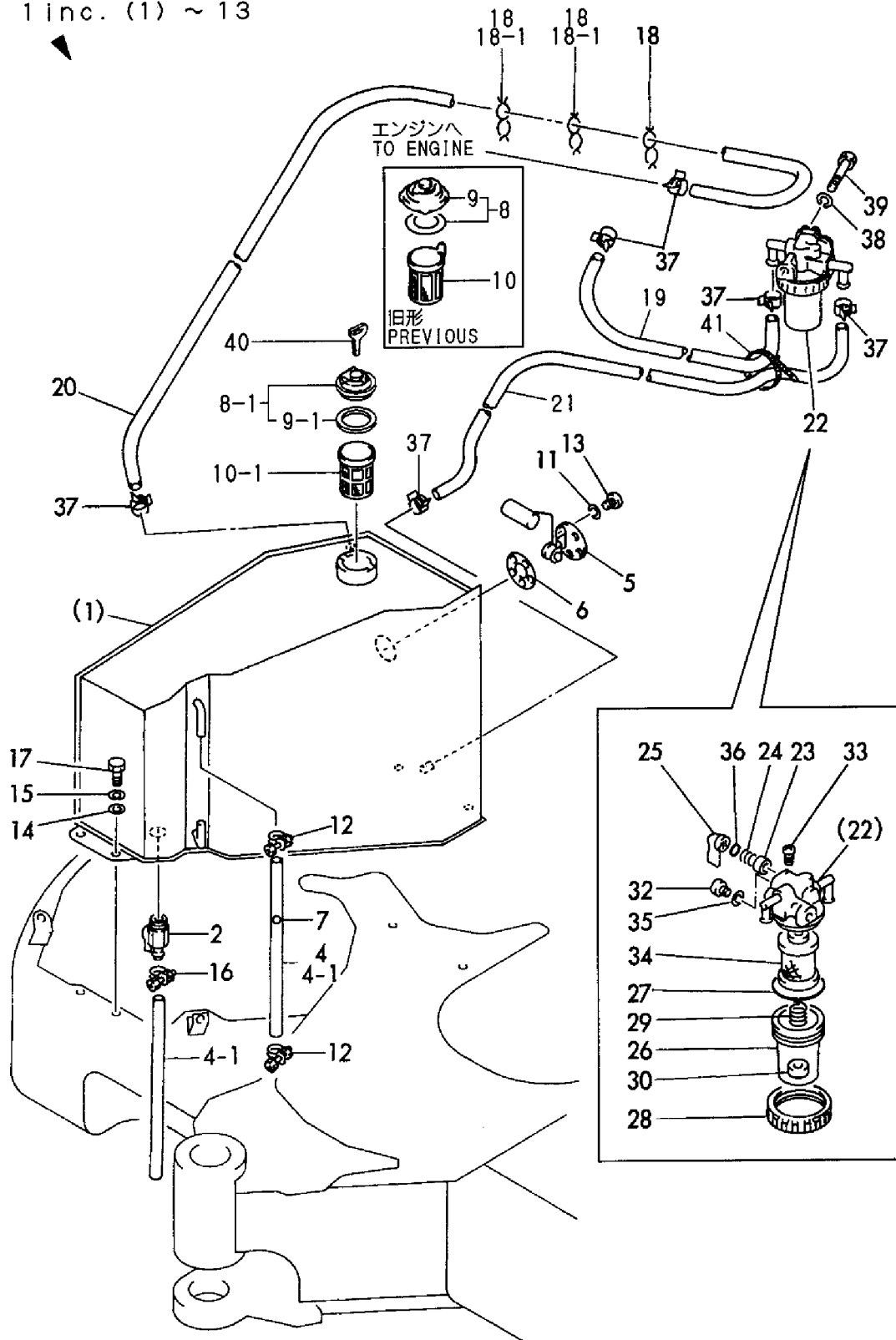

1,1,,172164-16100,, "CORD(+), BATTERY",1,1,,,,,,,,,,,,,
2,1,,172165-16102,, BATTERY,1,1,,,,,,,,,,,,,
3,1,,172164-16110,, "CABLE (-), BATTERY",1,1,,,,,,,,,,,,,
4,1,,124550-77030,, "COVER, TERMINAL",1,1,,,,,,,,,,,,,
5,1,,22137-100000,, "WASHER 10,POLISHED",2,2,,,,,,,,,,,,,
6,1,,22217-080000,, "SPRING WASHER 8",1,1,,,,,,,,,,,,,
7,1,,22217-100000,, "SPRING WASHER 10",2,2,,,,,,,,,,,,,
8,1,,22217-100000,, "SPRING WASHER 10",1,1,,,,,,,,,,,,,
9,1,,26116-100162,, "BOLT M10X 16 PLATED",2,2,,,,,,,,,,,,,
10,1,,26116-100162,, "BOLT M10X 16 PLATED",1,1,,,,,,,,,,,,,
11,1,,26716-080002,, "NUT M 8",1,1,,,,,,,,,,,,,
12,1,,933171-15801,, "WIRE, EARTH",1,1,,,,,,,,,,,,,
13,1,,172164-16340,, ANGLE,1,1,,,,,,,,,,,,,
14,1,,172164-16370,, ROD,2,2,,,,,,,,,,,,,
15,1,,172164-16300,, "MOUNT, BATTERY",1,1,,,,,,,,,,,,,
16,1,,172164-16560,, CLAMP,1,1,,,,,,,,,,,,,
17,1,,22157-080000,, "WASHER 8",2,2,,,,,,,,,,,,,
18,1,,22217-060000,, "SPRING WASHER 6",1,1,,,,,,,,,,,,,
19,1,,26013-100202,, "BOLT W/WASHER M10X20",3,3,,,,,,,,,,,,,
20,1,,26116-060162,, "BOLT 6X16",1,1,,,,,,,,,,,,,
21,1,,26716-080002,, "NUT M 8",4,4,,,,,,,,,,,,,

Fig. 16 バッテリ BATTERY

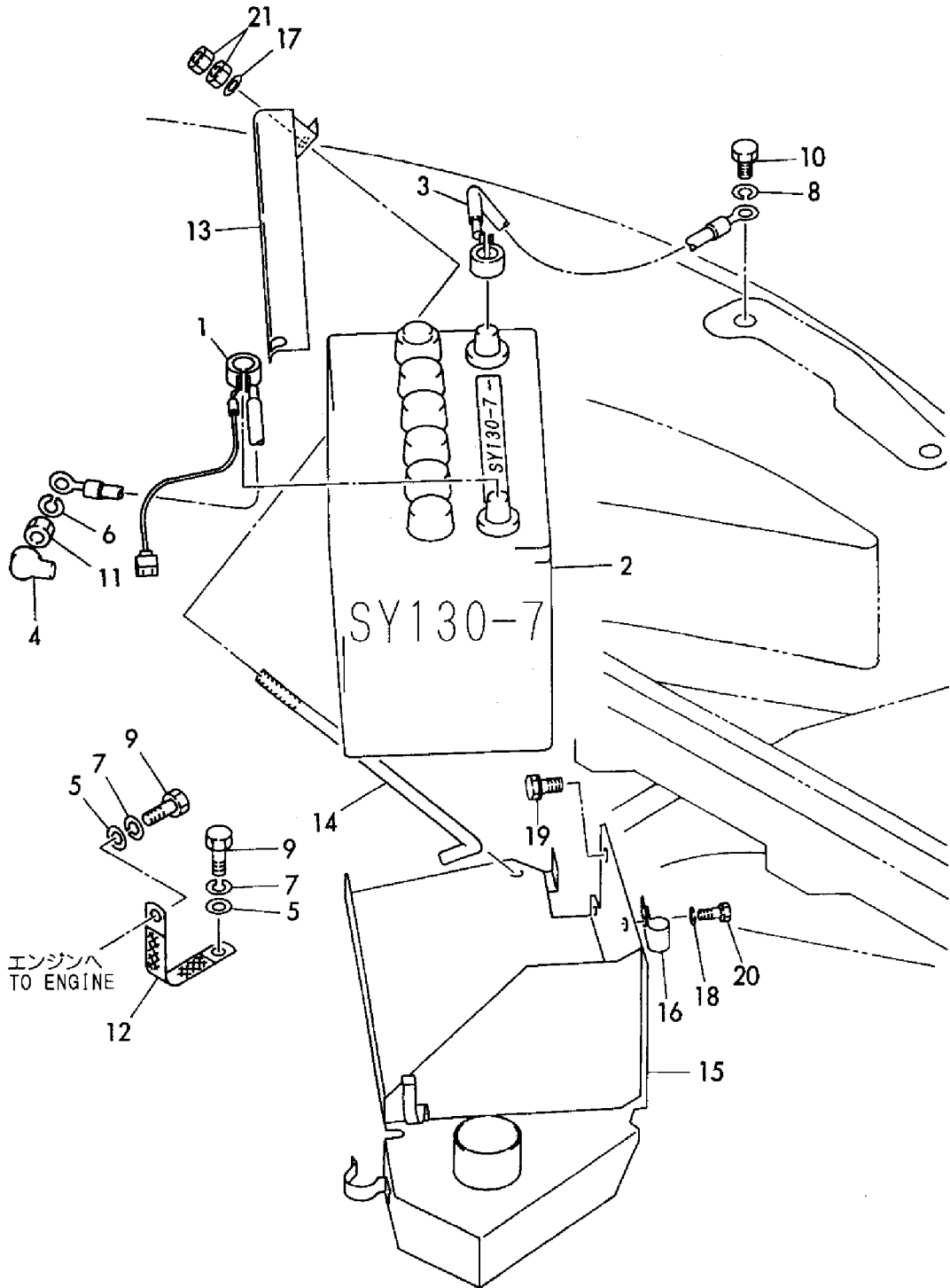

1,1,,172165-16500,, "HARNESS A",1,1,,,,,,,,,,,,,
1-1,1,,172176-16500,, "HARNESS A",1,1,,,,,S,,M/#00832,,M/#00832,,,,,
2,1,,172164-16511,, "HARNESS (B)",1,1,,,,,,,,,,,,,
2-1,1,,172164-16512,, "HARNESS (B)",1,1,,,,,S,1,,M/#00618,,M/#00618,,,,,
2-2,1,,172164-16513,, "HARNESS B",1,1,,,,,S,,M/#00832,,M/#00832,,,,,
2-3,1,,172164-16514,, "HARNESS B",1,1,,,,,F,2,,M/#00965,,M/#00965,,,,,
3,1,,172164-16521,, "HARNESS C",1,1,,,,,,,,,,,,,
3-1,1,,172164-16522,, "HARNESS C",1,1,,,,,F,2,,M/#00965,,M/#00965,,,,,
3-2,1,,172164-16523,, "HARNESS C",1,1,,,,,S,,M/#01014,,M/#01014,,,,,
4,1,,172151-16530,, "WIRE, LEAD",1,1,,,,,,,,,,,,,
4-1,1,,172151-16531,, "WIRE, LEAD",1,1,,,,,S,1,,M/#00618,,M/#00618,,,,,
5,1,,172165-16530,, "HARNESS D",1,1,,,,,,,,,,,,,
6,1,,172126-16540,, "CLAMP 10X70",2,2,,,,,,,,,,,,,
6-1,1,,172126-16540,, "CLAMP 10X70",3,3,,,,,K,,M/#00832,,MXXX,,,,,
7,1,,172137-16560,, "BAND",5,5,,,,,,,,,,,,,
8,1,,172122-16570,, "LINK, FUSIBLE",1,1,,,,,,,,,,,,,
9,1,,194250-51660,, "BAND 250",1,1,,,,,,,,,,,,,
10,1,,1A1380-58050,, "GROMMET 16X20X4.5",1,1,,,,,,,,,,,,,
11,1,,22217-050000,, "SPRING WASHER 5",1,1,,,,,,,,,,,,,
12,1,,22217-100000,, "SPRING WASHER 10",2,2,,,,,,,,,,,,,
13,1,,26116-100162,, "BOLT M10X 16 PLATED",2,2,,,,,,,,,,,,,
14,1,,26716-050002,, "NUT M 5",1,1,,,,,,,,,,,,,
15,1,,933152-09280,, "BAND 170",5,5,,,,,,,,,,,,,
16,1,,172151-17100,, "LAMP, CHECKER",1,1,,,,,,,,,,,,,
17,1,,172162-17101,, "BOX ASSY, INDICATOR",1,1,,,,,,,,,,,,,
18,2,,172162-17120,, "VALVE",4,4,,,,,,,,,,,,,
18A,2,,172162-17130,, "HOURMETER",1,1,,,,,,,,,,,,,
18B,2,,172162-17270,, "COVER, FRONT",1,1,,,,,W,,M/#01121,,M/#01121,,,,,
18C,2,,172162-17240,, "METER ASSY, FUEL",1,1,,,,,W,,M/#01121,,M/#01121,,,,,
18D,2,,172162-17250,, "HARNESS",1,1,,,,,W,,M/#01121,,M/#01121,,,,,
19,1,,172164-17100,, "FUSE BOX",1,1,,,,,,,,,,,,,
19A,2,,172164-17110,, "BOX, FESE",1,1,,,,,,,,,,,,,
20,2,,29420-150000,, "HUSE",7,7,,,,,,,,,,,,,
21,2,,29420-300000,, "FUSE B30",3,3,,,,,,,,,,,,,
22,1,,172164-17120,, "SWITCH",1,1,,,,,,,,,,,,,
22-1,1,,172164-17121,, "SWITCH",1,1,,,,,F,2,,M/#00965,,M/#00965,,,,,
22-2,1,,172164-17121,, "SWITCH",1,1,,,,,Z,,M/#01014,,M/#01014,,,,,
23,2,,172141-17230,, "BULB 24V- 6W",1,1,,,,,Z,,M/#01014,,M/#01014,,,,,
24,1,,172141-17150,, "BUZZER",1,1,,,,,,,,,,,,,
25,1,,172141-17190,, "SWITCH, WORK LAMP",1,1,,,,,,,,,,,,,
26,2,,172141-17230,, "BULB 24V- 6W",1,1,,,,,,,,,,,,,
27,1,,172164-17250,, "BRACKET, RELAY",1,1,,,,,,,,,,,,,
28,1,,172162-17410,, "LAMP ASSY, HEADLIGHT",1,1,,,,,,,,,,,,,
29,2,,29220-788200,, "BULB",1,1,,,,,,,,,,,,,
30,1,,129136-77100,, "RELAY, SAFETY",1,1,,,,,,,,,,,,,
31,1,,119650-77910,, "RELAY, GROW",1,1,,,,,,,,,,,,,
34,1,,119632-77920,, "TIMER",1,1,,,,,,,,,,,,,
34-1,1,,119632-77921,, "TIMER(1 SEC.",1,1,,,,,N,,M/#00870,,M/#00870,,,,,
34-2,1,,119632-77922,, "TIMER",1,1,,,,,N,,M/#01074,,M/#01074,,,,,
35,1,,22137-040000,, "WASHER 4, POLISHED",4,4,,,,,,,,,,,,,
36,1,,22137-060000,, "WASHER 6, POLISHED",1,1,,,,,,,,,,,,,
37,1,,22217-080000,, "SPRING WASHER 8",2,2,,,,,,,,,,,,,
38,1,,22217-080000,, "SPRING WASHER 8",2,2,,,,,,,,,,,,,
39,1,,26013-060122,, "BOLT M 6X 12",2,2,,,,,,,,,,,,,
40,1,,26022-050162,, "SCREW M 5X 16",2,2,,,,,,,,,,,,,
41,1,,26022-060122,, "SCREW M 6X 12",1,1,,,,,,,,,,,,,
42,1,,26022-060122,, "SCREW M 6X 12",2,2,,,,,,,,,,,,,
43,1,,26022-060122,, "SCREW M 6X 12",2,2,,,,,,,,,,,,,
44,1,,26022-060162,, "SCREW M 6X 16",1,1,,,,,,,,,,,,,
45,1,,26022-060202,, "SCREW M 6X 20",2,2,,,,,,,,,,,,,
46,1,,26116-080162,, "BOLT 8X16",2,2,,,,,,,,,,,,,
47,1,,26116-080202,, "BOLT M 8X 20 PLATED",2,2,,,,,,,,,,,,,
48,1,,26589-040202,, "SCREW M4,BINDING",4,4,,,,,,,,,,,,,

49,1,,26716-040002,, "NUT M 4",4,4,,,,,,,,,,,,,
50,1,,933110-00100,, "SWITCH ASSY, STARTER",1,1,,,,,,,,,,,,,
51,2,,933110-00200,, "SWITCH ASSY,STARTER",1,1,,,,,,,,,,,,,
52,2,,933110-00301,, "KEY ASSY",1,1,,,,,,,,,,,,,
53,1,,933110-05300,, HORN,1,1,,,,,,,,,,,,,
54,1,,933113-15900,, "COVER, SWITCH TERMI.",1,1,,,,,,,,,,,,,
55,1,,194464-52190,, "SWITCH, SAFETY START",1,1,,,,,,,,,,,,,
55-1,1,,194464-52190,, "SWITCH, SAFETY
START",2,2,,,,,K,,,M/#00832,,M/#00832,,,,,
55-2,1,,194464-52190,, "SWITCH, SAFETY
START",1,1,,,,,K,,,M/#00965,,M/#00965,,,,,
56,1,,22137-180000,, "WASHER 18",1,1,,,,,Z,,,M/#00832,,M/#00832,,,,,
57,1,,26776-180002,, "NUT M18,LOCK",1,1,,,,,,,,,,,,,
57-1,1,,26776-180002,, "NUT M18,LOCK",2,2,,,,,K,,,M/#00832,,M/#00832,,,,,
57-2,1,,26776-180002,, "NUT M18,LOCK",1,1,,,,,K,,,M/#00965,,M/#00965,,,,,
58,1,,172164-17140,, SWITCH,1,1,,,,,W,2,,M/#00965,,M/#00965,,,,,
58-1,1,,172164-17140,, SWITCH,,2,,,,,K,,,,,M/#01014,,,,,
59,1,,26776-160002,, "LOCK NUT M16 PLATED",1,1,,,,,W,2,,M/#00965,,M/#00965,,,,,
59-1,1,,26776-160002,, "LOCK NUT M16 PLATED",,2,,,,,K,,,,,M/#01014,,,,,
60,1,,172190-16500,, HARNESS,1,,,,,W,,,M/#01014,,,,,

Fig. 17 電装品 (キャビン、キャノピ)
ELECTRIC PART (CABIN, CANOPY)

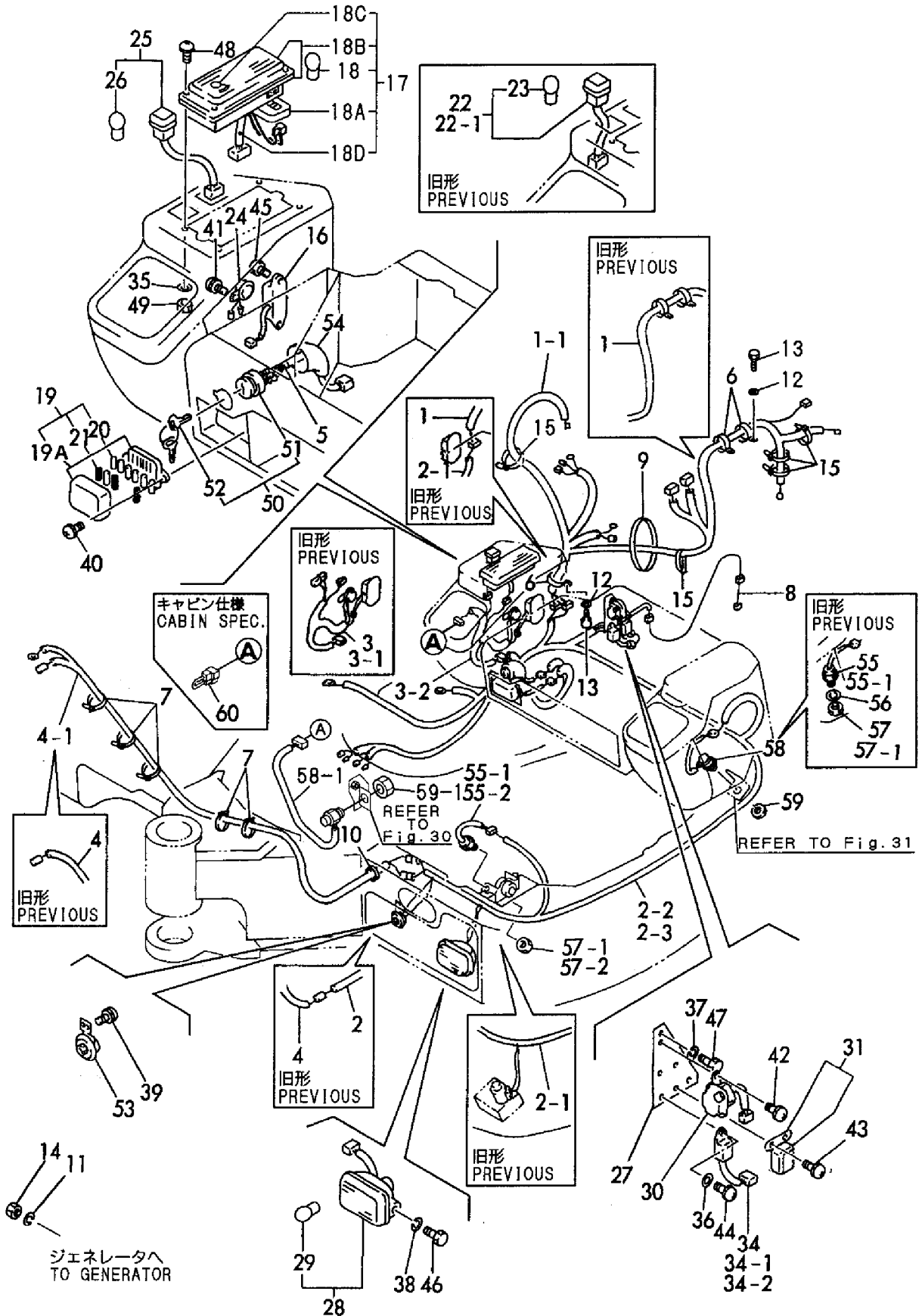

1,1,,172176-16500,, "HARNESS A",1,1,,,,,,,,,,,,,,,,,,,,,
2,1,,172164-16514,, "HARNESS B",1,1,,,,,,,,,,,,,,,,,,,,,
3,1,,172164-16523,, "HARNESS C",1,1,,,,,,,,,,,,,,,,,,,,,
4,1,,172151-16531,, "WIRE, LEAD",1,1,,,,,,,,,,,,,,,,,,,,,
5,1,,172165-16530,, "HARNESS D",1,1,,,,,,,,,,,,,,,,,,,,,
6,1,,172126-16540,, "CLAMP 10X70",3,3,,,,,,,,,,,,,,,,,,,,,
7,1,,172137-16560,, BAND,5,5,,,,,,,,,,,,,,,,,,,,,
8,1,,172122-16570,, "LINK, FUSIBLE",1,1,,,,,,,,,,,,,,,,,,,,,
9,1,,194250-51660,, "BAND 250",1,1,,,,,,,,,,,,,,,,,,,,,
10,1,,1A1380-58050,, "GROMMET 16X20X4.5",1,1,,,,,,,,,,,,,,,,,,,,,
11,1,,22217-050000,, "SPRING WASHER 5",1,1,,,,,,,,,,,,,,,,,,,,,
12,1,,22217-100000,, "SPRING WASHER 10",2,2,,,,,,,,,,,,,,,,,,,,,
13,1,,26116-100162,, "BOLT M10X 16 PLATED",2,2,,,,,,,,,,,,,,,,,,,,,
14,1,,26716-050002,, "NUT M 5",1,1,,,,,,,,,,,,,,,,,,,,,
15,1,,933152-09280,, "BAND 170",5,5,,,,,,,,,,,,,,,,,,,,,
16,1,,172190-16500,, HARNESS,1,,,,,,,,,,,,,,,,,,,,,
17,1,,172164-17140,, SWITCH,1,2,,,,,,,,,,,,,,,,,,,,,
18,1,,194464-52190,, "SWITCH, SAFETY START",1,1,,,,,,,,,,,,,,,,,,,,,
19,1,,26776-160002,, "LOCK NUT M16 PLATED",1,2,,,,,,,,,,,,,,,,,,,,,
20,1,,26776-180002,, "NUT M18,LOCK",1,1,,,,,,,,,,,,,,,,,,,,,
21,1,,172151-17100,, "LAMP, CHECKER",1,1,,,,,,,,,,,,,,,,,,,,,
22,1,,172164-17100,, "FUSE BOX",1,1,,,,,,,,,,,,,,,,,,,,,
23,2,,172164-17110,, "BOX, FESE",1,1,,,,,,,,,,,,,,,,,,,,,
24,2,,29420-150000,, HUSE,7,7,,,,,,,,,,,,,,,,,,,,,
25,2,,29420-300000,, "FUSE B30",3,3,,,,,,,,,,,,,,,,,,,,,
26,1,,172141-17150,, BUZZER,1,1,,,,,,,,,,,,,,,,,,,,,
27,1,,172141-17190,, "SWITCH, WORK LAMP",1,1,,,,,,,,,,,,,,,,,,,,,
28,2,,172141-17230,, "BULB 24V- 6W",1,1,,,,,,,,,,,,,,,,,,,,,
29,1,,172162-17410,, "LAMP ASSY, HEADLIGHT",1,1,,,,,,,,,,,,,,,,,,,,,
30,2,,29220-788200,, BULB,1,1,,,,,,,,,,,,,,,,,,,,,
31,1,,129136-77100,, "RELAY, SAFETY",1,1,,,,,,,,,,,,,,,,,,,,,
32,1,,119650-77910,, "RELAY, GROW",1,1,,,,,,,,,,,,,,,,,,,,,
33,1,,119632-77922,, TIMER,1,1,,,,,,,,,,,,,,,,,,,,,
34,1,,22137-060000,, "WASHER 6, POLISHED",1,1,,,,,,,,,,,,,,,,,,,,,
35,1,,22217-080000,, "SPRING WASHER 8",2,2,,,,,,,,,,,,,,,,,,,,,
36,1,,22217-080000,, "SPRING WASHER 8",2,2,,,,,,,,,,,,,,,,,,,,,
37,1,,26013-060122,, "BOLT M 6X 12",2,2,,,,,,,,,,,,,,,,,,,,,
38,1,,26022-050162,, "SCREW M 5X 16",2,2,,,,,,,,,,,,,,,,,,,,,
39,1,,26022-060122,, "SCREW M 6X 12",1,1,,,,,,,,,,,,,,,,,,,,,
40,1,,26022-060122,, "SCREW M 6X 12",2,2,,,,,,,,,,,,,,,,,,,,,
41,1,,26022-060122,, "SCREW M 6X 12",2,2,,,,,,,,,,,,,,,,,,,,,
42,1,,26022-060162,, "SCREW M 6X 16",1,1,,,,,,,,,,,,,,,,,,,,,
43,1,,26022-060202,, "SCREW M 6X 20",2,2,,,,,,,,,,,,,,,,,,,,,
44,1,,26116-080162,, "BOLT 8X16",2,2,,,,,,,,,,,,,,,,,,,,,
45,1,,26116-080202,, "BOLT M 8X 20 PLATED",2,2,,,,,,,,,,,,,,,,,,,,,
46,1,,933110-00100,, "SWITCH ASSY, STARTER",1,1,,,,,,,,,,,,,,,,,,,,,
47,2,,933110-00200,, "SWITCH ASSY,STARTER",1,1,,,,,,,,,,,,,,,,,,,,,
48,2,,933110-00301,, "KEY ASSY",1,1,,,,,,,,,,,,,,,,,,,,,
49,1,,933110-05300,, HORN,1,1,,,,,,,,,,,,,,,,,,,,,
50,1,,933113-15900,, "COVER, SWITCH TERMI.",1,1,,,,,,,,,,,,,,,,,,,,,
51,1,,172164-16650,, "HARNESS (DECEL",1,1,,,,,,,,,,,,,,,,,,,,,
52,1,,933152-09280,, "BAND 170",9,9,,,,,,,,,,,,,,,,,,,,,
53,1,,172176-17100,, "BOX, INDICATOR",1,1,,,,,,,,,,,,,,,,,,,,,
54,2,,172162-17120,, VALVE,5,5,,,,,,,,,,,,,,,,,,,,,
55,2,,172176-17120,, "METER, FUEL",1,1,,,,,,,,,,,,,,,,,,,,,
56,2,,172162-17130,, HOURMETER,1,1,,,,,,,,,,,,,,,,,,,,,
57,2,,172176-17130,, HARNESS,1,1,,,,,,,,,,,,,,,,,,,,,
58,2,,172162-17250,, HARNESS,1,1,,,,,,,,,,,,,,,,,,,,,
59,2,,172162-17270,, "COVER, FRONT",1,1,,,,,,,,,,,,,,,,,,,,,
60,1,,172162-17180,, SOLENOID,1,1,,,,,,,,,,,,,,,,,,,,,
61,1,,172190-17220,, "RELEY, TIMER",1,1,,,,,,,,,,,,,,,,,,,,,
62,1,,172164-17270,, "BRACKET, TIMER",1,1,,,,,,,,,,,,,,,,,,,,,
63,1,,22137-040000,, "WASHER 4, POLISHED",4,4,,,,,,,,,,,,,,,,,,,,,

64,1,,26013-060162,, "BOLT M 6X 16",2,2,,,,,,,,,,,,,,,,,,,,,
65,1,,26022-060252,, "SCREW M 6X 25",2,2,,,,,,,,,,,,,,,,,,,,,
66,1,,26589-040202,, "SCREW M4,BINDING",4,4,,,,,,,,,,,,,,,,,,,,,
67,1,,26716-040002,, "NUT M 4",4,4,,,,,,,,,,,,,,,,,,,,,

Fig. 18 電装品 (キャビン、キャノピ/ワンタッチデセル)
 ELECTRIC PART (CABIN, CANOPY / ONE TOUCH DECEL)

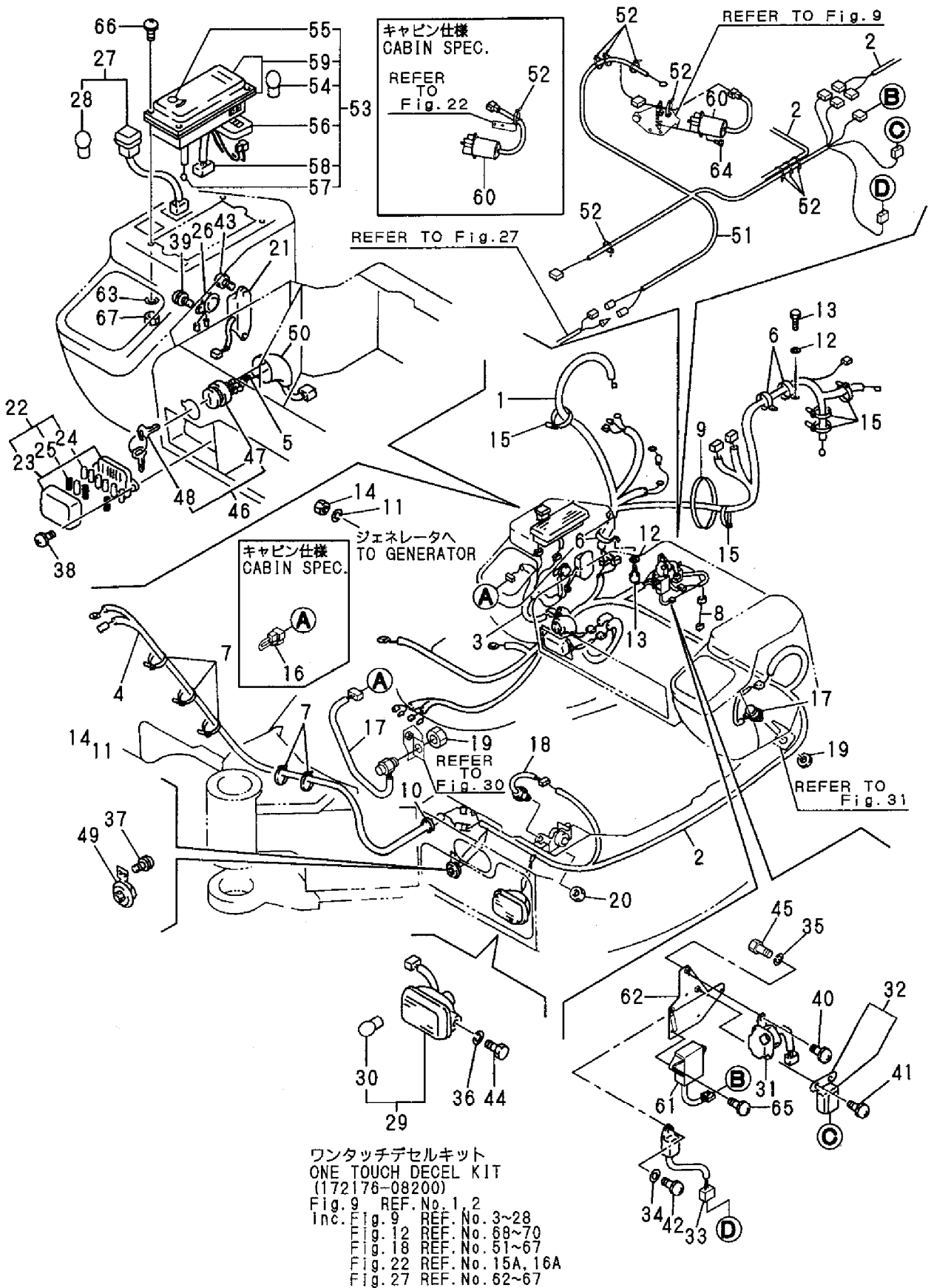

1,1,,172164-16600,, "HARNES F",1,,,,,,,,,,,,,
1-1,1,,172164-16601,, "HARNES F",1,,,,,N,,,M/#01245,,,,,
2,1,,22857-400100,, "SCREW 4X10",2,,,,,,,,,,,,,
3,1,,933113-05150,, "LAMP, ROOM",1,,,,,,,,,,,,,
4,2,,933113-05160,, "BULB (12V5W)",1,,,,,,,,,,,,,
5,1,,933113-15000,, "CIGAR LIGHTER ASSY",1,,,,,,,,,,,,,
6,1,,172176-17150,, "ASHTRAY",1,,,,,,,,,,,,,
7,1,,172164-17200,, "MOTOR, WIPER",1,,,,,,,,,,,,,
8,1,,172164-17210,, "ARM, WIPER",1,,,,,,,,,,,,,
9,1,,172162-17320,, "BLADE 400,WIPER",1,,,,,,,,,,,,,
10,1,,172162-17330,, "SWITCH,WIPER",1,,,,,,,,,,,,,
11,1,,26013-060122,, "BOLT M 6X 12",3,,,,,,,,,,,,,
12,1,,26022-050202,, "SCREW M 5X 20",1,,,,,,,,,,,,,
13,1,,172164-16610,, "HARNES M",1,,,,,,,,,,,,,
13-1,1,,172164-16611,, "HARNES M, WIRE",1,,,,,N,,,M/#00960,,,,,
14,1,,119247-77100,, "RELAY, SAFETY",1,,,,,W,,,M/#00960,,,,,
15,1,,26022-060122,, "SCREW M 6X 12",1,,,,,W,,,M/#00960,,,,,
16,1,,22137-060000,, "WASHER 6, POLISHED",1,,,,,W,,,M/#00960,,,,,
17,1,,172176-17160,, "BEZEL",1,,,,,W,1,,M/#01106,,,,,
18,1,,172187-17450,, "BRAKER",1,,,,,W,,,M/#01245,,,,,

Fig. 19 電装品 (キャビン)
ELECTRIC PART (CABIN)

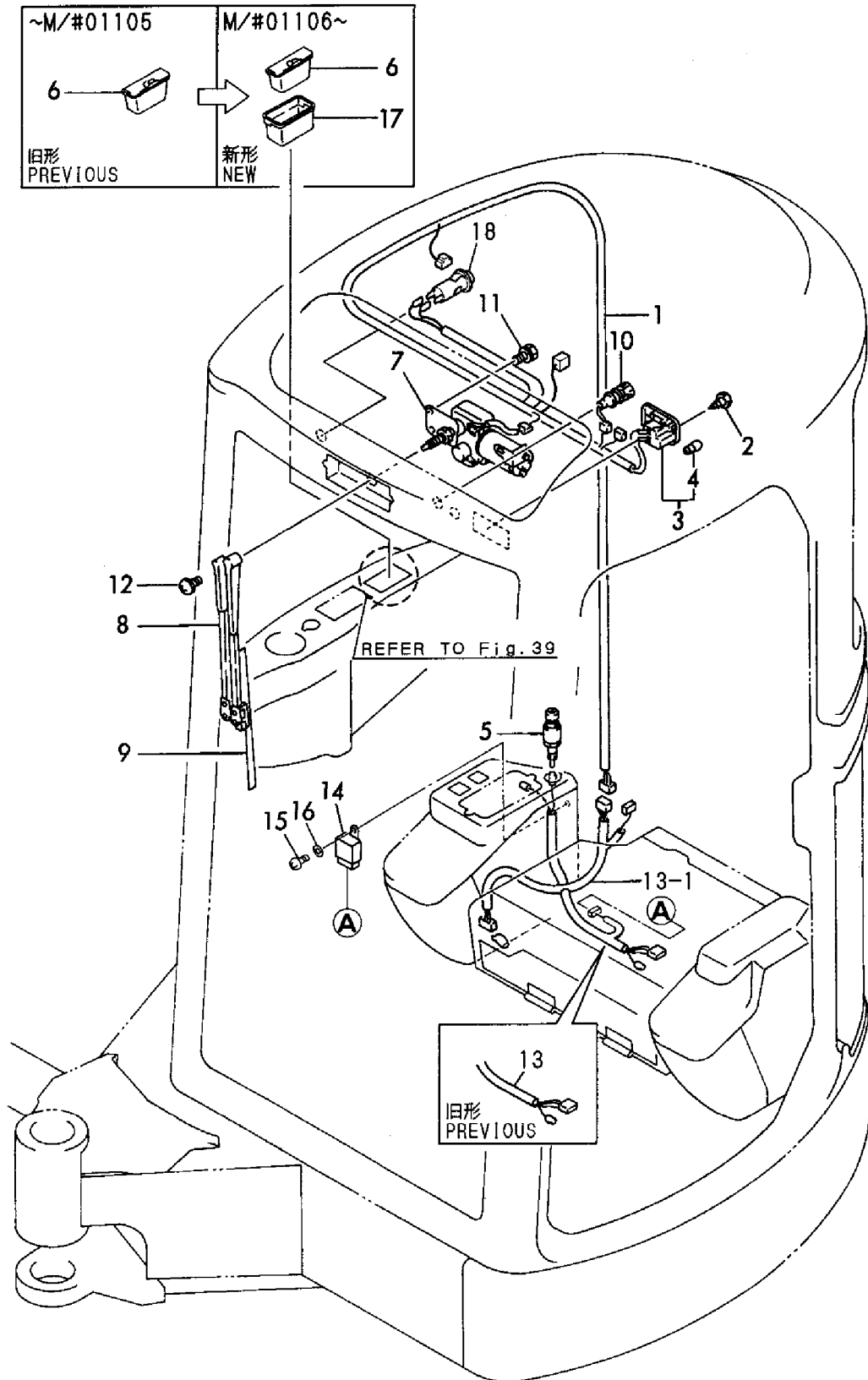

1,2,,172126-11510,, "BAND 300",1,,,,,,,,,,,,,,,,,,,,,
2,2,,172122-16590,, "BAND 200F",2,,,,,,,,,,,,,,,,,,,,,
3,2,,172164-16700,, "HARNESS, WIRE",1,,,,,,,,,,,,,,,,,,,,,
3-1,2,,172164-16701,, "HARNESS, WIRE",1,,,,,,,,,N,,,M/#00960,,,,,,,,,,,,,
3-2,2,,172164-16702,, "HARNESS,WIRE(COOL A",1,,,,,,F,1,,M/#01358,,,,,,,,,,,,,
4,2,,172164-16710,, "HARNESS, WIRE",1,,,,,,,,,,,,,,,,,,,,,
5,2,,119247-77100,, "RELAY, SAFETY",5,,,,,,,,,,,,,,,,,,,,,
6,2,,22137-060000,, "WASHER 6, POLISHED",5,,,,,,,,,,,,,,,,,,,,,
7,2,,22857-400120,, "SCREW 4X12",2,,,,,,,,,,,,,,,,,,,,,
8,2,,26022-060122,, "SCREW M 6X 12",5,,,,,,,,,,,,,,,,,,,,,
9,2,,933168-55770,, "BAND 146",2,,,,,,W,,, "FROM 1ST",,,,,,,,,,,,,,
10,2,,172164-16750,, "HARNESS,WIRE(COOL C",1,,,,,,W,,,M/#01358,,,,,,,,,,,,,
11,2,,172164-16770,, "BRACKET",1,,,,,,W,,,M/#01358,,,,,,,,,,,,,

Fig. 20 電装品 (クーラー仕様) ELECTRIC PART (COOLER SPEC.)

クーラーキット
COOLER KIT
(172176-08100)

Fig. 11 REF. No. 1
1 inc.

Fig. 11	REF. No. 2~34
Fig. 12	REF. No. 1~10
Fig. 13	REF. No. 1~62
Fig. 14	REF. No. 1~49
Fig. 20	REF. No. 1~11
Fig. 34	REF. No. 1, 2
Fig. 36	REF. No. 1
Fig. 37	REF. No. 1~5
Fig. 38	REF. No. 1~5
Fig. 39	REF. No. 18B, 23, 24, 53~55
Fig. 41	REF. No. 16B, 22B, 23B, 34

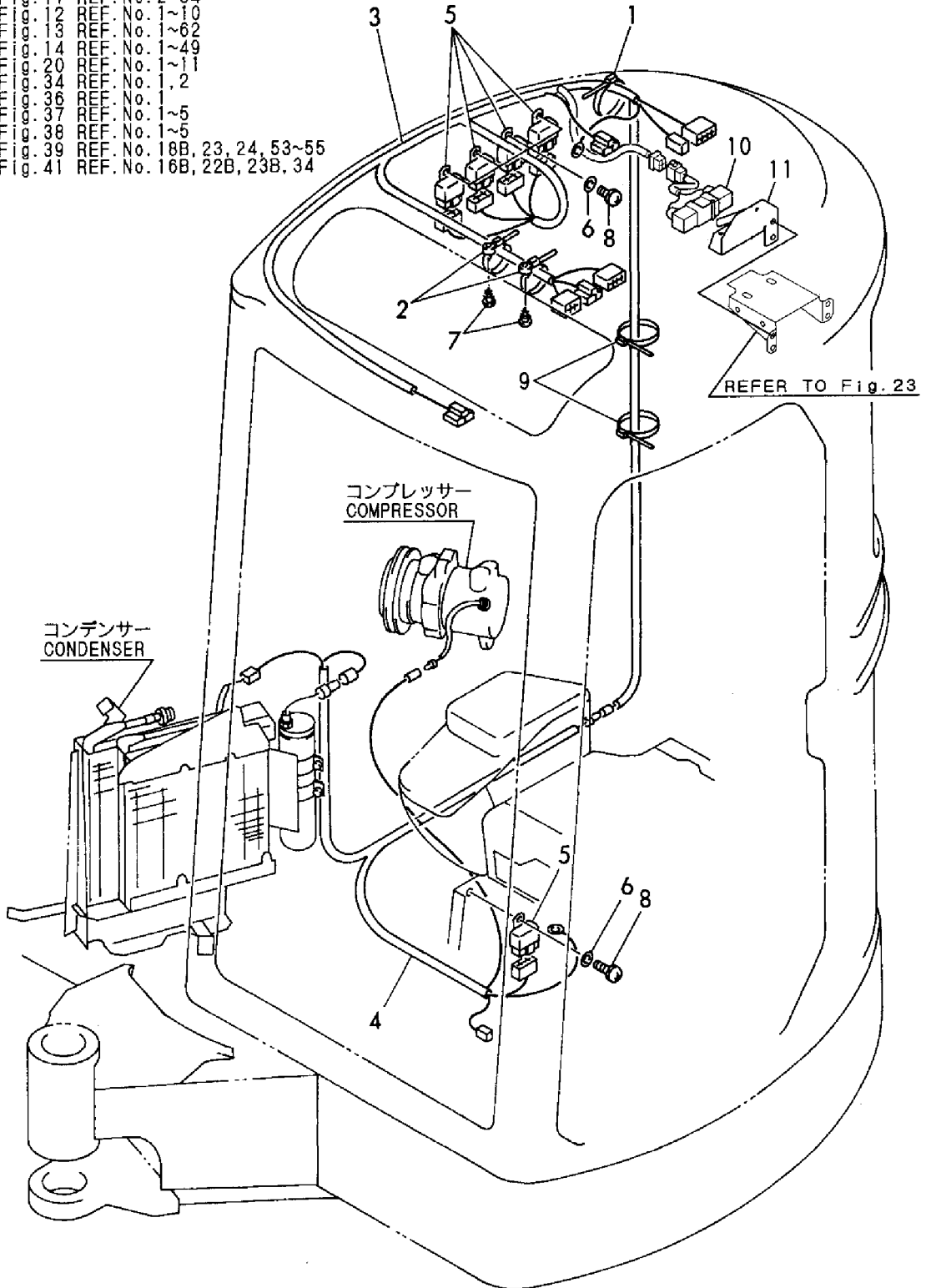

1,1,,172141-17201,, "LAMP, WORK",1,1,,,,,,,,,,,,,,,,,
2,2,,172141-17211,, "BULB 12V55W",1,1,,,,,,,,,,,,,,,,,
3,1,,172137-17401-4,, "COVER, WORK LAMP",1,1,,,,,,,,,,,,,,,,,
4,1,,26013-120302,, "BOLT W/WASHER M12X30",1,1,,,,,,,,,,,,,,,,,
4-1,1,,26013-120252,, "BOLT M12X 25",1,1,,,,,R,,,M/#01074,,M/#01074,,,,,
5,1,,933152-03700,, "WASHER, SIDE CLUTCH",1,1,,,,,,,,,,,,,,,,,
6,1,,22137-130000,, "WASHER 13",2,2,,,,,W,1,,M/#00618,,M/#00618,,,,,

Fig. **21** ワークランプ
WORK LAMP

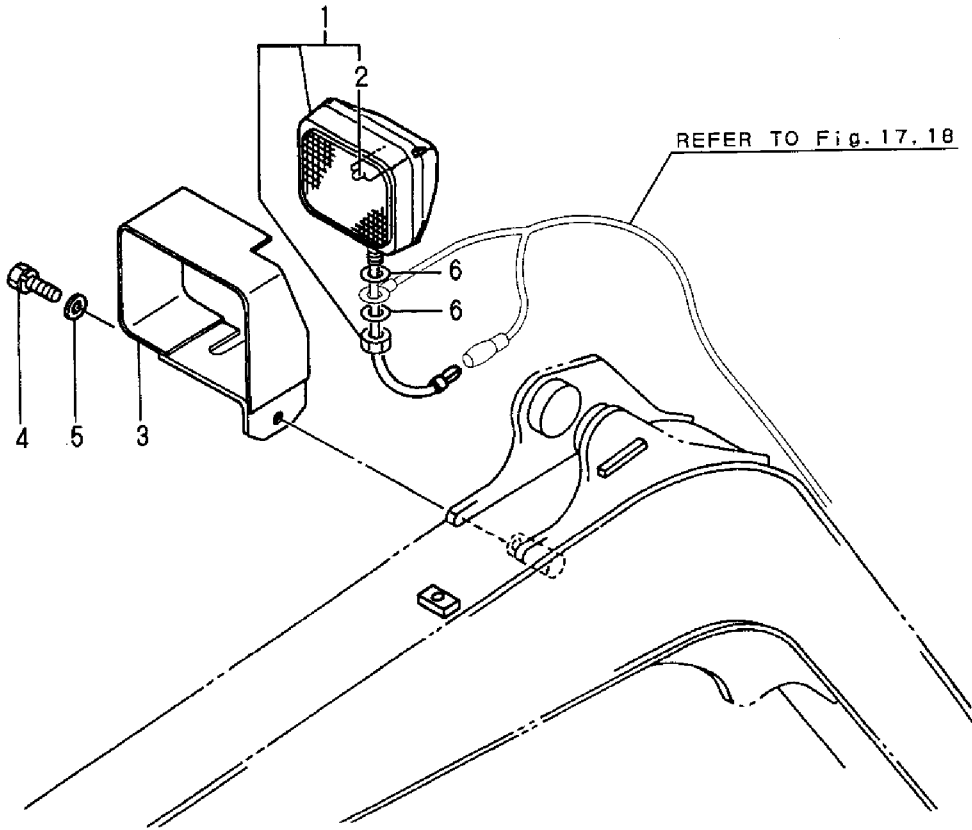

1,1,,772164-17600,, "HEATER ASSY.",1,1,,,,,1,,,,,
1A,1,,772164-17610,, "HEATER ASSY, OD",1,1,,,,,2,,,,,
2,2,,172312-17600,, HEATER,1,1,,,,,
3,2,,172162-17610,, "SWITCH,HEATER",1,1,,,,,
4,2,,172164-17610,, "HOSE, HEATER",2,2,,,,,
5,3,,172164-17630,, "HOSE, HEATER",2,2,,,,,
6,3,,172164-17620,, TUBE,2,2,,,,,
7,2,,172124-17630,, "VALVE, MINIATURE",1,1,,,,,
8,2,,172124-17640,, "JOINT 3/8",2,2,,,,,
9,2,,172732-76161,, ELBOW,1,1,,,,,
9-1,2,,23392-030000,, JOINT,1,1,,,,,F,3,,M/#01220,,M/#01220,,,,,
9A,2,,172168-79520,, ELBOW,1,1,,,,,W,,M/#01104,,M/#01104,,,,,
9B,2,,172135-76100,, "ELBOW 3/8",1,1,,,,,W,3,,M/#01220,,M/#01220,,,,,
10,2,,22137-100000,, "WASHER 10,POLISHED",4,4,,,,,
11,2,,23000-022000,, "CLAMP 22",4,4,,,,,
12,2,,26013-100202,, "BOLT W/WASHER M10X20",4,4,,,,,
13,2,,933152-09280,, "BAND 170",3,3,,,,,
14,2,,933171-15680,, "GROMMET 40X13",2,2,,,,,
15,2,,172165-18770,, "GUIDE, HOSE",1,1,,,,,
15A,2,,172164-17670,, "GUIDE, HOSE",1,1,,,,,2,,,,,
16,2,,26013-080252,, "BOLT M 8X 25",2,2,,,,,
16A,2,,26013-080122,, "BOLT M 8X 12",2,2,,,,,2,,,,,
17,1,,772164-17700,, "DEFROSTER ASSY",1,,,,,
17-1,1,,772164-17701,, "DEFROSTER ASSY",1,,,,,N,,M/#00643,,,,,
18,2,,172122-16590,, "BAND 200F",2,,,,,Z,,M/#00643,,,,,
19,2,,172164-17640,, HOSE,1,,,,,
20,2,,172164-17700,, BRACKET,1,,,,,
20-1,2,,172164-17701,, BRACKET(DEFROSTER,1,,,,,N,,M/#00643,,,,,
21,2,,172120-17710,, "NOZZLE, DEFROSTER",1,,,,,
22,2,,172122-17730,, "COVER, DEFROSTER",1,,,,,
23,2,,172164-61560,, COVER,1,,,,,
24,2,,22857-400120,, "SCREW 4X12",2,,,,,Z,,M/#00643,,,,,
25,2,,26013-080202,, "BOLT W/WASHER M8X20",2,,,,,
26,2,,26557-050102,, "SCREW M 5X 10",2,,,,,
27,2,,172158-78250,, "CLAMP 45",1,,,,,W,,M/#00643,,,,,
28,2,,22137-100000,, "WASHER 10,POLISHED",1,,,,,W,,M/#00586,,,,,
29,2,,26013-100202,, "BOLT W/WASHER M10X20",1,,,,,W,,M/#00643,,,,,

Fig. 22 ヒータ&デフロスタ (オプション) HEATER & DEFROSTER (OPTIONAL)

見出しNo. 1Aは、見出しNo. 2から16Aを含みます。
1A inc. 2 ~ 16A

ワンタッチデセル仕様
ONE TOUCH DECEL SPEC.

ワンタッチデセルキット
ONE TOUCH DECEL KIT
(172176-08200)

Fig. 9 REF. No. 1, 2
inc. Fig. 9 REF. No. 3 ~ 28
Fig. 12 REF. No. 68~70
Fig. 18 REF. No. 61~67
Fig. 22 REF. No. 15A, 16A
Fig. 27 REF. No. 62~67

見出しNo. 1は、見出しNo. 2から16を含みます。
1 inc. 2 ~ 16

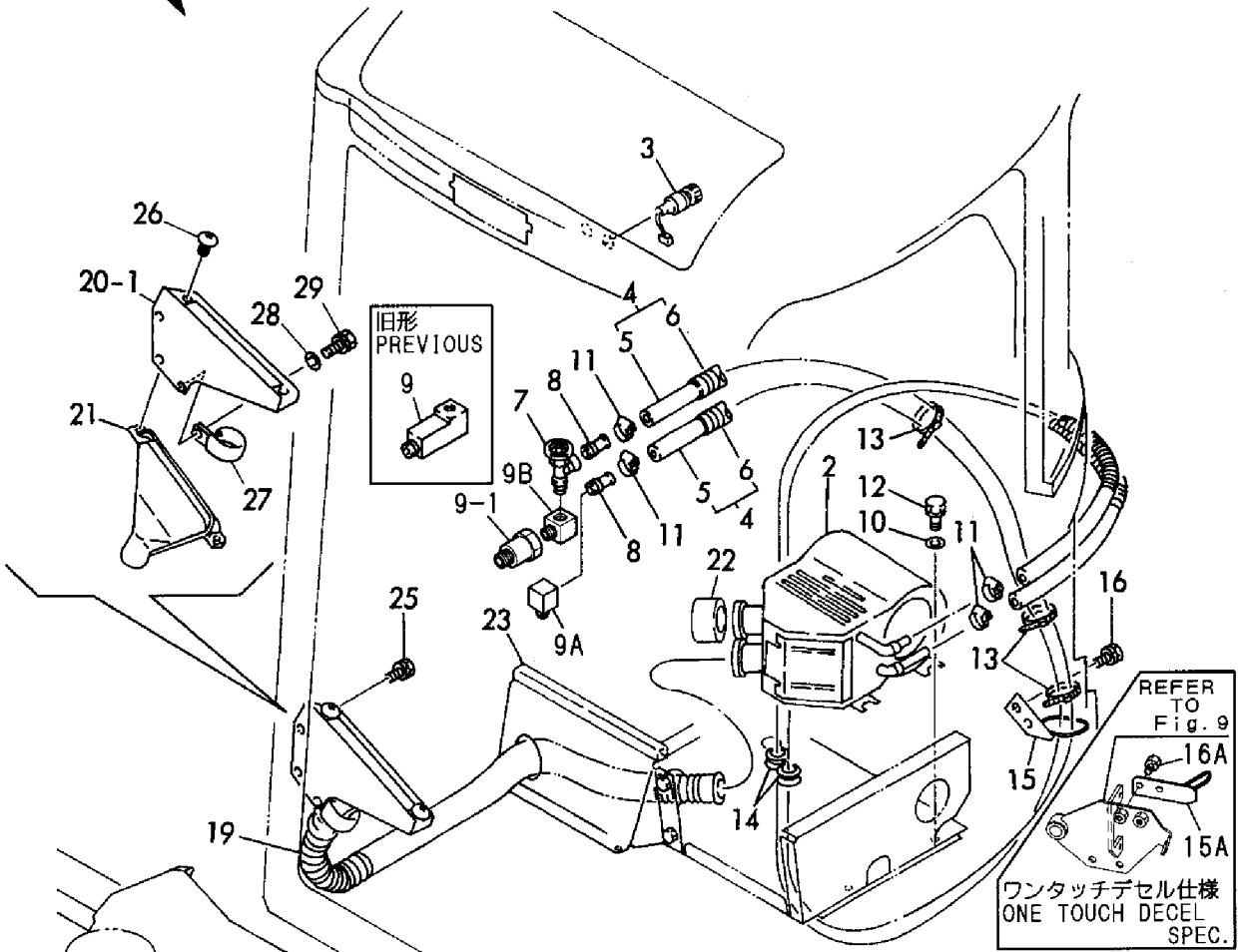

見出しNo. 17-1は、
見出しNo. 19から
29を含みます。
17-1 inc. 19 ~ 29

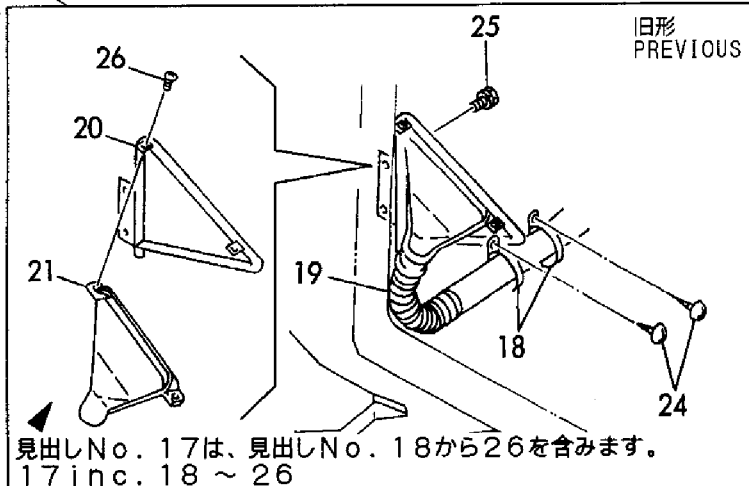

1,1,,772176-17800,, "RADIO W/CASSETTE",1,,,,,,,,,,,,,
2,2,,172112-17190,, "ANTENNA (NCP-314)",1,,,,,,,,,,,,,
3,2,,172176-17800,, "RADIO W/CASSETTE",1,,,,,,,,,,,,,
3-1,2,,172176-17801,, "RADIO CASSETTE",1,,,,,F,1,,M/#01063,,,,,
3-2,2,,172176-17802,, "RADIO CASSETTE",1,,,,,F,2,,M/#01505,,,,,
4,2,,172176-17810,, "HARNESS, RADIO",1,,,,,,,,,,,,,
4-1,2,,172176-17811,, "HARNESS, RADIO",1,,,,,S,,M/#01063,,,,,
5,2,,172176-17820,,SPEAKER,2,,,,,,,,,,,,,
5-1,2,,172176-17821,,SPEAKER,2,,,,,N,,M/#01063,,,,,
6,2,,172176-17830,, "STAY A, SPEAKER",2,,,,,,,,,,,,,
7,2,,26013-080252,, "BOLT M 8X 25",8,,,,,,,,,,,,,
8,2,,172176-17850,, "STAY B, SPEAKER",2,,,,,,,,,,,,,
9,2,,172176-17870,,MOUNT,2,,,,,,,,,,,,,
10,2,,197821-89270,, "COVER,SPEAKER",2,,,,,,,,,,,,,
11,2,,22117-060000,, "WASHER 6",8,,,,,,,,,,,,,
12,2,,26013-080162,, "BOLT W/WASHER M8X16",8,,,,,,,,,,,,,
13,2,,26557-040102,, "SCREW M 4X 10",8,,,,,,,,,,,,,
14,2,,26557-040102,, "SCREW M 4X 10",2,,,,,,,,,,,,,
14-1,2,,26557-040202,, "SCREW M 4X 20",2,,,,,N,,M/#00767,,,,,
15,2,,26557-050102,, "SCREW M 5X 10",4,,,,,,,,,,,,,
16,2,,26589-060162,, "SCREW M6,BINDING",8,,,,,,,,,,,,,
17,2,,26716-040002,, "NUT M 4",2,,,,,,,,,,,,,
18,2,,26716-060002,, "NUT 6",8,,,,,,,,,,,,,
19,2,,172176-17890,, "CORD,ANTENNA",1,,,,,W,,M/#01063,,,,,
19-1,2,,172176-17891,, "CORD,ANTENNA",1,,,,,S,,M/#01505,,,,,

Fig. 23 ラジオカセット (オプション) RADIO CASSETTE (OPTIONAL)

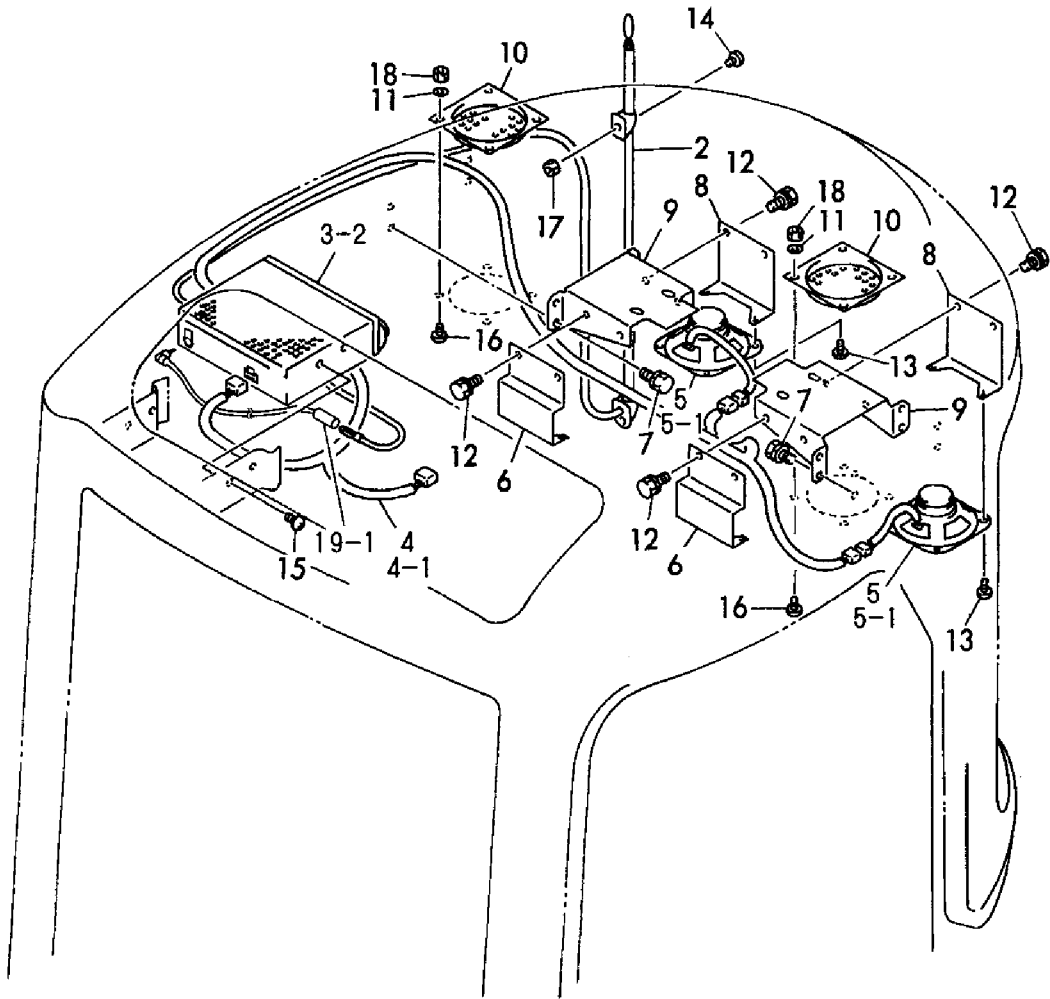
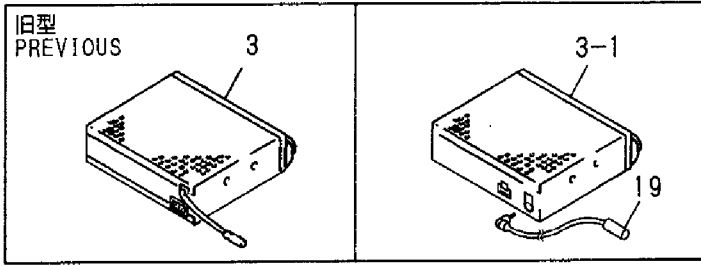

▲
見出しNo. 1は、見出しNo. 2から19を含みます。
1 inc. 2 ~ 19

1,1,,172112-17190,, "ANTENNA (NCP-314)",1,,,,,,,,,,,,,
2,1,,172176-17811,, "HARNESS, RADIO",1,,,,,,,,,,,,,
3,1,,172176-17821,, "SPEAKER",2,,,,,,,,,,,,,
4,1,,172176-17830,, "STAY A, SPEAKER",2,,,,,,,,,,,,,
5,2,,26013-080252,, "BOLT M 8X 25",8,,,,,,,,,,,,,
6,1,,172176-17850,, "STAY B, SPEAKER",2,,,,,,,,,,,,,
7,1,,172176-17870,, "MOUNT",2,,,,,,,,,,,,,
8,1,,197821-89270,, "COVER, SPEAKER",2,,,,,,,,,,,,,
9,1,,22117-060000,, "WASHER 6",8,,,,,,,,,,,,,
10,1,,26013-080162,, "BOLT W/WASHER M8X16",8,,,,,,,,,,,,,
11,1,,26557-040102,, "SCREW M 4X 10",8,,,,,,,,,,,,,
12,1,,26557-040202,, "SCREW M 4X 20",2,,,,,,,,,,,,,
13,1,,26589-060162,, "SCREW M6, BINDING",8,,,,,,,,,,,,,
14,1,,26716-040002,, "NUT M 4",2,,,,,,,,,,,,,
15,1,,26716-060002,, "NUT 6",8,,,,,,,,,,,,,
16,1,,172176-17890,, "CORD, ANTENNA",1,,,,,,,,,,,,,

Fig. **24** ラジオカセット (EP)
RADIO CASSETTE (EP)

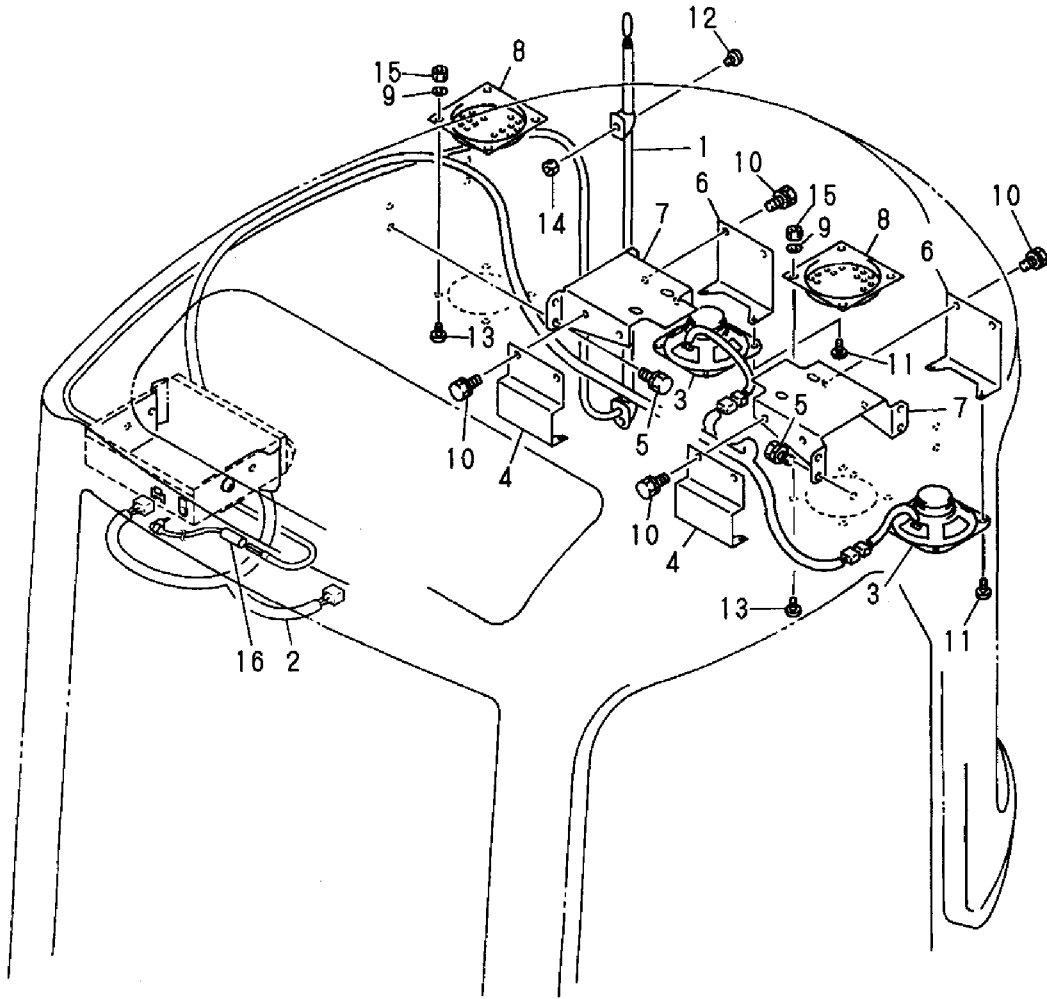

1,1,,172119-35010,,SPROCKET,2,2,,,,,,,,,,,,,
2,1,,22217-140000,,,"SPRING WASHER 14",18,18,,,,,,,,,,,,,
3,1,,26116-140352,,,"BOLT M14X 35 PLATED",18,18,,,,,,,,,,,,,
4,1,,772147-37300,,,"ROLLER ASSY,TRACK",8,8,,,,,,,,,,,,,
5,2,,172147-37300,,ROLLER,8,8,,,,,,,,,,,,,
6,3,,172124-37310,,,"BUSH, ROLLER",16,16,,,,,,,,,,,,,
8,2,,172147-37320,,,"SHAFT, ROLLER",8,8,,,,,,,,,,,,,
11,2,,172147-37340,,,"COVER, SEAL",8,8,,,,,,,,,,,,,
12,2,,22242-000300,,,"CIRCLIP 30",8,8,,,,,,,,,,,,,
13,2,,24321-000350,,,"O-RING 1A G-35.0",8,8,,,,,,,,,,,,,
14,2,,933112-00400,,,"SEAL 64 78 25",16,16,,,,,,,,,,,,,
15,2,,933171-13691,,,"PLUG PT1/8",8,8,,,,,,,,,,,,,
16,1,,172113-36050,,,"BOLT, ROLLER ADJUST",6,6,,,,,,,,,,,,,
17,1,,172113-36050,,,"BOLT, ROLLER ADJUST",8,8,,,,,,,,,1,,,,,,,,,,,,,
18,1,,172116-37350,,,"BOLT, ROLLER ADJUST",2,2,,,,,,,,,,,,,
19,1,,22217-160000,,,"SPRING WASHER 16",8,8,,,,,,,,,,,,,
20,1,,26657-160002,,,"CAP NUT M16",8,8,,,,,,,,,,,,,
21,1,,772147-37500,,,"ROLLER ASSY,CARIA",2,2,,,,,,,,,,,,,
23,2,,172147-37510,,,"SHAFT, CARIA ROLLER",2,2,,,,,,,,,,,,,
24,2,,172124-37520,,,"COVER, SEAL",2,2,,,,,,,,,,,,,
25,2,,172124-37530,,COVER,2,2,,,,,,,,,,,,,
26,2,,172124-37540,,,"O-RING P52",2,2,,,,,,,,,,,,,
27,2,,22252-000620,,,"CIRCLIP 62(H)",4,4,,,,,,,,,,,,,
28,2,,22252-000750,,,"CIRCLIP 75",2,2,,,,,,,,,,,,,
29,2,,24101-062064,,,"BALL BEARING",4,4,,,,,,,,,,,,,
30,2,,933171-13691,,,"PLUG PT1/8",2,2,,,,,,,,,,,,,
31,2,,933171-13820,,,"SEAL WSF30X62X20",2,2,,,,,,,,,,,,,
32,1,,22217-120000,,,"SPRING WASHER",2,2,,,,,,,,,,,,,
33,1,,26116-120652,,,"BOLT M12X 65 PLATED",2,2,,,,,,,,,,,,,
34,1,,26716-120002,,,"NUT 12",2,2,,,,,,,,,,,,,
35,1,,772124-37100,,,"IDLER ASSY",2,2,,,,,,,,,,,,,
35A,1,,772147-37100,,,"IDLER ASSY,",2,2,,,,,,,,,1,,,,,,,,,,,,,
35B,2,,172124-99490,,,"KIT, FRONT IDLER",2,2,,,,,,,,,,,,,
36,3,,172124-37120,,,"BUSH 40",4,4,,,,,,,,,,,,,
37,3,,172124-37130,,,"SHAFT, IDLER",2,2,,,,,,,,,,,,,
38,3,,172124-37160,,PIN,2,2,,,,,,,,,,,,,
39,3,,22242-000350,,,"CIRCLIP 35",2,2,,,,,,,,,,,,,
40,3,,24321-000350,,,"O-RING 1A G-35.0",4,4,,,,,,,,,,,,,
41,3,,933112-00500,,,"SEAL 66 86 28",4,4,,,,,,,,,,,,,
42,2,,172124-37100,,,"IDLER ASSY",2,2,,,,,,,,,,,,,
43,2,,172147-37100,,IDLER(R),2,2,,,,,,,,,1,,,,,,,,,,,,,
44,2,,172124-37140,,,"COVER(A),IDLER SEAL",2,2,,,,,,,,,,,,,
45,2,,172124-37150,,,"COVER(B),IDLER SEAL",2,2,,,,,,,,,,,,,
46,2,,933171-13691,,,"PLUG PT1/8",2,2,,,,,,,,,,,,,
47,1,,172147-37700,,PLAET,4,4,,,,,,,,,1,,,,,,,,,,,,,
48,1,,26013-120402,,,"BOLT M12X 40",8,8,,,,,,,,,,,,,
49,1,,26013-120502,,,"BOLT M12X 50",8,8,,,,,,,,,1,,,,,,,,,,,,,
50,1,,172124-37700,,,"SPRING, ADJUSTING",2,2,,,,,,,,,,,,,
51,1,,172122-37710,,,"HOLDER, ADJUSTER",2,2,,,,,,,,,,,,,
52,1,,172122-37752,,,"ADJUST CYLINDER",2,2,,,,,,,,,,,,,
53,2,,172122-37782,,,"ADJUST TUBE",2,2,,,,,,,,,,,,,
54,2,,172122-37810,,PISTON,2,2,,,,,,,,,,,,,
55,2,,172122-37820,,,"ADJUST SEAL SET",2,2,,,,,,,,,,,,,
56,1,,172122-37843,,,"VALVE ASSY, NIPPLE",2,2,,,,,,,,,,,,,
57,2,,24315-000140,,,"O-RING 1B P-14.0",2,2,,,,,,,,,,,,,
58,2,,24761-020000,,,"NIPPLE PT1/8,GREASE",2,2,,,,,,,,,,,,,

Fig. 25 ローラ&アジャスト ROLLER & ADJUST

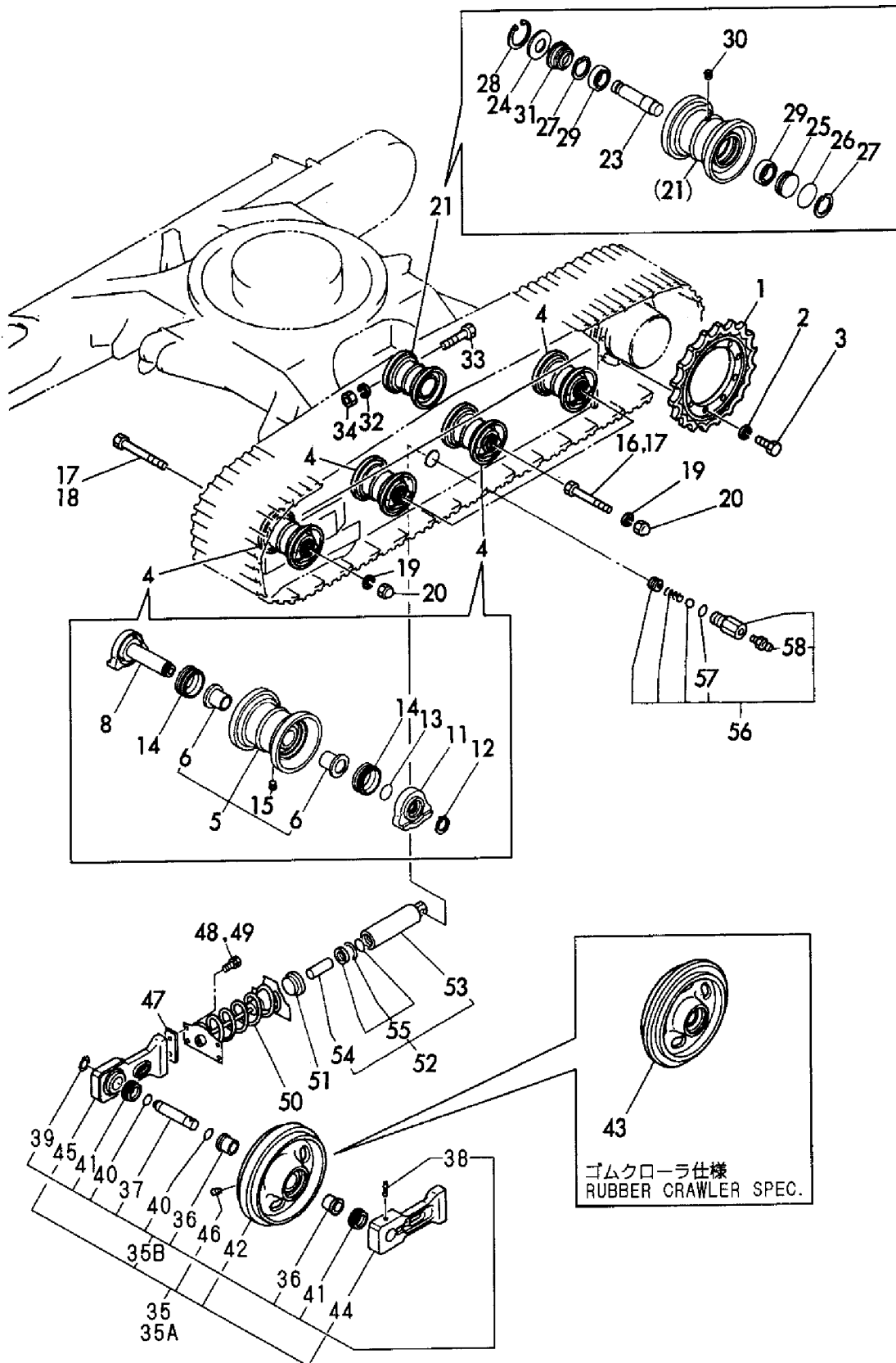

1,1,,772124-38101,, "CRAWLER ASSY, 380",2,2,,,,,,,,,,,,,
1-1,1,,772124-38102,, "CRAWLER ASSY, 400",2,2,,,,,S,,,M/#01121,,M/#01121,,,,,,
2,2,,172124-38250,, "PIN, MASTER",2,2,,,,,,,,,,,,,
3,2,,172124-38101,, "CRAWLER ASSY, 380",2,2,,,,,,,,,,,,,
3-1,2,,172124-38102,, "SHOE 400 ASSY, TRUCK",2,2,,,,,S,,,M/#01121,,M/#01121,,,,,,
4,3,,172124-38111,, "LINK ASSY, TRUCK",2,2,,,,,,,,,,,,,
5,4,,172112-38041,, "LINK (L), TRACK",72,72,,,,,,,,,,,,,
6,4,,172112-38051,, "LINK (R), TRACK",72,72,,,,,,,,,,,,,
7,4,,172124-38260,, "LINK (L), MASTER",2,2,,,,,,,,,,,,,
8,4,,172124-38270,, "LINK (R), MASTER",2,2,,,,,,,,,,,,,
9,4,,172112-38081,, "BUSH,74,74",,,,,,,,,,,,,,
10,4,,172112-38091,, "PIN, TRACK",72,72,,,,,,,,,,,,,
11,3,,172112-38130,, "BOLT, SHOE",296,296,,,,,,,,,,,,,
12,3,,172112-38140,, "NUT, SHOE",296,296,,,,,,,,,,,,,
13,3,,172112-38152,, "SHOW PLATE",74,74,,,,,,,,,,,,,
13-1,3,,172112-38153,, "SHOE PLATE 400",74,74,,,,,S,,,M/#01121,,M/#01121,,,,,,
14,2,,172112-38111,, "PIN, COTTER",2,2,,,,,,,,,,,,,
15,1,,172124-38140,, "MASTER TRUCK",2,2,,,,,,,,,,,,,
15-1,1,,172124-38141,, "MASTER TRUCK",2,2,,,,,S,,,M/#01121,,M/#01121,,,,,,
16,2,,172112-38130,, "BOLT, SHOE",8,8,,,,,,,,,,,,,
17,2,,172112-38140,, "NUT, SHOE",8,8,,,,,,,,,,,,,
18,2,,172112-38152,, "SHOW PLATE",2,2,,,,,,,,,,,,,
18-1,2,,172112-38153,, "SHOE PLATE 400",2,2,,,,,S,,,M/#01121,,M/#01121,,,,,,
19,2,,172124-38300,, "LINK, MASTER",2,2,,,,,,,,,,,,,
20,3,,172112-38081,, "BUSH,2,2",,,,,,,,,,,,,,
21,3,,172124-38260,, "LINK (L), MASTER",2,2,,,,,,,,,,,,,
22,3,,172124-38270,, "LINK (R), MASTER",2,2,,,,,,,,,,,,,
23,1,,172147-38601,, "CRAWLER, RUBBER",2,2,,,,,,,,,,,,,
23-1,1,,172976-38600,, "CRAWLER, RUBBER",2,2,,,,,N,,,M/#01121,,M/#01121,,,,,,

Fig. 26 クローラ CRAWLER

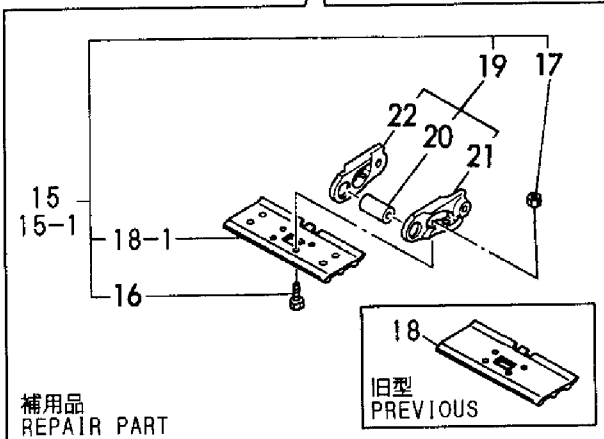
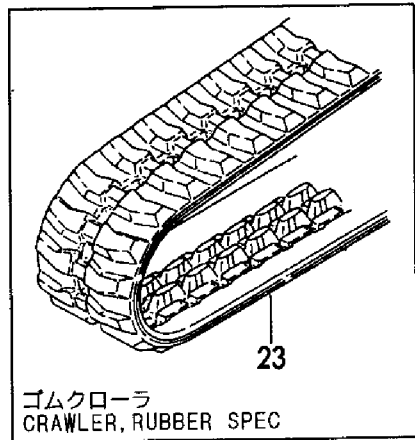
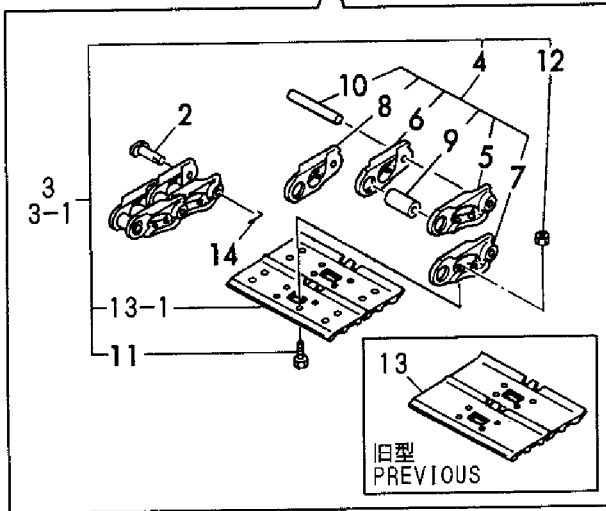
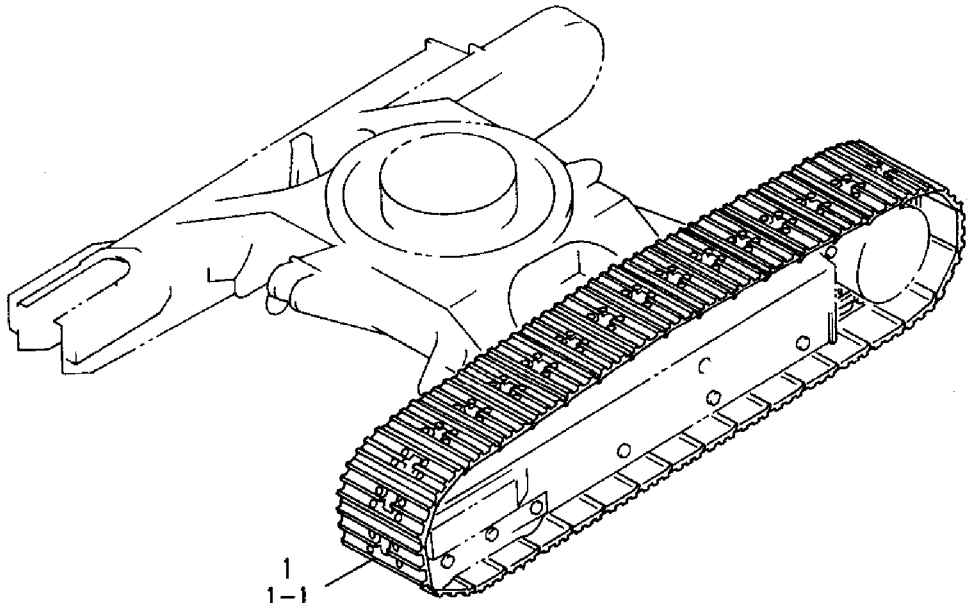

1,1,,172151-45010,, "BOOT P,LEVER",2,2,,,,,,,,,,,,,,,,,,,,,
2,1,,172164-45010,, "LEVER (R) ASSY",1,1,,,,,,,,,,,,,,,,,,,,,
3,1,,172164-45880,, "BOLT 6X 16",4,4,,,,,,,,,,,,,,,,,,,,,
4,1,,172165-47871,, "KNOB (A) ASSY",1,1,,,,,,,,,,,,,,,,,,,,,
5,1,,172165-45071,, "KNOB (L) ASSY",1,1,,,,,,,,,,,,,,,,,,,,,
6,1,,26116-100504,, "BOLT M10X 50 PLATED",4,4,,,,,,,,,,,,,,,,,,,,,
7,1,,26716-100002,, "NUT 10",4,4,,,,,,,,,,,,,,,,,,,,,
8,1,,26587-040062,, "SCREW M 4X 6",2,2,,,,,,,,,,,,,,,,,,,,,
9,1,,26013-100202,, "BOLT W/WASHER M10X20",3,3,,,,,,,,,,,,,,,,,,,,,
10,1,,26013-100202,, "BOLT W/WASHER M10X20",4,4,,,,,,,,,,,,,,,,,,,,,
11,1,,194145-04810,, "WASHER 10",1,1,,,,,,,,,,,,,,,,,,,,,
12,1,,172165-45620,, "COVER, SUPPORT",1,1,,,,,,,,,,,,,,,,,,,,,
13,1,,172164-45800,, "SUPPORT COMP.,SI",1,1,,,,,,,,,,,,,,,,,,,,,
13-1,1,,172164-45801,, SUPPORT,1,1,,,,,S,,,,M/#00832,,M/#00832,,,,,,
14,1,,172164-45840,, "COVER COMP.,SI",1,1,,,,,,,,,,,,,,,,,,,,,
14-1,1,,172164-45841,, COVER,1,1,,,,,S,,,,M/#00832,,M/#00832,,,,,,
15,1,,172164-45450,, "STAND (R) ASSY,LEVER",1,1,,,,,,,,,,,,,,,,,,,,,
15-1,1,,172164-45451,, "STAND(R), LEVER",1,1,,,,,N,,,,M/#00960,,M/#00960,,,,,,
15-2,1,,172164-45452,, "STAND(R),LEVER",1,1,,,,,N,,,,M/#01014,,M/#01014,,,,,,
16,2,,172164-62260,, "RUBBER, SEAL",1,1,,,,,,,,,,,,,,,,,,,,,
18,2,,172164-64400,, "RUBBER, SEAL",1,1,,,,,,,,,,,,,,,,,,,,,
19,1,,172164-45600,, "STAND (L) ASSY,LEVER",1,1,,,,,,,,,,,,,,,,,,,,,
20,2,,172141-41370,, "BUSH 2015",2,2,,,,,,,,,,,,,,,,,,,,,
22,2,,24550-025150,, "BUSH 25X15",2,2,,,,,,,,,,,,,,,,,,,,,
23,1,,172165-47710,, PLATE,2,2,,,,,,,,,,,,,,,,,,,,,
23-1,1,,172165-47711,, PLATE,2,2,,,,,N,,,,M/#01111,,M/#01111,,,,,,
24,1,,172164-45920,, "GUIDE L, HOSE",1,1,,,,,,,,,,,,,,,,,,,,,
25,1,,172164-45790,, COVER,1,1,,,,,,,,,,,,,,,,,,,,,
26,1,,172151-53430,, GROMMET,2,2,,,,,,,,,,,,,,,,,,,,,
26-1,1,,172151-53430,, GROMMET,1,1,,,,,K,,,,MXXX,,MXXX,,,,,,
27,1,,194630-62360,, GROMMET,4,4,,,,,,,,,,,,,,,,,,,,,
27-1,1,,194630-62360,, GROMMET,8,8,,,,,K,,,,MXXX,,MXXX,,,,,,
28,1,,172519-63240,, "BOLT 8X 16",5,5,,,,,,,,,,,,,,,,,,,,,
29,1,,172165-47990,, WASHER,1,1,,,,,,,,,,,,,,,,,,,,,
30,1,,26013-080162,, "BOLT W/WASHER M8X16",8,8,,,,,,,,,,,,,,,,,,,,,
31,1,,22217-100000,, "SPRING WASHER 10",5,5,,,,,,,,,,,,,,,,,,,,,
32,1,,22242-000250,, "CIRCLIP 25S",1,1,,,,,,,,,,,,,,,,,,,,,
33,1,,26013-080202,, "BOLT W/WASHER M8X20",2,2,,,,,,,,,,,,,,,,,,,,,
34,1,,172519-63240,, "BOLT 8X 16",2,2,,,,,,,,,,,,,,,,,,,,,
35,1,,26116-100202,, "BOLT M10X 20 PLATED",4,4,,,,,,,,,,,,,,,,,,,,,
36,1,,26116-100902,, "BOLT M10X 90 PLATED",1,1,,,,,,,,,,,,,,,,,,,,,
37,1,,24311-000340,, "O-RING 1A P-34.0",2,2,,,,,,,,,,,,,,,,,,,,,
38,1,,24761-020000,, "NIPPLE PT1/8,GREASE",2,2,,,,,,,,,,,,,,,,,,,,,
39,1,,172165-47980,, "SHIM 42X25.5X0.5",4,4,,,,,,,,,,,,,,,,,,,,,
39-1,1,,172165-47980,, "SHIM 42X25.5X0.5",2,2,,,,,K,,,,MXXX,,MXXX,,,,,,
40,1,,26776-140002,, "LOCK NUT M14 PLATED",2,2,,,,,,,,,,,,,,,,,,,,,
40-1,1,,26736-140002,, "NUT M14",2,2,,,,,N,,,,*1996.02,,*1996.02,,,,,,
41,1,,172164-45040,, "HINGE, LEVER",1,1,,,,,,,,,,,,,,,,,,,,,
41-1,1,,172164-45041,, HINGE,1,1,,,,,S,,,,M/#01339,,M/#01339,,,,,,
42,1,,172164-45050,, "PIN 8X 22",1,1,,,,,,,,,,,,,,,,,,,,,
43,1,,172164-45060,, "PIN, ROCK",1,1,,,,,,,,,,,,,,,,,,,,,
43-1,1,,172164-45061,, PIN,1,1,,,,,S,,,,M/#01339,,M/#01339,,,,,,
44,1,,172164-45070,, SPRING,1,1,,,,,,,,,,,,,,,,,,,,,
45,1,,172164-45080,, "SCREW M6",1,1,,,,,,,,,,,,,,,,,,,,,
46,1,,172165-47851,, "LEVER L, SI",1,1,,,,,,,,,,,,,,,,,,,,,
47,1,,22272-000060,, "CIRCLIP E- 6",1,1,,,,,,,,,,,,,,,,,,,,,
48,1,,172157-58830,, "KNOB 6.5X18X35",1,1,,,,,,,,,,,,,,,,,,,,,
49,1,,26116-060202,, "BOLT M 6X 20",2,2,,,,,,,,,,,,,,,,,,,,,
50,1,,26716-060002,, "NUT 6",2,2,,,,,,,,,,,,,,,,,,,,,
51,1,,172164-45860,, "COVER, LINK",1,1,,,,,,,,,,,,,,,,,,,,,
51-1,1,,172164-45861,, "COVER, LINK",1,1,,,,,N,,,,M/#01014,,M/#01014,,,,,,
53,2,,172164-45870,, "SEAL 155, RUBBER",2,2,,,,,,,,,,,,,,,,,,,,,
54,2,,172164-66670,, "RUBBER, SEAL 60",2,2,,,,,,,,,,,,,,,,,,,,,

55,1,,172164-45090,,CAP,1,1,,,,,,,,,,,,,
56,1,,933168-55770,, "BAND 146",2,2,,,,,,,,,,,,,
57,1,,172165-45490,,CUSHION,5,5,,,,,,,,,,,,,
58,1,,172176-45560,, "PLATE ASSY, LINK",1,1,,,,,,,,,,,,,
58-1,1,,172176-45561,, "PLATE ASSY, LINK",1,1,,,,,N,,,,M/#00852,,M/#00852,,,,,,
59,1,,22252-000280,, "CIRCLIP 28",5,5,,,,,,,,,,,,,
60,1,,26106-100352,, "BOLT M10X 35 PLATED",5,5,,,,,,,,,,,,,
61,1,,172164-46310,,RUBBER,1,1,,,,,W,,,,M/#00868,,M/#00868,,,,,,
62,1,,172176-47870,,KNOB,1,1,,,,,1,,,,,,,,,,,,,
63,1,,26587-040062,, "SCREW M 4X 6",1,1,,,,,1,,,,,,,,,,,,,
64,1,,172165-47711,,PLATE,1,1,,,,,1,,,,,,,,,,,,,
65,1,,26736-140002,, "NUT M14",1,1,,,,,1,,,,,,,,,,,,,
66,1,,172190-45080,, "LEVER L CMP(DECCEL",1,1,,,,,1,,,,,,,,,,,,,
67,1,,933168-55770,, "BAND 146",2,2,,,,,1,,,,,,,,,,,,,

Fig. 27 操縦装置 (作業レバー&スタンド) CONTROL EQUIP. (OPERATION LEVER & STAND)

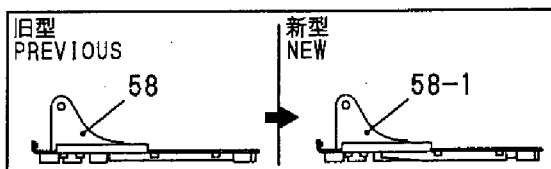
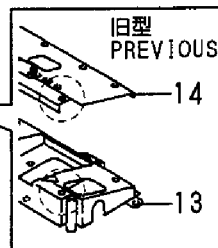
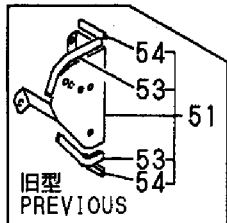
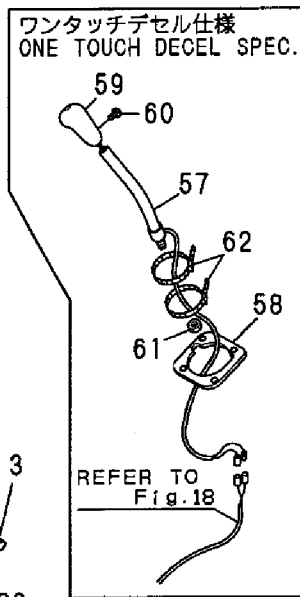
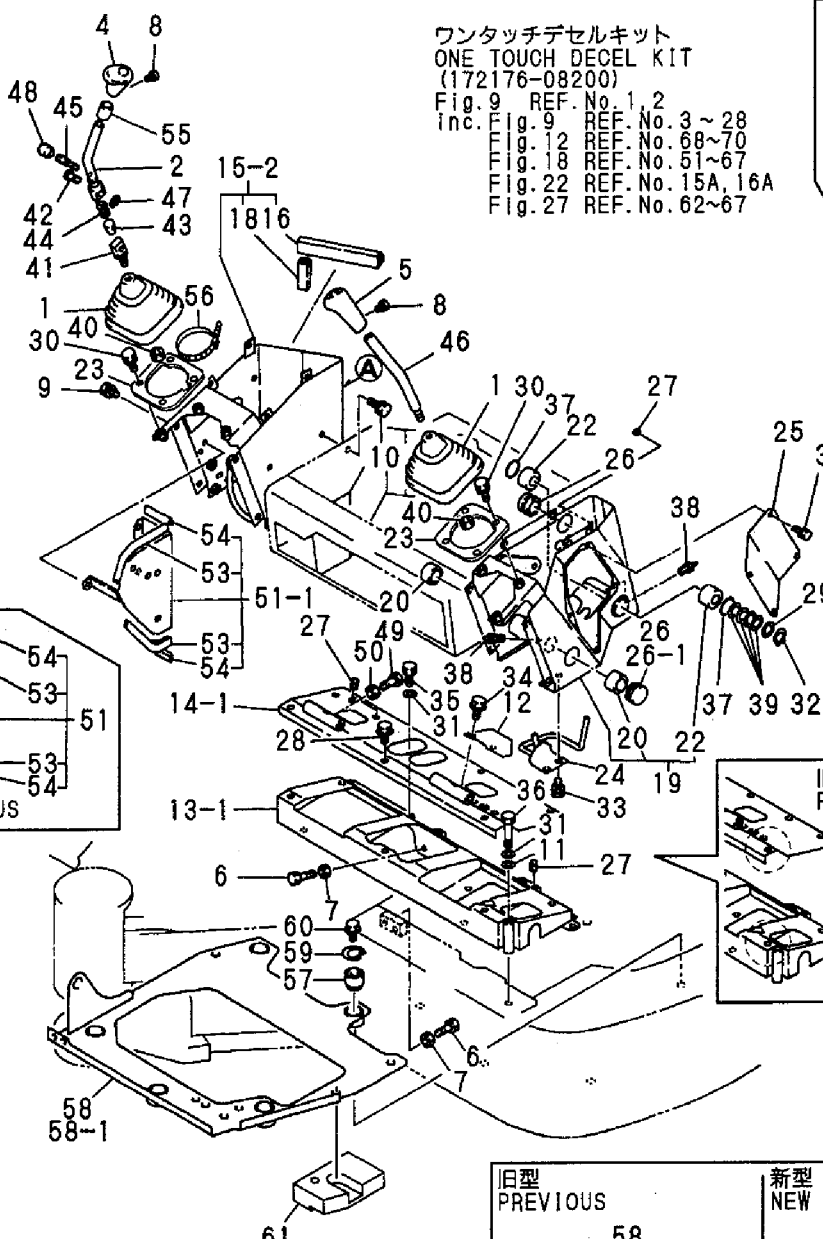
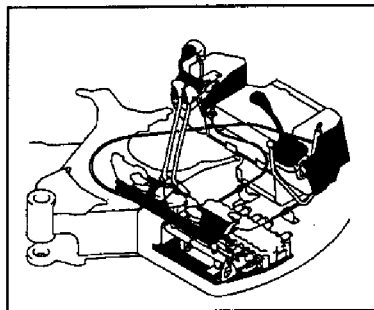
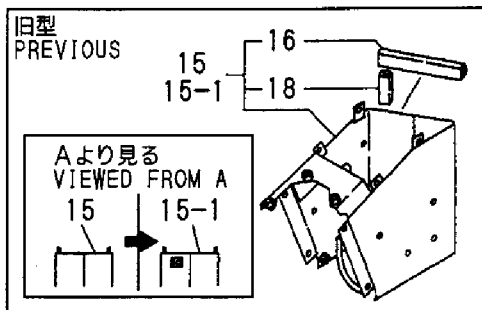

1,1,,172141-41340,,BOOTS,2,2,,,,,,,,,,,,,
2,1,,172164-45950,,,"GRIP L, DRIV.",1,1,,,,,,,,,,,,,
2-1,1,,172164-45951,,,"GRIP L, DRIV.",1,1,,,,,N,,,M/#01121,,M/#01121,,,,,,
3,1,,172164-45100,,,"LEVER(L), TRACK",1,1,,,,,,,,,,,,,
4,2,,172141-41370,,,"BUSH 2015",2,2,,,,,,,,,,,,,
6,1,,172176-45130,,,"LEVER(R), TRACK",1,1,,,,,,,,,,,,,
7,2,,172141-41370,,,"BUSH 2015",2,2,,,,,,,,,,,,,
9,1,,26756-100002,,,"LOCK NUT M10 PLATED",2,2,,,,,,,,,,,,,
10,1,,172164-45380,,,"ROD(95)",1,1,,,,,,,,,,,,,
11,1,,172164-45960,,,"GRIP R, DRIV.",1,1,,,,,,,,,,,,,
11-1,1,,172164-45961,,,"GRIP R, DRIV.",1,1,,,,,N,,,M/#01121,,M/#01121,,,,,,
12,1,,172164-45200,,,"SHAFT(A)ASSY,TRACK",1,1,,,,,,,,,,,,,
13,1,,172124-46200,,,"O-RING 27X5.7",3,3,,,,,,,,,,,,,
14,1,,24761-020000,,,"NIPPLE PT1/8,GREASE",2,2,,,,,,,,,,,,,
15,1,,26013-100252,,,"BOLT W/WASHER M10X25",2,2,,,,,,,,,,,,,
16,1,,172165-46100,,,"PEDAL L ASSY",1,1,,,,,,,,,,,,,
17,1,,172165-46150,,,"PEDAL R COMP",1,1,,,,,,,,,,,,,
18,1,,26013-060302,,,"BOLT M 6X 30",4,4,,,,,,,,,,,,,
19,1,,172164-45230,,,"ROD 135 ASSY",1,1,,,,,,,,,,,,,
20,1,,172122-46590,,,"ELBALL 8",2,2,,,,,,,,,,,,,
21,1,,22137-080000,,,"WASHER 8, POLISHED",2,2,,,,,,,,,,,,,
22,1,,22417-160160,,,"COTTER PIN 1.6X16",2,2,,,,,,,,,,,,,
23,1,,26051-080002,,,"NUT M 8",4,4,,,,,,,,,,,,,
24,1,,933110-54100,,,"PIN 4.75X14",2,2,,,,,,,,,,,,,
25,1,,172146-45691,,,"ROD(C), SPOOL",1,1,,,,,,,,,,,,,
26,1,,22217-080000,,,"SPRING WASHER 8",1,1,,,,,,,,,,,,,

Fig. 28 操縦装置 (走行) CONTROL EQUIP. (TRAVEL)

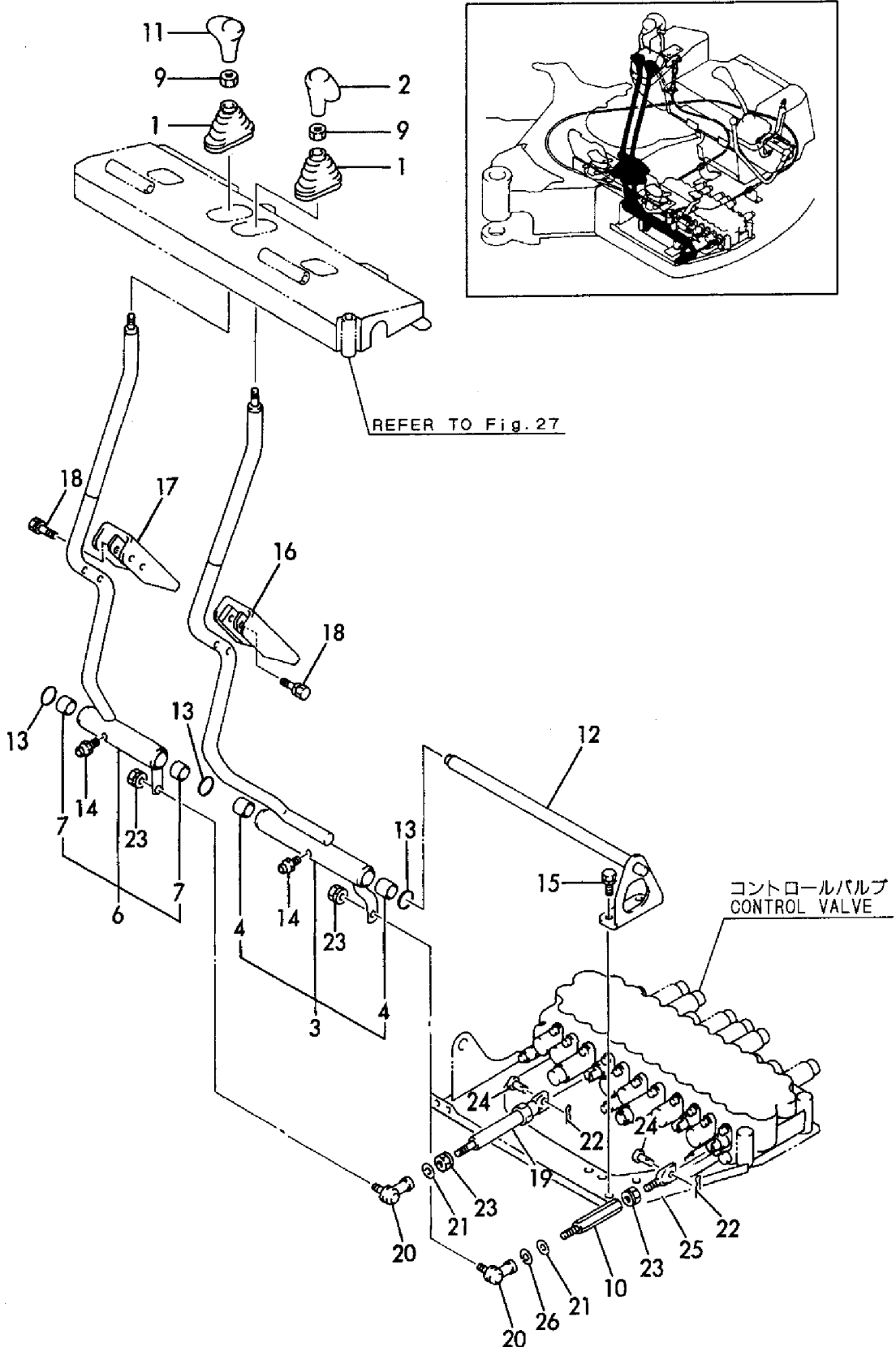

1,1,,1A1040-45890,, "WASHER 10 36 4.5",1,1,,,,,,,,,,,,,
2,1,,172124-46200,, "O-RING 27X5.7",2,2,,,,,,,,,,,,,
3,1,,172165-46300,, "LINK W/BUSH",1,1,,,,,,,,,,,,,
4,2,,172141-41360,, "BUSH 1415",2,2,,,,,,,,,,,,,
6,1,,172165-46350,, "BRACKET, PEDAL",1,1,,,,,,,,,,,,,
7,1,,172146-41910,, "PIN 14-100",1,1,,,,,,,,,,,,,
8,1,,172165-46800,, SHAFT,1,1,,,,,,,,,,,,,
9,1,,172165-46830,, "BOSS, SWING",1,1,,,,,,,,,,,,,
10,2,,172141-41370,, "BUSH 2015",2,2,,,,,,,,,,,,,
12,1,,22217-100000,, "SPRING WASHER 10",1,1,,,,,,,,,,,,,
13,1,,22351-040032,, "SPRING PIN 4X32",1,1,,,,,,,,,,,,,
14,1,,24761-020000,, "NIPPLE PT1/8,GREASE",1,1,,,,,,,,,,,,,
15,1,,24761-050000,, "NIPPLE C,GREASE",1,1,,,,,,,,,,,,,
16,1,,26013-100202,, "BOLT W/WASHER M10X20",2,2,,,,,,,,,,,,,
17,1,,26013-100252,, "BOLT W/WASHER M10X25",2,2,,,,,,,,,,,,,
18,1,,26116-100202,, "BOLT M10X 20 PLATED",1,1,,,,,,,,,,,,,
19,1,,172157-45990,, "BOOTS, PEDAL",1,1,,,,,,,,,,,,,
20,1,,172165-46230,, "SHAFT, SWING",2,2,,,,,,,,,,,,,
21,1,,172165-46261,, "COVER, PEDAL",2,2,,,,,,,,,,,,,
22,1,,172165-46281,, "PEDAL ASSY, SWING",1,1,,,,,,,,,,,,,
23,1,,172165-46340,, BOLT,2,2,,,,,,,,,,,,,
24,1,,22137-080000,, "WASHER 8, POLISHED",2,2,,,,,,,,,,,,,
25,1,,22351-040020,, "SPRING PIN 4X20",2,2,,,,,,,,,,,,,
26,1,,26116-080304,, "BOLT M8 X 30 PLATED",2,2,,,,,,,,,,,,,
27,1,,26716-080002,, "NUT M 8",2,2,,,,,,,,,,,,,
28,1,,26716-080002,, "NUT M 8",4,4,,,,,,,,,,,,,
29,1,,194200-37780,, "LS-NUT 8",1,1,,,,,,,,,,,,,
30,1,,172150-42620,, "ROD(B), BOOM",1,1,,,,,,,,,,,,,
31,1,,172147-45620,, "ROD, LINK 215",1,1,,,,,,,,,,,,,
32,1,,172146-45701,, "ROD(D), SPOOL",1,1,,,,,,,,,,,,,
32-1,1,,172146-45740,, "ROD(D), SPOOL",1,1,,,,,R,,,,M/#00501,,M/#00501,,,,,
33,1,,172122-46590,, "ELBALL 8",3,3,,,,,,,,,,,,,
34,1,,172165-46860,, "TURNBUCKLE M8",1,1,,,,,,,,,,,,,
35,1,,22137-080000,, "WASHER 8, POLISHED",3,3,,,,,,,,,,,,,
36,1,,22417-160160,, "COTTER PIN 1.6X16",1,1,,,,,,,,,,,,,
37,1,,26051-080002,, "NUT M 8",6,6,,,,,,,,,,,,,
38,1,,26716-080002,, "NUT M 8",1,1,,,,,,,,,,,,,
39,1,,933110-54100,, "PIN 4.75X14",1,1,,,,,,,,,,,,,
40,1,,24311-000210,, "O-RING 1A P-21.0",2,2,,,,,,,,,,,,,
41,1,,172068-28490,, "SPRING 8",4,4,,,,,,,,,,,,,

Fig. 29 操縦装置 (スイング) CONTROL EQUIP. (SWING)

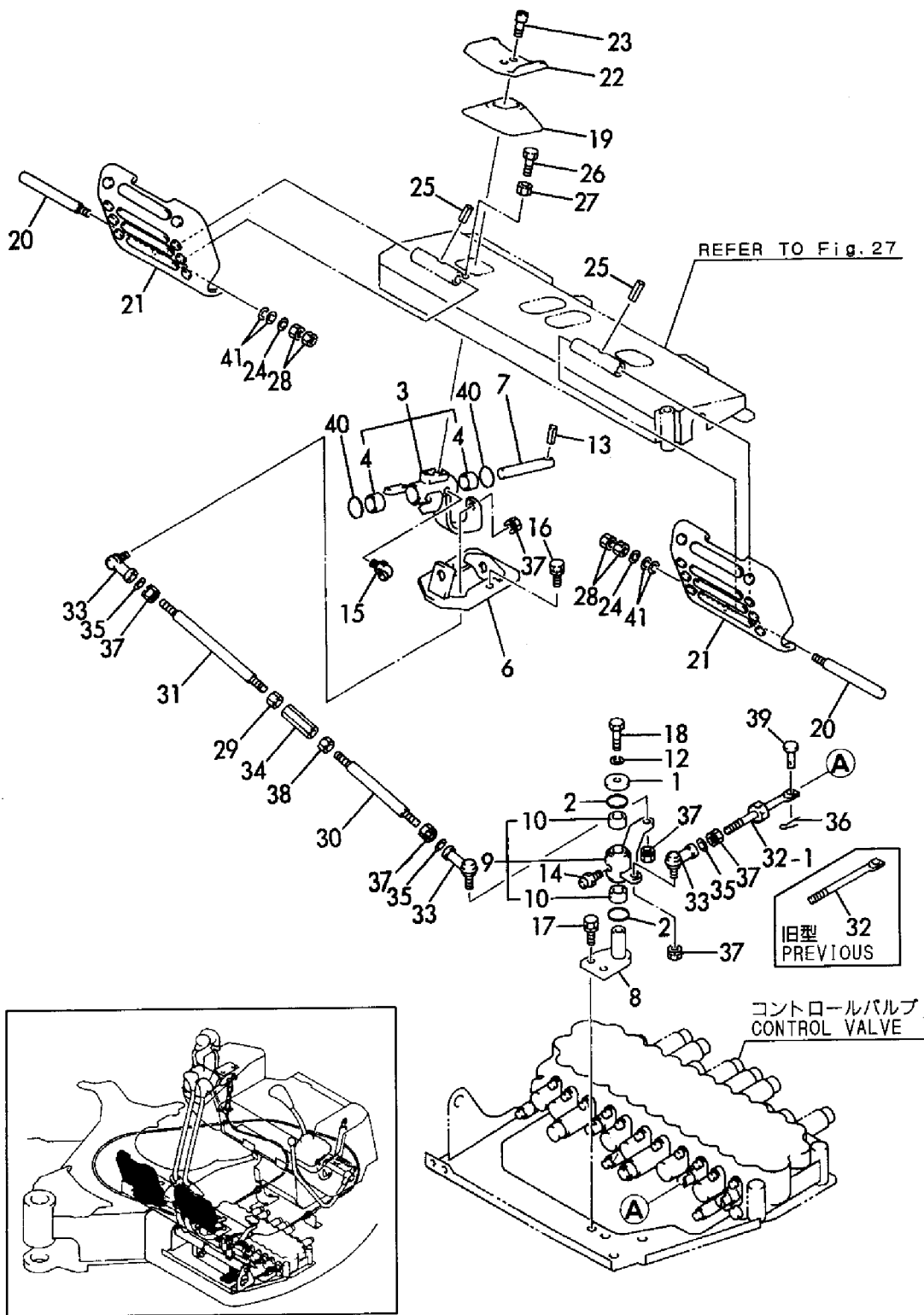

1,1,,172164-45180,, "LEVER ASSY, BLADE",1,1,,,,,,,,,,,,,
2,1,,172164-45970,, "GRIP, BLADE",1,1,,,,,,,,,,,,,
3,1,,22351-050032,, "SPRING PIN 5X32",1,1,,,,,,,,,,,,,
4,1,,172165-45140,, "LINK, BLADE",1,1,,,,,,,,,,,,,
5,1,,172165-45180,, "BRACKET ASSY, REAR",1,1,,,,,,,,,,,,,
5-1,1,,172164-46440,, "BRACKET ASY",1,1,,,,,S,,,,M/#01014,,M/#01014,,,,,
6,2,,172141-41360,, "BUSH 1415",2,2,,,,,,,,,,,,,
6-1,2,,172141-41360,, "BUSH 1415",4,4,,,,,K,,,,M/#01014,,M/#01014,,,,,
8,1,,24311-000210,, "O-RING 1A P-21.0",2,2,,,,,,,,,,,,,
9,1,,26013-100202,, "BOLT W/WASHER M10X20",3,3,,,,,,,,,,,,,
10,1,,26116-100354,, "BOLT M10X 35 PLATED",2,2,,,,,,,,,,,,,
11,1,,26716-100002,, "NUT 10",2,2,,,,,,,,,,,,,
12,1,,172165-45130,, "CABLE, BLADE",1,1,,,,,,,,,,,,,
13,1,,172141-42960,, "JOINT, CABLE",1,1,,,,,,,,,,,,,
14,1,,172165-45250,, "SUPPORT, BR CABLE",1,1,,,,,,,,,,,,,
15,1,,172142-45670,, "ROD, SPOOL",1,1,,,,,,,,,,,,,
16,1,,172122-46590,, "ELBALL 8",1,1,,,,,,,,,,,,,
17,1,,22417-160160,, "COTTER PIN 1.6X16",1,1,,,,,,,,,,,,,
18,1,,26013-100202,, "BOLT W/WASHER M10X20",2,2,,,,,,,,,,,,,
19,1,,26051-080002,, "NUT M 8",1,1,,,,,,,,,,,,,
20,1,,933110-54100,, "PIN 4.75X14",1,1,,,,,,,,,,,,,
21,1,,933168-28480,, "WASHER 20X9X3.2",1,1,,,,,,,,,,,,,
22,1,,22351-030032,, "SPRING PIN 3X32",1,1,,,,,,,,,,,,,
23,1,,1D4070-23580,, "GRIP, RED ROUND",,1,,,,,W,,,,,M/#01014,,,,,
24,1,,172165-45970,, "SPRING",,1,,,,,W,,,,,M/#01014,,,,,
25,1,,172164-46400,, "BRACKET CMP",,1,,,,,W,,,,,M/#01014,,,,,
26,1,,172164-46421,, "LEVER CMP, ROCK",,1,,,,,W,,,,,M/#01014,,,,,
27,1,,172164-46481,, "LINK CMP, ROCK",,1,,,,,W,,,,,M/#01014,,,,,
28,1,,22137-080000,, "WASHER 8, POLISHED",,2,,,,,W,,,,,M/#01014,,,,,
29,1,,22351-030032,, "SPRING PIN 3X32",,1,,,,,W,,,,,M/#01014,,,,,
30,1,,22351-050032,, "SPRING PIN 5X32",,1,,,,,W,,,,,M/#01014,,,,,
31,1,,24311-000210,, "O-RING 1A P-21.0",,1,,,,,W,,,,,M/#01014,,,,,
32,1,,26013-080202,, "BOLT W/WASHER M8X20",,2,,,,,W,,,,,M/#01014,,,,,

Fig. 30 操縦装置 (ブレード)
CONTROL EQUIP. (BLADE)

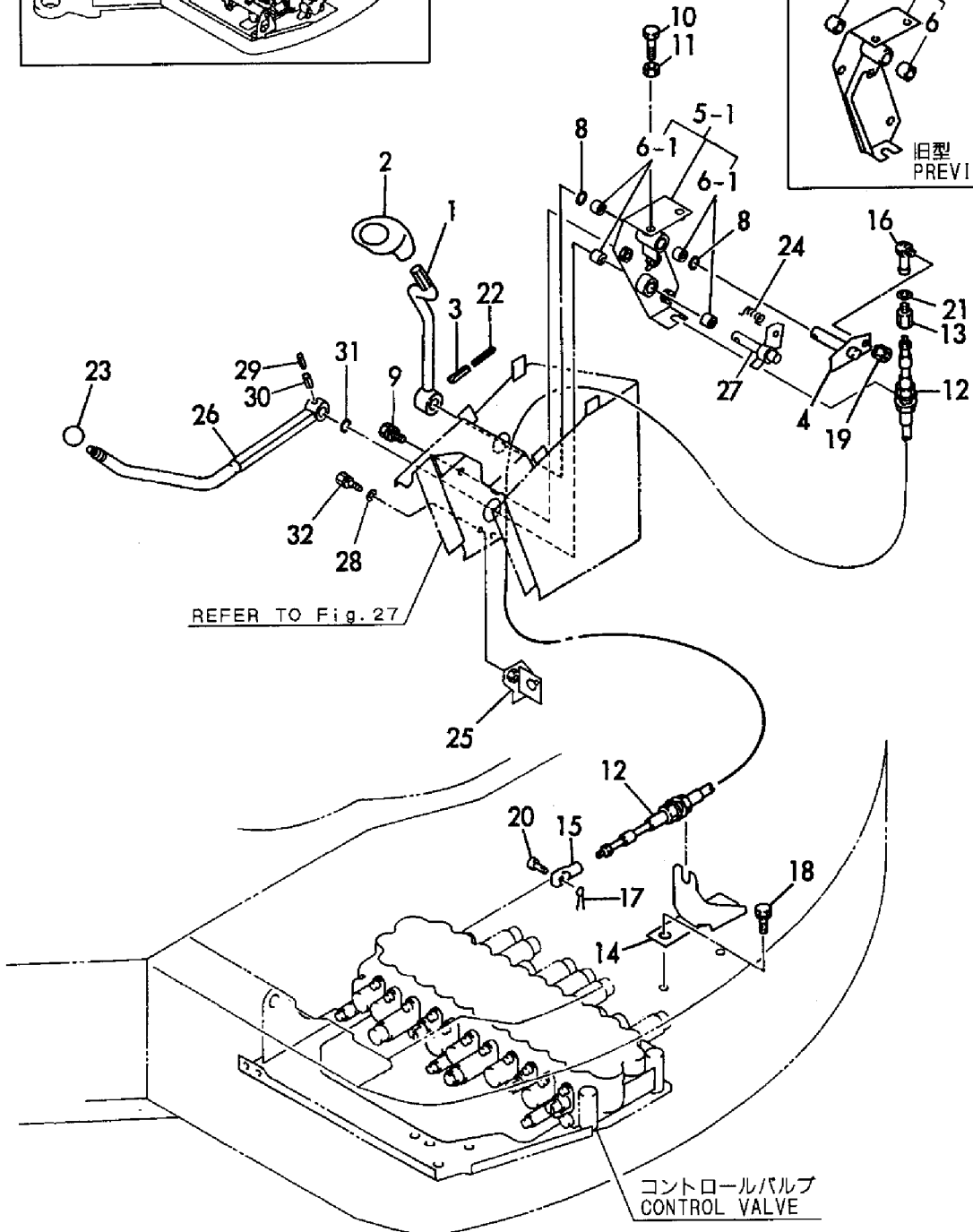
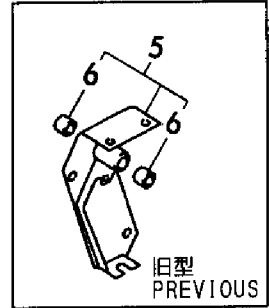
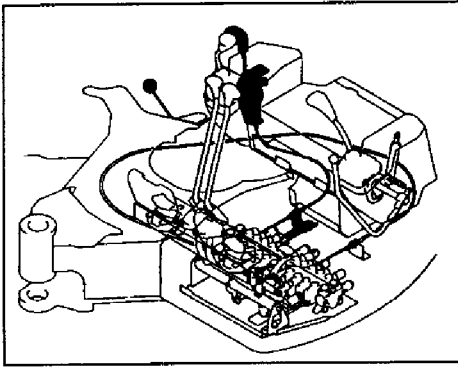

1,1,,172519-17111,,BRACKET,1,1,,,,,,,,,,,,,
1-1,1,,172519-17112,,BRACKET,1,1,,,,,N,,M/#00618,,M/#00618,,,,,
1-2,1,,172164-17150,,,"BRACKET, SWITCH",1,1,,,,,F,1,,M/#00965,,M/#00965,,,,,
2,1,,1D4070-23580,,,"GRIP,RED ROUND",1,1,,,,,,,,,,,,,
3,1,,172124-46200,,,"O-RING 27X5.7",2,2,,,,,,,,,,,,,
4,1,,172165-47450,,,"LEVER (L), LOCK",1,1,,,,,,,,,,,,,
5,1,,172165-47500,,,"ARM ASSY, LOCK",1,1,,,,,,,,,,,,,
6,1,,172165-47550,,,"BUSH,1,1,,,,,,,,,,,,,
7,1,,172165-47621,,,"GUIDE (L) ASSY, LOCK",1,1,,,,,,,,,,,,,
8,1,,172165-47801,,,"SPRING,GAS",1,1,,,,,,,,,,,,,
9,1,,1A1380-56661,,,"SPRING,ROTARY RETURN",1,1,,,,,,,,,,,,,
10,1,,22137-080000,,,"WASHER 8, POLISHED",2,2,,,,,,,,,,,,,
11,1,,22137-080000,,,"WASHER 8, POLISHED",2,2,,,,,,,,,,,,,
12,1,,22272-000070,,,"CIRCLIP E- 7",1,1,,,,,,,,,,,,,
13,1,,22351-060040,,,"SPRING PIN 6X40",1,1,,,,,,,,,,,,,
14,1,,22417-200200,,,"COTTER PIN 2.0X20",2,2,,,,,,,,,,,,,
15,1,,26013-080202,,,"BOLT W/WASHER M8X20",2,2,,,,,,,,,,,,,
16,1,,26013-100202,,,"BOLT W/WASHER M10X20",2,2,,,,,,,,,,,,,
17,1,,172164-45250,,,"BRACKET ASY,LOW-HIGH",1,1,,,,,Z,,M/#00831,,M/#00831,,,,,
18,2,,172141-41360,,,"BUSH 1415",2,2,,,,,Z,,M/#00831,,M/#00831,,,,,
19,1,,172164-45270,,,"SHAFT, LOW-HIGH",1,1,,,,,Z,,M/#00831,,M/#00831,,,,,
20,1,,172164-45290,,,"LINK, LOW-HIGH",1,1,,,,,Z,,M/#00831,,M/#00831,,,,,
21,2,,172141-41360,,,"BUSH 1415",2,2,,,,,Z,,M/#00831,,M/#00831,,,,,
22,1,,172164-45360,,,"PEDAL, LOW-HIGH",1,1,,,,,Z,,M/#00831,,M/#00831,,,,,
23,1,,172164-45390,,,"ROD(A), SPOOL",1,1,,,,,Z,,M/#00831,,M/#00831,,,,,
24,1,,172164-45400,,,"ROD(B,1,1,,,,,Z,,M/#00831,,M/#00831,,,,,
25,1,,172164-45410,,,"ROD C, SPOOL",1,1,,,,,Z,,M/#00831,,M/#00831,,,,,
26,1,,172122-45830,,,"PAD, METAL",1,1,,,,,,,,,,,,,
27,1,,22137-100000,,,"WASHER 10,POLISHED",1,1,,,,,Z,,M/#00831,,M/#00831,,,,,
28,1,,22157-100000,,,"WASHER 10",1,1,,,,,Z,,M/#00831,,M/#00831,,,,,
29,1,,22217-100000,,,"SPRING WASHER 10",1,1,,,,,,,,,,,,,
30,1,,22417-160160,,,"COTTER PIN 1.6X16",4,4,,,,,Z,,M/#00831,,M/#00831,,,,,
31,1,,22486-080160,,,"PIN 8X 16",3,3,,,,,Z,,M/#00831,,M/#00831,,,,,
32,1,,24311-000210,,,"O-RING 1A P-21.0",4,4,,,,,,,,,,,,,
32-1,1,,24311-000210,,,"O-RING 1A P-21.0",2,2,,,,,K,,M/#00832,,M/#00832,,,,,
33,1,,26013-100252,,,"BOLT W/WASHER M10X25",2,2,,,,,,,,,,,,,
33-1,1,,26013-100202,,,"BOLT W/WASHER
M10X20",2,2,,,,,R,,M/#00832,,M/#00832,,,,,
34,1,,26116-100504,,,"BOLT M10X 50 PLATED",1,1,,,,,,,,,,,,,
35,1,,26347-100002,,,"U-NUT M10",2,2,,,,,Z,,M/#00831,,M/#00831,,,,,
36,1,,26716-100002,,,"NUT 10",1,1,,,,,,,,,,,,,
37,1,,26716-100002,,,"NUT 10",1,1,,,,,Z,,M/#00831,,M/#00831,,,,,
38,1,,933110-54100,,,"PIN 4.75X14",1,1,,,,,Z,,M/#00831,,M/#00831,,,,,
39,1,,22351-035040,,,"SPRING PIN 3.5X40",1,1,,,,,,,,,,,,,
40,1,,172162-46690,,,"SPRING,1,1,,,,,W,,M/#00832,,M/#00832,,,,,
41,1,,172176-46400,,,"BRACKET,1,1,,,,,W,,M/#00832,,M/#00832,,,,,
42,2,,172141-41360,,,"BUSH 1415",2,2,,,,,W,,M/#00832,,M/#00832,,,,,
43,1,,172176-46450,,,"PADAL ASSY, LOW-HIGH",1,1,,,,,W,,M/#00832,,M/#00832,,,,,
44,1,,172176-46480,,,"LINK,1,1,,,,,W,,M/#00832,,M/#00832,,,,,
45,1,,22351-050025,,,"SPRING PIN 5X25",1,1,,,,,W,,M/#00832,,M/#00832,,,,,
46,1,,26716-060002,,,"NUT 6",1,1,,,,,W,,M/#00832,,M/#00832,,,,,
47,1,,26911-060202,,,"SCREW M 6X 20",1,1,,,,,W,,M/#00832,,M/#00832,,,,,

Fig. 31 操縦装置 (カットオフレバー&ローハイペダル)
CONTROL EQUIP. (CUT OFF LEVER & LOW-HIGH PEDAL)

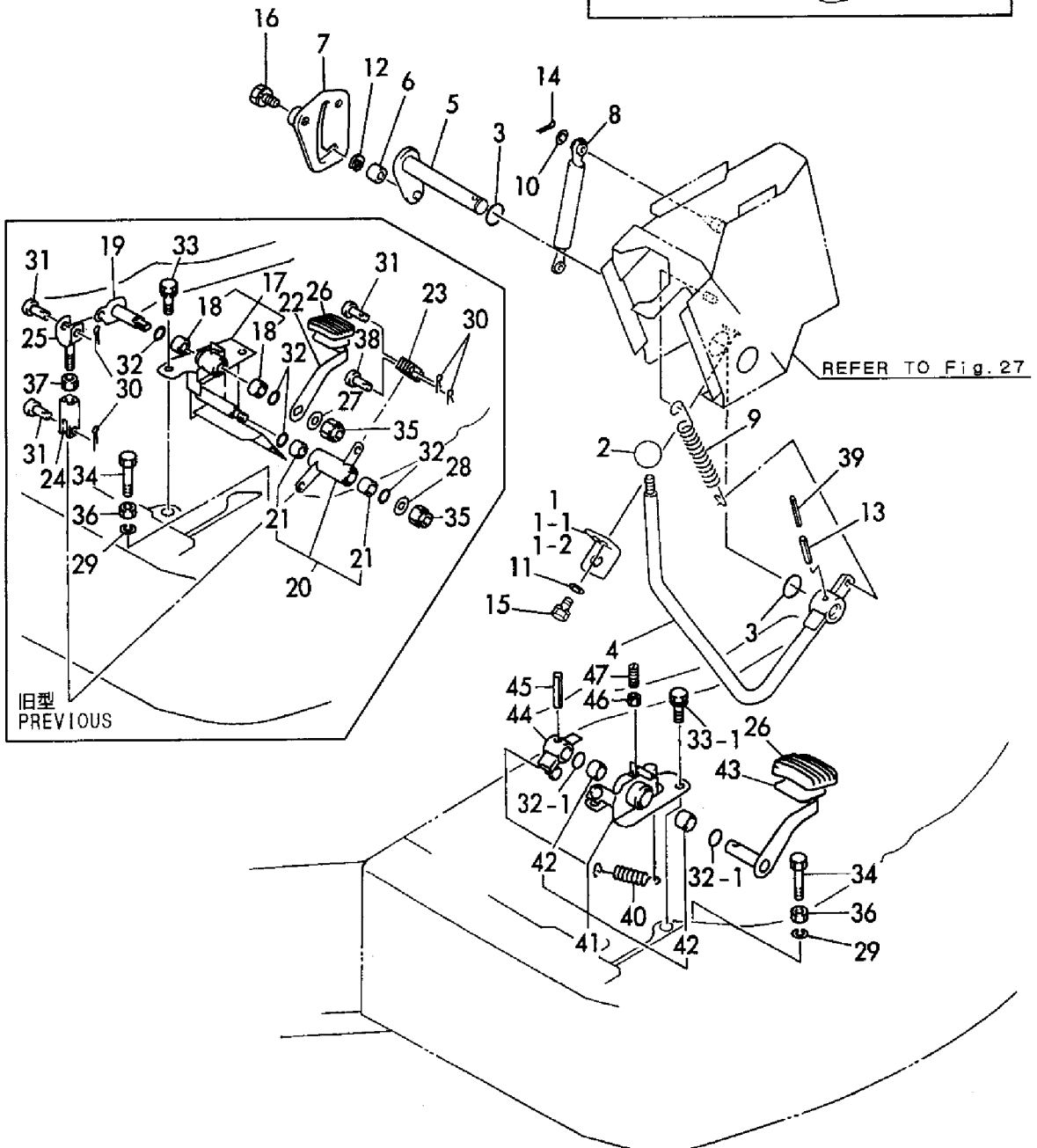
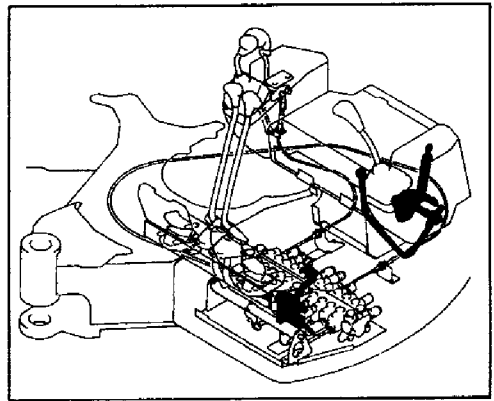

1,1,,172176-74500,, "P.T.O.KIT, FRAME END",1,1,,,,,,,,,,,,,,,,,
2,2,,933168-28480,, "WASHER 20X9X3.2",1,1,,,,,,,,,,,,,,,,,
3,2,,1C6141-35370,, "SPRING, LOCK",1,1,,,,,,,,,,,,,,,,,
4,2,,172141-42960,, "JOINT, CABLE",1,1,,,,,,,,,,,,,,,,,
5,2,,172165-45240,, "SUPPORT, CABLE",1,1,,,,,,,,,,,,,,,,,
6,2,,172165-45260,, CABLE(2300,1,1,,,,,,,,,,,,,,,,,
7,2,,172142-45670,, "ROD, SPOOL",1,1,,,,,,,,,,,,,,,,,
8,2,,172157-45990,, "BOOTS, PEDAL",1,1,,,,,,,,,,,,,,,,,
9,2,,172165-46281,, "PEDAL ASSY, SWING",1,1,,,,,,,,,,,,,,,,,
10,2,,172165-46340,, BOLT,2,2,,,,,,,,,,,,,,,,,
11,2,,172165-46350,, "BRACKET, PEDAL",1,1,,,,,,,,,,,,,,,,,
12,2,,172146-41910,, "PIN 14-100",1,1,,,,,,,,,,,,,,,,,
13,2,,172165-46450,, "LOCK CMP",1,1,,,,,,,,,,,,,,,,,
14,2,,172165-46480,, BOLT,1,1,,,,,,,,,,,,,,,,,
15,2,,172165-46490,, SHIM,5,5,,,,,,,,,,,,,,,,,
16,2,,172165-46500,, BRACKET,1,1,,,,,,,,,,,,,,,,,
17,2,,172122-46590,, "ELBALL 8",1,1,,,,,,,,,,,,,,,,,
18,2,,172165-46600,, "LINK, PEDAL",1,1,,,,,,,,,,,,,,,,,
19,3,,172141-41360,, "BUSH 1415",2,2,,,,,,,,,,,,,,,,,
21,2,,172165-46630,, PIN,1,1,,,,,,,,,,,,,,,,,
22,2,,22137-080000,, "WASHER 8, POLISHED",2,2,,,,,,,,,,,,,,,,,
23,2,,22137-100000,, "WASHER 10, POLISHED",2,2,,,,,,,,,,,,,,,,,
24,2,,22351-040032,, "SPRING PIN 4X32",1,1,,,,,,,,,,,,,,,,,
25,2,,22417-160160,, "COTTER PIN 1.6X16",1,1,,,,,,,,,,,,,,,,,
26,2,,24311-000210,, "O-RING 1A P-21.0",2,2,,,,,,,,,,,,,,,,,
27,2,,24761-050000,, "NIPPLE C, GREASE",1,1,,,,,,,,,,,,,,,,,
28,2,,26013-100202,, "BOLT W/WASHER M10X20",2,2,,,,,,,,,,,,,,,,,
29,2,,26013-100202,, "BOLT W/WASHER M10X20",1,1,,,,,,,,,,,,,,,,,
30,2,,26013-100202,, "BOLT W/WASHER M10X20",2,2,,,,,,,,,,,,,,,,,
31,2,,26013-100202,, "BOLT W/WASHER M10X20",2,2,,,,,,,,,,,,,,,,,
32,2,,26051-080002,, "NUT M 8",1,1,,,,,,,,,,,,,,,,,
33,2,,26116-080304,, "BOLT M8 X 30 PLATED",2,2,,,,,,,,,,,,,,,,,
34,2,,26716-080002,, "NUT M 8",2,2,,,,,,,,,,,,,,,,,
35,2,,26756-080002,, "LOCK NUT M 8 PLATED",2,2,,,,,,,,,,,,,,,,,
35-1,2,,26716-080002,, "NUT M 8",2,2,,,,,N,, "FROM 1ST", "FROM 1ST",,,,,,
36,2,,933110-54100,, "PIN 4.75X14",1,1,,,,,,,,,,,,,,,,,
37,2,,23391-060000,, "JOINT RGI 3/4",1,1,,,,,,,,,,,,,,,,,
38,2,,172164-76750,, "JOINT, 3RD",1,1,,,,,,,,,,,,,,,,,
39,2,,172141-76090,, "CONNECTOR 3/4L",1,1,,,,,,,,,,,,,,,,,
40,3,,24315-000240,, "O-RING 1B P-24.0",1,1,,,,,,,,,,,,,,,,,
41,2,,26013-100202,, "BOLT W/WASHER M10X20",2,2,,,,,,,,,,,,,,,,,
42,2,,172164-78800,, HOSE,2,2,,,,,,,,,,,,,,,,,
43,2,,172151-76600,, "ADAPTER PF3/4, BLIND",2,2,,,,,,,,,,,,,,,,,
44,2,,172142-76280,, "JOINT 3/4, SWIVEL",2,2,,,,,1,,,,,,,,,
44A,3,,172142-77050,, "SEAL SET",4,4,,,,,W,1,,M/#01121,,M/#01121,,,,,
45,2,,172176-76651,, "JOINT, 3RD",1,1,,,,,1,,,,,,,,,
46,2,,26013-100252,, "BOLT W/WASHER M10X25",2,2,,,,,1,,,,,,,,,
47,2,,172164-78760,, HOSE,1,1,,,,,1,,,,,,,,,
48,2,,172164-78770,, HOSE,1,1,,,,,1,,,,,,,,,
49,2,,172165-03230,, "LABEL, P.T.O.",1,1,,,,,,,,,,,,,,,,,
49-1,2,,172165-03231,, "LABEL, P.T.O.",1,1,,,,,N,,M/#00852,,M/#00852,,,,,
50,2,,172165-76320,, "CONNECTOR PF3/4 CMP",1,1,,,,,,,,,,,,,,,,,
51,3,,24315-000240,, "O-RING 1B P-24.0",1,1,,,,,,,,,,,,,,,,,
52,2,,172165-74230,, "RELIEF ASSY, PORT",1,1,,,,,,,,,,,,,,,,,
53,3,,172176-74200,, "O-RING ASSY",1,1,,,,,,,,,,,,,,,,,
54,4,,24311-000140,, "O-RING 1A P-14.0",1,1,,,,,,,,,,,,,,,,,
55,4,,172162-74330,, "RING, BACK UP",1,1,,,,,,,,,,,,,,,,,
56,4,,24315-240100,, "O-RING 1B P-10A",1,1,,,,,,,,,,,,,,,,,
57,1,,172151-79420,, COVER,1,1,,,,,2,,,,,,,,,
58,1,,172164-78960,, COVER,1,1,,,,,2,,,,,,,,,
59,1,,23000-041000,, "CLAMP 41",4,4,,,,,2,,,,,,,,

Fig. 32 操縦装置 (PTOコントロール)
CONTROL EQUIP. (P. T. O. CONTROL)

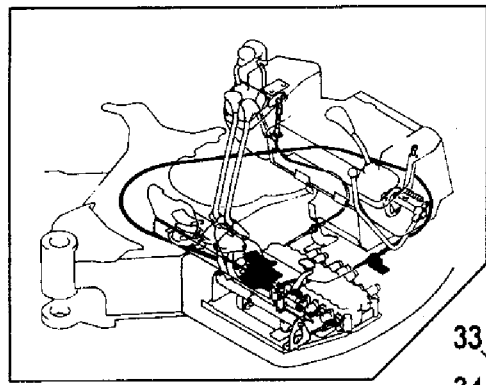

PTOキット (フレームエンド)
P. T. O. KIT (FRAME END)
(172176-74500)

見出しNo. 1は、見出しNo. 2から56を含みます。
1 inc. 2 ~ 56

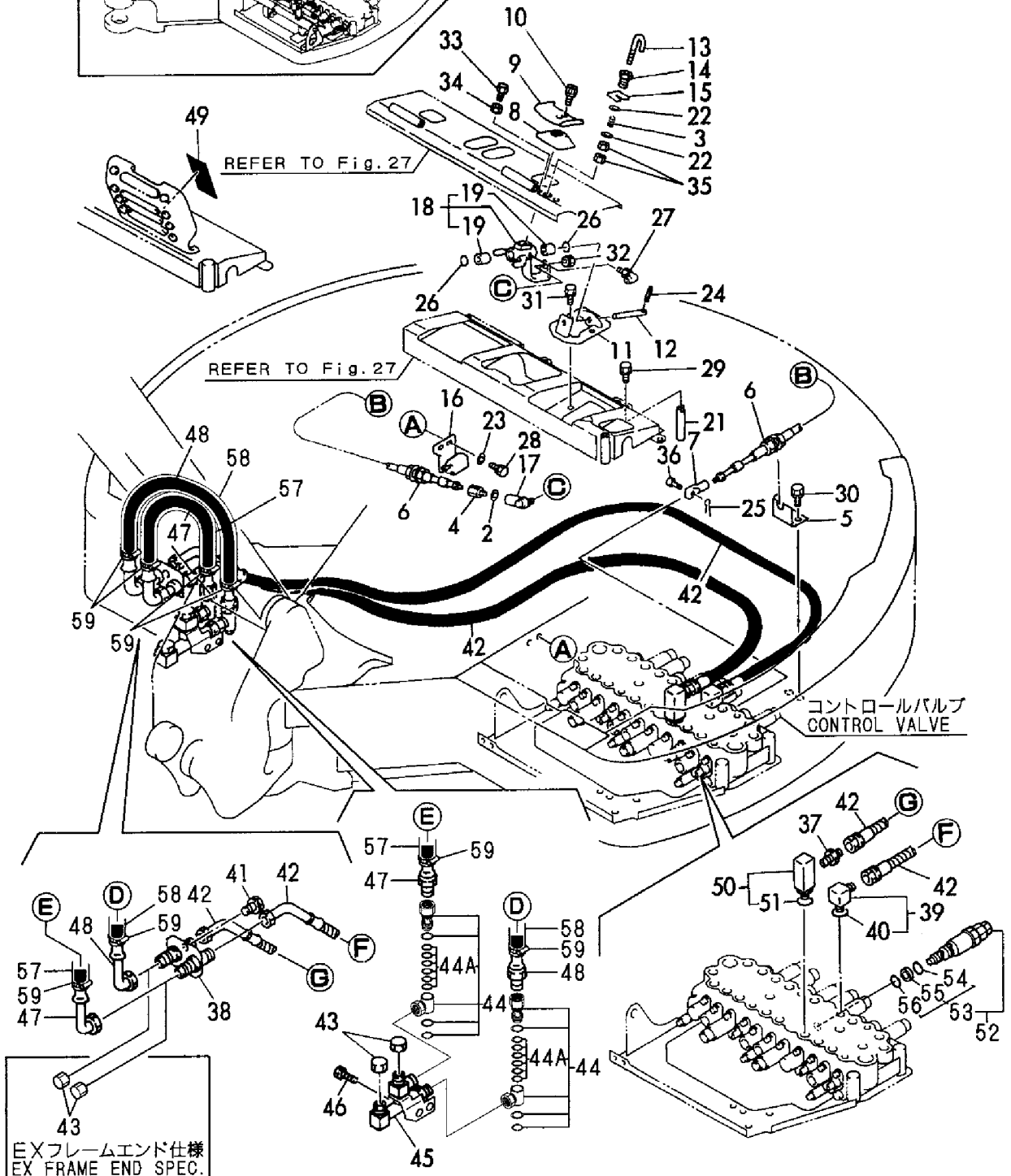

1,1,,172158-50102,, "FRAME, LOWER",1,1,,,,,,,,,,,,,,,,,
1-1,1,,172158-50103,, "FRAME, LOWER",1,1,,,,,N,,,M/#00832,,M/#00832,,,,,,
1-2,1,,172158-50104-1,, "FRAME",1,1,,,,,N,,,M/#00960,,M/#00960,,,,,,
1-3,1,,172158-50105,, "FRAME ASSY, LOWER",1,1,,,,,S,,,M/#01328,,M/#01328,,,,,,
2,1,,172147-50800-1,, "GUARD, CRAWLER",2,2,,,,,,,,,,,,,,,,,
3,1,,22217-160000,, "SPRING WASHER 16",8,8,,,,,,,,,,,,,,,,,
4,1,,26116-160452,, "BOLT M16X 45 PLATED",8,8,,,,,,,,,,,,,,,,,
5,1,,172176-53300,, "WEIGHT, CENTER",1,1,,,,,,,,,,,,,,,,,
6,1,,172147-50810-1,, "GUARD, CRAWLER",2,2,,,,,,,,,,,,,,,,,
7,1,,22217-160000,, "SPRING WASHER 16",3,3,,,,,,,,,,,,,,,,,
8,1,,26076-161702,, "BOLT 10.9 16X170",2,2,,,,,,,,,,,,,,,,,
9,1,,172176-54101,, "FRAME W/BUSH,TURNING",1,1,,,,,,,,,,,,,,,,,
9-1,1,,172176-54102,, "FRAME W/BUSH,TURNING",1,1,,,,,S,,,M/#01328,,M/#01328,,,,,,
10,1,,172164-54780,, "PLUG,RUBBER",1,1,,,,,,,,,,,,,,,,,
11,1,,172124-57600,, "BEARING,REVOLVE",1,1,,,,,,,,,,,,,,,,,
11-1,1,,172124-57601,, "BEARING,TURNING",1,1,,,,,R,,, "FROM 1ST",, "FROM 1ST",,,,,,
11-2,1,,172124-57602,, "BEARING, TURNING",1,1,,,,,N,,,M/#01505,,M/#01505,,,,,,
12,2,,172124-57620,, "SEAL, UPPER",1,1,,,,,,,,,,,,,,,,,
13,2,,172124-57630,, "SEAL, LOWER",1,1,,,,,,,,,,,,,,,,,
14,1,,172124-57610,, "BOLT M16X80",20,20,,,,,,,,,,,,,,,,,
15,1,,172122-57620,, "PARALLEL PIN 13X36",4,4,,,,,,,,,,,,,,,,,
16,1,,172162-57650,, "BOLT M16X90",20,20,,,,,,,,,,,,,,,,,
17,1,,172151-53430,, GROMMET,3,3,,,,,,,,,,,,,,,,,
18,1,,172165-67480,, CLIP,1,1,,,,,,,,,,,,,,,,,
18-1,1,,172176-68210,, TREE-CLIP,1,1,,,,,N,,,M/#01074,,M/#01074,,,,,,
19,1,,26076-162002,, "BOLT 10.9 16X200",1,1,,,,,,,,,,,,,,,,,
20,1,,172164-54870,, TREE-CLIP,1,1,,,,,,,,,,,,,,,,,
21,1,,172176-68210,, TREE-CLIP,1,1,,,,,,,,,,,,,,,,,
21-1,1,,172122-17190,, CLIP,1,1,,,,,N,,,M/#00870,,M/#00870,,,,,,
22,1,,172165-53500,, WASHER,3,3,,,,,W,,,M/#01154,,M/#01154,,,,,,

Fig. 33 フレーム&回転ベアリング
FRAME & TURNING BEARING

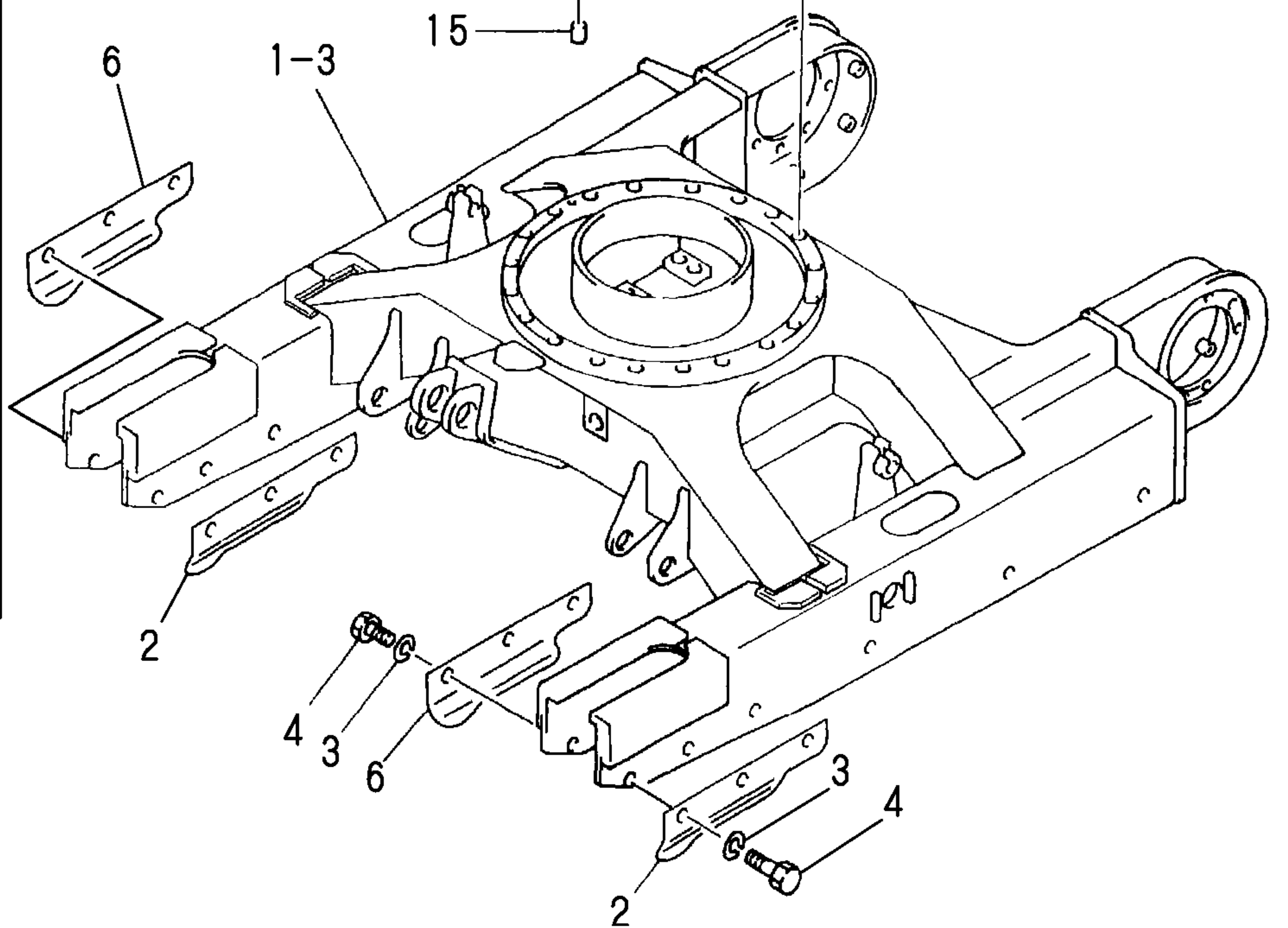
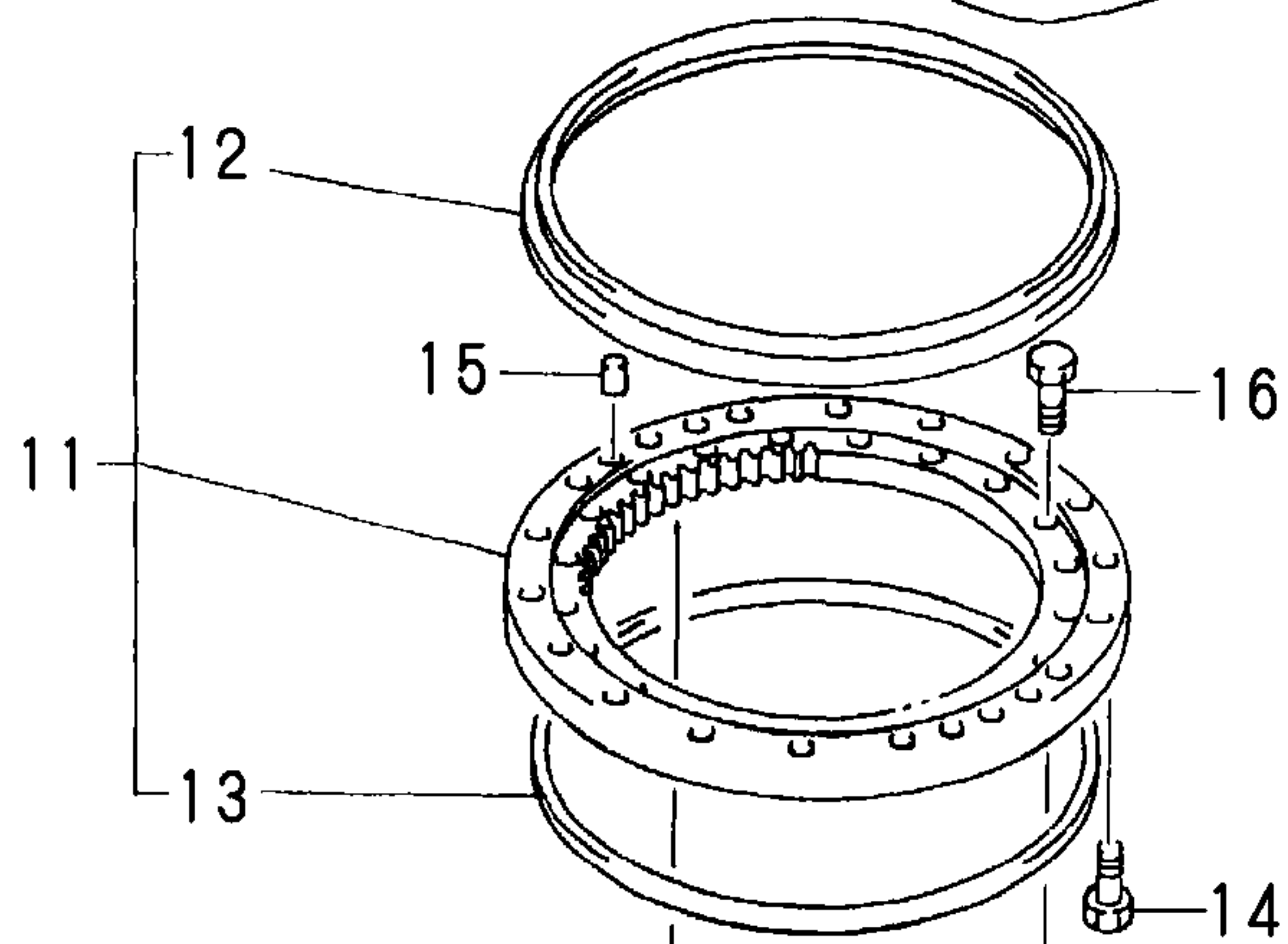
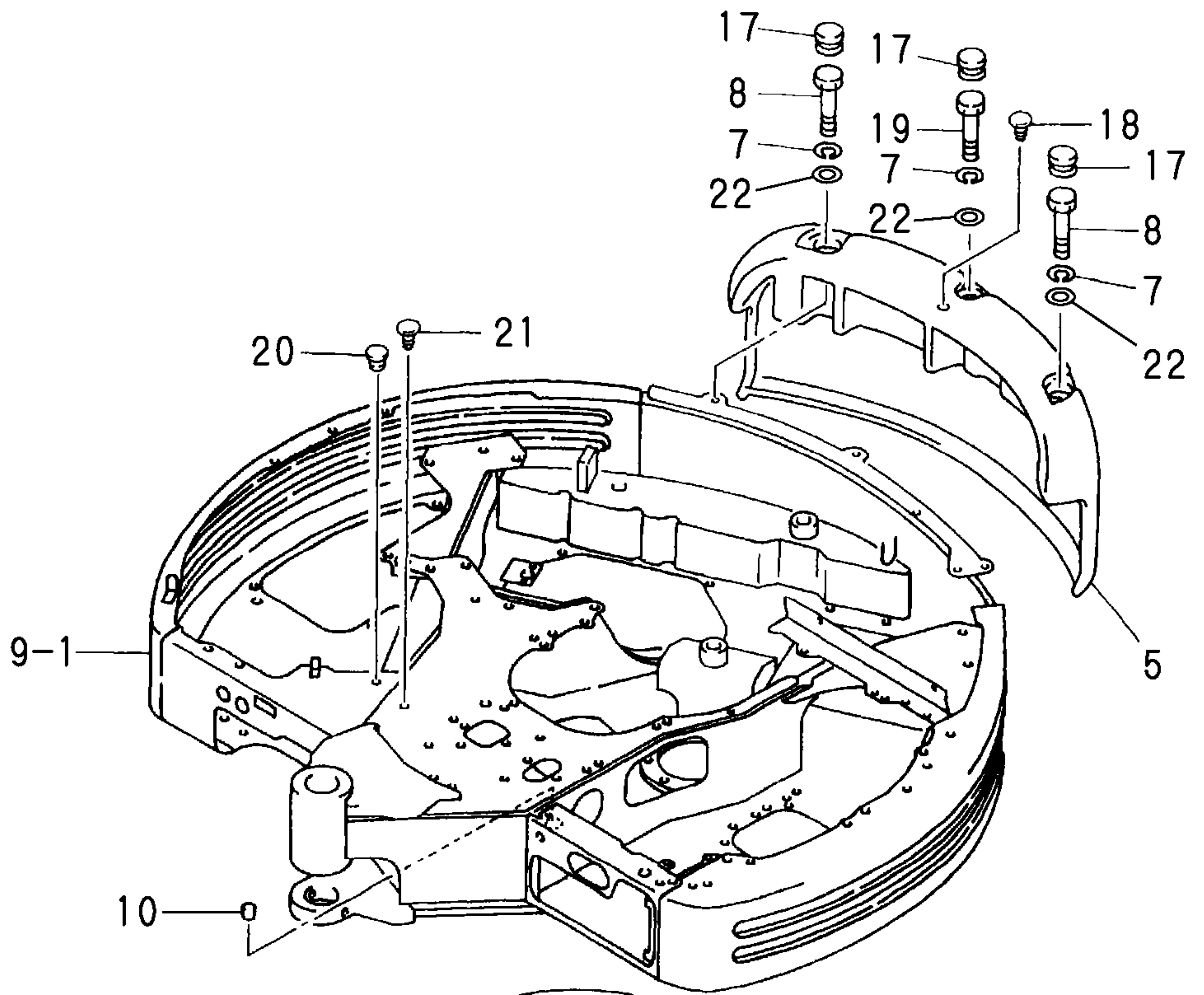
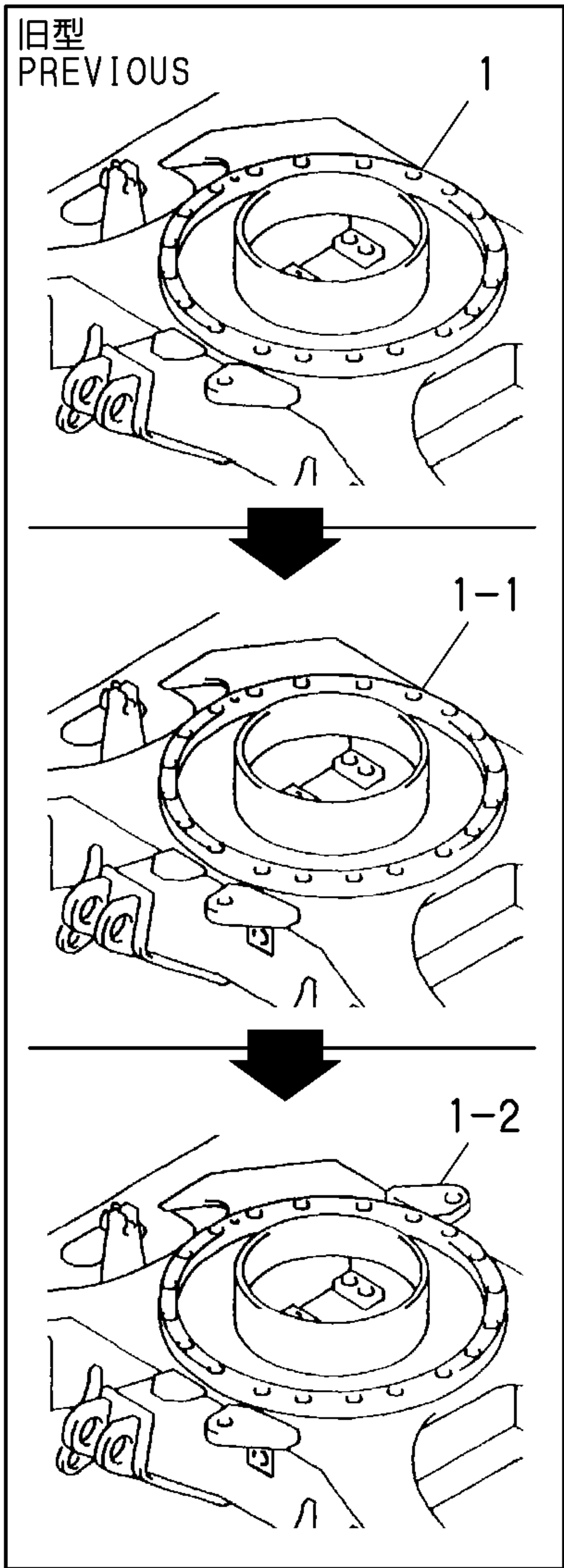
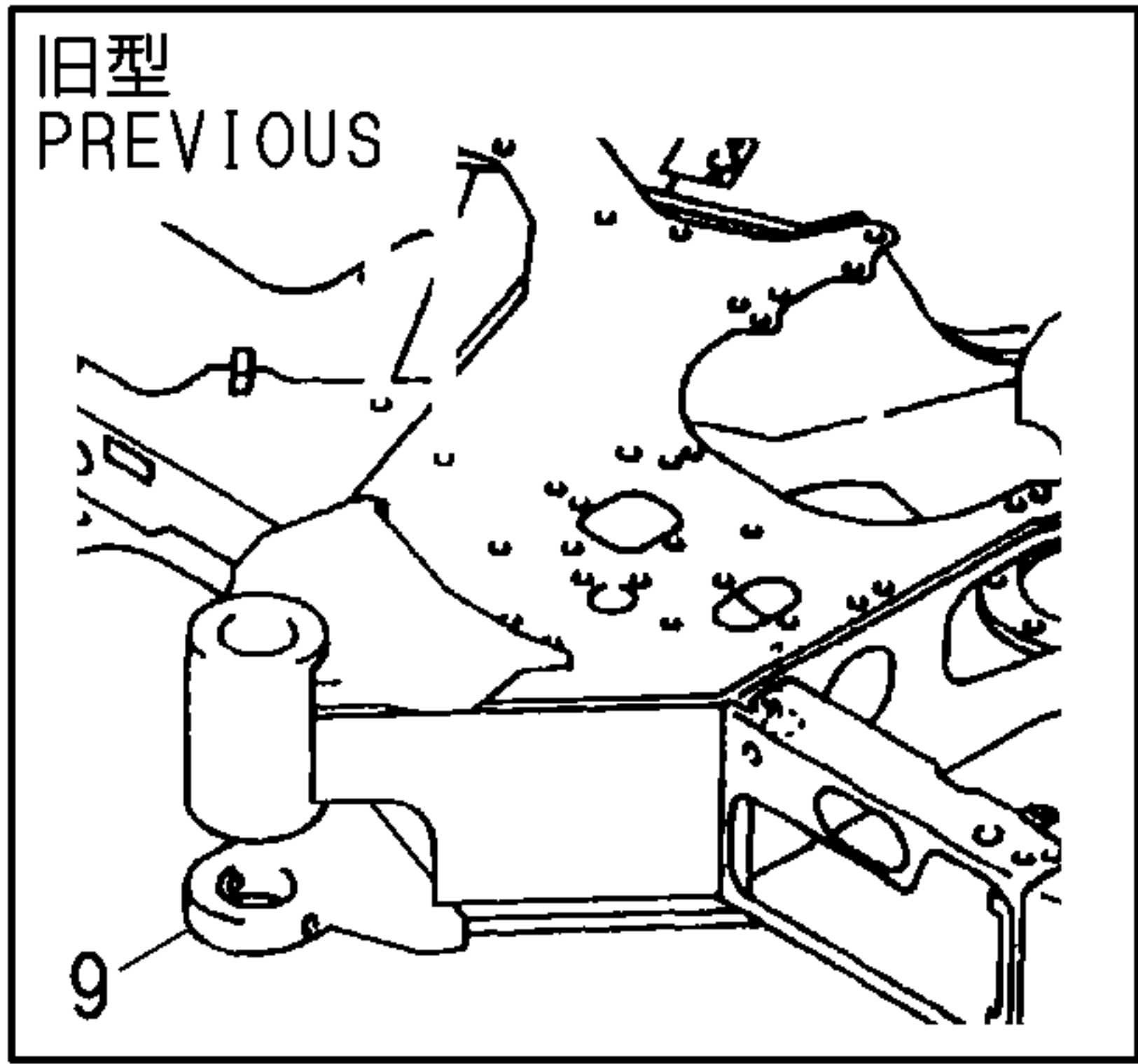

1,2,,172164-61700,,COVER,1,,,,,1,,,,,
2,2,,172164-61690,,COVER,1,,,,,1,,,,,
3,1,,172164-61150,, "COVER E",1,1,,,,,
4,1,,172164-61160,, "COVER,LAMP(GREEN:97)",1,1,,,,,
5,1,,172164-61181,, "COVER F",1,1,,,,,
6,1,,172164-61210,, "COVER (G)",,1,,,,,
7,1,,172164-61250,, "RUBBER, SEAL",1,1,,,,,
8,1,,172147-61300-2,, "COVER(R),DRIVING",1,1,,,,,
9,1,,172164-61280,,COVER,1,1,,,,,
10,1,,172164-61300,, "COVER, FRONT",,1,,,,,
11,1,,172164-61341,,COVER,1,1,,,,,
11-1,1,,172164-61342,,COVER,1,1,,,,,N,,M/#01014,,M/#01014,,,,,
13,2,,172164-61350,, "COVER, ABSORBER",1,1,,,,,
14,1,,172164-61360,, "COVER (J)",1,1,,,,,
15,1,,172164-61370,, "COVER ASSY",1,1,,,,,
17,2,,172164-61380,, "COVER, ABSORBER",1,1,,,,,
18,2,,172164-61390,, "COVER, ABSORBER",1,1,,,,,
19,1,,172164-61401,, "COVER L COMPL.",,1,,,,,
20,1,,172147-61450,, "COVER, UNDER",1,1,,,,,
21,1,,172164-61481,,COVER(B),1,1,,,,,
22,2,,172164-61121,, "COVER (B)",1,1,,,,,
23,2,,172164-61460,, "COVER, ABSORBER",1,1,,,,,
24,1,,172164-61490,, "COVER, ABSORBER",1,1,,,,,
25,2,,172164-61130,,COVER(C),1,1,,,,,
26,2,,172164-61470,, "COVER, ABSORBER",1,1,,,,,
27,1,,172165-61660,, "COVER K",1,1,,,,,
28,1,,172519-63240,, "BOLT 8X 16",4,4,,,,,
29,1,,172519-63240,, "BOLT 8X 16",2,2,,,,,
30,1,,22217-100000,, "SPRING WASHER 10",8,8,,,,,
30A,1,,22217-100000,, "SPRING WASHER 10",5,,,,,1,,,,,
31,1,,22217-100000,, "SPRING WASHER 10",16,16,,,,,
32,1,,22217-100000,, "SPRING WASHER 10",4,4,,,,,
33,1,,22217-100000,, "SPRING WASHER 10",3,3,,,,,
34,1,,22217-100000,, "SPRING WASHER 10",5,5,,,,,
35,1,,22217-100000,, "SPRING WASHER 10",6,6,,,,,
36,1,,22217-100000,, "SPRING WASHER 10",2,2,,,,,
37,1,,26013-080162,, "BOLT W/WASHER M8X16",2,2,,,,,
38,1,,22217-100000,, "SPRING WASHER 10",1,1,,,,,
39,1,,22217-100000,, "SPRING WASHER 10",,4,,,,,
40,1,,22217-100000,, "SPRING WASHER 10",2,2,,,,,
41,1,,22217-120000,, "SPRING WASHER",6,6,,,,,
42,1,,26116-100202,, "BOLT M10X 20 PLATED",2,2,,,,,
43,1,,26116-100202,, "BOLT M10X 20 PLATED",5,5,,,,,
44,1,,26116-100202,, "BOLT M10X 20 PLATED",4,4,,,,,
45,1,,26116-100202,, "BOLT M10X 20 PLATED",3,3,,,,,
46,1,,26116-100202,, "BOLT M10X 20 PLATED",5,5,,,,,
47,1,,26116-100202,, "BOLT M10X 20 PLATED",6,6,,,,,
48,1,,26116-100202,, "BOLT M10X 20 PLATED",2,2,,,,,
49,1,,172519-63240,, "BOLT 8X 16",4,4,,,,,
50,1,,26116-100202,, "BOLT M10X 20 PLATED",1,1,,,,,
51,1,,26116-100202,, "BOLT M10X 20 PLATED",16,16,,,,,
52,1,,26116-100252,, "BOLT M10X 25 PLATED",,4,,,,,
53,1,,26116-120302,, "BOLT M12X 30 PLATED",,2,,,,,
54,1,,26116-120252,, "BOLT M12X 25 PLATED",6,6,,,,,
55,1,,172519-63240,, "BOLT 8X 16",4,4,,,,,
56,1,,172164-61510,, "COVER, HEATER",1,,,,,
57,1,,172164-61530,,SPONGE,1,1,,,,,
58,1,,26116-100162,, "BOLT M10X 16 PLATED",3,3,,,,,
59,1,,172176-68210,,TREE-CLIP,2,,,,,
60,1,,172147-61310-2,, "COVER(L),DRIVING",1,1,,,,,
61,1,,172732-11510,,GROMMET,1,,,,,
62,1,,172164-61101,,COVER,1,1,,,,,
63,1,,172164-61140,, "COVER (D)",1,1,,,,,

Fig. 34 フレームカバー FRAME COVER

クーラーキット
COOLER KIT
(172176-08100)

Fig.	REF.	No.
Fig. 11	REF. No. 1	No. 2~34
Fig. 12	REF. No. 1	No. 1~10
Fig. 13	REF. No. 1	No. 1~62
Fig. 14	REF. No. 1	No. 1~49
Fig. 20	REF. No. 1	No. 1~11
Fig. 34	REF. No. 1	No. 1, 2
Fig. 36	REF. No. 1	No. 1~5
Fig. 37	REF. No. 1	No. 1~5
Fig. 38	REF. No. 1	No. 1~5
Fig. 39	REF. No. 18B	No. 23, 24, 53~55
Fig. 41	REF. No. 16B	No. 22B, 23B, 34

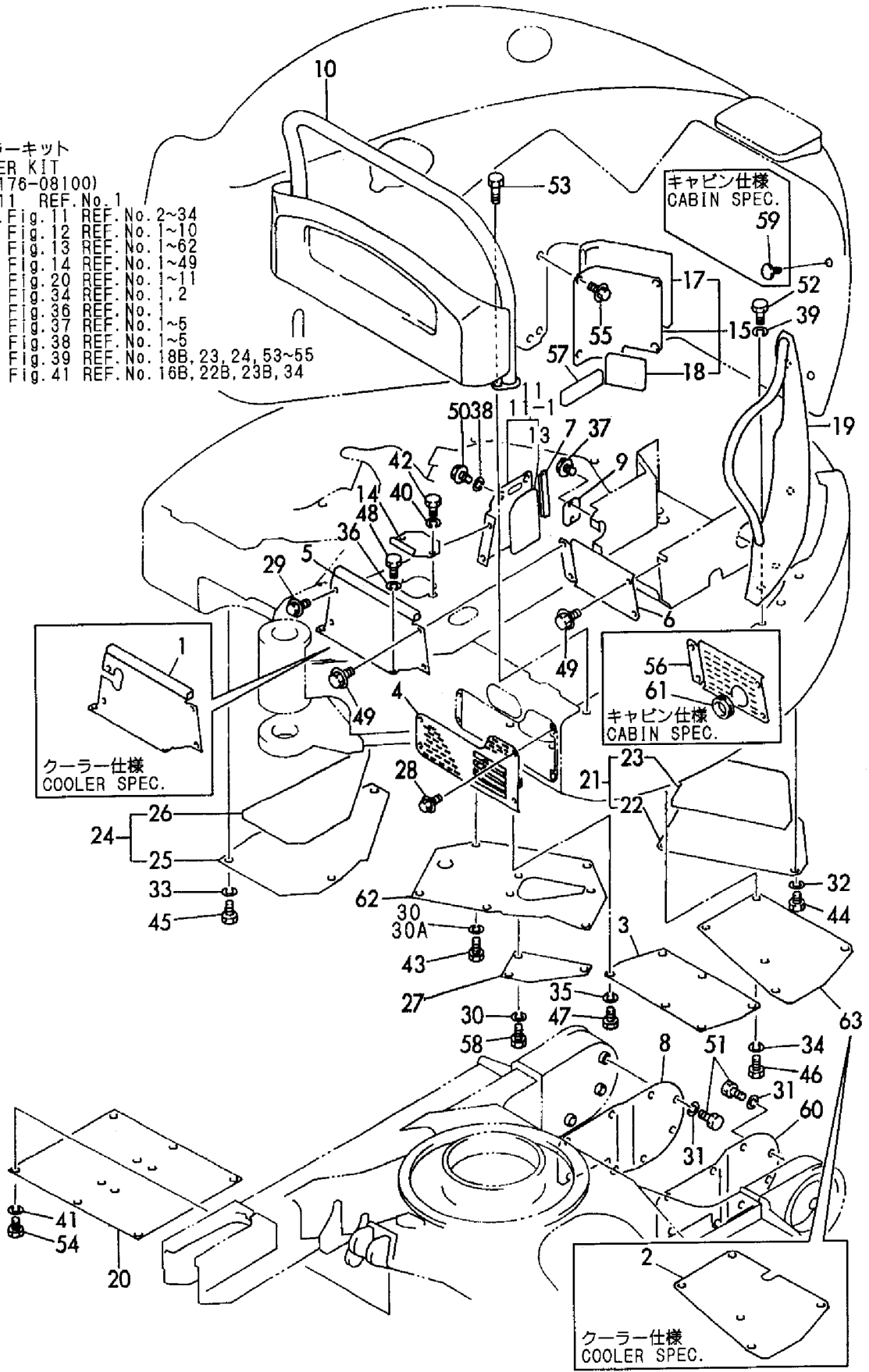

1,1,,194300-21460,,CAP,1,1,,,,,,,,,,,,,
2,1,,172164-63100,, "PANEL(L), INSTRUMENT",1,1,,,,,,,,,,,,,
3,1,,172164-63111,, "PANEL(R), INST(SI",1,1,,,,,,,,,,,,,
4,1,,172164-63150,, "SEAL, PANEL",1,1,,,,,,,,,,,,,
5,1,,172519-63240,, "BOLT 8X 16",16,16,,,,,,,,,,,,,
6,1,,172165-63600,, "COVER (R)",1,1,,,,,,,,,,,,,
7,1,,172165-63620,, "COVER (L)",1,1,,,,,,,,,,,,,
8,1,,172165-63650,, "PLUG 10,HOLE",1,1,,,,,,,,,,,,,
9,1,,172165-63660,,CAP,1,1,,,,,,,,,,,,,
9A,1,,172165-63660,,CAP,1,1,,,,,W,1,,M/#01014,,M/#01014,,,,,
10,1,,172162-64200,, "SEAT, OPERATOR",1,1,,,,,,,,,,,,,
11,2,,172162-64210,, "CUSHION ASSY",1,1,,,,,,,,,,,,,
12,2,,172162-64220,, "BACK ASSY",1,1,,,,,,,,,,,,,
13,2,,172162-64230,, "BACK (B) ASSY",1,1,,,,,,,,,,,,,
14,2,,172162-64240,, "PANEL, BACK",1,1,,,,,,,,,,,,,
15,3,,172162-64320,, "RUBBER A, EDGE",1,1,,,,,,,,,,,,,
16,3,,172162-64330,, "RUBBER B, EDGE",1,1,,,,,,,,,,,,,
17,2,,172162-64250,, "BRACKET L, SIDE",1,1,,,,,,,,,,,,,
18,2,,172162-64260,, "BRACKET R, SIDE",1,1,,,,,,,,,,,,,
19,2,,172162-64270,,ADJUSTER,1,1,,,,,,,,,,,,,
20,2,,172162-64280,,ADJUSTER,1,1,,,,,,,,,,,,,
23,2,,172162-64310,, "SCREW M5X10, TAPPING",3,3,,,,,,,,,,,,,
24,2,,26013-080202,, "BOLT W/WASHER M8X20",8,8,,,,,,,,,,,,,
25,2,,26022-080162,, "SCREW M 8X 16",4,4,,,,,,,,,,,,,
26,1,,172212-61230,, "FASTENER, DIAL",1,1,,,,,,,,,,,,,
27,1,,172164-64190,, "MOUNT, SEAT",1,1,,,,,,,,,,,,,
28,1,,172164-64350,, "COVER, MOUNT",1,1,,,,,,,,,,,,,
29,1,,172164-64370,, "PLATE, SEAT",1,1,,,,,,,,,,,,,
30,1,,22217-080000,, "SPRING WASHER 8",4,4,,,,,,,,,,,,,
31,1,,26013-100202,, "BOLT W/WASHER M10X20",4,4,,,,,,,,,,,,,
32,1,,26013-100202,, "BOLT W/WASHER M10X20",4,4,,,,,,,,,,,,,
33,1,,26577-050122,, "SCREW M 5X 12",2,2,,,,,,,,,,,,,
34,1,,26716-050002,, "NUT M 5",2,2,,,,,,,,,,,,,
35,1,,26716-080002,, "NUT M 8",4,4,,,,,,,,,,,,,
36,1,,172165-64750,, "CAP 8, SCREW",4,4,,,,,Z,,MXXX,,MXXX,,,,,
37,1,,22137-080000,, "WASHER 8, POLISHED",4,4,,,,,Z,,MXXX,,MXXX,,,,,
38,1,,22217-080000,, "SPRING WASHER 8",4,4,,,,,Z,,MXXX,,MXXX,,,,,
39,1,,26716-080002,, "NUT M 8",4,4,,,,,Z,,MXXX,,MXXX,,,,,

Fig. 35 シート&シートマウント SEAT & SEAT MOUNT

見出しNo. 10は、見出しNo. 11から25を含みます。
10 inc. 11 ~ 25

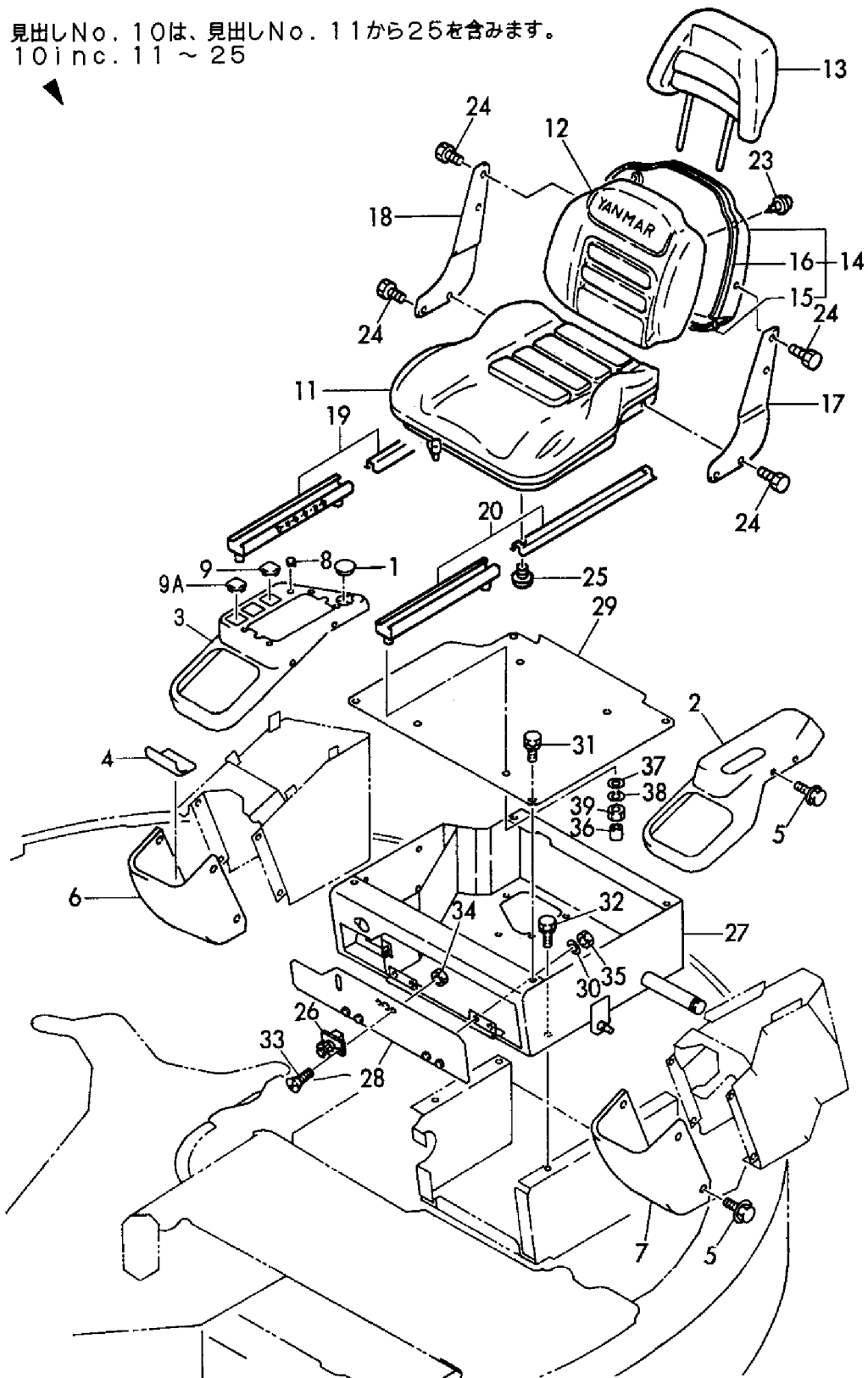

1,2,,172164-62600,,PLATE,1,,,,,2,,,,,
2,1,,172164-58800,, "LOCK PIN, TURN.",1,1,,,,,Z,,,M/#01328,,M/#01328,,,,,
3,1,,172164-58830,, "BRACKET, PIN",1,1,,,,,Z,,,M/#01328,,M/#01328,,,,,
4,1,,22217-100000,, "SPRING WASHER 10",2,2,,,,,Z,,,M/#01328,,M/#01328,,,,,
5,1,,26116-100202,, "BOLT M10X 20 PLATED",2,2,,,,,Z,,,M/#01328,,M/#01328,,,,,
6,1,,172164-62190,, "STEP C",1,1,,,,,
7,1,,172151-62240,,GROMMET,,3,,,,,
8,1,,172164-62300,, "MAT,FLOOR",1,1,,,,,
9,1,,172164-62310,, "BRACKET A",,1,,,,,
10,1,,172164-62340,, "PLATE B",1,1,,,,,
11,1,,172164-62370,,BRACKET,1,1,,,,,
12,1,,172164-62420,, "SHEET, FRAME",1,1,,,,,
13,1,,172164-62430,, "SEAT, SWING",1,1,,,,,
14,1,,172164-62450,, "STEP ASSY",1,1,,,,,
15,2,,172164-62270,,STEP,1,1,,,,,
16,2,,172164-62460,, "NOISE ABSORBER A",1,1,,,,,
17,2,,172164-62470,, "NOISE ABSORBER B",1,1,,,,,
18,2,,172164-62480,, "NOISE ABSORBER C",1,1,,,,,
19,1,,172164-62500,, "PLATE B, MULTI",1,1,,,,,1,,,,,
19-1,1,,172164-62501,, "PLATE B",1,1,,,,,S,4,,M/#01227,,M/#01227,,,,,
19-2,1,,172164-62502,, "PLATE B",1,1,,,,,N,1,,M/#01505,,M/#01505,,,,,
20,1,,172164-62530,,COVER,1,1,,,,,1,,,,,
20-1,1,,172164-62531,,COVER,1,1,,,,,S,1,,M/#01227,,M/#01227,,,,,
21,1,,22217-100000,, "SPRING WASHER 10",2,2,,,,,1,,,,,
22,1,,26013-100202,, "BOLT W/WASHER M10X20",,3,,,,,
23,1,,26013-100202,, "BOLT W/WASHER M10X20",9,9,,,,,
24,1,,26013-100202,, "BOLT W/WASHER M10X20",4,4,,,,,
25,1,,26013-100202,, "BOLT W/WASHER M10X20",4,4,,,,,
26,1,,26013-100202,, "BOLT W/WASHER M10X20",3,3,,,,,
27,1,,26647-100152,, "WING BOLT M10X15",2,2,,,,,1,,,,,
28,1,,172164-62490,, "SEAT, STEP",,1,,,,,
29,1,,172116-46630,, "KNOB, LOCK LEVER",1,1,,,,,Z,,,M/#01328,,M/#01328,,,,,
30,1,,172164-62620,,PLATE,1,,,,,3,,,,,
30-1,1,,172164-62621,, "PLATE B",1,,,,,S,5,,M/#01227,,,,,
30-2,1,,172164-62622,, "PLATE B",1,,,,,N,3,,M/#01505,,,,,

Fig. 36 ステップ STEP

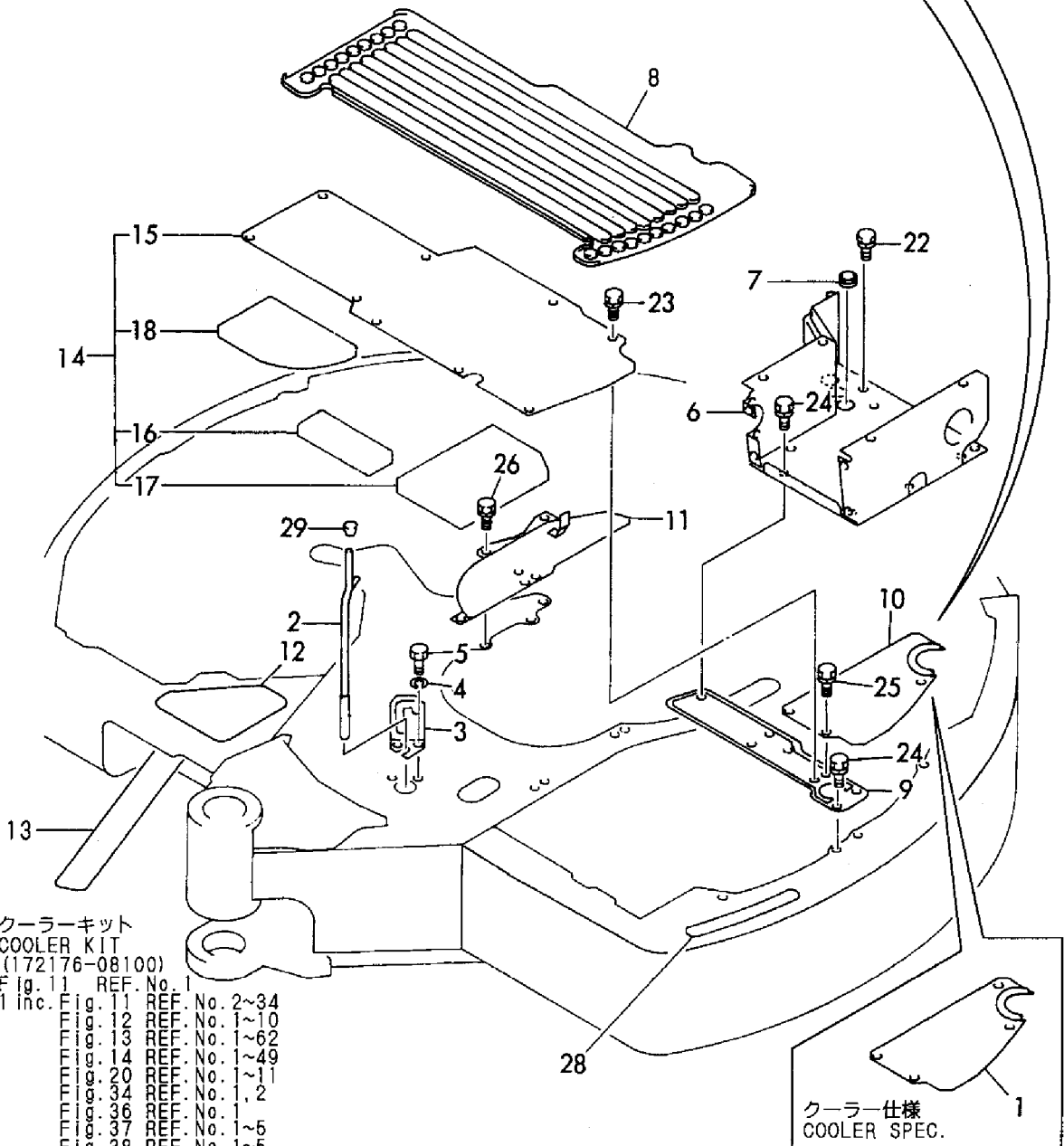
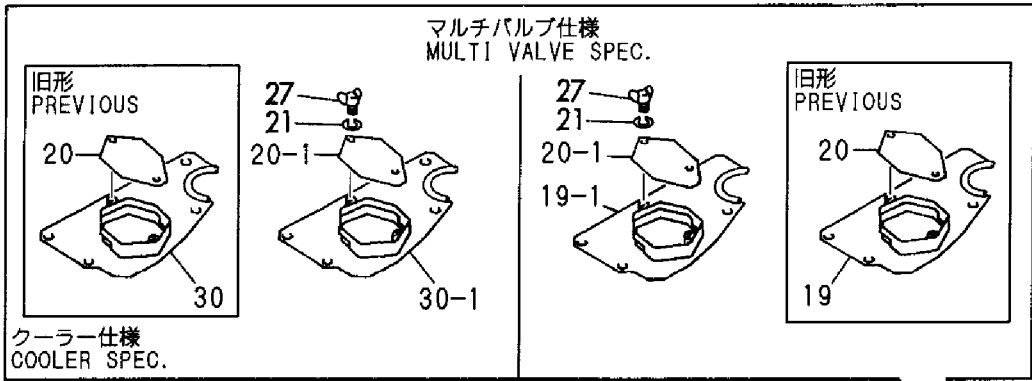

クーラーキット
COOLER KIT
(172176-08100)

Fig. No.	REF. No.
Fig. 11	REF. No. 2~34
Fig. 12	REF. No. 1~10
Fig. 13	REF. No. 1~62
Fig. 14	REF. No. 1~49
Fig. 20	REF. No. 1~11
Fig. 34	REF. No. 1, 2
Fig. 36	REF. No. 1
Fig. 37	REF. No. 1~5
Fig. 38	REF. No. 1~5
Fig. 39	REF. No. 18B, 23, 24, 53~55
Fig. 41	REF. No. 16B, 22B, 23B, 34

1,2,,194145-04810,, "WASHER 10",2,,,,,1,,,,,
2,2,,172164-66310,, "STOPPER, BONNET",1,,,,,1,,,,,
3,2,,172164-66320,, RUBBER,1,,,,,1,,,,,
4,2,,172164-66650,, "RUBBER, SEAL 95",1,,,,,1,,,,,
5,2,,26013-100202,, "BOLT W/WASHER M10X20",2,,,,,1,,,,,
6,1,,172168-46760,, "BOLT M10X20",1,1,,,,,
7,1,,26557-060102,, "SCREW 6X10",2,2,,,,,
8,1,,172164-65100,, "BONNET, ABSORBER",1,1,,,,,
10,2,,172164-65700,, "RUBBER, SEAL A",1,1,,,,,
11,2,,172164-65710,, "RUBBER, SEAL B",1,1,,,,,
12,2,,172164-65750,, "RUBBER, SEAL E",1,1,,,,,
13,2,,172164-65760,, "SEAL A",1,1,,,,,
14,2,,172164-65770,, SEAL,1,1,,,,,
15,2,,172164-65780,, SEAL,1,1,,,,,
16,2,,172164-65870,, "BONNET A, ABSORBER",1,1,,,,,
17,2,,172164-65880,, "BONNET B, ABSORBER",1,1,,,,,
18,2,,172164-65890,, "BONNET C, ABSORBER",1,1,,,,,
19,2,,172164-65900,, "BONNET D, ABSORBER",1,1,,,,,
20,2,,172164-66290,, "PAD, (RUBBER)",1,1,,,,,
21,1,,172734-65260,, "PIN, BONNET LEVER",1,1,,,,,
22,1,,172734-65270,, "SPRING, CATCH",1,1,,,,,
23,1,,172164-65280,, "LINK 165",2,2,,,,,
24,1,,172164-65291,, "LINK 110",2,2,,,,,
25,1,,172164-65300,, "COVER, ABSORBER",1,1,,,,,
26,2,,172164-61390,, "COVER, ABSORBER",1,1,,,,,
28,2,,172164-65720,, "RUBBER, SEAL C",1,1,,,,,
28-1,2,,172164-65721,, "RUBBER, SEAL C",1,1,,,,,R,,M/#00767,,M/#00767,,,,,
29,2,,172164-65740,, "RUBBER, SEAL E",1,1,,,,,
30,2,,172164-65760,, "SEAL A",1,1,,,,,
31,2,,172164-65770,, SEAL,1,1,,,,,
32,2,,172164-65780,, SEAL,1,1,,,,,
33,2,,172164-65910,, "BONNET COVER, ABSORB.",1,1,,,,,
34,2,,172164-65920,, "RUBBER, SEAL F",1,1,,,,,
35,2,,172164-65930,, "BONNET COVER, ABSORB.",1,1,,,,,
36,2,,172164-65940,, "BONNET COVER, ABSORB.",1,1,,,,,
37,2,,172164-66110,, "BONNET COVER, ABSORB.",1,1,,,,,
38,2,,172164-66620,, "RUBBER, SEAL 320",1,1,,,,,
39,1,,26557-080202,, "SCREW M 8X 20",2,2,,,,,
40,1,,172164-65450,, "SPRING, GAS",2,2,,,,,
41,1,,172164-65460,, "SEAL, DUCT",1,1,,,,,
42,1,,172124-65490,, "PLATE, CATCH",1,1,,,,,
43,1,,172164-65510,, COVER,1,1,,,,,
44,1,,172164-65560,, HINGE,1,1,,,,,
45,1,,172164-65580,, MOLDING,1,1,,,,,
46,1,,172164-65590,, PLATE,1,1,,,,,
47,1,,172164-65610,, COVER,1,1,,,,,
48,1,,172164-65640,, "WASHER 32X11X2.3",1,1,,,,,
49,1,,172164-65670,, "BRACKET COMPL.",1,1,,,,,
50,1,,172164-65801,, "HOOK COMP., KEY",1,1,,,,,
51,1,,172164-65840,, "LEVER, LOCK",1,1,,,,,
52,1,,172164-65860,, CATCHER,1,1,,,,,
53,1,,172164-66160,, "KEY ASSY, CYLINDER",1,1,,,,,
53-1,1,,172164-66161,, "KEY ASSY, CYLINDER",1,1,,,,,N,,M/#00797,,M/#00797,,,,,
53A,2,,172164-66131,, "PLATE, LOCK",1,1,,,,,
53B,2,,172164-66170,, "KEY ASSY, CYLINDER",1,1,,,,,
53C,2,,26347-100002,, "U-NUT M10",1,1,,,,,
54,1,,22137-060000,, "WASHER 6, POLISHED",2,2,,,,,
55,1,,22137-080000,, "WASHER 8, POLISHED",4,4,,,,,
56,1,,22137-080000,, "WASHER 8, POLISHED",4,4,,,,,
57,1,,22137-100000,, "WASHER 10, POLISHED",2,2,,,,,
58,1,,22157-100000,, "WASHER 10",3,3,,,,,
59,1,,22217-060000,, "SPRING WASHER 6",2,2,,,,,
60,1,,22217-060000,, "SPRING WASHER 6",2,2,,,,,

61,1,,22217-080000,, "SPRING WASHER 8",2,2,,,,,,,,,,,,,,,,,,,,,
62,1,,22217-080000,, "SPRING WASHER 8",4,4,,,,,,,,,,,,,,,,,,,,,
63,1,,22217-100000,, "SPRING WASHER 10",2,2,,,,,,,,,,,,,,,,,,,,,
64,1,,22217-100000,, "SPRING WASHER 10",8,8,,,,,,,,,,,,,,,,,,,,,
65,1,,22217-100000,, "SPRING WASHER 10",4,4,,,,,,,,,,,,,,,,,,,,,
66,1,,22417-200200,, "COTTER PIN 2.0X20",12,12,,,,,,,,,,,,,,,,,,,,,
66-1,1,,1C6281-52320,, "PIN 8,COME-OFF
SNAP",12,12,,,,,N,,M/#01505,,M/#01505,,,,,
67,1,,22417-200200,, "COTTER PIN 2.0X20",2,2,,,,,,,,,,,,,,,,,,,,,
68,1,,22487-080300,, "PIN 8X 30",2,2,,,,,,,,,,,,,,,,,,,,,
69,1,,22487-100260,, "PIN 10X26",4,4,,,,,,,,,,,,,,,,,,,,,
70,1,,26013-100252,, "BOLT W/WASHER M10X25",3,3,,,,,,,,,,,,,,,,,,,,,
71,1,,26116-060122,, "BOLT 6X12",2,2,,,,,,,,,,,,,,,,,,,,,
72,1,,26116-080162,, "BOLT 8X16",4,4,,,,,,,,,,,,,,,,,,,,,
73,1,,26116-080202,, "BOLT M 8X 20 PLATED",2,2,,,,,,,,,,,,,,,,,,,,,
74,1,,26116-100252,, "BOLT M10X 25 PLATED",4,4,,,,,,,,,,,,,,,,,,,,,
75,1,,26116-100202,, "BOLT M10X 20 PLATED",2,2,,,,,,,,,,,,,,,,,,,,,
76,1,,26116-100202,, "BOLT M10X 20 PLATED",8,8,,,,,,,,,,,,,,,,,,,,,
77,1,,26557-060082,, "SCREW M 6X 8",2,2,,,,,,,,,,,,,,,,,,,,,
78,1,,22137-100000,, "WASHER 10,POLISHED",8,8,,,,,,,,,,,,,,,,,,,,,
79,1,,933110-00301,, "KEY ASSY",1,1,,,,,,,,,,,,,,,,,,,,,
80,1,,172164-66150,, "SPONGE, RUBBER",1,1,,,,,,,,,,,,,,,,,,,,,
81,1,,1A1040-43900,, "SPRING WASHER",2,2,,,,,,,,,,,,,,,,,,,,,
82,1,,1A1040-45890,, "WASHER 10 36 4.5",8,8,,,,,,,,,,,,,,,,,,,,,
83,1,,1A1040-45890,, "WASHER 10 36 4.5",4,4,,,,,,,,,,,,,,,,,,,,,
84,1,,172164-45980,, "GRIP, BONNET",1,1,,,,,,,,,,,,,,,,,,,,,

Fig. 37 ボンネット BONNET

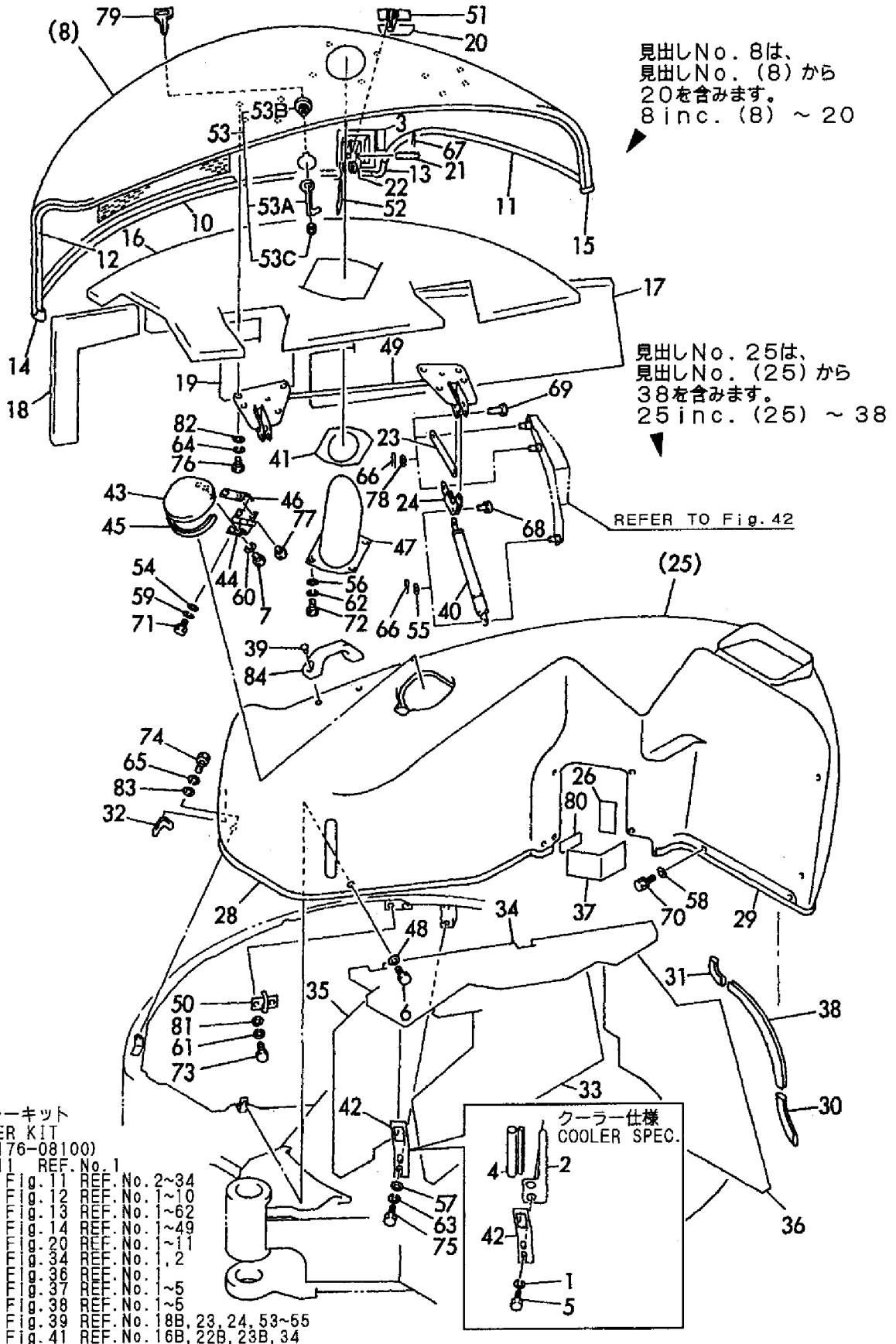

1,2,,172176-65750,, "DUCT (B) ASSY",1,,,,,1,,,,,
2,2,,172176-65790,, "DUCT (A) ASSY",1,,,,,1,,,,,
3,2,,26116-100162,, "BOLT M10X 16 PLATED",2,,,,,1,,,,,
4,2,,26116-100202,, "BOLT M10X 20 PLATED",2,,,,,1,,,,,
5,2,,22217-100000,, "SPRING WASHER 10",4,,,,,1,,,,,
6,1,,172164-66480,, "RUBBER 340, SEAL",1,1,,,,,
7,1,,172164-66490,, "BRACKET, RESERVOIR",1,1,,,,,
8,1,,26116-100202,, "BOLT M10X 20 PLATED",2,2,,,,,
9,1,,26116-100202,, "BOLT M10X 20 PLATED",2,2,,,,,
10,1,,172164-66600,, "SEAL (A)",1,1,,,,,
11,1,,172164-66620,, "RUBBER, SEAL 320",1,1,,,,,
12,1,,172164-66630,, "RUBBER, SEAL 530",1,1,,,,,
13,1,,172164-66640,, "RUBBER, SEAL 400",1,1,,,,,
14,1,,172164-66650,, "RUBBER, SEAL 95",1,1,,,,,
15,1,,172164-66680,, "PLATE",1,1,,,,,
16,1,,172164-66710,, "BRACKET ASSY",1,1,,,,,
17,1,,172164-66740,, "SEAL",1,1,,,,,
18,1,,172164-66800,, "RUBBER, SEAL 60",1,1,,,,,
19,1,,22137-100000,, "WASHER 10, POLISHED",1,1,,,,,
20,1,,22137-100000,, "WASHER 10, POLISHED",2,2,,,,,
21,1,,22137-100000,, "WASHER 10, POLISHED",2,2,,,,,
22,1,,22217-100000,, "SPRING WASHER 10",4,4,,,,,
23,1,,22217-100000,, "SPRING WASHER 10",4,4,,,,,
24,1,,22217-100000,, "SPRING WASHER 10",2,2,,,,,
25,1,,22217-100000,, "SPRING WASHER 10",2,2,,,,,
26,1,,22217-100000,, "SPRING WASHER 10",2,2,,,,,
27,1,,26116-100162,, "BOLT M10X 16 PLATED",4,4,,,,,
28,1,,26116-100162,, "BOLT M10X 16 PLATED",2,2,,,,,
29,1,,26116-100202,, "BOLT M10X 20 PLATED",4,4,,,,,
30,1,,172176-65650,, "DUCT ASSY",1,1,,,,,
32,2,,172176-65700,, "EV, PLATE A",1,1,,,,,
33,2,,172176-65710,, "EV, PLATE B",1,1,,,,,
34,1,,172164-13660,, "SEAL(C), MOUNT R",1,1,,,,,
35,1,,172164-54760,, "SEAL A, FRAME",1,1,,,,,
36,1,,172164-54770,, "SEAL B, FRAME",1,1,,,,,
37,1,,172168-65790,, "RUBBER",1,1,,,,,
38,1,,172164-66440,, "DUCT A",1,1,,,,,

Fig. 38 ダクト DUCT

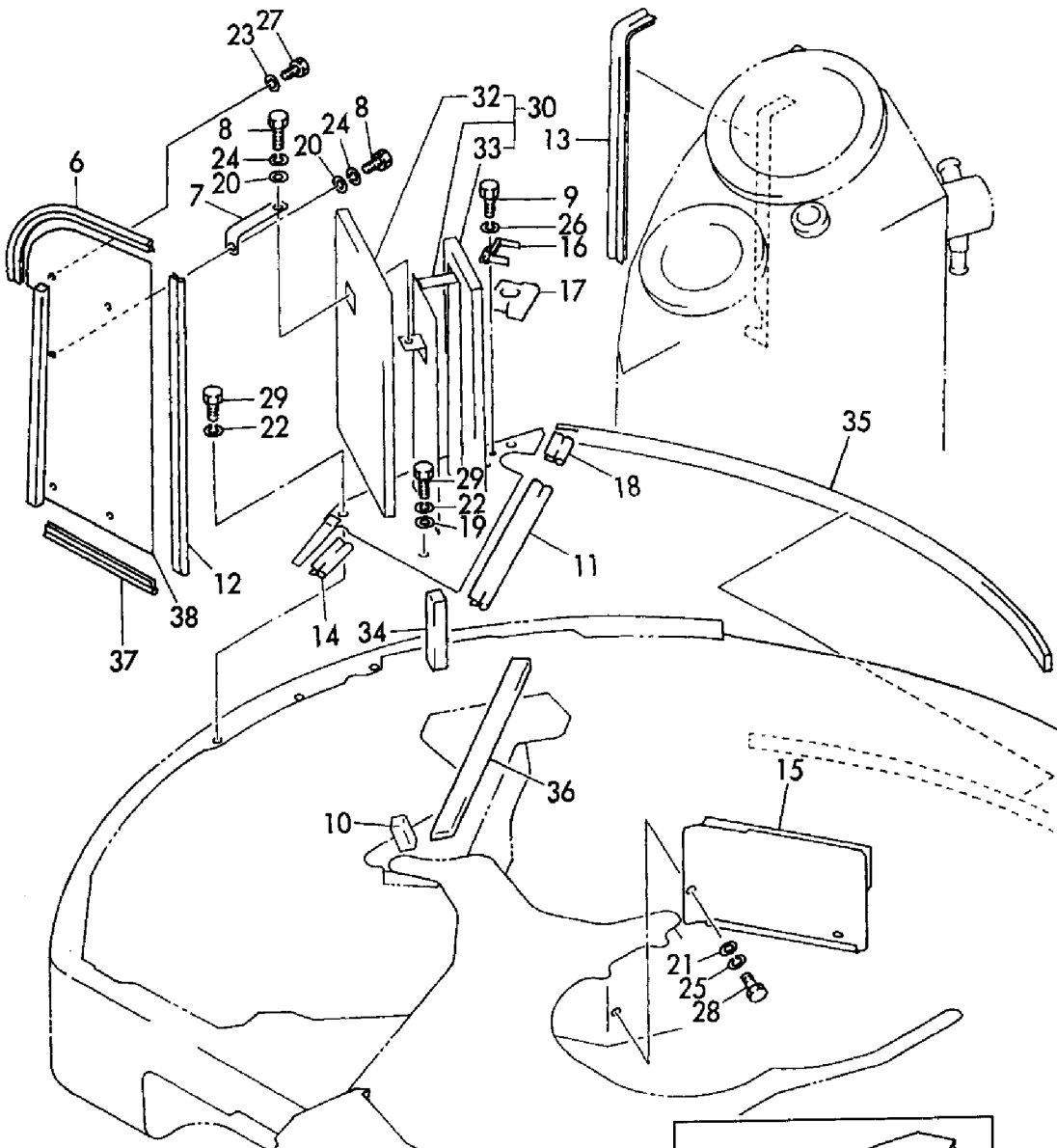

クーラーキット
COOLER KIT
(172176-08100)

Fig.	REF.	No.
Fig. 11	REF. No.	2~34
Fig. 12	REF. No.	1~10
Fig. 13	REF. No.	1~62
Fig. 14	REF. No.	1~49
Fig. 20	REF. No.	1~11
Fig. 34	REF. No.	1, 2
Fig. 36	REF. No.	1~5
Fig. 37	REF. No.	1~5
Fig. 38	REF. No.	1~5
Fig. 39	REF. No.	18B, 23, 24, 53~55
Fig. 41	REF. No.	16B, 22B, 23B, 34

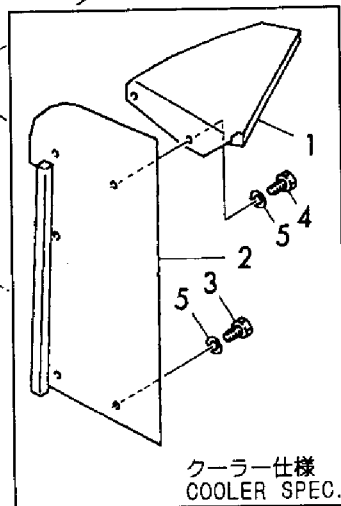

1A,1,,772176-68400,, "CABIN ASSY",1,,,,,1,,,,,
1A-1,1,,772425-68400-1,, "CABIN ASSY",1,,,,,S,1,M/#01505,,,,,
1B,1,,772164-68421,, "CABIN ASSY (CL)",1,,,,,2,,,,,
1B-1,1,,772425-68420-1,, "CABIN ASSY(CL)",1,,,,,S,2,M/#01505,,,,,
2,2,,172176-67040,, "COVER, LINK",1,,,,,
3,2,,172176-67180,, GRIP,2,,,,,
3-1,2,,172176-67181,, GRIP,2,,,,,N,,M/#00937,,,,,
4,2,,172137-68120,, PIN,2,,,,,
5,2,,172176-68400,, "CABIN ASSY",1,,,,,
5-1,2,,172176-68401,, "CABIN ASSY",1,,,,,F,3,M/#00870,,,,,
5-2,2,,172176-68402,, "CABIN ASSY",1,,,,,N,,M/#01245,,,,,
5-3,2,,172425-68400-1,, "CABIN ASSY",1,,,,,S,,M/#01505,,,,,
6,2,,172176-69300,, "SEAL (A)",1,,,,,
7,2,,172176-69310,, "SEAL (B)",1,,,,,
8,2,,172176-69320,, "SEAL,DOOR",1,,,,,
9,2,,172176-69890,, "LINK B",1,,,,,
10,2,,172111-16890,, "GROMMET 9",1,,,,,
10-1,2,,172176-67780,, GROMMET,1,,,,,S,,M/#01505,,,,,
11,2,,22137-080000,, "WASHER 8, POLISHED",2,,,,,
11-1,2,,22157-080000,, "WASHER 8",2,,,,,R,,M/#00745,,,,,
12,2,,22217-100000,, "SPRING WASHER 10",2,,,,,
13,2,,172176-67260,, "STAY, RADIO",2,,,,,
14,2,,26013-100252,, "BOLT W/WASHER M10X25",4,,,,,
14-1,2,,26013-100302,, "BOLT M10X 30",4,,,,,R,,M/#00745,,,,,
15,2,,26013-080162,, "BOLT W/WASHER M8X16",2,,,,,
16,2,,26013-080252,, "BOLT M 8X 25",2,,,,,
17,2,,26013-060162,, "BOLT M 6X 16",4,,,,,
18A,2,,26589-060162,, "SCREW M6,BINDING",4,,,,,4,,,,,
18B,2,,26589-060162,, "SCREW M6,BINDING",6,,,,,5,,,,,
19,2,,26716-100002,, "NUT 10",2,,,,,
20,2,,172176-67990,, "COVER ASSY,HARNESS",1,,,,,4,,,,,
21,3,,172176-68120,, "TRIM, HARNESS",1,,,,,4,,,,,
22,3,,172176-67910,, "COVER,HARNESS",1,,,,,4,,,,,
23,2,,172164-69250,, COVER,1,,,,,5,,,,,
24,2,,172164-69310,, TRIM,1,,,,,5,,,,,
25,2,,172176-67740,, "SHIM T=0.8",1,,,,,
25-1,2,,172176-67740,, "SHIM T=0.8",2,,,,,K,,M/#00745,,,,,
25-2,2,,172176-67740,, "SHIM T=0.8",5,,,,,K,,M/#00965,,,,,
26,2,,172176-67760,, "PANEL, FRONT",1,,,,,
27,2,,172176-67780,, GROMMET,1,,,,,
28,2,,172176-67790,, PLUG,2,,,,,
29,2,,172176-67820,, "SEAL, PLATE",1,,,,,
30,2,,172176-67830,, "BOLT 10X30",3,,,,,
30-1,2,,172176-67830,, "BOLT 10X30",2,,,,,K,,M/#00745,,,,,
31,2,,172176-67870,, TRAY,1,,,,,
32,2,,172176-67880,, HOLDER,1,,,,,
33,2,,172176-68160,, GROMMET,1,,,,,
34,2,,172176-68190,, "COVER, BONNET",1,,,,,
35,2,,26450-080202,, "BOLT M 8X 20",4,,,,,
36,2,,172176-67900,, "SEAL C",1,,,,,
37,2,,172176-68080,, "SEAL D",1,,,,,
37-1,2,,172176-68080,, "SEAL D",2,,,,,K,,M/#00745,,,,,
38,2,,26557-050162,, "SCREW M 5X 16",4,,,,,
38-1,2,,26022-050162,, "SCREW M 5X 16",4,,,,,R,,M/#00745,,,,,
39,2,,172176-68130,, "TRIM, PLATE",1,,,,,
39-1,2,,172176-68131,, TRIM,1,,,,,S,,M/#00870,,,,,
40,2,,172176-68030,, WASHER,2,,,,,
41,2,,172176-67341,, "LINK A",1,,,,,
42,2,,172162-69070,, COATHANGER,1,,,,,
42-1,2,,172162-69071,, COATHANGER,1,,,,,S,,M/#01096,,,,,
43,2,,22867-300080,, "SCREW 3X 8",2,,,,,
44,2,,172176-67741,, "SHIM T=1.2",1,,,,,
44-1,2,,172176-67741,, "SHIM T=1.2",2,,,,,K,,M/#00618,,,,,

44-2,2,,172176-67741,, "SHIM T=1.2",5,,,,,K,,,M/#00965,,,,,
45,2,,1A1686-52230,, "SCREW 6X16,PAN HD.MC",4,,,,,
45-1,2,,26022-060162,, "SCREW M 6X 16",4,,,,,R,,,M/#00745,,,,,
46,2,,172176-69780,,SEAL,1,,,,,W,,,M/#00643,,,,,
47,2,,172176-68090,,COLLAR,4,,,,,W,,,M/#00870,,,,,
48,2,,172176-68140,,CIRCLIP,4,,,,,W,,,M/#00870,,,,,
49,2,,22217-100000,, "SPRING WASHER 10",2,,,,,W,,,M/#00745,,,,,
50,2,,194145-04810,, "WASHER 10",6,,,,,W,,,M/#00745,,,,,
51,2,,172164-62490,, "SEAT, STEP",1,,,,,W,,,M/#01121,,,,,
52,2,,172122-17190,,CLIP,1,,,,,W,,,M/#01505,,,,,
53,2,,172164-69290,, "COVER B",1,,,,,5,,,,,
54,2,,172164-69320,,TRIM,1,,,,,5,,,,,
55,2,,172164-69200,,TRIM,1,,,,,5,,,,,

Fig. 39 キャビン (1) (本体) CABIN (1) (BODY)

キャビンASSY (標準)
CABIN ASSY (STANDARD)
(772176-68400)

Fig. 39 REF. No. 1A
(772425-68400-1)
Fig. 39 REF. No. 1A-1
inc. Fig. 39 REF. No. 2 ~ 52
Fig. 40 REF. No. 1 ~ 50
Fig. 41 REF. No. 1 ~ 35

キャビンASSY (クーラ仕様)
CABIN ASSY (COOLER SPEC.)
(772164-68421)

Fig. 39 REF. No. 1B
(772425-68420-1)
Fig. 39 REF. No. 1B-1
inc. Fig. 39 REF. No. 2 ~ 55
Fig. 40 REF. No. 1 ~ 50
Fig. 41 REF. No. 1 ~ 35

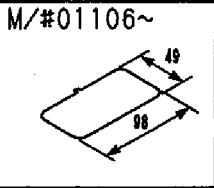
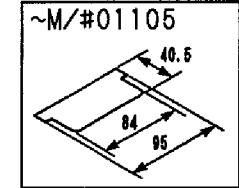
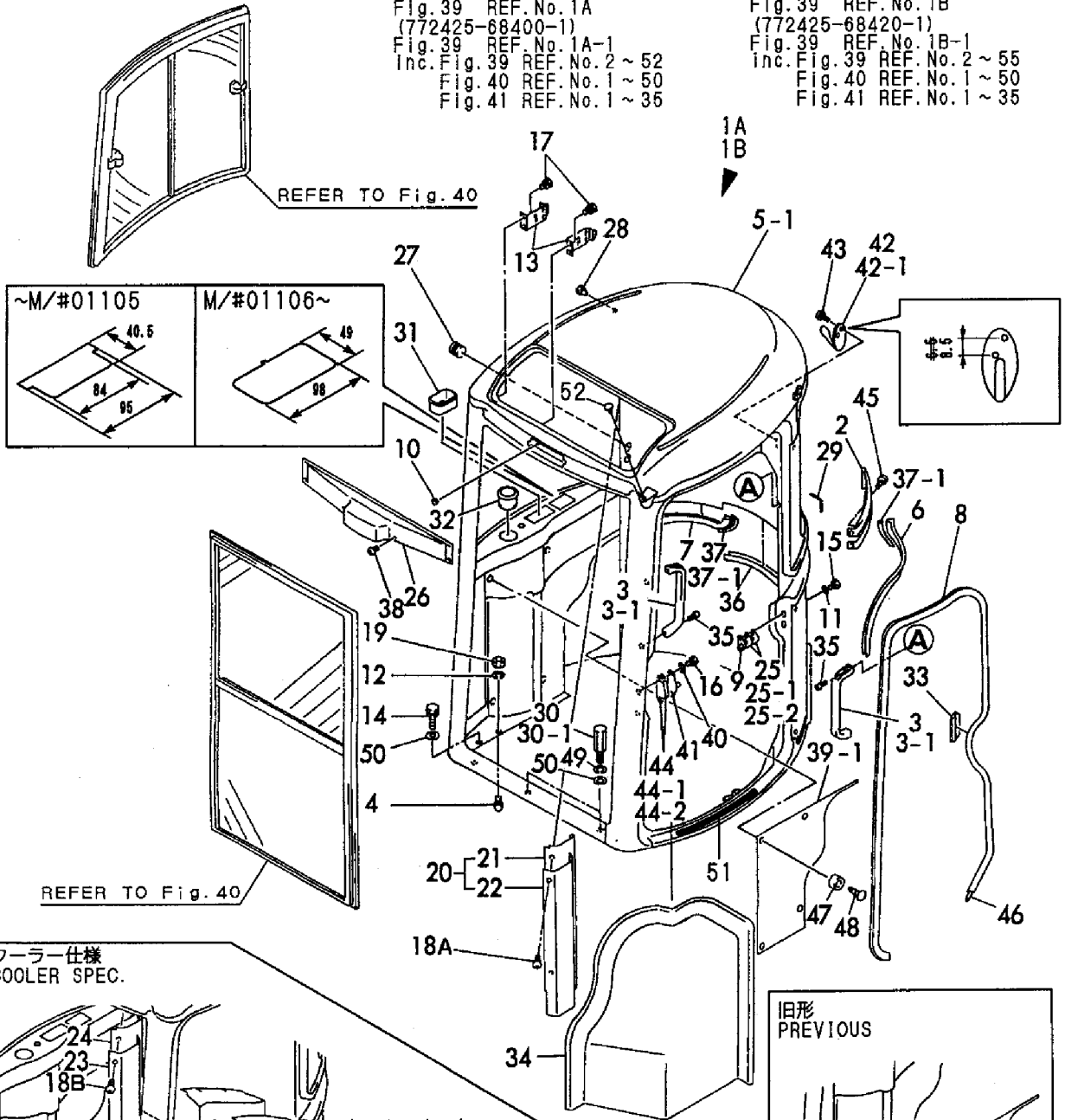

REFER TO Fig. 40

クーラー仕様
COOLER SPEC.

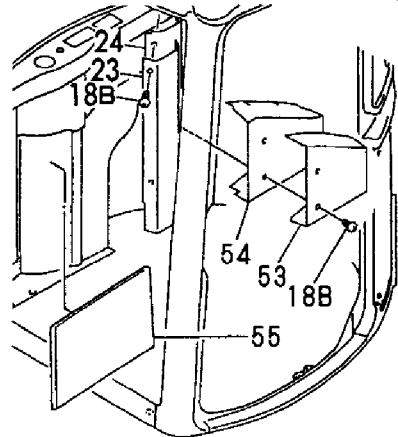

クーラーキット
COOLER KIT
(172176-08100)

Fig. 11 REF. No. 1
1 inc. Fig. 11 REF. No. 1
Fig. 11 REF. No. 2~34
Fig. 12 REF. No. 1~10
Fig. 13 REF. No. 1~62
Fig. 14 REF. No. 1~49
Fig. 20 REF. No. 1~11
Fig. 34 REF. No. 1, 2
Fig. 36 REF. No. 1
Fig. 37 REF. No. 1~5
Fig. 38 REF. No. 1~5
Fig. 39 REF. No. 18B, 23, 24, 53~55
Fig. 41 REF. No. 16B, 22B, 23B, 34

旧形
PREVIOUS

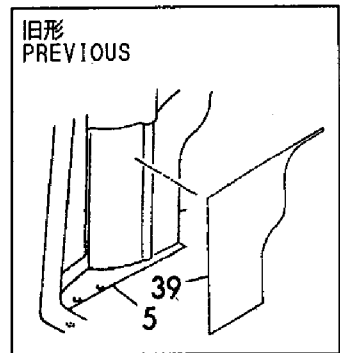

1,1,,172176-67050,,SASH,1,,,,,,,,,1,,,,,,,,,
2,2,,172176-66620,,,"FRAME ASSY",1,,,,,,,,,
4,3,,172176-66760,,,"GLASS RUN",1,,,,,,,,,
5,3,,172176-66770,,,"GLASS RUN",1,,,,,,,,,
6,3,,172176-66780,,,"RUBBER STOPPER",1,,,,,,,,,
7,3,,172176-66820,,,"RUBBER STOPPER",1,,,,,,,,,
8,2,,172176-66800,,GLASS,1,,,,,,,,,
9,3,,172176-66600,,LOCK,1,,,,,,,,,
12,4,,172176-66750,,SCREW,2,,,,,,,,,
14,2,,172176-66810,,GLASS,1,,,,,,,,,
15,3,,172176-66610,,LOCK,1,,,,,,,,,
17,4,,172176-66750,,SCREW,2,,,,,,,,,
19,3,,172176-66790,,,"CHANNEL, CENTER",1,,,,,,,,,
20,1,,172176-67060,,,"WINDOW, FRONT",1,,,,,1,,,,,,,,,
21,2,,172176-66590,,,"FRAME ASSY",1,,,,,,,,,
23,3,,172176-66890,,,"GLASS RUN",1,,,,,,,,,
24,3,,172176-66990,,,"GLASS RUN",1,,,,,,,,,
25,3,,172176-66900,,,"RUBBER STOPPER",2,,,,,,,,,
26,2,,172176-66970,,GLASS,1,,,,,,,,,
27,3,,172176-66550,,,"LOCK ASSY (LH)",1,,,,,,,,,
30,4,,172176-66950,,SCREW,2,,,,,,,,,
31,4,,172176-66960,,SCREW,1,,,,,,,,,
32,3,,172176-66560,,LOCK,1,,,,,,,,,
35,4,,172176-66950,,SCREW,2,,,,,,,,,
36,4,,172176-66960,,SCREW,1,,,,,,,,,
38,2,,172176-66980,,GLASS,1,,,,,,,,,
39,3,,172176-66570,,LOCK,1,,,,,,,,,
41,4,,172176-66930,,SCREW,2,,,,,,,,,
42,4,,172176-66940,,SCREW,1,,,,,,,,,
43,3,,172176-66580,,,"LOCK (RL)",1,,,,,,,,,
45,4,,172176-66930,,SCREW,2,,,,,,,,,
46,4,,172176-66940,,SCREW,1,,,,,,,,,
48,3,,172176-66910,,,"CHANNEL, CENTER",1,,,,,,,,,
49,1,,172176-67200,,,"RUBBER, FRONT",1,,,,,,,,,
50,1,,172176-67210,,,"RUBBER, SIDE",1,,,,,,,,,

Fig. 40 キャビン (2) (サッシ)
CABIN (2) (SASH)

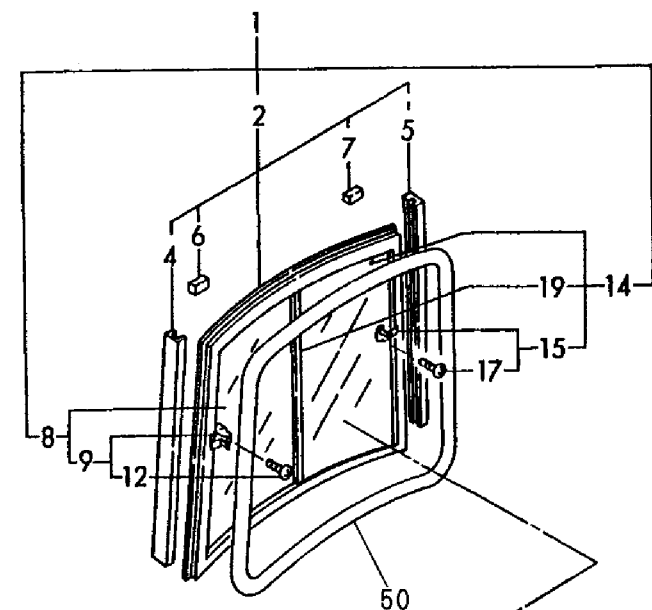

キャビン ASSY (標準)
CABIN ASSY (STANDARD)
(772176-68400)
Fig. 39 REF. No. 1A
(772425-68400-1)
Fig. 39 REF. No. 1A-1
inc. Fig. 39 REF. No. 2 ~ 52
Fig. 40 REF. No. 1 ~ 50
Fig. 41 REF. No. 1 ~ 35

キャビン ASSY (クーラ仕様)
CABIN ASSY (COOLER SPEC.)
(772164-68421)
Fig. 39 REF. No. 1B
(772425-68420-1)
Fig. 39 REF. No. 1B-1
inc. Fig. 39 REF. No. 2 ~ 55
Fig. 40 REF. No. 1 ~ 50
Fig. 41 REF. No. 1 ~ 35

REFER TO Fig. 39

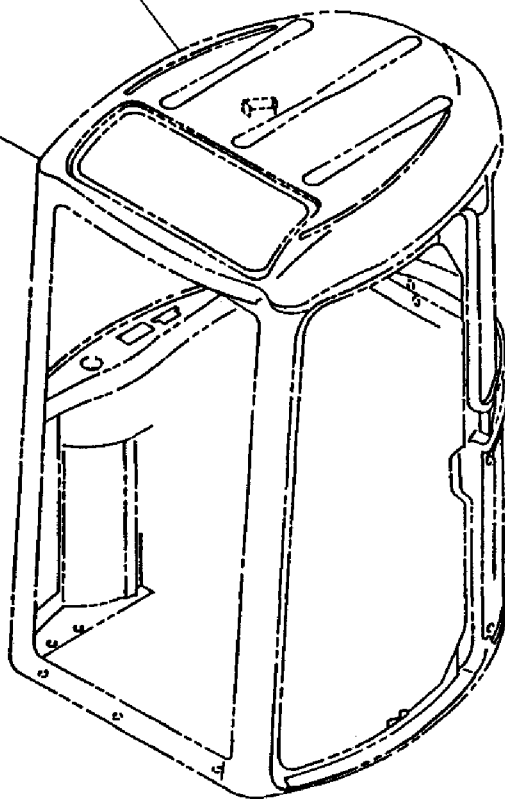
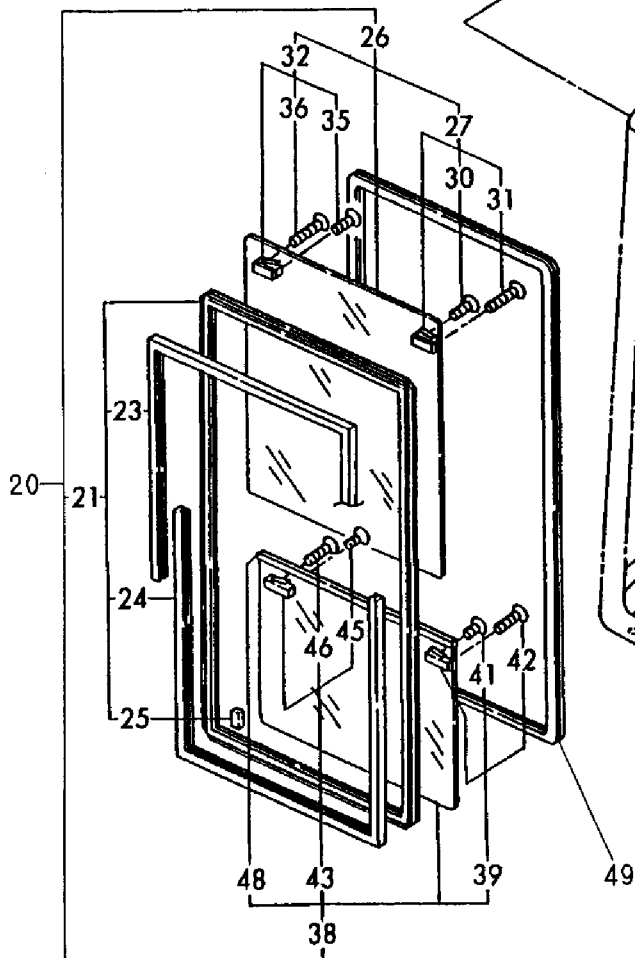

1,2,,172176-67070,, "ACRYLIC, ROOF",1,,,,,,,,,,,,,,,,,,,,,
2,2,,172176-67080,, "BRACKET, CABIN",1,,,,,,,,,,,,,,,,,,,,,
3,2,,172176-67110,, "TRIM, ROOF",1,,,,,,,,,,,,,,,,,,,,,
4,2,,172176-67141,, "TRIM, REAR",1,,,,,,,,,,,,,,,,,,,,,
5,2,,172176-67160,, "COVER A",1,,,,,,,,,,,,,,,,,,,,,
6,2,,26116-160902,, "BOLT M16X 90 PLATED",2,,,,,,,,,,,,,,,,,,,,,
7,2,,172176-69820,, "COLLAR, GLASS",10,,,,,,,,,,,,,,,,,,,,,
8,2,,172176-69830,, "GLASS, REAR",1,,,,,,,,,,,,,,,,,,,,,
9,2,,172176-69860,, "LINK A",1,,,,,,,,,,,,,,,,,,,,,
10,2,,22157-080000,, "WASHER 8",2,,,,,,,,,,,,,,,,,,,,,
11,2,,22217-160000,, "SPRING WASHER 16",4,,,,,,,,,,,,,,,,,,,,,
12,2,,26013-080202,, "BOLT W/WASHER M8X20",2,,,,,,,,,,,,,,,,,,,,,
13,2,,26013-080162,, "BOLT W/WASHER M8X16",2,,,,,,,,,,,,,,,,,,,,,
14,2,,172176-67290,, PLATE,1,,,,,,,,,,,,,,,,,,,,,
15,2,,933147-08501,, "WASHER 17X40X4.5",4,,,,,Z,,,,M/#00745,,,,,
15A,2,,22137-160000,, "WASHER 16,POLISHED",2,,,,,W,,,,M/#00745,,,,,
16A,2,,172176-68100,, "BRACKET B",1,,,,,1,,,,,
16B,2,,172164-18660,, "BRACKET ASSY",1,,,,,2,,,,,
17,2,,172176-67380,, PLATE,1,,,,,,,,,,,,,,,,,,,,,
18,2,,172176-67691,, "TRIM, SIDE",1,,,,,,,,,,,,,,,,,,,,,
19,2,,172176-67710,, "GLASS L",1,,,,,,,,,,,,,,,,,,,,,
20,2,,172176-67720,, "GLASS R",1,,,,,1,,,,,
21,2,,172176-67730,, RUBBER,1,,,,,,,,,,,,,,,,,,,,,
22A,2,,172176-67750,, "PANEL, FRONT",1,,,,,1,,,,,
22A-1,2,,172176-67751,, "PANEL, FRONT",1,,,,,N,1,M/#00852,,,,,
22A-2,2,,172176-67752,, "PANEL, FRONT",1,,,,,S,1,M/#01245,,,,,
22A-3,2,,172176-67753,, "PANEL,FRONT IN",1,,,,,N,1,M/#01505,,,,,
22B,2,,172176-67430,, "PANEL, FRONT (CL)",1,,,,,2,,,,,
22B-1,2,,172176-67431,, "PANEL, FRONT (CL)",1,,,,,S,2,M/#01245,,,,,
22B-2,2,,172176-67432,, "PANEL,FRONT (CL)",1,,,,,N,2,M/#01505,,,,,
23A,2,,172176-67770,, "PANEL, ROOF",1,,,,,1,,,,,
23A-1,2,,172176-67771,, "PANEL, ROOF",1,,,,,R,1,M/#01096,,,,,
23A-2,2,,172176-67772,, "PANEL,ROOF",1,,,,,N,,M/#01505,,,,,
23B,2,,172164-69100,, "PANEL, ROOF",1,,,,,2,,,,,
23B-1,2,,172164-69101,, "PANEL, ROOF CL",1,,,,,R,2,M/#01096,,,,,
23B-2,2,,172164-69102,, "PANEL,ROOF CL",1,,,,,N,2,M/#01505,,,,,
24,2,,172176-67810,, RIVET,4,,,,,,,,,,,,,,,,,,,,,
25,2,,26579-060202,, "SCREW 6X 20",10,,,,,,,,,,,,,,,,,,,,,
26,2,,172176-68200,, WASHER,10,,,,,,,,,,,,,,,,,,,,,
27,2,,26589-060162,, "SCREW M6,BINDING",10,,,,,,,,,,,,,,,,,,,,,
28,2,,26013-100302,, "BOLT M10X 30",4,,,,,,,,,,,,,,,,,,,,,
29,2,,172176-67810,, RIVET,4,,,,,,,,,,,,,,,,,,,,,
30,2,,26116-160702,, "BOLT M16X 70 PLATED",2,,,,,,,,,,,,,,,,,,,,,
31,2,,172176-69750,, SEAL,1,,,,,W,,M/#00695,,,,,
32,2,,172176-69770,, SEAL,1,,,,,W,,M/#00695,,,,,
33,2,,22157-100000,, "WASHER 10",4,,,,,,,,,,,,,,,,,,,,,
33-1,2,,172147-61520,, SPACER,4,,,,,S,,M/#00501,,,,,
34,2,,172164-69120,, "BRACKET ASSY",1,,,,,2,,,,,
35,2,,172176-68210,, TREE-CLIP,2,,,,,W,, "FROM 1ST",,,,,,
36A,1,,172176-67850,, "PANEL, FRONT RADIO",1,,,,,3,,,,,
36A-1,1,,172176-67851,, PANEL,1,,,,,N,3,M/#00852,,,,,
36A-2,1,,172176-67852,, PANEL,1,,,,,N,3,M/#01245,,,,,
36A-3,1,,172176-67853,, "PANEL,FRONT RADIO",1,,,,,N,3,M/#01505,,,,,
36B,1,,172176-67440,, PANEL,1,,,,,4,,,,,
36B-1,1,,172176-67441,, PANEL,1,,,,,S,4,M/#01245,,,,,
36B-2,1,,172176-67442,, "PANEL,FRONT R",1,,,,,N,4,M/#01505,,,,,
37A,1,,172176-67860,, "COVER, HARNESS",1,,,,,3,,,,,
37A-1,1,,172176-67861,, "PANEL, ROOF (RADIO",1,,,,,R,3,M/#01096,,,,,
37A-2,1,,172176-67862,, PANEL,1,,,,,N,3,M/#01505,,,,,
37B,1,,172164-69110,, PANEL,1,,,,,4,,,,,
37B-1,1,,172164-69111,, "PANEL, ROOF CL RADIO",1,,,,,R,4,M/#01096,,,,,
37B-2,1,,172164-69112,, "PANEL (ROOF CL",1,,,,,N,4,M/#01505,,,,,

Fig. 41 キャビン (3) (付属品) CABIN (3) (FITTING)

キャビンASSY (標準)
CABIN ASSY (STANDARD)
(772176-68400)

Fig. 39 REF. No. 1A
(772425-68400-1)
Fig. 39 REF. No. 1A-1
inc. Fig. 39 REF. No. 2 ~ 52
Fig. 40 REF. No. 1 ~ 50
Fig. 41 REF. No. 1 ~ 35

キャビンASSY (クーラー仕様)
CABIN ASSY (COOLER SPEC.)
(772164-68421)

Fig. 39 REF. No. 1B
(772425-68420-1)
Fig. 39 REF. No. 1B-1
inc. Fig. 39 REF. No. 2 ~ 55
Fig. 40 REF. No. 1 ~ 50
Fig. 41 REF. No. 1 ~ 35

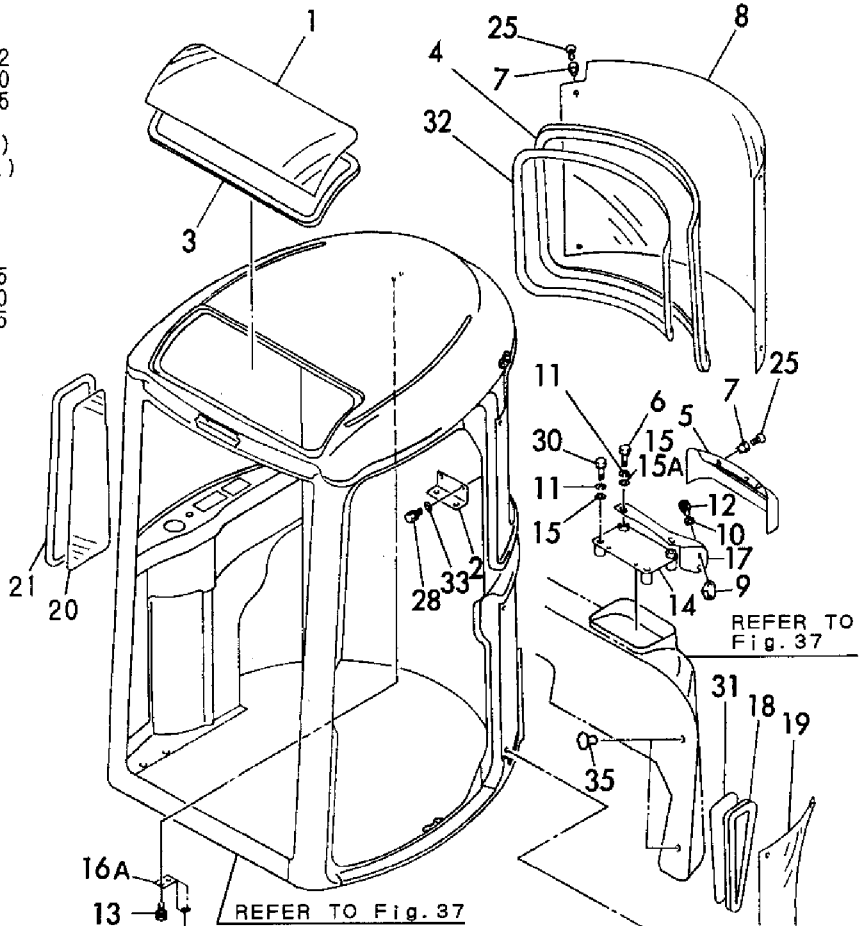
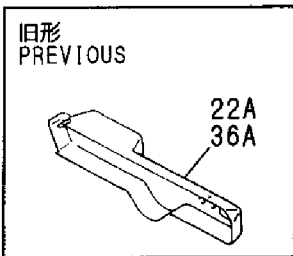
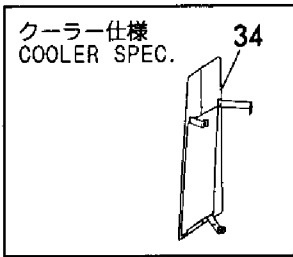

REFER TO Fig. 37

REFER TO Fig. 37

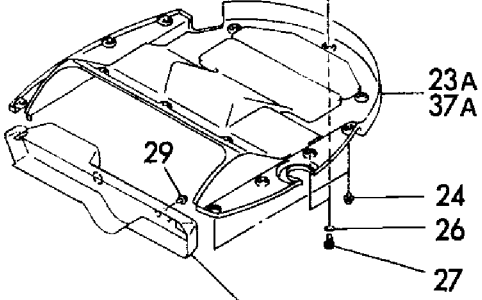
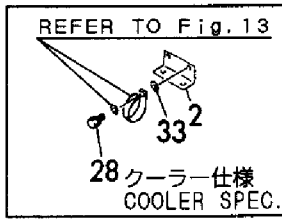

22A-2
36A-2

クーラーキット
COOLER KIT
(172176-08100)

Fig. 11 REF. No. 1
1 inc. Fig. 11 REF. No. 2~34
Fig. 12 REF. No. 1~10
Fig. 13 REF. No. 1~62
Fig. 14 REF. No. 1~49
Fig. 20 REF. No. 1~11
Fig. 34 REF. No. 1, 2
Fig. 36 REF. No. 1
Fig. 37 REF. No. 1~5
Fig. 38 REF. No. 1~5
Fig. 39 REF. No. 18B, 23, 24, 53~55
Fig. 41 REF. No. 16B, 22B, 23B, 34

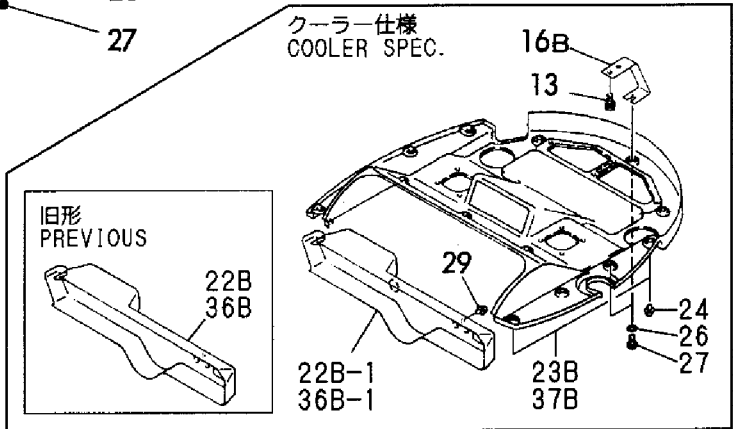

1,1,,772176-68900,, "DOOR ASSY",1,,,,,,,,,,,,,
1-1,1,,772176-68901,, "DOOR COMPL.",1,,,,,N,,,"FROM 1ST",,,,,,
1-2,1,,772176-68902,, "DOOR ASSY",1,,,,,N,,M/#00832,,,,,
2,2,,172176-67000,, "COVER A, DOOR",1,,,,,,,,,,,,,
3,2,,172176-67020,, "PLATE, LINK A",1,,,,,Z,,M/#00832,,,,,
4,2,,172176-67030,, "LINK, DOOR B",1,,,,,,,,,,,,,
4-1,2,,172176-67400,, ROD,1,,,,,F,1,,M/#00832,,,,,
5,2,,172176-67090,, CATCH,1,,,,,,,,,,,,,
6,2,,172176-67100,, "HANDLE ASSY.",1,,,,,,,,,,,,,
7,2,,172176-67121,, "TRIM, DOOR UN",1,,,,,,,,,,,,,
8,2,,172176-67131,, "TRIM, DOOR UP",1,,,,,,,,,,,,,
9,2,,172176-67150,, RUBBER,4,,,,,Z,,M/#00501,,,,,
10,2,,172176-68900,, "DOOR ASSY",1,,,,,,,,,,,,,
11,2,,172176-69340,, "BRACKET, DOOR U",2,,,,,,,,,,,,,
12,2,,172176-69390,, "LINK ASSY, DOOR",1,,,,,,,,,,,,,
13,3,,172141-41370,, "BUSH 2015",2,,,,,,,,,,,,,
15,2,,172176-69450,, "COVER U",2,,,,,,,,,,,,,
16,2,,172162-69460,, "KEY ASSY, CYLINDER",1,,,,,,,,,,,,,
17,2,,172176-69470,, "BRACKET A",1,,,,,,,,,,,,,
18,2,,172162-69480,, "LOCK ASSY",1,,,,,,,,,,,,,
19,2,,172162-69540,, "HANDLE, OUTER",1,,,,,,,,,,,,,
19-1,2,,172162-69541,, "HANDLE, OUTER",1,,,,,N,,M/#01358,,,,,
20,2,,172176-69800,, "GLASS, DOOR",1,,,,,,,,,,,,,
21,2,,172176-69810,, "SEAL, DOOR GLASS",1,,,,,,,,,,,,,
22,2,,172176-69820,, "COLLAR, GLASS",4,,,,,,,,,,,,,
23,2,,172176-67231,, "COVER B, DOOR",1,,,,,,,,,,,,,
24,2,,172176-69910,, "LINK C",1,,,,,,,,,,,,,
24-1,2,,172176-69911,, PLATE,1,,,,,N,,M/#00832,,,,,
25,2,,172176-69930,, "LINK D",1,,,,,,,,,,,,,
25-1,2,,172176-69931,, LEVER,1,,,,,N,,M/#00832,,,,,
26,2,,172176-69980,, "ARM W/BUSH, LINK",1,,,,,,,,,,,,,
28,3,,24550-014150,, "BUSH 14X15",4,,,,,,,,,,,,,
29,2,,22137-060000,, "WASHER 6, POLISHED",2,,,,,,,,,,,,,
29-1,2,,22137-060000,, "WASHER 6, POLISHED",3,,,,,K,,M/#00745,,,,,
29-2,2,,22137-060000,, "WASHER 6, POLISHED",3,,,,,Z,,M/#00832,,,,,
30,2,,22137-060000,, "WASHER 6, POLISHED",3,,,,,,,,,,,,,
31,2,,22217-060000,, "SPRING WASHER 6",2,,,,,Z,,M/#00832,,,,,
32,2,,172165-63650,, "PLUG 10,HOLE",3,,,,,Z,,M/#00730,,,,,
33,2,,22217-060000,, "SPRING WASHER 6",3,,,,,Z,,M/#00745,,,,,
34,2,,22217-100000,, "SPRING WASHER 10",4,,,,,,,,,,,,,
35,2,,22217-100000,, "SPRING WASHER 10",4,,,,,,,,,,,,,
36,2,,22252-000420,, "CIRCLIP 42",2,,,,,,,,,,,,,
37,2,,22351-040032,, "SPRING PIN 4X32",2,,,,,,,,,,,,,
38,2,,22351-040032,, "SPRING PIN 4X32",2,,,,,,,,,,,,,
39,2,,24311-000350,, "O-RING 1A P-35.0",4,,,,,,,,,,,,,
39-1,2,,24311-000220,, "O-RING 1A P-22.0",4,,,,,S,,M/#00745,,,,,
40,2,,26013-100202,, "BOLT W/WASHER M10X20",2,,,,,,,,,,,,,
41,2,,26013-060202,, "BOLT M 6X 20",2,,,,,,,,,,,,,
41-1,2,,26117-060202,, "BOLT M 6X 20",2,,,,,N,,M/#00745,,,,,
41-2,2,,26117-060202,, "BOLT M 6X 20",2,,,,,Z,,M/#00832,,,,,
42,2,,26022-050102,, "SCREW M 5X 10",8,,,,,,,,,,,,,
43,2,,26022-060122,, "SCREW M 6X 12",2,,,,,,,,,,,,,
44,2,,26022-060162,, "SCREW M 6X 16",3,,,,,,,,,,,,,
45,2,,26022-060122,, "SCREW M 6X 12",1,,,,,,,,,,,,,
46,2,,26557-060302,, "SCREW M 6X 30",3,,,,,,,,,,,,,
46-1,2,,26013-060302,, "BOLT M 6X 30",3,,,,,R,,M/#00745,,,,,
47,2,,26716-100002,, "NUT 10",4,,,,,,,,,,,,,
48,2,,26716-100002,, "NUT 10",4,,,,,,,,,,,,,
49,2,,26717-060002,, "NUT M 6",2,,,,,Z,,M/#00832,,,,,
50,2,,22157-100000,, "WASHER 10",2,,,,,,,,,,,,,
51,2,,172176-69990,, "BEARING 2542",2,,,,,,,,,,,,,
52,2,,172176-67800,, BOLT,1,,,,,,,,,,,,,
53,2,,172176-68390,, BOLT,8,,,,,,,,,,,,,

54,2,,172176-69600,,BRACKET,1,,,,,,,,,,,,,
55,2,,172176-69790,,SHAFT,2,,,,,,,,,,,,,
56,2,,933171-21630,, "PIN, SWING LINK",2,,,,,,,,,,,,,
56-1,2,,933171-21630,, "PIN, SWING LINK",1,,,,,K,,,,M/#00730,,,,,
56A,2,,172176-69560,,PIN,1,,,,,W,,,,M/#00832,,,,,
57,2,,172176-67890,, "MOLD, DOOR",1,,,,,,,,,,,,,
57-1,2,,172176-67891,, "MOLD, DOOR",1,,,,,N,,,,M/#01277,,,,,
58,2,,172176-68240,, "CORD, RUBBER",1,,,,,,,,,,,,,
59,2,,172176-67150,,RUBBER,2,,,,,,,,,,,,,
60,2,,172176-68170,, "RUBBER, STOPPER",2,,,,,,,,,,,,,
61,2,,172176-69960,, "BRACKET (B)",1,,,,,,,,,,,,,
62,2,,24321-000350,, "O-RING 1A G-35.0",2,,,,,,,,,,,,,
63,2,,26716-080002,, "NUT M 8",2,,,,,,,,,,,,,
64,2,,22417-200202,, "COTTER PIN 2.0X20",1,,,,,,,,,,,,,
64-1,2,,22417-200200,, "COTTER PIN 2.0X20",1,,,,,N,,,,MXXX,,,,,
65,2,,22137-060000,, "WASHER 6, POLISHED",1,,,,,,,,,,,,,
66,2,,26717-060002,, "NUT M 6",1,,,,,,,,,,,,,
66-1,2,,26716-060002,, "NUT 6",1,,,,,R,,,,M/#00745,,,,,
67,2,,26013-100252,, "BOLT W/WASHER M10X25",3,,,,,,,,,,,,,
68,2,,22137-100000,, "WASHER 10,POLISHED",4,,,,,,,,,,,,,
69,2,,22137-100000,, "WASHER 10,POLISHED",4,,,,,,,,,,,,,
70,2,,26579-060202,, "SCREW 6X 20",4,,,,,,,,,,,,,
71,2,,26013-100302,, "BOLT M10X 30",2,,,,,,,,,,,,,
71-1,2,,26013-100352,, "BOLT M10X 35",2,,,,,R,,,,M/#00745,,,,,
72,2,,172176-67250,, "PIPE 15",2,,,,,,,,,,,,,
73,2,,22137-100000,, "WASHER 10,POLISHED",3,,,,,,,,,,,,,
74,2,,172176-67410,,BOLT,1,,,,,W,,,,M/#00832,,,,,
75,2,,26716-080002,, "NUT M 8",1,,,,,W,,,,M/#00832,,,,,
76,2,,22137-060000,, "WASHER 6, POLISHED",1,,,,,W,,,,M/#00832,,,,,
77,2,,172176-69560,,PIN,1,,,,,W,,,,M/#00745,,,,,
78,2,,26716-080002,, "NUT M 8",4,,,,,W,,,,M/#00745,,,,,
79,2,,172176-69760,,SEAL,1,,,,,W,,,,M/#00695,,,,,
80,2,,172164-03210,, "LABEL, CAB.",1,,,,,W,,,, "FROM 1ST",,,,,,
81,1,,172176-69390,, "LINK ASSY, DOOR",1,,,,,,,,,,,,,
81-1,1,,172187-69350,, "LINK, DOOR (A)",1,,,,,F,2,,M/#01339,,,,,
82,2,,172141-41370,, "BUSH 2015",2,,,,,,,,,,,,,
83,2,,172176-69400,, "LINK ASSY, DOOR",1,,,,,,,,,,,,,
84,2,,172187-69390,, "LINK, DOOR (B)",1,,,,,W,,,,M/#01339,,,,,
85,2,,172187-69420,, "BOLT M16X 90",1,,,,,W,,,,M/#01339,,,,,
86,2,,172187-69490,, "NUT 16",1,,,,,W,,,,M/#01339,,,,,
87,2,,26716-160002,, "NUT M16",1,,,,,W,,,,M/#01339,,,,,
88,1,,933110-00301,, "KEY ASSY",1,,,,,,,,,,,,,

Fig. 42 キャビンドア CABIN DOOR

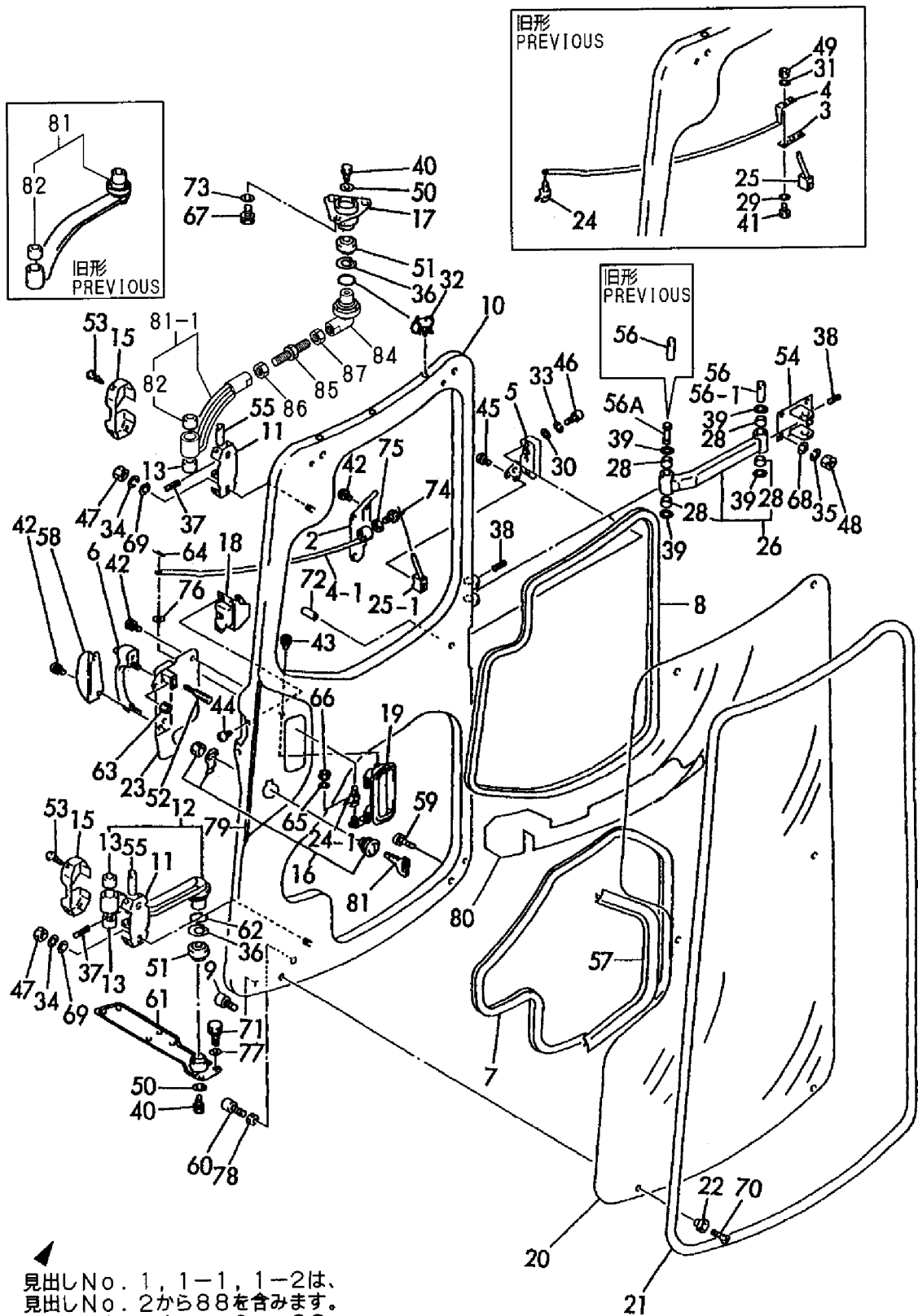

見出しNo. 1, 1-1, 1-2は、
見出しNo. 2から88を含みます。
1, 1-1, 2 inc. 2 ~ 88

1,1,,172164-68100,, "ROOF,CANOPY(GREEN:96" ,,1,,,,,,,,,,,,,,,,,,,,,
2,1,,172164-68112,, "POLE,CANOPY(GREEN:96" ,,1,,,,,,,,,,,,,,,,,,,,,
3,1,,172164-68190,, "BOOT, CANOPY" ,,1,,,,,,,,,,,,,,,,,,,,,
4,1,,172164-68250,, "PLATE ASSY" ,,2,,,,,,,,,,,,,,,,,,,,,
5,1,,172164-68270,, SPACER,,12,,,,,,,,,,,,,,,,,,,,,
6,1,,172164-68290,, PLATE,,2,,,,,,,,,,,,,,,,,,,,,
7,1,,22217-160000,, "SPRING WASHER 16" ,,4,,,,,,,,,,,,,,,,,,,,,
8,1,,26013-120302,, "BOLT W/WASHER M12X30" ,,6,,,,,,,,,,,,,,,,,,,,,
9,1,,26076-160402,, "BOLT 10.9 16X40" ,,4,,,,,,,,,,,,,,,,,,,,,
10,1,,26589-060252,, "SCREW M6X25,BIND.HD." ,,16,,,,,,,,,,,,,,,,,,,,,
11,1,,172730-05250,, "WASHER 12" ,,6,,,,,,,,,,,,,,,,,,,,,
12,1,,172730-05250,, "WASHER 12" ,,2,2,,,,,,,,,,,,,,,,,,,,,
13,1,,172165-68180,, "BOLT, M14X 35" ,,3,3,,,,,,,,,,,,,,,,,,,,,
14,1,,172164-68200,, "BRACKET COMPL." ,,1,1,,,,,,,,,,,,,,,,,,,,,
15,1,,172164-68301,, "BRACKET, CANOPY" ,,1,1,,,,,,,,,,,,,,,,,,,,,
16,1,,172164-68500,, "BRACKET ASSY (GREEN)" ,,1,1,,,,,,,,,,,,,,,,,,,,,
17,1,,172164-68511,, "BRACKET F" ,,1,1,,,,,,,,,,,,,,,,,,,,,
18,1,,172164-68641,, "BRACKET (R) ASSY" ,,1,1,,,,,,,,,,,,,,,,,,,,,
19,1,,172110-36010,, COLLAR,4,4,,,,,,,,,,,,,,,,,,,,,
20,1,,22217-100000,, "SPRING WASHER 10" ,,2,2,,,,,,,,,,,,,,,,,,,,,
21,1,,22217-140000,, "SPRING WASHER 14" ,,3,3,,,,,,,,,,,,,,,,,,,,,
22,1,,22217-160000,, "SPRING WASHER 16" ,,5,5,,,,,,,,,,,,,,,,,,,,,
23,1,,26013-100302,, "BOLT M10X 30" ,,4,4,,,,,,,,,,,,,,,,,,,,,
24,1,,26013-120402,, "BOLT M12X 40" ,,4,4,,,,,,,,,,,,,,,,,,,,,
25,1,,26116-100504,, "BOLT M10X 50 PLATED" ,,2,2,,,,,,,,,,,,,,,,,,,,,
26,1,,26116-160402,, "BOLT M16X 40 PLATED" ,,5,5,,,,,,,,,,,,,,,,,,,,,
27,1,,26716-100002,, "NUT 10" ,,2,2,,,,,,,,,,,,,,,,,,,,,
28,1,,172164-68470,, "COVER ASSY" ,,2,,,,,,1,,,,,,,,,,,,,

Fig. 43 **キャノピ&キャノピフレーム**
CANOPY & CANOPY FRAME

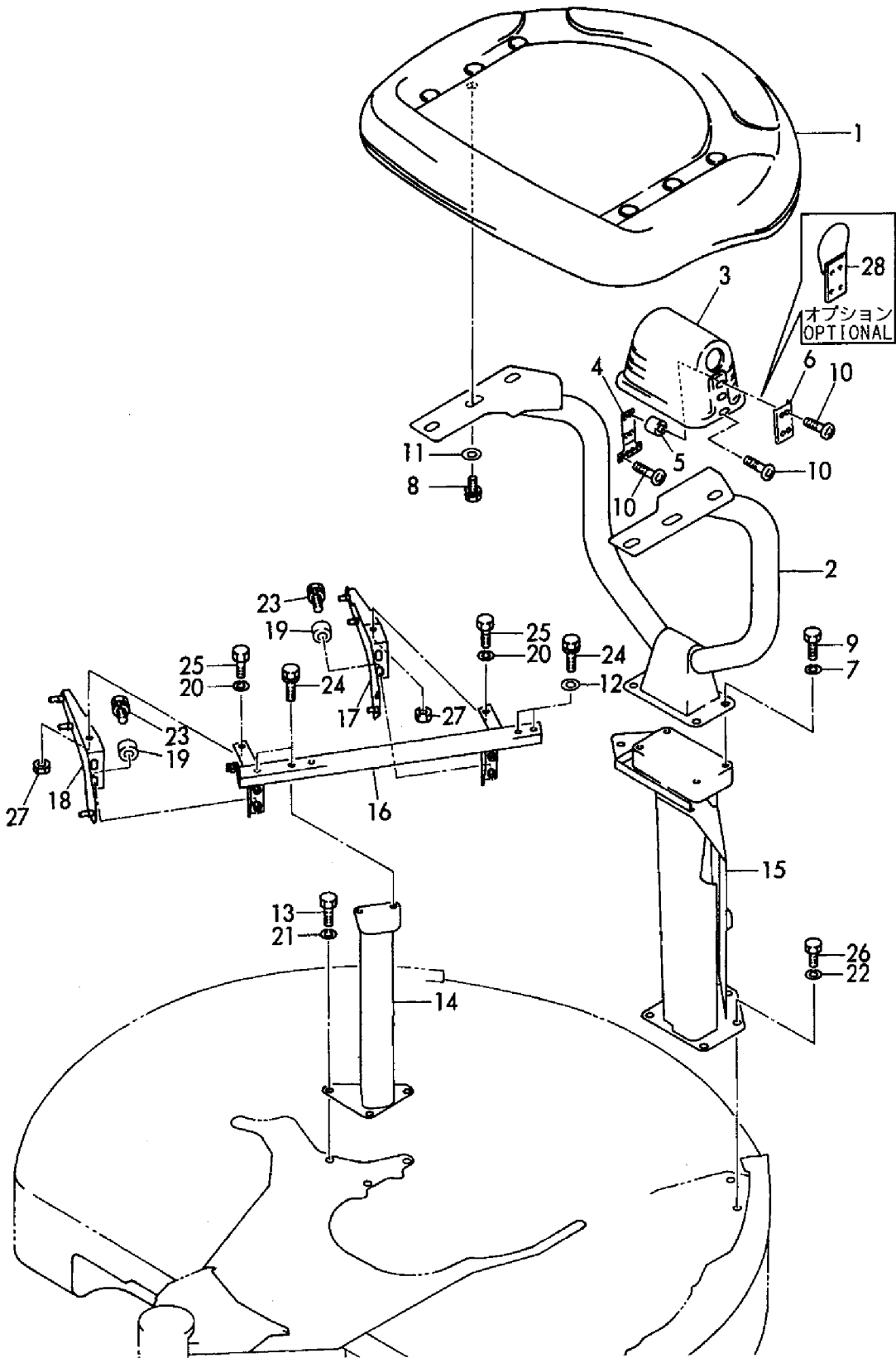

1,1,,172148-71101,, "COVER, FLYWHEEL",1,1,,,,,,,,,,,,,,,,,,,,,
2,1,,26013-100252,, "BOLT W/WASHER M10X25",6,6,,,,,,,,,,,,,,,,,,,,,
3,1,,26450-120402,, "BOLT M12X 40",3,3,,,,,,,,,,,,,,,,,,,,,
4,1,,172165-71200,, COUPLING,1,1,,,,,,,,,,,,,,,,,,,,,
5,1,,172176-73100,, "PUMP ASSY, HYD OIL",1,1,,,,,,,,,,,,,,,,,,,,,
6,2,,172165-73110,, "SHAFT UNIT COMPL.",1,1,,,,,,,,,,,,,,,,,,,,,
7,3,,172165-73120,, SHAFT,1,1,,,,,,,,,,,,,,,,,,,,,
8,3,,172165-73130,, "CASE, SEAL",1,1,,,,,,,,,,,,,,,,,,,,,
9,3,,172165-73140,, BEARING,1,1,,,,,,,,,,,,,,,,,,,,,
10,3,,22242-000280,, "CIRCLIP 28",1,1,,,,,,,,,,,,,,,,,,,,,
11,3,,22242-000300,, "CIRCLIP 30",1,1,,,,,,,,,,,,,,,,,,,,,
12,3,,172176-73130,, "SEAL ASSY",1,1,,,,,,,,,,,,,,,,,,,,,
15,3,,22252-000720,, "CIRCLIP 72",1,1,,,,,,,,,,,,,,,,,,,,,
17,2,,172162-73600,, PLATE,1,1,,,,,,,,,,,,,,,,,,,,,
18,2,,26450-060162,, "BOLT M 6X 16",4,4,,,,,,,,,,,,,,,,,,,,,
19,2,,172162-73610,, O-RING,1,1,,,,,,,,,,,,,,,,,,,,,
20,2,,172176-73110,, "ROTARY GROUP",1,1,,,,,,,,,,,,,,,,,,,,,
21,2,,172176-73120,, "COVER UNIT ASSY",1,1,,,,,,,,,,,,,,,,,,,,,
22,3,,172176-73140,, "PLATE, CONTROL",1,1,,,,,,,,,,,,,,,,,,,,,
23,3,,22312-060200,, "PARALLEL PIN 6X20",2,2,,,,,,,,,,,,,,,,,,,,,
24,3,,26450-120302,, "BOLT M12X30",4,4,,,,,,,,,,,,,,,,,,,,,
25,3,,172176-73150,, "O-RING ASSY",1,1,,,,,,,,,,,,,,,,,,,,,
29,3,,172165-73580,, ORIFICE,3,3,,,,,,,,,,,,,,,,,,,,,
30,3,,172165-73590,, BEARING,1,1,,,,,,,,,,,,,,,,,,,,,
31,3,,172142-74650,, "PLUG 1/8",1,1,,,,,,,,,,,,,,,,,,,,,
32,2,,172165-73600,, "CONTROL UNIT ASSY",1,1,,,,,,,,,,,,,,,,,,,,,
33,3,,172165-73610,, PLATE,1,1,,,,,,,,,,,,,,,,,,,,,
34,3,,172165-73620,, PLATE,1,1,,,,,,,,,,,,,,,,,,,,,
35,3,,172165-73630,, COVER,1,1,,,,,,,,,,,,,,,,,,,,,
36,3,,172165-73640,, "ADJUST SCREW",1,1,,,,,,,,,,,,,,,,,,,,,
37,3,,172165-73650,, SPRING,1,1,,,,,,,,,,,,,,,,,,,,,
38,3,,172165-73660,, SPRING,1,1,,,,,,,,,,,,,,,,,,,,,
39,3,,24311-000340,, "O-RING 1A P-34.0",1,1,,,,,,,,,,,,,,,,,,,,,
40,3,,26450-080302,, "BOLT M 8X 30",2,2,,,,,,,,,,,,,,,,,,,,,
41,3,,172165-73670,, "NUT M 6",1,1,,,,,,,,,,,,,,,,,,,,,
42,3,,172165-73680,, SHIM,2,2,,,,,,,,,,,,,,,,,,,,,
43,3,,172165-73690,, SHIM,2,2,,,,,,,,,,,,,,,,,,,,,
44,3,,172165-73700,, SHIM,2,2,,,,,,,,,,,,,,,,,,,,,
45,3,,172165-73710,, SHIM,2,2,,,,,,,,,,,,,,,,,,,,,
46,2,,172165-73720,, "PISTON UNIT ASSY",1,1,,,,,,,,,,,,,,,,,,,,,
47,3,,172165-73730,, CYLINDER,1,1,,,,,,,,,,,,,,,,,,,,,
48,3,,172165-73740,, PISTON,1,1,,,,,,,,,,,,,,,,,,,,,
49,3,,172165-73750,, "PARALLEL PIN",2,2,,,,,,,,,,,,,,,,,,,,,
50,3,,172165-73760,, "PALALLEL PIN 8",1,1,,,,,,,,,,,,,,,,,,,,,
51,3,,172142-74670,, "PLUG 3/8",1,1,,,,,,,,,,,,,,,,,,,,,
52,3,,26450-080252,, "BOLT M 8X 25",2,2,,,,,,,,,,,,,,,,,,,,,
53,3,,172165-73770,, SPRING,2,2,,,,,,,,,,,,,,,,,,,,,
54,3,,172176-73160,, "O-RING ASSY",1,1,,,,,,,,,,,,,,,,,,,,,
58,2,,172165-73800,, "GEAR PUMP",1,1,,,,,,,,,,,,,,,,,,,,,
59,3,,172165-73810,, "GSP2 GEAR PUMP",1,1,,,,,,,,,,,,,,,,,,,,,
60,4,,172165-73830,, PLATE,1,1,,,,,,,,,,,,,,,,,,,,,
61,4,,172141-73220,, PLATE,2,2,,,,,,,,,,,,,,,,,,,,,
62,4,,172141-73230,, GUIDE,2,2,,,,,,,,,,,,,,,,,,,,,
63,4,,172141-71550,, O-RING,2,2,,,,,,,,,,,,,,,,,,,,,
64,4,,172141-71520,, RING,2,2,,,,,,,,,,,,,,,,,,,,,
65,4,,172141-71560,, RING,2,2,,,,,,,,,,,,,,,,,,,,,
66,4,,172141-73240,, "PIN, PARALLEL",4,4,,,,,,,,,,,,,,,,,,,,,
67,4,,26450-100902,, "BOLT M10X 90",2,2,,,,,,,,,,,,,,,,,,,,,
68,4,,26450-100852,, "BOLT M10X85, HEX. SCKT",2,2,,,,,,,,,,,,,,,,,,,,,
69,4,,172165-73840,, COUPLING,2,2,,,,,,,,,,,,,,,,,,,,,
70,4,,172141-73210,, CIRCLIP,1,1,,,,,,,,,,,,,,,,,,,,,
71,3,,172165-73820,, "G1 GEAR PUMP",1,1,,,,,,,,,,,,,,,,,,,,,
72,4,,172164-73250,, "O-RING ASSY",1,1,,,,,,,,,,,,,,,,,,,,,

76,4,,172141-73240,, "PIN, PARALLEL",2,2,,,,,,,,,,,,,
77,4,,172165-73860,, COUPLING,1,1,,,,,,,,,,,,,
78,4,,26450-080452,, "BOLT M 8X 45",4,4,,,,,,,,,,,,,
79,4,,26450-080182,, "BOLT M 8X 18",2,2,,,,,,,,,,,,,
80,1,,26013-120352,, "BOLT M12X 35",2,2,,,,,,,,,,,,,
81,1,,172164-73110,, VALVE,1,1,,,,,,,,,,,,,

Fig. 44 油圧ポンプ&軸継手 (旧形)
HYD. OIL PUMP & JOINT (PREVIOUS)

~M/#00869

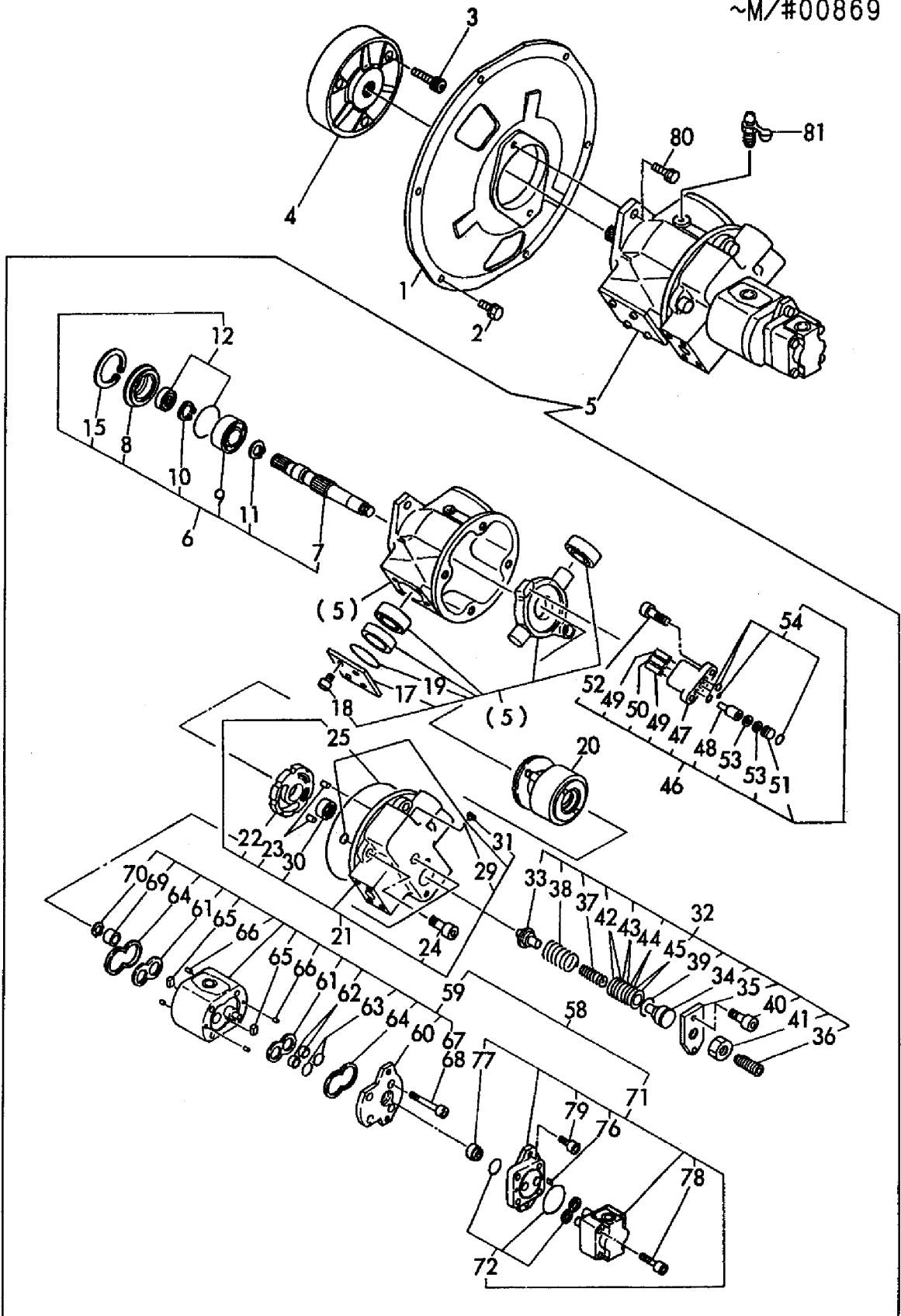

1,1,,172148-71102,, "COVER, FLYWHEEL",1,1,,,,,,,,,,,,,,,,,,,,,
2,1,,26013-100252,, "BOLT W/WASHER M10X25",6,6,,,,,,,,,,,,,,,,,,,,,
3,1,,26450-120402,, "BOLT M12X 40",3,3,,,,,,,,,,,,,,,,,,,,,
4,1,,172165-71200,, COUPLING,1,1,,,,,,,,,,,,,,,,,,,,,
5,1,,172176-73200,, "PUMP ASSY,HYD OIL",1,1,,,,,,,,,,,,,,,,,,,,,
5-1,1,,172176-73201,, "PUMP ASSY,HYD OIL",1,1,,,,,F,1,,M/#00965,,M/#00965,,,,,,
5-2,1,,172176-73202,, "PUMP ASSY",1,1,,,,,N,,M/#01389,,M/#01389,,,,,,
6,2,,172176-73210,, CASE,1,1,,,,,,,,,,,,,,,,,,,,,
7,2,,172176-73220,, "PLATE, VALVE",1,1,,,,,,,,,,,,,,,,,,,,,
8,2,,172176-73230,, "PLATE, THRUST",1,1,,,,,,,,,,,,,,,,,,,,,
9,2,,172176-73240,, SHAFT,1,1,,,,,,,,,,,,,,,,,,,,,
10,2,,172176-73250,, "PUMP, GEAR",1,1,,,,,,,,,,,,,,,,,,,,,
11,2,,172176-73260,, BEARING,1,1,,,,,,,,,,,,,,,,,,,,,
12,2,,172176-73280,, PIN,3,3,,,,,,,,,,,,,,,,,,,,,
13,2,,172176-73290,, "SHEET, SPRING",1,1,,,,,,,,,,,,,,,,,,,,,
14,2,,172176-73300,, "SHEET, SPRING",1,1,,,,,,,,,,,,,,,,,,,,,
15,2,,172176-73850,, "SHEET, SPRING",1,1,,,,,,,,,,,,,,,,,,,,,
16,2,,172176-73860,, "SET BOLT",1,1,,,,,,,,,,,,,,,,,,,,,
17,2,,172176-73870,, "SET SCREW",1,1,,,,,,,,,,,,,,,,,,,,,
18,2,,172176-73880,, "ROTOR ASSY,TROCHOID",1,1,,,,,,,,,,,,,,,,,,,,,
19,2,,172176-73890,, NUT,1,1,,,,,,,,,,,,,,,,,,,,,
20,2,,172176-73900,, BOLT,4,4,,,,,,,,,,,,,,,,,,,,,
21,2,,172176-73910,, "THRUST WASHER",1,1,,,,,,,,,,,,,,,,,,,,,
22,2,,172176-73920,, PLUG,1,1,,,,,,,,,,,,,,,,,,,,,
23,2,,172176-73390,, "SET SCREW",1,1,,,,,,,,,,,,,,,,,,,,,
24,2,,172176-73400,, "BOLT, SOCKET HEAD",2,2,,,,,,,,,,,,,,,,,,,,,
25,2,,172176-73410,, "BOLT, SOCKET HEAD",4,4,,,,,,,,,,,,,,,,,,,,,
26,2,,172176-73420,, SPRING,1,1,,,,,,,,,,,,,,,,,,,,,
27,2,,172176-73430,, SPRING,1,1,,,,,,,,,,,,,,,,,,,,,
28,2,,172176-73440,, PIN,2,2,,,,,,,,,,,,,,,,,,,,,
29,2,,172176-73450,, "COVER, TRUNNION",1,1,,,,,,,,,,,,,,,,,,,,,
30,2,,172176-73460,, "SPRING PIN",1,1,,,,,,,,,,,,,,,,,,,,,
31,2,,172176-73480,, COVER,1,1,,,,,,,,,,,,,,,,,,,,,
32,2,,172176-73490,, BUSH,1,1,,,,,,,,,,,,,,,,,,,,,
33,2,,172176-73500,, "DRIVE SCREW",2,2,,,,,,,,,,,,,,,,,,,,,
34,2,,172176-73510,, "BOLT, SOCKET HEAD",3,3,,,,,,,,,,,,,,,,,,,,,
35,2,,172176-73520,, STOPPER,1,1,,,,,,,,,,,,,,,,,,,,,
36,2,,172176-73530,, BUSH,1,1,,,,,,,,,,,,,,,,,,,,,
37,2,,172176-73540,, "THRUST WASHER",1,1,,,,,,,,,,,,,,,,,,,,,
38,2,,172176-73550,, "PLATE, LOADING",1,1,,,,,,,,,,,,,,,,,,,,,
38-1,2,,172176-73551,, PLATE,1,1,,,,,N,,M/#01389,,M/#01389,,,,,,
39,2,,172176-73560,, SPRING,1,1,,,,,,,,,,,,,,,,,,,,,
40,2,,172176-73570,, POPPET,1,1,,,,,,,,,,,,,,,,,,,,,
40-1,2,,172176-73940,, POPPET,1,1,,,,,F,1,,M/#00965,,M/#00965,,,,,,
41,2,,172176-73580,, PLUG;SHIPPING,2,2,,,,,,,,,,,,,,,,,,,,,
42,2,,172176-73590,, SHIM,2,2,,,,,,,,,,,,,,,,,,,,,
43,2,,172176-73600,, PLUG,1,1,,,,,,,,,,,,,,,,,,,,,
44,2,,172176-73610,, BUSH,3,3,,,,,,,,,,,,,,,,,,,,,
45,2,,172176-73620,, SPRING,2,2,,,,,,,,,,,,,,,,,,,,,
46,2,,172176-73630,, PLATE,1,1,,,,,,,,,,,,,,,,,,,,,
47,2,,172176-73640,, SCREW,2,2,,,,,,,,,,,,,,,,,,,,,
48,2,,172176-73650,, "COVER, TRUNNION",1,1,,,,,,,,,,,,,,,,,,,,,
49,2,,172176-73660,, NUT,1,1,,,,,,,,,,,,,,,,,,,,,
50,2,,172176-73670,, BUSH,1,1,,,,,,,,,,,,,,,,,,,,,
51,2,,172176-73680,, "VALVE S/A",1,1,,,,,,,,,,,,,,,,,,,,,
51-1,2,,172176-73681,, VALVE,1,1,,,,,F,1,,M/#00965,,M/#00965,,,,,,
52,2,,172176-73690,, "BREEDER, AIR",1,1,,,,,,,,,,,,,,,,,,,,,
53,2,,172176-73700,, "BOLT, SOCKET HEAD",2,2,,,,,,,,,,,,,,,,,,,,,
54,2,,172176-73710,, "FILTER, DISC",1,1,,,,,,,,,,,,,,,,,,,,,
55,2,,172176-73720,, "SNAP RING",1,1,,,,,,,,,,,,,,,,,,,,,
56,2,,172176-73730,, WASHER,2,2,,,,,,,,,,,,,,,,,,,,,
57,2,,172176-73740,, PIN,1,1,,,,,,,,,,,,,,,,,,,,,
57-1,2,,172176-73930,, PIN,1,1,,,,,F,1,,M/#00965,,M/#00965,,,,,,

58,2,,172176-73750,,WASHER,1,1,,,,,,,,,,,,,
59,2,,172176-73760,,CLAMP,1,1,,,,,,,,,,,,,
60,2,,172176-73770,,WASHER,1,1,,,,,,,,,,,,,
61,2,,172176-73780,, "BOLT, SOCKET HEAD",1,1,,,,,,,,,,,,,
62,2,,172176-73790,, "SEAL KIT, CASE",1,1,,,,,,,,,,,,,
63,3,,172176-73270,, "SEAL OIL",1,1,,,,,,,,,,,,,
63-1,3,,172176-73271,, "SEAL, OIL",1,1,,,,,N,,,M/#01389,,M/#01389,,,,,,
64,3,,24321-000700,, "O-RING 1A G-70.0",2,2,,,,,,,,,,,,,
65,3,,24315-000100,, "O-RING 1B P-10.0",3,3,,,,,,,,,,,,,
66,3,,24315-000110,, "O-RING 1B P-11.0",2,2,,,,,,,,,,,,,
67,3,,24315-000140,, "O-RING 1B P-14.0",3,3,,,,,,,,,,,,,
68,3,,24321-000500,, "O-RING 1A G-50.0",1,1,,,,,,,,,,,,,
69,2,,172176-73800,, "SEAL KIT,PORT BLOCK",1,1,,,,,,,,,,,,,
70,3,,24315-000080,, "O-RING 1B P-8.0",1,1,,,,,,,,,,,,,
71,3,,172176-73470,,O-RING,1,1,,,,,,,,,,,,,
71-1,3,,172176-73471,,O-RING,1,1,,,,,N,,,M/#01389,,M/#01389,,,,,,
72,3,,24321-000850,, "O-RING 1A G-85.0",1,1,,,,,,,,,,,,,
73,3,,24315-000180,, "O-RING 1B P-18.0",1,1,,,,,,,,,,,,,
74,3,,24315-000110,, "O-RING 1B P-11.0",1,1,,,,,,,,,,,,,
75,3,,24315-000060,, "O-RING 1B P-6.0",2,2,,,,,,,,,,,,,
76,2,,172176-73810,, "BLOCK KIT",1,1,,,,,,,,,,,,,
77,2,,172176-73820,, "COVER KIT",1,1,,,,,,,,,,,,,
78,2,,172176-73830,, "CYLINDER BLOCK KIT",1,1,,,,,,,,,,,,,
79,2,,172176-73840,, "RETAINER KIT",1,1,,,,,,,,,,,,,
80,1,,26013-120352,, "BOLT M12X 35",2,2,,,,,,,,,,,,,

Fig. 45 油圧ポンプ&軸継手 (新形) HYD. OIL PUMP & JOINT (NEW)

M/#00870~

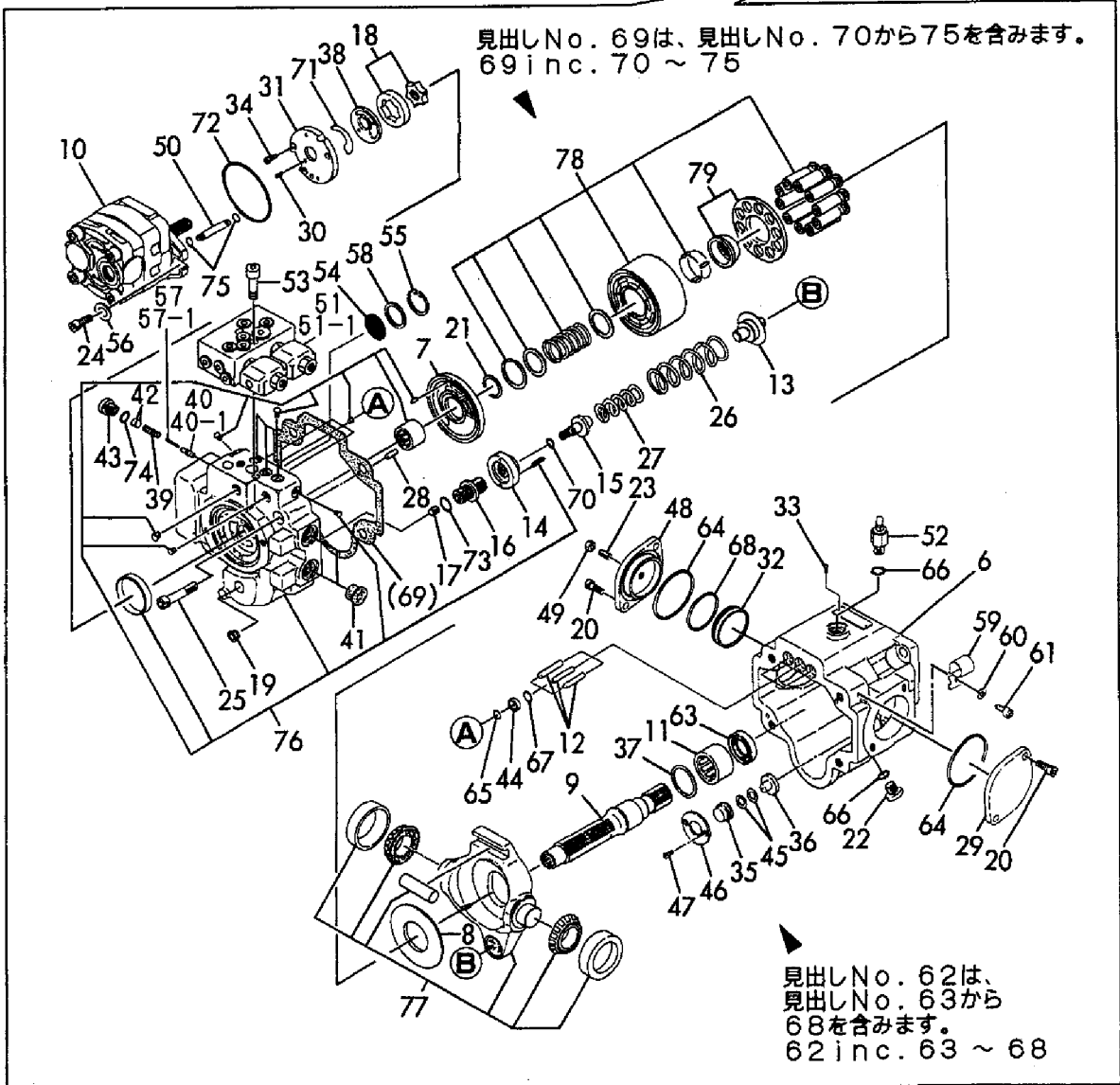
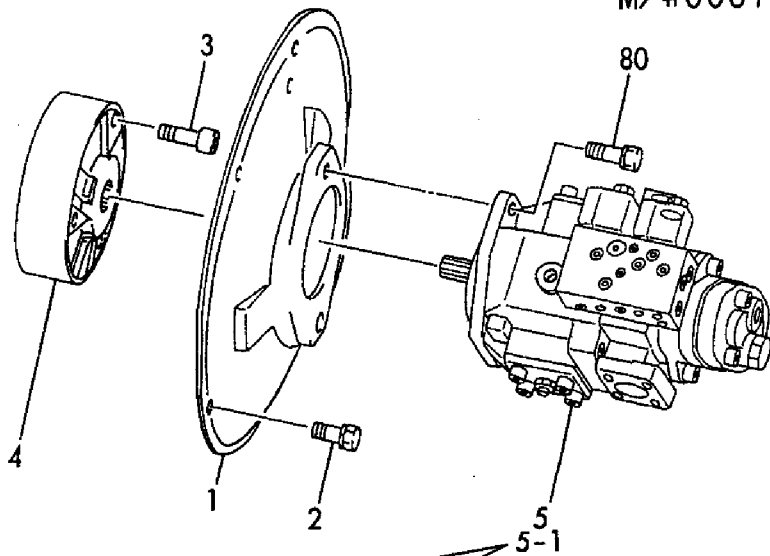

1,1,,172165-72250-4,, "CYLINDER, BOOM(GREEN)",1,,,,,,,,,,,,,
1-1,1,,172165-72201-4,, "CYLINDER, BOOM(GREEN)",1,,,,,,N,,,M/#00643,,,,,,
2,2,,172165-72600-4,, "TUBE, BOOM(C)(GREEN)",1,,,,,,,,,,,,,
2-1,2,,172165-72610-4,, "TUBE, BOOM(C)(GREEN)",1,,,,,,N,,,M/#00643,,,,,,
4,3,,172165-72300,, "PINBUSH 50X60",1,,,,,,,,,,,,,
5,3,,172165-81760,, "SEAL 50X60X4, DUST",2,,,,,,,,,,,,,
6,2,,172165-72620,, "ROD W/BUSH, BOOM",1,,,,,,,,,,,,,
6-1,2,,172165-72630,, "ROD W/BUSH, BOOM",1,,,,,,N,,,M/#00643,,,,,,
8,3,,172165-72300,, "PINBUSH 50X60",1,,,,,,,,,,,,,
9,3,,172165-81760,, "SEAL 50X60X4, DUST",2,,,,,,,,,,,,,
10,2,,172151-72220,, "HEAD 100 55",1,,,,,,,,,,,,,
11,3,,172151-72240,, "BUSH 55 35, ROD",1,,,,,,,,,,,,,
13,2,,172165-72640,, "CYLINDER KIT, BOOM",1,,,,,,,,,,,,,
20,3,,933126-00500,, "RING 72, SPRING",1,,,,,,,,,,,,,
21,3,,172151-72290,, "LOCK WASHER",1,,,,,,,,,,,,,
22,3,,22252-000800,, "CIRCLIP 80",1,,,,,,,,,,,,,
23,3,,172151-71800,, "SEAL SET, PISTON",1,,,,,,,,,,,,,
27,2,,172151-72330,, "CUSHION RING 62",1,,,,,,,,,,,,,
28,2,,172151-72250,, "PISTON 100",1,,,,,,,,,,,,,
29,2,,172151-72260,, "SPACER 100 39 20.5",1,,,,,,,,,,,,,
30,2,,172151-72270,, "U-NUT M39",1,,,,,,,,,,,,,
31,2,,933127-32001,, "PLUNGER 62, CUSHION",1,,,,,,,,,,,,,
32,2,,24764-020000,, "NIPPLE",2,,,,,,,,,,,,,
33,1,,933147-03400,, "WASHER, BRAKE ARM",1,,,,,,W,,,M/#00643,,,,,,
34,1,,22217-100000,, "SPRING WASHER 10",1,,,,,,W,,,M/#00643,,,,,,
35,1,,26116-100162,, "BOLT M10X 16 PLATED",1,,,,,,W,,,M/#00643,,,,,,
36,1,,172165-72351-4,, "COVER, SLIDE (GREEN)",1,,,,,,W,,,M/#00643,,,,,,
37,1,,933168-14170,, "SPRING 16",2,,,,,,W,,,M/#00643,,,,,,
38,1,,172162-61770,, "GUIDE, SLIDE",2,,,,,,W,,,M/#00643,,,,,,

Fig. 46 ブームシリンダ (キャビン) BOOM CYLINDER (CABIN)

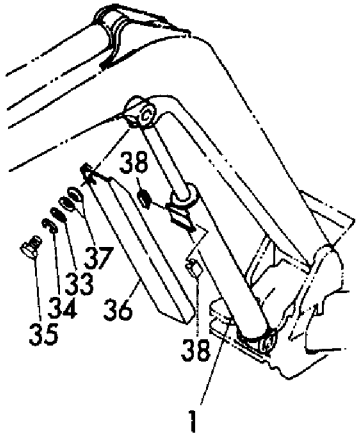
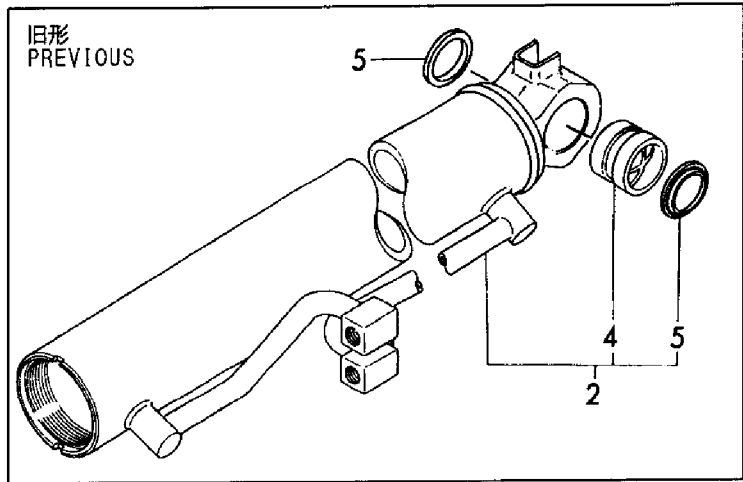

見出しNo. 1は、
見出しNo. 2から32を含みます。
1 inc. 2 ~ 32

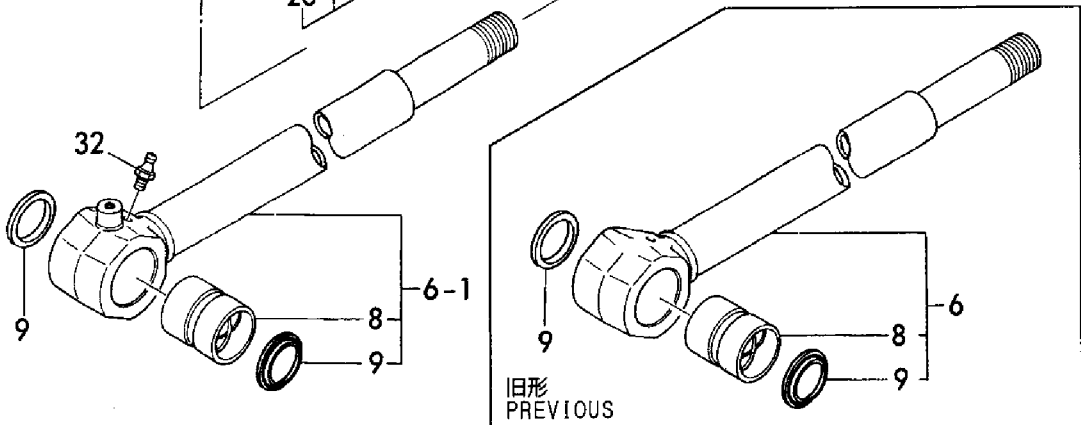
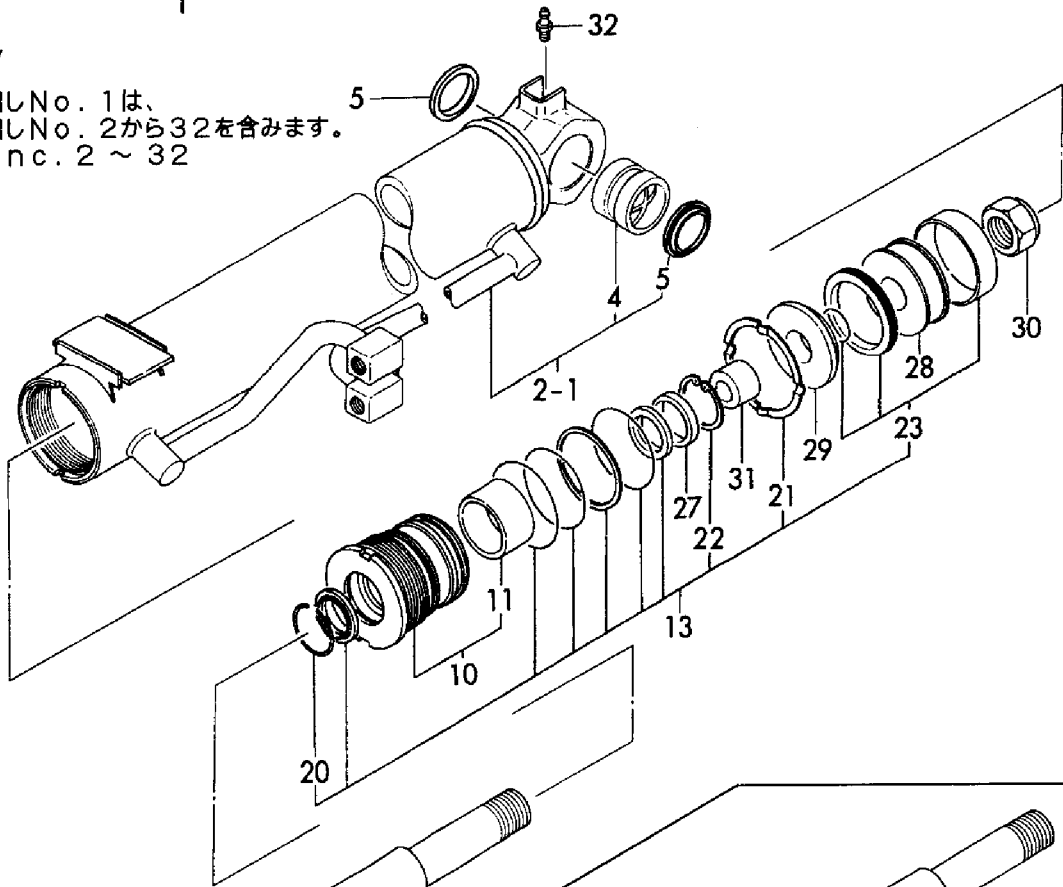

1,1,,172165-72101-4,, "CYLINDER, BOOM(GREEN)",,1,,,,,,,,,,,,,
2,2,,172165-72650-4,, "TUBE, BOOM(P) (GREEN)",,1,,,,,,,,,,,,,
4,3,,172165-72300,, "PINBUSH 50X60",,1,,,,,,,,,,,,,
5,3,,172165-81760,, "SEAL 50X60X4, DUST",,2,,,,,,,,,,,,,
6,2,,172165-72630,, "ROD W/BUSH, BOOM",,1,,,,,,,,,,,,,
8,3,,172165-72300,, "PINBUSH 50X60",,1,,,,,,,,,,,,,
9,3,,172165-81760,, "SEAL 50X60X4, DUST",,2,,,,,,,,,,,,,
10,2,,172151-72220,, "HEAD 100 55",,1,,,,,,,,,,,,,
11,3,,172151-72240,, "BUSH 55 35, ROD",,1,,,,,,,,,,,,,
13,2,,172165-72640,, "CYLINDER KIT, BOOM",,1,,,,,,,,,,,,,
20,3,,933126-00500,, "RING 72, SPRING",,1,,,,,,,,,,,,,
21,3,,172151-72290,, "LOCK WASHER",,1,,,,,,,,,,,,,
22,3,,22252-000800,, "CIRCLIP 80",,1,,,,,,,,,,,,,
23,3,,172151-71800,, "SEAL SET, PISTON",,1,,,,,,,,,,,,,
27,2,,172151-72330,, "CUSHION RING 62",,1,,,,,,,,,,,,,
28,2,,172151-72250,, "PISTON 100",,1,,,,,,,,,,,,,
29,2,,172151-72260,, "SPACER 100 39 20.5",,1,,,,,,,,,,,,,
30,2,,172151-72270,, "U-NUT M39",,1,,,,,,,,,,,,,
31,2,,933127-32001,, "PLUNGER 62, CUSHION",,1,,,,,,,,,,,,,
32,2,,24764-020000,, "NIPPLE",,2,,,,,,,,,,,,,
33,1,,933147-03400,, "WASHER, BRAKE ARM",,1,,,,,,,,,,,,,
34,1,,22217-100000,, "SPRING WASHER 10",,1,,,,,,,,,,,,,
35,1,,26116-100162,, "BOLT M10X 16 PLATED",,1,,,,,,,,,,,,,
36,1,,172165-72351-4,, "COVER, SLIDE (GREEN)",,1,,,,,,,,,,,,,
37,1,,933168-14170,, "SPRING 16",,2,,,,,,,,,,,,,
38,1,,172162-61770,, "GUIDE, SLIDE",,2,,,,,,,,,,,,,

Fig. **47** ブームシリンダ (キャノピ)
BOOM CYLINDER (CANOPY)

見出しNo. 1は、見出しNo. 2から32を含みます。
1 inc. 2 ~ 32

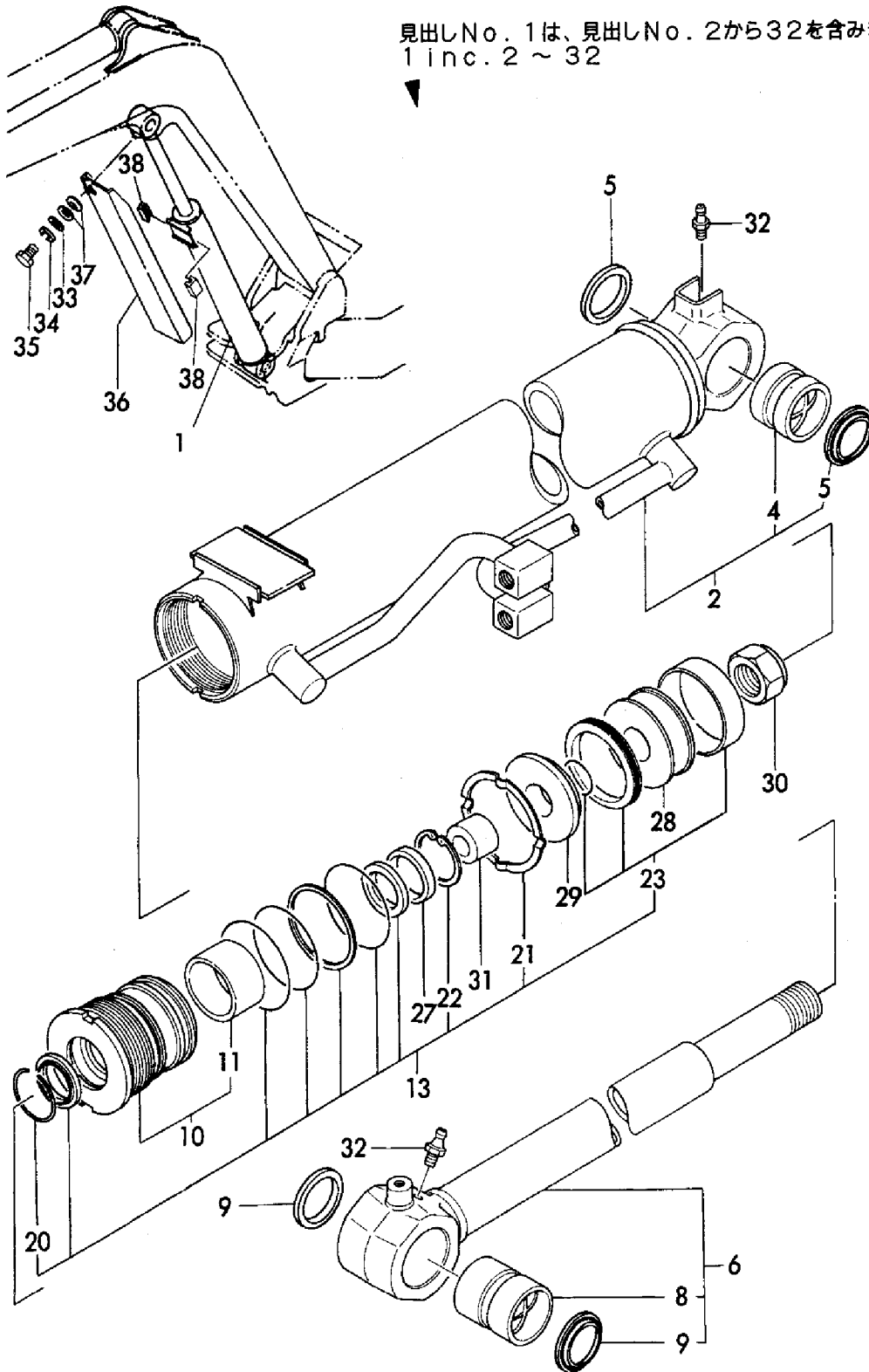

1,1,,172151-72450-4,, "CYLINDER, ARM (GREEN)",1,1,,,,,,,,,,,,,
2,2,,172151-72000-4,, "TUBE, ARM (GREEN)",1,1,,,,,,,,,,,,,
4,3,,172151-72591,, "BUSH 50X60",1,1,,,,,,,,,,,,,
5,3,,172165-81760,, "SEAL 50X60X4, DUST",2,2,,,,,,,,,,,,,
6,2,,172151-72010,, "ROD ASSY, ARM",1,1,,,,,,,,,,,,,
8,3,,172151-72591,, "BUSH 50X60",1,1,,,,,,,,,,,,,
9,3,,172165-81760,, "SEAL 50X60X4, DUST",2,2,,,,,,,,,,,,,
10,2,,172151-72520,, "HEAD 80 50",1,1,,,,,,,,,,,,,
11,3,,172151-72240,, "BUSH 55 35, ROD",1,1,,,,,,,,,,,,,
13,2,,172151-72020,, "CYLINDER KIT, ARM",1,1,,,,,,,,,,,,,
18,3,,933126-00500,, "RING 72, SPRING",1,1,,,,,,,,,,,,,
19,3,,172146-72270,, "LOCK WASHER 85",1,1,,,,,,,,,,,,,
20,3,,172151-71820,, "SEAL SET, PISTON",1,1,,,,,,,,,,,,,
23,2,,172151-72550,, "PISTON 80 36",1,1,,,,,,,,,,,,,
24,2,,172151-72560,, "SPACER 80 36 19",1,1,,,,,,,,,,,,,
25,2,,172151-72580,, "U-NUT M36",1,1,,,,,,,,,,,,,
26,2,,24761-040000,, "NIPPLE B,GREASE",2,2,,,,,,,,,,,,,

Fig. 48 アームシリンダ ARM CYLINDER

見出しNo. 1は、見出しNo. 2から26を含みます。
1 inc. 2 ~ 26

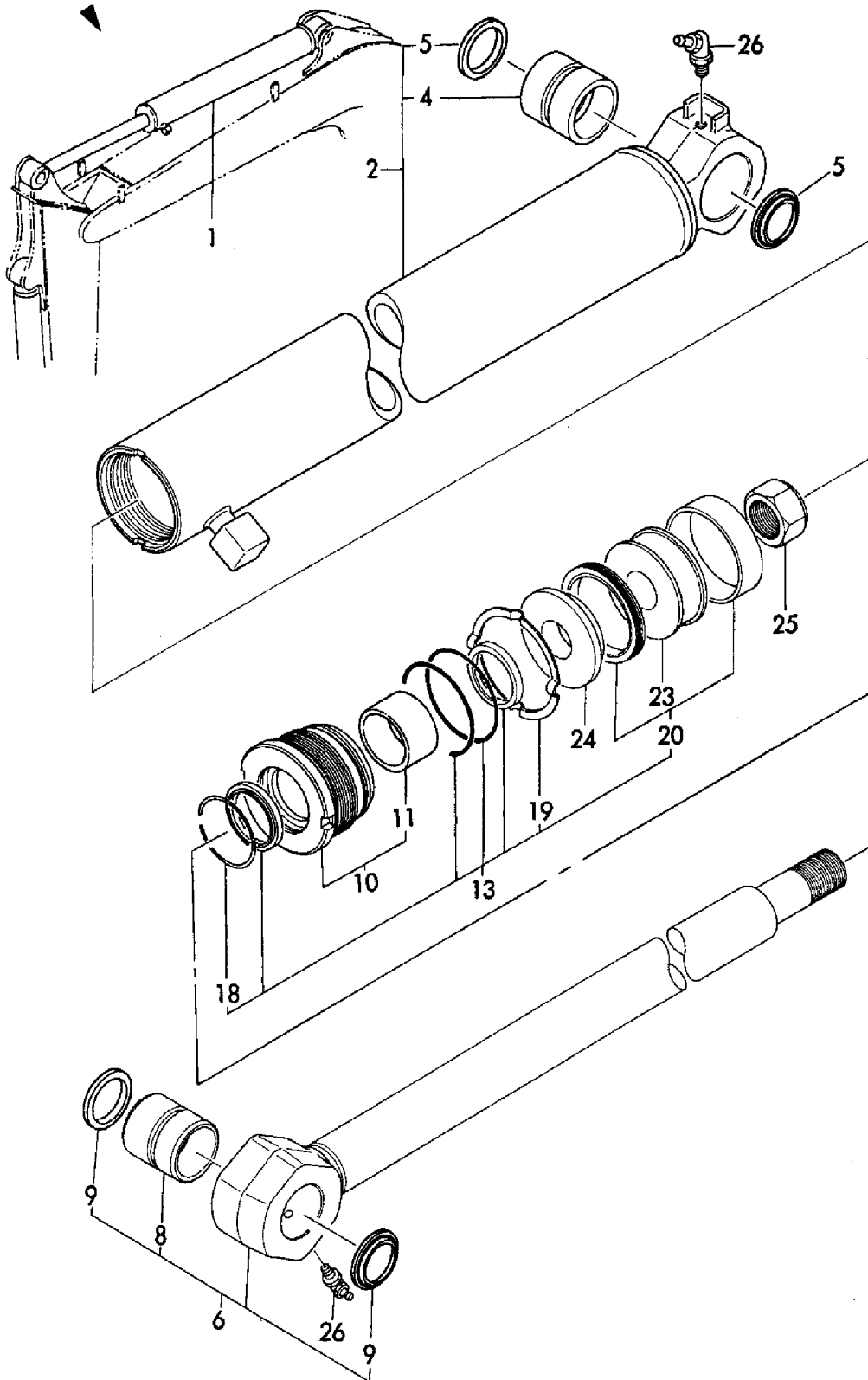

1,1,,172151-72600-4,, "CYLINDER, BUCKET(GREE",1,1,,,,,,,,,,,,,
1-1,1,,172176-72600,, "CYLINDER, BUCKET",1,1,,,,,S,,,M/#00832,,M/#00832,,,,,,
2,2,,172151-72030-4,, "TUBE, BUCKET (GREEN)",1,1,,,,,,,,,,,,,
2-1,2,,172176-72610,, "TUBE COMP., BUCKET",1,1,,,,,S,,,M/#00832,,M/#00832,,,,,,
4,3,,172165-72320,, "BUSH 45X40",1,1,,,,,,,,,,,,,
5,3,,172168-81410,, "SEAL 45X55X4, DUST",2,2,,,,,,,,,,,,,
6,2,,172151-72040,, "ROD ASSY, BUCKET",1,1,,,,,,,,,,,,,
6-1,2,,172176-72650,, "ROD COMP., BUCKET",1,1,,,,,S,,,M/#00832,,M/#00832,,,,,,
8,3,,172151-72670,, "BUSH 45 50",1,1,,,,,,,,,,,,,
9,3,,172168-81410,, "SEAL 45X55X4, DUST",2,2,,,,,,,,,,,,,
10,2,,172151-72710,, "HEAD 75 50",1,1,,,,,,,,,,,,,
11,3,,172151-72540,, "BUSH 50 35, ROD",1,1,,,,,,,,,,,,,
13,2,,172157-99420,, "CYLINDER KIT, BUCKET",1,1,,,,,,,,,,,,,
13A,3,,172151-71840,, "SEAL SET, HEAD",1,1,,,,,,,,,,,,,
18,3,,933111-26700,, "RING 65, SPRING",1,1,,,,,,,,,,,,,
19,3,,172141-72190,, "WASHER 75",1,1,,,,,,,,,,,,,
20,3,,172148-72930,, "SEAL SET, PISTON",1,1,,,,,,,,,,,,,
23,2,,172148-72050,, "PISTON 75",1,1,,,,,,,,,,,,,
24,2,,933111-20200,, "U-NUT M33",1,1,,,,,,,,,,,,,
25,2,,24761-040000,, "NIPPLE B, GREASE",2,2,,,,,,,,,,,,,
26,2,,172151-72680,, "TUBE",1,1,,,,,,,,,,,,,
26-1,2,,172176-72630,, "TUBE",1,1,,,,,S,,,M/#00832,,M/#00832,,,,,,
27,2,,22217-120000,, "SPRING WASHER",1,1,,,,,Z,,,M/#00832,,M/#00832,,,,,,
28,2,,26116-120252,, "BOLT M12X 25 PLATED",1,1,,,,,,,,,,,,,
28-1,2,,26013-100202,, "BOLT W/WASHER
M10X20",1,1,,,,,S,,,M/#00832,,M/#00832,,,,,,
29,2,,22137-120000,, "WASHER 12, POLISHED",1,1,,,,,,,,,,,,,
29-1,2,,194145-04810,, "WASHER 10",1,1,,,,,S,,,M/#00832,,M/#00832,,,,,,

Fig. 49 バケットシリンダ BUCKET CYLINDER

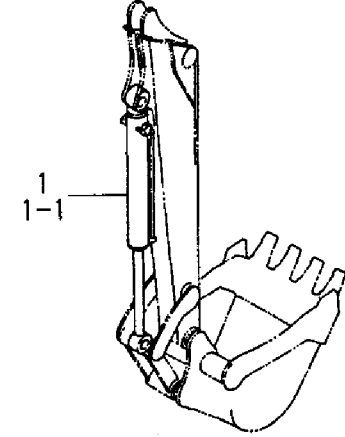
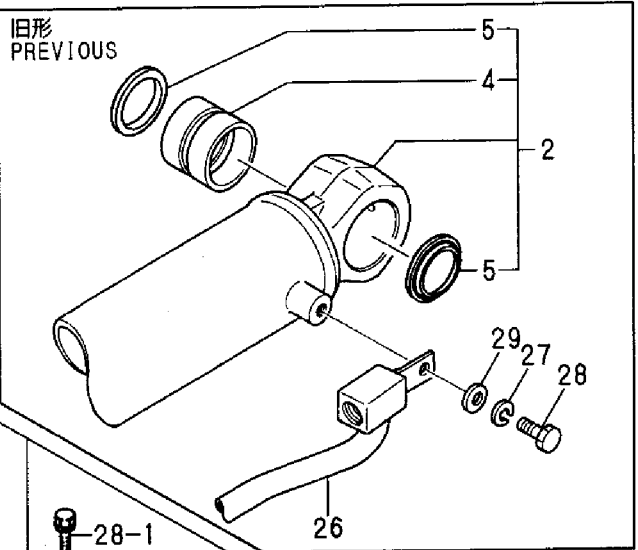

見出しNo. 1, 1-1は、
見出しNo. 2, 2-1から
29, 29-1を含みます。
1, 1-1 inc. 2, 2-1 ~
29, 29-1

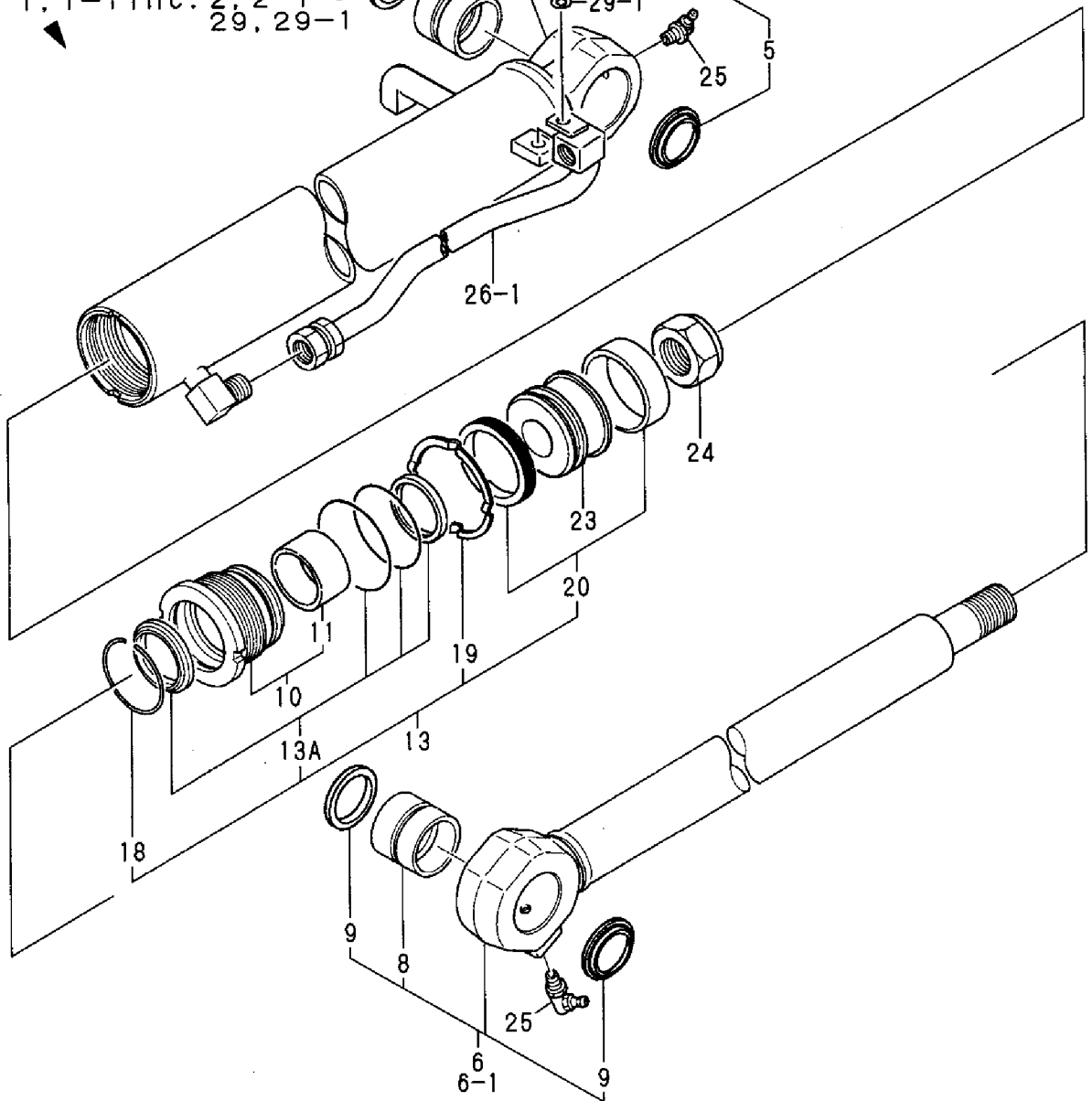

1,1,,172151-72753-3,, "CYLINDER ASSY, SWING",1,,,,,,,,,,,,,
2,2,,172151-72070-3,, "TUBE, SWING",1,,,,,,,,,,,,,
4,3,,172165-72310,, "BUSH 40X40",1,,,,,,,,,,,,,
5,3,,172165-81750,, "SEAL 40X50X5, DUST",2,,,,,,,,,,,,,
6,2,,172151-72060,, "ROD ASSY, SWING",1,,,,,,,,,,,,,
8,3,,172165-72310,, "BUSH 40X40",1,,,,,,,,,,,,,
9,3,,172165-81750,, "SEAL 40X50X5, DUST",2,,,,,,,,,,,,,
10,2,,172151-72840,, "HEAD 90 50",1,,,,,,,,,,,,,
11,3,,933135-14600,, "BUSH 40 30, ROD",1,,,,,,,,,,,,,
13,2,,172151-72080,, "CYLINDER KIT, SWING",1,,,,,,,,,,,,,
13A,3,,172151-71860,, "SEAL SET, HEAD",1,,,,,,,,,,,,,
20,3,,933111-26600,, "RING 55, SPRING",1,,,,,,,,,,,,,
21,3,,172151-72870,, "LOCK WASHER 90",1,,,,,,,,,,,,,
22,3,,22252-000561,, "CIRCRIP 56",1,,,,,,,,,,,,,
23,3,,172151-71850,, "SEAL SET, PISTON",1,,,,,,,,,,,,,
28,3,,172142-72810,, "CIRCLIP 22",1,,,,,,,,,,,,,
29,2,,172137-72730,, "RING 44B, CUSHION",1,,,,,,,,,,,,,
30,2,,172151-72950,, "PISTON 90",1,,,,,,,,,,,,,
31,2,,172151-72960,, "SPACER 90 27 19",1,,,,,,,,,,,,,
32,2,,172141-72250,, "U-NUT M27",1,,,,,,,,,,,,,
33,2,,933127-23001,, "CUSHION PLUNGER 44 C",1,,,,,,,,,,,,,
34,2,,172137-72710,, "COLLAR 40B, CUSHION",1,,,,,,,,,,,,,
35,2,,172137-72720,, "COLLAR 40A, CUSHION",1,,,,,,,,,,,,,
36,2,,172135-72800,, "RING 40 B, CUSHION",1,,,,,,,,,,,,,
37,2,,24761-020000,, "NIPPLE PT1/8, GREASE",1,,,,,,,,,,,,,
38,1,,22217-100000,, "SPRING WASHER 10",1,,,,,,,,,,,,,
39,1,,26116-100162,, "BOLT M10X 16 PLATED",1,,,,,,,,,,,,,
40,1,,22157-100000,, "WASHER 10",1,,,,,,,,,,,,,
41,1,,172165-72401-4,, "COVER, SWING(GREEN)",1,,,,,,,,,1,,,,,,,,,
42,1,,22217-100000,, "SPRING WASHER 10",1,,,,,,,,,1,,,,,,,,,
43,1,,26116-100162,, "BOLT M10X 16 PLATED",1,,,,,,,,,1,,,,,,,,,
44,1,,933147-03400,, "WASHER, BRAKE ARM",1,,,,,,,,,1,,,,,,,,,
45,1,,933168-14170,, "SPRING 16",2,,,,,,,,,1,,,,,,,,,

Fig. 50 スイングシリンダ (キャビン)
SWING CYLINDER (CABIN)

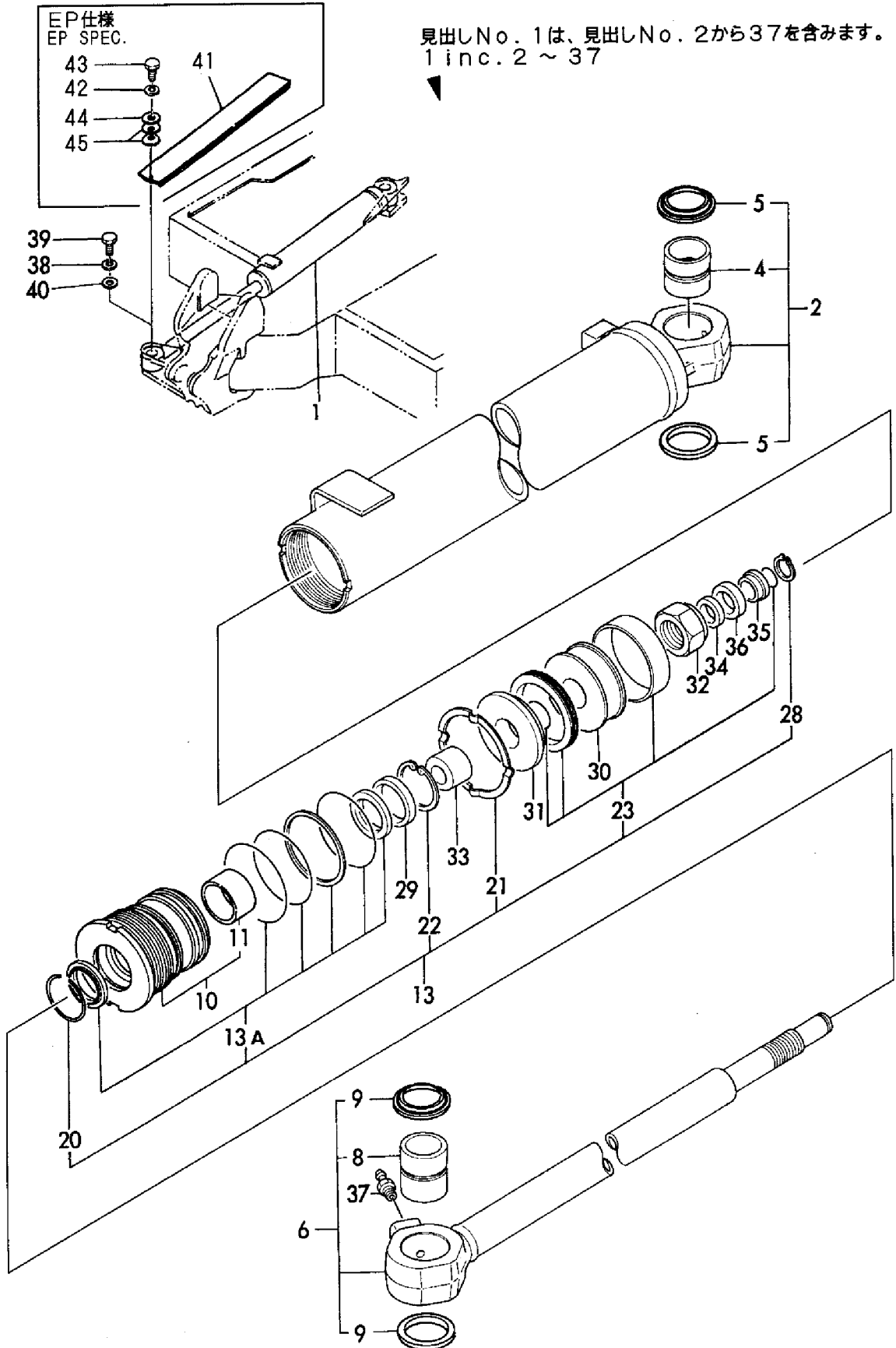

1,1,,172151-72753,, "CYLINDER ASSY, SWING" ,,1,,,,,,,,,,,,,
2,2,,172151-72070,, "TUBE W/BUSH, SWING" ,,1,,,,,,,,,,,,,
4,3,,172165-72310,, "BUSH 40X40" ,,1,,,,,,,,,,,,,
5,3,,172165-81750,, "SEAL 40X50X5, DUST" ,,2,,,,,,,,,,,,,
6,2,,172151-72060,, "ROD ASSY, SWING" ,,1,,,,,,,,,,,,,
8,3,,172165-72310,, "BUSH 40X40" ,,1,,,,,,,,,,,,,
9,3,,172165-81750,, "SEAL 40X50X5, DUST" ,,2,,,,,,,,,,,,,
10,2,,172151-72840,, "HEAD 90 50" ,,1,,,,,,,,,,,,,
11,3,,933135-14600,, "BUSH 40 30, ROD" ,,1,,,,,,,,,,,,,
13,2,,172151-72080,, "CYLINDER KIT, SWING" ,,1,,,,,,,,,,,,,
13A,3,,172151-71860,, "SEAL SET, HEAD" ,,1,,,,,,,,,,,,,
20,3,,933111-26600,, "RING 55, SPRING" ,,1,,,,,,,,,,,,,
21,3,,172151-72870,, "LOCK WASHER 90" ,,1,,,,,,,,,,,,,
22,3,,22252-000561,, "CIRCRIP 56" ,,1,,,,,,,,,,,,,
23,3,,172151-71850,, "SEAL SET, PISTON" ,,1,,,,,,,,,,,,,
28,3,,172142-72810,, "CIRCLIP 22" ,,1,,,,,,,,,,,,,
29,2,,172137-72730,, "RING 44B, CUSHION" ,,1,,,,,,,,,,,,,
30,2,,172151-72950,, "PISTON 90" ,,1,,,,,,,,,,,,,
31,2,,172151-72960,, "SPACER 90 27 19" ,,1,,,,,,,,,,,,,
32,2,,172141-72250,, "U-NUT M27" ,,1,,,,,,,,,,,,,
33,2,,933127-23001,, "CUSHION PLUNGER 44 C" ,,1,,,,,,,,,,,,,
34,2,,172137-72710,, "COLLAR 40B, CUSHION" ,,1,,,,,,,,,,,,,
35,2,,172137-72720,, "COLLAR 40A, CUSHION" ,,1,,,,,,,,,,,,,
36,2,,172135-72800,, "RING 40 B, CUSHION" ,,1,,,,,,,,,,,,,
37,2,,24761-020000,, "NIPPLE PT1/8, GREASE" ,,1,,,,,,,,,,,,,
38,1,,172165-72401-4,, "COVER, SWING(GREEN)" ,,1,,,,,,,,,,,,,
39,1,,933147-03400,, "WASHER, BRAKE ARM" ,,1,,,,,,,,,,,,,
40,1,,22217-100000,, "SPRING WASHER 10" ,,1,,,,,,,,,,,,,
41,1,,26116-100162,, "BOLT M10X 16 PLATED" ,,1,,,,,,,,,,,,,
42,1,,933168-14170,, "SPRING 16" ,,2,,,,,,,,,,,,,

Fig. 51 スイングシリンダ (キャノピ) SWING CYLINDER (CANOPY)

見出しNo. 1は、見出しNo. 2から37を含みます。
1 inc. 2 ~ 37

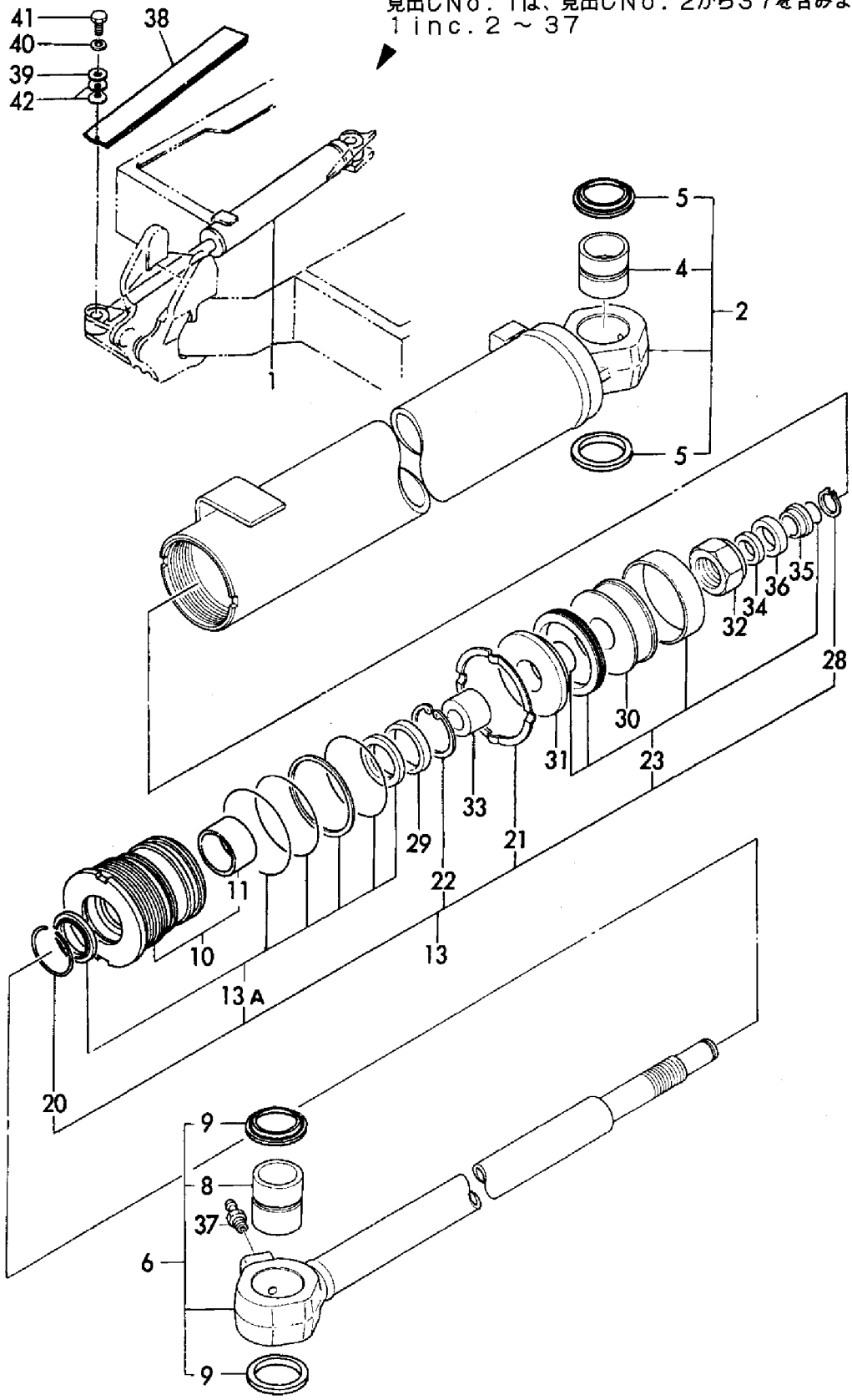

1,1,,172151-71500-1,, "CYLINDER, BLADE",1,1,,,,,,,,,,,,,
2,2,,172151-72920-1,, "TUBE, BLADE",1,1,,,,,,,,,,,,,
4,3,,172151-72670,, "BUSH 45 50",1,1,,,,,,,,,,,,,
5,3,,172168-81410,, "SEAL 45X55X4, DUST",2,2,,,,,,,,,,,,,
6,2,,172151-72930,, "ROD ASSY, BLADE",1,1,,,,,,,,,,,,,
8,3,,172151-72670,, "BUSH 45 50",2,2,,,,,,,,,,,,,
9,3,,172168-81410,, "SEAL 45X55X4, DUST",2,2,,,,,,,,,,,,,
10,2,,172151-71590,, "HEAD 90 50",1,1,,,,,,,,,,,,,
11,3,,172151-72540,, "BUSH 50 35, ROD",1,1,,,,,,,,,,,,,
13,2,,172151-72940,, "CYLINDER KIT, BLADE",1,1,,,,,,,,,,,,,
13A,3,,172151-71880,, "SEAL SET, HEAD",1,1,,,,,,,,,,,,,
18,3,,933111-26700,, "RING 65, SPRING",1,1,,,,,,,,,,,,,
19,3,,172151-72870,, "LOCK WASHER 90",1,1,,,,,,,,,,,,,
20,3,,172151-71870,, "SEAL SET, PISTON",1,1,,,,,,,,,,,,,
23,2,,172151-71610,, "PISTON",1,1,,,,,,,,,,,,,
23-1,2,,172164-72640,, "PISTON",1,1,,,,,S,,,M/#01451,,M/#01451,,,,,
24,2,,172151-71620,, "SPACER 90 36 19",1,1,,,,,Z,,,M/#01451,,M/#01451,,,,,
25,2,,172151-72580,, "U-NUT M36",1,1,,,,,,,,,,,,,
26,2,,172151-71640,, "TUBE",1,1,,,,,,,,,,,,,
27,2,,22217-100000,, "SPRING WASHER 10",1,1,,,,,,,,,,,,,
28,2,,26116-100202,, "BOLT M10X 20 PLATED",1,1,,,,,,,,,,,,,
29,2,,22137-100000,, "WASHER 10, POLISHED",1,1,,,,,,,,,,,,,

Fig. 52 ブレードシリンダ
BLADE CYLINDER

見出しNo. 1は、見出しNo. 2から29を含みます。
1 inc. 2 ~ 29

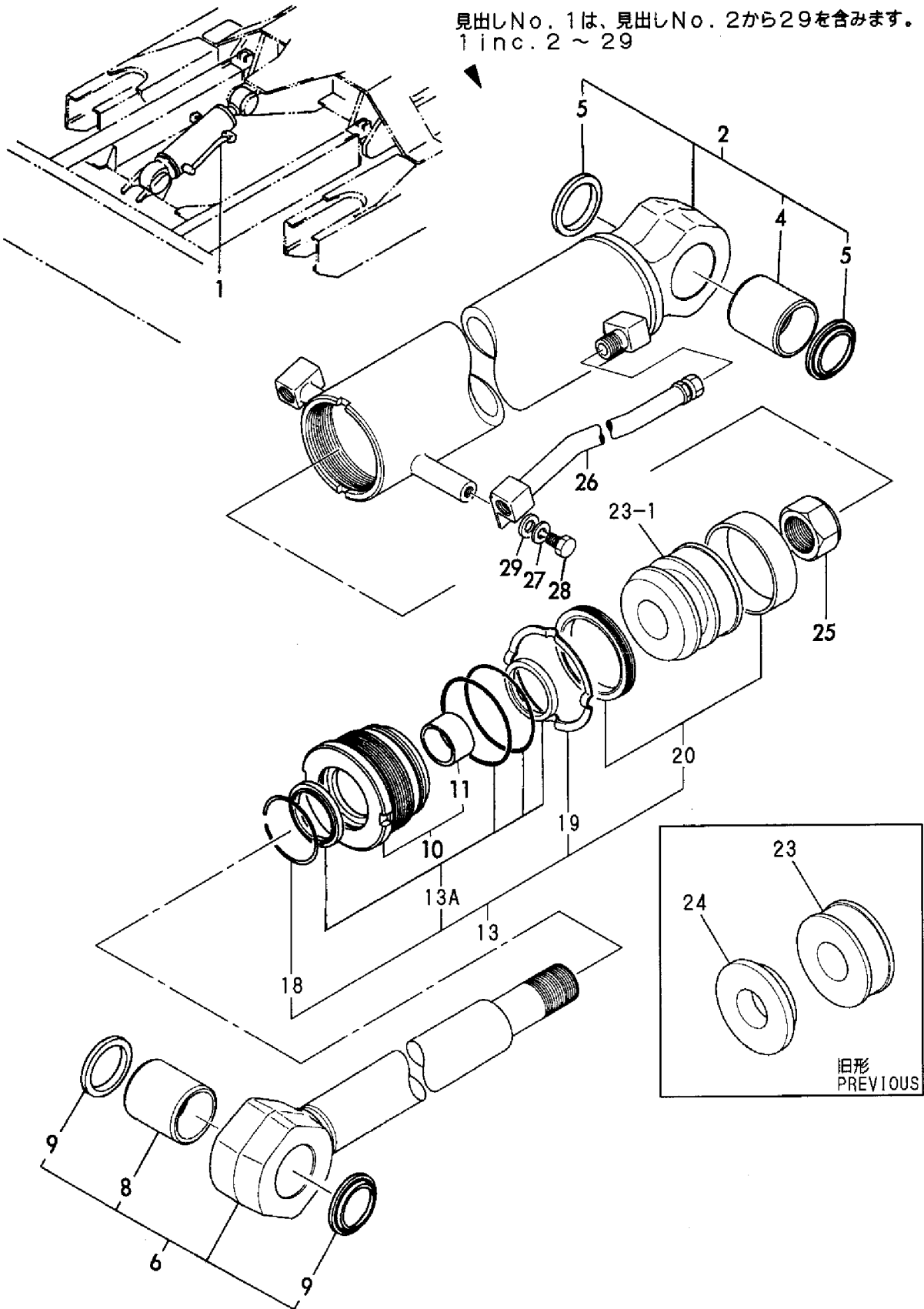

- 1,1,,172147-73300,, "MOTOR ASSY, DRIVING",2,2,,,,,,,,,,,,,,,,,,,,,
- 1-1,1,,172147-73301,, "MOTOR ASSY, DRIVING",2,2,,,,,N,,MXXX,,MXXX,,,,,,,
- 2,2,,172124-70010,, BEARING,2,2,,,,,,,,,,,,,,,,,,,,,
- 4,2,,172123-70020,, BALL,4,4,,,,,,,,,,,,,,,,,,,,,
- 5,2,,172147-70640,, "SEAL KIT, REDUCTION",2,2,,,,,,,,,,,,,,,,,,,,,
- 8,2,,172124-70030,, BALL,198,198,,,,,,,,,,,,,,,,,,,,,
- 9,2,,172147-70030,, "PLANETARY GEAR(B)",8,8,,,,,,,,,,,,,,,,,,,,,
- 10,2,,172147-70040,, "CAGE & ROLLER",8,8,,,,,,,,,,,,,,,,,,,,,
- 11,2,,172124-70050,, "RING NUT",2,2,,,,,,,,,,,,,,,,,,,,,
- 12,2,,172147-70050,, COLLAR,8,8,,,,,,,,,,,,,,,,,,,,,
- 13,2,,172147-70060,, "THRUST WASHER",8,8,,,,,,,,,,,,,,,,,,,,,
- 14,2,,172147-70070,, PLATE,2,2,,,,,,,,,,,,,,,,,,,,,
- 15,2,,172147-70080,, "GEAR, SUN",2,2,,,,,,,,,,,,,,,,,,,,,
- 16,2,,172147-70090,, "SNAP RING",2,2,,,,,,,,,,,,,,,,,,,,,
- 17,2,,172147-70100,, HOLDER,2,2,,,,,,,,,,,,,,,,,,,,,
- 18,2,,172141-70110,, SCREW,8,8,,,,,,,,,,,,,,,,,,,,,
- 19,2,,172147-70110,, "GEAR(A), PLANETARY",6,6,,,,,,,,,,,,,,,,,,,,,
- 20,2,,172147-70120,, "GAUGE & ROLLER",6,6,,,,,,,,,,,,,,,,,,,,,
- 21,2,,172147-70130,, "RACE, INNER",6,6,,,,,,,,,,,,,,,,,,,,,
- 22,2,,172147-70140,, "PIN, SPRING",6,6,,,,,,,,,,,,,,,,,,,,,
- 23,2,,172147-70150,, "DRIVE GEAR",2,2,,,,,,,,,,,,,,,,,,,,,
- 24,2,,172147-70160,, PLATE,2,2,,,,,1,,,,,,,,,,,,,,,,,,,,,
- 25,2,,172147-70170,, PLATE,2,2,,,,,1,,,,,,,,,,,,,,,,,,,,,
- 26,2,,172147-70180,, PLATE,2,2,,,,,1,,,,,,,,,,,,,,,,,,,,,
- 27,2,,172147-70190,, "COVER, SIDE",2,2,,,,,,,,,,,,,,,,,,,,,
- 28,2,,172147-70210,, WIRE,2,2,,,,,,,,,,,,,,,,,,,,,
- 29,2,,172147-70220,, PLUG,4,4,,,,,,,,,,,,,,,,,,,,,
- 30,2,,172147-70230,, SHAFT,2,2,,,,,,,,,,,,,,,,,,,,,
- 31,2,,172147-70240,, "BALL BEARING",2,2,,,,,,,,,,,,,,,,,,,,,
- 32,2,,172147-70650,, "SEAL SET, MOTOR",2,2,,,,,,,,,,,,,,,,,,,,,
- 39,2,,172147-70260,, PLATE,2,2,,,,,,,,,,,,,,,,,,,,,
- 40,2,,172147-70680,, "BLOCK ASSY, CYLINDER",2,2,,,,,,,,,,,,,,,,,,,,,
- 43,2,,172147-70280,, COLLAR,2,2,,,,,,,,,,,,,,,,,,,,,
- 44,2,,172147-70290,, SPRING,2,2,,,,,,,,,,,,,,,,,,,,,
- 45,2,,172147-70300,, "WASHER, LOCK",2,2,,,,,,,,,,,,,,,,,,,,,
- 46,2,,172147-70310,, "RING, SNAP",2,2,,,,,,,,,,,,,,,,,,,,,
- 47,2,,172147-70320,, PIN,6,6,,,,,,,,,,,,,,,,,,,,,
- 48,2,,172147-70330,, "HOLDER, RETAINER",2,2,,,,,,,,,,,,,,,,,,,,,
- 49,2,,172147-70340,, "PLATE, RETAINER",2,2,,,,,,,,,,,,,,,,,,,,,
- 50,2,,172147-70360,, SPRING,4,4,,,,,,,,,,,,,,,,,,,,,
- 51,2,,172147-70370,, "PLATE VALVE",2,2,,,,,,,,,,,,,,,,,,,,,
- 52,2,,172147-70390,, "BALL BEARING",2,2,,,,,,,,,,,,,,,,,,,,,
- 53,2,,172122-70410,, PIN,4,4,,,,,,,,,,,,,,,,,,,,,
- 57,2,,23871-030000,, "PLUG PT3/8, SCREW",10,10,,,,,,,,,,,,,,,,,,,,,
- 58,2,,172122-70430,, "VALVE, CHECK",4,4,,,,,,,,,,,,,,,,,,,,,
- 59,2,,172147-70430,, PLUG,4,4,,,,,,,,,,,,,,,,,,,,,
- 60,2,,172122-70440,, SPRING,4,4,,,,,,,,,,,,,,,,,,,,,
- 61,2,,172147-70440,, "SEAT, SPRING",4,4,,,,,,,,,,,,,,,,,,,,,
- 62,2,,172147-70450,, SPRING,4,4,,,,,,,,,,,,,,,,,,,,,
- 63,2,,172147-70460,, CAP,4,4,,,,,,,,,,,,,,,,,,,,,
- 64,2,,172147-70470,, ORIFICE,4,4,,,,,,,,,,,,,,,,,,,,,
- 65,2,,172141-70480,, PIN,2,2,,,,,,,,,,,,,,,,,,,,,
- 66,2,,172147-70490,, SPRING,2,2,,,,,,,,,,,,,,,,,,,,,
- 67,2,,172147-70500,, PLUG,6,6,,,,,,,,,,,,,,,,,,,,,
- 68,2,,172147-70510,, PLUG,4,4,,,,,,,,,,,,,,,,,,,,,
- 69,2,,172147-70520,, PLUG,2,2,,,,,,,,,,,,,,,,,,,,,
- 70,2,,172147-70530,, ORIFICE,8,8,,,,,,,,,,,,,,,,,,,,,
- 70-1,2,,172148-70340,, ORIFICE,8,8,,,,,N,,MXXX,,MXXX,,,,,,,
- 71,2,,172147-70540,, "HEAD BOLT, SOCKET",16,16,,,,,,,,,,,,,,,,,,,,,
- 73,2,,172147-70560,, "VALVE ASSY, CONTROL",2,2,,,,,,,,,,,,,,,,,,,,,
- 75,2,,172147-70660,, "SEAL KIT, BLOCK",2,2,,,,,,,,,,,,,,,,,,,,,
- 84,2,,172147-70590,, "PISTON, FREE",4,4,,,,,,,,,,,,,,,,,,,,,
- 85,2,,172147-70610,, SHIM,2,2,,,,,,,,,,,,,,,,,,,,,

86,2,,172147-70620,, "HEAD BOLT, SOCKET",8,8,,,,,,,,,,,,,
87,2,,172122-73430,, PLUG,4,4,,,,,,,,,,,,,
88,2,,23871-020000,, "PLUG PT1/4,SCREW",4,4,,,,,,,,,,,,,
89,2,,172147-70670,, SHIM,4,4,,,,,W,,,MXXX,MXXX,,,,,
90,1,,22217-140000,, "SPRING WASHER 14",18,18,,,,,,,,,,,,,
91,1,,26116-140352,, "BOLT M14X 35 PLATED",18,18,,,,,,,,,,,,,

Fig. 53 走行モータ TRAVEL MOTOR

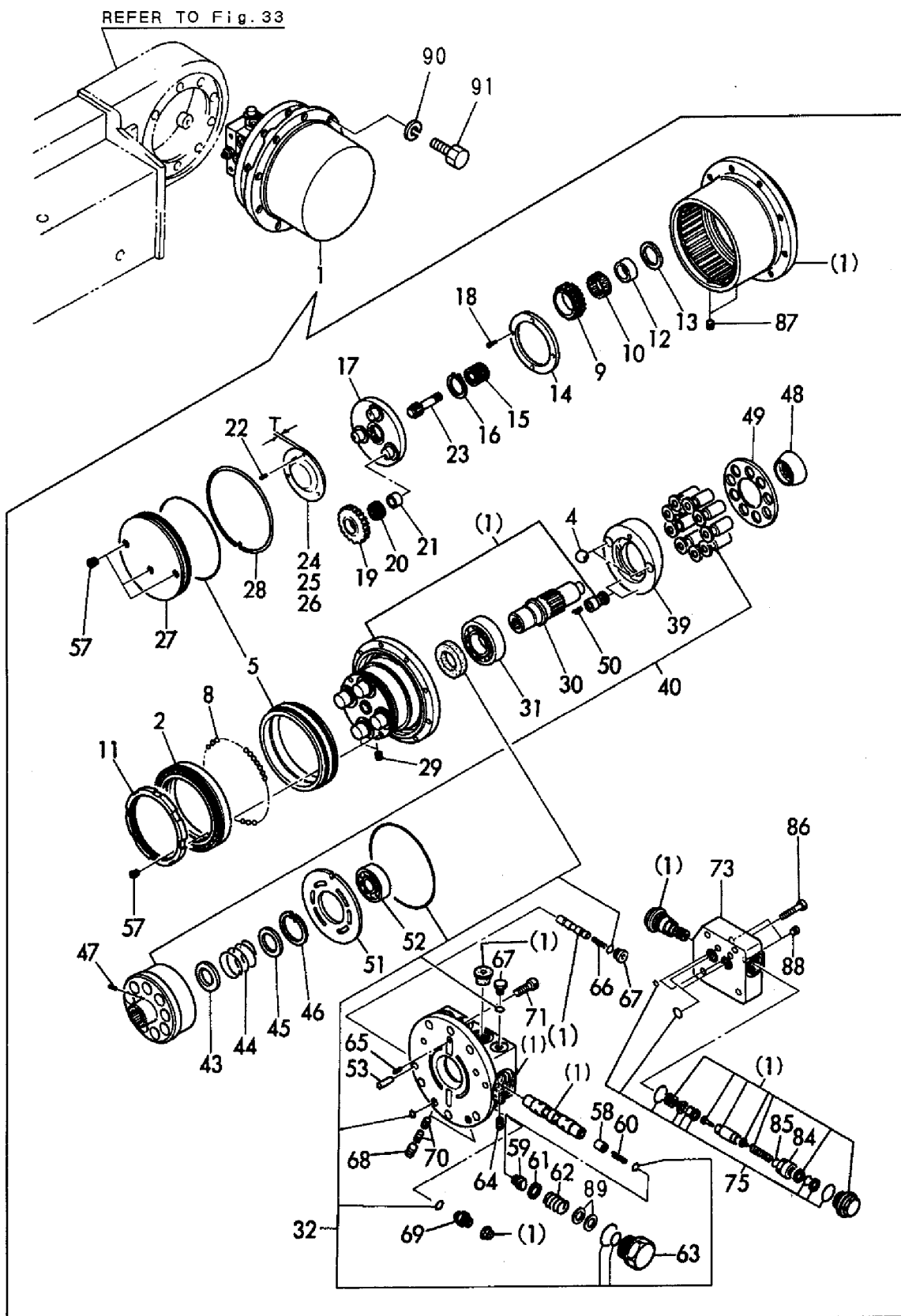

1,1,,172176-73311,, "MOTOR ASSY, TURNING",1,1,,,,,,,,,,,,,
2,2,,172176-73320,, "GEAR ASSY, REDUCTION",1,1,,,,,,,,,,,,,
3,3,,172165-73320,, "PINION SHAFT",1,1,,,,,,,,,,,,,
4,3,,172165-73330,, COLLER,1,1,,,,,,,,,,,,,
5,3,,172165-73350,, BEARING,1,1,,,,,,,,,,,,,
6,3,,172165-73360,, "GEAR CASE",1,1,,,,,,,,,,,,,
7,3,,172165-73380,, BEARING,1,1,,,,,,,,,,,,,
8,3,,172165-73390,, "HOLDER 2 ASSY",1,1,,,,,,,,,,,,,
9,3,,172165-73400,, GEAR,1,1,,,,,,,,,,,,,
10,3,,172165-73410,, "HOLDER 1 ASSY",1,1,,,,,,,,,,,,,
11,3,,172165-73420,, GEAR,1,1,,,,,,,,,,,,,
12,3,,26450-120802,, "BOLT M12X80",6,6,,,,,,,,,,,,,
13,3,,172165-73490,, "RING GEAR",1,1,,,,,,,,,,,,,
14,3,,172162-71540,, PIN,2,2,,,,,,,,,,,,,
15,3,,172165-73500,, COLLER,2,2,,,,,,,,,,,,,
16,3,,172162-71670,, "PLUG PT3/8",1,1,,,,,,,,,,,,,
17,3,,172164-73340,, "SEAL ASSY",1,1,,,,,,,,,,,,,
20,2,,172176-73330,, "MOTOR ASSY, HYD.",1,1,,,,,,,,,,,,,
21,3,,172176-73380,, COLLAR,1,1,,,,,,,,,,,,,
22,3,,172165-73430,, BEARING,1,1,,,,,,,,,,,,,
23,3,,172162-71870,, "PLATE,CAM",1,1,,,,,,,,,,,,,
24,3,,172162-71860,, "PLATE,RETURN",1,1,,,,,,,,,,,,,
25,3,,172162-71850,, SPRING,1,1,,,,,,,,,,,,,
26,3,,172176-73350,, "PLATE,BALANCE",1,1,,,,,,,,,,,,,
27,3,,172165-73440,, BUSH,4,4,,,,,,,,,,,,,
28,3,,172165-73450,, "TEFLON RING",4,4,,,,,,,,,,,,,
29,3,,172165-73460,, "CONED DISC SPRING",4,4,,,,,,,,,,,,,
30,3,,172176-73360,, PISTON,2,2,,,,,,,,,,,,,
31,3,,172162-71710,, "BEARING,NEEDLE",1,1,,,,,,,,,,,,,
32,3,,172165-73480,, "SNAP RING",1,1,,,,,,,,,,,,,
33,3,,172176-73370,, "TEFLON RING",2,2,,,,,,,,,,,,,
34,3,,172176-73340,, "RELIEF ASSY",2,2,,,,,,,,,,,,,
35,3,,172162-71960,, "PIN,STRAIGHT",2,2,,,,,,,,,,,,,
36,3,,26450-120302,, "BOLT M12X30",4,4,,,,,,,,,,,,,
37,3,,172164-73360,, "SEAL ASSY",1,1,,,,,,,,,,,,,
42,1,,194202-56460,, BAND,1,1,,,,,,,,,,,,,
43,1,,26116-160502,, "BOLT M16X 50 PLATED",8,8,,,,,,,,,,,,,
44,1,,172162-73330,, "CONNECTOR 2-PT3/8",1,1,,,,,,,,,,,,,
45,1,,172165-76600,, "CONNECTOR PT1/4",1,1,,,,,,,,,,,,,
46,1,,172164-78750,, HOSE,1,1,,,,,,,,,,,,,
47,1,,22217-160000,, "SPRING WASHER 16",8,8,,,,,,,,,,,,,
48,1,,22487-100200,, "PIN 10X20",1,1,,,,,,,,,,,,,
49,1,,23000-022000,, "CLAMP 22",2,2,,,,,,,,,,,,,
50,1,,23111-030000,, "ELBOW (PT 3/8)",1,1,,,,,,,,,,,,,
51,1,,23871-030000,, "PLUG PT3/8,SCREW",1,1,,,,,,,,,,,,,

Fig. 54 旋回モータ (旧形)
TURNING MOTOR (PREVIOUS)

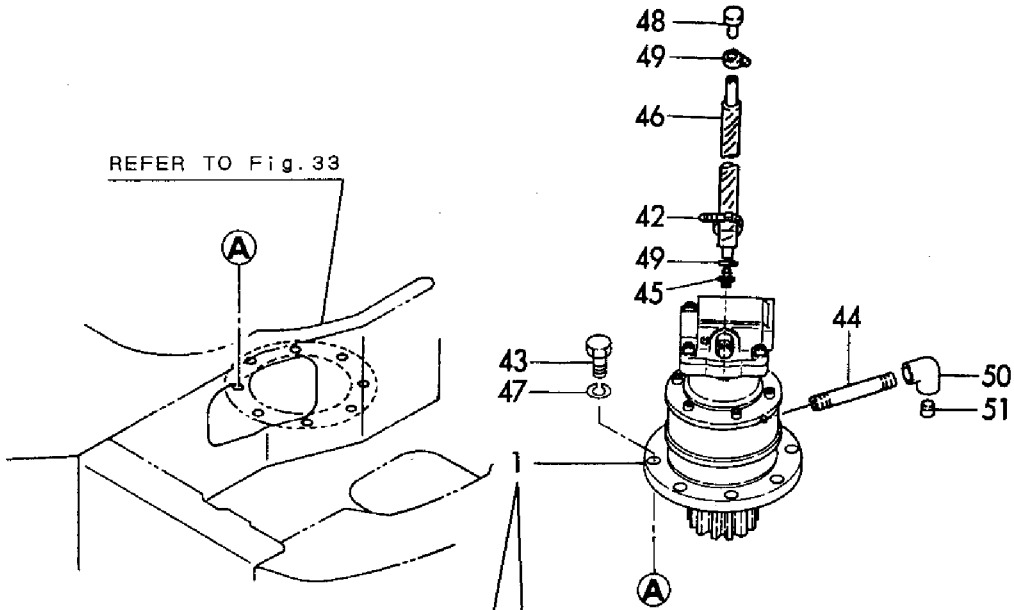

見出しNo. 2は、見出しNo. 3から17を含みます。
2 inc. 3 ~ 17

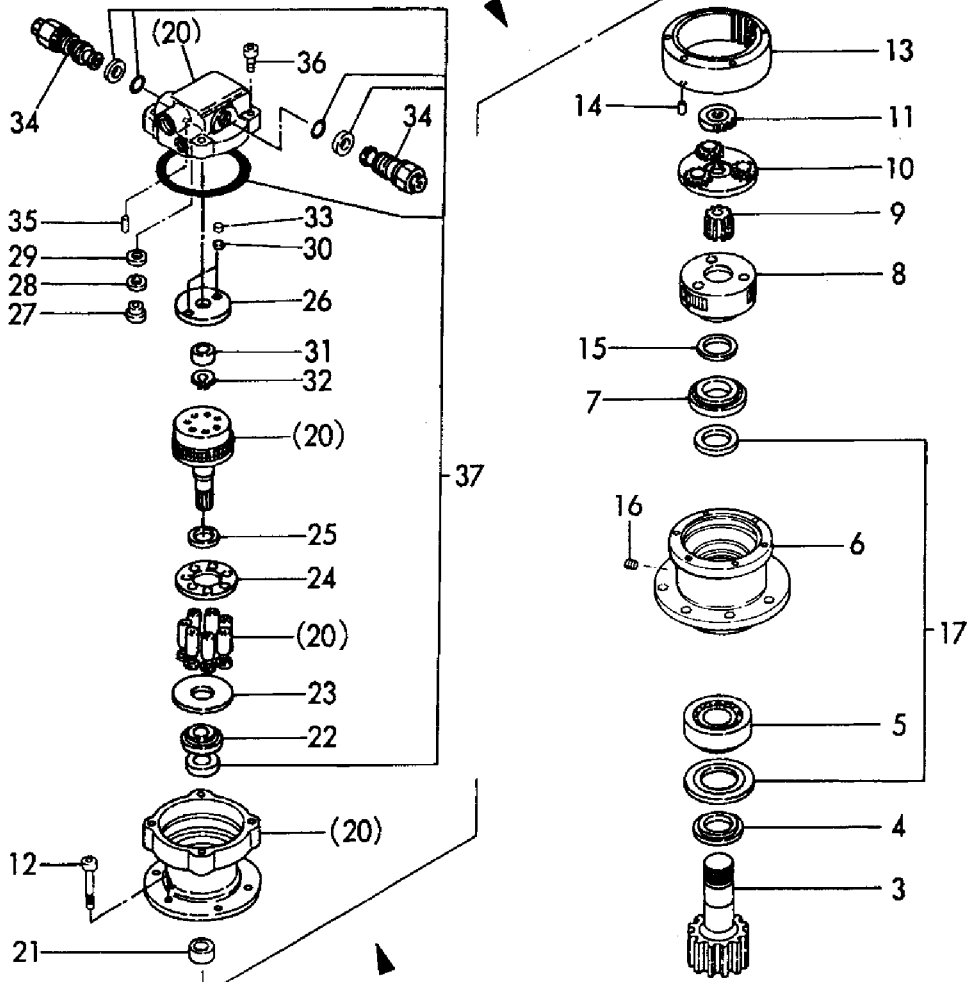

見出しNo. 20は、見出しNo. (20) から37を含みます。
20 inc. (20) ~ 37

1,1,,172176-73312,, "MOTOR ASSY, TURNING",1,1,,,,,,,,,,,,,
2,2,,172176-73321,, "GEAR ASSY, REDUCTION",1,1,,,,,,,,,,,,,
3,3,,172165-73320,, "PINION SHAFT",1,1,,,,,,,,,,,,,
4,3,,172165-73330,, COLLER,1,1,,,,,,,,,,,,,
5,3,,172165-73350,, BEARING,1,1,,,,,,,,,,,,,
6,3,,172165-73360,, "GEAR CASE",1,1,,,,,,,,,,,,,
7,3,,172165-73380,, BEARING,1,1,,,,,,,,,,,,,
8,3,,172176-73950,, "HOLDER 2 ASSY",1,1,,,,,,,,,,,,,
9,3,,172164-73290,, GEAR,1,1,,,,,,,,,,,,,
10,3,,172164-73430,, "HOLDER 1 ASSY",1,1,,,,,,,,,,,,,
11,3,,172165-73420,, GEAR,1,1,,,,,,,,,,,,,
12,3,,26450-120802,, "BOLT M12X80",6,6,,,,,,,,,,,,,
13,3,,172165-73490,, "RING GEAR",1,1,,,,,,,,,,,,,
14,3,,172162-71540,, PIN,2,2,,,,,,,,,,,,,
15,3,,172165-73500,, COLLER,2,2,,,,,,,,,,,,,
16,3,,172162-71670,, "PLUG PT3/8",1,1,,,,,,,,,,,,,
17,3,,172164-73340,, "SEAL ASSY",1,1,,,,,,,,,,,,,
20,2,,172176-73331,, "MOTOR ASSY, HYD.",1,1,,,,,,,,,,,,,
21,3,,172162-71900,, COLLAR,1,1,,,,,,,,,,,,,
22,3,,172165-73430,, BEARING,1,1,,,,,,,,,,,,,
23,3,,172162-71870,, "PLATE,CAM",1,1,,,,,,,,,,,,,
24,3,,172162-71860,, "PLATE,RETURN",1,1,,,,,,,,,,,,,
25,3,,172162-71850,, SPRING,1,1,,,,,,,,,,,,,
26,3,,172176-73350,, "PLATE,BALANCE",1,1,,,,,,,,,,,,,
27,3,,172164-73090,, BUSH,4,4,,,,,,,,,,,,,
28,3,,172164-73080,, "TEFLON RING",4,4,,,,,,,,,,,,,
29,3,,172165-73460,, "CONED DISC SPRING",4,4,,,,,,,,,,,,,
30,3,,172176-73360,, PISTON,2,2,,,,,,,,,,,,,
31,3,,172162-71710,, "BEARING,NEEDLE",1,1,,,,,,,,,,,,,
32,3,,172165-73480,, "SNAP RING",1,1,,,,,,,,,,,,,
33,3,,172176-73370,, "TEFLON RING",2,2,,,,,,,,,,,,,
34,3,,172176-73340,, "RELIEF ASSY",2,2,,,,,,,,,,,,,
35,3,,172162-71960,, "PIN,STRAIGHT",2,2,,,,,,,,,,,,,
36,3,,26450-120302,, "BOLT M12X30",4,4,,,,,,,,,,,,,
37,3,,172164-73361,, "SEAL ASSY",1,1,,,,,,,,,,,,,
44,3,,172162-71720,, "PLATE,FRICTION",1,1,,,,,,,,,,,,,
45,3,,172162-71730,, PLATE,1,1,,,,,,,,,,,,,
46,3,,172162-71830,, PISTON,1,1,,,,,,,,,,,,,
47,3,,172162-71820,, SPRING,16,16,,,,,,,,,,,,,
48,1,,194202-56460,, BAND,1,1,,,,,,,,,,,,,
49,1,,26116-160502,, "BOLT M16X 50 PLATED",8,8,,,,,,,,,,,,,
50,1,,172162-73330,, "CONNECTOR 2-PT3/8",1,1,,,,,,,,,,,,,
51,1,,172165-76600,, "CONNECTOR PT1/4",1,1,,,,,,,,,,,,,
52,1,,172164-78750,, HOSE,1,1,,,,,,,,,,,,,
53,1,,22217-160000,, "SPRING WASHER 16",8,8,,,,,,,,,,,,,
54,1,,22487-100200,, "PIN 10X20",1,1,,,,,,,,,,,,,
55,1,,23000-022000,, "CLAMP 22",2,2,,,,,,,,,,,,,
56,1,,23111-030000,, "ELBOW (PT 3/8)",1,1,,,,,,,,,,,,,
57,1,,23871-030000,, "PLUG PT3/8,SCREW",1,1,,,,,,,,,,,,,

Fig. 55 旋回モータ (新形) TURNING MOTOR (NEW)

M/#01328~

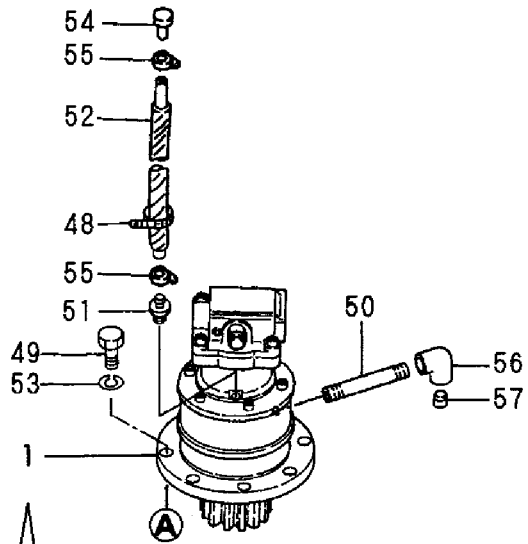
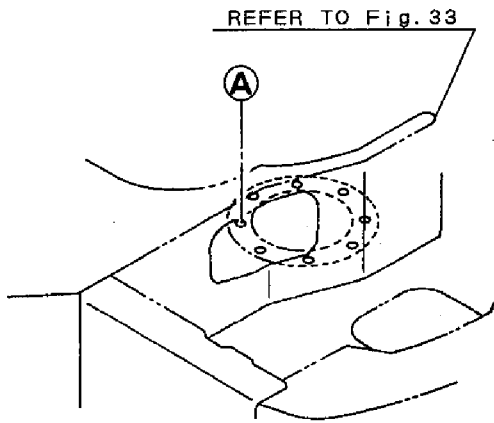

見出しNo. 20は、見出しNo. (20) から47を含みます。
20 inc. (20) ~ 47

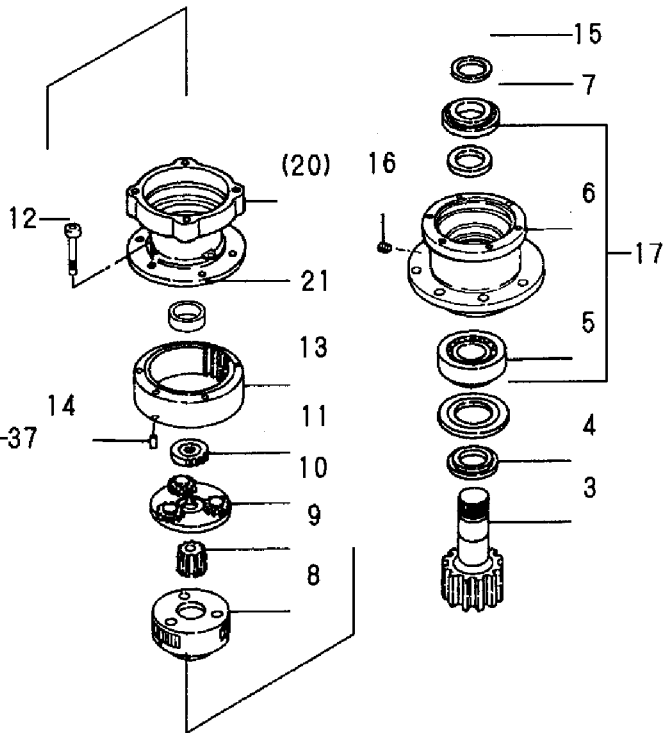
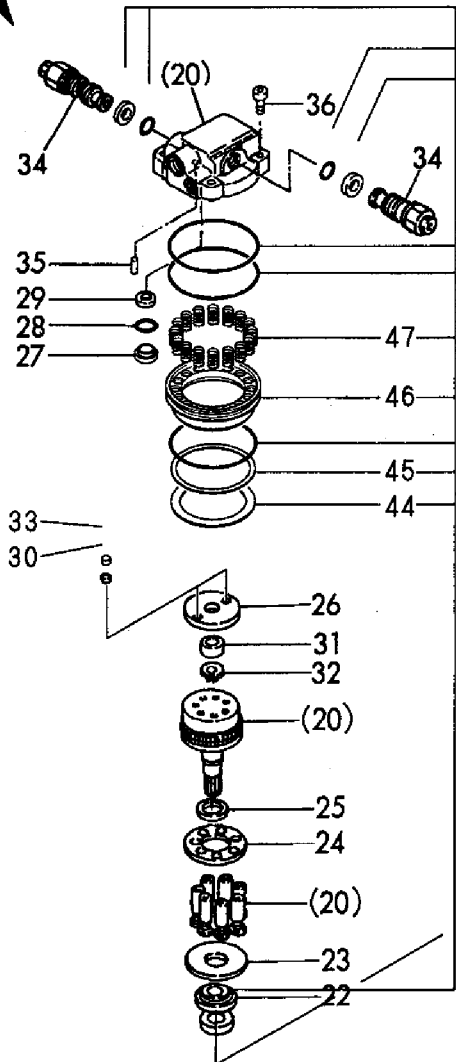

見出しNo. 2は、見出しNo. 3から17を含みます。
2 inc. 3 ~ 17

1,1,,172147-73800-1,, "JOINT ASSY,SWIVEL",1,1,,,,,,,,,,,,,
2,2,,172147-73810-1,, SHAFT,1,1,,,,,,,,,,,,,
3,2,,172147-73830-1,, "HUB,SWIVEL",1,1,,,,,,,,,,,,,
4,2,,172147-73850-1,, PLATE,1,1,,,,,,,,,,,,,
5,2,,172122-73860,, "SPACER, SWIVEL",1,1,,,,,,,,,,,,,
6,2,,172122-73870,, "THRUST WASHER",1,1,,,,,,,,,,,,,
7,2,,172147-73880,, "SEAL ASSY",1,1,,,,,,,,,,,,,
8,3,,172122-73890,, "SEAL, SWIVEL",8,8,,,,,,,,,,,,,
9,3,,24311-000800,, "O-RING 1A P-80.0",1,1,,,,,,,,,,,,,
10,3,,24311-001000,, "O-RING 1A P-100.0",1,1,,,,,,,,,,,,,
11,3,,24321-000950,, "O-RING 1A G-95.0",1,1,,,,,,,,,,,,,
12,2,,22242-000700,, "CIRCLIP 70",1,1,,,,,,,,,,,,,
13,2,,23871-030000,, "PLUG PT3/8,SCREW",4,4,,,,,,,,,,,,,
14,2,,26013-100402,, "BOLT M10X 40",4,4,,,,,,,,,,,,,
15,1,,26013-120502,, "BOLT M12X 50",4,4,,,,,,,,,,,,,

Fig. 56 スイベルジョイント SWIVEL JOINT

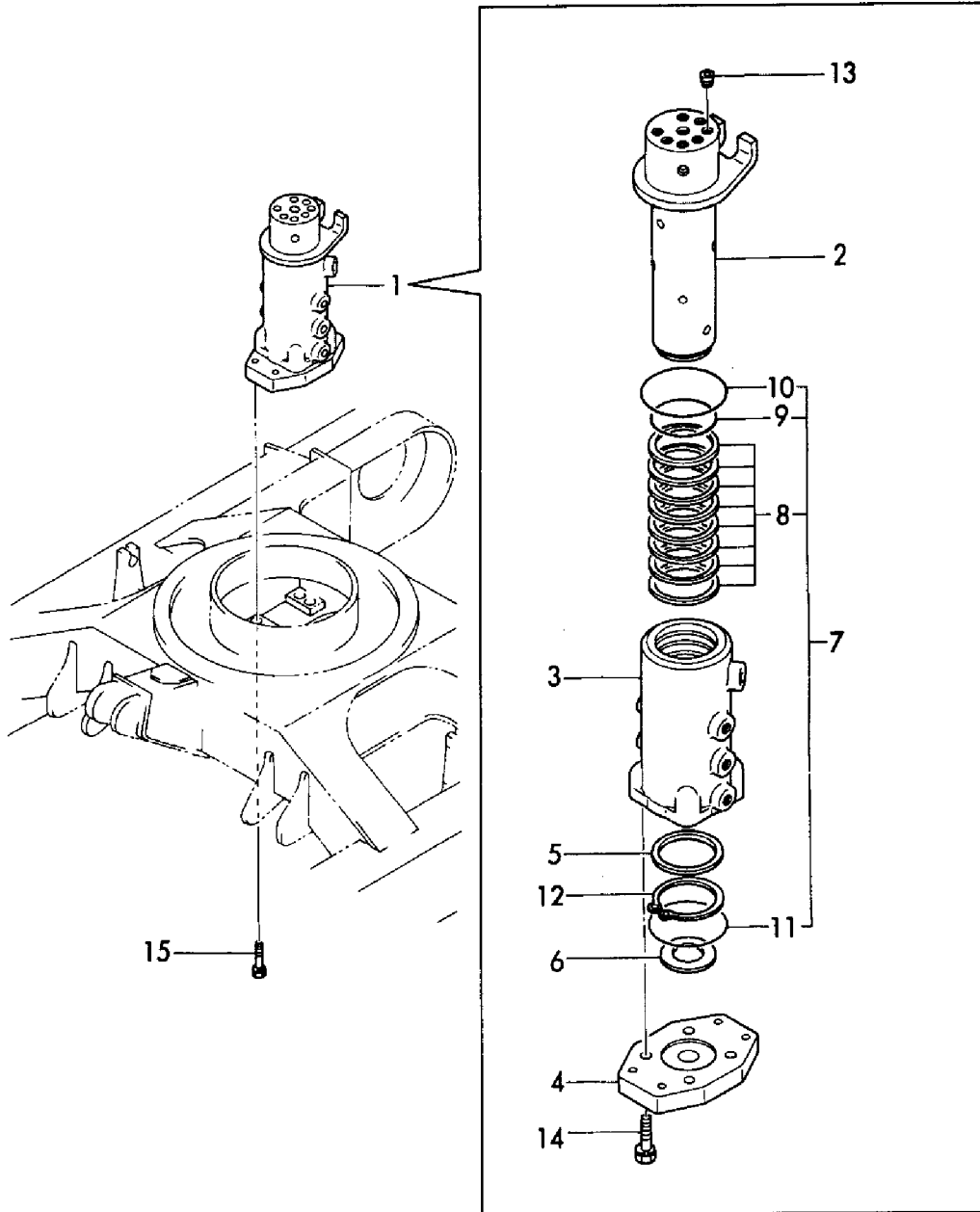

1,1,,172176-74100,, "VALVE ASSY, CONTROL",1,1,,,,,,,,,,,,,,,,,,,,,
1-1,1,,172176-74101,, "VALVE COMP.,CONTROL",1,1,,,,,N,,,M/#00832,,M/#00832,,,,,,
1-2,1,,172176-74102,, "VALVE COMP.,CONTROL",1,1,,,,,N,,,M/#01155,,M/#01155,,,,,,
2,2,,172165-74130,, "RELIEF ASSY, MAIN",2,2,,,,,,,,,,,,,,,,,,,,,
2A,3,,172176-74200,, "O-RING ASSY",2,2,,,,,,,,,,,,,,,,,,,,,
3,4,,24311-000140,, "O-RING 1A P-14.0",2,2,,,,,,,,,,,,,,,,,,,,,
4,4,,172162-74330,, "RING, BACK UP",2,2,,,,,,,,,,,,,,,,,,,,,
5,4,,24315-240100,, "O-RING 1B P-10A",2,2,,,,,,,,,,,,,,,,,,,,,
6,2,,172176-74120,, "RELIEF ASSY, MAIN",1,1,,,,,,,,,,,,,,,,,,,,,
6A,3,,172176-74200,, "O-RING ASSY",1,1,,,,,,,,,,,,,,,,,,,,,
7,4,,24311-000140,, "O-RING 1A P-14.0",1,1,,,,,,,,,,,,,,,,,,,,,
8,4,,172162-74330,, "RING, BACK UP",1,1,,,,,,,,,,,,,,,,,,,,,
9,4,,24315-240100,, "O-RING 1B P-10A",1,1,,,,,,,,,,,,,,,,,,,,,
10,2,,172165-74230,, "RELIEF ASSY, PORT",7,7,,,,,,,,,,,,,,,,,,,,,
10-1,2,,172165-74230,, "RELIEF ASSY, PORT",5,5,,,,,K,,,M/#01155,,M/#01155,,,,,,
10A,3,,172176-74200,, "O-RING ASSY",7,7,,,,,,,,,,,,,,,,,,,,,
10A-1,3,,172176-74200,, "O-RING ASSY",5,5,,,,,K,,,M/#01155,,M/#01155,,,,,,
11,4,,24311-000140,, "O-RING 1A P-14.0",7,7,,,,,,,,,,,,,,,,,,,,,
11-1,4,,24311-000140,, "O-RING 1A P-14.0",5,5,,,,,K,,,M/#01155,,M/#01155,,,,,,
12,4,,172162-74330,, "RING, BACK UP",7,7,,,,,,,,,,,,,,,,,,,,,
12-1,4,,172162-74330,, "RING, BACK UP",5,5,,,,,K,,,M/#01155,,M/#01155,,,,,,
13,4,,24315-240100,, "O-RING 1B P-10A",7,7,,,,,,,,,,,,,,,,,,,,,
13-1,4,,24315-240100,, "O-RING 1B P-10A",5,5,,,,,K,,,M/#01155,,M/#01155,,,,,,
13A,2,,172165-74260,, "RELIEF ASSY, PORT",1,1,,,,,W,,,M/#01155,,M/#01155,,,,,,
13B,3,,172176-74200,, "O-RING ASSY",2,2,,,,,W,,,M/#01155,,M/#01155,,,,,,
13C,4,,24311-000140,, "O-RING 1A P-14.0",2,2,,,,,W,,,M/#01155,,M/#01155,,,,,,
13D,4,,172162-74330,, "RING, BACK UP",2,2,,,,,W,,,M/#01155,,M/#01155,,,,,,
13E,4,,24315-240100,, "O-RING 1B P-10A",2,2,,,,,W,,,M/#01155,,M/#01155,,,,,,
14,2,,172165-74190,, "SPRING",2,2,,,,,,,,,,,,,,,,,,,,,
15,2,,172162-74350,, "VALVE ASSY, REDUCING",2,2,,,,,,,,,,,,,,,,,,,,,
15A,3,,172176-74210,, "O-RING ASSY",2,2,,,,,,,,,,,,,,,,,,,,,
16,4,,24311-000140,, "O-RING 1A P-14.0",2,2,,,,,,,,,,,,,,,,,,,,,
17,4,,24315-240100,, "O-RING 1B P-10A",2,2,,,,,,,,,,,,,,,,,,,,,
18,4,,24315-000090,, "O-RING 1B P- 9.0",2,2,,,,,,,,,,,,,,,,,,,,,
19,4,,172162-74370,, "RING, BACK UP",2,2,,,,,,,,,,,,,,,,,,,,,
20,2,,172162-74380,, "CAP,PLUNGER",5,5,,,,,,,,,,,,,,,,,,,,,
21,2,,172162-74390,, "COVER,SPRING",5,5,,,,,,,,,,,,,,,,,,,,,
22,2,,172162-74400,, "SPRING",4,4,,,,,,,,,,,,,,,,,,,,,
23,2,,172162-74550,, "SPRING",1,1,,,,,,,,,,,,,,,,,,,,,
24,2,,172162-74410,, "GUIDE,SPRING",10,10,,,,,,,,,,,,,,,,,,,,,
25,2,,24311-240100,, "O-RING 1A P-10A",18,18,,,,,,,,,,,,,,,,,,,,,
26,2,,172162-74420,, "RETAINER,SEAL",10,10,,,,,,,,,,,,,,,,,,,,,
26A,2,,172176-74190,, "O-RING ASSY",10,10,,,,,,,,,,,,,,,,,,,,,
27,3,,172162-74430,, "WIPER",10,10,,,,,,,,,,,,,,,,,,,,,
28,3,,172162-74440,, "O-RING",10,10,,,,,,,,,,,,,,,,,,,,,
29,2,,26450-060122,, "BOLT M 6X 12",10,10,,,,,,,,,,,,,,,,,,,,,
29A,2,,172176-74160,, "CAP ASSY",1,1,,,,,,,,,,,,,,,,,,,,,
30,3,,172162-74460,, "CAP",1,1,,,,,,,,,,,,,,,,,,,,,
31,3,,24315-000110,, "O-RING 1B P-11.0",1,1,,,,,,,,,,,,,,,,,,,,,
31A,2,,172176-74140,, "COVER ASSY",8,8,,,,,,,,,,,,,,,,,,,,,
32,3,,172162-74470,, "COVER",8,8,,,,,,,,,,,,,,,,,,,,,
33,3,,172162-74520,, "O-RING",8,8,,,,,,,,,,,,,,,,,,,,,
34,2,,172162-74500,, "CAP,PLUNGER",5,5,,,,,,,,,,,,,,,,,,,,,
35,2,,172162-74510,, "GUIDE, SPRING",5,5,,,,,,,,,,,,,,,,,,,,,
36,2,,172162-74490,, "SPACER",5,5,,,,,,,,,,,,,,,,,,,,,
37,2,,26450-060202,, "BOLT M 6X 20",24,24,,,,,,,,,,,,,,,,,,,,,
38,2,,172162-74540,, "SPRING",6,6,,,,,,,,,,,,,,,,,,,,,
39,2,,172162-74560,, "NUT,HEX. ",3,3,,,,,,,,,,,,,,,,,,,,,
40,2,,172162-74570,, "SPACER",3,3,,,,,,,,,,,,,,,,,,,,,
41,2,,172162-74580,, "SPACER",3,3,,,,,,,,,,,,,,,,,,,,,
42,2,,172162-74590,, "CAP,PLUNGER",3,3,,,,,,,,,,,,,,,,,,,,,
43,2,,172162-74600,, "GUIDE, SPRING",3,3,,,,,,,,,,,,,,,,,,,,,
44,2,,172162-74610,, "EYE F,PLUNGER",5,5,,,,,,,,,,,,,,,,,,,,,

45,2,,26450-060102,, "BOLT M 6X 10",10,10,,,,,,,,,,,,,
45A,2,,172176-74150,, "COVER ASSY",4,4,,,,,,,,,,,,,
46,3,,172162-74620,, O-RING,4,4,,,,,,,,,,,,,
47,3,,172162-74640,, COVER,4,4,,,,,,,,,,,,,
48,2,,172162-74630,, "CAP,PLUNGER",4,4,,,,,,,,,,,,,
49,2,,172165-74170,, SPRING,16,16,,,,,,,,,,,,,
50,2,,172162-74660,, SPRING,2,2,,,,,,,,,,,,,
51,2,,172162-74670,, "VALVE, CHECK",18,18,,,,,,,,,,,,,
51A,2,,172176-74170,, "CAP ASSY",4,4,,,,,,,,,,,,,
52,3,,172162-71910,, CAP,4,4,,,,,,,,,,,,,
53,3,,24315-000140,, "O-RING 1B P-14.0",4,4,,,,,,,,,,,,,
53A,2,,172176-74180,, "CAP ASSY",2,2,,,,,,,,,,,,,
53A-1,2,,172176-74180,, "CAP ASSY",3,3,,,,,K,,,M/#00832,,M/#00832,,,,,
54,3,,172165-74180,, CAP,2,2,,,,,,,,,,,,,
54-1,3,,172165-74180,, CAP,3,3,,,,,K,,,M/#00832,,M/#00832,,,,,
54A,3,,24311-000140,, "O-RING 1A P-14.0",2,2,,,,,,,,,,,,,
54A-1,3,,24311-000140,, "O-RING 1A P-14.0",3,3,,,,,K,,,M/#00832,,M/#00832,,,,,
55,2,,172176-74130,, PLUG,3,3,,,,,,,,,,,,,
55A,3,,172165-74160,, PLUG,3,3,,,,,,,,,,,,,
56,3,,172176-74200,, "O-RING ASSY",3,3,,,,,,,,,,,,,
56A,4,,24311-000140,, "O-RING 1A P-14.0",3,3,,,,,,,,,,,,,
57,4,,172162-74330,, "RING, BACK UP",3,3,,,,,,,,,,,,,
58,4,,24315-240100,, "O-RING 1B P-10A",3,3,,,,,,,,,,,,,
59,1,,22217-100000,, "SPRING WASHER 10",3,3,,,,,,,,,,,,,
60,1,,26116-100852,, "BOLT M10X 85 PLATED",3,3,,,,,,,,,,,,,
61,1,,172165-76580,, "PLUG PF1/2,HEX.",2,2,,,,,W,,, "M/#FORM 1",,"M/#FORM 1",,,,,,
62,1,,24315-000180,, "O-RING 1B P-18.0",2,2,,,,,W,,, "M/#FORM 1",,"M/#FORM
1",,,,,,
63,1,,172162-76850,, "PLUG PF3/8",2,2,,,,,W,,,MXXX,,MXXX,,,,,
64,1,,24315-000240,, "O-RING 1B P-24.0",2,2,,,,,W,,,MXXX,,MXXX,,,,,
65,1,,172165-76590,, "PLUG PF1/4",1,1,,,,,W,,,M/#00832,,M/#00832,,,,,
66,1,,24315-000110,, "O-RING 1B P-11.0",1,1,,,,,W,,,M/#00832,,M/#00832,,,,,

Fig. 57 コントロールバルブ CONTROL VALVE

見出しNo. 1は、
見出しNo. (1) から
58を含みます。
1 inc. (1) ~ 58

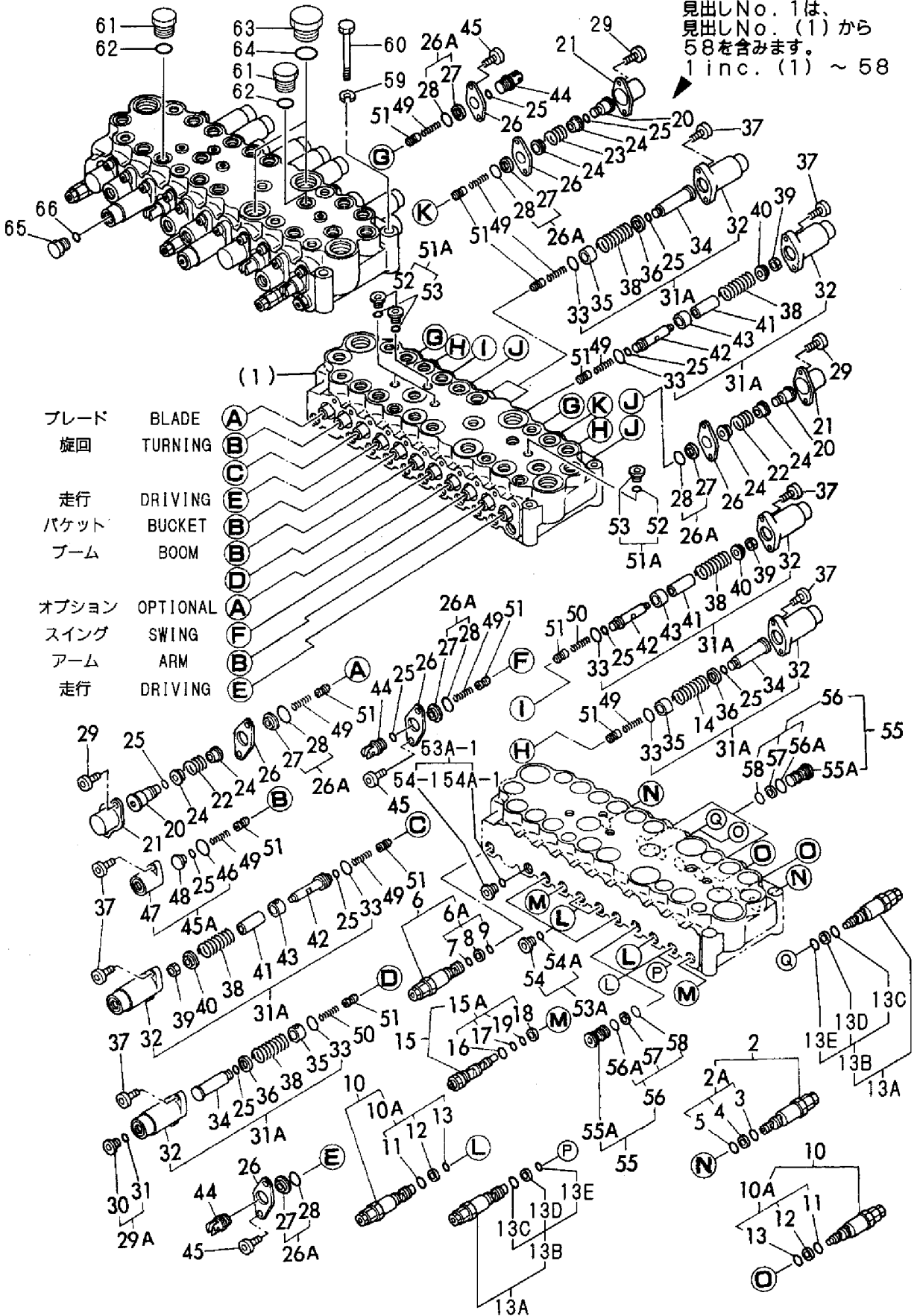

- ブレード BLADE
- 旋回 TURNING
- 走行 DRIVING
- バケット BUCKET
- ブーム BOOM
- オプション OPTIONAL
- スイング SWING
- アーム ARM
- 走行 DRIVING

- (A)
- (B)
- (C)
- (D)
- (E)
- (F)
- (G)
- (H)
- (I)
- (J)
- (K)
- (L)
- (M)
- (N)
- (O)
- (P)
- (Q)

1,1,,172176-74110,, "VALVE ASSY, CONTROL",1,1,,,,,,,,,,,,,,,,,,,,,
1-1,1,,172176-74111,, "VALVE ASSY,CONTROL",1,1,,,,,N,,,M/#00832,,M/#00832,,,,,,
1-2,1,,172176-74112,, "VALVE COMP.,CONTROL",1,1,,,,,N,,,M/#01155,,M/#01155,,,,,,
2,2,,172165-74130,, "RELIEF ASSY, MAIN",2,2,,,,,,,,,,,,,,,,,,,,,
2A,3,,172176-74200,, "O-RING ASSY",2,2,,,,,,,,,,,,,,,,,,,,,
3,4,,24311-000140,, "O-RING 1A P-14.0",2,2,,,,,,,,,,,,,,,,,,,,,
4,4,,172162-74330,, "RING, BACK UP",2,2,,,,,,,,,,,,,,,,,,,,,
5,4,,24315-240100,, "O-RING 1B P-10A",2,2,,,,,,,,,,,,,,,,,,,,,
6,2,,172176-74120,, "RELIEF ASSY, MAIN",1,1,,,,,,,,,,,,,,,,,,,,,
6A,3,,172176-74200,, "O-RING ASSY",1,1,,,,,,,,,,,,,,,,,,,,,
7,4,,24311-000140,, "O-RING 1A P-14.0",1,1,,,,,,,,,,,,,,,,,,,,,
8,4,,172162-74330,, "RING, BACK UP",1,1,,,,,,,,,,,,,,,,,,,,,
9,4,,24315-240100,, "O-RING 1B P-10A",1,1,,,,,,,,,,,,,,,,,,,,,
10,2,,172165-74230,, "RELIEF ASSY, PORT",8,8,,,,,,,,,,,,,,,,,,,,,
10-1,2,,172165-74230,, "RELIEF ASSY, PORT",6,6,,,,,K,,,M/#01155,,M/#01155,,,,,,
10A,3,,172176-74200,, "O-RING ASSY",8,8,,,,,,,,,,,,,,,,,,,,,
10A-1,3,,172176-74200,, "O-RING ASSY",6,6,,,,,K,,,M/#01155,,M/#01155,,,,,,
11,4,,24311-000140,, "O-RING 1A P-14.0",8,8,,,,,,,,,,,,,,,,,,,,,
11-1,4,,24311-000140,, "O-RING 1A P-14.0",6,6,,,,,K,,,M/#01155,,M/#01155,,,,,,
12,4,,172162-74330,, "RING, BACK UP",8,8,,,,,,,,,,,,,,,,,,,,,
12-1,4,,172162-74330,, "RING, BACK UP",6,6,,,,,K,,,M/#01155,,M/#01155,,,,,,
13,4,,24315-240100,, "O-RING 1B P-10A",8,8,,,,,,,,,,,,,,,,,,,,,
13-1,4,,24315-240100,, "O-RING 1B P-10A",6,6,,,,,K,,,M/#01155,,M/#01155,,,,,,
13A,2,,172165-74260,, "RELIEF ASSY, PORT",2,2,,,,,W,,,M/#01155,,M/#01155,,,,,,
13B,3,,172176-74200,, "O-RING ASSY",2,2,,,,,W,,,M/#01155,,M/#01155,,,,,,
13C,4,,24311-000140,, "O-RING 1A P-14.0",2,2,,,,,W,,,M/#01155,,M/#01155,,,,,,
13D,4,,172162-74330,, "RING, BACK UP",2,2,,,,,W,,,M/#01155,,M/#01155,,,,,,
13E,4,,24315-240100,, "O-RING 1B P-10A",2,2,,,,,W,,,M/#01155,,M/#01155,,,,,,
14,2,,172165-74190,, SPRING,2,2,,,,,,,,,,,,,,,,,,,,,
15,2,,172162-74350,, "VALVE ASSY, REDUCING",2,2,,,,,,,,,,,,,,,,,,,,,
15A,3,,172176-74210,, "O-RING ASSY",2,2,,,,,,,,,,,,,,,,,,,,,
16,4,,24311-000140,, "O-RING 1A P-14.0",2,2,,,,,,,,,,,,,,,,,,,,,
17,4,,24315-240100,, "O-RING 1B P-10A",2,2,,,,,,,,,,,,,,,,,,,,,
18,4,,24315-000090,, "O-RING 1B P- 9.0",2,2,,,,,,,,,,,,,,,,,,,,,
19,4,,172162-74370,, "RING, BACK UP",2,2,,,,,,,,,,,,,,,,,,,,,
20,2,,172162-74380,, "CAP,PLUNGER",5,5,,,,,,,,,,,,,,,,,,,,,
21,2,,172162-74390,, "COVER,SPRING",5,5,,,,,,,,,,,,,,,,,,,,,
22,2,,172162-74400,, SPRING,4,4,,,,,,,,,,,,,,,,,,,,,
23,2,,172162-74550,, SPRING,1,1,,,,,,,,,,,,,,,,,,,,,
24,2,,172162-74410,, "GUIDE,SPRING",10,10,,,,,,,,,,,,,,,,,,,,,
25,2,,24311-240100,, "O-RING 1A P-10A",18,18,,,,,,,,,,,,,,,,,,,,,
26,2,,172162-74420,, "RETAINER,SEAL",10,10,,,,,,,,,,,,,,,,,,,,,
26A,2,,172176-74190,, "O-RING ASSY",10,10,,,,,,,,,,,,,,,,,,,,,
27,3,,172162-74430,, WIPER,10,10,,,,,,,,,,,,,,,,,,,,,
28,3,,172162-74440,, O-RING,10,10,,,,,,,,,,,,,,,,,,,,,
29,2,,26450-060122,, "BOLT M 6X 12",10,10,,,,,,,,,,,,,,,,,,,,,
29A,2,,172176-74160,, "CAP ASSY",1,1,,,,,,,,,,,,,,,,,,,,,
30,3,,172162-74460,, CAP,1,1,,,,,,,,,,,,,,,,,,,,,
31,3,,24315-000110,, "O-RING 1B P-11.0",1,1,,,,,,,,,,,,,,,,,,,,,
31A,2,,172176-74140,, "COVER ASSY",8,8,,,,,,,,,,,,,,,,,,,,,
32,3,,172162-74470,, COVER,8,8,,,,,,,,,,,,,,,,,,,,,
33,3,,172162-74520,, O-RING,8,8,,,,,,,,,,,,,,,,,,,,,
34,2,,172162-74500,, "CAP,PLUNGER",5,5,,,,,,,,,,,,,,,,,,,,,
35,2,,172162-74510,, "GUIDE, SPRING",5,5,,,,,,,,,,,,,,,,,,,,,
36,2,,172162-74490,, SPACER,5,5,,,,,,,,,,,,,,,,,,,,,
37,2,,26450-060202,, "BOLT M 6X 20",24,24,,,,,,,,,,,,,,,,,,,,,
38,2,,172162-74540,, SPRING,6,6,,,,,,,,,,,,,,,,,,,,,
39,2,,172162-74560,, "NUT,HEX. ",3,3,,,,,,,,,,,,,,,,,,,,,
40,2,,172162-74570,, SPACER,3,3,,,,,,,,,,,,,,,,,,,,,
41,2,,172162-74580,, SPACER,3,3,,,,,,,,,,,,,,,,,,,,,
42,2,,172162-74590,, "CAP,PLUNGER",3,3,,,,,,,,,,,,,,,,,,,,,
43,2,,172162-74600,, "GUIDE, SPRING",3,3,,,,,,,,,,,,,,,,,,,,,
44,2,,172162-74610,, "EYE F,PLUNGER",5,5,,,,,,,,,,,,,,,,,,,,,

45,2,,26450-060102,, "BOLT M 6X 10",10,10,,,,,,,,,,,,,,,,,,,,,
45A,2,,172176-74150,, "COVER ASSY",4,4,,,,,,,,,,,,,,,,,,,,,
46,3,,172162-74620,, O-RING,4,4,,,,,,,,,,,,,,,,,,,,,
47,3,,172162-74640,, COVER,4,4,,,,,,,,,,,,,,,,,,,,,
48,2,,172162-74630,, "CAP,PLUNGER",4,4,,,,,,,,,,,,,,,,,,,,,
49,2,,172165-74170,, SPRING,16,16,,,,,,,,,,,,,,,,,,,,,
50,2,,172162-74660,, SPRING,2,2,,,,,,,,,,,,,,,,,,,,,
51,2,,172162-74670,, "VALVE, CHECK",18,18,,,,,,,,,,,,,,,,,,,,,
51A,2,,172176-74170,, "CAP ASSY",4,4,,,,,,,,,,,,,,,,,,,,,
52,3,,172162-71910,, CAP,4,4,,,,,,,,,,,,,,,,,,,,,
53,3,,24315-000140,, "O-RING 1B P-14.0",4,4,,,,,,,,,,,,,,,,,,,,,
53A,2,,172176-74180,, "CAP ASSY",2,2,,,,,,,,,,,,,,,,,,,,,
53A-1,2,,172176-74180,, "CAP ASSY",3,3,,,,,K,,,,M/#00832,,M/#00832,,,,,,
54,3,,172165-74180,, CAP,2,2,,,,,,,,,,,,,,,,,,,,,
54-1,3,,172165-74180,, CAP,3,3,,,,,K,,,,M/#00832,,M/#00832,,,,,,
54A,3,,24311-000140,, "O-RING 1A P-14.0",2,2,,,,,,,,,,,,,,,,,,,,,
54A-1,3,,24311-000140,, "O-RING 1A P-14.0",3,3,,,,,K,,,,M/#00832,,M/#00832,,,,,,
55,2,,172176-74130,, PLUG,1,1,,,,,,,,,,,,,,,,,,,,,
55A,3,,172165-74160,, PLUG,1,1,,,,,,,,,,,,,,,,,,,,,
56,3,,172176-74200,, "O-RING ASSY",1,1,,,,,,,,,,,,,,,,,,,,,
56A,4,,24311-000140,, "O-RING 1A P-14.0",1,1,,,,,,,,,,,,,,,,,,,,,
57,4,,172162-74330,, "RING, BACK UP",1,1,,,,,,,,,,,,,,,,,,,,,
58,4,,24315-240100,, "O-RING 1B P-10A",1,1,,,,,,,,,,,,,,,,,,,,,
59,2,,172165-74240,, "VALVE ASSY, UNLOAD",1,1,,,,,,,,,,,,,,,,,,,,,
60,3,,24311-000140,, "O-RING 1A P-14.0",1,1,,,,,,,,,,,,,,,,,,,,,
61,3,,172162-74330,, "RING, BACK UP",1,1,,,,,,,,,,,,,,,,,,,,,
62,3,,24315-240100,, "O-RING 1B P-10A",1,1,,,,,,,,,,,,,,,,,,,,,
63,1,,22217-100000,, "SPRING WASHER 10",3,3,,,,,,,,,,,,,,,,,,,,,
64,1,,26116-100852,, "BOLT M10X 85 PLATED",3,3,,,,,,,,,,,,,,,,,,,,,

Fig. 58 コントロールバルブ (PTO) CONTROL VALVE (P. T. O.)

見出しNo. 1は、見出しNo. (1) から62を含みます。
1 inc. (1) ~ 62

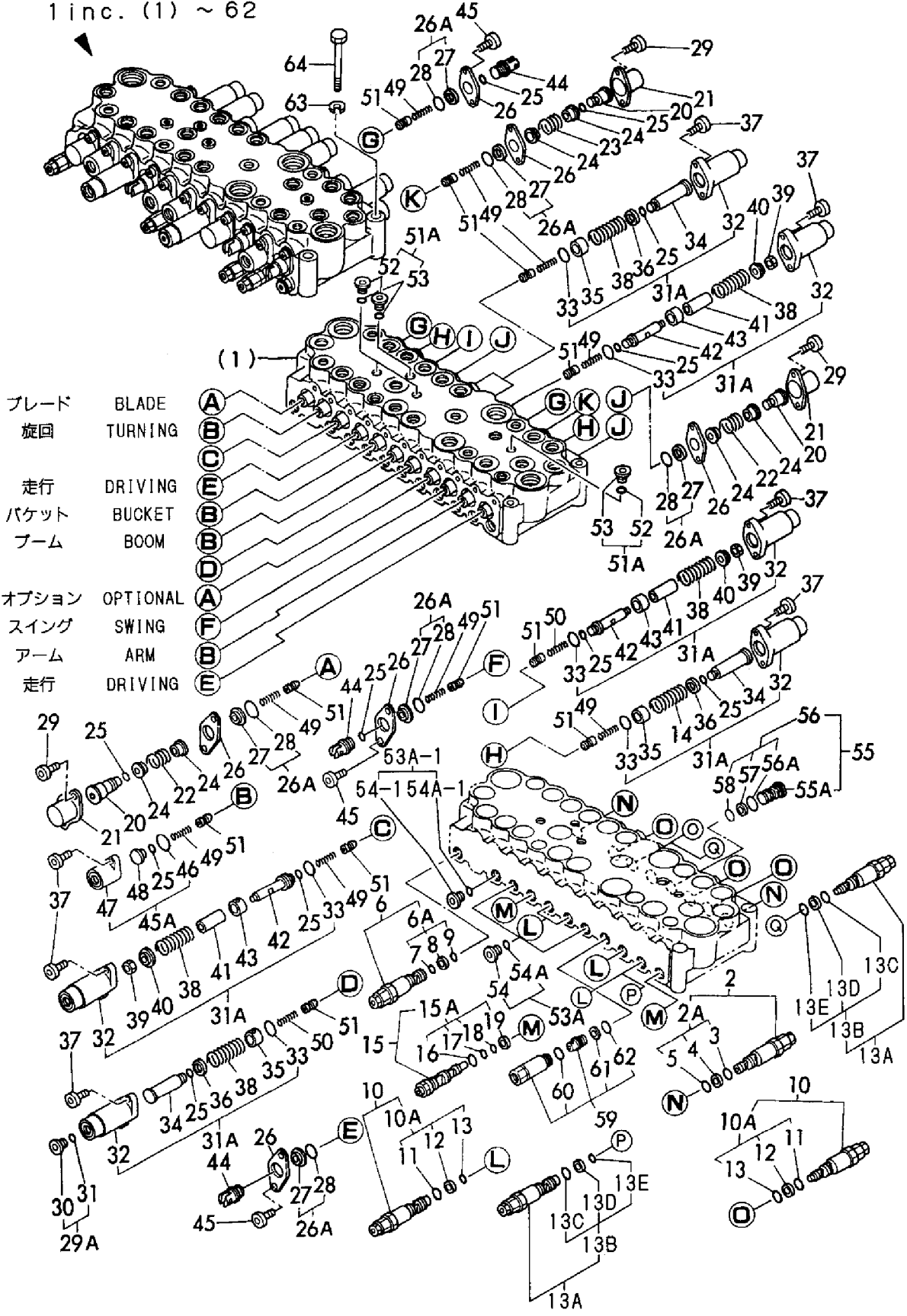

1,1,,172151-74610,, "VALVE ASSY,RMT.CONT." ,2,2,,,,,,,,,,,,,
1-1,1,,172151-74611,, "VALVE ASSY,RMT.CONT." ,2,2,,,,,N,,,M/#00818,,M/#00818,,,,,
2,2,,172151-74860,, "SHIM(COUNT. SET" ,8,8,,,,,,,,,,,,,
3,2,,172151-74870,, SPRING,8,8,,,,,,,,,,,,,
4,2,,172151-74880,, RETAINER,8,8,,,,,,,,,,,,,
5,2,,172151-74890,, "SP (SYN." ,8,8,,,,,,,,,,,,,
6,2,,172151-74900,, PISTON,8,8,,,,,,,,,,,,,
7,2,,172151-74910,, SEAL,8,8,,,,,,,,,,,,,
8,2,,172151-74920,, COLLAR,8,8,,,,,Z,,,M/#00818,,M/#00818,,,,,
8A,2,,172164-74610,, COLLAR,8,8,,,,,W,,,M/#00818,,M/#00818,,,,,
9,2,,172151-74930,, BOOT,2,2,,,,,,,,,,,,,
10,2,,172151-74940,, PLATE,2,2,,,,,,,,,,,,,
11,2,,172151-74950,, UNION,2,2,,,,,,,,,,,,,
12,2,,172151-74960,, DISK,2,2,,,,,Z,,,M/#00818,,M/#00818,,,,,
12A,2,,172164-74620,, DISC,2,2,,,,,W,,,M/#00818,,M/#00818,,,,,
13,2,,172151-74970,, NUT,2,2,,,,,Z,,,M/#00818,,M/#00818,,,,,
13A,2,,172164-74630,, NUT,2,2,,,,,W,,,M/#00818,,M/#00818,,,,,
14,2,,172151-74980,, PLATE,2,2,,,,,,,,,,,,,
15,2,,172151-74990,, PLUG,4,4,,,,,Z,,,M/#00818,,M/#00818,,,,,
15A,2,,172164-74650,, PLUG,4,4,,,,,W,,,M/#00818,,M/#00818,,,,,
16,2,,24311-000200,, "O-RING 1A P-20.0" ,8,8,,,,,,,,,,,,,
17,2,,24311-000700,, "O-RING 1A P-70.0" ,2,2,,,,,,,,,,,,,
18,2,,26116-060202,, "BOLT M 6X 20" ,8,8,,,,,,,,,,,,,
19,2,,172164-74560,, PLUG,4,4,,,,,W,,,M/#00818,,M/#00818,,,,,

Fig. 59 リモコンバルブ REMOTE CONTROL VALVE

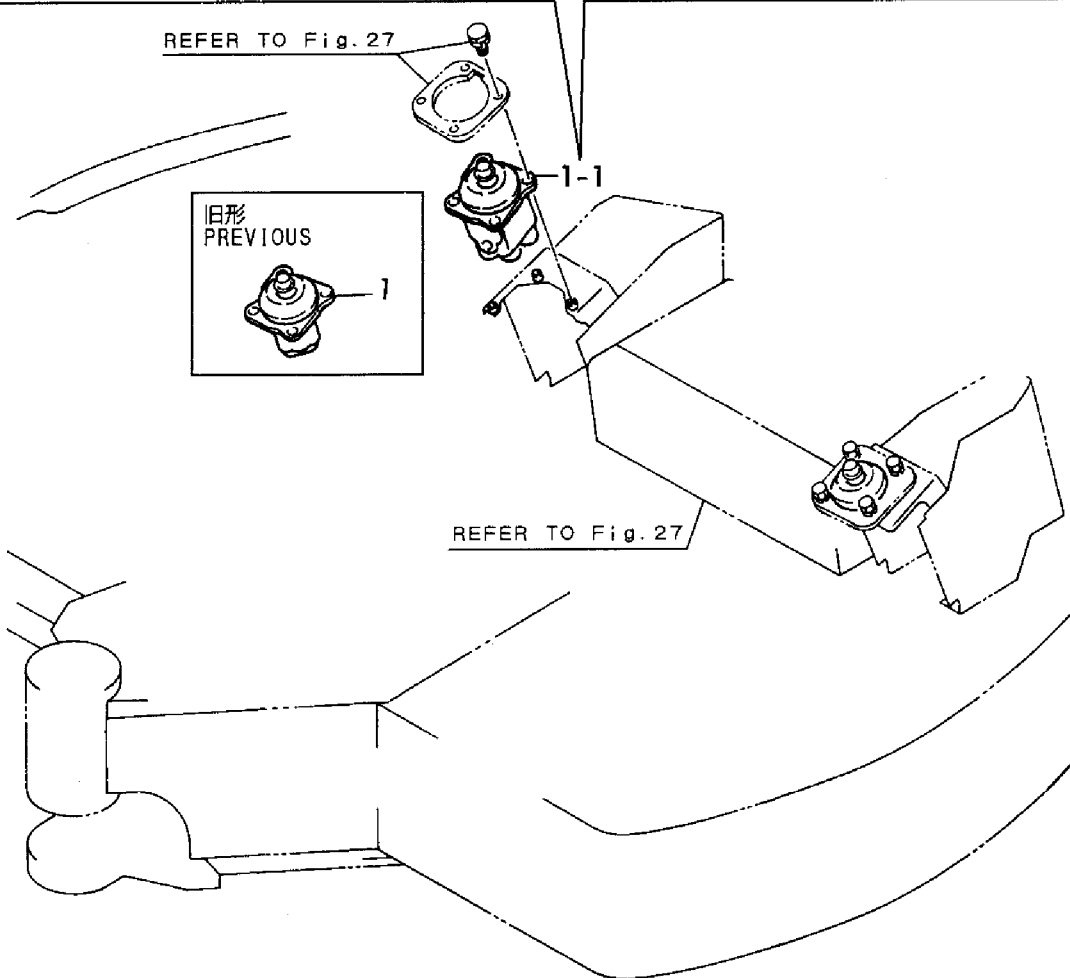
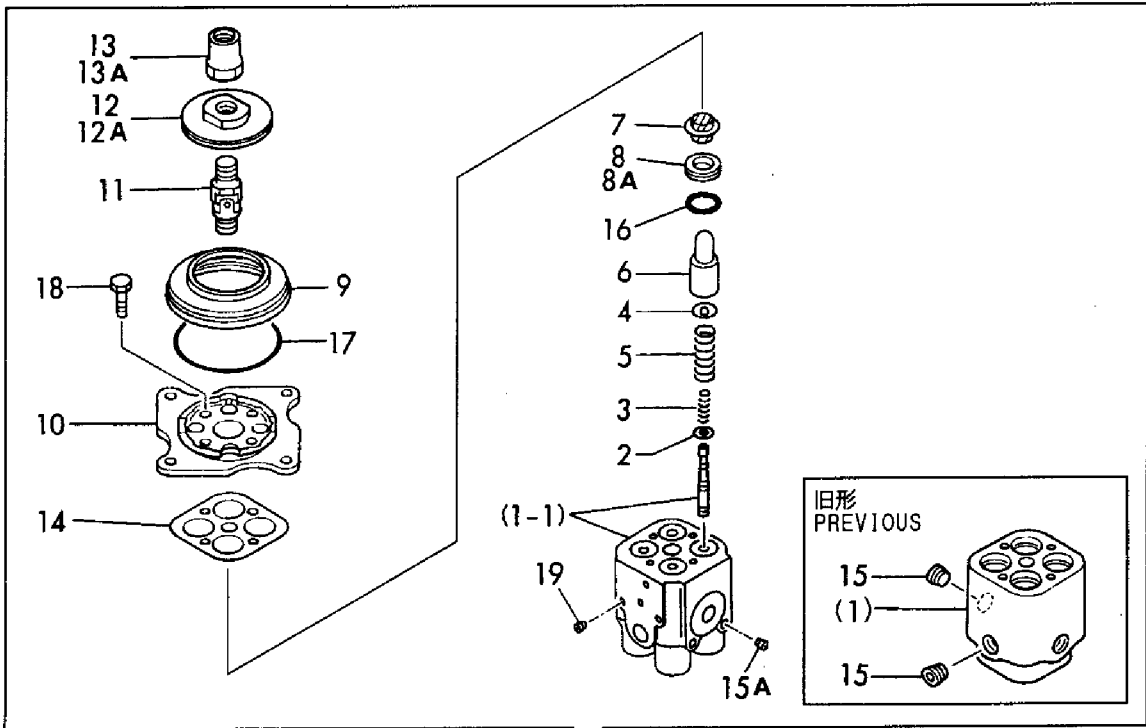

1,1,,172164-08700,, "2-WAY MULTI V KIT(P",,1,,,,,1,,,,,
2,1,,172164-08710,, "2-WAY MULTI V KIT(C",,1,,,,,2,,,,,
3,2,,172164-62500,, "PLATE B, MULTI",,1,1,,,,,
3-1,2,,172164-62501,, "PLATE B",,1,1,,,,,S,3,,M/#01277,,M/#01277,,,,,
3-2,2,,172164-62502,, "PLATE B",,1,1,,,,,N,,M/#01505,,M/#01505,,,,,
4,2,,172164-62530,, COVER,1,1,,,,,
4-1,2,,172164-62531,, COVER,1,1,,,,,S,3,,M/#01277,,M/#01277,,,,,
5,2,,22217-100000,, "SPRING WASHER 10",,2,2,,,,,
6,2,,26013-100202,, "BOLT W/WASHER M10X20",,4,4,,,,,
7,2,,26647-100152,, "WING BOLT M10X15",,2,2,,,,,
8,2,,172164-74900,, "BRACKET(ABV CMP",,1,1,,,,,
9,2,,26013-080252,, "BOLT M 8X 25",,3,3,,,,,
10,2,,26013-100402,, "BOLT M10X 40",,3,3,,,,,
11,2,,172173-03560,, "LABEL (YANMAR",,1,1,,,,,
12,2,,172173-03570,, "LABEL (KOMATSU",,1,1,,,,,
13,2,,172173-03550,, "LABEL (2-WAY",,1,,,,,
14,2,,172175-03550,, LABEL(2-WAY,1,,,,,
15,2,,172175-74700,, "VALVE, 2-WAY",,1,1,,,,,
16,3,,172175-74710,, PLATE,1,1,,,,,
17,3,,172175-74720,, GASKET,1,1,,,,,
18,3,,172175-74730,, LEVER,1,1,,,,,
19,3,,172151-74760,, WASHER,7,7,,,,,
20,3,,23871-010000,, "PLUG PT1/8,SCREW",,8,8,,,,,
21,3,,24311-000250,, "O-RING 1A P-25.0",,1,1,,,,,
22,3,,24311-000320,, "O-RING 1A P-32.0",,1,1,,,,,
23,3,,26116-060162,, "BOLT 6X16",,6,6,,,,,
24,3,,26647-060202,, "WING BOLT M 6X20",,1,1,,,,,

Fig. 60 2ウェイバルブ (2ウェイマルチチェンジ) 2-WAY VALVE (2-WAY MULTI CHANGE)

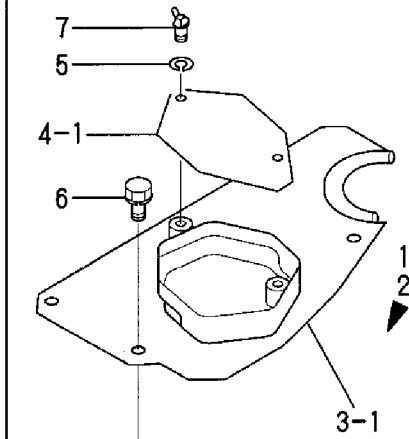
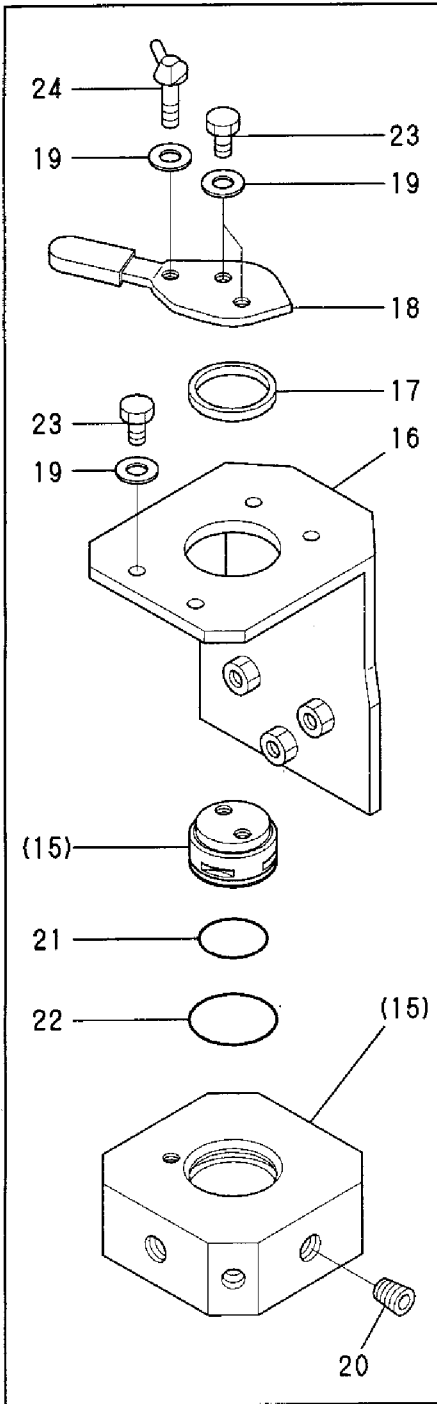

2ウェイマルチバルブキット (キャノピー)
2-WAY MULTI VALVE KIT (CANOPY)
(172164-08700)

Fig. 60 REF. No. 1
1 inc. Fig. 60 REF. No. 3~13, 15~24
Fig. 80 REF. No. 1~10

2ウェイマルチバルブキット (キャビン)
2-WAY MULTI VALVE KIT (CABIN)
(172164-08710)

Fig. 60 REF. No. 2
2 inc. Fig. 60 REF. No. 3~12, 14~24
Fig. 80 REF. No. 1~10

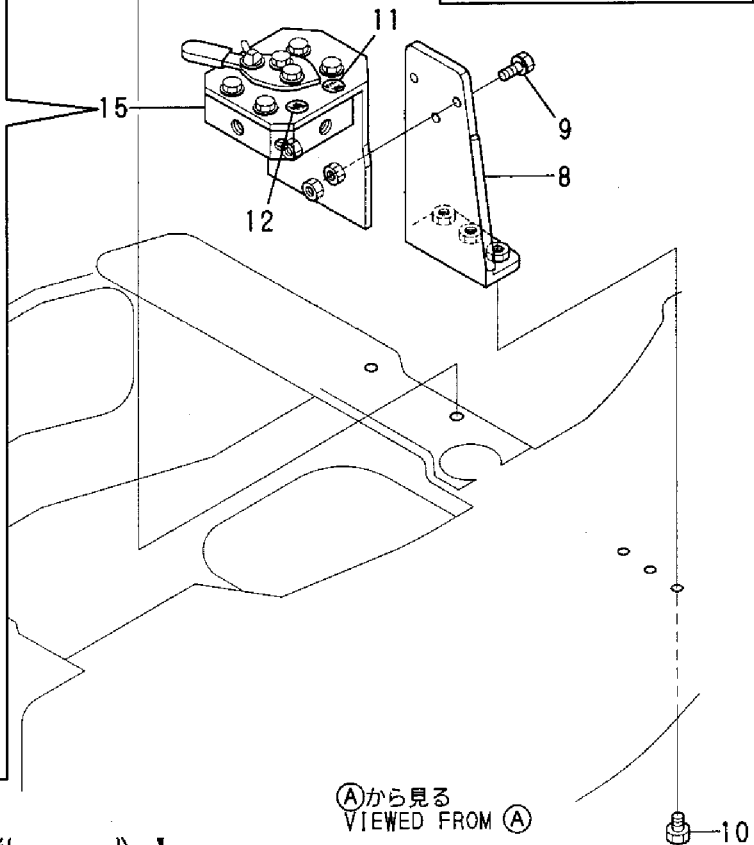
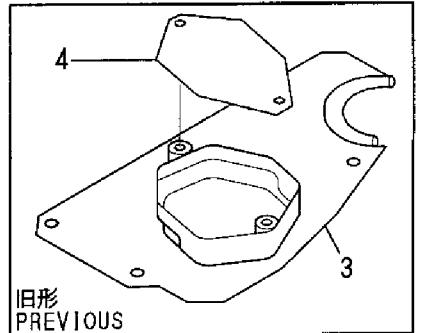

Aから見る
VIEWED FROM A

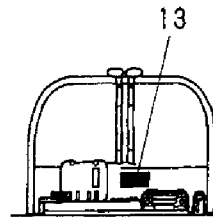
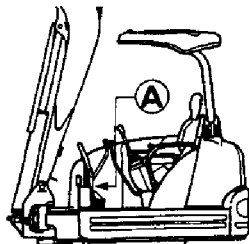
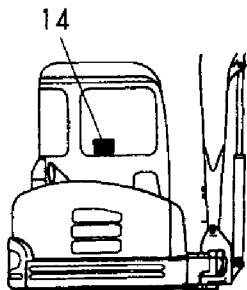

1,1,,172176-74530,, "VALVE(P)KIT, MULTI",,1,,,,,1,,,,,
1-1,1,,172176-74490,, "MULTI VALVE KIT",,1,,,,,N,1,,,,,"FROM 1ST",,,,,,
2,1,,172176-74540,, "VALVE(C) KIT, MULTI",,1,,,,,1,,,,,
2-1,1,,172176-74490,, "MULTI VALVE KIT",,1,,,,,N,1,,,,,"FROM 1ST",,,,,,
3,2,,172164-74200,, "BRACKET COMPL.",,1,1,,,,,
4,2,,172151-74600,, "VALVE CMP,MULTICHNG.",,1,1,,,,,
4-1,2,,172151-74601,, VALVE,1,1,,,,,F,3,,M/#01505,,M/#01505,,,,,
5,3,,172151-74700,, LEVER,1,1,,,,,
5-1,3,,182900-77250,, LEVER,1,1,,,,,S,,M/#01505,,M/#01505,,,,,
6,3,,172151-74710,, COVER,1,1,,,,,
6-1,3,,182900-77220,, COVER,1,1,,,,,S,,M/#01505,,M/#01505,,,,,
7,3,,172151-74720,, COVER,1,1,,,,,
7-1,3,,182900-16530,, COVER,1,1,,,,,N,,M/#01505,,M/#01505,,,,,
8,3,,172151-74730,, SPRING,1,1,,,,,
8-1,3,,182900-22300,, SPRING,1,1,,,,,N,,M/#01505,,M/#01505,,,,,
9,3,,172151-74740,, "PLATE, MARK",,1,1,,,,,
10,3,,172151-74750,, "PLATE, MARK",,1,1,,,,,Z,,M/#01505,,M/#01505,,,,,
11,3,,172151-74760,, WASHER,2,2,,,,,
11-1,3,,953KM0-00220,, WASHER,2,2,,,,,N,,M/#01505,,M/#01505,,,,,
12,3,,172151-74760,, WASHER,1,1,,,,,
12-1,3,,953KM0-00220,, WASHER,1,1,,,,,N,,M/#01505,,M/#01505,,,,,
13,3,,172151-74770,, "GASKET, CYL. HEAD",,1,1,,,,,Z,,M/#01505,,M/#01505,,,,,
14,3,,23871-010000,, "PLUG PT1/8,SCREW",,1,1,,,,,
14-1,3,,953KM0-10894,, PLUG,1,1,,,,,N,,M/#01505,,M/#01505,,,,,
15,3,,24190-100001,, "BALL 5/16, STEEL",,1,1,,,,,
16,3,,24311-000280,, "O-RING 1A P-28.0",,1,1,,,,,
17,3,,24321-000600,, "O-RING 1A G-60.0",,2,2,,,,,
18,3,,26450-060162,, "BOLT M 6X 16",,2,2,,,,,
18-1,3,,182900-77240,, BOLT,2,2,,,,,S,,M/#01505,,M/#01505,,,,,
19,3,,26450-060162,, "BOLT M 6X 16",,8,8,,,,,
19-1,3,,182900-77200,, BOLT,8,8,,,,,S,,M/#01505,,M/#01505,,,,,
20,3,,26450-060162,, "BOLT M 6X 16",,8,8,,,,,
20-1,3,,182900-77190,, BOLT,8,8,,,,,N,,M/#01505,,M/#01505,,,,,
21,3,,26647-060202,, "WING BOLT M 6X20",,1,1,,,,,
21-1,3,,182900-77230,, "WING BOLT",,1,1,,,,,R,,M/#01505,,M/#01505,,,,,
21A,3,,182900-77210,, "DUST SEAL",,1,1,,,,,W,,M/#01505,,M/#01505,,,,,
22,2,,26013-100252,, "BOLT W/WASHER M10X25",,3,3,,,,,
23,2,,26013-100402,, "BOLT M10X 40",,3,3,,,,,
24,2,,172151-03550,, "LABEL,PATTERN B",,1,,,,,4,,,,,
25,2,,172164-62500,, "PLATE B, MULTI",,1,1,,,,,
25-1,2,,172164-62501,, "PLATE B",,1,1,,,,,S,2,,M/#01277,,M/#01277,,,,,
25-2,2,,172164-62502,, "PLATE B",,1,1,,,,,N,,M/#01505,,M/#01505,,,,,
26,2,,172164-62530,, COVER,1,1,,,,,
26-1,2,,172164-62531,, COVER,1,1,,,,,S,2,,M/#01277,,M/#01277,,,,,
27,2,,22217-100000,, "SPRING WASHER 10",,2,2,,,,,
28,2,,26647-100152,, "WING BOLT M10X15",,2,2,,,,,
29,2,,172165-03471,, LABEL,1,,,,,5,,,,,

Fig. 61 ロータリバルブ (4ウェイマルチチェンジ) ROTARY VALVE (4-WAY MULTI CHANGE)

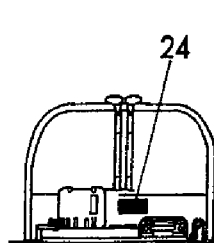
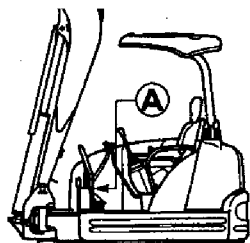
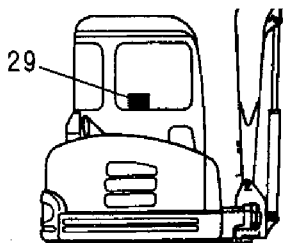
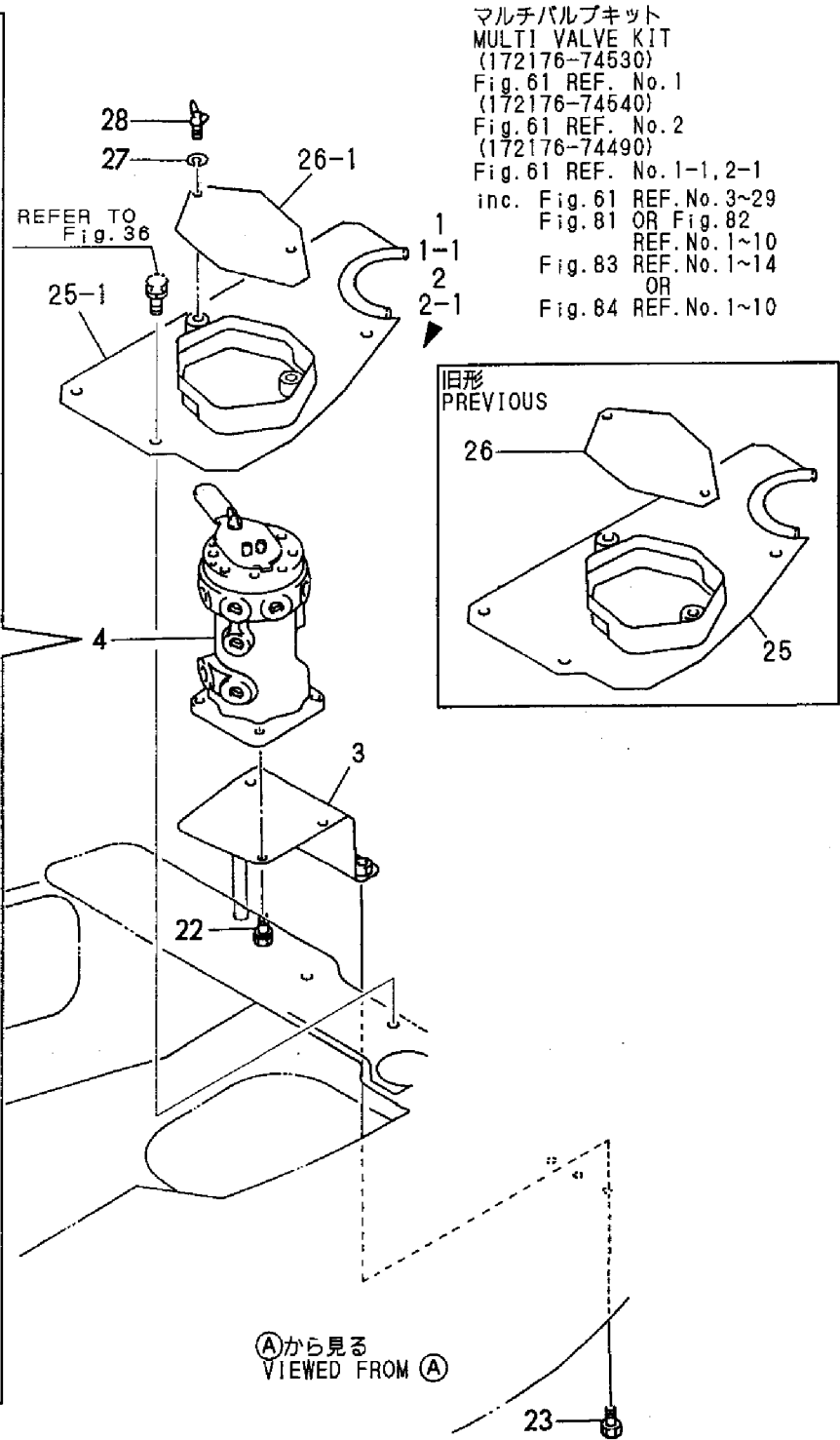
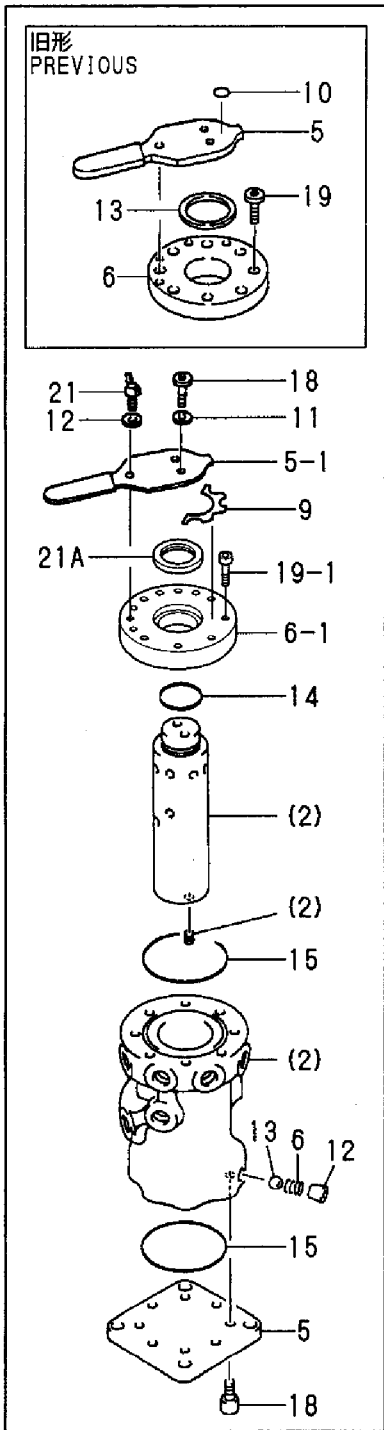

1,1,,172165-74704,, "VALVE ASSY, LOW-HIGH",1,1,,,,,1,,,,,
2,2,,172151-74420,, "BOLT M 4X 10",3,3,,,,,
3,2,,172165-74710,, SOLENOID,1,1,,,,,
4,2,,172165-74720,, "BOLT M5X16,HEX.SCKT.",2,2,,,,,
5,2,,172165-74730,, "BOLT M5X8,HEX.SCKT.",2,2,,,,,
6,2,,172165-74740,, SPRING,1,1,,,,,
7,2,,172165-74760,, SPRING,1,1,,,,,
8,2,,172165-74770,, PACKING,2,2,,,,,
9,2,,172165-74780,, PLATE,2,2,,,,,
10,2,,172165-74790,, COVER,1,1,,,,,
11,2,,23871-010000,, "PLUG PT1/8,SCREW",1,1,,,,,
12,2,,24311-000160,, "O-RING 1A P-16.0",1,1,,,,,
13,1,,26013-080162,, "BOLT W/WASHER M8X16",2,2,,,,,

Fig. **62** ローハイバルブ (旧形)
LOW-HIGH VALVE (PREVIOUS)

~M/#00869

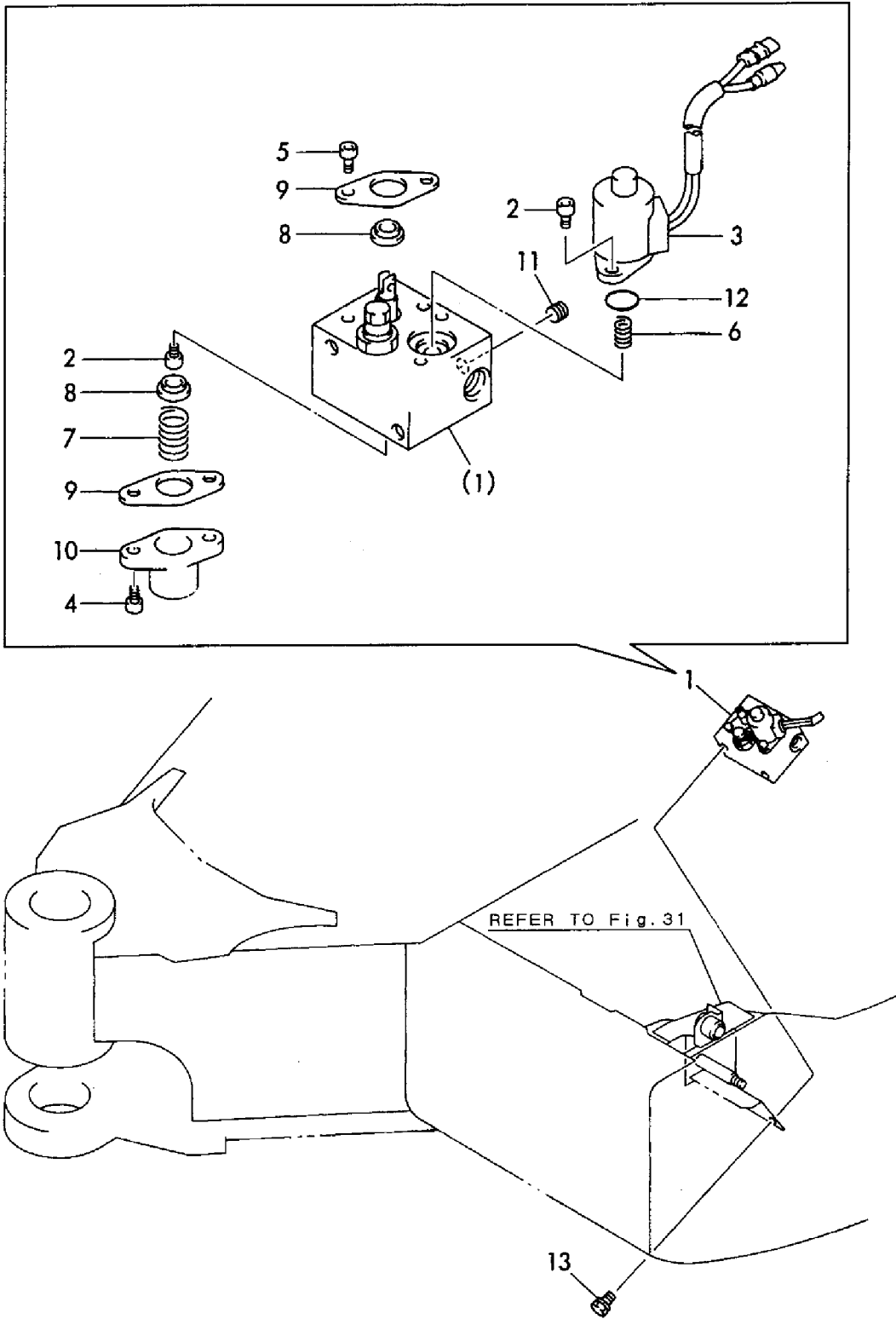

1,1,,172176-74520,, "P.T.O.KIT,JOIN",1,1,,,,,1,,,,,
1-1,1,,172176-74550,, "P.T.O.KIT,JOIN",1,1,,,,,S,2,,M/#00869,,M/#00869,,,,,
1-2,1,,172176-74551,, "P.T.O. KIT",1,1,,,,,S,3,,M/#01328,,M/#01328,,,,,
2,2,,172165-03211,, "LABEL, PTO SELECT",1,1,,,,,
2-1,2,,172165-03212,, "LABEL, PTO SELECT",1,1,,,,,N,,M/#00852,,M/#00852,,,,,
3,2,,172165-03280,, "LABEL, PTO SWITCH",1,1,,,,,
4,2,,172165-17000,, "SWITCH,ROTARY",1,1,,,,,
5,2,,172165-17010,, "HARNESS, P.T.O.",1,1,,,,,
6,2,,172165-17020,, "SWITCH W/LAMP",1,1,,,,,
7,2,,172176-74700,, "MOUNT ASSY, PTO V.",1,1,,,,,
8,2,,172165-74800,, "VALVE ASSY,PTO",1,1,,,,,
9,3,,172165-74710,, SOLENOID,1,1,,,,,
10,3,,172165-74740,, SPRING,2,2,,,,,
11,3,,172165-74810,, "BOLT M5X25,HEX.SCKT.",2,2,,,,,
12,3,,172165-74820,, "BOLT M4X8,HEX.SCKT.",4,4,,,,,
13,3,,172165-74830,, SPRING,1,1,,,,,
14,3,,172165-74840,, FLANGE,1,1,,,,,
15,3,,172165-74850,, SOLENOID,1,1,,,,,
16,3,,24311-000220,, "O-RING 1A P-22.0",3,3,,,,,
17,2,,119247-77100,, "RELAY, SAFETY",1,1,,,,,
18,2,,26013-080202,, "BOLT W/WASHER M8X20",2,2,,,,,
19,2,,26013-100202,, "BOLT W/WASHER M10X20",2,2,,,,,
20,2,,26022-060122,, "SCREW M 6X 12",1,1,,,,,

Fig. 63 P.T.Oバルブ P.T.O VALVE

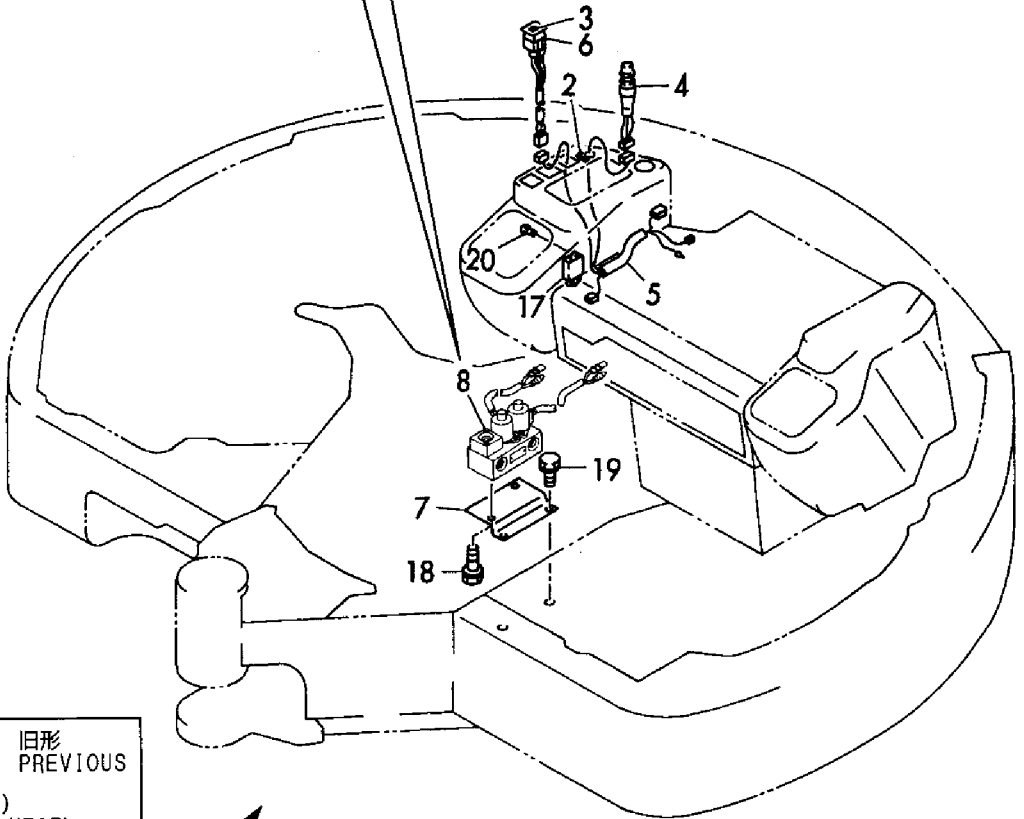
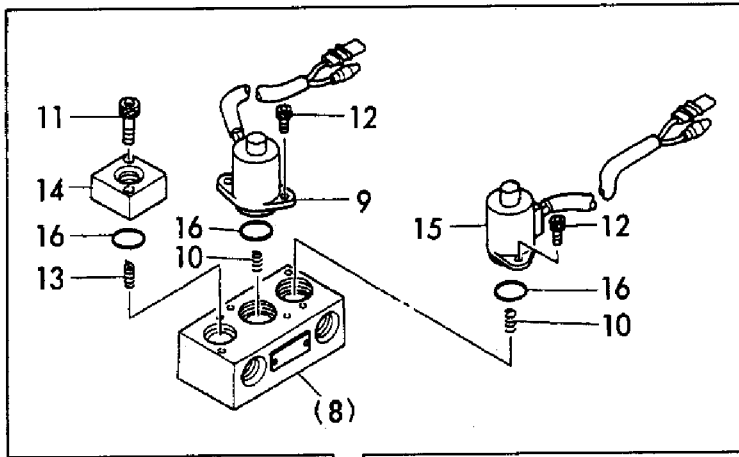

旧形
PREVIOUS

1
P.T.O.キット (合流)
P.T.O. KIT (CONFLUECE)
(172176-74520)
Fig. 63 REF. No. 1
inc. Fig. 63 REF. No. 2~20
Fig. 72 REF. No. 1~25
~ M/#00869

↓

1-1
P.T.O.キット (合流KYB)
P.T.O. KIT (CONFLUECE KYB)
(172176-74550)
Fig. 63 REF. No. 1-1
inc. Fig. 63 REF. No. 2~20
Fig. 73 REF. No. 1~26
M/#00870 ~ 01327

1-2
P.T.O.キット (合流)
P.T.O. KIT (CONFLUECE)
(172176-74551)
Fig. 63 REF. No. 1-2
inc. Fig. 63 REF. No. 2~20
Fig. 74 REF. No. 1~27

1,1,,772164-75100,, "TANK ASSY, HYD. OIL", 1,1,,,,,,,,,,,,,
3,2,,172164-75250,, COVER, 1,1,,,,,,,,,,,,,
4,2,,172122-75331-1,, "COVER, TANK (GREEN)", 1,1,,,,,,,,,,,,,
5,2,,172165-75450-4,, "PLATE (GRAY:72)", 1,1,,,,,,,,,,,,,
6,2,,172165-75460,, GASKET, 1,1,,,,,,,,,,,,,
7,2,,172165-75481,, ELEMENT, 1,1,,,,,,,,,,,,,
8,2,,172122-75600,, "GAUGE, OIL LEVEL", 1,1,,,,,,,,,,,,,
9,3,,172122-75620,, BOLT, 2,2,,,,,,,,,,,,,
10,3,,172122-75630,, GASKET, 4,4,,,,,,,,,,,,,
11,2,,172116-75850-4,, "PLUG, OIL FEED (72)", 1,1,,,,,,,,,,,,,
12,2,,24341-000300,, "O-RING 1A S-30.0", 1,1,,,,,,,,,,,,,
13,2,,22217-100000,, "SPRING WASHER 10", 4,4,,,,,,,,,,,,,
14,2,,22217-100000,, "SPRING WASHER 10", 4,4,,,,,,,,,,,,,
15,2,,22417-200160,, "COTTER PIN 2.0X16", 1,1,,,,,Z,,,M/#01505,,M/#01505,,,,,
16,2,,24311-000380,, "O-RING 1A P-38.0", 1,1,,,,,,,,,,,,,
17,2,,24321-001350,, "O-RING 1A G-135.0", 1,1,,,,,,,,,,,,,
18,2,,24321-001900,, "O-RING 1A G-190.0", 1,1,,,,,,,,,,,,,
19,2,,26022-050102,, "SCREW M 5X 10", 3,3,,,,,,,,,,,,,
20,2,,26116-100202,, "BOLT M10X 20 PLATED", 4,4,,,,,,,,,,,,,
21,2,,26116-100202,, "BOLT M10X 20 PLATED", 4,4,,,,,,,,,,,,,
22,2,,933171-23042,, MAGNET, 1,1,,,,,Z,,,M/#01505,,M/#01505,,,,,
23,2,,172183-75750,, "PLUG 24, DRAIN", 1,1,,,,,,,,,,,,,
23-1,2,,172187-75500,, "PLUG 24", 1,1,,,,,N,,,M/#01505,,M/#01505,,,,,
24,2,,172164-73700,, ROD, 1,1,,,,,,,,,,,,,
25,2,,172112-74801,, "STRAINER, SUCTION", 1,1,,,,,,,,,,,,,
26,2,,172112-74901,, "ELEMENT W/VALVE", 1,1,,,,,,,,,,,,,
27,3,,172112-74911,, ELEMENT, 1,1,,,,,,,,,,,,,
28,3,,172112-74971,, "VALVE, BY-PASS", 1,1,,,,,,,,,,,,,
29,2,,172112-75770,, "SPRING, STRAINER", 1,1,,,,,,,,,,,,,
30,2,,172112-75780,, "SPRING, STRAINER", 1,1,,,,,,,,,,,,,
31,2,,26716-100002,, "NUT 10", 1,1,,,,,,,,,,,,,
32,1,,124766-59050,, "CLAMP 12", 1,1,,,,,,,,,,,,,
33,1,,172165-75490,, HOSE, 1,1,,,,,,,,,,,,,
34,1,,22137-140000,, "WASHER 14, POLISHED", 4,4,,,,,,,,,,,,,
35,1,,22217-140000,, "SPRING WASHER 14", 4,4,,,,,,,,,,,,,
36,1,,26116-140402,, "BOLT M14X 40 PLATED", 4,4,,,,,,,,,,,,,
37,1,,933169-23070,, "SPACER (1.6)", 4,4,,,,,,,,,,,,,
37-1,1,,172117-53330,, SPACER, 4,4,,,,,R,,,M/#01358,,M/#01358,,,,,

Fig. 64 作動油タンク HYD. OIL TANK

見出しNo. 1は、見出しNo. (1) から31を含みます。
1 inc. (1) ~ 31

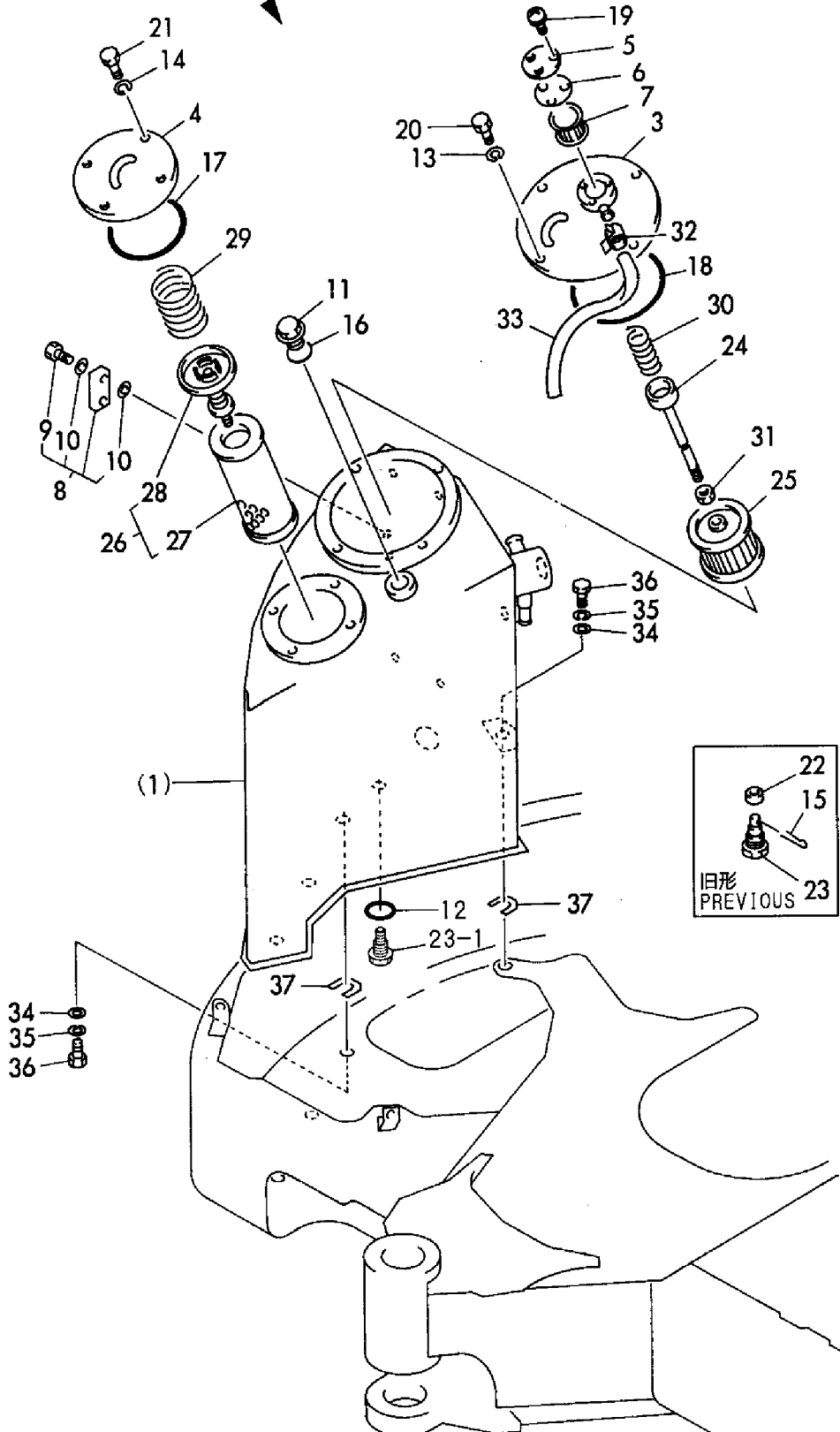

1,1,,172142-76100,,CONNECTOR,1,1,,,,,,,,,,,,,
2,1,,172147-76100,,FLANGE,1,1,,,,,,,,,,,,,
3,1,,172122-76131,, "CONNECTOR PT1/2-45",1,1,,,,,,,,,,,,,
4,2,,24315-000180,, "O-RING 1B P-18.0",1,1,,,,,,,,,,,,,
5,1,,172157-76130,, "JOINT PF1/2",1,1,,,,,,,,,,,,,
6,1,,172157-76150,, "CONNECTOR 3/8-1/4",1,1,,,,,,,,,,,,,
7,1,,172141-76900,, "CONNECTOR 1/2L",1,1,,,,,,,,,,,,,
8,2,,24315-000180,, "O-RING 1B P-18.0",1,1,,,,,,,,,,,,,
9,1,,172157-76150,, "CONNECTOR 3/8-1/4",1,1,,,,,,,,,,,,,
10,1,,172165-76311,,JOINT,1,1,,,,,,,,,,,,,
11,1,,172176-76200,, "JOINT PF1/2",1,1,,,,,,,,,,,,,
12,1,,172141-76900,, "CONNECTOR 1/2L",1,1,,,,,,,,,,,,,
13,2,,24315-000180,, "O-RING 1B P-18.0",1,1,,,,,,,,,,,,,
14,1,,24315-000180,, "O-RING 1B P-18.0",1,1,,,,,,,,,,,,,
15,1,,24315-000180,, "O-RING 1B P-18.0",1,1,,,,,,,,,,,,,
16,1,,24315-000240,, "O-RING 1B P-24.0",1,1,,,,,,,,,,,,,
17,1,,24321-000400,, "O-RING 1A G-40.0",1,1,,,,,,,,,,,,,
18,1,,26013-100252,, "BOLT W/WASHER M10X25",4,4,,,,,,,,,,,,,
19,1,,172164-76601,, "TUBE ASSY, SUCTION",1,1,,,,,,,,,,,,,
20,1,,26013-100202,, "BOLT W/WASHER M10X20",2,2,,,,,,,,,,,,,
21,1,,172176-78100,, "HOSE 38.5X51.5",1,1,,,,,,,,,,,,,
22,1,,172176-78110,, "HOSE 25.7X38.7",1,1,,,,,,,,,,,,,
23,1,,172176-78170,,HOSE,1,1,,,,,,,,,,,,,
24,1,,172176-78160,,HOSE,1,1,,,,,,,,,,,,,
25,1,,172164-78130,,HOSE,1,1,,,,,,,,,,,,,
26,1,,172164-78400,,HOSE,1,1,,,,,,,,,,,,,
27,1,,172176-78130,,HOSE,1,1,,,,,,,,,,,,,
28,1,,172176-78120,,HOSE,1,1,,,,,,,,,,,,,
29,1,,172112-78750,, "CLAMP (B), HOSE",3,3,,,,,,,,,,,,,
30,1,,23000-022000,, "CLAMP 22",4,4,,,,,,,,,,,,,
31,1,,23000-035000,, "CLAMP 35",4,4,,,,,,,,,,,,,
32,1,,23000-041000,, "CLAMP 41",4,4,,,,,,,,,,,,,
33,1,,23000-060000,, "CLAMP 60",4,4,,,,,,,,,,,,,
34,1,,23000-070000,, "CLAMP 70",4,4,,,,,,,,,,,,,
35,1,,172165-76780,,BODY,2,2,,,,,,,,,,,,,
36,1,,172164-76320,, "CONNECTOR 1 1/4X1/2",2,2,,,,,,,,,,,,,
37,1,,172168-76620,, "ELBOW,90°ADJUSTABLE",2,2,,,,,,,,,,,,,
38,2,,24315-000180,, "O-RING 1B P-18.0",2,2,,,,,,,,,,,,,
39,1,,23391-040000,, "JOINT RGI 1/2",2,2,,,,,,,,,,,,,
40,1,,172164-78410,,HOSE,1,1,,,,,,,,,,,,,
41,1,,23391-040000,, "JOINT RGI 1/2",1,1,,,,,,,,,,,,,
42,1,,24315-000180,, "O-RING 1B P-18.0",1,1,,,,,,,,,,,,,
43,1,,24315-000140,, "O-RING 1B P-14.0",1,1,,,,,,,,,,,,,

Fig. 65 油圧配管 (タンク~ポンプ~バルブ) (旧形)
HYD. OIL PIPING (TANK~PUMP~VALVE) (PREVIOUS)

~M/#00869

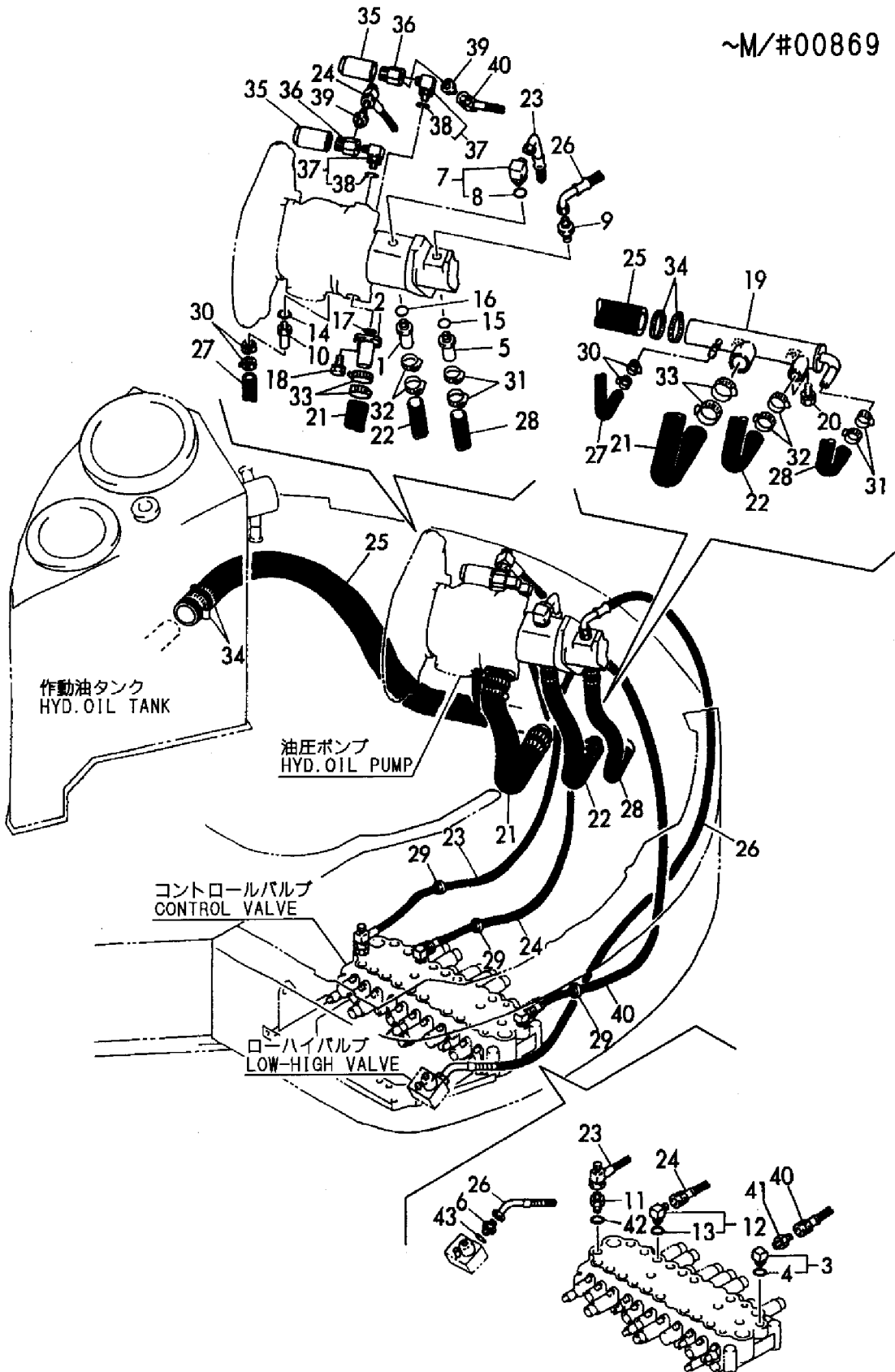

1,1,,172165-76860,,FLANGE,1,1,,,,,,,,,,,,,
2,1,,172122-76131,, "CONNECTOR PT1/2-45",1,1,,,,,,,,,,,,,
3,2,,24315-000180,, "O-RING 1B P-18.0",1,1,,,,,,,,,,,,,
4,1,,172176-76200,, "JOINT PF1/2",1,1,,,,,,,,,,,,,
5,1,,172141-76900,, "CONNECTOR 1/2L",1,1,,,,,,,,,,,,,
6,2,,24315-000180,, "O-RING 1B P-18.0",1,1,,,,,,,,,,,,,
7,1,,24321-000450,, "O-RING 1A G-45.0",1,1,,,,,,,,,,,,,
8,1,,26013-120302,, "BOLT W/WASHER M12X30",4,4,,,,,,,,,,,,,
9,1,,172176-76400,, TUBE,1,1,,,,,,,,,,,,,
10,1,,26013-100202,, "BOLT W/WASHER M10X20",2,2,,,,,,,,,,,,,
11,1,,172176-78101,, "HOSE 44.5X57.5",1,1,,,,,,,,,,,,,
12,1,,172176-78171,, HOSE,1,1,,,,,,,,,,,,,
13,1,,172176-78161,, HOSE,2,2,,,,,,,,,,,,,
14,1,,172164-78130,, HOSE,1,1,,,,,,,,,,,,,
15,1,,23000-070000,, "CLAMP 70",8,8,,,,,,,,,,,,,
16,1,,172164-76960,, BODY,2,2,,,,,,,,,,,,,
17,1,,172164-76950,, CONNECTOR,2,2,,,,,,,,,,,,,
17A,2,,24315-000180,, "O-RING 1B P-18.0",2,2,,,,,W,,,M/#01417,,M/#01417,,,,,
18,1,,23391-040000,, "JOINT RGI 1/2",2,2,,,,,,,,,,,,,
19,1,,23391-040000,, "JOINT RGI 1/2",1,1,,,,,,,,,,,,,
20,1,,24315-000180,, "O-RING 1B P-18.0",1,1,,,,,,,,,,,,,
21,1,,172112-77360,, "CONNECTOR PF1/2PF1/2",1,1,,,,,,,,,,,,,
22,1,,24315-000180,, "O-RING 1B P-18.0",1,1,,,,,,,,,,,,,
23,1,,172123-76120,, "CONNECTOR PF1/4",2,2,,,,,,,,,,,,,
24,1,,24315-000110,, "O-RING 1B P-11.0",2,2,,,,,,,,,,,,,
25,1,,22117-120000,, "WASHER 12",4,4,,,,,,,,,,,,,

Fig. **66** 油圧配管 (タンク~ポンプ~バルブ) (新形)
HYD. OIL PIPING (TANK~PUMP~VALVE) (NEW)

M/#00870~

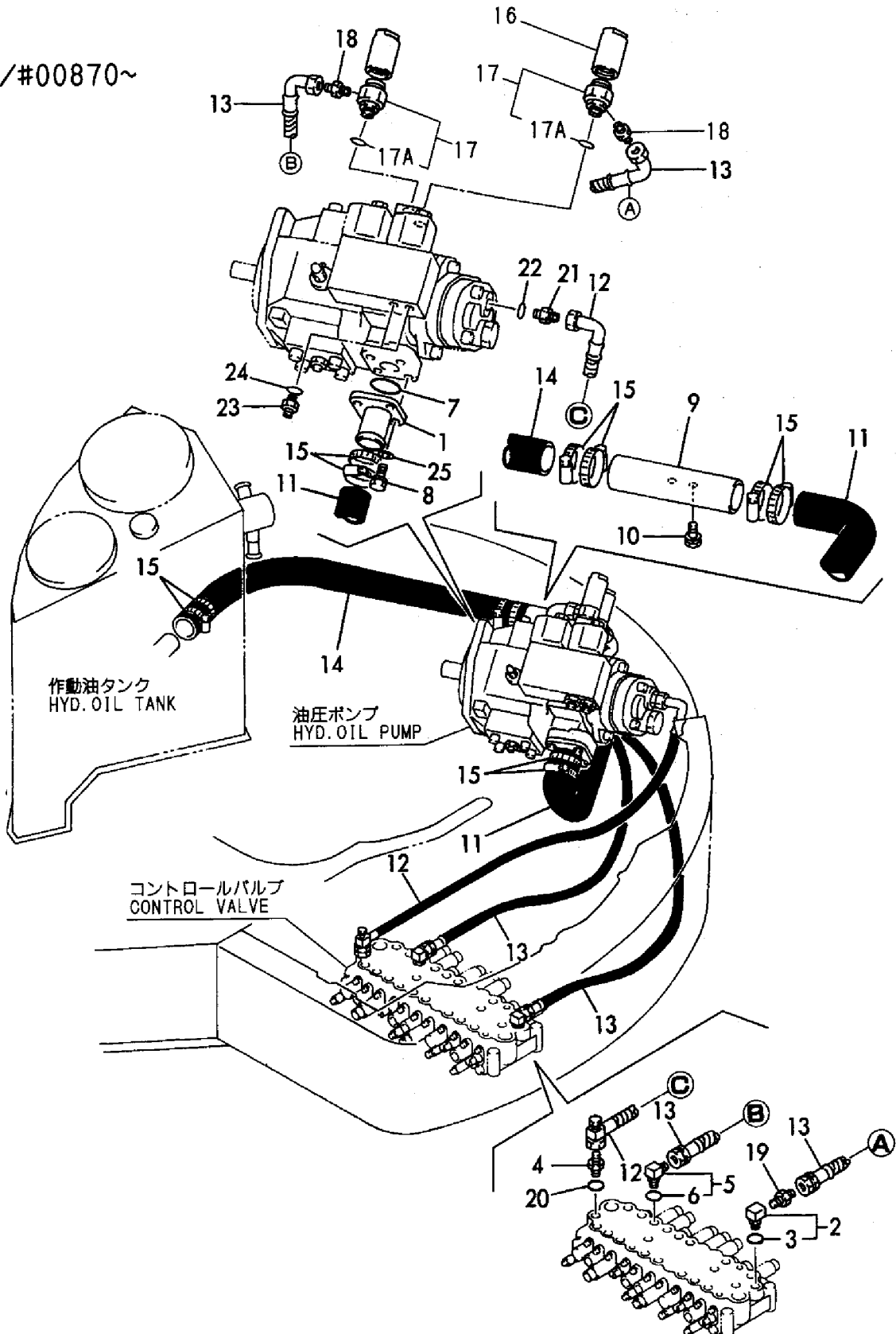

1,1,,172147-76270,,CONNECTOR,1,1,,,,,,,,,,,,,
2,1,,172165-76360,,,"JOINT PF1/2",1,1,,,,,,,,,,,,,
3,1,,172165-76360,,,"JOINT PF1/2",2,2,,,,,,,,,,,,,
4,1,,172176-78250,,HOSE,1,1,,,,,,,,,,,,,
5,1,,172165-76280,,,"CONNECTOR PF1/2-3/8",2,2,,,,,,,,,,,,,
6,1,,172112-77360,,,"CONNECTOR PF1/2PF1/2",2,2,,,,,,,,,,,,,
7,1,,24315-000180,,,"O-RING 1B P-18.0",8,8,,,,,,,,,,,,,
8,1,,172165-78150,,GROMMET,1,1,,,,,,,,,,,,,
9,1,,172176-78200,,HOSE,1,1,,,,,,,,,,,,,
10,1,,172176-78210,,HOSE,1,1,,,,,,,,,,,,,
11,1,,172176-78220,,HOSE,1,1,,,,,,,,,,,,,
12,1,,172176-78230,,HPSE,1,1,,,,,,,,,,,,,
13,1,,172176-78240,,HOSE,1,1,,,,,,,,,,,,,
14,1,,172176-78700,,,"SUPPORT COMP.,HOSE",1,1,,,,,,,,,,,,,
15,1,,172165-78741-2,,,"COVER ASSY",1,1,,,,,,,,,,,,,
16,2,,172165-78781,,RUBBER,1,1,,,,,,,,,,,,,
17,1,,26116-100202,,,"BOLT M10X 20 PLATED",2,2,,,,,,,,,,,,,
17-1,1,,26013-100202,,,"BOLT W/WASHER
M10X20",2,2,,,,,R,,M/#00832,,M/#00832,,,,,
18,1,,26116-100702,,,"BOLT M10X 70 PLATED",2,2,,,,,,,,,,,,,
19,1,,22217-100000,,,"SPRING WASHER 10",4,4,,,,,,,,,,,,,
19-1,1,,22217-100000,,,"SPRING WASHER 10",2,2,,,,,K,,M/#00832,,M/#00832,,,,,
20,1,,172164-78540,,HOSE,2,2,,,,,,,,,,,,,
21,1,,172157-76300,,,"ELBOW 3/8-1/2",2,2,,,,,,,,,,,,,
23,2,,24315-000180,,,"O-RING 1B P-18.0",2,2,,,,,,,,,,,,,
24,1,,172126-11510,,,"BAND 300",1,1,,,,,,,,,,,,,
25,1,,172151-53430,,GROMMET,2,2,,,,,,,,,,,,,
26,1,,172142-78800,,,"COVER 20-700, HOSE",5,5,,,,,1,,,,,
27,1,,172151-79410,,HOSE,1,1,,,,,1,,,,,
28,1,,23000-035000,,,"CLAMP 35",6,6,,,,,1,,,,,
29,1,,172122-79920,,CLAMP,6,6,,,,,1,,,,,

Fig. 67 油圧配管 (バルブ~モータ、ブーム)
HYD. OIL PIPING (VALVE~MOTOR, BOOM)

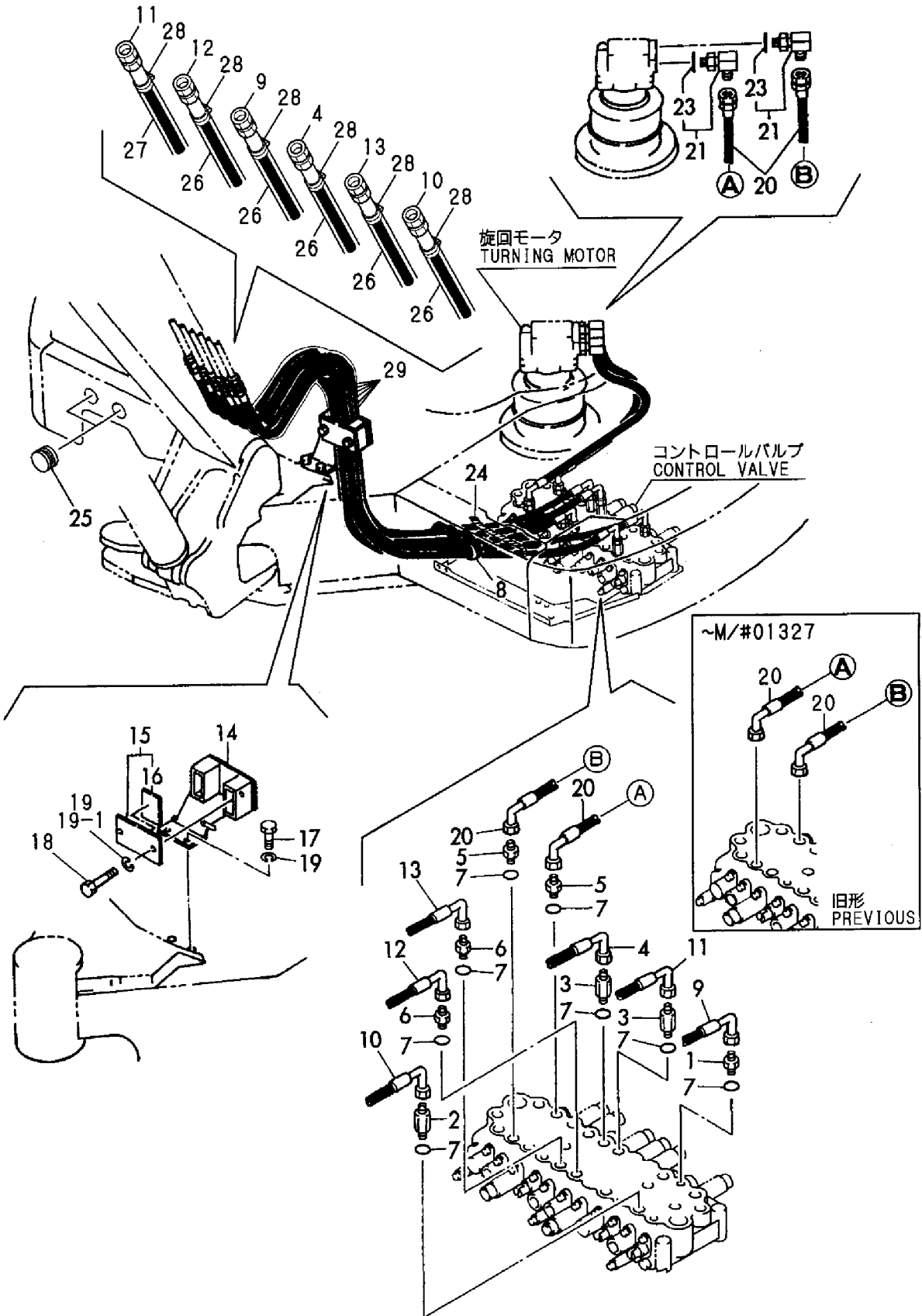

1,1,,172730-75140,,ADAPTOR,1,1,,,,,Z,,,M/#00831,,M/#00831,,,,,
2,1,,172730-75140,,ADAPTOR,2,2,,,,,
3,1,,172123-76120,, "CONNECTOR PF1/4",2,2,,,,,
4,1,,172157-76150,, "CONNECTOR 3/8-1/4",1,1,,,,,
5,1,,172141-76180,,CONNECTOR,1,1,,,,,
6,2,,24315-000110,, "O-RING 1B P-11.0",1,1,,,,,
7,1,,172147-76260,,CONNECTOR,1,1,,,,,
8,1,,172165-76350,, "CONNECTOR M17 PF3/8",1,1,,,,,Z,,,M/#00831,,M/#00831,,,,,
9,1,,172176-76210,, "JOINT PF1/2",2,2,,,,,
10,1,,172112-77360,, "CONNECTOR PF1/2PF1/2",2,2,,,,,
11,1,,23391-020000,, "JOINT RGI1/4",2,2,,,,,
12,1,,23393-030000,, "JOINT 90RGI 3/8",2,2,,,,,
13,1,,23393-040000,, "JOINT 90RGI 1/2",2,2,,,,,
14,1,,23394-040000,, "JOINT 45RGI1/4",2,2,,,,,
15,1,,24315-000110,, "O-RING 1B P-11.0",2,2,,,,,
16,1,,24315-000140,, "O-RING 1B P-14.0",6,6,,,,,
16-1,1,,24315-000140,, "O-RING 1B P-14.0",4,4,,,,,K,,,M/#00832,,M/#00832,,,,,
17,1,,24315-000180,, "O-RING 1B P-18.0",4,4,,,,,
18,1,,172165-78250,,HOSE,1,1,,,,,
19,1,,172176-78180,, "HOSE P208CC061S",2,2,,,,,
20,1,,172164-78280,, "HOSE P204BC330S",1,1,,,,,
21,1,,172164-78290,, "HOSE P204CE265S",1,1,,,,,
22,1,,172165-78300,,HOSE,1,1,,,,,
23,1,,172176-78150,, "HOSE G806BC045S",1,1,,,,,Z,,,M/#00831,,M/#00831,,,,,
24,1,,172165-78430,,HOSE,1,1,,,,,
25,1,,172165-78440,,HOSE,1,1,,,,,
26,1,,172165-79660,,HOSE,1,1,,,,,
27,1,,24315-000110,, "O-RING 1B P-11.0",1,1,,,,,
28,1,,172164-78260,,HOSE,1,1,,,,,

Fig. 68 油圧配管 (バルブ~スイベル、スイング)
HYD. OIL PIPING (VALVE~SWIVEL, SWING)

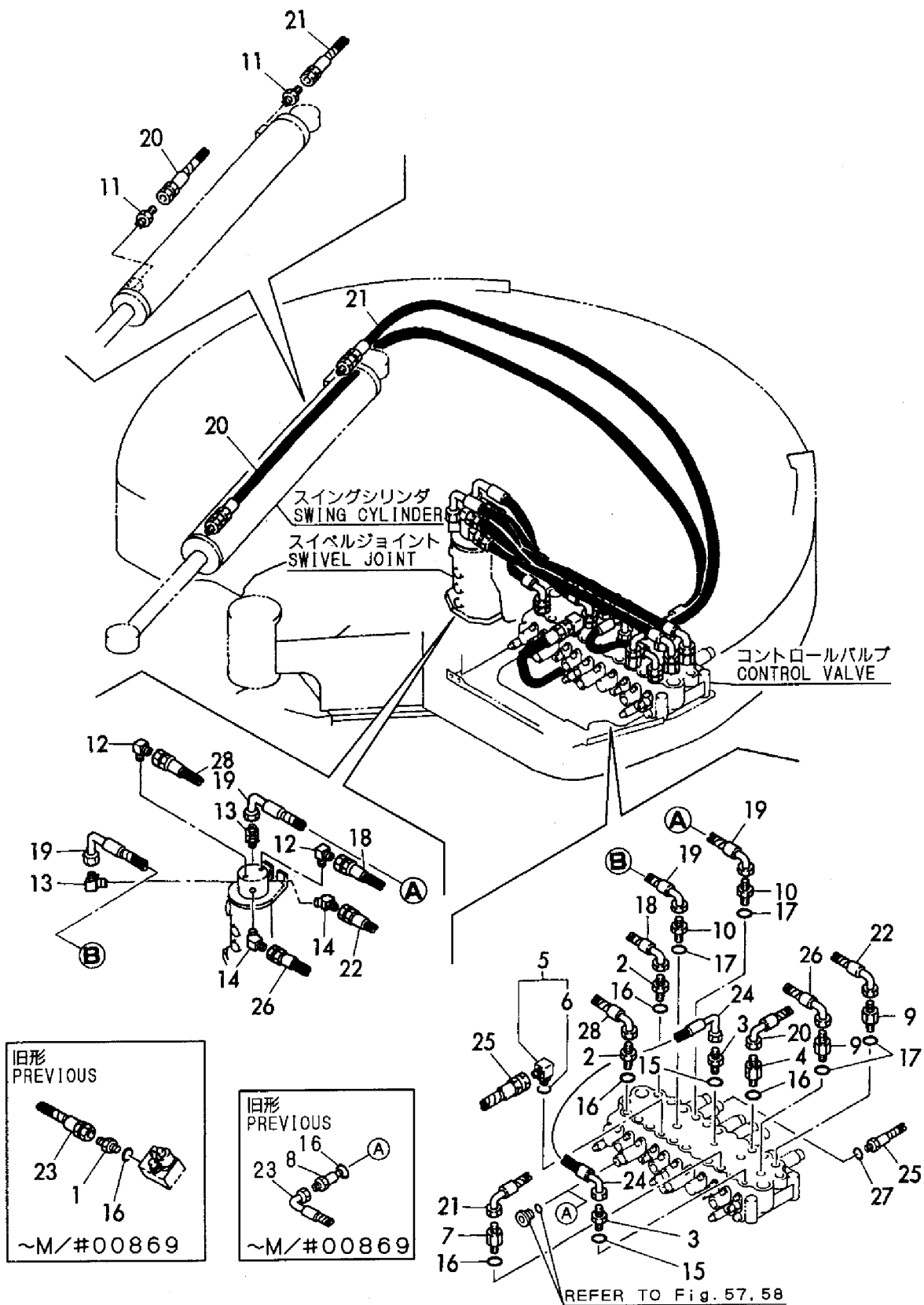

1,1,,172123-76120,, "CONNECTOR PF1/4",2,2,,,,,,,,,,,,,,,,,,,,,
2,1,,172157-76150,, "CONNECTOR 3/8-1/4",1,1,,,,,,,,,,,,,,,,,,,,,
3,1,,172164-76210,, "NIPPLE,ELBOW",2,2,,,,,,,,,,,,,,,,,,,,,
4,1,,172142-76240,, "JOINT PF3/4",1,1,,,,,,,,,,,,,,,,,,,,,
5,1,,172164-76240,, "JOINT COMPL.",1,1,,,,,,,,,,,,,,,,,,,,,
6,1,,172165-76340,, "CONNECTOR M17 PF1/2",1,1,,,,,,,,,,,,,,,,,,,,,
7,1,,172165-76380,, "CONNECTOR PF3/4M CMP",1,1,,,,,,,,,,,,,,,,,,,,,
8,2,,24315-000240,, "O-RING 1B P-24.0",1,1,,,,,,,,,,,,,,,,,,,,,
9,1,,172141-76900,, "CONNECTOR 1/2L",1,1,,,,,,,,,,,,,,,,,,,,,
10,2,,24315-000180,, "O-RING 1B P-18.0",1,1,,,,,,,,,,,,,,,,,,,,,
11,1,,23394-020000,, "JOINT 45RGI1/4",1,1,,,,,,,,,,,,,,,,,,,,,
12,1,,23871-020000,, "PLUG PT1/4,SCREW",1,1,,,,,,,,,,,,,,,,,,,,,
13,1,,24315-000140,, "O-RING 1B P-14.0",1,1,,,,,,,,,,,,,,,,,,,,,
14,1,,172176-78190,, "HOSE G612CY268S",1,1,,,,,,,,,,,,,,,,,,,,,
15,1,,172164-78330,, "HOSE G612BY120S",1,1,,,,,,,,,,,,,,,,,,,,,
16,1,,172164-78350,, "HOSE G612YY058S",1,1,,,,,,,,,,,,,,,,,,,,,
17,1,,172164-78360,, "HOSE G608BE100S",1,1,,,,,,,,,,,,,,,,,,,,,
18,1,,172165-78380,, "HOSE",1,1,,,,,,,,,,,,,,,,,,,,,
19,1,,172164-78450,, "HOSE G612YY080S",1,1,,,,,,,,,,,,,,,,,,,,,
20,1,,172165-78450,, "HOSE",1,1,,,,,,,,,,,,,,,,,,,,,
21,1,,172164-78460,, "HOSE G804BY080S",1,1,,,,,,,,,,,,,,,,,,,,,
22,1,,23000-016000,, "CLAMP 16",2,2,,,,,,,,,,,,,,,,,,,,,
23,1,,23871-040000,, "PLUG PT1/2,SCREW",1,1,,,,,,,,,,,,,,,,,,,,,
24,1,,24315-000140,, "O-RING 1B P-14.0",1,1,,,,,,,,,,,,,,,,,,,,,
25,1,,24315-000110,, "O-RING 1B P-11.0",2,2,,,,,,,,,,,,,,,,,,,,,
26,1,,23000-022000,, "CLAMP 22",2,2,,,,,,,,,,,,,,,,,,,,,
27,1,,172131-76130,, "ELBOW,NIPPLE",1,1,,,,,,,,,,,,,,,,,,,,,
28,1,,23000-035000,, "CLAMP 35",4,4,,,,,,,,,,,,,,,,,,,,,
29,1,,24315-000240,, "O-RING 1B P-24.0",1,1,,,,,,,,,,,,,,,,,,,,,

Fig. 69 油圧配管 (リターン) (旧形)
HYD. OIL PIPING (RETURN) (PREVIOUS)

~M/#00869

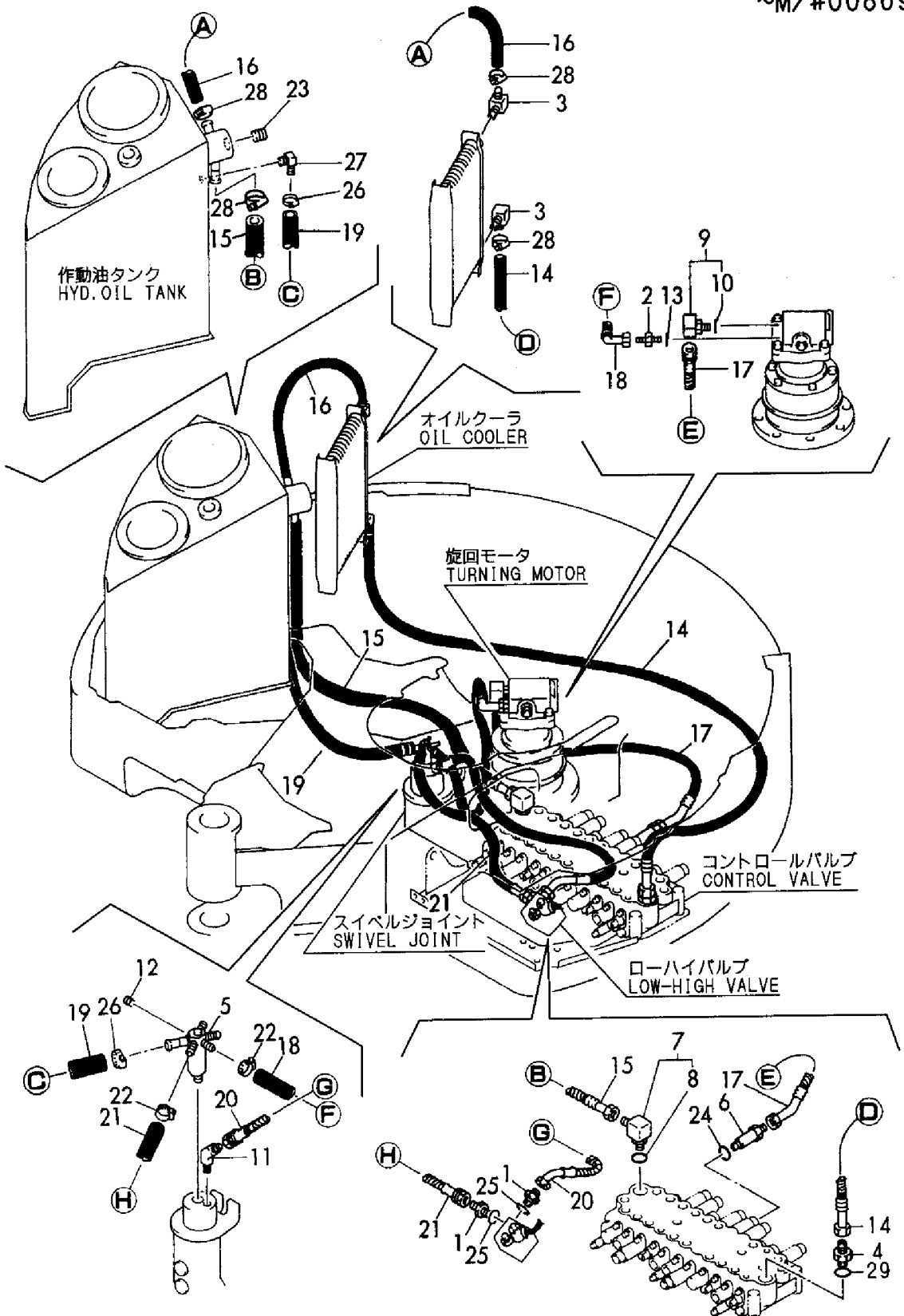

1,1,,24315-000140,, "O-RING 1B P-14.0",1,1,,,,,,,,,,,,,
2,1,,172157-76150,, "CONNECTOR 3/8-1/4",1,1,,,,,,,,,,,,,
3,1,,172164-76130,, ELBOW,2,2,,,,,,,,,,,,,
3-1,1,,172164-76131,, ELBOW,2,2,,,,,S,1,,M/#01104,,M/#01104,,,,,
3A,2,,24315-000180,, "O-RING 1B P-18.0",2,2,,,,,W,,,M/#01104,,M/#01104,,,,,
4,1,,172176-76250,, CONNECTOR,1,1,,,,,,,,,,,,,
5,1,,172164-76241,, JOINT,1,1,,,,,,,,,,,,,
6,1,,172165-76340,, "CONNECTOR M17 PF1/2",1,1,,,,,,,,,,,,,
7,1,,172176-76220,, ELBOW,1,1,,,,,,,,,,,,,
8,1,,172156-76240,, ELBOW,1,1,,,,,,,,,,,,,
9,1,,172141-76900,, "CONNECTOR 1/2L",1,1,,,,,,,,,,,,,
10,2,,24315-000180,, "O-RING 1B P-18.0",1,1,,,,,,,,,,,,,
11,1,,23394-020000,, "JOINT 45RGI1/4",1,1,,,,,,,,,,,,,
12,1,,23871-020000,, "PLUG PT1/4,SCREW",1,1,,,,,,,,,,,,,
13,1,,24315-000140,, "O-RING 1B P-14.0",1,1,,,,,,,,,,,,,
14,1,,172176-78191,, "HOSE G612YY268S",1,1,,,,,,,,,,,,,
15,1,,172164-78331,, HOSE,1,1,,,,,,,,,,,,,
16,1,,172164-78350,, "HOSE G612YY058S",1,1,,,,,,,,,,,,,
17,1,,172164-78360,, "HOSE G608BE100S",1,1,,,,,,,,,,,,,
18,1,,172165-78380,, HOSE,1,1,,,,,,,,,,,,,
19,1,,172164-78451,, HOSE,1,1,,,,,,,,,,,,,
20,1,,172165-78450,, HOSE,1,1,,,,,,,,,,,,,
21,1,,23000-035000,, "CLAMP 35",6,6,,,,,,,,,,,,,
22,1,,23000-016000,, "CLAMP 16",3,3,,,,,,,,,,,,,
23,1,,23871-040000,, "PLUG PT1/2,SCREW",1,1,,,,,,,,,,,,,
24,1,,24315-000240,, "O-RING 1B P-24.0",1,1,,,,,,,,,,,,,
25,1,,172164-76210,, "NIPPLE,ELBOW",1,1,,,,,,,,,,,,,
26,1,,172123-76120,, "CONNECTOR PF1/4",1,1,,,,,,,,,,,,,
27,1,,24315-000110,, "O-RING 1B P-11.0",1,1,,,,,,,,,,,,,

Fig. 70 油圧配管 (リターン) (旧形)
HYD. OIL PIPING (RETURN) (PREVIOUS)

M/#00870~01327

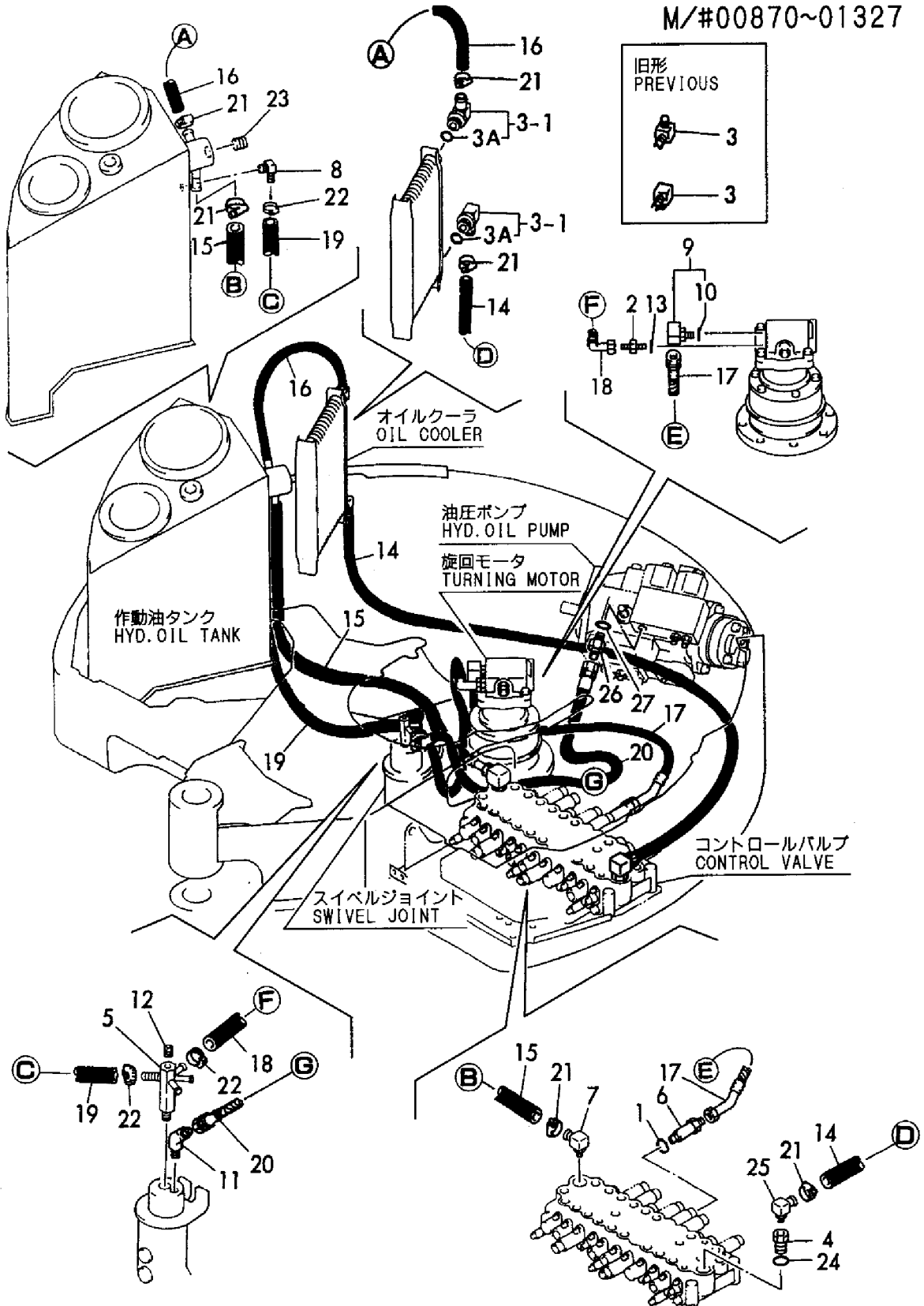

1,1,,24315-000140,, "O-RING 1B P-14.0",1,1,,,,,,,,,,,,,
2,1,,172157-76150,, "CONNECTOR 3/8-1/4",1,1,,,,,,,,,,,,,
3,1,,172164-76131,, ELBOW,2,2,,,,,,,,,,,,,
4,2,,24315-000180,, "O-RING 1B P-18.0",2,2,,,,,,,,,,,,,
5,1,,172164-76241,, JOINT,1,1,,,,,,,,,,,,,
6,1,,172165-76340,, "CONNECTOR M17 PF1/2",1,1,,,,,,,,,,,,,
7,1,,172176-76220,, ELBOW,1,1,,,,,,,,,,,,,
8,1,,172156-76240,, ELBOW,1,1,,,,,,,,,,,,,
9,1,,172141-76900,, "CONNECTOR 1/2L",1,1,,,,,,,,,,,,,
10,2,,24315-000180,, "O-RING 1B P-18.0",1,1,,,,,,,,,,,,,
11,1,,23394-020000,, "JOINT 45RGI1/4",1,1,,,,,,,,,,,,,
12,1,,23871-020000,, "PLUG PT1/4,SCREW",1,1,,,,,,,,,,,,,
13,1,,24315-000140,, "O-RING 1B P-14.0",1,1,,,,,,,,,,,,,
14,1,,172176-78191,, "HOSE G612YY268S",1,1,,,,,,,,,,,,,
15,1,,172164-78331,, HOSE,1,1,,,,,,,,,,,,,
16,1,,172164-78350,, "HOSE G612YY058S",1,1,,,,,,,,,,,,,
17,1,,172164-78360,, "HOSE G608BE100S",1,1,,,,,,,,,,,,,
18,1,,172165-78380,, HOSE,1,1,,,,,,,,,,,,,
19,1,,172164-78451,, HOSE,1,1,,,,,,,,,,,,,
20,1,,172165-78450,, HOSE,1,1,,,,,,,,,,,,,
21,1,,23000-035000,, "CLAMP 35",6,6,,,,,,,,,,,,,
22,1,,23000-016000,, "CLAMP 16",3,3,,,,,,,,,,,,,
23,1,,23871-040000,, "PLUG PT1/2,SCREW",1,1,,,,,,,,,,,,,
24,1,,24315-000240,, "O-RING 1B P-24.0",1,1,,,,,,,,,,,,,
25,1,,172164-76210,, "NIPPLE,ELBOW",1,1,,,,,,,,,,,,,
26,1,,172123-76120,, "CONNECTOR PF1/4",1,1,,,,,,,,,,,,,
27,1,,24315-000110,, "O-RING 1B P-11.0",1,1,,,,,,,,,,,,,
28,1,,172176-76250,, CONNECTOR,1,1,,,,,,,,,,,,,
29,1,,172175-79240,, HOSE,1,1,,,,,,,,,,,,,
30,1,,23393-020000,, "JOINT 90RGI1/4",1,1,,,,,,,,,,,,,
31,1,,172123-76120,, "CONNECTOR PF1/4",1,1,,,,,,,,,,,,,
32,1,,24315-000110,, "O-RING 1B P-11.0",1,1,,,,,,,,,,,,,

Fig. 71 油圧配管 (リターン) (新形) HYD. OIL PIPING (RETURN) (NEW)

M/#01328~

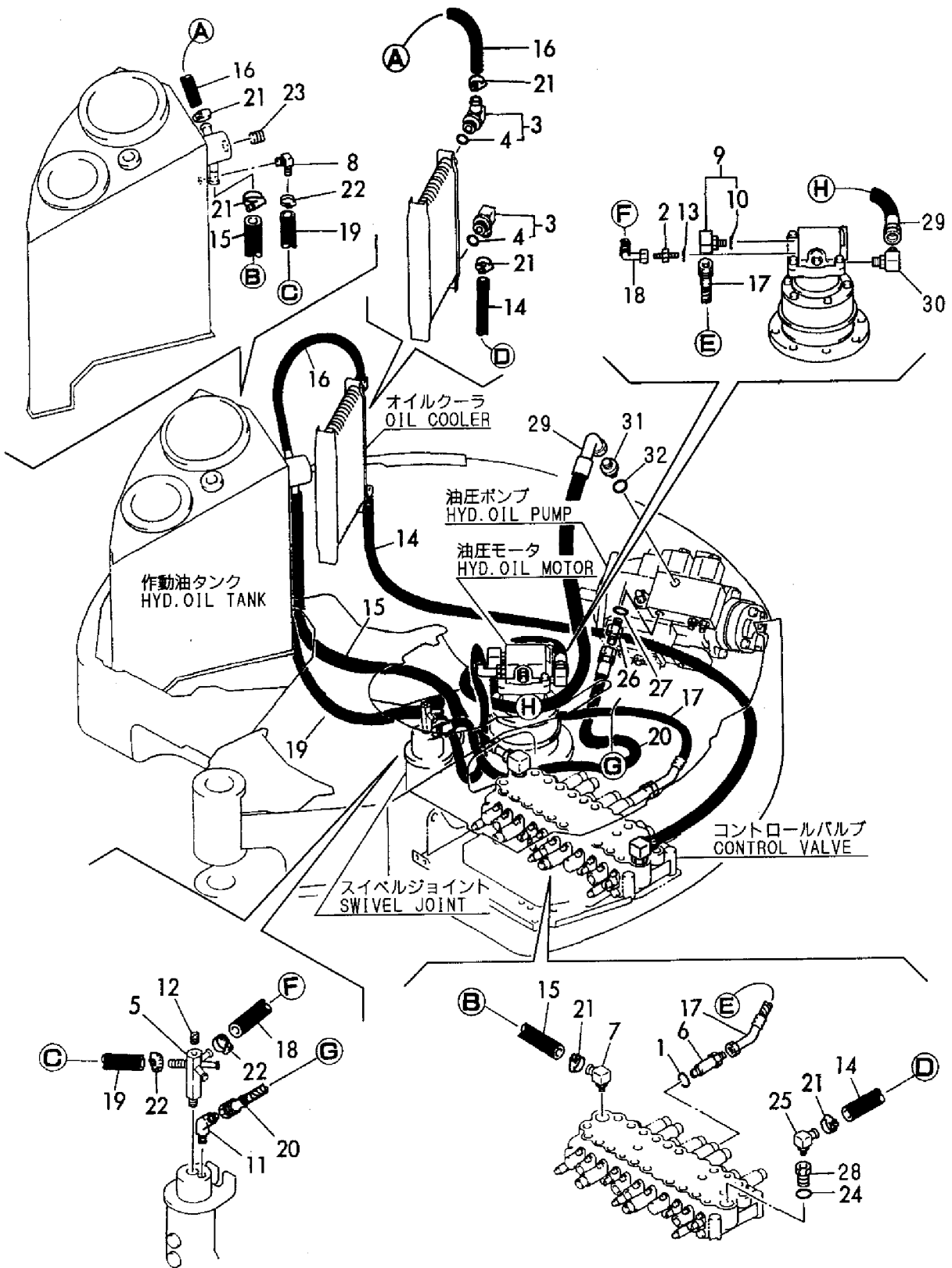

1,2,,172156-76110,,CONNECTOR,1,1,,,,,,,,,,,,,
2,2,,172123-76120,, "CONNECTOR PF1/4",1,1,,,,,,,,,,,,,
3,2,,172123-76120,, "CONNECTOR PF1/4",1,1,,,,,,,,,,,,,
4,2,,172123-76120,, "CONNECTOR PF1/4",1,1,,,,,,,,,,,,,
5,2,,172123-76120,, "CONNECTOR PF1/4",1,1,,,,,,,,,,,,,
6,2,,172123-76120,, "CONNECTOR PF1/4",1,1,,,,,,,,,,,,,
7,2,,172141-76180,,CONNECTOR,1,1,,,,,,,,,,,,,
8,3,,24315-000110,, "O-RING 1B P-11.0",1,1,,,,,,,,,,,,,
9,2,,172141-76220,,NIPPLE,1,1,,,,,,,,,,,,,
10,2,,172165-76280,, "CONNECTOR PF1/2-3/8",2,2,,,,,,,,,,,,,
11,2,,172112-77660,, "L-JOINT 1/8",2,2,,,,,,,,,,,,,
12,2,,172164-78440,,HOSE,1,1,,,,,,,,,,,,,
13,2,,172165-78510,,HOSE,1,1,,,,,,,,,,,,,
14,2,,172176-78520,, "HOSE P204CE150S",1,1,,,,,,,,,,,,,
15,2,,172176-78540,, "HOSE P202FF085",1,1,,,,,,,,,,,,,
16,2,,172162-78941,, "HOSE A G504BC039S",1,1,,,,,,,,,,,,,
17,2,,24315-000180,, "O-RING 1B P-18.0",2,2,,,,,,,,,,,,,
18,2,,172168-79140,, "HOSE G604BC070 E",1,1,,,,,,,,,,,,,
19,2,,23010-014000,, "CLAMP 14",1,1,,,,,,,,,,,,,
20,2,,23391-020000,, "JOINT RGI1/4",1,1,,,,,,,,,,,,,
21,2,,23871-010000,, "PLUG PT1/8,SCREW",1,1,,,,,,,,,,,,,
22,2,,23393-020000,, "JOINT 90RGI1/4",1,1,,,,,,,,,,,,,
23,2,,24315-000110,, "O-RING 1B P-11.0",6,6,,,,,,,,,,,,,
24,2,,172165-76300,, "CONNECTOR PT1/4 CMP",1,1,,,,,,,,,,,,,
25,2,,172165-74240,, "VALVE ASSY, UNLOAD",1,1,,,,,,,,,,,,,

Fig. 72 油圧配管 (PTOバルブ、フレーム) (旧形)
HYD. OIL PIPING (P. T. O. VALVE, FRAME) (PREVIOUS)

~M/#00869

PTOキット (合流)
P. T. O. KIT (CONFLUECE)
(172176-74520)
Fig. 63 REF. No. 1-2
inc. Fig. 63 REF. No. 2~20
Fig. 72 REF. No. 1~25

REFER TO Fig. 65

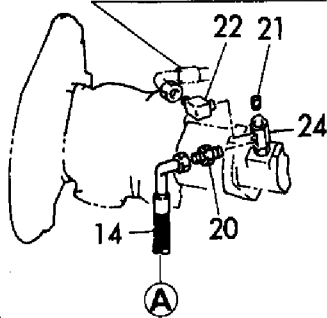

REFER TO Fig. 78

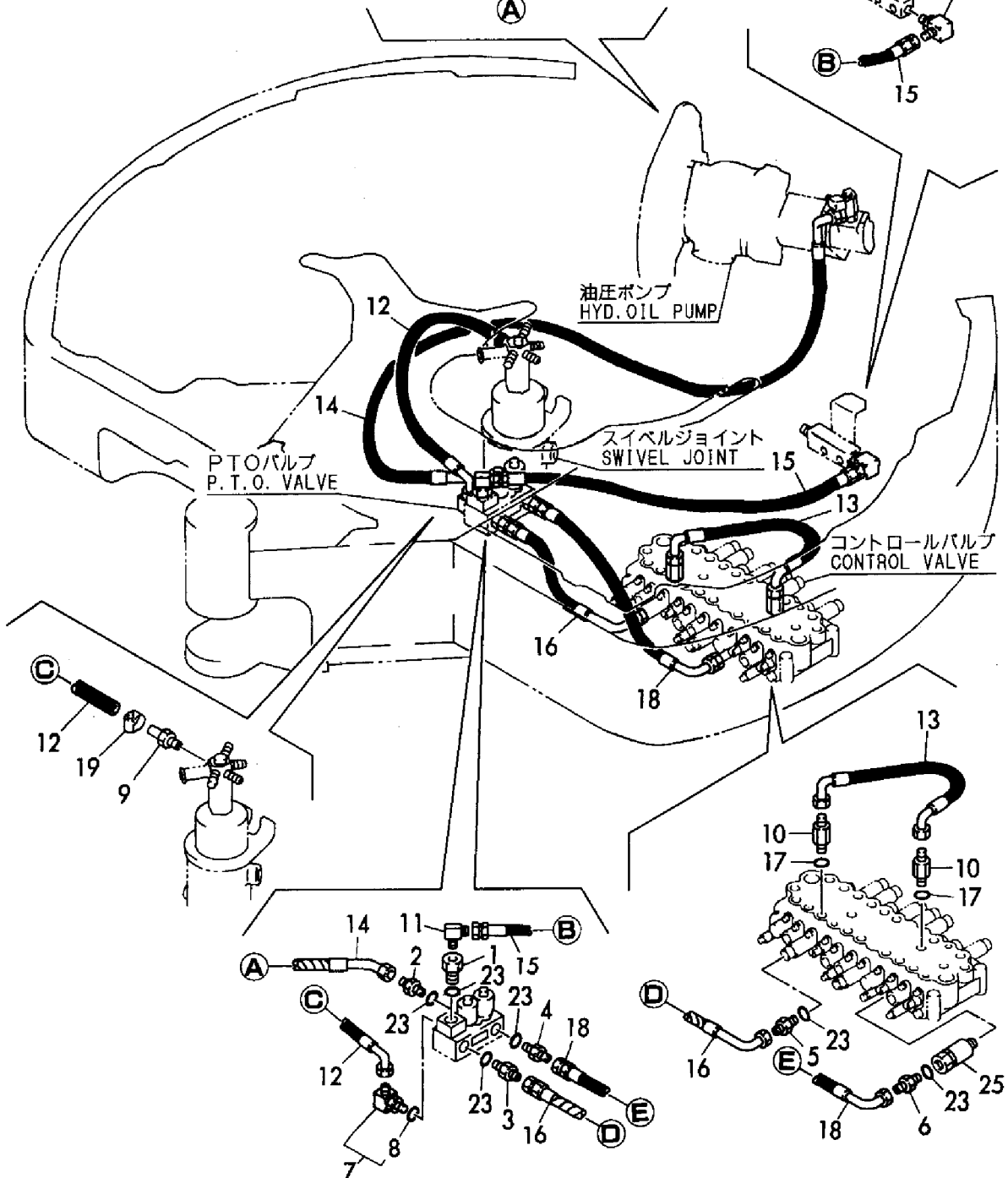
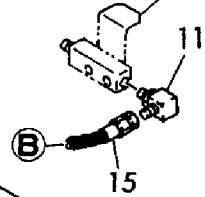

1,2,,172165-74240,, "VALVE ASSY, UNLOAD",1,1,,,,,,,,,,,,,
2,2,,172123-76120,, "CONNECTOR PF1/4",1,1,,,,,,,,,,,,,
3,2,,172123-76120,, "CONNECTOR PF1/4",1,1,,,,,,,,,,,,,
4,2,,172123-76120,, "CONNECTOR PF1/4",1,1,,,,,,,,,,,,,
5,2,,172123-76120,, "CONNECTOR PF1/4",1,1,,,,,,,,,,,,,
6,2,,172123-76120,, "CONNECTOR PF1/4",1,1,,,,,,,,,,,,,
7,2,,172141-76180,, "CONNECTOR",1,1,,,,,,,,,,,,,
8,3,,24315-000110,, "O-RING 1B P-11.0",1,1,,,,,,,,,,,,,
9,2,,172141-76220,, "NIPPLE",1,1,,,,,,,,,,,,,
10,2,,172165-76280,, "CONNECTOR PF1/2-3/8",2,2,,,,,,,,,,,,,
11,2,,24315-000110,, "O-RING 1B P-11.0",5,5,,,,,,,,,,,,,
12,2,,172164-78441,, "HOSE",1,1,,,,,,,,,,,,,
13,2,,172165-78510,, "HOSE",1,1,,,,,,,,,,,,,
14,2,,172164-79100,, "HOSE G604BB130 J",1,1,,,,,,,,,,,,,
15,2,,172164-78860,, "HOSE G604BB060S",1,1,,,,,,,,,,,,,
16,2,,172162-78941,, "HOSE A G504BC039S",1,1,,,,,,,,,,,,,
17,2,,24315-000180,, "O-RING 1B P-18.0",2,2,,,,,,,,,,,,,
18,2,,172168-79140,, "HOSE G604BC070 E",1,1,,,,,,,,,,,,,
19,2,,23010-014000,, "CLAMP 14",1,1,,,,,,,,,,,,,
20,2,,172141-76180,, "CONNECTOR",1,1,,,,,,,,,,,,,
21,3,,24315-000110,, "O-RING 1B P-11.0",1,1,,,,,,,,,,,,,
22,2,,172164-76700,, "T-JOINT 1/4",1,1,,,,,,,,,,,,,
23,3,,24315-000110,, "O-RING 1B P-11.0",1,1,,,,,,,,,,,,,
24,2,,172151-76080,, "CONNECTOR",1,1,,,,,W,,,"FROM 1ST",,"FROM 1ST",,,,,,
25,3,,24315-000110,, "O-RING 1B P-11.0",1,1,,,,,W,,,"FROM 1ST",,"FROM 1ST",,,,,,
26,2,,23393-020000,, "JOINT 90RGI1/4",1,1,,,,,W,,,"FROM 1ST",,"FROM 1ST",,,,,,
27,1,,194202-56460,, "BAND",1,1,,,,,,,,,,,,,

Fig. 73 油圧配管 (PTOバルブ、フレーム) (旧形)
HYD. OIL PIPING (P. T. O. VALVE, FRAME) (PREVIOUS)

M/#00870~01327

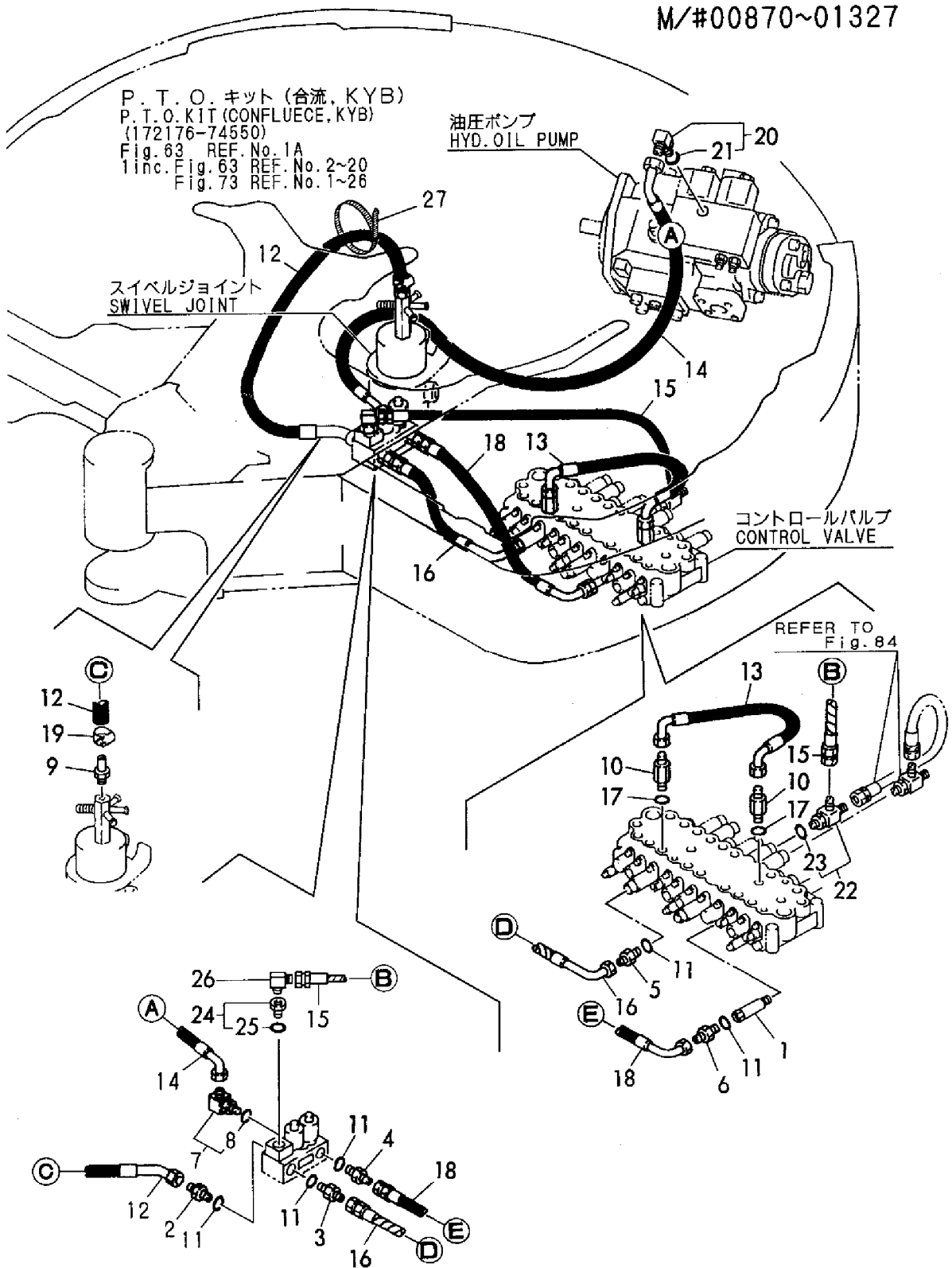

1,2,,172165-74240,, "VALVE ASSY, UNLOAD",1,1,,,,,,,,,,,,,
2,2,,172123-76120,, "CONNECTOR PF1/4",1,1,,,,,,,,,,,,,
3,2,,172123-76120,, "CONNECTOR PF1/4",1,1,,,,,,,,,,,,,
4,2,,172123-76120,, "CONNECTOR PF1/4",1,1,,,,,,,,,,,,,
5,2,,172123-76120,, "CONNECTOR PF1/4",1,1,,,,,,,,,,,,,
6,2,,172123-76120,, "CONNECTOR PF1/4",1,1,,,,,,,,,,,,,
7,2,,172141-76180,, "CONNECTOR",1,1,,,,,,,,,,,,,
8,3,,24315-000110,, "O-RING 1B P-11.0",1,1,,,,,,,,,,,,,
9,2,,172141-76220,, "NIPPLE",1,1,,,,,,,,,,,,,
10,2,,172165-76280,, "CONNECTOR PF1/2-3/8",2,2,,,,,,,,,,,,,
11,2,,24315-000110,, "O-RING 1B P-11.0",5,5,,,,,,,,,,,,,
12,2,,172164-78441,, "HOSE",1,1,,,,,,,,,,,,,
13,2,,172165-78510,, "HOSE",1,1,,,,,,,,,,,,,
14,2,,172164-79100,, "HOSE G604BB130 J",1,1,,,,,,,,,,,,,
15,2,,172164-78860,, "HOSE G604BB060S",1,1,,,,,,,,,,,,,
16,2,,172162-78941,, "HOSE A G504BC039S",1,1,,,,,,,,,,,,,
17,2,,24315-000180,, "O-RING 1B P-18.0",2,2,,,,,,,,,,,,,
18,2,,172168-79140,, "HOSE G604BC070 E",1,1,,,,,,,,,,,,,
19,2,,23010-014000,, "CLAMP 14",1,1,,,,,,,,,,,,,
20,2,,172164-76700,, "T-JOINT 1/4",1,1,,,,,,,,,,,,,
21,3,,24315-000110,, "O-RING 1B P-11.0",1,1,,,,,,,,,,,,,
22,2,,172151-76080,, "CONNECTOR",1,1,,,,,,,,,,,,,
23,3,,24315-000110,, "O-RING 1B P-11.0",1,1,,,,,,,,,,,,,
24,2,,23393-020000,, "JOINT 90RGI1/4",1,1,,,,,,,,,,,,,
25,2,,172137-76100,, "ELBOW PF1/4",1,1,,,,,,,,,,,,,
26,3,,24315-000110,, "O-RING 1B P-11.0",1,1,,,,,,,,,,,,,
27,2,,172162-76320,, "CONNECTOR 3-1/4",1,1,,,,,,,,,,,,,
28,1,,194202-56460,, "BAND",1,1,,,,,,,,,,,,,

Fig. 74 油圧配管 (PTOバルブ、フレーム) (新形) HYD. OIL PIPING (P. T. O. VALVE, FRAME) (NEW)

M/#01328~

PTOキット (合流)
P. T. O. KIT (CONFLUEGE)
(172176-74551)
Fig. 63 REF. No. 1-2
inc. Fig. 63 REF. No. 2~20
Fig. 74 REF. No. 1~27

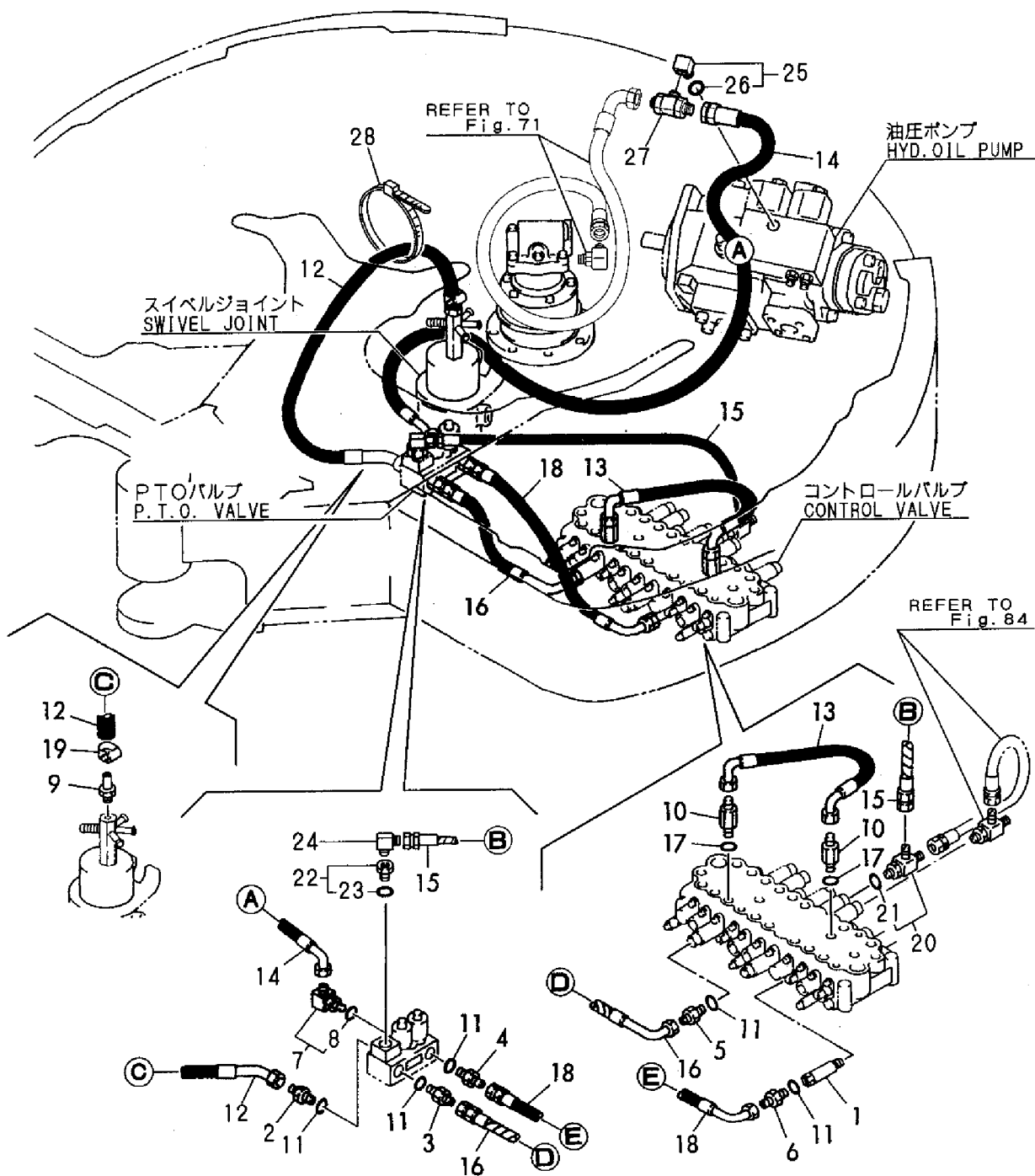

1,1,,172730-75140,,ADAPTOR,2,2,,,,,,,,,,,,,
2,1,,172112-77360,, "CONNECTOR PF1/2PF1/2",4,4,,,,,,,,,,,,,
3,1,,23391-040000,, "JOINT RGI 1/2",4,4,,,,,,,,,,,,,
4,1,,23394-020000,, "JOINT 45RGI1/4",2,2,,,,,,,,,,,,,
5,1,,24315-000180,, "O-RING 1B P-18.0",4,4,,,,,,,,,,,,,
6,1,,23391-030000,, "JOINT RGI 3/8",2,2,,,,,,,,,,,,,
7,1,,933152-24410,, "CONNECTOR (A)",2,2,,,,,,,,,,,,,
8,1,,24315-000140,, "O-RING 1B P-14.0",2,2,,,,,,,,,,,,,
9,1,,172165-78310,,HOSE,2,2,,,,,,,,,,,,,
10,1,,172165-78180,,PLATE,2,2,,,,,Z,,,M/#00832,,M/#00832,,,,,,
11,1,,22217-100000,, "SPRING WASHER 10",2,2,,,,,Z,,,M/#00832,,M/#00832,,,,,,
12,1,,26116-100162,, "BOLT M10X 16 PLATED",2,2,,,,,Z,,,M/#00832,,M/#00832,,,,,,
13,1,,172124-78321,, "HOSE G706BB140W",2,2,,,,,,,,,,,,,
14,1,,172158-78100,,HOSE,4,4,,,,,,,,,,,,,
15,1,,172158-78110,,HOSE,2,2,,,,,,,,,,,,,
16,1,,172165-78480,, "HOSE P206AB066W",2,2,,,,,,,,,,,,,
17,1,,172147-76260,,CONNECTOR,2,2,,,,,,,,,,,,,

1,1,,172112-76321-4,, "RETAINER (GREEN)",3,3,,,,,,,,,,,,,
1-1,1,,172176-76260,,CLAMP,3,3,,,,,S,,,M/#01074,,M/#01074,,,,,
2,1,,172165-76510-4,, "TUBE(A), ARM (GREEN)",1,1,,,,,,,,,,,,,
2-1,1,,172165-76511-4,, "TUBE(A), ARM
(GREEN)",1,1,,,,,S,2,,M/#01074,,M/#01074,,,,,
3,1,,172151-76460-4,, "TUBE(B), ARM (GREEN)",1,1,,,,,,,,,,,,,
4,1,,172165-76400-4,, "TUBE(A),BUCKET(GREEN)",1,1,,,,,,,,,,,,,
4-1,1,,172176-76440,, "TUBE(A), BUCKET",1,1,,,,,S,,,M/#00832,,M/#00832,,,,,
5,1,,172165-76420-4,, "TUBE(B),BUCKET(GREEN)",1,1,,,,,,,,,,,,,
5-1,1,,172176-76420,, "TUBE(B), BUCKET",1,1,,,,,S,,,M/#00832,,M/#00832,,,,,
6,1,,172165-76530-4,, "CLAMP, TUBE (GREEN)",1,1,,,,,,,,,,,,,
7,1,,172165-76540,, "RUBBER CLAMP, TUBE",2,2,,,,,,,,,,,,,
8,1,,172147-76750-4,, "CLAMP, TUBE(A)(GREEN)",1,1,,,,,,,,,,,,,
9,1,,172147-76760-4,, "CLAMP,TUBE(B)(GREEN)",1,1,,,,,,,,,,,,,
10,1,,172147-76770,, "CLAMP, RUBBER",2,2,,,,,,,,,,,,,
11,1,,172147-76780,, "CLAMP, RUBBER",2,2,,,,,,,,,,,,,
12,1,,172151-76400-4,, "TUBE, BOOM (GREEN)",1,1,,,,,,,,,,,,,
13,1,,172151-76420-4,, "TUBE, BOOM (GREEN)",1,1,,,,,,,,,,,,,
14,1,,172112-81720,, "CUSION RUBBER,PIPE",1,1,,,,,,,,,,,,,
15,1,,22217-080000,, "SPRING WASHER 8",6,6,,,,,Z,,,M/#01074,,M/#01074,,,,,
16,1,,22217-100000,, "SPRING WASHER 10",3,3,,,,,,,,,,,,,
17,1,,26116-100602,, "BOLT M10X 60 PLATED",3,3,,,,,,,,,,,,,
18,1,,26716-080002,, "NUT M 8",6,6,,,,,Z,,,M/#01074,,M/#01074,,,,,
19,1,,933155-09670-4,, "CLAMP, PIPE (GREEN)",1,1,,,,,,,,,,,,,
20,1,,172310-51290,, "SEAT, CLAMP",1,1,,,,,,,,,,,,,
21,1,,26013-100452,, "BOLT M10X 45",1,1,,,,,,,,,,,,,
22,1,,172124-78400,, "HOSE G208AB100W",2,2,,,,,,,,,,,,,
22-1,1,,172176-78270,, "HOSE G208AB087W",2,2,,,,,S,,,M/#00832,,M/#00832,,,,,
23,1,,23202-040801,, "PIPE 04X80",1,1,,,,,,,,,,,,,
24,1,,23202-040901,,HOSE,1,1,,,,,,,,,,,,,
25,1,,172176-78260,,HOSE,1,1,,,,,,,,,,,,,
26,1,,26116-100552,, "BOLT M10X 55 PLATED",3,3,,,,,,,,,,,,,
27,1,,22217-100000,, "SPRING WASHER 10",3,3,,,,,,,,,,,,,
28,1,,23202-040701,, "PIPE, HICH-PRESS.",1,1,,,,,,,,,,,,,
29,1,,172176-78400,, "HOSE G208AB110W",2,2,,,,,1,,,,,,,,,,,,,
29-1,1,,172176-78280,,HOSE,2,2,,,,,S,1,,M/#00832,,M/#00832,,,,,
30,1,,26013-120352,, "BOLT M12X 35",3,3,,,,,W,,,M/#01074,,M/#01074,,,,,
31,1,,172183-81160,, "TREE CLIP",2,2,,,,,W,,,M/#01043,,M/#01043,,,,,
32,1,,172151-79410,,HOSE,2,2,,,,,3,,,,,,,,,,,,,
33,1,,23000-035000,, "CLAMP 35",8,8,,,,,3,,,,,,,,,,,,,
34,1,,172142-78800,, "COVER 20-700, HOSE",2,2,,,,,3,,,,,,,,,,,,,

Fig. 76 油圧配管 (ブーム) HYD. OIL PIPING (BOOM)

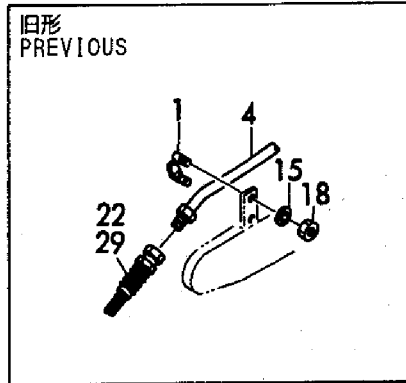
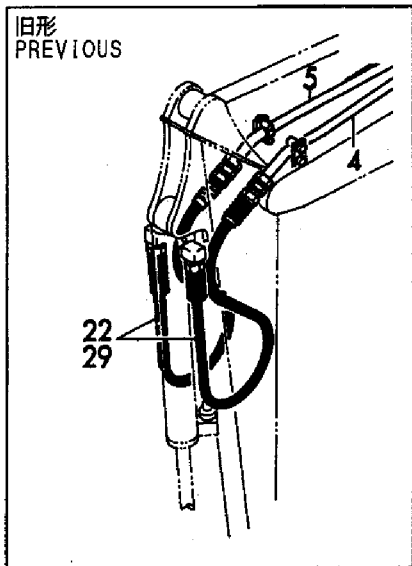
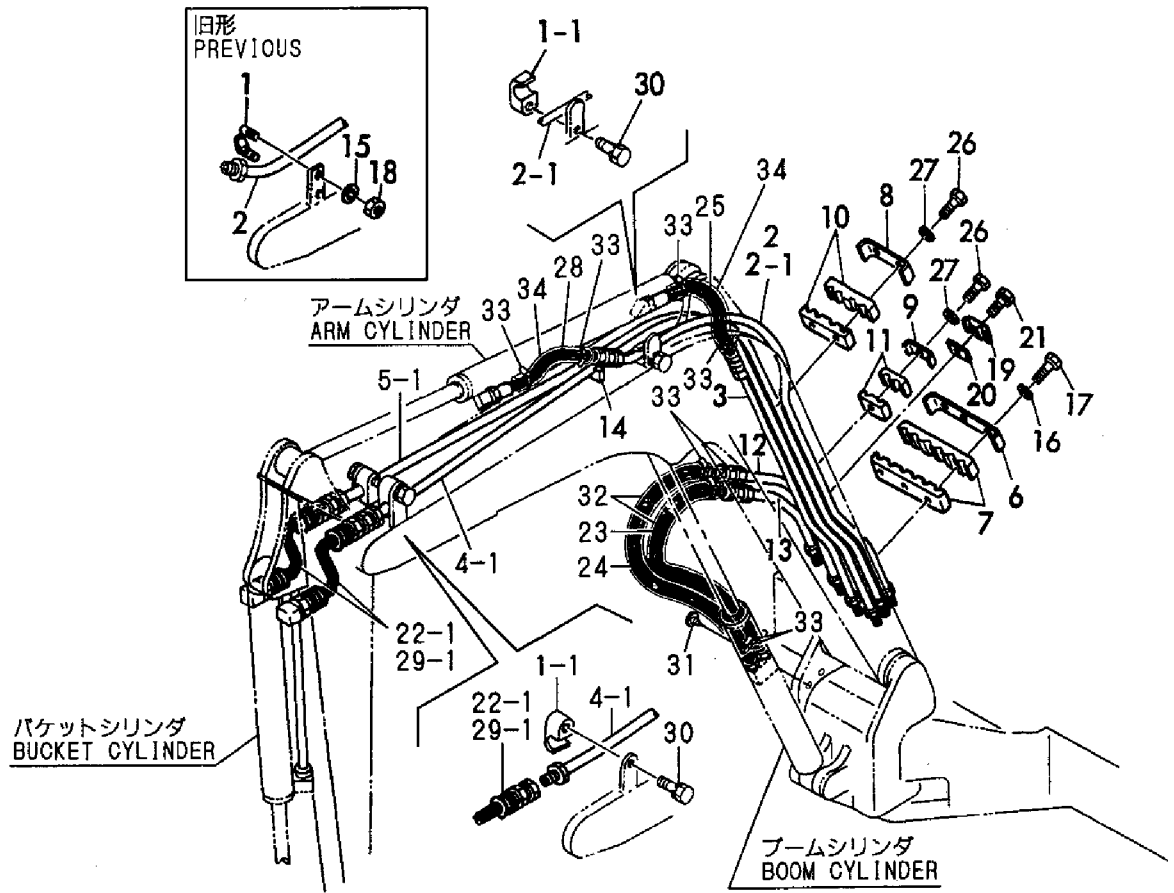

1,1,,172176-74510,, "P.T.O.KIT, ARM END",1,1,,,,,,,,,,,,,
1-1,1,,172176-74511,, "P.T.O.KIT, ARM END",1,1,,,,,S,,M/#01074,,M/#01074,,,,,
2,2,,172176-76520,, "TUBE(A) ASSY, 3RD",1,1,,,,,,,,,,,,,
2-1,2,,172176-76521,, "TUBE A ASSY,P.T.O.",1,1,,,,,N,,M/#00832,,M/#00832,,,,,
2-2,2,,172176-76522,, "TUBE A ASSY,P.T.O.",1,1,,,,,S,,M/#01074,,M/#01074,,,,,
3,2,,172176-76540,, "TUBE(B) ASSY, 3RD",1,1,,,,,,,,,,,,,
3-1,2,,172176-76541,, "TUBE B ASSY,P.T.O.",1,1,,,,,N,,M/#00832,,M/#00832,,,,,
3-2,2,,172176-76542,, "TUBE B ASSY,P.T.O.",1,1,,,,,S,,M/#01074,,M/#01074,,,,,
4,2,,172176-76560,, "TUBE C ASSY,P.T.O.",2,2,,,,,Z,,M/#01074,,M/#01074,,,,,
5,2,,172176-76870,, "JOINT PT 3/4",2,2,,,,,Z,,M/#01074,,M/#01074,,,,,
6,2,,172142-76940-4,, "CLAMP 3/4 (GREEN:97)",10,10,,,,,,,,,,,,,
6-1,2,,172142-76940-4,, "CLAMP 3/4
(GREEN:97)",6,6,,,,,K,,M/#01074,,M/#01074,,,,,
7,2,,172151-76650,, "VALVE SV-20,STOP",2,2,,,,,,,,,,,,,
7-1,2,,172151-76651,, "STOP VALVE",2,2,,,,,R,,M/#00832,,M/#00832,,,,,
7-2,2,,172176-76580,, "STOP VALVE(GREEN:97)",2,2,,,,,S,,M/#01074,,M/#01074,,,,,
8,3,,172151-76660,, "BODY,VALVE",2,2,,,,,Z,,M/#00832,,M/#00832,,,,,
9,3,,172151-76670,, "RING,BACKUP",2,2,,,,,Z,,M/#00832,,M/#00832,,,,,
10,3,,172151-76680,, "VALVE",2,2,,,,,Z,,M/#00832,,M/#00832,,,,,
11,3,,172151-76690,, "RING,BACKUP",2,2,,,,,Z,,M/#00832,,M/#00832,,,,,
12,3,,22242-000300,, "CIRCLIP 30",2,2,,,,,,,,,,,,,
13,3,,22351-050012,, "PIN 5X12,SPRING",2,2,,,,,Z,,M/#00832,,M/#00832,,,,,
14,3,,24325-000250,, "O-RING 1B G-25.0",4,4,,,,,Z,,M/#00832,,M/#00832,,,,,
15,3,,24325-000300,, "O-RING 1B G-30.0",2,2,,,,,Z,,M/#00832,,M/#00832,,,,,
15A,3,,172142-77150,, "SEAL SET",2,2,,,,,W,,M/#00832,,M/#00832,,,,,
16,2,,22217-120000,, "SPRING WASHER",10,10,,,,,,,,,,,,,
16-1,2,,22217-120000,, "SPRING WASHER",6,6,,,,,K,,M/#01074,,M/#01074,,,,,
17,2,,23871-060000,, "PLUG PT3/4,SCREW",2,2,,,,,,,,,,,,,
18,2,,26116-120552,, "BOLT M12X 55 PLATED",9,9,,,,,,,,,,,,,
18-1,2,,26116-120752,, "BOLT M12X 75 PLATED",2,2,,,,,S,,M/#01074,,M/#01074,,,,,
19,2,,172164-78870,, "HOSE",2,2,,,,,,,,,,,,,
20,2,,172164-78880,, "HOSE",2,2,,,,,,,,,,,,,
20-1,2,,172176-78571,, "HOSE",2,2,,,,,S,,M/#01074,,M/#01074,,,,,
21,2,,172141-81560,, "STAY C(M12,3RD VALVE",1,1,,,,,Z,,M/#01074,,M/#01074,,,,,
22,2,,172164-81730,, "BOSS A",2,2,,,,,Z,,M/#01074,,M/#01074,,,,,
23,2,,172142-81520,, "STAY(D), PIPING",1,1,,,,,Z,,M/#01074,,M/#01074,,,,,
24,2,,172164-81740,, "BOSS B",2,2,,,,,Z,,M/#01074,,M/#01074,,,,,
25,2,,172141-81560,, "STAY C(M12,3RD VALVE",4,4,,,,,Z,,M/#01074,,M/#01074,,,,,
26,2,,26116-120902,, "BOLT M12X 90 PLATED",1,1,,,,,,,,,,,,,
27,2,,172151-76790,, "PLATE, CLAMP",1,1,,,,,,,,,,,,,
28,2,,26013-100252,, "BOLT W/WASHER M10X25",4,4,,,,,W,,M/#01074,,M/#01074,,,,,
29,2,,26116-120552,, "BOLT M12X 55 PLATED",1,1,,,,,W,,M/#01074,,M/#01074,,,,,
30,2,,26116-120652,, "BOLT M12X 65 PLATED",2,2,,,,,W,,M/#01074,,M/#01074,,,,,
31,2,,172164-76660,, "PLATE",1,1,,,,,W,,M/#01074,,M/#01074,,,,,
32,1,,172176-78570,, "HOSE G212BC 100W",2,2,,,,,Z,1,M/#01074,,M/#01074,,,,,
33,1,,172137-79950,, "COVER",2,2,,,,,2,,,,,,,,,,,,,
34,1,,23000-041000,, "CLAMP 41",4,4,,,,,2,,,,,,,,,,,,,
35,1,,172151-76600,, "ADAPTER PF3/4,BLIND",2,2,,,,,2,,,,,,,,,,,,,

Fig. 77 油圧配管 (PTOバルブ、ブーム)
 HYD. OIL PIPING (P. T. O. VALVE, BOOM)

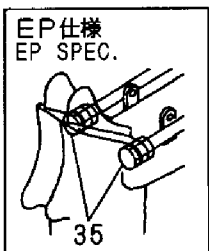
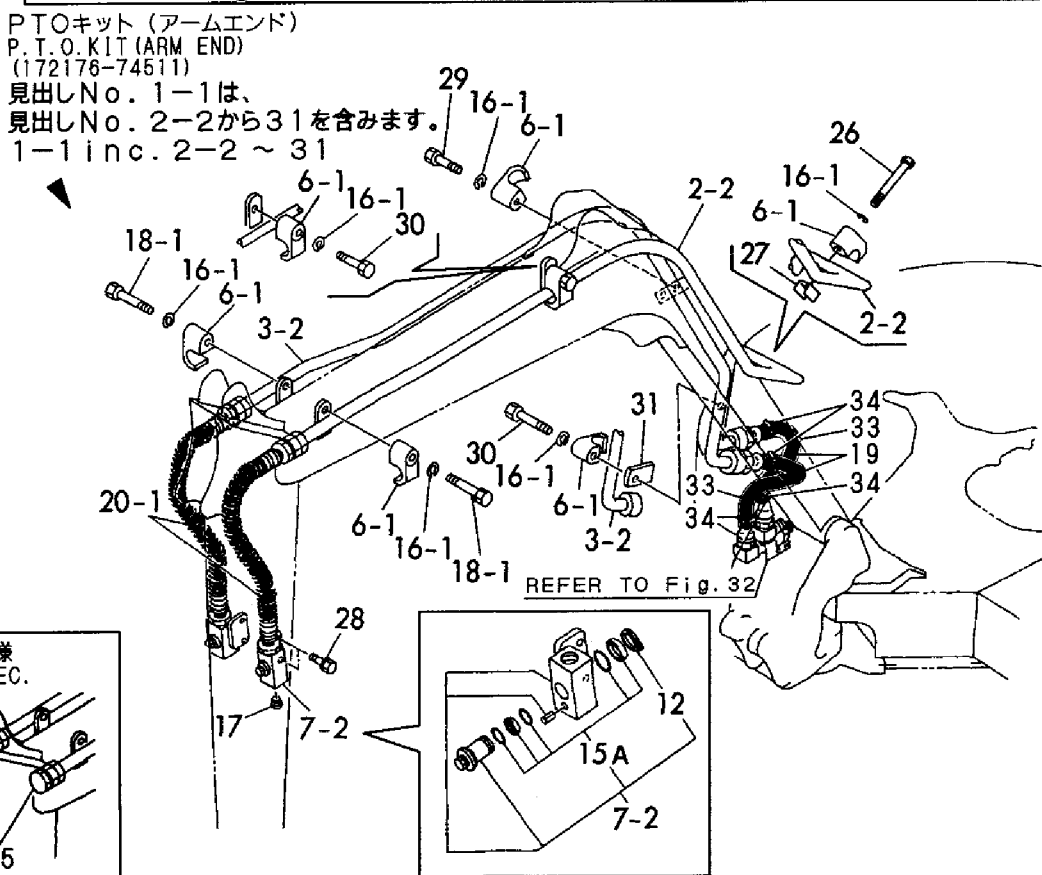
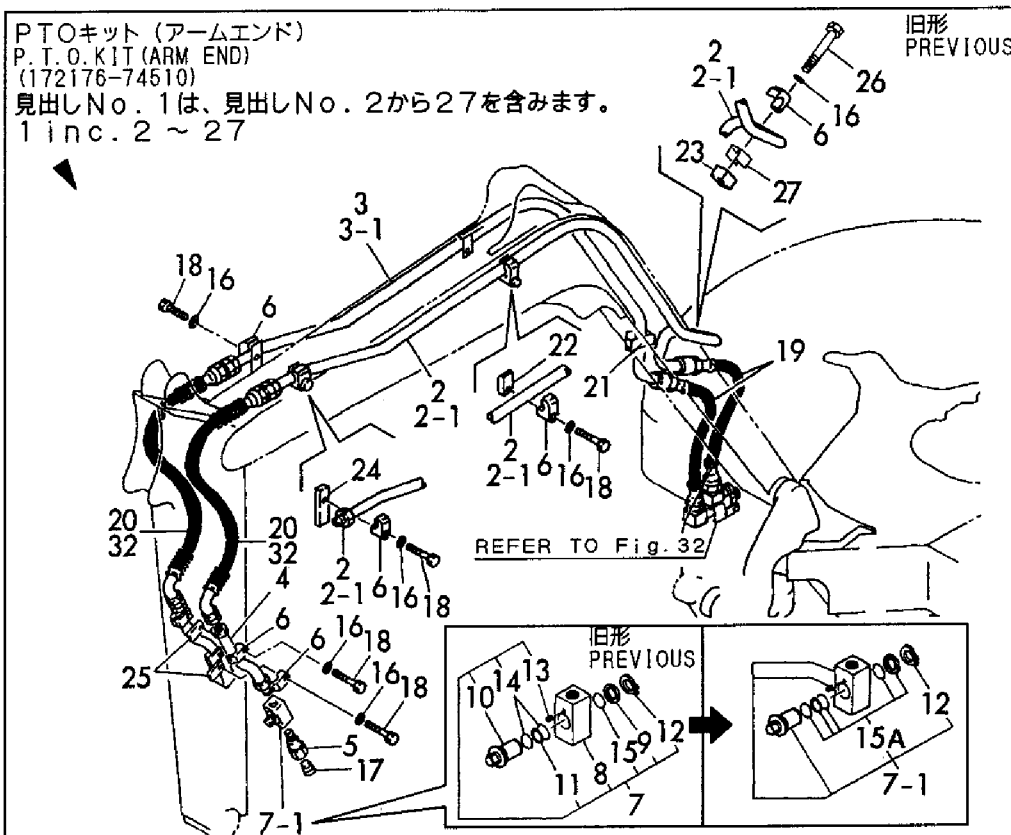

1,1,,172151-76030,, "BOLT, PIPE JOINT",2,2,,,,,,,,,,,,,,,,,
2,1,,172123-76120,, "CONNECTOR PF1/4",8,8,,,,,,,,,,,,,,,,,
3,1,,172151-76040,, "BOLT, PIPE JOINT",2,2,,,,,,,,,,,,,,,,,
4,1,,172165-78670,, HOSE,1,1,,,,,,,,,,,,,,,,,
5,1,,172165-79290,, HOSE,1,1,,,,,,,,,,,,,,,,,
6,1,,172165-79300,, HOSE,1,1,,,,,,,,,,,,,,,,,
7,1,,172165-79310,, HOSE,1,1,,,,,,,,,,,,,,,,,
8,1,,172164-78500,, "HOSE G604CW200S P",1,1,,,,,,,,,,,,,,,,,
9,1,,172164-78520,, "HOSE G604BY115S T",1,1,,,,,,,,,,,,,,,,,
10,1,,172165-79340,, HOSE,1,1,,,,,,,,,,,,,,,,,
11,1,,172165-79350,, HOSE,1,1,,,,,,,,,,,,,,,,,
12,1,,172165-79360,, HOSE,1,1,,,,,,,,,,,,,,,,,
13,1,,172165-79370,, HOSE,1,1,,,,,,,,,,,,,,,,,
14,1,,172164-78510,, "HOSE G604CW140S P",1,1,,,,,,,,,,,,,,,,,
15,1,,172164-78530,, "HOSE G604BY185S T",1,1,,,,,,,,,,,,,,,,,
16,1,,24315-000180,, "O-RING 1B P-18.0",8,8,,,,,,,,,,,,,,,,,
17,1,,24315-000110,, "O-RING 1B P-11.0",8,8,,,,,,,,,,,,,,,,,
18,1,,172123-76120,, "CONNECTOR PF1/4",4,4,,,,,,,,,,,,,,,,,
19,1,,24315-000110,, "O-RING 1B P-11.0",9,9,,,,,,,,,,,,,,,,,
20,1,,23393-020000,, "JOINT 90RGI1/4",1,1,,,,,,,,,,,,,,,,,
21,1,,172165-76290,, "CONNECTOR PF1/4-1/4",1,1,,,,,,,,,,,,,,,,,
21A,2,,24315-000110,, "O-RING 1B P-11.0",1,1,,,,,,,,,,,,,,,,,
22,1,,172162-76770,, "JOINT PF1/4",5,5,,,,,,,,,,,,,,,,,
23,1,,172165-79810,, SPONGE,2,2,,,,,,,,,,,,,,,,,
24,1,,172122-79930,, CLAMP,6,6,,,,,,,,,,,,,,,,,
25,1,,172122-79930,, CLAMP,1,1,,,,,,,,,,,,,,,,,
26,1,,172164-79940,, COVER,1,1,,,,,,,,,,,,,,,,,
27,1,,23010-014000,, "CLAMP 14",2,2,,,,,,,,,,,,,,,,,
28,1,,172176-76100,, "BRACKET ASSY",1,1,,,,,,,,,,,,,,,,,
29,1,,172168-79100,, "HOSE G604BC030 A",2,2,,,,,,,,,,,,,,,,,
30,1,,23391-020000,, "JOINT RGI1/4",2,2,,,,,,,,,,,,,,,,,
31,1,,23871-010000,, "PLUG PT1/8, SCREW",1,1,,,,,,,,,,,,,,,,,
32,1,,26013-100202,, "BOLT W/WASHER M10X20",2,2,,,,,,,,,,,,,,,,,

Fig. 78 コントロール配管 (ダイレクト) (旧形)
CONTROL PIPING (DIRECT) (PREVIOUS)

~M/#00869

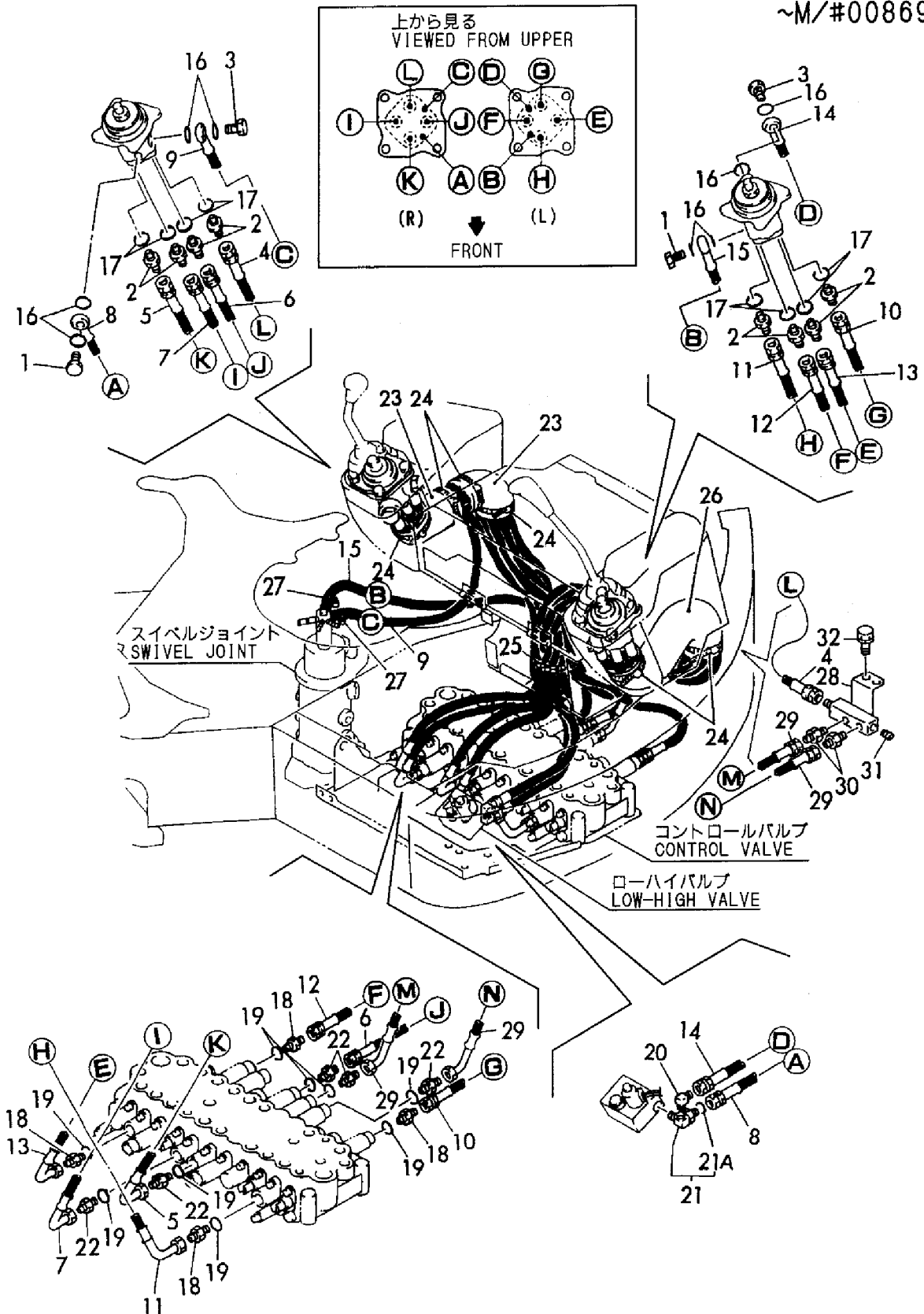

1,1,,172151-76030,, "BOLT, PIPE JOINT",2,2,,,,,,,,,,,,,,,,,,,,,
2,1,,172123-76120,, "CONNECTOR PF1/4",8,8,,,,,,,,,,,,,,,,,,,,,
3,1,,172151-76040,, "BOLT, PIPE JOINT",2,2,,,,,,,,,,,,,,,,,,,,,
4,1,,172165-78670,, HOSE,1,1,,,,,,,,,,,,,,,,,,,,,
5,1,,172165-79290,, HOSE,1,1,,,,,,,,,,,,,,,,,,,,,
6,1,,172165-79300,, HOSE,1,1,,,,,,,,,,,,,,,,,,,,,
7,1,,172165-79310,, HOSE,1,1,,,,,,,,,,,,,,,,,,,,,
8,1,,24315-000110,, "O-RING 1B P-11.0",6,6,,,,,,,,,,,,,,,,,,,,,
9,1,,172164-78520,, "HOSE G604BY115S T",1,1,,,,,,,,,,,,,,,,,,,,,
10,1,,172165-79340,, HOSE,1,1,,,,,,,,,,,,,,,,,,,,,
11,1,,172165-79350,, HOSE,1,1,,,,,,,,,,,,,,,,,,,,,
12,1,,172165-79360,, HOSE,1,1,,,,,,,,,,,,,,,,,,,,,
13,1,,172165-79370,, HOSE,1,1,,,,,,,,,,,,,,,,,,,,,
14,1,,172164-78510,, "HOSE G604CW140S P",2,2,,,,,,,,,,,,,,,,,,,,,
15,1,,172164-78530,, "HOSE G604BY185S T",1,1,,,,,,,,,,,,,,,,,,,,,
16,1,,24315-000180,, "O-RING 1B P-18.0",8,8,,,,,,,,,,,,,,,,,,,,,
17,1,,24315-000110,, "O-RING 1B P-11.0",8,8,,,,,,,,,,,,,,,,,,,,,
18,1,,172123-76120,, "CONNECTOR PF1/4",2,2,,,,,,,,,,,,,,,,,,,,,
19,1,,172162-76770,, "JOINT PF1/4",4,4,,,,,,,,,,,,,,,,,,,,,
20,1,,172165-79810,, SPONGE,2,2,,,,,,,,,,,,,,,,,,,,,
21,1,,172122-79930,, CLAMP,6,6,,,,,,,,,,,,,,,,,,,,,
22,1,,172122-79930,, CLAMP,1,1,,,,,,,,,,,,,,,,,,,,,
23,1,,172164-79940,, COVER,1,1,,,,,,,,,,,,,,,,,,,,,
24,1,,23010-014000,, "CLAMP 14",2,2,,,,,,,,,,,,,,,,,,,,,
25,1,,172168-79100,, "HOSE G604BC030 A",1,1,,,,,,,,,,,,,,,,,,,,,
26,1,,172164-76700,, "T-JOINT 1/4",1,1,,,,,,,,,,,,,,,,,,,,,
27,2,,24315-000110,, "O-RING 1B P-11.0",1,1,,,,,,,,,,,,,,,,,,,,,
28,1,,172964-78111,, "VALVE, CHECK",2,2,,,,,,,,,,,,,,,,,,,,,
29,1,,172122-17190,, CLIP,2,2,,,,,,,,,,,,,,,,,,,,,

Fig. 79 コントロール配管 (ダイレクト) (新形) CONTROL PIPING (DIRECT) (NEW)

M/#00870~

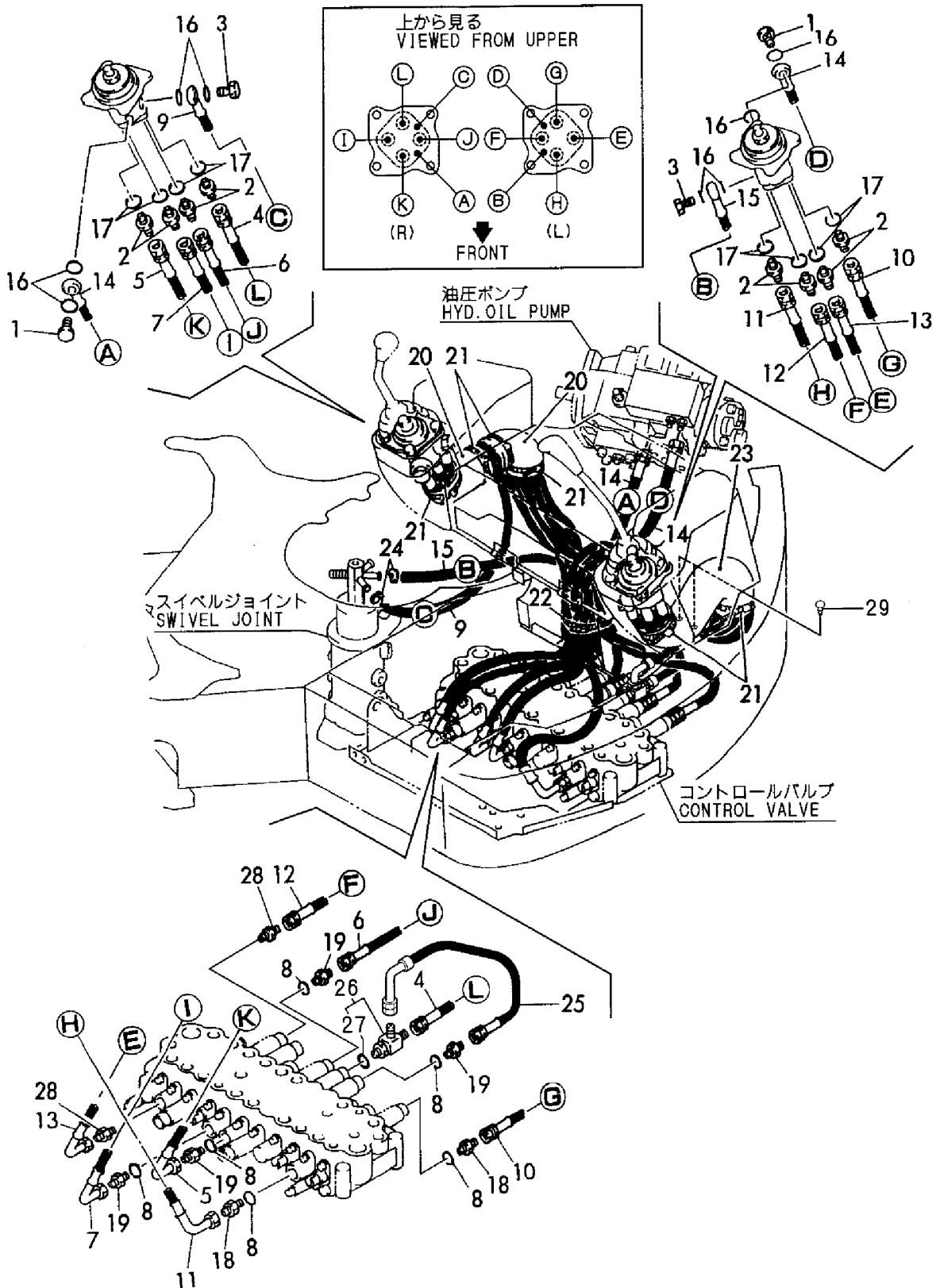

1,2,,172126-11510,, "BAND 300",2,2,,,,,,,,,,,,,,,,,,,,,
2,2,,172173-79300,, "HOSE G604BB057",1,1,,,,,,,,,,,,,,,,,,,,,
3,2,,172164-79400,, HOSE,1,1,,,,,,,,,,,,,,,,,,,,,
4,2,,172164-79410,, HOSE,1,1,,,,,,,,,,,,,,,,,,,,,
5,2,,172164-79420,, HOSE,1,1,,,,,,,,,,,,,,,,,,,,,
6,2,,172164-79430,, HOSE,1,1,,,,,,,,,,,,,,,,,,,,,
7,2,,172164-79440,, HOSE,1,1,,,,,,,,,,,,,,,,,,,,,
8,2,,172164-79450,, HOSE,1,1,,,,,,,,,,,,,,,,,,,,,
9,2,,172164-79460,, HOSE,1,1,,,,,,,,,,,,,,,,,,,,,
10,2,,23391-020000,, "JOINT RGI1/4",8,8,,,,,,,,,,,,,,,,,,,,,
11,1,,172151-76030,, "BOLT, PIPE JOINT",2,2,,,,,,,,,,,,,,,,,,,,,
12,1,,172151-76040,, "BOLT, PIPE JOINT",2,2,,,,,,,,,,,,,,,,,,,,,
13,1,,172123-76120,, "CONNECTOR PF1/4",2,2,,,,,,,,,,,,,,,,,,,,,
14,1,,172123-76120,, "CONNECTOR PF1/4",8,8,,,,,,,,,,,,,,,,,,,,,
15,1,,172164-76700,, "T-JOINT 1/4",1,1,,,,,,,,,,,,,,,,,,,,,
17,2,,24315-000110,, "O-RING 1B P-11.0",1,1,,,,,,,,,,,,,,,,,,,,,
18,1,,172162-76770,, "JOINT PF1/4",4,4,,,,,,,,,,,,,,,,,,,,,
19,1,,172964-78111,, "VALVE, CHECK",2,2,,,,,,,,,,,,,,,,,,,,,
20,1,,172164-78510,, "HOSE G604CW140S P",2,2,,,,,,,,,,,,,,,,,,,,,
21,1,,172164-78520,, "HOSE G604BY115S T",1,1,,,,,,,,,,,,,,,,,,,,,
22,1,,172164-78530,, "HOSE G604BY185S T",1,1,,,,,,,,,,,,,,,,,,,,,
23,1,,172165-78670,, HOSE,1,1,,,,,,,,,,,,,,,,,,,,,
24,1,,172168-79100,, "HOSE G604BC030 A",1,1,,,,,,,,,,,,,,,,,,,,,
25,1,,172165-79290,, HOSE,1,1,,,,,,,,,,,,,,,,,,,,,
26,1,,172165-79300,, HOSE,1,1,,,,,,,,,,,,,,,,,,,,,
27,1,,172165-79310,, HOSE,1,1,,,,,,,,,,,,,,,,,,,,,
28,1,,172165-79810,, SPONGE,2,2,,,,,,,,,,,,,,,,,,,,,
29,1,,172122-79930,, CLAMP,6,6,,,,,,,,,,,,,,,,,,,,,
30,1,,172122-79930,, CLAMP,1,1,,,,,,,,,,,,,,,,,,,,,
31,1,,172164-79940,, COVER,1,1,,,,,,,,,,,,,,,,,,,,,
32,1,,24315-000110,, "O-RING 1B P-11.0",8,8,,,,,,,,,,,,,,,,,,,,,
33,1,,24315-000110,, "O-RING 1B P-11.0",6,6,,,,,,,,,,,,,,,,,,,,,
34,1,,24315-000180,, "O-RING 1B P-18.0",8,8,,,,,,,,,,,,,,,,,,,,,
35,1,,23010-014000,, "CLAMP 14",2,2,,,,,,,,,,,,,,,,,,,,,
36,1,,172122-17190,, CLIP,2,2,,,,,,,,,,,,,,,,,,,,,

Fig. 80 **コントロール配管 (2ウェイバルブ~コントロールバルブ~リモコンバルブ)**
CONTROL PIPING (2-WAY VALVE ~ CONTROL VALVE
~ REMO.-CON. VALVE)

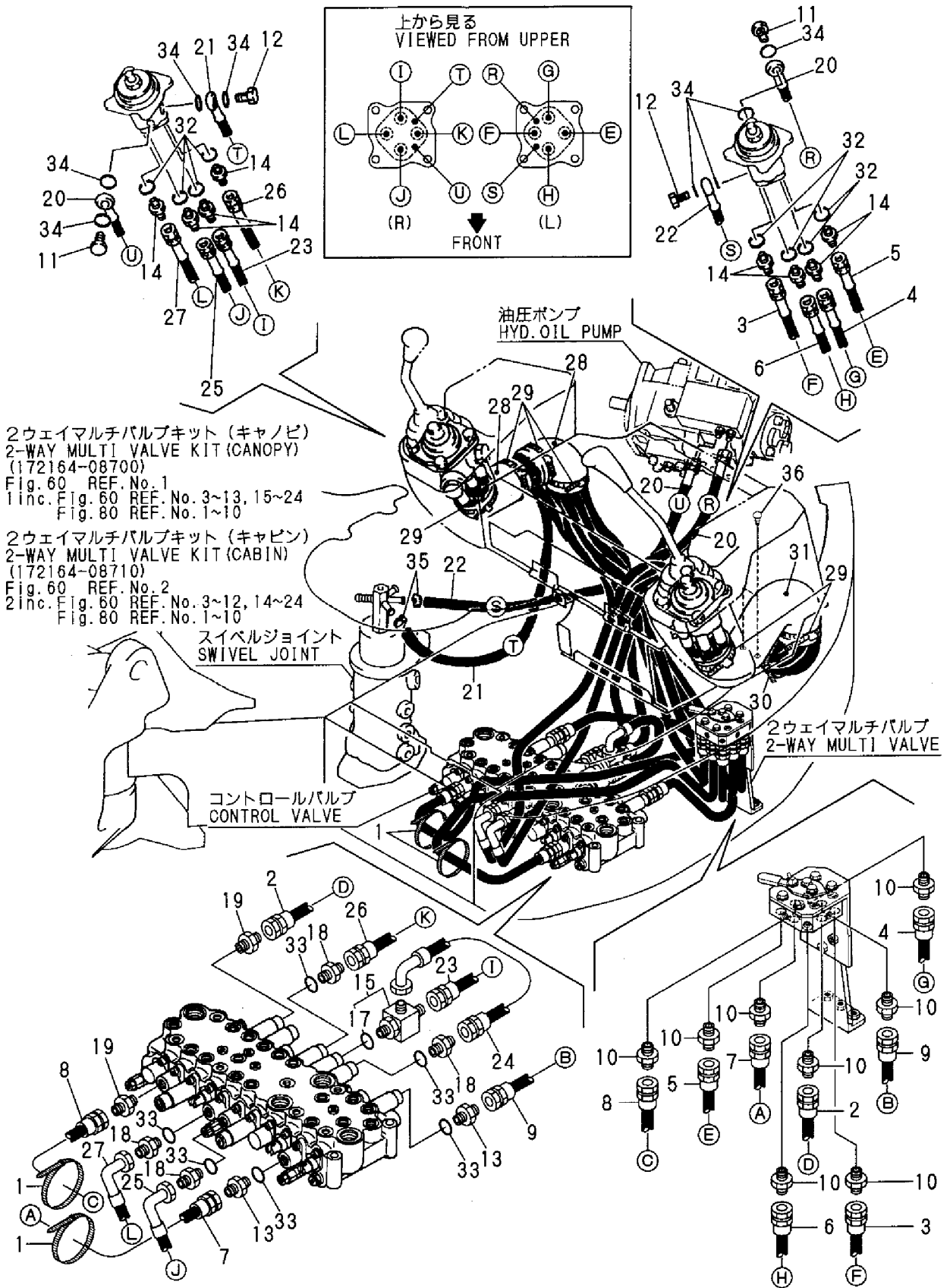

1,2,,172141-76180,,CONNECTOR,8,8,,,,,,,,,,,,,
2,3,,24315-000110,, "O-RING 1B P-11.0",8,8,,,,,,,,,,,,,
3,2,,172164-79100,, "HOSE G604BB130 J",1,1,,,,,,,,,,,,,
4,2,,172164-79130,, "HOSE G604BB100 I",1,1,,,,,,,,,,,,,
5,2,,172164-79120,, "HOSE G604BB100 K",1,1,,,,,,,,,,,,,
6,2,,172164-79110,, "HOSE G604BB100 L",1,1,,,,,,,,,,,,,
7,2,,172165-78900,,HOSE,1,1,,,,,,,,,,,,,
8,2,,172165-78910,,HOSE,1,1,,,,,,,,,,,,,
9,2,,172165-78920,,HOSE,1,1,,,,,,,,,,,,,
10,2,,172165-78930,,HOSE,1,1,,,,,,,,,,,,,
11,1,,24315-000110,, "O-RING 1B P-11.0",8,8,,,,,,,,,,,,,
12,1,,172123-76120,, "CONNECTOR PF1/4",8,8,,,,,,,,,,,,,
13,1,,172164-78520,, "HOSE G604BY115S T",1,1,,,,,,,,,,,,,
14,1,,172164-78500,, "HOSE G604CW200S P",1,1,,,,,,,,,,,,,
15,1,,172164-78530,, "HOSE G604BY185S T",1,1,,,,,,,,,,,,,
16,1,,172151-76030,, "BOLT, PIPE JOINT",2,2,,,,,,,,,,,,,
17,1,,172151-76040,, "BOLT, PIPE JOINT",2,2,,,,,,,,,,,,,
18,1,,24315-000180,, "O-RING 1B P-18.0",8,8,,,,,,,,,,,,,
19,1,,23393-020000,, "JOINT 90RGI1/4",1,1,,,,,,,,,,,,,
20,1,,172165-76290,, "CONNECTOR PF1/4-1/4",1,1,,,,,,,,,,,,,
20A,2,,24315-000110,, "O-RING 1B P-11.0",1,1,,,,,,,,,,,,,
21,1,,172165-79810,, SPONGE,2,2,,,,,,,,,,,,,
22,1,,172122-79930,, CLAMP,6,6,,,,,,,,,,,,,
23,1,,172164-78510,, "HOSE G604CW140S P",1,1,,,,,,,,,,,,,
24,1,,172164-79940,, COVER,1,1,,,,,,,,,,,,,
25,1,,23010-014000,, "CLAMP 14",2,2,,,,,,,,,,,,,
26,1,,172122-79930,, CLAMP,1,1,,,,,,,,,,,,,

Fig. 81 コントロール配管 (リモコンバルブ~ロータリバルブ) (旧形)
CONTROL PIPING (REMOTE CONTROL VALVE
~ ROTARY VALVE) (PREVIOUS)

~M/#00831

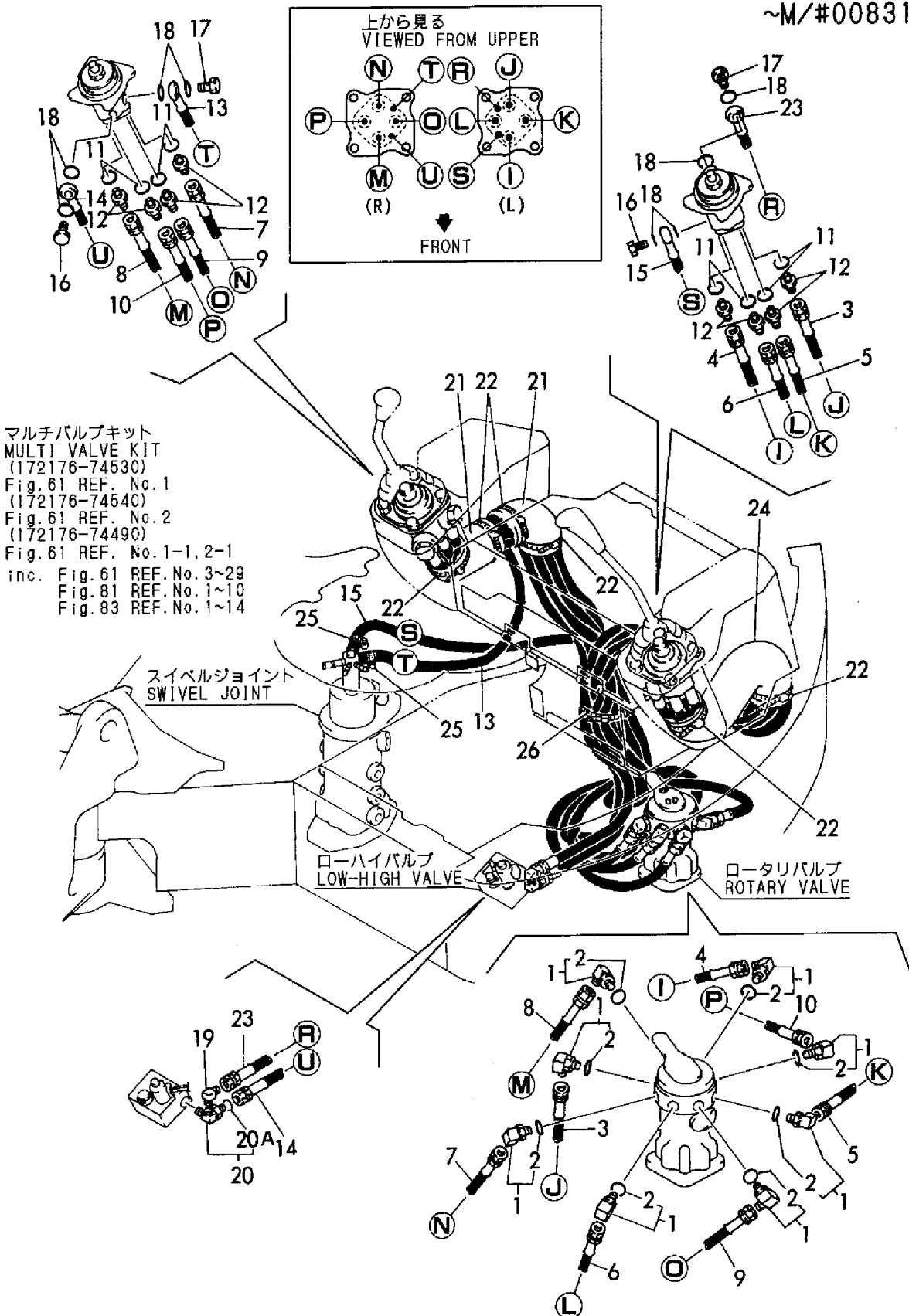

1,2,,172141-76180,,CONNECTOR,8,8,,,,,,,,,,,,,
2,3,,24315-000110,, "O-RING 1B P-11.0",8,8,,,,,,,,,,,,,
3,2,,172164-79100,, "HOSE G604BB130 J",1,1,,,,,,,,,,,,,
4,2,,172164-79130,, "HOSE G604BB100 I",1,1,,,,,,,,,,,,,
5,2,,172164-79120,, "HOSE G604BB100 K",1,1,,,,,,,,,,,,,
6,2,,172164-79110,, "HOSE G604BB100 L",1,1,,,,,,,,,,,,,
7,2,,172165-78900,,HOSE,1,1,,,,,,,,,,,,,
8,2,,172165-78910,,HOSE,1,1,,,,,,,,,,,,,
9,2,,172165-78920,,HOSE,1,1,,,,,,,,,,,,,
10,2,,172165-78930,,HOSE,1,1,,,,,,,,,,,,,
11,1,,24315-000110,, "O-RING 1B P-11.0",8,8,,,,,,,,,,,,,
12,1,,172123-76120,, "CONNECTOR PF1/4",8,8,,,,,,,,,,,,,
13,1,,172164-78520,, "HOSE G604BY115S T",1,1,,,,,,,,,,,,,
14,1,,172164-78530,, "HOSE G604BY185S T",1,1,,,,,,,,,,,,,
15,1,,172151-76030,, "BOLT, PIPE JOINT",2,2,,,,,,,,,,,,,
16,1,,172151-76040,, "BOLT, PIPE JOINT",2,2,,,,,,,,,,,,,
17,1,,24315-000180,, "O-RING 1B P-18.0",8,8,,,,,,,,,,,,,
18,1,,172165-79810,,SPONGE,2,2,,,,,,,,,,,,,
19,1,,172122-79930,,CLAMP,6,6,,,,,,,,,,,,,
20,1,,172164-78510,, "HOSE G604CW140S P",2,2,,,,,,,,,,,,,
21,1,,172164-79940,,COVER,1,1,,,,,,,,,,,,,
22,1,,23010-014000,, "CLAMP 14",2,2,,,,,,,,,,,,,
23,1,,172122-79930,,CLAMP,1,1,,,,,,,,,,,,,
24,1,,172122-17190,,CLIP,2,2,,,,,,,,,,,,,

Fig. 82 コントロール配管 (リモコンバルブ~ロータリバルブ) (新形) CONTROL PIPING (REMOTE CONTROL VALVE ~ ROTARY VALVE) (NEW)

M/#00832~

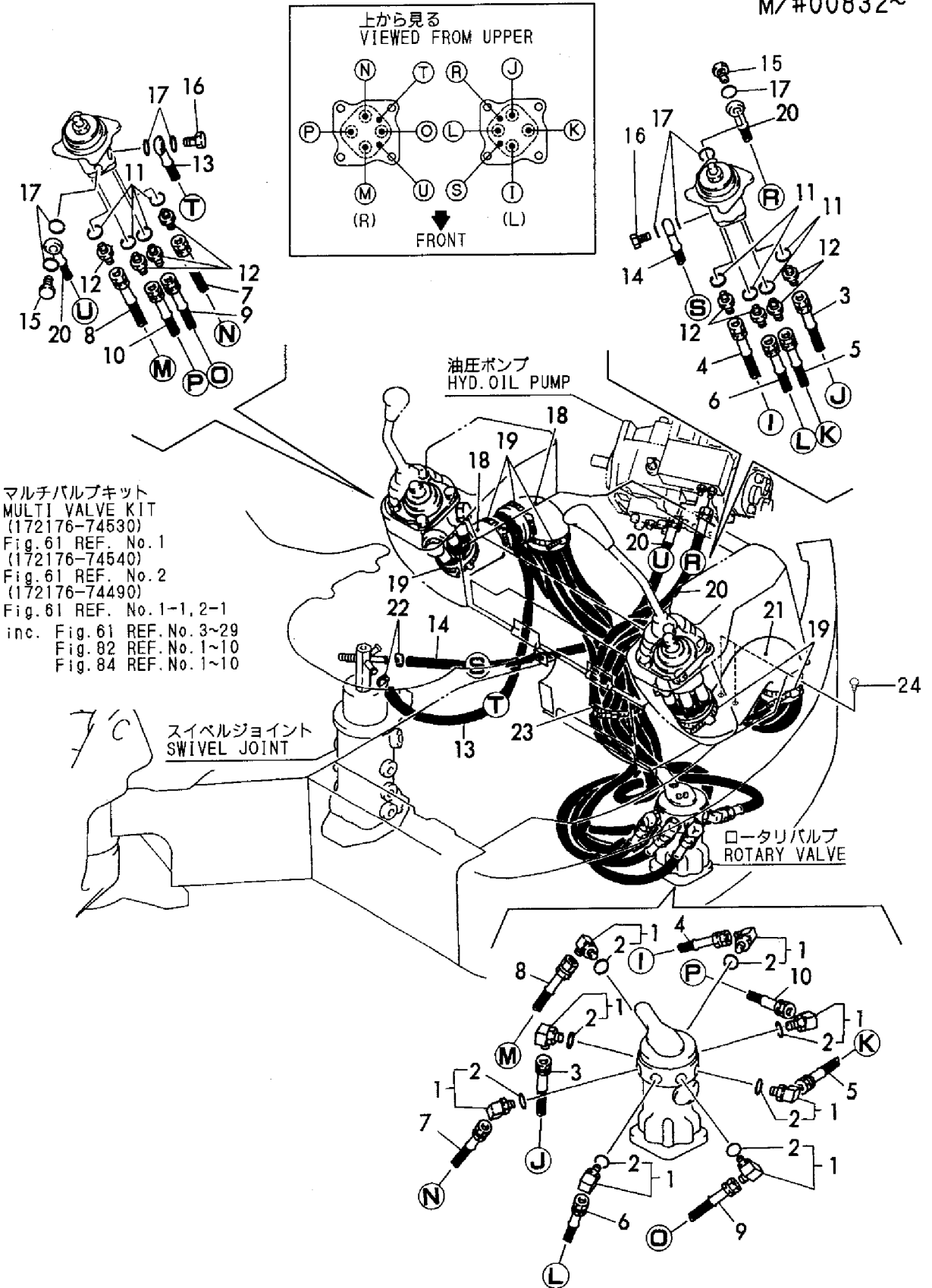

1,2,,172141-76180,,CONNECTOR,7,7,,,,,,,,,,,,,
2,3,,24315-000110,, "O-RING 1B P-11.0",7,7,,,,,,,,,,,,,
3,2,,172164-79200,, "HOSE G604BB055 B",2,2,,,,,,,,,,,,,
4,2,,23393-020000,, "JOINT 90RGI1/4",1,1,,,,,,,,,,,,,
5,2,,172165-78980,,HOSE,1,1,,,,,,,,,,,,,
6,2,,172164-79190,, "HOSE G604BB055 C",1,1,,,,,,,,,,,,,
7,2,,172165-79010,,HOSE,1,1,,,,,,,,,,,,,
8,2,,172164-79210,, "HOSE G604BB055 F",1,1,,,,,,,,,,,,,
9,2,,172165-79030,,HOSE,1,1,,,,,,,,,,,,,
10,2,,172164-79180,, "HOSE G604BB055 H",1,1,,,,,,,,,,,,,
11,2,,172165-79050,,HOSE,1,1,,,,,,,,,,,,,
12,2,,23871-010000,, "PLUG PT1/8,SCREW",1,1,,,,,,,,,,,,,
13,2,,172165-76250,,CONNECTOR,1,1,,,,,,,,,,,,,
14,3,,24315-000110,, "O-RING 1B P-11.0",1,1,,,,,,,,,,,,,
15,1,,172123-76120,, "CONNECTOR PF1/4",9,9,,,,,,,,,,,,,
16,1,,24315-000110,, "O-RING 1B P-11.0",9,9,,,,,,,,,,,,,

Fig. 83 コントロール配管 (ロータリバルブ~コントロールバルブ) (旧形) CONTROL PIPING (ROTARY VALVE ~ CONTROL VALVE) (PREVIOUS)

~M/#00831

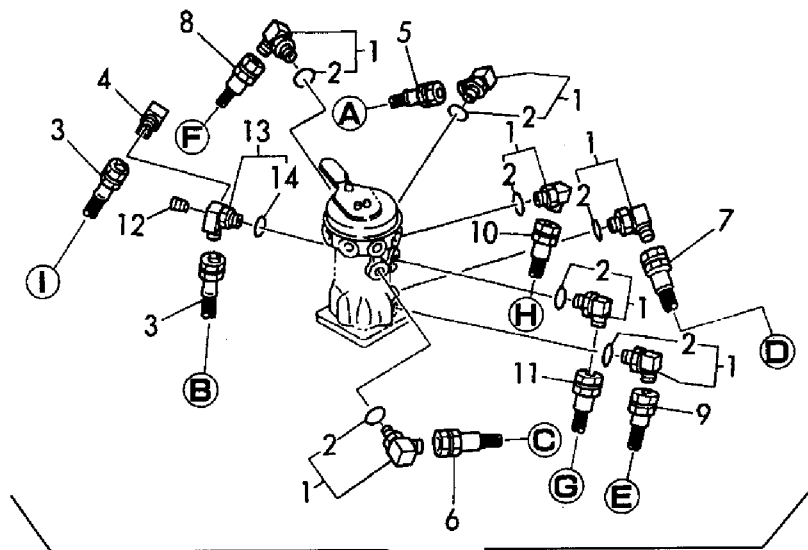

マルチバルブキット
MULTI VALVE KIT
(172176-74530)
Fig. 61 REF. No. 1
(172176-74540)
Fig. 61 REF. No. 2
(172176-74490)
Fig. 61 REF. No. 1-1, 2-1
inc. Fig. 61 REF. No. 3~29
Fig. 81 REF. No. 1~10
Fig. 83 REF. No. 1~14

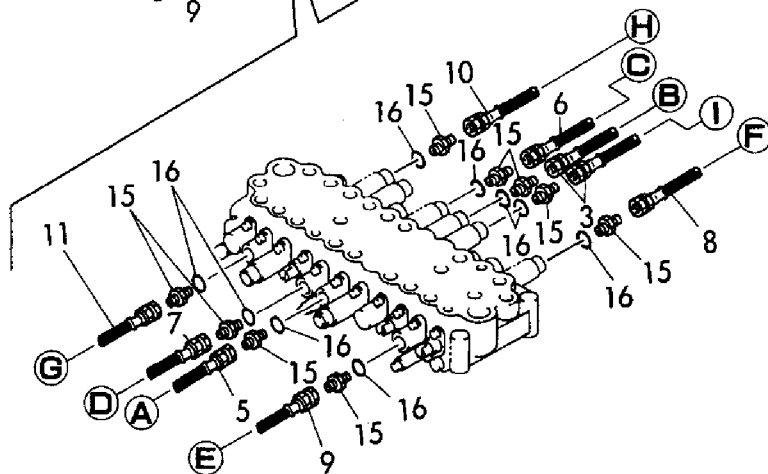
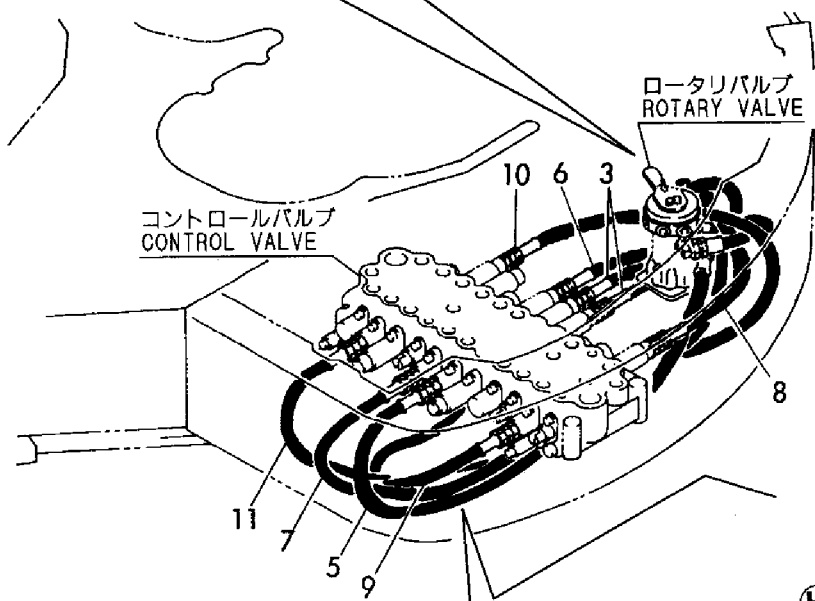

1,2,,172141-76180,,CONNECTOR,8,8,,,,,,,,,,,,,
2,3,,24315-000110,,,"O-RING 1B P-11.0",8,8,,,,,,,,,,,,,
3,2,,172164-79200,,,"HOSE G604BB055 B",1,1,,,,,,,,,,,,,
4,2,,172165-79050,,HOSE,1,1,,,,,,,,,,,,,
5,2,,172165-78980,,HOSE,1,1,,,,,,,,,,,,,
6,2,,172164-79190,,,"HOSE G604BB055 C",1,1,,,,,,,,,,,,,
7,2,,172165-79010,,HOSE,1,1,,,,,,,,,,,,,
8,2,,172164-79210,,,"HOSE G604BB055 F",1,1,,,,,,,,,,,,,
9,2,,172165-79030,,HOSE,1,1,,,,,,,,,,,,,
10,2,,172164-79180,,,"HOSE G604BB055 H",1,1,,,,,,,,,,,,,
11,1,,172123-76120,,,"CONNECTOR PF1/4",2,2,,,,,,,,,,,,,
12,1,,24315-000110,,,"O-RING 1B P-11.0",6,6,,,,,,,,,,,,,
13,1,,172162-76770,,,"JOINT PF1/4",4,4,,,,,,,,,,,,,
14,1,,172164-76700,,,"T-JOINT 1/4",1,1,,,,,,,,,,,,,
15,2,,24315-000110,,,"O-RING 1B P-11.0",1,1,,,,,,,,,,,,,
16,1,,172168-79100,,,"HOSE G604BC030 A",1,1,,,,,,,,,,,,,
17,1,,172964-78111,,,"VALVE, CHECK",2,2,,,,,,,,,,,,,
18,1,,172122-79930,,CLAMP,1,1,,,,,,,,,,,,,

Fig. 84 コントロール配管 (ロータリバルブ~コントロールバルブ) (新形) CONTROL PIPING (ROTARY VALVE ~ CONTROL VALVE) (NEW)

M/#00832~

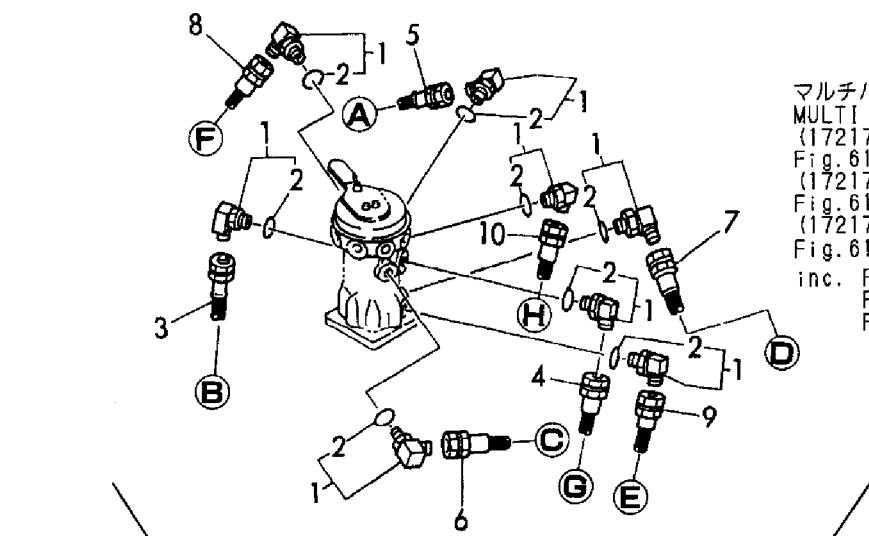

マルチバルブキット
MULTI VALVE KIT
(172176-74530)
Fig. 61 REF. No. 1
(172176-74540)
Fig. 61 REF. No. 2
(172176-74490)
Fig. 61 REF. No. 1-1, 2-1
inc. Fig. 61 REF. No. 3~29
Fig. 82 REF. No. 1~10
Fig. 84 REF. No. 1~10

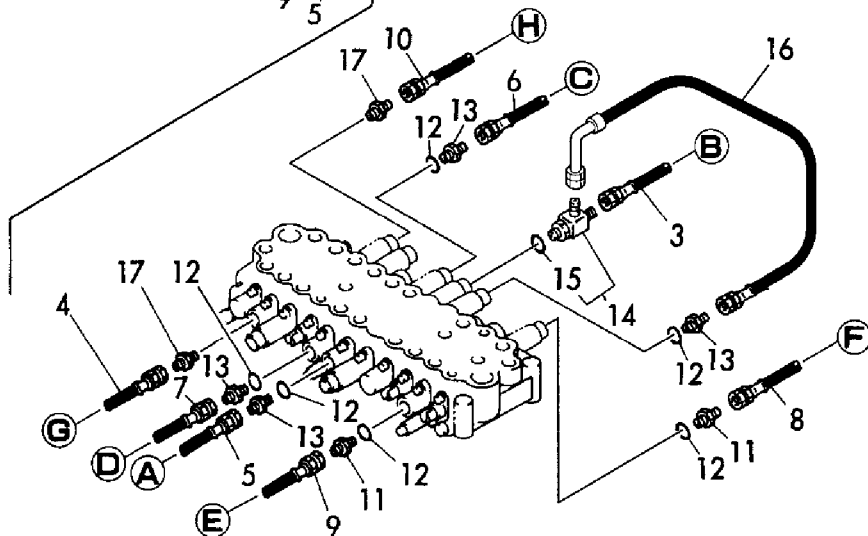
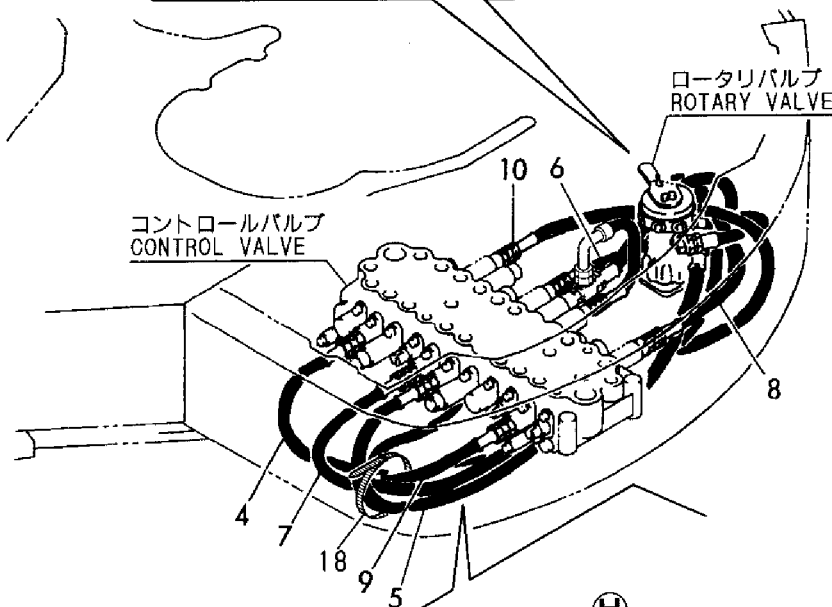

1,1,,172112-77580,, "JOINT 1/8",1,1,,,,,,,,,,,,,,,,,,,,,
2,1,,172112-77660,, "L-JOINT 1/8",1,1,,,,,,,,,,,,,,,,,,,,,
3,1,,172141-77800,, "JOINT, GREASE",4,4,,,,,,,,,,,,,,,,,,,,,
4,1,,172147-77800,, "CONNECTOR PT 1/8",1,1,,,,,,,,,,,,,,,,,,,,,
5,1,,172151-77801,, HOSE,1,1,,,,,,,,,,,,,,,,,,,,,
6,1,,172164-77810,, HOSE,1,1,,,,,,,,,,,,,,,,,,,,,
7,1,,172164-78560,, HOSE,1,1,,,,,,,,,,,,,,,,,,,,,
8,1,,24761-020000,, "NIPPLE PT1/8,GREASE",3,3,,,,,,,,,,,,,,,,,,,,,

Fig. **85** 遠隔グリーシング
GREASING

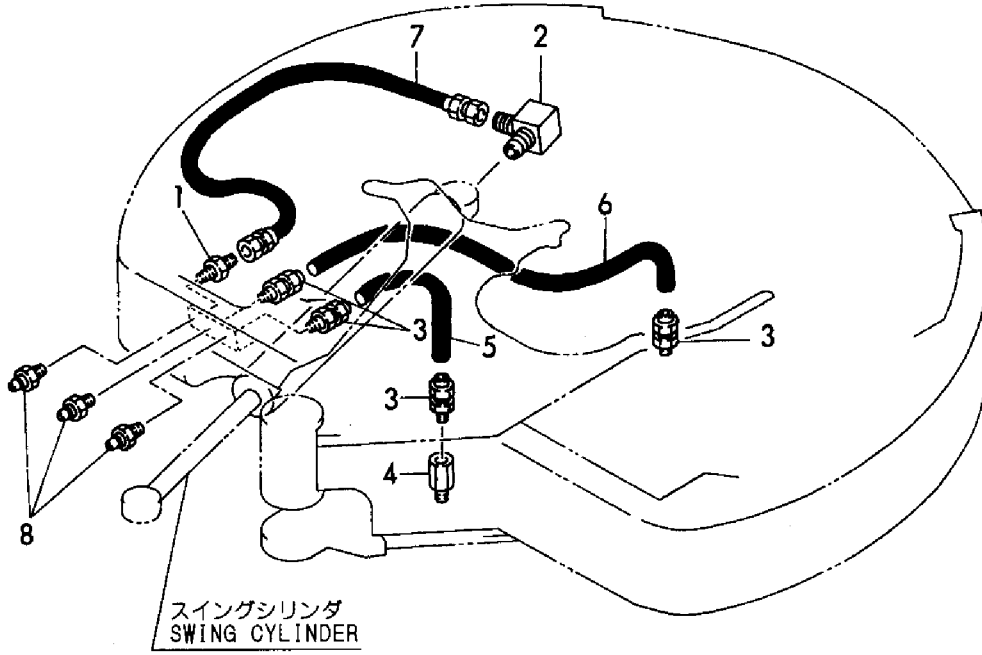

1,1,,172165-81101-4,, "BOOM ASSY (GREEN)",1,1,,,,,,,,,,,,,
1-1,1,,172165-81102-4,, "BOOM ASSY (GREEN)",1,1,,,,,N,,,M/#00832,,M/#00832,,,,,
1-2,1,,172165-81103-4,, "BOOM ASSY (GREEN)",1,1,,,,,S,,,M/#01074,,M/#01074,,,,,
2,2,,172147-81451,, "BUSH 50X75",2,2,,,,,,,,,,,,,
3,2,,172165-81760,, "SEAL 50X60X4, DUST",2,2,,,,,,,,,,,,,
4,1,,172176-81540,, "PIN 50-230",1,1,,,,,,,,,,,,,
4-1,1,,172176-81541,, "PIN 50X234",1,1,,,,,N,,,M/#01302,,M/#01302,,,,,
5,1,,172176-81620,, "PIN 50-155",1,1,,,,,,,,,,,,,
6,1,,172176-81580,, "PIN 50-183",1,1,,,,,,,,,,,,,
7,1,,172164-81670,, "SPACER",3,3,,,,,,,,,,,,,
8,1,,172165-82520,, "SHIM 50X85X0.5",1,1,,,,,,,,,,,,,
9,1,,172165-82530,, "SHIM 50X85X1.2",1,1,,,,,,,,,,,,,
10,1,,172165-82540,, "SHIM 50X85X1.6",1,1,,,,,,,,,,,,,
11,1,,26013-120302,, "BOLT W/WASHER M12X30",2,2,,,,,,,,,,,,,
12,1,,26716-160002,, "NUT M16",2,2,,,,,,,,,,,,,
13,1,,22157-120000,, "WASHER 12",3,3,,,,,,,,,,,,,
14,1,,24761-040000,, "NIPPLE B,GREASE",1,1,,,,,,,,,,,,,
15,1,,26013-120302,, "BOLT W/WASHER M12X30",3,3,,,,,,,,,,,,,
16,1,,172312-31120,, "BOLT M16X170",1,1,,,,,,,,,,,,,
17,1,,172176-81620,, "PIN 50-155",1,1,,,,,,,,,,,,,
18,1,,172176-81600,, "PIN 50-321",1,1,,,,,,,,,,,,,
19,1,,172164-81670,, "SPACER",2,2,,,,,,,,,,,,,
20,1,,172164-81680,, "PIN 40X111",1,1,,,,,,,,,,,,,
21,1,,172165-82301-4,, "BRACKET,BOOM (GREEN)",1,1,,,,,,,,,,,,,
22,2,,172165-81710,, "BUSH 70X85",2,2,,,,,,,,,,,,,
23,2,,172165-81770,, "SEAL 70X80X6, DUST",2,2,,,,,,,,,,,,,
25,2,,24321-000700,, "O-RING 1A G-70.0",2,2,,,,,,,,,,,,,
26,1,,172165-82340,, "PIN 40X122",1,1,,,,,,,,,,,,,
27,1,,172165-82360,, "PIN 70-400 CMP",1,1,,,,,,,,,,,,,
28,1,,172165-82520,, "SHIM 50X85X0.5",8,8,,,,,,,,,,,,,
29,1,,172165-82530,, "SHIM 50X85X1.2",8,8,,,,,,,,,,,,,
30,1,,172165-82540,, "SHIM 50X85X1.6",8,8,,,,,,,,,,,,,
31,1,,172165-82580,, "SHIM 40X75X0.5",4,4,,,,,,,,,,,,,
32,1,,172165-82590,, "SHIM 40X75X1.2",4,4,,,,,,,,,,,,,
33,1,,172165-82600,, "SHIM 40X75X1.6",4,4,,,,,,,,,,,,,
34,1,,172146-82910,, "SPACER",1,1,,,,,,,,,,,,,
35,1,,172117-83970-4,, "PLATE(C),LOCK(GREEN)",1,1,,,,,,,,,,,,,
36,1,,172112-87830,, "SHIM 70X4",2,2,,,,,,,,,,,,,
37,1,,22157-120000,, "WASHER 12",2,2,,,,,,,,,,,,,
38,1,,22242-000700,, "CIRCLIP 70",1,1,,,,,,,,,,,,,
39,1,,24761-040000,, "NIPPLE B,GREASE",1,1,,,,,,,,,,,,,
40,1,,24761-050000,, "NIPPLE C,GREASE",1,1,,,,,,,,,,,,,
41,1,,26013-100202,, "BOLT W/WASHER M10X20",2,2,,,,,,,,,,,,,
42,1,,26013-120252,, "BOLT M12X 25",1,1,,,,,,,,,,,,,
43,1,,172176-81300,, "BOOM W/BUSH, 3RD V.",1,1,,,,,1,,,,,,,,,,,,,
43-1,1,,172176-81301,, "BOOM ASSY, 3RD",1,1,,,,,N,1,,M/#00832,,M/#00832,,,,,
43-2,1,,172176-81301,, "BOOM ASSY, 3RD",1,1,,,,,Z,1,,M/#01074,,M/#01074,,,,,
44,2,,172147-81451,, "BUSH 50X75",2,2,,,,,Z,1,,M/#01074,,M/#01074,,,,,
45,2,,172165-81760,, "SEAL 50X60X4, DUST",2,2,,,,,Z,1,,M/#01074,,M/#01074,,,,,
46,1,,172183-81170,, "TREE CLIP",3,3,,,,,W,,,M/#01074,,M/#01074,,,,,
47,1,,172176-81700,, "SHIM",1,1,,,,,W,,,M/#01074,,M/#01074,,,,,
48,1,,172176-81710,, "SHIM",1,1,,,,,W,,,M/#01074,,M/#01074,,,,,
49,1,,172176-81650,, "COLLAR 45.5X65",1,1,,,,,W,,,M/#01302,,M/#01302,,,,,
50,1,,172176-81650,, "COLLAR 45.5X65",1,1,,,,,W,,,M/#01302,,M/#01302,,,,,
51,1,,22242-000451,, "CIRCLIP 45",1,1,,,,,W,,,M/#01302,,M/#01302,,,,,
52,1,,22242-000451,, "CIRCLIP 45",1,1,,,,,W,,,M/#01302,,M/#01302,,,,,
53,1,,172176-81660,, "COLLAR 45.5X60X1",2,2,,,,,W,,,M/#01486,,M/#01486,,,,,
54,1,,172176-81660,, "COLLAR 45.5X60X1",2,2,,,,,W,,,M/#01486,,M/#01486,,,,,

Fig. 86 **ブーム&ブームブラケット**
BOOM & BOOM BRACKET

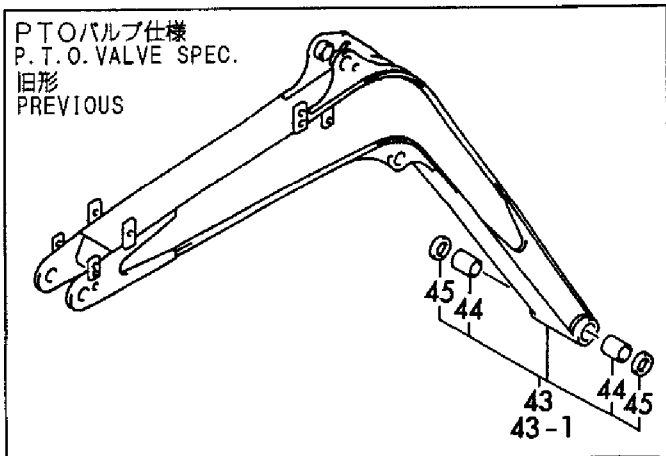
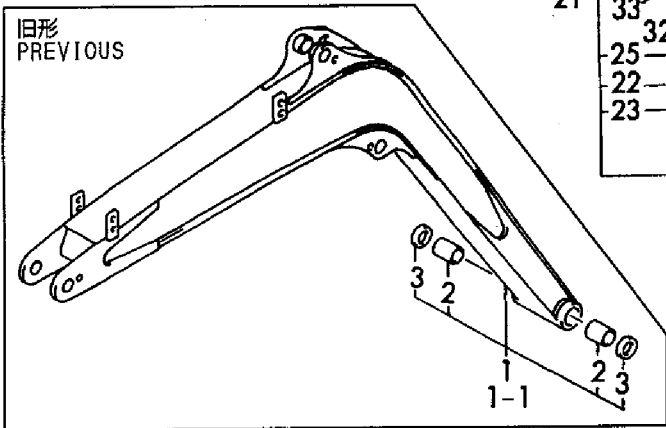
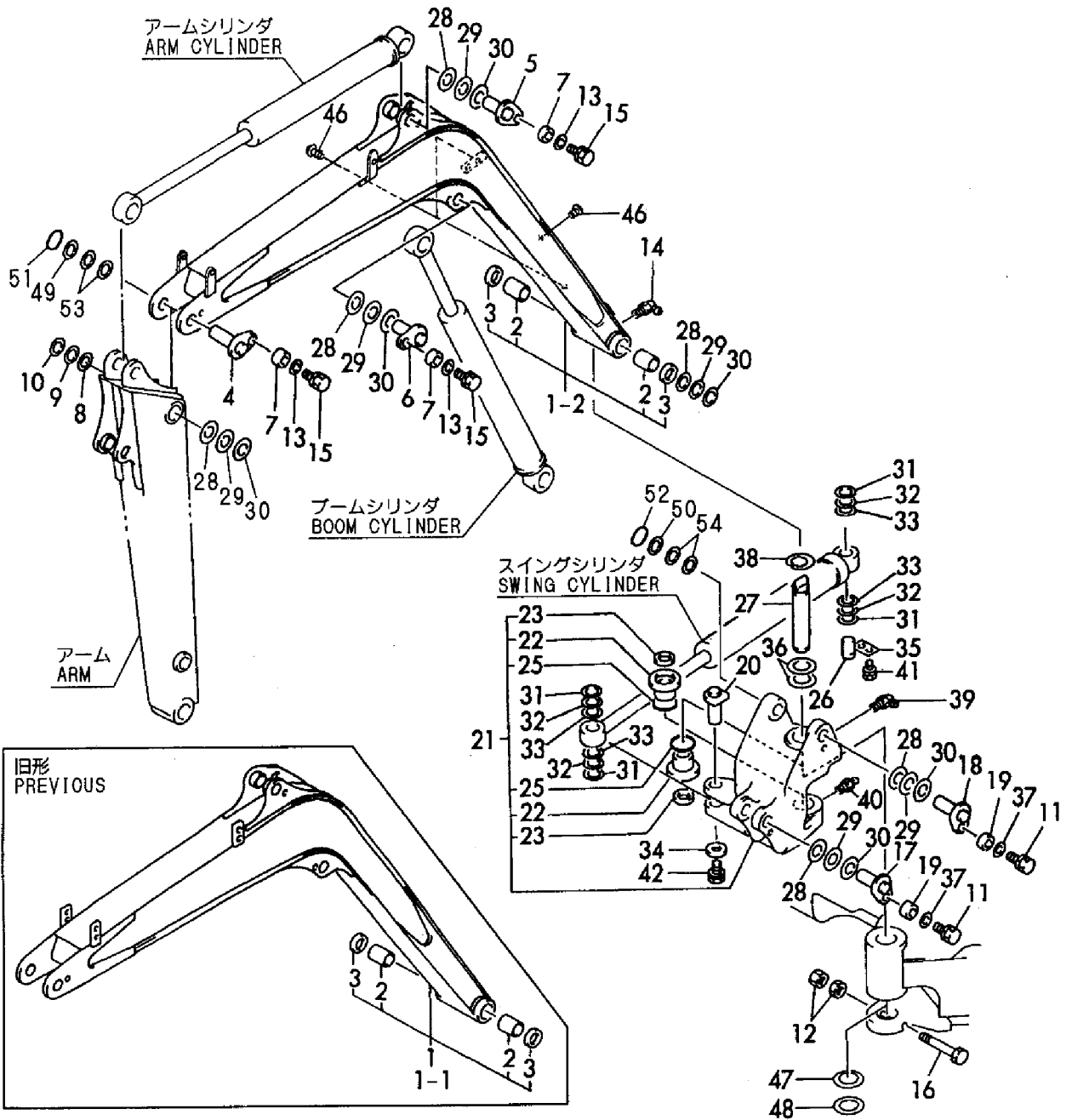

1,1,,172165-81201-4,, "ARM W/BUSH (GREEN)",1,1,,,,,,,,,,,,,
1-1,1,,172165-81202-4,, "ARM W/BUSH
(GREEN)",1,1,,,,,S,,M/#01074,,M/#01074,,,,,
2,2,,172147-81451,, "BUSH 50X75",2,2,,,,,,,,,,,,,
3,2,,172165-81760,, "SEAL 50X60X4, DUST",2,2,,,,,,,,,,,,,
4,2,,172165-81700,, "BUSH 45X65",2,2,,,,,,,,,,,,,
5,2,,172112-83530,, "SPACER 49.5X33",1,1,,,,,,,,,,,,,
6,2,,172112-83500,, "PIN BUSH 45X60",2,2,,,,,,,,,,,,,
7,2,,933126-44500,, "SEAL VAY45X55X4,DUST",4,4,,,,,,,,,,,,,
8,1,,172176-81500,, "PIN 45-112",1,1,,,,,,,,,,,,,
9,1,,172176-81520,, "PIN 50-122",1,1,,,,,,,,,,,,,
10,1,,172125-81280,, "O-RING 81X8",2,2,,,,,,,,,,,,,
11,1,,172164-81670,, "SPACER",2,2,,,,,,,,,,,,,
12,1,,22157-120000,, "WASHER 12",2,2,,,,,,,,,,,,,
13,1,,26013-120302,, "BOLT W/WASHER M12X30",2,2,,,,,,,,,,,,,
14,1,,172165-81500-1,, "KIT,ARM PIN",1,1,,,,,,,,,,,,,
15,2,,172165-81320-1,, "PIN 45X204",1,1,,,,,,,,,,,,,
16,2,,172165-81340-1,, "PIN 45X204",1,1,,,,,,,,,,,,,
17,2,,933110-86600,, "NUT M24, NYLON",2,2,,,,,,,,,,,,,
18,2,,933171-29760,, "WASHER",2,2,,,,,,,,,,,,,
19,2,,24761-020000,, "NIPPLE PT1/8,GREASE",1,1,,,,,,,,,,,,,
20,2,,172165-82550,, "SHIM 45X1.2",2,2,,,,,,,,,,,,,
21,2,,172165-82560,, "SHIM 45X80X1.2",2,2,,,,,,,,,,,,,
21A,2,,172165-82570,, "SHIM 45X80X1.6",2,2,,,,,,,,,,,,,
22,1,,172165-81300-4,, "ARM(L),BUCKET(GREEN)",1,1,,,,,,,,,,,,,
23,1,,172165-81310-4,, "ARM, BUCKET (GREEN)",1,1,,,,,,,,,,,,,
24,1,,172147-84400-4,, "LINK,BUCKET(GREEN)",1,1,,,,,,,,,,,,,
24-1,1,,172147-84401-
4,, "LINK,BUCKET(GREEN)",1,1,,,,,N,,M/#00767,,M/#00767,,,,,
25,2,,172112-83500,, "PIN BUSH 45X60",2,2,,,,,,,,,,,,,
26,2,,933126-44500,, "SEAL VAY45X55X4,DUST",6,6,,,,,,,,,,,,,
27,2,,172112-86250,, "BUSH 45X39, PIN",2,2,,,,,,,,,,,,,
28,1,,24761-020000,, "NIPPLE PT1/8,GREASE",2,2,,,,,,,,,,,,,
29,1,,24761-040000,, "NIPPLE B,GREASE",1,1,,,,,,,,,,,,,
30,1,,172176-81310,, "ARM ASSY, 3RD",1,1,,,,,Z,1,,M/#01074,,M/#01074,,,,,
31,2,,172147-81451,, "BUSH 50X75",2,2,,,,,Z,1,,M/#01074,,M/#01074,,,,,
32,2,,172165-81760,, "SEAL 50X60X4, DUST",2,2,,,,,Z,1,,M/#01074,,M/#01074,,,,,
33,2,,172165-81700,, "BUSH 45X65",2,2,,,,,Z,1,,M/#01074,,M/#01074,,,,,
34,2,,172112-83530,, "SPACER 49.5X33",1,1,,,,,Z,1,,M/#01074,,M/#01074,,,,,
35,2,,172112-83500,, "PIN BUSH 45X60",2,2,,,,,Z,1,,M/#01074,,M/#01074,,,,,
36,2,,933126-44500,, "SEAL VAY45X55X4,DUST",4,4,,,,,Z,1,,M/#01074,,M/#01074,,,,,
37,1,,172165-82520,, "SHIM 50X85X0.5",1,1,,,,,,,,,,,,,
38,1,,172165-82530,, "SHIM 50X85X1.2",1,1,,,,,,,,,,,,,
39,1,,172165-82540,, "SHIM 50X85X1.6",1,1,,,,,,,,,,,,,
40,1,,172165-82550,, "SHIM 45X1.2",1,1,,,,,,,,,,,,,
41,1,,172165-82560,, "SHIM 45X80X1.2",1,1,,,,,,,,,,,,,
42,1,,172165-82570,, "SHIM 45X80X1.6",1,1,,,,,,,,,,,,,
43,1,,172176-81200,, "ARM ASSY",1,1,,,,,2,,,,,,,,,,,,,
43-1,1,,172176-81201,, "ARM ASSY",1,1,,,,,S,2,,M/#01074,,M/#01074,,,,,
44,2,,172147-81451,, "BUSH 50X75",2,2,,,,,2,,,,,,,,,,,,,
45,2,,172165-81760,, "SEAL 50X60X4, DUST",2,2,,,,,2,,,,,,,,,,,,,
46,2,,172165-81700,, "BUSH 45X65",2,2,,,,,2,,,,,,,,,,,,,
47,2,,172112-83530,, "SPACER 49.5X33",1,1,,,,,2,,,,,,,,,,,,,
48,2,,172112-83500,, "PIN BUSH 45X60",2,2,,,,,2,,,,,,,,,,,,,
49,2,,933126-44500,, "SEAL VAY45X55X4,DUST",4,4,,,,,2,,,,,,,,,,,,,
50,1,,172176-81210,, "ARM ASSY",1,1,,,,,Z,3,,M/#01074,,M/#01074,,,,,
51,2,,172147-81451,, "BUSH 50X75",2,2,,,,,Z,3,,M/#01074,,M/#01074,,,,,
52,2,,172165-81760,, "SEAL 50X60X4, DUST",2,2,,,,,Z,3,,M/#01074,,M/#01074,,,,,
53,2,,172165-81700,, "BUSH 45X65",2,2,,,,,Z,3,,M/#01074,,M/#01074,,,,,
54,2,,172112-83530,, "SPACER 49.5X33",1,1,,,,,Z,3,,M/#01074,,M/#01074,,,,,
55,2,,172112-83500,, "PIN BUSH 45X60",2,2,,,,,Z,3,,M/#01074,,M/#01074,,,,,
56,2,,933126-44500,, "SEAL VAY45X55X4,DUST",4,4,,,,,Z,3,,M/#01074,,M/#01074,,,,,
57,1,,172183-81160,, "TREE CLIP",4,4,,,,,W,,M/#01074,,M/#01074,,,,,

Fig. 87 アーム&バケットリンク ARM & BUCKET LINK

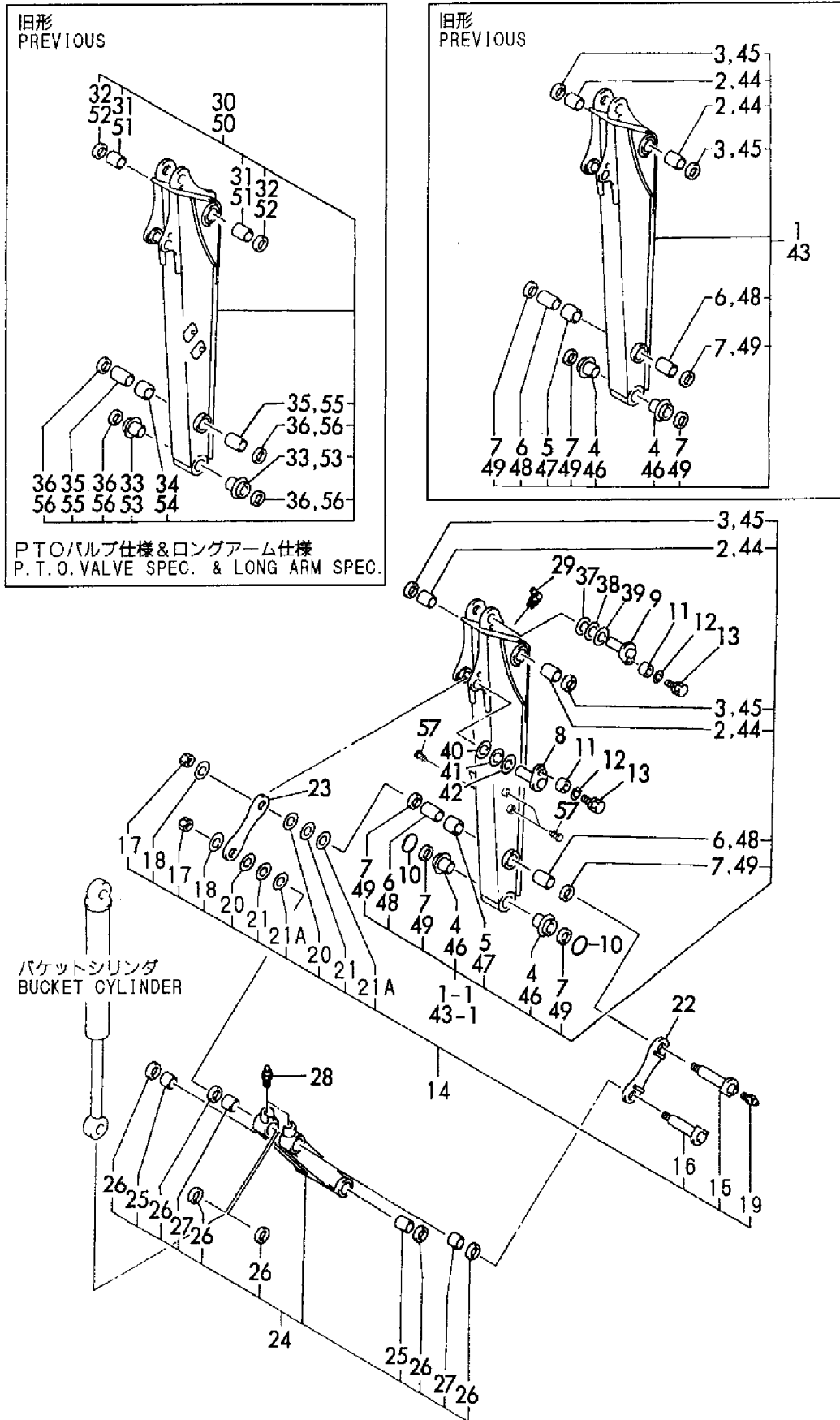

1,1,,172151-81500-4,,BUCKET(700S)(GREEN),1,1,,,,,3,,,,,
2,2,,172151-81510-4,,BUCKET(700S)(GREEN),1,1,,,,,3,,,,,
3,2,,172162-82820-4,, "CUTTER,SIDE(L)(GREEN",1,1,,,,,3,,,,,
4,2,,172162-82840-4,, "CUTTER,SIDE(R)(GREEN",1,1,,,,,3,,,,,
5,2,,172162-82930-4,, "BOLT M16X 50 (GREEN)",6,6,,,,,3,,,,,
6,2,,172162-82940-4,, "NUT M16 (GREEN)",6,6,,,,,3,,,,,
7,2,,22217-160000,, "SPRING WASHER 16",6,6,,,,,3,,,,,
8,2,,772151-81610-4,, "TEETH ASSY (GREEN)",4,4,,,,,3,,,,,
9,3,,172151-81600-4,, "POINT,TOOTH 18S(97)",4,4,,,,,3,,,,,
10,3,,172151-81620,, "PIN ASSY, LOCK",4,4,,,,,3,,,,,
11,4,,172151-81630,, PIN,4,4,,,,,3,,,,,
12,4,,172151-81640,, "LOCK,RUBBER BIN",4,4,,,,,3,,,,,
13,3,,172151-81610,, "ADAPTER, ETHER START",4,4,,,,,3,,,,,
14,1,,172176-81950,, "PIN KIT, BUCKET",2,2,,,,,3,,,,,
15,2,,172176-81560,, "PIN 45X271 CMP",2,2,,,,,3,,,,,
16,2,,172176-81640,, COLLAR,2,2,,,,,3,,,,,
17,2,,24761-020000,, "NIPPLE PT1/8,GREASE",2,2,,,,,3,,,,,
18,2,,26116-100752,, "BOLT M10X 75 PLATED",2,2,,,,,3,,,,,
19,2,,26716-100002,, "NUT 10",4,4,,,,,3,,,,,
20,2,,172124-81930,, "SHIM 45X0.8",2,2,,,,,3,,,,,
21,2,,172124-81940,, "SHIM 45X1.2",2,2,,,,,3,,,,,
22,1,,172151-86210,, "CUTTER (L) ASSY,SIDE",1,1,,,,,1,,,,,
23,1,,172151-86220,, "CUTTER (R) ASSY,SIDE",1,1,,,,,1,,,,,
24,1,,172151-86240,, "BOLT M16X 32",6,6,,,,,1,,,,,
25,1,,22217-160000,, "SPRING WASHER 16",6,6,,,,,1,,,,,
26,1,,172165-86500,, "TOOTH KIT, POINT",1,1,,,,,W,2,,M/#01451,,M/#01451,,,,,
28,2,,172151-81620,, "PIN ASSY, LOCK",1,1,,,,,W,2,,M/#01451,,M/#01451,,,,,

Fig. 88 バケットSタイプ BUCKET S TYPE

1(700S)

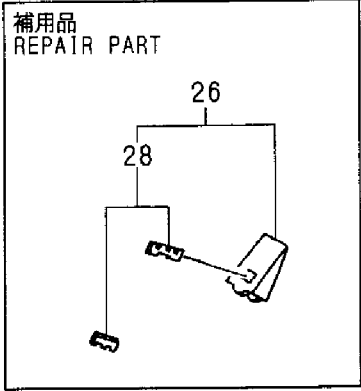
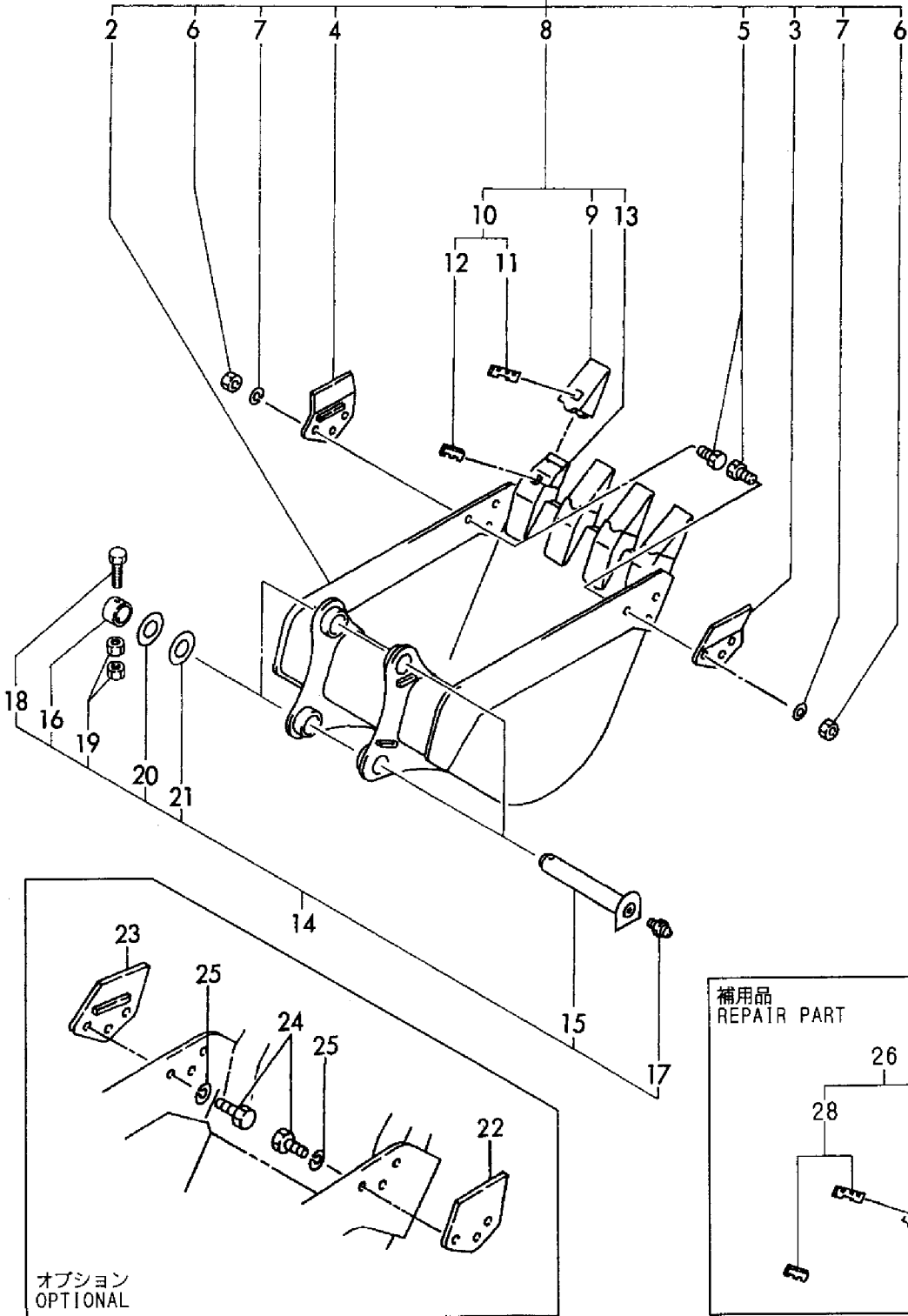

1,1,,172176-81950,, "PIN KIT, BUCKET",2,2,,,,,,,,,,,,,,,,,,,,,
2,2,,172176-81560,, "PIN 45X271 CMP",2,2,,,,,,,,,,,,,,,,,,,,,
3,2,,24761-020000,, "NIPPLE PT1/8,GREASE",2,2,,,,,,,,,,,,,,,,,,,,,
4,2,,172176-81640,, COLLAR,2,2,,,,,,,,,,,,,,,,,,,,,
5,2,,26116-100752,, "BOLT M10X 75 PLATED",2,2,,,,,,,,,,,,,,,,,,,,,
6,2,,26716-100002,, "NUT 10",4,4,,,,,,,,,,,,,,,,,,,,,
7,2,,172124-81930,, "SHIM 45X0.8",2,2,,,,,,,,,,,,,,,,,,,,,
8,2,,172124-81940,, "SHIM 45X1.2",2,2,,,,,,,,,,,,,,,,,,,,,
9,1,,172151-81700-4,, "BUCKET (450S)(GREEN)",1,1,,,,,,,,,,,,,,,,,,,,,
10,2,,172151-81710-4,, "BUCKET (450S)(GREEN)",1,1,,,,,,,,,,,,,,,,,,,,,
11,2,,172162-82820-4,, "CUTTER,SIDE(L)(GREEN)",1,1,,,,,,,,,,,,,,,,,,,,,
12,2,,172162-82840-4,, "CUTTER,SIDE(R)(GREEN)",1,1,,,,,,,,,,,,,,,,,,,,,
13,2,,172162-82930-4,, "BOLT M16X 50 (GREEN)",6,6,,,,,,,,,,,,,,,,,,,,,
14,2,,172162-82940-4,, "NUT M16 (GREEN)",6,6,,,,,,,,,,,,,,,,,,,,,
15,2,,22217-160000,, "SPRING WASHER 16",6,6,,,,,,,,,,,,,,,,,,,,,
16,2,,772151-81610-4,, "TEETH ASSY (GREEN)",3,3,,,,,,,,,,,,,,,,,,,,,
17,3,,172151-81600-4,, "POINT,TOOTH 18S(97)",3,3,,,,,,,,,,,,,,,,,,,,,
18,3,,172151-81620,, "PIN ASSY, LOCK",3,3,,,,,,,,,,,,,,,,,,,,,
19,4,,172151-81630,, PIN,3,3,,,,,,,,,,,,,,,,,,,,,
20,4,,172151-81640,, "LOCK,RUBBER BIN",3,3,,,,,,,,,,,,,,,,,,,,,
21,3,,172151-81610,, "ADAPTER, ETHER START",3,3,,,,,,,,,,,,,,,,,,,,,
22,1,,172151-81800-4,, "BUCKET(600S) (GREEN)",1,1,,,,,,,,,,,,,,,,,,,,,
23,2,,172151-81810-4,, "BUCKET(600S) (GREEN)",1,1,,,,,,,,,,,,,,,,,,,,,
24,2,,172162-82820-4,, "CUTTER,SIDE(L)(GREEN)",1,1,,,,,,,,,,,,,,,,,,,,,
25,2,,172162-82840-4,, "CUTTER,SIDE(R)(GREEN)",1,1,,,,,,,,,,,,,,,,,,,,,
26,2,,172162-82930-4,, "BOLT M16X 50 (GREEN)",6,6,,,,,,,,,,,,,,,,,,,,,
27,2,,172162-82940-4,, "NUT M16 (GREEN)",6,6,,,,,,,,,,,,,,,,,,,,,
28,2,,22217-160000,, "SPRING WASHER 16",6,6,,,,,,,,,,,,,,,,,,,,,
29,2,,772151-81610-4,, "TEETH ASSY (GREEN)",4,4,,,,,,,,,,,,,,,,,,,,,
30,3,,172151-81600-4,, "POINT,TOOTH 18S(97)",4,4,,,,,,,,,,,,,,,,,,,,,
31,3,,172151-81620,, "PIN ASSY, LOCK",4,4,,,,,,,,,,,,,,,,,,,,,
32,4,,172151-81630,, PIN,4,4,,,,,,,,,,,,,,,,,,,,,
33,4,,172151-81640,, "LOCK,RUBBER BIN",4,4,,,,,,,,,,,,,,,,,,,,,
34,3,,172151-81610,, "ADAPTER, ETHER START",4,4,,,,,,,,,,,,,,,,,,,,,
35,1,,172151-81900-4,, "BUCKET(650S) (GREEN)",1,1,,,,,,,,,,,,,,,,,,,,,
36,2,,172151-81910-4,, "BUCKET(650S) (GREEN)",1,1,,,,,,,,,,,,,,,,,,,,,
37,2,,172162-82820-4,, "CUTTER,SIDE(L)(GREEN)",1,1,,,,,,,,,,,,,,,,,,,,,
38,2,,172162-82840-4,, "CUTTER,SIDE(R)(GREEN)",1,1,,,,,,,,,,,,,,,,,,,,,
39,2,,172162-82930-4,, "BOLT M16X 50 (GREEN)",6,6,,,,,,,,,,,,,,,,,,,,,
40,2,,172162-82940-4,, "NUT M16 (GREEN)",6,6,,,,,,,,,,,,,,,,,,,,,
41,2,,22217-160000,, "SPRING WASHER 16",6,6,,,,,,,,,,,,,,,,,,,,,
42,2,,772151-81610-4,, "TEETH ASSY (GREEN)",4,4,,,,,,,,,,,,,,,,,,,,,
43,3,,172151-81600-4,, "POINT,TOOTH 18S(97)",4,4,,,,,,,,,,,,,,,,,,,,,
44,3,,172151-81620,, "PIN ASSY, LOCK",4,4,,,,,,,,,,,,,,,,,,,,,
45,4,,172151-81630,, PIN,4,4,,,,,,,,,,,,,,,,,,,,,
46,4,,172151-81640,, "LOCK,RUBBER BIN",4,4,,,,,,,,,,,,,,,,,,,,,
47,3,,172151-81610,, "ADAPTER, ETHER START",4,4,,,,,,,,,,,,,,,,,,,,,
48,1,,172151-82000-4,, "BUCKET(750S) (GREEN)",1,1,,,,,,,,,,,,,,,,,,,,,
49,2,,172151-82010-4,, "BUCKET(750S) (GREEN)",1,1,,,,,,,,,,,,,,,,,,,,,
50,2,,172162-82820-4,, "CUTTER,SIDE(L)(GREEN)",1,1,,,,,,,,,,,,,,,,,,,,,
51,2,,172162-82840-4,, "CUTTER,SIDE(R)(GREEN)",1,1,,,,,,,,,,,,,,,,,,,,,
52,2,,172162-82930-4,, "BOLT M16X 50 (GREEN)",6,6,,,,,,,,,,,,,,,,,,,,,
53,2,,172162-82940-4,, "NUT M16 (GREEN)",6,6,,,,,,,,,,,,,,,,,,,,,
54,2,,22217-160000,, "SPRING WASHER 16",6,6,,,,,,,,,,,,,,,,,,,,,
55,2,,772151-81610-4,, "TEETH ASSY (GREEN)",5,5,,,,,,,,,,,,,,,,,,,,,
56,3,,172151-81600-4,, "POINT,TOOTH 18S(97)",5,5,,,,,,,,,,,,,,,,,,,,,
57,3,,172151-81620,, "PIN ASSY, LOCK",5,5,,,,,,,,,,,,,,,,,,,,,
58,4,,172151-81630,, PIN,5,5,,,,,,,,,,,,,,,,,,,,,
59,4,,172151-81640,, "LOCK,RUBBER BIN",5,5,,,,,,,,,,,,,,,,,,,,,
60,3,,172151-81610,, "ADAPTER, ETHER START",5,5,,,,,,,,,,,,,,,,,,,,,
61,1,,172151-86210,, "CUTTER (L) ASSY,SIDE",1,1,,,,,1,,,,,,,,,,,,,
62,1,,172151-86220,, "CUTTER (R) ASSY,SIDE",1,1,,,,,1,,,,,,,,,,,,,
63,1,,172151-86240,, "BOLT M16X 32",6,6,,,,,1,,,,,,,,,,,,,

64,1,,22217-160000,, "SPRING WASHER 16",6,6,,,,,1,,,,,
65,1,,172165-86500,, "TOOTH KIT, POINT",1,1,,,,,W,2,,M/#01451,,M/#01451,,,,,
67,2,,172151-81620,, "PIN ASSY, LOCK",1,1,,,,,W,2,,M/#01451,,M/#01451,,,,,

Fig. 89 バケットSタイプ (アタッチメント) BUCKET S TYPE (ATTACHMENT)

9 (450S)
22 (600S)
35 (650S)
48 (750S)

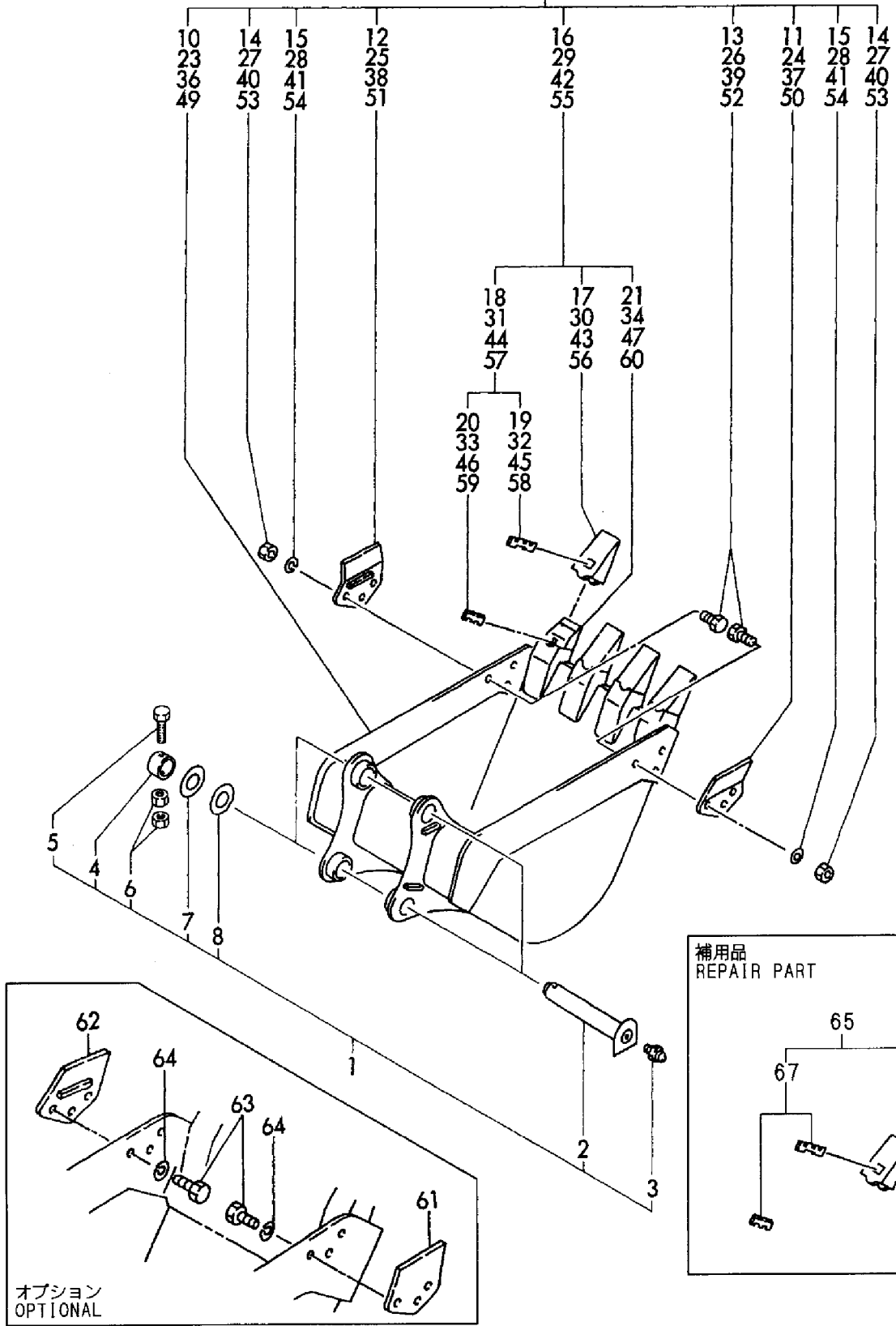

1,1,,772147-81411-4,, "BUCKET(450) (GREEN)",1,1,,,,,,,,,,,,,,,,,
3,2,,172162-82820-4,, "CUTTER,SIDE(L)(GREEN)",1,1,,,,,,,,,,,,,,,,,
4,2,,172162-82840-4,, "CUTTER,SIDE(R)(GREEN)",1,1,,,,,,,,,,,,,,,,,
5,2,,172162-82930-4,, "BOLT M16X 50 (GREEN)",6,6,,,,,,,,,,,,,,,,,
6,2,,172162-82940-4,, "NUT M16 (GREEN)",6,6,,,,,,,,,,,,,,,,,
7,2,,22217-160000,, "SPRING WASHER 16",6,6,,,,,,,,,,,,,,,,,
8,2,,772112-91303-4,, "TEETH (GREEN)",3,3,,,,,,,,,,,,,,,,,
9,3,,172151-81400-4,, "BOLT (GREEN)",6,6,,,,,,,,,,,,,,,,,
10,3,,172151-81410,, "SHIM SET, TEETH",3,3,,,,,,,,,,,,,,,,,
14,3,,172137-86780-4,, "NUT (GREEN)",6,6,,,,,,,,,,,,,,,,,
15,3,,172112-91303-4,, "TEETH (GREEN)",3,3,,,,,,,,,,,,,,,,,
16,1,,172176-81950,, "PIN KIT, BUCKET",2,2,,,,,,,,,,,,,,,,,
17,2,,172124-81930,, "SHIM 45X0.8",2,2,,,,,,,,,,,,,,,,,
18,2,,172176-81560,, "PIN 45X271 CMP",2,2,,,,,,,,,,,,,,,,,
19,2,,172124-81940,, "SHIM 45X1.2",2,2,,,,,,,,,,,,,,,,,
20,2,,24761-020000,, "NIPPLE PT1/8,GREASE",2,2,,,,,,,,,,,,,,,,,
21,2,,172176-81640,, "COLLAR,2,2,,,,,,,,,,,,,,,,,
22,2,,26116-100752,, "BOLT M10X 75 PLATED",2,2,,,,,,,,,,,,,,,,,
23,2,,26716-100002,, "NUT 10",4,4,,,,,,,,,,,,,,,,,
24,1,,772125-81471-4,, "BUCKET(600) (GREEN)",1,1,,,,,,,,,,,,,,,,,
26,2,,172162-82820-4,, "CUTTER,SIDE(L)(GREEN)",1,1,,,,,,,,,,,,,,,,,
27,2,,172162-82840-4,, "CUTTER,SIDE(R)(GREEN)",1,1,,,,,,,,,,,,,,,,,
28,2,,172162-82930-4,, "BOLT M16X 50 (GREEN)",6,6,,,,,,,,,,,,,,,,,
29,2,,172162-82940-4,, "NUT M16 (GREEN)",6,6,,,,,,,,,,,,,,,,,
30,2,,22217-160000,, "SPRING WASHER 16",6,6,,,,,,,,,,,,,,,,,
31,2,,772112-91303-4,, "TEETH (GREEN)",4,4,,,,,,,,,,,,,,,,,
32,3,,172151-81400-4,, "BOLT (GREEN)",8,8,,,,,,,,,,,,,,,,,
33,3,,172151-81410,, "SHIM SET, TEETH",4,4,,,,,,,,,,,,,,,,,
37,3,,172137-86780-4,, "NUT (GREEN)",8,8,,,,,,,,,,,,,,,,,
38,3,,172112-91303-4,, "TEETH (GREEN)",4,4,,,,,,,,,,,,,,,,,
39,1,,772124-81401-4,, "BUCKET(650) (GREEN)",1,1,,,,,,,,,,,,,,,,,
41,2,,172162-82820-4,, "CUTTER,SIDE(L)(GREEN)",1,1,,,,,,,,,,,,,,,,,
42,2,,172162-82840-4,, "CUTTER,SIDE(R)(GREEN)",1,1,,,,,,,,,,,,,,,,,
43,2,,172162-82930-4,, "BOLT M16X 50 (GREEN)",6,6,,,,,,,,,,,,,,,,,
44,2,,172162-82940-4,, "NUT M16 (GREEN)",6,6,,,,,,,,,,,,,,,,,
45,2,,22217-160000,, "SPRING WASHER 16",6,6,,,,,,,,,,,,,,,,,
46,2,,772112-91303-4,, "TEETH (GREEN)",4,4,,,,,,,,,,,,,,,,,
47,3,,172151-81400-4,, "BOLT (GREEN)",8,8,,,,,,,,,,,,,,,,,
48,3,,172151-81410,, "SHIM SET, TEETH",4,4,,,,,,,,,,,,,,,,,
52,3,,172137-86780-4,, "NUT (GREEN)",8,8,,,,,,,,,,,,,,,,,
53,3,,172112-91303-4,, "TEETH (GREEN)",4,4,,,,,,,,,,,,,,,,,
54,1,,772125-81403-4,, "BUCKET(700) (GREEN)",1,1,,,,,,,,,,,,,,,,,
56,2,,172162-82820-4,, "CUTTER,SIDE(L)(GREEN)",1,1,,,,,,,,,,,,,,,,,
57,2,,172162-82840-4,, "CUTTER,SIDE(R)(GREEN)",1,1,,,,,,,,,,,,,,,,,
58,2,,172162-82930-4,, "BOLT M16X 50 (GREEN)",6,6,,,,,,,,,,,,,,,,,
59,2,,172162-82940-4,, "NUT M16 (GREEN)",6,6,,,,,,,,,,,,,,,,,
60,2,,22217-160000,, "SPRING WASHER 16",6,6,,,,,,,,,,,,,,,,,
61,2,,772112-91303-4,, "TEETH (GREEN)",4,4,,,,,,,,,,,,,,,,,
62,3,,172151-81400-4,, "BOLT (GREEN)",8,8,,,,,,,,,,,,,,,,,
63,3,,172151-81410,, "SHIM SET, TEETH",4,4,,,,,,,,,,,,,,,,,
67,3,,172137-86780-4,, "NUT (GREEN)",8,8,,,,,,,,,,,,,,,,,
68,3,,172112-91303-4,, "TEETH (GREEN)",4,4,,,,,,,,,,,,,,,,,
69,1,,772147-81441-4,, "BUCKET(750) (GREEN)",1,1,,,,,,,,,,,,,,,,,
71,2,,172162-82820-4,, "CUTTER,SIDE(L)(GREEN)",1,1,,,,,,,,,,,,,,,,,
72,2,,172162-82840-4,, "CUTTER,SIDE(R)(GREEN)",1,1,,,,,,,,,,,,,,,,,
73,2,,172162-82930-4,, "BOLT M16X 50 (GREEN)",6,6,,,,,,,,,,,,,,,,,
74,2,,172162-82940-4,, "NUT M16 (GREEN)",6,6,,,,,,,,,,,,,,,,,
75,2,,22217-160000,, "SPRING WASHER 16",6,6,,,,,,,,,,,,,,,,,
76,2,,772112-91303-4,, "TEETH (GREEN)",5,5,,,,,,,,,,,,,,,,,
77,3,,172151-81400-4,, "BOLT (GREEN)",10,10,,,,,,,,,,,,,,,,,
78,3,,172151-81410,, "SHIM SET, TEETH",5,5,,,,,,,,,,,,,,,,,
82,3,,172137-86780-4,, "NUT (GREEN)",10,10,,,,,,,,,,,,,,,,,
83,3,,172112-91303-4,, "TEETH (GREEN)",5,5,,,,,,,,,,,,,,,,

84,1,,172151-86210,, "CUTTER (L) ASSY,SIDE",1,1,,,,,1,,,,,
85,1,,172151-86220,, "CUTTER (R) ASSY,SIDE",1,1,,,,,1,,,,,
86,1,,172151-86240,, "BOLT M16X 32",6,6,,,,,1,,,,,
87,1,,22217-160000,, "SPRING WASHER 16",6,6,,,,,1,,,,,

Fig. 90 バケット (アタッチメント) BUCKET (ATTACHMENT)

- 1 (450)
- 24 (600)
- 39 (650)
- 54 (700)
- 69 (750)

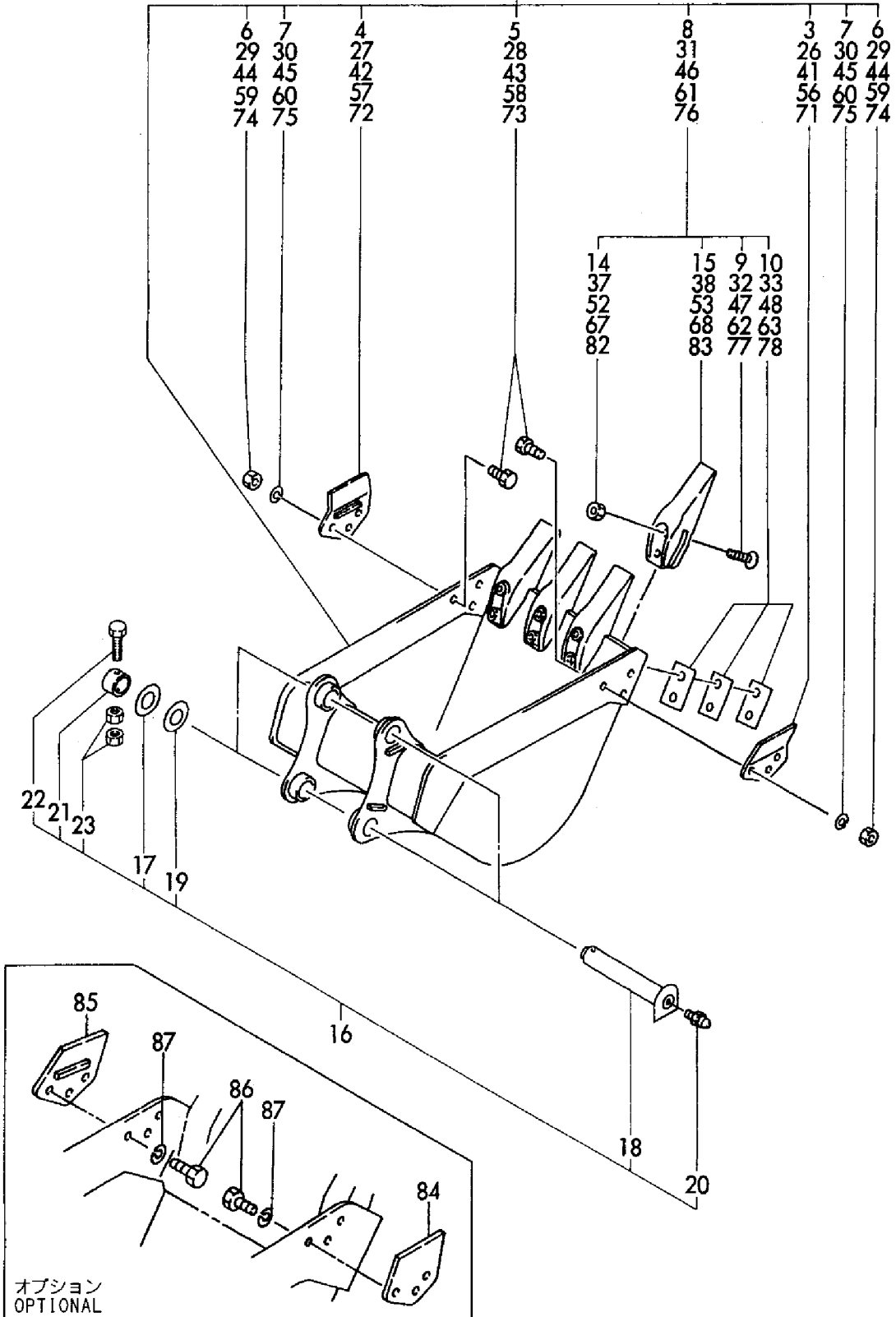

1,1,,172164-81650,, "PIN ASSY 45X122",2,2,,,,,,,,,,,,,
2,1,,172164-81670,, SPACER,2,2,,,,,,,,,,,,,
3,1,,172112-87840,, "SHIM 45X1",4,4,,,,,,,,,,,,,
4,1,,172158-94101-4,, "BLADE ASSY(GREEN:98)",1,1,,,,,,,,,,,,,
5,2,,172168-81410,, "SEAL 45X55X4, DUST",4,4,,,,,,,,,,,,,
6,1,,172124-94300,, "PIN 45-157, BLADE",2,2,,,,,,,,,,,,,
7,1,,172124-94310,, "PLATE, LOCK",2,2,,,,,,,,,,,,,
8,1,,22157-120000,, "WASHER 12",2,2,,,,,,,,,,,,,
9,1,,24761-020000,, "NIPPLE PT1/8,GREASE",2,2,,,,,,,,,,,,,
10,1,,24761-040000,, "NIPPLE B,GREASE",2,2,,,,,,,,,,,,,
11,1,,26013-100252,, "BOLT W/WASHER M10X25",4,4,,,,,,,,,,,,,
12,1,,26013-120302,, "BOLT W/WASHER M12X30",2,2,,,,,,,,,,,,,

Fig. 91 ブレード
BLADE

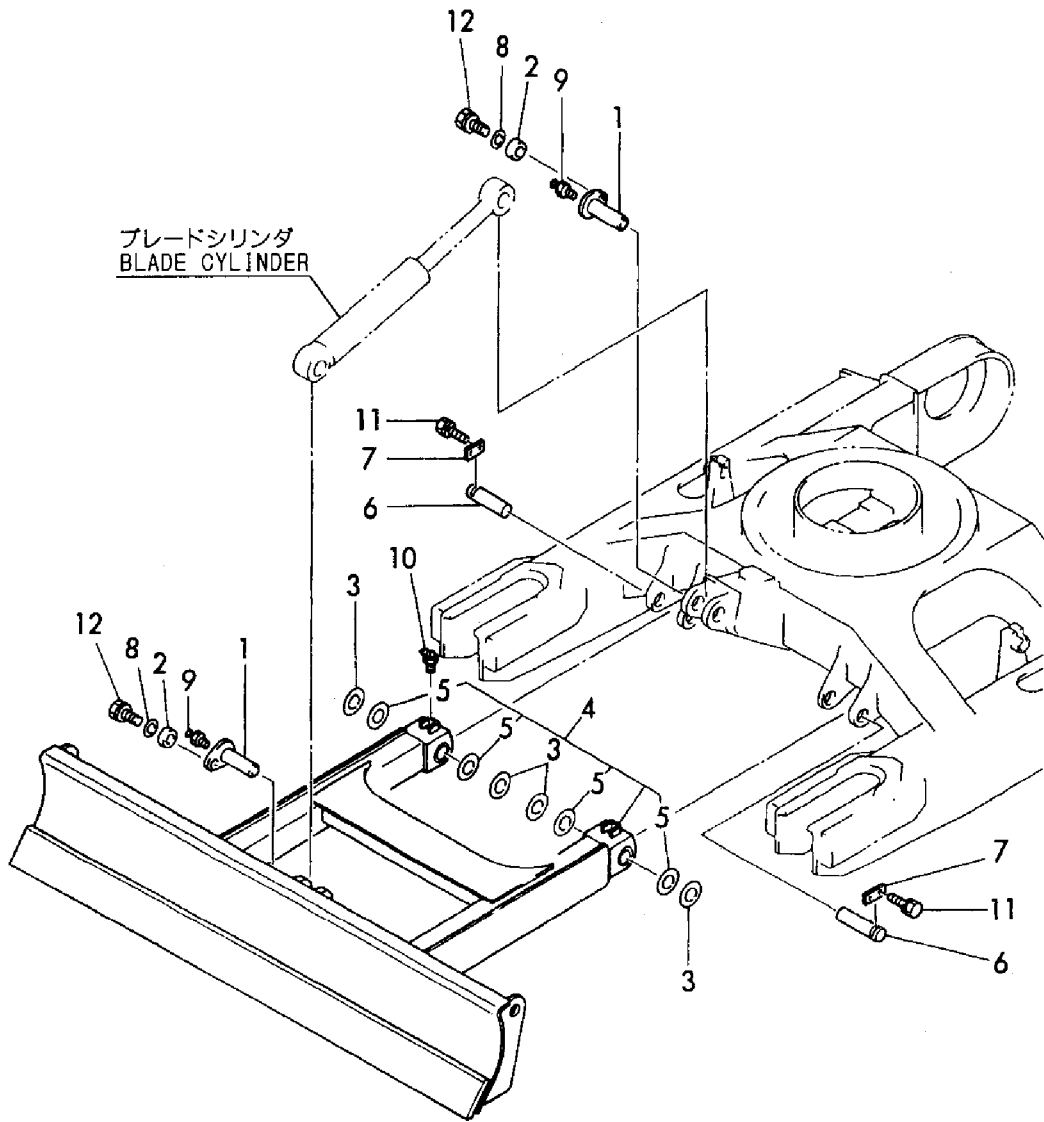

1,1,,172964-03610,, "LABEL A",1,1,,,,,,,,,,,,,
2,1,,172164-03500,, LABEL,1,1,,,,,,,,,,,,,
3,1,,172164-03540,, LABEL,1,1,,,,,,,,,,,,,
4,1,,172964-03370,, LABEL,1,1,,,,,,,,,,,,,
5,1,,172164-03510,, LABEL,1,1,,,,,,,,,,,,,
6,1,,172164-03520,, "LABEL,DANGER",1,1,,,,,,,,,,,,,
7,1,,172964-03390,, "LABEL,WARNING",1,1,,,,,,,,,,,,,
8,1,,172519-04180,, "LABEL,WARNING",1,1,,,,,,,,,,,,,
9,1,,172519-04290,, "LABEL,WARNING",1,1,,,,,,,,,,,,,
10,1,,172519-04300,, LABEL,1,1,,,,,,,,,,,,,
11,1,,172164-03560,, LABEL,1,1,,,,,,,,,,,,,
12,1,,172165-03661,, "LABEL,DANGER",1,1,,,,,,,,,,,,,
13,1,,172142-03302,, "LABEL,CAUTION",1,1,,,,,,,,,,,,,
14,1,,172141-03202,, "LABEL,CAUTION",1,1,,,,,,,,,,,,,
15,1,,172164-03530,, "LABEL,WARNING",2,2,,,,,,,,,,,,,
16,1,,172162-03241,, LABEL,1,,,,,,,,,,,,,
17,1,,172964-03480,, LABEL,1,1,,,,,,,,,,,,,
17-1,1,,172964-03481,, LABEL,1,1,,,,,N,,,M/#00993,,M/#00993,,,,,,

Fig. 92 安全銘板 (JP) SAFETY LABEL (JP)

COUNTRY	JP	EX	EP
Fig.No.	92	-	93

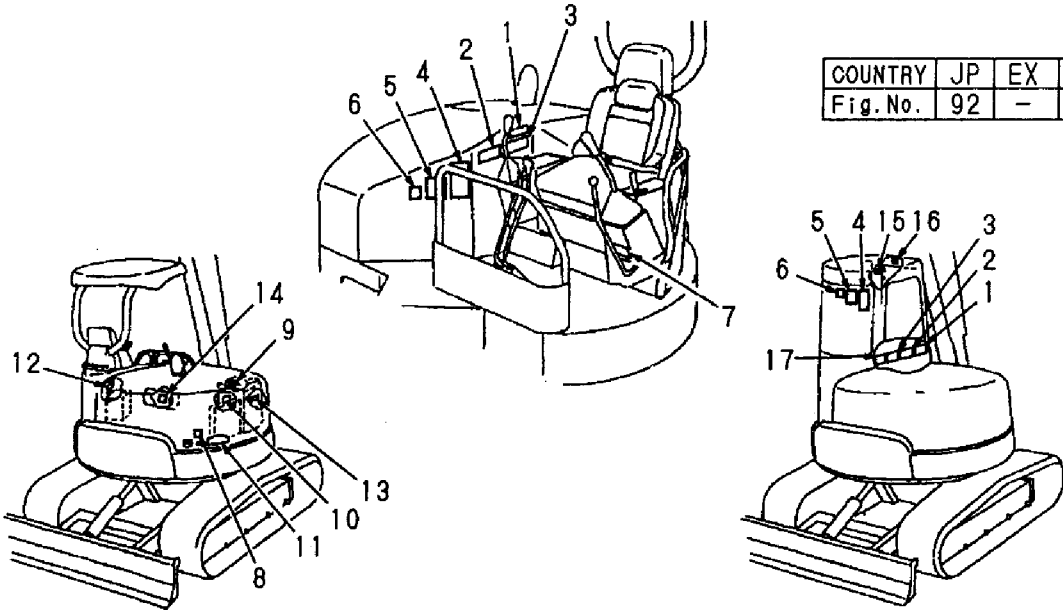

安全銘板の貼付け位置は、取扱説明書をご参照下さい。

1

2

3

4

5

6

7

8

9

10

11

12

13

14

15

16

17

17-1

取説収納庫内在中
IN THE OPERATION
MANUAL CASE

```
1,1,,172187-03600,,LABEL,1,,,,,,,,,,,,,  
2,1,,172187-03610,,LABEL,1,,,,,,,,,,,,,  
3,1,,172187-03620,,LABEL,2,,,,,,,,,,,,,  
4,1,,172171-03420,, "CAUTION PLATE ASSY",1,,,,,,,,,,,,,
```

Fig. **93** 安全銘板 (EP)
SAFETY LABEL (EP)

COUNTRY	JP	EX	EP
Fig. No.	92	-	93

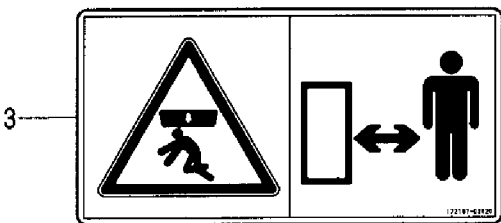
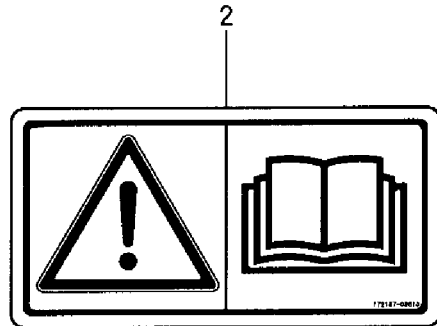
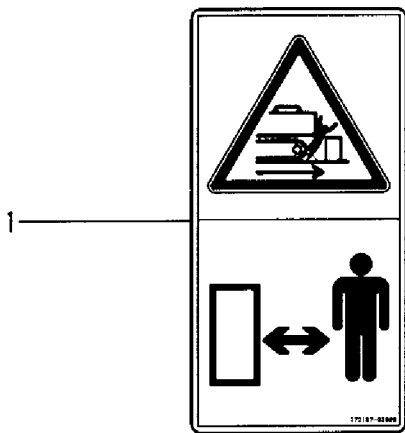
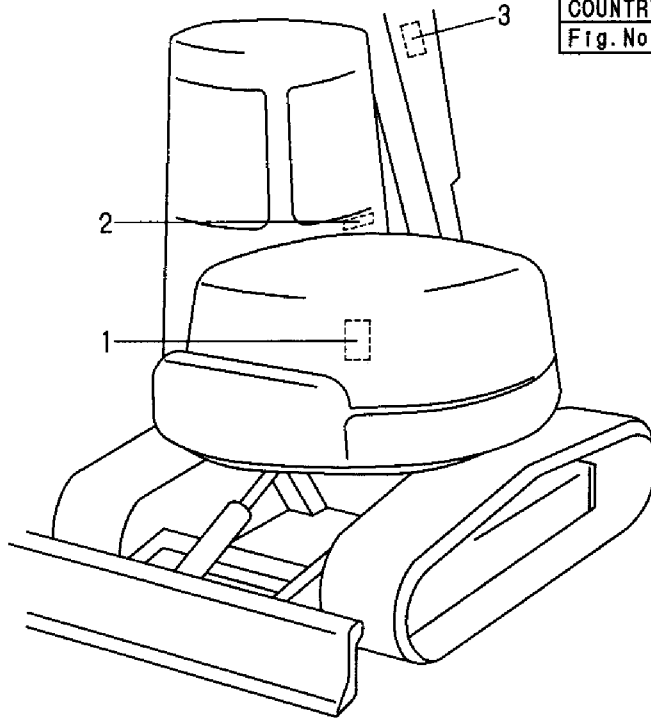

取説収納庫内在中
IN THE OPERATION
MANUAL CASE

1,1,,172176-08500,,P.T.O.KIT,1,1,,,,,1,,,,,
1-1,1,,172176-08501,,P.T.O.KIT,1,1,,,,,S,2,,M/#00870,,M/#00870,,,,,
1-2,1,,172176-08502,, "P.T.O KIT",1,1,,,,,S,2,,M/#01081,,M/#01081,,,,,
1-3,1,,172176-08503,,P.T.O.KIT,1,1,,,,,S,7,,M/#01328,,M/#01328,,,,,
2,2,,172176-74500,, "P.T.O.KIT, FRAME END",1,1,,,,,3,,,,,
3,2,,172176-74510,, "P.T.O.KIT, ARM END",1,1,,,,,4,,,,,
3-1,2,,172176-74511,, "P.T.O.KIT, ARM END",1,1,,,,,S,4,,M/#01081,,M/#01081,,,,,
4,2,,172176-74520,, "P.T.O.KIT,JOIN",1,1,,,,,5,,,,,
4-1,2,,172176-74550,, "P.T.O.KIT,JOIN",1,1,,,,,S,6,,M/#00870,,M/#00870,,,,,
4-2,2,,172176-74551,, "P.T.O. KIT",1,1,,,,,S,8,,M/#01328,,M/#01328,,,,,

Fig. 94 P.T.O. KIT

PTOキット
P.T.O. KIT

- 1 (172176-08500)
inc. Fig. 32 REF. No. 1
Fig. 77 REF. No. 1
Fig. 63 REF. No. 1
- 1-1 (172176-08501)
inc. Fig. 32 REF. No. 1
Fig. 77 REF. No. 1
Fig. 63 REF. No. 1A
- 1-2 (172176-08502)
inc. Fig. 32 REF. No. 1
Fig. 77 REF. No. 1-1
Fig. 63 REF. No. 1A
- 1-3 (172176-08503)
inc. Fig. 32 REF. No. 1
Fig. 77 REF. No. 1-1
Fig. 63 REF. No. 1A-1

PTOキット (合流)
P.T.O. KIT (CONFLUENCE)

- 4 (172176-74520)
inc. Fig. 63 REF. No. 2 ~ 20
inc. Fig. 72 REF. No. 1 ~ 25
- 4-1 (172176-74550)
inc. Fig. 63 REF. No. 2 ~ 20
inc. Fig. 73 REF. No. 1 ~ 26
- 4-2 (172176-74551)
inc. Fig. 63 REF. No. 2 ~ 20
inc. Fig. 74 REF. No. 1 ~ 27

PTOキット (フレームエンド)
P.T.O. KIT (FRAME END)

- 2 (172176-74500)
inc. Fig. 32 REF. No. 2 ~ 56

Fig. 32 操縦装置 (PTOコントロール)
CONTROL EQUIP. (P.T.O. CONTROL)

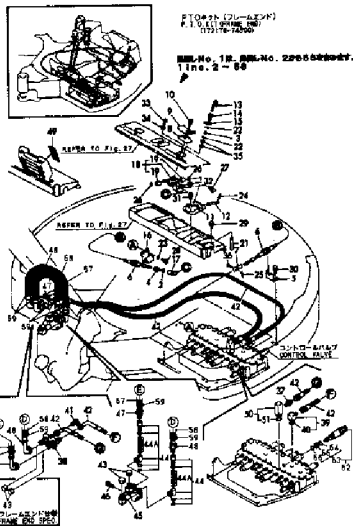

PTOキット (アームエンド)
P.T.O. KIT (ARM END)

- 3 (172176-74510)
inc. Fig. 77 REF. No. 2 ~ 27
- 3-1 (172176-74511)
inc. Fig. 77 REF. No. 2-2 ~ 31

Fig. 77 油圧配管 (PTOバルブ、ブーム)
HYD. OIL PIPING (P.T.O. VALVE, BOOM)

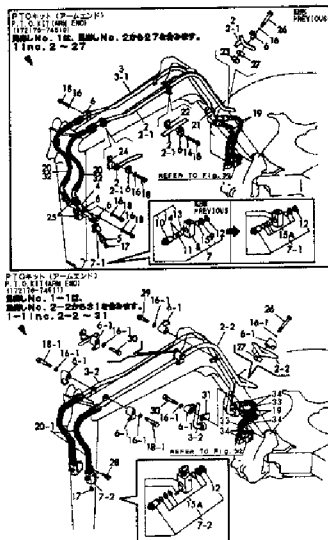

Fig. 63 PTOバルブ
P.T.O. VALVE

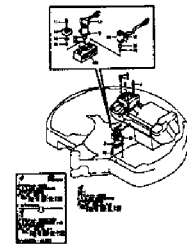

Fig. 72 油圧配管 (PTOバルブ、フレーム) (旧形)
HYD. OIL PIPING (P.T.O. VALVE, FRAME) (PREVIOUS)

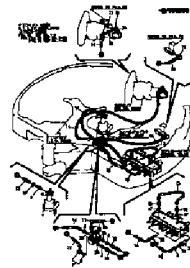

Fig. 73 油圧配管 (PTOバルブ、フレーム) (旧形)
HYD. OIL PIPING (P.T.O. VALVE, FRAME) (PREVIOUS)

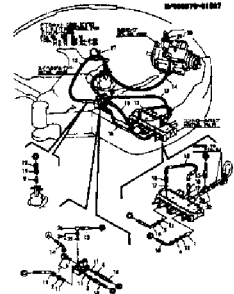
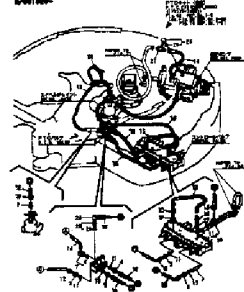

Fig. 74 油圧配管 (PTOバルブ、フレーム) (新形)
HYD. OIL PIPING (P.T.O. VALVE, FRAME) (NEW)



[Info]

PcNo=Y00K2912

PcName=VIO50

JpnUse=1

JpnSec1=Ēš<@

JpnSec2=fofbfNfz [

JpnSec3=VIO

JpnPreface=1

EngUse=1

EngSec1=CONSTRUCTION

EngSec2=EXCAVATOR (Vio)

EngSec3=VIO

EngPreface=1