

PREFACE

1. This parts catalog carries Yanmar crawler back - hoe V1040.
2. Parts catalog history

	Parts catalog No.	Published	Remarks
1st edition	000Y00K2890	May., 1994	Abolish old edition
1st revised	000Y00K2891	Oct., 1995	Abolish old edition
2nd revised	000Y00K2892	Jan., 1998	

3. Model name

SECTION	Column	Model name	Manufactured	M/#
I (Vehicle)	(A)	V1040 C(R)	1993/ 6 ~1997/ 6	00501~02611
	(B)	V1040 P(R)		
II (Engine)	(A)	3TNE88L - RBV	1993/ 6 ~1997/ 6	00101~14249

(Note) C:cabin, P:canopy, R:rubber crawler, JP:Japan, EP:Europe,
EX:export except Europe

4. Your understanding is asking that this parts catalog is not a technical data manual setting forth as servicing procedures, This parts catalog is using simplified illustration. Be sure to use Yanmar Genuine Parts in your maintenance servicing of Yanmar products. Be careful not to use the simple parts available in the market ; otherwise their use in repairing causes such as an early breakage, for instance.

SPECIFICATIONS

Name			YANMAR CRAWLER BACHOE	
Model			VIO40-P[R]	VIO40-C[R]
Engine	Model		3TNE88L-RBV	
	Type		Vertical 3-cylinder water-cooled diesel	
Dimensions	Transport length	mm	5000	
	Transport width	mm	1810 [1840]	
	Transport height	mm	2425	2470
Std. bucket capacity		m ³	0.11	
Std. bucket width(Outside)		mm	640	
Max. digging depth		mm	3400(Blade)	
Max. cutting height		mm	5300	4900
Max. dump height		mm	3920	3550
Max. reach at ground level		mm	5300	
Min. swing radius		mm	2000(Swing 1650)	2100(Swing 1750)
Boom swing angle		degree	Left 70 & Right 70	
Max. digging force(Std. bucket)		kgf	2750	
Travel speed(High/Low)		km/h	4.1 [4.3]/2.2 [2.3]	
Gradability		degree	30	
Average ground pressure		kgf/cm ²	0.27 [0.25]	0.28 [0.26]
Track shoe width(Std.)		mm	370 [400]	
Blade	Width×height	mm	1840×350	
	Capacity	m ³	0.22	
Machine mass		kg	4000	4120

[] shows to the specification of rubber crawler.

1 [本機塗装色] [PAINTED COLOR LIST]

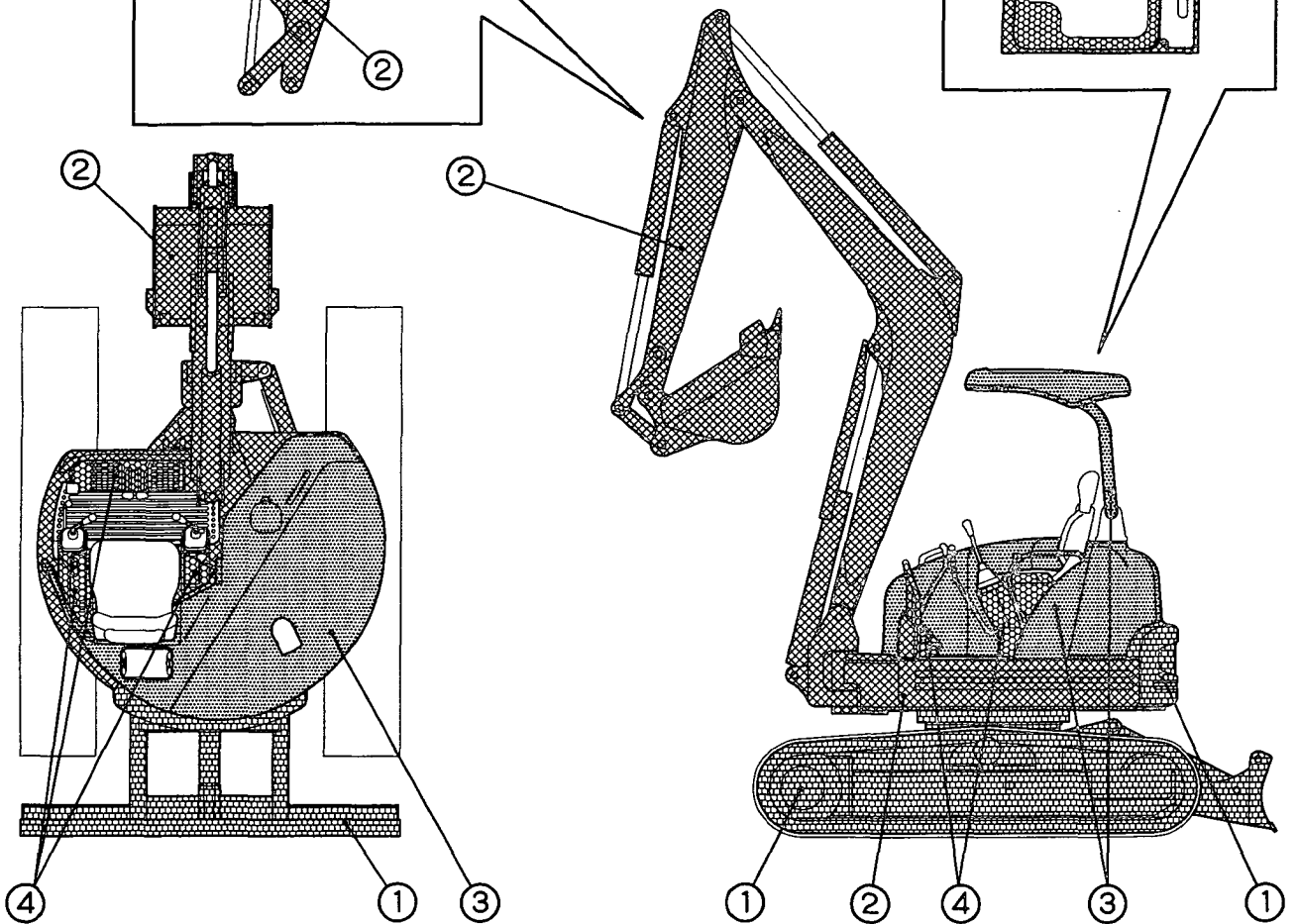
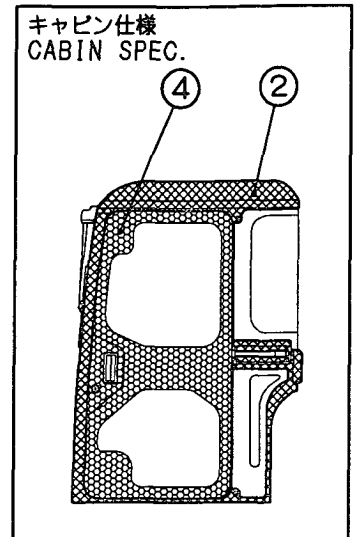
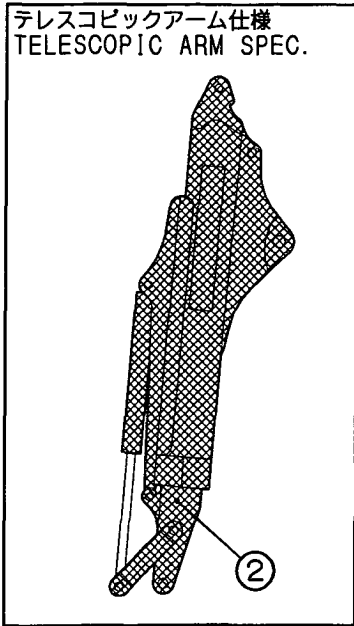

部所 PART	表示 DESC RIPTION	塗装色 マンセル記号	PAINTED COLOR MUNSEL No.	色区分 COLOR CODE
①		ヤンマーオーシャングリーン 7.62BG3/8.09	YANMAR OCEAN GREEN 7.62BG3/8.09	98
②		ヤンマーピーコックグリーン 3.85BG5.31/9.15	YANMAR PEACOCK GREEN 3.85BG5.31/9.15	97
③		ヤンマーシトラスグリーン 4.84GY8.42/6.99	YANMAR CITRUS GREEN 4.84GY8.42/6.99	96
④		ヤンマーダークオリーブグレー 5.39Y2.92/0.78	YANMAR DARK OLIVE GRAY 5.39Y2.92/0.78	72

2 [塗料部品番号] [PAINT PART No.]

部所 PART	塗装色 PAINTED COLOR	塗料部品番号 PAINT No.		
		16ℓ缶 16ℓCAN	4ℓ缶 4ℓCAN	スプレー SPRAY
①	ヤンマーオーシャングリーン YANMAR OCEAN GREEN	981101-09598	977620-40980	977620-30981
②	ヤンマーピーコックグリーン YANMAR PEACOCK GREEN	981101-09597	977620-40970	977620-30971
③	ヤンマーシトラスグリーン YANMAR CITRUS GREEN	981101-09599	977620-40990	977620-30991
④	ヤンマーダークオリーブグレー YANMAR DARK OLIVE GRAY	-----	977620-40720	TOR-90460003

3 [塗装色部品の表現] [EXPRESSION OF PAINTED PARTS]

部品番号 PART NO.	部品名 PART NAME	塗装色 PAINTED COLOR
172137-17401 -4	カバー, ランプ (グリーン: 97) COVER, WORK LAMP (GREEN: 97)	ヤンマーピーコックグリーン YANMAR PEACOCK GREEN

(注) 部品名末尾の () 内は塗装色を示す。
(NOTE) () at the end of part name shows Paint Color.

4 [主要部品の塗装色] [COLOR OF MAIN PARTS]

部所 PART	塗装色 PAINTED COLOR	主な部品 MAIN PARTS
①	ヤンマーオーシャングリーン YANMAR OCEAN GREEN	下部走行体 ブレード カウンターウエイト スイングシリンダ ブレードシリンダ UNDER TRAVELING BODY BLADE COUNTER WEIGHT SWING CYLINDER BLADE CYLINDER
②	ヤンマーピーコックグリーン YANMAR PEACOCK GREEN	ターニングフレーム キャビン ブーム アーム バケット スイングシリンダカバー フロントカバー TURNING FRAME CABIN BOOM ARM BUCKET SWING CYLINDER COVER FRONT COVER
③	ヤンマーシトラスグリーン YANMAR CITRUS GREEN	カバー (FOキャップ) ボンネット キャノピ ポール (キャノピ) カバー L COVER (FO CAP) BONNET CANOPY POLE (CANOPY) COVER L
④	ヤンマーダークオリーブグレー YANMAR DARK OLIVE GRAY	ステップ レバー類 インパネ ペダルカバー エンジン廻り STEP LEVER INSTRUMENT PANEL PEDAL COVER ENGINE RELATED PART

絵目次 (1) 主要部品 PICTURESQUE INDEX (1) . . . MAIN PARTS

銘板 . . . FIG. 1~5
LABEL
工具 . . . FIG. 6
TOOL
安全銘板 . . . FIG. 102, 103
SAFETY LABEL
PTOキット . . . FIG. 104
P. T. O. KIT

コンプレッサー&Vプーリ . . . FIG. 11
COMPRESSOR & V PULLEY
ラジエータ&オイルクーラ . . . FIG. 12
RADIATOR & OIL COOLER
燃料タンク&燃料パイプ . . . FIG. 16
FUEL TANK & FUEL PIPE
作動油タンク . . . FIG. 75
HYD. OIL TANK

カバー . . . FIG. 14
COVER
ラジオカセット . . . FIG. 23, 24
RADIO CASSETTE
フレームカバー . . . FIG. 36
FRAME COVER
シート&シートマウント . . . FIG. 37
SEAT & SEAT MOUNT
ステップ . . . FIG. 38
STEP
ボンネット . . . FIG. 39
BONNET
ダクト . . . FIG. 40
DUCT
キャビン . . . FIG. 41~43
CABIN
キャビンドア . . . FIG. 44
CABIN DOOR
キャノピ&キャノピフレーム . . . FIG. 45
CANOPY & CANOPY FRAME

吸気パイプ&排気パイプ . . . FIG. 7
SUC. PIPE & EXH. PIPE
エンジンマウント . . . FIG. 10
ENGINE MOUNT
バッテリー . . . FIG. 16
BATTERY
電装品 . . . FIG. 17~20
ELECTRIC PART
ヒータ&デフロスタ . . . FIG. 22
HEATER & DEFROSTER
油圧ポンプ&軸継手 . . . FIG. 46, 47
HYD. OIL PUMP & JOINT

ブーム&ブームブラケット . . . FIG. 95
BOOM & BOOM BRACKET

ワークランプ . . . FIG. 21
WORK LAMP

アームシリンダ . . . FIG. 50
ARM CYLINDER

ブームシリンダ . . . FIG. 48, 49
BOOM CYLINDER

スイングシリンダ . . . FIG. 54
SWING CYLINDER

ブレードシリンダ . . . FIG. 55
BLADE CYLINDER
ブレード . . . FIG. 101
BLADE

バケットシリンダ . . . FIG. 51, 52
BUCKET CYLINDER
アーム&バケットリンク . . . FIG. 96
ARM & BUCKET LINK
バケット . . . FIG. 98~100
BUCKET

スライドシリンダ . . . FIG. 53
SLIDE CYLINDER
テレスコピックアーム&バケットリンク . . . FIG. 97
TELESCOPIC ARM & BUCKET LINK

パイピング . . . FIG. 13
PIPING
ローハイバルブ . . . FIG. 74
LOW-HIGH VALVE
油圧配管 . . . FIG. 76~87
HYD. OIL PIPING
コントロール配管 . . . FIG. 88~93
CONTROL PIPING
遠隔グリースング . . . FIG. 94
GREASING

ローラ&アジャスト . . . FIG. 25
ROLLER & ADJUST
クローラ . . . FIG. 26
CRAWLER

走行モータ . . . FIG. 56
TRAVEL MOTOR

フレーム&旋回ベアリング . . . FIG. 35
FRAME & TURNING BEARING
旋回モータ . . . FIG. 57, 58
TURNING MOTOR
スィベルジョイント . . . FIG. 59
SWIVEL JOINT
コントロールバルブ . . . FIG. 60~69
CONTROL VALVE
PTOバルブ . . . FIG. 70
P. T. O. VALVE
2ウェイバルブ . . . FIG. 72
2-WAY VALVE
ロータリバルブ . . . FIG. 73
ROTARY VALVE

アクセラ . . . FIG. 8, 9
ACCELERATOR
操縦装置 . . . FIG. 27~33
CONTROL EQUIP.
PTOコントロール . . . FIG. 34
P. T. O. CONTROL
リモコンバルブ . . . FIG. 71
REMOTE CONTROL VALVE

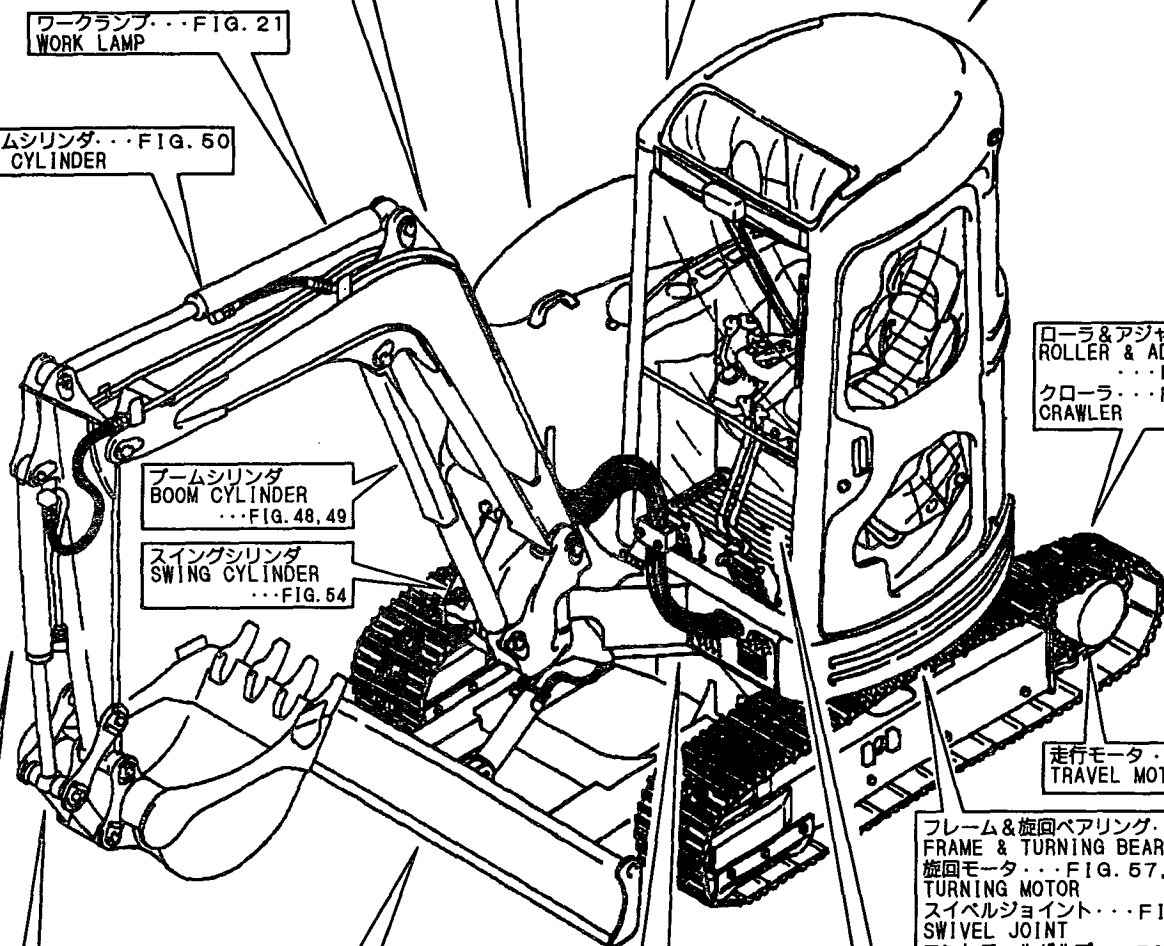

絵目次 (2) 油圧関係 PICTURESQUE INDEX (2) . . . HYDRAULIC SECTION

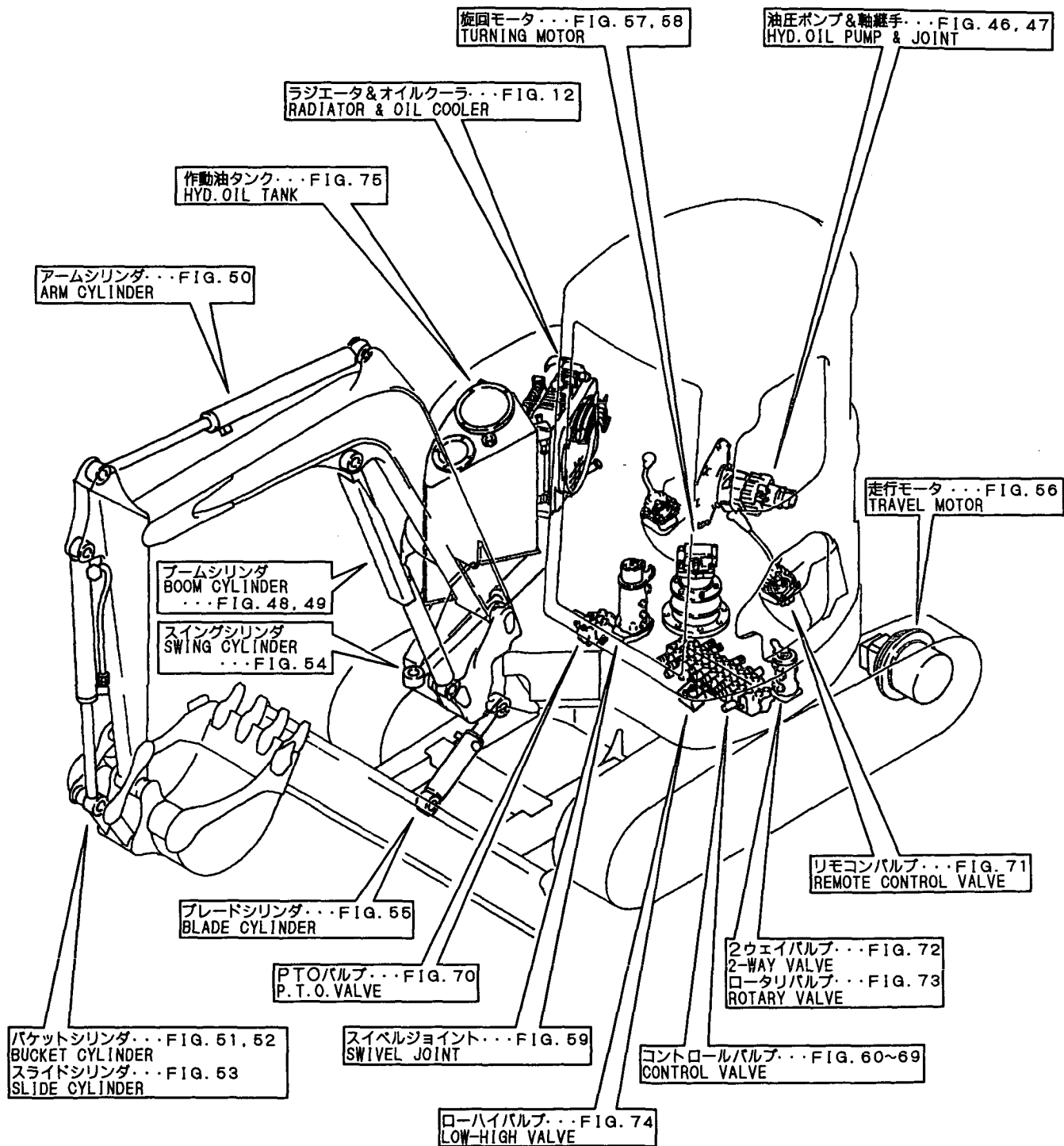

絵目次 (3) 項目別 PICTURESQUE INDEX (3) FIGURE

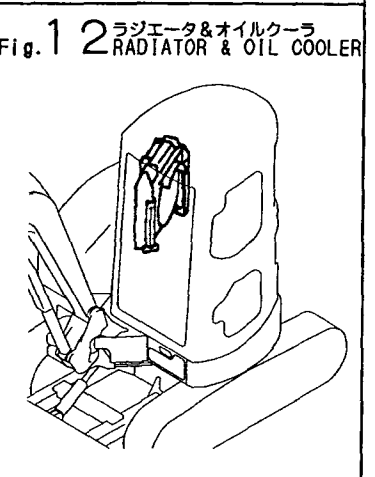
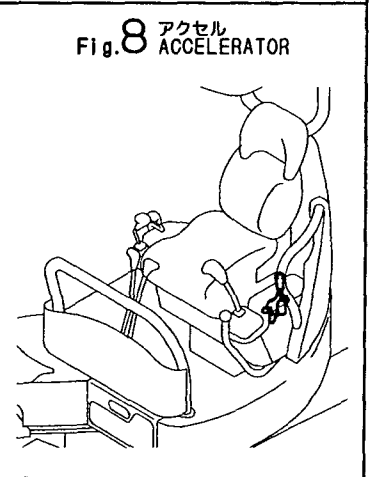
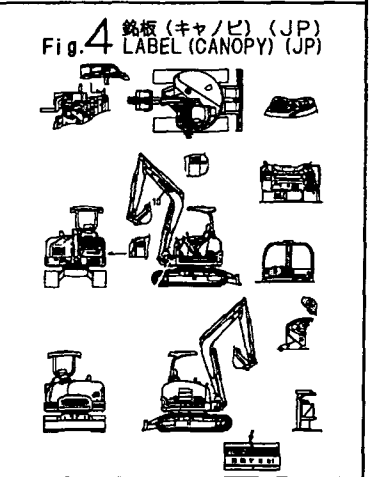
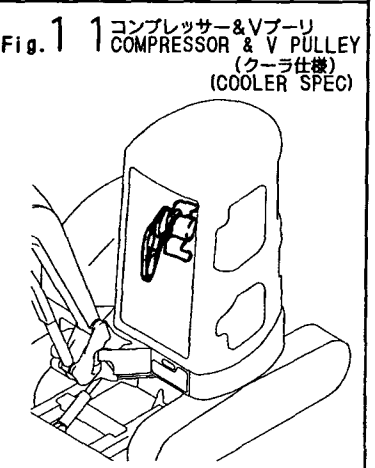
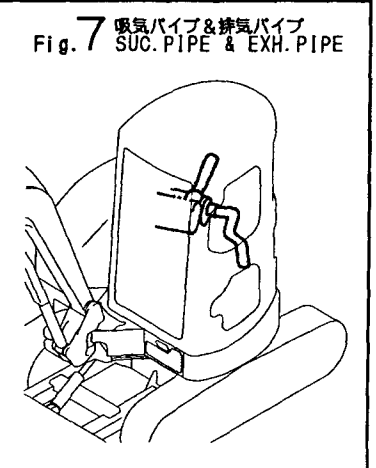
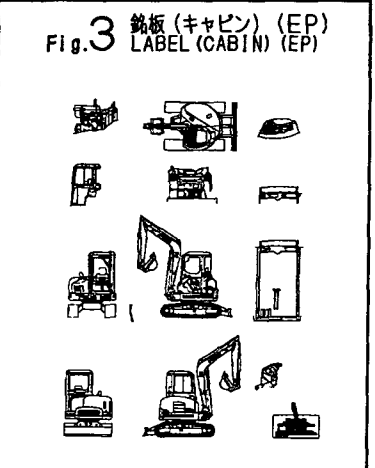
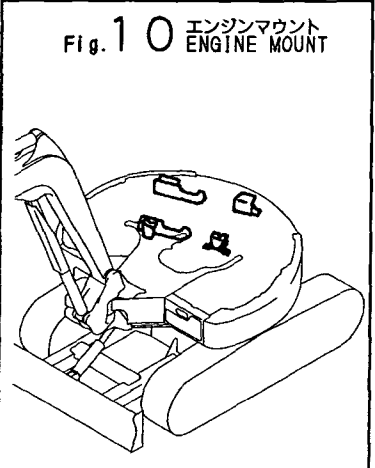
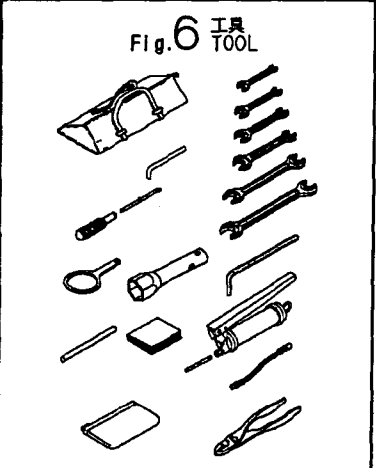
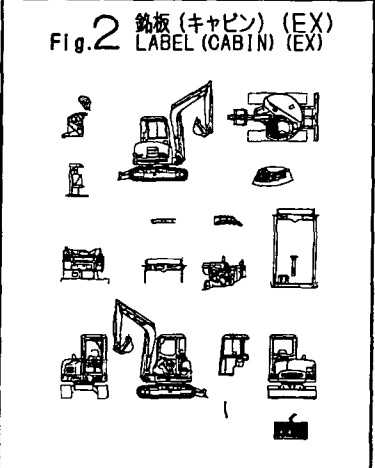
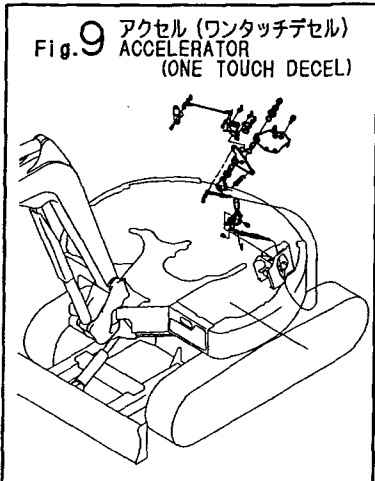
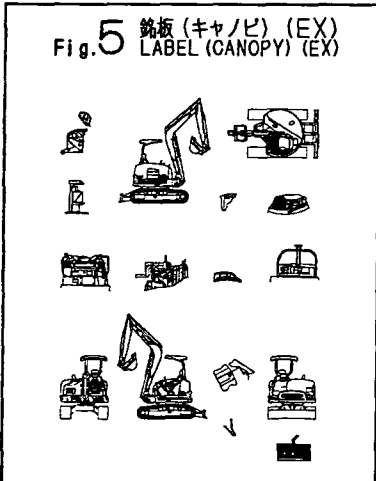
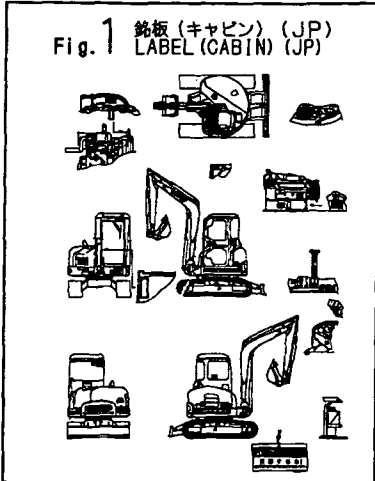

絵目次 (3) 項目別
PICTURESQUE INDEX (3) FIGURE

Fig.13 パイピング (クーラー仕様)
PIPING (COOLER SPEC.)

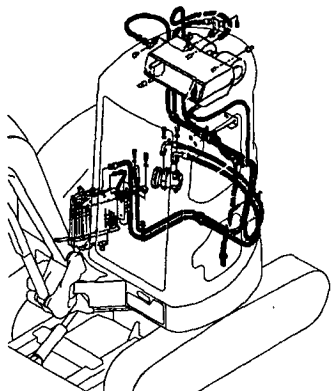

Fig.17 電装品
ELECTRIC PART
(キャビン、キャノピ)
(CABIN, CANOPY)

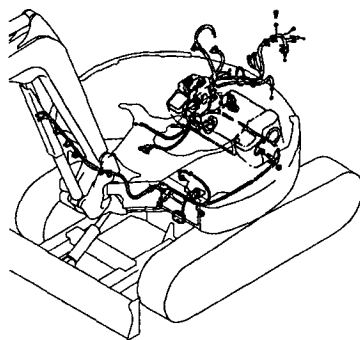

Fig.21 ワークランプ
WORK LAMP

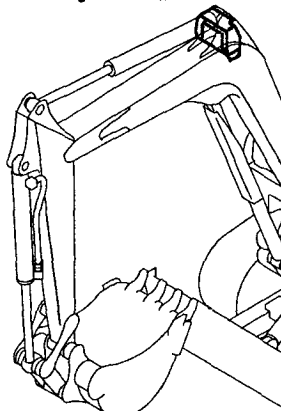

Fig.14 カバー (クーラー仕様)
COVER (COOLER SPEC.)

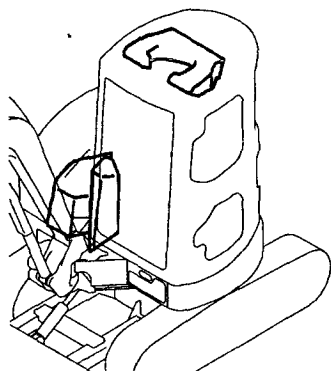

Fig.18 電装品 (キャビン、キャノピ)
ELECTRIC PART
(ワンタッチデセル)
(CABIN, CANOPY/ONE TOUCH DECEL)

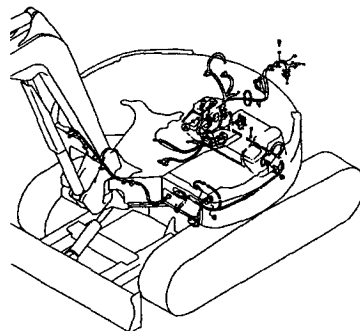

Fig.22 ヒータ&デフロスタ
HEATER & DEFROSTER
(オプション)
(OPTIONAL)

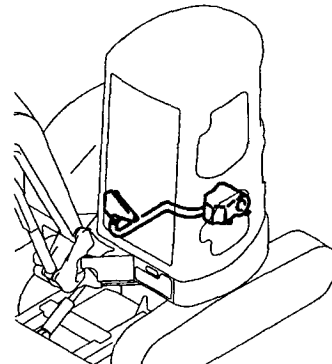

Fig.15 燃料タンク&燃料パイプ
FUEL TANK & FUEL PIPE

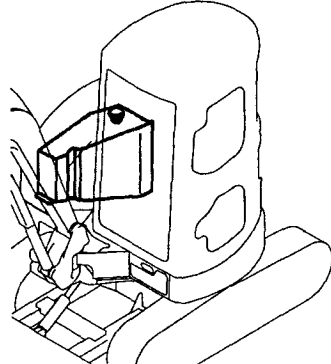

Fig.19 電装品 (キャビン)
ELECTRIC PART
(CABIN)

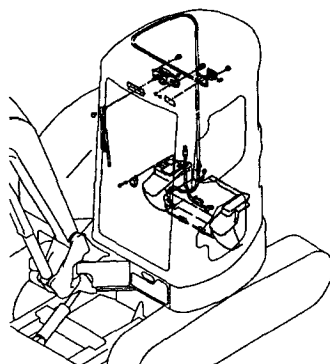

Fig.23 ラジオカセット (オプション)
RADIO CASSETTE
(OPTIONAL)

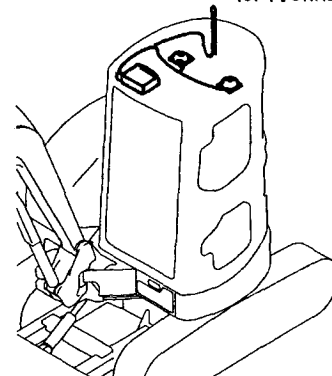

Fig.16 バッテリー
BATTERY

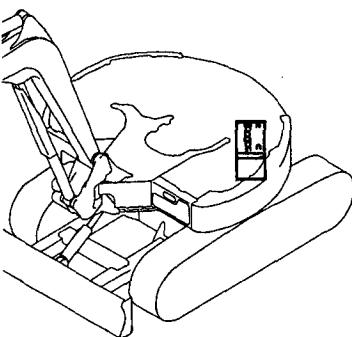

Fig.20 電装品 (クーラー仕様)
ELECTRIC PART
(COOLER SPEC.)

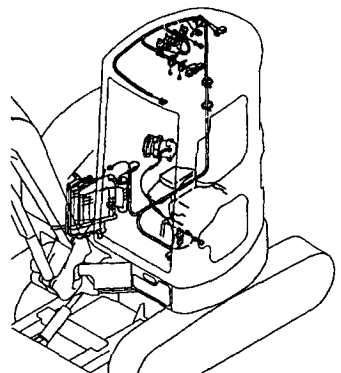
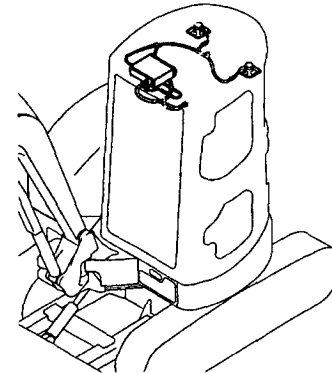
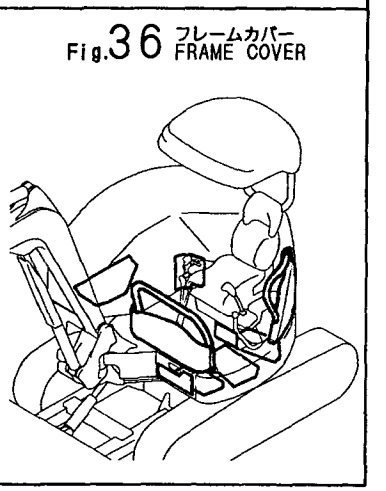
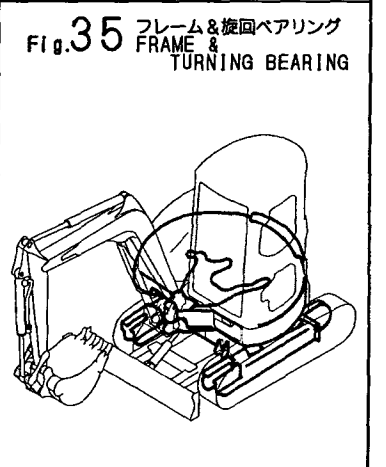
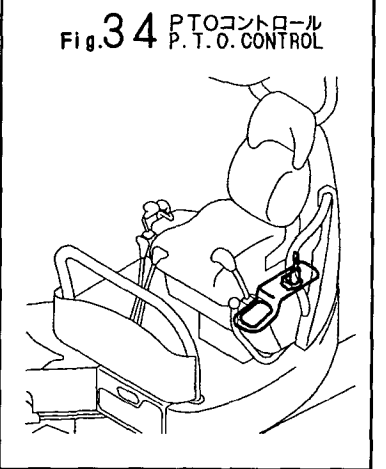
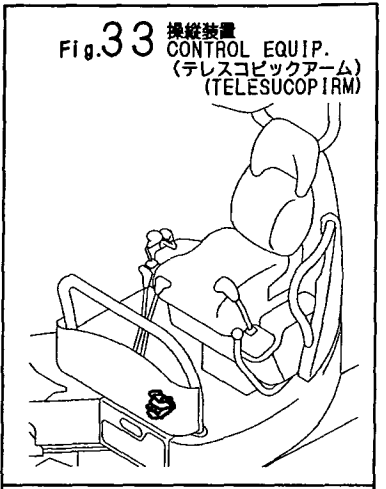
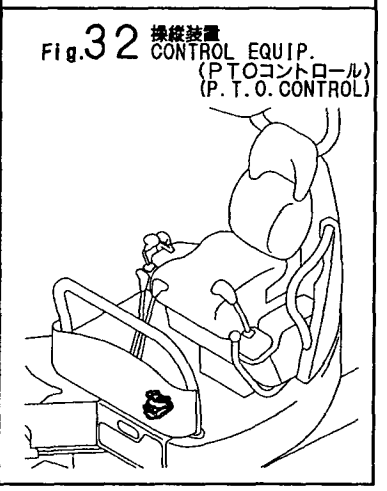
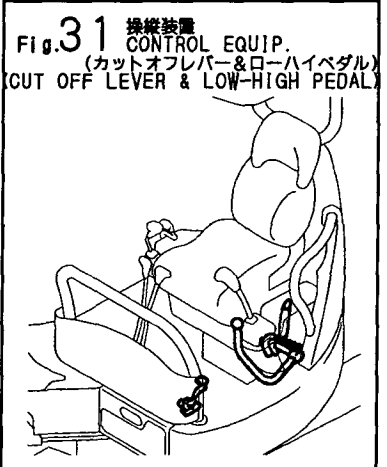
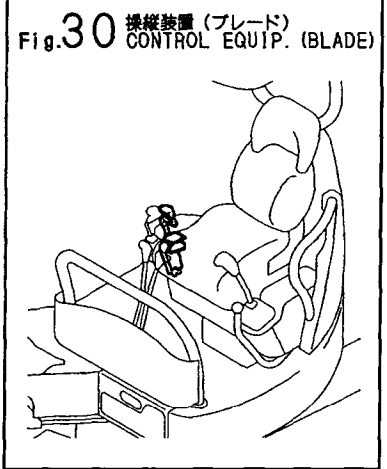
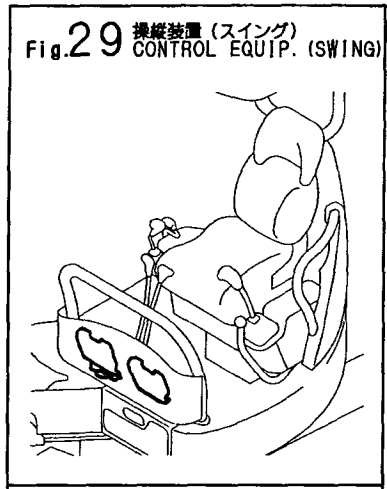
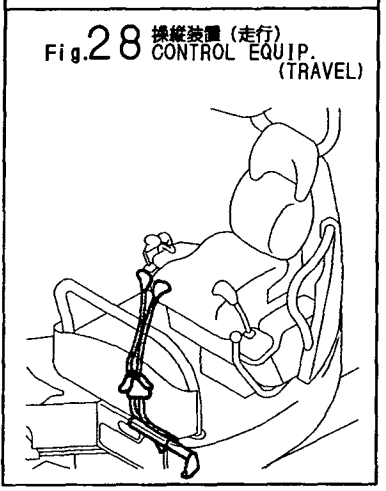
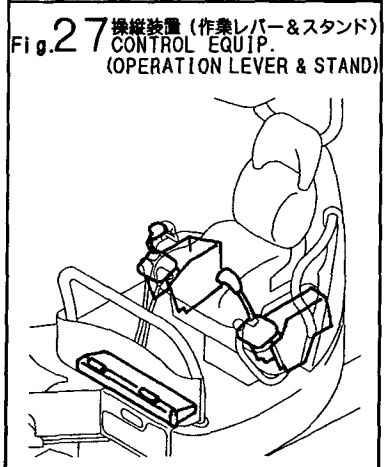
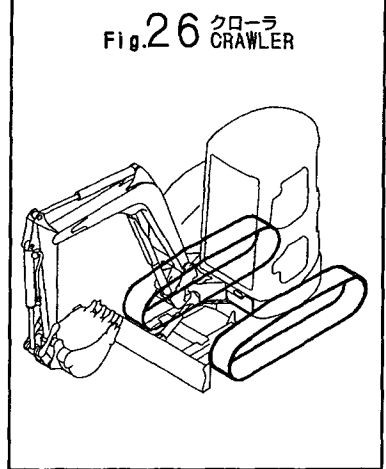
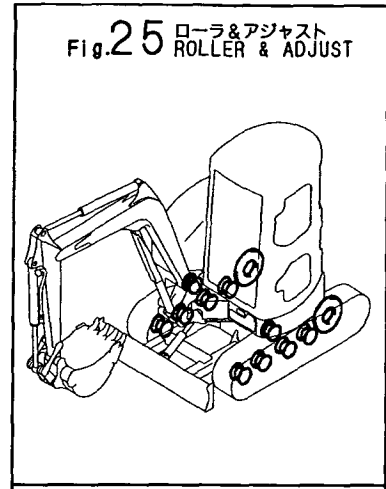

Fig.24 ラジオカセット (EP)
RADIO CASSETTE (EP)



絵目次 (3) 項目別
PICTURESQUE INDEX (3) FIGURE



絵目次 (3) 項目別
PICTURESQUE INDEX (3) FIGURE

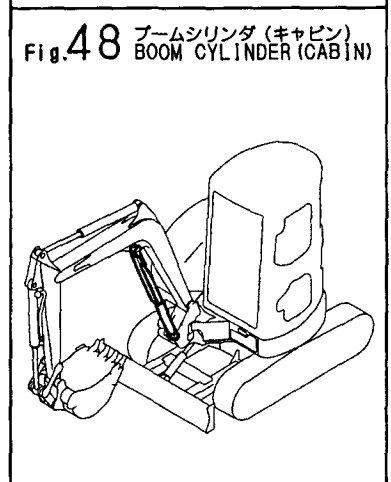
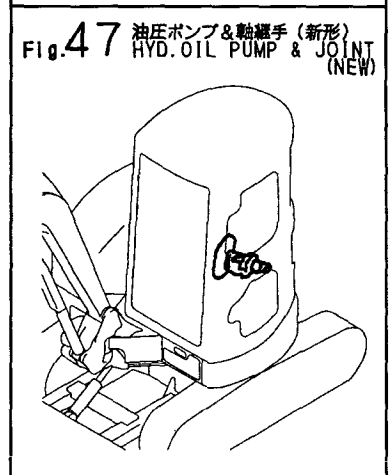
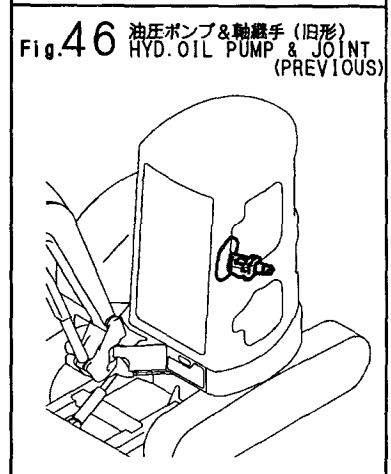
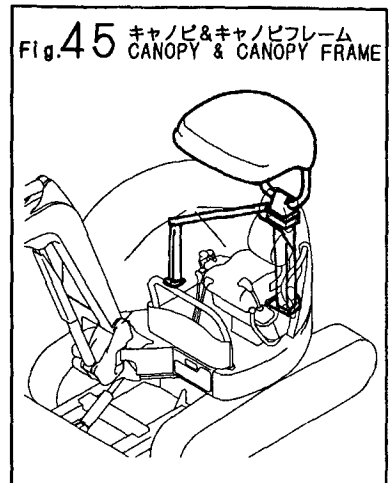
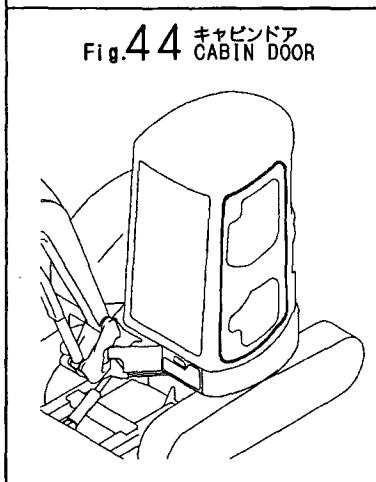
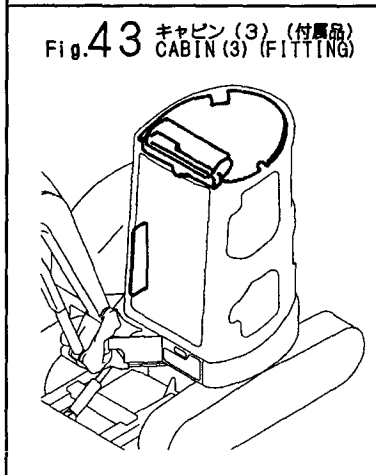
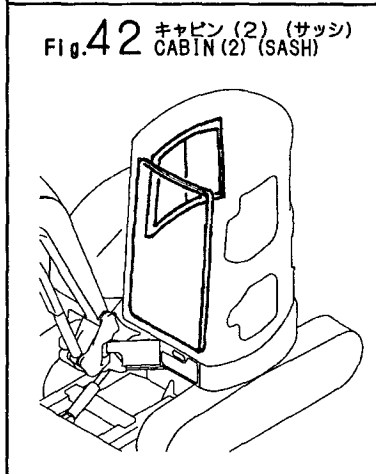
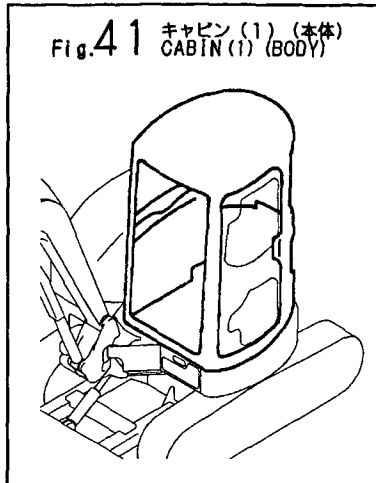
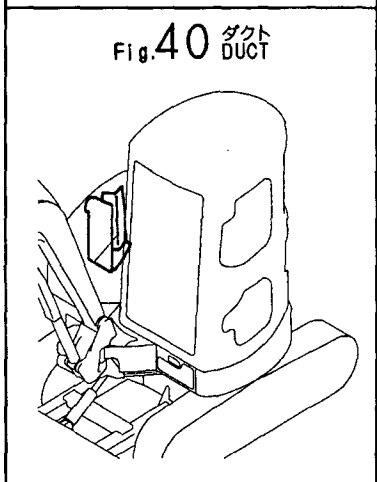
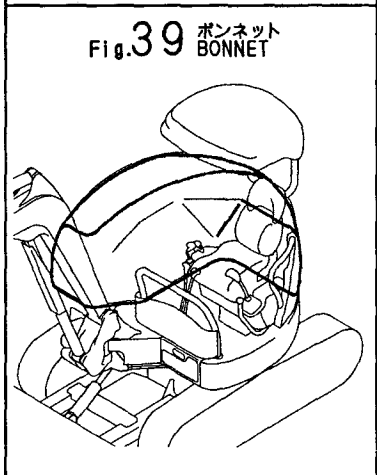
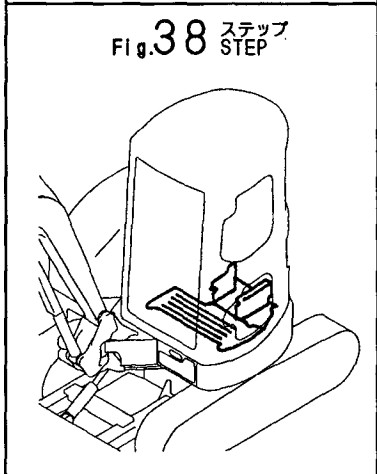
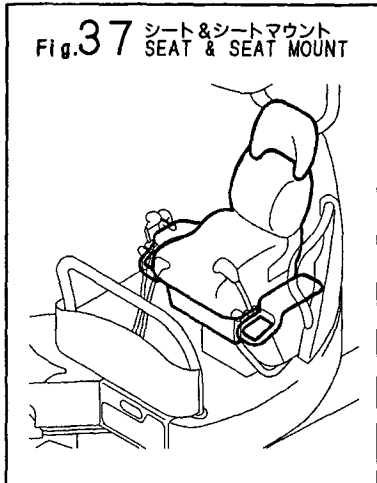

絵目次 (3) 項目別
PICTURESQUE INDEX (3) FIGURE

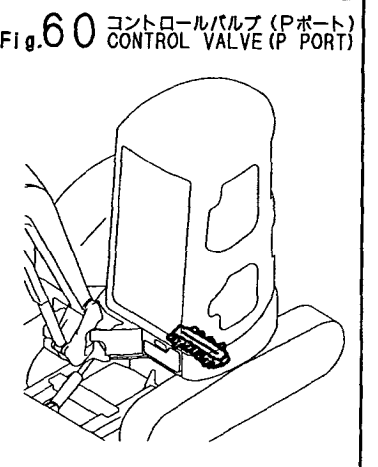
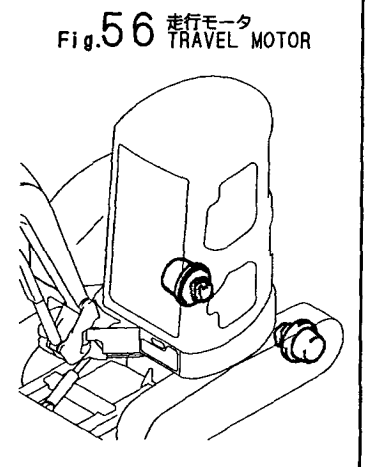
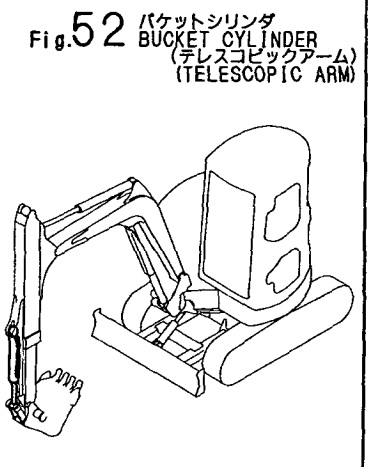
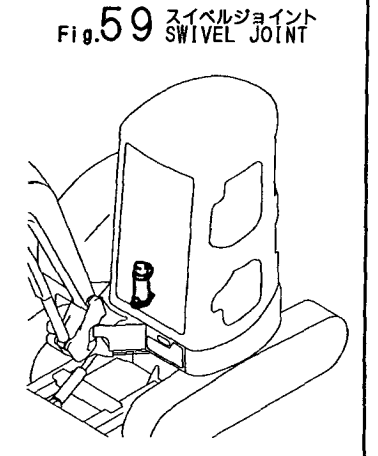
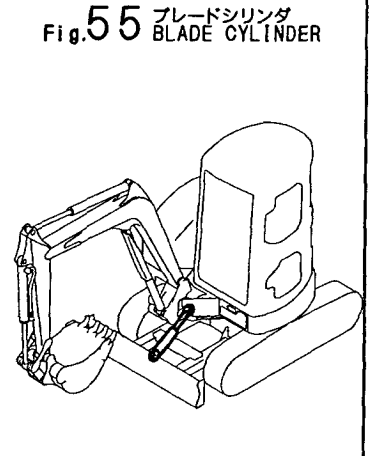
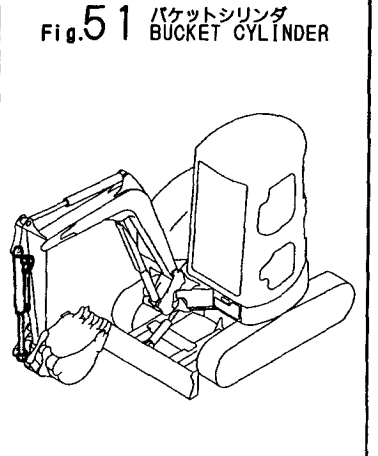
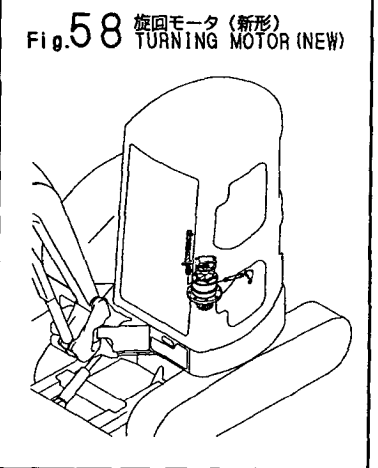
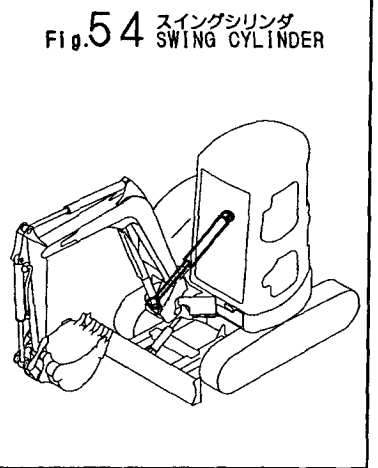
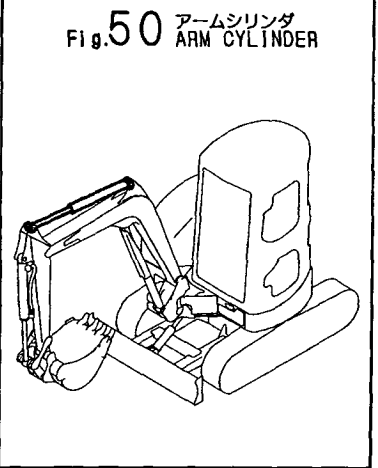
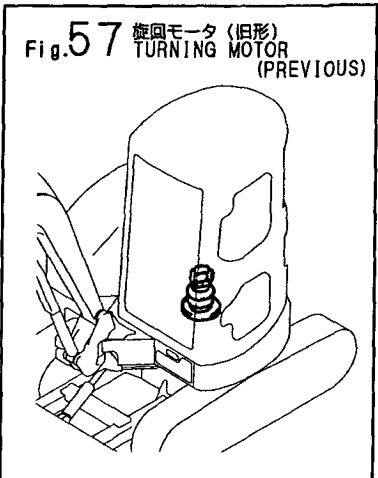
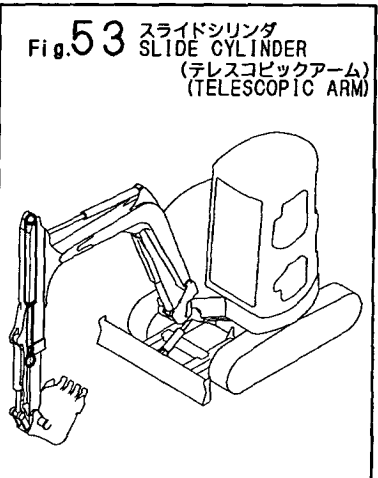
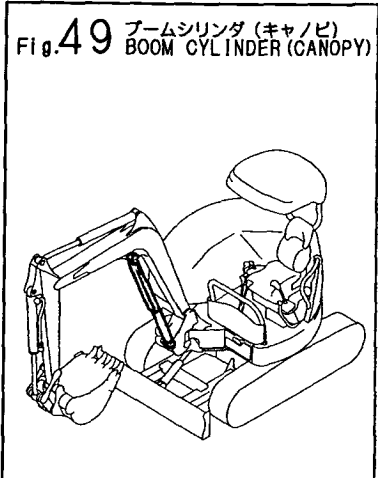

絵目次 (3) 項目別 PICTURESQUE INDEX (3) FIGURE

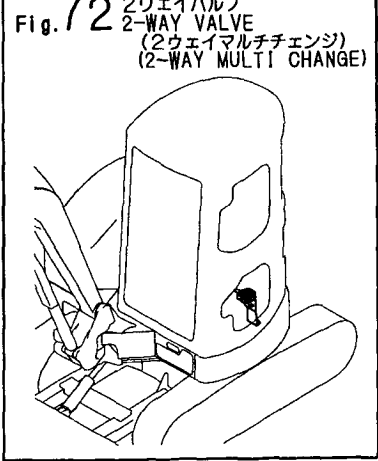
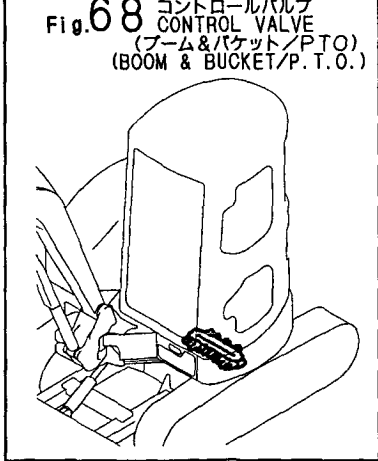
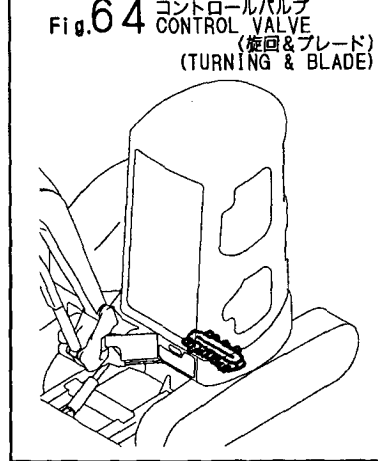
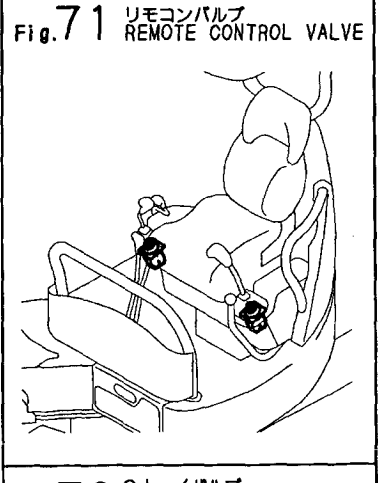
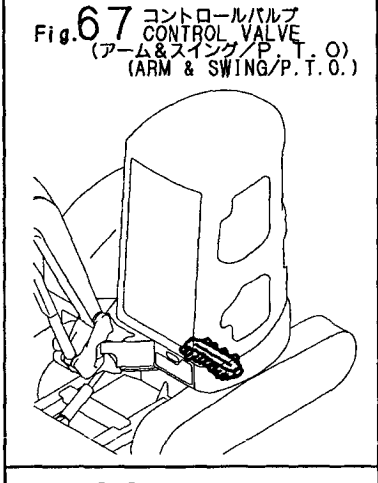
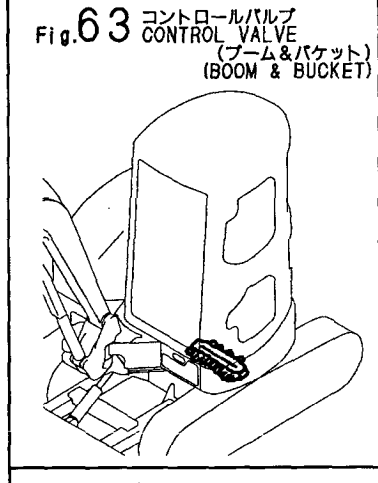
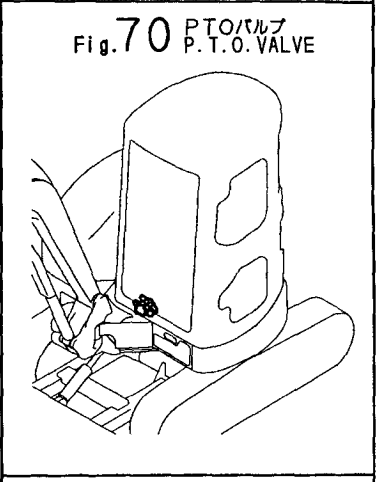
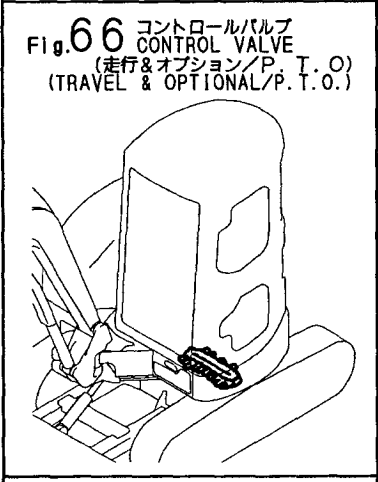
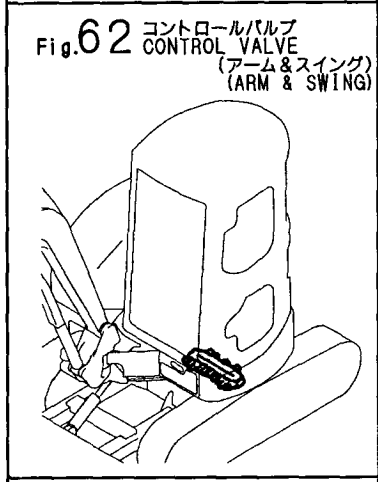
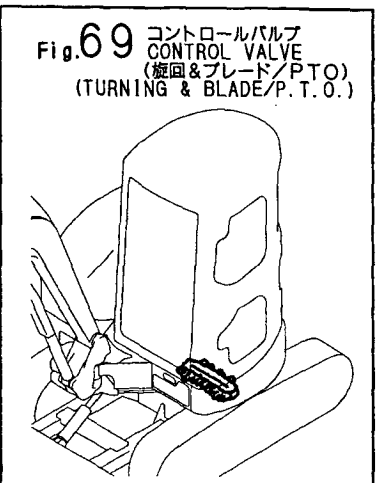
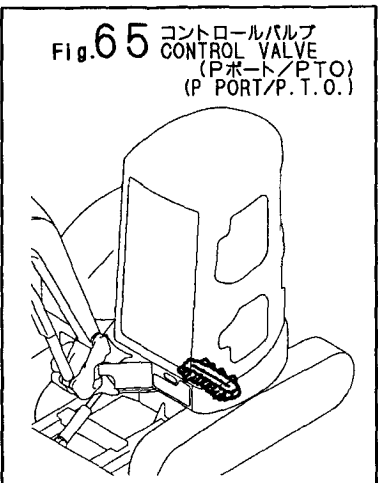
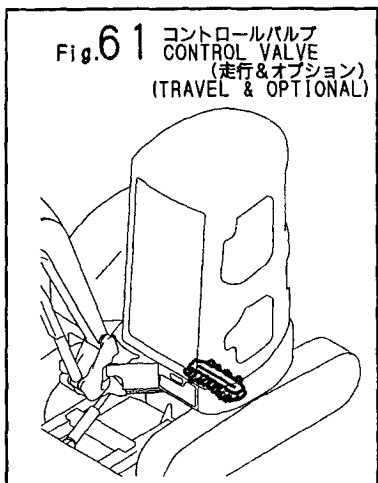

絵目次 (3) 項目別 PICTURESQUE INDEX (3) FIGURE

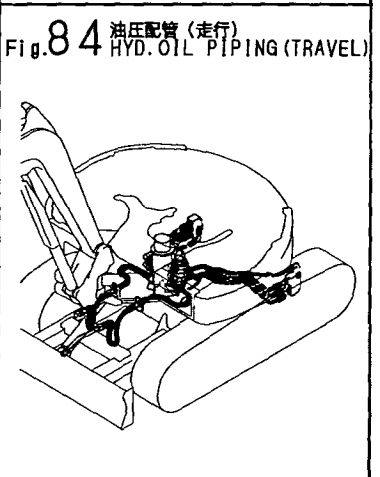
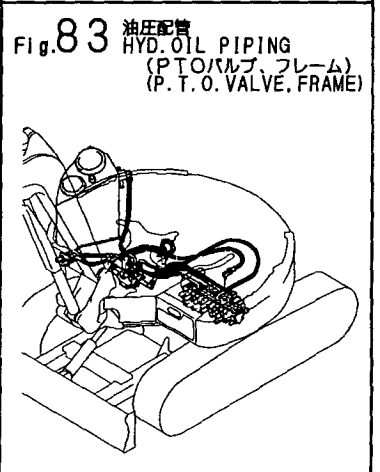
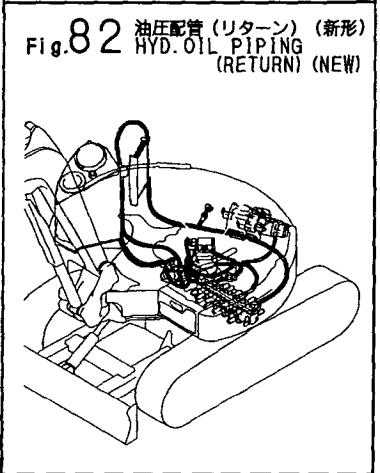
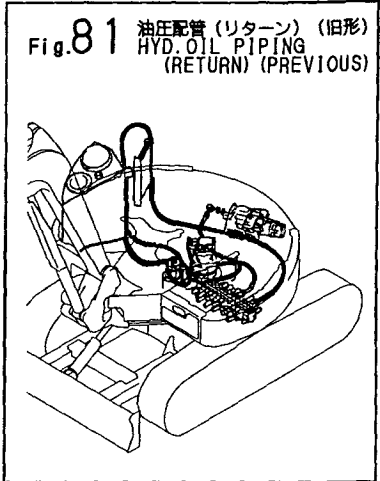
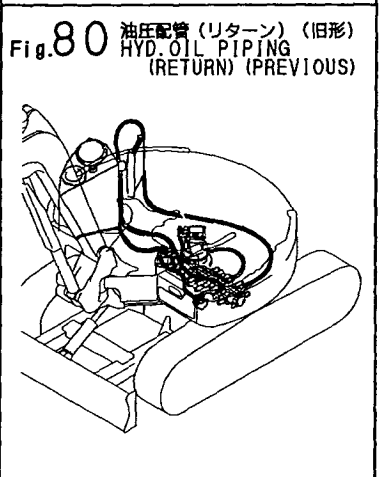
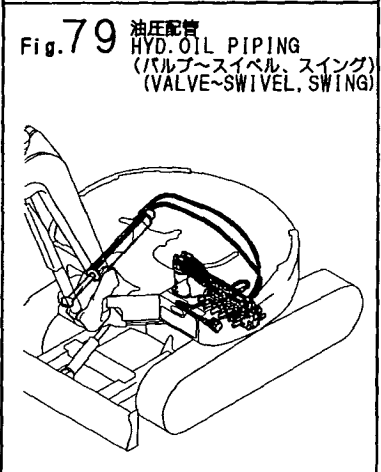
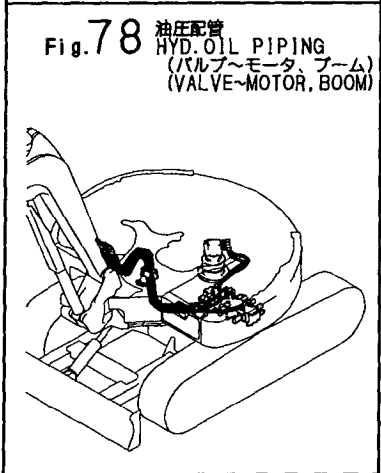
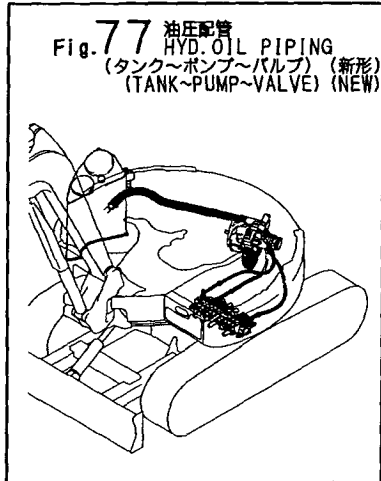
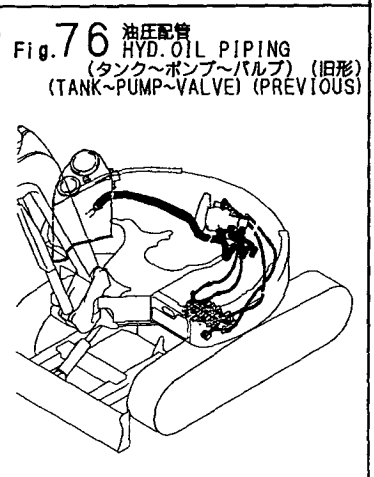
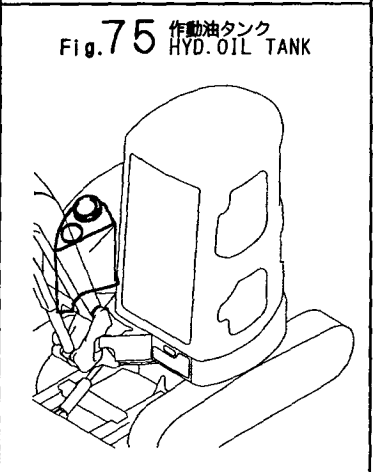
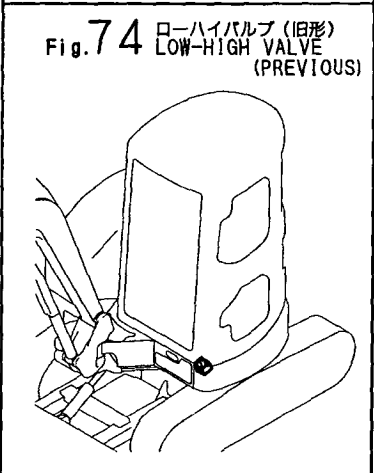
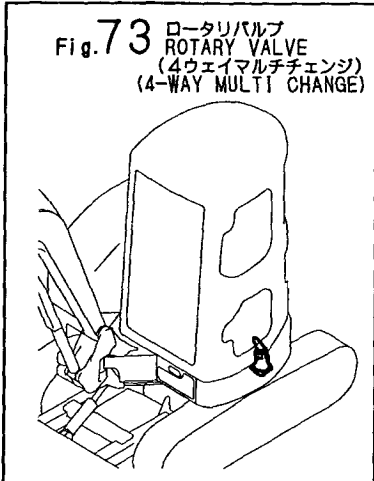

絵目次 (3) 項目別 PICTURESQUE INDEX (3) FIGURE

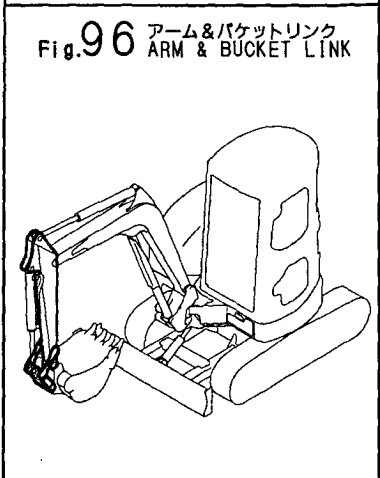
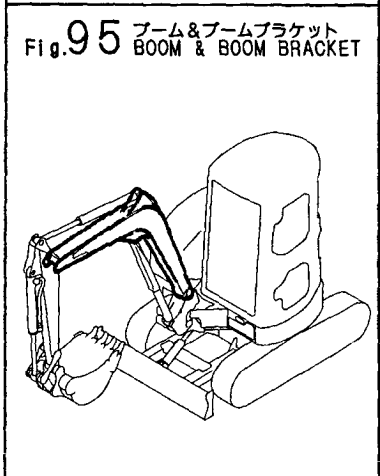
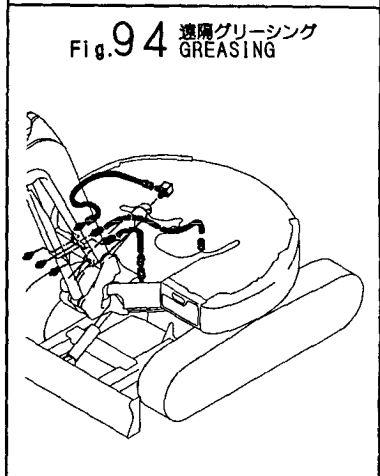
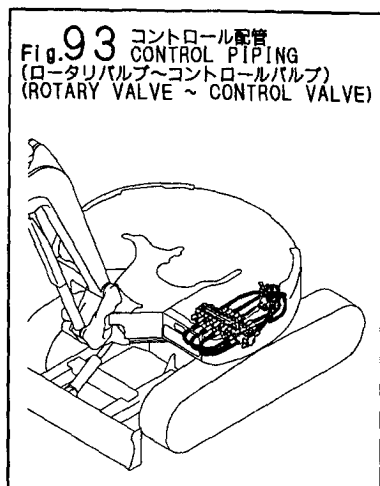
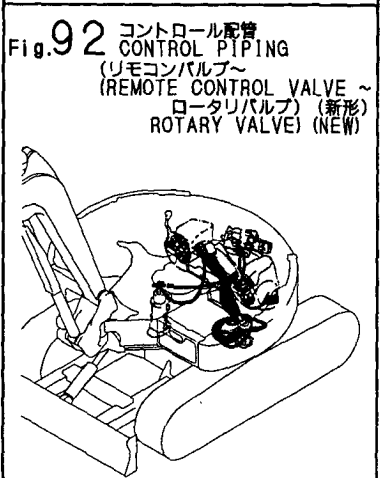
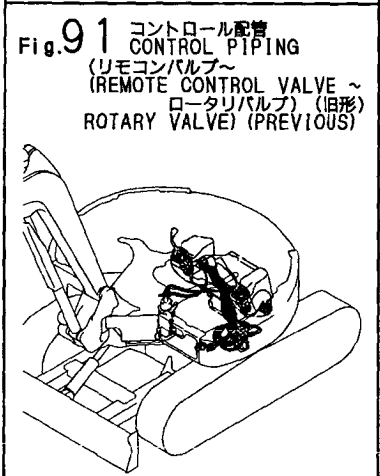
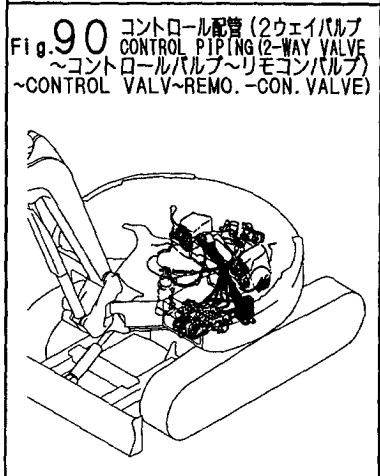
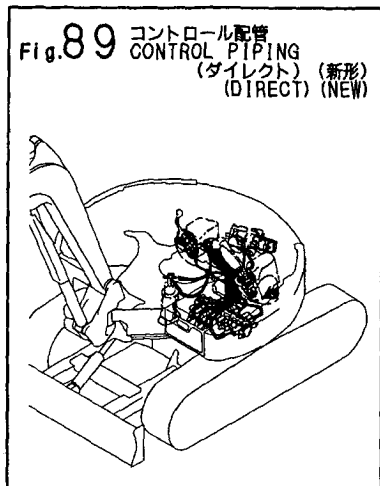
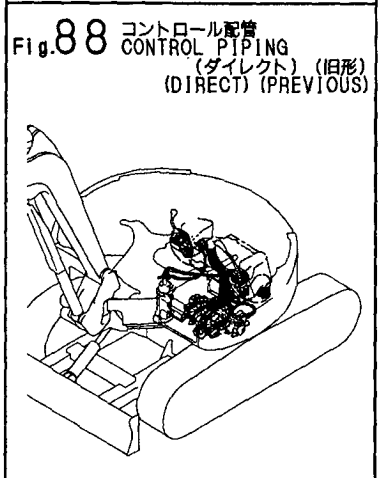
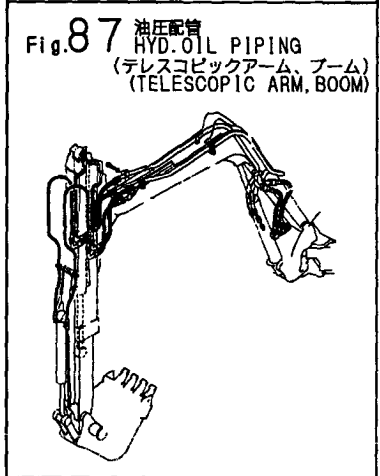
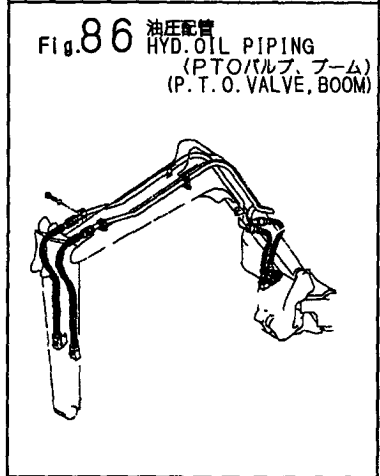
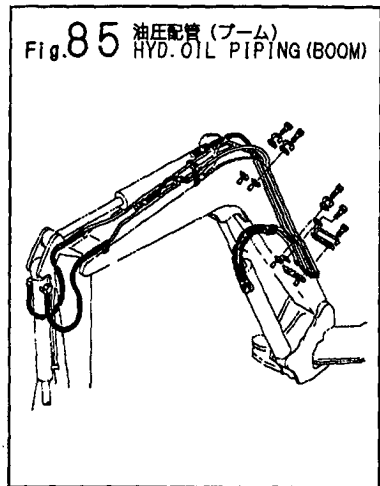

絵目次 (3) 項目別
PICTURESQUE INDEX (3) FIGURE

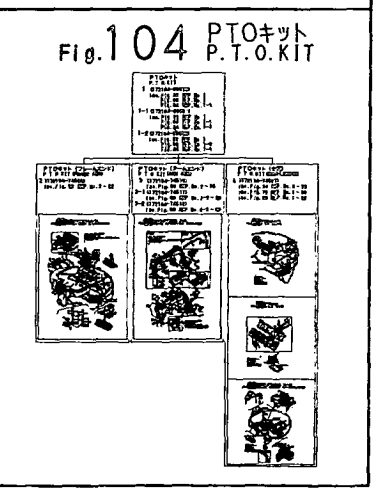
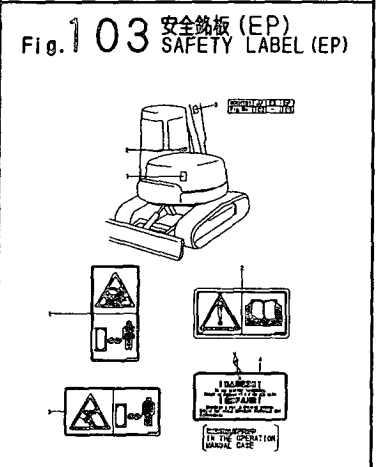
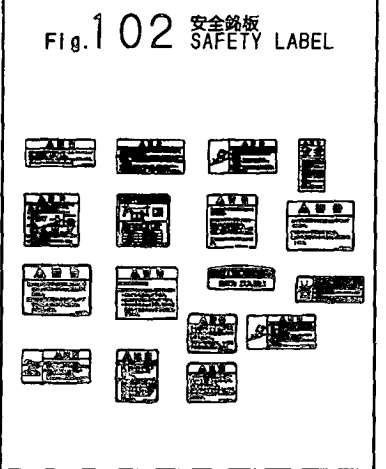
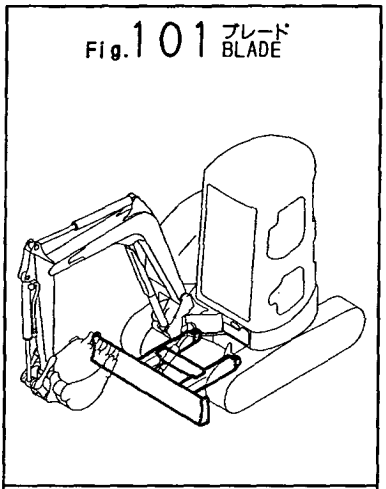
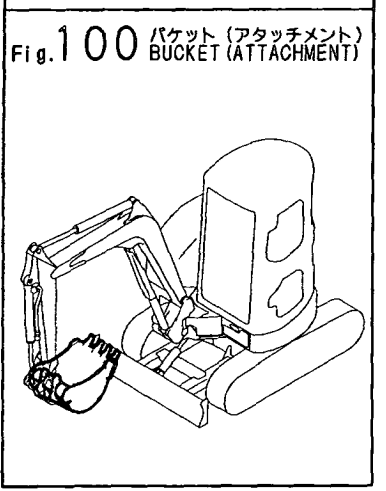
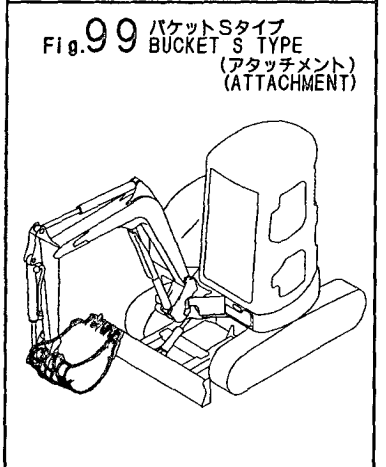
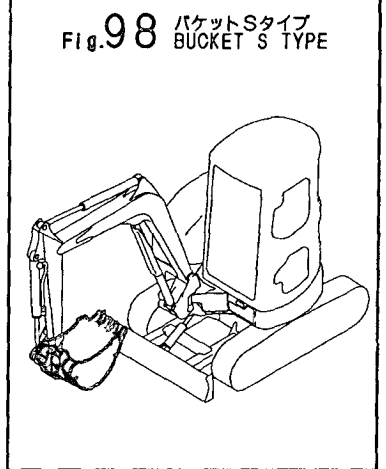
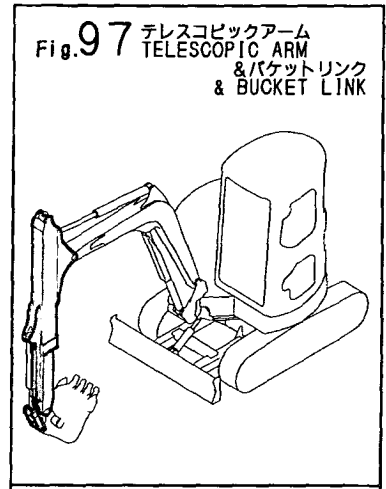

配線図 (1)
WIRING DIAGRAM (1)

初号機~M/#01186

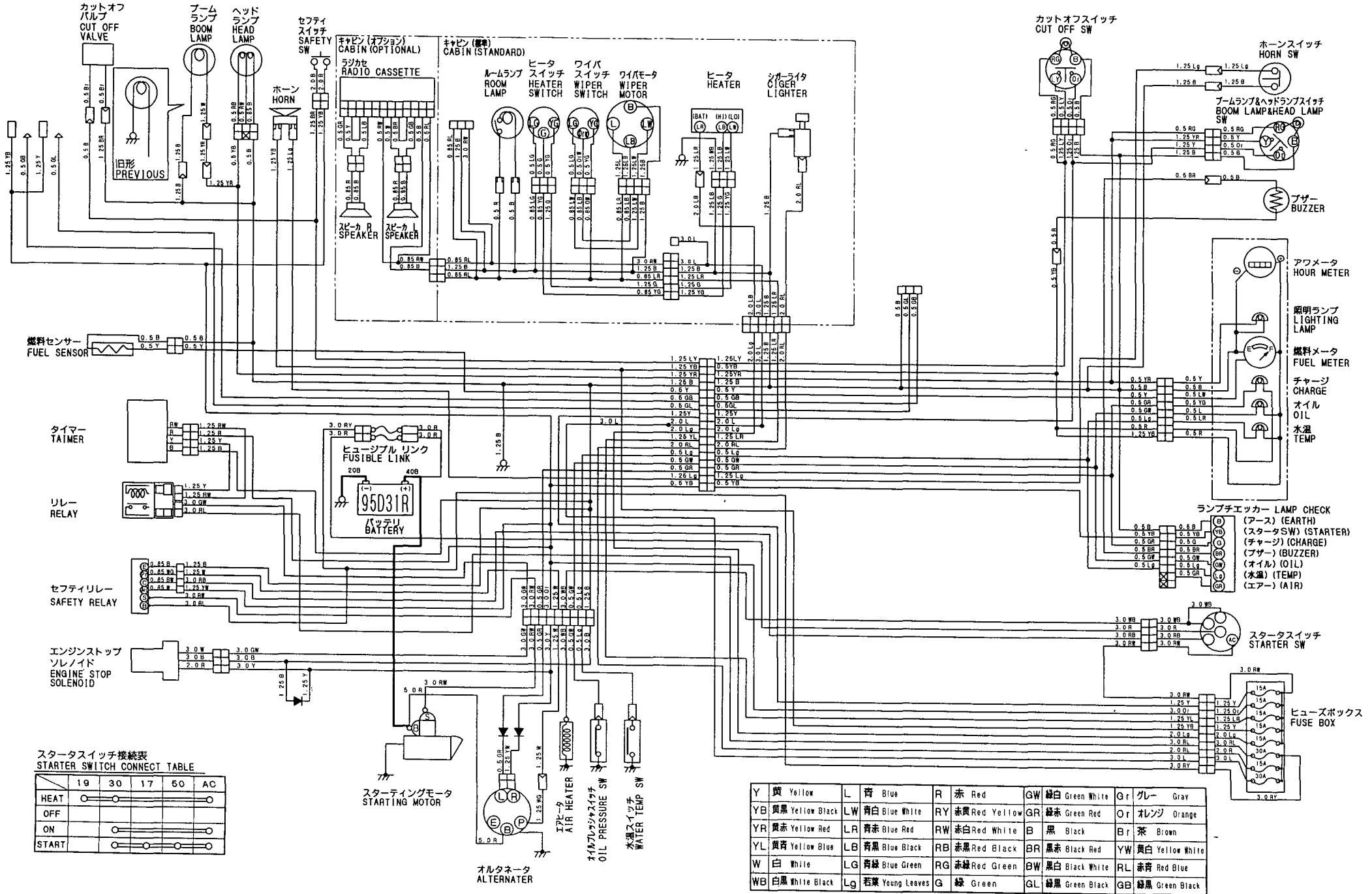

スタータスイッチ接続表
STARTER SWITCH CONNECT TABLE

	19	30	17	50	AC
HEAT	○	○	○	○	○
OFF					
ON	○	○	○	○	○
START	○	○	○	○	○

Y 黄 Yellow	L 青 Blue	R 赤 Red	GW 緑白 Green White	Gr グレー Gray
YB 黄黒 Yellow Black	LW 青白 Blue White	RY 赤黄 Red Yellow	GR 緑赤 Green Red	Or オレンジ Orange
YR 黄赤 Yellow Red	LR 青赤 Blue Red	RW 赤白 Red White	B 黒 Black	Br 茶 Brown
YL 黄青 Yellow Blue	LB 青黒 Blue Black	RB 赤黒 Red Black	BR 黒赤 Black Red	YW 黄白 Yellow White
W 白 White	LG 青緑 Blue Green	RG 赤緑 Red Green	BW 黒白 Black White	RL 赤青 Red Blue
WB 白黒 White Black	Lg 若葉 Young Leaves	G 緑 Green	GL 緑黒 Green Black	GB 緑黒 Green Black

配線図 (2) WIRING DIAGRAM (2)

M/#01187~M/#01426

<https://truckmanualshub.com/>

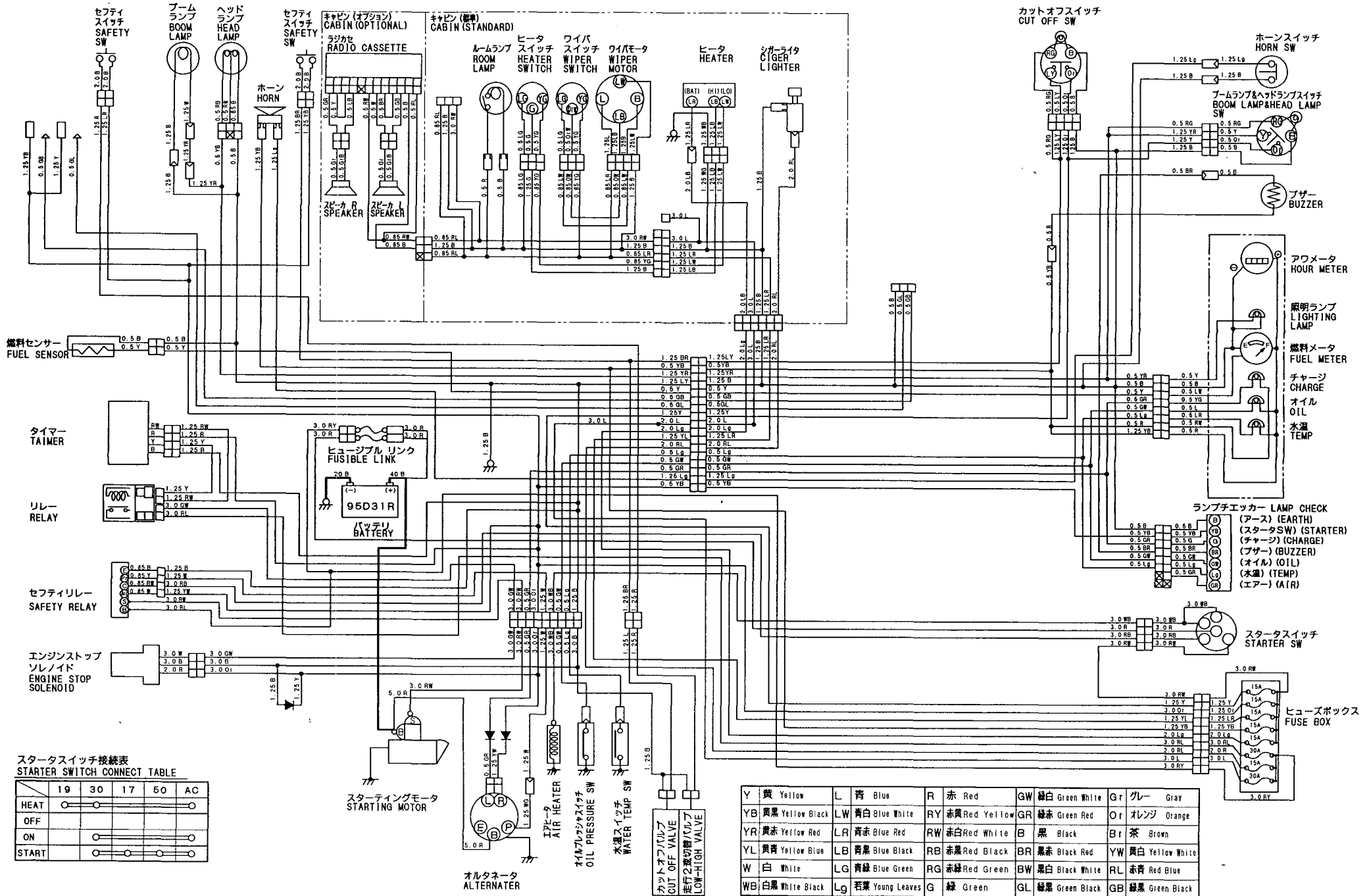

配線図 (3) WIRING DIAGRAM (3) M/#01427~M/#01536

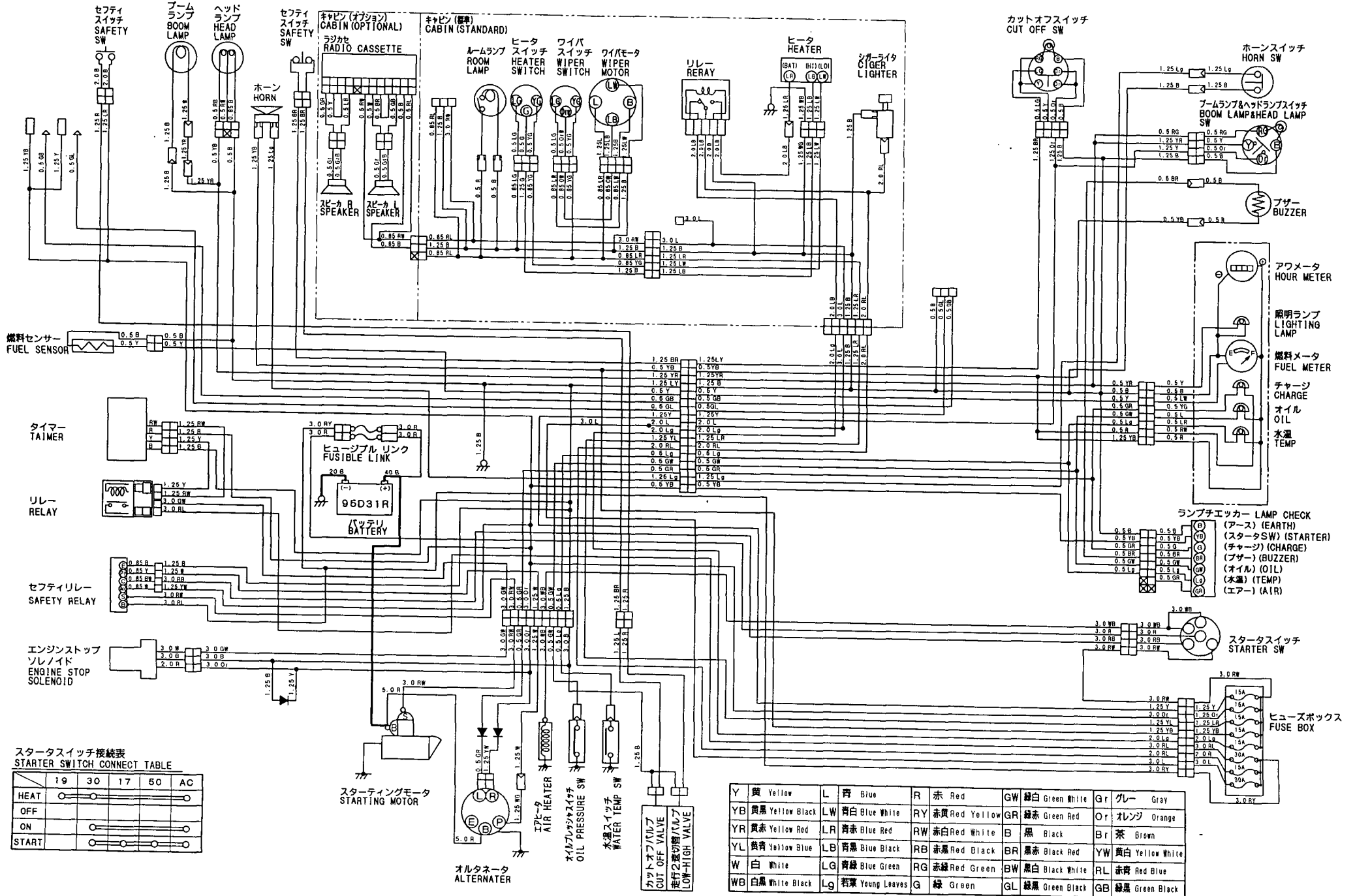

配線図 (4)
WIRING DIAGRAM (4)

M/#01537~

<https://truckmanualshub.com/>

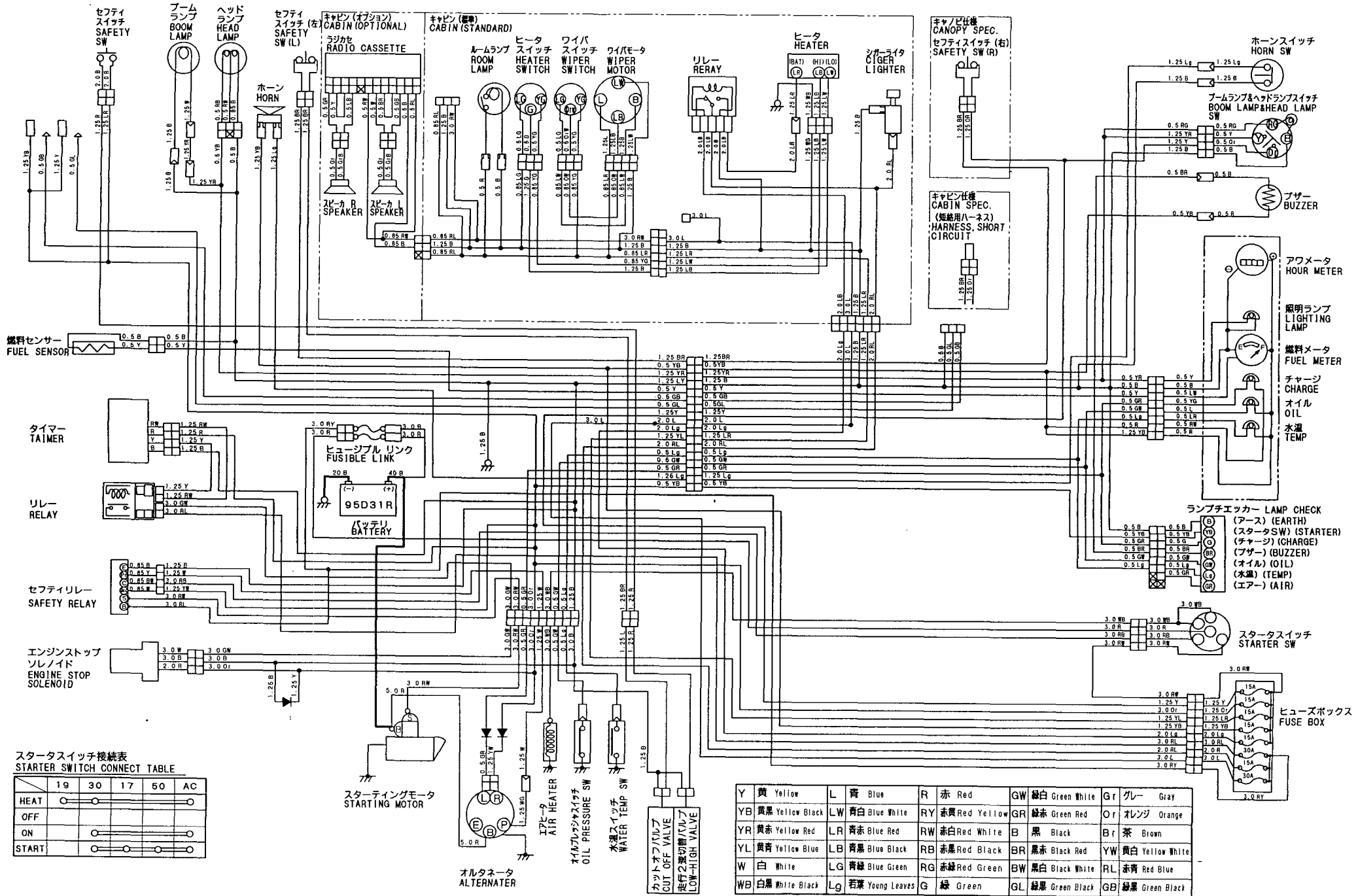

スタータスイッチ接続表
STARTER SWITCH CONNECT TABLE

	19	30	17	50	AC
HEAT	○	○	○	○	○
OFF	○	○	○	○	○
ON	○	○	○	○	○
START	○	○	○	○	○

Y 黄 Yellow	L 青 Blue	R 赤 Red	GW 緑白 Green White	Gf グレー Gray
YB 黄黒 Yellow Black	LW 青白 Blue White	RY 赤黄 Red Yellow	GR 緑赤 Green Red	Of オレンジ Orange
YR 黄赤 Yellow Red	LR 青赤 Blue Red	RW 赤白 Red White	B 黒 Black	Br 茶 Brown
YL 黄青 Yellow Blue	LB 青黒 Blue Black	RB 赤黒 Red Black	BR 黒赤 Black Red	YW 黄白 Yellow White
W 白 White	LG 青緑 Blue Green	RG 赤緑 Red Green	BW 黒白 Black White	RL 赤青 Red Blue
WB 白黒 White Black	Lg 若葉 Young Leaves	G 緑 Green	GL 緑黒 Green Black	GB 緑黒 Green Black

配線図 (ワンタッチデセル)
WIRING DIAGRAM (ONE TOUCH DECEL)

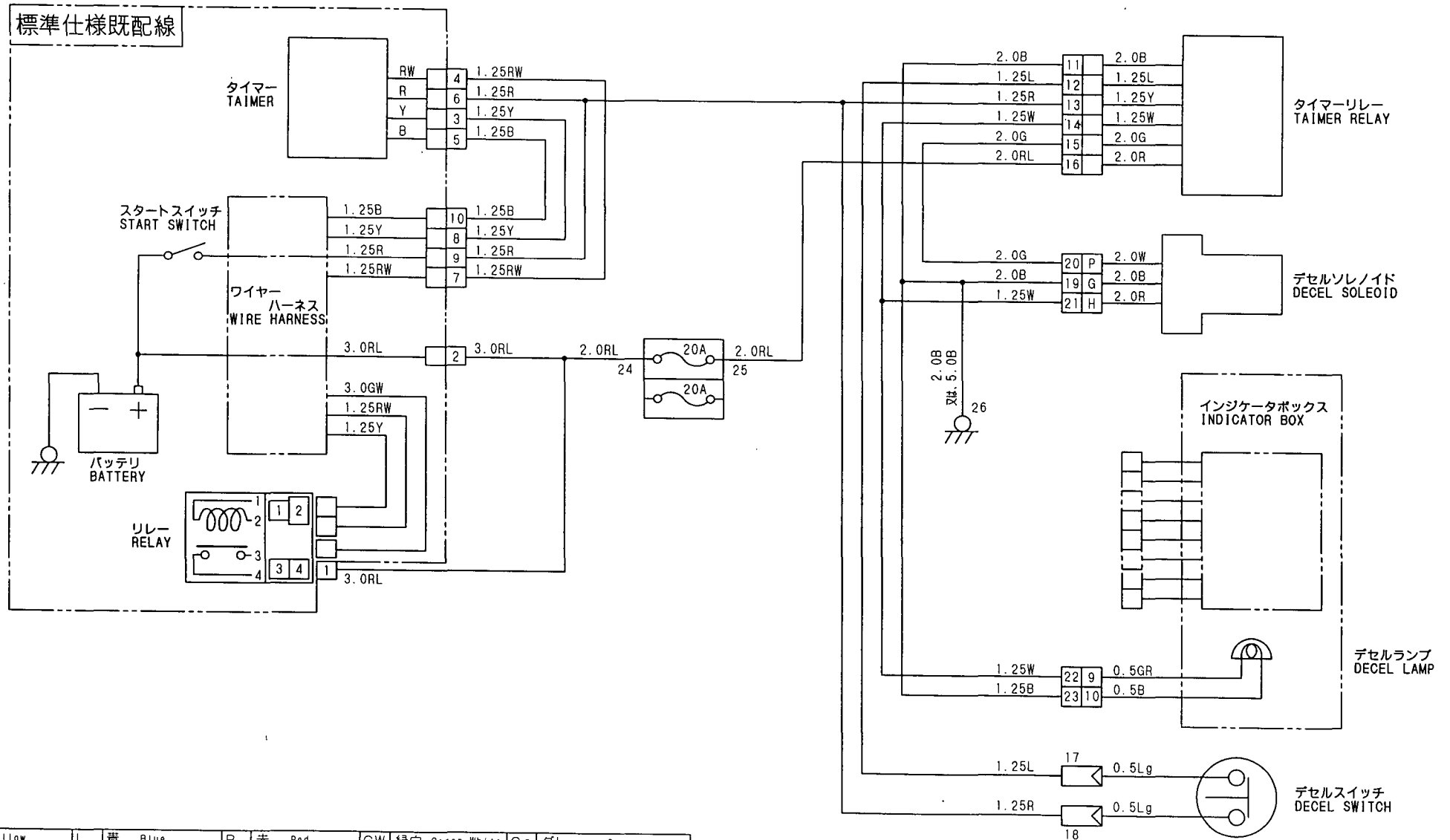

Y	黄 Yellow	L	青 Blue	R	赤 Red	GW	緑白 Green White	Gr	グレー Gray
YB	黄黒 Yellow Black	LW	青白 Blue White	RY	赤黄 Red Yellow	GR	緑赤 Green Red	Or	オレンジ Orange
YR	黄赤 Yellow Red	LR	青赤 Blue Red	RW	赤白 Red White	B	黒 Black	Br	茶 Brown
YL	黄青 Yellow Blue	LB	青黒 Blue Black	RB	赤黒 Red Black	BR	黒赤 Black Red	YW	黄白 Yellow White
W	白 White	LG	青緑 Blue Green	RG	赤緑 Red Green	BW	黒白 Black White	RL	赤青 Red Blue
WB	白黒 White Black	Lg	若菜 Young Leaves	G	緑 Green	GL	緑黒 Green Black	GB	緑黒 Green Black

1,1,,772164-03110,, "LABEL ASSY",1,,,,,,,,,,,,,
1-1,1,,772164-03111,, "LABEL ASSY",1,,,,,N,,M/#01437,,,,,
1A,1,,772164-03140,, "LABEL ASSY",1,,,,,3,,,,,
2,2,,172164-03110,, "LABEL, SPECIFICATION",1,,,,,
2A,2,,172164-03400,, LABEL,1,,,,,3,,,,,
3,2,,172164-03120,, "LABEL,FEED WATER",1,,,,,
4,2,,172164-03130,, "LABEL,GREASE FEED",1,,,,,
4A,2,,172164-03410,, LABEL,1,,,,,3,,,,,
5,2,,172164-03150,, "LABEL (VIO40",2,,,,,
5-1,2,,172164-03151,, LABEL(VIO40,2,,,,,N,,M/#00883,,,,,
6,2,,172519-03150,, "LABEL, ACCEL",1,,,,,
7,2,,172141-03170,, "LABEL, RESTART",1,,,,,
8,2,,172164-03170,, "REAR EMBLEM",1,,,,,
8-1,2,,172164-03171,, "EMBLEM, REAR",1,,,,,R,,M/#02206,,,,,
9,2,,172164-03180,, "MARK,NO.1",1,,,,,
10,2,,172169-03180,, LABEL,1,,,,,
11,2,,172164-03190,, "LABEL, TURN.",1,,,,,
11-1,2,,172164-03560,, LABEL,1,,,,,N,,M/#01437,,,,,
12,2,,172141-03201,, "LABEL,ENGINE ROOM(C)",1,,,,,
12-1,2,,172141-03202,, "LABEL,CAUTION",1,,,,,N,,M/#01437,,,,,
13,2,,172147-03210,, LABEL,1,,,,,
14,2,,172165-03220,, "LABEL, GREASE",1,,,,,
15,2,,172519-03290,, "LABEL, ENG.COVER",1,,,,,
15-1,2,,172519-04180,, "LABEL,WARNING",1,,,,,N,,M/#01437,,,,,
16,2,,172137-03301,, "LABEL, TURNING LOCK",1,,,,,Z,,M/#01920,,,,,
17,2,,172142-03301,, LABEL,1,,,,,
17-1,2,,172142-03302,, "LABEL,CAUTION",1,,,,,N,,M/#01437,,,,,
18,2,,172155-03310,, "LABEL, OILING",1,,,,,
19,2,,172141-03360,, "LABEL, START SWITCH",1,,,,,
20,2,,172165-03610,, "LABEL A",1,,,,,
20-1,2,,172964-03610,, "LABEL A",1,,,,,N,,M/#01437,,,,,
21,2,,172165-03620,, "LABEL B",1,,,,,
21-1,2,,172164-03500,, LABEL,1,,,,,N,,M/#01437,,,,,
22,2,,172165-03660,, "LABEL, BATTERY",1,,,,,
22-1,2,,172165-03661,, "LABEL,DANGER",1,,,,,N,,M/#01437,,,,,
23,2,,121470-44540,, "LABEL, SUB-TANK",1,,,,,
24,2,,933112-52400,, "LABEL, FUEL",1,,,,,
24-1,2,,172183-03250,, LABEL,1,,,,,N,,M/#01437,,,,,
25,2,,172162-03180,, "LABEL,HEATER SWITCH",1,,,,,Z,,M/#01217,,,,,
26,2,,172162-03190,, "LABEL,WIPER SWITCH",1,,,,,Z,,M/#01217,,,,,
27,2,,172164-03200,, "LABEL,BRAND",1,,,,,
28,2,,172164-03210,, "LABEL, CAB.",1,,,,,
29,2,,172165-03460,, "LABEL, PATERN A",1,,,,,
30,2,,172183-03280,, "LABEL, LOCK",1,,,,,W,,M/#00926,,,,,
31,2,,172164-03420,, LABEL,1,,,,,3,,,,,
32,2,,172162-03240,, "LABEL,WIPER",1,,,,,W,,M/#01362,,,,,
32-1,2,,172162-03241,, LABEL,1,,,,,N,,M/#01437,,,,,
32-2,2,,172162-03241,, LABEL,1,,,,,Z,,M/#01873,,,,,
33,2,,172164-03510,, LABEL,1,,,,,W,,M/#01437,,,,,
34,2,,172164-03520,, "LABEL,DANGER",1,,,,,W,,M/#01437,,,,,
35,2,,172164-03540,, LABEL,1,,,,,W,,M/#01437,,,,,
36,2,,172964-03370,, LABEL,1,,,,,W,,M/#01437,,,,,
37,2,,172964-03390,, "LABEL,WARNING",1,,,,,W,,M/#01437,,,,,
38,2,,172964-03480,, LABEL,1,,,,,W,,M/#01437,,,,,
38-1,2,,172964-03481,, LABEL,1,,,,,N,,M/#01499,,,,,
39,2,,172519-04290,, "LABEL,WARNING",1,,,,,W,,M/#01437,,,,,
40,2,,172519-04300,, LABEL,1,,,,,W,,M/#01437,,,,,
41,2,,172173-03250,, LABEL,1,,,,,W,,M/#01637,,,,,
42,2,,172164-03530,, "LABEL,WARNING",1,,,,,W,,M/#01437,,,,,
43,2,,172164-03350,, "LABEL,LIFTING",1,,,,,W,,M/#02054,,,,,
44,2,,172164-03550,, LABEL,1,,,,,W,3,M/#01437,,,,,
45,1,,172165-03230,, "LABEL, P.T.O.",1,,,,,1,,,,,
45-1,1,,172165-03231,, "LABEL, P.T.O.",1,,,,,N,1,M/#01217,,,,,

46,1,,172168-03301,, "LABEL, SELECT",1,,,,,1,,,,,
47,1,,172165-03240,, LABEL,1,,,,,2,,,,,
48,1,,172168-03401,, LABEL,1,,,,,W,M,,M/#01548,,,,,
49,1,,172168-03410,, LABEL,1,,,,,W,4,,M/#01548,,,,,
50,1,,172175-03550,, LABEL(2-WAY,1,,,,,5,,,,,
51,1,,172173-03560,, "LABEL (YANMAR",1,,,,,5,,,,,
52,1,,172173-03570,, "LABEL (KOMATSU",1,,,,,5,,,,,
53,1,,172165-03471,, LABEL,1,,,,,6,,,,,
54,1,,172312-03050,, LABEL,1,,,,,4,,,,,

Fig. 1 銘板 (キャビン) (JP) LABEL (CABIN) (JP)

見出しNo. 1-1は、見出しNo. 2から43を含みます。
1-1 inc. 2 ~ 43

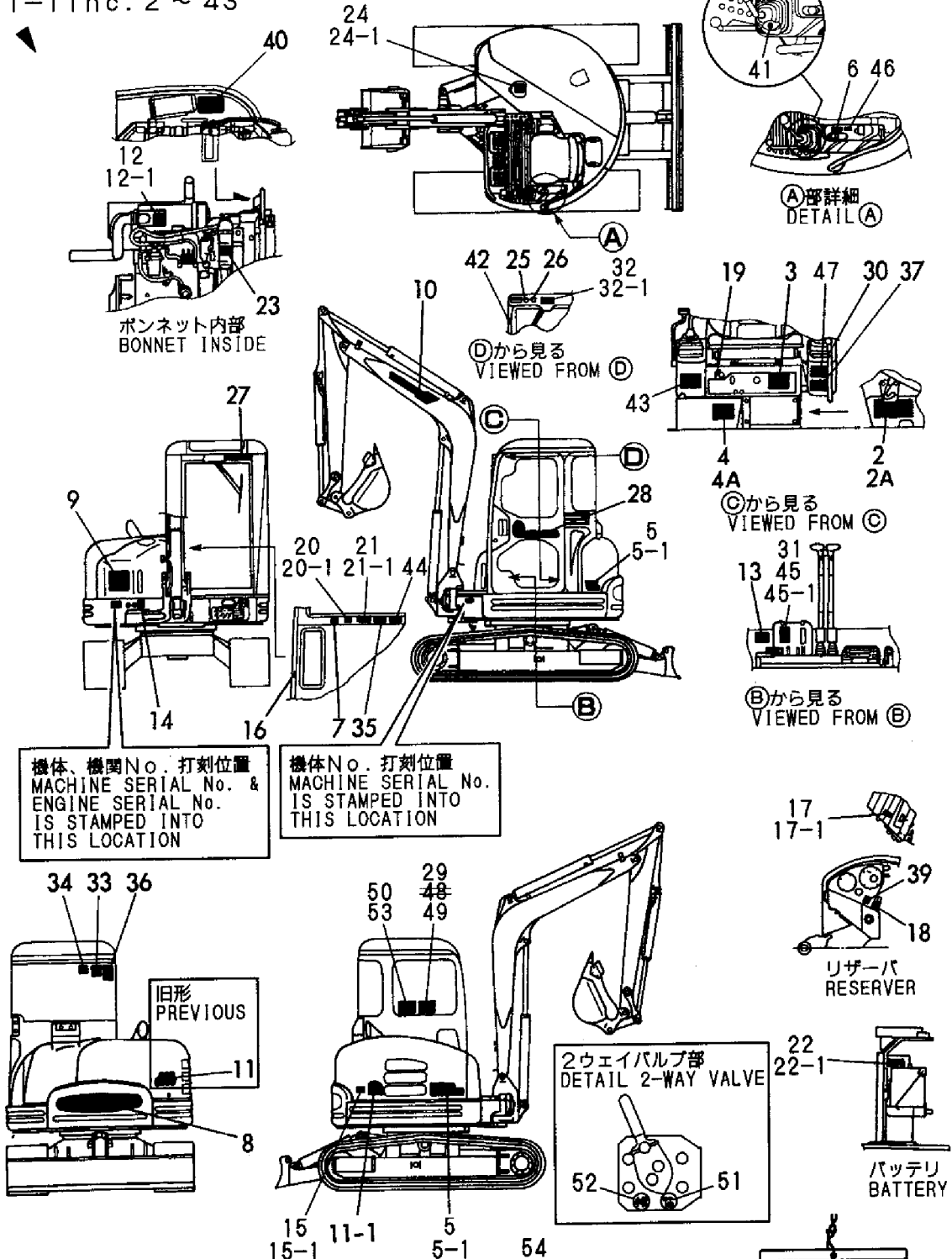

機体、機関No. 打刻位置
MACHINE SERIAL No. &
ENGINE SERIAL No.
IS STAMPED INTO
THIS LOCATION

機体No. 打刻位置
MACHINE SERIAL No.
IS STAMPED INTO
THIS LOCATION

旧形
PREVIOUS

リザーバ
RESERVER

2ウェイバルブ部
DETAIL 2-WAY VALVE

バッテリー
BATTERY

テレスコピックアーム仕様
TELESCOPIC ARM SPEC.
見出しNo. 1Aは、
見出しNo. 2Aから44を含みます。
1A inc. 2A ~ 44

警告
バケットフック使用上の注意
100kg (220lb) 以下に制限してください。
バケットフックは、作業中に常にバケットフックの中心に位置させ、バケットフックの先端を地面に落とさないでください。
バケットフックの先端を地面に落とすと、バケットフックの先端が破損し、バケットフックの先端が鋭くなる場合があります。鋭くなる場合は、バケットフックの先端を交換してください。

38 38-1
危険
運転中
取脱収納庫内在中
IN THE OPERATION
MANUAL CASE

1,1,,772164-03170,, "LABEL ASSY",1,,,,,,,,,,,,,
2,2,,172164-03151,, LABEL(VIO40,2,,,,,,,,,,,,,
3,2,,172519-03150,, "LABEL, ACCEL",1,,,,,,,,,,,,,
4,2,,172164-03171,, "EMBLEM, REAR",1,,,,,,,,,,,,,
5,2,,172164-03180,, "MARK,NO.1",1,,,,,,,,,,,,,
6,2,,172169-03180,, LABEL,1,,,,,,,,,,,,,
7,2,,172147-03210,, LABEL,1,,,,,,,,,,,,,
8,2,,172176-03330,, "LABEL,GREASE FEED(E",1,,,,,,,,,,,,,
9,2,,172141-03360,, "LABEL, START SWITCH",1,,,,,,,,,,,,,
10,2,,172171-03400,, PLATE,1,,,,,,,,,,,,,
13,2,,172141-03440,, LABEL,1,,,,,,,,,,,,,
14,2,,172183-03450,, "LABEL,FUEL",1,,,,,,,,,,,,,
15,2,,172171-03510,, "LABEL, GREASE",1,,,,,,,,,,,,,
16,2,,172164-03610,, "LABEL A",1,,,,,,,,,,,,,
17,2,,172164-03620,, LABEL,1,,,,,,,,,,,,,
18,2,,172171-03700,, LABEL,1,,,,,,,,,,,,,
19,2,,172171-03710,, LABEL,1,,,,,,,,,,,,,
20,2,,172171-03720,, LABEL,1,,,,,,,,,,,,,
21,2,,172171-03740,, LABEL,1,,,,,,,,,,,,,
22,2,,172171-03750,, LABEL,2,,,,,,,,,,,,,
23,2,,172171-03760,, LABEL,1,,,,,,,,,,,,,
24,2,,172171-03770,, LABEL,1,,,,,,,,,,,,,
25,2,,172171-03780,, LABEL,1,,,,,,,,,,,,,
26,2,,172155-03790,, LABEL,1,,,,,,,,,,,,,
27,2,,172171-03790,, "LABEL, RADIATOR",1,,,,,,,,,,,,,
28,2,,172171-03800,, LABEL,1,,,,,,,,,,,,,
29,2,,172171-03810,, LABEL,1,,,,,,,,,,,,,
30,2,,172125-03950,, "LABEL, AIR CLEANER",1,,,,,,,,,,,,,
31,2,,124764-44810,, "LABEL, SUB-TANK",1,,,,,,,,,,,,,
32,2,,172164-03200,, "LABEL,BRAND",1,,,,,,,,,,,,,
33,2,,172183-03280,, "LABEL, LOCK",1,,,,,,,,,,,,,
34,2,,172168-03301,, "LABEL, SELECT",1,,,,,,,,,,,,,
35,2,,172165-03460,, "LABEL, PATERN A",1,,,,,,,,,,,,,
36,2,,172141-03501,, "LABEL(ADJUST CRAWLER",1,,,,,,,,,,,,,
37,2,,172165-03231,, "LABEL, P.T.O.",1,,,,,,,,,,,,,
38,2,,172164-03700,, LABEL,1,,,,,,,,,,,,,
39,2,,172164-03710,, LABEL,1,,,,,,,,,,,,,
40,2,,172164-03210,, "LABEL, CAB.",1,,,,,W,,,M/#02404,,,,,,,,,

Fig. 2 銘板 (キャビン) (EX) LABEL (CABIN) (EX)

見出しNo. 1は、見出しNo. 2から40を含みます。
1 inc. 2 ~ 40

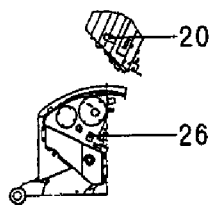

リザーバ
RESERVER

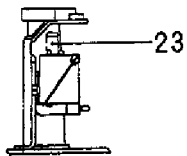

バッテリー
BATTERY

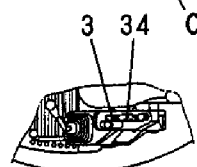
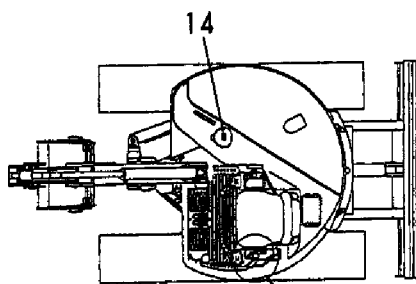
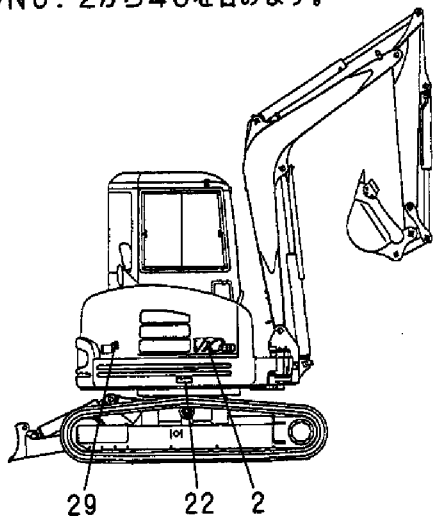

C部詳細
DETAIL C

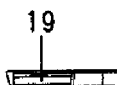

Pから見る
VIEWED FROM P

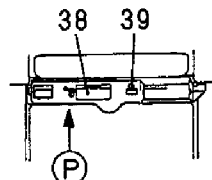

Dから見る
VIEWED FROM D

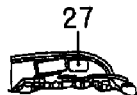

Hから見る
VIEWED FROM H

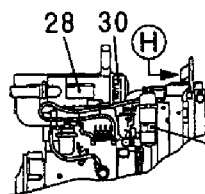

ボンネット内部
BONNET INSIDE

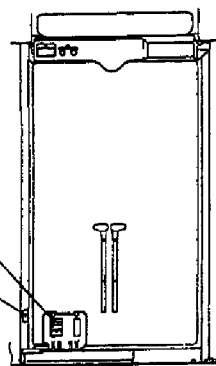

Dから見る
VIEWED FROM D

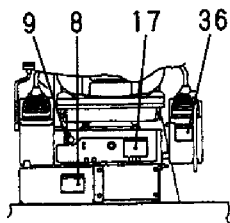

Aから見る
VIEWED FROM A

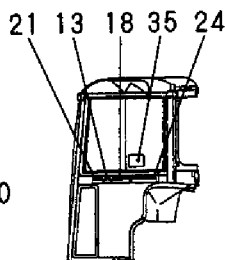
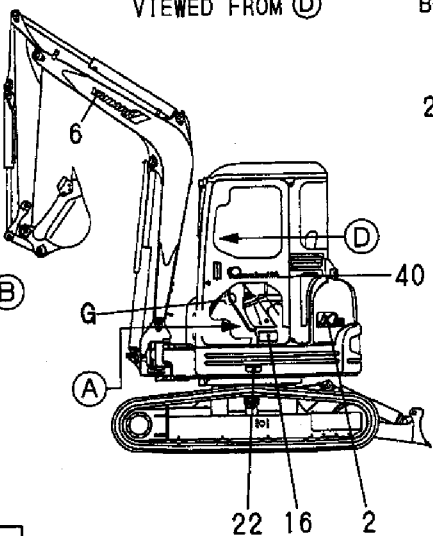

Bから見る
VIEWED FROM B

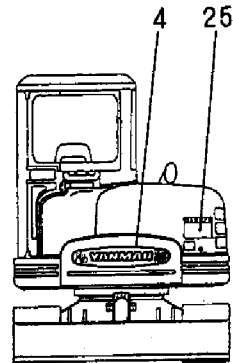

G部詳細
DETAIL G



機体、機関No. 打刻位置
MACHINE SERIAL No. &
ENGINE SERIAL No.
IS STAMPED INTO
THIS LOCATION

取説収納庫内在中
IN THE OPERATION
MANUAL CASE

1,1,,772164-03200,, "LABEL ASSY",1,,,,,,,,,,,,,
2,2,,172164-03640,, LABEL,1,,,,,,,,,,,,,
3,2,,172164-03630,, LABEL,1,,,,,,,,,,,,,
4,2,,172176-03230,, "LABEL, GREASE FEED",1,,,,,,,,,,,,,
5,2,,172164-03151,, LABEL(VIO40,2,,,,,,,,,,,,,
6,2,,172519-03150,, "LABEL, ACCEL",1,,,,,,,,,,,,,
7,2,,172143-03180,, LABEL,1,,,,,,,,,,,,,
8,2,,172164-03171,, "EMBLEM, REAR",1,,,,,,,,,,,,,
9,2,,172164-03180,, "MARK,NO.1",1,,,,,,,,,,,,,
10,2,,172142-03451,, "LABEL, BOOM",2,,,,,,,,,,,,,
11,2,,172164-03210,, "LABEL, CAB.",1,,,,,,,,,,,,,
12,2,,172147-03210,, LABEL,1,,,,,,,,,,,,,
13,2,,172165-03440,, "LABEL, GREASE",1,,,,,,,,,,,,,
14,2,,172187-03550,, "LABEL,OILING(F,G)",1,,,,,,,,,,,,,
15,2,,172141-03360,, "LABEL, START SWITCH",1,,,,,,,,,,,,,
16,2,,172165-03460,, "LABEL, PATERN A",1,,,,,,,,,,,,,
17,2,,172171-03420,, LABEL,1,,,,,,,,,,,,,
18,2,,933112-55700,, "LABEL, SUB-TANK",1,,,,,,,,,,,,,
19,2,,172187-03560,, "LABEL,FUEL(F,G)",1,,,,,,,,,,,,,
20,2,,172183-03280,, "LABEL, LOCK",1,,,,,,,,,,,,,
21,2,,172143-03250,, "LABEL,ADJUST CRAWLER",1,,,,,,,,,,,,,
22,2,,172168-03301,, "LABEL, SELECT",1,,,,,,,,,,,,,
23,2,,172165-03231,, "LABEL, P.T.O.",1,,,,,,,,,,,,,
24,2,,172164-03720,, LABEL,1,,,,,,,,,,,,,
25,2,,172164-03730,, LABEL,1,,,,,,,,,,,,,
26,2,,172164-03200,, "LABEL,BRAND",1,,,,,,,,,,,,,
27,1,,172187-03600,, LABEL,1,,,,,,,,,,,,,
28,1,,172187-03610,, LABEL,1,,,,,,,,,,,,,
29,1,,172187-03620,, LABEL,2,,,,,,,,,,,,,

Fig. 3 銘板 (キャビン) (EP) LABEL (CABIN) (EP)

見出しNo. 1は、見出しNo. 2から26を含みます。
1 inc. 2 ~ 26

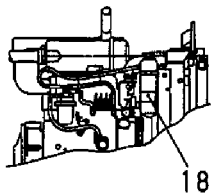

18
ボンネット内部
BONNET INSIDE

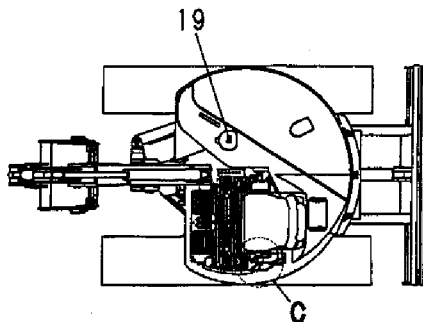

C

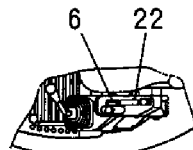

6 22
◎から見る
VIEWED FROM ◎

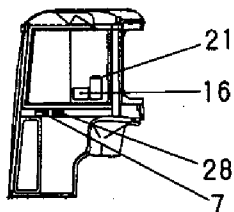

21 16 28 7
◎から見る
VIEWED FROM ◎

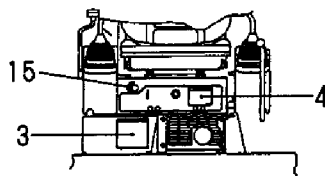

15 4 3
◎から見る
VIEWED FROM ◎

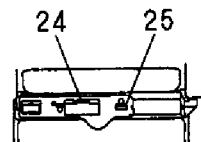

24 25
◎から見る
VIEWED FROM ◎

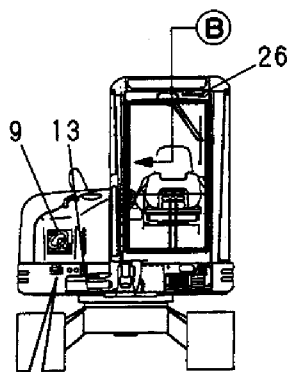

機体、機関No. 打刻位置
MACHINE SERIAL No. &
ENGINE SERIAL No.
IS STAMPED INTO
THIS LOCATION

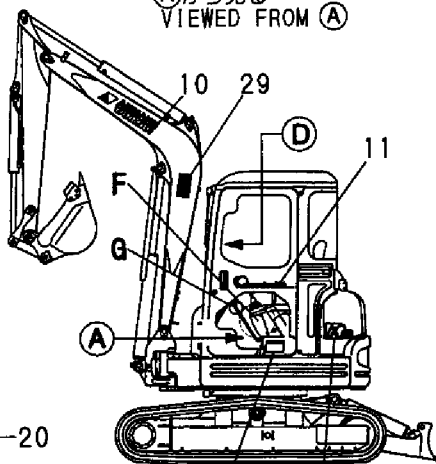

◎部詳細
DETAIL ◎

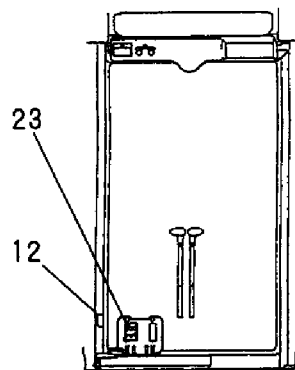

◎から見る
VIEWED FROM ◎

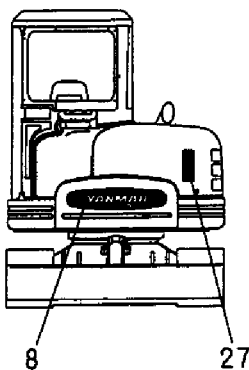

8 27

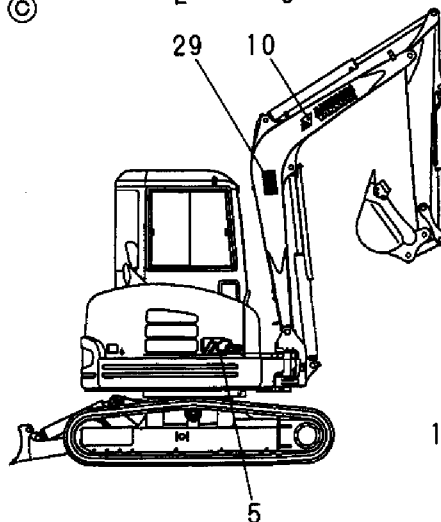

5

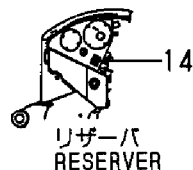

リザーバ
RESERVER



17

取脱収納庫内在中
IN THE OPERATION
MANUAL CASE

1,1,,772164-03100,, "LABEL ASSY",,1,,,,,,,,,,,,,
1-1,1,,772164-03101,, "LABEL ASSY",,1,,,,,N,,,,,M/#01437,,,,,
1A,1,,772164-03150,, "LABEL ASSY",,1,,,,,3,,,,,
2,2,,172164-03110,, "LABEL, SPECIFICATION",,1,,,,,,,,,,,,,
2A,2,,172164-03400,, LABEL,,1,,,,,3,,,,,
3,2,,172164-03120,, "LABEL,FEED WATER",,1,,,,,,,,,,,,,
4,2,,172164-03130,, "LABEL,GREASE FEED",,1,,,,,,,,,,,,,
4A,2,,172164-03410,, LABEL,,1,,,,,3,,,,,
5,2,,172164-03150,, "LABEL (VIO40",,2,,,,,
5-1,2,,172164-03151,, LABEL(VIO40,,2,,,,,N,,,,,M/#00883,,,,,
6,2,,172519-03150,, "LABEL, ACCEL",,1,,,,,,,,,,,,,
7,2,,172141-03170,, "LABEL, RESTART",,1,,,,,,,,,,,,,
8,2,,172164-03170,, "REAR EMBLEM",,1,,,,,,,,,,,,,
8-1,2,,172164-03171,, "EMBLEM, REAR",,1,,,,,R,,,,,M/#02206,,,,,
9,2,,172164-03180,, "MARK,NO.1",,1,,,,,,,,,,,,,
10,2,,172169-03180,, LABEL,,1,,,,,,,,,,,,,
11,2,,172164-03190,, "LABEL, TURN.",,1,,,,,,,,,,,,,
11-1,2,,172164-03560,, LABEL,,1,,,,,N,,,,,M/#01437,,,,,
12,2,,172141-03201,, "LABEL,ENGINE ROOM(C)",,1,,,,,,,,,,,,,
12-1,2,,172141-03202,, "LABEL,CAUTION",,1,,,,,N,,,,,M/#01437,,,,,
13,2,,172147-03210,, LABEL,,1,,,,,,,,,,,,,
14,2,,172165-03220,, "LABEL, GREASE",,1,,,,,,,,,,,,,
15,2,,172519-03290,, "LABEL, ENG.COVER",,1,,,,,,,,,,,,,
15-1,2,,172519-04180,, "LABEL,WARNING",,1,,,,,N,,,,,M/#01437,,,,,
16,2,,172137-03301,, "LABEL, TURNING LOCK",,1,,,,,Z,,,,,M/#01920,,,,,
17,2,,172142-03301,, LABEL,,1,,,,,,,,,,,,,
17-1,2,,172142-03302,, "LABEL,CAUTION",,1,,,,,N,,,,,M/#01437,,,,,
18,2,,172155-03310,, "LABEL, OILING",,1,,,,,,,,,,,,,
19,2,,172141-03360,, "LABEL, START SWITCH",,1,,,,,,,,,,,,,
20,2,,172165-03610,, "LABEL A",,1,,,,,,,,,,,,,
20-1,2,,172964-03610,, "LABEL A",,1,,,,,N,,,,,M/#01437,,,,,
21,2,,172165-03620,, "LABEL B",,1,,,,,,,,,,,,,
21-1,2,,172164-03500,, LABEL,,1,,,,,N,,,,,M/#01437,,,,,
22,2,,172165-03660,, "LABEL, BATTERY",,1,,,,,,,,,,,,,
22-1,2,,172165-03661,, "LABEL,DANGER",,1,,,,,N,,,,,M/#01437,,,,,
23,2,,121470-44540,, "LABEL, SUB-TANK",,1,,,,,,,,,,,,,
24,2,,933112-52400,, "LABEL, FUEL",,1,,,,,,,,,,,,,
24-1,2,,172183-03250,, LABEL,,1,,,,,N,,,,,M/#01437,,,,,
25,2,,172164-03140,, "LABEL,FRONT",,1,,,,,,,,,,,,,
26,2,,172151-03540,, "LABEL,PATTERN A",,1,,,,,,,,,,,,,
27,2,,172183-03280,, "LABEL, LOCK",,1,,,,,W,,,,,M/#00926,,,,,
27-1,2,,172183-03280,, "LABEL, LOCK",,2,,,,,K,,,,,M/#01537,,,,,
28,2,,172164-03420,, LABEL,,1,,,,,3,,,,,
29,2,,172164-03510,, LABEL,,1,,,,,W,,,,,M/#01437,,,,,
30,2,,172164-03520,, "LABEL,DANGER",,1,,,,,W,,,,,M/#01437,,,,,
31,2,,172164-03540,, LABEL,,1,,,,,W,,,,,M/#01437,,,,,
32,2,,172964-03370,, LABEL,,1,,,,,W,,,,,M/#01437,,,,,
33,2,,172964-03390,, "LABEL,WARNING",,1,,,,,W,,,,,M/#01437,,,,,
34,2,,172964-03480,, LABEL,,1,,,,,W,,,,,M/#01437,,,,,
34-1,2,,172964-03481,, LABEL,,1,,,,,N,,,,,M/#01499,,,,,
35,2,,172519-04290,, "LABEL,WARNING",,1,,,,,W,,,,,M/#01437,,,,,
36,2,,172519-04300,, LABEL,,1,,,,,W,,,,,M/#01437,,,,,
37,2,,172173-03250,, LABEL,,1,,,,,W,,,,,M/#01637,,,,,
38,2,,172164-03350,, "LABEL,LIFTING",,1,,,,,W,,,,,M/#02054,,,,,
39,2,,172164-03550,, LABEL,,1,,,,,W,3,,,,,M/#01437,,,,,
40,1,,172165-03230,, "LABEL, P.T.O.",,1,,,,,1,,,,,
40-1,1,,172165-03231,, "LABEL, P.T.O.",,1,,,,,N,1,,,,,M/#01217,,,,,
41,1,,172168-03301,, "LABEL, SELECT",,1,,,,,1,,,,,
42,1,,172165-03240,, LABEL,,1,,,,,2,,,,,
43,1,,172168-03401,, LABEL,,1,,,,,W,4,,,,,M/#01548,,,,,
44,1,,172168-03410,, LABEL,,1,,,,,W,M,,,,,M/#01548,,,,,
45,1,,172173-03550,, "LABEL (2-WAY",,1,,,,,5,,,,,
46,1,,172173-03560,, "LABEL (YANMAR",,1,,,,,5,,,,,

47,1,,172173-03570,, "LABEL (KOMATSU" ,,1,,,,,5,,,,,
48,1,,172151-03550,, "LABEL,PATTERN B" ,,1,,,,,6,,,,,
49,1,,172312-03050,, LABEL,,1,,,,,4,,,,,

Fig. 4 銘板 (キャノピ) (JP) LABEL (CANOPY) (JP)

見出しNo. 1-1は、見出しNo. 2から38を含みます。
1-1 inc. 2 ~ 38

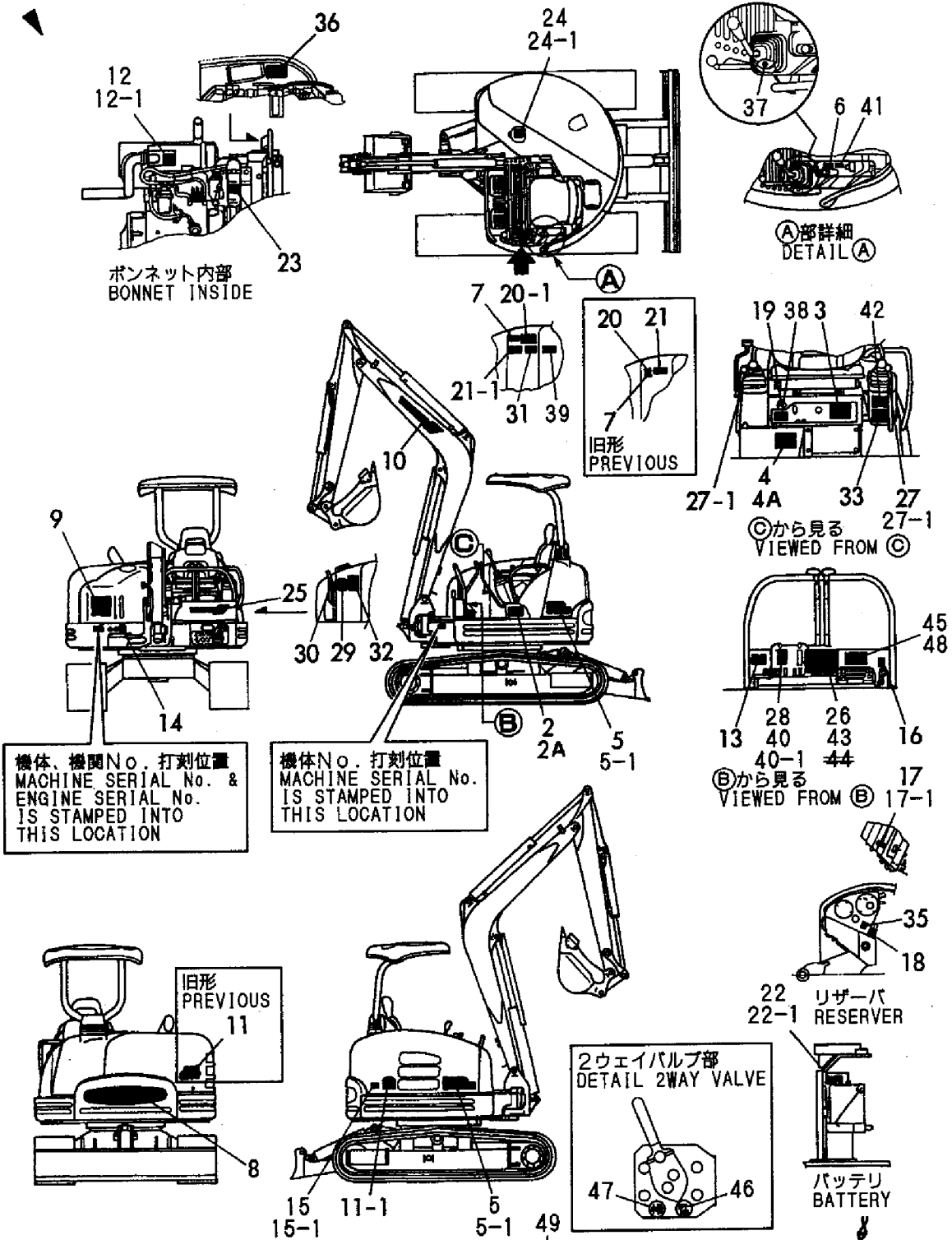

機体、機関No. 打刻位置
MACHINE SERIAL No. &
ENGINE SERIAL No.
IS STAMPED INTO
THIS LOCATION

機体No. 打刻位置
MACHINE SERIAL No.
IS STAMPED INTO
THIS LOCATION

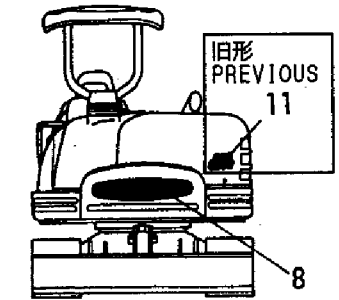

テレスコピックアーム仕様
TELESCOPIC ARM SPEC.
見出しNo. 1Aは、
見出しNo. 2Aから39を含みます。
1A inc. 2A ~ 39

警告

バケットフック使用上の注意
 作業安全基準に定められた4先による平衡の最大許容量は、
 100kg (標準機仕様) です。
 重量超過は、バケットフックの破損や変形の原因となります。
 ① 作業の最中にバケットフックを長時間吊り下すことは、バケットフックの破損や変形の原因となります。
 ② 作業の最中にバケットフックを長時間吊り下すことは、バケットフックの破損や変形の原因となります。
 ③ 作業の最中にバケットフックを長時間吊り下すことは、バケットフックの破損や変形の原因となります。

34
34-1

危険
運転中

取説収納庫内在中
IN THE OPERATION
MANUAL CASE

1,1,,772164-03120,, "LABEL ASSY",,1,,,,,,,,,,,,,,,,,,,,,
2,2,,172164-03151,, LABEL(VIO40,,2,,,,,,,,,,,,,,,,,,,,,
3,2,,172519-03150,, "LABEL, ACCEL",,1,,,,,,,,,,,,,,,,,,,,,
4,2,,172164-03171,, "EMBLEM, REAR",,1,,,,,,,,,,,,,,,,,,,,,
5,2,,172164-03180,, "MARK,NO.1",,1,,,,,,,,,,,,,,,,,,,,,
6,2,,172169-03180,, LABEL,,1,,,,,,,,,,,,,,,,,,,,,
7,2,,172147-03210,, LABEL,,1,,,,,,,,,,,,,,,,,,,,,
8,2,,172176-03330,, "LABEL,GREASE FEED(E",,1,,,,,,,,,,,,,,,,,,,,,
9,2,,172141-03360,, "LABEL, START SWITCH",,1,,,,,,,,,,,,,,,,,,,,,
10,2,,172171-03400,, PLATE,,1,,,,,,,,,,,,,,,,,,,,,
13,2,,172141-03440,, LABEL,,1,,,,,,,,,,,,,,,,,,,,,
14,2,,172183-03450,, "LABEL,FUEL",,1,,,,,,,,,,,,,,,,,,,,,
15,2,,172171-03510,, "LABEL, GREASE",,1,,,,,,,,,,,,,,,,,,,,,
16,2,,172164-03610,, "LABEL A",,1,,,,,,,,,,,,,,,,,,,,,
17,2,,172164-03620,, LABEL,,1,,,,,,,,,,,,,,,,,,,,,
18,2,,172171-03700,, LABEL,,1,,,,,,,,,,,,,,,,,,,,,
19,2,,172171-03710,, LABEL,,1,,,,,,,,,,,,,,,,,,,,,
20,2,,172171-03720,, LABEL,,1,,,,,,,,,,,,,,,,,,,,,
21,2,,172171-03740,, LABEL,,1,,,,,,,,,,,,,,,,,,,,,
22,2,,172171-03750,, LABEL,,2,,,,,,,,,,,,,,,,,,,,,
23,2,,172171-03760,, LABEL,,1,,,,,,,,,,,,,,,,,,,,,
24,2,,172171-03770,, LABEL,,1,,,,,,,,,,,,,,,,,,,,,
25,2,,172171-03780,, LABEL,,1,,,,,,,,,,,,,,,,,,,,,
26,2,,172155-03790,, LABEL,,1,,,,,,,,,,,,,,,,,,,,,
27,2,,172171-03790,, "LABEL, RADIATOR",,1,,,,,,,,,,,,,,,,,,,,,
28,2,,172171-03800,, LABEL,,1,,,,,,,,,,,,,,,,,,,,,
29,2,,172171-03810,, LABEL,,1,,,,,,,,,,,,,,,,,,,,,
30,2,,172125-03950,, "LABEL, AIR CLEANER",,1,,,,,,,,,,,,,,,,,,,,,
31,2,,124764-44810,, "LABEL, SUB-TANK",,1,,,,,,,,,,,,,,,,,,,,,
32,2,,172183-03280,, "LABEL, LOCK",,1,,,,,,,,,,,,,,,,,,,,,
33,2,,172164-03140,, "LABEL,FRONT",,1,,,,,,,,,,,,,,,,,,,,,
34,2,,172151-03540,, "LABEL,PATTERN A",,1,,,,,,,,,,,,,,,,,,,,,
35,2,,172168-03301,, "LABEL, SELECT",,1,,,,,,,,,,,,,,,,,,,,,
36,2,,172141-03501,, "LABEL(ADJUST CRAWLER",,1,,,,,,,,,,,,,,,,,,,,,
37,2,,172165-03231,, "LABEL, P.T.O.",,1,,,,,,,,,,,,,,,,,,,,,

Fig. 5 銘板 (キャノピ) (EX) LABEL (CANOPY) (EX)

見出しNo. 1は、見出しNo. 2から37を含みます。
1 inc. 2 ~ 37

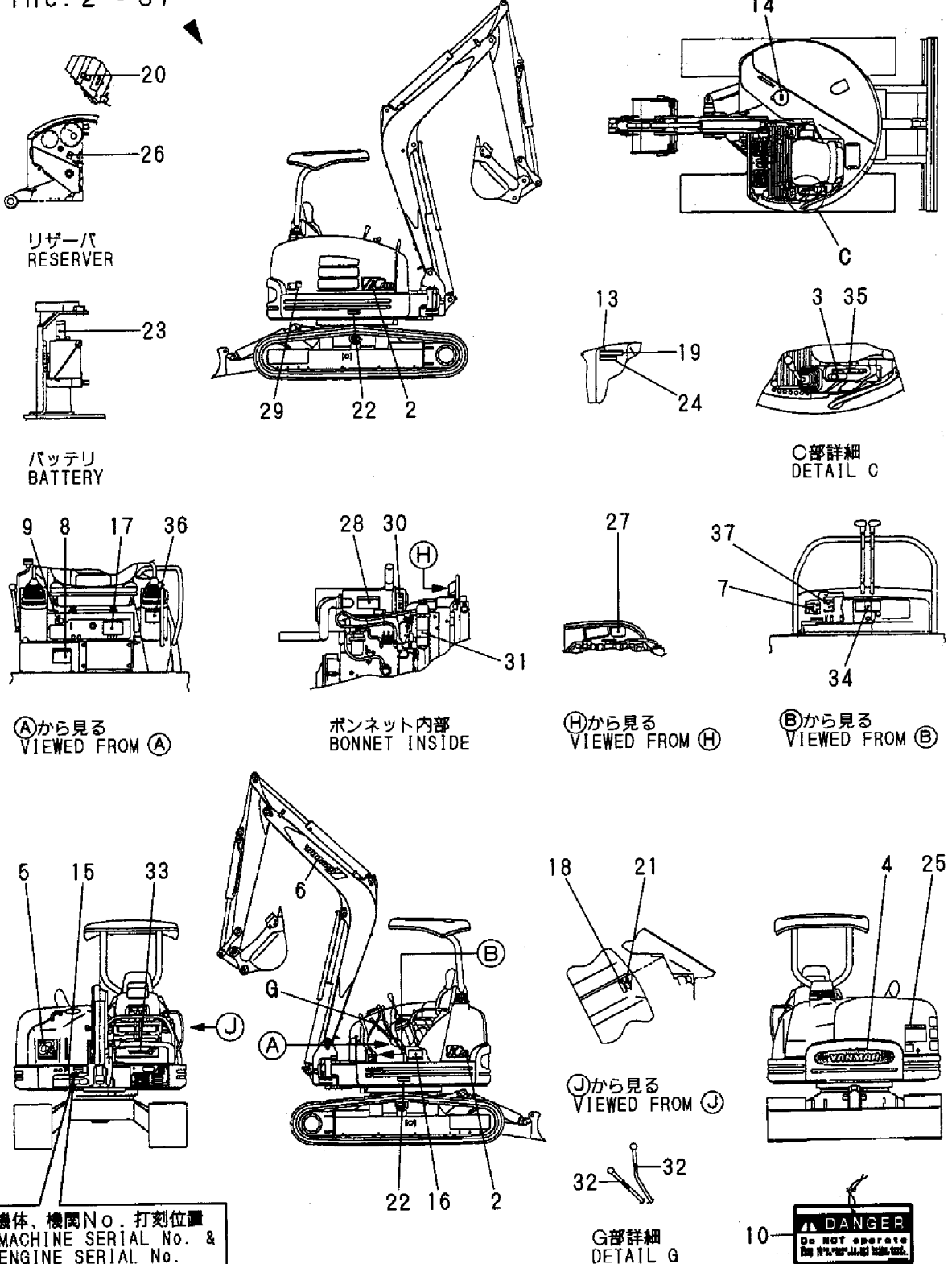

リザーバ
RESERVER

バッテリー
BATTERY

C部詳細
DETAIL C

Ⓐから見る
VIEWED FROM Ⓐ

ボンネット内部
BONNET INSIDE

Ⓗから見る
VIEWED FROM Ⓗ

Ⓑから見る
VIEWED FROM Ⓑ

機体、機関No. 打刻位置
MACHINE SERIAL No. &
ENGINE SERIAL No.
IS STAMPED INTO
THIS LOCATION



取説収納庫内在中
IN THE OPERATION
MANUAL CASE

1,1,,772164-05100,, "TOOL SET",1,1,,,,,,,,,,,,,
2,2,,933110-90000,, "BAG, TOOL",1,1,,,,,,,,,,,,,
3,2,,172614-38300,, "PIN 5X45, LOCK",4,4,,,,,,,,,,,,,
3-1,2,,172112-38111,, "PIN, COTTER",4,4,,,,,N,,,M/#02404,,M/#02404,,,,,
4,2,,104200-92350,, "DRIVER, SCREW",1,1,,,,,,,,,,,,,
5,2,,119640-92750,, "WRENCH, FILTER",1,1,,,,,,,,,,,,,
6,2,,172122-05100,, NOZZLE,1,1,,,,,,,,,,,,,
6-1,2,,172122-05101,, NOZZLE,1,1,,,,,N,,,M/#01427,,M/#01427,,,,,
7,2,,28110-080100,, "WRENCH 8X10",1,1,,,,,,,,,,,,,
8,2,,28110-120140,, "WRENCH 12X14",1,1,,,,,,,,,,,,,
8-1,2,,28110-120140,, "WRENCH 12X14",2,2,,,,,K,,,M/#01318,,M/#01318,,,,,
9,2,,28110-170190,, "WRENCH 17X19",1,1,,,,,,,,,,,,,
10,2,,28110-220240,, "WRENCH 22X24",1,1,,,,,,,,,,,,,
11,2,,28110-270300,, "WRENCH 27X30",1,1,,,,,,,,,,,,,
12,2,,28110-320360,, "WRENCH 32X36",1,1,,,,,Z,,,MXXX,MXXX,,,,,
13,2,,28150-080000,, "BAR WRENCH 8",1,1,,,,,,,,,,,,,
14,2,,28227-271400,, "BOX WRENCH 27X140",1,1,,,,,,,,,,,,,
15,2,,28230-120250,, "TURNING HANDLE",1,1,,,,,,,,,,,,,
16,2,,933110-09700,, "HOSE, GREASE",1,1,,,,,,,,,,,,,
16-1,2,,933110-09701,, "HOSE, GREASE",1,1,,,,,N,,,M/#01427,,M/#01427,,,,,
17,2,,933110-09800,, "GUN 800, GREASE",1,1,,,,,,,,,,,,,
17-1,2,,933110-09801,, "GUN 800, GREASE",1,1,,,,,N,,,M/#01427,,M/#01427,,,,,
18,2,,933171-00470,, "PLIERS 200",1,1,,,,,,,,,,,,,
22,1,,172176-07330,, "BAG, MANUAL",1,1,,,,,W,,,M/#01427,,M/#01427,,,,,

Fig. 6 工具 TOOL

見出しNo. 1は、見出しNo. 2から18を含みます。
1 inc. 2 ~ 18

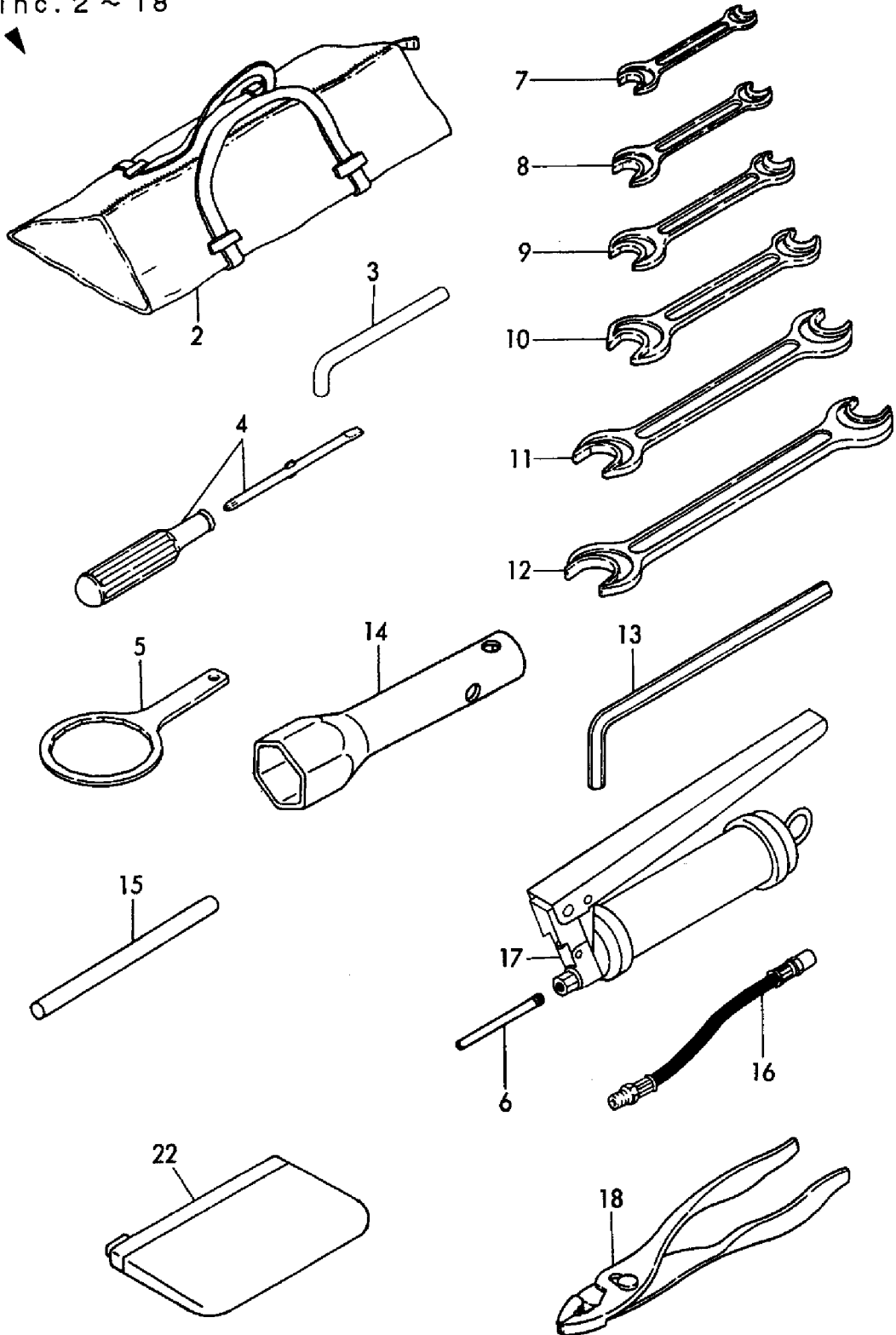

1,1,,172164-11300,, "PIPE, EXHAUST",1,1,,,,,Z,,,M/#01446,,M/#01446,,,,,
2,1,,121120-13580,,CLAMP,1,1,,,,,
3,1,,26106-100652,, "BOLT M10X 65 PLATED",1,1,,,,,
4,1,,26706-100002,, "NUT M10",1,1,,,,,
5,1,,172170-11540,, "HOSE,AIR CLEANER",1,,,,,
6,1,,194250-51660,, "BAND 250",1,1,,,,,
7,1,,23000-070000,, "CLAMP 70",1,1,,,,,
8,1,,172164-11410,,HOSE,1,,,,,
8-1,1,,172164-11411,, "HOSE, AIR CLEANER",1,,,,,N,,,M/#01187,,,,,
9,1,,172164-16470,,COVER,1,,,,,
9-1,1,,172164-16471,, "COVER ASSY",1,,,,,N,,,M/#01187,,,,,
10,1,,26013-100202,, "BOLT W/WASHER M10X20",2,,,,,
11,1,,172164-11290,, "PIPE, EXH.",1,1,,,,,W,,,M/#01446,,M/#01446,,,,,
13,2,,172164-11310,,MAT,1,1,,,,,W,,,M/#01446,,M/#01446,,,,,

Fig. 7 吸気パイプ&排気パイプ
SUC. PIPE & EXH. PIPE

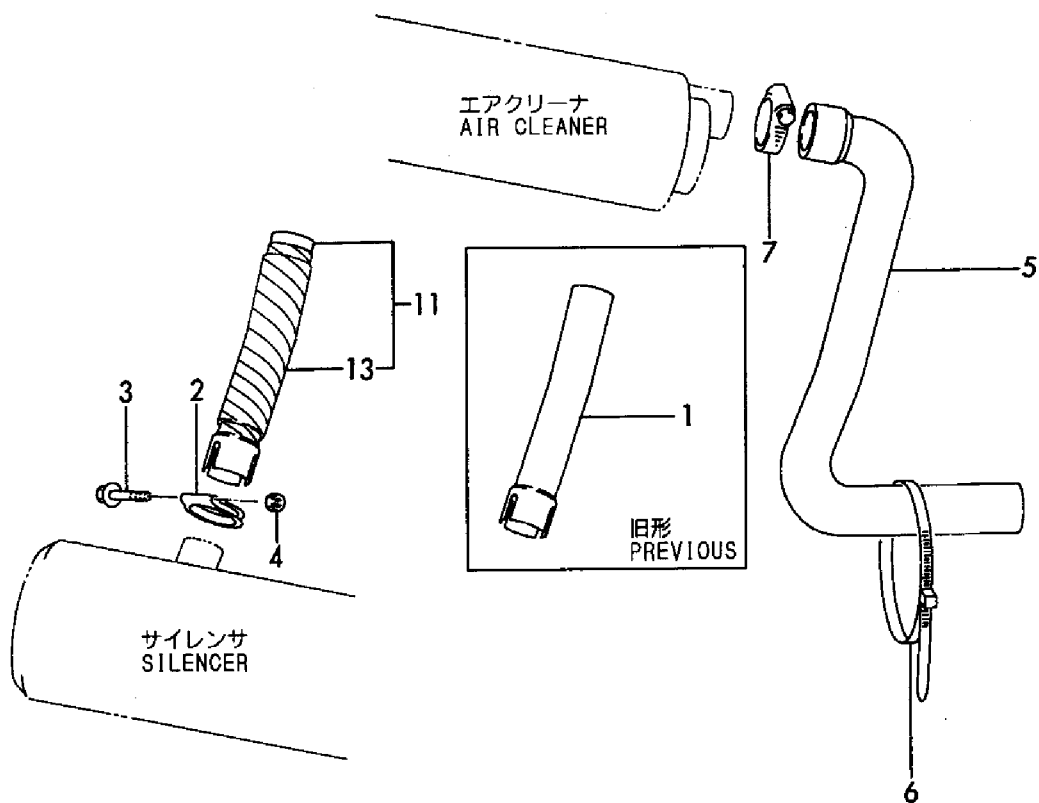
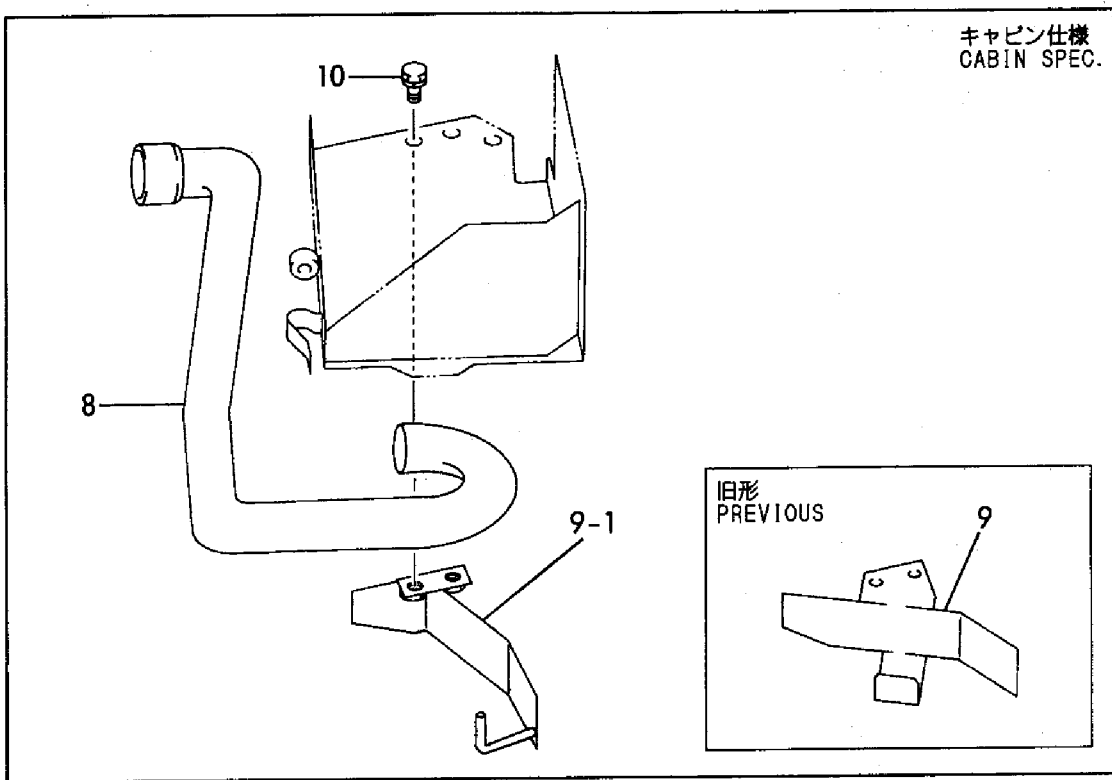

1,1,,172165-12100,, "LEVER ASSY, ACCEL.",1,1,,,,,,,,,,,,,
1A,2,,172165-12140,,GRIP(RED,1,1,,,,,W,,,M/#01843,,M/#01843,,,,,,
2,1,,172141-12280,, "CLAMP, ACCEL WIRE",1,1,,,,,,,,,,,,,
3,1,,172170-12110,,CABLE,1,1,,,,,,,,,,,,,
4,1,,172137-12270,, "JOINT, CABLE",1,1,,,,,,,,,,,,,
5,1,,172113-12521,, "PIN, CABLE",1,1,,,,,,,,,,,,,
6,1,,1C6281-52310,, "PIN 6,COME-OFF SNAP",2,2,,,,,,,,,,,,,
7,1,,1A1040-56900,, "PIN 6X 17",1,1,,,,,,,,,,,,,
8,1,,22137-060000,, "WASHER 6, POLISHED",2,2,,,,,,,,,,,,,
9,1,,22217-080000,, "SPRING WASHER 8",2,2,,,,,,,,,,,,,
10,1,,26116-080202,, "BOLT M 8X 20 PLATED",2,2,,,,,,,,,,,,,
11,1,,26013-100252,, "BOLT W/WASHER M10X25",2,2,,,,,,,,,,,,,

Fig. 8 アクセル
ACCELERATOR

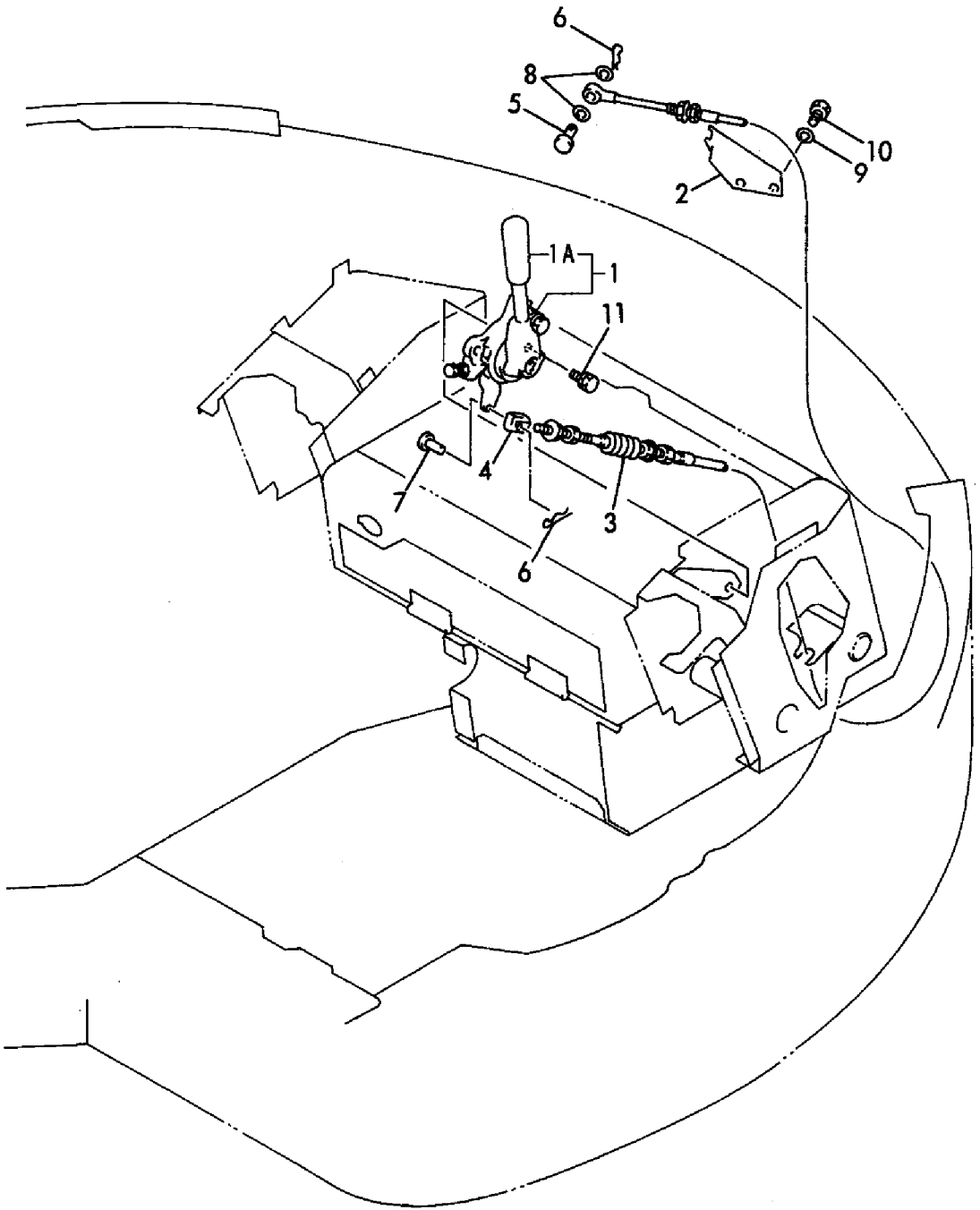

1,1,,172164-08200,, "DECELERATE KIT",1,1,,,,,1,,,,,,,,,
2,2,,26116-100162,, "BOLT M10X 16 PLATED",1,1,,,,,,,,,
3,2,,172164-12110,, "BASE CMP",1,1,,,,,,,,,
4,3,,24550-014200,, "BUSH 14X20",1,1,,,,,,,,,
5,2,,26013-080252,, "BOLT M 8X 25",2,2,,,,,,,,,
6,2,,172164-12230,, CABLE,1,1,,,,,,,,,
7,2,,172164-12250,, "CABLE(ACCELERATOR OD",1,1,,,,,,,,,
8,2,,172164-12160,, "LINK B CMP",1,1,,,,,,,,,
10,3,,24550-014200,, "BUSH 14X20",1,1,,,,,,,,,
11,2,,172164-12200,, "SHAFT CMP",1,1,,,,,,,,,
12,2,,172175-12230,, "LINK A",1,1,,,,,,,,,
13,2,,933166-17730,, "WASHER 10.5X30",1,1,,,,,,,,,
14,2,,172175-12350,, "SPRING, RETURN",1,1,,,,,,,,,
15,2,,172175-12370,, PLATE,1,1,,,,,,,,,
16,2,,26716-060002,, "NUT 6",1,1,,,,,,,,,
17,2,,1C6281-52310,, "PIN 6,COME-OFF SNAP",6,6,,,,,,,,,
18,2,,1A1040-56900,, "PIN 6X 17",2,2,,,,,,,,,
19,2,,1A3809-56915,, "PIN 6X 20",1,1,,,,,,,,,
20,2,,119620-66820,, JOINT,1,1,,,,,,,,,
21,2,,22137-060000,, "WASHER 6, POLISHED",7,7,,,,,,,,,
22,2,,22217-100000,, "SPRING WASHER 10",1,1,,,,,,,,,
23,2,,22351-040025,, "PIN 4X25,SPRING",1,1,,,,,,,,,
24,2,,24311-000210,, "O-RING 1A P-21.0",4,4,,,,,,,,,
25,1,,172137-12270,, "JOINT, CABLE",1,1,,,,,,,,,
26,1,,172165-12100,, "LEVER ASSY, ACCEL.",1,1,,,,,,,,,
27,2,,172165-12140,, GRIP(RED,1,1,,,,,,,,,
28,1,,26013-100252,, "BOLT W/WASHER M10X25",2,2,,,,,,,,,

Fig. 9 アクセル (ワンタッチデセル) ACCELERATOR (ONE TOUCH DECEL)

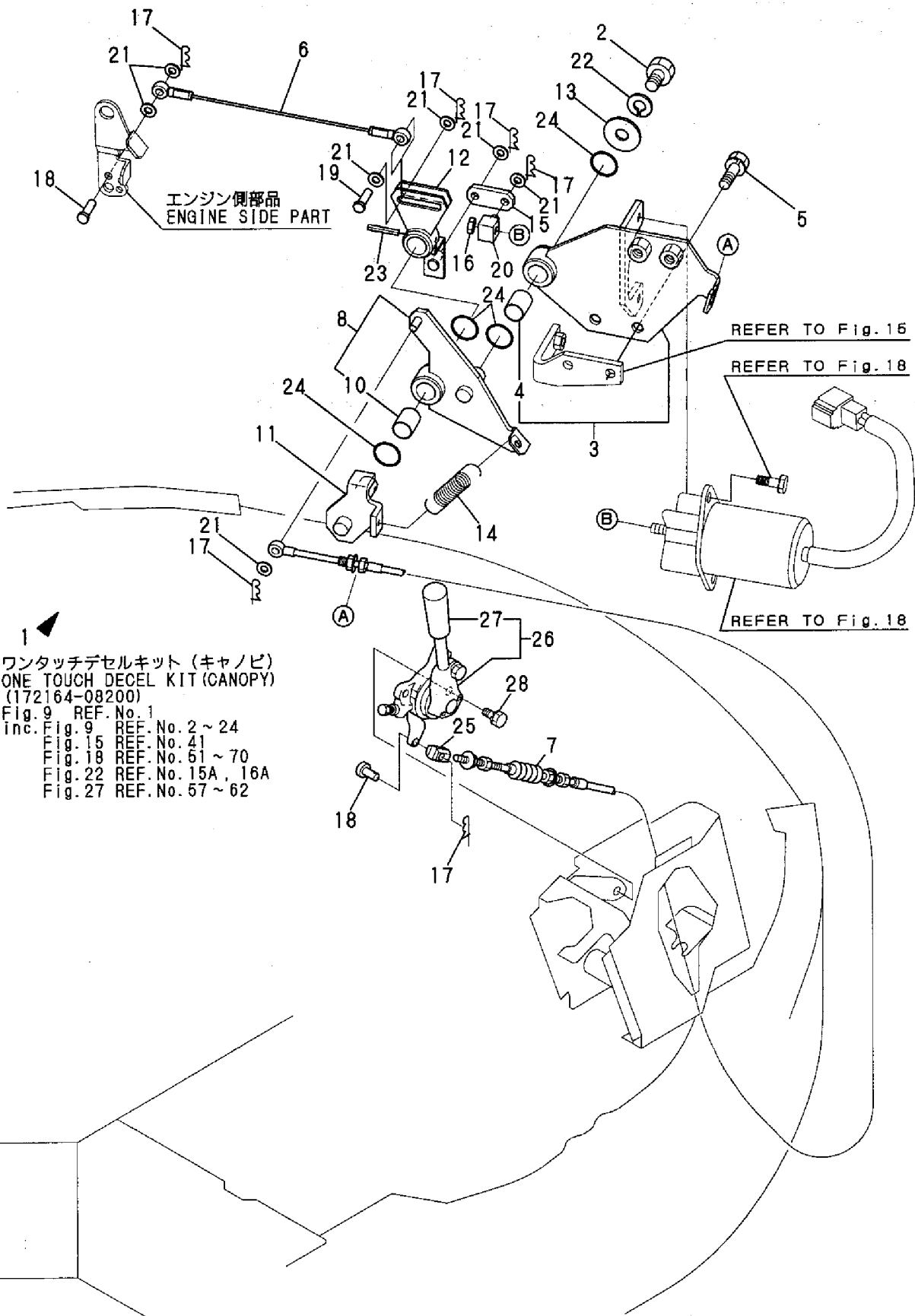

1,1,,196420-02310,, "ABSORBER, SHOCK",4,4,,,,,,,,,,,,,
2,1,,172146-13101,, BRACKET,1,1,,,,,,,,,,,,,
3,1,,172164-13100,, "BRACKET R",1,1,,,,,,,,,,,,,
4,1,,172146-13111,, BRACKET,1,1,,,,,,,,,,,,,
5,1,,172164-13110,, "BRACKET L",1,1,,,,,,,,,,,,,
6,1,,172168-13150,, BRACHET,2,2,,,,,,,,,,,,,
7,1,,172168-13180,, "BRACKET COMP.,ENGINE",2,2,,,,,,,,,,,,,
7-1,1,,172168-13181,, "BRACKET COMP.,ENGINE",2,2,,,,,N,,,M/#01318,,M/#01318,,,,,,
8,1,,172162-13200,, "BOLT M10X30",10,10,,,,,,,,,,,,,
9,1,,172162-13200,, "BOLT M10X30",8,8,,,,,,,,,,,,,
10,1,,172124-13230,, "STOPPER, ENGINE",4,4,,,,,,,,,,,,,
11,1,,172137-46040,, "SEAT, SPRING",10,10,,,,,,,,,,,,,
12,1,,172137-46040,, "SEAT, SPRING",8,8,,,,,,,,,,,,,
13,1,,22217-100000,, "SPRING WASHER 10",10,10,,,,,,,,,,,,,
14,1,,22217-100000,, "SPRING WASHER 10",8,8,,,,,,,,,,,,,
15,1,,22217-120000,, "SPRING WASHER",8,8,,,,,,,,,,,,,
16,1,,26013-100252,, "BOLT W/WASHER M10X25",8,8,,,,,,,,,,,,,
17,1,,26013-120302,, "BOLT W/WASHER M12X30",8,8,,,,,,,,,,,,,
18,1,,26716-120002,, "NUT 12",8,8,,,,,,,,,,,,,
19,1,,172162-13200,, "BOLT M10X30",9,,,,,1,,,,,,,,,,,,,
20,1,,172165-13610,, "BOLT M10X 40",1,,,,,1,,,,,,,,,,,,,

Fig. 10 エンジンマウント
ENGINE MOUNT

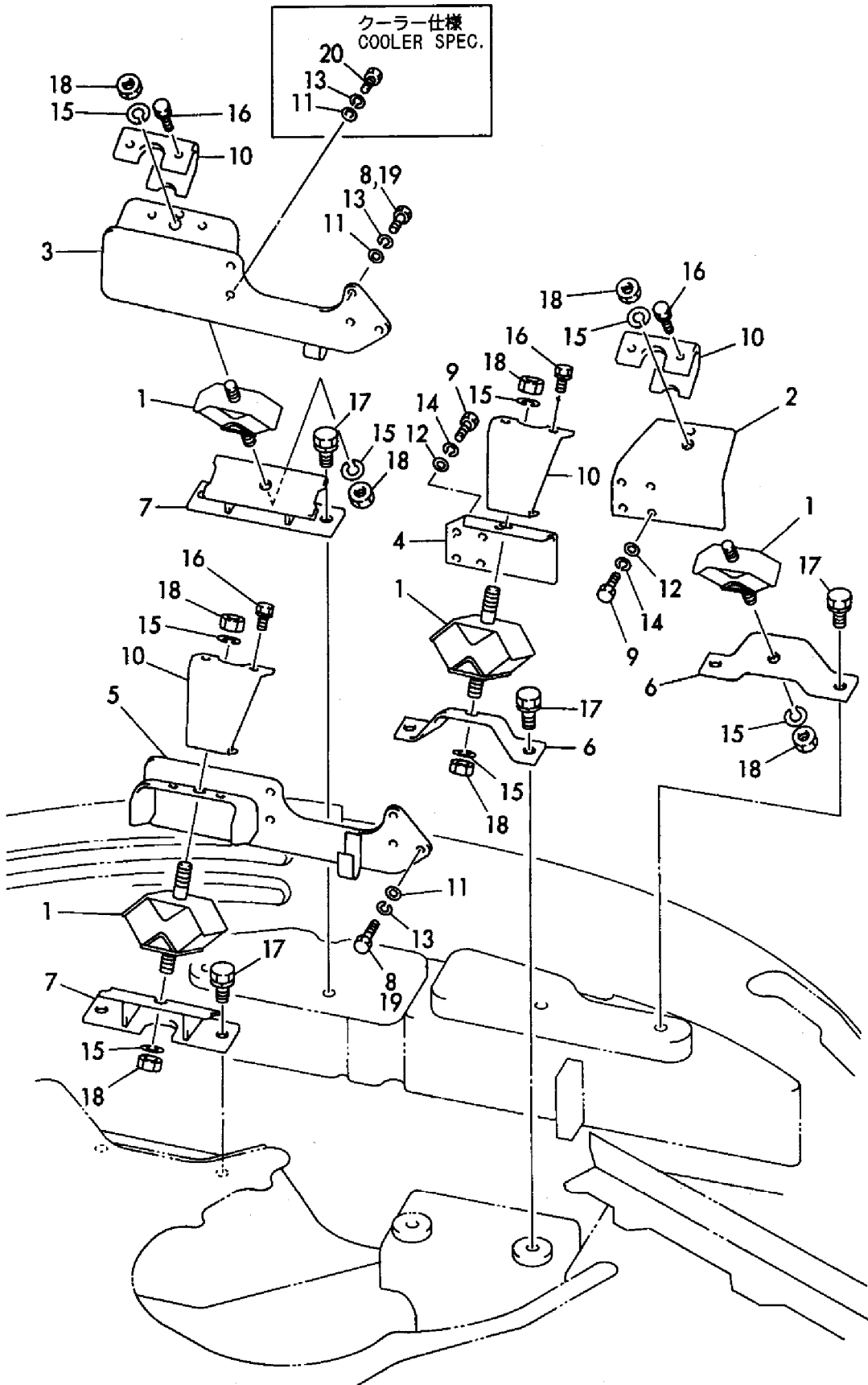

1,1,,172164-08100,, "COOLER KIT",1,,,,,,,,,1,,,,,,,,,
2,2,,172162-18020,, COMPRESSOR,1,,,,,,,,,
3,2,,172164-18261,, "COVER ASSY, PULLEY",1,,,,,,,,,
4,2,,172164-18350,, "BRACKET ASSY",1,,,,,,,,,
5,2,,172165-18751,, PLATE,1,,,,,,,,,
6,2,,22217-080000,, "SPRING WASHER 8",2,,,,,,,,,
7,2,,26013-080252,, "BOLT M 8X 25",4,,,,,,,,,
8,2,,26106-080552,, "BOLT M 8X 55 PLATED",1,,,,,,,,,
9,2,,26106-080552,, "BOLT M 8X 55 PLATED",2,,,,,,,,,
10,2,,26116-080202,, "BOLT M 8X 20 PLATED",2,,,,,,,,,
11,2,,172165-13610,, "BOLT M10X 40",1,,,,,,,,,
12,2,,172164-18290,, PULLEY,1,,,,,,,,,
13,2,,172165-18601,, "BRACKET ASSY",1,,,,,,,,,
14,2,,172165-18630,, "ADJUSTER ASSY",1,,,,,,,,,
15,2,,172165-18670,, BOSS,1,,,,,,,,,
16,2,,172165-18930,, "PULLEY, TENSION",1,,,,,,,,,
17,2,,172164-19310,, NUT,1,,,,,,,,,
18,2,,129430-42260,, V-BELT(HM38),1,,,,,,,,,
19,2,,129403-42380,, V-PULLEY(D=110),1,,,,,,,,,
20,2,,1A1040-43900,, "SPRING WASHER",1,,,,,,,,,
21,2,,22190-080002,, "SEAL WASHER 8S",4,,,,,,,,,
22,2,,22217-060000,, "SPRING WASHER 6",1,,,,,,,,,
23,2,,22217-080000,, "SPRING WASHER 8",1,,,,,,,,,
24,2,,22252-000400,, "CIRCLIP 40",1,,,,,,,,,
25,2,,24104-062034,, "BALL BEARING",1,,,,,,,,,
26,2,,26013-100252,, "BOLT W/WASHER M10X25",3,,,,,,,,,
27,2,,26106-080202,, "BOLT M 8X 20 PLATED",4,,,,,,,,,
28,2,,26716-060002,, "NUT 6",1,,,,,,,,,
29,2,,26716-080002,, "NUT M 8",1,,,,,,,,,

Fig. 11 コンプレッサー&Vプーリ (クーラ仕様)
COMPRESSOR & V PULLEY (COOLER SPEC.)

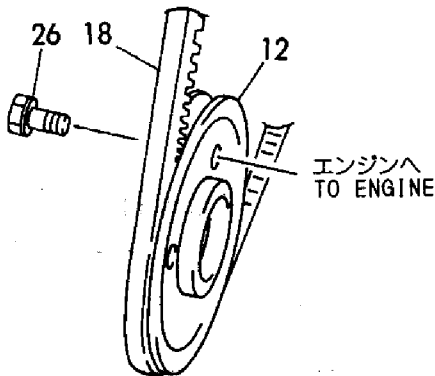
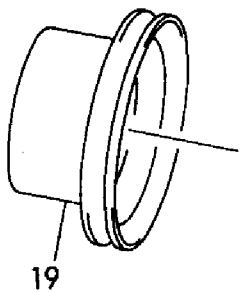
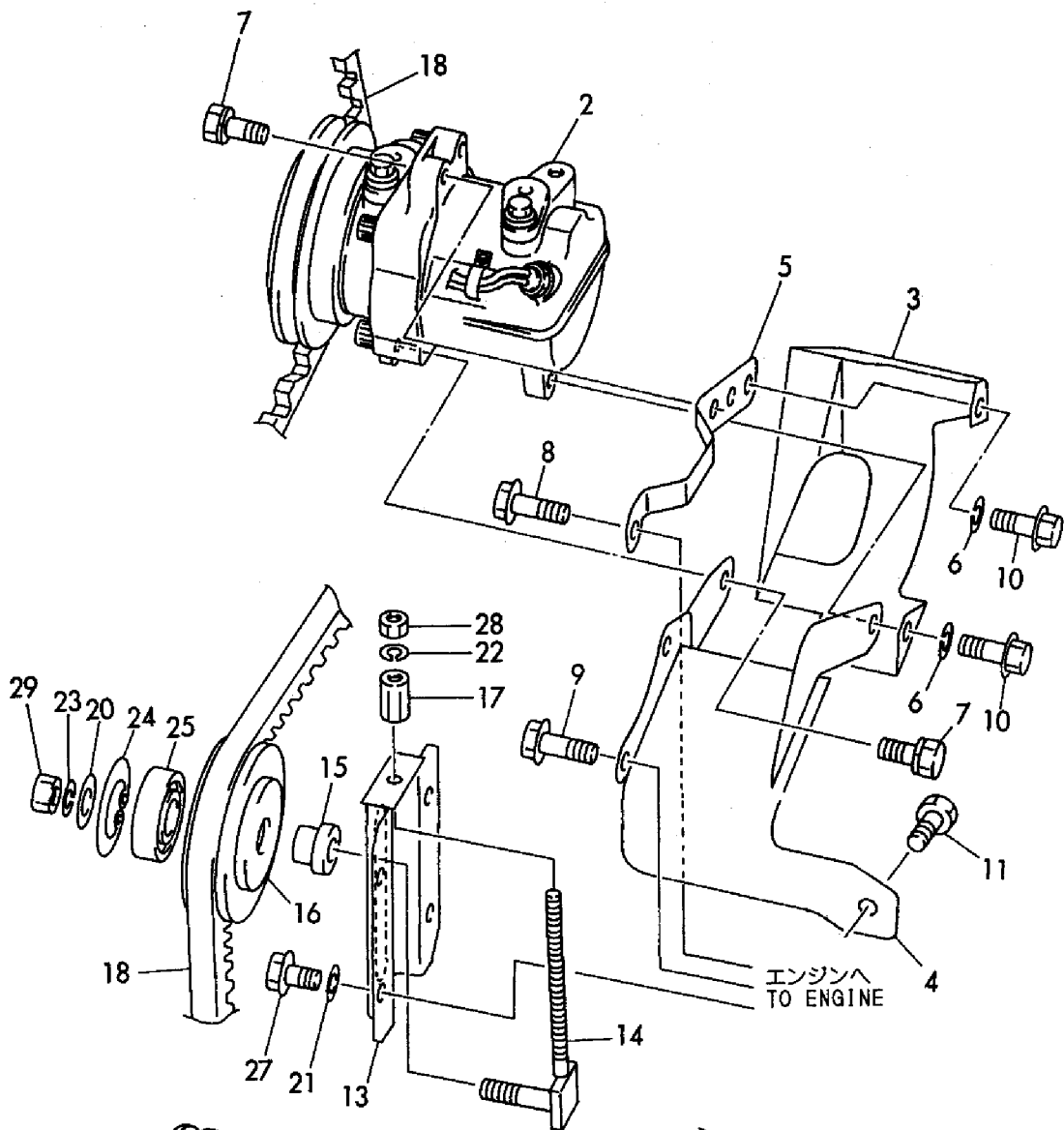

- 1
クーラーキット
COOLER KIT
(172164-08100)
Fig. 11 REF. No. 1
Inc. Fig. 11 REF. No. 2 ~ 29
Fig. 12 REF. No. 1 ~ 5
Fig. 13 REF. No. 1 ~ 62
Fig. 14 REF. No. 1 ~ 49
Fig. 20 REF. No. 1 ~ 11
Fig. 36 REF. No. 1, 2
Fig. 38 REF. No. 1
Fig. 39 REF. No. 1 ~ 5
Fig. 40 REF. No. 1 ~ 9
Fig. 41 REF. No. 18B, 23, 24, 52 ~ 54
Fig. 43 REF. No. 16B, 22B, 23B, 34

1,2,,172164-13240,,HOSE,1,,,,,1,,,,,
2,2,,172122-13400,, "CLAMP,RADIATOR HOSE",1,,,,,1,,,,,
3,2,,194250-51660,, "BAND 250",2,,,,,1,,,,,
4,2,,22217-080000,, "SPRING WASHER 8",1,,,,,1,,,,,
5,2,,26116-080162,, "BOLT 8X16",1,,,,,1,,,,,
6,1,,172116-13410,, "HOSE(B), WATER DRAIN",2,2,,,,,
6-1,1,,172116-13410,, "HOSE(B), WATER DRAIN",1,1,,,,,K,,,M/#01001,,M/#01001,,,,,
7,1,,172164-13430,, "BRACKET E",1,1,,,,,
8,1,,172164-13450,, "BRACKET F",1,1,,,,,
9,1,,172164-13520,, "RUBBER, SEAL",1,1,,,,,
10,1,,172734-14620,, "PIPE L=300, FUEL",1,1,,,,,W,,,M/#01001,,M/#01001,,,,,
11,1,,172164-13600,, "MOUNT L",1,1,,,,,
12,1,,172164-13630,, "MOUNT R",1,1,,,,,
13,1,,172164-13670,, "BRACKET(C), COOLER",1,1,,,,,
14,1,,172164-13691,, PLATE,1,1,,,,,
15,1,,172725-16380,, "GROMMET 15X20",1,1,,,,,
16,1,,129430-44500,, RADIATOR,1,1,,,,,
17,2,,124450-44590,, "CAP, RADIATOR",1,1,,,,,
19,2,,129430-44660,, SHROUD,1,1,,,,,
20,2,,124450-44800,, "LABEL, RADIATOR",1,1,,,,,
21,2,,26014-060122,, "BOLT M 6X 12",4,4,,,,,
22,1,,171064-44510,, "SUB-TANK ASSY",1,1,,,,,
23,2,,171064-44520,, "BODY, SUB-TANK",1,1,,,,,
24,2,,121450-44531,, CAP,1,1,,,,,
25,2,,124450-44560,, CLAMP,1,1,,,,,
26,2,,121470-44581,, GASKET,1,1,,,,,
27,2,,23065-070225,, "HOSE 7X 225",1,1,,,,,
28,1,,124450-44550,, "CLAMP, SUB-TANK",1,1,,,,,
29,1,,129403-44592,, "NET,WIRE",1,1,,,,,
30,1,,121256-44600,, "BRACKET, SUB-TANK",1,1,,,,,
31,1,,129137-49100,, "JOINT,WATER DRAIN",1,1,,,,,Z,,,M/#01187,,M/#01187,,,,,
32,1,,121450-49110,, "COCK ASSY, 3-WAY",1,1,,,,,
34,2,,121250-49121,, PLUG,1,1,,,,,
35,2,,24311-000160,, "O-RING 1A P-16.0",1,1,,,,,
36,1,,124766-59050,, "CLAMP 12",2,2,,,,,
37,1,,124766-59050,, "CLAMP 12",4,4,,,,,
38,1,,22137-080000,, "WASHER 8, POLISHED",6,6,,,,,
39,1,,22137-080000,, "WASHER 8, POLISHED",4,4,,,,,
40,1,,22137-080000,, "WASHER 8, POLISHED",4,4,,,,,
41,1,,22217-080000,, "SPRING WASHER 8",3,3,,,,,
42,1,,22217-080000,, "SPRING WASHER 8",2,2,,,,,Z,,,M/#01030,,M/#01030,,,,,
43,1,,22217-080000,, "SPRING WASHER 8",2,2,,,,,
44,1,,22217-080000,, "SPRING WASHER 8",12,12,,,,,
45,1,,22217-080000,, "SPRING WASHER 8",4,4,,,,,
46,1,,23010-038000,, "CLAMP 38",4,4,,,,,
47,1,,26013-080162,, "BOLT W/WASHER M8X16",4,4,,,,,
48,1,,26013-100252,, "BOLT W/WASHER M10X25",4,4,,,,,
49,1,,26051-080002,, "NUT M 8",8,8,,,,,
50,1,,26116-080202,, "BOLT M 8X 20 PLATED",12,12,,,,,
51,1,,26116-080202,, "BOLT M 8X 20 PLATED",2,2,,,,,
52,1,,26116-080202,, "BOLT M 8X 20 PLATED",3,3,,,,,
53,1,,26116-080202,, "BOLT M 8X 20 PLATED",4,4,,,,,
54,1,,26557-080202,, "SCREW M 8X 20",2,2,,,,,
54-1,1,,26022-080162,, "SCREW M 8X 16",2,2,,,,,N,,,M/#01030,,M/#01030,,,,,
55,1,,933168-55770,, "BAND 146",1,1,,,,,
56,1,,172165-74900,, "COOLER,OIL",1,1,,,,,
56-1,1,,172165-74901,, "OIL COOLER",1,1,,,,,F,2,,M/#01700,,M/#01700,,,,,
57,1,,26716-080002,, "NUT M 8",3,3,,,,,
58,1,,172164-13200,, "HOSE A",1,1,,,,,
58-1,1,,172164-13201,, "HOSE A",1,1,,,,,S,,,M/#01736,,M/#01736,,,,,
59,1,,172164-13210,, "HOSE B",1,1,,,,,
60,1,,172122-13310,, "MOUNT, RADIATOR",4,4,,,,,
61,1,,172164-13340,, "BRACKET A",1,1,,,,,

62,1,,172164-13370,, "BRACKET B",1,1,,,,,,,,,,,,,
63,1,,172116-13400,, "HOSE(A), WATER DRAIN",1,1,,,,,,,,,,,,,
63-1,1,,172116-14620,, "PIPE, FUEL",1,1,,,,,N,,,M/#01001,,M/#01001,,,,,
63-2,1,,172141-14610,, "HOSE, FUEL",1,1,,,,,S,,,M/#01187,,M/#01187,,,,,

Fig. 12 ラジエータ&オイルクーラ RADIATOR & OIL COOLER

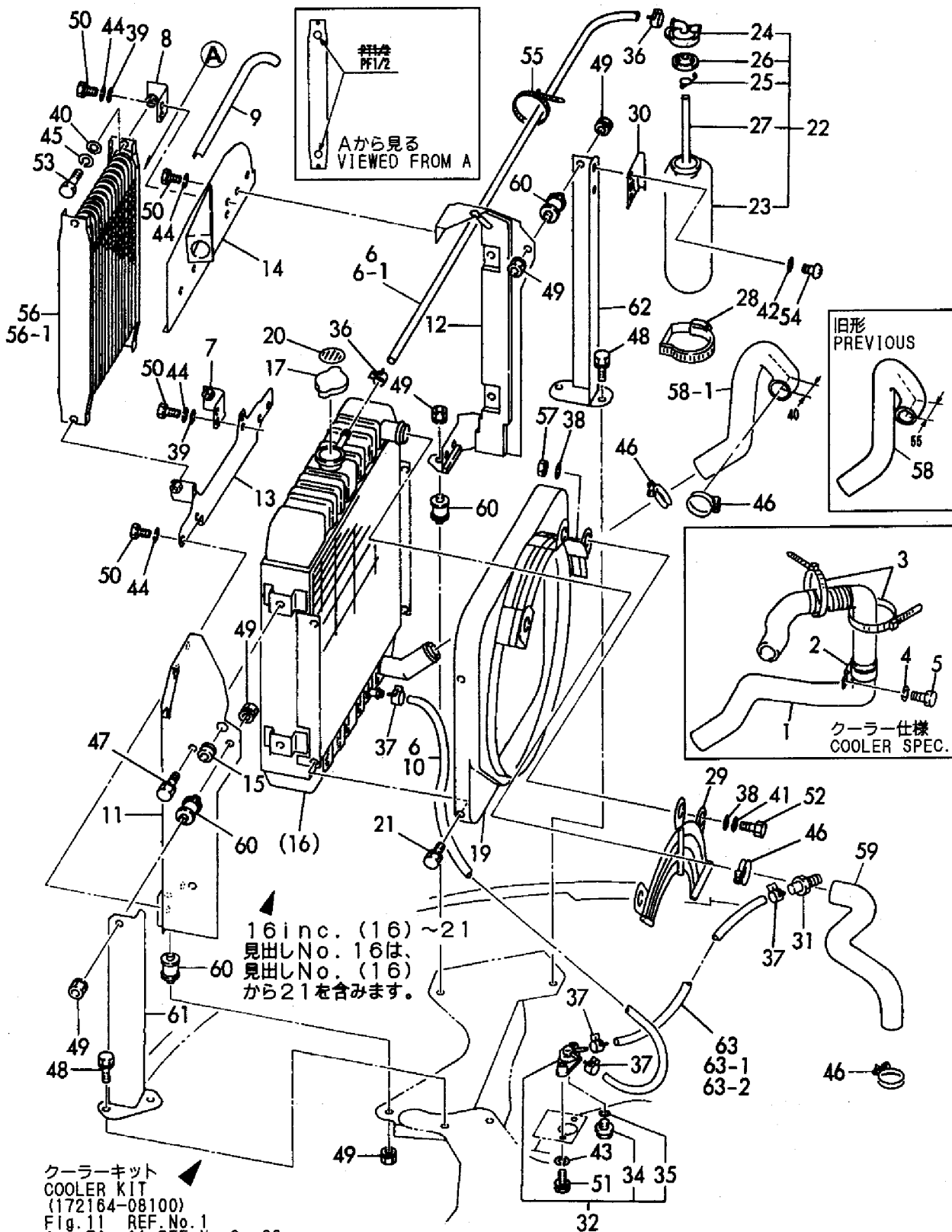

クーラーキット
COOLER KIT
(172164-08100)

- | | |
|------------------------------|---------------------------------------|
| Fig. 11 REF. No. 1 | Fig. 38 REF. No. 1 |
| inc. Fig. 11 REF. No. 2 ~ 29 | Fig. 39 REF. No. 1 ~ 5 |
| Fig. 12 REF. No. 1 ~ 5 | Fig. 40 REF. No. 1 ~ 9 |
| Fig. 13 REF. No. 1 ~ 62 | Fig. 41 REF. No. 18B, 23, 24, 52 ~ 54 |
| Fig. 14 REF. No. 1 ~ 49 | Fig. 43 REF. No. 16B, 22B, 23B, 34 |
| Fig. 20 REF. No. 1 ~ 11 | |
| Fig. 36 REF. No. 1, 2 | |

1,2,,194145-04810,, "WASHER 10",4,,,,,,,,,,,,,,,,,,,,,
2,2,,172126-11510,, "BAND 300",2,,,,,,,,,,,,,,,,,,,,,
3,2,,172122-13310,, "MOUNT, RADIATOR",4,,,,,,,,,,,,,,,,,,,,,
4,2,,172183-13480,, "RUBBER, SEAL",1,,,,,,,,,,,,,,,,,,,,,
5,2,,172164-18000,, "COOLER (A) ASSY",1,,,,,,,,,,,,,,,,,,,,,
6,3,,172162-18040,, BRACKET,1,,,,,,,,,,,,,,,,,,,,,
7,3,,172162-18070,, "PLUG, DRAIN",2,,,,,,,,,,,,,,,,,,,,,
8,3,,172164-18080,, MOTOR,1,,,,,,,,,,,,,,,,,,,,,
9,3,,172165-18080,, CONNECTOR,1,,,,,,,,,,,,,,,,,,,,,
10,3,,172164-18700,, HOSE,1,,,,,,,,,,,,,,,,,,,,,
11,3,,172164-18710,, HOSE,1,,,,,,,,,,,,,,,,,,,,,
12,3,,172164-18720,, HOSE,1,,,,,,,,,,,,,,,,,,,,,
13,3,,172164-18730,, TUBE,1,,,,,,,,,,,,,,,,,,,,,
14,3,,172164-18740,, HOSE,1,,,,,,,,,,,,,,,,,,,,,
15,3,,172164-18780,, CONDENSER,1,,,,,,,,,,,,,,,,,,,,,
16,3,,172164-18790,, FAN,1,,,,,,,,,,,,,,,,,,,,,
17,3,,172164-18800,, CLIP,1,,,,,,,,,,,,,,,,,,,,,
18,3,,172164-18810,, CLIP,1,,,,,,,,,,,,,,,,,,,,,
19,3,,172164-18820,, GROMMET,1,,,,,,,,,,,,,,,,,,,,,
20,3,,1E8080-79430,, "SWITCH ASSY, CONTROL",1,,,,,,,,,,,,,,,,,,,,,
21,3,,1E8080-79450,, "KNOB, FAN",2,,,,,,,,,,,,,,,,,,,,,
22,3,,1E8080-79470,, "NUT 4, JN",3,,,,,,,,,,,,,,,,,,,,,
23,3,,198325-87110,, DRYER,1,,,,,,,,,,,,,,,,,,,,,
24,3,,198325-87200,, "CASE, LOWER",1,,,,,,,,,,,,,,,,,,,,,
25,3,,197830-87910,, GRILLE,2,,,,,,,,,,,,,,,,,,,,,
26,3,,197821-88380,, INSULATOR,1,,,,,,,,,,,,,,,,,,,,,
27,3,,197830-88611,, GRILLE,2,,,,,,,,,,,,,,,,,,,,,
28,2,,933169-22940,, "SPACER, RESERVOIR",1,,,,,,,,,,,,,,,,,,,,,
28-1,2,,933171-17770,, "SHIM SET",1,,,,,N,,,,M/#02404,,,,,
29,2,,172164-18400,, "COVER ASSY",1,,,,,,,,,,,,,,,,,,,,,
30,2,,172164-18530,, "BRACKET ASSY",1,,,,,,,,,,,,,,,,,,,,,
31,2,,172164-18750,, "HOSE, DRAIN",1,,,,,,,,,,,,,,,,,,,,,
32,2,,172164-18760,, "HOSE, DRAIN",1,,,,,,,,,,,,,,,,,,,,,
33,2,,172164-18770,, "HOSE, DRAIN",1,,,,,,,,,,,,,,,,,,,,,
34,2,,172164-18850,, GROMMET,1,,,,,,,,,,,,,,,,,,,,,
35,2,,172164-18860,, "GUIDE ASSY, HOSE",2,,,,,,,,,,,,,,,,,,,,,
36,2,,172164-19190,, PLATE,1,,,,,,,,,,,,,,,,,,,,,
37,2,,172164-19200,, RUBBER,1,,,,,,,,,,,,,,,,,,,,,
38,2,,172164-19230,, EV,2,,,,,,,,,,,,,,,,,,,,,
39,2,,172164-19240,, SPONGE,1,,,,,,,,,,,,,,,,,,,,,
40,2,,1A1380-59480,, "CLAMP A, SM. & DYN. CORD",2,,,,,,,,,,,,,,,,,,,,,
41,2,,172137-62970,, "GROMMET 16",2,,,,,,,,,,,,,,,,,,,,,
42,2,,172164-66640,, "RUBBER, SEAL 400",1,,,,,,,,,,,,,,,,,,,,,
43,2,,22137-060000,, "WASHER 6, POLISHED",4,,,,,,,,,,,,,,,,,,,,,
44,2,,22137-060000,, "WASHER 6, POLISHED",2,,,,,,,,,,,,,,,,,,,,,
45,2,,22137-080000,, "WASHER 8, POLISHED",2,,,,,,,,,,,,,,,,,,,,,
46,2,,22157-100000,, "WASHER 10",2,,,,,,,,,,,,,,,,,,,,,
47,2,,22217-060000,, "SPRING WASHER 6",4,,,,,,,,,,,,,,,,,,,,,
48,2,,22217-080000,, "SPRING WASHER 8",8,,,,,,,,,,,,,,,,,,,,,
49,2,,22869-400160,, SCREW,12,,,,,,,,,,,,,,,,,,,,,
50,2,,26013-060162,, "BOLT M 6X 16",2,,,,,,,,,,,,,,,,,,,,,
51,2,,26013-060252,, "BOLT M 6X 25",2,,,,,,,,,,,,,,,,,,,,,
52,2,,26013-080162,, "BOLT W/WASHER M8X16",2,,,,,,,,,,,,,,,,,,,,,
53,2,,26013-080202,, "BOLT W/WASHER M8X20",2,,,,,,,,,,,,,,,,,,,,,
54,2,,26013-080252,, "BOLT M 8X 25",2,,,,,,,,,,,,,,,,,,,,,
55,2,,26013-100252,, "BOLT W/WASHER M10X25",2,,,,,,,,,,,,,,,,,,,,,
56,2,,26013-100302,, "BOLT M10X 30",4,,,,,,,,,,,,,,,,,,,,,
57,2,,26023-050122,, "SCREW M 5X 12",3,,,,,,,,,,,,,,,,,,,,,
58,2,,26116-060602,, "BOLT M 6X 60 PLATED",4,,,,,,,,,,,,,,,,,,,,,
59,2,,26367-050002,, "NUT M 5",1,,,,,,,,,,,,,,,,,,,,,
60,2,,26716-080002,, "NUT M 8",8,,,,,,,,,,,,,,,,,,,,,
61,2,,933166-16110,, "GROMMET 30X9.5",1,,,,,,,,,,,,,,,,,,,,,
62,2,,172164-18100,, "MOUNT ASSY",1,,,,,,,,,,,,,,,,,,,,,

Fig. 13 パイピング (クーラ仕様) PIPING (COOLER SPEC.)

見出しNo. 5は、見出しNo. 6から27を含みます。
5 inc. 6 ~ 27

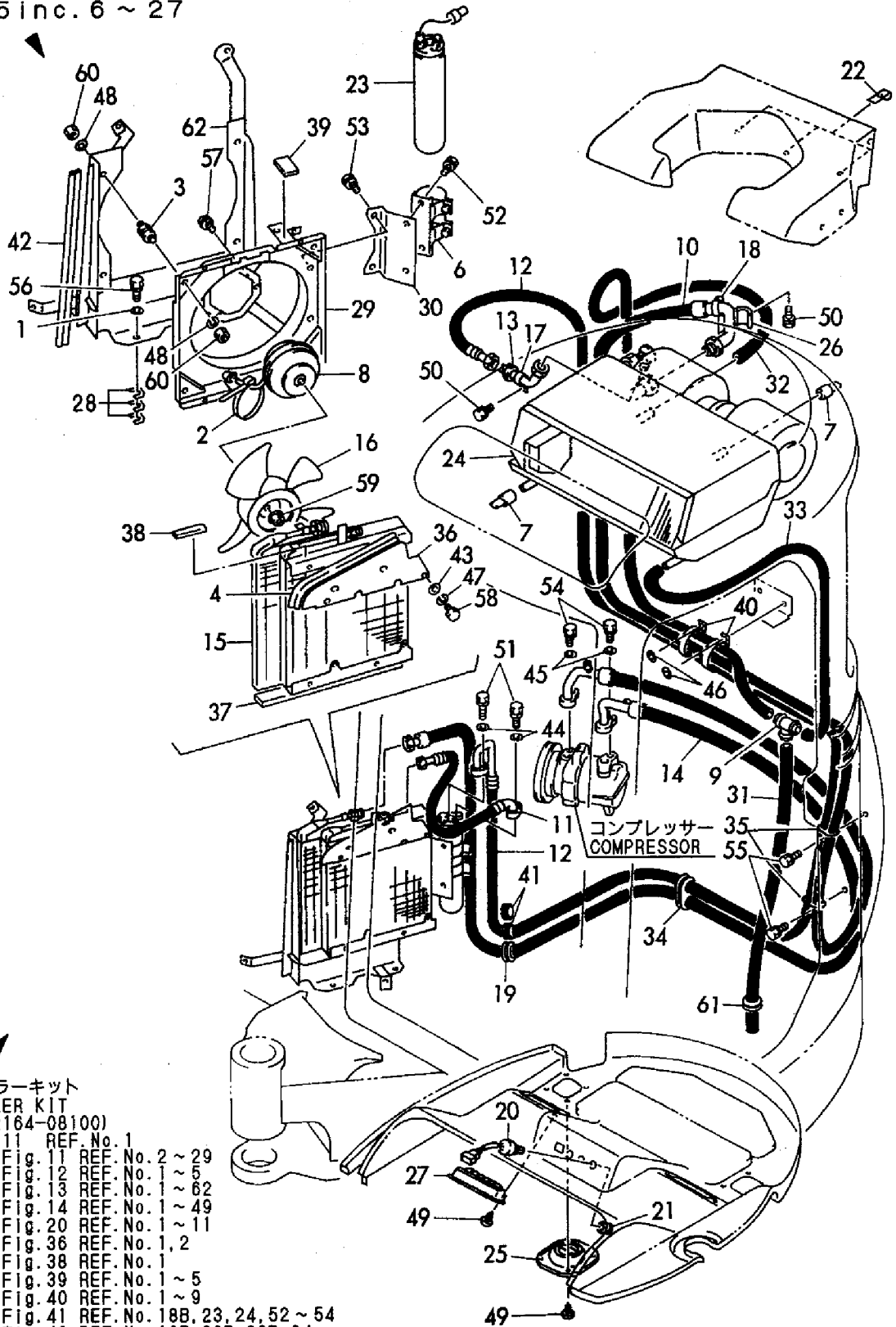

クーラーキット
COOLER KIT
(172164-08100)

- Fig. 11 REF. No. 1
- inc. Fig. 11 REF. No. 2 ~ 29
- Fig. 12 REF. No. 1 ~ 5
- Fig. 13 REF. No. 1 ~ 62
- Fig. 14 REF. No. 1 ~ 49
- Fig. 20 REF. No. 1 ~ 11
- Fig. 36 REF. No. 1, 2
- Fig. 38 REF. No. 1
- Fig. 39 REF. No. 1 ~ 5
- Fig. 40 REF. No. 1 ~ 9
- Fig. 41 REF. No. 18B, 23, 24, 52 ~ 54
- Fig. 43 REF. No. 16B, 22B, 23B, 34

1,2,,172122-13310,, "MOUNT, RADIATOR",3,,,,,,,,,,,,,,,,,,,,,
2,2,,172176-17870,, MOUNT,2,,,,,,,,,,,,,,,,,,,,,
3,2,,172164-18300,, "COVER ASSY",1,,,,,,,,,,,,,,,,,,,,,
4,2,,172164-18550,, "BRACKET ASSY",1,,,,,,,,,,,,,,,,,,,,,
5,2,,172164-18650,, PLATE,1,,,,,,,,,,,,,,,,,,,,,
6,2,,172164-18830,, MOUNT,2,,,,,,,,,,,,,,,,,,,,,
7,2,,172164-18900,, DUCT,1,,,,,,,,,,,,,,,,,,,,,
8,2,,172164-18910,, PLATE,1,,,,,,,,,,,,,,,,,,,,,
9,2,,172164-18920,, FILTER,1,,,,,,,,,,,,,,,,,,,,,
10,2,,172164-18960,, "PANEL ASSY",1,,,,,,,,,,,,,,,,,,,,,
11,2,,172164-19100,, "SWITCH W/LAMP",1,,,,,,,,,,,,,,,,,,,,,
12,2,,172164-19110,, PLATE,2,,,,,,,,,,,,,,,,,,,,,
13,2,,172164-19130,, "BOLT M10X 25",4,,,,,,,,,,,,,,,,,,,,,
14,2,,172164-19150,, BRACKET,1,,,,,,,,,,,,,,,,,,,,,
15,2,,172164-19170,, "PLATE ASSY",2,,,,,,,,,,,,,,,,,,,,,
16,2,,172164-19210,, "RUBBER SEAL",1,,,,,,,,,,,,,,,,,,,,,
17,2,,172164-19220,, "RUBBER SEAL",1,,,,,,,,,,,,,,,,,,,,,
18,2,,172164-19260,, SEAL,1,,,,,,,,,,,,,,,,,,,,,
19,2,,172164-19270,, SEAL,1,,,,,,,,,,,,,,,,,,,,,
20,2,,172164-19300,, "COVER ASSY",1,,,,,,,,,,,,,,,,,,,,,
21,2,,194167-61650,, "NUT 5008",4,,,,,,,,,,,,,,,,,,,,,
22,2,,194940-61790,, "SCRFW 5X16",5,,,,,,,,,,,,,,,,,,,,,
23,2,,194940-61790,, "SCRFW 5X16",4,,,,,,,,,,,,,,,,,,,,,
24,2,,172151-62240,, GROMMET,1,,,,,,,,,,,,,,,,,,,,,
25,2,,172519-63240,, "BOLT 8X 16",2,,,,,,,,,,,,,,,,,,,,,
26,2,,172164-65640,, "WASHER 32X11X2.3",4,,,,,,,,,,,,,,,,,,,,,
27,2,,172164-65710,, "RUBBER, SEAL B",2,,,,,,,,,,,,,,,,,,,,,
28,2,,172165-66980,, "BOLT M 8X 25",3,,,,,,,,,,,,,,,,,,,,,
29,2,,172176-68200,, WASHER,2,,,,,,,,,,,,,,,,,,,,,
30,2,,1E8385-79310,, "WASHER 8",3,,,,,,,,,,,,,,,,,,,,,
31,2,,22157-080000,, "WASHER 8",4,,,,,,,,,,,,,,,,,,,,,
32,2,,22217-080000,, "SPRING WASHER 8",1,,,,,,,,,,,,,,,,,,,,,
33,2,,22217-080000,, "SPRING WASHER 8",5,,,,,,,,,,,,,,,,,,,,,
34,2,,26013-080202,, "BOLT W/WASHER M8X20",4,,,,,,,,,,,,,,,,,,,,,
35,2,,26013-080202,, "BOLT W/WASHER M8X20",4,,,,,,,,,,,,,,,,,,,,,
36,2,,26013-080202,, "BOLT W/WASHER M8X20",6,,,,,,,,,,,,,,,,,,,,,
37,2,,26013-080252,, "BOLT M 8X 25",2,,,,,,,,,,,,,,,,,,,,,
38,2,,26589-060162,, "SCREW M6,BINDING",2,,,,,,,,,,,,,,,,,,,,,
39,2,,26716-080002,, "NUT M 8",1,,,,,,,,,,,,,,,,,,,,,
40,2,,26716-080002,, "NUT M 8",5,,,,,,,,,,,,,,,,,,,,,
41,2,,22137-050000,, "WASHER 5, POLISHED",4,,,,,,,,,,,,,,,,,,,,,
42,2,,172164-03300,, "LABEL, CONTROL PANEL",1,,,,,,,,,,,,,,,,,,,,,
43,2,,172162-03510,, "LABEL, CAUTION",1,,,,,,,,,,,,,,,,,,,,,
44,2,,22137-080000,, "WASHER 8, POLISHED",1,,,,,,,,,,,,,,,,,,,,,
45,2,,172164-66150,, "SPONGE, RUBBER",1,,,,,,,,,,,,,,,,,,,,,
46,2,,22217-050000,, "SPRING WASHER 5",4,,,,,,,,,,,,,,,,,,,,,
47,2,,26116-050162,, "BOLT M 5X 16 PLATED",4,,,,,,,,,,,,,,,,,,,,,
48,2,,22137-080000,, "WASHER 8, POLISHED",4,,,,,,,,,,,,,,,,,,,,,
49,2,,933152-09280,, "BAND 170",1,,,,,,W,,,,M/#02568,,,,,,

Fig. 14 カバー (クーラ仕様) COVER (COOLER SPEC.)

クーラーキット

COOLER KIT

(172164-08100)

Fig. 11 REF. No. 1

inc. Fig. 11 REF. No. 2 ~ 29

Fig. 12 REF. No. 1 ~ 5

Fig. 13 REF. No. 1 ~ 62

Fig. 14 REF. No. 1 ~ 49

Fig. 20 REF. No. 1 ~ 11

Fig. 36 REF. No. 1, 2

Fig. 38 REF. No. 1

Fig. 39 REF. No. 1 ~ 5

Fig. 40 REF. No. 1 ~ 9

Fig. 41 REF. No. 18B, 23, 24, 52 ~ 54

Fig. 43 REF. No. 16B, 22B, 23B, 34

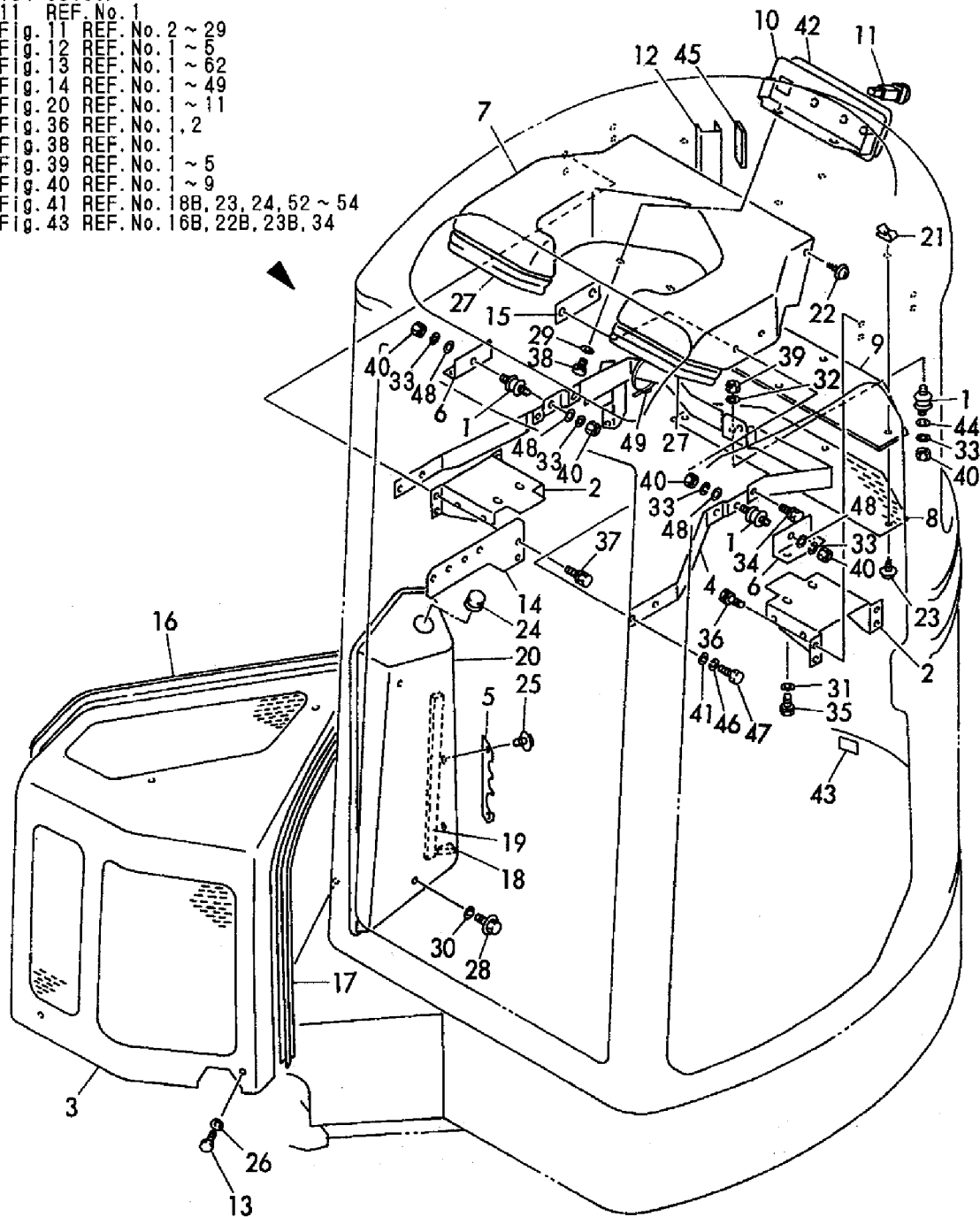

1,1,,772164-14100,, "TANK ASSY, FUEL",1,1,,,,,,,,,,,,,
2,2,,104200-11920,, COCK,1,1,,,,,,,,,,,,,
4,2,,172164-14170,, "GAUGE, FUEL",1,1,,,,,,,,,,,,,
4-1,2,,172164-14171,, HOSE,2,2,,,,,N,,,M/#01031,,M/#01031,,,,,
5,2,,172162-14180,, "GAUGE UNIT,FUEL",1,1,,,,,,,,,,,,,
6,2,,172162-14200,, GASKET,1,1,,,,,,,,,,,,,
7,2,,172141-14260,, FLOAT,1,1,,,,,,,,,,,,,
8,2,,172122-14300,, "CAP, FUEL TANK",1,1,,,,,,,,,,,,,
8-1,2,,172122-14301,, "CAP, FUEL TANK",1,1,,,,,N,,,M/#01977,,M/#01977,,,,,
9,3,,105430-55070,, GASKET,1,1,,,,,,,,,,,,,
9-1,3,,172122-14350,, GASKET,1,1,,,,,S,,,M/#01977,,M/#01977,,,,,
10,2,,101504-55101,, "STRAINER,FUEL INLET",1,1,,,,,,,,,,,,,
10-1,2,,172183-14250,, "FILTER (FUEL",1,1,,,,,N,,,M/#01651,,M/#01651,,,,,
11,2,,22217-050000,, "SPRING WASHER 5",5,5,,,,,,,,,,,,,
12,2,,23010-014000,, "CLAMP 14",2,2,,,,,,,,,,,,,
13,2,,26557-050122,, "SCREW M 5X 12",5,5,,,,,,,,,,,,,
14,2,,23080-013000,, "CLAMP 13,HOSE",1,1,,,,,1,,,,,,,,,,,,,
15,1,,22217-140000,, "SPRING WASHER 14",4,4,,,,,,,,,,,,,
16,1,,22137-140000,, "WASHER 14,POLISHED",4,4,,,,,,,,,,,,,
17,1,,26116-140352,, "BOLT M14X 35 PLATED",4,4,,,,,,,,,,,,,
18,1,,172171-14300,, W-CLAMP,2,2,,,,,,,,,,,,,
19,1,,172164-14600,, STAY,1,1,,,,,,,,,,,,,
20,1,,172164-14620,, "HOSE 1200",2,2,,,,,,,,,,,,,
21,1,,172164-14630,, "HOSE 400",1,1,,,,,,,,,,,,,
22,1,,129335-55700,, "SEPARATOR, WATER",1,1,,,,,,,,,,,,,
23,2,,104200-55321,, "VALVE, TAPER",1,1,,,,,,,,,,,,,
24,2,,104200-55330,, "SPRING, TAPER VALVE",1,1,,,,,,,,,,,,,
25,2,,104200-55341,, "HANDLE, COCK",1,1,,,,,,,,,,,,,
26,2,,124064-55510,, "BOWL, FUEL STRAINER",1,1,,,,,,,,,,,,,
27,2,,102103-55520,, O-RING,1,1,,,,,,,,,,,,,
28,2,,110250-55610,, "RING, RETAINING",1,1,,,,,,,,,,,,,
29,2,,121257-55720,, "SPRING, SCREEN",1,1,,,,,,,,,,,,,
30,2,,121257-55731,, FLOAT,1,1,,,,,,,,,,,,,
32,2,,101720-55750,, "PLUG 6",2,2,,,,,,,,,,,,,
33,2,,104200-55750,, "SCREW M 4",1,1,,,,,,,,,,,,,
34,2,,171081-55910,, SCREEN,1,1,,,,,,,,,,,,,
35,2,,23418-060000,, "GASKET 6, NYLON",2,2,,,,,,,,,,,,,
36,2,,24311-240100,, "O-RING 1A P-10A",1,1,,,,,,,,,,,,,
37,1,,124766-59050,, "CLAMP 12",6,6,,,,,,,,,,,,,
38,1,,22217-080000,, "SPRING WASHER 8",1,1,,,,,,,,,,,,,
39,1,,26116-080702,, "BOLT M 8X 70 PLATED",1,1,,,,,,,,,,,,,
40,1,,933110-00301,, "KEY ASSY",1,1,,,,,,,,,,,,,
41,1,,172164-14650,, STAY,1,1,,,,,2,,,,,,,,,,,,,

Fig. 15 燃料タンク&燃料パイプ FUEL TANK & FUEL PIPE

見出しNo. 1は、見出しNo. (1) から14を含みます。
Inc. (1) ~ 14

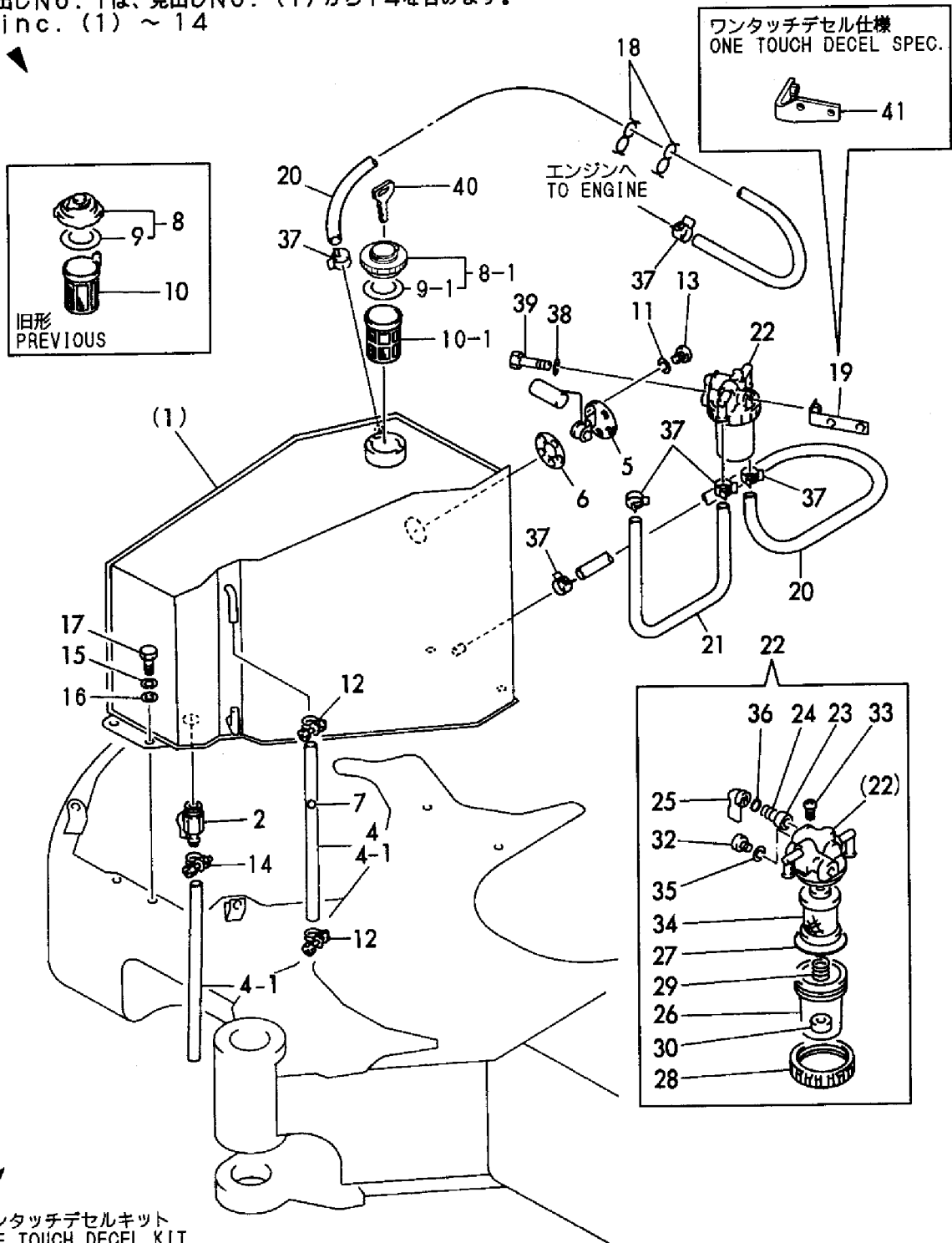

ワンタッチデセルキット
ONE TOUCH DECEL KIT
(172164-08200)

- Fig. 9 REF. No. 1
- Inc. Fig. 9 REF. No. 2 ~ 24
- Fig. 15 REF. No. 41
- Fig. 18 REF. No. 51 ~ 70
- Fig. 22 REF. No. 15A, 16A
- Fig. 27 REF. No. 57 ~ 62

1,1,,172164-16100,, "CORD(+), BATTERY",1,1,,,,,,,,,,,,,
2,1,,172165-16102,, BATTERY,1,1,,,,,,,,,,,,,
3,1,,172164-16110,, "CABLE (-), BATTERY",1,1,,,,,,,,,,,,,
4,1,,124550-77030,, "COVER, TERMINAL",1,1,,,,,,,,,,,,,
5,1,,22137-100000,, "WASHER 10,POLISHED",2,2,,,,,,,,,,,,,
6,1,,22217-080000,, "SPRING WASHER 8",1,1,,,,,,,,,,,,,
7,1,,22217-100000,, "SPRING WASHER 10",2,2,,,,,,,,,,,,,
8,1,,22217-100000,, "SPRING WASHER 10",1,1,,,,,,,,,,,,,
9,1,,26116-100162,, "BOLT M10X 16 PLATED",2,2,,,,,,,,,,,,,
10,1,,26116-100162,, "BOLT M10X 16 PLATED",1,1,,,,,,,,,,,,,
11,1,,26716-080002,, "NUT M 8",1,1,,,,,,,,,,,,,
12,1,,933171-15801,, "WIRE, EARTH",1,1,,,,,,,,,,,,,
13,1,,172164-16340,, ANGLE,1,1,,,,,,,,,,,,,
14,1,,172164-16370,, ROD,2,2,,,,,,,,,,,,,
15,1,,172164-16430,, "MOUNT, BATTERY",1,1,,,,,,,,,,,,,
16,1,,172164-16560,, CLAMP,1,1,,,,,,,,,,,,,
17,1,,172158-78250,, "CLAMP 45",1,1,,,,,,,,,,,,,
18,1,,22137-100000,, "WASHER 10,POLISHED",1,1,,,,,,,,,,,,,
19,1,,22157-080000,, "WASHER 8",2,2,,,,,,,,,,,,,
20,1,,22217-060000,, "SPRING WASHER 6",1,1,,,,,,,,,,,,,
21,1,,26013-100202,, "BOLT W/WASHER M10X20",3,3,,,,,,,,,,,,,
22,1,,26013-100202,, "BOLT W/WASHER M10X20",1,1,,,,,,,,,,,,,
23,1,,26116-060162,, "BOLT 6X16",1,1,,,,,,,,,,,,,
24,1,,26716-080002,, "NUT M 8",4,4,,,,,,,,,,,,,

Fig. 16 バッテリ
BATTERY

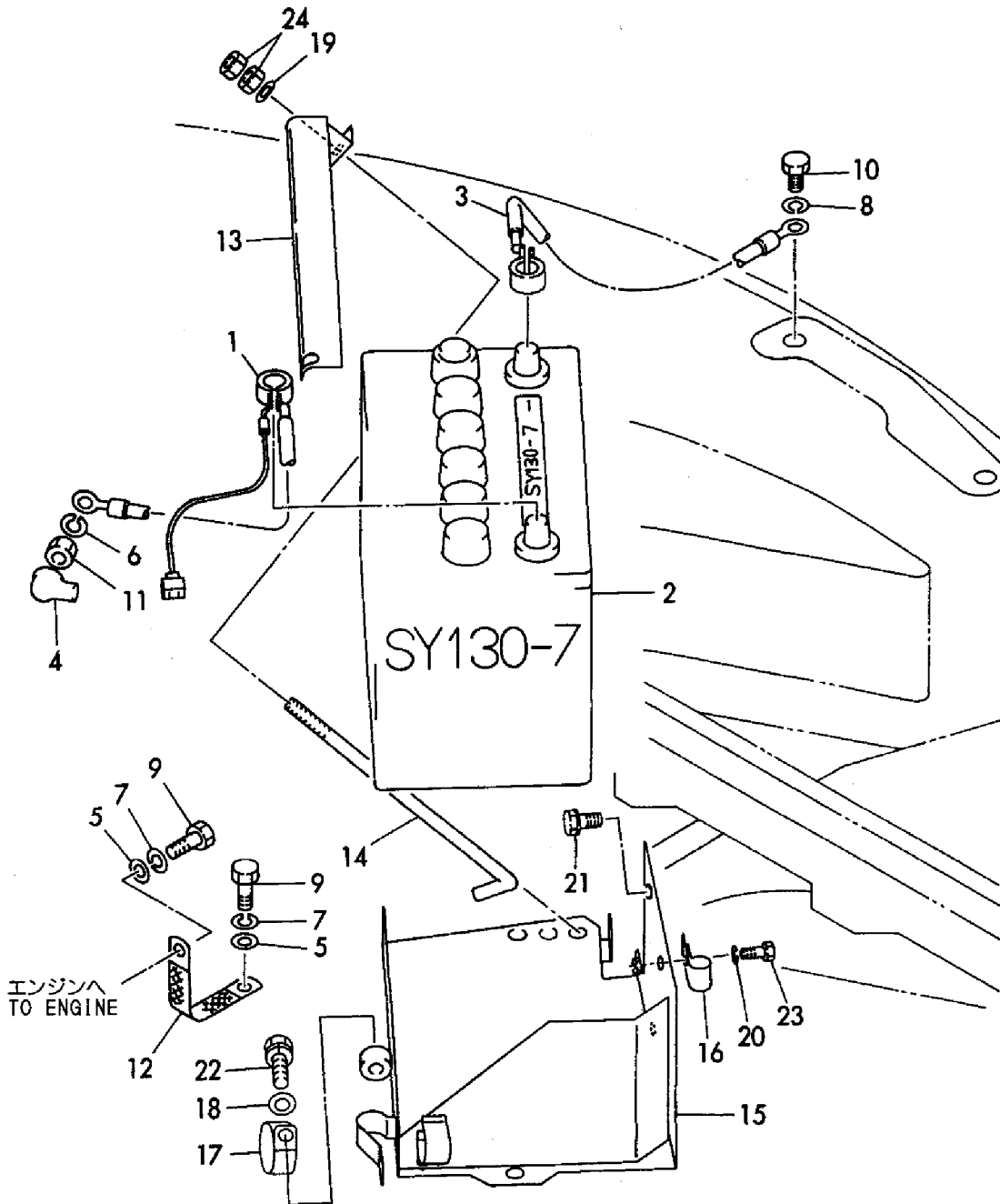

1,1,,172164-16500,, "HARNESS A",1,1,,,,,,,,,,,,,,,,,,,,,
1-1,1,,172164-16501,, "HARNESS A",1,1,,,,,S,,,M/#01187,,M/#01187,,,,,
2,1,,172164-16511,, "HARNESS (B)",1,1,,,,,,,,,,,,,,,,,,,,,
2-1,1,,172164-16512,, "HARNESS (B)",1,1,,,,,S,,,M/#00926,,M/#00926,,,,,
2-2,1,,172164-16513,, "HARNESS B",1,1,,,,,S,,,M/#01187,,M/#01187,,,,,
2-3,1,,172164-16514,, "HARNESS B",1,1,,,,,F,1,,M/#01427,,M/#01427,,,,,
3,1,,172164-16521,, "HARNESS C",1,1,,,,,,,,,,,,,,,,,,,,,
3-1,1,,172164-16522,, "HARNESS C",1,1,,,,,F,1,,M/#01427,,M/#01427,,,,,
3-2,1,,172164-16523,, "HARNESS C",1,1,,,,,S,,,M/#01537,,M/#01537,,,,,
4,1,,172151-16530,, "WIRE, LEAD",1,1,,,,,,,,,,,,,,,,,,,,,
4-1,1,,172151-16531,, "WIRE, LEAD",1,1,,,,,S,,,M/#00926,,M/#00926,,,,,
5,1,,172165-16530,, "HARNESS D",1,1,,,,,,,,,,,,,,,,,,,,,
6,1,,172126-16540,, "CLAMP 10X70",2,2,,,,,,,,,,,,,,,,,,,,,
6-1,1,,172126-16540,, "CLAMP 10X70",3,3,,,,,K,,,M/#01187,,M/#01187,,,,,
7,1,,172137-16560,, "BAND",5,5,,,,,,,,,,,,,,,,,,,,,
8,1,,172122-16570,, "LINK, FUSIBLE",1,1,,,,,,,,,,,,,,,,,,,,,
9,1,,194250-51660,, "BAND 250",1,1,,,,,,,,,,,,,,,,,,,,,
10,1,,1A1380-58050,, "GROMMET 16X20X4.5",1,1,,,,,,,,,,,,,,,,,,,,,
11,1,,22217-050000,, "SPRING WASHER 5",1,1,,,,,,,,,,,,,,,,,,,,,
12,1,,22217-100000,, "SPRING WASHER 10",3,3,,,,,,,,,,,,,,,,,,,,,
13,1,,26116-100162,, "BOLT M10X 16 PLATED",3,3,,,,,,,,,,,,,,,,,,,,,
14,1,,26716-050002,, "NUT M 5",1,1,,,,,,,,,,,,,,,,,,,,,
15,1,,933152-09280,, "BAND 170",5,5,,,,,,,,,,,,,,,,,,,,,
16,1,,172151-17100,, "LAMP, CHECKER",1,1,,,,,,,,,,,,,,,,,,,,,
17,1,,172162-17100,, "BOX ASSY, INDICATOR",1,1,,,,,,,,,,,,,,,,,,,,,
17-1,1,,172162-17101,, "BOX ASSY, INDICATOR",1,1,,,,,N,,,M/#01001,,M/#01001,,,,,
17A,2,,172162-17270,, "COVER, FRONT",1,1,,,,,W,,,M/#01677,,M/#01677,,,,,
17B,2,,172162-17240,, "METER ASSY, FUEL",1,1,,,,,W,,,M/#01677,,M/#01677,,,,,
17C,2,,172162-17250,, "HARNESS",1,1,,,,,W,,,M/#01677,,M/#01677,,,,,
18,2,,172162-17120,, "VALVE",4,4,,,,,,,,,,,,,,,,,,,,,
18A,2,,172162-17130,, "HOURMETER",1,1,,,,,W,,,M/#01001,,M/#01001,,,,,
19,1,,172164-17100,, "FUSE BOX",1,1,,,,,,,,,,,,,,,,,,,,,
19A,2,,172164-17110,, "BOX, FESE",1,1,,,,,,,,,,,,,,,,,,,,,
20,2,,29420-150000,, "HUSE",7,7,,,,,,,,,,,,,,,,,,,,,
21,2,,29420-300000,, "FUSE B30",3,3,,,,,,,,,,,,,,,,,,,,,
22,1,,172164-17120,, "SWITCH",1,1,,,,,,,,,,,,,,,,,,,,,
22-1,1,,172164-17121,, "SWITCH",1,1,,,,,F,1,,M/#01446,,M/#01446,,,,,
22-2,1,,172164-17121,, "SWITCH",1,1,,,,,Z,,,M/#01537,,M/#01537,,,,,
23,2,,172141-17230,, "BULB 24V- 6W",1,1,,,,,Z,,,M/#01537,,M/#01537,,,,,
24,1,,172141-17150,, "BUZZER",1,1,,,,,,,,,,,,,,,,,,,,,
25,1,,172141-17190,, "SWITCH, WORK LAMP",1,1,,,,,,,,,,,,,,,,,,,,,
26,2,,172141-17230,, "BULB 24V- 6W",1,1,,,,,,,,,,,,,,,,,,,,,
27,1,,172164-17250,, "BRACKET, RELAY",1,1,,,,,,,,,,,,,,,,,,,,,
28,1,,172162-17410,, "LAMP ASSY, HEADLIGHT",1,1,,,,,,,,,,,,,,,,,,,,,
29,2,,29220-788200,, "BULB",1,1,,,,,,,,,,,,,,,,,,,,,
30,1,,129136-77100,, "RELAY, SAFETY",1,1,,,,,,,,,,,,,,,,,,,,,
31,1,,119650-77910,, "RELAY, GROW",1,1,,,,,,,,,,,,,,,,,,,,,
34,1,,119632-77920,, "TIMER",1,1,,,,,,,,,,,,,,,,,,,,,
34-1,1,,119632-77921,, "TIMER(1 SEC.",1,1,,,,,N,,,M/#01251,,M/#01251,,,,,
34-2,1,,119632-77922,, "TIMER",1,1,,,,,N,,,M/#01625,,M/#01625,,,,,
35,1,,22137-040000,, "WASHER 4, POLISHED",4,4,,,,,,,,,,,,,,,,,,,,,
36,1,,22137-060000,, "WASHER 6, POLISHED",1,1,,,,,,,,,,,,,,,,,,,,,
37,1,,22217-080000,, "SPRING WASHER 8",2,2,,,,,,,,,,,,,,,,,,,,,
38,1,,22217-080000,, "SPRING WASHER 8",2,2,,,,,,,,,,,,,,,,,,,,,
39,1,,26013-060122,, "BOLT M 6X 12",2,2,,,,,,,,,,,,,,,,,,,,,
40,1,,26022-050162,, "SCREW M 5X 16",2,2,,,,,,,,,,,,,,,,,,,,,
41,1,,26022-060122,, "SCREW M 6X 12",1,1,,,,,,,,,,,,,,,,,,,,,
42,1,,26022-060122,, "SCREW M 6X 12",2,2,,,,,,,,,,,,,,,,,,,,,
43,1,,26022-060122,, "SCREW M 6X 12",2,2,,,,,,,,,,,,,,,,,,,,,
44,1,,26022-060162,, "SCREW M 6X 16",1,1,,,,,,,,,,,,,,,,,,,,,
45,1,,26022-060202,, "SCREW M 6X 20",2,2,,,,,,,,,,,,,,,,,,,,,
46,1,,26116-080162,, "BOLT 8X16",2,2,,,,,,,,,,,,,,,,,,,,,
47,1,,26116-080202,, "BOLT M 8X 20 PLATED",2,2,,,,,,,,,,,,,,,,,,,,,

48,1,,26589-040202,, "SCREW M4,BINDING",4,4,,,,,,,,,,,,,
49,1,,26716-040002,, "NUT M 4",4,4,,,,,,,,,,,,,
50,1,,933110-00100,, "SWITCH ASSY, STARTER",1,1,,,,,,,,,,,,,
51,2,,933110-00200,, "SWITCH ASSY,STARTER",1,1,,,,,,,,,,,,,
52,2,,933110-00301,, "KEY ASSY",1,1,,,,,,,,,,,,,
53,1,,933110-05300,, HORN,1,1,,,,,,,,,,,,,
54,1,,933113-15900,, "COVER, SWITCH TERMI.",1,1,,,,,,,,,,,,,
55,1,,194464-52190,, "SWITCH, SAFETY START",1,1,,,,,,,,,,,,,
55-1,1,,194464-52190,, "SWITCH, SAFETY
START",2,2,,,,,K,,,M/#01187,,M/#01187,,,,,
55-2,1,,194464-52190,, "SWITCH, SAFETY
START",1,1,,,,,K,,,M/#01446,,M/#01446,,,,,
56,1,,22137-180000,, "WASHER 18",1,1,,,,,Z,,,M/#01187,,M/#01187,,,,,
57,1,,26776-180002,, "NUT M18,LOCK",1,1,,,,,,,,,,,,,
57-1,1,,26776-180002,, "NUT M18,LOCK",2,2,,,,,K,,,M/#01187,,M/#01187,,,,,
57-2,1,,26776-180002,, "NUT M18,LOCK",1,1,,,,,K,,,M/#01446,,M/#01446,,,,,
58,1,,172164-17140,, SWITCH,1,1,,,,,W,1,,M/#01446,,M/#01446,,,,,
58-1,1,,172164-17140,, SWITCH,,2,,,,,K,,,,,M/#01537,,,,,
59,1,,26776-160002,, "LOCK NUT M16 PLATED",1,1,,,,,W,1,,M/#01446,,M/#01446,,,,,
59-1,1,,26776-160002,, "LOCK NUT M16 PLATED",,2,,,,,K,,,,,M/#01537,,,,,
60,1,,172190-16500,, HARNESS,1,,,,,W,,,M/#01537,,,,,

Fig. 17 電装品 (キャビン、キャノピ)
ELECTRIC PART (CABIN, CANOPY)

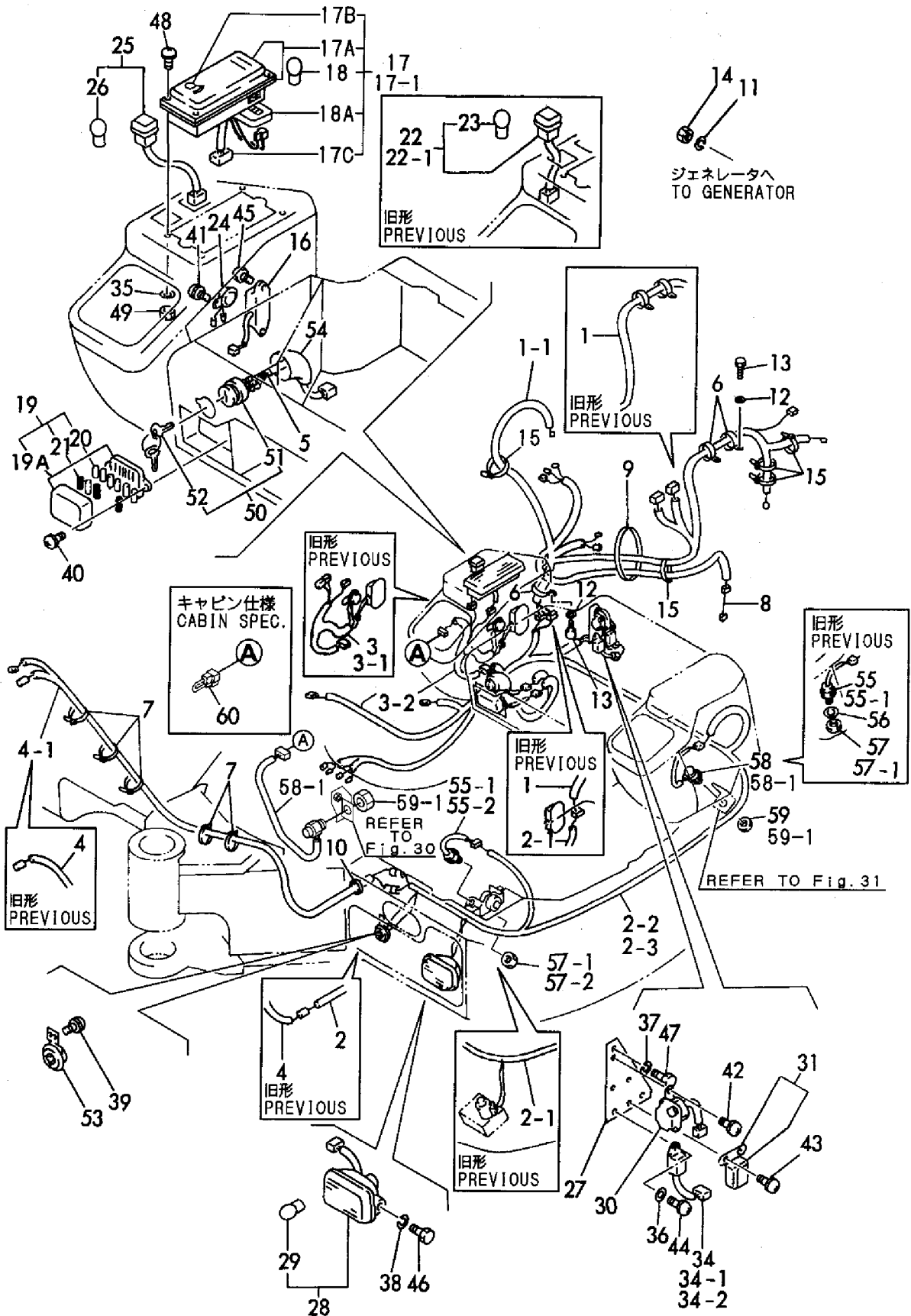

1,1,,172164-16501,, "HARNES A",1,1,,,,,,,,,,,,,,,,,,,,,
2,1,,172164-16514,, "HARNES B",1,1,,,,,,,,,,,,,,,,,,,,,
3,1,,172164-16523,, "HARNES C",1,1,,,,,,,,,,,,,,,,,,,,,
4,1,,172151-16531,, "WIRE, LEAD",1,1,,,,,,,,,,,,,,,,,,,,,
5,1,,933110-05300,, HORN,1,1,,,,,,,,,,,,,,,,,,,,,
6,1,,172126-16540,, "CLAMP 10X70",3,3,,,,,,,,,,,,,,,,,,,,,
7,1,,172137-16560,, BAND,5,5,,,,,,,,,,,,,,,,,,,,,
8,1,,26116-080202,, "BOLT M 8X 20 PLATED",2,2,,,,,,,,,,,,,,,,,,,,,
9,1,,194250-51660,, "BAND 250",1,1,,,,,,,,,,,,,,,,,,,,,
10,1,,1A1380-58050,, "GROMMET 16X20X4.5",1,1,,,,,,,,,,,,,,,,,,,,,
11,1,,22217-050000,, "SPRING WASHER 5",1,1,,,,,,,,,,,,,,,,,,,,,
12,1,,22217-100000,, "SPRING WASHER 10",3,3,,,,,,,,,,,,,,,,,,,,,
13,1,,26116-100162,, "BOLT M10X 16 PLATED",3,3,,,,,,,,,,,,,,,,,,,,,
14,1,,26716-050002,, "NUT M 5",1,1,,,,,,,,,,,,,,,,,,,,,
15,1,,933152-09280,, "BAND 170",5,5,,,,,,,,,,,,,,,,,,,,,
16,1,,172190-16500,, HARNES,1,,,,,,,,,,,,,,,,,,,,,
17,1,,172164-17140,, SWITCH,1,2,,,,,,,,,,,,,,,,,,,,,
18,1,,194464-52190,, "SWITCH, SAFETY START",1,1,,,,,,,,,,,,,,,,,,,,,
19,1,,26776-160002,, "LOCK NUT M16 PLATED",1,2,,,,,,,,,,,,,,,,,,,,,
20,1,,26776-180002,, "NUT M18,LOCK",1,1,,,,,,,,,,,,,,,,,,,,,
21,1,,172151-17100,, "LAMP, CHECKER",1,1,,,,,,,,,,,,,,,,,,,,,
22,1,,172164-17100,, "FUSE BOX",1,1,,,,,,,,,,,,,,,,,,,,,
23,2,,172164-17110,, "BOX, FESE",1,1,,,,,,,,,,,,,,,,,,,,,
24,2,,29420-150000,, HUSE,7,7,,,,,,,,,,,,,,,,,,,,,
25,2,,29420-300000,, "FUSE B30",3,3,,,,,,,,,,,,,,,,,,,,,
26,1,,172141-17150,, BUZZER,1,1,,,,,,,,,,,,,,,,,,,,,
27,1,,172141-17190,, "SWITCH, WORK LAMP",1,1,,,,,,,,,,,,,,,,,,,,,
28,2,,172141-17230,, "BULB 24V- 6W",1,1,,,,,,,,,,,,,,,,,,,,,
29,1,,172162-17410,, "LAMP ASSY, HEADLIGHT",1,1,,,,,,,,,,,,,,,,,,,,,
30,2,,29220-788200,, BULB,1,1,,,,,,,,,,,,,,,,,,,,,
31,1,,129136-77100,, "RELAY, SAFETY",1,1,,,,,,,,,,,,,,,,,,,,,
32,1,,119650-77910,, "RELAY, GROW",1,1,,,,,,,,,,,,,,,,,,,,,
33,1,,119632-77922,, TIMER,1,1,,,,,,,,,,,,,,,,,,,,,
34,1,,22137-060000,, "WASHER 6, POLISHED",1,1,,,,,,,,,,,,,,,,,,,,,
35,1,,22217-080000,, "SPRING WASHER 8",2,2,,,,,,,,,,,,,,,,,,,,,
36,1,,22217-080000,, "SPRING WASHER 8",2,2,,,,,,,,,,,,,,,,,,,,,
37,1,,26013-060122,, "BOLT M 6X 12",2,2,,,,,,,,,,,,,,,,,,,,,
38,1,,26022-050162,, "SCREW M 5X 16",2,2,,,,,,,,,,,,,,,,,,,,,
39,1,,26022-060122,, "SCREW M 6X 12",1,1,,,,,,,,,,,,,,,,,,,,,
40,1,,26022-060122,, "SCREW M 6X 12",2,2,,,,,,,,,,,,,,,,,,,,,
41,1,,26022-060122,, "SCREW M 6X 12",2,2,,,,,,,,,,,,,,,,,,,,,
42,1,,26022-060162,, "SCREW M 6X 16",1,1,,,,,,,,,,,,,,,,,,,,,
43,1,,26022-060202,, "SCREW M 6X 20",2,2,,,,,,,,,,,,,,,,,,,,,
44,1,,26116-080162,, "BOLT 8X16",2,2,,,,,,,,,,,,,,,,,,,,,
45,1,,933110-00100,, "SWITCH ASSY, STARTER",1,1,,,,,,,,,,,,,,,,,,,,,
46,2,,933110-00200,, "SWITCH ASSY,STARTER",1,1,,,,,,,,,,,,,,,,,,,,,
47,2,,933110-00301,, "KEY ASSY",1,1,,,,,,,,,,,,,,,,,,,,,
48,1,,172165-16530,, "HARNES D",1,1,,,,,,,,,,,,,,,,,,,,,
49,1,,933113-15900,, "COVER, SWITCH TERMI.",1,1,,,,,,,,,,,,,,,,,,,,,
50,1,,172122-16570,, "LINK, FUSIBLE",1,1,,,,,,,,,,,,,,,,,,,,,
51,1,,172164-16650,, "HARNES (DECEL",1,1,,,,,,,,,,,,,,,,,,,,,
52,1,,933152-09280,, "BAND 170",9,9,,,,,,,,,,,,,,,,,,,,,
53,1,,172176-17100,, "BOX, INDICATOR",1,1,,,,,,,,,,,,,,,,,,,,,
54,2,,172162-17120,, VALVE,5,5,,,,,,,,,,,,,,,,,,,,,
55,2,,172176-17120,, "METER, FUEL",1,1,,,,,,,,,,,,,,,,,,,,,
56,2,,172162-17130,, HOURMETER,1,1,,,,,,,,,,,,,,,,,,,,,
57,2,,172176-17130,, HARNES,1,1,,,,,,,,,,,,,,,,,,,,,
58,2,,172162-17250,, HARNES,1,1,,,,,,,,,,,,,,,,,,,,,
59,2,,172162-17270,, "COVER, FRONT",1,1,,,,,,,,,,,,,,,,,,,,,
62,1,,172162-17180,, SOLENOID,1,1,,,,,,,,,,,,,,,,,,,,,
63,1,,172190-17220,, "RELEY, TIMER",1,1,,,,,,,,,,,,,,,,,,,,,
64,1,,172164-17270,, "BRACKET, TIMER",1,1,,,,,,,,,,,,,,,,,,,,,
65,1,,22137-040000,, "WASHER 4, POLISHED",4,4,,,,,,,,,,,,,,,,,,,,,

66,1,,26013-060162,, "BOLT M 6X 16",2,2,,,,,,,,,,,,,
67,1,,26022-060252,, "SCREW M 6X 25",2,2,,,,,,,,,,,,,
68,1,,26589-040202,, "SCREW M4,BINDING",4,4,,,,,,,,,,,,,
69,1,,26716-040002,, "NUT M 4",4,4,,,,,,,,,,,,,
70,1,,172126-16540,, "CLAMP 10X70",1,1,,,,,,,,,,,,,

Fig. 18 電装品 (キャビン、キャノピ/ワンタッチデセル) ELECTRIC PART (CABIN, CANOPY/ONE TOUCH DECEL)

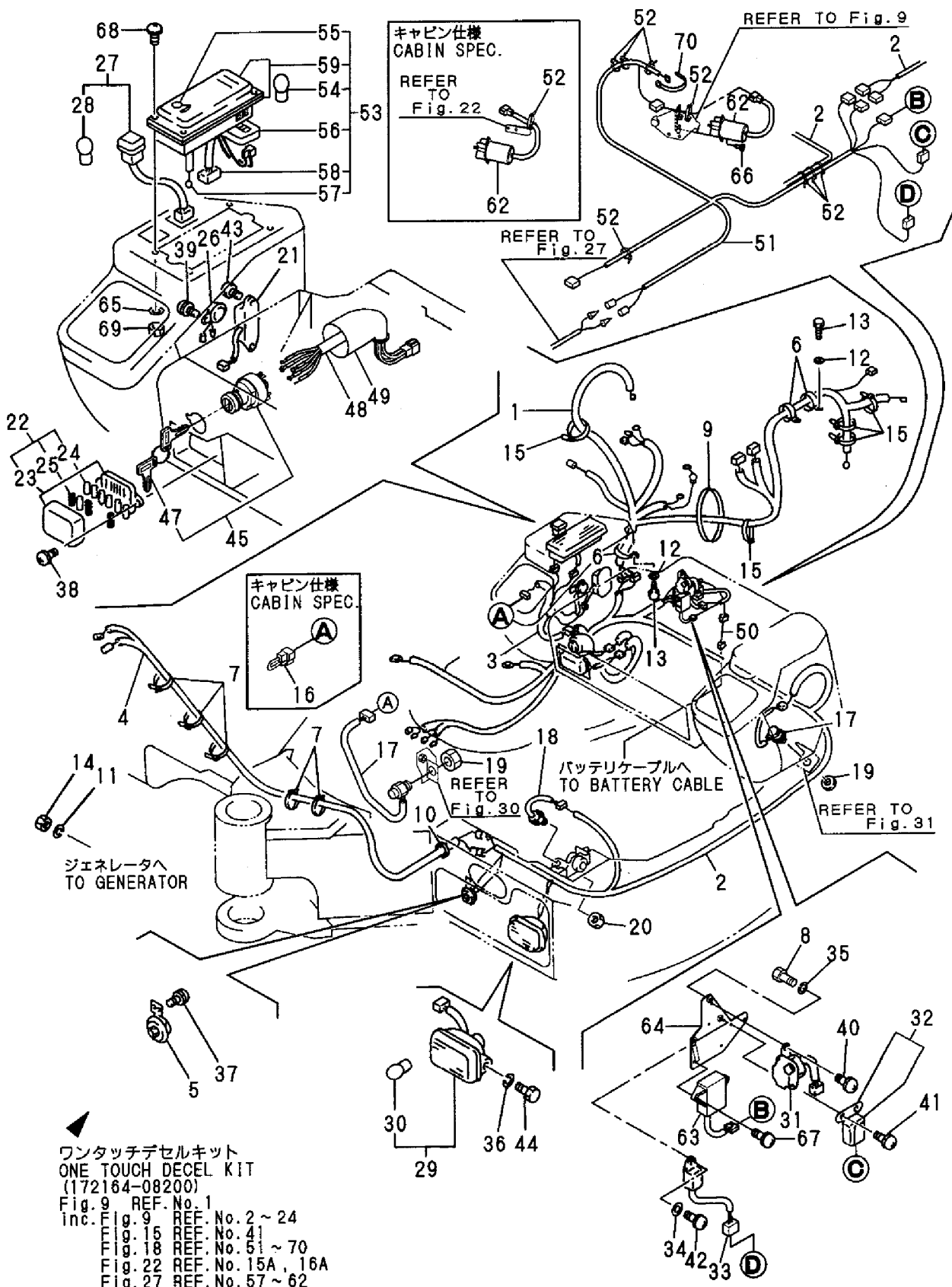

ワンタッチデセルキット
ONE TOUCH DECEL KIT
(172164-08200)

- Fig. 9 REF. No. 1
- inc. Fig. 9 REF. No. 2 ~ 24
- Fig. 15 REF. No. 41
- Fig. 18 REF. No. 51 ~ 70
- Fig. 22 REF. No. 15A, 16A
- Fig. 27 REF. No. 57 ~ 62

1,1,,172164-16600,, "HARNES F",1,,,,,,,,,,,,,
1-1,1,,172164-16601,, "HARNES F",1,,,,,N,,,M/#01873,,,,,
2,1,,22857-400100,, "SCREW 4X10",2,,,,,,,,,,,,,
3,1,,933113-05150,, "LAMP, ROOM",1,,,,,,,,,,,,,
4,2,,933113-05160,, "BULB (12V5W)",1,,,,,,,,,,,,,
5,1,,933113-15000,, "CIGAR LIGHTER ASSY",1,,,,,,,,,,,,,
6,1,,172176-17150,, "ASHTRAY",1,,,,,,,,,,,,,
7,1,,172164-17200,, "MOTOR, WIPER",1,,,,,,,,,,,,,
8,1,,172164-17210,, "ARM, WIPER",1,,,,,,,,,,,,,
9,1,,172162-17320,, "BLADE 400,WIPER",1,,,,,,,,,,,,,
10,1,,172162-17330,, "SWITCH,WIPER",1,,,,,,,,,,,,,
11,1,,26013-060122,, "BOLT M 6X 12",3,,,,,,,,,,,,,
12,1,,26022-050202,, "SCREW M 5X 20",1,,,,,,,,,,,,,
13,1,,172164-16610,, "HARNES M",1,,,,,,,,,,,,,
13-1,1,,172164-16611,, "HARNES M, WIRE",1,,,,,N,,,M/#01427,,,,,
14,1,,119247-77100,, "RELAY, SAFETY",1,,,,,W,,,M/#01427,,,,,
15,1,,26022-060122,, "SCREW M 6X 12",1,,,,,W,,,M/#01427,,,,,
16,1,,22137-060000,, "WASHER 6, POLISHED",1,,,,,W,,,M/#01427,,,,,
17,1,,172176-17160,, "BEZEL",1,,,,,W,1,,M/#01672,,,,,
18,1,,172187-17450,, "BRAKER",1,,,,,W,,,M/#01920,,,,,

Fig. 19 電装品 (キャビン)
ELECTRIC PART (CABIN)

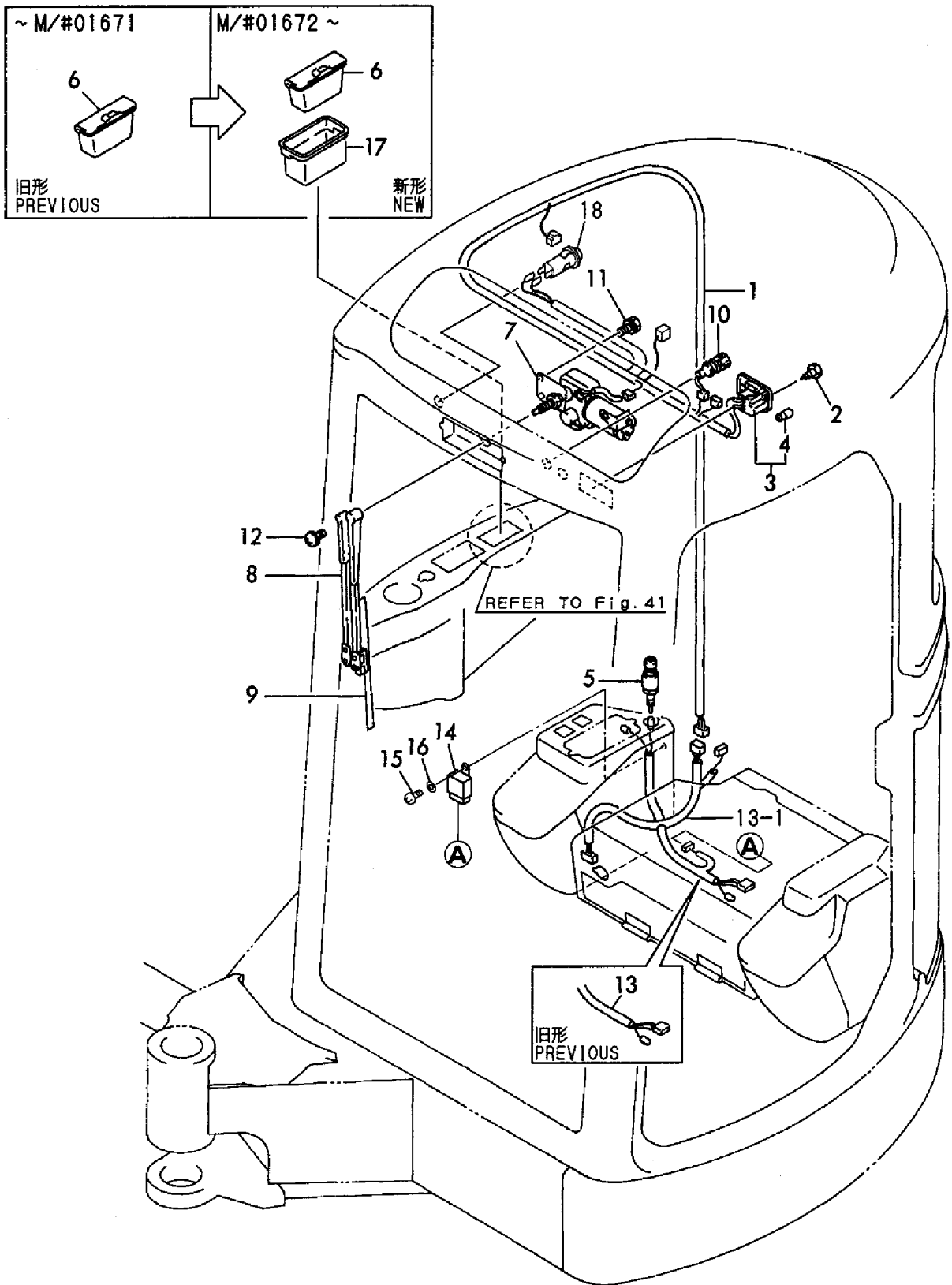

1,2,,172126-11510,, "BAND 300",1,,,,,,,,,,,,,,,,,,,,,
2,2,,172122-16590,, "BAND 200F",2,,,,,,,,,,,,,,,,,,,,,
3,2,,172164-16700,, "HARNESS, WIRE",1,,,,,,,,,,,,,,,,,,,,,
3-1,2,,172164-16701,, "HARNESS, WIRE",1,,,,,,N,,,,M/#01400,,,,,,
3-2,2,,172164-16702,, "HARNESS,WIRE(COOL A",1,,,,,,F,1,,M/#02206,,,,,,
4,2,,172164-16710,, "HARNESS, WIRE",1,,,,,,,,,,,,,,,,,,,,,
5,2,,119247-77100,, "RELAY, SAFETY",5,,,,,,,,,,,,,,,,,,,,,
6,2,,22137-060000,, "WASHER 6, POLISHED",5,,,,,,,,,,,,,,,,,,,,,
7,2,,22857-400120,, "SCREW 4X12",2,,,,,,,,,,,,,,,,,,,,,
8,2,,26022-060122,, "SCREW M 6X 12",5,,,,,,,,,,,,,,,,,,,,,
9,2,,933168-55770,, "BAND 146",2,,,,,,,,,,,,,,,,,,,,,
10,2,,172164-16750,, "HARNESS,WIRE(COOL C",1,,,,,,W,,,,M/#02206,,,,,,
11,2,,172164-16770,, "BRACKET",1,,,,,,W,,,,M/#02206,,,,,,

Fig. 20 電装品 (クーラー仕様)
ELECTRIC PART (COOLER SPEC.)

クーラーキット
COOLER KIT
(172164-08100)

- Fig. 11 REF. No. 1
Inc. Fig. 11 REF. No. 2 ~ 29
Fig. 12 REF. No. 1 ~ 56
Fig. 13 REF. No. 1 ~ 62
Fig. 14 REF. No. 1 ~ 49
Fig. 20 REF. No. 1 ~ 11
Fig. 36 REF. No. 1, 2
Fig. 38 REF. No. 1
Fig. 39 REF. No. 1 ~ 5
Fig. 40 REF. No. 1 ~ 9
Fig. 41 REF. No. 18B, 23, 24, 52 ~ 54
Fig. 43 REF. No. 16B, 22B, 23B, 34

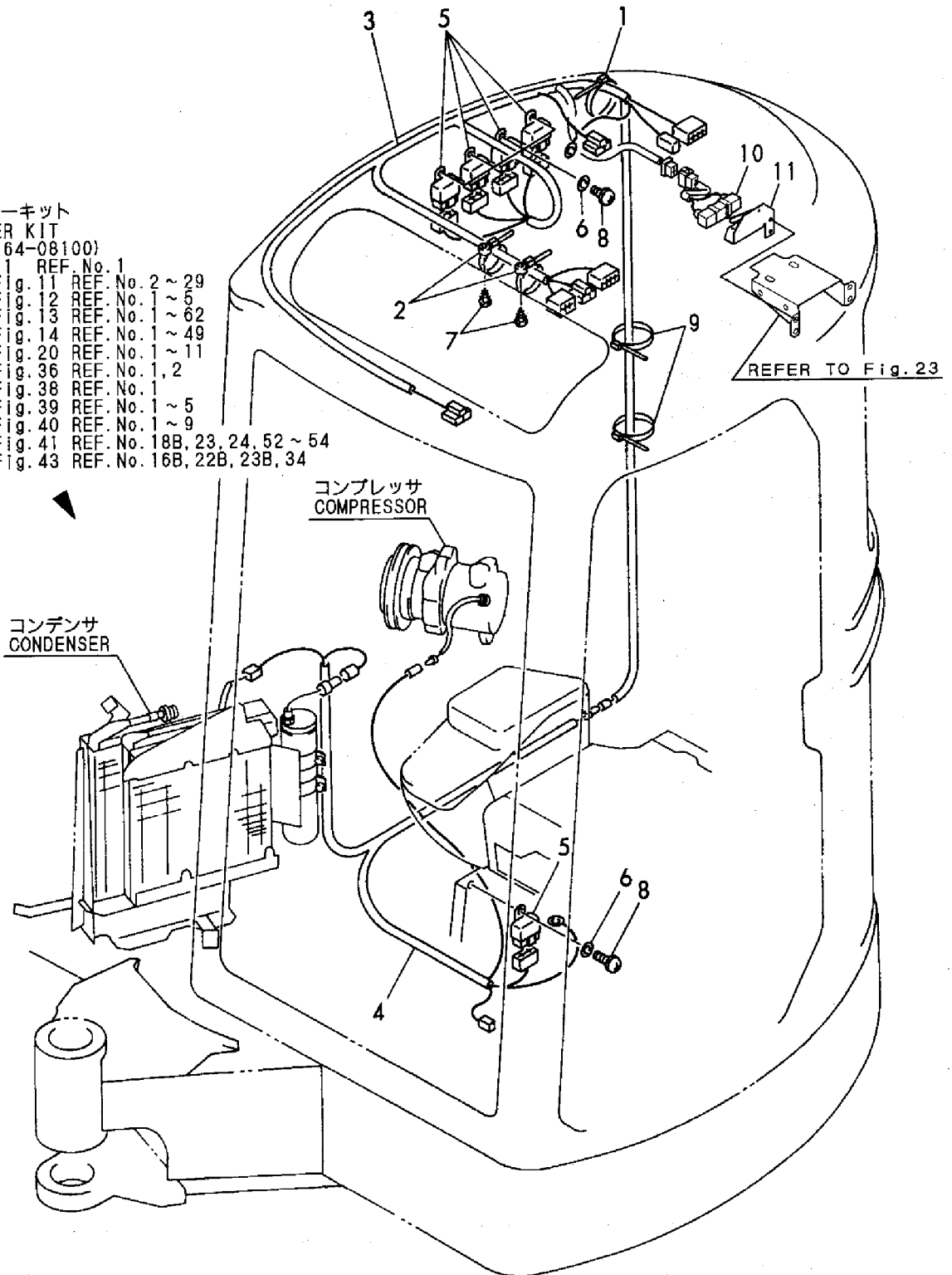

1,1,,172141-17201,, "LAMP, WORK",1,1,,,,,,,,,,,,,,,,,,,,,
2,2,,172141-17211,, "BULB 12V55W",1,1,,,,,,,,,,,,,,,,,,,,,
3,1,,172137-17401-4,, "COVER, WORK LAMP",1,1,,,,,,,,,,,,,,,,,,,,,
4,1,,26013-120302,, "BOLT W/WASHER M12X30",1,1,,,,,,,,,,,,,,,,,,,,,
4-1,1,,26013-120252,, "BOLT M12X 25",1,1,,,,,R,,,,M/#01625,,M/#01625,,,,,,
5,1,,933152-03700,, "WASHER, SIDE CLUTCH",1,1,,,,,,,,,,,,,,,,,,,,,
6,1,,22137-130000,, "WASHER 13",2,2,,,,,W,,,,M/#00926,,M/#00926,,,,,,

Fig. **21** ワークランプ
WORK LAMP

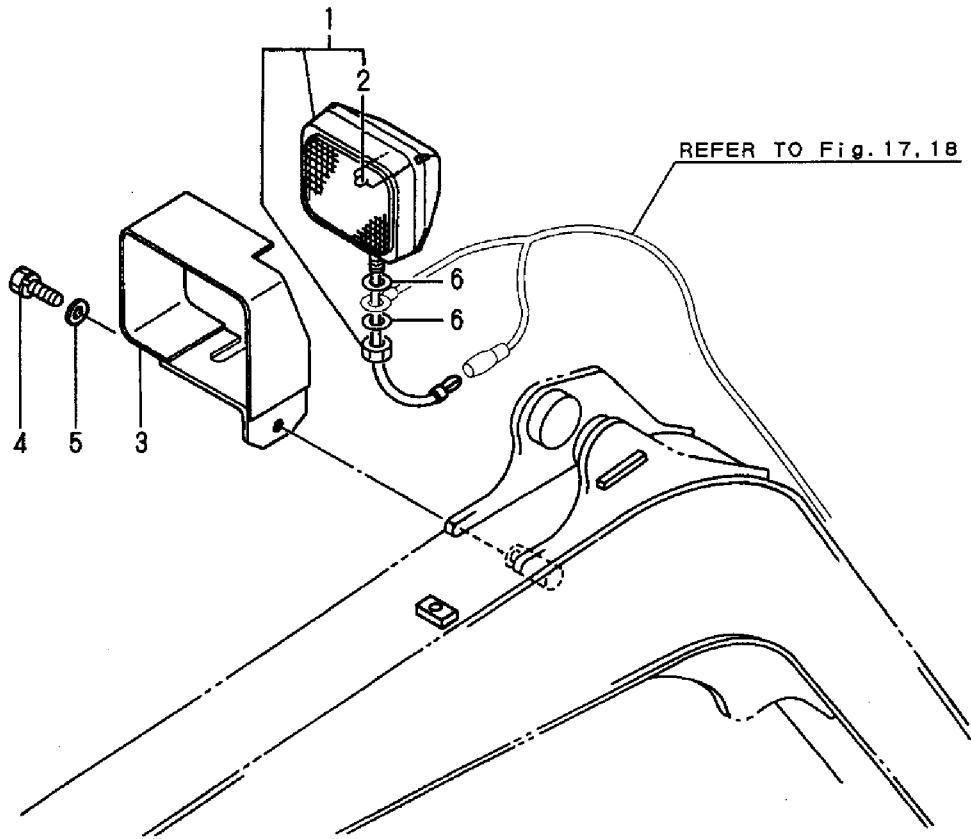

1,1,,772164-17600,, "HEATER ASSY.",1,1,,,,,1,,,,,
1A,1,,772164-17610,, "HEATER ASSY, OD",1,1,,,,,3,,,,,
2,2,,172312-17600,, HEATER,1,1,,,,,
3,2,,172162-17610,, "SWITCH,HEATER",1,1,,,,,
4,2,,172164-17610,, "HOSE, HEATER",2,2,,,,,
5,3,,172164-17630,, "HOSE, HEATER",2,2,,,,,
6,3,,172164-17620,, TUBE,2,2,,,,,
7,2,,172124-17630,, "VALVE, MINIATURE",1,1,,,,,
8,2,,172124-17640,, "JOINT 3/8",2,2,,,,,
9,2,,172732-76161,, ELBOW,1,1,,,,,
9-1,2,,23392-030000,, JOINT,1,1,,,,,F,2,,M/#01887,,M/#01887,,,,,
9A,2,,172135-76100,, "ELBOW 3/8",1,1,,,,,W,2,,M/#01887,,M/#01887,,,,,
10,2,,22137-100000,, "WASHER 10,POLISHED",4,4,,,,,
11,2,,23000-022000,, "CLAMP 22",4,4,,,,,
12,2,,26013-100202,, "BOLT W/WASHER M10X20",4,4,,,,,
13,2,,933152-09280,, "BAND 170",3,3,,,,,
14,2,,933171-15680,, "GROMMET 40X13",2,2,,,,,
15,2,,172165-18770,, "GUIDE, HOSE",1,1,,,,,
15A,2,,172164-17670,, "GUIDE, HOSE",1,1,,,,,3,,,,,
16,2,,26013-080252,, "BOLT M 8X 25",2,2,,,,,
16A,2,,26013-080122,, "BOLT M 8X 12",2,2,,,,,3,,,,,
16B,2,,172168-79520,, ELBOW,1,1,,,,,W,,M/#01736,,M/#01736,,,,,
17,1,,772164-17700,, "DEFROSTER ASSY",1,,,,,
17-1,1,,772164-17701,, "DEFROSTER ASSY",1,,,,,N,,M/#00912,,,,,
18,2,,172122-16590,, "BAND 200F",2,,,,,Z,,M/#00912,,,,,
19,2,,172164-17640,, HOSE,1,,,,,
20,2,,172164-17700,, BRACKET,1,,,,,
20-1,2,,172164-17701,, BRACKET(DEFROSTER,1,,,,,N,,M/#00912,,,,,
21,2,,172120-17710,, "NOZZLE, DEFROSTER",1,,,,,
22,2,,172122-17730,, "COVER, DEFROSTER",1,,,,,
23,2,,172164-61560,, COVER,1,,,,,
24,2,,22857-400120,, "SCREW 4X12",2,,,,,Z,,M/#00912,,,,,
25,2,,26013-080202,, "BOLT W/WASHER M8X20",2,,,,,
26,2,,26557-050102,, "SCREW M 5X 10",2,,,,,
27,2,,172158-78250,, "CLAMP 45",1,,,,,W,,M/#00912,,,,,
28,2,,22137-100000,, "WASHER 10,POLISHED",1,,,,,W,,M/#00912,,,,,
29,2,,26013-100202,, "BOLT W/WASHER M10X20",1,,,,,W,,M/#00912,,,,,

Fig. 22 ヒータ&デフロスタ (オプション) HEATER & DEFROSTER (OPTIONAL)

見出しNo. 1, 1Aは、見出しNo. 2から16Bを含みます。
1, 1A inc. 2 ~ 16B

ワンタッチデセルキット
ONE TOUCH DECEL KIT
(172164-08200)
Fig. 9 REF. No. 1
inc. Fig. 9 REF. No. 2 ~ 24
Fig. 15 REF. No. 41
Fig. 18 REF. No. 51 ~ 70
Fig. 22 REF. No. 15A, 16A
Fig. 27 REF. No. 57 ~ 62

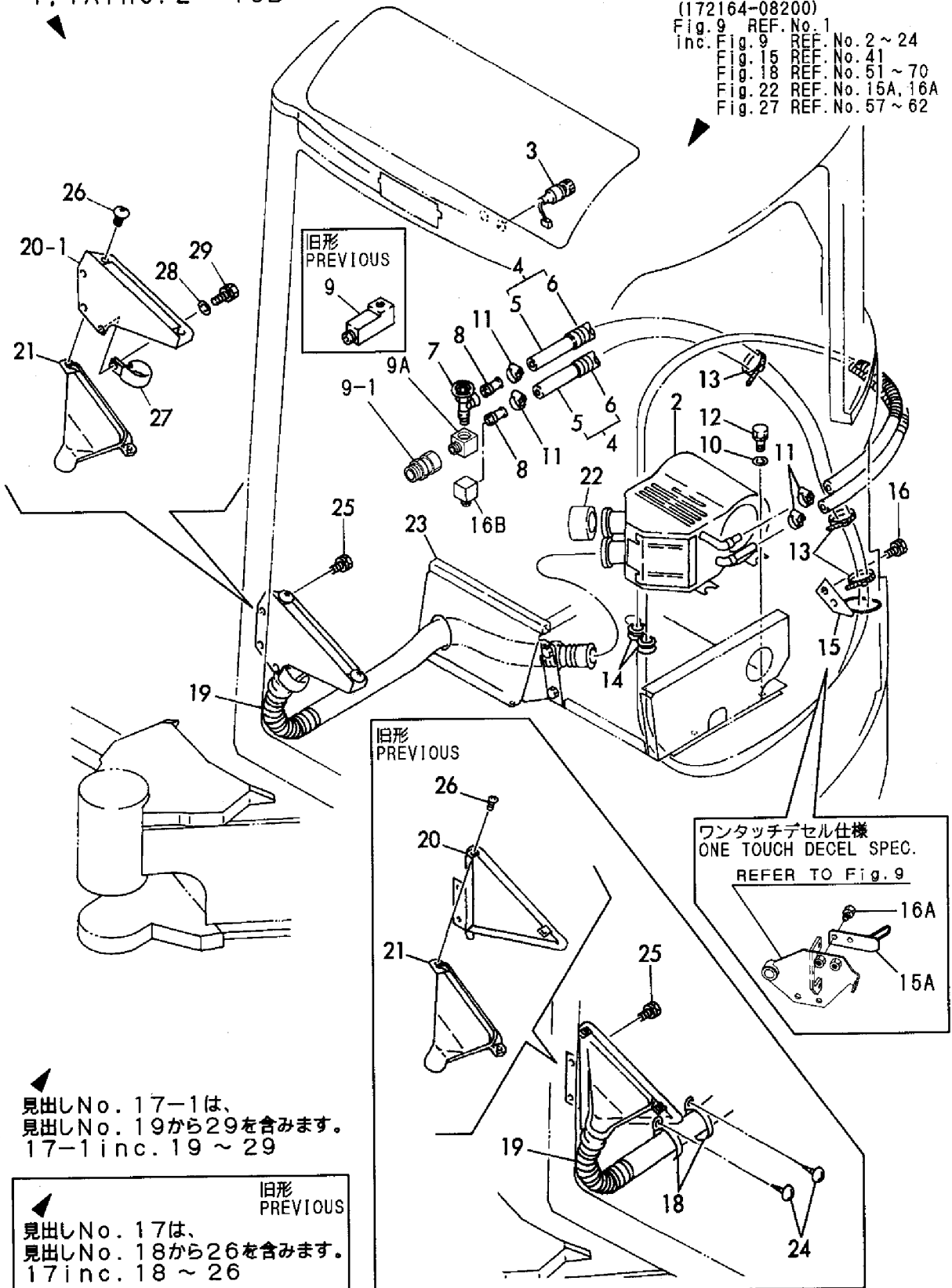

見出しNo. 17-1は、
見出しNo. 19から29を含みます。
17-1 inc. 19 ~ 29

旧形 PREVIOUS
見出しNo. 17は、
見出しNo. 18から26を含みます。
17 inc. 18 ~ 26

1,1,,772176-17800,, "RADIO W/CASSETTE",1,,,,,,,,,,,,,
2,2,,172112-17190,, "ANTENNA (NCP-314)",1,,,,,,,,,,,,,
3,2,,172176-17800,, "RADIO W/CASSETTE",1,,,,,,,,,,,,,
3-1,2,,172176-17801,, "RADIO CASSETTE",1,,,,,F,1,,M/#01677,,,,,
3-2,2,,172176-17802,, "RADIO CASSETTE",1,,,,,F,2,,M/#02625,,,,,
4,2,,172176-17810,, "HARNESS, RADIO",1,,,,,,,,,,,,,
4-1,2,,172176-17811,, "HARNESS, RADIO",1,,,,,S,,M/#01677,,,,,
5,2,,172176-17820,,SPEAKER,2,,,,,,,,,,,,,
5-1,2,,172176-17821,,SPEAKER,2,,,,,N,,M/#01677,,,,,
6,2,,172176-17830,, "STAY A, SPEAKER",2,,,,,,,,,,,,,
7,2,,26013-080252,, "BOLT M 8X 25",8,,,,,,,,,,,,,
8,2,,172176-17850,, "STAY B, SPEAKER",2,,,,,,,,,,,,,
9,2,,172176-17870,,MOUNT,2,,,,,,,,,,,,,
10,2,,197821-89270,, "COVER,SPEAKER",2,,,,,,,,,,,,,
11,2,,22117-060000,, "WASHER 6",8,,,,,,,,,,,,,
12,2,,26013-080162,, "BOLT W/WASHER M8X16",8,,,,,,,,,,,,,
13,2,,26557-040102,, "SCREW M 4X 10",8,,,,,,,,,,,,,
14,2,,26557-040102,, "SCREW M 4X 10",2,,,,,,,,,,,,,
14-1,2,,26557-040202,, "SCREW M 4X 20",2,,,,,N,, "FROM 1ST",,,,,,
15,2,,26557-050102,, "SCREW M 5X 10",4,,,,,,,,,,,,,
16,2,,26589-060162,, "SCREW M6,BINDING",8,,,,,,,,,,,,,
17,2,,26716-040002,, "NUT M 4",2,,,,,,,,,,,,,
18,2,,26716-060002,, "NUT 6",8,,,,,,,,,,,,,
19,2,,172176-17890,, "CORD,ANTENNA",1,,,,,W,,M/#01677,,,,,
19-1,2,,172176-17891,, "CORD,ANTENNA",1,,,,,S,,M/#02625,,,,,

Fig. 23 ラジオカセット (オプション) RADIO CASSETTE (OPTIONAL)

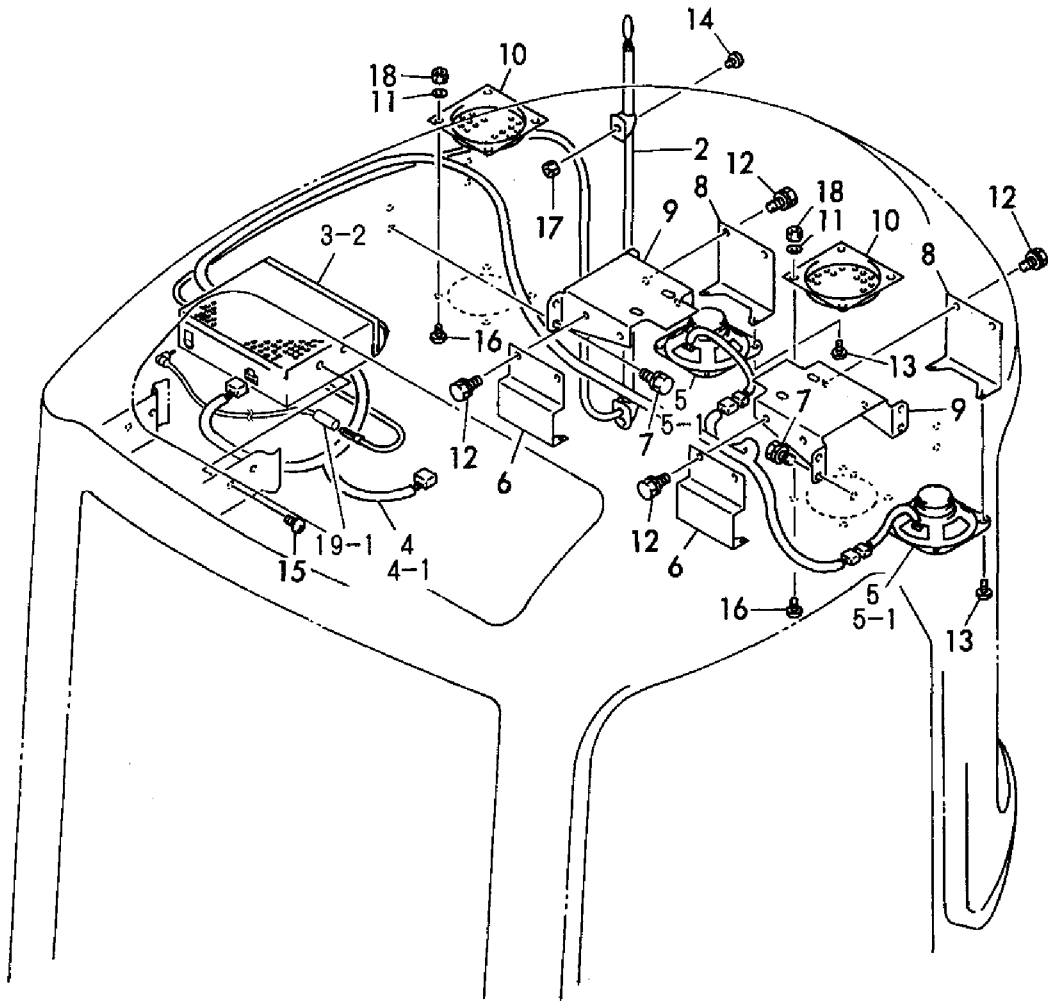
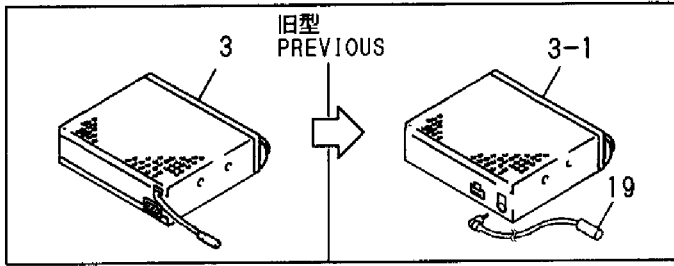

見出しNo. 1は、見出しNo. 2から19を含みます。
1 inc. 2 ~ 19

1,1,,172112-17190,, "ANTENNA (NCP-314)",1,,,,,,,,,,,,,
2,1,,172176-17811,, "HARNESS, RADIO",1,,,,,,,,,,,,,
3,1,,172176-17821,, "SPEAKER",2,,,,,,,,,,,,,
4,1,,172176-17830,, "STAY A, SPEAKER",2,,,,,,,,,,,,,
5,1,,26013-080252,, "BOLT M 8X 25",8,,,,,,,,,,,,,
6,1,,172176-17850,, "STAY B, SPEAKER",2,,,,,,,,,,,,,
7,1,,172176-17870,, "MOUNT",2,,,,,,,,,,,,,
8,1,,197821-89270,, "COVER, SPEAKER",2,,,,,,,,,,,,,
9,1,,22117-060000,, "WASHER 6",8,,,,,,,,,,,,,
10,1,,26013-080162,, "BOLT W/WASHER M8X16",8,,,,,,,,,,,,,
11,1,,26557-040102,, "SCREW M 4X 10",8,,,,,,,,,,,,,
12,1,,26557-040202,, "SCREW M 4X 20",2,,,,,,,,,,,,,
13,1,,26589-060162,, "SCREW M6, BINDING",8,,,,,,,,,,,,,
14,1,,26716-040002,, "NUT M 4",2,,,,,,,,,,,,,
15,1,,26716-060002,, "NUT 6",8,,,,,,,,,,,,,
16,1,,172176-17890,, "CORD, ANTENNA",1,,,,,,,,,,,,,

Fig. 24 ラジオカセット (EP)
RADIO CASSETTE (EP)

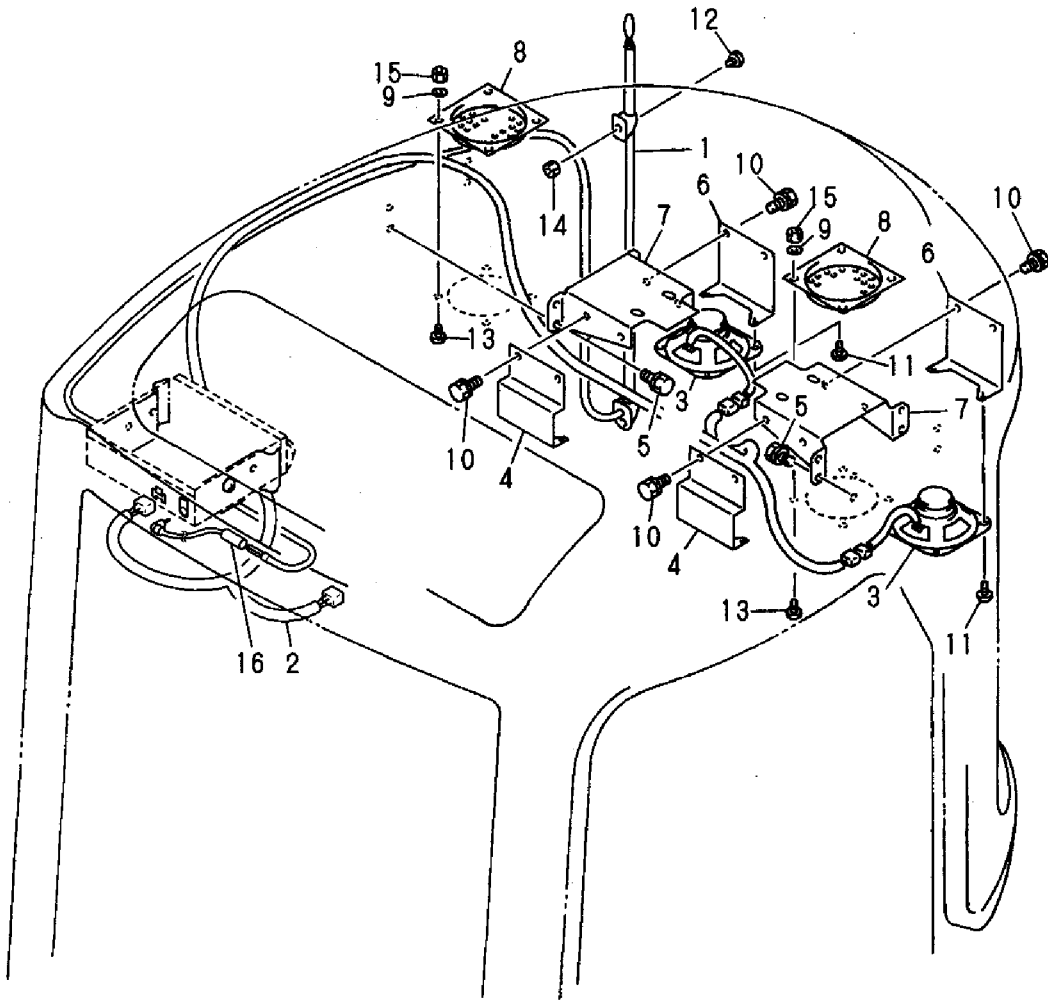

1,1,,172148-29100,,SPROCKET,2,2,,,,,,,,,,,,,,,,,,,,,
2,1,,26013-120352,, "BOLT M12X 35",18,18,,,,,,,,,,,,,,,,,,,,,
3A,1,,772164-37100,, "FRONT IDLER ASSY",2,2,,,,,,,,,,,,,,,,,,,,,
3B,1,,772164-37110,, "IDLER, FRONT (R)",2,2,,,,,,,,,1,,,,,,,,,,,,,
4A,2,,172631-37120,, "IDLER 295",2,2,,,,,,,,,,,,,,,,,,,,,
4B,2,,172164-37110,, "IDLER(304,2,2,,,,,,,,,1,,,,,,,,,,,,,
5,2,,172164-37130,, "KIT, FRONT IDLER",2,2,,,,,,,,,,,,,,,,,,,,,
6,3,,172631-37150,, "COLLER 35X45X34",2,2,,,,,,,,,,,,,,,,,,,,,
7,3,,172631-37160,, "COLLER 35X45X22.5",4,4,,,,,,,,,,,,,,,,,,,,,
8,3,,172164-37120,, "SEAL 45 85 8.5 19",4,4,,,,,,,,,,,,,,,,,,,,,
9,3,,172631-37180,, "SHAFT, IDLER",2,2,,,,,,,,,,,,,,,,,,,,,
10,3,,22242-000300,, "CIRCLIP 30",2,2,,,,,,,,,,,,,,,,,,,,,
11,3,,22242-000350,, "CIRCLIP 35",2,2,,,,,,,,,,,,,,,,,,,,,
12,3,,24101-063074,, "BEARING",4,4,,,,,,,,,,,,,,,,,,,,,
13,2,,172631-37200,, "COVER (A)",2,2,,,,,,,,,,,,,,,,,,,,,
14,2,,172631-37210,, "COVER (B)",2,2,,,,,,,,,,,,,,,,,,,,,
15A,2,,933171-13691,, "PLUG PT1/8",2,2,,,,,,,,,,,,,,,,,,,,,
15B,2,,194630-42120,, "PLUG PT1/8",2,2,,,,,,,,,1,,,,,,,,,,,,,
16,1,,772164-37300,, "ROLLER ASSY, TRACK",8,8,,,,,,,,,,,,,,,,,,,,,
16-1,1,,772164-37301,, "ROLLER ASSY, TRACK",8,8,,,,,N,,M/#01625,,M/#01625,,,,,,
18,2,,172164-37320,, "COVER (A)",8,8,,,,,,,,,,,,,,,,,,,,,
18-1,2,,172164-37321,, "COVER (A)",8,8,,,,,N,,M/#01625,,M/#01625,,,,,,
19,2,,172164-37330,, "COVER (B)",8,8,,,,,,,,,,,,,,,,,,,,,
19-1,2,,172164-37331,, "COVER (B)",8,8,,,,,N,,M/#01625,,M/#01625,,,,,,
20,2,,172164-37350,, "SEAL 35721120",16,16,,,,,,,,,,,,,,,,,,,,,
20-1,2,,172141-37140,, "SEAL 357220",16,16,,,,,N,,M/#01977,,M/#01977,,,,,,
20-2,2,,172164-37351,, "SEAL, OIL",16,16,,,,,N,,M/#02404,,M/#02404,,,,,,
21,2,,22252-000720,, "CIRCLIP 72",16,16,,,,,,,,,,,,,,,,,,,,,
22,2,,24101-062074,, "BALL BEARING",16,16,,,,,,,,,,,,,,,,,,,,,
23,2,,172164-37340,, "SHAFT, ROLLER",8,8,,,,,,,,,,,,,,,,,,,,,
23A,2,,933171-13691,, "PLUG PT1/8",8,8,,,,,W,,M/#01625,,M/#01625,,,,,,
23B,2,,172164-37200,, "COLLER",16,16,,,,,W,,M/#01625,,M/#01625,,,,,,
23C,2,,22252-000850,, "CIRCLIP 85",16,16,,,,,W,,M/#01625,,M/#01625,,,,,,
24,1,,172113-36050,, "BOLT, ROLLER ADJUST",8,8,,,,,,,,,,,,,,,,,,,,,
25,1,,22217-160000,, "SPRING WASHER 16",8,8,,,,,,,,,,,,,,,,,,,,,
26,1,,26657-160002,, "CAP NUT M16",8,8,,,,,,,,,,,,,,,,,,,,,
27,1,,772164-37500,, "ROLLER ASSY, CARIA",2,2,,,,,,,,,,,,,,,,,,,,,
28,2,,172124-37520,, "COVER, SEAL",2,2,,,,,,,,,,,,,,,,,,,,,
30,2,,172147-37510,, "SHAFT, CARIA ROLLER",2,2,,,,,,,,,,,,,,,,,,,,,
31,2,,172124-37530,, "COVER",2,2,,,,,,,,,,,,,,,,,,,,,
32,2,,22252-000750,, "CIRCLIP 75",2,2,,,,,,,,,,,,,,,,,,,,,
33,2,,24101-062064,, "BALL BEARING",4,4,,,,,,,,,,,,,,,,,,,,,
34,2,,172124-37540,, "O-RING P52",2,2,,,,,,,,,,,,,,,,,,,,,
35,2,,1A1030-48250,, "SEAL QLF30621218,OIL",2,2,,,,,,,,,,,,,,,,,,,,,
36,2,,22252-000620,, "CIRCLIP 62(H)",4,4,,,,,,,,,,,,,,,,,,,,,
37,1,,22217-120000,, "SPRING WASHER",2,2,,,,,,,,,,,,,,,,,,,,,
38,1,,26116-120652,, "BOLT M12X 65 PLATED",2,2,,,,,,,,,,,,,,,,,,,,,
39,1,,26716-120002,, "NUT 12",2,2,,,,,,,,,,,,,,,,,,,,,
40,1,,172164-37720,, "PLATE, IDRER FORK",4,4,,,,,1,,,,,,,,,,,,,
41,1,,172122-37710,, "HOLDER, ADJUSTER",2,2,,,,,,,,,,,,,,,,,,,,,
42,1,,172164-37710,, "SPRING, ADJUSTING",2,2,,,,,,,,,,,,,,,,,,,,,
42-1,1,,172164-37711,, "SPRING, ADJUSTING",2,2,,,,,N,,M/#01160,,M/#01160,,,,,,
43,1,,172122-37752,, "ADJUST CYLINDER",2,2,,,,,,,,,,,,,,,,,,,,,
44,2,,172122-37782,, "ADJUST TUBE",2,2,,,,,,,,,,,,,,,,,,,,,
45,2,,172122-37810,, "PISTON",2,2,,,,,,,,,,,,,,,,,,,,,
46,2,,172122-37820,, "ADJUST SEAL SET",2,2,,,,,,,,,,,,,,,,,,,,,
47,1,,172122-37843,, "VALVE ASSY, NIPPLE",2,2,,,,,,,,,,,,,,,,,,,,,
48,2,,24315-000140,, "O-RING 1B P-14.0",2,2,,,,,,,,,,,,,,,,,,,,,
49,2,,24761-020000,, "NIPPLE PT1/8,GREASE",2,2,,,,,,,,,,,,,,,,,,,,,
50,1,,26013-120402,, "BOLT M12X 40",8,8,,,,,,,,,,,,,,,,,,,,,

Fig. 25 ローラ&アジャスト
ROLLER & ADJUST

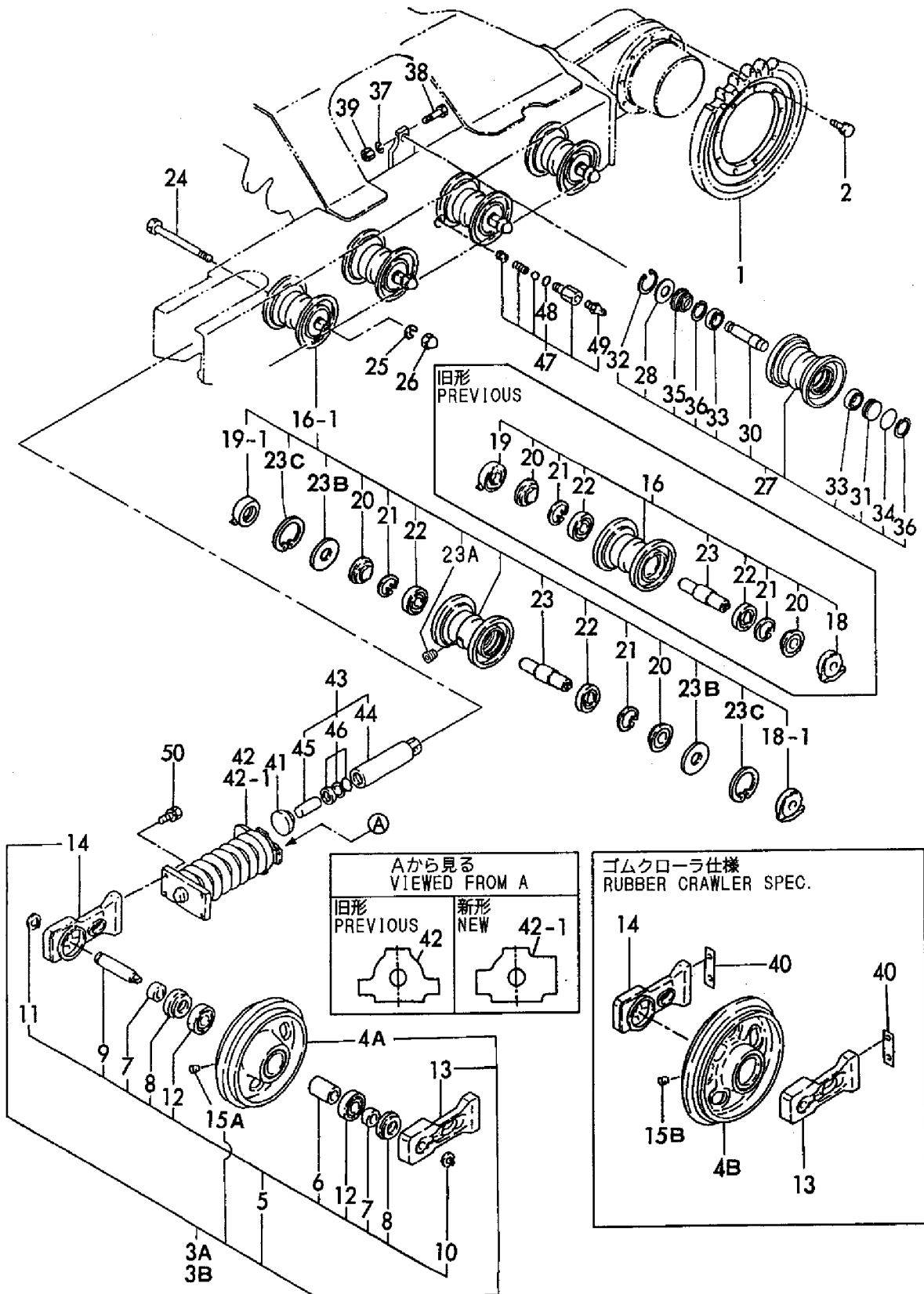

Aから見る
VIEWED FROM A

旧形 PREVIOUS	新形 NEW
42	42-1

ゴムクローラ仕様
RUBBER CRAWLER SPEC.

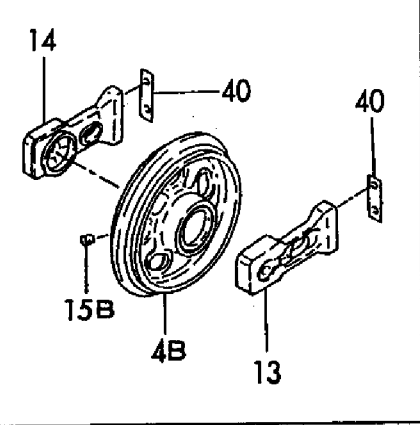

1,1,,772164-38100,, "SHOE, TRACK",1,1,,,,,,,,,,,,,
2,2,,172164-38100,, "CRAWLER 370R",1,1,,,,,,,,,,,,,
2-1,2,,172164-38101,, "CRAWLER 370R",1,1,,,,,N,,,M/#01719,,M/#01719,,,,,,
3,3,,172164-38110,, "SHOE R, TRACK",1,1,,,,,,,,,,,,,
4,4,,172113-38180,, BUSH,47,47,,,,,,,,,,,,,
5,4,,172614-38210,, "PIN, TRACK",46,46,,,,,,,,,,,,,
6,3,,172071-61021,, "PLATE, SHOE 370",47,47,,,,,,,,,,,,,
6-1,3,,172071-61022,, "PLATE,SHOE 370",47,47,,,,,N,,,M/#01719,,M/#01719,,,,,,
7,2,,172614-38290,, "PIN, MASTER",1,1,,,,,,,,,,,,,
8,2,,172614-38300,, "PIN 5X45, LOCK",1,1,,,,,,,,,,,,,
8-1,2,,172112-38111,, "PIN, COTTER",1,1,,,,,N,,,M/#02404,,M/#02404,,,,,,
9,1,,772164-38110,, "CRAWLER(L) ASSY",1,1,,,,,,,,,,,,,
10,2,,172164-38120,, "CRAWLER 370L",1,1,,,,,,,,,,,,,
10-1,2,,172164-38121,, CRAWLER(L)CMP(370,1,1,,,,,N,,,M/#01719,,M/#01719,,,,,,
11,3,,172164-38130,, "SHOE L, TRACK",1,1,,,,,,,,,,,,,
12,4,,172113-38180,, BUSH,47,47,,,,,,,,,,,,,
13,4,,172614-38210,, "PIN, TRACK",46,46,,,,,,,,,,,,,
14,3,,172071-61021,, "PLATE, SHOE 370",47,47,,,,,,,,,,,,,
14-1,3,,172071-61022,, "PLATE,SHOE 370",47,47,,,,,N,,,M/#01719,,M/#01719,,,,,,
15,2,,172614-38290,, "PIN, MASTER",1,1,,,,,,,,,,,,,
16,2,,172614-38300,, "PIN 5X45, LOCK",1,1,,,,,,,,,,,,,
16-1,2,,172112-38111,, "PIN, COTTER",1,1,,,,,N,,,M/#02404,,M/#02404,,,,,,
17,1,,172122-38731,, "TRACK 370G(R),MASTER",1,1,,,,,,,,,,,,,
17-1,1,,172122-38732,, "TRACK 370R,MASTER",1,1,,,,,N,,,M/#01719,,M/#01719,,,,,,
18,1,,172122-38741,, "TRACK 370G(L),MASTER",1,1,,,,,,,,,,,,,
18-1,1,,172122-38742,, "TRACK 370L,MASTER",1,1,,,,,N,,,M/#01719,,M/#01719,,,,,,
19,1,,172164-38600,, "CRAWLER ASSY, RUBBER",2,2,,,,,,,,,,,,,
19-1,1,,172964-38600,, "CRAWLER ASSY,
RUBBER",2,2,,,,,N,,,M/#01427,,M/#01427,,,,,,

Fig. 26 クローラ CRAWLER

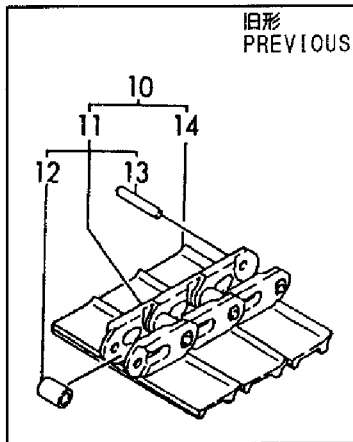
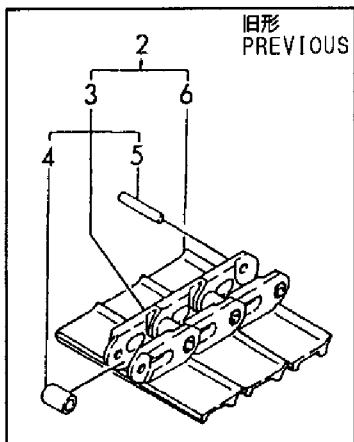
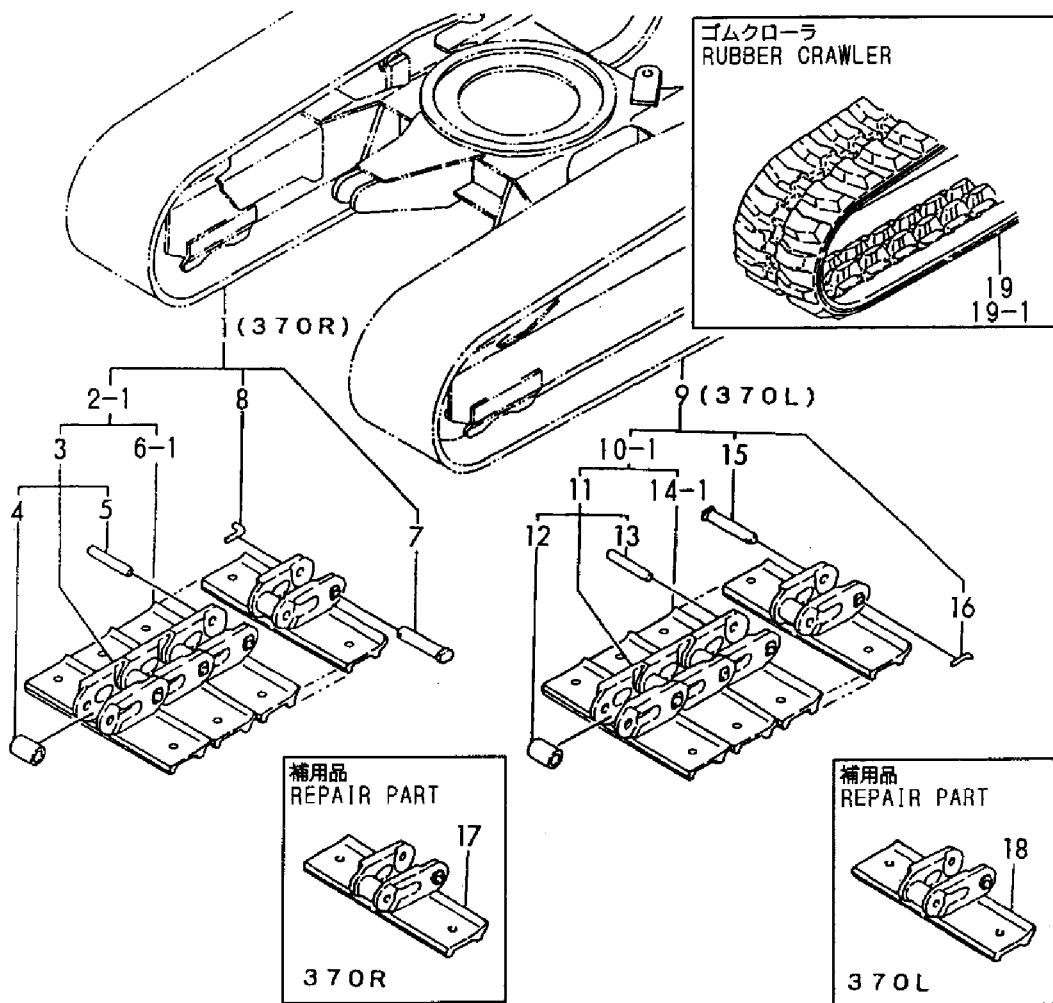

1,1,,172151-45010,, "BOOT P,LEVER",2,2,,,,,,,,,,,,,,,,,,,,,
2,1,,172164-45010,, "LEVER (R) ASSY",1,1,,,,,,,,,,,,,,,,,,,,,
3,1,,172164-45880,, "BOLT 6X 16",4,4,,,,,,,,,,,,,,,,,,,,,
4,1,,172165-47871,, "KNOB (A) ASSY",1,1,,,,,,,,,,,,,,,,,,,,,
5,1,,172165-45071,, "KNOB (L) ASSY",1,1,,,,,,,,,,,,,,,,,,,,,
6,1,,26116-100504,, "BOLT M10X 50 PLATED",4,4,,,,,,,,,,,,,,,,,,,,,
7,1,,26716-100002,, "NUT 10",4,4,,,,,,,,,,,,,,,,,,,,,
8,1,,26587-040062,, "SCREW M 4X 6",2,2,,,,,,,,,,,,,,,,,,,,,
9,1,,26013-100202,, "BOLT W/WASHER M10X20",3,3,,,,,,,,,,,,,,,,,,,,,
10,1,,26013-100202,, "BOLT W/WASHER M10X20",4,4,,,,,,,,,,,,,,,,,,,,,
11,1,,194145-04810,, "WASHER 10",1,1,,,,,,,,,,,,,,,,,,,,,
12,1,,172165-45620,, "COVER, SUPPORT",1,1,,,,,,,,,,,,,,,,,,,,,
13,1,,172164-45800,, "SUPPORT COMP.,SI",1,1,,,,,,,,,,,,,,,,,,,,,
13-1,1,,172164-45801,, SUPPORT,1,1,,,,,S,,,,M/#01300,,M/#01300,,,,,,
14,1,,172164-45840,, "COVER COMP.,SI",1,1,,,,,,,,,,,,,,,,,,,,,
14-1,1,,172164-45841,, COVER,1,1,,,,,S,,,,M/#01300,,M/#01300,,,,,,
15,1,,172164-45450,, "STAND (R) ASSY,LEVER",1,1,,,,,,,,,,,,,,,,,,,,,
15-1,1,,172164-45451,, "STAND(R), LEVER",1,1,,,,,N,,,,M/#01427,,M/#01427,,,,,,
15-2,1,,172164-45452,, "STAND(R),LEVER",1,1,,,,,N,,,,M/#01537,,M/#01537,,,,,,
16,2,,172164-62260,, "RUBBER, SEAL",1,1,,,,,,,,,,,,,,,,,,,,,
18,2,,172164-64400,, "RUBBER, SEAL",1,1,,,,,,,,,,,,,,,,,,,,,
19,1,,172164-45600,, "STAND (L) ASSY,LEVER",1,1,,,,,,,,,,,,,,,,,,,,,
20,2,,172141-41370,, "BUSH 2015",2,2,,,,,,,,,,,,,,,,,,,,,
22,2,,24550-025150,, "BUSH 25X15",2,2,,,,,,,,,,,,,,,,,,,,,
23,1,,172165-47710,, PLATE,2,2,,,,,,,,,,,,,,,,,,,,,
23-1,1,,172165-47711,, PLATE,2,2,,,,,N,,,,M/#01666,,M/#01666,,,,,,
24,1,,172164-45920,, "GUIDE L, HOSE",1,1,,,,,,,,,,,,,,,,,,,,,
25,1,,172164-45790,, COVER,1,1,,,,,,,,,,,,,,,,,,,,,
26,1,,172151-53430,, GROMMET,2,2,,,,,,,,,,,,,,,,,,,,,
27,1,,194630-62360,, GROMMET,8,8,,,,,,,,,,,,,,,,,,,,,
28,1,,172519-63240,, "BOLT 8X 16",5,5,,,,,,,,,,,,,,,,,,,,,
29,1,,172165-47990,, WASHER,1,1,,,,,,,,,,,,,,,,,,,,,
30,1,,26013-080162,, "BOLT W/WASHER M8X16",8,8,,,,,,,,,,,,,,,,,,,,,
31,1,,22217-100000,, "SPRING WASHER 10",5,5,,,,,,,,,,,,,,,,,,,,,
32,1,,22242-000250,, "CIRCLIP 25S",1,1,,,,,,,,,,,,,,,,,,,,,
33,1,,26013-080202,, "BOLT W/WASHER M8X20",2,2,,,,,,,,,,,,,,,,,,,,,
34,1,,172519-63240,, "BOLT 8X 16",2,2,,,,,,,,,,,,,,,,,,,,,
35,1,,26116-100202,, "BOLT M10X 20 PLATED",4,4,,,,,,,,,,,,,,,,,,,,,
36,1,,26116-100902,, "BOLT M10X 90 PLATED",1,1,,,,,,,,,,,,,,,,,,,,,
37,1,,24311-000340,, "O-RING 1A P-34.0",2,2,,,,,,,,,,,,,,,,,,,,,
38,1,,24761-020000,, "NIPPLE PT1/8,GREASE",2,2,,,,,,,,,,,,,,,,,,,,,
39,1,,172165-47980,, "SHIM 42X25.5X0.5",2,2,,,,,,,,,,,,,,,,,,,,,
40,1,,26776-140002,, "LOCK NUT M14 PLATED",2,2,,,,,,,,,,,,,,,,,,,,,
40-1,1,,26736-140002,, "NUT M14",2,2,,,,,N,,,,M/#01677,,M/#01677,,,,,,
41,1,,172164-45040,, "HINGE, LEVER",1,1,,,,,,,,,,,,,,,,,,,,,
41-1,1,,172164-45041,, HINGE,1,1,,,,,S,1,,M/#02054,,M/#02054,,,,,,
42,1,,172164-45050,, "PIN 8X 22",1,1,,,,,,,,,,,,,,,,,,,,,
43,1,,172164-45060,, "PIN, ROCK",1,1,,,,,,,,,,,,,,,,,,,,,
43-1,1,,172164-45061,, PIN,1,1,,,,,S,1,,M/#02054,,M/#02054,,,,,,
44,1,,172164-45070,, SPRING,1,1,,,,,,,,,,,,,,,,,,,,,
45,1,,172164-45080,, "SCREW M6",1,1,,,,,,,,,,,,,,,,,,,,,
46,1,,172165-47851,, "LEVER L, SI",1,1,,,,,,,,,,,,,,,,,,,,,
47,1,,22272-000060,, "CIRCLIP E- 6",1,1,,,,,,,,,,,,,,,,,,,,,
48,1,,172157-58830,, "KNOB 6.5X18X35",1,1,,,,,,,,,,,,,,,,,,,,,
49,1,,26116-060202,, "BOLT M 6X 20",2,2,,,,,,,,,,,,,,,,,,,,,
50,1,,26716-060002,, "NUT 6",2,2,,,,,,,,,,,,,,,,,,,,,
51,1,,172164-45860,, "COVER, LINK",1,1,,,,,,,,,,,,,,,,,,,,,
51-1,1,,172164-45861,, "COVER, LINK",1,1,,,,,N,,,,M/#01537,,M/#01537,,,,,,
53,2,,172164-45870,, "SEAL 155, RUBBER",2,2,,,,,,,,,,,,,,,,,,,,,
54,2,,172164-66670,, "RUBBER, SEAL 60",2,2,,,,,,,,,,,,,,,,,,,,,
55,1,,172164-45090,, CAP,1,1,,,,,,,,,,,,,,,,,,,,,
56,1,,933168-55770,, "BAND 146",2,2,,,,,,,,,,,,,,,,,,,,,
57,1,,172190-45080,, "LEVER L CMP(DECCEL",1,1,,,,,2,,,,,,,,,,,,,,,,,,,,,

58,1,,172165-47711,,PLATE,1,1,,,,,2,,,,,
59,1,,172176-47870,,KNOB,1,1,,,,,2,,,,,
60,1,,26587-040062,, "SCREW M 4X 6",1,1,,,,,2,,,,,
61,1,,26736-140002,, "NUT M14",1,1,,,,,2,,,,,
62,1,,933168-55770,, "BAND 146",2,2,,,,,2,,,,,

Fig. 27 操縦装置 (作業レバー&スタンド)
CONTROL EQUIP. (OPERATION LEVER & STAND)

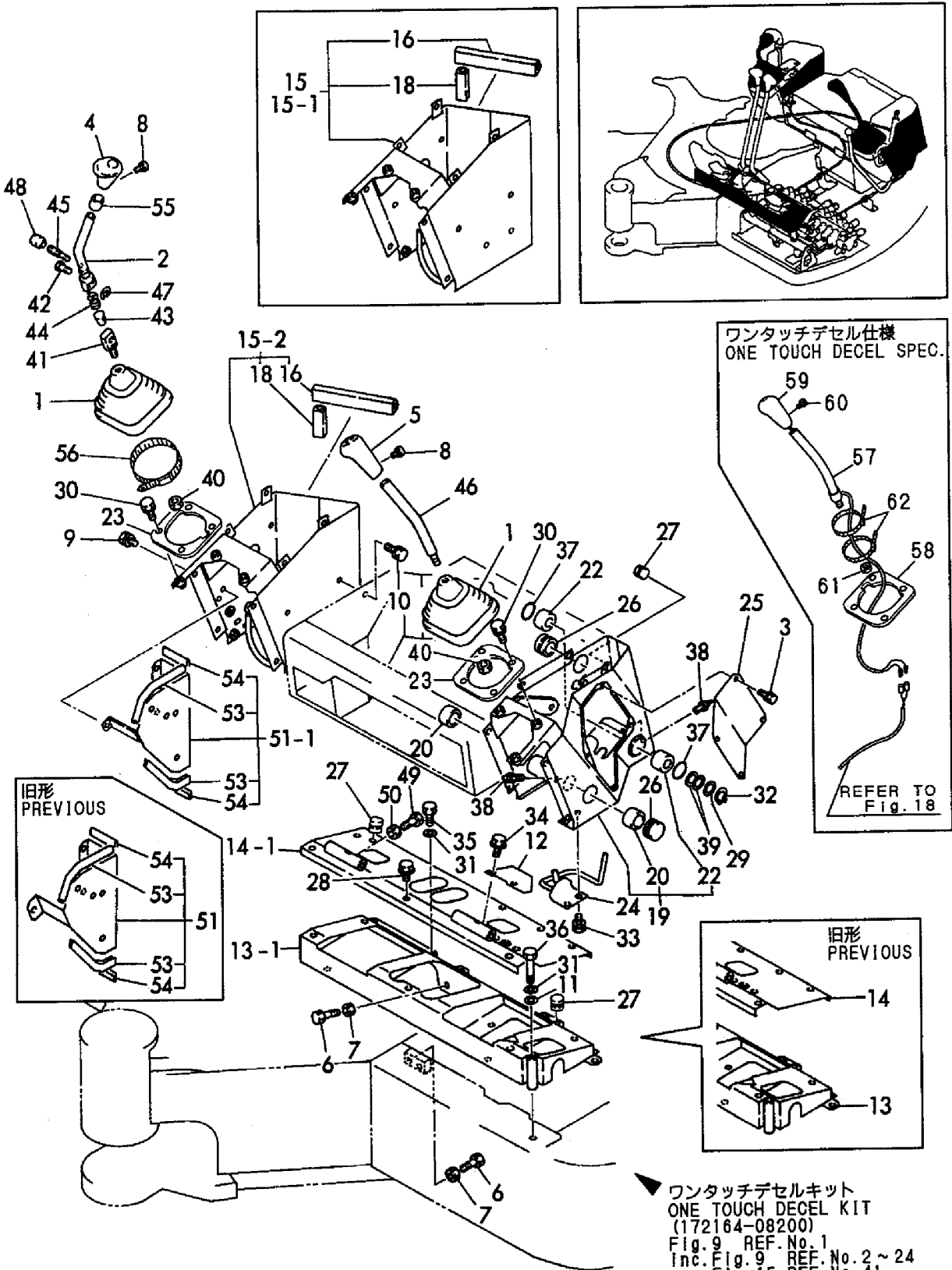

ワンタッチデセルキット
ONE TOUCH DECEL KIT
(172164-08200)
Fig. 9 REF. No. 1
Inc. Fig. 9 REF. No. 2 ~ 24
Fig. 15 REF. No. 41
Fig. 18 REF. No. 51 ~ 70
Fig. 22 REF. No. 15A, 16A
Fig. 27 REF. No. 57 ~ 62

1,1,,172141-41340,,BOOTS,2,2,,,,,,,,,,,,,
2,1,,172164-45950,,,"GRIP L, DRIV.",1,1,,,,,,,,,,,,,
2-1,1,,172164-45951,,,"GRIP L, DRIV.",1,1,,,,,N,,,M/#01666,,M/#01666,,,,,,
3,1,,172164-45100,,,"LEVER(L), TRACK",1,1,,,,,,,,,,,,,
4,2,,172141-41370,,,"BUSH 2015",2,2,,,,,,,,,,,,,
6,1,,172164-45130,,,"LEVER(R), TRACK",1,1,,,,,,,,,,,,,
7,2,,172141-41370,,,"BUSH 2015",2,2,,,,,,,,,,,,,
9,1,,26756-100002,,,"LOCK NUT M10 PLATED",2,2,,,,,,,,,,,,,
10,1,,172164-45380,,,"ROD(95)",1,1,,,,,,,,,,,,,
11,1,,172164-45960,,,"GRIP R, DRIV.",1,1,,,,,,,,,,,,,
11-1,1,,172164-45961,,,"GRIP R, DRIV.",1,1,,,,,N,,,M/#01666,,M/#01666,,,,,,
12,1,,172164-45200,,,"SHAFT(A)ASSY,TRACK",1,1,,,,,,,,,,,,,
13,1,,172124-46200,,,"O-RING 27X5.7",3,3,,,,,,,,,,,,,
14,1,,24761-020000,,,"NIPPLE PT1/8,GREASE",2,2,,,,,,,,,,,,,
15,1,,26013-100252,,,"BOLT W/WASHER M10X25",2,2,,,,,,,,,,,,,
16,1,,172165-46100,,,"PEDAL L ASSY",1,1,,,,,,,,,,,,,
17,1,,172165-46150,,,"PEDAL R COMP",1,1,,,,,,,,,,,,,
18,1,,26013-060302,,,"BOLT M 6X 30",4,4,,,,,,,,,,,,,
19,1,,172164-45230,,,"ROD 135 ASSY",1,1,,,,,,,,,,,,,
20,1,,172122-46590,,,"ELBALL 8",2,2,,,,,,,,,,,,,
21,1,,22137-080000,,,"WASHER 8, POLISHED",2,2,,,,,,,,,,,,,
22,1,,22417-160160,,,"COTTER PIN 1.6X16",2,2,,,,,,,,,,,,,
23,1,,26051-080002,,,"NUT M 8",4,4,,,,,,,,,,,,,
24,1,,933110-54100,,,"PIN 4.75X14",2,2,,,,,,,,,,,,,
25,1,,172146-45691,,,"ROD(C), SPOOL",1,1,,,,,,,,,,,,,
26,1,,22217-080000,,,"SPRING WASHER 8",1,1,,,,,,,,,,,,,

Fig. 28 操縦装置 (走行) CONTROL EQUIP. (TRAVEL)

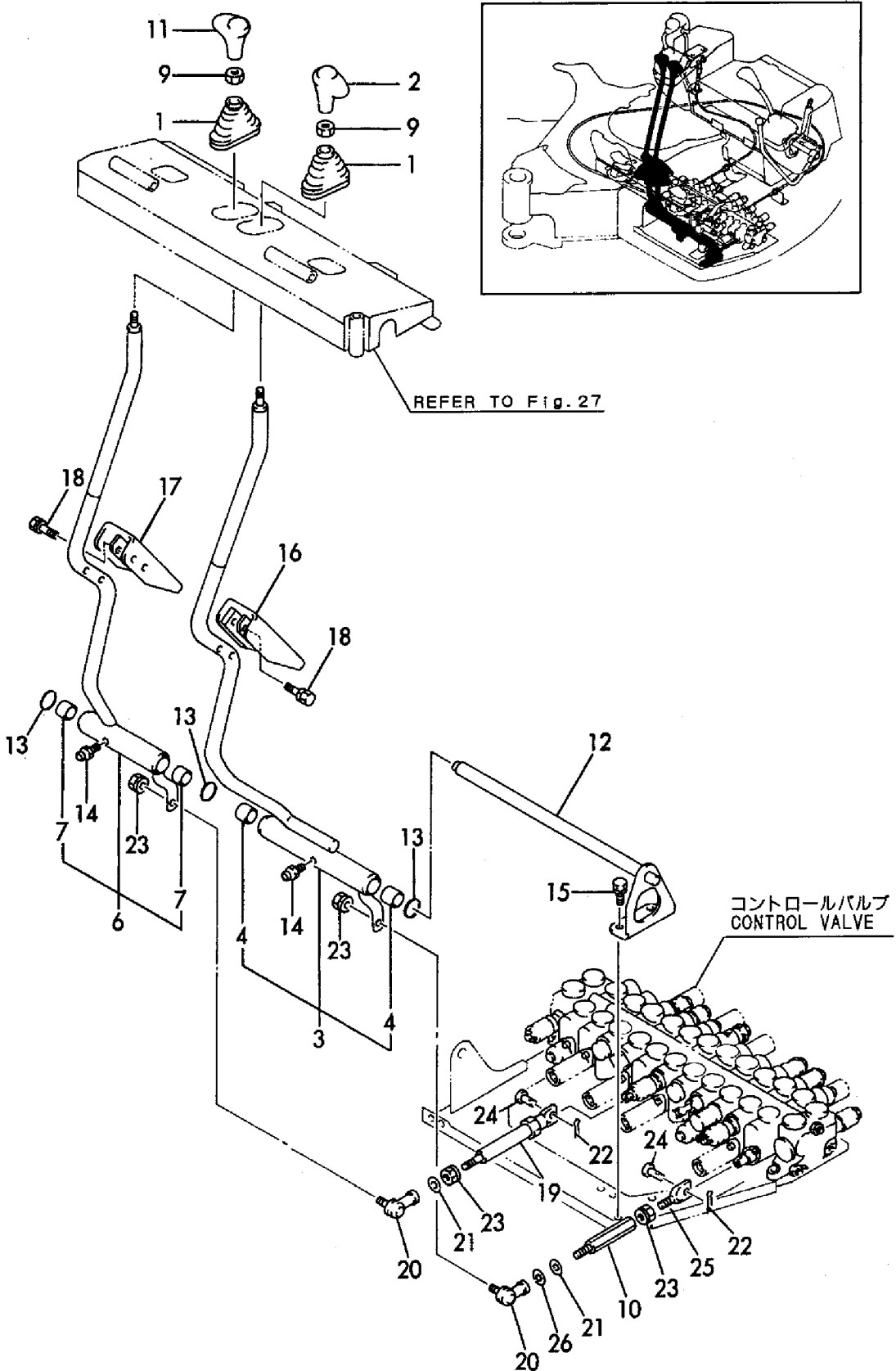

1,1,,1A1040-45890,, "WASHER 10 36 4.5",1,1,,,,,,,,,,,,,
2,1,,172124-46200,, "O-RING 27X5.7",2,2,,,,,,,,,,,,,
3,1,,172165-46300,, "LINK W/BUSH",1,1,,,,,,,,,,,,,
4,2,,172141-41360,, "BUSH 1415",2,2,,,,,,,,,,,,,
6,1,,172165-46350,, "BRACKET, PEDAL",1,1,,,,,,,,,,,,,
7,1,,172146-41910,, "PIN 14-100",1,1,,,,,,,,,,,,,
8,1,,172165-46800,, "SHAFT",1,1,,,,,,,,,,,,,
9,1,,172165-46830,, "BOSS, SWING",1,1,,,,,,,,,,,,,
10,2,,172141-41370,, "BUSH 2015",2,2,,,,,,,,,,,,,
12,1,,22217-100000,, "SPRING WASHER 10",1,1,,,,,,,,,,,,,
13,1,,22351-040032,, "SPRING PIN 4X32",1,1,,,,,,,,,,,,,
14,1,,24761-020000,, "NIPPLE PT1/8,GREASE",1,1,,,,,,,,,,,,,
15,1,,24761-050000,, "NIPPLE C,GREASE",1,1,,,,,,,,,,,,,
16,1,,26013-100202,, "BOLT W/WASHER M10X20",2,2,,,,,,,,,,,,,
17,1,,26013-100252,, "BOLT W/WASHER M10X25",2,2,,,,,,,,,,,,,
18,1,,26116-100202,, "BOLT M10X 20 PLATED",1,1,,,,,,,,,,,,,
19,1,,172157-45990,, "BOOTS, PEDAL",1,1,,,,,,,,,,,,,
20,1,,172165-46230,, "SHAFT, SWING",2,2,,,,,,,,,,,,,
21,1,,172165-46261,, "COVER, PEDAL",2,2,,,,,,,,,,,,,
22,1,,172165-46281,, "PEDAL ASSY, SWING",1,1,,,,,,,,,,,,,
23,1,,172165-46340,, "BOLT",2,2,,,,,,,,,,,,,
24,1,,22137-080000,, "WASHER 8, POLISHED",2,2,,,,,,,,,,,,,
25,1,,22351-040020,, "SPRING PIN 4X20",2,2,,,,,,,,,,,,,
26,1,,26116-080304,, "BOLT M 8X 30",2,2,,,,,,,,,,,,,
27,1,,26716-080002,, "NUT M 8",2,2,,,,,,,,,,,,,
28,1,,26716-080002,, "NUT M 8",4,4,,,,,,,,,,,,,
29,1,,194200-37780,, "LS-NUT 8",1,1,,,,,,,,,,,,,
30,1,,172150-42620,, "ROD(B), BOOM",1,1,,,,,,,,,,,,,
31,1,,172147-45620,, "ROD, LINK 215",1,1,,,,,,,,,,,,,
32,1,,172146-45701,, "ROD(D), SPOOL",1,1,,,,,,,,,,,,,
32-1,1,,172146-45740,, "ROD(D), SPOOL",1,1,,,,,R,,,,M/#01072,,M/#01072,,,,,
33,1,,172122-46590,, "ELBALL 8",3,3,,,,,,,,,,,,,
34,1,,172165-46860,, "TURNBUCKLE M8",1,1,,,,,,,,,,,,,
35,1,,22137-080000,, "WASHER 8, POLISHED",3,3,,,,,,,,,,,,,
36,1,,22417-160160,, "COTTER PIN 1.6X16",1,1,,,,,,,,,,,,,
37,1,,26051-080002,, "NUT M 8",6,6,,,,,,,,,,,,,
38,1,,26716-080002,, "NUT M 8",1,1,,,,,,,,,,,,,
39,1,,933110-54100,, "PIN 4.75X14",1,1,,,,,,,,,,,,,
40,1,,24311-000210,, "O-RING 1A P-21.0",2,2,,,,,,,,,,,,,
41,1,,172068-28490,, "SPRING 8",4,4,,,,,,,,,,,,,

Fig. 29 操縦装置 (スイング) CONTROL EQUIP. (SWING)

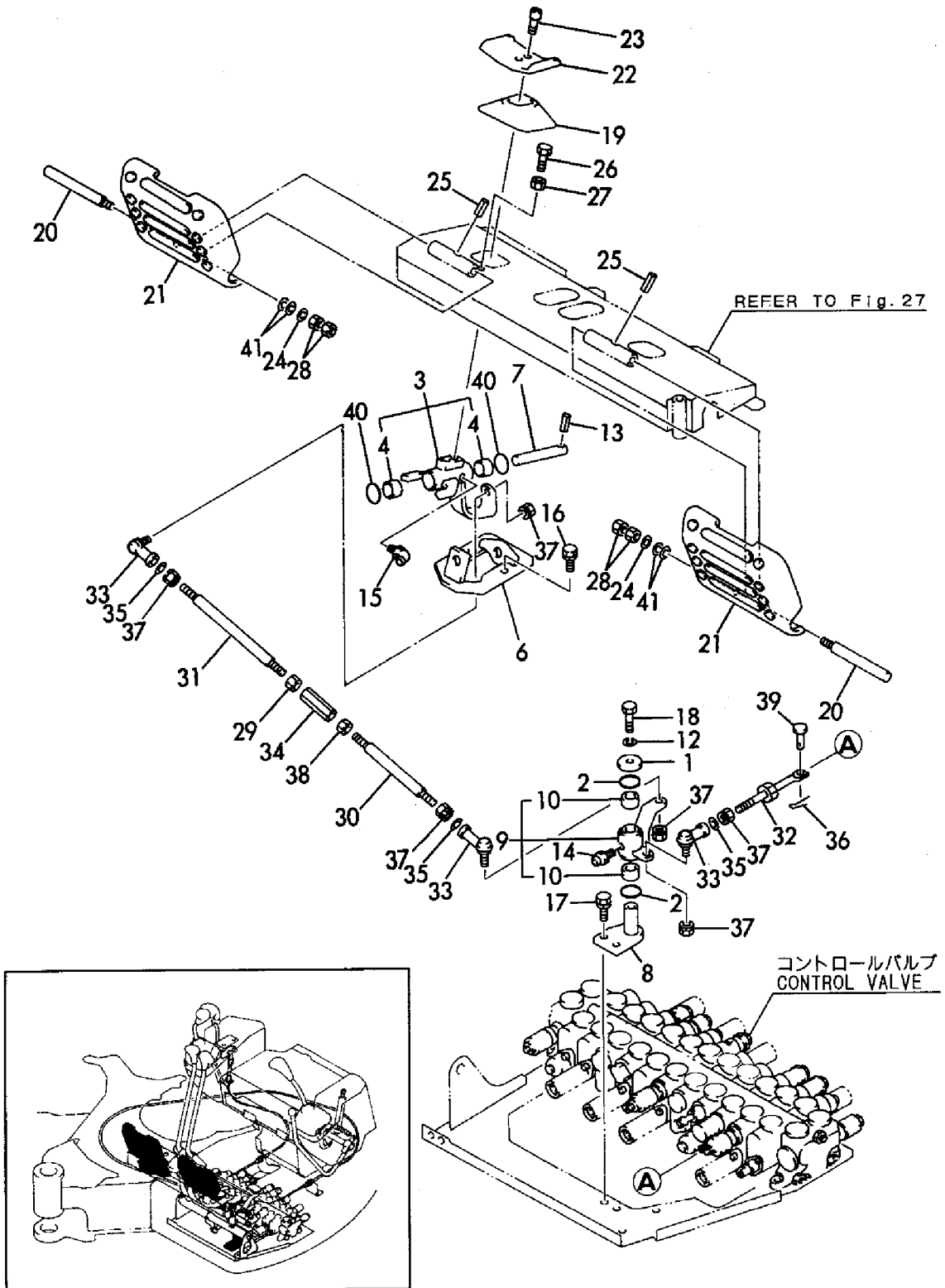

1,1,,172164-45180,, "LEVER ASSY, BLADE",1,1,,,,,,,,,,,,,
2,1,,172164-45970,, "GRIP, BLADE",1,1,,,,,,,,,,,,,
3,1,,22351-050032,, "SPRING PIN 5X32",1,1,,,,,,,,,,,,,
4,1,,172165-45140,, "LINK, BLADE",1,1,,,,,,,,,,,,,
5,1,,172165-45180,, "BRACKET ASSY, REAR",1,1,,,,,,,,,,,,,
5-1,1,,172164-46440,, "BRACKET ASY",1,1,,,,,S,,,,M/#01537,,M/#01537,,,,,
6,2,,172141-41360,, "BUSH 1415",2,2,,,,,,,,,,,,,
6-1,2,,172141-41360,, "BUSH 1415",4,4,,,,,K,,,,M/#01537,,M/#01537,,,,,
8,1,,24311-000210,, "O-RING 1A P-21.0",2,2,,,,,,,,,,,,,
9,1,,26013-100202,, "BOLT W/WASHER M10X20",3,3,,,,,,,,,,,,,
10,1,,26116-100354,, "BOLT M10X 35 PLATED",2,2,,,,,,,,,,,,,
11,1,,26716-100002,, "NUT 10",2,2,,,,,,,,,,,,,
12,1,,172165-45130,, "CABLE, BLADE",1,1,,,,,,,,,,,,,
13,1,,172141-42960,, "JOINT, CABLE",1,1,,,,,,,,,,,,,
14,1,,172165-45250,, "SUPPORT, BR CABLE",1,1,,,,,,,,,,,,,
15,1,,172142-45670,, "ROD, SPOOL",1,1,,,,,,,,,,,,,
16,1,,172122-46590,, "ELBALL 8",1,1,,,,,,,,,,,,,
17,1,,22417-160160,, "COTTER PIN 1.6X16",1,1,,,,,,,,,,,,,
18,1,,26013-100202,, "BOLT W/WASHER M10X20",2,2,,,,,,,,,,,,,
19,1,,26051-080002,, "NUT M 8",1,1,,,,,,,,,,,,,
20,1,,933110-54100,, "PIN 4.75X14",1,1,,,,,,,,,,,,,
21,1,,933168-28480,, "WASHER 20X9X3.2",1,1,,,,,,,,,,,,,
22,1,,22351-030032,, "SPRING PIN 3X32",1,1,,,,,,,,,,,,,
23,1,,1D4070-23580,, "GRIP, RED ROUND",,1,,,,,W,,,,,M/#01537,,,,,
24,1,,172165-45970,, "SPRING",,1,,,,,W,,,,,M/#01537,,,,,
25,1,,172164-46400,, "BRACKET CMP",,1,,,,,W,,,,,M/#01537,,,,,
26,1,,172164-46421,, "LEVER CMP, ROCK",,1,,,,,W,,,,,M/#01537,,,,,
27,1,,172164-46481,, "LINK CMP, ROCK",,1,,,,,W,,,,,M/#01537,,,,,
28,1,,22137-080000,, "WASHER 8, POLISHED",,2,,,,,W,,,,,M/#01537,,,,,
29,1,,22351-030032,, "SPRING PIN 3X32",,1,,,,,W,,,,,M/#01537,,,,,
30,1,,22351-050032,, "SPRING PIN 5X32",,1,,,,,W,,,,,M/#01537,,,,,
31,1,,24311-000210,, "O-RING 1A P-21.0",,1,,,,,W,,,,,M/#01537,,,,,
32,1,,26013-080202,, "BOLT W/WASHER M8X20",,2,,,,,W,,,,,M/#01537,,,,,

Fig. 30 操縦装置 (ブレード) CONTROL EQUIP. (BLADE)

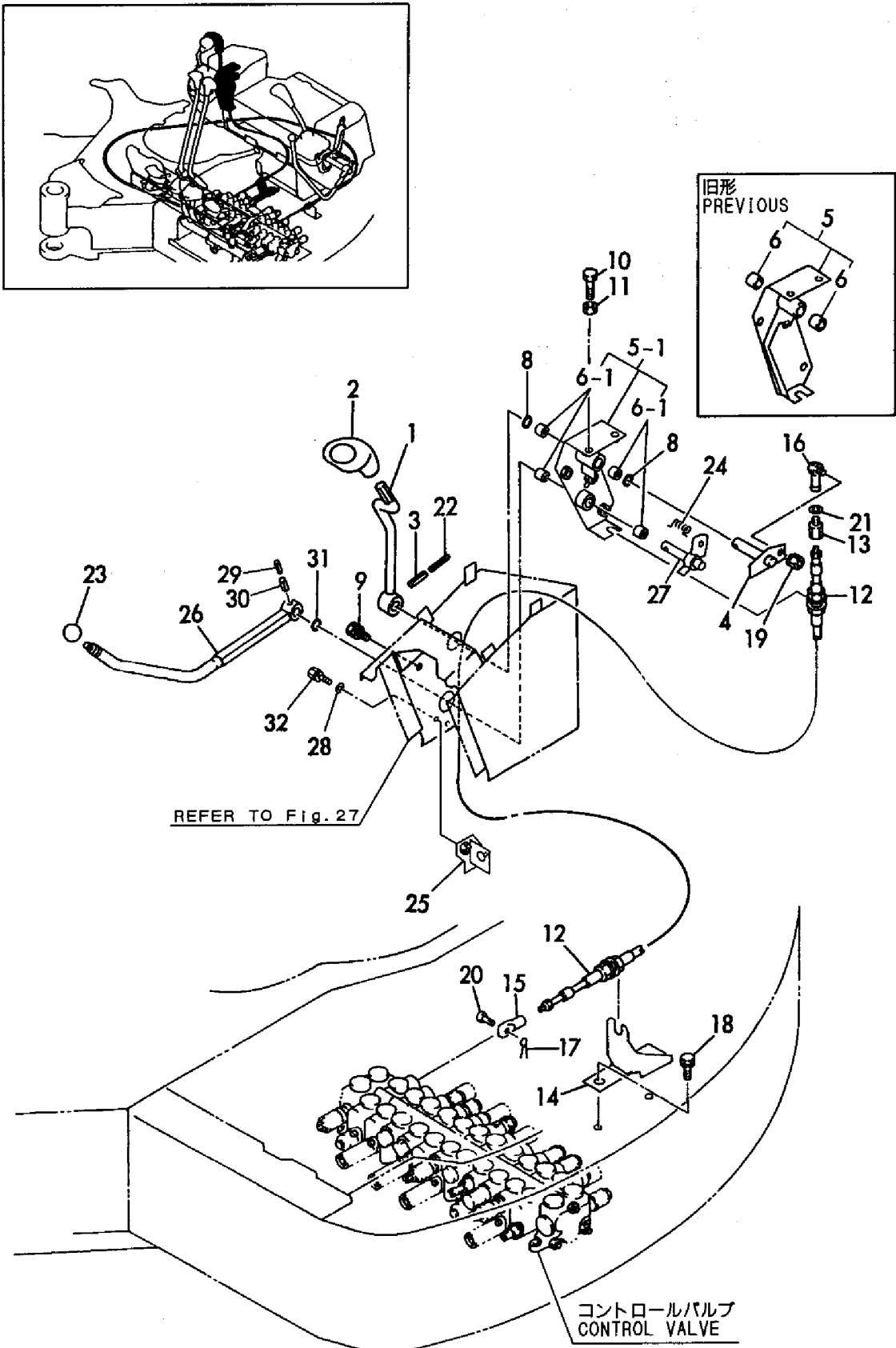

1,1,,172519-17111,,BRACKET,1,1,,,,,,,,,,,,,
1-1,1,,172519-17112,,BRACKET,1,1,,,,,N,,,M/#00926,,M/#00926,,,,,
1-2,1,,172164-17150,,,"BRACKET, SWITCH",1,1,,,,,F,1,,M/#01446,,M/#01446,,,,,
2,1,,1D4070-23580,,,"GRIP,RED ROUND",1,1,,,,,,,,,,,,,
3,1,,172124-46200,,,"O-RING 27X5.7",2,2,,,,,,,,,,,,,
4,1,,172165-47450,,,"LEVER (L), LOCK",1,1,,,,,,,,,,,,,
5,1,,172165-47500,,,"ARM ASSY, LOCK",1,1,,,,,,,,,,,,,
6,1,,172165-47550,,,"BUSH,1,1,,,,,,,,,,,,,
7,1,,172165-47621,,,"GUIDE (L) ASSY, LOCK",1,1,,,,,,,,,,,,,
8,1,,172165-47801,,,"SPRING,GAS",1,1,,,,,,,,,,,,,
9,1,,1A1380-56661,,,"SPRING,ROTARY RETURN",1,1,,,,,,,,,,,,,
10,1,,22137-080000,,,"WASHER 8, POLISHED",2,2,,,,,,,,,,,,,
11,1,,22137-080000,,,"WASHER 8, POLISHED",2,2,,,,,,,,,,,,,
12,1,,22272-000070,,,"CIRCLIP E- 7",1,1,,,,,,,,,,,,,
13,1,,22351-060040,,,"SPRING PIN 6X40",1,1,,,,,,,,,,,,,
14,1,,22417-200200,,,"COTTER PIN 2.0X20",2,2,,,,,,,,,,,,,
15,1,,26013-080202,,,"BOLT W/WASHER M8X20",2,2,,,,,,,,,,,,,
16,1,,26013-100202,,,"BOLT W/WASHER M10X20",2,2,,,,,,,,,,,,,
17,1,,172164-45250,,,"BRACKET ASY,LOW-HIGH",1,1,,,,,Z,,,M/#01187,,M/#01187,,,,,
18,2,,172141-41360,,,"BUSH 1415",2,2,,,,,Z,,,M/#01187,,M/#01187,,,,,
19,1,,172164-45270,,,"SHAFT, LOW-HIGH",1,1,,,,,Z,,,M/#01187,,M/#01187,,,,,
20,1,,172164-45290,,,"LINK, LOW-HIGH",1,1,,,,,Z,,,M/#01187,,M/#01187,,,,,
21,2,,172141-41360,,,"BUSH 1415",2,2,,,,,Z,,,M/#01187,,M/#01187,,,,,
22,1,,172164-45360,,,"PEDAL, LOW-HIGH",1,1,,,,,Z,,,M/#01187,,M/#01187,,,,,
23,1,,172164-45390,,,"ROD(A), SPOOL",1,1,,,,,Z,,,M/#01187,,M/#01187,,,,,
24,1,,172164-45400,,,"ROD(B,1,1,,,,,Z,,,M/#01187,,M/#01187,,,,,
25,1,,172164-45410,,,"ROD C, SPOOL",1,1,,,,,Z,,,M/#01187,,M/#01187,,,,,
26,1,,172122-45830,,,"PAD, METAL",1,1,,,,,,,,,,,,,
27,1,,22137-100000,,,"WASHER 10,POLISHED",1,1,,,,,Z,,,M/#01187,,M/#01187,,,,,
28,1,,22157-100000,,,"WASHER 10",1,1,,,,,Z,,,M/#01187,,M/#01187,,,,,
29,1,,22217-100000,,,"SPRING WASHER 10",1,1,,,,,,,,,,,,,
30,1,,22417-160160,,,"COTTER PIN 1.6X16",4,4,,,,,Z,,,M/#01187,,M/#01187,,,,,
31,1,,22486-080160,,,"PIN 8X 16",3,3,,,,,Z,,,M/#01187,,M/#01187,,,,,
32,1,,24311-000210,,,"O-RING 1A P-21.0",4,4,,,,,,,,,,,,,
32-1,1,,24311-000210,,,"O-RING 1A P-21.0",2,2,,,,,K,,,M/#01187,,M/#01187,,,,,
33,1,,26013-100252,,,"BOLT W/WASHER M10X25",2,2,,,,,,,,,,,,,
33-1,1,,26013-100202,,,"BOLT W/WASHER
M10X20",2,2,,,,,R,,,M/#01187,,M/#01187,,,,,
34,1,,26116-100504,,,"BOLT M10X 50 PLATED",1,1,,,,,,,,,,,,,
35,1,,26347-100002,,,"U-NUT M10",2,2,,,,,Z,,,M/#01187,,M/#01187,,,,,
36,1,,26716-100002,,,"NUT 10",1,1,,,,,,,,,,,,,
37,1,,26716-100002,,,"NUT 10",1,1,,,,,Z,,,M/#01187,,M/#01187,,,,,
38,1,,933110-54100,,,"PIN 4.75X14",1,1,,,,,Z,,,M/#01187,,M/#01187,,,,,
39,1,,22351-030032,,,"SPRING PIN 3X32",1,1,,,,,,,,,,,,,
39-1,1,,22351-035040,,,"SPRING PIN 3.5X40",1,1,,,,,N,,,,"FROM 1ST",,"FROM
1ST",,,,,,
40,1,,172162-46690,,,"SPRING,1,1,,,,,W,,,M/#01187,,M/#01187,,,,,
41,1,,172176-46400,,,"BRACKET,1,1,,,,,W,,,M/#01187,,M/#01187,,,,,
42,2,,172141-41360,,,"BUSH 1415",2,2,,,,,W,,,M/#01187,,M/#01187,,,,,
43,1,,172176-46450,,,"PADAL ASSY, LOW-HIGH",1,1,,,,,W,,,M/#01187,,M/#01187,,,,,
44,1,,172176-46480,,,"LINK,1,1,,,,,W,,,M/#01187,,M/#01187,,,,,
45,1,,22351-050025,,,"SPRING PIN 5X25",1,1,,,,,W,,,M/#01187,,M/#01187,,,,,
46,1,,26716-060002,,,"NUT 6",1,1,,,,,W,,,M/#01187,,M/#01187,,,,,
47,1,,26911-060202,,,"SCREW M 6X 20",1,1,,,,,W,,,M/#01187,,M/#01187,,,,,

Fig. 31 操縦装置 (カットオフレバー&ローハイペダル)
CONTROL EQUIP. (CUT OFF LEVER & LOW-HIGH PEDAL)

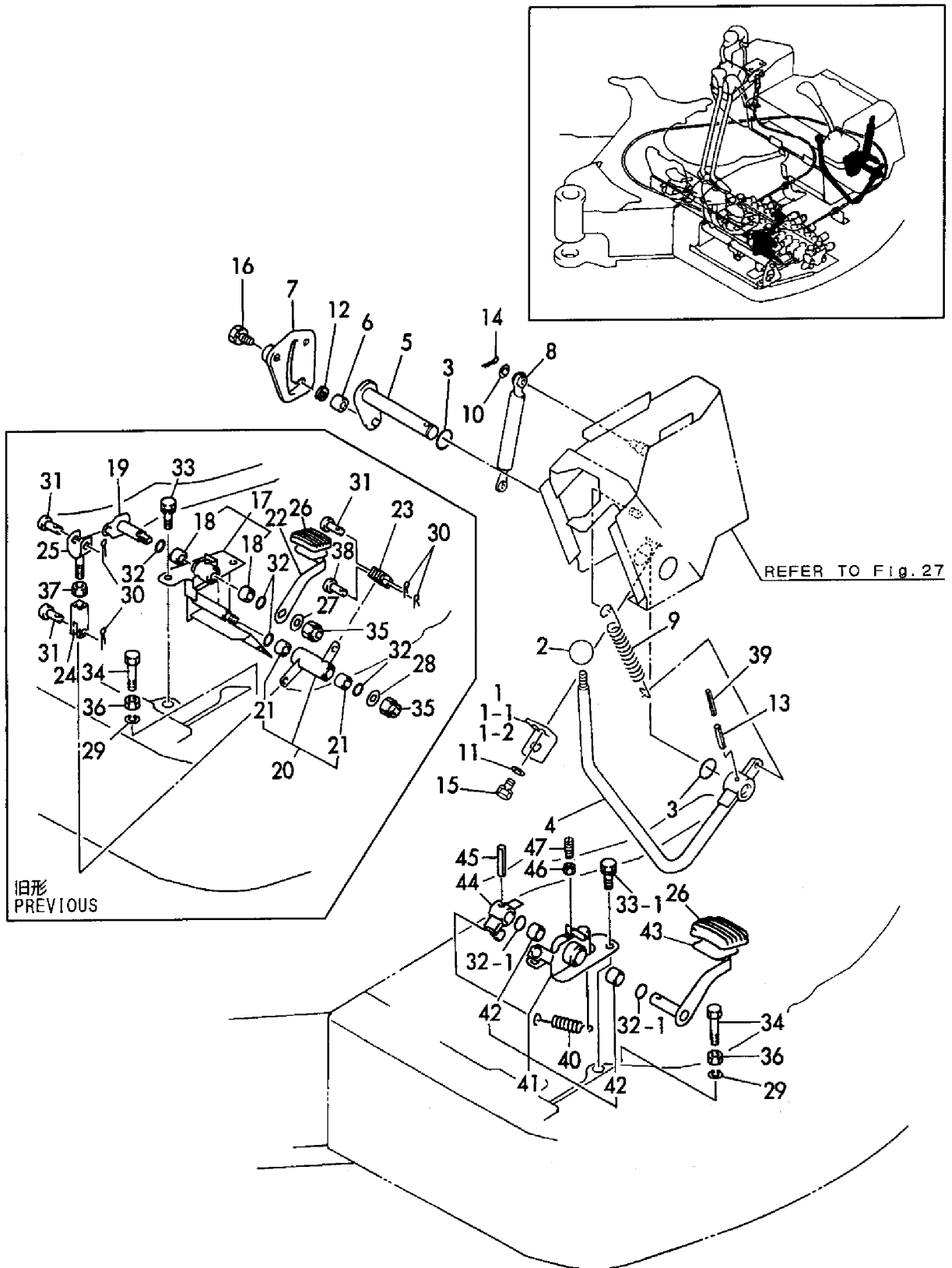

1,1,,172164-74500,, "P.T.O.KIT, FRAME END",1,1,,,,,,,,,,,,,,,,,
2,2,,933168-28480,, "WASHER 20X9X3.2",1,1,,,,,,,,,,,,,,,,,
3,2,,1C6141-35370,, "SPRING,LOCK",1,1,,,,,,,,,,,,,,,,,
4,2,,172141-42960,, "JOINT, CABLE",1,1,,,,,,,,,,,,,,,,,
5,2,,172164-46250,, "SUPPORT,CABLE",1,1,,,,,,,,,,,,,,,,,
6,2,,172165-45260,, CABLE(2300,1,1,,,,,,,,,,,,,,,,,
7,2,,172142-45670,, "ROD, SPOOL",1,1,,,,,,,,,,,,,,,,,
8,2,,172157-45990,, "BOOTS, PEDAL",1,1,,,,,,,,,,,,,,,,,
9,2,,172165-46281,, "PEDAL ASSY, SWING",1,1,,,,,,,,,,,,,,,,,
10,2,,172165-46340,, BOLT,2,2,,,,,,,,,,,,,,,,,
11,2,,172165-46350,, "BRACKET, PEDAL",1,1,,,,,,,,,,,,,,,,,
12,2,,172146-41910,, "PIN 14-100",1,1,,,,,,,,,,,,,,,,,
13,2,,172165-46450,, "LOCK CMP",1,1,,,,,,,,,,,,,,,,,
14,2,,172165-46480,, BOLT,1,1,,,,,,,,,,,,,,,,,
15,2,,172165-46490,, SHIM,5,5,,,,,,,,,,,,,,,,,
16,2,,172165-46500,, BRACKET,1,1,,,,,,,,,,,,,,,,,
17,2,,172122-46590,, "ELBALL 8",1,1,,,,,,,,,,,,,,,,,
18,2,,172165-46600,, "LINK, PEDAL",1,1,,,,,,,,,,,,,,,,,
19,3,,172141-41360,, "BUSH 1415",2,2,,,,,,,,,,,,,,,,,
21,2,,172165-46630,, PIN,1,1,,,,,,,,,,,,,,,,,
22,2,,22137-080000,, "WASHER 8, POLISHED",2,2,,,,,,,,,,,,,,,,,
23,2,,22137-100000,, "WASHER 10,POLISHED",2,2,,,,,,,,,,,,,,,,,
24,2,,22351-040032,, "SPRING PIN 4X32",1,1,,,,,,,,,,,,,,,,,
25,2,,22417-160160,, "COTTER PIN 1.6X16",1,1,,,,,,,,,,,,,,,,,
26,2,,24311-000210,, "O-RING 1A P-21.0",2,2,,,,,,,,,,,,,,,,,
27,2,,24761-050000,, "NIPPLE C,GREASE",1,1,,,,,,,,,,,,,,,,,
28,2,,26013-100202,, "BOLT W/WASHER M10X20",2,2,,,,,,,,,,,,,,,,,
29,2,,26013-100202,, "BOLT W/WASHER M10X20",1,1,,,,,,,,,,,,,,,,,
30,2,,26013-100202,, "BOLT W/WASHER M10X20",2,2,,,,,,,,,,,,,,,,,
31,2,,26013-100202,, "BOLT W/WASHER M10X20",2,2,,,,,,,,,,,,,,,,,
32,2,,26051-080002,, "NUT M 8",1,1,,,,,,,,,,,,,,,,,
33,2,,26116-080304,, "BOLT M 8X 30",2,2,,,,,,,,,,,,,,,,,
34,2,,26716-080002,, "NUT M 8",2,2,,,,,,,,,,,,,,,,,
35,2,,26756-080002,, "LOCK NUT M 8 PLATED",2,2,,,,,,,,,,,,,,,,,
35-1,2,,26716-080002,, "NUT M 8",2,2,,,,,R,,,"FROM 1ST",,"FROM 1ST",,,,,,
36,2,,933110-54100,, "PIN 4.75X14",1,1,,,,,,,,,,,,,,,,,
37,2,,172162-76140,, "ADAPTER 1/2-3/4",1,1,,,,,,,,,,,,,,,,,
38,2,,172164-76750,, "JOINT, 3RD",1,1,,,,,,,,,,,,,,,,,
39,2,,172112-77261,, "CONNECTOR PF1/2L-42",1,1,,,,,,,,,,,,,,,,,
40,3,,933152-24120,, "O-RING (B)",1,1,,,,,,,,,,,,,,,,,
41,2,,26013-100202,, "BOLT W/WASHER M10X20",2,2,,,,,,,,,,,,,,,,,
42,2,,172164-78800,, HOSE,2,2,,,,,,,,,,,,,,,,,
43,2,,172151-76600,, "ADAPTER PF3/4,BLIND",2,2,,,,,,,,,,,,,,,,,
44,2,,172142-76280,, "JOINT 3/4, SWIVEL",2,2,,,,,,,,,,,,,,,,,
44A,3,,172142-77050,, "SEAL SET",2,2,,,,,W,,M/#01719,,M/#01719,,,,,
45,2,,172164-76820,, "JOINT, 3RD",1,1,,,,,,,,,,,,,,,,,
46,2,,26013-100252,, "BOLT W/WASHER M10X25",2,2,,,,,,,,,,,,,,,,,
47,2,,172164-78760,, HOSE,1,1,,,,,,,,,,,,,,,,,
48,2,,172164-78770,, HOSE,1,1,,,,,,,,,,,,,,,,,
49,2,,172165-03230,, "LABEL, P.T.O.",1,1,,,,,,,,,,,,,,,,,
49-1,2,,172165-03231,, "LABEL, P.T.O.",1,1,,,,,N,,M/#01217,,M/#01217,,,,,
50,2,,172165-76320,, "CONNECTOR PF3/4 CMP",1,1,,,,,,,,,,,,,,,,,
51,3,,24315-000240,, "O-RING 1B P-24.0",1,1,,,,,,,,,,,,,,,,,
52,2,,23391-060000,, "JOINT RGI 3/4",1,1,,,,,,,,,,,,,,,,,
53,1,,172164-78960,, COVER,1,,,,,1,,,,,,,,,,,,,,,,,
54,1,,172151-79420,, COVER,1,,,,,1,,,,,,,,,,,,,,,,,
55,1,,23000-041000,, "CLAMP 41",4,,,,,1,,,,,,,,,,,,,,,,

Fig. 32 操縦装置 (PTOコントロール) CONTROL EQUIP. (P. T. O. CONTROL)

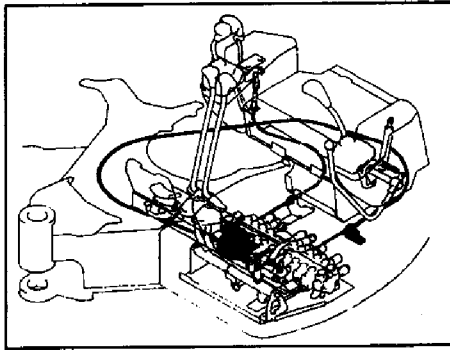

PTOキット (フレームエンド)
P. T. O. KIT (FRAME END)
(172164-74500)

見出しNo. 1は、見出しNo. 2から52を含みます。
1 inc. 2 ~ 52

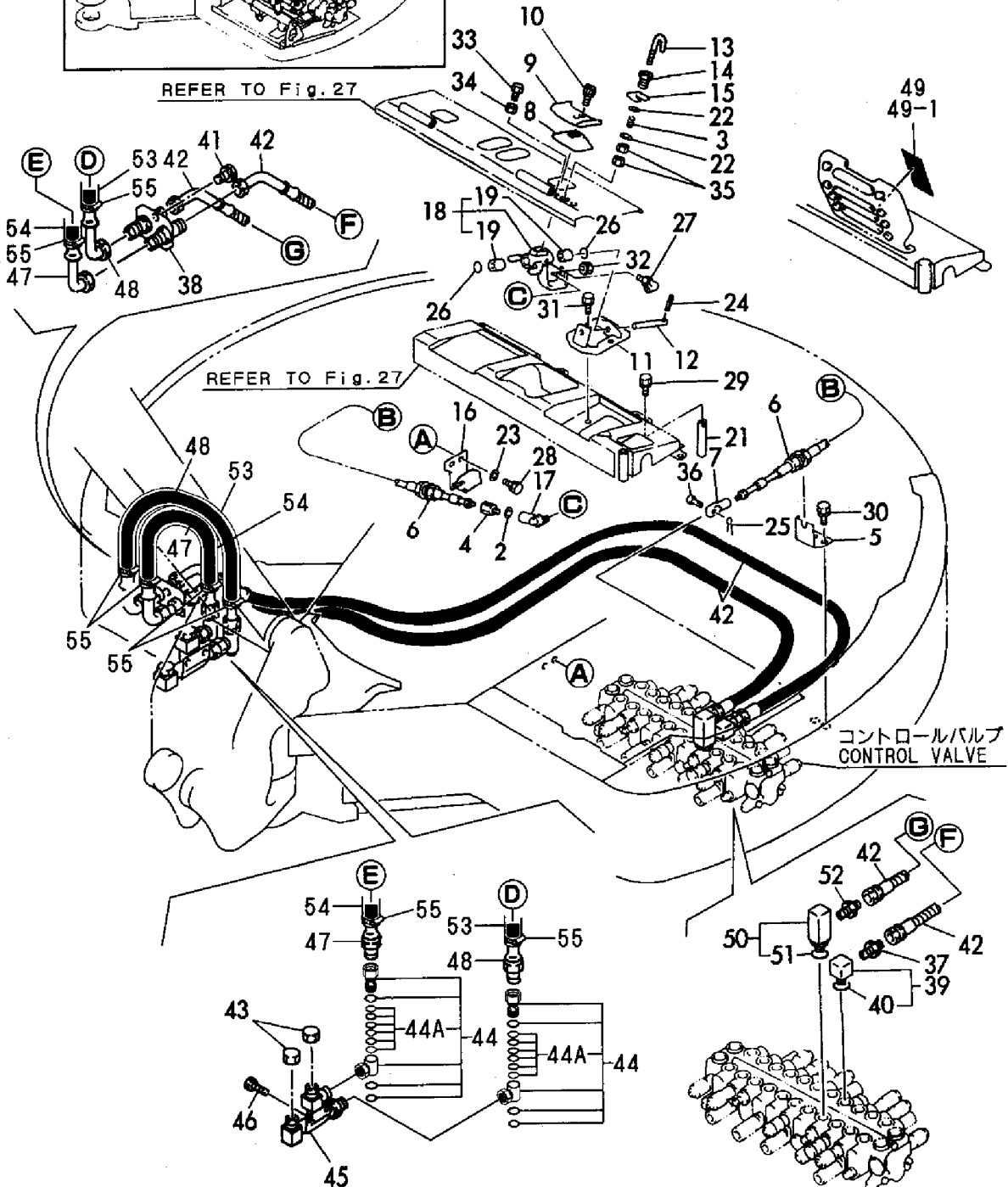

1,1,,26013-100252,, "BOLT W/WASHER M10X25",2,2,,,,,,,,,,,,,,,,,
2,1,,933168-28480,, "WASHER 20X9X3.2",1,1,,,,,,,,,,,,,,,,,
3,1,,26116-160202,, "BOLT M16X 20",1,1,,,,,,,,,,,,,,,,,
4,1,,172141-42960,, "JOINT, CABLE",1,1,,,,,,,,,,,,,,,,,
5,1,,172164-46250,, "SUPPORT,CABLE",1,1,,,,,,,,,,,,,,,,,
6,1,,172165-45260,, CABLE(2300,1,1,,,,,,,,,,,,,,,,,
7,1,,172142-45670,, "ROD, SPOOL",1,1,,,,,,,,,,,,,,,,,
8,1,,172157-45990,, "BOOTS, PEDAL",1,1,,,,,,,,,,,,,,,,,
9,1,,172165-46281,, "PEDAL ASSY, SWING",1,1,,,,,,,,,,,,,,,,,
10,1,,172165-46340,, BOLT,2,2,,,,,,,,,,,,,,,,,
11,1,,172165-46350,, "BRACKET, PEDAL",1,1,,,,,,,,,,,,,,,,,
12,1,,172146-41910,, "PIN 14-100",1,1,,,,,,,,,,,,,,,,,
13,1,,22137-160000,, "WASHER 16,POLISHED",1,1,,,,,,,,,,,,,,,,,
14,1,,172168-76130,, "CONNECTOR UN3/4PF3/8",1,1,,,,,,,,,,,,,,,,,
15,2,,933152-24120,, "O-RING (B)",1,1,,,,,,,,,,,,,,,,,
16,1,,172165-46500,, BRACKET,1,1,,,,,,,,,,,,,,,,,
17,1,,172122-46590,, "ELBALL 8",1,1,,,,,,,,,,,,,,,,,
18,1,,172165-46600,, "LINK, PEDAL",1,1,,,,,,,,,,,,,,,,,
19,2,,172141-41360,, "BUSH 1415",2,2,,,,,,,,,,,,,,,,,
21,1,,172165-46630,, PIN,1,1,,,,,,,,,,,,,,,,,
22,1,,172162-76140,, "ADAPTER 1/2-3/4",2,2,,,,,,,,,,,,,,,,,
23,1,,22137-100000,, "WASHER 10,POLISHED",2,2,,,,,,,,,,,,,,,,,
24,1,,22351-040032,, "SPRING PIN 4X32",1,1,,,,,,,,,,,,,,,,,
25,1,,22417-160160,, "COTTER PIN 1.6X16",1,1,,,,,,,,,,,,,,,,,
26,1,,24311-000210,, "O-RING 1A P-21.0",2,2,,,,,,,,,,,,,,,,,
27,1,,24761-050000,, "NIPPLE C,GREASE",1,1,,,,,,,,,,,,,,,,,
28,1,,26013-100202,, "BOLT W/WASHER M10X20",2,2,,,,,,,,,,,,,,,,,
29,1,,26013-100202,, "BOLT W/WASHER M10X20",1,1,,,,,,,,,,,,,,,,,
30,1,,26013-100202,, "BOLT W/WASHER M10X20",2,2,,,,,,,,,,,,,,,,,
31,1,,26013-100202,, "BOLT W/WASHER M10X20",2,2,,,,,,,,,,,,,,,,,
32,1,,26051-080002,, "NUT M 8",1,1,,,,,,,,,,,,,,,,,
33,1,,26116-080304,, "BOLT M 8X 30",2,2,,,,,,,,,,,,,,,,,
34,1,,26716-080002,, "NUT M 8",2,2,,,,,,,,,,,,,,,,,
35,1,,172183-78590,, "HOSE P206BB036",1,1,,,,,,,,,,,,,,,,,
36,1,,933110-54100,, "PIN 4.75X14",1,1,,,,,,,,,,,,,,,,,
37,1,,172164-78760,, HOSE,1,1,,,,,,,,,,,,,,,,,
38,1,,172164-76750,, "JOINT, 3RD",1,1,,,,,,,,,,,,,,,,,
39,1,,172112-77261,, "CONNECTOR PF1/2L-42",1,1,,,,,,,,,,,,,,,,,
40,2,,933152-24120,, "O-RING (B)",1,1,,,,,,,,,,,,,,,,,
41,1,,26013-100202,, "BOLT W/WASHER M10X20",2,2,,,,,,,,,,,,,,,,,
42,1,,172164-78800,, HOSE,2,2,,,,,,,,,,,,,,,,,
43,1,,172164-78770,, HOSE,1,1,,,,,,,,,,,,,,,,,
44,1,,172142-76280,, "JOINT 3/4, SWIVEL",2,2,,,,,,,,,,,,,,,,,
44A,2,,172142-77050,, "SEAL SET",2,2,,,,,W,,,M/#01719,,M/#01719,,,,,
45,1,,172164-76820,, "JOINT, 3RD",1,1,,,,,,,,,,,,,,,,,
46,1,,933166-24120,, "CONNECTOR PF1/2-10",1,1,,,,,,,,,,,,,,,,,
47,1,,933152-24120,, "O-RING (B)",1,1,,,,,,,,,,,,,,,,,
48,1,,933152-24410,, "CONNECTOR (A)",1,1,,,,,,,,,,,,,,,,,
49,1,,933169-24091,, CONNECTOR,1,1,,,,,,,,,,,,,,,,,
51,2,,933152-24120,, "O-RING (B)",1,1,,,,,,,,,,,,,,,,,

Fig. 33 操縦装置 (テレスコピックアーム)
CONTROL EQUIP. (TELESCOPIC ARM)

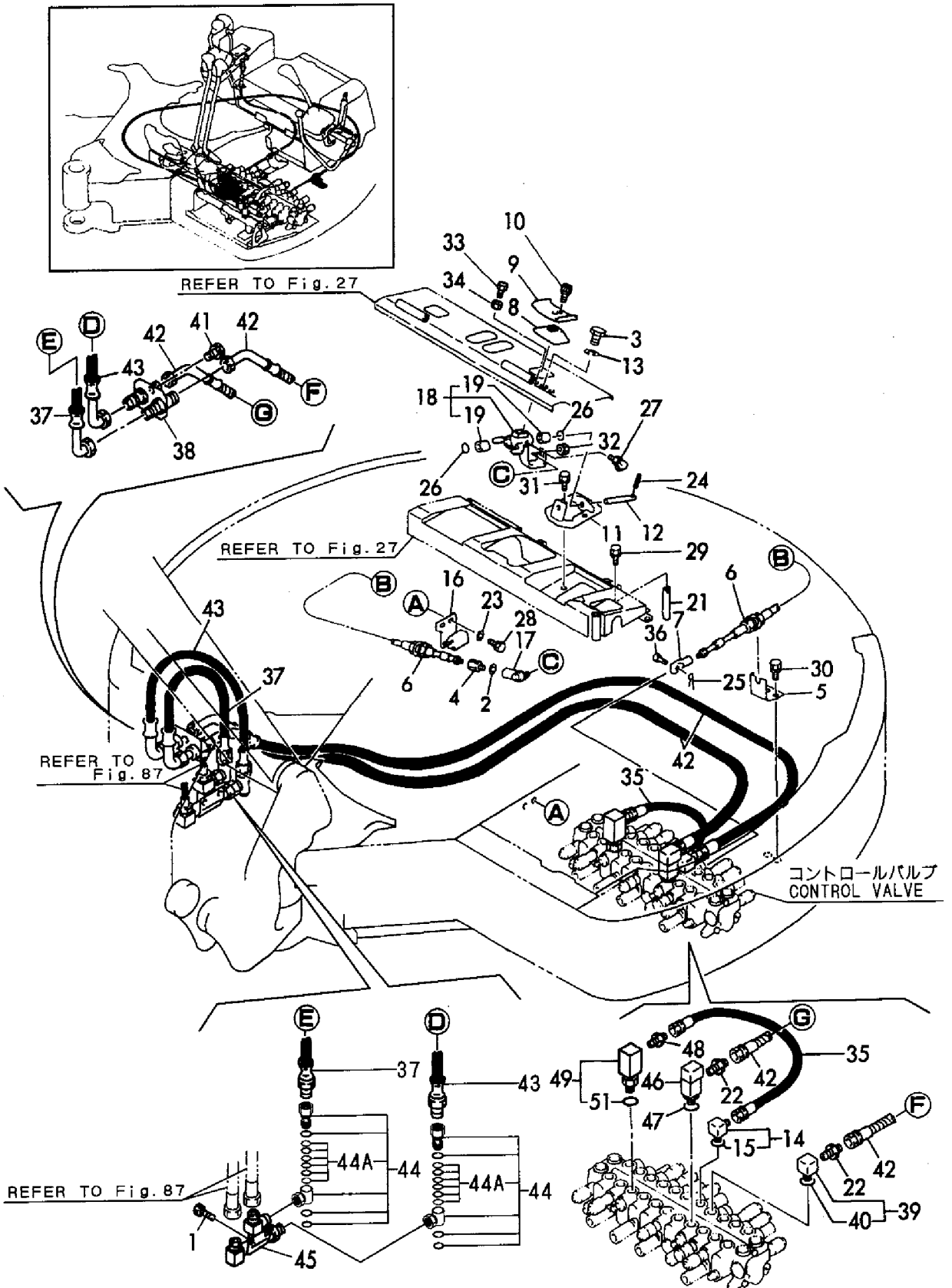

1,1,,172164-74520,, "P.T.O.KIT, JOIN",1,1,,,,,1,,,,,,,,,
1-1,1,,172164-74521,, "P.T.O.KIT, JOIN",1,1,,,,,N,1,,M/#01187,,M/#01187,,,,,
2,2,,194150-01190,, "KNOB, THROTTLE LEVER",1,1,,,,,,,,,
3,2,,172141-42960,, "JOINT, CABLE",2,2,,,,,,,,,
4,2,,1A1040-45890,, "WASHER 10 36 4.5",2,2,,,,,,,,,
5,2,,172312-45930,, "SPRING 13X1.2X70",1,1,,,,,,,,,
6,2,,172164-46100,, "CABLE, 3RD",1,1,,,,,,,,,
7,2,,172164-46110,, "BRACKET COMPL.",1,1,,,,,,,,,
8,2,,172164-46140,, "LINK, 3RD",1,1,,,,,,,,,
9,3,,172141-41370,, "BUSH 2015",2,2,,,,,,,,,
11,2,,172164-46160,, "BRACKET, CABLE",1,1,,,,,,,,,
12,2,,172164-46170,, "LINK COMPL.",1,1,,,,,,,,,
13,3,,172141-41370,, "BUSH 2015",2,2,,,,,,,,,
15,2,,172164-46190,, "LEVER, REGULATOR",1,1,,,,,,,,,
16,2,,172124-46200,, "O-RING 27X5.7",4,4,,,,,,,,,
17,2,,172164-46210,, "BRACKET COMPL.",1,1,,,,,,,,,
18,2,,172164-46260,, "LOD 70",1,1,,,,,,,,,
19,2,,172122-46590,, "ELBALL 8",3,3,,,,,,,,,
20,2,,22137-080000,, "WASHER 8, POLISHED",1,1,,,,,,,,,
21,2,,22217-100000,, "SPRING WASHER 10",2,2,,,,,,,,,
22,2,,22351-080020,, "SPRING PIN 8X20",1,1,,,,,,,,,
23,2,,22417-160160,, "COTTER PIN 1.6X16",1,1,,,,,,,,,
24,2,,24761-050000,, "NIPPLE C,GREASE",2,2,,,,,,,,,
25,2,,26013-100202,, "BOLT W/WASHER M10X20",3,3,,,,,,,,,
26,2,,26013-100202,, "BOLT W/WASHER M10X20",2,2,,,,,,,,,
27,2,,26013-100202,, "BOLT W/WASHER M10X20",2,2,,,,,,,,,
28,2,,26051-080002,, "NUT M 8",4,4,,,,,,,,,
29,2,,26116-100202,, "BOLT M10X 20 PLATED",2,2,,,,,,,,,
30,2,,933110-54100,, "PIN 4.75X14",1,1,,,,,,,,,
31,2,,933168-28480,, "WASHER 20X9X3.2",2,2,,,,,,,,,
32,2,,172168-03300,, "LABEL, SELECT",1,1,,,,,,,,,
32-1,2,,172168-03301,, "LABEL, SELECT",1,1,,,,,R,,M/#01217,,M/#01217,,,,,
33,2,,172164-63120,, "INSTRUMENT PANEL L",1,1,,,,,,,,,

Fig. 34 P.T.O. CONTROL

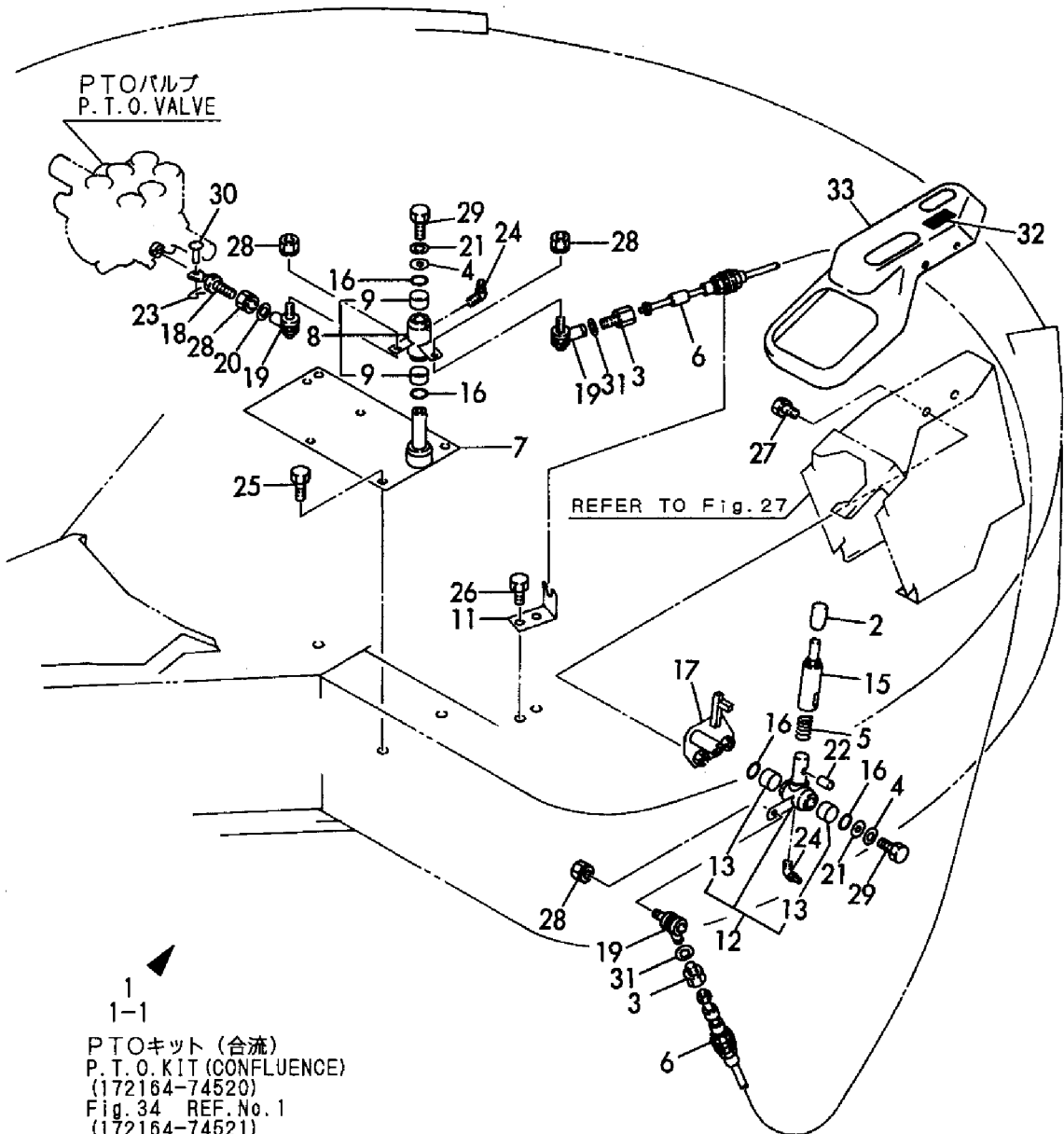

1
1-1
PTOキット (合流)
P. T. O. KIT (CONFLUENCE)
(172164-74520)
Fig. 34 REF.No.1
(172164-74521)
Fig. 34 REF.No.1-1
Inc. Fig. 34 REF.No.2 ~ 33
Fig. 70 REF.No.1 ~ 39
Fig. 83 REF.No.1 ~ 29

1,1,,172164-50101,, "FRAME, LOWER",1,1,,,,,,,,,,,,,
1-1,1,,172164-50102,, "FRAME, LOWER",1,1,,,,,N,,,M/#01187,,M/#01187,,,,,
1-2,1,,172164-50103,, "FRAME, LOWER",1,1,,,,,N,,,M/#01427,,M/#01427,,,,,
1-3,1,,172164-50104,, "FRAME ASSY, LOWER",1,1,,,,,S,,,M/#02029,,M/#02029,,,,,
2,1,,172148-50800-1,, "GUARD,CRAWLER",4,4,,,,,,,,,,,,,
3,1,,22217-160000,, "SPRING WASHER 16",12,12,,,,,,,,,,,,,
4,1,,26116-160452,, "BOLT M16X 45 PLATED",12,12,,,,,,,,,,,,,
5,1,,172164-53300,, "WEIGHT, CENTER",1,1,,,,,,,,,,,,,
6,1,,172165-53500,, "WASHER,2,2,,,,,,,,,,,,,
7,1,,22217-160000,, "SPRING WASHER 16",2,2,,,,,,,,,,,,,
8,1,,26076-160802,, "BOLT 10.9 16X80",2,2,,,,,,,,,,,,,
9,1,,172164-54101,, "FRAME, TURN.",1,1,,,,,,,,,,,,,
9-1,1,,172164-54102,, "FRAME, TURN.",1,1,,,,,S,,,M/#02029,,M/#02029,,,,,
10,1,,172164-54780,, "PLUG,RUBBER",1,1,,,,,,,,,,,,,
11,1,,172124-57600,, "BEARING,REVOLVE",1,1,,,,,,,,,,,,,
11-1,1,,172124-57601,, "BEARING,TURNING",1,1,,,,,R,,,M/#01300,,M/#01300,,,,,
11-2,1,,172124-57602,, "BEARING, TURNING",1,1,,,,,N,,,M/#02612,,M/#02612,,,,,
12,2,,172124-57620,, "SEAL, UPPER",1,1,,,,,,,,,,,,,
13,2,,172124-57630,, "SEAL, LOWER",1,1,,,,,,,,,,,,,
14,1,,172124-57610,, "BOLT M16X80",20,20,,,,,,,,,,,,,
15,1,,172122-57620,, "PARALLEL PIN 13X36",4,4,,,,,,,,,,,,,
16,1,,172162-57650,, "BOLT M16X90",20,20,,,,,,,,,,,,,
17,1,,172164-54870,, "TREE-CLIP,1,1,,,,,W,,,M/#00912,,M/#00912,,,,,
18,1,,172176-68210,, "TREE-CLIP,1,1,,,,,W,,,M/#00912,,M/#00912,,,,,
18-1,1,,172122-17190,, "CLIP,1,1,,,,,N,,,M/#01300,,M/#01300,,,,,
19,1,,172164-50400,, "WEIGHT, LOWER",2,2,,,,,1,,,,,,,,,
20,1,,22137-160000,, "WASHER 16,POLISHED",4,4,,,,,1,,,,,,,,,
21,1,,22217-160000,, "SPRING WASHER 16",4,4,,,,,1,,,,,,,,,
22,1,,26116-160302,, "BOLT M16X 30 PLATED",4,4,,,,,1,,,,,,,,,

Fig. 35 フレーム&旋回ベアリング FRAME & TURNING BEARING

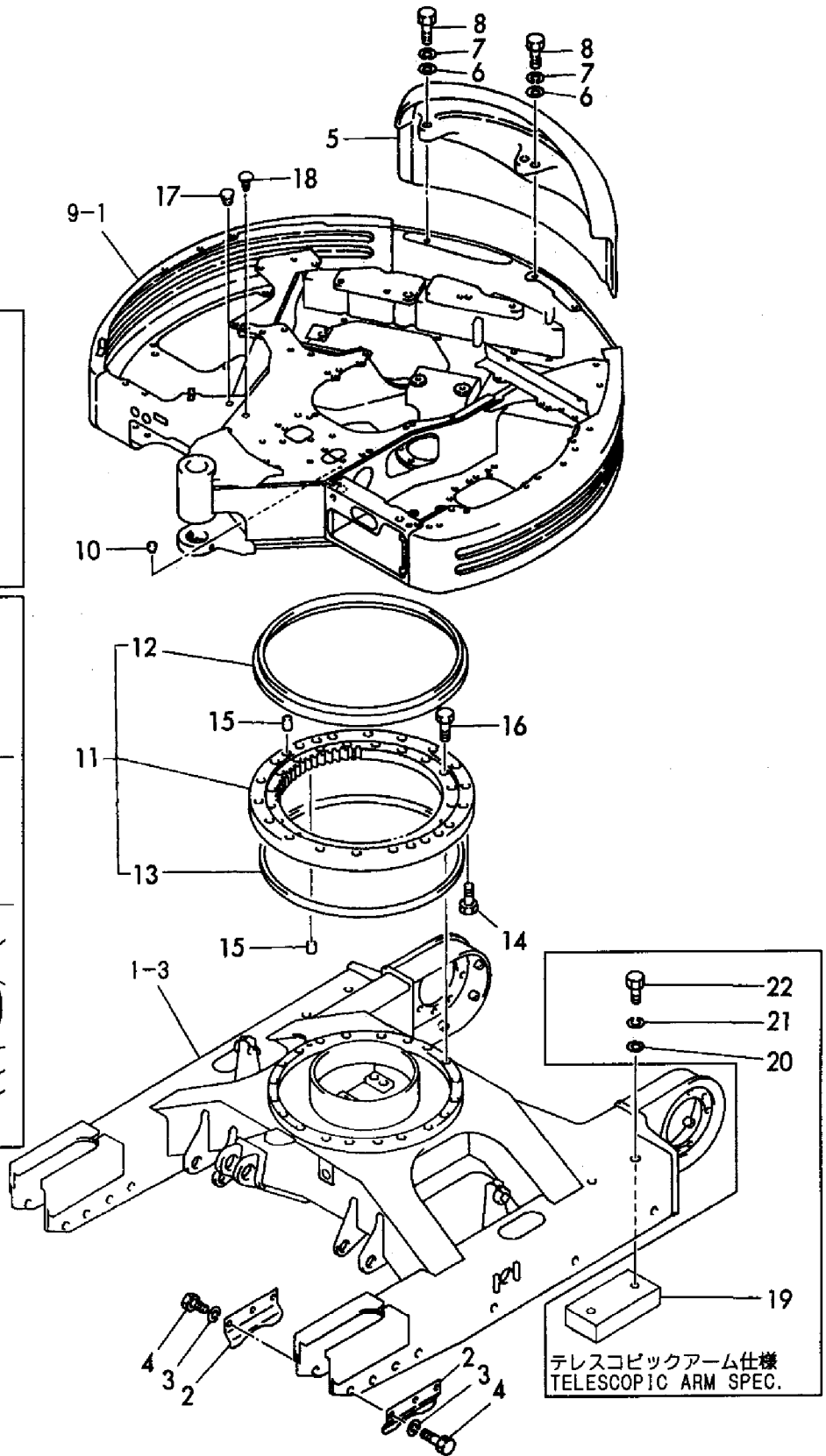
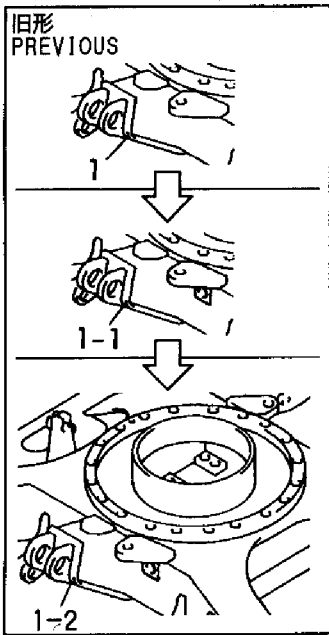
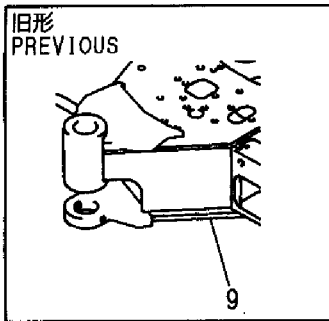

1,2,,172164-61690,,COVER,1,,,,,1,,,,,
2,2,,172164-61700,,COVER,1,,,,,1,,,,,
3,1,,172164-61150,, "COVER E",1,1,,,,,
4,1,,172164-61160,, "COVER,LAMP(GREEN:97)",1,1,,,,,
5,1,,172164-61181,, "COVER F",1,1,,,,,
6,1,,172164-61210,, "COVER (G)",,1,,,,,
7,1,,172164-61250,, "RUBBER, SEAL",1,1,,,,,
8,1,,172164-61260,,COVER,2,2,,,,,
9,1,,172164-61280,,COVER,1,1,,,,,
10,1,,172164-61300,, "COVER, FRONT",,1,,,,,
11,1,,172164-61341,,COVER,1,1,,,,,
11-1,1,,172164-61342,,COVER,1,1,,,,,N,,M/#01537,,M/#01537,,,,,
13,2,,172164-61350,, "COVER, ABSORBER",1,1,,,,,
14,1,,172164-61360,, "COVER (J)",1,1,,,,,
15,1,,172164-61370,, "COVER ASSY",1,1,,,,,
17,2,,172164-61380,, "COVER, ABSORBER",1,1,,,,,
18,2,,172164-61390,, "COVER, ABSORBER",1,1,,,,,
19,1,,172164-61400,, "COVER L COMPL.",,1,,,,,
19-1,1,,172164-61401,, "COVER L COMPL.",,1,,,,,R,,,,M/#00912,,,,,
20,1,,172147-61450,, "COVER, UNDER",1,1,,,,,
21,1,,172164-61481,,COVER(B),1,1,,,,,
22,2,,172164-61121,, "COVER (B)",1,1,,,,,
23,2,,172164-61460,, "COVER, ABSORBER",1,1,,,,,
24,1,,172164-61490,, "COVER, ABSORBER",1,1,,,,,
25,2,,172164-61130,,COVER(C),1,1,,,,,
26,2,,172164-61470,, "COVER, ABSORBER",1,1,,,,,
27,1,,172165-61660,, "COVER K",1,1,,,,,
28,1,,172519-63240,, "BOLT 8X 16",4,4,,,,,
29,1,,172519-63240,, "BOLT 8X 16",2,2,,,,,
30,1,,22217-100000,, "SPRING WASHER 10",8,8,,,,,
31,1,,22217-100000,, "SPRING WASHER 10",12,12,,,,,
32,1,,22217-100000,, "SPRING WASHER 10",4,4,,,,,
33,1,,22217-100000,, "SPRING WASHER 10",3,3,,,,,
34,1,,22217-100000,, "SPRING WASHER 10",5,5,,,,,
35,1,,22217-100000,, "SPRING WASHER 10",6,6,,,,,
36,1,,22217-100000,, "SPRING WASHER 10",2,2,,,,,
37,1,,26013-080162,, "BOLT W/WASHER M8X16",2,2,,,,,
38,1,,22217-100000,, "SPRING WASHER 10",1,1,,,,,
39,1,,22217-100000,, "SPRING WASHER 10",,4,,,,,
40,1,,22217-100000,, "SPRING WASHER 10",2,2,,,,,
41,1,,22217-120000,, "SPRING WASHER",6,6,,,,,
42,1,,26116-100202,, "BOLT M10X 20 PLATED",2,2,,,,,
43,1,,26116-100202,, "BOLT M10X 20 PLATED",5,5,,,,,
44,1,,26116-100202,, "BOLT M10X 20 PLATED",4,4,,,,,
45,1,,26116-100202,, "BOLT M10X 20 PLATED",3,3,,,,,
46,1,,26116-100202,, "BOLT M10X 20 PLATED",5,5,,,,,
47,1,,26116-100202,, "BOLT M10X 20 PLATED",6,6,,,,,
48,1,,26116-100202,, "BOLT M10X 20 PLATED",2,2,,,,,
49,1,,172519-63240,, "BOLT 8X 16",4,4,,,,,
50,1,,26116-100202,, "BOLT M10X 20 PLATED",1,1,,,,,
51,1,,26116-100202,, "BOLT M10X 20 PLATED",12,12,,,,,
52,1,,26116-100252,, "BOLT M10X 25 PLATED",,4,,,,,
53,1,,26116-120302,, "BOLT M12X 30 PLATED",,2,,,,,
54,1,,26116-120252,, "BOLT M12X 25 PLATED",6,6,,,,,
55,1,,172519-63240,, "BOLT 8X 16",4,4,,,,,
56,1,,172164-61510,, "COVER, HEATER",1,,,,,
57,1,,172164-61530,,SPONGE,1,1,,,,,
58,1,,26116-100162,, "BOLT M10X 16 PLATED",3,3,,,,,
59,1,,172176-68210,,TREE-CLIP,2,,,,,
60,1,,172176-61100,, "EV, TURNING",1,,,,,W,,M/#00501,,,,,
61,1,,172176-61180,, "COVER ASSY",1,,,,,W,,M/#00501,,,,,
62,1,,172732-11510,,GROMMET,1,,,,,W,,M/#00501,,,,,
63,1,,172164-61101,,COVER,1,1,,,,,

64,1,,172164-61140,, "COVER (D)",1,1,,,,,,,,,,,,,,,,,,,,,

Fig. 36 フレームカバー FRAME COVER

クーラーキット

COOLER KIT
(172164-08100)

Fig. 11 REF. No. 1

Inc. Fig. 11 REF. No. 2 ~ 29

Fig. 12 REF. No. 1 ~ 5

Fig. 13 REF. No. 1 ~ 62

Fig. 14 REF. No. 1 ~ 49

Fig. 20 REF. No. 1 ~ 11

Fig. 36 REF. No. 1, 2

Fig. 38 REF. No. 1

Fig. 39 REF. No. 1 ~ 5

Fig. 40 REF. No. 1 ~ 9

Fig. 41 REF. No. 18B, 23, 24, 52 ~ 54

Fig. 43 REF. No. 16B, 22B, 23B, 34

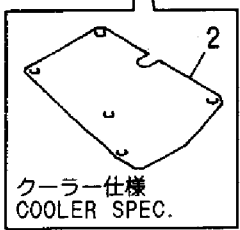
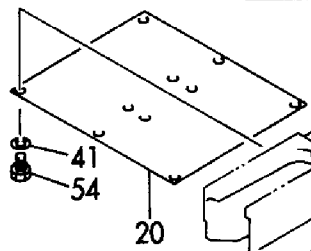
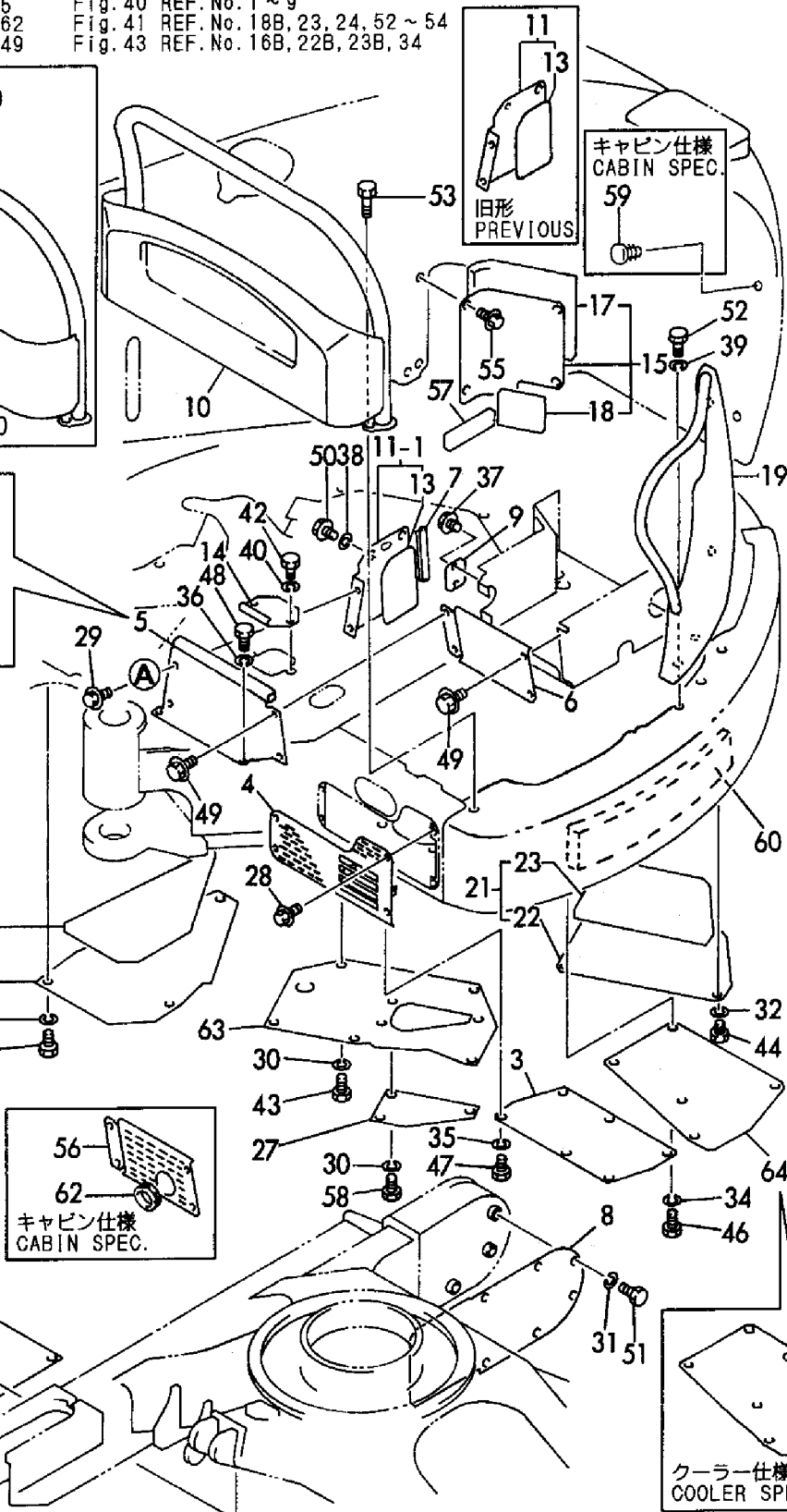
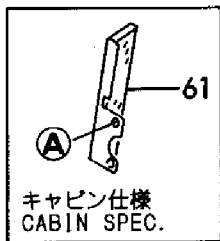
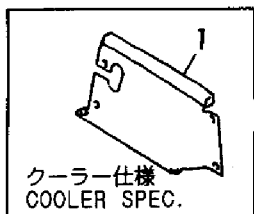
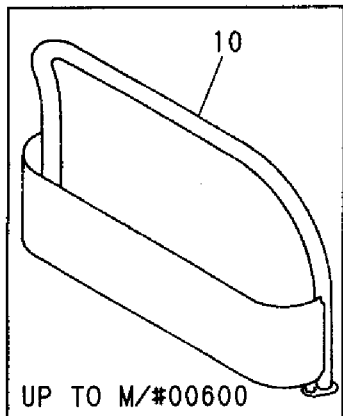

1,1,,194300-21460,,CAP,1,1,,,,,,,,,,,,,
2,1,,172164-63100,, "PANEL(L), INSTRUMENT",1,1,,,,,,,,,,,,,
3,1,,172164-63111,, "PANEL(R), INST(SI",1,1,,,,,,,,,,,,,
4,1,,172164-63150,, "SEAL, PANEL",1,1,,,,,,,,,,,,,
5,1,,172519-63240,, "BOLT 8X 16",16,16,,,,,,,,,,,,,
6,1,,172165-63600,, "COVER (R)",1,1,,,,,,,,,,,,,
7,1,,172165-63620,, "COVER (L)",1,1,,,,,,,,,,,,,
8,1,,172165-63650,, "PLUG 10,HOLE",1,1,,,,,,,,,,,,,
9,1,,172165-63660,,CAP,1,1,,,,,,,,,,,,,
9-1,1,,172165-63660,,CAP,2,2,,,,,K,,,,M/#01537,,M/#01537,,,,,
10,1,,172162-64200,, "SEAT, OPERATOR",1,1,,,,,,,,,,,,,
11,2,,172162-64210,, "CUSHION ASSY",1,1,,,,,,,,,,,,,
12,2,,172162-64220,, "BACK ASSY",1,1,,,,,,,,,,,,,
13,2,,172162-64230,, "BACK (B) ASSY",1,1,,,,,,,,,,,,,
14,2,,172162-64240,, "PANEL, BACK",1,1,,,,,,,,,,,,,
15,3,,172162-64320,, "RUBBER A, EDGE",1,1,,,,,,,,,,,,,
16,3,,172162-64330,, "RUBBER B, EDGE",1,1,,,,,,,,,,,,,
17,2,,172162-64250,, "BRACKET L, SIDE",1,1,,,,,,,,,,,,,
18,2,,172162-64260,, "BRACKET R, SIDE",1,1,,,,,,,,,,,,,
19,2,,172162-64270,,ADJUSTER,1,1,,,,,,,,,,,,,
20,2,,172162-64280,,ADJUSTER,1,1,,,,,,,,,,,,,
23,2,,172162-64310,, "SCREW M5X10, TAPPING",3,3,,,,,,,,,,,,,
24,2,,26013-080202,, "BOLT W/WASHER M8X20",8,8,,,,,,,,,,,,,
25,2,,26022-080162,, "SCREW M 8X 16",4,4,,,,,,,,,,,,,
26,1,,172212-61230,, "FASTENER, DIAL",1,1,,,,,,,,,,,,,
27,1,,172164-64190,, "MOUNT, SEAT",1,1,,,,,,,,,,,,,
28,1,,172164-64350,, "COVER, MOUNT",1,1,,,,,,,,,,,,,
29,1,,172164-64370,, "PLATE, SEAT",1,1,,,,,,,,,,,,,
30,1,,22217-080000,, "SPRING WASHER 8",4,4,,,,,,,,,,,,,
31,1,,26013-100202,, "BOLT W/WASHER M10X20",4,4,,,,,,,,,,,,,
32,1,,26013-100202,, "BOLT W/WASHER M10X20",4,4,,,,,,,,,,,,,
33,1,,26577-050122,, "SCREW M 5X 12",2,2,,,,,,,,,,,,,
34,1,,26716-050002,, "NUT M 5",2,2,,,,,,,,,,,,,
35,1,,26716-080002,, "NUT M 8",4,4,,,,,,,,,,,,,
36,1,,172165-64750,, "CAP 8, SCREW",4,4,,,,,,,,,,,,,
37,1,,22137-080000,, "WASHER 8, POLISHED",4,4,,,,,,,,,,,,,
38,1,,22217-080000,, "SPRING WASHER 8",4,4,,,,,,,,,,,,,
39,1,,26716-080002,, "NUT M 8",4,4,,,,,,,,,,,,,
40,1,,172164-63120,, "INSTRUMENT PANEL L",1,1,,,,,1,,,,,,,,,,,,,
41,1,,172176-61110,, ABSORBER,1,,,,,W,,,,M/#00501,,,,,

Fig. 37 シート & シートマウント SEAT & SEAT MOUNT

見出しNo. 10は、見出しNo. 11から25を含みます。
10 inc. 11 ~ 25

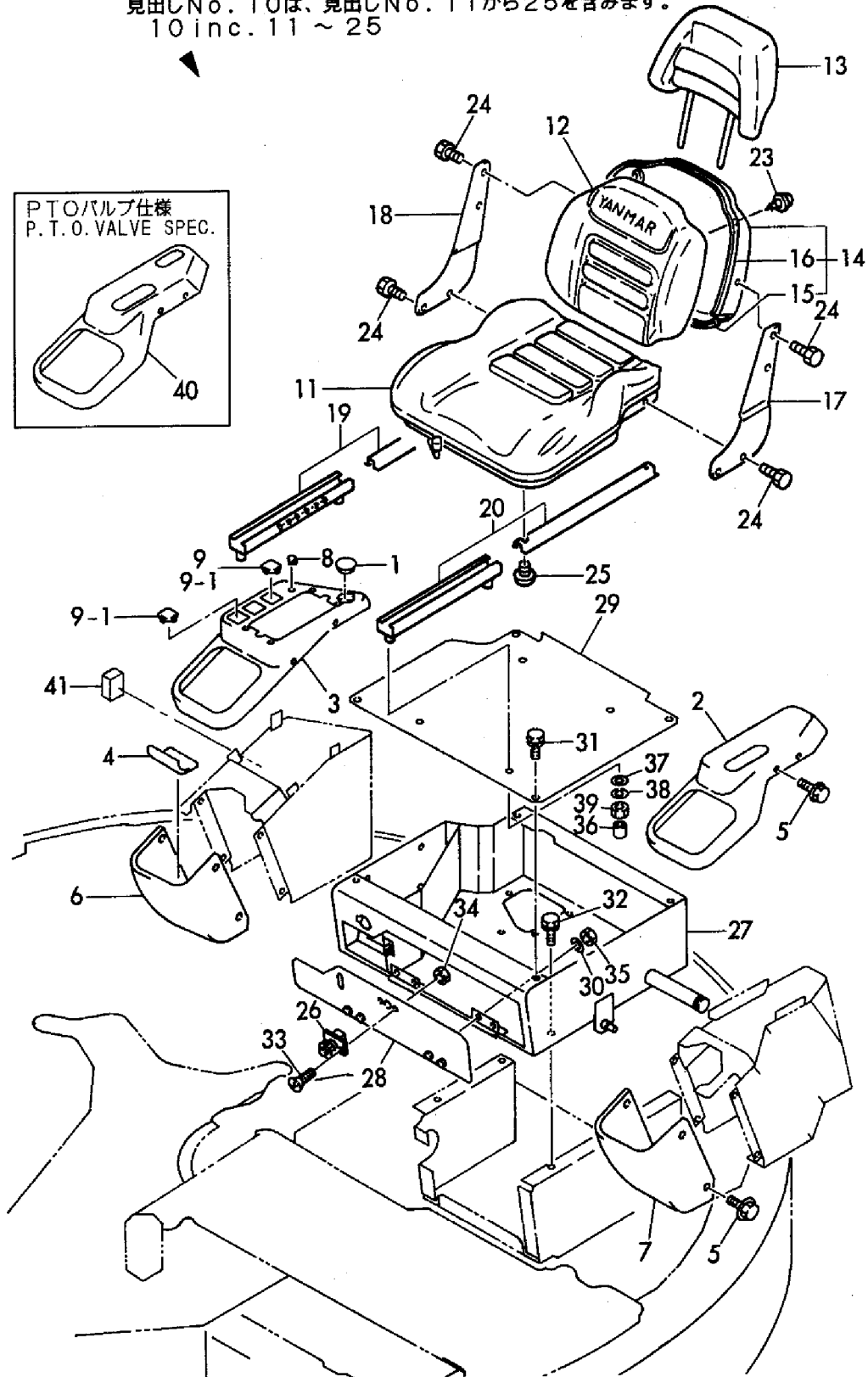
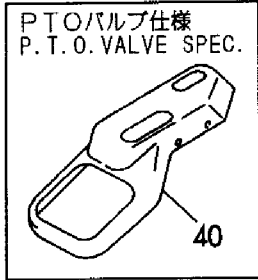

1,2,,172164-62600,,PLATE,1,,,,,2,,,,,
2,1,,172164-58800,, "LOCK PIN, TURN.",1,1,,,,,Z,,,M/#02113,,M/#02113,,,,,
3,1,,172164-58830,, "BRACKET, PIN",1,1,,,,,Z,,,M/#02113,,M/#02113,,,,,
4,1,,22217-100000,, "SPRING WASHER 10",2,2,,,,,Z,,,M/#02113,,M/#02113,,,,,
5,1,,26116-100202,, "BOLT M10X 20 PLATED",2,2,,,,,Z,,,M/#02113,,M/#02113,,,,,
6,1,,172164-62190,, "STEP C",1,1,,,,,
7,1,,172151-62240,,GROMMET,,3,,,,,
8,1,,172164-62300,, "MAT,FLOOR",1,1,,,,,
9,1,,172164-62310,, "BRACKET A",,1,,,,,
10,1,,172164-62340,, "PLATE B",1,1,,,,,
11,1,,172164-62370,,BRACKET,1,1,,,,,
12,1,,172164-62420,, "SHEET, FRAME",1,1,,,,,6,,,,,
13,1,,172164-62430,, "SEAT, SWING",1,1,,,,,
14,1,,172164-62450,, "STEP ASSY",1,1,,,,,
15,2,,172164-62270,,STEP,1,1,,,,,
16,2,,172164-62460,, "NOISE ABSORBER A",1,1,,,,,
17,2,,172164-62470,, "NOISE ABSORBER B",1,1,,,,,
18,2,,172164-62480,, "NOISE ABSORBER C",1,1,,,,,
19,1,,172164-62500,, "PLATE B, MULTI",1,1,,,,,1,,,,,
19-1,1,,172164-62501,, "PLATE B",1,1,,,,,S,4,,M/#01977,,M/#01977,,,,,
19-2,1,,172164-62502,, "PLATE B",,1,,,,,N,1,,M/#02619,,M/#02619,,,,,
20,1,,172164-62530,,COVER,1,1,,,,,1,,,,,
20-1,1,,172164-62531,,COVER,1,1,,,,,S,1,,M/#01977,,M/#01977,,,,,
21,1,,22217-100000,, "SPRING WASHER 10",2,2,,,,,1,,,,,
22,1,,26013-100202,, "BOLT W/WASHER M10X20",,3,,,,,
23,1,,26013-100202,, "BOLT W/WASHER M10X20",9,9,,,,,
24,1,,26013-100202,, "BOLT W/WASHER M10X20",4,4,,,,,
25,1,,26013-100202,, "BOLT W/WASHER M10X20",4,4,,,,,
26,1,,26013-100202,, "BOLT W/WASHER M10X20",3,3,,,,,
27,1,,26647-100152,, "WING BOLT M10X15",2,2,,,,,1,,,,,
28,1,,172164-62490,, "SEAT, STEP",,1,,,,,W,,,M/#00912,,,,,
29,1,,172116-46630,, "KNOB, LOCK LEVER",1,1,,,,,Z,,,M/#02113,,M/#02113,,,,,
30,1,,172164-62620,,PLATE,1,,,,,3,,,,,
30-1,1,,172164-62621,, "PLATE B",1,,,,,S,5,,M/#01977,,M/#01977,,,,,
30-2,1,,172164-62622,, "PLATE B",1,,,,,N,3,,M/#02619,,,,,

Fig. 38 ステップ STEP

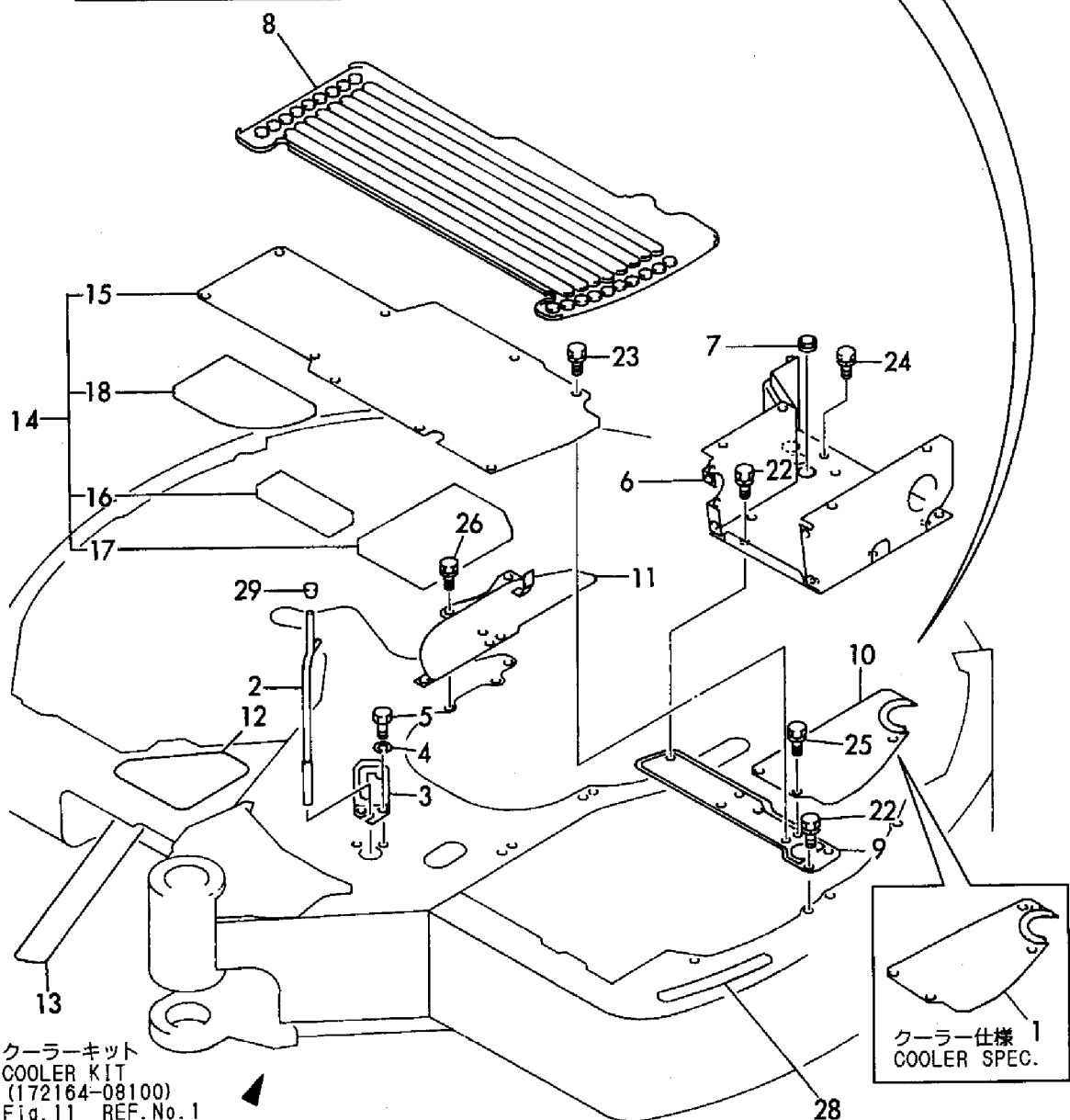
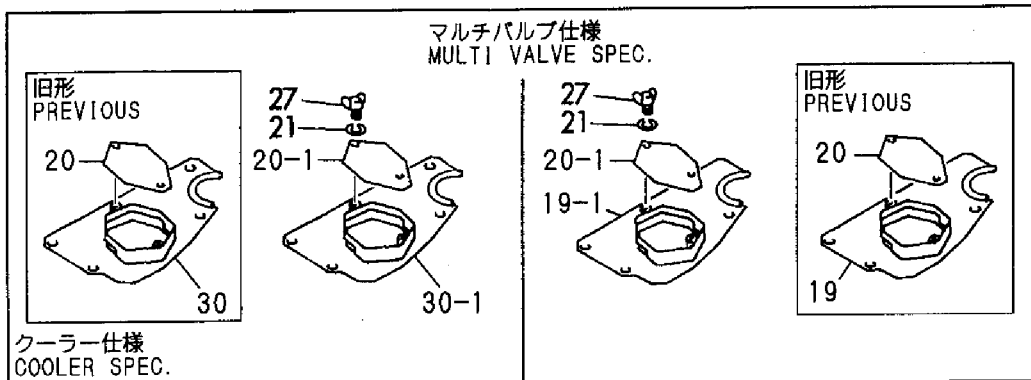

クーラーキット
COOLER KIT
(172164-09100)
Fig. 11 REF. No. 1
Inc. Fig. 11 REF. No. 2 ~ 29
Fig. 12 REF. No. 1 ~ 5
Fig. 13 REF. No. 1 ~ 62
Fig. 14 REF. No. 1 ~ 49
Fig. 20 REF. No. 1 ~ 11
Fig. 36 REF. No. 1, 2

Fig. 38 REF. No. 1
Fig. 39 REF. No. 1 ~ 5
Fig. 40 REF. No. 1 ~ 9
Fig. 41 REF. No. 18B, 23, 24, 52 ~ 54
Fig. 43 REF. No. 16B, 22B, 23B, 34

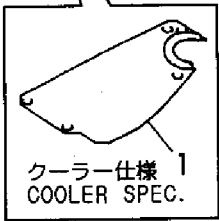

1,2,,194145-04810,, "WASHER 10",2,,,,,1,,,,,
2,2,,172164-66310,, "STOPPER, BONNET",1,,,,,1,,,,,
3,2,,172164-66320,, RUBBER,1,,,,,1,,,,,
4,2,,172164-66650,, "RUBBER, SEAL 95",1,,,,,1,,,,,
5,2,,26013-100202,, "BOLT W/WASHER M10X20",2,,,,,1,,,,,
6,1,,172168-46760,, "BOLT M10X20",1,1,,,,,
7,1,,26557-060102,, "SCREW 6X10",2,2,,,,,
8,1,,172164-65100,, "BONNET, ABSORBER",1,1,,,,,
10,2,,172164-65700,, "RUBBER, SEAL A",1,1,,,,,
11,2,,172164-65710,, "RUBBER, SEAL B",1,1,,,,,
12,2,,172164-65750,, "RUBBER, SEAL E",1,1,,,,,
13,2,,172164-65760,, "SEAL A",1,1,,,,,
14,2,,172164-65770,, SEAL,1,1,,,,,
15,2,,172164-65780,, SEAL,1,1,,,,,
16,2,,172164-65870,, "BONNET A, ABSORBER",1,1,,,,,
17,2,,172164-65880,, "BONNET B, ABSORBER",1,1,,,,,
18,2,,172164-65890,, "BONNET C, ABSORBER",1,1,,,,,
19,2,,172164-65900,, "BONNET D, ABSORBER",1,1,,,,,
20,2,,172164-66290,, "PAD, (RUBBER)",1,1,,,,,
21,1,,172734-65260,, "PIN, BONNET LEVER",1,1,,,,,
22,1,,172734-65270,, "SPRING, CATCH",1,1,,,,,
23,1,,172164-65280,, "LINK 165",2,2,,,,,
24,1,,172164-65291,, "LINK 110",2,2,,,,,
25,1,,172164-65300,, "COVER, ABSORBER",1,1,,,,,
26,2,,172164-61390,, "COVER, ABSORBER",1,1,,,,,
28,2,,172164-65720,, "RUBBER, SEAL C",1,1,,,,,
28-1,2,,172164-65721,, "RUBBER, SEAL C",1,1,,,,,R,,M/#01072,,M/#01072,,,,,
29,2,,172164-65740,, "RUBBER, SEAL E",1,1,,,,,
30,2,,172164-65760,, "SEAL A",1,1,,,,,
31,2,,172164-65770,, SEAL,1,1,,,,,
32,2,,172164-65780,, SEAL,1,1,,,,,
33,2,,172164-65910,, "BONNET COVER, ABSORB.",1,1,,,,,
34,2,,172164-65920,, "RUBBER, SEAL F",1,1,,,,,
35,2,,172164-65930,, "BONNET COVER, ABSORB.",1,1,,,,,
36,2,,172164-65940,, "BONNET COVER, ABSORB.",1,1,,,,,
37,2,,172164-66110,, "BONNET COVER, ABSORB.",1,1,,,,,
38,2,,172164-66620,, "RUBBER, SEAL 320",1,1,,,,,
39,1,,26557-080202,, "SCREW M 8X 20",2,2,,,,,
40,1,,172164-65450,, "SPRING, GAS",2,2,,,,,
41,1,,172164-65460,, "SEAL, DUCT",1,1,,,,,
42,1,,172124-65490,, "PLATE, CATCH",1,1,,,,,
43,1,,172164-65510,, COVER,1,1,,,,,
44,1,,172164-65560,, HINGE,1,1,,,,,
45,1,,172164-65580,, MOLDING,1,1,,,,,
46,1,,172164-65590,, PLATE,1,1,,,,,
47,1,,172164-65610,, COVER,1,1,,,,,
48,1,,172164-65640,, "WASHER 32X11X2.3",1,1,,,,,
49,1,,172164-65670,, "BRACKET COMPL.",1,1,,,,,
50,1,,172164-65801,, "HOOK COMP., KEY",1,1,,,,,
51,1,,172164-65840,, "LEVER, LOCK",1,1,,,,,
52,1,,172164-65860,, CATCHER,1,1,,,,,
53,1,,172164-66160,, "KEY ASSY, CYLINDER",1,1,,,,,
53-1,1,,172164-66161,, "KEY ASSY, CYLINDER",1,1,,,,,N,,M/#01123,,M/#01123,,,,,
53A,2,,172164-66131,, "PLATE, LOCK",1,1,,,,,W,,M/#01123,,M/#01123,,,,,
53B,2,,172164-66170,, "KEY ASSY, CYLINDER",1,1,,,,,W,,M/#01123,,M/#01123,,,,,
53C,2,,26347-100002,, "U-NUT M10",1,1,,,,,W,,M/#01123,,M/#01123,,,,,
54,1,,22137-060000,, "WASHER 6, POLISHED",2,2,,,,,
55,1,,22137-080000,, "WASHER 8, POLISHED",4,4,,,,,
56,1,,22137-080000,, "WASHER 8, POLISHED",4,4,,,,,
57,1,,22137-100000,, "WASHER 10, POLISHED",2,2,,,,,
58,1,,22157-100000,, "WASHER 10",3,3,,,,,
59,1,,22217-060000,, "SPRING WASHER 6",2,2,,,,,
60,1,,22217-060000,, "SPRING WASHER 6",2,2,,,,,

61,1,,22217-080000,, "SPRING WASHER 8",2,2,,,,,,,,,,,,,,,,,,,,,
62,1,,22217-080000,, "SPRING WASHER 8",4,4,,,,,,,,,,,,,,,,,,,,,
63,1,,22217-100000,, "SPRING WASHER 10",2,2,,,,,,,,,,,,,,,,,,,,,
64,1,,22217-100000,, "SPRING WASHER 10",8,8,,,,,,,,,,,,,,,,,,,,,
65,1,,22217-100000,, "SPRING WASHER 10",4,4,,,,,,,,,,,,,,,,,,,,,
66,1,,22417-200200,, "COTTER PIN 2.0X20",12,12,,,,,,,,,,,,,,,,,,,,,
66-1,1,,1C6281-52320,, "PIN 8,COME-OFF
SNAP",12,12,,,,,N,,,,M/#02625,,M/#02625,,,,,,
67,1,,22417-200200,, "COTTER PIN 2.0X20",2,2,,,,,,,,,,,,,,,,,,,,,
68,1,,22487-080300,, "PIN 8X 30",2,2,,,,,,,,,,,,,,,,,,,,,
69,1,,22487-100260,, "PIN 10X26",4,4,,,,,,,,,,,,,,,,,,,,,
70,1,,26013-100252,, "BOLT W/WASHER M10X25",3,3,,,,,,,,,,,,,,,,,,,,,
71,1,,26116-060122,, "BOLT 6X12",2,2,,,,,,,,,,,,,,,,,,,,,
72,1,,26116-080162,, "BOLT 8X16",4,4,,,,,,,,,,,,,,,,,,,,,
73,1,,26116-080202,, "BOLT M 8X 20 PLATED",2,2,,,,,,,,,,,,,,,,,,,,,
74,1,,26116-100252,, "BOLT M10X 25 PLATED",4,4,,,,,,,,,,,,,,,,,,,,,
75,1,,26116-100202,, "BOLT M10X 20 PLATED",2,2,,,,,,,,,,,,,,,,,,,,,
76,1,,26116-100202,, "BOLT M10X 20 PLATED",8,8,,,,,,,,,,,,,,,,,,,,,
77,1,,26557-060082,, "SCREW M 6X 8",2,2,,,,,,,,,,,,,,,,,,,,,
78,1,,22137-100000,, "WASHER 10,POLISHED",8,8,,,,,,,,,,,,,,,,,,,,,
79,1,,933110-00301,, "KEY ASSY",1,1,,,,,,,,,,,,,,,,,,,,,
80,1,,172164-66150,, "SPONGE, RUBBER",1,1,,,,,,,,,,,,,,,,,,,,,
81,1,,1A1040-43900,, "SPRING WASHER",2,2,,,,,,,,,,,,,,,,,,,,,
82,1,,1A1040-45890,, "WASHER 10 36 4.5",8,8,,,,,,,,,,,,,,,,,,,,,
83,1,,1A1040-45890,, "WASHER 10 36 4.5",4,4,,,,,,,,,,,,,,,,,,,,,
84,1,,172164-45980,, "GRIP, BONNET",1,1,,,,,,,,,,,,,,,,,,,,,

Fig. 39 ボンネット BONNET

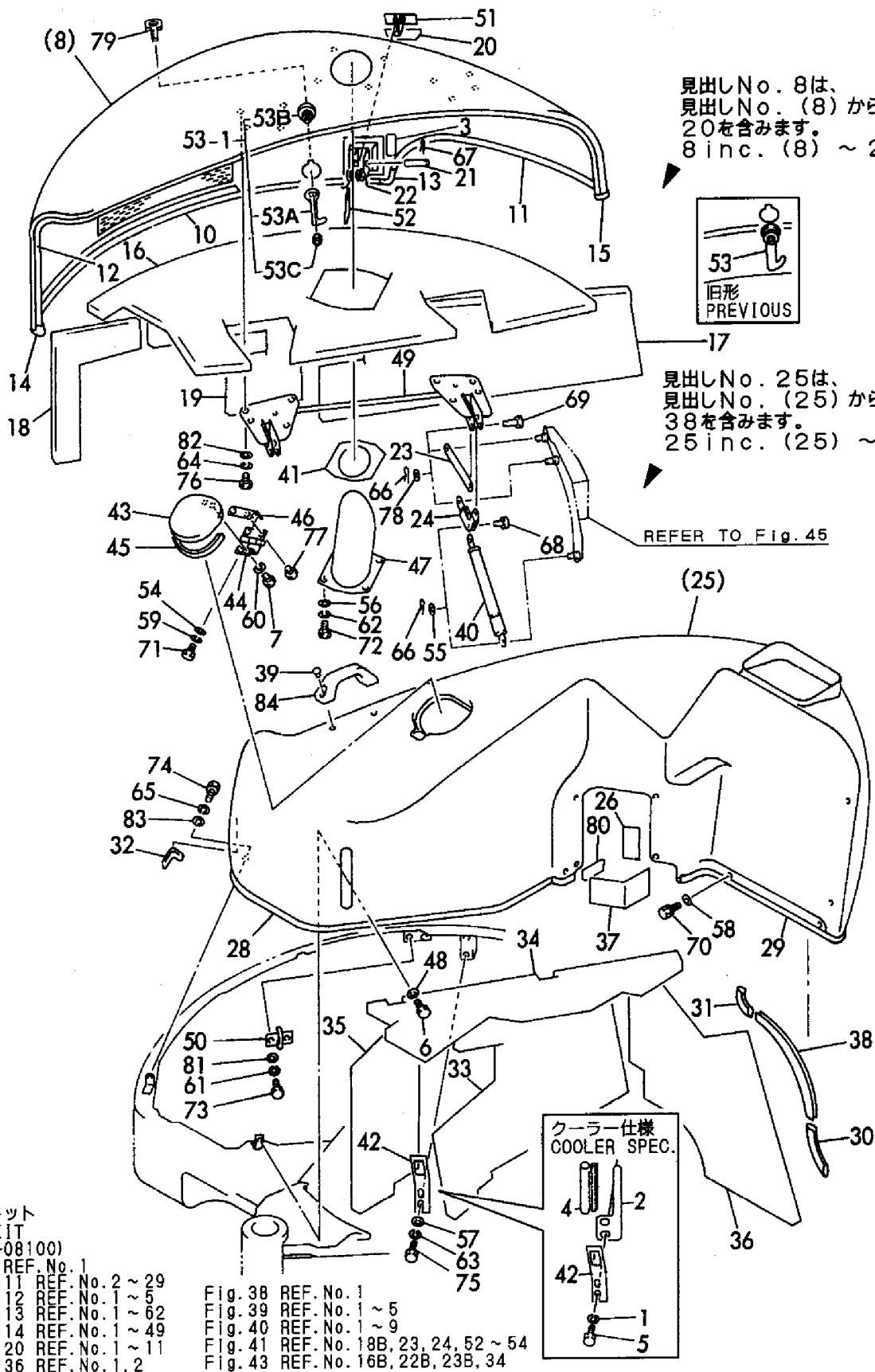

見出しNo. 8は、
見出しNo. (8) から
20を含みます。
8 inc. (8) ~ 20

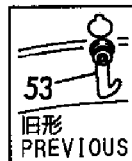

見出しNo. 25は、
見出しNo. (25) から
38を含みます。
25 inc. (25) ~ 38

REFER TO Fig. 45

- クーラーキット
COOLER KIT
(172164-08100)
Fig. 11 REF. No. 1
Inc. Fig. 11 REF. No. 2 ~ 29
Fig. 12 REF. No. 1 ~ 5
Fig. 13 REF. No. 1 ~ 62
Fig. 14 REF. No. 1 ~ 49
Fig. 20 REF. No. 1 ~ 11
Fig. 36 REF. No. 1, 2

- Fig. 38 REF. No. 1
Fig. 39 REF. No. 1 ~ 5
Fig. 40 REF. No. 1 ~ 9
Fig. 41 REF. No. 18B, 23, 24, 52 ~ 54
Fig. 43 REF. No. 16B, 22B, 23B, 34

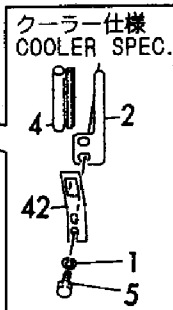

1,2,,172176-65750,, "DUCT (B) ASSY",1,,,,,1,,,,,
2,2,,172176-65790,, "DUCT (A) ASSY",1,,,,,1,,,,,
3,2,,26116-100162,, "BOLT M10X 16 PLATED",2,,,,,1,,,,,
4,2,,26116-100202,, "BOLT M10X 20 PLATED",2,,,,,1,,,,,
5,2,,22217-100000,, "SPRING WASHER 10",4,,,,,1,,,,,
6,2,,172176-65650,, "DUCT ASSY",1,,,,,1,,,,,
8,3,,172176-65700,, "EV, PLATE A",1,,,,,1,,,,,
9,3,,172176-65710,, "EV, PLATE B",1,,,,,1,,,,,
10,1,,172164-66600,, "SEAL (A)",1,1,,,,,
11,1,,172164-66620,, "RUBBER, SEAL 320",1,1,,,,,
12,1,,172164-66630,, "RUBBER, SEAL 530",1,1,,,,,
13,1,,172164-66640,, "RUBBER, SEAL 400",1,1,,,,,
14,1,,172164-66650,, "RUBBER, SEAL 95",1,1,,,,,
15,1,,172164-66680,, "PLATE",1,1,,,,,
16,1,,172164-66710,, "BRACKET ASSY",1,1,,,,,
17,1,,172164-66740,, "SEAL",1,1,,,,,
18,1,,172164-66800,, "RUBBER, SEAL 60",1,1,,,,,
19,1,,22137-100000,, "WASHER 10, POLISHED",1,1,,,,,
20,1,,22137-100000,, "WASHER 10, POLISHED",2,2,,,,,
21,1,,22137-100000,, "WASHER 10, POLISHED",2,2,,,,,
22,1,,22217-100000,, "SPRING WASHER 10",4,4,,,,,
23,1,,22217-100000,, "SPRING WASHER 10",4,4,,,,,
24,1,,22217-100000,, "SPRING WASHER 10",2,2,,,,,
25,1,,22217-100000,, "SPRING WASHER 10",2,2,,,,,
26,1,,22217-100000,, "SPRING WASHER 10",2,2,,,,,
27,1,,26116-100162,, "BOLT M10X 16 PLATED",4,4,,,,,
28,1,,26116-100162,, "BOLT M10X 16 PLATED",2,2,,,,,
29,1,,26116-100202,, "BOLT M10X 20 PLATED",4,4,,,,,
30,1,,26116-100202,, "BOLT M10X 20 PLATED",2,2,,,,,
31,1,,26116-100202,, "BOLT M10X 20 PLATED",2,2,,,,,
32,1,,172164-13660,, "SEAL(C), MOUNT R",1,1,,,,,
33,1,,172164-54760,, "SEAL A, FRAME",1,1,,,,,
34,1,,172164-54770,, "SEAL B, FRAME",1,1,,,,,
35,1,,172168-65790,, "RUBBER",1,1,,,,,
36,1,,172164-66440,, "DUCT A",1,1,,,,,
37,1,,172164-66480,, "RUBBER 340, SEAL",1,1,,,,,
38,1,,172164-66490,, "BRACKET, RESERVOIR",1,1,,,,,
39,1,,172164-66500,, "DUCT B",1,1,,,,,
40,2,,172164-66560,, "DUCT B, ABSORBER",1,1,,,,,

Fig. 40 ダクト DUCT

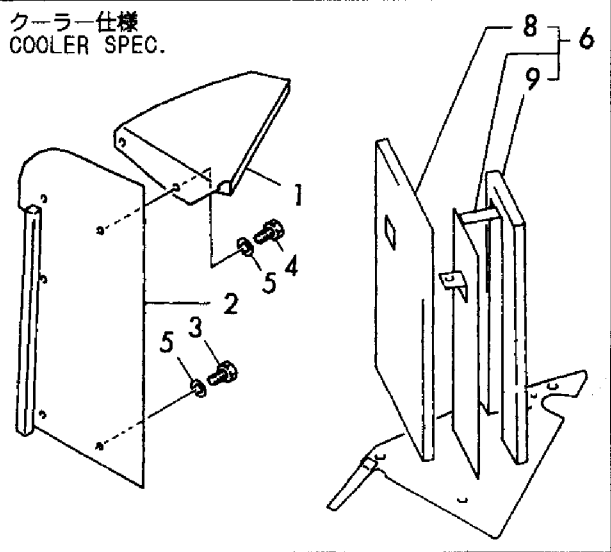
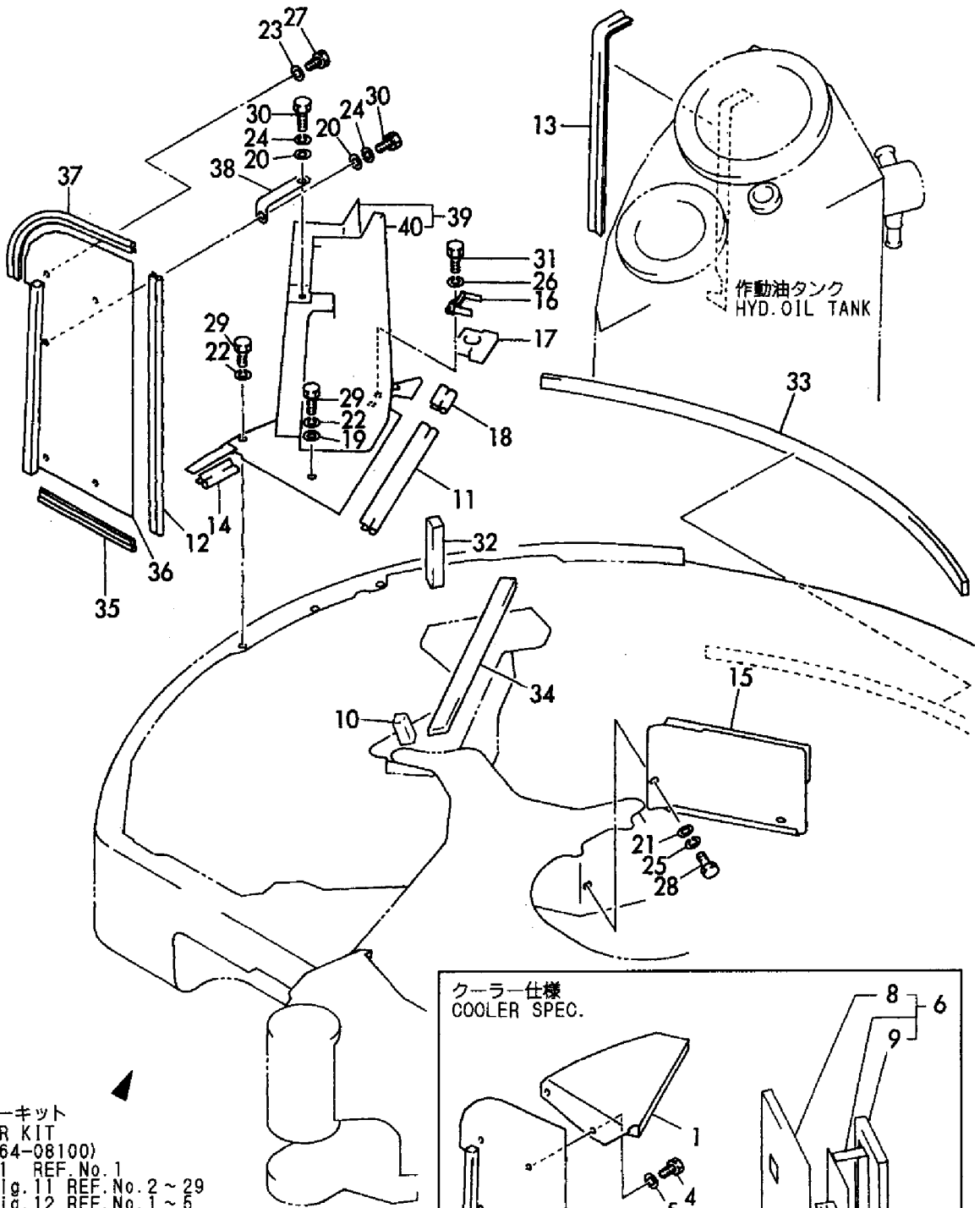

クーラーキット
COOLER KIT

(172164-08100)

Fig. 11 REF. No. 1

Inc. Fig. 11 REF. No. 2 ~ 29

Fig. 12 REF. No. 1 ~ 6

Fig. 13 REF. No. 1 ~ 62

Fig. 14 REF. No. 1 ~ 49

Fig. 20 REF. No. 1 ~ 11

Fig. 36 REF. No. 1, 2

Fig. 38 REF. No. 1

Fig. 39 REF. No. 1 ~ 5

Fig. 40 REF. No. 1 ~ 9

Fig. 41 REF. No. 18B, 23, 24, 52 ~ 54

Fig. 43 REF. No. 16B, 22B, 23B, 34

1A,1,,772176-68400,, "CABIN ASSY",1,,,,,1,,,,,
1A-1,1,,772425-68400-1,, "CABIN ASSY",1,,,,,S,1,M/#02612,,,,,
1B,1,,772164-68421,, "CABIN ASSY (CL)",1,,,,,2,,,,,
1B-1,1,,772425-68420-1,, "CABIN ASSY(CL)",1,,,,,S,2,M/#02612,,,,,
2,2,,172176-67040,, "COVER, LINK",1,,,,,
3,2,,172176-67180,, GRIP,2,,,,,
3-1,2,,172176-67181,, GRIP,2,,,,,N,,M/#01362,,,,,
4,2,,172137-68120,, PIN,2,,,,,
5,2,,172176-68400,, "CABIN ASSY",1,,,,,
5-1,2,,172176-68401,, "CABIN ASSY",1,,,,,F,3,M/#01251,,,,,
5-2,2,,172176-68402,, "CABIN ASSY",1,,,,,N,,M/#01873,,,,,
5-3,2,,172425-68400-1,, "CABIN ASSY",1,,,,,S,,M/#02612,,,,,
6,2,,172176-69300,, "SEAL (A)",1,,,,,
7,2,,172176-69310,, "SEAL (B)",1,,,,,
8,2,,172176-69320,, "SEAL,DOOR",1,,,,,
9,2,,172176-69890,, "LINK B",1,,,,,
10,2,,172111-16890,, "GROMMET 9",1,,,,,
10-1,2,,172176-67780,, GROMMET,1,,,,,S,,M/#02612,,,,,
11,2,,22137-080000,, "WASHER 8, POLISHED",2,,,,,
11-1,2,,22157-080000,, "WASHER 8",2,,,,,R,,M/#01041,,,,,
12,2,,22217-100000,, "SPRING WASHER 10",2,,,,,
13,2,,172176-67260,, "STAY, RADIO",2,,,,,
14,2,,26013-100252,, "BOLT W/WASHER M10X25",4,,,,,
14-1,2,,26013-100302,, "BOLT M10X 30",4,,,,,R,,M/#01041,,,,,
15,2,,26013-080162,, "BOLT W/WASHER M8X16",2,,,,,
16,2,,26013-080252,, "BOLT M 8X 25",2,,,,,
17,2,,26013-060162,, "BOLT M 6X 16",4,,,,,
18A,2,,26589-060162,, "SCREW M6,BINDING",4,,,,,4,,,,,
18B,2,,26589-060162,, "SCREW M6,BINDING",6,,,,,5,,,,,
19,2,,26716-100002,, "NUT 10",2,,,,,
20,2,,172176-67990,, "COVER ASSY,HARNESS",1,,,,,4,,,,,
21,3,,172176-68120,, "TRIM, HARNESS",1,,,,,4,,,,,
22,3,,172176-67910,, "COVER,HARNESS",1,,,,,4,,,,,
23,2,,172164-69250,, COVER,1,,,,,5,,,,,
24,2,,172164-69310,, TRIM,1,,,,,5,,,,,
25,2,,172176-67740,, "SHIM T=0.8",1,,,,,
25-1,2,,172176-67740,, "SHIM T=0.8",2,,,,,K,,M/#01041,,,,,
25-2,2,,172176-67740,, "SHIM T=0.8",5,,,,,K,,M/#01446,,,,,
26,2,,172176-67760,, "PANEL, FRONT",1,,,,,
27,2,,172176-67780,, GROMMET,1,,,,,
28,2,,172176-67790,, PLUG,2,,,,,
29,2,,172176-67820,, "SEAL, PLATE",1,,,,,
30,2,,172176-67830,, "BOLT 10X30",3,,,,,
30-1,2,,172176-67830,, "BOLT 10X30",2,,,,,K,,M/#01041,,,,,
31,2,,172176-67870,, TRAY,1,,,,,
32,2,,172176-67880,, HOLDER,1,,,,,
33,2,,172176-68160,, GROMMET,1,,,,,
34,2,,172176-68190,, "COVER, BONNET",1,,,,,
35,2,,26450-080202,, "BOLT M 8X 20",4,,,,,
36,2,,172176-67900,, "SEAL C",1,,,,,
37,2,,172176-68080,, "SEAL D",1,,,,,
37-1,2,,172176-68080,, "SEAL D",2,,,,,K,,M/#01041,,,,,
38,2,,26557-050162,, "SCREW M 5X 16",4,,,,,
38-1,2,,26022-050162,, "SCREW M 5X 16",4,,,,,R,,M/#01041,,,,,
39,2,,172176-68130,, "TRIM, PLATE",1,,,,,
39-1,2,,172176-68131,, TRIM,1,,,,,S,,M/#01251,,,,,
40,2,,172176-68030,, WASHER,2,,,,,
41,2,,172176-67341,, "LINK A",1,,,,,
42,2,,172162-69070,, COATHANGER,1,,,,,
42-1,2,,172162-69071,, COATHANGER,1,,,,,S,,M/#01651,,,,,
43,2,,22867-300080,, "SCREW 3X 8",2,,,,,
44,2,,172176-67741,, "SHIM T=1.2",1,,,,,
44-1,2,,172176-67741,, "SHIM T=1.2",2,,,,,K,,M/#01041,,,,,

44-2,2,,172176-67741,, "SHIM T=1.2",5,,,,,K,,,M/#01446,,,,,
45,2,,1A1686-52230,, "SCREW 6X16,PAN HD.MC",4,,,,,
45-1,2,,26022-060162,, "SCREW M 6X 16",4,,,,,R,,,M/#01041,,,,,
46,2,,172176-69780,,SEAL,1,,,,,W,,,M/#00883,,,,,
47,2,,172176-68090,,COLLAR,4,,,,,W,,,M/#01251,,,,,
48,2,,172176-68140,,CIRCLIP,4,,,,,W,,,M/#01251,,,,,
49,2,,22217-100000,, "SPRING WASHER 10",2,,,,,W,,,M/#01041,,,,,
49A,2,,172164-62490,, "SEAT, STEP",1,,,,,W,,,M/#01736,,,,,
50,2,,194145-04810,, "WASHER 10",6,,,,,W,,,M/#01041,,,,,
51,2,,172122-17190,,CLIP,1,,,,,W,,,M/#02612,,,,,
52,2,,172164-69200,,TRIM,1,,,,,5,,,,,
53,2,,172164-69290,, "COVER B",1,,,,,5,,,,,
54,2,,172164-69320,,TRIM,1,,,,,5,,,,,

Fig. 41 キャビン (1) (本体) CABIN (1) (BODY)

キャビンASSY (標準)
CABIN ASSY (STANDARD)
(772176-68400)

Fig. 41 REF. No. 1A
(772425-68400-1)
Fig. 41 REF. No. 1A-1
Inc. Fig. 41 REF. No. 2 ~ 51
Fig. 42 REF. No. 1 ~ 50
Fig. 43 REF. No. 1 ~ 35

キャビンASSY (クーラ仕様)
CABIN ASSY (COOLER SPEC.)
(772164-68421)

Fig. 41 REF. No. 1B
(772425-68420-1)
Fig. 41 REF. No. 1B-1
Inc. Fig. 41 REF. No. 2 ~ 54
Fig. 42 REF. No. 1 ~ 50
Fig. 43 REF. No. 1 ~ 35

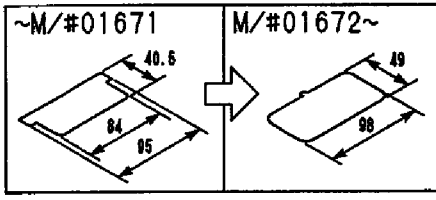
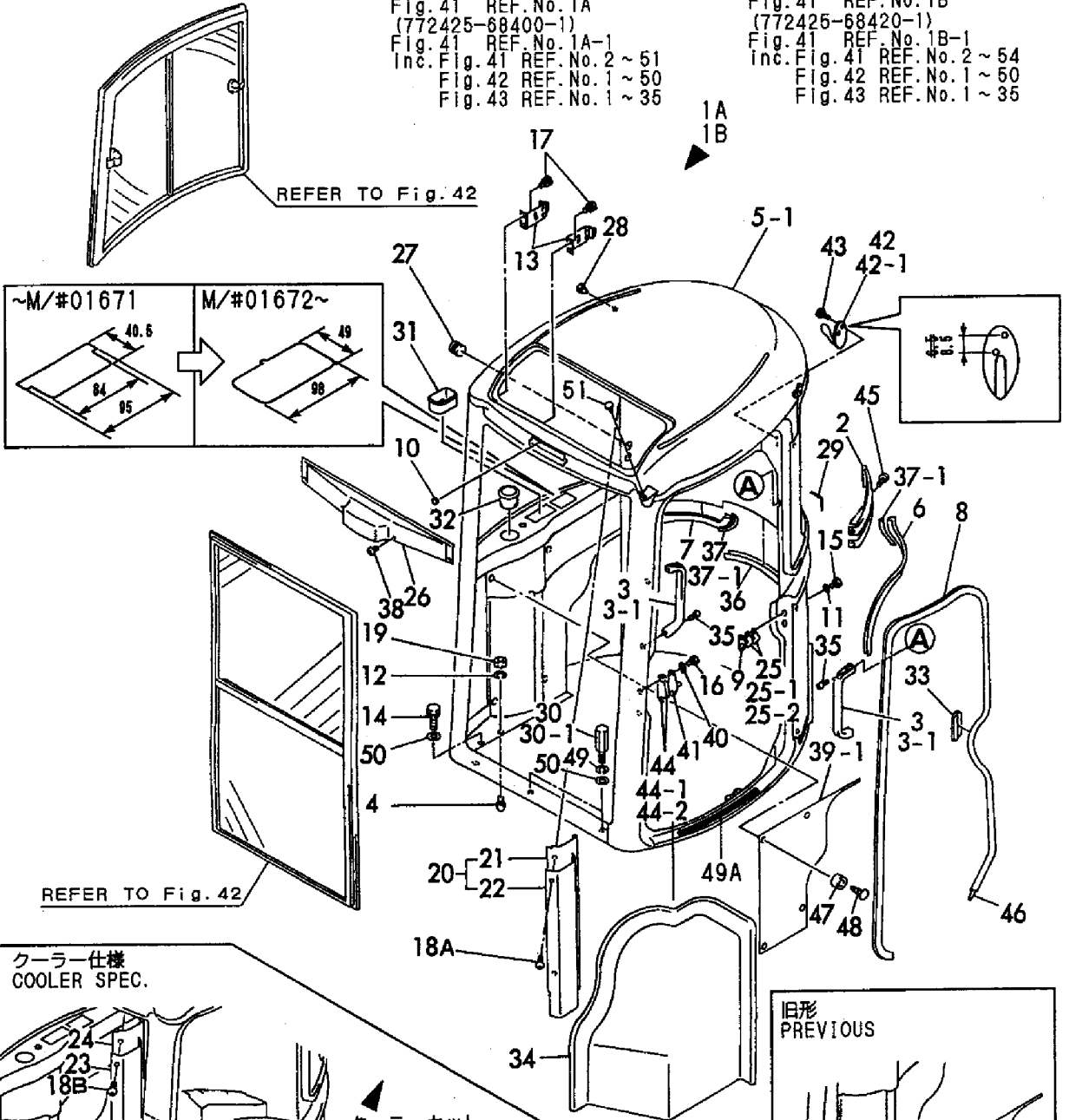

REFER TO Fig. 42

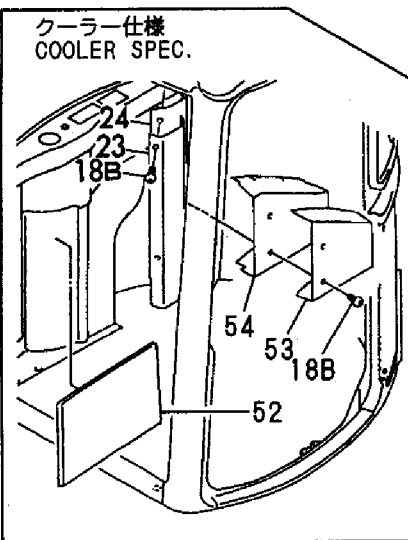

クーラーキット
COOLER KIT
(172164-08100)
Fig. 11 REF. No. 1
Inc. Fig. 11 REF. No. 2 ~ 29
Fig. 12 REF. No. 1 ~ 5
Fig. 13 REF. No. 1 ~ 62
Fig. 14 REF. No. 1 ~ 49
Fig. 20 REF. No. 1 ~ 11
Fig. 38 REF. No. 1, 2
Fig. 38 REF. No. 1
Fig. 39 REF. No. 1 ~ 5
Fig. 40 REF. No. 1 ~ 9
Fig. 41 REF. No. 18B, 23, 24, 52 ~ 54
Fig. 43 REF. No. 16B, 22B, 23B, 34

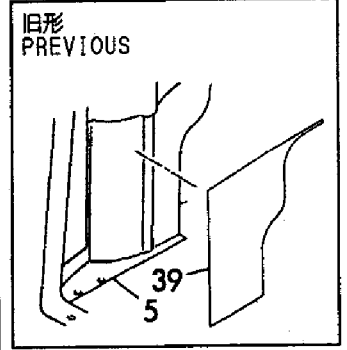

1,1,,172176-67050,,SASH,1,,,,,,,,,1,,,,,,,,,
2,2,,172176-66620,, "FRAME ASSY",1,,,,,,,,,
4,3,,172176-66760,, "GLASS RUN",1,,,,,,,,,
5,3,,172176-66770,, "GLASS RUN",1,,,,,,,,,
6,3,,172176-66780,, "RUBBER STOPPER",1,,,,,,,,,
7,3,,172176-66820,, "RUBBER STOPPER",1,,,,,,,,,
8,2,,172176-66800,,GLASS,1,,,,,,,,,
9,3,,172176-66600,,LOCK,1,,,,,,,,,
12,4,,172176-66750,,SCREW,2,,,,,,,,,
14,2,,172176-66810,,GLASS,1,,,,,,,,,
15,3,,172176-66610,,LOCK,1,,,,,,,,,
17,4,,172176-66750,,SCREW,2,,,,,,,,,
19,3,,172176-66790,, "CHANNEL, CENTER",1,,,,,,,,,
20,1,,172176-67060,, "WINDOW, FRONT",1,,,,,1,,,,,,,,,
21,2,,172176-66590,, "FRAME ASSY",1,,,,,,,,,
23,3,,172176-66890,, "GLASS RUN",1,,,,,,,,,
24,3,,172176-66990,, "GLASS RUN",1,,,,,,,,,
25,3,,172176-66900,, "RUBBER STOPPER",2,,,,,,,,,
26,2,,172176-66970,,GLASS,1,,,,,,,,,
27,3,,172176-66550,, "LOCK ASSY (LH)",1,,,,,,,,,
30,4,,172176-66950,,SCREW,2,,,,,,,,,
31,4,,172176-66960,,SCREW,1,,,,,,,,,
32,3,,172176-66560,,LOCK,1,,,,,,,,,
35,4,,172176-66950,,SCREW,2,,,,,,,,,
36,4,,172176-66960,,SCREW,1,,,,,,,,,
38,2,,172176-66980,,GLASS,1,,,,,,,,,
39,3,,172176-66570,,LOCK,1,,,,,,,,,
41,4,,172176-66930,,SCREW,2,,,,,,,,,
42,4,,172176-66940,,SCREW,1,,,,,,,,,
43,3,,172176-66580,, "LOCK (RL)",1,,,,,,,,,
45,4,,172176-66930,,SCREW,2,,,,,,,,,
46,4,,172176-66940,,SCREW,1,,,,,,,,,
48,3,,172176-66910,, "CHANNEL, CENTER",1,,,,,,,,,
49,1,,172176-67200,, "RUBBER, FRONT",1,,,,,1,,,,,,,,,
50,1,,172176-67210,, "RUBBER, SIDE",1,,,,,1,,,,,,,,,

Fig. 42 キャビン (2) (サッシ)
CABIN (2) (SASH)

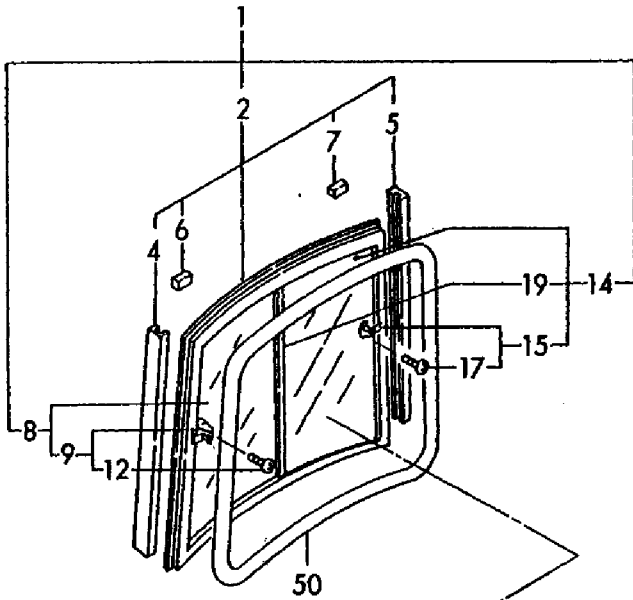

キャビンASSY (標準)
CABIN ASSY (STANDARD)
(772176-68400)
Fig. 41 REF. No. 1A
(772425-68400-1)
Fig. 41 REF. No. 1A-1
inc. Fig. 41 REF. No. 2 ~ 51
Fig. 42 REF. No. 1 ~ 50
Fig. 43 REF. No. 1 ~ 35
キャビンASSY (クーラ仕様)
CABIN ASSY (COOLER SPEC.)
(772164-68421)
Fig. 41 REF. No. 1B
(772425-68420-1)
Fig. 41 REF. No. 1B-1
inc. Fig. 41 REF. No. 2 ~ 54
Fig. 42 REF. No. 1 ~ 50
Fig. 43 REF. No. 1 ~ 35

REFER TO Fig. 35

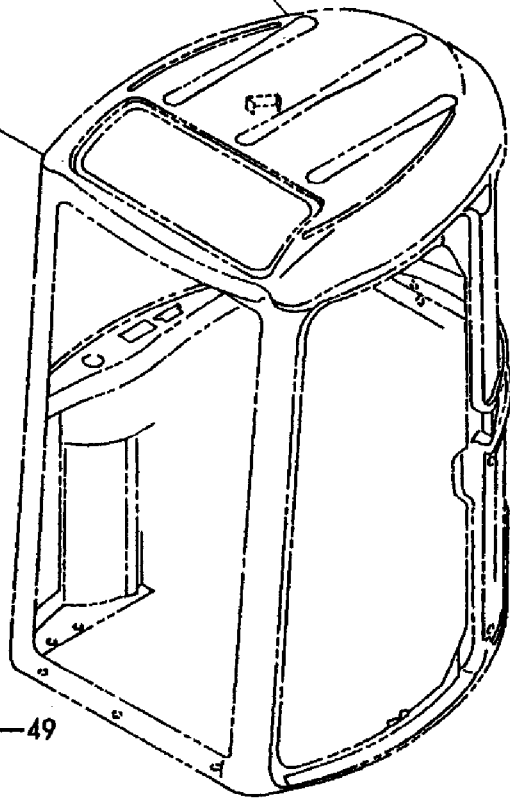
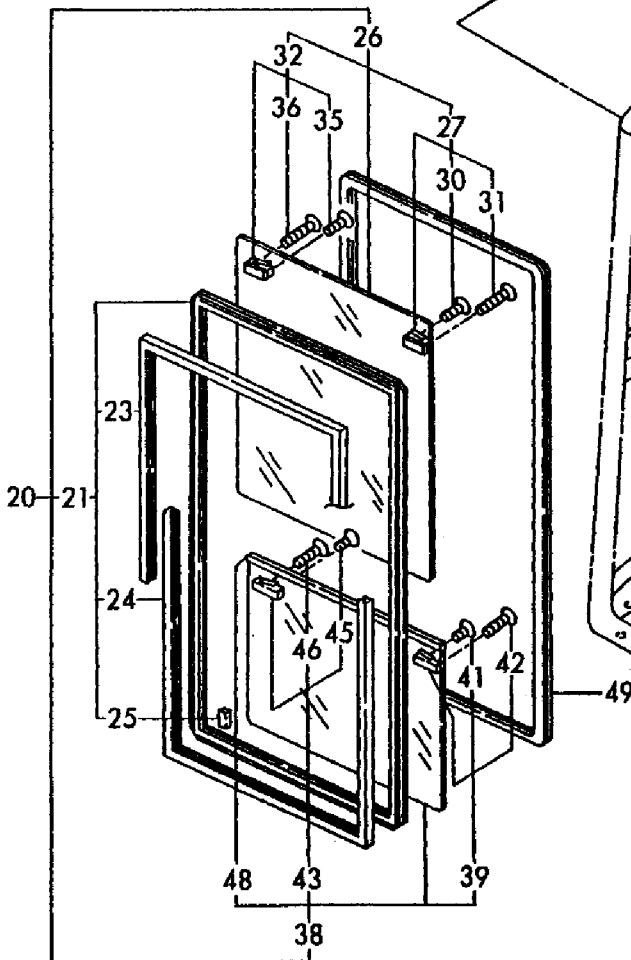

1,2,,172176-67070,, "ACRYLIC, ROOF",1,,,,,,,,,,,,,,,,,,,,,
2,2,,172176-67080,, "BRACKET, CABIN",1,,,,,,,,,,,,,,,,,,,,,
3,2,,172176-67110,, "TRIM, ROOF",1,,,,,,,,,,,,,,,,,,,,,
4,2,,172176-67141,, "TRIM, REAR",1,,,,,,,,,,,,,,,,,,,,,
5,2,,172176-67160,, "COVER A",1,,,,,,,,,,,,,,,,,,,,,
6,2,,26116-160902,, "BOLT M16X 90 PLATED",2,,,,,,,,,,,,,,,,,,,,,
7,2,,172176-69820,, "COLLAR, GLASS",10,,,,,,,,,,,,,,,,,,,,,
8,2,,172176-69830,, "GLASS, REAR",1,,,,,,,,,,,,,,,,,,,,,
9,2,,172176-69860,, "LINK A",1,,,,,,,,,,,,,,,,,,,,,
10,2,,22157-080000,, "WASHER 8",2,,,,,,,,,,,,,,,,,,,,,
11,2,,22217-160000,, "SPRING WASHER 16",4,,,,,,,,,,,,,,,,,,,,,
12,2,,26013-080202,, "BOLT W/WASHER M8X20",2,,,,,,,,,,,,,,,,,,,,,
13,2,,26013-080162,, "BOLT W/WASHER M8X16",2,,,,,,,,,,,,,,,,,,,,,
14,2,,172176-67290,, PLATE,1,,,,,,,,,,,,,,,,,,,,,
15,2,,933147-08501,, "WASHER 17X40X4.5",4,,,,,Z,,M/#01041,,,,,
15A,2,,22137-160000,, "WASHER 16,POLISHED",2,,,,,W,,M/#01041,,,,,
16A,2,,172176-68100,, "BRACKET B",1,,,,,1,,,,,
16B,2,,172164-18660,, "BRACKET ASSY",1,,,,,2,,,,,
17,2,,172176-67380,, PLATE,1,,,,,,,,,,,,,,,,,,,,,
18,2,,172176-67691,, "TRIM, SIDE",1,,,,,,,,,,,,,,,,,,,,,
19,2,,172176-67710,, "GLASS L",1,,,,,,,,,,,,,,,,,,,,,
20,2,,172176-67720,, "GLASS R",1,,,,,1,,,,,
21,2,,172176-67730,, RUBBER,1,,,,,,,,,,,,,,,,,,,,,
22A,2,,172176-67750,, "PANEL, FRONT",1,,,,,1,,,,,
22A-1,2,,172176-67751,, "PANEL, FRONT",1,,,,,N,1,M/#01217,,,,,
22A-2,2,,172176-67752,, "PANEL, FRONT",1,,,,,S,1,M/#01873,,,,,
22A-3,2,,172176-67753,, "PANEL,FRONT IN",1,,,,,N,1,M/#02612,,,,,
22B,2,,172176-67430,, "PANEL, FRONT (CL)",1,,,,,2,,,,,
22B-1,2,,172176-67431,, "PANEL, FRONT (CL)",1,,,,,S,2,M/#01873,,,,,
22B-2,2,,172176-67432,, "PANEL,FRONT (CL)",1,,,,,N,2,M/#02612,,,,,
23A,2,,172176-67770,, "PANEL, ROOF",1,,,,,1,,,,,
23A-1,2,,172176-67771,, "PANEL, ROOF",1,,,,,R,1,M/#01641,,,,,
23A-2,2,,172176-67772,, "PANEL,ROOF",1,,,,,N,1,M/#02612,,,,,
23B,2,,172164-69100,, "PANEL, ROOF",1,,,,,2,,,,,
23B-1,2,,172164-69101,, "PANEL, ROOF CL",1,,,,,R,2,M/#01641,,,,,
23B-2,2,,172164-69102,, "PANEL,ROOF CL",1,,,,,N,2,M/#02612,,,,,
24,2,,172176-67810,, RIVET,4,,,,,,,,,,,,,,,,,,,,,
25,2,,26579-060202,, "SCREW 6X 20",10,,,,,,,,,,,,,,,,,,,,,
26,2,,172176-68200,, WASHER,10,,,,,,,,,,,,,,,,,,,,,
27,2,,26589-060162,, "SCREW M6,BINDING",10,,,,,,,,,,,,,,,,,,,,,
28,2,,26013-100302,, "BOLT M10X 30",4,,,,,,,,,,,,,,,,,,,,,
29,2,,172176-67810,, RIVET,4,,,,,,,,,,,,,,,,,,,,,
30,2,,26116-160702,, "BOLT M16X 70 PLATED",2,,,,,,,,,,,,,,,,,,,,,
31,2,,172176-69750,, SEAL,1,,,,,W,,M/#01006,,,,,
32,2,,172176-69770,, SEAL,1,,,,,W,,M/#01006,,,,,
33,2,,172147-61520,, SPACER,4,,,,,,,,,,,,,,,,,,,,,
34,2,,172164-69120,, "BRACKET ASSY",1,,,,,2,,,,,
35,2,,172176-68210,, TREE-CLIP,2,,,,,W,, "FROM 1ST",,,,,,
36A,1,,172176-67850,, "PANEL, FRONT RADIO",1,,,,,W,3,M/#00501,,,,,
36A-1,1,,172176-67851,, PANEL,1,,,,,N,3,M/#01217,,,,,
36A-2,1,,172176-67852,, PANEL,1,,,,,S,3,M/#01873,,,,,
36A-3,1,,172176-67853,, "PANEL,FRONT RADIO",1,,,,,N,3,M/#02612,,,,,
36B,1,,172176-67440,, PANEL,1,,,,,4,,,,,
36B-1,1,,172176-67441,, PANEL,1,,,,,S,4,M/#01873,,,,,
36B-2,1,,172176-67442,, "PANEL,FRONT R",1,,,,,N,4,M/#02612,,,,,
37A,1,,172176-67860,, "COVER, HARNESS",1,,,,,W,3,M/#00501,,,,,
37A-1,1,,172176-67861,, "PANEL, ROOF (RADIO",1,,,,,R,3,M/#01641,,,,,
37A-2,1,,172176-67862,, PANEL,1,,,,,N,,M/#02612,,,,,
37B,1,,172164-69110,, PANEL,1,,,,,4,,,,,
37B-1,1,,172164-69111,, "PANEL, ROOF CL RADIO",1,,,,,R,4,M/#01641,,,,,
37B-2,1,,172164-69112,, "PANEL (ROOF CL",1,,,,,N,4,M/#02612,,,,,

Fig. 43 キャビン (3) (付属品) CABIN (3) (FITTING)

キャビンASSY (標準)
CABIN ASSY (STANDARD)
(772176-68400)

Fig. 41 REF. No. 1A
(772425-68400-1)
Fig. 41 REF. No. 1A-1
Inc. Fig. 41 REF. No. 2 ~ 51
Fig. 42 REF. No. 1 ~ 50
Fig. 43 REF. No. 1 ~ 35

キャビンASSY (クーラ仕様)
CABIN ASSY (COOLER SPEC.)
(772164-68421)

Fig. 41 REF. No. 1B
(772425-68420-1)
Fig. 41 REF. No. 1B-1
Inc. Fig. 41 REF. No. 2 ~ 54
Fig. 42 REF. No. 1 ~ 50
Fig. 43 REF. No. 1 ~ 35

クーラー仕様
COOLER SPEC.

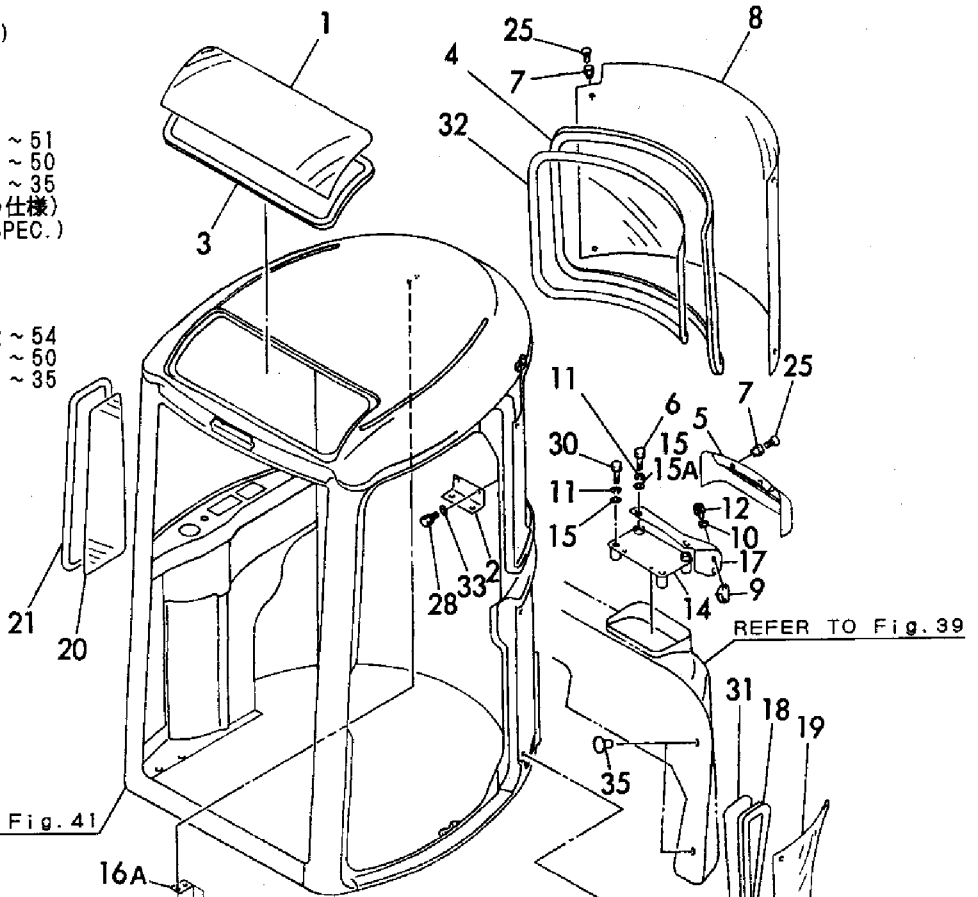

REFER TO Fig. 41

REFER TO Fig. 39

REFER TO Fig. 13

クーラー仕様
COOLER SPEC.

クーラー仕様
COOLER SPEC.

旧形
PREVIOUS

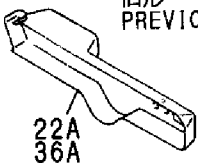

22A-2
36A-2

クーラーキット
COOLER KIT
(172164-08100)

Fig. 11 REF. No. 1
Inc. Fig. 11 REF. No. 2 ~ 29
Fig. 12 REF. No. 1 ~ 5
Fig. 13 REF. No. 1 ~ 62
Fig. 14 REF. No. 1 ~ 49
Fig. 20 REF. No. 1 ~ 11
Fig. 36 REF. No. 1, 2
Fig. 38 REF. No. 1
Fig. 39 REF. No. 1 ~ 5
Fig. 40 REF. No. 1 ~ 9
Fig. 41 REF. No. 18B, 23, 24, 52 ~ 54
Fig. 43 REF. No. 16B, 22B, 23B, 34

旧形
PREVIOUS

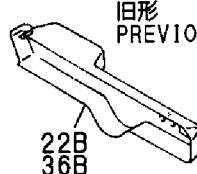

22B
36B

1,1,,772176-68900,, "DOOR ASSY",1,,,,,,,,,,,,,
1-1,1,,772176-68901,, "DOOR COMPL.",1,,,,,N,,,"FROM 1ST",,,,,,
1-2,1,,772176-68902,, "DOOR ASSY",1,,,,,N,,M/#01187,,,,,
2,2,,172176-67000,, "COVER A, DOOR",1,,,,,,,,,,,,,
3,2,,172176-67020,, "PLATE, LINK A",1,,,,,Z,,M/#01187,,,,,
4,2,,172176-67030,, "LINK, DOOR B",1,,,,,,,,,,,,,
4-1,2,,172176-67400,, ROD,1,,,,,F,1,,M/#01187,,,,,
5,2,,172176-67090,, CATCH,1,,,,,,,,,,,,,
6,2,,172176-67100,, "HANDLE ASSY.",1,,,,,,,,,,,,,
7,2,,172176-67121,, "TRIM, DOOR UN",1,,,,,,,,,,,,,
8,2,,172176-67131,, "TRIM, DOOR UP",1,,,,,,,,,,,,,
9,2,,172176-67150,, RUBBER,4,,,,,Z,,MXXX,,,,,
10,2,,172176-68900,, "DOOR ASSY",1,,,,,,,,,,,,,
11,2,,172176-69340,, "BRACKET, DOOR U",2,,,,,,,,,,,,,
12,2,,172176-69390,, "LINK ASSY, DOOR",1,,,,,,,,,,,,,
13,3,,172141-41370,, "BUSH 2015",2,,,,,,,,,,,,,
15,2,,172176-69450,, "COVER U",2,,,,,,,,,,,,,
16,2,,172162-69460,, "KEY ASSY, CYLINDER",1,,,,,,,,,,,,,
17,2,,172176-69470,, "BRACKET A",1,,,,,,,,,,,,,
18,2,,172162-69480,, "LOCK ASSY",1,,,,,,,,,,,,,
19,2,,172162-69540,, "HANDLE, OUTER",1,,,,,,,,,,,,,
19-1,2,,172162-69541,, "HANDLE, OUTER",1,,,,,N,,M/#2206,,,,,
20,2,,172176-69800,, "GLASS, DOOR",1,,,,,,,,,,,,,
21,2,,172176-69810,, "SEAL, DOOR GLASS",1,,,,,,,,,,,,,
22,2,,172176-69820,, "COLLAR, GLASS",4,,,,,,,,,,,,,
23,2,,172176-67231,, "COVER B, DOOR",1,,,,,,,,,,,,,
24,2,,172176-69910,, "LINK C",1,,,,,,,,,,,,,
24-1,2,,172176-69911,, PLATE,1,,,,,N,,M/#01187,,,,,
25,2,,172176-69930,, "LINK D",1,,,,,,,,,,,,,
25-1,2,,172176-69931,, LEVER,1,,,,,N,,M/#01187,,,,,
26,2,,172176-69980,, "ARM W/BUSH, LINK",1,,,,,,,,,,,,,
28,3,,24550-014150,, "BUSH 14X15",4,,,,,,,,,,,,,
29,2,,22137-060000,, "WASHER 6, POLISHED",2,,,,,Z,,M/#01187,,,,,
30,2,,22137-060000,, "WASHER 6, POLISHED",3,,,,,,,,,,,,,
31,2,,22217-060000,, "SPRING WASHER 6",2,,,,,Z,,M/#01187,,,,,
32,2,,172165-63650,, "PLUG 10,HOLE",3,,,,,Z,,M/#01030,,,,,
33,2,,22217-060000,, "SPRING WASHER 6",3,,,,,Z,,M/#01041,,,,,
34,2,,22217-100000,, "SPRING WASHER 10",4,,,,,,,,,,,,,
35,2,,22217-100000,, "SPRING WASHER 10",4,,,,,,,,,,,,,
36,2,,22252-000420,, "CIRCLIP 42",2,,,,,,,,,,,,,
37,2,,22351-040032,, "SPRING PIN 4X32",2,,,,,,,,,,,,,
38,2,,22351-040032,, "SPRING PIN 4X32",2,,,,,,,,,,,,,
39,2,,24311-000220,, "O-RING 1A P-22.0",4,,,,,Z,,M/#02054,,,,,
40,2,,26013-100202,, "BOLT W/WASHER M10X20",2,,,,,,,,,,,,,
41,2,,26013-060202,, "BOLT M 6X 20",2,,,,,,,,,,,,,
41-1,2,,26117-060202,, "BOLT M 6X 20",2,,,,,N,,M/#01041,,,,,
41-2,2,,26117-060202,, "BOLT M 6X 20",2,,,,,Z,,M/#01187,,,,,
42,2,,26022-050102,, "SCREW M 5X 10",8,,,,,,,,,,,,,
43,2,,26022-060122,, "SCREW M 6X 12",2,,,,,,,,,,,,,
44,2,,26022-060162,, "SCREW M 6X 16",3,,,,,,,,,,,,,
45,2,,26022-060122,, "SCREW M 6X 12",1,,,,,,,,,,,,,
46,2,,26557-060302,, "SCREW M 6X 30",3,,,,,,,,,,,,,
46-1,2,,26013-060302,, "BOLT M 6X 30",3,,,,,R,,M/#01041,,,,,
47,2,,26716-100002,, "NUT 10",4,,,,,,,,,,,,,
48,2,,26716-100002,, "NUT 10",4,,,,,,,,,,,,,
49,2,,26717-060002,, "NUT M 6",2,,,,,Z,,M/#01187,,,,,
50,2,,22157-100000,, "WASHER 10",2,,,,,,,,,,,,,
51,2,,172176-69990,, "BEARING 2542",2,,,,,,,,,,,,,
52,2,,172176-67800,, BOLT,1,,,,,,,,,,,,,
53,2,,172176-68390,, BOLT,8,,,,,,,,,,,,,
54,2,,172176-69600,, BRACKET,1,,,,,,,,,,,,,
55,2,,172176-69790,, SHAFT,2,,,,,,,,,,,,,
56,2,,933171-21630,, "PIN, SWING LINK",2,,,,,,,,,,,,,

56-1,2,,933171-21630,, "PIN, SWING LINK",1,,,,,K,,M/#01030,,,,,
56A,2,,172176-69560,,PIN,1,,,,,W,,M/#01030,,,,,
57,2,,172176-67890,, "MOLD, DOOR",1,,,,,
57-1,2,,172176-67891,, "MOLD, DOOR",1,,,,,N,,M/#01977,,,,,
58,2,,172176-68240,, "CORD, RUBBER",1,,,,,
59,2,,172176-67150,,RUBBER,2,,,,,
60,2,,172176-68170,, "RUBBER, STOPPER",2,,,,,
61,2,,172176-69960,, "BRACKET (B)",1,,,,,
62,2,,24321-000350,, "O-RING 1A G-35.0",2,,,,,
63,2,,26716-080002,, "NUT M 8",2,,,,,
64,2,,22417-200200,, "COTTER PIN 2.0X20",1,,,,,
65,2,,22137-060000,, "WASHER 6, POLISHED",1,,,,,
66,2,,26717-060002,, "NUT M 6",1,,,,,
66-1,2,,26716-060002,, "NUT 6",1,,,,,R,,M/#01041,,,,,
67,2,,26013-100252,, "BOLT W/WASHER M10X25",3,,,,,
68,2,,22137-100000,, "WASHER 10,POLISHED",4,,,,,
69,2,,22137-100000,, "WASHER 10,POLISHED",4,,,,,
70,2,,26579-060202,, "SCREW 6X 20",4,,,,,
71,2,,26013-100302,, "BOLT M10X 30",2,,,,,
71-1,2,,26013-100352,, "BOLT M10X 35",2,,,,,R,,M/#01041,,,,,
72,2,,172176-67250,, "PIPE 15",2,,,,,
73,2,,22137-100000,, "WASHER 10,POLISHED",3,,,,,
74,2,,172176-67410,,BOLT,1,,,,,W,,M/#01187,,,,,
75,2,,26716-080002,, "NUT M 8",1,,,,,W,,M/#01187,,,,,
76,2,,22137-060000,, "WASHER 6, POLISHED",1,,,,,W,,M/#01187,,,,,
77,2,,194145-04810,, "WASHER 10",2,,,,,W,,M/#01041,,,,,
78,2,,26716-080002,, "NUT M 8",4,,,,,W,,M/#01041,,,,,
79,2,,172176-69760,,SEAL,1,,,,,W,,M/#01006,,,,,
80,2,,172164-03210,, "LABEL, CAB.",1,,,,,W,, "FROM 1ST",,,,,,
81,2,,172176-69390,, "LINK ASSY, DOOR",1,,,,,
81-1,2,,172187-69350,, "LINK, DOOR (A)",1,,,,,F,2,,M/#02135,,,,,
82,3,,172141-41370,, "BUSH 2015",2,,,,,
84,2,,172187-69390,, "LINK, DOOR (B)",1,,,,,W,,M/#02135,,,,,
85,2,,172187-69420,, "BOLT M16X 90",1,,,,,W,,M/#02135,,,,,
86,2,,172187-69490,, "NUT 16",1,,,,,W,,M/#02135,,,,,
87,2,,26716-160002,, "NUT M16",1,,,,,W,,M/#02135,,,,,
88,1,,933110-00301,, "KEY ASSY",1,,,,,

Fig. 44 キャビンドア CABIN DOOR

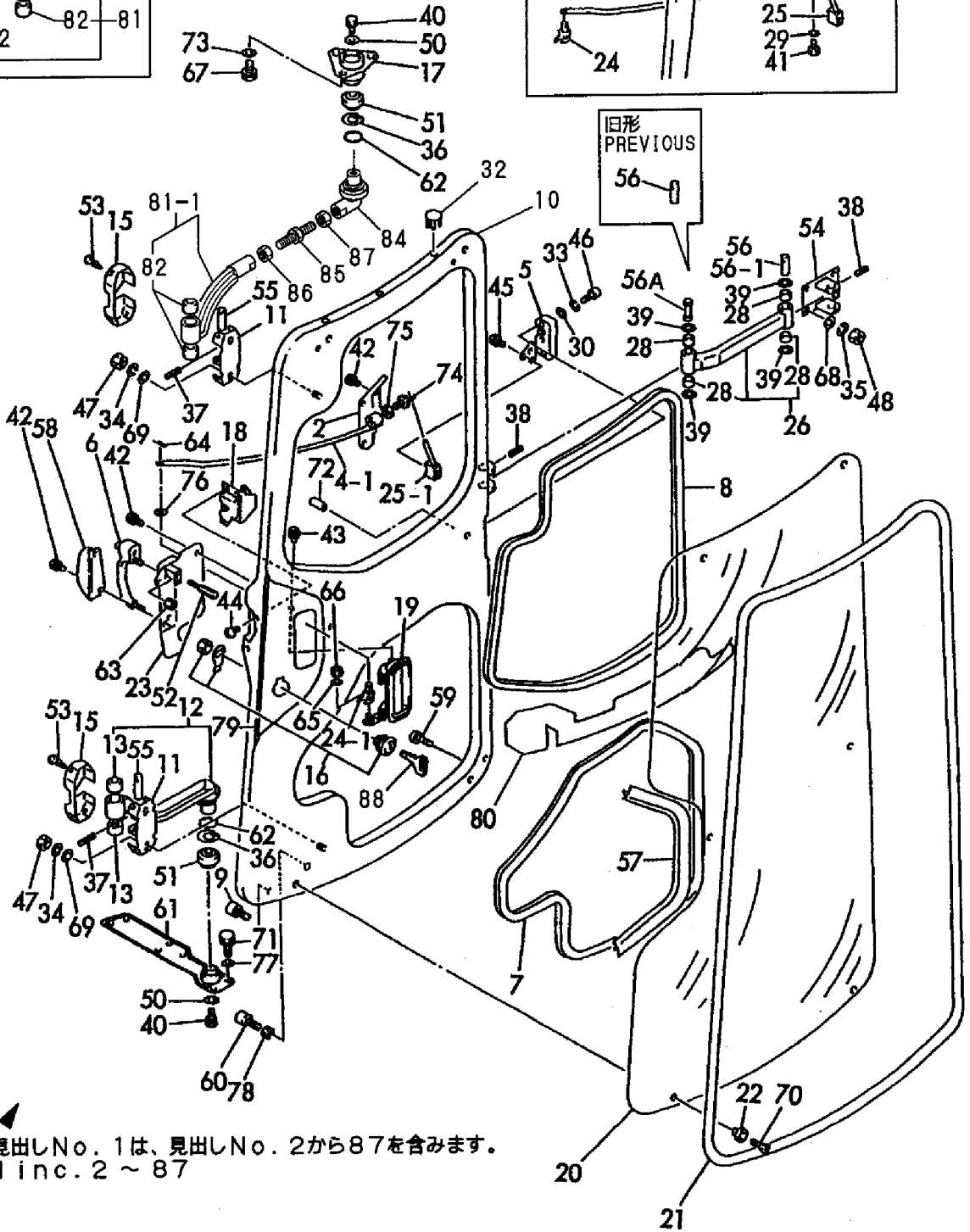
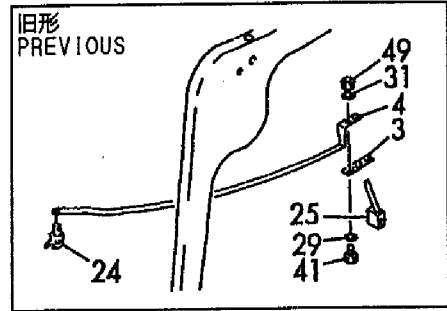
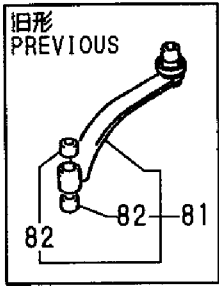

見出しNo. 1は、見出しNo. 2から87を含みます。
1 inc. 2 ~ 87

1,1,,172164-68100,, "ROOF,CANOPY(GREEN:96" ,1,,,,,,,,,,,,,
2,1,,172164-68111,, "POLE, CANOPY" ,1,,,,,,,,,,,,,
2-1,1,,172164-68112,, "POLE,CANOPY(GREEN:96" ,1,,,,,N,,,,,M/#00883,,,,,
3,1,,172164-68190,, "BOOT, CANOPY" ,1,,,,,,,,,,,,,
4,1,,172164-68250,, "PLATE ASSY" ,2,,,,,,,,,,,,,
5,1,,172164-68270,, SPACER,,12,,,,,,,,,,,,,
6,1,,172164-68290,, PLATE,,2,,,,,,,,,,,,,
7,1,,22217-160000,, "SPRING WASHER 16" ,4,,,,,,,,,,,,,
8,1,,26013-120302,, "BOLT W/WASHER M12X30" ,6,,,,,,,,,,,,,
9,1,,26076-160402,, "BOLT 10.9 16X40" ,4,,,,,,,,,,,,,
10,1,,26589-060252,, "SCREW M6X25,BIND.HD." ,16,,,,,,,,,,,,,
11,1,,26716-100002,, "NUT 10" ,2,2,,,,,,,,,,,,,
12,1,,172730-05250,, "WASHER 12" ,2,2,,,,,,,,,,,,,
13,1,,172165-68180,, "BOLT, M14X 35" ,3,3,,,,,,,,,,,,,
14,1,,172164-68200,, "BRACKET COMPL." ,1,1,,,,,,,,,,,,,
15,1,,172164-68301,, "BRACKET, CANOPY" ,1,1,,,,,,,,,,,,,
16,1,,172164-68500,, "BRACKET ASSY (GREEN)" ,1,1,,,,,,,,,,,,,
17,1,,172164-68511,, "BRACKET F" ,1,1,,,,,,,,,,,,,
18,1,,172164-68641,, "BRACKET (R) ASSY" ,1,1,,,,,,,,,,,,,
19,1,,172110-36010,, COLLAR,4,4,,,,,,,,,,,,,
20,1,,22217-100000,, "SPRING WASHER 10" ,2,2,,,,,,,,,,,,,
21,1,,22217-140000,, "SPRING WASHER 14" ,3,3,,,,,,,,,,,,,
22,1,,22217-160000,, "SPRING WASHER 16" ,5,5,,,,,,,,,,,,,
23,1,,26013-100302,, "BOLT M10X 30" ,4,4,,,,,,,,,,,,,
24,1,,26013-120402,, "BOLT M12X 40" ,4,4,,,,,,,,,,,,,
25,1,,26116-100504,, "BOLT M10X 50 PLATED" ,2,2,,,,,,,,,,,,,
26,1,,26116-160402,, "BOLT M16X 40 PLATED" ,5,5,,,,,,,,,,,,,
27,1,,172730-05250,, "WASHER 12" ,6,,,,,W,,,,,M/#00883,,,,,
28,1,,172164-68470,, "COVER ASSY" ,2,,,,,W,1,,,,,M/#00948,,,,,

Fig. 45 **キャノピ&キャノピフレーム**
CANOPY & CANOPY FRAME

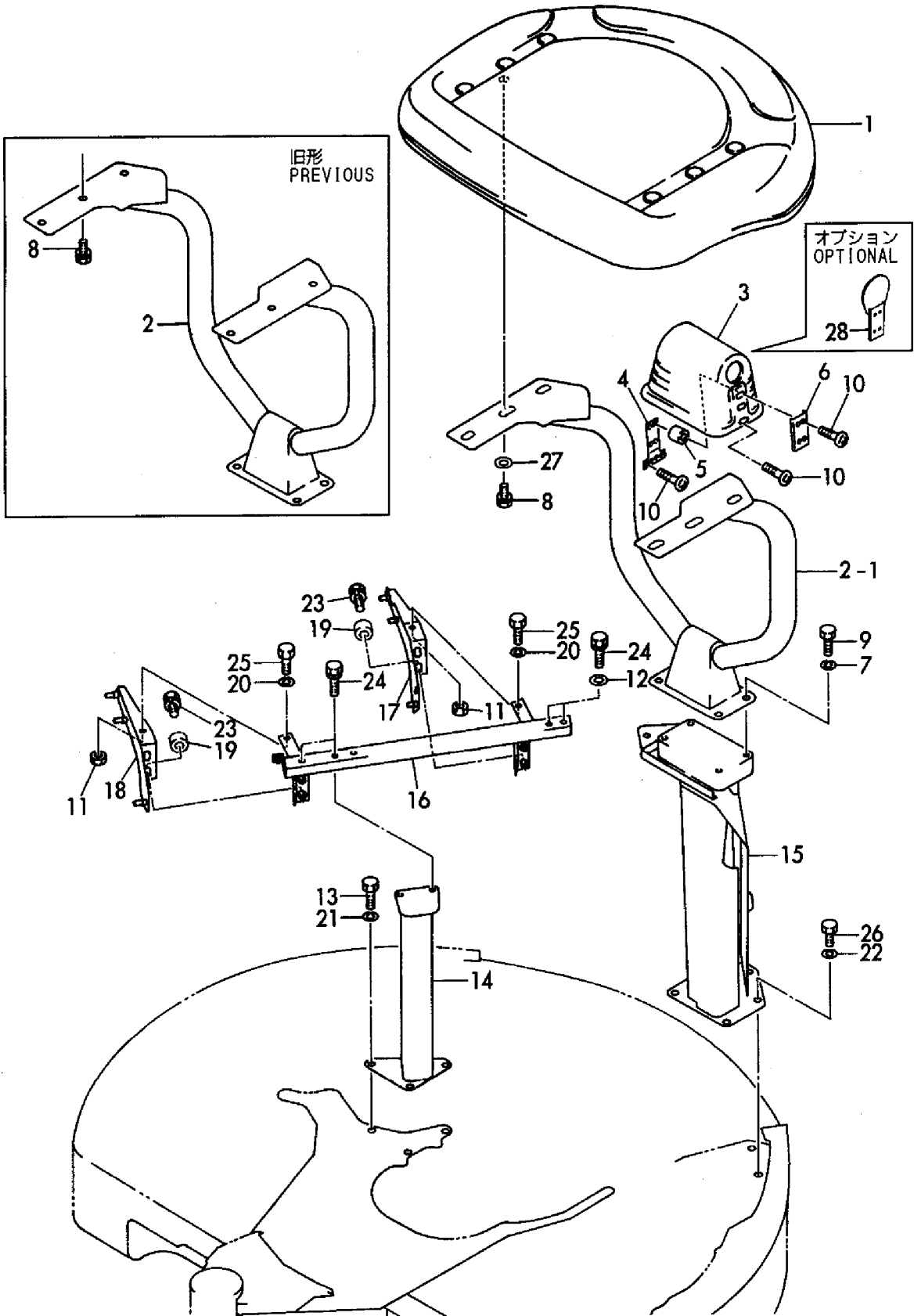

1,1,,172168-71101,, "COVER, FLYWHEEL",1,1,,,,,,,,,,,,,
2,1,,26013-100302,, "BOLT M10X 30",8,8,,,,,,,,,,,,,
3,1,,172165-71200,, COUPLING,1,1,,,,,,,,,,,,,
4,1,,26450-120402,, "BOLT M12X 40",3,3,,,,,,,,,,,,,
5,1,,172164-73101,, "PUMP ASSY",1,1,,,,,,,,,,,,,
6,2,,172168-71200,, "SHAFT ASSY, ROCKER",1,1,,,,,,,,,,,,,
7,3,,172168-71310,, SHAFT,1,1,,,,,,,,,,,,,
8,3,,172168-71320,, "SEAL CASE",1,1,,,,,,,,,,,,,
9,3,,172168-71330,, BEARING,1,1,,,,,,,,,,,,,
10,3,,172164-73170,, "SEAL ASSY",1,1,,,,,,,,,,,,,
13,3,,22242-000250,, "CIRCLIP 25S",2,2,,,,,,,,,,,,,
14,3,,22252-000620,, "CIRCLIP 62(H)",1,1,,,,,,,,,,,,,
16,2,,172168-71340,, O-RING,1,1,,,,,,,,,,,,,
17,2,,172168-71550,, COVER,1,1,,,,,,,,,,,,,
18,2,,26450-060162,, "BOLT M 6X 16",4,4,,,,,,,,,,,,,
19,2,,172164-73120,, "ROTORY SET",1,1,,,,,,,,,,,,,
20,2,,172164-73130,, "COVER ASSY, GEAR CASE",1,1,,,,,,,,,,,,,
22,3,,172168-71360,, "GASKET, BONNET",1,1,,,,,,,,,,,,,
23,3,,172168-71370,, CPUPRING,1,1,,,,,,,,,,,,,
24,3,,172168-71560,, BEARING,1,1,,,,,,,,,,,,,
25,3,,172141-73210,, CIRCLIP,1,1,,,,,,,,,,,,,
26,3,,172165-73580,, ORIFICE,3,3,,,,,,,,,,,,,
27,3,,172142-74650,, "PLUG 1/8",1,1,,,,,,,,,,,,,
28,3,,22312-060140,, "PARALLEL PIN 6X14",2,2,,,,,,,,,,,,,
29,3,,24315-000080,, "O-RING 1B P-8.0",1,1,,,,,,,,,,,,,
32,2,,172164-73140,, "SPRING, CONTROL",1,1,,,,,,,,,,,,,
38,3,,172168-71430,, O-RING,1,1,,,,,,,,,,,,,
45,2,,172164-73150,, "PISTON ASSY, CONTROL",1,1,,,,,,,,,,,,,
50,3,,172164-73220,, "O-RING ASSY",1,1,,,,,,,,,,,,,
57,2,,172164-73160,, "PUMP ASSY, DUPLX. GEAR",1,1,,,,,,,,,,,,,
58,3,,172164-73230,, "PUMP, HYD. OIL",1,1,,,,,,,,,,,,,
59,4,,172141-71520,, RING,2,2,,,,,,,,,,,,,
60,4,,172141-73230,, GUIDE,2,2,,,,,,,,,,,,,
61,4,,172168-71540,, PLATE,1,1,,,,,,,,,,,,,
62,4,,172141-71550,, O-RING,2,2,,,,,,,,,,,,,
63,4,,172141-71560,, RING,2,2,,,,,,,,,,,,,
64,4,,172141-73220,, PLATE,2,2,,,,,,,,,,,,,
65,4,,172141-73240,, "PIN, PARALLEL",4,4,,,,,,,,,,,,,
66,4,,26450-100852,, "BOLT M10X85, HEX. SCKT",4,4,,,,,,,,,,,,,
67,3,,172168-71300,, "PUMP, HYD. OIL",1,1,,,,,,,,,,,,,
68,4,,172141-73240,, "PIN, PARALLEL",2,2,,,,,,,,,,,,,
69,4,,172165-73860,, COUPLING,1,1,,,,,,,,,,,,,
70,4,,172164-73250,, "O-RING ASSY",1,1,,,,,,,,,,,,,
74,4,,26450-080182,, "BOLT M 8X 18",2,2,,,,,,,,,,,,,
75,4,,26450-080402,, "BOLT 8X40",4,4,,,,,,,,,,,,,
76,1,,172164-73110,, VALVE,1,1,,,,,,,,,,,,,
77,1,,26013-120352,, "BOLT M12X 35",2,2,,,,,,,,,,,,,

Fig. 46 油圧ポンプ&軸継手 (旧形)
HYD. OIL PUMP & JOINT (PREVIOUS)

~M/#01186

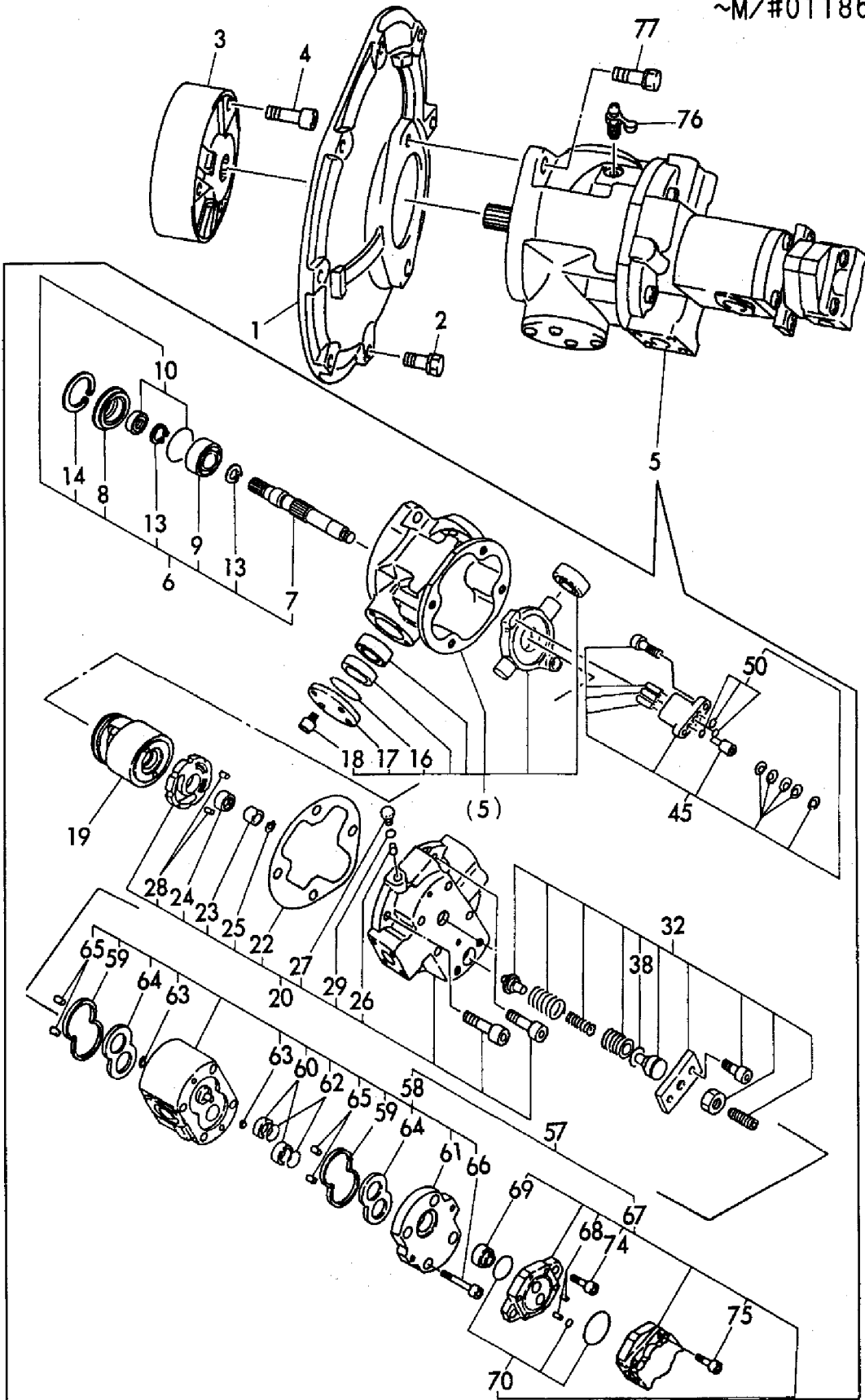

1,1,,172168-71101,, "COVER, FLYWHEEL",1,1,,,,,,,,,,,,,
2,1,,26013-100302,, "BOLT M10X 30",8,8,,,,,,,,,,,,,
3,1,,172165-71200,, COUPLING,1,1,,,,,,,,,,,,,
4,1,,26450-120402,, "BOLT M12X 40",3,3,,,,,,,,,,,,,
5,1,,172164-73110,, VALVE,1,1,,,,,,,,,,,,,
6,1,,26013-120352,, "BOLT M12X 35",2,2,,,,,,,,,,,,,
7,1,,172164-73400,, "HYD.PUMP ASSY",1,1,,,,,,,,,,,,,
7-1,1,,172164-73401,, "PUMP ASSY",1,1,,,,,F,1,,M/#01446,,M/#01446,,,,,
7-2,1,,172164-73402,, "PUMP ASSY",1,1,,,,,N,,M/#01920,,M/#01920,,,,,
8,2,,172168-71200,, "SHAFT ASSY, ROCKER",1,1,,,,,,,,,,,,,
9,3,,172168-71310,, SHAFT,1,1,,,,,,,,,,,,,
10,3,,172168-71320,, "SEAL CASE",1,1,,,,,,,,,,,,,
11,3,,172168-71330,, BEARING,1,1,,,,,,,,,,,,,
12,3,,172164-73170,, "SEAL ASSY",1,1,,,,,,,,,,,,,
15,3,,22242-000250,, "CIRCLIP 25S",2,2,,,,,,,,,,,,,
16,3,,22252-000620,, "CIRCLIP 62(H)",1,1,,,,,,,,,,,,,
21,2,,172168-71340,, O-RING,1,1,,,,,,,,,,,,,
22,2,,172168-71550,, COVER,1,1,,,,,,,,,,,,,
23,2,,26450-060162,, "BOLT M 6X 16",4,4,,,,,,,,,,,,,
24,2,,172175-73110,, "ROTARY GROUP",1,1,,,,,,,,,,,,,
24-1,2,,172175-73111,, "ROTARY COMP.",1,1,,,,,S,,M/#01920,,M/#01920,,,,,
25,2,,172164-73410,, "COVER, AIR CLEANER",1,1,,,,,,,,,,,,,
27,3,,172175-73150,, "PLATE, CONTROL",1,1,,,,,,,,,,,,,
28,3,,22312-060142,, "PARALLER PIN 6X 14",2,2,,,,,,,,,,,,,
28-1,3,,22312-060140,, "PARALLEL PIN 6X14",2,2,,,,,N,, "FROM 1ST",, "FROM
1ST",,,,,,
29,3,,26450-100302,, "BOLT M10X 30",3,3,,,,,,,,,,,,,
31,3,,172165-73580,, ORIFICE,3,3,,,,,,,,,,,,,
32,3,,172168-71560,, BEARING,1,1,,,,,,,,,,,,,
33,3,,172142-74650,, "PLUG 1/8",4,4,,,,,,,,,,,,,
34,3,,24315-000080,, "O-RING 1B P-8.0",5,5,,,,,,,,,,,,,
35,3,,172168-71360,, "GASKET, BONNET",1,1,,,,,,,,,,,,,
36,3,,172164-73660,, FILTER,1,1,,,,,,,,,,,,,
37,3,,172164-73670,, CIRCLIP,1,1,,,,,,,,,,,,,
38,3,,26450-100502,, "BOLT 10X 50",1,1,,,,,,,,,,,,,
39,3,,26450-100552,, "BOLT M10X 55",1,1,,,,,,,,,,,,,
41,2,,172164-73420,, "SPRING, CONTROL",1,1,,,,,,,,,,,,,
42,3,,172168-71380,, RETAINER,1,1,,,,,,,,,,,,,
43,3,,172168-71390,, RETAINER,1,1,,,,,,,,,,,,,
44,3,,172164-73720,, COVER,1,1,,,,,,,,,,,,,
45,3,,172165-73640,, "ADJUST SCREW",1,1,,,,,,,,,,,,,
46,3,,172175-73160,, SPRING,1,1,,,,,,,,,,,,,
47,3,,172164-73730,, "SPRING, RETERN",1,1,,,,,,,,,,,,,
48,3,,172168-71430,, O-RING,1,1,,,,,,,,,,,,,
49,3,,26450-080302,, "BOLT M 8X 30",2,2,,,,,,,,,,,,,
50,3,,172165-73760,, "PALALLEL PIN 8",1,1,,,,,,,,,,,,,
51,3,,172168-71440,, SHIM,2,2,,,,,,,,,,,,,
52,3,,172168-71450,, SHIM,2,2,,,,,,,,,,,,,
53,3,,172168-71460,, SHIM,2,2,,,,,,,,,,,,,
54,2,,172164-73150,, "PISTON ASSY, CONTROL",1,1,,,,,,,,,,,,,
55,3,,172168-71470,, CYLINDER,1,1,,,,,,,,,,,,,
56,3,,172164-73210,, PISTON,1,1,,,,,,,,,,,,,
57,3,,172168-71490,, "PARALLEL PIN",2,2,,,,,,,,,,,,,
58,3,,172168-71500,, "PARALLEL PIN",1,1,,,,,,,,,,,,,
59,3,,172164-73220,, "O-RING ASSY",1,1,,,,,,,,,,,,,
63,3,,172168-71520,, "CONICAL SPRING",4,4,,,,,,,,,,,,,
63-1,3,,172168-71520,, "CONICAL SPRING",3,3,,,,,K,, "FROM 1ST",, "FROM 1ST",,,,,,
64,3,,172168-71530,, RETAINER,1,1,,,,,,,,,,,,,
65,3,,26450-080252,, "BOLT M 8X 25",2,2,,,,,,,,,,,,,
66,2,,172164-73440,, "PUMP ASSY, HYDL.OIL",1,1,,,,,,,,,,,,,
71,3,,172141-71520,, RING,2,2,,,,,,,,,,,,,
72,3,,172141-71550,, O-RING,2,2,,,,,,,,,,,,,
73,3,,172141-71560,, RING,2,2,,,,,,,,,,,,,

74,3,,172141-73210,,CIRCLIP,1,1,,,,,,,,,,,,,
75,3,,172141-73220,,PLATE,3,3,,,,,,,,,,,,,
76,3,,172141-73230,,GUIDE,2,2,,,,,,,,,,,,,
77,3,,172141-73240,, "PIN, PARALLEL",4,4,,,,,,,,,,,,,
78,3,,172147-73650,,O-RING,2,2,,,,,,,,,,,,,
80,3,,172141-73240,, "PIN, PARALLEL",1,1,,,,,,,,,,,,,
88,3,,26450-080402,, "BOLT 8X40",4,4,,,,,,,,,,,,,
89,3,,172164-73750,, "FRAME, FRONT",1,1,,,,,,,,,,,,,
91,3,,172164-73770,, "FRAME, MIDDLE",1,1,,,,,,,,,,,,,
94,3,,172164-73830,,COUPLING,1,1,,,,,,,,,,,,,
95,3,,172164-73840,,BUSH,1,1,,,,,,,,,,,,,
96,3,,172164-73850,, "HEX.HEAD BOLT",4,4,,,,,,,,,,,,,
97,3,,172164-73870,,COUPLING,1,1,,,,,,,,,,,,,
98,3,,172165-73870,,O-RING,1,1,,,,,,,,,,,,,
99,3,,172164-73880,,O-RING,1,1,,,,,,,,,,,,,
100,3,,172164-73890,,O-RING,1,1,,,,,,,,,,,,,
102,3,,24315-000100,, "O-RING 1B P-10.0",3,3,,,,,,,,,,,,,
103,3,,26450-100252,, "BOLT M10X 25",2,2,,,,,,,,,,,,,
105,2,,172164-73460,,VALVE,1,1,,,,,,,,,,,,,
105-1,2,,172164-73461,,VALVE,1,1,,,,,F,1,,M/#01446,,M/#01446,,,,,
109,3,,24311-000160,, "O-RING 1A P-16.0",4,4,,,,,,,,,,,,,
110,3,,172162-74820,,SPRING,2,2,,,,,,,,,,,,,
111,3,,172162-74860,,BOLT,4,4,,,,,,,,,,,,,
112,3,,26450-080252,, "BOLT M 8X 25",2,2,,,,,,,,,,,,,
116,3,,172164-73030,,COVER,1,1,,,,,,,,,,,,,
117,3,,172164-73040,,BAND,2,2,,,,,,,,,,,,,
118,2,,172164-73470,, "VALVE ASSY, RELIEF",1,1,,,,,,,,,,,,,
121,3,,172141-74430,,O-RING,1,1,,,,,,,,,,,,,
122,3,,172164-73380,, "SPRING, RETERN",1,1,,,,,,,,,,,,,
123,3,,172164-73390,,NUT,1,1,,,,,,,,,,,,,
124,3,,172164-73990,,SHIM,1,1,,,,,,,,,,,,,
127,2,,172164-73490,,CLAMP,1,1,,,,,,,,,,,,,
128,2,,172164-73500,,WASHER,1,1,,,,,,,,,,,,,
129,2,,172162-74860,,BOLT,1,1,,,,,,,,,,,,,

Fig. 47 油圧ポンプ&軸継手 (新形)
HYD. OIL PUMP & JOINT (NEW)

M/#01187~

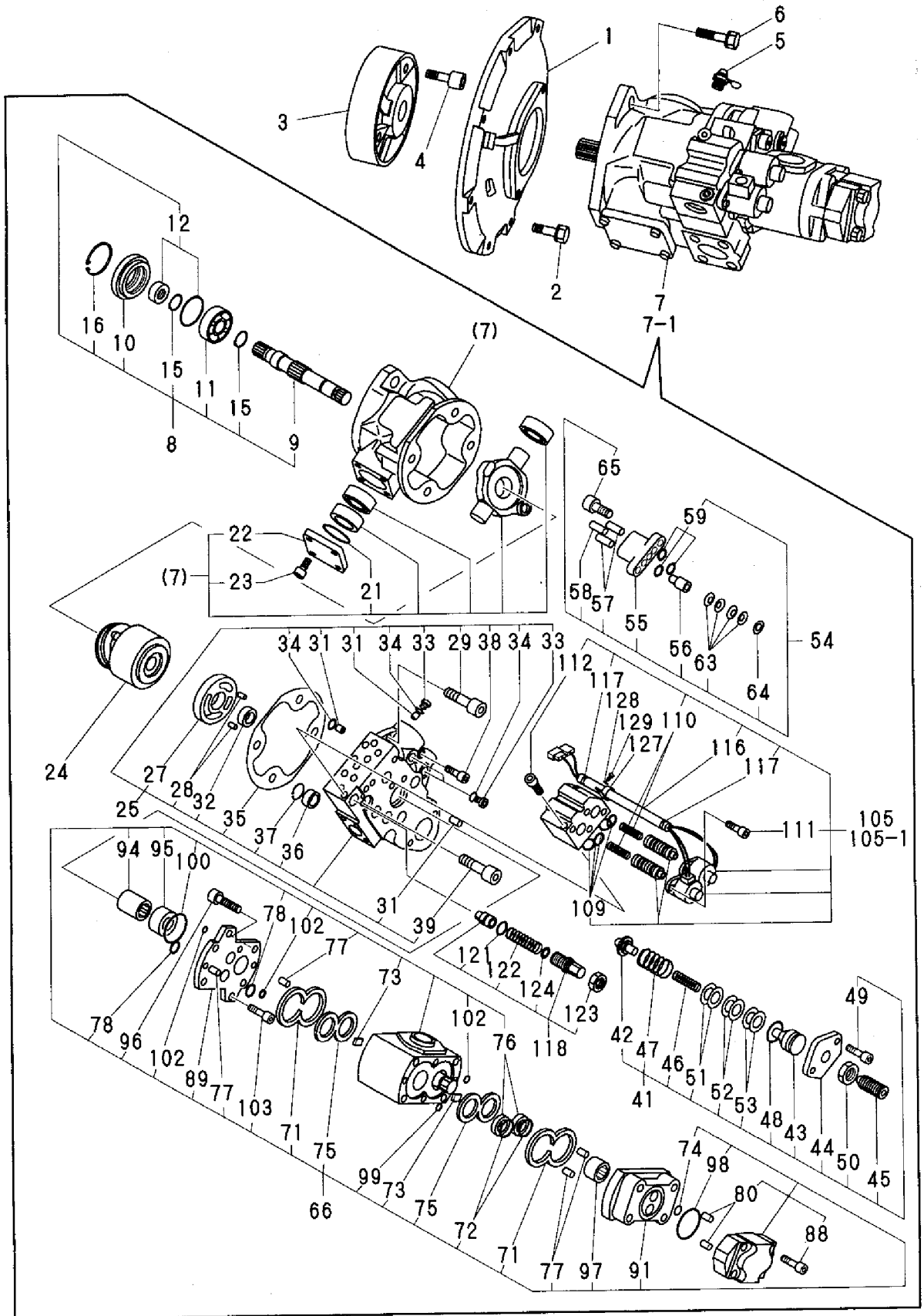

1,1,,172164-72020,, "CYLINDER ASSY,BOOM C",1,,,,,,,,,,,,,
1-1,1,,172164-72021,, "CYLINDER ASSY,BOOM C",1,,,,,,N,,,M/#00948,,,,,,
2,2,,172164-72030,, "TUBE, BOOM C",1,,,,,,,,,,,,,
2-1,2,,172164-72031,, "TUBE, BOOM C",1,,,,,,N,,,M/#00948,,,,,,
3,3,,172146-72310,, "BUSH 45 50",1,,,,,,,,,,,,,
4,3,,933126-44500,, "SEAL VAY45X55X4,DUST",2,,,,,,,,,,,,,
5,2,,172164-72070,, "ROD, BOOM L",1,,,,,,,,,,,,,
5-1,2,,172164-72200,, "ROD, BOOM",1,,,,,,N,,,M/#00948,,,,,,
6,3,,172146-72310,, "BUSH 45 50",1,,,,,,,,,,,,,
7,3,,933126-44500,, "SEAL VAY45X55X4,DUST",2,,,,,,,,,,,,,
8,2,,172312-72200,, "HEAD 90 50 W/BUSH",1,,,,,,,,,,,,,
9,3,,172151-72540,, "BUSH 50 35, ROD",1,,,,,,,,,,,,,
11,2,,172164-72370,, "CYLINDER KIT,BOOM",1,,,,,,,,,,,,,
12,3,,172164-72380,, "SEAL SET, HEAD",1,,,,,,,,,,,,,
19,3,,933111-26700,, "RING 65, SPRING",1,,,,,,,,,,,,,
20,3,,172151-72870,, "LOCK WASHER 90",1,,,,,,,,,,,,,
21,3,,22252-000701,, "CIRCLIP 70",1,,,,,,,,,,,,,
22,3,,172164-72390,, "SEAL SET, PISTON",1,,,,,,,,,,,,,
26,2,,172130-72800,, "RING 56, CUSHION",1,,,,,,,,,,,,,
27,2,,172312-72220,, "PISTON 90",1,,,,,,,,,,,,,
28,2,,172312-72141,, "SPACER 90 39 19",1,,,,,,,,,,,,,
29,2,,172151-72270,, "U-NUT M39",1,,,,,,,,,,,,,
30,2,,172312-72100,, "PLUNGER, CUSHION",1,,,,,,,,,,,,,
31,2,,24761-020000,, "NIPPLE PT1/8,GREASE",2,,,,,,,,,,,,,
32,1,,172165-72351-4,, "COVER, SLIDE (GREEN)",1,,,,,,W,,,M/#00948,,,,,,
33,1,,172162-61770,, "GUIDE,SLIDE",2,,,,,,W,,,M/#00948,,,,,,
34,1,,933147-03400,, "WASHER, BRAKE ARM",1,,,,,,W,,,M/#00948,,,,,,
35,1,,933168-14170,, "SPRING 16",2,,,,,,W,,,M/#00948,,,,,,
36,1,,22217-100000,, "SPRING WASHER 10",1,,,,,,W,,,M/#00948,,,,,,
37,1,,26116-100162,, "BOLT M10X 16 PLATED",1,,,,,,W,,,M/#00948,,,,,,

Fig. 48 ブームシリンダ (キャビン)
BOOM CYLINDER (CABIN)

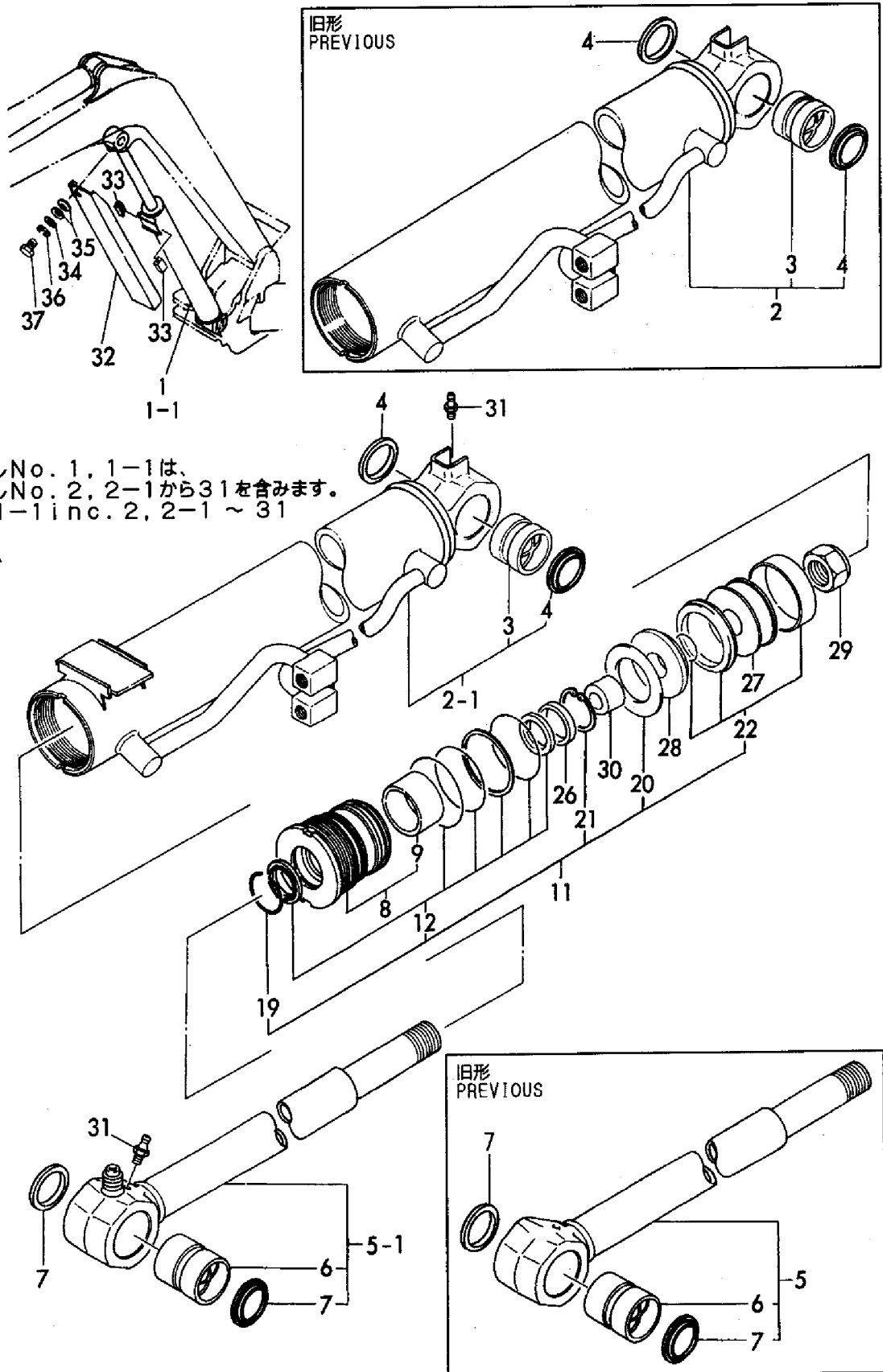

1,1,,172164-72100,, "CYLINDER, BOOM",,1,,,,,,,,,,,,,
1-1,1,,172164-72101,, "CYLINDER, BOOM",,1,,,,,N,,,,,M/#00948,,,,,
2,2,,172164-72110,, "TUBE, BOOM",,1,,,,,,,,,,,,,
2-1,2,,172164-72111,, "TUBE, BOOM",,1,,,,,S,,,,,M/#00948,,,,,
3,3,,172146-72310,, "BUSH 45 50",,1,,,,,,,,,,,,,
4,3,,933126-44500,, "SEAL VAY45X55X4,DUST",,2,,,,,,,,,,,,,
5,2,,172164-72200,, "ROD, BOOM",,1,,,,,,,,,,,,,
6,3,,172146-72310,, "BUSH 45 50",,1,,,,,,,,,,,,,
7,3,,933126-44500,, "SEAL VAY45X55X4,DUST",,2,,,,,,,,,,,,,
8,2,,172312-72200,, "HEAD 90 50 W/BUSH",,1,,,,,,,,,,,,,
9,3,,172151-72540,, "BUSH 50 35, ROD",,1,,,,,,,,,,,,,
11,2,,172164-72300,, "CYLINDER KIT,BOOM",,1,,,,,,,,,,,,,
12,3,,172164-72310,, "SEAL SET, HEAD",,1,,,,,,,,,,,,,
19,3,,933111-26700,, "RING 65, SPRING",,1,,,,,,,,,,,,,
20,3,,172151-72870,, "LOCK WASHER 90",,1,,,,,,,,,,,,,
21,3,,22252-000701,, "CIRCLIP 70",,1,,,,,,,,,,,,,
22,3,,172164-72320,, "SEAL SET, PISTON",,1,,,,,,,,,,,,,
26,2,,172130-72800,, "RING 56, CUSHION",,1,,,,,,,,,,,,,
27,2,,172312-72220,, "PISTON 90",,1,,,,,,,,,,,,,
28,2,,172312-72141,, "SPACER 90 39 19",,1,,,,,,,,,,,,,
29,2,,172151-72270,, "U-NUT M39",,1,,,,,,,,,,,,,
30,2,,172312-72100,, "PLUNGER, CUSHION",,1,,,,,,,,,,,,,
31,2,,24761-020000,, "NIPPLE PT1/8,GREASE",,2,,,,,,,,,,,,,
32,1,,933147-03400,, "WASHER, BRAKE ARM",,1,,,,,,,,,,,,,
33,1,,22217-100000,, "SPRING WASHER 10",,1,,,,,,,,,,,,,
34,1,,26116-100162,, "BOLT M10X 16 PLATED",,1,,,,,,,,,,,,,
35,1,,172165-72351-4,, "COVER, SLIDE (GREEN)",,1,,,,,,,,,,,,,
36,1,,933168-14170,, "SPRING 16",,2,,,,,,,,,,,,,
37,1,,172162-61770,, "GUIDE,SLIDE",,2,,,,,W,,,,,M/#00501,,,,,

Fig. **49** ブームシリンダ (キャノピ)
BOOM CYLINDER (CANOPY)

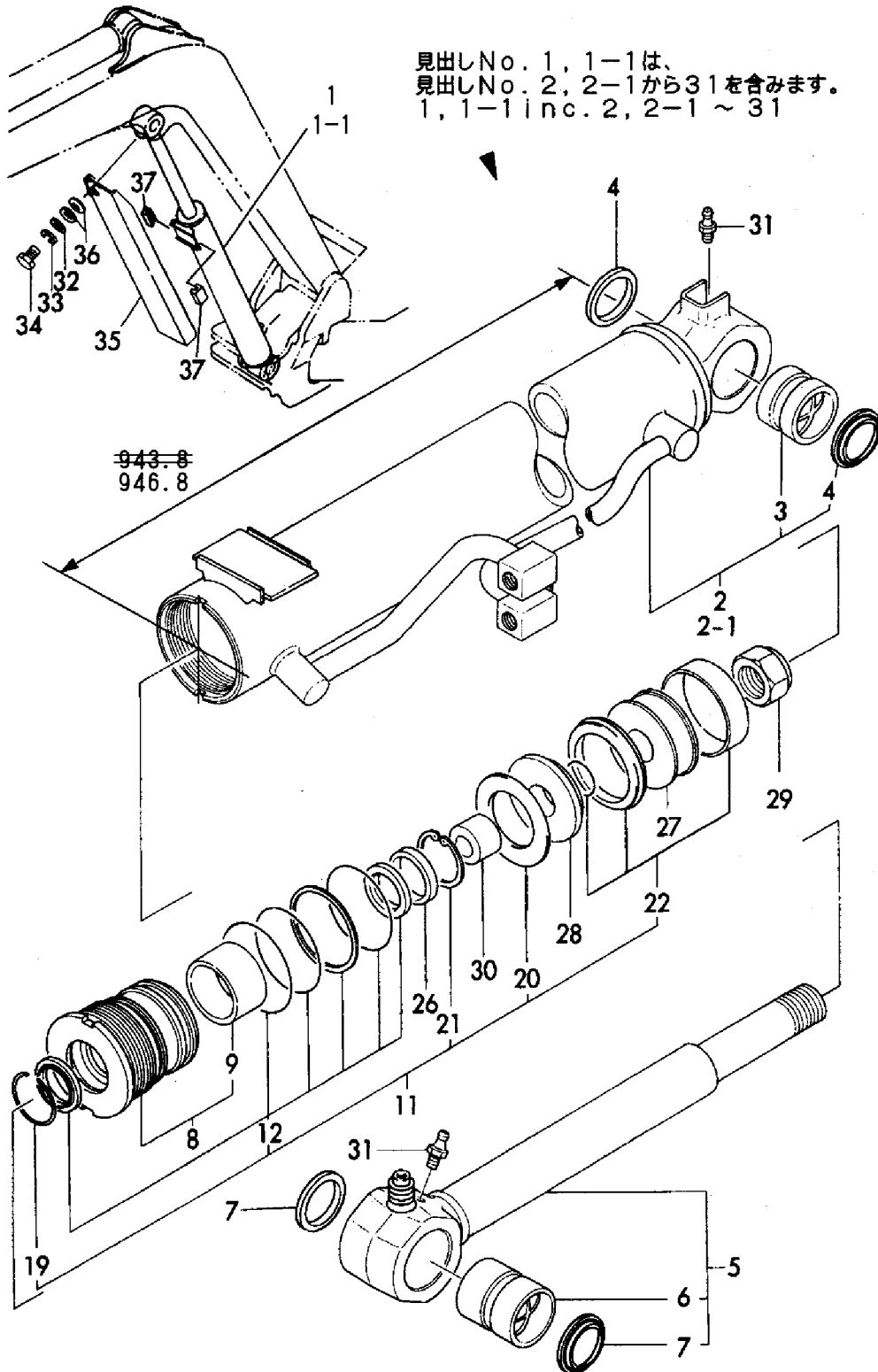

1,1,,172164-72450,, "CYLINDER, ARM",1,1,,,,,,,,,,,,,
2,2,,172164-72460,, "TUBE COMP.,ARM",1,1,,,,,,,,,,,,,
3,3,,172168-72410,, "BUSH 40X50X40",1,1,,,,,,,,,,,,,
4,3,,172165-81750,, "SEAL 40X50X5, DUST",2,2,,,,,,,,,,,,,
5,2,,172164-72500,, "ROD COMP.,ARM",1,1,,,,,,,,,,,,,
6,3,,172168-72410,, "BUSH 40X50X40",1,1,,,,,,,,,,,,,
7,3,,172165-81750,, "SEAL 40X50X5, DUST",2,2,,,,,,,,,,,,,
8,2,,172148-72390,, "HEAD 75 45",1,1,,,,,,,,,,,,,
9,3,,194300-24130,, "BUSH 45X50X30",1,1,,,,,,,,,,,,,
11,2,,172164-72330,, "CYLINDER KIT,ARM",1,1,,,,,,,,,,,,,
12,3,,172164-72340,, "SEAL SET, HEAD",1,1,,,,,,,,,,,,,
17,3,,933125-94500,, "RING 60, SPRING",1,1,,,,,,,,,,,,,
18,3,,172141-72190,, "WASHER 75",1,1,,,,,,,,,,,,,
19,3,,172164-72350,, "SEAL SET, PISTON",1,1,,,,,,,,,,,,,
22,2,,172148-72050,, "PISTON 75",1,1,,,,,,,,,,,,,
23,2,,24761-050000,, "NIPPLE C,GREASE",1,1,,,,,,,,,,,,,
24,2,,933111-20200,, "U-NUT M33",1,1,,,,,,,,,,,,,
25,2,,24761-040000,, "NIPPLE B,GREASE",1,1,,,,,,,,,,,,,

Fig. 50 アームシリンダ
ARM CYLINDER

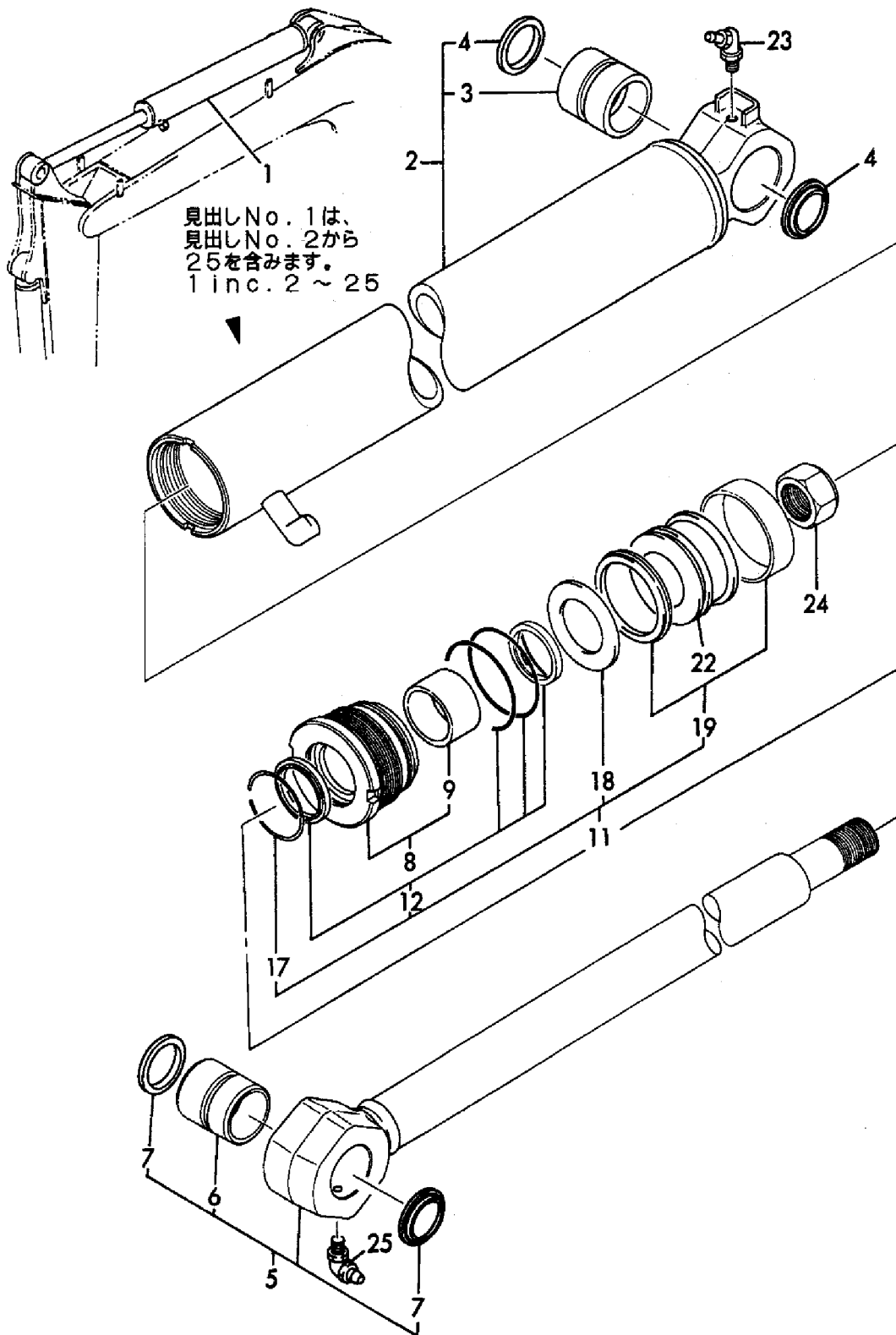

1,1,,933120-48602-1,, "CYLINDER ASSY, BUCKET",1,1,,,,,,,,,,,,,
2,2,,933121-48302-1,, "TUBE ASSY, BUCKET",1,1,,,,,,,,,,,,,
3,3,,172171-72150,, "BUSH 38X50X40",1,1,,,,,,,,,,,,,
4,3,,172168-81270,, "SEAL, DUST 38X50X4",2,2,,,,,,,,,,,,,
5,2,,172312-72311,, "ROD COMP., BUCKET",1,1,,,,,,,,,,,,,
6,3,,172171-72150,, "BUSH 38X50X40",1,1,,,,,,,,,,,,,
7,3,,172168-81270,, "SEAL, DUST 38X50X4",2,2,,,,,,,,,,,,,
8,2,,172143-72400,, "HEAD 70 40",1,1,,,,,,,,,,,,,
9,3,,933135-14600,, "BUSH 40 30, ROD",1,1,,,,,,,,,,,,,
11,2,,172164-72360,, "CYLINDER KIT, BUCKET",1,1,,,,,,,,,,,,,
12,3,,172146-72930,, "SEAL SET, HEAD",1,1,,,,,,,,,,,,,
17,3,,933111-26600,, "RING 55, SPRING",1,1,,,,,,,,,,,,,
18,3,,172141-72420,, "WASHER 70, LOCK",1,1,,,,,,,,,,,,,
19,3,,172143-72010,, "SEAL SET, PISTON",1,1,,,,,,,,,,,,,
22,2,,172141-73021,, "PISTON 70 27 A",1,1,,,,,,,,,,,,,
23,2,,172141-72250,, "U-NUT M27",1,1,,,,,,,,,,,,,
24,2,,24761-040000,, "NIPPLE B, GREASE",2,2,,,,,,,,,,,,,
25,2,,933136-40503,, "TUBE",1,1,,,,,,,,,,,,,
26,2,,172141-73041,, "PISTON 70 27 C",1,1,,,,,,,,,,,,,
27,2,,26013-100202,, "BOLT W/WASHER M10X20",1,1,,,,,,,,,,,,,
28,2,,22137-100000,, "WASHER 10, POLISHED",1,1,,,,,,,,,,,,,

Fig. **51** バケットシリンダ
BUCKET CYLINDER

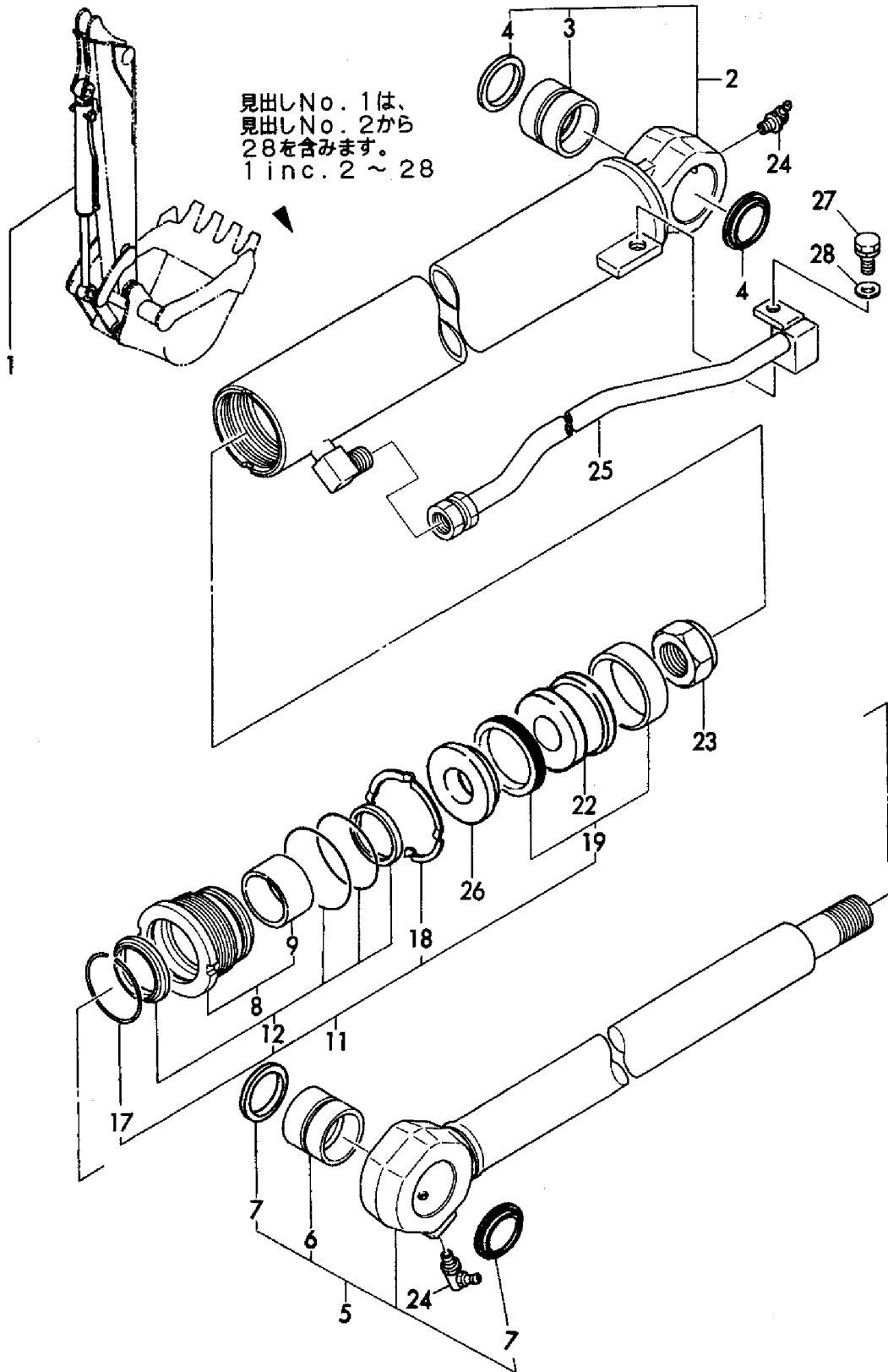

1,1,,172164-79800,, "CYLINDER, BUCKET(97)",1,1,,,,,,,,,,,,,
2,2,,172142-99420,, "CYLINDER KIT, BUCKET",1,1,,,,,,,,,,,,,
3,3,,172142-72560,, "WASHER 65, LOCK",1,1,,,,,,,,,,,,,
4,3,,172142-72920,, "SEAL SET, HEAD",1,1,,,,,,,,,,,,,
9,3,,172148-72940,, "SEAL SET, PISTON",1,1,,,,,,,,,,,,,
12,3,,933111-26600,, "RING 55, SPRING",1,1,,,,,,,,,,,,,
13,2,,172141-72250,, "U-NUT M27",1,1,,,,,,,,,,,,,
14,2,,172142-72501,, "ROD, BUCKET",1,1,,,,,,,,,,,,,
15,3,,172168-72240,, "BUSH 38X50X40",1,1,,,,,,,,,,,,,
16,3,,172168-81270,, "SEAL,DUST 38X50X4",2,2,,,,,,,,,,,,,
17,2,,172142-72510,, "HEAD 65 40 W/BUSH",1,1,,,,,,,,,,,,,
19,3,,933135-14600,, "BUSH 40 30, ROD",1,1,,,,,,,,,,,,,
20,2,,172148-72790,, "PISTON 65",1,1,,,,,,,,,,,,,
21,2,,172164-79810,, "TUBE,BUCKET(GREEN:97)",1,1,,,,,,,,,,,,,
22,3,,172168-72240,, "BUSH 38X50X40",1,1,,,,,,,,,,,,,
23,3,,172168-81270,, "SEAL,DUST 38X50X4",2,2,,,,,,,,,,,,,
24,2,,24761-040000,, "NIPPLE B,GREASE",2,2,,,,,,,,,,,,,

Fig. 52 バケットシリンダ (テレスコピックアーム)
BUCKET CYLINDER (TELESCOPIC ARM)

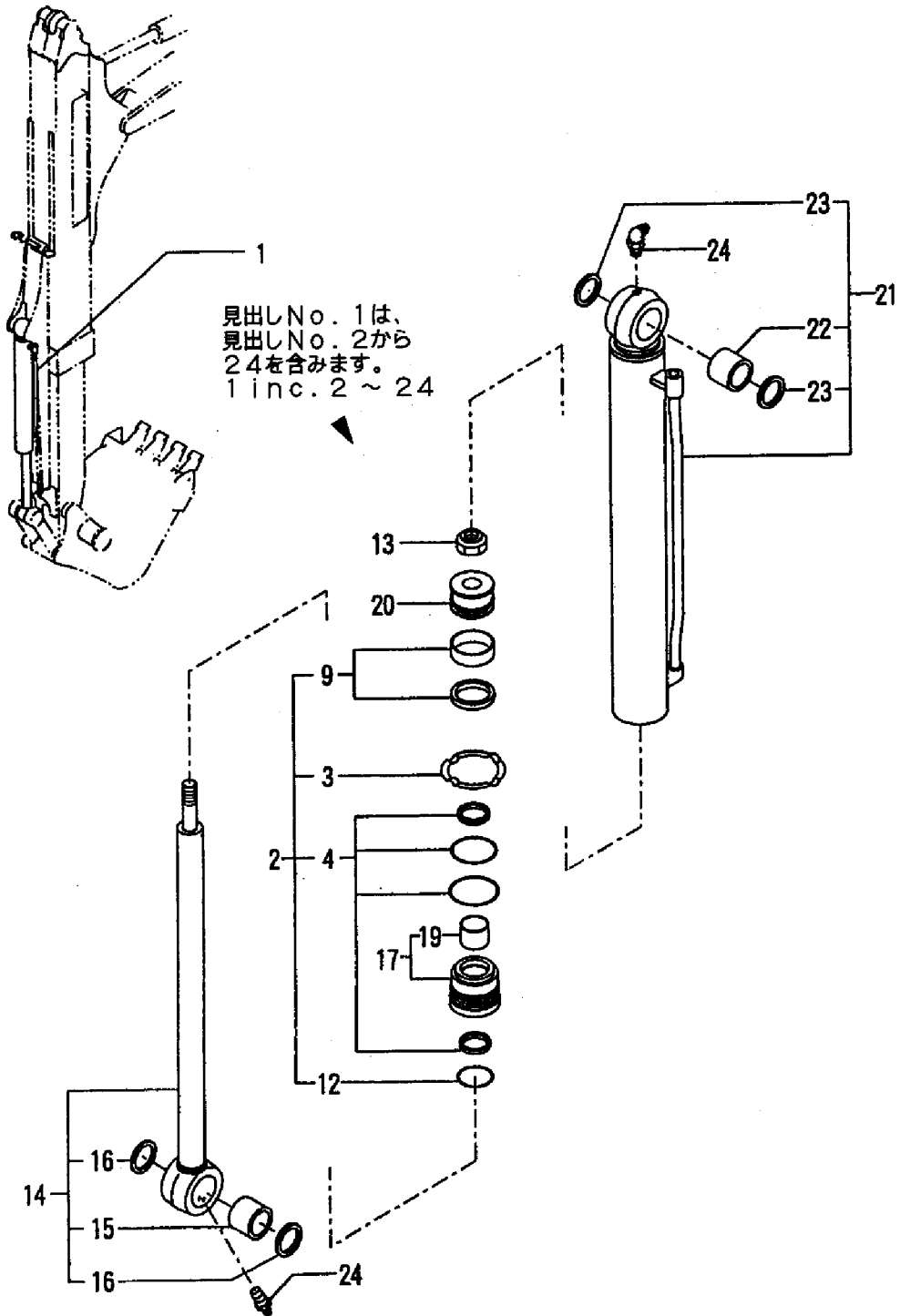

1,1,,172164-79600,,CYLINDER,1,1,,,,,,,,,,,,,
2,2,,172168-72010,, "SEAL KIT",1,1,,,,,,,,,,,,,
3,3,,172168-72020,, "SEAL SET, HEAD 70X40",1,1,,,,,,,,,,,,,
8,3,,172168-72030,, "PISTON SEAL SET70X40",1,1,,,,,,,,,,,,,
11,3,,172141-72420,, "WASHER 70, LOCK",1,1,,,,,,,,,,,,,
12,3,,933111-26600,, "RING 55, SPRING",1,1,,,,,,,,,,,,,
13,2,,172141-72250,, "U-NUT M27",1,1,,,,,,,,,,,,,
14,2,,172143-72400,, "HEAD 70 40",1,1,,,,,,,,,,,,,
16,3,,933135-14600,, "BUSH 40 30, ROD",1,1,,,,,,,,,,,,,
17,2,,172141-73021,, "PISTON 70 27 A",1,1,,,,,,,,,,,,,
18,2,,172141-73041,, "PISTON 70 27 C",1,1,,,,,,,,,,,,,
19,2,,172164-79610,, TUBE,1,1,,,,,,,,,,,,,
20,3,,172168-72410,, "BUSH 40X50X40",1,1,,,,,,,,,,,,,
21,3,,172165-81750,, "SEAL 40X50X5, DUST",2,2,,,,,,,,,,,,,
22,2,,172164-79680,, SLIDE,2,2,,,,,,,,,,,,,
23,2,,172164-79700,, ROD,1,1,,,,,,,,,,,,,
24,3,,172168-72410,, "BUSH 40X50X40",1,1,,,,,,,,,,,,,
25,3,,172165-81750,, "SEAL 40X50X5, DUST",2,2,,,,,,,,,,,,,
26,2,,24761-040000,, "NIPPLE B,GREASE",1,1,,,,,,,,,,,,,

Fig. 53 スライドシリンダ (テレスコピックアーム)
SLIDE CYLINDER (TELESCOPIC ARM)

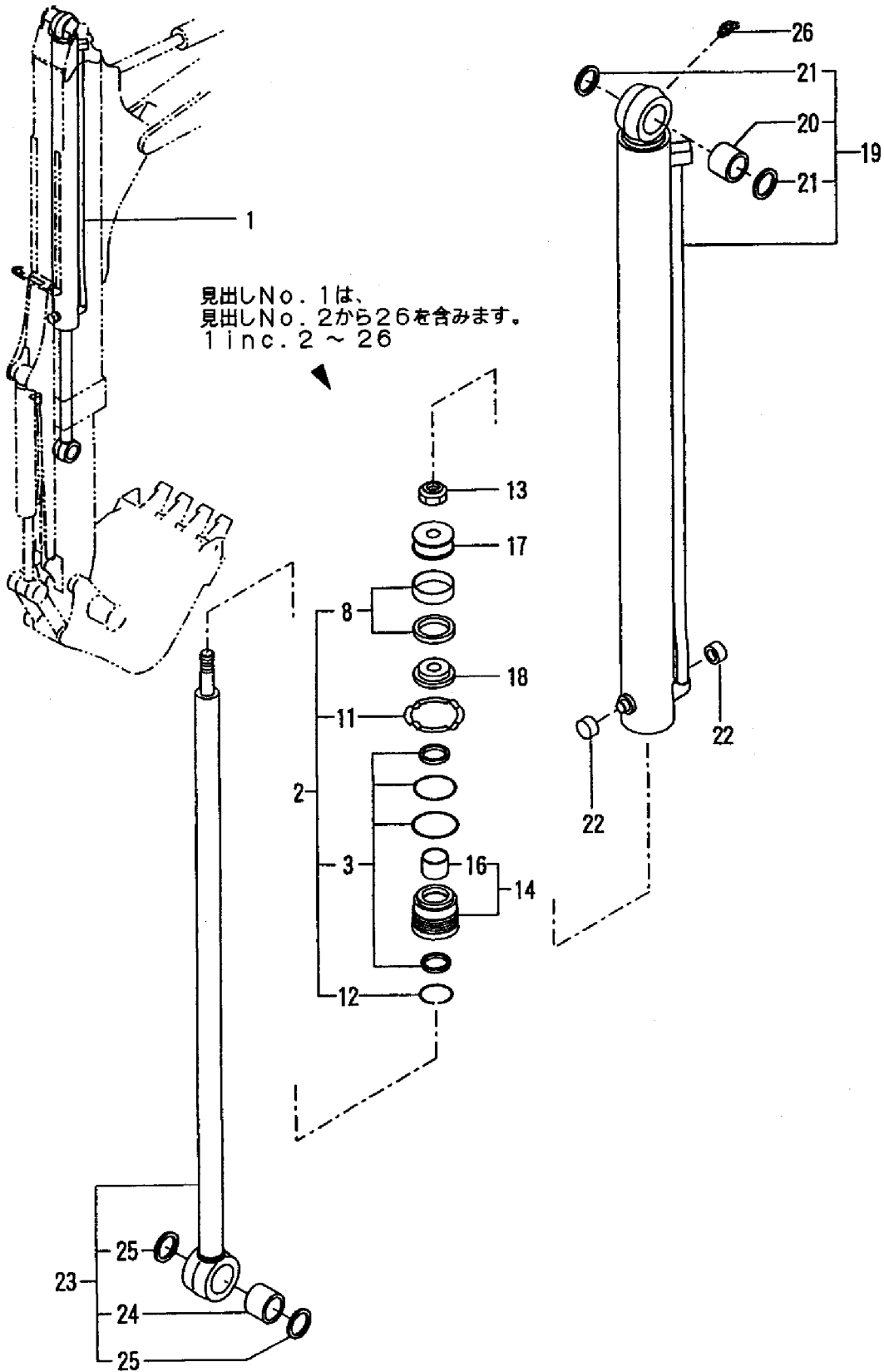

1,1,,172151-72753-1,, "CYLINDER ASSY, SWING",1,1,,,,,,,,,,,,,
2,2,,172151-72070-3,, "TUBE, SWING",1,1,,,,,,,,,,,,,
4,3,,172165-72310,, "BUSH 40X40",1,1,,,,,,,,,,,,,
5,3,,172165-81750,, "SEAL 40X50X5, DUST",2,2,,,,,,,,,,,,,
6,2,,172151-72060,, "ROD ASSY, SWING",1,1,,,,,,,,,,,,,
8,3,,172165-72310,, "BUSH 40X40",1,1,,,,,,,,,,,,,
9,3,,172165-81750,, "SEAL 40X50X5, DUST",2,2,,,,,,,,,,,,,
10,2,,172151-72840,, "HEAD 90 50",1,1,,,,,,,,,,,,,
11,3,,933135-14600,, "BUSH 40 30, ROD",1,1,,,,,,,,,,,,,
13,2,,172151-72080,, "CYLINDER KIT, SWING",1,1,,,,,,,,,,,,,
14,3,,172151-71860,, "SEAL SET, HEAD",1,1,,,,,,,,,,,,,
21,3,,933111-26600,, "RING 55, SPRING",1,1,,,,,,,,,,,,,
22,3,,172151-72870,, "LOCK WASHER 90",1,1,,,,,,,,,,,,,
23,3,,22252-000561,, "CIRCLIP 56",1,1,,,,,,,,,,,,,
24,3,,172151-71850,, "SEAL SET, PISTON",1,1,,,,,,,,,,,,,
29,3,,172142-72810,, "CIRCLIP 22",1,1,,,,,,,,,,,,,
30,2,,172137-72730,, "RING 44B, CUSHION",1,1,,,,,,,,,,,,,
31,2,,172151-72950,, "PISTON 90",1,1,,,,,,,,,,,,,
32,2,,172151-72960,, "SPACER 90 27 19",1,1,,,,,,,,,,,,,
33,2,,172141-72250,, "U-NUT M27",1,1,,,,,,,,,,,,,
34,2,,933127-23001,, "CUSHION PLUNGER 44 C",1,1,,,,,,,,,,,,,
35,2,,172137-72710,, "COLLAR 40B, CUSHION",1,1,,,,,,,,,,,,,
36,2,,172137-72720,, "COLLAR 40A, CUSHION",1,1,,,,,,,,,,,,,
37,2,,172135-72800,, "RING 40 B, CUSHION",1,1,,,,,,,,,,,,,
38,2,,24761-020000,, "NIPPLE PT1/8, GREASE",1,1,,,,,,,,,,,,,
39,1,,172165-72401-4,, "COVER, SWING(GREEN)",1,,,,,,,,,,,,,
40,1,,933147-03400,, "WASHER, BRAKE ARM",1,,,,,,,,,,,,,
41,1,,22217-100000,, "SPRING WASHER 10",1,1,,,,,,,,,,,,,
42,1,,26116-100162,, "BOLT M10X 16 PLATED",1,1,,,,,,,,,,,,,
43,1,,933168-14170,, "SPRING 16",2,,,,,,,,,,,,,

Fig. 54 スイングシリンダ
SWING CYLINDER

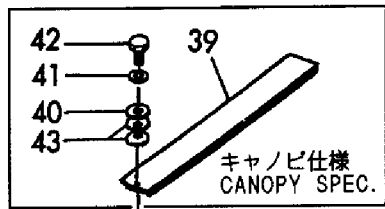

見出しNo. 1は、
見出しNo. 2から
38を含みます。
1 inc. 2 ~ 38

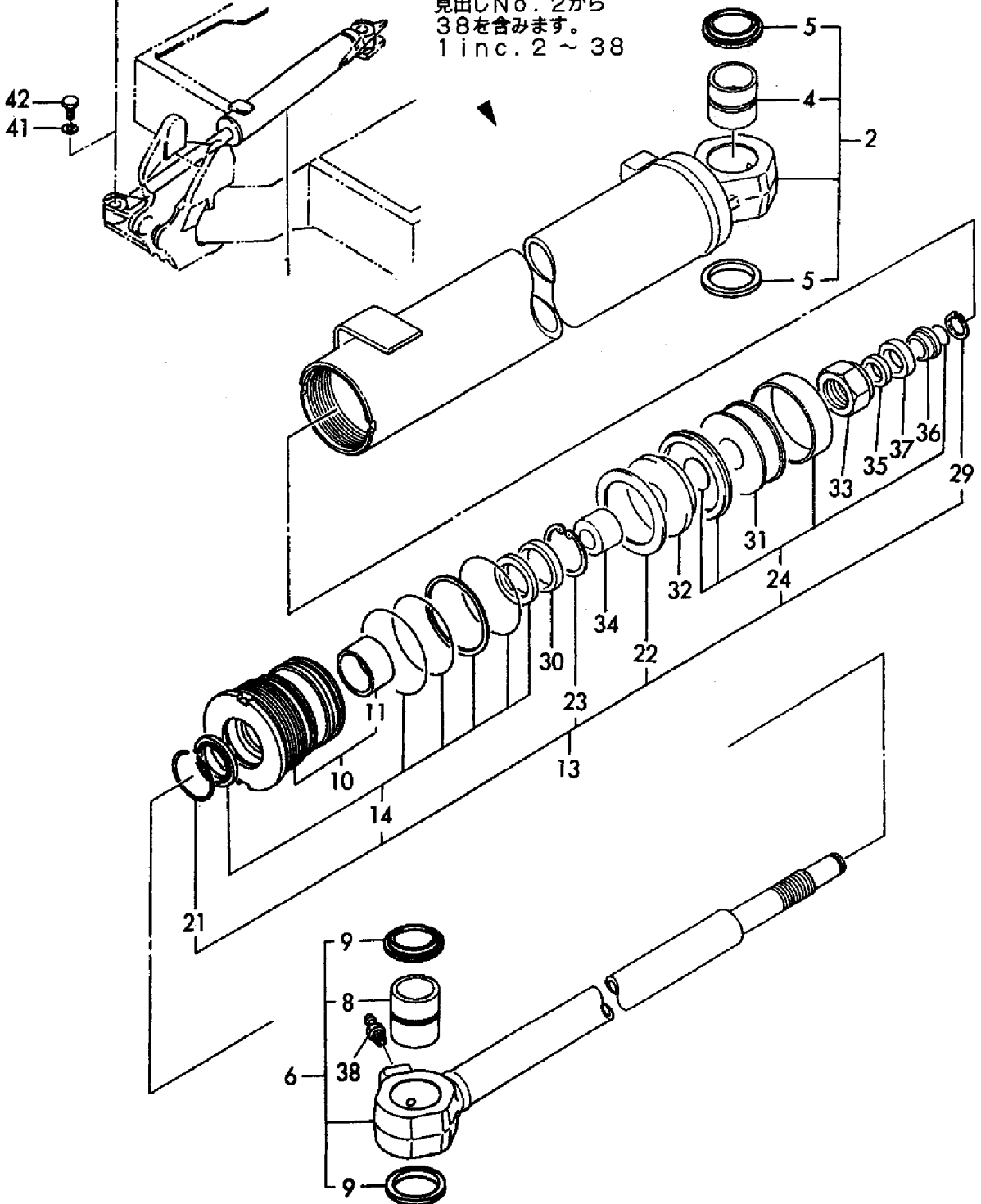

1,1,,172164-72600,, "CYLINDER, BLADE",1,1,,,,,,,,,,,,,
2,2,,172151-72920-1,, "TUBE, BLADE",1,1,,,,,,,,,,,,,
4,3,,172151-72670,, "BUSH 45 50",1,1,,,,,,,,,,,,,
5,3,,933126-44500,, "SEAL VAY45X55X4,DUST",2,2,,,,,,,,,,,,,
6,2,,172164-72630,, "ROD ASSY(BLADE",1,1,,,,,,,,,,,,,
8,3,,172151-72670,, "BUSH 45 50",1,1,,,,,,,,,,,,,
9,3,,933126-44500,, "SEAL VAY45X55X4,DUST",2,2,,,,,,,,,,,,,
10,2,,172151-71590,, "HEAD 90 50",1,1,,,,,,,,,,,,,
11,3,,172151-72540,, "BUSH 50 35, ROD",1,1,,,,,,,,,,,,,
13,2,,172151-72940,, "CYLINDER KIT, BLADE",1,1,,,,,,,,,,,,,
14,3,,172151-71880,, "SEAL SET, HEAD",1,1,,,,,,,,,,,,,
19,3,,933111-26700,, "RING 65, SPRING",1,1,,,,,,,,,,,,,
20,3,,172151-72870,, "LOCK WASHER 90",1,1,,,,,,,,,,,,,
21,3,,172151-71870,, "SEAL SET, PISTON",1,1,,,,,,,,,,,,,
24,2,,172151-71610,, PISTON,1,1,,,,,,,,,,,,,
24-1,2,,172164-72640,, PISTON,1,1,,,,,S,,,M/#02529,,M/#02529,,,,,
25,2,,172151-71620,, "SPACER 90 36 19",1,1,,,,,Z,,,M/#02529,,M/#02529,,,,,
26,2,,172151-72580,, "U-NUT M36",1,1,,,,,,,,,,,,,
27,2,,172151-71640,, TUBE,1,1,,,,,,,,,,,,,
28,2,,22217-100000,, "SPRING WASHER 10",1,1,,,,,,,,,,,,,
29,2,,26116-100202,, "BOLT M10X 20 PLATED",1,1,,,,,,,,,,,,,
30,2,,22137-100000,, "WASHER 10,POLISHED",1,1,,,,,,,,,,,,,

Fig. 55 ブレードシリンダ BLADE CYLINDER

見出しNo. 1は、見出しNo. 2から30を含みます。
1 inc. 2 ~ 30

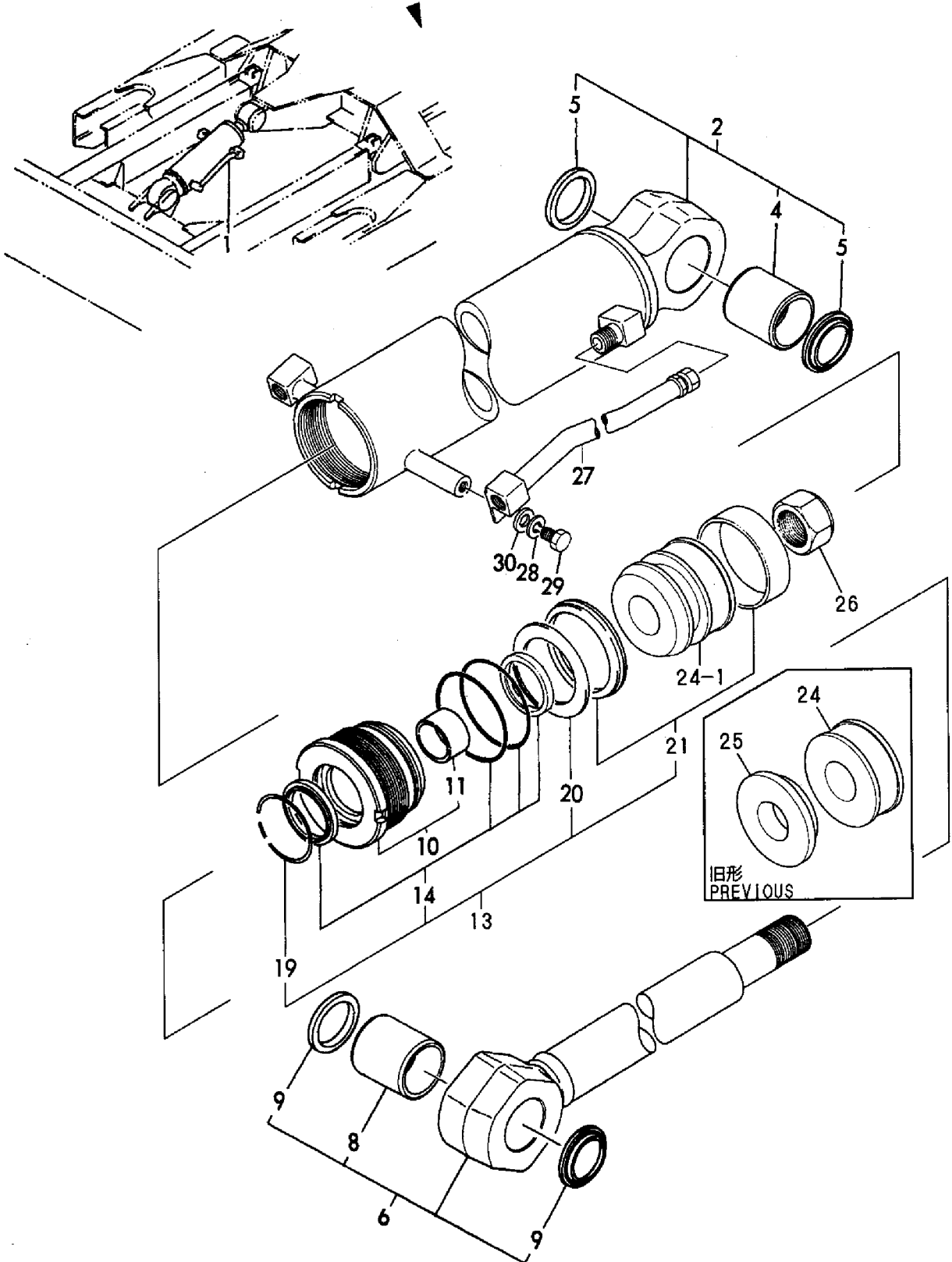

1,1,,172164-73300,, "MOTOR ASSY,DRIVING",2,2,,,,,,,,,,,,,
2,2,,172123-70020,, BALL,4,4,,,,,,,,,,,,,
4,2,,172147-70490,, SPRING,2,2,,,,,,,,,,,,,
5,2,,172141-70040,, "NUT, RING",2,2,,,,,,,,,,,,,
6,2,,172164-70150,, "PLATE, THRUST",2,2,,,,,,,,,,,,,
7,2,,172141-70110,, SCREW,8,8,,,,,,,,,,,,,
8,2,,172148-70110,, "BEARING, ANGULAR",2,2,,,,,,,,,,,,,
9,2,,172164-70110,, "GEAR(B), PLANETARY",8,8,,,,,,,,,,,,,
10,2,,172164-70120,, "CAGE & ROLLER",8,8,,,,,,,,,,,,,
11,2,,172164-70130,, COLLAR,8,8,,,,,,,,,,,,,
12,2,,172147-70120,, "GAUGE & ROLLER",6,6,,,,,,,,,,,,,
13,2,,172141-70090,, "WASHER, THRUST",8,8,,,,,,,,,,,,,
14,2,,172147-70130,, "RACE, INNER",6,6,,,,,,,,,,,,,
15,2,,172164-70160,, "GEAR, SUN",2,2,,,,,,,,,,,,,
16,2,,172164-70170,, HOLDER,2,2,,,,,,,,,,,,,
17,2,,172141-70180,, "PLATE(T1.8), THRUST",2,2,,,,,,,,,1,,,,,,,,,
18,2,,172164-70180,, "GEAR(A), PLANETARY",6,6,,,,,,,,,,,,,
19,2,,172141-70190,, "PLATE(T2.3), THRUST",2,2,,,,,,,,,1,,,,,,,,,
20,2,,172164-70210,, "GEAR, DRIVE",2,2,,,,,,,,,,,,,
21,2,,172141-70200,, "PLATE(T2.8), THRUST",2,2,,,,,,,,,1,,,,,,,,,
22,2,,172141-70210,, COVER,2,2,,,,,,,,,,,,,
23,2,,172147-70500,, PLUG,2,2,,,,,,,,,,,,,
24,2,,172141-70230,, WIRE,2,2,,,,,,,,,,,,,
25,2,,172122-70350,, BALL,264,264,,,,,,,,,,,,,
25-1,2,,172122-70350,, BALL,330,330,,,,,K,,,M/#00943,,M/#00943,,,,,
26,2,,172122-73430,, PLUG,4,4,,,,,,,,,,,,,
27,2,,22242-000352,, "CIRCLIP 35",2,2,,,,,,,,,,,,,
28,2,,22351-050020,, "SPRING PIN 5X20",6,6,,,,,,,,,,,,,
29,2,,23871-020000,, "PLUG PT1/4,SCREW",4,4,,,,,,,,,,,,,
30,2,,23871-030000,, "PLUG PT3/8,SCREW",4,4,,,,,,,,,,,,,
31,2,,172164-70230,, SHAFT,2,2,,,,,,,,,,,,,
32,2,,172148-70210,, PLATE,2,2,,,,,,,,,,,,,
33,2,,172147-70220,, PLUG,4,4,,,,,,,,,,,,,
34,2,,172147-70220,, PLUG,4,4,,,,,,,,,,,,,
35,2,,172147-70520,, PLUG,2,2,,,,,,,,,,,,,
36,2,,172147-70470,, ORIFICE,4,4,,,,,,,,,,,,,
37,2,,172122-70540,, "BOLT, SOCKET",12,12,,,,,,,,,,,,,
38,2,,24101-060054,, "BALL BEARING",2,2,,,,,,,,,,,,,
39,2,,172164-70290,, "BLOCK SET, RELIEF",2,2,,,,,,,,,2,,,,,,,,,
41,3,,172164-70310,, "VALVE SET, RELIEF",4,4,,,,,,,,,,,,,
45,3,,172148-70350,, BOLT,8,8,,,,,,,,,,,,,
46,2,,172147-70280,, COLLAR,2,2,,,,,,,,,,,,,
47,2,,172147-70290,, SPRING,2,2,,,,,,,,,,,,,
48,2,,172122-70670,, WASHER,2,2,,,,,,,,,,,,,
49,2,,172164-70350,, PLUG,4,4,,,,,,,,,,,,,
50,2,,172122-70630,, "SNAP RING",2,2,,,,,,,,,,,,,
51,2,,172147-70320,, PIN,6,6,,,,,,,,,,,,,
52,2,,172147-70330,, "HOLDER, RETAINER",2,2,,,,,,,,,,,,,
53,2,,172147-70340,, "PLATE, RETAINER",2,2,,,,,,,,,,,,,
54,2,,172312-74790,, ORIFICE,8,8,,,,,,,,,,,,,
55,2,,172147-70360,, SPRING,4,4,,,,,,,,,,,,,
56,2,,172147-70370,, "PLATE VALVE",2,2,,,,,,,,,,,,,
57,2,,172147-70390,, "BALL BEARING",2,2,,,,,,,,,,,,,
58,2,,172122-70410,, PIN,4,4,,,,,,,,,,,,,
59,2,,172122-70460,, "SPRING SEAT",4,4,,,,,,,,,,,,,
60,2,,172122-70840,, SPRING,4,4,,,,,,,,,,,,,
61,2,,172147-70460,, CAP,4,4,,,,,,,,,,,,,
62,2,,172122-73470,, PIN,2,2,,,,,,,,,,,,,
63,2,,172164-70380,, "SEAL KIT",2,2,,,,,,,,,,,,,
64,3,,172164-70360,, "SEAL KIT, REDUCTION",2,2,,,,,,,,,,,,,
67,3,,172148-70320,, "SEAL KIT, MOTOR",2,2,,,,,,,,,,,,,
75,3,,172164-70370,, "SEAL KIT, RELIEF",2,2,,,,,,,,,,,,,
83,2,,172164-70240,, "PISTON W/RINGS",4,4,,,,,,,,,,,,,

84,2,,172164-70390,, "CYLINDER BLOCK KIT",2,2,,,,,,,,,,,,,
87,2,,172164-70400,, "BASE PLATE KIT",2,2,,,,,,,,,,,,,
90,3,,172164-70250,, "PLUNGER ASSY",2,2,,,,,,,,,,,,,
95,1,,26013-120352,, "BOLT M12X 35",18,18,,,,,,,,,,,,,

Fig. 56 走行モータ TRAVEL MOTOR

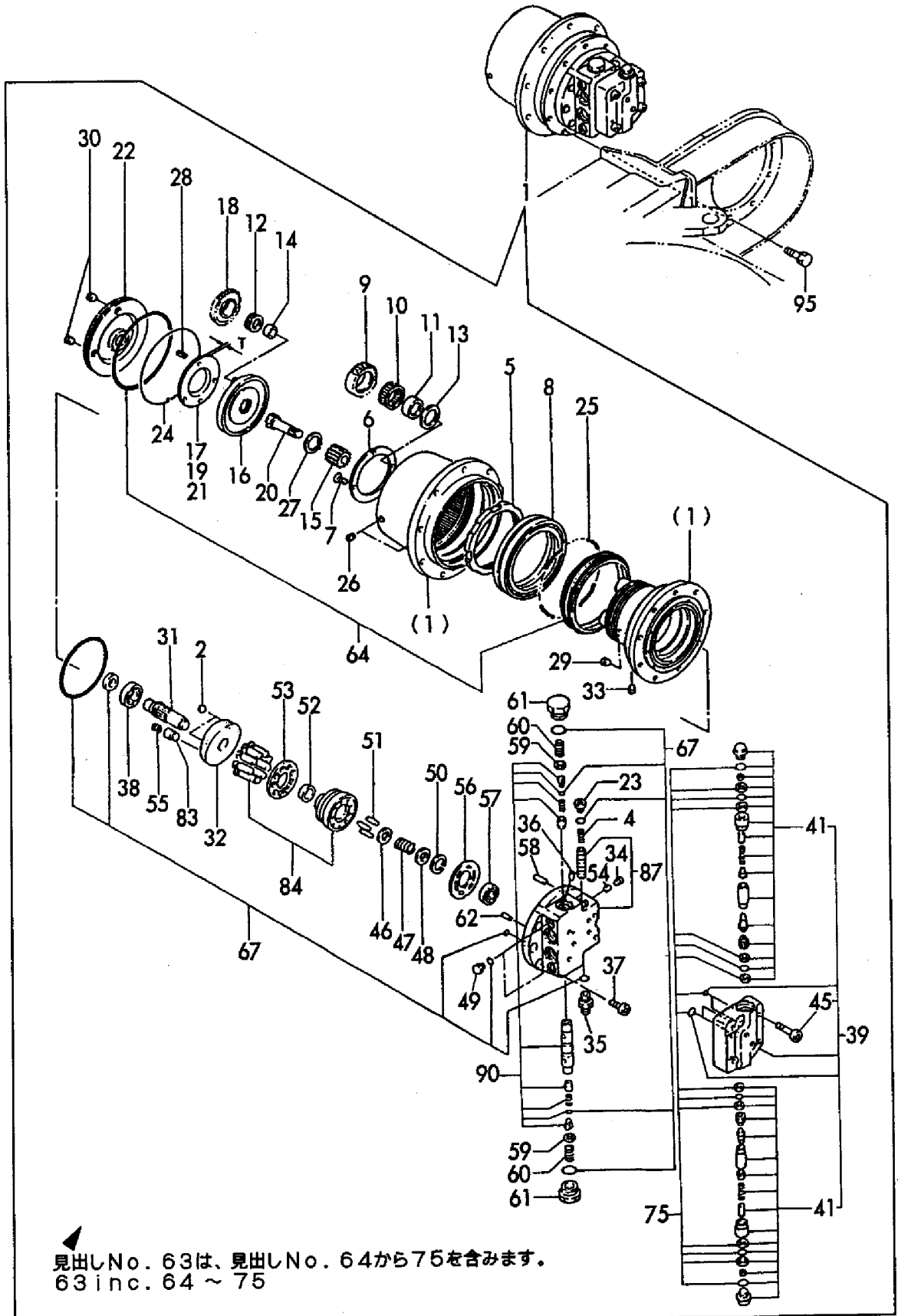

1,1,,172164-73311,, "MOTOR, TURNING",1,1,,,,,,,,,,,,,
2,2,,172164-73320,, "GEAR ASSY, REDUCTION",1,1,,,,,,,,,,,,,
3,3,,172165-73320,, "PINION SHAFT",1,1,,,,,,,,,,,,,
4,3,,172165-73330,, COLLER,1,1,,,,,,,,,,,,,
5,3,,172165-73350,, BEARING,1,1,,,,,,,,,,,,,
6,3,,172165-73360,, "GEAR CASE",1,1,,,,,,,,,,,,,
7,3,,172165-73380,, BEARING,1,1,,,,,,,,,,,,,
8,3,,172165-73390,, "HOLDER 2 ASSY",1,1,,,,,,,,,,,,,
9,3,,172165-73400,, GEAR,1,1,,,,,,,,,,,,,
10,3,,172165-73410,, "HOLDER 1 ASSY",1,1,,,,,,,,,,,,,
11,3,,172165-73420,, GEAR,1,1,,,,,,,,,,,,,
12,3,,26450-120802,, "BOLT M12X80",6,6,,,,,,,,,,,,,
13,3,,172165-73490,, "RING GEAR",1,1,,,,,,,,,,,,,
14,3,,172162-71540,, PIN,1,1,,,,,,,,,,,,,
15,3,,172165-73500,, COLLER,2,2,,,,,,,,,,,,,
16,3,,172162-71670,, "PLUG PT3/8",1,1,,,,,,,,,,,,,
17,3,,172164-73340,, "SEAL ASSY",1,1,,,,,,,,,,,,,
20,2,,172164-73330,, "MOTOR, HYD. OIL",1,1,,,,,,,,,,,,,
21,3,,172162-71900,, COLLAR,1,1,,,,,,,,,,,,,
22,3,,172165-73430,, BEARING,1,1,,,,,,,,,,,,,
23,3,,172162-71870,, "PLATE,CAM",1,1,,,,,,,,,,,,,
24,3,,172162-71860,, "PLATE,RETURN",1,1,,,,,,,,,,,,,
25,3,,172162-71850,, SPRING,1,1,,,,,,,,,,,,,
26,3,,172162-71750,, "PLATE,BALANCE",1,1,,,,,,,,,,,,,
27,3,,172165-73440,, BUSH,4,4,,,,,,,,,,,,,
28,3,,172165-73450,, "TEFLON RING",4,4,,,,,,,,,,,,,
29,3,,172165-73460,, "CONED DISC SPRING",4,4,,,,,,,,,,,,,
30,3,,172165-73470,, PISTON,2,2,,,,,,,,,,,,,
31,3,,172162-71710,, "BEARING,NEEDLE",1,1,,,,,,,,,,,,,
32,3,,172165-73480,, "SNAP RING",1,1,,,,,,,,,,,,,
33,3,,172165-73510,, "TEFLON RING",2,2,,,,,,,,,,,,,
34,3,,172164-73350,, "RELIEF ASSY",2,2,,,,,,,,,,,,,
35,3,,172162-71960,, "PIN,STRAIGHT",2,2,,,,,,,,,,,,,
36,3,,26450-120302,, "BOLT M12X30",4,4,,,,,,,,,,,,,
37,3,,172164-73360,, "SEAL ASSY",1,1,,,,,,,,,,,,,
42,1,,194202-56460,, BAND,1,1,,,,,,,,,,,,,
43,1,,26116-160502,, "BOLT M16X 50 PLATED",8,8,,,,,,,,,,,,,
44,1,,172162-73330,, "CONNECTOR 2-PT3/8",1,1,,,,,,,,,,,,,
45,1,,172165-76600,, "CONNECTOR PT1/4",1,1,,,,,,,,,,,,,
46,1,,172164-78750,, HOSE,1,1,,,,,,,,,,,,,
47,1,,22217-160000,, "SPRING WASHER 16",8,8,,,,,,,,,,,,,
48,1,,22487-100200,, "PIN 10X20",1,1,,,,,,,,,,,,,
49,1,,23000-022000,, "CLAMP 22",2,2,,,,,,,,,,,,,
50,1,,23111-030000,, "ELBOW (PT 3/8)",1,1,,,,,,,,,,,,,
51,1,,23871-030000,, "PLUG PT3/8,SCREW",1,1,,,,,,,,,,,,,

Fig. 57 旋回モータ (旧形)
TURNING MOTOR (PREVIOUS)

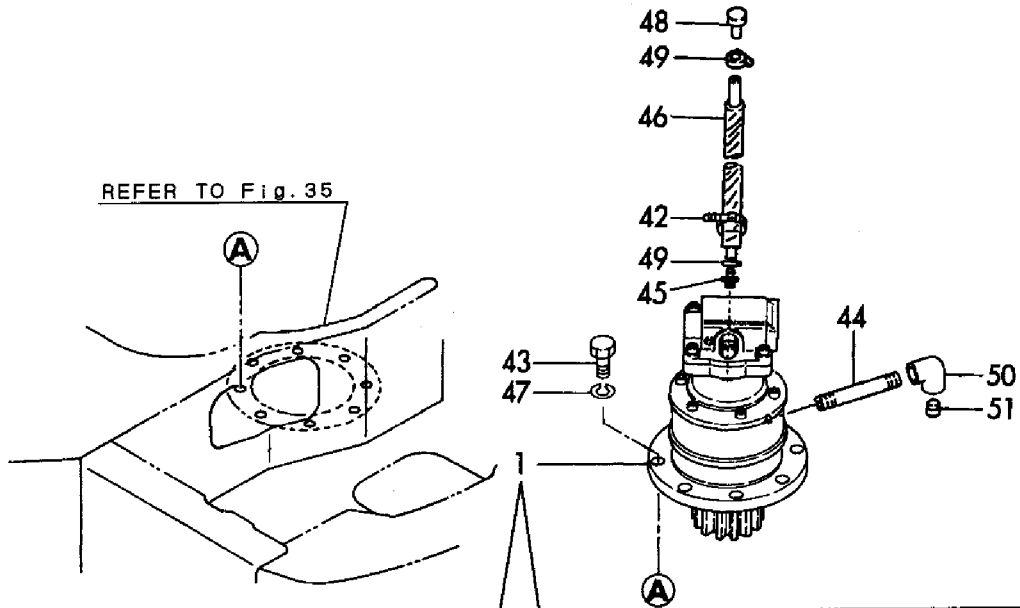

見出しNo. 20は、見出しNo. (20) から37を含みます。
20 inc. (20) ~ 37

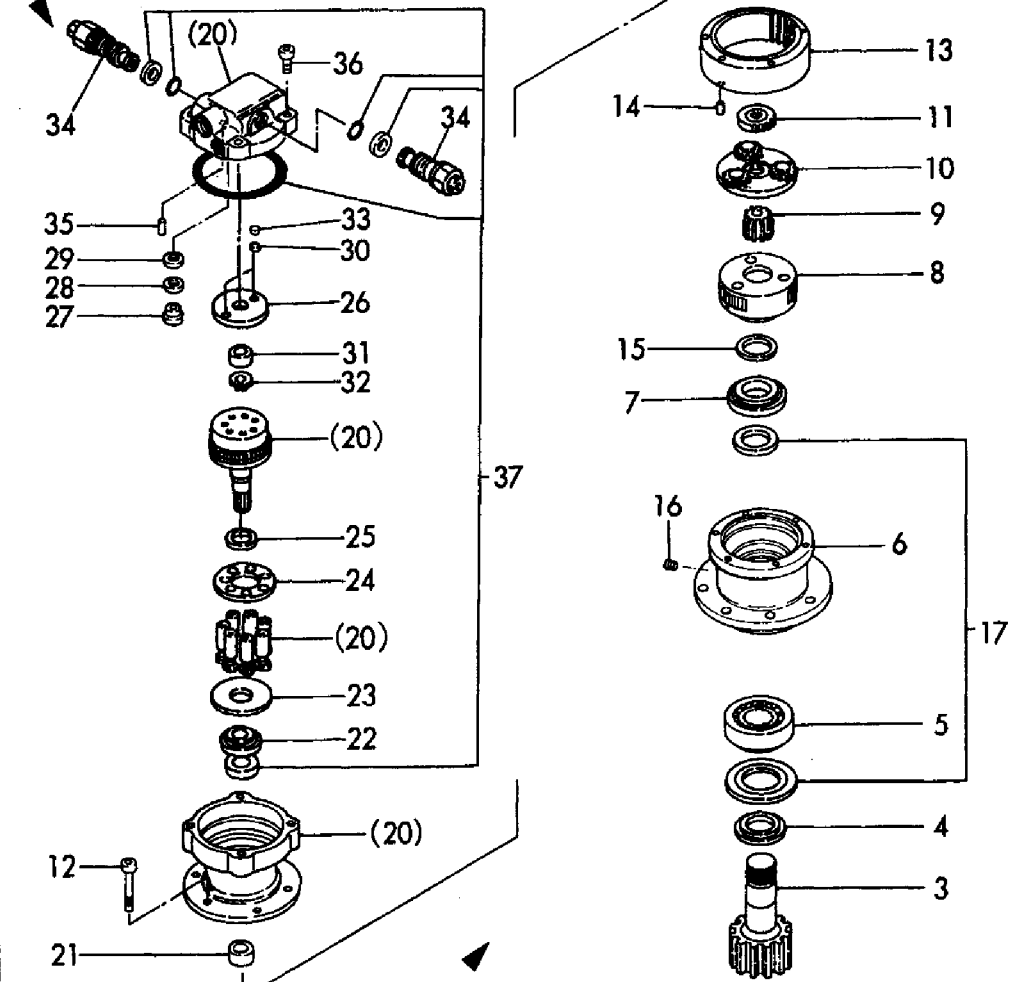

見出しNo. 2は、見出しNo. 3から17を含みます。
2 inc. 3 ~ 17

1,1,,172164-73312,, "MOTOR CMP,TURNING",1,1,,,,,,,,,,,,,
2,2,,172164-73321,, "GEAR ASSY, REDUCTION",1,1,,,,,,,,,,,,,
3,3,,172165-73320,, "PINION SHAFT",1,1,,,,,,,,,,,,,
4,3,,172165-73330,, COLLER,1,1,,,,,,,,,,,,,
5,3,,172165-73350,, BEARING,1,1,,,,,,,,,,,,,
6,3,,172165-73360,, "GEAR CASE",1,1,,,,,,,,,,,,,
7,3,,172165-73380,, BEARING,1,1,,,,,,,,,,,,,
8,3,,172165-73390,, "HOLDER 2 ASSY",1,1,,,,,,,,,,,,,
9,3,,172164-73290,, GEAR,1,1,,,,,,,,,,,,,
10,3,,172164-73430,, "HOLDER 1 ASSY",1,1,,,,,,,,,,,,,
11,3,,172165-73420,, GEAR,1,1,,,,,,,,,,,,,
12,3,,26450-120802,, "BOLT M12X80",6,6,,,,,,,,,,,,,
13,3,,172165-73490,, "RING GEAR",1,1,,,,,,,,,,,,,
14,3,,172162-71540,, PIN,1,1,,,,,,,,,,,,,
15,3,,172165-73500,, COLLER,2,2,,,,,,,,,,,,,
16,3,,172162-71670,, "PLUG PT3/8",1,1,,,,,,,,,,,,,
17,3,,172164-73340,, "SEAL ASSY",1,1,,,,,,,,,,,,,
20,2,,172164-73331,, "MOTOR, HYD. OIL",1,1,,,,,,,,,,,,,
21,3,,172162-71900,, COLLAR,1,1,,,,,,,,,,,,,
22,3,,172165-73430,, BEARING,1,1,,,,,,,,,,,,,
23,3,,172162-71870,, "PLATE,CAM",1,1,,,,,,,,,,,,,
24,3,,172162-71860,, "PLATE,RETURN",1,1,,,,,,,,,,,,,
25,3,,172162-71850,, SPRING,1,1,,,,,,,,,,,,,
26,3,,172176-73350,, "PLATE,BALANCE",1,1,,,,,,,,,,,,,
27,3,,172164-73090,, BUSH,4,4,,,,,,,,,,,,,
28,3,,172164-73080,, "TEFLON RING",4,4,,,,,,,,,,,,,
29,3,,172165-73460,, "CONED DISC SPRING",4,4,,,,,,,,,,,,,
30,3,,172176-73360,, PISTON,2,2,,,,,,,,,,,,,
31,3,,172162-71710,, "BEARING,NEEDLE",1,1,,,,,,,,,,,,,
32,3,,172165-73480,, "SNAP RING",1,1,,,,,,,,,,,,,
33,3,,172176-73370,, "TEFLON RING",2,2,,,,,,,,,,,,,
34,3,,172164-73350,, "RELIEF ASSY",2,2,,,,,,,,,,,,,
35,3,,172162-71960,, "PIN,STRAIGHT",2,2,,,,,,,,,,,,,
36,3,,26450-120302,, "BOLT M12X30",4,4,,,,,,,,,,,,,
37,3,,172164-73361,, "SEAL ASSY",1,1,,,,,,,,,,,,,
44,3,,172162-71720,, "PLATE,FRICTION",1,1,,,,,,,,,,,,,
45,3,,172162-71730,, PLATE,1,1,,,,,,,,,,,,,
46,3,,172162-71830,, PISTON,1,1,,,,,,,,,,,,,
47,3,,172162-71820,, SPRING,16,16,,,,,,,,,,,,,
48,1,,194202-56460,, BAND,1,1,,,,,,,,,,,,,
49,1,,26116-160502,, "BOLT M16X 50 PLATED",8,8,,,,,,,,,,,,,
50,1,,172162-73330,, "CONNECTOR 2-PT3/8",1,1,,,,,,,,,,,,,
51,1,,172165-76600,, "CONNECTOR PT1/4",1,1,,,,,,,,,,,,,
52,1,,172164-78750,, HOSE,1,1,,,,,,,,,,,,,
53,1,,22217-160000,, "SPRING WASHER 16",8,8,,,,,,,,,,,,,
54,1,,22487-100200,, "PIN 10X20",1,1,,,,,,,,,,,,,
55,1,,23000-022000,, "CLAMP 22",2,2,,,,,,,,,,,,,
56,1,,23111-030000,, "ELBOW (PT 3/8)",1,1,,,,,,,,,,,,,
57,1,,23871-030000,, "PLUG PT3/8,SCREW",1,1,,,,,,,,,,,,,

Fig. 58 旋回モータ (新形) TURNING MOTOR (NEW)

M/#02107 ~

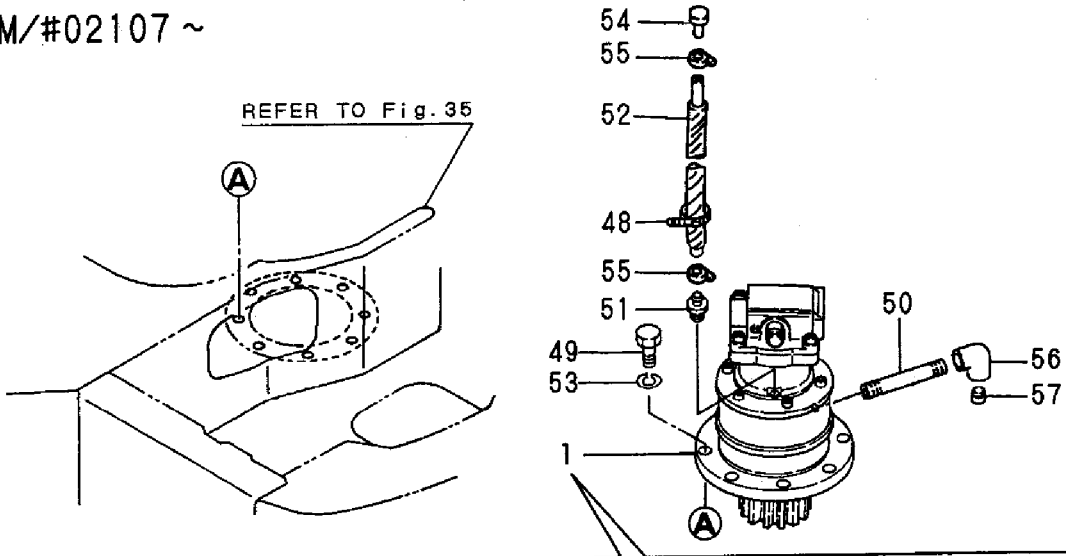

REFER TO Fig. 35

見出しNo. 2は、見出しNo. 3から17を含みます。
2 inc. 3 ~ 17
見出しNo. 20は、見出しNo. (20) から47を含みます。
20 inc. (20) ~ 47

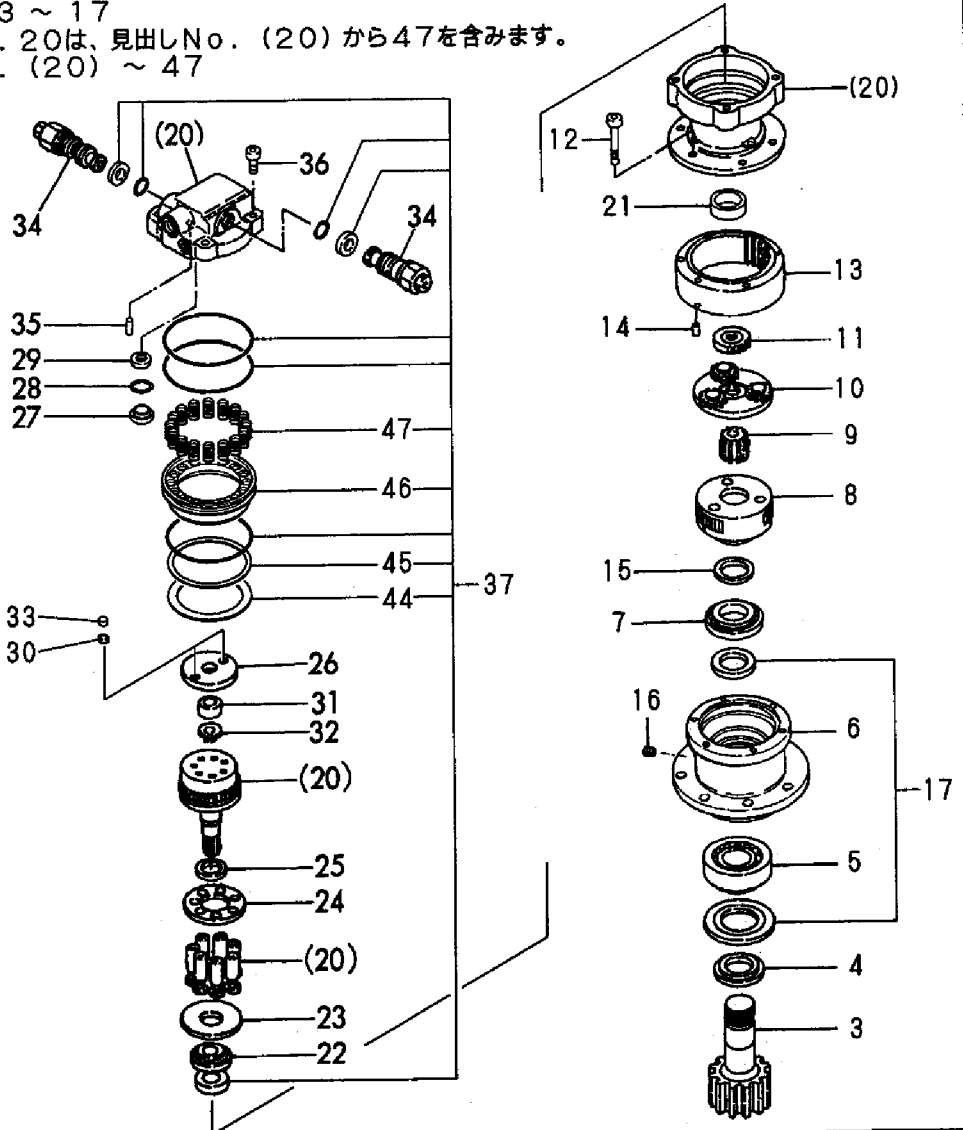

1,1,,172147-73800-1,, "JOINT ASSY, SWIVEL",1,1,,,,,,,,,,,,,
2,2,,172147-73810-1,, SHAFT,1,1,,,,,,,,,,,,,
3,2,,172147-73830,, "HUB, SWIVEL",1,1,,,,,,,,,,,,,
4,2,,172147-73850,, PLATE,1,1,,,,,,,,,,,,,
5,2,,172122-73860,, "SPACER, SWIVEL",1,1,,,,,,,,,,,,,
6,2,,172122-73870,, "THRUST WASHER",1,1,,,,,,,,,,,,,
7,2,,172147-73880,, "SEAL ASSY",1,1,,,,,,,,,,,,,
8,3,,172122-73890,, "SEAL, SWIVEL",8,8,,,,,,,,,,,,,
9,3,,24311-000800,, "O-RING 1A P-80.0",1,1,,,,,,,,,,,,,
10,3,,24311-001000,, "O-RING 1A P-100.0",1,1,,,,,,,,,,,,,
11,3,,24321-000950,, "O-RING 1A G-95.0",1,1,,,,,,,,,,,,,
12,2,,22242-000700,, "CIRCLIP 70",1,1,,,,,,,,,,,,,
13,2,,23871-030000,, "PLUG PT3/8, SCREW",4,4,,,,,,,,,,,,,
14,2,,26013-100402,, "BOLT M10X 40",4,4,,,,,,,,,,,,,
15,1,,26013-120502,, "BOLT M12X 50",4,4,,,,,,,,,,,,,

Fig. **59** スイベルジョイント
SWIVEL JOINT

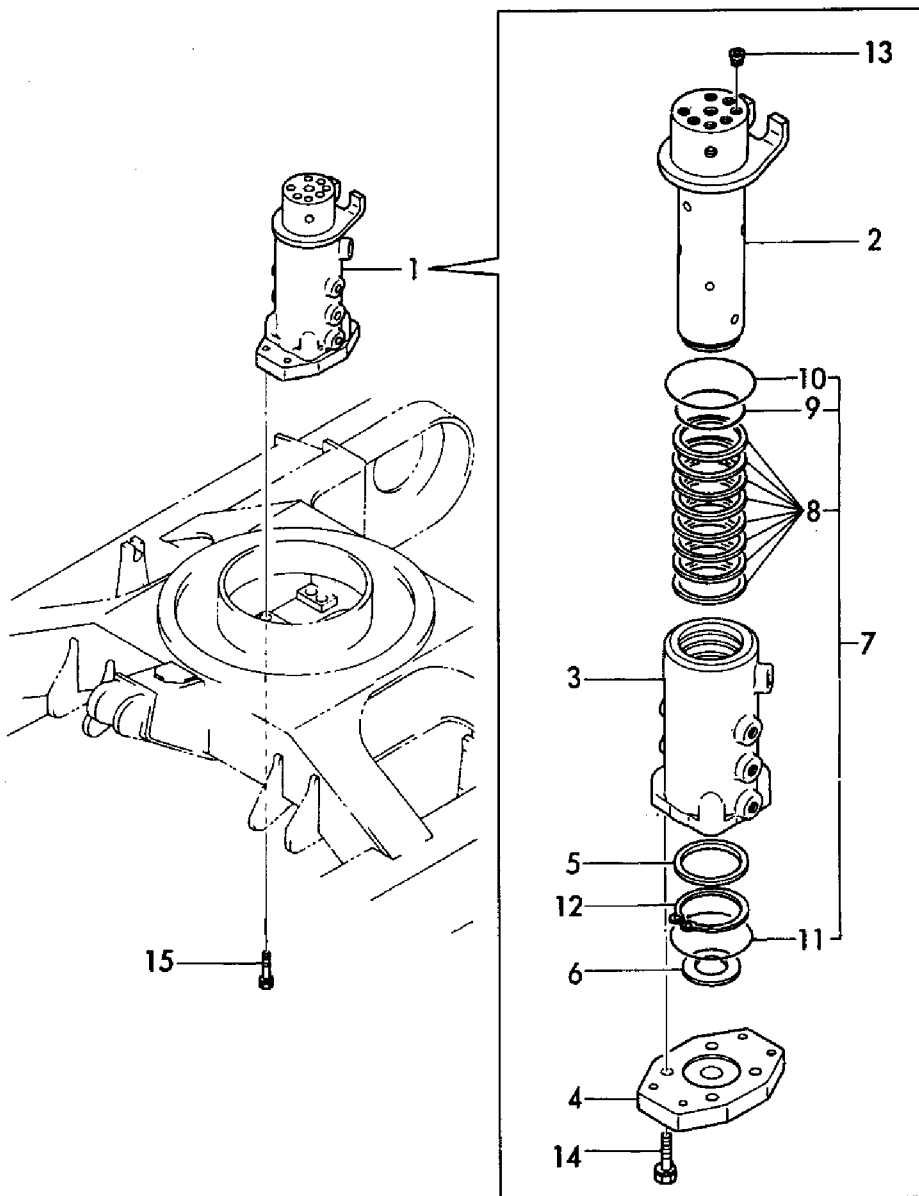

1,1,,172164-74100,, "VALVE ASSY, CONTROL",1,1,,,,,1,,,,,
1-1,1,,172164-74101,, "VALVE ASSY, CONTROL",1,1,,,,,N,1,,M/#00912,,M/#00912,,,,,
1-2,1,,172164-74102,, "VALVE ASSY, CONTROL",1,1,,,,,N,1,,M/#01187,,M/#01187,,,,,
2,2,,172164-74120,, "SECTION KIT,INLET",1,1,,,,,
3,3,,172164-74330,, "VALVE 175/25,RELIEF",1,1,,,,,
4,4,,172116-74150,, O-RING,1,1,,,,,
5,3,,172122-74520,, "SECTION, INLET",1,1,,,,,
6,4,,933171-80590,, O-RING,1,1,,,,,
7,2,,172164-74130,, "INLET SECTION ASSY",1,1,,,,,
8,3,,172164-74340,, "VALVE 190/35,RELIEF",1,1,,,,,
9,4,,172116-74150,, O-RING,1,1,,,,,
10,3,,172122-74520,, "SECTION, INLET",1,1,,,,,
11,4,,933171-80590,, O-RING,1,1,,,,,
12,2,,172164-74170,, "SECTION ASSY.,SPACER",1,1,,,,,
13,3,,172164-74270,, "SECTION KIT, SPOOL",1,1,,,,,
13A,4,,172122-73430,, PLUG,1,1,,,,,W,,M/#00501,,M/#00501,,,,,
14,3,,172175-74350,, "PLUG ASSY",1,1,,,,,W,, "FROM 1ST", "FROM 1ST",,,,,,
15,4,,172116-74150,, O-RING,1,1,,,,,
16,3,,172175-74270,, "PLUG ASSY",2,2,,,,,W,, "FROM 1ST", "FROM 1ST",,,,,,
17,4,,172112-06490,, O-RING,2,2,,,,,
18,2,,172164-74220,, "SPACER SECTION ASSY",1,1,,,,,
19,3,,172164-74330,, "VALVE 175/25,RELIEF",1,1,,,,,
20,4,,172116-74150,, O-RING,1,1,,,,,
21,3,,172146-74680,, "SECTION ASSY, SPACER",1,1,,,,,
22,4,,933171-80590,, O-RING,1,1,,,,,
23,3,,172168-72740,, "PLUG ASSY",1,1,,,,,
24,4,,172116-74150,, O-RING,1,1,,,,,
25,3,,172175-74270,, "PLUG ASSY",1,1,,,,,W,, "FROM 1ST", "FROM 1ST",,,,,,
26,4,,172112-06490,, O-RING,1,1,,,,,
27,2,,172151-74110,, TIE-ROD,2,2,,,,,
28,2,,172151-74120,, TIE-ROD,1,1,,,,,
29,2,,26716-080002,, "NUT M 8",4,4,,,,,
30,2,,26716-100002,, "NUT 10",2,2,,,,,
31,1,,172164-45560,, "PLATE COMP.,LINK",1,1,,,,,
31-1,1,,172164-45561,, "PLATE, LINK",1,1,,,,,N,,M/#01217,,M/#01217,,,,,
32,1,,172165-45490,, CUSHION,5,5,,,,,
33,1,,22252-000280,, "CIRCLIP 28",5,5,,,,,
34,1,,26106-100352,, "BOLT M10X 35 PLATED",5,5,,,,,
35,1,,26013-100302,, "BOLT M10X 30",3,3,,,,,
35-1,1,,26013-100352,, "BOLT M10X 35",3,3,,,,,N,, "FROM 1ST", "FROM 1ST",,,,,,
36,1,,26716-100002,, "NUT 10",1,1,,,,,
37,1,,172164-46310,, RUBBER,1,1,,,,,W,,M/#01247,,M/#01247,,,,,

Fig. 60 コントロールバルブ (Pポート)
CONTROL VALVE (P PORT)

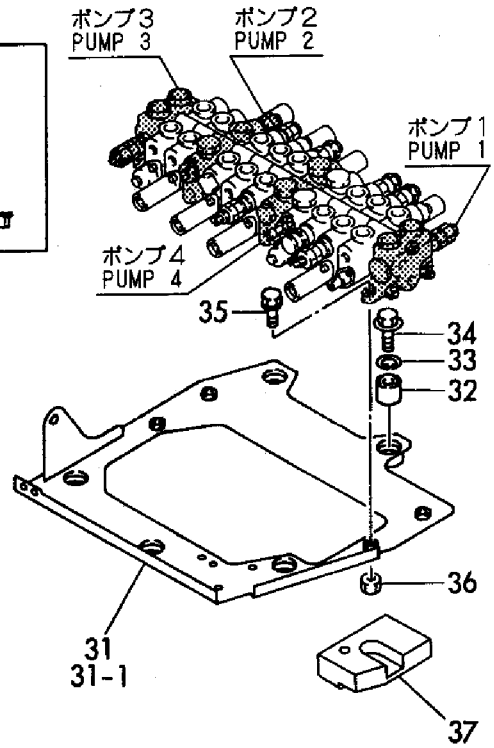
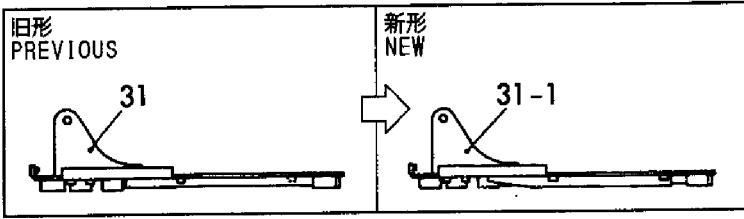

コントロールバルブASSY
CONTROL VALVE ASSY
(172164-74100)
Fig. 60 REF. No. 1
(172164-74101)
Fig. 60 REF. No. 1-1
(172164-74102)
Fig. 60 REF. No. 1-2
Inc. Fig. 60 REF. No. 2 ~ 30
Fig. 61 REF. No. 1 ~ 47
Fig. 62 REF. No. 1 ~ 44
Fig. 63 REF. No. 1 ~ 40
Fig. 64 REF. No. 1 ~ 29

1
1-1
1-2

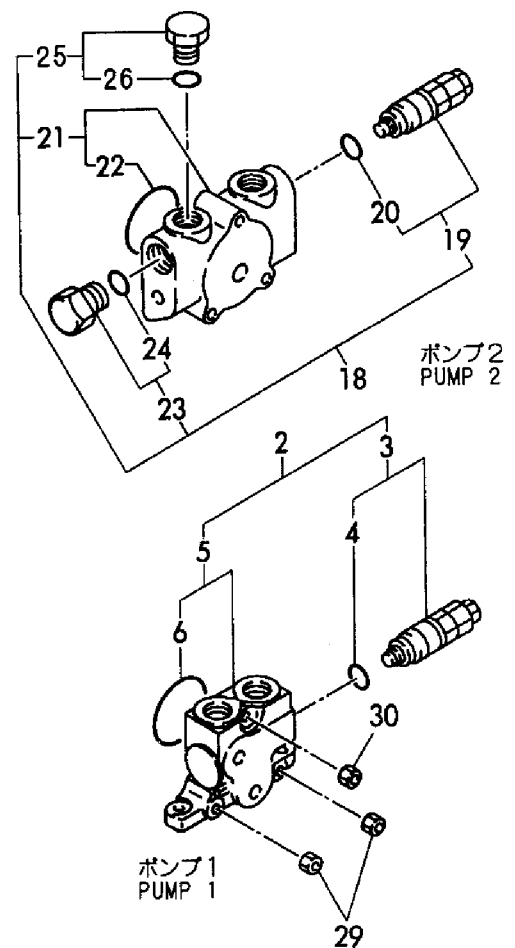
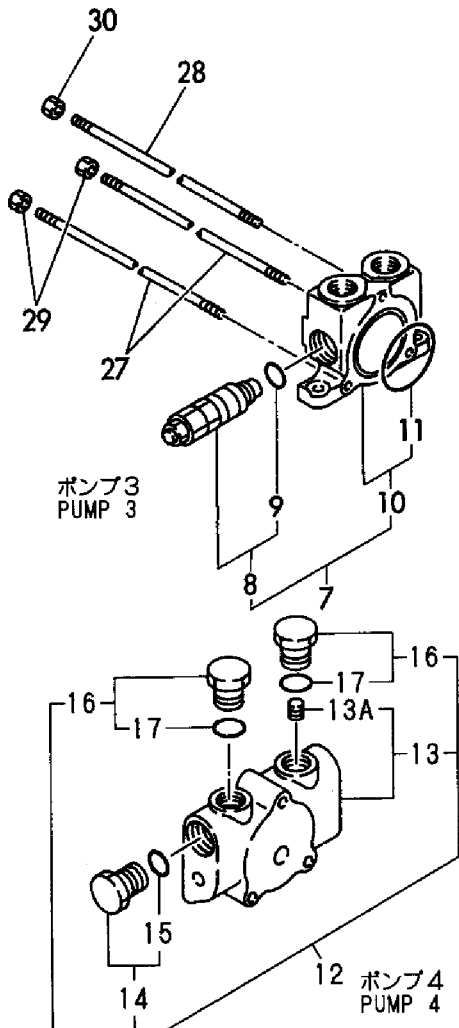

1,2,,172164-74160,, "SECTION ASSY.,SPOOL",1,1,,,,,,,,,,,,,
2,3,,172164-74260,, "SECTION ASSY, SPOOL",1,1,,,,,,,,,,,,,
3,4,,172164-74400,, "O-RING ASSY",1,1,,,,,1,,,,,,,,,,,,,
4,4,,933166-80520,, WIPER,2,2,,,,,,,,,,,,,
5,4,,933171-80610,, O-RING,2,2,,,,,,,,,,,,,
6,4,,933166-80530,, CAP,1,1,,,,,W,,,M/#00501,,M/#00501,,,,,
7,4,,933171-80590,, O-RING,1,1,,,,,,,,,,,,,
8,4,,172116-74190,, "PLATE, SEAL",2,2,,,,,W,,,M/#00501,,M/#00501,,,,,
9,4,,933171-80510,, "SEAT, SPRING",2,2,,,,,W,,,M/#00501,,M/#00501,,,,,
10,4,,933166-80550,, "SCREW, CAP",1,1,,,,,W,,,M/#00501,,M/#00501,,,,,
11,4,,172122-74050,, SPRING,1,1,,,,,W,,,M/#00501,,M/#00501,,,,,
12,4,,172122-74130,, POPPET,1,1,,,,,W,,,M/#00501,,M/#00501,,,,,
13,4,,172168-72750,, "SPRING,CHECK VALVE",1,1,,,,,W,,,M/#00501,,M/#00501,,,,,
14,4,,172116-74220,, SCREW,2,2,,,,,W,,,M/#00501,,M/#00501,,,,,
15,4,,172151-74060,, "BOLT, SOCKET HEAD",2,2,,,,,W,,,M/#00501,,M/#00501,,,,,
16,3,,172146-74720,, "VALVE ASSY, SHUT-OFF",2,2,,,,,,,,,,,,,
17,4,,172116-74150,, O-RING,2,2,,,,,,,,,,,,,
18,4,,24311-240100,, "O-RING 1A P-10A",2,2,,,,,,,,,,,,,
19,3,,172175-74270,, "PLUG ASSY",2,2,,,,,W,,, "FROM 1ST",, "FROM 1ST",,,,,,
20,4,,172112-06490,, O-RING,2,2,,,,,,,,,,,,,
21,2,,172164-74290,, "SECTION ASSY.,SPOOL",1,1,,,,,,,,,,,,,
22,3,,172164-74400,, "O-RING ASSY",1,1,,,,,,,,,,,,,
23,4,,933166-80520,, WIPER,2,2,,,,,,,,,,,,,
24,4,,933171-80610,, O-RING,2,2,,,,,,,,,,,,,
25,4,,933166-80530,, CAP,1,1,,,,,W,,,M/#00501,,M/#00501,,,,,
26,3,,933171-80590,, O-RING,1,1,,,,,,,,,,,,,
27,3,,172116-74190,, "PLATE, SEAL",2,2,,,,,W,,,M/#00501,,M/#00501,,,,,
28,3,,933171-80510,, "SEAT, SPRING",2,2,,,,,W,,,M/#00501,,M/#00501,,,,,
29,3,,933166-80550,, "SCREW, CAP",1,1,,,,,W,,,M/#00501,,M/#00501,,,,,
30,3,,172122-74050,, SPRING,1,1,,,,,W,,,M/#00501,,M/#00501,,,,,
31,3,,172116-74220,, SCREW,2,2,,,,,W,,,M/#00501,,M/#00501,,,,,
32,3,,172151-74060,, "BOLT, SOCKET HEAD",2,2,,,,,W,,,M/#00501,,M/#00501,,,,,
33,2,,172168-72640,, "SECTION ASSY, SPOOL",1,1,,,,,,,,,,,,,
34,3,,172164-74400,, "O-RING ASSY",1,1,,,,,,,,,,,,,
35,4,,933166-80520,, WIPER,2,2,,,,,,,,,,,,,
36,4,,933171-80610,, O-RING,2,2,,,,,,,,,,,,,
37,4,,933166-80530,, CAP,1,1,,,,,W,,,M/#00501,,M/#00501,,,,,
38,3,,933171-80590,, O-RING,1,1,,,,,,,,,,,,,
39,3,,172116-74190,, "PLATE, SEAL",2,2,,,,,W,,,M/#00501,,M/#00501,,,,,
40,3,,933171-80510,, "SEAT, SPRING",2,2,,,,,W,,,M/#00501,,M/#00501,,,,,
41,3,,933166-80550,, "SCREW, CAP",1,1,,,,,W,,,M/#00501,,M/#00501,,,,,
42,3,,172122-74050,, SPRING,1,1,,,,,W,,,M/#00501,,M/#00501,,,,,
43,3,,172116-74220,, SCREW,2,2,,,,,W,,,M/#00501,,M/#00501,,,,,
44,3,,172151-74060,, "BOLT, SOCKET HEAD",2,2,,,,,W,,,M/#00501,,M/#00501,,,,,
45,2,,172168-72740,, "PLUG ASSY",1,1,,,,,W,M,M/#01187,,M/#01187,,,,,
45-1,2,,172175-74350,, "PLUG ASSY",1,1,,,,,W,,,M/#01187,,M/#01187,,,,,
47,3,,172116-74150,, O-RING,1,1,,,,,W,,,M/#01187,,M/#01187,,,,,

Fig. 61 コントロールバルブ (走行&オプション) CONTROL VALVE (TRAVEL & OPTIONAL)

コントロールバルブ ASSY
CONTROL VALVE ASSY
(172164-74100)
Fig. 60 REF. No. 1
(172164-74101)
Fig. 60 REF. No. 1-1
(172164-74102)
Fig. 60 REF. No. 1-2
Inc. Fig. 60 REF. No. 2 ~ 30
Fig. 61 REF. No. 1 ~ 47
Fig. 62 REF. No. 1 ~ 44
Fig. 63 REF. No. 1 ~ 40
Fig. 64 REF. No. 1 ~ 29

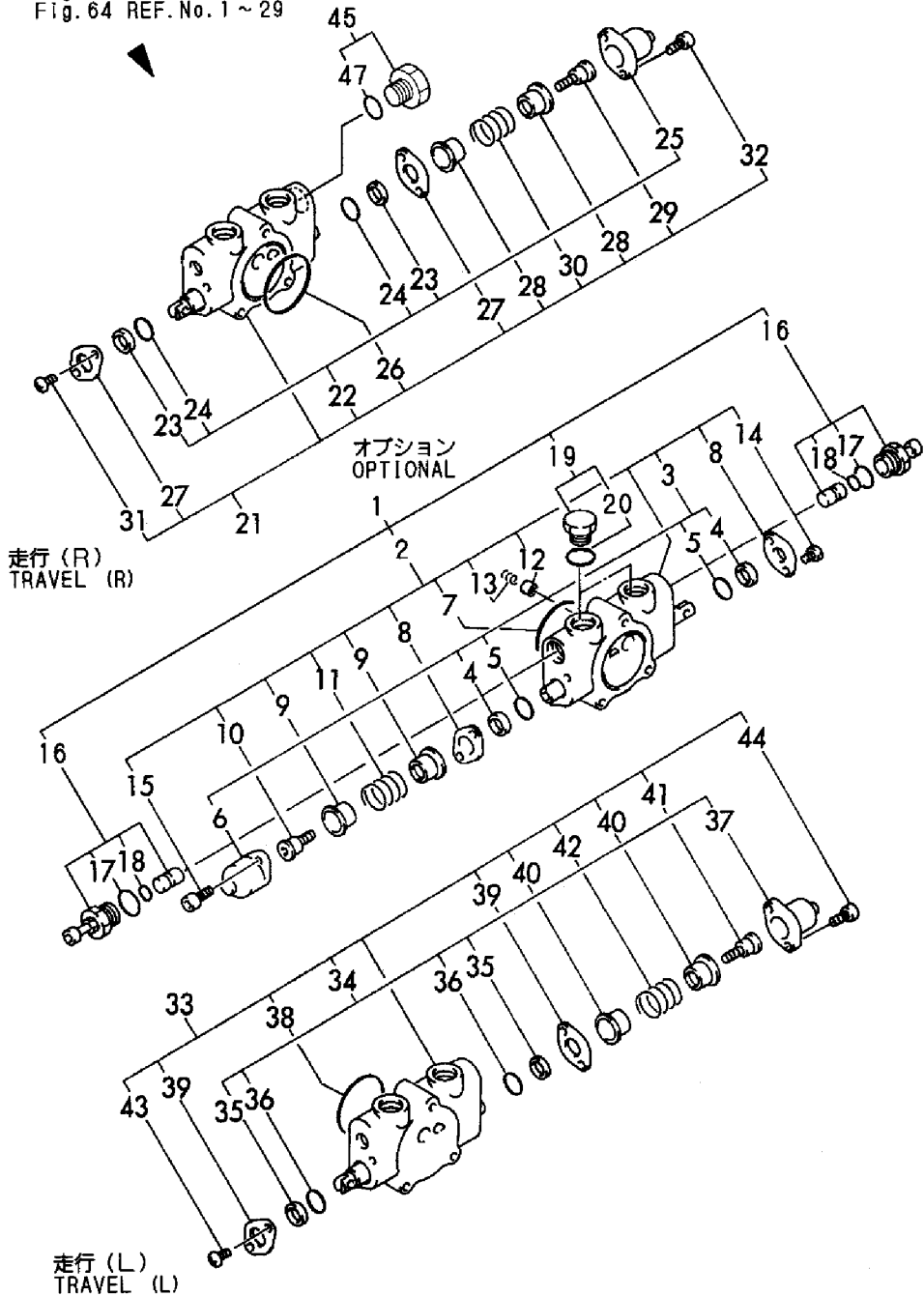
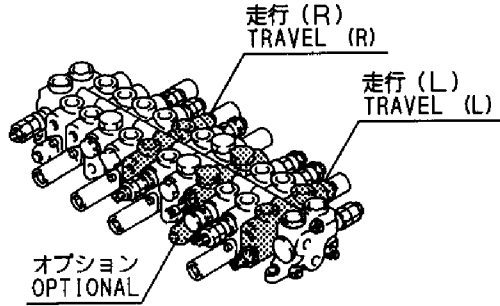

1,2,,172164-74140,, "SECTION ASSY, SPOOL",1,1,,,,,,,,,,,,,
2,3,,172164-74240,, "SECTION ASSY, SPOOL",1,1,,,,,,,,,,,,,
3,4,,172164-74380,, "CAP ASSY",1,1,,,,,1,,,,,,,,,,,,,
4,4,,172151-74320,, O-RING,1,1,,,,,,,,,,,,,
5,4,,172168-72840,, "CAP, FILLER",1,1,,,,,W,,,M/#00501,,M/#00501,,,,,
6,4,,933171-80590,, O-RING,1,1,,,,,,,,,,,,,
7,4,,172164-74390,, "CAP ASSY",1,1,,,,,2,,,,,,,,,,,,,
8,4,,172151-74320,, O-RING,1,1,,,,,,,,,,,,,
9,4,,172175-74320,, CAP,1,1,,,,,W,,,M/#00501,,M/#00501,,,,,
10,4,,172312-74230,, O-RING,2,2,,,,,,,,,,,,,
11,4,,172122-74270,, O-RING,1,1,,,,,,,,,,,,,
12,4,,172175-74310,, "END, SPOOL",1,1,,,,,W,,,M/#00501,,M/#00501,,,,,
13,4,,172175-74220,, "SEAT, SPRING",1,1,,,,,W,,,M/#00501,,M/#00501,,,,,
14,4,,172175-74240,, SPRING,1,1,,,,,W,,,M/#00501,,M/#00501,,,,,
15,4,,172168-72860,, "SEAT, SPRING",1,1,,,,,W,,,M/#00501,,M/#00501,,,,,
16,4,,172151-74290,, "BOLT, SOCKET HEAD",4,4,,,,,W,,,M/#00501,,M/#00501,,,,,
17,4,,172122-74130,, POPPET,1,1,,,,,W,,,M/#00501,,M/#00501,,,,,
18,4,,172168-72750,, "SPRING, CHECK VALVE",1,1,,,,,W,,,M/#00501,,M/#00501,,,,,
19,4,,172151-74140,, SPRING,1,1,,,,,W,,,M/#00501,,M/#00501,,,,,
20,4,,172312-74220,, SPACER,2,2,,,,,W,,,M/#00501,,M/#00501,,,,,
21,3,,172164-74360,, "RELIEF VALVE",1,1,,,,,,,,,,,,,
22,4,,172116-74150,, O-RING,1,1,,,,,,,,,,,,,
23,3,,172164-74350,, "RELIEF VALVE",1,1,,,,,M,,,,,,,,,,,,,
23-1,3,,172164-74360,, "RELIEF VALVE",1,1,,,,,,,,,,,,,
24,4,,172116-74150,, O-RING,1,1,,,,,,,,,,,,,
25,2,,172164-74150,, "SECTION ASSY, SPOOL",1,1,,,,,,,,,,,,,
26,3,,172164-74250,, "SECTION ASSY, SPOOL",1,1,,,,,,,,,,,,,
27,4,,172164-74400,, "O-RING ASSY",1,1,,,,,3,,,,,,,,,,,,,
28,4,,933166-80520,, WIPER,2,2,,,,,,,,,,,,,
29,4,,933171-80610,, O-RING,2,2,,,,,,,,,,,,,
30,4,,933166-80530,, CAP,1,1,,,,,W,,,M/#00501,,M/#00501,,,,,
31,4,,933171-80590,, O-RING,1,1,,,,,,,,,,,,,
32,4,,172116-74190,, "PLATE, SEAL",2,2,,,,,W,,,M/#00501,,M/#00501,,,,,
33,4,,933171-80510,, "SEAT, SPRING",2,2,,,,,W,,,M/#00501,,M/#00501,,,,,
34,4,,933166-80550,, "SCREW, CAP",1,1,,,,,W,,,M/#00501,,M/#00501,,,,,
35,4,,172122-74050,, SPRING,1,1,,,,,W,,,M/#00501,,M/#00501,,,,,
36,4,,172122-74130,, POPPET,1,1,,,,,W,,,M/#00501,,M/#00501,,,,,
37,4,,172168-72750,, "SPRING, CHECK VALVE",1,1,,,,,W,,,M/#00501,,M/#00501,,,,,
38,4,,172116-74220,, SCREW,2,2,,,,,W,,,M/#00501,,M/#00501,,,,,
39,4,,172151-74060,, "BOLT, SOCKET HEAD",2,2,,,,,W,,,M/#00501,,M/#00501,,,,,
40,4,,172146-74740,, WASHER,1,1,,,,,W,,,M/#00501,,M/#00501,,,,,
41,3,,172164-74370,, "RELIEF VALVE",1,1,,,,,,,,,,,,,
42,4,,172116-74150,, O-RING,1,1,,,,,,,,,,,,,
43,3,,172146-74730,, "VALVE ASSY",1,1,,,,,,,,,,,,,
44,4,,172116-74150,, O-RING,1,1,,,,,,,,,,,,,

Fig. 62 コントロールバルブ (アーム&スイング) CONTROL VALVE (ARM & SWING)

コントロールバルブASSY
CONTROL VALVE ASSY

(172164-74100)

Fig. 60 REF. No. 1

(172164-74101)

Fig. 60 REF. No. 1-1

(172164-74102)

Fig. 60 REF. No. 1-2

Inc. Fig. 60 REF. No. 2 ~ 30

Fig. 61 REF. No. 1 ~ 47

Fig. 62 REF. No. 1 ~ 44

Fig. 63 REF. No. 1 ~ 40

Fig. 64 REF. No. 1 ~ 29

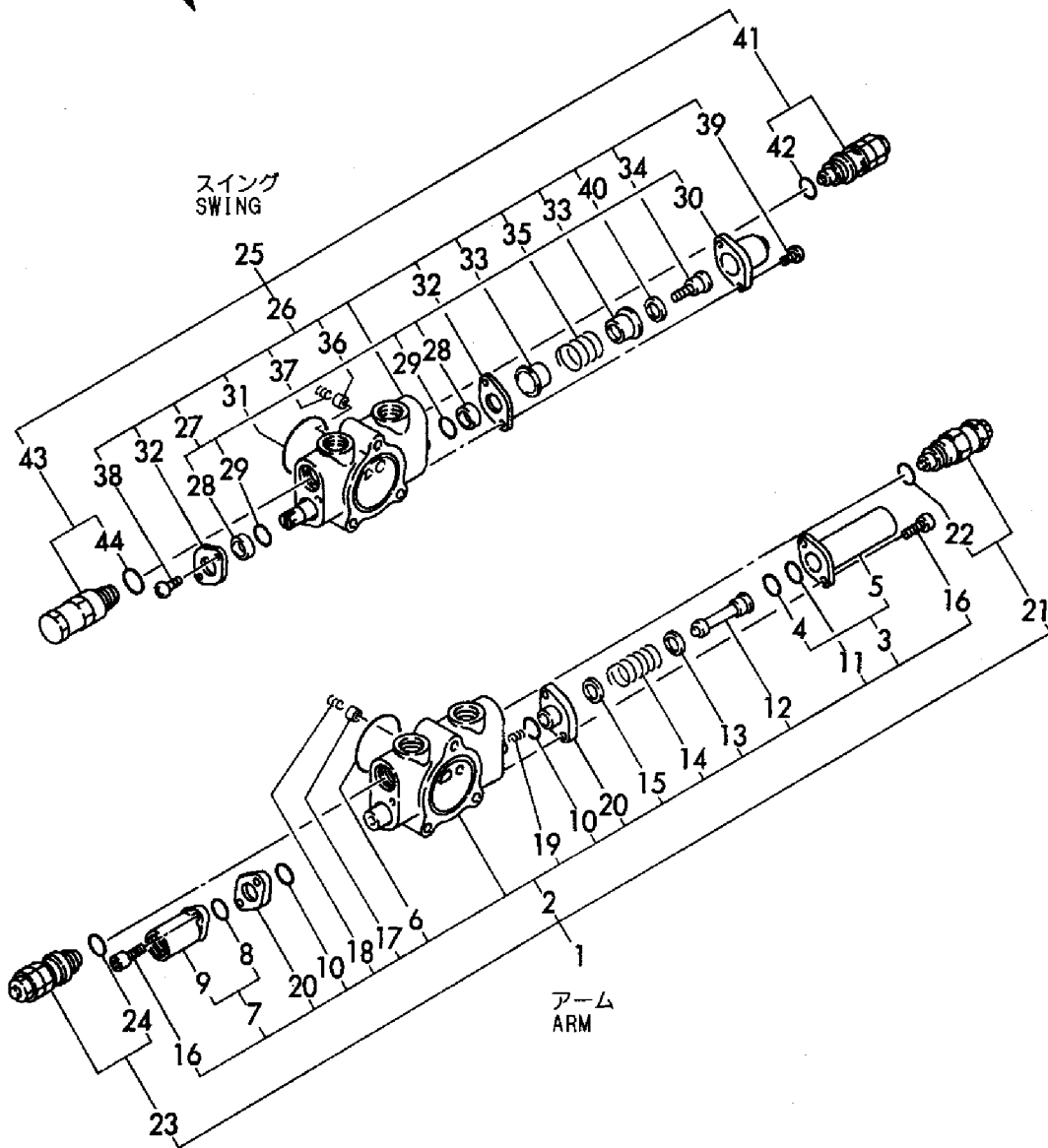
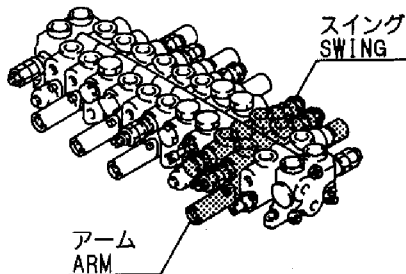

1,2,,172164-74180,, "SECTION KIT, SPOOL",1,1,,,,,,,,,,,,,
2,3,,172164-74280,, "SECTION ASSY, SPOOL",1,1,,,,,,,,,,,,,
3,4,,172164-74440,, "O-RING ASSY",1,1,,,,,1,,,,,,,,,,,,,
4,4,,172151-74320,, O-RING,1,1,,,,,,,,,,,,,
5,4,,172168-72870,, CAP,1,1,,,,,W,,,M/#00501,,M/#00501,,,,,
6,4,,172164-74380,, "CAP ASSY",1,1,,,,,2,,,,,,,,,,,,,
7,4,,172151-74320,, O-RING,1,1,,,,,,,,,,,,,
8,4,,172168-72840,, "CAP, FILLER",1,1,,,,,W,,,M/#00501,,M/#00501,,,,,
9,4,,933171-80590,, O-RING,1,1,,,,,,,,,,,,,
10,4,,172168-72850,, "END, SPOOL",1,1,,,,,W,,,M/#00501,,M/#00501,,,,,
11,4,,933171-80510,, "SEAT, SPRING",1,1,,,,,W,,,M/#00501,,M/#00501,,,,,
12,4,,172175-74240,, SPRING,1,1,,,,,W,,,M/#00501,,M/#00501,,,,,
13,4,,172168-72860,, "SEAT,SPRING",1,1,,,,,W,,,M/#00501,,M/#00501,,,,,
14,4,,172151-74060,, "BOLT, SOCKET HEAD",4,4,,,,,W,,,M/#00501,,M/#00501,,,,,
15,4,,172122-74130,, POPPET,2,2,,,,,W,,,M/#00501,,M/#00501,,,,,
16,4,,172168-72750,, "SPRING,CHECK VALVE",2,2,,,,,W,,,M/#00501,,M/#00501,,,,,
17,3,,172164-74370,, "RILIEF VALVE",1,1,,,,,,,,,,,,,
18,4,,172116-74150,, O-RING,1,1,,,,,,,,,,,,,
19,3,,172164-74350,, "RILIEF VALVE",1,1,,,,,,,,,,,,,
20,4,,172116-74150,, O-RING,1,1,,,,,,,,,,,,,
21,2,,172164-74190,, "SECTION ASSY, SPOOL",1,1,,,,,,,,,,,,,
22,3,,172164-74300,, "SECTION ASSY, SPOOL",1,1,,,,,,,,,,,,,
23,4,,172164-74450,, "CAP ASSY",1,1,,,,,3,,,,,,,,,,,,,
24,4,,172151-74320,, O-RING,1,1,,,,,,,,,,,,,
25,4,,172168-72890,, CAP,1,1,,,,,W,,,M/#00501,,M/#00501,,,,,
26,4,,172164-74460,, "CAP ASSY",1,1,,,,,4,,,,,,,,,,,,,
27,4,,172151-74320,, O-RING,1,1,,,,,,,,,,,,,
28,4,,172168-72900,, CAP,1,1,,,,,W,,,M/#00501,,M/#00501,,,,,
29,4,,933171-80590,, O-RING,1,1,,,,,,,,,,,,,
30,4,,172168-72850,, "END, SPOOL",1,1,,,,,W,,,M/#00501,,M/#00501,,,,,
31,4,,172175-74220,, "SEAT, SPRING",1,1,,,,,W,,,M/#00501,,M/#00501,,,,,
32,4,,172168-72880,, SPRING,1,1,,,,,W,,,M/#00501,,M/#00501,,,,,
33,4,,172168-72860,, "SEAT,SPRING",1,1,,,,,W,,,M/#00501,,M/#00501,,,,,
34,4,,172151-74060,, "BOLT, SOCKET HEAD",4,4,,,,,W,,,M/#00501,,M/#00501,,,,,
35,4,,172122-74130,, POPPET,1,1,,,,,W,,,M/#00501,,M/#00501,,,,,
36,4,,172168-72750,, "SPRING,CHECK VALVE",1,1,,,,,W,,,M/#00501,,M/#00501,,,,,
37,3,,172164-74350,, "RILIEF VALVE",1,1,,,,,,,,,,,,,
38,4,,172116-74150,, O-RING,1,1,,,,,,,,,,,,,
39,3,,172310-79180,, VALVE,1,1,,,,,,,,,,,,,
40,4,,172116-74150,, O-RING,1,1,,,,,,,,,,,,,

Fig. 63 コントロールバルブ (ブーム&バケット) CONTROL VALVE (BOOM & BUCKET)

コントロールバルブアッシー
CONTROL VALVE ASSY
(172164-74100)
Fig. 60 REF. No. 1
(172164-74101)
Fig. 60 REF. No. 1-1
(172164-74102)
Fig. 60 REF. No. 1-2
inc. Fig. 60 REF. No. 2 ~ 30
Fig. 61 REF. No. 1 ~ 47
Fig. 62 REF. No. 1 ~ 44
Fig. 63 REF. No. 1 ~ 40
Fig. 64 REF. No. 1 ~ 29

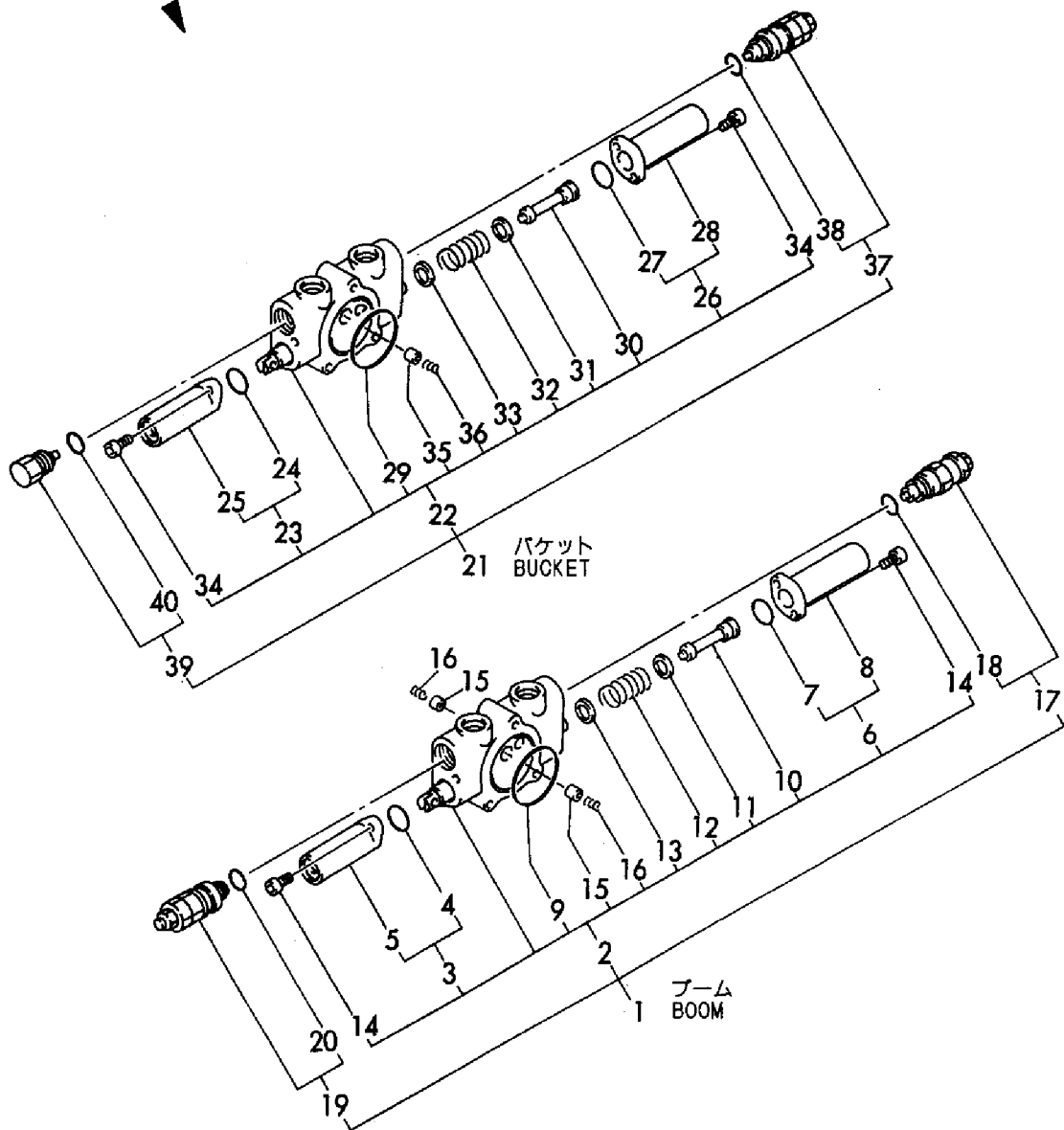
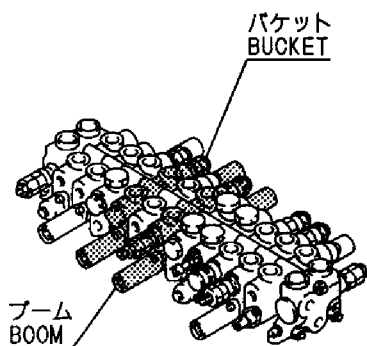

1,2,,172164-74310,, "SECTION ASSY, SPOOL",1,1,,,,,,,,,,,,,
2,3,,172164-74440,, "O-RING ASSY",1,1,,,,,,,,,,,,,
3,4,,172151-74320,, O-RING,1,1,,,,,,,,,,,,,
4,4,,172168-72870,, CAP,1,1,,,,,W,,,M/#00501,,M/#00501,,,,,
5,3,,172164-74380,, "CAP ASSY",1,1,,,,,,,,,,,,,
6,4,,172151-74320,, O-RING,1,1,,,,,,,,,,,,,
7,4,,172168-72840,, "CAP, FILLER",1,1,,,,,W,,,M/#00501,,M/#00501,,,,,
8,3,,933171-80590,, O-RING,1,1,,,,,,,,,,,,,
9,3,,172168-72850,, "END, SPOOL",1,1,,,,,W,,,M/#00501,,M/#00501,,,,,
10,3,,172175-74220,, "SEAT, SPRING",1,1,,,,,W,,,M/#00501,,M/#00501,,,,,
11,3,,172175-74240,, SPRING,1,1,,,,,W,,,M/#00501,,M/#00501,,,,,
12,3,,172168-72860,, "SEAT, SPRING",1,1,,,,,W,,,M/#00501,,M/#00501,,,,,
13,3,,172151-74060,, "BOLT, SOCKET HEAD",4,4,,,,,W,,,M/#00501,,M/#00501,,,,,
14,3,,172122-74130,, POPPET,1,1,,,,,W,,,M/#00501,,M/#00501,,,,,
15,3,,172168-72750,, "SPRING,CHECK VALVE",1,1,,,,,W,,,M/#00501,,M/#00501,,,,,
16,2,,172164-74320,, "SECTION ASSY, SPOOL",1,1,,,,,,,,,,,,,
17,3,,172164-74400,, "O-RING ASSY",1,1,,,,,,,,,,,,,
18,4,,933166-80520,, WIPER,2,2,,,,,,,,,,,,,
19,4,,933171-80610,, O-RING,2,2,,,,,,,,,,,,,
20,4,,933166-80530,, CAP,1,1,,,,,W,,,M/#00501,,M/#00501,,,,,
21,3,,933171-80590,, O-RING,1,1,,,,,,,,,,,,,
22,3,,172116-74190,, "PLATE, SEAL",2,2,,,,,W,,,M/#00501,,M/#00501,,,,,
23,3,,933171-80510,, "SEAT, SPRING",2,2,,,,,W,,,M/#00501,,M/#00501,,,,,
24,3,,933166-80550,, "SCREW, CAP",1,1,,,,,W,,,M/#00501,,M/#00501,,,,,
25,3,,172122-74050,, SPRING,1,1,,,,,W,,,M/#00501,,M/#00501,,,,,
26,3,,172122-74130,, POPPET,1,1,,,,,W,,,M/#00501,,M/#00501,,,,,
27,3,,172168-72750,, "SPRING,CHECK VALVE",1,1,,,,,W,,,M/#00501,,M/#00501,,,,,
28,3,,172116-74220,, SCREW,2,2,,,,,W,,,M/#00501,,M/#00501,,,,,
29,3,,172151-74060,, "BOLT, SOCKET HEAD",2,2,,,,,W,,,M/#00501,,M/#00501,,,,,

Fig. 64 コントロールバルブ (旋回&ブレード) CONTROL VALVE (TURNING & BLADE)

コントロールバルブASSY
CONTROL VALVE ASSY
(172164-74100)
Fig. 60 REF. No. 1
(172164-74101)
Fig. 60 REF. No. 1-1
(172164-74102)
Fig. 60 REF. No. 1-2
inc. Fig. 60 REF. No. 2 ~ 30
Fig. 61 REF. No. 1 ~ 47
Fig. 62 REF. No. 1 ~ 44
Fig. 63 REF. No. 1 ~ 40
Fig. 64 REF. No. 1 ~ 29

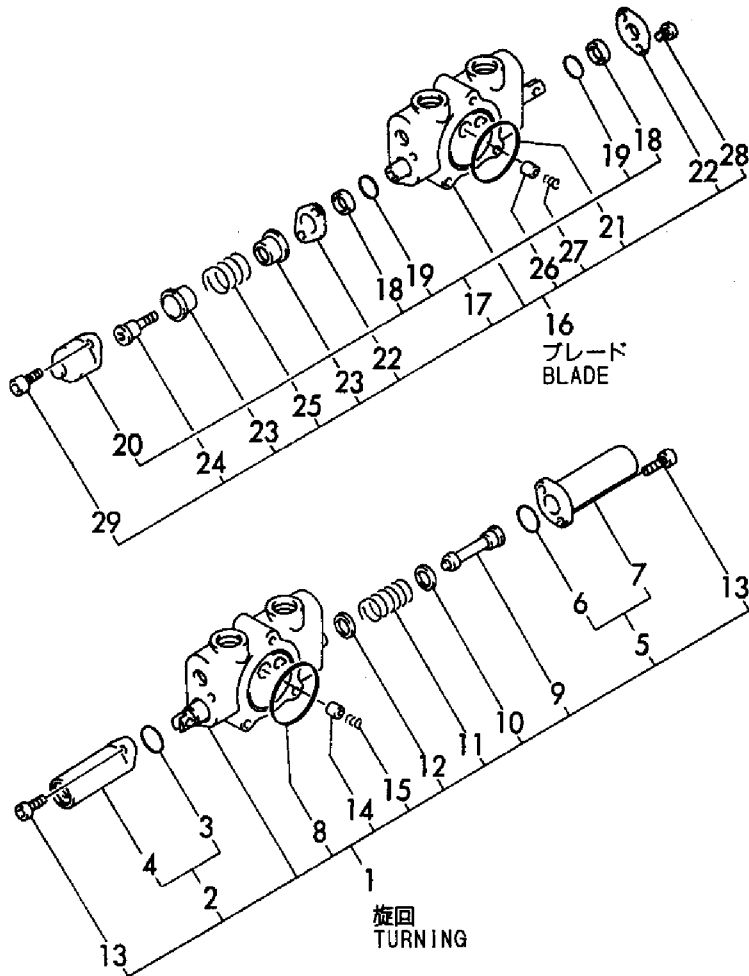
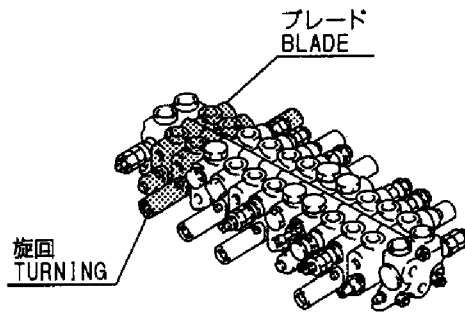

1,1,,172164-74110,, "VALVE ASSY, 3RD",1,1,,,,,1,,,,,
1-1,1,,172164-74111,, "VALVE ASSY, 3RD",1,1,,,,,N,1,,M/#00912,,M/#00912,,,,,
1-2,1,,172164-74112,, "VALVE ASSY, 3RD",1,1,,,,,N,1,,M/#01187,,M/#01187,,,,,
2,2,,172164-74120,, "SECTION KIT,INLET",1,1,,,,,
3,3,,172164-74330,, "VALVE 175/25,RELIEF",1,1,,,,,
4,4,,172116-74150,, O-RING,1,1,,,,,
5,3,,172122-74520,, "SECTION, INLET",1,1,,,,,
6,4,,933171-80590,, O-RING,1,1,,,,,
7,2,,172164-74130,, "INLET SECTION ASSY",1,1,,,,,
8,3,,172164-74340,, "VALVE 190/35,RELIEF",1,1,,,,,
9,4,,172116-74150,, O-RING,1,1,,,,,
10,3,,172122-74520,, "SECTION, INLET",1,1,,,,,
11,4,,933171-80590,, O-RING,1,1,,,,,
12,2,,172164-74420,, "SECTION ASSY.,SPACER",1,1,,,,,
13,3,,172164-74270,, "SECTION KIT, SPOOL",1,1,,,,,
13A,4,,172122-73430,, PLUG,1,1,,,,,W,,M/#00501,,M/#00501,,,,,
14,3,,172175-74350,, "PLUG ASSY",1,1,,,,,W,, "FROM 1ST", "FROM 1ST",,,,,,
15,3,,172116-74150,, O-RING,1,1,,,,,
16,3,,172175-74270,, "PLUG ASSY",1,1,,,,,W,, "FROM 1ST", "FROM 1ST",,,,,,
16A,4,,172112-06480,, PLUG,1,1,,,,,
17,4,,172112-06490,, O-RING,1,1,,,,,
18,2,,172164-74430,, "SPACER SECTION ASSY",1,1,,,,,
19,3,,172164-74330,, "VALVE 175/25,RELIEF",1,1,,,,,
20,4,,172116-74150,, O-RING,1,1,,,,,
21,3,,172146-74680,, "SECTION ASSY, SPACER",1,1,,,,,
22,4,,933171-80590,, O-RING,1,1,,,,,
23,3,,172146-74720,, "VALVE ASSY, SHUT-OFF",1,1,,,,,
24,4,,172116-74150,, O-RING,1,1,,,,,
24A,4,,24311-240100,, "O-RING 1A P-10A",1,1,,,,,W,, "FROM 1ST", "FROM 1ST",,,,,,
25,2,,172151-74110,, TIE-ROD,2,2,,,,,
26,2,,172151-74120,, TIE-ROD,1,1,,,,,
27,2,,26716-080002,, "NUT M 8",4,4,,,,,
28,2,,26716-100002,, "NUT 10",2,2,,,,,
29,1,,172164-45560,, "PLATE COMP.,LINK",1,1,,,,,
29-1,1,,172164-45561,, "PLATE, LINK",1,1,,,,,N,,M/#01217,,M/#01217,,,,,
30,1,,172165-45490,, CUSHION,5,5,,,,,
31,1,,22252-000280,, "CIRCLIP 28",5,5,,,,,
32,1,,26106-100352,, "BOLT M10X 35 PLATED",5,5,,,,,
33,1,,26013-100302,, "BOLT M10X 30",3,3,,,,,
33-1,1,,26013-100352,, "BOLT M10X 35",3,3,,,,,N,, "FROM 1ST", "FROM 1ST",,,,,,
34,1,,26716-100002,, "NUT 10",1,1,,,,,
35,1,,172164-46310,, RUBBER,1,1,,,,,W,,M/#01247,,M/#01247,,,,,

Fig. 65 コントロールバルブ (Pポート/PTO) CONTROL VALVE (P PORT/P.T.O.)

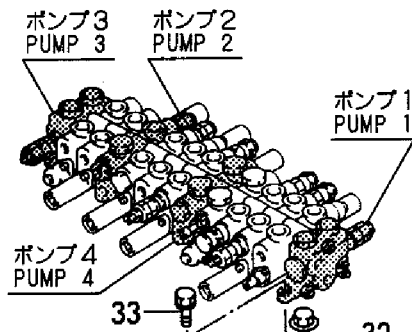
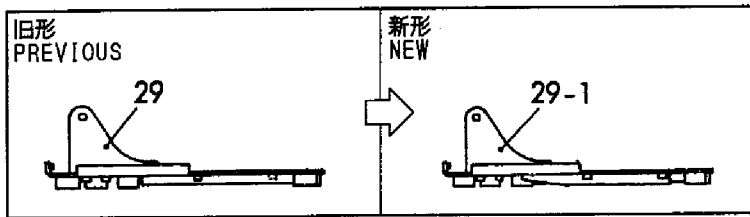

コントロールバルブアッシー

CONTROL VALVE ASSY

(172164-74110)

Fig. 65 REF. No. 1

(172164-74111)

Fig. 65 REF. No. 1-1

(172164-74112)

Fig. 66 REF. No. 1-2

Inc. Fig. 65 REF. No. 2 ~ 28

Fig. 66 REF. No. 1 ~ 45

Fig. 67 REF. No. 1 ~ 44

Fig. 68 REF. No. 1 ~ 40

Fig. 69 REF. No. 1 ~ 29

1
1-1
1-2

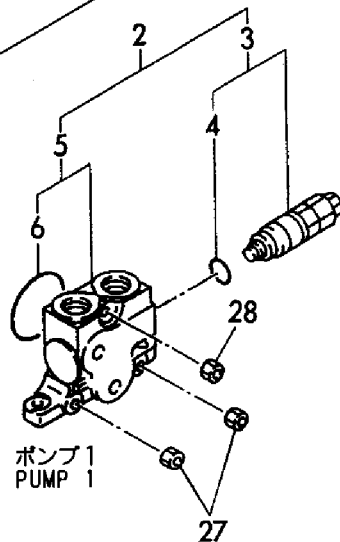
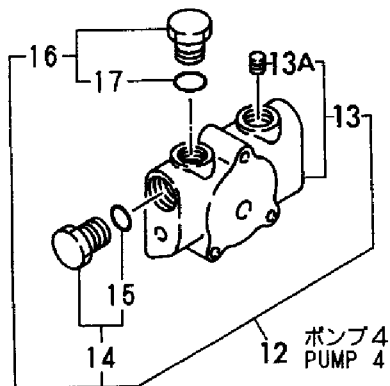
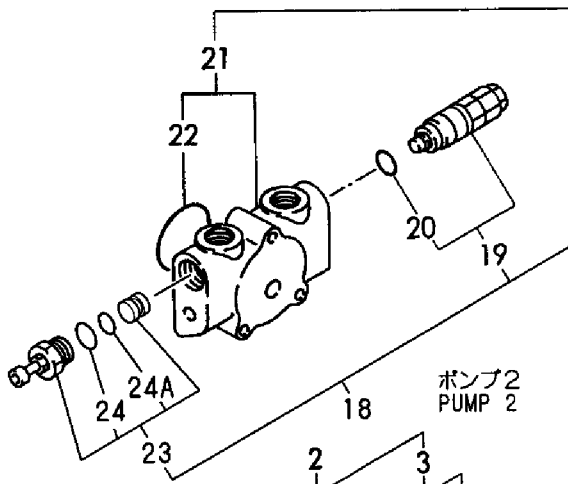
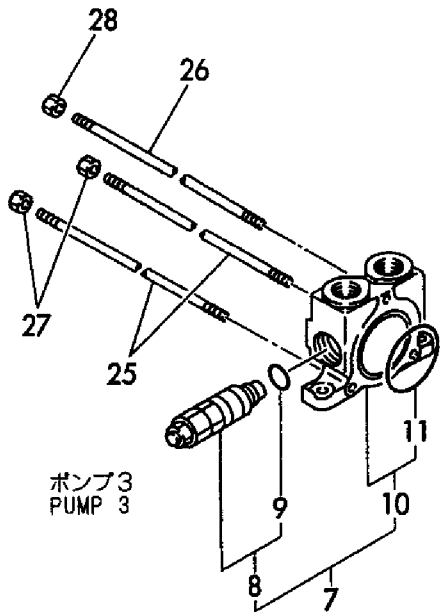

1,2,,172164-74410,, "SECTION ASSY.,SPOOL",1,1,,,,,,,,,,,,,
2,3,,172164-74260,, "SECTION ASSY, SPOOL",1,1,,,,,,,,,,,,,
3,4,,172164-74400,, "O-RING ASSY",1,1,,,,,1,,,,,,,,,,,,,
4,4,,933166-80520,, WIPER,2,2,,,,,,,,,,,,,
5,4,,933171-80610,, O-RING,2,2,,,,,,,,,,,,,
6,4,,933166-80530,, CAP,1,1,,,,,W,,,M/#00501,,M/#00501,,,,,
7,4,,933171-80590,, O-RING,1,1,,,,,,,,,,,,,
8,4,,172116-74190,, "PLATE, SEAL",2,2,,,,,W,,,M/#00501,,M/#00501,,,,,
9,4,,933171-80510,, "SEAT, SPRING",2,2,,,,,W,,,M/#00501,,M/#00501,,,,,
10,4,,933166-80550,, "SCREW, CAP",1,1,,,,,W,,,M/#00501,,M/#00501,,,,,
11,4,,172122-74050,, SPRING,1,1,,,,,W,,,M/#00501,,M/#00501,,,,,
12,4,,172122-74130,, POPPET,1,1,,,,,W,,,M/#00501,,M/#00501,,,,,
13,4,,172168-72750,, "SPRING,CHECK VALVE",1,1,,,,,W,,,M/#00501,,M/#00501,,,,,
14,4,,172116-74220,, SCREW,2,2,,,,,W,,,M/#00501,,M/#00501,,,,,
15,4,,172151-74060,, "BOLT, SOCKET HEAD",2,2,,,,,W,,,M/#00501,,M/#00501,,,,,
16,3,,172146-74720,, "VALVE ASSY, SHUT-OFF",2,2,,,,,,,,,,,,,
17,4,,172116-74150,, O-RING,2,2,,,,,,,,,,,,,
18,4,,24311-240100,, "O-RING 1A P-10A",2,2,,,,,,,,,,,,,
19,2,,172164-74290,, "SECTION ASSY.,SPOOL",1,1,,,,,,,,,,,,,
20,3,,172164-74400,, "O-RING ASSY",1,1,,,,,,,,,,,,,
21,4,,933166-80520,, WIPER,2,2,,,,,,,,,,,,,
22,4,,933171-80610,, O-RING,2,2,,,,,,,,,,,,,
23,4,,933166-80530,, CAP,1,1,,,,,W,,,M/#00501,,M/#00501,,,,,
24,3,,933171-80590,, O-RING,1,1,,,,,,,,,,,,,
25,3,,172116-74190,, "PLATE, SEAL",2,2,,,,,W,,,M/#00501,,M/#00501,,,,,
26,3,,933171-80510,, "SEAT, SPRING",2,2,,,,,W,,,M/#00501,,M/#00501,,,,,
27,3,,933166-80550,, "SCREW, CAP",1,1,,,,,W,,,M/#00501,,M/#00501,,,,,
28,3,,172122-74050,, SPRING,1,1,,,,,W,,,M/#00501,,M/#00501,,,,,
29,3,,172116-74220,, SCREW,2,2,,,,,W,,,M/#00501,,M/#00501,,,,,
30,3,,172151-74060,, "BOLT, SOCKET HEAD",2,2,,,,,W,,,M/#00501,,M/#00501,,,,,
31,2,,172168-72640,, "SECTION ASSY, SPOOL",1,1,,,,,,,,,,,,,
32,3,,172164-74400,, "O-RING ASSY",1,1,,,,,,,,,,,,,
33,4,,933166-80520,, WIPER,2,2,,,,,,,,,,,,,
34,4,,933171-80610,, O-RING,2,2,,,,,,,,,,,,,
35,4,,933166-80530,, CAP,1,1,,,,,W,,,M/#00501,,M/#00501,,,,,
36,3,,933171-80590,, O-RING,1,1,,,,,,,,,,,,,
37,3,,172116-74190,, "PLATE, SEAL",2,2,,,,,W,,,M/#00501,,M/#00501,,,,,
38,3,,933171-80510,, "SEAT, SPRING",2,2,,,,,W,,,M/#00501,,M/#00501,,,,,
39,3,,933166-80550,, "SCREW, CAP",1,1,,,,,W,,,M/#00501,,M/#00501,,,,,
40,3,,172122-74050,, SPRING,1,1,,,,,W,,,M/#00501,,M/#00501,,,,,
41,3,,172116-74220,, SCREW,2,2,,,,,W,,,M/#00501,,M/#00501,,,,,
42,3,,172151-74060,, "BOLT, SOCKET HEAD",2,2,,,,,W,,,M/#00501,,M/#00501,,,,,
43,2,,172168-72740,, "PLUG ASSY",1,1,,,,,W,M,M/#01187,,M/#01187,,,,,
43-1,2,,172175-74350,, "PLUG ASSY",1,1,,,,,W,,,M/#01187,,M/#01187,,,,,
45,3,,172116-74150,, O-RING,1,1,,,,,W,,,M/#01187,,M/#01187,,,,,

Fig. 66 コントロールバルブ (走行&オプション/P.T.O.) CONTROL VALVE (TRAVEL & OPTIONAL/P.T.O.)

コントロールバルブアッシー
CONTROL VALVE ASSY
(172164-74110)
Fig. 65 REF. No. 1
(172164-74111)
Fig. 65 REF. No. 1-1
(172164-74112)
Fig. 65 REF. No. 1-2
Inc. Fig. 65 REF. No. 2 ~ 28
Fig. 66 REF. No. 1 ~ 45
Fig. 67 REF. No. 1 ~ 44
Fig. 68 REF. No. 1 ~ 40
Fig. 69 REF. No. 1 ~ 29

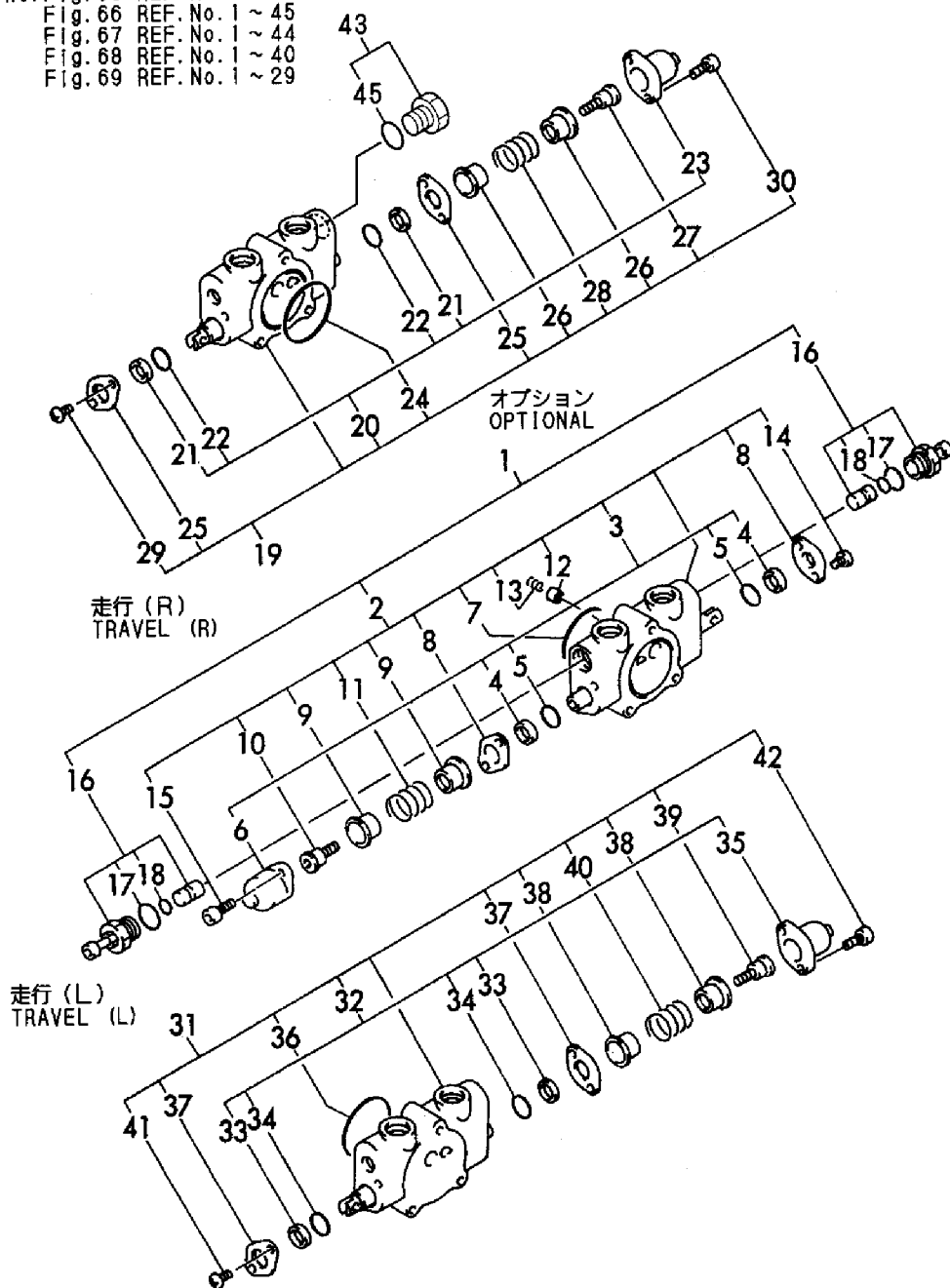
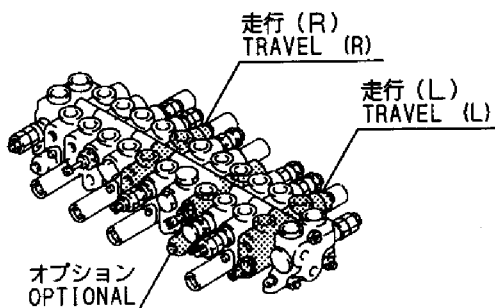

1,2,,172164-74140,, "SECTION ASSY, SPOOL",1,1,,,,,,,,,,,,,
2,3,,172164-74240,, "SECTION ASSY, SPOOL",1,1,,,,,,,,,,,,,
3,4,,172164-74380,, "CAP ASSY",1,1,,,,,1,,,,,,,,,,,,,
4,4,,172151-74320,, O-RING,1,1,,,,,,,,,,,,,
5,4,,172168-72840,, "CAP, FILLER",1,1,,,,,W,,,M/#00501,,M/#00501,,,,,
6,4,,933171-80590,, O-RING,1,1,,,,,,,,,,,,,
7,4,,172164-74390,, "CAP ASSY",1,1,,,,,2,,,,,,,,,,,,,
8,4,,172151-74320,, O-RING,1,1,,,,,,,,,,,,,
9,4,,172175-74320,, CAP,1,1,,,,,W,,,M/#00501,,M/#00501,,,,,
10,4,,172312-74230,, O-RING,2,2,,,,,,,,,,,,,
11,4,,172122-74270,, O-RING,1,1,,,,,,,,,,,,,
12,4,,172175-74310,, "END, SPOOL",1,1,,,,,W,,,M/#00501,,M/#00501,,,,,
13,4,,172175-74220,, "SEAT, SPRING",1,1,,,,,W,,,M/#00501,,M/#00501,,,,,
14,4,,172175-74240,, SPRING,1,1,,,,,W,,,M/#00501,,M/#00501,,,,,
15,4,,172168-72860,, "SEAT,SPRING",1,1,,,,,W,,,M/#00501,,M/#00501,,,,,
16,4,,172151-74290,, "BOLT, SOCKET HEAD",4,4,,,,,W,,,M/#00501,,M/#00501,,,,,
17,4,,172122-74130,, POPPET,1,1,,,,,W,,,M/#00501,,M/#00501,,,,,
18,4,,172168-72750,, "SPRING,CHECK VALVE",1,1,,,,,W,,,M/#00501,,M/#00501,,,,,
19,4,,172151-74140,, SPRING,1,1,,,,,W,,,M/#00501,,M/#00501,,,,,
20,4,,172312-74220,, SPACER,2,2,,,,,W,,,M/#00501,,M/#00501,,,,,
21,3,,172164-74360,, "RILIEF VALVE",1,1,,,,,,,,,,,,,
22,4,,172116-74150,, O-RING,1,1,,,,,,,,,,,,,
23,3,,172164-74350,, "RILIEF VALVE",1,1,,,,,M,,,,,,,,,,,,,
23-1,3,,172164-74360,, "RILIEF VALVE",1,1,,,,,,,,,,,,,
24,4,,172116-74150,, O-RING,1,1,,,,,,,,,,,,,
25,2,,172164-74150,, "SECTION ASSY, SPOOL",1,1,,,,,,,,,,,,,
26,3,,172164-74250,, "SECTION ASSY, SPOOL",1,1,,,,,,,,,,,,,
27,4,,172164-74400,, "O-RING ASSY",1,1,,,,,3,,,,,,,,,,,,,
28,4,,933166-80520,, WIPER,2,2,,,,,,,,,,,,,
29,4,,933171-80610,, O-RING,2,2,,,,,,,,,,,,,
30,4,,933166-80530,, CAP,1,1,,,,,W,,,M/#00501,,M/#00501,,,,,
31,4,,933171-80590,, O-RING,1,1,,,,,,,,,,,,,
32,4,,172116-74190,, "PLATE, SEAL",2,2,,,,,W,,,M/#00501,,M/#00501,,,,,
33,4,,933171-80510,, "SEAT, SPRING",2,2,,,,,W,,,M/#00501,,M/#00501,,,,,
34,4,,933166-80550,, "SCREW, CAP",1,1,,,,,W,,,M/#00501,,M/#00501,,,,,
35,4,,172122-74050,, SPRING,1,1,,,,,W,,,M/#00501,,M/#00501,,,,,
36,4,,172122-74130,, POPPET,1,1,,,,,W,,,M/#00501,,M/#00501,,,,,
37,4,,172168-72750,, "SPRING,CHECK VALVE",1,1,,,,,W,,,M/#00501,,M/#00501,,,,,
38,4,,172116-74220,, SCREW,2,2,,,,,W,,,M/#00501,,M/#00501,,,,,
39,4,,172151-74060,, "BOLT, SOCKET HEAD",2,2,,,,,W,,,M/#00501,,M/#00501,,,,,
40,4,,172146-74740,, WASHER,1,1,,,,,W,,,M/#00501,,M/#00501,,,,,
41,3,,172164-74370,, "RILIEF VALVE",1,1,,,,,,,,,,,,,
42,4,,172116-74150,, O-RING,1,1,,,,,,,,,,,,,
43,3,,172146-74730,, "VALVE ASSY",1,1,,,,,,,,,,,,,
44,4,,172116-74150,, O-RING,1,1,,,,,,,,,,,,,

Fig. 67 コントロールバルブ (アーム&スイング/PTO) CONTROL VALVE (ARM & SWING/P.T.O.)

コントロールバルブASSY
CONTROL VALVE ASSY
(172164-74110)
Fig. 65 REF.No.1
(172164-74111)
Fig. 65 REF.No.1-1
(172164-74112)
Fig. 65 REF.No.1-2
inc. Fig. 65 REF.No.2 ~ 28
Fig. 66 REF.No.1 ~ 45
Fig. 67 REF.No.1 ~ 44
Fig. 68 REF.No.1 ~ 40
Fig. 69 REF.No.1 ~ 29

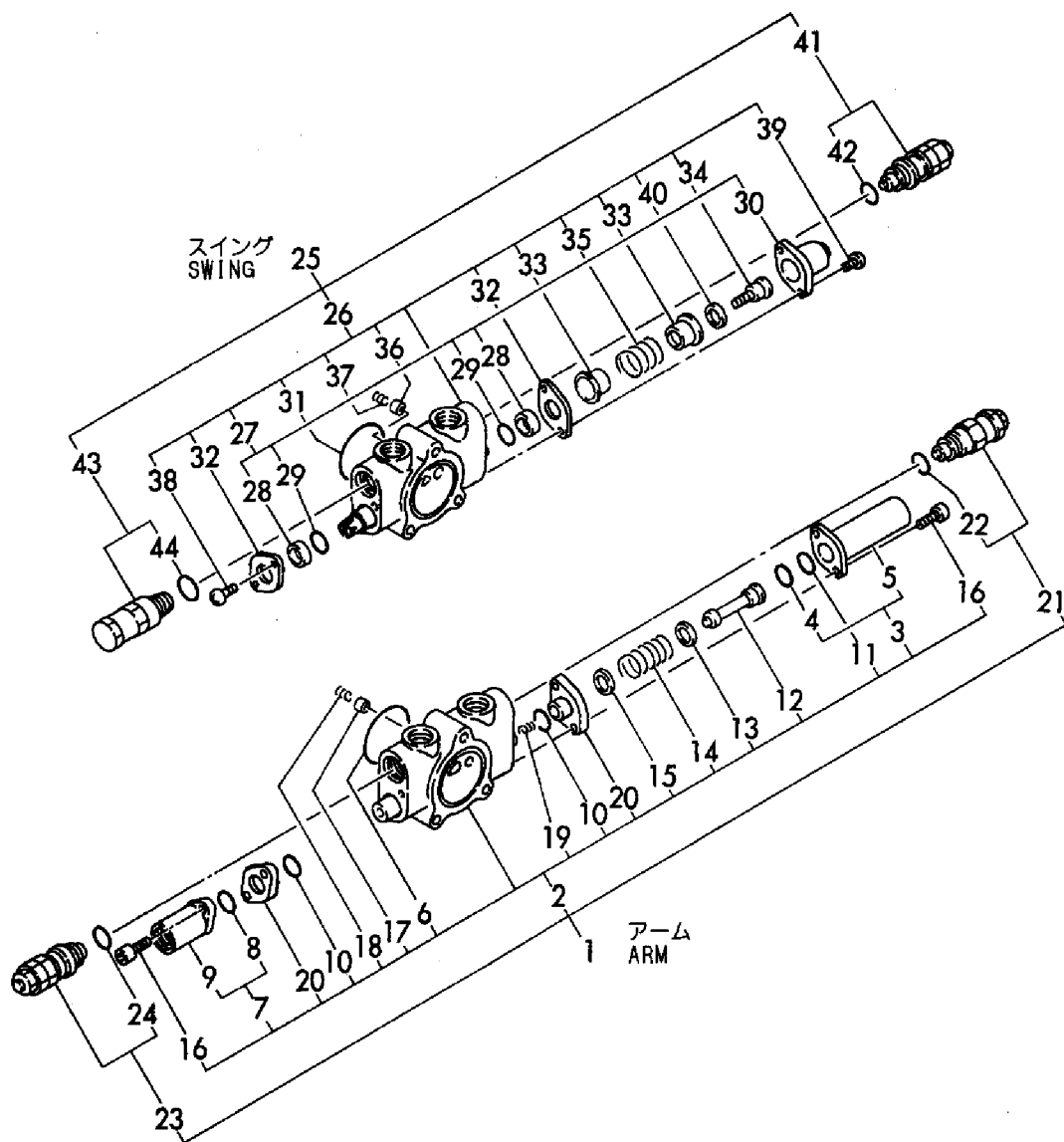
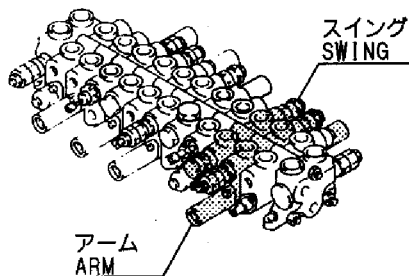

1,2,,172164-74180,, "SECTION KIT, SPOOL",1,1,,,,,,,,,,,,,
2,3,,172164-74280,, "SECTION ASSY, SPOOL",1,1,,,,,,,,,,,,,
3,4,,172164-74440,, "O-RING ASSY",1,1,,,,,1,,,,,,,,,,,,,
4,4,,172151-74320,, O-RING,1,1,,,,,,,,,,,,,
5,4,,172168-72870,, CAP,1,1,,,,,W,,,M/#00501,,M/#00501,,,,,
6,4,,172164-74380,, "CAP ASSY",1,1,,,,,2,,,,,,,,,,,,,
7,4,,172151-74320,, O-RING,1,1,,,,,,,,,,,,,
8,4,,172168-72840,, "CAP, FILLER",1,1,,,,,W,,,M/#00501,,M/#00501,,,,,
9,4,,933171-80590,, O-RING,1,1,,,,,,,,,,,,,
10,4,,172168-72850,, "END, SPOOL",1,1,,,,,W,,,M/#00501,,M/#00501,,,,,
11,4,,933171-80510,, "SEAT, SPRING",1,1,,,,,W,,,M/#00501,,M/#00501,,,,,
12,4,,172175-74240,, SPRING,1,1,,,,,W,,,M/#00501,,M/#00501,,,,,
13,4,,172168-72860,, "SEAT,SPRING",1,1,,,,,W,,,M/#00501,,M/#00501,,,,,
14,4,,172151-74060,, "BOLT, SOCKET HEAD",4,4,,,,,W,,,M/#00501,,M/#00501,,,,,
15,4,,172122-74130,, POPPET,2,2,,,,,W,,,M/#00501,,M/#00501,,,,,
16,4,,172168-72750,, "SPRING,CHECK VALVE",2,2,,,,,W,,,M/#00501,,M/#00501,,,,,
17,3,,172164-74370,, "RILIEF VALVE",1,1,,,,,,,,,,,,,
18,4,,172116-74150,, O-RING,1,1,,,,,,,,,,,,,
19,3,,172164-74350,, "RILIEF VALVE",1,1,,,,,,,,,,,,,
20,4,,172116-74150,, O-RING,1,1,,,,,,,,,,,,,
21,2,,172164-74190,, "SECTION ASSY, SPOOL",1,1,,,,,,,,,,,,,
22,3,,172164-74300,, "SECTION ASSY, SPOOL",1,1,,,,,,,,,,,,,
23,4,,172164-74450,, "CAP ASSY",1,1,,,,,3,,,,,,,,,,,,,
24,4,,172151-74320,, O-RING,1,1,,,,,,,,,,,,,
25,4,,172168-72890,, CAP,1,1,,,,,W,,,M/#00501,,M/#00501,,,,,
26,4,,172164-74460,, "CAP ASSY",1,1,,,,,4,,,,,,,,,,,,,
27,4,,172151-74320,, O-RING,1,1,,,,,,,,,,,,,
28,4,,172168-72900,, CAP,1,1,,,,,W,,,M/#00501,,M/#00501,,,,,
29,4,,933171-80590,, O-RING,1,1,,,,,,,,,,,,,
30,4,,172168-72850,, "END, SPOOL",1,1,,,,,W,,,M/#00501,,M/#00501,,,,,
31,4,,172175-74220,, "SEAT, SPRING",1,1,,,,,W,,,M/#00501,,M/#00501,,,,,
32,4,,172168-72880,, SPRING,1,1,,,,,W,,,M/#00501,,M/#00501,,,,,
33,4,,172168-72860,, "SEAT,SPRING",1,1,,,,,W,,,M/#00501,,M/#00501,,,,,
34,4,,172151-74060,, "BOLT, SOCKET HEAD",4,4,,,,,W,,,M/#00501,,M/#00501,,,,,
35,4,,172122-74130,, POPPET,1,1,,,,,W,,,M/#00501,,M/#00501,,,,,
36,4,,172168-72750,, "SPRING,CHECK VALVE",1,1,,,,,W,,,M/#00501,,M/#00501,,,,,
37,3,,172164-74350,, "RILIEF VALVE",1,1,,,,,,,,,,,,,
38,4,,172116-74150,, O-RING,1,1,,,,,,,,,,,,,
39,3,,172310-79180,, VALVE,1,1,,,,,,,,,,,,,
40,4,,172116-74150,, O-RING,1,1,,,,,,,,,,,,,

Fig. 68 コントロールバルブ (ブーム&バケット/PTO) CONTROL VALVE (BOOM & BUCKET/P.T.O.)

コントロールバルブ ASSY
CONTROL VALVE ASSY
(172164-74110)
Fig. 65 REF. No. 1
(172164-74111)
Fig. 65 REF. No. 1-1
(172164-74112)
Fig. 65 REF. No. 1-2
inc. Fig. 65 REF. No. 2 ~ 28
Fig. 66 REF. No. 1 ~ 45
Fig. 67 REF. No. 1 ~ 44
Fig. 68 REF. No. 1 ~ 40
Fig. 69 REF. No. 1 ~ 29

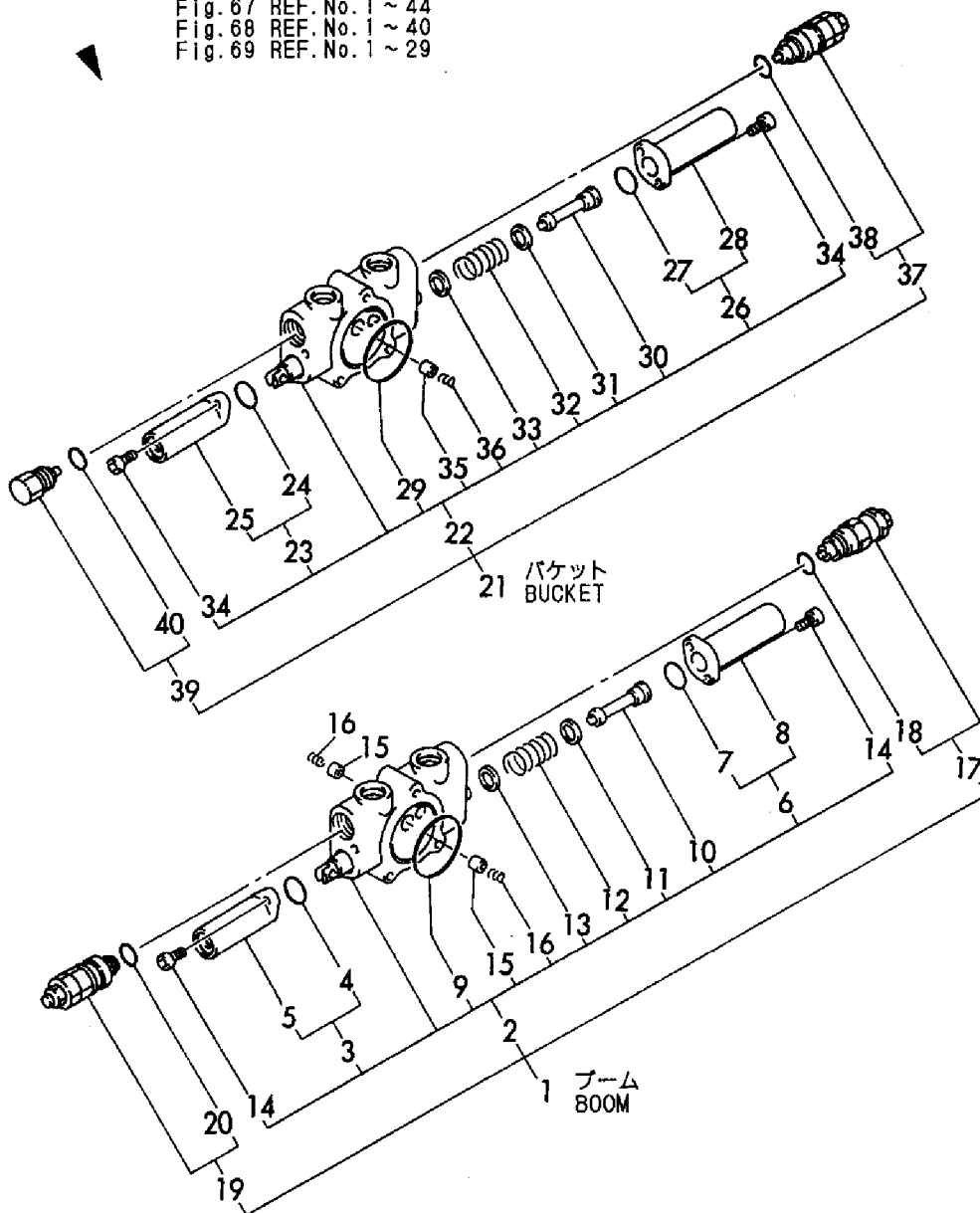
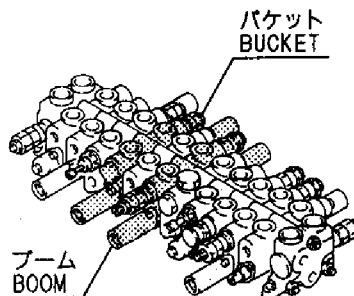

1,2,,172164-74310,, "SECTION ASSY, SPOOL",1,1,,,,,,,,,,,,,
2,3,,172164-74440,, "O-RING ASSY",1,1,,,,,,,,,,,,,
3,4,,172151-74320,, O-RING,1,1,,,,,,,,,,,,,
4,4,,172168-72870,, CAP,1,1,,,,,W,,,M/#00501,,M/#00501,,,,,
5,3,,172164-74380,, "CAP ASSY",1,1,,,,,,,,,,,,,
6,4,,172151-74320,, O-RING,1,1,,,,,,,,,,,,,
7,4,,172168-72840,, "CAP, FILLER",1,1,,,,,W,,,M/#00501,,M/#00501,,,,,
8,3,,933171-80590,, O-RING,1,1,,,,,,,,,,,,,
9,3,,172168-72850,, "END, SPOOL",1,1,,,,,W,,,M/#00501,,M/#00501,,,,,
10,3,,172175-74220,, "SEAT, SPRING",1,1,,,,,W,,,M/#00501,,M/#00501,,,,,
11,3,,172175-74240,, SPRING,1,1,,,,,W,,,M/#00501,,M/#00501,,,,,
12,3,,172168-72860,, "SEAT, SPRING",1,1,,,,,W,,,M/#00501,,M/#00501,,,,,
13,3,,172151-74060,, "BOLT, SOCKET HEAD",4,4,,,,,W,,,M/#00501,,M/#00501,,,,,
14,3,,172122-74130,, POPPET,1,1,,,,,W,,,M/#00501,,M/#00501,,,,,
15,3,,172168-72750,, "SPRING,CHECK VALVE",1,1,,,,,W,,,M/#00501,,M/#00501,,,,,
16,2,,172164-74320,, "SECTION ASSY, SPOOL",1,1,,,,,,,,,,,,,
17,3,,172164-74400,, "O-RING ASSY",1,1,,,,,,,,,,,,,
18,4,,933166-80520,, WIPER,2,2,,,,,,,,,,,,,
19,4,,933171-80610,, O-RING,2,2,,,,,,,,,,,,,
20,4,,933166-80530,, CAP,1,1,,,,,W,,,M/#00501,,M/#00501,,,,,
21,3,,933171-80590,, O-RING,1,1,,,,,,,,,,,,,
22,3,,172116-74190,, "PLATE, SEAL",2,2,,,,,W,,,M/#00501,,M/#00501,,,,,
23,3,,933171-80510,, "SEAT, SPRING",2,2,,,,,W,,,M/#00501,,M/#00501,,,,,
24,3,,933166-80550,, "SCREW, CAP",1,1,,,,,W,,,M/#00501,,M/#00501,,,,,
25,3,,172122-74050,, SPRING,1,1,,,,,W,,,M/#00501,,M/#00501,,,,,
26,3,,172122-74130,, POPPET,1,1,,,,,W,,,M/#00501,,M/#00501,,,,,
27,3,,172168-72750,, "SPRING,CHECK VALVE",1,1,,,,,W,,,M/#00501,,M/#00501,,,,,
28,3,,172116-74220,, SCREW,2,2,,,,,W,,,M/#00501,,M/#00501,,,,,
29,3,,172151-74060,, "BOLT, SOCKET HEAD",2,2,,,,,W,,,M/#00501,,M/#00501,,,,,

Fig. 69 コントロールバルブ (旋回&ブレード/PTO) CONTROL VALVE (TURNING & BLADE/P.T.O.)

コントロールバルブ ASSY
CONTROL VALVE ASSY
(172164-74110)
Fig. 65 REF. No. 1
(172164-74111)
Fig. 65 REF. No. 1-1
(172164-74112)
Fig. 65 REF. No. 1-2
inc. Fig. 65 REF. No. 2 ~ 28
Fig. 66 REF. No. 1 ~ 45
Fig. 67 REF. No. 1 ~ 44
Fig. 68 REF. No. 1 ~ 40
Fig. 69 REF. No. 1 ~ 29

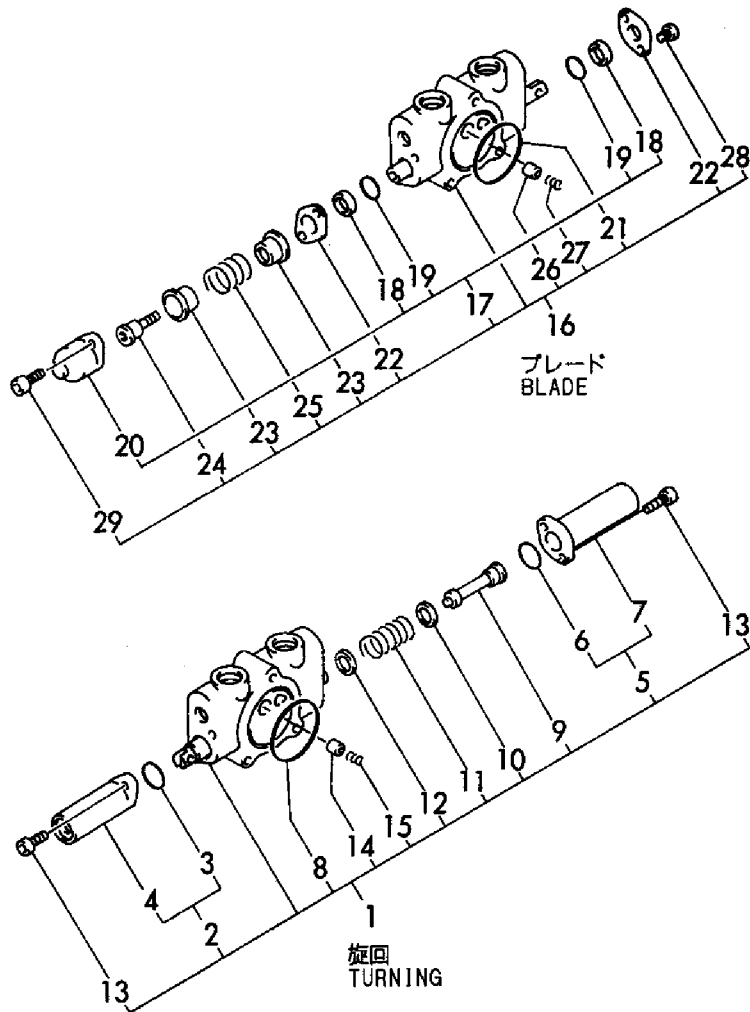
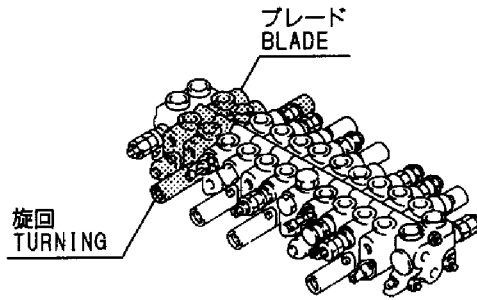

1,2,,172164-74700,, "VALVE ASSY,PTO",1,1,,,,,,,,,,,,,
2,3,,26716-080002,, "NUT M 8",4,4,,,,,,,,,,,,,
3,3,,172122-74230,, TIE-ROD,2,2,,,,,,,,,,,,,
4,3,,26716-100002,, "NUT 10",2,2,,,,,,,,,,,,,
5,3,,172124-74330,, TIE-ROD,1,1,,,,,,,,,,,,,
6,3,,172168-74810,, "SECTION ASSY., INLET",1,1,,,,,,,,,,,,,
7,4,,933171-80590,, O-RING,1,1,,,,,,,,,,,,,
8,3,,933171-80420,, "SECTION, OUTLET",1,1,,,,,,,,,,,,,
9,3,,172164-74710,, "SECTION SET, SPOOL",1,1,,,,,,,,,,,,,
10,4,,172164-74400,, "O-RING ASSY",1,1,,,,,1,,,,,,,,,,,,,
11,4,,933171-80610,, O-RING,2,2,,,,,,,,,,,,,
12,4,,933166-80520,, WIPER,2,2,,,,,,,,,,,,,
13,4,,933166-80530,, CAP,1,1,,,,,W,,M/#00501,,M/#00501,,,,,,
14,4,,933171-80590,, O-RING,1,1,,,,,,,,,,,,,
15,4,,172312-74230,, O-RING,2,2,,,,,,,,,,,,,
16,4,,172116-74190,, "PLATE, SEAL",2,2,,,,,W,,M/#00501,,M/#00501,,,,,,
17,4,,172168-74830,, SPACER,1,1,,,,,W,,M/#00501,,M/#00501,,,,,,
18,4,,172168-74840,, PIN,1,1,,,,,W,,M/#00501,,M/#00501,,,,,,
19,4,,172168-74850,, SLEEVE,1,1,,,,,W,,M/#00501,,M/#00501,,,,,,
20,4,,172168-74860,, "BOLT, SOCKET HEAD",2,2,,,,,W,,M/#00501,,M/#00501,,,,,,
21,4,,172151-74290,, "BOLT, SOCKET HEAD",2,2,,,,,W,,M/#00501,,M/#00501,,,,,,
22,4,,172168-74870,, "BALL,STAINLESS STEEL",2,2,,,,,W,,M/#00501,,M/#00501,,,,,,
23,4,,172168-74880,, SPRING,1,1,,,,,W,,M/#00501,,M/#00501,,,,,,
24,4,,172312-74220,, SPACER,2,2,,,,,W,,M/#00501,,M/#00501,,,,,,
25,3,,172164-74720,, "SECTION KIT, SPOOL",1,1,,,,,,,,,,,,,
26,4,,172164-74380,, "CAP ASSY",1,1,,,,,2,,,,,,,,,,,,,
27,4,,172151-74320,, O-RING,1,1,,,,,,,,,,,,,
28,4,,172168-72840,, "CAP, FILLER",1,1,,,,,W,,M/#00501,,M/#00501,,,,,,
29,4,,172164-74440,, "O-RING ASSY",1,1,,,,,3,,,,,,,,,,,,,
30,4,,172151-74320,, O-RING,1,1,,,,,,,,,,,,,
31,4,,172168-72870,, CAP,1,1,,,,,W,,M/#00501,,M/#00501,,,,,,
32,4,,933171-80590,, O-RING,1,1,,,,,,,,,,,,,
33,4,,172168-72850,, "END, SPOOL",1,1,,,,,W,,M/#00501,,M/#00501,,,,,,
34,4,,172175-74220,, "SEAT, SPRING",1,1,,,,,W,,M/#00501,,M/#00501,,,,,,
35,4,,172176-74450,, SPRING,1,1,,,,,W,,M/#00501,,M/#00501,,,,,,
36,4,,172168-72860,, "SEAT,SPRING",1,1,,,,,W,,M/#00501,,M/#00501,,,,,,
37,4,,172151-74060,, "BOLT, SOCKET HEAD",4,4,,,,,W,,M/#00501,,M/#00501,,,,,,
38,4,,172175-74270,, "PLUG ASSY",2,2,,,,,W,,M/#00501,,M/#00501,,,,,,
39,2,,26013-100302,, "BOLT M10X 30",3,3,,,,,,,,,,,,,

Fig. 70 P.T.O.バルブ
P. T. O. VALVE

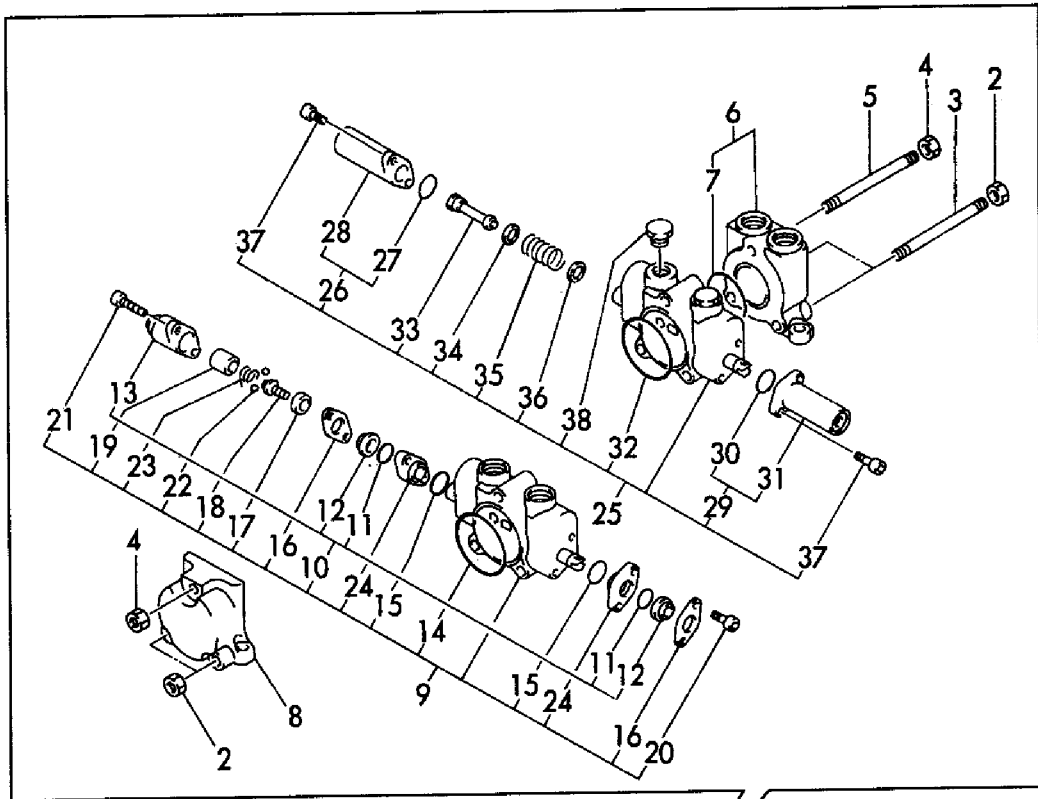

PTOキット (合流)
P. T. O. KIT (CONFLUENCE)
(172164-74520)
Fig. 34 REF. No. 1
(172164-74521)
Fig. 34 REF. No. 1-1
Inc. Fig. 34 REF. No. 2 ~ 33
Fig. 70 REF. No. 1 ~ 39
Fig. 83 REF. No. 1 ~ 29

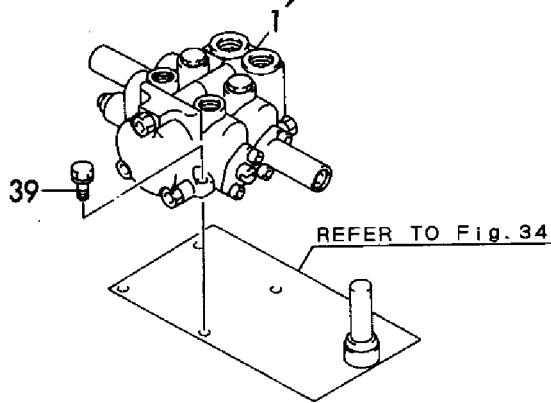

1,1,,172151-74610,, "VALVE ASSY,RMT.CONT." ,2,2,,,,,,,,,,,,,
1-1,1,,172151-74611,, "VALVE ASSY,RMT.CONT." ,2,2,,,,,N,,,M/#01072,,M/#01072,,,,,,
2,2,,172151-74860,, "SHIM(COUNT. SET" ,8,8,,,,,,,,,,,,,
3,2,,172151-74870,, SPRING,8,8,,,,,,,,,,,,,
4,2,,172151-74880,, RETAINER,8,8,,,,,,,,,,,,,
5,2,,172151-74890,, "SP (SYN." ,8,8,,,,,,,,,,,,,
6,2,,172151-74900,, PISTON,8,8,,,,,,,,,,,,,
7,2,,172151-74910,, SEAL,8,8,,,,,,,,,,,,,
8,2,,172151-74920,, COLLAR,8,8,,,,,Z,,,M/#01072,,M/#01072,,,,,,
8A,2,,172164-74610,, COLLAR,8,8,,,,,W,,,M/#01072,,M/#01072,,,,,,
9,2,,172151-74930,, BOOT,2,2,,,,,,,,,,,,,
10,2,,172151-74940,, PLATE,2,2,,,,,,,,,,,,,
11,2,,172151-74950,, UNION,2,2,,,,,,,,,,,,,
12,2,,172151-74960,, DISK,2,2,,,,,Z,,,M/#01072,,M/#01072,,,,,,
12A,2,,172164-74620,, DISC,2,2,,,,,W,,,M/#01072,,M/#01072,,,,,,
13,2,,172151-74970,, NUT,2,2,,,,,Z,,,M/#01072,,M/#01072,,,,,,
13A,2,,172164-74630,, NUT,2,2,,,,,W,,,M/#01072,,M/#01072,,,,,,
14,2,,172151-74980,, PLATE,2,2,,,,,,,,,,,,,
15,2,,172151-74990,, PLUG,4,4,,,,,Z,,,M/#01072,,M/#01072,,,,,,
15A,2,,172164-74650,, PLUG,4,4,,,,,W,,,M/#01072,,M/#01072,,,,,,
16,2,,24311-000200,, "O-RING 1A P-20.0" ,8,8,,,,,,,,,,,,,
17,2,,24311-000700,, "O-RING 1A P-70.0" ,2,2,,,,,,,,,,,,,
18,2,,26116-060202,, "BOLT M 6X 20" ,8,8,,,,,,,,,,,,,
19,2,,172164-74560,, PLUG,4,4,,,,,W,,,M/#01072,,M/#01072,,,,,,

Fig. 71 リモコンバルブ
REMOTE CONTROL VALVE

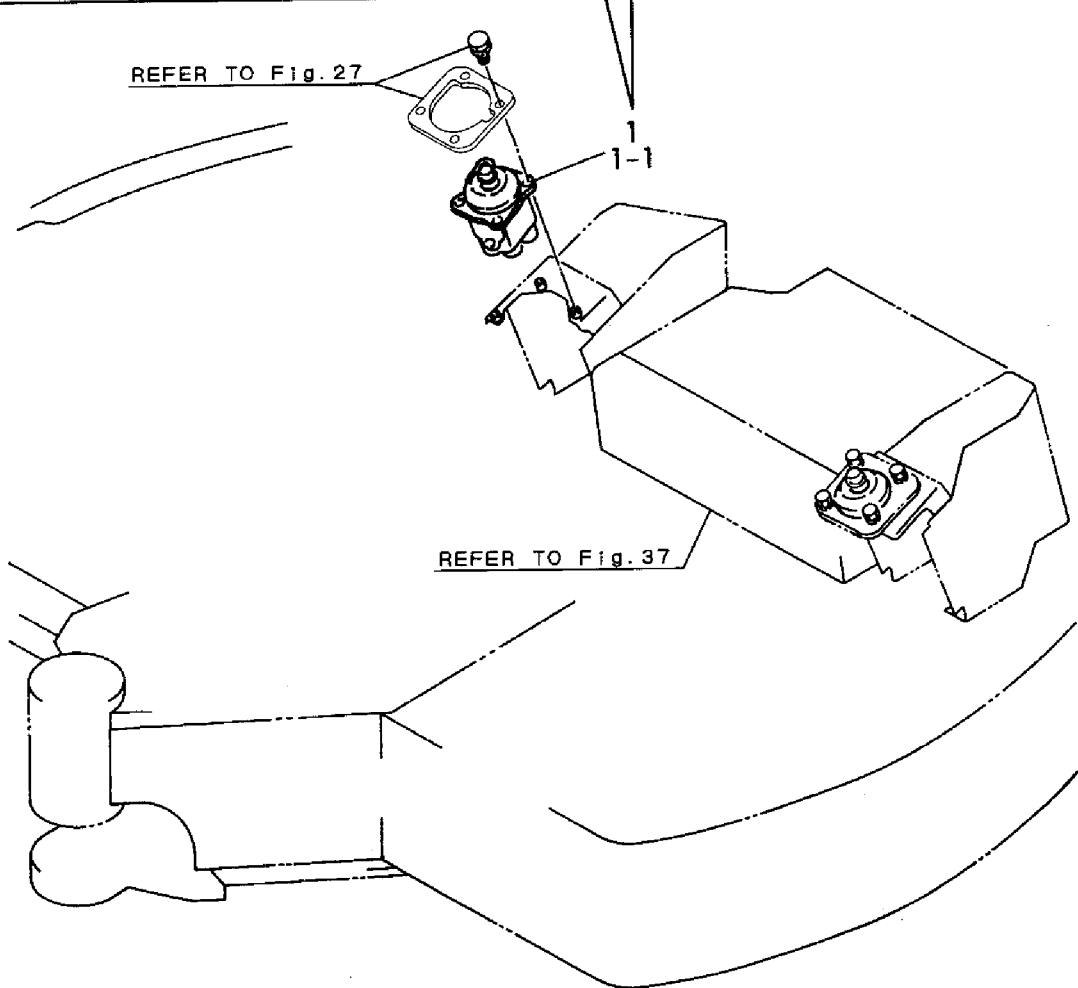
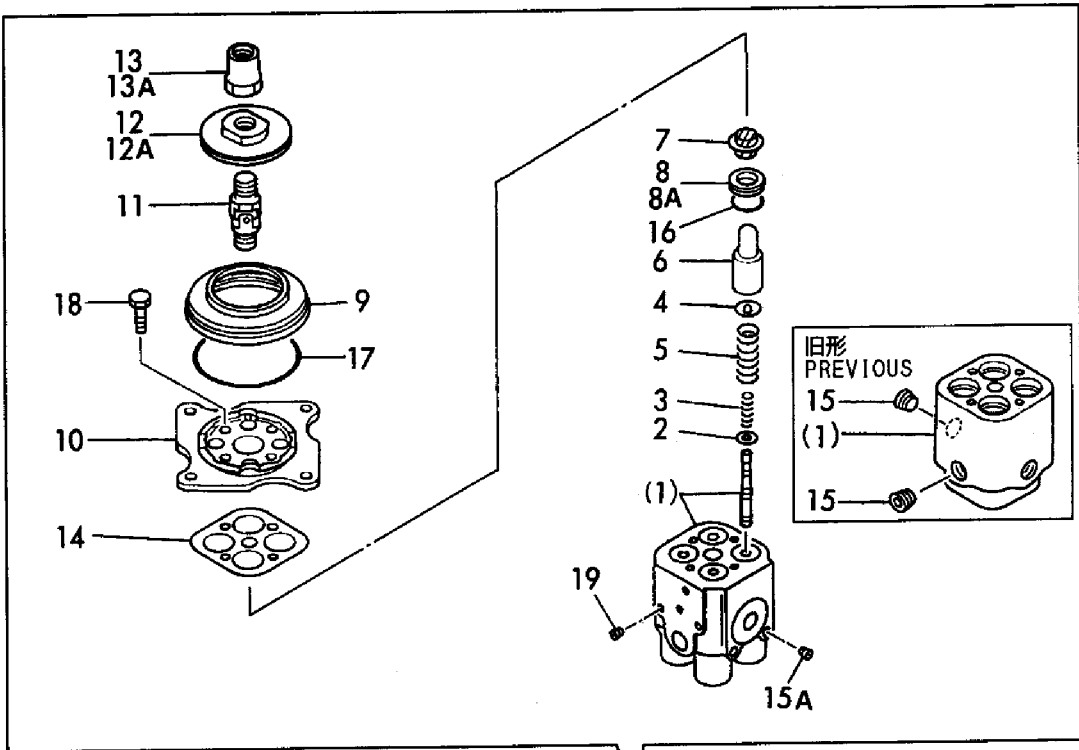

1,1,,172164-08700,, "2-WAY MULTI V KIT(P",,1,,,,,1,,,,,
2,1,,172164-08710,, "2-WAY MULTI V KIT(C",,1,,,,,2,,,,,
3,2,,172164-62500,, "PLATE B, MULTI",,1,1,,,,,
3-1,2,,172164-62501,, "PLATE B",,1,1,,,,,S,3,,M/#01277,,M/#01277,,,,,
3-2,2,,172164-62502,, "PLATE B",,1,1,,,,,N,,M/#2619,,M/#2619,,,,,
4,2,,172164-62530,, COVER,1,1,,,,,
4-1,2,,172164-62531,, COVER,1,1,,,,,S,3,,M/#01277,,M/#01277,,,,,
5,2,,22217-100000,, "SPRING WASHER 10",,2,2,,,,,
6,2,,26013-100202,, "BOLT W/WASHER M10X20",,4,4,,,,,
7,2,,26647-100152,, "WING BOLT M10X15",,2,2,,,,,
8,2,,172164-74900,, "BRACKET(ABV CMP",,1,1,,,,,
9,2,,26013-080252,, "BOLT M 8X 25",,3,3,,,,,
10,2,,26013-100402,, "BOLT M10X 40",,3,3,,,,,
11,2,,172173-03560,, "LABEL (YANMAR",,1,1,,,,,
12,2,,172173-03570,, "LABEL (KOMATSU",,1,1,,,,,
13,2,,172173-03550,, "LABEL (2-WAY",,1,,,,,
14,2,,172175-03550,, LABEL(2-WAY,1,,,,,
15,2,,172175-74700,, "VALVE, 2-WAY",,1,1,,,,,
16,3,,172175-74710,, PLATE,1,1,,,,,
17,3,,172175-74720,, GASKET,1,1,,,,,
18,3,,172175-74730,, LEVER,1,1,,,,,
19,3,,172151-74760,, WASHER,7,7,,,,,
20,3,,23871-010000,, "PLUG PT1/8,SCREW",,8,8,,,,,
21,3,,24311-000250,, "O-RING 1A P-25.0",,1,1,,,,,
22,3,,24311-000320,, "O-RING 1A P-32.0",,1,1,,,,,
23,3,,26116-060162,, "BOLT 6X16",,6,6,,,,,
24,3,,26647-060202,, "WING BOLT M 6X20",,1,1,,,,,

Fig. 72 2ウェイバルブ (2ウェイマルチチェンジ) 2-WAY VALVE (2-WAY MULTI CHANGE)

2ウェイマルチバルブキット (キャノピー)
2-WAY MULTI VALVE KIT (CANOPY)
(172164-08700)
Fig. 72 REF. No. 1
inc. Fig. 72 REF. No. 3~13, 15~24
Fig. 90 REF. No. 1~10

2ウェイマルチバルブキット (キャビン)
2-WAY MULTI VALVE KIT (CABIN)
(172164-08710)
Fig. 72 REF. No. 2
inc. Fig. 72 REF. No. 3~12, 14~24
Fig. 90 REF. No. 1~10

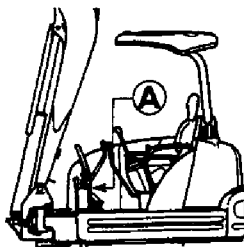
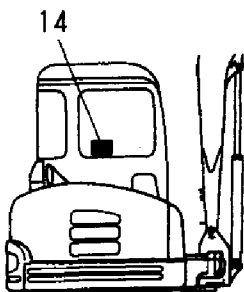
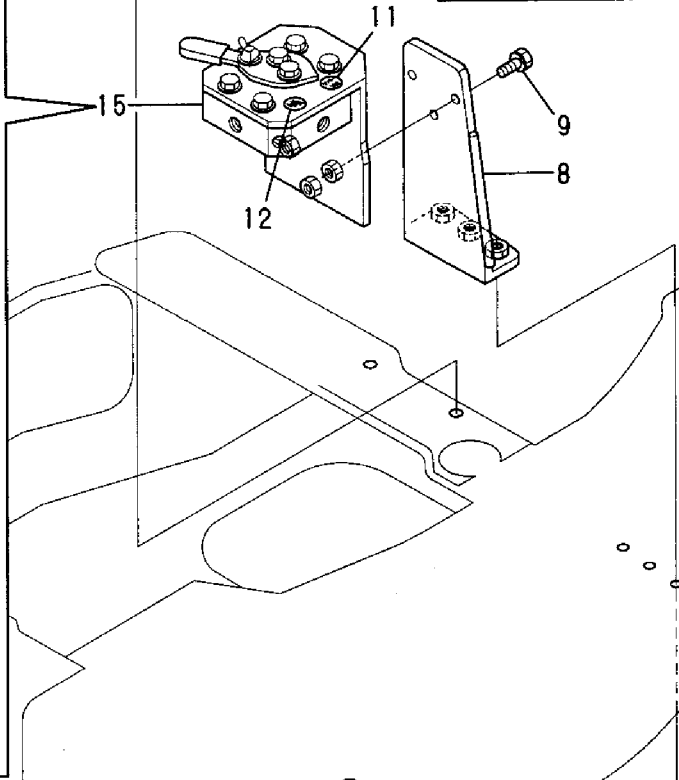
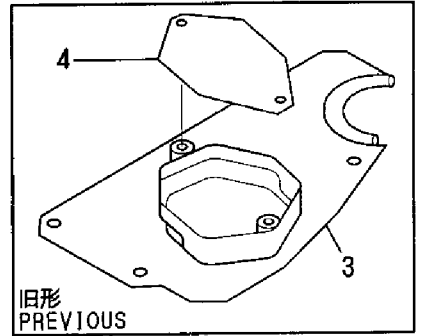
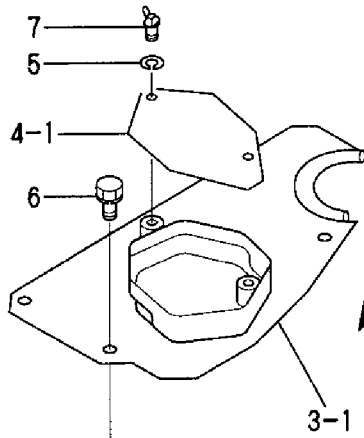
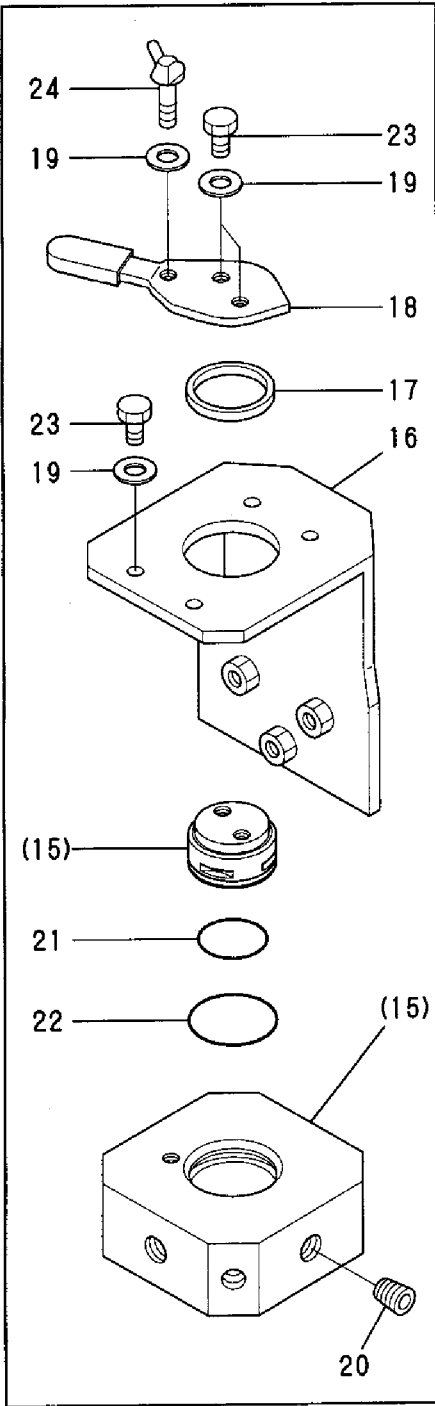

Ⓐから見る
VIEWED FROM Ⓐ

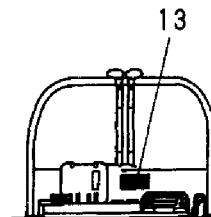

10

1,1,,172164-74530,, "MULTI VALVE KIT",,1,,,,,1,,,,,
1-1,1,,172164-74490,, "MULTI VALVE KIT",,1,,,,,N,1,,,,,"FROM 1ST",,,,,,
2,1,,172164-74540,, "MULTI VALVE KIT",,1,,,,,1,,,,,
2-1,1,,172164-74490,, "MULTI VALVE KIT",,1,,,,,N,1,,,,,"FROM 1ST",,,,,,
3,2,,172164-74200,, "BRACKET COMPL.",,1,1,,,,,
4,2,,172151-74600,, "VALVE CMP,MULTICHNG.",,1,1,,,,,
4-1,2,,172151-74601,, VALVE,1,1,,,,,F,3,,M/#02612,,M/#02612,,,,,
5,3,,172151-74700,, LEVER,1,1,,,,,
5-1,3,,182900-77250,, LEVER,1,1,,,,,S,,M/#02612,,M/#02612,,,,,
6,3,,172151-74710,, COVER,1,1,,,,,
6-1,3,,182900-77220,, COVER,1,1,,,,,N,,M/#02612,,M/#02612,,,,,
7,3,,172151-74720,, COVER,1,1,,,,,
7-1,3,,182900-16530,, COVER,1,1,,,,,N,,M/#02612,,M/#02612,,,,,
8,3,,172151-74730,, SPRING,1,1,,,,,
8-1,3,,182900-22300,, SPRING,1,1,,,,,N,,M/#02612,,M/#02612,,,,,
9,3,,172151-74740,, "PLATE, MARK",,1,1,,,,,
10,3,,172151-74750,, "PLATE, MARK",,1,1,,,,,Z,,M/#02612,,M/#02612,,,,,
11,3,,172151-74760,, WASHER,2,2,,,,,
11-1,3,,953KM0-00220,, WASHER,2,2,,,,,N,,M/#02612,,M/#02612,,,,,
12,3,,172151-74760,, WASHER,1,1,,,,,
12-1,3,,953KM0-00220,, WASHER,1,1,,,,,N,,M/#02612,,M/#02612,,,,,
13,3,,172151-74770,, "GASKET, CYL. HEAD",,1,1,,,,,Z,,M/#02612,,M/#02612,,,,,
14,3,,23871-010000,, "PLUG PT1/8,SCREW",,1,1,,,,,
14-1,3,,953KM0-10894,, PLUG,1,1,,,,,N,,M/#02612,,M/#02612,,,,,
15,3,,24190-100001,, "BALL 5/16, STEEL",,1,1,,,,,
16,3,,24311-000280,, "O-RING 1A P-28.0",,1,1,,,,,
17,3,,24321-000600,, "O-RING 1A G-60.0",,2,2,,,,,
18,3,,26450-060162,, "BOLT M 6X 16",,2,2,,,,,
18-1,3,,182900-77240,, BOLT,2,2,,,,,S,,M/#02612,,M/#02612,,,,,
19,3,,26450-060162,, "BOLT M 6X 16",,8,8,,,,,
19-1,3,,182900-77190,, BOLT,8,8,,,,,N,,M/#02612,,M/#02612,,,,,
20,3,,26450-060162,, "BOLT M 6X 16",,8,8,,,,,
20-1,3,,182900-77200,, BOLT,8,8,,,,,S,,M/#02612,,M/#02612,,,,,
21,3,,26647-060202,, "WING BOLT M 6X20",,1,1,,,,,
21-1,3,,182900-77230,, "WING BOLT",,1,1,,,,,R,,M/#02612,,M/#02612,,,,,
21A,3,,182900-77210,, "DUST SEAL",,1,1,,,,,W,,M/#02612,,M/#02612,,,,,
22,2,,26013-100252,, "BOLT W/WASHER M10X25",,3,3,,,,,
23,2,,26013-100402,, "BOLT M10X 40",,3,3,,,,,
24,2,,172151-03550,, "LABEL,PATTERN B",,1,1,,,,,4,,,,,
25,2,,172164-62500,, "PLATE B, MULTI",,1,1,,,,,
25-1,2,,172164-62501,, "PLATE B",,1,1,,,,,S,2,,M/#01977,,M/#01977,,,,,
25-2,2,,172164-62502,, "PLATE B",,1,1,,,,,N,,M/#02612,,M/#02612,,,,,
26,2,,172164-62530,, COVER,1,1,,,,,
26-1,2,,172164-62531,, COVER,1,1,,,,,S,2,,M/#01977,,M/#01977,,,,,
27,2,,22217-100000,, "SPRING WASHER 10",,2,2,,,,,
28,2,,26647-100152,, "WING BOLT M10X15",,2,2,,,,,
29,2,,172165-03471,, LABEL,1,1,,,,,5,,,,,

Fig. 73 ロータリバルブ (4ウェイマルチチェンジ) ROTARY VALVE (4-WAY MULTI CHANGE)

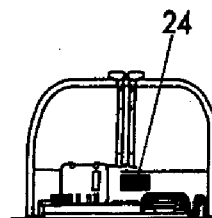
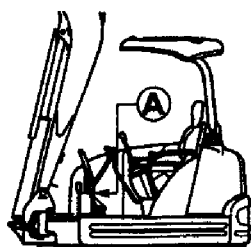
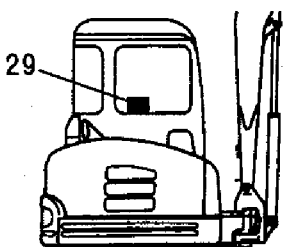
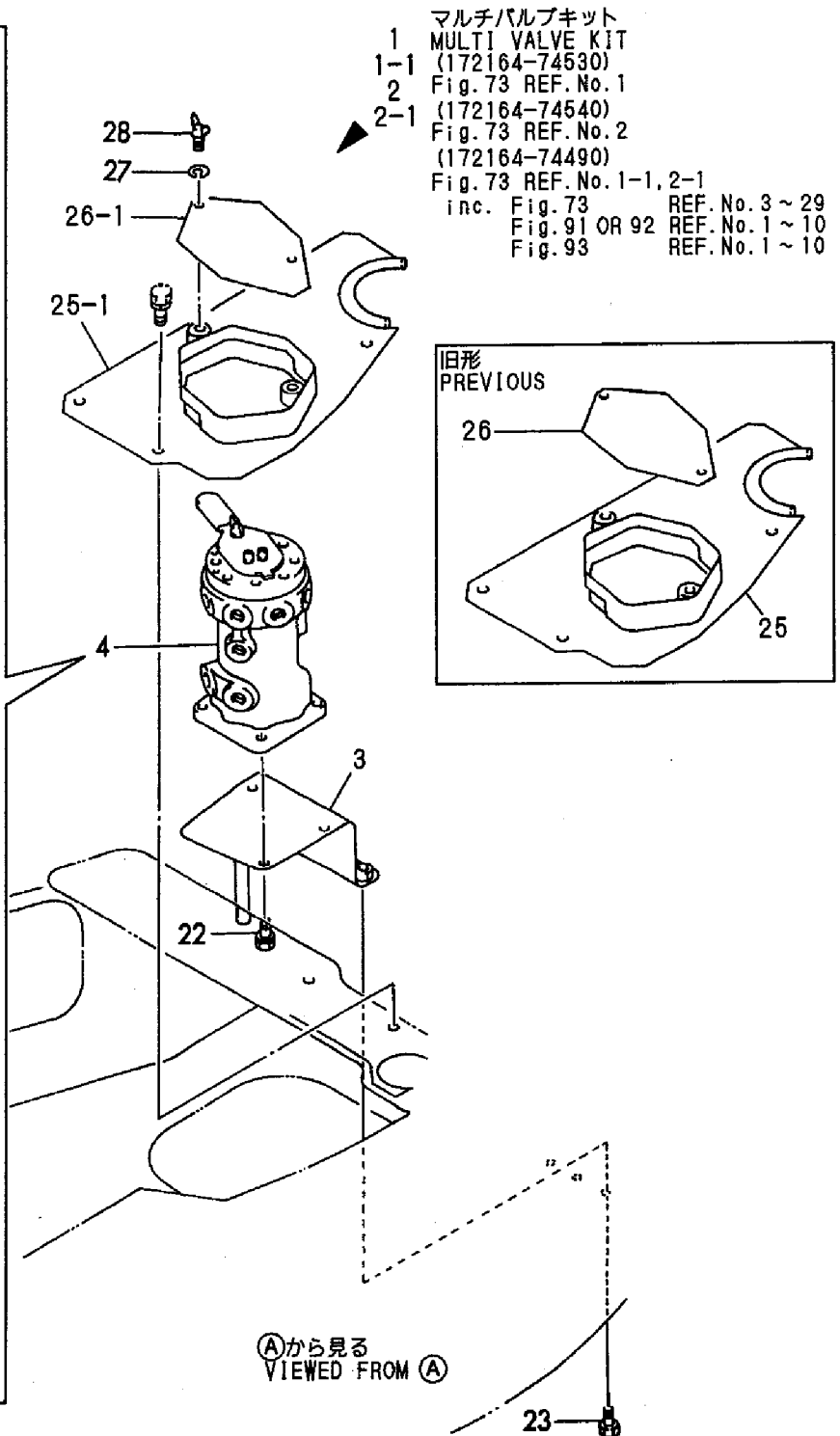
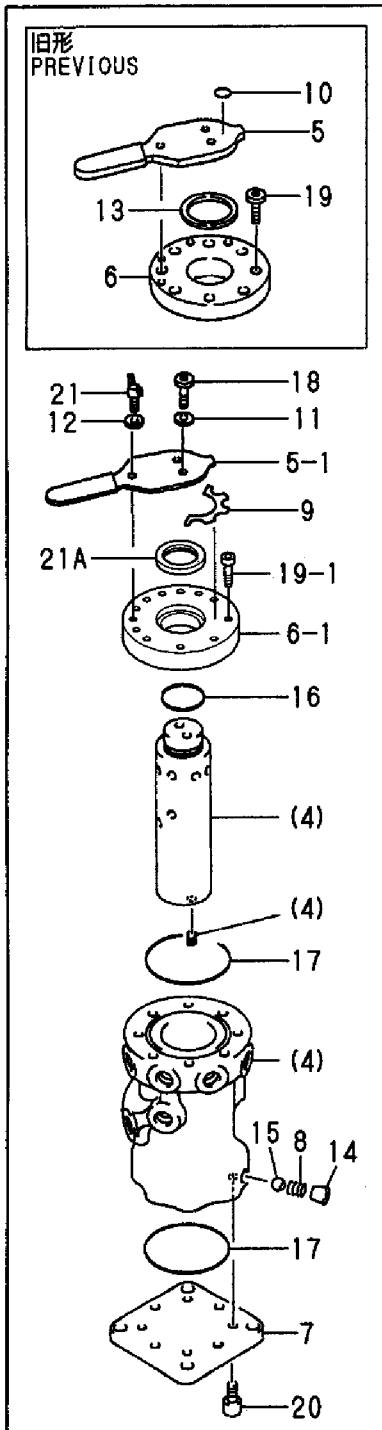

1,1,,172165-74704,, "VALVE ASSY, LOW-HIGH",1,1,,,,,1,,,,,
2,2,,172151-74420,, "BOLT M 4X 10",3,3,,,,,
3,2,,172165-74710,, SOLENOID,1,1,,,,,
4,2,,172165-74720,, "BOLT M5X16,HEX.SCKT.",2,2,,,,,
5,2,,172165-74730,, "BOLT M5X8,HEX.SCKT.",2,2,,,,,
6,2,,172165-74740,, SPRING,1,1,,,,,
7,2,,172165-74760,, SPRING,1,1,,,,,
8,2,,172165-74770,, PACKING,2,2,,,,,
9,2,,172165-74780,, PLATE,2,2,,,,,
10,2,,172165-74790,, COVER,1,1,,,,,
11,2,,23871-010000,, "PLUG PT1/8,SCREW",1,1,,,,,
12,2,,24311-000160,, "O-RING 1A P-16.0",1,1,,,,,
13,1,,26013-080162,, "BOLT W/WASHER M8X16",2,2,,,,,

Fig. 74 ローハイバルブ (旧形)
LOW-HIGH VALVE (PREVIOUS)

~M/#01186

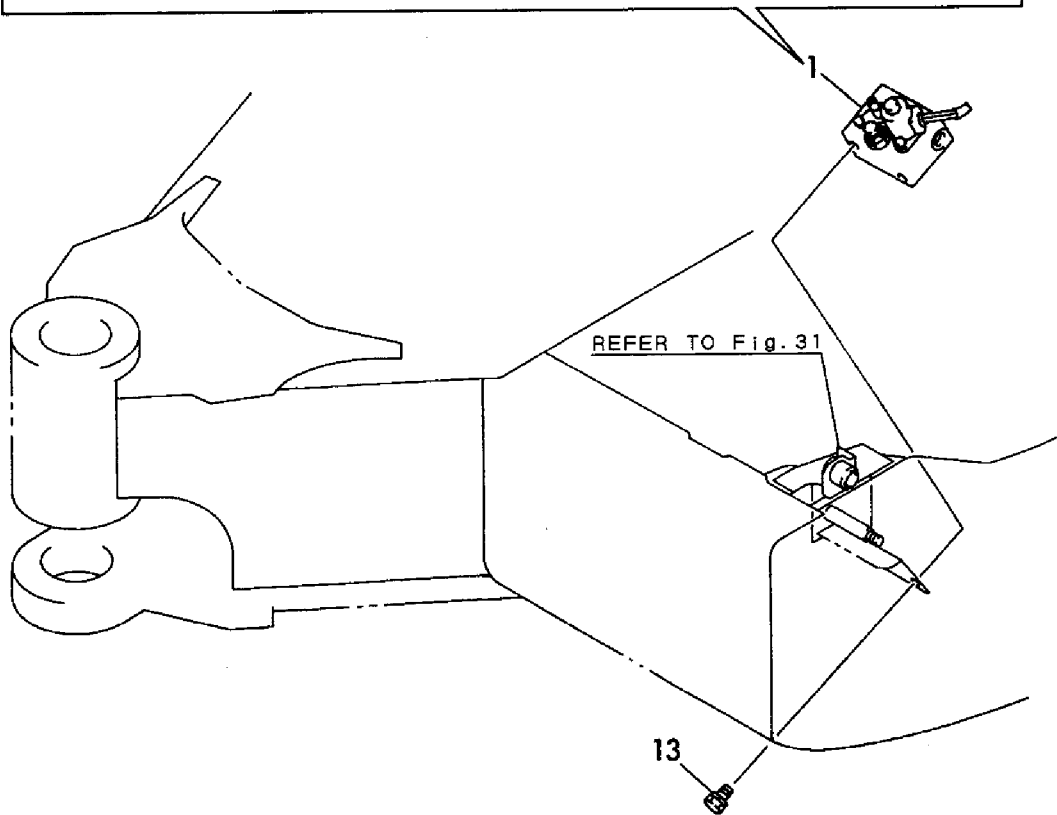
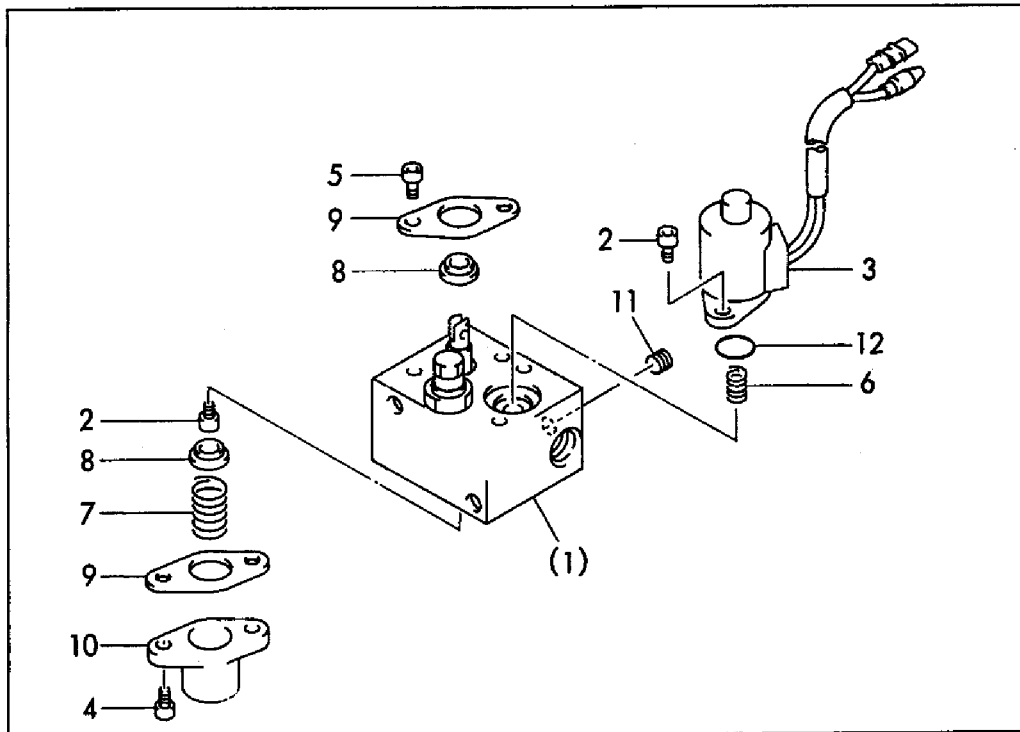

1,1,,772164-75100,, "TANK ASSY, HYD. OIL", 1,1,,,,,,,,,,,,,
3,2,,172164-75250,, COVER, 1,1,,,,,,,,,,,,,
4,2,,172122-75331-2,, "COVER (B), RESERVOIR", 1,1,,,,,,,,,,,,,
5,2,,172165-75450-4,, PLATE, 1,1,,,,,,,,,,,,,
6,2,,172165-75460,, GASKET, 1,1,,,,,,,,,,,,,
7,2,,172165-75481,, ELEMENT, 1,1,,,,,,,,,,,,,
8,2,,172122-75600,, "GAUGE, OIL LEVEL", 1,1,,,,,,,,,,,,,
9,3,,172122-75620,, BOLT, 2,2,,,,,,,,,,,,,
10,3,,172122-75630,, GASKET, 4,4,,,,,,,,,,,,,
11,2,,172116-75850-4,, "PLUG, OIL FEED", 1,1,,,,,,,,,,,,,
12,2,,24341-000300,, "O-RING 1A S-30.0", 1,1,,,,,,,,,,,,,
13,2,,22217-100000,, "SPRING WASHER 10", 4,4,,,,,,,,,,,,,
14,2,,22217-100000,, "SPRING WASHER 10", 4,4,,,,,,,,,,,,,
15,2,,22417-200160,, "COTTER PIN 2.0X16", 1,1,,,,,Z,,M/#02619,,M/#02619,,,,,
16,2,,24311-000380,, "O-RING 1A P-38.0", 1,1,,,,,,,,,,,,,
17,2,,24321-001350,, "O-RING 1A G-135.0", 1,1,,,,,,,,,,,,,
18,2,,24321-001900,, "O-RING 1A G-190.0", 1,1,,,,,,,,,,,,,
19,2,,26022-050102,, "SCREW M 5X 10", 3,3,,,,,,,,,,,,,
20,2,,26116-100202,, "BOLT M10X 20 PLATED", 4,4,,,,,,,,,,,,,
21,2,,26116-100202,, "BOLT M10X 20 PLATED", 4,4,,,,,,,,,,,,,
22,2,,933171-23042,, MAGNET, 1,1,,,,,Z,,M/#02619,,M/#02619,,,,,
23,2,,172183-75750,, "PLUG 24, DRAIN", 1,1,,,,,,,,,,,,,
23-1,2,,172187-75500,, "PLUG 24", 1,1,,,,,R,,M/#02619,,M/#02619,,,,,
24,2,,172164-73700,, ROD, 1,1,,,,,,,,,,,,,
25,2,,172112-74801,, "STRAINER, SUCTION", 1,1,,,,,,,,,,,,,
26,2,,172112-74901,, "ELEMENT W/VALVE", 1,1,,,,,,,,,,,,,
27,3,,172112-74911,, ELEMENT, 1,1,,,,,,,,,,,,,
28,3,,172112-74971,, "VALVE, BY-PASS", 1,1,,,,,,,,,,,,,
29,2,,172112-75770,, "SPRING, STRAINER", 1,1,,,,,,,,,,,,,
30,2,,172112-75780,, "SPRING, STRAINER", 1,1,,,,,,,,,,,,,
31,2,,26716-100002,, "NUT 10", 1,1,,,,,,,,,,,,,
32,1,,124766-59050,, "CLAMP 12", 1,1,,,,,,,,,,,,,
33,1,,172165-75490,, HOSE, 1,1,,,,,,,,,,,,,
34,1,,22137-140000,, "WASHER 14, POLISHED", 4,4,,,,,,,,,,,,,
35,1,,22217-140000,, "SPRING WASHER 14", 4,4,,,,,,,,,,,,,
36,1,,26116-140402,, "BOLT M14X 40 PLATED", 4,4,,,,,,,,,,,,,
37,1,,933169-23070,, "SPACER (1.6)", 4,4,,,,,,,,,,,,,
37-1,1,,172117-53330,, SPACER, 4,4,,,,,R,,M/#02206,,M/#02206,,,,,

Fig. 75 作動油タンク HYD. OIL TANK

見出しNo. 1は、見出しNo. (1)から31を含みます。
1 inc. (1) ~ 31

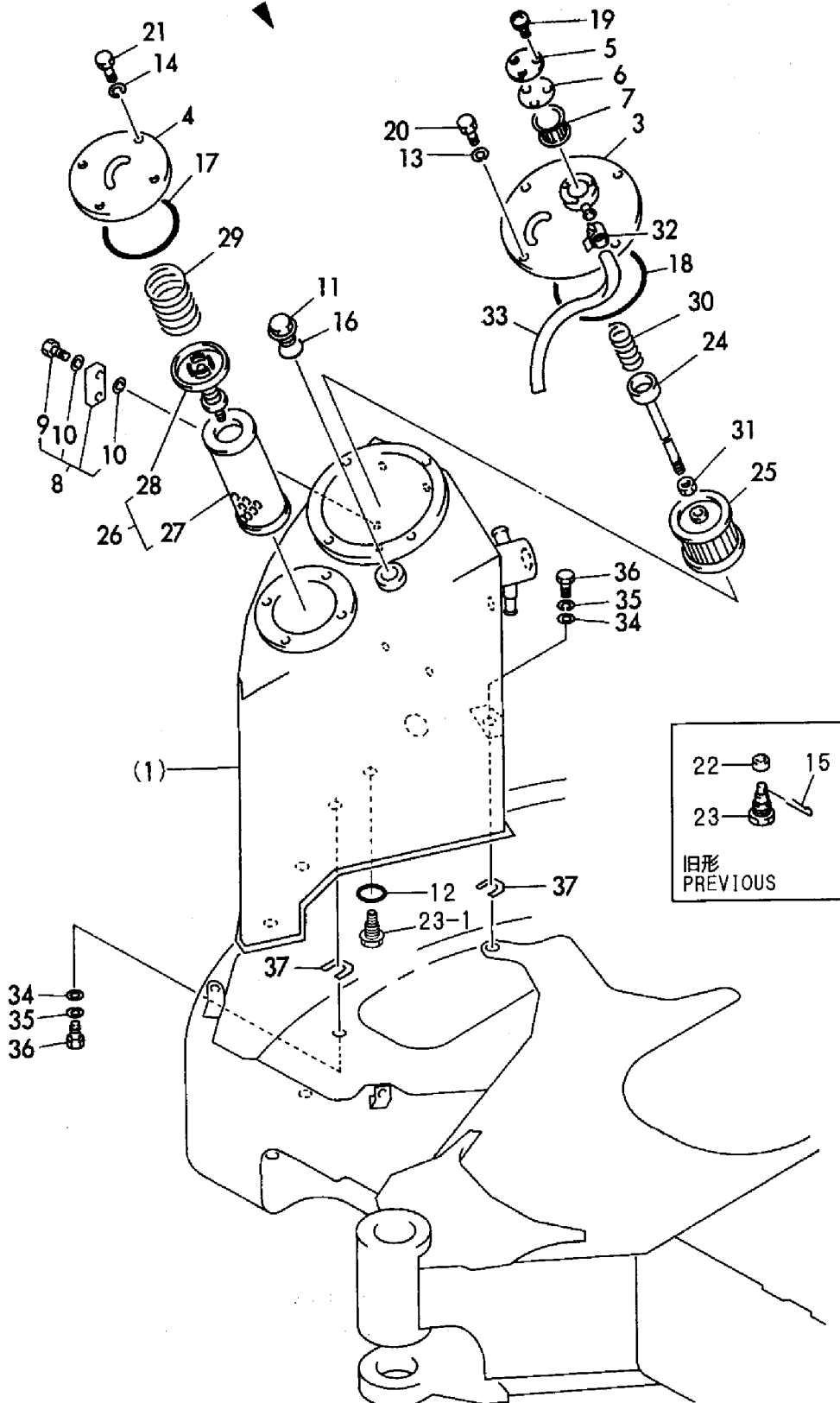

1,1,,172142-76100,,CONNECTOR,1,1,,,,,,,,,,,,,
2,1,,172147-76100,,FLANGE,1,1,,,,,,,,,,,,,
3,1,,933152-07274,,CONNECTOR,1,1,,,,,,,,,,,,,
4,1,,933152-07400,, "O-RING (A)",2,2,,,,,,,,,,,,,
5,1,,172157-76130,, "JOINT PF1/2",1,1,,,,,,,,,,,,,
6,1,,172157-76150,, "CONNECTOR 3/8-1/4",1,1,,,,,,,,,,,,,
7,1,,172141-76900,, "CONNECTOR 1/2L",1,1,,,,,,,,,,,,,
8,2,,24315-000180,, "O-RING 1B P-18.0",1,1,,,,,,,,,,,,,
9,1,,172157-76150,, "CONNECTOR 3/8-1/4",1,1,,,,,,,,,,,,,
10,1,,172164-76220,, "JOINT PF3/8",1,1,,,,,,,,,,,,,
11,1,,172168-76240,, "CONNECTOR UN7/8PF1/2",1,1,,,,,,,,,,,,,
12,1,,172116-76121,,CONNECTOR,1,1,,,,,,,,,,,,,
13,1,,933152-24120,, "O-RING (B)",1,1,,,,,,,,,,,,,
14,1,,24315-000140,, "O-RING 1B P-14.0",2,2,,,,,,,,,,,,,
15,1,,24315-000180,, "O-RING 1B P-18.0",1,1,,,,,,,,,,,,,
16,1,,24315-000240,, "O-RING 1B P-24.0",1,1,,,,,,,,,,,,,
17,1,,24321-000400,, "O-RING 1A G-40.0",1,1,,,,,,,,,,,,,
18,1,,26013-100252,, "BOLT W/WASHER M10X25",4,4,,,,,,,,,,,,,
19,1,,172164-76601,, "TUBE ASSY, SUCTION",1,1,,,,,,,,,,,,,
20,1,,26013-100352,, "BOLT M10X 35",2,2,,,,,,,,,,,,,
21,1,,172164-78100,, "HOSE 38.5X51.5",1,1,,,,,,,,,,,,,
22,1,,172164-78110,, "HOSE 25.7X38.7",1,1,,,,,,,,,,,,,
23,1,,172164-78420,,HOSE,1,1,,,,,,,,,,,,,
24,1,,172164-78430,,HOSE,1,1,,,,,,,,,,,,,
25,1,,172164-78130,,HOSE,1,1,,,,,,,,,,,,,
26,1,,172164-78400,,HOSE,1,1,,,,,,,,,,,,,
27,1,,172164-78140,,HOSE,1,1,,,,,,,,,,,,,
28,1,,172164-78120,,HOSE,1,1,,,,,,,,,,,,,
29,1,,172112-78750,, "CLAMP (B), HOSE",3,3,,,,,,,,,,,,,
30,1,,23000-022000,, "CLAMP 22",4,4,,,,,,,,,,,,,
31,1,,23000-035000,, "CLAMP 35",4,4,,,,,,,,,,,,,
32,1,,23000-041000,, "CLAMP 41",4,4,,,,,,,,,,,,,
33,1,,23000-060000,, "CLAMP 60",4,4,,,,,,,,,,,,,
34,1,,23000-070000,, "CLAMP 70",4,4,,,,,,,,,,,,,
35,1,,172165-76780,,BODY,2,2,,,,,,,,,,,,,
36,1,,172164-76320,, "CONNECTOR 11/4X1/2",2,2,,,,,,,,,,,,,
37,1,,172168-76620,, "ELBOW,90°ADJUSTABLE",2,2,,,,,,,,,,,,,
38,2,,24315-000180,, "O-RING 1B P-18.0",2,2,,,,,,,,,,,,,
39,1,,23391-040000,, "JOINT RGI 1/2",2,2,,,,,,,,,,,,,
40,1,,172164-78410,,HOSE,1,1,,,,,,,,,,,,,

Fig. 76 油圧配管 (タンク~ポンプ~バルブ) (旧形)
HYD. OIL PIPING (TANK~PUMP~VALVE) (PREVIOUS)

~M/#01186

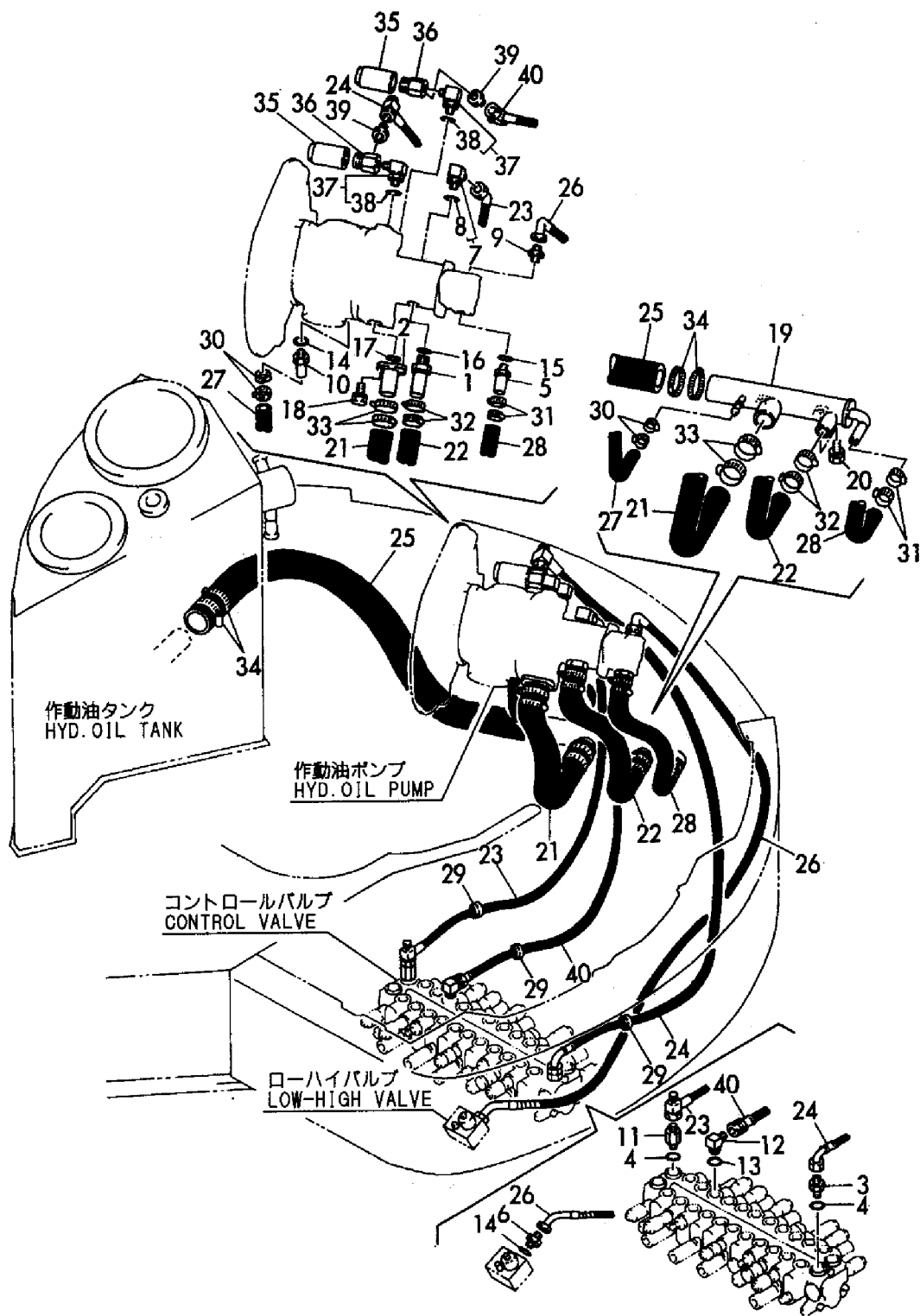

1,1,,172165-76860,,FLANGE,1,1,,,,,,,,,,,,,
2,1,,933152-07274,,CONNECTOR,1,1,,,,,,,,,,,,,
3,1,,933152-07400,,,"O-RING (A)",2,2,,,,,,,,,,,,,
4,1,,172168-76240,,,"CONNECTOR UN7/8PF1/2",1,1,,,,,,,,,,,,,
5,1,,172116-76121,,CONNECTOR,1,1,,,,,,,,,,,,,
6,1,,24321-000450,,,"O-RING 1A G-45.0",1,1,,,,,,,,,,,,,
7,1,,26013-120302,,,"BOLT W/WASHER M12X30",4,4,,,,,,,,,,,,,
8,1,,172176-76400,,TUBE,1,1,,,,,,,,,,,,,
9,1,,26013-100352,,,"BOLT M10X 35",2,2,,,,,,,,,,,,,
10,1,,172164-78101,,HOSE,1,1,,,,,,,,,,,,,
11,1,,172164-78421,,HOSE,1,1,,,,,,,,,,,,,
12,1,,172164-78411,,HOSE,1,1,,,,,,,,,,,,,
13,1,,172164-78130,,HOSE,1,1,,,,,,,,,,,,,
14,1,,23000-070000,,,"CLAMP 70",8,8,,,,,,,,,,,,,
15,1,,172164-78431,,HOSE,1,1,,,,,,,,,,,,,
16,1,,172141-76900,,,"CONNECTOR 1/2L",1,1,,,,,,,,,,,,,
17,2,,24315-000180,,,"O-RING 1B P-18.0",1,1,,,,,,,,,,,,,
18,1,,172164-76950,,CONNECTOR,2,2,,,,,,,,,,,,,
18A,2,,24315-000180,,,"O-RING 1B P-18.0",2,2,,,,,W,,,M/#02484,,M/#02484,,,,,,
19,1,,172164-76960,,BODY,2,2,,,,,,,,,,,,,
20,1,,23391-040000,,,"JOINT RGI 1/2",2,2,,,,,,,,,,,,,
21,1,,22137-120000,,,"WASHER 12,POLISHED",4,4,,,,,,,,,,,,,
22,1,,172112-78750,,,"CLAMP (B), HOSE",3,3,,,,,,,,,,,,,
23,1,,172141-76180,,CONNECTOR,2,2,,,,,,,,,,,,,
24,2,,24315-000110,,,"O-RING 1B P-11.0",2,2,,,,,,,,,,,,,

Fig. 77 油圧配管 (タンク~ポンプ~バルブ) (新形)
HYD. OIL PIPING (TANK~PUMP~VALVE) (NEW)

M/#01187~

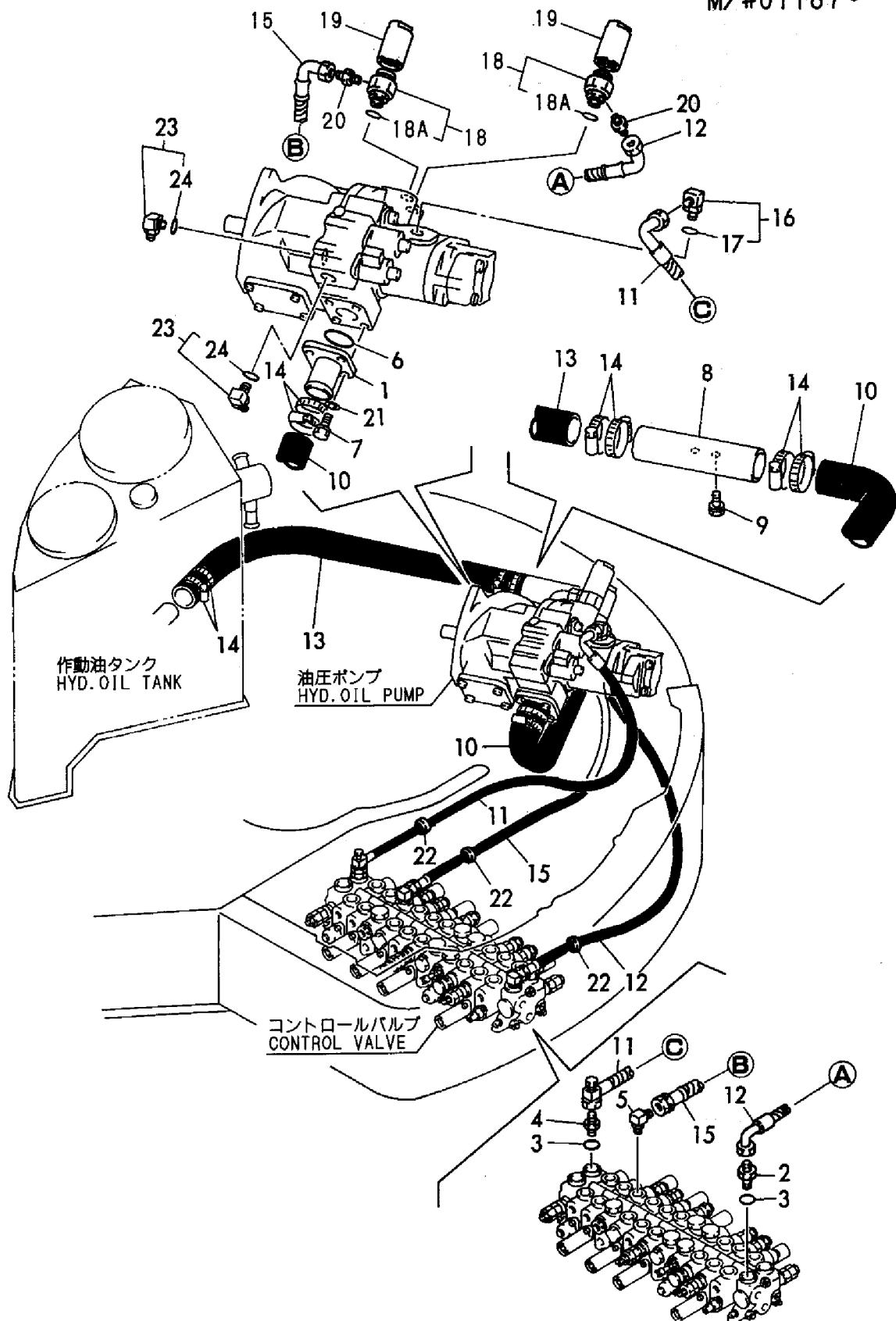

1,1,,172122-76140,, "CONNECTOR PF3/8-55",1,1,,,,,,,,,,,,,
2,1,,933155-08481,, "CONNECTOR (A)",1,1,,,,,,,,,,,,,
3,1,,172142-76160,, "JOINT 3/4UN-3/8",1,1,,,,,,,,,,,,,
4,1,,172142-76160,, "JOINT 3/4UN-3/8",1,1,,,,,,,,,,,,,
5,1,,933155-08481,, "CONNECTOR (A)",1,1,,,,,,,,,,,,,
6,1,,933155-08481,, "CONNECTOR (A)",1,1,,,,,,,,,,,,,
7,1,,933152-24120,, "O-RING (B)",8,8,,,,,,,,,,,,,
8,1,,172165-78150,, GROMMET,1,1,,,,,,,,,,,,,
9,1,,172164-78600,, "HOSE G206BC166S",1,1,,,,,,,,,,,,,
10,1,,172164-78610,, "HOSE G206BC170",1,1,,,,,,,,,,,,,
11,1,,172164-78630,, "HOSE G206BC166S",1,1,,,,,,,,,,,,,
12,1,,172164-78620,, "HOSE G206BC177",1,1,,,,,,,,,,,,,
13,1,,172164-78640,, "HOSE G206BC164",1,1,,,,,,,,,,,,,
14,1,,172164-78700,, "SUPPORT COMP.,HOSE",1,1,,,,,,,,,,,,,
15,1,,172168-78740-4,, "COVER ASSY",1,1,,,,,,,,,,,,,
16,2,,172168-78760,, RUBBER,1,1,,,,,,,,,,,,,
17,1,,26013-100202,, "BOLT W/WASHER M10X20",2,2,,,,,,,,,,,,,
18,1,,26116-100652,, "BOLT M10X 65 PLATED",2,2,,,,,,,,,,,,,
19,1,,172164-78650,, "HOSE G206BC170",1,1,,,,,,,,,,,,,
20,1,,172164-78540,, HOSE,2,2,,,,,,,,,,,,,
21,1,,172157-76300,, "ELBOW 3/8-1/2",2,2,,,,,,,,,,,,,
23,2,,24315-000180,, "O-RING 1B P-18.0",2,2,,,,,,,,,,,,,
24,1,,933155-08481,, "CONNECTOR (A)",2,2,,,,,,,,,,,,,
25,1,,22217-100000,, "SPRING WASHER 10",2,2,,,,,,,,,,,,,
26,1,,172126-11510,, "BAND 300",1,1,,,,,W,,,"FROM 1ST",,"FROM 1ST",,,,,,
27,1,,172151-53430,, GROMMET,2,2,,,,,W,,,"FROM 1ST",,"FROM 1ST",,,,,,
28,1,,172175-78750,, "HOSE COVER 16-700",5,,,,,1,,,,,
29,1,,172164-78950,, COVER,1,,,,,1,,,,,
30,1,,172122-79920,, CLAMP,6,,,,,1,,,,,
31,1,,23000-025000,, "CLAMP 25",6,,,,,1,,,,,

Fig. 78 油圧配管 (バルブ~モータ、ブーム)
HYD. OIL PIPING (VALVE~MOTOR, BOOM)

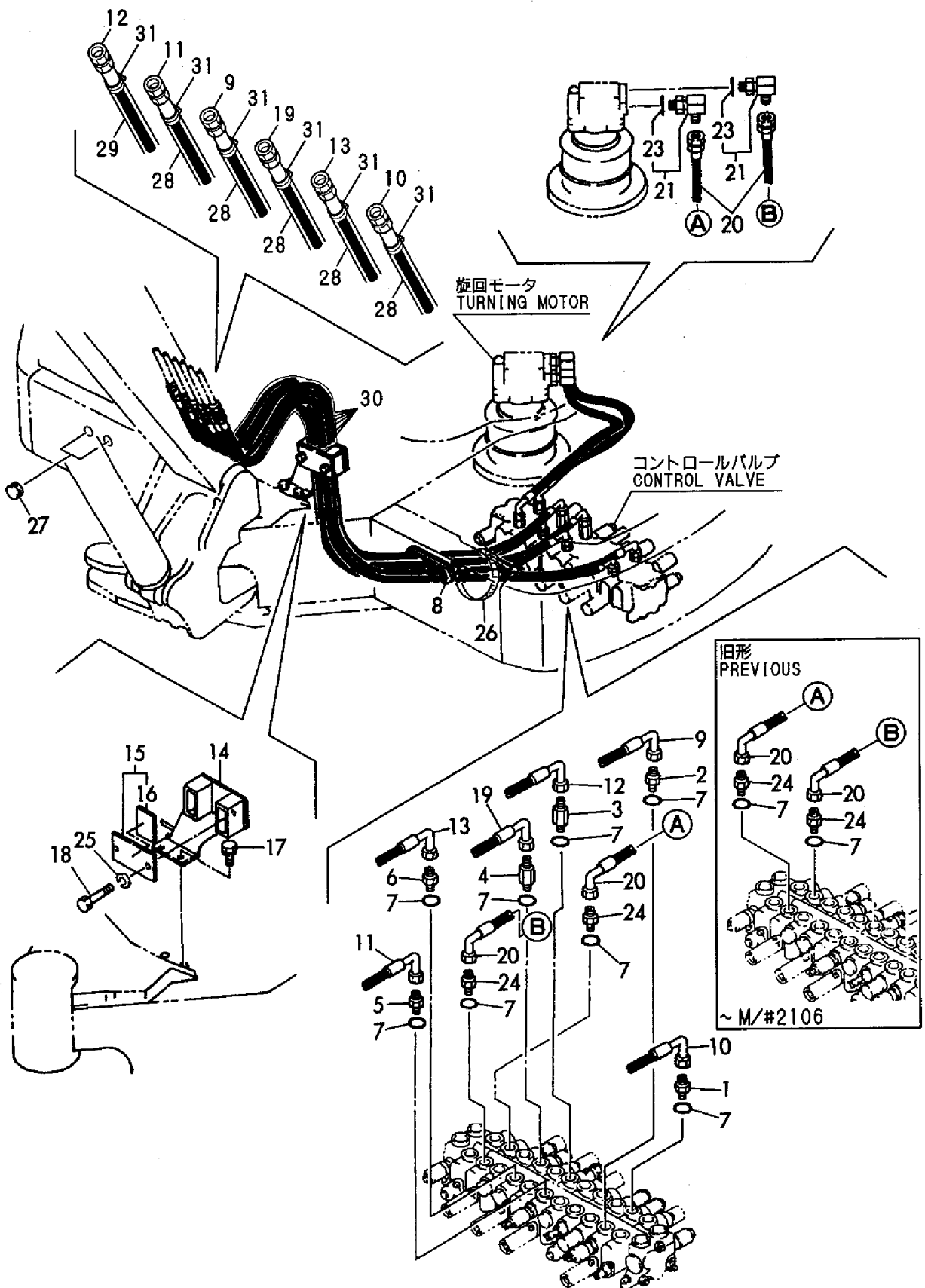

1,1,,172730-75140,,ADAPTOR,1,1,,,,,Z,,,M/#01186,,M/#01186,,,,,
2,1,,172123-76130,, "CONNECTOR 3/4-1/4-55",1,1,,,,,
3,1,,172168-76150,, "CONNECTOR UN7/8PF1/2",1,1,,,,,Z,,,M/#01186,,M/#01186,,,,,
4,2,,933152-07400,, "O-RING (A)",1,1,,,,,Z,,,M/#01186,,M/#01186,,,,,
5,1,,172124-76170,, "NIPPLE 3/4U-PF1/2",2,2,,,,,
6,1,,172312-76220,, "CONNECTOR 1/4-3/4UN",1,1,,,,,
7,1,,933155-08481,, "CONNECTOR (A)",1,1,,,,,
8,1,,933155-08481,, "CONNECTOR (A)",1,1,,,,,
9,1,,933166-24130,, "CONNECTOR PF1/2-35",1,1,,,,,
10,1,,933166-24130,, "CONNECTOR PF1/2-35",1,1,,,,,
11,1,,23391-020000,, "JOINT RGI1/4",2,2,,,,,
12,1,,23393-030000,, "JOINT 90RGI 3/8",2,2,,,,,
13,1,,23393-040000,, "JOINT 90RGI 1/2",2,2,,,,,
14,1,,23394-040000,, "JOINT 45RGI1/4",2,2,,,,,
15,1,,933152-24120,, "O-RING (B)",8,8,,,,,
16,1,,24315-000140,, "O-RING 1B P-14.0",1,1,,,,,Z,,,M/#01186,,M/#01186,,,,,
17,1,,172164-78260,,HOSE,2,2,,,,,
18,1,,172164-78270,,HOSE,2,2,,,,,
19,1,,172164-78280,, "HOSE P204BC330S",1,1,,,,,
20,1,,172164-78290,, "HOSE P204CE265S",1,1,,,,,
21,1,,172165-78300,,HOSE,1,1,,,,,
22,1,,172164-78380,,HOSE,1,1,,,,,Z,,,M/#01186,,M/#01186,,,,,
23,1,,172165-79660,,HOSE,1,1,,,,,

Fig. 79 油圧配管 (バルブ~スイベル、スイング)
HYD. OIL PIPING (VALVE~SWIVEL, SWING)

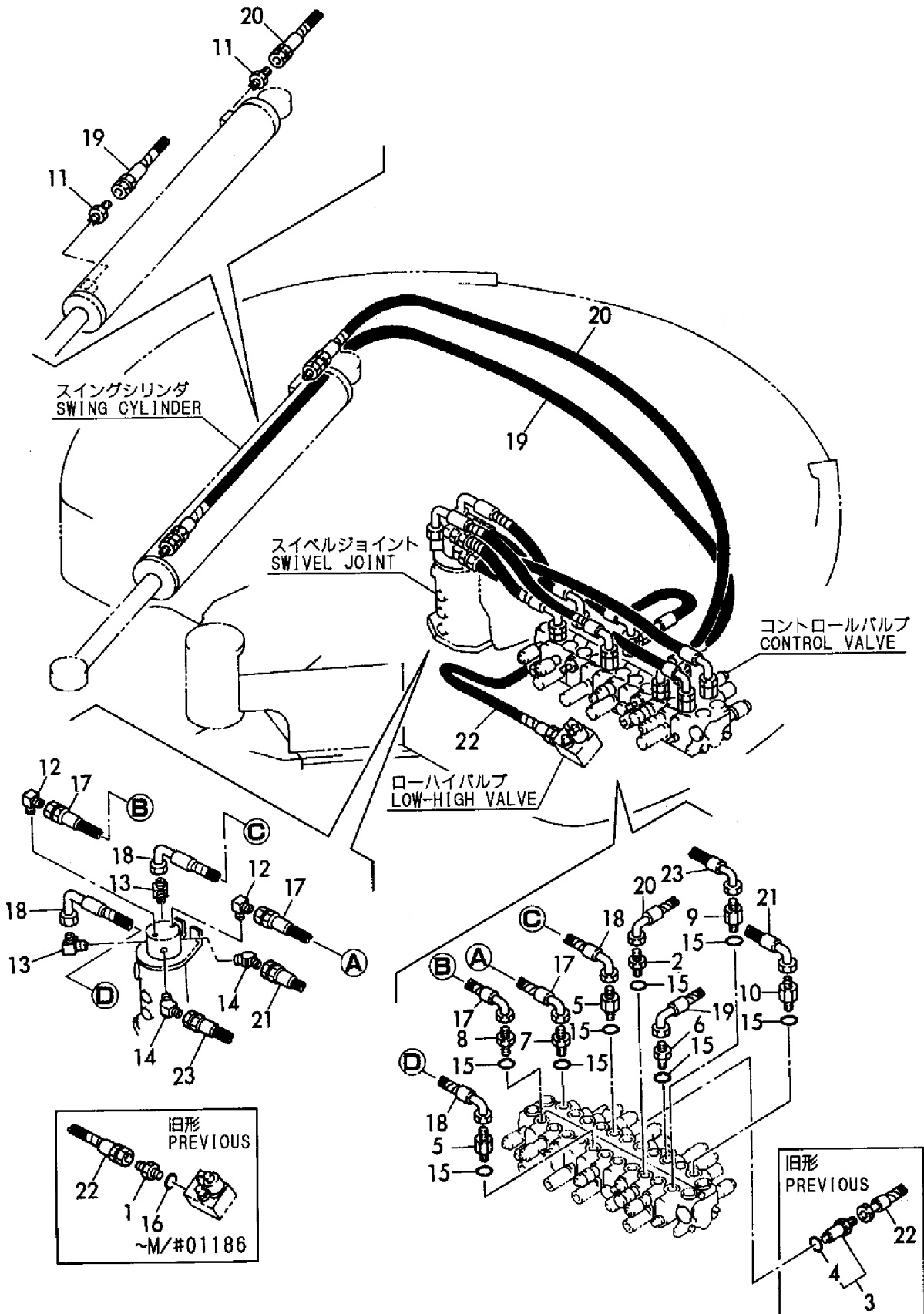

1,1,,172123-76120,, "CONNECTOR PF1/4",2,2,,,,,,,,,,,,,,,,,,,,,
2,1,,172157-76150,, "CONNECTOR 3/8-1/4",1,1,,,,,,,,,,,,,,,,,,,,,
3,1,,172164-76210,, "NIPPLE,ELBOW",2,2,,,,,,,,,,,,,,,,,,,,,
4,1,,23391-060000,, "JOINT RGI 3/4",2,2,,,,,,,,,,,,,,,,,,,,,
5,1,,172164-76240,, "JOINT COMPL.",1,1,,,,,,,,,,,,,,,,,,,,,
6,1,,172164-76200,, "CONNECTOR",1,1,,,,,,,,,,,,,,,,,,,,,
7,1,,933171-24901,, "CONNECTOR",2,2,,,,,,,,,,,,,,,,,,,,,
8,2,,933152-07400,, "O-RING (A)",2,2,,,,,,,,,,,,,,,,,,,,,
9,1,,172141-76900,, "CONNECTOR 1/2L",1,1,,,,,,,,,,,,,,,,,,,,,
10,2,,24315-000180,, "O-RING 1B P-18.0",1,1,,,,,,,,,,,,,,,,,,,,,
11,1,,23394-020000,, "JOINT 45RGI1/4",1,1,,,,,,,,,,,,,,,,,,,,,
12,1,,23871-020000,, "PLUG PT1/4,SCREW",1,1,,,,,,,,,,,,,,,,,,,,,
13,1,,24315-000140,, "O-RING 1B P-14.0",1,1,,,,,,,,,,,,,,,,,,,,,
14,1,,172164-78470,, "HOSE G612BY260S",1,1,,,,,,,,,,,,,,,,,,,,,
15,1,,172164-78330,, "HOSE G612BY120S",1,1,,,,,,,,,,,,,,,,,,,,,
16,1,,172164-78350,, "HOSE G612YY058S",1,1,,,,,,,,,,,,,,,,,,,,,
17,1,,172164-78360,, "HOSE G608BE100S",1,1,,,,,,,,,,,,,,,,,,,,,
18,1,,172165-78380,, "HOSE",1,1,,,,,,,,,,,,,,,,,,,,,
19,1,,172164-78450,, "HOSE G612YY080S",1,1,,,,,,,,,,,,,,,,,,,,,
20,1,,172165-78450,, "HOSE",1,1,,,,,,,,,,,,,,,,,,,,,
21,1,,172164-78460,, "HOSE G804BY080S",1,1,,,,,,,,,,,,,,,,,,,,,
22,1,,23000-016000,, "CLAMP 16",2,2,,,,,,,,,,,,,,,,,,,,,
23,1,,23871-040000,, "PLUG PT1/2,SCREW",1,1,,,,,,,,,,,,,,,,,,,,,
24,1,,933152-07400,, "O-RING (A)",1,1,,,,,,,,,,,,,,,,,,,,,
25,1,,24315-000110,, "O-RING 1B P-11.0",2,2,,,,,,,,,,,,,,,,,,,,,
26,1,,23000-022000,, "CLAMP 22",2,2,,,,,,,,,,,,,,,,,,,,,
27,1,,172131-76130,, "ELBOW,NIPPLE",1,1,,,,,,,,,,,,,,,,,,,,,
28,1,,23000-035000,, "CLAMP 35",4,4,,,,,,,,,,,,,,,,,,,,,

Fig. 80 油圧配管 (リターン) (旧形)
HYD. OIL PIPING (RETURN) (PREVIOUS)

~M/#01186

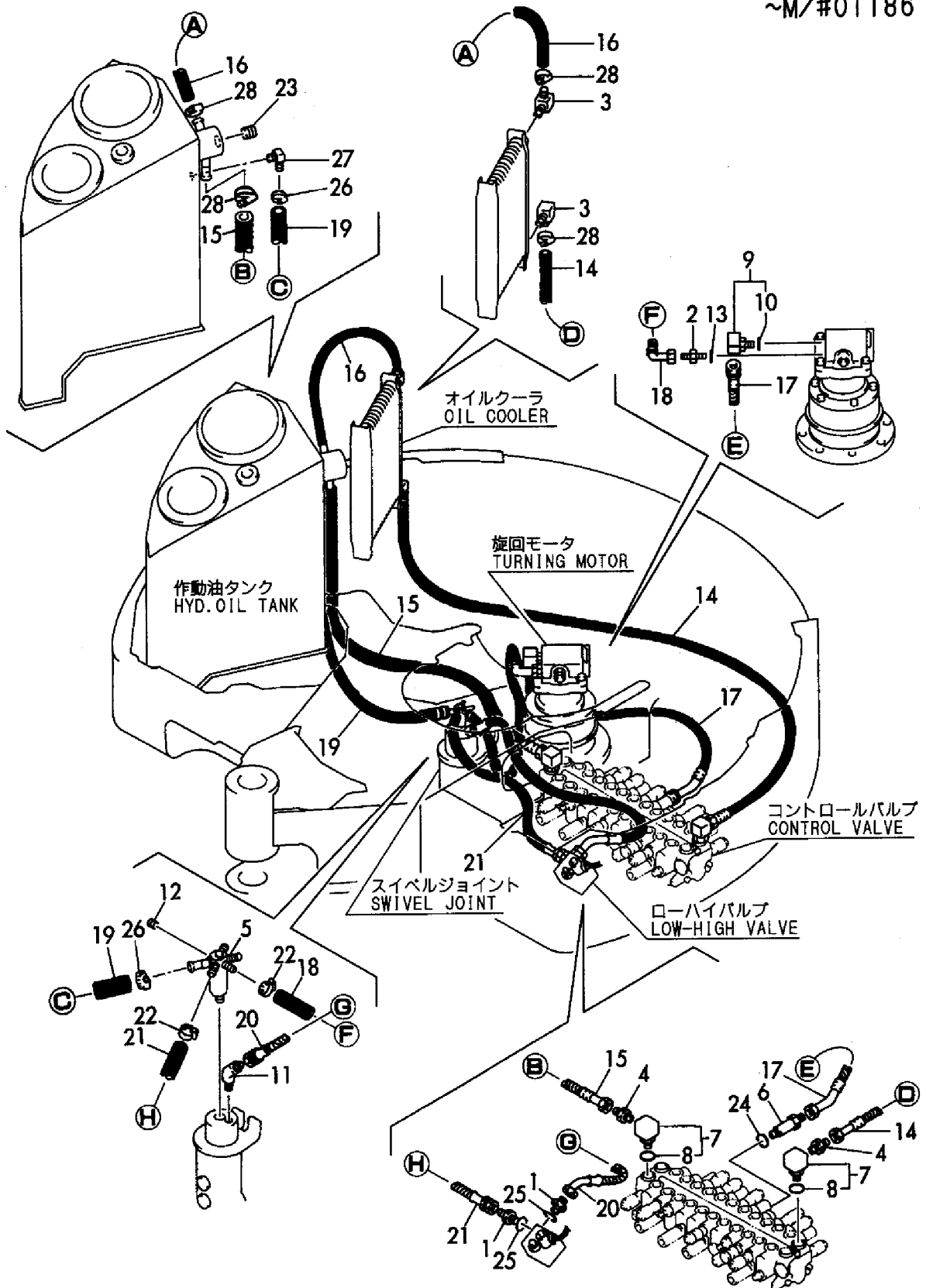

1,1,,172156-76240,,ELBOW,1,1,,,,,,,,,,,,,
2,1,,172157-76150,,,"CONNECTOR 3/8-1/4",1,1,,,,,,,,,,,,,
3,1,,172164-76130,,ELBOW,2,2,,,,,,,,,,,,,
3-1,1,,172164-76131,,ELBOW,2,2,,,,,S,1,,M/#01700,,M/#01700,,,,,
3A,2,,24315-000180,,,"O-RING 1B P-18.0",2,2,,,,,W,,,M/#01700,,M/#01700,,,,,
4,1,,172164-76110,,ELBOW,2,2,,,,,,,,,,,,,
5,1,,172164-76241,,JOINT,1,1,,,,,,,,,,,,,
6,1,,172168-76150,,,"CONNECTOR UN7/8PF1/2",1,1,,,,,,,,,,,,,
7,2,,933152-07400,,,"O-RING (A)",1,1,,,,,,,,,,,,,
8,1,,23000-035000,,,"CLAMP 35",6,6,,,,,,,,,,,,,
9,1,,172141-76900,,,"CONNECTOR 1/2L",1,1,,,,,,,,,,,,,
10,2,,24315-000180,,,"O-RING 1B P-18.0",1,1,,,,,,,,,,,,,
11,1,,23394-020000,,,"JOINT 45RGI1/4",1,1,,,,,,,,,,,,,
12,1,,23871-020000,,,"PLUG PT1/4,SCREW",1,1,,,,,,,,,,,,,
13,1,,24315-000140,,,"O-RING 1B P-14.0",1,1,,,,,,,,,,,,,
14,1,,172164-78471,,HOSE,1,1,,,,,,,,,,,,,
15,1,,172164-78331,,HOSE,1,1,,,,,,,,,,,,,
16,1,,172164-78350,,,"HOSE G612YY058S",1,1,,,,,,,,,,,,,
17,1,,172164-78360,,,"HOSE G608BE100S",1,1,,,,,,,,,,,,,
18,1,,172165-78380,,HOSE,1,1,,,,,,,,,,,,,
19,1,,172164-78451,,HOSE,1,1,,,,,,,,,,,,,
20,1,,172171-78180,,,"HOSE P204BE127S",1,1,,,,,,,,,,,,,
21,1,,172151-76080,,CONNECTOR,1,1,,,,,,,,,,,,,
22,2,,24315-000110,,,"O-RING 1B P-11.0",1,1,,,,,,,,,,,,,
23,1,,23000-016000,,,"CLAMP 16",3,3,,,,,,,,,,,,,
24,1,,23871-040000,,,"PLUG PT1/2,SCREW",1,1,,,,,,,,,,,,,
25,1,,23393-020000,,,"JOINT 90RGI1/4",1,1,,,,,,,,,,,,,

Fig. 81 油圧配管 (リターン) (旧形)
HYD. OIL PIPING (RETURN) (PREVIOUS)

M/#01187~02106

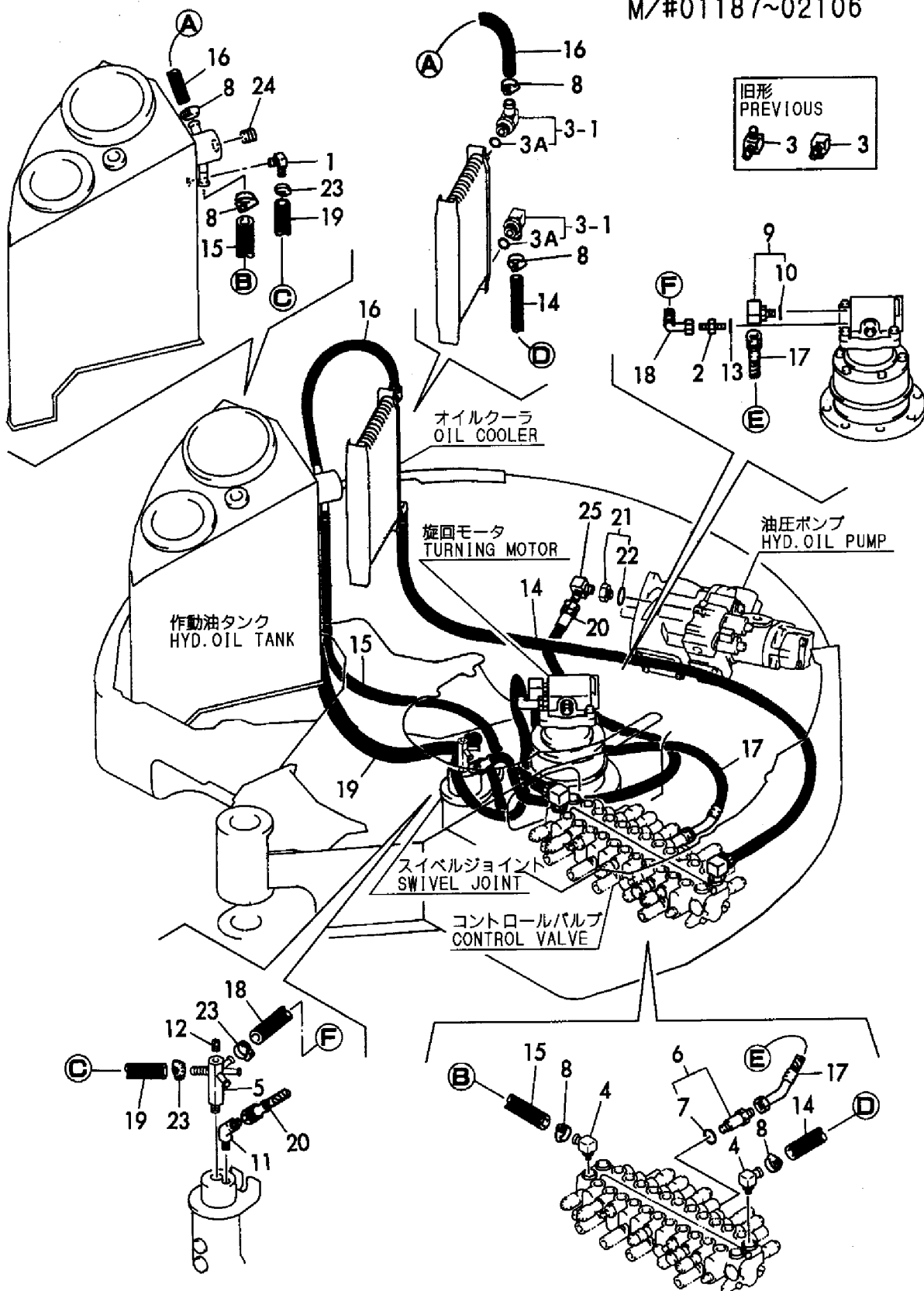

1,1,,172156-76240,,ELBOW,1,1,,,,,,,,,,,,,
2,1,,172157-76150,, "CONNECTOR 3/8-1/4",1,1,,,,,,,,,,,,,
3,1,,172164-76131,,ELBOW,2,2,,,,,,,,,,,,,
4,2,,24315-000180,, "O-RING 1B P-18.0",2,2,,,,,,,,,,,,,
5,1,,172164-76241,,JOINT,1,1,,,,,,,,,,,,,
6,1,,172168-76150,, "CONNECTOR UN7/8PF1/2",1,1,,,,,,,,,,,,,
7,2,,933152-07400,, "O-RING (A)",1,1,,,,,,,,,,,,,
8,1,,23000-035000,, "CLAMP 35",6,6,,,,,,,,,,,,,
9,1,,172141-76900,, "CONNECTOR 1/2L",1,1,,,,,,,,,,,,,
10,2,,24315-000180,, "O-RING 1B P-18.0",1,1,,,,,,,,,,,,,
11,1,,23394-020000,, "JOINT 45RGI1/4",1,1,,,,,,,,,,,,,
12,1,,23871-020000,, "PLUG PT1/4,SCREW",1,1,,,,,,,,,,,,,
13,1,,24315-000140,, "O-RING 1B P-14.0",1,1,,,,,,,,,,,,,
14,1,,172164-78471,,HOSE,1,1,,,,,,,,,,,,,
15,1,,172164-78331,,HOSE,1,1,,,,,,,,,,,,,
16,1,,172164-78350,, "HOSE G612YY058S",1,1,,,,,,,,,,,,,
17,1,,172164-78360,, "HOSE G608BE100S",1,1,,,,,,,,,,,,,
18,1,,172165-78380,,HOSE,1,1,,,,,,,,,,,,,
19,1,,172164-78451,,HOSE,1,1,,,,,,,,,,,,,
20,1,,172171-78180,, "HOSE P204BE127S",1,1,,,,,,,,,,,,,
21,1,,172151-76080,,CONNECTOR,1,1,,,,,,,,,,,,,
22,2,,24315-000110,, "O-RING 1B P-11.0",1,1,,,,,,,,,,,,,
23,1,,23000-016000,, "CLAMP 16",3,3,,,,,,,,,,,,,
24,1,,23871-040000,, "PLUG PT1/2,SCREW",1,1,,,,,,,,,,,,,
25,1,,172164-76110,,ELBOW,2,2,,,,,,,,,,,,,
26,1,,172175-79120,,HOSE,1,1,,,,,,,,,,,,,
27,1,,172164-76360,,ELBOW,1,1,,,,,,,,,,,,,
28,2,,24315-000080,, "O-RING 1B P-8.0",1,1,,,,,,,,,,,,,
29,1,,23871-010000,, "PLUG PT1/8,SCREW",1,1,,,,,,,,,,,,,
30,1,,23393-020000,, "JOINT 90RGI1/4",1,1,,,,,,,,,,,,,
31,1,,23393-020000,, "JOINT 90RGI1/4",1,1,,,,,,,,,,,,,

Fig. 82 油圧配管 (リターン) (新形) HYD. OIL PIPING (RETURN) (NEW)

M/#02107 ~

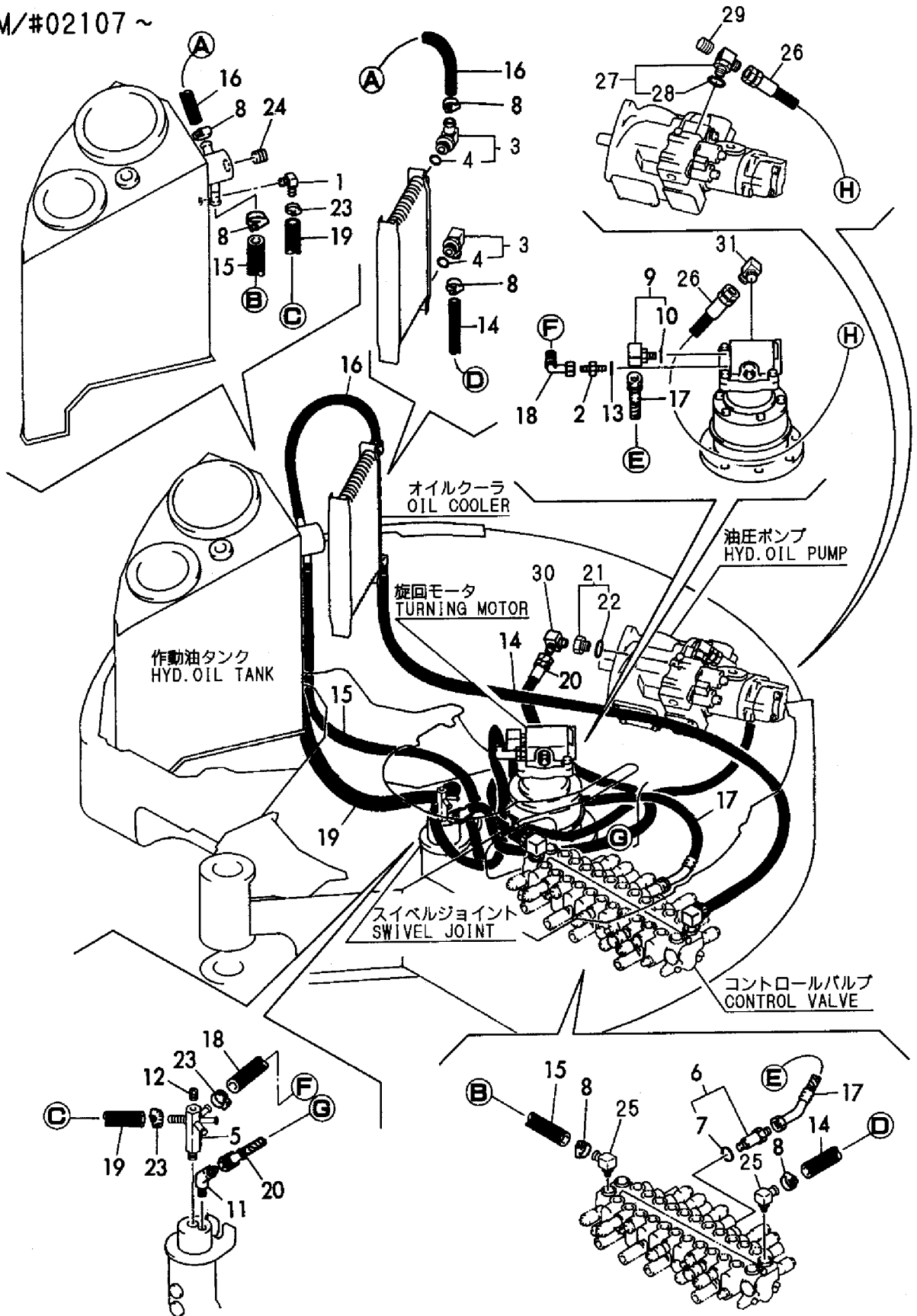

1,2,,172123-76120,, "CONNECTOR PF1/4",1,1,,,,,,,,,,,,,
2,2,,172162-76140,, "ADAPTER 1/2-3/4",1,1,,,,,,,,,,,,,
3,2,,172141-76180,,CONNECTOR,1,1,,,,,,,,,,,,,
4,3,,24315-000110,, "O-RING 1B P-11.0",1,1,,,,,,,,,,,,,
5,2,,172168-76180,, "CONNECTOR UN3/4PT1/2",1,1,,,,,,,,,,,,,
6,3,,933152-24120,, "O-RING (B)",1,1,,,,,,,,,,,,,
7,2,,172164-76210,, "NIPPLE,ELBOW",1,1,,,,,,,,,,,,,
8,2,,172141-76220,,NIPPLE,1,1,,,,,,,,,,,,,
9,2,,172164-76700,, "T-JOINT 1/4",1,1,,,,,,,,,,,,,
10,3,,24315-000110,, "O-RING 1B P-11.0",1,1,,,,,,,,,,,,,
11,2,,23391-040000,, "JOINT RGI 1/2",1,1,,,,,,,,,,,,,
12,2,,24315-000110,, "O-RING 1B P-11.0",1,1,,,,,,,,,,,,,
13,2,,933152-07274,,CONNECTOR,1,1,,,,,,,,,,,,,
14,2,,933152-07400,, "O-RING (A)",2,2,,,,,,,,,,,,,
15,2,,933152-24120,, "O-RING (B)",1,1,,,,,,,,,,,,,
16,2,,933152-24120,, "O-RING (B)",1,1,,,,,,,,,,,,,
17,2,,933152-24120,, "O-RING (B)",1,1,,,,,,,,,,,,,
18,2,,933166-24090,, "CONNECTOR PF3/4-9.5",1,1,,,,,,,,,,,,,
19,2,,933166-24120,, "CONNECTOR PF1/2-10",4,4,,,,,,,,,,,,,
20,2,,172164-78440,,HOSE,1,1,,,,,,,,,,,,,
20-1,2,,172164-78441,,HOSE,1,1,,,,,S,,,M/#01187,,M/#01187,,,,,
21,2,,172164-78810,,HOSE,1,1,,,,,,,,,,,,,
22,2,,172164-78820,,HOSE,1,1,,,,,,,,,,,,,
23,2,,172164-78830,,HOSE,1,1,,,,,,,,,,,,,
24,2,,172164-78840,,HOSE,1,1,,,,,,,,,,,,,
25,2,,172164-78850,,HOSE,1,1,,,,,,,,,,,,,
26,2,,172164-78860,, "HOSE G604BB060S",1,1,,,,,,,,,,,,,
27,2,,23000-035000,, "CLAMP 35",1,1,,,,,,,,,,,,,
28,2,,23010-014000,, "CLAMP 14",1,1,,,,,,,,,,,,,
29,2,,933152-24120,, "O-RING (B)",1,1,,,,,,,,,,,,,
30,1,,172164-78800,,HOSE,1,1,,,,,,,,,,,,,

Fig. 83 油圧配管 (PTOバルブ、フレーム)
 HYD. OIL PIPING (P. T. O. VALVE, FRAME)

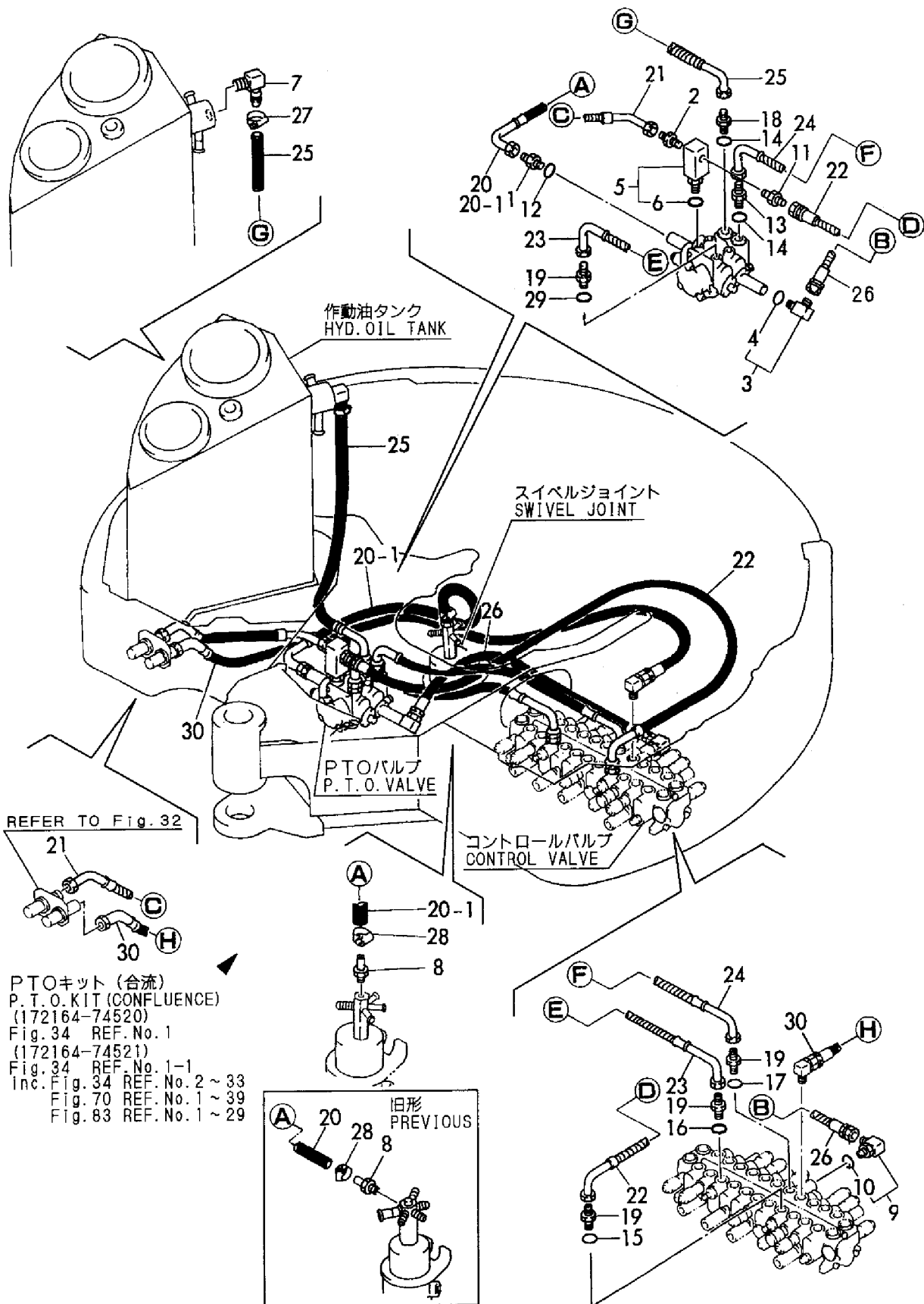

1,1,,172157-76220,, "CONNECTOR 1/4-3/8",2,2,,,,,,,,,,,,,
2,1,,172112-77360,, "CONNECTOR PF1/2PF1/2",4,4,,,,,,,,,,,,,
3,1,,23391-040000,, "JOINT RGI 1/2",4,4,,,,,,,,,,,,,
4,1,,23394-020000,, "JOINT 45RGI1/4",2,2,,,,,,,,,,,,,
5,1,,24315-000180,, "O-RING 1B P-18.0",4,4,,,,,,,,,,,,,
6,1,,23391-030000,, "JOINT RGI 3/8",2,2,,,,,,,,,,,,,
7,1,,933152-24410,, "CONNECTOR (A)",2,2,,,,,,,,,,,,,
8,1,,24315-000140,, "O-RING 1B P-14.0",2,2,,,,,,,,,,,,,
9,1,,172165-78310,,HOSE,2,2,,,,,,,,,,,,,
10,1,,172165-78180,,PLATE,2,2,,,,,Z,,,M/#01187,,M/#01187,,,,,
11,1,,22217-100000,, "SPRING WASHER 10",2,2,,,,,Z,,,M/#01187,,M/#01187,,,,,
12,1,,26116-100162,, "BOLT M10X 16 PLATED",2,2,,,,,Z,,,M/#01187,,M/#01187,,,,,
13,1,,172124-78321,, "HOSE G706BB140W",2,2,,,,,,,,,,,,,
14,1,,172147-78620,,HOSE,4,4,,,,,,,,,,,,,
15,1,,172147-78680,,HOSE,2,2,,,,,,,,,,,,,
16,1,,172165-78480,, "HOSE P206AB066W",2,2,,,,,,,,,,,,,

Fig. 84 油圧配管 (走行) HYD. OIL PIPING (TRAVEL)

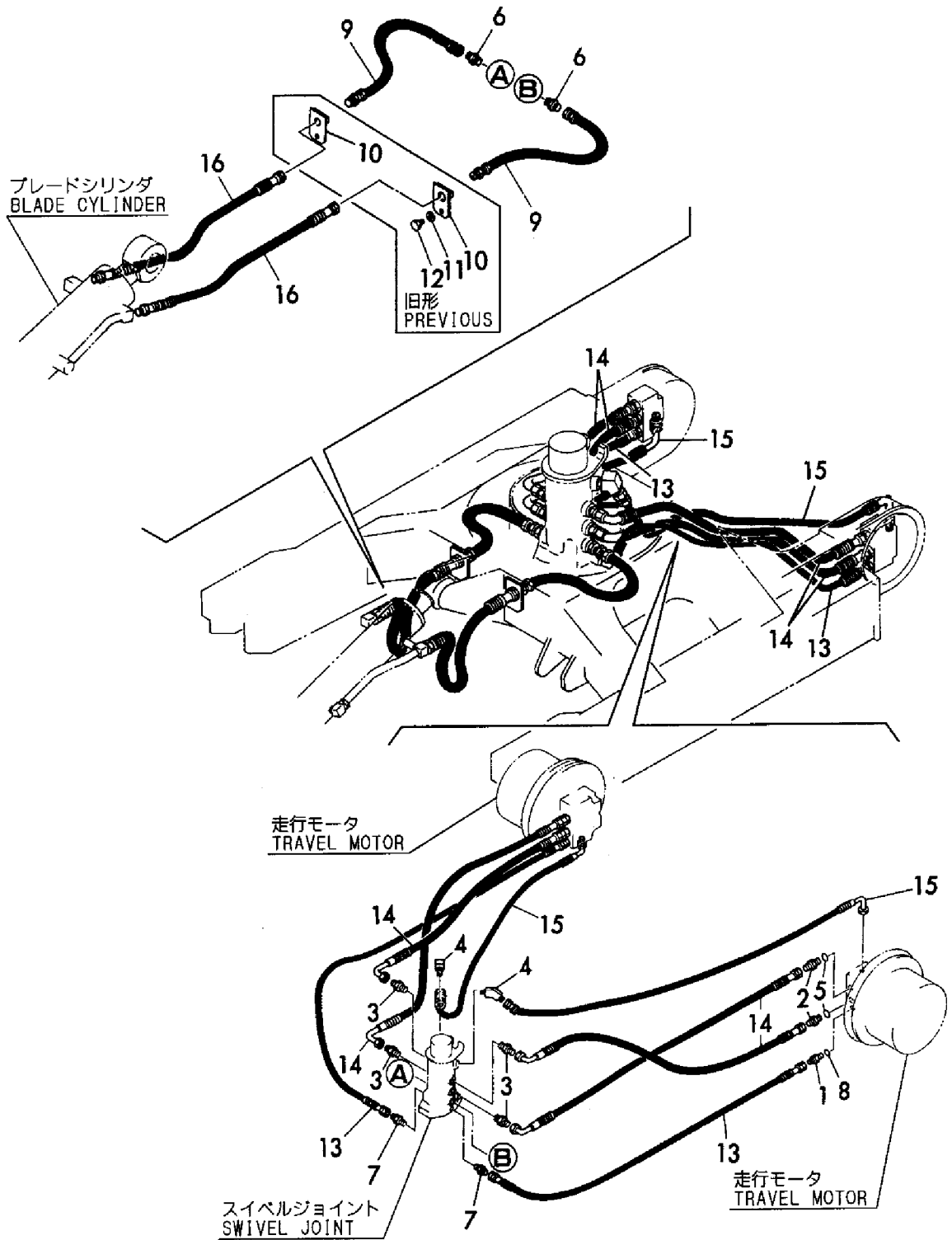

1,1,,172112-76321-4,, "RETAINER (GREEN)",3,3,,,,,,,,,,,,,
1-1,1,,172164-76150,,CLAMP,3,3,,,,,S,,M/#01628,,M/#01628,,,,,
2,1,,172164-76440,, "TUBE A, ARM",1,1,,,,,,,,,,,,,
3,1,,172164-76460,, "TUBE B, ARM",1,1,,,,,,,,,,,,,
4,1,,172164-76480,, "TUBE A, BUCKET",1,1,,,,,,,,,,,,,
5,1,,172164-76500,, "TUBE B, BUCKET",1,1,,,,,,,,,,,,,
6,1,,933155-09670,, "CLAMP, PIPE",1,1,,,,,,,,,,,,,
7,1,,172164-76400,, "TUBE A, BOOM",1,1,,,,,,,,,,,,,
8,1,,172164-76420,, "TUBE B, BOOM",1,1,,,,,,,,,,,,,
9,1,,172142-76620,,RUBBER,1,1,,,,,,,,,,,,,
10,1,,22217-080000,, "SPRING WASHER 8",6,6,,,,,Z,,M/#01628,,M/#01628,,,,,
11,1,,26013-100402,, "BOLT M10X 40",6,6,,,,,,,,,,,,,
12,1,,26716-080002,, "NUT M 8",6,6,,,,,Z,,M/#01628,,M/#01628,,,,,
13,1,,172171-78770,, "HOSE G206AB078W",2,2,,,,,1,,,,,,,,,
14,1,,172149-78470,,HOSE,1,1,,,,,,,,,,,,,
15,1,,172164-78170,, "HOSE G206AB075",1,1,,,,,,,,,,,,,
16,1,,172312-78280,, "PIPE P206AB060",2,2,,,,,,,,,,,,,
16-1,1,,172312-78281,,HOSE,2,2,,,,,N,,M/#00501,,M/#00501,,,,,
17,1,,172164-76270,, "CLAMP, TUBE",1,1,,,,,,,,,,,,,
18,1,,172164-76280,, "RUBBER TUBE, CLAMP",2,2,,,,,,,,,,,,,
19,1,,172164-76290,, "COLLAR, CLAMP",5,5,,,,,,,,,,,,,
20,1,,172164-76300,, "CLAMP, TUBE",3,3,,,,,,,,,,,,,
21,1,,172164-76310,, "RUBBER TUBE, CLAMP",6,6,,,,,,,,,,,,,
22,1,,172164-81710,, "PLATE (C)",1,1,,,,,,,,,,,,,
23,1,,26013-120352,, "BOLT M12X 35",3,3,,,,,W,,M/#01628,,M/#01628,,,,,
24,1,,172183-81160,, "TREE CLIP",2,2,,,,,W,,M/#01586,,M/#01586,,,,,
25,1,,172142-78760,, "COVER 16-650, HOSE",1,,,,,2,,,,,,,,,
26,1,,172142-78770,, "COVER 16-730, HOSE",1,,,,,2,,,,,,,,,
27,1,,172149-78980,, "COVER, HOSE",2,,,,,2,,,,,,,,,
28,1,,23000-025000,, "CLAMP 25",8,,,,,2,,,,,,,,,

Fig. 85 油圧配管 (ブーム)
HYD. OIL PIPING (BOOM)

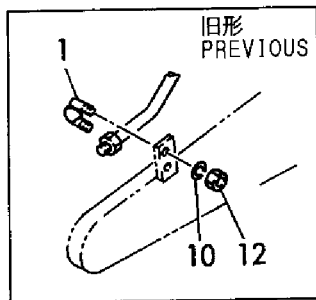
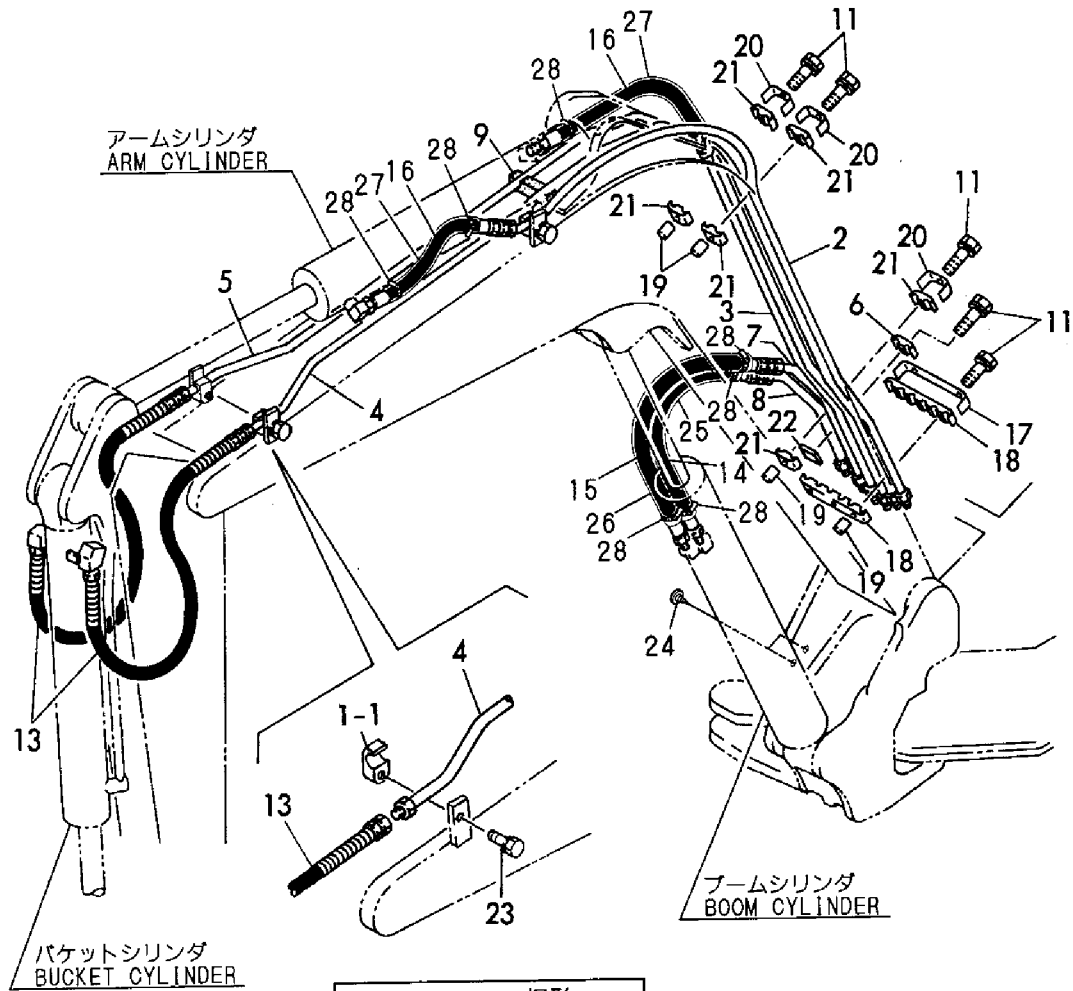

1,1,,172164-74510,, "P.T.O.KIT, ARM END",1,1,,,,,,,,,,,,,
1-1,1,,172164-74511,, "P.T.O. KIT(ARM END)",1,1,,,,,S,,,M/#01628,,M/#01628,,,,,
1-2,1,,172164-74512,, "P.T.O.KIT,ARM END",1,1,,,,,S,,,M/#01693,,M/#01693,,,,,
2,2,,172164-76520,, "TUBE A, BUCKET",1,1,,,,,,,,,,,,,
2-1,2,,172164-76521,, "TUBE A COMP.,3RD",1,1,,,,,N,,,M/#01187,,M/#01187,,,,,
2-2,2,,172164-76522,, "TUBE A COMP.,3RD",1,1,,,,,S,,,M/#01628,,M/#01628,,,,,
3,2,,172164-76540,, "TUBE B, BUCKET",1,1,,,,,,,,,,,,,
3-1,2,,172164-76541,, "TUBE B COMP.,3RD",1,1,,,,,N,,,M/#01187,,M/#01187,,,,,
3-2,2,,172164-76542,, "TUBE B COMP.,3RD",1,1,,,,,S,,,M/#01628,,M/#01628,,,,,
4,2,,172164-76560,, "TUBE C, 3RD",2,2,,,,,Z,,,M/#01628,,M/#01628,,,,,
5,2,,172164-76870,, "JOINT PT 1/2",2,2,,,,,,,,,,,,,
5-1,2,,172164-76650,,BUSH,2,2,,,,,S,1,,M/#01628,,M/#01628,,,,,
6,2,,172142-76940-4,, "CLAMP 3/4",10,10,,,,,,,,,,,,,
6-1,2,,172142-76940-4,, "CLAMP 3/4",6,6,,,,,K,,,M/#01628,,M/#01628,,,,,
7,2,,172142-77100-4,, "STOP VALVE",2,2,,,,,,,,,,,,,
7-1,2,,172142-77101-4,, "VALVE, STOP",2,2,,,,,R,,,M/#01187,,M/#01187,,,,,
7-1A,3,,172142-77150,, "SEAL SET",2,2,,,,,W,,,M/#01187,,M/#01187,,,,,
7-1F,3,,22242-000300,, "CIRCLIP 30",2,2,,,,,W,,,M/#01187,,M/#01187,,,,,
7-2,2,,172176-76580,, "STOP
VALVE(GREEN:97)",2,2,,,,,S,1,,M/#01628,,M/#01628,,,,,
8,3,,172142-77110,, "BODY, VALVE",2,2,,,,,Z,,,M/#01187,,M/#01187,,,,,
9,3,,172142-77120,, "RING, BACK UP",2,2,,,,,Z,,,M/#01187,,M/#01187,,,,,
10,3,,172142-77130,, VALVE,2,2,,,,,Z,,,M/#01187,,M/#01187,,,,,
11,3,,172142-77140,, "RING, BACK UP",2,2,,,,,Z,,,M/#01187,,M/#01187,,,,,
12,3,,22242-000200,, "CIRCLIP 20",2,2,,,,,Z,,,M/#01187,,M/#01187,,,,,
13,3,,22351-040010,, "SPRING PIN 4X10",2,2,,,,,Z,,,M/#01187,,M/#01187,,,,,
14,3,,24315-000160,, "O-RING 1B P-16.0",4,4,,,,,Z,,,M/#01187,,M/#01187,,,,,
15,3,,24315-000200,, "O-RING 1B P-20.0",2,2,,,,,Z,,,M/#01187,,M/#01187,,,,,
16,2,,22217-120000,, "SPRING WASHER",10,10,,,,,,,,,,,,,
16-1,2,,22217-120000,, "SPRING WASHER",6,6,,,,,K,,,M/#01628,,M/#01628,,,,,
17,2,,23871-040000,, "PLUG PT1/2,SCREW",2,2,,,,,1,,,,,,,,,
18,2,,26116-120552,, "BOLT M12X 55 PLATED",10,10,,,,,,,,,,,,,
18-1,2,,26116-120752,, "BOLT M12X 75 PLATED",2,2,,,,,S,,,M/#01628,,M/#01628,,,,,
19,2,,172164-78870,, HOSE,2,2,,,,,,,,,,,,,
20,2,,172164-78880,, HOSE,2,2,,,,,1,,,,,,,,,
20-1,2,,172164-78881,, HOSE,2,2,,,,,S,1,,M/#01628,,M/#01628,,,,,
20-2,2,,172164-78882,, HOSE,2,2,,,,,S,1,,M/#01693,,M/#01693,,,,,
21,2,,172141-81560,, "STAY C(M12,3RD VALVE",1,1,,,,,Z,,,M/#01628,,M/#01628,,,,,
22,2,,172164-81730,, "BOSS A",2,2,,,,,Z,,,M/#01628,,M/#01628,,,,,
23,2,,172142-81700,, STAY(A,1,1,,,,,Z,,,M/#01628,,M/#01628,,,,,
24,2,,172164-81740,, "BOSS B",2,2,,,,,Z,,,M/#01628,,M/#01628,,,,,
25,2,,172141-81560,, "STAY C(M12,3RD VALVE",4,4,,,,,Z,,,M/#01628,,M/#01628,,,,,
26,2,,172164-76660,, PLATE,1,1,,,,,W,,,M/#01628,,M/#01628,,,,,
27,2,,26116-120652,, "BOLT M12X 65 PLATED",2,2,,,,,W,,,M/#01628,,M/#01628,,,,,
28,2,,26116-120552,, "BOLT M12X 55 PLATED",2,2,,,,,W,,,M/#01628,,M/#01628,,,,,
29,2,,26013-100252,, "BOLT W/WASHER M10X25",4,4,,,,,W,1,,M/#01628,,M/#01628,,,,,
30,1,,172137-75570,, "ADAPTER PF1/2",2,2,,,,,2,,,,,,,,,
31,1,,172137-79950,, COVER,2,,,,,,,,,2,,,,,,,,,
32,1,,23000-041000,, "CLAMP 41",4,,,,,2,,,,,,,,,

Fig. 86 油圧配管 (PTOバルブ、ブーム)
 HYD. OIL PIPING (P. T. O. VALVE, BOOM)

旧形
 PREVIOUS

PTOキット (アームエンド)
 P. T. O. KIT (ARM END)
 (172164-74510)

見出しNo. 1は、見出しNo. 2から25を含みます。
 1 inc. 2 ~ 25

旧形
 PREVIOUS

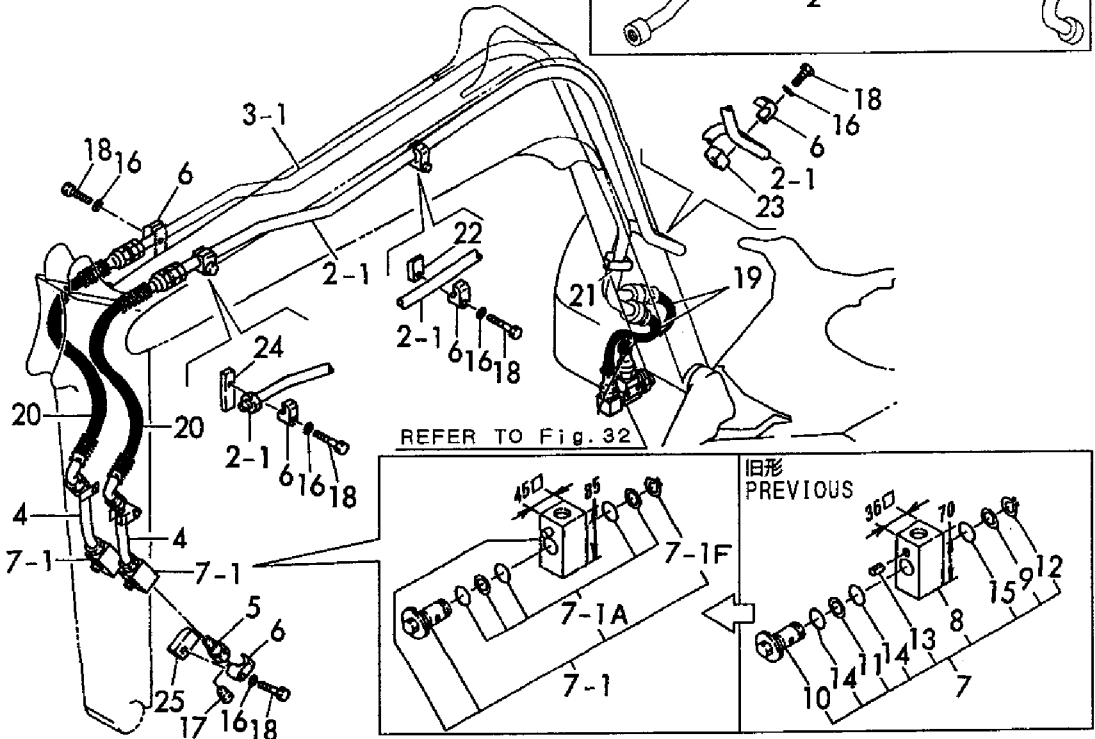
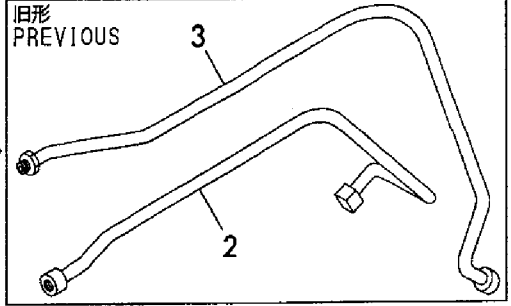

REFER TO Fig. 32

旧形
 PREVIOUS

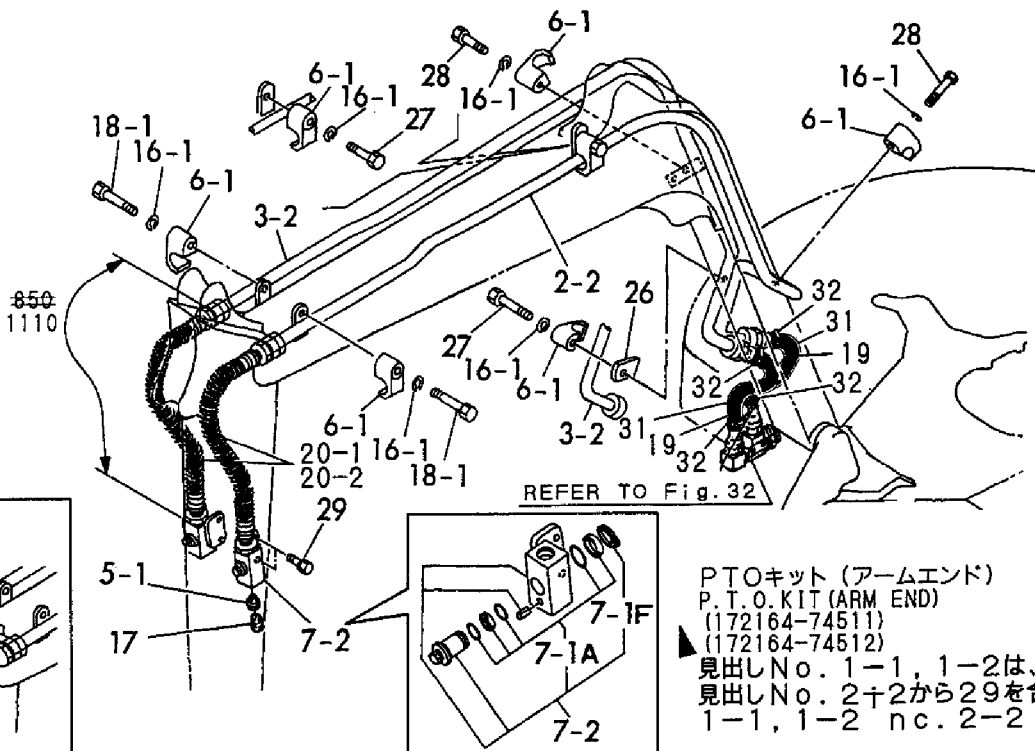
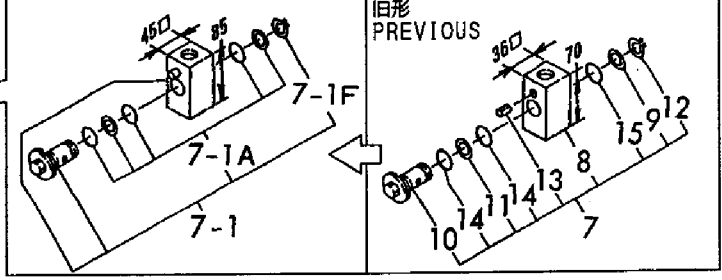

REFER TO Fig. 32

PTOキット (アームエンド)
 P. T. O. KIT (ARM END)
 (172164-74511)
 (172164-74512)

見出しNo. 1-1, 1-2は、
 見出しNo. 2+2から29を含みます。
 1-1, 1-2 inc. 2-2 ~ 29

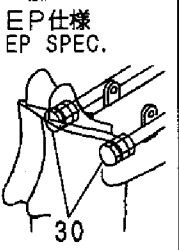

1,1,,23391-030000,, "JOINT RGI 3/8",2,2,,,,,,,,,,,,,,,,,,,,,
2,1,,172164-79540,, HOSE,2,2,,,,,,,,,,,,,,,,,,,,,
3,1,,172164-79550,, HOSE,2,2,,,,,,,,,,,,,,,,,,,,,
4,1,,933160-02760,, "ADAPTER 3/8-53",2,2,,,,,,,,,,,,,,,,,,,,,
5,1,,172164-79560,, HOSE,4,4,,,,,,,,,,,,,,,,,,,,,
6,1,,172142-76950-4,, "CLAMP 1/2",6,6,,,,,,,,,,,,,,,,,,,,,
7,1,,26116-120402,, "BOLT M12X 40",5,5,,,,,,,,,,,,,,,,,,,,,
7-1,1,,26013-120402,, "BOLT M12X 40",2,2,,,,,S,,,M/#01625,,M/#01625,,,,,,
8,1,,172164-76900,, "TUBE (A)",1,1,,,,,,,,,,,,,,,,,,,,,
8-1,1,,172164-76901,, TUBE(A),1,1,,,,,S,,,M/#01625,,M/#01625,,,,,,
9,1,,172164-76920,, "TUBE (B)",1,1,,,,,,,,,,,,,,,,,,,,,
9-1,1,,172164-76921,, TUBE(B),1,1,,,,,S,,,M/#01625,,M/#01625,,,,,,
10,1,,172164-78870,, HOSE,2,2,,,,,,,,,,,,,,,,,,,,,
11,1,,172164-76720,, "BULB (3.0)",1,1,,,,,,,,,,,,,,,,,,,,,
12,1,,933152-22780,, ADAPTER,1,1,,,,,,,,,,,,,,,,,,,,,
13,1,,26116-120552,, "BOLT M12X 55 PLATED",2,2,,,,,W,,,M/#01625,,M/#01625,,,,,,
14,1,,26116-120652,, "BOLT M12X 65 PLATED",2,2,,,,,W,,,M/#01625,,M/#01625,,,,,,
15,1,,22217-120000,, "SPRING WASHER",4,4,,,,,W,,,M/#01625,,M/#01625,,,,,,
16,1,,172164-76660,, PLATE,1,1,,,,,W,,,M/#01625,,M/#01625,,,,,,

Fig. 87 油圧配管 (テレスコピックアーム、ブーム)
HYD. OIL PIPING (TELESCOPIC ARM, BOOM)

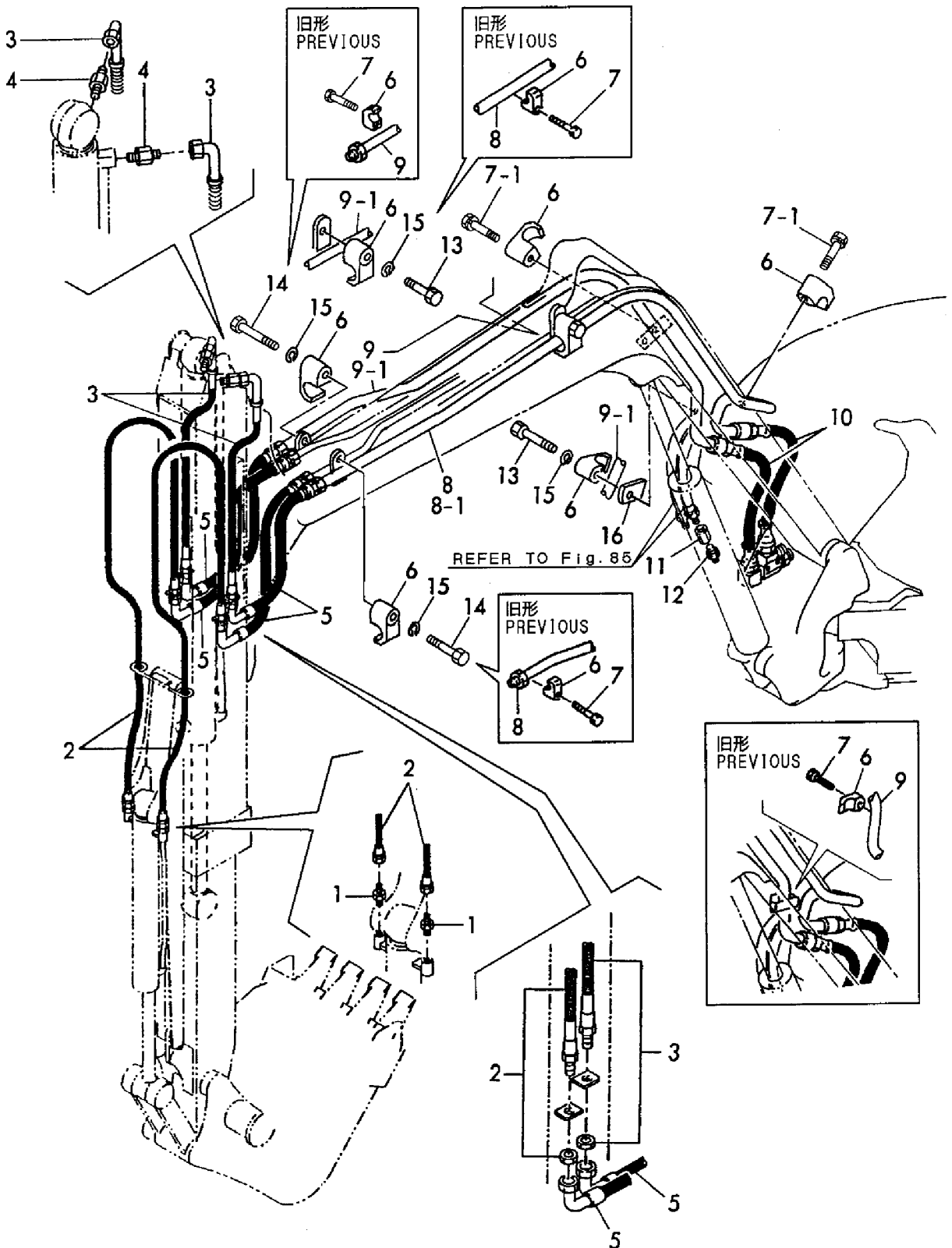

1,1,,172151-76030,, "BOLT, PIPE JOINT",2,2,,,,,,,,,,,,,
2,1,,172123-76120,, "CONNECTOR PF1/4",8,8,,,,,,,,,,,,,
3,1,,172151-76040,, "BOLT, PIPE JOINT",2,2,,,,,,,,,,,,,
4,1,,172165-79220,, HOSE,1,1,,,,,,,,,,,,,
5,1,,172165-79290,, HOSE,1,1,,,,,,,,,,,,,
6,1,,172165-79300,, HOSE,1,1,,,,,,,,,,,,,
7,1,,172165-79310,, HOSE,1,1,,,,,,,,,,,,,
8,1,,172164-78500,, "HOSE G604CW200S P",1,1,,,,,,,,,,,,,
9,1,,172164-78520,, "HOSE G604BY115S T",1,1,,,,,,,,,,,,,
10,1,,172165-79340,, HOSE,1,1,,,,,,,,,,,,,
11,1,,172165-79350,, HOSE,1,1,,,,,,,,,,,,,
12,1,,172165-79360,, HOSE,1,1,,,,,,,,,,,,,
13,1,,172165-79370,, HOSE,1,1,,,,,,,,,,,,,
14,1,,172164-78510,, "HOSE G604CW140S P",1,1,,,,,,,,,,,,,
15,1,,172164-78530,, "HOSE G604BY185S T",1,1,,,,,,,,,,,,,
16,1,,24315-000180,, "O-RING 1B P-18.0",8,8,,,,,,,,,,,,,
17,1,,24315-000110,, "O-RING 1B P-11.0",8,8,,,,,,,,,,,,,
18,1,,172123-76120,, "CONNECTOR PF1/4",4,4,,,,,,,,,,,,,
19,1,,24315-000110,, "O-RING 1B P-11.0",8,8,,,,,,,,,,,,,
20,1,,23393-020000,, "JOINT 90RGI1/4",1,1,,,,,,,,,,,,,
21,1,,172165-76290,, "CONNECTOR PF1/4-1/4",1,1,,,,,,,,,,,,,
21A,2,,24315-000110,, "O-RING 1B P-11.0",1,1,,,,,W,,,,M/#01160,,M/#01160,,,,,
22,1,,172164-76330,, "JOINT PF1/4-0.7",4,4,,,,,,,,,,,,,
23,1,,172165-79810,, SPONGE,2,2,,,,,,,,,,,,,
24,1,,172122-79930,, CLAMP,6,6,,,,,,,,,,,,,
25,1,,172122-17190,, CLIP,2,2,,,,,,,,,,,,,
26,1,,172122-79930,, CLAMP,1,1,,,,,,,,,,,,,
27,1,,172164-79940,, COVER,1,1,,,,,,,,,,,,,
28,1,,23010-014000,, "CLAMP 14",2,2,,,,,,,,,,,,,
29,1,,172176-61130,, "SPONGE, HOSE",1,,,,,W,,,,M/#00501,,,,,
30,1,,172122-79930,, CLAMP,2,,,,,W,,,,M/#00501,,,,,

Fig. 88 コントロール配管 (ダイレクト) (旧形)
CONTROL PIPING (DIRECT) (PREVIOUS) ~M/#01186

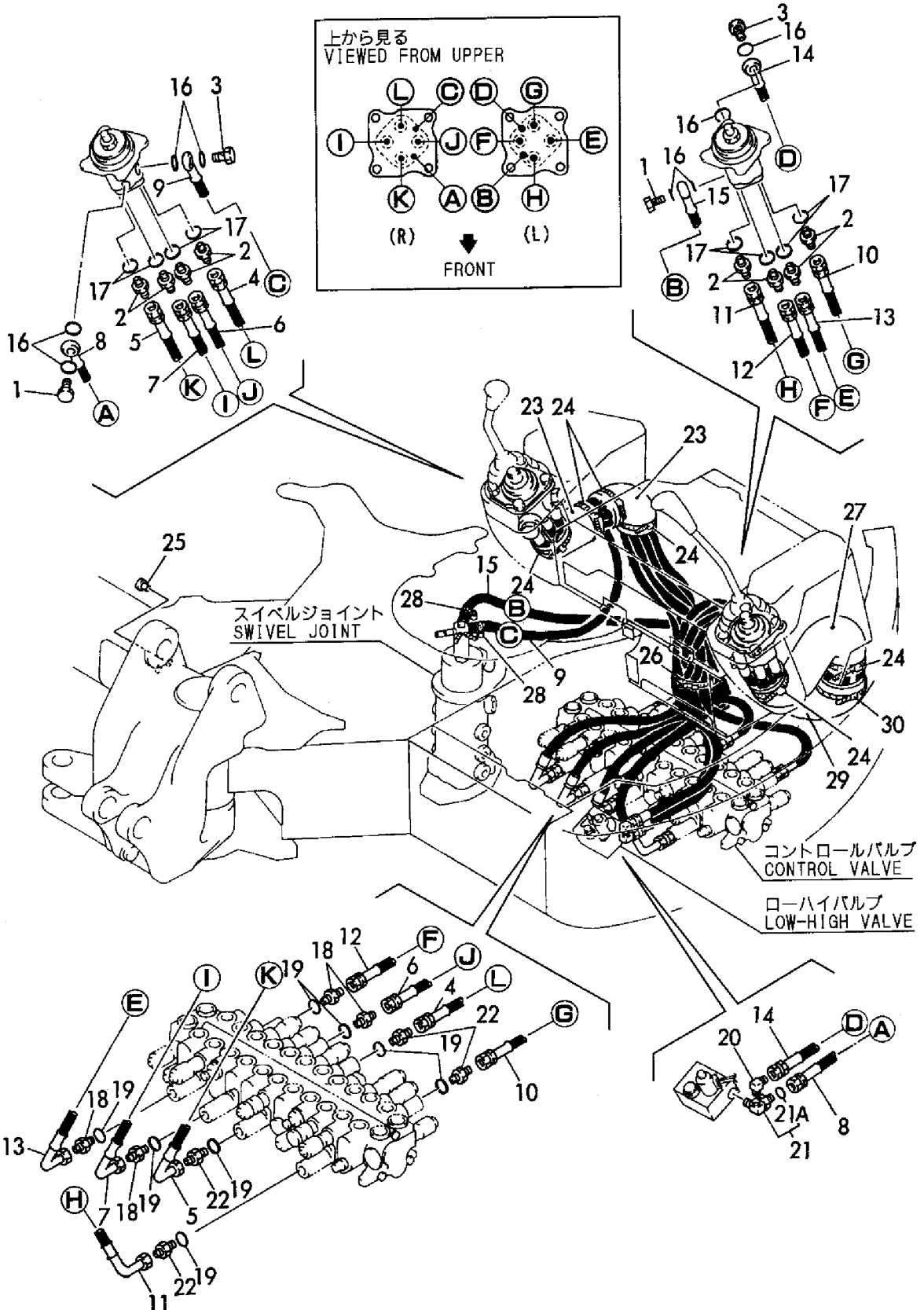

1,1,,172151-76030,, "BOLT, PIPE JOINT",2,2,,,,,,,,,,,,,
2,1,,172123-76120,, "CONNECTOR PF1/4",8,8,,,,,,,,,,,,,
3,1,,172151-76040,, "BOLT, PIPE JOINT",2,2,,,,,,,,,,,,,
4,1,,172165-79220,, HOSE,1,1,,,,,,,,,,,,,
5,1,,172165-79290,, HOSE,1,1,,,,,,,,,,,,,
6,1,,172165-79300,, HOSE,1,1,,,,,,,,,,,,,
7,1,,172165-79310,, HOSE,1,1,,,,,,,,,,,,,
8,1,,172164-78510,, "HOSE G604CW140S P",2,2,,,,,,,,,,,,,
9,1,,172164-78520,, "HOSE G604BY115S T",1,1,,,,,,,,,,,,,
10,1,,172165-79340,, HOSE,1,1,,,,,,,,,,,,,
11,1,,172165-79350,, HOSE,1,1,,,,,,,,,,,,,
12,1,,172165-79360,, HOSE,1,1,,,,,,,,,,,,,
13,1,,172165-79370,, HOSE,1,1,,,,,,,,,,,,,
14,1,,23010-014000,, "CLAMP 14",2,2,,,,,,,,,,,,,
15,1,,172164-78530,, "HOSE G604BY185S T",1,1,,,,,,,,,,,,,
16,1,,24315-000180,, "O-RING 1B P-18.0",8,8,,,,,,,,,,,,,
17,1,,24315-000110,, "O-RING 1B P-11.0",8,8,,,,,,,,,,,,,
18,1,,172123-76120,, "CONNECTOR PF1/4",4,4,,,,,,,,,,,,,
18-1,1,,172123-76120,, "CONNECTOR PF1/4",2,2,,,,,K,,,M/#01651,,M/#01651,,,,,,
19,1,,24315-000110,, "O-RING 1B P-11.0",8,8,,,,,,,,,,,,,
19-1,1,,24315-000110,, "O-RING 1B P-11.0",6,6,,,,,K,,,M/#01651,,M/#01651,,,,,,
20,1,,172164-76330,, "JOINT PF1/4-0.7",4,4,,,,,,,,,,,,,
21,1,,172165-79810,, SPONGE,2,2,,,,,,,,,,,,,
22,1,,172122-79930,, CLAMP,6,6,,,,,,,,,,,,,
23,1,,172122-17190,, CLIP,2,2,,,,,,M,,,,,,,,,,,,,
24,1,,172122-79930,, CLAMP,1,1,,,,,,,,,,,,,
25,1,,172164-79940,, COVER,1,1,,,,,,,,,,,,,
26,1,,172176-61130,, "SPONGE, HOSE",1,,,,,,,,,,,,,
27,1,,172122-79930,, CLAMP,2,,,,,,,,,,,,,
28,1,,172964-78111,, "VALVE, CHECK",2,2,,,,,W,,,M/#01651,,M/#01651,,,,,,

Fig. 89 コントロール配管 (ダイレクト) (新形)
CONTROL PIPING (DIRECT) (NEW)
M/#01187~

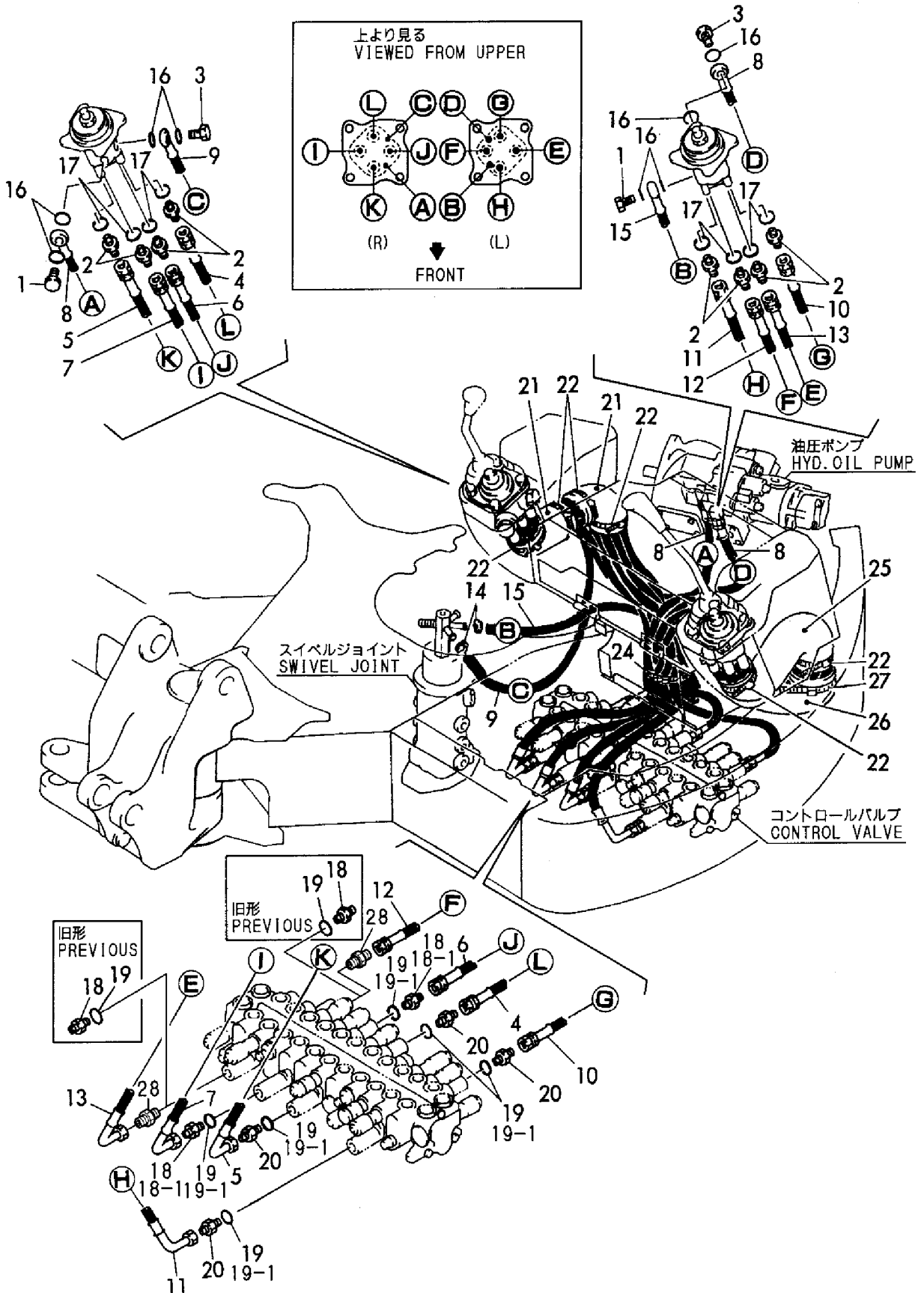

1,2,,172126-11510,, "BAND 300",2,2,,,,,,,,,,,,,
2,2,,172173-79300,, "HOSE G604BB057",1,1,,,,,,,,,,,,,
3,2,,172164-79400,, HOSE,1,1,,,,,,,,,,,,,
4,2,,172164-79410,, HOSE,1,1,,,,,,,,,,,,,
5,2,,172164-79420,, HOSE,1,1,,,,,,,,,,,,,
6,2,,172164-79430,, HOSE,1,1,,,,,,,,,,,,,
7,2,,172164-79440,, HOSE,1,1,,,,,,,,,,,,,
8,2,,172164-79450,, HOSE,1,1,,,,,,,,,,,,,
9,2,,172164-79460,, HOSE,1,1,,,,,,,,,,,,,
10,2,,23391-020000,, "JOINT RGI1/4",8,8,,,,,,,,,,,,,
11,1,,172151-76030,, "BOLT, PIPE JOINT",2,2,,,,,,,,,,,,,
12,1,,172151-76040,, "BOLT, PIPE JOINT",2,2,,,,,,,,,,,,,
13,1,,172123-76120,, "CONNECTOR PF1/4",2,2,,,,,,,,,,,,,
14,1,,172123-76120,, "CONNECTOR PF1/4",8,8,,,,,,,,,,,,,
15,1,,172164-76330,, "JOINT PF1/4-0.7",4,4,,,,,,,,,,,,,
16,1,,172964-78111,, "VALVE, CHECK",2,2,,,,,,,,,,,,,
17,1,,172164-78510,, "HOSE G604CW140S P",2,2,,,,,,,,,,,,,
18,1,,172164-78520,, "HOSE G604BY115S T",1,1,,,,,,,,,,,,,
19,1,,172164-78530,, "HOSE G604BY185S T",1,1,,,,,,,,,,,,,
20,1,,172165-79220,, HOSE,1,1,,,,,,,,,,,,,
21,1,,172165-79290,, HOSE,1,1,,,,,,,,,,,,,
22,1,,172165-79300,, HOSE,1,1,,,,,,,,,,,,,
23,1,,172165-79310,, HOSE,1,1,,,,,,,,,,,,,
24,1,,172165-79810,, SPONGE,2,2,,,,,,,,,,,,,
25,1,,172122-79930,, CLAMP,6,6,,,,,,,,,,,,,
26,1,,172122-79930,, CLAMP,1,1,,,,,,,,,,,,,
27,1,,172164-79940,, COVER,1,1,,,,,,,,,,,,,
28,1,,24315-000110,, "O-RING 1B P-11.0",8,8,,,,,,,,,,,,,
29,1,,24315-000110,, "O-RING 1B P-11.0",6,6,,,,,,,,,,,,,
30,1,,24315-000180,, "O-RING 1B P-18.0",8,8,,,,,,,,,,,,,
31,1,,23010-014000,, "CLAMP 14",2,2,,,,,,,,,,,,,
32,1,,172122-17190,, CLIP,2,2,,,,,,,,,,,,,

Fig. 90 コントロール配管 (2ウェイバルブ~コントロールバルブ
~リモコンバルブ)
CONTROL PIPING (2-WAY VALVE~CONTROL VALVE
~REMO.-CON. VALVE)

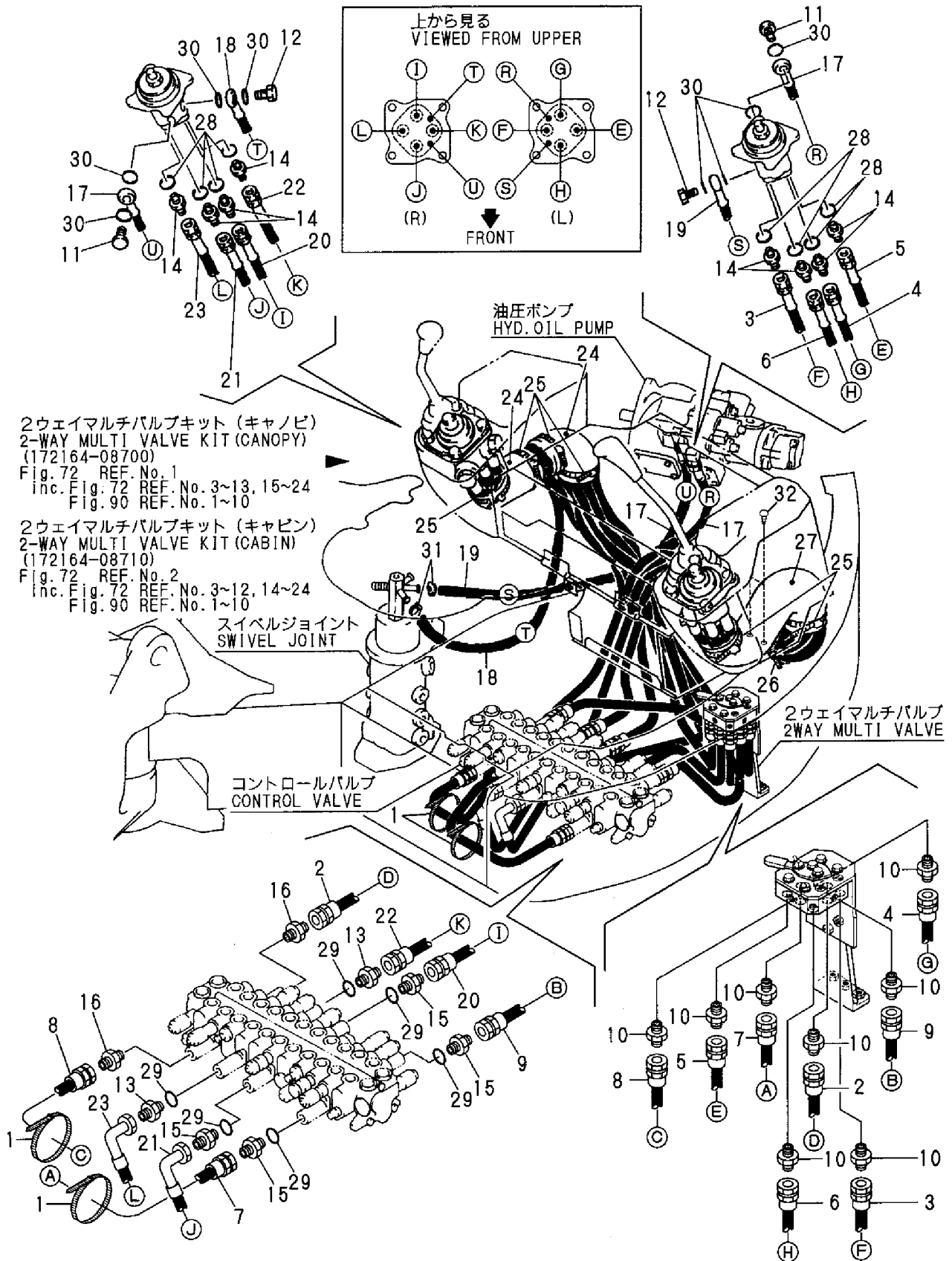

1,2,,172141-76180,,CONNECTOR,8,8,,,,,,,,,,,,,
2,3,,24315-000110,, "O-RING 1B P-11.0",8,8,,,,,,,,,,,,,
3,2,,172164-79100,, "HOSE G604BB130 J",1,1,,,,,,,,,,,,,
4,2,,172164-79130,, "HOSE G604BB100 I",1,1,,,,,,,,,,,,,
5,2,,172164-79120,, "HOSE G604BB100 K",1,1,,,,,,,,,,,,,
6,2,,172164-79110,, "HOSE G604BB100 L",1,1,,,,,,,,,,,,,
7,2,,172165-78900,,HOSE,1,1,,,,,,,,,,,,,
8,2,,172165-78910,,HOSE,1,1,,,,,,,,,,,,,
9,2,,172165-78920,,HOSE,1,1,,,,,,,,,,,,,
10,2,,172165-78930,,HOSE,1,1,,,,,,,,,,,,,
11,1,,24315-000110,, "O-RING 1B P-11.0",8,8,,,,,,,,,,,,,
12,1,,172123-76120,, "CONNECTOR PF1/4",8,8,,,,,,,,,,,,,
13,1,,172164-78520,, "HOSE G604BY115S T",1,1,,,,,,,,,,,,,
14,1,,172164-78500,, "HOSE G604CW200S P",1,1,,,,,,,,,,,,,
15,1,,172164-78530,, "HOSE G604BY185S T",1,1,,,,,,,,,,,,,
16,1,,172151-76030,, "BOLT, PIPE JOINT",2,2,,,,,,,,,,,,,
17,1,,172151-76040,, "BOLT, PIPE JOINT",2,2,,,,,,,,,,,,,
18,1,,24315-000180,, "O-RING 1B P-18.0",8,8,,,,,,,,,,,,,
19,1,,23393-020000,, "JOINT 90RGI1/4",1,1,,,,,,,,,,,,,
20,1,,172165-76290,, "CONNECTOR PF1/4-1/4",1,1,,,,,,,,,,,,,
20A,2,,24315-000110,, "O-RING 1B P-11.0",1,1,,,,,W,,,M/#01160,,,M/#01160,,,,,
21,1,,172165-79810,,SPONGE,2,2,,,,,,,,,,,,,
22,1,,172122-79930,,CLAMP,6,6,,,,,,,,,,,,,
23,1,,172164-78510,, "HOSE G604CW140S P",1,1,,,,,,,,,,,,,
24,1,,172164-79940,,COVER,1,1,,,,,,,,,,,,,
25,1,,23010-014000,, "CLAMP 14",2,2,,,,,,,,,,,,,
26,1,,172122-79930,,CLAMP,1,1,,,,,,,,,,,,,
27,1,,172176-61130,, "SPONGE, HOSE",1,,,,,W,,,M/#00501,,,,,
28,1,,172122-79930,,CLAMP,2,,,,,W,,,M/#00501,,,,,

Fig. 91 コントロール配管 (リモコンバルブ~ロータリバルブ) (旧形)
CONTROL PIPING (REMO.-CON. VALVE
~ROTARY VALVE) (PREVIOUS)

~M/#01186

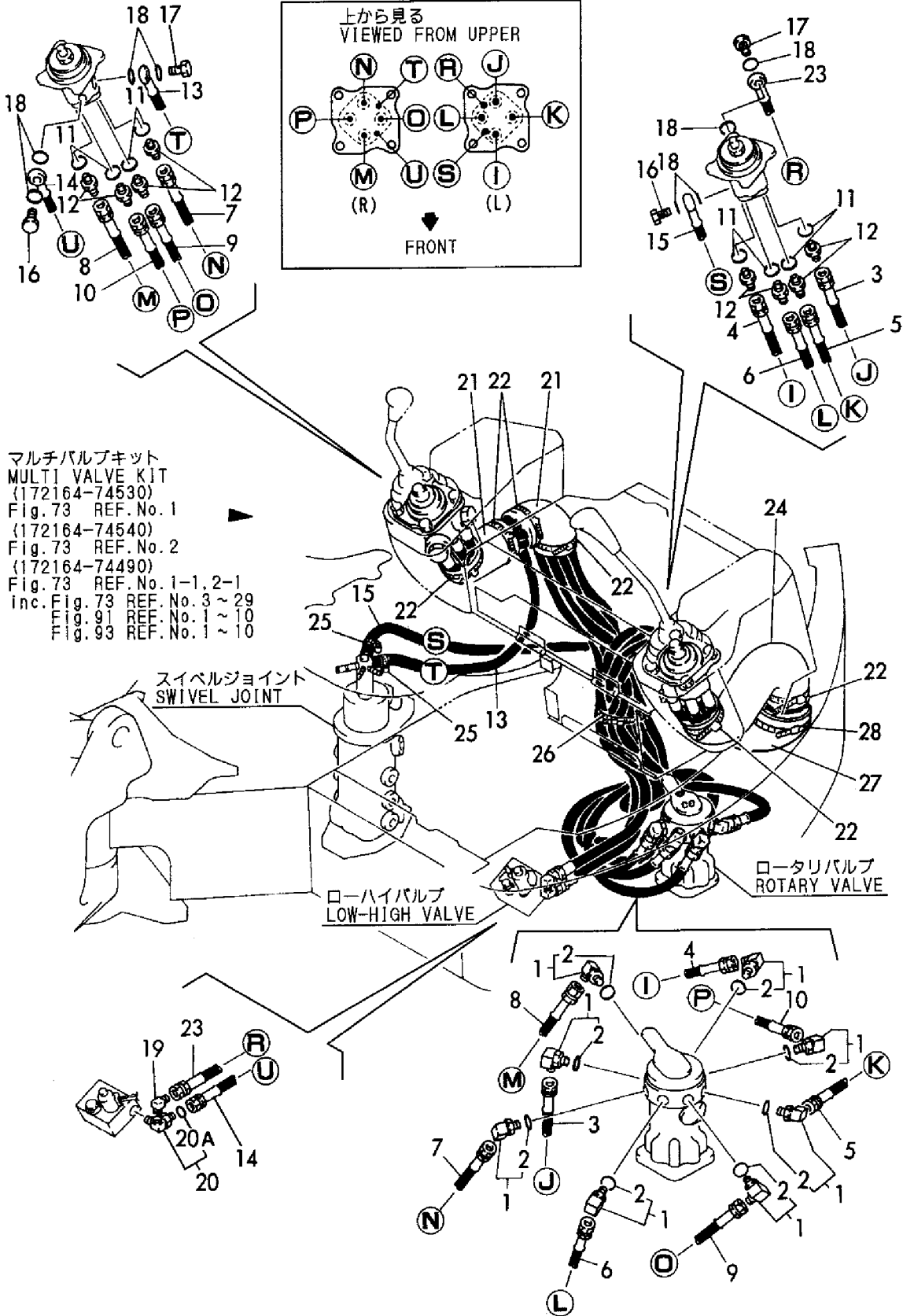

マルチバルブキット
MULTI VALVE KIT
(172164-74530)
Fig. 73 REF. No. 1
(172164-74540)
Fig. 73 REF. No. 2
(172164-74490)
Fig. 73 REF. No. 1-1, 2-1
Inc. Fig. 73 REF. No. 3 ~ 29
Fig. 91 REF. No. 1 ~ 10
Fig. 93 REF. No. 1 ~ 10

スィベルジョイント
SWIVEL JOINT

ローハイバルブ
LOW-HIGH VALVE

ロータリバルブ
ROTARY VALVE

1,2,,172141-76180,,CONNECTOR,8,8,,,,,,,,,,,,,
2,3,,24315-000110,, "O-RING 1B P-11.0",8,8,,,,,,,,,,,,,
3,2,,172164-79100,, "HOSE G604BB130 J",1,1,,,,,,,,,,,,,
4,2,,172164-79130,, "HOSE G604BB100 I",1,1,,,,,,,,,,,,,
5,2,,172164-79120,, "HOSE G604BB100 K",1,1,,,,,,,,,,,,,
6,2,,172164-79110,, "HOSE G604BB100 L",1,1,,,,,,,,,,,,,
7,2,,172165-78900,,HOSE,1,1,,,,,,,,,,,,,
8,2,,172165-78910,,HOSE,1,1,,,,,,,,,,,,,
9,2,,172165-78920,,HOSE,1,1,,,,,,,,,,,,,
10,2,,172165-78930,,HOSE,1,1,,,,,,,,,,,,,
11,1,,24315-000110,, "O-RING 1B P-11.0",8,8,,,,,,,,,,,,,
12,1,,172123-76120,, "CONNECTOR PF1/4",8,8,,,,,,,,,,,,,
13,1,,172164-78520,, "HOSE G604BY115S T",1,1,,,,,,,,,,,,,
14,1,,172164-78510,, "HOSE G604CW140S P",2,2,,,,,,,,,,,,,
15,1,,172164-78530,, "HOSE G604BY185S T",1,1,,,,,,,,,,,,,
16,1,,172151-76030,, "BOLT, PIPE JOINT",2,2,,,,,,,,,,,,,
17,1,,172151-76040,, "BOLT, PIPE JOINT",2,2,,,,,,,,,,,,,
18,1,,24315-000180,, "O-RING 1B P-18.0",8,8,,,,,,,,,,,,,
19,1,,172165-79810,,SPONGE,2,2,,,,,,,,,,,,,
20,1,,172122-79930,,CLAMP,6,6,,,,,,,,,,,,,
21,1,,172164-79940,,COVER,1,1,,,,,,,,,,,,,
22,1,,23010-014000,, "CLAMP 14",2,2,,,,,,,,,,,,,
23,1,,172122-79930,,CLAMP,2,2,,,,,,,,,,,,,
24,1,,172176-61130,, "SPONGE, HOSE",1,,,,,,,,,,,,,
25,1,,172122-79930,,CLAMP,2,,,,,,,,,,,,,

Fig. 92 コントロール配管 (リモコンバルブ~ロータリバルブ) (新形) CONTROL PIPING (REMO.-CON. VALVE ~ROTARY VALVE) (NEW)

M/#01187~

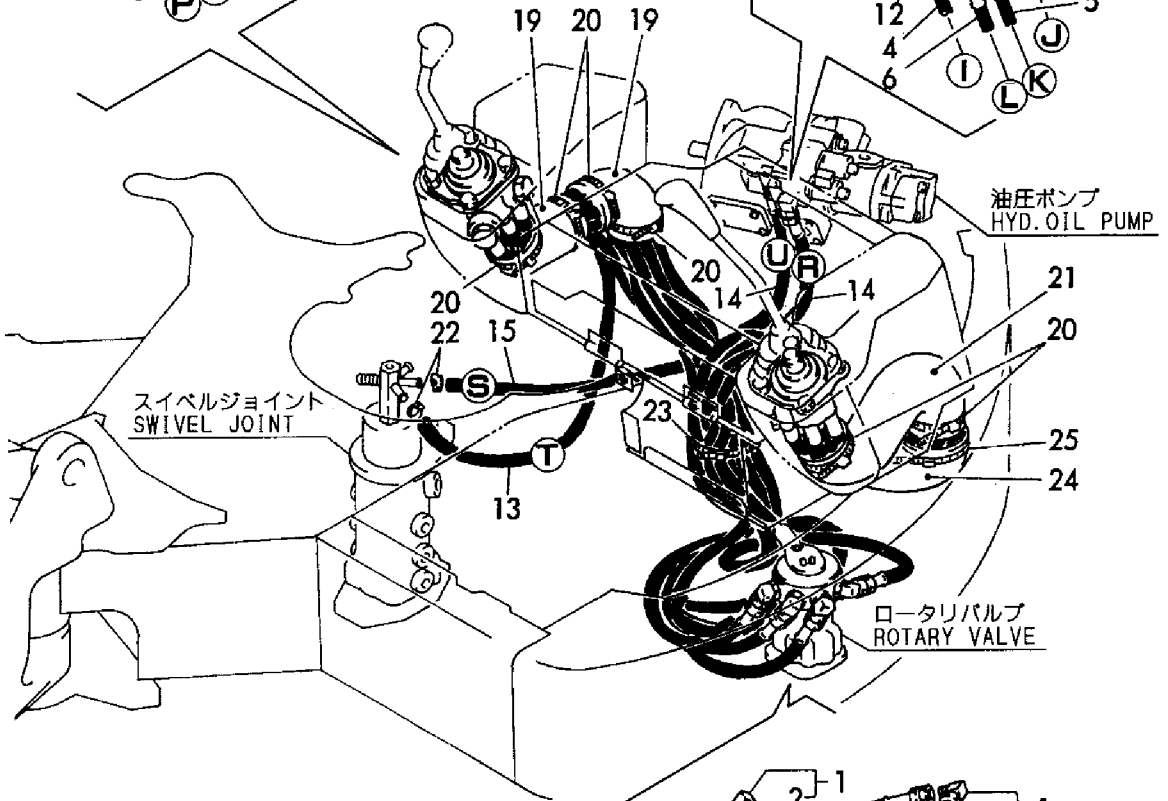
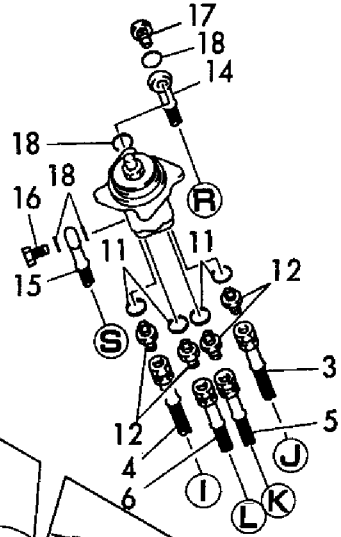
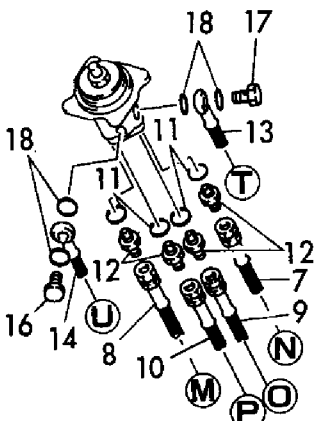
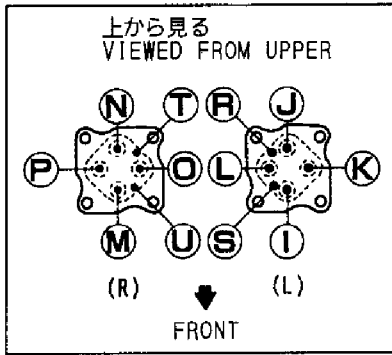

マルチバルブキット
MULTI VALVE KIT
(172164-74530)
Fig. 73 REF. No. 1
(172164-74540)
Fig. 73 REF. No. 2
(172164-74490)
Fig. 73 REF. No. 1-1, 2-1
Inc. Fig. 73 REF. No. 3 ~ 29
Fig. 92 REF. No. 1 ~ 10
Fig. 93 REF. No. 1 ~ 10

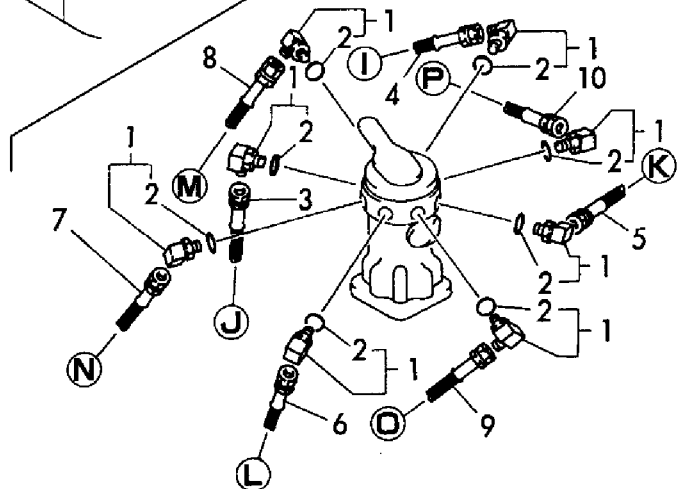

1,2,,172141-76180,,CONNECTOR,8,8,,,,,,,,,,,,,
2,3,,24315-000110,,,"O-RING 1B P-11.0",8,8,,,,,,,,,,,,,
3,2,,172164-79200,,,"HOSE G604BB055 B",1,1,,,,,,,,,,,,,
4,2,,172165-79050,,HOSE,1,1,,,,,,,,,,,,,
5,2,,172165-78980,,HOSE,1,1,,,,,,,,,,,,,
6,2,,172164-79190,,,"HOSE G604BB055 C",1,1,,,,,,,,,,,,,
7,2,,172165-79010,,HOSE,1,1,,,,,,,,,,,,,
8,2,,172164-79210,,,"HOSE G604BB055 F",1,1,,,,,,,,,,,,,
9,2,,172165-79030,,HOSE,1,1,,,,,,,,,,,,,
10,2,,172164-79180,,,"HOSE G604BB055 H",1,1,,,,,,,,,,,,,
11,1,,172123-76120,,,"CONNECTOR PF1/4",4,4,,,,,,,,,,,,,
11-1,1,,172123-76120,,,"CONNECTOR PF1/4",2,2,,,,,K,,M/#01680,,M/#01680,,,,,
12,1,,24315-000110,,,"O-RING 1B P-11.0",8,8,,,,,,,,,,,,,
12-1,1,,24315-000110,,,"O-RING 1B P-11.0",6,6,,,,,K,,M/#01680,,M/#01680,,,,,
13,1,,172164-76330,,,"JOINT PF1/4-0.7",4,4,,,,,,,,,,,,,
14,1,,172964-78111,,,"VALVE, CHECK",2,2,,,,,W,,M/#01680,,M/#01680,,,,,

Fig. 93 コントロール配管 (ロータリバルブ~コントロールバルブ) CONTROL PIPING (ROTARY VALVE~CONTROL VALVE)

マルチバルブキット
MULTI VALVE KIT
(172164-74530)
Fig. 73 REF. No. 1
(172164-74540)
Fig. 73 REF. No. 2
(172164-74490)
Fig. 73 REF. No. 1-1, 2-1
Inc. Fig. 73 REF. No. 3 ~ 29
Fig. 91 OR 92 REF. No. 1 ~ 10
Fig. 93 REF. No. 1 ~ 10

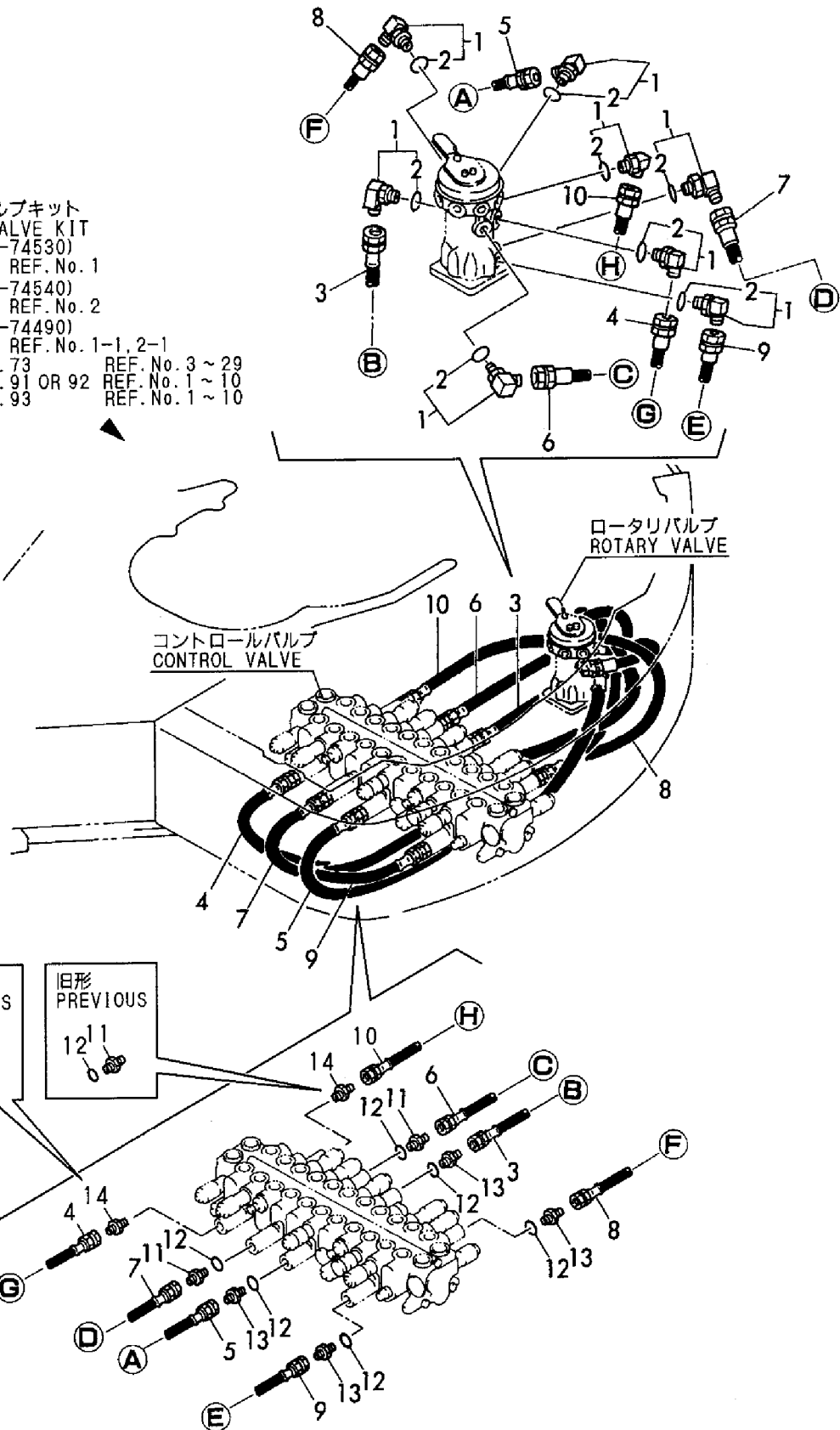

1,1,,172112-77580,, "JOINT 1/8",1,1,,,,,,,,,,,,,,,,,,,,,
2,1,,172112-77660,, "L-JOINT 1/8",1,1,,,,,,,,,,,,,,,,,,,,,
3,1,,172141-77800,, "JOINT, GREASE",4,4,,,,,,,,,,,,,,,,,,,,,
4,1,,172147-77800,, "CONNECTOR PT 1/8",1,1,,,,,,,,,,,,,,,,,,,,,
5,1,,172151-77801,, HOSE,1,1,,,,,,,,,,,,,,,,,,,,,
6,1,,172164-77810,, HOSE,1,1,,,,,,,,,,,,,,,,,,,,,
7,1,,172164-78560,, HOSE,1,1,,,,,,,,,,,,,,,,,,,,,
8,1,,24761-020000,, "NIPPLE PT1/8,GREASE",3,3,,,,,,,,,,,,,,,,,,,,,

Fig. **94** 遠隔グリーシング
GREASING

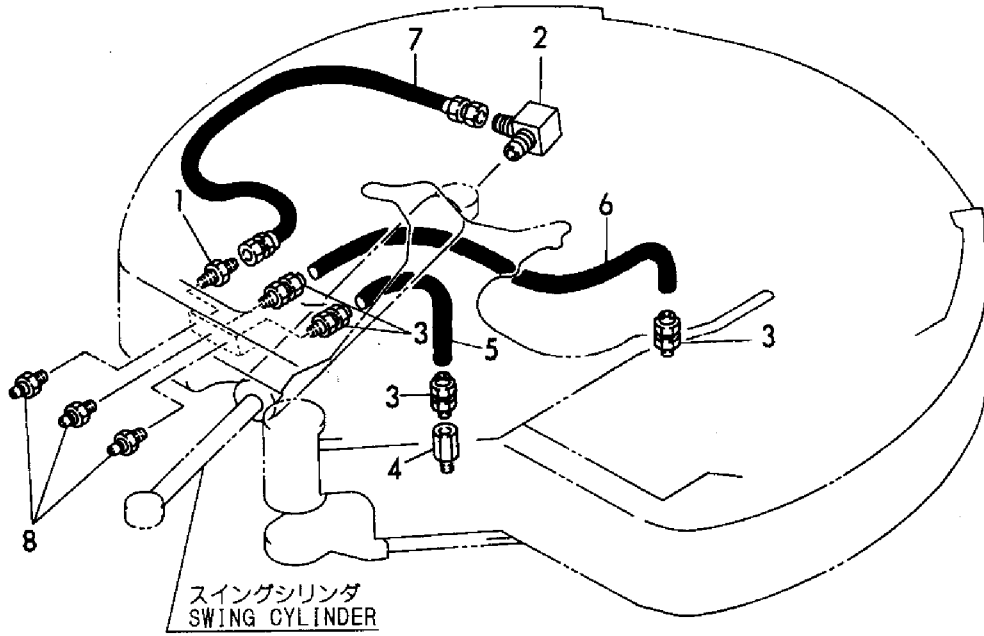

1,1,,172164-81101,, "BOOM W/BUSH",1,1,,,,,,,,,,,,,,,,,,,,,
1-1,1,,172164-81102,, "BOOM W/BUSH",1,1,,,,,S,,,M/#01628,,M/#01628,,,,,
2,2,,172146-81300,, "BUSH 45 60",2,2,,,,,,,,,,,,,,,,,,,,,
3,2,,172168-81410,, "SEAL 45X55X4, DUST",2,2,,,,,,,,,,,,,,,,,,,,,
4,1,,172164-81550,, "PIN 45X201",1,1,,,,,,,,,,,,,,,,,,,,,
4-1,1,,172164-81551,, "PIN 45X205",1,1,,,,,N,,,M/#02054,,M/#02054,,,,,
5,1,,172164-81570,, PIN,1,1,,,,,,,,,,,,,,,,,,,,,
6,1,,172164-81590,, "PIN 45X149",1,1,,,,,,,,,,,,,,,,,,,,,
7,1,,172164-81670,, SPACER,3,3,,,,,,,,,,,,,,,,,,,,,
8,1,,172165-82550,, "SHIM 45X1.2",1,1,,,,,,,,,,,,,,,,,,,,,
9,1,,172165-82560,, "SHIM 45X80X1.2",1,1,,,,,,,,,,,,,,,,,,,,,
10,1,,172165-82570,, "SHIM 45X80X1.6",1,1,,,,,,,,,,,,,,,,,,,,,
11,1,,172112-87840,, "SHIM 45X1",1,1,,,,,,,,,,,,,,,,,,,,,
12,1,,172112-87860,, "SHIM 40X1",2,2,,,,,,,,,,,,,,,,,,,,,
13,1,,22157-120000,, "WASHER 12",3,3,,,,,,,,,,,,,,,,,,,,,
14,1,,24761-040000,, "NIPPLE B,GREASE",1,1,,,,,,,,,,,,,,,,,,,,,
15,1,,26013-120302,, "BOLT W/WASHER M12X30",3,3,,,,,,,,,,,,,,,,,,,,,
16,1,,172312-31120,, "BOLT M16X170",1,1,,,,,,,,,,,,,,,,,,,,,
17,1,,172164-81590,, "PIN 45X149",1,1,,,,,,,,,,,,,,,,,,,,,
18,1,,172164-81610,, "PIN 45X276",1,1,,,,,,,,,,,,,,,,,,,,,
18-1,1,,172164-81611,, "PIN 45X280",1,1,,,,,N,,,M/#02054,,M/#02054,,,,,
19,1,,172164-81670,, SPACER,2,2,,,,,,,,,,,,,,,,,,,,,
20,1,,172164-81680,, "PIN 40X111",1,1,,,,,,,,,,,,,,,,,,,,,
21,1,,172164-82301,, "BRACKET ASSY. BOOM",1,1,,,,,,,,,,,,,,,,,,,,,
22,2,,172165-81710,, "BUSH 70X85",2,2,,,,,,,,,,,,,,,,,,,,,
23,2,,172165-81770,, "SEAL 70X80X6, DUST",2,2,,,,,,,,,,,,,,,,,,,,,
25,2,,24321-000700,, "O-RING 1A G-70.0",2,2,,,,,,,,,,,,,,,,,,,,,
26,1,,172165-82340-1,, "PIN 40X122",1,1,,,,,,,,,,,,,,,,,,,,,
27,1,,172165-82360,, "PIN 70-400 CMP",1,1,,,,,,,,,,,,,,,,,,,,,
28,1,,172165-82550,, "SHIM 45X1.2",1,1,,,,,,,,,,,,,,,,,,,,,
29,1,,172165-82560,, "SHIM 45X80X1.2",1,1,,,,,,,,,,,,,,,,,,,,,
30,1,,172165-82570,, "SHIM 45X80X1.6",1,1,,,,,,,,,,,,,,,,,,,,,
31,1,,172165-82580,, "SHIM 40X75X0.5",4,4,,,,,,,,,,,,,,,,,,,,,
32,1,,172165-82590,, "SHIM 40X75X1.2",4,4,,,,,,,,,,,,,,,,,,,,,
33,1,,172165-82600,, "SHIM 40X75X1.6",4,4,,,,,,,,,,,,,,,,,,,,,
34,1,,172146-82910,, SPACER,1,1,,,,,,,,,,,,,,,,,,,,,
35,1,,172117-83970-2,, "PLATE(C), LOCK",1,1,,,,,,,,,,,,,,,,,,,,,
36,1,,172112-87840,, "SHIM 45X1",4,4,,,,,,,,,,,,,,,,,,,,,
37,1,,22157-120000,, "WASHER 12",2,2,,,,,,,,,,,,,,,,,,,,,
38,1,,22242-000700,, "CIRCLIP 70",1,1,,,,,,,,,,,,,,,,,,,,,
39,1,,24761-040000,, "NIPPLE B,GREASE",1,1,,,,,,,,,,,,,,,,,,,,,
40,1,,24761-050000,, "NIPPLE C,GREASE",1,1,,,,,,,,,,,,,,,,,,,,,
41,1,,26013-100202,, "BOLT W/WASHER M10X20",2,2,,,,,,,,,,,,,,,,,,,,,
42,1,,26013-120252,, "BOLT M12X 25",1,1,,,,,,,,,,,,,,,,,,,,,
43,1,,26013-120302,, "BOLT W/WASHER M12X30",2,2,,,,,,,,,,,,,,,,,,,,,
44,1,,26716-160002,, "NUT M16",2,2,,,,,,,,,,,,,,,,,,,,,
45,1,,172164-81300,, "BOOM W/BUSH, 3RD",1,1,,,,,1,,,,,,,,,,,,,
45-1,1,,172164-81301,, "BOOM W/BUSH, 3RD",1,1,,,,,N,1,,M/#01187,,M/#01187,,,,,
45-2,1,,172164-81301,, "BOOM W/BUSH, 3RD",1,1,,,,,Z,,,M/#01628,,M/#01628,,,,,
46,2,,172146-81300,, "BUSH 45 60",2,2,,,,,Z,1,,M/#01628,,M/#01628,,,,,
47,2,,172168-81410,, "SEAL 45X55X4, DUST",2,2,,,,,Z,1,,M/#01628,,M/#01628,,,,,
48,1,,172164-81170,, "TREE CLIP",3,3,,,,,W,,,M/#01628,,M/#01628,,,,,
48-1,1,,172183-81170,, "TREE CLIP",3,3,,,,,S,,,M/#01586,,M/#01586,,,,,
49,1,,172176-81700,, SHIM,1,1,,,,,W,,,M/#01628,,M/#01628,,,,,
50,1,,172176-81710,, SHIM,1,1,,,,,W,,,M/#01628,,M/#01628,,,,,
51,1,,172164-81760,, "COLLAR 40.5X60",1,1,,,,,W,,,M/#02054,,M/#02054,,,,,
52,1,,22242-000401,, "CIRCLIP 40-S",1,1,,,,,W,,,M/#02054,,M/#02054,,,,,
53,1,,172164-81760,, "COLLAR 40.5X60",1,1,,,,,W,,,M/#02054,,M/#02054,,,,,
54,1,,22242-000401,, "CIRCLIP 40-S",1,1,,,,,W,,,M/#02054,,M/#02054,,,,,
55,1,,172164-81770,, "COLLAR 40.5X60X1",2,2,,,,,W,,,M/#02568,,M/#02568,,,,,
56,1,,172164-81770,, "COLLAR 40.5X60X1",2,2,,,,,W,,,M/#02568,,M/#02568,,,,,

Fig. 95 ブーム&ブームブラケット BOOM & BOOM BRACKET

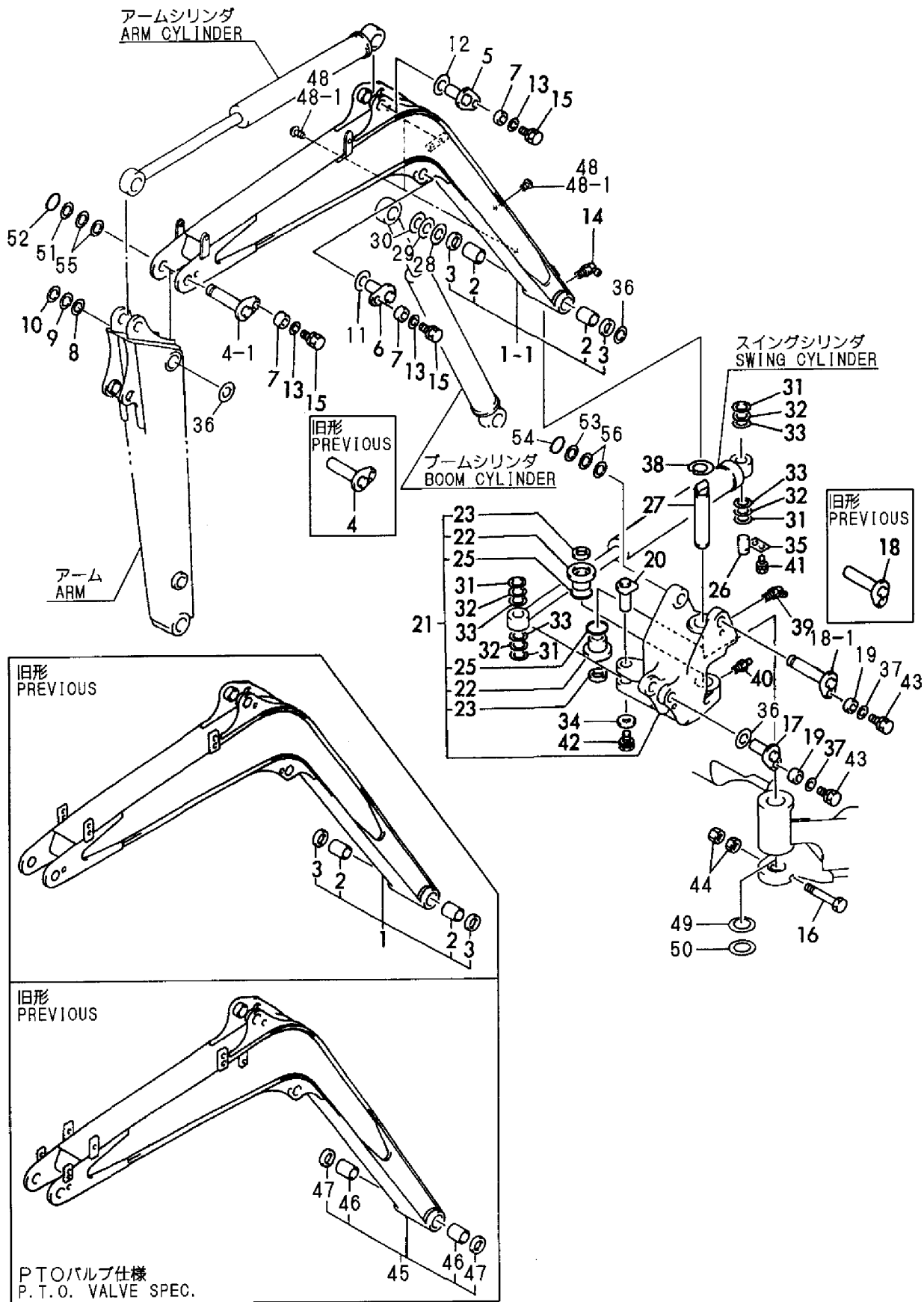

1,1,,172164-81201,, "ARM 1530 ASSY",1,1,,,,,,,,,,,,,
1-1,1,,172164-81202,, "ARM 1530 ASSY",1,1,,,,,S,,,M/#01628,,M/#01628,,,,,
1-2,1,,172164-81203,, "ARM 1530 ASSY",1,1,,,,,S,,,M/#01719,,M/#01719,,,,,
2,2,,172168-81260,, "BUSH 38X55",2,2,,,,,,,,,,,,,
3,2,,172168-81410,, "SEAL 45X55X4, DUST",2,2,,,,,,,,,,,,,
4,2,,172164-81880,, "BUSH 38X55, PIN",2,2,,,,,,,,,,,,,
5,2,,172122-82290,, "SEAL, DUST",4,4,,,,,,,,,,,,,
6,2,,172112-83500,, "PIN BUSH 45X60",2,2,,,,,,,,,,,,,
7,1,,172164-81500,, "PIN 38X106",1,1,,,,,,,,,,,,,
8,1,,172164-81530,, "PIN 40X111",1,1,,,,,,,,,,,,,
9,1,,172142-81620,, O-RING,2,2,,,,,,,,,,,,,
10,1,,172164-81670,, SPACER,2,2,,,,,,,,,,,,,
11,1,,172112-87860,, "SHIM 40X1",2,2,,,,,,,,,,,,,
12,1,,22157-120000,, "WASHER 12",2,2,,,,,,,,,,,,,
13,1,,26013-120302,, "BOLT W/WASHER M12X30",2,2,,,,,,,,,,,,,
14,1,,933171-29750,, "SHIM SET, PIN 38",1,1,,,,,,,,,,,,,
15,1,,172164-81960,, "PIN KIT, BUCKET ARM",1,1,,,,,,,,,,,,,
16,2,,172164-81830,, "PIN 38X170A",1,1,,,,,,,,,,,,,
17,2,,172164-81850,, "PIN 38X170B",1,1,,,,,,,,,,,,,
18,2,,933110-86600,, "NUT M24, NYLON",2,2,,,,,,,,,,,,,
19,2,,933171-29750,, "SHIM SET, PIN 38",2,2,,,,,,,,,,,,,
19-1,2,,933171-29751,, "SHIM
SET,38X(0.8,1.2)",2,2,,,,,N,,,M/#00926,,M/#00926,,,,,
20,2,,933171-29760,, WASHER,2,2,,,,,,,,,,,,,
21,2,,24761-020000,, "NIPPLE PT1/8,GREASE",1,1,,,,,,,,,,,,,
22,1,,172164-81810,, "ARM(L),BUCKET(GREEN)",1,1,,,,,,,,,,,,,
23,1,,172164-81820,, "ARM(R),BUCKET(GREEN)",1,1,,,,,,,,,,,,,
24,1,,172168-84401-2,, "LINK ASSY,BUCKET",1,1,,,,,,,,,,,,,
24-1,1,,172168-84402-4,, "LINK, BUCKET
(GREEN)",1,1,,,,,N,,,M/#00912,,M/#00912,,,,,
25,2,,172164-81880,, "BUSH 38X55, PIN",2,2,,,,,,,,,,,,,
26,2,,172122-82290,, "SEAL, DUST",6,6,,,,,,,,,,,,,
27,2,,172168-84411,, "BUSH 38-48-33.5",2,2,,,,,,,,,,,,,
28,1,,24761-020000,, "NIPPLE PT1/8,GREASE",2,2,,,,,,,,,,,,,
29,1,,24761-040000,, "NIPPLE B,GREASE",1,1,,,,,,,,,,,,,
30,1,,172164-81310,, "ARM ASSY, 3RD",1,1,,,,,Z,1,,M/#01628,,M/#01628,,,,,
31,2,,172168-81260,, "BUSH 38X55",2,2,,,,,Z,1,,M/#01628,,M/#01628,,,,,
32,2,,172168-81410,, "SEAL 45X55X4, DUST",2,2,,,,,Z,1,,M/#01628,,M/#01628,,,,,
33,2,,172164-81880,, "BUSH 38X55, PIN",2,2,,,,,Z,1,,M/#01628,,M/#01628,,,,,
34,2,,172122-82290,, "SEAL, DUST",4,4,,,,,Z,1,,M/#01628,,M/#01628,,,,,
35,2,,172112-83500,, "PIN BUSH 45X60",2,2,,,,,Z,1,,M/#01628,,M/#01628,,,,,
36,1,,172183-81160,, "TREE CLIP",4,4,,,,,W,,,M/#01628,,M/#01628,,,,,

Fig. 96 アーム&バケットリンク ARM & BUCKET LINK

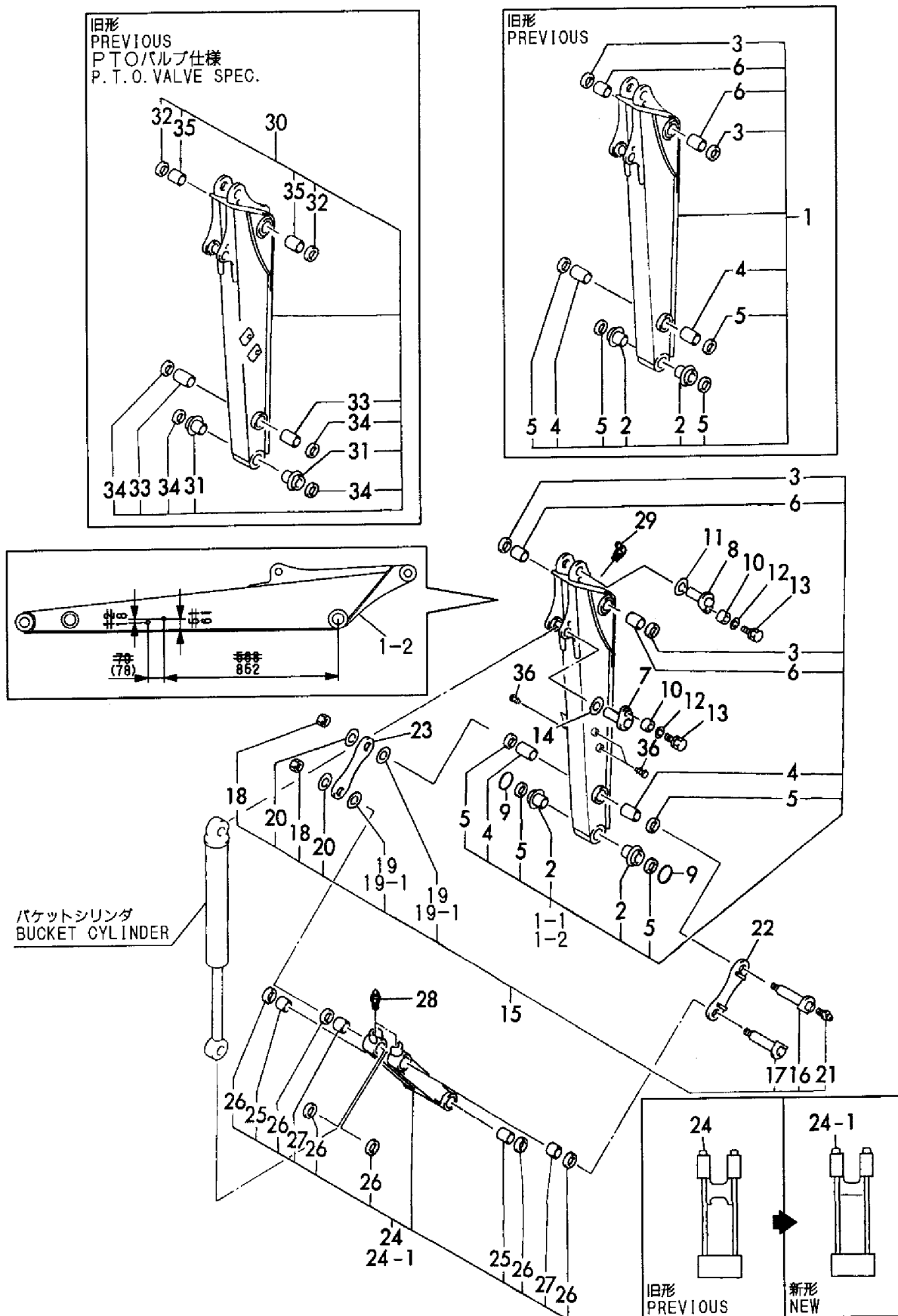

1,1,,172010-01640,,SPACER,1,1,,,,,,,,,,,,,
2,1,,172156-81400,, "SHIM 25-45",1,1,,,,,,,,,,,,,
6,1,,172142-81620,, O-RING,2,2,,,,,,,,,,,,,
7,1,,172164-81670,, SPACER,1,1,,,,,,,,,,,,,
8,1,,172164-81670,, SPACER,1,1,,,,,,,,,,,,,
9,1,,172164-81670,, SPACER,1,1,,,,,,,,,,,,,
10,1,,172164-85100,, "ARM, OUTER",1,1,,,,,,,,,,,,,
11,2,,172168-81410,, "SEAL 45X55X4, DUST",2,2,,,,,,,,,,,,,
12,2,,172112-83500,, "PIN BUSH 45X60",2,2,,,,,,,,,,,,,
13,1,,172164-85340,, "PIN 40X169",1,1,,,,,,,,,,,,,
14,1,,172164-85360,, "PIN 40X135",1,1,,,,,,,,,,,,,
15,1,,172164-85400,, "ARM, INNER (GREEN:97)",1,1,,,,,,,,,,,,,
16,2,,172168-81260,, "BUSH 38X55",2,2,,,,,,,,,,,,,
17,2,,172122-82290,, "SEAL, DUST",4,4,,,,,,,,,,,,,
18,2,,172116-82400,, "PIN BUSH 38X55",2,2,,,,,,,,,,,,,
19,1,,172164-85570,, "PIN 25X110",1,1,,,,,,,,,,,,,
20,1,,172164-85600,, "SLIDE ROD (GREEN:97)",1,1,,,,,,,,,,,,,
21,1,,172164-85720,, "PIN 38X110",1,1,,,,,,,,,,,,,
22,1,,172164-85750,, "SEAT, SCREW",8,8,,,,,,,,,,,,,
23,1,,172164-85780,, "PLATE, SLIDE",1,1,,,,,,,,,,,,,
27,1,,172168-85810,, PIN,1,1,,,,,,,,,,,,,
28,1,,172164-85820,, "PLATE, SLIDE",1,1,,,,,,,,,,,,,
32,1,,172164-85860,, "GUIDE, SLIDE",2,2,,,,,,,,,,,,,
33,1,,172164-85900,, "COVER L (GREEN:97)",1,1,,,,,,,,,,,,,
34,1,,172164-85910,, "COVER R (GREEN:97)",1,1,,,,,,,,,,,,,
35,1,,172164-85950,, GUIDE,1,1,,,,,,,,,,,,,
36,1,,172112-87860,, "SHIM 40X1",2,2,,,,,,,,,,,,,
37,1,,22157-100000,, "WASHER 10",1,1,,,,,,,,,,,,,
38,1,,22157-120000,, "WASHER 12",1,1,,,,,,,,,,,,,
39,1,,22157-120000,, "WASHER 12",1,1,,,,,,,,,,,,,
40,1,,22157-120000,, "WASHER 12",1,1,,,,,,,,,,,,,
41,1,,22242-000400,, "CIRCLIP 40",1,1,,,,,,,,,,,,,
42,1,,24761-020000,, "NIPPLE PT1/8, GREASE",1,1,,,,,,,,,,,,,
43,1,,24761-040000,, "NIPPLE B, GREASE",1,1,,,,,,,,,,,,,
44,1,,26013-080202,, "BOLT W/WASHER M8X20",6,6,,,,,,,,,,,,,
45,1,,26013-080202,, "BOLT W/WASHER M8X20",2,2,,,,,,,,,,,,,
46,1,,26013-080202,, "BOLT W/WASHER M8X20",16,16,,,,,,,,,,,,,
47,1,,26013-100252,, "BOLT W/WASHER M10X25",1,1,,,,,,,,,,,,,
48,1,,26013-120302,, "BOLT W/WASHER M12X30",1,1,,,,,,,,,,,,,
49,1,,26013-120302,, "BOLT W/WASHER M12X30",1,1,,,,,,,,,,,,,
50,1,,26013-120302,, "BOLT W/WASHER M12X30",1,1,,,,,,,,,,,,,
51,1,,933171-29751,, "SHIM SET, 38X(0.8,1.2)",1,1,,,,,,,,,,,,,
54,1,,172164-84500,, "BUCKET ARM L(GREEN97)",1,1,,,,,,,,,,,,,
55,1,,172164-84510,, "BUCKET ARM R(GREEN97)",1,1,,,,,,,,,,,,,
56,1,,172164-84550,, "BUCKET LING, 335(97)",1,1,,,,,,,,,,,,,
57,2,,172122-82290,, "SEAL, DUST",6,6,,,,,,,,,,,,,
58,2,,172116-82400,, "PIN BUSH 38X55",2,2,,,,,,,,,,,,,
59,2,,172168-84411,, "BUSH 38-48-33.5",2,2,,,,,,,,,,,,,
60,1,,24761-020000,, "NIPPLE PT1/8, GREASE",2,2,,,,,,,,,,,,,
61,1,,172164-81960,, "PIN KIT, BUCKET ARM",1,1,,,,,,,,,,,,,
62,2,,172164-81830,, "PIN 38X170A",1,1,,,,,,,,,,,,,
63,2,,172164-81850,, "PIN 38X170B",1,1,,,,,,,,,,,,,
64,2,,24761-020000,, "NIPPLE PT1/8, GREASE",1,1,,,,,,,,,,,,,
65,2,,933110-86600,, "NUT M24, NYLON",2,2,,,,,,,,,,,,,
66,2,,933171-29751,, "SHIM SET, 38X(0.8,1.2)",2,2,,,,,,,,,,,,,
67,1,,933171-29760,, WASHER,2,2,,,,,,,,,,,,,

Fig. 97 テレスコピックアーム&バケットリンク
TELESCOPIC ARM & BUCKET LINK

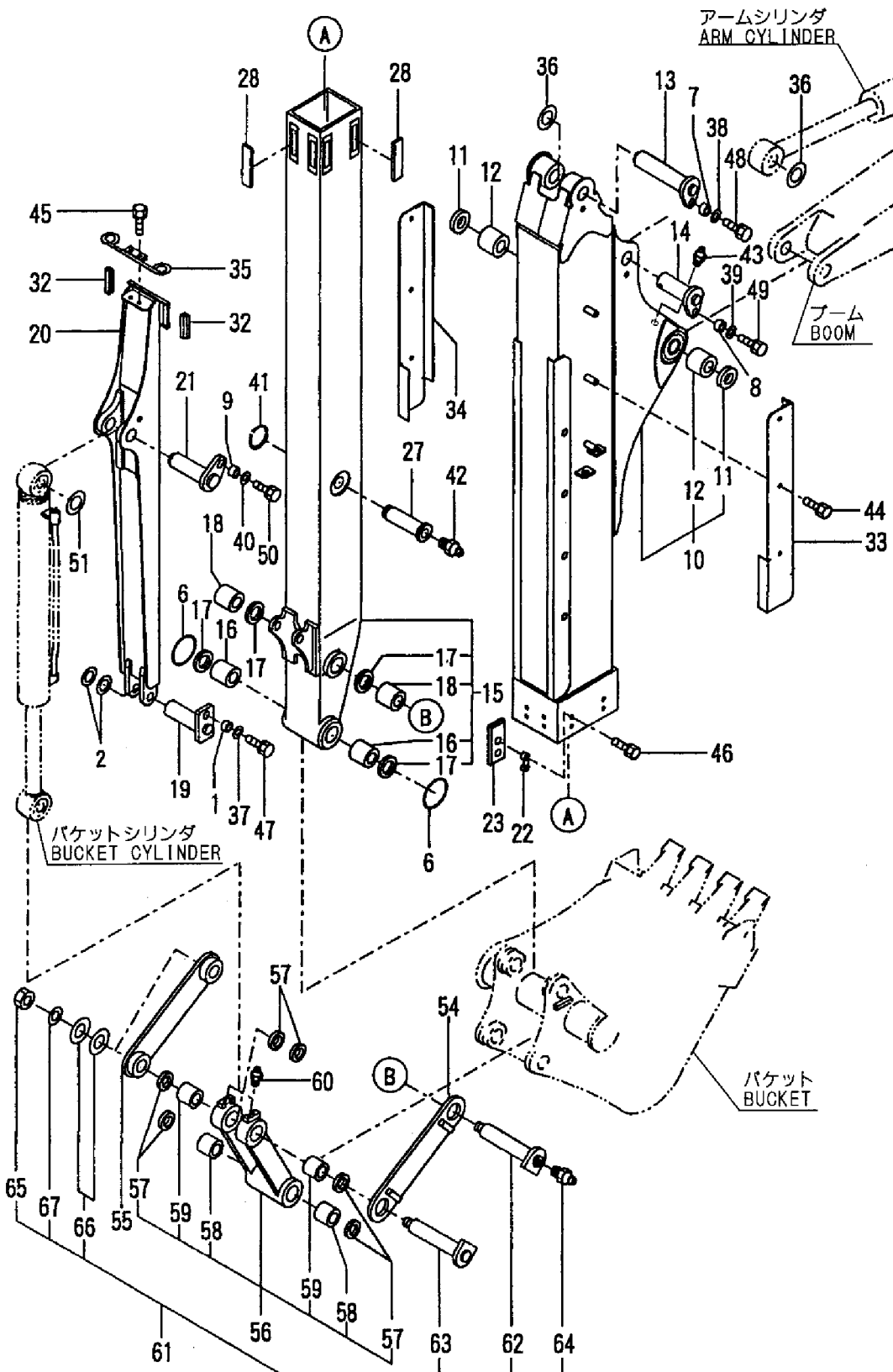

1,1,,172142-86400-4,,BUCKET(640S)(GREEN97,1,1,,,,,3,,,,,
2,2,,172142-86410-4,,BUCKET(640S)(GREEN97,1,1,,,,,3,,,,,
3,2,,172142-86150-4,, "CUTTER(L),SIDE(GREEN",1,1,,,,,3,,,,,
4,2,,172142-86160-4,, "CUTTER(R),SIDE(GREEN",1,1,,,,,3,,,,,
5,2,,172142-86280,, "BOLT M14X 40",6,6,,,,,3,,,,,
6,2,,172142-86290,, "NUT 14",6,6,,,,,3,,,,,
7,2,,22217-140000,, "SPRING WASHER 14",6,6,,,,,3,,,,,
8,2,,772142-86140-4,, "TEETH ASSY (GREEN)",4,4,,,,,3,,,,,
9,3,,172151-81600-4,, "POINT,TOOTH 18S(97)",4,4,,,,,3,,,,,
10,3,,172151-81620,, "PIN ASSY, LOCK",4,4,,,,,3,,,,,
11,4,,172151-81630,, PIN,4,4,,,,,3,,,,,
12,4,,172151-81640,, "LOCK,RUBBER BIN",4,4,,,,,3,,,,,
13,3,,172142-86140,, "ADAPTER 16",4,4,,,,,3,,,,,
14,1,,172164-81950-4,, "PIN KIT,BUCKET(GREEN",2,2,,,,,
15,2,,172164-81630-4,, "PIN 38X229 (GREEN)",2,2,,,,,
16,2,,172164-81700,, COLLAR,2,2,,,,,
17,2,,24761-020000,, "NIPPLE PT1/8,GREASE",2,2,,,,,
18,2,,26116-100652,, "BOLT M10X 65 PLATED",2,2,,,,,
19,2,,26716-100002,, "NUT 10",4,4,,,,,
20,2,,933171-29751,, "SHIM SET,38X(0.8,1.2)",2,2,,,,,
23,1,,772142-81600-
4,, "CUTTER(S),SIDE(GREEN",1,1,,,,,W,1,,M/#01072,,M/#01072,,,,,
24,2,,172142-86510-
4,, "CUTTER(L),SIDE(GREEN",1,1,,,,,W,1,,M/#01072,,M/#01072,,,,,
25,2,,172142-86520-
4,, "CUTTER(R),SIDE(GREEN",1,1,,,,,W,1,,M/#01072,,M/#01072,,,,,
26,2,,172142-86540,, "BOLT M14X 30",6,6,,,,,W,1,,M/#01072,,M/#01072,,,,,
27,2,,22217-140000,, "SPRING WASHER 14",6,6,,,,,W,1,,M/#01072,,M/#01072,,,,,
28,1,,172142-86200-4,, BUCKET(540S)(GREEN97,1,1,,,,,2,,,,,
29,2,,172142-86210-4,, BUCKET(540S)(GREEN97,1,1,,,,,2,,,,,
30,2,,172142-86150-4,, "CUTTER(L),SIDE(GREEN",1,1,,,,,2,,,,,
31,2,,172142-86160-4,, "CUTTER(R),SIDE(GREEN",1,1,,,,,2,,,,,
32,2,,172142-86280,, "BOLT M14X 40",6,6,,,,,2,,,,,
33,2,,172142-86290,, "NUT 14",6,6,,,,,2,,,,,
34,2,,22217-140000,, "SPRING WASHER 14",6,6,,,,,2,,,,,
35,2,,772142-86140-4,, "TEETH ASSY (GREEN)",4,4,,,,,2,,,,,
36,3,,172151-81600-4,, "POINT,TOOTH 18S(97)",4,4,,,,,2,,,,,
37,3,,172151-81620,, "PIN ASSY, LOCK",4,4,,,,,2,,,,,
38,4,,172151-81630,, PIN,4,4,,,,,2,,,,,
39,4,,172151-81640,, "LOCK,RUBBER BIN",4,4,,,,,2,,,,,
40,3,,172142-86140,, "ADAPTER 16",4,4,,,,,2,,,,,
41,1,,172165-86500,, "TOOTH KIT, POINT",1,1,,,,,W,4,,M/#02529,,M/#02529,,,,,
43,2,,172151-81620,, "PIN ASSY, LOCK",1,1,,,,,W,4,,M/#02529,,M/#02529,,,,,

Fig. 98 バケットSタイプ BUCKET S TYPE

バケットSタイプ仕様表
BUCKET S TYPE SPEC. LIST

	340S	490S	540S	590S	640S	690S
標準機 STANDARD	○	○	○	○	○	○
テレスコピックアーム機 TELESCOPIC ARM	○	○	○	○	×	×

1(640S)
28(590S) (テレスコピックアーム仕様)
(TELESCOPIC ARM SPEC.)

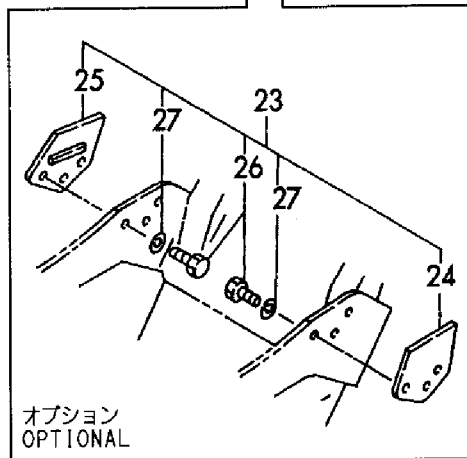
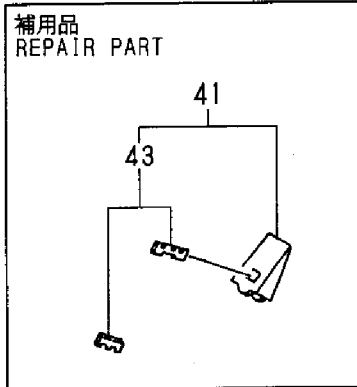
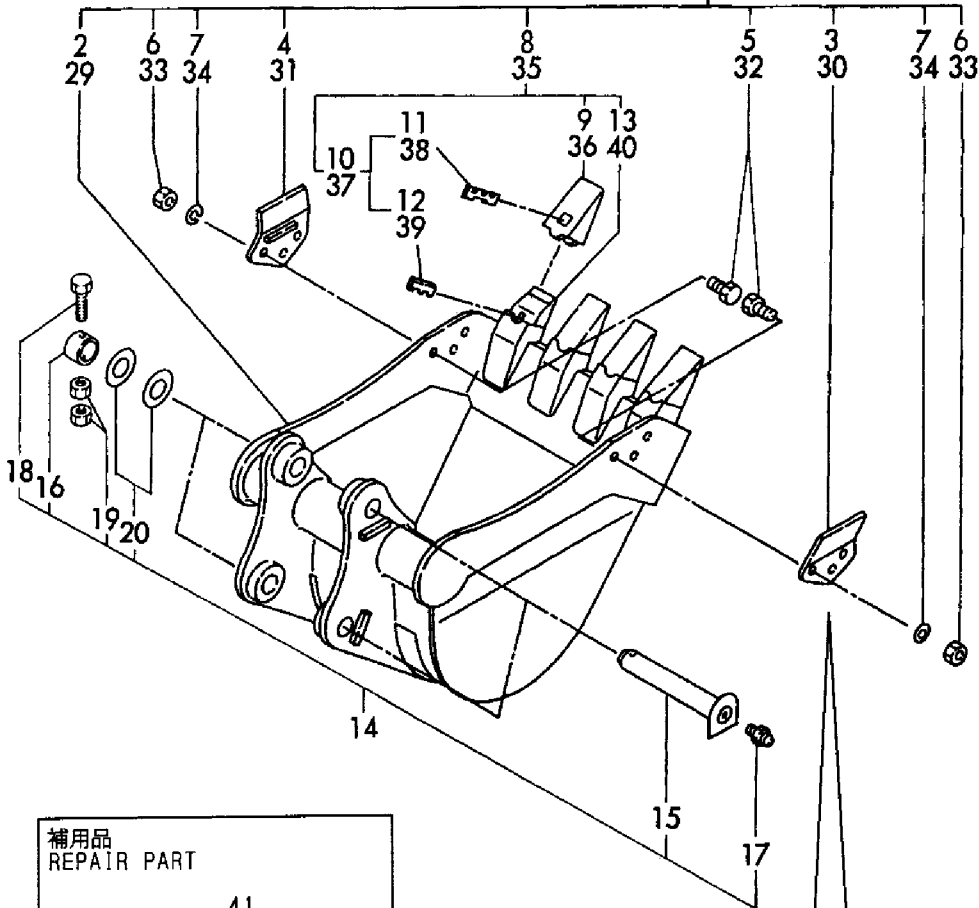

1,1,,172164-81950-4,, "PIN KIT,BUCKET(GREEN",2,2,,,,,,,,,,,,,
2,2,,172164-81630-4,, "PIN 38X229 (GREEN)",2,2,,,,,,,,,,,,,
3,2,,24761-020000,, "NIPPLE PT1/8,GREASE",2,2,,,,,,,,,,,,,
4,2,,172164-81700,, COLLAR,2,2,,,,,,,,,,,,,
5,2,,26116-100652,, "BOLT M10X 65 PLATED",2,2,,,,,,,,,,,,,
6,2,,26716-100002,, "NUT 10",4,4,,,,,,,,,,,,,
6A,2,,933171-29751,, "SHIM SET,38X(0.8,1.2)",2,2,,,,,,,,,,,,,
7,1,,172142-86300-4,, BUCKET(340S)(GREEN97,1,1,,,,,,,,,,,,,
8,2,,172142-86310-4,, BUCKET(340S)(GREEN97,1,1,,,,,,,,,,,,,
9,2,,172142-86150-4,, "CUTTER(L),SIDE(GREEN",2,2,,,,,,,,,,,,,
10,2,,172151-81600-4,, "POINT,TOOTH 18S(97)",2,2,,,,,,,,,,,,,
11,2,,172142-86280,, "BOLT M14X 40",6,6,,,,,,,,,,,,,
12,2,,172142-86290,, "NUT 14",6,6,,,,,,,,,,,,,
13,2,,22217-140000,, "SPRING WASHER 14",6,6,,,,,,,,,,,,,
14,2,,772142-86140-4,, "TEETH ASSY (GREEN)",2,2,,,,,,,,,,,,,
15,3,,172151-81600-4,, "POINT,TOOTH 18S(97)",2,2,,,,,,,,,,,,,
16,3,,172151-81620,, "PIN ASSY, LOCK",2,2,,,,,,,,,,,,,
17,4,,172151-81630,, PIN,2,2,,,,,,,,,,,,,
18,4,,172151-81640,, "LOCK,RUBBER BIN",2,2,,,,,,,,,,,,,
19,3,,172142-86140,, "ADAPTER 16",2,2,,,,,,,,,,,,,
20,1,,172142-86100-4,, BUCKET(490S)(GREEN97,1,1,,,,,,,,,,,,,
20-1,1,,172142-86101-
4,, BUCKET(490S)(GREEN97,1,1,,,,,N,,M/#00943,,M/#00943,,,,,
21,2,,172142-86110-4,, BUCKET(490S)(GREEN97,1,1,,,,,,,,,,,,,
21-1,2,,172142-86111-
4,, BUCKET(490S)(GREEN97,1,1,,,,,N,,M/#00943,,M/#00943,,,,,
22,2,,172142-86150-4,, "CUTTER(L),SIDE(GREEN",1,1,,,,,,,,,,,,,
23,2,,172142-86160-4,, "CUTTER(R),SIDE(GREEN",1,1,,,,,,,,,,,,,
24,2,,172142-86280,, "BOLT M14X 40",6,6,,,,,,,,,,,,,
25,2,,172142-86290,, "NUT 14",6,6,,,,,,,,,,,,,
26,2,,22217-140000,, "SPRING WASHER 14",6,6,,,,,,,,,,,,,
27,2,,772142-86140-4,, "TEETH ASSY (GREEN)",4,4,,,,,,,,,,,,,
27-1,2,,772142-86140-4,, "TEETH ASSY
(GREEN)",3,3,,,,,K,,M/#00943,,M/#00943,,,,,
28,3,,172151-81600-4,, "POINT,TOOTH 18S(97)",4,4,,,,,,,,,,,,,
28-1,3,,172151-81600-4,, "POINT,TOOTH
18S(97)",3,3,,,,,K,,M/#00943,,M/#00943,,,,,
29,3,,172151-81620,, "PIN ASSY, LOCK",4,4,,,,,,,,,,,,,
29-1,3,,172151-81620,, "PIN ASSY, LOCK",3,3,,,,,K,,M/#00943,,M/#00943,,,,,
30,4,,172151-81630,, PIN,4,4,,,,,,,,,,,,,
30-1,4,,172151-81630,, PIN,3,3,,,,,K,,M/#00943,,M/#00943,,,,,
31,4,,172151-81640,, "LOCK,RUBBER BIN",4,4,,,,,,,,,,,,,
31-1,4,,172151-81640,, "LOCK,RUBBER BIN",3,3,,,,,K,,M/#00943,,M/#00943,,,,,
32,3,,172142-86140,, "ADAPTER 16",4,4,,,,,,,,,,,,,
32-1,3,,172142-86140,, "ADAPTER 16",3,3,,,,,K,,M/#00943,,M/#00943,,,,,
33,1,,172142-86200-4,, BUCKET(540S)(GREEN97,1,1,,,,,,,,,,,,,
34,2,,172142-86210-4,, BUCKET(540S)(GREEN97,1,1,,,,,,,,,,,,,
35,2,,172142-86150-4,, "CUTTER(L),SIDE(GREEN",1,1,,,,,,,,,,,,,
36,2,,172142-86160-4,, "CUTTER(R),SIDE(GREEN",1,1,,,,,,,,,,,,,
37,2,,172142-86280,, "BOLT M14X 40",6,6,,,,,,,,,,,,,
38,2,,172142-86290,, "NUT 14",6,6,,,,,,,,,,,,,
39,2,,22217-140000,, "SPRING WASHER 14",6,6,,,,,,,,,,,,,
40,2,,772142-86140-4,, "TEETH ASSY (GREEN)",4,4,,,,,,,,,,,,,
41,3,,172151-81600-4,, "POINT,TOOTH 18S(97)",4,4,,,,,,,,,,,,,
42,3,,172151-81620,, "PIN ASSY, LOCK",4,4,,,,,,,,,,,,,
43,4,,172151-81630,, PIN,4,4,,,,,,,,,,,,,
44,4,,172151-81640,, "LOCK,RUBBER BIN",4,4,,,,,,,,,,,,,
45,3,,172142-86140,, "ADAPTER 16",4,4,,,,,,,,,,,,,
46,1,,172142-86350-4,, BUCKET(590S)(GREEN97,1,1,,,,,,,,,,,,,
47,2,,172142-86360-4,, BUCKET(590S)(GREEN97,1,1,,,,,,,,,,,,,
48,2,,172142-86150-4,, "CUTTER(L),SIDE(GREEN",1,1,,,,,,,,,,,,,
49,2,,172142-86160-4,, "CUTTER(R),SIDE(GREEN",1,1,,,,,,,,,,,,,
50,2,,172142-86280,, "BOLT M14X 40",6,6,,,,,,,,,,,,,

51,2,,172142-86290,, "NUT 14",6,6,,,,,,,,,,,,,
52,2,,22217-140000,, "SPRING WASHER 14",6,6,,,,,,,,,,,,,
53,2,,772142-86140-4,, "TEETH ASSY (GREEN)",4,4,,,,,,,,,,,,,
54,3,,172151-81600-4,, "POINT,TOOTH 18S(97)",4,4,,,,,,,,,,,,,
55,3,,172151-81620,, "PIN ASSY, LOCK",4,4,,,,,,,,,,,,,
56,4,,172151-81630,, PIN,4,4,,,,,,,,,,,,,
57,4,,172151-81640,, "LOCK,RUBBER BIN",4,4,,,,,,,,,,,,,
58,3,,172142-86140,, "ADAPTER 16",4,4,,,,,,,,,,,,,
59,1,,172164-81900-4,, BUCKET(690S)(GREEN97,1,1,,,,,2,,,,,
60,2,,172164-81910-4,, BUCKET(690S)(GREEN97,1,1,,,,,2,,,,,
61,2,,172142-86150-4,, "CUTTER(L),SIDE(GREEN",1,1,,,,,2,,,,,
62,2,,172142-86160-4,, "CUTTER(R),SIDE(GREEN",1,1,,,,,2,,,,,
63,2,,172142-86280,, "BOLT M14X 40",6,6,,,,,2,,,,,
64,2,,172142-86290,, "NUT 14",6,6,,,,,2,,,,,
65,2,,22217-140000,, "SPRING WASHER 14",6,6,,,,,2,,,,,
66,2,,772142-86140-4,, "TEETH ASSY (GREEN)",5,5,,,,,2,,,,,
67,3,,172151-81600-4,, "POINT,TOOTH 18S(97)",5,5,,,,,2,,,,,
68,3,,172151-81620,, "PIN ASSY, LOCK",5,5,,,,,2,,,,,
69,4,,172151-81630,, PIN,5,5,,,,,2,,,,,
70,4,,172151-81640,, "LOCK,RUBBER BIN",5,5,,,,,2,,,,,
71,3,,172142-86140,, "ADAPTER 16",5,5,,,,,2,,,,,
72,1,,772142-81600-
4,, "CUTTER(S),SIDE(GREEN",1,1,,,,,W,1,,M/#01072,,M/#01072,,,,,
73,2,,172142-86510-
4,, "CUTTER(L),SIDE(GREEN",1,1,,,,,W,1,,M/#01072,,M/#01072,,,,,
74,2,,172142-86520-
4,, "CUTTER(R),SIDE(GREEN",1,1,,,,,W,1,,M/#01072,,M/#01072,,,,,
75,2,,172142-86540,, "BOLT M14X 30",6,6,,,,,W,1,,M/#01072,,M/#01072,,,,,
76,2,,22217-140000,, "SPRING WASHER 14",6,6,,,,,W,1,,M/#01072,,M/#01072,,,,,
77,1,,172165-86500,, "TOOTH KIT, POINT",1,1,,,,,W,3,,M/#02529,,M/#02529,,,,,
79,2,,172151-81620,, "PIN ASSY, LOCK",1,1,,,,,W,3,,M/#02529,,M/#02529,,,,,

Fig. 99 バケットSタイプ (アタッチメント) BUCKET S TYPE (ATTACHMENT)

バケットSタイプ仕様表
BUCKET S TYPE SPEC. LIST

	340S	490S	540S	590S	640S	690S
標準機 STANDARD	○	○	○	○	○	○
テレスコピックアーム機 TELESCOPIC ARM	○	○	○	○	×	×

7 (3 4 0 S)
20 (4 9 0 S)
33 (5 4 0 S)
46 (5 9 0 S)
59 (6 9 0 S)

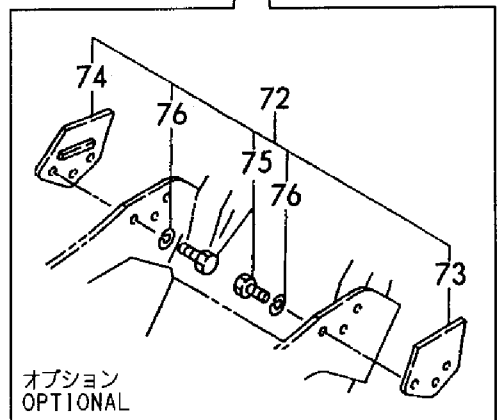
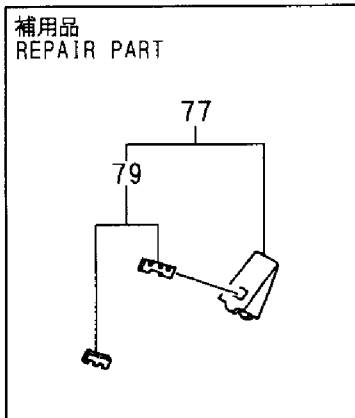
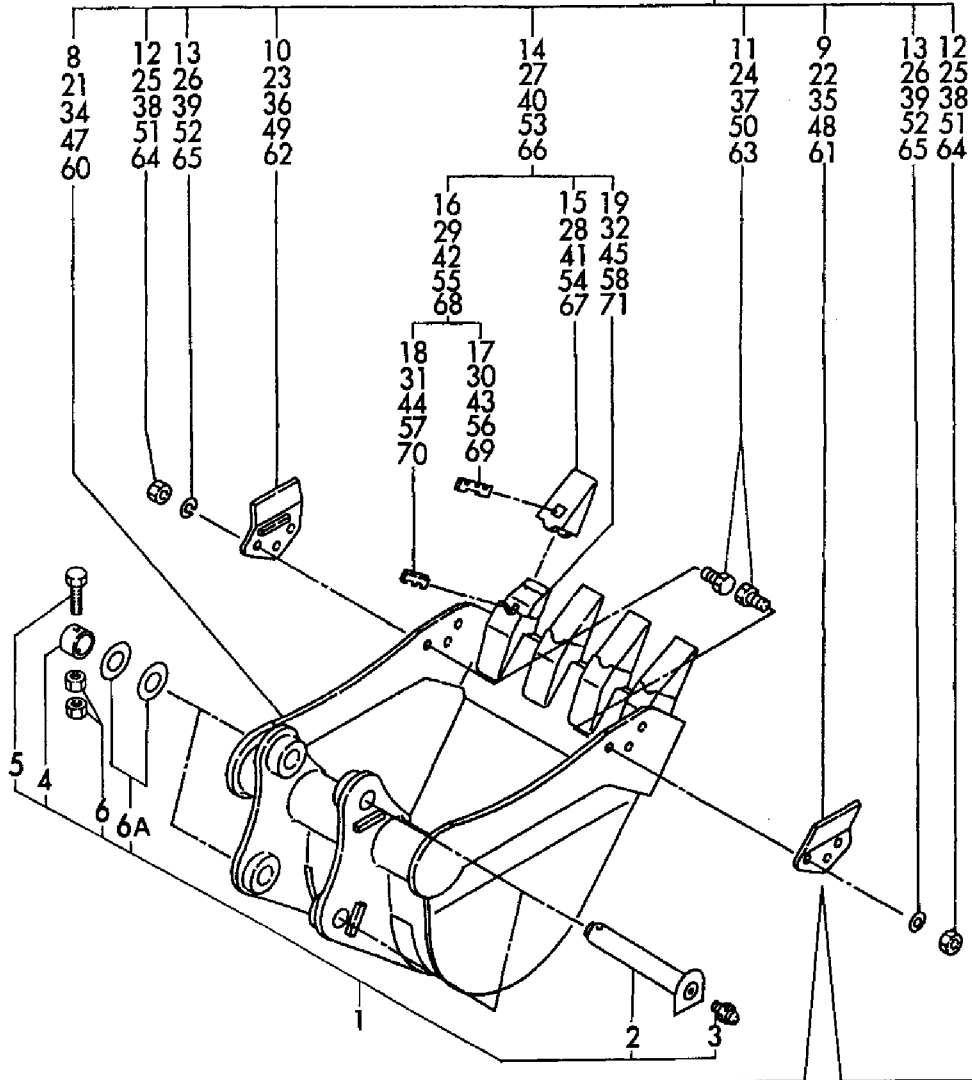

1,1,,772122-81402-4,, "BUCKET ASSY 490",1,1,,,,,,,,,,,,,,,,,
3,2,,172142-86150-4,, "CUTTER(L),SIDE(GREEN",1,1,,,,,,,,,,,,,,,,,
4,2,,172142-86160-4,, "CUTTER(R),SIDE(GREEN",1,1,,,,,,,,,,,,,,,,,
5,2,,172142-86280,, "BOLT M14X 40",6,6,,,,,,,,,,,,,,,,,
6,2,,172142-86290,, "NUT 14",6,6,,,,,,,,,,,,,,,,,
7,2,,22217-140000,, "SPRING WASHER 14",6,6,,,,,,,,,,,,,,,,,
8,2,,772122-86123-4,, "TEETH ASSY (GREEN)",4,4,,,,,,,,,,,,,,,,,
9,3,,172142-81380,, BOLT,8,8,,,,,,,,,,,,,,,,,
10,3,,172142-81390,, NUT,8,8,,,,,,,,,,,,,,,,,
11,3,,172113-86123-4,, "TEETH (GREEN)",4,4,,,,,,,,,,,,,,,,,
12,3,,172137-86710,, "TEETH SHIM 17 SET",4,4,,,,,,,,,,,,,,,,,
16,1,,172164-81950-4,, "PIN KIT,BUCKET(GREEN",2,2,,,,,,,,,,,,,,,,,
17,2,,24761-020000,, "NIPPLE PT1/8,GREASE",2,2,,,,,,,,,,,,,,,,,
18,2,,172164-81630-4,, "PIN 38X229 (GREEN)",2,2,,,,,,,,,,,,,,,,,
19,2,,172164-81700,, COLLAR,2,2,,,,,,,,,,,,,,,,,
20,2,,26116-100652,, "BOLT M10X 65 PLATED",2,2,,,,,,,,,,,,,,,,,
21,2,,26716-100002,, "NUT 10",4,4,,,,,,,,,,,,,,,,,
21A,2,,933171-29751,, "SHIM SET,38X(0.8,1.2",2,2,,,,,,,,,,,,,,,,,
22,1,,772122-81422-4,, "BUCKET ASSY 340",1,1,,,,,,,,,,,,,,,,,
24,2,,172142-86150-4,, "CUTTER(L),SIDE(GREEN",1,1,,,,,,,,,,,,,,,,,
25,2,,172142-86160-4,, "CUTTER(R),SIDE(GREEN",1,1,,,,,,,,,,,,,,,,,
26,2,,172142-86280,, "BOLT M14X 40",6,6,,,,,,,,,,,,,,,,,
27,2,,172142-86290,, "NUT 14",6,6,,,,,,,,,,,,,,,,,
28,2,,22217-140000,, "SPRING WASHER 14",6,6,,,,,,,,,,,,,,,,,
29,2,,772122-86123-4,, "TEETH ASSY (GREEN)",2,2,,,,,,,,,,,,,,,,,
30,3,,172142-81380,, BOLT,4,4,,,,,,,,,,,,,,,,,
31,3,,172142-81390,, NUT,4,4,,,,,,,,,,,,,,,,,
32,3,,172113-86123-4,, "TEETH (GREEN)",2,2,,,,,,,,,,,,,,,,,
33,3,,172137-86710,, "TEETH SHIM 17 SET",2,2,,,,,,,,,,,,,,,,,
37,1,,772122-81412-4,, "BUCKET ASSY 540",1,1,,,,,,,,,,,,,,,,,
39,2,,172142-86150-4,, "CUTTER(L),SIDE(GREEN",1,1,,,,,,,,,,,,,,,,,
40,2,,172142-86160-4,, "CUTTER(R),SIDE(GREEN",1,1,,,,,,,,,,,,,,,,,
41,2,,172142-86280,, "BOLT M14X 40",6,6,,,,,,,,,,,,,,,,,
42,2,,172142-86290,, "NUT 14",6,6,,,,,,,,,,,,,,,,,
43,2,,22217-140000,, "SPRING WASHER 14",6,6,,,,,,,,,,,,,,,,,
44,2,,772122-86123-4,, "TEETH ASSY (GREEN)",4,4,,,,,,,,,,,,,,,,,
45,3,,172142-81380,, BOLT,8,8,,,,,,,,,,,,,,,,,
46,3,,172142-81390,, NUT,8,8,,,,,,,,,,,,,,,,,
47,3,,172113-86123-4,, "TEETH (GREEN)",4,4,,,,,,,,,,,,,,,,,
48,3,,172137-86710,, "TEETH SHIM 17 SET",4,4,,,,,,,,,,,,,,,,,
52,1,,772122-81432-4,, "BUCKET ASSY 590",1,1,,,,,,,,,,,,,,,,,
54,2,,172142-86150-4,, "CUTTER(L),SIDE(GREEN",1,1,,,,,,,,,,,,,,,,,
55,2,,172142-86160-4,, "CUTTER(R),SIDE(GREEN",1,1,,,,,,,,,,,,,,,,,
56,2,,172142-86280,, "BOLT M14X 40",6,6,,,,,,,,,,,,,,,,,
57,2,,172142-86290,, "NUT 14",6,6,,,,,,,,,,,,,,,,,
58,2,,22217-140000,, "SPRING WASHER 14",6,6,,,,,,,,,,,,,,,,,
59,2,,772122-86123-4,, "TEETH ASSY (GREEN)",4,4,,,,,,,,,,,,,,,,,
60,3,,172142-81380,, BOLT,8,8,,,,,,,,,,,,,,,,,
61,3,,172142-81390,, NUT,8,8,,,,,,,,,,,,,,,,,
62,3,,172113-86123-4,, "TEETH (GREEN)",4,4,,,,,,,,,,,,,,,,,
63,3,,172137-86710,, "TEETH SHIM 17 SET",4,4,,,,,,,,,,,,,,,,,
67,1,,772122-81442-4,, "BUCKET ASSY 640",1,1,,,,,2,,,,,,,,,,,,,
69,2,,172142-86150-4,, "CUTTER(L),SIDE(GREEN",1,1,,,,,2,,,,,,,,,,,,,
70,2,,172142-86160-4,, "CUTTER(R),SIDE(GREEN",1,1,,,,,2,,,,,,,,,,,,,
71,2,,172142-86280,, "BOLT M14X 40",6,6,,,,,2,,,,,,,,,,,,,
72,2,,172142-86290,, "NUT 14",6,6,,,,,2,,,,,,,,,,,,,
73,2,,22217-140000,, "SPRING WASHER 14",6,6,,,,,2,,,,,,,,,,,,,
74,2,,772122-86123-4,, "TEETH ASSY (GREEN)",4,4,,,,,2,,,,,,,,,,,,,
75,3,,172142-81380,, BOLT,8,8,,,,,2,,,,,,,,,,,,,
76,3,,172142-81390,, NUT,8,8,,,,,2,,,,,,,,,,,,,
77,3,,172113-86123-4,, "TEETH (GREEN)",4,4,,,,,2,,,,,,,,,,,,,
78,3,,172137-86710,, "TEETH SHIM 17 SET",4,4,,,,,2,,,,,,,,,,,,,
82,1,,772312-81402-4,, "BUCKET ASSY 690",1,1,,,,,2,,,,,,,,,,,,,

84,2,,172142-86150-4,, "CUTTER(L),SIDE(GREEN",1,1,,,,,2,,,,,
85,2,,172142-86160-4,, "CUTTER(R),SIDE(GREEN",1,1,,,,,2,,,,,
86,2,,172142-86280,, "BOLT M14X 40",6,6,,,,,2,,,,,
87,2,,172142-86290,, "NUT 14",6,6,,,,,2,,,,,
88,2,,22217-140000,, "SPRING WASHER 14",6,6,,,,,2,,,,,
89,2,,772122-86123-4,, "TEETH ASSY (GREEN)",4,4,,,,,2,,,,,
90,3,,172142-81380,,BOLT,10,10,,,,,2,,,,,
91,3,,172142-81390,,NUT,10,10,,,,,2,,,,,
92,3,,172113-86123-4,, "TEETH (GREEN)",5,5,,,,,2,,,,,
93,3,,172137-86710,, "TEETH SHIM 17 SET",5,5,,,,,2,,,,,
97,1,,772142-81600-
4,, "CUTTER(S),SIDE(GREEN",1,1,,,,,W,1,,M/#01072,,M/#01072,,,,,
98,2,,172142-86510-
4,, "CUTTER(L),SIDE(GREEN",1,1,,,,,W,1,,M/#01072,,M/#01072,,,,,
99,2,,172142-86520-
4,, "CUTTER(R),SIDE(GREEN",1,1,,,,,W,1,,M/#01072,,M/#01072,,,,,
100,2,,172142-86540,, "BOLT M14X 30",6,6,,,,,W,1,,M/#01072,,M/#01072,,,,,
101,2,,22217-140000,, "SPRING WASHER 14",6,6,,,,,W,1,,M/#01072,,M/#01072,,,,,

Fig. 100 バケット (アタッチメント) BUCKET (ATTACHMENT)

バケット仕様表
BUCKET SPEC. LIST

	340	490	540	590	640	690
標準機 STANDARD	○	○	○	○	○	○
テレスコピックアーム機 TELESCOPIC ARM	○	○	○	○	×	×

1 (490)
22 (340)
37 (540)
52 (590)
67 (640)
82 (690)

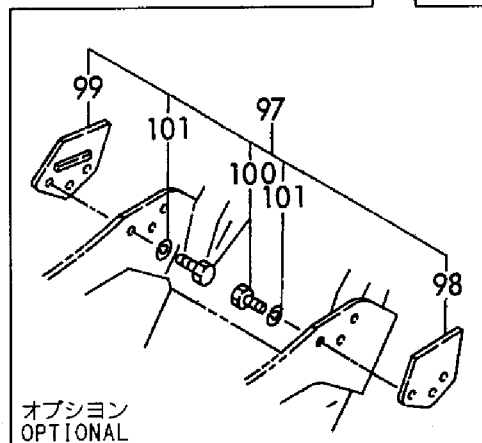
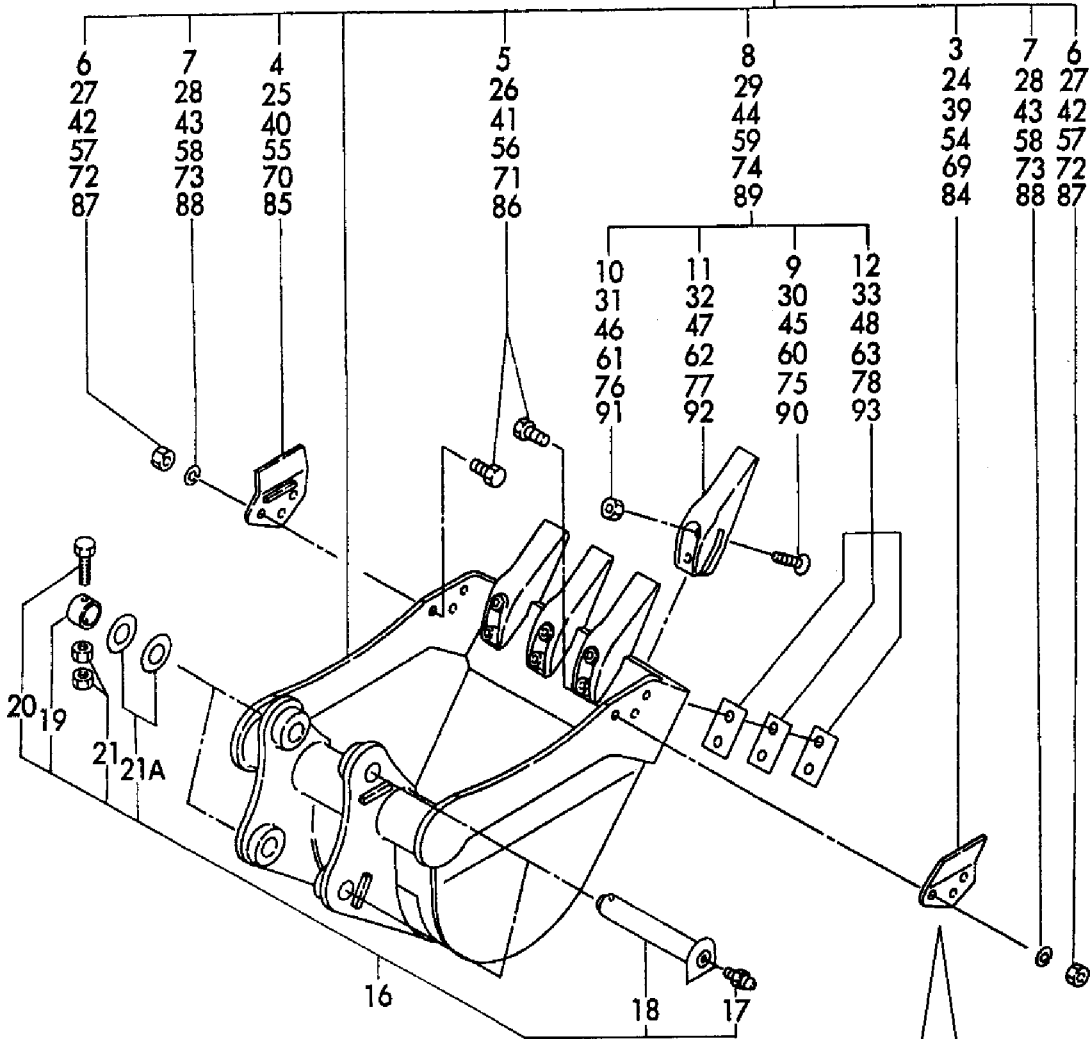

1,1,,172164-81650,, "PIN ASSY 45X122",2,2,,,,,,,,,,,,,,,,,,,,,
2,1,,172164-81670,, SPACER,2,2,,,,,,,,,,,,,,,,,,,,,
3,1,,172112-87840,, "SHIM 45X1",4,4,,,,,,,,,,,,,,,,,,,,,
4,1,,172151-94103-1,, "BLADE ASSY",1,1,,,,,,,,,,,,,,,,,,,,,
5,2,,172168-81410,, "SEAL 45X55X4, DUST",4,4,,,,,,,,,,,,,,,,,,,,,
6,1,,172124-94300,, "PIN 45-157, BLADE",2,2,,,,,,,,,,,,,,,,,,,,,
7,1,,172124-94310,, "PLATE, LOCK",2,2,,,,,,,,,,,,,,,,,,,,,
8,1,,22157-120000,, "WASHER 12",2,2,,,,,,,,,,,,,,,,,,,,,
9,1,,24761-020000,, "NIPPLE PT1/8,GREASE",2,2,,,,,,,,,,,,,,,,,,,,,
10,1,,24761-040000,, "NIPPLE B,GREASE",2,2,,,,,,,,,,,,,,,,,,,,,
11,1,,26013-100252,, "BOLT W/WASHER M10X25",4,4,,,,,,,,,,,,,,,,,,,,,
12,1,,26013-120302,, "BOLT W/WASHER M12X30",2,2,,,,,,,,,,,,,,,,,,,,,

Fig. 101 ブレード
BLADE

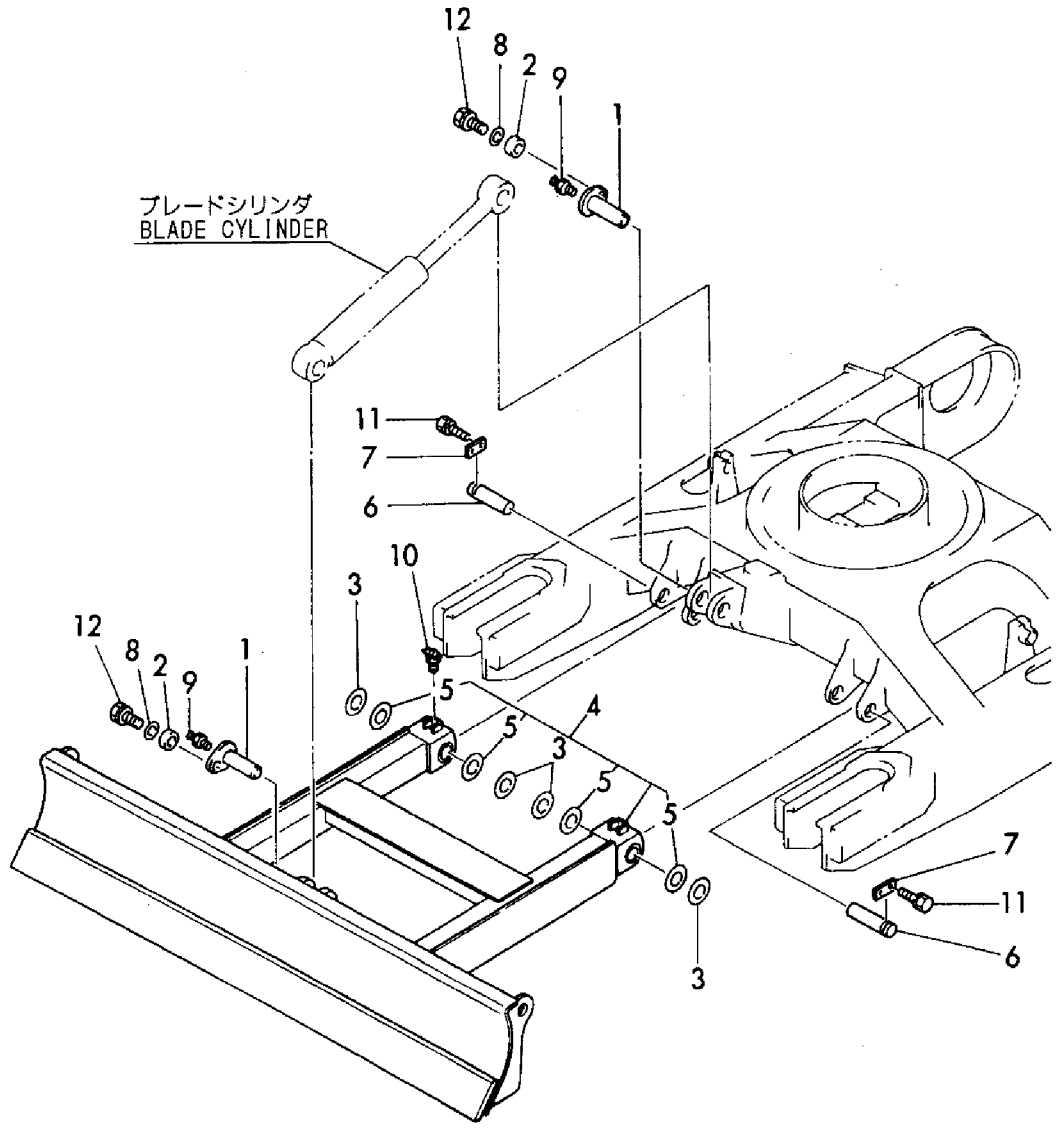

1,1,,172964-03610,, "LABEL A",1,1,,,,,,,,,,,,,
2,1,,172164-03500,, LABEL,1,1,,,,,,,,,,,,,
3,1,,172164-03540,, LABEL,1,1,,,,,,,,,,,,,
4,1,,172964-03370,, LABEL,1,1,,,,,,,,,,,,,
5,1,,172164-03510,, LABEL,1,1,,,,,,,,,,,,,
6,1,,172164-03520,, "LABEL,DANGER",1,1,,,,,,,,,,,,,
7,1,,172964-03390,, "LABEL,WARNING",1,1,,,,,,,,,,,,,
8,1,,172519-04180,, "LABEL,WARNING",1,1,,,,,,,,,,,,,
9,1,,172519-04290,, "LABEL,WARNING",1,1,,,,,,,,,,,,,
10,1,,172519-04300,, LABEL,1,1,,,,,,,,,,,,,
11,1,,172164-03560,, LABEL,1,1,,,,,,,,,,,,,
12,1,,172165-03661,, "LABEL,DANGER",1,1,,,,,,,,,,,,,
13,1,,172142-03302,, "LABEL,CAUTION",1,1,,,,,,,,,,,,,
14,1,,172141-03202,, "LABEL,CAUTION",1,1,,,,,,,,,,,,,
15,1,,172164-03530,, "LABEL,WARNING",2,2,,,,,,,,,,,,,
16,1,,172162-03241,, LABEL,1,,,,,,,,,,,,,
17,1,,172164-03550,, LABEL,1,1,,,,,,,,,,,,,
18,1,,172964-03480,, LABEL,1,1,,,,,,,,,,,,,
18-1,1,,172964-03481,, LABEL,1,1,,,,,N,,M/#01499,,M/#01499,,,,,,

Fig. 102 安全銘板 (JP) SAFETY LABEL (JP)

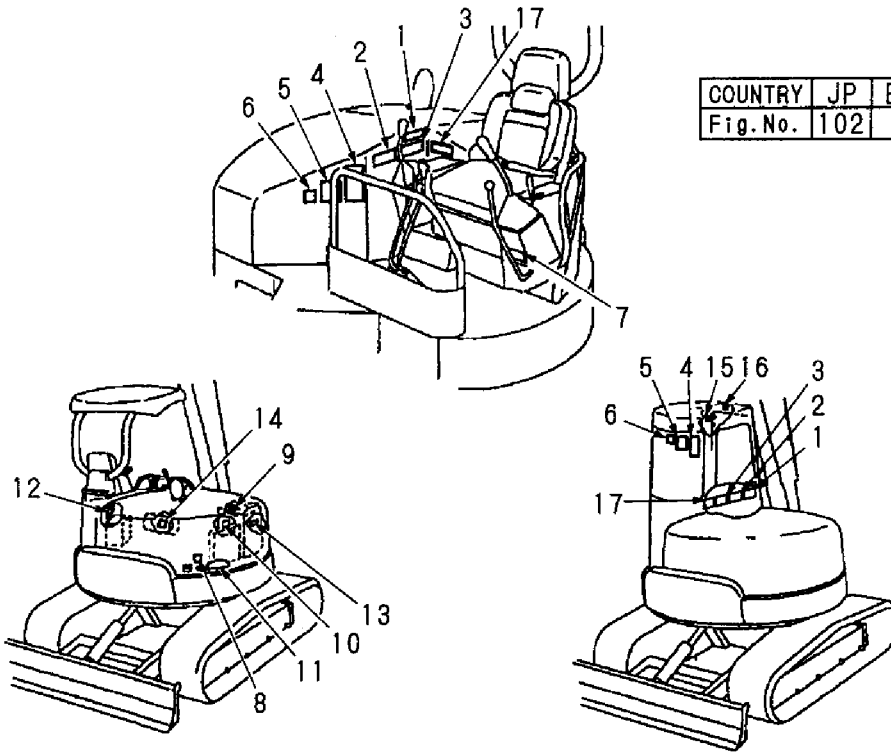

COUNTRY	JP	EX	EP
Fig.No.	102	-	103

安全銘板の貼付け位置は、取扱説明書をご参照下さい。

1 **警告**
OPERATOR MUST WEAR SEAT BELT AND FASTEN IT BEFORE STARTING ENGINE. DO NOT OPERATE WITH SEAT BELT UNFASTENED.

2 **警告**
エンジンが停止するまで、キャップをはずさないでください。エンジンが停止するまで、キャップをはずさないでください。

3 **警告**
エンジンが停止するまで、キャップをはずさないでください。エンジンが停止するまで、キャップをはずさないでください。

4 **警告**
エンジンが停止するまで、キャップをはずさないでください。エンジンが停止するまで、キャップをはずさないでください。

5 **警告**
エンジンが停止するまで、キャップをはずさないでください。エンジンが停止するまで、キャップをはずさないでください。

6 **注意**
エンジンが停止するまで、キャップをはずさないでください。エンジンが停止するまで、キャップをはずさないでください。

7 **警告**
エンジンが停止するまで、キャップをはずさないでください。エンジンが停止するまで、キャップをはずさないでください。

8 **警告**
エンジンが停止するまで、キャップをはずさないでください。エンジンが停止するまで、キャップをはずさないでください。

9 **警告**
作業油タンクの給油口を開ける際は必ずエンジンを停止してください。作業油タンクに高圧油が漏れ出す危険があります。作業油タンクに高圧油が漏れ出す危険があります。

10 **警告**
作業油タンクの給油口を開ける際は必ずエンジンを停止してください。作業油タンクに高圧油が漏れ出す危険があります。作業油タンクに高圧油が漏れ出す危険があります。

11 **危険**
取込内 立入禁止

12 **注意**
エンジンが停止するまで、キャップをはずさないでください。エンジンが停止するまで、キャップをはずさないでください。

13 **注意**
作業油タンクの給油口を開ける際は必ずエンジンを停止してください。作業油タンクに高圧油が漏れ出す危険があります。作業油タンクに高圧油が漏れ出す危険があります。

14 **注意**
エンジンが停止するまで、キャップをはずさないでください。エンジンが停止するまで、キャップをはずさないでください。

15 **警告**
エンジンを始動するときは、両側のロックピンで確実にロックしてください。エンジンを始動するときは、両側のロックピンで確実にロックしてください。

16 **注意**
ワイパー使用時は、ワイパーブレードをストッパーからはずさないでください。ワイパーブレードをストッパーからはずさないでください。

17 **警告**
エンジンを始動するときは、両側のロックピンで確実にロックしてください。エンジンを始動するときは、両側のロックピンで確実にロックしてください。

18 **危険**
取込収納庫内在中 IN THE OPERATION MANUAL CASE

```
1,1,,172187-03600,,LABEL,1,,,,,,,,,,,,,  
2,1,,172187-03610,,LABEL,1,,,,,,,,,,,,,  
3,1,,172187-03620,,LABEL,2,,,,,,,,,,,,,  
4,1,,172171-03420,,LABEL,1,,,,,,,,,,,,,
```

Fig. 103 安全銘板 (EP)
SAFETY LABEL (EP)

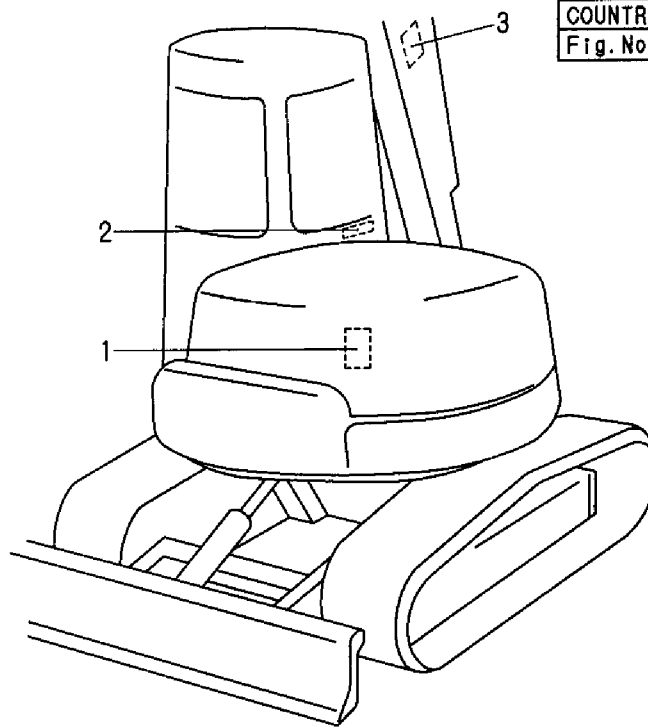

COUNTRY	JP	EX	EP
Fig. No.	102	-	103

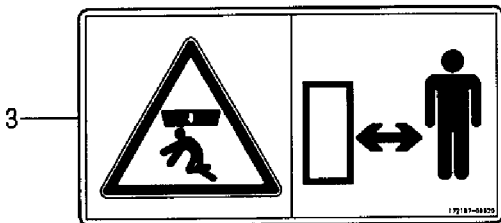
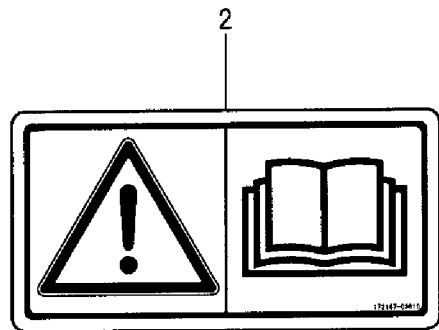
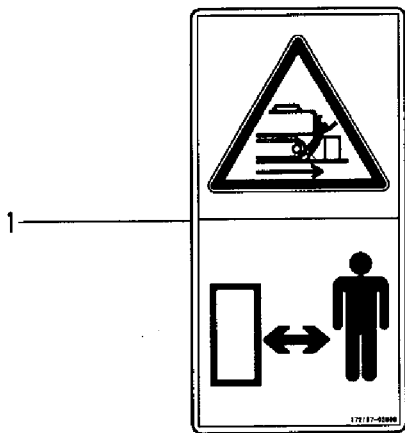

取説収納庫内在中
IN THE OPERATION
MANUAL CASE

1,1,,172164-08500,, "P.T.O. KIT",1,1,,,,,1,,,,,
1-1,1,,172164-08501,, "P.T.O. KIT",1,1,,,,,S,1,,M/#01628,,M/#01628,,,,,
1-2,1,,172164-08502,, "P.T.O KIT",1,1,,,,,S,1,,M/#01693,,M/#01693,,,,,
2,2,,172164-74500,, "P.T.O.KIT, FRAME END",1,1,,,,,2,,,,,
3,2,,172164-74510,, "P.T.O.KIT, ARM END",1,1,,,,,3,,,,,
3-1,2,,172164-74511,, "P.T.O. KIT(ARM END)",1,1,,,,,S,3,,M/#01628,,M/#01628,,,,,
3-2,2,,172164-74512,, "P.T.O.KIT,ARM END",1,1,,,,,S,3,,M/#01693,,M/#01693,,,,,
4,2,,172164-74521,, "P.T.O.KIT, JOIN",1,1,,,,,4,,,,,

Fig. 104 PTOキット P.T.O.KIT

- PTOキット
P.T.O.KIT
- 1 (172164-08500)
 - inc. Fig. 32 REF. No. 1
 - Fig. 86 REF. No. 1
 - Fig. 34 REF. No. 1-1
 - 1-1 (172164-08501)
 - inc. Fig. 32 REF. No. 1
 - Fig. 86 REF. No. 1-1
 - Fig. 34 REF. No. 1-1
 - 1-2 (172164-08502)
 - inc. Fig. 32 REF. No. 1
 - Fig. 86 REF. No. 1-2
 - Fig. 34 REF. No. 1-1

PTOキット (フレームエンド)
P.T.O.KIT (FRAME END)

2 (172164-74500)
inc. Fig. 32 REF. No. 2 ~ 52

Fig. 82 操縦装置 (PTOコントロール)
CONTROL EQUIP. (P.T.O. CONTROL)

PTOキット (アームエンド)
P.T.O.KIT (ARM END)

3 (172164-74510)
inc. Fig. 86 REF. No. 2 ~ 25

3-1 (172164-74511)
inc. Fig. 86 REF. No. 2-2 ~ 29

3-2 (172164-74512)
inc. Fig. 86 REF. No. 2-2 ~ 29

Fig. 88 油圧配管 (PTO/バルブ、フレーム)
HYD. OIL PIPING (P.T.O. VALVE, FRAME)

PTOキット (合流)
P.T.O.KIT (CONFLUENCE)

4 (172164-74521)
inc. Fig. 34 REF. No. 2 ~ 33
inc. Fig. 70 REF. No. 1 ~ 39
inc. Fig. 83 REF. No. 1 ~ 29

Fig. 84 PTOコントロール
P.T.O. CONTROL

Fig. 70 PTO/バルブ
P.T.O. VALVE

Fig. 83 油圧配管 (PTO/バルブ、フレーム)
HYD. OIL PIPING (P.T.O. VALVE, FRAME)

[Info]

PcNo=Y00K2892

PcName=VIO40(B4972)

JpnUse=1

JpnSec1=Ēš<@

JpnSec2=fofbfNfz [

JpnSec3=VIO

JpnPreface=1

EngUse=1

EngSec1=CONSTRUCTION

EngSec2=EXCAVATOR (ViO)

EngSec3=VIO

EngPreface=1