

## PREFACE

This manual covers service procedures for the HONDA BF75 and BF100 Outboard Motors, serial numbers 1000004 and subsequent.

ALL INFORMATION, ILLUSTRATIONS, DIRECTIONS AND SPECIFICATIONS INCLUDED IN THIS PUBLICATION ARE BASED ON THE LATEST PRODUCT INFORMATION AVAILABLE AT THE TIME OF APPROVAL FOR PRINTING. HONDA MOTOR CO., LTD. RESERVES THE RIGHT TO MAKE CHANGES WITHOUT INCURRING ANY OBLIGATION WHATEVER. NO PART OF THIS PUBLICATION MAY BE REPRODUCED WITHOUT WRITTEN PERMISSION.

HONDA MOTOR CO., LTD.  
SERVICE PUBLICATIONS OFFICE

SPECIFICATIONS	1
SERVICE INFORMATION	2
MAINTENANCE	3
DISASSEMBLY AND SERVICE	4
CONSTRUCTION AND FUNCTION	5
SUPPLEMENT BF 75 · BF 100	6
SUPPLEMENT BF 8A	7
SHOP MANUAL NEWS	

---

## CONTENTS

I. SPECIFICATIONS .....	3	IV. DISASSEMBLY AND SERVICE .....	30
1. SPECIFICATIONS .....	3	1. DISASSEMBLY CHART .....	30
2. DIMENSIONAL DRAWINGS .....	4	2. RECOIL STARTER .....	31
II. SERVICE INFORMATION .....	5	3. CARBURETOR/FUEL PUMP .....	34
1. GENERAL SAFETY .....	5	4. ELECTRICAL .....	38
2. SERVICE RULES .....	6	5. ENGINE/LOWER UNIT REMOVAL .....	53
3. SERIAL NUMBER LOCATION .....	6	6. CYLINDER HEAD REMOVAL .....	57
4. MAINTENANCE STANDARDS .....	7	7. CAM SHAFT/VALVE/OIL PUMP .....	58
5. TORQUE VALUES .....	8	8. CRANKSHAFT/PISTON .....	66
6. SPECIAL TOOLS .....	9	9. HANDLEBAR/SHIFT LEVER .....	72
7. WIRING DIAGRAM .....	11	10. SWIVEL CASE/STERN BRACKET .....	76
8. TUBING LAYOUT .....	16	11. PROPELLER/GEAR CASE .....	79
9. TROUBLESHOOTING .....	17	12. OPTIONAL PARTS .....	87
10. MAINTENANCE SCHEDULE .....	20	V. CONSTRUCTION AND FUNCTION .....	93
11. RECOMMENDED SERVICE MATERIALS ..	21	1. LUBRICATION SYSTEM .....	93
12. ALTERNATE PROPELLERS .....	22	2. COOLING SYSTEM .....	94
13. LUBRICATION CHART .....	23	3. FUEL SYSTEM .....	95
III. MAINTENANCE .....	24	4. POWER TRANSMITTING SYSTEM .....	97
1. ENGINE OIL CHANGE .....	24	5. ELECTRICAL SYSTEM .....	98
2. GEAR OIL CHANGE .....	24	6. TILT AND REVERSE LOCK MECHANISM .....	102
3. SPARK PLUG CLEANING/ ADJUSTMENT .....	25	VI. SUPPLEMENT .....	104
4. IGNITION TIMING ADJUSTMENT .....	25	VII. SUPPLEMENT .....	113
5. VALVE CLEARANCE ADJUSTMENT .....	26		
6. CARBURETOR ADJUSTMENT .....	27		
7. SHIFT ROD ADJUSTMENT .....	27		
8. THROTTLE CABLE ADJUSTMENT .....	28		
9. THROTTLE GRIP FRICTION ADJUSTMENT .....	28		
10. STEERING HANDLEBAR FRICTION ADJUSTMENT .....	28		
11. CYLINDER COMPRESSION CHECK .....	29		
12. SPARK TEST .....	29		

# I. SPECIFICATIONS

**HONDA**  
BF75/BF100

## 1. SPECIFICATIONS

## 2. DIMENSIONAL DRAWINGS

### 1. SPECIFICATIONS

Dimensions · Weight		BF 75 Short	BF 75 Long	BF 100 Short	BF 100 Long
Overall length		515 mm (20.3 in)	←	←	←
Overall width		315 mm (12.4 in)	←	←	←
Overall height		1,010 mm (39.8 in)	1,160 mm (45.7 in)	1,010 mm (39.8 in)	1,160 mm (45.7 in)
Dry weight		34 kg (75.0 lb)	35 kg (77.2 lb)	34 kg (75.0 lb)	35 kg (77.2 lb)
Operating weight (incl. oil)		35 kg (77.2 lb)	36 kg (79.4 lb)	35 kg (77.2 lb)	36 kg (79.4 lb)
Transom height		422 mm (16.6 in)	572 mm (22.5 in)	422 mm (16.6 in)	572 mm (22.5 in)
Transom angle		4-stage (3° - 8° - 13° - 18°)			
Tilting		2-stage (32.5° - 72°)			
Swivel angle		R: 45°, L: 45°			
<b>Engine</b>					
Type		2 cylinder, in-line, 4 stroke, water-cooled, OHC			
Total piston displacement		197 cc (12.0 cu in)			
Bore x stroke		56 x 40 mm (2.20 x 1.57 in)			
Maximum horsepower		7.5 ps (7.4 hp)/5,200 rpm ←		9.9 ps (9.8 hp)/5,700 rpm ←	
Maximum torque		110 kg-cm (7.96 ft-lb) ←		130 kg-cm (9.40 ft-lb) ←	
Compression ratio		8.6 : 1			
Fuel consumption ratio		270 g/ps-h (0.60 lb/hp-h)			
Cooling system		Forced water circulation by impeller pump with thermostat			
Ignition system		Engine serial number 1000004-1199999: Flywheel magneto Engine serial number 1200001 and subsequent: CDI			
Ignition timing		15° - 35° B.T.D.C.			
Spark plug		DR-5HS (NGK) (Standard)			
Carburetor		Horizontal type, butterfly valves			
Advance type		Centrifugal spark advance			
Lubrication system		Pressure lubrication by trochoid pump			
Lubricant capacity		0.8ℓ (0.85 US qt, 0.70 Imp qt) (SAE 10W-40 Service Classification SE or SF)			
Starting system		Recoil starter			
Stopping system		Grounding of primary circuit			
Fuel		Regular automotive gasoline			
Fuel tank capacity		13ℓ (3.4 US gal, 2.9 Imp gal)			
Fuel pump		Diaphragm type			
Exhaust system		In-water type			
<b>Lower Unit</b>					
Clutch		Dog clutch (Forward - Neutral - Reverse)			
Gear ratio		12 : 29			
Gear case oil capacity		0.23ℓ (0.49 US pt)			
<b>Propeller</b>					
No. of blades-Dia. x Pitch		3 - 240 mm x 220 mm (3 - 9-1/2 x 8-3/4 in)			
Rotating direction		Clockwise (viewed from rear)			

### 2. DIMENSIONAL DRAWINGS

	H: HEIGHT	T: TRANSOM HEIGHT
BF 75S BF 100S	1,010 mm (39.8 in)	422 mm (16.6 in)
BF 75L BF 100L	1,160 mm (45.7 in)	572 mm (22.5 in)

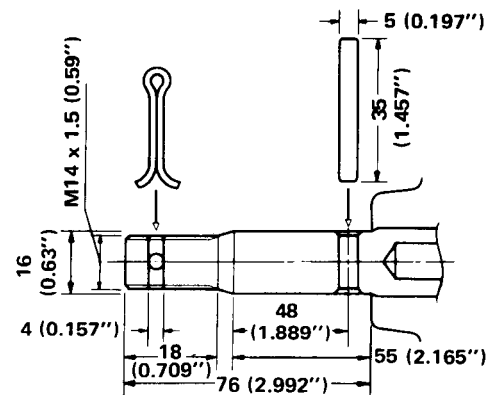
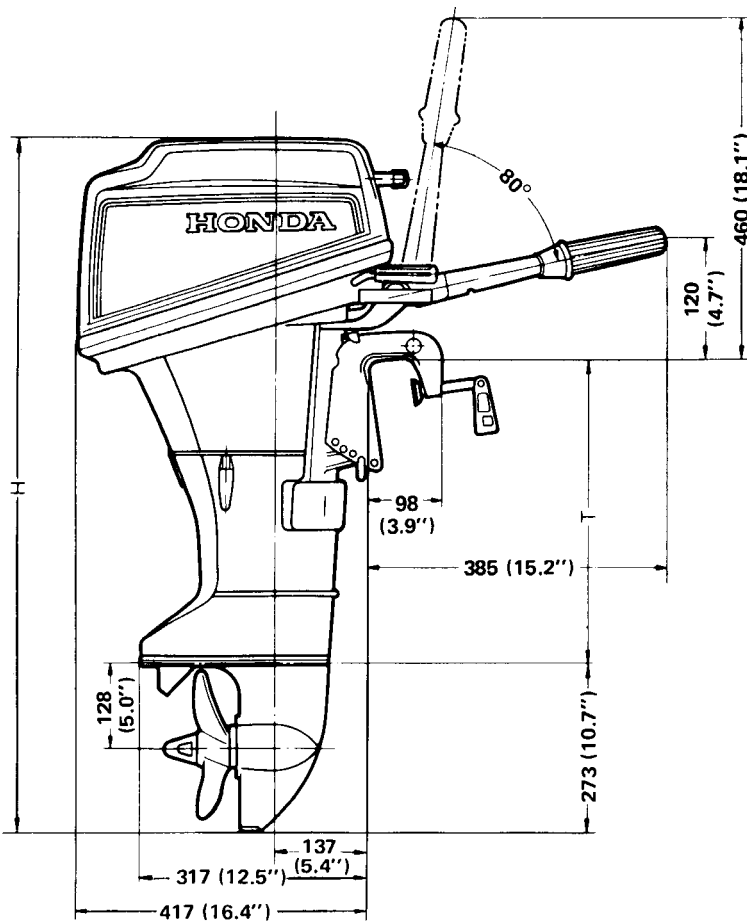
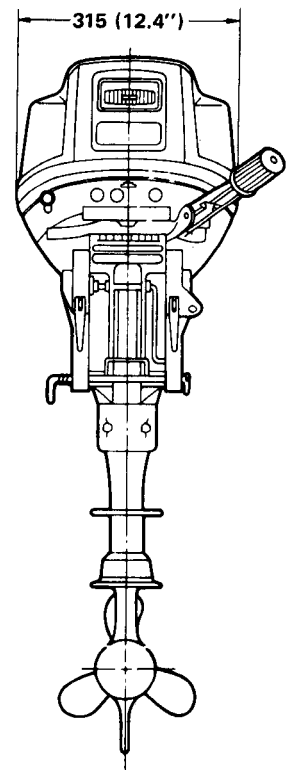
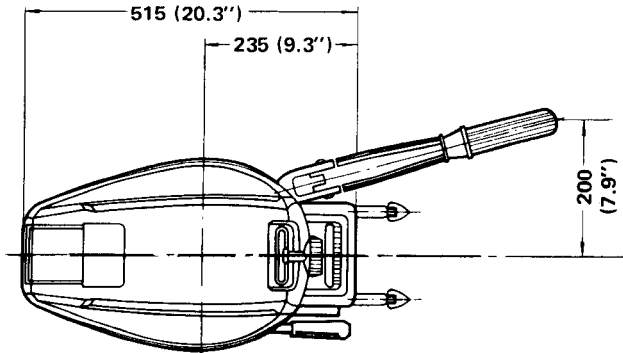

- |                           |                                   |
|---------------------------|-----------------------------------|
| 1. GENERAL SAFETY         | 8. TUBING LAYOUT                  |
| 2. SERVICE RULES          | 9. TROUBLESHOOTING                |
| 3. SERIAL NUMBER LOCATION | 10. MAINTENANCE SCHEDULE          |
| 4. MAINTENANCE STANDARD   | 11. RECOMMENDED SERVICE MATERIALS |
| 5. TORQUE VALUES          | 12. ALTERNATE PROPELLERS          |
| 6. SPECIAL TOOLS          | 13. LUBRICATION CHART             |
| 7. WIRING DIAGRAM         |                                   |

## 1. GENERAL SAFETY

Pay attention to these symbols and their meaning:

 **WARNING** Indicates a strong possibility of severe personal injury or loss of life if instructions are not followed.

**CAUTION:** Indicates a possibility of personal injury or equipment damage if instructions are not followed.

 **WARNING**

If the motor must be running to do some work, make sure the area is well ventilated. Never run the engine in a closed area. The exhaust contains poisonous carbon monoxide gas.

 **WARNING**

Gasoline is extremely flammable and is explosive under certain conditions. Do not smoke or allow flames or sparks in your working area.

**CAUTION:**

Keep away from rotating or hot parts and high tension wires when the engine is run with the cover off.

**CAUTION:**

Make sure the water level is above the anti-cavitation plate when testing the unit in a tank. Otherwise the pump will be destroyed and the engine will overheat.

## 2. SERVICE RULES

1. Use genuine Honda or Honda-recommended parts and lubricants or their equivalents. Parts that do not meet Honda's design specifications may damage the unit.
2. Use the special tools designed for the product.
3. Install new gaskets, O-rings, etc. when reassembling.
4. When torquing bolts or nuts, begin with larger-diameter or inner bolt first and tighten to the specified torque diagonally, unless a particular sequence is specified.
5. Clean parts in cleaning solvent upon disassembly. Lubricate any sliding surfaces before reassembly.
6. After reassembly, check all parts for proper installation and operation.
7. Follow the instructions represented by these symbols when they are used:



: Apply grease.

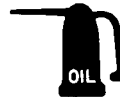

: Apply oil.

## 3. SERIAL NUMBER LOCATION

The serial number is stamped on the name plate attached to the swivel case. Always specify this number when inquiring or ordering parts in order to get correct parts for the unit being serviced.

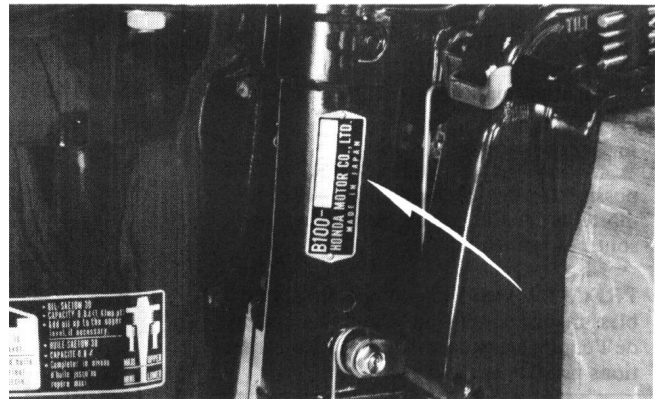

## 4. MAINTENANCE STANDARDS

Item		Standard	Service Limit	
Engine	Idle speed	1,200 ± 100 rpm (in neutral)		
	Cylinder compression	BF75 10.0 kg/cm <sup>2</sup> (142 lb/in <sup>2</sup> )/600 rpm BF100 10.6 kg/cm <sup>2</sup> (151 lb/in <sup>2</sup> )/600 rpm		
Carburetor	Main jet	#88		
	Pilot screw opening	2-1/4 turns [1-3/4 turns]		
Thermostat	Float height	10.0 mm (0.39 in)		
	Opens	60°–70°C (140°–158°F) [70°–80°C (158°–176°F)]		
	Valve lift	3–4 mm (0.12–0.16 in)		
Spark plug	Gap	0.6–0.7 mm (0.024–0.028 in)		
Valve	Valve tappet clearance (IN/EX)	0.06–0.1 mm (0.02–0.004 in)		
	Valve stem O.D.	IN 5.5 mm (0.22 in) EX 5.5 mm (0.22 in)	5.08 mm (0.2 in) 4.75 mm (0.187 in)	
	Valve guide I.D.	5.5 mm (0.22 in)	5.54 mm (0.218 in)	
	Valve seat width	0.7 mm (0.03 in)	2.0 mm (0.079 in)	
	Valve spring free length	28.9 mm (1.138 in)	27.4 mm (1.079 in)	
Rocker arm	Rocker arm I.D.	13.0 mm (0.51 in)	13.06 mm (0.514 in)	
	Rocker arm shaft O.D.	13.0 mm (0.51 in)	12.92 mm (0.509 in)	
Camshaft	Cam height	IN BF75 26.5 mm (1.04 in) [23.0 mm (0.91 in)] BF100 25.2 mm (0.99 in) [25.0 mm (0.98 in)] EX BF75 23.2 mm (0.91 in) [23.0 mm (0.91 in)] BF100 25.2 mm (0.99 in) [25.0 mm (0.98 in)]	26.25 mm (1.033 in) [22.75 mm (0.896 in)] 24.95 mm (0.982 in) [24.75 mm (0.974 in)] 22.95 mm (0.904 in) [22.75 mm (0.896 in)] 24.95 mm (0.982 in) [24.75 mm (0.974 in)]	
		O.D. (at oil pump)	16.0 mm (0.63 in) 15.916 mm (0.627 in)	
		Body I.D.	23.0 mm (0.91 in) 23.23 mm (0.915 in)	
		Inner rotor-to-outer rotor clearance	0.15 mm (0.006 in) 0.20 mm (0.008 in)	
Oil pump	Outer rotor-to-body clearance	0.15 mm (0.006 in) 0.26 mm (0.010 in)		
Piston	O.D. (at skirt)	56.0 mm (2.2 in)	55.880 mm (2.2 in)	
	Piston pin hole I.D.	14.0 mm (0.55 in)	14.048 mm (0.553 in)	
	Piston pin O.D.	14.0 mm (0.55 in)	13.954 mm (0.549 in)	
	Piston ring width	Top	1.5 mm (0.06 in)	1.36 mm (0.054 in)
		Second	1.5 mm (0.06 in)	1.37 mm (0.054 in)
		Oil	2.5 mm (0.10 in)	2.37 mm (0.093 in)
	Piston ring side clearance	Top	0.025 mm (0.001 in)	0.10 mm (0.004 in)
		Second	0.025 mm (0.001 in)	0.10 mm (0.004 in)
		Oil	0.015 mm (0.0006 in)	0.10 mm (0.004 in)
	Ring end gap	Top	0.15 mm (0.006 in)	1.0 mm (0.039 in)
Second		0.15 mm (0.006 in)	1.0 mm (0.039 in)	
Oil		0.15 mm (0.006 in)	1.0 mm (0.039 in)	
Cylinder	Sleeve I.D.	56.0 mm (2.2 in)	56.165 mm (2.211 in)	
	Piston-to-cylinder clearance	0.010–0.055 mm (0.0004–0.0022 in)		
Connecting rod	Small end I.D.	14.0 mm (0.55 in)	14.070 mm (0.554 in)	
	Big end radial clearance	0.04 mm (0.002 in)	0.083 mm (0.003 in)	
Crankshaft	Big end axial clearance	0.6 mm (0.02 in)	1.3 mm (0.051 in)	
	Crankpin O.D.	28.0 mm (1.10 in)	27.952 mm (1.100 in)	
Propeller shaft	O.D. (at bevel gear)	17.0 mm (0.67 in)	16.930 mm (0.667 in)	
	Bevel gear I.D.	17.0 mm (0.67 in)	17.06 mm (0.672 in)	

[ ] : Engine serial number range 1000004–1199999

**5. TORQUE VALUES**

Part	Fasteners	Torque (kg-m) (ft-lb)
Flywheel	14 mm nut	6.0-7.0 (43.4-50.8)
Timing pulley	24 mm nut	2.0-2.5 (14.5-18.1)
Cam pulley	6 mm bolt	0.8-1.2 (5.8-8.7)
Cylinder head	8 mm bolt	2.0-2.5 (14.5-18.1)
Crankcase	8 mm bolt	2.0-2.4 (14.5-17.4)
	6 mm bolt	0.9-1.2 (6.5-8.7)
Connecting rod	6 mm special bolt	0.9-1.1 (6.5-8.0)
Engine mounting	6 mm bolt	0.8-1.2 (5.8-8.7)
Pressure switch		0.7-1.0 (5.1-7.2)
Steering handlebar	Handlebar pivot screw	2.0-2.8 (14.5-20.2)
Standard torques	5 mm bolt and nut	0.4-0.7 (2.9-5.1)
	6 mm bolt and nut	0.8-1.2 (5.8-8.7)
	8 mm bolt and nut	2.0-2.8 (14.5-20.2)
	10 mm bolt and nut	3.5-4.0 (25.3-28.9)



**6. SPECIAL TOOLS**

Ref. No.	Tool No.	Tool Name	Application	Ref. Page
1	07708-0030400	Adjusting wrench B	Valve adjuster	26
2	07935-8050002	Flywheel puller	Flywheel (disassembly)	38
3	07925-8930000	Pulley holder or commercially available band strap wrench	Flywheel (dis/reassembly)	38
4	07936-9350001	Bearing remover set	{ 6302 bearing (disassembly)	83
5	07742-0010100	Valve guide remover	{ Gear case needle roller bearing	85
6	07942-9350000	Valve guide driver	Valve guide (disassembly)	60
7	07944-9350100	2.5 mm Pin driver	Valve guide (assembly)	60
8	07944-9350200	4 mm Pin driver	Spring pin	78
9	07944-9350300	6 mm Pin driver	Spring pin	73
10	07945-9350001	Bearing remover	Spring pin	79
			{ 6203 bearing (disassembly)	79
			{ 17 mm water sed (disassembly)	79
			{ Coupling seal (assembly)	79
11	07946-9350101	Attachment driver A	6203 bearing (assembly)	79
			{ 17 mm water seal (assembly)	79
12	07946-9350200	Attachment driver B	{ 15 mm water seal (assembly)	83
			{ 6302 bearing (assembly)	83
13	07749-0010000	Driver handle	• Handle for tools (11) and (12)	
14	07955-8810000	Piston slider or commercially available piston ring compressor	Piston (assembly)	67
15	07757-0010000	Valve spring compressor	Valve cotter	59
16	07968-9350000	4 mm pin, pin flare tool	Shifter pin	85
17	07780-0010200	45° Cutter	Valve seat (refacing)	65
18	07780-0012100	Flat cutter (IN)	Valve seat (refacing)	65
19	07780-0012000	Flat cutter (EX)	Valve seat (refacing)	65
20	07781-0010100	Cutter holder	• Holder for cutters (17) thru (19)	65
21	07984-2000000	Valve guide reamer (5.5 mm)	Valve guide (reaming)	60
22	07973-8810001	Water tube guide	Water tube (assembly)	81
23	07975-8810002	Test propeller, SPACER	{ For testing in water tank	
24	07979-8810010	SPACER		

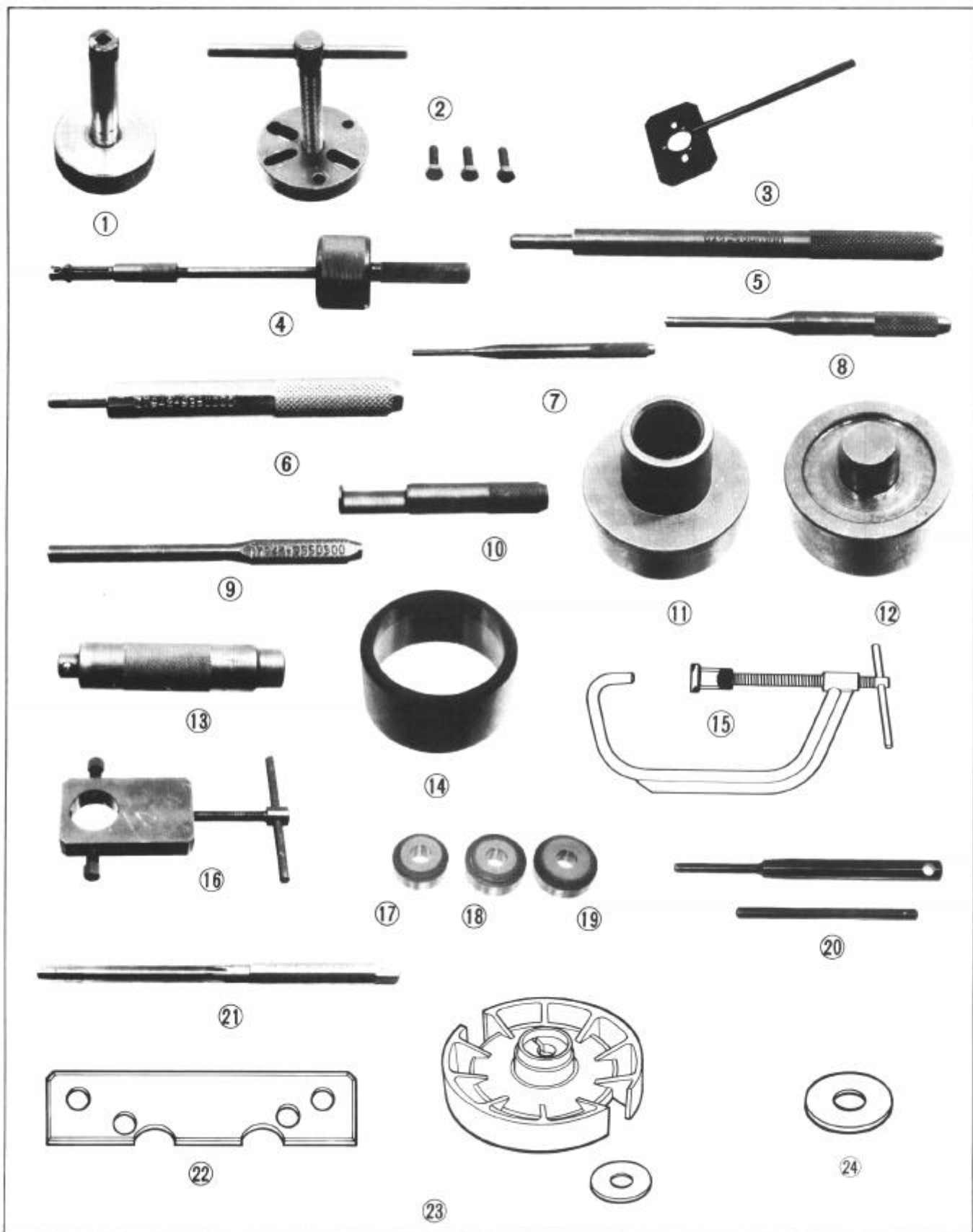

**7. WIRING DIAGRAM**

**a. CONTACT BREAKER TYPE**

(Engine serial number 1000004—1199999)

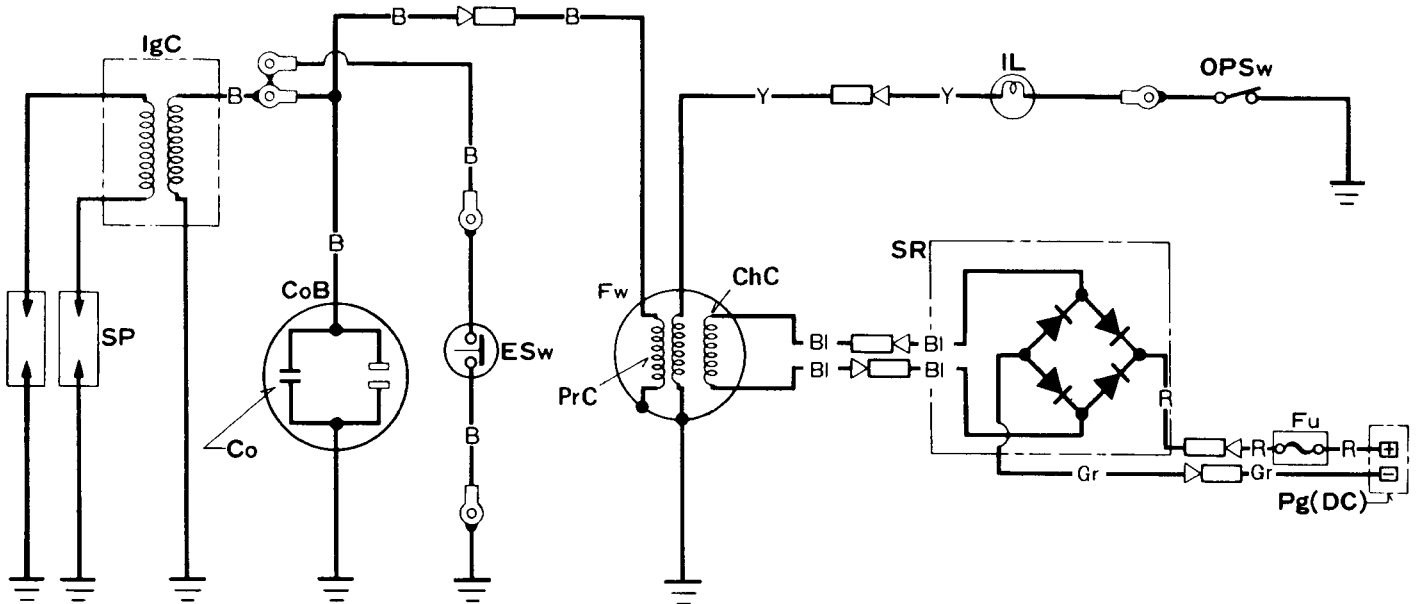

Code	Part Name
ChC	Charging Coil
Co	Condenser
CoB	Contact Breaker
ESw	Engine Switch
Fu	Fuse
Fw	Flywheel
IgC	Ignition Coil
IL	Indicator Lamp
OPSw	Oil Pressure Switch
Pg (DC)	DC Output Plug
PrC	Primary Coil
SP	Spark Plug
SR	Silicon Rectifier

Code	Wire Color
B	Black
Bl	Blue
Gr	Green
R	Red
Y	Yellow

Engine serial number 1000004-1199999

Code	Wire Color
B	Black
Bl	Blue
Gr	Green
R	Red
Y	Yellow

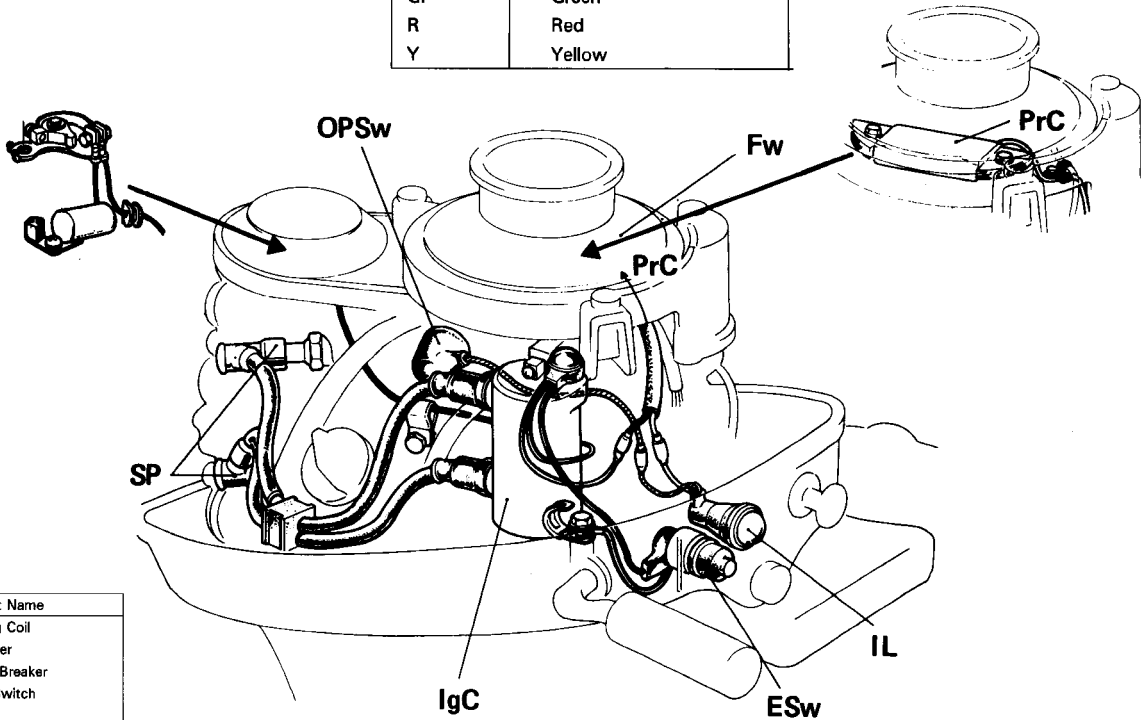

Code	Part Name
ChC	Charging Coil
Co	Condenser
CoB	Contact Breaker
ESw	Engine Switch
Fu	Fuse
Fw	Flywheel
IgC	Ignition Coil
IL	Indicator Lamp
OPSw	Oil Pressure Switch
Pg (DC)	DC Output Plug
PrC	Primary Coil
SP	Spark Plug
SR	Silicon Rectifier

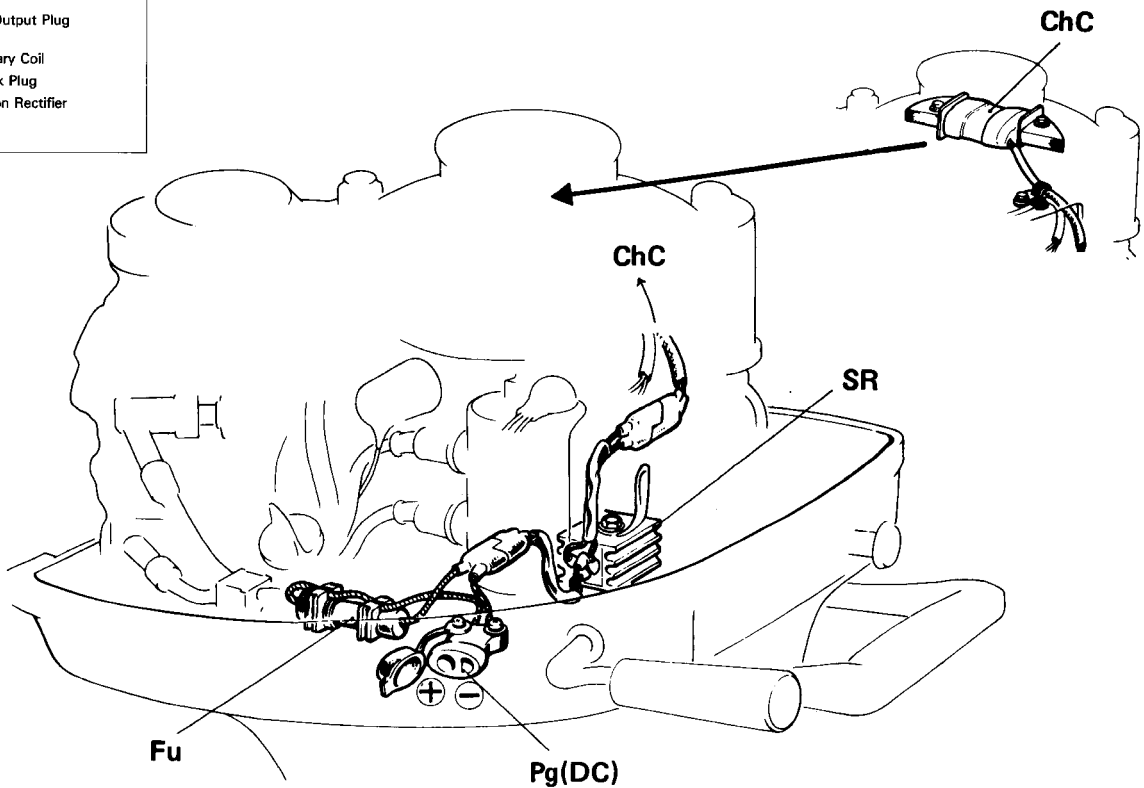

**b. C.D.I. TYPE (Engine serial number 1200001 and subsequent)**

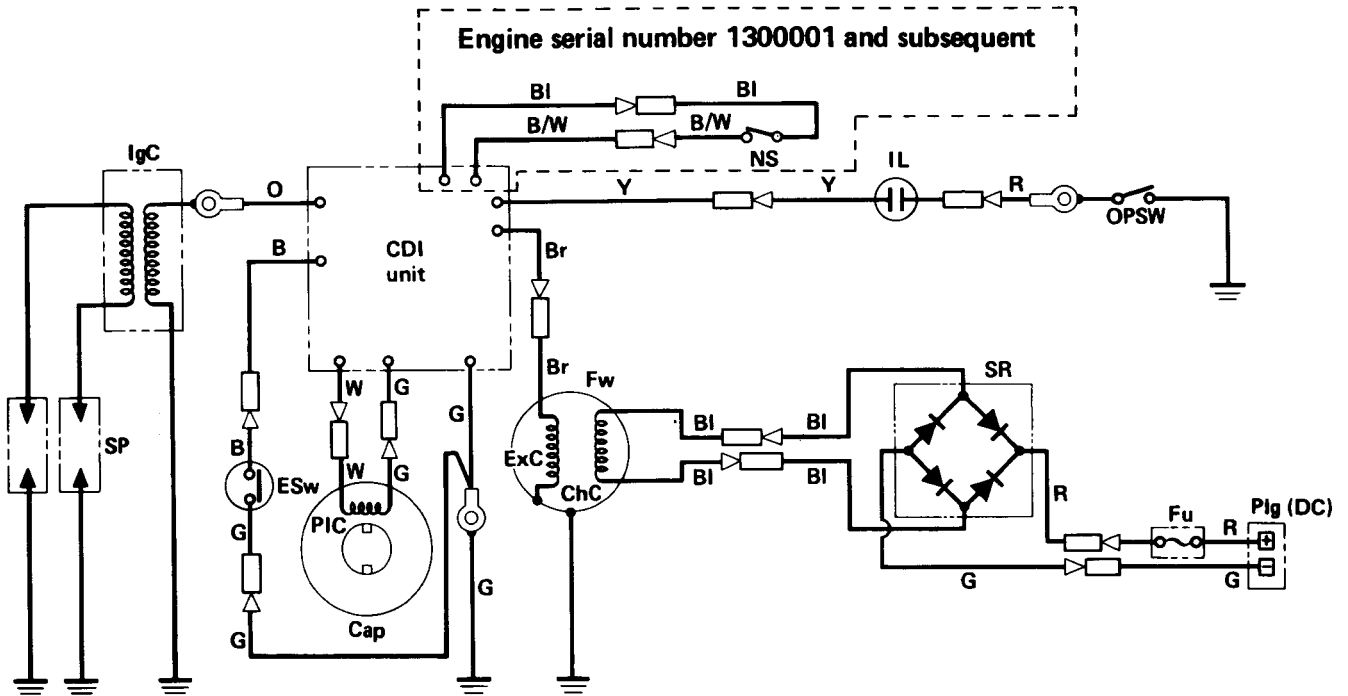

Code	Part Name
Cap	Cam Pulley
ChC	Charging Coil
ESw	Engine Switch
ExC	Exciter Coil
Fu	Fuse
Fw	Flywheel
IgC	Ignition Coil
IL	Indicator Lamp
NS	Neutral Switch
Plg (DC)	DC Output Plug
PIC	Pulser Coil
SP	Spark Plug
SR	Silicon Rectifier
OPSW	Oil Pressure Switch

Code	Wire Color
B	Black
BI	Blue
Br	Brown
G	Green
O	Orange
R	Red
W	White
Y	Yellow

• Engine serial number 1200001–1299999

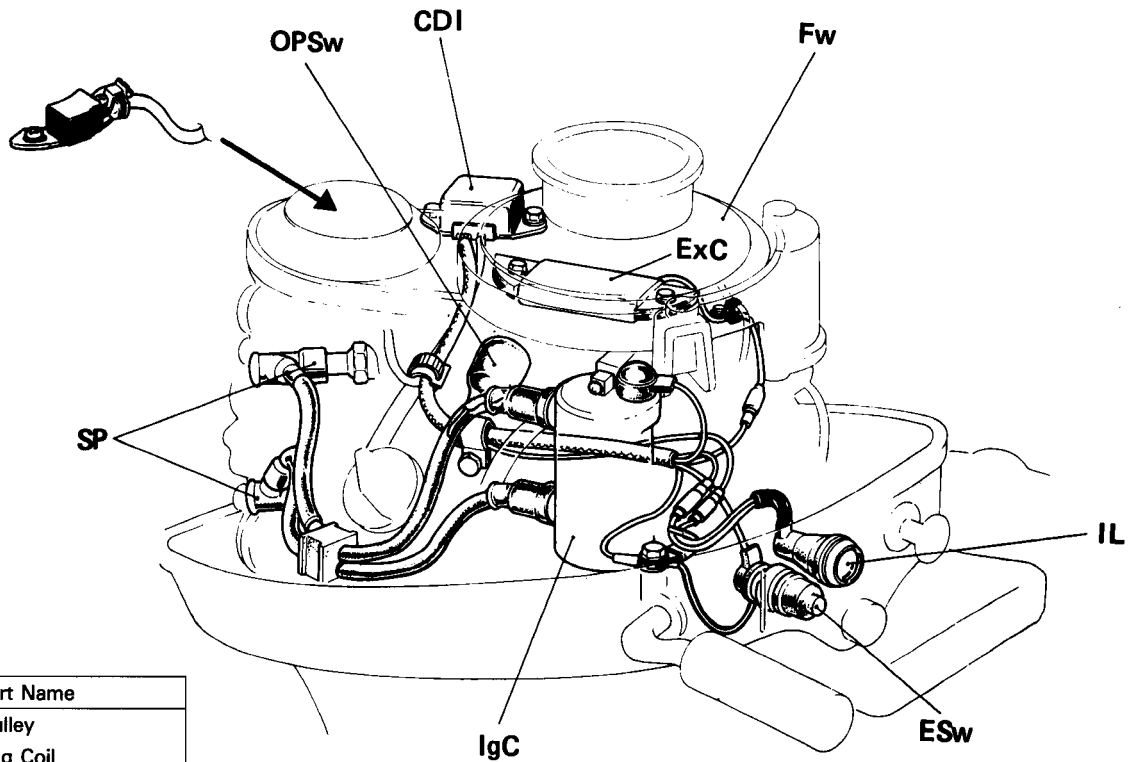

Code	Part Name
Cap	Cam Pulley
ChC	Charging Coil
ESw	Engine Switch
ExC	Exciter Coil
Fu	Fuse
Fw	Flywheel
IgC	Ignition Coil
IL	Indicator Lamp
NS	Neutral Switch
Plg (DC)	DC Output Plug
PIC	Pulser Coil
SP	Spark Plug
SR	Silicon Rectifier
OPSw	Oil Pressure Switch

Code	Wire Color
B	Black
Bl	Blue
Br	Brown
G	Green
O	Orange
R	Red
W	White
Y	Yellow

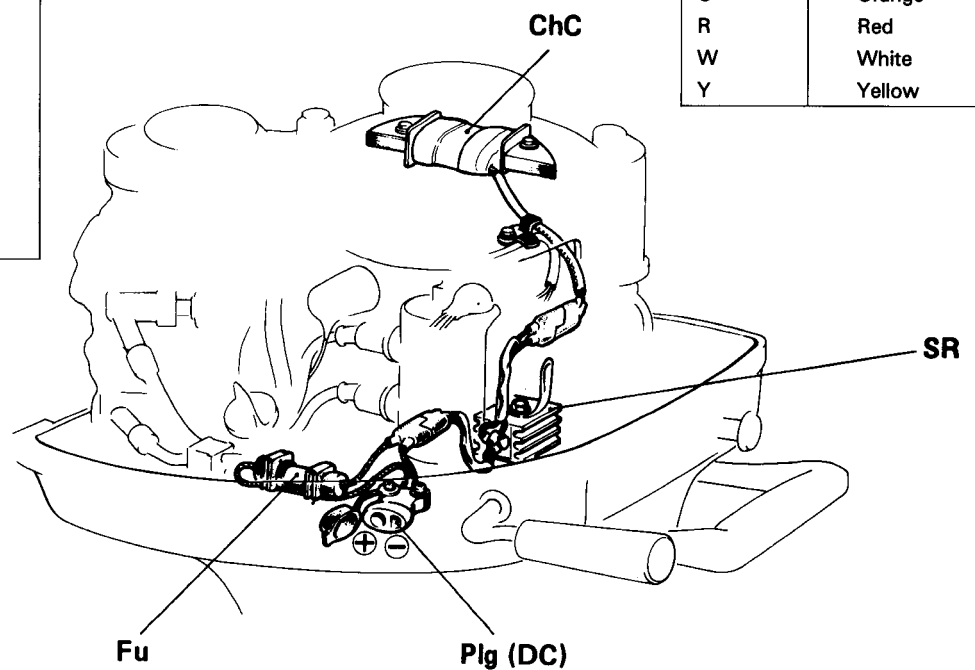

- Engine serial numbers 1300001 and subsequent

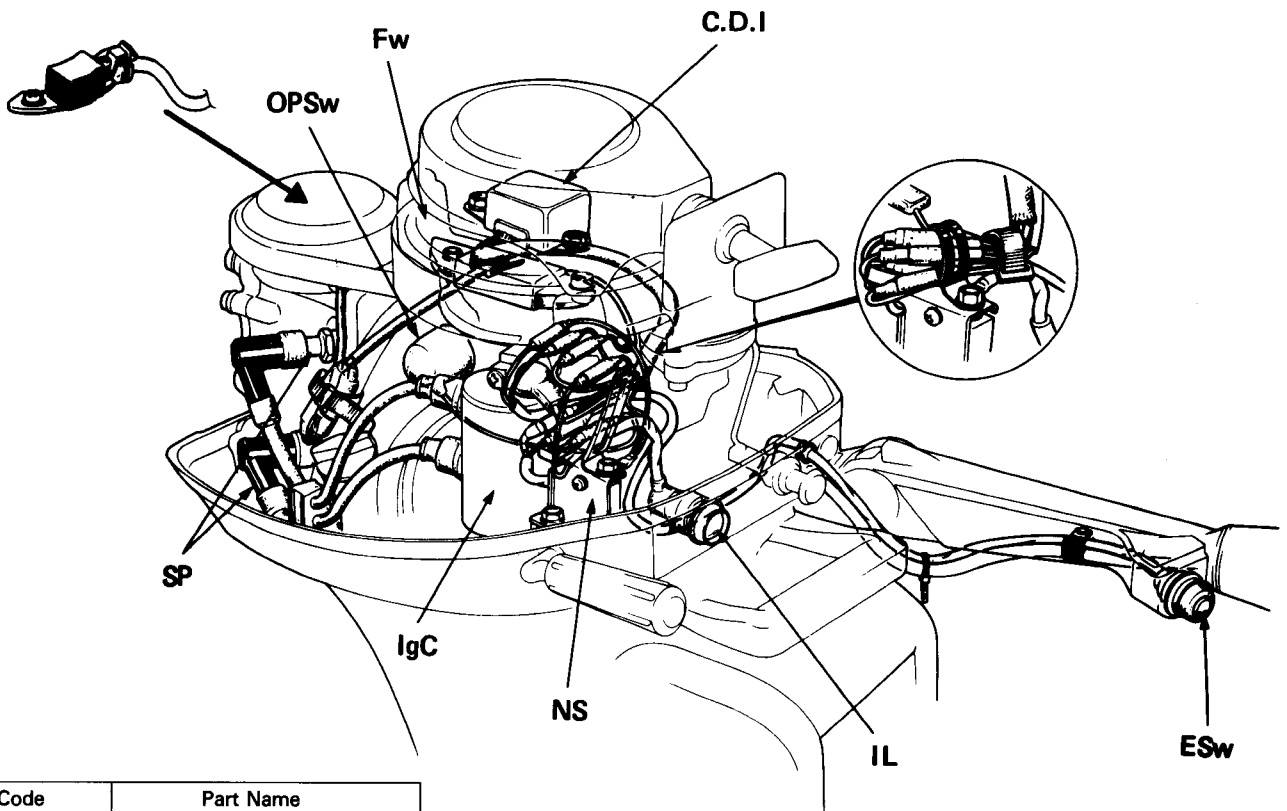

Code	Part Name
Cap	Cam Pulley
ChC	Charging Coil
ESw	Engine Switch
ExC	Exciter Coil
Fu	Fuse
Fw	Flywheel
IgC	Ignition Coil
IL	Indicator Lamp
NS	Neutral Switch
Plg (DC)	DC Output Plug
PIC	Pulser Coil
SP	Spark Plug
SR	Silicon Rectifier
OPSw	Oil Pressure Switch

Code	Wire Color
B	Black
Bl	Blue
Br	Brown
G	Green
O	Orange
R	Red
W	White
Y	Yellow

**8. TUBING LAYOUT**

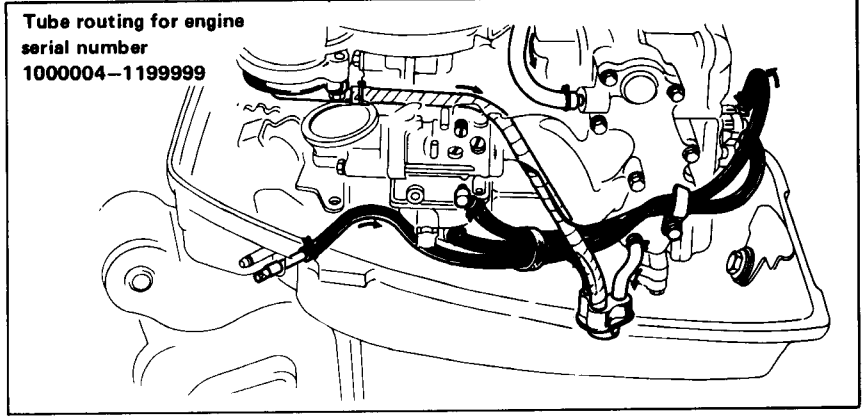
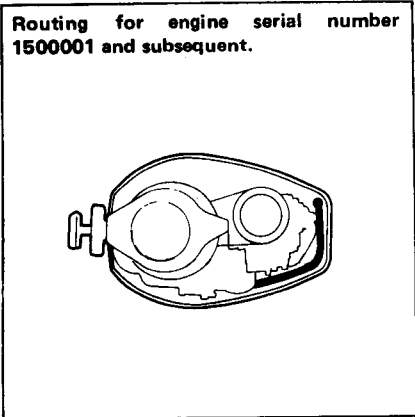
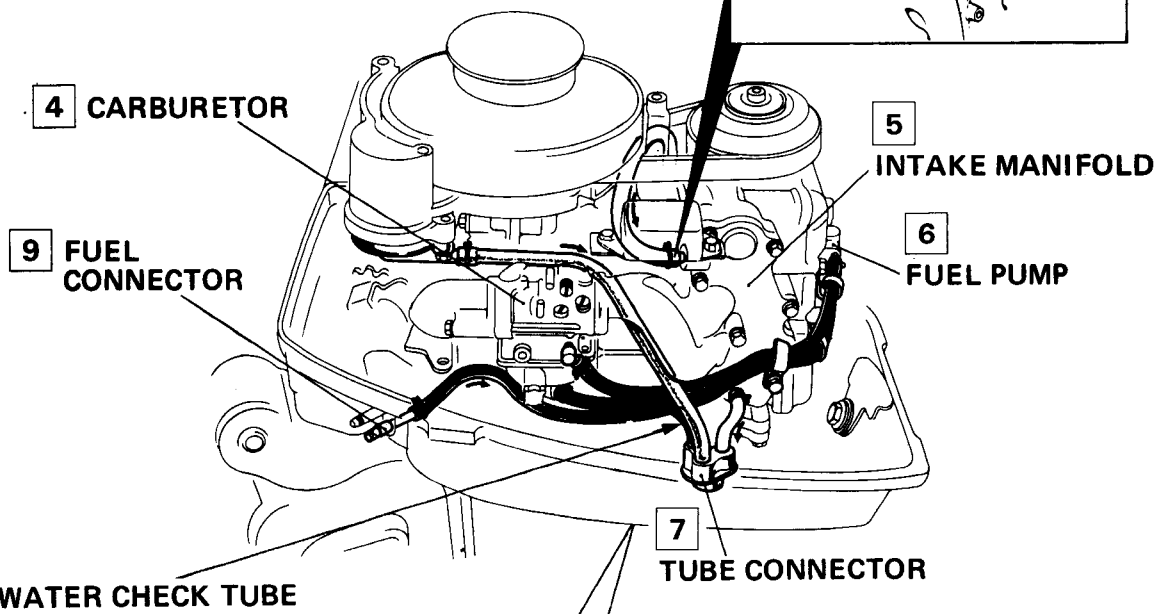
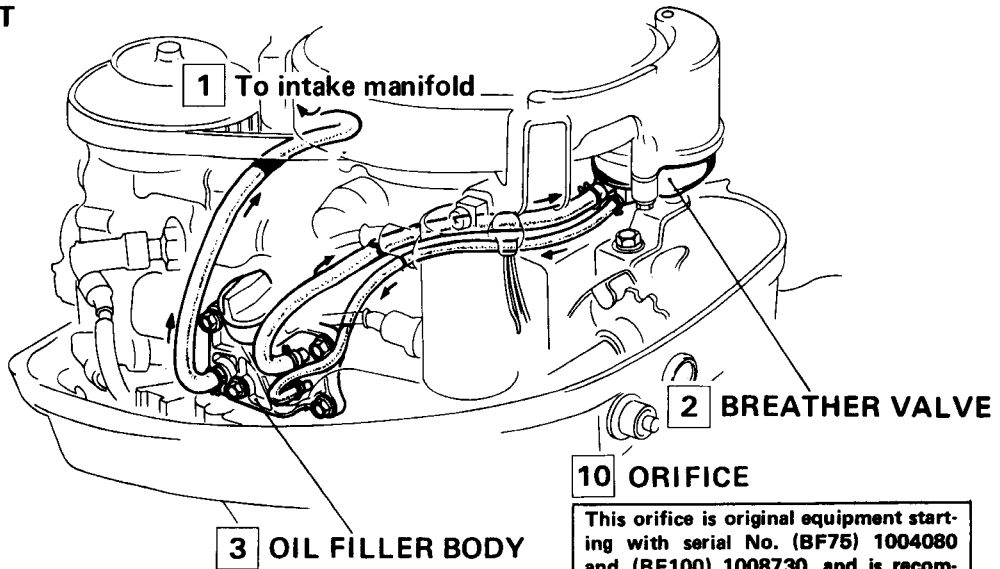



## 9. TROUBLESHOOTING

### a. SYMPTOMS AND PROBABLE CAUSES

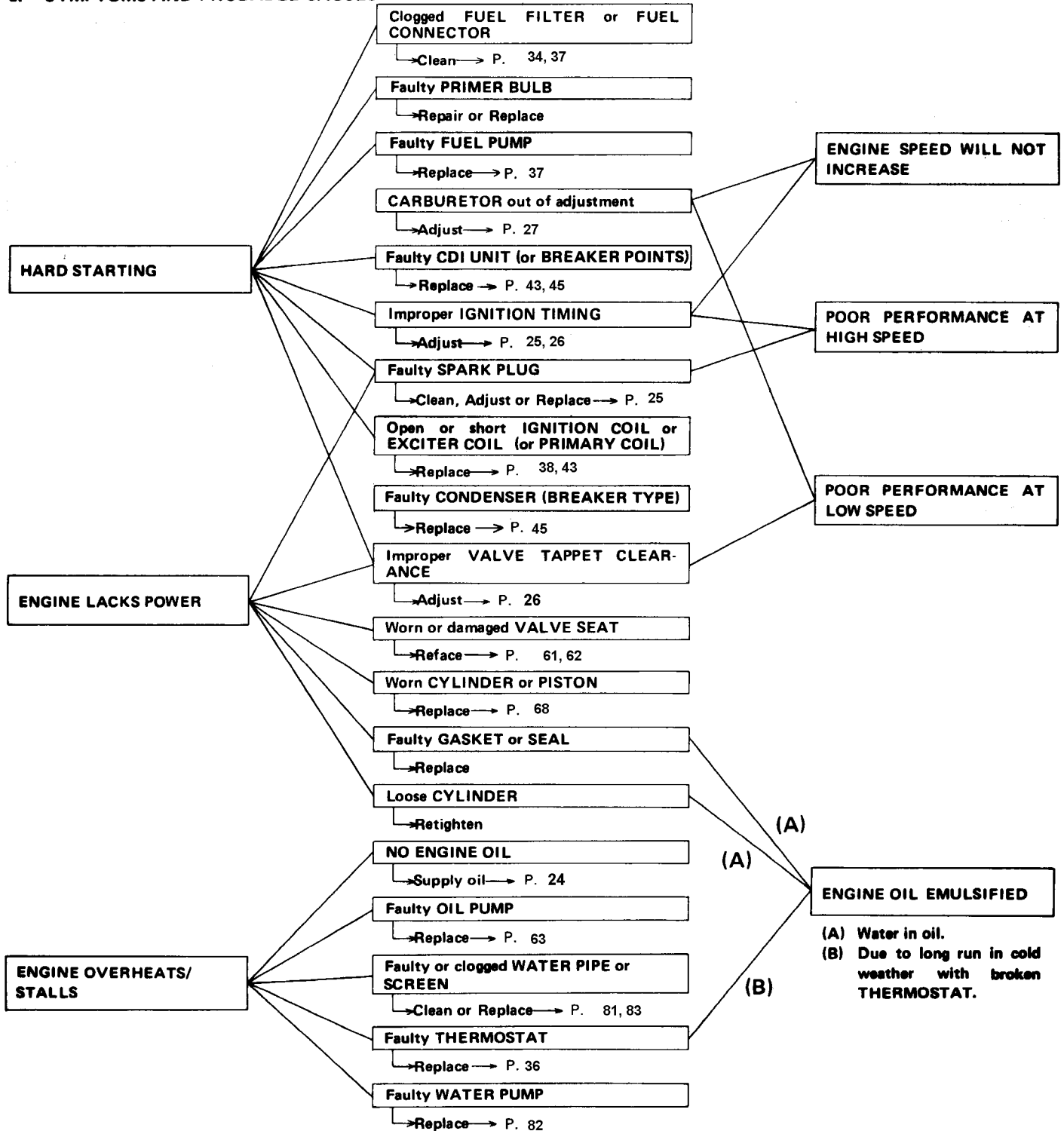

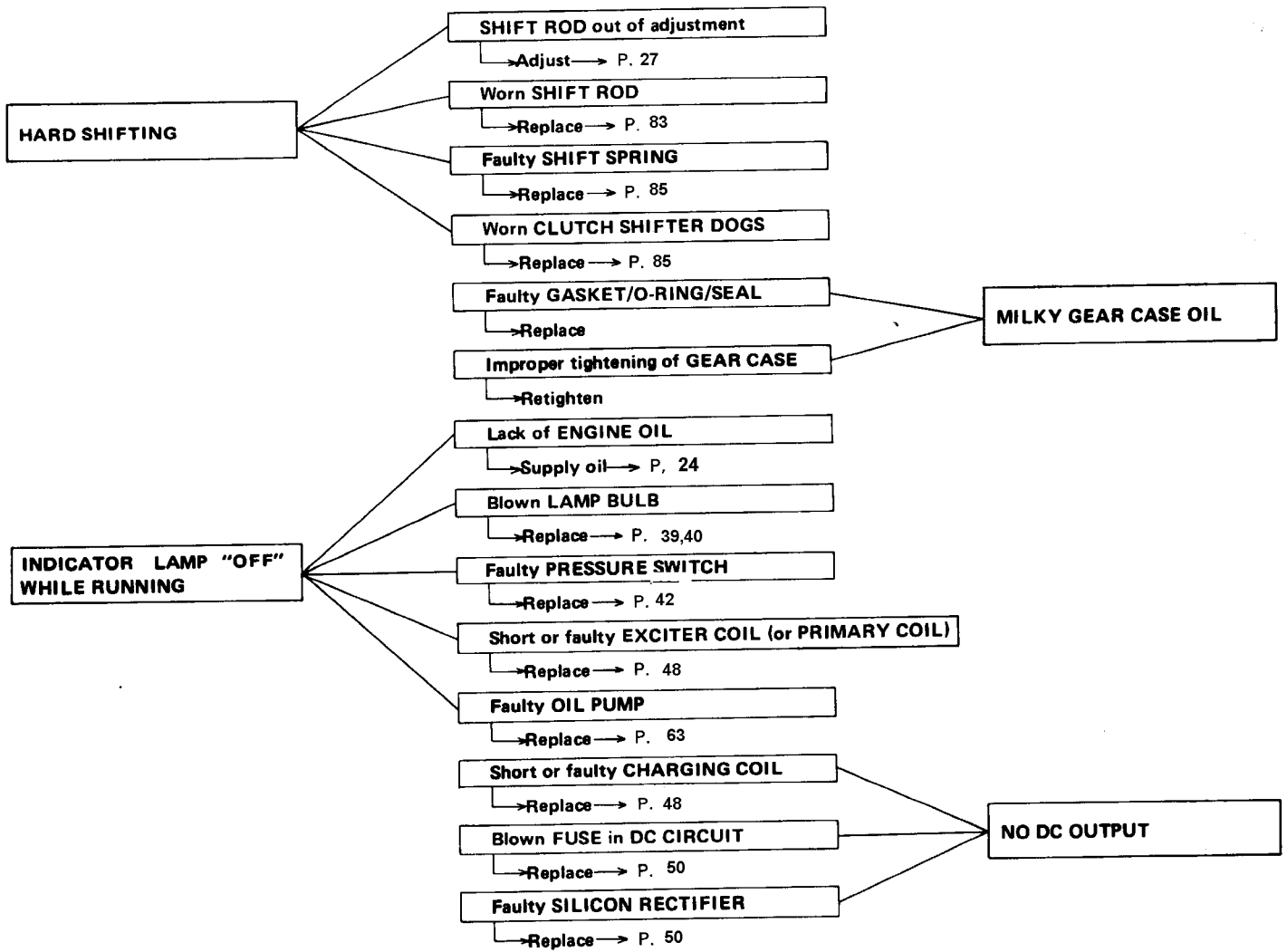

## b. HARD STARTING

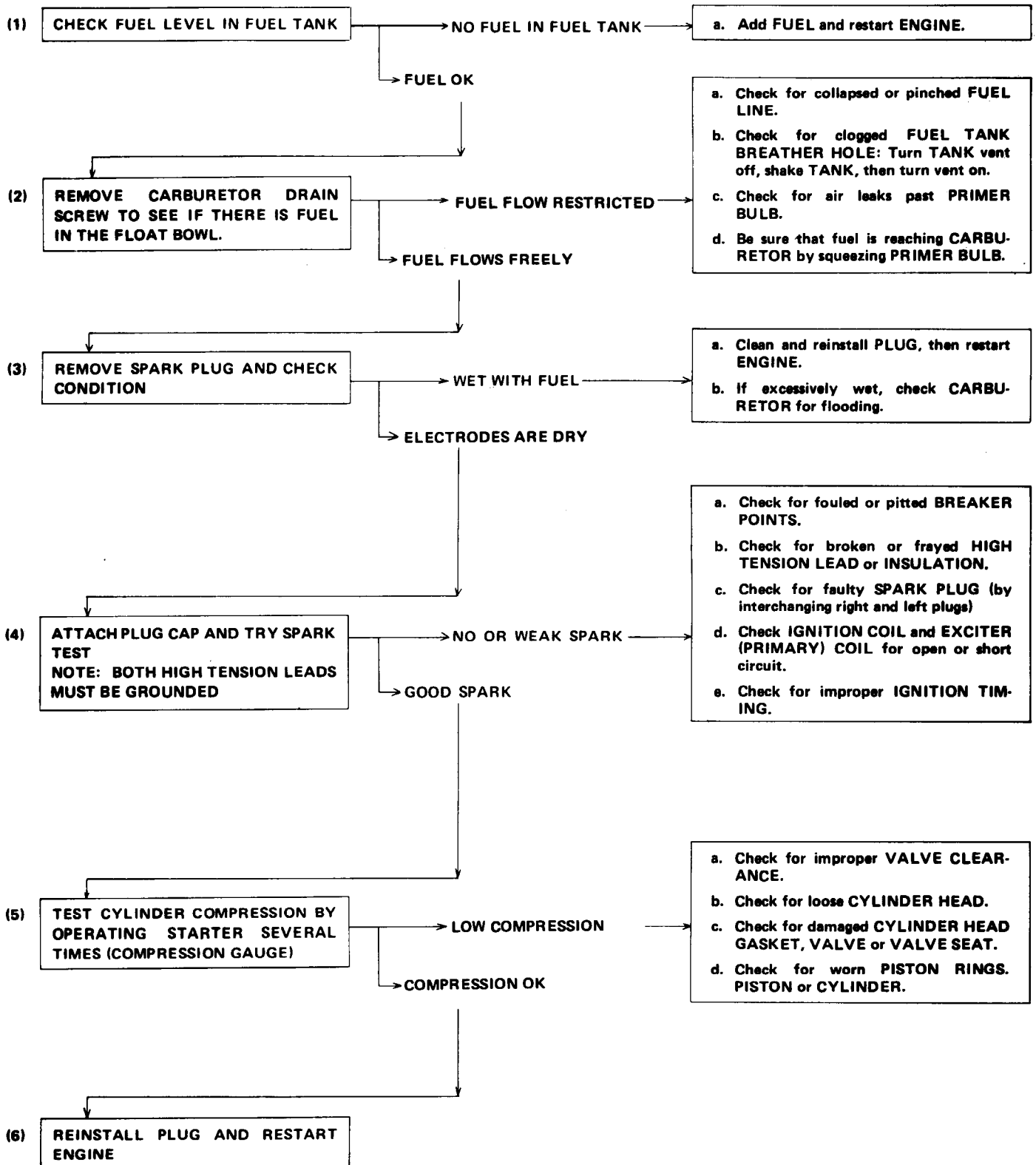

**10. MAINTENANCE SCHEDULE**

ITEM	Regular Service Period. Perform at every indicated month or operating hour interval, whichever occurs first.	First 15 hours or 1 Month	Every 100 hours or 6 Months	Every 200 hours or 1 Year	Ref. Page
ENGINE OIL	CHANGE	○	○		P. 24
GEAR CASE OIL	CHANGE	○		○	P. 24
GEAR CASE OIL	CHECK FOR WATER	EVERY 50 HOURS			P. 24
SPARK PLUG	CLEANING · ADJUST		○		P. 25
IGNITION TIMING (Contact breaker type only)	ADJUSTMENT	○		○	P. 25
VALVE TAPPET CLEARANCE	ADJUSTMENT	○		○	P. 26
CARBURETOR LINKAGE	CHECK	○	○		P. 34
FUEL FILTER	CHECK			○	P. 37
FUEL LINE	CHECK (Replace, if necessary)			○	
FUEL TANK	CLEANING			○	
THERMOSTAT	CHECK			○	P. 36
SHEAR PIN	CHECK		○		P. 79
LUBRICATION	GREASE		○		P. 23

**11. RECOMMENDED SERVICE MATERIALS**

Types of Lubricants or Materials	Items to be Serviced	Brand	Remarks
OIL	ENGINE OIL PAN	SAE 10W-40 SE or SF Rated	Capacity: 0.8ℓ (0.85 US qt, 0.70 Imp qt)
	GEAR CASE	SAE 90 MARINE	Capacity: 0.23ℓ (0.49 US pt, 0.40 Imp pt)
PACKING	CRANKCASE	THREE-BOND · 5TW	} or equivalent
ADHESIVE	EXTENSION CASE	CEMEDINE 521	
	OIL FILLER BODY	CEMEDINE 521	
	OIL FILTER	THREE-BOND · No. 50	
	OIL PRESSURE SWITCH	CEMEDINE 521	
SEALER	HANDLEBAR GRIP RUBBER	LOCTITE	With anti-rust agent
	BOLTS		

**12. ALTERNATE PROPELLERS**

The following propellers, or their equivalents, may be used on this unit in place of the Honda part:

<b>Manufacturer</b>	<b>Model</b>	<b>Dia. X Pitch (in)</b>	<b>Application</b>
<b>MICHIGAN</b>	<b>PJ-16</b>	<b>9 x 10</b>	<b>Light duty</b>
<b>MICHIGAN</b>	<b>PJ-21</b>	<b>9 x 8</b>	<b>Medium duty</b>
<b>MICHIGAN</b>	<b>SMC-39</b>	<b>9-1/4 x 7</b>	<b>Heavy duty</b>

13. LUBRICATION CHART

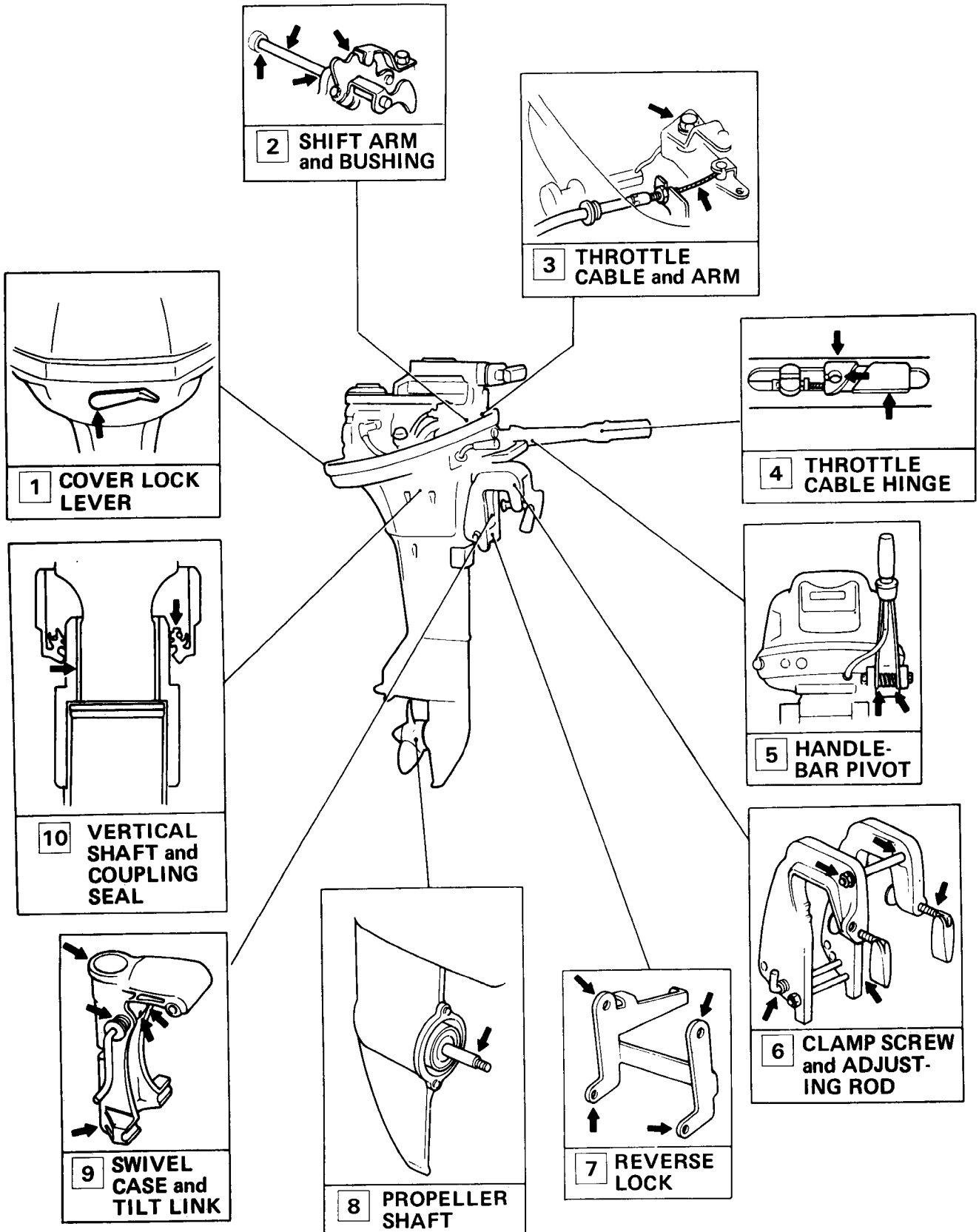

1. ENGINE OIL CHANGE
2. GEAR OIL CHANGE
3. SPARK PLUG CLEANING/ADJUSTMENT
4. IGNITION TIMING ADJUSTMENT
5. VALVE CLEARANCE ADJUSTMENT
6. CARBURETOR ADJUSTMENT
7. SHIFT ROD ADJUSTMENT
8. THROTTLE CABLE ADJUSTMENT
9. THROTTLE GRIP FRICTION ADJUSTMENT
10. STEERING HANDLEBAR FRICTION ADJUSTMENT
11. CYLINDER COMPRESSION CHECK
12. SPARK TEST

## 1. ENGINE OIL CHANGE

**NOTE:** Secure the unit vertically to change the oil.

- (1) Remove the oil filler cap and drain plug to drain oil thoroughly.
- (2) Replace the drain plug and pour fresh oil up to the UPPER level mark on the filler cap/dipstick through the oil filler opening.

**ENGINE OIL CAPACITY:** 0.8ℓ (0.85 US qt, 0.70 Imp qt)

**RECOMMENDED OIL:** SAE 10W-40: API Service Classification SE or SF

- (A) OIL FILLER CAP/DIPSTICK
- (B) DRAIN PLUG
- (C) OIL LEVEL GAUGE
- (D) UPPER LIMIT
- (E) LOWER LIMIT

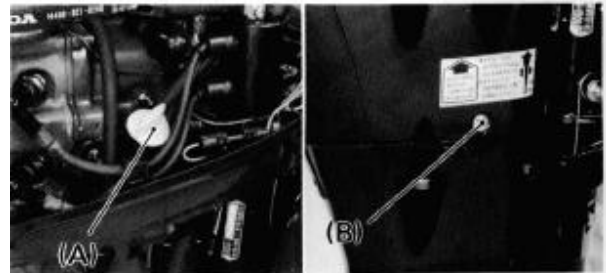

## 2. GEAR OIL CHANGE

- (1) Remove the oil level plug and drain plug to drain oil thoroughly.
- (2) Squeeze fresh oil through the drain plug hole until oil is flowing out of the level plug hole. Use the oil tube available as an optional part.

**GEAR OIL CAPACITY:** 0.23ℓ (0.49 US pt, 0.40 Imp pt)

**RECOMMENDED GEAR OIL:** SAE 90 MARINE

- (A) LEVEL PLUG
- (B) DRAIN PLUG

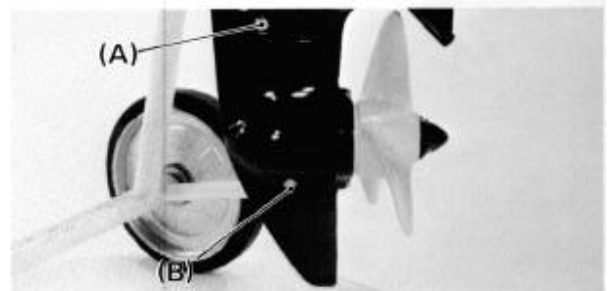



### 3. SPARK PLUG CLEANING/ADJUSTMENT

- (1) Remove carbon and other deposits from the spark plugs with a stiff wire brush.
- (2) Measure the spark plug gap with a feeler gauge. To adjust, bend the negative (grounded) electrode.

**STANDARD PLUG GAP: 0.6–0.7 mm (0.024–0.028 in)**

**STANDARD SPARK PLUG: DR–5HS (NGK)  
ALTERNATE: DR–4HS (NGK)**

**NOTE: If the DR–5HS plugs tend to get heavily carboned or wet fouled, try the DR–4HS type.**

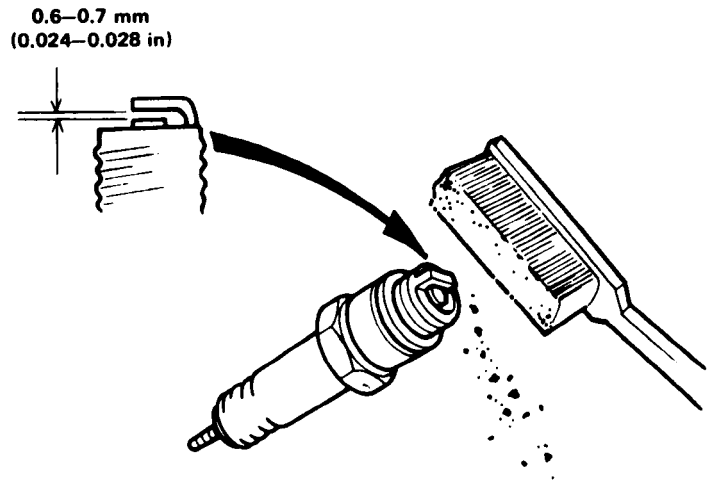

### 4. IGNITION TIMING ADJUSTMENT

#### CONTACT BRAKER TYPE

- (1) Connect a timing tester or ohmmeter as shown.
- (2) Rotate the flywheel to align the "F" mark on the flywheel to the index mark on the starter case. At this time, the contact breaker points should just start to open (15° B.T.D.C.)
- (3) To adjust the timing, loosen the breaker plate locking screw and move the contact breaker plate to achieve correct timing. Retighten the locking screw.
- (4) Rotate the flywheel one full turn, and check ignition timing for the other cylinder. Readjust the contact breaker points, if necessary, so the ignition timing will be as correct as possible for both cylinders.

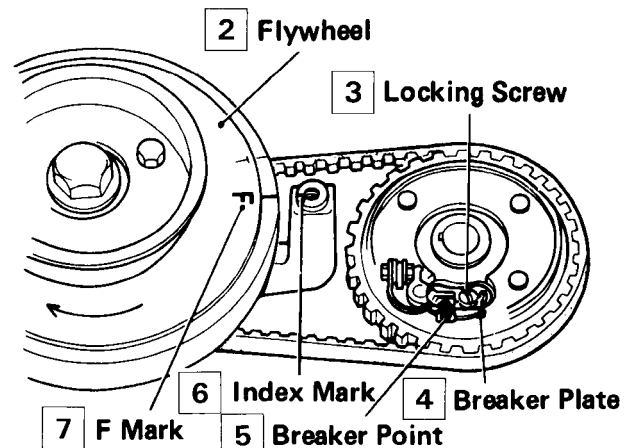
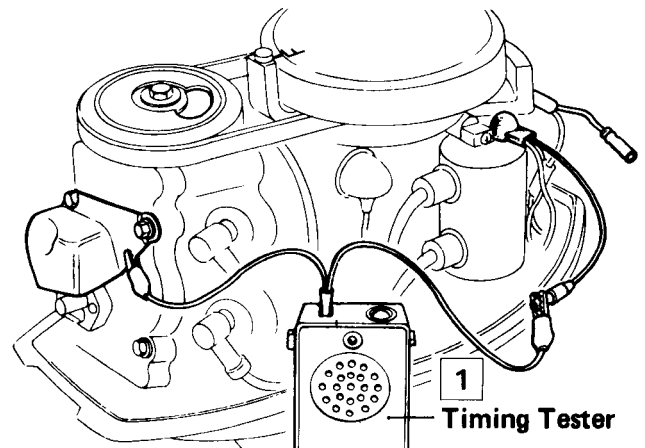

## CDI TYPE

**NOTE:** A CDI system does not require adjustment, except when the CDI unit is replaced and/or the pulser coil is removed. The timing remains unchanged as long as the set parts remain undisturbed.

- (1) To set timing, align the flywheel "T" mark and the punch mark on the cam pulley as shown, then install the timing belt.
- (2) Rotate the flywheel one complete turn and align the "F" mark with the aligning mark.  
Loosen the two screws and move the pulser coil so the marks on the coil and advancer rotor are in line.

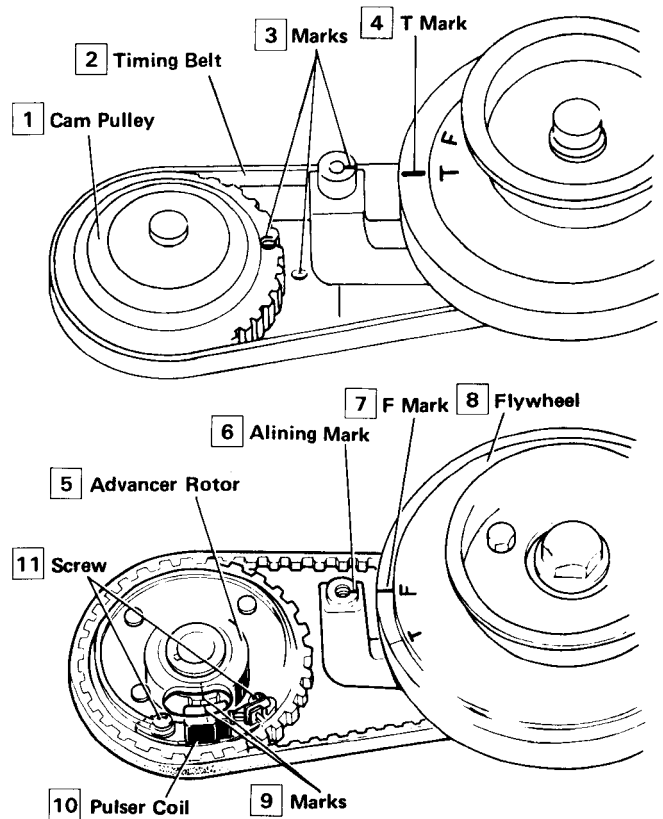

## 5. VALVE CLEARANCE ADJUSTMENT

- (1) Rotate the flywheel to align the "T" mark on the flywheel to the index mark on the starter case.
- (2) Check the clearance of both valves on the camshaft base circle by inserting the feeler gauge between the adjusting screw and the valve stem.

STANDARD CLEARANCE : 0.06 – 0.10 mm (0.002 – 0.004 in)  
(IN/EX)

- (3) If adjustment is necessary, loosen the lock nut and turn the adjusting screw by using the special tool "Adjusting wrench B 07708–0030400" until there is a slight drag on the feeler gauge. Hold the adjusting screw in this position and tighten the lock nut. Recheck the clearance with the gauge.

Tightening torque: 60–100 kg-cm (4.3 – 7.2 ft-lb)

### NOTE:

- Perform this operation with the engine cold and the cylinders at T.D.C. on the compression stroke.
- When the cylinder is at T.D.C. on the compression stroke, the intake and exhaust valves should be fully closed.

- (4) To adjust the remaining cylinder, rotate the flywheel 360° further.

- (A) "T" MARK  
(B) FEELER GAUGE  
(C) ADJUSTING SCREW  
(D) LOCK NUT

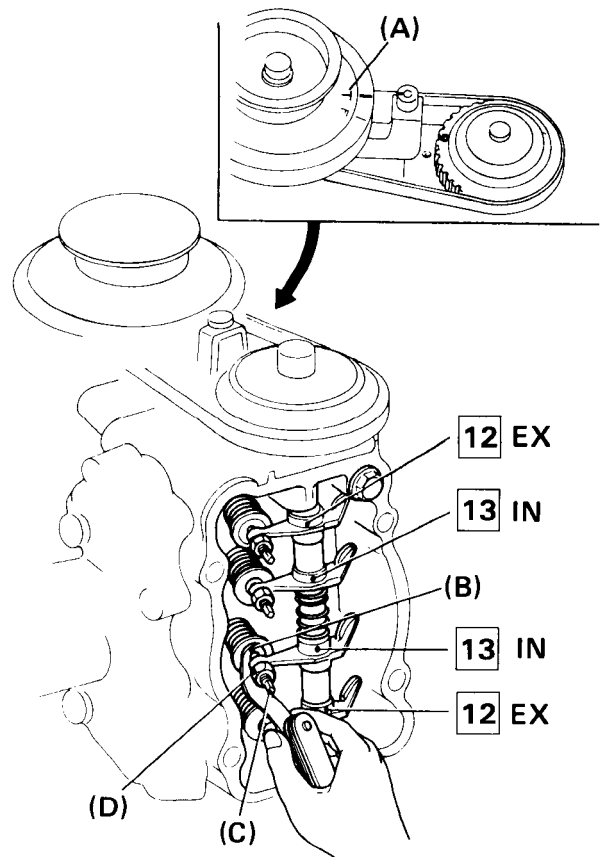

## 6. CARBURETOR ADJUSTMENT

### \* Idle Speed

- (1) Start the engine and run at idle until a normal operating temperature is obtained.
- (2) Turn the throttle stop screw in or out as necessary until the specified idle speed is obtained.

Specified idle speed	1,200 ± 100 rpm (in neutral)
----------------------	---------------------------------

### \* Pilot Screw

If the pilot screw setting needs adjustment,

- (1) Turn the pilot screw in or out until the highest idle rpm is reached.
- (2) Readjust to the specified idle speed using the throttle stop screw.

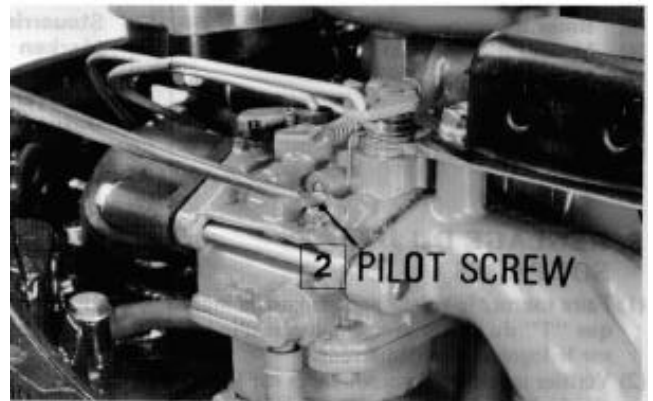

## 7. SHIFT ROD ADJUSTMENT

With the shift rod and shift arm in the forward position, and the linkage pin removed, turn the shift rod joint to align the linkage pin holes. Install the pin.

**NOTE:** The holes will usually align if the shift rod joint is turned all the way in and then unscrewed 4½ turns.

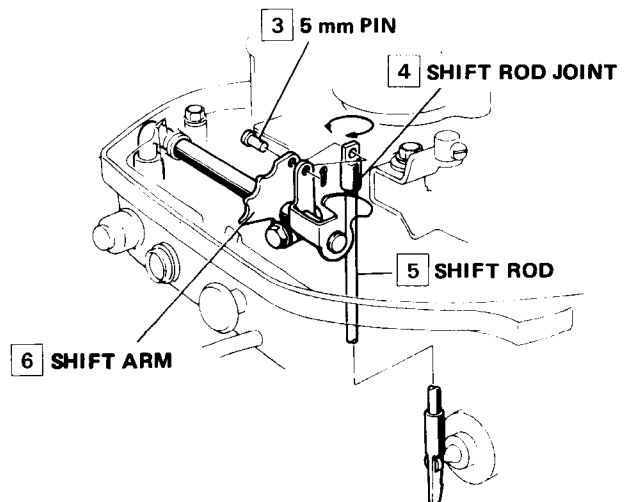

## 8. THROTTLE CABLE ADJUSTMENT

- (1) Put the shift lever in NEUTRAL and turn the throttle grip to START position.
- (2) Adjust the length of the cable so that the throttle arm contacts with the shift arm by turning the lock nuts.
- (3) Tighten the lock nuts securely.
- (4) Close the throttle grip fully and adjust the stop screw so that the carburetor throttle is fully closed.
- (5) After adjustment, shift the engine into each position and make sure that it attains the following maximum speeds.

Maximum engine speed:

Engine Serial Number 1000004 and subsequent:

F BF75: 5,200 rpm    BF100: 5,700 rpm

N 5,000 ± 200 rpm

R 3,200 ± 200 rpm

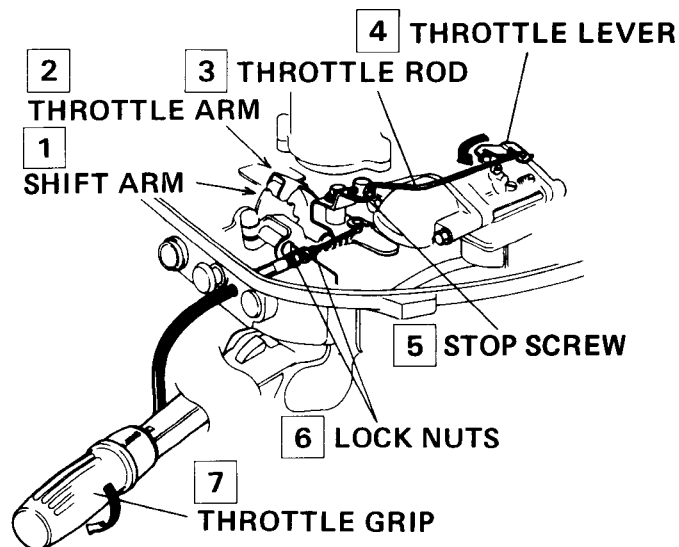

## 9. THROTTLE GRIP FRICTION ADJUSTMENT

Engine Serial Number 1000004–1299999:

- (1) Adjust the friction by turning the throttle grip end screw.

- (A) Turn to RIGHT: To tighten
- (B) Turn to LEFT: To loosen

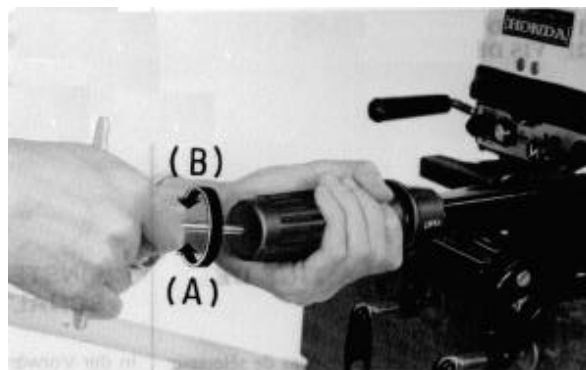

Engine Serial Number 1300001 and subsequent:

- (1) Adjust the friction by turning the throttle grip end adjuster.

- (A) Turn to RIGHT: To tighten
- (B) Turn to LEFT: To loosen

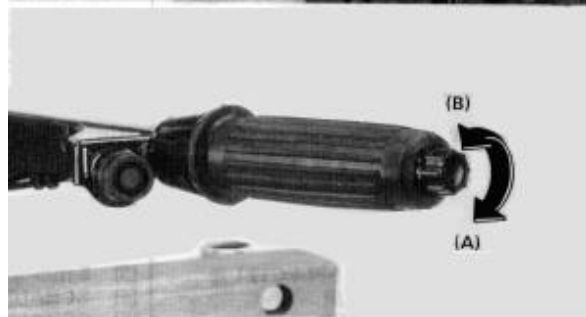

## 10. STEERING HANDLEBAR FRICTION ADJUSTMENT

- (1) Adjust the friction by turning the adjusting bolt on the swivel case.

- (A) Turn to RIGHT: To tighten
- (B) Turn to LEFT: To loosen

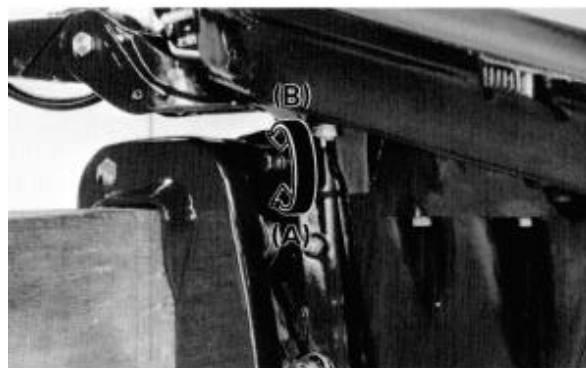

## 11. CYLINDER COMPRESSION CHECK

- (1) Remove both spark plugs and connect a compression tester to the cylinder by screwing the adaptor into the spark plug hole.
- (2) With the throttle valve wide open, and the engine stop button depressed, or a wire attached to ground the coil primary terminal, crank the engine several times. Note the maximum reading on the compression gauge.

**CAUTION:** The ignition coil may be damaged by cranking the engine with the spark plugs removed, unless the engine stop button is depressed or the coil primary terminal is otherwise grounded.

- (3) Measure the compression of both cylinders.

### STANDARD COMPRESSION

BF75	10.0 kg/cm <sup>2</sup> (142 lb/in <sup>2</sup> )/600 rpm
BF100	10.6 kg/cm <sup>2</sup> (151 lb/in <sup>2</sup> )/600 rpm

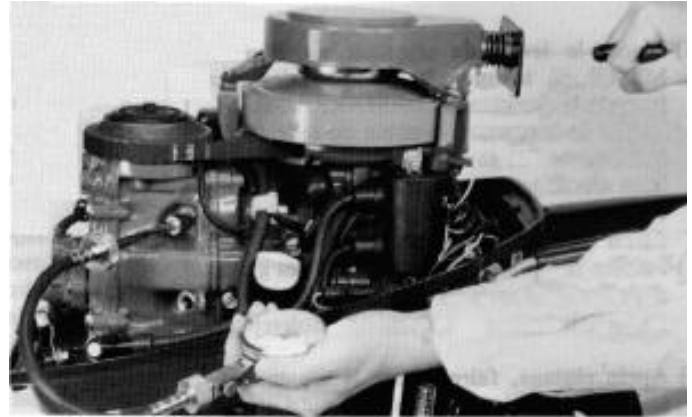

## 12. SPARK TEST

### WARNING

- When spark-checking, keep your hands away from high tension electrical parts.
- Make sure that no fuel has been spilt on the engine and that the plug is not wet with fuel.

- (1) Remove the spark plug, attach the plug cap and ground the circuit by touching the negative (side) electrode to the cylinder block as shown.
- (2) Pull the recoil starter and check to see if sparks jump across the electrodes.



# IV. DISASSEMBLY AND SERVICE

**HONDA**  
BF75/BF100

- |  |                               |
|--|-------------------------------|
| 1. DISASSEMBLY CHART                           | 7. CAM SHAFT/VALVE/OIL PUMP   |
| 2. RECOIL STARTER                              | 8. CRANKSHAFT/PISTON          |
| 3. CARBURETOR/FUEL PUMP                        | 9. HANDLEBAR/SHIFT LEVER      |
| 4. ELECTRICAL                                  | 10. SWIVEL CASE/STERN BRACKET |
| 5. ENGINE/LOWER UNIT REMOVAL                   | 11. PROPELLER/GEAR CASE       |
| 6. CYLINDER HEAD REMOVAL<br>(SINGLE OPERATION) | 12. OPTIONAL PARTS            |

## 1. DISASSEMBLY CHART

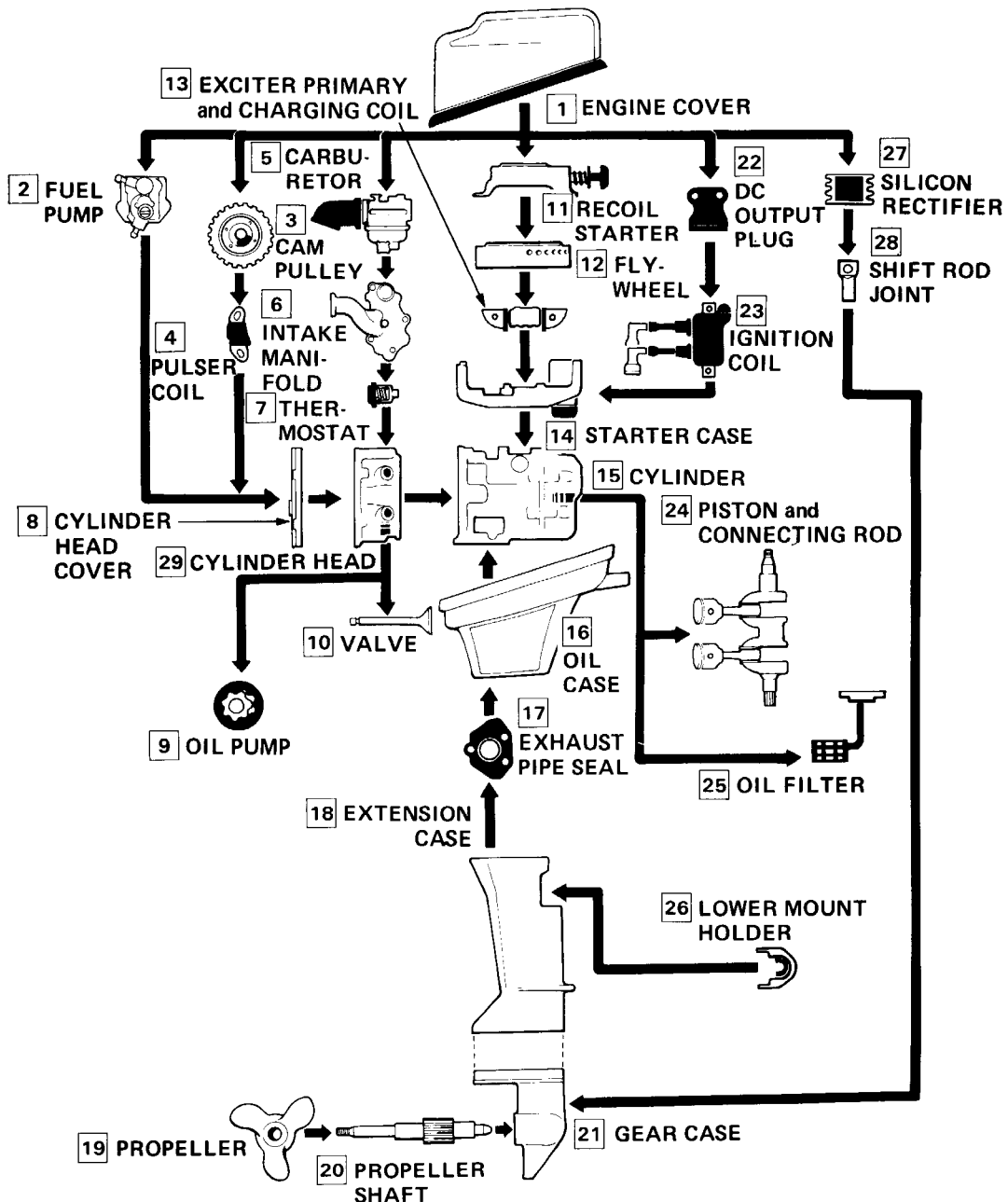

**2. RECOIL STARTER**

●ENGINE COVER

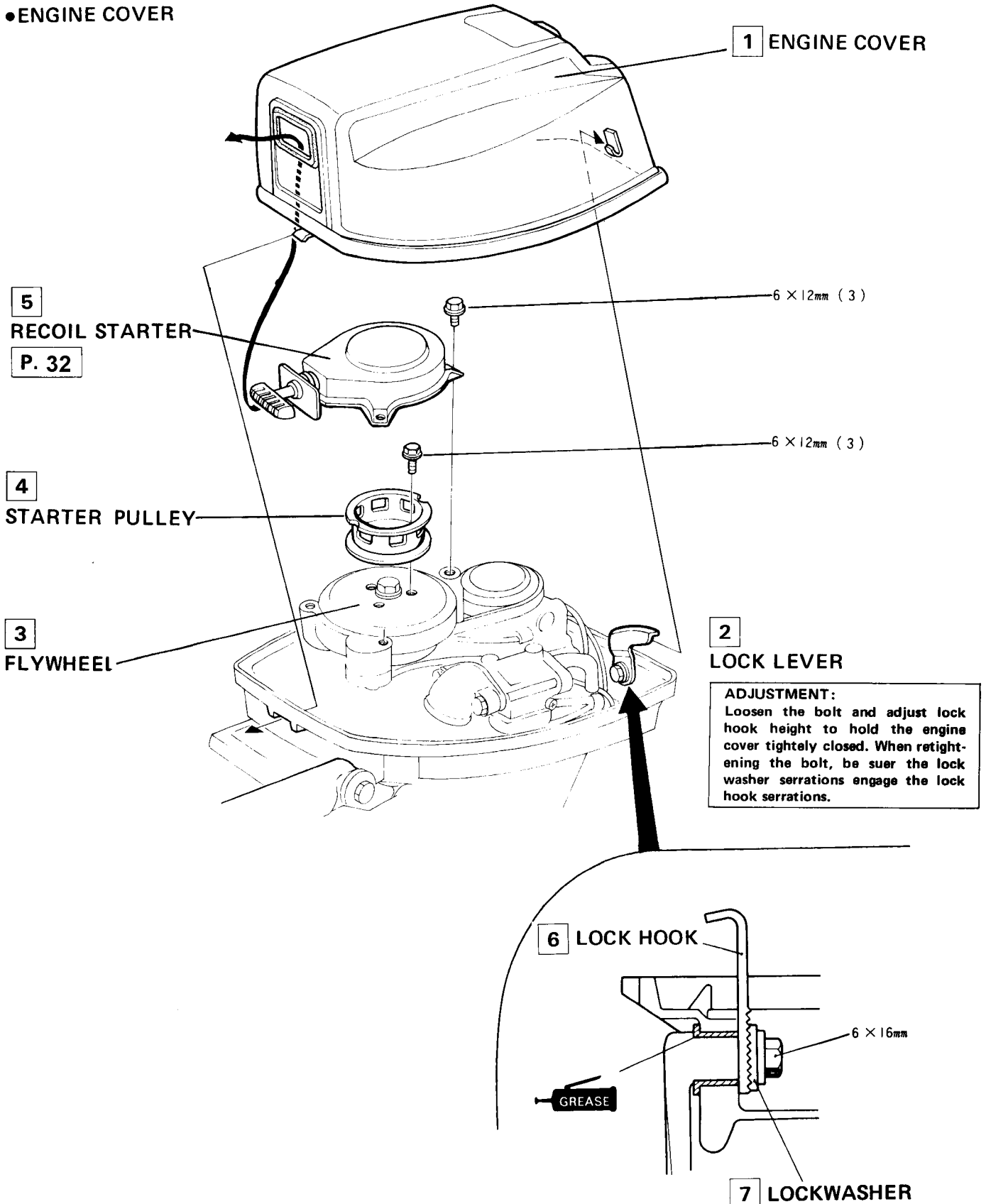

## ● FRICTION PLATE

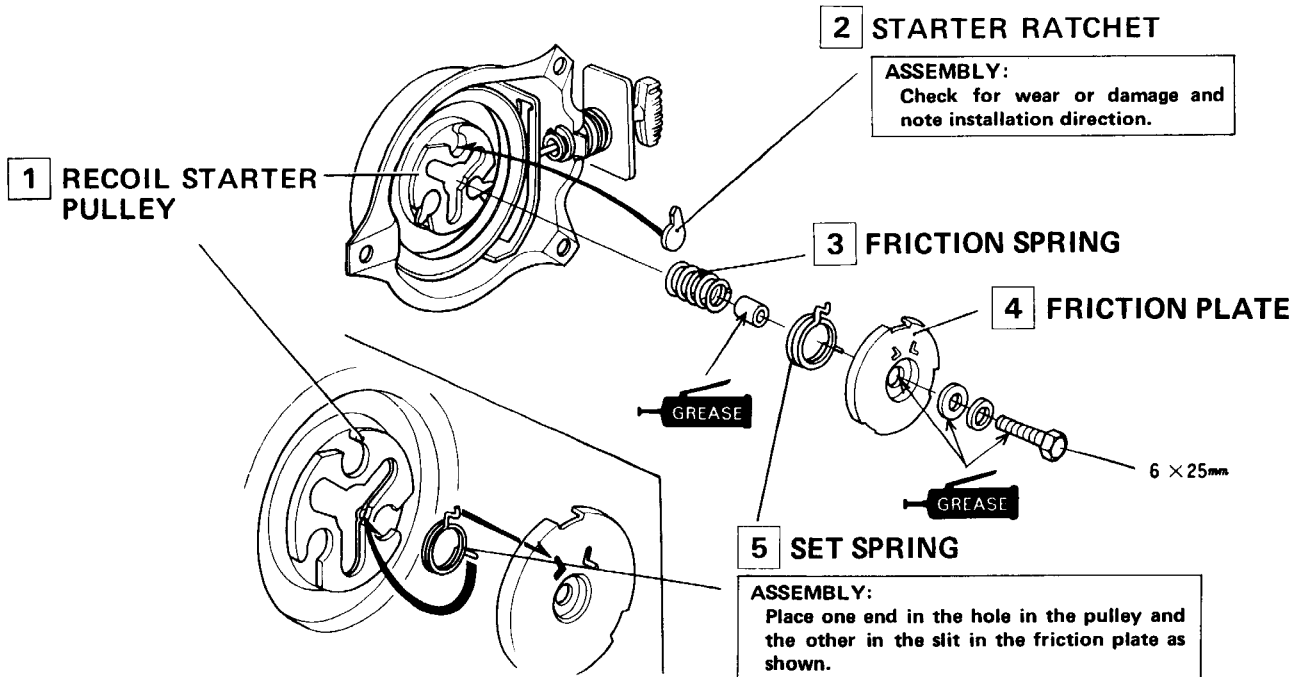

## ● RETURN SPRING

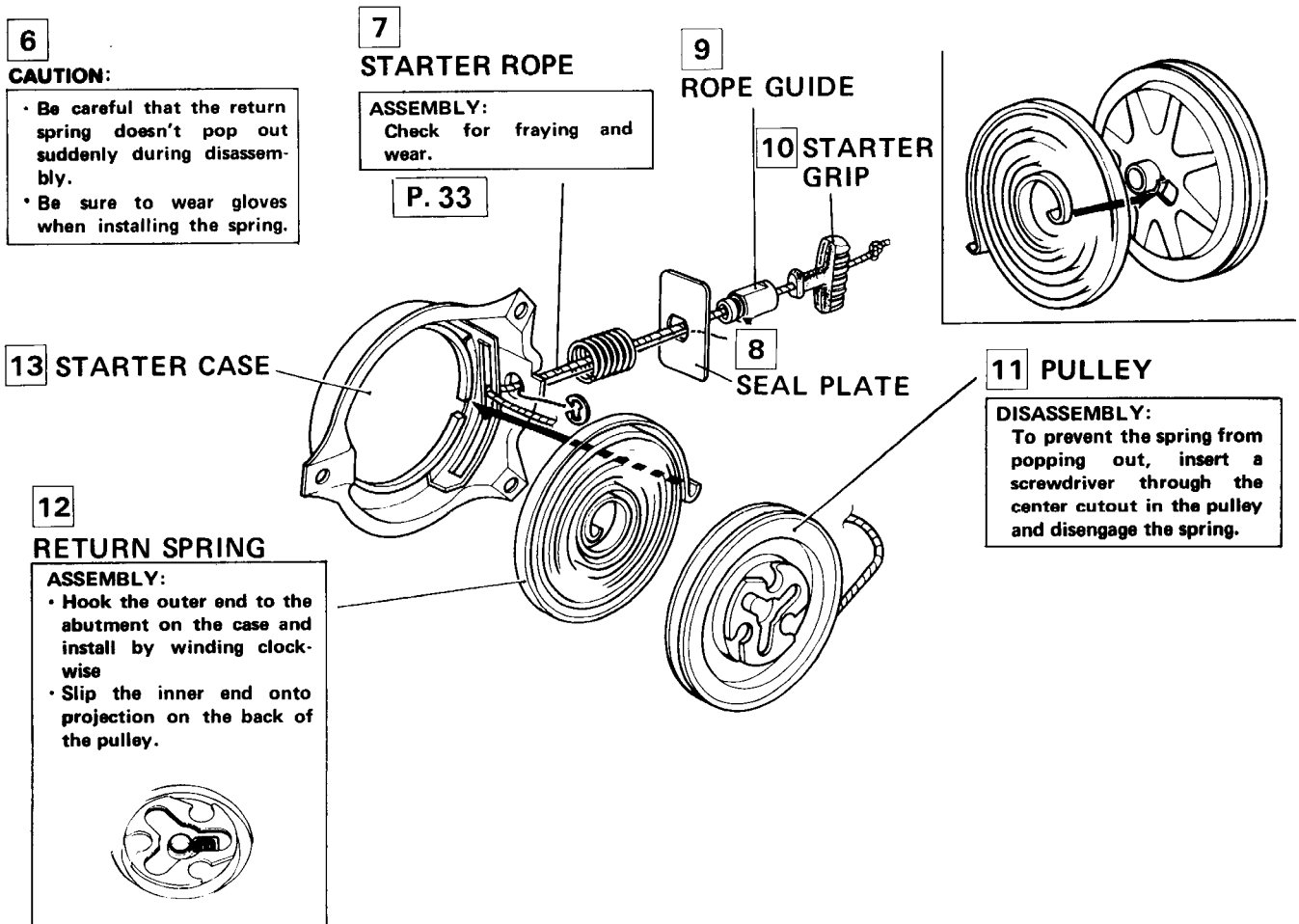



• **STARTER ROPE ASSEMBLY**

- 1) Route one end of the starter rope (2) through the hole in the starter pulley (1) and tie a knot in the end. Secure the rope with tab (3) on the pulley.

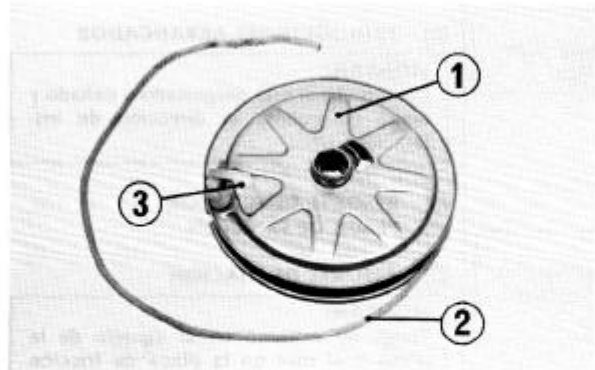

- 2) Wind the rope around the pulley. Set the pulley in the case (4).



- 3) Install the springs (5), ratchets (6) and friction plate (7), in order. Rotate the plate 1/3 turn clockwise and secure with the 6 mm bolt. Tighten securely.

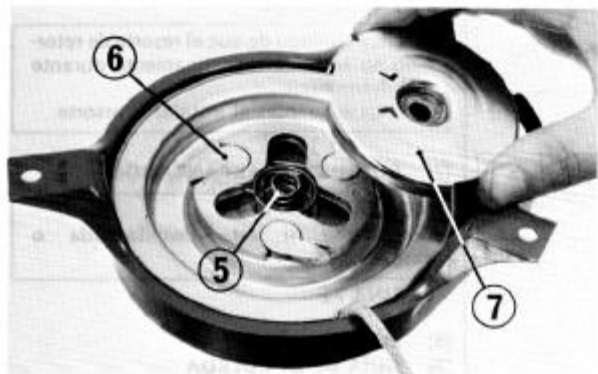

- 4) While holding the rope end in the cut-out (8) in the pulley, rotate the pulley 3 to 4 turns in the direction of the arrow.

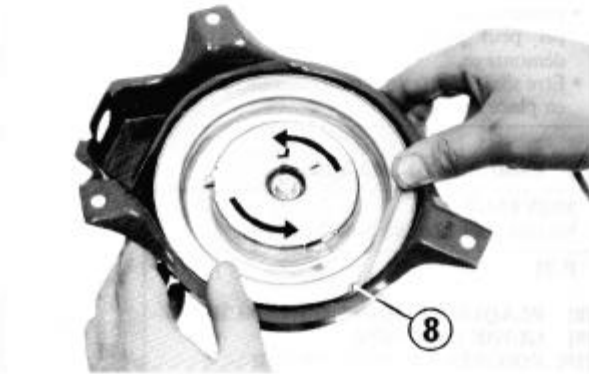

- 5) Attach a spring scale to the rope end and measure the force with which the rope is pulled out. If it does not fall within 1.3–2.3 kg (2.9–5.2 lbs), turn the pulley in or out as required.



- 6) Slip the rope guide (9), seal plate (10) and grip (11), over the rope and tie a knot in the end of the rope. Secure the rope guide with the E-ring (12). After assembling, check the operation of the starter ratchets and return of the rope.

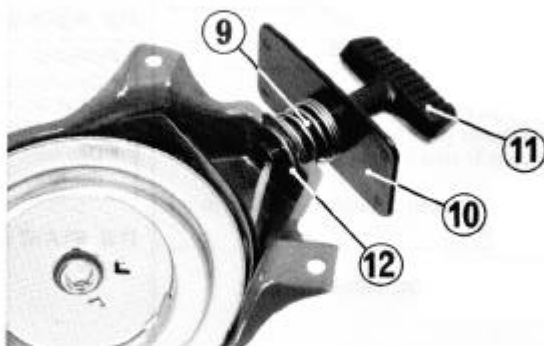

### 3. CARBURETOR/FUEL PUMP

- CARBURETOR **1** AIR GUIDE (Model with engine serial numbers 1300001 and subsequent shown)

**ASSEMBLY :**  
Before installing the guide, remove all dust and dirt from the screen.

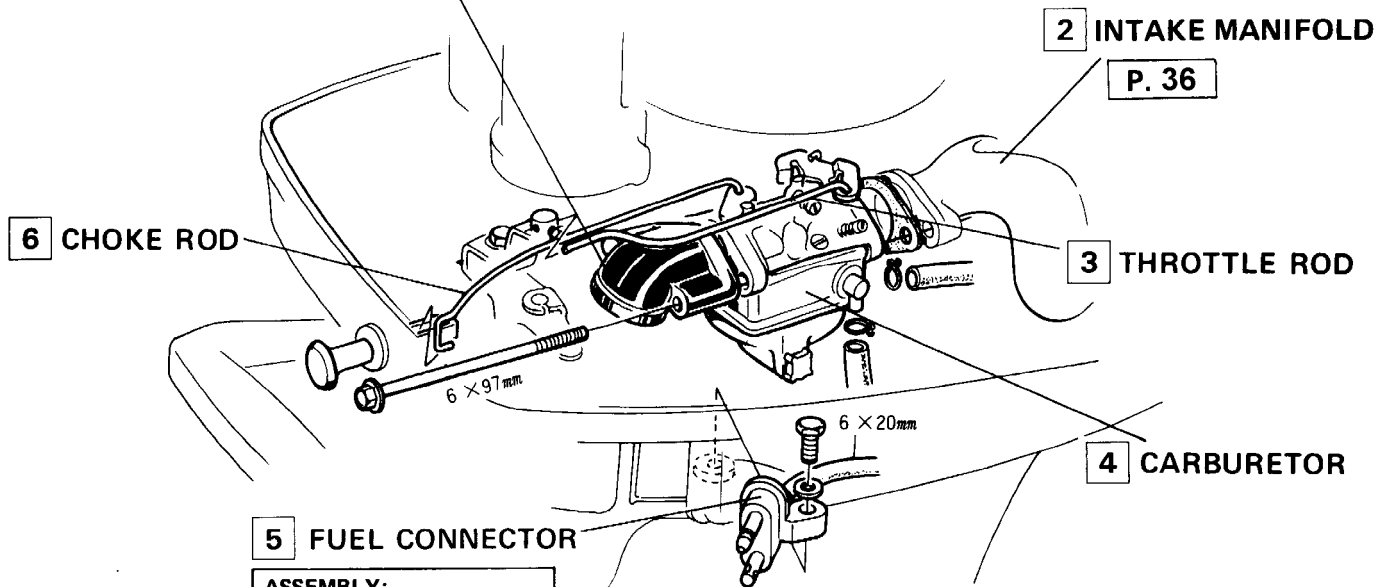

- 5** FUEL CONNECTOR

**ASSEMBLY:**  
Blow out fuel passages with compressed air.

- LINKAGE

- 7** CHOKE ROD

**ASSEMBLY :**  
Push in the choke knob fully to ensure that the choke lever is in FULL OPEN position.

- 8** CHOKE LEVER

- 9** THROTTLE LEVER

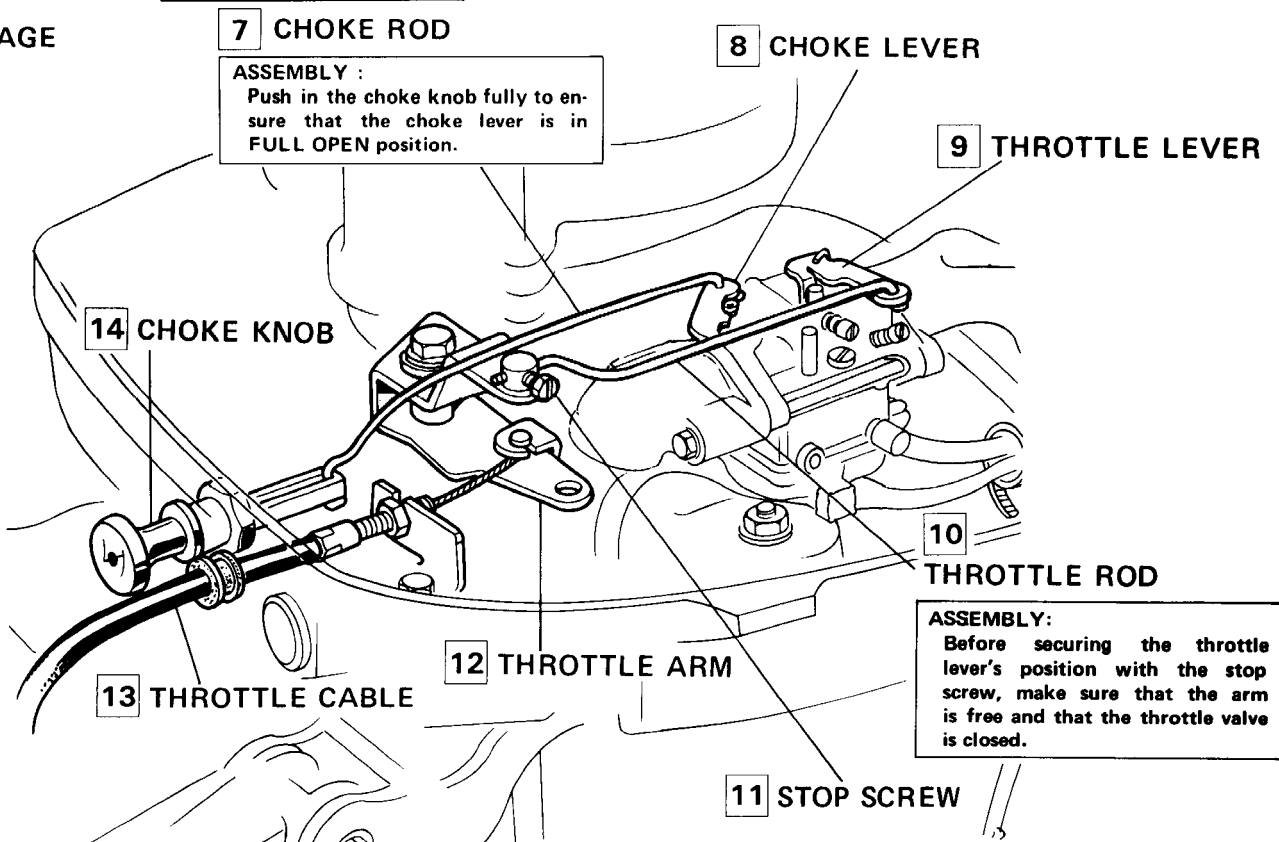

**ASSEMBLY:**  
Before securing the throttle lever's position with the stop screw, make sure that the arm is free and that the throttle valve is closed.

## • FLOAT/MAIN JET

**CAUTION:** Always drain the carburetor before assembly.

- Hold the carburetor as shown with the float valve just touching the float tang and measure the distance between the top of the float and carburetor body.

**SPECIFIED FLOAT HEIGHT:** 9.85–10.15 mm (0.388–0.400 in.)

- Bend the tab to adjust incorrect float height.
- See page 27 for carburetor adjustment.

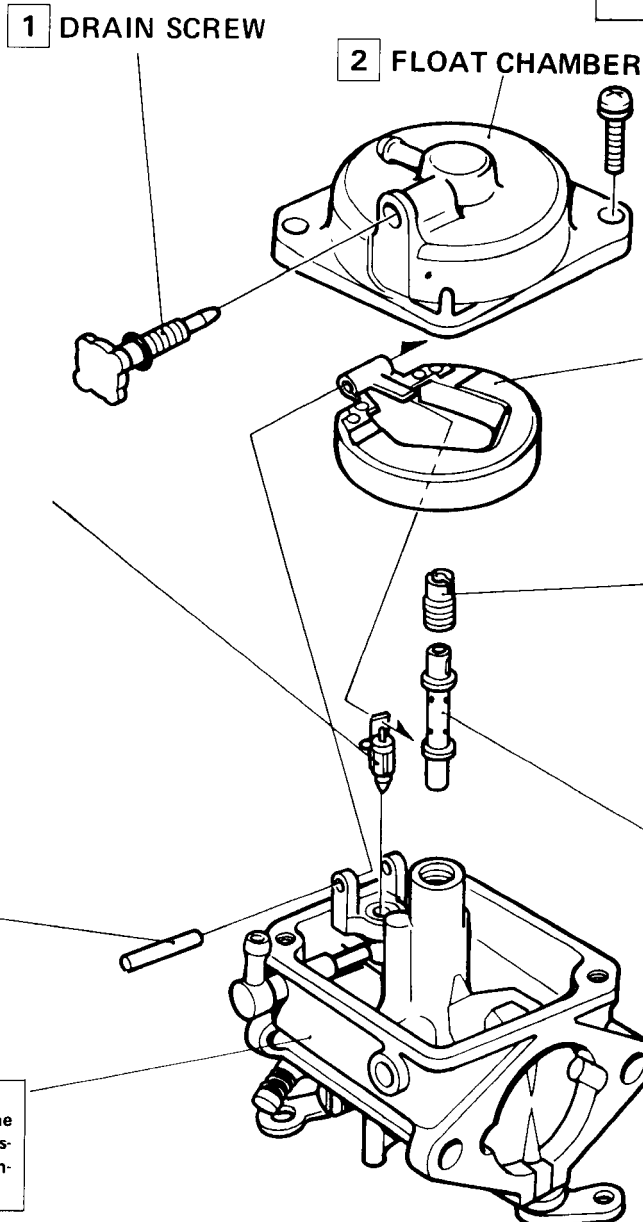

### 8 FLOAT VALVE

**ASSEMBLY :**

- Check the valve for wear or scores, and the needle spring condition.
- Hook the steel wire over the float arm tang to facilitate installation.

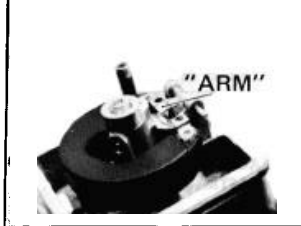

### 3 FLOAT

**ASSEMBLY :**

- After installing, check operation by pushing down lightly with your finger. Check height.

### 4 MAIN JET

- Standard jet is #88.

**CAUTION :**

- Blow out with compressed air before installing the main jet.

### 5 MAIN NOZZLE

**ASSEMBLY :**

- Blow out with compressed air.

### 7 FLOAT PIN

### 6 BODY

**ASSEMBLY :**

- Wash all residue from the body and blow out all passages or circuits with compressed air.

## ● INTAKE MANIFOLD/FUEL PUMP

NOTE: For tubing installation, see page 16.

### 1 THERMOSTAT

#### INSPECTION:

Suspend the thermostat in heated water. Measure water temperature and valve lift.

**HIGH TEMPERATURE THERMOSTAT** – no longer available: original equipment through serial No. (BF75) 1004085 and (BF100) 1009155.

Water Temperature	Valve Lift
Below 70°C (158°F)	0 mm
Above 80°C (176°F)	3–4 mm (0.12–0.16 in)

**MEDIUM TEMPERATURE THERMOSTAT:** original equipment starting with serial No. (BF75) 1004086 and (BF100) 1009156.

Water Temperature	Valve Lift
Below 60°C (140°F)	0 mm
Above 70°C (158°F)	2–3 mm (0.08–0.12 in)

**LOW TEMPERATURE THERMOSTAT** – original equipment starting with serial No. 1600001. (Kanada: BF75, 100 Long types only)

Water Temperature	Valve Lift
Below 50°C (122°F)	0 mm
Above 60°C (140°F)	2–3 mm (0.08–0.12 in)

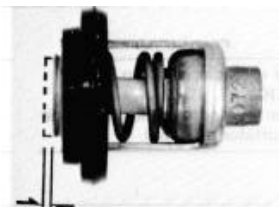

VALVE LIFT

### EARLY MODEL FUEL PUMP

Engine serial numbers:

BF75 : 1000004–1102880

BF100: 1000004–1101260

NOTE: If installing a late model replacement fuel pump, discard the pump cover and add two fuel tube clips as shown in the lower illustration.

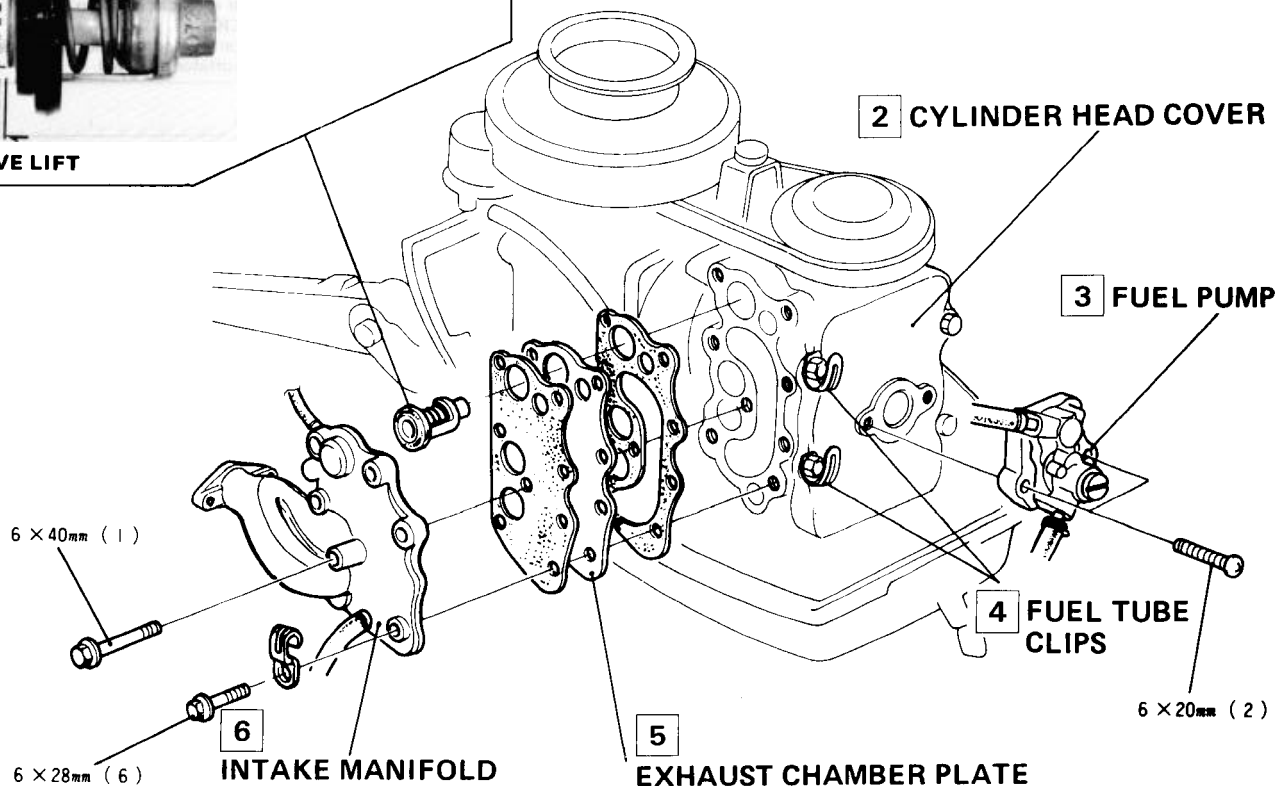
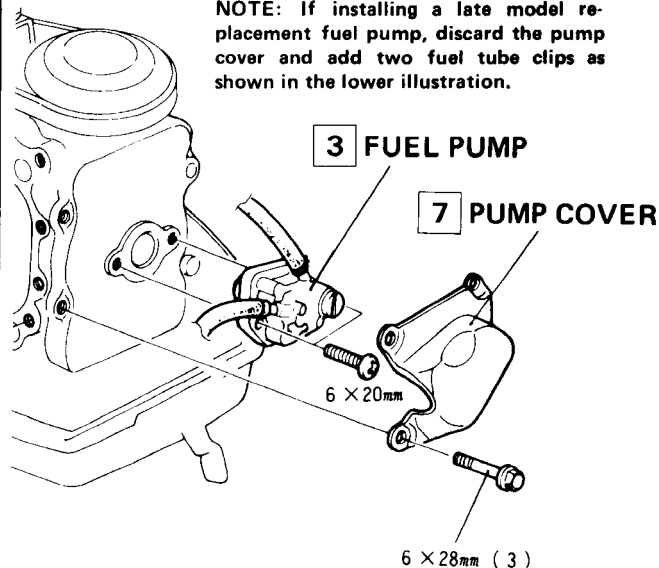

#### ASSEMBLY:

Blow out all passages with compressed air before installing.

#### ASSEMBLY:

Note installation direction and location.

## ● FUEL PUMP

Engine serial numbers:

BF75 : 1000004-1102880

BF100: 1000004-1101260

Engine serial numbers:

BF75 : 1102881 and subsequent

BF100: 1101261 and subsequent

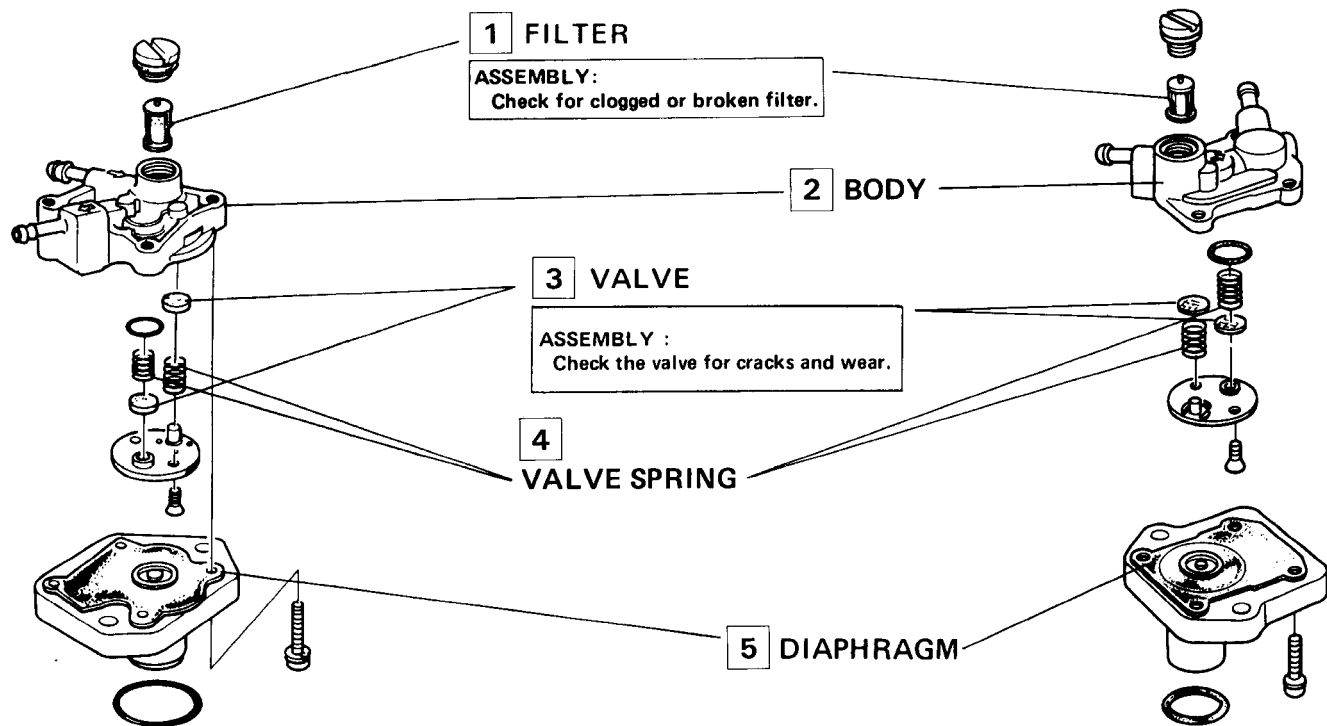

## ● DIAPHRAGM

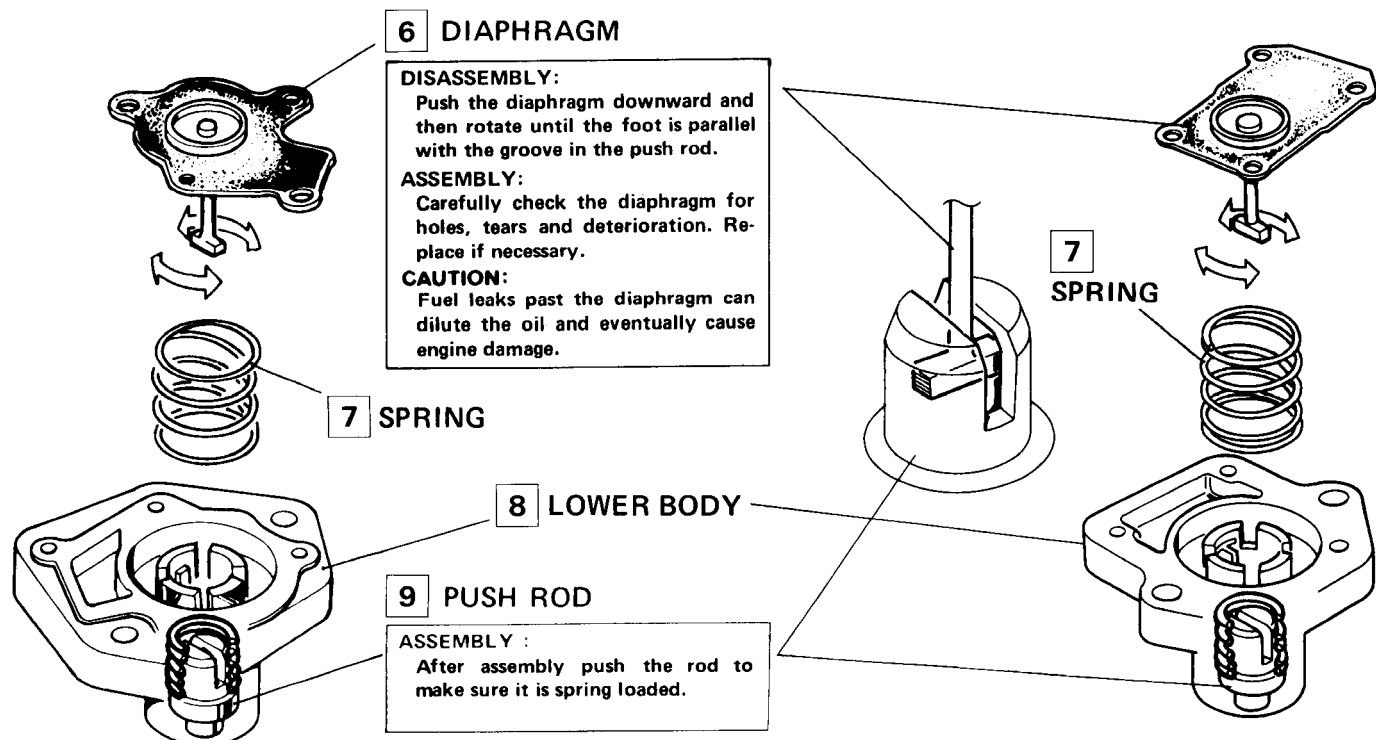

## 4. ELECTRICAL

### a. DISASSEMBLY/ASSEMBLY

#### • FLYWHEEL

1

#### ASSEMBLY :

See page 12 for wire connections.

### 2 CHARGING COIL

P. 42

14mm

650 kg-cm  
(47 ft-lb)

### 3 FLYWHEEL

#### DISASSEMBLY:

07925-8930000  
PULLEY HOLDER  
or commercially available band  
strap wrench.  
07935-8050002  
FLYWHEEL PULLER

#### ASSEMBLY:

Clean the crankshaft taper before installation.

### 11 TIMING BELT

#### DISASSEMBLY:

Remove the belt from the cam pulley with your fingers. Do not use a screwdriver.

#### ASSEMBLY:

- Check for wear or cracks.
- Align the "T" mark on the flywheel and the punch mark on the pulley to their respective aligning marks.
- Always install the belt so that "HONDA" can be read.

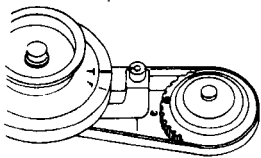

6 × 35mm (2)

### 4 EXCITER COIL

#### ASSEMBLY :

After installation, make sure that the coil does not interfere with the flywheel.

### 5 PRIMARY COIL

#### CONTACT BREAKER TYPE

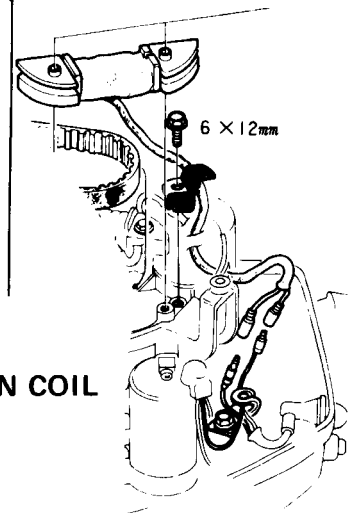

6 × 12mm

### 10 CAM PULLEY

P. 45

### 9 WOODRUFF KEY

#### ASSEMBLY :

Do not forget to install and be sure it is in place.

### 8 STARTER CASE

P. 44

### 6 IGNITION COIL

P. 43

### 7 TIMING PULLEY

P. 44

• INDICATOR LAMP/ENGINE SWITCH  
 Engine serial numbers 1000004–1199999

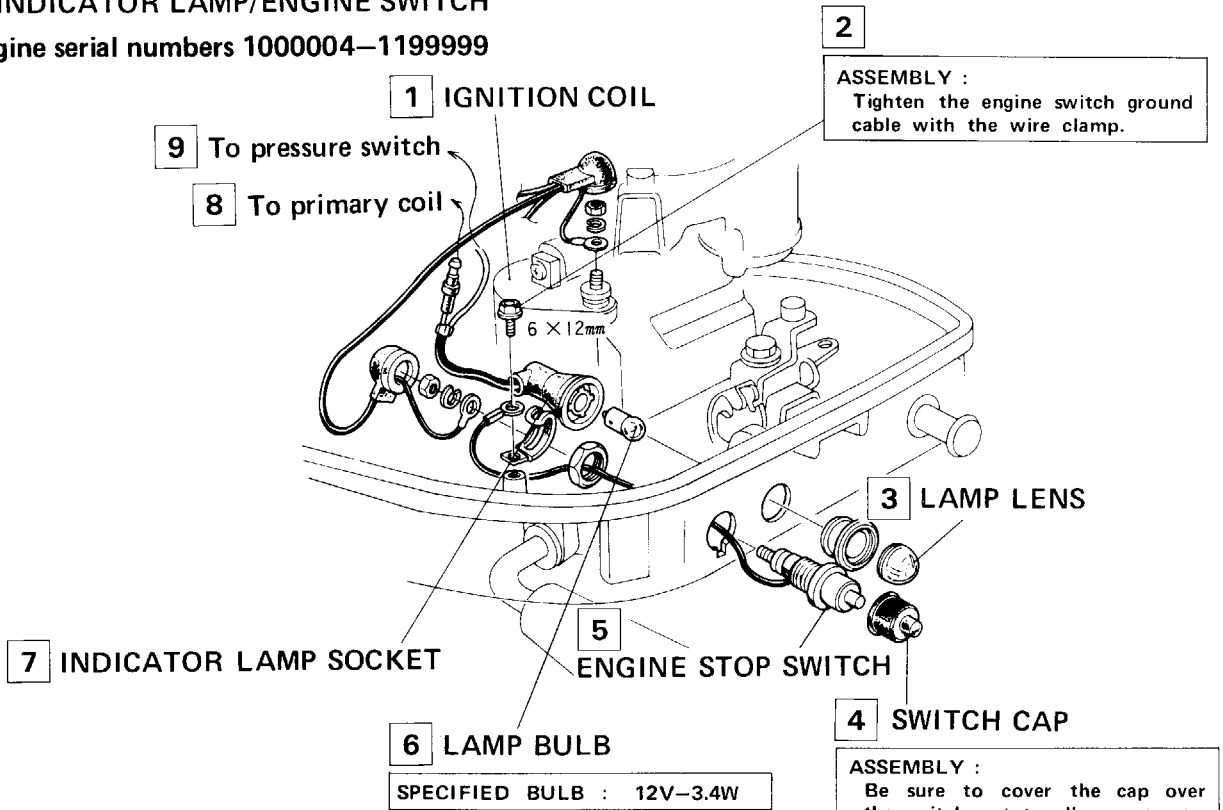

Engine serial numbers  
 1200001–1299999

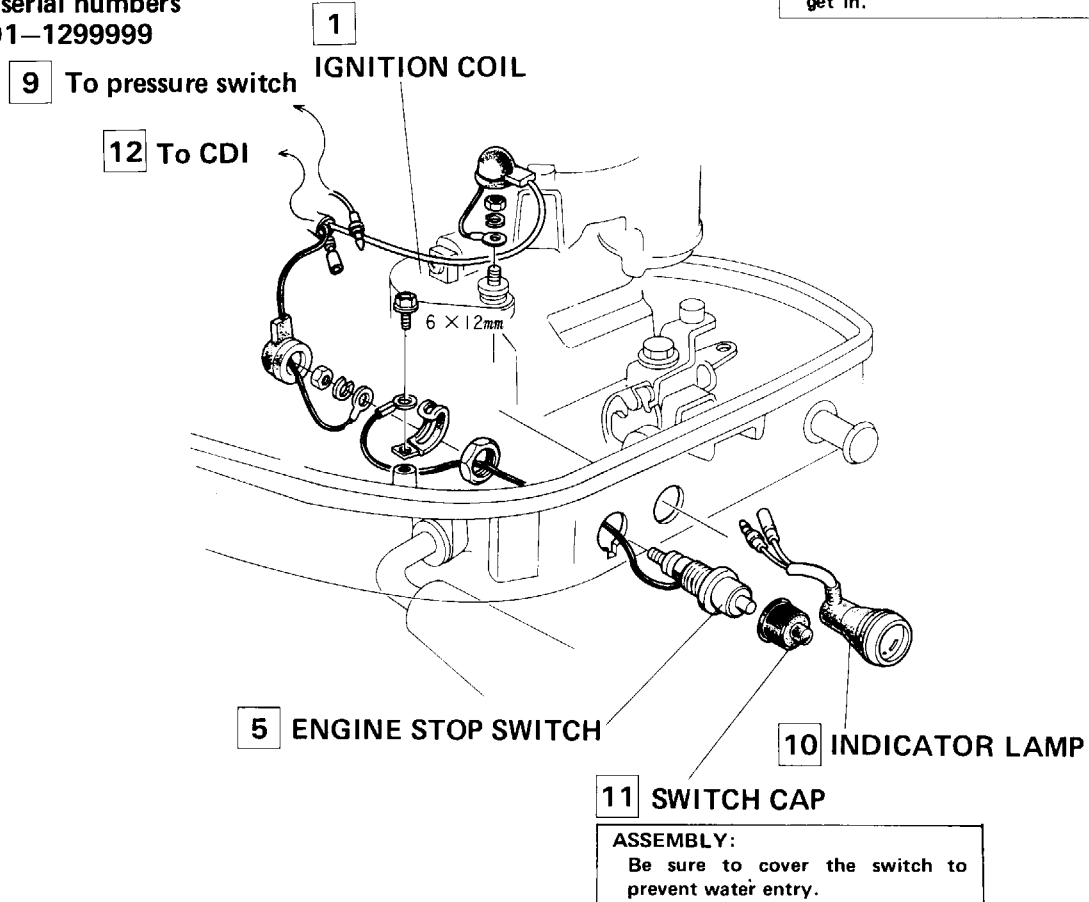

Engine serial number 1300001 and subsequent

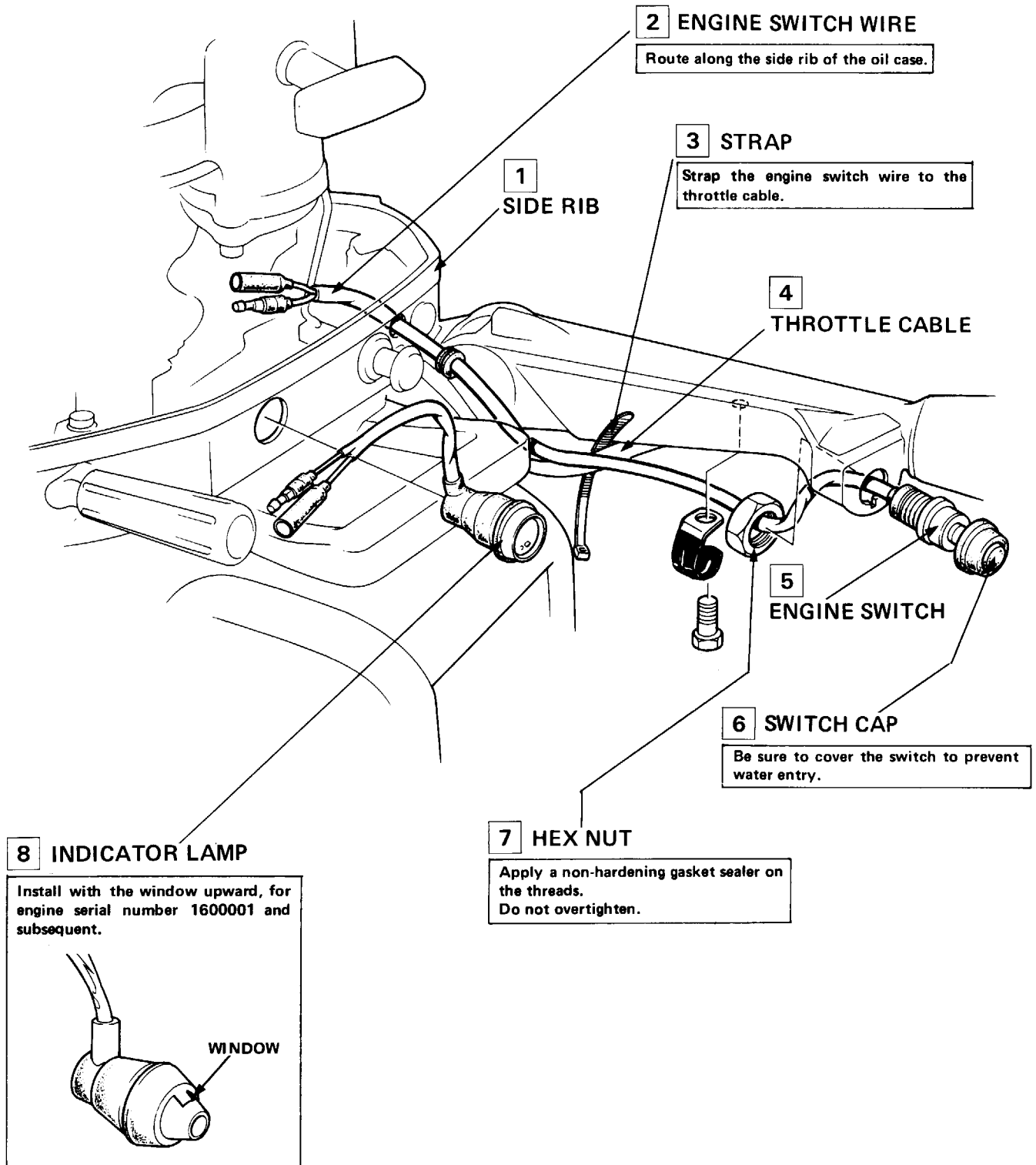



• NEUTRAL SWITCH (Engine serial number 1300001 and subsequent)

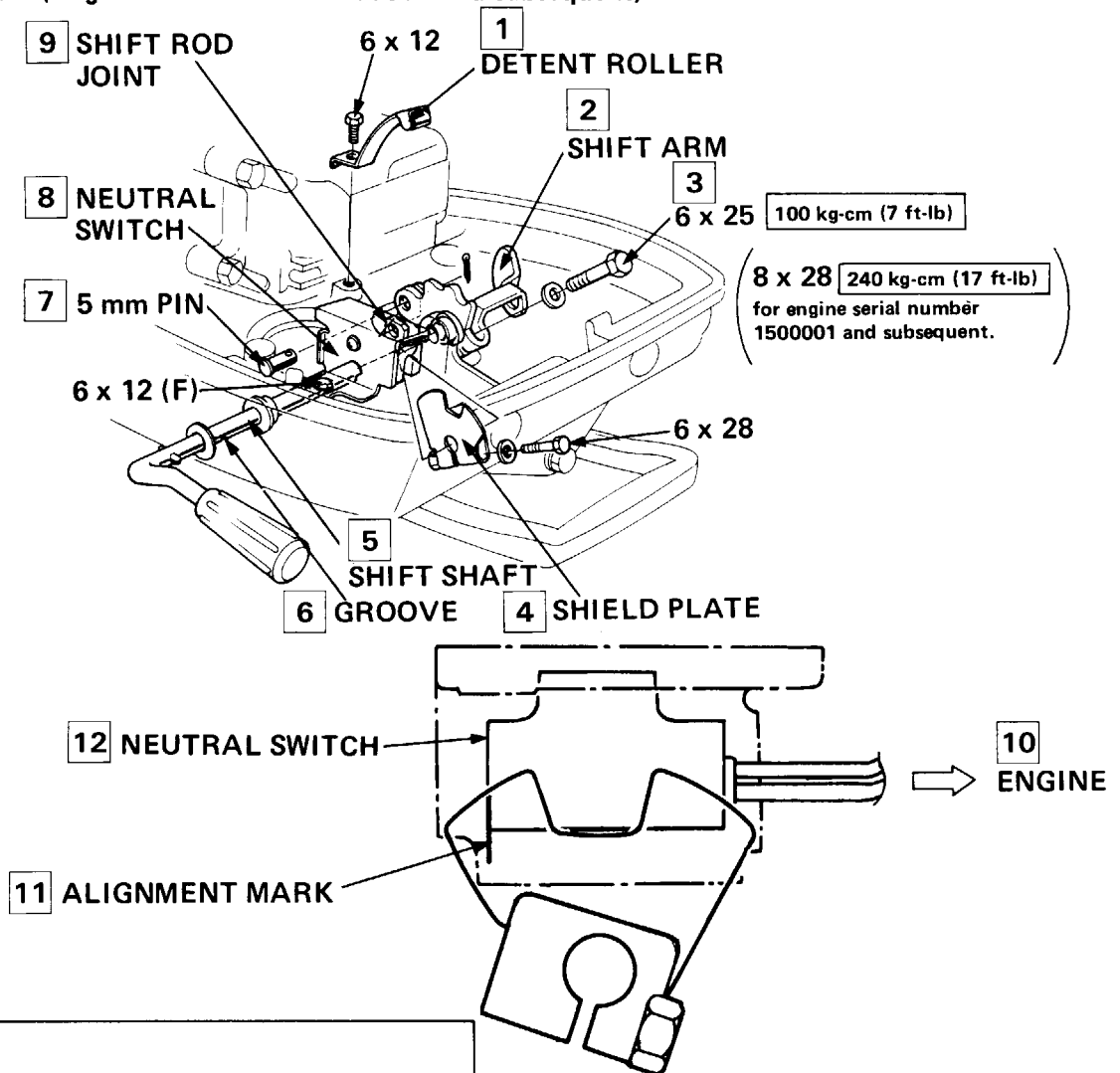

13

**ASSEMBLY:**

1. Install the shift shaft through the shield plate and shift arm.  
NOTE: Be sure the shaft goes all the way through the arm.
2. Secure the shift arm on the shaft with the 6 x 25 mm or the 8 x 28 mm bolt and washer, then install the detent roller.
3. With the transmission in neutral (the detent roller in the middle notch on the shift arm) slide the clevis pin through the shift arm and shift rod joint. Install the cotter pin.  
NOTE: The pin should go in without binding. If adjustment is necessary, turn the shift rod joint as required: counter-clockwise to raise it, clockwise to lower it.
4. Install the neutral switch with the 6 x 12 mm bolt.
5. Put the shift lever in REVERSE so the shaft groove is accessible. Secure the shield plate on the shaft with the 6 x 28 mm bolt through the groove.
6. Put the shift lever in NEUTRAL and check that the mark on the shield plate aligns with the end of the neutral switch body. If not, loosen the 6 x 28 mm bolt and adjust the shield plate position. Retighten the bolt.
7. Check switch continuity as described below.

• D.C. OUTPUT CIRCUIT

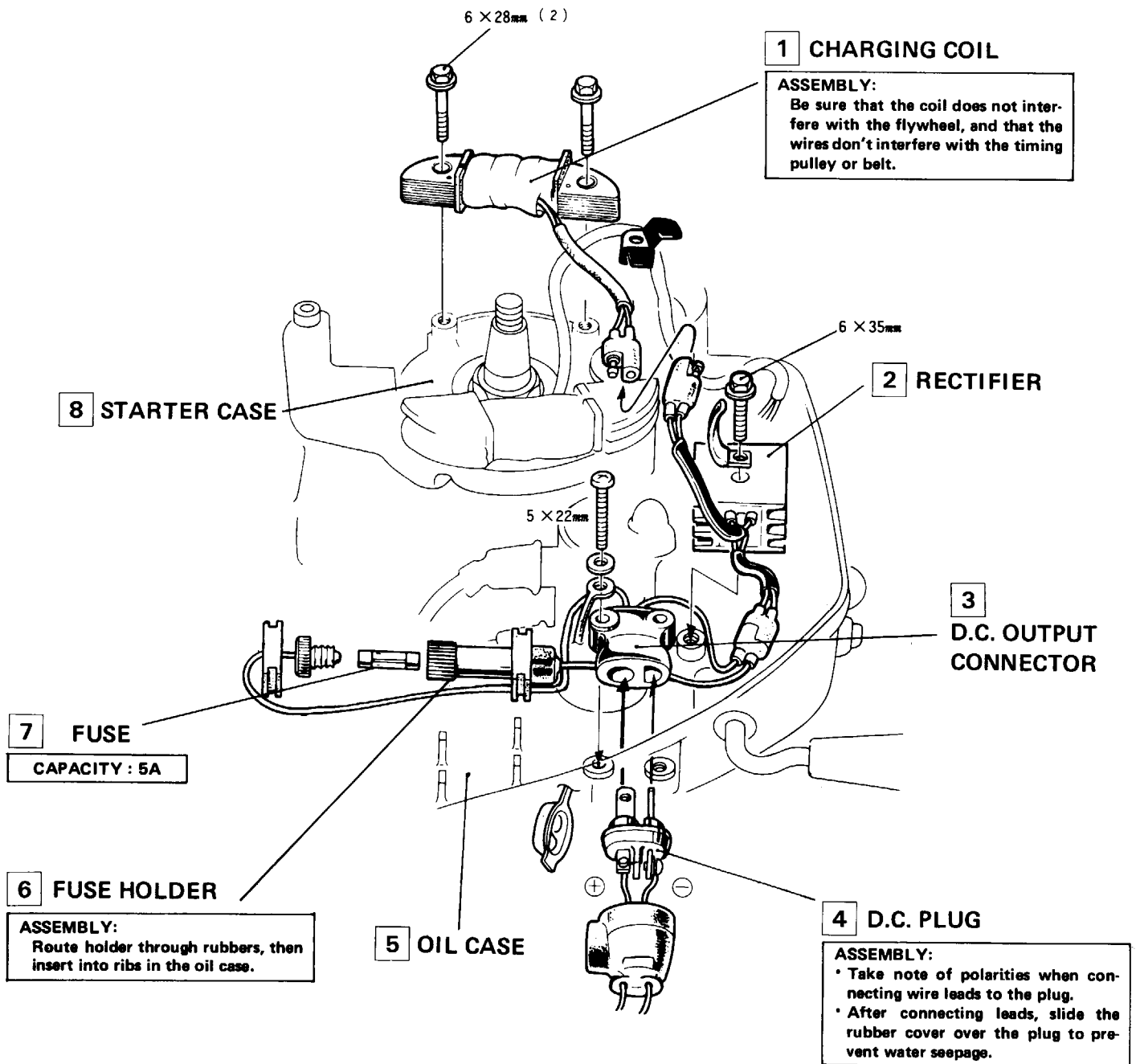

### • IGNITION COIL

Engine serial numbers 1000004–1199999

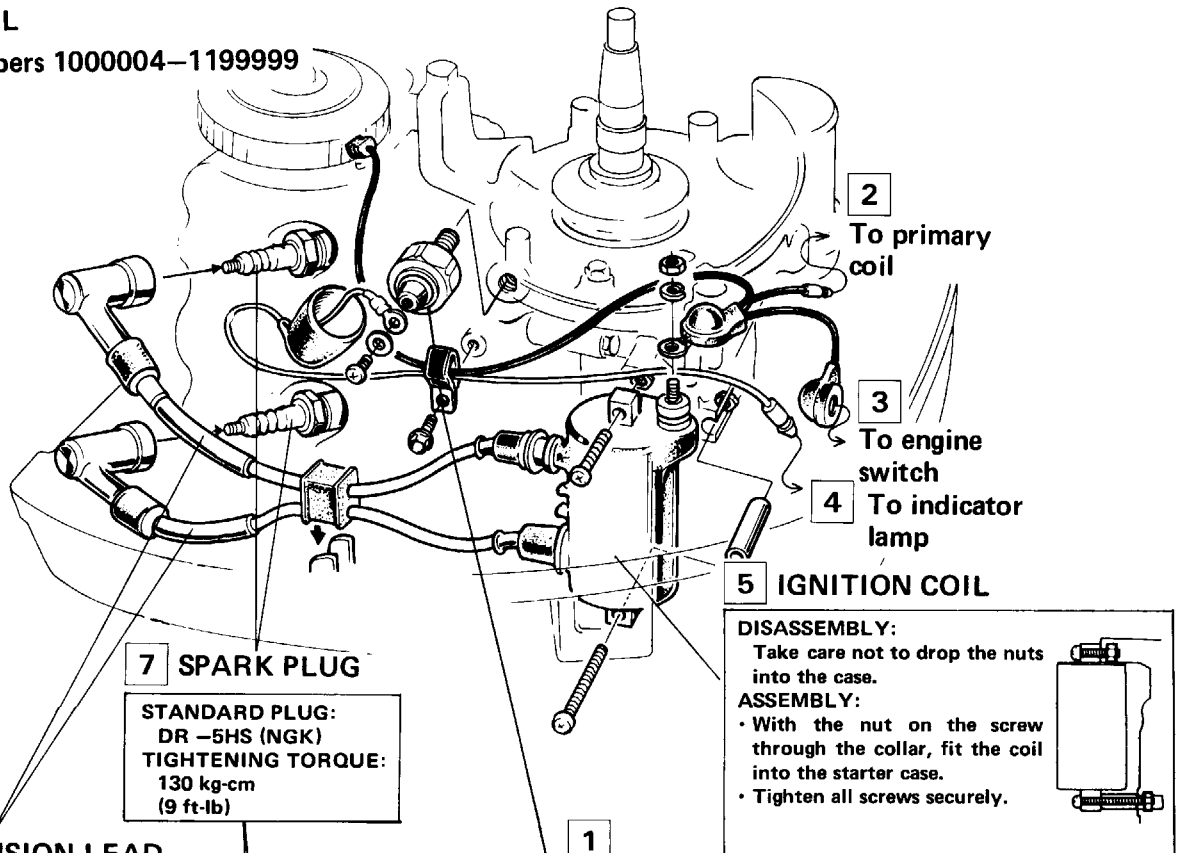

### **6** HIGH TENSION LEAD

**ASSEMBLY:**  
Be sure the insulators are not frayed or broken.

### **1** PRESSURE SWITCH

**ASSEMBLY:**  
Apply a small amount of adhesive to the threads.

**TORQUE SPECIFICATION:**  
90 kg-cm (6 ft-lb)

Engine serial number 1200001 and subsequent

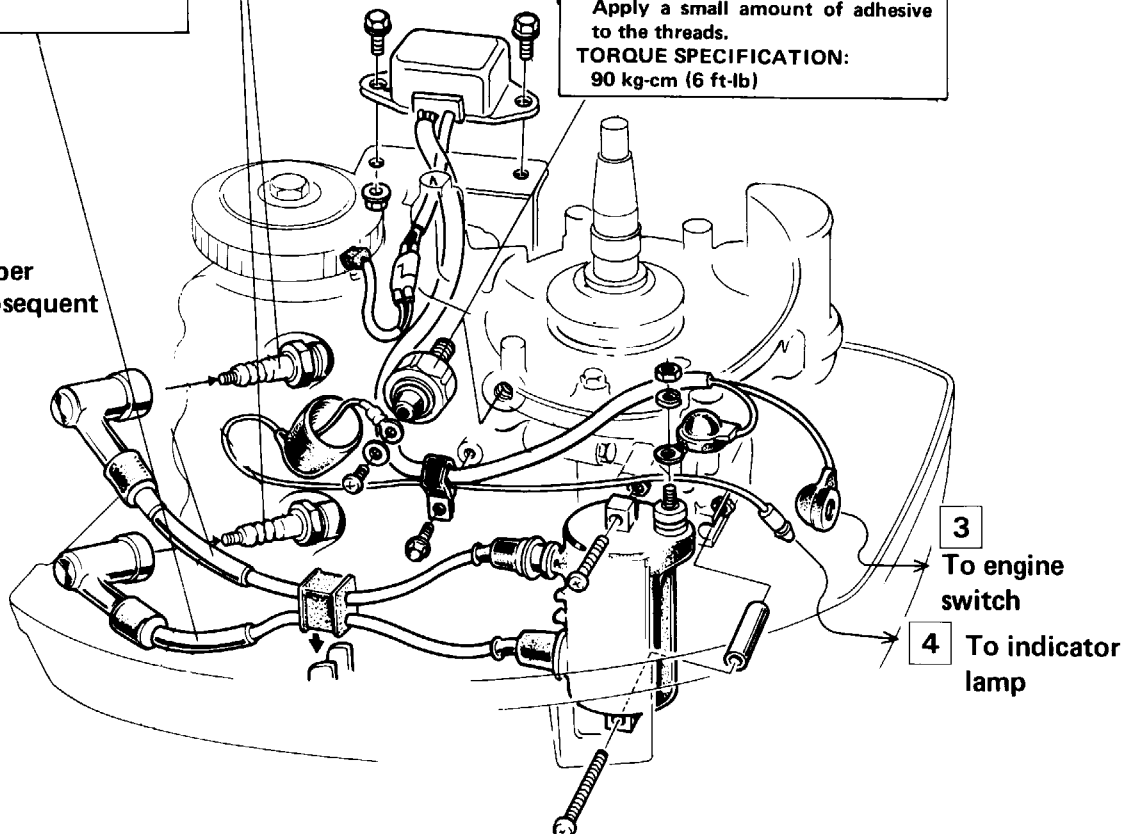

• STARTER CASE

1

**ASSEMBLY :**

Connect all tubes as illustrated on page 34.

2 BREATHER CHAMBER

P. 102

3

8 x 10 mm DOWEL PINS (2)

**ASSEMBLY :**

Be sure to install the pins in the correct positions.

9 STARTER CASE

4

LOCK WASHER

**ASSEMBLY :**

- Install the washer so that the inner tang fits into groove in the pulley flange.
- Bend the washer against the 24 mm nut at two places after the nut has been tightened.

24 mm NUT

2.0-2.5Kg-m  
(14.5-18.1 ft-lb)

8

TIMING PULLEY

**ASSEMBLY :**

Install the pulley with the mark "FLYWHEEL" facing up.

7

WOODRUFF KEY

**ASSEMBLY :**

Do not forget to install and be sure it is in place.

5

PULLEY FLANGES

**ASSEMBLY :**

Install the flanges so that the curved surfaces are positioned away from each other.

6 CRANKSHAFT

6 x 28mm (3)

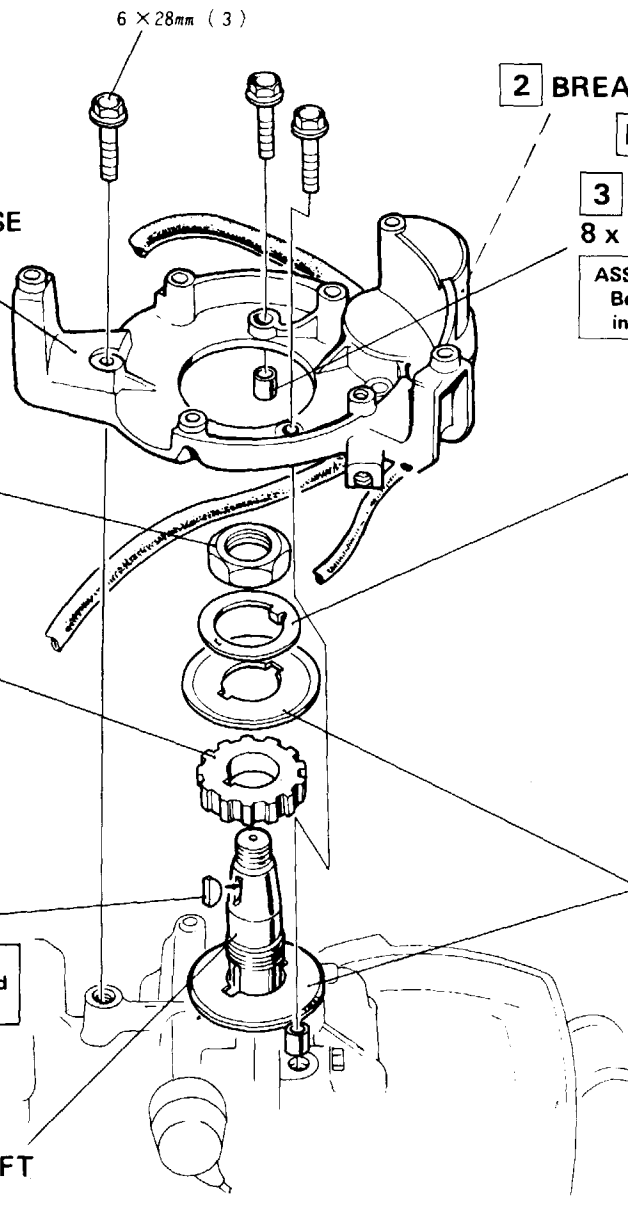

● CONTACT BREAKER (Engine serial numbers 1000004–1199999)

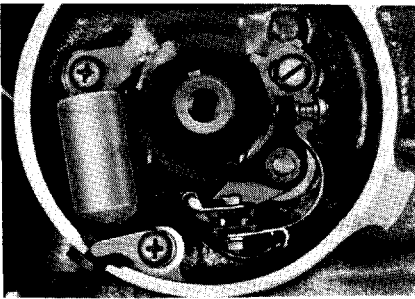

**1**  
POINT COVER

**ASSEMBLY :**  
Align the keyway in the cover with the woodruff key in the crankshaft. Make sure that the cover is seated.

**WARNING**

The engine should not be run until the cover has been installed; otherwise, the contact breaker points may become contaminated.



**10**  
CAM PULLEY

**DISASSEMBLY :** Do not hammer.

6 × 22mm

100 kg-cm  
(7 ft-lbs)

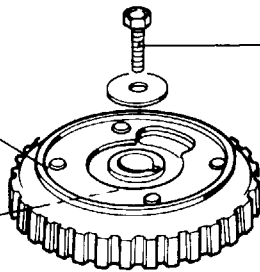

**9** SPARK ADVANCER

P. 40

**2**  
CONTACT BREAKER

**ASSEMBLY :**  
Check the points for pitting or corrosion.

**8** CONDENSER

**3**  
WIRE CLAMP PLATE

**ASSEMBLY :**  
Note the installation direction. If the plate is not installed properly, the contact breaker will be grounded, making it impossible to start the engine.

**7** CYLINDER HEAD COVER

**Engine serial numbers:**  
BF75 : 1000004–1102880  
BF100: 1000004–1101260

**ASSEMBLY :**  
If equipped with the early model fuel pump (page 36), install the fuel pump, then install the pump cover together with the cylinder head cover.

**4**  
To ignition coil

**6**  
FUEL TUBE CLIPS

Fuel tube clips are required if equipped with a late model fuel pump (page 36)

6 × 28mm

**5** WOODRUFF KEY

**ASSEMBLY :**  
Do not forget to install the key. Make sure it is seated properly.

- PULSER COIL (Engine serial number 1200001 and subsequent)

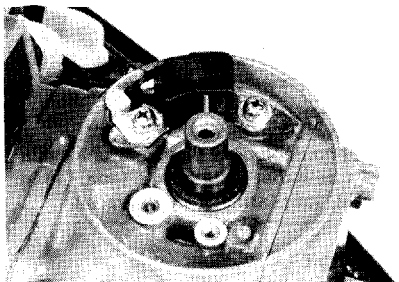

1  
COVER

8  
CAM PULLEY

**DISASSEMBLY :** Do not hammer.  
**ASSEMBLY :**  
• Align the keyway in the pulley with the woodruff key in the camshaft. Make sure the pulley is seated before tightening the bolt.

6 × 22mm  
100 kg-cm  
(7 ft-lb)

7  
SPARK ADVANCER

2  
WIRE CLAMP

6  
PULSER COIL

5  
CYLINDER HEAD COVER

4  
FUEL TUBE CLIPS

3  
WOODRUFF KEY

6 × 28mm (4)

**ASSEMBLY :**  
Do not forget to install the key. Make sure it is seated properly.

• SPARK ADVANCER

1

After assembling, pull the weight outward to be certain that the rotor turns freely in the direction of the arrow. It should return to the original position smoothly when the weight is released.

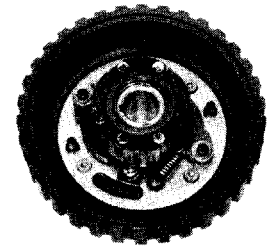

5

**WEIGHT**

**ASSEMBLY :**  
Insert advancer weight heels into groove.

4

**CAM PULLEY**

2

**ROTOR (Motors, with serial number 1200001 and subsequent)**

3

**RETAINER**

**ASSEMBLY:**  
Insert the retainer into the groove in the rotor and tighten it firmly after the rotor and weights have been installed.

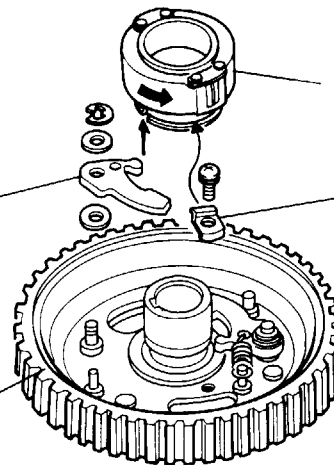

• CRANKCASE BREATHER/SEPARATOR

8

**STARTER CASE**

6

**BREATHER VALVE BODY**

**ASSEMBLY:**  
Installing the body backward will cause an oil leak.

7

**COVER**

**ASSEMBLY :**  
Replace the cover if broken or damaged.

6 × 22mm ( 2 )

100 kg-cm  
( 7 ft-lb )

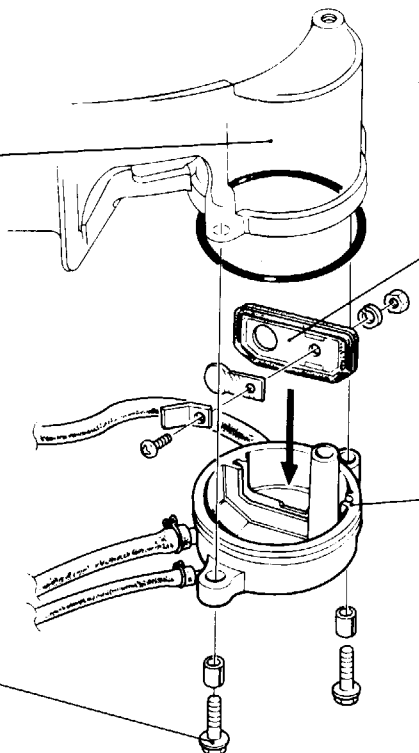

**b. INSPECTION**

● **PRIMARY COIL (CONTACT BREAKER TYPE)**

**INSPECTION :**

Measure the resistance between the two wires with an ohmmeter.

**RESISTANCE :  $2.0\Omega$**

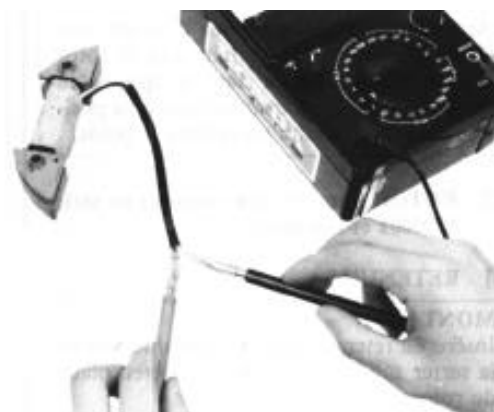

● **EXCITER COIL (CDI TYPE)**

**INSPECTION**

Measure the resistance between the wire lead end and the core.

**RESISTANCE:  $330\Omega \pm 10\%$**



● **CHARGING COIL**

**INSPECTION**

Measure the resistance between both wire terminals with an ohmmeter.

**RESISTANCE:  $0.13\Omega \pm 10\%$**



● **IGNITION COIL**

**INSPECTION**

Remove the spark plug caps and measure the resistance between the high tension wires.

**RESISTANCE:  $8k\Omega \pm 20\%$**

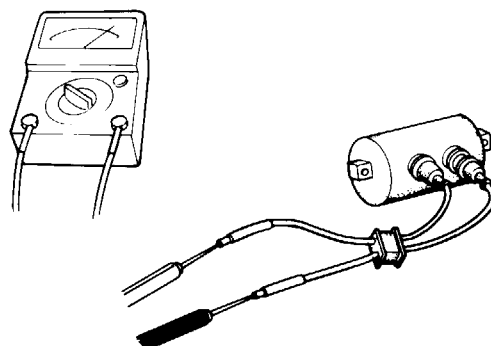



RESISTANCE:  $0.56\Omega \pm 10\%$

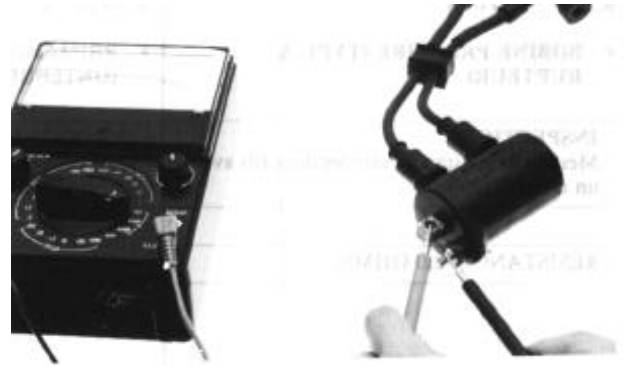

## ● PULSER COIL (CDI TYPE)

### INSPECTION

Measure the resistance between both wire leads.

RESISTANCE:  $120\Omega \pm 10\%$

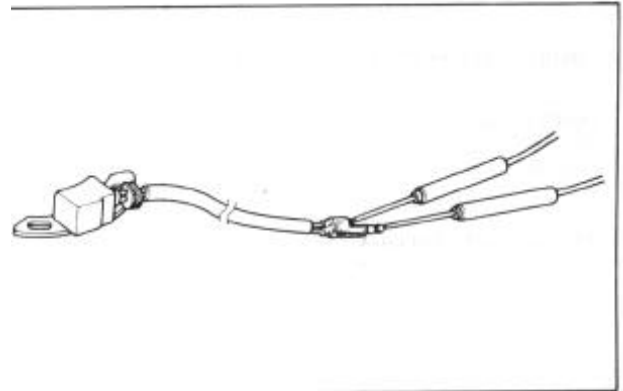

## ● ENGINE SWITCH

### INSPECTION:

Engine serial numbers 1000004–1299999: Check continuity between the black lead and ground, while pushing the engine stop button.

Engine serial number 1300001 and subsequent: Check continuity between the black lead and green lead while pushing the engine stop button.

ENGINE SWITCH	CONTINUITY
Pushed	YES
Released	NO



## ● PRESSURE SWITCH

### INSPECTION:

(1) Remove the pressure switch and run the engine at idle. Check that the engine oil comes out. If not, inspect the oil pump.

(2) If the oil pressure is normal, reinstall the pressure switch and check if there is continuity between the wire and ground. If continuity exists, the switch is normal.



## ● INDICATOR LAMP

When the lamp doesn't come on, check the engine oil level p.56, and the pressure switch p. 49. If there's no fault, replace the lamp. If the lamp still doesn't light, replace the CDI.

## ● DIODE RECTIFIER

### INSPECTION :

- Measure resistance between terminals with an ohmmeter.
- Measure both blue lead terminals.

Tester Probe		Continuity
+	-	
Green	Blue	No Continuity
Blue	Green	Exists
Blue	Red	No Continuity
Red	Blue	Exists

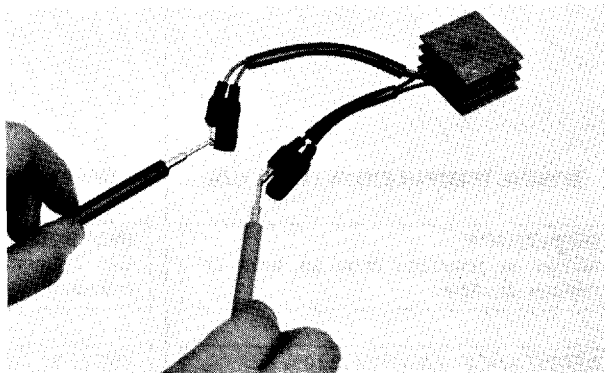

## ● FUSE/FUSE HOLDER

### INSPECTION :

Check fuse and fuse holder (fuse in) for continuity.

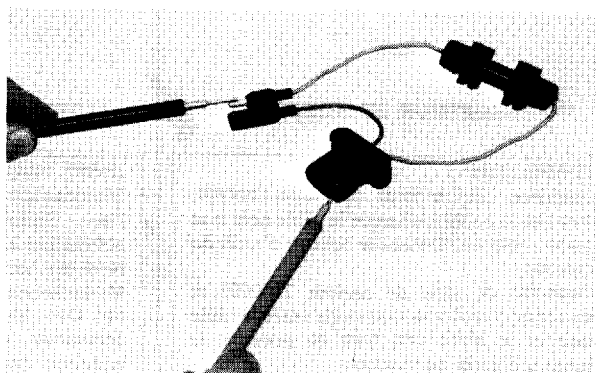

## ● D.C. OUTPUT CONNECTOR

### INSPECTION :

- Short circuit the connector and check for continuity.
- Before checking, make sure fuse is not blown out.

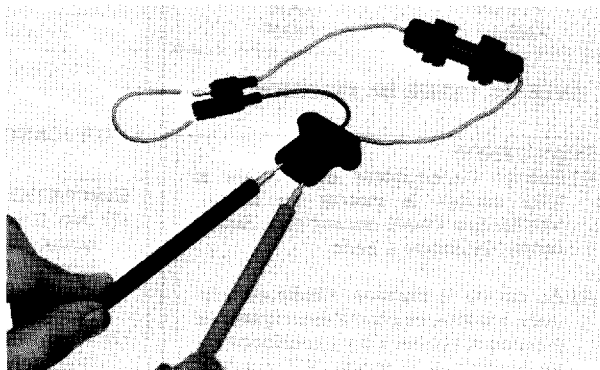

● CONTACT BREAKER POINT (Engine serial numbers 1000004–1199999)

**INSPECTION:**

With ignition timing correctly adjusted, check maximum point gap with feeler gauge.

STANDARD POINT GAP : 0.3–0.4 mm (0.012–0.016 in)

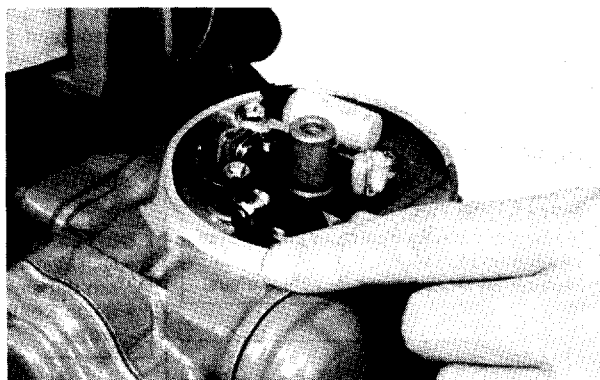

**INSPECTION :**

Check for pitting, fouling, misalignment or metal transfer.

• To polish point surfaces, use a fine emery cloth or point file.

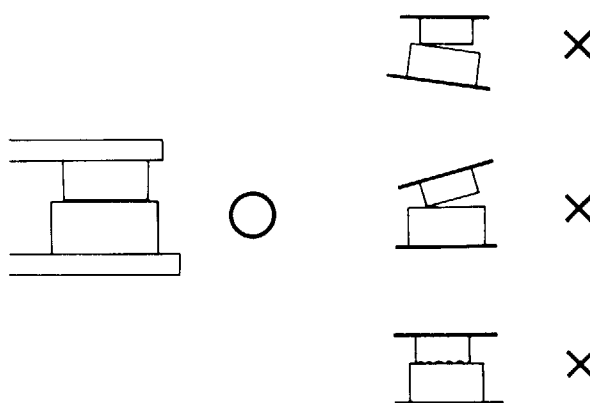

● CONDENSER (CONTACT BREAKER TYPE)

**INSPECTION :**

Discharge condenser before testing capacity.

Capacity : 0.24  $\mu$ F

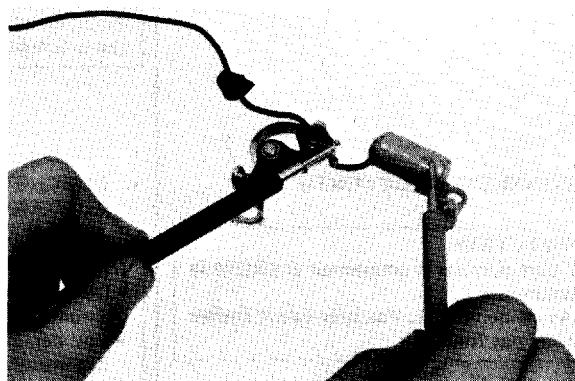

● NEUTRAL SWITCH (Engine serial number 1300001 and subsequent)

Before inspection, be sure the neutral switch, shift shaft and shield plate are installed securely. Check for continuity between blue and black/white wire leads.

SHIFT LEVER POSITION	CONTINUITY
REVERSE	NO
NEUTRAL	YES
FORWARD	NO

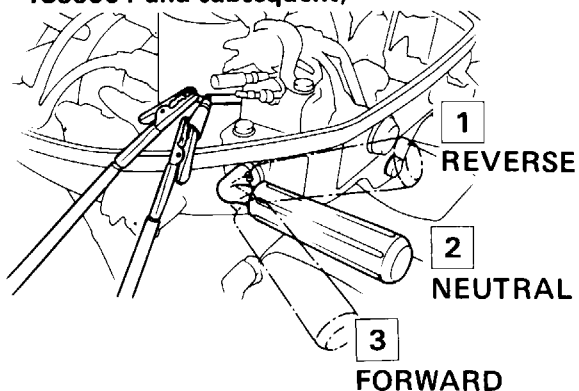

## • CDI UNIT

Disconnect wiring and check the continuity of CDI terminals. Replace the CDI unit if the readings do not fall within the limits shown in the table.

**NOTE:**

- The CDI unit is fully transistorized.
- For accurate testing, it is necessary to use a specified electrical tester. Use of an improper tester or measurements in improper range may give false readings.
- Use SANWA ELECTRICAL TESTER (P/N 07308-0020000) or KOWA SEIKI TESTER (P/N KS-TH-5H-1 or KS-AHM-32-003).

### Engine serial numbers 1200001 – 1299999

[kΩ]

(-) Probe \ (+) Probe	Brown	Green	Black	Yellow	Orange	White
Brown		6 – 10	0 – 0.5	10 – 20	∞	∞
Green	0.5 – 10		0.5 – 10	15 – 30	∞	∞
Black	0 – 0.5	6 – 10		10 – 20	∞	∞
Yellow	10 – 20	15 – 30	10 – 20		∞	∞
Orange	100 – 400	100 – 400	100 – 400	100 – 400		∞
White	10 – 100	10 – 100	10 – 100	10 – 100	∞	

### Engine serial number 1300001 – 1300700:

[kΩ]

(-) Probe \ (+) Probe	Brown	Green	Black	Yellow	Orange	Blue	Black/White	White
Brown		6 – 10	0 – 0.5	10 – 20	∞	6 – 10	8 – 30	∞
Green	0.5 – 10		0.5 – 10	15 – 30	∞	0.05 – 5	1 – 20	∞
Black	0 – 0.5	6 – 10		10 – 20	∞	6 – 10	8 – 30	∞
Yellow	10 – 20	15 – 30	10 – 20		∞	15 – 30	15 – 50	∞
Orange	100 – 400	100 – 400	100 – 400	100 – 400		100 – 400	100 – 400	∞
Blue	0.5 – 10	0.05 – 5	0.5 – 10	15 – 30	∞		1 – 20	∞
Black/White	20 – 40	15 – 25	20 – 40	35 – 70	∞	15 – 25		∞
White	10 – 100	10 – 100	10 – 100	10 – 100	∞	20 –	0.5 – 10	

### Engine serial number 1300701/1300703 (BF75/BF100) and subsequent:

[kΩ]

(-) Probe \ (+) Probe	Brown	Green	Black	Yellow	Orange	Blue	Black/White	White
Brown		35 – 100	0 – 0.5	10 – 20	∞	30 – 100	30 – 100	∞
Green	0.5 – 10		0.5 – 10	15 – 30	∞	10 – 40	0	∞
Black	0 – 0.5	20 – 100		10 – 20	∞	30 – 100	30 – 100	∞
Yellow	10 – 20	30 – 200	10 – 20		∞	30 – 200	30 – 200	∞
Orange	∞	∞	∞	∞		∞	∞	∞
Blue	3 – 30	0.5 – 10	3 – 30	20 – 200	∞		0.5 – 10	∞
Black/White	0.5 – 10	0	0.5 – 10	15 – 30	∞	10 – 40		∞
White	2 – 20	0.5 – 10	2 – 20	20 – 200	∞	20 – 200	0.5 – 10	

## 5. ENGINE/LOWER UNIT REMOVAL

### a. REMOVAL

#### • ENGIN (See also P. 56)

(1) Turn lock lever (1) and remove engine cover (2).



(2) If equipped with the early model fuel pump, remove the pump cover (BF75 serial numbers 1000004–1102880 and BF100 serial numbers 1000004–1101260). Disconnect fuel tubes (4) from pump (3).

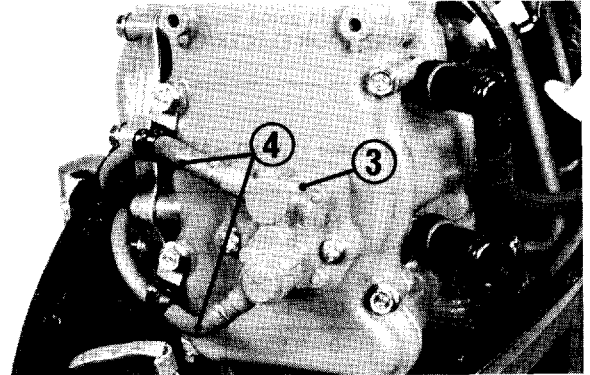

(3) Remove breather tube (5), carburetor overflow tube (6) and cooling water tube (7) from tube connector (8).

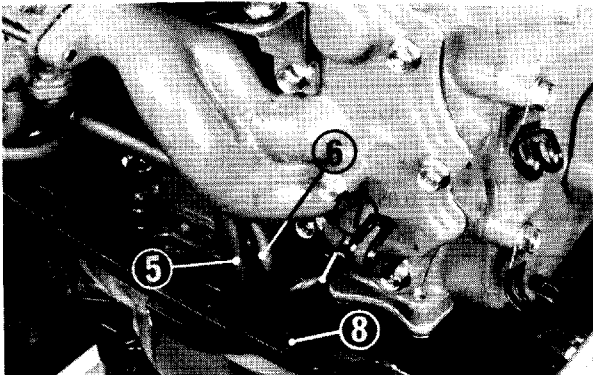

(4) Loosen lock screw (9) and remove throttle link (10). Remove choke link (11) from choke knob (12).

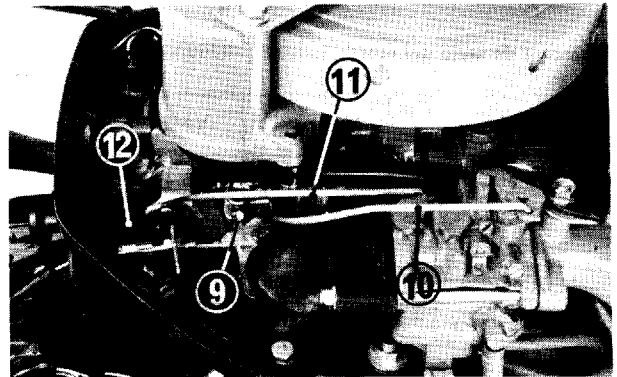

(5) Remove rectifier (13) by unscrewing the 6 mm bolt. Remove the cotter pin and 5 mm clevis pin (14).

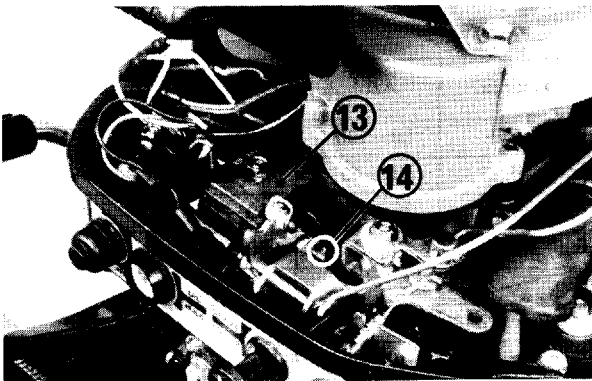

(6) Disconnect wire leads (15), (16) and (17) coming from the rectifier, engine switch and oil indicator lamp at their connections.

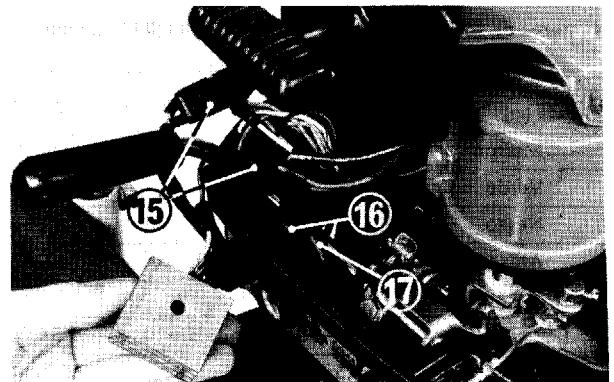

(7) Disconnect wire lead (18) from the oil pressure switch.

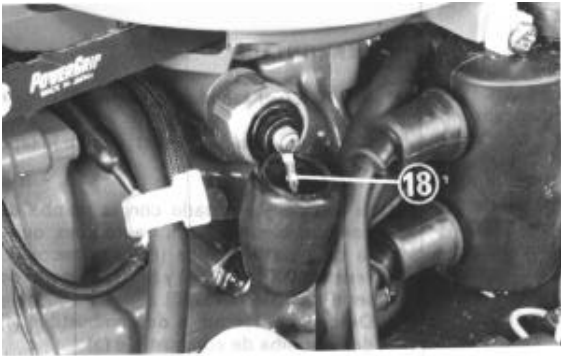

(8) Remove lower mount housing (20) by unscrewing two 8 mm bolts (19).

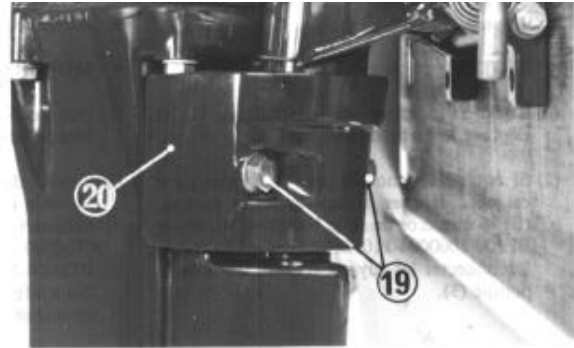

(9) Removing four 8 mm bolts (21), and separate extension case (22) from oil case (23).

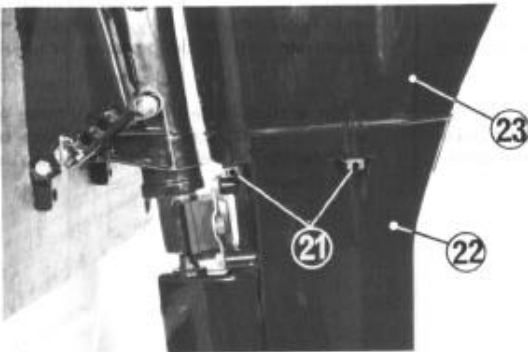

(10) Remove three 6 mm bolts (24) and exhaust pipe seal (25).

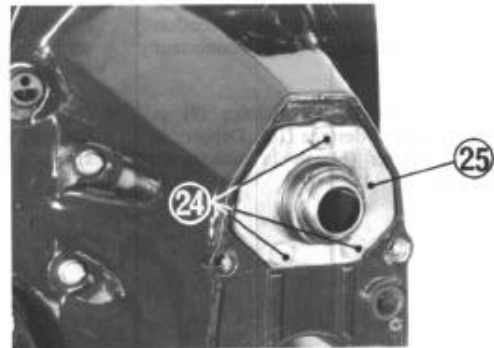

(11) Remove eight 6 mm bolts (26) and take the power head out of oil case (27).

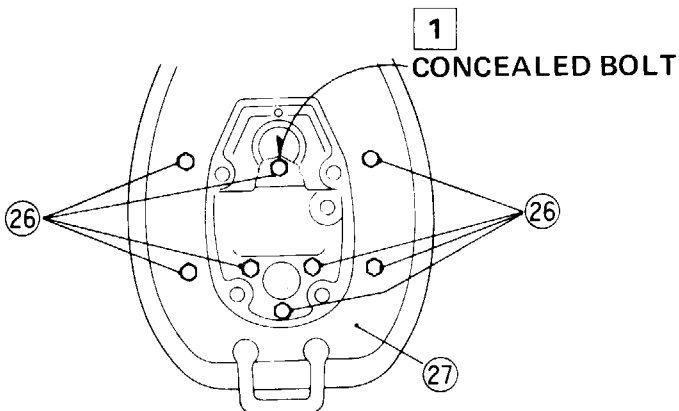

**NOTE:**

- One bolt is concealed as indicated in the illustration.
- Coat bolts with grease for corrosion protection.

b. DISASSEMBLY/ASSEMBLY

• EXTENSION CASE

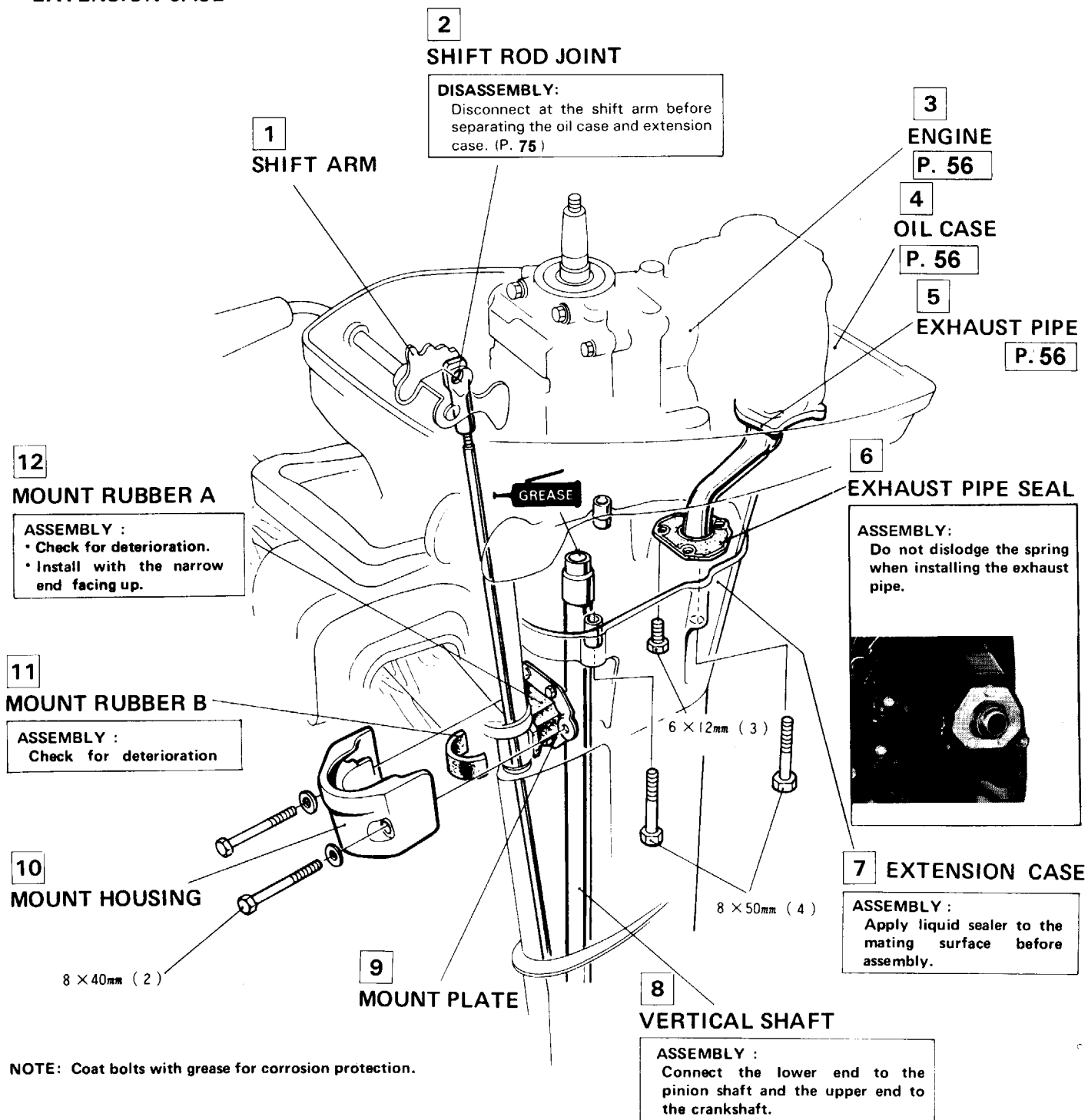

● ENGINE

1

**ASSEMBLY:**  
After assembly, connect tubing.

2

ENGINE

3 CHECK VALVE

**CAUTION:**

The valve is assembled over the check valve spring. The installation order must be followed or serious engine damage will result.

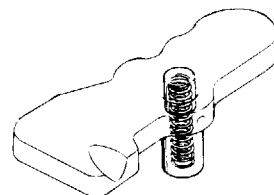

4

CHECK VALVE SPRING

**ASSEMBLY :**  
Check for low spring tension.

13

OIL LEVEL GAUGE

12

OIL FILLER BODY

5 FILTER FLANGE

6 × 22mm ( 2 )

6

OIL FILTER

**ASSEMBLY:**  
• Check for damage.  
• Note the installation direction.

6 × 22mm ( 4 )

11

6 × 16mm ( 3 )

EXHAUST PIPE

7

THRUST MOUNT RUBBER

10

O-RING

**ASSEMBLY :**  
Do not forget to install.

8

OIL CASE

**DISASSEMBLY:**

- The oil case can be removed from the swivel case without removing the engine.
- Remove the two nuts fastening the lower mount housing and oil case, and the thrust mount rubber nut.

9

ENGINE MOUNTING BOLTS

**ASSEMBLY :**  
Make sure the bolts are used in their correct positions.

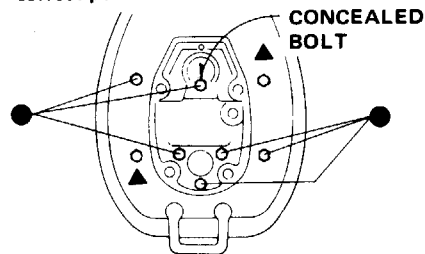

●; 6 × 32mm ( 6 )

▲; 6 × 45mm ( 2 )

**NOTE:** Coat bolts with grease for corrosion protection.



## 6. CYLINDER HEAD REMOVAL (SINGLE OPERATION)

(1) Turn lock lever (1) and remove engine cover (2).

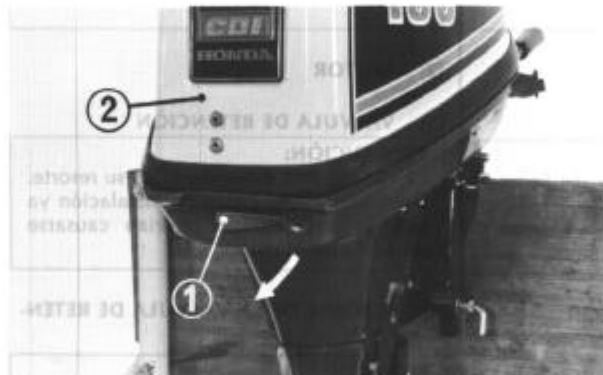

(3) Unscrew the two 6 mm bolts to separate carburetor assembly (7) from intake manifold (9). Loosen the three 6 mm bolts (6) to remove CDI unit (8) from the manifold. Disconnect cooling water check tube (10) and bypass tube (11) from the inlet manifold.

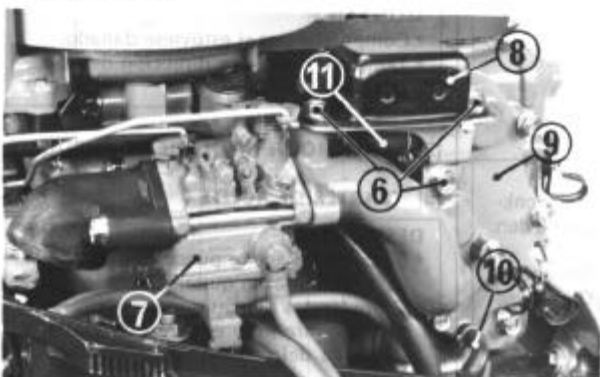

(5) On contact breaker type, remove the contact breaker, condenser and clamp plate.  
On CDI type, unscrew the two screws and remove pulser coil (16).

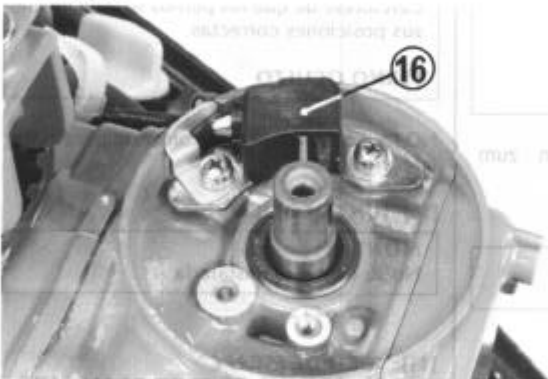

(2) Remove four 6 mm bolts (3) to remove cylinder head cover (4). Raise tube clamps (5) to release the tubes.

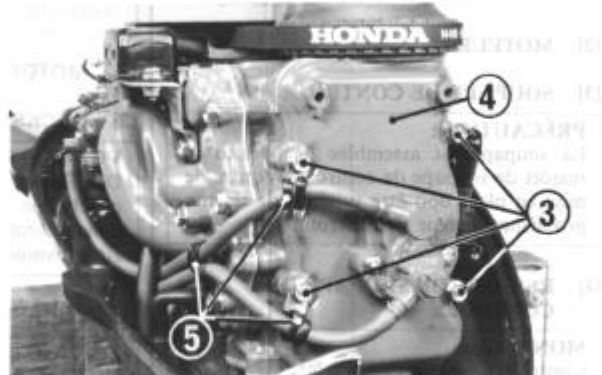

(4) Remove cover (12) and 6 mm bolt (13) to release cam pulley (14) from the camshaft and timing belt (15).



(6) After removing six 8 mm bolts (17), remove cylinder head (18) with the intake manifold, exhaust pipe, oil pump and valve train installed.

**CAUTION:** When reassembling, apply a coat of grease on the exhaust pipe end and insert it through the exhaust pipe seal. Be careful not to dislodge the seal spring.

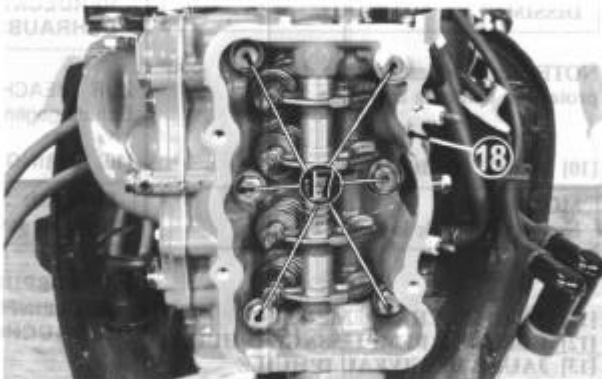

## 7. CAMSHAFT/VALVE/OIL PUMP

### a. DISASSEMBLY/ASSEMBLY

#### ● CAMSHAFT/ROCKER ARM

#### 2 ARM COLLAR B

**ASSEMBLY:**  
Follow assembling order carefully.

12

ARM COLLAR A

11

LOCK NUT

10

ADJUSTING SCREW

9

VALVES

P. 59

8

CYLINDER HEAD

P. 59

3

ROCKER ARM

5

THRUST WASHER

7

CAMSHAFT

**ASSEMBLY:**

- Be sure to install the thrust washers when reassembling.
- Insert until the rocker arm rests on the cam lobes properly.
- For identification purposes, a punch mark is stamped on the BF75 camshaft.



1

**DISASSEMBLY:**

Loosen the lock nuts and adjusting screws to unload the valve springs before removing the cam and rocker arm shafts.

**ASSEMBLY:**

After assembling, adjust valve clearances. (See page 26)

4

ROCKER ARM SHAFT

**DISASSEMBLY :**

Remove by unscrewing the 10 mm x 1.25 mm bolt.

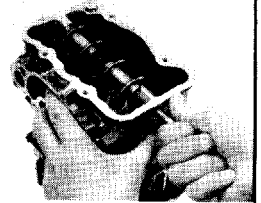

**ASSEMBLY :**

Insert with the threaded end toward you.

6 × 28mm ( 3 )

90 kg-cm  
(6 ft-lb)

6 OIL PUMP P. 60

**ASSEMBLY :**

Align the pin inside the camshaft to the groove in the pump shaft.

### • VALVES

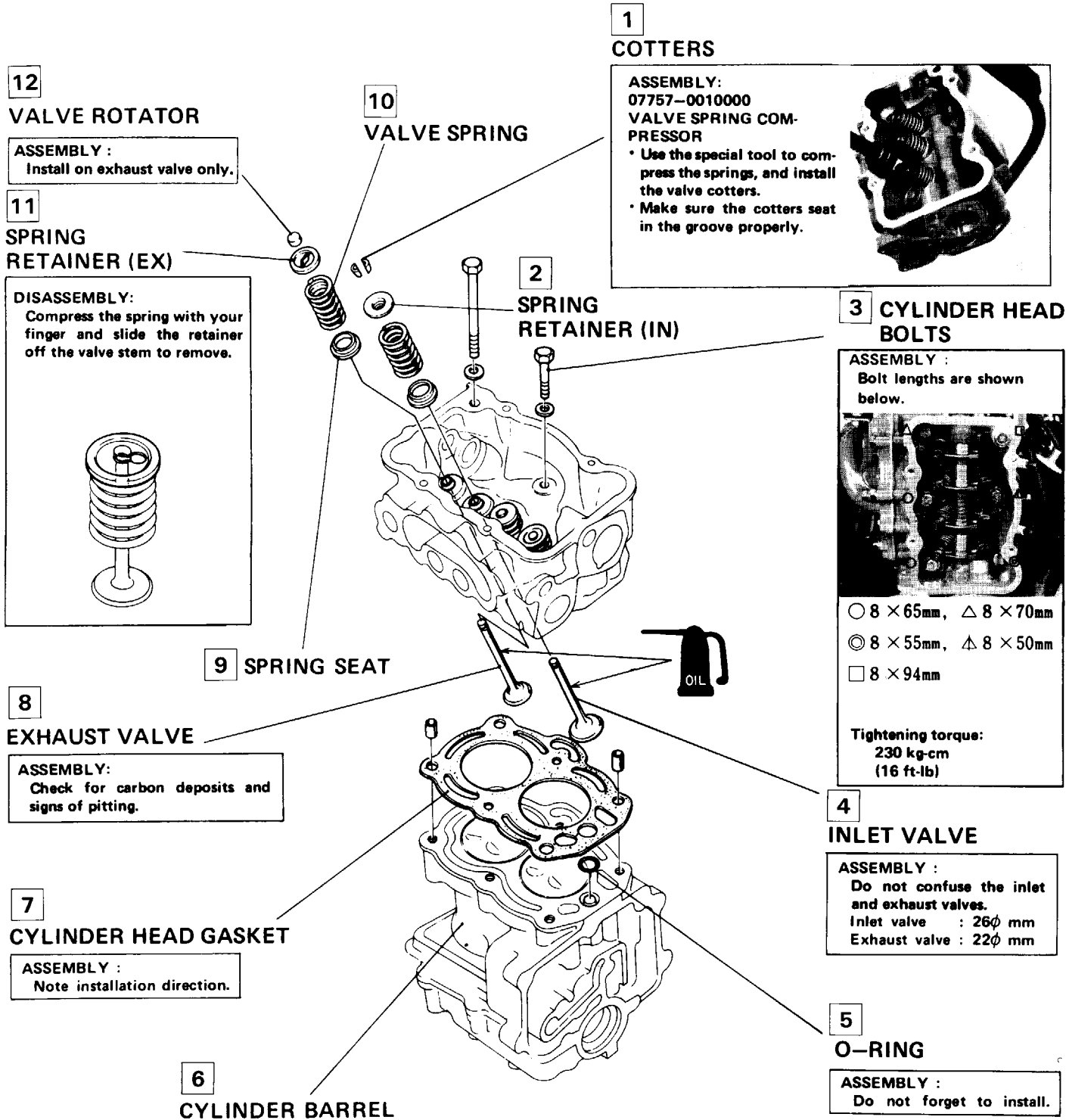

• OIL PUMP

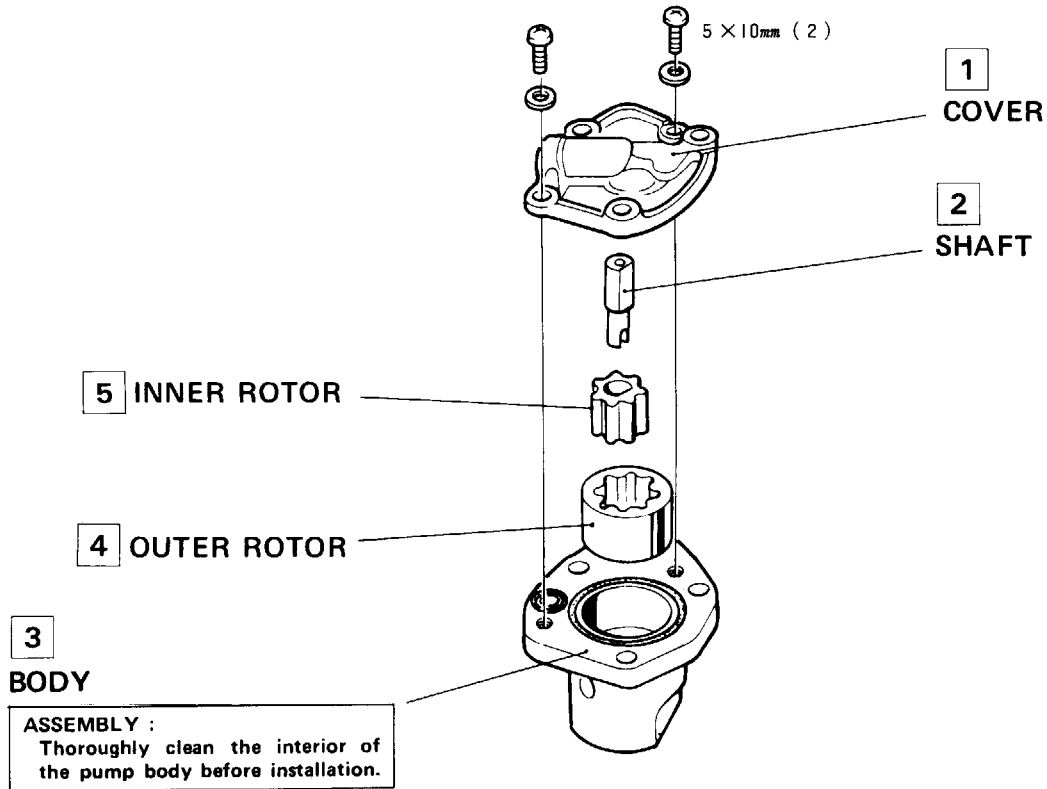

• VALVE GUIDE

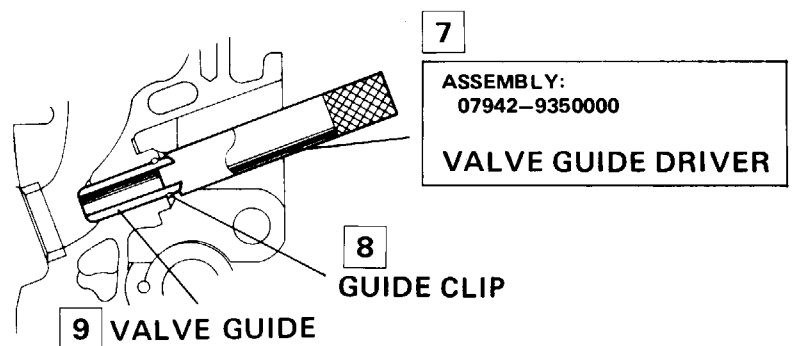
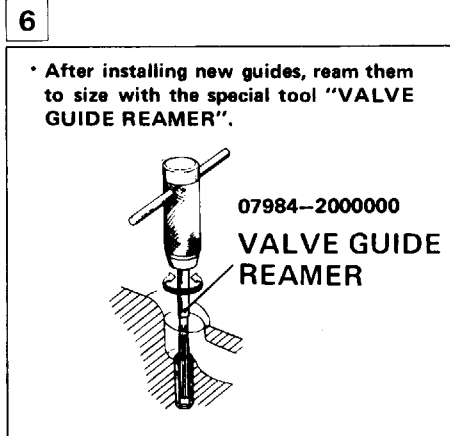

**DISASSEMBLY :**  
Drive the guide out of the head from the combustion chamber by using valve guide remover 07742-0010100.

**ASSEMBLY :**  
Install the clip on the new guides and drive them to the depths shown.

IN : 15 mm (0.59 in)  
EX : 13 mm (0.51 in)

b. INSPECTION

• VALVE STEM O.D.

	STANDARD	SERVICE LIMIT
IN	5.468–5.480 mm (0.215–0.216 in)	5.08 mm (0.2 in) min.
EX	5.435–5.450 mm (0.214–0.2145 in)	4.75 mm (0.187 in) min.

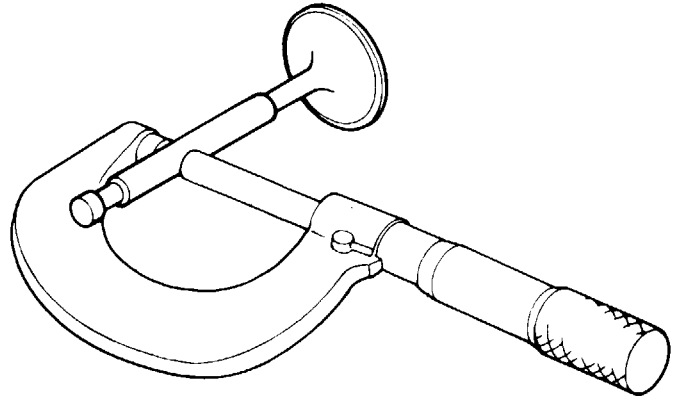

• VALVE GUIDE I.D.

	STANDARD	SERVICE LIMIT
	5.500–5.512 mm (0.2165–0.2170 in)	5.54 mm (0.218 in) max.

- For replacement, see Page 60.

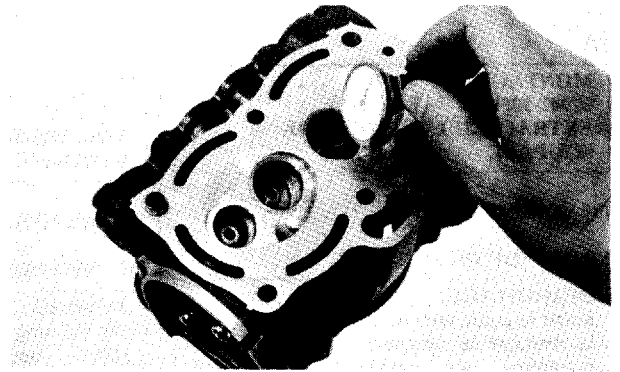

• VALVE SEAT WIDTH

	STANDARD	SERVICE LIMIT
	0.7 mm (0.03 in)	2.0 mm (0.079 in) max.

- For refacing, see Page 65.

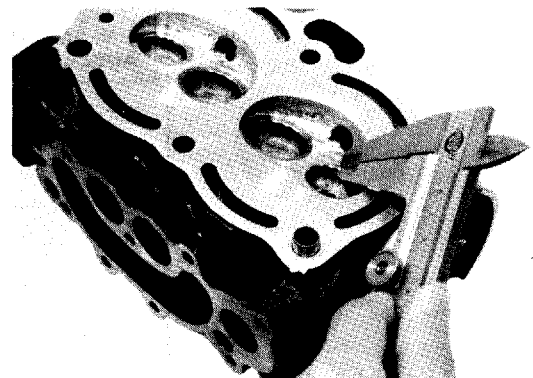

• VALVE SPRING FREE LENGTH

STANDARD	SERVICE LIMIT
28.9 mm (1.148 in)	27.4 mm (1.079 in) min.

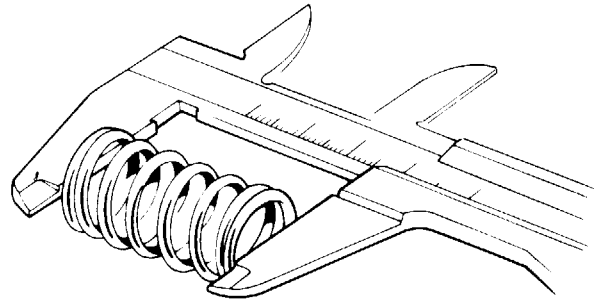

• ROCKER ARM SHAFT O.D.

STANDARD	SERVICE LIMIT
12.947–12.968 mm (0.510–0.511 in)	12.92 mm (0.509 in) min.

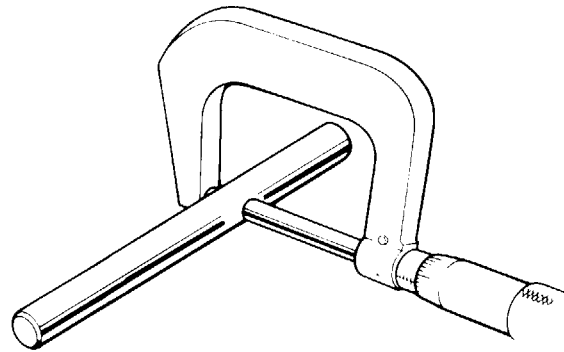

• ROCKER ARM I.D.

STANDARD	SERVICE LIMIT
13.00–13.03 mm (0.512–0.513 in)	13.06 mm (0.514 in) max.

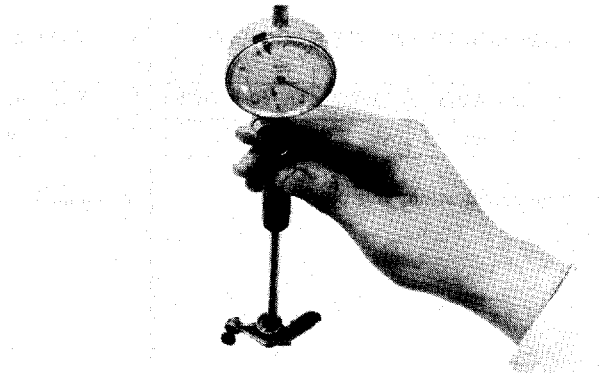

● PUMP BODY I.D.

STANDARD	SERVICE LIMIT
23.15–23.18 mm (0.911–0.913 in)	23.23 mm (0.915 in) max.

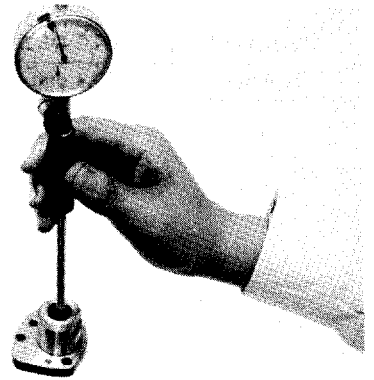

● INNER ROTOR-TO-OUTER ROTOR CLEARANCE

STANDARD	SERVICE LIMIT
0.15 mm (0.006 in)	0.20 mm (0.008 in) max.

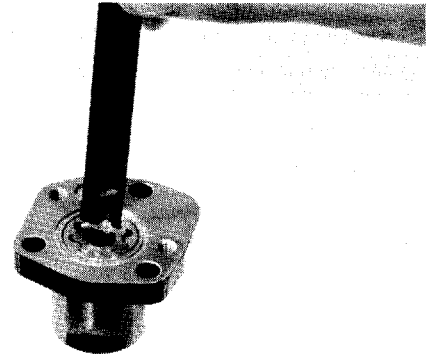

● OUTER ROTOR-TO-BODY CLEARANCE

STANDARD	SERVICE LIMIT
0.15 mm (0.006 in)	0.26 mm (0.010 in) max.

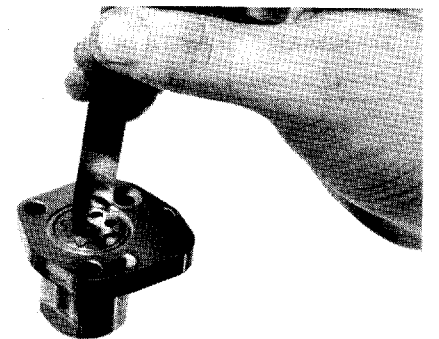

• CAM HEIGHT

CDI TYPE

		STANDARD	SERVICE LIMIT
BF100		25.2 mm (0.99 in)	24.95 mm (0.982 in)
BF75	IN	26.5 mm (1.04 in)	26.25 mm (1.033 in)
	EX	23.2 mm (0.91 in)	22.95 mm (0.904 in)

CONTACT BREAKER TYPE

		STANDARD	SERVICE LIMIT
BF100		25.0 mm (0.98 in)	24.75 mm (0.974 in)
BF75		23.0 mm (0.91 in)	22.75 mm (0.896 in)

• CAMSHAFT O.D. (OIL PUMP SIDE)

STANDARD	SERVICE LIMIT
15.966–15.984 mm (0.6285–0.6292 in)	15.916 mm (0.627 in) min.



## c. REPAIR

### ● REFACING VALVE SEATS

- (1) Cut the valve seats to a true 45° angle using the 45° cutter.
- (2) Cut the seat outer edge with the flat-face cutter.
- (3) Reface the seat again with the 45° cutter to bring it within the limits.

- (4) Check the valve and valve seat for proper contact by applying prussian blue.

Specified seat width : 0.7 mm (0.03 in)

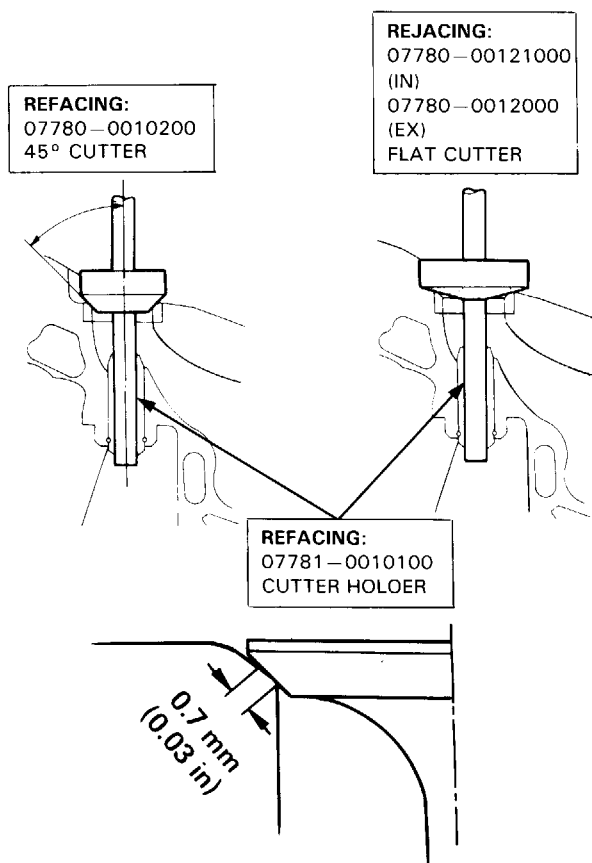

- (5) Fit the valve and valve seat by lapping after the seat has been refaced.

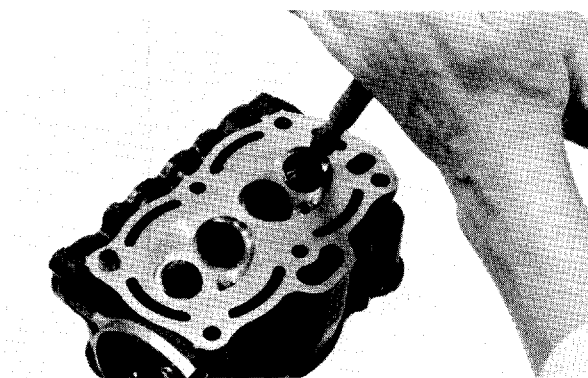

## 8. CRANKSHAFT/PISTON

### a. DISASSEMBLY/ASSEMBLY

#### • CRANKSHAFT

6 × 25mm ( 5 )

6 × 35mm ( 1 )

8 × 45mm ( 4 )

110 kg-cm  
(8 ft-lb)

110 kg-cm  
(8 ft-lb)

230 kg-cm  
(16 ft-lb)

100 kg-cm  
(7 ft-lb)

11

### LOCK WASHER

#### ASSEMBLY :

Bend up the tab of the lock washer against one side of the head of each bolt.

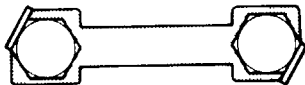

10

### LOWER OIL SEAL

#### ASSEMBLY :

The seal is marked "LOWER" for identification. Do not confuse the upper and lower seals. Otherwise, oil leakage will result.

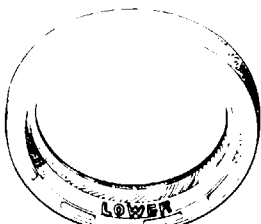

### 9 CRANKSHAFT

#### ASSEMBLY :

Note the installation direction.

### 8 CYLINDER BARREL

#### ASSEMBLY :

Apply liquid packing to the crankcase mating surface.

7 PISTON P. 67

### 1 CRANKCASE

#### ASSEMBLY :

- Check that the oil seals are in place.
- Note the bolt positions.

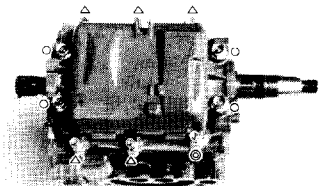

○ 8 × 45mm, △ 6 × 25mm,  
● 6 × 35mm

### 5 CONNECTING ROD/LOWER CAP

#### DISASSEMBLY :

During disassembly, mark the rods and caps so that they can be placed back in their original locations.

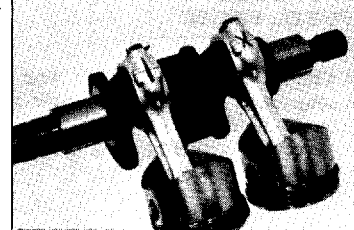

4

"LOCKING LUG"

2

### THRUST BEARING

#### ASSEMBLY :

- Install the bearing with the grooved end inside.
- Fit the locking lug in the notch in the cylinder barrel.

3

### UPPER OIL SEAL

#### ASSEMBLY :

The seal is marked "UPPER" for identification. Do not confuse the upper and lower seals. Otherwise, oil leakage will result.

### • PISTON

1

#### ASSEMBLY :

After installing both pistons and connecting rods in the cylinders, secure the rods to the crankshaft. (p. 66)

10 TOP RING

#### ASSEMBLY :

Chrome plated. Do not interchange with SECOND RING.

2

### PISTON RINGS

#### ASSEMBLY :

- Install the rings with the markings facing up.
- Stagger the ring end gaps 120° apart. Do not align with the piston pin or thrust sides.

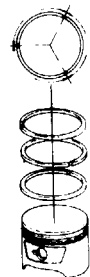

9 SECOND RING

8 OIL RING

3

"VALVE RELIEF"

7

### PISTON

#### ASSEMBLY :

- Install the piston so that the valve reliefs are on the valve side.
- Use the special tool and push the piston in with your fingers as shown.

07955-8810000  
PISTON SLIDER  
or commercially available  
piston ring compressor.



4

PISTON PIN

5

PIN CLIP

#### ASSEMBLY :

- Set one end of the clip into the groove in the piston around and work the other end around in the groove using a pair of pliers.

6

CONNECTING ROD

#### DISASSEMBLY :

- Mark the rods so they can be placed back in their original positions.

b. INSPECTION

● PISTON O.D. (at skirt)

STANDARD	SERVICE LIMIT
55.960–55.990 mm (2.203–2.204 in)	55.880 mm (2.2 in) min.

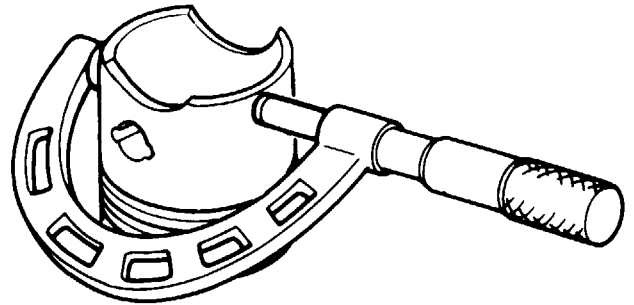

● PISTON PIN I.D.

STANDARD	SERVICE LIMIT
14.002–14.008 mm (0.5513–0.5515 in)	14.048 mm (0.553 in) max.

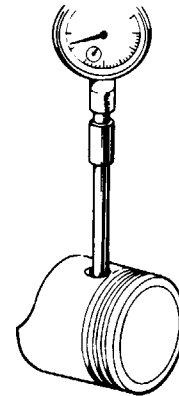

● CYLINDER I.D.

STANDARD	SERVICE LIMIT
56.000–56.015 mm (2.2047–2.2053 in)	56.165 mm (2.211 in) max.

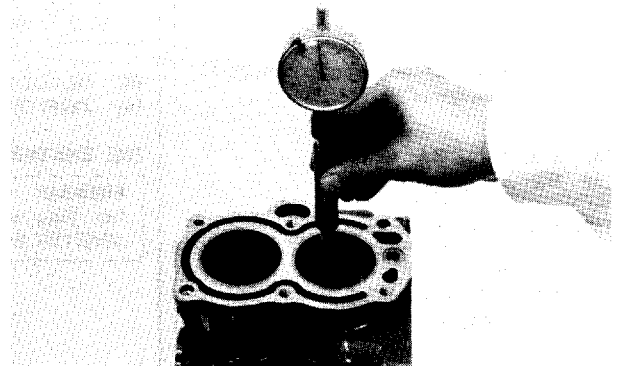

● PISTON-TO-CYLINDER CLEARANCE

STANDARD	SERVICE LIMIT
0.010–0.055 mm (0.0004–0.0022 in)	0.12 mm (0.0047 in) max.

**● PISTON PIN O.D.**

STANDARD	SERVICE LIMIT
13.994–14.00 mm (0.5509–0.5512 in)	13.954 mm (0.549 in) min.

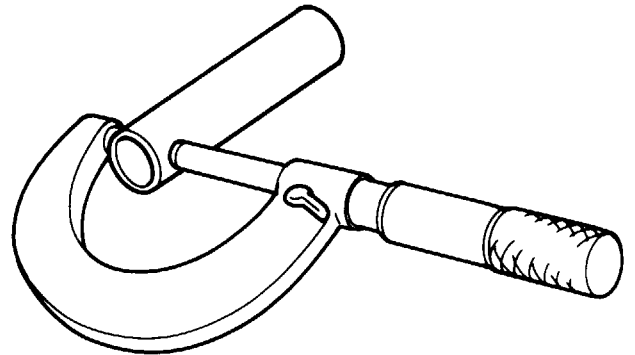
**● PISTON RING WIDTH**

	STANDARD	SERVICE LIMIT
TOP	1.460–1.475 mm (0.057–0.058 in)	1.36 mm (0.054 in) min.
SECOND	1.475–1.490 mm (0.058–0.059 in)	1.37 mm (0.054 in) min.
OIL	2.475–2.490 mm (0.097–0.098 in)	2.37 mm (0.093 in) min.

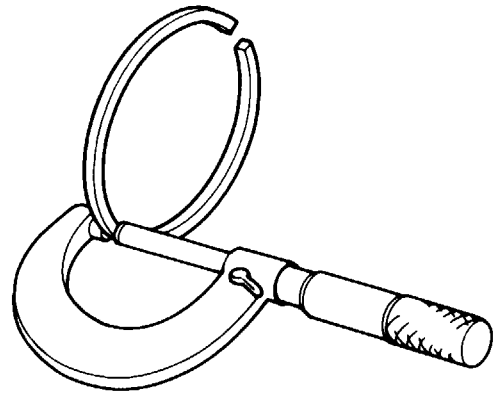
**● PISTON RING SIDE CLEARANCE**

	STANDARD	SERVICE LIMIT
TOP	0.025 mm (0.001 in)	0.10 mm (0.004 in) max.
SECOND	0.025 mm (0.001 in)	0.10 mm (0.004 in) max.
OIL	0.015 mm (0.0006 in)	0.10 mm (0.004 in) max.

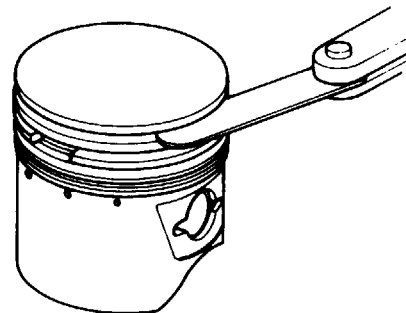

● PISTON RING END GAP

STANDARD	SERVICE LIMIT
0.15–0.35 mm (0.006–0.014 in)	1.0 mm (0.039 in) max.

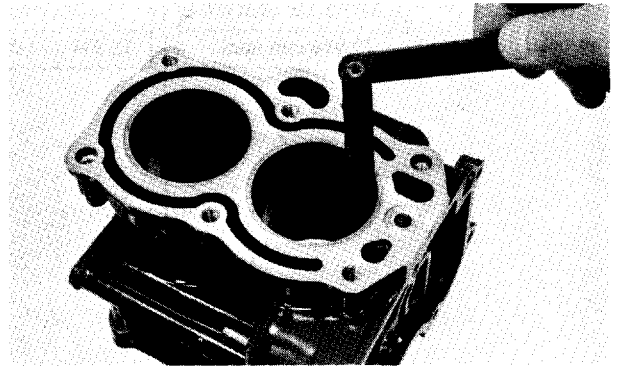

● CONNECTING ROD SMALL END I.D.

STANDARD	SERVICE LIMIT
14.005–14.020 mm (0.5514–0.5520 in)	14.07 mm (0.554 in) max.

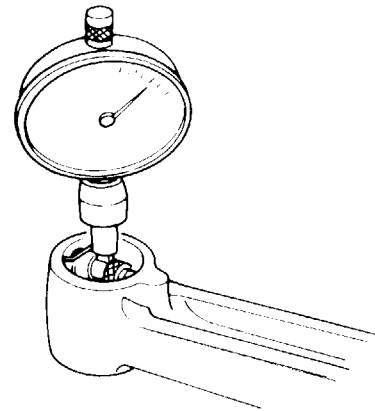

● CONNECTING ROD BIG END OIL CLEARANCE

<b>INSPECTION:</b> Measure the clearances with plastigauge.
--

STANDARD	SERVICE LIMIT
0.040–0.068 mm (0.002–0.003 in)	0.083 mm (0.003 in) max.

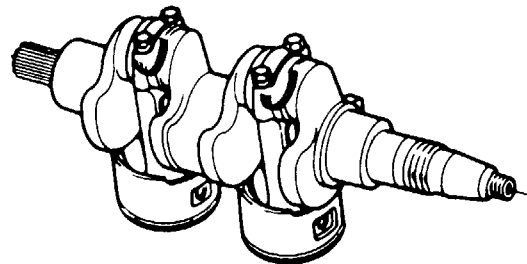

● CRANKSHAFT MAIN BEARING OIL CLEARANCE

<b>INSPECTION:</b> Measure the clearances with plastigauge.
--

STANDARD	SERVICE LIMIT
0.020–0.065 mm (0.001–0.003 in)	0.080 mm (0.003 in) max.

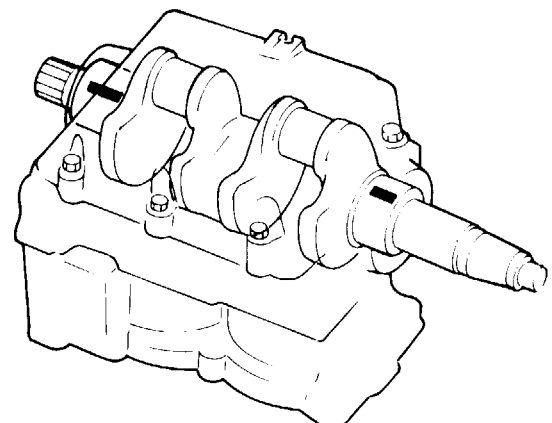

- CONNECTING ROD BIG END AXIAL CLEARANCE

STANDARD	SERVICE LIMIT
0.6 mm (0.02 in)	1.3 mm (0.051 in) max.

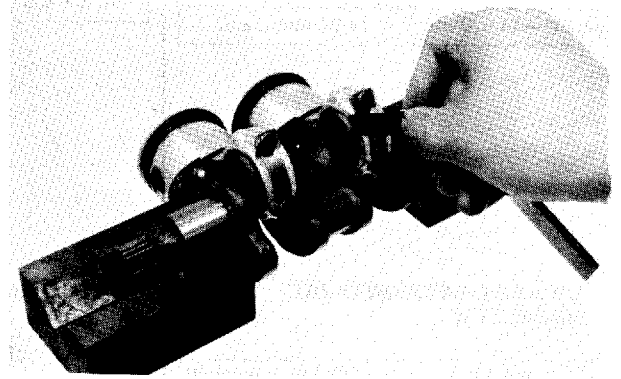

- CRANKPIN O.D.

STANDARD	SERVICE LIMIT
27.967–27.980 mm (1.1010–1.1016 in)	27.952 mm (1.100 in) min.

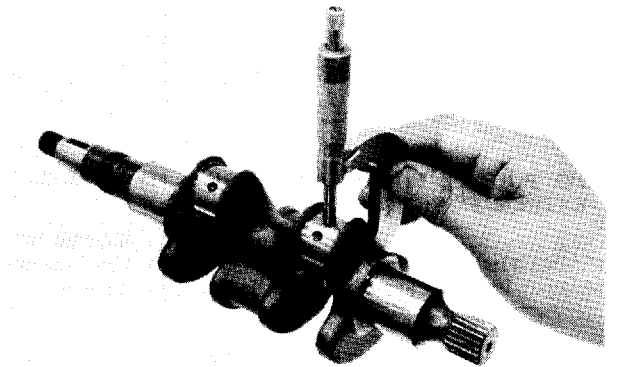

## 9. HANDLEBAR/SHIFT LEVER.

### ● HANDLEBAR AND GRIP

1

After assembly, adjust the throttle cable and throttle grip friction.  
Page 12.

2

### HANDLEBAR PIVOT SCREW

#### ASSEMBLY

Be sure that the handlebar moves freely without binding.

TIGHTENING TORQUE:  
240 kg-cm (17 ft-lb)

3

### GRIP PIPE COVER P. 73

#### ASSEMBLY:

Align the word "SHIFT" on the cover with the red dot on the handlebar when installing.

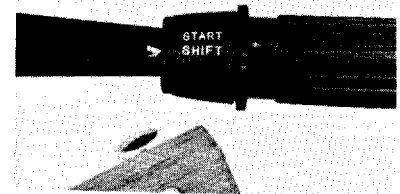

13

### THROTTLE ARM

P. 73

4

### HANDLEBAR

5

### CABLE HINGE

P. 73

6

### FRICTION UNIT

#### ASSEMBLY :

Align the ears on the nut with the grooves in the grip pipe. Then, push the nut into the pipe and slide it onto the handlebar.

12

### THROTTLE CABLE

GREASE

GREASE

7

### GRIP PIPE

11

### PIVOT SPRING

#### ASSEMBLY :

Check for weakened tension.

10

### PIPE GUIDE

P. 73

Engine serial number  
1000004-1299999

### 9 GUIDE STOPPER

#### ASSEMBLY :

Screw the stopper from the bottom, through the grooves in the grip pipe (1) and pipe guide (2) and the holes in the cable stopper (3), into the cable holder (4). See page 32. Tighten securely.

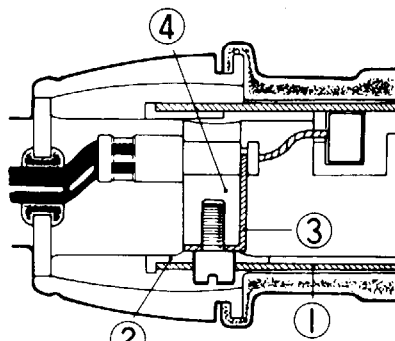

Engine serial number  
1000004-1299999

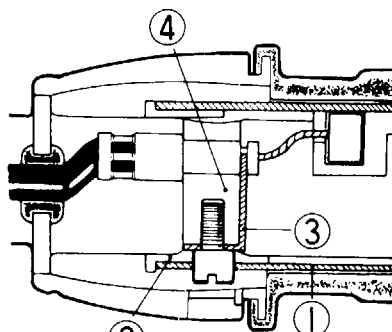

Engine serial number  
1300001 and subsequent

8

### GRIP RUBBER

Engine serial number  
1300001 and subsequent

#### DISASSEMBLY :

Apply clean engine oil to the inner face to facilitate removal.

#### ASSEMBLY :

- Coat the inner face with adhesive prior to assembly. Fit the rubber on the grip pipe with light hammer blows on the end.
- Apply adhesive to the lip and insert it into the groove in the pipe cover.



• THROTTLE CABLE

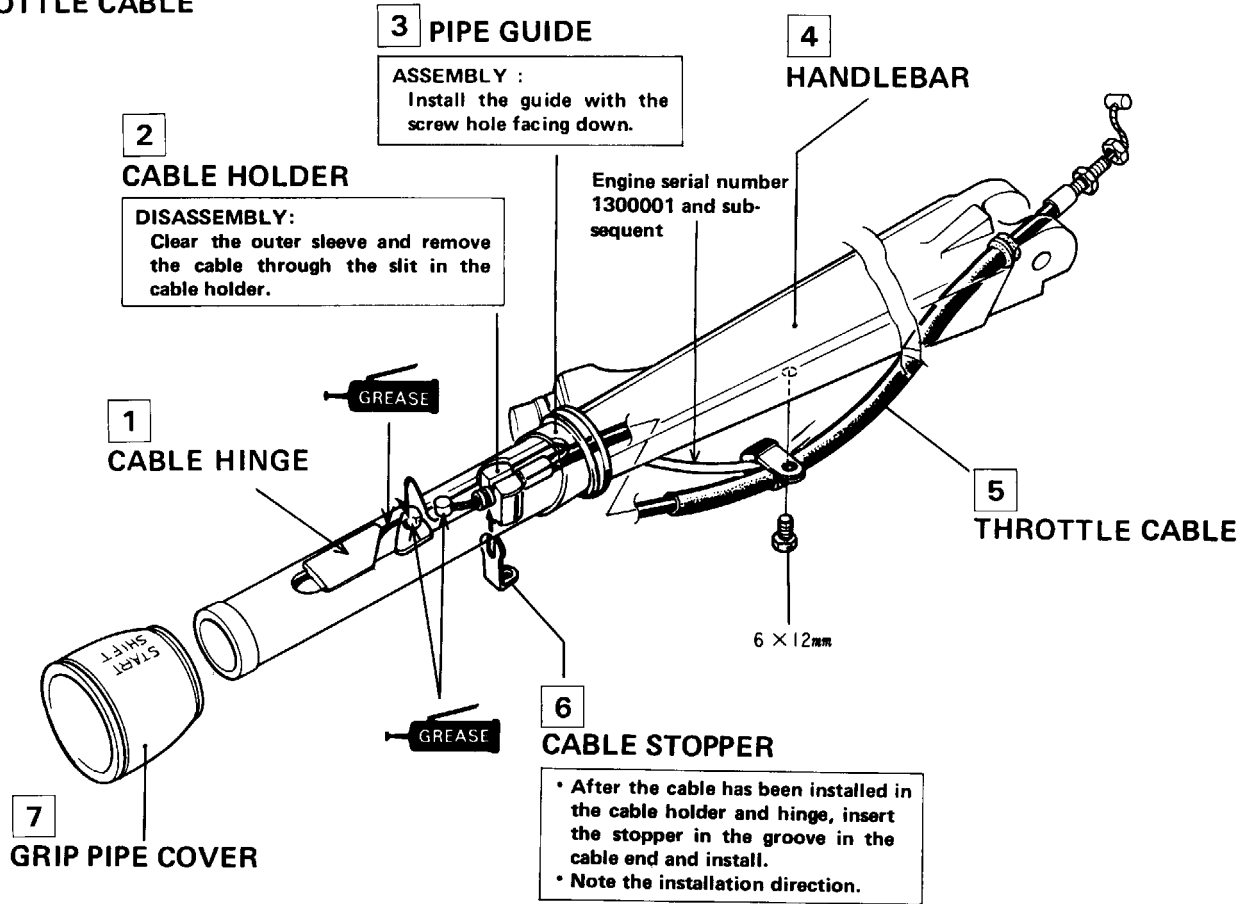

• HANDLEBAR STOPPER

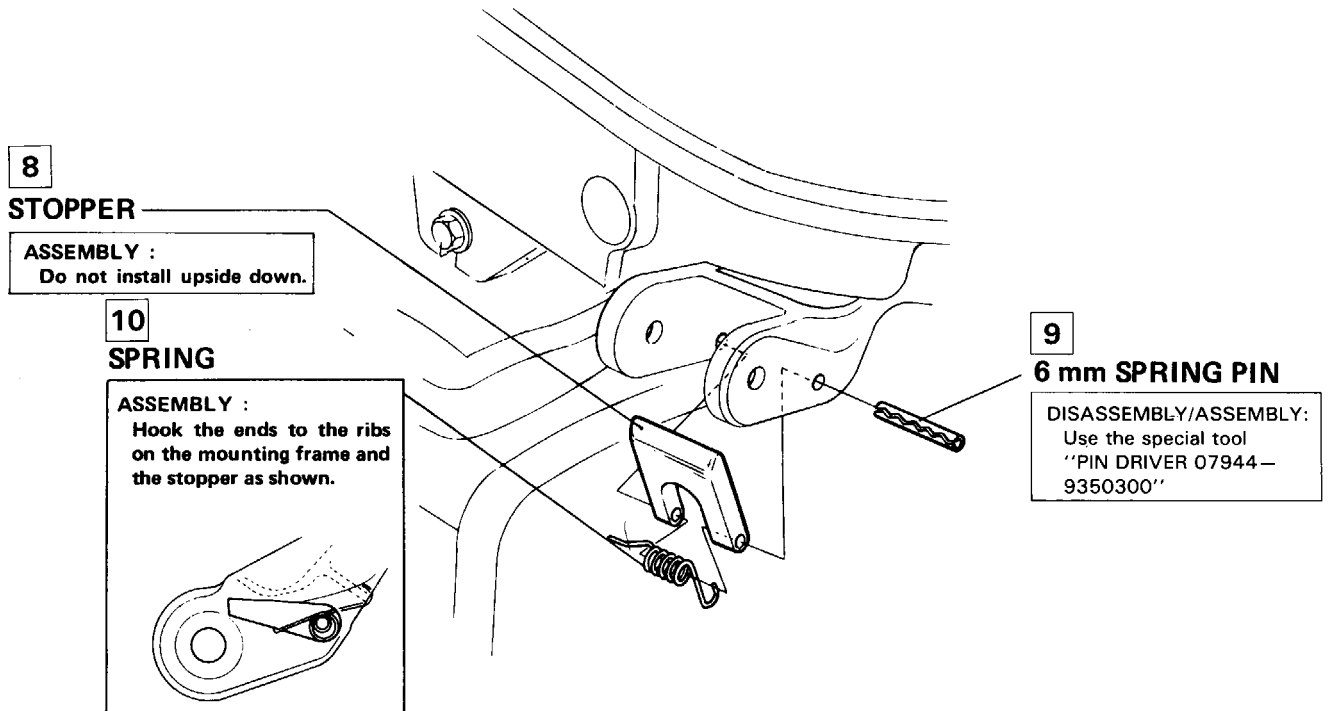

• THROTTLE ARM

1

**ASSEMBLY :**  
Connect the rods as illustrated on Page 34.

3

**CHOKE ROD**

Do not bend or straighten when disassembling or assembling.

2

**THROTTLE ROD**

4

**CABLE STOPPER**

13

**THROTTLE ARM**

5

**16 mm PLASTIC NUT**

**ASSEMBLY :**  
Take care not to cross thread.



9

**SHAFT BUSHING**

10

**PIVOT COLLAR**

11

**ARM SPRING**

12

**PIVOT WASHER**

6

**CHOKE KNOB**

7

**ARM SPRING**

8

**SHIFT SHAFT**

P. 75

**ASSEMBLY :**

Hook one end on the throttle arm and the other on the cylinder.

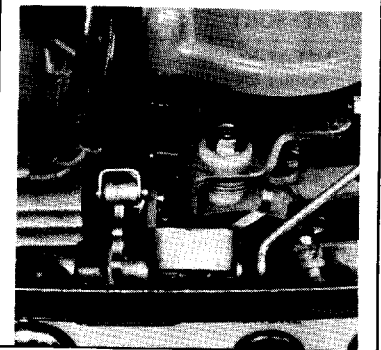

● **SHIFT SHAFT (Engine serial number range 1000004–1299999)**

NOTE: For models with neutral switch (engine serial number 1300001 and subsequent), see page 41.

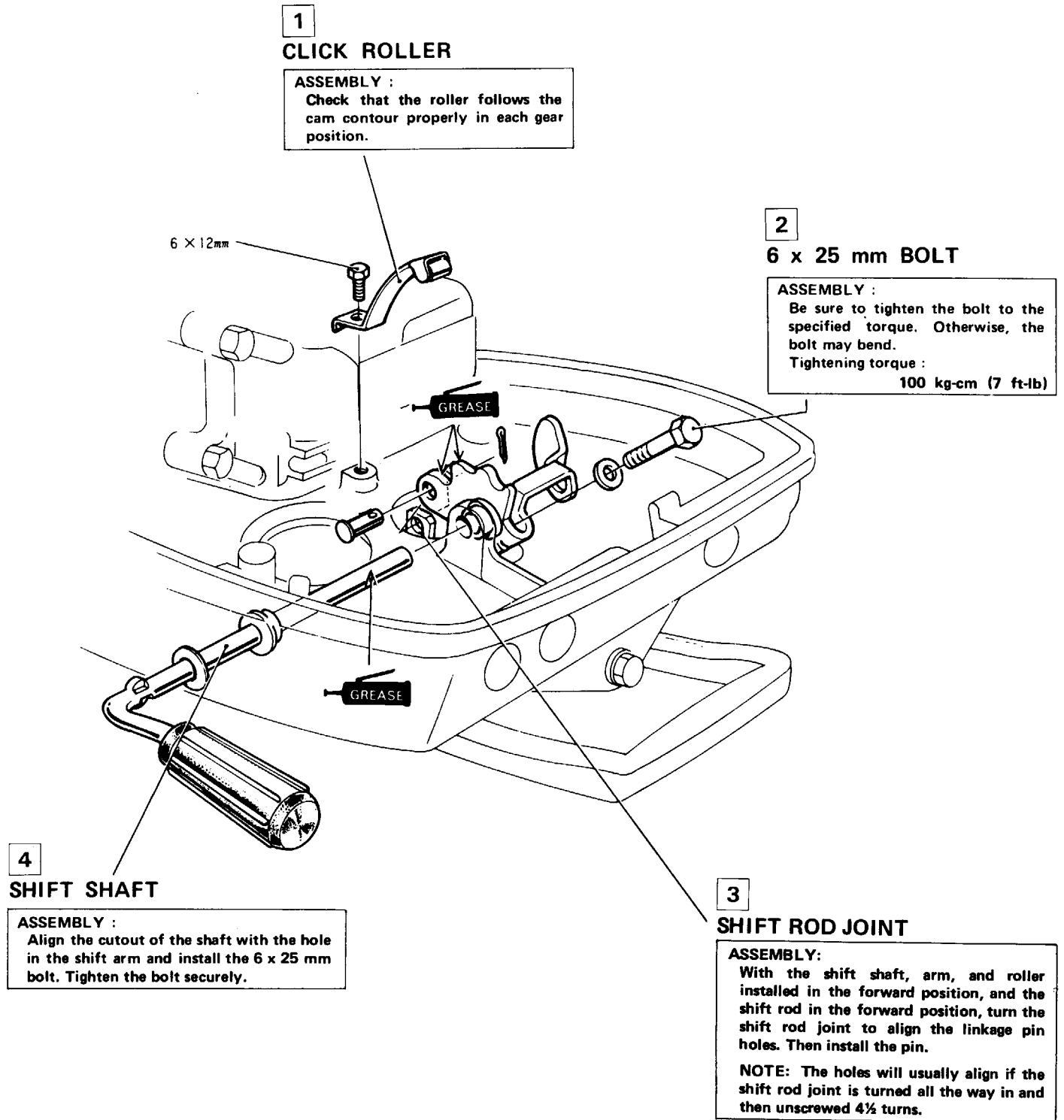

### 10. SWIVEL CASE/STERN BRACKET

#### a. DISASSEMBLY/ASSEMBLY

##### • SWIVEL SHAFT

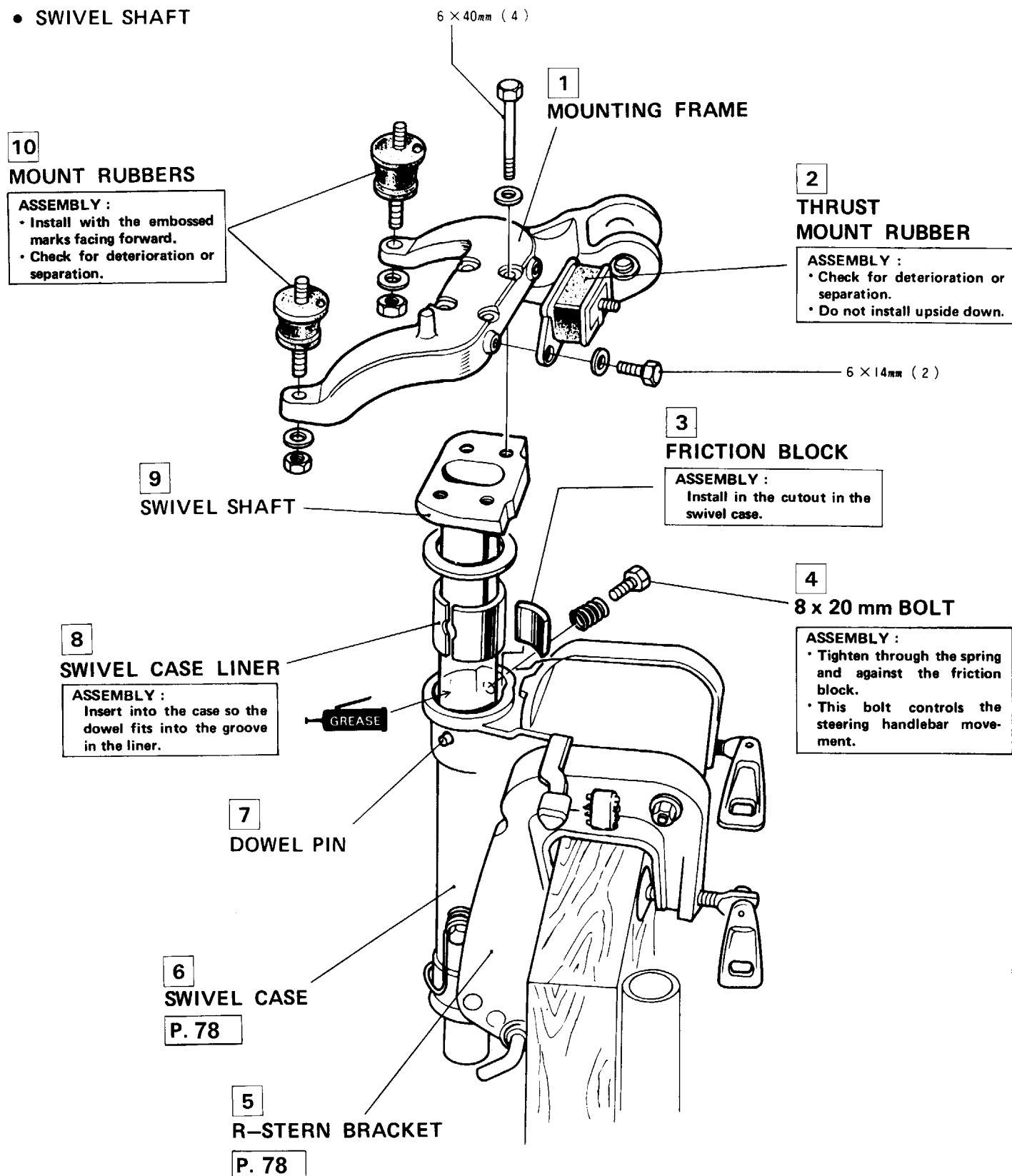

• REVERSE LOCK



**1 RETURN HOOK SPRING**

**ASSEMBLY :**

Hook both ends of the spring on the reverse lock with the center resting on the swivel case.

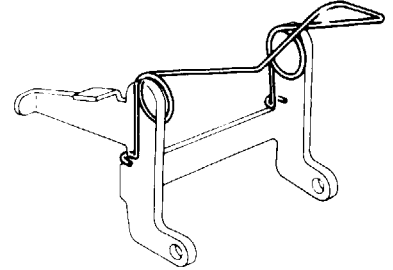

**9**

To tilt lever

**2**

SWIVEL CASE

**8**

REVERSE LOCK SPRING

**DISASSEMBLY :**

Secure the lock in a vice, and remove the spring.

6 × 16mm

**3**

6 mm COLLAR

**4**

REVERSE LOCK

**ASSEMBLY :**

After assembly, check operation.

**7**

L-STERN BRACKET

**5**

ADJUSTING ROD

GREASE

**DISASSEMBLY :**

To install and remove, push in the rod fully and turn it to straighten the pawl.

6 × 160mm

**6**

DISTANCE COLLAR

## • SWIVEL CASE/TILT LEVER

### 12 RELEASE ROD

**ASSEMBLY :**

Connect one end to the tilt lever and the other end to the hole in the reverse lock. (Page 77)

### 1 TILT LEVER SPRING

**ASSEMBLY :**

• Hook the spring on the tilt lever bracket and tilt lever from the outside as shown.

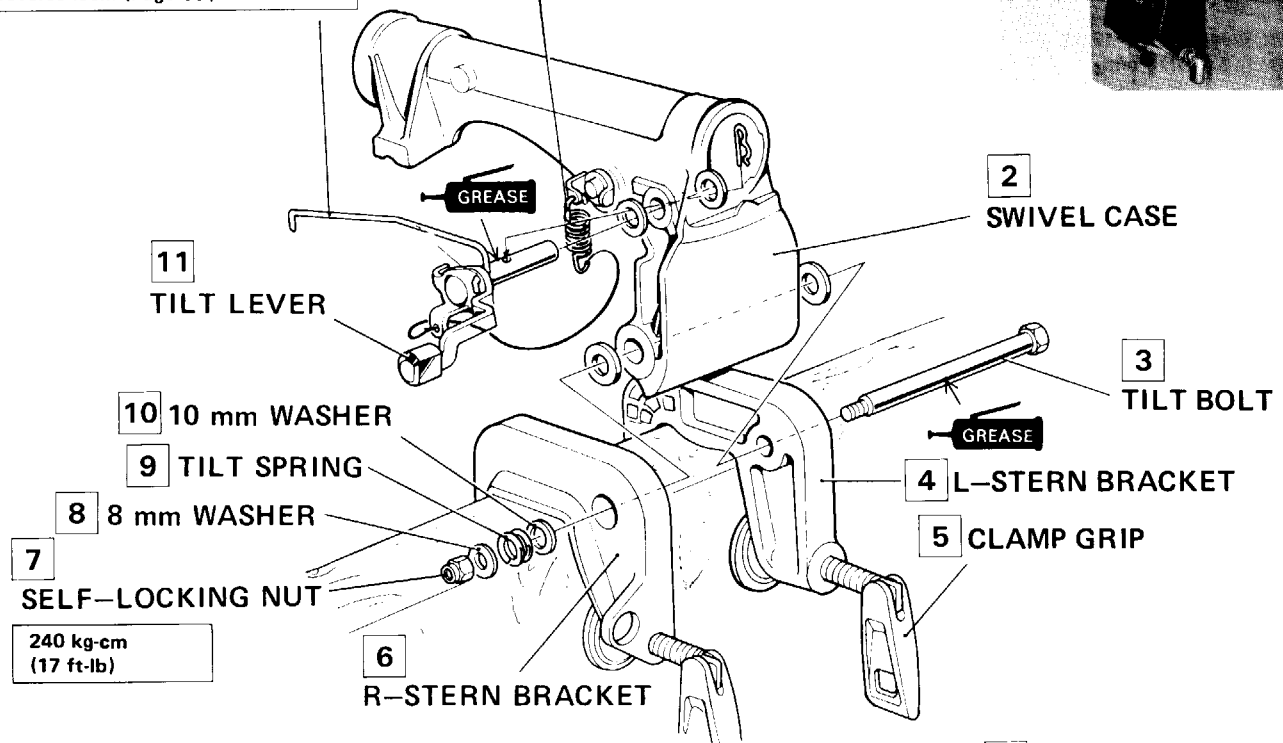
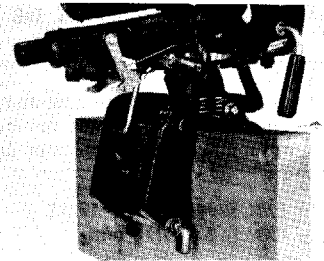

## • TILT LINK

### 13 SWIVEL CASE

### 14 4 mm SPRING PIN

DISASSEMBLY/ASSEMBLY:  
USE THE SPECIAL TOOL "PIN DRIVER  
07944-9350200"

### 19 TILT LEVER BUSHING

### 15 TILT LEVER BRACKET

**ASSEMBLY :**  
Do not install the bracket upside  
down.

### 18 TILT LINK

### 17 GREASE NIPPLE

### 16 LINK SPRING

**ASSEMBLY :**  
Hook the spring on the swivel case  
and tilt link as shown.

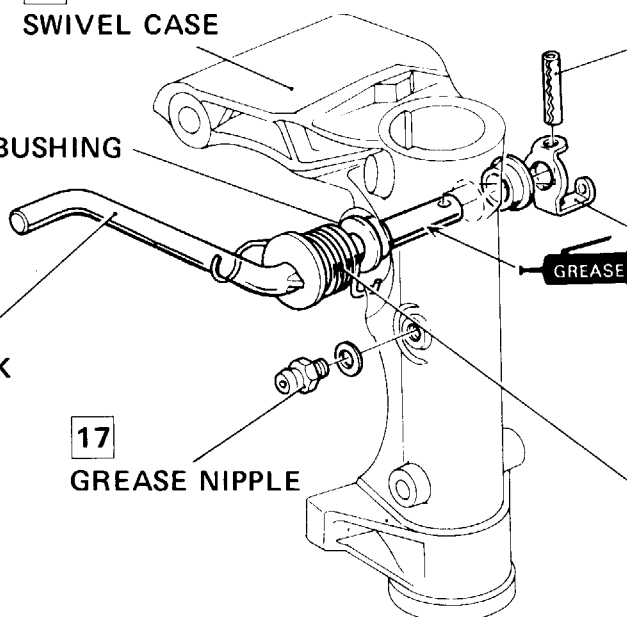

### 11. PROPELLER/GEAR CASE

#### a. DISASSEMBLY/ASSEMBLY

##### • PROPELLER

##### 2 ANODE METAL

###### ASSEMBLY :

- Replace if corroded.
- When large size anode metal is installed for early model (optional), drill holes in the plate as shown.

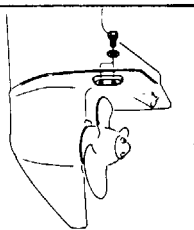

##### 1 GEAR CASE

##### 3 COTTER PIN

###### ASSEMBLY :

- Always use the HONDA part (stainless steel).
- Align the hole in the propeller cap with the hole in the propeller shaft.

##### 7 6203 BALL BEARING

###### DISASSEMBLY:

Remove the bearing by using the special tool "Bearing remover 07945-9350001."

###### ASSEMBLY:

Compress the bearing by using the special tool Attachment driver A 07946-9350101".

##### 5 SHEAR PIN

GREASE

##### 4 FORWARD BEVEL GEAR

##### 11 REVERSE BEVEL GEAR

##### 6 SHAFT HOLDER

##### 8 CAP

##### 12 SHAFT P. 84

**DISASSEMBLY/ASSEMBLY :**  
When removing and installing the propeller shaft, make sure the transmission is set in FORWARD.

##### 10 THRUST WASHER

###### ASSEMBLY :

- Install with the groove end facing the gear.
- For further detail, refer to page 85.

6 × 20mm ( 2 )

##### 9 PROPELLER

###### ASSEMBLY :

- Check that the shear pin is properly positioned in the groove in the bushing.

##### 13 17 mm WATER SEAL

###### DISASSEMBLY:

Remove the bearing by using the special tool "Bearing remover 07945-9350001."

###### ASSEMBLY:

Compress the bearing by using the special tool "Attachment driver A 07946-9350101".

• GEAR CASE  
(See also P. 81)

(1) Turn lock lever (1) and remove engine cover (2).

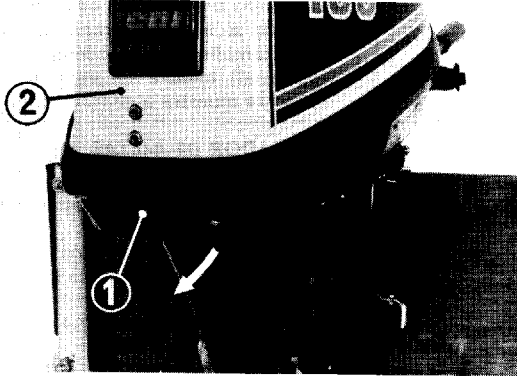

(2) Remove rectifier (3), the cotter pin, and 5 mm clevis pin (4).

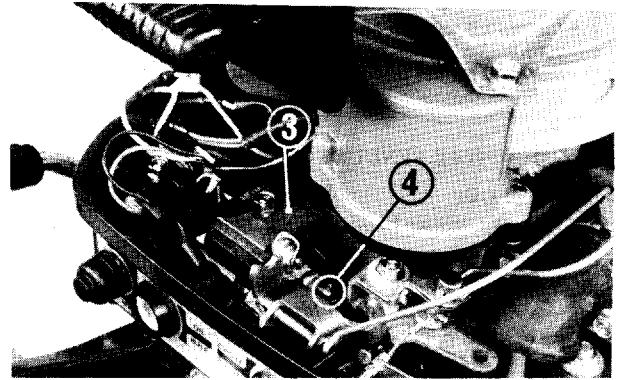

(3) Remove the 6 mm bolt to remove click roller (5). Remove shift rod joint (6) by turning it out.

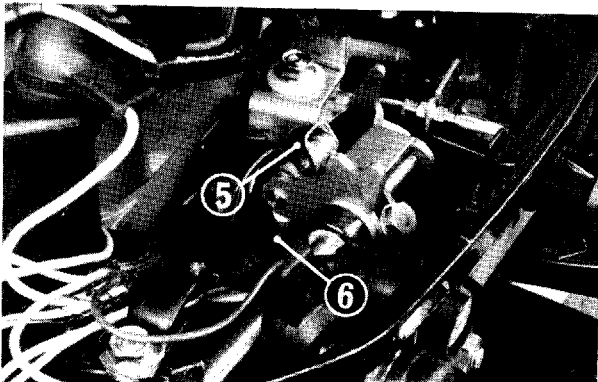

(4) Remove five 6 mm bolts (7) and separate gear case (8) from extension case (9).

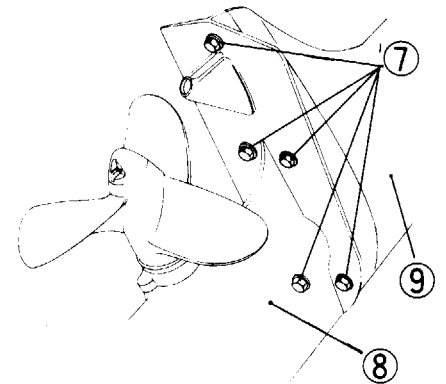



• GEAR AND EXTENSION CASES

**1** ROD JOINT

**DISASSEMBLY :**  
Remove the joint to separate the gear case from the extension case.

**ASSEMBLY :**  
Screw the shift rod joint all the way down, then unscrew 4 turns (see SHIFT ROD ADJUSTMENT, page 27.).

**2** VERTICAL SHAFT

**ASSEMBLY :**  
Connect the vertical shaft to the pinion shaft and crankshaft.

**3** SEAL RING

**4** WATER TUBE

07973-8810001  
WATER TUBE GUIDE

**ASSEMBLY :**

- Install the tube so it does not interfere with the vertical shaft.
- Place the guide over the water tube, and position it on the extension case with a dowel pin at each end.

**NOTE:** The guide has alignment holes for two water tube diameters. Install the guide either side up, so the guide hole matches tube diameter.

- Tighten the 6 mm bolt and remove the guide.

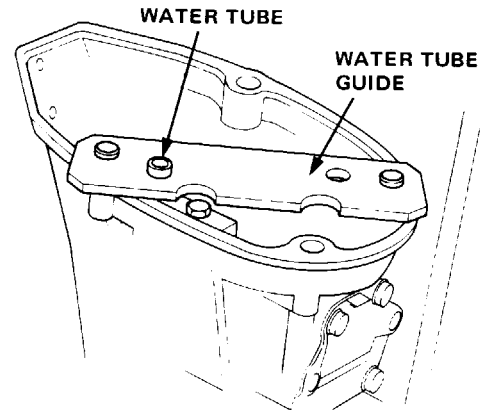

**8** EXTENSION CASE

**9** SHIFT ROD



**7** PINION SHAFT  
P. 83

**5** SEAL RING  
**ASSEMBLY :**  
Do not forget to install.

**6** GEAR CASE

6 × 40mm (5)

### ● IMPELLER PUMP

1

#### HOUSING

**ASSEMBLY :**

Install the housing while rotating the pinion shaft clockwise.

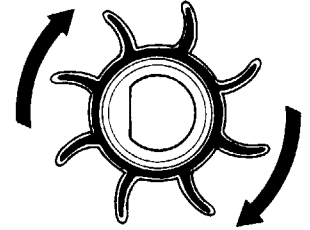

8

#### DISTANCE COLLAR

**ASSEMBLY :**

Use the collars in the proper locations:

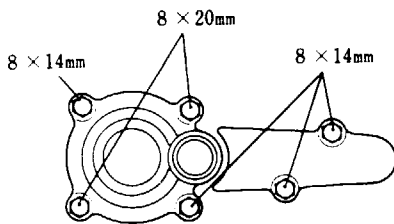

6 × 28mm ( 4 )

6 × 28mm ( 2 )

7

#### IMPELLER

**ASSEMBLY :**

- Check for wear or cracks.
- Slide the impeller over the pinion shaft by aligning their sections.

6

#### GASKETS

3

#### COVER

**ASSEMBLY :**

Make sure the cover is placed between the gaskets.

4

#### PINION SHAFT

5

#### GEAR CASE

• PINION SHAFT/FORWARD BEVEL GEAR

12

**15 mm WATER SEAL**

**DISASSEMBLY:**  
Remove the bearing by using the special tool  
"Bearing remover set  
07936-9350001."  
**ASSEMBLY:**  
Compress the bearing by using the special tool  
"Attachment driver B  
07946-9350200"

1  
**PINION SHAFT**

2  
**WATER SCREEN**

**DISASSEMBLY:**  
Push the screen out of the gear case from the inside with the flat end of a screwdriver.  
**ASSEMBLY:**  
Check for clogging or breakage before assembly.

11  
**SHIFT ROD**

10

**6302 BALL BEARING**

**DISASSEMBLY:**  
Remove the bearing by using the special tool  
"Bearing remover set  
07936-9350001."  
**ASSEMBLY:**  
Compress the bearing by using the special tool  
"Attachment driver B  
07946-9350200"

3  
**THRUST BEARING WASHER**

**ASSEMBLY:**  
For detail, see page 38.

9  
**NEEDLE ROLLER BEARING**

P. 85

8

**GEAR SHIM**

For detail, see page 84.

7  
**6005 BALL BEARING**

4  
**THRUST BEARING**

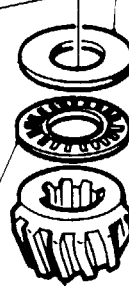

5  
**BEVEL PINION**

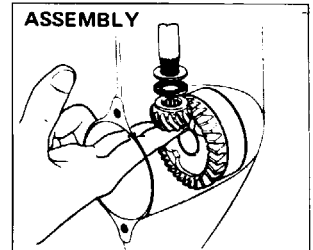

6  
**FORWARD BEVEL GEAR**

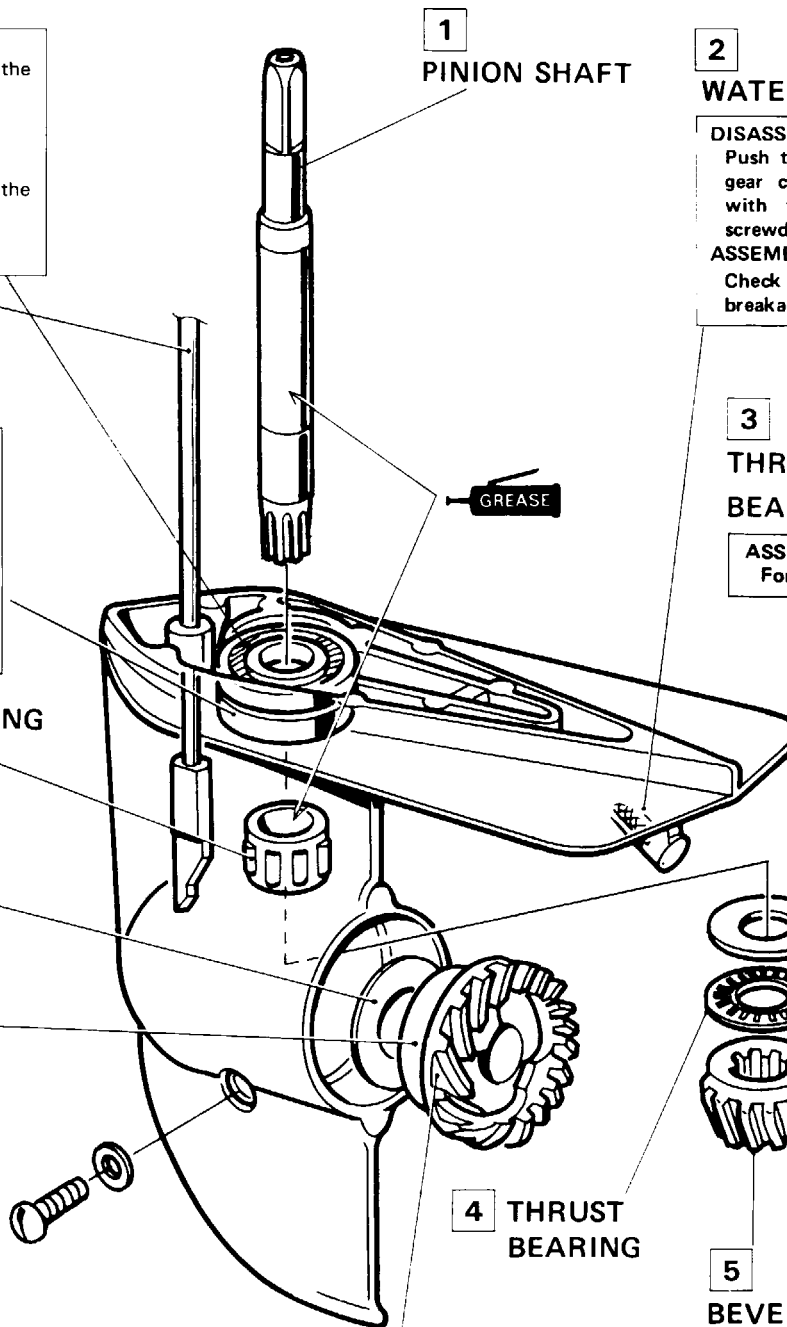

## ● SHIM AND WASHER SELECTION

1

To ensure proper adjustment of the bevel gear and pinion, different size shims, thrust bearing washers and thrust washers are available. Select the proper shims and washers according to the markings inside the gear case.

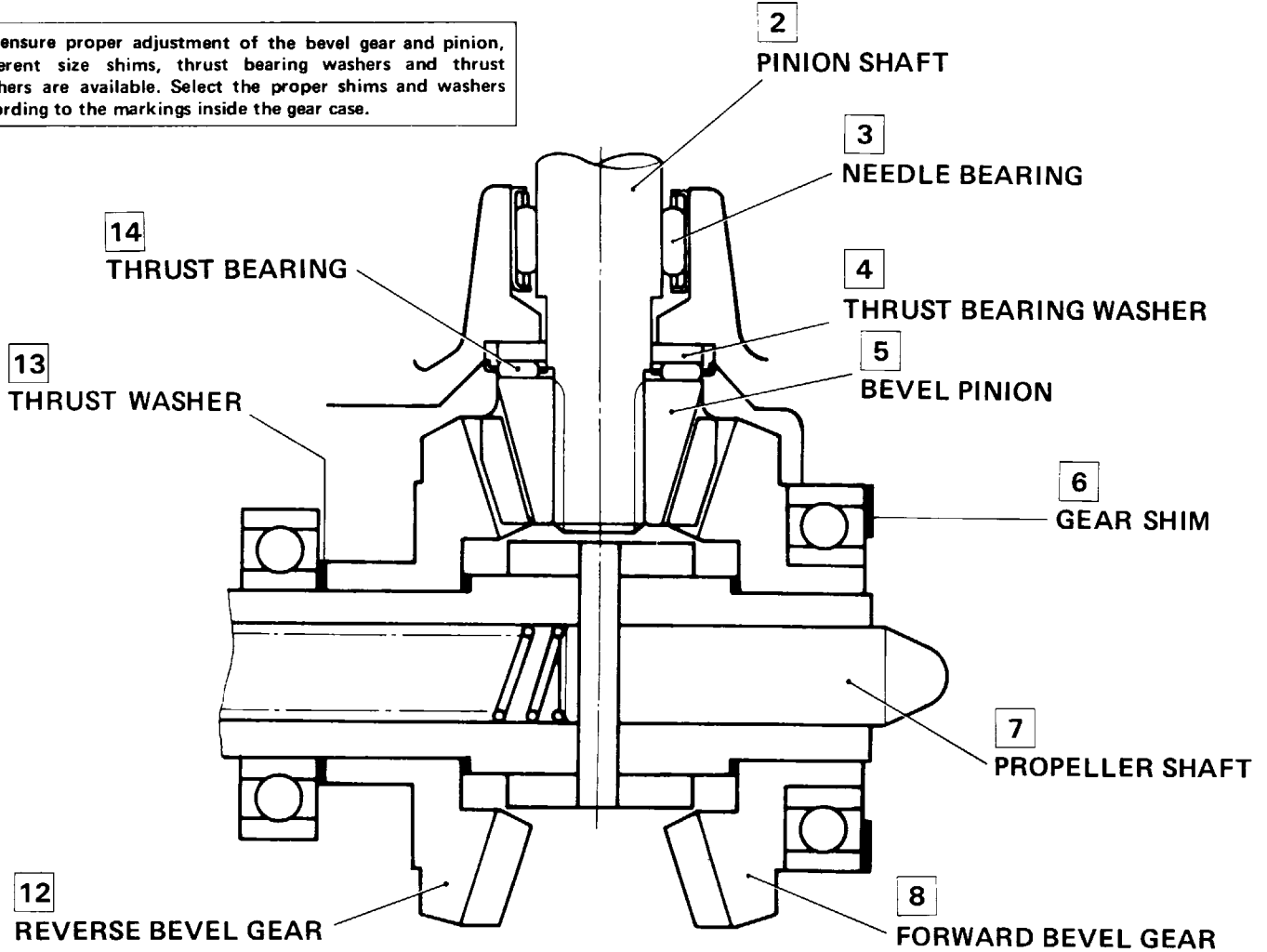

### 15 GEAR SHIM

CASE MARK	SHIM	SIZE
イ	A+A	A: 0.10mm(one)
ロ	A+B	B: 0.15mm(one)

### 16 THRUST BEARING WASHER

CASE MARK	WASHER	SIZE
A	A	A: 2.00mm(one)
B	B	B: 2.05mm(one)
C	C	C: 2.10mm(one)

### 17 THRUST WASHER

CASE MARK	WASHER	SIZE
1	C	C: 2.10mm(one)
2	D	D: 2.15mm(one)

18

—Example—

CASE MARK : "イ B1"

- ① : Gear shim                   A (0.10 mm) x 2
- ② : Thrust bearing washer    B (2.05 mm) x 1
- ③ : Thrust washer             C (2.10 mm) x 1

• PROPELLER SHAFT

1

**DISASSEMBLY:**

Using the special tool, push the shifter pin out to remove the push rod, clutch shifter and spring from the propeller shaft.

2

**ASSEMBLY :**

Flare both ends out after a new pin has been installed.

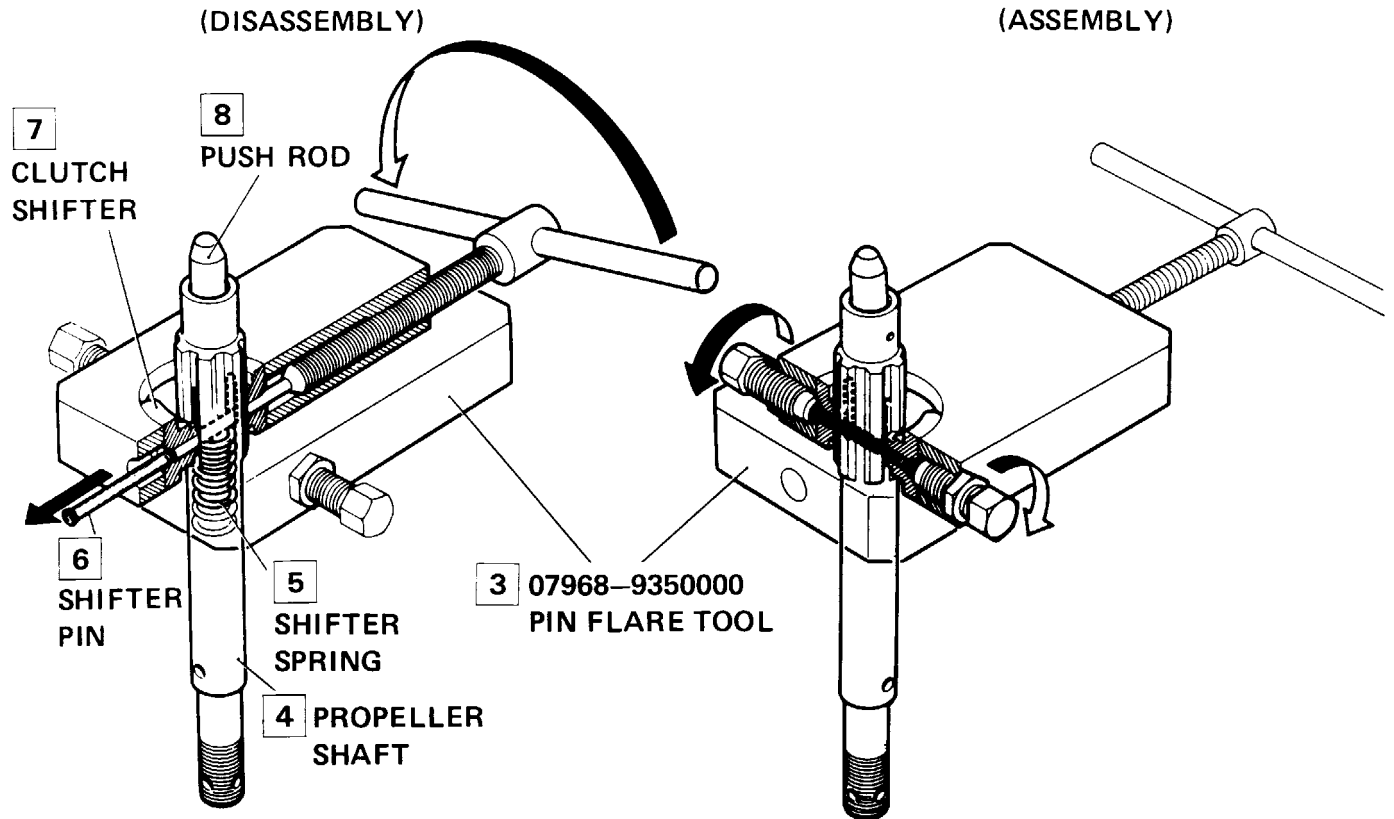

• GEAR CASE NEEDLE ROLLER BEARING DISASSEMBLY

9

**DISASSEMBLY:**

Set the special tool in the bearing as shown and turn the handle clockwise until tight. Throw the weight against the handle by sliding it over the rod. Repeat until the bearing comes out.

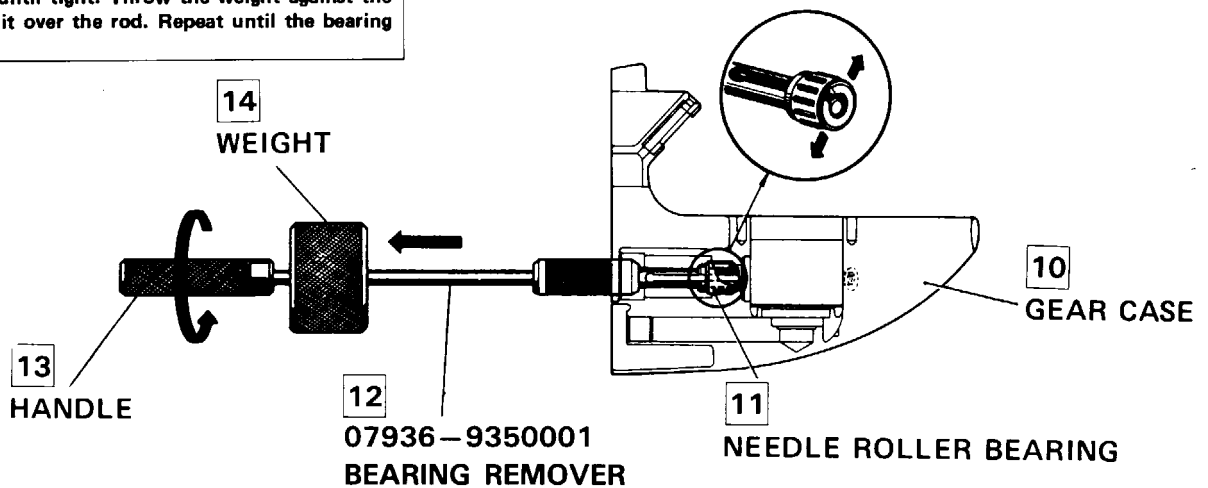

**b. INSPECTION****PROPELLER SHAFT O.D.  
(Gear Contact Points)**

STANDARD	SERVICE LIMIT
16.973–16.984 mm (0.6682–0.6687 in)	16.930 mm (0.667 in) min.

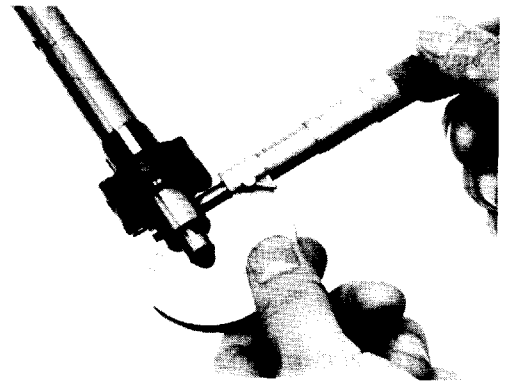
**BEVEL GEAR I.D. (FORWARD AND REVERSE)**

STANDARD	SERVICE LIMIT
17.00–17.018 mm (0.669–0.670 in)	17.06 mm (0.672 in) max.

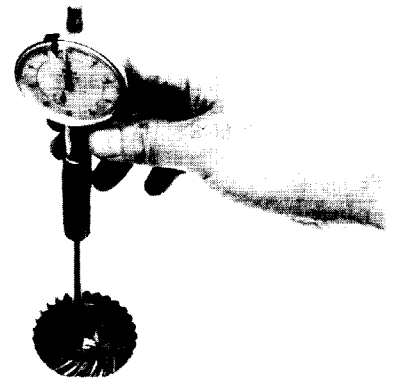

**12. OPTIONAL PARTS**

• **VERTICAL STARTER**

**1**  
**ROPE GUIDE**

**ASSEMBLY :**  
After installation, rotate the guide so the groove is not aligned with the groove in the stay bracket.

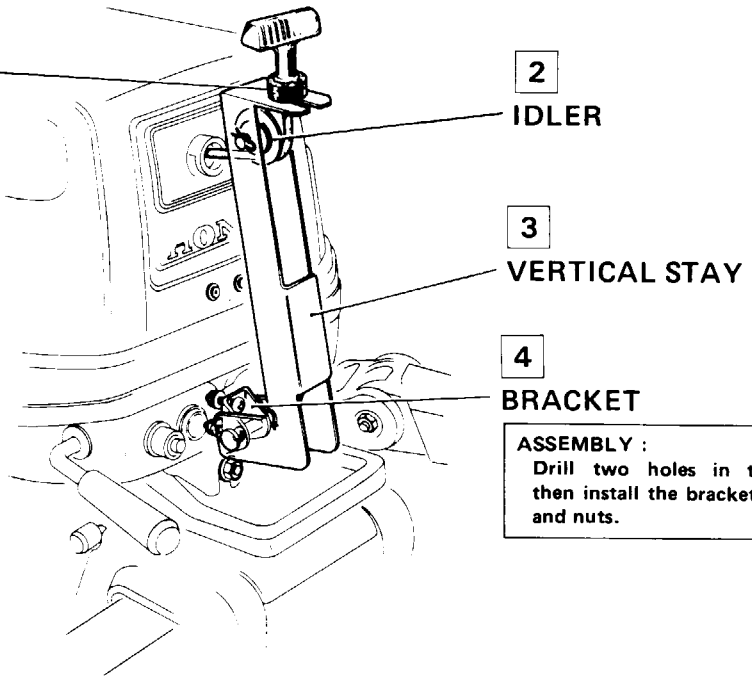

**ASSEMBLY :**  
Drill two holes in the oil case then install the bracket with screws and nuts.

• **SAFETY SWITCH**

**5**  
**SWITCH KIT**  
P/No. 06360-881-810

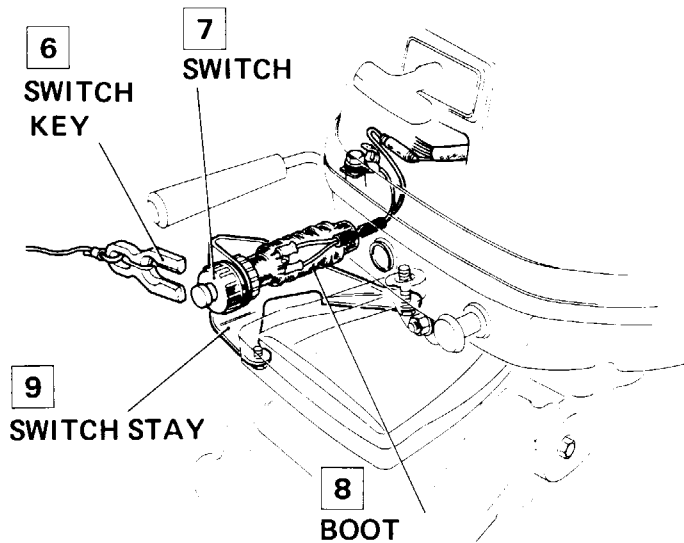

**ASSEMBLY :**  
Make sure the boot fits properly at both ends so that the wires are protected from water.

**10**  
**SWITCH KIT**  
P/No. 06360-881-813

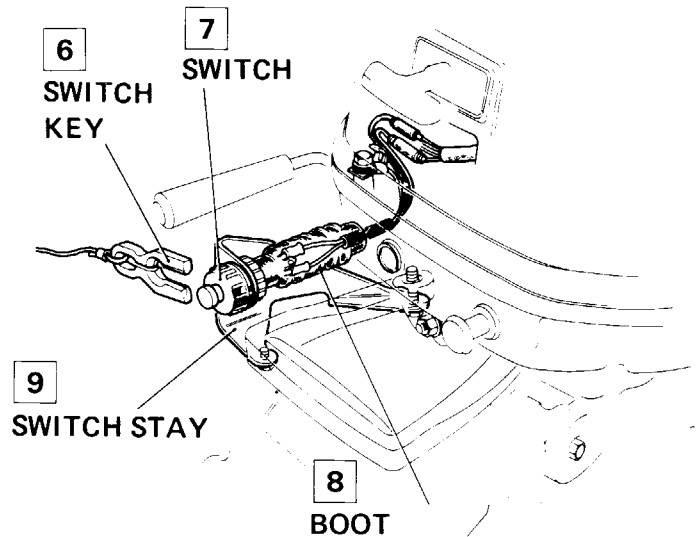

**ASSEMBLY :**  
Make sure the boot fits properly at both ends so that the wires are protected from water.

## • REMOTE CONTROL BRACKET KIT

Ref. No.	Part No.	Description
1	17851-881-811	Steering bracket
2	17941-881-810	Throttle arm stopper
3	24701-881-812	Shift lever
4	90504-921-010	Washer, plain, 6 mm
5	92000-05010-4J	Bolt, hex, head, 5 x 10 mm
6	92000-06012-4J	Bolt, hex. head, 6 x 12 mm
7	94251-06000	Pin, lock, 6 mm
•	06170-881-811	Bracket, remote control

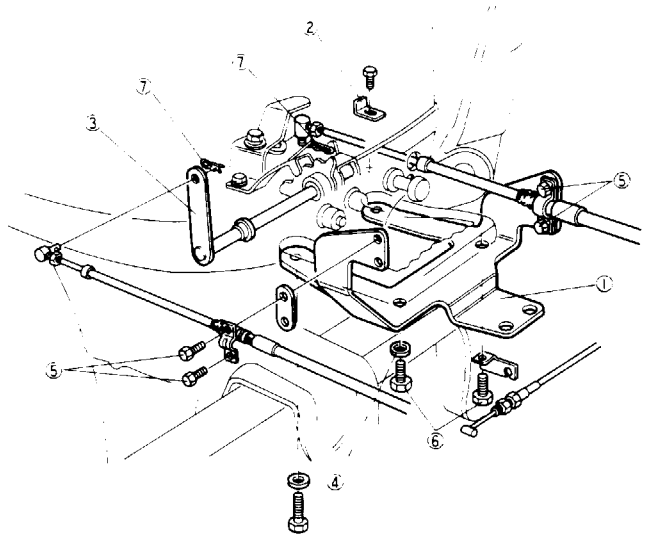

### a. SELECTION OF REMOTE CONTROL UNIT

The remote control unit to be used with the HONDA Remote Control Bracket Kit must conform to these specifications:

- SHIFT LEVER STROKE: 38 mm (1.5 in) or 35 mm (1.4 in)

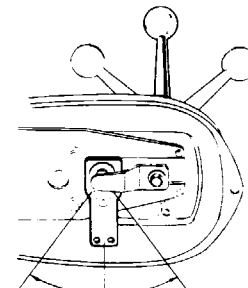

38 mm (1.5 in.) or 35 mm (1.4 in.)  
 38 mm (1.5 in.) or 35 mm (1.4 in.)

- CABLE CLAMP MOUNTING PITCH: 25.4 mm (1.0 in)

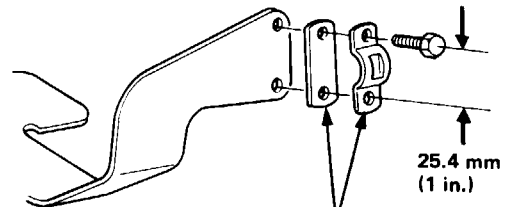

(1) WIRE CLAMPS  
 (Not included in Kit)

- CABLE END MOUNTING PIVOT: 6.4 mm (0.25 in)
- CABLE TYPE (SHIFT and THROTTLE) : 33C

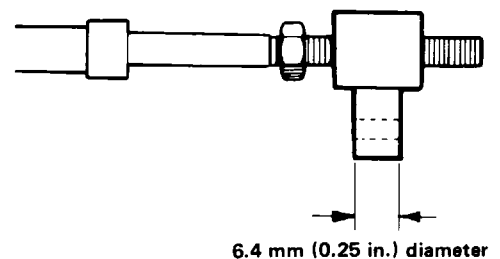

6.4 mm (0.25 in.) diameter



## b. Bracket Installation

**NOTE:** These procedures apply to the BF75/BF100 even though photographs or illustrations may differ from the actual unit.

(1) Release the lock lever and remove the engine cover.

**NOTE:** For convenience, these procedures include remote control cable hook-up at the outboard.

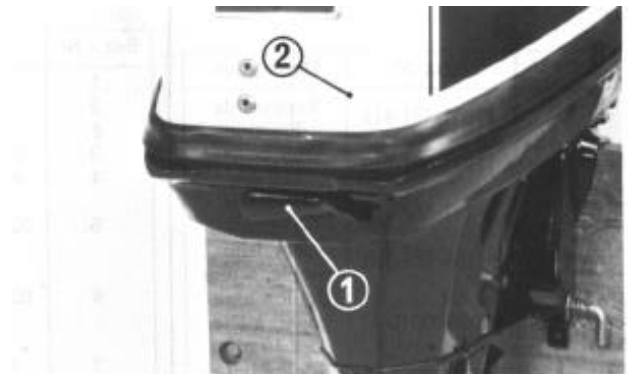

① LOCK LEVER    ② ENGINE COVER

(2) Loosen the lock nut and remove the throttle cable holder from the cable by unscrewing the 6 mm bolt. Disconnect the cable from the throttle arm.

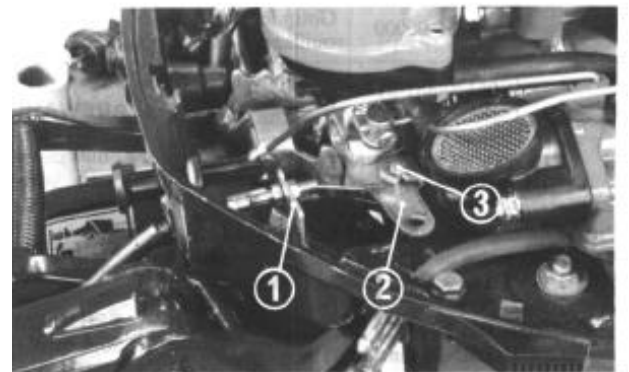

① THROTTLE CABLE HOLDER  
② THROTTLE ARM  
③ THROTTLE CABLE

(3) Pull out the cable with the cable grommet. Remove the oil case grommet. Reinstall the cable holder and lock nut on the cable.

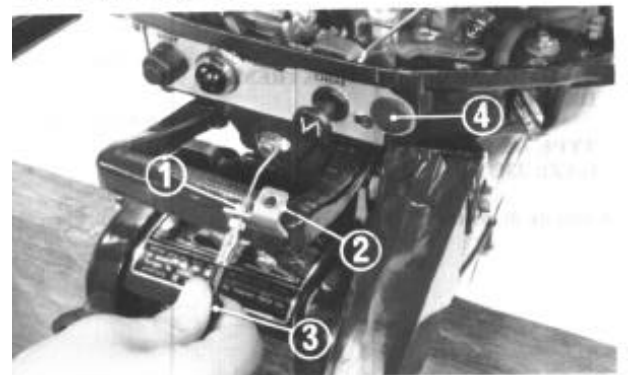

(4) Install the throttle arm stopper in the cable holder mounting holes. When installed, the stopper should contact the throttle arm with the throttle fully open.

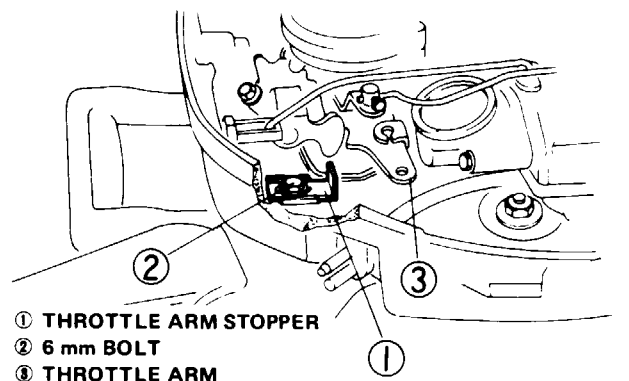

① THROTTLE ARM STOPPER  
② 6 mm BOLT  
③ THROTTLE ARM

(5) With the shift lever in **REVERSE**, remove the 6 mm bolt and washer from the shift shaft, then take out the shaft.

**NOTE:** If the shaft is difficult to remove, expand the shift arm groove with a screwdriver.

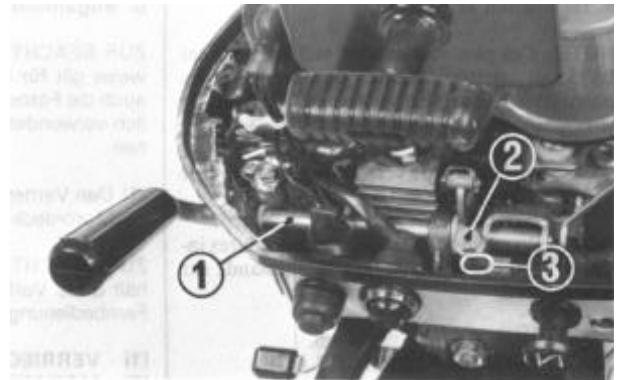

① SHIFT SHAFT      ③ SHIFT ARM GROOVE  
② 6 mm BOLT

(6) Align the cutout in the remote control shift lever end with the hole in the shift arm and install the lever in the shaft hole. Secure with the 6 mm bolt and washer removed in Step (5) above.

**NOTE:**

- Do not drop the washer and collar.
- For engine serial number 1300001 and subsequent, see additional instruction on page 90.

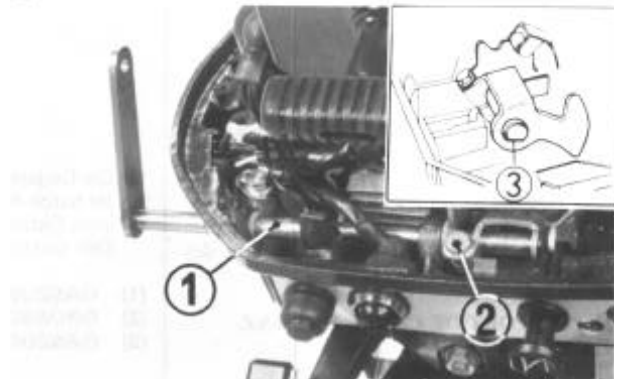

① REMOTE CONTROL SHIFT LEVER  
② 6 mm BOLT  
③ CUTOUT

(7) Remove two 8 mm bolts and washers attaching the carrying handle. Position the steering bracket under the handle and install using the 8 mm bolts and washers. Tighten securely.

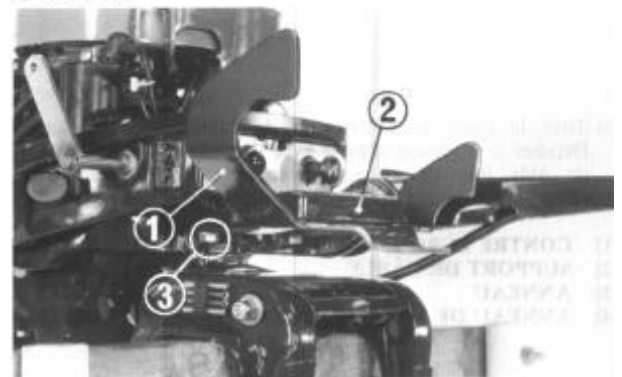

① STEERING BRACKET  
② CARRYING HANDLE  
③ 8 mm BOLT

(8) Tighten the bracket and carrying handle together using 6 x 12 mm bolts, with the cable holder on the right and a 6 mm plain washer on the left side.

**NOTE:** Raise the steering handle when installing the cable holder.

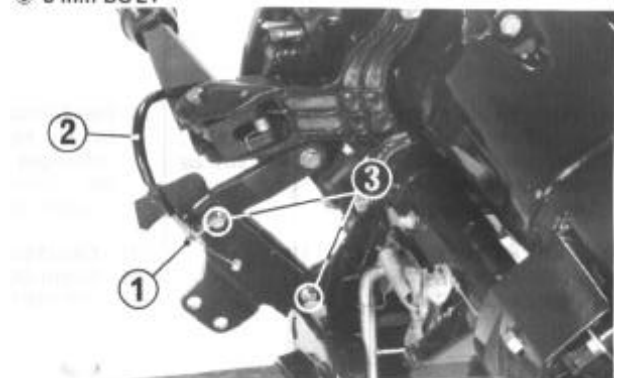

① CABLE HOLDER  
② THROTTLE CABLE  
③ 6 x 12 mm BOLT

- (9) Attach the throttle control cable to the inside, and the shift control cable to the outside of the bracket using cable clamps and 5 x 10 mm bolts.

**NOTE:**

- Align the outer clamp inner lug with the cable outer groove.
- Cut the hole in oil case grommet and install the throttle control cable through it.

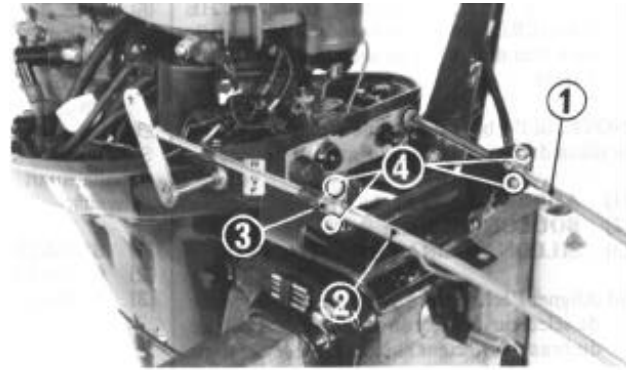

① THROTTLE CONTROL CABLE      ③ CABLE CLAMP  
② SHIFT CONTROL CABLE      ④ 5 x 10 mm BOLT

- (10) Install the pivots on the cables, then insert pivots into the shift lever mounting hole (shift side) and the throttle arm mounting hole (throttle side). Secure with lock pins.

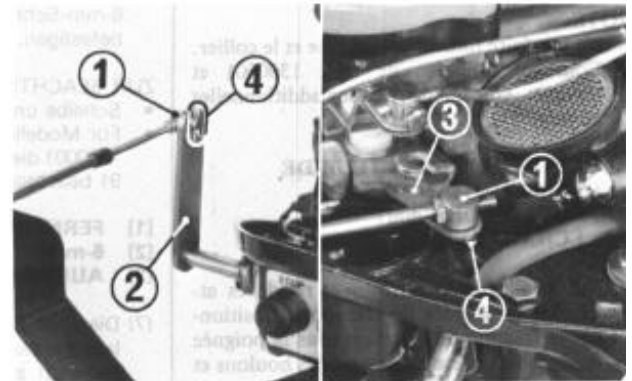

① PIVOT      ③ THROTTLE ARM  
② SHIFT LEVER      ④ LOCK PIN

Shift lever stroke of remote control unit (p. 88)	Shift lever hole	Pivot setting position
38 mm (1.5 in)	Upper	Center of the cable threads
35 mm (1.4 in)	Lower	End of the cable threads

- (11) With the throttle fully closed, set the shift lever in NEUTRAL. The remote control unit can now be connected.

Before using the remote control, be sure that the throttle does not move until the shift lever is fully in gear. If the throttle moves during shifting, the engine will rev and the gears will be stripped.

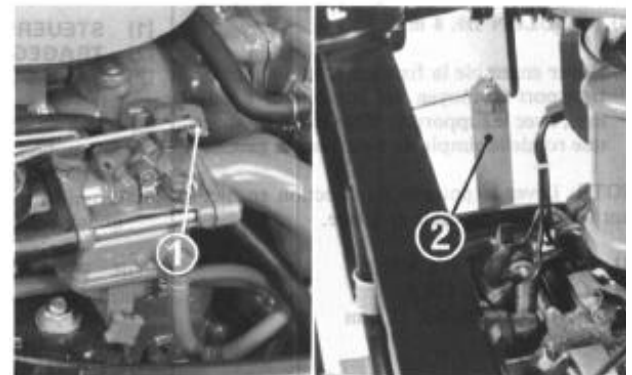

① CARBURETOR THROTTLE      ② SHIFT LEVER

- (12) Set the remote control lever to FORWARD and REVERSE to make sure that the detent roller is properly positioned in the corresponding FORWARD and REVERSE positions. If adjustment is needed, turn the cable end pivot as necessary. Be sure to reinstall the lock pin on the pivot after adjusting. Check that the throttle will not operate while shifting the control lever to the FORWARD and REVERSE positions. If it will, adjust the throttle control cable length in accordance with the instruction manual furnished with the remote control kit.

**NOTE:** For engine serial number 1300001 and subsequent, see shield plate instructions on page 90.

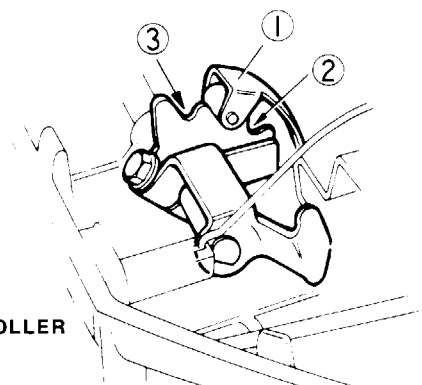

① DETENT ROLLER  
② FORWARD  
③ REVERSE

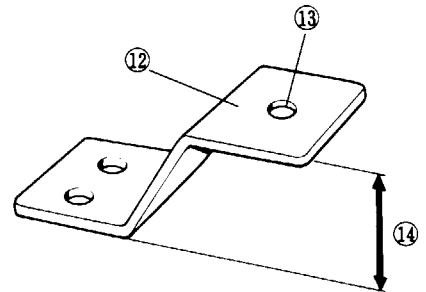
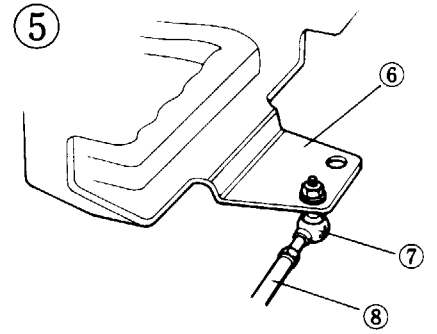
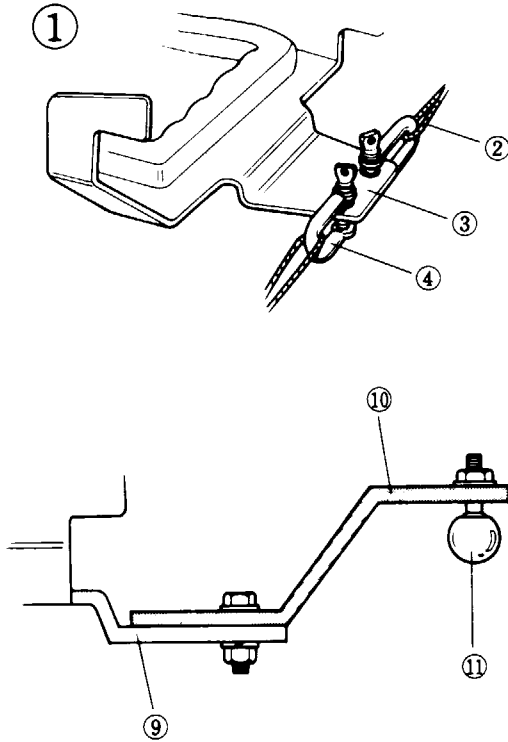

**WHEN INSTALLING THE STEERING DEVICE –**

The bracket is designed to be used with wire-type steering equipment. If a joint-rod device is to be installed please note:

The motor may be tilted to the first level (32.5°) with a joint rod installed; but a full tilt (72°) is beyond the rod's range. To tilt the motor completely, either remove the joint each time or install a bracket adapter as shown. Tilt the motor to the second level and adjust the adapter height as required when installing.

- ① WIRE-TYPE
- ② Wire.
- ③ Bracket
- ④ Shackle
- ⑤ JOINT-ROD-TYPE
- ⑥ Bracket
- ⑦ Ball Joint
- ⑧ Joint-rod
- ⑨ Bracket
- ⑩ Adapter
- ⑪ Ball Joint
- ⑫ Adapter
- ⑬ Ball joint attaching hole
- ⑭ Height (to be adjusted)

- |                              |                                    |
|------------------------------|------------------------------------|
| 1. LUBRICATION SYSTEM        | 5. ELECTRICAL SYSTEM               |
| 2. COOLING SYSTEM            | 6. TILT AND REVERSE LOCK MECHANISM |
| 3. FUEL SYSTEM               |                                    |
| 4. POWER TRANSMITTING SYSTEM |                                    |

## 1. LUBRICATION SYSTEM

Oil from the oil sump is forced through the pressure lubrication system by a trochoid pump.

### a. Oil circulation:

Oil (1) is drawn from the sump by the pump (2) through a filter (9), where dirt and metal particles are removed, and delivered under pressure to the various parts of the engine.

Oil from the oil pump flows through the drilled passages in the camshaft (3) to the valves (4) and rocker arms (5).

The oil also travels up through the oil gallery in the cylinder block. The oil gallery is divided into two parallel passages which index the oil holes in the upper and lower main journals of the crankshaft (6).

As the oil enters through the oil hole in the upper journal, it travels down through the drilled passage in the crankshaft to lubricate the upper crankpin. The lower crankpin is lubricated by the oil coming up from the lower main journal via the crankshaft passage.

Splash from the crankpin holes lubricates the connecting rod (7), piston (8) and cylinder.

### b. Oil pump:

The pump is a trochoid type and consists of an inner rotor, outer rotor and pump body.

The inner rotor is driven by the camshaft. The outer rotor is free in the pump body and is driven by the inner rotor.

Volumetric changes in the oil between the rotors force the oil out and into the engine.

### c. Oil pressure warning devices:

The lubrication system incorporates an oil pressure switch and indicator lamp.

They warn if oil pressure is low due to insufficient oil in the oil case. (See page 99).

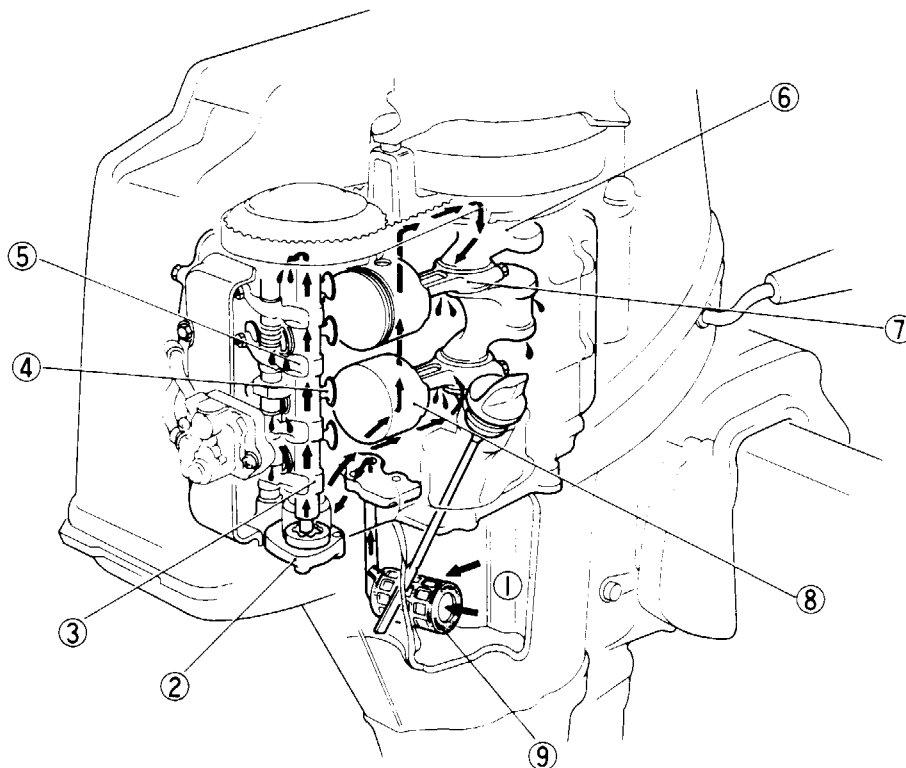

## 2. COOLING SYSTEM

Water is drawn into the water pump (2) from the port screen (1) under the anticavitation plate.

It is then pumped through a water pipe (3) into the water jackets (4) to cool the entire length of each cylinder wall. After cooling the cylinders, the water is directed into the cylinder head (6), and from there back outside through the exhaust pipe (7) with the exhaust gases.

A thermostat (5), located at the outlet of the cylinder jackets, opens and closes to the water temperature from the cylinder jackets to maintain a constant cooling water temperature. When the water is cold, it cannot pass into the cylinder head; that is, it is just circulated through the intake manifold (11). The water from the pump outlet is directly returned outside through the water check pipe (9) and exhaust pipe via the bypass tube (8). The pump is an impeller type and is located on the gear case. It is driven by the pinion shaft (10).

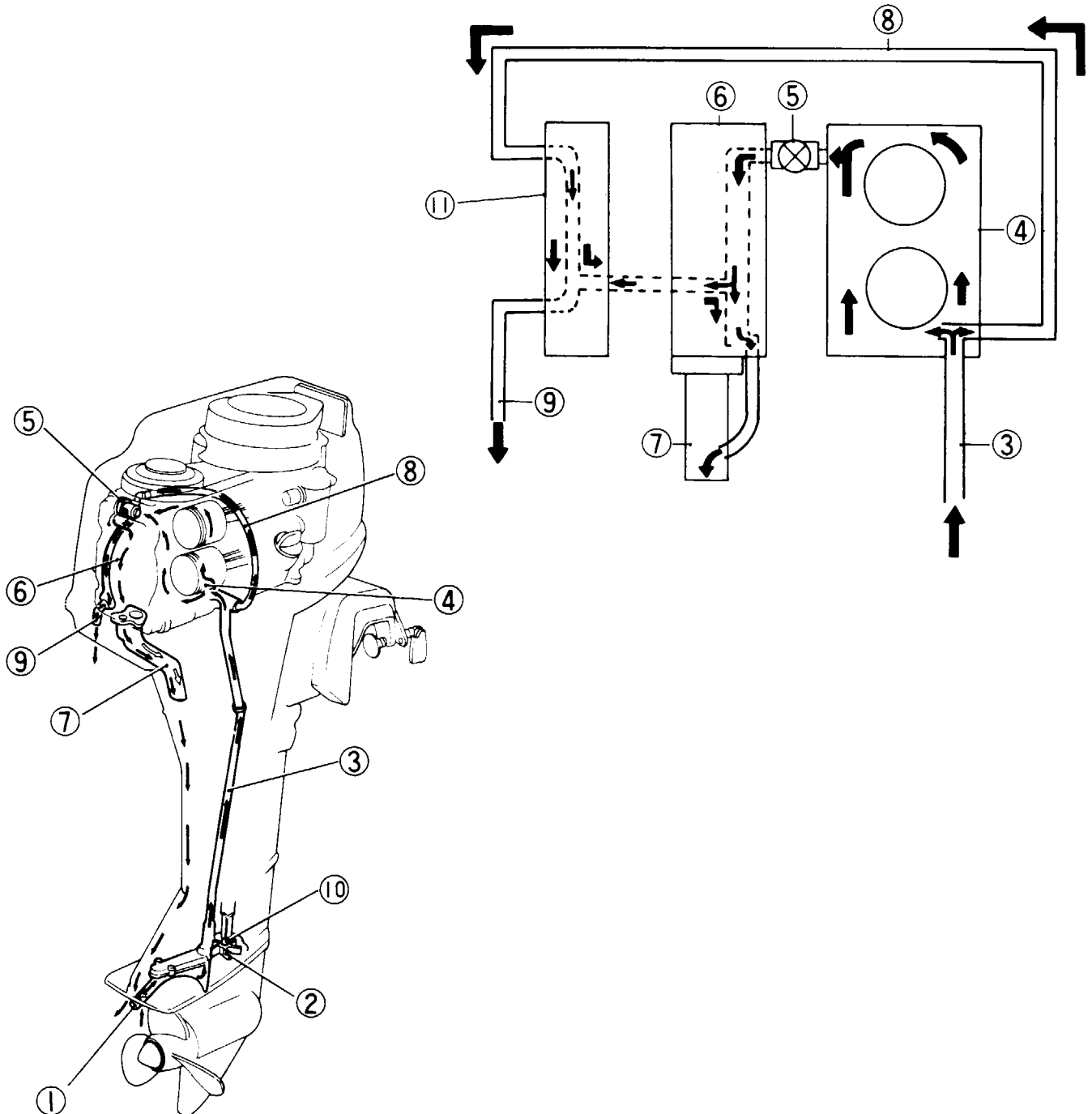

## 3. FUEL SYSTEM

### a. Fuel Tank

The fuel tank assembly consists of the fuel tank (1), filler cap (2), fuel connectors (3), fuel pipe (4) and primer bulb (5). Squeezing the bulb creates a vacuum to prime the carburetor.

The filler cap incorporates a fuel gauge and a breather valve to prevent leakage during transport.

The fuel pipe may be disconnected at the fuel tank for easy handling.

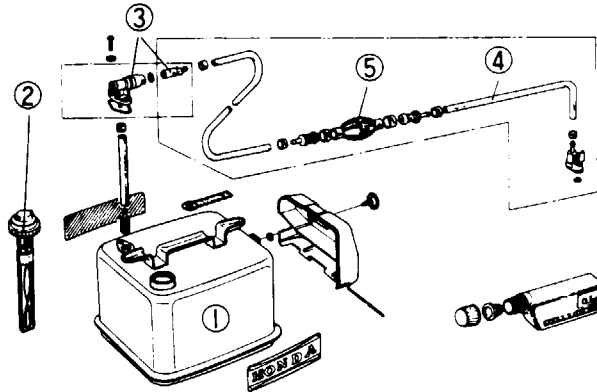

### b. Fuel Pump

The fuel pump (6) delivers fuel from the fuel tank to the carburetor (7). The pump is a diaphragm type driven by the rocker arm. The rocker arm pushes the diaphragm up and spring pressure forces it down, pumping fuel into the carburetor.

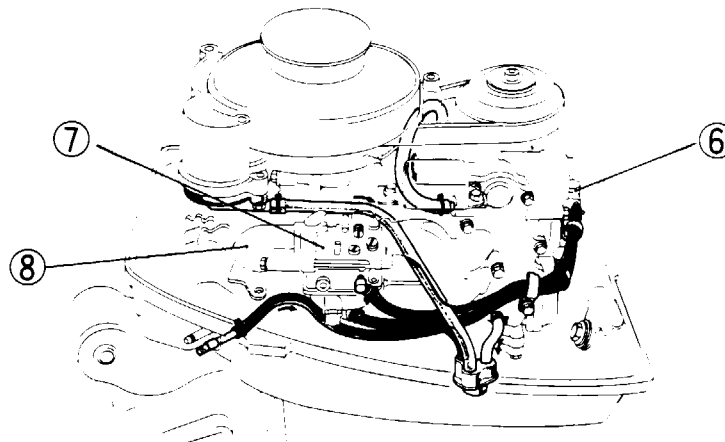

### c. Carburetor

The carburetor is a horizontal butterfly valve type.

#### ● Main circuit

When the throttle valve (10) is opened, enough air is moving through the air guide (8) and carburetor air horn to produce an appreciable vacuum in the venturi (9).

Since the main nozzle (11) is centered in the venturi, atmospheric pressure forces fuel in the float chamber (12) out into the main nozzle via the main jet (13).

As the fuel enters the main nozzle, it meets air flowing through the air jet (14) and air bleed (15) in the main nozzle. They mix and flow past the main nozzle. The mixture has a high proportion of fuel. It leans out as it mixes with air flowing through the air horn to produce the final mixture.

#### ● Slow circuit

When the throttle is opened slightly, a vacuum is produced in the pilot outlet (16) and bypass (17). Fuel in the float chamber is forced out, flowing through the main jet.

The metered fuel then mixes with air from the pilot air jet (19). Then they mix and flow past the bypass and pilot outlet into the carburetor air horn.

As the mixture flows into the air horn, it mixes with more air moving through the air horn, thereby producing the final mixture for slow speed operation.

● Float chamber

Fuel from the fuel pump flows past the valve seat (20) and float valve (21) into the float chamber. The float (22) then moves up and pushes the float valve onto the seat with the float arm (23). This shuts off the fuel inlet clearance between the valve and valve seat. New fuel can not flow into the carburetor float chamber. If the fuel level is lowered, the float moves down, allowing the valve to move away from the valve seat. In this way a constant fuel level is maintained in the float chamber.

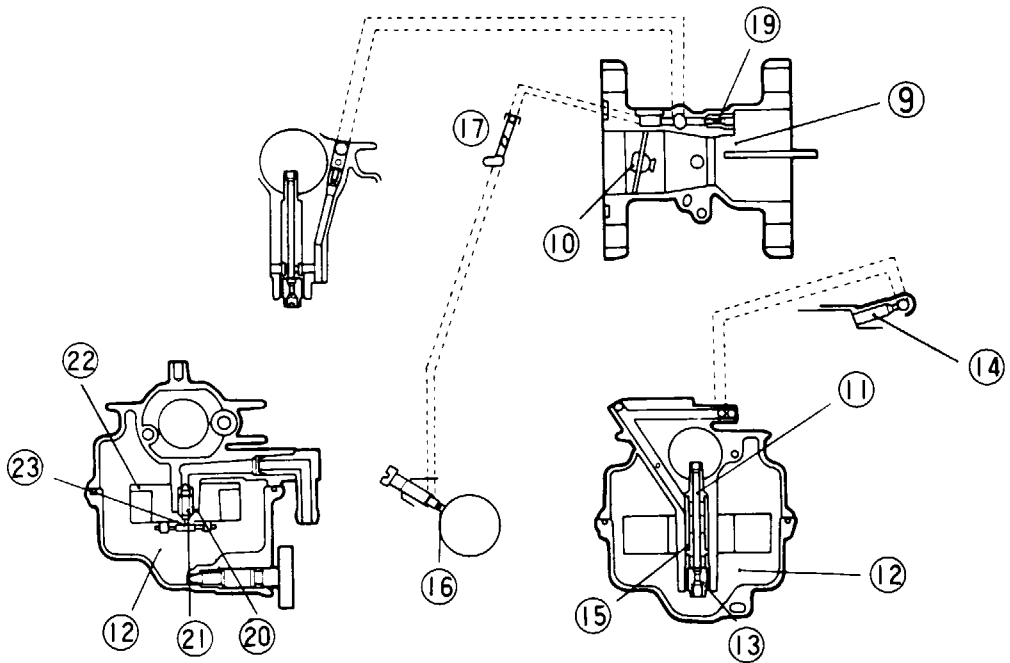

d. Throttle Limiter

The carburetor has a limiter which comes into operation when the shift lever is set in Neutral or Reverse. As the shift lever (24) is placed in Neutral or reverse, the cam (25) on the shift shaft is rotated in direction "A". With the cam in this position, the throttle arm (26) is stopped (in direction B) once it reaches the half-open position.

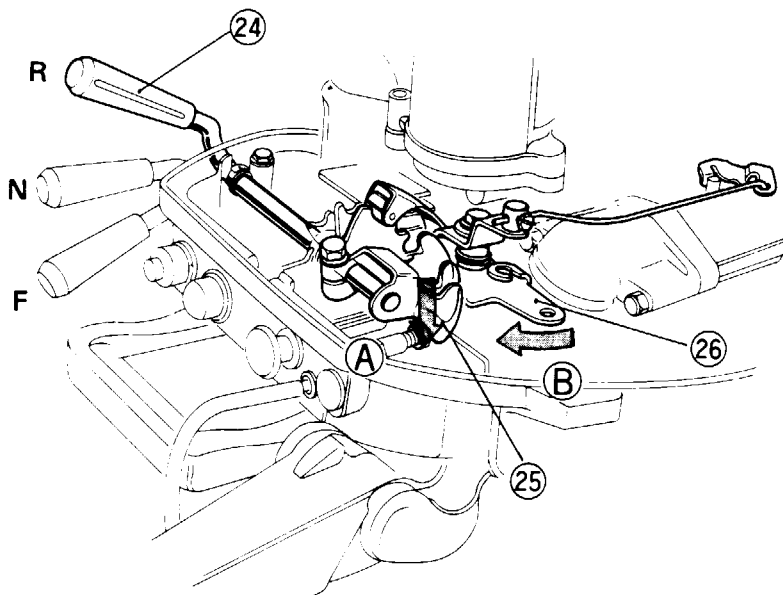



## 4. POWER TRANSMITTING SYSTEM

A 4-cycle, water cooled, 2-cylinder, 197 cc overhead camshaft gasoline engine is installed on the BF75 and BF100. The turning effort of the crankshaft (1) is transmitted to the propeller shaft (5) through the vertical shaft (2), pinion shaft (3) and bevel gears (4).

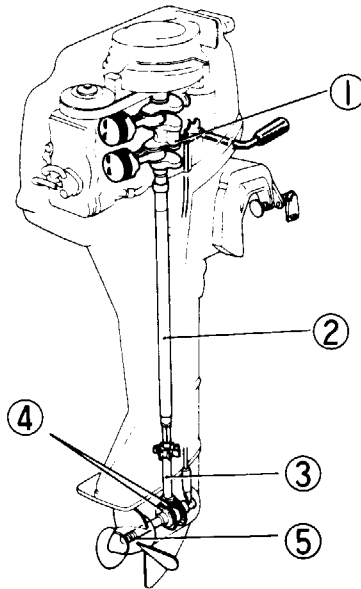

### a. Power Flow – Forward

When the shift lever (6) is placed in Forward, the shift rod (8) is moved in direction "A" through the shift shaft (7).

This causes the spring to move the clutch shifter in direction "B"; and into engagement with the forward bevel gear (10). Power from the engine is then transmitted through the bevel pinion (11), forward bevel gear, clutch shifter (9) and propeller shaft (5) to the propeller. The propeller rotates clockwise.

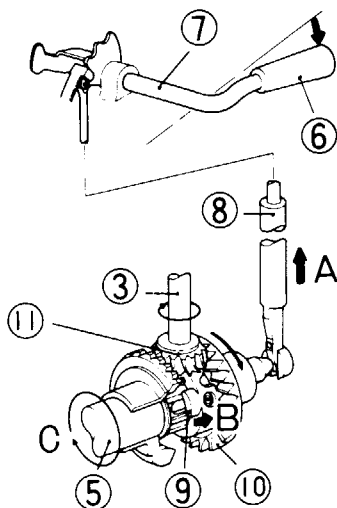

### b. Power Flow – Neutral

In Neutral, effort on the shift lever causes the shift rod to move the shifter out of engagement with the bevel gears.

Since the shifter is disengaged, no power can be transmitted to the propeller shaft. The bevel pinion is placed midway between the two bevel gears.

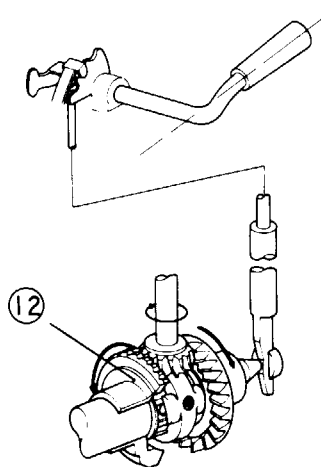

### c. Power Flow – Reverse

When the shift lever is placed in Reverse, the shift rod is moved in direction "D". The movement is transmitted to the clutch shifter, causing it to move in direction "E". Rotation is reversed since the shifter is in engagement with the reverse bevel gear (12).

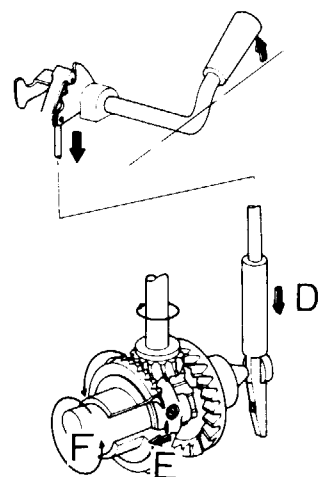

## 5. ELECTRICAL SYSTEM

### a. Ignition System

A C.D.I. (Capacitor Discharge Ignition) system is employed in motors with engine serial number 1200001 and subsequent. It uses a semi-conductor switching element called "SCR" (for Silicon Controlled Rectifier), or more commonly, "thyristor".

### OPERATING PRINCIPLE

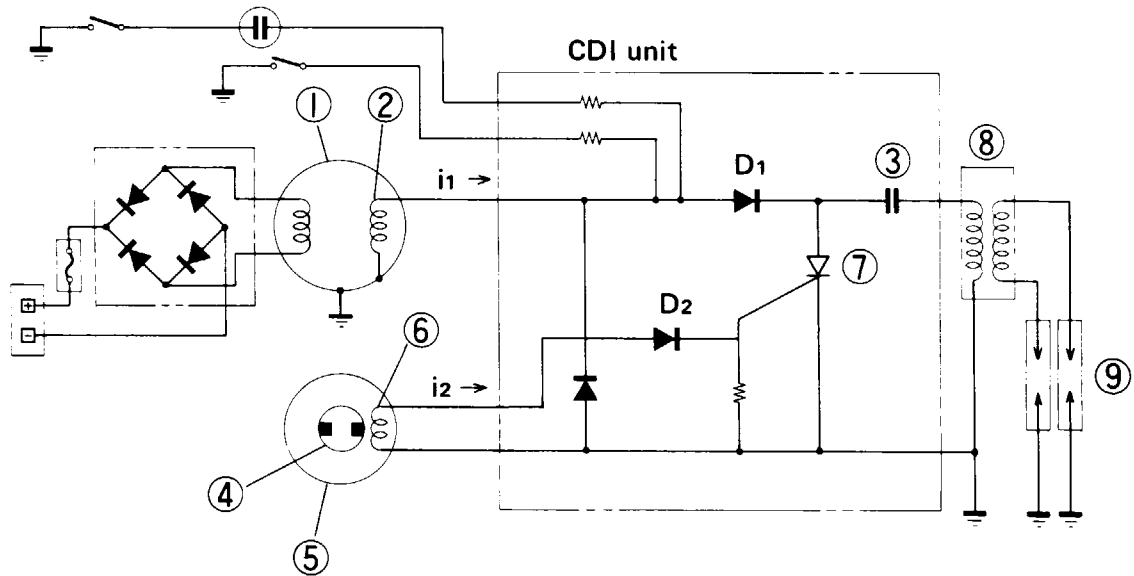

- 1) With the engine running, the flywheel magneto (1) induces alternating current in the exciter coil (2). Positive half-cycle current flows in direction  $i_1$  through diode  $D_1$  in the CDI unit to charge the capacitor (3).
- 2) When the advancer rotor (4) in the cam pulley (5) turns to the ignition position alternating current is induced in the pulser coil (6). The current flows in direction  $i_2$  through diode  $D_2$  and triggers the thyristor (7) into a conductive state, causing the capacitor (3) to discharge into the ignition coil (8).
- 3) This momentary inrush of discharging current induces a high voltage surge in the ignition coil secondary winding causing a spark at the plugs (9).

b. Spark Advancer

The spark advancer is housed in the cam pulley. When engine speed increases, centrifugal force moves the advancer weights (11) outward, causing the rotor (10) to turn in the direction shown by the arrows. This advances ignition timing in proportion to engine rpm.

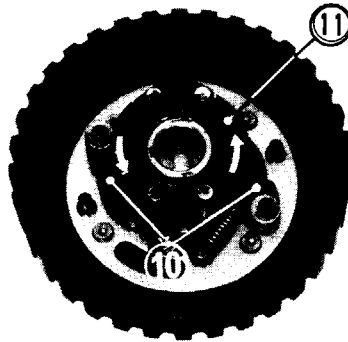

c. Oil Pressure Warning Device

The oil pressure warning device consists of a pressure switch (13), a lamp (12) and wiring. The switch is installed on the cylinder block.

As the engine starts, oil pressure closes the switch and the exciter coil output causes the lamp to glow. As engine speed reaches 2000–2500 rpm, the light will be plainly visible.

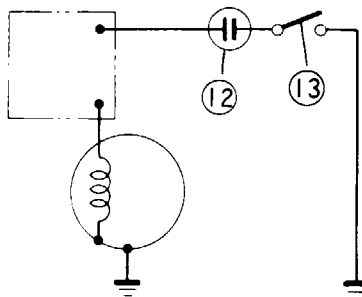

### d. D.C. Output Circuit—Battery Charging

The entire circuit consists of a charging coil, connectors, a fuse and a silicon diode rectifier. A.C. output from the charging coil (14) under the flywheel is rectified by means of the rectifier (15) and is available at the D.C. output receptacle (16). A fuse (17) is inserted in the circuit between the rectifier and the receptacle to protect against damage to the circuits.

#### CAUTION:

When the battery charging plug is not inserted in the D.C. receptacle, the exposed plug prongs can short circuit your battery if they contact any metal surface.

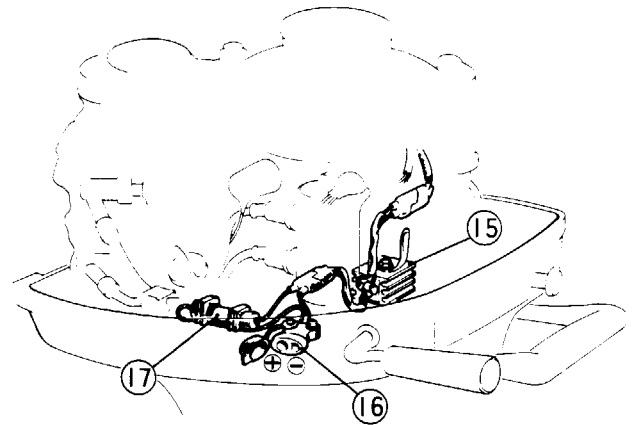
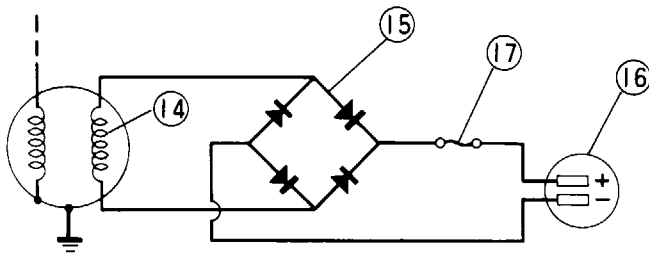

### e. Engine Stop Switch

When the switch is depressed, the ignition primary circuit is grounded, thereby stopping the engine.

A safety switch is also available as an optional part.

Since the safety key (14) switch cord is tied around the wrist or waist of the operator, the switch (15) will be turned off if the operator falls overboard. There will be no possibility of the motor running unattended.

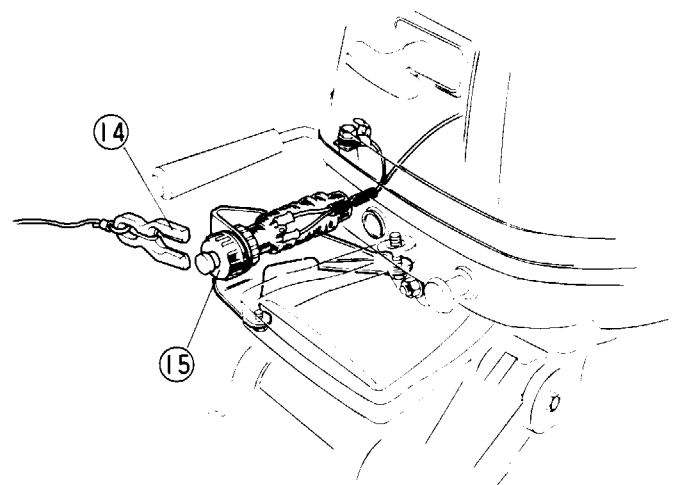
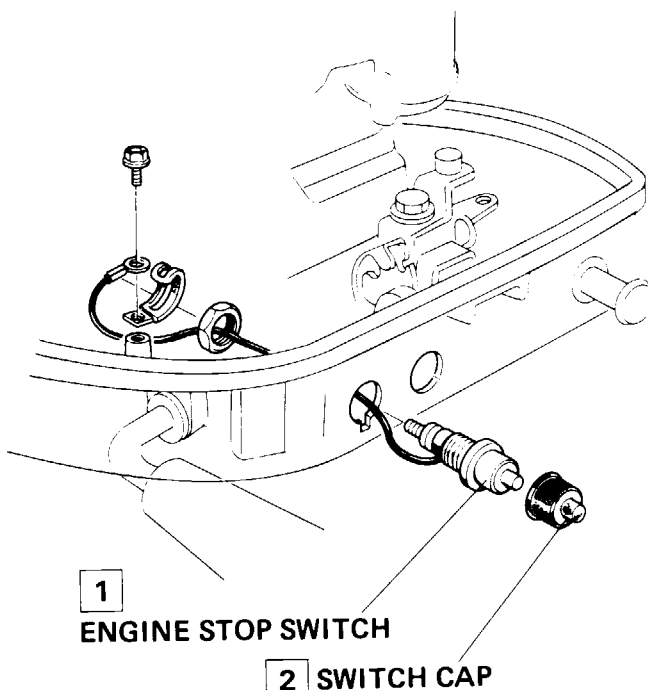

NOTE: The stop switch shown here is for engine serial number 1000004—1299999. See page 15 for engine serial number 1300001 and subsequent.

f. Neutral Switch (Engine serial number 1300001 and subsequent)

A neutral start system prevents the engine from starting when the shift lever is in the FORWARD or REVERSE position. The system's neutral switch consists of a lead switch on one side and a magnet on the other. A shield installed on the shaft either allows the magnetic force to reach the switch or obstructs the field, depending on the gear selected.

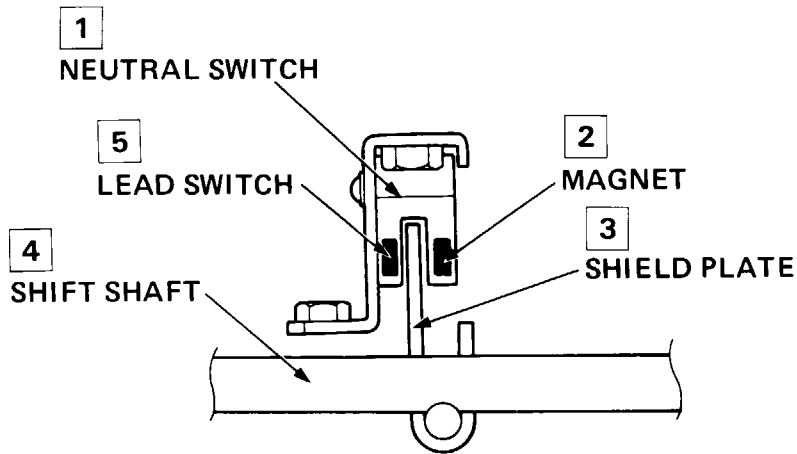

1) Neutral

When the shift lever is in NEUTRAL, the unobstructed magnetic force between the lead switch and the magnet creates a closed field to transmit the ignition circuit.

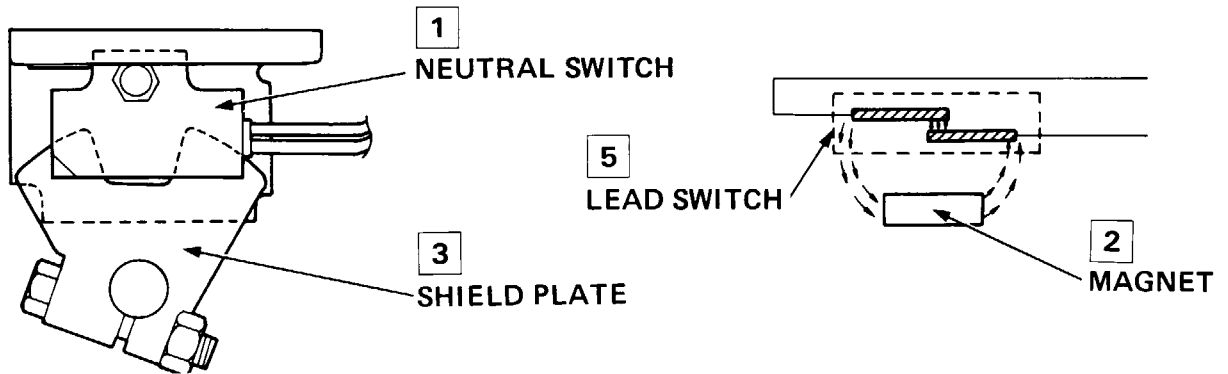

2) Forward/Reverse

When the shift lever is in FORWARD or REVERSE, the shield plate obstructs the magnetic force between the lead switch and the magnet. There is no closed field to transmit ignition.

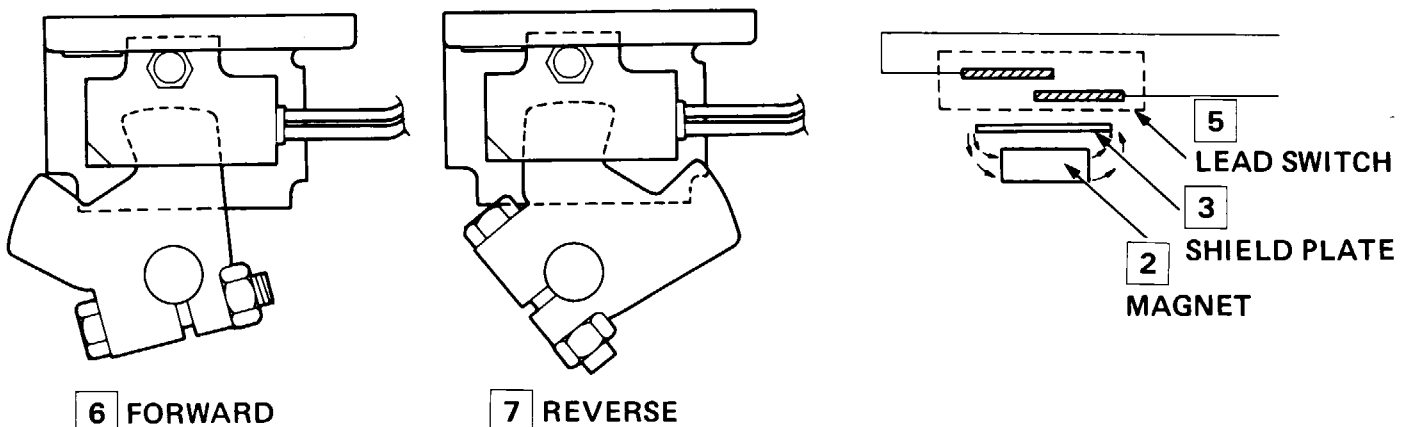

## 6. TILT AND REVERSE LOCK MECHANISM

### a. Tilt Mechanism

The tilt mechanism is used to tilt the motor in relation to the stern bracket when operating in shallow water.

As the tilt lever (1) is moved to TILT, the release rod (2) is raised, causing the reverse lock (3) to disengage from the adjusting rod (4). The unit can be set at 32.5° or 72° by raising the extension case. To release the tilt mechanism, return the tilt lever to "RUN" and raise the extension case slightly toward you, and lower it slowly.

The tilt lever should be kept in RUN while operating the outboard.

### b. Adjust Rod

The installation angle at the transom can be adjusted in four stages by repositioning the adjust rod (3°, 8°, 13° and 18°).

### c. Reverse Lock Mechanism

The mechanism is engaged when the tilt lever is in the RUN position so that the unit cannot be tilted.

**NOTE:** Do not shift the motor into reverse with the tilt lever in the TILT position. This causes the reverse lock hook to disengage with the adjust rod.

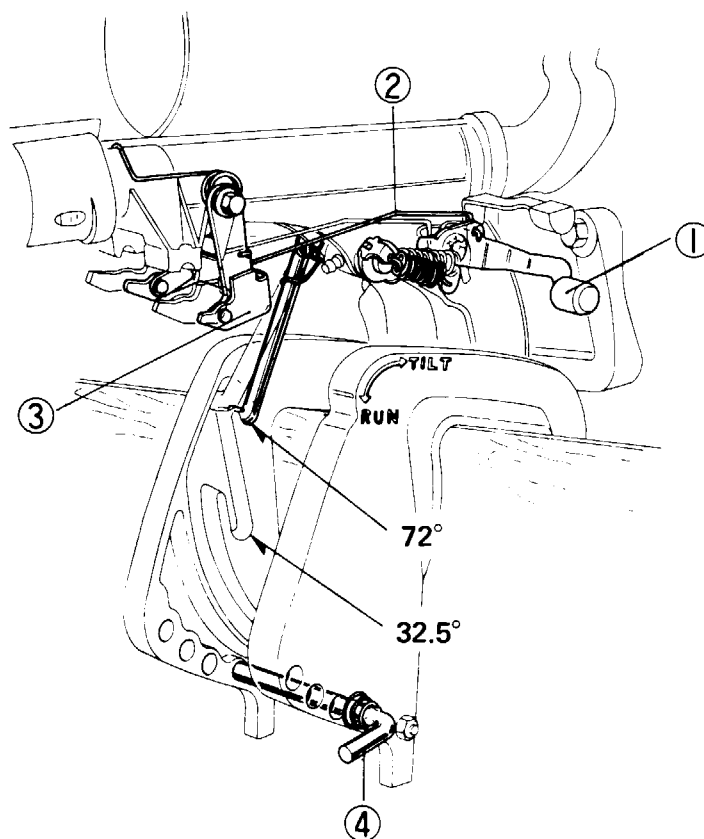

# HONDA

## BF75·BF100

'85

SUPPLEMENT

CONTENTS



# **HONDA**

## **BF75/BF100**

---

### **PREFACE**

This supplement describes service procedures for the '85 BF75 and '85 BF100 Outboard Motors, serial numbers 1700001 and subsequent.

Refer to the base shop manual (No. 6688120) for service procedures and data not included in this supplement.

ALL INFORMATION, ILLUSTRATIONS, DIRECTIONS AND SPECIFICATIONS INCLUDED IN THIS PUBLICATION ARE BASED ON THE LATEST PRODUCT INFORMATION AVAILABLE AT THE TIME OF APPROVAL FOR PRINTING HONDA MOTOR CO., LTD. RESERVES THE RIGHT TO MAKE CHANGES WITHOUT INCURRING ANY OBLIGATION WHATEVER.

NO PART OF THIS PUBLICATION MAY BE REPRODUCED WITHOUT WRITTEN PERMISSION.

HONDA MOTOR CO., LTD.  
SERVICE PUBLICATIONS OFFICE



**CONTENTS**

I.	SERVICE INFORMATION .....	106
1.	TUBE ROUTING .....	106
2.	MAINTENANCE SCHEDULE .....	107
II.	MAINTENANCE.....	108
1.	THERMOSTAT CHECK .....	108
2.	FUEL STRAINER REPLACEMENT .....	108
III.	MAJOR MODIFICATIONS .....	109
1.	ENGINE PART .....	109
2.	FRAME PART .....	110

1. TUBE ROUTING

2. MAINTENANCE SCHEDULE

## 1. TUBE ROUTING

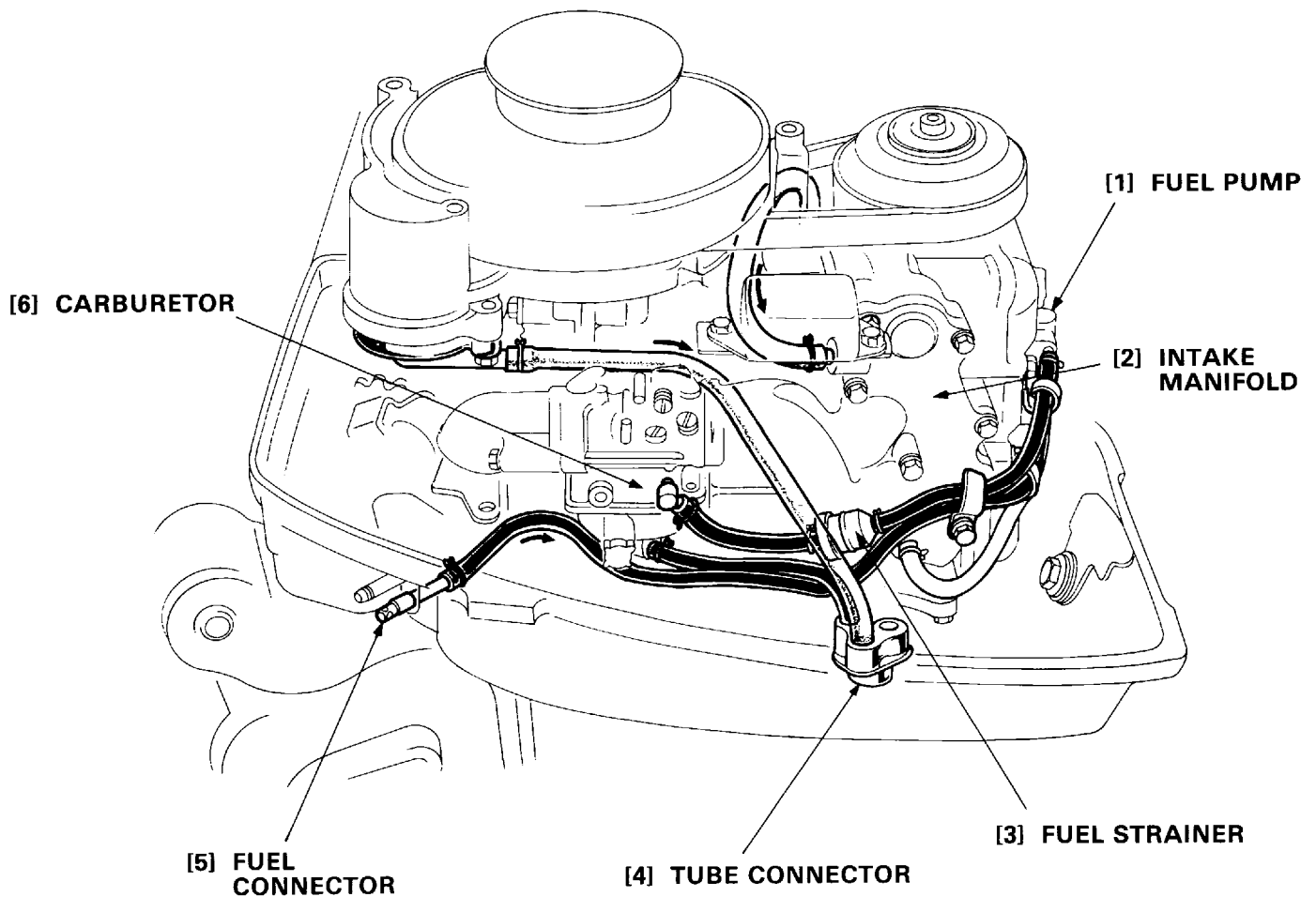

## 2. MAINTENANCE SCHEDULE

REGULAR SERVICE PERIOD Performed at every indicated month or operating hour interval, whichever comes first.		EACH USE	FIRST MONTH OR 20 HRS	EVERY 6 MONTHS OR 100 HRS	EVERY YEAR OR 200 HRS
ITEM					
Engine oil	Check level	○			
	Change		○	○	
Gear case oil	Check level	○			
	Change		○		○
	Check for water contamination			○	
Carburetor linkage	Check		○		
Valve clearance	Check-Readjust		○		○
Spark plug	Clean-Readjust			○	
Shear pin	Check			○(1)	
Lubrication	Grease			○	
Fuel tank and fuel filter	Clean				○
Fuel strainer	Replace				○
Thermostat	Check				○
Fuel line	Check (Replace if necessary)	Every 3 years			

NOTE: (1) Lubricate more frequently when used in salt water.

## 1. THERMOSTAT CHECK

### 1. THERMOSTAT CHECK

- 1) Suspend the thermostat in heated water.
- 2) Measure water temperature and valve lift.

Water Temperature	Valve Lift
Below 60°C (140°F)	0 mm
Above 70°C (158°F)	3–4 mm (0.12–0.16 in)

#### NOTE

Between 60°C and 70°C, the valve may or may not operate. In either case, it is not a malfunction. Thermostats not complying with the figures listed above should be replaced with new parts.

## 2. FUEL STRAINER REPLACEMENT

### ((SERVICE PERIOD))

Every 200 operating hours or every one year

- 1) Disconnect the fuel tank line from the motor.
- 2) Remove the engine cover and remove the fuel strainer.

#### NOTE

Before removing the strainer, place clamps on the fuel tubes on each side of the strainer to prevent fuel leakage.

- 3) Install the new fuel strainer with the arrow mark pointing toward the carburetor.

#### NOTE

Fuel flow will be impeded if the strainer is installed backward.

Remove the clamps used to close the fuel tubes. Connect the fuel tank line to the motor.

Turn the fuel tank vent knob to the ON position, pump the primer bulb, and check for leaks.

#### WARNING

- Always work in a well-ventilated area.
- Be sure that any fuel drained from the outboard motor is stored in a safe container.
- Wipe up any spilled gasoline at once.

## 2. FUEL STRAINER REPLACEMENT

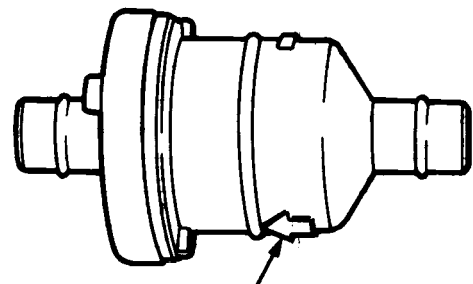
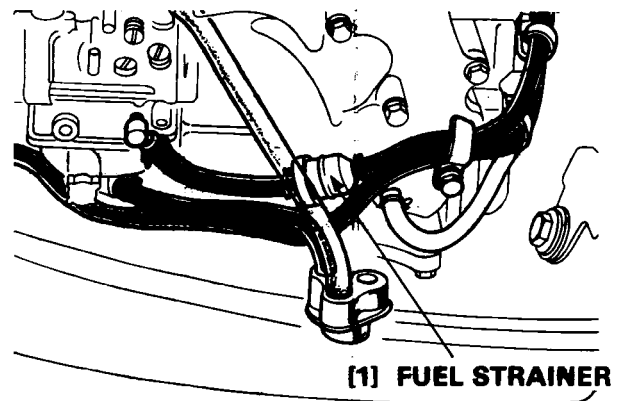
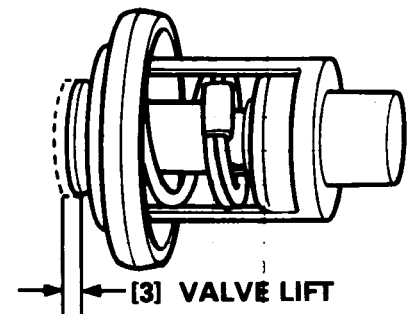
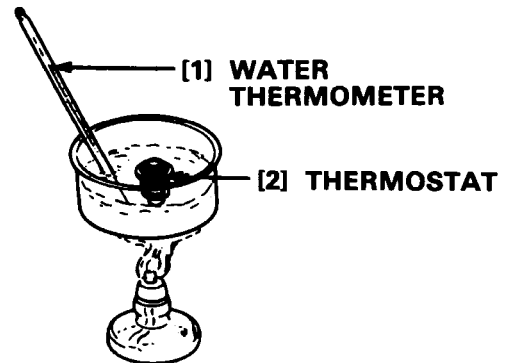

[2] The arrow mark indicates the fuel flow direction.

# III. MAJOR MODIFICATIONS

**HONDA**  
BF75/BF100

## 1. ENGINE PART

## 2. FRAME PART

### 1. ENGINE PART

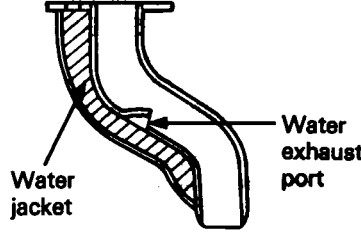
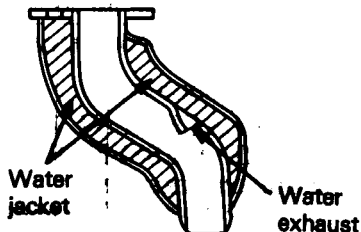
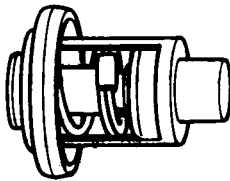
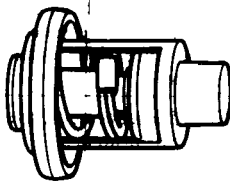
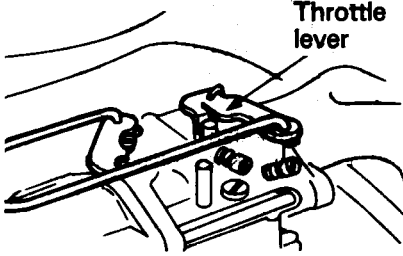
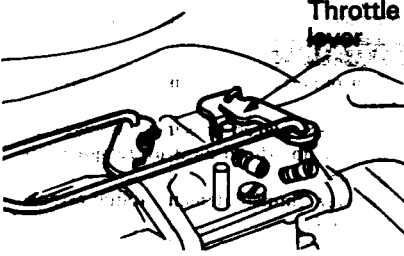
Items	Serial number ~1699999	Serial number 1700001 ~
<ul style="list-style-type: none"> <li>• Cylinder head</li> <li>• Cylinder barrel</li> <li>• Inlet manifold</li> <li>• Oilcase</li> </ul> <p>Internal surface of water jacket for above parts has had its anti-corrosion finish modified.</p>		<p>Zinc chromate finish (anti-corrosion finish)</p>
<ul style="list-style-type: none"> <li>• Exhaust pipe</li> </ul> <p>Shape modification</p>	 <p>Water jacket</p> <p>Water exhaust port</p> <p>Half-surface cooling</p>	 <p>Water jacket</p> <p>Water exhaust port</p> <p>Full circumference water jacket, and position of water exhaust port has been changed (full surface cooling).</p>
<p>Thermostat material revised. Increase in lift amount at full open.</p>	 <p>Material C2720 (brass) Full open lift 2½ mm</p>	 <p>Material C5101 (bronze) Full open lift 3½ mm</p>
<p>Throttle lever material revised.</p>	 <p>Throttle lever</p> <p>Material B6BM (brass)</p>	 <p>Throttle lever</p> <p>Material resin POM</p>

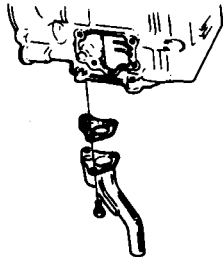
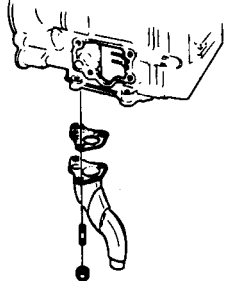
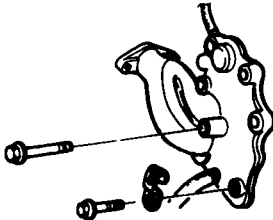
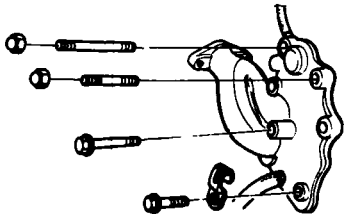
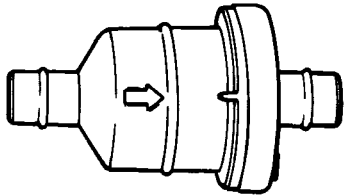
Items	Serial number ~ 1699999	Serial number 1700001 ~
<p>Tightening bolt for inlet manifold and exhaust manifold (pipe)</p>	 <p>Flange bolt</p>	 <p>Stud bolt and capnut</p>
	 <p>Flange bolt</p>	 <p>Stud bolt and capnut</p>
<p>Fuel strainer</p>		 <p>Installed between carburetor and fuel pump</p>

**2. FRAME PART**

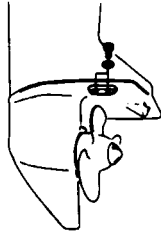
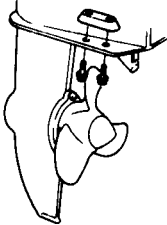
Items	Serial number ~ 1699999	Serial number 1700001 ~
Revised positioning of anode metal	 <p data-bbox="546 641 891 670">Lower surface of cavitation plate</p>	 <p data-bbox="1020 641 1366 670">Upper surface of cavitation plate</p>

\* Design of side cover emblem has also been revised.

# **HONDA**

## **BF8A**

---

**SUPPLEMENT**  
**CONTENTS**



## PREFACE

This supplement describes service procedures for the BF8A Outboard Motors, which are not covered in the base Shop manual BF75.BF100 (6688121).

ALL INFORMATION, ILLUSTRATIONS, DIRECTIONS AND SPECIFICATIONS INCLUDED IN THIS PUBLICATION ARE BASED ON THE LATEST PRODUCT INFORMATION AVAILABLE AT THE TIME OF APPROVAL FOR PRINTING HONDA MOTOR CO., LTD. RESERVES THE RIGHT TO MAKE CHANGES WITHOUT INCURRING ANY OBLIGATION WHATSOEVER.

NO PART OF THIS PUBLICATION MAY BE REPRODUCED WITHOUT WRITTEN PERMISSION.

HONDA MOTOR CO., LTD.  
SERVICE PUBLICATIONS OFFICE

## CONTENTS

I. SPECIFICATIONS .....	114
1. SPECIFICATIONS .....	114
II. SERVICE INFORMATION .....	115
1. OUTLINE OF CHANGES .....	115
III. DISASSEMBLY AND SERVICE .....	116
1. REVERSE LOCK/SWIVEL CASE .....	116

# I. SPECIFICATIONS

**HONDA**  
**BF8A**

## 1. SPECIFICATIONS

### • DIMENSIONS AND WEIGHT

Model	S	L
Description code	BACS	BACL
Overall length	525 mm (20.67 in)	
Overall width	315 mm (12.4 in)	
Overall height	1,010 mm (39.76 in)	1,160 mm (45.67 in)
Operating weight	36.0 kg (79.1 lb)	37.0 kg (81.3 lb)

### • FRAME

Transom height	422 mm (16.6 in)	572 mm (22.5 in)
Transom angle	5-stages (3° – 7° – 11° – 15° – 19°)	
Tilting	3-stages (30° – 45° – 70°)	
Swivel angle	40°	



### • ENGINE

Type	2 cylinder, in-line, 4 stroke, water-cooled, OHC
Displacement	197 cc (12.0 cu in)
Bore and stroke	56 x 40 mm (2.20 x 1.57 in)
Max. horsepower	5.88 KW (8.0 ps)/5,500 min <sup>-1</sup> (rpm)
Max. torque	11.8 N·m (120 kg·cm, 8.68 ft·lb)/4,500 min <sup>-1</sup> (rpm)
Ignition system	C.D.I.
Ignition timing	15° BTDC

# II. SERVICE INFORMATION

**HONDA**  
**BF8A**

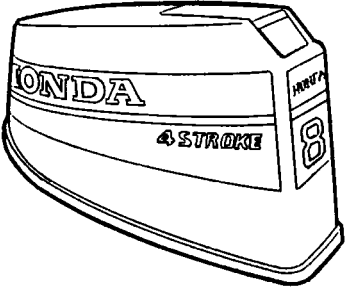
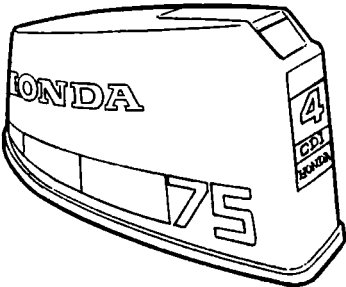
## 1. OUTLINE OF CHANGES

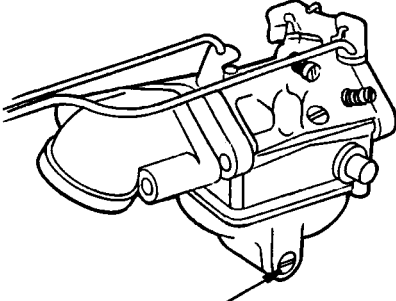
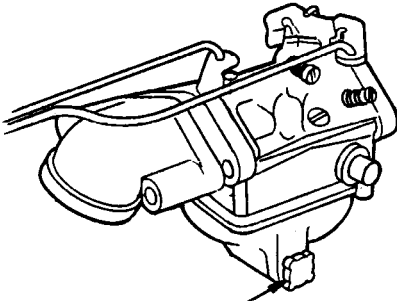
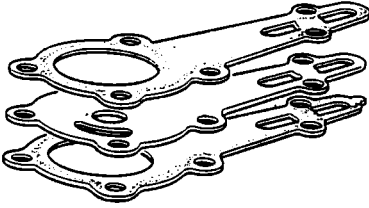
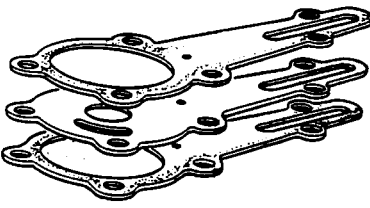
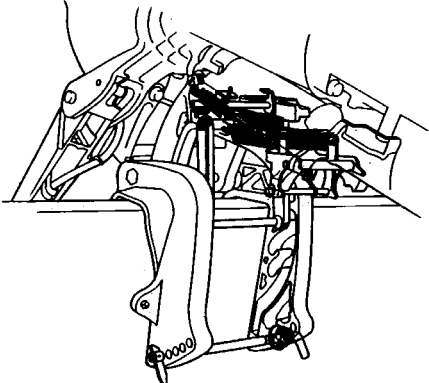
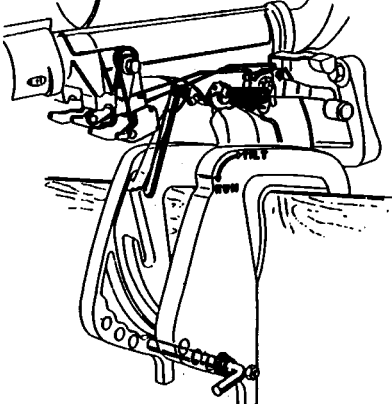
PARTS DESCRIPTION	BF8A	BF75/BF100
ENGINE COVER		
CAMSHAFT	 <p data-bbox="450 820 934 903">Valve tappet clearance IN : <math>0.12 \pm 0.02</math> mm (<math>0.0047 \pm 0.0006</math> in) EX : <math>0.20 \pm 0.02</math> mm (<math>0.0079 \pm 0.0006</math> in)</p>	 <p data-bbox="949 820 1433 903">Valve tappet clearance IN : <math>0.08 \pm 0.02</math> mm (<math>0.0031 \pm 0.0006</math> in) EX : <math>0.08 \pm 0.02</math> mm (<math>0.0031 \pm 0.0006</math> in)</p>
CARBURETOR	 <p data-bbox="500 1234 677 1259">DRAIN SCREW</p>	 <p data-bbox="1010 1234 1186 1259">DRAIN SCREW</p>
IMPELLER PUMP COVER AND GASKETS		
REVERSE LOCK SYSTEM		

# III. DISASSEMBLY AND SERVICE

**HONDA**  
**BF8A**

## 1. REVERSE LOCK/SWIVEL CASE

### a. DISASSEMBLY/REASSEMBLY

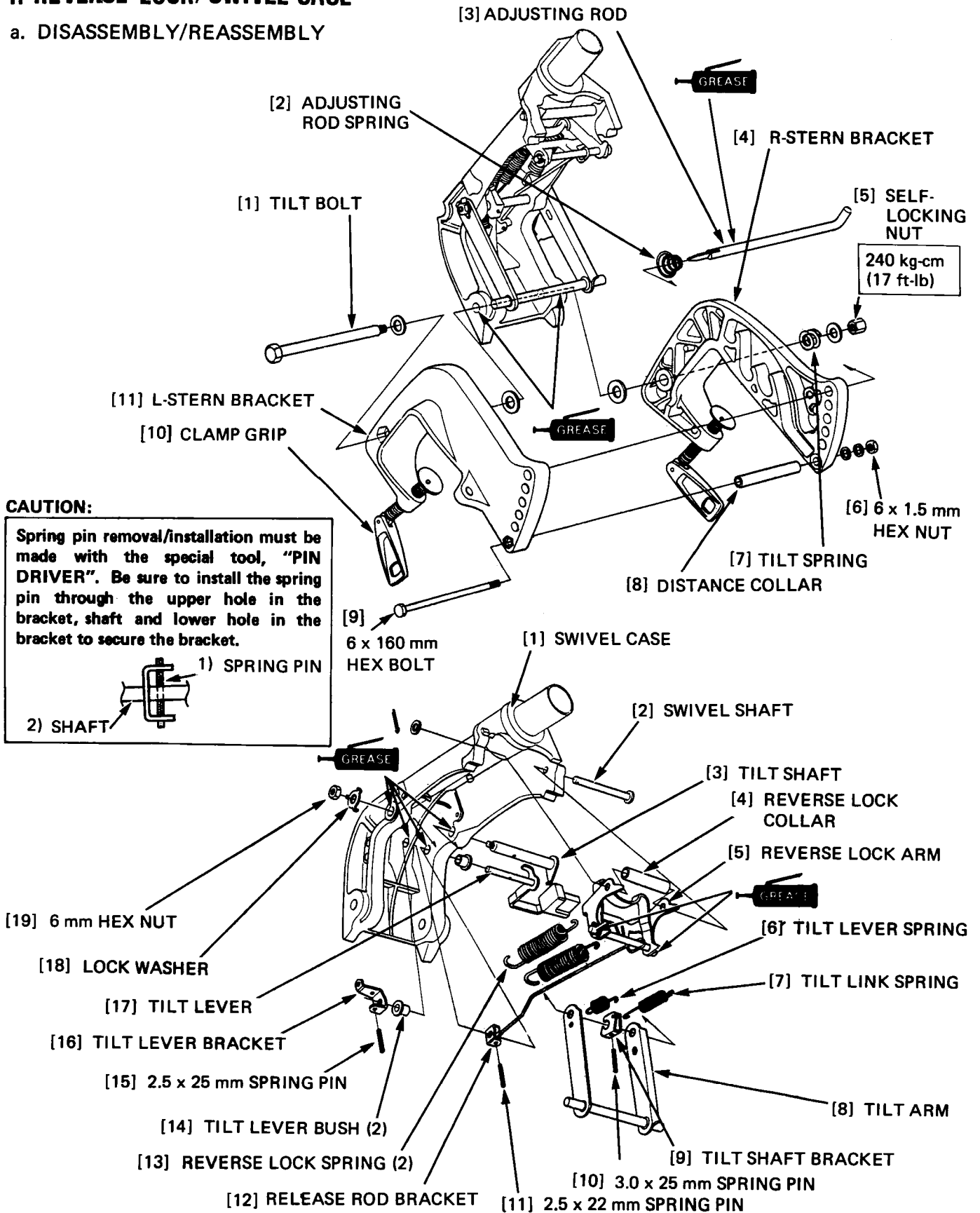



**SOME PARTS OF BF75, BF100 AND BF8A ARE CHANGED**

**Page 1 of 2**

Applicable information	Publication No
Honda outboard motor BF75·BF100·BF8A shop manual	6688122

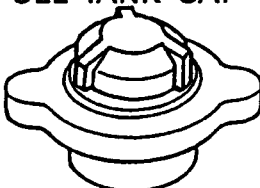
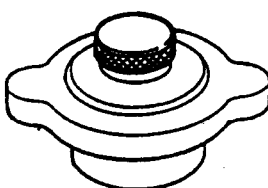
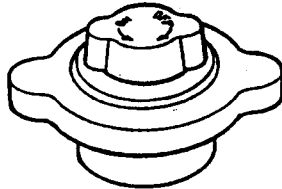
**CHANGE LOCATIONS**

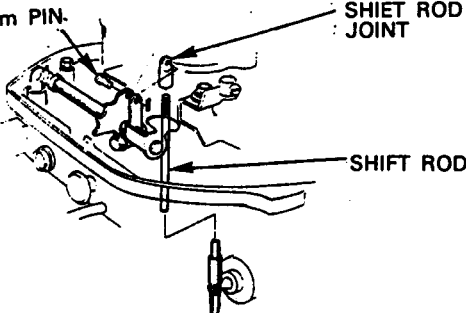
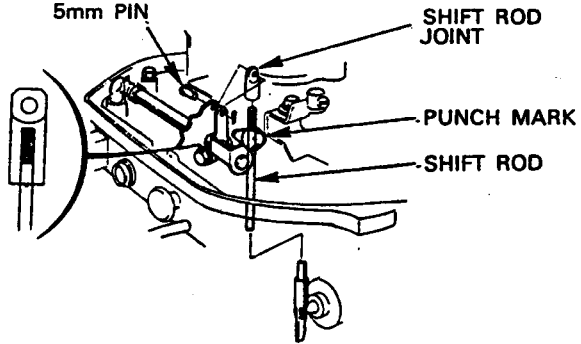
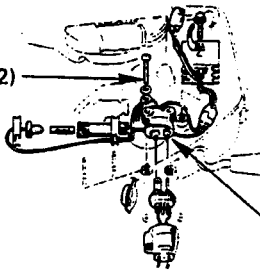
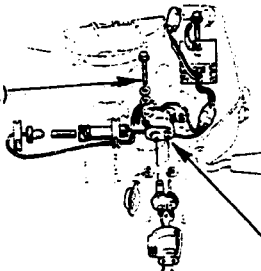
BEFORE MODIFICATION Frame serial number 1000001~1099999	AFTER MODIFICATION Frame serial number 1100001 to subsequent
<p><b>No.1 FUEL TANK CAP</b> P. 200</p>   <p>(SC, LC types)</p>	<p>• Except SC, LC types</p> 
<p><b>No.2 FUEL LINE CONNECTOR A</b> P. 200</p> 	 <p>JOINT INNER SEAL</p>
<p><b>No.3 SIFT ROD</b> P. 62, 120, 160, 172</p>  <p>5mm PIN SHIET ROD JOINT SHIFT ROD</p>	 <p>5mm PIN SHIFT ROD JOINT PUNCH MARK SHIFT ROD</p> <p>• The holes will usually align when the shift rod joint is turned in all the way, and then unscrewed 4½ turns. (Adjustment is possible without the punch mark)</p>
<p><b>No.4 D.C. OUTPUT CONNECTOR</b> P. 92</p>  <p>5×22mm SCREW(2) D.C. OUTPUT CONNECTOR</p>	 <p>5×22mm FLANGE BOLT(2) CHARGE RECEPTACLE (NAME CHANGED)</p>

## BEFORE MODIFICATION Frame serial number 100001~109999

### No.5 EMERGENCY STOP SWITCH (OPTIONAL PARTS) P.184

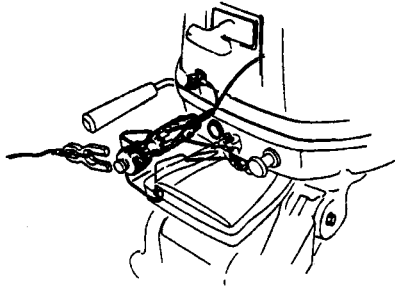

## AFTER MODIFICATION Frame serial number 1100001 to subsequent

### • Standard equipment

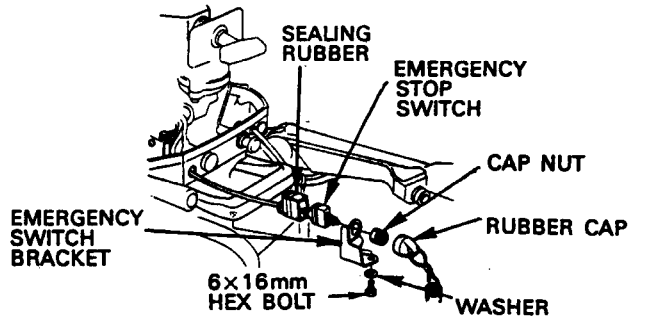

### No.6 WIRE ROUTING P.32

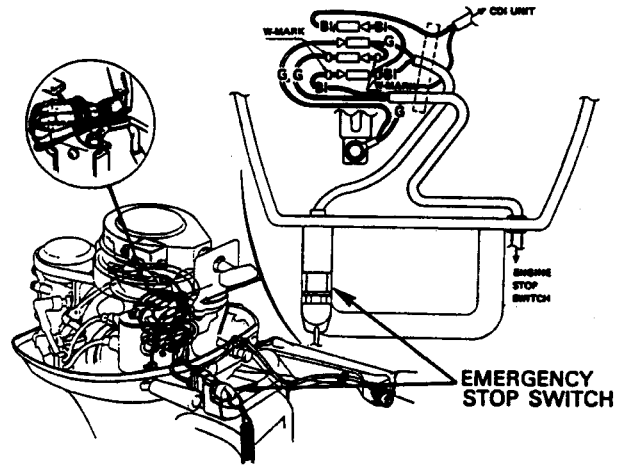
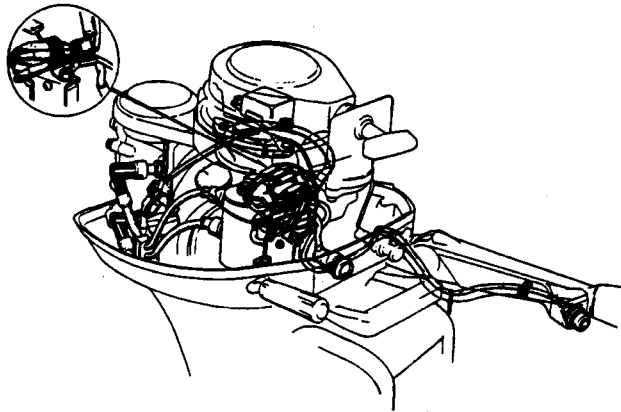

### No.7 WIRING DIAGRAM P.28

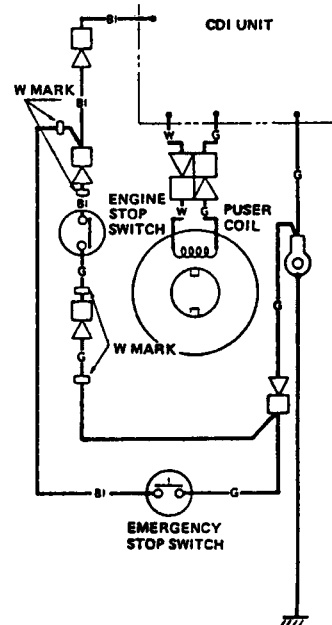
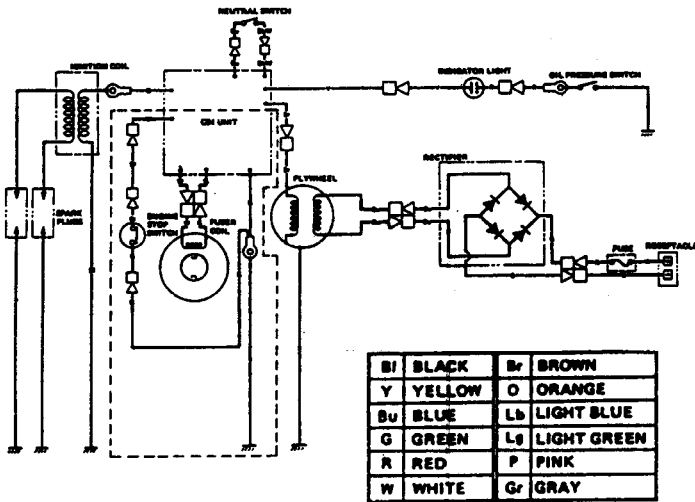

<b>1.</b>	<b>Specifications</b>	<b>3 - 4</b>
<b>2.</b>	<b>Service Information</b>	<b>5 - 23</b>
<b>3.</b>	<b>Maintenance</b>	<b>24 - 29</b>
<b>4.</b>	<b>Disassembly and Service</b>	<b>30 - 93</b>
<b>5.</b>	<b>Construction and Function</b>	<b>94 - 102</b>
<b>6.</b>	<b>Supplement BF75 . BF100</b>	<b>103 - 111</b>
<b>7.</b>	<b>Supplement BF 8A</b>	<b>112 - 116</b>
<b>8.</b>	<b>Shop Manual News</b>	<b>117 - 118</b>