

# INTRODUCTION

This manual covers installation and pre-delivery service of remote control units for use with Honda outboard motors above 15 hp. Installation and pre-delivery service must be performed by an authorized Honda Marine dealer. These instructions are for dealer use only.

All information contained in this manual is based on the latest production information available at the time of printing. Honda Motor Co., Ltd. reserves the right to discontinue or change specifications or design at anytime without notice and without incurring any obligation whatever.

No part of this publication may be reproduced, stored in a retrieval system, or transmitted, in any form, by any means, electronic, mechanical, photocopying, recording, or otherwise, without prior written permission of the publisher; this includes text, figures, and tables.

## CONTENTS

<b>2. REMOTE CONTROL INSTALLATION</b> . . . . .	2
COMPONENT IDENTIFICATION . . . . .	2
Side-Mount Control . . . . .	2
Panel-Mount Control . . . . .	3
Top-Mount Control . . . . .	4
CONTROL CABLE SELECTION . . . . .	5
CONTROL MODULE AND CABLE MATCHING . . . . .	6
MODIFICATION FOR PORT-SIDE MOUNTING . . . . .	7
REMOTE CONTROL CABLE INSTALLATION . . . . .	9
Remote Control End . . . . .	9
REMOTE CONTROL INSTALLATION . . . . .	11
Side-Mount Control . . . . .	11
Panel-Mount Control . . . . .	11
Top-Mount Control . . . . .	14
THROTTLE CABLE INSPECTION/ADJUSTMENT . . . . .	17
CONTROL LEVER FRICTION ADJUSTMENT . . . . .	17
SWITCH PANEL INSTALLATION . . . . .	18
WIRE HARNESS CONNECTION . . . . .	18
Panel-Mount and Single Top-Mount . . . . .	19
Dual Top-Mount . . . . .	20
<b>3. TEMPLATES</b> . . . . .	21
PANEL-MOUNT CONTROL (starboard) . . . . .	21
PANEL-MOUNT CONTROL (port) . . . . .	23
PANEL-MOUNT CONTROL (30° up) . . . . .	25
PANEL-MOUNT CONTROL (30° down) . . . . .	27
TOP-MOUNT CONTROL (single lever) . . . . .	29
TOP-MOUNT CONTROL (dual lever) . . . . .	31
SWITCH PANEL . . . . .	33

# 1. REMOTE CONTROL INSTALLATION

## COMPONENT IDENTIFICATION

[SIDE-MOUNT CONTROL]

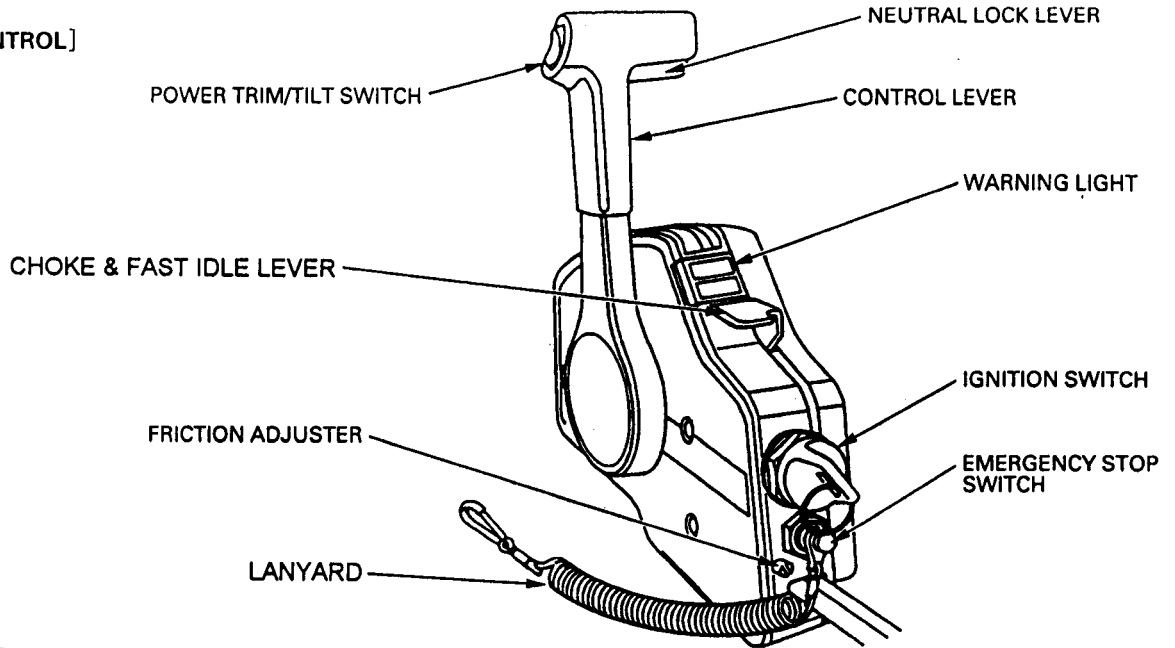

- CONTROL LEVER: ..... Controls gear selection and throttle opening.
- POWER TRIM/TILT SWITCH: .... Adjusts the trim angle and operates tilt UP and DOWN.
- CHOKE & FAST IDLE LEVER: . Operates the throttle and choke when the gear is in neutral.
- FRICTION ADJUSTER: ..... Adjusts the operating resistance of the control lever.
- NEUTRAL LOCK LEVER: ..... Must be raised when operating the control lever to shift from neutral to another gear.
- WARNING LIGHT: ..... Indicates the operating condition of the outboard motor. (Engine oil and overheat warning)
- IGNITION SWITCH: ..... For starting and stopping the outboard motor.
- EMERGENCY STOP SWITCH: ... Stops the engine if the lanyard is pulled, in case the operator falls overboard.

## OPERATION

Start the engine with the control lever in the neutral position. For cold starts, the choke & fast idle lever should be fully raised, then lowered slowly to avoid stalling.

The choke & fast idle lever cannot be raised unless the control lever is in the neutral position, and the control lever cannot be moved away from neutral unless the choke & fast idle lever is lowered.

With the choke & fast idle lever lowered, squeezing the control lever grip to raise the neutral lock lever enables the control lever to be moved to the forward or reverse position.

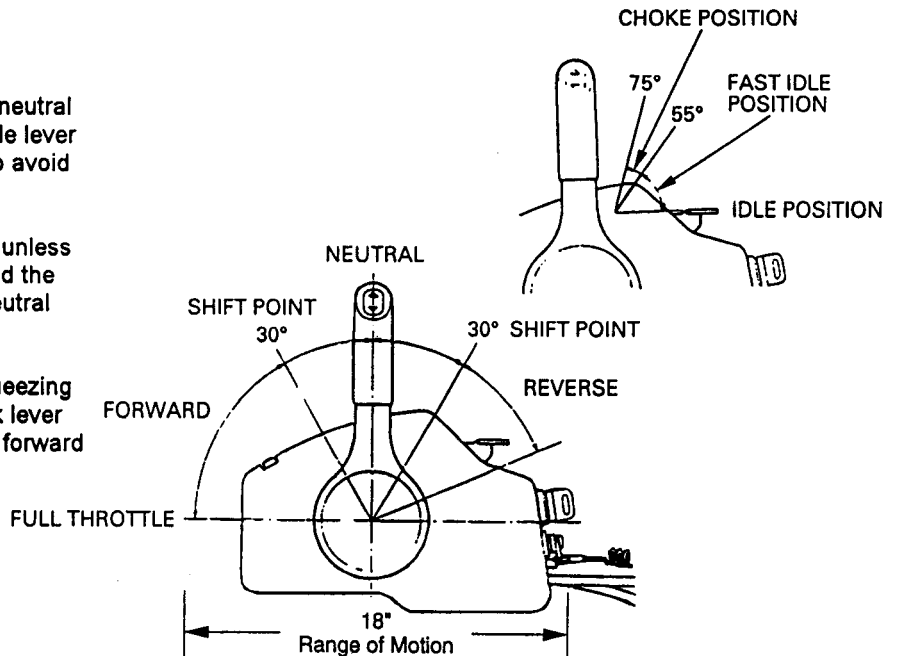

**[PANEL-MOUNT CONTROL]**

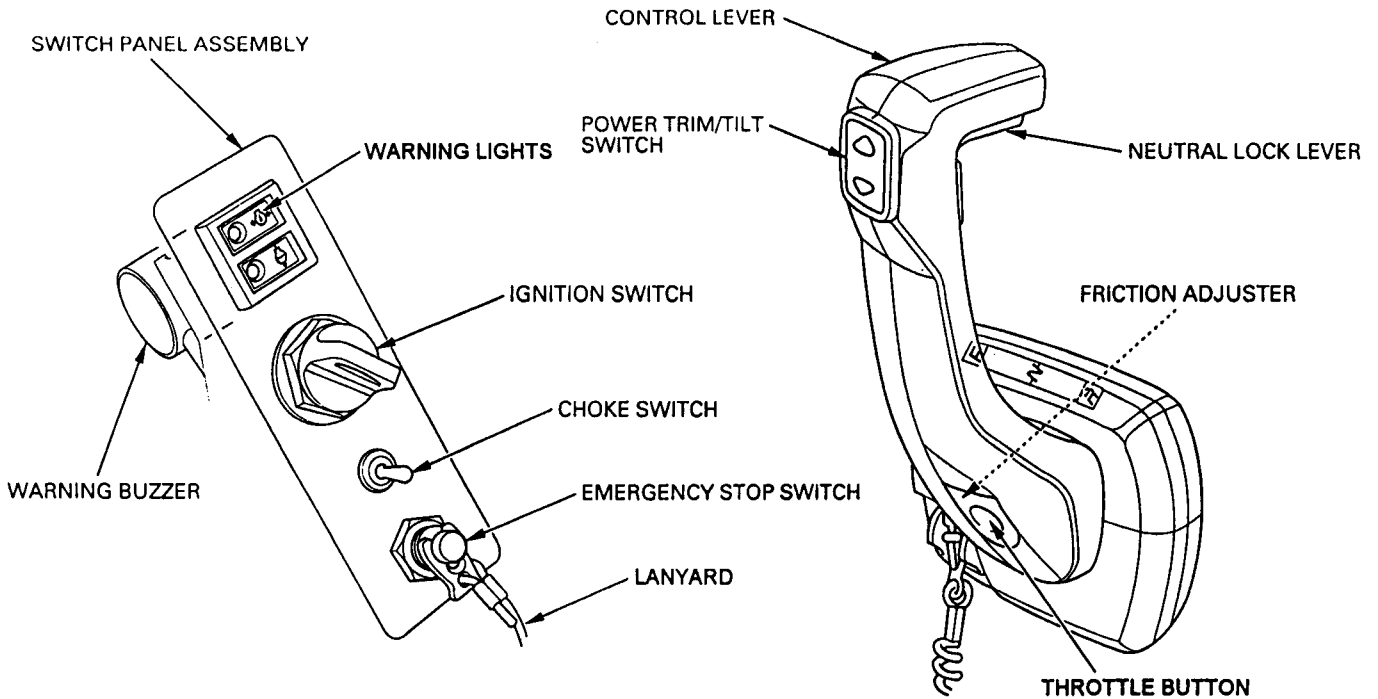

- CONTROL LEVER:** ..... Controls gear selection and throttle opening.
- POWER TRIM/TILT SWITCH:** ..... Adjusts the trim angle and operates tilt UP and DOWN.
- THROTTLE BUTTON:** ..... Must be pushed to operate the throttle with the gear in neutral.
- FRICTION ADJUSTER:** ..... Adjusts the operating resistance of the control lever.
- NEUTRAL LOCK LEVER:** ..... Must be raised when operating the control lever to shift from neutral to another gear.
- CHOKE SWITCH:** ..... Operates the choke.
- WARNING LIGHTS:** ..... Indicates the operating condition of the outboard motor. (Engine oil and overheat warning)
- IGNITION SWITCH:** ..... For starting and stopping the outboard motor.
- EMERGENCY STOP SWITCH:** ..... Stops the engine if the lanyard is pulled, in case the operator falls overboard.

**OPERATION**

Move the control lever to the neutral position and start the engine. Then, pushing the throttle button, move the control lever to forward or reverse position and warm up the engine. The throttle button can be pushed only when the control lever is in the neutral position. After warming up the engine, return the control lever to the neutral position to shift. The control lever cannot be moved unless the neutral lock lever is squeezed.

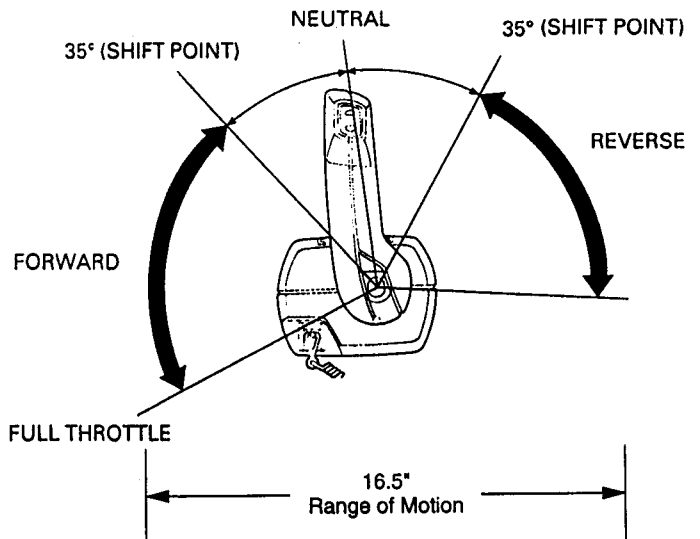

[TOP-MOUNT CONTROL]

SWITCH PANEL ASSEMBLY

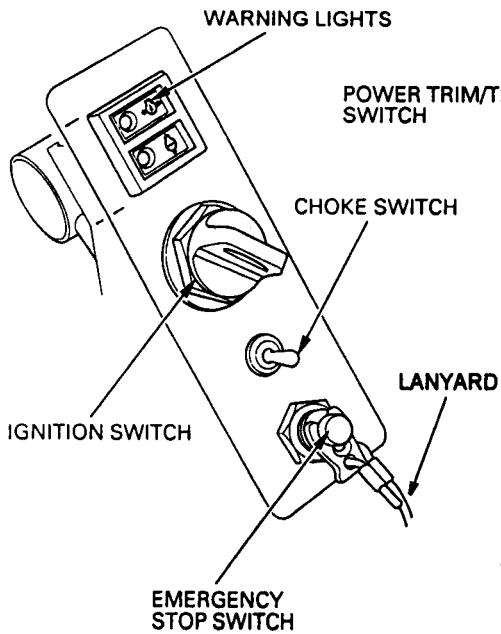

CONTROL LEVER

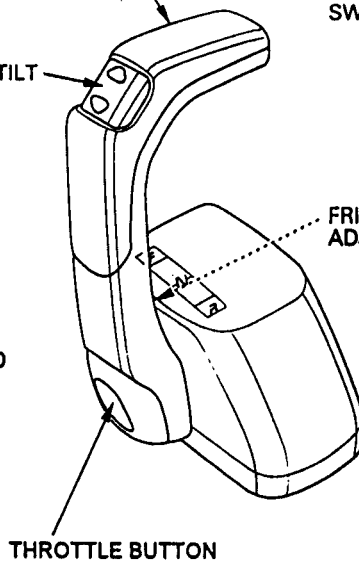

CONTROL LEVERS

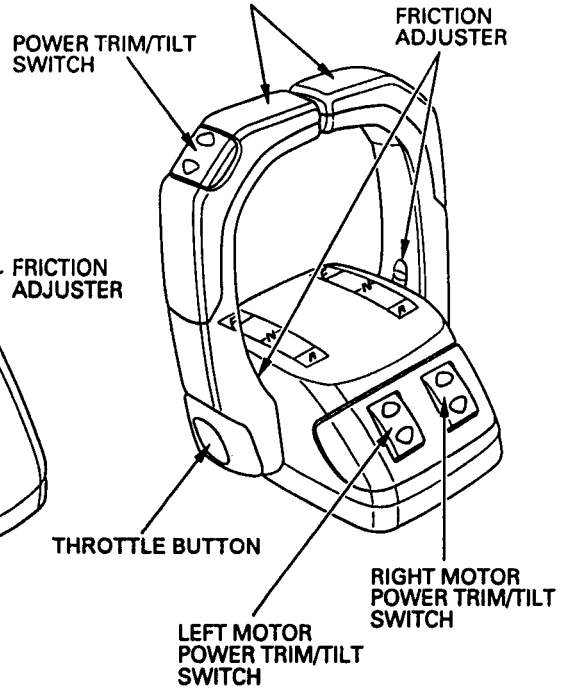

- CONTROL LEVER:..... Controls gear selection and throttle opening.
- POWER TRIM/TILT SWITCH:..... Adjusts the trim angle and operates tilt UP and DOWN.  
Lever side: Operates the two outboard motors simultaneously.  
Mount side: Can operate the individual outboard motor and can make minor adjustment between the outboard motors.
- THROTTLE BUTTON:..... Must be pushed when operating the throttle in neutral.
- FRICTION ADJUSTER:..... Adjusts the operating resistance of the control lever.
- CHOKE SWITCH:..... Operates the choke.
- WARNING LIGHTS:..... Indicates the operating condition of the outboard motor. (Engine oil and overheat warning)
- IGNITION SWITCH:..... For starting and stopping the outboard motor.
- EMERGENCY STOP SWITCH:..... Stops the engine if the lanyard is pulled, in case the operator falls overboard.

OPERATION

Move the control lever to the neutral position and start the engine. Then, pushing the throttle button, move the control lever to forward or reverse position and warm up the engine. The throttle button can be pushed only when the control lever is in the neutral position. After warming up the engine, return the control lever to the neutral position to shift.

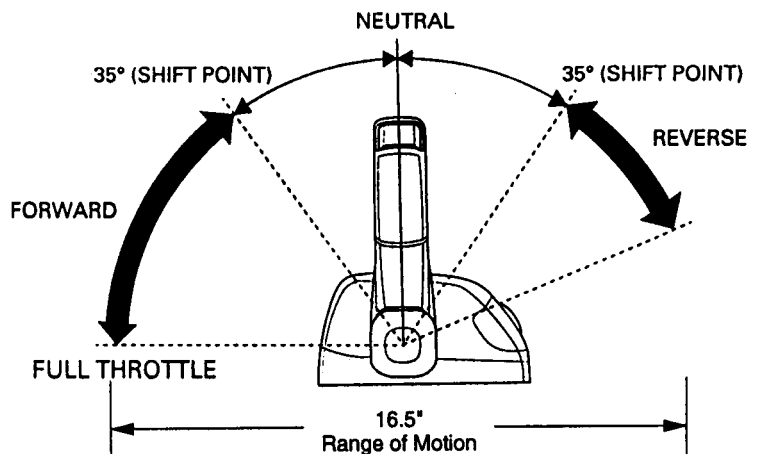

## CONTROL CABLE SELECTION

1. Select a mounting location which allows easy access and unrestricted operation of the control lever, and make sure that there are no other parts obstructing the cables and all components between the remote control box and the outboard motor.

### Recommended installation position:

- Near a corner of the front seat, the control lever should be placed in the neutral position.
- The bottom of the remote control box is at the same level as the upper surface of the seat.

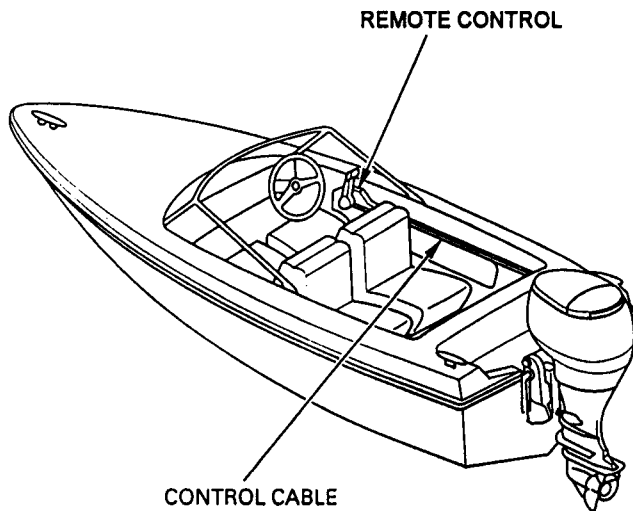

### Side-mount control:

- The control unit is normally mounted on the starboard side, but can be modified for installation on the port side (see page 7).
- Insert a spacer between the control unit and the installation surface if more clearance is needed for the control lever.

### Panel-mount control:

- There must be enough space behind the control unit for cable routing (see page 11).
- The control unit should be mounted on a panel that is not more than 25 mm (1.0 in) thick.

### Top-mount control:

- There must be enough space under the control unit for control cable routing (see page 13).

2. Calculate the control cable length. Measure the dimensions L1 and L2 and calculate the control cable length as follows.

- Side mount control box and panel-mount control box:  
Required cable length:  
 $L1 + L2 + 300 - 450 \text{ mm (12 - 18 in)}$

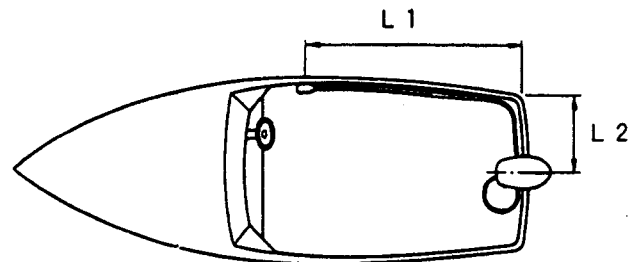

- Mounting two engines:

Measure L2 which is to the center of the respective outboard motors, and calculate the control cable length.

- Top-mount control:

Measure the distance along the actual cable routing and add 300–450 mm (12–18 in) to the measurement.

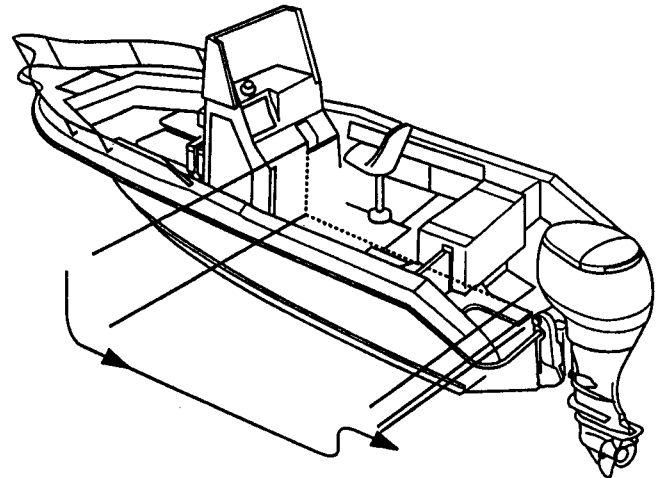

- The bending diameter of a cable must never be less than 300 mm (12 in).
- If the cable is routed in a tight arc, resistance on the control lever will increase, and smooth throttle operation will no longer be possible. This may lead to a loss of control of the craft.
- The cable length must be calculated in such a way that unrestricted operation is possible, even if the outboard motors are tilted or turned to one side.
- If the cable becomes slack at some point of the routing, or if it is hard to route the cable normally, add some extra length to the cable length.

## CONTROL MODULE AND CABLE MATCHING

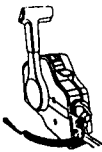
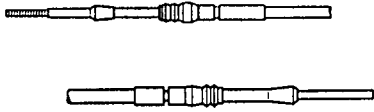
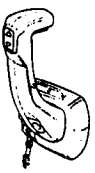
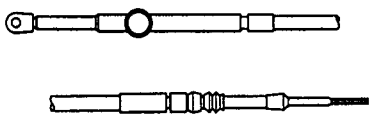
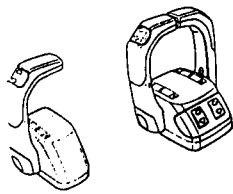
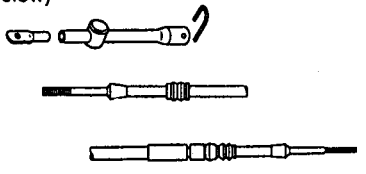
Remote Control	Control cable
<p>Side-mount type</p> 	<p>Teleflex Universal / Morse 33C cable</p> 
<p>Panel-mount Type*</p> 	<p>Mariner cable</p> 
<p>Top-mount Type*</p> 	<p>or Teleflex Universal / Morse 33C cable w/ adapter kit (modify as instructed below)</p> 

\* You must use a Travel Limiter when installing Panel or Top-mount controllers on Honda outboard motors other than BF 75/90.

Description		Part Number
<b>Mariner Cables for Panel and Top-Mount Controllers</b>		
Cable, Remote Con (10')		24910-ZW1-003AH
Cable, Remote Con (11')		24911-ZW1-003AH
Cable, Remote Con (12')		24912-ZW1-003AH
Cable, Remote Con (13')		24913-ZW1-003AH
Cable, Remote Con (14')		24914-ZW1-003AH
Cable, Remote Con (15')		24915-ZW1-003AH
Cable, Remote Con (16')		24916-ZW1-003AH
Cable, Remote Con (17')		24917-ZW1-003AH
Cable, Remote Con (18')		24918-ZW1-003AH
Cable, Remote Con (19')		24919-ZW1-003AH
Cable, Remote Con (20')		24920-ZW1-003AH
<b>Teleflex Universal Cables for Side-mount Controllers</b>		
Type	Description	Part Number
Standard	Cable, Remote Con (10')	24911-ZW1-V00
	Cable, Remote Con (11')	24912-ZW1-V00
	Cable, Remote Con (12')	24913-ZW1-V00
Tournament	Cable, Remote Con (13')	24914-ZW1-V00
	Cable, Remote Con (14')	24915-ZW1-V00
	Cable, Remote Con (15')	24916-ZW1-V00
	Cable, Remote Con (16')	24917-ZW1-V00
	Cable, Remote Con (17')	24918-ZW1-V00
	Cable, Remote Con (18')	24919-ZW1-V00
	Cable, Remote Con (19')	24920-ZW1-V00
	Cable, Remote Con (20')	24921-ZW1-V00
Travel Limiter		06600-ZV4-000AH
Remote Con Cable Adapter*		24931-ZW1-000

All cable ends have a 10-32 UNF-2 SAE thread and 3 inches of inner cable travel.

\* Adapter allows Teleflex cables to be used with Top or Panel- Control models.

When the Teleflex Universal cable is connected to the panel-mount/top-mount control box, attach the terminal kit in the following procedure.

1. Remove the nut, rod seal and boot from the cable end (remote control end).
2. Install the adapter sleeve.
3. Insert the retainer clip aligning it with the cable hub groove and bend the clip as shown to secure.
4. Screw in the terminal as far as it will go.

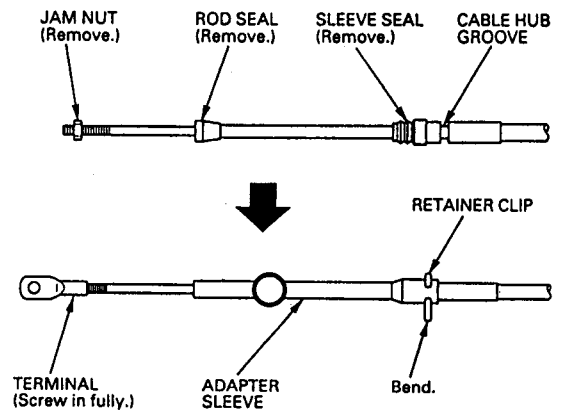

## MODIFICATION FOR PORT-SIDE MOUNTING

### [Side-mount remote control only]

The side-mount remote control unit is supplied in a configuration for starboard mounting, but the control lever can be installed on the opposite side of the unit for port mounting.

1. Remove the two screws and housing cover C.

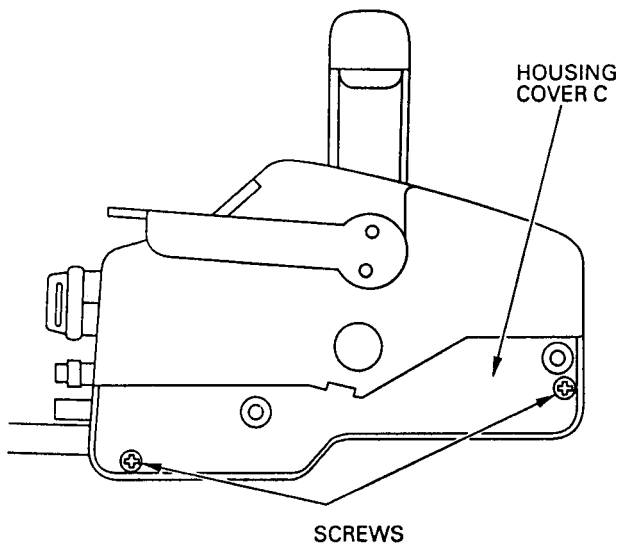

2. Remove the two screws and the holddown plate.
3. Disconnect the power trim/tilt switch wire connectors.

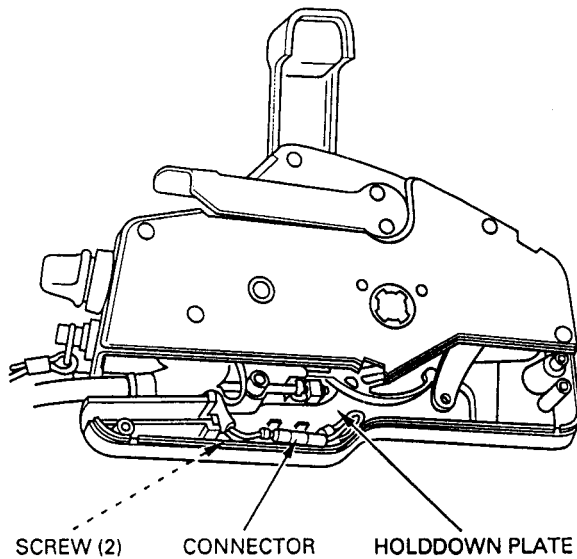

4. Put the control lever in the neutral position. Remove the 8 mm lever lock bolt and remove the control lever.

Be careful to avoid damaging the power tilt/trim switch harness.

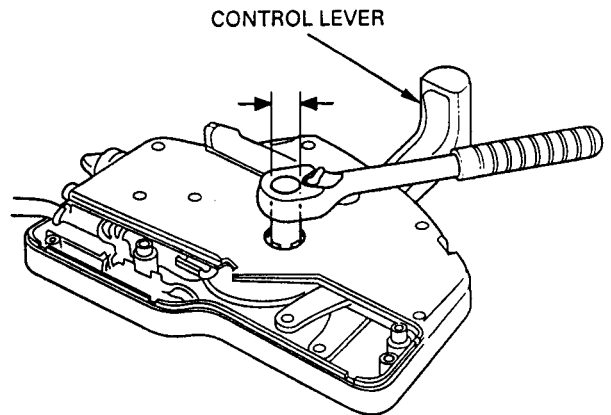

5. Remove the two screws and neutral lock block.

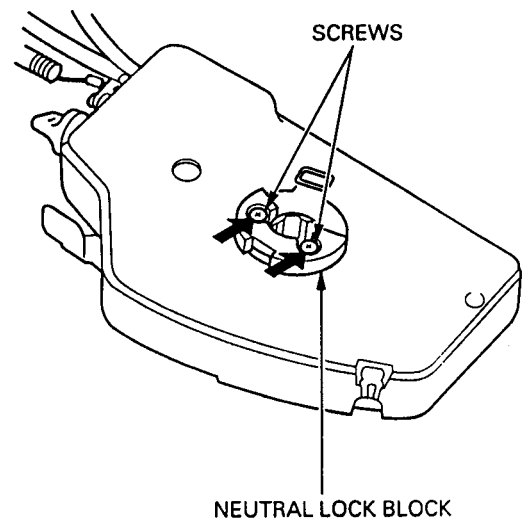

6. Install the neutral lock block to the reverse side of the control box and tighten the two screws.

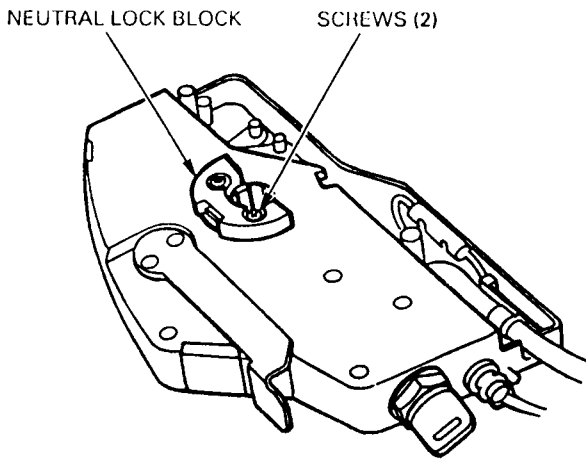

7. With the control lever in the neutral position, install it from the housing B side.

Set the switch wire grommet to the control housing B securely by aligning the groove to the housing cutout.

8. Route the power trim/tilt switch harness as shown and connect the connectors.

9. Install the hold-down plate with the two screws.

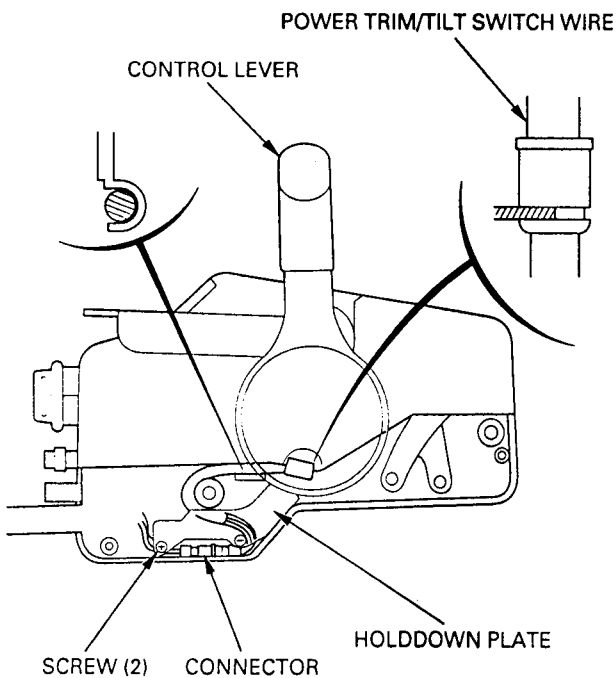

10. Tighten the 8 mm lock bolt.

TORQUE: 20 N·m (2.0 kgf·m, 14 lbf·ft)

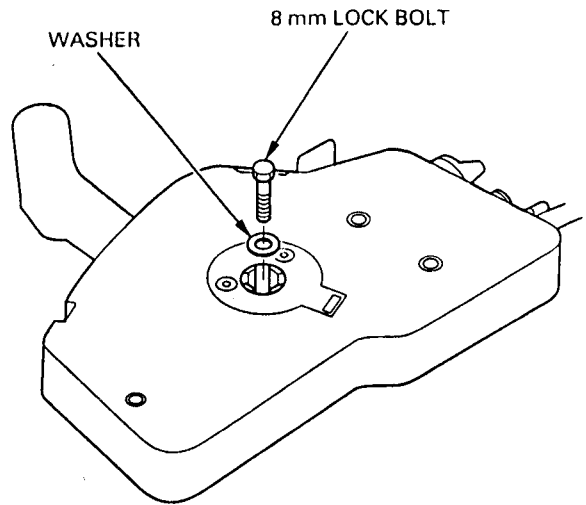

11. Tighten the housing cover C with two screws.

TORQUE: 2 N·m (0.2 kgf·m, 1.4 lbf·ft)

**NOTICE**

**Do not overtighten.**

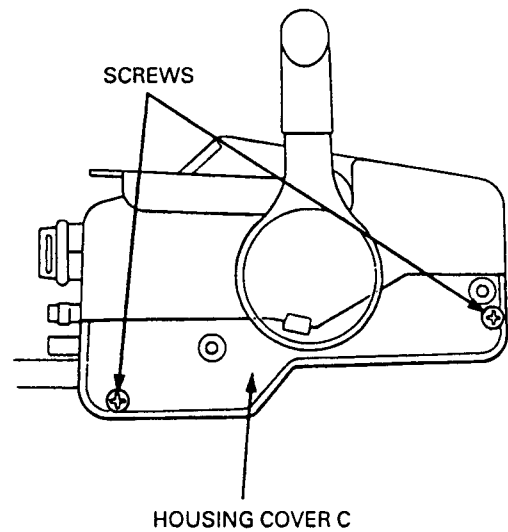



## REMOTE CONTROL CABLE INSTALLATION (REMOTE CONTROL END)

### [SIDE-MOUNT CONTROL]

Route the remote control cable and connect to the remote control box side first.

1. Remove the two screws and housing cover C.

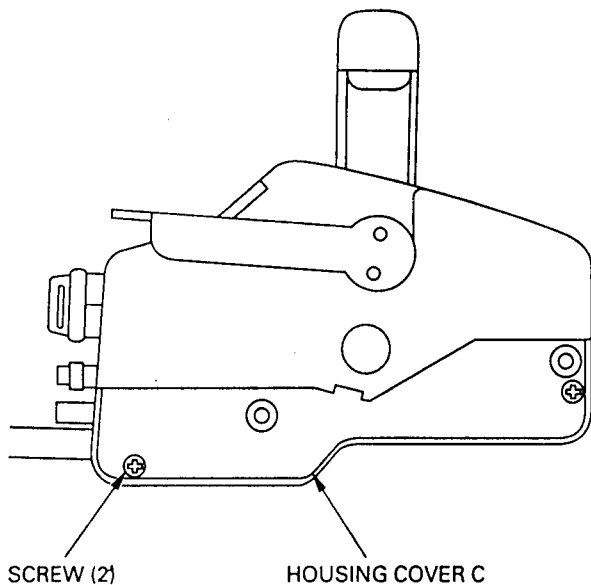

2. Screw the lock nuts and eye ends more than 8 mm (0.3 in) onto the control box side of the remote control cable and tighten the lock nut securely to hold the pivot. Apply marine grease to the hole of the eye end.

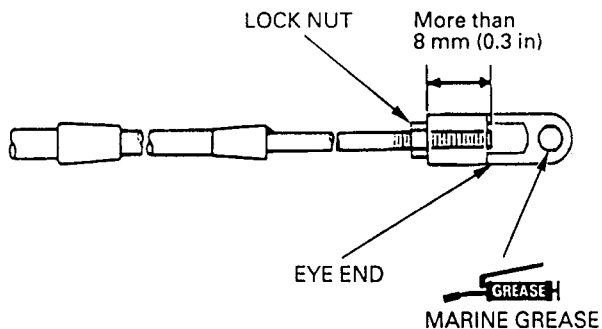

3. Install the shift cable by aligning the groove of the control cable with the cable guide plate.
4. Connect the eye end to the shift lever using the washer and 6 mm lock pin.

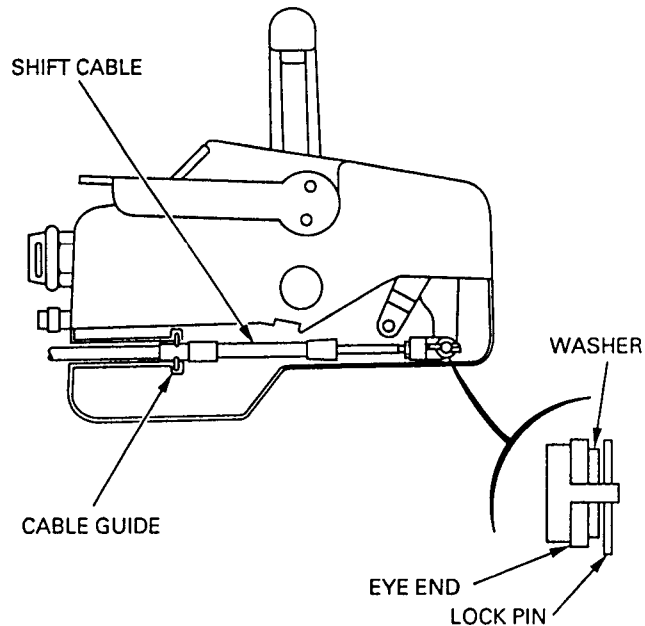

5. Install the cable clamp spacer.
6. Install the throttle control cable by aligning the groove with the cable guide plate.
7. Connect the eye end to the shift lever using the washer and 6 mm lock pin.
8. Install the housing cover C and secure with the two screws.

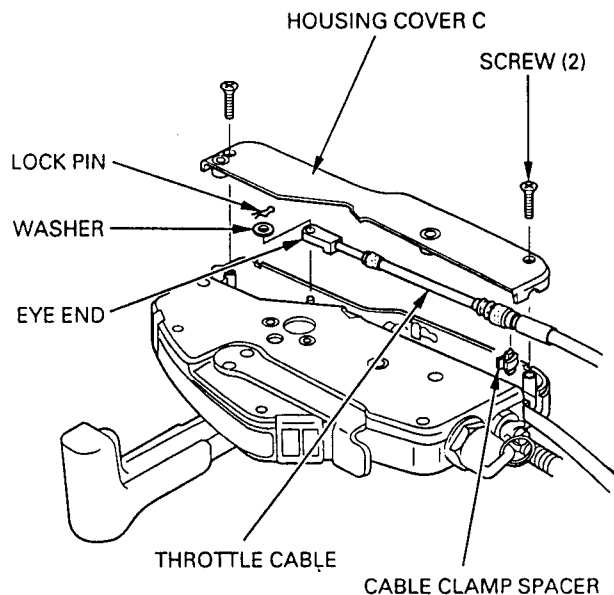

[PANEL-MOUNT/TOP-MOUNT CONTROL] \*

- When the Morse 33C cable is used, install the adapter kit at the cable end according to the instruction on page 6.
- The arm position to which the control cable is connected differs according to the type and the installation position of the control box.
- The following procedures represent the control cable connection to the side mount control box mounted on the starboard side. For connection to the other types of the control box, see the instructions shown on the right of this page and connect the control cable to the corresponding arm properly.

1. Remove the screw and washer and remove the control module back plate.

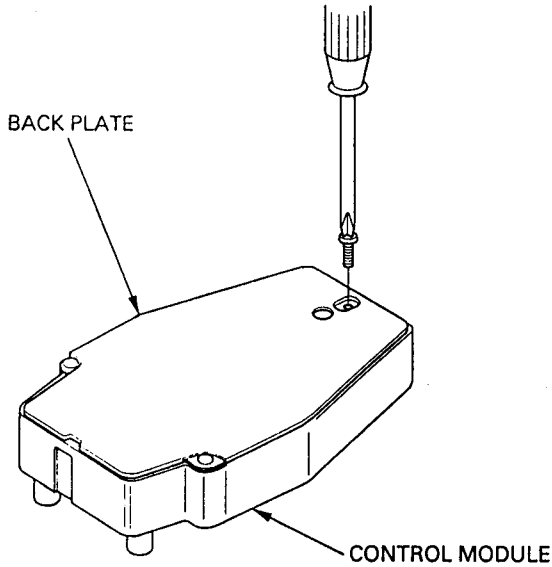

2. Connect the shift cable to the shift arm and connect the throttle cable to the throttle arm.  
Apply the thread locking agent to the threaded portion of the screw and tighten the screw.  
Note that the cable connection and grommet setting point differs according to the control box type and location. See the table shown on the right side of this page and install properly.

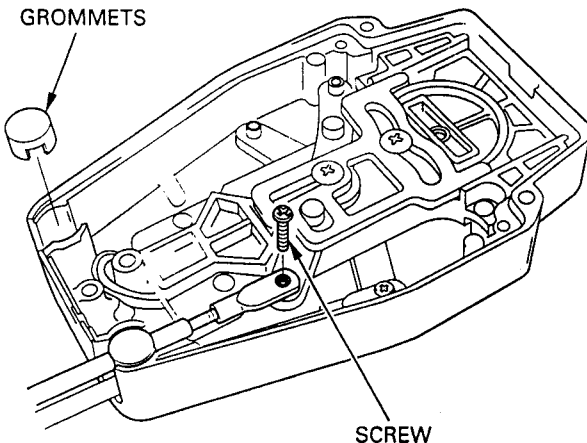

Shift cable connection points:

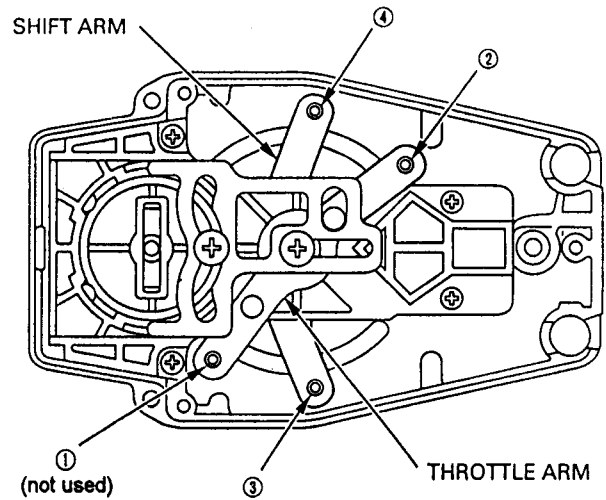

[Panel-mount control]

On starboard side:  
Shift cable: ④  
Throttle cable: ②



On port side:  
Shift cable: ③  
Throttle cable: ②

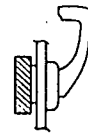

[Top-mount, single handle]

On starboard side:  
Shift cable: ④  
Throttle cable: ②



On port side:  
Shift cable: ③  
Throttle cable: ②



[Top-mount, dual handle]

Right:  
Shift cable: ③  
Throttle cable: ②

Left:  
Shift cable: ④  
Throttle cable: ②

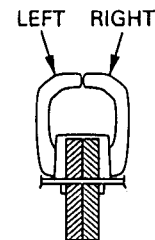

\* You must use a Travel Limiter (P/N 06600-ZV4-000AH) when installing Panel or Top-mount controllers on Honda outboard motors other than BF 75/90.

## REMOTE CONTROL INSTALLATION

### [SIDE-MOUNT CONTROL]

- Connect the control cable before installing the control unit (page 9).
- Be sure to put the control lever in the neutral position before installing.
- Select a mounting location which allows easy access and unrestricted operation of the control lever, and make sure that there are no other parts obstructing the cables and all components between the remote control and outboard motor.

1. Hold the remote control at the installation position, and mark drill points for installing the screws.
2. Drill 7 mm (1/4 in) holes at the marked points.
3. Install the remote control box using the washers, nuts and screws.

If more control lever clearance is needed, insert a spacer and/or washers between the remote control unit and the installation surface, as shown.

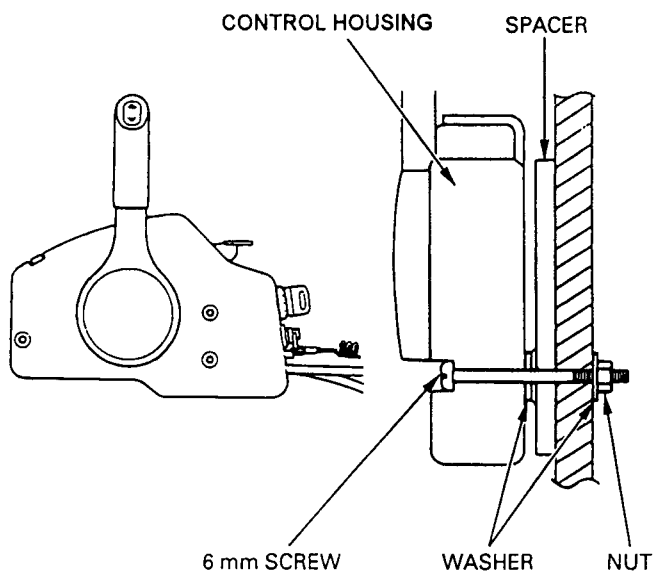

### [PANEL-MOUNT CONTROL]

- Select a mounting location which allows easy access and unrestricted operation of the control lever, and make sure that there are no other parts obstructing the cables and all components between the remote control unit and outboard motor.
- Max. panel thickness for installation of the control box: 25 mm (1.0 in)
- See the following drawings for the required clearance for installation of the remote control box.

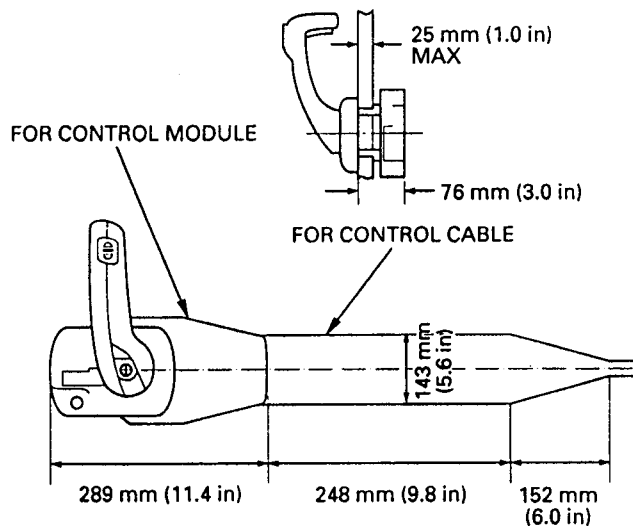

- The panel-mount remote control unit can be mounted on either the starboard or port side (see page 10). If mounting the remote control unit on the port side, be sure to change the shift indicator seal plate (separately available).

1. Using tape or equivalent material, attach the appropriate template (see contents page) to the determined mounting surface.
2. Wear eye protection, then drill the mounting holes as indicated on the template. The control module can be changed to 90°, 30° upward and 30° downward to the installation surface.

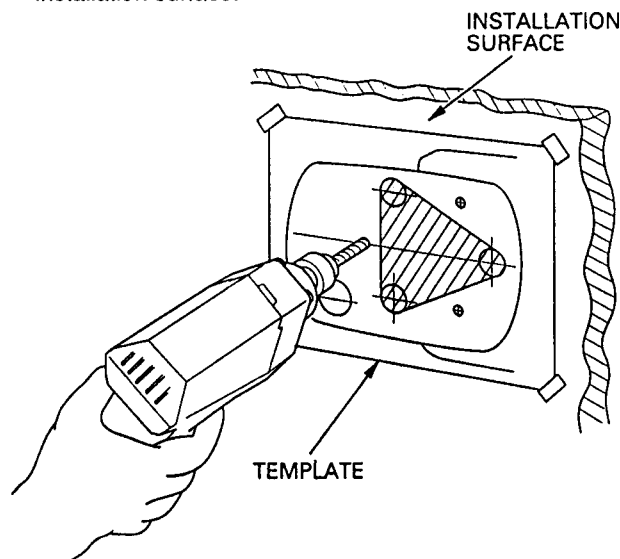

- Position the control base, and install the three bolts, washers, and nuts. Tighten to the specified torque.

TORQUE: 11.1 N·m (1.13 kgf·m, 8.2 lbf·ft)

The bolts are coated with the thread locking agent. When any of these bolts are removed after having been tightened or when reinstalling one of these bolts, apply the thread locking agent to the threaded portion of the bolt again and tighten to the torque of 2.7N·m(0.28kgf·m, 2.0 lbf·ft).

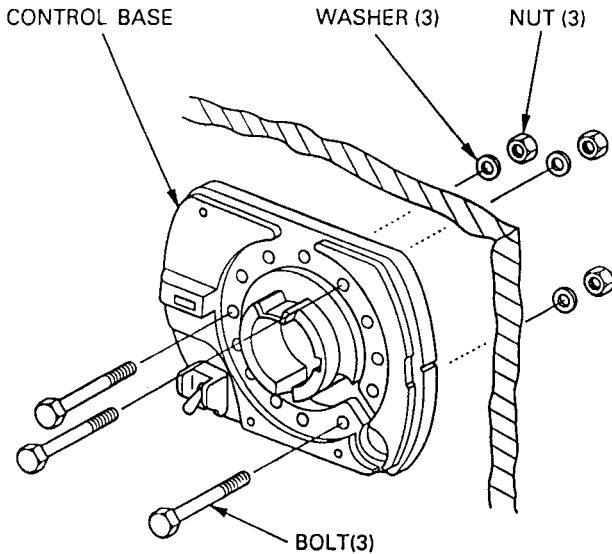

- Connect the control cables to the control module. Note that the control cable connection for a port-side remote control is different from that for a starboard-side remote control (see page 10).

Apply the thread locking agent to the threaded portion of the screw and tighten the screw securely.

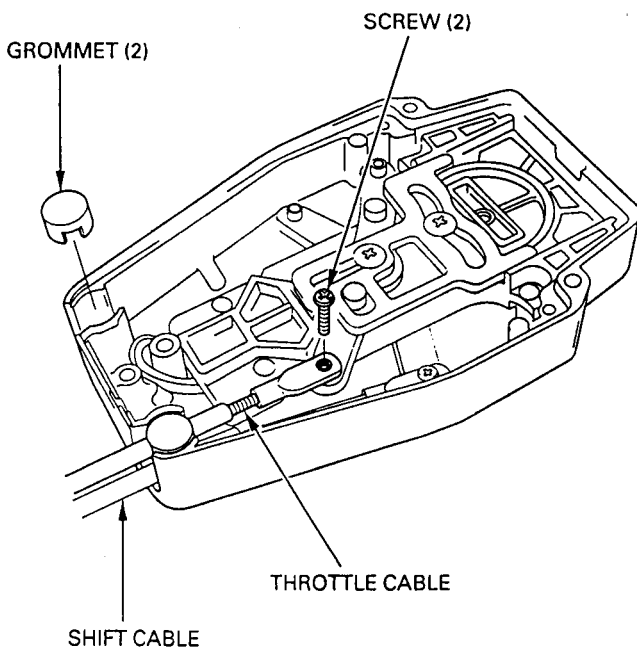

- Route the trim/tilt switch wire from the control lever through the groove in the base opening as shown.

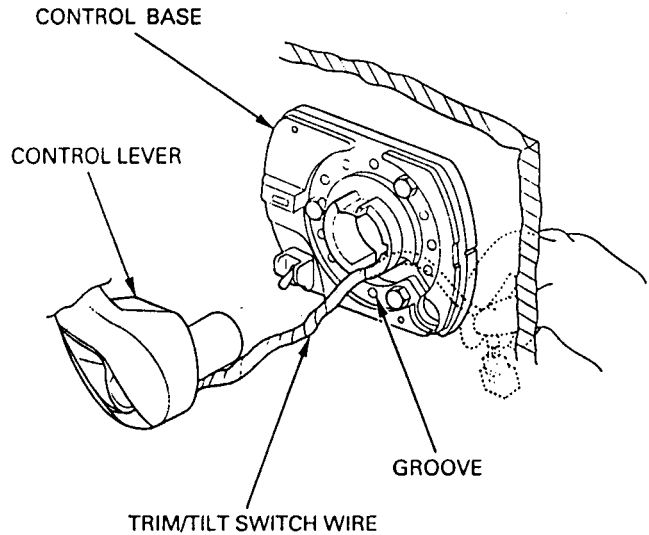

- Attach the control module to the installation surface from the outside and secure with the three mounting bolts.

Be sure the switch wire is not pinched between the control module and the installation surface.

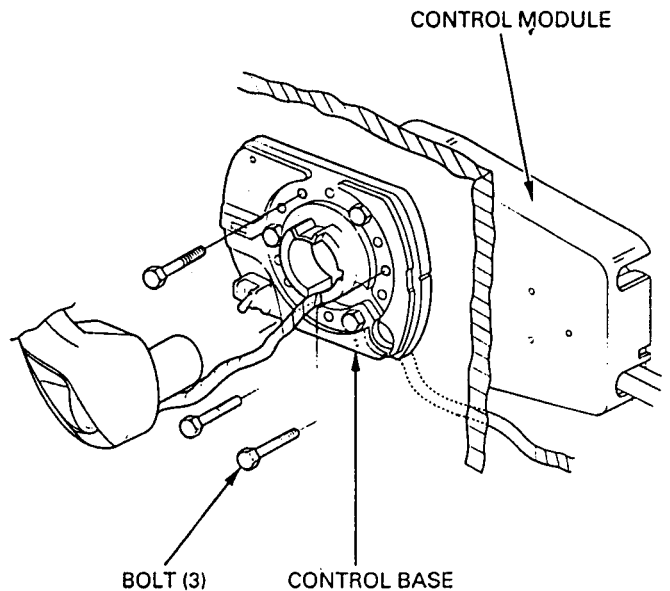

7. Set the bushing in the opening of the base aligning the cutout in the flange of the bushing with the protection of the base.
8. Install the upper cover, then install the lower cover.

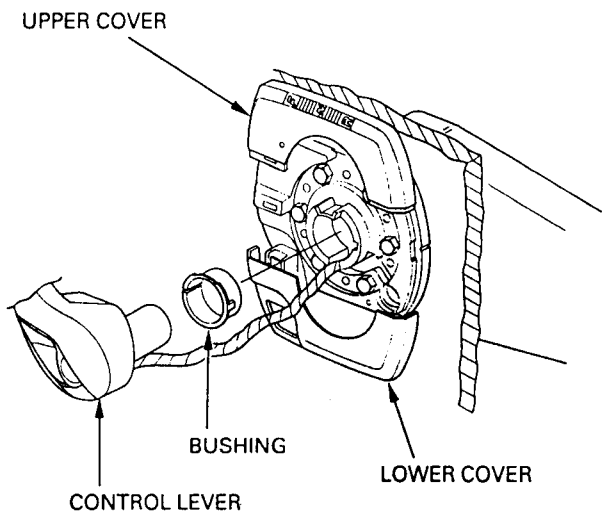

9. Install the control lever on the remote control module. Be sure that the control handle is in the neutral position.
10. Apply the thread locking agent to the threaded portion of the lever mounting bolt and tighten the bolt to the specified torque.

TORQUE: 17 N·m (1.7 kgf·m, 12 lbf·ft)

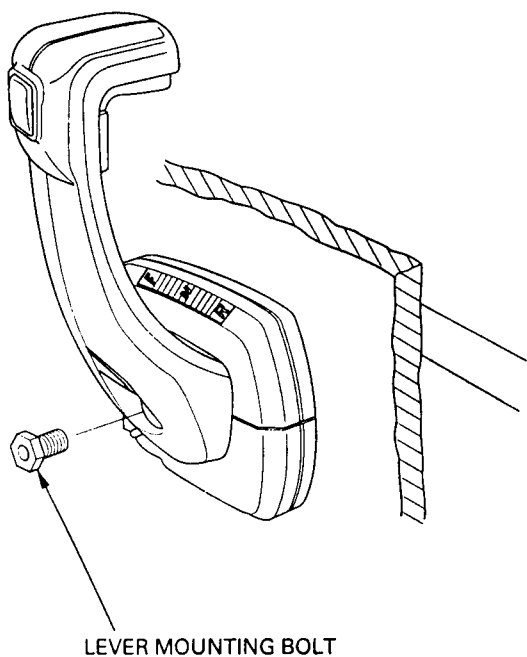

11. Install the throttle button.

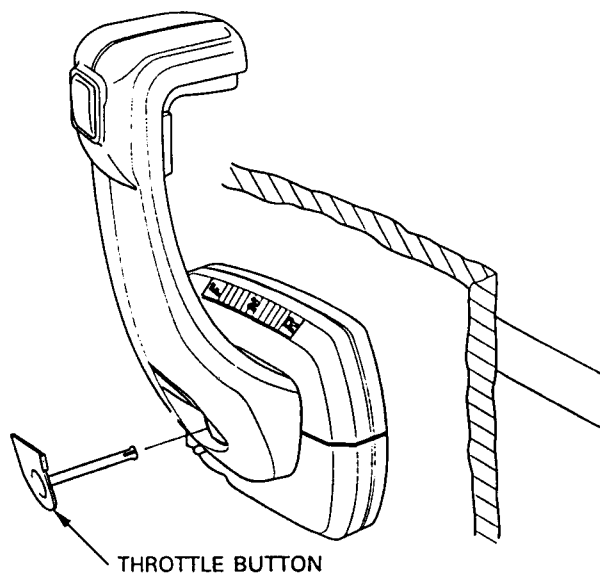

12. Connect the switch wire to the remote control wire harness (page 17).
13. Adjust the control lever friction (page 15).

#### NOTICE

If the removal of the throttle button is required, it will be necessary to put the handle in the throttle only position. Push "IN" on the button and place the control handel forward. The throttle button can now be removed.

**Place Control Handel in Throttle Only Position Before Attempting to Remove Button**

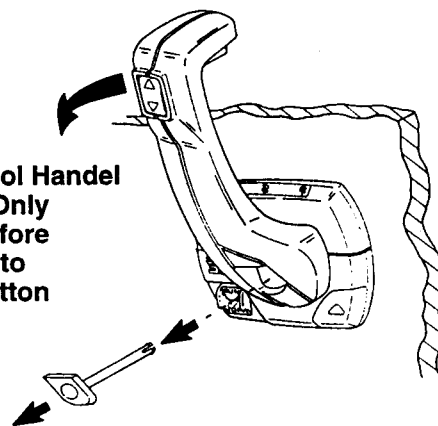

[TOP-MOUNT CONTROL]

- Select a mounting location which allows easy access and unrestricted operation of the control lever, and make sure that there are no other parts obstructing the cables and all components between the remote control and outboard motor.
- See the following drawings for the required clearance for installation of the remote control.

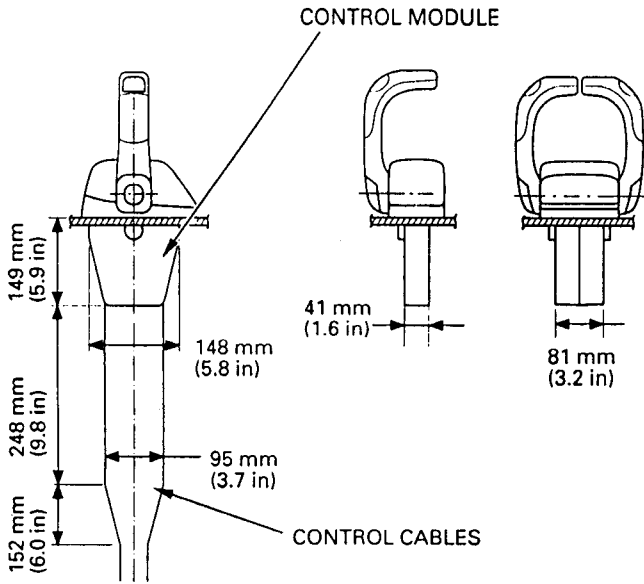

- The single lever type remote control box can be mounted on the starboard side or the port side. When it is mounted on the port side, be sure to change the control label (separately available).

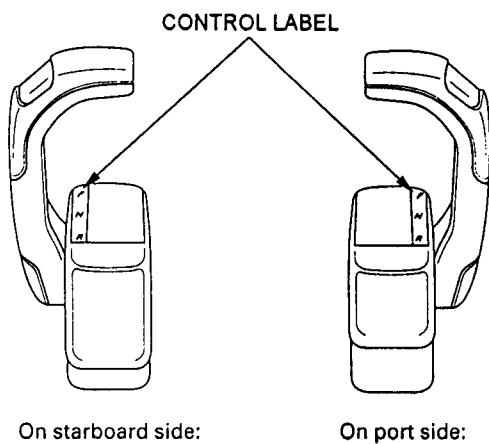

- Templates for installing single-lever and dual-lever controls are not interchangeable.

1. Attach the template enclosed with this manual to the installation surface. Wear eye protection, then drill and cut as indicated on the template. Route the control cables and wire harness through the cutout.

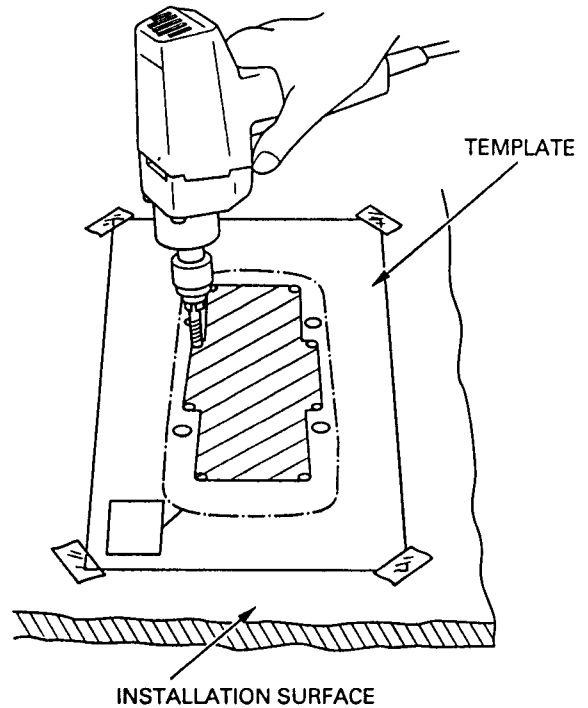

2. Pass the control cables through the gasket and the control base and connect the control cables to the control module. Apply thread locking agent to the threaded portion of the screws and tighten the screws securely. See page 10 for control cable connection.

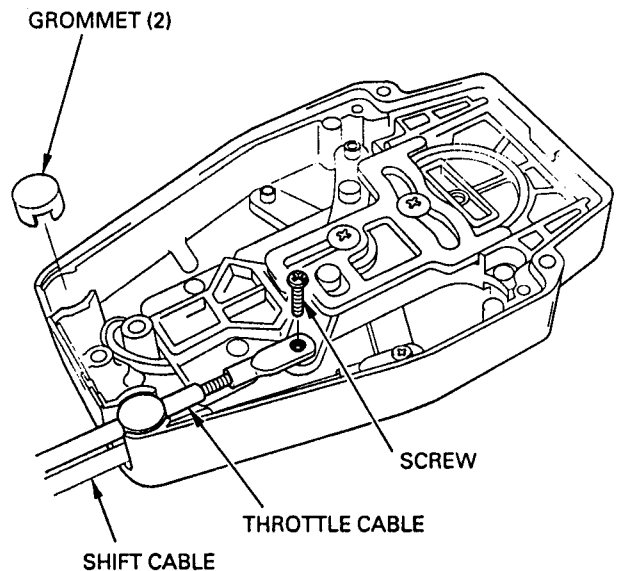

3. Screw the mounting screws into the well-nuts so that the flanged portion faces up. Set the four well-nuts in the installation holes and remove the mounting screws.

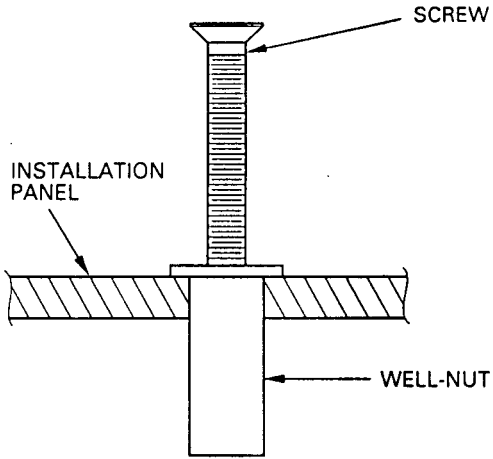

4. Install the mounting bracket on the control module using the bolts and the lock nuts.

Single lever type:

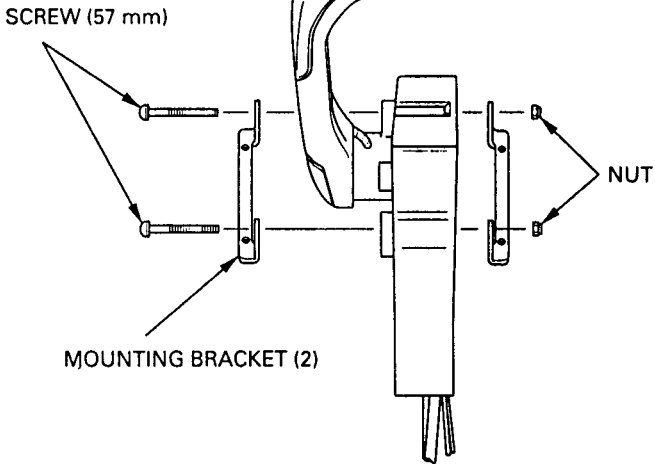

Dual lever type:

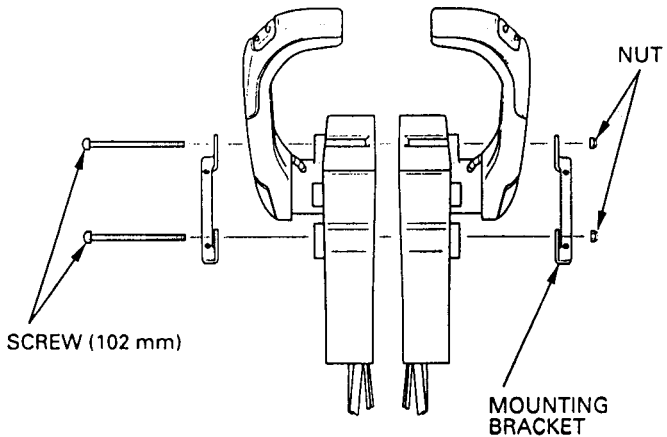

5. When the control lever is not mounted, install the control lever with it in the neutral position. Be sure to apply a thread locking agent to the threaded portion of the mounting bolt and tighten the bolt to the specified torque.

TORQUE: 17 N·m (1.7 kgf·m, 12 lbf·ft)

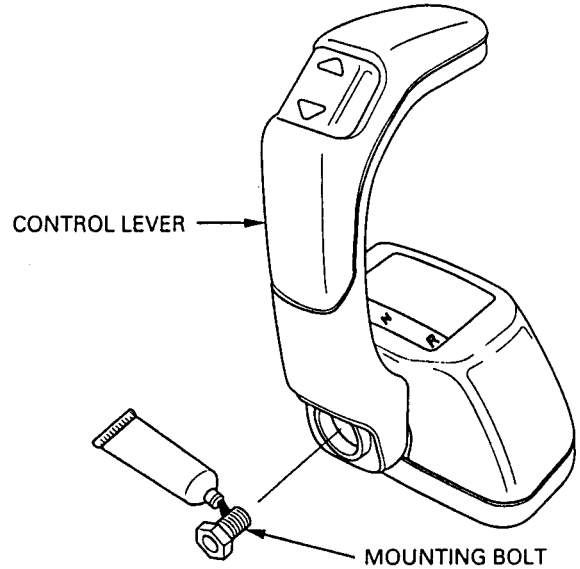

### NOTICE

If the removal of the throttle button is required, it will be necessary to put the handle in the throttle only position. Push "IN" on the button and place the control handel forward. The throttle button can now be removed.

6. Install the mounting bracket with the screws.  
Before installation, be sure to connect the switch wire to the remote control wire harness (see page 19).  
Note that one of the four bolts shown below tightens the cable clamp holder together with the mounting bracket.

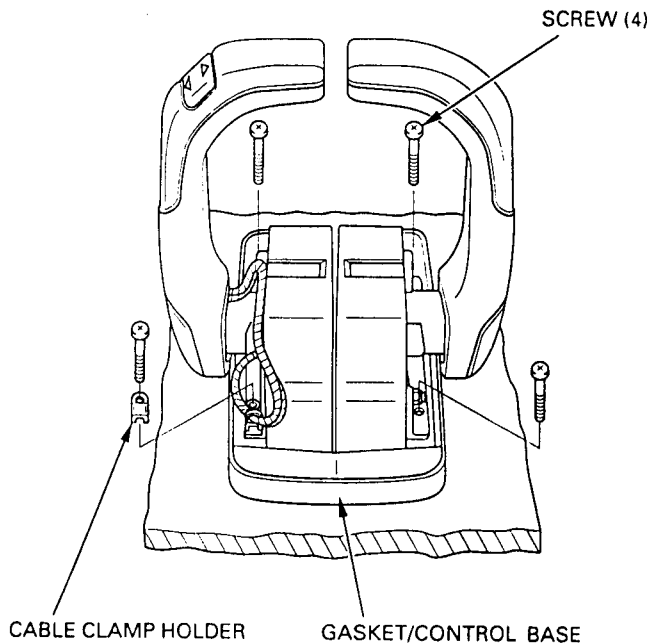

Mounting two engines:

Before installing the control module, fix the diode unit on the boat and connect the cover side trim/tilt switch wire properly. (see page 20 for wire connection).

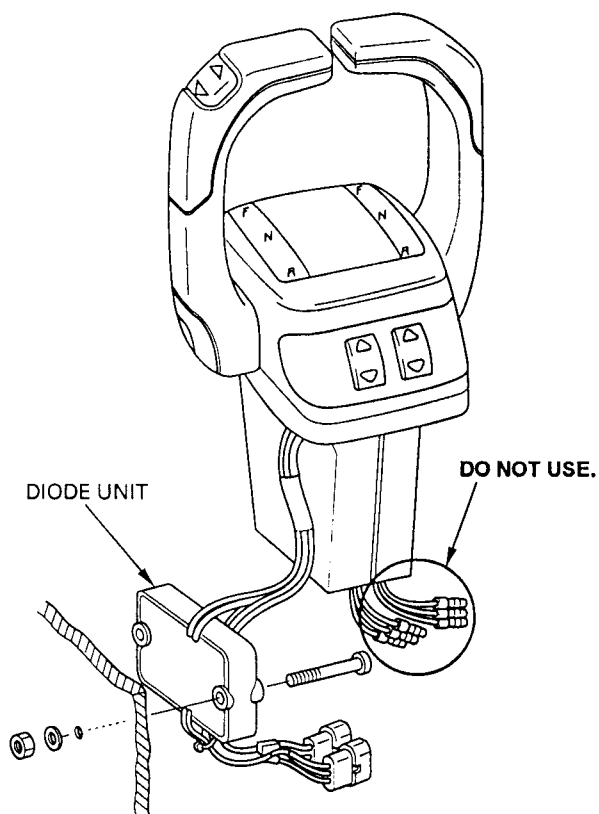

7. Fasten the trim/tilt switch wire to the cable holder using the cable clamp.

Operate the control lever, and check to be sure the wiring does not pull taut or catch on any part.

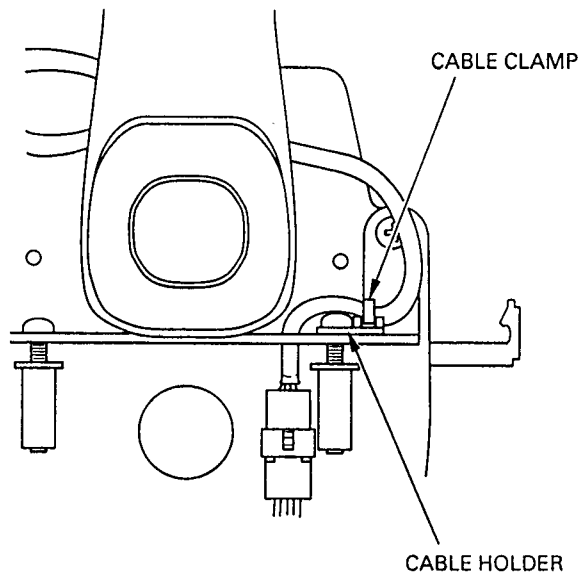

8. Install the cover.  
**Make sure that the trim/tilt switch harness does not bind.**

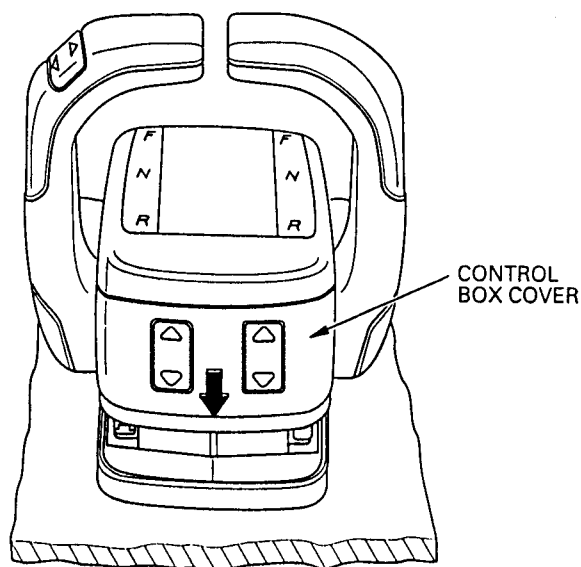



## THROTTLE CABLE INSPECTION / ADJUSTMENT

Actual throttle adjustment procedures vary with each installation. Refer to the specific throttle adjustment procedure in the installation manual or the shop manual.

### Special note about Top Mount Controllers

Depending on the motor and installation, the dual or single top mount controller lever may not have enough stroke to fully open the throttle. With most installations, this condition can be cured by careful adjustment of the throttle cable.

Should you still be unable to get full stroke out of the top mount controller lever, install a commercially available one (1) inch thick spacer that raises the entire controller.

DUAL CONTROL  
SPACER

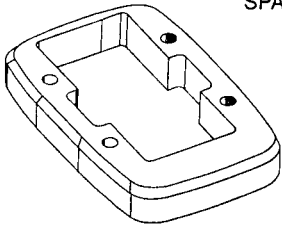

## CONTROL LEVER FRICTION ADJUSTMENT

1. The control lever friction can be adjusted by turning the friction adjustment screw right or left.

### SIDE-MOUNT

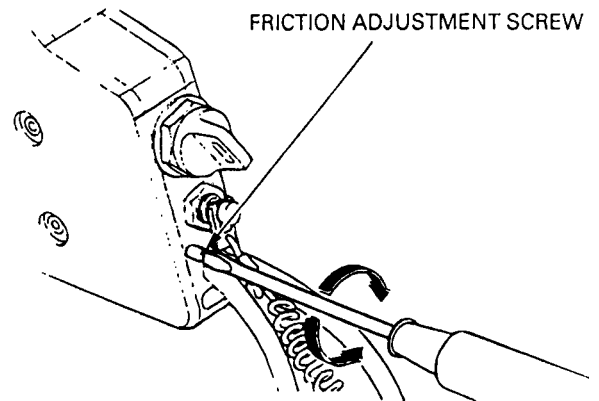

### TOP-MOUNT

FRICTION ADJUSTING SCREW

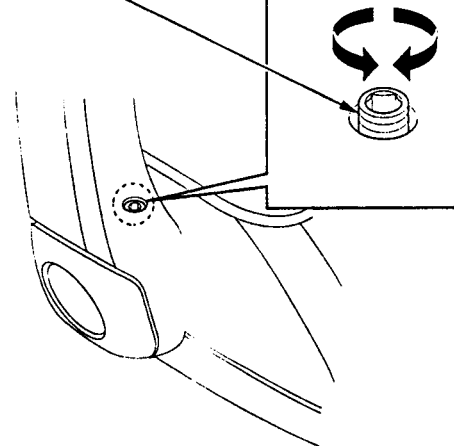

### PANEL-MOUNT

FRICTION ADJUSTING SCREW

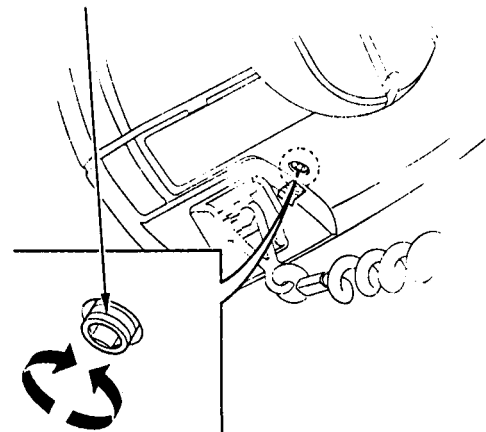

## SWITCH PANEL INSTALLATION

When using the panel-mount or top-mount remote control, install a Honda switch panel (standard with BF75/90).

P/N 32340-ZW1-V01 } Both parts required  
P/N 32580-ZW1-V00 } for installation

When converting a side-mount Honda remote control for panel operation, use the optional switch plate kit.  
P/N 06200-ZV5-010A11

1. Locate the switch panel near the operator's seat, in a position where it will not obstruct the operation of the boat.
2. Attach the template enclosed with this manual to the switch panel installation surface.
3. Wear eye protection, then drill and cut as indicated on the template.

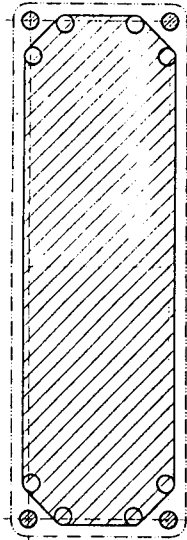

4. Connect the wire harness to the remote control wire harness and the trim/tilt switch harness. (See pages 19-20 for wire harness connection).
5. Install the switch panel on the installation surface using the four 5 x 40 mm screws and the four 5 mm washers, lock washers, and flange nuts.

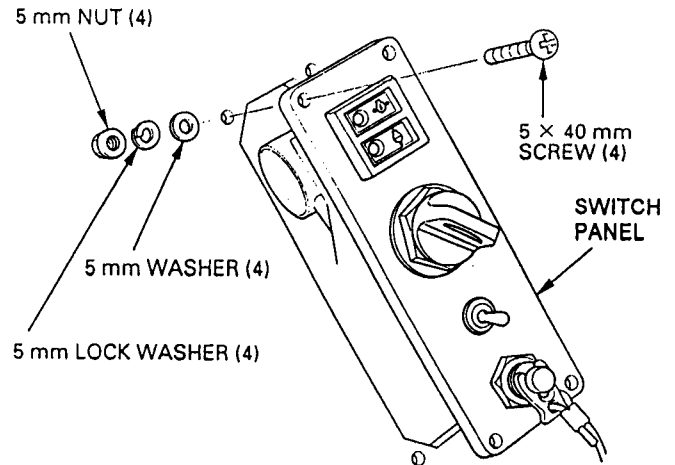

## WIRE HARNESS CONNECTION

- When modifying the remote control wire harness or using the other harnesses;
  - Check whether the wire harnesses are connected as shown on the wiring diagram.
  - Connect the leads and the terminals securely. Wrap the connections with a piece of vinyl tape to make the connection water-proof.
  - Use 1.25 mm-diameter lead wires.
- Wire harness connections are different according to the type of the remote control box. Observe the following instructions.
- If the control box wire harness, which is 5 m (16 ft) in length, is too short, additional extension cable can be used, but not to exceed 9 m (29 ft) in length.
- Connect the wire harness securely. If a terminal is oxidized or corroded, remove the oxidation or corrosion with a non-conductive plastic scrub pad or contact cleaner before reconnecting it.
- Check the insulators to make sure that they surround their connectors completely. Do not fold up the mouths of insulators.
- Do not break the coverings of the wire harness. If the covering is broken, either repair it with electrician's tape, or replace it.
- Attach the free terminals to the adjacent main harness with a piece of vinyl tape to keep them from interfering with the surrounding parts.
- Connect each wire harness properly as instructed on the wiring diagram.
- After connection of each wire and harness, turn the main power on to check for proper operation.

**PANEL-MOUNT, SINGLE TOP-MOUNT CONTROL**

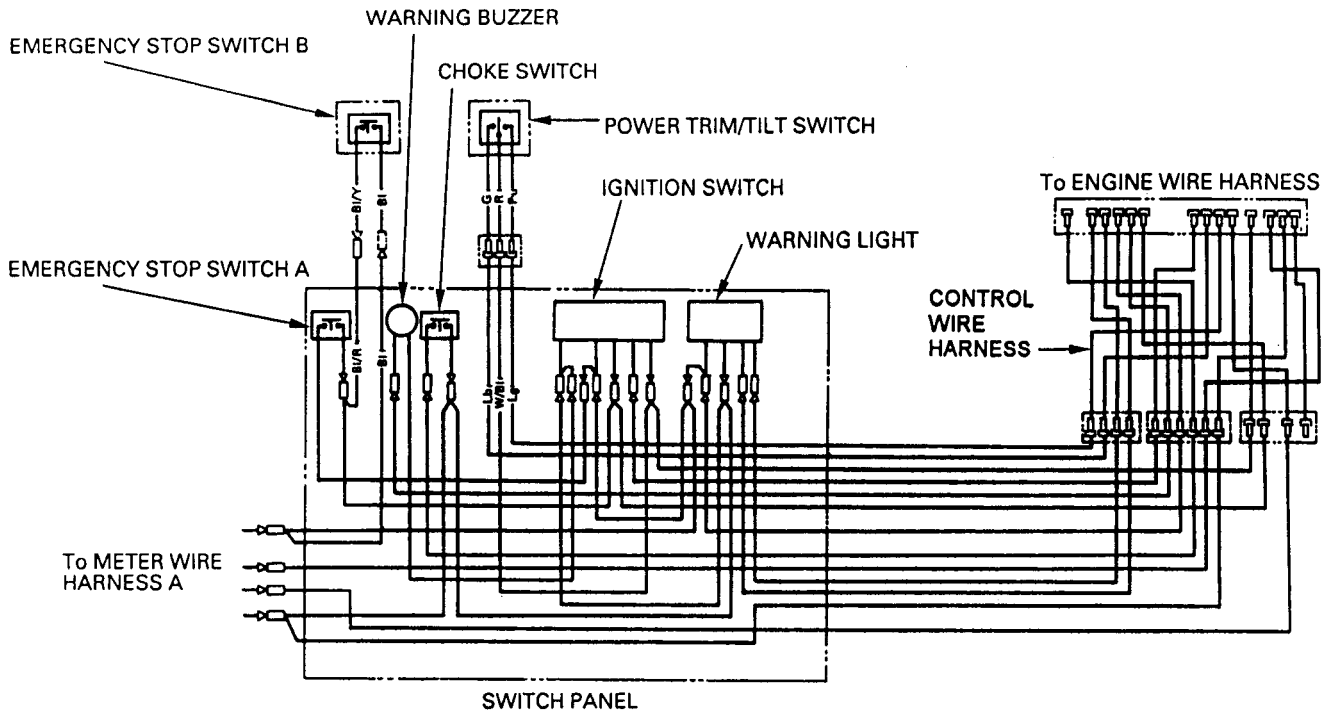

Remove the cover from the switch panel wire harness 3P coupler, then connect the couplers and wrap the connection point with vinyl tape 3 to 5 times around.

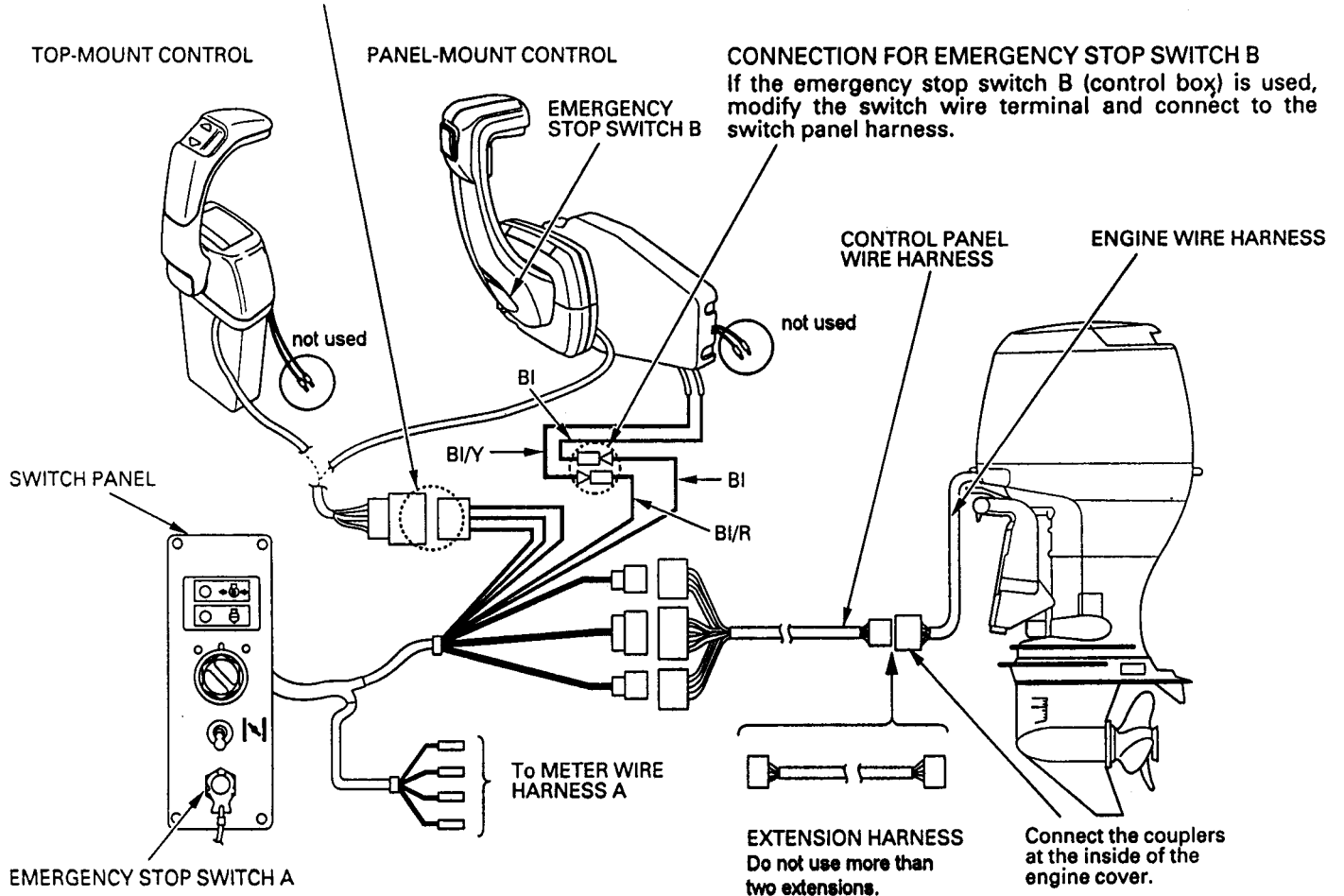

# TOP-MOUNT DUAL CONTROL

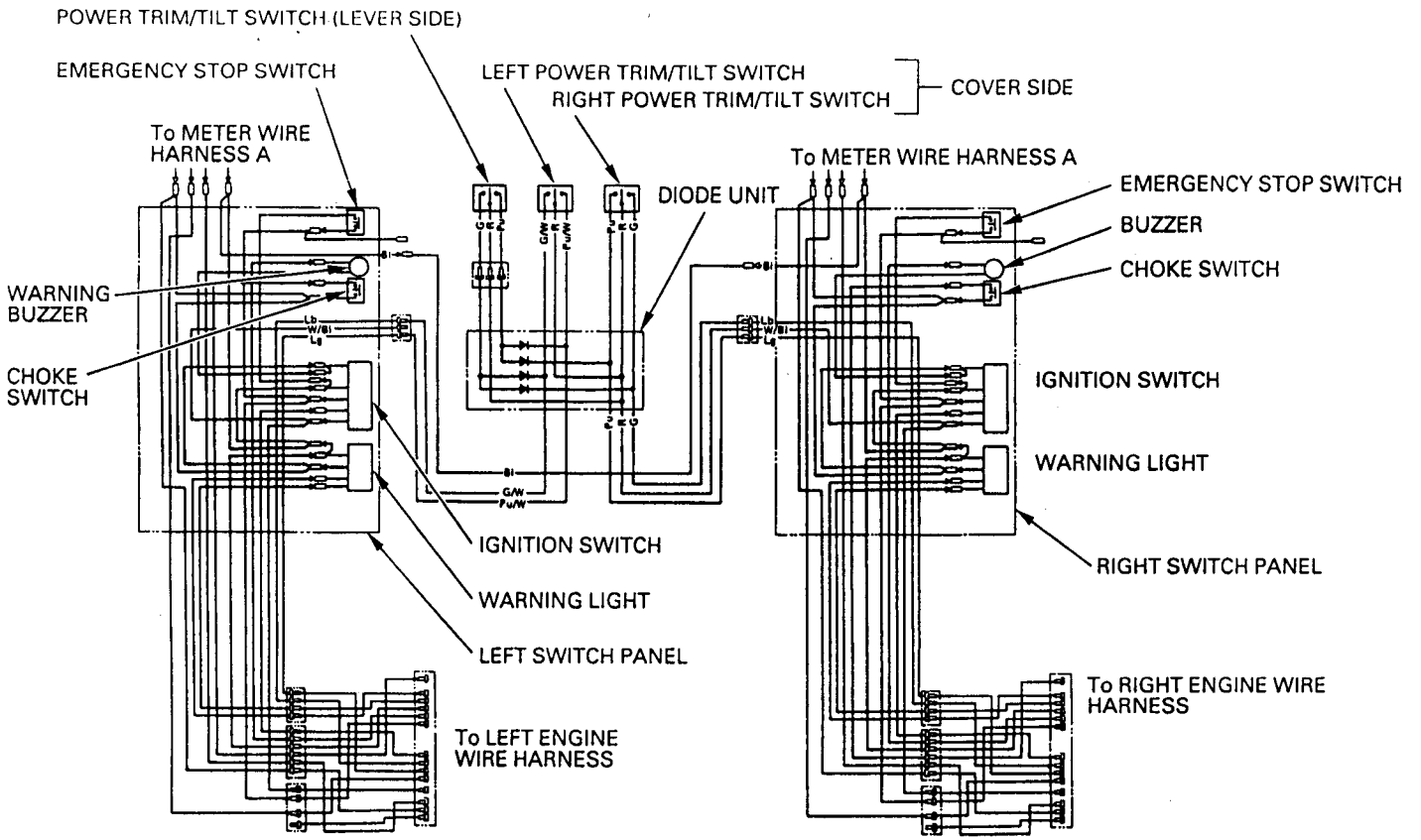

Remove the cover from the switch panel wire harness 3P coupler, then connect the couplers and wrap the connection point with vinyl tape 3 to 5 times around.

• Use separate batteries for the two outboard motors. In the event that a battery failure makes it necessary to temporarily use one battery for both engines, disconnect the ground wire from between the switch panels.

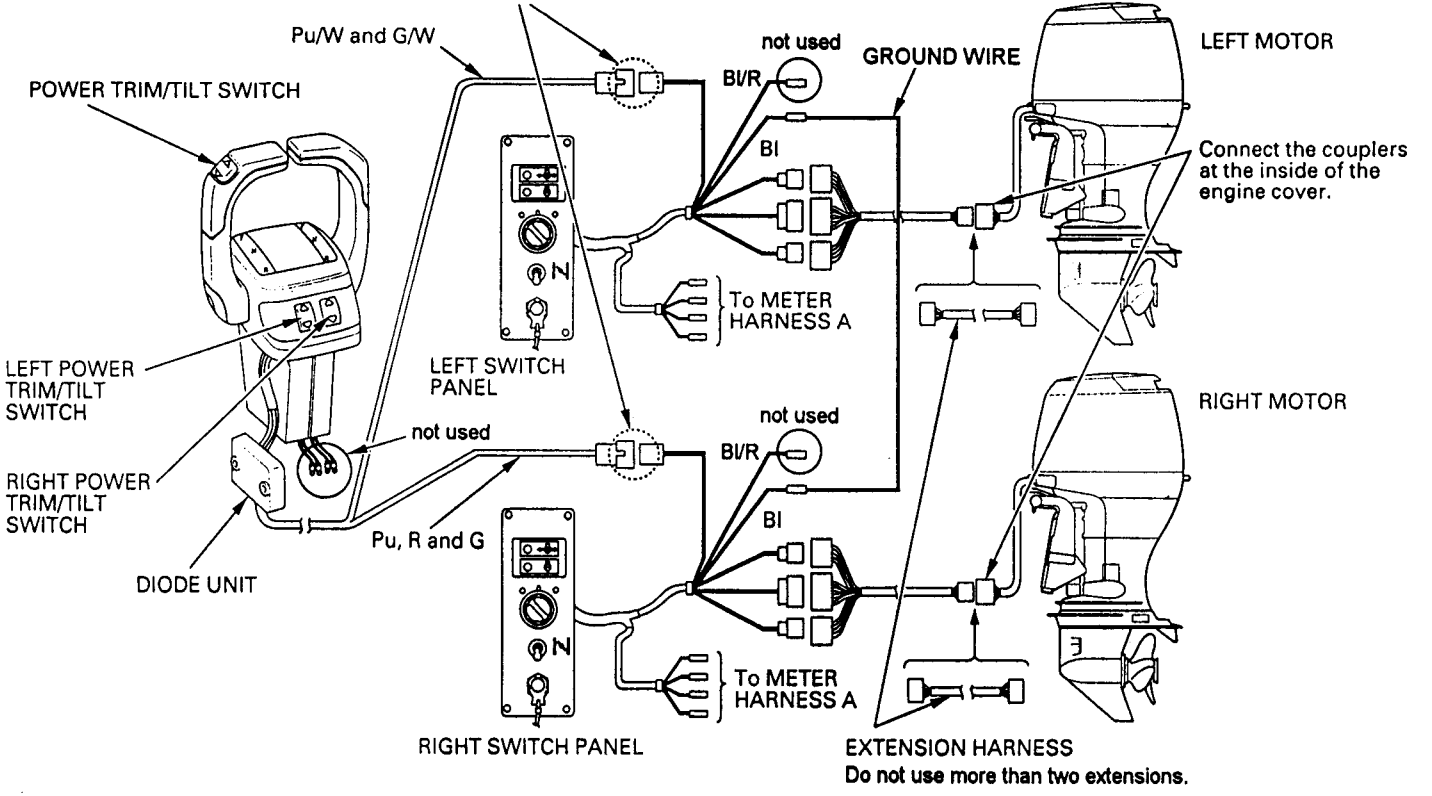

## 2. TEMPLATES

### PANEL-MOUNT CONTROL TEMPLATE

STARBOARD MOUNTED (CONTROL MODULE MOUNTED HORIZONTAL)

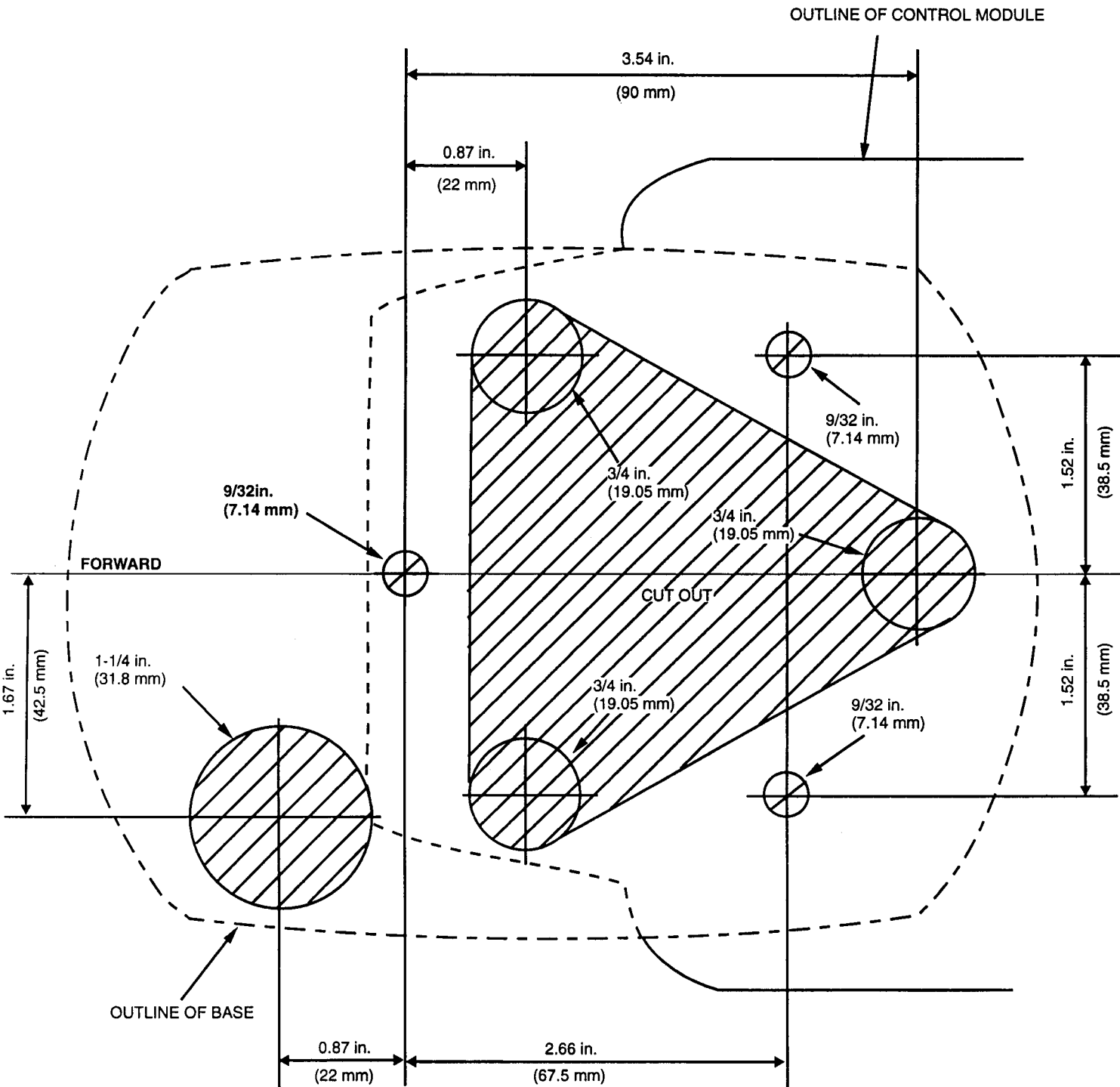

Drill and cut out shaded areas as indicated.



# PANEL-MOUNT CONTROL TEMPLATE

PORT SIDE MOUNTED (CONTROL MODULE MOUNTED HORIZONTAL)

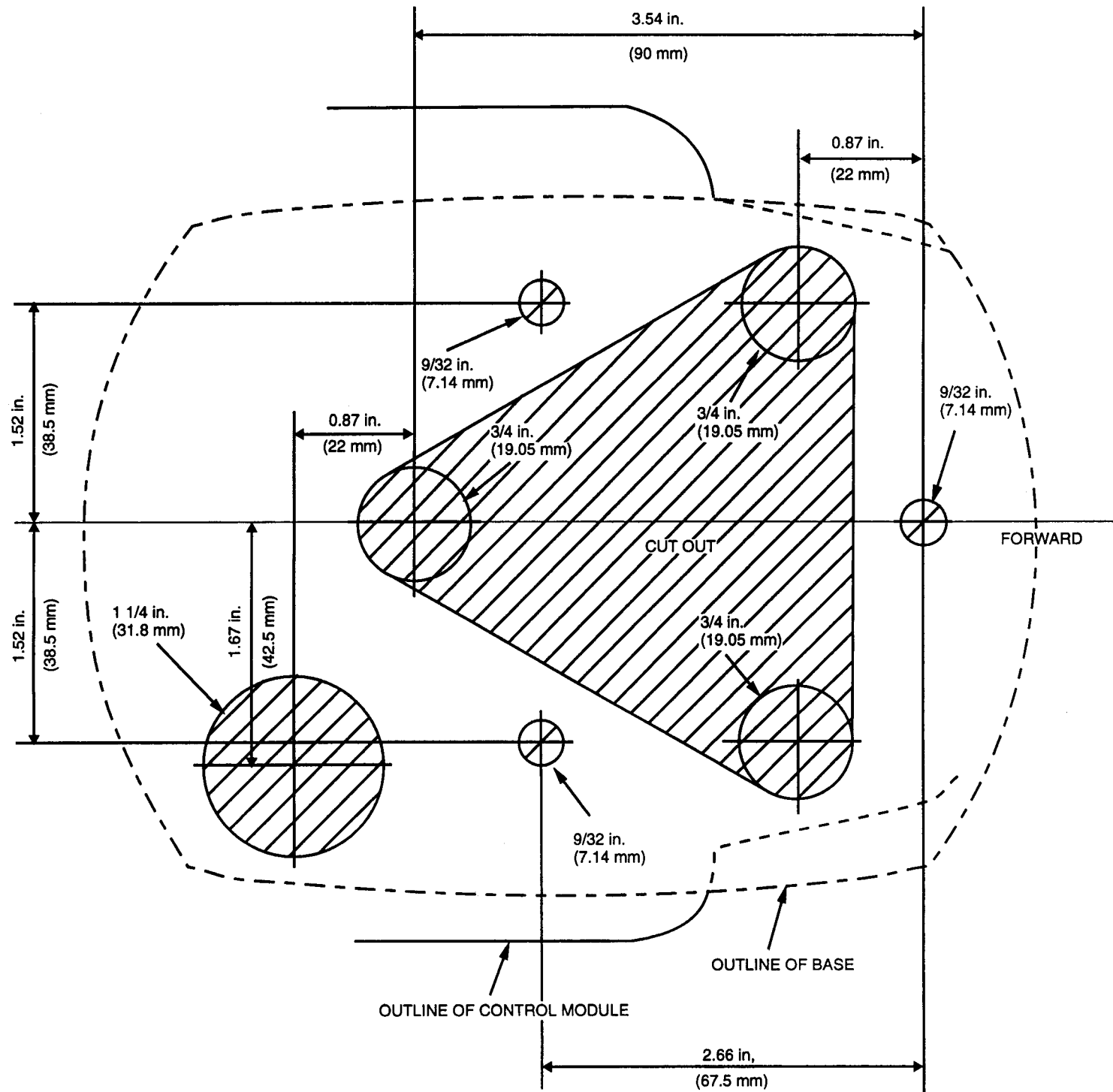

Drill and cut out shaded areas as indicated.





# PANEL-MOUNT CONTROL TEMPLATE

CONTROL MODULE MOUNTED 30° UP

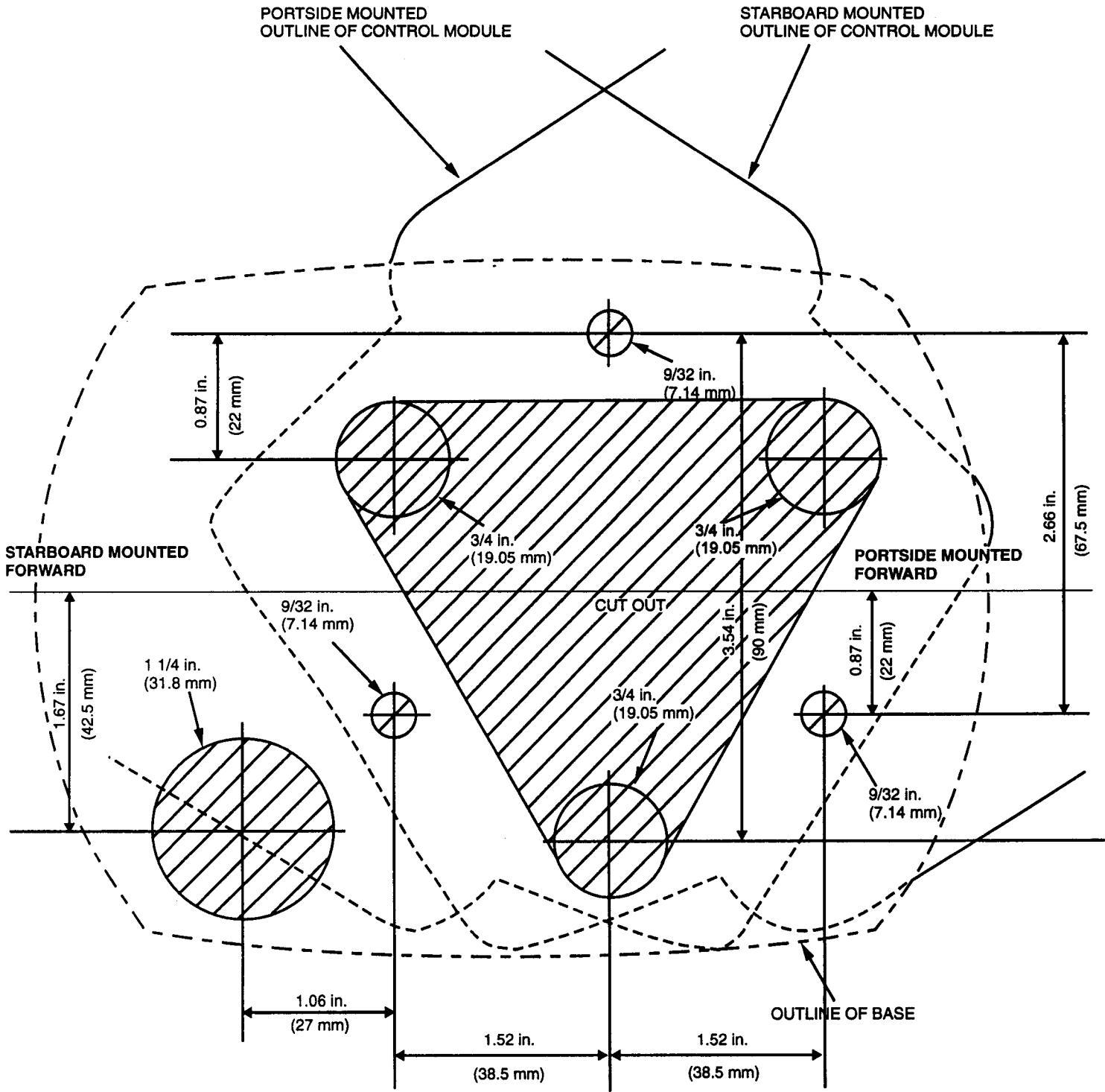

Drill and cut out shaded areas as indicated.



# PANEL-MOUNT CONTROL TEMPLATE

CONTROL MODULE MOUNTED 30° DOWN

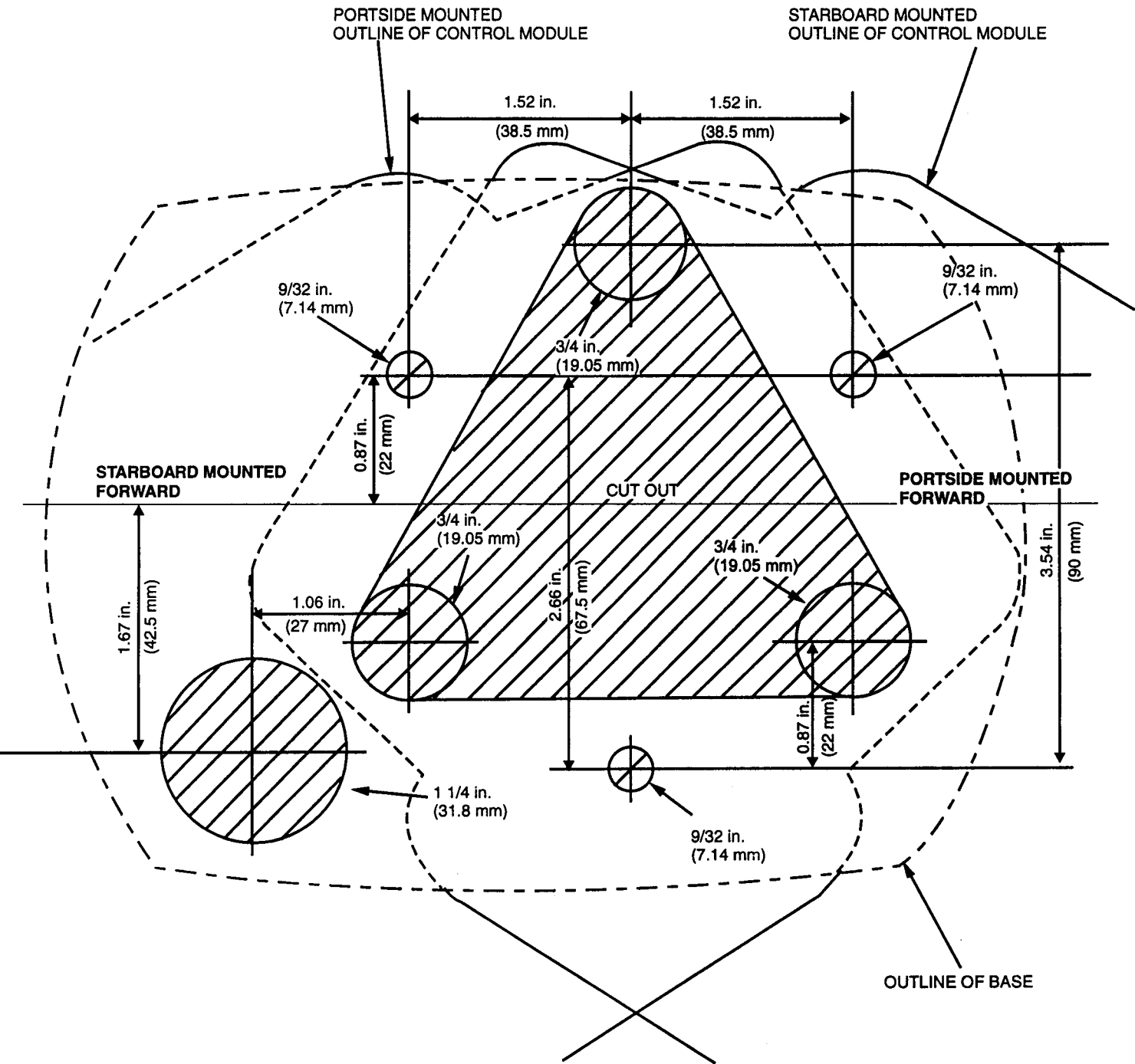

Drill and cut out shaded areas as indicated..



# Console Mount Control Template

Dual Handle Console Mount Remote Control

Forward



Starboard Mount

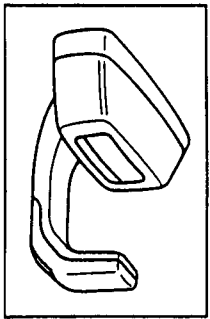
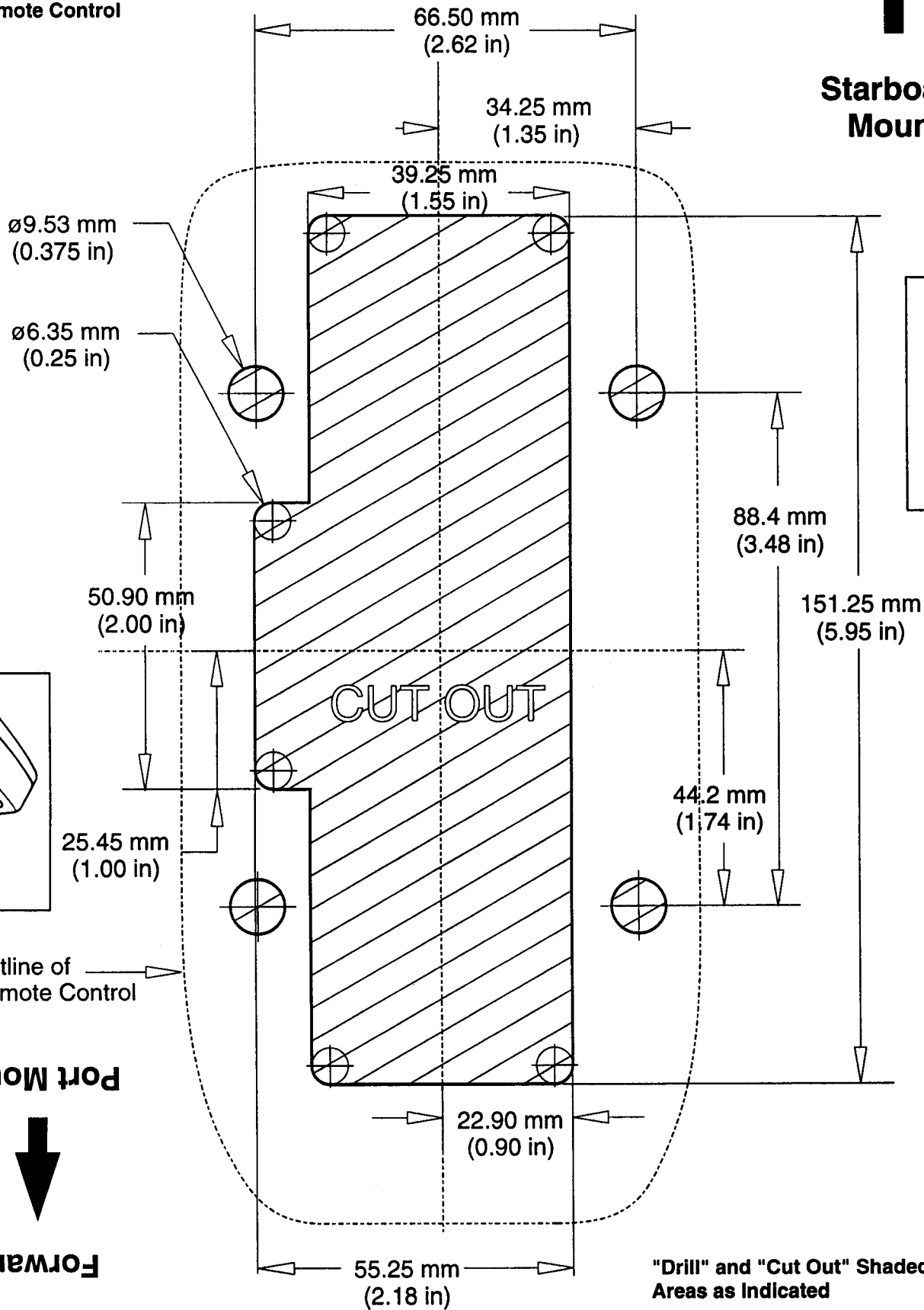
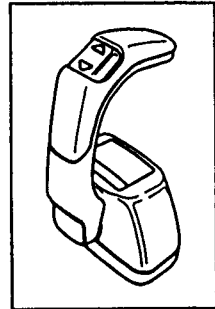

Outline of Remote Control

Port Mount



Forward



**Dual Handle Console  
Mount Remote Control**

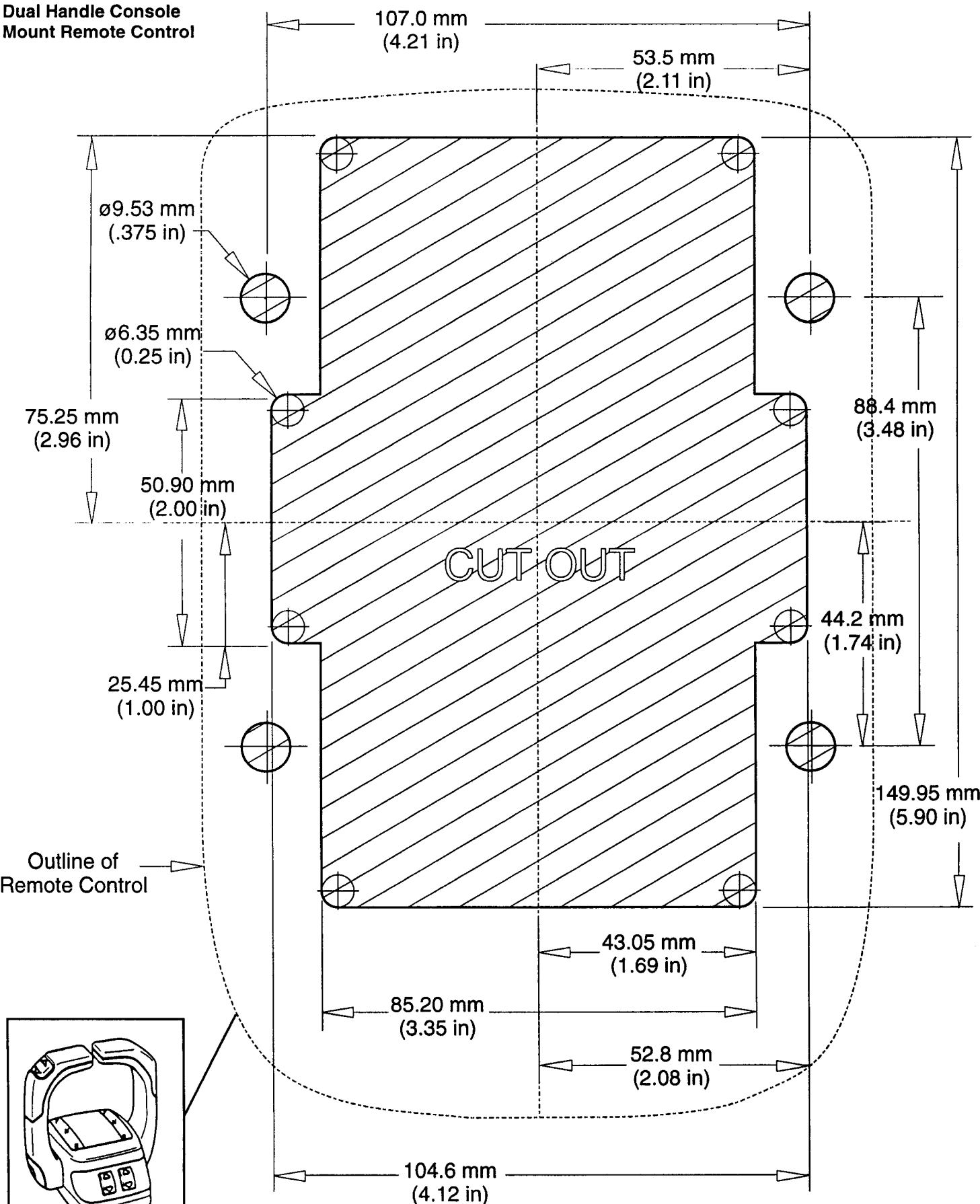

Outline of Remote Control

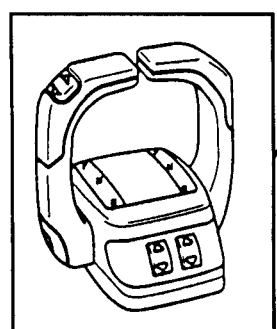

**Dual Control**

"Drill" and "Cut Out" Shaded Areas as Indicated





# SWITCH PANEL TEMPLATE

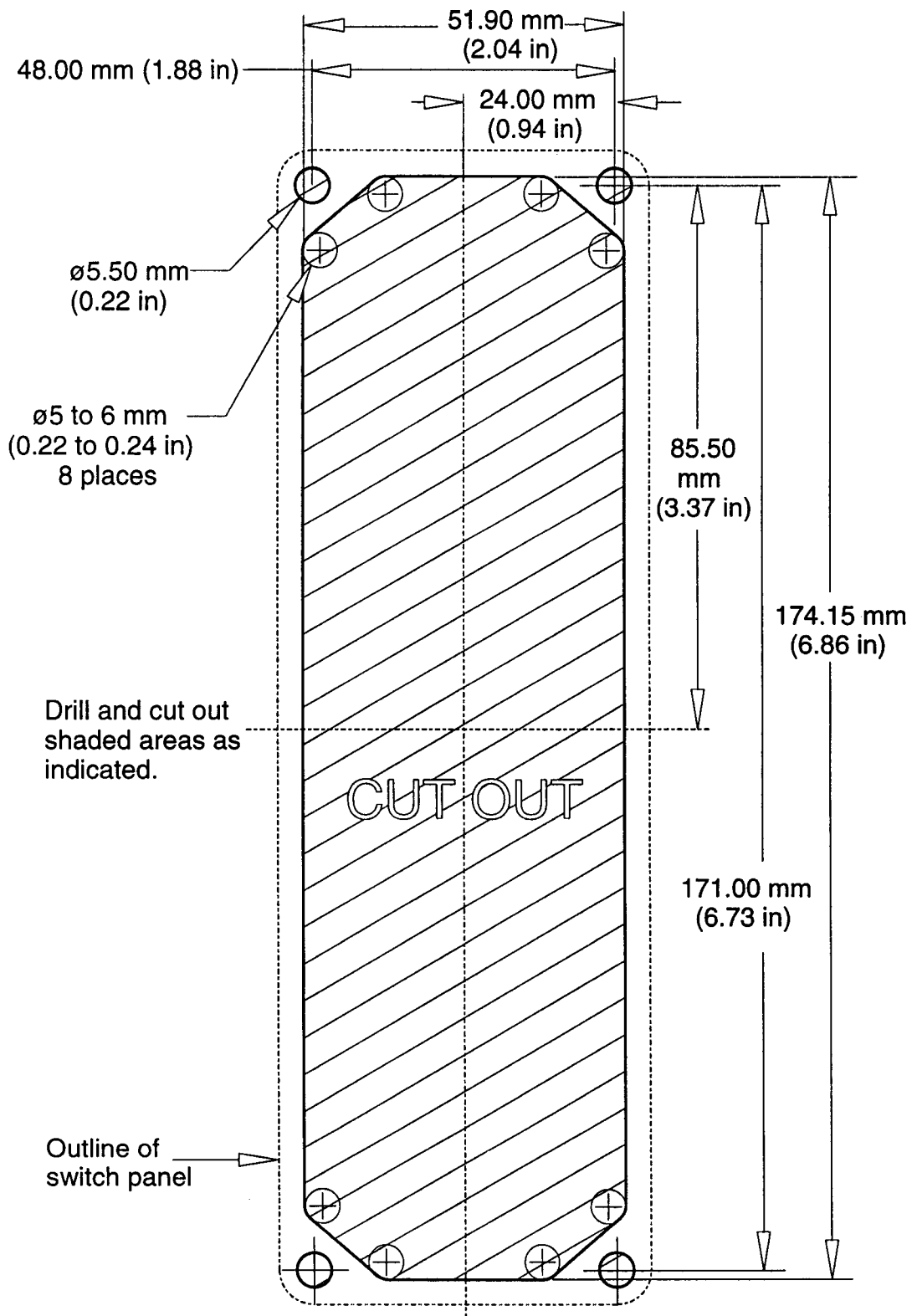

# IMPORTANCE OF INSTALLATION AND PRE-DELIVERY SERVICE

Proper installation and pre-delivery service are essential to operator safety and the reliability of the machine. Any error or oversight made by the technician installing and servicing a new unit can easily result in faulty operation, damage to the machine, or injury to the operator.

## **⚠ WARNING**

Improper set-up or pre-delivery service can cause an unsafe condition that can lead to serious injury or death.

Follow the procedures and precautions in set-up and pre-delivery instructions and shop manuals carefully.

Some of the most important safety precautions are given below. However, we cannot warn you of every conceivable hazard that can arise in performing installation and pre-delivery service. Only you can decide whether or not you should perform a given task.

## **⚠ WARNING**

Failure to properly follow set-up and pre-delivery instructions and precautions can cause you to be seriously hurt or killed.

Follow the procedures and precautions in set-up and pre-delivery instructions carefully.

# IMPORTANT SAFETY PRECAUTIONS

Be sure you have a clear understanding of all basic shop safety practices and that you are wearing appropriate clothing and safety equipment. When performing maintenance or repairs, be especially careful of the following:

- Read the instructions before you begin, and be sure you have the tools and skills required to perform the tasks safely.

Be sure the engine is off before you begin any maintenance or repairs. This will reduce the possible of several hazards:

- **Carbon monoxide poisoning from engine exhaust.**  
Be sure there is adequate ventilation whenever you run the engine.
- **Burns from hot parts.**  
let the engine cool before you touch it.
- **Injury from moving parts.**  
Do not run the engine unless the instruction tells you to do so. Even then keep your hands, fingers, and clothing away.

To reduce the possibility of a fire or explosion, be careful when working around gasoline. Use only a nonflammable solvent, not gasoline, to clean parts. Keep all cigarettes, sparks, and flames away from the battery and all fuel-related parts.

# TORQUE VALUES

FASTENER APPLICATION	DESCRIPTION	TIGHTENING TORQUE		
		ft-lb	kg-m	N'm
Control box base bolts (3)	Initial installation	8.2	1.13	11.1
	Reinstallation	2.0	0.28	2.7
Control lever lock bolt	8 mm	14	2.0	20
Control lever mounting bolt		12	1.7	17
Propeller lock nut		55	7.6	75
Separate cover bolts	6 x 28 mm (2)	8.7	1.2	11.8
	6 x 35 mm	7.2	1.0	9.8
Steering link rod bolt	3/8 in, 24 UNF	16	2.2	22
Steering link rod nut	8 mm self-locking	13	1.8	18
Steering plate nuts (2)	10 mm self-locking	25	3.5	34
Stem bracket mounting bolts (4)	12 x 119 mm	40	5.5	54
Tiller handle mounting bolt	8 x 32 mm	16	2.2	22
Tiller handle mounting nuts (2)	10 mm self-locking	25	3.5	34
Standard hardware	5 mm screw, bolt, nut	3.6	0.5	4.9
	6 mm screw	6.5	0.9	8.8
	6 mm bolt, nut	7.2	1.0	9.8
	6 mm flange bolt, nut	8.0	1.1	10.8
	8 mm bolt, nut	15	2.1	21
	8 mm flange bolt, nut	16	2.2	22
	10 mm bolt, nut	25	3.5	34

How to measure hardware and components:

MILLIMETERS



INCHES

