



PARTS CATALOGUE

YFM7FGPX (3B4H) U.S.A.

YFM7FGPX (3B4J) CANADA

YFM7FGPX (3B4K) EUROPE



2008/7/15

1G3B4-100EA

(2G3B4-100EA)

NEWS NO.	DATE	COMMENT
PE0-MC-080028	May,23,2008	FIG.10:THROTTLE BODY ASSY 1 LIST/ILLUST CORRECTION
PE0-MC-080025	May,22,2008	FIG.23:SIDE COVER ILLUSTRATION CORRECTION
PE0-MC-080037	June,30,2008	FIG.35,36:LIST CORRECTION

YFM7FGPX
PARTS CATALOGUE
©2007 by Yamaha Motor Co., Ltd.
1st edition, May 2007
All rights reserved.
Any reprinting or unauthorized use
without the written permission of
Yamaha Motor Co., Ltd.
is expressly prohibited.

A3

FOREWORD

This Parts Catalogue is related to the parts for the model(s) on the cover page. When you are ordering replacement parts, please refer to this Parts Catalogue and quote both part numbers and part names correctly.

1. Modifications or additions which have been made after the issue of the Parts Catalogue will be announced in the Parts News.

It is advisable that you make the necessary corrections to the Parts Catalogue according to the Parts News.

2. Abbreviations

The following abbreviations are used in this Parts Catalogue.

“UR” Use specified parts number.

“UN” Use as many as needed.

“AP” Alternate Parts

“LM” Locally Made (Parts need to be ordered locally)

“F#” Frame No. (Applicable machine No.)

“O/S” Over Size

3. The number of components for assembly

- Parts, which are to be supplied in an assembly, are listed with a dot (.) in front of the part name as shown below.
- The numeral appearing to the right of each component part indicates the quantity of parts for each assembly unit.

PART NO.	DESCRIPTION	Q'TY	REMARKS
2F5-83310-60	FRONT FLASHER LIGHT ASSY	2	
115-83311-60	.BULB (6V-18W)	1	

4. Applicable colours of graphics are represented in the “REMARKS” as shown below.

PART NO.	DESCRIPTION	Q'TY	REMARKS
2N4-24110-00-X5	FUEL TANK COMP.	2	MXR
3J1-24240-10	.GRAPHIC, FUEL TANK	1	FOR MXR

5. Note that the illustrations for reference in finding parts numbers are not to be used for assembling. When assembling, please use the applicable service manual.

6. The asterisk (*) before a reference number indicates modified items after the first edition.

FOREWORD

7. Applicable Serial No.

Engine Serial No.

Frame Serial No.

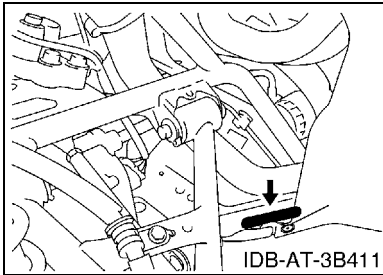
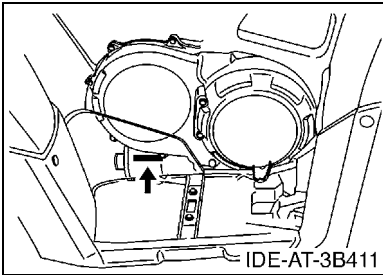

8. Applicable Colour Code (The (*) mark shows Model colour.)

Abbreviation	Colour Name	Colour Code
YB(*)	YAMAHA BLACK	0033

9. Quantity Column Information

Column No.	Name Of Q'ty Column	Destination
1	USA	U.S.A.
2	CAN	CANADA
3	EUR	EUROPE

CONTENTS

ENGINE

CYLINDER HEAD	B2
CYLINDER	B3
CRANKSHAFT & PISTON	B4
VALVE	B6
CAMSHAFT & CHAIN	B7
WATER PUMP	B8
RADIATOR & HOSE	B9
OIL PUMP	B10
INTAKE	B11
THROTTLE BODY ASSY 1	B12
EXHAUST	B13
CRANKCASE	B15
CRANKCASE COVER 1	C2
STARTER CLUTCH	C4
CLUTCH	C5
TRANSMISSION	C7
MIDDLE DRIVE GEAR	C9
SHIFT CAM & FORK	C11
SHIFT SHAFT	C13

CHASSIS

FRAME	C15
FRONT FENDER	D3
REAR FENDER	D6
SIDE COVER	D7
REAR ARM	D9
REAR SUSPENSION	D11
DRIVE SHAFT	D12
FRONT DIFFERENTIAL	D15
STEERING	E3
FRONT SUSPENSION & WHEEL	E5
FUEL TANK	E7
SEAT	E9
FRONT WHEEL	E10
FRONT WHEEL 2	E11
FRONT BRAKE CALIPER	E12
REAR WHEEL	E14
REAR WHEEL 2	F2
REAR BRAKE CALIPER	F4
STEERING HANDLE & CABLE	F6
FRONT MASTER CYLINDER	F8

REAR MASTER CYLINDER	F9
STAND & FOOTREST	F11
GUARD	F12
GENERATOR	F13
STARTING MOTOR	F14
METER	F15
HEADLIGHT	G2
TAILLIGHT	G3
TAILLIGHT 2	G4
ELECTRICAL 1	G5
ELECTRICAL 2	G8
GRAPHICS	G9
EMBLEM & LABEL 1	G10
EMBLEM & LABEL 2	G11
EMBLEM & LABEL 3	G12

INDEX

NUMERICAL INDEX	M1
-----------------------	----

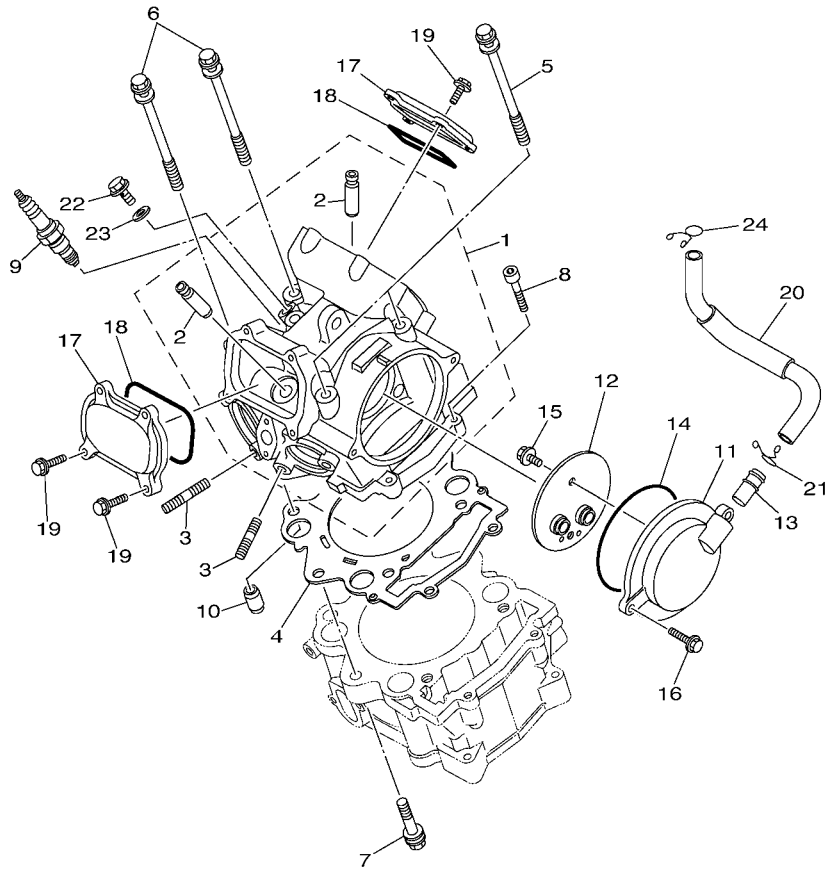

3B49100-G010

FIG. 1 CYLINDER HEAD

REF. NO.	PART NO.	DESCRIPTION	USA	CAN	EUR	REMARKS
1	3B4-11101-00	CYLINDER HEAD ASSY	1	1	1	
2	4G0-11133-11	.GUIDE, VALVE 1	4	4	4	
3	95612-08625	BOLT, STUD	4	4	4	
4	3B4-11181-00	GASKET, CYLINDER HEAD 1	1	1	1	
5	90109-09003	BOLT	2	2	2	
6	90109-09002	BOLT	2	2	2	
7	90109-09005	BOLT	2	2	2	
8	91312-06030	BOLT	2	2	2	
9	94701-00420	PLUG, SPARK (NGK CPR7EA)	1	1	1	
10	93612-16254	PIN, DOWEL	2	2	2	
11	3B4-11185-00	COVER, CYLINDER HEAD SIDE 1	1	1	1	
12	3B4-11165-00	PLATE, BREATHER	1	1	1	
13	371-11167-01	PIPE, BREATHER 2	1	1	1	
14	93210-96601	O-RING	1	1	1	
15	95022-06012	BOLT, FLANGE	2	2	2	
16	95022-06020	BOLT, FLANGE	2	2	2	
17	1S3-11186-00	COVER, CYLINDER HEAD SIDE 2	2	2	2	
18	93210-78544	O-RING	2	2	2	
19	95022-06020	BOLT, FLANGE	8	8	8	
20	3B4-11166-01	PIPE, BREATHER 1	1	1	1	
21	90467-140A4	CLIP	1	1	1	
22	90401-08004	BOLT, UNION	1	1	1	
23	90430-08119	GASKET	1	1	1	
24	90467-150A2	CLIP	1	1	1	

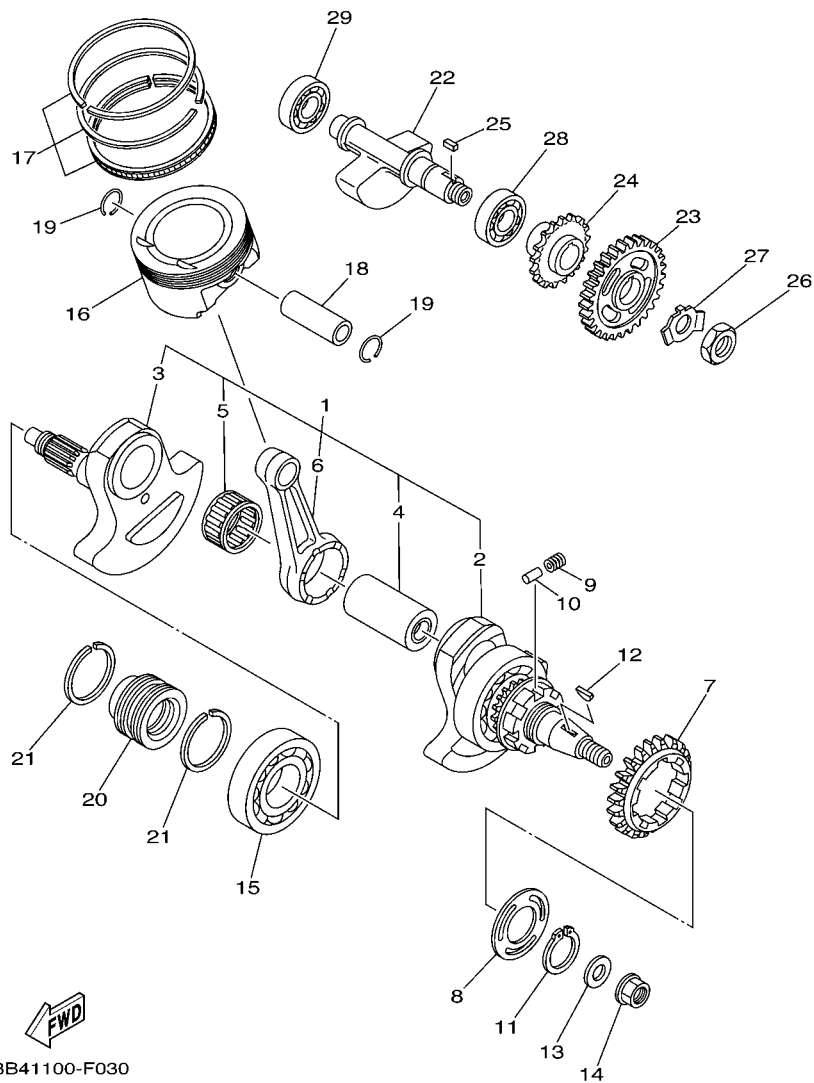
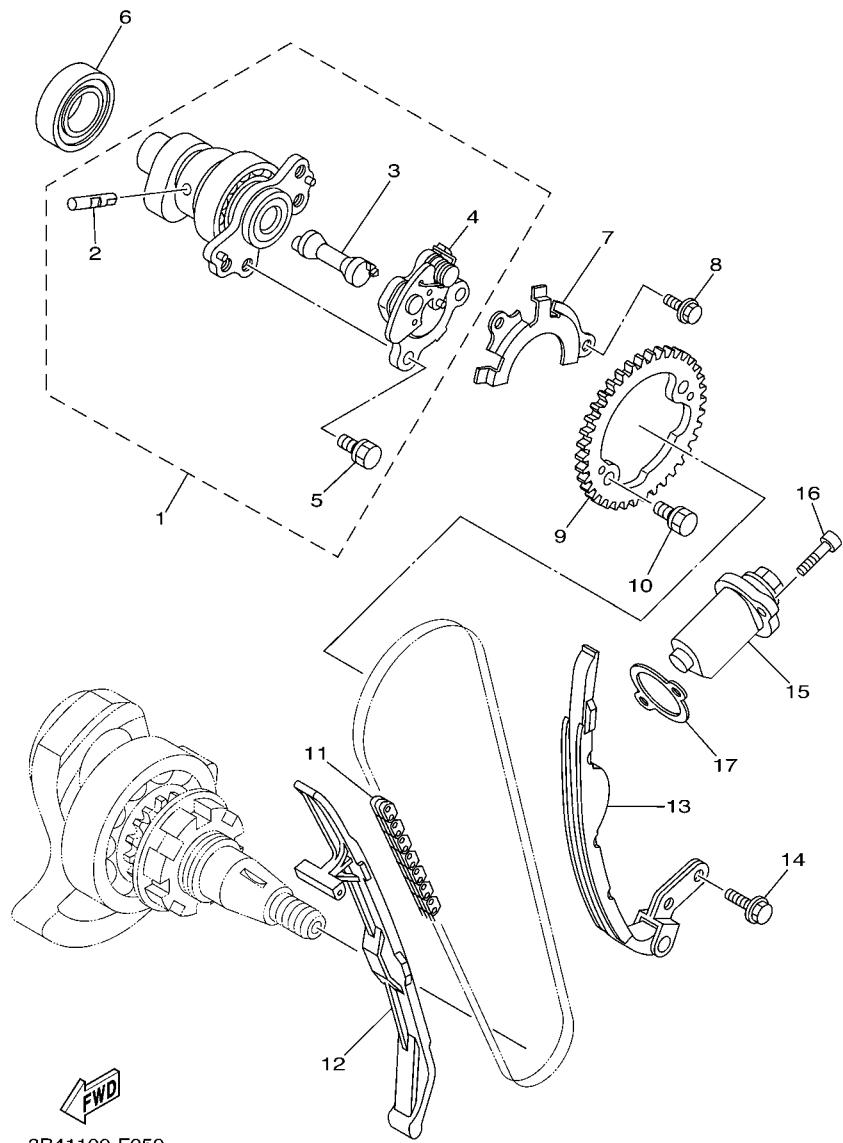

FIG. 3 CRANKSHAFT & PISTON

REF. NO.	PART NO.	DESCRIPTION	USA	CAN	EUR	REMARKS
1	3B4-11400-00	CRANKSHAFT ASSY	1	1	1	
2	3B4-11401-09	.CRANK SUB ASSY 1	1	1	1	
3	3B4-11402-09	.CRANK SUB ASSY 2	1	1	1	
4	1S3-11681-00	.PIN, CRANK 1	1	1	1	
5	93310-84017	.BEARING	1	1	1	
6	1S3-11651-00	.ROD, CONNECTING	1	1	1	
7	5KM-11536-10	GEAR, DRIVE (46T)	1	1	1	
8	5KM-11565-00	WASHER, BEARING COVER	1	1	1	
9	90501-220A1	SPRING, COMPRESSION	8	8	8	
10	93606-09002	PIN, DOWEL	4	4	4	
11	99009-35400	CIRCLIP	1	1	1	
12	90280-05001	KEY, WOODRUFF	1	1	1	
13	90201-165H4	WASHER, PLATE	1	1	1	
14	90179-16004	NUT	1	1	1	
15	93306-30810	BEARING	1	1	1	
16	1S3-11631-10	PISTON (STD)	1	1	1	
17	1S3-11603-10	PISTON RING SET (STD)	1	1	1	
18	5VK-11633-00	PIN, PISTON	1	1	1	
19	93450-24154	CIRCLIP	2	2	2	
20	3B4-16181-00	SPACER 1	1	1	1	
21	3B4-11447-00	SEAL, CRANK	2	2	2	
22	3B4-11454-00	WEIGHT 1	1	1	1	
23	3B4-11531-00	GEAR, BALANCE WEIGHT	1	1	1	
24	3B4-13354-00	SPROCKET, DRIVE	1	1	1	
25	90282-05007	KEY, STRAIGHT	1	1	1	
26	90170-18003	NUT	1	1	1	
27	90215-18001	WASHER, LOCK	1	1	1	



3B41100-F050

FIG. 5 CAMSHAFT & CHAIN

REF. NO.	PART NO.	DESCRIPTION	USA	CAN	EUR	REMARKS
1	3B4-12170-01	CAMSHAFT ASSY 1	1	1	1	
2	5VK-12284-00	.PIN, DECOMPRESSION LEVER	1	1	1	
3	1S3-12290-00	.LEVER, DECOMPRESSION SPRING	1	1	1	
4	1S3-12280-01	.DECOMPRESSION ASSY	1	1	1	
5	90105-07004	.BOLT, FLANGE	2	2	2	
6	93306-07209	BEARING	1	1	1	
7	5VK-1111F-00	PLATE	1	1	1	
8	90105-06078	BOLT, FLANGE	2	2	2	
9	1S3-12176-00	SPROCKET, CAM CHAIN	1	1	1	
10	90105-07004	BOLT, FLANGE	2	2	2	
11	94591-57126	CHAIN (98XRH2010-126M)	1	1	1	
12	3B4-12231-01	GUIDE, STOPPER 1	1	1	1	
13	3B4-12241-00	GUIDE, STOPPER 2	1	1	1	
14	90105-06082	BOLT, FLANGE	2	2	2	
15	3TB-12210-00	TENSIONER ASSY, CAM CHAIN	1	1	1	
16	91312-06025	BOLT	2	2	2	
17	4DW-12213-00	GASKET, TENSIONER CASE	1	1	1	

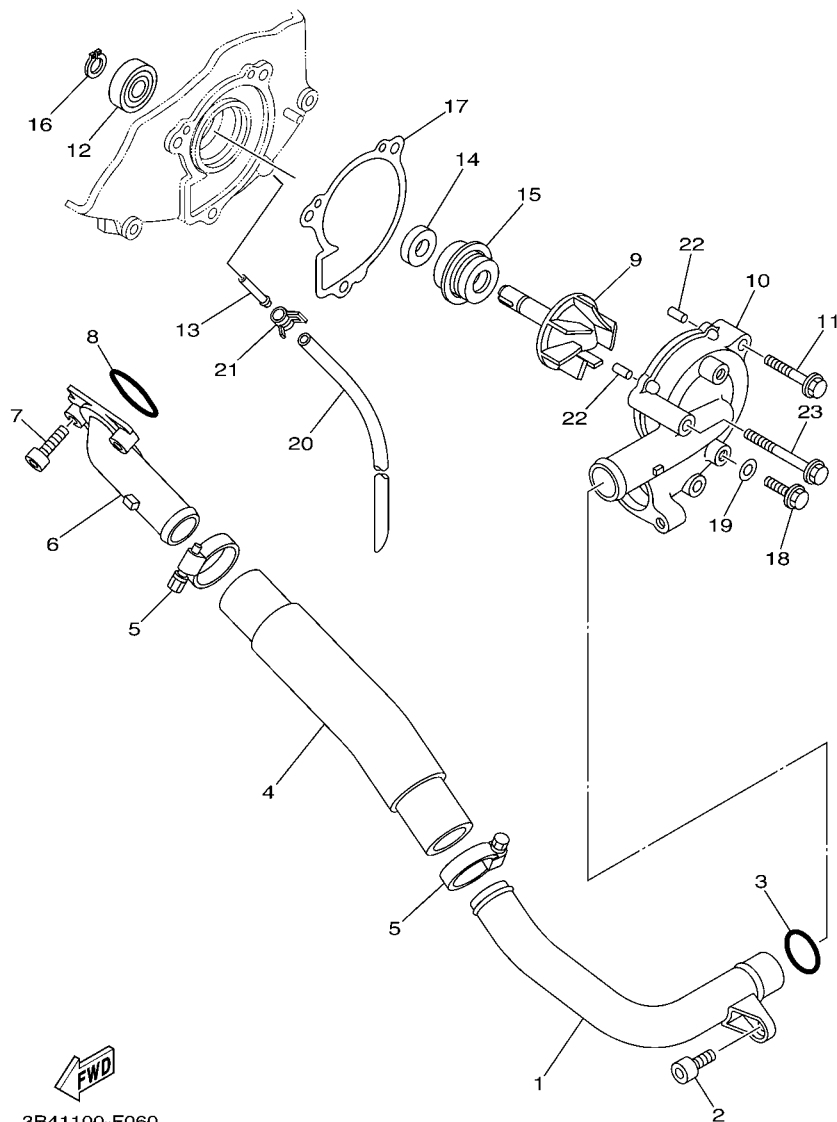
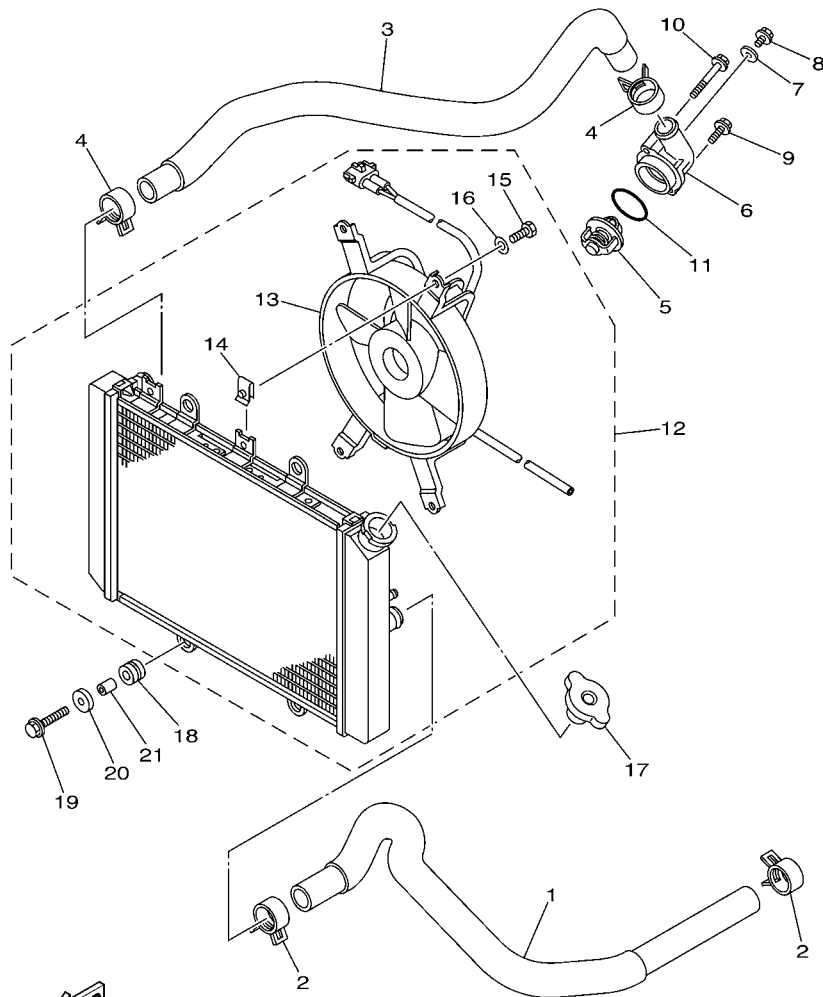

FIG. 6 WATER PUMP

REF. NO.	PART NO.	DESCRIPTION	USA	CAN	EUR	REMARKS
1	3B4-12481-00	PIPE 1	1	1	1	
2	91312-06012	BOLT	1	1	1	
3	93210-21190	O-RING	1	1	1	
4	3B4-12577-00	HOSE 2	1	1	1	
5	90450-32015	HOSE CLAMP ASSY	2	2	2	
6	5KM-12469-00	JOINT 1	1	1	1	
7	91312-06020	BOLT	2	2	2	
8	93210-33786	O-RING	1	1	1	
9	3B4-12450-00	IMPELLER SHAFT ASSY	1	1	1	
10	3B4-12422-00	COVER, HOUSING	1	1	1	
11	95022-06030	BOLT, FLANGE	1	1	1	
12	93306-00006	BEARING	1	1	1	
13	5D3-1243K-00	PIPE, DRAIN	1	1	1	
14	93101-10090	OIL SEAL	1	1	1	
15	11H-12438-10	SEAL, MECHANICAL	1	1	1	
16	99009-10400	CIRCLIP	1	1	1	
17	3B4-12428-00	GASKET, HOUSING COVER 2	1	1	1	
18	95022-06010	BOLT, FLANGE	2	2	2	
19	90430-06014	GASKET	2	2	2	
20	90445-07340	HOSE (L310)	1	1	1	
21	90467-07093	CLIP	1	1	1	
22	93604-10011	PIN, DOWEL	2	2	2	
23	95022-06050	BOLT, FLANGE	1	1	1	





 3B41100-F070

FIG. 7 RADIATOR & HOSE

REF. NO.	PART NO.	DESCRIPTION	USA	CAN	EUR	REMARKS
1	3B4-12576-00	HOSE 1	1	1	1	
2	90467-26189	CLIP	2	2	2	
3	3B4-12578-00	HOSE 3	1	1	1	
4	90467-26189	CLIP	2	2	2	
5	3B4-12411-00	THERMOSTAT	1	1	1	
6	1S3-12413-00	COVER, THERMOSTAT	1	1	1	
7	90430-06014	GASKET	1	1	1	
8	95022-06010	BOLT, FLANGE	1	1	1	
9	95022-06020	BOLT, FLANGE	1	1	1	
10	95022-06045	BOLT, FLANGE	1	1	1	
11	93210-41042	O-RING	1	1	1	
12	3B4-1240A-10	RADIATOR ASSY	1	1	1	
13	3B4-12405-00	.BLOWER ASSY	1	1	1	
14	1AA-12535-00	.PLATE	4	4	4	
15	97017-06010	.BOLT	4	4	4	
16	92907-06600	.WASHER, PLATE	4	4	4	
17	22W-12462-00	CAP, RADIATOR	1	1	1	
18	90480-15235	GROMMET	4	4	4	
19	95802-06020	BOLT, FLANGE	2	2	2	
20	90209-06012	WASHER	2	2	2	
21	90387-06113	COLLAR	2	2	2	

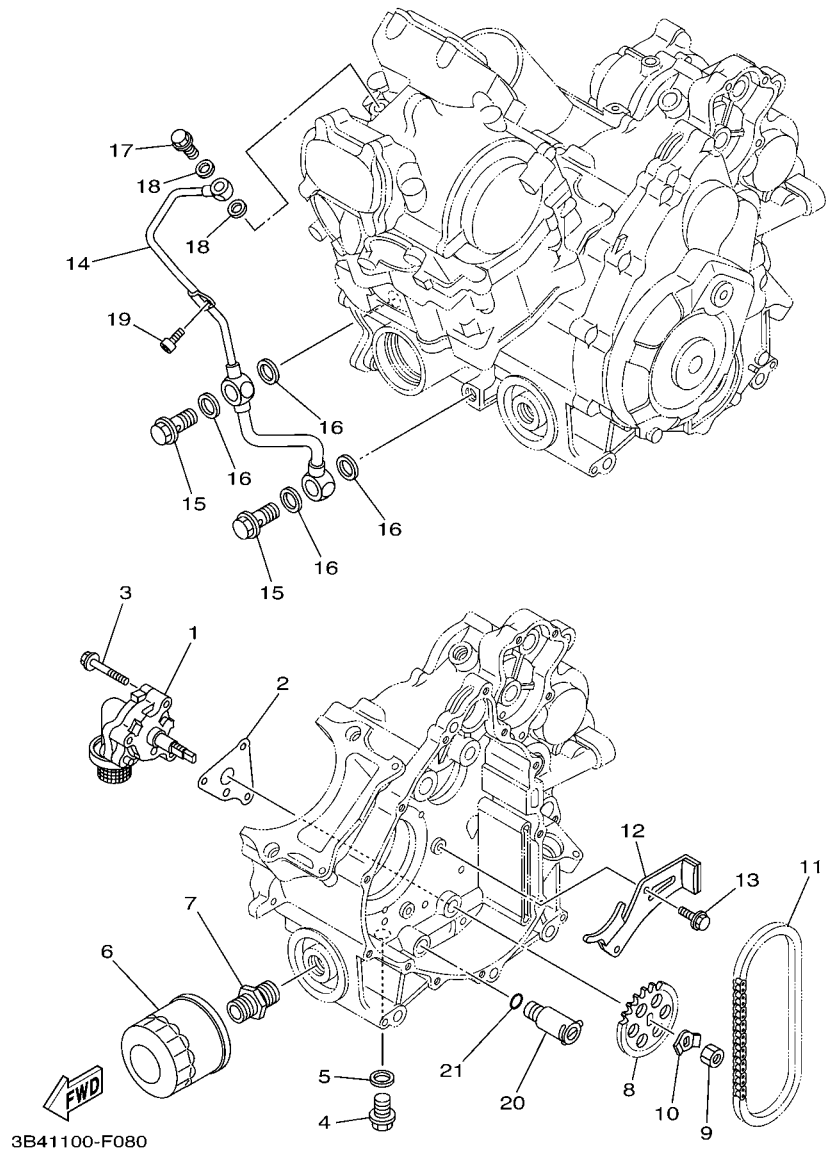
FIG. 8 OIL PUMP



REF. NO.	PART NO.	DESCRIPTION	USA	CAN	EUR	REMARKS
1	3B4-13300-00	OIL PUMP ASSY	1	1	1	
2	3B4-13329-00	GASKET, PUMP COVER	1	1	1	
3	95022-06040	BOLT, FLANGE	3	3	3	
4	90340-14132	PLUG, STRAIGHT SCREW	1	1	1	
5	214-11198-01	GASKET	1	1	1	
6	5GH-13440-20	ELEMENT ASSY, OIL CLEANER	1	1	1	
7	90401-20003	BOLT, UNION	1	1	1	
8	3B4-13355-00	SPROCKET, DRIVEN	1	1	1	
9	95312-10600	NUT	1	1	1	
10	90215-10008	WASHER, LOCK	1	1	1	
11	94580-31074	CHAIN (DID 25HT)	1	1	1	
12	3B4-12221-00	GUIDE, STOPPER 3	1	1	1	
13	90105-06082	BOLT, FLANGE	2	2	2	
14	3B4-13171-00	PIPE, DELIVERY 2	1	1	1	
15	90401-14118	BOLT, UNION	2	2	2	
16	90430-14043	GASKET	4	4	4	
17	90401-10024	BOLT, UNION	1	1	1	
18	90430-10188	GASKET	2	2	2	
19	91312-06012	BOLT	1	1	1	
20	25G-13490-00	RELIEF VALVE ASSY	1	1	1	
21	93210-10096	O-RING	1	1	1	

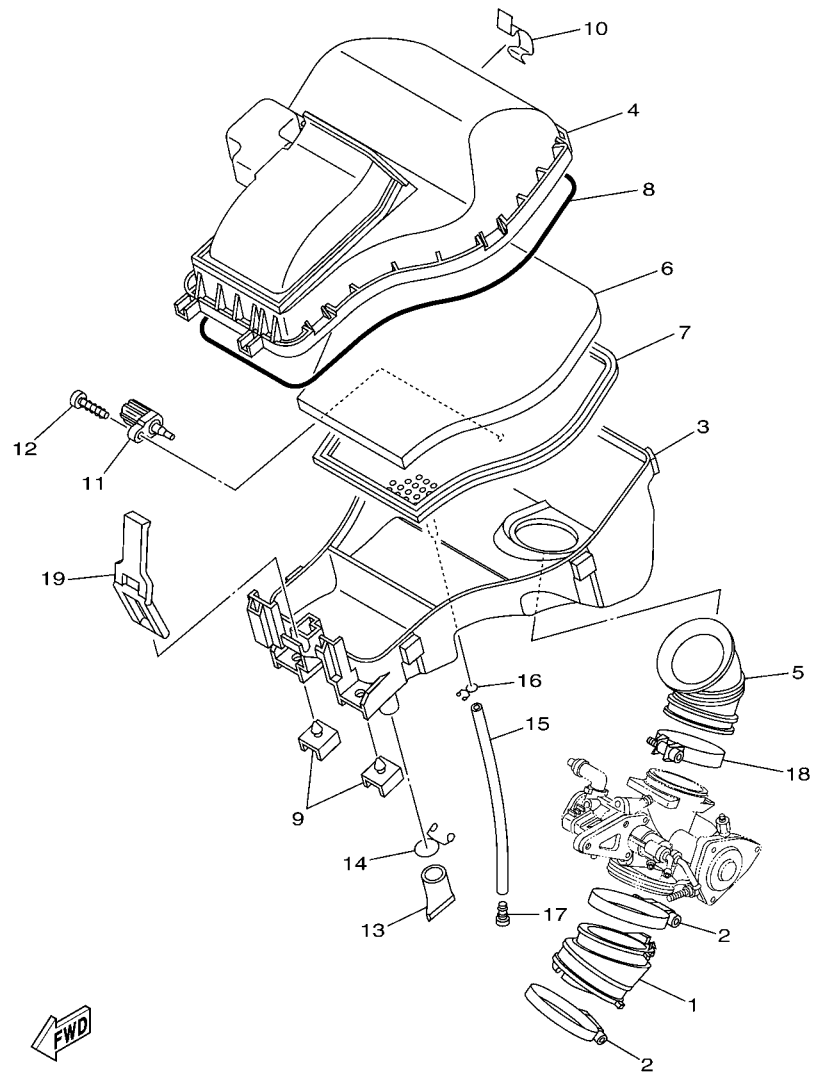

FWD
3B41100-F090

FIG. 9 INTAKE

REF. NO.	PART NO.	DESCRIPTION	USA	CAN	EUR	REMARKS
1	3B4-13586-00	JOINT, CARBURETOR 1	1	1	1	
2	90450-72004	HOSE CLAMP ASSY	2	2	2	
3	3B4-14411-10	CASE, AIR CLEANER 1	1	1	1	
4	3B4-14402-01	CAP ASSY, AIR CLEANER	1	1	1	
5	3B4-14453-00	JOINT, AIR CLEANER 1	1	1	1	
6	3B4-14451-00	ELEMENT, AIR CLEANER	1	1	1	
7	3B4-14472-00	PLATE, ELEMENT	1	1	1	
8	3B4-14457-00	SEAL	1	1	1	
9	3B4-14409-00	DAMPER	2	2	2	
10	3B4-14424-00	CLIP, CAP FITTING	6	6	6	
11	8FP-85886-00	SENSOR, AIR TEMPERATURE	1	1	1	
12	97702-50520	SCREW, TAPPING	1	1	1	
13	59V-14457-00	SEAL	1	1	1	
14	90467-220A1	CLIP	1	1	1	
15	91A20-07020	TUBE, FLEXIBLE VINYL (L200)	1	1	1	
16	90467-10041	CLIP	1	1	1	
17	90338-08174	PLUG	1	1	1	
18	90450-59006	HOSE CLAMP ASSY	1	1	1	
19	3B4-14455-00	BAND	1	1	1	

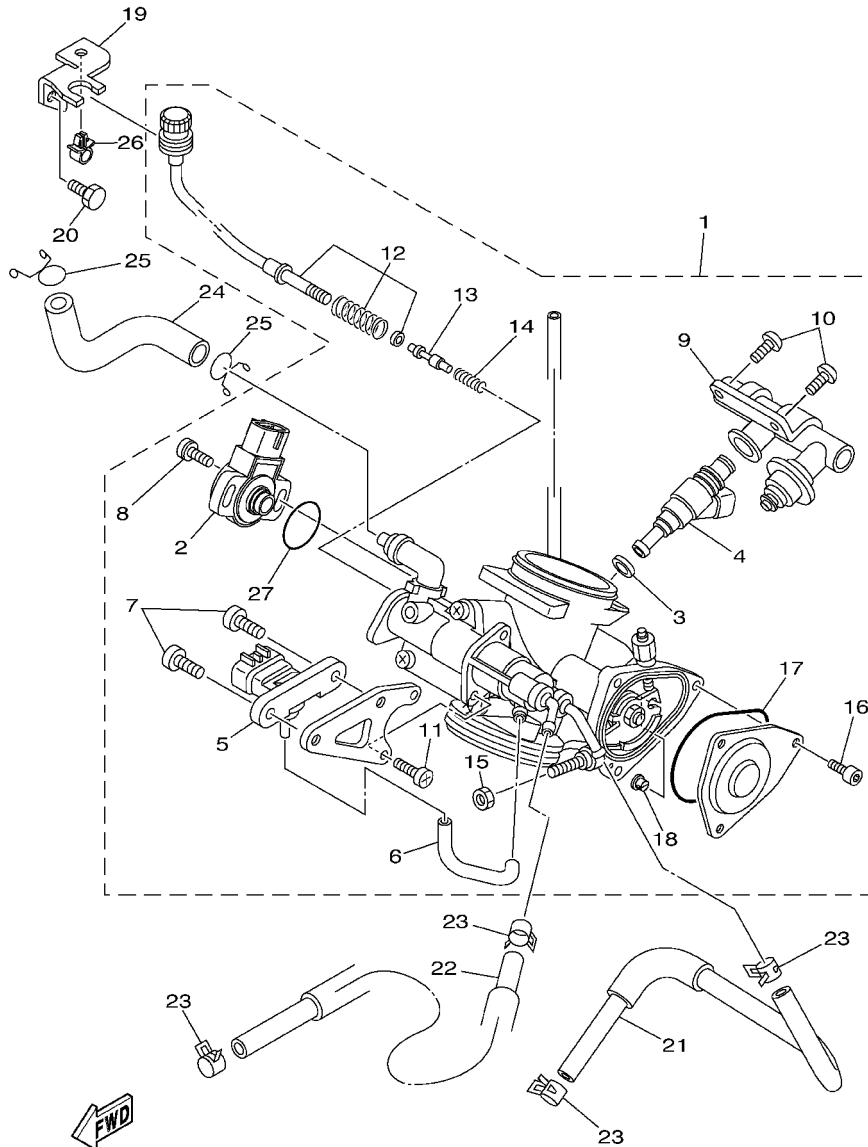

3B49100G1001

FIG. 10 THROTTLE BODY ASSY 1

REF. NO.	PART NO.	DESCRIPTION	USA	CAN	EUR	REMARKS
1	3B4-13750-10	THROTTLE BODY ASSY	1	1	1	
2	3B4-85885-00	.THROTTLE SENSOR SET	1	1	1	
3	8FP-13556-00	.GASKET, MANIFOLD	1	1	1	
4	3B4-13761-00	.INJECTOR	1	1	1	
5	1C7-82380-00	.SENSOR, PRESSURE	1	1	1	
6	5JW-14348-00	.PIPE 1	1	1	1	
7	98507-06010	.SCREW, PAN HEAD	2	2	2	
8	8CC-14216-10	.SCREW	2	2	2	
9	3B4-13160-00	.DELIVERY PIPE ASSY 1	1	1	1	
10	98507-06012	.SCREW, PAN HEAD	2	2	2	
11	98507-05012	.SCREW, PAN HEAD	2	2	2	
12	3B4-14503-00	.ADJUST SCREW SET	1	1	1	
13	1S3-13493-00	.PLUNGER	1	1	1	
14	4BH-14134-00	.SPRING, AIR ADJUSTING	1	1	1	
15	1S3-14161-00	.NUT, CABLE ADJUSTING	1	1	1	
16	91312-04006	.BOLT	3	3	3	
17	5LP-14147-00	.O-RING	1	1	1	
18	1UY-14155-00	.GUIDE, CABLE	1	1	1	
19	3B4-14413-10	STAY	1	1	1	
20	97002-06012	BOLT	1	1	1	
21	3B4-1243A-00	HOSE 1	1	1	1	
22	90445-12006	HOSE (L630)	1	1	1	
23	90467-110A2	CLIP	4	4	4	
24	3B4-13545-00	HOSE 1	1	1	1	
25	90467-140A4	CLIP	2	2	2	
26	90464-06007	CLAMP	1	1	1	
27	5YP-14562-00	.O-RING	1	1	1	

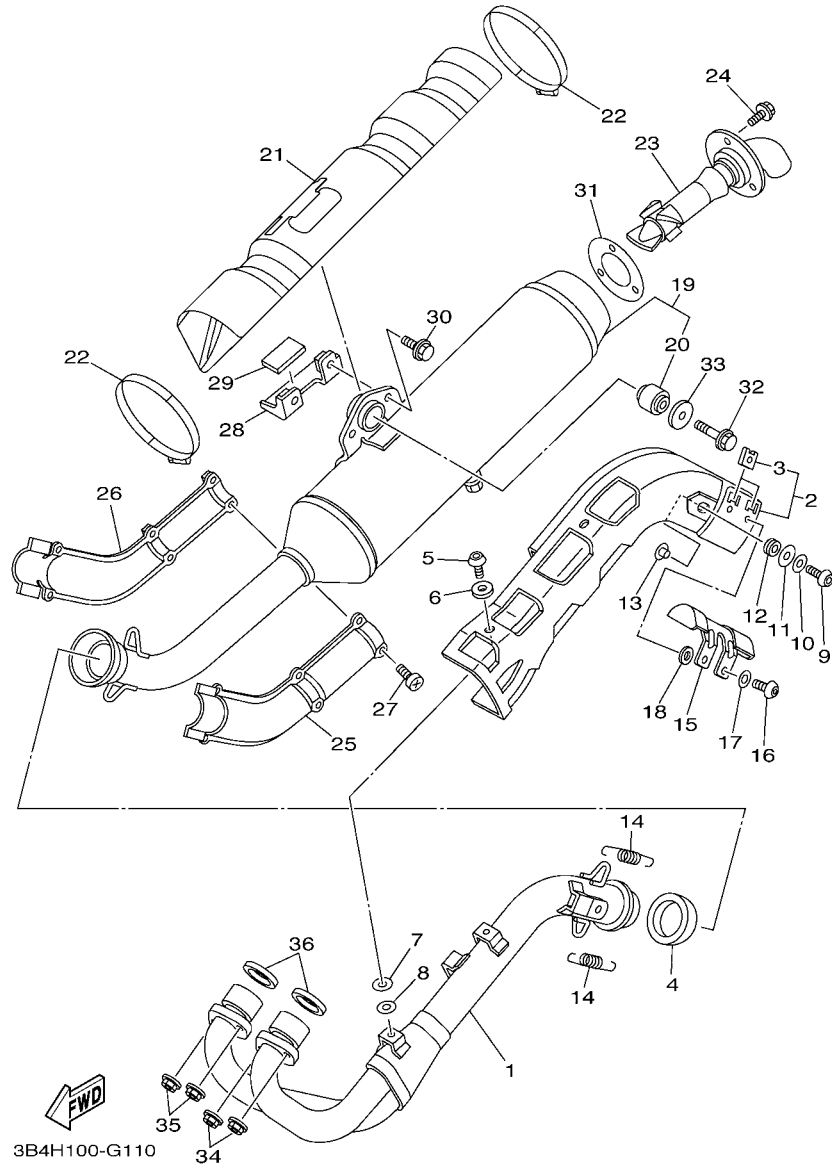
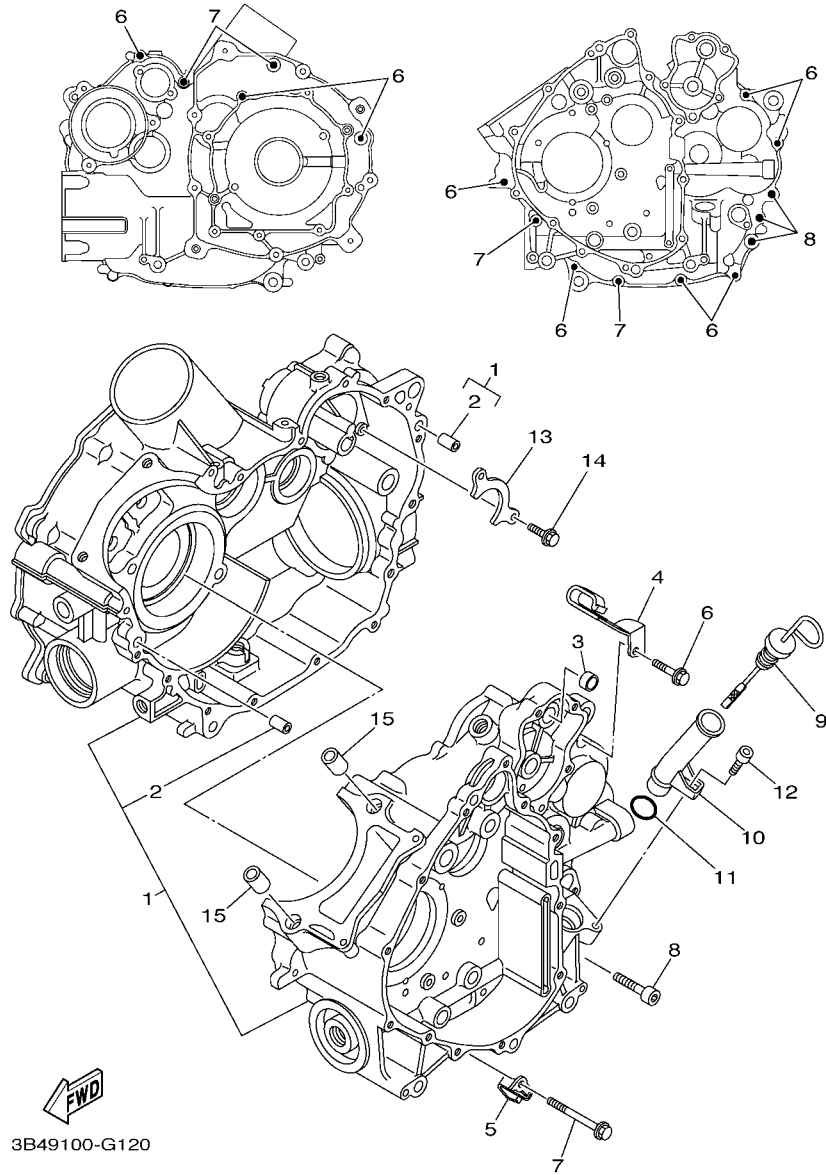

FIG. 11 EXHAUST

REF. NO.	PART NO.	DESCRIPTION	USA	CAN	EUR	REMARKS
1	3B4-14611-01	PIPE, EXHAUST 1	1	1	1	
2	3B4-14627-01	COVER, EXHAUST	1	1	1	
3	90183-060A2	.NUT, SPRING	2	2	2	
4	3B4-14714-10	GASKET, MUFFLER	1	1	1	
5	92012-06014	BOLT, BUTTON HEAD	3	3	3	
6	3B4-14617-00	WASHER	3	3	3	
7	90201-06019	WASHER, PLATE	3	3	3	
8	90201-05019	WASHER, PLATE	3	3	3	
9	92012-06020	BOLT, BUTTON HEAD	1	1	1	
10	90201-06036	WASHER, PLATE	1	1	1	
11	90201-06081	WASHER, PLATE	1	1	1	
12	90480-17001	GROMMET	1	1	1	
13	3B4-14638-00	COLLAR	1	1	1	
14	90506-30006	SPRING, TENSION	2	2	2	
15	3B4-14758-01	PROTECTOR, SILENCER	1	1	1	
16	92012-06012	BOLT, BUTTON HEAD	2	2	2	
17	92902-06200	WASHER	2	2	2	
18	90201-05015	WASHER, PLATE	2	2	2	
19	3B4-W1471-10	MUFFLER COMP. 1	1	1	1	
20	5KM-27414-01	.DAMPER	1	1	1	
21	3B4-14718-10	PROTECTOR, MUFFLER 1	1	1	1	
22	90450-99010	HOSE CLAMP ASSY	3	3	3	
23	3B4-14752-00	PIPE, OUTLET	1	1	1	
24	95022-06008	BOLT, FLANGE	3	3	3	
25	3B4-1471C-00	PROTECTOR ASSY 1	1	1	1	
26	3B4-1472C-00	PROTECTOR ASSY., 2	1	1	1	
27	98502-06016	SCREW, PAN HEAD	6	6	6	



3B49100-G120

FIG. 12 CRANKCASE

REF. NO.	PART NO.	DESCRIPTION	USA	CAN	EUR	REMARKS
1	3B4-15100-23	CRANKCASE ASSY	1	1	1	
2	99530-10116	.PIN, DOWEL	2	2	2	
3	3B4-18581-00	SPACER, CAM SHAFT	1	1	1	
4	90462-16003	CLAMP	1	1	1	
5	90462-08049	CLAMP	1	1	1	
6	95022-06030	BOLT, FLANGE	9	9	9	
7	95022-06060	BOLT, FLANGE	4	4	4	
8	91312-08040	BOLT	3	3	3	
9	3B4-15362-00	PLUG, OIL LEVEL	1	1	1	
10	3B4-15112-01	PIPE, OIL	1	1	1	
11	93210-21631	O-RING	1	1	1	
12	91312-06012	BOLT	1	1	1	
13	3B4-15388-00	PLATE, BEARING COVER	1	1	1	
14	90105-06082	BOLT, FLANGE	2	2	2	
15	99530-14016	PIN, DOWEL	2	2	2	

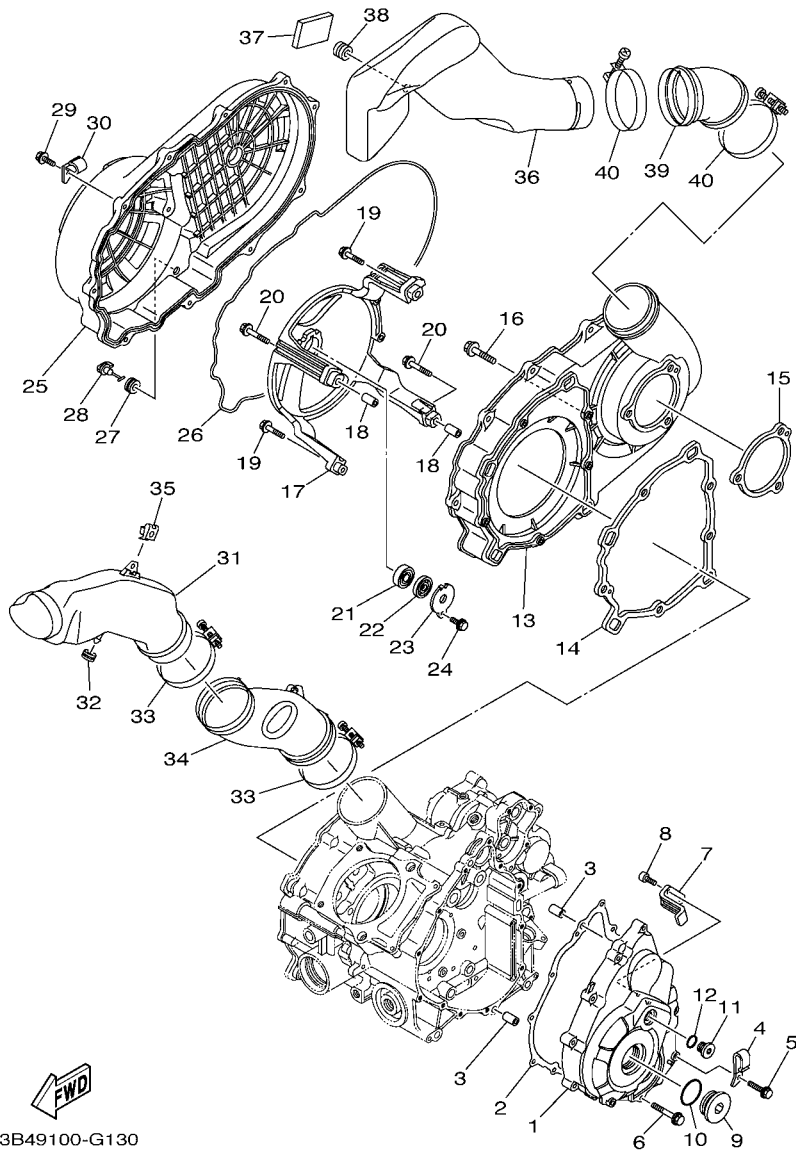

3B49100-G130

FIG. 13 CRANKCASE COVER 1

REF. NO.	PART NO.	DESCRIPTION	USA	CAN	EUR	REMARKS
1	3B4-15411-00	COVER, CRANKCASE 1	1	1	1	
2	3B4-15451-00	GASKET, CRANKCASE COVER 1	1	1	1	
3	99530-10116	PIN, DOWEL	2	2	2	
4	90461-08004	CLAMP	1	1	1	
5	95022-06030	BOLT, FLANGE	11	11	11	
6	95022-06050	BOLT, FLANGE	1	1	1	
7	3B4-15113-00	PLATE	1	1	1	
8	90110-05031	BOLT, HEXAGON SOCKET HEAD	2	2	2	
9	90340-36002	PLUG, STRAIGHT SCREW	1	1	1	
10	93210-357A3	O-RING	1	1	1	
11	90340-14011	PLUG, STRAIGHT SCREW	1	1	1	
12	93210-14369	O-RING	1	1	1	
13	3B4-15421-00	COVER, CRANKCASE 2	1	1	1	
14	3B4-15453-00	GASKET	1	1	1	
15	3B4-15315-00	SEAL, CRANKCASE	1	1	1	
16	95822-06030	BOLT, FLANGE	8	8	8	
17	3B4-15442-00	HOUSING, BEARING	1	1	1	
18	99530-10116	PIN, DOWEL	2	2	2	
19	95822-06030	BOLT, FLANGE	2	2	2	
20	95822-06040	BOLT, FLANGE	2	2	2	
21	93306-20120	BEARING	1	1	1	
22	93101-12168	OIL SEAL	1	1	1	
23	4WV-15381-00	PLATE, BEARING COVER	1	1	1	
24	95022-06016	BOLT, FLANGE	1	1	1	
25	3B4-15431-00	COVER, CRANKCASE 3	1	1	1	
26	3B4-15379-00	SEAL, CRANKCASE	1	1	1	
27	90480-13018	GROMMET	1	1	1	

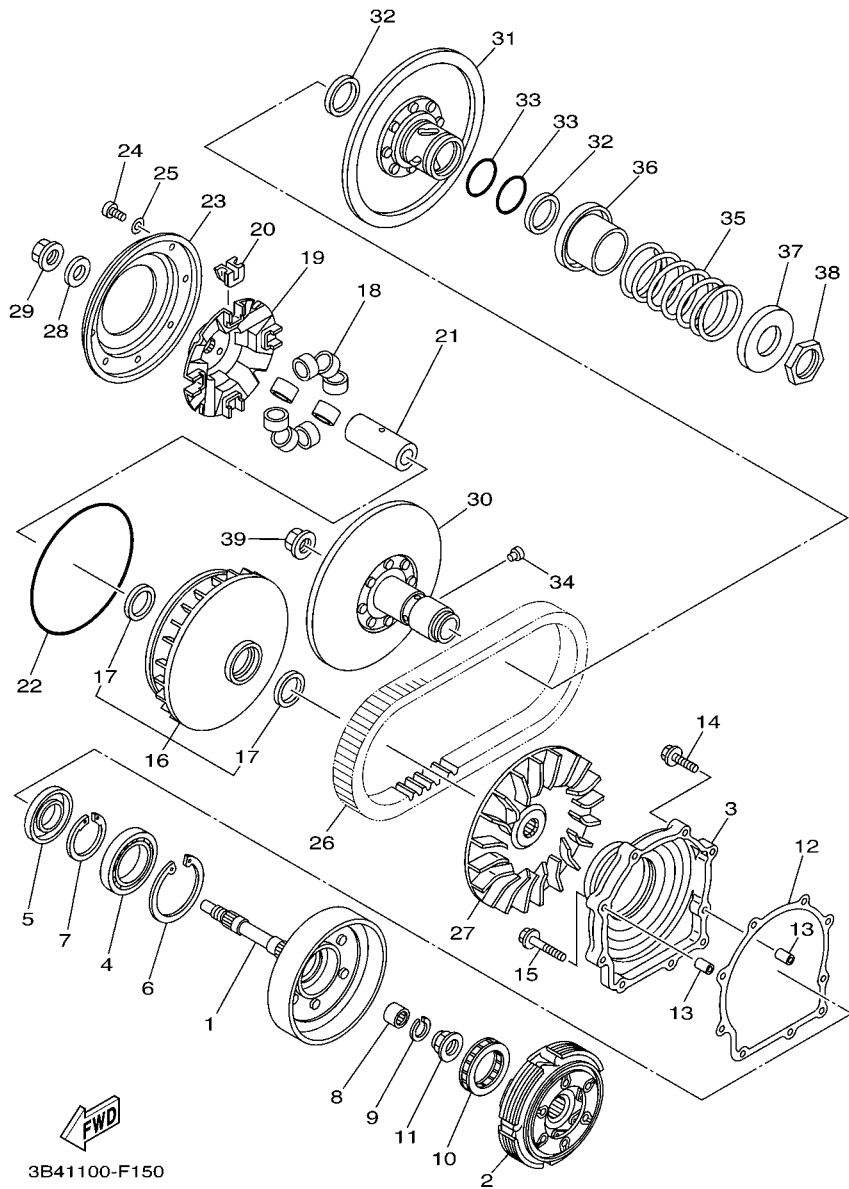
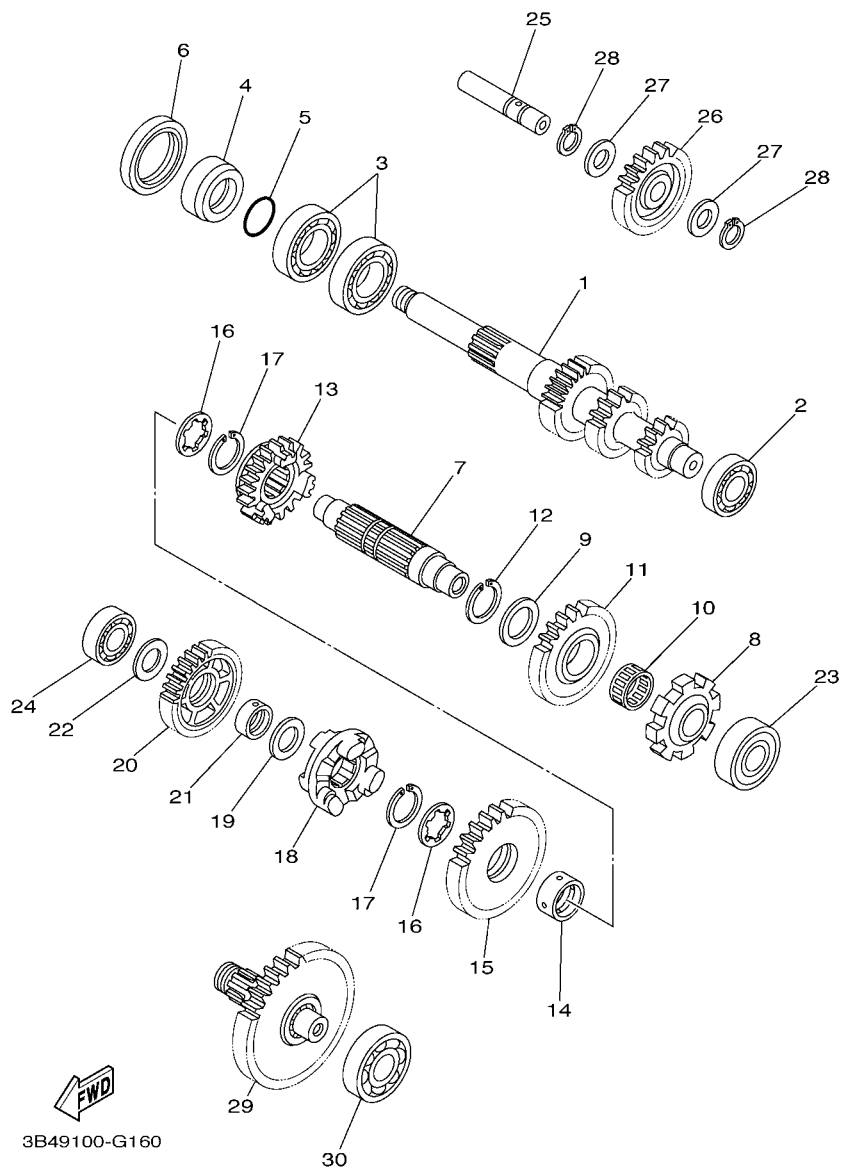

FIG. 15 CLUTCH

REF. NO.	PART NO.	DESCRIPTION	USA	CAN	EUR	REMARKS
1	3B4-16611-00	CLUTCH HOUSING COMP.	1	1	1	
2	3B4-16620-00	CLUTCH CARRIER ASSY	1	1	1	
3	3B4-15163-00	HOUSING, BEARING 1	1	1	1	
4	93316-01003	BEARING	1	1	1	
5	93102-35004	OIL SEAL	1	1	1	
6	99009-80500	CIRCLIP	1	1	1	
7	93410-46079	CIRCLIP	1	1	1	
8	93315-21813	BEARING	1	1	1	
9	93450-24062	CIRCLIP	1	1	1	
10	4SH-16664-00	BEARING, ONE WAY	1	1	1	
11	90179-22021	NUT	1	1	1	
12	3B4-15463-00	GASKET, COVER PINION 2	1	1	1	
13	99530-10116	PIN, DOWEL	2	2	2	
14	95022-06030	BOLT, FLANGE	7	7	7	
15	95022-06040	BOLT, FLANGE	2	2	2	
16	3B4-17606-00	PRIMARY SLIDING SHEAVE COMP.	1	1	1	
17	93101-35001	.OIL SEAL	2	2	2	
18	3B4-17632-00	WEIGHT	8	8	8	
19	3B4-17623-00	CAM	1	1	1	
20	3B4-17653-00	SLIDER	4	4	4	
21	3B4-17645-00	COLLAR	1	1	1	
22	93211-594A4	O-RING	1	1	1	
23	4WV-17639-10	STOPPER	1	1	1	
24	90157-04006	SCREW, PAN HEAD	8	8	8	
25	90201-047R9	WASHER, PLATE	8	8	8	
26	3B4-17641-00	V-BELT	1	1	1	
27	3B4-17611-00	SHEAVE, PRIMARY FIXED	1	1	1	

FIG. 16 TRANSMISSION



REF. NO.	PART NO.	DESCRIPTION	USA	CAN	EUR	REMARKS
1	3B4-17681-10	SHAFT, SECONDARY	1	1	1	
2	93306-00426	BEARING	1	1	1	
3	93306-07801	BEARING	2	2	2	
4	90387-26001	COLLAR	1	1	1	
5	93210-26001	O-RING	1	1	1	
6	93102-42004	OIL SEAL	1	1	1	
7	3B4-17421-00	AXLE, DRIVE	1	1	1	
8	3B4-17473-00	STOPPER	1	1	1	
9	90201-25290	WASHER, PLATE	1	1	1	
10	93310-32590	BEARING	1	1	1	
11	3B4-17253-00	GEAR, REVERSE WHEEL 2 (28T)	1	1	1	
12	93440-25084	CIRCLIP	1	1	1	
13	3B4-17582-00	GEAR, MIDDLE DRIVE (21T)	1	1	1	
14	90387-250R3	COLLAR	1	1	1	
15	3B4-17233-00	GEAR, LOW WHEEL (31T)	1	1	1	
16	90214-22007	WASHER, CLAW	2	2	2	
17	93440-25084	CIRCLIP	2	2	2	
18	3B4-17285-00	CLUTCH, DOG	1	1	1	
19	90201-20028	WASHER, PLATE	1	1	1	
20	3B4-17223-10	GEAR, HIGH WHEEL (29T)	1	1	1	
21	90387-20021	COLLAR	1	1	1	
22	90201-170U8	WASHER, PLATE	1	1	1	
23	93306-20464	BEARING	1	1	1	
24	93306-20309	BEARING	1	1	1	
25	3B4-17432-00	AXLE, IDLE	1	1	1	
26	3B4-17243-00	GEAR, REVERSE WHEEL 1 (23T)	1	1	1	
27	90201-150U6	WASHER, PLATE	2	2	2	

FIG. 16 TRANSMISSION

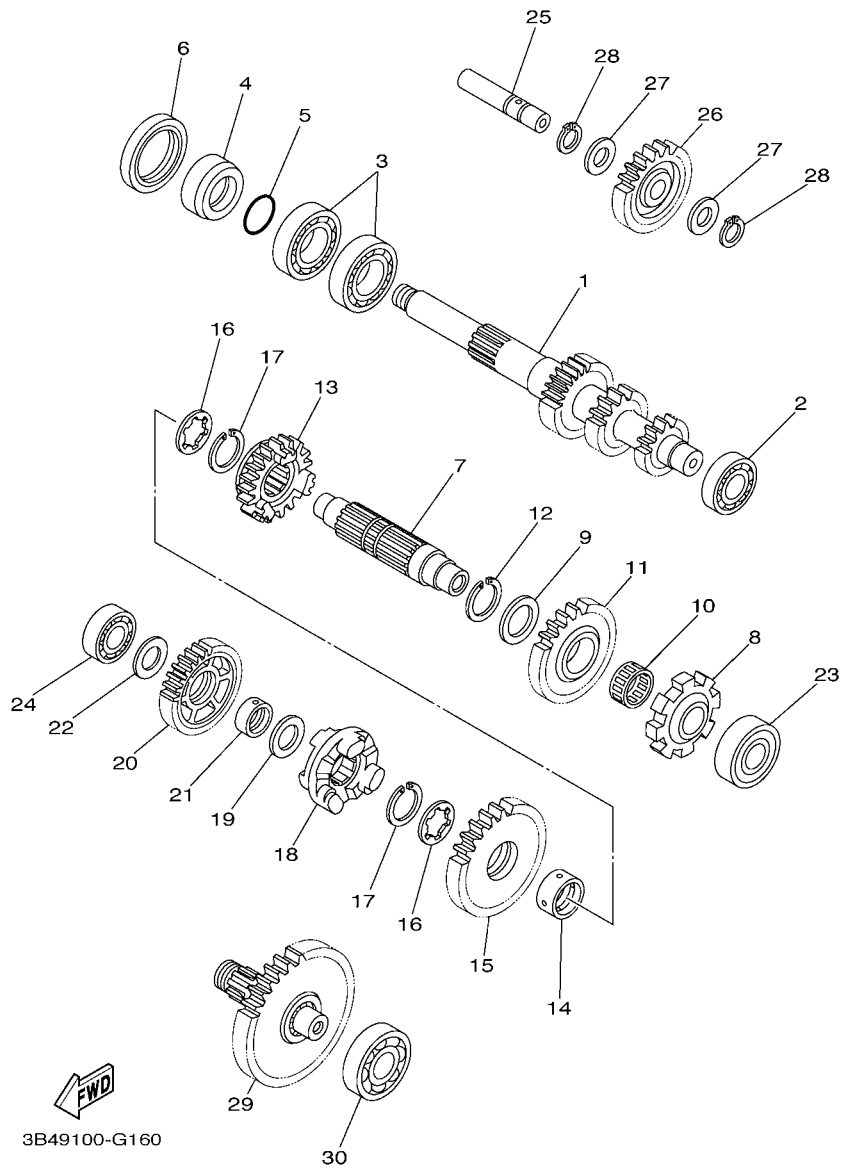

REF. NO.	PART NO.	DESCRIPTION	USA	CAN	EUR	REMARKS
28	93440-15012	CIRCLIP	2	2	2	
29	3B4-17520-00	DRIVE PINION ASSY (41T)	1	1	1	
30	93306-30438	BEARING	1	1	1	

FIG. 17 MIDDLE DRIVE GEAR

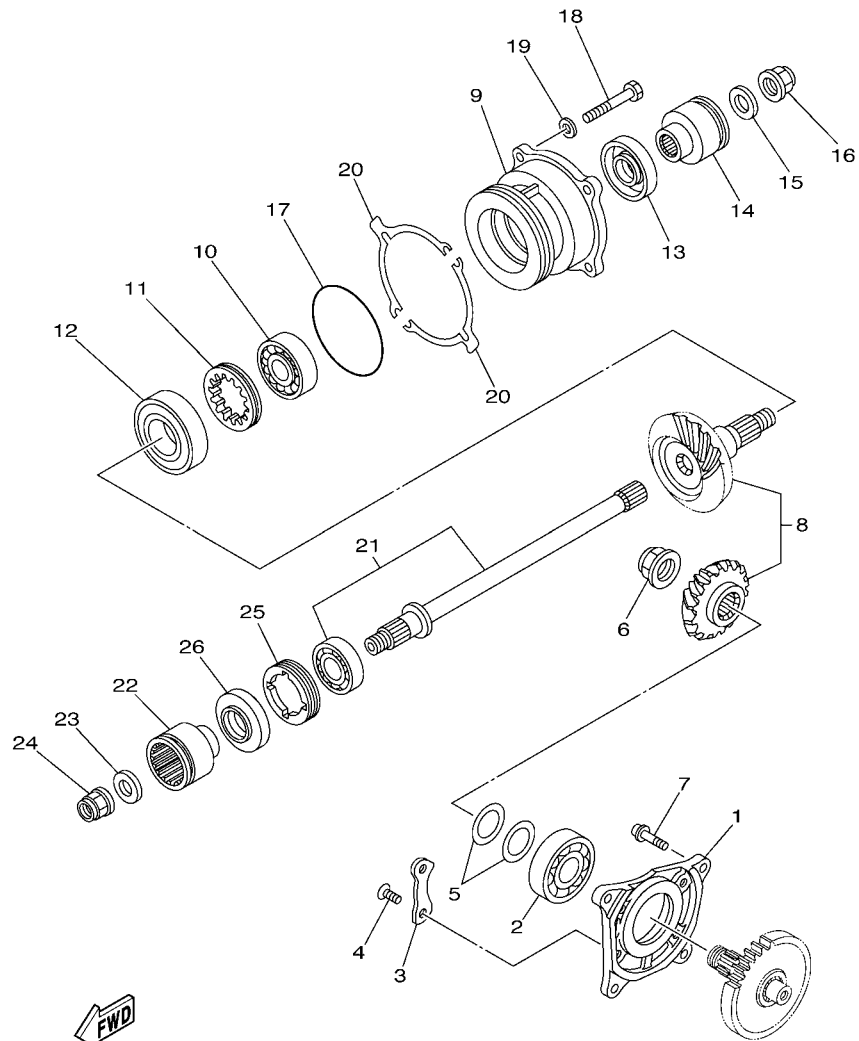

3B49100-G170

REF. NO.	PART NO.	DESCRIPTION	USA	CAN	EUR	REMARKS
1	3B4-17521-00	HOUSING, BEARING	1	1	1	
2	93306-30537	BEARING	1	1	1	
3	11H-15383-02	PLATE, BEARING COVER	2	2	2	
4	90149-08013	SCREW	4	4	4	
5	5KM-17531-50	SHIM, PINION (0.5T)	2	2	2	UR
5KM-17531-60	SHIM, PINION (0.55T)	2	2	2	UR	
5KM-17531-70	SHIM, PINION (0.6T)	2	2	2	UR	
5KM-17531-80	SHIM, PINION (0.7T)	2	2	2	UR	
5KM-17531-90	SHIM, PINION (0.8T)	2	2	2	UR	
5KM-17531-A0	SHIM, PINION (0.9T)	2	2	2	UR	
5KM-17531-B0	SHIM, PINION (1.0T)	2	2	2	UR	
6	90179-22013	NUT	1	1	1	
7	90110-08091	BOLT, HEXAGON SOCKET HEAD	4	4	4	
8	3B4-17530-00	PINION SET	1	1	1	
9	3B4-17551-00	HOUSING, BEARING	1	1	1	
10	93306-37206	BEARING	1	1	1	
11	90179-60001	NUT	1	1	1	
12	93306-20654	BEARING	1	1	1	
13	93102-30010	OIL SEAL	1	1	1	
14	3B4-17832-00	COUPLING	1	1	1	
15	90201-16021	WASHER, PLATE	1	1	1	
16	90179-16006	NUT	1	1	1	
17	93210-78544	O-RING	1	1	1	
18	97022-08030	BOLT	4	4	4	
19	92902-08600	WASHER, PLATE	4	4	4	
20	3B4-17531-00	SHIM, PINION (0.1T)	2	2	2	UR
3B4-17531-10	SHIM, PINION (0.15T)	2	2	2	UR	

FIG. 17 MIDDLE DRIVE GEAR

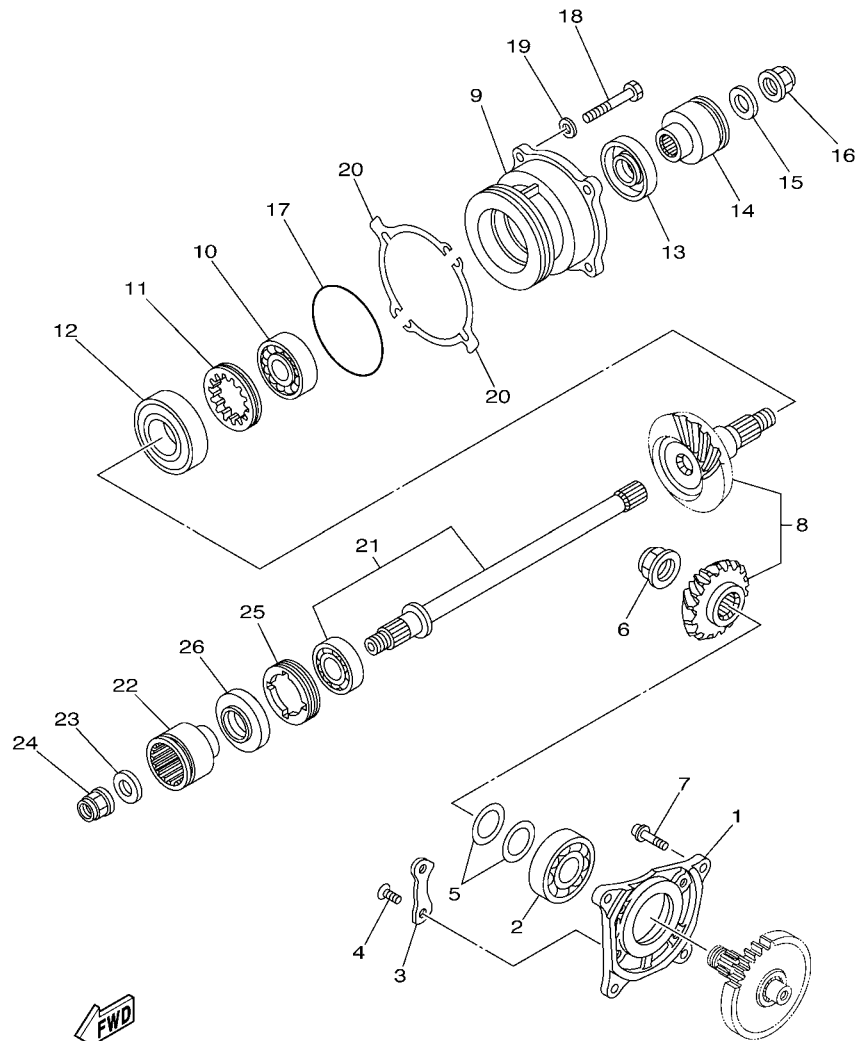

3B49100-G170

REF. NO.	PART NO.	DESCRIPTION	USA	CAN	EUR	REMARKS
20	3B4-17531-20	SHIM, PINION (0.2T)	2	2	2	UR
	3B4-17531-30	SHIM, PINION (0.3T)	2	2	2	UR
	3B4-17531-40	SHIM, PINION (0.4T)	2	2	2	UR
	3B4-17531-50	SHIM, PINION (0.5T)	2	2	2	UR
	3B4-17531-60	SHIM, PINION (0.6T)	2	2	2	UR
21	3B4-1755A-00	MIDDLE DRIVEN SHAFT ASSY	1	1	1	
22	3B4-17832-00	COUPLING	1	1	1	
23	90201-16021	WASHER, PLATE	1	1	1	
24	90179-16006	NUT	1	1	1	
25	90179-55660	NUT	1	1	1	
26	93102-30010	OIL SEAL	1	1	1	

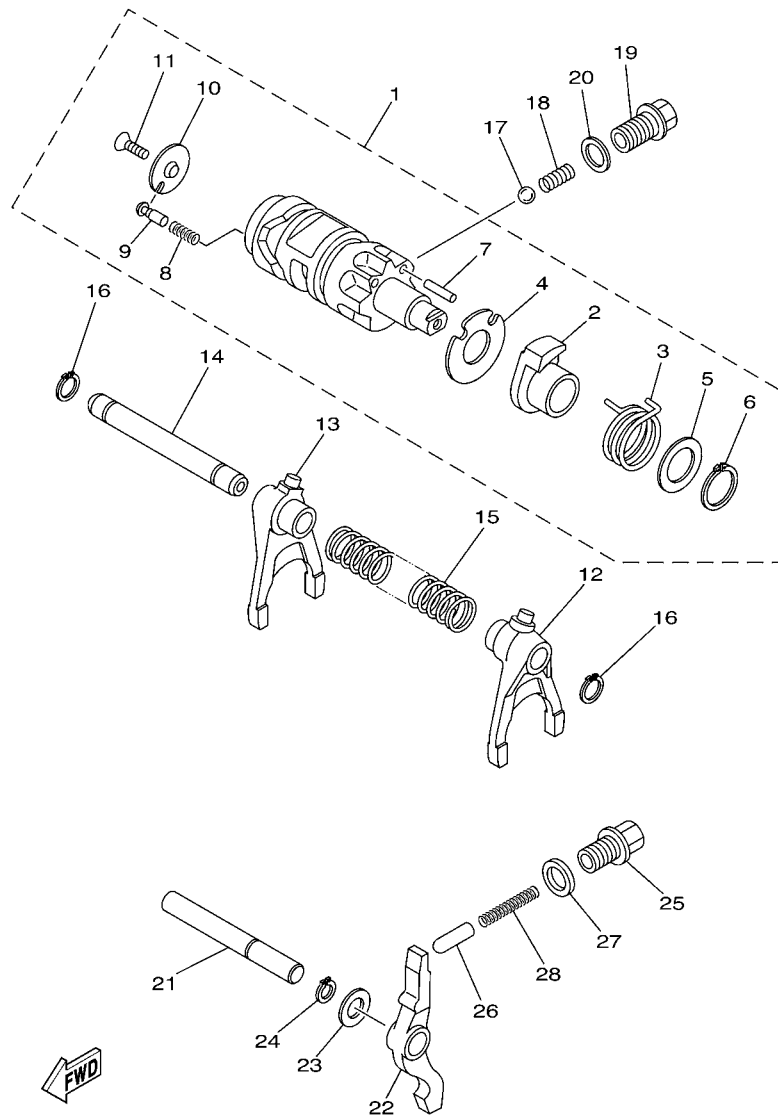

3B41100-F180

FIG. 18 SHIFT CAM & FORK

REF. NO.	PART NO.	DESCRIPTION	USA	CAN	EUR	REMARKS
1	3B4-18540-00	SHIFT CAM ASSY	1	1	1	
2	5KM-18171-00	.CAM, LEVER	1	1	1	
3	90508-32018	.SPRING, TORSION	1	1	1	
4	3B4-18331-00	.PLATE, SHIFT CAM	1	1	1	
5	90201-20792	.WASHER, PLATE	1	1	1	
6	93410-20038	.CIRCLIP	1	1	1	
7	93604-18100	.PIN, DOWEL	1	1	1	
8	90501-06022	.SPRING, COMPRESSION	1	1	1	
9	5KM-18542-00	.POINT, NEUTRAL	1	1	1	
10	4UN-18566-00	.PLATE, SIDE 2	1	1	1	
11	90149-05016	.SCREW	1	1	1	
12	3B4-18511-00	FORK, SHIFT 1	1	1	1	
13	3B4-18512-00	FORK, SHIFT 2	1	1	1	
14	3B4-18531-00	BAR, SHIFT FORK GUIDE 1	1	1	1	
15	90501-140A2	SPRING, COMPRESSION	1	1	1	
16	99009-12400	CIRCLIP	2	2	2	
17	93503-08007	BALL	1	1	1	
18	90501-10353	SPRING, COMPRESSION	1	1	1	
19	90105-14003	BOLT, FLANGE	1	1	1	
20	90430-14194	GASKET	1	1	1	
21	3B4-18318-00	SHAFT, SHIFTER	1	1	1	
22	3B4-18148-00	LEVER, STOPPER	1	1	1	
23	90201-127J6	WASHER, PLATE	1	1	1	
24	99009-12400	CIRCLIP	1	1	1	
25	90109-14002	BOLT	1	1	1	
26	1J7-18547-00	STOPPER, CAM	1	1	1	
27	90430-14043	GASKET	1	1	1	

FIG. 18 SHIFT CAM & FORK

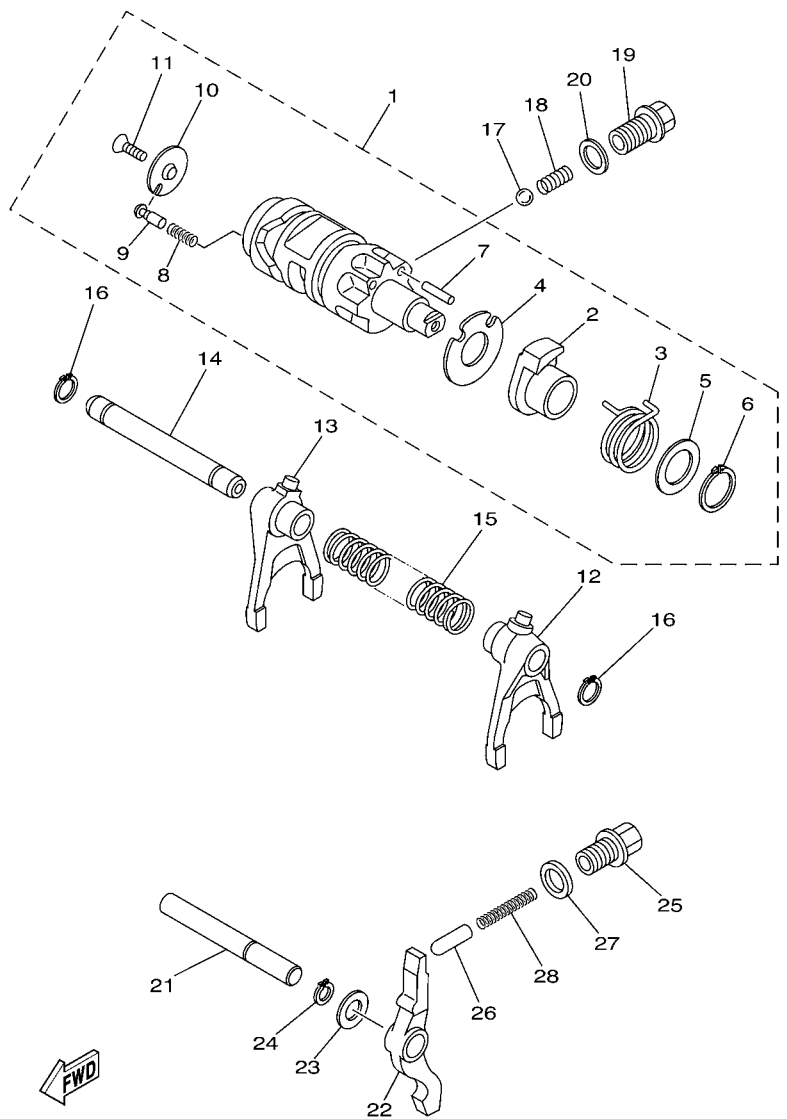

REF. NO.	PART NO.	DESCRIPTION	USA	CAN	EUR	REMARKS
28	90501-12004	SPRING, COMPRESSION	1	1	1	

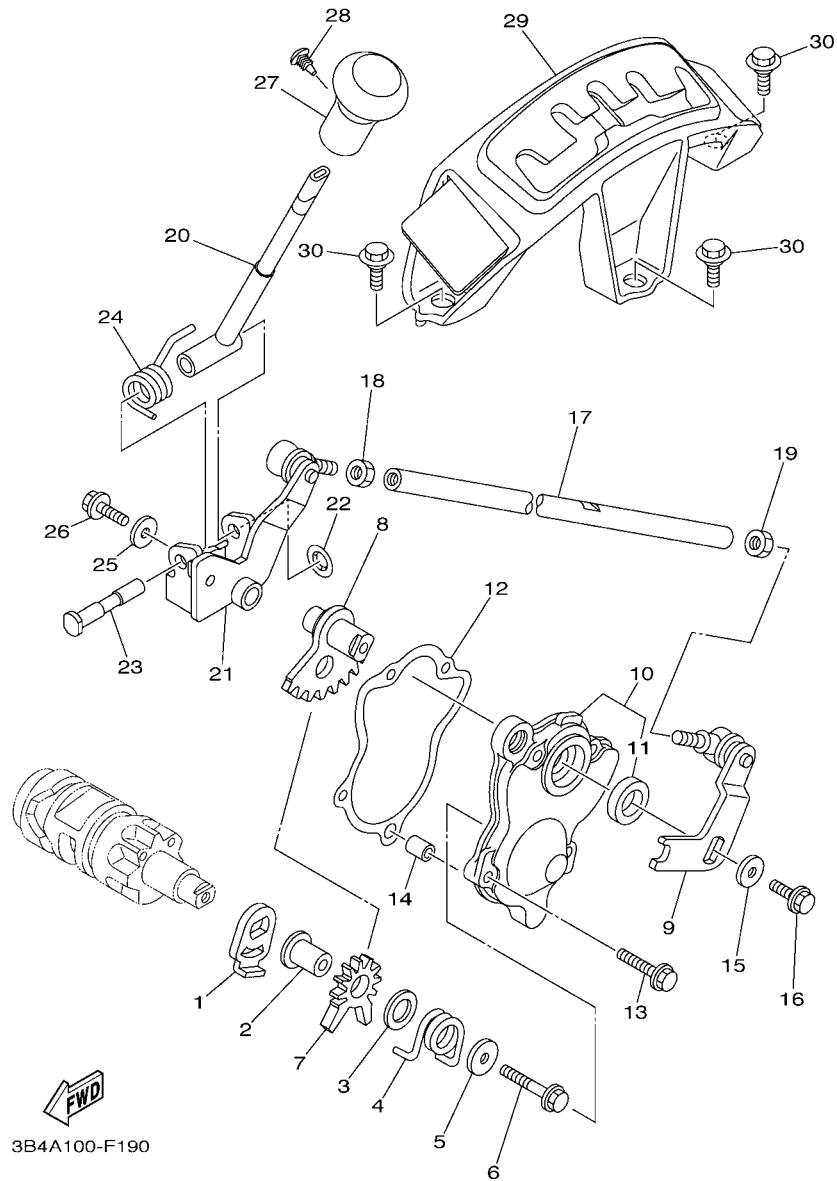

3B4A100-F190

FIG. 19 SHIFT SHAFT

REF. NO.	PART NO.	DESCRIPTION	USA	CAN	EUR	REMARKS
1	4SH-18198-00	LEVER	1	1	1	
2	90387-0613B	COLLAR	1	1	1	
3	90201-132G5	WASHER, PLATE	1	1	1	
4	90508-35764	SPRING, TORSION	1	1	1	
5	90201-06036	WASHER, PLATE	1	1	1	
6	95812-06035	BOLT, FLANGE	1	1	1	
7	5KM-18191-00	LEVER	1	1	1	
8	3B4-18103-10	SHIFT SHAFT COMP.	1	1	1	
9	3B4-18104-20	SHIFT GUIDE COMP.	1	1	1	
10	3B4-18380-00	SHIFTER BRKT. ASSY	1	1	1	
11	93102-15212	.OIL SEAL	1	1	1	
12	3B4-18146-00	GASKET	1	1	1	
13	95022-06020	BOLT, FLANGE	4	4	4	
14	99530-08012	PIN, DOWEL	1	1	1	
15	90201-06036	WASHER, PLATE	1	1	1	
16	95812-06016	BOLT, FLANGE	1	1	1	
17	3B4-18115-00	ROD, SHIFT	1	1	1	
18	90170-08358	NUT	1	1	1	
19	95302-08700	NUT	1	1	1	
20	3B4-18190-01	LEVER COMP. 1	1	1	1	
21	3B4-18169-10	ARM, SHIFT 2	1	1	1	
22	90183-080A1	NUT, SPRING	1	1	1	
23	3B4-18125-00	SHAFT, SHIFT	1	1	1	
24	3B4-18196-00	SPRING, RETURN	1	1	1	
25	90201-06036	WASHER, PLATE	1	1	1	
26	95812-06016	BOLT, FLANGE	1	1	1	
27	3B4-18174-01	KNOB, SHIFT LEVER	1	1	1	

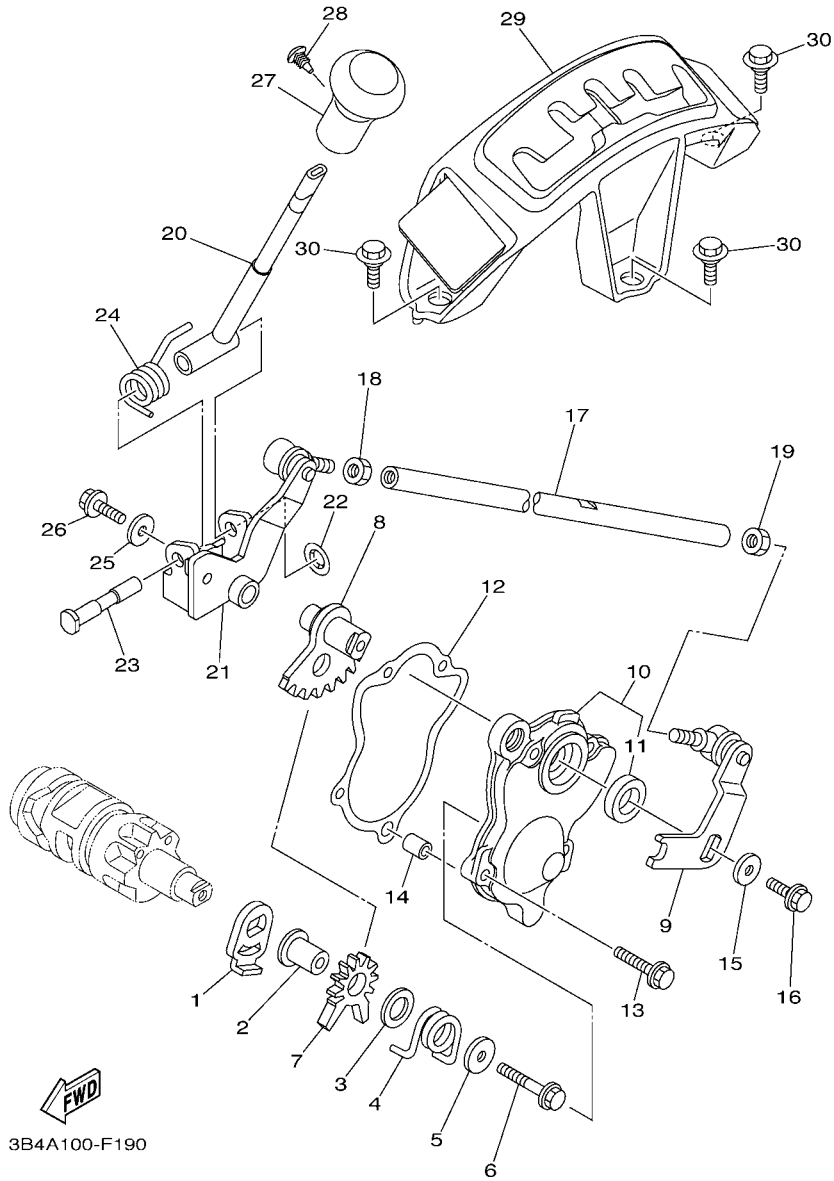
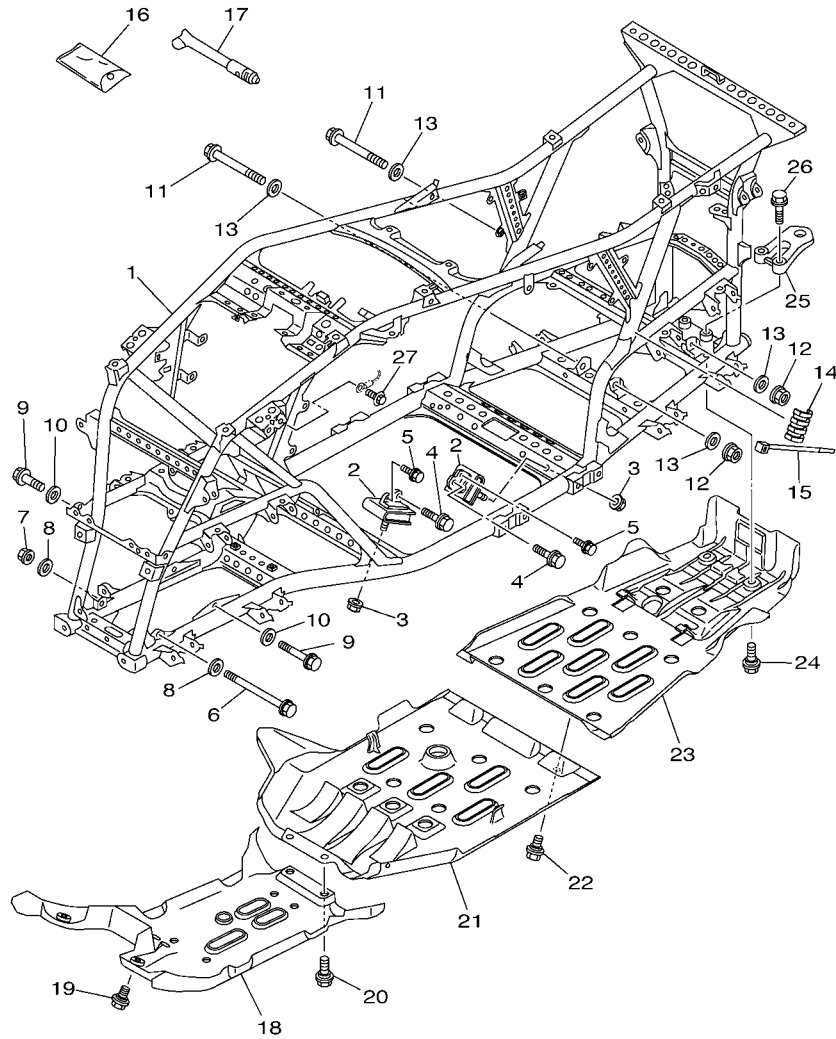

FIG. 19 SHIFT SHAFT

REF. NO.	PART NO.	DESCRIPTION	USA	CAN	EUR	REMARKS
28	90269-05055	RIVET	1	1	1	
29	3B4-18160-00	SHIFT GUIDE ASSY	1	1	1	
30	90109-06172	BOLT	3	3	3	



3B49100-G200

FIG. 20 FRAME

REF. NO.	PART NO.	DESCRIPTION	USA	CAN	EUR	REMARKS
1	3B4-21110-20	FRAME COMP.	1	1		
	3B4-21110-30	FRAME COMP.			1	
2	3B4-21485-00	DAMPER, RUBBER 1	4	4	4	
3	95602-10200	NUT, U FLANGE	4	4	4	
4	95812-10035	BOLT, FLANGE	4	4	4	
5	90105-06639	BOLT, FLANGE	4	4	4	
6	90105-10219	BOLT, FLANGE	1	1	1	
7	90185-10011	NUT, SELF-LOCKING	1	1	1	
8	90201-10035	WASHER, PLATE	2	2	2	
9	90105-10237	BOLT, FLANGE	2	2	2	
10	90201-10035	WASHER, PLATE	2	2	2	
11	90105-10238	BOLT, FLANGE	2	2	2	
12	90185-10011	NUT, SELF-LOCKING	2	2	2	
13	90201-10035	WASHER, PLATE	4	4	4	
14	3B4-2113B-00	DAMPER	1	1	1	
15	90464-35132	CLAMP	1	1	1	
16	5TG-28100-00	TOOL KIT	1	1	1	
17	1NV-2811A-01	GAUGE, AIR	1	1	1	
18	3B4-2147A-00	GUARD, ENGINE 1	1	1	1	
19	90109-06202	BOLT	2	2	2	
20	90109-06214	BOLT	2	2	2	
21	3B4-2147E-00	GUARD, ENGINE 2	1	1	1	
22	90109-06214	BOLT	2	2	2	
23	3B4-2147F-00	GUARD, ENGINE 3	1	1	1	
24	90109-06202	BOLT	2	2	2	
25	3B4-28488-00	HOOK	1	1	1	
26	95812-10035	BOLT, FLANGE	2	2	2	

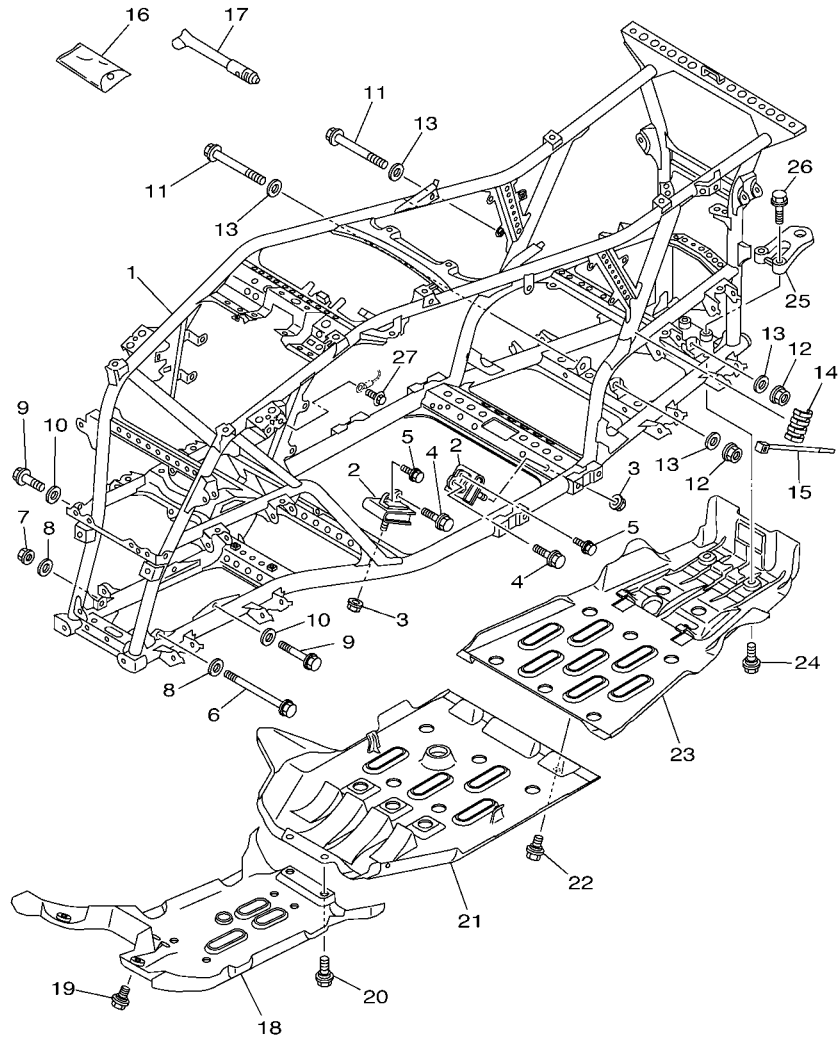

3B49100-G200

FIG. 20 FRAME

REF. NO.	PART NO.	DESCRIPTION	USA	CAN	EUR	REMARKS
27	95802-06012	BOLT, FLANGE	1	1	1	

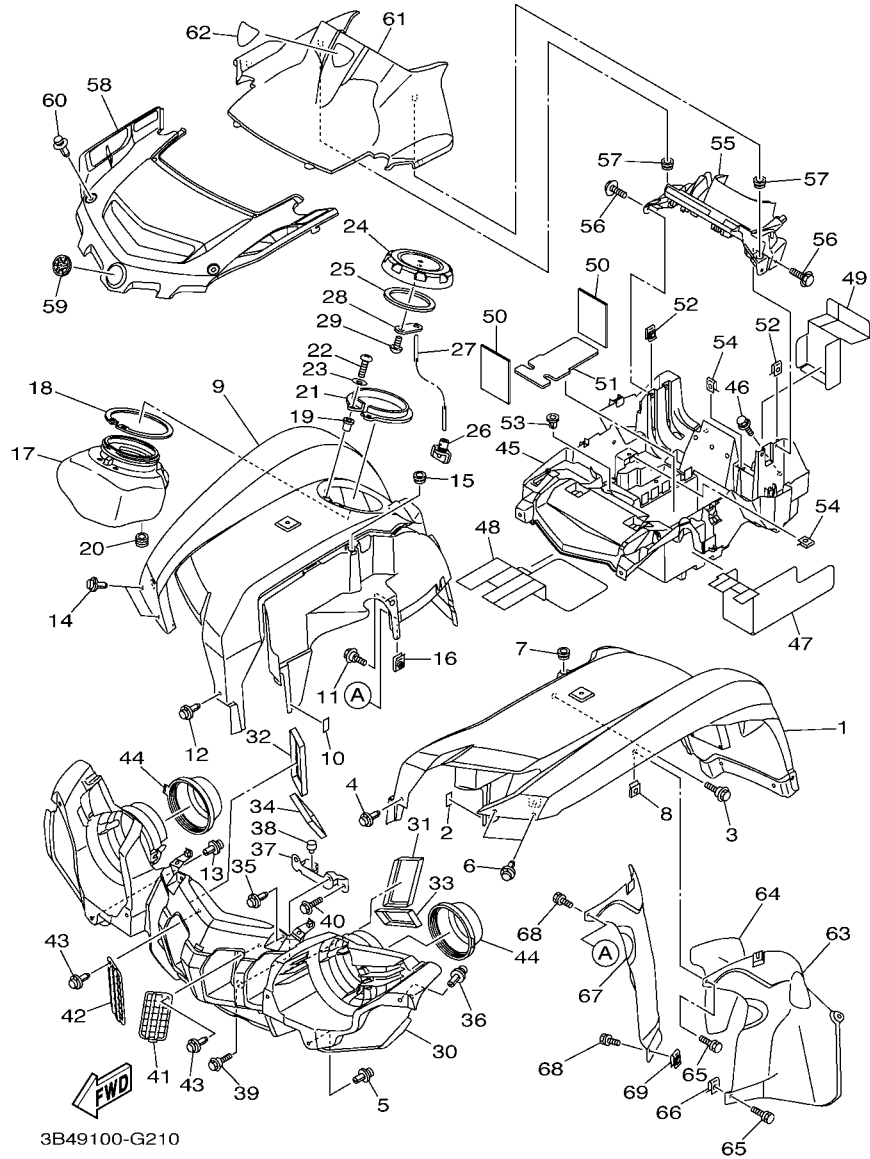

FIG. 21 FRONT FENDER

REF. NO.	PART NO.	DESCRIPTION	USA	CAN	EUR	REMARKS
1	3B4-W2151-D0	FRONT FENDER COMP.	1			
	3B4-W215C-D0	FRONT FENDER COMP.2		1		
	3B4-W215B-D0	FRONT FENDER COMP. 2			1	
2	3B4-21541-00	DAMPER 1	1	1	1	
3	90109-06172	BOLT	1	1	1	
4	90269-07012	RIVET	1	1	1	
5	90269-07077	RIVET	1	1	1	
6	90269-07012	RIVET	2	2	2	
7	90480-13398	GROMMET	1	1	1	
8	90183-06053	NUT, SPRING	1	1	1	
9	3B4-21556-D0	FENDER, FRONT 2	1		1	
	3B4-W215D-D0	FRONT FENDER COMP. 2		1		
10	3B4-21541-00	DAMPER 1	1	1	1	
11	90109-06172	BOLT	1	1	1	
12	90269-07012	RIVET	1	1	1	
13	90269-07077	RIVET	1	1	1	
14	90269-07012	RIVET	2	2	2	
15	90480-13398	GROMMET	1	1	1	
16	90183-06053	NUT, SPRING	1	1	1	
17	3B4-2838K-00	BOX 1	1	1	1	
18	3B4-2838M-00	SEAL, BOX 1	1	1	1	
19	90179-05523	NUT	2	2	2	
20	90480-13004	GROMMET	1	1	1	
21	3B4-2839N-00	HOLDER	1	1	1	
22	98502-05016	SCREW, PAN HEAD	2	2	2	
23	92902-05600	WASHER, PLATE	2	2	2	
24	3B4-2151B-00	CAP	1	1	1	

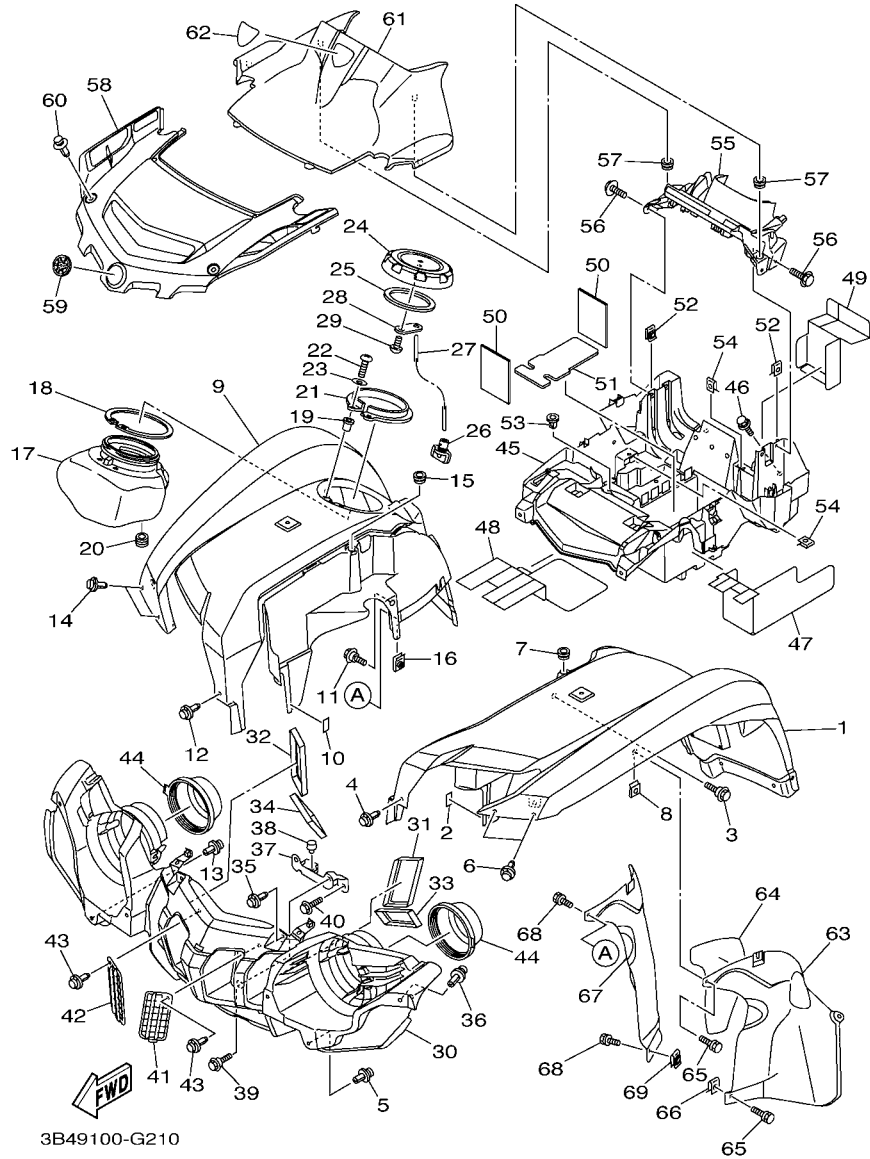

FIG. 21 FRONT FENDER

REF. NO.	PART NO.	DESCRIPTION	USA	CAN	EUR	REMARKS
25	3B4-28307-00	SEAL	1	1	1	
26	3B4-215A1-00	PLUG, DRAIN	1	1	1	
27	3B4-2845L-00	STOPPER, OPEN	1	1	1	
28	3B4-28487-00	PLATE 2	1	1	1	
29	97702-50512	SCREW, TAPPING	1	1	1	
30	3B4-28309-00	GRILLE, FRONT	1	1	1	
31	3B4-28217-00	DAMPER 1	1	1	1	
32	3B4-28227-00	DAMPER 2	1	1	1	
33	3B4-28237-00	DAMPER 3	1	1	1	
34	3B4-28247-00	DAMPER 4	1	1	1	
35	90269-07010	RIVET	2	2	2	
36	90269-07077	RIVET	2	2	2	
37	3B4-28332-00	STAY, LEG SHIELD	1	1	1	
38	5RU-24768-00	STOPPER	2	2	2	
39	90109-06172	BOLT	2	2	2	
40	95802-06012	BOLT, FLANGE	2	2	2	
41	3B4-2837N-00	GRILL, AIR INTAKE 1	1	1	1	
42	3B4-2837R-00	GRILL, AIR INTAKE 2	1	1	1	
43	90269-07077	RIVET	2	2	2	
44	3B4-28349-00	CAP	2	2	2	
45	3B4-21523-00	PLATE 1	1	1	1	
46	90119-06152	BOLT, WITH WASHER	3	3	3	
47	3B4-8253E-10	INSULATOR 1	1	1	1	
48	3B4-8253F-10	INSULATOR 2	1	1	1	
49	3B4-8254E-10	INSULATOR	1	1	1	
50	3B4-8233W-10	INSU.	2	2	2	
51	3B4-82122-00	SEAT, BATTERY	1	1	1	

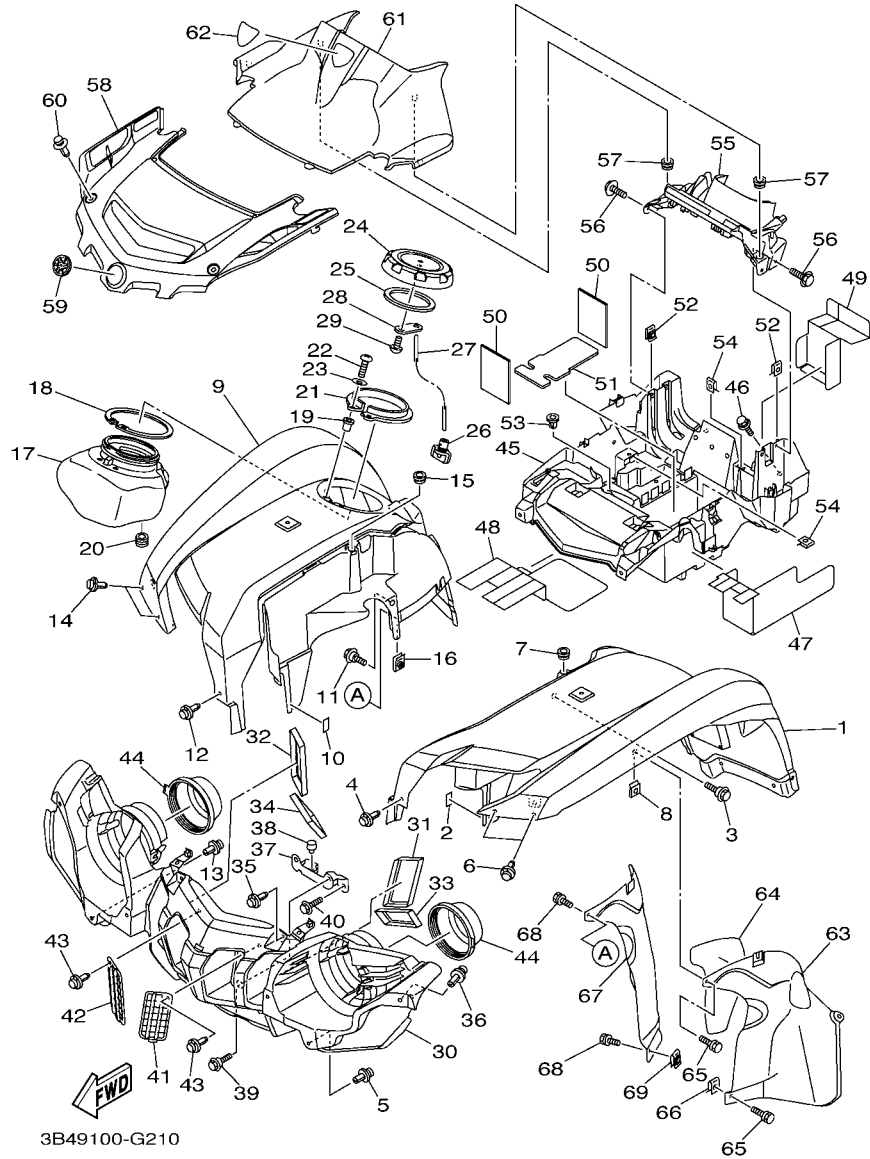
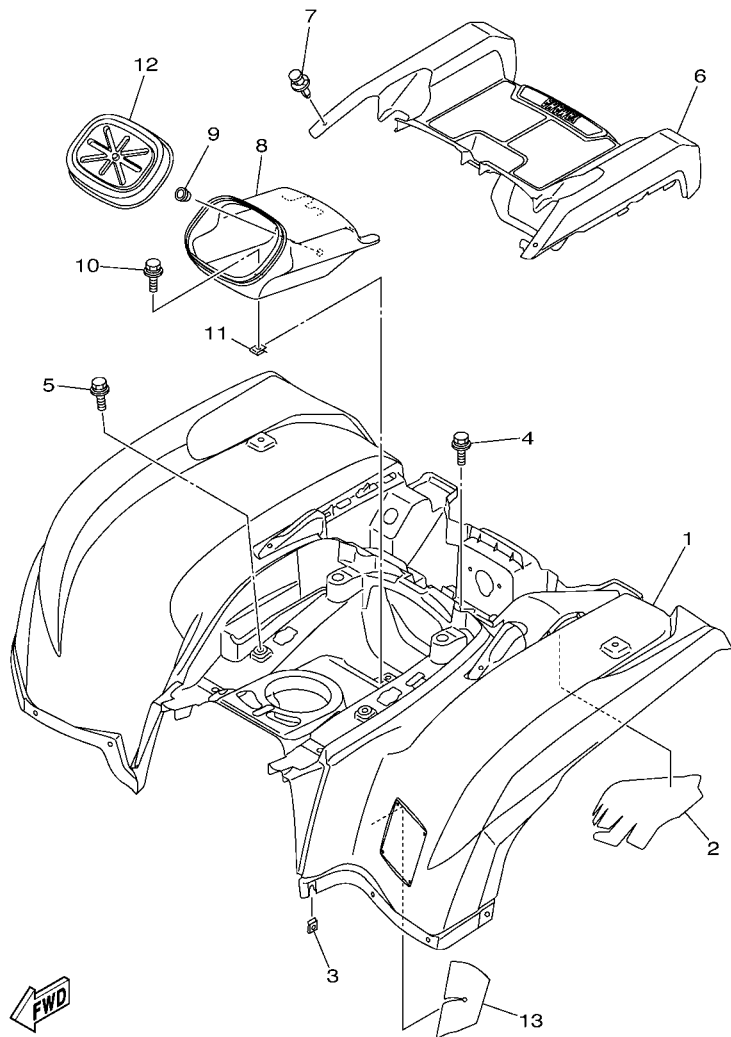

FIG. 21 FRONT FENDER

REF. NO.	PART NO.	DESCRIPTION	USA	CAN	EUR	REMARKS
52	90183-06053	NUT, SPRING	4	4	4	
53	90338-08226	PLUG	2	2	2	
54	90183-05008	NUT, SPRING	2	2	2	
55	3B4-2837L-00	PANEL, CONSOLE 1	1	1	1	
56	90119-06152	BOLT, WITH WASHER	4	4	4	
57	90480-13567	GROMMET	2	2	2	
58	3B4-23391-00	PANEL, FRONT	1	1	1	
59	5KM-2175B-00	TUNING FORK MARK	1	1	1	
60	90269-07010	RIVET	2	2	2	
61	3B4-28313-00	LID	1	1	1	
62	3B4-26232-00	EMBLEM 3D	1	1	1	
63	3B4-21552-00	FENDER, INNER	1	1	1	
64	3B4-21575-10	SEAL 1	1	1	1	
65	90119-06152	BOLT, WITH WASHER	2	2	2	
66	90183-06053	NUT, SPRING	1	1	1	
67	3B4-21553-00	FENDER, INNER 2	1	1	1	
68	90119-06152	BOLT, WITH WASHER	3	3	3	
69	90183-06053	NUT, SPRING	2	2	2	



3B49100-G220

FIG. 22 REAR FENDER

REF. NO.	PART NO.	DESCRIPTION	USA	CAN	EUR	REMARKS
1	3B4-W2161-D0	REAR FENDER COMP.	1			
	3B4-W216C-D0	REAR FENDER COMP.2		1		
	3B4-W216B-D0	REAR FENDER COMP.2			1	
2	3B4-21652-00	PROTECTOR	1	1	1	
3	90183-06053	NUT, SPRING	1	1	1	
4	90119-06152	BOLT, WITH WASHER	2	2	2	
5	90119-06152	BOLT, WITH WASHER	2	2	2	
6	3B4-21651-00	COVER, REAR FENDER	1	1	1	
7	90269-07010	RIVET	2	2	2	
8	3B4-2160E-00	BOX	1	1	1	
9	90338-09130	PLUG	1	1	1	
10	90119-06152	BOLT, WITH WASHER	1	1	1	
11	90183-06053	NUT, SPRING	1	1	1	
12	3B4-2160F-00	LID	1	1	1	
13	3B4-21669-00	SEAL	1	1	1	

FIG. 23 SIDE COVER

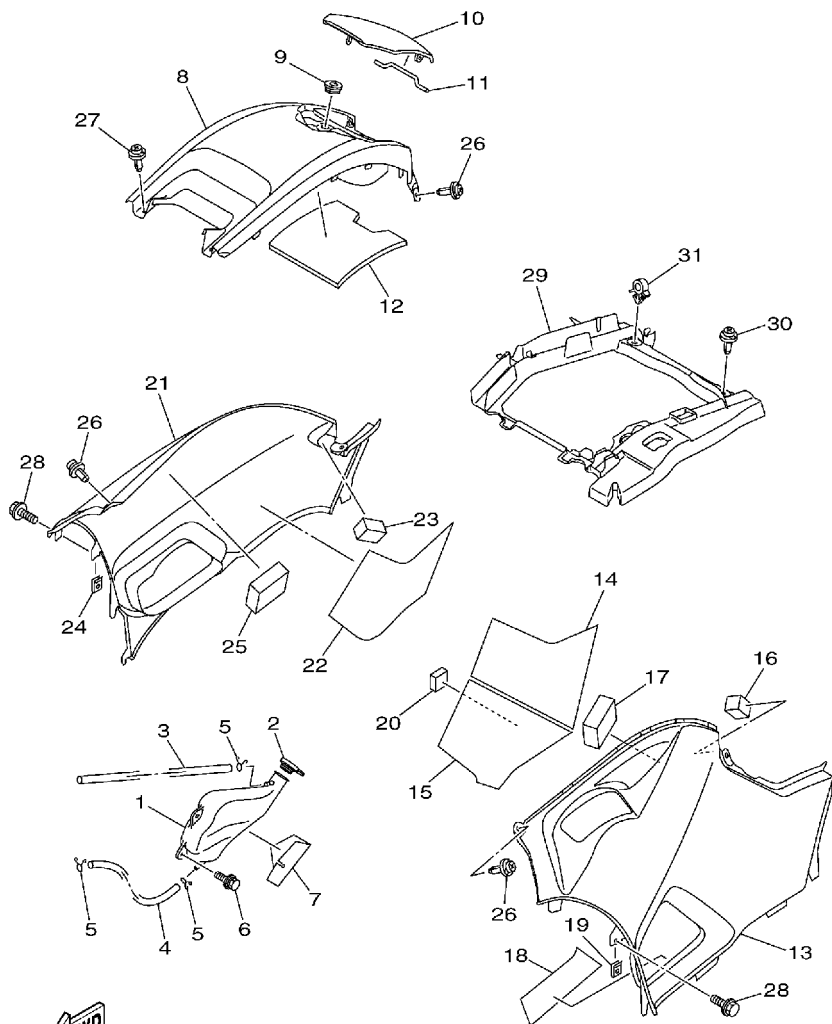

3B49100G2301



REF. NO.	PART NO.	DESCRIPTION	USA	CAN	EUR	REMARKS
1	3B4-21871-00	TANK, RECOVERY	1	1	1	
2	1S3-21875-00	CAP	1	1	1	
3	90445-09117	HOSE (L540)	1	1	1	
4	90445-09110	HOSE (L420)	1	1	1	
5	90467-08003	CLIP	3	3	3	
6	90119-06152	BOLT, WITH WASHER	2	2	2	
7	3B4-2176E-00	PLATE	1	1	1	
8	3B4-2171A-00	COVER, TOP	1	1	1	
9	90480-01558	GROMMET	1	1	1	
10	3B4-2177B-00	LID, COVER	1	1	1	
11	3B4-2177K-00	PIN, HINGE	1	1	1	
12	3B4-21747-00	DAMPER	1	1	1	
13	3B4-21711-D0	COVER, SIDE 1	1	1	1	
14	3B4-2174A-00	INSULATOR, SIDE COVER	1	1	1	
15	3B4-2173N-00	SEAL 4	1	1	1	
16	3B4-21717-00	DAMPER	1	1	1	
17	3B4-2174Y-00	DAMPER	1	1	1	
18	3B4-2173M-00	SEAL 3	1	1	1	
19	90183-06053	NUT, SPRING	1	1	1	
20	3B4-2177N-00	DAMPER, LOCATING 4	1	1	1	
21	3B4-21721-D0	COVER, SIDE 2	1	1	1	
22	3B4-2174T-00	INSULATOR, SIDE COVER 2	1	1	1	
23	3B4-21717-00	DAMPER	1	1	1	
24	90183-06053	NUT, SPRING	1	1	1	
25	3B4-2174Y-00	DAMPER	1	1	1	
26	90269-07076	RIVET	4	4	4	
27	90269-06081	RIVET	2	2	2	

FIG. 23 SIDE COVER

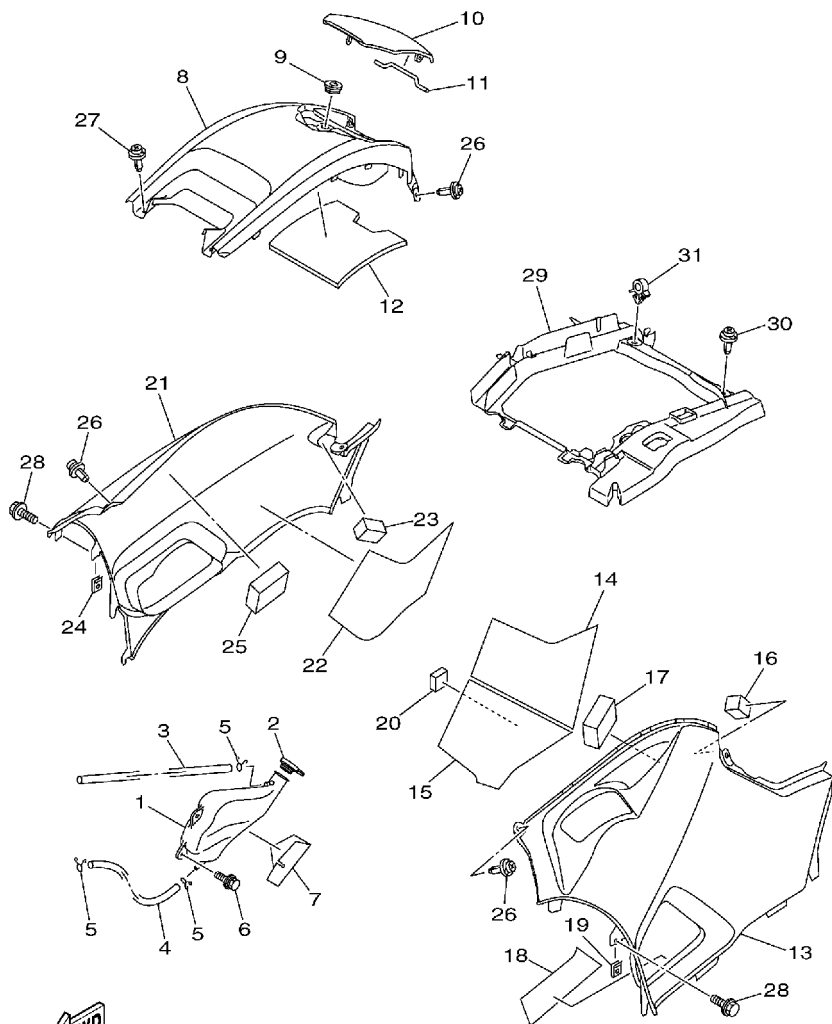

3B49100G2301

REF. NO.	PART NO.	DESCRIPTION	USA	CAN	EUR	REMARKS
28	90119-06152	BOLT, WITH WASHER	2	2	2	
29	3B4-2414H-00	DAMPER, PLATE 1	1	1	1	
30	90269-07010	RIVET	1	1	1	
31	90464-16012	CLAMP	1	1	1	

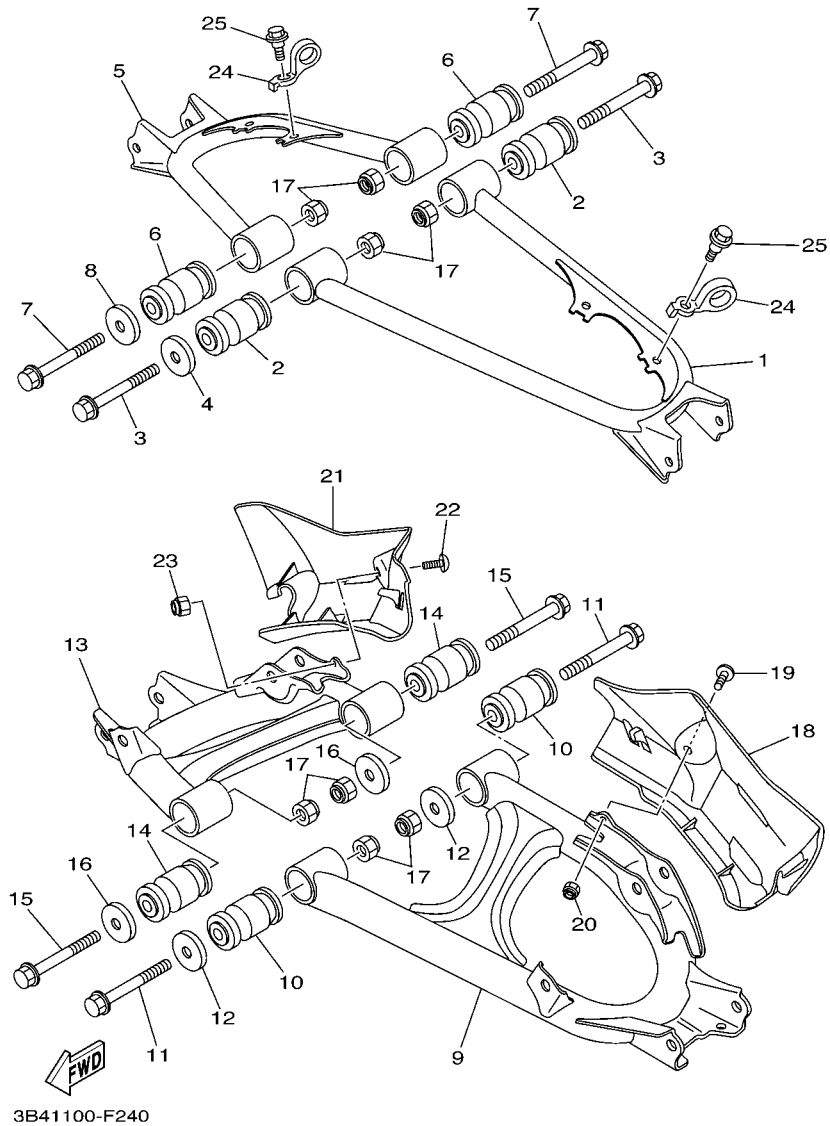

FIG. 24 REAR ARM

REF. NO.	PART NO.	DESCRIPTION	USA	CAN	EUR	REMARKS
1	3B4-22171-00	ARM, REAR 1	1	1		
	3B4-22171-11	ARM, REAR 1			1	
2	5KM-23526-10	BUSH	2	2	2	
3	90105-10222	BOLT, FLANGE	2	2	2	
4	5KM-22149-10	WASHER	1	1	1	
5	3B4-22172-00	ARM, REAR 2	1	1		
	3B4-22172-11	ARM, REAR 2			1	
6	5KM-23526-10	BUSH	2	2	2	
7	90105-10222	BOLT, FLANGE	2	2	2	
8	5KM-22149-10	WASHER	1	1	1	
9	3B4-2217M-00	ARM 1	1	1		
	3B4-2217M-11	ARM 1			1	
10	5KM-23526-10	BUSH	2	2	2	
11	90105-10222	BOLT, FLANGE	2	2	2	
12	5KM-22149-10	WASHER	2	2	2	
13	3B4-2217N-00	ARM 2	1	1		
	3B4-2217N-11	ARM 2			1	
14	5KM-23526-10	BUSH	2	2	2	
15	90105-10222	BOLT, FLANGE	2	2	2	
16	5KM-22149-10	WASHER	2	2	2	
17	90185-10012	NUT, SELF-LOCKING	8	8	8	
18	3B4-22128-00	COVER, THRUST 1	1	1	1	
19	90110-06200	BOLT, HEXAGON SOCKET HEAD	1	1	1	
20	95702-06300	NUT, NYLON	1	1	1	
21	3B4-22129-00	COVER, THRUST 2	1	1	1	
22	90110-06200	BOLT, HEXAGON SOCKET HEAD	1	1	1	
23	95702-06300	NUT, NYLON	1	1	1	

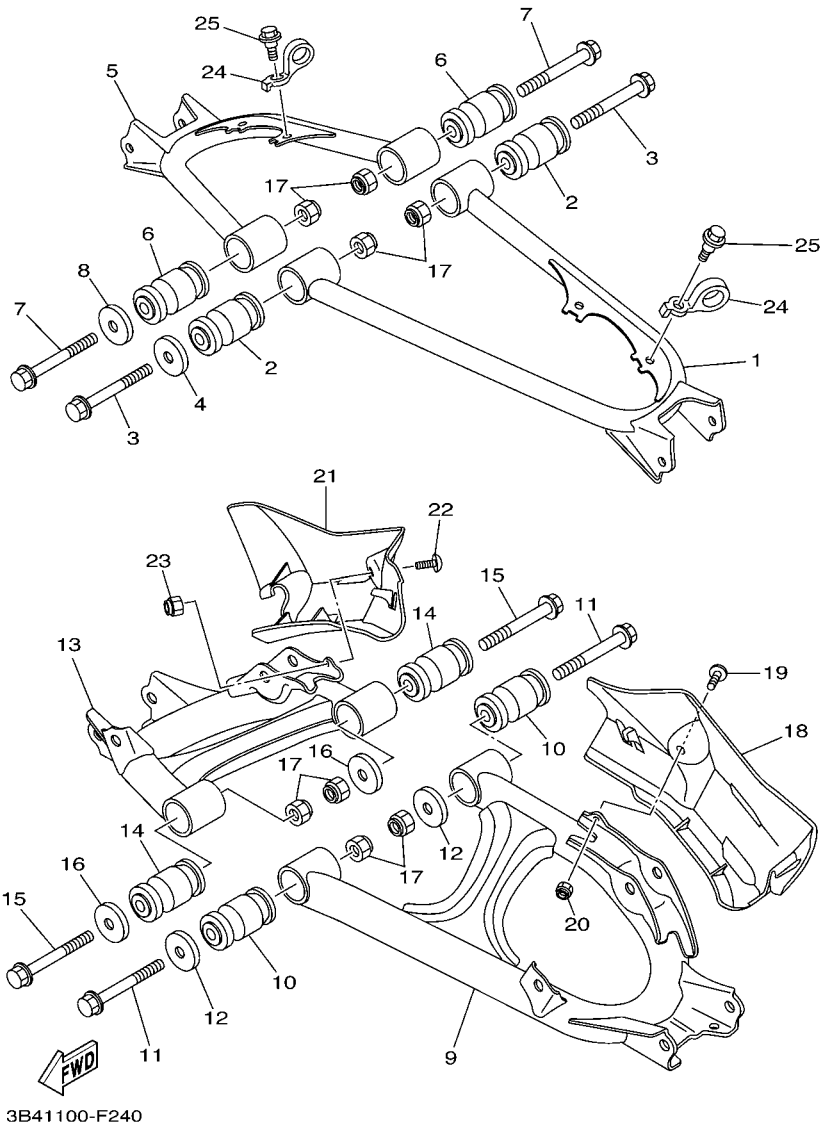
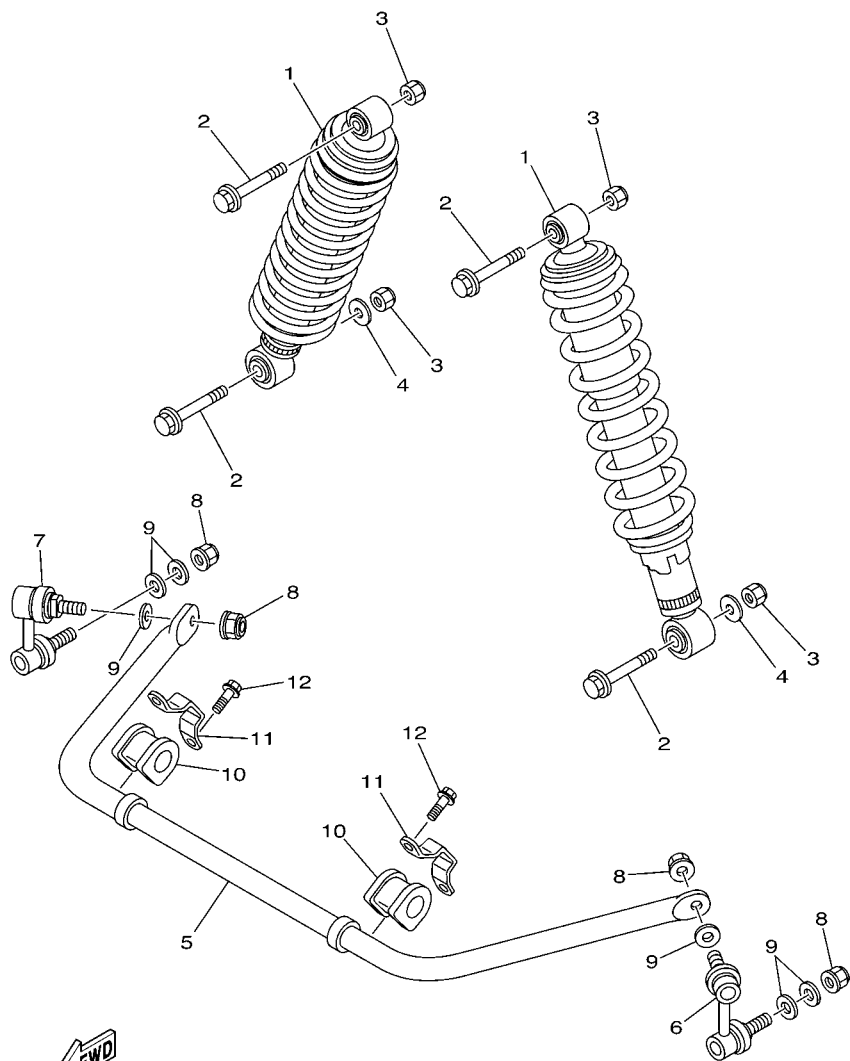

FIG. 24 REAR ARM

REF. NO.	PART NO.	DESCRIPTION	USA	CAN	EUR	REMARKS
24	3B4-25875-00	HOLDER, BRAKE HOSE 1	4	4	4	
25	90109-06172	BOLT	4	4	4	

FIG. 25 REAR SUSPENSION



3B41100-F250

REF. NO.	PART NO.	DESCRIPTION	USA	CAN	EUR	REMARKS
1	3B4-22210-01	SHOCK ABSORBER ASSY, REAR	2	2	2	
2	90105-10131	BOLT, FLANGE	4	4	4	
3	90185-10012	NUT, SELF-LOCKING	4	4	4	
4	90201-10035	WASHER, PLATE	2	2	2	
5	3B4-47491-00	BAR, STABILIZER	1	1	1	
6	5KM-2385L-01	JOINT, STABILIZER 1	1	1	1	
7	5KM-2385M-01	JOINT, STABILIZER 2	1	1	1	
8	95602-10200	NUT, U FLANGE	4	4	4	
9	90201-10035	WASHER, PLATE	6	6	6	
10	3B4-2386G-00	BUSH, STABILIZER FRONT	2	2	2	
11	3B4-2386H-00	COVER, STABILIZER FRONT	2	2	2	
12	95812-08014	BOLT, FLANGE	4	4	4	

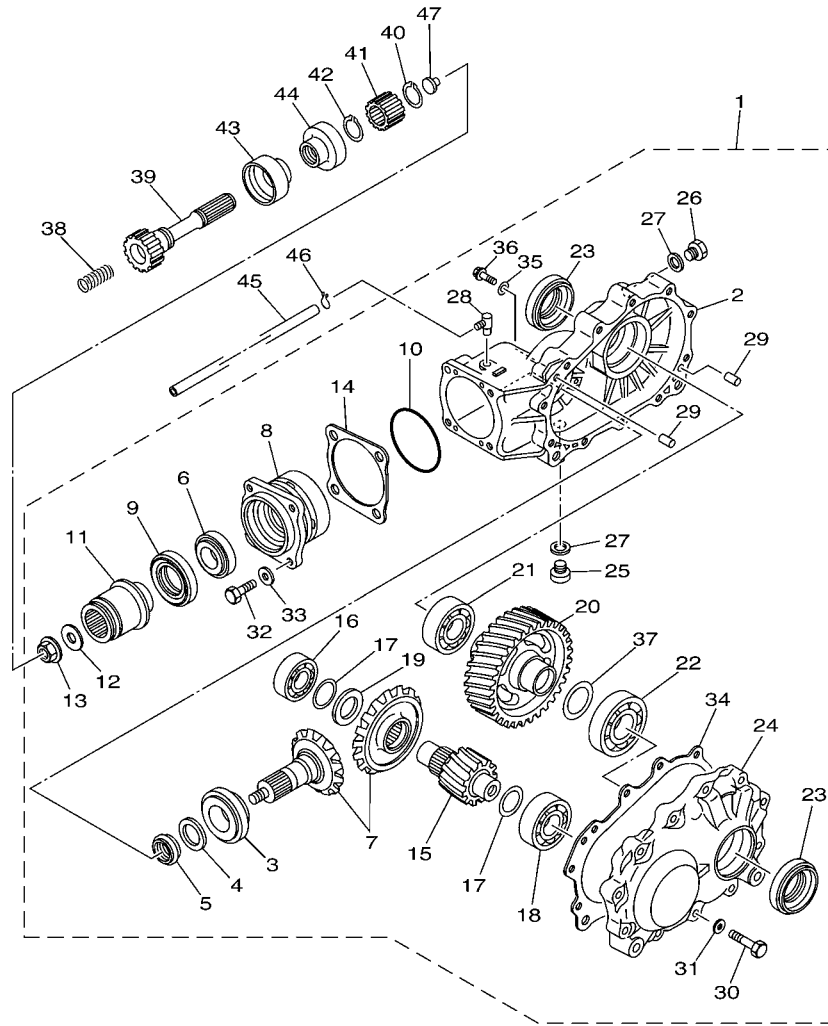

3B41100-F260

FIG. 26 DRIVE SHAFT

REF. NO.	PART NO.	DESCRIPTION	USA	CAN	EUR	REMARKS
1	3B4-46101-01	REAR AXLE GEAR CASE ASSY	1	1	1	
2	3B4-46151-00	.HOUSING, DRIVE SHAFT	1	1	1	
3	93332-00046	.BEARING	1	1	1	
4	90201-25634	.WASHER, PLATE	1	1	1	
5	3B4-46129-00	.SPACER, EXPANSION	1	1	1	
6	93332-00053	.BEARING	1	1	1	
7	3B4-461A0-00	.RING GEAR SET	1	1	1	
8	3B4-46144-00	.HOUSING, PINION BEARING	1	1	1	
9	93102-35009	.OIL SEAL	1	1	1	
10	93210-626A7	.O-RING	1	1	1	
11	3B4-46126-00	.COUPLING	1	1	1	
12	90201-12029	.WASHER, PLATE	1	1	1	
13	90179-12005	.NUT	1	1	1	
14	2HR-46127-00-25	.SHIM, DRIVE PISTON (0.25T)	1	1	1	UR
	2HR-46127-00-30	.SHIM, DRIVE PISTON (0.30T)	1	1	1	UR
	2HR-46127-00-35	.SHIM, DRIVE PISTON (0.35T)	1	1	1	UR
	2HR-46127-00-40	.SHIM, DRIVE PISTON (0.40T)	1	1	1	UR
	2HR-46127-00-45	.SHIM, DRIVE PISTON (0.45T)	1	1	1	UR
	2HR-46127-00-50	.SHIM, DRIVE PISTON (0.50T)	1	1	1	UR
15	3B4-46316-00	.GEAR, PINION 1	1	1	1	
16	93306-205U0	.BEARING	1	1	1	
17	3B4-46119-00	.SHIM, THRUST (0.25T)	2	2	2	UR
	3B4-46119-10	.SHIM, THRUST (0.30T)	2	2	2	UR
	3B4-46119-20	.SHIM, THRUST (0.35T)	2	2	2	UR
	3B4-46119-30	.SHIM, THRUST (0.40T)	2	2	2	UR
	3B4-46119-40	.SHIM, THRUST (0.45T)	2	2	2	UR
	3B4-46119-50	.SHIM, THRUST (0.50T)	2	2	2	UR

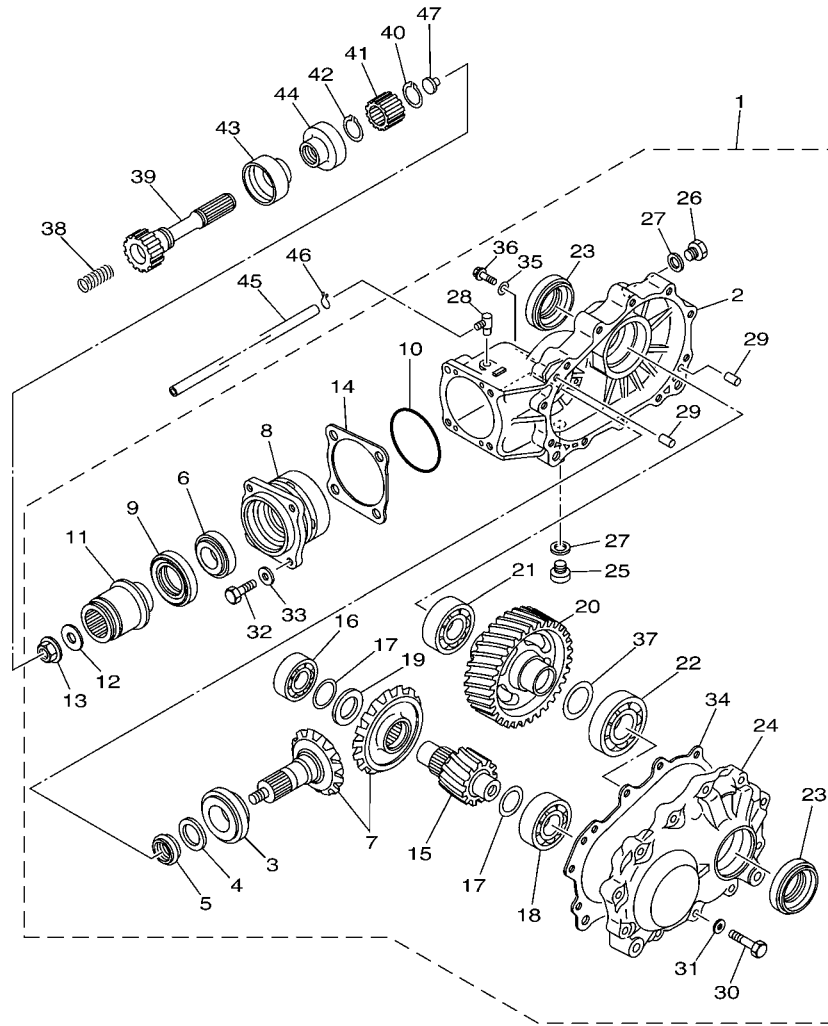



 3B41100-F260

FIG. 26 DRIVE SHAFT

REF. NO.	PART NO.	DESCRIPTION	USA	CAN	EUR	REMARKS
18	93306-30523	.BEARING	1	1	1	
19	3B4-4621F-00	.SHIM, THRUST (4.5T)	1	1	1	UR
	3B4-4621F-10	.SHIM, THRUST (4.8T)	1	1	1	UR
	3B4-4621F-20	.SHIM, THRUST (5.1T)	1	1	1	UR
	3B4-4621F-30	.SHIM, THRUST (5.4T)	1	1	1	UR
20	3B4-46326-00	.GEAR, WHEEL 1	1	1	1	
21	93306-00704	.BEARING	1	1	1	
22	93306-207U0	.BEARING	1	1	1	
23	93102-35009	.OIL SEAL	2	2	2	
24	3B4-46152-00	.HOUSING, BEARING	1	1	1	
25	90340-14002	.PLUG, STRAIGHT SCREW	1	1	1	
26	90340-14029	.PLUG, STRAIGHT SCREW	1	1	1	
27	214-11198-01	.GASKET	2	2	2	
28	5UG-15371-00	.BREATHER	1	1	1	
29	99530-10014	.PIN, DOWEL	2	2	2	
30	97022-08035	.BOLT	11	11	11	
31	92902-08600	.WASHER, PLATE	11	11	11	
32	97022-08025	.BOLT	4	4	4	
33	92902-08600	.WASHER, PLATE	4	4	4	
34	3B4-4631A-01	.GSKT., CASE	1	1	1	
35	90201-08087	.WASHER, PLATE	1	1	1	
36	95022-08012	.BOLT, FLANGE	1	1	1	
37	3B4-46344-00	.SHIM (0.25T)	1	1	1	UR
	3B4-46344-10	.SHIM (0.30T)	1	1	1	UR
	3B4-46344-20	.SHIM (0.35T)	1	1	1	UR
	3B4-46344-30	.SHIM (0.40T)	1	1	1	UR
	3B4-46344-40	.SHIM (0.45T)	1	1	1	UR

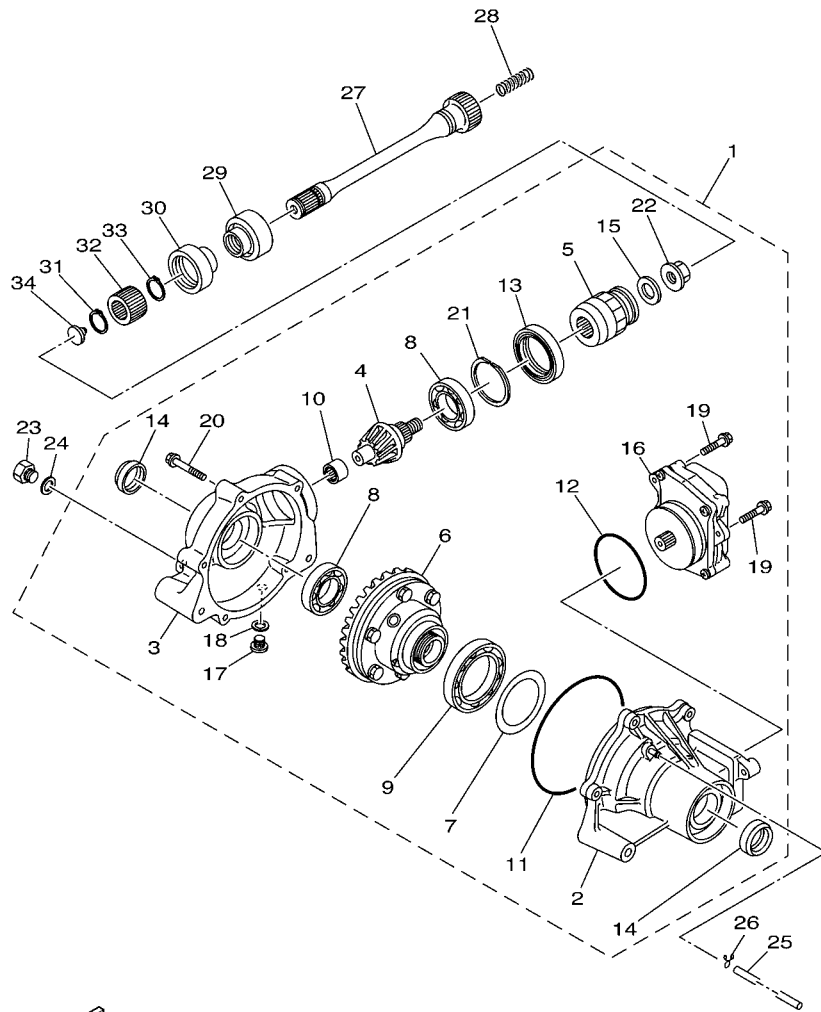
FIG. 27 FRONT DIFFERENTIAL



3B41100-F270

REF. NO.	PART NO.	DESCRIPTION	USA	CAN	EUR	REMARKS
1	3B4-46160-00	FRONT AXLE GEAR CASE COMP.	1	1	1	
2	3B4-46162-00	.HOUSING, BEARING 2	1	1	1	
3	3B4-46161-00	.HOUSING, SHAFT DRIVE 2	1	1	1	
4	3B4-46141-00	.PINION, DRIVE 2	1	1	1	
5	3B4-67839-00	.COUPLING	1	1	1	
6	3B4-46470-00	.LIMITED SLIP DIFF. ASSY	1	1	1	
7	3B4-46117-00	.SHIM, RING GEAR (0.1T)	1	1	1	UR
	3B4-46117-10	.SHIM, RING GEAR (0.2T)	1	1	1	UR
	3B4-46117-20	.SHIM, RING GEAR (0.3T)	1	1	1	UR
	3B4-46117-30	.SHIM, RING GEAR (0.4T)	1	1	1	UR
8	93306-00613	.BEARING	2	2	2	
9	3B4-46164-00	.BEARING 1	1	1	1	
10	3B4-46166-00	.BEARING 3	1	1	1	
11	3B4-46134-00	.O-RING 1	1	1	1	
12	3B4-46135-00	.O-RING 2	1	1	1	
13	93105-46001	.OIL SEAL	1	1	1	
14	3B4-46163-00	.SEAL,OIL 1	2	2	2	
15	3B4-47359-00	.WASHER	1	1	1	
16	3B4-4616A-00	.SERVO MOTOR COMP	1	1	1	
17	90340-10001	.PLUG, STRAIGHT SCREW	1	1	1	
18	90430-10003	.GASKET	1	1	1	
19	95812-06014	.BOLT, FLANGE	3	3	3	
20	95812-08040	.BOLT, FLANGE	5	5	5	
21	3B4-46142-00	.RING,HOLE SNAP 1	1	1	1	
22	4WV-46145-10	.NUT 1	1	1	1	
23	90340-14029	PLUG, STRAIGHT SCREW	1	1	1	
24	214-11198-01	GASKET	1	1	1	

FIG. 28 STEERING

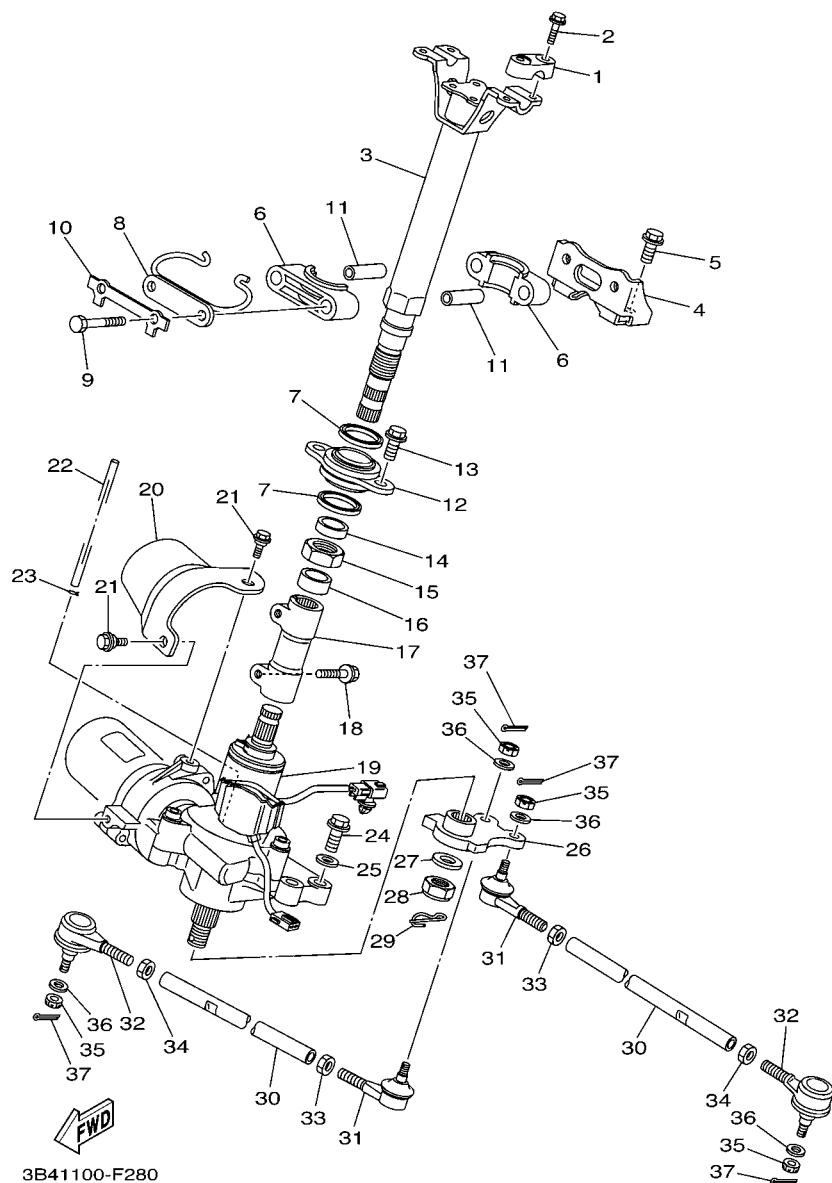

REF. NO.	PART NO.	DESCRIPTION	USA	CAN	EUR	REMARKS
1	8K1-23814-00	HOLDER, HANDLE	2	2	2	
2	95822-08030	BOLT, FLANGE	4	4	4	
3	3B4-23813-00	COLUMN, STEERING 2	1	1	1	
4	3B4-22517-00	SUPT., STRG. COLUMN	1	1	1	
5	90105-10204	BOLT, FLANGE	2	2	2	
6	1UY-23812-00	PLANE BEARING, STEERING	2	2	2	
7	93112-31011	OIL SEAL	2	2	2	
8	5GH-23868-00	BRACKET, STEERING LOWER	1	1	1	
9	97022-08060	BOLT	2	2	2	
10	1UY-23894-01	WASHER, LOCK 1	1	1	1	
11	90387-090R0	COLLAR	2	2	2	
12	3B4-23875-00	PLANE BEARING, STEERING LOWER	1	1	1	
13	90105-10204	BOLT, FLANGE	2	2	2	
14	90387-22014	COLLAR	1	1	1	
15	90185-22008	NUT, SELF-LOCKING	1	1	1	
16	90387-22591	COLLAR	1	1	1	
17	3B4-2381B-00	JOINT	1	1	1	
18	90119-08106	BOLT, WITH WASHER	2	2	2	
19	3B4-238B0-10	POWER STRG. ACTUATOR ASSY	1	1	1	
20	3B4-238B6-00	COVER, MOTOR	1	1	1	
21	90109-06172	BOLT	2	2	2	
22	90445-070F1	HOSE (L950)	1	1	1	
23	90467-07029	CLIP	1	1	1	
24	90105-08153	BOLT, FLANGE	4	4	4	
25	90201-08048	WASHER, PLATE	4	4	4	
26	3B4-23816-00	ARM, PITMAN	1	1	1	
27	90201-16021	WASHER, PLATE	1	1	1	

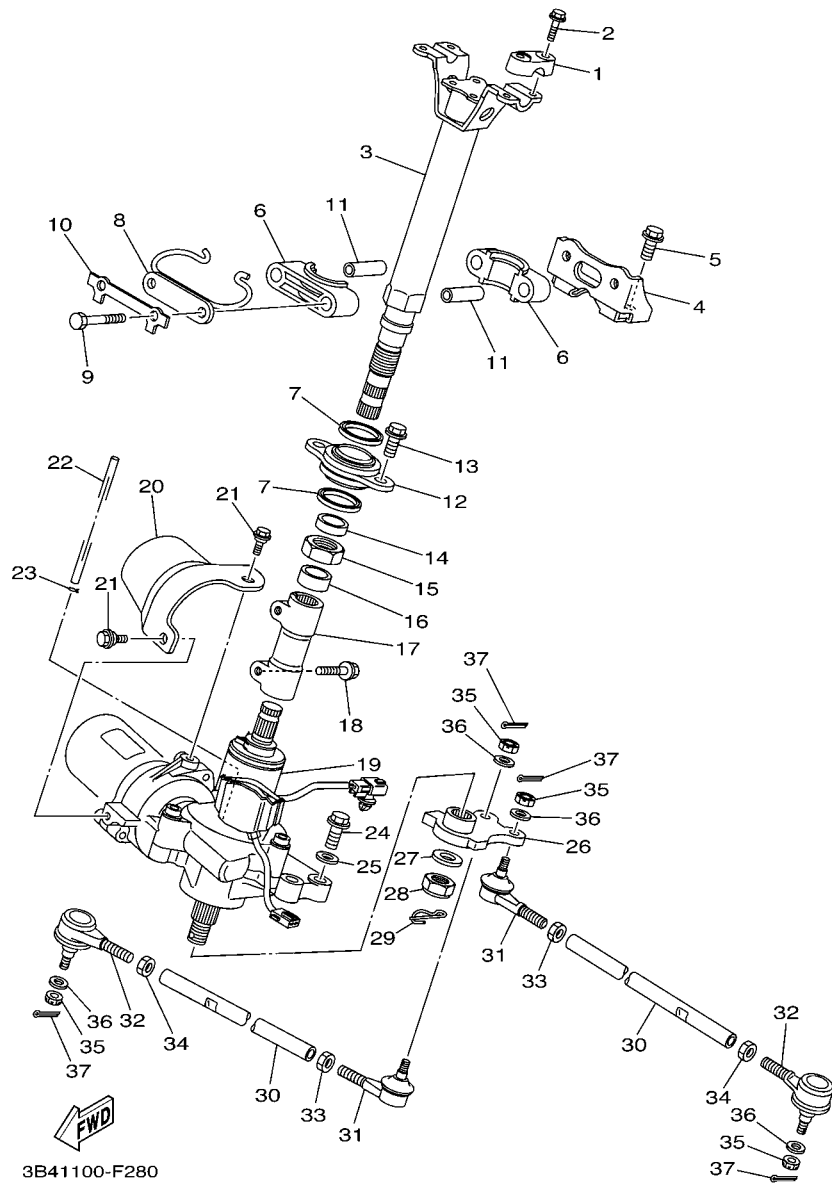
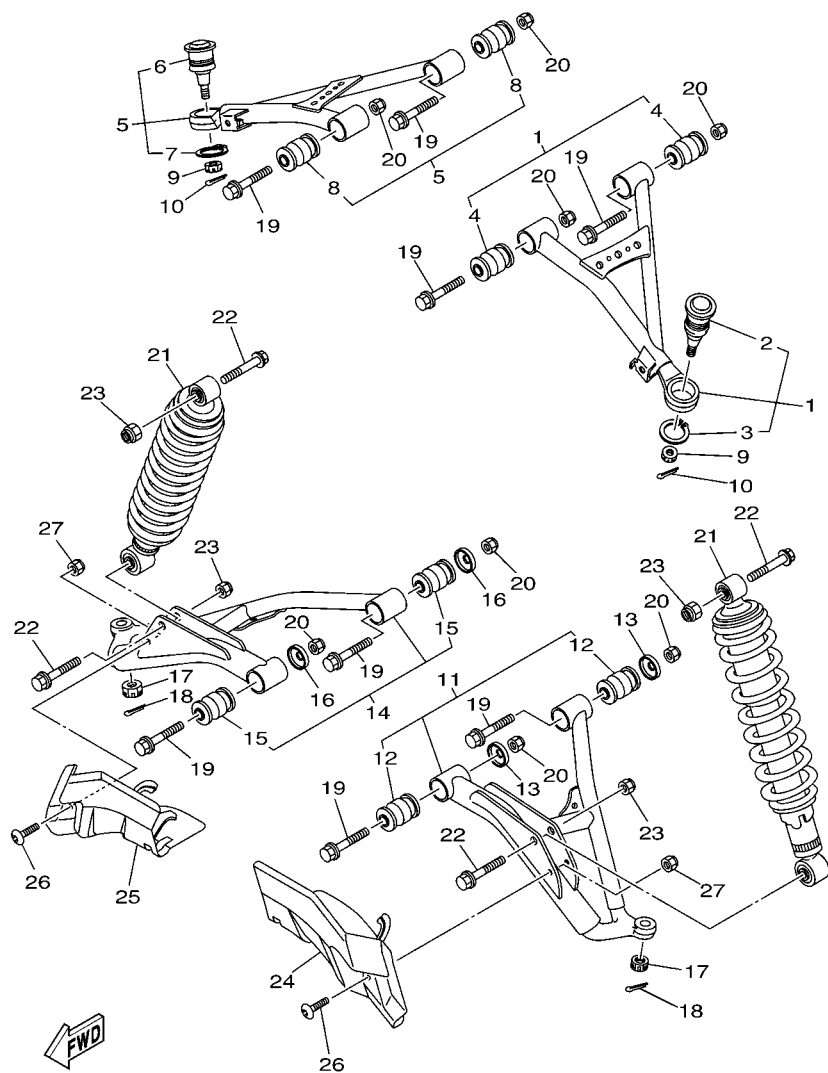

FIG. 28 STEERING

REF. NO.	PART NO.	DESCRIPTION	USA	CAN	EUR	REMARKS
28	95612-16100	NUT, U	1	1	1	
29	90468-18195	CLIP	1	1	1	
30	5KM-23831-00	ROD, TIE	2	2	2	
31	1UY-23841-01	JOINT, UNIVERSAL 1	2	2	2	
32	1UY-23845-01	JOINT, UNIVERSAL 2	2	2	2	
33	95302-10700	NUT	2	2	2	
34	90170-10010	NUT	2	2	2	(L.H. THREAD)
35	90171-10001	NUT, CASTLE	4	4	4	
36	90209-10229	WASHER	4	4	4	
37	91401-20020	PIN, COTTER	4	4	4	

FIG. 29 FRONT SUSPENSION & WHEEL



3B41100-F290

REF. NO.	PART NO.	DESCRIPTION	USA	CAN	EUR	REMARKS
1	3B4-23540-00	FRONT UPPER ARM COMP. (LEFT)	1	1		
	3B4-23540-11	FRONT UPPER ARM COMP. (LEFT)			1	
2	5LP-23579-00	.BALL JOINT 2	1	1	1	
3	99009-30400	.CIRCLIP	1	1	1	
4	5KM-23526-10	.BUSH	2	2	2	
5	3B4-23550-00	FRONT UPPER ARM COMP. (RIGHT)	1	1		
	3B4-23550-11	FRONT UPPER ARM COMP. (RIGHT)			1	
6	5LP-23579-00	.BALL JOINT 2	1	1	1	
7	99009-30400	.CIRCLIP	1	1	1	
8	5KM-23526-10	.BUSH	2	2	2	
9	90171-10001	NUT, CASTLE	2	2	2	
10	91401-20020	PIN, COTTER	2	2	2	
11	3B4-23570-00	FRONT LOWER ARM COMP. (LEFT)	1	1		
	3B4-23570-11	FRONT LOWER ARM COMP. (LEFT)			1	
12	5KM-23526-10	.BUSH	2	2	2	
13	5KM-22149-10	WASHER	2	2	2	
14	3B4-23580-00	FRONT LOWER ARM COMP. (RIGHT)	1	1		
	3B4-23580-11	FRONT LOWER ARM COMP. (RIGHT)			1	
15	5KM-23526-10	.BUSH	2	2	2	
16	5KM-22149-10	WASHER	2	2	2	
17	90171-12001	NUT, CASTLE	2	2	2	
18	91490-25020	PIN, COTTER	2	2	2	
19	90105-10222	BOLT, FLANGE	8	8	8	
20	90185-10012	NUT, SELF-LOCKING	8	8	8	
21	3B4-23350-01	SHOCK ABSORBER ASSY	2	2	2	
22	90105-10131	BOLT, FLANGE	4	4	4	
23	90185-10012	NUT, SELF-LOCKING	4	4	4	

FIG. 29 FRONT SUSPENSION & WHEEL

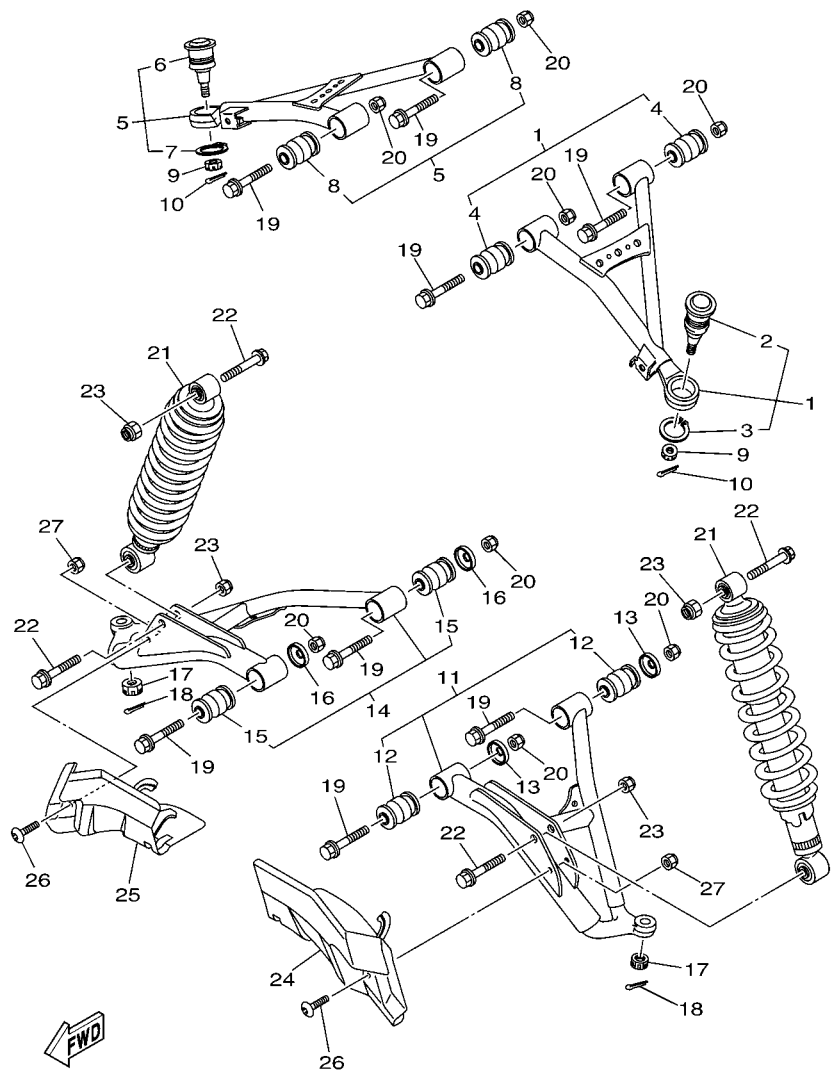

3B41100-F290

REF. NO.	PART NO.	DESCRIPTION	USA	CAN	EUR	REMARKS
24	3B4-23123-00	COVER, LOWER 1	1	1	1	
25	3B4-23133-00	COVER, LOWER 2	1	1	1	
26	90110-06200	BOLT, HEXAGON SOCKET HEAD	2	2	2	
27	95702-06300	NUT, NYLON	2	2	2	

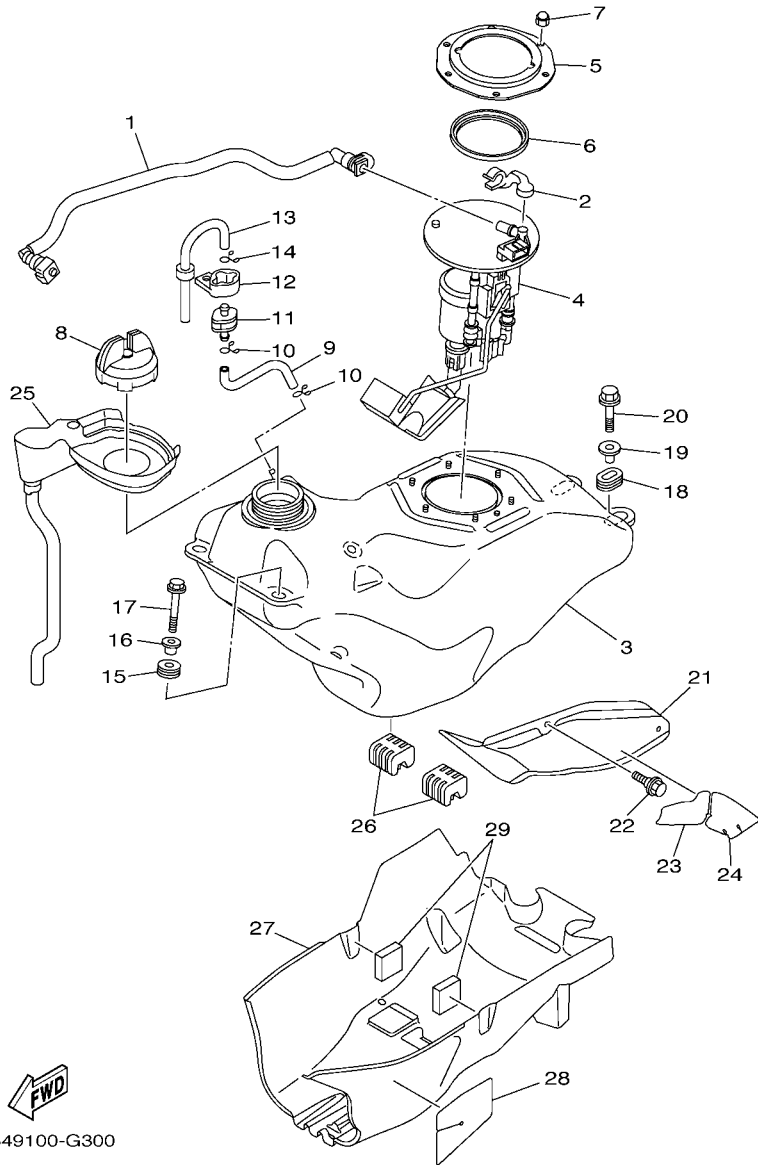

3B49100-G300

FIG. 30 FUEL TANK

REF. NO.	PART NO.	DESCRIPTION	USA	CAN	EUR	REMARKS
1	3B4-13971-10	PIPE, FUEL 1	1	1		
	3B4-13971-00	PIPE, FUEL 1			1	
2	90464-14004	CLAMP	1	1	1	
3	3B4-24110-10	FUEL TANK COMP.	1	1		
	3B4-24110-00	FUEL TANK COMP.			1	
4	3B4-13907-00	FUEL PUMP COMP.	1	1	1	
5	3B4-24491-00	BRACKET, FUEL PUMP	1	1	1	
6	1S3-24486-00	O-RING	1	1	1	
7	95302-06800	NUT, CROWN	6	6	6	
8	3B4-24610-00	CAP ASSY	1	1	1	
9	3B4-24312-00	PIPE 2	1	1	1	
10	90467-09006	CLIP	2	2	2	
11	3B4-24380-10	PIPE JOINT ASSY	1	1	1	
12	3B4-24398-00	BAND 1	1	1	1	
13	3B4-24313-00	PIPE 3	1	1	1	
14	90467-09006	CLIP	1	1	1	
15	90480-18290	GROMMET	2	2	2	
16	90387-066J1	COLLAR	2	2	2	
17	95802-06030	BOLT, FLANGE	2	2	2	
18	90480-01400	GROMMET	2	2	2	
19	90387-07021	COLLAR	2	2	2	
20	95802-06030	BOLT, FLANGE	2	2	2	
21	3B4-24129-00	COVER, SIDE 1	1	1	1	
22	90109-06172	BOLT	2	2	2	
23	3B4-2414J-00	DAMPER, PLATE 2	1	1	1	
24	3B4-2414K-00	DAMPER, PLATE 3	1	1	1	
25	3B4-2414F-00	COVER, FILLER COMP.	1	1	1	

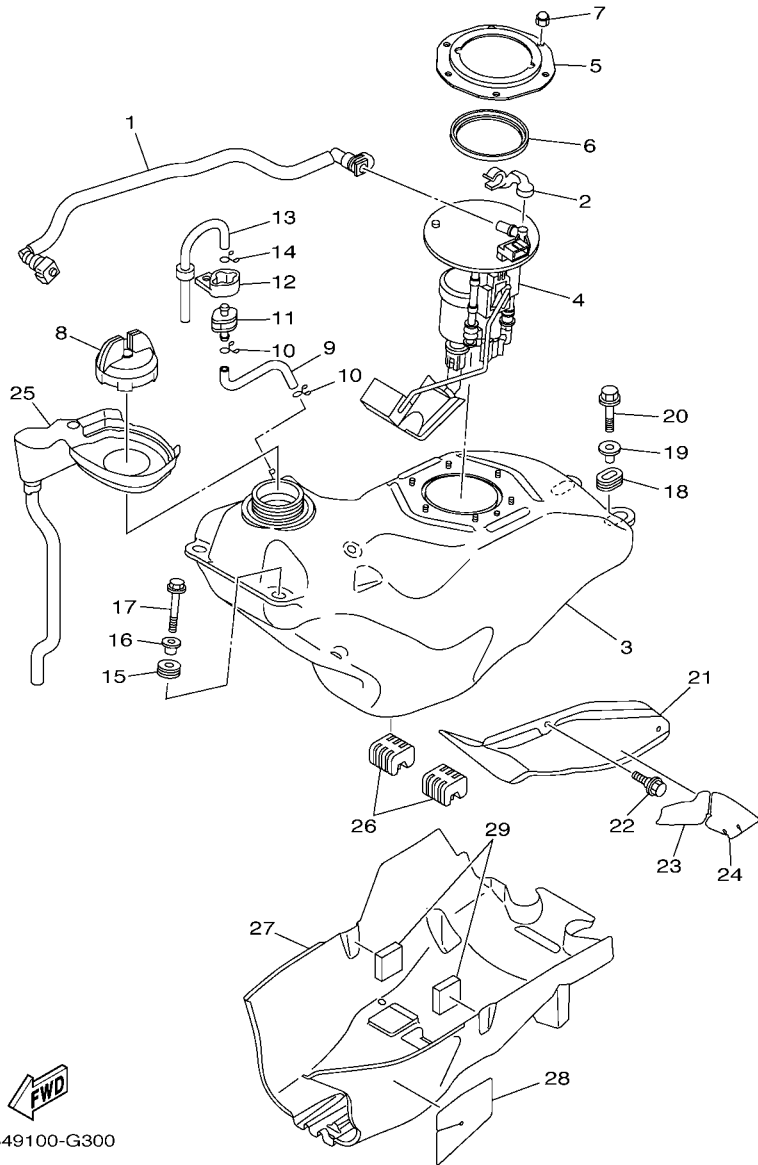
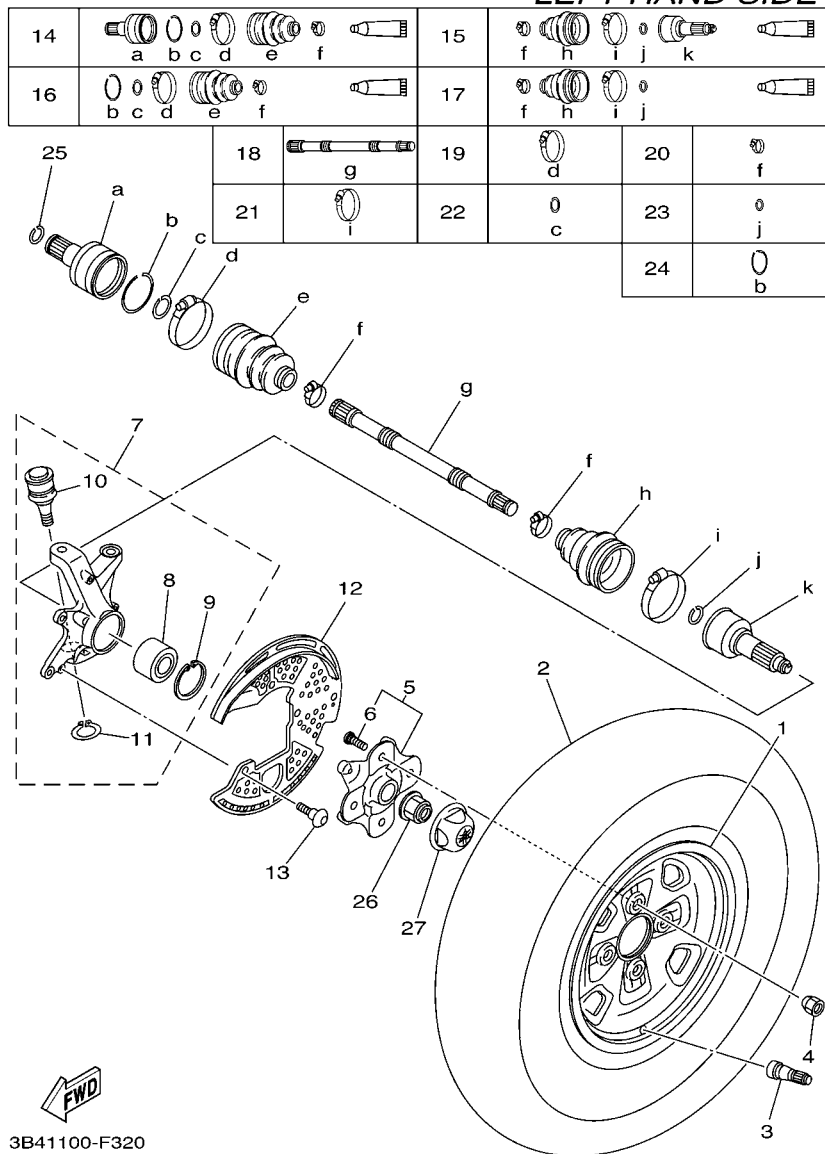

FIG. 30 FUEL TANK

REF. NO.	PART NO.	DESCRIPTION	USA	CAN	EUR	REMARKS
26	3B4-24181-00	DAMPER, LOCATING 1	2	2	2	
27	3B4-24141-00	PROTECTOR, FUEL TANK	1	1	1	
28	3B4-2416G-00	INSULATOR, FUEL TANK 2	1	1	1	
29	3B4-24182-00	DAMPER, LOCATING 2	2	2		

FIG. 32 FRONT WHEEL

LEFT HAND SIDE





3B41100-F320

REF. NO.	PART NO.	DESCRIPTION	USA	CAN	EUR	REMARKS
1	3B4-25180-10	WHEEL COMP.	1	1	1	
2	94108-12012	TIRE (AT25X8-12** KT421 T/L N)	1	1	1	DUNLOP
3	93900-00030	VALVE, RIM (TR412)	1	1	1	TAIHEIYO
4	90179-10020	NUT	4	4	4	
5	3B4-25111-10	HUB, FRONT	1	1	1	
6	90114-10014	.BOLT, SERRATION	4	4	4	
7	3B4-23501-00	STEERING KNUCKLE ASSY (LEFT)	1	1	1	
8	93305-00602	.BEARING	1	1	1	
9	99009-55500	.CIRCLIP	1	1	1	
10	3B4-23579-00	.BALL JOINT 2	1	1	1	
11	99009-30400	.CIRCLIP	1	1	1	
12	3B4-2514A-00	RING, WHEEL 1 (LEFT)	1	1	1	
13	90154-06014	SCREW, BINDING	3	3	3	
14	3B4-2510J-00	DOUBLE OFF SET JOINT	1	1	1	
15	3B4-2510F-00	BALL JOINT SET	1	1	1	
16	3B4-2510H-00	BOOT SET(DOUBLE OFFSET JOINT)	1	1	1	
17	3B4-2510G-00	BOOT SET (BALL JOINT)	1	1	1	
18	3B4-2518E-00	SHAFT	1	1	1	
19	3B4-2511H-00	BOOT BAND(DOUBLE OFFSET JOINT)	1	1	1	
20	3B4-2512G-00	BOOT BAND (SMALL)	2	2	2	
21	3B4-2511G-00	BOOT BAND (BALL JOINT)	1	1	1	
22	3B4-2512J-00	SNAP RING	1	1	1	
23	3B4-2512H-00	CIRCLIP	1	1	1	
24	3B4-25182-00	CIRCLIP	1	1	1	
25	93450-22119	CIRCLIP	1	1	1	
26	90179-20016	NUT	1	1	1	
27	3B4-2512A-00	CAP, WHEEL	1	1	1	

FIG. 33 FRONT WHEEL 2

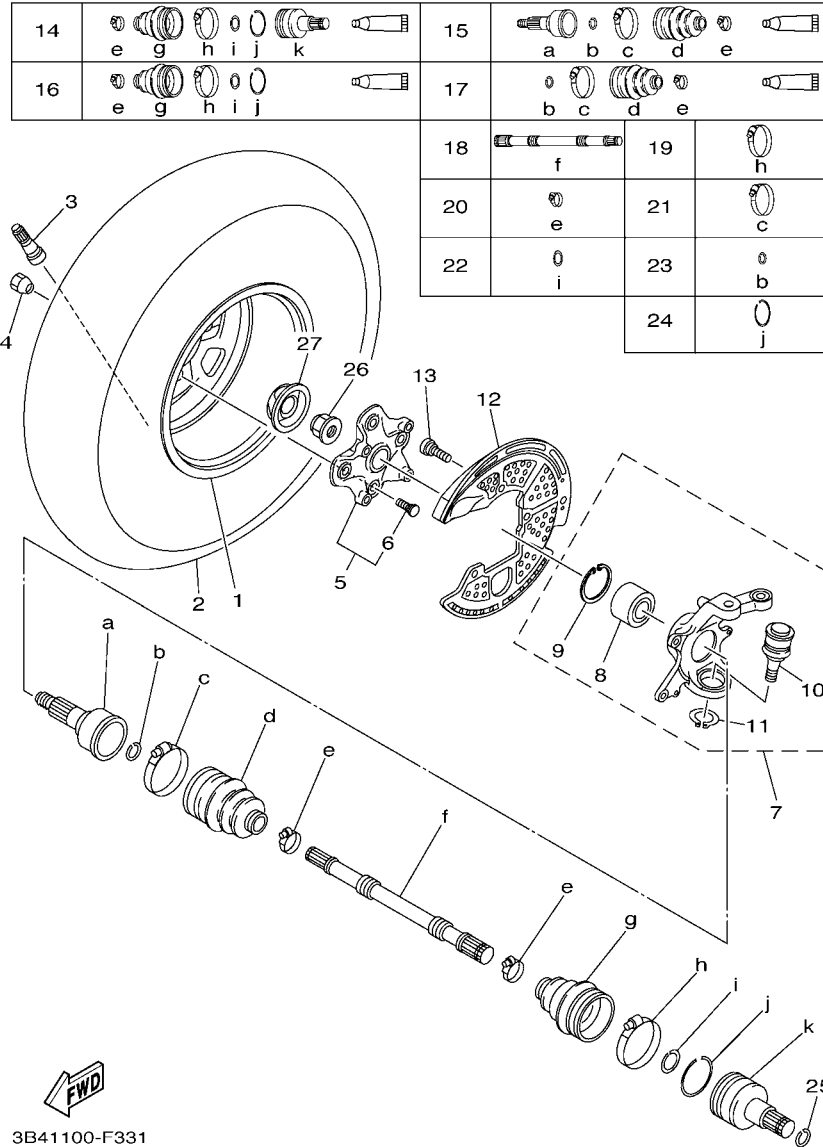
RIGHT HAND SIDE



3B41100-F331

REF. NO.	PART NO.	DESCRIPTION	USA	CAN	EUR	REMARKS
1	3B4-25180-10	WHEEL COMP.	1	1	1	
2	94108-12012	TIRE (AT25X8-12** KT421 T/L N)	1	1	1	DUNLOP
3	93900-00030	VALVE, RIM (TR412)	1	1	1	TAIHEIYO
4	90179-10020	NUT	4	4	4	
5	3B4-25111-10	HUB, FRONT	1	1	1	
6	90114-10014	.BOLT, SERRATION	4	4	4	
7	3B4-23502-00	STEERING KNUCKLE ASSY (RIGHT)	1	1	1	
8	93305-00602	.BEARING	1	1	1	
9	99009-55500	.CIRCLIP	1	1	1	
10	3B4-23579-00	.BALL JOINT 2	1	1	1	
11	99009-30400	.CIRCLIP	1	1	1	
12	3B4-2515A-00	RING, WHEEL 2 (RIGHT)	1	1	1	
13	90154-06014	SCREW, BINDING	3	3	3	
14	3B4-2510J-00	DOUBLE OFF SET JOINT	1	1	1	
15	3B4-2510F-00	BALL JOINT SET	1	1	1	
16	3B4-2510H-00	BOOT SET(DOUBLE OFFSET JOINT)	1	1	1	
17	3B4-2510G-00	BOOT SET (BALL JOINT)	1	1	1	
18	3B4-2518E-00	SHAFT	1	1	1	
19	3B4-2511H-00	BOOT BAND(DOUBLE OFFSET JOINT)	1	1	1	
20	3B4-2512G-00	BOOT BAND (SMALL)	2	2	2	
21	3B4-2511G-00	BOOT BAND (BALL JOINT)	1	1	1	
22	3B4-2512J-00	SNAP RING	1	1	1	
23	3B4-2512H-00	CIRCLIP	1	1	1	
24	3B4-25182-00	CIRCLIP	1	1	1	
25	93450-22119	CIRCLIP	1	1	1	
26	90179-20016	NUT	1	1	1	
27	3B4-2512A-00	CAP, WHEEL	1	1	1	

FIG. 34 FRONT BRAKE CALIPER

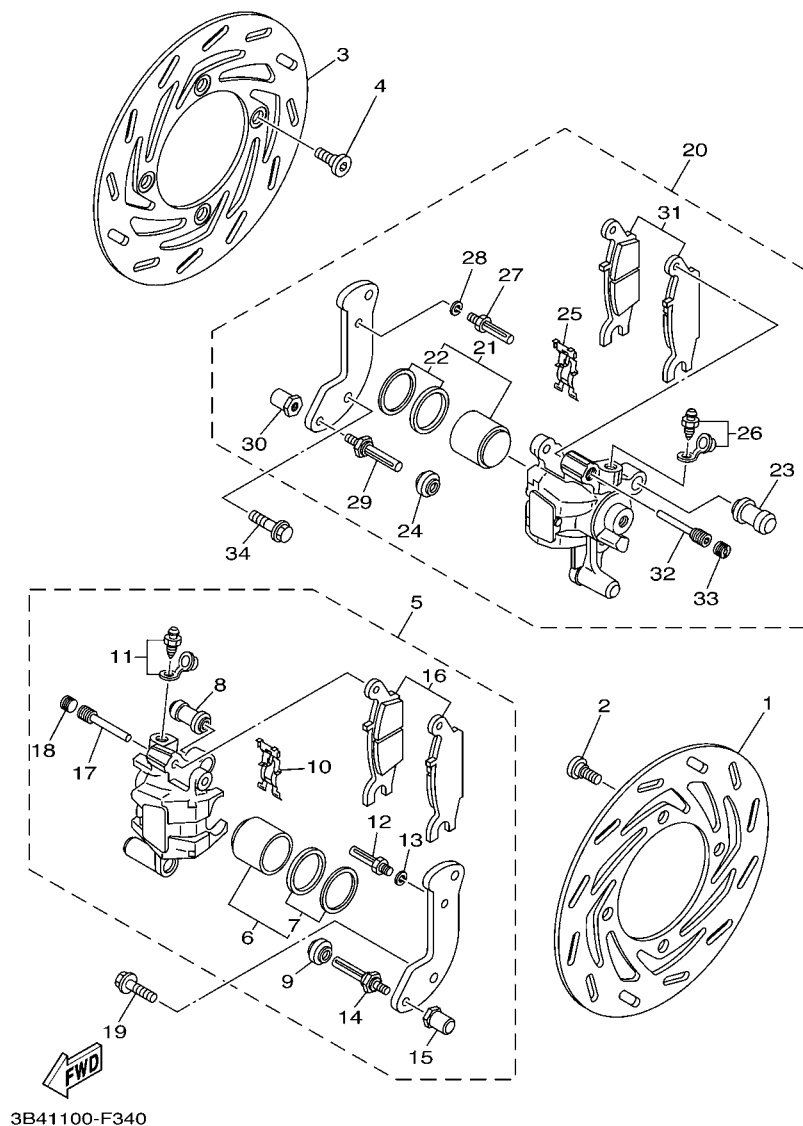

REF. NO.	PART NO.	DESCRIPTION	USA	CAN	EUR	REMARKS
1	3B4-2582T-01	DISC, BRAKE (LEFT)	1	1	1	
2	90109-08101	BOLT	4	4	4	
3	3B4-2582T-01	DISC, BRAKE (LEFT)	1	1	1	
4	90109-08101	BOLT	4	4	4	
5	3B4-2580T-01	CALIPER ASSY (LEFT)	1	1	1	
6	3B4-W0057-00	.PISTON ASSY, CALIPER	1	1	1	
7	3B4-W0047-00	..CALIPER SEAL KIT	1	1	1	
8	1UY-25937-51	.BOOT 2	1	1	1	
9	3JD-25917-00	.BOOT, CALIPER	1	1	1	
10	5DH-25919-00	.SUPPORT, PAD	1	1	1	
11	1UY-W0048-50	.BLEED SCREW KIT	1	1	1	
12	1UY-25926-51	.BOLT	1	1	1	
13	1UY-25938-51	.WASHER, SPRING	1	1	1	
14	3JD-25926-00	.BOLT	1	1	1	
15	3JD-25961-00	.NUT	1	1	1	
16	3B4-W0045-00	.BRAKE PAD KIT	1	1	1	
17	5DH-25933-00	.PIN, PAD	1	1	1	
18	8CR-25926-00	.BOLT	1	1	1	
19	90105-08161	BOLT, FLANGE	2	2	2	
20	3B4-2580U-01	CALIPER ASSY (RIGHT)	1	1	1	
21	3B4-W0057-00	.PISTON ASSY, CALIPER	1	1	1	
22	3B4-W0047-00	..CALIPER SEAL KIT	1	1	1	
23	1UY-25937-51	.BOOT 2	1	1	1	
24	3JD-25917-00	.BOOT, CALIPER	1	1	1	
25	5DH-25919-00	.SUPPORT, PAD	1	1	1	
26	1UY-W0048-50	.BLEED SCREW KIT	1	1	1	
27	1UY-25926-51	.BOLT	1	1	1	

FIG. 35 REAR WHEEL

LEFT HAND SIDE

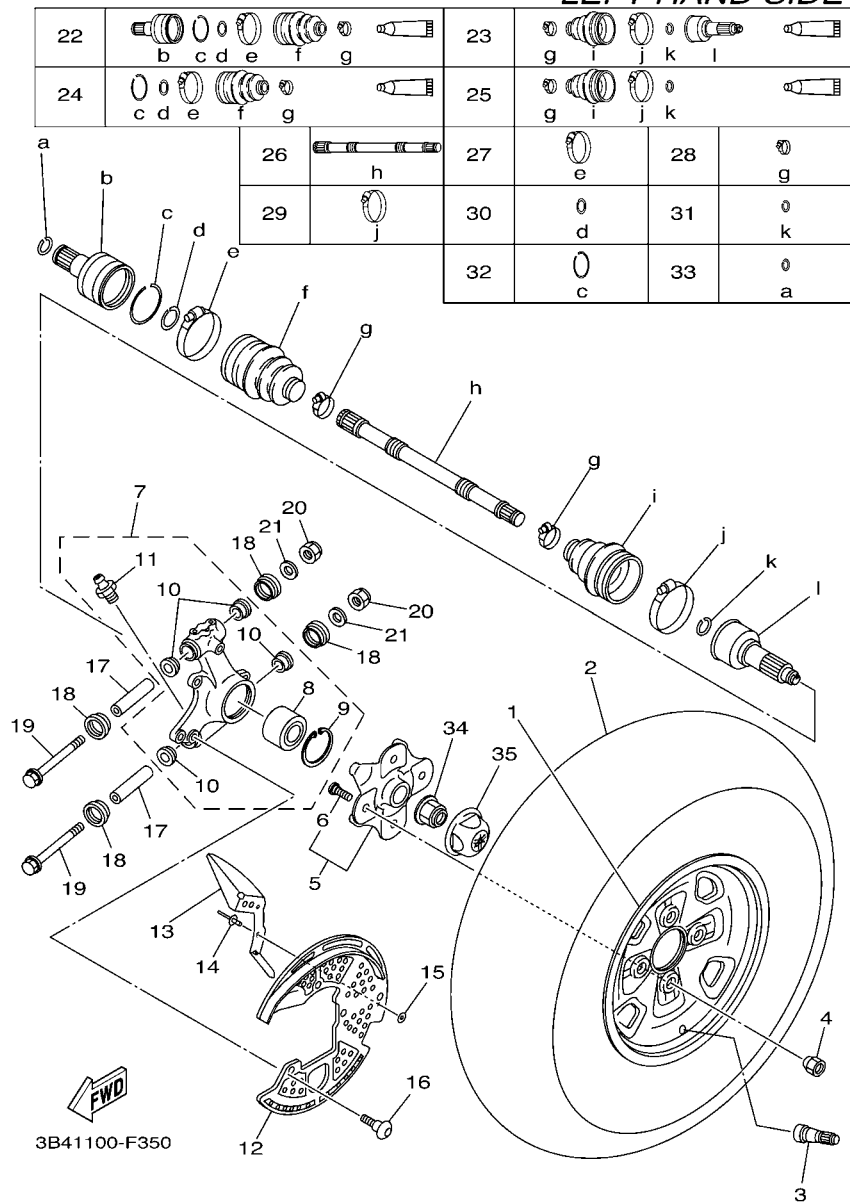

REF. NO.	PART NO.	DESCRIPTION	USA	CAN	EUR	REMARKS
1	3B4-25390-10	REAR WHEEL COMP.	1	1	1	
2	94110-12012	TIRE (AT25X10-12** KT425T/L N)	1	1	1	DUNLOP
3	93900-00030	VALVE, RIM (TR412)	1	1	1	TAIHEIYO
4	90179-10020	NUT	4	4	4	
5	3B4-25111-10	HUB, FRONT	1	1	1	
6	90114-10014	.BOLT, SERRATION	4	4	4	
7	3B4-2530F-00	REAR KNUCKLE ASSY	1	1	1	
8	93305-00602	.BEARING	1	1	1	
9	99009-55500	.CIRCLIP	1	1	1	
10	90381-17067	.BUSH, SOLID	4	4	4	
11	93700-06004	.NIPPLE, GREASE	2	2	2	
12	3B4-2514A-00	RING, WHEEL 1 (LEFT)	1	1	1	
13	3B4-2539F-00	PLATE 1	1	1	1	
14	90267-47187	RIVET, BLIND	2	2	2	
15	90201-04027	WASHER, PLATE	2	2	2	
16	90154-06014	SCREW, BINDING	3	3	3	
17	5KM-23448-00	SPACER	2	2	2	
18	2NL-23517-00	COVER, THRUST 1	4	4	4	
19	90105-10185	BOLT, FLANGE	2	2	2	
20	90185-10012	NUT, SELF-LOCKING	2	2	2	
21	90201-10035	WASHER, PLATE	2	2	2	
22	3B4-2530V-00	DOUBLE OFF SET JOINT	1	1	1	
23	3B4-2510F-00	BALL JOINT SET	1	1	1	
24	3B4-2510H-00	BOOT SET(DOUBLE OFFSET JOINT)	1	1	1	
25	3B4-2510G-00	BOOT SET (BALL JOINT)	1	1	1	
26	3B4-2518E-10	SHAFT	1	1	1	
27	3B4-2511H-00	BOOT BAND(DOUBLE OFFSET JOINT)	1	1	1	

FIG. 36 REAR WHEEL 2

RIGHT HAND SIDE

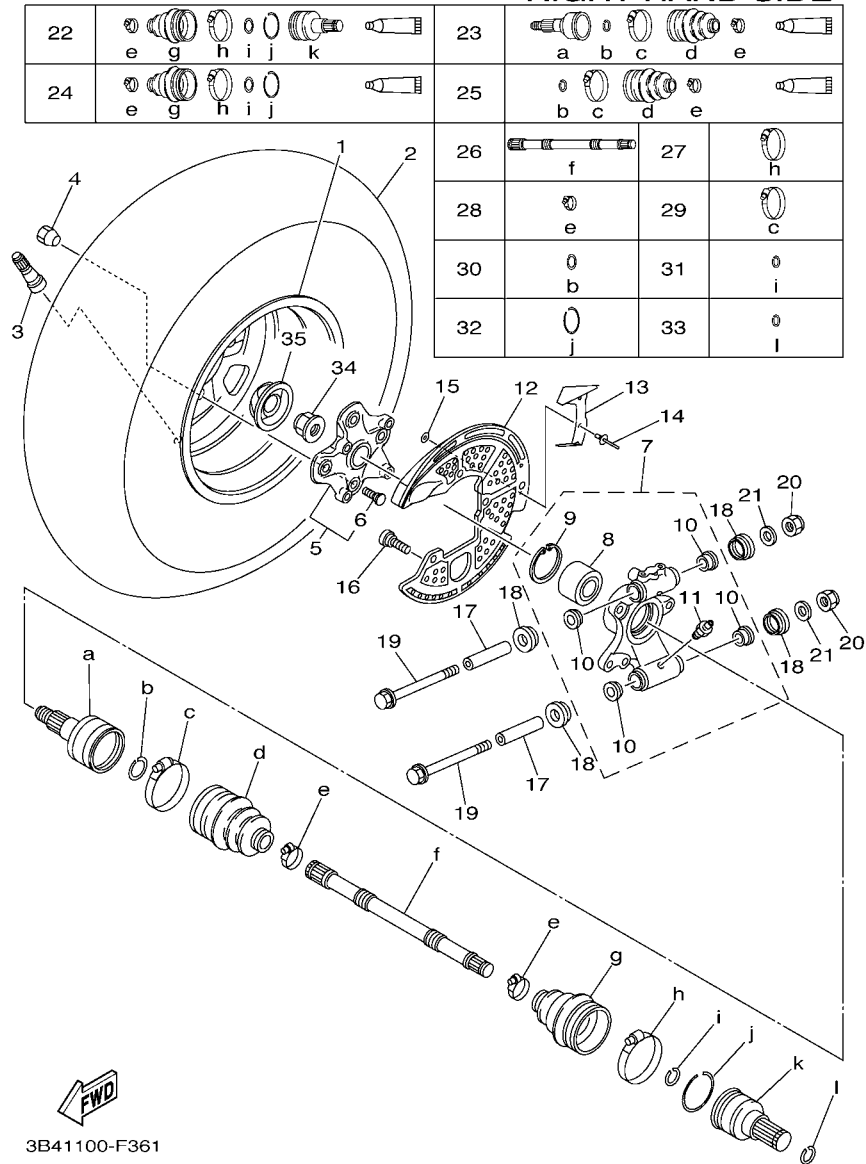

3B41100-F361

REF. NO.	PART NO.	DESCRIPTION	USA	CAN	EUR	REMARKS
1	3B4-25390-10	REAR WHEEL COMP.	1	1	1	
2	94110-12012	TIRE (AT25X10-12** KT425T/L N)	1	1	1	DUNLOP
3	93900-00030	VALVE, RIM (TR412)	1	1	1	TAIHEIYO
4	90179-10020	NUT	4	4	4	
5	3B4-25111-10	HUB, FRONT	1	1	1	
6	90114-10014	.BOLT, SERRATION	4	4	4	
7	3B4-2532F-00	REAR KNUCKLE ASSY.,2	1	1	1	
8	93305-00602	.BEARING	1	1	1	
9	99009-55500	.CIRCLIP	1	1	1	
10	90381-17067	.BUSH, SOLID	4	4	4	
11	93700-06004	.NIPPLE, GREASE	2	2	2	
12	3B4-2515A-00	RING, WHEEL 2 (RIGHT)	1	1	1	
13	3B4-2539G-00	PLATE 2	1	1	1	
14	90267-47187	RIVET, BLIND	2	2	2	
15	90201-04027	WASHER, PLATE	2	2	2	
16	90154-06014	SCREW, BINDING	3	3	3	
17	5KM-23448-00	SPACER	2	2	2	
18	2NL-23517-00	COVER, THRUST 1	4	4	4	
19	90105-10185	BOLT, FLANGE	2	2	2	
20	90185-10012	NUT, SELF-LOCKING	2	2	2	
21	90201-10035	WASHER, PLATE	2	2	2	
22	3B4-2530V-00	DOUBLE OFF SET JOINT	1	1	1	
23	3B4-2510F-00	BALL JOINT SET	1	1	1	
24	3B4-2510H-00	BOOT SET(DOUBLE OFFSET JOINT)	1	1	1	
25	3B4-2510G-00	BOOT SET (BALL JOINT)	1	1	1	
26	3B4-2518E-10	SHAFT	1	1	1	
27	3B4-2511H-00	BOOT BAND(DOUBLE OFFSET JOINT)	1	1	1	

FIG. 37 REAR BRAKE CALIPER

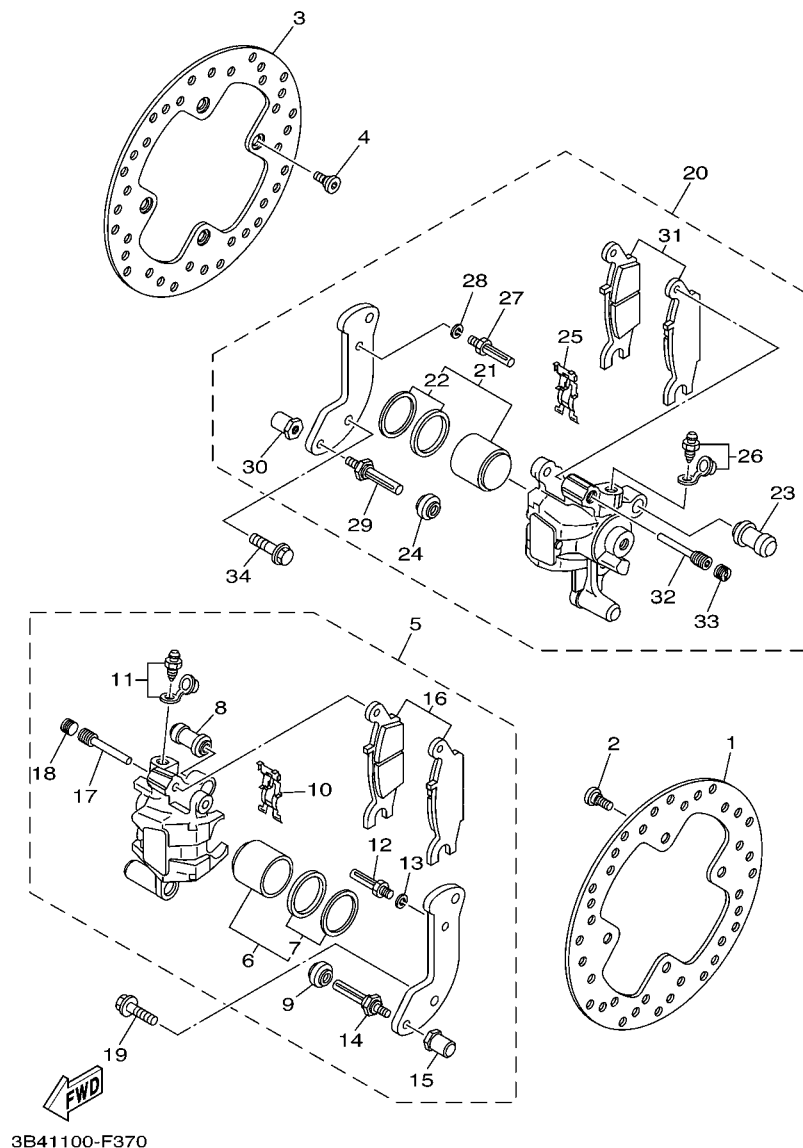

REF. NO.	PART NO.	DESCRIPTION	USA	CAN	EUR	REMARKS
1	3B4-2582V-00	DISC, REAR BRAKE 1	1	1	1	
2	90109-08101	BOLT	4	4	4	
3	3B4-2582V-00	DISC, REAR BRAKE 1	1	1	1	
4	90109-08101	BOLT	4	4	4	
5	3B4-2580V-01	CALIPER ASSY, REAR 1	1	1	1	
6	3B4-W0057-10	.PISTON ASSY, CALIPER	1	1	1	
7	3B4-W0047-00	..CALIPER SEAL KIT	1	1	1	
8	1UY-25937-51	.BOOT 2	1	1	1	
9	3JD-25917-00	.BOOT, CALIPER	1	1	1	
10	5DH-25919-50	.SUPPORT, PAD	1	1	1	
11	1UY-W0048-50	.BLEED SCREW KIT	1	1	1	
12	1UY-25926-51	.BOLT	1	1	1	
13	1UY-25938-51	.WASHER, SPRING	1	1	1	
14	3JD-25926-00	.BOLT	1	1	1	
15	3JD-25961-00	.NUT	1	1	1	
16	3B4-W0046-00	.BRAKE PAD KIT 2	1	1	1	
17	3GD-25933-00	.PIN, PAD	1	1	1	
18	5DH-25916-00	.PLUG	1	1	1	
19	90105-08161	BOLT, FLANGE	2	2	2	
20	3B4-2580W-01	CALIPER ASSY, REAR 2	1	1	1	
21	3B4-W0057-10	.PISTON ASSY, CALIPER	1	1	1	
22	3B4-W0047-00	..CALIPER SEAL KIT	1	1	1	
23	1UY-25937-51	.BOOT 2	1	1	1	
24	3JD-25917-00	.BOOT, CALIPER	1	1	1	
25	5DH-25919-50	.SUPPORT, PAD	1	1	1	
26	1UY-W0048-50	.BLEED SCREW KIT	1	1	1	
27	1UY-25926-51	.BOLT	1	1	1	

FIG. 38 STEERING HANDLE & CABLE

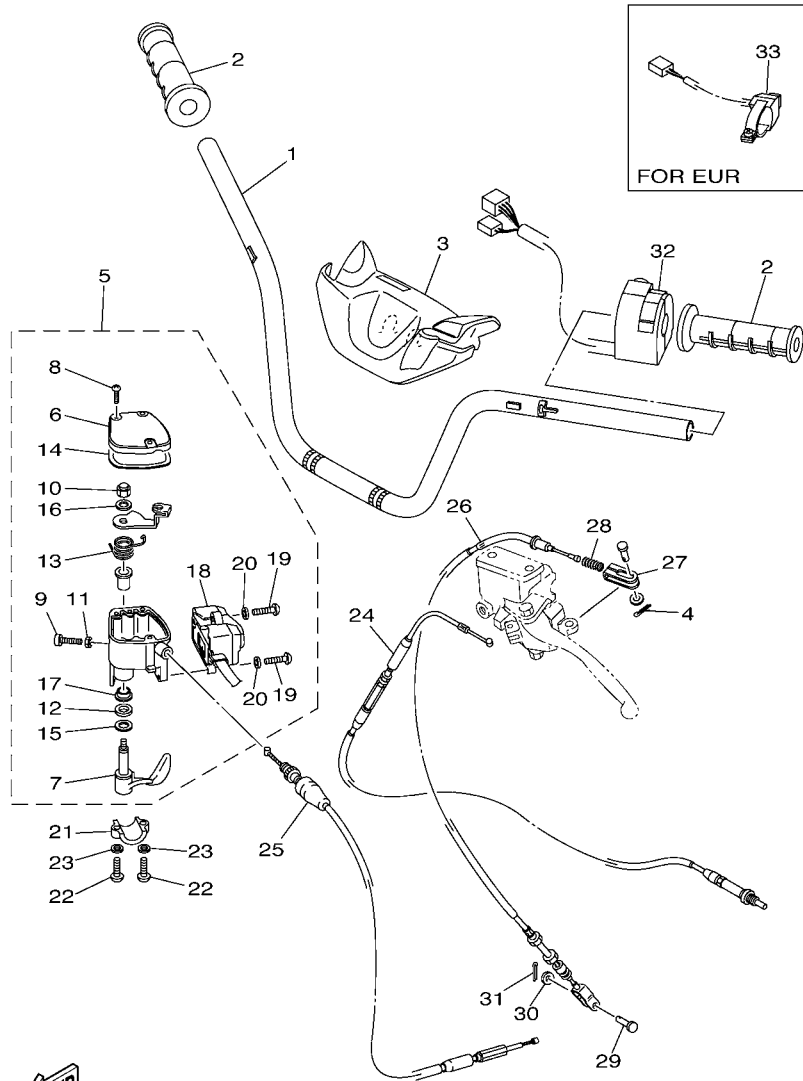

3B4H100-G380

REF. NO.	PART NO.	DESCRIPTION	USA	CAN	EUR	REMARKS
1	3B4-26111-20	HANDLEBAR	1	1	1	
2	5LP-26241-00	GRIP	2	2	2	
3	3B4-26124-00	PROTECTOR, HANDLEBAR	1	1	1	
4	91401-16012	PIN, COTTER	1	1	1	
5	5KM-26250-20	THROTTLE LEVER ASSY	1	1	1	
6	4KB-2628F-10	.CAP, GEAR	1	1	1	
7	1NV-2625G-01	.LEVER, THROTTLE	1	1	1	
8	90149-04278	.SCREW	3	3	3	
9	98507-05020	.SCREW, PAN HEAD	1	1	1	
10	95607-05100	.NUT, U	1	1	1	
11	95307-05700	.NUT	1	1	1	
12	93104-09025	.OIL SEAL	1	1	1	
13	1NV-26304-00	.SPRING	1	1	1	
14	4KB-2628G-00	.GASKET	1	1	1	
15	1NV-26129-00	.WASHER	1	1	1	
16	1NV-26398-00	.WASHER	1	1	1	
17	1NV-2625K-00	.COLLAR	1	1	1	
18	5KM-83976-20	.SWITCH, HANDLE 1	1	1	1	
19	98507-04016	.SCREW, PAN HEAD	2	2	2	
20	92907-04600	.WASHER	2	2	2	
21	4V4-82913-00	HOLDER, LEVER LOWER 1	1	1	1	
22	98502-05020	SCREW, PAN HEAD	2	2	2	
23	92902-05600	WASHER, PLATE	2	2	2	
24	3B4-2637F-10	CABLE, CONTROL 2	1	1	1	
25	3B4-26311-10	CABLE, THROTTLE 1	1	1	1	
26	3B4-26341-00	WIRE, BRAKE 1	1	1	1	
27	3B4-26347-00	JOINT, CABLE	1	1	1	

FIG. 38 STEERING HANDLE & CABLE

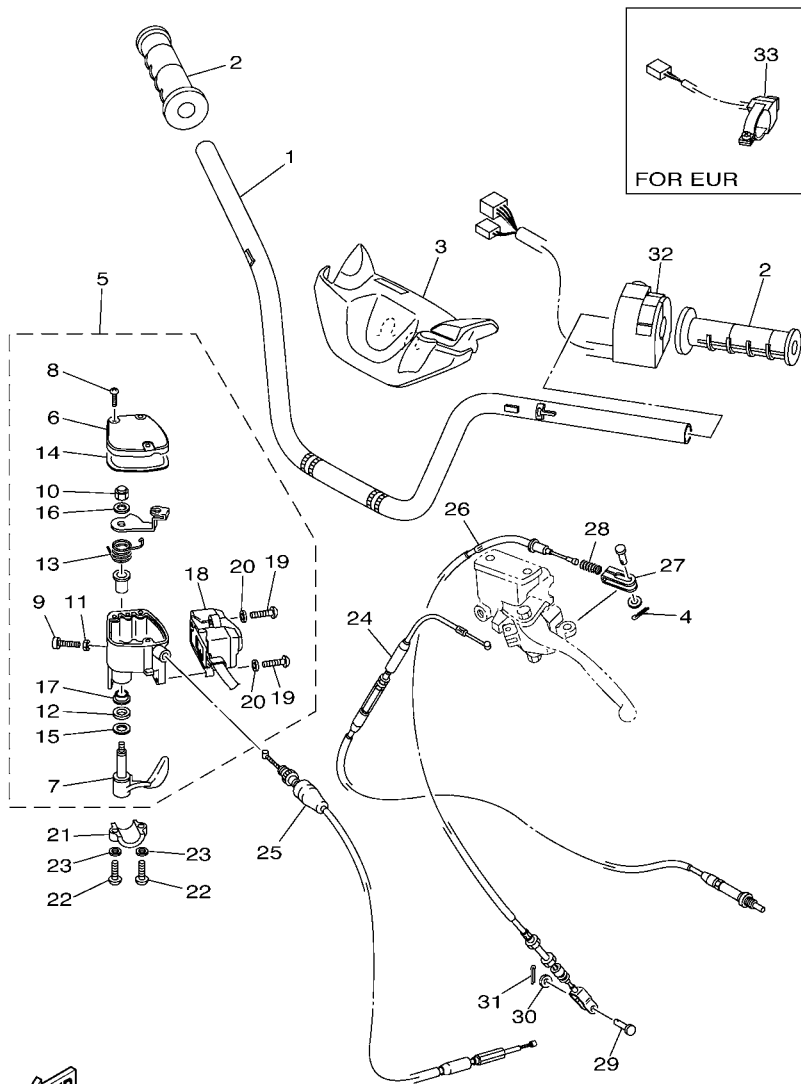

REF. NO.	PART NO.	DESCRIPTION	USA	CAN	EUR	REMARKS
28	90501-08665	SPRING, COMPRESSION	1	1	1	
29	90240-06076	PIN, CLEVIS	1	1	1	
30	92907-06200	WASHER	1	1	1	
31	91401-20012	PIN, COTTER	1	1	1	
32	3B4-83972-00	SWITCH, HANDLE 4	1	1	1	
33	3B4-83976-00	SWITCH, HANDLE 1			1	

3B4H100-G380

FIG. 39 FRONT MASTER CYLINDER

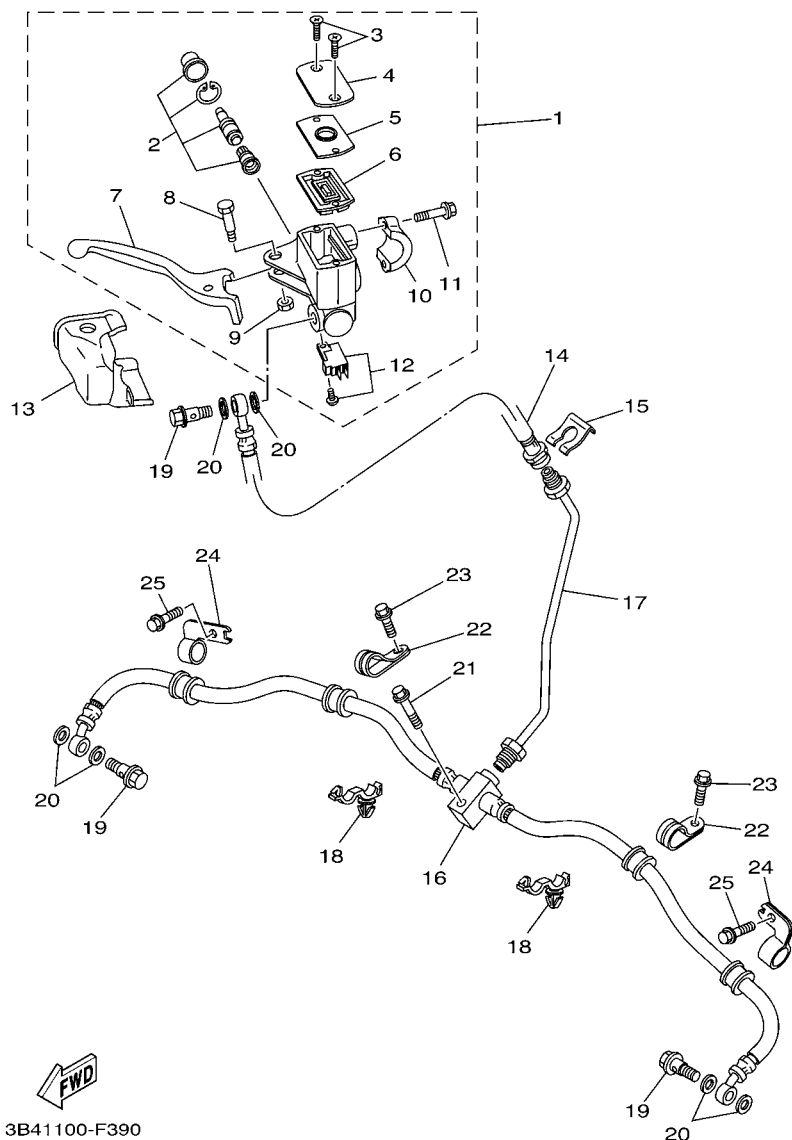

3B41100-F390

REF. NO.	PART NO.	DESCRIPTION	USA	CAN	EUR	REMARKS
1	3B4-2583T-00	MASTER CYLINDER ASSY	1	1	1	
2	5D3-W0041-00	.CYLINDER KIT, MASTER	1	1	1	
3	98706-04012	.SCREW, FLAT HEAD	2	2	2	
4	3GM-25852-22	.CAP, RESERVOIR	1	1	1	
5	3B4-2585B-00	.PLATE, DIAPHRAGM	1	1	1	
6	4TT-25854-00	.DIAPHRAGM, RESERVOIR	1	1	1	
7	3B4-83922-00	.LEVER 2	1	1	1	
8	3B4-2589F-00	.BOLT, LEVER	1	1	1	
9	95604-06100	.NUT, U	1	1	1	
10	56A-25867-00	.BRACKET, MASTER CYLINDER	1	1	1	
11	5EB-26332-00	.BOLT	2	2	2	
12	4HM-83980-00	.FRONT STOP SWITCH ASSY	1	1	1	
13	3B4-2637A-01	COVER, HANDLE LEVER 2	1	1	1	
14	3B4-25872-10	HOSE, BRAKE 1	1	1	1	
15	2GU-25866-00	CIRCLIP	1	1	1	
16	3B4-25873-10	HOSE, BRAKE 2	1	1	1	
17	3B4-25871-10	PIPE, BRAKE	1	1	1	
18	90464-20010	CLAMP	2	2	2	
19	90401-10015	BOLT, UNION	3	3	3	
20	90201-10118	WASHER, PLATE	6	6	6	
21	95822-06025	BOLT, FLANGE	1	1	1	
22	3B4-25886-00	HOLDER, BRAKE HOSE	2	2	2	
23	95802-06012	BOLT, FLANGE	2	2	2	
24	3B4-25876-10	HOLDER, BRAKE HOSE 2	2	2	2	
25	95802-06012	BOLT, FLANGE	2	2	2	

FIG. 40 REAR MASTER CYLINDER

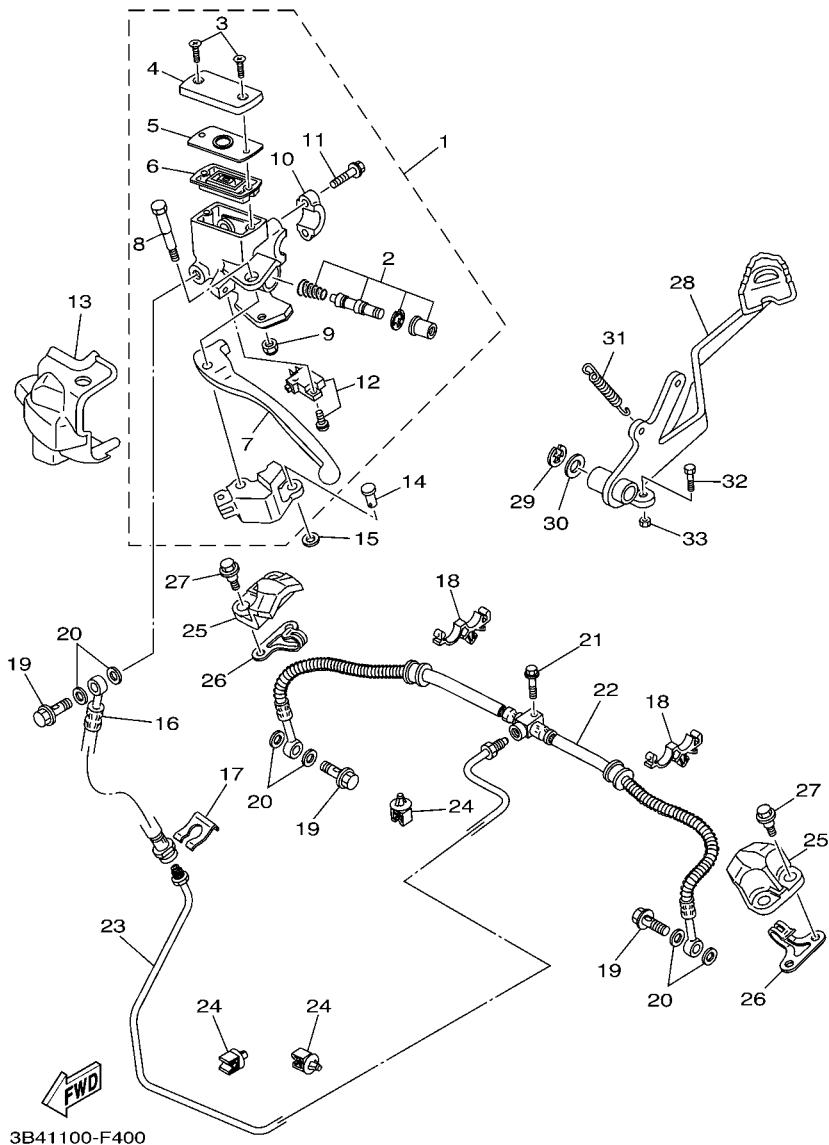

3B41100-F400

REF. NO.	PART NO.	DESCRIPTION	USA	CAN	EUR	REMARKS
1	3B4-2583V-00	RR. MASTER CYLINDER ASSY.	1	1	1	
2	5LP-W0041-00	.CYLINDER KIT, MASTER	1	1	1	
3	98706-04012	.SCREW, FLAT HEAD	2	2	2	
4	3GM-25852-22	.CAP, RESERVOIR	1	1	1	
5	3B4-2585B-00	.PLATE, DIAPHRAGM	1	1	1	
6	4TT-25854-00	.DIAPHRAGM, RESERVOIR	1	1	1	
7	3B4-83912-00	.LEVER 1	1	1	1	
8	3B4-2589F-10	.BOLT, LEVER	1	1	1	
9	3B4-26294-00	.NUT 1	1	1	1	
10	56A-25867-00	.BRACKET, MASTER CYLINDER	1	1	1	
11	5EB-26332-00	.BOLT	2	2	2	
12	3B4-83980-00	.FRONT STOP SWITCH ASSY	1	1	1	
13	3B4-26372-00	COVER, HANDLE LEVER 1	1	1	1	
14	90240-08013	PIN, CLEVIS	1	1	1	
15	92902-08600	WASHER, PLATE	1	1	1	
16	3B4-25872-10	HOSE, BRAKE 1	1	1	1	
17	2GU-25866-00	CIRCLIP	1	1	1	
18	90464-16006	CLAMP	2	2	2	
19	90401-10015	BOLT, UNION	3	3	3	
20	90201-10118	WASHER, PLATE	6	6	6	
21	95822-06025	BOLT, FLANGE	1	1	1	
22	3B4-25874-10	HOSE, BRAKE	1	1	1	
23	3B4-25882-10	PIPE, BRAKE 2	1	1	1	
24	5KM-81677-00	CLAMP 1	4	4	4	
25	3B4-25715-00	COVER 1	2	2	2	
26	3B4-2588F-00	HOLDER, BRAKE HOSE 5	2	2	2	
27	90109-06172	BOLT	4	4	4	

FIG. 40 REAR MASTER CYLINDER

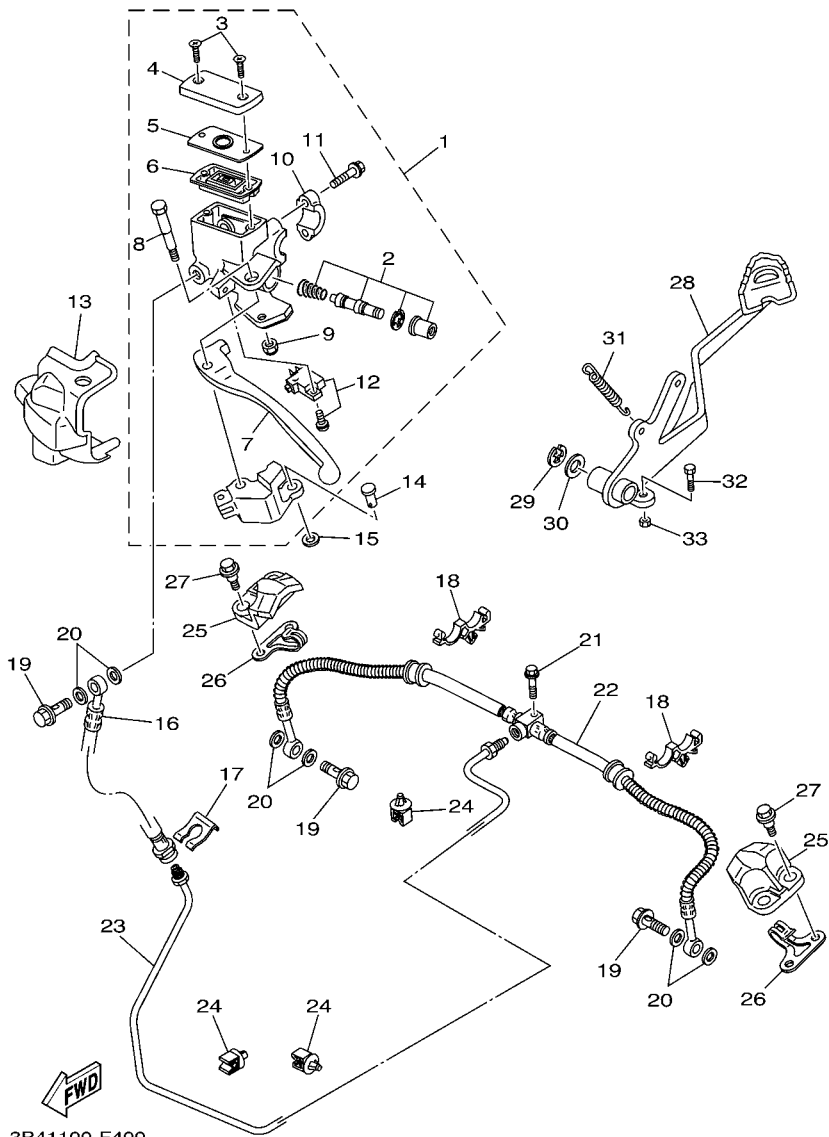

REF. NO.	PART NO.	DESCRIPTION	USA	CAN	EUR	REMARKS
28	3B4-27211-00	PEDAL, BRAKE	1	1	1	
29	99001-10600	CIRCLIP	1	1	1	
30	90201-14023	WASHER, PLATE	1	1	1	
31	90506-16318	SPRING, TENSION	1	1	1	
32	97022-06014	BOLT	1	1	1	
33	95312-06600	NUT	1	1	1	

FIG. 41 STAND & FOOTREST

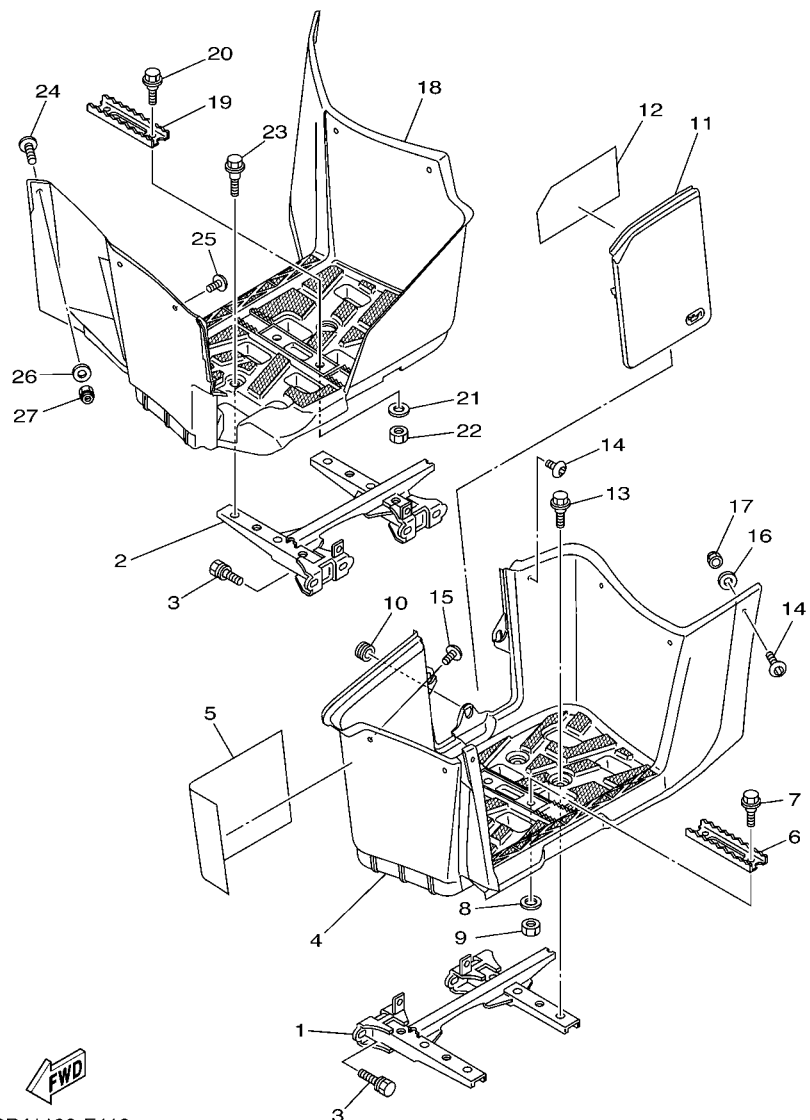

3B41100-F410

REF. NO.	PART NO.	DESCRIPTION	USA	CAN	EUR	REMARKS
1	3B4-27452-00	BRACKET, FOOTREST 1	1	1	1	
2	3B4-27462-00	BRACKET, FOOTREST 2	1	1	1	
3	90119-10044	BOLT, WITH WASHER	8	8	8	
4	3B4-27453-01	COVER 1	1	1	1	
5	3B4-21732-00	SEAL 1	1	1	1	
6	5GH-2741A-10	ARM 1	1	1	1	
7	90109-06214	BOLT	2	2	2	
8	90201-06033	WASHER, PLATE	2	2	2	
9	95312-06600	NUT	2	2	2	
10	90480-14532	GROMMET	1	1	1	
11	3B4-28239-00	COVER 3	1	1	1	
12	3B4-21735-00	SEAL 2	1	1	1	
13	90109-06172	BOLT	4	4	4	
14	90110-06200	BOLT, HEXAGON SOCKET HEAD	6	6	6	
15	90111-06086	BOLT, HEX. SOCKET BUTTON	1	1	1	
16	90201-06078	WASHER, PLATE	6	6	6	
17	95702-06300	NUT, NYLON	6	6	6	
18	3B4-27463-01	COVER 2	1	1	1	
19	5GH-2741A-10	ARM 1	1	1	1	
20	90109-06214	BOLT	2	2	2	
21	90201-06033	WASHER, PLATE	2	2	2	
22	95312-06600	NUT	2	2	2	
23	90109-06172	BOLT	4	4	4	
24	90110-06200	BOLT, HEXAGON SOCKET HEAD	5	5	5	
25	90111-06086	BOLT, HEX. SOCKET BUTTON	1	1	1	
26	90201-06078	WASHER, PLATE	6	6	6	
27	95702-06300	NUT, NYLON	6	6	6	

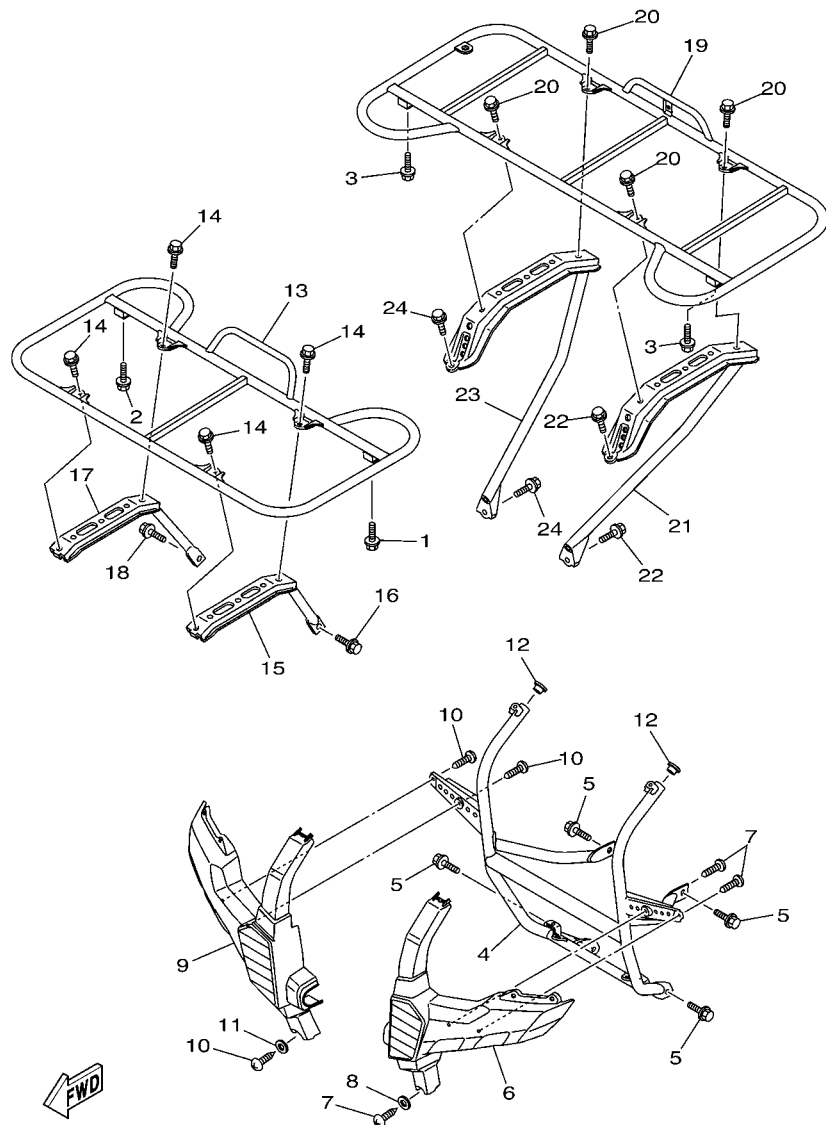

3B41100-F420

FIG. 42 GUARD

REF. NO.	PART NO.	DESCRIPTION	USA	CAN	EUR	REMARKS
1	90119-06152	BOLT, WITH WASHER	1	1	1	
2	90119-06152	BOLT, WITH WASHER	1	1	1	
3	90119-06152	BOLT, WITH WASHER	2	2	2	
4	3B4-2845N-00	BAR, CARRY FRONT	1	1	1	
5	95812-08014	BOLT, FLANGE	4	4	4	
6	3B4-2842M-00	COVER 1	1		1	
	3B4-2842M-10	COVER 1		1		
7	97702-50516	SCREW, TAPPING	3	3	3	
8	92902-05200	WASHER	1	1	1	
9	3B4-2842N-00	COVER 2	1		1	
	3B4-2842N-10	COVER 2		1		
10	97702-50516	SCREW, TAPPING	3	3	3	
11	92902-05200	WASHER	1	1	1	
12	90338-18122	PLUG	2	2	2	
13	3B4-24841-00	CARRIER, FRONT	1	1	1	
14	95812-08014	BOLT, FLANGE	4	4	4	
15	3B4-24821-00	STAY, FRONT CARRIER 1	1	1	1	
16	90119-08118	BOLT, WITH WASHER	1	1	1	
17	3B4-24822-00	STAY, FRONT CARRIER 2	1	1	1	
18	90119-08118	BOLT, WITH WASHER	1	1	1	
19	3B4-24842-00	CARRIER, REAR	1		1	
	3B4-24842-10	CARRIER, REAR		1		
20	95812-08014	BOLT, FLANGE	4	4	4	
21	3B4-2482J-01	FRAME, CARRIER 1	1	1	1	
22	90119-10044	BOLT, WITH WASHER	2	2	2	
23	3B4-2482K-01	FRAME, CARRIER 2	1	1	1	
24	90119-10044	BOLT, WITH WASHER	2	2	2	

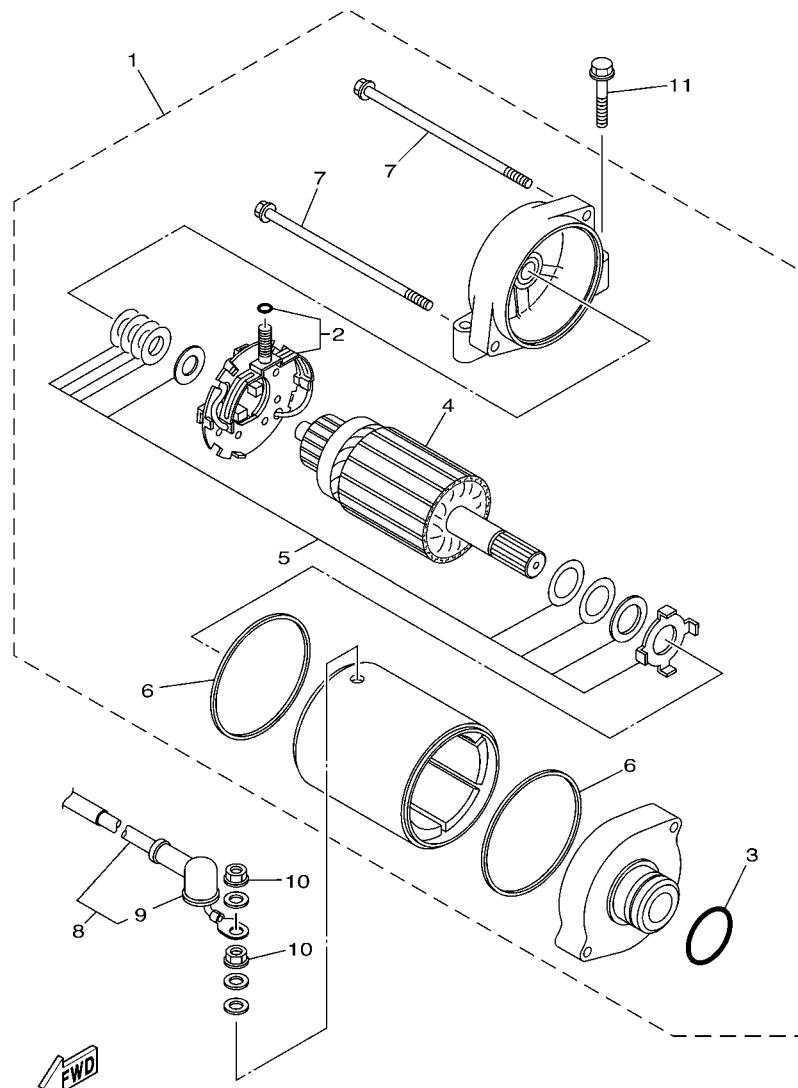

3B41100-F440

FIG. 44 STARTING MOTOR

REF. NO.	PART NO.	DESCRIPTION	USA	CAN	EUR	REMARKS
1	1S3-81890-00	MOTOR ASSY	1	1	1	
2	3AJ-81801-00	.BRUSH SET	1	1	1	
3	1FK-81847-00	.O-RING	1	1	1	
4	4NK-81850-00	.ARMATURE ASSY	1	1	1	
5	3KS-81809-00	.WASHER KIT	1	1	1	
6	11H-81844-00	.GASKET	2	2	2	
7	3AJ-81826-00	.BOLT	2	2	2	
8	3B4-81815-00	CORD, STARTER MOTOR	1	1	1	
9	4G0-81871-00	.CAP	1	1	1	
10	4XV-8182A-00	NUT	2	2	2	
11	95022-06030	BOLT, FLANGE	2	2	2	

FIG. 45 METER

REF. NO.	PART NO.	DESCRIPTION	USA	CAN	EUR	REMARKS
1	3B4-83500-01	METER ASSY	1			MILE/H
	3B4-83500-11	METER ASSY		1	1	KM/H
2	95302-05800	NUT, CROWN	3	3	3	
3	90201-05039	WASHER, PLATE	3	3	3	

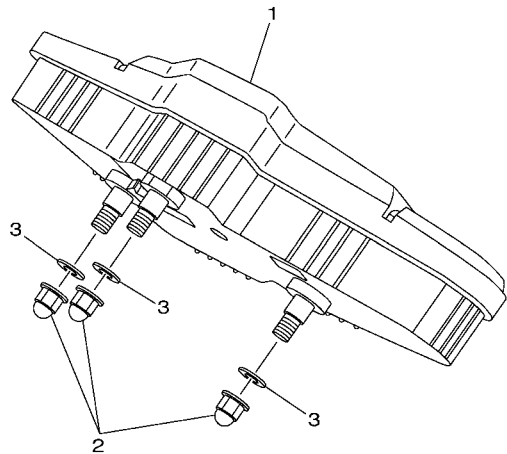



3B49100-G450

FIG. 51 GRAPHICS

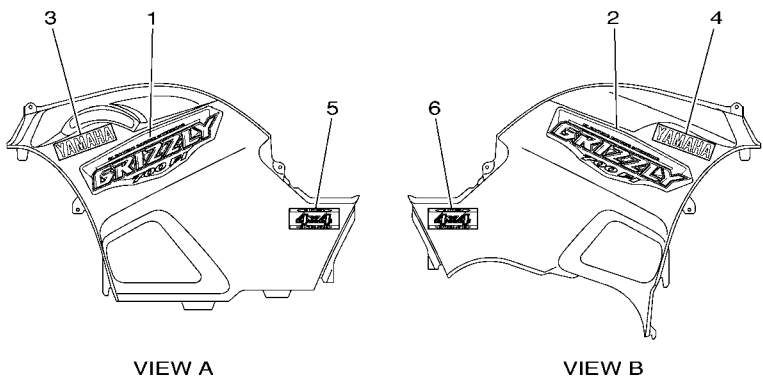
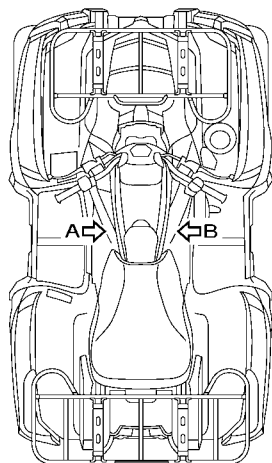
REF. NO.	PART NO.	DESCRIPTION	USA	CAN	EUR	REMARKS
1	3B4-2173E-40	GRAPHIC 1	1	1	1	
2	3B4-2173E-40	GRAPHIC 1	1	1	1	
3	3GD-2153E-30	EMBLEM, YAMAHA	1	1	1	
4	3GD-2153E-30	EMBLEM, YAMAHA	1	1	1	
5	3B4-2163G-50	EMBLEM 1	1	1	1	
6	3B4-2163G-50	EMBLEM 1	1	1	1	

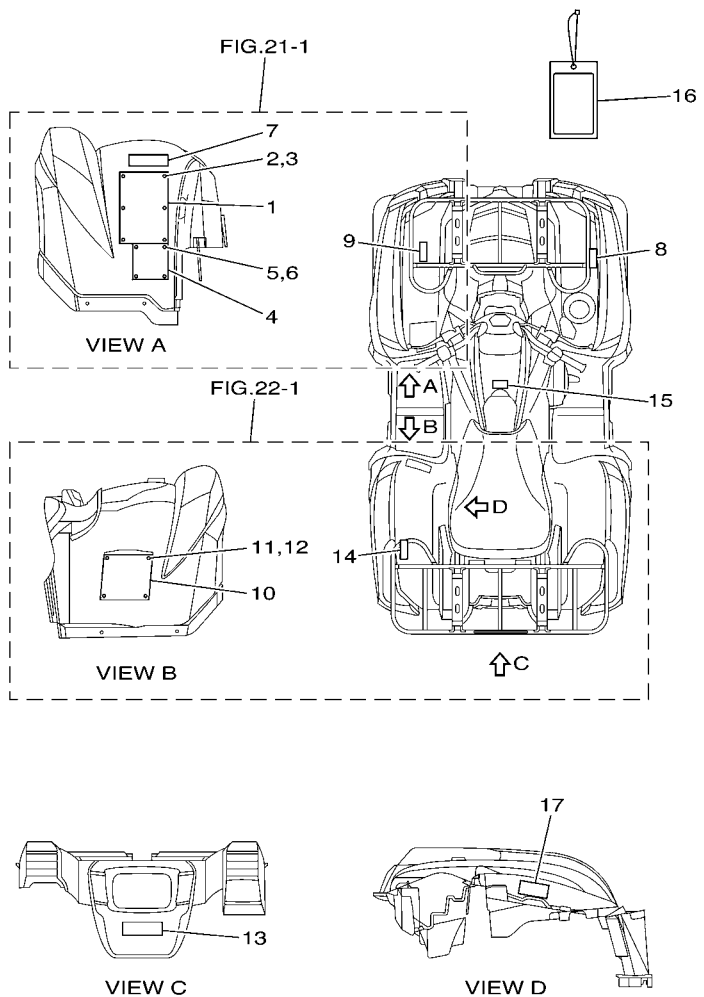

3B49100-G510



3B41100-F520

FIG. 52 EMBLEM & LABEL 1

REF. NO.	PART NO.	DESCRIPTION	USA	CAN	EUR	REMARKS
1	5FE-21568-01	LABEL, WARNING	1			ENGLISH
2	90267-32004	RIVET, BLIND	6			
3	90201-03008	WASHER, PLATE	6			
4	5FE-21697-01	LABEL, CAUTION 2	1			ENGLISH
5	90267-32004	RIVET, BLIND	4			
6	90201-03008	WASHER, PLATE	4			
7	5GH-2151E-00	LABEL 2	1			ENGLISH
8	3B4-2151F-00	LABEL 3	1			ENGLISH
9	3B4-24875-00	LABEL 1	1			ENGLISH
10	5KM-21696-00	LABEL, CAUTION	1			ENGLISH
11	90267-32004	RIVET, BLIND	4			
12	90201-03008	WASHER, PLATE	4			
13	5KM-2151K-00	LABEL 7	1			ENGLISH
14	3B4-24875-20	LABEL 1	1			ENGLISH
15	5KM-21558-00	LABEL, WARNING 2	1			ENGLISH
16	3GH-2819R-00	TAG, WARNING	1			
17	3B4-2177C-10	PLATE, EPA OFFROAD ATV 1	1			

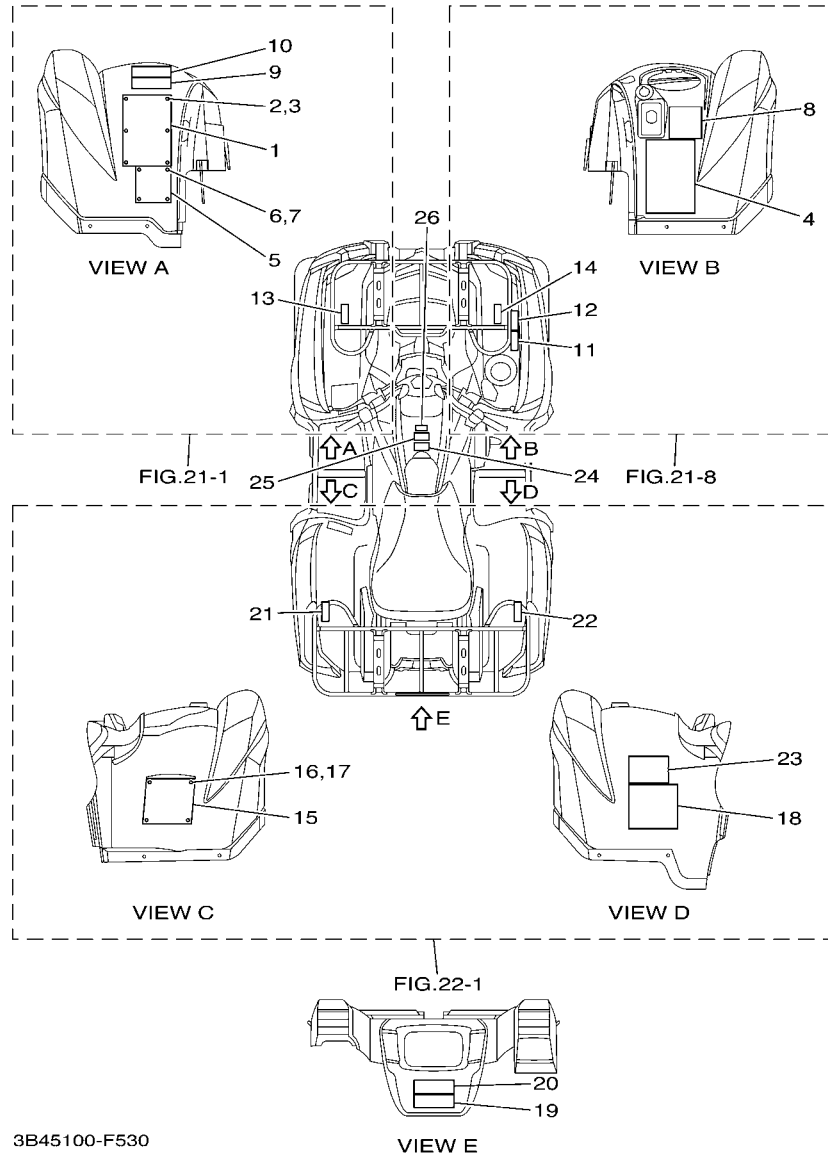

FIG. 53 EMBLEM & LABEL 2

REF. NO.	PART NO.	DESCRIPTION	USA	CAN	EUR	REMARKS
1	5FE-21568-01	LABEL, WARNING		1		ENGLISH
2	90267-32004	RIVET, BLIND		6		
3	90201-03008	WASHER, PLATE		6		
4	4WU-21568-10	LABEL, WARNING		1		FRENCH
5	5FE-21697-01	LABEL, CAUTION 2		1		ENGLISH
6	90267-32004	RIVET, BLIND		4		
7	90201-03008	WASHER, PLATE		4		
8	3JM-21697-10	LABEL, CAUTION 2		1		FRENCH
9	5GH-2151E-00	LABEL 2		1		ENGLISH
10	5GH-2151E-10	LABEL 2		1		FRENCH
11	3B4-2151F-00	LABEL 3		1		ENGLISH
12	3B4-2151F-10	LABEL 3		1		FRENCH
13	3B4-24875-00	LABEL 1		1		ENGLISH
14	3B4-24875-10	LABEL 1		1		FRENCH
15	5KM-21696-00	LABEL, CAUTION		1		ENGLISH
16	90267-32004	RIVET, BLIND		4		
17	90201-03008	WASHER, PLATE		4		
18	5KM-21696-10	LABEL, CAUTION		1		FRENCH
19	5KM-2151K-00	LABEL 7		1		ENGLISH
20	5KM-2151K-10	LABEL 7		1		FRENCH
21	3B4-24875-20	LABEL 1		1		ENGLISH
22	3B4-24875-30	LABEL 1		1		FRENCH
23	4WU-2151H-10	LABEL 5		1		FRENCH
24	5KM-21558-00	LABEL, WARNING 2		1		ENGLISH
25	5KM-21558-10	LABEL, WARNING 2		1		FRENCH
26	4SH-2416E-00	LABEL, CAUTION CANADA		1		ENGLISH

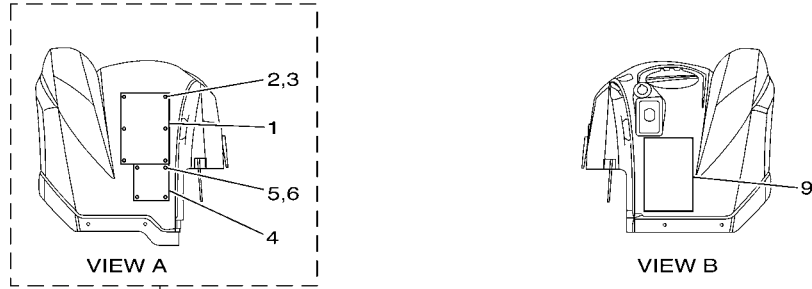

FIG.21-1

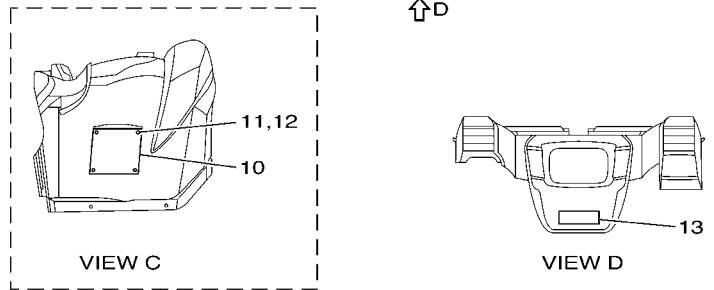
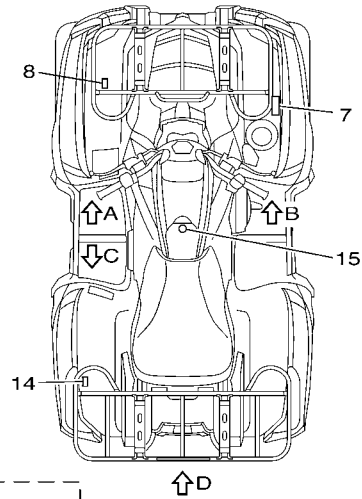

FIG.22-1

3B43300-F510

FIG. 54 EMBLEM & LABEL 3

REF. NO.	PART NO.	DESCRIPTION	USA	CAN	EUR	REMARKS
1	5FK-21568-00	LABEL, WARNING			1	
2	90267-32004	RIVET, BLIND			6	
3	90201-03008	WASHER, PLATE			6	
4	5FK-21697-00	LABEL, CAUTION 2			1	
5	90267-32004	RIVET, BLIND			4	
6	90201-03008	WASHER, PLATE			4	
7	3B4-24877-A0	LABEL, CAUTION			1	ENGLISH
8	3GC-24877-A0	LABEL, CAUTION			1	ENGLISH
9	5KM-21558-20	LABEL, WARNING 2			1	
10	5KM-21696-M0	LABEL, CAUTION			1	
11	90267-32004	RIVET, BLIND			4	
12	90201-03008	WASHER, PLATE			4	
13	5KM-2151K-00	LABEL 7			1	ENGLISH
14	4WV-24877-A0	LABEL, CAUTION			1	ENGLISH
15	3ME-2415E-01	LABEL, CAUTION			1	

NUMERICAL INDEX

PART NO.	GRID NO.	PART NO.	GRID NO.	PART NO.	GRID NO.	PART NO.	GRID NO.	PART NO.	GRID NO.	PART NO.	GRID NO.
3B4-11101-00	B - 2	3B4-12405-00	B - 9	3B4-14455-00	B - 11	3B4-16181-00	B - 4	3B4-18104-20	C - 13	3B4-21556-D0	D - 3
5VK-1111F-00	B - 7	3B4-1240A-10	B - 9	3B4-14457-00	B - 11	3B4-16611-00	C - 5	3B4-18115-00	C - 13	5KM-21558-00	G - 10
4G0-11133-11	B - 2	3B4-12411-00	B - 9	59V-14457-00	B - 11	3B4-16620-00	C - 5	3B4-18125-00	C - 13		G - 11
3B4-11165-00	B - 2	1S3-12413-00	B - 9	3B4-14472-00	B - 11	4SH-16664-00	C - 5	3B4-18146-00	C - 13	5KM-21558-10	G - 11
3B4-11166-01	B - 2	3B4-12422-00	B - 8	3B4-14503-00	B - 12	3B4-17223-10	C - 7	3B4-18148-00	C - 11	5KM-21558-20	G - 12
371-11167-01	B - 2	3B4-12428-00	B - 8	3B4-14611-01	B - 13	3B4-17233-00	C - 7	3B4-18160-00	C - 14	5FK-21568-00	G - 12
3B4-11181-00	B - 2	11H-12438-10	B - 8	3YF-14613-01	B - 14	3B4-17243-00	C - 7	3B4-18169-10	C - 13	5FE-21568-01	G - 10
3B4-11185-00	B - 2	3B4-1243A-00	B - 12	3B4-14617-00	B - 13	3B4-17253-00	C - 7	5KM-18171-00	C - 11		G - 11
1S3-11186-00	B - 2	5D3-1243K-00	B - 8	3B4-14627-01	B - 13	3B4-17285-00	C - 7	3B4-18174-01	C - 13	4WU-21568-10	G - 11
214-11198-01	B - 10	3B4-12450-00	B - 8	3B4-14638-00	B - 13	3B4-17421-00	C - 7	3B4-18190-01	C - 13	3B4-21575-10	D - 5
	D - 13	22W-12462-00	B - 9	3B4-14714-10	B - 13	3B4-17432-00	C - 7	5KM-18191-00	C - 13	3B4-215A1-00	D - 4
	D - 15	5KM-12469-00	B - 8	3B4-14718-10	B - 13	3B4-17473-00	C - 7	3B4-18196-00	C - 13	3B4-2160E-00	D - 6
3B4-11311-10	B - 3	3B4-12481-00	B - 8	3B4-1471C-00	B - 13	3B4-17520-00	C - 8	4SH-18198-00	C - 13	3B4-2160F-00	D - 6
1S3-11351-00	B - 3	5Y9-12491-00	G - 6	3B4-1472C-00	B - 13	3B4-17521-00	C - 9	3B4-18318-00	C - 11	3B4-2163G-50	G - 9
3B4-11400-00	B - 4	1AA-12535-00	B - 9	3B4-14733-00	B - 14	3B4-17530-00	C - 9	3B4-18331-00	C - 11	3B4-21651-00	D - 6
3B4-11401-09	B - 4	3B4-12576-00	B - 9	3B4-14752-00	B - 13	3B4-17531-00	C - 9	3B4-18380-00	C - 13	3B4-21652-00	D - 6
3B4-11402-09	B - 4	3B4-12577-00	B - 8	3B4-14755-00	B - 14	3B4-17531-10	C - 9	3B4-18511-00	C - 11	3B4-21669-00	D - 6
3B4-11447-00	B - 4	3B4-12578-00	B - 9	3B4-14758-01	B - 13	3B4-17531-20	C - 10	3B4-18512-00	C - 11	5KM-21696-00	G - 10
3B4-11454-00	B - 4	3B4-13160-00	B - 12	3B4-14759-00	B - 14	3B4-17531-30	C - 10	3B4-18531-00	C - 11		G - 11
3B4-11531-00	B - 4	3B4-13171-00	B - 10	3B4-1477U-00	B - 14	3B4-17531-40	C - 10	3B4-18540-00	C - 11	5KM-21696-10	G - 11
5KM-11536-10	B - 4	3B4-13300-00	B - 10	3B4-15100-23	B - 15	3B4-17531-50	C - 10	5KM-18542-00	C - 11	5KM-21696-M0	G - 12
5KM-11565-00	B - 4	3B4-13329-00	B - 10	3B4-15112-01	B - 15	5KM-17531-50	C - 9	1J7-18547-00	C - 11	5FK-21697-00	G - 12
1S3-11603-10	B - 4	3B4-13354-00	B - 4	3B4-15113-60	C - 2	3B4-17531-60	C - 10	4UN-18566-00	C - 11	5FE-21697-01	G - 10
1S3-11631-10	B - 4	3B4-13355-00	B - 10	3B4-15163-00	C - 5	5KM-17531-60	C - 9	3B4-18581-00	B - 15		G - 11
5VK-11633-00	B - 4	5GH-13440-20	B - 10	3B4-15315-00	C - 2	5KM-17531-70	C - 9	3B4-21110-20	C - 15	3JM-21697-10	G - 11
1S3-11651-00	B - 4	25G-13490-00	B - 10	5KM-15351-00	C - 3	5KM-17531-80	C - 9	3B4-21110-30	C - 15	3B4-21711-D0	D - 7
1S3-11681-00	B - 4	1S3-13493-00	B - 12	3B4-15362-00	B - 15	5KM-17531-90	C - 9	3B4-2113B-00	C - 15	3B4-21717-00	D - 7
5VK-12111-00	B - 6	3B4-13545-00	B - 12	5UG-15371-00	D - 13	5KM-17531-A0	C - 9	3B4-2147A-00	C - 15	3B4-2171A-00	D - 7
5VK-12113-00	B - 6	8FP-13556-00	B - 12	3B4-15379-00	C - 2	5KM-17531-B0	C - 9	3B4-2147E-00	C - 15	3B4-21721-D0	D - 7
3YF-12116-00	B - 6	3B4-13586-00	B - 11	4WV-15381-00	C - 2	3B4-17551-00	C - 9	3B4-2147F-00	C - 15	3B4-21732-00	F - 11
3YF-12117-01	B - 6	3B4-13750-10	B - 12	11H-15383-02	C - 9	3B4-1755A-00	C - 10	3B4-21485-00	C - 15	3B4-21735-00	F - 11
4G0-12118-00	B - 6	3B4-13761-00	B - 12	3B4-15388-00	B - 15	3B4-17582-00	C - 7	3B4-2151B-00	D - 3	3B4-2173E-40	G - 9
5H0-12119-00	B - 6	3B4-13907-00	E - 7	3B4-15411-00	C - 2	3B4-17606-00	C - 5	5GH-2151E-00	G - 10	3B4-2173M-00	D - 7
5VK-12121-00	B - 6	3B4-13971-00	E - 7	3B4-15421-00	C - 2	3B4-17611-00	C - 5		G - 11	3B4-2173N-00	D - 7
5VK-12146-00	B - 6	3B4-13971-10	E - 7	3B4-15431-00	C - 2	3B4-17623-00	C - 5	5GH-2151E-10	G - 11	3B4-21747-00	D - 7
5VK-12151-00	B - 6	4BH-14134-00	B - 12	3B4-15442-00	C - 2	3B4-17632-00	C - 5	3B4-2151F-00	G - 10	3B4-2174A-00	D - 7
5XT-12159-00	B - 6	5LP-14147-00	B - 12	3B4-15451-00	C - 2	4WV-17639-10	C - 5		G - 11	3B4-2174T-00	D - 7
5VK-12161-00	B - 6	1UY-14155-00	B - 12	3B4-15453-00	C - 2	3B4-17641-00	C - 5	3B4-2151F-10	G - 11	3B4-2174Y-00	D - 7
3B4-12170-01	B - 7	1S3-14161-00	B - 12	3B4-15463-00	C - 5	4WV-17644-00	C - 6	4WU-2151H-10	G - 11	5KM-2175B-00	D - 5
1S3-12176-00	B - 7	8CC-14216-10	B - 12	3B4-15471-00	C - 3	3B4-17645-00	C - 5	5KM-2151K-00	G - 10	3B4-2176E-00	D - 7
3TB-12210-00	B - 7	5JW-14348-00	B - 12	3B4-15472-00	C - 3	3B4-17653-00	C - 5		G - 11	3B4-2177B-00	D - 7
4DW-12213-00	B - 7	3B4-14402-01	B - 11	3B4-15473-00	C - 3	3B4-17660-00	C - 6		G - 12	3B4-2177C-10	G - 10
3B4-12221-00	B - 10	3B4-14409-00	B - 11	3B4-15474-00	C - 3	4CW-17664-00	C - 6	5KM-2151K-10	G - 11	3B4-2177K-00	D - 7
3B4-12231-01	B - 7	3B4-14411-10	B - 11	3B4-15515-00	C - 4	3B4-17670-00	C - 6	3B4-21523-00	D - 4	3B4-2177N-00	D - 7
3B4-12241-00	B - 7	3B4-14413-10	B - 12	3B4-15517-00	C - 4	3B4-17681-10	C - 7	3GD-2153E-30	G - 9	3B4-21871-00	D - 7
1S3-12280-01	B - 7	3B4-14424-00	B - 11	3B4-15522-00	C - 4	4WV-17684-00	C - 6	3B4-21541-00	D - 3	1S3-21875-00	D - 7
5VK-12284-00	B - 7	3B4-14451-00	B - 11	1S3-15560-00	C - 4	3B4-17832-00	C - 9	3B4-21552-00	D - 5	3B4-22128-00	D - 9
1S3-12290-00	B - 7	3B4-14453-00	B - 11	5KM-15590-00	C - 4	3B4-18103-10	C - 13	3B4-21553-00	D - 5	3B4-22129-00	D - 9

NUMERICAL INDEX

PART NO.	GRID NO.	PART NO.	GRID NO.	PART NO.	GRID NO.	PART NO.	GRID NO.	PART NO.	GRID NO.	PART NO.	GRID NO.
5KM-22149-10	D - 9	3B4-23875-00	E - 3	3B4-2510F-00	E - 10	3B4-25182-00	E - 10	3B4-2589F-10	F - 9	1NV-2811A-01	C - 15
	E - 5	1UY-23894-01	E - 3		E - 11		E - 11	5DH-25916-00	F - 4	3GH-2819R-00	G - 10
3B4-22171-00	D - 9	3B4-238B0-10	E - 3		E - 14		E - 15	3JD-25917-00	E - 12	3B4-28217-00	D - 4
3B4-22171-11	D - 9	3B4-238B6-00	E - 3		F - 2		F - 3		F - 4	3B4-28227-00	D - 4
3B4-22172-00	D - 9	3B4-24110-00	E - 7	3B4-2510G-00	E - 10	3B4-2518E-00	E - 10	5DH-25919-00	E - 12	3B4-28237-00	D - 4
3B4-22172-11	D - 9	3B4-24110-10	E - 7		E - 11		E - 11	5DH-25919-50	F - 4	3B4-28239-00	F - 11
3B4-2217M-00	D - 9	3B4-24129-00	E - 7		E - 14	3B4-2518E-10	E - 14	3JD-25926-00	E - 12	3B4-28247-00	D - 4
3B4-2217M-11	D - 9	3B4-24141-00	E - 8		F - 2		F - 2		F - 4	3B4-28307-00	D - 4
3B4-2217N-00	D - 9	3B4-2414F-00	E - 7	3B4-2510H-00	E - 10	3B4-2530F-00	E - 14	8CR-25926-00	E - 12	3B4-28309-00	D - 4
3B4-2217N-11	D - 9	3B4-2414H-00	D - 8		E - 11	3B4-2530V-00	E - 14	1UY-25926-51	E - 12	3B4-28313-00	D - 5
3B4-22210-01	D - 11	3B4-2414J-00	E - 7		E - 14		F - 2		F - 4	3B4-28332-00	D - 4
3B4-22517-00	E - 3	3B4-2414K-00	E - 7		F - 2	3B4-2532F-00	F - 2	3GD-25933-00	F - 4	3B4-28349-00	D - 4
3B4-23123-00	E - 6	3ME-2415E-01	G - 12	3B4-2510J-00	E - 10	3B4-2536E-00	E - 15	5DH-25933-00	E - 12	3B4-2837L-00	D - 5
3B4-23133-00	E - 6	4SH-2416E-00	G - 11		E - 11		F - 3	1UY-25937-51	E - 12	3B4-2837N-00	D - 4
3B4-23350-01	E - 5	3B4-2416G-00	E - 8	3B4-25111-10	E - 10	3B4-25390-10	E - 14		F - 4	3B4-2837R-00	D - 4
3B4-23391-00	D - 5	3B4-24181-00	E - 8		E - 11		F - 2	1UY-25938-51	E - 12	3B4-2838K-00	D - 3
5KM-23448-00	E - 14	3B4-24182-00	E - 8		E - 14	3B4-2539F-00	E - 14		F - 4	3B4-2838M-00	D - 3
	F - 2	3B4-24312-00	E - 7		F - 2	3B4-2539G-00	F - 2	3JD-25961-00	E - 12	3B4-2839N-00	D - 3
3B4-23501-00	E - 10	3B4-24313-00	E - 7	3B4-2511G-00	E - 10	3B4-25715-00	F - 9		F - 4	3B4-2842M-00	F - 12
3B4-23502-00	E - 11	3B4-24380-10	E - 7		E - 11	3B4-2580T-01	E - 12	3B4-26111-20	F - 6	3B4-2842M-10	F - 12
2NL-23517-00	E - 14	3B4-24398-00	E - 7		E - 15	3B4-2580U-01	E - 12	3B4-26124-00	F - 6	3B4-2842N-00	F - 12
	F - 2	1S3-24486-00	E - 7		F - 3	3B4-2580V-01	F - 4	1NV-26129-00	F - 6	3B4-2842N-10	F - 12
5KM-23526-10	D - 9	3B4-24491-00	E - 7	3B4-2511H-00	E - 10	3B4-2580W-01	F - 4	3B4-26232-00	D - 5	3B4-2845L-00	D - 4
	E - 5	3B4-24610-00	E - 7		E - 11	3B4-2582T-01	E - 12	5LP-26241-00	F - 6	3B4-2845N-00	F - 12
3B4-23540-00	E - 5	3B4-2470F-00	E - 9		E - 14	3B4-2582V-00	F - 4	5KM-26250-20	F - 6	3B4-28487-00	D - 4
3B4-23540-11	E - 5	3B4-2470F-30	E - 9		F - 2	3B4-2583T-00	F - 8	1NV-2625G-01	F - 6	3B4-28488-00	C - 15
3B4-23550-00	E - 5	3B4-24710-01	E - 9	3B4-2512A-00	E - 10	3B4-2583V-00	F - 9	1NV-2625K-00	F - 6	3B4-46101-01	D - 12
3B4-23550-11	E - 5	3B4-24710-31	E - 9		E - 11	3GM-25852-22	F - 8	4KB-2628F-10	F - 6	3B4-46117-00	D - 15
3B4-23570-00	E - 5	3B4-24725-00	E - 9		E - 15		F - 9	4KB-2628G-00	F - 6	3B4-46117-10	D - 15
3B4-23570-11	E - 5	22W-24741-00	E - 9		F - 3	4TT-25854-00	F - 8	3B4-26294-00	F - 9	3B4-46117-20	D - 15
3B4-23579-00	E - 10		G - 5	3B4-2512G-00	E - 10		F - 9	1NV-26304-00	F - 6	3B4-46117-30	D - 15
	E - 11	5RU-24768-00	D - 4		E - 11	3B4-2585B-00	F - 8	3B4-26311-10	F - 6	3B4-46119-00	D - 12
5LP-23579-00	E - 5	3B4-24821-00	F - 12		E - 15		F - 9	5EB-26332-00	F - 8	3B4-46119-10	D - 12
3B4-23580-00	E - 5	3B4-24822-00	F - 12		F - 3	2GU-25866-00	F - 8		F - 9	3B4-46119-20	D - 12
3B4-23580-11	E - 5	3B4-2482J-01	F - 12	3B4-2512H-00	E - 10		F - 9	3B4-26341-00	F - 6	3B4-46119-30	D - 12
1UY-23812-00	E - 3	3B4-2482K-01	F - 12		E - 11	56A-25867-00	F - 8	3B4-26347-00	F - 6	3B4-46119-40	D - 12
3B4-23813-00	E - 3	3B4-24841-00	F - 12		E - 15		F - 9	3B4-26372-00	F - 9	3B4-46119-50	D - 12
8K1-23814-00	E - 3	3B4-24842-00	F - 12		F - 3	3B4-25871-10	F - 8	3B4-2637A-01	F - 8	3B4-46126-00	D - 12
3B4-23816-00	E - 3	3B4-24842-10	F - 12	3B4-2512J-00	E - 10	3B4-25872-10	F - 8	3B4-2637F-10	F - 6	5KM-46126-00	D - 14
3B4-2381B-00	E - 3	3B4-24875-00	G - 10		E - 11		F - 9	1NV-26398-00	F - 6		E - 2
5KM-23831-00	E - 4		G - 11		E - 15	3B4-25873-10	F - 8	3B4-27211-00	F - 10	2HR-46127-00-25	D - 12
1UY-23841-01	E - 4	3B4-24875-10	G - 11		F - 3	3B4-25874-10	F - 9	5KM-27414-01	B - 13	2HR-46127-00-30	D - 12
1UY-23845-01	E - 4	3B4-24875-20	G - 10	3B4-2514A-00	E - 10	3B4-25875-00	D - 10	5GH-2741A-10	F - 11	2HR-46127-00-35	D - 12
5KM-2385L-01	D - 11		G - 11		E - 14	3B4-25876-10	F - 8	3B4-27452-00	F - 11	2HR-46127-00-40	D - 12
5KM-2385M-01	D - 11	3B4-24875-30	G - 11	3B4-2515A-00	E - 11	3B4-25882-10	F - 9	3B4-27453-01	F - 11	2HR-46127-00-45	D - 12
5GH-23868-00	E - 3	3B4-24877-A0	G - 12		F - 2	3B4-25886-00	F - 8	3B4-27462-00	F - 11	2HR-46127-00-50	D - 12
3B4-2386G-00	D - 11	3GC-24877-A0	G - 12	3B4-25180-10	E - 10	3B4-2588F-00	F - 9	3B4-27463-01	F - 11	3B4-46129-00	D - 12
3B4-2386H-00	D - 11	4WV-24877-A0	G - 12		E - 11	3B4-2589F-00	F - 8	5TG-28100-00	C - 15	3B4-46134-00	D - 15

NUMERICAL INDEX

PART NO.	GRID NO.	PART NO.	GRID NO.	PART NO.	GRID NO.	PART NO.	GRID NO.	PART NO.	GRID NO.	PART NO.	GRID NO.
3B4-46135-00	D - 15	11H-81844-00	F - 14	3B4-83755-00	G - 5	90105-06078	B - 7	90119-06152	D - 4	90183-051A0	G - 8
5KM-46136-00	D - 14	1FK-81847-00	F - 14	3B4-83912-00	F - 9	90105-06082	B - 7		D - 6	90183-06053	D - 3
	E - 2	4NK-81850-00	F - 14	3B4-83922-00	F - 8		B - 10		D - 7		D - 6
5KM-46137-00	D - 14	4G0-81871-00	F - 14	437-83936-01	G - 6		B - 15		F - 12		D - 7
	E - 2	1S3-81890-00	F - 14	3B4-83972-00	F - 7	90105-06639	C - 15	90119-08106	E - 3		G - 7
3B4-46141-00	D - 15	3B4-81940-00	G - 5	3B4-83976-00	F - 7	90105-07004	B - 7	90119-08118	F - 12	90183-060A2	B - 13
3B4-46142-00	D - 15	5DM-81950-00	G - 6	5KM-83976-20	F - 6	90105-08153	E - 3	90119-10023	B - 3	90183-060A5	C - 3
3B4-46144-00	D - 12	5EA-81950-20	G - 6	3B4-83980-00	F - 9	90105-08161	E - 12	90119-10044	F - 11	90183-080A1	C - 13
4WV-46145-10	D - 15	29U-81950-93	G - 6	4HM-83980-00	F - 8		F - 4		F - 12	90185-10011	C - 15
3B4-46151-00	D - 12	5EA-81952-00	G - 6	3B4-84300-00	G - 2	90105-10131	D - 11	90149-04278	F - 6	90185-10012	D - 9
3B4-46152-00	D - 13	1D7-81960-00	G - 5	3B4-84314-00	G - 2		E - 5	90149-05016	C - 11		D - 11
3B4-46160-00	D - 15	4WA-81980-00	G - 6	2GU-84334-00	G - 2	90105-10185	E - 14	90149-08013	C - 9		E - 5
3B4-46161-00	D - 15	5TJ-81980-00	G - 6	3B4-84340-00	G - 2		F - 2	90149-08018	C - 4		E - 14
3B4-46162-00	D - 15	5VG-81980-00	G - 6	5GH-84703-10	G - 2	90105-10204	E - 3	90154-05021	G - 2		F - 2
3B4-46163-00	D - 15	4SH-82100-22	G - 5	3FA-84710-00	G - 3	90105-10219	C - 15	90154-06014	E - 10	90185-22008	E - 3
3B4-46164-00	D - 15	3B4-82116-10	G - 5		G - 4	90105-10222	D - 9		E - 11	90201-03008	G - 10
3B4-46166-00	D - 15	3B4-82122-00	D - 4	1A2-84714-41	G - 3		E - 5		E - 14		G - 11
3B4-4616A-00	D - 15	1S3-82123-00	C - 3		G - 4	90105-10237	C - 15		F - 2		G - 12
3B4-46172-00	D - 14	3B4-82128-00	G - 5	3B4-84751-00	G - 4	90105-10238	C - 15	90157-04006	C - 5	90201-04027	E - 14
3B4-46173-00	E - 2	3B4-82129-00	G - 5	2EK-85111-00	G - 8	90105-14003	C - 11	90159-05044	G - 2		F - 2
3B4-461A0-00	D - 12	3B4-82133-10	G - 5	3Y6-85130-02	G - 8	90109-06172	C - 14	90170-06128	B - 6	90201-047R9	C - 5
3B4-4621F-00	D - 13	5PS-82151-00	G - 6	449-85131-02	G - 8		D - 3	90170-08358	C - 13	90201-05015	B - 13
3B4-4621F-10	D - 13	5JJ-82151-10	G - 6	8CC-85790-01	G - 5		D - 10	90170-10010	E - 4	90201-05019	B - 13
3B4-4621F-20	D - 13	5JJ-82151-30	G - 6	5FL-85885-02	B - 12		E - 3	90170-18003	B - 4	90201-05039	F - 15
3B4-4621F-30	D - 13	5JJ-82151-90	G - 6	8FP-85886-00	B - 11		E - 7	90170-36279	C - 6	90201-06019	B - 13
3B4-46316-00	D - 12	4GB-82180-00	G - 6	3B4-8591A-10	G - 5		F - 9	90171-10001	E - 4	90201-06033	F - 11
3B4-4631A-01	D - 13	3B4-82309-00	G - 7	3B4-859A0-10	G - 6		F - 11		E - 5	90201-06036	B - 13
3B4-46326-00	D - 13	1D7-82310-00	G - 5	5KM-86171-00	G - 7	90109-06202	C - 15	90171-12001	E - 5		C - 13
3B4-46344-00	D - 13	3B4-8233W-10	D - 4	5D3-W0041-00	F - 8	90109-06214	C - 15	90179-05523	D - 3	90201-06078	F - 11
3B4-46344-10	D - 13	5VK-82370-00	G - 5	5LP-W0041-00	F - 9		F - 11	90179-08029	B - 14	90201-06081	B - 13
3B4-46344-20	D - 13	1C7-82380-00	B - 12	3B4-W0045-00	E - 12	90109-08101	E - 12	90179-10020	E - 10	90201-06097	G - 3
3B4-46344-30	D - 13	3B4-82510-00	G - 5	3B4-W0045-10	E - 13		F - 4		E - 11		G - 4
3B4-46344-40	D - 13	3B4-8253E-10	D - 4	3B4-W0046-00	F - 4	90109-09002	B - 2		E - 14	90201-08048	E - 3
3B4-46344-50	D - 14	3B4-8253F-10	D - 4	3B4-W0046-10	F - 5	90109-09003	B - 2		F - 2	90201-08087	D - 13
3B4-46470-00	D - 15	3B4-82540-01	G - 5	3B4-W0047-00	E - 12	90109-09005	B - 2	90179-12005	D - 12	90201-10035	C - 15
5KM-46559-00	D - 14	3GB-82540-01	G - 5		F - 4	90109-14002	C - 11	90179-16004	B - 4		D - 11
	E - 2	3B4-8254B-00	G - 6	1UY-W0048-50	E - 12	90110-05031	C - 2	90179-16005	C - 6		E - 14
3B4-47359-00	D - 15	3B4-8254E-10	D - 4		F - 4		F - 13	90179-16006	C - 9		F - 2
3B4-47491-00	D - 11	4GB-82560-00	G - 6	3B4-W0057-00	E - 12	90110-06200	D - 9	90179-20016	E - 10	90201-10118	F - 8
3B4-67839-00	D - 15	3HN-82569-00	G - 5	3B4-W0057-10	F - 4		E - 6		E - 11		F - 9
3B4-81410-00	F - 13	3B4-82576-00	G - 7	3B4-W1471-10	B - 13		F - 11		E - 15	90201-12029	D - 12
3B4-81450-00	F - 13	3HN-82579-00	G - 6	3B4-W2151-D0	D - 3	90110-08091	C - 9		F - 3	90201-127J6	C - 11
5KM-81677-00	F - 9	3B4-82590-20	G - 6	3B4-W215B-D0	D - 3	90111-06086	F - 11	90179-22013	C - 9	90201-132G5	C - 13
3AJ-81801-00	F - 14	3B4-82590-30	G - 6	3B4-W215C-D0	D - 3	90114-10014	E - 10	90179-22021	C - 5	90201-14023	F - 10
3KS-81809-00	F - 14	4V4-82913-00	F - 6	3B4-W215D-D0	D - 3		E - 11	90179-55660	C - 10	90201-150U6	C - 7
3B4-81815-00	F - 14	3B4-83371-00	G - 7	3B4-W2161-D0	D - 6		E - 14	90179-60001	C - 9	90201-16021	C - 9
3AJ-81826-00	F - 14	3B4-83500-01	F - 15	3B4-W216B-D0	D - 6		F - 2	90183-05008	D - 5		E - 3
4XV-8182A-00	F - 14	3B4-83500-11	F - 15	3B4-W216C-D0	D - 6	90119-06137	G - 5		G - 2	90201-165H4	B - 4

NUMERICAL INDEX

PART NO.	GRID NO.	PART NO.	GRID NO.	PART NO.	GRID NO.	PART NO.	GRID NO.	PART NO.	GRID NO.	PART NO.	GRID NO.
90201-170U8	C - 7	90387-090R0	E - 3	90464-16006	F - 9	91312-04006	B - 12	93210-21190	B - 8	93450-22119	E - 10
90201-190T7	C - 6	90387-20021	C - 7	90464-16012	D - 8	91312-06012	B - 8	93210-21631	B - 15		E - 11
90201-20028	C - 7	90387-22014	E - 3	90464-20010	F - 8		B - 10	93210-26001	C - 7	93450-24062	C - 5
90201-20792	C - 11	90387-22591	E - 3		G - 7		B - 15	93210-29196	G - 5	93450-24154	B - 4
90201-25290	C - 7	90387-250R3	C - 7	90464-20181	G - 6	91312-06020	B - 8	93210-33786	B - 8	93503-08007	C - 11
90201-25634	D - 12	90387-26001	C - 7	90464-20237	G - 7		G - 5	93210-357A3	C - 2	93604-10011	B - 8
90201-286K9	C - 4	90401-08004	B - 2	90464-35132	C - 15	91312-06025	B - 7	93210-41042	B - 9	93604-18100	C - 11
90209-06012	B - 9	90401-10015	F - 8	90465-10098	G - 6	91312-06030	B - 2	93210-44545	C - 6	93606-09002	B - 4
90209-10229	E - 4		F - 9	90467-07029	D - 14	91312-06040	B - 3	93210-626A7	D - 12	93612-16254	B - 2
90214-22007	C - 7	90401-10024	B - 10		E - 2	91312-08040	B - 15	93210-78544	B - 2	93700-06004	E - 14
90215-10008	B - 10	90401-14118	B - 10		E - 3	91401-16012	F - 6		C - 9		F - 2
90215-18001	B - 4	90401-20003	B - 10	90467-07093	B - 8	91401-20012	F - 7	93210-96601	B - 2	93900-00030	E - 10
90240-06076	F - 7	90430-06014	B - 8	90467-08003	D - 7	91401-20020	E - 4	93211-594A4	C - 5		E - 11
90240-08013	F - 9		B - 9	90467-09006	E - 7		E - 5	93305-00602	E - 10		E - 14
90267-32004	G - 10	90430-08119	B - 2	90467-10041	B - 11	91490-25020	E - 5		E - 11		F - 2
	G - 11	90430-10003	D - 15	90467-110A2	B - 12	91A20-07020	B - 11		E - 14	94108-12012	E - 10
	G - 12	90430-10148	G - 5	90467-140A4	B - 2	92012-06012	B - 13		F - 2		E - 11
90267-47187	E - 14	90430-10188	B - 10		B - 12	92012-06014	B - 13	93306-00006	B - 8	94110-12012	E - 14
	F - 2	90430-12202	G - 5	90467-150A2	B - 2	92012-06020	B - 13	93306-00426	C - 7		F - 2
90269-05055	C - 14	90430-14043	B - 10	90467-220A1	B - 11	92012-06030	F - 13	93306-00613	D - 15	94580-31074	B - 10
90269-06081	D - 7		C - 11	90467-26189	B - 9		G - 4	93306-00704	D - 13	94591-57126	B - 7
90269-07010	D - 4	90430-14194	C - 11	90468-18195	E - 4	92902-05200	F - 12	93306-07209	B - 7	94701-00420	B - 2
	D - 6	90445-070F1	E - 2	90480-01400	E - 7		G - 8	93306-07801	C - 7	95022-06008	B - 13
	D - 8		E - 3	90480-01558	D - 7	92902-05600	D - 3	93306-20120	C - 2		G - 5
90269-07012	D - 3	90445-07340	B - 8	90480-13004	D - 3		F - 6	93306-20309	C - 7	95022-06010	B - 8
90269-07076	D - 7	90445-074F6	D - 14	90480-13018	C - 2		G - 7	93306-20464	C - 7		B - 9
90269-07077	D - 3	90445-09110	D - 7	90480-13398	C - 3	92902-06200	B - 13	93306-205U0	D - 12	95022-06012	B - 2
90280-05001	B - 4	90445-09117	D - 7		D - 3	92902-06600	G - 4	93306-20654	C - 9	95022-06016	C - 2
90282-05007	B - 4	90445-09220	G - 3	90480-13567	C - 3	92902-08600	C - 9	93306-207U0	D - 13	95022-06020	B - 2
90338-08174	B - 11		G - 4		D - 5		D - 13	93306-30438	B - 5		B - 9
90338-08226	D - 5	90445-12006	B - 12	90480-14532	F - 11		F - 9		C - 8		C - 13
90338-09130	D - 6	90450-32015	B - 8	90480-15235	B - 9	92907-04600	F - 6	93306-30523	D - 13	95022-06030	B - 8
90338-18122	F - 12	90450-59006	B - 11	90480-17001	B - 13	92907-06200	F - 7	93306-30534	B - 5		B - 15
90340-10001	D - 15	90450-72004	B - 11	90480-18290	E - 7	92907-06600	B - 9	93306-30537	C - 9		C - 2
90340-14002	D - 13	90450-99010	B - 13	90501-05764	G - 2	93101-10090	B - 8	93306-30810	B - 4		C - 5
90340-14011	C - 2	90460-85135	C - 3	90501-06022	C - 11	93101-12168	C - 2	93306-37206	C - 9		F - 14
90340-14029	D - 13	90461-08004	C - 2	90501-08665	F - 7	93101-35001	C - 5	93310-32590	C - 7	95022-06040	B - 10
	D - 15	90462-08049	B - 15	90501-10353	C - 11	93102-15212	C - 13	93310-84017	B - 4		C - 5
90340-14132	B - 10	90462-08055	C - 3	90501-12004	C - 12	93102-30010	C - 9	93315-21813	C - 5	95022-06045	B - 9
90340-36002	C - 2	90462-16003	B - 15	90501-140A2	C - 11	93102-35004	C - 5	93316-01003	C - 5	95022-06050	B - 8
90380-10002	C - 4	90464-06007	B - 12	90501-18002	D - 14	93102-35009	D - 12	93332-00046	D - 12		C - 2
90381-17067	E - 14	90464-09013	G - 7		E - 2	93102-42004	C - 7	93332-00053	D - 12	95022-06060	B - 15
	F - 2	90464-10112	G - 6	90501-220A1	B - 4	93104-09025	F - 6	93410-20038	C - 11	95022-08012	D - 13
90387-06113	B - 9	90464-12045	G - 7	90501-650A0	C - 6	93104-41119	C - 6	93410-22039	D - 14	95302-05600	G - 8
90387-0613B	C - 13	90464-13073	G - 6	90506-16318	F - 10	93105-46001	D - 15		E - 2	95302-05800	F - 15
90387-065G1	G - 4	90464-14004	E - 7	90506-30006	B - 13	93112-31011	E - 3	93410-46079	C - 5	95302-06800	E - 7
90387-066J1	E - 7	90464-15157	G - 6	90508-32018	C - 11	93210-10096	B - 10	93440-15012	C - 8		G - 4
90387-07021	E - 7	90464-15195	G - 6	90508-35764	C - 13	93210-14369	C - 2	93440-25084	C - 7	95302-08700	C - 13

NUMERICAL INDEX

PART NO.	GRID NO.	PART NO.	GRID NO.	PART NO.	GRID NO.	PART NO.	GRID NO.	PART NO.	GRID NO.	PART NO.	GRID NO.
95302-10700	E - 4	97022-08060	E - 3								
95307-05700	F - 6	97702-50512	D - 4								
95312-06600	F - 10	97702-50516	F - 12								
	F - 11	97702-50520	B - 11								
95312-10600	B - 10	97702-60025	G - 5								
95602-10200	C - 15	98502-03530	G - 2								
	D - 11	98502-05016	D - 3								
95604-06100	F - 8	98502-05020	F - 6								
95607-05100	F - 6	98502-06016	B - 13								
95612-08625	B - 2	98507-04016	F - 6								
95612-16100	E - 4	98507-05012	B - 12								
95702-06300	D - 9	98507-05020	F - 6								
	E - 6	98507-06010	B - 12								
	F - 11	98507-06012	B - 12								
	G - 3	98706-04012	F - 8								
	G - 4		F - 9								
95702-06500	G - 5	98902-06020	G - 7								
95702-08500	B - 14	99001-10600	F - 10								
95802-06012	D - 2	99009-10400	B - 8								
	D - 4	99009-12400	C - 11								
	F - 8	99009-19400	D - 14								
95802-06020	B - 9		E - 2								
	G - 5	99009-30400	E - 5								
95802-06030	E - 7		E - 10								
95812-06012	G - 7		E - 11								
95812-06014	D - 15	99009-35400	B - 4								
95812-06016	C - 13	99009-55500	E - 10								
95812-06035	C - 13		E - 11								
95812-08014	D - 11		E - 14								
	F - 12		F - 2								
95812-08040	B - 14	99009-80500	C - 5								
	D - 15	99530-08012	C - 13								
95812-10035	C - 15	99530-10014	D - 13								
95822-06020	C - 3	99530-10116	B - 15								
95822-06025	F - 8		C - 2								
	F - 9		C - 5								
95822-06030	C - 2	99530-14016	B - 15								
95822-06040	C - 2										
95822-08012	B - 14										
95822-08030	E - 3										
97002-05016	G - 7										
97002-06012	B - 12										
97002-06016	G - 5										
97017-06010	B - 9										
97022-06014	F - 10										
97022-08025	D - 13										
97022-08030	C - 9										
97022-08035	D - 13										