

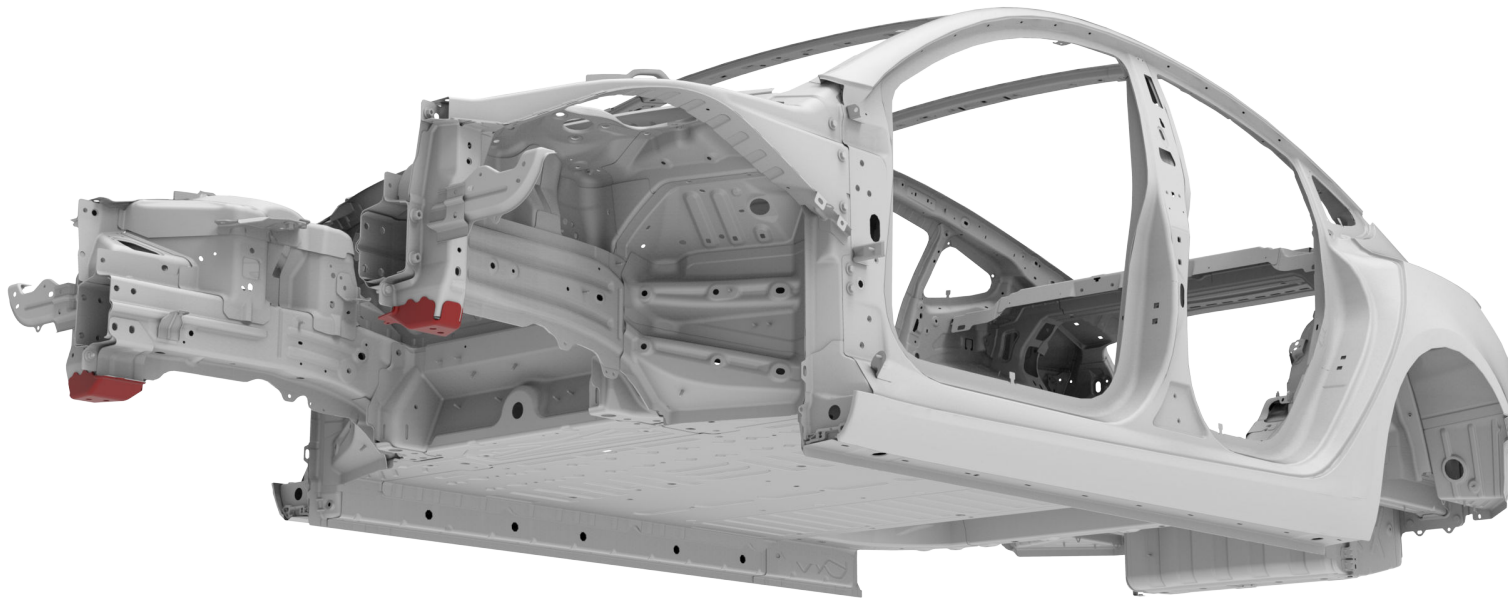





Front Subframe Mount Cap





Parts List

Quantity	Part Number	Description	Image / Notes
1	1074845-S0-A (LH) 1074846-S0-A (RH)	Front Subframe Mount Cap	
15 rivets needed; order 20 rivets.	1454538-00-A	 High Strength Structural Rivet, 6.5 mm	All rivets come in packages of 10; order all rivets in multiples of 10.
1	—	Structural Adhesive	 WARNING: Use only Tesla-approved structural adhesive; refer to BR-15-92-008 , "Approved Structural Adhesive and Urethane Sealants" for a list of current approved structural adhesives. Source locally; not available from Tesla.
1	—	Seam Sealer	Source locally; not available from Tesla.

These part numbers were current at the time of publication. Use the revisions listed or later, unless otherwise specified in the [Parts Manual](#).



Repair Information

Repair Information	Warnings and Cautions	Special Tools
<p>This procedure is for the left-hand component; the procedure is identical for the right-hand component.</p> <p>Installation fasteners that replace factory spot welds in steel-to-steel panel interfaces are specified in this procedure where an approved squeeze-type resistance spot welder with the base welding accessories might not be able to reach. If your approved welder can access a factory spot weld location where this procedure specifies a fastener, an installation spot weld is recommended in place of the specified fastener.</p>	<p>⚠ WARNING: Wear the appropriate personal protective equipment (PPE) when performing this procedure.</p>	<p>The special tool listed below is required to perform this procedure:</p> <ul style="list-style-type: none">• GMA welder <p>Use only an approved GMA welder. Refer to BR-16-92-007, "Approved Welders" for a list of current approved GMA welders.</p>



Removal

Remove the original component.

A

Use a drill with a spot weld bit to drill out the factory spot welds.
Use a belt sander to sand down any factory spot welds that cannot be reached with a drill.

▲ Factory Spot Weld



NOTE: Factory spot weld locations shown are approximate. Exact spot weld locations and number vary from vehicle to vehicle.

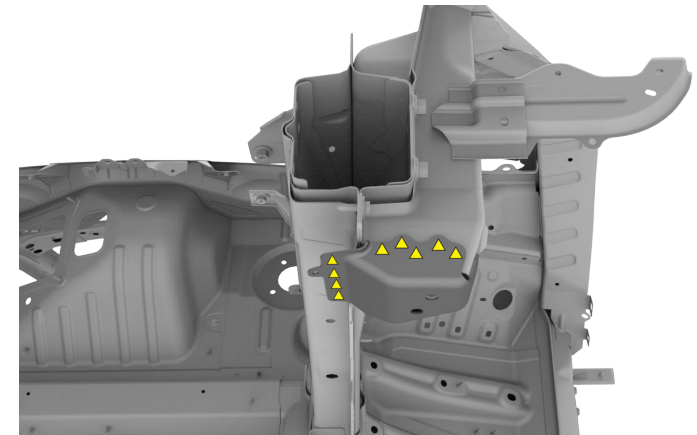
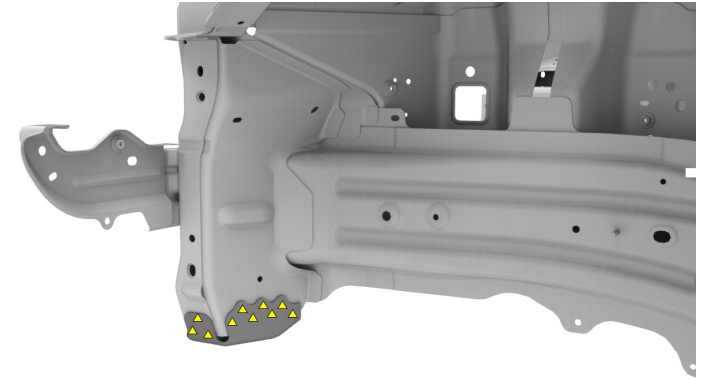



Removal

Remove the original component (continued).

B Use a heat gun to heat the adhesive joints, and then use a hammer and chisel to remove the remaining pieces of the original component.



WARNING: Do not heat the adhesive joints above 100°C (212°F). Heating the adhesive joints above 100°C (212°F) can weaken the aluminum and compromise vehicle crash integrity.



WARNING: Do not heat any adhesive joints of components that are not being removed. Heating adhesive joints weakens the adhesive bond and could compromise vehicle crash integrity.

C

Use a disc sander with a medium-abrasive surface conditioning disc to remove any remaining materials from the mating surfaces. Use a belt sander with a medium-abrasive belt for any areas that cannot be reached with a disc sander. Vacuum any adhesive dust.



WARNING: Remove the epoxy adhesive in a well-ventilated area. Wear suitable personal protective equipment.



Replacement

1 Prepare for installation.

A Put the new component into position and secure it in place.

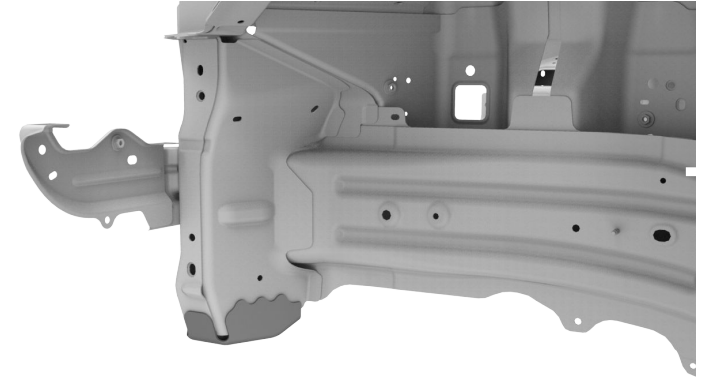

B Mark the fastener locations on the new component.
● High Strength Structural Rivet, 6.5 mm (x10)

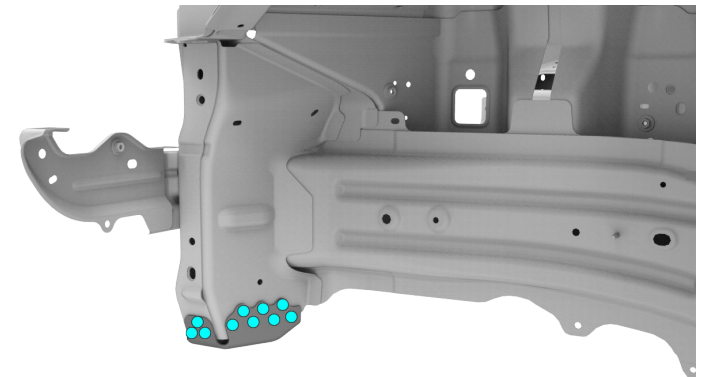



Replacement

1 Prepare for installation (continued).

C Mark the fastener locations on the new component.
● High Strength Structural Rivet, 6.5 mm (x5)

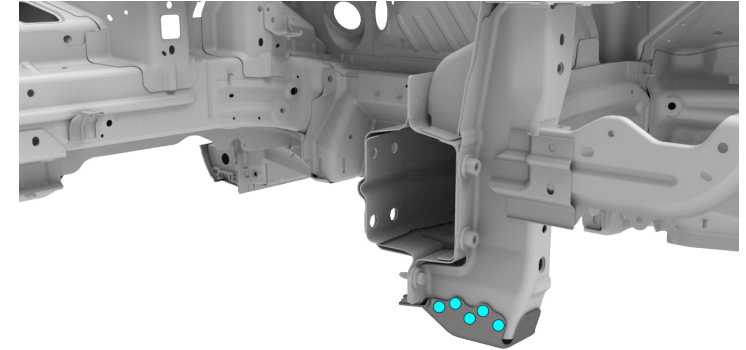

D Mark holes for plug welds on the new component.
▲ Steel Plug Weld





Replacement

1 Prepare for installation (continued).

E

Drill 6.7 mm holes for structural rivets.



NOTE: Install a grip screw after drilling each hole to keep the panel aligned while drilling the remaining holes.

F

Drill 10 mm holes for plug welds.



NOTE: Drill holes through only one panel; either the Front Subframe Mount Cap or the Front Subframe Mount Front Inner.



Replacement

- 1 Prepare for installation (continued).
 - G Mark boundary lines along all mating surfaces between the new component and the vehicle for surface preparation.
 - H Remove the new component.



Replacement

2 Prepare the surfaces.

A Use a disc sander with a medium-abrasive surface conditioning disc to remove the e-coat from the mating surfaces of the new components. Use a belt sander with a medium-abrasive belt for any areas that cannot be reached with a disc sander.



WARNING: Remove the e-coat in a well-ventilated area. Wear suitable personal protective equipment.

B Use a red Scotch-Brite pad or equivalent to scuff the e-coat on the mating surfaces of the new component.

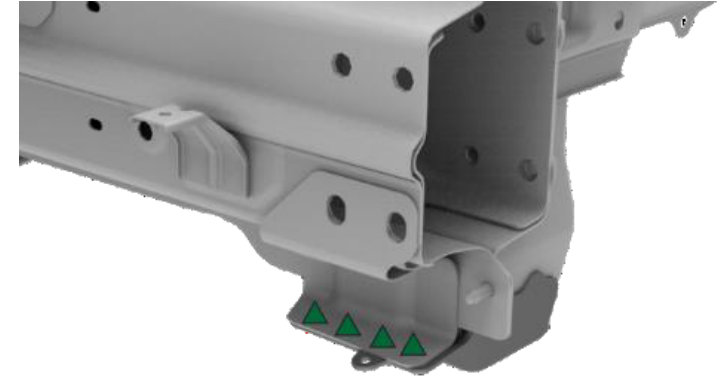



Replacement

2 Prepare the surfaces (continued).

C Clean all the mating surfaces and weld areas of the new component or components and the vehicle with isopropyl alcohol (IPA).



WARNING: Wipe off the remaining isopropyl alcohol with a clean, dry towel immediately after application. Do not let the remaining isopropyl alcohol air dry. Allowing the remaining isopropyl alcohol to air dry can compromise the adhesive bond.

3 Apply structural adhesive.

A Spread a thin coating of structural adhesive as a primer layer on the mating surfaces of the vehicle and the new component.



CAUTION: If any bare metal mating surfaces have been exposed for two hours or longer, abrade the mating surfaces again to remove oxidation, then clean the mating surfaces with isopropyl alcohol (IPA).



WARNING: Do not apply structural adhesive within 25 mm of the GMA weld locations. Applying structural adhesive within 25 mm of the GMA weld locations can cause weld failure.



NOTE: Assembly must be performed while the primer layer is still wet. The drying time of the adhesive varies depending on temperature and humidity.



Replacement

- 3 Apply structural adhesive (continued).
 - B While the primer layer is still wet, apply a bead of structural adhesive on top of the primer layer on the vehicle.

- 4 Install the new component.
 - A Put the new component into position and secure it in place.

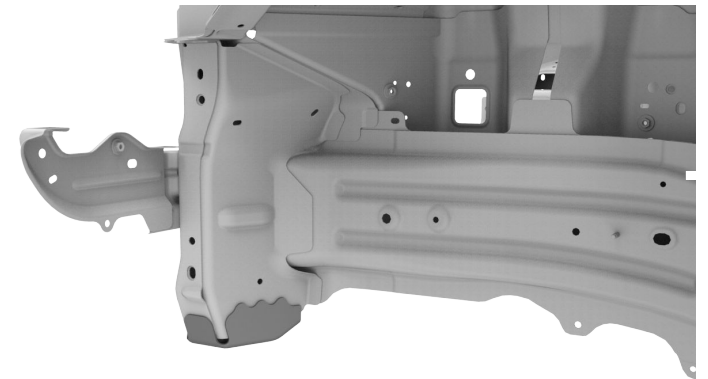



Replacement

4 Install the new component (continued).

B Insert the structural rivets.
● High Strength Structural Rivet, 6.5 mm (x10)

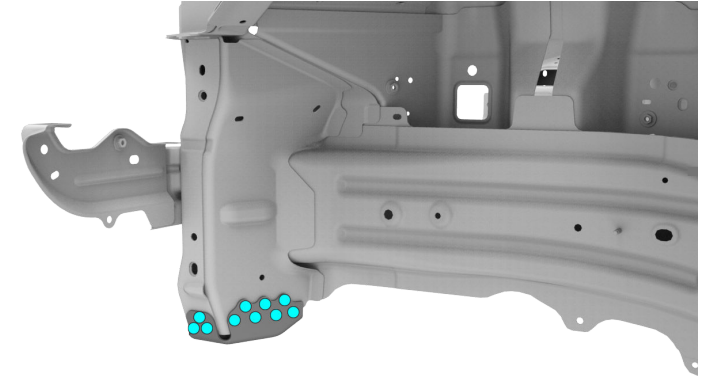

C Insert the structural rivets.
● High Strength Structural Rivet, 6.5 mm (x5)

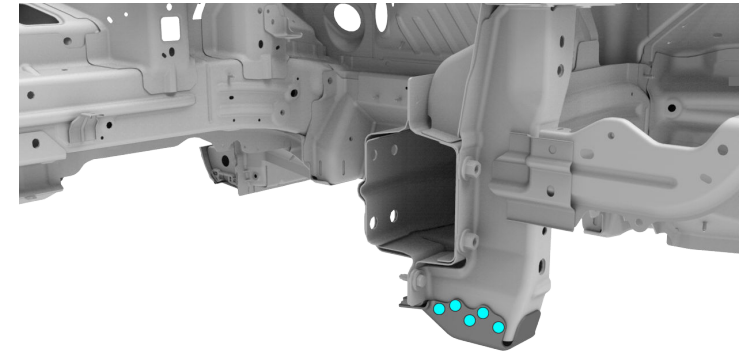



Replacement

4 Install the new component (continued).

D Install the structural rivets.

E Wipe off any excess adhesive.



Replacement

4 Install the new component (continued).

F

Bake the structural adhesive so that the bonded panels reach a temperature of 60°C–80°C (140°F–176°F) for at least 30 minutes to achieve full strength.



WARNING: Do not allow the High Voltage Battery to reach a temperature above 74°C (165°F). Heating the High Voltage Battery above 74°C (165°F) for an extended period could result in injury to personnel and/or damage to the battery.

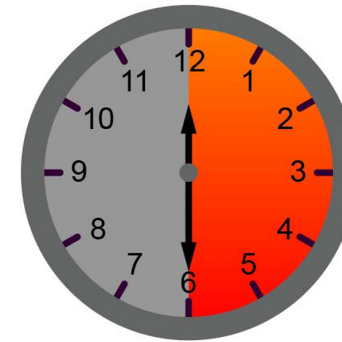

00:30:00+

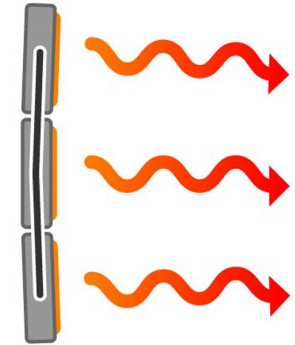

60°C–80°C



Replacement

4 Install the new component (continued).

G

Plug weld the steel areas.

▲ Steel Plug Weld (x4)



WARNING: Failure to follow all welding safety precautions, including the use of personal protective equipment, could result in serious injury or property damage. Only technicians who have successfully met Tesla's requirements for welding training are authorized to weld structural components on Tesla vehicles.



WARNING: To maintain vehicle crash integrity, use only approved welding wire and an approved GMA welder to perform GMA welding on Tesla vehicles. Refer to [BR-15-92-010](#), "Approved GMA Welding Wires for Structural Repairs" for information on approved welding wire and [BR-16-92-007](#), "Approved Welders" for information on approved GMA welders.



WARNING: Before GMA welding, make sure that the structural adhesive is dry to the touch. If the structural adhesive is not dry to the touch before GMA welding, the strength of the adhesive bond might be compromised.



CAUTION: Do not weld on a Tesla vehicle with an energized high voltage or 12V system. Welding on a Tesla vehicle with an energized high voltage or 12V system might damage vehicle components.

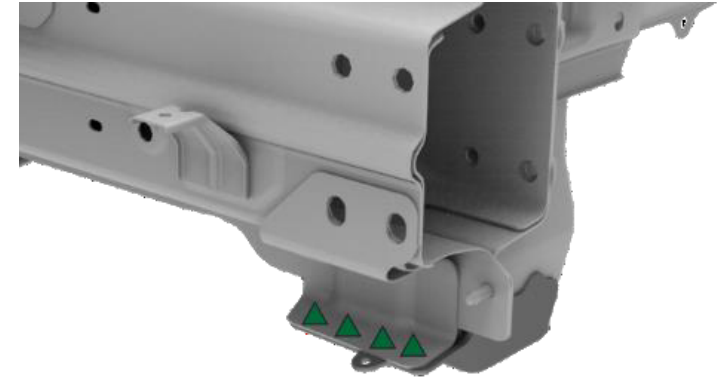



Replacement

4 Install the new component (continued).

H Seal the seams in the factory locations, and as necessary.